



Kevin M. Ellis
H. B. Robinson Steam
Electric Plant Unit 2
Manager – Nuclear Support Services

Duke Energy
3581 West Entrance Road
Hartsville, SC 29550

O: 843 951 1329
F: 843 951 1319

Kevin.Ellis@duke-energy.com

Serial: RA-19-0175

April 08, 2019

ATTN: Document Control Desk
U.S. Nuclear Regulatory Commission
Washington, DC 20555-0001

10 CFR 50.36a(a)(2)
TS 5.5.1.c.3
TS 5.6.3

H. B. ROBINSON STEAM ELECTRIC PLANT (HBRSEP), UNIT NO. 2
DOCKET NO. 50-261 / RENEWED LICENSE NO. DPR-23

2018 ANNUAL RADIOACTIVE EFFLUENT RELEASE REPORT AND OFFSITE
DOSE CALCULATION MANUAL, REVISION 36

Ladies and Gentlemen:

Enclosed is the Annual Radioactive Effluent Release Report for H. B. Robinson Steam Electric Plant, Unit No. 2 (HBRSEP2), for the period of January 1, 2018 through December 31, 2018. This report is submitted in accordance with 10 CFR 50.4, as required by 10 CFR 50.36a(a)(2) and HBRSEP2 Technical Specifications (TS) Sections 5.5.1.c.3 and 5.6.3. Attachment 9 of the Enclosure contains a copy of the HBRSEP Offsite Dose Calculation Manual, Revision 36.

This letter contains no new regulatory commitments.

Should you have any questions regarding this matter, please contact Justin Wild, Regulatory Affairs, at (843) 951-3283.

Sincerely,

Kevin M. Ellis
Manager – Nuclear Support Services

KME/jmw

United States Nuclear Regulatory Commission

Serial: RA-19-0175

Page 2 of 2

Enclosure: 2018 Annual Radioactive Effluent Release Report

c: NRC Regional Administrator, NRC Region II
N. Jordan, NRC Project Manager, NRR (w/o Enclosures)
NRC Resident Inspector, HBRSEP
S. E. Jenkins, SCDHEC

United States Nuclear Regulatory Commission
Enclosure to Serial: RA-19-0175
316 Pages (including this cover sheet)

2018 ANNUAL RADIOACTIVE EFFLUENT RELEASE REPORT

JANUARY 1, 2018 – DECEMBER 31, 2018



H.B. Robinson Steam Electric Plant Unit 2

Annual Radioactive Effluent Release Report

January 1, 2018 through December 31, 2018

Docket 50-261



Introduction

The Annual Radioactive Effluent Release Report is pursuant to H.B. Robinson Steam Electric Plant Technical Specification 5.6.3 and ODCM 9.1. The below listed attachments to this report provide the required information. In addition, the ODCM is included pursuant to H.B. Robinson Steam Electric Plant Technical Specification 5.5.1.

- Attachment 1 Summary of Gaseous and Liquid Effluents
- Attachment 2 Supplemental Information
- Attachment 3 Solid Radioactive Waste Disposal
- Attachment 4 Meteorological Data
- Attachment 5 Unplanned Offsite Releases
- Attachment 6 Assessment of Radiation Dose from Radioactive Effluents to Members of the Public
- Attachment 7 Information to Support the NEI Ground Water Protection Initiative
- Attachment 8 Inoperable Equipment
- Attachment 9 Summary of Changes to the Offsite Dose Calculation Manual
- Attachment 10 Summary of Changes to the Process Control Program
- Attachment 11 Summary of Major Modifications to the Radioactive Waste Treatment Systems
- Attachment 12 Errata to a Previous Year's ARERR

Attachment 1
Summary of Gaseous and Liquid Effluents

H.B. Robinson Steam Electric Plant Unit 2
Period 1/1/2018 - 12/31/2018

ATTACHMENT 1

Summary of Gaseous and Liquid Effluents

This attachment includes a summary of the quantities of radioactive liquid and gaseous effluents as outlined in Regulatory Guide 1.21, Appendix B.

Attachment 1
Summary of Gaseous and Liquid Effluents

H.B. Robinson Steam Electric Plant Unit 2
 Period 1/1/2018 - 12/31/2018

Gaseous Effluents - Summation of All Releases

	<u>Units</u>	<u>Qtr 1</u>	<u>Qtr 2</u>	<u>Qtr 3</u>	<u>Qtr 4</u>	<u>Year</u>
A. Fission and Activation Gases						
1. Total Release	Ci	3.66E-02	6.29E-02	1.43E-01	8.47E-02	3.27E-01
2. Avg. Release Rate	µCi/sec	4.71E-03	8.01E-03	1.79E-02	1.07E-02	1.04E-02
B. Iodine-131						
1. Total Release	Ci	0.00E+00	0.00E+00	0.00E+00	0.00E+00	0.00E+00
2. Avg. Release Rate	µCi/sec	0.00E+00	0.00E+00	0.00E+00	0.00E+00	0.00E+00
C. Particulates Half-Life ≥ 8 days						
1. Total Release	Ci	1.31E-10	1.17E-06	1.75E-04	3.89E-05	2.15E-04
2. Avg. Release Rate	µCi/sec	1.69E-11	1.49E-07	2.20E-05	4.89E-06	6.82E-06
D. Tritium						
1. Total Release	Ci	3.39E+00	3.51E+00	3.02E+00	7.02E+00	1.69E+01
2. Avg. Release Rate	µCi/sec	4.35E-01	4.46E-01	3.80E-01	8.83E-01	5.36E-01
E. Carbon-14						
1. Total Release	Ci	1.77E+00	1.79E+00	1.81E+00	1.81E+00	7.18E+00
2. Avg. Release Rate	µCi/sec	2.25E-01	2.27E-01	2.30E-01	2.30E-01	2.28E-01
F. Gross Alpha						
1. Total Release	Ci	0.00E+00	0.00E+00	0.00E+00	0.00E+00	0.00E+00
2. Avg. Release Rate	µCi/sec	0.00E+00	0.00E+00	0.00E+00	0.00E+00	0.00E+00

Attachment 1
Summary of Gaseous and Liquid Effluents

H.B. Robinson Steam Electric Plant Unit 2
 Period 1/1/2018 - 12/31/2018

Gaseous Effluents - Elevated Releases - Continuous Mode *

	<u>Units</u>	<u>Qtr 1</u>	<u>Qtr 2</u>	<u>Qtr 3</u>	<u>Qtr 4</u>	<u>Year</u>
A. Fission and Activation Gases						
N/A	Ci	-	-	-	-	-
Total for Period	Ci	-	-	-	-	-
B. Iodines						
N/A	Ci	-	-	-	-	-
Total for Period	Ci	-	-	-	-	-
C. Particulates Half-Life \geq 8 days						
N/A	Ci	-	-	-	-	-
Total for Period	Ci	-	-	-	-	-
D. Tritium						
N/A	Ci	-	-	-	-	-
E. Carbon-14						
N/A	Ci	-	-	-	-	-
F. Gross Alpha						
Total for Period	Ci	-	-	-	-	-

* H.B. Robinson Steam Electric Plant Unit 2 does not have elevated releases.

**Attachment 1
Summary of Gaseous and Liquid Effluents**

H.B. Robinson Steam Electric Plant Unit 2
Period 1/1/2018 - 12/31/2018

Gaseous Effluents - Elevated Releases - Batch Mode *

	<u>Units</u>	<u>Qtr 1</u>	<u>Qtr 2</u>	<u>Qtr 3</u>	<u>Qtr 4</u>	<u>Year</u>
A. Fission and Activation Gases						
N/A	Ci	-	-	-	-	-
Total for Period	Ci	-	-	-	-	-
B. Iodines						
N/A	Ci	-	-	-	-	-
Total for Period	Ci	-	-	-	-	-
C. Particulates Half-Life \geq 8 days						
N/A	Ci	-	-	-	-	-
Total for Period	Ci	-	-	-	-	-
D. Tritium						
N/A	Ci	-	-	-	-	-
E. Carbon-14						
N/A	Ci	-	-	-	-	-
F. Gross Alpha						
Total for Period	Ci	-	-	-	-	-

* H.B. Robinson Steam Electric Plant Unit 2 does not have elevated releases.

Attachment 1
Summary of Gaseous and Liquid Effluents

H.B. Robinson Steam Electric Plant Unit 2
 Period 1/1/2018 - 12/31/2018

Gaseous Effluents - Ground & Mixed-Mode Releases - Continuous Mode

	<u>Units</u>	<u>Qtr 1</u>	<u>Qtr 2</u>	<u>Qtr 3</u>	<u>Qtr 4</u>	<u>Year</u>
A. Fission and Activation Gases						
Xe-133	Ci	0.00E+00	2.56E-02	0.00E+00	6.19E-02	8.75E-02
Total for Period	Ci	0.00E+00	2.56E-02	0.00E+00	6.19E-02	8.75E-02
B. Iodines						
None	Ci	0.00E+00	0.00E+00	0.00E+00	0.00E+00	0.00E+00
Total for Period	Ci	0.00E+00	0.00E+00	0.00E+00	0.00E+00	0.00E+00
C. Particulates Half-Life \geq 8 days						
Co-58	Ci	0.00E+00	1.17E-06	0.00E+00	0.00E+00	1.17E-06
Total for Period	Ci	0.00E+00	1.17E-06	0.00E+00	0.00E+00	1.17E-06
D. Tritium						
H-3	Ci	3.31E+00	3.37E+00	2.84E+00	7.01E+00	1.65E+01
E. Carbon-14						
C-14	Ci	1.09E+00	1.10E+00	1.11E+00	1.11E+00	4.42E+00
F. Gross Alpha						
Total for Period	Ci	0.00E+00	0.00E+00	0.00E+00	0.00E+00	0.00E+00

Attachment 1
Summary of Gaseous and Liquid Effluents

H.B. Robinson Steam Electric Plant Unit 2
Period 1/1/2018 - 12/31/2018

Gaseous Effluents - Ground & Mixed Mode Releases - Batch Mode

	<u>Units</u>	<u>Qtr 1</u>	<u>Qtr 2</u>	<u>Qtr 3</u>	<u>Qtr 4</u>	<u>Year</u>
A. Fission and Activation Gases						
Ar-41	Ci	3.65E-02	3.41E-02	4.46E-02	1.20E-02	1.27E-01
Kr-85m	Ci	0.00E+00	0.00E+00	2.66E-04	0.00E+00	2.66E-04
Kr-88	Ci	0.00E+00	0.00E+00	1.59E-04	0.00E+00	1.59E-04
Xe-131m	Ci	0.00E+00	0.00E+00	0.00E+00	3.85E-05	3.85E-05
Xe-133m	Ci	0.00E+00	2.21E-05	1.74E-03	4.04E-05	1.80E-03
Xe-133	Ci	8.09E-05	3.21E-03	7.80E-02	1.07E-02	9.20E-02
Xe-135	Ci	0.00E+00	0.00E+00	1.77E-02	0.00E+00	1.77E-02
Total for Period	Ci	3.66E-02	3.74E-02	1.43E-01	2.28E-02	2.39E-01
B. Iodines						
None	Ci	0.00E+00	0.00E+00	0.00E+00	0.00E+00	0.00E+00
Total for Period	Ci	0.00E+00	0.00E+00	0.00E+00	0.00E+00	0.00E+00
C. Particulates Half-Life ≥ 8 days						
Mn-54	Ci	0.00E+00	0.00E+00	1.58E-07	0.00E+00	1.58E-07
Co-57	Ci	0.00E+00	0.00E+00	8.60E-07	0.00E+00	8.60E-07
Co-58	Ci	0.00E+00	3.88E-10	1.63E-04	3.73E-05	2.00E-04
Co-60	Ci	1.31E-10	0.00E+00	8.86E-06	1.57E-06	1.04E-05
Zr-95	Ci	0.00E+00	0.00E+00	7.12E-07	0.00E+00	7.12E-07
Nb-95	Ci	0.00E+00	0.00E+00	1.45E-06	0.00E+00	1.45E-06
Total for Period	Ci	1.31E-10	3.88E-10	1.75E-04	3.89E-05	2.14E-04
D. Tritium						
H-3	Ci	7.38E-02	1.39E-01	1.79E-01	6.09E-03	3.98E-01
E. Carbon-14						
C-14	Ci	6.79E-01	6.86E-01	6.93E-01	6.93E-01	2.75E+00
F. Gross Alpha						
Total for Period	Ci	0.00E+00	0.00E+00	0.00E+00	0.00E+00	0.00E+00

Attachment 1
Summary of Gaseous and Liquid Effluents

H.B. Robinson Steam Electric Plant Unit 2
 Period 1/1/2018 - 12/31/2018

Liquid Effluents - Summation of All Releases

	<u>Units</u>	<u>Qtr 1</u>	<u>Qtr 2</u>	<u>Qtr 3</u>	<u>Qtr 4</u>	<u>Year</u>
A. Fission and Activation Products *						
1. Total Release	Ci	4.42E-04	1.16E-04	6.98E-03	6.02E-03	1.36E-02
2. Avg. Diluted Conc.	µCi/ml	1.76E-12	4.20E-12	2.24E-11	3.74E-11	1.64E-11
B. Tritium						
1. Total Release	Ci	7.51E+01	2.89E+02	2.29E+02	7.41E+01	6.67E+02
2. Avg. Diluted Conc.	µCi/ml	2.99E-07	1.05E-06	7.35E-07	4.60E-07	6.36E-07
C. Dissolved & Entrained Gases						
1. Total Release	Ci	0.00E+00	4.07E-04	1.48E-03	3.14E-04	2.20E-03
2. Avg. Diluted Conc.	µCi/ml	0.00E+00	1.47E-12	4.77E-12	1.95E-12	2.05E-12
D. Gross Alpha						
1. Total Release	Ci	0.00E+00	0.00E+00	0.00E+00	0.00E+00	0.00E+00
2. Avg. Diluted Conc.	µCi/ml	0.00E+00	0.00E+00	0.00E+00	0.00E+00	0.00E+00
E. Volume of Liquid Waste						
1. Total	liters	1.92E+05	4.29E+05	9.19E+05	1.18E+06	2.72E+06
F. Volume of Dilution Water						
1. Total	liters	2.51E+11	2.76E+11	3.11E+11	1.61E+11	9.99E+11

* Excludes tritium, dissolved and entrained noble gases, and gross alpha.

Attachment 1
Summary of Gaseous and Liquid Effluents

H.B. Robinson Steam Electric Plant Unit 2
 Period 1/1/2018 - 12/31/2018

Liquid Effluents - Continuous Mode

	<u>Units</u>	<u>Qtr 1</u>	<u>Qtr 2</u>	<u>Qtr 3</u>	<u>Qtr 4</u>	<u>Year</u>
A. Fission and Activation Products						
None	Ci	0.00E+00	0.00E+00	0.00E+00	0.00E+00	0.00E+00
Total for Period	Ci	0.00E+00	0.00E+00	0.00E+00	0.00E+00	0.00E+00
B. Tritium						
H-3	Ci	0.00E+00	0.00E+00	0.00E+00	0.00E+00	0.00E+00
C. Dissolved & Entrained Gases						
None	Ci	0.00E+00	0.00E+00	0.00E+00	0.00E+00	0.00E+00
Total for Period	Ci	0.00E+00	0.00E+00	0.00E+00	0.00E+00	0.00E+00
D. Gross Alpha						
Total for Period	Ci	0.00E+00	0.00E+00	0.00E+00	0.00E+00	0.00E+00

Attachment 1
Summary of Gaseous and Liquid Effluents

H.B. Robinson Steam Electric Plant Unit 2
 Period 1/1/2018 - 12/31/2018

Liquid Effluents - Batch Mode

	<u>Units</u>	<u>Qtr 1</u>	<u>Qtr 2</u>	<u>Qtr 3</u>	<u>Qtr 4</u>	<u>Year</u>
A. Fission and Activation Products						
Fe-55	Ci	0.00E+00	1.96E-05	1.35E-04	2.49E-04	4.04E-04
Fe-59	Ci	0.00E+00	0.00E+00	1.80E-05	1.05E-05	2.85E-05
Co-57	Ci	8.07E-06	7.63E-06	2.35E-05	1.37E-05	5.29E-05
Co-58	Ci	2.07E-04	7.23E-05	4.61E-03	3.54E-03	8.43E-03
Co-60	Ci	2.05E-04	6.24E-04	6.42E-04	4.80E-04	1.95E-03
Ni-63	Ci	1.17E-05	3.69E-04	1.53E-03	4.60E-04	2.37E-03
Se-75	Ci	1.65E-06	0.00E+00	0.00E+00	0.00E+00	1.65E-06
Nb-95	Ci	0.00E+00	0.00E+00	1.90E-06	0.00E+00	1.90E-06
Ag-110m	Ci	0.00E+00	0.00E+00	0.00E+00	9.91E-07	9.91E-07
Sn-117m	Ci	0.00E+00	0.00E+00	7.85E-06	5.26E-04	5.34E-04
Sb-124	Ci	0.00E+00	0.00E+00	4.27E-07	4.97E-05	5.01E-05
Sb-125	Ci	5.26E-06	5.75E-05	0.00E+00	1.14E-04	1.77E-04
Te-123m	Ci	0.00E+00	0.00E+00	8.05E-06	5.39E-04	5.47E-04
Te-131m	Ci	0.00E+00	0.00E+00	2.16E-06	3.31E-06	5.47E-06
Te-132	Ci	0.00E+00	0.00E+00	1.18E-06	1.06E-05	1.18E-05
I-132	Ci	0.00E+00	0.00E+00	0.00E+00	1.15E-05	1.15E-05
Cs-137	Ci	3.53E-06	1.12E-05	3.07E-06	1.61E-06	1.94E-05
Ba-133	Ci	0.00E+00	0.00E+00	0.00E+00	6.06E-06	6.06E-06
Np-239	Ci	0.00E+00	0.00E+00	0.00E+00	4.56E-06	4.56E-06
Total for Period	Ci	4.42E-04	1.16E-03	6.98E-03	6.02E-03	1.46E-02
B. Tritium						
H-3	Ci	7.51E+01	2.89E+02	2.29E+02	7.41E+01	6.67E+02
C. Dissolved & Entrained Gases						
Xe-133	Ci	0.00E+00	4.07E-04	1.48E-03	3.14E-04	2.20E-03
Xe-135	Ci	0.00E+00	2.88E-07	0.00E+00	0.00E+00	2.88E-07
Total for Period	Ci	0.00E+00	4.07E-04	1.48E-03	3.14E-04	2.20E-03
D. Gross Alpha						
Total for Period	Ci	0.00E+00	0.00E+00	0.00E+00	0.00E+00	0.00E+00

**Attachment 2
Supplemental Information**

H.B. Robinson Steam Electric Plant Unit 2
Period 1/1/2018 - 12/31/2018

ATTACHMENT 2

Supplemental Information

This attachment includes supplemental information to the gaseous and liquid effluents report.

Attachment 2 Supplemental Information

H.B. Robinson Steam Electric Plant Unit 2
Period 1/1/2018 - 12/31/2018

I. Regulatory Limits - Per Unit

A. Noble Gases - Air Dose

1. Calendar Quarter Gamma Dose	= 5	mRAD
2. Calendar Quarter Beta Dose	= 10	mRAD
3. Calendar Year Gamma Dose	= 10	mRAD
4. Calendar Year Beta Dose	= 20	mRAD

B. Liquid Effluents – Dose

1. Calendar Quarter Total Body Dose	= 1.5	mREM
2. Calendar Quarter Organ Dose	= 5	mREM
3. Calendar Year Total Body Dose	= 3	mREM
4. Calendar Year Organ Dose	= 10	mREM

C. Gaseous Effluents - Iodine-131 & 133, Tritium, and Particulates with Half-lives > 8 days

1. Calendar Quarter Organ Dose	= 7.5	mREM
2. Calendar Year Organ Dose	= 15	mREM

II. Maximum Permissible Effluent Concentrations

A. Gaseous Effluents

- Information found in Offsite Dose Calculation Manual

B. Liquid Effluents

- Information found in 10 CFR Part 20, Appendix B, Table 2, Column 2

III. Average Energy

(not applicable)

IV. Measurements and Approximations of Total Radioactivity

Analyses of specific radionuclides in selected or composited samples as described in the ODCM are used to determine the radionuclide composition of the effluent. A summary description of the method used for estimating overall errors associated with radioactivity measurements is provided as part of this attachment.

V. Batch Releases

A. Liquid Effluents

		Jan - Jun	Jul - Dec
1. Total Number of Batch Releases	=	23	79
2. Total Time (min) for Batch Releases	=	5.00E+03	1.68E+04
3. Maximum Time (min) for a Batch Release	=	3.07E+02	7.94E+02
4. Average Time (min) for Batch Releases	=	2.17E+02	2.13E+02
5. Minimum Time (min) for a Batch Release	=	1.36E+02	2.00E+00
6. Average Dilution Water Flow During Release (gpm)	=	4.00E+05	2.71E+05

B. Gaseous Effluents

		Jan - Jun	Jul - Dec
1. Total Number of Batch Releases	=	63	73
2. Total Time (min) for Batch Releases	=	2.46E+04	1.14E+05
3. Maximum Time (min) for a Batch Release	=	1.19E+03	1.06E+04
4. Average Time (min) for Batch Releases	=	3.91E+02	1.56E+03
5. Minimum Time (min) for a Batch Release	=	2.70E+01	2.90E+01

VI. Abnormal Releases

See Attachment 5, Unplanned Offsite Releases.

Attachment 2 Supplemental Information

H.B. Robinson Steam Electric Plant Unit 2
Period 1/1/2018 - 12/31/2018

Carbon-14

Carbon-14 (C-14), with a half-life of 5730 years, is a naturally occurring isotope of carbon produced by cosmic ray interactions in the atmosphere. Nuclear weapons testing in the 1950s and 1960s significantly increased the amount of C-14 in the atmosphere. C-14 is also produced in commercial nuclear reactors, but the amounts produced are much less than those produced naturally or from weapons testing.

In Regulatory Guide 1.21, Revision 2, "Measuring, Evaluating, and Reporting Radioactive Material in Liquid and Gaseous Effluents and Solid Waste", the NRC recommends U.S. nuclear power plants evaluate whether C-14 is a "principal radionuclide", and if so, report the amount of C-14 released. Improvements over the years in effluent management practices and fuel performance have resulted in a decrease in gaseous radionuclide (non-C-14) concentrations, and a change in the distribution of gaseous radionuclides released to the environment. As a result, many sites show C-14 has become a "principal radionuclide" for the gaseous effluent pathway, as defined in Regulatory Guide 1.21, Rev. 2. H.B. Robinson Steam Electric Plant 2015 ARERR contains estimates of C-14 radioactivity released in 2018, and estimates of public dose resulting from the C-14 effluent.

Because the dose contribution of C-14 from liquid radioactive waste is much less than that contributed by gaseous radioactive waste, evaluation of C-14 in liquid radioactive waste is not required (Ref. Reg. Guide 1.21, Rev. 2). The quantity of gaseous C-14 released to the environment can be estimated by use of a C-14 source term scaling factor based on power generation (Ref. Reg. Guide 1.21, Rev. 2). Many documents provide information related to the magnitude of C-14 in typical effluents from commercial nuclear power plants. Those documents suggest that nominal annual releases of C-14 in gaseous effluents are approximately 5 to 7.3 curies from PWRs (Ref. Reg. Guide 1.21, Rev. 2). A more recent study recommends a higher C-14 gaseous source term scaling factor of approximately 9.0 to 9.8 Ci/GWe-yr for a PWR (Westinghouse) (Ref. EPRI 1021106). The H.B. Robinson Steam Electric Plant ODCM states the expected C-14 generation to be 7.3 Curies assuming 292 effective full power days (EFPD) in a calendar year. 2.8 of the 7.3 Curies are released in batch mode from the Containment building and Waste Gas Decay Tanks. The remaining 4.5 Curies are released in continuous mode from the Auxiliary and Fuel Handling buildings. The total C-14 activity released compares favorably with more recent studies. For the H.B. Robinson Steam Electric Plant 2018 ARERR, a source term scaling factor using actual EFPD of 287.01 days is assumed. Using the source term scaling factor from H.B. Robinson Steam Electric Plant in 2018 results in a site total C-14 gaseous release estimate to the environment of 7.17 Curies, 2.75 Curies in batch mode and 4.42 Curies in continuous mode.

C-14 releases in PWRs occur primarily as a mix of organic carbon and carbon dioxide released from the waste gas system. Since the PWR operates with a reducing chemistry, most, if not all, of the C-14 species initially produced are organic (e.g., methane). As a general rule, C-14 in the primary coolant is essentially all organic with a large fraction as a gaseous species. Any time the RCS liquid or gas is exposed to an oxidizing environment (e.g. during shutdown or refueling), a slow transformation from an organic to an inorganic chemical form can occur. Various studies documenting measured C-14 releases from PWRs suggest a range of 70% to 95% organic with an average of 80% organic with the remainder being CO₂ (Ref. EPRI TR-105715). For the H.B. Robinson Steam Electric Plant 2018 ARERR a value of 70% organic C-14 is assumed.

Public dose estimates from airborne C-14 are performed using dose models in and Regulatory Guide 1.109. The dose models and assumptions used are documented in the H.B. Robinson Steam Electric Plant ODCM. The estimated C-14 dose impact on the maximum organ dose from airborne effluents released from H.B. Robinson Steam Electric Plant in 2018 is well below the 10CFR50, Appendix I, ALARA design objective (i.e., 15 mrem/yr per unit).

Attachment 2 Supplemental Information

H.B. Robinson Steam Electric Plant Unit 2
Period 1/1/2018 - 12/31/2018

Dose from Evaporation of Lake Robinson

Evaporation of water containing tritium in Lake Robinson creates an exposure pathway to a member of the public. Murray and Trettle, Inc. was contracted to perform an evaluation of the dose to a member of the public from evaporation of tritium in Lake Robinson. Results of the evaluation are contained in report "*Impact of Tritium Release from Lake Robinson at the Robinson Nuclear Plant for 2018*". Using the methodology described in ODCM 2.5.3, the following is a summary of tritium activity released through evaporation and resulting dose for 2018.

	<u>Units</u>	<u>Year</u>
1. H-3 Activity Released	Ci	5.52E+01
2. H-3 Dose	mREM	2.94E-01

Receptor Location **6.38 km N**
Critical Age **CHILD**
Critical Organ **N/A ***

Tritium in Fish from Lake Robinson

Concentrations of radionuclides used in this specific fish consumption pathway are determined by averaging the monthly concentrations detected in environmental location (REMP) SW-40. In 2018, no plant related gamma emitting radionuclides were detected. Since tritium is consistently detected in Lake Robinson REMP samples, tritium concentration in the fish is assumed to be in equilibrium with Lake Robinson. Using the methodology and data described in NRC Regulatory Guide 1.109, Rev.1, October 1977, Equation A-1, Table E-5, and Table E-11, the following is a summary of average concentration consumed and resulting dose for 2018.

	<u>Units</u>	<u>Year</u>
1. Avg. H-3 Concentration	pCi/L	3.13E+03
2. H-3 Dose	mREM	6.89E-03

Critical Age **ADULT**
Critical Organ **N/A ***

* The dose factor for H-3 is the same for all organs and Total Body (with the exception of Bone, which is 0.00E+00).

Attachment 2
Supplemental Information

H.B. Robinson Steam Electric Plant Unit 2
Period 1/1/2018 - 12/31/2018

Overall Estimate of Error for Effluent Radioactivity Release Reported

The estimated percentage of overall error for both Liquid and Gaseous effluent release data at H.B. Robinson Steam Electric Plant has been determined to be $\pm 30.3\%$. This value was derived by taking the square root of the sum of the squares of the following discrete individual estimates of error:

1. Flow Rate Determining Devices = $\pm 20\%$
2. Counting Statistical Error = $\pm 20\%$
3. Calibration Error = $\pm 10\%$
4. Calibration Source Error = $\pm 2.5\%$
5. Sample Preparation Error = $\pm 3\%$

Attachment 2 Supplemental Information

H.B. Robinson Steam Electric Plant Unit 2
Period 1/1/2018 - 12/31/2018

Summary of Changes in Land Use Census Affecting Effluent Dose Calculations

The 2018 Land Use Census was performed July 18-19, 2018, and the results were certified and made available for use on October 10, 2018. The following are changes to residences, gardens, and milk animals from the previous year.

Residences

The residence in the WSW sector (57 degrees 0.46 miles) at 2353 Lake Robinson Circle from the 2017 census was replaced with a new residence at 59 degrees 0.46 miles at 3625 Lake Robinson Circle. The 2017 residence appeared empty and no mailbox was present; therefore, was replaced with the new 2018 residence.

Gardens

NOTE: There were no gardens within the 5-mile radius in any of the 16 meteorological sectors identified by the census as being irrigated from plant discharge water. Any of the irrigation sources identified by the census are from other sources; such as wells or public utilities.

The garden in the N sector (3.28 miles) was no longer present and no other garden was found in the N sector within the 5-mile radius.

The garden in the NNE sector (2.16 miles) was no longer present and was replaced with a new garden at 2.75 miles.

The garden in the NE sector (2.86 miles) was no longer present and was replaced with a new garden at 2.57 miles.

The garden in the ENE sector (0.94 miles) was no longer present and was replaced with a new garden at 1.08 miles.

The garden in the SSE sector (2.39 miles) was no longer present and was replaced with a new garden at 2.61 miles.

The garden in the NW sector (1.62 miles) was no longer present and was replaced with a new garden at 2.36 miles.

Meat Animals

NOTE: Meat animals were only identified at the nearest garden or closer in each sector.

There were no meat animals found during the 2017 census in the NE sector at or closer than the nearest garden; however, the 2018 census identified a meat animal in the NE sector (2.57 miles) at or closer than the nearest garden. The meat animal in the E sector (3.00 miles) was no longer present and a replacement could not be found at or closer than the nearest garden in the E sector.

There were no meat animals found during the 2017 census in the SE sector at or closer than the nearest garden; however, the 2018 census identified a meat animal in the SE sector (1.96 miles) at or closer than the nearest garden.

The meat animal in the SSW sector (4.38 miles) was no longer present and a replacement could not be found at or closer than the nearest garden in the SSW sector.

The meat animal in the WSW sector (0.86 miles) was no longer present and a replacement could not be found at or closer than the nearest garden in the WSW sector.

The meat animal in the NW sector (1.62 miles) was no longer present and a replacement could not be found at or closer than the nearest garden in the NW sector.

Milk Animals

No milk animals (cows or goats) were identified in the 5-mile radius in any of the 16 meteorological sectors by the 2018 census.

Environmental Monitoring Locations

No changes to environmental monitoring locations in each sector.

Attachment 3
Solid Radioactive Waste Disposal

H.B. Robinson Steam Electric Plant Unit 2
Period 1/1/2018 - 12/31/2018

ATTACHMENT 3

Solid Radioactive Waste Disposal

This attachment includes a summary of the solid waste shipped off-site for burial and/or disposal, including:

- Container volume
- Total Curie content (specify whether determined by measurement or estimate)
- Principal Radionuclides
- Source/Type of waste
- Solidification agent or absorbent
- Type of shipping container
- Number of shipments
- Other relevant information as necessary

Attachment 3 Solid Radioactive Waste Disposal

H.B. Robinson Steam Electric Plant Unit 2
Period 1/1/2018 - 12/31/2018

Type of Waste Shipped	Number of Shipments	Number of Containers	Waste Class	Container Type	Solidification Agent	Burial Volume (m ³)	Total Activity (Curies)
1. <u>Waste from Liquid Systems</u>							
a. Dewatered Secondary Resins	N/A	N/A	N/A	N/A	N/A	N/A	N/A
b. Dewatered Primary Resins	2	2	(1) A-S (1) B	(1) 8-120 Poly HIC (1) 10-160 Poly HIC	N/A	7.54	143.0
c. Evaporator Concentrates	N/A	N/A	N/A	N/A	N/A	N/A	N/A
d. Dewatered Mechanical Filters	2	2	A-U	Metal Drum	N/A	0.42	0.0092
e. Dewatered Demineralizers	N/A	N/A	N/A	N/A	N/A	N/A	N/A
f. Solidified (cement) Acids, Oils, Sludge	N/A	N/A	N/A	N/A	N/A	N/A	N/A
g. <i>Other (add as necessary)</i>	N/A	N/A	N/A	N/A	N/A	N/A	N/A
2. <u>Dry Solid Waste</u>							
a. Dry Active Waste (compacted)	4	6	A-U	20' Sealand	N/A	183.0	0.0741
b. Dry Active Waste (non-compacted)	N/A	N/A	N/A	N/A	N/A	N/A	N/A
c. Dry Active Waste (brokered)	N/A	N/A	N/A	N/A	N/A	N/A	N/A
d. Irradiated Components (brokered)	N/A	N/A	N/A	N/A	N/A	N/A	N/A
e. Sources for Disposal (brokered)	N/A	N/A	N/A	N/A	N/A	N/A	N/A
3. <u>Total Solid Waste</u>	8	10	N/A	N/A	N/A	190.96	143.0833

Attachment 3 Solid Radioactive Waste Disposal

H.B. Robinson Steam Electric Plant Unit 2
Period 1/1/2018 - 12/31/2018

Type of Waste Shipped	Radionuclide	% Abundance
1. <u>Waste from Liquid Systems</u>		
a. Dewatered Secondary Resins	N/A	N/A
b. Dewatered Primary Resins	Ni-63	52.4
	Co-60	33.2
	Fe-55	7.25
	Co-58	3.54
	Mn-54	1.37
	Cs-137	0.579
	Co-57	0.543
	Ni-59	0.293
	C-14	0.246
	I-129	0.215
	Zn-65	0.163
	Ce-144	0.0478
	Cs-134	0.0382
	Sr-90	0.0206
	Pu-241	0.00480
	H-3	0.00412
	Sb-125	0.00184
	Tc-99	0.00181
	Pu-238	0.000271
c. Evaporator Concentrates	N/A	N/A
d. Dewatered Mechanical Filters	Co-58	32.1
	Ni-63	24.4
	Co-60	18.4
	Fe-55	11.7
	H-3	7.36
	C-14	4.02
	Co-57	0.735
	Ce-144	0.488
	Mn-54	0.206
	Tc-99	0.192
	Cs-137	0.192
	Zr-95	0.138
	Nb-95	0.0942
	I-129	0.0238
	Ag-110m	0.00135
	Cr-51	0.000463
	Sr-90	0.000306
	Fe-59	0.000209
	Sb-124	0.000170
e. Dewatered Demineralizers	N/A	N/A
f. Solidified (cement) Acids, Oils, Sludge	N/A	N/A
g. Other (add as necessary)	N/A	N/A

Attachment 3
Solid Radioactive Waste Disposal

H.B. Robinson Steam Electric Plant Unit 2
Period 1/1/2018 - 12/31/2018

2.

a. Dry Active Waste (compacted)	Fe-55	38.5
	Co-58	12.6
	Co-60	11.8
	Nb-95	9.14
	Ni-63	8.59
	Tc-99	6.83
	H-3	5.98
	Zr-95	4.35
	Co-57	0.927
	C-14	0.349
	Mn-54	0.301
	Ag-110m	0.263
	Ce-144	0.253
	Cs-137	0.201
	I-129	0.0143
b. Dry Active Waste (non-compacted)	N/A	N/A
c. Dry Active Waste (brokered)	N/A	N/A
d. Irradiated Components	N/A	N/A
e. Sources (for Disposal)	N/A	N/A

**Attachment 4
Meteorological Data**

H.B. Robinson Steam Electric Plant Unit 2
Period 1/1/2018 - 12/31/2018

ATTACHMENT 4

Meteorological Data

This attachment includes a summary of meteorological joint frequency distributions of wind speed, wind direction, and atmospheric stability (hours of occurrence).

Attachment 4 Meteorological Data

H.B. Robinson Steam Electric Plant Unit 2
Period 1/1/2018 - 12/31/2018

Stability Class	Wind Speed (mph)	Hours of Occurrence															
		Sector															
		N	NNE	NE	ENE	E	ESE	SE	SSE	S	SSW	SW	WSW	W	WNW	NW	NNW
A	0.75-3.50	0	0	1	0	2	3	3	1	0	2	1	0	0	1	0	0
	3.51-7.50	5	4	1	5	2	9	7	2	3	11	11	8	6	2	0	0
	7.51-12.50	10	1	1	0	0	0	0	1	13	25	23	11	8	12	9	7
	12.51-18.50	0	0	0	0	0	0	0	0	0	0	3	0	0	0	4	0
	18.51-25.00	0	0	0	0	0	0	0	0	0	0	0	0	0	0	0	0
	25+	0	0	0	0	0	0	0	0	0	0	0	0	0	0	0	0
B	0.75-3.50	0	0	1	3	1	1	2	1	1	1	1	2	0	0	0	0
	3.51-7.50	10	14	8	6	4	6	10	8	9	19	23	12	11	6	0	0
	7.51-12.50	7	6	0	0	0	0	0	3	6	14	8	2	1	7	3	2
	12.51-18.50	0	0	0	0	0	0	0	0	0	0	1	0	0	0	1	2
	18.51-25.00	0	0	0	0	0	0	0	0	0	0	0	0	0	0	0	0
	25+	0	0	0	0	0	0	0	0	0	0	0	0	0	0	0	0
C	0.75-3.50	0	0	1	3	8	14	9	3	1	0	2	5	3	3	0	1
	3.51-7.50	20	18	10	12	6	7	12	4	13	26	22	20	8	8	2	4
	7.51-12.50	7	4	0	0	0	0	1	1	10	11	6	6	2	2	6	4
	12.51-18.50	0	0	0	0	0	0	0	1	1	0	2	0	0	0	1	1
	18.51-25.00	0	0	0	0	0	0	0	0	0	0	0	0	0	0	0	0
	25+	0	0	0	0	0	0	0	0	0	0	0	0	0	0	0	0
D	0.75-3.50	12	40	75	85	67	79	67	42	29	25	22	37	28	19	13	12
	3.51-7.50	148	225	105	100	69	41	54	154	126	103	96	85	62	44	28	40
	7.51-12.50	51	46	2	1	8	1	0	19	60	58	37	22	3	22	27	58
	12.51-18.50	10	6	0	0	0	0	0	1	5	1	3	2	0	0	0	5
	18.51-25.00	0	0	0	0	0	0	0	1	0	0	0	0	0	0	0	0
	25+	0	0	0	0	0	0	0	0	0	0	0	0	0	0	0	0

Attachment 4 Meteorological Data

H.B. Robinson Steam Electric Plant Unit 2
Period 1/1/2018 - 12/31/2018

Stability Class	Wind Speed (mph)	Hours of Occurrence															
		Sector															
		N	NNE	NE	ENE	E	ESE	SE	SSE	S	SSW	SW	WSW	W	WNW	NW	NNW
E	0.75-3.50	62	79	95	72	49	51	77	103	177	146	116	91	60	49	41	43
	3.51-7.50	117	99	51	36	26	18	39	207	216	186	109	80	42	51	64	110
	7.51-12.50	34	17	3	2	0	1	8	28	58	44	34	9	1	6	12	63
	12.51-18.50	2	7	0	0	0	0	0	1	4	2	3	0	1	0	0	11
	18.51-25.00	2	0	0	0	0	0	0	0	0	0	0	0	0	0	0	9
	25+	0	0	0	0	0	0	0	0	0	0	0	0	0	0	0	0
F	0.75-3.50	46	26	19	19	18	13	18	75	97	73	54	71	53	28	68	89
	3.51-7.50	14	18	15	10	7	7	6	37	30	22	21	25	10	16	40	42
	7.51-12.50	4	0	0	1	2	0	0	9	11	9	2	1	0	1	1	3
	12.51-18.50	0	0	0	0	0	0	0	1	0	1	0	0	0	0	0	0
	18.51-25.00	0	0	0	0	0	0	0	0	0	0	0	0	0	0	0	0
	25+	0	0	0	0	0	0	0	0	0	0	0	0	0	0	0	0
G	0.75-3.50	62	22	8	5	4	6	24	52	49	37	35	42	33	33	83	125
	3.51-7.50	6	0	1	0	0	0	0	3	5	4	3	2	1	1	3	21
	7.51-12.50	0	0	0	0	0	0	0	0	0	1	1	1	0	0	0	0
	12.51-18.50	0	0	0	0	0	0	0	0	0	0	0	0	0	0	0	0
	18.51-25.00	0	0	0	0	0	0	0	0	0	0	0	0	0	0	0	0
	25+	0	0	0	0	0	0	0	0	0	0	0	0	0	0	0	0

**Attachment 5
Unplanned Offsite Releases**

H.B. Robinson Steam Electric Plant Unit 2
Period 1/1/2018 - 12/31/2018

ATTACHMENT 5

Unplanned Offsite Releases

This attachment includes a summary of the unplanned offsite releases of gaseous and liquid radioactive effluents.

Attachment 5
Unplanned Offsite Releases

H.B. Robinson Steam Electric Plant Unit 2
Period 1/1/2018 - 12/31/2018

H.B. Robinson Steam Electric Plant had zero (0) unplanned liquid release in 2018.

H.B. Robinson Steam Electric Plant had zero (0) unplanned gaseous release in 2018.

Attachment 6
Assessment of Radiation Dose from Radioactive Effluents to Members of the Public

H.B. Robinson Steam Electric Plant Unit 2
Period 1/1/2018 - 12/31/2018

ATTACHMENT 6

Assessment of Radiation Dose from Radioactive Effluents to Members of the Public
(includes fuel cycle dose calculation results)

This attachment includes an assessment of radiation doses to the maximum exposed member of the public due to radioactive liquid and gaseous effluents released from the site for each calendar quarter for the calendar year of the report as well as the total dose for the calendar year.

This attachment also includes an assessment of radiation doses to the maximum exposed member of the public from all uranium fuel cycle sources within 8 km of the site for the calendar year of this report to show conformance with 40 CFR Part 190.

Methods for calculating the dose contribution from liquid and gaseous effluents are given in the Offsite Dose Calculation Manual (ODCM).

Attachment 6
Assessment of Radiation Dose from Radioactive Effluents to Members of the Public

H.B. Robinson Steam Electric Plant Unit 2
 Period 1/1/2018 - 12/31/2018

Gaseous Effluents Dose Summary

	<u>Units</u>	<u>Qtr 1</u>	<u>Qtr 2</u>	<u>Qtr 3</u>	<u>Qtr 4</u>	<u>Year</u>
A. Noble Gases						
1. Maximum Gamma Air	mRAD	8.70E-04	8.39E-04	1.23E-03	3.51E-04	3.29E-03
(a) Limit	mRAD	5.00	5.00	5.00	5.00	10.00
(b) % of Limit		1.74E-02	1.68E-02	2.46E-02	7.03E-03	3.29E-02
2. Maximum Beta Air	mRAD	3.07E-04	3.64E-04	7.06E-04	2.96E-04	1.67E-03
(a) Limit	mRAD	10.00	10.00	10.00	10.00	20.00
(b) % of Limit		3.07E-03	3.64E-03	7.06E-03	2.96E-03	8.37E-03

Receptor Location **0.42 km SSE**

B. Iodine, H-3, & Particulates						
1. Maximum Organ Dose	mREM	1.21E-01	1.22E-01	1.24E-01	1.23E-01	4.90E-01
(a) Limit	mREM	7.50	7.50	7.50	7.50	15.00
(b) % of Limit		1.61E+00	1.63E+00	1.65E+00	1.64E+00	3.26E+00

Receptor Location **0.42 km SSE**

Critical Age **CHILD**

Critical Organ **BONE**

Attachment 6
Assessment of Radiation Dose from Radioactive Effluents to Members of the Public

H.B. Robinson Steam Electric Plant Unit 2
 Period 1/1/2018 - 12/31/2018

Liquid Effluents Dose Summary

	<u>Units</u>	<u>Qtr 1</u>	<u>Qtr 2</u>	<u>Qtr 3</u>	<u>Qtr 4</u>	<u>Year</u>
A. Batch & Continuous Mode						
1. Maximum Organ Dose	mREM	5.56E-06	1.92E-05	3.61E-05	3.04E-04	3.64E-04
(a) Limit	mREM	5.00	5.00	5.00	5.00	10.00
(b) % of Limit		1.11E-04	3.85E-04	7.22E-04	6.07E-03	3.64E-03
2. Maximum Total Body Dose	mREM	5.55E-06	1.97E-05	2.81E-05	8.95E-05	1.43E-04
(a) Limit	mREM	1.50	1.50	1.50	1.50	3.00
(b) % of Limit		3.70E-04	1.31E-03	1.87E-03	5.97E-03	4.76E-03

Critical Age **ADULT**
Critical Organ **GI-LLI**

Attachment 6 Assessment of Radiation Dose from Radioactive Effluents to Members of the Public

H.B. Robinson Steam Electric Plant Unit 2
Period 1/1/2018 - 12/31/2018

40 CFR Part 190 Uranium Fuel Cycle Dose Calculation Results

In accordance with the requirements of 40 CFR Part 190, the annual dose commitment to any member of the general public shall be calculated to assure that doses are limited to 25 millirems to the total body or any organ with the exception of the thyroid which is limited to 75 millirems. The fuel cycle dose assessment for H.B. Robinson Steam Electric Plant includes liquid and gaseous effluent dose contributions from H.B. Robinson Steam Electric Plant and direct and air-scatter dose from the onsite ISFSI. No other direct or air-scatter source or uranium fuel cycle facility contributes significantly to the maximum exposed individual. Included in the gaseous effluent dose below is the estimated dose contributed by Carbon-14 (Ref. Attachment 2, Supplemental Information, of this report for further information). Also included is dose from evaporation of H-3 in Lake Robinson and H-3 in fish from Lake Robinson. The combined dose to a maximum exposed individual from effluent releases, combined with the additional dose pathways, is below 40 CFR Part 190 limits as shown by the following summary.

Note: The 40 CFR Part 190 effluent dose analysis to the maximum exposed individual from liquid and gas releases does not include the dose from noble gases (i.e., total body and skin) due to the low significance compared to other dose pathways.

40 CFR Part 190 Effluent Dose Summary

A. Gaseous Effluent Dose	
1. Location	0.42 km SSE
2. Critical Age	CHILD
3. Critical Organ	BONE
4. Organ Dose (mREM)	4.90E-01
5. Total Body Dose (mREM)	3.31E-01
B. Liquid Effluent Dose	
1. Location	6.76 km NE
2. Critical Age	ADULT
3. Critical Organ	GI-LLI
4. Organ Dose (mREM)	3.64E-04
5. Total Body Dose (mREM)	1.43E-04
C. Lake Robinson Evaporation H-3 Dose*	
1. Location	6.38 km N
2. Critical Age	CHILD
3. Critical Organ	N/A
4. Organ Dose (mREM)	2.94E-01
5. Total Body Dose (mREM)	2.94E-01
D. H-3 in Fish from Lake Robinson*	
1. Location	Lake
2. Critical Age	ADULT
3. Critical Organ	N/A
4. Organ Dose (mREM)	6.89E-03
5. Total Body Dose (mREM)	6.89E-03

* = Ref. Attachment 2, Supplemental Information, of this report.

Attachment 6 Assessment of Radiation Dose from Radioactive Effluents to Members of the Public

H.B. Robinson Steam Electric Plant Unit 2 Period 1/1/2018 - 12/31/2018

Dose contributions from Carbon-14 in gaseous effluents have been determined from ODCM 3.16, Methodology for Carbon-14 Dose. The maximum dose rate to the nearest real individual from the release of Carbon-14 in batch and continuous gaseous effluents is conservatively calculated to be less than 4.89E-01 mrem/yr based on 7.17 Curies released in 2018 (Ref. Attachment 2, Supplemental Information, of this report).

Direct and air-scatter radiation dose contributions from the onsite ISFSI at H.B. Robinson Steam Electric Plant have been calculated and documented in the ISFSI Safety Analysis Report, Chapter 7 Radiation Protection, Revision 22. The dose rate to the maximum exposed individual from the ISFSI is conservatively calculated to be less than 5 mrem/yr.

The below excerpt from the H.B. Robinson Steam Electric Plant ISFSI Safety Analysis Report is provided to document the conclusion that the H.B. Robinson Steam Electric Plant ISFSI contributes less than 5 mrem/year to the maximum exposed individual.

7.6.2 ANALYSIS OF MULTIPLE CONTRIBUTION

The maximally exposed member of the public would receive approximately 1.6 mrem per year from an ISFSI made up of a three-unit HSM (reference Figure 7.6.1). An ISFSI consisting of an eight-unit HSM would contribute approximately 4.3 mrem per year. This is a result of external radiation only; there are no gaseous, particulate, or liquid effluents associated with the normal operation of the ISFSI. It can be concluded that the actual exposure contribution from the ISFSI along with the total of all other uranium fuel cycle activities is within the regulatory limits set forth in 40CFR190.

Assessment of the actual dose from direct radiation is performed as part of the H.B. Robinson Steam Electric Plant REMP and reported in the AREOR. During 2018, the assessment of dose from direct radiation, performed as part of the REMP, demonstrated no measurable contribution above background attributable to H.B. Robinson Steam Electric Plant operations.

Total dose from liquid and gaseous effluents from H.B. Robinson Steam Electric Plant and the additional pathways listed in table above is conservatively estimated to be less than 6 mrem/yr for total body and organ. It is recognized summing dose for different organs and age groups is not entirely accurate. However, the sum of the organ and age specific doses will always be less than the sum of the maximums of each. Therefore, summing the maximum values of each provides the most conservative value to ensure compliance with 40 CFR 190. The dose from all pathways related to operation of H.B. Robinson Steam Electric Plant meets the 40 CFR Part 190 requirements of an annual dose commitment to any member of the general public of less than 25 mrem total body or any organ and 75 mrem to the thyroid.

Attachment 7
Information to Support the NEI Ground Water Protection Initiative

H.B. Robinson Steam Electric Plant Unit 2
Period 1/1/2018 - 12/31/2018

ATTACHMENT 7

Information to Support the NEI Ground Water Protection Initiative

This attachment includes a summary of voluntary reports made in accordance with the NEI Ground Water Protection Initiative and a summary of ground water well sample data.

Attachment 7 Information to Support the NEI Ground Water Protection Initiative

H.B. Robinson Steam Electric Plant Unit 2 Period 1/1/2018 - 12/31/2018

H.B. Robinson Steam Electric Plant has implemented a Ground Water Protection program in accordance with NEI 07-07. This initiative was developed to ensure timely and effective management of situations involving inadvertent releases of licensed material to ground water. As part of this program, H.B. Robinson Steam Electric Plant monitored 39 wells in 2018. 38 wells not sampled as part of the ODCM REMP are reported below. The remaining 1 well is sampled in accordance with the ODCM REMP and reported in the AREOR.

Wells are sampled quarterly. Ground water samples are analyzed for tritium and gamma emitters. No gamma, other than naturally occurring radionuclides, were identified in well samples during 2018. There were no anomalous results identified in 2018.

Results from sampling during 2018 are shown in the table below.

No events meeting the criteria for voluntary notification per NEI 07-07, Industry Ground Water Protection Initiative, occurred at H.B. Robinson Steam Electric Plant in 2018. No special dose calculations were performed as part of the Ground Water Protection program.

Key to below table.

NS	-	Not scheduled to be sampled, not sampled due to insufficient volume in well, or well inaccessible during outage.
pCi/l	-	picocuries per liter.
< MDA	-	less than minimum detectable activity, typically 250 pCi/l.
20,000 pCi/l	-	the Environmental Protection Agency drinking water standard for tritium. This standard applies only to water used for drinking.
1,000,000 pCi/l	-	the 10 CFR Part 20, Appendix B, Table 2, Column 2, Effluent Concentration Limit for tritium.

Attachment 7
Information to Support the NEI Ground Water Protection Initiative

H.B. Robinson Steam Electric Plant Unit 2
 Period 1/1/2018 - 12/31/2018

Well Name	Location / Description	Tritium Concentration (pCi/l)				# of Samples
		1st Qtr	2nd Qtr	3rd Qtr	4th Qtr	
R42	Unit 1 North Deep Wells	NS	<MDA	NS	<MDA	2
R64(1)	Artesian Well - 0.6 miles SE	<MDA	<MDA	3.71E+02	<MDA	4
R68	Well A - Between Unit 1 Switchyard and breakroom	NS	4.14E+02	NS	3.12E+02	2
R69	Well B - Behind the Training Building	NS	<MDA	NS	<MDA	2
R70	Well C - Between the O&M Building & Fab Shop	NS	<MDA	NS	<MDA	2
R72	MW-06 - 0.10 miles E - U1 North Deep Well Pump	NS	<MDA	NS	<MDA	2
R73	MW-13 - 0.11 miles ENE - Near Discharge Canal	8.32E+02	4.51E+02	4.77E+02	4.72E+02	4
R75	PSW-02 - 0.05 miles NE - By U/1 boundary fence	NS	<MDA	NS	<MDA	2
R76	PSW-03 - 0.49 miles N - Northeast corner of MET Tower Station	NS	<MDA	NS	<MDA	2
R77	TS-01B - 0.25 miles SSE - By entrance road to Unit 1	<MDA	<MDA	<MDA	<MDA	4
R78	TS-02C - 0.17 miles SSE - Northeast corner by East Settling Pond	NS	<MDA	NS	<MDA	2
R79	TS-07C - 1.0 miles N - South corner by cove & Discharge Canal	4.53E+02	4.34E+02	5.42E+02	4.04E+02	4
R81(2)	TS-17B - 0.19 miles SSE - West of West Settling Pond	3.11E+02	6.01E+02	1.82E+03	1.42E+03	4
R82	PDW-01 - 0.30 miles SSE - By entrance road to Unit 1	NS	<MDA	NS	<MDA	2
RDW6	Robinson Deep Well #6	5.00E+02	4.96E+02	5.23E+02	3.74E+02	4
RMW07	MW-07 - Robinson Monitoring Well	NS	<MDA	NS	<MDA	2
RMW09	MW-09 - Robinson Monitoring Well	NS	<MDA	NS	<MDA	2
RMW-101D	MW-101D - Robinson Monitoring Well	3.12E+02	<MDA	3.01E+02	2.75E+02	4
RMW-101S	MW-101S - Robinson Monitoring Well	<MDA	<MDA	<MDA	<MDA	4
RMW-102	MW-102 - Robinson Monitoring Well	1.01E+03	4.02E+02	2.34E+02	3.36E+02	4
RMW-103D	MW-103D - Robinson Monitoring Well	3.31E+02	3.47E+02	<MDA	3.85E+02	4
RMW-103S	MW-103S - Robinson Monitoring Well	<MDA	<MDA	<MDA	<MDA	4
RMW-104	MW-104 - Robinson Monitoring Well	<MDA	<MDA	<MDA	<MDA	4
RMW-105	MW-105 - Robinson Monitoring Well	<MDA	<MDA	<MDA	<MDA	4
RMW-106	MW-106 - Robinson Monitoring Well	8.79E+02	5.56E+02	9.61E+02	7.63E+03	4
RMW-107	MW-107 - Robinson Monitoring Well	<MDA	<MDA	<MDA	<MDA	4
RMW-108	MW-108 - Robinson Monitoring Well	6.08E+02	5.14E+02	3.35E+02	1.37E+03	4
RMW1RASH	MW-1R (NPDES) ASH - Robinson	<MDA	<MDA	<MDA	<MDA	4
RMW2RASH	MW-2R (NPDES) ASH - Robinson	<MDA	<MDA	<MDA	<MDA	4
RMW3RASH	MW-3R (NPDES) ASH - Robinson	1.03E+03	9.06E+02	8.19E+02	8.15E+02	4
RMW4RASH	MW-4R (NPDES) ASH - Robinson	NS	2.55E+02	NS	2.93E+02	2
RMW5ASH	MW-5 (NPDES) ASH- Robinson	3.99E+02	3.73E+02	3.17E+02	3.45E+02	4
RMW6ASH	MW-6 (NPDES) ASH - Robinson	3.14E+02	2.91E+02	<MDA	<MDA	4
RMW7ASH	MW-7 (NPDES) ASH - Robinson	<MDA	2.11E+02	<MDA	<MDA	4
RP1	P1 (North of discharge canal) - Robinson Monitoring Well	3.92E+02	2.77E+02	1.94E+02	3.92E+02	4
RP2	P2 (South of discharge canal) - Robinson Monitoring Well	<MDA	<MDA	<MDA	<MDA	4
RPSW04	PSW-04	<MDA	<MDA	<MDA	<MDA	4
RPSW05	SW of Plant grass area on Entrance Road (Background Well)	NS	<MDA	NS	<MDA	2
RTS04B	RTS04B	NS	<MDA	NS	<MDA	2
U1SDEEP	Unit 1 South Deep Well	NS	NS	NS	<MDA	1

**Attachment 8
Inoperable Equipment**

H.B. Robinson Steam Electric Plant Unit 2
Period 1/1/2018 - 12/31/2018

ATTACHMENT 8

Inoperable Equipment

This attachment includes an explanation of inoperable instruments related to effluent monitoring in excess of allowed time defined by licensing bases and an explanation of permanent or temporary outside liquid storage tanks exceeding 10 Curies total activity (excluding tritium and dissolved or entrained noble gases).

Attachment 8 Inoperable Equipment

H.B. Robinson Steam Electric Plant Unit 2
Period 1/1/2018 - 12/31/2018

H.B. Robinson Steam Electric Plant experienced four (4) instances of inoperable equipment relevant to effluent monitoring in excess of ODCM/TRMS limits during 2018. Details are described below.

H.B. Robinson Steam Electric Plant did not experience permanent or temporary outside liquid storage tanks not surrounded by liners, dikes, or walls, capable of holding the tank's contents and that does not have tank overflows and surrounding area drains connected to the Liquid Waste Disposal System exceeding 10 Curies total activity (excluding tritium and dissolved or entrained noble gases) during 2018.

ODCM # or TRMS #	Title	Completion Time	Description
TRMS 3.11	Waste Gas Holdup System Explosive Gas Monitoring System	14 Days	<p><u>NCR 02176165:</u> THE HIGH OXYGEN ALARM WAS RECEIVED FOR THE IN-SERVICE WASTE GAS DECAY TANK. THE IAO HEARD THE ALARM IN THE ROOM BUT IT WAS NOT ALARMING ON THE WASTE DISPOSAL BORON RECYCLE PANEL (WDBRP) OR IN THE CONTROL ROOM. CHEMISTRY TECHNICIAN AND IAO INVESTIGATED FURTHER AND FOUND THE ANALYZER READING APPROXIMATELY 0.5% OXYGEN. THE HIGH OXYGEN ALARM COMES IN AT 3% OXYGEN. THE HIGH ALARM CONDITION HAD CLEARED AND THE CHEMISTRY TECHNICIAN WAS INSTRUCTED TO RESET THE ALARM. AT THAT TIME AN ALARM WAS RECEIVED ON THE WDBRP. THE WDBRP AND CONTROL ROOM ALARMS SHOULD BE RECEIVED WHEN THE ALARM CONDITION IS MET, NOT WHEN THE ALARM IS RESET. PRIOR TO EC 283701 THE WDBRP AND CONTROL ROOM ALARMS WERE FUNCTIONING PROPERLY. IAW TRM 3.11 IF THE GAS ANALYZER IS OOS, IT IS REQUIRED TO OBTAIN AND ANALYZE A GRAB SAMPLE ONCE PER 24 HOURS, IF OOS FOR SOLELY DUE TO AN INOPERABLE ALARM, MONITOR READOUT MAY BE USED IN LIEU OF GRAB SAMPLES. THE CHEMISTRY SHIFT TECHNICIAN CURRENTLY TAKES READINGS ONCE A SHIFT (EVERY 12HOURS) SO ANY OOS ACTIONS ARE ALREADY BEING MET. FOLLOW UP ACTIONS: INVESTIGATE AND REPAIR.</p> <p>At 1731 hrs on 1/9/18 TRM 3.11 Condition A was entered due to the Gas Analyzer alarm not functioning. Condition A.2 states to restore the Waste Gas Holdup System Explosive Gas Monitoring System Oxygen Monitor to OPERABLE status within 14 days. Condition B states that if the required completion time of Condition A.2 is not met then prepare and submit in the Radioactive Effluent Release Report the reason the inoperability was not corrected in a timely manner. The 14-day requirement was exceeded at 1731 hrs on 1/23/18 and the reporting required by Condition B applies. Chemistry has been notified of the need to include this event in the next RERR.</p>

Attachment 8 Inoperable Equipment

H.B. Robinson Steam Electric Plant Unit 2
Period 1/1/2018 - 12/31/2018

TRMS 3.11	Waste Gas Holdup System Explosive Gas Monitoring System	14 days	<p><u>NCR 02188671</u>: GAS ANALYZER IS IN A GAS ANALYZER LOW GAS FLOW (FE-722 FAILURE) FT-11383 AND THE PUMP (PMP-1) WAS OFF. FE-722 SHOULD BE READING BETWEEN 0.1 – 0.3 LPM IAW CP-COA-602. SEVERAL ATTEMPTS TO ADJUST FLOW ON FE-722 (FT-11383) AT WD-3410 IAW APP-020 WERE UNSUCCESSFUL. CRS AND CHEMISTRY SUPERVISION NOTIFIED, COMPENSATORY MEASURES ESTABLISHED TO SAMPLE THE IN-SERVICE WGDT ONCE PER SHIFT IAW CP-COA-602.</p> <p>At 2230 hrs on 3/2/18 TRM 3.11 Condition A was entered due to the Gas Analyzer pump failing. Condition A.2 states restore the Waste Gas Holdup System Explosive Gas Monitoring. System Oxygen Monitor to OPERABLE status within 14 days. The 14-day requirement was exceeded at 2230 hrs on 3/16/18 and the reporting required by Condition B applies.</p>
TRMS 3.11	Waste Gas Holdup System Explosive Gas Monitoring System	14 days	<p><u>NCR 02237427</u>: FOLLOWING THE REPLACEMENT OF PCV-1073B, THE TRAPS WERE DRAINED, AND THE GAS ANALYZER WAS STARTED. THE ANALYZER WENT INTO ALARM FOR "INSTRUMENT FAULT" AND "LOW FLOW". PCV-1073B READS A PRESSURE OF ~5 PSI, PI-1048 INSIDE THE GA ROOM ~5 PSI, AND PRV-1 ~10 PSI, WHICH ARE ALL ACCEPTABLE PER PROCEDURE. IT WAS NOTICED THAT FT-11383, GAS SAMPLE RETURN MASS FLOW METER, WHICH NORMALLY READS ~0.2 LPM WAS 0.01 LPM AND THE INLET PRESSURE, PRV-3, WAS LOW.</p> <p>Gas Analyzer has been OOS >14 days. TRM 3.11 requires to prepare and submit in Radioactive Effluent Release Report reason inoperability was not corrected in a timely manner.</p>
ODCM 3.10.3	R-11, Containment Vessel Particulate Monitor	30 days	<p><u>NCR 02186971/02194019</u>: R-11 Process Monitor was declared OOS 2/23/2018 due to cyclic count rate. NCR# 02186971 was initiated for UNPLANNED LCO and ODCM entries. At 1000 on 02/23/18, R-11 was removed from service. A cross functional troubleshooting team was formed with representatives from Engineering, Operations, FIN I&C, Chemistry, and Radiation Protection. Multiple actives were performed to ensure the equipment was restored and is now operating properly. The cause of the changes in counts is due to radioactive particulates from the CV atmosphere being measured on R-11 filter paper. A review of long term trends identified that increasing and cycling counts on R-11 are not unexpected given seasonal temperature rises in the containment structure. Time in core life also impacts R-11 counts. R-11 can perform its design function as described in FSAR 5.2.5 and Technical Specification 3.3.6 and 3.4.15. Current values for R-11 are well within the most restrictive setpoint limits as described in the ODCM and ITS 5.5.4. There is also sufficient margin to procedurally driven safeguard actuation setpoint of 1.8 times containment background described in OMM-014.</p>

Attachment 9
Summary of Changes to the Offsite Dose Calculation Manual

H.B. Robinson Steam Electric Plant Unit 2
Period 1/1/2018 - 12/31/2018

ATTACHMENT 9

Summary of Changes to the Offsite Dose Calculation Manual

This attachment includes a summary of changes to the ODCM and Radiological Effluent Controls.

Attachment 9 Summary of Changes to the Offsite Dose Calculation Manual

H.B. Robinson Steam Electric Plant Unit 2
Period 1/1/2018 - 12/31/2018

ODCM Revision 36

The H.B. Robinson Steam Electric Plant ODCM Revision 36 is provided in entirety in this section.

ODCM Revision 36 was approved by the On-Site Review Committee (ORC) on October 18, 2018. Changes driven by Document Revision Requests (DRR) are noted by DRR number.

All ODCM changes are reviewed by knowledgeable individual(s), the ORC Chairman, and approved by the Plant Manager. Revision 36 changes do not adversely impact the accuracy or reliability of effluent, dose, or setpoint calculations.

SUMMARY OF CHANGES

Section 2.1.1 Page 2-1

Modified discussion on dilution for R-37 setpoint to include service water, from: *“The setpoint for R-37 is calculated using only circulating water for dilution.”* to: *“The setpoint for R-37 is calculated using circulating water for dilution, or service water when circulating water is unavailable.”* Change made per DRR 02236939 to allow for use of service water pumps for dilution of liquid radwaste releases when circulating water is unavailable. This allows for more operational flexibility. Setpoint, compliance with 10CFR20 Appendix B, and compliance with 10CFR50 Appendix I methodologies are unchanged.

Section 2.1.1.1 Page 2-2

Added line item for service water pump flow to definition of ‘F’. Change made per DRR 02236939 to allow for use of service water pumps for dilution of liquid radwaste releases when circulating water is unavailable. This allows for more operational flexibility. Setpoint, compliance with 10CFR20 Appendix B, and compliance with 10CFR50 Appendix I methodologies are unchanged.

Section 2.1.2 Page 2-3

Modified discussion on dilution for R-37 setpoint to include service water, from: *“The setpoint for R-37 is calculated using only circulating water for dilution.”* to: *“The setpoint for R-37 is calculated using circulating water for dilution, or service water when circulating water is unavailable.”* Change made per DRR 02236939 to allow for use of service water pumps for dilution of liquid radwaste releases when circulating water is unavailable. This allows for more operational flexibility. Setpoint, compliance with 10CFR20 Appendix B, and compliance with 10CFR50 Appendix I methodologies are unchanged.

Section 2.1.2.2 Page 2-4

Added line item for service water pump flow to definition of ‘F_{avail}’. Change made per DRR 02236939 to allow for use of service water pumps for dilution of liquid radwaste releases when circulating water is unavailable. This allows for more operational flexibility. Setpoint, compliance with 10CFR20 Appendix B, and compliance with 10CFR50 Appendix I methodologies are unchanged.

Section 2.1 References Page 2-6

Added Reference 4: RNP-M/MECH-1653, Service Water System Hydraulic Evaluation

Change made per DRR 02236939 to allow for use of service water pumps for dilution of liquid radwaste releases when circulating water is unavailable. This allows for more operational flexibility. Setpoint, compliance with 10CFR20 Appendix B, and compliance with 10CFR50 Appendix I methodologies are unchanged.

Attachment 9 Summary of Changes to the Offsite Dose Calculation Manual

H.B. Robinson Steam Electric Plant Unit 2
Period 1/1/2018 - 12/31/2018

Section 2.3.2.1 Page 2-10

Revised description of ' D_{fr} ' to include service water pumps and added line item for service water pump flow to definition. Change made per DRR 02236939 to allow for use of service water pumps for dilution of liquid radwaste releases when circulating water is unavailable. This allows for more operational flexibility. Setpoint, compliance with 10CFR20 Appendix B, and compliance with 10CFR50 Appendix I methodologies are unchanged.

Section 2.3.2.1 Page 2-11

Revised discussion on liquid radwaste effluent line discharges from: *“For HBR, the liquid radwaste effluent line discharges to the circulating water system. Therefore, the dilution flow rate (D_{fr}) is a function of the number of circulating water pumps operating. At least one circulating water pump must be operating during any liquid waste discharge.”* to: *“For HBR, the liquid radwaste effluent line discharges to the circulating water system. Therefore, the dilution flow rate (D_{fr}) is a function of the number of circulating water pumps operating, or one Unit 2 service water pump when no circulating water pumps are available. At least one circulating water pump must be operating during any liquid waste discharge during normal plant operation. During periods when no circulating water pumps are available (e.g. refueling outage), one Unit 2 service water pump may be used for dilution.”* Change made per DRR 02236939 to allow for use of service water pumps for dilution of liquid radwaste releases when circulating water is unavailable. This allows for more operational flexibility. Setpoint, compliance with 10CFR20 Appendix B, and compliance with 10CFR50 Appendix I methodologies are unchanged.

Section 2.3.2.2 Page 2-13

Revised description of ' D_{fr} ' to include service water pumps. Modified sentence from: *“The circulating water pump flow rates were given in Section 2.3.2.1 above.”* to: *“The circulating water pump and service water pump flow rates were given in Section 2.3.2.1 above.”* Change made per DRR 02236939 to allow for use of service water pumps for dilution of liquid radwaste releases when circulating water is unavailable. This allows for more operational flexibility. Setpoint, compliance with 10CFR20 Appendix B, and compliance with 10CFR50 Appendix I methodologies are unchanged.

Table 2.7-1 Page 2-34

Reformatted table to better align Pathway/Instruments column with requirements columns. Editorial changes only, no changes to surveillance requirements. Change made per DRR 02210035.

H.B. Robinson Steam Electric Plant Unit 2



ODCM

Offsite Dose
Calculation Manual

Docket No. 50-261



H.B. Robinson Steam Electric Plant
Unit 2

**OFFSITE DOSE CALCULATION MANUAL
(ODCM)**

Revision 36

Docket Number: 50-261

Effective Date: 10/18/2018

Prepared By: Christopher C. Courtenay Fleet Scientific Services RP	 Signature	10/15/2018 Date
Reviewed By: Kenneth W. Hatchell Jr. RNP Chemistry	 Signature	10/16/18 Date
Reviewed By (Print):  RNP ORC Chairman	 Signature	10/18/18 Date
Approved By: John A. Krakuszeski RNP Plant Manager	 Signature	10/18/18 Date



LIST OF EFFECTIVE PAGES

Effective Pages

Revision

All 36

TABLE OF CONTENTS

List of Effective Pages	i
Table of Contents	ii
List of Tables	iv
List of Figures	vii
1.0 Introduction	1-1
2.0 Liquid Effluents	2-1
2.1 Monitor Alarm Setpoint Determination	2-1
2.2 Requirements for Compliance with 10 CFR 20 (Liquids)	2-7
2.3 Compliance with 10 CFR 20 (Liquids)	2-9
2.4 Requirements for Compliance with 10 CFR 50 (Liquids)	2-14
2.5 Compliance with 10 CFR 50 (Liquids)	2-16
2.6 Radioactive Liquid Monitoring Instrumentation	2-25
2.7 Radioactive Liquid Monitoring Instrumentation Surveillance Requirements	2-33
2.8 Radioactive Liquid Effluents Sampling and Analysis Requirements	2-36
2.9 Liquid Radwaste Treatment System	2-40
3.0 Gaseous Effluents	3-1
3.1 Monitor Alarm Setpoint Determination	3-1
3.2 Requirements for Compliance with 10 CFR 20 (Gaseous)	3-11
3.3 Compliance with 10 CFR 20 (Gaseous)	3-12
3.4 Requirements for Compliance with 10 CFR 50 (Gaseous)	3-20
3.5 Compliance with 10 CFR 50 (Gaseous)	3-22
3.6 Methodology for R-11 Setpoint (Air Particulate)	3-67
3.7 Deleted	3-69
3.8 Deleted	3-69
3.9 Methodology for R-22 Setpoint Determination for the Iodine and Particulate Monitors	3-70
3.10 Radioactive Gaseous Effluent Monitoring Instrumentation	3-73
3.11 Radioactive Gaseous Effluent Monitoring Instrumentation Surveillance Requirements	3-86
3.12 Radioactive Gaseous Effluents Sampling and Analysis Requirements	3-87
3.13 Radionoble Gases - Cumulative Doses	3-90
3.14 Radioiodines, Radioactive Materials in Particulate Form, and Radionuclides Other Than Radionoble Gases - Cumulative Doses	3-91
3.15 Gaseous Radwaste and Ventilation Exhaust Treatment Systems	3-92
3.16 Methodology for Carbon-14 Dose	3-94
4.0 Radiological Environmental Monitoring Program	4-1
4.1 Monitoring Program - Implementation	4-1
4.2 Land Use Census - Implementation	4-11
4.3 Monitoring Program - Sampling Requirements	4-13
4.4 Land Use Census - Surveillance Requirements	4-14
4.5 Analysis and Sample Point Description	4-15

H.B. Robinson Steam Electric Plant Unit 2
 Offsite Dose Calculation Manual (ODCM)

5.0 Inter-laboratory Comparison Program	5-1
5.1 Through 5.4 Specifications	5-1
5.5 Inter-laboratory Comparison Studies - Program Requirements	5-2
5.5.1 Objective	5-2
5.6 Program	5-2
6.0 Compliance with 40 CFR 190	6-1
6.1 Requirements for Compliance With 40 CFR Part 190 - Radioactive Effluents From Uranium Fuel Cycle Sources	6-1
6.2 Total Dose (40 CFR 190) Conformance	6-4
6.3 Calculations of Total Body Dose	6-5
6.4 Thyroid Dose	6-6
6.5 Dose Projections	6-6
6.6 Radioactive Effluents From Uranium Fuel Cycle Sources - Cumulative Doses	6-6
7.0 Definitions	7-1
8.0 Controls Applicability and Surveillance/Compensatory Requirements	8-1
8.1 Controls Applicability	8-1
8.2 Surveillance Requirements	8-3
8.3 Compensatory Requirements	8-5
9.0 Reporting Requirements	9-1
9.1 Annual Radioactive Effluent Release Report	9-1
9.2 Annual Radiological Environmental Operating Report	9-5
9.3 Special Radiological Effluent Reports	9-6
9.4 Special Ground Water Protection Reports	9-8
10.0 Licensee Initiated Changes	10-1
Appendix A - Meteorological Dispersion Factor Computations	A-1
Appendix B - Dose Parameters for Radioiodines, Particulates, and Tritium	B-1
Appendix C - Lower Limit of Detectability	C-1
Appendix D - Liquid and Gaseous Process Monitors and Radwaste Systems	D-1
Appendix E - Map of Lake Robinson	E-1

H.B. Robinson Steam Electric Plant Unit 2
 Offsite Dose Calculation Manual (ODCM)

LIST OF TABLES

<u>No.</u>	<u>Title</u>	<u>Page</u>
2.5-1	A _{ir} Values for the Adult for the H.B. Robinson Steam Electric Plant	2-23
2.6-1	Radioactive Liquid Effluent Monitoring Instrumentation	2-27
2.7-1	Radioactive Liquid Effluent Monitoring Instrumentation Surveillance Requirements	2-34
2.8-1	Radioactive Liquid Waste Sampling and Analysis Program	2-37
3.1-1	Gaseous Source Terms	3-9
3.1-2	Dose Factors and Constants	3-10
3.3-1	Releases from H.B. Robinson Unit No. 2	3-15
3.3-2	Distance to Special Locations for the H.B. Robinson Plant (miles)	3-16
3.3-3	Dose Factors for Noble Gases and Daughters	3-17
3.3-4	P _i Values for a Child for the H.B. Robinson Unit No. 2	3-18
3.5-1 to 3.5-19	R Values for the H.B. Robinson Steam Electric Plant	3-32 to 3-66
3.10-1	Radioactive Gaseous Effluent Monitoring Instrumentation	3-74
3.11-1	Radioactive Gaseous Effluent Monitoring Instrumentation Surveillance Requirements	3-84
3.12-1	Radioactive Gaseous Waste Sampling and Analysis Program	3-87
3.16-1	Inhalation Dose Factors from Carbon-14	3-101
3.16-2	Ingestion Dose Factors from Carbon-14	3-102
3.16-3	Carbon-14 Source Terms	3-103
4.1-1	Radiological Environmental Monitoring Program	4-4
4.1-2	Reporting Levels For Radioactivity Concentrations in Environmental Samples	4-7
4.1-3	Lower Limits of Detection (LLDs)	4-8
4.5-1	H. B. Robinson Radiological Environmental Monitoring Program	4-16
8.2-1	Surveillance Requirements	8-4
A-1	X/Q Values for Long-Term Ground Level Releases at Special Locations (sec/m ³)	A-3

LIST OF TABLES (cont.)

<u>No.</u>	<u>Title</u>	<u>Page</u>
A-2	Depleted X/Q Values for Long-Term Ground Level Releases at Special Locations (sec/m ³)	A-4
A-3	D/Q Values for Long-Term Ground Level Releases at Special Locations (m ⁻²)	A-5
A-4	X/Q Values for Long-Term Ground Level Releases at Standard Distances (sec/m ³)	A-6
A-5	Depleted X/Q Values for Long-Term Ground Level Releases at Standard Distances (sec/m ³)	A-7
A-6	D/Q Values for Long-Term Ground Level Releases at Standard Distances (m ⁻²)	A-8
A-7	X/Q Value for Short-Term Ground Level Releases at Special Locations (sec/m ³)	A-9
A-8	Depleted X/Q Values for Short-Term Ground Level Releases at Special Locations (sec/m ³)	A-10
A-9	D/Q Values for Short-Term Ground Level Releases at Special Locations (m ⁻²)	A-11
A-10	X/Q Values for Long-Term Mixed Mode Releases at Special Locations (sec/m ³)	A-12
A-11	Depleted X/Q Values for Long-Term Mixed Mode Releases at Special Locations (sec/m ³)	A-13
A-12	D/Q Values for Long-Term Mixed Mode Releases at Special Locations (m ⁻²)	A-14
A-13	X/Q Values for Long-Term Mixed Mode Releases at Standard Distances (sec/m ³)	A-15
A-14	Depleted X/Q Values for Long-Term Mixed Mode Releases at Standard Distances (sec/m ³)	A-16
A-15	D/Q Values for Long-Term Mixed Mode Releases at Standard Distances (m ⁻²)	A-17
A-16	X/Q Values for Short-Term Mixed Mode Releases at Special Locations (sec/m ³)	A-18
A-17	Depleted X/Q Values for Short-Term Mixed Mode Releases at Special Locations (sec/m ³)	A-19
A-18	D/Q Values for Short-Term Mixed Mode Releases at Special Locations (m ⁻²)	A-20

H.B. Robinson Steam Electric Plant Unit 2
Offsite Dose Calculation Manual (ODCM)

LIST OF TABLES (cont.)

<u>No.</u>	<u>Title</u>	<u>Page</u>
A-19	Robinson Plant Site Information to be Used for Ground Level Calculations with NRC "XOQDOQ" Program	A-21
A-20	Robinson Plant Site Information to be Used for Mixed Mode Release Calculations with NRC "XOQDOQ" Program	A-24
B-1	Parameters for Cow and Goat Milk Pathways	B-12
B-2	Parameters for the Meat Pathway	B-13
B-3	Parameters for the Vegetable Pathway	B-14
D-1	Liquid Process Monitors	D-2
D-2	Gaseous Process Monitors	D-3

LIST OF FIGURES

<u>No.</u>	<u>Title</u>	<u>Page</u>
4-1	Radiological Sample Locations Near Site	4-25
4-2	Radiological Sample Distant Locations	4-26
7-1	Plant Site Boundary and Exclusion Zone	7-5
D-1	H.B. Robinson Liquid Radwaste Effluent System	D-4
D-2	H.B. Robinson Gaseous Radwaste Effluent System	D-5
E-1	Map of the Five Sections of Lake Robinson	E-2

1.0 INTRODUCTION

The Off-Site Dose Calculation Manual (ODCM) provides the information and methodologies to be used by H. B. Robinson Steam Electric Plant Unit 2 (HBR) to assure compliance with 10 CFR 20, Appendix I of 10 CFR 50, and 40 CFR 190.

The ODCM is based on "Radiological Effluent Technical Specifications for PWRs (NUREG 0472, Rev. 3, Draft 7), "Preparation of Radiological Effluent Technical Specifications for Nuclear Power Plants" (NUREG 0133), and guidance from the United States Nuclear Regulatory Commission (NRC). Specific plant procedures for implementation of this manual are presented in H. B. Robinson Unit 2 Plant Operating Manual. These procedures will be utilized by the operating staff of HBR to assure compliance with technical specifications.

Changes to the ODCM which affect the methodologies showing compliance with 10 CFR 20, Appendix I of 10 CFR 50, and 40 CFR 190 will be properly reviewed and approved as indicated in the Administrative Control Section of Plant Technical Specifications. Site specific parameters such as vent fractions, dilution water flow rates (gpm), and liquid/gaseous discharge flow rates are listed in this document as typical system values. Actual values derived from actual operating Plant conditions should be used in lieu of these typical values. Specific Plant procedures control the values of the above parameters; therefore, minimizing the need for frequent revisions to the ODCM.

The Annual Radioactive Effluent Release Report will be prepared as outlined in Regulatory Guide 1.21, "Measuring, Evaluating, and Reporting Radioactivity in Solid Waste and Radioactive Materials in Liquid and Gaseous Effluents from Light-Water-Cooled Nuclear Power Plants" (Revision 1, June 1974) with data summarized on a quarterly basis following the format of Appendix B thereof. This report will be inclusive of the requirements as outlined in the HBR Technical Specifications.

The gaseous and liquid radwaste systems at HBR are used to collect and treat gaseous and liquid radiochemical byproducts of unit operation. These systems produce effluents that can be discharged in discrete and measurable quantities to the environment.

After processing, liquid wastes may be discharged from the Steam Generator Blowdown Flash Tank, a series of Waste Condensate Tanks, or a series of Monitor Tanks.

Gaseous wastes are mainly discharged from the Plant Vent Stack. Less significant sources of gaseous waste may come from the Upper Fuel Handling Building Exhaust, Lower Fuel Handling Building Exhaust, E&RC Laboratory Exhaust, Radwaste Building Exhaust, or Building 457. Building 457 is used only intermittently mainly for pre-outage activities, therefore effluent accountability will be performed as needed. Additionally, secondary system steam releases may occur from normal plant operation or system response. Any secondary system steam releases containing licensed radioactivity are evaluated for inclusion in the site effluent release total.

2.0 LIQUID EFFLUENTS

2.1 Monitor Alarm Setpoint Determination

This methodology determines the monitor alarm setpoint that indicates if the concentration of radionuclides in the liquid effluent released from the site to unrestricted areas exceeds 10 times the concentrations specified in 10 CFR 20, Appendix B, Table 2, Column 2, for radionuclides other than dissolved or entrained noble gases or exceeds a concentration 2E-04 $\mu\text{Ci/ml}$ for dissolved or entrained noble gases. Two methodologies may be utilized to calculate monitor alarm setpoints. Section 2.1.1 determines a fixed setpoint based on the worst case assumptions that Cs-134 is the only nuclide being discharged. This is consistent with the limit of 10 CFR 20, Appendix B, Note 2. Section 2.1.2 methodology determines the setpoint based on the radionuclide mix via analysis prior to release to demonstrate compliance with 10 CFR 20, Appendix B, limits and may also be used as an alternative method for calculating setpoints.

2.1.1 Setpoint Based on Cs-134

The following method applies to liquid releases via the discharge canal when determining the alarm/trip setpoint for the Condensate Polisher Liquid Waste Monitor (R-37) and the Steam Generator Blowdown Monitor (R-19A, R-19B, and R-19C) during operational conditions when there is no primary to secondary leaks. The Condensate Polisher Sump discharge (monitored by R-37) discharges to the Settling Ponds prior to release via the discharge canal. Even though the Settling Ponds provide additional dilution prior to discharge, no dilution from the Settling Ponds is used in calculating setpoints for R-37. The setpoint for R-37 is calculated using circulating water for dilution, or service water when circulating water is unavailable. This methodology complies with Specification 2.2.1 of the ODCM by satisfying the following equation:

$$\frac{c * f}{f + F} \leq C$$

where:

- C = The effluent concentration (EC) limit (Specification 2.2.1) implementing 10 CFR 20 for the site ($\mu\text{Ci/ml}$).
- c = The setpoint of the radioactivity monitor measuring the radioactivity concentration in the effluent line prior to dilution and subsequent release; the setpoint represents a value which, if exceeded, would result in concentrations exceeding 10 times the limits of 10 CFR 20 in the unrestricted area. ($\mu\text{Ci/ml}$)
- f = The waste effluent flow rate (gpm).
- F = The dilution water flow rate (gpm).

2.1.1.1 Determine 'c' (the effluent monitor setpoint) in $\mu\text{Ci/ml}$ for each of the dilution water flow rates.

$$c = \frac{C * (F + f)}{f} * S$$

where:

C = 9E-07, the effluent concentration limit based on 10 CFR 20, Appendix B, for Cs-134 ($\mu\text{Ci/ml}$).

F = Dilution water flow rate (gpm).
= 160,000 gpm from one circulating water pump¹, Unit 2.
= 250,000 gpm from two circulating water pumps¹, Unit 2.
= 400,000 gpm from three circulating water pumps¹, Unit 2.

OR

= 50,000 gpm from one circulating water pump², Retired Fossil Plant.
= 80,000 gpm from two circulating water pumps², Retired Fossil Plant.

OR

= 7,000 gpm from one service water pump⁴, Unit 2.

f = The maximum acceptable discharge flow rate prior to dilution (gpm).
= 60 gpm for the Waste Disposal System Liquid Effluent Monitor³.
= 160 gpm for each Steam Generator Blowdown Monitor.
= 130 gpm for each Steam Generator Blowdown Monitor while draining a steam generator.
= 300 gpm for the Condensate Polisher Liquid Waste Monitor.

S = 0.5, safety factor used as a conservatism to assure that the radionuclide concentrations are less than the limits specified in 10 CFR 20, Appendix B, at the point of discharge (dimensionless).

2.1.1.2 Determine 'CR' (calculated monitor count rate in corrected counts per minute ccpm) attributed to the radionuclides for each of the dilution water flow rates.

$$CR = c * E$$

where:

E = The applicable effluent monitor efficiency located in the Station Curve Book. Use the radioactivity concentration 'c' to find CR.

2.1.1.3 Determine 'SP' (the monitor alarm/trip setpoint including background cpm) for each of the dilution water flow rates.

$$SP = (T_m * CR) + Bkg$$

where:

T_m = Fraction of the radioactivity from the site that may be released via the monitored pathway to ensure that the site boundary limit is not exceeded due to simultaneous releases from several pathways (dimensionless).
 = 0.16 for each Steam Generator Blowdown Monitor (R-19A, R-19B, and R-19C).
 = 0.25 for the Condensate Polisher Liquid Waste (R-37).

Bkg = the monitor background (cpm).

2.1.2 Setpoint Based on an Analysis of Liquid Prior to Discharge.

The following method applies to liquid releases via the discharge canal when determining the alarm setpoint for the Waste Disposal System liquid Effluent Monitor (R-18), the Steam Generator Blowdown Monitors (R-19A, R-19B, and R-19C), and the Condensate Polisher Liquid Waste Monitor (R-37) when an analysis of the activity of the principal gamma emitters has been made prior to or during the release. The Condensate Polisher Sump discharge (monitored by R-37) discharges to the Settling Ponds prior to release via the discharge canal. Even though the Settling Ponds provide additional dilution prior to discharge, no dilution from the Settling Ponds is used in calculating setpoints for R-37. The setpoint for R-37 is calculated using circulating water for dilution, or service water when circulating water is unavailable.

2.1.2.1 Determine D_{req} (the minimum acceptable dilution factor).

$$D_{req} = D_{req,g} + D_{req,ng}$$

$$D_{req,g} = \frac{\sum_{i=g} \frac{C_i}{ECL_i}}{S * R_{max}} \qquad D_{req,ng} = \frac{\sum_{i=ng} \frac{C_i}{ECL_i}}{S * R_{max}}$$

where:

$D_{req,g}$ = Required dilution factor for gamma-emitters (dimensionless).

$D_{req,ng}$ = Required dilution factor for non-gamma-emitters, e.g. Gross Alpha, H-3, Sr-89, Sr-90, and Fe-55 (dimensionless).

ECL_i = Effluent concentration limit of nuclide 'i' ($\mu\text{Ci/ml}$).

C_i = The concentration of nuclide 'i', if all gamma-emitting are < LLD (as defined in ODCM Table 2.8-1), C_i may be assumed to consist only of Cs-134 at concentration of $9.0E-07$ $\mu\text{Ci/ml}$. This nuclide has the lowest ECL of any nuclides to be found in liquid effluents and provides a conservative basis for a monitor setpoint ($\mu\text{Ci/ml}$).

S = 0.5, a safety factor used for conservatism to assure that the radionuclide concentrations are less than the limits specified in 10 CFR Part 20 Appendix B, at the point of discharge (dimensionless).

R_{max} = The maximum ECL ratio limit (dimensionless).

2.1.2.2 Determine the maximum waste flow, R_{cwmax} .

$$R_{\text{cwmax}} = \frac{F_{\text{avail}} * F_{\text{alloc}}}{(D_{\text{req}} - 1.0)}$$

where:

R_{cwmax} = Maximum allowable release flowrate from the waste source (gpm).

F_{avail} = Available dilution flow (gpm).
 = 160,000 gpm from one circulating water pump¹, Unit 2.
 = 250,000 gpm from two circulating water pumps¹, Unit 2.
 = 400,000 gpm from three circulating water pumps¹, Unit 2.

OR

= 50,000 gpm from one circulating water pump², Retired Fossil Plant.
 = 80,000 gpm from two circulating water pumps², Retired Fossil Plant.

OR

= 7,000 gpm from one service water pump⁴, Unit 2.

F_{alloc} = Fraction of the radioactivity from the site that may be released via the monitored pathway to ensure that the site boundary limit is not exceeded due to simultaneous releases from more than one pathway (dimensionless).
 = 0.25 for the Waste Disposal System Liquid Effluent Monitor (R-18).
 = 0.16 for each of the Steam Generator Blowdown Monitor (R-19A, R-19B or R-19C).
 = 0.25 for the Condensate Polisher Liquid Waste (R-37)

If it is determined that:

$$\frac{(F_{avail} + F_{waste})}{D_{req} * F_{waste}} < 1$$

where:

- F_{waste} = Waste flow anticipated for this release (gpm).
- = 60 gpm for the Waste Disposal System Liquid Effluent Monitor³.
- = 160 gpm for each Steam Generator Blowdown Monitor.
- = 130 gpm for each Steam Generator Blowdown Monitor while draining a steam generator.
- = 300 gpm for the Condensate Polisher Liquid Waste Monitor

Then the release cannot be made.

If it is determined that:

$$\frac{(F_{avail} + F_{waste})}{D_{req} * F_{waste}} > 1$$

Then the release can be made.

2.1.2.3 Determine the setpoint adjustment factor, S_{adj}.

$$S_{adj} = \frac{\left[\frac{(F_{alloc} * F_{avail}) + F_{waste}}{F_{waste}} \right] - D_{req,ng}}{D_{req,g}}$$

2.1.2.4 Determine S_{max} monitor alarm setpoint (μCi/ml).

$$S_{max} = S_{adj} * \sum_i C_i$$

where:

- C_i = Concentration of gamma emitting nuclide 'i' (μCi/ml).

2.1.2.5 Determine the monitor alarm setpoint, S_{maxcpm} (cpm).

$$S_{maxcpm} = (S_{max} * E_m) + Bkg$$

where:

- E_m = The applicable effluent monitor efficiency based on S_{max} from the efficiency curves located in the Station Curve Book.
- Bkg = The monitor background (cpm).

Section 2.1 References

1. Carolina Power & Light Company Drawing Number G-190825. Using the System Q-H Curve for Emergency Low Water Level.
2. Carolina Power & Light Company, Darlington County S.E. Plant. 1960-182 MW Installation, Unit 1. SYSTEM HEAD CURVES Unit 1 Circulating Water System Draining Quosig.
3. H.B. Robinson Electric Plant Unit 2, Updated Final Safety Analysis Report.
4. RNP-M/MECH-1653, Service Water System Hydraulic Evaluation. |

2.2 Requirements for Compliance with 10 CFR Part 20 (Liquids)

Applicability

Applies to radioactive material in liquid effluents released from the site to unrestricted areas.

Objective

To define the concentration limits of 10 CFR 20 for radioactive material in liquid effluents released to unrestricted areas.

Specification

CONTROLS

2.2.1 The concentration of radioactive material in liquid effluents released at any time from the site to unrestricted areas (see Figure 7-1) shall be limited to 10 times the concentrations specified in 10 CFR 20, Appendix B, Table 2, Column 2 for radionuclides other than dissolved or entrained noble gases. For dissolved or entrained noble gases, the concentration shall be limited to $2E-04$ $\mu\text{Ci/ml}$ total activity.

ACTIONS

2.2.2 With the concentration of radioactive material in liquid effluents released from the site to unrestricted areas exceeding the above limits, without delay restore the concentration to within the above limits. In addition, notification must be made to the Commission in accordance with 10 CFR 50.72 and 10 CFR 50.73.

2.2.3 The provisions of Specification 8.1 are not applicable.

Bases

Compliance With 10 CFR Part 20 - Radioactive Materials in Liquid Effluents

This specification is provided to ensure that the concentration of radioactive materials in liquid effluents released from the site to unrestricted areas will be less than 10 times the concentrations specified in 10 CFR Part 20, Appendix B, Table 2, Column 2. This limitation provides the additional assurance that the concentrations of radioactive materials in bodies of water outside the site will result in exposures within the limits of 10 CFR Part 20.1302 to the population. The concentration limit for dissolved or entrained noble gases is based upon the assumption that Xe-135 is the controlling radionuclide and its EC in air (submersion) was converted to an equivalent concentration in water using the methods described in International Commission on Radiological Protection (ICRP) Publication 2.

The required detection capabilities for radioactive materials in liquid waste samples are tabulated in terms of the lower limits of detection (LLDs). Detailed discussion of the LLD, and other detection limits can be found in HASL Procedures Manual, HASL-300 (revised annually), Currie, L.A., "Limits for Qualitative Detection and Quantitative Determination - Application to Radiochemistry", *Anal. Chem.* 40, 586-93 (1968), and Hartwell, J. K., "Detection limits for Radioanalytical Counting Techniques", Atlantic Richfield Hanford Company Report ARH-SA-215 (June 1975).

2.3 Compliance with 10 CFR 20 (Liquids)

Liquid effluents from H.B. Robinson Unit 2 (HBR) will occur both continuously and on a batch basis. The following sections discuss the methodology which will be utilized by the HBR to show compliance with 10 CFR 20.

2.3.1 Continuous Releases

Steam generator blowdown may be a continuous release from HBR. During release periods grab samples will be taken of steam generator blowdown and analyzed for I-131, fission, activation, and corrosion products as outlined in Table 2.8-1 of the ODCM for HBR. These samples are then composited at a rate using the following equation:

$$V_{up} = V_{cp} * \frac{V_a}{V_t}$$

where:

V_{up} = Volume to be replaced/updated (milliliters).

V_{cp} = Volume of the composite (milliliters).

V_a = Actual volume released from grab sample (gallons).

V_t = Total waste volume released to date, including volume V_a , within the compositing period (gallons).

Compliance with 10 CFR 20 during actual release is established through the steam generator blowdown effluent monitor alarm setpoint. This setpoint is based upon Cs-134 as noted in Section 2.1. However, if a continuous release should occur in which the effluent monitor alarm setpoint is exceeded, then actual compliance with 10 CFR 20 may be determined utilizing the actual radionuclide mix and the following equation:

$$Conc_i = \frac{C_{ic} * V_c}{V_{dc}} \tag{2.3-1}$$

where:

$Conc_i$ = Concentration of radionuclide 'i' at the unrestricted area ($\mu\text{Ci/ml}$).

C_{ic} = Concentration of radionuclide 'i' in the continuous release ($\mu\text{Ci/ml}$).

V_c = Volume of continuous effluent released (gallons).

V_{dc} = Volume of dilution flow during release (gallons).

2.3.2 Batch Releases

Batch releases will occur during normal operation. When this does occur at HBR, a continuous release will usually be occurring at the same time. However, during certain shutdown conditions, only batch releases may occur at HBR. Therefore, both situations are treated here to provide the methodology to show compliance with 10 CFR 20.

2.3.2.1 Pre-release

The radioactivity content of each batch release will be determined prior to release in accordance with Table 2.8-1 of the ODCM for HBR. HBR will show compliance with 10 CFR 20 in the following manner:

For the case where only a batch release is to occur, the concentration of the various radionuclides in the batch release, determined in accordance with Table 2.8-1 of the ODCM for HBR, is multiplied by the ratio of the maximum release rate of the potential batch release to the dilution flow rate to obtain the concentration at the unrestricted area. This calculation is shown in the following equation:

$$Conc_i = \frac{C_{ib} * R_b}{D_{fr} * T_m} \quad (2.3-2)$$

where:

Conc_i = Concentration of radionuclide 'i' at the unrestricted area (μCi/ml).

C_{ib} = Concentration of radionuclide 'i' in the potential batch release (μCi/ml).

R_b = Release rate of the potential batch release (gpm).

D_{fr} = The dilution flow rate based upon the number of circulating water pumps in service, or service water pumps when circulating water pumps are unavailable, during the release (gpm).

= 160,000 gpm from one circulating water pump, Unit 2.

= 250,000 gpm from two circulating water pumps, Unit 2.

= 400,000 gpm from three circulating water pumps, Unit 2.

OR

= 50,000 gpm from one circulating water pump, Retired Fossil Plant.

= 80,000 gpm from two circulating water pumps, Retired Fossil Plant.

OR

= 7,000 gpm from one service water pump, Unit 2.

T_m = Fraction of dilution flow allocated to this release (dimensionless).

The concentration in the unrestricted area is compared to 10 times the concentrations in Appendix B, Table 2, Column 2, of 10 CFR 20. Before release may occur, the mixture of radionuclides released must be of such concentration that Equation 2.3-3 is met:

$$\sum_i \frac{Conc_i}{10 * EC_i} \leq 1 \quad (2.3-3)$$

where:

EC_i = Effluent Concentration Limit of radionuclide 'i' from Appendix B, Table 2, Column 2 of 10 CFR 20 ($\mu\text{Ci/ml}$).

For those cases where batch releases may be occurring at the same time that continuous releases are occurring, the concentration in the unrestricted area will be calculated by the following equation:

$$Conc_i = \frac{(C_{ib} * R_b) + (C_{ic} * R_c)}{D_{fr} * \sum T_m} \quad (2.3-4)$$

where:

R_c = Maximum continuous liquid effluent release rate (gpm).

$\sum T_m$ = Summation of allocation fractions for those concurrent releases (dimensionless).

The mixture of radionuclides released must be of such concentrations that Equation 2.3-3 must be met.

For HBR, the liquid radwaste effluent line discharges to the circulating water system. Therefore, the dilution flow rate (D_{fr}) is a function of the number of circulating water pumps operating, or one Unit 2 service water pump when no circulating water pumps are available. At least one circulating water pump must be operating during any liquid waste discharge during normal plant operation. During periods when no circulating water pumps are available (e.g. refueling outage), one Unit 2 service water pump may be used for dilution.

Batch releases from the HBR liquid radwaste system may occur from the waste condensate tanks, the monitor tanks, and the steam generators (during drainage). Continuous release may occur from Steam Generator Blowdown and the Condensate Polisher Liquid Waste. The maximum administrative release rate (R_b) is 160 gpm for each of the steam generators during blowdown, 60 gpm from the monitor and waste condensate tanks, and 300 gpm for the Condensate Polisher Liquid Wastes, and 130 gpm for each of the steam generators during drainage.

2.3.2.2 Post-release

The Steam Generation Blowdown Monitor (R-19A, R-19B, and R-19C), the Waste Disposal System Liquid Monitor (R-18), and the Condensate Polisher Liquid Waste Monitor (R-37) setpoint will each be limited to 50 percent of 10 times the 10 CFR 20 limits. These setpoints will ensure that 10 times the 10 CFR 20 limits are met. However, because they are based upon a given mix, the possibility exists that the alarm trip setpoints may be exceeded, while 10 times the 10 CFR 20 limits are not exceeded. The following methodology is provided to determine whether actual releases exceeded 10 times the 10 CFR 20 limits.

The concentration of each radionuclide in the unrestricted area following release from a batch tank will be calculated in the following manner:

For the case where only batch releases are occurring, the total activity of radionuclide 'i' released is divided by the actual dilution flow to obtain the concentration in the unrestricted area. This calculation is shown in the following equation:

$$Conc_{ik} = \frac{C_{ikb} * V_{kb}}{V_{kd}} \quad (2.3-5)$$

where:

Conc_{ik} = The concentration of radionuclide 'i' at the unrestricted area during release 'k' (μCi/ml).

C_{ikb} = Concentration of radionuclide 'i' in the batch release 'k' (μCi/ml).

V_{kb} = Volume of batch release 'k' (gal).

V_{kd} = Actual volume of dilution during release 'k' (gal).

To show compliance with 10 CFR 20, the following relationship must hold:

$$\sum_i \frac{Conc_{ik}}{10 * EC_i} \leq 1 \quad (2.3-6)$$

The actual dilution volume during release 'k' (V_{kd}) is calculated by the following equation:

$$V_{kd} = 60 * \sum_k D_{fr} * t_k \quad (2.3-7)$$

where :

60 = Conversion factor (min/hr).

t_k = Duration of release 'k' (hr).

D_{fr} = Dilution flow rate from circulating water pumps or service water pump during release 'k' (gpm).

The circulating water pump and service water pump flow rates were given in Section 2.3.2.1 above.

For the case where a batch release is occurring at the same time that a continuous release is occurring, the compliance with 10 CFR 20 limits may be determined by the following equation:

$$Conc_{ik} = \frac{(C_{ikb} * V_{kb}) + (C_{ikc} * V_{kc})}{V_{kd}} \quad (2.3-8)$$

where:

C_{ikc} = Concentration of radionuclide 'i' in continuous releases during release period 'k' ($\mu\text{Ci/ml}$).

V_{kc} = Volume of continuous release during period 'k' (gal).

Calculated concentrations are to be compared to 10 times the concentrations in Appendix B, Table 2, Column 2, of 10 CFR 20.

2.4 Requirements for Compliance with 10 CFR 50 (Liquids)

Applicability

Applies to radioactive material in liquid effluents released from the site to unrestricted areas.

Objective

To define the calculated dose limits of 10 CFR 50 for radioactive materials in liquid effluents released to unrestricted areas.

Specification

CONTROLS

2.4.1 The dose commitment at all times to a member of the public from radioactive material in liquid effluents released to unrestricted areas (See Figure 7-1) shall be limited:

- a. During any calendar quarter to ≤ 1.5 mrem to the total body and to ≤ 5 mrem to any organ.

AND

- b. During any calendar year to ≤ 3 mrem to the total body and to ≤ 10 mrem to any organ.

ACTIONS

2.4.2 With the calculated dose commitment from the release of radioactive materials in liquid effluents exceeding any of the limits prescribed by ODCM Specification 2.4.1 above, prepare and submit a report to the Commission in accordance with the ODCM Specification 9.3.

Bases

Compliance With 10 CFR Part 50 - Radioactive Materials in Liquid Effluents

This specification is provided to implement the requirements of Sections II.A, and III.A and IV.A of Appendix I, 10 CFR Part 50. The Control implements the guides set forth in Section II.A of Appendix I. The action statement provides the required operating flexibility and at the same time implements the guides set forth in Section IV.A of Appendix I of 10 CFR Part 50 to assure that the release of radioactive material in liquid effluents will be kept "as low as is reasonably achievable." The dose calculations in the ODCM implement the requirements in Section III.A of Appendix I that conformance with the guides of Appendix I be shown by calculative procedures based on models and data, such that the actual exposure of an individual through appropriate pathways is unlikely to be substantially underestimated. The equations specified in the ODCM for calculating the doses due to the actual release rates of radioactive materials in liquid effluents are consistent with the methodology provided in the Regulatory Guide 1.109, "Calculation of Annual Doses to Man from Routine Releases of Reactor Effluents for the Purpose of Evaluating Compliance with 10 CFR Part 50, Appendix I," Revision 1, October 1977 and Regulatory Guide 1.113, "Estimating Aquatic Dispersion of Effluents from Accidental and Routine Reactor Releases for the Purpose of Implementing Appendix I," April, 1977.

2.5 Compliance with 10 CFR 50 (Liquids)

2.5.1 Cumulation of Doses

The dose contribution from the release of liquid effluents will be calculated once per month, and a cumulative summation of these total body and any organ doses should be maintained for each calendar quarter. The dose contribution for all batch releases will be calculated using the following equation:

$$D_{\tau b} = \sum_k \sum_i A_{i\tau} * t_{kb} * C_{ikb} * F_{kb} \quad (2.5-1)$$

where:

- $A_{i\tau}$ = The site-related dose commitment factor to the total body or any organ τ for each identified principal gamma and beta emitter based on ingestion of aquatic food and shore line sediment exposure (mrem/hr per $\mu\text{Ci/ml}$).
- t_{kb} = The length of time of batch release 'k' over which C_{ikb} and F_{kb} are averaged for each batch liquid release (hr).
- C_{ikb} = The average concentration of radionuclide 'i' in undiluted batch liquid effluent during batch release 'k' ($\mu\text{Ci/ml}$).
- F_{kb} = The near-field average dilution factor for C_{ikb} during any batch liquid effluent release 'k'. Defined as the ratio of the volume of undiluted liquid waste released to the product of the dilution volume from the site discharge structure to unrestricted receiving waters times 1.0. (1.0 is the site-specific applicable factor for the mixing effect of the HBR discharge structure as defined in NUREG-0133, October 1978).

$$F_{kb} = \frac{V_{kb}}{V_{kd} * 1.0}$$

where V_{kb} and V_{kd} are as defined in Equation 2.3-5.

The dose factor $A_{i\tau}$ was calculated for an adult for each isotope using the following equation:

$$A_{i\tau} = (1.14 \times 10^5 * 21 * BF_i * DF_{i\tau}) + [1.14 \times 10^5 * 100 * 12 * 0.3 * T_i * e^{-\lambda_i * t_p} * (1 - e^{-\lambda_i * t_b}) * DFG_i] \quad (2.5-2)$$

where:

$$1.14 \times 10^5 = \frac{10^6 \text{ pCi}}{\mu\text{Ci}} * \frac{10^3 \text{ ml}}{\text{l}} * \frac{1 \text{ yr}}{8760 \text{ hr}}$$

21 = Adult fish consumption rate from Table E-5 of Regulatory Guide 1.109, Revision 1 (kg/yr).

BF_i = Bioaccumulation factor for radionuclide 'i' in fish from Table A-1 of Regulatory Guide 1.109, Revision 1 ($\rho\text{Ci/kg}$ per $\rho\text{Ci/l}$).

$DF_{i\tau}$ = Dose conversion factor for radionuclide 'i' for adults for a particular organ τ from Table E-11 of Regulatory Guide 1.109, Revision 1 (mrem/ ρCi).

100 = Sediment proportionality constant from Regulatory Guide 1.109, Revision 1 (liters per m^2 -day).

12 = Adult shoreline exposure rate from Table E-5 of Regulatory Guide 1.109, Revision 1 (hrs/yr).

0.3 = Shoreline width factor from Table A-2 of Regulatory Guide 1.109, Revision 1.

T_i = Nuclide half-life for radionuclide 'i' (days).

λ_i = Nuclide decay constant for radionuclide 'i' (sec^{-1}).

t_p = Average transit time to point of exposure (0 seconds).

t_b = Sediment exposure time of $4.73\text{E}+08$ seconds (15 years) from page 1.109-14 of Regulatory Guide 1.109, Revision 1.

DFG_i = The ground plane dose conversion factor for radionuclide 'i' from Table E-6 of Regulatory Guide 1.109, Revision 1 (mrem/hr per pCi/m^2).

The potable water pathway does not exist either within Lake Robinson or downstream of the Lake Robinson dam. Therefore, the potable water term was excluded from the calculation of $A_{i\tau}$ values. Table 2.5-1 presents $A_{i\tau}$ values for an adult at HBR.

As noted in Section 2.3.1, steam generator blowdown is continuously released from HBR. The dose from continuous releases will be calculated using the following equation:

$$D_{\tau c} = \sum_k \sum_i A_{i\tau} * t_{kc} * C_{ikc} * F_{kc} \quad (2.5-3)$$

where:

- $D_{\tau c}$ = The cumulative dose commitment to the total body or any organ τ , from liquid effluents for continuous releases (mrem).
- t_{kc} = The length of time of continuous release period 'k' over which C_{ikc} and F_{kc} are averaged for all continuous liquid releases (hours).
- C_{ikc} = The average concentration of radionuclide 'i' in undiluted liquid effluent during continuous release period 'k' from any continuous liquid release ($\mu\text{Ci/ml}$).
- F_{kc} = The near-field average dilution factor for C_{ikc} during continuous liquid effluent release 'k'. Defined as the ratio of the volume of undiluted liquid waste released to the product of the dilution volume from the site discharge structure to unrestricted receiving waters times 1.0. (1.0 is the site-specific applicable factor for the mixing effect of the HBR discharge structure as defined in NUREG-0133, October 1978).

$$F_{kc} = \frac{V_{kc}}{V_{kd} * 1.0}$$

where V_{kc} and V_{kd} are as defined in Equation 2.3-8 and Equation 2.3-5, respectively, only now distinguished for continuous releases.

The sum of the cumulative dose from all batch and continuous releases for a quarter are compared to one half the design objectives for total body and any organ. The sum of the cumulative doses from all batch and continuous releases for a calendar year are compared to the design objective doses. The following relationships should hold for HBR to show compliance with Specification 2.4.1 of the ODCM for H.B. Robinson Unit 2.

For the calendar quarter:

$$D_{\tau} \leq 1.5 \text{ mrem total body} \quad (2.5-4)$$

$$D_{\tau} \leq 5 \text{ mrem any organ} \quad (2.5-5)$$

For the calendar year:

$$D_{\tau} \leq 3 \text{ mrem total body} \quad (2.5-6)$$

$$D_{\tau} \leq 10 \text{ mrem any organ} \quad (2.5-7)$$

where:

D_{τ} = Cumulative total dose to any organ τ or the total body from continuous and batch releases (mrem).

$$= D_{tb} + D_{\tau c}$$

The quarterly limits given above represent one half the annual design objective of Section II.A of Appendix I of 10 CFR 50. If any of the limits in Expressions 2.5-4 through 2.5-7 are exceeded, a special report pursuant to ODCM Specification 9.3 must be filed with the NRC. This report complies with Section IV.A, of Appendix I of 10 CFR 50.

2.5.2 Projection of Doses

Doses resulting from the release of liquid effluents will be projected once per 31 days. These projections will include a safety margin, based upon expected operational conditions, which will take into consideration both planned and unplanned releases. Projected dose will be calculated as follows:

$$PD = \frac{92 * (DA + DB)}{TE} + M \quad (2.5-8)$$

where:

- PD = projected doses (mrem).
92 = time in quarter (days).
DA = dose accumulated during current quarter (mrem).
DB = projected dose from this release (mrem).
TE = time elapsed in quarter (days).
M = safety margin (mrem).

If the projected doses exceed 0.2 mrem to the whole body or 0.6 mrem to any organ when averaged over a calendar quarter, the liquid radwaste equipment will be operated to reduce the radioactive materials in the liquid effluent.

2.5.3 Dose from Evaporation of Lake Robinson

Dose resulting from the evaporation of previously discharged liquids to Lake Robinson shall be calculated annually for inclusion in the Annual Effluent Report. The curies released by evaporation from Lake Robinson will be calculated based on annual meteorological data, lake temperature, and the monthly lake composite tritium data. Due to the size and length of Lake Robinson, the lake was split into five sections to more accurately quantify the resulting dose (Refer to figure D-3). To show compliance with 10 CFR 50, Equation 2.5-9 is evaluated at the limiting pathway location. The limiting location is defined as a resident with a vegetable garden and beef animal present at 3.96 miles in the north sector. The critical receptor is a child.

H. B. Robinson air dispersion and deposition factors are calculated annually from annual averaged air concentrations and deposition values obtained during routine releases. The methodology for calculating air dispersion and deposition factors are discussed in Appendix A. Five year climatology (2005 – 2009) data was used to generated air dispersion factors listed below. Annually, air dispersion factors are compared to the five year data for each of the Lake Sections. If the newly calculated annual air dispersion and deposition factors do not result in a significant increase in the calculated offsite dose relative to the 10CFR50, Appendix I dose objectives then the 5-year χ/Q and D/Q factors are not revised. An increase in calculated offsite dose that is greater than five percent of the 10CFR50, Appendix I dose objectives would be considered significant enough to warrant a change in the χ/Q and D/Q factors. If an increasing trend in the annual χ/Q and D/Q factors compared to the 5-year values is noted then a revised set of 5-year χ/Q and D/Q factors will be generated.

X/Q values were obtained based on 2005 through 2009 meteorological data.

Lake Section	X/Q (sec/m ³)
1	1.33E-6
2	2.61E-6
3	7.97E-6
4	1.26E-4
5	1.52E-6

$$D_{\tau} = 3.17 \times 10^{-8} * (R_{TB} + R_{TI} + R_{TV}) * \sum_{i=1}^5 [(\overline{\chi/Q})_i * Q_i] \quad (2.5-9)$$

where:

- D_{τ} = Dose to any organ τ from tritium (mrem).
- 3.17×10^{-8} = Inverse of the number of seconds in a year (sec/year)⁻¹.
- R_{TB} = Organ dose factor for tritium meat pathway (mrem/yr per $\mu\text{Ci}/\text{m}^3$).
- R_{TI} = Organ dose factor for tritium inhalation pathway (mrem/yr per $\mu\text{Ci}/\text{m}^3$).
- R_{TV} = Organ dose factor for tritium vegetation pathway (mrem/yr per $\mu\text{Ci}/\text{m}^3$).
- $(\overline{\chi/Q})_i$ = Relative concentration from Lake Section 'i' (sec/m³).
- Q_i = Release of tritium from Lake Section 'i' (μCi).

Tritium released from each lake section is determined using lake evaporation, lake section area, and average monthly tritium concentration from REMP Surface Water location SW-40. Evaporation is derived using annual meteorological data, including wind speed and humidity, and average lake temperature. Lake section evaporation is determined annually from any of the following: a proprietary vendor method, Duke Energy internal calculation, values published by National Oceanic and Atmospheric Administration, or estimates from the State Climatology Office. Q_i values use in Equation 2.5-9 are reported annually in ARERR.

$$Q_i = A_i * E_i * C_i * 10^{-6} \quad (2.5-10)$$

where:

- A_i = Area of lake section 'i' listed in Appendix E (m²).
- E_i = Monthly evaporation of lake section 'i' (mm H₂O).
- C_i = Monthly concentration of tritium from REMP Surface Water location SW-40 (pCi/L).
- 10^{-6} = Conversion (1E-03 mm/m * 1E-06 μCi/pCi * 1E+03 L/m³).

2.5.4 Dose from Tritium in Fish in Lake Robinson

The concentration of tritium in fish is directly related to the concentration in Lake Robinson. Equilibrium ratios between the concentration of tritium in the water and concentration of tritium in the flesh is based upon the bioaccumulation factor for tritium. Because the adult age group will always have the maximum dose from fish consumption, adult is the only age group considered. This calculation is performed annually for inclusion in the ARERR.

$$R_{apj} = U_{ap} * D_{apj} * C_{ip} * BF_i \quad (2.5-11)$$

where:

- R_{apj} = Annual dose to organ 'j' from tritium ingestion to adult age group (mrem/yr).
- U_{ap} = Usage term for adult from Regulatory Guide 1.109 Table E-11 (21 kg/yr).
- D_{apj} = Adult dose factor for tritium ingestion, same for Total Body and all organs (1.05E-07 mrem/pCi).
- C_{ip} = Concentration of tritium from REMP Surface Water location SW-40 (pCi/L).
- BF_i = Bioaccumulation factor for tritium in fish from Regulatory Guide 1.109 Table A-1 (0.90 pCi/kg per pCi/L).

TABLE 2.5-1
A_{it} VALUES FOR THE ADULT FOR THE
H.B. ROBINSON STEAM ELECTRIC PLANT
 (mrem/hr per $\mu\text{Ci/ml}$)

<u>Nuclide</u>	<u>Bone</u>	<u>Liver</u>	<u>T.Body</u>	<u>Thyroid</u>	<u>Kidney</u>	<u>Lung</u>	<u>GI-LLI</u>	<u>Skin</u>
H-3	0.00E+00	2.27E-01	2.27E-01	2.27E-01	2.27E-01	2.27E-01	2.27E-01	2.27E-01
F-18	2.30E-02	2.13E-02	2.15E-02	2.13E-02	2.13E-02	2.13E-02	2.13E-02	2.51E-02
NA-24	1.35E+02	1.35E+02	1.35E+02	1.35E+02	1.35E+02	1.35E+02	1.35E+02	7.45E-01
CR-51	2.51E-01	2.51E-01	1.49E+00	9.94E-01	5.25E-01	1.90E+00	3.13E+02	2.96E-01
MN-54	7.45E+01	4.45E+03	9.09E+02	7.45E+01	1.38E+03	7.45E+01	1.35E+04	8.74E+01
MN-56	4.86E-02	2.23E-01	7.94E-02	4.86E-02	2.69E-01	4.86E-02	5.60E+00	5.74E-02
FE-55	6.59E+02	4.55E+02	1.06E+02	0.00E+00	0.00E+00	2.54E+02	2.61E+02	0.00E+00
FE-59	1.04E+03	2.42E+03	9.38E+02	1.47E+01	1.47E+01	6.88E+02	8.04E+03	1.72E+01
CO-57	1.01E+01	2.89E+01	4.49E+01	1.01E+01	1.01E+01	1.01E+01	5.41E+02	1.11E+01
CO-58	2.04E+01	1.09E+02	2.19E+02	2.04E+01	2.04E+01	2.04E+01	1.81E+03	2.39E+01
CO-60	1.16E+03	1.41E+03	1.72E+03	1.16E+03	1.16E+03	1.16E+03	5.98E+03	1.36E+03
NI-63	3.12E+04	2.16E+03	1.05E+03	0.00E+00	0.00E+00	0.00E+00	4.51E+02	0.00E+00
NI-65	1.88E-01	3.83E-02	2.62E-02	1.60E-02	1.60E-02	1.60E-02	5.83E-01	1.86E-02
CU-64	3.26E-02	2.73E+00	1.30E+00	3.26E-02	6.83E+00	3.26E-02	2.30E+02	3.70E-02
ZN-65	2.32E+04	7.37E+04	3.33E+04	4.02E+01	4.93E+04	4.02E+01	4.64E+04	4.62E+01
BR-82	1.15E+00	1.15E+00	1.42E+03	1.15E+00	1.15E+00	1.15E+00	1.63E+03	1.33E+00
BR-83	2.62E-04	2.62E-04	3.87E-02	2.62E-04	2.62E-04	2.62E-04	5.56E-02	3.81E-04
BR-84	1.09E-02	1.09E-02	1.09E-02	1.09E-02	1.09E-02	1.09E-02	1.09E-02	1.27E-02
RB-86	4.83E-01	9.75E+04	4.54E+04	4.83E-01	4.83E-01	4.83E-01	1.92E+04	5.52E-01
RB-88	1.78E-03	1.78E-03	1.78E-03	1.78E-03	1.78E-03	1.78E-03	1.78E-03	2.03E-03
RB-89	6.61E-03	6.61E-03	6.61E-03	6.61E-03	6.61E-03	6.61E-03	6.61E-03	7.93E-03
SR-89	2.19E+04	1.16E-03	6.27E+02	1.16E-03	1.16E-03	1.16E-03	3.51E+03	1.35E-03
SR-90	5.45E+05	0.00E+00	1.34E+05	0.00E+00	0.00E+00	0.00E+00	1.58E+04	0.00E+00
SR-91	7.09E+01	1.16E-01	2.98E+00	1.16E-01	1.16E-01	1.16E-01	3.37E+02	1.35E-01
SR-92	3.76E-01	4.18E-02	5.62E-02	4.18E-02	4.18E-02	4.18E-02	6.66E+00	4.64E-02
Y-91M	5.39E-03	5.39E-03	5.39E-03	5.39E-03	5.39E-03	5.39E-03	5.39E-03	6.24E-03
Y-91	8.41E+00	5.77E-02	2.81E-01	5.77E-02	5.77E-02	5.77E-02	4.60E+03	6.49E-02
Y-92	1.02E-02	9.70E-03	9.72E-03	9.70E-03	9.70E-03	9.70E-03	8.09E+00	1.15E-02
Y-93	4.08E-02	9.86E-03	1.07E-02	9.86E-03	9.86E-03	9.86E-03	9.82E+02	1.35E-02
ZR-95	1.34E+01	1.32E+01	1.32E+01	1.32E+01	1.33E+01	1.32E+01	2.55E+02	1.53E+01
ZR-97	1.64E-01	1.60E-01	1.60E-01	1.59E-01	1.61E-01	1.59E-01	3.11E+02	1.85E-01
NB-95	4.46E+02	2.51E+02	1.39E+02	7.35E+00	2.49E+02	7.35E+00	1.48E+06	8.65E+00
NB-97	9.47E-03	9.47E-03	9.47E-03	9.47E-03	9.47E-03	9.47E-03	1.29E-02	1.11E-02
MO-99	2.15E-01	8.06E+01	1.55E+01	2.15E-01	1.82E+02	2.15E-01	1.86E+02	2.49E-01
TC-99M	1.05E-02	1.15E-02	3.01E-02	9.90E-03	3.40E-02	1.07E-02	9.47E-01	1.13E-02
TC-101	1.09E-03	1.09E-03	1.09E-03	1.09E-03	1.09E-03	1.09E-03	1.09E-03	1.22E-03
RU-103	1.02E+01	5.82E+00	7.70E+00	5.82E+00	2.25E+01	5.82E+00	5.15E+02	6.79E+00
RU-105	4.29E-02	3.42E-02	3.77E-02	3.42E-02	1.47E-01	3.42E-02	5.36E+00	3.88E-02
RU-106	8.85E+01	2.27E+01	3.10E+01	2.27E+01	1.50E+02	2.27E+01	4.28E+03	2.72E+01
AG-110M	1.86E+02	1.86E+02	1.85E+02	1.85E+02	1.86E+02	1.85E+02	5.17E+02	2.16E+02
SN-113	2.00E+03	7.80E+01	1.90E+03	2.80E+01	5.75E+01	7.66E-01	3.50E+04	2.19E+00
SB-124	3.88E+01	3.23E+01	3.48E+01	3.22E+01	3.22E+01	3.73E+01	2.21E+02	3.71E+01
SB-125	1.30E+02	1.26E+02	1.27E+02	1.26E+02	1.26E+02	1.29E+02	1.73E+02	1.42E+02
TE-129M	1.08E+04	4.03E+03	1.71E+03	3.71E+03	4.51E+04	1.06E+00	5.44E+04	1.24E+00
TE-129	1.43E-03	1.42E-03	1.42E-03	1.42E-03	1.49E-03	1.41E-03	1.42E-03	1.67E-03
TE-131M	9.54E+02	4.67E+02	3.89E+02	7.39E+02	4.72E+03	4.32E-01	4.63E+04	5.09E-01
TE-132	1.95E+03	1.26E+03	1.19E+03	1.40E+03	1.22E+04	2.28E-01	5.98E+04	2.68E-01
I-131	1.38E+02	1.97E+02	1.13E+02	6.44E+04	3.38E+02	9.25E-01	5.27E+01	1.12E+00
I-132	7.23E-02	8.11E-02	7.19E-02	5.61E-01	8.95E-02	6.70E-02	6.96E-02	7.88E-02
I-133	2.31E+01	4.01E+01	1.23E+01	5.87E+03	6.98E+01	1.32E-01	3.60E+01	1.60E-01
I-134	2.40E-02	2.40E-02	2.40E-02	2.40E-02	2.40E-02	2.40E-02	2.40E-02	2.85E-02
I-135	1.42E+00	3.50E+00	1.38E+00	2.22E+02	5.54E+00	1.36E-01	3.94E+00	1.59E-01

TABLE 2.5-1 (continued)
 A_{it} VALUES FOR THE ADULT FOR THE
H.B. ROBINSON STEAM ELECTRIC PLANT
 (mrem/hr per $\mu\text{Ci/ml}$)

Nuclide	Bone	Liver	T.Body	Thyroid	Kidney	Lung	GI-LLI	Skin
CS-134	2.98E+05	7.10E+05	5.80E+05	3.69E+02	2.30E+05	7.66E+04	1.28E+04	4.30E+02
CS-136	2.96E+04	1.17E+05	8.42E+04	8.12E+00	6.51E+04	8.93E+03	1.33E+04	9.20E+00
CS-137	3.83E+05	5.23E+05	3.43E+05	5.55E+02	1.78E+05	5.95E+04	1.07E+04	6.47E+02
CS-138	1.93E-02	1.93E-02	1.93E-02	1.93E-02	1.93E-02	1.93E-02	1.93E-02	2.21E-02
BA-139	5.70E-03	5.69E-03	5.69E-03	5.69E-03	5.69E-03	5.69E-03	5.70E-03	6.41E-03
BA-140	1.86E+02	1.34E+00	1.32E+01	1.10E+00	1.18E+00	1.24E+00	3.81E+02	1.26E+00
BA-142	2.41E-03	2.41E-03	2.41E-03	2.41E-03	2.41E-03	2.41E-03	2.41E-03	2.75E-03
LA-140	1.13E+00	1.08E+00	1.05E+00	1.03E+00	1.03E+00	1.03E+00	3.67E+03	1.17E+00
LA-142	4.09E-02	4.09E-02	4.09E-02	4.09E-02	4.09E-02	4.09E-02	4.16E-02	4.90E-02
CE-141	7.57E-01	7.50E-01	7.37E-01	7.35E-01	7.42E-01	7.35E-01	5.75E+01	8.28E-01
CE-143	1.27E-01	1.89E+00	1.25E-01	1.24E-01	1.25E-01	1.24E-01	6.62E+01	1.41E-01
CE-144	4.91E+00	4.23E+00	3.80E+00	3.74E+00	4.03E+00	3.74E+00	3.98E+02	4.32E+00
PR-144	9.87E-05	9.87E-05	9.87E-05	9.87E-05	9.87E-05	9.87E-05	9.87E-05	1.13E-04
HF-181	1.33E+01	1.06E+01	1.09E+01	1.06E+01	1.06E+01	1.06E+01	2.12E+02	1.50E+01
W-187	1.48E+02	1.23E+02	4.32E+01	1.26E-01	1.26E-01	1.26E-01	4.04E+04	1.47E-01
NP-239	1.13E-01	9.41E-02	9.31E-02	9.20E-02	9.85E-02	9.20E-02	4.29E+02	1.06E-01

2.6 Radioactive Liquid Effluent Monitoring Instrumentation

Applicability

Applies to the radioactive liquid effluent instrumentation system.

Objective

To define the operating requirements for the radioactive liquid effluent instrumentation system.

Specification

CONTROLS

2.6.1 The radioactive liquid effluent monitoring instrumentation channels shown in Table 2.6-1 shall be operable with their alarm/trip setpoint set to ensure that the limits of ODCM Specification 2.2.1 are not exceeded. The alarm/trip setpoints shall be determined in accordance with the ODCM.

ACTIONS

- 2.6.2 With the calculated dose commitment from the release of radioactive materials in liquid effluents exceeding any of the limits prescribed by ODCM Specification 2.4.1 above, prepare and submit a report to the Commission in accordance with the ODCM Specification 9.3.
- 2.6.3 With less than the minimum number of radioactive liquid effluent monitoring instrumentation operable, take the action shown in Table 2.6-1.
- 2.6.4 The provisions of Specification 8.1 are not applicable.

Bases

Radioactive Liquid Effluent Instrumentation

The radioactive liquid effluent monitoring instrumentation is provided to monitor and control, as applicable, the releases of radioactive materials in liquid effluents during actual or potential releases of liquid effluents. The alarm/trip setpoints for these instruments shall be calculated in accordance with the procedures in the ODCM to ensure that the alarm/trip will occur prior to exceeding 10 times the limits of 10 CFR Part 20, Appendix B, Table 2, Column 2. The operability and use of this instrumentation are consistent with the requirements of General Design Criteria 60, 63, and 64 of Appendix A to 10 CFR Part 50.

TABLE 2.6-1
RADIOACTIVE LIQUID EFFLUENT MONITORING INSTRUMENTATION

Release Pathway / Instrumentation	MCO*	Compensatory Measures
1. Liquid Radwaste Effluent Discharge Line a. Monitor (R-18) provides automatic termination of release upon exceeding alarm/trip setpoint.	1	With the number of channels operable less than the MCO requirements: a. Exert best efforts to return the instruments to operable status within 30 days and, if unsuccessful, explain in the next Annual Radioactive Effluent Release Report why the inoperability was not corrected in a timely manner in accordance with Technical Specification 5.6.3 and, b. Effluent releases via this pathway may continue provided that prior to initiating a release: 1. Two independent samples are analyzed in accordance with the Surveillance Requirements of ODCM Specification 2.2.1 and; 2. Two members of the facility staff independently verify the release rate calculations and the discharge line valving.
b. Flow rate measurement device	1	With the number of channels operable less than the MCO requirement: a. Exert best efforts to return the instruments to operable status within 30 days and, if unsuccessful, explain in the next Annual Radioactive Effluent Release Report why the inoperability was not corrected in a timely manner in accordance with Technical Specification 5.6.3 and, b. Effluent releases via this pathway may be continued, provided that the flow rate is estimated at least once per 4 hours during actual releases. Pump performance curves generated "in situ" and tank volumes may be used to estimate flow.

*MCO - Minimum Channels Operable

TABLE 2.6-1 (continued)
RADIOACTIVE LIQUID EFFLUENT MONITORING INSTRUMENTATION

Release Pathway / Instrumentation	MCO*	Compensatory Measures
<p>2. Steam Generator Blowdown Effluent Line</p> <p>a. Monitor (R-19A,B, and C) provides automatic termination of blowdown from the affected Steam Generators upon exceeding alarm/trip setpoint.</p>	<p>1 per S/G</p>	<p>With the number of channels operable less than the MCO requirement:</p> <p>a. Exert best efforts to return the instruments to operable status within 30 days and, if unsuccessful, explain in the next Annual Radioactive Effluent Release Report why the inoperability was not corrected in a timely manner in accordance with Technical Specification 5.6.3 and,</p> <p>b. Effluent releases via this pathway may continue provided that grab samples are analyzed for gross radioactivity (beta or gamma) with a lower limit of detection of at least 1.0E-07μCi/ml or are analyzed for principle gamma emitters consistent with Table 2.8-1;</p> <p>1. Once per 24 hours when the specific activity of the secondary coolant is ≤ 0.01 μCi/ml Dose Equivalent I-131, or;</p> <p>2. Once per 12 hours when the specific activity of the secondary coolant is >0.01 μCi/ml dose Equivalent I-131.</p>
<p>b. Flow rate measurement devices - each Steam Generator has its own blowdown flow rate measuring device. These devices only measure flow directed through the heat recovery system, and will not measure flow which bypasses the heat recovery system.</p>	<p>1 per S/G</p>	<p>With the number of channels operable less than the MCO requirement due to inoperable equipment:</p> <p>a. Exert best efforts to return the instruments to operable status within 30 days and, if unsuccessful, explain in the next Annual Radioactive Effluent Release Report why the inoperability was not corrected in a timely manner in accordance with Technical Specification 5.6.3 AND,</p> <p>With the number of channels operable less than the MCO requirement due to inoperable equipment, OR if the steam generator blowdown system is aligned such that any flow bypasses the flow measurement device(s) (i.e. heat recovery is not in service):</p> <p>b. Effluent releases via this pathway may continue provided that the flow rate for the affected blowdown line(s) is estimated at least once per 24 hours.</p>

*MCO - Minimum Channels Operable

TABLE 2.6-1 (continued)
RADIOACTIVE LIQUID EFFLUENT MONITORING INSTRUMENTATION

Release Pathway/Instrumentation	MCO*	Compensatory Measures
2. Steam Generator Blowdown Effluent Line (continued) c. R-19A, B and C flow measurement device – each monitor has its own flow rate measurement device	1 per S/G	With the number of channels operable less than the MCO requirement due to inoperable equipment: a. Exert best efforts to return the instruments to operable status within 30 days and, if unsuccessful, explain in the next Annual Radioactive Effluent Release Report why the inoperability was not corrected in a timely manner in accordance with Technical Specification 5.6.3 and, b. Effluent releases via this pathway may continue provided that the flow rate for the affected monitor line(s) is estimated at least once per 24 hours.
3. Discharge Canal Flow	Note 1	With the number of channels operable less than the MCO requirement suspend effluent release via this pathway.
4. Tank Level Indicating Devices a. Refueling Water Storage Tank b. Monitor Tanks Tank A Tank B c. Waste Condensate Tanks Tank C Tank D Tank E d. Deleted	1 1 1 1 1 1	With the number of channels operable less than the MCO requirement: a. Exert best efforts to return the instruments to operable status within 30 days and, if unsuccessful, explain in the next Annual Radioactive Effluent Release Report why the inoperability was not corrected in a timely manner in accordance with Technical Specification 5.6.3 and, b. Liquid additions to the affected tank(s) may continue provided that the liquid level for the affected tanks is estimated during all liquid additions to the affected tank(s).

*MCO - Minimum Channels Operable

TABLE 2.6-1 (continued)
RADIOACTIVE LIQUID EFFLUENT MONITORING INSTRUMENTATION

Release Pathway/Instrumentation	MCO*	Compensatory Measures
5. Containment Fan Cooling Water Monitor (Service Water Effluent Line) a. Monitor (R-16) does not provide automatic termination of release upon exceeding alarm setpoint.	1	With the number of channels operable less than the MCO requirement: a. Exert best efforts to return the instruments to operable status within 30 days and, if unsuccessful, explain in the next Annual Radioactive Effluent Release Report why the inoperability was not corrected in a timely manner in accordance with Technical Specification 5.6.3 and, b. Effluent releases via this pathway may continue provided that, once per 24 hours, grab samples are collected and analyzed for gross radioactivity (beta or gamma) with a lower limit of detection of at least 1.0E-07 µCi/ml or are analyzed for principal gamma emitters consistent with Table 2.8-1.
6. Composite Sampler for Settling Ponds	1	With the number of channels operable less than the MCO requirement: a. Exert best efforts to return the instruments to operable status within 30 days and, if unsuccessful, explain in the next Annual Radioactive Effluent Release Report why the inoperability was not corrected in a timely manner in accordance with Technical Specification 5.6.3 and, b. Effluent releases via this pathway may continue provided that, grab samples are collected and composited three times per week and analyzed in accordance with Table 2.8-1.

*MCO - Minimum Channels Operable

TABLE 2.6-1 (continued)
RADIOACTIVE LIQUID EFFLUENT MONITORING INSTRUMENTATION

Release Pathway/Instrumentation	MCO*	Compensatory Measures
7. Condensate Polisher Liquid Waste Monitor a. Monitor (R-37) provides automatic termination of release upon exceeding alarm/trip setpoint	1	With the number of channels operable less than the MCO requirement: a. Exert best efforts to return the instruments to operable status within 30 days and, if unsuccessful, explain in the next Annual Radioactive Effluent Release Report why the inoperability was not corrected in a timely manner in accordance with Technical Specification 5.6.3 and, b. Effluent releases via this pathway may continue provided that, once per 24 hours, grab samples are collected and analyzed for gross radioactivity (beta or gamma) with a lower limit of detection of at least 1.0E-07 µCi/ml or are analyzed for principal gamma emitters consistent with Table 2.8-1.

*MCO - Minimum Channels Operable

NOTES TO TABLE 2.6-1

- Note 1 Pump curves for Unit 2 operating circulating water pumps may be used to satisfy this MCO. If no Unit 2 circulating water pumps are operating the pump curves for circulating water pumps operating in Retired Fossil Plant may be used to satisfy this MCO.
- Note 2 Deleted

2.7 Radioactive Liquid Effluent Monitoring Instrumentation - Surveillance Requirements

Applicability

Applies to the radioactive liquid effluent instrumentation system.

Objective

To ascertain that the radioactive liquid effluent instrumentation system is functioning properly in order to accurately monitor radioactive liquid effluent releases.

Specification

SURVEILLANCE REQUIREMENTS

- 2.7.1 Each radioactive liquid effluent monitoring instrumentation channel shall be demonstrated operable by performance of the channel check, source check, channel calibration, and Channel Operational Test operations at the frequencies shown in Table 2.7-1.

TABLE 2.7-1
RADIOACTIVE LIQUID EFFLUENT MONITORING INSTRUMENTATION SURVEILLANCE REQUIREMENTS

Pathway/Instruments	Channel Check	Source Check	Channel Calibration	Channel Operational Test
1. Liquid Radwaste Effluent Line				
a. Monitor (R-18)	D	P	R (Note 3)	Q (Note 4)
b. Flow rate measurement device	(Note 1)	N.A.	R	N.A.
2. Steam Generator Blowdown Effluent Line				
a. Monitor (R-19A)	D	M	R (Note 3)	Q (Note 4)
(R-19B)	D	M	R (Note 3)	Q (Note 4)
(R-19C)	D	M	R (Note 3)	Q (Note 4)
b. Flow rate measurement devices for measuring flow of sample to R-19	(Note 2)	N.A.	N.A.	N.A.
c. Flow rate measuring devices for each steam generator blowdown line	(Note 2)	N.A.	R	N.A.
3. Containment Fan Cooling Water Monitor (Service Water Effluent Line)				
a. Monitor (R-16)	D	M	R (Note 3)	Q (Note 5)
4. Tank Level Indicating Devices				
a. Refueling Water Storage Tank	D	N.A.	R	Q
b. Monitor Tanks A & B	D*	N.A.	R	Q
c. Waste Condensate Tanks C D & E	D*	N.A.	R	Q
5. Condensate Polisher Waste Monitor (R-37)	D	M	R	Q

* During liquid additions to the tank

NOTES TO TABLE 2.7-1

- Note 1 The channel check shall consist of verifying indication of flow at least once during each batch type release or shall consist of verifying indication of flow at least once per 24 hours for continuous type releases.
- Note 2 The channel check shall consist of verifying indication of flow at least once during each batch type release or shall consist of verifying indication of flow at least once per 24 hours for continuous releases, except during steam generator drain at cold shutdown.
- Note 3 The channel calibration shall be performed using one or more of the reference standards certified by the National Institute of Standards and Technology (NIST) or using standards that have been obtained from suppliers that participate in measurement assurance activities or otherwise NIST traceable.
- Note 4 The Channel Operational Test shall also demonstrate that automatic isolation of this pathway and Control Room alarm annunciation occur if any of the following conditions exists:
1. Instrument indicates measured levels above the alarm/trip setpoint.
 2. Power failure.
 3. Instrument controls not set in operate mode.
- Note 5 The Channel Operational Test shall also demonstrate that Control Room alarm annunciation occurs if any of the following conditions exists:
1. Instrument indicates measured levels above the alarm setpoint.
 2. Power failure.
 3. Instrument indicates a downscale failure.
 4. Instrument controls not set in operate mode.

NOTATION

- P Completed prior to making a radioactive materials release
D At least once per 24 hours
W At least once per 7 days
N.A. Not applicable
M At least once per 31 days
R At least once per 18 months
Q At least once per 92 days

2.8 Radioactive Liquid Effluents Sampling and Analysis Requirements

Applicability

Applies to the monitoring of radioactive liquid effluents.

Objective

To ascertain that radioactive liquid effluent releases are being maintained as low as reasonably achievable and within allowable limits.

Specification

SURVEILLANCE REQUIREMENTS

- 2.8.1 The radioactivity content of each batch of radioactive liquid waste to be discharge shall be determined prior to release by sampling and analysis in accordance with Table 2.8-1. The results of pre-release analyses shall be used with the calculative methods in the ODCM to assure that the concentration at the point of release to the unrestricted area is maintained within the limits of Specification 2.2.1.
- 2.8.2 Analyses of samples composited from batch releases shall be performed in accordance with Table 2.8-1. The results of the post-release analyses shall be used with the calculative methods in the ODCM to assure that the concentrations at the point of release were maintained within the limits of Specification 2.2.1.
- 2.8.3 The concentration of radioactive materials in liquid effluents discharged from continuous release points shall be determined by collection and analysis of samples in accordance with Table 2.8-1. The results of the analyses shall be used with the calculative methods in the ODCM to assure that the concentrations at the point of release are maintained within the limits of Specification 2.2.1.
- 2.8.4 Dose Calculations: Cumulative dose commitments for the current calendar quarter and calendar year from liquid effluents shall be determined in accordance with the ODCM once per 31 days.

TABLE 2.8-1
RADIOACTIVE LIQUID WASTE SAMPLING AND ANALYSIS PROGRAM

Type of Release	Sampling Frequency	Minimum Analysis Frequency	Required Activity Analysis	Required LLD ^a μ Ci/ml	
<u>Batch Waste Releases</u> ^b	P Grab Sample	P on Grab Sample	Principal Gamma Emitters ^c	5E-07	
			I-131	1E-06	
	1. Monitor Tanks	P Grab Sample One Batch/M	M on Grab Sample	Dissolved and Entrained Gases (gamma emitters)	1E-05
				2. Waste Condensate Tanks	P Grab Sample Each Batch and Composited ^d
	Gross Alpha	1E-07			
	3. Drainage of Systems	P Grab Sample Each Batch and Composited ^d	Q on Composite		Sr-89, Sr-90
				Fe-55	1E-06
	<u>Continuous Releases</u> ^e	3/W Grab Sample	W on Composite	Principal Gamma Emitters ^{c, i}	5E-07
				I-131 ⁱ	1E-06
1. Steam Generator Blowdown		M Grab Sample	M on Grab Sample	Dissolved and Entrained Gases (gamma emitters)	1E-05
				2. Condensate Polisher Waste Water Discharge ^g	3/W Grab Sample and Composited ^{d, f}
Gross Alpha		1E-07			
3. Settling Ponds ^g		3/W Grab Sample and Composited ^{d, f}	Q on Composite	Sr-89, Sr-90	5E-08
				Fe-55	1E-06

TABLE NOTATION

- a. The LLD is defined, for purposes of these specifications, as the smallest concentration of radioactive material in a sample that will yield a net count, above system background, that will be detected with 95% probability with only 5% probability of falsely concluding that a blank observation represents a "real" signal.

For a particular measurement system, which may include radiochemical separation:

$$LLD = \frac{4.66 * S_b}{E * V * 2.22 \times 10^6 * Y * e^{-\lambda \Delta t}}$$

where:

LLD is the "a priori" lower limit of detection as defined above, as microcuries per unit mass or volume,

S_b is the standard deviation of the background counting rate or of the counting rate of a blank sample as appropriate, as counts per minute,

E is the counting efficiency, as counts per disintegration,

V is the sample size in units of mass or volume,

2.22×10^6 is the number of disintegrations per minute per microcurie,

Y is the fractional radiochemical yield, when applicable,

λ is the radioactive decay constant for the particular radionuclide, and

Δt for plant effluents is the elapsed time between the midpoint of sample collection and time of counting.

Typical values of efficiency (E), volume/mass (V), chemical yield (Y), and radionuclide decay correction time (Δt) are to be used in the calculation.

It should be recognized that the LLD is defined as an a priori (before the fact) limit representing the capability of a measurement system and not as an a posteriori (after the fact) limit for a particular measurement.

- b. A batch release is the discharge of liquid wastes of a discrete volume. Prior to sampling for analyses each batch shall be isolated and thoroughly mixed whenever possible, to assure representative sampling. Residual liquids in systems such as feedwater heaters and lines cannot be thoroughly mixed for representative samples of their respective system. Grab samples from these systems will be accepted as representative of their respective system.

- c. The principal gamma emitters for which the LLD specification applies exclusively are the following radionuclides: Mn-54, Fe-59, Co-58, Co-60, Zn-65, Mo-99, Cs-134, Cs-137, Ce-141, and Ce-144. This list does not mean that only these nuclides are to be detected and reported. Other peaks which are measurable and identifiable, together with the above nuclides, shall also be identified and reported.
- d. A composite sample is one in which the quantity of liquid sampled is proportional to the quantity of liquid waste discharged and in which the method of sampling employed results in a specimen which is representative of the liquids released.
- e. A continuous release is the discharge of liquid wastes of a nondiscrete volume; e.g., from a system that has an input flow during the continuous release.
- f. Grab sample of continuous flows taken for compositing purposes will be taken in volumes proportional to the existing flow rate of the system in a manner described in the ODCM.
- g. Normal grab sampling for the Condensate Polisher Waste Water Discharge & Settling Ponds is performed by an automatic composite sampler on the discharge line in lieu of three times per week sampling. If composite sampler is rendered inoperable, manual grab samples should be collected and composited.
- h. In lieu of a tritium analysis being performed on a batch tank composite sample, each individual release may be analyzed for tritium.
- i. For continuous releases, where a periodic grab sample is performed, a gamma or tritium analysis may be performed on each sample in lieu of a composite analysis.

NOTATION

P	Completed prior to making a radioactive materials release
W	At least once per 7 days
M	At least once per 31 days
Q	At least once per 92 days
3/W	3 times per week

2.9 Liquid Radwaste Treatment System

Applicability

Applies to the liquid radwaste treatment system.

Objective

To define the operating requirements for the liquid radwaste treatment system and to ascertain that the concentration of radioactive materials in the liquid waste treatment system is maintained as low as reasonably achievable and within allowable limits.

Specification

CONTROLS

2.9.1 The appropriate portions of the Liquid Radwaste Treatment System shall be maintained and used to reduce the concentrations of radioactive materials in liquid wastes prior to their discharge when the projected dose commitments, due to the release of radioactive liquid effluents to unrestricted areas (See Figure 7-1) when averaged over a calendar quarter, would exceed 0.2 mrem to the total body or 0.6 mrem to any organ.

ACTIONS

2.9.2 With radioactive liquid wastes being discharged without treatment while in excess of the limits of ODCM Specification 2.9.1 above, prepare and submit a report to the Commission in accordance with ODCM Specification 9.3.b.

SURVEILLANCE REQUIREMENTS

2.9.3 Dose commitments from liquid releases shall be projected at least once per 31 days, in accordance with the ODCM to ensure the provisions of ODCM Specification 2.9.1 are satisfied when the Liquid Radwaste Treatment System is not in use.

Bases

Liquid Radwaste Treatment System

The requirements that the appropriate portions of this system be maintained and used when specified provides assurance that the releases of radioactive materials in liquid effluents will be kept "as low as reasonably achievable".

This specification implements the requirements of 10 CFR Part 50.36a, General Design Criterion 60 of Appendix A to 10 CFR Part 50 and the design objective given in Section II.D of Appendix I to 10 CFR Part 50. The specified limits governing the use of appropriate portions of the Liquid Radwaste Treatment System were specified as the dose design objective set forth in Section II.A of Appendix I, 10 CFR Part 50, for liquid effluents.

3.0 GASEOUS EFFLUENTS

3.1 Monitor Alarm Setpoint Determination

This methodology determines the monitor alarm setpoint if the dose rate in the unrestricted areas due to radionoble gases in the gaseous effluent released from the site to areas at and beyond the site boundary exceeds 500 mrem/year to the whole body or exceeds 3000 mrem/year to the skin using a conservative mix (GALE Code).

The methodology described in Section 3.1.2 provides an alternative means to determine monitor alarm setpoints when an analysis is performed prior to release.

3.1.1 Setpoint Based on Conservative Radionuclide Mix (Ground and Mixed Mode Releases)

Releases through the steam generator flash tank vent can only occur through this vent when significant primary-to-secondary leakage exists within the steam generators and the blowdown is not going through heat recovery. Steam generator blowdown is continuously monitored by R-19A, R-19B, and R-19C as a liquid pathway. The condenser vacuum pump vent discharges via plant vent which is monitored by R-14.

The following method applies to gaseous releases via the plant vent when determining the high-alarm setpoint for the plant vent gas monitor (R-14C) and the Fuel Handling Basement Exhaust Monitor (R-20), using the GALE code during the following operational conditions:

- Continuous release via the plant vent (R-14C).
- Continuous release via the Fuel Handling Basement Exhaust (R-20).

3.1.1.1 Determine the "mix" (noble gas radionuclides and composition) of the gaseous effluent.

$$S_i = \frac{A_i}{\sum_i A_i} \quad (3.1-1)$$

where:

- S_i = The fraction of the total noble gas radioactivity in the gaseous effluent comprised by noble gas radionuclide 'i' for each individual noble gas radionuclide in the gaseous effluent or the S_i from Table 3.1-1 when using GALE Code.
- A_i = The radioactivity of noble gas radionuclide 'i' in the gaseous effluent from Table 3.1-1 (Ci/yr).

3.1.1.2 Determine the Q_m , the maximum acceptable total release rate ($\mu\text{Ci}/\text{sec}$) of all noble gas radionuclides in the gaseous effluent based upon the whole body exposure limit of 500 mrem/year by:

$$Q_m = \frac{500}{(\overline{\chi/Q}) * \sum_i (K_i * S_i)} \quad (3.1-2)$$

where:

- $(\overline{\chi/Q})$ = The highest calculated annual average relative dispersion factor for any area at or beyond the unrestricted area boundary for all sectors (sec/m^3).
- = 8.1E-05 sec/m^3 (Continuous Ground Release) from Table A-1, Appendix A.
- = 9.9E-07 sec/m^3 (Mixed Mode Release) from Table A-10, Appendix A.
- K_i = The total whole body dose factor due to gamma emissions from noble gas radionuclide 'i' from Table 3.1-2 (mrem/yr per $\mu\text{Ci}/\text{m}^3$).

3.1.1.3 Determine the Q_m , the maximum acceptable release rate ($\mu\text{Ci}/\text{sec}$) of all gas radionuclides in the gaseous effluent based upon the skin exposure limit of 3000 mrem/year by:

$$Q_m = \frac{3000}{(\overline{\chi/Q}) * \sum_i [(L_i + 1.11M_i) * S_i]} \quad (3.1-3)$$

where:

- $L_i + 1.11M_i$ = The total skin dose factor due to emissions from noble gas radionuclide 'i' from Table 3.1-2 (mrem/yr per $\mu\text{Ci}/\text{m}^3$).

3.1.1.4 Determine the C_m , the maximum acceptable total radioactivity concentration ($\mu\text{Ci}/\text{cm}^3$) of all noble gas radionuclides in the gaseous effluent.

$$C_m = \frac{2.12 \times 10^{-3} * Q_m}{F} * T_m * S \quad (3.1-4)$$

NOTE: Use the lower of the Q_m values obtained in Sections 3.1.1.2 and 3.1.1.3. This will protect both the skin and total body from being exposed to the limit.

where:

- T_m = Fraction of the radioactivity from the site that may be released via the monitored pathway to ensure that the site boundary limit is not exceeded due to simultaneous releases from several pathways (dimensionless).
- = 0.92 for Plant Vent Gas Monitor (R-14C).
- = 0.05 for the Fuel Handling Basement Exhaust Monitor (R-20).

- F = The maximum acceptable effluent flow rate at the point of release (cfm).
= 60,600 cfm for plant vent.
= 10,200 cfm for the fuel-handling building.
- 2.12×10^{-3} = Unit conversion constant to convert $\mu\text{Ci}/\text{sec}/\text{cfm}$ to $\mu\text{Ci}/\text{cm}^3$.
= $\frac{\text{sec}-\text{ft}^3}{\text{min}-\text{cm}^3}$
- S = 0.5, an engineering factor used to provide a margin of safety for cumulated measurement uncertainties (dimensionless).

3.1.1.5 Determine CR, the calculated monitor count rate above background attributed to the noble gas radionuclides (cpm) by:

$$CR = C_m * E_m \quad (3.1-5)$$

where:

- E_m = Obtained from the applicable effluent monitor efficiency curve located in the Station Curve Book. Use the radioactivity concentration ' C_m ' to find CR.

3.1.1.6 Determine HSP, the monitor high-alarm setpoint including background (cpm) by:

$$HSP = CR + background \quad (3.1-6)$$

3.1.2 Setpoint Based on Sample Analysis Prior to Release

The following method applies to gaseous releases when determining the high-alarm setpoint with prior sample analysis and using the maximum acceptable effluent flow rate at the point of release. The method applies to the following conditions.

Batch Releases

- Containment purge.*
- Containment pressure relief.
- Waste gas decay tanks.

Continuous Releases

- Plant vent.
- Fuel handling basement exhaust.
- Environmental and Radiation Control Building Hood Exhaust.
- Containment purge.
- Radwaste Building exhaust vent.

* Batch containment purge is considered as one volume of containment air removed.

3.1.2.1 Determine R_i , the noble gas release rate ($\mu\text{Ci}/\text{sec}$) for radionuclide 'i':

$$R_i = 472 * C_i * F \quad (3.1-7)$$

where:

472 = A conversion factor to convert cfm to cm^3/sec .

C_i = The radioactivity concentration of noble gas radionuclide 'i' from analysis of gaseous effluent from the Plant Vent (stack), Fuel Handling Basement Exhaust, Environmental & Radiation Control (E&RC) Building Hood Exhaust, Radwaste Building Exhaust Vent and the Containment Vessel when R-12 is sampling from the Containment. If there are no isotopes identified in the sample, the EC for Xe-133 may be used as an actual value for the purpose of the setpoint calculation ($\mu\text{Ci}/\text{cm}^3$).

Containment Purge: Used for R-14 or R-12 when R-11/12 aligned to the Plant Vent.

$$= \left(\frac{\mu\text{Ci}}{\text{cm}^3} \text{ from analysis of Containment Vent} * 0.366 \right) + \left(\frac{\mu\text{Ci}}{\text{cm}^3} \text{ from analysis of Plant Vent} * 0.634 \right)$$

0.366 = Dilution correction factor for C.V. Purge.
 $= \frac{35,000 \text{ cfm}}{(60,600+35,000) \text{ cfm}}$

0.634 = Dilution correction factor for Plant Vent during C.V. Purge.
 $= \frac{60,600 \text{ cfm}}{(60,600+35,000) \text{ cfm}}$

Containment Pressure Relief: Used for R-14 or R-12 when R-11/12 aligned to the Plant Vent.

$$= \left(\frac{\mu\text{Ci}}{\text{cm}^3} \text{ from analysis of Containment Vent} * 0.040 \right) + \left(\frac{\mu\text{Ci}}{\text{cm}^3} \text{ from analysis of Plant Vent} * 0.960 \right)$$

0.040 = Dilution correction factor for C.V. Pressure Relief.
 $= \frac{2,500^\dagger \text{ cfm}}{(60,600+2,500^\dagger) \text{ cfm}}$

0.960 = Dilution correction factor for Plant Vent during C.V. Pressure Relief.
 $= \frac{60,600 \text{ cfm}}{(60,600+2,500^\dagger) \text{ cfm}}$

[†] 2,500 CFM - Refer to Appendix B.3 for additional information

Waste Gas Decay Tanks (WGDT).

$$= \left(\frac{\mu\text{Ci}}{\text{cm}^3} \text{ from analysis of WGDT} * 0.0016 \right) + \left(\frac{\mu\text{Ci}}{\text{cm}^3} \text{ from analysis of Plant Vent} * 0.9984 \right)$$

0.0016 = Dilution correction factor for WGDT.

$$= \frac{100 \text{ cfm}}{(60,600+100) \text{ cfm}}$$

0.9984 = Dilution correction factor for Plant Vent during WGDT Release.

$$= \frac{60,600 \text{ cfm}}{(60,600+100) \text{ cfm}}$$

WGDT during Containment Purge.

$$= \left(\frac{\mu\text{Ci}}{\text{cm}^3} \text{ from analysis of WGDT} * 0.001 \right) + \left(\frac{\mu\text{Ci}}{\text{cm}^3} \text{ from analysis of Plant Vent} * 0.633 \right) + \left(\frac{\mu\text{Ci}}{\text{cm}^3} \text{ from analysis of C. V.} * 0.366 \right)$$

0.001 = Dilution correction factor for WGDT during a Continuous C.V. Purge and Plant Vent Release.

$$= \frac{100 \text{ cfm}}{(60,600+35,000+100) \text{ cfm}}$$

0.633 = Dilution correction factor for Plant Vent during a Continuous C.V. Purge and Plant Vent Release.

$$= \frac{60,600 \text{ cfm}}{(60,600+35,000+100) \text{ cfm}}$$

0.366 = Dilution correction factor for Continuous C.V. Purge during WGDT Release.

$$= \frac{35,000 \text{ cfm}}{(60,600+35,000+100) \text{ cfm}}$$

F = The maximum acceptable effluent flow rate at the point of release (cfm)

- = 60,600 CFM for the plant vent
- = 10,200 CFM for the fuel handling basement exhaust
- = 11,500 CFM for the E&RC building hood exhaust
- = 15,000 CFM for the Radwaste Building exhaust vent
- = 60,700 CFM for the waste gas decay tank
- = 95,700 CFM for the WGDT during a continuous containment vessel purge
- = 95,600 CFM for the containment vessel purge plus plant vent (R-14 or R-12 when R-11/12 is sampling from the Plant Vent)
- = 63,100 CFM for the containment vessel pressure relief (R-14 or R-12 when R-11/12 is sampling from the Plant Vent)
- = 35,000 CFM for containment vessel purge or continuous release (R-12 when R-11/12 is sampling from the Containment Vessel)
- = 2,500 CFM for containment vessel pressure relief releases (R-12 when R-11/12 is sampling from the Containment Vessel)

† 2,500 CFM - Refer to Appendix B.3 for additional information

3.1.2.2 Determine the monitor alarm setpoint based on total body and skin dose rate:

- a. Determine dose rate for total body (mrem/yr).

$$DR_{TB} = (\overline{\chi/Q}) * \sum_i (K_i * R_i) \quad (3.1-8)$$

where:

- $(\overline{\chi/Q})$ = The highest calculated annual average relative dispersion factor for any area at or beyond the unrestricted area boundary for all sectors from Appendix A (sec/m^3).
- = 8.1E-05 sec/m^3 (continuous ground release) from Table A-1, Appendix A. To be conservative this can be used for all releases.
- = 9.9E-07 sec/m^3 (continuous mixed mode release) from Table A-10, Appendix A, only with upper wind speeds of ≤ 9 mph.
- = 5.1E-05 sec/m^3 (batch ground release) from Table A-7, Appendix A.
- = 2.9E-06 sec/m^3 (batch mixed mode release) from Table A-16, Appendix A.
- K_i = The total whole body dose factor due to gamma emissions from noble gas radionuclide 'i' from Table 3.1-2 (mrem/yr per $\mu\text{Ci/m}^3$).

- b. Determine dose rate for skin (mrem/yr).

$$DR_{SK} = (\overline{\chi/Q}) * \sum_i [(L_i + 1.11M_i) * R_i] \quad (3.1-9)$$

where:

- $L_i + 1.11M_i$ = The total skin dose factor for noble gas emission 'i' radionuclide from Table 3.1-2 (mrem/yr per $\mu\text{Ci/m}^3$).

- c. Determine the noble gas emission Projected Dose Rate Ratio (PDRR) for Total Body and Skin.

$$PDRR_{TB} = \frac{DR_{TB}}{500} \quad (3.1-10)$$

$$PDRR_{SK} = \frac{DR_{SK}}{3000} \quad (3.1-11)$$

where:

- 500 = The allowable total body dose rate due to noble gas gamma emissions (mrem/yr).
 3000 = The allowable skin dose rate due to noble gas beta emissions (mrem/yr).

- d. Determine the maximum monitor setpoint concentration ($\mu\text{Ci}/\text{cm}^3$) for total body and skin.

$$\text{Maximum Monitor Total Body Setpoint} = \frac{\sum_i C_i}{PDRR_{TB}} * S * T_m \quad (3.1-12)$$

$$\text{Maximum Monitor Skin Setpoint} = \frac{\sum_i C_i}{PDRR_{SK}} * S * T_m \quad (3.1-13)$$

where:

- S = 0.5, an engineering factor used to provide a margin of safety for cumulative uncertainties of measurements (dimensionless).
 T_m = Fraction of the radioactivity from the site that may be released via the monitored pathway to ensure that the site boundary limit is not exceeded due to simultaneous releases from several pathways (dimensionless).
 = 0.92 for the Plant Vent Gas Monitor (R-14C).
 = 0.05 for the Fuel Handling Basement Exhaust Monitor (R-20).
 = 0.01 for other potential release points.
 = 0.01 for the E&RC Building Hood Exhaust Monitor (R-22).
 = 0.01 for the Radwaste Building exhaust vent Monitor (R-23).
 = 0.81 for C.V. releases via R-11 and R-12.
 [This indicates 0.81 of 10 CFR 20 limits for Containment releases and is also monitored by R-14C. 0.92 = 0.81 + 0.11 (Normal Plant Releases)]

- e. Determine the maximum monitor setpoint (cpm) for total body (S_t) and skin (S_s).

$$S_t = \frac{\text{Maximum Monitor Total Body Setpoint}}{\text{Monitor Efficiency}} + Bkg \quad (3.1-14)$$

$$S_s = \frac{\text{Maximum Monitor Skin Setpoint}}{\text{Monitor Efficiency}} + Bkg \quad (3.1-15)$$

where:

Monitor Efficiency = Obtained from the applicable effluent monitor efficiency curve located in the Station Curve Book. Use the radioactivity concentration ($\mu\text{Ci/cc}$) to find (CPM).

Bkg = The monitor background (CPM)

- f. Determine the actual gaseous monitor setpoint:

The setpoints that were determined based on the dose rate limits to the total body (S_t) and to the skin (S_s) are compared and the lesser value is used as the actual setpoint.

TABLE 3.1-1
GASEOUS SOURCE TERMS*

Radionuclide	Plant Vent Release ¹		Condenser Vacuum Pump Vent ²		Containment Purge or Pressure Relief		Waste Gas Decay Tanks ³	
	A _i (Ci/yr)	S _i	A _i (Ci/yr)	S _i	A _i (Ci/yr)	S _i	A _i (Ci/yr)	S _i
Kr-85m	2.0E+00	5.26E-02	1.0E+00	4.35E-02	0.00	0.00	0.00	0.00
Kr-85	0.00	0.00	0.00	0.00	0.00	0.00	1.6E+02	8.00E-01
Kr-87	1.0E+00	2.63E-02	0.00	0.00	0.00	0.00	0.00	0.00
Kr-88	3.0E+00	7.89E-02	2.0E+00	8.70E-02	1.0E+00	2.90E-03	0.00	0.00
Xe-131m	0.00	0.00	0.00	0.00	1.0E+00	2.90E-03	9.0E+00	4.50E-02
Xe-133m	0.00	0.00	0.00	0.00	4.0E+00	1.16E-02	0.00	0.00
Xe-133	2.8E+01	7.37E-01	1.8E+01	7.83E-01	3.1E+02	8.99E-01	3.1E+01	1.55E-01
Xe-135	4.0E+00	1.05E-01	2.0E+00	8.70E-02	4.0E+00	1.16E-02	0.00	0.00
Ar-41	0.00	0.00	0.00	0.00	2.5E+01	7.25E-02	0.00	0.00
TOTAL	3.8E+01		2.3E+01		3.45E+02		2.0E+02	

* Source terms are based upon GALE Code (not actual releases) from the evaluation of H.B. Robinson Unit 2 to demonstrate conformance to the design objectives of 10 CFR 50, Appendix I, Table 2-4. These values are only for routine releases and not for a complete inventory of gases in an emergency.

¹ These values are used to determine the monitor alarm setpoints for the Plant Vent Gas Monitor (R-14C).

² These values are used to determine the monitor alarm setpoint for the Condenser Vacuum Pump Vent Monitor (R-15). R-15 is a process monitor and its effluents are monitored by R-14C. This column is intentionally left for reference.

³ These values are used to determine the monitor alarm setpoint for the Fuel Handling Basement Exhaust Monitor (R-20).

TABLE 3.1-2
DOSE FACTORS AND CONSTANTS*

<u>Radionuclide</u>	<u>Total Whole Body Dose Factor (K_i) (mrem/yr per $\mu\text{Ci}/\text{m}^3$)</u>	<u>Total Skin Dose Factor ($L_i + 1.11 M_i$) (mrem/yr per $\mu\text{Ci}/\text{m}^3$)</u>
Kr-83m	7.56E-02	2.12E+01
Kr-85m	1.17E+03	2.81E+03
Kr-85	1.61E+01	1.36E+03
Kr-87	5.92E+03	1.65E+04
Kr-88	1.47E+04	1.91E+04
Kr-89	1.66E+04	2.91E+04
Kr-90	1.56E+04	2.52E+04
Xe-131m	9.15E+01	6.48E+02
Xe-133m	2.51E+02	1.35E+03
Xe-133	2.94E+02	6.94E+02
Xe-135m	3.12E+03	4.41E+03
Xe-135	1.81E+03	3.97E+03
Xe-137	1.42E+03	1.39E+04
Xe-138	8.83E+03	1.43E+04
Xe-139	0.00	0.00
Ar-41	8.84E+03	1.29E+04

*Regulatory Guide 1.109, October 1977, Table B-1, times (1.0E+06 $\rho\text{Ci}/\mu\text{Ci}$).

3.2 Requirements for Compliance with 10 CFR 20 (Gaseous)

Applicability

Applies to radioactive materials in gaseous effluents released from the site to unrestricted areas.

Objective

To define the dose rate limits for radioactive materials in gaseous effluents released to unrestricted areas.

Specification

CONTROLS

3.2.1 The dose rate due to radioactive materials in gaseous effluents released from the site boundary (see Figure 7-1) shall be limited to the following:

- a. For radionoble gases: ≤ 500 mrem/yr to total body, ≤ 3000 mrem/yr to skin

AND

- b. For I-131, I-133, and tritium, and for all radioactive materials in particulate form, inhalation pathway only, with half-lives greater than 8 days: ≤ 1500 mrem/yr to any organ.

ACTIONS

3.2.2 With the dose rate(s) exceeding the above limits, without delay decrease the release rate to within the above limits. In addition, a notification must be made to the Commission in accordance with 10 CFR 50.72 and 10 CFR 50.73.

BASES

Compliance With 10 CFR Part 20 - Radioactive Materials in Gaseous Effluents

This specification is provided to ensure that the dose rate at any time at the site boundary from gaseous effluents from H. B. Robinson Unit No. 2 will be within the annual dose limits of 10 CFR Part 20 for unrestricted areas. The annual dose limits are the doses associated with the concentrations of 10 CFR Part 20 Appendix B, Table 2, Column 1. These limits provide reasonable assurance that radioactive material discharged in gaseous effluents will result in the exposure of individuals outside the site boundary, to annual average concentrations within the limits specified in Appendix B Table 2 of 10 CFR Part 20, (10 CFR Part 20.1302). For individuals who may at times be within the site boundary, the occupancy of the individual will be sufficiently low to compensate for any increase in the atmospheric diffusion factor above that for the site boundary unrestricted area. The specified release rate limits restrict, at all times, the corresponding gamma and beta dose rate equivalents above background to an individual in unrestricted areas to ≤ 500 mrem/year to the total body or to ≤ 3000 mrem/year to the skin.

3.3 Compliance with 10 CFR 20 (Gaseous)

3.3.1 Noble Gases

The gaseous effluent monitors setpoints are utilized to show compliance with 10 CFR 20 for noble gases. However, because they are based upon a conservative mix of radionuclides, the possibility exists that the setpoints could be exceeded and yet 10 CFR 20 limits may actually be met. Therefore, the following methodology has been provided in the event that if the alarm trip setpoints are exceeded, a determination may be made as to whether the actual releases have exceeded 10 CFR 20.

The dose rate in unrestricted areas resulting from noble gas effluents is limited to 500 mrem/year to the total body and 3000 mrem/year to the skin. Based upon NRC Regulatory Guide 1.109, Revision 1, and NUREG 0133, the following are used to show compliance with 10 CFR 20.

$$S_F * \sum_i \left[K_i * \left(\overline{(\chi/Q)}_v * \dot{Q}_{iv} + \overline{(\chi/Q)}_e * \dot{Q}_{ie} \right) \right] \leq 500 \text{ mrem/yr} \quad (3.3-1)$$

$$S_F * \sum_i \left[(L_i + 1.11M_i) * \left(\overline{(\chi/Q)}_v * \dot{Q}_{iv} + \overline{(\chi/Q)}_e * \dot{Q}_{ie} \right) \right] \leq 3000 \text{ mrem/yr} \quad (3.3-2)$$

where:

- $\overline{(\chi/Q)}_v$ = Annual average relative dilution for plant vent releases at the site boundary (sec/m³).
 = From Table A-1 for ground level releases used for additional conservatism.
 = From Table A-10 for mixed mode releases.
- $\overline{(\chi/Q)}_e$ = Annual average relative dilution for the Fuel Handling Basement Exhaust, the Environmental and Radiation Control Building Exhaust, and Radwaste Building Exhaust releases at the site boundary (sec/m³).
 = From Table A-1 for ground level releases.
- K_i = The total body dose factor due to gamma emissions for noble gas radionuclide 'i' (mrem/year per $\mu\text{Ci}/\text{m}^3$).
- L_i = The skin dose factor due to beta emissions for noble gas radionuclide 'i' (mrem/year per $\mu\text{Ci}/\text{m}^3$).
- M_i = The air dose factor due to gamma emissions for noble gas radionuclide 'i' (mrad/year per $\mu\text{Ci}/\text{m}^3$).
- 1.11 = The ratio of the tissue to air absorption coefficients over the energy range of the photon of interest (mrem/mrad). (reference NRC Regulatory Guide 1.109, Revision 1)

- \dot{Q}_{ie} = The release rate of noble gas radionuclide 'i' in gaseous effluents from the radwaste building exhaust vent, fuel handling basement exhaust, and the environmental and radiation control building hood exhaust ($\mu\text{Ci}/\text{sec}$).
- \dot{Q}_{iv} = The release rate of noble gas radionuclide 'i' in gaseous effluents from the plant vent ($\mu\text{Ci}/\text{sec}$).
- S_F = 1.0, shielding factor accounting for the dose reduction due to shielding provided by residential structures (dimensionless).

The determination of limiting location for implementation of 10CFR20 for noble gases is a function of the radionuclide mix, release rate, and the meteorology. For the most limiting location, the radionuclide mix will be based on sample analysis of the effluent gases.

The χ/Q value utilized in the equations for implementation of 10 CFR 20 is based upon the maximum long-term annual average ($\overline{\chi/Q}$) in the unrestricted area. Table 3.3-2 presents the distances from HBR to the nearest area for each of the 16 sectors as well as to the nearest residence, vegetable garden, cow, goat, and beef animal. Long-term annual average ($\overline{\chi/Q}$) values for the HBR release points to the special locations in Table 3.3-2 are presented in Appendix A. A description of their derivation is also provided in this appendix.

To select the limiting location, the highest annual average ($\overline{\chi/Q}$) value for the ground level releases and the mixed mode releases was used. Since mixed mode releases may not necessarily decrease with distance (i.e., the site boundary may not have the highest ($\overline{\chi/Q}$) value), long-term annual average ($\overline{\chi/Q}$) values, calculated at the midpoint of 10 standard distances as given in Appendix A were also considered. For HBR, mixed mode release χ/Q values decrease with distance for all directions except the WNW, NW, and NNW so that the maximum site boundary χ/Q is usually greater at the site boundary than at distances greater than the site boundary. In addition, the maximum site boundary χ/Q for both the ground level and mixed mode releases occurs at the SSE site boundary. Therefore, the limiting location for implementation of 10 CFR 20 for noble gases is the SSE site boundary.

Values for K_i , L_i , and M_i , which were used in the determination of the limiting location and which are to be used by HBR in Expressions 3.3-1 and 3.3-2 to show compliance with 10CFR20, are presented in Table 3.3-3. These values were taken from Table B-1 of NRC Regulatory Guide 1.109, Revision 1. The values have been multiplied by $1.0\text{E}+06$ to convert picocuries to microcuries for use in equations 3.3-1 and 3.3-2.

3.3.2 Radioiodines, Particulates, and Tritium

The dose rate in an unrestricted area resulting from the release of radioiodines, tritium, and particulates with half-lives > 8 days is limited to 1500 mrem/yr to any organ. Based upon NUREG 0133, the following is used to show compliance with 10 CFR 20:

$$\sum_i \left[P_{ii} * \left((\overline{\chi/Q})_v * \dot{Q}_{iv} + (\overline{\chi/Q})_e * \dot{Q}_{ie} \right) \right] \leq 1500 \text{ mrem/yr} \quad (3.3-3)$$

where:

P_{ii} = The dose parameter for Iodine-131, Iodine-133, tritium, and all radionuclides in particulate form with half-lives > 8 days for the inhalation pathway only in the most restrictive sector. The dose factor is based on the most restrictive group (child) and most restrictive organ at the SITE BOUNDARY (see Table 3.3-4) (mrem/yr per $\mu\text{Ci}/\text{m}^3$).

$(\overline{\chi/Q})_v$ = Annual average relative dilution for plant vent releases at the site boundary (sec/m^3).

\dot{Q}_{iv} = Release rate of radionuclide 'i' from the plant vent ($\mu\text{Ci}/\text{sec}$).

$(\overline{\chi/Q})_e$ = Annual average relative dilution for fuel handling building basement exhaust, environmental and radiation control building exhaust, and radwaste building exhaust vent releases at the site boundary (sec/m^3).

\dot{Q}_{ie} = The release rate of radionuclide 'i' from the radwaste building exhaust vent, fuel handling basement exhaust, and the environmental and radiation control building hood exhaust ($\mu\text{Ci}/\text{sec}$).

In the calculation to show compliance with 10 CFR 20, only the inhalation is considered. A description of the methodology used in calculating the P_i values is presented in Appendix B. Compliance with 10 CFR 20 is achieved if the dose rate via inhalation pathway to a child is ≤ 1500 mrem/year.

TABLE 3.3-1
RELEASES FROM H.B. ROBINSON UNIT NO. 2*
 (Ci/yr)

<u>Isotope</u>	<u>Plant Vent</u>	<u>Condenser Vacuum</u>	<u>Total</u>
	(Q) _v	Pump Vent (Q) _c	
Kr-85m	2.0E+00	1.0E+00	3.0E+00
Kr-85	1.6E+02	0.00	1.6E+02
Kr-87	1.0E+00	0.00	1.0E+00
Kr-88	4.0E+00	2.0E+00	6.0E+00
Xe-131m	1.0E+01	0.00	1.0E+01
Xe-133m	4.0E+00	0.00	4.0E+00
Xe-133	3.7E+02	1.8E+01	3.9E+02
Xe-135	8.0E+00	2.0E+00	1.0E+01
I-131	3.6E-02	2.3E-02	5.9E-02
I-133	5.4E-02	3.4E-02	9.8E-02
Mn-54	4.7E-03	0.00	4.7E-03
Fe-59	1.6E-03	0.00	1.6E-03
Co-58	1.6E-02	0.00	1.6E-02
Co-60	7.3E-03	0.00	7.3E-03
Sr-89	3.4E-04	0.00	3.4E-04
Sr-90	6.3E-05	0.00	6.3E-05
Cs-134	4.7E-03	0.00	4.7E-03
Cs-137	7.8E-03	0.00	7.8E-03

* Calculations based upon GALE Code and do not reflect actual release data from the Evaluation Conformance to the Design Objectives of 10CFR50, Appendix I. These values are only for routine releases and not for a complete inventory of gases in an emergency. Condenser vacuum pump vent is intentionally left in for reference.

TABLE 3.3-2
DISTANCE TO SPECIAL LOCATIONS FOR THE H.B. ROBINSON PLANT (MILES)

<u>Sector</u>	<u>Site Boundary</u>	<u>Milk Cow</u>	<u>Milk Goat</u>	<u>Meat Animal</u>	<u>Nearest Resident</u>	<u>Nearest Garden</u>
NNE	1.26	-	-	1.65	1.3	1.4
NE	1.01	-	-	1.16	1.2	1.3
ENE	0.86	-	-	2.41	0.9	2.2
E	0.61	4.2	-	3.12	0.8	2.8
ESE	0.50	-	-	1.99	0.6	0.6
SE	0.29	-	-	-	0.3	0.3
SSE	0.26	-	-	-	0.3	0.3
S	0.28	-	-	2.32	0.3	0.4
SSW	0.29	-	-	2.08	0.3	0.5
SW	0.36	-	2.5*	2.27	0.4	0.5
WSW	0.36	-	-	2.69	0.4	0.6
W	0.50	-	-	3.97	0.6	0.6
WNW	0.55	-	-	4.07	0.7	0.9
NW	1.23	-	-	1.60	1.3	1.3
NNW	1.89	-	-	2.84	2.9	3.0
N	1.94	-	-	2.93	2.9	2.9

* Milk is not presently used for human consumption.

TABLE 3.3-3
DOSE FACTORS FOR NOBLE GASES AND DAUGHTERS*

<u>Radionuclide</u>	<u>Total Body Dose Factor</u> <u>K_i</u> <u>(mrem/yr per $\mu\text{Ci}/\text{m}^3$)</u>	<u>Skin Dose Factor</u> <u>L_i</u> <u>(mrem/yr per $\mu\text{Ci}/\text{m}^3$)</u>	<u>Gamma Air Dose Factor</u> <u>M_i</u> <u>(mrad/yr per $\mu\text{Ci}/\text{m}^3$)</u>	<u>Beta Air Dose Factor</u> <u>N_i</u> <u>(mrad/yr per $\mu\text{Ci}/\text{m}^3$)</u>
Kr-83m	7.56E-02	---	1.93E+01	2.88E+02
Kr-85m	1.17E+03	1.46E+03	1.23E+03	1.97E+03
Kr-85	1.61E+01	1.34E+03	1.72E+01	1.95E+03
Kr-87	5.92E+03	9.73E+03	6.17E+03	1.03E+04
Kr-88	1.47E+04	2.37E+03	1.52E+04	2.93E+03
Kr-89	1.66E+04	1.01E+04	1.73E+04	1.06E+04
Kr-90	1.56E+04	7.29E+03	1.63E+04	7.83E+03
Xe-131m	9.15E+01	4.76E+02	1.56E+02	1.11E+03
Xe-133m	2.51E+02	9.94E+02	3.27E+02	1.48E+03
Xe-133	2.94E+02	3.06E+02	3.53E+02	1.05E+03
Xe-135m	3.12E+03	7.11E+02	3.36E+03	7.39E+02
Xe-135	1.81E+03	1.86E+03	1.92E+03	2.46E+03
Xe-137	1.42E+03	1.22E+04	1.51E+03	1.27E+04
Xe-138	8.83E+03	4.13E+03	9.21E+03	4.75E+03
Ar-41	8.84E+03	2.69E+03	9.30E+03	3.28E+03

* The listed dose factors are for radionuclides that may be detected in gaseous effluents.

H.B. Robinson Steam Electric Plant Unit 2
Offsite Dose Calculation Manual (ODCM)

TABLE 3.3-4
P_i VALUES FOR A CHILD FOR H.B. ROBINSON UNIT NO. 2¹

Nuclide	P _i Bone	P _i Liver	P _i T.Body	P _i Thyroid	P _i Kidney	P _i Lung	P _i GI-Tract	P _i Skin
H-3	0.00E+00	1.12E+03	1.12E+03	1.12E+03	1.12E+03	1.12E+03	1.12E+03	1.12E+03
F-18	6.96E+03	0.00E+00	6.85E+02	0.00E+00	0.00E+00	0.00E+00	1.25E+03	0.00E+00
NA-24	1.61E+04	1.61E+04	1.61E+04	1.61E+04	1.61E+04	1.61E+04	1.61E+04	0.00E+00
CR-51	0.00E+00	0.00E+00	1.54E+02	8.55E+01	2.43E+01	1.70E+04	1.08E+03	0.00E+00
MN-54	0.00E+00	4.29E+04	9.51E+03	0.00E+00	1.00E+04	1.58E+06	2.29E+04	0.00E+00
MN-56	0.00E+00	1.66E+00	3.12E-01	0.00E+00	1.67E+00	1.31E+04	1.23E+05	0.00E+00
FE-55	4.74E+04	2.52E+04	7.77E+03	0.00E+00	0.00E+00	1.11E+05	2.87E+03	0.00E+00
FE-59	2.07E+04	3.34E+04	1.67E+04	0.00E+00	0.00E+00	1.27E+06	7.07E+04	0.00E+00
CO-57	0.00E+00	9.03E+02	1.07E+03	0.00E+00	0.00E+00	5.07E+05	1.32E+04	0.00E+00
CO-58	0.00E+00	1.77E+03	3.16E+03	0.00E+00	0.00E+00	1.11E+06	3.44E+04	0.00E+00
CO-60	0.00E+00	1.31E+04	2.26E+04	0.00E+00	0.00E+00	7.07E+06	9.62E+04	0.00E+00
NI-65	2.99E+00	2.96E-01	1.64E-01	0.00E+00	0.00E+00	8.18E+03	8.40E+04	0.00E+00
CU-64	0.00E+00	1.99E+00	1.07E+00	0.00E+00	6.03E+00	9.58E+03	3.67E+04	0.00E+00
ZN-65	4.26E+04	1.13E+05	7.03E+04	0.00E+00	7.14E+04	9.95E+05	1.63E+04	0.00E+00
BR-82	0.00E+00	0.00E+00	2.09E+04	0.00E+00	0.00E+00	0.00E+00	0.00E+00	0.00E+00
BR-83	0.00E+00	0.00E+00	4.74E+02	0.00E+00	0.00E+00	0.00E+00	0.00E+00	0.00E+00
BR-84	0.00E+00	0.00E+00	5.48E+02	0.00E+00	0.00E+00	0.00E+00	0.00E+00	0.00E+00
RB-86	0.00E+00	1.98E+05	1.14E+05	0.00E+00	0.00E+00	0.00E+00	7.99E+03	0.00E+00
RB-88	0.00E+00	5.62E+02	3.66E+02	0.00E+00	0.00E+00	0.00E+00	1.72E+01	0.00E+00
RB-89	0.00E+00	3.45E+02	2.90E+02	0.00E+00	0.00E+00	0.00E+00	1.89E+00	0.00E+00
SR-89	5.99E+05	0.00E+00	1.72E+04	0.00E+00	0.00E+00	2.16E+06	1.67E+05	0.00E+00
SR-90	1.01E+08	0.00E+00	6.44E+06	0.00E+00	0.00E+00	1.48E+07	3.43E+05	0.00E+00
SR-91	1.21E+02	0.00E+00	4.59E+00	0.00E+00	0.00E+00	5.33E+04	1.74E+05	0.00E+00
SR-92	1.31E+01	0.00E+00	5.25E-01	0.00E+00	0.00E+00	2.40E+04	2.42E+05	0.00E+00
Y-91M	5.07E-01	0.00E+00	1.84E-02	0.00E+00	0.00E+00	2.81E+03	1.72E+03	0.00E+00
Y-91	9.14E+05	0.00E+00	2.44E+04	0.00E+00	0.00E+00	2.63E+06	1.84E+05	0.00E+00
Y-92	2.04E+01	0.00E+00	5.81E-01	0.00E+00	0.00E+00	2.39E+04	2.39E+05	0.00E+00
Y-93	1.86E+02	0.00E+00	5.11E+00	0.00E+00	0.00E+00	7.44E+04	3.89E+05	0.00E+00
ZR-95	1.90E+05	4.18E+04	3.70E+04	0.00E+00	5.96E+04	2.23E+06	6.11E+04	0.00E+00
ZR-97	1.88E+02	2.72E+01	1.60E+01	0.00E+00	3.88E+01	1.13E+05	3.51E+05	0.00E+00
NB-95	2.35E+04	9.18E+03	6.55E+03	0.00E+00	8.62E+03	6.14E+05	3.70E+04	0.00E+00
NB-97	4.29E-01	7.70E-02	3.50E-02	0.00E+00	8.55E-02	3.42E+03	2.78E+16	0.00E+00
MO-99	0.00E+00	1.72E+02	4.25E+01	0.00E+00	3.92E+02	1.35E+05	1.27E+05	0.00E+00
TC-99M	1.78E-03	3.48E-03	5.77E-02	0.00E+00	5.07E-02	9.51E+02	4.81E+03	0.00E+00
TC-101	8.10E-05	8.51E-05	1.08E-03	0.00E+00	1.45E-03	5.85E+02	1.63E+01	0.00E+00
RU-103	2.79E+03	0.00E+00	1.07E+03	0.00E+00	7.03E+03	6.62E+05	4.48E+04	0.00E+00
RU-105	1.53E+00	0.00E+00	5.55E-01	0.00E+00	1.34E+00	1.59E+04	9.95E+04	0.00E+00
RU-106	1.36E+05	0.00E+00	1.69E+04	0.00E+00	1.84E+05	1.43E+07	4.29E+05	0.00E+00
AG-110M	1.69E+04	1.14E+04	9.14E+03	0.00E+00	2.12E+04	5.48E+06	1.00E+05	0.00E+00
SN-113	8.99E+03	2.90E+02	9.81E+03	1.19E+02	2.03E+02	3.40E+05	7.44E+03	0.00E+00
SB-124	5.74E+04	7.40E+02	2.00E+04	1.26E+02	0.00E+00	3.24E+06	1.64E+05	0.00E+00
SB-125	9.84E+04	7.59E+02	2.07E+04	9.10E+01	0.00E+00	2.32E+06	4.03E+04	0.00E+00
TE-129M	1.92E+04	6.85E+03	3.04E+03	6.33E+03	5.03E+04	1.76E+06	1.82E+05	0.00E+00
TE-129	9.77E-02	3.50E-02	2.38E-02	7.14E-02	2.57E-01	2.93E+03	2.55E+04	0.00E+00
TE-131M	1.34E+02	5.92E+01	5.07E+01	9.77E+01	4.00E+02	2.06E+05	3.08E+05	0.00E+00
TE-132	4.81E+02	2.72E+02	2.63E+02	3.17E+02	1.77E+03	3.77E+05	1.38E+05	0.00E+00
I-131	4.81E+04	4.81E+04	2.73E+04	1.62E+07	7.88E+04	0.00E+00	2.84E+03	0.00E+00
I-132	2.12E+03	4.07E+03	1.88E+03	1.94E+05	6.25E+03	0.00E+00	3.20E+03	0.00E+00
I-133	1.66E+04	2.03E+04	7.70E+03	3.85E+06	3.38E+04	0.00E+00	5.48E+03	0.00E+00
I-134	1.17E+03	2.16E+03	9.95E+02	5.07E+04	3.30E+03	0.00E+00	9.55E+02	0.00E+00
I-135	4.92E+03	8.73E+03	4.14E+03	7.92E+05	1.34E+04	0.00E+00	4.44E+03	0.00E+00
CS-134	6.51E+05	1.01E+06	2.25E+05	0.00E+00	3.30E+05	1.21E+05	3.85E+03	0.00E+00
CS-136	6.51E+04	1.71E+05	1.16E+05	0.00E+00	9.55E+04	1.45E+04	4.18E+03	0.00E+00
CS-137	9.07E+05	8.25E+05	1.28E+05	0.00E+00	2.82E+05	1.04E+05	3.62E+03	0.00E+00
CS-138	6.33E+02	8.40E+02	5.55E+02	0.00E+00	6.22E+02	6.81E+01	2.70E+02	0.00E+00
BA-139	1.84E+00	9.84E-04	5.36E-02	0.00E+00	8.62E-04	5.77E+03	5.77E+04	0.00E+00
BA-140	7.40E+04	6.48E+01	4.33E+03	0.00E+00	2.11E+01	1.74E+06	1.02E+05	0.00E+00
BA-142	4.99E-02	3.60E-05	2.79E-03	0.00E+00	2.91E-05	1.64E+03	2.74E+00	0.00E+00
LA-140	6.44E+02	2.25E+02	7.55E+01	0.00E+00	0.00E+00	1.83E+05	2.26E+05	0.00E+00
LA-142	1.29E+00	4.11E-01	1.29E-01	0.00E+00	0.00E+00	8.70E+03	7.59E+04	0.00E+00
CE-141	3.92E+04	1.95E+04	2.90E+03	0.00E+00	8.55E+03	5.44E+05	5.66E+04	0.00E+00
CE-143	3.66E+02	1.99E+02	2.87E+01	0.00E+00	8.36E+01	1.15E+05	1.27E+05	0.00E+00

TABLE 3.3-4 (continued)
P_i VALUES FOR A CHILD FOR H.B. ROBINSON UNIT NO. 2¹

<u>Nuclide</u>	<u>P_i Bone</u>	<u>P_i Liver</u>	<u>P_i T.Body</u>	<u>P_i Thyroid</u>	<u>P_i Kidney</u>	<u>P_i Lung</u>	<u>P_i GI-Tract</u>	<u>P_i Skin</u>
CE-144	6.77E+06	2.12E+06	3.61E+05	0.00E+00	1.17E+06	1.20E+07	3.89E+05	0.00E+00
PR-144	5.96E-02	1.85E-02	3.00E-03	0.00E+00	9.77E-03	1.57E+03	1.97E+02	0.00E+00
HF-181	8.33E+04	3.28E+02	8.47E+03	2.76E+02	2.63E+02	7.96E+05	5.29E+04	0.00E+00
W-187	1.63E+01	9.66E+00	4.33E+00	0.00E+00	0.00E+00	4.11E+04	9.10E+04	0.00E+00
NP-239	4.66E+02	3.34E+01	2.35E+01	0.00E+00	9.73E+01	5.81E+04	6.40E+04	0.00E+00

- ¹
- (a) NUREG 0133, Section 5.2.1.1 (Calculation of P_i (Inhalation)).
 - (b) Regulatory Guide 1.109, Table E-5 and Table E-9 (Breathing Rate Constant and Inhalation dose factors).
 - (c) Units are mrem/yr per μCi/m³.

3.4 Requirements for Compliance with 10 CFR 50 (Gaseous)

Applicability

Applies to radionoble gases released in gaseous effluents to unrestricted areas.

Objective

To define the air dose limits of 10 CFR 50 Appendix I for radionoble gases released in gaseous effluents to unrestricted areas.

Specification

CONTROLS

- 3.4.1 The air dose commitment due to radionoble gases released in gaseous effluents to areas at and beyond the site boundary (See Figure 7-1) shall be limited, at all times, to the following:
- a. During any calendar quarter, to ≤ 5 mrad for gamma radiation and ≤ 10 mrad for beta radiation;
 - b. During any calendar year, to ≤ 10 mrad for gamma radiation and ≤ 20 mrad for beta radiation.

ACTIONS

- 3.4.2 With the calculated air dose commitment from radioactive noble gases in gaseous effluents exceeding any of the limits, prescribed by ODCM Specification 3.4.1 above, prepare and submit a report to the Commission in accordance with the ODCM Specification 9.3.

Bases

Compliance With 10 CFR part 50 - Radionoble Gases

This specification is provided to implement the requirements of Section II.B, III.A and IV.A of Appendix I, 10 CFR Part 50. The Control implementing the guides set forth in Section IV.A of Appendix I to assure that the releases of radioactive material in gaseous effluents will be kept "as low as reasonable achievable". The Surveillance Requirements implement the requirements in Section III.A of Appendix I that conformance with the guides of Appendix I be shown by calculative procedures based on models and data such that the actual exposure of an individual through appropriate pathways is unlikely to be substantially underestimated. The methods established in the ODCM for calculating the doses due to the actual release rates of radioactive noble gases in gaseous effluents are consistent with the methodology provided in the Regulatory Guide 1.109, "Calculation of Annual Doses to Man from Routine Releases of Reactor Effluents for the Purpose of Evaluating Compliance with 10 CFR Part 50, Appendix I", Revision 1, October 1977 and Regulatory Guide 1.111, "Methods for Estimating Atmospheric Transport and Dispersion of Gaseous Effluents in Routine Releases from Light-Water Cooled Reactors", Revision 1, July, 1977. The ODCM equations provided for determining the air dose commitments at the site boundary are based upon historical average atmospheric conditions.

3.5 Compliance with 10 CFR 50 (Gaseous)

3.5.1 Noble Gases

3.5.1.1 Cumulation of Doses

Based upon NUREG 0133, the air dose in the unrestricted area due to noble gases released in gaseous effluents can be determined by the following equations:

$$D_{\gamma} = 3.17 \times 10^{-8} * \sum_i \left[M_i * \left[\left(\overline{(\chi/Q)}_v * \bar{Q}_{iv} \right) + \left(\overline{(\chi/q)}_v * \bar{q}_{iv} \right) + \left(\overline{(\chi/Q)}_e * \bar{Q}_{ie} \right) \right] \right] \quad (3.5-1)$$

$$D_{\beta} = 3.17 \times 10^{-8} * \sum_i \left[N_i * \left[\left(\overline{(\chi/Q)}_v * \bar{Q}_{iv} \right) + \left(\overline{(\chi/q)}_v * \bar{q}_{iv} \right) + \left(\overline{(\chi/Q)}_e * \bar{Q}_{ie} \right) \right] \right] \quad (3.5-2)$$

where:

- D_{γ} = The air dose from gamma radiation (mrad).
- D_{β} = The air dose from beta radiation (mrad).
- M_i = The air dose factor due to gamma emissions for each identified noble gas radionuclide 'i' (mrad/year per $\mu\text{Ci}/\text{m}^3$).
- N_i = The air dose factor due to beta emissions for each identified noble gas radionuclide 'i' (mrad/year per $\mu\text{Ci}/\text{m}^3$).
- $\overline{(\chi/Q)}_v$ = The annual average dilution for areas at or beyond the unrestricted area boundary for long-term plant vent releases, > 500 hrs/year (sec/m^3).
 = From Table A-1 for ground level releases used for conservatism.
 = From Table A-10 for mixed mode releases.
- $\overline{(\chi/q)}_v$ = The dilution for areas at or beyond the unrestricted area boundary for short-term plant vent releases, < 500 hrs/year (sec/m^3).
 = From Table A-1 for ground level continuous release for conservatism.
 = From Table A-7 for ground level releases.
 = From Table A-16 for mixed mode releases.
- $\overline{(\chi/Q)}_e$ = Annual average relative dilution for fuel handling basement exhaust, the environmental and radiation control building exhaust, and radwaste building exhaust vent releases at the site boundary, > 500 hrs/year (sec/m^3).
 = From Table A-1 for ground level releases.
- \bar{Q}_{iv} = The average release of noble gas radionuclide 'i' in gaseous effluents for long-term vent releases, > 500 hrs/year (μCi).

\bar{Q}_{iv} = The average release of noble gas radionuclide 'i' in gaseous releases for short-term plant releases, < 500 hrs/year (μCi).

\bar{Q}_{ie} = The average release of noble gas radionuclide 'i' in gaseous releases for long-term fuel handling basement exhaust, the environmental and radiation control building exhaust, and radwaste building exhaust, > 500 hrs/year (μCi).

3.17×10^{-8} = The inverse of the number of seconds in a year (sec/year)⁻¹.

At HBR the limiting location is 0.26 miles SSE. Based upon the tables presented in Appendix A, substitution of the short-term χ/Q value into Equation 3.5-1 yields lower dose value than the long-term χ/Q values used. In order to be conservative, for purposes of this document only, long-term annual average ($\overline{\chi/Q}$) values will be used. Should the calculated doses exceed 10 CFR 50 limits, recalculation of doses may be performed using short-term X/Q values for batch releases.

To select the limiting location, the highest annual average ($\overline{\chi/Q}$) value for ground level and mixed mode releases and the highest short-term χ/Q value for ground level and mixed mode releases were considered. Since mixed mode releases may increase and then decrease with distance (i.e., the site boundary may not have the highest χ/Q value), long-term χ/Q values were calculated at the midpoint of 10 standard distances as given in Appendix A. The calculated values decreased with the distance for all but the WNW, NW, and NNW sectors. The values for these sectors were not found to be limiting such that the maximum site boundary χ/Q for both long-term and short-term ground level and mixed mode releases occurred at the SSE site boundary. The limiting location for implementation of 10 CFR 20 for noble gases is the SSE site boundary.

Values for M_i and N_i which are utilized in the calculation of the gamma air and beta air doses in Equation 3.5-1 to show compliance with 10 CFR 50 were presented in Table 3.3-3. These values originate from NUREG 0472, Revision 0, and were taken from Table B-1 of the NRC Regulatory Guide 1.109, Revision 1. The values have been multiplied by 1.0E6 to convert from picocuries to microcuries. The following relationship should hold for HBR to show compliance with HBR's ODCM Specification 3.4.1.

For the calendar quarter:

$$D_\gamma \leq 5 \text{ mrad} \quad (3.5-3)$$

$$D_\beta \leq 10 \text{ mrad} \quad (3.5-4)$$

For the calendar year:

$$D_\gamma \leq 10 \text{ mrad} \quad (3.5-5)$$

$$D_\beta \leq 20 \text{ mrad} \quad (3.5-6)$$

The quarterly limits given above represent one-half of the annual design objectives of Section II.B.1 of Appendix I of 10 CFR 50. If any of the limits of Equations 3.5-3 through 3.5-6 are exceeded, a special report pursuant to ODCM Specification 9.3 must be filed with the NRC. This report complies with Section IV.A of Appendix I of 10 CFR 50.

3.5.1.2 Projection of Doses

Doses resulting from the release of gaseous effluents will be projected once per 31 days. These projections will include a safety margin based upon expected operational conditions which will take into consideration both planned and unplanned releases. Projected dose will be calculated as follows:

$$PD = \frac{92 * (DA + DB)}{TE} + M \quad (3.5-7)$$

where:

- PD = projected doses (mrad).
- 92 = time in quarter (days).
- DA = dose accumulated during current quarter (mrad).
- DB = projected dose from this release (mrad).
- TE = time elapsed in quarter (days).
- M = safety margin (mrad).

If the projected doses exceed 0.6 mrad for gamma radiation or 1.3 mrad for beta radiation when averaged over a calendar quarter, the ventilation exhaust treatment system will be operated to reduce releases of radioactive materials.

3.5.2 Compliance with 10 CFR Part 50 - Radioiodines, Radioactive Materials in Particulate Form, and Radionuclides other than Radionoble Gases

Applicability

Applies to radioiodines, radioactive materials in particulate form, and radionuclides other than radionoble gases released from the site to unrestricted areas.

Objective

To define the dose limits of 10 CFR 50 for radioiodines, radioactive materials in particulate form, and radionuclides other than radionoble gases released from the site to unrestricted areas.

Specification

CONTROLS

3.5.2.1 The dose to a member of the public from I-131, I-133, tritium and radioactive materials in particulate form, with half-lives greater than 8 days in gaseous effluents released to unrestricted areas (See Figure 7-1), shall be limited, at all times, to the following:

- a. During any calendar quarter, ≤ 7.5 mrem to an organ

AND

- b. During any calendar year, ≤ 15 mrem to any organ.

ACTIONS

3.5.2.2 With the calculated dose commitment from the release of I-131, I-133, tritium and radioactive materials in particulate form, with half-lives greater than 8 days, in gaseous effluents exceeding any of the limits prescribed by ODCM Specification 3.5.2.1 above, prepare and submit a report to the Commission in accordance with ODCM Specification 9.3.

BASES

Compliance With 10 CFR Part 50 - Radioiodines, Radioactive Materials in Particulate Form, and Radionuclides Other Than Radionoble Gases

This specification is provided to implement the requirements of Section II.C, III.A, and IV.A of Appendix I, 10 CFR Part 50. The Control implements the guides set forth in Section II.C of Appendix I. The action statement provides the required operating flexibility and at the same time implements the guides set forth in Section IV.A of Appendix I to assure that the releases of radioactive materials as gaseous effluents will be kept "as low as reasonably achievable." The surveillance requirements implement the requirements in Section III.A of Appendix I that conformance with the guides of Appendix I be shown by calculative procedures based on models and data, such that the actual exposure of an individual through appropriate pathways is unlikely to be substantially underestimated. The methods established in the ODCM for calculating the doses due to the actual release rates of the subject materials are consistent with the methodology provided in Regulatory Guide 1.109, "Calculation of Annual Doses to Man from Routine Releases of Reactor Effluents for the Purpose of Evaluating Compliance with 10 CFR Part 50, Appendix I", Revision 1, October 1977 and Regulatory Guide 1.111, "Methods for Estimating Atmospheric Transport and Dispersion of Gaseous Effluents in Routine Releases from Light-Water-Cooled Reactors", Revision 1, July 1977. The ODCM equations provided for determining the commitment are based upon historical average atmospheric conditions.

3.5.3 Radioiodine, Particulates, and Tritium

3.5.3.1 Cumulation of Doses

Section II.C of Appendix I of 10 CFR 50 limits the release of radioiodines and radioactive material in particulate form from each reactor such that estimated annual dose or dose commitment to an individual in an unrestricted area from all pathways of exposure is not in excess of 15 mrem to any organ. Based upon NUREG 0133, the dose to an organ of an individual from radioiodines, tritium, and particulates with half-lives ≥ 8 days in gaseous effluents released to unrestricted areas can be determined by the following equation:

$$\begin{aligned}
 D_{\tau} = & 3.17 \times 10^{-8} * \sum_i R_{iI} * \left[\left(\overline{(\chi/Q)}_v * \bar{Q}_{iv} \right) + \left(\overline{(\chi/q)}_v * \bar{q}_{iv} \right) + \left(\overline{(\chi/Q)}_e * \bar{Q}_{ie} \right) \right] \\
 & + (R_{iB} + R_{iM} + R_{iV} + R_{iG}) * \left[\left(\overline{(D/Q)}_v * \bar{Q}_{iv} \right) + \left(\overline{(D/q)}_v * \bar{q}_{iv} \right) + \left(\overline{(D/Q)}_e * \bar{Q}_{ie} \right) \right] \\
 & + (R_{TM} + R_{TB} + R_{TI} + R_{TV}) * \left[\left(\overline{(\chi/Q)}_v * \bar{Q}_{Tv} \right) + \left(\overline{(\chi/q)}_v * \bar{q}_{Tv} \right) + \left(\overline{(\chi/Q)}_e * \bar{Q}_{TE} \right) \right]
 \end{aligned}
 \tag{3.5-8}$$

where:

- D_{τ} = Dose to any organ τ from I-131, I-133, particulates with ≥ 8 day half-lives, and Tritium (mrem).
- 3.17×10^{-8} = The inverse of the number of seconds in a year (sec/year)⁻¹.
- $\overline{(\chi/Q)}_v$ = Annual average relative concentration for plant vent releases, > 500 hrs/yr (sec/m³).
 = From Table A-1 for ground level releases for conservatism.
 = From Table A-10 for mixed mode releases.
- $\overline{(\chi/q)}_v$ = Annual average relative concentration for plant vent releases, ≤ 500 hrs/yr (sec/m³).
 = From Table A-7 for ground release.
 = From Table A-16 for mixed mode releases.
- $\overline{(\chi/Q)}_e$ = Annual average dilution for radwaste building vent, fuel handling basement exhaust, and the environmental and radiation control building hood exhaust releases, > 500 hrs/yr (sec/m³).
 = From Table A-1 for ground level releases.
- $\overline{(D/Q)}_v$ = Annual average deposition factor for plant vent releases, > 500 hrs/yr (m⁻²).
 = From Table A-3 for ground level releases for conservatism.
 = From Table A-12 for mixed mode releases.

- $(\overline{D/q})_v$ = Relative deposition factor for short-term plant vent releases, < 500 hrs/yr (m^{-2}).
 = From Table A-3 for ground level continuous releases for conservatism.
 = From Table A-9 for ground level releases.
 = From Table A-18 for mixed mode releases.
- $(\overline{D/Q})_e$ = Annual average relative deposition factor for radwaste building vent, fuel handling basement exhaust, and the environmental and radiation control building hood exhaust releases, > 500 hrs/yr (m^{-2}).
 = From Table A-3 for ground level releases.
- \overline{Q}_{iv} = Release of radionuclide 'i' in gaseous effluents for long-term plant vent releases > 500 hrs/yr (μCi).
- \overline{q}_{iv} = Release of radionuclide 'i' in gaseous effluents for short-term plant vent releases < 500 hrs/yr (μCi).
- \overline{Q}_{ie} = Release of radionuclide 'i' in gaseous effluents for long-term radwaste building vent, fuel handling basement exhaust, and the environmental and radiation control building hood exhaust releases, > 500 hrs/yr (μCi).
- \overline{Q}_{Tv} = Release of tritium in gaseous effluents for long-term plant vent releases > 500 hrs/yr (μCi).
- \overline{q}_{Tv} = Release of tritium in gaseous effluents for short-term plant vent releases < 500 hrs/yr (μCi).
- \overline{Q}_{TE} = Release of tritium in gaseous effluents for long-term radwaste building vent, fuel handling basement exhaust, and the environmental and radiation control building hood exhaust > 500 hrs/yr (μCi).
- R_{iI} = Dose factor for an organ for radionuclide 'i' for the inhalation pathway ($mrem/yr$ per $\mu Ci/m^3$).
- R_{iB} = Dose factor for an organ for radionuclide 'i' for the meat exposure pathway (m^2 - $mrem/yr$ per $\mu Ci/sec$).
- R_{iM} = Dose factor for an organ for radionuclide 'i' for the milk exposure pathway (m^2 - $mrem/yr$ per $\mu Ci/sec$).
- R_{iV} = Dose factor for an organ for radionuclide 'i' for the vegetable pathway (m^2 - $mrem/yr$ per $\mu Ci/sec$).
- R_{iG} = Dose factor for an organ for radionuclide 'i' for the ground plane exposure pathway (m^2 - $mrem/yr$ per $\mu Ci/sec$).

R_{TM}	=	Dose factor for an organ for tritium for the milk pathway (mrem/yr per $\mu\text{Ci}/\text{m}^3$).
R_{TB}	=	Dose factor for an organ for tritium for the meat pathway (mrem/yr per $\mu\text{Ci}/\text{m}^3$).
R_{TI}	=	Dose factor for an organ for tritium for the inhalation pathway (mrem/yr per $\mu\text{Ci}/\text{m}^3$).
R_{TV}	=	Dose factor for an organ for tritium for the vegetable pathway (mrem/yr per $\mu\text{Ci}/\text{m}^3$).

To show compliance with 10 CFR 50, Equation 3.5-8 is evaluated at the limiting pathway location. At HBR this location is the vegetable garden 0.3 miles in the SSE sector. The critical receptor is a child. Substitution of the appropriate χ/Q and D/Q values from tables in Appendix A into Equation 3.5-8 would yield an equation with the short-term χ/Q and D/Q values being less than the long-term values. Therefore, for this document, only long-term annual χ/Q and D/Q values (i.e., more conservative values) are used.

The determination of a limiting location for implementation of 10 CFR 50 for radioiodines and particulates is a function of:

1. Radionuclide mix and isotopic release
2. Meteorology
3. Exposure pathway
4. Receptor's age

In the determination of the limiting location, the radionuclide mix of radioiodines and particulates was based upon the source terms calculated using the GALE Code. This mix is presented in Table 3.3-1 as a function of release point. The only source of short-term releases from the plant vent is containment purges. In the determination of the limiting location, all of the exposure pathways, as presented in Table 3.3-2, were evaluated. These include cow milk, goat milk, beef and vegetable ingestion, and inhalation and ground plane exposure.

An infant was assumed to be present at all milk pathway locations. A child was assumed to be present at all vegetable garden and beef animal locations. The ground plane exposure pathway was not considered a viable pathway for an infant. Naturally, the inhalation pathway was present everywhere an individual was present. HBR ODCM Specification 4.4.1 requires that a land-use census survey be conducted on an annual basis. The age groupings at the various receptor locations are also determined during this survey; a new limiting location and receptor age group can result.

For the determination of the limiting location, the highest D/Q values for the vegetable garden, cow milk, and goat milk pathways were selected. The thyroid dose was calculated at each of these locations using the radionuclide mix and releases of Table 3.3-1. Based upon these calculations, it was determined that the limiting receptor pathway is the vegetable/child pathway.

In the determination of the limiting location, annual average γ/Q and D/Q values are used. A description of the derivation of the various γ/Q and D/Q values is presented in Appendix A. Short-term and long-term γ/Q and D/Q values for ground level releases and for long-term mixed mode releases are provided in tables in Appendix A. They may be utilized if an additional special location arises different from those presented in the special locations of Table 3.3-2.

Tables 3.5-1 through 3.5-19 present R_i values for the total body, GI-tract, bone, liver, kidney, thyroid, skin, and lung organs for the ground plane, inhalation, cow milk, goat milk, vegetable, and meat ingestion pathways for the infant, child, teen, and adult age groups as appropriate to the pathways. These values were calculated using the methodology described in NUREG 0133 using a grazing period of eight months. A description of the methodology is presented in Appendix B.

The following relationship should hold for HBR to show compliance with HBR ODCM Specification 3.5.2.1.

For the calendar quarter:

$$D_{\tau} \leq 7.5 \text{ mrem} \quad (3.5-9)$$

For the calendar year:

$$D_{\tau} \leq 15 \text{ mrem} \quad (3.5-10)$$

The quarterly limit given above represent one-half the annual design objectives of Section II.C of Appendix I of 10 CFR 50. If any of the limits of Equations 3.5-9 or 3.5-10 are exceeded, a special report pursuant ODCM Specification 9.3 must be filed with the NRC. This report complies with Section IV.A of Appendix I of 10 CFR 50.

3.5.3.2 Projection of Doses

Doses resulting from release of radioiodines and particulate effluents will be projected once per 31 days. These projections will include a safety margin based upon expected operational conditions which will take into consideration both planned and unplanned releases. Projected dose will be calculated as follows:

$$PD = \frac{92 * (DA + DB)}{TE} + M \quad (3.5-11)$$

where:

- PD = Projected doses (mrem).
92 = time in quarter (days).
DA = Dose accumulated during current quarter (mrem).
DB = Projected dose from this release (mrem).
TE = Time elapsed in quarter (days).
M = Safety margin (mrem).

If the projected doses exceed 1.0 mrem to any organ when averaged over a calendar quarter, the ventilation exhaust treatment system will be operated to reduce releases of radioactive materials.

H.B. Robinson Steam Electric Plant Unit 2
Offsite Dose Calculation Manual (ODCM)

TABLE 3.5-1
R VALUES for the H.B. ROBINSON STEAM ELECTRIC PLANT¹
(Reference Regulatory Guide 1.109)

PATHWAY = Ground

Nuclide	Bone	Liver	T.Body	Thyroid	Kidney	Lung	GI-Tract	Skin
F-18	3.96E+05	3.96E+05	3.96E+05	3.96E+05	3.96E+05	3.96E+05	3.96E+05	4.66E+05
NA-24	1.19E+07	1.19E+07	1.19E+07	1.19E+07	1.19E+07	1.19E+07	1.19E+07	1.39E+07
CR-51	4.66E+06	4.66E+06	4.66E+06	4.66E+06	4.66E+06	4.66E+06	4.66E+06	5.51E+06
MN-54	1.39E+09	1.39E+09	1.39E+09	1.39E+09	1.39E+09	1.39E+09	1.39E+09	1.62E+09
MN-56	9.03E+05	9.03E+05	9.03E+05	9.03E+05	9.03E+05	9.03E+05	9.03E+05	1.07E+06
FE-59	2.73E+08	2.73E+08	2.73E+08	2.73E+08	2.73E+08	2.73E+08	2.73E+08	3.21E+08
CO-57	1.88E+08	1.88E+08	1.88E+08	1.88E+08	1.88E+08	1.88E+08	1.88E+08	2.07E+08
CO-58	3.79E+08	3.79E+08	3.79E+08	3.79E+08	3.79E+08	3.79E+08	3.79E+08	4.44E+08
CO-60	2.15E+10	2.15E+10	2.15E+10	2.15E+10	2.15E+10	2.15E+10	2.15E+10	2.53E+10
NI-65	2.97E+05	2.97E+05	2.97E+05	2.97E+05	2.97E+05	2.97E+05	2.97E+05	3.45E+05
CU-64	6.07E+05	6.07E+05	6.07E+05	6.07E+05	6.07E+05	6.07E+05	6.07E+05	6.88E+05
ZN-65	7.47E+08	7.47E+08	7.47E+08	7.47E+08	7.47E+08	7.47E+08	7.47E+08	8.59E+08
BR-82	2.14E+07	2.14E+07	2.14E+07	2.14E+07	2.14E+07	2.14E+07	2.14E+07	2.47E+07
BR-83	4.87E+03	4.87E+03	4.87E+03	4.87E+03	4.87E+03	4.87E+03	4.87E+03	7.08E+03
BR-84	2.03E+05	2.03E+05	2.03E+05	2.03E+05	2.03E+05	2.03E+05	2.03E+05	2.36E+05
RB-86	8.99E+06	8.99E+06	8.99E+06	8.99E+06	8.99E+06	8.99E+06	8.99E+06	1.03E+07
RB-88	3.31E+04	3.31E+04	3.31E+04	3.31E+04	3.31E+04	3.31E+04	3.31E+04	3.78E+04
RB-89	1.23E+05	1.23E+05	1.23E+05	1.23E+05	1.23E+05	1.23E+05	1.23E+05	1.48E+05
SR-89	2.16E+04	2.16E+04	2.16E+04	2.16E+04	2.16E+04	2.16E+04	2.16E+04	2.51E+04
SR-91	2.15E+06	2.15E+06	2.15E+06	2.15E+06	2.15E+06	2.15E+06	2.15E+06	2.51E+06
SR-92	7.77E+05	7.77E+05	7.77E+05	7.77E+05	7.77E+05	7.77E+05	7.77E+05	8.63E+05
Y-91M	1.00E+05	1.00E+05	1.00E+05	1.00E+05	1.00E+05	1.00E+05	1.00E+05	1.16E+05
Y-91	1.07E+06	1.07E+06	1.07E+06	1.07E+06	1.07E+06	1.07E+06	1.07E+06	1.21E+06
Y-92	1.80E+05	1.80E+05	1.80E+05	1.80E+05	1.80E+05	1.80E+05	1.80E+05	2.14E+05
Y-93	1.83E+05	1.83E+05	1.83E+05	1.83E+05	1.83E+05	1.83E+05	1.83E+05	2.51E+05
ZR-95	2.45E+08	2.45E+08	2.45E+08	2.45E+08	2.45E+08	2.45E+08	2.45E+08	2.84E+08
ZR-97	2.96E+06	2.96E+06	2.96E+06	2.96E+06	2.96E+06	2.96E+06	2.96E+06	3.44E+06
NB-95	1.37E+08	1.37E+08	1.37E+08	1.37E+08	1.37E+08	1.37E+08	1.37E+08	1.61E+08
NB-97	1.76E+05	1.76E+05	1.76E+05	1.76E+05	1.76E+05	1.76E+05	1.76E+05	2.07E+05
MO-99	3.99E+06	3.99E+06	3.99E+06	3.99E+06	3.99E+06	3.99E+06	3.99E+06	4.63E+06
TC-99M	1.84E+05	1.84E+05	1.84E+05	1.84E+05	1.84E+05	1.84E+05	1.84E+05	2.11E+05
TC-101	2.04E+04	2.04E+04	2.04E+04	2.04E+04	2.04E+04	2.04E+04	2.04E+04	2.26E+04
RU-103	1.08E+08	1.08E+08	1.08E+08	1.08E+08	1.08E+08	1.08E+08	1.08E+08	1.26E+08
RU-105	6.36E+05	6.36E+05	6.36E+05	6.36E+05	6.36E+05	6.36E+05	6.36E+05	7.21E+05
RU-106	4.22E+08	4.22E+08	4.22E+08	4.22E+08	4.22E+08	4.22E+08	4.22E+08	5.07E+08
AG-110M	3.44E+09	3.44E+09	3.44E+09	3.44E+09	3.44E+09	3.44E+09	3.44E+09	4.01E+09
SN-113	1.42E+07	1.42E+07	1.42E+07	1.42E+07	1.42E+07	1.42E+07	1.42E+07	4.08E+07
SB-124	5.98E+08	5.98E+08	5.98E+08	5.98E+08	5.98E+08	5.98E+08	5.98E+08	6.90E+08
SB-125	2.34E+09	2.34E+09	2.34E+09	2.34E+09	2.34E+09	2.34E+09	2.34E+09	2.64E+09
TE-129M	1.98E+07	1.98E+07	1.98E+07	1.98E+07	1.98E+07	1.98E+07	1.98E+07	2.31E+07
TE-129	2.62E+04	2.62E+04	2.62E+04	2.62E+04	2.62E+04	2.62E+04	2.62E+04	3.10E+04
TE-131M	8.03E+06	8.03E+06	8.03E+06	8.03E+06	8.03E+06	8.03E+06	8.03E+06	9.46E+06
TE-132	4.23E+06	4.23E+06	4.23E+06	4.23E+06	4.23E+06	4.23E+06	4.23E+06	4.98E+06
I-131	1.72E+07	1.72E+07	1.72E+07	1.72E+07	1.72E+07	1.72E+07	1.72E+07	2.09E+07
I-132	1.25E+06	1.25E+06	1.25E+06	1.25E+06	1.25E+06	1.25E+06	1.25E+06	1.46E+06
I-133	2.45E+06	2.45E+06	2.45E+06	2.45E+06	2.45E+06	2.45E+06	2.45E+06	2.98E+06
I-134	4.47E+05	4.47E+05	4.47E+05	4.47E+05	4.47E+05	4.47E+05	4.47E+05	5.30E+05
I-135	2.53E+06	2.53E+06	2.53E+06	2.53E+06	2.53E+06	2.53E+06	2.53E+06	2.95E+06
CS-134	6.86E+09	6.86E+09	6.86E+09	6.86E+09	6.86E+09	6.86E+09	6.86E+09	8.00E+09
CS-136	1.51E+08	1.51E+08	1.51E+08	1.51E+08	1.51E+08	1.51E+08	1.51E+08	1.71E+08
CS-137	1.03E+10	1.03E+10	1.03E+10	1.03E+10	1.03E+10	1.03E+10	1.03E+10	1.20E+10
CS-138	3.59E+05	3.59E+05	3.59E+05	3.59E+05	3.59E+05	3.59E+05	3.59E+05	4.10E+05
BA-139	1.06E+05	1.06E+05	1.06E+05	1.06E+05	1.06E+05	1.06E+05	1.06E+05	1.19E+05
BA-140	2.05E+07	2.05E+07	2.05E+07	2.05E+07	2.05E+07	2.05E+07	2.05E+07	2.35E+07
BA-142	4.49E+04	4.49E+04	4.49E+04	4.49E+04	4.49E+04	4.49E+04	4.49E+04	5.11E+04

¹ R Values in units of mrem/yr per $\mu\text{Ci}/\text{m}^3$ for inhalation and tritium, and units of $\text{m}^2\text{-mrem}/\text{yr}$ per $\mu\text{Ci}/\text{sec}$ for all others.

TABLE 3.5-1 (continued)
R VALUES for the H.B. ROBINSON STEAM ELECTRIC PLANT¹

PATHWAY = Ground

<u>Nuclide</u>	<u>Bone</u>	<u>Liver</u>	<u>T.Body</u>	<u>Thyroid</u>	<u>Kidney</u>	<u>Lung</u>	<u>GI-Tract</u>	<u>Skin</u>
LA-140	1.92E+07	1.92E+07	1.92E+07	1.92E+07	1.92E+07	1.92E+07	1.92E+07	2.18E+07
LA-142	7.60E+05	7.60E+05	7.60E+05	7.60E+05	7.60E+05	7.60E+05	7.60E+05	9.11E+05
CE-141	1.37E+07	1.37E+07	1.37E+07	1.37E+07	1.37E+07	1.37E+07	1.37E+07	1.54E+07
CE-143	2.31E+06	2.31E+06	2.31E+06	2.31E+06	2.31E+06	2.31E+06	2.31E+06	2.63E+06
CE-144	6.95E+07	6.95E+07	6.95E+07	6.95E+07	6.95E+07	6.95E+07	6.95E+07	8.04E+07
PR-144	1.83E+03	1.83E+03	1.83E+03	1.83E+03	1.83E+03	1.83E+03	1.83E+03	2.11E+03
HF-181	1.96E+08	1.96E+08	1.96E+08	1.96E+08	1.96E+08	1.96E+08	1.96E+08	2.80E+08
W-187	2.35E+06	2.35E+06	2.35E+06	2.35E+06	2.35E+06	2.35E+06	2.35E+06	2.73E+06
NP-239	1.71E+06	1.71E+06	1.71E+06	1.71E+06	1.71E+06	1.71E+06	1.71E+06	1.98E+06

¹ R Values in units of mrem/yr per $\mu\text{Ci}/\text{m}^3$ for inhalation and tritium, and units of $\text{m}^2\text{-mrem}/\text{yr}$ per $\mu\text{Ci}/\text{sec}$ for all others.

H.B. Robinson Steam Electric Plant Unit 2
Offsite Dose Calculation Manual (ODCM)

TABLE 3.5-2
R VALUES for the H.B. ROBINSON STEAM ELECTRIC PLANT²
(Reference Regulatory Guide 1.109)

PATHWAY = Vegetation
AGE GROUP = Adult

Nuclide	Bone	Liver	T.Body	Thyroid	Kidney	Lung	GI-Tract	Skin
H-3	0.00E+00	2.26E+03	2.26E+03	2.26E+03	2.26E+03	2.26E+03	2.26E+03	2.26E+03
F-18	4.22E+00	0.00E+00	4.68E-01	0.00E+00	0.00E+00	0.00E+00	1.25E-01	0.00E+00
NA-24	2.68E+05	2.68E+05	2.68E+05	2.68E+05	2.68E+05	2.68E+05	2.68E+05	0.00E+00
CR-51	0.00E+00	0.00E+00	4.59E+04	2.74E+04	1.01E+04	6.09E+04	1.15E+07	0.00E+00
MN-54	0.00E+00	3.08E+08	5.87E+07	0.00E+00	9.15E+07	0.00E+00	9.42E+08	0.00E+00
MN-56	0.00E+00	1.54E+01	2.74E+00	0.00E+00	1.96E+01	0.00E+00	4.93E+02	0.00E+00
FE-55	2.00E+08	1.38E+08	3.22E+07	0.00E+00	0.00E+00	7.70E+07	7.91E+07	0.00E+00
FE-59	1.24E+08	2.90E+08	1.11E+08	0.00E+00	0.00E+00	8.11E+07	9.68E+08	0.00E+00
CO-57	0.00E+00	1.01E+07	1.88E+07	0.00E+00	0.00E+00	0.00E+00	2.86E+08	0.00E+00
CO-58	0.00E+00	2.99E+07	6.70E+07	0.00E+00	0.00E+00	0.00E+00	6.06E+08	0.00E+00
CO-60	0.00E+00	1.67E+08	3.67E+08	0.00E+00	0.00E+00	0.00E+00	3.13E+09	0.00E+00
NI-65	5.97E+01	7.75E+00	3.54E+00	0.00E+00	0.00E+00	0.00E+00	1.97E+02	0.00E+00
CU-64	0.00E+00	9.19E+03	4.31E+03	0.00E+00	2.32E+04	0.00E+00	7.83E+05	0.00E+00
ZN-65	4.01E+08	1.28E+09	5.77E+08	0.00E+00	8.54E+08	0.00E+00	8.04E+08	0.00E+00
BR-82	0.00E+00	0.00E+00	1.55E+06	0.00E+00	0.00E+00	0.00E+00	1.78E+06	0.00E+00
BR-83	0.00E+00	0.00E+00	3.10E+00	0.00E+00	0.00E+00	0.00E+00	4.47E+00	0.00E+00
BR-84	0.00E+00	0.00E+00	2.21E-11	0.00E+00	0.00E+00	0.00E+00	1.73E-16	0.00E+00
RB-86	0.00E+00	2.21E+08	1.03E+08	0.00E+00	0.00E+00	0.00E+00	4.35E+07	0.00E+00
RB-88	0.00E+00	2.66E-22	1.41E-22	0.00E+00	0.00E+00	0.00E+00	3.67E-33	0.00E+00
RB-89	0.00E+00	2.90E-26	2.04E-26	0.00E+00	0.00E+00	0.00E+00	0.00E+00	0.00E+00
SR-89	9.77E+09	0.00E+00	2.80E+08	0.00E+00	0.00E+00	0.00E+00	1.57E+09	0.00E+00
SR-90	6.71E+11	0.00E+00	1.65E+11	0.00E+00	0.00E+00	0.00E+00	1.94E+10	0.00E+00
SR-91	3.02E+05	0.00E+00	1.22E+04	0.00E+00	0.00E+00	0.00E+00	1.44E+06	0.00E+00
SR-92	4.15E+02	0.00E+00	1.79E+01	0.00E+00	0.00E+00	0.00E+00	8.22E+03	0.00E+00
Y-91M	4.76E-09	0.00E+00	1.84E-10	0.00E+00	0.00E+00	0.00E+00	1.40E-08	0.00E+00
Y-91	4.98E+06	0.00E+00	1.33E+05	0.00E+00	0.00E+00	0.00E+00	2.74E+09	0.00E+00
Y-92	8.96E-01	0.00E+00	2.62E-02	0.00E+00	0.00E+00	0.00E+00	1.57E+04	0.00E+00
Y-93	1.68E+02	0.00E+00	4.65E+00	0.00E+00	0.00E+00	0.00E+00	5.34E+06	0.00E+00
ZR-95	1.14E+06	3.66E+05	2.48E+05	0.00E+00	5.75E+05	0.00E+00	1.16E+09	0.00E+00
ZR-97	3.36E+02	6.78E+01	3.10E+01	0.00E+00	1.02E+02	0.00E+00	2.10E+07	0.00E+00
NB-95	1.40E+05	7.80E+04	4.19E+04	0.00E+00	7.71E+04	0.00E+00	4.73E+08	0.00E+00
NB-97	2.02E-06	5.11E-07	1.87E-07	0.00E+00	5.96E-07	0.00E+00	1.89E-03	0.00E+00
MO-99	0.00E+00	6.18E+06	1.18E+06	0.00E+00	1.40E+07	0.00E+00	1.43E+07	0.00E+00
TC-99M	3.10E+00	8.75E+00	1.11E+02	0.00E+00	1.33E+02	4.29E+00	5.18E+03	0.00E+00
TC-101	6.00E-31	8.64E-31	8.47E-30	0.00E+00	1.56E-29	4.41E-31	0.00E+00	0.00E+00
RU-103	4.72E+06	0.00E+00	2.03E+06	0.00E+00	1.80E+07	0.00E+00	5.51E+08	0.00E+00
RU-105	5.30E+01	0.00E+00	2.09E+01	0.00E+00	6.85E+02	0.00E+00	3.24E+04	0.00E+00
RU-106	1.95E+08	0.00E+00	2.47E+07	0.00E+00	3.76E+08	0.00E+00	1.26E+10	0.00E+00
AG-110M	1.13E+07	1.05E+07	6.22E+06	0.00E+00	2.06E+07	0.00E+00	4.27E+09	0.00E+00
SN-113	1.43E+07	5.50E+05	1.35E+07	1.94E+05	4.04E+05	0.00E+00	2.49E+08	0.00E+00
SB-124	1.01E+08	1.91E+06	4.01E+07	2.45E+05	0.00E+00	7.88E+07	2.87E+09	0.00E+00
SB-125	1.34E+08	1.50E+06	3.20E+07	1.37E+05	0.00E+00	1.04E+08	1.48E+09	0.00E+00
TE-129M	2.94E+08	1.10E+08	4.65E+07	1.01E+08	1.23E+09	0.00E+00	1.48E+09	0.00E+00
TE-129	7.52E-04	2.83E-04	1.83E-04	5.77E-04	3.16E-03	0.00E+00	5.68E-04	0.00E+00
TE-131M	9.63E+05	4.71E+05	3.93E+05	7.46E+05	4.77E+06	0.00E+00	4.68E+07	0.00E+00
TE-132	4.58E+06	2.96E+06	2.78E+06	3.27E+06	2.85E+07	0.00E+00	1.40E+08	0.00E+00
I-131	8.07E+07	1.15E+08	6.61E+07	3.78E+10	1.98E+08	0.00E+00	3.04E+07	0.00E+00
I-132	5.57E+01	1.49E+02	5.21E+01	5.21E+03	2.37E+02	0.00E+00	2.80E+01	0.00E+00
I-133	2.08E+06	3.61E+06	1.10E+06	5.31E+08	6.31E+06	0.00E+00	3.25E+06	0.00E+00
I-134	8.84E-05	2.40E-04	8.59E-05	4.16E-03	3.82E-04	0.00E+00	2.09E-07	0.00E+00
I-135	3.85E+04	1.01E+05	3.72E+04	6.65E+06	1.62E+05	0.00E+00	1.14E+05	0.00E+00

² R Values in units of mrem/yr per $\mu\text{Ci}/\text{m}^3$ for inhalation and tritium, and units of $\text{m}^2\text{-mrem}/\text{yr}$ per $\mu\text{Ci}/\text{sec}$ for all others.

TABLE 3.5-2 (continued)
R VALUES for the H.B. ROBINSON STEAM ELECTRIC PLANT²

PATHWAY = Vegetation
 AGE GROUP = Adult

<u>Nuclide</u>	<u>Bone</u>	<u>Liver</u>	<u>T.Body</u>	<u>Thyroid</u>	<u>Kidney</u>	<u>Lung</u>	<u>GI-Tract</u>	<u>Skin</u>
CS-134	4.55E+09	1.08E+10	8.84E+09	0.00E+00	3.50E+09	1.16E+09	1.89E+08	0.00E+00
CS-136	4.26E+07	1.68E+08	1.21E+08	0.00E+00	9.36E+07	1.28E+07	1.91E+07	0.00E+00
CS-137	6.64E+09	9.08E+09	5.95E+09	0.00E+00	3.08E+09	1.03E+09	1.76E+08	0.00E+00
CS-138	3.39E-11	6.70E-11	3.32E-11	0.00E+00	4.92E-11	4.86E-12	2.86E-16	0.00E+00
BA-139	2.70E-02	1.93E-05	7.91E-04	0.00E+00	1.80E-05	1.09E-05	4.79E-02	0.00E+00
BA-140	1.28E+08	1.61E+05	8.40E+06	0.00E+00	5.47E+04	9.22E+04	2.64E+08	0.00E+00
LA-140	1.97E+03	9.95E+02	2.63E+02	0.00E+00	0.00E+00	0.00E+00	7.30E+07	0.00E+00
LA-142	1.92E-04	8.75E-05	2.18E-05	0.00E+00	0.00E+00	0.00E+00	6.39E-01	0.00E+00
CE-141	1.94E+05	1.31E+05	1.49E+04	0.00E+00	6.10E+04	0.00E+00	5.02E+08	0.00E+00
CE-143	9.96E+02	7.36E+05	8.15E+01	0.00E+00	3.24E+02	0.00E+00	2.75E+07	0.00E+00
CE-144	3.15E+07	1.32E+07	1.69E+06	0.00E+00	7.81E+06	0.00E+00	1.07E+10	0.00E+00
PR-144	2.36E-26	9.81E-27	1.20E-27	0.00E+00	5.53E-27	0.00E+00	3.40E-33	0.00E+00
HF-181	9.50E+06	5.36E+04	1.08E+06	3.40E+04	4.47E+04	0.00E+00	7.05E+08	0.00E+00
W-187	3.79E+04	3.17E+04	1.11E+04	0.00E+00	0.00E+00	0.00E+00	1.04E+07	0.00E+00
NP-239	1.43E+03	1.40E+02	7.73E+01	0.00E+00	4.37E+02	0.00E+00	2.88E+07	0.00E+00

² R Values in units of mrem/yr per $\mu\text{Ci}/\text{m}^3$ for inhalation and tritium, and units of $\text{m}^2\text{-mrem}/\text{yr}$ per $\mu\text{Ci}/\text{sec}$ for all others.

TABLE 3.5-3
R VALUES for the H.B. ROBINSON STEAM ELECTRIC PLANT³
 (Reference Regulatory Guide 1.109)

PATHWAY = Vegetation
 AGE GROUP = Teen

Nuclide	Bone	Liver	T.Body	Thyroid	Kidney	Lung	GI-Tract	Skin
H-3	0.00E+00	2.59E+03	2.59E+03	2.59E+03	2.59E+03	2.59E+03	2.59E+03	2.59E+03
F-18	3.83E+00	0.00E+00	4.20E-01	0.00E+00	0.00E+00	0.00E+00	3.45E-01	0.00E+00
NA-24	2.38E+05	2.38E+05	2.38E+05	2.38E+05	2.38E+05	2.38E+05	2.38E+05	0.00E+00
CR-51	0.00E+00	0.00E+00	6.09E+04	3.38E+04	1.34E+04	8.70E+04	1.02E+07	0.00E+00
MN-54	0.00E+00	4.47E+08	8.86E+07	0.00E+00	1.33E+08	0.00E+00	9.16E+08	0.00E+00
MN-56	0.00E+00	1.39E+01	2.48E+00	0.00E+00	1.76E+01	0.00E+00	9.17E+02	0.00E+00
FE-55	3.10E+08	2.20E+08	5.13E+07	0.00E+00	0.00E+00	1.40E+08	9.53E+07	0.00E+00
FE-59	1.76E+08	4.10E+08	1.58E+08	0.00E+00	0.00E+00	1.29E+08	9.70E+08	0.00E+00
CO-57	0.00E+00	1.72E+07	2.89E+07	0.00E+00	0.00E+00	0.00E+00	3.21E+08	0.00E+00
CO-58	0.00E+00	4.24E+07	9.78E+07	0.00E+00	0.00E+00	0.00E+00	5.85E+08	0.00E+00
CO-60	0.00E+00	2.48E+08	5.58E+08	0.00E+00	0.00E+00	0.00E+00	3.23E+09	0.00E+00
NI-65	5.56E+01	7.10E+00	3.23E+00	0.00E+00	0.00E+00	0.00E+00	3.85E+02	0.00E+00
CU-64	0.00E+00	8.33E+03	3.92E+03	0.00E+00	2.11E+04	0.00E+00	6.46E+05	0.00E+00
ZN-65	5.36E+08	1.86E+09	8.68E+08	0.00E+00	1.19E+09	0.00E+00	7.88E+08	0.00E+00
BR-82	0.00E+00	0.00E+00	1.37E+06	0.00E+00	0.00E+00	0.00E+00	0.00E+00	0.00E+00
BR-83	0.00E+00	0.00E+00	2.91E+00	0.00E+00	0.00E+00	0.00E+00	0.00E+00	0.00E+00
BR-84	0.00E+00	0.00E+00	2.01E-11	0.00E+00	0.00E+00	0.00E+00	0.00E+00	0.00E+00
RB-86	0.00E+00	2.75E+08	1.29E+08	0.00E+00	0.00E+00	0.00E+00	4.07E+07	0.00E+00
RB-88	0.00E+00	2.46E-22	1.31E-22	0.00E+00	0.00E+00	0.00E+00	2.11E-29	0.00E+00
RB-89	0.00E+00	2.61E-26	1.84E-26	0.00E+00	0.00E+00	0.00E+00	4.00E-35	0.00E+00
SR-89	1.48E+10	0.00E+00	4.25E+08	0.00E+00	0.00E+00	0.00E+00	1.77E+09	0.00E+00
SR-90	8.33E+11	0.00E+00	2.06E+11	0.00E+00	0.00E+00	0.00E+00	2.34E+10	0.00E+00
SR-91	2.83E+05	0.00E+00	1.12E+04	0.00E+00	0.00E+00	0.00E+00	1.28E+06	0.00E+00
SR-92	3.86E+02	0.00E+00	1.65E+01	0.00E+00	0.00E+00	0.00E+00	9.84E+03	0.00E+00
Y-91M	4.43E-09	0.00E+00	1.69E-10	0.00E+00	0.00E+00	0.00E+00	2.09E-07	0.00E+00
Y-91	7.64E+06	0.00E+00	2.05E+05	0.00E+00	0.00E+00	0.00E+00	3.13E+09	0.00E+00
Y-92	8.42E-01	0.00E+00	2.43E-02	0.00E+00	0.00E+00	0.00E+00	2.31E+04	0.00E+00
Y-93	1.58E+02	0.00E+00	4.33E+00	0.00E+00	0.00E+00	0.00E+00	4.82E+06	0.00E+00
ZR-95	1.67E+06	5.28E+05	3.63E+05	0.00E+00	7.76E+05	0.00E+00	1.22E+09	0.00E+00
ZR-97	3.11E+02	6.15E+01	2.83E+01	0.00E+00	9.33E+01	0.00E+00	1.67E+07	0.00E+00
NB-95	1.89E+05	1.05E+05	5.78E+04	0.00E+00	1.02E+05	0.00E+00	4.49E+08	0.00E+00
NB-97	1.87E-06	4.65E-07	1.70E-07	0.00E+00	5.44E-07	0.00E+00	1.11E-02	0.00E+00
MO-99	0.00E+00	5.67E+06	1.08E+06	0.00E+00	1.30E+07	0.00E+00	1.02E+07	0.00E+00
TC-99M	2.73E+00	7.62E+00	9.87E+01	0.00E+00	1.13E+02	4.23E+00	5.00E+03	0.00E+00
TC-101	5.58E-31	7.93E-31	7.79E-30	0.00E+00	1.43E-29	4.83E-31	1.36E-37	0.00E+00
RU-103	6.75E+06	0.00E+00	2.88E+06	0.00E+00	2.38E+07	0.00E+00	5.64E+08	0.00E+00
RU-105	4.93E+01	0.00E+00	1.91E+01	0.00E+00	6.22E+02	0.00E+00	3.98E+04	0.00E+00
RU-106	3.13E+08	0.00E+00	3.94E+07	0.00E+00	6.03E+08	0.00E+00	1.50E+10	0.00E+00
AG-110M	1.63E+07	1.54E+07	9.37E+06	0.00E+00	2.94E+07	0.00E+00	4.33E+09	0.00E+00
SN-113	1.88E+07	7.89E+05	2.00E+07	2.60E+05	5.58E+05	0.00E+00	2.26E+08	0.00E+00
SB-124	1.51E+08	2.78E+06	5.88E+07	3.42E+05	0.00E+00	1.32E+08	3.04E+09	0.00E+00
SB-125	2.11E+08	2.30E+06	4.92E+07	2.01E+05	0.00E+00	1.85E+08	1.64E+09	0.00E+00
TE-129M	4.23E+08	1.57E+08	6.69E+07	1.36E+08	1.77E+09	0.00E+00	1.59E+09	0.00E+00
TE-129	7.04E-04	2.63E-04	1.71E-04	5.03E-04	2.96E-03	0.00E+00	3.85E-03	0.00E+00
TE-131M	8.92E+05	4.28E+05	3.57E+05	6.43E+05	4.46E+06	0.00E+00	3.43E+07	0.00E+00
TE-132	4.16E+06	2.64E+06	2.48E+06	2.78E+06	2.53E+07	0.00E+00	8.35E+07	0.00E+00
I-131	7.67E+07	1.07E+08	5.77E+07	3.14E+10	1.85E+08	0.00E+00	2.13E+07	0.00E+00
I-132	5.02E+01	1.31E+02	4.72E+01	4.43E+03	2.07E+02	0.00E+00	5.73E+01	0.00E+00
I-133	1.93E+06	3.27E+06	9.99E+05	4.57E+08	5.74E+06	0.00E+00	2.48E+06	0.00E+00
I-134	7.99E-05	2.12E-04	7.61E-05	3.53E-03	3.34E-04	0.00E+00	2.79E-06	0.00E+00
I-135	3.48E+04	8.96E+04	3.32E+04	5.77E+06	1.42E+05	0.00E+00	9.93E+04	0.00E+00

³ R Values in units of mrem/yr per $\mu\text{Ci}/\text{m}^3$ for inhalation and tritium, and units of $\text{m}^2\text{-mrem}/\text{yr}$ per $\mu\text{Ci}/\text{sec}$ for all others.

TABLE 3.5-3 (continued)
R VALUES for the H.B. ROBINSON STEAM ELECTRIC PLANT³

PATHWAY = Vegetation
 AGE GROUP = Teen

Nuclide	Bone	Liver	T.Body	Thyroid	Kidney	Lung	GI-Tract	Skin
CS-134	6.92E+09	1.63E+10	7.55E+09	0.00E+00	5.17E+09	1.97E+09	2.02E+08	0.00E+00
CS-136	4.36E+07	1.72E+08	1.15E+08	0.00E+00	9.35E+07	1.47E+07	1.38E+07	0.00E+00
CS-137	1.06E+10	1.41E+10	4.90E+09	0.00E+00	4.79E+09	1.86E+09	2.00E+08	0.00E+00
CS-138	3.13E-11	6.01E-11	3.01E-11	0.00E+00	4.44E-11	5.16E-12	2.73E-14	0.00E+00
BA-139	2.54E-02	1.79E-05	7.41E-04	0.00E+00	1.69E-05	1.23E-05	2.27E-01	0.00E+00
BA-140	1.38E+08	1.69E+05	8.87E+06	0.00E+00	5.72E+04	1.13E+05	2.12E+08	0.00E+00
LA-140	1.80E+03	8.86E+02	2.36E+02	0.00E+00	0.00E+00	0.00E+00	5.09E+07	0.00E+00
LA-142	1.77E-04	7.85E-05	1.95E-05	0.00E+00	0.00E+00	0.00E+00	2.39E+00	0.00E+00
CE-141	2.79E+05	1.86E+05	2.14E+04	0.00E+00	8.76E+04	0.00E+00	5.32E+08	0.00E+00
CE-143	9.31E+02	6.77E+05	7.56E+01	0.00E+00	3.04E+02	0.00E+00	2.04E+07	0.00E+00
CE-144	5.05E+07	2.09E+07	2.71E+06	0.00E+00	1.25E+07	0.00E+00	1.27E+10	0.00E+00
PR-144	2.22E-26	9.07E-27	1.12E-27	0.00E+00	5.20E-27	0.00E+00	2.44E-29	0.00E+00
HF-181	1.38E+07	7.58E+04	1.54E+06	4.62E+04	6.30E+04	0.00E+00	6.89E+08	0.00E+00
W-187	3.53E+04	2.87E+04	1.01E+04	0.00E+00	0.00E+00	0.00E+00	7.78E+06	0.00E+00
NP-239	1.38E+03	1.31E+02	7.25E+01	0.00E+00	4.10E+02	0.00E+00	2.10E+07	0.00E+00

³ R Values in units of mrem/yr per $\mu\text{Ci}/\text{m}^3$ for inhalation and tritium, and units of $\text{m}^2\text{-mrem}/\text{yr}$ per $\mu\text{Ci}/\text{sec}$ for all others.

TABLE 3.5-4
R VALUES for the H.B. ROBINSON STEAM ELECTRIC PLANT⁴
 (Reference Regulatory Guide 1.109)

PATHWAY = Vegetation
 AGE GROUP = Child

Nuclide	Bone	Liver	T.Body	Thyroid	Kidney	Lung	GI-Tract	Skin
H-3	0.00E+00	4.01E+03	4.01E+03	4.01E+03	4.01E+03	4.01E+03	4.01E+03	4.01E+03
F-18	6.84E+00	0.00E+00	6.78E-01	0.00E+00	0.00E+00	0.00E+00	1.85E+00	0.00E+00
NA-24	3.72E+05	3.72E+05	3.72E+05	3.72E+05	3.72E+05	3.72E+05	3.72E+05	0.00E+00
CR-51	0.00E+00	0.00E+00	1.16E+05	6.42E+04	1.75E+04	1.17E+05	6.14E+06	0.00E+00
MN-54	0.00E+00	6.54E+08	1.74E+08	0.00E+00	1.83E+08	0.00E+00	5.49E+08	0.00E+00
MN-56	0.00E+00	1.82E+01	4.11E+00	0.00E+00	2.20E+01	0.00E+00	2.64E+03	0.00E+00
FE-55	7.63E+08	4.05E+08	1.25E+08	0.00E+00	0.00E+00	2.29E+08	7.50E+07	0.00E+00
FE-59	3.89E+08	6.30E+08	3.14E+08	0.00E+00	0.00E+00	1.83E+08	6.56E+08	0.00E+00
CO-57	0.00E+00	2.88E+07	5.83E+07	0.00E+00	0.00E+00	0.00E+00	2.36E+08	0.00E+00
CO-58	0.00E+00	6.27E+07	1.92E+08	0.00E+00	0.00E+00	0.00E+00	3.65E+08	0.00E+00
CO-60	0.00E+00	3.77E+08	1.11E+09	0.00E+00	0.00E+00	0.00E+00	2.09E+09	0.00E+00
NI-65	1.02E+02	9.60E+00	5.60E+00	0.00E+00	0.00E+00	0.00E+00	1.18E+03	0.00E+00
CU-64	0.00E+00	1.10E+04	6.63E+03	0.00E+00	2.65E+04	0.00E+00	5.15E+05	0.00E+00
ZN-65	1.03E+09	2.74E+09	1.70E+09	0.00E+00	1.72E+09	0.00E+00	4.81E+08	0.00E+00
BR-82	0.00E+00	0.00E+00	2.10E+06	0.00E+00	0.00E+00	0.00E+00	0.00E+00	0.00E+00
BR-83	0.00E+00	0.00E+00	5.36E+00	0.00E+00	0.00E+00	0.00E+00	0.00E+00	0.00E+00
BR-84	0.00E+00	0.00E+00	3.41E-11	0.00E+00	0.00E+00	0.00E+00	0.00E+00	0.00E+00
RB-86	0.00E+00	4.55E+08	2.80E+08	0.00E+00	0.00E+00	0.00E+00	2.93E+07	0.00E+00
RB-88	0.00E+00	3.39E-22	2.36E-22	0.00E+00	0.00E+00	0.00E+00	1.66E-23	0.00E+00
RB-89	0.00E+00	3.43E-26	3.05E-26	0.00E+00	0.00E+00	0.00E+00	2.99E-28	0.00E+00
SR-89	3.52E+10	0.00E+00	1.01E+09	0.00E+00	0.00E+00	0.00E+00	1.36E+09	0.00E+00
SR-90	1.38E+12	0.00E+00	3.50E+11	0.00E+00	0.00E+00	0.00E+00	1.86E+10	0.00E+00
SR-91	5.20E+05	0.00E+00	1.96E+04	0.00E+00	0.00E+00	0.00E+00	1.15E+06	0.00E+00
SR-92	7.08E+02	0.00E+00	2.84E+01	0.00E+00	0.00E+00	0.00E+00	1.34E+04	0.00E+00
Y-91M	8.12E-09	0.00E+00	2.95E-10	0.00E+00	0.00E+00	0.00E+00	1.59E-05	0.00E+00
Y-91	1.82E+07	0.00E+00	4.86E+05	0.00E+00	0.00E+00	0.00E+00	2.42E+09	0.00E+00
Y-92	1.55E+00	0.00E+00	4.44E-02	0.00E+00	0.00E+00	0.00E+00	4.48E+04	0.00E+00
Y-93	2.91E+02	0.00E+00	7.98E+00	0.00E+00	0.00E+00	0.00E+00	4.34E+06	0.00E+00
ZR-95	3.75E+06	8.25E+05	7.34E+05	0.00E+00	1.18E+06	0.00E+00	8.60E+08	0.00E+00
ZR-97	5.68E+02	8.20E+01	4.84E+01	0.00E+00	1.18E+02	0.00E+00	1.24E+07	0.00E+00
NB-95	4.04E+05	1.57E+05	1.12E+05	0.00E+00	1.48E+05	0.00E+00	2.91E+08	0.00E+00
NB-97	3.41E-06	6.16E-07	2.88E-07	0.00E+00	6.84E-07	0.00E+00	1.90E-01	0.00E+00
SR-91	5.20E+05	0.00E+00	1.96E+04	0.00E+00	0.00E+00	0.00E+00	1.15E+06	0.00E+00
SR-92	7.08E+02	0.00E+00	2.84E+01	0.00E+00	0.00E+00	0.00E+00	1.34E+04	0.00E+00
Y-91M	8.12E-09	0.00E+00	2.95E-10	0.00E+00	0.00E+00	0.00E+00	1.59E-05	0.00E+00
Y-91	1.82E+07	0.00E+00	4.86E+05	0.00E+00	0.00E+00	0.00E+00	2.42E+09	0.00E+00
Y-92	1.55E+00	0.00E+00	4.44E-02	0.00E+00	0.00E+00	0.00E+00	4.48E+04	0.00E+00
Y-93	2.91E+02	0.00E+00	7.98E+00	0.00E+00	0.00E+00	0.00E+00	4.34E+06	0.00E+00
ZR-95	3.75E+06	8.25E+05	7.34E+05	0.00E+00	1.18E+06	0.00E+00	8.60E+08	0.00E+00
ZR-97	5.68E+02	8.20E+01	4.84E+01	0.00E+00	1.18E+02	0.00E+00	1.24E+07	0.00E+00
NB-95	4.04E+05	1.57E+05	1.12E+05	0.00E+00	1.48E+05	0.00E+00	2.91E+08	0.00E+00
NB-97	3.41E-06	6.16E-07	2.88E-07	0.00E+00	6.84E-07	0.00E+00	1.90E-01	0.00E+00
MO-99	0.00E+00	7.75E+06	1.92E+06	0.00E+00	1.65E+07	0.00E+00	6.41E+06	0.00E+00
TC-99M	4.70E+00	9.21E+00	1.53E+02	0.00E+00	1.34E+02	4.68E+00	5.24E+03	0.00E+00
TC-101	1.03E-30	1.07E-30	1.36E-29	0.00E+00	1.83E-29	5.68E-31	3.41E-30	0.00E+00
RU-103	1.52E+07	0.00E+00	5.83E+06	0.00E+00	3.82E+07	0.00E+00	3.92E+08	0.00E+00
RU-105	9.02E+01	0.00E+00	3.27E+01	0.00E+00	7.93E+02	0.00E+00	5.89E+04	0.00E+00
RU-106	7.54E+08	0.00E+00	9.40E+07	0.00E+00	1.02E+09	0.00E+00	1.17E+10	0.00E+00
AG-110M	3.45E+07	2.33E+07	1.86E+07	0.00E+00	4.34E+07	0.00E+00	2.77E+09	0.00E+00
SN-113	3.60E+07	1.16E+06	3.93E+07	4.75E+05	7.96E+05	0.00E+00	1.44E+08	0.00E+00
SB-124	3.43E+08	4.46E+06	1.20E+08	7.58E+05	0.00E+00	1.91E+08	2.15E+09	0.00E+00
SB-125	4.91E+08	3.79E+06	1.03E+08	4.55E+05	0.00E+00	2.74E+08	1.17E+09	0.00E+00

⁴ R Values in units of mrem/yr per $\mu\text{Ci}/\text{m}^3$ for inhalation and tritium, and units of $\text{m}^2\text{-mrem}/\text{yr}$ per $\mu\text{Ci}/\text{sec}$ for all others.

TABLE 3.5-4 (continued)
R VALUES for the H.B. ROBINSON STEAM ELECTRIC PLANT⁴

PATHWAY = Vegetation
 AGE GROUP = Child

Nuclide	Bone	Liver	T.Body	Thyroid	Kidney	Lung	GI-Tract	Skin
TE-129M	9.83E+08	2.74E+08	1.53E+08	3.17E+08	2.89E+09	0.00E+00	1.20E+09	0.00E+00
TE-129	1.30E-03	3.64E-04	3.09E-04	9.30E-04	3.81E-03	0.00E+00	8.12E-02	0.00E+00
TE-131M	1.63E+06	5.63E+05	5.99E+05	1.16E+06	5.45E+06	0.00E+00	2.28E+07	0.00E+00
TE-132	7.46E+06	3.30E+06	3.99E+06	4.81E+06	3.07E+07	0.00E+00	3.32E+07	0.00E+00
I-131	1.43E+08	1.44E+08	8.16E+07	4.75E+10	2.36E+08	0.00E+00	1.28E+07	0.00E+00
I-132	8.92E+01	1.64E+02	7.53E+01	7.60E+03	2.51E+02	0.00E+00	1.93E+02	0.00E+00
I-133	3.52E+06	4.35E+06	1.65E+06	8.08E+08	7.25E+06	0.00E+00	1.75E+06	0.00E+00
I-134	1.42E-04	2.64E-04	1.21E-04	6.07E-03	4.03E-04	0.00E+00	1.75E-04	0.00E+00
I-135	6.18E+04	1.11E+05	5.27E+04	9.86E+06	1.71E+05	0.00E+00	8.48E+04	0.00E+00
CS-134	1.56E+10	2.56E+10	5.41E+09	0.00E+00	7.94E+09	2.85E+09	1.38E+08	0.00E+00
CS-136	8.22E+07	2.26E+08	1.46E+08	0.00E+00	1.20E+08	1.79E+07	7.94E+06	0.00E+00
CS-137	2.50E+10	2.39E+10	3.53E+09	0.00E+00	7.79E+09	2.80E+09	1.50E+08	0.00E+00
CS-138	5.69E-11	7.92E-11	5.02E-11	0.00E+00	5.57E-11	5.99E-12	3.65E-11	0.00E+00
BA-139	4.69E-02	2.50E-05	1.36E-03	0.00E+00	2.18E-05	1.47E-05	2.71E+00	0.00E+00
BA-140	2.76E+08	2.42E+05	1.61E+07	0.00E+00	7.87E+04	1.44E+05	1.40E+08	0.00E+00
LA-140	3.24E+03	1.13E+03	3.82E+02	0.00E+00	0.00E+00	0.00E+00	3.16E+07	0.00E+00
LA-142	3.20E-04	1.02E-04	3.20E-05	0.00E+00	0.00E+00	0.00E+00	2.02E+01	0.00E+00
CE-141	6.46E+05	3.22E+05	4.79E+04	0.00E+00	1.41E+05	0.00E+00	4.02E+08	0.00E+00
CE-143	1.71E+03	9.29E+05	1.35E+02	0.00E+00	3.90E+02	0.00E+00	1.36E+07	0.00E+00
CE-144	1.22E+08	3.82E+07	6.50E+06	0.00E+00	2.11E+07	0.00E+00	9.95E+09	0.00E+00
PR-144	4.11E-26	1.27E-26	2.07E-27	0.00E+00	6.73E-27	0.00E+00	2.74E-23	0.00E+00
HF-181	3.12E+07	1.22E+05	3.14E+06	1.03E+05	9.80E+04	0.00E+00	5.18E+08	0.00E+00
W-187	6.41E+04	3.80E+04	1.70E+04	0.00E+00	0.00E+00	0.00E+00	5.34E+06	0.00E+00
NP-239	2.56E+03	1.84E+02	1.29E+02	0.00E+00	5.31E+02	0.00E+00	1.36E+07	0.00E+00

⁴ R Values in units of mrem/yr per $\mu\text{Ci}/\text{m}^3$ for inhalation and tritium, and units of $\text{m}^2\text{-mrem}/\text{yr}$ per $\mu\text{Ci}/\text{sec}$ for all others.

TABLE 3.5-5
R VALUES for the H.B. ROBINSON STEAM ELECTRIC PLANT⁵
 (Reference Regulatory Guide 1.109)

PATHWAY = Meat
 AGE GROUP = Adult

Nuclide	Bone	Liver	T.Body	Thyroid	Kidney	Lung	GI-Tract	Skin
H-3	0.00E+00	3.24E+02	3.24E+02	3.24E+02	3.24E+02	3.24E+02	3.24E+02	3.24E+02
NA-24	1.39E-03	1.39E-03	1.39E-03	1.39E-03	1.39E-03	1.39E-03	1.39E-03	0.00E+00
CR-51	0.00E+00	0.00E+00	6.30E+03	3.76E+03	1.39E+03	8.36E+03	1.58E+06	0.00E+00
MN-54	0.00E+00	7.33E+06	1.40E+06	0.00E+00	2.18E+06	0.00E+00	2.24E+07	0.00E+00
FE-55	2.28E+08	1.58E+08	3.68E+07	0.00E+00	0.00E+00	8.81E+07	9.06E+07	0.00E+00
FE-59	2.28E+08	5.36E+08	2.05E+08	0.00E+00	0.00E+00	1.50E+08	1.79E+09	0.00E+00
CO-57	0.00E+00	4.01E+06	7.43E+06	0.00E+00	0.00E+00	0.00E+00	1.13E+08	0.00E+00
CO-58	0.00E+00	1.52E+07	3.40E+07	0.00E+00	0.00E+00	0.00E+00	3.07E+08	0.00E+00
CO-60	0.00E+00	5.96E+07	1.31E+08	0.00E+00	0.00E+00	0.00E+00	1.12E+09	0.00E+00
CU-64	0.00E+00	2.80E-07	1.31E-07	0.00E+00	7.05E-07	0.00E+00	2.38E-05	0.00E+00
ZN-65	3.20E+08	1.02E+09	4.60E+08	0.00E+00	6.81E+08	0.00E+00	6.42E+08	0.00E+00
BR-82	0.00E+00	0.00E+00	1.25E+03	0.00E+00	0.00E+00	0.00E+00	1.43E+03	0.00E+00
RB-86	0.00E+00	4.53E+08	2.11E+08	0.00E+00	0.00E+00	0.00E+00	8.94E+07	0.00E+00
SR-89	2.57E+08	0.00E+00	7.37E+06	0.00E+00	0.00E+00	0.00E+00	4.12E+07	0.00E+00
SR-90	1.03E+10	0.00E+00	2.53E+09	0.00E+00	0.00E+00	0.00E+00	2.98E+08	0.00E+00
SR-91	1.58E-10	0.00E+00	6.39E-12	0.00E+00	0.00E+00	0.00E+00	7.53E-10	0.00E+00
Y-91	9.53E+05	0.00E+00	2.55E+04	0.00E+00	0.00E+00	0.00E+00	5.24E+08	0.00E+00
Y-93	4.87E-12	0.00E+00	1.35E-13	0.00E+00	0.00E+00	0.00E+00	1.55E-07	0.00E+00
ZR-95	1.57E+06	5.02E+05	3.40E+05	0.00E+00	7.88E+05	0.00E+00	1.59E+09	0.00E+00
ZR-97	2.11E-05	4.27E-06	1.95E-06	0.00E+00	6.44E-06	0.00E+00	1.32E+00	0.00E+00
NB-95	2.01E+06	1.12E+06	6.02E+05	0.00E+00	1.11E+06	0.00E+00	6.79E+09	0.00E+00
MO-99	0.00E+00	1.01E+05	1.92E+04	0.00E+00	2.28E+05	0.00E+00	2.33E+05	0.00E+00
TC-99M	4.76E-21	1.35E-20	1.71E-19	0.00E+00	2.04E-19	6.59E-21	7.96E-18	0.00E+00
RU-103	9.15E+07	0.00E+00	3.94E+07	0.00E+00	3.49E+08	0.00E+00	1.07E+10	0.00E+00
RU-105	6.30E-28	0.00E+00	2.49E-28	0.00E+00	8.15E-27	0.00E+00	3.86E-25	0.00E+00
RU-106	2.26E+09	0.00E+00	2.85E+08	0.00E+00	4.36E+09	0.00E+00	1.46E+11	0.00E+00
AG-110M	5.57E+06	5.15E+06	3.06E+06	0.00E+00	1.01E+07	0.00E+00	2.10E+09	0.00E+00
SN-113	3.94E+07	1.52E+06	3.73E+07	5.36E+05	1.12E+06	0.00E+00	6.89E+08	0.00E+00
SB-124	1.66E+07	3.14E+05	6.60E+06	4.03E+04	0.00E+00	1.30E+07	4.72E+08	0.00E+00
SB-125	1.51E+07	1.69E+05	3.59E+06	1.53E+04	0.00E+00	1.16E+07	1.66E+08	0.00E+00
TE-129M	1.07E+09	3.99E+08	1.69E+08	3.67E+08	4.46E+09	0.00E+00	5.38E+09	0.00E+00
TE-131M	4.66E+02	2.28E+02	1.90E+02	3.61E+02	2.31E+03	0.00E+00	2.26E+04	0.00E+00
TE-132	1.46E+06	9.44E+05	8.86E+05	1.04E+06	9.09E+06	0.00E+00	4.46E+07	0.00E+00
I-131	1.06E+07	1.51E+07	8.66E+06	4.95E+09	2.59E+07	0.00E+00	3.99E+06	0.00E+00
I-133	3.72E-01	6.47E-01	1.97E-01	9.51E+01	1.13E+00	0.00E+00	5.82E-01	0.00E+00
I-135	4.69E-17	1.23E-16	4.53E-17	8.10E-15	1.97E-16	0.00E+00	1.39E-16	0.00E+00
CS-134	5.18E+08	1.23E+09	1.01E+09	0.00E+00	3.99E+08	1.32E+08	2.16E+07	0.00E+00
CS-136	1.15E+07	4.54E+07	3.27E+07	0.00E+00	2.53E+07	3.46E+06	5.16E+06	0.00E+00
CS-137	7.04E+08	9.63E+08	6.31E+08	0.00E+00	3.27E+08	1.09E+08	1.86E+07	0.00E+00
BA-140	2.75E+07	3.45E+04	1.80E+06	0.00E+00	1.17E+04	1.98E+04	5.66E+07	0.00E+00
LA-140	3.74E-02	1.89E-02	4.99E-03	0.00E+00	0.00E+00	0.00E+00	1.38E+03	0.00E+00
CE-141	1.24E+04	8.37E+03	9.49E+02	0.00E+00	3.89E+03	0.00E+00	3.20E+07	0.00E+00
CE-143	2.03E-02	1.50E+01	1.66E-03	0.00E+00	6.61E-03	0.00E+00	5.61E+02	0.00E+00
CE-144	1.15E+06	4.82E+05	6.19E+04	0.00E+00	2.86E+05	0.00E+00	3.90E+08	0.00E+00
HF-181	1.79E+08	1.01E+06	2.03E+07	6.41E+05	8.41E+05	0.00E+00	1.33E+10	0.00E+00
W-187	2.08E-02	1.74E-02	6.09E-03	0.00E+00	0.00E+00	0.00E+00	5.71E+00	0.00E+00
NP-239	2.61E-01	2.56E-02	1.41E-02	0.00E+00	8.00E-02	0.00E+00	5.26E+03	0.00E+00

⁵ R Values in units of mrem/yr per $\mu\text{Ci}/\text{m}^3$ for inhalation and tritium, and units of $\text{m}^2\text{-mrem}/\text{yr}$ per $\mu\text{Ci}/\text{sec}$ for all others.

TABLE 3.5-6
R VALUES for the H.B. ROBINSON STEAM ELECTRIC PLANT⁶
 (Reference Regulatory Guide 1.109)

PATHWAY = Meat
 AGE GROUP = Teen

Nuclide	Bone	Liver	T.Body	Thyroid	Kidney	Lung	GI-Tract	Skin
H-3	0.00E+00	1.93E+02	1.93E+02	1.93E+02	1.93E+02	1.93E+02	1.93E+02	1.93E+02
NA-24	1.11E-03	1.11E-03	1.11E-03	1.11E-03	1.11E-03	1.11E-03	1.11E-03	0.00E+00
CR-51	0.00E+00	0.00E+00	5.04E+03	2.80E+03	1.10E+03	7.19E+03	8.46E+05	0.00E+00
MN-54	0.00E+00	5.59E+06	1.11E+06	0.00E+00	1.67E+06	0.00E+00	1.15E+07	0.00E+00
FE-55	1.86E+08	1.32E+08	3.07E+07	0.00E+00	0.00E+00	8.35E+07	5.69E+07	0.00E+00
FE-59	1.82E+08	4.25E+08	1.64E+08	0.00E+00	0.00E+00	1.34E+08	1.01E+09	0.00E+00
CO-57	0.00E+00	3.59E+06	6.02E+06	0.00E+00	0.00E+00	0.00E+00	6.70E+07	0.00E+00
CO-58	0.00E+00	1.17E+07	2.69E+07	0.00E+00	0.00E+00	0.00E+00	1.61E+08	0.00E+00
CO-60	0.00E+00	4.62E+07	1.04E+08	0.00E+00	0.00E+00	0.00E+00	6.02E+08	0.00E+00
CU-64	0.00E+00	2.28E-07	1.07E-07	0.00E+00	5.77E-07	0.00E+00	1.77E-05	0.00E+00
ZN-65	2.25E+08	7.82E+08	3.65E+08	0.00E+00	5.00E+08	0.00E+00	3.31E+08	0.00E+00
BR-82	0.00E+00	0.00E+00	9.94E+02	0.00E+00	0.00E+00	0.00E+00	0.00E+00	0.00E+00
RB-86	0.00E+00	3.78E+08	1.78E+08	0.00E+00	0.00E+00	0.00E+00	5.60E+07	0.00E+00
SR-89	2.17E+08	0.00E+00	6.21E+06	0.00E+00	0.00E+00	0.00E+00	2.58E+07	0.00E+00
SR-90	6.68E+09	0.00E+00	1.65E+09	0.00E+00	0.00E+00	0.00E+00	1.88E+08	0.00E+00
SR-91	1.33E-10	0.00E+00	5.29E-12	0.00E+00	0.00E+00	0.00E+00	6.04E-10	0.00E+00
Y-91	8.03E+05	0.00E+00	2.15E+04	0.00E+00	0.00E+00	0.00E+00	3.29E+08	0.00E+00
Y-93	4.11E-12	0.00E+00	1.13E-13	0.00E+00	0.00E+00	0.00E+00	1.26E-07	0.00E+00
ZR-95	1.25E+06	3.96E+05	2.72E+05	0.00E+00	5.82E+05	0.00E+00	9.13E+08	0.00E+00
ZR-97	1.76E-05	3.49E-06	1.61E-06	0.00E+00	5.29E-06	0.00E+00	9.44E-01	0.00E+00
NB-95	1.57E+06	8.72E+05	4.80E+05	0.00E+00	8.45E+05	0.00E+00	3.73E+09	0.00E+00
MO-99	0.00E+00	8.33E+04	1.59E+04	0.00E+00	1.91E+05	0.00E+00	1.49E+05	0.00E+00
TC-99M	3.78E-21	1.05E-20	1.37E-19	0.00E+00	1.57E-19	5.85E-21	6.92E-18	0.00E+00
RU-103	7.45E+07	0.00E+00	3.18E+07	0.00E+00	2.63E+08	0.00E+00	6.22E+09	0.00E+00
RU-105	5.27E-28	0.00E+00	2.05E-28	0.00E+00	6.65E-27	0.00E+00	4.26E-25	0.00E+00
RU-106	1.90E+09	0.00E+00	2.39E+08	0.00E+00	3.66E+09	0.00E+00	9.11E+10	0.00E+00
AG-110M	4.21E+06	3.99E+06	2.43E+06	0.00E+00	7.60E+06	0.00E+00	1.12E+09	0.00E+00
SN-113	2.78E+07	1.16E+06	2.95E+07	3.84E+05	8.23E+05	0.00E+00	3.33E+08	0.00E+00
SB-124	1.36E+07	2.50E+05	5.30E+06	3.08E+04	0.00E+00	1.19E+07	2.74E+08	0.00E+00
SB-125	1.24E+07	1.35E+05	2.89E+06	1.18E+04	0.00E+00	1.09E+07	9.61E+07	0.00E+00
TE-129M	8.96E+08	3.32E+08	1.42E+08	2.89E+08	3.75E+09	0.00E+00	3.36E+09	0.00E+00
TE-131M	3.89E+02	1.86E+02	1.55E+02	2.80E+02	1.94E+03	0.00E+00	1.50E+04	0.00E+00
TE-132	1.19E+06	7.56E+05	7.12E+05	7.97E+05	7.25E+06	0.00E+00	2.40E+07	0.00E+00
I-131	8.78E+06	1.23E+07	6.60E+06	3.59E+09	2.12E+07	0.00E+00	2.43E+06	0.00E+00
I-133	3.11E-01	5.28E-01	1.61E-01	7.37E+01	9.26E-01	0.00E+00	3.99E-01	0.00E+00
I-135	3.82E-17	9.83E-17	3.64E-17	6.32E-15	1.55E-16	0.00E+00	1.09E-16	0.00E+00
CS-134	4.12E+08	9.69E+08	4.50E+08	0.00E+00	3.08E+08	1.18E+08	1.21E+07	0.00E+00
CS-136	8.97E+06	3.53E+07	2.37E+07	0.00E+00	1.92E+07	3.03E+06	2.84E+06	0.00E+00
CS-137	5.85E+08	7.78E+08	2.71E+08	0.00E+00	2.65E+08	1.03E+08	1.11E+07	0.00E+00
BA-140	2.27E+07	2.78E+04	1.46E+06	0.00E+00	9.44E+03	1.87E+04	3.50E+07	0.00E+00
LA-140	3.08E-02	1.51E-02	4.02E-03	0.00E+00	0.00E+00	0.00E+00	8.69E+02	0.00E+00
CE-141	1.04E+04	6.94E+03	7.97E+02	0.00E+00	3.27E+03	0.00E+00	1.98E+07	0.00E+00
CE-143	1.71E-02	1.24E+01	1.39E-03	0.00E+00	5.58E-03	0.00E+00	3.74E+02	0.00E+00
CE-144	9.71E+05	4.02E+05	5.22E+04	0.00E+00	2.40E+05	0.00E+00	2.44E+08	0.00E+00
HF-181	1.47E+08	8.06E+05	1.64E+07	4.91E+05	6.70E+05	0.00E+00	7.33E+09	0.00E+00
W-187	1.75E-02	1.42E-02	4.99E-03	0.00E+00	0.00E+00	0.00E+00	3.85E+00	0.00E+00
NP-239	2.28E-01	2.15E-02	1.19E-02	0.00E+00	6.75E-02	0.00E+00	3.46E+03	0.00E+00

⁶ R Values in units of mrem/yr per $\mu\text{Ci}/\text{m}^3$ for inhalation and tritium, and units of $\text{m}^2\text{-mrem}/\text{yr}$ per $\mu\text{Ci}/\text{sec}$ for all others.

H.B. Robinson Steam Electric Plant Unit 2
 Offsite Dose Calculation Manual (ODCM)

TABLE 3.5-7
R VALUES for the H.B. ROBINSON STEAM ELECTRIC PLANT⁷
 (Reference Regulatory Guide 1.109)

PATHWAY = Meat
 AGE GROUP = Child

Nuclide	Bone	Liver	T.Body	Thyroid	Kidney	Lung	GI-Tract	Skin
H-3	0.00E+00	2.33E+02	2.33E+02	2.33E+02	2.33E+02	2.33E+02	2.33E+02	2.33E+02
NA-24	1.77E-03	1.77E-03	1.77E-03	1.77E-03	1.77E-03	1.77E-03	1.77E-03	0.00E+00
CR-51	0.00E+00	0.00E+00	7.85E+03	4.36E+03	1.19E+03	7.96E+03	4.16E+05	0.00E+00
MN-54	0.00E+00	6.39E+06	1.70E+06	0.00E+00	1.79E+06	0.00E+00	5.37E+06	0.00E+00
FE-55	3.56E+08	1.89E+08	5.85E+07	0.00E+00	0.00E+00	1.07E+08	3.50E+07	0.00E+00
FE-59	3.23E+08	5.23E+08	2.60E+08	0.00E+00	0.00E+00	1.51E+08	5.44E+08	0.00E+00
CO-57	0.00E+00	4.69E+06	9.50E+06	0.00E+00	0.00E+00	0.00E+00	3.85E+07	0.00E+00
CO-58	0.00E+00	1.37E+07	4.18E+07	0.00E+00	0.00E+00	0.00E+00	7.97E+07	0.00E+00
CO-60	0.00E+00	5.49E+07	1.62E+08	0.00E+00	0.00E+00	0.00E+00	3.04E+08	0.00E+00
CU-64	0.00E+00	3.06E-07	1.85E-07	0.00E+00	7.41E-07	0.00E+00	1.44E-05	0.00E+00
ZN-65	3.38E+08	9.00E+08	5.60E+08	0.00E+00	5.67E+08	0.00E+00	1.58E+08	0.00E+00
BR-82	0.00E+00	0.00E+00	1.56E+03	0.00E+00	0.00E+00	0.00E+00	0.00E+00	0.00E+00
RB-86	0.00E+00	5.37E+08	3.30E+08	0.00E+00	0.00E+00	0.00E+00	3.45E+07	0.00E+00
SR-89	4.10E+08	0.00E+00	1.17E+07	0.00E+00	0.00E+00	0.00E+00	1.59E+07	0.00E+00
SR-90	8.64E+09	0.00E+00	2.19E+09	0.00E+00	0.00E+00	0.00E+00	1.16E+08	0.00E+00
SR-91	2.50E-10	0.00E+00	9.42E-12	0.00E+00	0.00E+00	0.00E+00	5.51E-10	0.00E+00
Y-91	1.52E+06	0.00E+00	4.06E+04	0.00E+00	0.00E+00	0.00E+00	2.02E+08	0.00E+00
Y-93	7.73E-12	0.00E+00	2.12E-13	0.00E+00	0.00E+00	0.00E+00	1.15E-07	0.00E+00
ZR-95	2.23E+06	4.90E+05	4.36E+05	0.00E+00	7.01E+05	0.00E+00	5.11E+08	0.00E+00
ZR-97	3.28E-05	4.74E-06	2.80E-06	0.00E+00	6.80E-06	0.00E+00	7.18E-01	0.00E+00
NB-95	2.71E+06	1.06E+06	7.55E+05	0.00E+00	9.92E+05	0.00E+00	1.95E+09	0.00E+00
MO-99	0.00E+00	1.16E+05	2.87E+04	0.00E+00	2.47E+05	0.00E+00	9.58E+04	0.00E+00
TC-99M	6.63E-21	1.30E-20	2.15E-19	0.00E+00	1.89E-19	6.60E-21	7.40E-18	0.00E+00
RU-103	1.35E+08	0.00E+00	5.18E+07	0.00E+00	3.39E+08	0.00E+00	3.48E+09	0.00E+00
RU-105	9.84E-28	0.00E+00	3.57E-28	0.00E+00	8.65E-27	0.00E+00	6.42E-25	0.00E+00
RU-106	3.58E+09	0.00E+00	4.46E+08	0.00E+00	4.83E+09	0.00E+00	5.56E+10	0.00E+00
AG-110M	6.99E+06	4.72E+06	3.77E+06	0.00E+00	8.79E+06	0.00E+00	5.61E+08	0.00E+00
SN-113	4.17E+07	1.34E+06	4.56E+07	5.51E+05	9.23E+05	0.00E+00	1.67E+08	0.00E+00
SB-124	2.46E+07	3.19E+05	8.62E+06	5.43E+04	0.00E+00	1.36E+07	1.54E+08	0.00E+00
SB-125	2.25E+07	1.73E+05	4.71E+06	2.08E+04	0.00E+00	1.25E+07	5.37E+07	0.00E+00
TE-129M	1.69E+09	4.71E+08	2.62E+08	5.44E+08	4.96E+09	0.00E+00	2.06E+09	0.00E+00
TE-131M	7.23E+02	2.50E+02	2.66E+02	5.14E+02	2.42E+03	0.00E+00	1.01E+04	0.00E+00
TE-132	2.18E+06	9.65E+05	1.17E+06	1.41E+06	8.96E+06	0.00E+00	9.71E+06	0.00E+00
I-131	1.63E+07	1.64E+07	9.30E+06	5.41E+09	2.69E+07	0.00E+00	1.46E+06	0.00E+00
I-133	5.78E-01	7.15E-01	2.71E-01	1.33E+02	1.19E+00	0.00E+00	2.88E-01	0.00E+00
I-135	6.91E-17	1.24E-16	5.88E-17	1.10E-14	1.91E-16	0.00E+00	9.47E-17	0.00E+00
CS-134	7.26E+08	1.19E+09	2.51E+08	0.00E+00	3.69E+08	1.33E+08	6.43E+06	0.00E+00
CS-136	1.55E+07	4.26E+07	2.75E+07	0.00E+00	2.27E+07	3.38E+06	1.50E+06	0.00E+00
CS-137	1.08E+09	1.03E+09	1.52E+08	0.00E+00	3.36E+08	1.21E+08	6.45E+06	0.00E+00
BA-140	4.19E+07	3.67E+04	2.45E+06	0.00E+00	1.20E+04	2.19E+04	2.12E+07	0.00E+00
LA-140	5.64E-02	1.97E-02	6.64E-03	0.00E+00	0.00E+00	0.00E+00	5.49E+02	0.00E+00
CE-141	1.96E+04	9.76E+03	1.45E+03	0.00E+00	4.28E+03	0.00E+00	1.22E+07	0.00E+00
CE-143	3.21E-02	1.74E+01	2.52E-03	0.00E+00	7.29E-03	0.00E+00	2.55E+02	0.00E+00
CE-144	1.83E+06	5.74E+05	9.77E+04	0.00E+00	3.18E+05	0.00E+00	1.50E+08	0.00E+00
HF-181	2.66E+08	1.04E+06	2.68E+07	8.75E+05	8.35E+05	0.00E+00	4.42E+09	0.00E+00
W-187	3.24E-02	1.92E-02	8.60E-03	0.00E+00	0.00E+00	0.00E+00	2.69E+00	0.00E+00
NP-239	4.29E-01	3.08E-02	2.16E-02	0.00E+00	8.90E-02	0.00E+00	2.28E+03	0.00E+00

⁷ R Values in units of mrem/yr per $\mu\text{Ci}/\text{m}^3$ for inhalation and tritium, and units of $\text{m}^2\text{-mrem}/\text{yr}$ per $\mu\text{Ci}/\text{sec}$ for all others.

TABLE 3.5-8
R VALUES for the H.B. ROBINSON STEAM ELECTRIC PLANT⁸
 (Reference Regulatory Guide 1.109)

PATHWAY = Cow Milk
 AGE GROUP = Adult

Nuclide	Bone	Liver	T.Body	Thyroid	Kidney	Lung	GI-Tract	Skin
H-3	0.00E+00	7.63E+02	7.63E+02	7.63E+02	7.63E+02	7.63E+02	7.63E+02	7.63E+02
F-18	4.57E-03	0.00E+00	5.07E-04	0.00E+00	0.00E+00	0.00E+00	1.35E-04	0.00E+00
NA-24	2.45E+06	2.45E+06	2.45E+06	2.45E+06	2.45E+06	2.45E+06	2.45E+06	0.00E+00
CR-51	0.00E+00	0.00E+00	2.55E+04	1.53E+04	5.62E+03	3.39E+04	6.42E+06	0.00E+00
MN-54	0.00E+00	6.71E+06	1.28E+06	0.00E+00	2.00E+06	0.00E+00	2.06E+07	0.00E+00
MN-56	0.00E+00	4.21E-03	7.47E-04	0.00E+00	5.35E-03	0.00E+00	1.34E-01	0.00E+00
FE-55	1.96E+07	1.35E+07	3.15E+06	0.00E+00	0.00E+00	7.54E+06	7.75E+06	0.00E+00
FE-59	2.55E+07	5.99E+07	2.30E+07	0.00E+00	0.00E+00	1.67E+07	2.00E+08	0.00E+00
CO-57	0.00E+00	9.10E+05	1.69E+06	0.00E+00	0.00E+00	0.00E+00	2.57E+07	0.00E+00
CO-58	0.00E+00	3.92E+06	8.79E+06	0.00E+00	0.00E+00	0.00E+00	7.95E+07	0.00E+00
CO-60	0.00E+00	1.30E+07	2.87E+07	0.00E+00	0.00E+00	0.00E+00	2.44E+08	0.00E+00
NI-65	3.76E-01	4.88E-02	2.23E-02	0.00E+00	0.00E+00	0.00E+00	1.24E+00	0.00E+00
CU-64	0.00E+00	2.39E+04	1.12E+04	0.00E+00	6.04E+04	0.00E+00	2.04E+06	0.00E+00
ZN-65	1.23E+09	3.93E+09	1.78E+09	0.00E+00	2.63E+09	0.00E+00	2.47E+09	0.00E+00
BR-82	0.00E+00	0.00E+00	3.27E+07	0.00E+00	0.00E+00	0.00E+00	3.75E+07	0.00E+00
BR-83	0.00E+00	0.00E+00	9.98E-02	0.00E+00	0.00E+00	0.00E+00	1.44E-01	0.00E+00
BR-84	0.00E+00	0.00E+00	1.75E-23	0.00E+00	0.00E+00	0.00E+00	1.37E-28	0.00E+00
RB-86	0.00E+00	2.41E+09	1.12E+09	0.00E+00	0.00E+00	0.00E+00	4.76E+08	0.00E+00
SR-89	1.23E+09	0.00E+00	3.54E+07	0.00E+00	0.00E+00	0.00E+00	1.98E+08	0.00E+00
SR-90	3.89E+10	0.00E+00	9.54E+09	0.00E+00	0.00E+00	0.00E+00	1.12E+09	0.00E+00
SR-91	2.91E+04	0.00E+00	1.17E+03	0.00E+00	0.00E+00	0.00E+00	1.38E+05	0.00E+00
SR-92	4.95E-01	0.00E+00	2.14E-02	0.00E+00	0.00E+00	0.00E+00	9.82E+00	0.00E+00
Y-91M	6.27E-20	0.00E+00	2.43E-21	0.00E+00	0.00E+00	0.00E+00	1.84E-19	0.00E+00
Y-91	7.23E+03	0.00E+00	1.93E+02	0.00E+00	0.00E+00	0.00E+00	3.98E+06	0.00E+00
Y-92	5.64E-05	0.00E+00	1.65E-06	0.00E+00	0.00E+00	0.00E+00	9.88E-01	0.00E+00
Y-93	2.24E-01	0.00E+00	6.19E-03	0.00E+00	0.00E+00	0.00E+00	7.11E+03	0.00E+00
ZR-95	7.89E+02	2.53E+02	1.71E+02	0.00E+00	3.97E+02	0.00E+00	8.02E+05	0.00E+00
ZR-97	4.34E-01	8.76E-02	4.01E-02	0.00E+00	1.32E-01	0.00E+00	2.71E+04	0.00E+00
NB-95	7.23E+04	4.02E+04	2.16E+04	0.00E+00	3.97E+04	0.00E+00	2.44E+08	0.00E+00
NB-97	3.40E-12	8.59E-13	3.14E-13	0.00E+00	1.00E-12	0.00E+00	3.17E-09	0.00E+00
MO-99	0.00E+00	2.48E+07	4.72E+06	0.00E+00	5.62E+07	0.00E+00	5.76E+07	0.00E+00
TC-99M	3.35E+00	9.48E+00	1.21E+02	0.00E+00	1.44E+02	4.64E+00	5.61E+03	0.00E+00
RU-103	8.85E+02	0.00E+00	3.81E+02	0.00E+00	3.38E+03	0.00E+00	1.03E+05	0.00E+00
RU-105	8.65E-04	0.00E+00	3.41E-04	0.00E+00	1.12E-02	0.00E+00	5.29E-01	0.00E+00
RU-106	1.64E+04	0.00E+00	2.08E+03	0.00E+00	3.17E+04	0.00E+00	1.06E+06	0.00E+00
AG-110M	4.85E+07	4.49E+07	2.66E+07	0.00E+00	8.82E+07	0.00E+00	1.83E+10	0.00E+00
SN-113	3.87E+06	1.49E+05	3.66E+06	5.26E+04	1.10E+05	0.00E+00	6.77E+07	0.00E+00
SB-124	2.16E+07	4.09E+05	8.58E+06	5.25E+04	0.00E+00	1.68E+07	6.14E+08	0.00E+00
SB-125	1.61E+07	1.80E+05	3.84E+06	1.64E+04	0.00E+00	1.24E+07	1.78E+08	0.00E+00
TE-129M	5.67E+07	2.12E+07	8.98E+06	1.95E+07	2.37E+08	0.00E+00	2.86E+08	0.00E+00
TE-129	2.97E-10	1.12E-10	7.25E-11	2.28E-10	1.25E-09	0.00E+00	2.25E-10	0.00E+00
TE-131M	3.69E+05	1.80E+05	1.50E+05	2.86E+05	1.83E+06	0.00E+00	1.79E+07	0.00E+00
TE-132	2.46E+06	1.59E+06	1.49E+06	1.76E+06	1.53E+07	0.00E+00	7.52E+07	0.00E+00
I-131	2.91E+08	4.16E+08	2.38E+08	1.36E+11	7.13E+08	0.00E+00	1.10E+08	0.00E+00
I-132	1.67E-01	4.47E-01	1.56E-01	1.56E+01	7.12E-01	0.00E+00	8.39E-02	0.00E+00
I-133	3.88E+06	6.74E+06	2.06E+06	9.91E+08	1.18E+07	0.00E+00	6.06E+06	0.00E+00
I-134	2.11E-12	5.72E-12	2.05E-12	9.92E-11	9.10E-12	0.00E+00	4.99E-15	0.00E+00
I-135	1.29E+04	3.38E+04	1.25E+04	2.23E+06	5.42E+04	0.00E+00	3.82E+04	0.00E+00

⁸ R Values in units of mrem/yr per $\mu\text{Ci}/\text{m}^3$ for inhalation and tritium, and units of $\text{m}^2\text{-mrem}/\text{yr}$ per $\mu\text{Ci}/\text{sec}$ for all others.

TABLE 3.5-8 (continued)
R VALUES for the H.B. ROBINSON STEAM ELECTRIC PLANT⁸

PATHWAY = Cow Milk
 AGE GROUP = Adult

<u>Nuclide</u>	<u>Bone</u>	<u>Liver</u>	<u>T.Body</u>	<u>Thyroid</u>	<u>Kidney</u>	<u>Lung</u>	<u>GI-Tract</u>	<u>Skin</u>
CS-134	4.45E+09	1.06E+10	8.66E+09	0.00E+00	3.43E+09	1.14E+09	1.85E+08	0.00E+00
CS-136	2.51E+08	9.91E+08	7.14E+08	0.00E+00	5.52E+08	7.56E+07	1.13E+08	0.00E+00
CS-137	5.96E+09	8.15E+09	5.34E+09	0.00E+00	2.77E+09	9.20E+08	1.58E+08	0.00E+00
CS-138	9.72E-24	1.92E-23	9.51E-24	0.00E+00	1.41E-23	1.39E-24	8.19E-29	0.00E+00
BA-139	4.54E-08	3.24E-11	1.33E-09	0.00E+00	3.03E-11	1.84E-11	8.06E-08	0.00E+00
BA-140	2.57E+07	3.23E+04	1.68E+06	0.00E+00	1.10E+04	1.85E+04	5.29E+07	0.00E+00
LA-140	4.52E+00	2.28E+00	6.01E-01	0.00E+00	0.00E+00	0.00E+00	1.67E+05	0.00E+00
LA-142	1.90E-11	8.66E-12	2.16E-12	0.00E+00	0.00E+00	0.00E+00	6.32E-08	0.00E+00
CE-141	4.27E+03	2.89E+03	3.27E+02	0.00E+00	1.34E+03	0.00E+00	1.10E+07	0.00E+00
CE-143	4.16E+01	3.08E+04	3.40E+00	0.00E+00	1.35E+01	0.00E+00	1.15E+06	0.00E+00
CE-144	2.83E+05	1.18E+05	1.52E+04	0.00E+00	7.01E+04	0.00E+00	9.56E+07	0.00E+00
HF-181	8.46E+03	4.77E+01	9.57E+02	3.03E+01	3.97E+01	0.00E+00	6.28E+05	0.00E+00
W-187	6.52E+03	5.45E+03	1.90E+03	0.00E+00	0.00E+00	0.00E+00	1.78E+06	0.00E+00
NP-239	3.67E+00	3.61E-01	1.99E-01	0.00E+00	1.13E+00	0.00E+00	7.41E+04	0.00E+00

⁸ R Values in units of mrem/yr per $\mu\text{Ci}/\text{m}^3$ for inhalation and tritium, and units of $\text{m}^2\text{-mrem}/\text{yr}$ per $\mu\text{Ci}/\text{sec}$ for all others.

TABLE 3.5-9
R VALUES for the H.B. ROBINSON STEAM ELECTRIC PLANT⁹
 (Reference Regulatory Guide 1.109)

PATHWAY = Cow Milk
 AGE GROUP = Teen

Nuclide	Bone	Liver	T.Body	Thyroid	Kidney	Lung	GI-Tract	Skin
H-3	0.00E+00	9.93E+02	9.93E+02	9.93E+02	9.93E+02	9.93E+02	9.93E+02	9.93E+02
F-18	8.16E-03	0.00E+00	8.94E-04	0.00E+00	0.00E+00	0.00E+00	7.35E-04	0.00E+00
A-24	4.27E+06	4.27E+06	4.27E+06	4.27E+06	4.27E+06	4.27E+06	4.27E+06	0.00E+00
CR-51	0.00E+00	0.00E+00	4.46E+04	2.48E+04	9.77E+03	6.36E+04	7.49E+06	0.00E+00
MN-54	0.00E+00	1.12E+07	2.22E+06	0.00E+00	3.34E+06	0.00E+00	2.29E+07	0.00E+00
MN-56	0.00E+00	7.47E-03	1.33E-03	0.00E+00	9.45E-03	0.00E+00	4.91E-01	0.00E+00
FE-55	3.47E+07	2.46E+07	5.74E+06	0.00E+00	0.00E+00	1.56E+07	1.06E+07	0.00E+00
FE-59	4.45E+07	1.04E+08	4.01E+07	0.00E+00	0.00E+00	3.27E+07	2.45E+08	0.00E+00
CO-57	0.00E+00	1.78E+06	2.99E+06	0.00E+00	0.00E+00	0.00E+00	3.32E+07	0.00E+00
CO-58	0.00E+00	6.60E+06	1.52E+07	0.00E+00	0.00E+00	0.00E+00	9.10E+07	0.00E+00
CO-60	0.00E+00	2.20E+07	4.96E+07	0.00E+00	0.00E+00	0.00E+00	2.87E+08	0.00E+00
NI-65	6.88E-01	8.79E-02	4.00E-02	0.00E+00	0.00E+00	0.00E+00	4.76E+00	0.00E+00
CU-64	0.00E+00	4.27E+04	2.01E+04	0.00E+00	1.08E+05	0.00E+00	3.31E+06	0.00E+00
ZN-65	1.90E+09	6.58E+09	3.07E+09	0.00E+00	4.21E+09	0.00E+00	2.79E+09	0.00E+00
BR-82	0.00E+00	0.00E+00	5.68E+07	0.00E+00	0.00E+00	0.00E+00	0.00E+00	0.00E+00
BR-83	0.00E+00	0.00E+00	1.84E-01	0.00E+00	0.00E+00	0.00E+00	0.00E+00	0.00E+00
BR-84	0.00E+00	0.00E+00	3.13E-23	0.00E+00	0.00E+00	0.00E+00	0.00E+00	0.00E+00
RB-86	0.00E+00	4.40E+09	2.07E+09	0.00E+00	0.00E+00	0.00E+00	6.51E+08	0.00E+00
SR-89	2.28E+09	0.00E+00	6.52E+07	0.00E+00	0.00E+00	0.00E+00	2.71E+08	0.00E+00
SR-90	5.49E+10	0.00E+00	1.36E+10	0.00E+00	0.00E+00	0.00E+00	1.54E+09	0.00E+00
SR-91	5.34E+04	0.00E+00	2.12E+03	0.00E+00	0.00E+00	0.00E+00	2.42E+05	0.00E+00
SR-92	9.07E-01	0.00E+00	3.87E-02	0.00E+00	0.00E+00	0.00E+00	2.31E+01	0.00E+00
Y-91M	1.15E-19	0.00E+00	4.39E-21	0.00E+00	0.00E+00	0.00E+00	5.42E-18	0.00E+00
Y-91	1.33E+04	0.00E+00	3.56E+02	0.00E+00	0.00E+00	0.00E+00	5.45E+06	0.00E+00
Y-92	1.04E-04	0.00E+00	3.01E-06	0.00E+00	0.00E+00	0.00E+00	2.86E+00	0.00E+00
Y-93	4.14E-01	0.00E+00	1.13E-02	0.00E+00	0.00E+00	0.00E+00	1.26E+04	0.00E+00
ZR-95	1.38E+03	4.35E+02	2.99E+02	0.00E+00	6.40E+02	0.00E+00	1.00E+06	0.00E+00
ZR-97	7.90E-01	1.56E-01	7.20E-02	0.00E+00	2.37E-01	0.00E+00	4.23E+04	0.00E+00
NB-95	1.23E+05	6.84E+04	3.76E+04	0.00E+00	6.63E+04	0.00E+00	2.92E+08	0.00E+00
NB-99	6.19E-12	1.54E-12	5.61E-13	0.00E+00	1.80E-12	0.00E+00	3.67E-08	0.00E+00
MO-99	0.00E+00	4.48E+07	8.55E+06	0.00E+00	1.03E+08	0.00E+00	8.03E+07	0.00E+00
TC-99M	5.82E+00	1.62E+01	2.10E+02	0.00E+00	2.42E+02	9.01E+00	1.07E+04	0.00E+00
RU-103	1.57E+03	0.00E+00	6.73E+02	0.00E+00	5.55E+03	0.00E+00	1.31E+05	0.00E+00
RU-105	1.58E-03	0.00E+00	6.13E-04	0.00E+00	1.99E-02	0.00E+00	1.28E+00	0.00E+00
RU-106	3.02E+04	0.00E+00	3.81E+03	0.00E+00	5.83E+04	0.00E+00	1.45E+06	0.00E+00
AG-110M	8.02E+07	7.59E+07	4.61E+07	0.00E+00	1.45E+08	0.00E+00	2.13E+10	0.00E+00
SN-113	5.95E+06	2.49E+05	6.33E+06	8.23E+04	1.76E+05	0.00E+00	7.14E+07	0.00E+00
SB-124	3.86E+07	7.11E+05	1.51E+07	8.75E+04	0.00E+00	3.37E+07	7.78E+08	0.00E+00
SB-125	2.89E+07	3.15E+05	6.75E+06	2.76E+04	0.00E+00	2.54E+07	2.25E+08	0.00E+00
TE-129M	1.04E+08	3.85E+07	1.64E+07	3.35E+07	4.34E+08	0.00E+00	3.90E+08	0.00E+00
TE-129	5.48E-10	2.04E-10	1.33E-10	3.91E-10	2.30E-09	0.00E+00	2.99E-09	0.00E+00
TE-131M	6.71E+05	3.22E+05	2.69E+05	4.84E+05	3.36E+06	0.00E+00	2.58E+07	0.00E+00
TE-132	4.39E+06	2.78E+06	2.62E+06	2.93E+06	2.67E+07	0.00E+00	8.81E+07	0.00E+00
I-131	5.28E+08	7.39E+08	3.97E+08	2.16E+11	1.27E+09	0.00E+00	1.46E+08	0.00E+00
I-132	2.96E-01	7.75E-01	2.78E-01	2.61E+01	1.22E+00	0.00E+00	3.38E-01	0.00E+00
I-133	7.08E+06	1.20E+07	3.66E+06	1.68E+09	2.11E+07	0.00E+00	9.09E+06	0.00E+00
I-134	3.74E-12	9.93E-12	3.56E-12	1.65E-10	1.56E-11	0.00E+00	1.31E-13	0.00E+00
I-135	2.29E+04	5.91E+04	2.19E+04	3.80E+06	9.33E+04	0.00E+00	6.54E+04	0.00E+00

⁹ R Values in units of mrem/yr per $\mu\text{Ci}/\text{m}^3$ for inhalation and tritium, and units of $\text{m}^2\text{-mrem}/\text{yr}$ per $\mu\text{Ci}/\text{sec}$ for all others.

TABLE 3.5-9 (continued)
R VALUES for the H.B. ROBINSON STEAM ELECTRIC PLANT⁹

PATHWAY = Cow Milk
 AGE GROUP = Teen

<u>Nuclide</u>	<u>Bone</u>	<u>Liver</u>	<u>T.Body</u>	<u>Thyroid</u>	<u>Kidney</u>	<u>Lung</u>	<u>GI-Tract</u>	<u>Skin</u>
CS-134	7.73E+09	1.82E+10	8.44E+09	0.00E+00	5.78E+09	2.21E+09	2.26E+08	0.00E+00
CS-136	4.27E+08	1.68E+09	1.13E+09	0.00E+00	9.16E+08	1.44E+08	1.35E+08	0.00E+00
CS-137	1.08E+10	1.44E+10	5.01E+09	0.00E+00	4.89E+09	1.90E+09	2.05E+08	0.00E+00
CS-138	1.76E-23	3.38E-23	1.69E-23	0.00E+00	2.50E-23	2.91E-24	1.54E-26	0.00E+00
BA-139	8.40E-08	5.91E-11	2.45E-09	0.00E+00	5.57E-11	4.07E-11	7.50E-07	0.00E+00
BA-140	4.64E+07	5.68E+04	2.99E+06	0.00E+00	1.93E+04	3.82E+04	7.15E+07	0.00E+00
LA-140	8.11E+00	3.99E+00	1.06E+00	0.00E+00	0.00E+00	0.00E+00	2.29E+05	0.00E+00
LA-142	3.44E-11	1.53E-11	3.80E-12	0.00E+00	0.00E+00	0.00E+00	4.64E-07	0.00E+00
CE-141	7.82E+03	5.22E+03	6.00E+02	0.00E+00	2.46E+03	0.00E+00	1.49E+07	0.00E+00
CE-143	7.65E+01	5.56E+04	6.22E+00	0.00E+00	2.50E+01	0.00E+00	1.67E+06	0.00E+00
CE-144	5.20E+05	2.15E+05	2.80E+04	0.00E+00	1.29E+05	0.00E+00	1.31E+08	0.00E+00
HF-181	1.51E+04	8.32E+01	1.69E+03	5.06E+01	6.91E+01	0.00E+00	7.57E+05	0.00E+00
W-187	1.19E+04	9.72E+03	3.40E+03	0.00E+00	0.00E+00	0.00E+00	2.63E+06	0.00E+00
NP-239	7.01E+00	6.61E-01	3.67E-01	0.00E+00	2.08E+00	0.00E+00	1.06E+05	0.00E+00

⁹ R Values in units of mrem/yr per $\mu\text{Ci}/\text{m}^3$ for inhalation and tritium, and units of $\text{m}^2\text{-mrem}/\text{yr}$ per $\mu\text{Ci}/\text{sec}$ for all others.

H.B. Robinson Steam Electric Plant Unit 2
Offsite Dose Calculation Manual (ODCM)

TABLE 3.5-10
R VALUES for the H.B. ROBINSON STEAM ELECTRIC PLANT¹⁰
(Reference Regulatory Guide 1.109)

PATHWAY = Cow Milk
AGE GROUP = Child

Nuclide	Bone	Liver	T.Body	Thyroid	Kidney	Lung	GI-Tract	Skin
H-3	0.00E+00	1.57E+03	1.57E+03	1.57E+03	1.57E+03	1.57E+03	1.57E+03	1.57E+03
F-18	1.94E-02	0.00E+00	1.92E-03	0.00E+00	0.00E+00	0.00E+00	5.25E-03	0.00E+00
NA-24	8.88E+06	8.88E+06	8.88E+06	8.88E+06	8.88E+06	8.88E+06	8.88E+06	0.00E+00
CR-51	0.00E+00	0.00E+00	9.09E+04	5.05E+04	1.38E+04	9.21E+04	4.82E+06	0.00E+00
MN-54	0.00E+00	1.67E+07	4.46E+06	0.00E+00	4.69E+06	0.00E+00	1.40E+07	0.00E+00
MN-56	0.00E+00	1.30E-02	2.94E-03	0.00E+00	1.57E-02	0.00E+00	1.89E+00	0.00E+00
FE-55	8.71E+07	4.62E+07	1.43E+07	0.00E+00	0.00E+00	2.61E+07	8.56E+06	0.00E+00
FE-59	1.03E+08	1.67E+08	8.31E+07	0.00E+00	0.00E+00	4.84E+07	1.74E+08	0.00E+00
CO-57	0.00E+00	3.04E+06	6.16E+06	0.00E+00	0.00E+00	0.00E+00	2.49E+07	0.00E+00
CO-58	0.00E+00	1.01E+07	3.09E+07	0.00E+00	0.00E+00	0.00E+00	5.88E+07	0.00E+00
CO-60	0.00E+00	3.42E+07	1.01E+08	0.00E+00	0.00E+00	0.00E+00	1.89E+08	0.00E+00
NI-65	1.68E+00	1.58E-01	9.24E-02	0.00E+00	0.00E+00	0.00E+00	1.94E+01	0.00E+00
CU-64	0.00E+00	7.50E+04	4.53E+04	0.00E+00	1.81E+05	0.00E+00	3.52E+06	0.00E+00
ZN-65	3.72E+09	9.91E+09	6.16E+09	0.00E+00	6.24E+09	0.00E+00	1.74E+09	0.00E+00
BR-82	0.00E+00	0.00E+00	1.16E+08	0.00E+00	0.00E+00	0.00E+00	0.00E+00	0.00E+00
BR-83	0.00E+00	0.00E+00	4.52E-01	0.00E+00	0.00E+00	0.00E+00	0.00E+00	0.00E+00
BR-84	0.00E+00	0.00E+00	7.08E-23	0.00E+00	0.00E+00	0.00E+00	0.00E+00	0.00E+00
RB-86	0.00E+00	8.16E+09	5.02E+09	0.00E+00	0.00E+00	0.00E+00	5.25E+08	0.00E+00
SR-89	5.63E+09	0.00E+00	1.61E+08	0.00E+00	0.00E+00	0.00E+00	2.18E+08	0.00E+00
SR-90	9.28E+10	0.00E+00	2.35E+10	0.00E+00	0.00E+00	0.00E+00	1.25E+09	0.00E+00
SR-91	1.31E+05	0.00E+00	4.94E+03	0.00E+00	0.00E+00	0.00E+00	2.89E+05	0.00E+00
SR-92	2.21E+00	0.00E+00	8.88E-02	0.00E+00	0.00E+00	0.00E+00	4.19E+01	0.00E+00
Y-91M	2.80E-19	0.00E+00	1.02E-20	0.00E+00	0.00E+00	0.00E+00	5.49E-16	0.00E+00
Y-91	3.28E+04	0.00E+00	8.78E+02	0.00E+00	0.00E+00	0.00E+00	4.38E+06	0.00E+00
Y-92	2.56E-04	0.00E+00	7.32E-06	0.00E+00	0.00E+00	0.00E+00	7.39E+00	0.00E+00
Y-93	1.02E+00	0.00E+00	2.79E-02	0.00E+00	0.00E+00	0.00E+00	1.51E+04	0.00E+00
ZR-95	3.20E+03	7.04E+02	6.27E+02	0.00E+00	1.01E+03	0.00E+00	7.35E+05	0.00E+00
ZR-97	1.92E+00	2.78E-01	1.64E-01	0.00E+00	3.99E-01	0.00E+00	4.21E+04	0.00E+00
NB-95	2.78E+05	1.08E+05	7.74E+04	0.00E+00	1.02E+05	0.00E+00	2.00E+08	0.00E+00
NB-97	1.50E-11	2.72E-12	1.27E-12	0.00E+00	3.01E-12	0.00E+00	8.38E-07	0.00E+00
MO-99	0.00E+00	8.16E+07	2.02E+07	0.00E+00	1.74E+08	0.00E+00	6.75E+07	0.00E+00
TC-99M	1.33E+01	2.62E+01	4.34E+02	0.00E+00	3.80E+02	1.33E+01	1.49E+04	0.00E+00
RU-103	3.72E+03	0.00E+00	1.43E+03	0.00E+00	9.37E+03	0.00E+00	9.62E+04	0.00E+00
RU-105	3.86E-03	0.00E+00	1.40E-03	0.00E+00	3.39E-02	0.00E+00	2.52E+00	0.00E+00
RU-106	7.45E+04	0.00E+00	9.29E+03	0.00E+00	1.01E+05	0.00E+00	1.16E+06	0.00E+00
AG-110M	1.74E+08	1.17E+08	9.39E+07	0.00E+00	2.19E+08	0.00E+00	1.40E+10	0.00E+00
SN-113	1.17E+07	3.76E+05	1.28E+07	1.54E+05	2.59E+05	0.00E+00	4.67E+07	0.00E+00
SB-124	9.13E+07	1.18E+06	3.20E+07	2.01E+05	0.00E+00	5.07E+07	5.71E+08	0.00E+00
SB-125	6.87E+07	5.30E+05	1.44E+07	6.36E+04	0.00E+00	3.83E+07	1.64E+08	0.00E+00
TE-129M	2.56E+08	7.14E+07	3.97E+07	8.25E+07	7.51E+08	0.00E+00	3.12E+08	0.00E+00
TE-129	1.35E-09	3.77E-10	3.21E-10	9.64E-10	3.95E-09	0.00E+00	8.41E-08	0.00E+00
TE-131M	1.63E+06	5.65E+05	6.02E+05	1.16E+06	5.47E+06	0.00E+00	2.29E+07	0.00E+00
TE-132	1.05E+07	4.64E+06	5.61E+06	6.76E+06	4.31E+07	0.00E+00	4.67E+07	0.00E+00
I-131	1.28E+09	1.29E+09	7.32E+08	4.26E+11	2.11E+09	0.00E+00	1.15E+08	0.00E+00
I-132	7.01E-01	1.29E+00	5.92E-01	5.97E+01	1.97E+00	0.00E+00	1.52E+00	0.00E+00
I-133	1.72E+07	2.13E+07	8.05E+06	3.95E+09	3.55E+07	0.00E+00	8.57E+06	0.00E+00
I-134	8.87E-12	1.65E-11	7.57E-12	3.79E-10	2.52E-11	0.00E+00	1.09E-11	0.00E+00
I-135	5.43E+04	9.77E+04	4.62E+04	8.66E+06	1.50E+05	0.00E+00	7.45E+04	0.00E+00

¹⁰ R Values in units of mrem/yr per $\mu\text{Ci}/\text{m}^3$ for inhalation and tritium, and units of $\text{m}^2\text{-mrem}/\text{yr}$ per $\mu\text{Ci}/\text{sec}$ for all others.

H.B. Robinson Steam Electric Plant Unit 2
 Offsite Dose Calculation Manual (ODCM)

TABLE 3.5-10 (continued)
R VALUES for the H.B. ROBINSON STEAM ELECTRIC PLANT¹⁰

PATHWAY = Cow Milk
 AGE GROUP = Child

<u>Nuclide</u>	<u>Bone</u>	<u>Liver</u>	<u>T.Body</u>	<u>Thyroid</u>	<u>Kidney</u>	<u>Lung</u>	<u>GI-Tract</u>	<u>Skin</u>
CS-134	1.78E+10	2.93E+10	6.17E+09	0.00E+00	9.07E+09	3.25E+09	1.58E+08	0.00E+00
CS-136	9.65E+08	2.65E+09	1.72E+09	0.00E+00	1.41E+09	2.11E+08	9.32E+07	0.00E+00
CS-137	2.60E+10	2.49E+10	3.68E+09	0.00E+00	8.12E+09	2.92E+09	1.56E+08	0.00E+00
CS-138	4.27E-23	5.94E-23	3.77E-23	0.00E+00	4.18E-23	4.50E-24	2.74E-23	0.00E+00
BA-139	2.06E-07	1.10E-10	5.98E-09	0.00E+00	9.62E-11	6.48E-11	1.19E-05	0.00E+00
BA-140	1.12E+08	9.80E+04	6.53E+06	0.00E+00	3.19E+04	5.85E+04	5.67E+07	0.00E+00
LA-140	1.94E+01	6.79E+00	2.29E+00	0.00E+00	0.00E+00	0.00E+00	1.89E+05	0.00E+00
LA-142	8.30E-11	2.64E-11	8.28E-12	0.00E+00	0.00E+00	0.00E+00	5.24E-06	0.00E+00
CE-141	1.93E+04	9.61E+03	1.43E+03	0.00E+00	4.21E+03	0.00E+00	1.20E+07	0.00E+00
CE-143	1.88E+02	1.02E+05	1.47E+01	0.00E+00	4.27E+01	0.00E+00	1.49E+06	0.00E+00
CE-144	1.28E+06	4.02E+05	6.85E+04	0.00E+00	2.23E+05	0.00E+00	1.05E+08	0.00E+00
HF-181	3.59E+04	1.40E+02	3.61E+03	1.18E+02	1.13E+02	0.00E+00	5.96E+05	0.00E+00
W-187	2.89E+04	1.71E+04	7.68E+03	0.00E+00	0.00E+00	0.00E+00	2.40E+06	0.00E+00
NP-239	1.73E+01	1.24E+00	8.71E-01	0.00E+00	3.58E+00	0.00E+00	9.17E+04	0.00E+00

¹⁰ R Values in units of mrem/yr per $\mu\text{Ci}/\text{m}^3$ for inhalation and tritium, and units of $\text{m}^2\text{-mrem}/\text{yr}$ per $\mu\text{Ci}/\text{sec}$ for all others.

H.B. Robinson Steam Electric Plant Unit 2
Offsite Dose Calculation Manual (ODCM)

TABLE 3.5-11
R VALUES for the H.B. ROBINSON STEAM ELECTRIC PLANT¹¹
(Reference Regulatory Guide 1.109)

PATHWAY = Cow Milk
AGE GROUP = Infant

Nuclide	Bone	Liver	T.Body	Thyroid	Kidney	Lung	GI-Tract	Skin
H-3	0.00E+00	2.38E+03	2.38E+03	2.38E+03	2.38E+03	2.38E+03	2.38E+03	2.38E+03
F-18	4.04E-02	0.00E+00	3.45E-03	0.00E+00	0.00E+00	0.00E+00	9.51E-03	0.00E+00
NA-24	1.55E+07	1.55E+07	1.55E+07	1.55E+07	1.55E+07	1.55E+07	1.55E+07	0.00E+00
CR-51	0.00E+00	0.00E+00	1.44E+05	9.40E+04	2.05E+04	1.83E+05	4.20E+06	0.00E+00
MN-54	0.00E+00	3.11E+07	7.05E+06	0.00E+00	6.90E+06	0.00E+00	1.14E+07	0.00E+00
MN-56	0.00E+00	3.19E-02	5.50E-03	0.00E+00	2.74E-02	0.00E+00	2.90E+00	0.00E+00
FE-55	1.05E+08	6.80E+07	1.82E+07	0.00E+00	0.00E+00	3.32E+07	8.63E+06	0.00E+00
FE-59	1.93E+08	3.36E+08	1.33E+08	0.00E+00	0.00E+00	9.94E+07	1.61E+08	0.00E+00
CO-57	0.00E+00	7.10E+06	1.15E+07	0.00E+00	0.00E+00	0.00E+00	2.42E+07	0.00E+00
CO-58	0.00E+00	2.02E+07	5.03E+07	0.00E+00	0.00E+00	0.00E+00	5.03E+07	0.00E+00
CO-60	0.00E+00	6.98E+07	1.65E+08	0.00E+00	0.00E+00	0.00E+00	1.66E+08	0.00E+00
NI-65	3.56E+00	4.03E-01	1.83E-01	0.00E+00	0.00E+00	0.00E+00	3.07E+01	0.00E+00
CU-64	0.00E+00	1.86E+05	8.63E+04	0.00E+00	3.15E+05	0.00E+00	3.83E+06	0.00E+00
ZN-65	5.00E+09	1.71E+10	7.90E+09	0.00E+00	8.31E+09	0.00E+00	1.45E+10	0.00E+00
BR-82	0.00E+00	0.00E+00	1.96E+08	0.00E+00	0.00E+00	0.00E+00	0.00E+00	0.00E+00
BR-83	0.00E+00	0.00E+00	9.60E-01	0.00E+00	0.00E+00	0.00E+00	0.00E+00	0.00E+00
BR-84	0.00E+00	0.00E+00	1.37E-22	0.00E+00	0.00E+00	0.00E+00	0.00E+00	0.00E+00
RB-86	0.00E+00	2.07E+10	1.02E+10	0.00E+00	0.00E+00	0.00E+00	5.30E+08	0.00E+00
SR-89	1.07E+10	0.00E+00	3.07E+08	0.00E+00	0.00E+00	0.00E+00	2.20E+08	0.00E+00
SR-90	1.01E+11	0.00E+00	2.57E+10	0.00E+00	0.00E+00	0.00E+00	1.26E+09	0.00E+00
SR-91	2.73E+05	0.00E+00	9.87E+03	0.00E+00	0.00E+00	0.00E+00	3.23E+05	0.00E+00
SR-92	4.71E+00	0.00E+00	1.75E-01	0.00E+00	0.00E+00	0.00E+00	5.08E+01	0.00E+00
Y-91M	5.94E-19	0.00E+00	2.03E-20	0.00E+00	0.00E+00	0.00E+00	1.98E-15	0.00E+00
Y-91	6.16E+04	0.00E+00	1.64E+03	0.00E+00	0.00E+00	0.00E+00	4.42E+06	0.00E+00
Y-92	5.44E-04	0.00E+00	1.53E-05	0.00E+00	0.00E+00	0.00E+00	1.04E+01	0.00E+00
Y-93	2.16E+00	0.00E+00	5.90E-02	0.00E+00	0.00E+00	0.00E+00	1.71E+04	0.00E+00
ZR-95	5.69E+03	1.39E+03	9.83E+02	0.00E+00	1.49E+03	0.00E+00	6.91E+05	0.00E+00
ZR-97	4.07E+00	6.99E-01	3.19E-01	0.00E+00	7.04E-01	0.00E+00	4.46E+04	0.00E+00
NB-95	5.19E+05	2.14E+05	1.24E+05	0.00E+00	1.53E+05	0.00E+00	1.81E+08	0.00E+00
NB-97	3.18E-11	6.78E-12	2.45E-12	0.00E+00	5.30E-12	0.00E+00	2.14E-06	0.00E+00
MO-99	0.00E+00	2.09E+08	4.07E+07	0.00E+00	3.12E+08	0.00E+00	6.87E+07	0.00E+00
TC-99M	2.78E+01	5.73E+01	7.37E+02	0.00E+00	6.16E+02	2.99E+01	1.66E+04	0.00E+00
RU-103	7.54E+03	0.00E+00	2.52E+03	0.00E+00	1.57E+04	0.00E+00	9.17E+04	0.00E+00
RU-105	8.13E-03	0.00E+00	2.74E-03	0.00E+00	5.98E-02	0.00E+00	3.23E+00	0.00E+00
RU-106	1.53E+05	0.00E+00	1.92E+04	0.00E+00	1.81E+05	0.00E+00	1.16E+06	0.00E+00
AG-110M	3.21E+08	2.35E+08	1.55E+08	0.00E+00	3.36E+08	0.00E+00	1.22E+10	0.00E+00
SN-113	1.78E+07	6.79E+05	1.84E+07	2.59E+05	3.65E+05	0.00E+00	3.79E+07	0.00E+00
SB-124	1.76E+08	2.59E+06	5.45E+07	4.67E+05	0.00E+00	1.10E+08	5.43E+08	0.00E+00
SB-125	1.18E+08	1.14E+06	2.43E+07	1.48E+05	0.00E+00	6.83E+07	1.57E+08	0.00E+00
TE-129M	5.25E+08	1.80E+08	8.09E+07	2.02E+08	1.31E+09	0.00E+00	3.14E+08	0.00E+00
TE-129	2.86E-09	9.87E-10	6.69E-10	2.40E-09	7.13E-09	0.00E+00	2.29E-07	0.00E+00
TE-131M	3.45E+06	1.39E+06	1.15E+06	2.82E+06	9.56E+06	0.00E+00	2.34E+07	0.00E+00
TE-132	2.16E+07	1.07E+07	9.98E+06	1.58E+07	6.69E+07	0.00E+00	3.96E+07	0.00E+00
I-131	2.67E+09	3.15E+09	1.38E+09	1.03E+12	3.68E+09	0.00E+00	1.12E+08	0.00E+00
I-132	1.45E+00	2.95E+00	1.05E+00	1.38E+02	3.29E+00	0.00E+00	2.39E+00	0.00E+00
I-133	3.63E+07	5.29E+07	1.55E+07	9.62E+09	6.22E+07	0.00E+00	8.95E+06	0.00E+00
I-134	1.84E-11	3.77E-11	1.34E-11	8.78E-10	4.21E-11	0.00E+00	3.89E-11	0.00E+00
I-135	1.13E+05	2.25E+05	8.19E+04	2.01E+07	2.50E+05	0.00E+00	8.13E+04	0.00E+00

¹¹ R Values in units of mrem/yr per $\mu\text{Ci}/\text{m}^3$ for inhalation and tritium, and units of $\text{m}^2\text{-mrem}/\text{yr}$ per $\mu\text{Ci}/\text{sec}$ for all others.

TABLE 3.5-11 (continued)
R VALUES for the H.B. ROBINSON STEAM ELECTRIC PLANT¹¹

PATHWAY = Cow Milk
 AGE GROUP = Infant

<u>Nuclide</u>	<u>Bone</u>	<u>Liver</u>	<u>T.Body</u>	<u>Thyroid</u>	<u>Kidney</u>	<u>Lung</u>	<u>GI-Tract</u>	<u>Skin</u>
CS-134	2.87E+10	5.36E+10	5.41E+09	0.00E+00	1.38E+10	5.65E+09	1.46E+08	0.00E+00
CS-136	1.88E+09	5.54E+09	2.07E+09	0.00E+00	2.21E+09	4.52E+08	8.42E+07	0.00E+00
CS-137	4.16E+10	4.86E+10	3.45E+09	0.00E+00	1.31E+10	5.29E+09	1.52E+08	0.00E+00
CS-138	9.01E-23	1.47E-22	7.10E-23	0.00E+00	7.31E-23	1.14E-23	2.34E-22	0.00E+00
BA-139	4.39E-07	2.91E-10	1.27E-08	0.00E+00	1.75E-10	1.77E-10	2.78E-05	0.00E+00
BA-140	2.30E+08	2.30E+05	1.19E+07	0.00E+00	5.47E+04	1.41E+05	5.66E+07	0.00E+00
LA-140	4.06E+01	1.60E+01	4.11E+00	0.00E+00	0.00E+00	0.00E+00	1.88E+05	0.00E+00
LA-142	1.74E-10	6.40E-11	1.53E-11	0.00E+00	0.00E+00	0.00E+00	1.09E-05	0.00E+00
CE-141	3.82E+04	2.33E+04	2.74E+03	0.00E+00	7.18E+03	0.00E+00	1.20E+07	0.00E+00
CE-143	3.97E+02	2.64E+05	3.01E+01	0.00E+00	7.68E+01	0.00E+00	1.54E+06	0.00E+00
CE-144	1.84E+06	7.52E+05	1.03E+05	0.00E+00	3.04E+05	0.00E+00	1.05E+08	0.00E+00
HF-181	6.86E+04	3.22E+02	6.06E+03	2.73E+02	1.89E+02	0.00E+00	5.62E+05	0.00E+00
W-187	6.08E+04	4.23E+04	1.46E+04	0.00E+00	0.00E+00	0.00E+00	2.49E+06	0.00E+00
NP-239	3.65E+01	3.26E+00	1.84E+00	0.00E+00	6.51E+00	0.00E+00	9.44E+04	0.00E+00

¹¹ R Values in units of mrem/yr per $\mu\text{Ci}/\text{m}^3$ for inhalation and tritium, and units of $\text{m}^2\text{-mrem}/\text{yr}$ per $\mu\text{Ci}/\text{sec}$ for all others.

TABLE 3.5-12
R VALUES for the H.B. ROBINSON STEAM ELECTRIC PLANT¹²
 (Reference Regulatory Guide 1.109)

PATHWAY = Goat Milk
 AGE GROUP = Adult

Nuclide	Bone	Liver	T.Body	Thyroid	Kidney	Lung	GI-Tract	Skin
H-3	0.00E+00	1.56E+03	1.56E+03	1.56E+03	1.56E+03	1.56E+03	1.56E+03	1.56E+03
F-18	5.48E-04	0.00E+00	6.08E-05	0.00E+00	0.00E+00	0.00E+00	1.63E-05	0.00E+00
NA-24	2.93E+05	2.93E+05	2.93E+05	2.93E+05	2.93E+05	2.93E+05	2.93E+05	0.00E+00
CR-51	0.00E+00	0.00E+00	3.06E+03	1.83E+03	6.75E+02	4.06E+03	7.70E+05	0.00E+00
MN-54	0.00E+00	8.06E+05	1.54E+05	0.00E+00	2.40E+05	0.00E+00	2.47E+06	0.00E+00
MN-56	0.00E+00	5.05E-04	8.96E-05	0.00E+00	6.42E-04	0.00E+00	1.61E-02	0.00E+00
FE-55	2.54E+05	1.76E+05	4.10E+04	0.00E+00	0.00E+00	9.80E+04	1.01E+05	0.00E+00
FE-59	3.31E+05	7.79E+05	2.98E+05	0.00E+00	0.00E+00	2.18E+05	2.60E+06	0.00E+00
CO-57	0.00E+00	1.09E+05	2.02E+05	0.00E+00	0.00E+00	0.00E+00	3.09E+06	0.00E+00
CO-58	0.00E+00	4.71E+05	1.05E+06	0.00E+00	0.00E+00	0.00E+00	9.54E+06	0.00E+00
CO-60	0.00E+00	1.56E+06	3.44E+06	0.00E+00	0.00E+00	0.00E+00	2.93E+07	0.00E+00
NI-65	4.51E-02	5.86E-03	2.67E-03	0.00E+00	0.00E+00	0.00E+00	1.49E-01	0.00E+00
CU-64	0.00E+00	2.67E+03	1.25E+03	0.00E+00	6.73E+03	0.00E+00	2.27E+05	0.00E+00
ZN-65	1.48E+08	4.71E+08	2.13E+08	0.00E+00	3.15E+08	0.00E+00	2.97E+08	0.00E+00
BR-82	0.00E+00	0.00E+00	3.93E+06	0.00E+00	0.00E+00	0.00E+00	4.50E+06	0.00E+00
BR-83	0.00E+00	0.00E+00	1.20E-02	0.00E+00	0.00E+00	0.00E+00	1.73E-02	0.00E+00
BR-84	0.00E+00	0.00E+00	2.10E-24	0.00E+00	0.00E+00	0.00E+00	1.65E-29	0.00E+00
RB-86	0.00E+00	2.90E+08	1.35E+08	0.00E+00	0.00E+00	0.00E+00	5.71E+07	0.00E+00
SR-89	2.59E+09	0.00E+00	7.44E+07	0.00E+00	0.00E+00	0.00E+00	4.16E+08	0.00E+00
SR-90	8.16E+10	0.00E+00	2.00E+10	0.00E+00	0.00E+00	0.00E+00	2.36E+09	0.00E+00
SR-91	6.10E+04	0.00E+00	2.46E+03	0.00E+00	0.00E+00	0.00E+00	2.91E+05	0.00E+00
SR-92	1.04E+00	0.00E+00	4.50E-02	0.00E+00	0.00E+00	0.00E+00	2.06E+01	0.00E+00
Y-91M	7.52E-21	0.00E+00	2.91E-22	0.00E+00	0.00E+00	0.00E+00	2.21E-20	0.00E+00
Y-91	8.67E+02	0.00E+00	2.32E+01	0.00E+00	0.00E+00	0.00E+00	4.77E+05	0.00E+00
Y-92	6.77E-06	0.00E+00	1.98E-07	0.00E+00	0.00E+00	0.00E+00	1.19E-01	0.00E+00
Y-93	2.69E-02	0.00E+00	7.43E-04	0.00E+00	0.00E+00	0.00E+00	8.53E+02	0.00E+00
ZR-95	9.47E+01	3.04E+01	2.06E+01	0.00E+00	4.76E+01	0.00E+00	9.62E+04	0.00E+00
ZR-97	5.21E-02	1.05E-02	4.81E-03	0.00E+00	1.59E-02	0.00E+00	3.26E+03	0.00E+00
NB-95	8.67E+03	4.82E+03	2.59E+03	0.00E+00	4.77E+03	0.00E+00	2.93E+07	0.00E+00
NB-97	4.08E-13	1.03E-13	3.76E-14	0.00E+00	1.20E-13	0.00E+00	3.80E-10	0.00E+00
MO-99	0.00E+00	2.98E+06	5.67E+05	0.00E+00	6.75E+06	0.00E+00	6.91E+06	0.00E+00
TC-99M	4.03E-01	1.14E+00	1.45E+01	0.00E+00	1.73E+01	5.57E-01	6.73E+02	0.00E+00
RU-103	1.06E+02	0.00E+00	4.58E+01	0.00E+00	4.05E+02	0.00E+00	1.24E+04	0.00E+00
RU-105	1.04E-04	0.00E+00	4.10E-05	0.00E+00	1.34E-03	0.00E+00	6.35E-02	0.00E+00
RU-106	1.97E+03	0.00E+00	2.50E+02	0.00E+00	3.81E+03	0.00E+00	1.28E+05	0.00E+00
AG-110M	5.82E+06	5.38E+06	3.20E+06	0.00E+00	1.06E+07	0.00E+00	2.20E+09	0.00E+00
SN-113	4.64E+05	1.79E+04	4.39E+05	6.31E+03	1.32E+04	0.00E+00	8.12E+06	0.00E+00
SB-124	2.60E+06	4.90E+04	1.03E+06	6.29E+03	0.00E+00	2.02E+06	7.37E+07	0.00E+00
SB-125	1.94E+06	2.16E+04	4.61E+05	1.97E+03	0.00E+00	1.49E+06	2.13E+07	0.00E+00
TE-129M	6.81E+06	2.54E+06	1.08E+06	2.34E+06	2.84E+07	0.00E+00	3.43E+07	0.00E+00
TE-129	3.57E-11	1.34E-11	8.70E-12	2.74E-11	1.50E-10	0.00E+00	2.69E-11	0.00E+00
TE-131M	4.43E+04	2.17E+04	1.80E+04	3.43E+04	2.19E+05	0.00E+00	2.15E+06	0.00E+00
TE-132	2.95E+05	1.91E+05	1.79E+05	2.11E+05	1.84E+06	0.00E+00	9.02E+06	0.00E+00
I-131	3.49E+08	4.99E+08	2.86E+08	1.64E+11	8.56E+08	0.00E+00	1.32E+08	0.00E+00
I-132	2.00E-01	5.36E-01	1.88E-01	1.88E+01	8.54E-01	0.00E+00	1.01E-01	0.00E+00
I-133	4.65E+06	8.09E+06	2.47E+06	1.19E+09	1.41E+07	0.00E+00	7.27E+06	0.00E+00
I-134	2.53E-12	6.87E-12	2.46E-12	1.19E-10	1.09E-11	0.00E+00	5.99E-15	0.00E+00
I-135	1.55E+04	4.06E+04	1.50E+04	2.68E+06	6.51E+04	0.00E+00	4.58E+04	0.00E+00

¹² R Values in units of mrem/yr per $\mu\text{Ci}/\text{m}^3$ for inhalation and tritium, and units of $\text{m}^2\text{-mrem}/\text{yr}$ per $\mu\text{Ci}/\text{sec}$ for all others.

TABLE 3.5-12 (continued)
R VALUES for the H.B. ROBINSON STEAM ELECTRIC PLANT¹²

PATHWAY = Goat Milk
 AGE GROUP = Adult

<u>Nuclide</u>	<u>Bone</u>	<u>Liver</u>	<u>T.Body</u>	<u>Thyroid</u>	<u>Kidney</u>	<u>Lung</u>	<u>GI-Tract</u>	<u>Skin</u>
CS-134	1.34E+10	3.18E+10	2.60E+10	0.00E+00	1.03E+10	3.41E+09	5.56E+08	0.00E+00
CS-136	7.53E+08	2.97E+09	2.14E+09	0.00E+00	1.65E+09	2.27E+08	3.38E+08	0.00E+00
CS-137	1.79E+10	2.45E+10	1.60E+10	0.00E+00	8.30E+09	2.76E+09	4.73E+08	0.00E+00
CS-138	2.91E-23	5.76E-23	2.85E-23	0.00E+00	4.23E-23	4.18E-24	2.46E-28	0.00E+00
BA-139	5.45E-09	3.88E-12	1.60E-10	0.00E+00	3.63E-12	2.20E-12	9.67E-09	0.00E+00
BA-140	3.08E+06	3.87E+03	2.02E+05	0.00E+00	1.32E+03	2.22E+03	6.35E+06	0.00E+00
LA-140	5.42E-01	2.73E-01	7.22E-02	0.00E+00	0.00E+00	0.00E+00	2.00E+04	0.00E+00
LA-142	2.28E-12	1.04E-12	2.59E-13	0.00E+00	0.00E+00	0.00E+00	7.58E-09	0.00E+00
CE-141	5.12E+02	3.46E+02	3.93E+01	0.00E+00	1.61E+02	0.00E+00	1.32E+06	0.00E+00
CE-143	4.99E+00	3.69E+03	4.09E-01	0.00E+00	1.63E+00	0.00E+00	1.38E+05	0.00E+00
CE-144	3.39E+04	1.42E+04	1.82E+03	0.00E+00	8.41E+03	0.00E+00	1.15E+07	0.00E+00
HF-181	1.01E+03	5.73E+00	1.15E+02	3.63E+00	4.77E+00	0.00E+00	7.53E+04	0.00E+00
W-187	7.82E+02	6.54E+02	2.29E+02	0.00E+00	0.00E+00	0.00E+00	2.14E+05	0.00E+00
NP-239	4.41E-01	4.34E-02	2.39E-02	0.00E+00	1.35E-01	0.00E+00	8.89E+03	0.00E+00

¹² R Values in units of mrem/yr per $\mu\text{Ci}/\text{m}^3$ for inhalation and tritium, and units of $\text{m}^2\text{-mrem}/\text{yr}$ per $\mu\text{Ci}/\text{sec}$ for all others.

H.B. Robinson Steam Electric Plant Unit 2
Offsite Dose Calculation Manual (ODCM)

TABLE 3.5-13
R VALUES for the H.B. ROBINSON STEAM ELECTRIC PLANT¹³
(Reference Regulatory Guide 1.109)

PATHWAY = Goat Milk
AGE GROUP = Teen

Nuclide	Bone	Liver	T.Body	Thyroid	Kidney	Lung	GI-Tract	Skin
H-3	0.00E+00	2.03E+03	2.03E+03	2.03E+03	2.03E+03	2.03E+03	2.03E+03	2.03E+03
F-18	9.79E-04	0.00E+00	1.07E-04	0.00E+00	0.00E+00	0.00E+00	8.82E-05	0.00E+00
NA-24	5.12E+05	5.12E+05	5.12E+05	5.12E+05	5.12E+05	5.12E+05	5.12E+05	0.00E+00
CR-51	0.00E+00	0.00E+00	5.35E+03	2.97E+03	1.17E+03	7.64E+03	8.99E+05	0.00E+00
MN-54	0.00E+00	1.34E+06	2.66E+05	0.00E+00	4.00E+05	0.00E+00	2.75E+06	0.00E+00
MN-56	0.00E+00	8.96E-04	1.59E-04	0.00E+00	1.13E-03	0.00E+00	5.90E-02	0.00E+00
FE-55	4.51E+05	3.20E+05	7.46E+04	0.00E+00	0.00E+00	2.03E+05	1.38E+05	0.00E+00
FE-59	5.78E+05	1.35E+06	5.21E+05	0.00E+00	0.00E+00	4.25E+05	3.19E+06	0.00E+00
CO-57	0.00E+00	2.14E+05	3.58E+05	0.00E+00	0.00E+00	0.00E+00	3.99E+06	0.00E+00
CO-58	0.00E+00	7.92E+05	1.83E+06	0.00E+00	0.00E+00	0.00E+00	1.09E+07	0.00E+00
CO-60	0.00E+00	2.64E+06	5.95E+06	0.00E+00	0.00E+00	0.00E+00	3.44E+07	0.00E+00
NI-65	8.25E-02	1.05E-02	4.80E-03	0.00E+00	0.00E+00	0.00E+00	5.72E-01	0.00E+00
CU-64	0.00E+00	4.75E+03	2.24E+03	0.00E+00	1.20E+04	0.00E+00	3.69E+05	0.00E+00
ZN-65	2.27E+08	7.90E+08	3.68E+08	0.00E+00	5.05E+08	0.00E+00	3.34E+08	0.00E+00
BR-82	0.00E+00	0.00E+00	6.82E+06	0.00E+00	0.00E+00	0.00E+00	0.00E+00	0.00E+00
BR-83	0.00E+00	0.00E+00	2.21E-02	0.00E+00	0.00E+00	0.00E+00	0.00E+00	0.00E+00
BR-84	0.00E+00	0.00E+00	3.75E-24	0.00E+00	0.00E+00	0.00E+00	0.00E+00	0.00E+00
RB-86	0.00E+00	5.28E+08	2.48E+08	0.00E+00	0.00E+00	0.00E+00	7.81E+07	0.00E+00
SR-89	4.78E+09	0.00E+00	1.37E+08	0.00E+00	0.00E+00	0.00E+00	5.69E+08	0.00E+00
SR-90	1.15E+11	0.00E+00	2.85E+10	0.00E+00	0.00E+00	0.00E+00	3.24E+09	0.00E+00
SR-91	1.12E+05	0.00E+00	4.46E+03	0.00E+00	0.00E+00	0.00E+00	5.08E+05	0.00E+00
SR-92	1.90E+00	0.00E+00	8.12E-02	0.00E+00	0.00E+00	0.00E+00	4.85E+01	0.00E+00
Y-91M	1.38E-20	0.00E+00	5.26E-22	0.00E+00	0.00E+00	0.00E+00	6.50E-19	0.00E+00
Y-91	1.59E+03	0.00E+00	4.28E+01	0.00E+00	0.00E+00	0.00E+00	6.54E+05	0.00E+00
Y-92	1.25E-05	0.00E+00	3.62E-07	0.00E+00	0.00E+00	0.00E+00	3.43E-01	0.00E+00
Y-93	4.96E-02	0.00E+00	1.36E-03	0.00E+00	0.00E+00	0.00E+00	1.52E+03	0.00E+00
ZR-95	1.66E+02	5.22E+01	3.59E+01	0.00E+00	7.68E+01	0.00E+00	1.21E+05	0.00E+00
ZR-97	9.48E-02	1.88E-02	8.64E-03	0.00E+00	2.84E-02	0.00E+00	5.08E+03	0.00E+00
NB-95	1.48E+04	8.20E+03	4.52E+03	0.00E+00	7.95E+03	0.00E+00	3.51E+07	0.00E+00
NB-97	7.43E-13	1.84E-13	6.73E-14	0.00E+00	2.16E-13	0.00E+00	4.40E-09	0.00E+00
MO-99	0.00E+00	5.38E+06	1.03E+06	0.00E+00	1.23E+07	0.00E+00	9.63E+06	0.00E+00
TC-99M	6.98E-01	1.95E+00	2.52E+01	0.00E+00	2.90E+01	1.08E+00	1.28E+03	0.00E+00
RU-103	1.89E+02	0.00E+00	8.07E+01	0.00E+00	6.66E+02	0.00E+00	1.58E+04	0.00E+00
RU-105	1.90E-04	0.00E+00	7.36E-05	0.00E+00	2.39E-03	0.00E+00	1.53E-01	0.00E+00
RU-106	3.63E+03	0.00E+00	4.57E+02	0.00E+00	7.00E+03	0.00E+00	1.74E+05	0.00E+00
AG-110M	9.62E+06	9.10E+06	5.54E+06	0.00E+00	1.74E+07	0.00E+00	2.56E+09	0.00E+00
SN-113	7.14E+05	2.99E+04	7.59E+05	9.88E+03	2.12E+04	0.00E+00	8.57E+06	0.00E+00
SB-124	4.63E+06	8.53E+04	1.81E+06	1.05E+04	0.00E+00	4.04E+06	9.33E+07	0.00E+00
SB-125	3.46E+06	3.78E+04	8.10E+05	3.31E+03	0.00E+00	3.04E+06	2.69E+07	0.00E+00
TE-129M	1.25E+07	4.62E+06	1.97E+06	4.02E+06	5.21E+07	0.00E+00	4.68E+07	0.00E+00
TE-129	6.57E-11	2.45E-11	1.60E-11	4.69E-11	2.76E-10	0.00E+00	3.59E-10	0.00E+00
TE-131M	8.06E+04	3.86E+04	3.22E+04	5.81E+04	4.03E+05	0.00E+00	3.10E+06	0.00E+00
TE-132	5.27E+05	3.34E+05	3.14E+05	3.52E+05	3.20E+06	0.00E+00	1.06E+07	0.00E+00
I-131	6.34E+08	8.87E+08	4.76E+08	2.59E+11	1.53E+09	0.00E+00	1.75E+08	0.00E+00
I-132	3.55E-01	9.30E-01	3.34E-01	3.13E+01	1.47E+00	0.00E+00	4.05E-01	0.00E+00
I-133	8.50E+06	1.44E+07	4.40E+06	2.01E+09	2.53E+07	0.00E+00	1.09E+07	0.00E+00
I-134	4.49E-12	1.19E-11	4.28E-12	1.99E-10	1.88E-11	0.00E+00	1.57E-13	0.00E+00
I-135	2.75E+04	7.09E+04	2.63E+04	4.56E+06	1.12E+05	0.00E+00	7.85E+04	0.00E+00

¹³ R Values in units of mrem/yr per $\mu\text{Ci}/\text{m}^3$ for inhalation and tritium, and units of $\text{m}^2\text{-mrem}/\text{yr}$ per $\mu\text{Ci}/\text{sec}$ for all others.

TABLE 3.5-13 (continued)
R VALUES for the H.B. ROBINSON STEAM ELECTRIC PLANT¹³

PATHWAY = Goat Milk
 AGE GROUP = Teen

<u>Nuclide</u>	<u>Bone</u>	<u>Liver</u>	<u>T.Body</u>	<u>Thyroid</u>	<u>Kidney</u>	<u>Lung</u>	<u>GI-Tract</u>	<u>Skin</u>
CS-134	2.32E+10	5.46E+10	2.53E+10	0.00E+00	1.73E+10	6.62E+09	6.79E+08	0.00E+00
CS-136	1.28E+09	5.05E+09	3.39E+09	0.00E+00	2.75E+09	4.33E+08	4.06E+08	0.00E+00
CS-137	3.24E+10	4.31E+10	1.50E+10	0.00E+00	1.47E+10	5.70E+09	6.14E+08	0.00E+00
CS-138	5.29E-23	1.02E-22	5.08E-23	0.00E+00	7.50E-23	8.72E-24	4.61E-26	0.00E+00
BA-139	1.01E-08	7.09E-12	2.94E-10	0.00E+00	6.69E-12	4.89E-12	8.99E-08	0.00E+00
BA-140	5.56E+06	6.82E+03	3.58E+05	0.00E+00	2.31E+03	4.58E+03	8.58E+06	0.00E+00
LA-140	9.73E-01	4.78E-01	1.27E-01	0.00E+00	0.00E+00	0.00E+00	2.75E+04	0.00E+00
LA-142	4.12E-12	1.83E-12	4.56E-13	0.00E+00	0.00E+00	0.00E+00	5.57E-08	0.00E+00
CE-141	9.39E+02	6.27E+02	7.20E+01	0.00E+00	2.95E+02	0.00E+00	1.79E+06	0.00E+00
CE-143	9.18E+00	6.68E+03	7.46E-01	0.00E+00	3.00E+00	0.00E+00	2.01E+05	0.00E+00
CE-144	6.24E+04	2.58E+04	3.35E+03	0.00E+00	1.54E+04	0.00E+00	1.57E+07	0.00E+00
HF-181	1.82E+03	9.98E+00	2.03E+02	6.08E+00	8.29E+00	0.00E+00	9.08E+04	0.00E+00
W-187	1.43E+03	1.17E+03	4.09E+02	0.00E+00	0.00E+00	0.00E+00	3.16E+05	0.00E+00
NP-239	8.42E-01	7.94E-02	4.41E-02	0.00E+00	2.49E-01	0.00E+00	1.28E+04	0.00E+00

¹³ R Values in units of mrem/yr per $\mu\text{Ci}/\text{m}^3$ for inhalation and tritium, and units of $\text{m}^2\text{-mrem}/\text{yr}$ per $\mu\text{Ci}/\text{sec}$ for all others.

TABLE 3.5-14
R VALUES for the H.B. ROBINSON STEAM ELECTRIC PLANT¹⁴
 (Reference Regulatory Guide 1.109)

PATHWAY = Goat Milk
 AGE GROUP = Child

Nuclide	Bone	Liver	T.Body	Thyroid	Kidney	Lung	GI-Tract	Skin
H-3	0.00E+00	3.20E+03	3.20E+03	3.20E+03	3.20E+03	3.20E+03	3.20E+03	3.20E+03
F-18	2.33E-03	0.00E+00	2.31E-04	0.00E+00	0.00E+00	0.00E+00	6.30E-04	0.00E+00
NA-24	1.07E+06	1.07E+06	1.07E+06	1.07E+06	1.07E+06	1.07E+06	1.07E+06	0.00E+00
CR-51	0.00E+00	0.00E+00	1.09E+04	6.05E+03	1.65E+03	1.11E+04	5.79E+05	0.00E+00
MN-54	0.00E+00	2.01E+06	5.35E+05	0.00E+00	5.63E+05	0.00E+00	1.69E+06	0.00E+00
MN-56	0.00E+00	1.56E-03	3.53E-04	0.00E+00	1.89E-03	0.00E+00	2.26E-01	0.00E+00
FE-55	1.13E+06	6.00E+05	1.86E+05	0.00E+00	0.00E+00	3.40E+05	1.11E+05	0.00E+00
FE-59	1.34E+06	2.17E+06	1.08E+06	0.00E+00	0.00E+00	6.29E+05	2.26E+06	0.00E+00
CO-57	0.00E+00	3.65E+05	7.39E+05	0.00E+00	0.00E+00	0.00E+00	2.99E+06	0.00E+00
CO-58	0.00E+00	1.21E+06	3.71E+06	0.00E+00	0.00E+00	0.00E+00	7.06E+06	0.00E+00
CO-60	0.00E+00	4.11E+06	1.21E+07	0.00E+00	0.00E+00	0.00E+00	2.27E+07	0.00E+00
NI-65	2.02E-01	1.90E-02	1.11E-02	0.00E+00	0.00E+00	0.00E+00	2.33E+00	0.00E+00
CU-64	0.00E+00	8.35E+03	5.05E+03	0.00E+00	2.02E+04	0.00E+00	3.92E+05	0.00E+00
ZN-65	4.46E+08	1.19E+09	7.40E+08	0.00E+00	7.49E+08	0.00E+00	2.09E+08	0.00E+00
BR-82	0.00E+00	0.00E+00	1.40E+07	0.00E+00	0.00E+00	0.00E+00	0.00E+00	0.00E+00
BR-83	0.00E+00	0.00E+00	5.42E-02	0.00E+00	0.00E+00	0.00E+00	0.00E+00	0.00E+00
BR-84	0.00E+00	0.00E+00	8.49E-24	0.00E+00	0.00E+00	0.00E+00	0.00E+00	0.00E+00
RB-86	0.00E+00	9.79E+08	6.02E+08	0.00E+00	0.00E+00	0.00E+00	6.30E+07	0.00E+00
SR-89	1.18E+10	0.00E+00	3.38E+08	0.00E+00	0.00E+00	0.00E+00	4.58E+08	0.00E+00
SR-90	1.95E+11	0.00E+00	4.94E+10	0.00E+00	0.00E+00	0.00E+00	2.62E+09	0.00E+00
SR-91	2.75E+05	0.00E+00	1.04E+04	0.00E+00	0.00E+00	0.00E+00	6.07E+05	0.00E+00
SR-92	4.65E+00	0.00E+00	1.86E-01	0.00E+00	0.00E+00	0.00E+00	8.81E+01	0.00E+00
Y-91M	3.36E-20	0.00E+00	1.22E-21	0.00E+00	0.00E+00	0.00E+00	6.59E-17	0.00E+00
Y-91	3.94E+03	0.00E+00	1.05E+02	0.00E+00	0.00E+00	0.00E+00	5.25E+05	0.00E+00
Y-92	3.07E-05	0.00E+00	8.78E-07	0.00E+00	0.00E+00	0.00E+00	8.87E-01	0.00E+00
Y-93	1.22E-01	0.00E+00	3.35E-03	0.00E+00	0.00E+00	0.00E+00	1.82E+03	0.00E+00
ZR-95	3.85E+02	8.45E+01	7.53E+01	0.00E+00	1.21E+02	0.00E+00	8.82E+04	0.00E+00
ZR-97	2.31E-01	3.33E-02	1.97E-02	0.00E+00	4.79E-02	0.00E+00	5.05E+03	0.00E+00
NB-95	3.34E+04	1.30E+04	9.29E+03	0.00E+00	1.22E+04	0.00E+00	2.40E+07	0.00E+00
NB-97	1.80E-12	3.26E-13	1.52E-13	0.00E+00	3.62E-13	0.00E+00	1.01E-07	0.00E+00
MO-99	0.00E+00	9.79E+06	2.42E+06	0.00E+00	2.09E+07	0.00E+00	8.10E+06	0.00E+00
TC-99M	1.60E+00	3.14E+00	5.20E+01	0.00E+00	4.56E+01	1.59E+00	1.79E+03	0.00E+00
RU-103	4.47E+02	0.00E+00	1.72E+02	0.00E+00	1.12E+03	0.00E+00	1.15E+04	0.00E+00
RU-105	4.63E-04	0.00E+00	1.68E-04	0.00E+00	4.07E-03	0.00E+00	3.02E-01	0.00E+00
RU-106	8.93E+03	0.00E+00	1.11E+03	0.00E+00	1.21E+04	0.00E+00	1.39E+05	0.00E+00
AG-110M	2.09E+07	1.41E+07	1.13E+07	0.00E+00	2.62E+07	0.00E+00	1.68E+09	0.00E+00
SN-113	1.40E+06	4.52E+04	1.53E+06	1.85E+04	3.10E+04	0.00E+00	5.61E+06	0.00E+00
SB-124	1.10E+07	1.42E+05	3.84E+06	2.42E+04	0.00E+00	6.08E+06	6.85E+07	0.00E+00
SB-125	8.25E+06	6.36E+04	1.73E+06	7.64E+03	0.00E+00	4.60E+06	1.97E+07	0.00E+00
TE-129M	3.07E+07	8.57E+06	4.76E+06	9.90E+06	9.01E+07	0.00E+00	3.74E+07	0.00E+00
TE-129	1.62E-10	4.53E-11	3.85E-11	1.16E-10	4.74E-10	0.00E+00	1.01E-08	0.00E+00
TE-131M	1.96E+05	6.78E+04	7.22E+04	1.39E+05	6.57E+05	0.00E+00	2.75E+06	0.00E+00
TE-132	1.26E+06	5.57E+05	6.73E+05	8.11E+05	5.17E+06	0.00E+00	5.61E+06	0.00E+00
I-131	1.54E+09	1.55E+09	8.78E+08	5.11E+11	2.54E+09	0.00E+00	1.38E+08	0.00E+00
I-132	8.41E-01	1.55E+00	7.11E-01	7.17E+01	2.36E+00	0.00E+00	1.82E+00	0.00E+00
I-133	2.06E+07	2.55E+07	9.66E+06	4.74E+09	4.25E+07	0.00E+00	1.03E+07	0.00E+00
I-134	1.06E-11	1.98E-11	9.09E-12	4.54E-10	3.02E-11	0.00E+00	1.31E-11	0.00E+00
I-135	6.52E+04	1.17E+05	5.55E+04	1.04E+07	1.80E+05	0.00E+00	8.94E+04	0.00E+00

¹⁴ R Values in units of mrem/yr per $\mu\text{Ci}/\text{m}^3$ for inhalation and tritium, and units of $\text{m}^2\text{-mrem}/\text{yr}$ per $\mu\text{Ci}/\text{sec}$ for all others.

TABLE 3.5-14 (continued)
R VALUES for the H.B. ROBINSON STEAM ELECTRIC PLANT¹⁴

PATHWAY = Goat Milk
 AGE GROUP = Child

<u>Nuclide</u>	<u>Bone</u>	<u>Liver</u>	<u>T.Body</u>	<u>Thyroid</u>	<u>Kidney</u>	<u>Lung</u>	<u>GI-Tract</u>	<u>Skin</u>
CS-134	5.35E+10	8.78E+10	1.85E+10	0.00E+00	2.72E+10	9.76E+09	4.73E+08	0.00E+00
CS-136	2.89E+09	7.96E+09	5.15E+09	0.00E+00	4.24E+09	6.32E+08	2.80E+08	0.00E+00
CS-137	7.81E+10	7.48E+10	1.10E+10	0.00E+00	2.44E+10	8.77E+09	4.68E+08	0.00E+00
CS-138	1.28E-22	1.78E-22	1.13E-22	0.00E+00	1.25E-22	1.35E-23	8.21E-23	0.00E+00
BA-139	2.48E-08	1.32E-11	7.18E-10	0.00E+00	1.15E-11	7.78E-12	1.43E-06	0.00E+00
BA-140	1.34E+07	1.18E+04	7.84E+05	0.00E+00	3.83E+03	7.01E+03	6.80E+06	0.00E+00
LA-140	2.33E+00	8.14E-01	2.75E-01	0.00E+00	0.00E+00	0.00E+00	2.27E+04	0.00E+00
LA-142	9.95E-12	3.17E-12	9.94E-13	0.00E+00	0.00E+00	0.00E+00	6.29E-07	0.00E+00
CE-141	2.31E+03	1.15E+03	1.71E+02	0.00E+00	5.05E+02	0.00E+00	1.44E+06	0.00E+00
CE-143	2.25E+01	1.22E+04	1.77E+00	0.00E+00	5.12E+00	0.00E+00	1.79E+05	0.00E+00
CE-144	1.54E+05	4.82E+04	8.21E+03	0.00E+00	2.67E+04	0.00E+00	1.26E+07	0.00E+00
HF-181	4.30E+03	1.68E+01	4.33E+02	1.42E+01	1.35E+01	0.00E+00	7.15E+04	0.00E+00
W-187	3.47E+03	2.05E+03	9.22E+02	0.00E+00	0.00E+00	0.00E+00	2.89E+05	0.00E+00
NP-239	2.07E+00	1.49E-01	1.05E-01	0.00E+00	4.30E-01	0.00E+00	1.10E+04	0.00E+00

¹⁴ R Values in units of mrem/yr per $\mu\text{Ci}/\text{m}^3$ for inhalation and tritium, and units of $\text{m}^2\text{-mrem}/\text{yr}$ per $\mu\text{Ci}/\text{sec}$ for all others.

TABLE 3.5-15
R VALUES for the H.B. ROBINSON STEAM ELECTRIC PLANT¹⁵
 (Reference Regulatory Guide 1.109)

PATHWAY = Goat Milk
 AGE GROUP = Infant

Nuclide	Bone	Liver	T.Body	Thyroid	Kidney	Lung	GI-Tract	Skin
H-3	0.00E+00	4.86E+03	4.86E+03	4.86E+03	4.86E+03	4.86E+03	4.86E+03	4.86E+03
F-18	4.85E-03	0.00E+00	4.14E-04	0.00E+00	0.00E+00	0.00E+00	1.14E-03	0.00E+00
NA-24	1.86E+06	1.86E+06	1.86E+06	1.86E+06	1.86E+06	1.86E+06	1.86E+06	0.00E+00
CR-51	0.00E+00	0.00E+00	1.73E+04	1.13E+04	2.46E+03	2.19E+04	5.04E+05	0.00E+00
MN-54	0.00E+00	3.73E+06	8.46E+05	0.00E+00	8.28E+05	0.00E+00	1.37E+06	0.00E+00
MN-56	0.00E+00	3.83E-03	6.60E-04	0.00E+00	3.29E-03	0.00E+00	3.48E-01	0.00E+00
FE-55	1.37E+06	8.84E+05	2.36E+05	0.00E+00	0.00E+00	4.32E+05	1.12E+05	0.00E+00
FE-59	2.50E+06	4.37E+06	1.72E+06	0.00E+00	0.00E+00	1.29E+06	2.09E+06	0.00E+00
CO-57	0.00E+00	8.52E+05	1.39E+06	0.00E+00	0.00E+00	0.00E+00	2.90E+06	0.00E+00
CO-58	0.00E+00	2.42E+06	6.04E+06	0.00E+00	0.00E+00	0.00E+00	6.03E+06	0.00E+00
CO-60	0.00E+00	8.38E+06	1.98E+07	0.00E+00	0.00E+00	0.00E+00	1.99E+07	0.00E+00
NI-65	4.27E-01	4.84E-02	2.20E-02	0.00E+00	0.00E+00	0.00E+00	3.68E+00	0.00E+00
CU-64	0.00E+00	2.08E+04	9.62E+03	0.00E+00	3.51E+04	0.00E+00	4.26E+05	0.00E+00
ZN-65	5.99E+08	2.06E+09	9.48E+08	0.00E+00	9.97E+08	0.00E+00	1.74E+09	0.00E+00
BR-82	0.00E+00	0.00E+00	2.35E+07	0.00E+00	0.00E+00	0.00E+00	0.00E+00	0.00E+00
BR-83	0.00E+00	0.00E+00	1.15E-01	0.00E+00	0.00E+00	0.00E+00	0.00E+00	0.00E+00
BR-84	0.00E+00	0.00E+00	1.64E-23	0.00E+00	0.00E+00	0.00E+00	0.00E+00	0.00E+00
RB-86	0.00E+00	2.48E+09	1.23E+09	0.00E+00	0.00E+00	0.00E+00	6.36E+07	0.00E+00
SR-89	2.25E+10	0.00E+00	6.45E+08	0.00E+00	0.00E+00	0.00E+00	4.62E+08	0.00E+00
SR-90	2.12E+11	0.00E+00	5.40E+10	0.00E+00	0.00E+00	0.00E+00	2.65E+09	0.00E+00
SR-91	5.73E+05	0.00E+00	2.07E+04	0.00E+00	0.00E+00	0.00E+00	6.78E+05	0.00E+00
SR-92	9.89E+00	0.00E+00	3.67E-01	0.00E+00	0.00E+00	0.00E+00	1.07E+02	0.00E+00
Y-91M	7.13E-20	0.00E+00	2.43E-21	0.00E+00	0.00E+00	0.00E+00	2.38E-16	0.00E+00
Y-91	7.40E+03	0.00E+00	1.97E+02	0.00E+00	0.00E+00	0.00E+00	5.30E+05	0.00E+00
Y-92	6.52E-05	0.00E+00	1.83E-06	0.00E+00	0.00E+00	0.00E+00	1.24E+00	0.00E+00
Y-93	2.60E-01	0.00E+00	7.08E-03	0.00E+00	0.00E+00	0.00E+00	2.05E+03	0.00E+00
ZR-95	6.83E+02	1.66E+02	1.18E+02	0.00E+00	1.79E+02	0.00E+00	8.29E+04	0.00E+00
ZR-97	4.89E-01	8.38E-02	3.83E-02	0.00E+00	8.45E-02	0.00E+00	5.35E+03	0.00E+00
NB-95	6.23E+04	2.57E+04	1.48E+04	0.00E+00	1.84E+04	0.00E+00	2.17E+07	0.00E+00
NB-97	3.82E-12	8.14E-13	2.93E-13	0.00E+00	6.36E-13	0.00E+00	2.57E-07	0.00E+00
MO-99	0.00E+00	2.50E+07	4.88E+06	0.00E+00	3.74E+07	0.00E+00	8.24E+06	0.00E+00
TC-99M	3.33E+00	6.87E+00	8.85E+01	0.00E+00	7.39E+01	3.59E+00	2.00E+03	0.00E+00
RU-103	9.04E+02	0.00E+00	3.02E+02	0.00E+00	1.88E+03	0.00E+00	1.10E+04	0.00E+00
RU-105	9.76E-04	0.00E+00	3.29E-04	0.00E+00	7.17E-03	0.00E+00	3.88E-01	0.00E+00
RU-106	1.84E+04	0.00E+00	2.30E+03	0.00E+00	2.18E+04	0.00E+00	1.40E+05	0.00E+00
AG-110M	3.86E+07	2.81E+07	1.86E+07	0.00E+00	4.03E+07	0.00E+00	1.46E+09	0.00E+00
SN-113	2.13E+06	8.15E+04	2.20E+06	3.10E+04	4.37E+04	0.00E+00	4.55E+06	0.00E+00
SB-124	2.11E+07	3.11E+05	6.54E+06	5.61E+04	0.00E+00	1.32E+07	6.52E+07	0.00E+00
SB-125	1.42E+07	1.37E+05	2.91E+06	1.77E+04	0.00E+00	8.20E+06	1.89E+07	0.00E+00
TE-129M	6.30E+07	2.16E+07	9.71E+06	2.42E+07	1.58E+08	0.00E+00	3.76E+07	0.00E+00
TE-129	3.44E-10	1.18E-10	8.02E-11	2.88E-10	8.56E-10	0.00E+00	2.75E-08	0.00E+00
TE-131M	4.14E+05	1.67E+05	1.38E+05	3.38E+05	1.15E+06	0.00E+00	2.81E+06	0.00E+00
TE-132	2.59E+06	1.28E+06	1.20E+06	1.89E+06	8.02E+06	0.00E+00	4.75E+06	0.00E+00
I-131	3.21E+09	3.78E+09	1.66E+09	1.24E+12	4.41E+09	0.00E+00	1.35E+08	0.00E+00
I-132	1.74E+00	3.54E+00	1.26E+00	1.66E+02	3.95E+00	0.00E+00	2.87E+00	0.00E+00
I-133	4.36E+07	6.35E+07	1.86E+07	1.15E+10	7.46E+07	0.00E+00	1.07E+07	0.00E+00
I-134	2.21E-11	4.52E-11	1.61E-11	1.05E-09	5.05E-11	0.00E+00	4.67E-11	0.00E+00
I-135	1.36E+05	2.70E+05	9.83E+04	2.42E+07	3.00E+05	0.00E+00	9.76E+04	0.00E+00

¹⁵ R Values in units of mrem/yr per $\mu\text{Ci}/\text{m}^3$ for inhalation and tritium, and units of $\text{m}^2\text{-mrem}/\text{yr}$ per $\mu\text{Ci}/\text{sec}$ for all others.

TABLE 3.5-15 (continued)
R VALUES for the H.B. ROBINSON STEAM ELECTRIC PLANT¹⁵

PATHWAY = Goat Milk
 AGE GROUP = Infant

<u>Nuclide</u>	<u>Bone</u>	<u>Liver</u>	<u>T.Body</u>	<u>Thyroid</u>	<u>Kidney</u>	<u>Lung</u>	<u>GI-Tract</u>	<u>Skin</u>
CS-134	8.62E+10	1.61E+11	1.62E+10	0.00E+00	4.14E+10	1.70E+10	4.37E+08	0.00E+00
CS-136	5.65E+09	1.66E+10	6.21E+09	0.00E+00	6.63E+09	1.35E+09	2.52E+08	0.00E+00
CS-137	1.25E+11	1.46E+11	1.03E+10	0.00E+00	3.92E+10	1.59E+10	4.56E+08	0.00E+00
CS-138	2.70E-22	4.40E-22	2.13E-22	0.00E+00	2.19E-22	3.42E-23	7.03E-22	0.00E+00
BA-139	5.27E-08	3.49E-11	1.53E-09	0.00E+00	2.10E-11	2.12E-11	3.34E-06	0.00E+00
BA-140	2.76E+07	2.76E+04	1.42E+06	0.00E+00	6.56E+03	1.70E+04	6.79E+06	0.00E+00
LA-140	4.87E+00	1.92E+00	4.94E-01	0.00E+00	0.00E+00	0.00E+00	2.25E+04	0.00E+00
LA-142	2.09E-11	7.68E-12	1.84E-12	0.00E+00	0.00E+00	0.00E+00	1.30E-06	0.00E+00
CE-141	4.58E+03	2.80E+03	3.29E+02	0.00E+00	8.62E+02	0.00E+00	1.44E+06	0.00E+00
CE-143	4.77E+01	3.16E+04	3.61E+00	0.00E+00	9.21E+00	0.00E+00	1.85E+05	0.00E+00
CE-144	2.21E+05	9.03E+04	1.24E+04	0.00E+00	3.65E+04	0.00E+00	1.27E+07	0.00E+00
HF-181	8.23E+03	3.87E+01	7.27E+02	3.28E+01	2.27E+01	0.00E+00	6.75E+04	0.00E+00
W-187	7.30E+03	5.08E+03	1.75E+03	0.00E+00	0.00E+00	0.00E+00	2.98E+05	0.00E+00
NP-239	4.38E+00	3.92E-01	2.21E-01	0.00E+00	7.81E-01	0.00E+00	1.13E+04	0.00E+00

¹⁵ R Values in units of mrem/yr per $\mu\text{Ci}/\text{m}^3$ for inhalation and tritium, and units of $\text{m}^2\text{-mrem/yr}$ per $\mu\text{Ci}/\text{sec}$ for all others.

TABLE 3.5-16
R VALUES for the H.B. ROBINSON STEAM ELECTRIC PLANT¹⁶
 (Reference Regulatory Guide 1.109)

PATHWAY = Inhalation
 AGE GROUP = Adult

Nuclide	Bone	Liver	T.Body	Thyroid	Kidney	Lung	GI-Tract	Skin
H-3	0.00E+00	1.26E+03	1.26E+03	1.26E+03	1.26E+03	1.26E+03	1.26E+03	1.26E+03
F-18	4.99E+03	0.00E+00	5.54E+02	0.00E+00	0.00E+00	0.00E+00	1.48E+02	0.00E+00
NA-24	1.02E+04	1.02E+04	1.02E+04	1.02E+04	1.02E+04	1.02E+04	1.02E+04	0.00E+00
CR-51	0.00E+00	0.00E+00	1.00E+02	5.95E+01	2.28E+01	1.44E+04	3.32E+03	0.00E+00
MN-54	0.00E+00	3.96E+04	6.30E+03	0.00E+00	9.84E+03	1.40E+06	7.74E+04	0.00E+00
MN-56	0.00E+00	1.24E+00	1.83E-01	0.00E+00	1.30E+00	9.44E+03	2.02E+04	0.00E+00
FE-55	2.46E+04	1.70E+04	3.94E+03	0.00E+00	0.00E+00	7.21E+04	6.03E+03	0.00E+00
FE-59	1.18E+04	2.78E+04	1.06E+04	0.00E+00	0.00E+00	1.02E+06	1.88E+05	0.00E+00
CO-57	0.00E+00	6.92E+02	6.71E+02	0.00E+00	0.00E+00	3.70E+05	3.14E+04	0.00E+00
CO-58	0.00E+00	1.58E+03	2.07E+03	0.00E+00	0.00E+00	9.28E+05	1.06E+05	0.00E+00
CO-60	0.00E+00	1.15E+04	1.48E+04	0.00E+00	0.00E+00	5.97E+06	2.85E+05	0.00E+00
NI-65	1.54E+00	2.10E-01	9.12E-02	0.00E+00	0.00E+00	5.60E+03	1.23E+04	0.00E+00
CU-64	0.00E+00	1.46E+00	6.15E-01	0.00E+00	4.62E+00	6.78E+03	4.90E+04	0.00E+00
ZN-65	3.24E+04	1.03E+05	4.66E+04	0.00E+00	6.90E+04	8.64E+05	5.34E+04	0.00E+00
BR-82	0.00E+00	0.00E+00	1.35E+04	0.00E+00	0.00E+00	0.00E+00	1.04E+04	0.00E+00
BR-83	0.00E+00	0.00E+00	2.41E+02	0.00E+00	0.00E+00	0.00E+00	2.32E+02	0.00E+00
BR-84	0.00E+00	0.00E+00	3.13E+02	0.00E+00	0.00E+00	0.00E+00	1.64E-03	0.00E+00
RB-86	0.00E+00	1.35E+05	5.90E+04	0.00E+00	0.00E+00	0.00E+00	1.66E+04	0.00E+00
RB-88	0.00E+00	3.87E+02	1.93E+02	0.00E+00	0.00E+00	0.00E+00	3.34E-09	0.00E+00
RB-89	0.00E+00	2.56E+02	1.70E+02	0.00E+00	0.00E+00	0.00E+00	9.28E-12	0.00E+00
SR-89	3.04E+05	0.00E+00	8.72E+03	0.00E+00	0.00E+00	1.40E+06	3.50E+05	0.00E+00
SR-90	9.92E+07	0.00E+00	6.10E+06	0.00E+00	0.00E+00	9.60E+06	7.22E+05	0.00E+00
SR-91	6.19E+01	0.00E+00	2.50E+00	0.00E+00	0.00E+00	3.65E+04	1.91E+05	0.00E+00
SR-92	6.74E+00	0.00E+00	2.91E-01	0.00E+00	0.00E+00	1.65E+04	4.30E+04	0.00E+00
Y-91M	2.61E-01	0.00E+00	1.02E-02	0.00E+00	0.00E+00	1.92E+03	1.33E+00	0.00E+00
Y-91	4.62E+05	0.00E+00	1.24E+04	0.00E+00	0.00E+00	1.70E+06	3.85E+05	0.00E+00
Y-92	1.03E+01	0.00E+00	3.02E-01	0.00E+00	0.00E+00	1.57E+04	7.35E+04	0.00E+00
Y-93	9.44E+01	0.00E+00	2.61E+00	0.00E+00	0.00E+00	4.85E+04	4.22E+05	0.00E+00
ZR-95	1.07E+05	3.44E+04	2.33E+04	0.00E+00	5.42E+04	1.77E+06	1.50E+05	0.00E+00
ZR-97	9.68E+01	1.96E+01	9.04E+00	0.00E+00	2.97E+01	7.87E+04	5.23E+05	0.00E+00
NB-95	1.41E+04	7.82E+03	4.21E+03	0.00E+00	7.74E+03	5.05E+05	1.04E+05	0.00E+00
NB-97	2.22E-01	5.62E-02	2.05E-02	0.00E+00	6.54E-02	2.40E+03	2.42E+02	0.00E+00
MO-99	0.00E+00	1.21E+02	2.30E+01	0.00E+00	2.91E+02	9.12E+04	2.48E+05	0.00E+00
TC-99M	1.03E-03	2.91E-03	3.70E-02	0.00E+00	4.42E-02	7.64E+02	4.16E+03	0.00E+00
TC-101	4.18E-05	6.02E-05	5.90E-04	0.00E+00	1.08E-03	3.99E+02	1.09E-11	0.00E+00
RU-103	1.53E+03	0.00E+00	6.58E+02	0.00E+00	5.83E+03	5.05E+05	1.10E+05	0.00E+00
RU-105	7.90E-01	0.00E+00	3.11E-01	0.00E+00	1.02E+00	1.10E+04	4.82E+04	0.00E+00
RU-106	6.91E+04	0.00E+00	8.72E+03	0.00E+00	1.34E+05	9.36E+06	9.12E+05	0.00E+00
AG-110M	1.08E+04	1.00E+04	5.94E+03	0.00E+00	1.97E+04	4.63E+06	3.02E+05	0.00E+00
SN-113	6.86E+03	2.66E+02	6.48E+03	9.28E+01	1.97E+02	2.99E+05	2.48E+04	0.00E+00
SB-124	3.12E+04	5.89E+02	1.24E+04	7.55E+01	0.00E+00	2.48E+06	4.06E+05	0.00E+00
SB-125	5.34E+04	5.95E+02	1.26E+04	5.40E+01	0.00E+00	1.74E+06	1.01E+05	0.00E+00
TE-129M	9.76E+03	4.67E+03	1.58E+03	3.44E+03	3.66E+04	1.16E+06	3.83E+05	0.00E+00
TE-129	4.98E-02	2.39E-02	1.24E-02	3.90E-02	1.87E-01	1.94E+03	1.57E+02	0.00E+00
TE-131M	6.99E+01	4.36E+01	2.90E+01	5.50E+01	3.09E+02	1.46E+05	5.56E+05	0.00E+00
TE-132	2.60E+02	2.15E+02	1.62E+02	1.90E+02	1.46E+03	2.88E+05	5.10E+05	0.00E+00

¹⁶ R Values in units of mrem/yr per $\mu\text{Ci}/\text{m}^3$ for inhalation and tritium, and units of $\text{m}^2\text{-mrem}/\text{yr}$ per $\mu\text{Ci}/\text{sec}$ for all others.

TABLE 3.5-16 (continued)
R VALUES for the H.B. ROBINSON STEAM ELECTRIC PLANT¹⁶

PATHWAY = Inhalation
AGE GROUP = Adult

Nuclide	Bone	Liver	T.Body	Thyroid	Kidney	Lung	GI-Tract	Skin
I-131	2.52E+04	3.58E+04	2.05E+04	1.19E+07	6.13E+04	0.00E+00	6.28E+03	0.00E+00
I-132	1.16E+03	3.26E+03	1.16E+03	1.14E+05	5.18E+03	0.00E+00	4.06E+02	0.00E+00
I-133	8.64E+03	1.48E+04	4.52E+03	2.15E+06	2.58E+04	0.00E+00	8.88E+03	0.00E+00
I-134	6.44E+02	1.73E+03	6.15E+02	2.98E+04	2.75E+03	0.00E+00	1.01E+00	0.00E+00
I-135	2.68E+03	6.98E+03	2.57E+03	4.48E+05	1.11E+04	0.00E+00	5.25E+03	0.00E+00
CS-134	3.73E+05	8.48E+05	7.28E+05	0.00E+00	2.87E+05	9.76E+04	1.04E+04	0.00E+00
CS-136	3.90E+04	1.46E+05	1.10E+05	0.00E+00	8.56E+04	1.20E+04	1.17E+04	0.00E+00
CS-137	4.78E+05	6.21E+05	4.28E+05	0.00E+00	2.22E+05	7.52E+04	8.40E+03	0.00E+00
CS-138	3.31E+02	6.21E+02	3.24E+02	0.00E+00	4.80E+02	4.86E+01	1.86E-03	0.00E+00
BA-139	9.36E-01	6.66E-04	2.74E-02	0.00E+00	6.22E-04	3.76E+03	8.96E+02	0.00E+00
BA-140	3.90E+04	4.90E+01	2.57E+03	0.00E+00	1.67E+01	1.27E+06	2.18E+05	0.00E+00
BA-142	2.63E-02	2.70E-05	1.66E-03	0.00E+00	2.29E-05	1.19E+03	1.57E-16	0.00E+00
LA-140	3.44E+02	1.74E+02	4.58E+01	0.00E+00	0.00E+00	1.36E+05	4.58E+05	0.00E+00
LA-142	6.83E-01	3.10E-01	7.72E-02	0.00E+00	0.00E+00	6.33E+03	2.11E+03	0.00E+00
CE-141	1.99E+04	1.35E+04	1.53E+03	0.00E+00	6.26E+03	3.62E+05	1.20E+05	0.00E+00
CE-143	1.86E+02	1.38E+02	1.53E+01	0.00E+00	6.08E+01	7.98E+04	2.26E+05	0.00E+00
CE-144	3.43E+06	1.43E+06	1.84E+05	0.00E+00	8.48E+05	7.78E+06	8.16E+05	0.00E+00
PR-144	3.01E-02	1.25E-02	1.53E-03	0.00E+00	7.05E-03	1.02E+03	2.15E-08	0.00E+00
HF-181	4.56E+04	2.57E+02	5.15E+03	1.63E+03	2.14E+02	5.98E+05	1.29E+05	0.00E+00
W-187	8.48E+00	7.08E+00	2.48E+00	0.00E+00	0.00E+00	2.90E+04	1.55E+05	0.00E+00
NP-239	2.30E+02	2.26E+01	1.24E+01	0.00E+00	7.00E+01	3.76E+04	1.19E+05	0.00E+00

¹⁶ R Values in units of mrem/yr per $\mu\text{Ci}/\text{m}^3$ for inhalation and tritium, and units of $\text{m}^2\text{-mrem}/\text{yr}$ per $\mu\text{Ci}/\text{sec}$ for all others.

TABLE 3.5-17
R VALUES for the H.B. ROBINSON STEAM ELECTRIC PLANT¹⁷
 (Reference Regulatory Guide 1.109)

PATHWAY = Inhalation
 AGE GROUP = Teen

Nuclide	Bone	Liver	T.Body	Thyroid	Kidney	Lung	GI-Tract	Skin
H-3	0.00E+00	1.27E+03	1.27E+03	1.27E+03	1.27E+03	1.27E+03	1.27E+03	1.27E+03
F-18	5.22E+03	0.00E+00	5.68E+02	0.00E+00	0.00E+00	0.00E+00	3.11E+02	0.00E+00
NA-24	1.38E+04	1.38E+04	1.38E+04	1.38E+04	1.38E+04	1.38E+04	1.38E+04	0.00E+00
CR-51	0.00E+00	0.00E+00	1.35E+02	7.50E+01	3.07E+01	2.10E+04	3.00E+03	0.00E+00
MN-54	0.00E+00	5.11E+04	8.40E+03	0.00E+00	1.27E+04	1.98E+06	6.68E+04	0.00E+00
MN-56	0.00E+00	1.70E+00	2.52E-01	0.00E+00	1.79E+00	1.52E+04	5.74E+04	0.00E+00
FE-55	3.34E+04	2.38E+04	5.54E+03	0.00E+00	0.00E+00	1.24E+05	6.39E+03	0.00E+00
FE-59	1.59E+04	3.70E+04	1.43E+04	0.00E+00	0.00E+00	1.53E+06	1.78E+05	0.00E+00
CO-57	0.00E+00	9.44E+02	9.20E+02	0.00E+00	0.00E+00	5.86E+05	3.14E+04	0.00E+00
CO-58	0.00E+00	2.07E+03	2.78E+03	0.00E+00	0.00E+00	1.34E+06	9.52E+04	0.00E+00
CO-60	0.00E+00	1.51E+04	1.98E+04	0.00E+00	0.00E+00	8.72E+06	2.59E+05	0.00E+00
NI-65	2.18E+00	2.93E-01	1.27E-01	0.00E+00	0.00E+00	9.36E+03	3.67E+04	0.00E+00
CU-64	0.00E+00	2.03E+00	8.48E-01	0.00E+00	6.41E+00	1.11E+04	6.14E+04	0.00E+00
ZN-65	3.86E+04	1.34E+05	6.24E+04	0.00E+00	8.64E+04	1.24E+06	4.66E+04	0.00E+00
BR-82	0.00E+00	0.00E+00	1.82E+04	0.00E+00	0.00E+00	0.00E+00	0.00E+00	0.00E+00
BR-83	0.00E+00	0.00E+00	3.44E+02	0.00E+00	0.00E+00	0.00E+00	0.00E+00	0.00E+00
BR-84	0.00E+00	0.00E+00	4.33E+02	0.00E+00	0.00E+00	0.00E+00	0.00E+00	0.00E+00
RB-86	0.00E+00	1.90E+05	8.40E+04	0.00E+00	0.00E+00	0.00E+00	1.77E+04	0.00E+00
RB-88	0.00E+00	5.46E+02	2.72E+02	0.00E+00	0.00E+00	0.00E+00	2.92E-05	0.00E+00
RB-89	0.00E+00	3.52E+02	2.33E+02	0.00E+00	0.00E+00	0.00E+00	3.38E-07	0.00E+00
SR-89	4.34E+05	0.00E+00	1.25E+04	0.00E+00	0.00E+00	2.42E+06	3.71E+05	0.00E+00
SR-90	1.08E+08	0.00E+00	6.68E+06	0.00E+00	0.00E+00	1.65E+07	7.65E+05	0.00E+00
SR-91	8.80E+01	0.00E+00	3.51E+00	0.00E+00	0.00E+00	6.07E+04	2.59E+05	0.00E+00
SR-92	9.52E+00	0.00E+00	4.06E-01	0.00E+00	0.00E+00	2.74E+04	1.19E+05	0.00E+00
Y-91M	3.70E-01	0.00E+00	1.42E-02	0.00E+00	0.00E+00	3.20E+03	3.02E+01	0.00E+00
Y-91	6.61E+05	0.00E+00	1.77E+04	0.00E+00	0.00E+00	2.94E+06	4.09E+05	0.00E+00
Y-92	1.47E+01	0.00E+00	4.29E-01	0.00E+00	0.00E+00	2.68E+04	1.65E+05	0.00E+00
Y-93	1.35E+02	0.00E+00	3.72E+00	0.00E+00	0.00E+00	8.32E+04	5.79E+05	0.00E+00
ZR-95	1.46E+05	4.58E+04	3.15E+04	0.00E+00	6.74E+04	2.69E+06	1.49E+05	0.00E+00
ZR-97	1.38E+02	2.72E+01	1.26E+01	0.00E+00	4.12E+01	1.30E+05	6.30E+05	0.00E+00
NB-95	1.86E+04	1.03E+04	5.66E+03	0.00E+00	1.00E+04	7.51E+05	9.68E+04	0.00E+00
NB-97	3.14E-01	7.78E-02	2.84E-02	0.00E+00	9.12E-02	3.93E+03	2.17E+03	0.00E+00
MO-99	0.00E+00	1.69E+02	3.22E+01	0.00E+00	4.11E+02	1.54E+05	2.69E+05	0.00E+00
TC-99M	1.38E-03	3.86E-03	4.99E-02	0.00E+00	5.76E-02	1.15E+03	6.13E+03	0.00E+00
TC-101	5.92E-05	8.40E-05	8.24E-04	0.00E+00	1.52E-03	6.67E+02	8.72E-07	0.00E+00
RU-103	2.10E+03	0.00E+00	8.96E+02	0.00E+00	7.43E+03	7.83E+05	1.09E+05	0.00E+00
RU-105	1.12E+00	0.00E+00	4.34E-01	0.00E+00	1.41E+00	1.82E+04	9.04E+04	0.00E+00
RU-106	9.84E+04	0.00E+00	1.24E+04	0.00E+00	1.90E+05	1.61E+07	9.60E+05	0.00E+00
AG-110M	1.38E+04	1.31E+04	7.99E+03	0.00E+00	2.50E+04	6.75E+06	2.73E+05	0.00E+00
SN-113	8.16E+03	3.44E+02	8.64E+03	1.13E+02	2.46E+02	4.26E+05	2.03E+04	0.00E+00
SB-124	4.30E+04	7.94E+02	1.68E+04	9.76E+01	0.00E+00	3.85E+06	3.98E+05	0.00E+00
SB-125	7.38E+04	8.08E+02	1.72E+04	7.04E+01	0.00E+00	2.74E+06	9.92E+04	0.00E+00
TE-129M	1.39E+04	6.58E+03	2.25E+03	4.58E+03	5.19E+04	1.98E+06	4.05E+05	0.00E+00
TE-129	7.10E-02	3.38E-02	1.76E-02	5.18E-02	2.66E-01	3.30E+03	1.62E+03	0.00E+00
TE-131M	9.84E+01	6.01E+01	4.02E+01	7.25E+01	4.39E+02	2.38E+05	6.21E+05	0.00E+00
TE-132	3.60E+02	2.90E+02	2.19E+02	2.46E+02	1.95E+03	4.49E+05	4.63E+05	0.00E+00

¹⁷ R Values in units of mrem/yr per $\mu\text{Ci}/\text{m}^3$ for inhalation and tritium, and units of $\text{m}^2\text{-mrem}/\text{yr}$ per $\mu\text{Ci}/\text{sec}$ for all others.

TABLE 3.5-17 (continued)
R VALUES for the H.B. ROBINSON STEAM ELECTRIC PLANT¹⁷

PATHWAY = Inhalation
 AGE GROUP = Teen

Nuclide	Bone	Liver	T.Body	Thyroid	Kidney	Lung	GI-Tract	Skin
I-131	3.54E+04	4.91E+04	2.64E+04	1.46E+07	8.40E+04	0.00E+00	6.49E+03	0.00E+00
I-132	1.59E+03	4.38E+03	1.58E+03	1.51E+05	6.92E+03	0.00E+00	1.27E+03	0.00E+00
I-133	1.22E+04	2.05E+04	6.22E+03	2.92E+06	3.59E+04	0.00E+00	1.03E+04	0.00E+00
I-134	8.88E+02	2.32E+03	8.40E+02	3.95E+04	3.66E+03	0.00E+00	2.04E+01	0.00E+00
I-135	3.70E+03	9.44E+03	3.49E+03	6.21E+05	1.49E+04	0.00E+00	6.95E+03	0.00E+00
CS-134	5.02E+05	1.13E+06	5.49E+05	0.00E+00	3.75E+05	1.46E+05	9.76E+03	0.00E+00
CS-136	5.15E+04	1.94E+05	1.37E+05	0.00E+00	1.10E+05	1.78E+04	1.09E+04	0.00E+00
CS-137	6.70E+05	8.48E+05	3.11E+05	0.00E+00	3.04E+05	1.21E+05	8.48E+03	0.00E+00
CS-138	4.66E+02	8.56E+02	4.46E+02	0.00E+00	6.62E+02	7.87E+01	2.70E-01	0.00E+00
BA-139	1.34E+00	9.44E-04	3.90E-02	0.00E+00	8.88E-04	6.46E+03	6.45E+03	0.00E+00
BA-140	5.47E+04	6.70E+01	3.52E+03	0.00E+00	2.28E+01	2.03E+06	2.29E+05	0.00E+00
BA-142	3.70E-02	3.70E-05	2.27E-03	0.00E+00	3.14E-05	1.91E+03	4.79E-10	0.00E+00
LA-140	4.79E+02	2.36E+02	6.26E+01	0.00E+00	0.00E+00	2.14E+05	4.87E+05	0.00E+00
LA-142	9.60E-01	4.25E-01	1.06E-01	0.00E+00	0.00E+00	1.02E+04	1.20E+04	0.00E+00
CE-141	2.84E+04	1.90E+04	2.17E+03	0.00E+00	8.88E+03	6.14E+05	1.26E+05	0.00E+00
CE-143	2.66E+02	1.94E+02	2.16E+01	0.00E+00	8.64E+01	1.30E+05	2.55E+05	0.00E+00
CE-144	4.89E+06	2.02E+06	2.62E+05	0.00E+00	1.21E+06	1.34E+07	8.64E+05	0.00E+00
PR-144	4.30E-02	1.76E-02	2.18E-03	0.00E+00	1.01E-02	1.75E+03	2.35E-04	0.00E+00
HF-181	6.31E+04	3.47E+02	7.04E+03	2.12E+02	2.90E+02	9.36E+05	1.20E+05	0.00E+00
W-187	1.20E+01	9.76E+00	3.43E+00	0.00E+00	0.00E+00	4.74E+04	1.77E+05	0.00E+00
NP-239	3.38E+02	3.19E+01	1.77E+01	0.00E+00	1.00E+02	6.49E+04	1.32E+05	0.00E+00

¹⁷ R Values in units of mrem/yr per $\mu\text{Ci}/\text{m}^3$ for inhalation and tritium, and units of $\text{m}^2\text{-mrem}/\text{yr}$ per $\mu\text{Ci}/\text{sec}$ for all others.

TABLE 3.5-18
R VALUES for the H.B. ROBINSON STEAM ELECTRIC PLANT¹⁸
 (Reference Regulatory Guide 1.109)

PATHWAY = Inhalation
 AGE GROUP = Child

Nuclide	Bone	Liver	T.Body	Thyroid	Kidney	Lung	GI-Tract	Skin
H-3	0.00E+00	1.12E+03	1.12E+03	1.12E+03	1.12E+03	1.12E+03	1.12E+03	1.12E+03
F-18	6.96E+03	0.00E+00	6.85E+02	0.00E+00	0.00E+00	0.00E+00	1.25E+03	0.00E+00
NA-24	1.61E+04	1.61E+04	1.61E+04	1.61E+04	1.61E+04	1.61E+04	1.61E+04	0.00E+00
CR-51	0.00E+00	0.00E+00	1.54E+02	8.55E+01	2.43E+01	1.70E+04	1.08E+03	0.00E+00
MN-54	0.00E+00	4.29E+04	9.51E+03	0.00E+00	1.00E+04	1.58E+06	2.29E+04	0.00E+00
MN-56	0.00E+00	1.66E+00	3.12E-01	0.00E+00	1.67E+00	1.31E+04	1.23E+05	0.00E+00
FE-55	4.74E+04	2.52E+04	7.77E+03	0.00E+00	0.00E+00	1.11E+05	2.87E+03	0.00E+00
FE-59	2.07E+04	3.34E+04	1.67E+04	0.00E+00	0.00E+00	1.27E+06	7.07E+04	0.00E+00
CO-57	0.00E+00	9.03E+02	1.07E+03	0.00E+00	0.00E+00	5.07E+05	1.32E+04	0.00E+00
CO-58	0.00E+00	1.77E+03	3.16E+03	0.00E+00	0.00E+00	1.11E+06	3.44E+04	0.00E+00
CO-60	0.00E+00	1.31E+04	2.26E+04	0.00E+00	0.00E+00	7.07E+06	9.62E+04	0.00E+00
NI-65	2.99E+00	2.96E-01	1.64E-01	0.00E+00	0.00E+00	8.18E+03	8.40E+04	0.00E+00
CU-64	0.00E+00	1.99E+00	1.07E+00	0.00E+00	6.03E+00	9.58E+03	3.67E+04	0.00E+00
ZN-65	4.26E+04	1.13E+05	7.03E+04	0.00E+00	7.14E+04	9.95E+05	1.63E+04	0.00E+00
BR-82	0.00E+00	0.00E+00	2.09E+04	0.00E+00	0.00E+00	0.00E+00	0.00E+00	0.00E+00
BR-83	0.00E+00	0.00E+00	4.74E+02	0.00E+00	0.00E+00	0.00E+00	0.00E+00	0.00E+00
BR-84	0.00E+00	0.00E+00	5.48E+02	0.00E+00	0.00E+00	0.00E+00	0.00E+00	0.00E+00
RB-86	0.00E+00	1.98E+05	1.14E+05	0.00E+00	0.00E+00	0.00E+00	7.99E+03	0.00E+00
RB-88	0.00E+00	5.62E+02	3.66E+02	0.00E+00	0.00E+00	0.00E+00	1.72E+01	0.00E+00
RB-89	0.00E+00	3.45E+02	2.90E+02	0.00E+00	0.00E+00	0.00E+00	1.89E+00	0.00E+00
SR-89	5.99E+05	0.00E+00	1.72E+04	0.00E+00	0.00E+00	2.16E+06	1.67E+05	0.00E+00
SR-90	1.01E+08	0.00E+00	6.44E+06	0.00E+00	0.00E+00	1.48E+07	3.43E+05	0.00E+00
SR-91	1.21E+02	0.00E+00	4.59E+00	0.00E+00	0.00E+00	5.33E+04	1.74E+05	0.00E+00
SR-92	1.31E+01	0.00E+00	5.25E-01	0.00E+00	0.00E+00	2.40E+04	2.42E+05	0.00E+00
Y-91M	5.07E-01	0.00E+00	1.84E-02	0.00E+00	0.00E+00	2.81E+03	1.72E+03	0.00E+00
Y-91	9.14E+05	0.00E+00	2.44E+04	0.00E+00	0.00E+00	2.63E+06	1.84E+05	0.00E+00
Y-92	2.04E+01	0.00E+00	5.81E-01	0.00E+00	0.00E+00	2.39E+04	2.39E+05	0.00E+00
Y-93	1.86E+02	0.00E+00	5.11E+00	0.00E+00	0.00E+00	7.44E+04	3.89E+05	0.00E+00
ZR-95	1.90E+05	4.18E+04	3.70E+04	0.00E+00	5.96E+04	2.23E+06	6.11E+04	0.00E+00
ZR-97	1.88E+02	2.72E+01	1.60E+01	0.00E+00	3.88E+01	1.13E+05	3.51E+05	0.00E+00
NB-95	2.35E+04	9.18E+03	6.55E+03	0.00E+00	8.62E+03	6.14E+05	3.70E+04	0.00E+00
NB-97	4.29E-01	7.70E-02	3.50E-02	0.00E+00	8.55E-02	3.42E+03	2.78E+16	0.00E+00
MO-99	0.00E+00	1.72E+02	4.25E+01	0.00E+00	3.92E+02	1.35E+05	1.27E+05	0.00E+00
TC-99M	1.78E-03	3.48E-03	5.77E-02	0.00E+00	5.07E-02	9.51E+02	4.81E+03	0.00E+00
TC-101	8.10E-05	8.51E-05	1.08E-03	0.00E+00	1.45E-03	5.85E+02	1.63E+01	0.00E+00
RU-103	2.79E+03	0.00E+00	1.07E+03	0.00E+00	7.03E+03	6.62E+05	4.48E+04	0.00E+00
RU-105	1.53E+00	0.00E+00	5.55E-01	0.00E+00	1.34E+00	1.59E+04	9.95E+04	0.00E+00
RU-106	1.36E+05	0.00E+00	1.69E+04	0.00E+00	1.84E+05	1.43E+07	4.29E+05	0.00E+00
AG-110M	1.69E+04	1.14E+04	9.14E+03	0.00E+00	2.12E+04	5.48E+06	1.00E+05	0.00E+00
SN-113	8.99E+03	2.90E+02	9.81E+03	1.19E+02	2.03E+02	3.40E+05	7.44E+03	0.00E+00
SB-124	5.74E+04	7.40E+02	2.00E+04	1.26E+02	0.00E+00	3.24E+06	1.64E+05	0.00E+00
SB-125	9.84E+04	7.59E+02	2.07E+04	9.10E+01	0.00E+00	2.32E+06	4.03E+04	0.00E+00
TE-129M	1.92E+04	6.85E+03	3.04E+03	6.33E+03	5.03E+04	1.76E+06	1.82E+05	0.00E+00
TE-129	9.77E-02	3.50E-02	2.38E-02	7.14E-02	2.57E-01	2.93E+03	2.55E+04	0.00E+00
TE-131M	1.34E+02	5.92E+01	5.07E+01	9.77E+01	4.00E+02	2.06E+05	3.08E+05	0.00E+00
TE-132	4.81E+02	2.72E+02	2.63E+02	3.17E+02	1.77E+03	3.77E+05	1.38E+05	0.00E+00

¹⁸ R Values in units of mrem/yr per $\mu\text{Ci}/\text{m}^3$ for inhalation and tritium, and units of $\text{m}^2\text{-mrem}/\text{yr}$ per $\mu\text{Ci}/\text{sec}$ for all others.

TABLE 3.5-18 (continued)
R VALUES for the H.B. ROBINSON STEAM ELECTRIC PLANT¹⁸

PATHWAY = Inhalation
 AGE GROUP = Child

Nuclide	Bone	Liver	T.Body	Thyroid	Kidney	Lung	GI-Tract	Skin
I-131	4.81E+04	4.81E+04	2.73E+04	1.62E+07	7.88E+04	0.00E+00	2.84E+03	0.00E+00
I-132	2.12E+03	4.07E+03	1.88E+03	1.94E+05	6.25E+03	0.00E+00	3.20E+03	0.00E+00
I-133	1.66E+04	2.03E+04	7.70E+03	3.85E+06	3.38E+04	0.00E+00	5.48E+03	0.00E+00
I-134	1.17E+03	2.16E+03	9.95E+02	5.07E+04	3.30E+03	0.00E+00	9.55E+02	0.00E+00
I-135	4.92E+03	8.73E+03	4.14E+03	7.92E+05	1.34E+04	0.00E+00	4.44E+03	0.00E+00
CS-134	6.51E+05	1.01E+06	2.25E+05	0.00E+00	3.30E+05	1.21E+05	3.85E+03	0.00E+00
CS-136	6.51E+04	1.71E+05	1.16E+05	0.00E+00	9.55E+04	1.45E+04	4.18E+03	0.00E+00
CS-137	9.07E+05	8.25E+05	1.28E+05	0.00E+00	2.82E+05	1.04E+05	3.62E+03	0.00E+00
CS-138	6.33E+02	8.40E+02	5.55E+02	0.00E+00	6.22E+02	6.81E+01	2.70E+02	0.00E+00
BA-139	1.84E+00	9.84E-04	5.36E-02	0.00E+00	8.62E-04	5.77E+03	5.77E+04	0.00E+00
BA-140	7.40E+04	6.48E+01	4.33E+03	0.00E+00	2.11E+01	1.74E+06	1.02E+05	0.00E+00
BA-142	4.99E-02	3.60E-05	2.79E-03	0.00E+00	2.91E-05	1.64E+03	2.74E+00	0.00E+00
LA-140	6.44E+02	2.25E+02	7.55E+01	0.00E+00	0.00E+00	1.83E+05	2.26E+05	0.00E+00
LA-142	1.29E+00	4.11E-01	1.29E-01	0.00E+00	0.00E+00	8.70E+03	7.59E+04	0.00E+00
CE-141	3.92E+04	1.95E+04	2.90E+03	0.00E+00	8.55E+03	5.44E+05	5.66E+04	0.00E+00
CE-143	3.66E+02	1.99E+02	2.87E+01	0.00E+00	8.36E+01	1.15E+05	1.27E+05	0.00E+00
CE-144	6.77E+06	2.12E+06	3.61E+05	0.00E+00	1.17E+06	1.20E+07	3.89E+05	0.00E+00
PR-144	5.96E-02	1.85E-02	3.00E-03	0.00E+00	9.77E-03	1.57E+03	1.97E+02	0.00E+00
HF-181	8.33E+04	3.28E+02	8.47E+03	2.76E+02	2.63E+02	7.96E+05	5.29E+04	0.00E+00
W-187	1.63E+01	9.66E+00	4.33E+00	0.00E+00	0.00E+00	4.11E+04	9.10E+04	0.00E+00
NP-239	4.66E+02	3.34E+01	2.35E+01	0.00E+00	9.73E+01	5.81E+04	6.40E+04	0.00E+00

¹⁸ R Values in units of mrem/yr per $\mu\text{Ci}/\text{m}^3$ for inhalation and tritium, and units of $\text{m}^2\text{-mrem}/\text{yr}$ per $\mu\text{Ci}/\text{sec}$ for all others.

TABLE 3.5-19
R VALUES for the H.B. ROBINSON STEAM ELECTRIC PLANT¹⁹
 (Reference Regulatory Guide 1.109)

PATHWAY = Inhalation
 AGE GROUP = Infant

Nuclide	Bone	Liver	T.Body	Thyroid	Kidney	Lung	GI-Tract	Skin
H-3	0.00E+00	6.47E+02	6.47E+02	6.47E+02	6.47E+02	6.47E+02	6.47E+02	6.47E+02
F-18	5.49E+03	0.00E+00	4.66E+02	0.00E+00	0.00E+00	0.00E+00	8.54E+02	0.00E+00
NA-24	1.06E+04	1.06E+04	1.06E+04	1.06E+04	1.06E+04	1.06E+04	1.06E+04	0.00E+00
CR-51	0.00E+00	0.00E+00	8.95E+01	5.75E+01	1.32E+01	1.28E+04	3.57E+02	0.00E+00
MN-54	0.00E+00	2.53E+04	4.98E+03	0.00E+00	4.98E+03	1.00E+06	7.06E+03	0.00E+00
MN-56	0.00E+00	1.54E+00	2.21E-01	0.00E+00	1.10E+00	1.25E+04	7.17E+04	0.00E+00
FE-55	1.97E+04	1.17E+04	3.33E+03	0.00E+00	0.00E+00	8.69E+04	1.09E+03	0.00E+00
FE-59	1.36E+04	2.35E+04	9.48E+03	0.00E+00	0.00E+00	1.02E+06	2.48E+04	0.00E+00
CO-57	0.00E+00	6.51E+02	6.41E+02	0.00E+00	0.00E+00	3.79E+05	4.86E+03	0.00E+00
CO-58	0.00E+00	1.22E+03	1.82E+03	0.00E+00	0.00E+00	7.77E+05	1.11E+04	0.00E+00
CO-60	0.00E+00	8.02E+03	1.18E+04	0.00E+00	0.00E+00	4.51E+06	3.19E+04	0.00E+00
NI-65	2.39E+00	2.84E-01	1.23E-01	0.00E+00	0.00E+00	8.12E+03	5.01E+04	0.00E+00
CU-64	0.00E+00	1.88E+00	7.74E-01	0.00E+00	3.98E+00	9.30E+03	1.50E+04	0.00E+00
ZN-65	1.93E+04	6.26E+04	3.11E+04	0.00E+00	3.25E+04	6.47E+05	5.14E+04	0.00E+00
BR-82	0.00E+00	0.00E+00	1.33E+04	0.00E+00	0.00E+00	0.00E+00	0.00E+00	0.00E+00
BR-83	0.00E+00	0.00E+00	3.81E+02	0.00E+00	0.00E+00	0.00E+00	0.00E+00	0.00E+00
BR-84	0.00E+00	0.00E+00	4.00E+02	0.00E+00	0.00E+00	0.00E+00	0.00E+00	0.00E+00
RB-86	0.00E+00	1.90E+05	8.82E+04	0.00E+00	0.00E+00	0.00E+00	3.04E+03	0.00E+00
RB-88	0.00E+00	5.57E+02	2.87E+02	0.00E+00	0.00E+00	0.00E+00	3.39E+02	0.00E+00
RB-89	0.00E+00	3.21E+02	2.06E+02	0.00E+00	0.00E+00	0.00E+00	6.82E+01	0.00E+00
SR-89	3.98E+05	0.00E+00	1.14E+04	0.00E+00	0.00E+00	2.03E+06	6.40E+04	0.00E+00
SR-90	4.09E+07	0.00E+00	2.59E+06	0.00E+00	0.00E+00	1.12E+07	1.31E+05	0.00E+00
SR-91	9.56E+01	0.00E+00	3.46E+00	0.00E+00	0.00E+00	5.26E+04	7.34E+04	0.00E+00
SR-92	1.05E+01	0.00E+00	3.91E-01	0.00E+00	0.00E+00	2.38E+04	1.40E+05	0.00E+00
Y-91M	4.07E-01	0.00E+00	1.39E-02	0.00E+00	0.00E+00	2.79E+03	2.35E+03	0.00E+00
Y-91	5.88E+05	0.00E+00	1.57E+04	0.00E+00	0.00E+00	2.45E+06	7.03E+04	0.00E+00
Y-92	1.64E+01	0.00E+00	4.61E-01	0.00E+00	0.00E+00	2.45E+04	1.27E+05	0.00E+00
Y-93	1.50E+02	0.00E+00	4.07E+00	0.00E+00	0.00E+00	7.64E+04	1.67E+05	0.00E+00
ZR-95	1.15E+05	2.79E+04	2.03E+04	0.00E+00	3.11E+04	1.75E+06	2.17E+04	0.00E+00
ZR-97	1.50E+02	2.56E+01	1.17E+01	0.00E+00	2.59E+01	1.10E+05	1.40E+05	0.00E+00
NB-95	1.57E+04	6.43E+03	3.78E+03	0.00E+00	4.72E+03	4.79E+05	1.27E+04	0.00E+00
NB-97	3.42E-01	7.29E-02	2.63E-02	0.00E+00	5.70E-02	3.32E+03	2.69E+04	0.00E+00
MO-99	0.00E+00	1.65E+02	3.23E+01	0.00E+00	2.65E+02	1.35E+05	4.87E+04	0.00E+00
TC-99M	1.40E-03	2.88E-03	3.72E-02	0.00E+00	3.11E-02	8.11E+02	2.03E+03	0.00E+00
TC-101	6.51E-05	8.23E-05	8.12E-04	0.00E+00	9.79E-04	5.84E+02	8.44E+02	0.00E+00
RU-103	2.02E+03	0.00E+00	6.79E+02	0.00E+00	4.24E+03	5.52E+05	1.61E+04	0.00E+00
RU-105	1.22E+00	0.00E+00	4.10E-01	0.00E+00	8.99E-01	1.57E+04	4.84E+04	0.00E+00
RU-106	8.68E+04	0.00E+00	1.09E+04	0.00E+00	1.07E+05	1.16E+07	1.64E+05	0.00E+00
AG-110M	9.98E+03	7.22E+03	5.00E+03	0.00E+00	1.09E+04	3.67E+06	3.30E+04	0.00E+00
SN-113	4.68E+03	1.74E+02	4.89E+03	6.72E+01	9.94E+01	2.30E+05	2.28E+03	0.00E+00
SB-124	3.04E+04	5.56E+02	1.20E+04	1.01E+02	0.00E+00	2.65E+06	3.42E+04	0.00E+00
SB-125	5.17E+04	4.77E+02	1.09E+04	6.23E+00	5.70E-02	3.32E+03	2.69E+04	0.00E+00
TE-129M	1.41E+04	6.09E+03	2.23E+03	5.47E+03	3.18E+04	1.68E+06	6.90E+04	0.00E+00
TE-129	7.88E-02	3.47E-02	1.88E-02	6.75E-02	1.75E-01	3.00E+03	2.63E+04	0.00E+00
TE-131M	1.07E+02	5.50E+01	3.63E+01	8.93E+01	2.65E+02	1.99E+05	1.19E+05	0.00E+00
TE-132	3.72E+02	2.37E+02	1.76E+02	2.79E+02	1.03E+03	3.40E+05	4.41E+04	0.00E+00

¹⁹ R Values in units of mrem/yr per $\mu\text{Ci}/\text{m}^3$ for inhalation and tritium, and units of $\text{m}^2\text{-mrem}/\text{yr}$ per $\mu\text{Ci}/\text{sec}$ for all others.

TABLE 3.5-19 (continued)
R VALUES for the H.B. ROBINSON STEAM ELECTRIC PLANT¹⁹

PATHWAY = Inhalation
 AGE GROUP = Infant

Nuclide	Bone	Liver	T.Body	Thyroid	Kidney	Lung	GI-Tract	Skin
I-131	3.79E+04	4.44E+04	1.96E+04	1.48E+07	5.18E+04	0.00E+00	1.06E+03	0.00E+00
I-132	1.69E+03	3.54E+03	1.26E+03	1.69E+05	3.95E+03	0.00E+00	1.90E+03	0.00E+00
I-133	1.32E+04	1.92E+04	5.60E+03	3.56E+06	2.24E+04	0.00E+00	2.16E+03	0.00E+00
I-134	9.21E+02	1.88E+03	6.65E+02	4.45E+04	2.09E+03	0.00E+00	1.29E+03	0.00E+00
I-135	3.86E+03	7.60E+03	2.77E+03	6.96E+05	8.47E+03	0.00E+00	1.83E+03	0.00E+00
CS-134	3.96E+05	7.03E+05	7.45E+04	0.00E+00	1.90E+05	7.97E+04	1.33E+03	0.00E+00
CS-136	4.83E+04	1.35E+05	5.29E+04	0.00E+00	5.64E+04	1.18E+04	1.43E+03	0.00E+00
CS-137	5.49E+05	6.12E+05	4.55E+04	0.00E+00	1.72E+05	7.13E+04	1.33E+03	0.00E+00
CS-138	5.05E+02	7.81E+02	3.98E+02	0.00E+00	4.10E+02	6.54E+01	8.76E+02	0.00E+00
BA-139	1.48E+00	9.84E-04	4.30E-02	0.00E+00	5.92E-04	5.95E+03	5.10E+04	0.00E+00
BA-140	5.60E+04	5.60E+01	2.90E+03	0.00E+00	1.34E+01	1.60E+06	3.84E+04	0.00E+00
BA-142	3.98E-02	3.30E-05	1.96E-03	0.00E+00	1.90E-05	1.55E+03	6.93E+02	0.00E+00
LA-140	5.05E+02	2.00E+02	5.15E+01	0.00E+00	0.00E+00	1.68E+05	8.48E+04	0.00E+00
LA-142	1.03E+00	3.77E-01	9.04E-02	0.00E+00	0.00E+00	8.22E+03	5.95E+04	0.00E+00
CE-141	2.77E+04	1.67E+04	1.99E+03	0.00E+00	5.25E+03	5.17E+05	2.16E+04	0.00E+00
CE-143	2.93E+02	1.93E+02	2.21E+01	0.00E+00	5.64E+01	1.16E+05	4.97E+04	0.00E+00
CE-144	3.19E+06	1.21E+06	1.76E+05	0.00E+00	5.38E+05	9.84E+06	1.48E+05	0.00E+00
PR-144	4.79E-02	1.85E-02	2.41E-03	0.00E+00	6.72E-03	1.61E+03	4.28E+03	0.00E+00
HF-181	5.64E+04	2.66E+02	5.05E+03	2.25E+02	1.58E+02	6.72E+05	1.90E+04	0.00E+00
W-187	1.30E+01	9.02E+00	3.12E+00	0.00E+00	0.00E+00	3.96E+04	3.56E+04	0.00E+00
NP-239	3.71E+02	3.32E+01	1.88E+01	0.00E+00	6.62E+01	5.95E+04	2.49E+04	0.00E+00

¹⁹ R Values in units of mrem/yr per $\mu\text{Ci}/\text{m}^3$ for inhalation and tritium, and units of $\text{m}^2\text{-mrem}/\text{yr}$ per $\mu\text{Ci}/\text{sec}$ for all others.

3.6 Methodology for R-11 Setpoint (Air Particulate)

Determine the Monitor Alarm Setpoint based on the inhalation pathway to the child. The most restrictive organ 'j' will be determined from the following methodology.

3.6.1 Determine dose rate for organ 'j' (mrem/yr).

$$DR_j = (\overline{\chi/Q}) \sum_i (R_{ij} * Q_i) \tag{3.6-1}$$

where:

$(\overline{\chi/Q})$ = the highest calculated annual average relative dispersion factor for any area at or beyond the unrestricted area boundary for all sectors from Appendix A (sec/m^3).
 = $8.1\text{E-}05 \text{ sec/m}^3$ (continuous ground release) from Table A-1, Appendix A.

R_{ij} = the organ 'j' dose factor due to gamma emissions from particulates greater than or equal to 8 day half-life, I-133, I-131, and H-3.

Q_i = the particulate release rate for radionuclide 'i' ($\mu\text{Ci/sec}$).

$$Q_i = 472 * C_i * F$$

where:

472 = A conversion factor to convert cfm to cm^3/sec .

When R-11 is sampling the Plant Vent for C.V. Purges:

C_i = $(\frac{\mu\text{Ci}}{\text{cm}^3} \text{ from analysis of Containment Vessel} * 0.366 * \text{DF}) + (\frac{\mu\text{Ci}}{\text{cm}^3} \text{ from analysis of Plant Vent} * 0.634)$

0.366 = Dilution correction factor for C.V. Purge.
 = $\frac{35,000 \text{ cfm}}{(60,600+35,000) \text{ cfm}}$

0.634 = Dilution correction factor for Plant Vent during C.V. Purge.
 = $\frac{60,600 \text{ cfm}}{(60,600+35,000) \text{ cfm}}$

When R-11 is sampling the Plant Vent for C.V. Pressure Relief:

$$C_i = \left(\frac{\mu\text{Ci}}{\text{cm}^3} \text{ from analysis of Containment Vent} * 0.040 * DF \right) + \left(\frac{\mu\text{Ci}}{\text{cm}^3} \text{ from analysis of Plant Vent} * 0.960 \right)$$

$$0.040 = \text{Dilution correction factor for C.V. Pressure Relief.}$$

$$= \frac{2,500^\dagger \text{ cfm}}{(60,600 + 2,500^\dagger) \text{ cfm}}$$

$$0.960 = \text{Dilution correction factor for Plant Vent during C.V. Pressure Relief.}$$

$$= \frac{60,600 \text{ cfm}}{(60,600 + 2,500^\dagger) \text{ cfm}}$$

When R-11 is sampling C.V. :

$$C_i = \left(\frac{\mu\text{Ci}}{\text{cm}^3} \text{ from analysis of Containment Vent} * DF \right)$$

$$DF = \text{Filter removal factor (dimensionless).}$$

$$= 1.0 \text{ for Tritium.}$$

$$= 10 \text{ for Iodines when using charcoal filters.}$$

$$= 100 \text{ for Particulates } \geq 8 \text{ day half-lives when using HEPA Filters.}$$

$$F = \text{The maximum acceptable effluent flow rate at the point of release (cfm).}$$

$$= 95,600 \text{ cfm for CV purge when R-11 is sampling from Plant Vent.}$$

$$= 35,000 \text{ cfm for CV purge when R-11 is sampling from CV.}$$

$$= 2,500 \text{ cfm for CV pressure relief when R-11 is sampling from CV.}$$

$$= 63,100 \text{ cfm for CV pressure relief when R-11 is sampling Plant Vent.}$$

† 2,500 CFM - Refer to Appendix B.3 for additional information

3.6.2 Determine the particulate emission Projected Dose Rate Ratio (PDRR) for the most critical organ 'j'.

$$PDRR_j = \frac{DR_j}{1500} \tag{3.6-2}$$

where:

$$1500 = \text{the allowable organ dose rate due to particulates with } \geq 8 \text{ day half-life, I-131, I-133, H-3 (mrem/year).}$$

3.6.3 Determine the maximum monitor setpoint concentration ($\mu\text{Ci}/\text{cm}^3$) for the most critical organ 'j'.

$$\text{Maximum Monitor Setpoint for Organ 'j'} = \frac{\sum_i C_i}{PDRR_j} * S * T_m * TL \quad (3.6-3)$$

where:

- S = 0.5, an engineering factor used to provide a margin of safety for cumulative measurement uncertainties.
- T_m = fraction of the radioactivity from the site that may be released via the monitored pathway to ensure that the site boundary limit is not exceeded due to simultaneous releases from several pathways.
= 0.81 for R-11 particulate monitor.
- T_L = total activity divided by $\sum_i C_i$, where the total activity is the sum of all detectable particulates from analysis of particulate filter divided by the detectable particulates of ≥ 8 day half-lives. If this ratio is not known use 1.0.
= 1.0 when R-11 sampling from Plant Vent.

3.6.4 Determine the maximum monitor setpoint (cpm) for the most critical organ 'j'.

$$\text{Setpoint} = \left(\text{Maximum Monitor Setpoint for Organ 'j' in } \frac{\mu\text{Ci}}{\text{cm}^3} \right) * (\text{Monitor Eff}) + \text{Bkg} \quad (3.6-4)$$

where:

- Monitor Eff = monitor efficiency obtained from the applicable effluent monitor curve efficiency located in the Station Curve Book. Use the radioactivity concentration ($\mu\text{Ci}/\text{cc}$) to find cpm.
- Bkg = the monitor background (cpm).

3.7 Deleted

3.8 Deleted

3.9 Methodology for R-22 Setpoint Determination for the Iodine and Particulate Monitors

This section describes the methodology in determining high alarm setpoint for the particulate and iodine channels for the Environmental and Radiation Control Building (R-22) based on the inhalation pathway to the most restrictive organ and age group (child).

3.9.1

The dose rate in an unrestricted area resulting from the release of radioiodines, tritium, and particulates with half-lives ≥ 8 days is limited to 1500 mrem/yr to any organ via inhalation (10 CFR 20). The iodine and particulate monitor setpoints for R-22 are limited to 1.0% of 10 CFR 20 over one hour period. Therefore, the iodine and particulate channels high alarms shall be set to 1.0% of 10 CFR 20 for any given hour.

3.9.2 Determine Q_i , the maximum release rate ($\mu\text{Ci}/\text{sec}$) for Iodine-131 and Cobalt-60 (the most restrictive particulate ≥ 8 day half-life) based on the most restrictive organ 'j' via inhalation to a child.

$$Q_i = \frac{15}{R_i * (\overline{\chi/Q})} \quad (3.9-1)$$

where:

15 = 1.0% of the maximum allowable dose rate in an unrestricted area in gaseous effluents due to radioparticulates with half-lives greater than or equal to 8 days, radioiodine, and tritium via the inhalation pathway to the child (mrem/yr).

R_i = The dose factor based on the most restrictive age group (child) and the most restrictive organ (thyroid) for Iodine-131 ($1.62\text{E}+07$ mrem/yr per $\mu\text{Ci}/\text{m}^3$) and lung for Co-60 ($7.06\text{E}+06$ mrem/yr per $\mu\text{Ci}/\text{m}^3$) at the most restrictive location (SITE BOUNDARY).

$(\overline{\chi/Q})$ = Annual average relative dilution for continuous ground level releases for the most restrictive section at the SITE BOUNDARY ($8.08\text{E}-05$ sec/ m^3 for the SSE sector from Table A-1).

Therefore:

$Q_{i,\text{Iodine-131}}$ = $1.15\text{E}-02$ $\mu\text{Ci}/\text{sec}$

$Q_{i,\text{Cobalt-60}}$ = $2.63\text{E}-22$ $\mu\text{Ci}/\text{sec}$

3.9.3 Determine $S_{C,i}$, the air particulate filter and charcoal cartridge sample collection rate ($\mu\text{Ci}/\text{sec}$) by:

$$S_{C,i} = Q_i * \frac{f}{F} \tag{3.9-2}$$

where:

f = typical value is 2.5 cfm for R-22, sampler flow rate (cfm).

F = typical value is 11,500 cfm, Environmental and Radiation Control Building exhaust vent flow rate (cfm).

Therefore:

The typical Co-60 sample collection rate is 5.72E-06 $\mu\text{Ci}/\text{sec}$ for R-22.

The typical I-131 sample collection rate is 2.5E-06 $\mu\text{Ci}/\text{sec}$ for R-22.

3.9.4 Determine $Q_{m,i}$, the setpoint activity (μCi) accumulated on the air particulate filter and charcoal filter for any given hour by:

$$Q_{m,i} = S_{C,i} * T \tag{3.9-3}$$

where:

T = 3600 (sec/hr).

Therefore:

The typical setpoint activity for the air particulate filter and the charcoal cartridge is:

<u>Monitor</u>	<u>Particulate</u>	<u>Iodine</u>
R-22	2.06E-02	9.00E-03

3.9.5 Determine HSP, the High Alarm Setpoint including background (cpm) by:

$$HSP = (Q_{m,i} * E_m) + Bkg \quad (3.9-4)$$

where:

E_m = efficiency of the detector (cpm/ μ Ci).

Bkg = the background of the detector (cpm).

The above methodology shall be used for the iodine cartridge and air particulate filter setpoint determinations for the Environmental and Radiation Control Building. The sampling and building vent flow rates used in the above equations are subject to change and shall be controlled by plant procedures. If or when this occurs, the recalculations of setpoints shall be performed by approved procedures using the above methodology.

3.10 Radioactive Gaseous Effluent Monitoring Instrumentation

Applicability

Applies to the radioactive gaseous effluent instrumentation system.

Objective

To define the operating requirements for the radioactive gaseous effluent instrumentation system.

Specification

CONTROLS

3.10.1 The radioactive gaseous effluent monitoring instrumentation channels shown in Table 3.10-1 shall be operable with their alarm/trip setpoints set to ensure that the limits of ODCM Specification 3.2.1 are not exceeded. The alarm/trip setpoints of these channels shall be determined in accordance with the ODCM.

ACTIONS

3.10.2 With a radioactive effluent monitoring instrumentation channel alarm/trip setpoint less conservative than required by the above specification, without delay suspend the release of radioactive gaseous effluents, change the setpoint so it is acceptably conservative, or declare the channel not operable.

3.10.3 With less than the minimum number of radioactive gaseous effluent monitoring instrumentation channels operable take the action shown in Table 3.10-1.

3.10.4 The provisions of ODCM Specification 8.1 are not applicable.

BASES

Radioactive Gaseous Effluent Instrumentation

The radioactive gaseous effluent monitoring instrumentation is provided to monitor and control, as applicable, the releases of radioactive materials in gaseous effluents during actual or potential releases of gaseous effluents. The alarm/trip setpoints for these instruments shall be calculated in accordance with the procedures in the ODCM to ensure that the alarm/trip will occur prior to exceeding the limits of 10 CFR Part 20, Appendix B, Table 2, Column 1. The operability and use of this instrumentation are consistent with the requirements of General Design Criteria 60, 63, and 64 of Appendix A to 10 CFR Part 50.

TABLE 3.10-1
RADIOACTIVE GASEOUS EFFLUENT MONITORING INSTRUMENTATION

Release Pathway/Instrumentation	MCO*	Compensatory Measures
<p>1. Plant Vent (R-14)</p> <p>a. Radionoble gas monitor (R14C) provides automatic termination of Waste Gas Decay Tank releases upon exceeding alarm/trip setpoint.</p> <p>b. Radionoble gas monitor (R14C) monitors all effluents from Auxiliary Building Ventilation System without providing automatic termination of release upon exceeding their respective alarm setpoints.</p>	<p>1</p> <p>1</p>	<p>With the number of channels operable less than the MCO requirements:</p> <p>a. Exert best efforts to return the instruments to operable status within 30 days and, if unsuccessful, explain in the next Annual Radioactive Effluent Release Report why the inoperability was not corrected in a timely manner in accordance with Technical Specification 5.6.3 and,</p> <p>b. Effluent releases via this pathway may continue provided that prior to initiating a waste gas decay tank release:</p> <ol style="list-style-type: none"> 1. Two independent samples are analyzed in accordance with the Surveillance Requirements of ODCM Specification 3.2.1 and; 2. Two members of the facility staff independently verify the release rate calculations and the discharge line valving. <p>With the number of channels operable less than the MCO requirement:</p> <p>a. Exert best efforts to return the instruments to operable status within 30 days and, if unsuccessful, explain in the next Annual Radioactive Effluent Release Report why the inoperability was not corrected in a timely manner in accordance with Technical Specification 5.6.3 and,</p> <p>b. Effluent releases via this pathway may continue provided that grab samples are collected once per 12 hours and are analyzed for radionoble gases within 24 hours.</p>

* MCO - Minimum Channels Operable

TABLE 3.10-1 (continued)
RADIOACTIVE GASEOUS EFFLUENT MONITORING INSTRUMENTATION

Release Pathway/Instrumentation	MCO*	Compensatory Measures
1. Plant Vent (Continued)		
c. Radioiodine Sampler	1	With the number of channels operable less than the MCO requirements: a. Exert best efforts to return the instruments to operable status within 30 days and, if unsuccessful, explain in the next Annual Radioactive Effluent Release Report why the inoperability was not corrected in a timely manner in accordance with Technical Specification 5.6.3 and, b. Effluent releases via this pathway may continue provided that a continuous sample is collected utilizing auxiliary sampling equipment as required by Table 3.12-1. (note 1)
d. Particulate Sampler	1	With the number of channels operable less than the MCO requirement: a. Exert best efforts to return the instruments to operable status within 30 days and, if unsuccessful, explain in the next Annual Radioactive Effluent Release Report why the inoperability was not corrected in a timely manner in accordance with Technical Specification 5.6.3 and, b. Effluent releases via this pathway may be continued, provided that a continuous sample is collected utilizing auxiliary sampling equipment as required by Table 3.12-1. (note 1)
e. Sampler flow rate monitor	1	With the number of channels operable less than the MCO requirement: a. Exert best efforts to return the instruments to operable status within 30 days and, if unsuccessful, explain in the next Annual Radioactive Effluent Release Report why the inoperability was not corrected in a timely manner in accordance with Technical Specification 5.6.3 and, b. Effluent releases via this pathway may continue provided the flow rate is estimated once per 4 hours.

* MCO - Minimum Channels Operable

TABLE 3.10-1 (continued)
RADIOACTIVE GASEOUS EFFLUENT MONITORING INSTRUMENTATION

Release Pathway/Instrumentation	MCO*	Compensatory Measures
1. Plant Vent (Continued) f. Plant Vent flow rate	1	With the number of channels operable less than the MCO requirement: a. Exert best efforts to return the instruments to operable status within 30 days and, if unsuccessful, explain in the next Annual Radioactive Effluent Release Report why the inoperability was not corrected in a timely manner in accordance with Technical Specification 5.6.3 and, b. Effluent releases via this pathway may continue provided that flow rate is estimated once per 4 hours.
2. Containment Vessel via Plant Vent a. Radionoble gas monitor (R-12) provides automatic termination of Containment Vessel releases upon exceeding alarm/trip Setpoint.	1	With the number of channels operable less than the MCO requirement: a. Exert best efforts to return the instruments to operable status within 30 days and, if unsuccessful, explain in the next Annual Radioactive Effluent Release Report why the inoperability was not corrected in a timely manner in accordance with Technical Specification 5.6.3 and, b. Effluent releases via this pathway may continue provided that the Plant Vent Radionoble Gas Monitor (R14C) is operable; otherwise, suspend all releases via this pathway. (note 2)
b. Radioparticulate Monitor (R-11) provides automatic termination of containment vessel releases exceeding alarm/trip setpoints.	1	With the number of channels operable less than the MCO requirement: a. Exert best efforts to return the instruments to operable status within 30 days and, if unsuccessful, explain in the next Annual Radioactive Effluent Release Report why the inoperability was not corrected in a timely manner in accordance with Technical Specification 5.6.3 and, b. Effluent releases via this pathway may continue provided that the Plant Vent Radionoble Gas Monitor (R14C) is operable; otherwise, suspend all releases via this pathway. (note 2)

* MCO - Minimum Channels Operable

TABLE 3.10-1 (continued)
RADIOACTIVE GASEOUS EFFLUENT MONITORING INSTRUMENTATION

Release Pathway/Instrumentation	MCO*	Compensatory Measures
2. Containment Vessel via Plant Vent (Continued) c. Sampler flow rate monitor (R-11)	1	With the number of channels operable less than the MCO requirement: a. Exert best efforts to return the instruments to operable status within 30 days and, if unsuccessful, explain in the next Annual Radioactive Effluent Release Report why the inoperability was not corrected in a timely manner in accordance with Technical Specification 5.6.3 and, b. Effluent releases via this pathway may continue provided that either the Plant Vent Radionoble Gas Monitor (R-14C) is operable or the flow rate is estimated once per 4 hours. (note 2)
3. Fuel Handling Building Lower Level Exhaust Vent a. Radionoble gas monitor (R-20) b. Sampler flow rate monitor (R-20)	1	With the number of channels operable less than the MCO requirement: a. Exert best efforts to return the instruments to operable status within 30 days and, if unsuccessful, explain in the next Annual Radioactive Effluent Release Report why the inoperability was not corrected in a timely manner in accordance with Technical Specification 5.6.3 and, b. Effluent releases via this pathway may continue provided that grab samples are taken once per 12 hours and analyzed for radionoble gases within 24 hours. With the number of channels operable less than the MCO requirement: a. Exert best efforts to return the instruments to operable status within 30 days and, if unsuccessful, explain in the next Annual Radioactive Effluent Release Report why the inoperability was not corrected in a timely manner in accordance with Technical Specification 5.6.3 and, b. Effluent releases via this pathway may continue provided the flow rate is estimated once per 4 hours.

* MCO - Minimum Channels Operable

TABLE 3.10-1 (continued)
RADIOACTIVE GASEOUS EFFLUENT MONITORING INSTRUMENTATION

Release Pathway/Instrumentation	MCO*	Compensatory Measures
3. Fuel Handling Building Lower Level Exhaust Vent (continued) c. Radioiodine sampler d. Particulate sampler	1 1	With the number of channels operable less than the MCO requirements: <ul style="list-style-type: none"> a. Exert best efforts to return the instruments to operable status within 30 days and, if unsuccessful, explain in the next Annual Radioactive Effluent Release Report why the inoperability was not corrected in a timely manner in accordance with Technical Specification 5.6.3 and, b. Effluent releases via this pathway may continue provided that a continuous sample is collected utilizing auxiliary sampling equipment as required by Table 3.12-1. (note 1) With the number of channels operable less than the MCO requirement: <ul style="list-style-type: none"> a. Exert best efforts to return the instruments to operable status within 30 days and, if unsuccessful, explain in the next Annual Radioactive Effluent Release Report why the inoperability was not corrected in a timely manner in accordance with Technical Specification 5.6.3 and, b. Effluent releases via this pathway may be continued, provided that a continuous sample is collected utilizing auxiliary sampling equipment as required by Table 3.12-1. (note 1)

* MCO - Minimum Channels Operable

TABLE 3.10-1 (continued)
RADIOACTIVE GASEOUS EFFLUENT MONITORING INSTRUMENTATION

Release Pathway/Instrumentation	MCO*	Compensatory Measures
<p>4. Fuel Handling Building Upper Level Exhaust Vent</p> <p>a. Radionoble gas monitor (R-21) trips the exhaust and supply fans for the upper level of the Fuel Handling Building upon exceeding alarm/trip setpoint.</p> <p>b. Sampler flow rate monitor (R-21)</p>	<p>1</p> <p>1</p>	<p>With the number of channels operable less than the MCO requirement:</p> <p>a. Exert best efforts to return the instruments to operable status within 30 days and, if unsuccessful, explain in the next Annual Radioactive Effluent Release Report why the inoperability was not corrected in a timely manner in accordance with Technical Specification 5.6.3 and,</p> <p>b. Effluent releases via this pathway may continue provided that:</p> <ol style="list-style-type: none"> 1. The Plant Vent Radionoble Gas Monitor (R14C) is operable, or; 2. Grab samples are collected once per 12 hours and are analyzed within 24 hours for radionoble gases. <p>With the number of channels operable less than the MCO requirement:</p> <p>a. Exert best efforts to return the instruments to operable status within 30 days and, if unsuccessful, explain in the next Annual Radioactive Effluent Release Report why the inoperability was not corrected in a timely manner in accordance with Technical Specification 5.6.3 and,</p> <p>b. Effluent releases via this pathway may continue provided the flow rate is estimated once per 4 hours.</p>

* MCO - Minimum Channels Operable

TABLE 3.10-1 (continued)
RADIOACTIVE GASEOUS EFFLUENT MONITORING INSTRUMENTATION

Release Pathway/Instrumentation	MCO*	Compensatory Measures
5. E&RC Building Exhaust (R-22) <ul style="list-style-type: none"> a. Radionoble gas monitor (R-22C) monitors all effluents from E&RC Laboratory Building Ventilation System without providing automatic termination of release upon exceeding their respective alarm setpoints. b. Radioiodine Sampler c. Particulate Sampler 	<ul style="list-style-type: none"> 1 1 1 	<ul style="list-style-type: none"> With the number of channels operable less than the MCO requirement: <ul style="list-style-type: none"> a. Exert best efforts to return the instruments to operable status within 30 days and, if unsuccessful, explain in the next Annual Radioactive Effluent Release Report why the inoperability was not corrected in a timely manner in accordance with Technical Specification 5.6.3 and, b. Effluent releases via this pathway may continue provided that grab samples are collected once per 12 hours and are analyzed for radionoble gases within 24 hours. With the number of channels operable less than the MCO requirements: <ul style="list-style-type: none"> a. Exert best efforts to return the instruments to operable status within 30 days and, if unsuccessful, explain in the next Annual Radioactive Effluent Release Report why the inoperability was not corrected in a timely manner in accordance with Technical Specification 5.6.3 and, b. Effluent releases via this pathway may continue provided that a continuous sample is collected utilizing auxiliary sampling equipment as required by Table 3.12-1. (note 1) With the number of channels operable less than the MCO requirements: <ul style="list-style-type: none"> a. Exert best efforts to return the instruments to operable status within 30 days and, if unsuccessful, explain in the next Annual Radioactive Effluent Release Report why the inoperability was not corrected in a timely manner in accordance with Technical Specification 5.6.3 and, b. Effluent releases via this pathway may continue provided that a continuous sample is collected utilizing auxiliary sampling equipment as required by Table 3.12-1. (note 1)

* MCO - Minimum Channels Operable

TABLE 3.10-1 (continued)
RADIOACTIVE GASEOUS EFFLUENT MONITORING INSTRUMENTATION

Release Pathway/Instrumentation	MCO*	Compensatory Measures
6. Radwaste Building Exhaust (Continued) c. Sampler flow rate gauge	1	With the number of channels operable less than the MCO requirement: a. Exert best efforts to return the instruments to operable status within 30 days and, if unsuccessful, explain in the next Annual Radioactive Effluent Release Report why the inoperability was not corrected in a timely manner in accordance with Technical Specification 5.6.3 and, b. Effluent releases via this pathway may continue provided the flow rate is estimated once per 4 hours.
7. Deleted.	NA	NA

* MCO - Minimum Channels Operable

NOTES TO TABLE 3.10-1

Note 1 - No auxiliary sampling is required for periods when normal sampling is off \leq 45 minutes.

Note 2 - This MCO is required during Modes 1, 2, 3, 4, and during the movement of recently irradiated fuel assemblies within the containment.

3.11 Radioactive Gaseous Effluent Monitoring Instrumentation Surveillance Requirements

Applicability

Applies to the radioactive gaseous effluent instrumentation system.

Objective

To ascertain that the radioactive gaseous effluent instrumentation system is functioning properly in order to accurately monitor radioactive gaseous effluent releases.

Specification

SURVEILLANCE REQUIREMENTS

- 3.11.1 Each radioactive gaseous effluent monitoring instrumentation channel shall be demonstrated operable by performance of the channel check, source check, channel calibration, and Channel Operational Test operations at the frequencies shown in Table 3.11-1.

TABLE 3.11-1
RADIOACTIVE GASEOUS EFFLUENT MONITORING INSTRUMENTATION SURVEILLANCE REQUIREMENTS

Pathway / Instruments	Channel Check	Source Check	Channel Calibration	Channel Operational Test
1. Plant Vent (R-14)				
a. (Deleted)	(Deleted)	(Deleted)	(Deleted)	(Deleted)
b. (Deleted)	(Deleted)	(Deleted)	(Deleted)	(Deleted)
c. Radionoble gas (R14C)	P (Note 4)/D	P (Note 4)/M	R (Note 2)	Q (Note 5)
d. Sampler flow rate	D (Note 1)	N.A.	R	Q
e. Plant Vent flow rate monitor (F14)	D (Note 1)	N.A.	R	Q
2. Containment Vessel via Plant Vent				
a. Radioparticulate Monitor (R-11)	D	D	R (Note 2)	Q
b. Radionoble gas monitor (R-12)	D	P (Note 3)	R (Note 2)	Q
c. Sampler flow rate monitor (R-12)	D	N.A.	R	Q
3. Fuel Handling Building Lower Level Exhaust Vent				
a. Radionoble gas monitor (R-20)	D	M	R (Note 2)	Q
b. Sampler flow rate monitor (R-20)	D (Note 1)	N.A.	N.A.	N.A.
4. Fuel Handling Building Upper Level Exhaust Vent				
a. Radionoble gas monitor (R-21)	D	M	R (Note 2)	Q
b. Sampler flow rate monitor (R-21)	D (Note 1)	N.A.	N.A.	N.A.
5. Environmental and Radiation Control Laboratory Exhaust				
a. Radionoble gas monitor (R-22C)	D	M	R (Note 2)	Q
b. Sampler flow rate monitor (R-22)	D (Note 1)	N.A.	N.A.	N.A.
6. Radwaste Building Exhaust				
a. Sampler flow rate monitor	D (Note 1)	N.A.	N.A.	N.A.
7. Deleted.	N.A.	N.A.	N.A.	N.A.

NOTES TO TABLE 3.11-1

- Note 1 The channel check shall consist of verifying indication of flow whenever plant conditions dictate that flow is supposed to be present.
- Note 2 The channel calibration shall be performed using one or more of the reference standards certified by the National Institute of Standards and Technology (NIST) or using standards that have been obtained from suppliers that participate in measurement assurance activities or otherwise NIST traceable.
- Note 3 Prior to each containment release.
- Note 4 Prior to each Waste Gas Decay Tank release.
- Note 5 The Channel Operational Test shall also demonstrate that automatic isolation of this pathway and control room alarm annunciation occur if any of the following conditions exists:
1. Instrument indicates measured levels above the alarm/trip setpoint.
 2. Power failure.
 3. Channel Fail Alarm.
- Note 6 The Channel Operational Test shall also demonstrate that Control Room alarm annunciation occurs if any of the following conditions exists:
1. Instrument indicates measured levels above the alarm setpoint.
 2. Power failure.
 3. Instrument indicates a downscale failure.
 4. Instrument controls not set in operate mode.

NOTATION

- P Completed prior to making a radioactive materials release
D At least once per 24 hours
W At least once per 7 days
N.A. Not applicable
M At least once per 31 days
R At least once per 18 months
Q At least once per 92 days

3.12 Radioactive Gaseous Effluents Sampling and Analysis Requirements

Applicability

Applies to the monitoring of radioactive gaseous effluents.

Objective

To ascertain that radioactive gaseous effluent releases are being maintained as low as reasonably achievable and within allowable limits.

Specification

SURVEILLANCE REQUIREMENTS

3.12.1 The dose rate due to radioactive materials in gaseous effluents shall be determined to be within the limits of ODCM Specification 3.2.1 in accordance with the methods and procedures of the ODCM by obtaining representative samples and performing analyses in accordance with the sampling and analysis program specified in Table 3.12-1.

TABLE 3.12-1
RADIOACTIVE GASEOUS WASTE SAMPLING ANALYSIS PROGRAM

Type of Release	Sampling Frequency	Minimum Analysis Frequency	Required Activity Analysis	Required LLD ^a $\mu\text{Ci/ml}$
Waste Gas Decay Tanks	P	P	Principal Gamma Emitters ^c	1E-04
			Tritium	1E-06
Containment Pressure Reliefs and Containment Purges	P, M ^e Grab Sample	P, M ^e on Grab Sample	Principal Gamma Emitters ^c	1E-04
			Tritium	1E-06
<u>Continuous Releases</u>				
1. Plant Vent	M ^{e, g, h} Grab Sample for Radionoble Gases and Tritium	M ^e on Grab Sample	Principal Gamma Emitters ^c	1E-04
			Tritium	1E-06
2. E&RC Building				
3. Lower Fuel Handling Building	Continuous ^{d, j} Radioiodine Sample	W ^f	I-131 I-133 on Sample	1E-12 1E-10
	Continuous ^{d, j} Particulate Sample	W ^f on Sample	Principal Gamma Emitters ^c	1E-11
4. Radwaste Building ^k	Continuous ^d Particulate Samples to be Composited	Q On Composite	Sr-89, Sr-90	1E-11
		M On Composite	Alpha	1E-11
	Continuous	Noble Gas Monitor	Noble Gases Gross Beta and Gamma	2E-5 $\mu\text{Ci/cm}^3$

TABLE 3.12-1 NOTATION

- a. Lower Limit of Detection (LLD) is an "a priori" limit representing the capability of a measurement system. LLD is calculated in accordance with methodology established in ODCM Table 2.8-1, Note a.
- b. (deleted)
- c. The principal gamma emitters for which the LLD specification applies exclusively are the following radionuclides: Kr-87, Kr-88, Xe-133, Xe-133m, Xe-135, and Xe-138 for gaseous emissions, I-131 for halogen emissions, and Mn-54, Fe-59, Co-58, Co-60, Zn-65, Mo-99, Cs-134, Cs-137, Ce-141, and Ce-144 for particulate emissions. This list does not mean that only these nuclides are to be detected and reported. Other peaks which are measurable and identifiable, together with the above nuclides, shall also be identified and reported.
- d. The ratio of the sample flow rate to the sampled stream flow rate shall be known for the time period covered by each dose or dose rate calculation.
- e. Sampling and analysis shall also be performed following shutdown, startup, or a power change exceeding 15 percent of rated power within one hour unless (1) analysis shows that the dose equivalent I-131 concentration in the primary coolant has not increased more than a factor of 3; (2) the noble gas activity monitor shows that effluent activity has not increased by more than a factor of 3.
- f. Samples shall be changed once per 7 days and analyses shall be completed within 48 hours after changing (or after removal from sampler). Sampling and analyses shall also be performed once per 24 hours for 7 days following shutdown, start-up or thermal power level change exceeding 15% of rated thermal power in one hour and if I-131 Dose Equivalent in the RCS is greater than $0.1 \mu\text{Ci}/\text{cm}^3$. When samples collected for 24 hours are analyzed, the corresponding LLD's may be increased by a factor of 10. The analyses shall be performed within 48 hours.
- g. Tritium grab samples shall be taken at least once per 24 hours when the refueling canal is flooded.
- h. Tritium grab samples shall be taken at least once per 7 days from the ventilation exhaust from the spent fuel pool area, whenever spent fuel is in the spent fuel pool.
- i. (deleted)
- j. No auxiliary sampling is required for periods when normal sampling is off ≤ 45 minutes.

TABLE 3.12-1 NOTATION (continued)

- k. Monthly grab samples to be analyzed for principle gamma emitters and tritium are not applicable for the Radwaste Building release point. Additionally, the Radwaste Building release point does not have a noble gas monitor and, therefore, the noble gas monitor requirements do not apply.

NOTATION

P	Completed prior to making a radioactive materials release
W	At least once per 7 days
M	At least once per 31 days
Q	At least once per 92 days

3.13 Radionoble Gases - Cumulative Doses

Applicability

Applies to the determination of cumulative doses from radionoble gases.

Objective

To ascertain that cumulative doses from radionoble gases are being maintained as low as reasonably achievable and within allowable limits.

Specification

SURVEILLANCE REQUIREMENTS

- 3.13.1 Cumulative dose commitments for the current calendar quarter and current calendar year shall be determined in accordance with the ODCM once per 31 days.

3.14 Radioiodines, Radioactive Materials in Particulate Form, and Radionuclides Other Than Radionoble Gases - Cumulative Doses

Applicability

Applies to the determination of cumulative doses from radioiodines, radioactive materials in particulate form, and radionuclides other than radionoble gases.

Objective

To ascertain that cumulative doses from radioiodines, radioactive materials in particulate form, and radionuclides other than radionoble gases are maintained as low as reasonably achievable and within allowable limits.

Specification

SURVEILLANCE REQUIREMENTS

- 3.14.1 Cumulative dose contributions for the current calendar quarter and current calendar year for I-131, I-133, tritium, and radionuclides in particulate form with half-lives greater than 8 days shall be determined in accordance with the methodology and parameters in the ODCM at least once per 31 days.

3.15 Gaseous Radwaste and Ventilation Exhaust Treatment Systems

Applicability

Applies to the gaseous radwaste and ventilation exhaust treatment systems.

Objective

To define the operating requirements for the gaseous radwaste and ventilation exhaust treatment systems and to ascertain that the concentration of radioactive materials in the gaseous radwaste and ventilation exhaust treatment systems is maintained as low as reasonably achievable and within allowable limits.

Specification

CONTROLS

3.15.1 The appropriate portions of the Gaseous Radwaste Treatment System and the Ventilation Exhaust Treatment System shall be maintained and used to reduce the concentrations of radioactive materials in gaseous wastes prior to their discharge when the projected dose commitments due to the release of gaseous effluents to unrestricted areas (See Figure 7-1) when averaged over a calendar quarter would exceed:

- a. 0.6 mrem for gamma radiation and 1.3 mrem for beta radiation due to radionoble gases

OR

- b. 1.0 mrem to any organ due to radioiodines, radioactive materials in particulate form, and radionuclides other than radionoble gases.

ACTIONS

3.15.2 With the Gaseous Radwaste Treatment System and/or the Ventilation Exhaust Treatment System not operable and with radioactive gaseous wastes being discharged without treatment while in excess of the limits of ODCM Specification 3.15.1 above, prepare and submit a report to the Commission in accordance with ODCM Specification 9.3.b.

SURVEILLANCE REQUIREMENTS

3.15.3 Dose commitments due to gaseous releases shall be projected at least once per 31 days, in accordance with the ODCM to ensure the provisions of ODCM Specification 3.15.1 are satisfied.

BASES

Gaseous Radwaste and Ventilation Exhaust Treatment Systems

The requirements that the appropriate portions of these systems be maintained and used when specified provides reasonable assurance that the releases of radioactive materials in gaseous effluents will be kept "as low as reasonably achievable". This specification implements the requirements of 10 CFR Part 50.36a, General Design Criterion 60 of Appendix A to 10 CFR Part 50, and the design objectives given in Section II.D of Appendix I to 10 CFR Part 50. The specified limits governing the use of appropriate portions of the systems were specified as the dose design objectives set forth in Section II.B and II.C of Appendix I, 10 CFR Part 50, for gaseous effluents.

3.16 Methodology for Carbon-14 Dose

Applicability

Applies to the determination of cumulative doses from the releases of C-14 from gaseous effluent releases.

Objective

To define the methodology to be used for the determination of the cumulative doses from C-14 from release of gaseous effluents.

Specification

SURVEILLANCE REQUIREMENTS

3.16.1 Cumulative dose commitments from the release of C-14 in gaseous effluents shall be determined once per year in accordance with the ODCM.

CONTROLS

3.16.2 Annual Dose from Inhalation of Carbon-14 Releases in Air.

3.16.2.1 Airborne Concentration for Short Term Mixed Mode Release at Receptor.

Determine the annual average airborne concentration pCi/m³ for C-14 at the location with respect to the release point for short term mixed mode releases from WGDT and Containment releases.

$$X_S = 3.17 \times 10^4 * Q_{SY} * (\overline{\chi/q})_v \quad (3.16-1)$$

where:

X_S = The annual average ground-level concentration of C-14 in air from short term mixed mode WGDT and Containment Building releases (pCi/m³).

$(\overline{\chi/q})_v$ = Annual average relative concentration for the short term mixed mode plant vent releases, < 500 hrs/yr, from Table A-16, (2.90E-06 sec/m³).

3.17×10^4 = The number of pCi/Ci divided by the number of sec/yr.

$$Q_{SY} = \text{Estimated pro-rated release rate of C-14 for short term mixed mode releases based on actual EFPD for the year.}$$

$$= Q_S * \frac{EFPD}{292}$$

where:

$$Q_S = 2.8 \text{ Ci/yr for short term mixed mode releases, Table 3.16-3.}$$

$$EFPD = \text{Effective full power days for the year.}$$

$$292 = \text{Effective full power days per year which NUREG-0017 release rates are based on.}$$

3.16.2.2 Airborne Concentration for Long Term Mixed Mode Release at Receptor.

Determine the annual average airborne concentration pCi/m³ for C-14 at the location with respect to the release point for long term mixed mode releases from the Auxiliary Building and Upper Fuel Handling Building.

$$X_L = 3.17 \times 10^4 * Q_{LY} * (\overline{\chi/Q})_v \tag{3.16-2}$$

where:

$$X_L = \text{The annual average ground-level concentration of C-14 in air from mixed mode long term releases from Auxiliary Building and Upper Fuel Handling Building Releases (pCi/m}^3\text{).}$$

$$(\overline{\chi/Q})_v = \text{Annual average relative concentration for the long term plant vent mixed mode releases, } > 500 \text{ hrs/yr, from Table A-10, (9.94E-07 sec/m}^3\text{)}$$

$$3.17 \times 10^4 = \text{The number of pCi/Ci divided by the number of sec/yr.}$$

$$Q_{LY} = \text{Estimated pro-rated release rate of C-14 for long term mixed mode releases based on actual EFPD for the year.}$$

$$= Q_L * \frac{\text{EFPD}}{292}$$

where:

$$Q_L = 4.5 \text{ Ci/yr for short term mixed mode releases, Table 3.16-4.}$$

$$\text{EFPD} = \text{Effective full power days for the year.}$$

$$292 = \text{Effective full power days per year which NUREG-0017 release rates are based on.}$$

3.16.2.3 Inhalation Dose.

Determine the annual inhalation dose from C-14, to organ (j) to an age group (a) for both the short term and long term releases using the following equation:

$$D_{ja,Inhal} = U_{ga} * DFA_{ja} * (X_S + X_L) \tag{3.16-3}$$

where:

$$D_{ja,Inhal} = \text{Annual dose from inhalation to an organ (j) of an age group (a) from C-14 (mrem/yr).}$$

$$U_{ga} = \text{Inhalation rate for age group (a), Section B.2.1 (m}^3\text{/yr).}$$

$$DFA_{ja} = \text{Dose factor for an organ (j) from C-14 for the inhalation pathway to an age group (a), Table 3.16-1 (mrem/pCi).}$$

$$X_S = \text{Annual average ground-level concentration of C-14 in air from WGDT and Containment Building short term mixed mode releases (pCi/m}^3\text{).}$$

$$X_L = \text{Annual average ground-level concentration of C-14 in air from Aux. Building, Upper Fuel Handling Building long term mixed mode releases (pCi/m}^3\text{).}$$

3.16.3 Annual Dose from Ingestion of Carbon-14 Released in Air.

3.16.3.1 Concentration of Airborne Carbon-14 in vegetation.

Determine the concentration of Carbon-14 in vegetation at location with respect to the release point for both the short term and long term releases using the following equation:

$$C_V = 3.17 \times 10^7 * p * \frac{0.11}{0.16} * \left[\left(Q_{SY} * 0.30 * (\overline{\chi/q})_v \right) + \left(Q_{LY} * 0.30 * (\overline{\chi/Q})_v \right) \right] \quad (3.16-4)$$

where:

- C_V = The concentration of C-14 in vegetation (pCi/kg)
- 3.17×10^7 = $(10^{12} \text{ pCi/Ci}) * (10^3 \text{ g/kg}) / (3.15 \times 10^7 \text{ sec/yr})$
- p = 1.0, the fractional equilibrium ratio fraction (dimensionless).
- 0.11 = Fraction of total plant mass that is natural carbon (dimensionless).
- 0.16 = Concentration of natural carbon in the atmosphere (g/m^3).
- 0.30 = Fractional estimate of C-14 as CO_2 , EPRI Technical Report 1021106, 2010, page 4-28 (dimensionless).
- $(\overline{\chi/q})_v$ = Annual average relative concentration for the short term plant vent mixed mode releases, < 500 hrs/yr, from Table A-16 ($2.90 \times 10^{-6} \text{ sec/m}^3$).
- $(\overline{\chi/Q})_v$ = Annual average relative concentration for the long term plant vent mixed mode releases, >500 hrs/yr, from Table A-10 ($9.94 \times 10^{-7} \text{ sec/m}^3$).

3.16.3.2 Concentration of Airborne Carbon-14 in Milk.

Determine the concentration of Carbon-14 in milk at location with respect to the release point for both the short and long term releases.

$$C_M = F_M * C_V * Q_f \quad (3.16-5)$$

where:

C_M = The concentration of C-14 in milk (pCi/L).

F_M = 0.012 days/liter, average fraction of the animal's daily intake of C-14 that appears in each liter of milk.

C_V = The concentration of C-14 in vegetation (pCi/kg).

Q_f = Amount of feed consumed by the animal per day, Table B-1 (kg/day).

3.16.3.3 Concentration of Airborne Carbon-14 in Meat.

Determine the concentration of Carbon-14 in meat at location with respect to the release point for both the short term and long term releases.

$$C_{Meat} = F_f * C_V * Q_f \quad (3.16-6)$$

where:

C_{Meat} = The concentration of C-14 in meat (pCi/kg).

F_f = 0.031 days/kg, average fraction of the animal's daily intake of C-14 that appears in each kilogram of flesh.

C_V = The concentration of C-14 in vegetation (pCi/kg).

Q_f = Amount of feed consumed by the animal per day, Table B-1 (kg/day).

3.16.3.4 Annual Dose from Ingestion (Produce, Milk, Meat & Leafy Vegetation).

Determine the annual dose from atmospherically released Carbon-14 from foods for both short term and long term releases.

$$D_{ja,Ingest} = DFI_{ja} * [(U_a^S * f_g * C_V) + (U_{ap,Milk} * C_{Milk}) + (U_{ap,Meat} * C_{Meat}) + (U_a^L * f_L * C_V)] \quad (3.16-7)$$

where:

- $D_{ja,Ingest}$ group (a) and = The annual dose to organ (j) of an individual in age group (a) resulting from ingestion of C-14 in produce, milk, meat, and leafy vegetables for both the short term and long term releases (mrem/yr).
- DFI_{ja} = The dose conversion factor for the ingestion of Carbon-14, organ (j), and age group (a), Table 3.16-2 (mrem/pCi).
- U_a^S = Ingestion rate of produce (non-leafy vegetables, fruit, grains), Table B-3 (kg/yr).
- f_g = 0.76, fraction of produce ingested grown in garden of interest (dimensionless).
- C_V = The concentration of C-14 in vegetation (pCi/kg).
- $U_{ap,Milk}$ = Ingestion rate of milk, Table B-1 (L/yr).
- C_{Milk} = The concentration of C-14 in milk (pCi/L).
- $U_{ap,Meat}$ = Ingestion rate of meat and poultry, Table B-1 (kg/yr).
- C_{Meat} = The concentration of C-14 in meat (pCi/kg).
- U_a^L = Ingestion rate of leafy vegetables, Table B-3 (kg/yr).
- f_L = 1.0, fraction of leafy vegetables grown in garden of interest (dimensionless).

3.16.4 Total Annual Dose from Inhalation and Food Consumption for Carbon-14 Releases.

Determine the total annual C-14 dose to organ (j) in an age group (a) for inhalation and ingestion for both the short term and long term releases using the following equation:

$$D_{ja,Tot} = D_{ja,Inhal} + D_{ja,Ingest} \quad (3.16-8)$$

where:

$D_{ja,Tot}$ = The total annual C-14 dose to an organ (j) of an individual in age group (a) resulting from the inhalation and ingestion of C-14 from short term and long term mixed mode releases (mrem/yr).

$D_{ja,Inhal}$ = The annual inhalation dose from C-14, to organ (j) in an age group (a) (mrem/yr).

$D_{ja,Ingest}$ = The annual ingestion dose from C-14, to organ (j) in an age group (a) (mrem/yr).

TABLE 3.16-1
INHALATION DOSE FACTORS FROM CARBON-14

<u>Age Group</u>	<u>Bone</u>	<u>Liver</u>	<u>T.Body</u>	<u>Thyroid</u>	<u>Kidney</u>	<u>Lung</u>	<u>GI-LLI</u>
Infant	1.89E-05	3.79E-06	3.79E-06	3.79E-06	3.79E-06	3.79E-06	3.79E-06
Child	9.70E-06	1.82E-06	1.82E-06	1.82E-06	1.82E-06	1.82E-06	1.82E-06
Teen	3.25E-06	6.09E-07	6.09E-07	6.09E-07	6.09E-07	6.09E-07	6.09E-07
Adult	2.27E-06	4.26E-07	4.26E-07	4.26E-07	4.26E-07	4.26E-07	4.26E-07

NRC regulatory Guide 1.109, Rev. 1, Tables E-7 to E-10

TABLE 3.16-2
INGESTION DOSE FACTORS FROM CARBON-14

<u>Individual</u>	<u>Bone</u>	<u>Liver</u>	<u>T.Body</u>	<u>Thyroid</u>	<u>Kidney</u>	<u>Lung</u>	<u>GI-LLI</u>
Infant	2.37E-05	5.06E-06	5.06E-06	5.06E-06	5.06E-06	5.06E-06	5.06E-06
Child	1.21E-05	2.42E-06	2.42E-06	2.42E-06	2.42E-06	2.42E-06	2.42E-06
Teen	4.06E-06	8.12E-07	8.12E-07	8.12E-07	8.12E-07	8.12E-07	8.12E-07
Adult	2.84E-06	5.68E-07	5.68E-07	5.68E-07	5.68E-07	5.68E-07	5.68E-07

NRC regulatory Guide 1.109, Rev. 1, Tables E-11 to E-14

TABLE 3.16-3
CARBON-14 SOURCE TERMS

<u>Release Points</u>	<u>Ci/yr Released</u>
Containment Building	1.6
Aux. Bldg. & Fuel Handling	4.5
Waste Decay Tanks	1.2
Total	7.3

NUREG-0017, REV 1 (GALE CODE) SECTION 2.2.25.2, PAGE 2-90, TABLES 2-38 & 2-39,
SECTION 1.5.1.1 CAPACITY FACTOR = 80% (292 EFFECTIVE FULL POWER DAYS/YR)

BASES

Carbon-14 is produced by several nuclear reactions. In a nuclear reactor the most dominate mechanism is the reaction of O-17 in the fuel or water with a neutron to produce C-14 and an alpha particle. C-14 releases in PWRs occur primarily as a mix of organic carbon and carbon dioxide released from the waste gas system. Because the dose contribution of C-14 from liquid radioactive waste is much less than that contributed by gaseous radioactive waste, evaluation of C-14 in liquid waste is not required. The dose rate and subsequent dose to an individual from C-14 intake depends upon the specific activity of the food from each source and the amount of the ingested C-14 which is retained over the period under consideration.

The quantity of C-14 discharged can be estimated by sample measurements or by use of a normalized C-14 source term and scaling factors based upon power generation. NUREG-0017 Rev 1 "Calculation of Releases of Radioactive Materials in Gaseous and Liquid Effluents from Pressurized Reactors" gives a C-14 source term based on measurements at 10 operating power plants. The C-14 source term according to NUREG-0017 is 7.3 curies/year for an 80% capacity factory or 292 Effective Full Power Days. It is not necessary to calculate uncertainties for C-14 or to include C-14 uncertainty in any calculation of overall uncertainty.

In the determination of the limiting sector, all age groups and all of the exposure pathways based on land-use census are evaluated using the highest mixed mode χ/Q value in Appendix A for short and long term releases. These could include milk, meat and vegetable ingestion, and inhalation pathways. Atmosphere Carbon Dioxide (CO₂) is incorporated in cellular material by the photosynthetic actions of green plants. Plants and grasses, from which most foodstuff are derived, equilibrate with the C-14 CO₂ of the air. Due to the Primary Water System reducing environment, only 30% of the C-14 is released in the organic form.

To show compliance with 10 CFR 50, equation 3.16-8 is evaluated at the limiting pathway location. At HBR this location is the vegetable garden 0.3 miles in the SSE sector. The critical receptor is a child.

RNP ODCM Radiological Environmental Monitoring Program 4.2.1 requires that a land-use census survey be conducted on an annual basis. The age groupings at the various receptor locations are also determined during this survey. Thus, depending on the results of the survey, a new limiting location and receptor age group could result.

Regulatory Guide 1.109 provides the detailed implementation guidance to show compliance with Appendix I of 10 CFR 50 limits.

4.0 RADIOLOGICAL ENVIRONMENTAL MONITORING PROGRAM

4.1 Monitoring Program - Implementation

Applicability

Applies to the radiological environmental monitoring program.

Objective

To define the requirements for implementation of the radiological environmental monitoring program.

Specification

CONTROLS

- 4.1.1 The Radiological Environmental Monitoring Program shall be conducted as specified in Table 4.1-1.

ACTIONS

- 4.1.2 With the Radiological Environmental Monitoring Program not being conducted as specified in Table 4.1-1, prepare and submit to the Commission, in the Annual Radiological Environmental Operating Report required by Technical Specification 5.6.2, a description of the reasons for not conducting the program as required and the plans for preventing a recurrence.
- 4.1.3 With the level of radioactivity as the result of plant effluents in an environmental sampling medium at a specified location exceeding the reporting levels of Table 4.1-2 when averaged over any calendar quarter, prepare and submit to the Commission within 30 days, pursuant to ODCM Specification 9.5, a Special Report that identifies the cause(s) for exceeding the limit(s) and defines the corrective actions to be taken to reduce radioactive effluents so that the potential annual dose* to a member of the public is less than the calendar year limits of ODCM Specifications 2.4.1, 3.4.1, and 3.5.2.1. When more than one of the radionuclides in Table 4.1-2 are detected in the sampling medium, this report shall be submitted if:

$$\frac{\text{concentration (1)}}{\text{reporting level (1)}} + \frac{\text{concentration (2)}}{\text{reporting level (2)}} + \dots \geq 1.0$$

When radionuclides other than those in Table 4.1-2 are detected and are the result of plant effluents, this report shall be submitted if the potential annual dose* to a member of the public is equal to or greater than the calendar year limits of ODCM Specifications 2.4.1, 3.4.1, and 3.5.2.1. This report is not required if the measured level of radioactivity was not the result of plant effluents; however, in such an event, the condition shall be reported and described in the Annual Radiological Environmental Operating Report.

* the methodology and parameters used to estimate the potential annual dose to a member of the public shall be indicated in this report.

- 4.1.4 With milk or fresh leafy vegetable samples unavailable from one or more of the sample locations required by Table 4.1-1, identify locations for obtaining replacement samples and add them to the radiological environmental monitoring program within 30 days. The specific locations from which samples were unavailable may then be deleted from the monitoring program. Pursuant to Technical Specification 5.6.2, identify the cause of the unavailability of samples and identify the new location(s) for obtaining replacement samples in the next Annual Radioactive Effluent Release Report and also include in the report a revised figure(s) and table for the ODCM reflecting the new location(s).
- 4.1.5 The provisions of ODCM Specification 8.1 are not applicable.
- 4.1.6 Deviations are permitted from the required sampling schedule if specimens are unobtainable due to hazardous conditions, seasonal unavailability, or to malfunction of automatic sampling equipment. If the latter, every effort shall be made to complete corrective action prior to the end of the next sampling period.

BASES

Monitoring Program

The radiological environmental monitoring program required by this specification provides representative measurements of radiation and of radioactive materials in those exposure pathways and for those radionuclides that lead to the highest potential radiation exposures of members of the public resulting from the station operation. This monitoring program implements Section IV.B.2 of Appendix I to 10 CFR Part 50 and thereby supplements the radiological effluent monitoring program by verifying that the measurable concentrations of radioactive materials and levels of radiation are not higher than expected on the basis of the effluent measurements and the modeling of the environmental exposure pathways. Guidance for this monitoring program is provided by the Radiological Assessment Branch Technical Position on Environmental Monitoring. The initially specified monitoring program will be effective for at least the first three years of commercial operation. Following this period, program changes may be initiated based on operational experience.

The required detection capabilities for environmental sample analyses are tabulated in terms of the lower limits of detection (LLD). The LLDs required by Table 4.1-3 are considered optimum for routine environmental measurements in industrial laboratories. It should be recognized that the LLD is defined as an a priori (before the fact) limit representing the capability of a measurement system and not as a posteriori (after the fact) limit for a particular measurement.

Detailed discussion of the LLD, and other detection limits, can be found in HASL Procedures Manual, HASL-300 (revised annually), Currie, L. A., "Limits for Qualitative Detection and Quantitative Determination - Application to Radiochemistry," *Anal. Chem.* 40, 586-93 (1968), and Hartwell, J. K., "Detection Limits for Radioanalytical Counting Techniques," Atlantic Richfield Hanford Company Report ARH-SA-215 (June 1975).

TABLE 4.1-1
RADIOLOGICAL ENVIRONMENTAL MONITORING PROGRAM

Exposure Pathway and/or Sample	Number of Representative Samples and Sample Locations	Sampling and Collection Frequency	Type and Frequency of Analysis
1. DIRECT RADIATION ^a	33 routine monitoring stations with two or more dosimeters or with one instrument for measuring and recording dose rate continuously, placed as follows: an inner ring of stations, one in each of the 16 meteorological sectors in the general area of the site boundary; an outer ring of stations, one in each of the 16 meteorological sectors in the 6- to 8-km range from site; area to serve as a control ^b station.	Quarterly	Gamma dose quarterly.
2. AIRBORNE Radioiodine and Particulates	Samples from 5 locations 3 samples from close to the 3 site boundary locations, in different sectors, of the highest calculated annual average ground level D/Q. 1 sample from the vicinity of a community having the highest calculated annual average ground level D/Q. 1 sample from a control ^b location, as for example 15-30 km distant and in the least prevalent wind direction.	Continuous sampler operation with sample collection weekly, or more frequently if required by dust loading.	<u>Radioiodine Canister:</u> I-131 analysis weekly. <u>Particulate Sampler:</u> Gross beta radioactivity analysis following filter change; Gamma isotopic analysis ^d of composite (by location) quarterly.

TABLE 4.1-1 (continued)
RADIOLOGICAL ENVIRONMENTAL MONITORING PROGRAM

Exposure Pathway and/or Sample	Number of Representative Samples and Sample Locations	Sampling and Collection	Type and Frequency of Analysis
3. WATERBORNE a. Surface ^e	1 sample upstream control location ^b 1 sample downstream	Composite sample over 1-month period ^f	Gamma isotopic analysis ^d monthly. Composite for tritium analysis quarterly.
b. Ground ^g	1 sample	Quarterly	Gamma isotopic ^d and tritium analysis quarterly.
c. Sediment from shoreline	1 sample from downstream area with existing or potential recreational value	Semiannually	Gamma isotopic analysis ^d semiannually.
4. INGESTION a. Milk ^j	1 sample from milking animals within 5 km distance having the highest dose potential. If there are none, then, 1 sample from milking animals between 5 to 8 km distant where doses are calculated to be greater than 1 mrem per year ^h .	Semimonthly when animals are on pasture, monthly at other times	Gamma isotopic ^d and I-131 analysis semimonthly when animals are on pasture; monthly at other times.
	1 sample from milking animals at a control location. ^b 15-30 km distant and in the least prevalent wind direction.		
b. Fish	1 sample of recreationally important species in vicinity of plant discharge area including at least one free swimmer and one bottom feeder.	Semiannually	Gamma isotopic analysis ^d on edible portions semiannually.
	1 sample of comparable species in areas not influenced by plant discharge to serve as control location. ^b		
c. Food Products	1 sample of each principal class of food products from any area that is irrigated by water in which liquid plant wastes have been discharged.	At time of harvest ⁱ	Gamma isotopic analyses ^d on edible portion
	Samples of 3 different kinds of broad leaf vegetation grown nearest each of two different locations at or near the site boundary of highest predicted annual average ground level D/Q if milk sampling is not performed.	Monthly when available	Gamma isotopic ^d and I-131 analysis.
	1 sample of each of the similar broad leaf vegetation grown 15-30 km distant in the least prevalent wind direction if milk sampling is not performed.	Monthly when available	Gamma isotopic ^d and I-131 analysis.

TABLE 4.1-1 NOTATION

- a. One or more instruments, such as a pressurized ion chamber, for measuring and recording dose rate continuously may be used in place of, or in addition to, integrating dosimeters. For the purposes of this table, a thermoluminescent dosimeter (TLD) is considered to be one phosphor; two or more phosphors in a packet are considered as two or more dosimeters. Film badges shall not be used as dosimeters for measuring direct radiation.
- b. The purpose of this sample is to obtain background information.
- c. Airborne particulate sample filters shall be analyzed for gross beta radioactivity 24 hours or more after sampling to allow for radon and thoron daughter decay. If gross beta activity in air particulate samples is greater than ten times the yearly mean of control samples, gamma isotopic analysis shall be performed on the individual samples.
- d. Gamma isotopic analysis means the identification and quantification of gamma-emitting radionuclides that may be attributable to the effluents from the facility.
- e. The "upstream sample" shall be taken at a distance beyond significant influence of the discharge. The "downstream" sample shall be taken in an area beyond but near the mixing zone.
- f. A composite sample is one which the quantity (aliquot) of liquid sampled is proportional to the quantity of flowing liquid and in which the method of sampling employed results in a specimen that is representative of the liquid flow. In this program composite sample aliquots shall be collected at time intervals that are very short (e.g., hourly) relative to the compositing period (e.g., monthly) in order to assure obtaining a representative sample.
- g. Ground water samples shall be taken when this source is tapped for drinking or irrigation purposes in areas where the hydraulic gradient or recharge properties are suitable for contamination.
- h. The dose shall be calculated for the maximum organ and age group, using the methodology and parameters in the ODCM.
- i. If harvest occurs more than once a year, sampling shall be performed during each discrete harvest. If harvest occurs continuously, sampling shall be monthly. Attention shall be paid to including samples of tuberous and root food products.
- j. There are currently no identified milk producing animals. Doses to a MEMBER OF THE PUBLIC due to a milk pathway will be evaluated annually, but not included in the annual report. Doses via this pathway will be estimated as ≤ 1 mrem/yr, unless it can be shown to exist.

TABLE 4.1-2
REPORTING LEVELS FOR RADIOACTIVITY CONCENTRATIONS IN ENVIRONMENTAL SAMPLES

Radionuclide	Water (pCi/l)	Airborne (pCi/m ³)	Fish (pCi/Kg, wet)	Milk (pCi/l)	Food Products (pCi/Kg, wet)
H-3	2E+04 ^a				
Mn-54	1E+03		3E+04		
Fe-59	4E+02		1E+04		
Co-58	1E+03		3E+04		
Co-60	3E+02		1E+04		
Zn-65	3E+02		2E+04		
Zr-Nb-95	4E+02				
I-131	2E+00 ^b	9E-01		3E+00	1E+02
Cs-134	3E+01	1E+01	1E+03	6E+01	1E+03
Cs-137	5E+01	2E+01	2E+03	7E+01	2E+03
Ba-La-140	2E+02			3E+02	

^a For drinking water samples. This is a 40 CFR Part 141 value. If no drinking water pathway exists, a value of 30,000 pCi/l may be used.

^b If no drinking water pathway exists, a value of 20 pCi/l may be used.

H.B. Robinson Steam Electric Plant Unit 2
 Offsite Dose Calculation Manual (ODCM)

TABLE 4.1-3
LOWER LIMITS OF DETECTION (LLD)^a

Analysis	Water (pCi/l)	Airborne (pCi/m ³)	Fish (pCi/Kg,wet)	Milk (pCi/l)	Food Products (pCi/Kg,wet)	Sediment (pCi/Kg,dry)
gross beta		1E-02				
H-3	2E+03 ^c					
Mn-54	1.5E+01		1.3E+02			
Fe-59	3E+01		2.6E+02			
Co-58,60	1.5E+01		1.3E+02			
Zn-65	3E+01		2.6E+02			
Zr-Nb-95 ^b	1.5E+01					
I-131	1.0E+00 ^d	7E-02		1E+00	6E+01	
Cs-134	1.5E+01	5E-02	1.3E+02	1.5E+01	6E+01	1.5E+02
Cs-137	1.8E+01	6E-02	1.5E+02	1.8E+01	8E+01	1.8E+02
Ba-La-140 ^b	1.5E+01			1.5E+01		

TABLE 4.1-3 NOTATION

- a. The LLD is defined, for purposes of these specifications, as the smallest concentration of radioactive material in a sample that will yield a net count, above system background, that will be detected with 95% probability with only 5% probability of falsely concluding that a blank observation represents a "real" signal.

For a particular measurement system, which may include radiochemical separation:

$$LLD = \frac{4.66 * S_b}{E * V * 2.22 * Y * e^{(-\lambda * \Delta t)}}$$

where:

LLD is the "a priori" lower limit of detection as defined above, as picocuries per unit mass or volume,

S_b is the standard deviation of the background counting rate or of the counting rate of a blank sample as appropriate, as counts per minute,

E is the counting efficiency, as counts per disintegration,

V is the sample size in units of mass or volume,

2.22 is the number of disintegrations per minute per picocurie,

Y is the fractional radiochemical yield, when applicable,

λ is the radioactive decay constant for the particular radionuclide, and

Δt for environmental samples is the elapsed time between sample collection, or end of the sample collection period, and time of counting

Typical values of efficiency (E), volume/mass (V), chemical yield (Y), and radionuclide decay correction time (Δt) are to be used in the calculation.

It should be recognized that the LLD is defined as a priori (before the fact) limit representing the capability of a measurement system and not as an a posteriori (after the fact) limit for a particular measurement. Analysis shall be performed in such a manner that the stated LLDs will be achieved under routine conditions. Occasionally background fluctuations, unavoidable small sample sizes, the presence of interfering nuclides, or other uncontrollable circumstances may render these LLDs unachievable. In such cases, the contributing factors shall be identified and described in the Annual Radiological Environmental Operating Report pursuant to Technical Specification 5.6.2.

TABLE 4.1-3 NOTATION (continued)

- b. The specified LLD applies to the daughter nuclide of an equilibrium mixture of the parent and daughter nuclides.
- c. If no drinking water pathway exists, a value of 3,000 pCi/l may be used.
- d. If no drinking water pathway exists, a value of 15 pCi/l may be used.

4.2 Land Use Census - Implementation

Applicability

Applies to the land use census.

Objective

To define the requirements for the conduct of the land use census.

Specification

CONTROLS

- 4.2.1 A land use census shall be conducted and shall identify the location of the nearest milk animal, the nearest residence and the nearest garden of greater than 500 square feet producing fresh leafy vegetables in each of the 16 meteorological sectors within a distance of five miles.

ACTIONS

- 4.2.2 With a land use census identifying a location(s) that yields a calculated dose or dose commitment greater than the values currently being calculated in ODCM Specification 3.14.1, identify the new location(s) in the next Annual Radioactive Effluent Release report, pursuant to Technical Specification 5.6.3.
- 4.2.3 With the land use census identifying a location which yields an annual calculated dose or dose commitment of a specific pathway which is 20% greater than that at a current sampling location:
- a. Add the new location(s) to the radiological environmental monitoring program within 30 days.

AND

- b. If desired, delete the sampling location having the lowest calculated dose or dose commitments via the same exposure pathway, excluding the control station location, from the monitoring program after October 31 of the year in which the land use census was conducted.

AND

- c. Identify the new location(s) in the next Annual Radioactive Effluent Release Report, Technical Specification 5.6.3, including a revised figure(s) and table for the ODCM reflecting the new location(s).

BASES

Land Use Census

This specification is provided to ensure that changes in the use of areas at and beyond the Site Boundary are identified and that modifications to the monitoring program are made if required by the results of the census. This census satisfies the requirements of Section IV.B.3 of Appendix I to 10 CFR Part 50. Restricting the census to gardens of greater than 500 square feet provides assurance that significant exposure pathways via leafy vegetables will be identified and monitored since a garden of this size is the minimum required to produce the quantity (26 kg/year) of leafy vegetables assumed in Regulatory Guide 1.109, Revision 1 for consumption by a child. To determine this minimum garden size, the following assumptions were used: 1) that 20% of the garden was used for growing broad leaf vegetation (i.e., similar to lettuce and cabbage), and 2) a vegetation yield of 2 kg/square meter.

4.3 Monitoring Program - Sampling Requirements

Applicability

Applies to the radiological environmental monitoring program.

Objective

To ascertain that radiological environmental monitoring samples are collected and analyzed in accordance with the radiological environmental monitoring program.

Specification

SURVEILLANCE REQUIREMENTS

- 4.3.1 The radiological environmental monitoring samples shall be collected pursuant to Table 4.1-1 from the locations defined in the ODCM and shall be analyzed pursuant to the requirements of Tables 4.1-2 and 4.1-3.

4.4 Land Use Census - Surveillance Requirements

Applicability

Applies to the land use census.

Objective

To ascertain that the land use census is conducted in accordance with the radiological environmental monitoring program.

Specification

SURVEILLANCE REQUIREMENTS

- 4.4.1 The land use census shall be conducted once per 12 months during the growing season by any one of the following methods: door-to-door survey, aerial survey, and by consulting local agriculture authorities. This sampling may be performed at the site boundary in each of two different direction sectors with the highest predicted D/Qs in lieu of the garden census. Specifications for broad leaf vegetation sampling in Table 4.1-1, Item 4.C shall be followed, including analysis of control samples.

4.5 Analysis and Sample Point Description

Table 4.5-1 contains the sample point description, sampling and collection frequency analysis, and analysis frequency for various exposure pathways in the vicinity of HBR for the Radiological Monitoring Program. Figures 4-1 and 4-2 show the location of the various sampling points.

At the time of initial preparation of this manual, the limiting cow milk location was 1.3 miles in the NE sector. As of the time of submittal of this manual, there is no longer a cow present at this location. The radiological environmental monitoring program has been altered to reflect this change. However, the χ/Q , and D/Q values associated with this location have been retained for future reference.

TABLE 4.5-1
H. B. ROBINSON RADIOLOGICAL ENVIRONMENTAL MONITORING PROGRAM

Exposure Pathway and/or Sample	Sample Point	Sample Point Description, Distance, and Direction	Sampling and Collection Frequency	Analysis ¹ Frequency	Analysis ¹
1. Airborne Particulates and Radioiodines	1.	Florence, S. C. (Control Station) ² 24.4 miles ESE	Continuous operating sampler with sample collection at least weekly	Weekly	I-131 for Air Cartridges
	2.	Information Center 0.2 miles S		Weekly	Gross Beta ³
	3.	Microwave tower 0.5 miles N		Quarterly	Gamma Scan ⁴ of composite (by location)
	4.	Spillway 0.4 miles ESE			
	5.	East Shore of lake near Johnson's Landing 0.9 miles ENE			
	6.	Information Center 0.2 miles SSW			
	7.	CP&L facility on Railroad Ave., Hartsville 6.4 miles ESE			
	55.	South of the West Settling Pond 0.2 miles SSE			
	60.	Robinson Picnic Area 0.2 miles SE			
	61.	West parking lot near RR tracks 0.3 miles WSW			

TABLE 4.5-1 (continued)
H. B. ROBINSON RADIOLOGICAL ENVIRONMENTAL MONITORING PROGRAM

Exposure Pathway and/or Sample	Sample Point	Sample Point Description, Distance, and Direction	Sampling and Collection Frequency	Analysis ¹ Frequency	Analysis ¹
2. Direct Radiation	1.	Florence, S. C. (Control Station) ² 24.4 miles ESE	Continuous measurement with readout at least once per quarter (TLDs)	Quarterly	Gamma Dose ⁵
	2.	Information Center ^{10,11} 0.2 mile S			
	3.	Microwave tower 0.5 mile N			
	4.	Spillway 0.4 mile ESE			
	5.	East shore of lake near Johnson's landing 0.9 mile ENE			
	6.	Information Center ^{10,11} 0.2 mile SSW			
	7.	CP&L facility on Railroad Ave., Hartsville 6.4 miles ESE			
	8.	Transmission right-of-way 0.8 mile SSE			
	9.	Transmission right-of-way 1.0 mile S			

TABLE 4.5-1 (continued)
H. B. ROBINSON RADIOLOGICAL ENVIRONMENTAL MONITORING PROGRAM

Exposure Pathway and/or Sample	Sample Point	Sample Point Description, Distance, and Direction	Sampling and Collection Frequency	Analysis ¹ Frequency	Analysis ¹
2. Direct Radiation (continued)	10.	Clyde Church of God 1.0 mile WSW	Continuous measurement with readout at least once per quarter (TLDs)	Quarterly	Gamma Dose ⁵
	11.	Old Camden Road 1.0 mile SW			
	12.	Off of Old Camden Road 1.2 miles SSW			
	13.	Corner of Saluda and Sandpit Roads 0.7 miles W			
	14.	First Baptist Church of Pine Ridge 0.8 mile WNW			
	15.	Transmission right-of-way 0.7 miles NW			
	16.	South side of Darlington County I.C. Turbine Plant 1.0 mile NNW			
	17.	Darlington County Plant emergency fire pump 1.2 miles N			

TABLE 4.5-1 (continued)
H. B. ROBINSON RADIOLOGICAL ENVIRONMENTAL MONITORING PROGRAM

Exposure Pathway and/or Sample	Sample Point	Sample Point Description, Distance, and Direction	Sampling and Collection Frequency	Analysis ¹ Frequency	Analysis ¹
2. Direct Radiation (continued)	18.	Old Black Creek RR trestle 0.7 mile SE	Continuous measurement with readout at least once per quarter (TLDS)	Quarterly	Gamma Dose ⁵
	19.	Old Camden Road (#S-16-23) 1.0 mile E			
	20.	New Market Road (#S-16-39) 1.0 miles ENE			
	21.	New Market Road (#S-16-39) 1.4 miles NE			
	22.	Shady Rest entrance off of Cloverdale Drive 1.7 miles NNE			
	23.	New Market Road (#S-16-39) 1.0 miles ESE			
	24.	Sowell Road (#S-13-711) 4.6 miles NW			
	25.	Lake Robinson Road (#S-13-346) 4.0 miles NNW			
	26.	Lake Robinson Road (#S-13-346) 5.0 miles N			

TABLE 4.5-1 (continued)
H. B. ROBINSON RADIOLOGICAL ENVIRONMENTAL MONITORING PROGRAM

Exposure Pathway and/or Sample	Sample Point	Sample Point Description, Distance, and Direction	Sampling and Collection Frequency	Analysis ¹ Frequency	Analysis ¹
2. Direct Radiation (continued)	27.	Prospect Church Road (#S-13-763) 5.4 miles NNE	Continuous measurement with readout at least once per quarter (TLDs)	Quarterly	Gamma Dose ⁵
	28.	New Market Road (#S-13-39) 4.3 miles NE			
	29.	Ruby Road (#S-16-20) 4.0 mile ENE			
	30.	Ruby Road (#S-16-20) 4.4 miles E			
	31.	Lakeshore Drive 4.6 miles ESE			
	32.	Transmission right-of-way 4.0 miles SE			
	33.	Bay Road (#S-16-493) 4.5 miles SSE			
	34.	Kellybell Road (#S-16-772) 4.7 miles S			

TABLE 4.5-1 (continued)
H. B. ROBINSON RADIOLOGICAL ENVIRONMENTAL MONITORING PROGRAM

Exposure Pathway and/or Sample	Sample Point	Sample Point Description, Distance, and Direction	Sampling and Collection Frequency	Analysis ¹ Frequency	Analysis ¹
2. Direct Radiation (continued)	35.	Kelly Bridge Road (#S-31-51) 4.5 miles SSW	Continuous measurement with readout at least once per quarter (TLDs)	Quarterly	Gamma Dose ⁵
	36.	Kingston Drive 5.0 miles SW			
	37.	Pine Cone Road 5.0 miles WSW			
	38.	Union Church Road 4.9 miles W			
	39.	King's Pond Road 5.1 miles WNW			
	55.	South of the West Settling Pond 0.2 miles SSE			
	56.	North of the center of the 7P-ISFSI ^{10,11} 0.4 miles NNW			
	61.	West parking lot near RR tracks ¹¹ 0.3 miles WSW			
	65.	Northwest of the 24P-ISFSI ¹¹ 0.3 miles WNW			

H.B. Robinson Steam Electric Plant Unit 2
Offsite Dose Calculation Manual (ODCM)

TABLE 4.5-1 (continued)
H. B. ROBINSON RADIOLOGICAL ENVIRONMENTAL MONITORING PROGRAM

Exposure Pathway and/or Sample	Sample Point	Sample Point Description, Distance, and Direction	Sampling and Collection Frequency	Analysis ¹ Frequency	Analysis ¹	
3. Waterborne a. Surface Water	40.	Black Creek at Old Camden Road (S-16-23) 0.6 mile ESE	Composite sample ⁶ over one-month period	Monthly	Gamma Scan ⁴ H-3	
	41.	Black Creek at US Highway 1 (Control Station) ² 8.0 miles N				
	b. Groundwater	64.	Artesian Well (0.6 miles SE)	Quarterly Grab	Quarterly	Gamma Scan ⁴ H-3
	c. Drinking water	NA	Not required ⁷			
d. Shoreline Sediment	44.	East Shore of Lake, Shady Rest Club 1.6 miles NNE	Semi-annually	Semi-annually	Gamma Scan ⁴	
4. Ingestion a. Milk	NA	(There are no milk samples available within 8 Km of Plant. Broad-leaf vegetation are to be sampled and analyzed in lieu of milk samples.)	NA	NA	NA	
b. Broadleaf	50.	SSE Close to Site Boundary ⁹	Monthly when available (3 different kinds of broad-leaf vegetation)	Each sample	Gamma Scan ⁴ I-131	
	51.	SSW Close to Site Boundary.				
	52.	10 miles W, near Bethune (Control Station for Broad-leaf Vegetation).				
	62.	SE Close to Site Boundary.				
	67.	S Close to Site Boundary ⁹				
c. Fish	45.	Site varies within lake Robinson	Semiannually (collect comparable species at all three locations)	Each sample	Gamma Scan ⁴ Edible portion	
	46.	Site varies within Prestwood Lake				
	47.	Control station ² , Any lake not influenced by plant discharge.				
d. Food Products leafy vegetables	54.	Auburndale Plantation ⁸ 10.1 miles E (One sample of each principal class of irrigated food products).	Annual at harvest	Each sample	Gamma Scan ⁴	

TABLE 4.5-1 NOTATION

1. The LLD for each analysis is specified in Table 4.1-3 of the HBR ODCM.
2. Control stations are locations outside the influence of plant effluents.
3. Airborne particulate sample filter shall be analyzed for gross beta radioactivity 24 hours or more after sampling to allow for radon and thoron daughter decay. If gross beta activity in air particulate is greater than ten times the yearly mean of control samples, gamma isotopic analysis shall be performed on the individual samples.
4. Gamma scan means the identification and quantification of gamma-emitting radionuclides that may be attributable to the effluents from the facility.
5. Thermoluminescent dosimeter (TLD) is considered to be one phosphor; two or more phosphors in a packet are considered as two or more dosimeters.
6. Composite sample aliquots shall be collected at time interval that are short (5 or 6 times daily) relative to the compositing period (monthly in order to assure obtaining a representative sample).
7. Collection of drinking water samples is not required since there are no known reservoirs on Black Creek used for drinking purposes.
8. Water from Black Creek is sometimes used to irrigate food crops at Auburndale Plantation which is located 11 miles east @ 90° from the plant.
9. Sample Points 50 and 67 are the highest and the second highest D/Q values, respectively.
10. These samples are required for monitoring of the 7P-ISFSI.
11. These samples are required for monitoring of the 24P-ISFSI.

FIGURE 4-1
RADIOLOGICAL SAMPLE LOCATIONS NEAR SITE

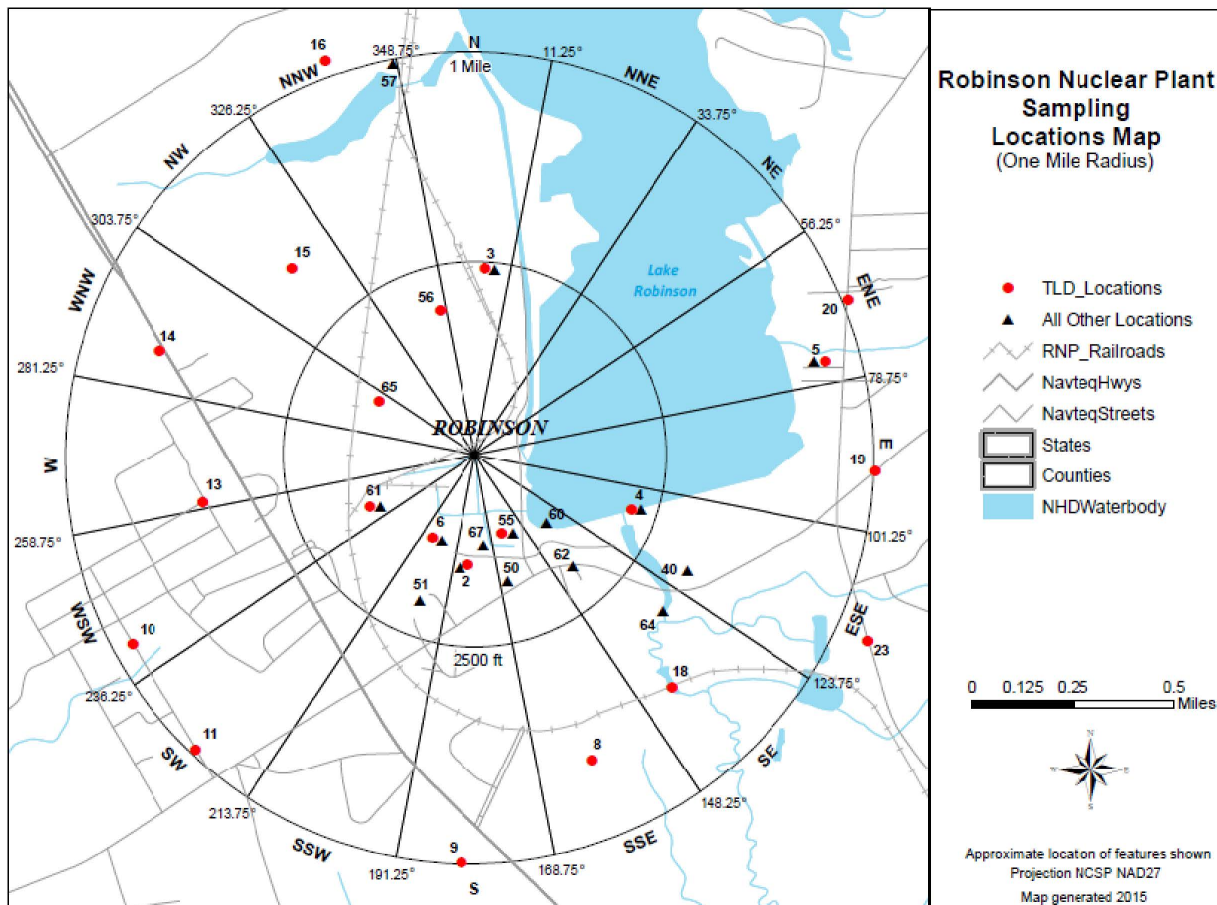

Sample Types

Air Cartridge & Particulate
 Shoreline Sediment
 Ground Water
 Broadleaf Vegetation
 Surface Water
 Thermoluminescent Dosimeter
 Fish
 Food Products

Sample Locations

1 – 7, 55, 60, 61
 44
 64
 50, 51, 52, 62, 67
 40, 41
 1 – 39, 55, 56, 61, 65
 45 – 47
 54

FIGURE 4-2
RADIOLOGICAL SAMPLE LOCATIONS DISTANT LOCATIONS

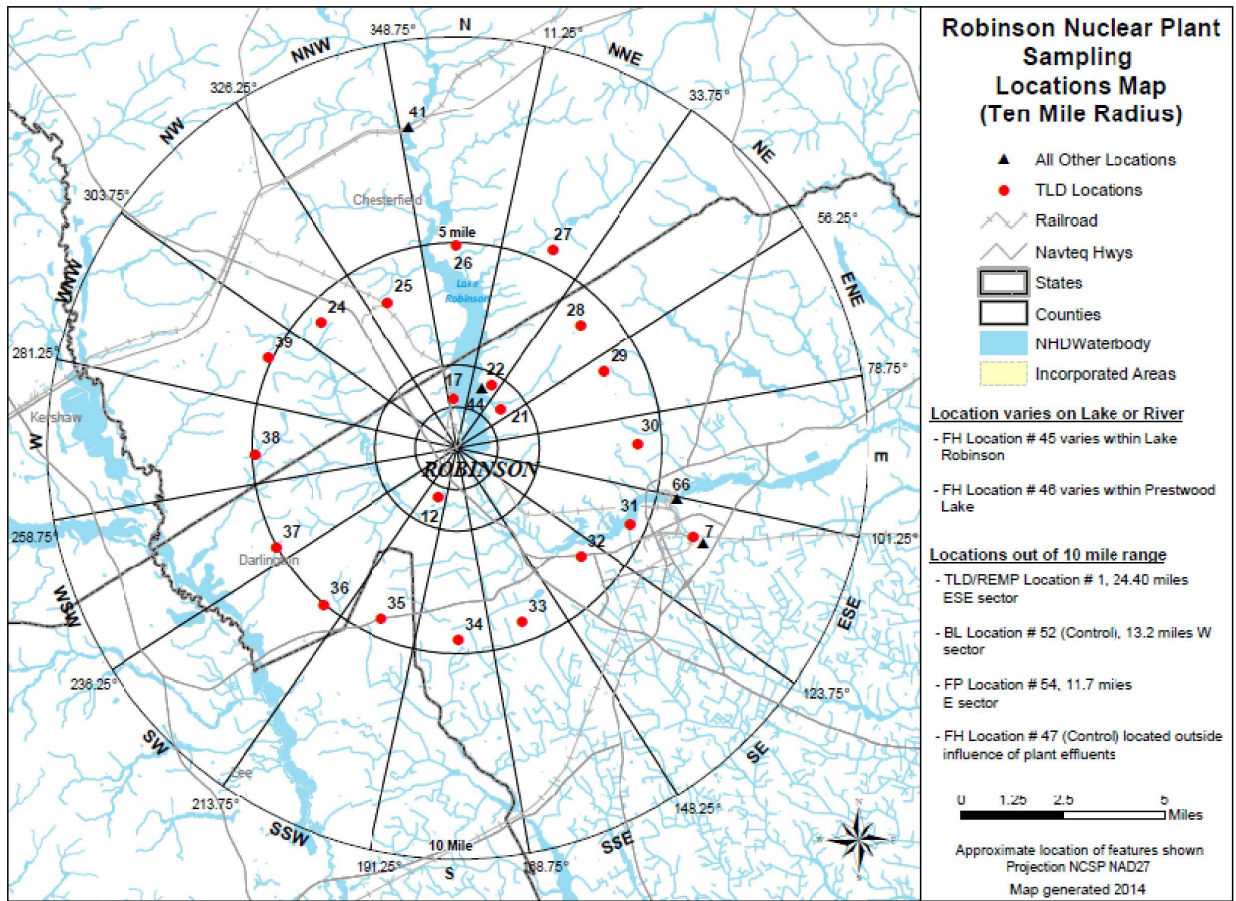

Sample Types

Air Cartridge & Particulate
 Shoreline Sediment
 Ground Water
 Broadleaf Vegetation
 Surface Water
 Thermoluminescent Dosimeter
 Fish
 Food Products

Sample Locations

1 – 7, 55, 60, 61
 44
 64
 50, 51, 52, 62, 67
 40, 41
 1 – 39, 55, 56, 61, 65
 45 – 47
 54

5.0 INTERLABORATORY COMPARISON PROGRAM

Applicability

Applies to the interlaboratory comparison program of like media.

Objective

To ensure precision and accuracy of laboratory analyses.

Specification

CONTROLS

- 5.1 Analyses shall be performed on radioactive materials supplied as a part of an Interlaboratory Comparison Program of like media within the environmental program as per Table 4.1-1 and pursuant to ODCM Specification 5.2, 5.3, and 5.4.

ACTIONS

- 5.2 With analyses not being performed as required above, report the corrective action taken to prevent a recurrence to the Commission in the Annual Radiological Environmental Operating Report pursuant to Technical Specification 5.6.2.
- 5.3 The provisions of ODCM Specification 8.1 are not applicable.

SURVEILLANCE REQUIREMENTS

- 5.4 The Interlaboratory Comparison Program shall be described in the ODCM. A summary of the results obtained as part of the above required Interlaboratory Comparison Program shall be included in the Annual Radiological Environmental Operating Report pursuant to Technical Specification 5.6.2.

BASES

Interlaboratory Comparison Program

The requirement for participation in an approved Interlaboratory Comparison Program is provided to ensure that independent checks on the precision and accuracy of the measurements of radioactive material in environmental sample matrices are performed as part of the quality assurance program for environmental monitoring in order to demonstrate that the results are valid for the purposes of Section IV.B.2 of Appendix I to 10 CFR Part 50.

5.5 Interlaboratory Comparison Studies - Program Requirements

5.5.1 Objective

The objective of this program is to evaluate the total laboratory analysis process by comparing results with results obtained by a separate laboratory or laboratories for an equivalent sample.

5.6 Program

5.6.1 Environmental Sample Analyses Comparison Program

Environmental samples from the HBR environs are to be analyzed by the EnRad Laboratories or by a qualified contracting laboratory. These laboratories will participate at least annually in a nationally recognized interlaboratory comparison study. The results of the laboratories' performances in the study will be provided to HBR E&RC and will be included in the Annual Radiological Environmental Operating Report.

5.6.2 Effluent Release Analyses Program

HBR E&RC will perform sample analyses for gamma-emitting radionuclides in effluent releases. The E&RC radiochemistry laboratory will participate annually in a corporate interlaboratory comparison study or an equivalent study. The results of these studies will be provided to the NRC upon request.

5.6.3 Abnormal Results

Company Internal laboratory or vendor laboratory results shall be compared to the criteria established in the USNRC Inspection Manual (Procedure 84750) for Radioactive Waste Treatment, Effluent, and Environmental monitoring. The referenced criteria is as follows:

- a. Divide each standard result by its associated uncertainty to obtain resolution (the uncertainty is defined as the relative standard deviation, one sigma, of the standard result as calculated from counting statistics).
- b. Divide each laboratory result by the corresponding standard result to obtain the ratio (laboratory result/standard).
- c. The laboratory measurement is in agreement if the value of the ratio falls within the limits shown below for the corresponding resolution:

<u>Resolution</u>	<u>Ratio</u>
< 4	0.40 - 2.50
4 - 7	0.50 - 2.00
8 - 15	0.60 - 1.66
16 - 50	0.75 - 1.33
51 - 200	0.80 - 1.25
> 200	0.85 - 1.18

If the Company Internal laboratory or vendor laboratory results lie outside the ratio criteria, an evaluation will be performed to identify any recommended actions to reduce anomalous errors. Complete documentation of the evaluation will be available to HBR and will be provided to the USNRC upon request.

6.0 COMPLIANCE WITH 40 CFR PART 190

6.1 Requirements For Compliance With 40 CFR Part 190 - Radioactive Effluents From Uranium Fuel Cycle Sources

Applicability

Applies to radioactive effluents from uranium fuel cycle sources.

Objective

To define the dose limits of 40 CFR 190 for radioactive effluents from uranium fuel cycle sources.

Specification

CONTROLS

- 6.1.1 The dose commitment to any member of the public, due to releases of licensed materials and radiation, from uranium fuel cycle sources shall be limited to ≤ 25 mrem to the total body or any organ except the thyroid, which shall be limited to ≤ 75 mrem over 12 consecutive months. This specification is applicable to Robinson Unit 2 only for the area within a five mile radius around the Robinson Plant.

ACTIONS

- 6.1.2 With the calculated doses from the release of the radioactive materials in liquid or gaseous effluents exceeding twice the limits of ODCM Specification 2.4.1.a, 2.4.1.b, 3.4.1.a, 3.4.1.b, 3.5.2.1.a, or 3.5.2.1.b, calculations should be made including direct radiation contributions from the reactor unit and from outside storage tanks to determine whether the above limits of ODCM Specification 6.1.1 have been exceeded. If such is the case, prepare and submit to the Commission within 30 days, pursuant to ODCM Specification 9.3.d, a Special Report that defines the corrective action to be taken to reduce subsequent releases to prevent recurrence of exceeding the above limits and includes the schedule for achieving conformance with the above limits.

This Special Report, as defined in 10 CFR Part 20.2203(a)(4), shall include an analysis that estimates the radiation exposure (dose) to a member of the public from uranium fuel cycle sources, including all effluent pathways and direct radiation, for the calendar year that includes the release(s) covered by this report. It shall also describe levels of radiation and concentrations of radioactive material involved, and the cause of the exposure levels or concentrations. If the estimated dose(s) exceeds the above limits, and if the release condition resulting in violation of 40 CFR Part 190 has not already been corrected, the Special Report shall include a request for a variance in accordance with the provisions of 40 CFR Part 190. Submittal of the report is considered a timely request, and a variance is granted until staff action on the same request is complete.

- 6.1.3 The provisions of ODCM Specification 8.1 are not applicable.

BASES

Compliance with 40 CFR Part 190 - Radioactive Effluents From Uranium Fuel Cycle Sources

This specification is provided to meet the dose limitations of 40 CFR Part 190 that have been incorporated into 10 CFR Part 20 by 46 FR 18525. The specification requires the preparation and submittal of a Special Report whenever the calculated doses from plant generated radioactive effluents and direct radiation exceed 25 mrem to the total body or any organ, except the thyroid, which shall be limited to less than or equal to 75 mrem. It is highly unlikely that the resultant dose to a member of the public will exceed dose limits of 40 CFR Part 190 if the reactor remains within twice the dose design objectives of Appendix I, and if direct radiation doses from the reactor unit and outside storage tanks are kept small. The Special Report will describe a course of action that should result in the limitation of the annual dose to a member of the public to within the 40 CFR part 190 limits. For the purposes of the Special Report, it may be assumed that the dose commitment to the member of the public from other uranium fuel cycle sources is negligible, with the exception that dose contributions from other nuclear fuel cycle facilities at the same site or within a radius of 8 km must be considered. If the dose to any member of the public is estimated to exceed the requirements of 40 CFR Part 190, the Special Report with a request for a variance (provided the release conditions resulting in violation of 40 CFR Part 190 have not already been corrected), in accordance with the provisions of 40 CFR Part 190.11 and 10 CFR Part 20.2203(a)(4), is considered to be a timely request and fulfills the requirements of 40 CFR Part 190 until NRC staff action is completed. The variance only relates to the limits of 40 CFR Part 190, and does not apply in any way to the other requirements for dose limitation of 10 CFR Part 20, as addressed in ODCM Specifications 2.2.1 and 3.2.1. An individual is not considered a member of the public during any period in which he/she is engaged in carrying out any operation that is part of the nuclear fuel cycle.

6.2 Total Dose (40 CFR 190 Conformance)

6.2.1 Compliance with 40 CFR 190

Compliance with 40 CFR 190 as prescribed by ODCM Specification 6.1 is to be demonstrated only when one or more of ODCM Specifications 2.4.1.a, 2.4.1.b, 3.4.1.a, 3.4.1.b, 3.5.2.1.a, and 3.5.2.1.b is exceeded by a factor of 2. Once this occurs the Company has 30 days to submit this report in accordance with ODCM Specification 9.3.

6.2.1 Calculations Evaluating Conformance with 40 CFR 190

To perform the calculations to evaluate conformance with 40 CFR 190, an effort is made to develop doses that are realistic by removing assumptions that lead to overestimates of dose to a MEMBER OF THE PUBLIC (i.e., calculations for compliance with 10 CFR 50, App.I). To accomplish this the following calculational rules are used:

1. Doses to a MEMBER OF THE PUBLIC via the liquid release pathway will be calculated.
2. Doses to a MEMBER OF THE PUBLIC due to a milk pathway will be evaluated only as can be shown to exist. Otherwise, doses via this pathway will be estimated as ≤ 1 mrem / yr.
3. Environmental sampling data which demonstrate that no pathway exists may be used to delete a pathway to man from a calculation.
4. To sum numbers represented as "less than" (<), use the value of the largest number in the group.

$$(i.e. <5 + <1 + <1 + <3 = 5)$$

5. When doses via direct radiation are added to doses via inhalation pathway, they will be calculated for the same distance in the same sector.
6. The calculational locations for a MEMBER OF THE PUBLIC will only be at residences or places of employment.

NOTE: Additional assumptions may be used to provide situation-specific parameters, provided they are documented along with their concomitant bases.

6.3 Calculations of Total Body Dose

Estimates will be made for each of the following exposure pathways to the same location by age class. Only those age classes known to exist at a location are considered.

6.3.1 Direct Radiation

The component of dose to a MEMBER OF THE PUBLIC due to direct radiation will be determined by:

1. Determine the direct radiation dose at the plant boundary in each sector, $D_{B,\theta}$.
2. Extrapolate that dose to the calculational location as follows:

$$D_{L,\theta} = \frac{D_{B,\theta} * 1.49E+06}{(X_{L,\theta})^2}$$

where:

$D_{L,\theta}$ = Dose at calculational location in sector θ (mrem).

1.49E+06 = Square of mean distance to the site boundary (1220^2 m²).

$X_{L,\theta}$ = Distance to calculational locations in sector θ (m).

6.3.2 Inhalation Dose

The inhalation dose will be determined at the calculational locations for each age class at risk according to the methods outlined in Section 3.5 of this manual.

6.3.3 Ingestion Pathway

The dose via the ingestion pathway will be calculated at the consumer locations for the consumers at risk. If no milk pathway exists in a sector, the dose via this pathway will be treated as < 1 mrem/yr.

6.3.4 Other Uranium Fuel Cycle Sources

The dose from other fuel cycle sources will be treated as < 1 mrem/yr.

6.4 Thyroid Dose

The dose of the thyroid will be calculated for each sector as the sum of inhalation dose and milk ingestion dose (if existing). The calculational methods will be those identified in Section 3.5 of this manual.

6.5 Dose Projections

Dose projections are to incorporate planned plant operations such as power reduction or outages for the projected period.

6.6 Radioactive Effluents from Uranium Fuel Cycle Sources - Cumulative Doses

Applicability

Applies to the determination of cumulative doses from radioactive effluents from uranium fuel cycle sources.

Objective

To ascertain that cumulative doses from radioactive effluents from uranium fuel cycle sources are maintained as low as reasonably achievable and within allowable limits.

Specification

SURVEILLANCE REQUIREMENTS

- 6.6.1 Cumulative dose contributions from liquid and gaseous effluents shall be determined in accordance with ODCM Specifications 2.4.1, 3.4.1, and 3.5.2.1 in accordance with the methodology and parameters in the ODCM. For the purposes of this Surveillance Requirement, it may be assumed that fuel cycle sources are negligible, with the exception that dose contributions from other nuclear fuel cycle facilities at the same site or within a radius of 5 miles must be considered. In addition, an individual is not considered a member of the public during any period in which he/she is engaged in carrying out any operation which is part of the nuclear fuel cycle.
- 6.6.2 Cumulative dose contributions from direct radiation from the reactor units and from radwaste storage tanks shall be determined in accordance with the methodology and parameters in the ODCM. This requirement is applicable only under conditions set forth in ODCM Specification 6.1.2.

7.0 DEFINITIONS

The following frequently used terms are defined for the uniform interpretation of the specifications.

7.1 Rated Thermal Power

RTP shall be a total reactor core heat transfer (RTP) rate to the reactor coolant of 2339 MWt.

7.2 Mode

A mode shall be as required by Technical Specifications.

7.3 Operable - Operability

A system, subsystem, train, component, or device shall be OPERABLE or have OPERABILITY when it is capable of performing its specified safety function(s) and when all necessary attendant instrumentation, controls, normal or emergency electrical power, cooling and seal water, lubrication, and other auxiliary equipment that are required for the system, subsystem, train, component, or device to perform its specified safety function(s) are also capable of performing their related support function(s).

7.4 Instrumentation Surveillance

7.4.1 Action

Action shall be that part of a specification which prescribes remedial measures required under designated conditions.

7.4.2 Channel Calibration

A CHANNEL CALIBRATION shall be the adjustment, as necessary, of the channel so that it responds within the required range and accuracy to known input. The CHANNEL CALIBRATION shall encompass the entire channel, including the required sensor, alarm, interlock, display, and trip functions.

7.4.3 Channel Check

A CHANNEL CHECK shall be the qualitative assessment, by observation, of channel behavior during operation. This determination shall include, where possible, comparison of the channel indication and status to other indications or status derived from independent instrument channels measuring the same parameter.

7.4.4 Channel Operational Test (COT)

A COT shall be the injection of a simulated or actual signal into the channel as close to the sensor as practicable to verify the OPERABILITY of required alarm, interlock, display, and trip functions. The COT shall include adjustments, as necessary, of the required alarm, interlock, and trip setpoints so that the setpoints are within the required range and accuracy.

7.4.5 Source Check

A source check shall be the qualitative assessment of channel response when the channel sensor is exposed to a radioactive source.

7.5 Gaseous Radwaste Treatment System

The Gaseous Radwaste Treatment System is the system designed and installed to reduce radioactive gaseous effluents by collecting primary coolant system off-gases from the primary system and providing for delay or holdup for the purpose of reducing the total radioactivity prior to release to the environment.

7.6 Ventilation Exhaust Treatment System

The Ventilation Exhaust Treatment System is the system designed and installed to reduce gaseous radioiodine or radioactive material in particulate form in effluents by passing ventilation or vent exhaust gases through charcoal absorbers and/or HEPA filters prior to their release to the environment. Engineered Safety Feature (ESF) atmospheric cleanup systems are not considered to be Ventilation Exhaust Treatment System components.

7.7 Offsite Dose Calculation Manual

- a. The ODCM shall contain the methodology and parameters used in the calculation of offsite doses resulting from radioactive gaseous and liquid effluents, in the calculation of gaseous and liquid effluent monitoring alarm and trip setpoints, and in the conduct of the radiological environmental monitoring program; and
- b. The ODCM shall also contain the radioactive effluent controls and radiological environmental monitoring activities, and descriptions of the information that should be included in the Annual Radiological Environmental Operating, and Radioactive Effluent Release Reports required by Specification 5.6.2 and Specification 5.6.3.
- c. Licensee initiated changes to the ODCM:
 1. Shall be documented and records of reviews performed shall be retained. This documentation shall contain:
 - (a) sufficient information to support the change(s) together with the appropriate analyses or evaluations justifying the change(s),

AND
 - (b) a determination that the change(s) maintain the levels of radioactive effluent control required by 10 CFR 20.1302, 40 CFR 190, 10 CFR 50.36a, and 10 CFR 50, Appendix I, and do not adversely impact the accuracy or reliability of effluent, dose, or setpoint calculations;
 2. Shall become effective after the approval of the Plant Manager;

AND
 3. Shall be submitted to the NRC in the form of a complete, legible copy of the entire ODCM as a part of or concurrent with the Radioactive Effluent Release Report for the period of the report in which any change in the ODCM was made. "Each change shall be identified by markings in the margin of the affected pages. Each change, affected page number(s) and technical justification will be listed in Chapter 10, Licensee Initiated Changes. .

7.8 Dose Equivalent I-131

The Dose Equivalent I-131 shall be that concentration of I-131 (microcuries/gram) that alone would produce the same dose as the quantity and isotopic mixture of I-131, I-132, I-133, I-134, and I-135 actually present. The dose conversion factors used for this calculation shall be those listed under the "Effective" column of Table 2.1 of Federal Guidance Report 11.

7.9 Purge - Purging

Purge or purging is the controlled process of discharging air or gas from a confinement to maintain temperature, pressure, humidity, concentration or other operating condition, in such a manner that replacement air or gas is required to purify the confinement.

7.10 Venting

Venting is the controlled process of discharging air or gas from a confinement to maintain temperature, pressure, humidity, concentration or other operating condition, in such a manner that replacement air or gas is not provided or required during venting. Vent, used in system names, does not imply a venting process.

7.11 Site Boundary

The site boundary shall be that line beyond which the land is not owned, leased, or otherwise controlled by the licensee, as defined by Figure 7-1.

7.12 Member(s) of the Public

Member(s) of the public shall include all individuals who by virtue of their occupational status have no formal association with the plant. This category shall include non-employees of the licensee who are permitted to use portions of the site for recreational, occupational or other purposes not associated with plant function. This category shall not include non-employees such as vending machine servicemen, or postmen who, as part of their formal job function, occasionally enter an area that is controlled by the licensee for the purposes of protection of individuals from exposure to radiation and radioactive materials.

7.13 Unrestricted Area

Unrestricted area shall be any area at or beyond the Site Boundary to which access is not controlled by the licensee for purposes of protection of individuals from exposure to radiation and radioactive materials, or any area within the Site Boundary used for residential quarters or for industrial, commercial, institutional, and/or recreational purposes.

FIGURE 7-1
PLANT SITE BOUNDARY AND EXCLUSION ZONE

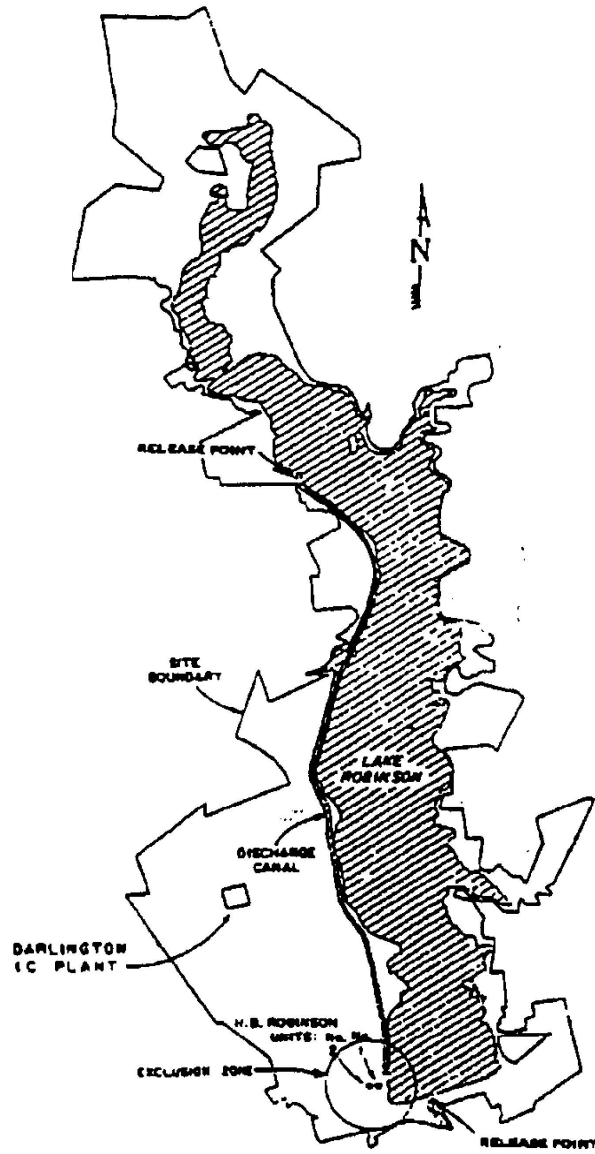

8.0 CONTROLS APPLICABILITY AND SURVEILLANCE/COMPENSATORY REQUIREMENTS

8.1 Controls Applicability

CONTROL 8.1.1 CONTROLS shall be met during the MODES or other specified conditions in the Applicability, except as provided in CONTROL 8.1.2.

CONTROL 8.1.2 Upon discovery of a failure to meet an CONTROL, the Required COMPENSATORY MEASURES of the associated Conditions shall be met, except as provided in CONTROL 8.1.5.

If the CONTROL is met or is no longer applicable prior to expiration of the specified Completion Time(s), completion of the Required Action(s) is not required unless otherwise stated.

CONTROL 8.1.3 When an CONTROL is not met and the associated COMPENSATORY MEASURES are not met, an associated ACTION is not provided, or if directed by the associated COMPENSATORY MEASURES, the unit shall be placed in a MODE or other specified condition in which the CONTROL is not applicable. Action shall be initiated within 1 hour to place the unit, as applicable, in:

- a. MODE 3 within 7 hours; and
- b. MODE 4 within 13 hours; and
- c. MODE 5 within 37 hours.

Exceptions to this Specification are stated in the individual Specifications.

Where corrective measures are completed that permit operation in accordance with the CONTROL or COMPENSATORY MEASURES, completion of the COMPENSATORY MEASURES required by CONTROL 8.1.3 is not required.

CONTROL 3.0.3 is only applicable in MODES 1, 2, 3, and 4

CONTROL 8.1.4 When a CONTROL is not met, entry into a MODE or other specified condition in the Applicability shall not be made except when the associated COMPENSATORY MEASURES to be entered permit continued operation in the MODE or other specified condition in the Applicability for an unlimited period of time.

This Specification shall not prevent changes in MODES or other specified conditions in the Applicability that are required to comply with COMPENSATORY MEASURES or that are part of a shutdown of the unit.

Exceptions to this Specification are stated in the individual Specifications. These exceptions allow entry into MODES or other specified conditions in the Applicability when the associated COMPENSATORY MEASURES to be entered allow unit operation in the MODE or other specified condition in the Applicability only for a limited period of time.

CONTROL 8.1.4 is only applicable for entry into a MODE or other specified condition in the Applicability in MODES 1, 2, 3, and 4.

CONTROL 8.1.5 Equipment removed from service or declared inoperable to comply with COMPENSATORY MEASURES may be returned to service under administrative control solely to perform testing required to demonstrate its OPERABILITY or the OPERABILITY of other equipment. This is an exception to CONTROL 8.1.2 for the system returned to service under administrative control to perform the testing required to demonstrate OPERABILITY.

8.2 Surveillance Requirements

SR 8.2.1 SRs shall be met during the MODES or other specified conditions in the Applicability for individual CONTROLS, unless otherwise stated in the SR. Failure to meet a Surveillance, whether such failure is experienced during the performance of the Surveillance or between performances of the Surveillance, shall be failure to meet the CONTROL. Failure to perform a Surveillance within the specified Frequency shall be failure to meet the CONTROL except as provided in SR 8.2.3. Surveillances do not have to be performed on inoperable equipment or variables outside specified limits.

SR 8.2.2 The specified Frequency for each SR is met if the Surveillance is performed within 1.25 times the interval specified in the Frequency, as measured from the previous performance or as measured from the time a specified condition of the Frequency is met.

For Frequencies specified as "once," the above interval extension does not apply.

If a Completion Time requires periodic performance on a "once per...." basis, the above Frequency extension applies to each performance after the initial performance.

Exceptions to this Specification are stated in the individual Specifications.

SR 8.2.3 If it is discovered that a Surveillance was not performed within its specified Frequency, then compliance with the requirement to declare the CONTROL not met may be delayed, from the time of discovery, up to 24 hours or up to the limit of the specified Frequency, whichever is less. This delay period is permitted to allow performance of the Surveillance.

If the Surveillance is not performed within the delay period, the CONTROL must immediately be declared not met, and the applicable Condition(s) must be entered.

When the Surveillance is performed within the delay period and the Surveillance is not met, the CONTROL must immediately be declared not met, and the applicable Condition(s) must be entered.

SR 8.2.4 Entry into a MODE or other specified condition in the Applicability of an CONTROL shall not be made unless the CONTROL's Surveillances have been met within their specified Frequency. This provision shall not prevent entry into MODES or other specified conditions in the Applicability that are required to comply with COMPENSATORY MEASURES or that are part of a shutdown of the unit.

SR 8.2.4 is only applicable for entry into a MODE or other specified condition in the Applicability in MODES 1, 2, 3, and 4.

SR 8.2.5 Surveillance Requirements shall be applicable as follows in Table 8.2-1:

TABLE 8.2-1
SURVEILLANCE REQUIREMENTS

<u>Frequency</u>	<u>Time Interval</u>
P	Completed prior to making a radioactive materials release.
D	At least once per 24 hours.
W	At least once per 7 days.
M	At least once per 31 days.
Q	At least once per 92 days.
R	At least once per 18 months.
3/W	At least 3 times per week.

8.3 Compensatory Requirements

CR 8.3.1 CR 8.3.1 establishes the requirements for meeting the specified Frequency for any Required Compensatory Measure with a Completion Time that requires the periodic performance of the Required Compensatory Measure on a "once per..." interval.

CR 8.3.1 permits a 25% extension of the interval specified in the Frequency. This extension facilitates scheduling and considers plant operating conditions that may not be suitable for conducting the Test (e.g., transient conditions or other ongoing Test or maintenance activities).

The 25% extension does not significantly degrade the reliability that results from performing the action at its specified Frequency. This is based on the recognition that the most probable result of any particular Test being performed is the verification of conformance with the applicable requirements. The 25% extension also does not apply to the initial portion of a periodic Completion Time that requires performance on a "once per..." basis. The 25% extension applies to each performance after the initial performance. The initial performance of the Required Compensatory Measure is considered a single compensatory measure with a single Completion Time.

The provisions of CR 8.3.1 are not intended to be used repeatedly merely as an operational convenience to extend periodic Completion Time intervals beyond those specified.

Exceptions to this Specification are stated in the individual Specifications.

9.0 REPORTING REQUIREMENTS

9.1 Annual Radioactive Effluent Release Report

Routine radioactive effluent release reports covering the operation of the unit during the previous twelve months shall be submitted within twelve months of the previous report in accordance with Technical Specification 5.6.3. The report shall be submitted by May 1 of each year. Those portions of the report shall include:

9.1.1

A summary of the quantities of radioactive liquid and gaseous effluent and solid waste released from the unit as outlined in Regulatory Guide 1.21, "Measuring, Evaluating, and Reporting Radioactivity in Solid Wastes and Radioactive Materials in Liquid and Gaseous Effluents from Light Water Cooled Nuclear Power Plants" (Revision 1, June 1974), with data summarized on a quarterly basis following the format of Appendix B thereof.

9.1.2

The Radioactive Effluent Release Report shall include an annual summary of hourly meteorological data collected over the previous year. This annual summary may be either in the form of an hour-by-hour listing on magnetic tape of wind speed, wind direction, atmospheric stability, and precipitation (if measured), or in the form of joint frequency distributions of wind speed, wind direction, and atmospheric stability.* This same report shall include an assessment of the radiation doses due to the radioactive liquid and gaseous effluents released from the unit or station during the previous calendar year. For the assessment of radiation doses, approximate and conservative approximate methods are acceptable. The assessment of radiation doses shall be performed in accordance with the methodology and parameters in the Offsite Dose Calculation Manual (ODCM).

* In lieu of submission with the Radioactive Effluent Releases Report, the licensee has the option of retaining this summary of required meteorological data on site in a file that shall be provided to the NRC upon request.

9.1.3

The Radioactive Effluent Release Report shall also include an assessment of radiation doses to the likely most exposed member of the public from reactor releases and other nearby uranium fuel cycle sources, including doses from primary effluent pathways and direct radiation, for the previous calendar year to show conformance with 40 CFR Part 190, Environmental Radiation Protection Standards for Nuclear Power Operation.

9.1.4

The Radioactive Effluent Release Report shall include the following information for each class of solid waste (as defined by 10 CFR Part 61) shipped offsite during the report period:

- a. Waste volume.
- b. Total curie quantity (specify whether determined by measurement or estimate).
- c. Principal radionuclides (specify whether determined by measurement or estimate).
- d. Source of waste and processing employed (e.g., dewatered spent resin, compacted dry waste, evaporator bottoms).
- e. Deleted.
- f. Deleted.
- g. The number of shipments, the mode of transport, and the destination.

9.1.5

The Radioactive Effluent Release Report shall include a list and description of unplanned releases from the site to unrestricted areas of radioactive materials in gaseous and liquid effluents made during the reporting period.

9.1.6

The Radioactive Effluent Release Report shall include any changes made during the reporting period to the Process Control Program (PCP) and to the Offsite Dose Calculation Manual (ODCM), as well as a listing of new locations for dose calculations and/or environmental monitoring identified by the land use census pursuant to ODCM Specification 4.2.2.

9.1.7

Changes to the radioactive waste systems (liquid, gaseous, and solid) shall be reported to the Commission in the Annual Radioactive Effluent Release Report for the period in which the evaluation was reviewed by the Plant Nuclear Safety Committee (PNSC).^{*} The discussion of each change shall contain:

- a. A summary of the evaluation that led to the determination that the change could be made in accordance with 10 CFR Part 50.59.
- b. Sufficient detailed information to totally support the reason for the change without benefit of additional or supplemental information.
- c. A detailed description of the equipment, components and processes involved and the interfaces with other plant systems.
- d. An evaluation of the change, which shows the predicted releases of radioactive materials in liquid and gaseous effluents and/or quantity of solid waste that differ from those previously predicted in the license application and amendments thereto.
- e. An evaluation of the change, which shows the expected maximum exposures to an individual in the unrestricted area and to the general population that differ from those previously estimated in the license application and amendments thereto.
- f. A comparison of the predicted releases of radioactive materials, in liquid and gaseous effluents and in solid waste, to the actual releases for the period prior to when the changes are to be made.
- g. An estimate of the exposure to plant operating personnel as a result of the change.
- h. Documentation of the fact that the change was reviewed and found acceptable by the PNSC.

* The licensee may choose to submit the information called for in this Specification as part of the annual FSAR update

9.1.8

Changes to the radioactive waste systems (liquid, gaseous, and solid) shall become effective upon review and acceptance by the PNSC.

9.1.9

The Radioactive Effluent Release Report shall include results from any groundwater samples that are drawn IAW the REMP program during the reporting period that are not described in the ODCM.

9.1.10

Deleted.

9.1.11

The Radioactive Effluent Release Report shall include a summary of any on-site spills and leaks that occurred during the reporting period that are communicated IAW ODCM 9.4 Special Ground Water Protection Reports.

9.2 Annual Radiological Environmental Operating Report

Routine radiological environmental operating reports covering the operation of the unit during the previous calendar year shall be submitted prior to May 15 of each year in accordance with Technical Specification 5.6.2. With the radiological environmental monitoring program not being conducted as specified in Table 4.1-1, a description of the reasons for not conducting the program as required and the plans for preventing a recurrence shall be included.

The Annual Radiological Environmental Operating Reports shall include summaries, interpretations, and analysis of trends of the results of the radiological environmental surveillance activities for the report period, including a comparison with preoperational studies, operational controls (as appropriate), and previous environmental surveillance reports and an assessment of the observed impacts of the plant operations on the environment. The reports shall also include the results of land use censuses required by ODCM Specification 4.2.

The Annual Radiological Environmental Operating Reports shall include the results of analysis of all radiological environmental samples and of all environmental radiation measurements taken during the period pursuant to the locations specified in the Table and Figures in the ODCM, as well as summarized and tabulated results of these analyses and measurements in the format of the table in the Radiological Assessment Branch Technical Position, Revision 1, November 1979. In the event that some individual results are not available for inclusion with the report, the report shall be submitted noting and explaining the reasons for the missing results. The missing data shall be submitted as soon as possible in a supplementary report.

The reports shall also include the following: a summary description of the radiological environmental monitoring program; at least two legible maps* covering all sampling locations keyed to a table giving distances and directions from the centerline of the reactor, the results of licensee participation in the Interlaboratory Comparison Program, required by ODCM Specification 5.0; discussion of all deviations from the sampling schedule of Table 4.1-1; and discussion of all analyses in which the LLD required by Table 4.1-3 was not achievable.

* One map shall cover stations near the site boundary; a second shall be the more distant stations

9.3 Special Radiological Effluent Report

The Special radiological effluent reports discussed below shall be the subject of written reports to the NRC within 30 days of the occurrence of the event.

- a. Exceeding any of the limits prescribed by ODCM Specification 2.4.1, 3.4.1, and/or 3.5.2.1. This report shall include the following information:
 1. The cause for exceeding the limit(s).
 2. The corrective action(s) to be taken to reduce the releases of radioactive materials in the affected effluents (i.e., liquid, radionoble gas, and/or radioiodines, particulates) within the specification and the proposed corrective actions to be taken to assure that subsequent releases will be in compliance with the above limits.
 3. If any of the limits of ODCM Specification 2.4.1 were exceeded, the report must include a statement that no drinking water source exists that could be affected or include the results of radiological impact on finished drinking water supplied with regard to the requirements of 40 CFR 141, Safe Drinking Water Act.
- b. Exceeding any of the limits prescribed by ODCM Specification 2.9.1, and/or 3.15.1. This report shall include the following information:
 1. Identification of equipment or subsystem that rendered the affected radwaste system not operable.
 2. The corrective action(s) taken to restore the affected radwaste treatment system to an operable status.
 3. A summary description of the action(s) taken to prevent a similar recurrence.
- c. Exceeding the reporting level for environmental sample media as specified in ODCM Specifications 4.1.3. This report shall include the following information:
 1. An evaluation of any environmental factor, release condition or other aspect which may have caused the reporting level to be exceeded.
 2. A description of action(s) taken or planned to reduce the levels of licensed materials in the affected environmental media to below reporting level.

- d. Exceeding the limits prescribed by ODCM Specification 6.1.1. This report shall be made in lieu of any other report and shall include the following:
 1. The corrective action(s) to be taken to reduce subsequent releases to prevent recurrence of exceeding the limits prescribed by ODCM Specification 6.1.1.
 2. An analysis which estimates the dose commitment to a member of the general public from uranium fuel cycle source including all effluent pathways and direct radiation for a 12 month period that includes releases covered by this report.
 3. If the release conditions resulting in violation of 40 CFR 190 have not already been corrected, include a request for a variance in accordance with the provisions of 40 CFR 190 and include the specified information of 40 CFR 190.11(b).

9.4 Special Groundwater Protection Reports

- a. Special Ground Water Protection Reports as listed below in 9.4.c, d, & e are not required for subsequent samples results that are from the same plume and have already been reported in accordance with this section.
- b. Notification time requirements for water samples that exceed the reporting criteria start following the notification of sample results from the applicable vendor or corporate laboratory to the RNP Environmental & Chemistry Section.
- c. If any sample result for onsite groundwater, that is or may be used as a source of drinking water, exceeds the reporting criteria of ODCM Table 4.1-2, then submit a special 30 day written report to the NRC. Additionally, a copy of this report shall be forwarded to designated state/local offices listed in ODCM 9.4.f.
- d. If any of the following samples exceed the reporting criteria of ODCM Table 4.1-2,
 1. Any offsite groundwater, or
 2. Any offsite surface water, or
 3. Any onsite groundwater monitoring well, or
 4. Any onsite surface water that is hydrologically connected to groundwaterthen make informal notification to the designated state/local offices listed in ODCM 9.4.f by the end of the next business day.
- e. If a liquid spill or leak from any of the following has the potential to enter groundwater,
 1. Spill or leak that exceeds or may have exceeded 100 gallons from a source containing licensed material, or
 2. Deleted
 3. Any spill or leak, regardless of volume or activity, deemed by the licensee to warrant voluntary communication,then make informal notification to the designated state/local offices listed in ODCM 9.4.f by the end of the next business day.

- f. Designated state/local offices for notification:
1. Office of the Darlington County Director of Emergency Management
 2. Office of the SC DHEC Director of Water Monitoring Assessment and Protection Division, Bureau of Water
 3. Office of the SC DHEC Director, Bureau of Radiological Health
 4. American Nuclear Insurers (ANI)

10.0 LICENSEE INITIATED CHANGES

All ODCM changes are reviewed by knowledgeable individual(s), the ORC Chairman, and approved by the Plant Manager. Revision 36 changes do not adversely impact the accuracy or reliability of effluent, dose, or setpoint calculations.

ODCM Revision 36 - Implementation Date: refer to Cover Page

Section 2.1.1 Page 2-1

Modified discussion on dilution for R-37 setpoint to include service water, from:

“The setpoint for R-37 is calculated using only circulating water for dilution.”

to:

“The setpoint for R-37 is calculated using circulating water for dilution, or service water when circulating water is unavailable.”

Change made per DRR 02236939 to allow for use of service water pumps for dilution of liquid radwaste releases when circulating water is unavailable. This allows for more operational flexibility. Setpoint, compliance with 10CFR20 Appendix B, and compliance with 10CFR50 Appendix I methodologies are unchanged.

Section 2.1.1.1 Page 2-2

Added line item for service water pump flow to definition of ‘F’.

Change made per DRR 02236939 to allow for use of service water pumps for dilution of liquid radwaste releases when circulating water is unavailable. This allows for more operational flexibility. Setpoint, compliance with 10CFR20 Appendix B, and compliance with 10CFR50 Appendix I methodologies are unchanged.

Section 2.1.2 Page 2-3

Modified discussion on dilution for R-37 setpoint to include service water, from:

“The setpoint for R-37 is calculated using only circulating water for dilution.”

to:

“The setpoint for R-37 is calculated using circulating water for dilution, or service water when circulating water is unavailable.”

Change made per DRR 02236939 to allow for use of service water pumps for dilution of liquid radwaste releases when circulating water is unavailable. This allows for more operational flexibility. Setpoint, compliance with 10CFR20 Appendix B, and compliance with 10CFR50 Appendix I methodologies are unchanged.

Section 2.1.2.2 Page 2-4

Added line item for service water pump flow to definition of 'F_{avail}'.

Change made per DRR 02236939 to allow for use of service water pumps for dilution of liquid radwaste releases when circulating water is unavailable. This allows for more operational flexibility. Setpoint, compliance with 10CFR20 Appendix B, and compliance with 10CFR50 Appendix I methodologies are unchanged.

Section 2.1 References Page 2-6

Added Reference 4:

4. RNP-M/MECH-1653, Service Water System Hydraulic Evaluation

Change made per DRR 02236939 to allow for use of service water pumps for dilution of liquid radwaste releases when circulating water is unavailable. This allows for more operational flexibility. Setpoint, compliance with 10CFR20 Appendix B, and compliance with 10CFR50 Appendix I methodologies are unchanged.

Section 2.3.2.1 Page 2-10

Revised description of 'D_{fr}' to include service water pumps and added line item for service water pump flow to definition.

Change made per DRR 02236939 to allow for use of service water pumps for dilution of liquid radwaste releases when circulating water is unavailable. This allows for more operational flexibility. Setpoint, compliance with 10CFR20 Appendix B, and compliance with 10CFR50 Appendix I methodologies are unchanged.

Section 2.3.2.1 Page 2-11

Revised discussion on liquid radwaste effluent line discharges from:

“For HBR, the liquid radwaste effluent line discharges to the circulating water system. Therefore, the dilution flow rate (D_{fr}) is a function of the number of circulating water pumps operating. At least one circulating water pump must be operating during any liquid waste discharge.”

to:

“For HBR, the liquid radwaste effluent line discharges to the circulating water system. Therefore, the dilution flow rate (D_{fr}) is a function of the number of circulating water pumps operating, or one Unit 2 service water pump when no circulating water pumps are available. At least one circulating water pump must be operating during any liquid waste discharge during normal plant operation. During periods when no circulating water pumps are available (e.g. refueling outage), one Unit 2 service water pump may be used for dilution.”

Change made per DRR 02236939 to allow for use of service water pumps for dilution of liquid radwaste releases when circulating water is unavailable. This allows for more operational flexibility. Setpoint, compliance with 10CFR20 Appendix B, and compliance with 10CFR50 Appendix I methodologies are unchanged.

Section 2.3.2.2 Page 2-13

Revised description of 'D_{fr}' to include service water pumps.

Modified sentence from:

"The circulating water pump flow rates were given in Section 2.3.2.1 above."

to:

"The circulating water pump and service water pump flow rates were given in Section 2.3.2.1 above."

Change made per DRR 02236939 to allow for use of service water pumps for dilution of liquid radwaste releases when circulating water is unavailable. This allows for more operational flexibility. Setpoint, compliance with 10CFR20 Appendix B, and compliance with 10CFR50 Appendix I methodologies are unchanged.

Table 2.7-1 Page 2-34

Reformatted table to better align Pathway/Instruments column with requirements columns. Editorial changes only, no changes to surveillance requirements. Change made per DRR 02210035.

APPENDIX A: METEOROLOGICAL DISPERSION FACTOR COMPUTATIONS

Carolina Power & Light Company (CP&L) engaged the services of Dames & Moore to assess the transport and dispersion of the effluent in the atmosphere as outlined in Preparation of Radiological Effluent Technical Specifications for Nuclear Power Plants, NUREG 0133 (USNRC 1978). The methodology for this assessment was based on guidelines presented in Regulatory Guide (RG) 1.111, Revision 1 (USNRC 1977). The results of the assessment were to provide the relative deposition flux and relative concentrations (undepleted and depleted) based on numerical models acceptable for use in Appendix I evaluations.

Regulatory Guide 1.111 presented three acceptable diffusion models for use in estimating deposition flux and concentrations. These were (1) particle-in-cell model (a variable trajectory model based on the gradient-transport theory), (2) puff-advection model (a variable trajectory model based on the statistical approach to diffusion), and (3) the constant mean wind direction model referred to here as the straight-line trajectory Gaussian diffusion model (the most widely used model based on a statistical approach). It was resolved that for operational efficiency, the straight-line described in XOQDOQ Program for the Meteorological Evaluation of Routine Effluent Releases at Nuclear Power Stations (Draft), NUREG 0324 (USNRC September 1977) would be used for generating the required analyses of Appendix I. To provide a more realistic accounting of the variability of wind around the plant site, terrain/recirculation correction factors (TCF) were to be determined from a combined puff-advection/straight-line scheme for a one-year meteorological data base.

Dames & Moore was provided a one-year record of meteorological data from the on-site meteorological program at the H. B. Robinson Steam Electric Plant. These data consisted of all collected parameters at both the 11.03-meter and 62.39-meter tower levels for the year 1977. Dames & Moore computed dispersions and depositions using the model described in the reference. The following tables from the reference provide the basis for the meteorological dilution factor development of the technical specifications for Appendix I and were the source of the X/Q and D/Q values used to show compliance with 10 CFR 20 and 10 CFR 50 for noble gases and radioiodines and particulates.

Tables A-1 through A-6 Relative undepleted concentration, relative depleted concentration, and relative deposition flux estimates for ground level releases for both standard distances and special locations for long-term releases.

Tables A-7 through A-9 Relative undepleted concentration, relative depleted concentration, and relative deposition flux estimates for ground level releases for special locations for short-term releases.

The χ/Q and D/Q values which are used in Appendix B for showing compliance with 10 CFR 20 and 10 CFR 50 when the HBR Plant vent has been modified such that it qualifies as a mixed mode release were based upon the following tables:

Tables A-10 through A-15 Relative undepleted concentration, relative depleted concentration, and relative deposition flux estimates for elevated release for both standard distances and special locations for long-term releases.

Tables A-16 through A-18 Relative undepleted concentration, relative depleted concentration, and relative deposition flux estimates for mixed mode releases for special locations for short-term releases.

It should be noted that the short-term releases were based upon 100 hours per year of containment purges.

Future Operation Computations

NRC's XOQDOQ program will be used to determine the annual averaged χ/Q and D/Q values for annual radiological effluent release reporting.

In general, Dames & Moore concluded that the straight-line model is as reasonable a projection of concentrations as the puff-advection model. By inclusion of the terrain correction factors developed by a combination of the puff-advection/straight-line scheme with the results of the XOQDOQ Program, ready evaluation of on-site meteorological data may be made.

For routine meteorological dispersion evaluations, the "XOQDOQ" Program will be run with the appropriate physical plant data, appropriate meteorological information for the standard distances, and special locations of interest without a terrain/recirculation factor. The resulting computations will have applied the TCFs to produce a final atmospheric diffusion estimate for the site. The input to "XOQDOQ" for ground level releases at HBR are presented in Table A-19 and for mixed mode releases at HBR in Table A-20.

Reference

Chandler, Martin W. and George Hoopes, Revised Radiological Effluent Technical Specifications. Gaseous Effluent Dilution Factors, Prepared for Carolina Power & Light Company, Robinson Facility, Dames & Moore, January 18, 1979.

TABLE A-1
 χ /Q VALUES FOR LONG-TERM GROUND LEVEL RELEASES
AT SPECIAL LOCATIONS (sec/m³)^{*}

Carolina Power & Light Company - Robinson
 Release Type: Annual
 Release Mode: Ground Level
 Variable: Relative Concentration (Sec./Cubic Meter)
 Calculation Points: Special
 Model: Straight Line (ANNX0Q9)
 Application of Terrain Correction Factors: Yes
 Number of Observations: 8703

<u>Affected Sector</u>	<u>Site Boundary</u>	<u>Meat</u>	<u>Dairy</u>	<u>Resident</u>	<u>Garden</u>
NNE	6.67E-06	4.13E-06	0.00	6.26E-06	5.56E-06
NE	3.02E-06	2.56E-06	2.13E-06	2.44E-06	2.13E-06
ENE	4.41E-06	4.93E-07	0.00	4.18E-06	7.36E-07
E	6.39E-06	3.02E-07	1.44E-07	3.51E-06	3.68E-07
ESE	1.12E-05	1.18E-06	0.00	7.90E-06	7.90E-06
SE	3.28E-05	0.00	0.00	3.27E-05	3.27E-05
SSE	8.08E-05	0.00	0.00	6.01E-05	6.01E-05
S	3.29E-05	4.22E-07	0.00	2.78E-05	1.65E-05
SSW	2.10E-05	5.61E-07	0.00	2.04E-05	8.07E-06
SW	8.91E-06	2.61E-07	2.14E-07**	6.90E-06	5.38E-06
WSW	3.97E-06	1.16E-07	0.00	3.22E-06	1.83E-06
W	2.11E-06	3.89E-08	0.00	1.38E-06	1.38E-06
WNW	1.62E-06	5.32E-08	0.00	1.03E-06	6.06E-07
NW	7.93E-07	5.06E-07	0.00	7.39E-07	7.39E-07
NNW	1.31E-06	4.78E-07	0.00	4.42E-07	3.82E-07
N	1.45E-06	6.44E-07	0.00	6.67E-07	6.67E-07

* Zeroes indicate that this point was not calculated

** A milk goat was located here

TABLE A-2
DEPLETED γ/Q VALUES FOR LONG-TERM GROUND LEVEL RELEASES
AT SPECIAL LOCATIONS (sec/m³)*

Carolina Power & Light Company - Robinson
 Release Type: Annual
 Release Mode: Ground Level
 Variable: Relative Depleted Concentration (Sec./Cubic Meter)
 Calculation Points: Special
 Model: Straight Line (ANNX0Q9)
 Application of Terrain Correction Factors: Yes
 Number of Observations: 8703

<u>Affected Sector</u>	<u>Site Boundary</u>	<u>Meat</u>	<u>Dairy</u>	<u>Resident</u>	<u>Garden</u>
NNE	5.84E-06	3.38E-06	0.00	5.25E-06	4.77E-06
NE	2.68E-06	2.21E-06	1.79E-06	2.09E-06	1.79E-06
ENE	3.95E-06	3.99E-07	0.00	3.72E-06	5.93E-07
E	5.79E-06	2.42E-07	1.08E-07	3.12E-06	2.86E-07
ESE	1.01E-05	9.72E-07	0.00	7.11E-06	7.11E-06
SE	3.08E-05	0.00	0.00	3.05E-05	3.05E-05
SSE	7.46E-05	0.00	0.00	5.61E-05	5.61E-05
S	3.11E-05	3.42E-07	0.00	2.61E-05	1.53E-05
SSW	1.91E-05	4.55E-07	0.00	1.96E-05	7.35E-06
SW	8.25E-06	2.14E-07	2.44E-07**	6.44E-06	4.88E-06
WSW	3.68E-06	8.92E-08	0.00	2.94E-06	1.68E-06
W	1.98E-06	2.96E-08	0.00	1.26E-06	1.26E-06
WNW	1.47E-06	4.07E-08	0.00	9.26E-07	5.42E-07
NW	6.71E-07	4.19E-07	0.00	6.31E-07	6.31E-07
NNW	1.09E-06	3.80E-07	0.00	3.48E-07	2.98E-07
N	1.24E-06	5.11E-07	0.00	5.24E-07	5.24E-07

* Zeroes indicate that this point was not calculated

** A milk goat was located here

TABLE A-3
D/Q VALUES FOR LONG-TERM GROUND LEVEL RELEASES
AT SPECIAL LOCATIONS (m⁻²)^{*}

Carolina Power & Light Company - Robinson
 Release Type: Annual
 Release Mode: Ground Level
 Variable: Relative Deposition Rate (Meter ⁻²)
 Calculation Points: Special
 Model: Straight Line (ANNX0Q9)
 Application of Terrain Correction Factors: Yes
 Number of Observations: 8703

<u>Affected Sector</u>	<u>Site Boundary</u>	<u>Meat</u>	<u>Dairy</u>	<u>Resident</u>	<u>Garden</u>
NNE	9.80E-09	5.63E-09	0.00	9.09E-09	7.74E-09
NE	5.59E-09	4.65E-09	3.70E-09	4.42E-09	3.70E-09
ENE	8.06E-09	6.96E-10	0.00	7.59E-09	1.05E-09
E	1.24E-08	4.13E-10	1.80E-10	6.43E-09	5.11E-10
ESE	1.71E-08	1.46E-09	0.00	1.20E-08	1.20E-08
SE	4.23E-08	0.00	0.00	4.14E-08	4.14E-08
SSE	8.08E-08	0.00	0.00	6.21E-08	6.21E-08
S	4.39E-08	4.77E-10	0.00	3.82E-08	2.33E-08
SSW	5.92E-08	1.38E-09	0.00	6.12E-08	2.33E-08
SW	2.80E-08	6.49E-10	5.17E-10**	2.15E-08	1.65E-08
WSW	1.91E-08	4.37E-10	0.00	1.54E-08	8.84E-09
W	8.84E-09	1.09E-10	0.00	5.75E-09	5.75E-09
WNW	8.10E-09	1.88E-10	0.00	5.08E-09	2.97E-09
NW	2.44E-09	1.45E-09	0.00	2.16E-09	2.16E-09
NNW	2.44E-09	7.45E-10	0.00	6.83E-10	5.73E-10
N	1.76E-09	6.44E-10	0.00	6.67E-10	6.67E-10

* Zeroes indicate that this point was not calculated

** A milk goat was located here

TABLE A-4
λ/Q VALUES FOR LONG-TERM GROUND LEVEL RELEASES
AT STANDARD DISTANCES (sec/m³)

Carolina Power & Light Company - Robinson
 Release Type: Annual
 Release Mode: Ground Level
 Variable: Relative Concentration (Sec./Cubic Meter)
 Calculation Points: Standard
 Model: Straight Line (ANNX0Q9)
 Application of Terrain Correction Factors: Yes
 Number of Observations: 8703

BASE DISTANCE IN MILES/KILOMETERS

<u>Sector</u>	<u>Mi→</u>	<u>.25</u>	<u>.75</u>	<u>1.25</u>	<u>1.75</u>	<u>2.25</u>	<u>2.75</u>	<u>3.25</u>	<u>3.75</u>	<u>4.25</u>	<u>4.75</u>
	<u>Km→</u>	<u>.40</u>	<u>1.21</u>	<u>2.01</u>	<u>2.82</u>	<u>3.62</u>	<u>4.42</u>	<u>5.23</u>	<u>6.03</u>	<u>6.84</u>	<u>7.64</u>
NNE		8.8E-05	1.5E-05	6.4E-06	3.5E-06	2.3E-06	1.7E-06	1.1E-06	8.0E-07	5.5E-07	3.7E-07
NE		3.9E-05	4.6E-06	2.0E-06	1.1E-06	6.9E-07	4.6E-07	3.5E-07	2.8E-07	2.2E-07	1.7E-07
ENE		3.2E-05	5.2E-06	1.8E-06	9.7E-07	5.3E-07	3.8E-07	2.6E-07	2.1E-07	1.7E-07	1.5E-07
E		2.9E-05	4.5E-06	1.6E-06	8.3E-07	6.2E-07	3.3E-07	2.7E-07	1.9E-07	1.3E-07	9.5E-08
ESE		3.6E-05	5.4E-06	2.3E-06	1.3E-06	9.2E-07	6.2E-07	5.1E-07	3.6E-07	2.7E-07	1.9E-07
SE		4.0E-05	5.4E-06	2.6E-06	1.3E-06	8.5E-07	4.8E-07	3.6E-07	2.1E-07	1.9E-07	1.6E-07
SSE		8.2E-05	1.2E-05	5.0E-06	2.6E-06	1.5E-06	9.2E-07	6.5E-07	5.5E-07	4.5E-07	4.0E-07
S		3.6E-05	4.4E-06	1.7E-06	9.1E-07	4.2E-07	3.3E-07	2.6E-07	2.1E-07	1.7E-07	1.4E-07
SSW		2.5E-05	4.6E-06	1.9E-06	7.9E-07	4.5E-07	3.0E-07	2.1E-07	1.6E-07	1.2E-07	9.8E-08
SW		1.5E-05	2.2E-06	8.3E-07	3.7E-07	2.3E-07	1.6E-07	1.2E-07	8.8E-08	7.1E-08	5.9E-08
WSW		6.5E-06	1.0E-06	3.7E-07	2.0E-07	1.6E-07	1.0E-07	6.9E-08	5.8E-08	4.8E-08	3.7E-08
W		6.5E-06	8.3E-07	3.2E-07	1.7E-07	1.3E-07	8.8E-08	6.7E-08	4.3E-08	3.0E-08	2.4E-08
WNW		6.1E-06	7.8E-07	3.0E-07	1.8E-07	1.3E-07	9.6E-08	7.1E-08	5.4E-08	4.0E-08	3.0E-08
NW		1.1E-05	1.6E-06	7.4E-07	4.2E-07	2.4E-07	1.3E-07	8.0E-08	6.7E-08	5.3E-08	4.4E-08
NNW		2.0E-05	3.6E-06	1.9E-06	1.4E-06	9.4E-07	5.2E-07	2.7E-07	1.8E-07	1.2E-07	9.2E-08
N		5.2E-05	8.0E-06	3.3E-06	1.6E-06	1.0E-06	7.1E-07	4.9E-07	3.7E-07	2.9E-07	2.4E-07

Number of Valid Observations = 8703

Number of Invalid Observations = 57

Number of Calms Lower Level = 398

Number of Calms Upper Limit = 0

TABLE A-5
DEPLETED γ/Q VALUES FOR LONG-TERM GROUND LEVEL RELEASES
AT STANDARD DISTANCES (sec/m³)

Carolina Power & Light Company - Robinson
 Release Type: Annual
 Release Mode: Ground Level
 Variable: Relative Concentration (Sec./Cubic Meter)
 Calculation Points: Standard
 Model: Straight Line (ANNX0Q9)
 Application of Terrain Correction Factors: Yes
 Number of Observations: 8703

BASE DISTANCE IN MILES/KILOMETERS

<u>Sector</u>	<u>Mi→</u>	<u>.25</u>	<u>.75</u>	<u>1.25</u>	<u>1.75</u>	<u>2.25</u>	<u>2.75</u>	<u>3.25</u>	<u>3.75</u>	<u>4.25</u>	<u>4.75</u>
	<u>Km→</u>	<u>.40</u>	<u>1.21</u>	<u>2.01</u>	<u>2.82</u>	<u>3.62</u>	<u>4.42</u>	<u>5.23</u>	<u>6.03</u>	<u>6.84</u>	<u>7.64</u>
NNE		8.3E-05	1.3E-05	5.4E-06	3.0E-06	2.0E-06	1.3E-07	8.3E-06	6.2E-07	4.1E-07	2.7E-07
NE		3.6E-05	4.1E-06	1.7E-06	9.2E-07	5.6E-07	3.6E-07	2.7E-07	2.1E-07	1.6E-07	1.3E-07
ENE		3.1E-05	4.6E-06	1.5E-06	8.3E-07	4.3E-07	3.0E-07	2.0E-07	1.6E-07	1.3E-07	1.1E-07
E		2.7E-05	4.1E-06	1.3E-06	6.9E-07	5.0E-07	2.7E-07	2.1E-07	1.4E-07	9.4E-08	7.2E-08
ESE		3.4E-05	4.9E-06	2.0E-06	1.1E-06	7.4E-07	5.0E-07	4.0E-07	2.9E-07	2.1E-07	1.5E-07
SE		3.8E-05	4.9E-06	2.2E-06	1.1E-06	7.0E-07	3.8E-07	2.8E-07	1.7E-07	1.4E-07	1.2E-07
SSE		7.8E-05	1.1E-05	4.4E-06	2.2E-06	1.3E-06	7.6E-07	5.1E-07	4.3E-07	3.3E-07	2.9E-07
S		3.5E-05	3.9E-06	1.4E-06	7.6E-07	3.5E-07	2.6E-07	2.0E-07	1.6E-07	1.3E-07	1.1E-07
SSW		2.3E-05	4.1E-06	1.6E-06	6.6E-07	3.7E-07	2.4E-07	1.7E-07	1.2E-07	8.9E-08	6.9E-08
SW		1.4E-05	1.9E-06	7.1E-07	3.1E-07	1.9E-07	1.2E-07	9.8E-08	6.7E-08	5.0E-08	4.3E-08
WSW		6.2E-06	9.2E-07	3.2E-07	1.7E-07	1.3E-07	8.0E-08	5.4E-08	4.4E-08	3.6E-08	2.7E-08
W		6.1E-06	7.5E-07	2.8E-07	1.4E-07	1.1E-07	6.8E-08	5.2E-08	3.3E-08	2.3E-08	1.8E-08
WNW		5.8E-06	7.0E-07	2.6E-07	1.5E-07	1.1E-07	7.6E-08	5.5E-08	4.2E-08	3.0E-08	2.2E-08
NW		1.1E-05	1.4E-06	6.4E-07	1.4E-07	2.0E-07	1.0E-07	6.1E-08	5.0E-08	4.0E-08	3.3E-08
NNW		1.9E-05	3.1E-06	1.6E-06	1.1E-06	7.6E-07	4.2E-07	2.0E-07	1.3E-07	8.8E-08	7.1E-08
N		4.9E-05	7.2E-06	2.8E-06	1.4E-06	8.1E-07	5.6E-07	3.8E-07	2.9E-07	2.2E-07	1.8E-07

Number of Valid Observations = 8703
 Number of Invalid Observations = 57
 Number of Calms Lower Level = 398
 Number of Calms Upper Limit = 0

TABLE A-6
D/Q VALUES FOR LONG-TERM GROUND LEVEL RELEASES
AT STANDARD DISTANCES (m⁻²)

Carolina Power & Light Company - Robinson
 Release Type: Annual
 Release Mode: Ground Level
 Variable: Relative Concentration (Meter ⁻²)
 Calculation Points: Standard
 Model: Straight Line (ANNX0Q9)
 Application of Terrain Correction Factors: Yes
 Number of Observations: 8703

BASE DISTANCE IN MILES/KILOMETERS

<u>Sector</u>	<u>Mi→</u>	<u>.25</u>	<u>.75</u>	<u>1.25</u>	<u>1.75</u>	<u>2.25</u>	<u>2.75</u>	<u>3.25</u>	<u>3.75</u>	<u>4.25</u>	<u>4.75</u>
	<u>Km→</u>	<u>.40</u>	<u>1.21</u>	<u>2.01</u>	<u>2.82</u>	<u>3.62</u>	<u>4.42</u>	<u>5.23</u>	<u>6.03</u>	<u>6.84</u>	<u>7.64</u>
NNE		1.3E-07	2.4E-08	9.3E-09	4.8E-09	3.0E-09	2.0E-09	1.2E-09	8.2E-10	5.4E-10	3.4E-10
NE		7.1E-08	8.9E-09	3.4E-09	1.8E-09	1.0E-09	6.5E-10	4.6E-10	3.4E-10	2.6E-10	2.0E-10
ENE		5.5E-08	9.6E-09	3.1E-09	1.5E-09	7.9E-10	5.1E-10	3.3E-10	2.6E-10	1.9E-10	1.6E-10
E		5.1E-08	8.7E-09	2.7E-09	1.4E-09	9.4E-10	4.7E-10	3.6E-10	2.4E-10	1.5E-10	1.1E-10
ESE		5.0E-08	8.2E-09	3.2E-09	1.6E-09	1.1E-09	6.9E-10	5.1E-10	3.6E-10	2.5E-10	1.8E-10
SE		4.8E-08	7.0E-09	3.1E-09	1.5E-09	8.6E-10	4.5E-10	3.1E-10	1.8E-10	1.5E-10	1.2E-10
SSE		8.2E-08	1.3E-08	5.2E-09	2.6E-09	1.4E-09	7.7E-10	4.9E-10	3.9E-10	3.0E-10	2.5E-10
S		4.8E-08	6.3E-09	2.2E-09	1.2E-09	4.8E-10	3.5E-10	2.6E-10	1.9E-10	1.6E-10	1.2E-10
SSW		7.2E-08	1.4E-08	5.1E-09	2.0E-09	1.1E-09	6.8E-10	4.5E-10	3.2E-10	2.3E-10	1.8E-10
SW		4.2E-08	6.5E-09	2.3E-09	1.0E-09	5.7E-10	3.7E-10	2.7E-10	1.8E-10	1.4E-10	1.1E-10
WSW		3.0E-08	4.9E-09	1.7E-09	8.5E-10	6.3E-10	3.8E-10	2.5E-10	1.9E-10	1.6E-10	1.2E-10
W		2.7E-08	3.4E-09	1.2E-09	6.1E-10	4.4E-10	2.7E-10	2.0E-10	1.3E-10	8.5E-11	6.7E-11
WNW		3.0E-08	3.9E-09	1.4E-09	7.4E-10	5.4E-10	3.7E-10	2.6E-10	2.0E-10	1.4E-10	1.0E-10
NW		3.4E-08	5.2E-09	2.2E-09	1.2E-09	6.3E-10	3.2E-10	1.8E-10	1.5E-10	1.1E-10	9.0E-11
NNW		4.1E-08	7.4E-09	3.6E-09	2.5E-09	1.6E-09	8.0E-10	3.9E-10	2.4E-10	1.5E-10	1.2E-10
N		6.7E-08	1.1E-08	4.1E-09	2.0E-09	1.1E-09	7.2E-10	4.7E-10	3.3E-10	2.5E-10	2.0E-10

Number of Valid Observations = 8703

Number of Invalid Observations = 57

Number of Calms Lower Level = 398

Number of Calms Upper Limit = 0

TABLE A-7
 χ /Q VALUES FOR SHORT-TERM GROUND LEVEL RELEASES
AT SPECIAL LOCATIONS (sec/m³)*

Carolina Power & Light Company - Robinson
 Release Type: Purge
 Release Mode: Ground Level
 Variable: Relative Concentration (Sec./Cubic Meter)
 Calculation Points: Special
 Model: Purge (ACNPURG2)
 Application of Terrain Correction Factors: No
 Number of Observations: 8703
 Purge Time: 100 Hours

<u>Affected Sector</u>	<u>Site Boundary</u>	<u>Meat</u>	<u>Dairy</u>	<u>Resident</u>	<u>Garden</u>
NNE	7.20E-06	5.00E-06	0.00	6.80E-06	6.20E-06
NE	5.30E-06	4.60E-06	4.00E-06	4.40E-06	4.00E-06
ENE	6.90E-06	1.50E-06	0.00	6.70E-06	1.90E-06
E	1.00E-05	1.10E-06	6.40E-07	6.20E-06	1.20E-06
ESE	1.50E-05	2.60E-06	0.00	1.10E-05	1.10E-05
SE	3.40E-05	0.00	0.00	3.30E-05	3.30E-05
SSE	5.10E-05	0.00	0.00	4.10E-05	4.10E-05
S	3.00E-05	1.20E-06	0.00	2.60E-05	1.80E-05
SSW	2.10E-05	1.30E-06	0.00	2.00E-05	9.80E-06
SW	1.10E-05	7.80E-07	6.70E-07**	9.10E-06	7.20E-06
WSW	8.10E-06	5.50E-07	0.00	6.90E-06	4.20E-06
W	5.50E-06	3.00E-07	0.00	4.20E-06	4.20E-06
WNW	5.30E-06	3.90E-07	0.00	3.70E-06	2.50E-06
NW	2.30E-06	1.70E-06	0.00	2.20E-06	2.20E-06
NNW	2.40E-06	1.20E-06	0.00	1.20E-06	1.10E-06
N	2.70E-06	1.50E-06	0.00	1.50E-06	1.50E-06

* Zeroes indicate that this point was not calculated

** A milk goat was located here

TABLE A-8
DEPLETED γ/Q VALUES FOR SHORT-TERM GROUND LEVEL RELEASES
AT SPECIAL LOCATIONS (sec/m³)*

Carolina Power & Light Company - Robinson
 Release Type: Purge
 Release Mode: Ground Level
 Variable: Relative Depleted Concentration (Sec./Cubic Meter)
 Calculation Points: Special
 Model: Purge (ACNPURG2)
 Application of Terrain Correction Factors: No
 Number of Observations: 8703
 Purge Time: 100 Hours

<u>Affected Sector</u>	<u>Site Boundary</u>	<u>Meat</u>	<u>Dairy</u>	<u>Resident</u>	<u>Garden</u>
NNE	6.30E-06	4.09E-06	0.00	5.71E-06	5.31E-06
NE	4.71E-06	3.97E-06	3.37E-06	3.77E-06	3.37E-06
ENE	6.19E-06	1.21E-06	0.00	5.96E-06	1.53E-06
E	9.06E-06	8.80E-07	4.80E-07	5.51E-06	9.34E-07
ESE	1.36E-05	2.14E-06	0.00	9.90E-06	9.90E-06
SE	3.19E-05	0.00	0.00	3.08E-05	3.08E-05
SSE	4.71E-05	0.00	0.00	3.83E-05	3.83E-05
S	2.83E-05	9.74E-07	0.00	2.44E-05	1.67E-05
SSW	1.91E-05	1.05E-06	0.00	1.92E-05	8.93E-06
SW	1.02E-05	6.38E-07	7.64E-07**	8.49E-06	6.52E-06
WSW	7.50E-06	4.23E-07	0.00	6.30E-06	3.85E-06
W	5.16E-06	2.28E-07	0.00	3.85E-06	3.85E-06
WNW	4.82E-06	2.98E-07	0.00	3.33E-06	2.23E-06
NW	1.95E-06	1.41E-06	0.00	1.88E-06	1.88E-06
NNW	1.99E-06	9.53E-07	0.00	9.46E-07	8.59E-07
N	2.31E-06	1.19E-06	0.00	1.18E-06	1.18E-06

* Zeroes indicate that this point was not calculated

** A milk goat was located here

TABLE A-9
D/Q VALUES FOR SHORT-TERM GROUND LEVEL RELEASES
AT SPECIAL LOCATIONS (m⁻²)*

Carolina Power & Light Company - Robinson
 Release Type: Purge
 Release Mode: Ground Level
 Variable: Relative Deposition Rate (Meter⁻²)
 Calculation Points: Special
 Model: Purge (ACNPURG2)
 Application of Terrain Correction Factors: No
 Number of Observations: 8703
 Purge Time: 100 Hours

<u>Affected Sector</u>	<u>Site Boundary</u>	<u>Meat</u>	<u>Dairy</u>	<u>Resident</u>	<u>Garden</u>
NNE	1.06E-08	6.80E-09	0.00	9.86E-09	8.62E-09
NE	9.80E-09	8.37E-09	6.96E-09	7.96E-09	6.96E-09
ENE	1.26E-08	2.12E-09	0.00	1.21E-08	2.72E-09
E	1.94E-08	1.51E-09	8.00E-10	1.13E-08	1.67E-09
ESE	2.29E-08	3.22E-09	0.00	1.68E-08	1.68E-08
SE	4.25E-08	0.00	0.00	4.19E-08	4.19E-08
SSE	5.10E-08	0.00	0.00	4.22E-08	4.22E-08
S	3.99E-08	1.36E-09	0.00	3.59E-08	2.54E-08
SSW	5.92E-08	3.18E-09	0.00	6.00E-08	2.83E-08
SW	3.46E-08	1.93E-09	1.61E-09**	2.83E-08	2.20E-08
WSW	3.90E-08	2.07E-09	0.00	3.30E-08	2.03E-08
W	2.30E-08	8.40E-10	0.00	1.75E-08	1.75E-08
WNW	2.65E-08	1.38E-09	0.00	1.82E-08	1.22E-08
NW	7.08E-09	4.86E-09	0.00	6.42E-09	6.42E-09
NNW	4.46E-09	1.87E-09	0.00	1.86E-09	1.65E-09
N	3.27E-09	1.50E-09	0.00	1.50E-09	1.50E-09

* Zeroes indicate that this point was not calculated

** A milk goat was located here

TABLE A-10
 χ/Q VALUES FOR LONG-TERM MIXED MODE RELEASES
AT SPECIAL LOCATIONS (sec/m³)*

Carolina Power & Light Company - Robinson
 Release Type: Annual
 Release Mode: Mixed Mode
 Variable: Relative Concentration (Sec./Cubic Meter)
 Calculation Points: Special
 Model: Straight Line (ANNX0Q9)
 Application of Terrain Correction Factors: Yes
 Number of Observations: 8703

<u>Affected Sector</u>	<u>Site Boundary</u>	<u>Meat</u>	<u>Dairy</u>	<u>Resident</u>	<u>Garden</u>
NNE	3.33E-07	2.82E-07	0.00	3.23E-07	3.18E-07
NE	1.34E-07	1.40E-07	1.23E-07	1.39E-07	1.23E-07
ENE	2.74E-07	1.23E-07	0.00	2.79E-07	8.51E-08
E	2.40E-07	1.11E-07	5.39E-08	2.53E-07	1.33E-07
ESE	2.75E-07	1.25E-07	0.00	2.17E-07	2.17E-07
SE	5.13E-07	0.00	0.00	5.23E-07	5.23E-07
SSE	9.94E-07	0.00	0.00	7.61E-07	7.61E-07
S	4.57E-07	3.61E-08	0.00	4.00E-07	2.50E-07
SSW	5.54E-07	1.27E-07	0.00	5.71E-07	2.69E-07
SW	2.31E-07	5.38E-08	4.72E-08**	1.84E-07	1.51E-07
WSW	2.06E-07	4.64E-08	0.00	1.68E-07	1.02E-07
W	9.36E-08	1.87E-08	0.00	7.13E-08	7.13E-08
WNW	1.02E-07	4.28E-08	0.00	9.55E-08	9.80E-08
NW	1.52E-07	1.30E-07	0.00	1.54E-07	1.54E-07
NNW	1.71E-07	8.86E-08	0.00	8.30E-08	7.28E-08
N	9.32E-08	5.66E-08	0.00	5.80E-08	5.80E-08

* Zeroes indicate that this point was not calculated

** A milk goat was located here

TABLE A-11
DEPLETED γ/Q VALUES FOR LONG-TERM MIXED MODE RELEASES
AT SPECIAL LOCATIONS (sec/m³)*

Carolina Power & Light Company - Robinson
 Release Type: Annual
 Release Mode: Mixed Mode
 Variable: Relative Concentration (Sec./Cubic Meter)
 Calculation Points: Special
 Model: Straight Line (ANNX0Q9)
 Application of Terrain Correction Factors: Yes
 Number of Observations: 8703

<u>Affected Sector</u>	<u>Site Boundary</u>	<u>Meat</u>	<u>Dairy</u>	<u>Resident</u>	<u>Garden</u>
NNE	3.33E-07	2.82E-07	0.00	3.23E-07	2.98E-07
NE	1.23E-07	1.28E-07	1.23E-07	1.28E-07	1.23E-07
ENE	2.59E-07	1.23E-07	0.00	2.63E-07	8.12E-08
E	2.40E-07	1.11E-07	4.39E-08	2.53E-07	1.23E-07
ESE	2.54E-07	1.18E-07	0.00	1.96E-07	1.96E-07
SE	4.93E-07	0.00	0.00	5.02E-07	5.02E-07
SSE	9.32E-07	0.00	0.00	7.21E-07	7.21E-07
S	4.39E-07	3.42E-08	0.00	3.82E-07	2.33E-07
SSW	5.35E-07	1.27E-07	0.00	5.51E-07	2.51E-07
SW	2.31E-07	5.14E-08	5.31E-08**	1.84E-07	1.45E-07
WSW	2.06E-07	4.46E-08	0.00	1.68E-07	9.91E-08
W	9.10E-08	1.82E-08	0.00	6.90E-08	6.90E-08
WNW	9.88E-08	4.07E-08	0.00	9.26E-08	9.54E-08
NW	1.51E-07	1.27E-07	0.00	1.54E-07	1.54E-07
NNW	1.64E-07	8.44E-08	0.00	8.04E-08	6.92E-08
N	8.91E-08	5.42E-08	0.00	5.56E-08	5.56E-08

* Zeroes indicate that this point was not calculated

** A milk goat was located here

TABLE A-12
D/Q VALUES FOR LONG-TERM MIXED MODE RELEASES
AT SPECIAL LOCATIONS (m⁻²)*

Carolina Power & Light Company - Robinson
 Release Type: Annual
 Release Mode: Mixed Mode
 Variable: Relative Deposition Rate (Meter⁻²)
 Calculation Points: Special
 Model: Straight Line (ANNX0Q9)
 Application of Terrain Correction Factors: Yes
 Number of Observations: 8703

<u>Affected Sector</u>	<u>Site Boundary</u>	<u>Meat</u>	<u>Dairy</u>	<u>Resident</u>	<u>Garden</u>
NNE	2.29E-09	1.39E-09	0.00	2.22E-09	1.89E-09
NE	1.79E-09	1.51E-09	1.23E-09	1.39E-09	1.23E-09
ENE	3.19E-09	3.41E-10	0.00	3.10E-09	4.78E-10
E	4.99E-09	2.31E-10	1.15E-10	2.92E-09	2.76E-10
ESE	4.86E-09	5.90E-10	0.00	3.75E-09	3.75E-09
SE	6.98E-09	0.00	0.00	7.20E-09	7.20E-09
SSE	6.22E-09	0.00	0.00	5.21E-09	5.21E-09
S	7.31E-09	1.77E-10	0.00	6.60E-09	5.17E-09
SSW	1.01E-08	7.41E-10	0.00	1.06E-08	6.81E-09
SW	4.62E-09	3.32E-10	2.66E-10**	4.14E-09	3.87E-09
WSW	4.85E-09	2.59E-10	0.00	4.34E-09	3.35E-09
W	2.64E-09	6.74E-11	0.00	1.95E-09	1.95E-09
WNW	2.59E-09	1.25E-10	0.00	1.94E-09	1.29E-09
NW	1.20E-09	7.66E-10	0.00	1.12E-09	1.12E-09
NNW	7.77E-10	2.53E-10	0.00	2.41E-10	2.03E-10
N	3.62E-10	1.41E-10	0.00	1.51E-10	1.51E-10

* Zeroes indicate that this point was not calculated

** A milk goat was located here

TABLE A-13
 γ/Q VALUES FOR LONG-TERM MIXED MODE RELEASES
AT STANDARD DISTANCES (sec/m³)

Carolina Power & Light Company - Robinson
 Release Type: Annual
 Release Mode: Mixed Mode
 Variable: Relative Concentration (Sec./Cubic Meter)
 Calculation Points: Standard
 Model: Straight Line (ANNX0Q9)
 Application of Terrain Correction Factors: Yes
 Number of Observations: 8703

BASE DISTANCE IN MILES/KILOMETERS

<u>Sector</u>	<u>Mi→</u>	<u>.25</u>	<u>.75</u>	<u>1.25</u>	<u>1.75</u>	<u>2.25</u>	<u>2.75</u>	<u>3.25</u>	<u>3.75</u>	<u>4.25</u>	<u>4.75</u>
	<u>Km→</u>	<u>.40</u>	<u>1.21</u>	<u>2.01</u>	<u>2.82</u>	<u>3.62</u>	<u>4.42</u>	<u>5.23</u>	<u>6.03</u>	<u>6.84</u>	<u>7.64</u>
NNE		1.5E-06	3.9E-07	3.1E-07	2.7E-07	2.3E-07	2.0E-07	1.6E-07	1.4E-07	9.8E-08	6.5E-08
NE		1.0E-06	1.5E-07	1.1E-07	9.0E-08	6.7E-08	5.2E-08	7.8E-08	3.8E-08	5.4E-08	3.4E-08
ENE		8.6E-07	2.6E-07	1.9E-07	1.7E-07	1.2E-07	1.1E-07	7.4E-08	6.2E-08	4.8E-08	4.2E-08
E		7.2E-07	2.6E-07	2.2E-07	2.0E-07	2.1E-07	1.2E-07	9.4E-08	7.0E-08	4.7E-08	3.6E-08
ESE		7.8E-07	1.9E-07	1.7E-07	1.3E-07	1.0E-07	7.6E-08	6.6E-08	4.9E-08	3.8E-08	2.9E-08
SE		5.9E-07	1.0E-07	7.5E-08	5.1E-08	3.8E-08	2.4E-08	1.9E-08	1.2E-08	1.2E-08	1.1E-08
SSE		1.0E-06	1.8E-07	1.2E-07	8.0E-08	5.4E-08	3.6E-08	2.6E-08	2.3E-08	1.9E-08	1.8E-08
S		5.0E-07	9.4E-08	7.0E-08	5.9E-08	3.5E-08	3.2E-08	2.9E-08	2.5E-08	2.2E-08	1.9E-08
SSW		6.3E-07	2.7E-07	2.4E-07	1.5E-07	1.2E-07	8.4E-08	6.3E-08	4.7E-08	3.6E-08	3.1E-08
SW		3.5E-07	9.9E-08	8.8E-08	6.1E-08	4.6E-08	3.7E-08	3.2E-08	2.3E-08	2.0E-08	1.7E-08
WSW		3.0E-07	6.5E-08	6.2E-08	5.4E-08	5.4E-08	4.1E-08	3.0E-08	2.7E-08	2.4E-08	1.9E-08
W		2.4E-07	6.2E-08	6.0E-08	4.9E-08	4.9E-08	3.5E-08	3.0E-08	2.0E-08	1.5E-08	1.2E-08
WNW		2.8E-07	8.4E-08	8.6E-08	6.8E-08	6.3E-08	5.2E-08	4.2E-08	3.6E-08	3.6E-08	3.4E-08
NW		3.8E-07	1.2E-07	1.5E-07	1.2E-07	9.2E-08	6.5E-08	4.7E-08	4.1E-08	3.5E-08	2.9E-08
NNW		4.2E-07	1.8E-07	1.4E-07	1.6E-07	1.4E-07	9.2E-08	5.4E-08	3.7E-08	2.5E-08	2.1E-08
N		7.8E-07	1.7E-07	1.3E-07	9.3E-08	7.2E-08	5.9E-08	4.5E-08	3.8E-08	3.3E-08	2.9E-08

Number of Valid Observations = 8703

Number of Invalid Observations = 57

Number of Calms Lower Level = 60

Number of Calms Upper Limit = 5

TABLE A-14
DEPLETED χ/Q VALUES FOR LONG-TERM MIXED MODE RELEASES
AT STANDARD DISTANCES (sec/m³)

Carolina Power & Light Company - Robinson
 Release Type: Annual
 Release Mode: Mixed Mode
 Variable: Relative Depleted Concentration (Sec./Cubic Meter)
 Calculation Points: Standard
 Model: Straight Line (ANNX0Q9)
 Application of Terrain Correction Factors: Yes
 Number of Observations: 8703

BASE DISTANCE IN MILES/KILOMETERS

<u>Sector</u>	<u>Mi→</u>	<u>.25</u>	<u>.75</u>	<u>1.25</u>	<u>1.75</u>	<u>2.25</u>	<u>2.75</u>	<u>3.25</u>	<u>3.75</u>	<u>4.25</u>	<u>4.75</u>
	<u>Km→</u>	<u>.40</u>	<u>1.21</u>	<u>2.01</u>	<u>2.82</u>	<u>3.62</u>	<u>4.42</u>	<u>5.23</u>	<u>6.03</u>	<u>6.84</u>	<u>7.64</u>
NNE		1.5E-06	3.7E-07	3.1E-07	2.5E-07	2.2E-07	1.8E-07	1.5E-07	1.3E-07	8.9E-08	6.1E-08
NE		9.8E-07	1.4E-07	1.1E-07	8.5E-08	6.4E-08	4.9E-08	7.8E-08	3.6E-08	5.2E-08	3.1E-08
ENE		8.3E-07	2.5E-07	1.8E-07	1.6E-07	1.2E-07	1.0E-07	6.9E-08	5.7E-08	4.5E-08	4.0E-08
E		7.0E-07	2.4E-07	2.0E-07	1.9E-07	2.1E-07	1.1E-07	9.4E-08	6.6E-08	4.5E-08	3.4E-08
ESE		7.3E-07	1.8E-07	1.6E-07	1.2E-07	9.6E-08	7.2E-08	6.1E-08	4.6E-08	3.6E-08	2.7E-08
SE		5.7E-07	9.6E-08	6.9E-08	4.7E-08	3.6E-08	2.3E-08	1.8E-08	1.2E-08	1.0E-08	9.9E-09
SSE		9.6E-07	1.7E-07	1.1E-07	7.4E-08	4.9E-08	3.3E-08	2.4E-08	2.1E-08	1.7E-08	1.6E-08
S		4.8E-07	8.9E-08	6.7E-08	5.8E-08	3.8E-08	3.1E-08	2.7E-08	2.4E-08	2.1E-08	1.8E-08
SSW		6.1E-07	2.5E-07	2.4E-07	1.5E-07	1.1E-07	8.0E-08	6.0E-08	4.5E-08	3.4E-08	2.9E-08
SW		3.4E-07	9.5E-08	8.5E-08	5.8E-08	4.4E-08	3.6E-08	3.1E-08	2.2E-08	1.9E-08	1.6E-08
WSW		2.9E-07	6.3E-08	6.1E-08	5.2E-08	5.2E-08	4.0E-08	2.9E-08	2.6E-08	2.2E-08	1.8E-08
W		2.4E-07	6.0E-08	5.9E-08	4.8E-08	4.7E-08	3.4E-08	2.9E-08	1.9E-08	1.4E-08	1.2E-08
WNW		2.6E-07	8.3E-08	8.4E-08	6.6E-08	6.2E-08	5.0E-08	4.0E-08	3.4E-08	3.4E-08	3.2E-08
NW		3.8E-07	1.1E-07	1.5E-07	1.1E-07	9.0E-08	6.3E-08	4.5E-08	3.9E-08	3.0E-08	2.4E-08
NNW		4.1E-07	1.2E-07	1.4E-07	1.6E-07	1.4E-07	8.8E-08	5.2E-08	3.5E-08	2.4E-08	2.0E-08
N		7.5E-07	1.5E-07	1.2E-07	8.8E-08	6.9E-08	5.7E-08	4.3E-08	3.6E-08	3.1E-08	2.7E-08

Number of Valid Observations = 8703

Number of Invalid Observations = 57

Number of Calms Lower Level = 60

Number of Calms Upper Limit = 5

TABLE A-15
D/Q VALUES FOR LONG-TERM MIXED MODE RELEASES
AT STANDARD DISTANCES (m⁻²)

Carolina Power & Light Company - Robinson
 Release Type: Annual
 Release Mode: Mixed Mode
 Variable: Relative Deposition Rate (Meter-2)
 Calculation Points: Standard
 Model: Straight Line (ANNX0Q9)
 Application of Terrain Correction Factors: Yes
 Number of Observations: 8703

BASE DISTANCE IN MILES/KILOMETERS

<u>Sector</u>	<u>Mi→</u>	<u>.25</u>	<u>.75</u>	<u>1.25</u>	<u>1.75</u>	<u>2.25</u>	<u>2.75</u>	<u>3.25</u>	<u>3.75</u>	<u>4.25</u>	<u>4.75</u>
	<u>Km→</u>	<u>.40</u>	<u>1.21</u>	<u>2.01</u>	<u>2.82</u>	<u>3.62</u>	<u>4.42</u>	<u>5.23</u>	<u>6.03</u>	<u>6.84</u>	<u>7.64</u>
NNE		1.6E-08	5.0E-09	2.1E-09	1.2E-09	7.5E-10	5.2E-10	3.4E-10	2.7E-10	2.0E-10	1.4E-10
NE		1.1E-08	2.6E-09	1.2E-09	6.2E-10	3.5E-10	2.3E-10	1.8E-10	1.2E-10	1.2E-10	1.0E-10
ENE		1.1E-08	3.8E-09	1.4E-09	7.6E-10	3.7E-10	2.7E-10	1.8E-10	1.4E-10	1.2E-10	1.1E-10
E		1.1E-08	3.7E-09	1.4E-09	7.2E-10	5.0E-10	2.6E-10	2.1E-10	1.4E-10	1.0E-10	7.8E-11
ESE		8.6E-09	2.7E-09	1.2E-09	6.7E-10	4.3E-10	2.8E-10	2.1E-10	1.5E-10	1.0E-10	7.3E-11
SE		7.0E-09	1.9E-09	9.5E-10	4.7E-10	2.8E-10	1.5E-10	1.1E-10	5.9E-11	5.0E-11	4.2E-11
SSE		6.2E-09	1.8E-09	8.6E-10	4.6E-10	2.6E-10	1.5E-10	9.5E-11	7.7E-11	5.9E-11	5.0E-11
S		7.1E-09	1.8E-09	7.6E-10	4.2E-10	1.8E-10	1.3E-10	9.9E-11	7.3E-11	6.1E-11	4.8E-11
SSW		1.0E-08	5.0E-09	2.6E-09	1.1E-09	6.1E-10	3.9E-10	2.6E-10	1.8E-10	1.3E-10	1.0E-10
SW		5.0E-09	2.0E-09	9.8E-10	4.7E-10	2.9E-10	1.9E-10	1.5E-10	9.8E-11	7.6E-11	6.4E-11
WSW		4.9E-09	1.9E-09	8.4E-10	4.8E-10	3.7E-10	2.3E-10	1.5E-10	1.2E-10	1.0E-10	7.1E-11
W		4.0E-09	1.4E-09	6.3E-10	3.4E-10	2.6E-10	1.6E-10	1.3E-10	7.9E-11	5.4E-11	4.1E-11
WNW		4.6E-09	1.5E-09	7.1E-10	4.2E-10	3.2E-10	2.2E-10	1.6E-10	1.2E-10	9.9E-11	7.4E-11
NW		5.6E-09	2.2E-09	1.1E-09	6.4E-10	3.6E-10	1.9E-10	1.2E-10	1.0E-10	1.1E-10	9.6E-11
NNW		4.5E-09	1.9E-09	1.1E-09	8.1E-10	5.2E-10	2.7E-10	1.4E-10	8.8E-11	5.7E-11	4.5E-11
N		5.9E-09	1.8E-09	8.2E-10	4.0E-10	2.4E-10	1.6E-10	1.0E-10	7.4E-11	5.8E-11	4.7E-11

Number of Valid Observations = 8703

Number of Invalid Observations = 57

Number of Calms Lower Level = 60

Number of Calms Upper Limit = 5

TABLE A-16
 χ /Q VALUES FOR SHORT-TERM MIXED MODE RELEASES
AT SPECIAL LOCATIONS (sec/m³)^{*}

Carolina Power & Light Company - Robinson
 Release Type: Purge
 Release Mode: Mixed Mode
 Variable: Relative Concentration (Sec./Cubic Meter)
 Calculation Points: Special
 Model: Purge (ACNPURG2)
 Application of Terrain Correction Factors: No
 Number of Observations: 8703
 Purge Time: 100 Hours

<u>Affected Sector</u>	<u>Site Boundary</u>	<u>Meat</u>	<u>Dairy</u>	<u>Resident</u>	<u>Garden</u>
NNE	8.40E-07	7.00E-07	0.00	8.30E-07	7.90E-07
NE	5.40E-07	5.30E-07	4.70E-07	5.20E-07	4.70E-07
ENE	8.90E-07	4.20E-07	0.00	8.80E-07	3.10E-07
E	1.00E-06	4.00E-07	2.50E-07	9.20E-07	4.50E-07
ESE	1.24E-06	4.70E-07	0.00	1.00E-06	1.00E-06
SE	2.20E-06	0.00	0.00	2.10E-06	2.10E-06
SSE	2.90E-06	0.00	0.00	2.40E-06	2.40E-06
S	1.90E-06	2.00E-07	0.00	1.70E-06	1.20E-06
SSW	2.00E-06	4.00E-07	0.00	2.00E-06	1.10E-06
SW	1.10E-06	2.40E-07	2.10E-07**	9.50E-07	7.70E-07
WSW	1.20E-06	2.20E-07	0.00	9.90E-07	6.30E-07
W	7.40E-07	1.30E-07	0.00	5.90E-07	5.90E-07
WNW	7.90E-07	2.20E-07	0.00	6.80E-07	6.20E-07
NW	6.30E-07	5.10E-07	0.00	6.20E-07	6.20E-07
NNW	5.10E-07	3.20E-07	0.00	3.10E-07	2.90E-07
N	3.50E-07	2.30E-07	0.00	2.40E-07	2.40E-07

* Zeroes indicate that this point was not calculated

** A milk goat was located here

TABLE A-17
DEPLETED γ/Q VALUES FOR SHORT-TERM MIXED MODE RELEASES
AT SPECIAL LOCATIONS (sec/m³) *

Carolina Power & Light Company - Robinson
 Release Type: Purge
 Release Mode: Mixed Mode
 Variable: Relative Depleted Concentration (Sec./Cubic Meter)
 Calculation Points: Special
 Model: Purge (ACNPURG2)
 Application of Terrain Correction Factors: No
 Number of Observations: 8703
 Purge Time: 100 Hours

<u>Affected Sector</u>	<u>Site Boundary</u>	<u>Meat</u>	<u>Dairy</u>	<u>Resident</u>	<u>Garden</u>
NNE	8.40E-07	7.00E-07	0.00	8.30E-07	7.41E-07
NE	4.95E-07	4.86E-07	4.70E-07	4.77E-07	4.70E-07
ENE	8.40E-07	4.20E-07	0.00	8.31E-07	2.96E-07
E	1.00E-06	4.00E-07	2.03E-07	9.20E-07	4.15E-07
ESE	1.11E-06	4.44E-07	0.00	9.00E-07	9.00E-07
SE	2.11E-06	0.00	0.00	2.01E-06	2.01E-06
SSE	2.72E-07	0.00	0.00	2.27E-06	2.27E-06
S	1.82E-06	1.90E-07	0.00	1.63E-06	1.12E-06
SSW	1.93E-06	4.00E-07	0.00	1.93E-06	1.03E-06
SW	1.10E-06	2.29E-07	2.35E-07**	9.50E-07	7.36E-07
WSW	1.20E-06	2.12E-07	0.00	9.90E-07	6.11E-07
W	7.19E-07	1.26E-07	0.00	5.71E-07	5.71E-07
WNW	7.65E-07	2.09E-07	0.00	6.59E-07	6.04E-07
NW	6.24E-07	4.99E-07	0.00	6.20E-07	6.20E-07
NNW	4.90E-07	3.05E-07	0.00	3.00E-07	2.76E-07
N	3.35E-07	2.20E-07	0.00	2.30E-07	2.30E-07

* Zeroes indicate that this point was not calculated

** A milk goat was located here

TABLE A-18
D/Q VALUES FOR SHORT-TERM MIXED MODE RELEASES
AT SPECIAL LOCATIONS (m⁻²)^{*}

Carolina Power & Light Company - Robinson
 Release Type: Purge
 Release Mode: Mixed Mode
 Variable: Relative Deposition Rate (Meter⁻²)
 Calculation Points: Special
 Model: Purge (ACNPURG2)
 Application of Terrain Correction Factors: No
 Number of Observations: 8703
 Purge Time: 100 Hours

<u>Affected Sector</u>	<u>Site Boundary</u>	<u>Meat</u>	<u>Dairy</u>	<u>Resident</u>	<u>Garden</u>
NNE	5.77E-09	3.45E-09	0.00	5.70E-09	4.68E-09
NE	7.18E-09	5.72E-09	4.70E-09	5.20E-09	4.70E-09
ENE	1.04E-08	1.16E-09	0.00	9.77E-09	1.74E-09
E	2.08E-08	8.36E-10	5.32E-10	1.06E-08	9.36E-10
ESE	2.12E-08	2.22E-09	0.00	1.73E-08	1.73E-08
SE	2.99E-08	0.00	0.00	2.88E-08	2.88E-08
SSE	1.81E-08	0.00	0.00	1.64E-08	1.64E-08
S	3.04E-08	9.84E-10	0.00	2.80E-08	2.48E-08
SSW	3.66E-08	2.33E-09	0.00	3.72E-08	2.78E-08
SW	2.20E-08	1.48E-09	1.18E-09**	2.14E-08	1.97E-08
WSW	2.83E-08	1.23E-09	0.00	2.55E-08	2.07E-08
W	2.09E-08	4.69E-10	0.00	1.62E-08	1.62E-08
WNW	2.01E-08	6.45E-10	0.00	1.38E-08	8.18E-09
NW	4.98E-09	3.00E-09	0.00	4.53E-09	4.53E-09
NNW	2.32E-09	9.15E-10	0.00	8.99E-10	8.09E-10
N	1.36E-09	5.75E-10	0.00	6.24E-10	6.24E-10

* Zeroes indicate that this point was not calculated

** A milk goat was located here

TABLE A-19
ROBINSON PLANT SITE INFORMATION TO BE USED FOR
GROUND LEVEL CALCULATIONS WITH NRC "XOQDOQ" PROGRAM

<u>CARD TYPE</u>	<u>COLUMNS</u>	<u>DESCRIPTION</u>	<u>VALUE TO BE USED IN</u> <u>XOQDOQ</u>
1	1 38 39 41 55 56 58	Print input data Calculate annual X/Qs for points of interest Calculate annual X/Q averages for site radial segments Print out set distance X/Qs and D/Qs Calculate annual D/Q averages for the set radial segments Allow depleted X/Qs (if Decays (1), (2), or (3) are negative) Calculate annual D/Qs for points of interest	1 1 1 1 1 1 1
2	1-80	Title card	N/A
3	1-5 6-10 11-15 16-20 21-25 26-30 31-35	Number of wind velocity categories Number of stability categories Number of distances within terrain data for each sector Total number of hours in joint wind frequency distribution Increment in % for which plotted results are to be printed Number of titles of receptor types Number or release exit locations	7 7 5 (1) 5 5 3
4	1-5 6-20	Height of the measured wind (meters) Half-life (days) used in the X/Q calculations	11 101.00 226 -8.00
5	N/A	N/A	---
6	1-80	Joint wind frequency distribution	(1)

TABLE A-19 (continued)
ROBINSON PLANT SITE INFORMATION TO BE USED FOR
GROUND LEVEL CALCULATIONS WITH NRC "XOQDOQ" PROGRAM

<u>CARD TYPE</u>	<u>COLUMNS</u>	<u>DESCRIPTION</u>	<u>VALUE TO BE USED IN</u> <u>XOQDOQ</u>
7	1-5 6-75	Wind velocity units correction Maximum wind speed in each wind class (m/sec)	200.00 0.75 3.50 7.50 12.50 18.50 25.00 26.00
8	1-80	Distance in meters at which terrain heights are given	(2)
9	1-80	Terrain heights (in meters, above plant grade) correspond to distance in Card Type 8	(2)
10	1-25	Number of receptor locations for a particular receptor type	Site boundary = 16 Dairy = 1 Meat = 14 Residence = 16 Garden = 16
11	1-16	Title of receptor type for receptor locations	Site Boundary Dairy Meat Residence Garden
12	1-80	Receptor direction and distance	(See Table 1)
13	1-80	Title for release point whose characteristics are described on Card Type 14	(1)

TABLE A-19 (continued)
ROBINSON PLANT SITE INFORMATION TO BE USED FOR
GROUND LEVEL CALCULATIONS WITH NRC "XOQDOQ" PROGRAM

<u>CARD TYPE</u>	<u>COLUMNS</u>	<u>DESCRIPTION</u>	<u>VALUE TO BE USED IN XOQDOQ</u>
14	1-5	Vent average velocity (m/sec)	20.1
	6-10	Vent inside diameter (m)	1.0
	11-15	Height of vent release point (m)	0.000
	16-20	Height of the vent's building (m)	59.0
	21-25	Minimum cross-sectional area for the vent's building (m ²)	1370.0
	26-30	Wind height used for vent elevated release	11.0
	31-35	Vent heat emission rate (cal/sec)	0.0
15	1	Identification for release point	A
	2-5	Intermittent releases	1
	6-10	Number of intermittent releases per year for this release point	100
	11-15	Average number of hours per intermittent release	1

- (1) Appropriate data to be supplied
- (2) Obtained from cross-sectional topographic maps

TABLE A-20
ROBINSON PLANT SITE INFORMATION TO BE USED FOR
MIXED MODE RELEASE CALCULATIONS WITH NRC "XOQDOQ" PROGRAM

<u>CARD TYPE</u>	<u>COLUMNS</u>	<u>DESCRIPTION</u>	<u>VALUE TO BE USED IN XOQDOQ</u>
1	1 38 39 41 55 56 58	Print input data Calculate annual X/Qs for points of interest Calculate annual X/Q averages for site radial segments Print out set distance X/Qs and D/Qs Calculate annual D/Q averages for the set radial segments Allow depleted X/Qs (if Decays (1), (2), or (3) are negative) Calculate annual D/Qs for points of interest	1 1 1 1 1 1 1
2	1-80	Title card	N/A
3	1-5 6-10 11-15 16-20 21-25 26-30 31-35	Number of wind velocity categories Number of stability categories Number of distances within terrain data for each sector Total number of hours in joint wind frequency distribution Increment in % for which plotted results are to be printed Number of titles of receptor types Number of release exit locations	7 7 5 (1) 5 5 3
4	1-5 6-20	Height of the measured wind (meters) Half-life (days) used in the X/Q calculations	11 101.00 226 -8.00
5	N/A	N/A	---
6	1-80	Joint wind frequency distribution	(1)

TABLE A-20 (continued)
ROBINSON PLANT SITE INFORMATION TO BE USED FOR
MIXED MODE RELEASE CALCULATIONS WITH NRC "XOQDOQ" PROGRAM

<u>CARD TYPE</u>	<u>COLUMNS</u>	<u>DESCRIPTION</u>	<u>VALUE TO BE USED IN</u> <u>XOQDOQ</u>
7	1-5 6-75	Wind velocity units correction Maximum wind speed in each wind class (m/sec)	200.00 0.75 3.50 7.50 12.50 18.50 25.00 26.00
8	1-80	Distance in meters at which terrain heights are given	(2)
9	1-80	Terrain heights (in meters, above plant grade) corresponding to distances in Card Type 8	(2)
10	1-25	Number of receptor locations for a particular receptor type	Site boundary = 16 Dairy = 1 Meat = 14 Residence = 16 Garden = 16
11	1-16	Title of receptor type for receptor locations	Site Boundary Dairy Meat Residence Garden
12	1-80	Receptor direction and distance	(See Table 1)
13	1-80	Title for release point whose characteristics are described on Card Type 14	(1)

TABLE A-20 (continued)
ROBINSON PLANT SITE INFORMATION TO BE USED FOR
MIXED MODE RELEASE CALCULATIONS WITH NRC "XOQDOQ" PROGRAM

<u>CARD TYPE</u>	<u>COLUMNS</u>	<u>DESCRIPTION</u>	<u>VALUE TO BE USED IN XOQDOQ</u>
14	1-5	Vent average velocity (m/sec)	20.1
	6-10	Vent inside diameter (m)	1.0
	11-15	Height of vent release point (m)	60.7
	16-20	Height of the vent's building (m)	59.0
	21-25	Minimum cross-sectional area for the vent's building (m ²)	1370.0
	26-30	Wind height used for vent elevated release	11.
	31-35	Vent heat emission rate (cal/sec)	0.
15	1	Identification for release point	A
	2-5	Intermittent releases	1
	6-10	Number of intermittent releases per year for this release point	100
	11-15	Average number of hours per intermittent release	1

- (1) Appropriate data to be supplied
- (2) Obtained from cross-sectional topographic maps

APPENDIX B:

DOSE PARAMETERS FOR RADIOIODINES, PARTICULATES, AND TRITIUM

This appendix contains the methodology which was used to calculate the dose parameters for radioiodines, particulates, and tritium to show compliance with 10 CFR 20 and Appendix I of 10 CFR 50 for gaseous effluents. These dose parameters, P_i and R_i , were calculated using the methodology outlined in NUREG 0133 along with Regulatory Guide 1.109, Revision 1. The following sections provide the specific methodology which was utilized in calculating the P_i and R_i values for the various exposure pathways.

B.1 Calculation of P_i

The dose parameter, P_i , contained in the radioiodine and particulates portion of Section 3.3 includes pathway transport parameters of the 'i' radionuclide, the receptor's usage of the pathway media, and the dosimetry of the exposure. Pathway usage rates and the internal dosimetry are functions of the receptor's age. The following sections provide in detail the methodology which was used in calculating the P_i values for inclusion into this ODCM.

B.1.1 Inhalation Pathway

The dose factor from inhalation pathway is calculated by:

$$P_{ii} = K' * BR * DFA_i \tag{B.1-1}$$

where:

P_{ii} = Dose parameter for radionuclide 'i' for the inhalation pathway (mrem/yr per $\mu\text{Ci}/\text{m}^3$).

K' = 10^6 , a constant of unit conversion (pCi/ μCi).

BR = The breathing rate of the child age group (m^3/yr).

DFA_i = The organ inhalation dose factor for the child age group for radionuclide 'i' (mrem/pCi).

The age group considered is the child group. The child's breathing rate is taken as $3700 \text{ m}^3/\text{yr}$ from Table E-5 of Regulatory Guide 1.109, Revision 1. The inhalation dose factors for the child, DFA_i , are presented in Table E-10 of Regulatory Guide 1.109 in units of mrem/pCi. The total body is considered as an organ in the selection of DFA_i .

The incorporation of breathing rate of a child and the unit conversion factor results in the following equation:

$$P_{ii} = 3.7 \times 10^9 * DFA_i \tag{B.1-2}$$

B.1.2 Ground Plane Pathway

The dose factor from ground plane pathway is calculated by:

$$P_{iG} = K' * K'' * DFG_i * \frac{1 - e^{-\lambda_i * t}}{\lambda_i} \tag{B.1-3}$$

where:

P_{iG} = Dose parameter for radionuclide 'i' for the ground plane pathway (m²-mrem/yr per μ Ci/sec).

K' = 10⁶, a constant of unit conversion (pCi/ μ Ci).

K'' = 8760, a constant of unit conversion (hr/yr).

DFG_i = The ground plane dose conversion factor for radionuclide 'i' (mrem/hr per ρ Ci/m²).

λ_i = The radiological decay constant for radionuclide 'i' (sec⁻¹).

t = 3.17x10⁷, the exposure period of 1 year (sec).

The deposition rate onto the ground plane results in a ground plane concentration that is assumed to persist over a year with radiological decay, the only operating removal mechanism for each radionuclide. The ground plane dose conversion factors for radionuclide 'i', DFG_i , are presented in Table E-6 of Regulatory Guide 1.109, Revision 1. Resolution of the units yields:

$$P_{iG} = 8.76 \times 10^9 * DFG_i * \frac{1 - e^{-\lambda_i * t}}{\lambda_i} \tag{B.1-4}$$

B.1.3 Milk

The dose factor from the cow/goat-milk-man pathway is calculated by:

$$P_{iM} = \frac{K' * r * Q_F * U_{ap} * F_m}{Y_p * (\lambda_i + \lambda_w)} * DFL_i * e^{-\lambda_i * t_f} \quad (B.1-5)$$

where:

- P_{iM} = Dose parameter for radionuclide 'i' for the cow milk or goat milk pathway (m²-mrem/yr per μ Ci/sec).
- K' = 10⁶, a constant of unit conversion (ρ Ci/ μ Ci).
- r = Fraction of deposited activity retained on cow's or goat's feed grass (dimensionless).
- Q_F = The cow's or goat's consumption rate of feed (kg/day, wet weight).
- U_{ap} = The child's milk consumption rate (liters/yr).
- F_m = The stable element transfer coefficient (ρ Ci/liter per ρ Ci/day).
- Y_p = The agricultural productivity by unit area (kg/m²).
- λ_i = The radiological decay constant for radionuclide 'i' (sec⁻¹).
- λ_w = 5.73x10⁻⁷ (corresponding to a 14 day half-life), the decay constant for removal of activity on leaf and plant surfaces by weathering (sec⁻¹).
- DFL_i = The maximum organ ingestion dose factor for radionuclide 'i' (mrem/ ρ Ci).
- t_f = The transport time from pasture, to cow or goat, to milk, to child (sec).

A fraction of the airborne deposition is captured by the ground plane vegetation cover. The captured material is removed from the vegetation (grass) by both radiological decay and weathering processes.

Various parameters which were utilized to determine the P_i values for the cow and goat milk pathways are provided in Table B-1. Table E-1 of Regulatory Guide 1.109, Revision 1, provides the stable element transfer coefficients, F_m ; and Table E-14 of the same regulatory guide provides the ingestion dose factors, DFL_i , for the child's organs. The organ with the maximum value of DFL_i was used in the determination of P_i for this pathway. The incorporation of the various constants of Table B-1 into Equation B.1-5 results in the following:

For radioiodines and particulates from cow's milk:

$$P_{iM} = 2.4 \times 10^{10} * \frac{r * F_m}{\lambda_i + \lambda_w} * DFL_i * e^{-\lambda_i * t_f} \quad (\text{B.1-6})$$

For radioiodines and particulates from goat's milk pathway:

$$P_{iM} = 2.8 \times 10^9 * \frac{r * F_m}{\lambda_i + \lambda_w} * DFL_i * e^{-\lambda_i * t_f} \quad (\text{B.1-7})$$

The concentration of tritium in milk is based on its airborne concentration rather than the deposition rate and is calculated by:

$$P_{TM} = K' * K''' * F_m * Q_F * U_{ap} * DFL_T * 0.75 * \frac{0.5}{H} \quad (\text{B.1-8})$$

where:

- P_{TM} = Dose parameter for tritium for the cow milk and goat milk pathways (mrem/yr per $\mu\text{Ci}/\text{m}^3$).
- K''' = 10^3 , a constant of unit conversion (gm/kg).
- DFL_T = Maximum organ ingestion dose factor for tritium (mrem/pCi).
- H = Absolute humidity of the atmosphere (gm/m^3).
- 0.75 = The fraction of total feed that is water (dimensionless).
- 0.5 = The ratio of the specific activity of the feed grass water to the atmospheric water (dimensionless).

B.2 Calculation of R_i Followign Regulatory Guide 1.109 Methodology

The radioiodine and particulate ODCM Specification 3.5.2.1 is applicable to the location in the unrestricted area where the combination of existing pathways and receptor age groups indicates that the maximum potential exposure occurs. The inhalation and ground plane exposure pathways shall be considered to exist at all locations. The grass-goat-milk, the grass-cow-milk, grass-cow-meat, and vegetation pathways are considered based on their existence at the various locations. R_i values have been calculated for the adult, teen, and child age groups for the inhalation, ground plane, cow milk, goat milk, vegetable, and beef ingestion pathways. R_i values have been calculated for the infant age group for the inhalation, ground plane, cow milk, and goat milk pathways. The methodology which was utilized to calculate these values (see Tables 3.5-1 through 3.5-19) is presented below and follows the guidance given in Regulatory Guide 1.109.

B.2.1 Inhalation Pathway

The dose factor from the inhalation pathway is calculated by:

$$R_{il} = K' * BR_a * (DFA_i)_a \tag{B.2-1}$$

where:

- R_{il} = Dose factor for each identified radionuclide 'i' of the organ of interest (mrem/yr per μCi/m³).
- K' = 10⁶, a constant of unit conversion (ρCi/μCi).
- BR_a = Breathing rate of the receptor of age group 'a' (m³/yr).
- (DFA_i)_a = Organ inhalation dose factor for radionuclide 'i' for the receptor of age group 'a' (mrem/ρCi).

The breathing rates BR_a for the various age groups are tabulated below, as given in Table E-5 of Regulatory Guide 1.109, Revision 1.

<u>Age Group (a)</u>	<u>Breathing Rate (m³/yr)</u>
Infant	1400
Child	3700
Teen	8000
Adult	8000

Inhalation dose factors (DFA_i)_a for the various age groups are given in Tables E-7 through E-10 of Regulatory Guide 1.109, Revision 1.

B.2.2 Ground Plane Pathway

The ground plane pathway dose factor is calculated by:

$$R_{iG} = I_i * K' * K'' * S_F * DFG_i * \frac{1 - e^{-\lambda_i * t}}{\lambda_i} \quad (\text{B.2-2})$$

where:

- R_{iG} = Dose factor for the ground plane pathway for each identified radionuclide 'i' for the organ of interest ($\text{m}^2\text{-mrem/hr per } \mu\text{Ci/sec}$).
- I_i = 1.0, factor to account for fractional deposition of radionuclide 'i'. For radionuclides other than iodine, the factor I_i is equal to 1.0. For radioiodines, the value of I_i may vary. However, a value of 1.0 was used in calculating the R values in Table 3.5-1 (dimensionless).
- K' = 10^6 , a constant of unit conversion ($\rho\text{Ci}/\mu\text{Ci}$).
- K'' = 8760, a constant of unit conversion (hr/yr).
- S_F = 0.7, the shielding factor suggested in Table E-15 of Regulatory Guide 1.109, Revision 1 (dimensionless).
- DFG_i = The ground plane dose conversion factor for radionuclide 'i'. A tabulation of DFG_i values is presented in Table E-6 of Regulatory Guide 1.109, Revision 1 ($\text{mrem/hr per } \rho\text{Ci/m}^2$).
- λ_i = The radiological decay constant for radionuclide 'i' (sec^{-1}).
- t = 4.73×10^8 , exposure time in seconds over 15 years (sec).

B.2.3 Grass Cow or Goat Milk Pathway

The dose factor for the cow milk or goat milk pathway for each radionuclide for each organ is calculated by:

$$\begin{aligned}
 R_{iM} = & I_i * K' * Q_F * U_{ap} * F_m * (DFL_i)_a * e^{-\lambda_i * t_f} \\
 & * \left[\left[f_p * f_s * \left(\frac{r * (1 - e^{-\lambda_{E_i} * t_e})}{Y_p * \lambda_{E_i}} + \frac{B_{iV} * (1 - e^{-\lambda_i * t_b})}{P * \lambda_i} \right) \right] \right. \\
 & \left. + \left[(1 - f_p * f_s) * \left(\frac{r * (1 - e^{-\lambda_{E_i} * t_e})}{Y_s * \lambda_{E_i}} + \frac{B_{iV} * (1 - e^{-\lambda_i * t_b})}{P * \lambda_i} \right) * (e^{-\lambda_i * t_h}) \right] \right]
 \end{aligned}
 \tag{B.2-3}$$

where:

- R_{iM} = Dose factor for the cow milk or goat milk pathway for each identified radionuclide 'i' for the organ of interest (m²-mrem/yr per μ Ci/sec).
- I_i = 1.0, factor to account for fractional deposition of radionuclide 'i'. For radionuclides other than iodine, the factor I_i is equal to 1.0. For radioiodines, the value of I_i may vary. However, a value of 1.0 was used in calculating the R values in Tables 3.5-8 through 3.5-15 (dimensionless).
- K' = 10⁶, a constant of unit conversion (ρ Ci/ μ Ci).
- Q_F = The cow's or goat's consumption rate of feed (kg/day, wet weight).
- U_{ap} = The receptor's milk consumption rate for age group 'a' (liters/yr).
- F_m = The stable element transfer coefficient (ρ Ci/liter per ρ Ci/day).
- $(DFL_i)_a$ = The organ ingestion dose for radionuclide 'i' for the receptor in age group 'a' (mrem/ ρ Ci).
- λ_i = The radiological decay constant for radionuclide 'i' (sec⁻¹).
- t_f = The transport time from feed to cow or goat to milk to receptor (sec).
- f_p = Fraction of the year that the cow or goat is on pasture (dimensionless).
- f_s = Fraction of the cow or goat feed that is pasture grass while the animal is on pasture (dimensionless).
- r = Fraction of deposited activity retained on cow's or goat's feed grass (dimensionless).
- λ_{E_i} = $\lambda_i + \lambda_w$ (sec⁻¹).

- λ_w = 5.73×10^{-7} , the decay constant for removal of activity on leaf and plant surfaces by weathering (corresponding to a 14 day half-life) (sec^{-1}).
- t_e = Period of pasture grass and crop exposure during the growing season (sec).
- Y_p = The agricultural productivity by unit area of pasture feed grass (kg/m^2).
- B_{iV} = Concentration factor for uptake of radionuclide 'i' from the soil by the edible parts of crops ($\rho\text{Ci}/\text{kg}$ wet weight per $\rho\text{Ci}/\text{kg}$ dry soil).
- t_b = Period of time that sediment is exposed to gaseous effluents (sec).
- P = Effective surface density for soil (kg dry soil/ m^2).
- Y_s = The agricultural productivity by unit area of stored feed (kg/m^2).
- t_h = The transport time for harvest, to cow or goat, to consumption (sec).

In lieu of site specific information regarding the fraction feed of milk cattle and goats, all feed will be considered to be from pasture grass. Therefore using the guidance from Regulatory Guide 1.109, Revision 1, the values of f_s and f_p are considered unity in lieu of site-specific information.

Table B-1 contains the appropriate parameter values and their source in Regulatory Guide 1.109, Revision 1.

The concentration of tritium in milk is based on the airborne concentration rather than the deposition. Therefore, the R_i is based on χ/Q :

$$R_{TM} = K' * K''' * F_m * Q_F * U_{ap} * (DFL_i)_a * 0.75 * \frac{0.5}{H} \quad (\text{B.2-4})$$

where:

- R_{TM} = Dose parameter for the cow or goat milk pathways for tritium for organ of interest (mrem/yr per $\mu\text{Ci}/\text{m}^3$).
- K''' = 10^3 , a constant of unit conversion (gm/kg).
- H = 8, used in lieu of site-specific information, absolute humidity of the atmosphere (gm/m^3).
- 0.75 = The fraction of total feed that is water (dimensionless).
- 0.5 = The ratio of the specific activity of the feed grass water to the atmospheric water (dimensionless).

All other terms remain the same as previously defined.

B.2.4 Grass-Cow-Meat Pathway

The integrated concentration in meat follows in a similar manner to the development for the milk pathway, therefore:

$$\begin{aligned}
 R_{iB} = & I_i * K' * Q_F * U_{ap} * F_f * (DFL_i)_a * e^{-\lambda_i * t_s} \\
 & * \left[f_p * f_s * \left(\frac{r * (1 - e^{-\lambda_{E_i} * t_e})}{Y_p * \lambda_{E_i}} + \frac{B_{iV} * (1 - e^{-\lambda_i * t_b})}{P * \lambda_i} \right) \right] \\
 & + \left[(1 - f_p * f_s) * \left(\frac{r * (1 - e^{-\lambda_{E_i} * t_e})}{Y_s * \lambda_{E_i}} + \frac{B_{iV} * (1 - e^{-\lambda_i * t_b})}{P * \lambda_i} \right) * (e^{-\lambda_i * t_h}) \right]
 \end{aligned}
 \tag{B.2-5}$$

where:

R_{iB} = Dose factor for the meat ingestion pathway for radionuclide 'i' for any organ of interest (m^2 -mrem/yr per μ Ci/sec).

I_i = 1.0, factor to account for fractional deposition of radionuclide 'i'. For radionuclides other than iodine, the factor I_i is equal to 1.0. For radioiodines, the value of I_i may vary. However, a value of 1.0 was used in calculating the R values in Tables 3.5-8 through 3.5-15 (dimensionless).

U_{ap} = The receptor's meat consumption rate for age group 'a' (kg/yr).

F_f = The stable element transfer coefficients (ρ Ci/Kg per ρ Ci/day).

t_s = The transport time from slaughter to consumption (sec).

t_e = Period of pasture grass and crop exposure during the growing season (sec).

t_h = The transport time from harvest to animal consumption (sec).

All other terms remain the same as defined in Equation B.2-3. Table B-2 contains the values which were used in calculating R_i for the meat pathway.

The concentration of tritium in meat is based on its airborne concentration rather than the deposition. Therefore, the R_i is based on χ/Q :

$$R_{TB} = K' * K''' * F_f * Q_F * U_{ap} * (DFL_i)_a * 0.75 * \frac{0.5}{H}
 \tag{B.2-6}$$

where:

R_{TB} = Dose parameter for the meat ingestion pathways for tritium for organ of interest (mrem/yr per μ Ci/ m^3).

All other terms are defined in Equations B.2-4 and B.2-5.

B.2.5 Vegetation Pathway

The integrated concentration in vegetation consumed by man follows the expression developed in the derivation of the milk factor. Man is considered to consume two types of vegetation (fresh and stored) that differ only in the time period between harvest and consumption, therefore:

$$R_{iV} = I_i * K' * (DFL_i)_a * \left[\left[U_a^L * f_L * e^{-\lambda_i * t_L} * \left(\frac{r * (1 - e^{-\lambda_{E_i} * t_e})}{Y_V * \lambda_{E_i}} + \frac{B_{iV} * (1 - e^{-\lambda_i * t_b})}{P * \lambda_i} \right) \right] + \left[U_a^S * f_g * e^{-\lambda_i * t_h} * \left(\frac{r * (1 - e^{-\lambda_{E_i} * t_e})}{Y_V * \lambda_{E_i}} + \frac{B_{iV} * (1 - e^{-\lambda_i * t_b})}{P * \lambda_i} \right) \right] \right] \quad (B.2-7)$$

where:

- R_{iV} = Dose factor for the vegetable pathway for radionuclide 'i' for any organ of interest (m^2 -mrem/yr per $\mu Ci/sec$).
- I_i = 1.0, factor to account for fractional deposition of radionuclide 'i'. For radionuclides other than iodine, the factor I_i is equal to 1.0. For radioiodines, the value of I_i may vary. However, a value of 1.0 was used in calculating the R values in Tables 3.5-8 through 3.5-15 (dimensionless).
- K' = 10^6 , a constant of unit conversion ($\rho Ci/\mu Ci$).
- U_a^L = Consumption rate of fresh leafy vegetation by receptor in age group 'a' (kg/yr).
- f_L = 1.0, used in lieu of site-specific data, fraction of the annual intake of fresh leafy vegetation grown locally. Value of 1.0, obtained from Table E-15 of Regulatory Guide 1.109, Revision 1, was used in the calculations of R_{iV} (dimensionless).
- t_L = Average time between harvest of leafy vegetation and its consumption (sec).
- t_e = Period of leafy vegetable exposure during growing season (sec).
- Y_V = Vegetation areal density (kg/m^2).
- U_a^S = Consumption rate of stored vegetation by receptor in age group 'a' (kg/yr).

f_g = 0.76, used in lieu of site-specific data, fraction of annual intake of stored vegetation grown locally. Value of 0.76, obtained from Table E-15 of Regulatory Guide 1.109, Revision 1, was used in the calculations of R_{IV} (dimensionless).

t_h = Average time between harvest of stored vegetation and its consumption (sec).

All other factors as defined before.

Table B-3 presents the appropriate parameter values and their source in Regulatory Guide 1.109, Revision 1.

The concentration of tritium in vegetation is based on the airborne concentration rather than the deposition. Therefore, the R_i is based on χ/Q :

$$R_{TV} = K' * K''' * (U_a^L * f_L + U_a^S * f_g) * (DFL_i)_a * 0.75 * \frac{0.5}{H} \quad (\text{B.2-8})$$

where:

R_{TV} = Dose factor for the vegetable pathway for tritium for organ of interest (mrem/yr per $\mu\text{Ci}/\text{m}^3$).

All other terms are defined in Equations B.2-4 and B.2-7.

B.3

The calculations that support the 2500 CFM maximum instantaneous flow rate for a C.V. pressure relief as calculated by CP&L Nuclear Fuels Section, Project 86-0015, as found in File 2486-0015 and were performed by Mr. Talmage Clements, 10 February 1986.

TABLE B-1
PARAMETERS FOR COW AND GOAT MILK PATHWAYS

Parameter	Value	Reg. Guide 1.109, Rev. 1 Reference
Q _F (kg/day)	50 (cow)	Table E-3
	6 (goat)	Table E-3
Y _p (kg/m ²)	0.7	Table E-15
t _f (seconds)	1.73 x 10 ⁵ (2 days)	Table E-15
r (dimensionless)	1.0 (radioiodines)	Table E-15
	0.2 (particulates)	Table E-15
(DFL _i) _a (mrem/ρCi)	Each radionuclide	Tables E-11 to E-14
F _m (ρCi/liter per ρCi/day)	Each stable element	Table E-1 (cow)
		Table E-2 (goat)
t _b (seconds)	4.73 x 10 ⁸ (15 yr)	Table E-15
Y _s (kg/m ²)	2.0	Table E-15
Y _p (kg/m ²)	0.7	Table E-15
t _h (seconds)	7.78 x 10 ⁶ (90 days)	Table E-15
U _{ap} (liters/yr)	330 infant	Table E-5
	330 child	Table E-5
	400 teen	Table E-5
	310 adult	Table E-5
t _e (seconds)	2.59 x 10 ⁶ (pasture)	Table E-15
	5.18 x 10 ⁶ (stored feed)	Table E-15
B _{iv} (ρCi/kg wet weight per ρCi/kg dry soil)	Each stable element	Table E-1
P kg (dry soil/m ²)	240	Table E-15

TABLE B-2
PARAMETERS FOR THE MEAT PATHWAY

Parameter	Value	Reg. Guide 1.109, Rev. 1 Reference
r (dimensionless)	1.0 (radioiodines)	Table E-15
	0.2 (particulates)	Table E-15
F _f (pCi/kg per pCi/day)	Each stable element	Table E-1
U _{ap} (kg/yr)	0 infant	Table E-5
	41 child	Table E-5
	65 teen	Table E-5
	110 adult	Table E-5
(DFL _i) _a (mrem/pCi)	Each radionuclide	Tables E-11 to E-14
Y _p (kg/m ²)	0.7	Table E-15
Y _s (kg/m ²)	2.0	Table E-15
t _b (seconds)	4.73 x 10 ⁸ (15 yr)	Table E-15
t _s (seconds)	1.73 x 10 ⁶ (20 days)	Table E-15
t _h (seconds)	7.78 x 10 ⁶ (90 days)	Table E-15
t _e (seconds)	2.59 x 10 ⁶ (pasture)	Table E-15
	5.18 x 10 ⁶ (stored feed)	Table E-15
Q _F (kg/day)	50	Table E-3
B _{iV} (pCi/kg wet weight per pCi/kg dry soil)	Each stable element	Table E-1
P (kg dry soil/m ²)	240	Table E-15

TABLE B-3
PARAMETERS FOR THE VEGETABLE PATHWAY

Parameter	Value	Reg. Guide 1.109, Rev. 1 Reference
r (dimensionless)	1.0 (radioiodines)	Table E-1
	0.2 (particulates)	Table E-1
(DFL _i) _a (mrem/Ci)	Each radionuclide	Tables E-11 to E-14
Q _F (kg/day)	50 (cow)	Table E-3
	6 (goat)	Table E-3
U _a ^L (kg/yr)	0 Infant	Table E-5
	26 Child	Table E-5
	42 Teen	Table E-5
	64 Adult	Table E-5
U _a ^S (kg/yr)	0 Infant	Table E-5
	520 Child	Table E-5
	630 Teen	Table E-5
	520 Adult	Table E-5
t _L (seconds)	8.6 x 10 ⁴ (1 day)	Table E-15
t _h (seconds)	5.18 x 10 ⁶ (60 days)	Table E-15
Y _V (kg/m ²)	2.0	Table E-15
t _e (seconds)	5.18 x 10 ⁶ (60 days)	Table E-15
t _b (seconds)	4.73 x 10 ⁸ (15 yr)	Table E-15
P (kg dry soil/m ²)	240	Table E-15
B _{iV} (pCi/kg wet weight per pCi/kg dry soil)	Each stable element	Table E-1

APPENDIX C: LOWER LIMIT OF DETECTABILITY

C.1 Radiological Environmental Monitoring Program

The LLD^{1,2} is defined as the smallest concentration of radioactive material in a sample that will yield a net count, above system background, that will be detected with 95% probability with only 5% probability of falsely concluding that a blank observation represents a "real" signal. For a particular measurement system, which may include radiochemical separation:

$$LLD = \frac{4.66 * S_b}{E * V * 2.22 * Y * e^{-\lambda * \Delta t}}$$

where:

LLD = "A priori" lower limit of detection as defined above, as picocuries per unit mass or volume.

S_b = Standard deviation of the background counting rate or of the counting rate of a blank sample, as appropriate, as counts per minute.

E = Counting efficiency, as counts per disintegration.

V = Sample size in units of mass or volume.

2.22 = Number of disintegrations per minute per picocurie.

Y = Fractional radiochemical yield, when applicable.

λ = Radioactive decay constant for the particular radionuclide.

Δt = The elapsed time between sample collection or end of the sample collection period and time of counting.

Typical values of efficiency (E), volume/mass (V), chemical yield (Y), and radionuclide decay correction time (Δt) are to be used in the calculation.

It should be recognized that the LLD is defined as an a priori (before the fact) limit representing the capability of a measurement system and not as an a posteriori (after the fact) limit for a particular measurement. Analyses shall be performed in such a manner that the stated LLDs will be achieved under routine conditions. Occasionally background fluctuations, unavoidable small sample sizes, the presence of interfering nuclides, or other uncontrollable circumstances may render these LLDs unachievable. In such cases, the contributing factors shall be identified and described in the Annual Radiological Environmental Operating Report pursuant to Technical Specification 5.6.2.

C.2 Radioactive Waste Sampling and Analysis Program

The LLD is defined as the smallest concentration of radioactive material in a sample that will yield a net count, above system background, that will be detected with 95% probability with only 5% probability of falsely concluding that a blank observation represents a "real" signal. For a particular measurement system, which may include radiochemical separation:

$$LLD = \frac{4.66 * S_b}{E * V * 2.22 \times 10^6 * Y * e^{-\lambda * \Delta t}}$$

where:

- LLD = "A priori" lower limit of detection as defined above, as microcuries per unit mass or volume.
- S_b = Standard deviation of the background counting rate or of the counting rate of a blank sample, as appropriate, as counts per minute.
- E = Counting efficiency, as counts per disintegration.
- V = Sample size in units of mass or volume.
- 2.22×10^6 = Number of disintegrations per minute per microcurie.
- Y = Fractional radiochemical yield, when applicable.
- λ = Radioactive decay constant for the particular radionuclide.
- Δt = The elapsed time between sample collection or end of the sample collection period and time of counting.

Typical values of efficiency (E), volume/mass (V), chemical yield (Y), and radionuclide decay correction time (Δt) are to be used in the calculation.

It should be recognized that the LLD is defined as an a priori (before the fact) limit representing the capability of a measurement system and not as an a posteriori (after the fact) limit for a particular measurement.

C.3 Radioactive Gaseous Waste Monitoring System

The LLD is defined as the smallest concentration of radioactive material in a sample that will yield a net count, above system background, that will be detected with 95% probability with only 5% probability of falsely concluding that a blank observation represents a "real" signal. For a particular measurement system³:

$$LLD = \frac{4.66 * \sqrt{\frac{Bkg}{2 * \tau}}}{E}$$

where:

LLD = "A priori" lower limit of detection as defined above, as microcuries per cubic centimeter.

Bkg = the background counting rate as counts per minute.

E = counting efficiency, as counts per minute over microcurie per cubic centimeter.

τ = the time constant for the particular measurement system.

Typical values of E, and Bkg should be used in the calculation.

It should be recognized that the LLD is defined as an a priori (before the fact) limit representing the capability of a measurement system and not as an a posteriori (after the fact) limit for a particular measurement.

Appendix C References

1. HASL-300 (Suppl. 4), HASL Procedures Manual, (1972).
2. NBS SP456 "The Minimum Detectable Activity Concept," J. C. Lockamy (1976).
3. NUREG/CR-4007, Lower Limit of Detection: Definition and Elaboration of a Proposed Position for Radiological Effluent and Environmental Measurements, (September 1984).

APPENDIX D: LIQUID AND GASEOUS PROCESS MONITORS AND RADWASTE SYSTEMS

D.1

This appendix contains tables and figures describing the liquid and gaseous process monitors and radwaste systems.

TABLE D-1
LIQUID PROCESS MONITORS

<u>Name</u>	<u>R#</u>	<u>ID #</u>	<u>Drawing #</u>
Containment Vessel Fan Cooling Water	16	R-16	C997261
Component Cooling Water	17	R-17	C997246
Liquid Waste Disposal	18	PI 871109	NRC Industries 4PI Liquid Sample Manual
Condensate Polisher Liquid Waste	37	R-37	Plant Mod.-723, H.B.R.-2-9065
	19A	R-19A	
Steam Generator Blowdown	19B	R-19B	Mod 898
	19C	R-19C	

Liquid Radwaste Flow Measurement Devices

Liquid Radwaste Flow Indicator	N/A	FIT 1064	A-190299 5379-00920 Sheet 4 (EC 60209)
-----------------------------------	-----	----------	---

TABLE D-2
GASEOUS PROCESS MONITORS

<u>Name</u>	<u>R #</u>	<u>ID #</u>	<u>Drawing #</u>	<u>Sample Flow Rate Measurement Device</u>	<u>System Flow Rate Measurement Device</u>
Containment Vessel Particulate	11	R-11	D997556	F&P Co. Flow Tube FP- 3/4-27-G 10/80	UGC Microflow 3000 (if sampling stack)
Containment Vessel Gaseous	12	R-12	D997556	F&P Co. Flow Tube FP- 3/4-27-G 10/80	UGC Microflow 3000 (if sampling stack)
Plant Vent Low Range	14C	R-14	EC 52464	1) Fluid Components Intl, AF89S Mass Flowmeter 2) F&P Flowmeter FP-1-35-G-10/55	F-14 Plant Vent Stack Flow Monitor (Kurz)
Fuel Handling Building Basement Exhaust	20	R-20	C998233	Fisher Porter Flowmeter Mod. 10A35755Z Serial 6908A0837A1	None (Use fan ratings)
Fuel Handling Building Upper Level Exhaust	21	R-21	C9988233	Fisher Porter Flowmeter Mod. 1043565 Serial 6908A0837A1	None (Use fan ratings)

FIGURE D-1
 *H.B. ROBINSON LIQUID RADWASTE PROCESS / EFFLUENT SYSTEM

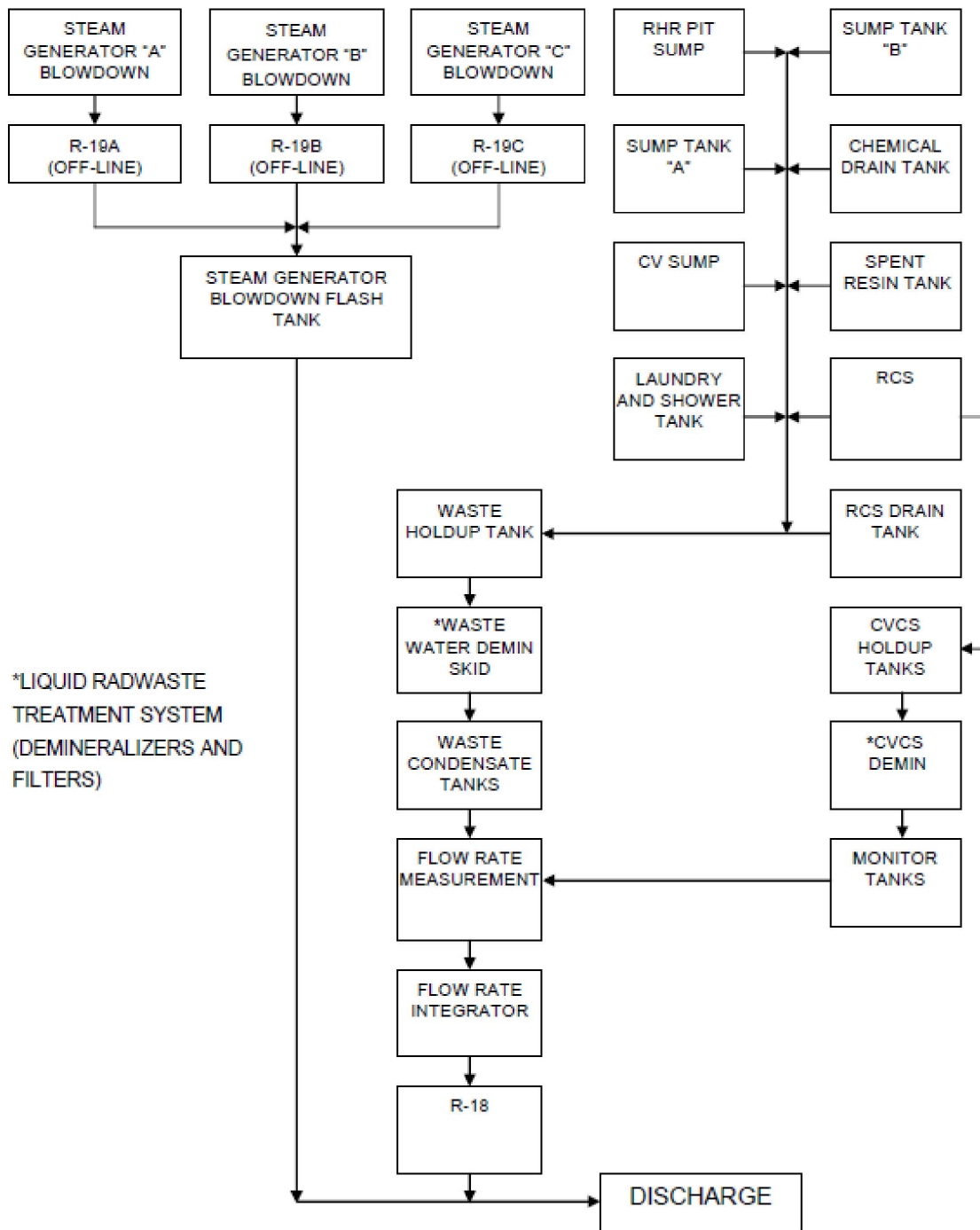
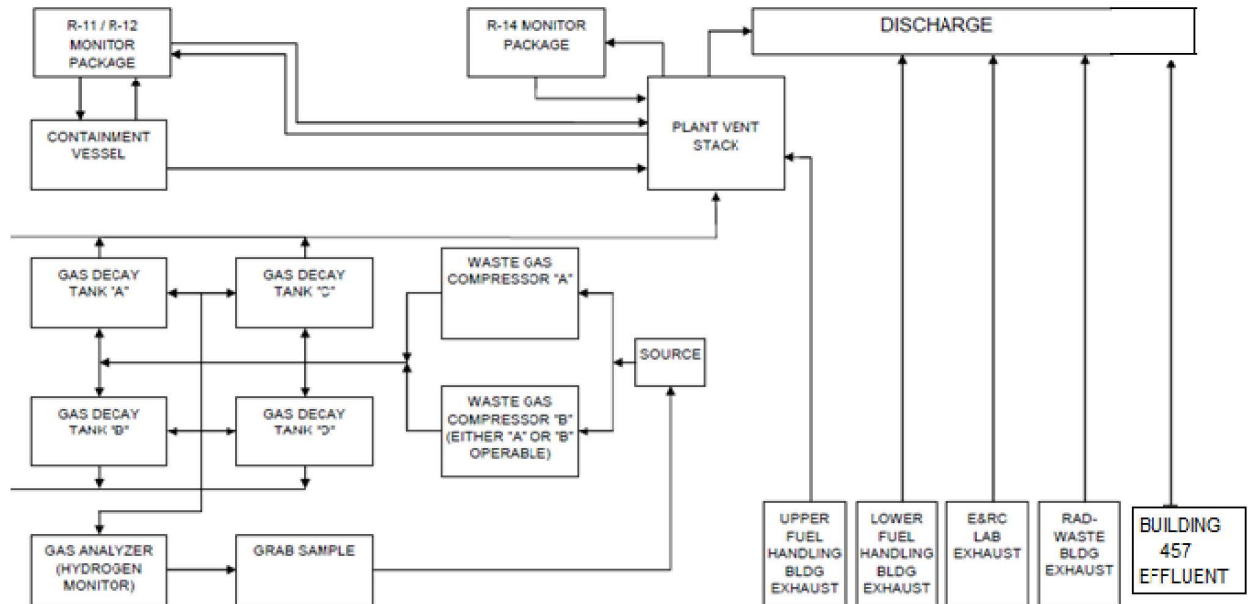

FIGURE D-2
***H.B. ROBINSON GASEOUS RADWASTE PROCESS / EFFLUENT SYSTEM**



*SIMPLIFIED BLOCK FLOW DIAGRAM, THE GASEOUS RADWASTE SYSTEM MAY BE COMPRISED OF ONE WASTE GAS COMPRESSOR AND ONE WASTE GAS DECAY TANK.

APPENDIX E: MAP OF LAKE ROBINSON

E.1

This appendix contains map sections of Lake Robinson.

FIGURE E-1
MAP OF THE FIVE SECTIONS OF LAKE ROBINSON

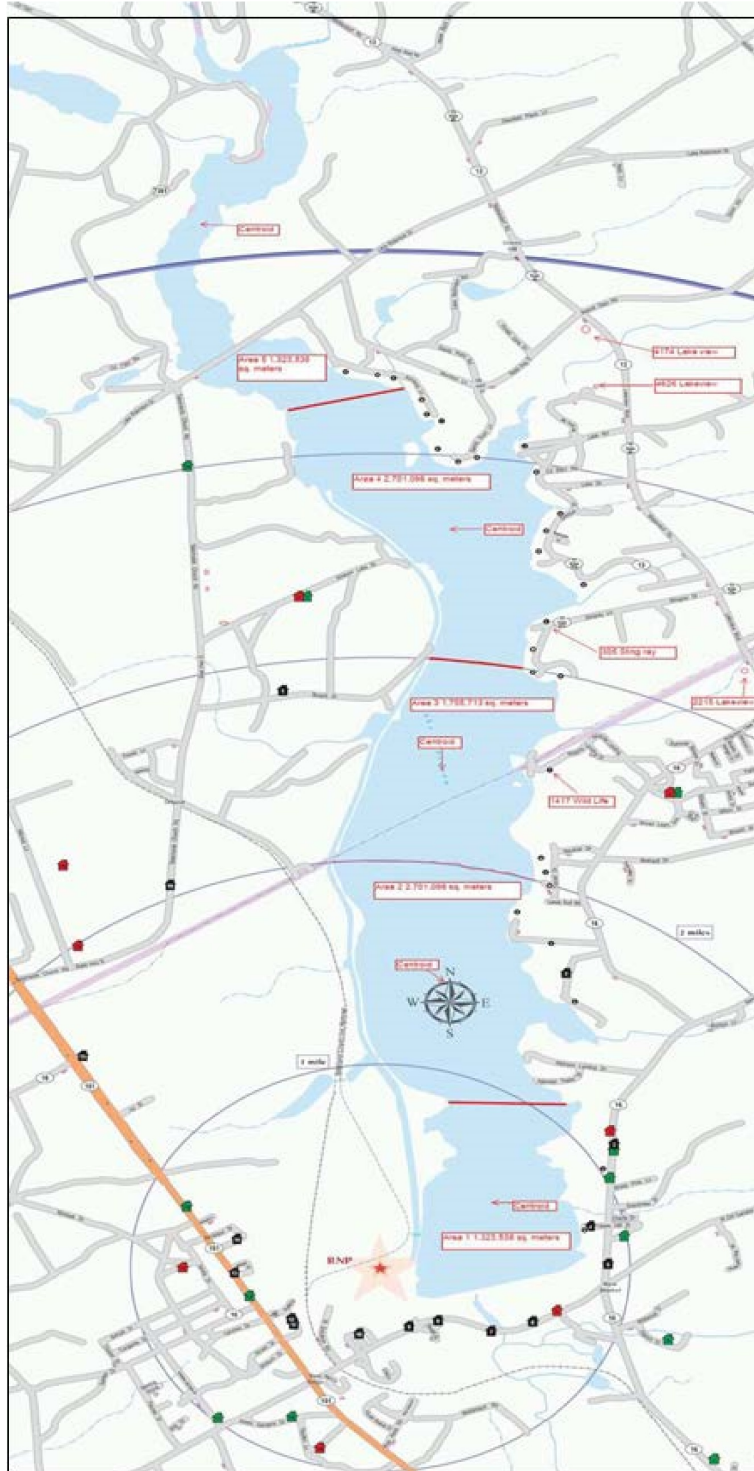

FIGURE E-1 (continued)
MAP OF THE FIVE SECTIONS OF LAKE ROBINSON

Lake Robinson is about 10 kilometers long and about 1 kilometer wide. Black Creek empties into the Lake at the North end of the Lake. The hot water released from the heat exchangers is discharged in the Lake about 6 kilometers north of the plant. Temperature in the Lake varies from north to south. In order to get a more accurate tritium evaporation analysis, the lake is divided into five sections. Section 5 is the northern most section, and Section 1 is the southernmost. The hot water discharge point (weir) is located in Section 4. The following table shows area of each section.

Section 1 Area 1323538 square meters
Section 2 Area 2701098 square meters
Section 3 Area 1755713 square meters
Section 4 Area 2161223 square meters
Section 5 Area 1285791 square meters

Attachment 10
Summary of Changes to the Process Control Program

H.B. Robinson Steam Electric Plant Unit 2
Period 1/1/2018 - 12/31/2018

ATTACHMENT 10

Summary of Changes to the Process Control Program

This attachment includes a summary of changes to the PCP.

Attachment 10
Summary of Changes to the Process Control Program

H.B. Robinson Steam Electric Plant Unit 2
Period 1/1/2018 - 12/31/2018

The H.B. Robinson Steam Electric Plant Unit 2 Process Control Program was not revised in 2018 . The most recent revision is #6 and a copy is attached.

PROGRESS ENERGY
H. B. ROBINSON - UNIT 2
PROCESS CONTROL PROGRAM
(PCP)
REVISION 6
DOCKET NO. 50-261

EFFECTIVE DATE: 01-07-10

REVIEWED AND ACCEPTED BY PNSC: Spaunders DATE: 01-07-10
PNSC CHAIRMAN

LIST OF EFFECTIVE PAGES

<u>EFFECTIVE PAGES</u>	<u>REVISION</u>
Cover Sheet	6
LEP	6
3 through 6	6

SUMMARY OF CHANGES

Revised Section 2.0 to specify dewatering and solidification may be performed by qualified vendor or qualified Progress Energy personnel in accordance with a qualified PCP or a program approved by the NRC or burial site facility.

Revised Section 3.1.2 to include review of both vendor and RNP operating procedures, retention of both vendor and RNP completed records, and monitoring of both vendor and RNP operations for compliance with TRMS 3.22 requirements.

Revised Section 3.1.3 to include RC Supervisor (with accountability for radioactive waste processing) responsibility for advising the RC Superintendent on the adequacy of both vendor and RNP operating procedures.

Revised Section 3.2 to clarify that specified vendor requirements apply to vendors who supply both solidification and dewatering services to RNP.

H.B. ROBINSON

PROCESS CONTROL PROGRAM

1.0 SCOPE

This program established the management systems and controls that the Robinson Nuclear Plant (RNP) uses to ensure safe and effective solidification and dewatering of various low-level radioactive waste liquids and slurries for offsite disposal.

2.0 OBJECTIVE

It is the objective of this program that solidification and/or dewatering of various low-level radioactive waste liquids and slurries (including oily wastes) for offsite disposal will be performed by either qualified vendors or qualified Progress Energy personnel, in accordance with a qualified PCP or a program approved by the NRC or burial site facility. The quality of the solidified and/or dewatered product shall meet or exceed regulatory requirements and the disposal site criteria prior to release from the RNP site for shallow disposal.

3.0 MANAGEMENT PROGRAM

3.1 Responsibilities

- 3.1.1 The Plant General Manager is responsible for ensuring that waste is shipped in accordance with the appropriate state and federal regulations.
- 3.1.2 The Superintendent – Radiation Control (RC) or designee is responsible for:
 - a. Advising the Plant General Manager on the appropriate technical standards, regulations and requirements as related to solidification, dewatering and shipping.
 - b. Ensuring changes to the vendor's Process Control Program (PCP), vendor and RNP operating procedures, and proposed contractual agreements are reviewed and advising the Plant General Manager as to their adequacy.
 - c. Retaining vendor – supplied documentation and completed RNP records for NRC inspection and review.

3.1 Responsibilities (continued)

d. Ensuring vendor and RNP operations are monitored for compliance with:

1. Section 3.22 Technical Requirements Manual (TRMS). The Solid Radwaste System shall be used in accordance with a PCP to process wet radioactive waste to meet shipping and burial ground requirements.
2. Section 3.22.A TRMS. With the provisions of the PCP not satisfied, immediately suspend shipments of defectively processed or defectively packaged solid radioactive waste from the site.
3. Section 3.22.B TRMS. If any test specimen, as required by the PCP, fails to verify solidification, the solidification of the batch under test shall be immediately suspended until such time as additional test specimens can be obtained, alternative solidification parameters can be determined in accordance with Section 5.5.17 of the TRMS. Solidification of the batch may then be resumed using alternative solidification parameters as determined by the PCP.
4. Section 3.22.1 TRMS. The PCP shall be used to verify the solidification of one representative test specimen from every tenth batch of wet radioactive waste.

3.1 Responsibilities (continued)

Note: The following step is only required to be met if the initial test specimen from a batch of waste fails to verify solidification and continues until at least three consecutive initial test specimens demonstrate solidification.

5. Section 3.22.2 TRMS. Collect and test representative test specimens of every consecutive batch of the same type of wet radioactive waste to verify solidification in accordance with the PCP.

3.1.3 The RC Supervisor with accountability for radioactive waste processing is responsible for advising the Superintendent-RC on:

- a. The appropriate technical standards, regulations and requirements as related to solidification, dewatering and shipping.
- b. The adequacy of the vendor's PCP, vendor and RNP operating procedures, and proposed contractual agreements.

3.2 Specification of Vendors

The qualified solidification and/or dewatering vendor will:

- 3.2.1 Provide a qualified PCP or a program approved by:
 - a. NRC
 - b. Disposal site licensee
- 3.2.2 The vendor will perform the tests described in the PCP.
- 3.2.3 The vendor will supply the Superintendent – RC with all documentation required to demonstrate compliance with dewatering and/or solidification requirements.
- 3.2.4 The Superintendent – RC will retain documentation required to demonstrate compliance with solidification requirements and standards.

4.0 MANAGEMENT/CONTRACTOR INTERACTIONS

- 4.1 The vendor is accountable to the Superintendent – RC for the solidification and/or dewatering of liquid wastes.
- 4.2 The RC Supervisor with accountability for radioactive waste processing handles the shipping of solidified and dewatering wastes and maintains required documentation. The vendor and the RC Supervisor may communicate on the matters as necessary.

5.0 ATTACHMENTS

- 5.1 None Applicable

Attachment 11
Summary of Major Modifications to the Radioactive Waste Treatment Systems

H.B. Robinson Steam Electric Plant Unit 2
Period 1/1/2018 - 12/31/2018

ATTACHMENT 11

Summary of Major Modifications to the Radioactive Waste Treatment Systems

This attachment includes a description of major modifications to the radioactive waste treatment systems that are anticipated to affect effluent releases.

Attachment 11
Summary of Major Modifications to the Radioactive Waste Treatment Systems

H.B. Robinson Steam Electric Plant Unit 2
Period 1/1/2018 - 12/31/2018

No major modifications to liquid, gaseous, solid, or mobile radioactive waste treatment systems occurred at H.B. Robinson Steam Electric Plant in 2018.

Attachment 12
Errata to a Previous Year's ARERR

H.B. Robinson Steam Electric Plant Unit 2
Period 1/1/2018 - 12/31/2018

ATTACHMENT 12

Errata to a Previous Year's ARERR

This attachment includes any amended pages from a previous year's ARERR.

Attachment 12
Errata to a Previous Year's ARERR

H.B. Robinson Steam Electric Plant Unit 2
Period 1/1/2018 - 12/31/2018

There were no changes to a previous year's ARERR.