



April 30, 2018

NRC 2018-0020
10 CFR 72.44
TS 5.6.2

U.S. Nuclear Regulatory Commission
ATTN: Document Control Desk
Washington, DC 20555

Point Beach Nuclear Plant, Units 1 and 2
Dockets 50-266, 50-301 and 72-005
Renewed License Nos. DPR-24 and DPR-27

2017 Annual Monitoring Report

In accordance with Point Beach Nuclear Plant (PBNP) Technical Specification 5.6.2, enclosed is the Annual Monitoring Report for PBNP Units 1 and 2, for the period January 1 through December 31, 2017.

The Annual Monitoring Report contains information relating to the effluent impact upon the public, as well as information relating to plant releases, solid waste shipments, results from the radiological environmental monitoring program, the groundwater protection program, and miscellaneous monitoring activities which occurred in 2017. The report also covers the results of radiological monitoring of the PBNP Independent Spent Fuel Storage Installation (ISFSI), as required by 10 CFR 72.44. The contracted laboratory's final Radiological Environmental Monitoring Program results are included in Appendix 1. The revised Offsite Dose Calculation Manual (ODCM) is included in Appendix 2.

This letter contains no new regulatory commitments and no revisions to existing regulatory commitments.

Very truly yours,
NextEra Energy Point Beach, LLC

A handwritten signature in black ink, appearing to read "Eric Schultz", is written over a horizontal line.

Eric Schultz
Licensing Manager

Enclosure

cc: Administrator, Region III, USNRC
Project Manager, Point Beach Nuclear Plant, USNRC
Resident Inspector, Point Beach Nuclear Plant, USNRC
PSCW
American Nuclear Insurers
WI Division of Public Health, Radiation Protection Section
Office of Nuclear Material Safety and Safeguards, USNRC

ENCLOSURE

ANNUAL MONITORING REPORT 2017

NEXTERA ENERGY POINT BEACH, LLC POINT BEACH NUCLEAR PLANT

DOCKETS 50-266 (UNIT 1), 50-301 (UNIT 2), 72-005 (ISFSI)
RENEWED LICENSES DPR-24 and DPR-27



January 1, 2017 through December 31, 2017

TABLE OF CONTENTS

Summary	1
Part A: Effluent Monitoring	
1.0 Introduction	4
2.0 Radioactive Liquid Releases	5
3.0 Radioactive Airborne Releases	12
4.0 Radioactive Solid Waste Shipments	18
5.0 Nonradioactive Chemical Releases	20
6.0 Circulating Water System Operation	21
Part B: Miscellaneous Reporting Requirements	
7.0 Additional Reporting Requirements	22
Part C: Radiological Environmental Monitoring	
8.0 Introduction	24
9.0 Program Description	25
10.0 Results	37
11.0 Discussion	42
12.0 REMP Conclusion	59
Part D: Groundwater Monitoring	
13.0 Program Description	60
14.0 Results and Discussion	63
15.0 Groundwater Summary	68
Appendix 1: Environmental, Inc. Midwest Laboratory, "Final Report for Point Beach Nuclear Plant"	
Appendix 2: Offsite Dose Calculation Manual, Revision 19, issued 03/08/2017	

LIST OF TABLES

Table 2-1	Comparison of 2017 Liquid Effluent Calculated Doses to 10 CFR 50 Appendix I Design Objectives	5
Table 2-2	Summary of Circulating Water Discharge	8
Table 2-3	Isotopic Composition of Circulating Water Discharges	9
Table 2-4	Subsoil System Drains - Tritium Summary	10
Table 3-1	Comparison of 2017 Airborne Effluent Calculated Doses to 10 CFR 50 Appendix I Design Objectives	15
Table 3-2	Radioactive Airborne Effluent Release Summary	15
Table 3-3	Isotopic Composition of Airborne Releases	16
Table 3-4	Comparison of Airborne Effluent Doses	17
Table 4-1	Quantities and Types of Waste Shipped from PBNP in 2017	18
Table 4-2	2017 PBNP Radioactive Waste Shipments	18
Table 4-3	2017 Estimated Solid Waste Major Radionuclide Composition	19
Table 6-1	Circulating Water System Operation for 2017	21
Table 9-1	PBNP REMP Sample Analysis and Frequency	28
Table 9-2	PBNP REMP Sampling Locations	29
Table 9-3	ISFSI Sampling Sites	33
Table 9-4	Minimum Acceptable Sample Size	33
Table 9-5	Deviations from Scheduled Sampling and Frequency During 2017	34
Table 9-6	Sample Collection for the State of Wisconsin	34
Table 10-1	Summary of Radiological Environmental Monitoring Results for 2017	39-40
Table 10-2	Feed Crops Grown on Point Beach Land	41
Table 10-3	Average ISFSI Fence TLD Results for 2017	41
Table 11-1	Average Indicator TLD Results from 1993-2017	42
Table 11-2	Average ISFSI Fence TLD Results (mR/7days)	43
Table 11-3	Average TLD Results Surrounding the ISFSI (mR/7days)	45
Table 14-1	Intermittent Streams and Bogs	63
Table 14-2	2017 Beach Drain Tritium	64
Table 14-3	2017 East Yard Area Manhole Tritium (pCi/L)	65
Table 14-4	2017 Façade Well Water Tritium (pCi/L)	66
Table 14-5	2016 and 2017 Unit 2 Façade SSD Sump H-3 (pCi/L)	66
Table 14-6	2017 Potable Well Water Tritium Concentration (pCi/L)	68
Table 14-7	2017 Quarterly Monitoring Well Tritium (pCi/L)	68

LIST OF FIGURES

Figure 9-1	PBNP REMP Sampling Sites	30
Figure 9-2	Map of REMP Sampling Sites Located Around PBNP	31
Figure 9-3	Enhanced Map Showing REMP Sampling Sites Closest to PBNP	32
Figure 11-1	ISFSI Area TLD Results (1995 – 2017)	44
Figure 11-2	Comparison of ISFSI Fence TLDs to Selected REMP TLDs	45
Figure 11-3	Sr-90 Concentration in Milk (1997 – 2017)	47
Figure 11-4	Annual Average Air Gross β (1993 – 2017)	48
Figure 11-5	2017 Airborne Gross Beta	48
Figure 11-6	2015 Airborne Gross Beta	49
Figure 11-7	E-01 Results 1971 – 2017	56
Figure 11-8	Comparison of E-03 and E-20 Results 1971 – 2017	57
Figure 11-9	Comparison of E-01, E-02, E-03, and E-04 Results 1992 - 2017	57

Figure 11-10 E-03, E-31, and Background Site E-20 Results 1992 – 2017
Figure 13-1 Groundwater Monitoring Locations

58
62

SUMMARY

The Annual Monitoring Report for the period from January 1, 2017, through December 31, 2017, is submitted in accordance with Point Beach Nuclear Plant (PBNP) Units 1 and 2, Technical Specification 5.6.2 and filed under Dockets 50-266 and 50-301 for Renewed Facility Operating Licenses DPR-24 and DPR-27, respectively. It also contains results of monitoring in support of the Independent Spent Fuel Storage Installation (ISFSI) Docket 72-005. The report presents the results of effluent and environmental monitoring programs, solid waste shipments, non-radioactive chemical releases, and circulating water system operation.

During 2017, the following Curies (Ci) of radioactive material were released via the liquid and atmospheric pathways:

	Liquid	Atmospheric
Tritium (Ci)	887	148
¹ Particulate (Ci)	0.0736	0.00025
Noble Gas (Ci)	(-)	0.615
C-14 ²	0.0222	11.74

(-)Noble gases in the liquids are added to the atmospheric release totals.

¹Atmospheric particulate includes radioiodine (I-131 - I-133).

²Liquid is measured, atmospheric is calculated.

For the purpose of compliance with the effluent design objectives of Appendix I to 10 CFR 50, doses from effluents are calculated for the hypothetical maximally exposed individual (MEI) for each age group and compared to the Appendix I objectives. Doses less than or equal to the Appendix I values are considered to be evidence that PBNP releases are as low as reasonably achievable (ALARA) and comply with the EPA's limits in 40CFR190. The maximum annual calculated doses in millirem (mrem) or millirad (mrad) are shown below and compared to the corresponding design objectives of 10 CFR 50, Appendix I.

LIQUID RELEASES

<u>Dose Category</u>	<u>Calculated Dose</u>	<u>Appendix I Dose</u>	<u>% Appendix I</u>
Whole body dose	0.00227 mrem	6 mrem	0.038
Organ dose	0.00613 mrem	20 mrem	0.031

ATMOSPHERIC RELEASES

<u>Dose Category</u>	<u>Calculated Dose</u>	<u>Appendix I Dose</u>	<u>% Appendix I</u>
Particulate organ dose	0.0183 mrem	30 mrem	0.061
Noble gas beta air dose	0.0000379 mrad	40 mrad	0.00010
Noble gas gamma ray air dose	0.0000984 mrad	20 mrad	0.00049
Noble gas dose to the skin	0.000137 mrem	30 mrem	0.00046
Noble gas dose to the whole body	0.0000932 mrem	10 mrem	0.00093

The results show that during 2017, the doses from PBNP effluents were $\leq 0.061\%$ of the Appendix I design objectives. This is slightly lower than the 2016 results of 0.085%. Therefore, operation of the PBNP radwaste treatment system continues to be ALARA.

A survey of land use with respect to the location of dairy cattle was made pursuant to Section 12.2.5 of the PBNP ODCM. As in previous years, no dairy cattle were found to be grazing at the site boundary. Therefore, the assumption that cattle graze at the site boundary used in the evaluation of doses from PBNP effluents remains conservative. Of the sixteen compass sectors around PBNP, six are over Lake Michigan. A land use census (LUC) of the remaining ten sectors over land identifies any changes in the closest garden, occupied dwelling, and dairy in each sector. The 2014 LUC results confirmed the assumption that, for the purpose of calculating effluent doses, the maximally exposed person lives at the south boundary remains conservative. This conclusion is still valid based on the results of the 2017 LUC.

The 2017 Radiological Environmental Monitoring Program (REMP) collected 788 individual samples for radiological analyses. Quarterly composites of weekly air particulate filters generated an additional 24 samples and quarterly composites of monthly lake water samples resulted in a further 16 samples. This yielded a total of 828 samples. The ambient radiation measurements in the vicinity of PBNP and the ISFSI were conducted using 144 sets of thermoluminescent dosimeters (TLDs).

Air monitoring from six different sites did not reveal any effect from Point Beach effluents.

Terrestrial monitoring consisting of soil, vegetation, crops, and milk found no influence from PBNP. Similarly, samples from the aquatic environment, consisting of lake and well water, algae, and fish revealed no buildup of PBNP radionuclides released in liquid effluents. Therefore, the data show no plant effect on its environs.

No new, loaded dry storage units were added to the ISFSI in 2017. The total number now is 44 dry storage casks: 16 ventilated, vertical storage casks (VSC-24) and 28 NUHOMS®, horizontally stacked storage modules. The subset of the PBNP REMP samples used to evaluate the environmental impact of the PBNP ISFSI showed no environmental impact from its operation.

The environmental monitoring conducted during 2017 confirmed that the effluent control program at PBNP ensured a minimal impact on the environment.

One-hundred-fifty-three (153) samples were analyzed for H-3 as part of the groundwater protection program (GWPP). These samples came from drinking water wells, monitoring wells, yard drain outfalls, yard manholes, surface water on site, the sump for the subsurface drainage system (SSD - located under the plant foundation), and four groundwater foundation integrity monitoring wells located in the facades. The results for all but the SSD sump show no substantial change in H-3 from previous years. However, the H-3 concentration in the SSD sump, which collects groundwater from under the plant foot print, spiked in October to roughly nine times the normal concentration of about 1000 pCi/L to almost 9000 pCi/L. This sump is discharged to Lake Michigan via the wastewater effluent system. No gamma emitters were found in the elevated H-3 samples. Further analyses found no Sr-90, Fe-55, or Ni-63 in the high H-3 samples. No drinking water wells (depth >100 feet) have any detectable H-3. Tritium continues to be confined to the upper soil layer where the flow is toward the lake. Groundwater samples from wells in the vicinity of the remediated, former earthen retention pond continue to show low levels of H-3 whereas none was detectable in the wells monitoring the potential offsite

tritium movement. Gamma scans of groundwater samples originating within the power block found no plant related gamma emitters.

The results of GWPP monitoring indicate no significant change from previous years for all but the SSD sump.

Part A

EFFLUENT MONITORING

1.0 INTRODUCTION

The PBNP effluent monitoring program is designed to comply with federal regulations for ensuring the safe operation of PBNP with respect to releases of radioactive material to the environment and its subsequent impact on the public. Pursuant to 10 CFR 50.34a, operations should be conducted to keep the levels of radioactive material in effluents to unrestricted areas as low as reasonably achievable (ALARA). In 10 CFR 50, Appendix I, the Nuclear Regulatory Commission (NRC) provides the numerical values for what it considers to be the appropriate ALARA design objectives to which the licensee's calculated effluent doses may be compared. These doses are a small fraction of the dose limits specified by 10 CFR 20.1301 and lower than the Environmental Protection Agency (EPA) limits specified in 40 CFR 190.

10 CFR 20.1302 directs PBNP to make the appropriate surveys of radioactive materials in effluents released to unrestricted and controlled areas. Liquid wastes are monitored by inline radiation monitors as well as by isotopic analyses of samples of the waste stream prior to discharge from PBNP. Airborne releases of radioactive wastes are monitored in a similar manner. The appropriate portions of the radwaste treatment systems are used as required to keep both liquid and atmospheric releases ALARA. Prior to release, results of isotopic analyses are used to adjust the release rate of discrete volumes of liquid and atmospheric wastes (from liquid waste holdup tanks and from gas decay tanks) such that the concentrations of radioactive material in the air and water beyond PBNP are below the PBNP Technical Specification concentration limits for liquid effluents and release rate limits for gaseous effluents.

Solid wastes are shipped offsite for disposal at NRC licensed facilities. The amount of radioactivity in the solid waste is determined prior to shipment in order to determine the proper shipping configuration as regulated by the Department of Transportation and the NRC.

10 CFR 72.210 grants a general license for an Independent Spent Fuel Storage Installation (ISFSI) to all nuclear power reactor sites operating under 10 CFR 50. The annual reporting requirement pursuant to 10 CFR 72.44(d)(3) is no longer applicable. Any release of radioactive materials from the operation of the ISFSI must comply with the limits of Part 20 and Part 50 Appendix I design objectives. The dose criteria for effluents and direct radiation specified by 10 CFR 72.104 states that during normal operations and anticipated occurrences, the annual dose equivalent to any real individual beyond the controlled area must not exceed 25 mrem to the whole body, 75 mrem to the thyroid, and 25 mrem to any other organ. The dose from naturally occurring radon and its decay products are exempt. Because the loading of the storage casks occurs within the primary auxiliary building of PBNP, the doses from effluents due to the loading process will be assessed and quantified as part of the PBNP Radiological Effluent Control Program.

2.0 RADIOACTIVE LIQUID RELEASES

The radioactive liquid release path to the environment is via the circulating water discharge. A liquid waste treatment system in conjunction with administrative controls is used to minimize the impact on the environment and maintain doses to the public ALARA from the liquid releases.

2.1 Doses From Liquid Effluent

Doses from liquid effluent are calculated using the methodology of the Offsite Dose Calculation Manual (ODCM). These calculated doses use parameters such as the amount of radioactive material released, the total volume of liquid, the total volume of dilution water, and usage factors (e.g., water and fish consumption, shoreline and swimming factors). These calculations produce a conservative estimation of the dose. For compliance with 10 CFR 50, Appendix I design objectives, the annual dose is calculated to the hypothetical maximally exposed individual (MEI). The MEI is assumed to reside at the site boundary in the highest χ/Q sector and is maximized with respect to occupancy, food consumption, and other uses of this area. As such, the MEI represents an individual with reasonable deviations from the average for the general population in the vicinity of PBNP. A comparison of the calculated doses to the 10 CFR 50, Appendix I design objectives is presented in Table 2-1. The conservatively calculated dose to the MEI is a very small fraction of the Appendix I design objective.

**Table 2-1
Comparison of 2017 Liquid Effluent Calculated Doses to
10 CFR 50 Appendix I Design Objectives**

Annual Limit [mrem]	Highest Total Calculated Dose [mrem]	% of Design Objective
6 (whole body)	0.00227	0.038
20 (any organ)	0.00613	0.031

2.2 2017 Circulating Water Radionuclide Release Summary

Radioactive liquid releases via the circulating water discharge are summarized by individual source and total curies released on a monthly basis semi-annual and annual totals (Table 2-2). These releases are composed of processed waste, wastewater effluent, and blowdown from Units 1 and 2. The wastewater effluent consists of liquid from turbine hall sumps, plant well house backwashes, sewage treatment plant effluent, water treatment plant backwashes, the Unit 1 and 2 facade sumps and the subsurface drainage system sump.

2.3 2017 Isotopic Composition of Circulating Water Discharges

The isotopic composition of circulating water discharges during the current reporting period is presented in Table 2-3. The noble gases released in liquids are reported with the airborne releases in Section 3.

The 2017 processed waste volume (Table 2-2) increased about 25% from 2016 (7.92E+05 to 9.89E+05 gallons). This is attributable to having two outages in 2017. However, there was a decrease in the total isotopic curie distribution of gamma emitters plus hard-to-detects from 9.98E-02 Ci to 7.36E-02 Ci. Also, in spite of the higher than expected total antimony during March, the total for the year decreased from 1.30E-02 Ci in 2016 to 5.87E-03 Ci in 2017. As mentioned in the 2016 AMR, the higher Sb in 2016 was attributable to bypassing of Sb specific resin beds. By contrast, Zr-Nb increased about 30% from 2.48E-03 in 2016 to 3.19E-03 in 2017 and the tin isotopes Sn-113/117m increased from 2.64E-03 Ci to 7.97E-03, or about 200%. The 2017 C-14 was slightly down from 2.43E-02 Ci in 2016 to 2.22E-02 in 2017. As in 2013 - 2016, no Sr-89 was detected in liquids. No Sr-90 was detected in 2017 as in the years 2013 – 2015. A small amount, 1.49 μ Ci, of short-lived Sr-92 was detected in 2017 during the spring outage. H-3 increased from 518 Ci in 2016 to 887 Ci in 2017, a roughly 70% increase. The 2017 amount is comparable to the 866 Ci discharged in 2015.

2.4 Beach Drain System Releases Tritium Summary

Beach drain is the term used to describe the point at which the site yard drainage system empties onto the beach of Lake Michigan. Six of these outfalls carry yard and roof drain runoff to the beach. A seventh outfall drains a small portion of the grassy area on top of the bluff overlooking the lake.

The plant foundation has a subsurface drainage system (SSD) around the external base of the foundation. This SSD relieves hydrostatic pressure on the foundation by draining water away from the foundation. The drainage pipes empty out onto the beach. In 2014, the SSD outfalls, designated as S-12 and S-13, were added to the beach drain sampling program. Their quarterly results are presented with the other beach drains.

The quarterly results from the monthly beach drain and SSD samples are presented in Table 2-4. The total monthly flow is calculated assuming that the flow rate at the time of sampling persists for the whole month. In 2017, no tritium was observed at the effluent LLDs. H-3 found in the beach drains is not included in the effluent totals unless it can be shown to be the result of a spill or similar event. Because the source of beach drain H-3 has been determined to be recapture, including beach drain H-3 in the effluent totals would be double counting (NRC RIS 2008-03, Return/re-use of previously discharged radioactive effluents).

The principle source of water for the beach drains is the yard drain system. Yard drain water sources are rain and snow melt containing recaptured H-3. During the winter, natural melting is the principle source. (In the past, runoff has been enhanced by the use of snow melting machines where the melt water is emptied into the yard drains. [See Section 14.2 for further discussion.]) Additionally, various roof drains connect to the yard drain system. In addition to precipitation, the roof drains also carry condensate from various building AC units. A secondary source may be groundwater in leakage. This is evidenced by flow during periods of no precipitation.

Because there are no external storage tanks or piping that carries radioactive liquids, the main source of radioactivity for this system is recapture/washout of airborne H-3 discharges via the yard drain system. Because of these various recapture sources, the beach drains also are sampled as part of the groundwater monitoring program. These results and other groundwater monitoring results are presented in Part D of this Annual Monitoring Report.

Table 2-2
Summary of Circulating Water Discharge
 January 1, 2017 through December 31, 2017

	Jan	Feb	Mar	Apr	May	Jun	Total Jan-Jun	Jul	Aug	Sep	Oct	Nov	Dec	Annual Total
Total Activity Released (Ci)														
Gamma Scan(+HTDs) ¹	5.07E-03	1.06E-02	3.15E-03	3.52E-02	3.25E-03	1.88E-03	5.92E-02	8.30E-04	3.76E-03	1.05E-03	6.29E-03	1.66E-03	8.70E-04	7.36E-02
Gross Alpha	0.00E+00	0.00E+00	0.00E+00	0.00E+00	0.00E+00	0.00E+00	0.00E+00	0.00E+00	0.00E+00	0.00E+00	0.00E+00	0.00E+00	0.00E+00	0.00E+00
Tritium	1.27E+02	1.23E+02	7.28E+01	1.08E+02	4.77E+01	5.22E+01	5.30E+02	6.35E+01	1.46E+02	3.78E+01	5.48E+01	1.07E+01	4.33E+01	8.87E+02
Strontium (89/90/92)	0.00E+00	0.00E+00	1.49E-06	0.00E+00	0.00E+00	0.00E+00	1.49E-06	0.00E+00	0.00E+00	0.00E+00	0.00E+00	0.00E+00	0.00E+00	1.49E-06
Noble Gases	9.49E-04	2.31E-03	7.81E-04	5.65E-03	9.01E-04	1.31E-03	1.19E-02	1.70E-03	8.52E-03	1.72E-03	5.48E-04	4.46E-04	1.37E-03	2.62E-02
Total Vol Released (gal)														
Processed Waste	6.93E+04	8.18E+04	1.09E+05	2.24E+05	5.27E+04	4.85E+04	5.85E+05	3.85E+04	6.18E+04	4.36E+04	1.41E+05	6.93E+04	4.90E+04	9.89E+05
Waste Water Effluent	3.21E+06	2.82E+06	4.95E+06	3.64E+06	3.68E+06	3.64E+06	2.19E+07	3.53E+06	3.51E+06	3.40E+06	3.24E+06	3.96E+06	3.70E+06	4.33E+07
U1 SG Blowdown	2.70E+06	2.41E+06	2.68E+06	2.68E+06	2.63E+06	2.84E+06	1.57E+07	3.77E+06	2.63E+06	2.57E+06	7.25E+05	4.80E+06	2.68E+06	3.29E+07
U2 SG Blowdown	2.65E+06	2.43E+06	1.53E+06	3.36E+06	3.96E+06	3.04E+06	1.70E+07	2.69E+06	2.69E+06	2.57E+06	2.67E+06	2.60E+06	2.68E+06	3.29E+07
Total Gallons	8.64E+06	7.75E+06	9.27E+06	9.91E+06	1.03E+07	9.37E+06	5.52E+07	1.00E+07	8.89E+06	8.59E+06	6.78E+06	1.14E+07	9.10E+06	1.10E+08
Total cc	3.27E+10	2.93E+10	3.51E+10	3.75E+10	3.91E+10	3.55E+10	2.09E+11	3.79E+10	3.37E+10	3.25E+10	2.57E+10	4.33E+10	3.45E+10	4.17E+11
Dilution vol(cc) ²	7.91E+13	7.14E+13	6.33E+13	8.57E+13	1.26E+14	1.22E+14	5.47E+14	1.27E+14	1.27E+14	1.23E+14	8.26E+13	1.21E+14	9.72E+13	1.22E+15
Avg diluted discharge conc (µCi/cc)														
Gamma Scan (+HTDs) ¹	6.41E-11	1.49E-10	4.98E-11	4.10E-10	2.59E-11	1.54E-11		6.54E-12	2.96E-11	8.55E-12	7.61E-11	1.37E-11	8.95E-12	
Gross Alpha	0.00E+00	0.00E+00	0.00E+00	0.00E+00	0.00E+00	0.00E+00		0.00E+00	0.00E+00	0.00E+00	0.00E+00	0.00E+00	0.00E+00	0.00E+00
Tritium	1.60E-06	1.73E-06	1.15E-06	1.25E-06	3.80E-07	4.28E-07		5.01E-07	1.15E-06	3.08E-07	6.63E-07	8.79E-08	4.45E-07	
Strontium (89/90/92)	0.00E+00	0.00E+00	2.35E-14	0.00E+00	0.00E+00	0.00E+00		0.00E+00	0.00E+00	0.00E+00	0.00E+00	0.00E+00	0.00E+00	0.00E+00
Noble Gases	1.20E-11	3.23E-11	1.23E-11	6.60E-11	7.16E-12	1.07E-11		1.34E-11	6.71E-11	1.40E-11	6.63E-12	3.68E-12	1.41E-11	
Max Batch Discharge Conc (µCi/cc)														
Tritium	2.75E-05	3.63E-05	3.65E-05	3.61E-05	2.96E-05	4.21E-05		3.44E-05	3.79E-05	2.09E-05	1.80E-05	3.24E-06	2.91E-05	
Gamma Scan	1.19E-10	7.85E-10	5.73E-10	1.86E-08	2.15E-10	2.13E-10		7.12E-11	1.13E-10	2.32E-11	5.44E-09	5.52E-10	1.81E-10	

1 HTDs include Fe-55, C-14, Ni-63, and Tc-99. Does not include strontium which is totaled separately.

2 Circulating water discharge from both units.

Note: Dissolved noble gases detected in liquid effluents (e.g., Xe-133, Xe-135, etc.) are added to the atmospheric release summaries

Table 2-3
Isotopic Composition of Circulating Water Discharges (Ci)
 January, 2017 through December 31, 2017

Nuclide	Total												Total Jan-Dec	
	Jan	Feb	Mar	Apr	May	Jun	Jan-Jun	Jul	Aug	Sep	Oct	Nov		Dec
H-3	1.27E+02	1.23E+02	7.28E+01	1.08E+02	4.77E+01	5.22E+01	5.30E+02	6.35E+01	1.46E+02	3.78E+01	5.48E+01	1.07E+01	4.33E+01	8.87E+02
C-14	3.93E-03	8.98E-03	7.00E-04	1.61E-03	2.39E-03	9.73E-04	1.86E-02	2.62E-04	2.34E-03	6.10E-04	1.07E-04	0.00E+00	2.97E-04	2.22E-02
F-18	3.88E-04	7.13E-04	8.81E-04	3.10E-04	4.85E-04	3.88E-04	3.16E-03	3.74E-04	9.03E-04	3.81E-04	0.00E+00	0.00E+00	0.00E+00	4.82E-03
Cr-51	0.00E+00	0.00E+00	1.22E-05	7.85E-03	0.00E+00	0.00E+00	7.86E-03	0.00E+00	0.00E+00	0.00E+00	2.06E-04	1.49E-05	0.00E+00	8.08E-03
Mn-54	0.00E+00	0.00E+00	0.00E+00	2.19E-04	0.00E+00	0.00E+00	2.19E-04	0.00E+00	0.00E+00	0.00E+00	1.83E-05	0.00E+00	0.00E+00	2.37E-04
Fe-55	0.00E+00	0.00E+00	0.00E+00	0.00E+00	0.00E+00	0.00E+00	0.00E+00	0.00E+00	0.00E+00	0.00E+00	0.00E+00	0.00E+00	0.00E+00	0.00E+00
Fe-59	0.00E+00	0.00E+00	0.00E+00	1.74E-04	0.00E+00	0.00E+00	1.74E-04	0.00E+00	0.00E+00	0.00E+00	0.00E+00	0.00E+00	0.00E+00	1.74E-04
Co-57	0.00E+00	0.00E+00	0.00E+00	7.71E-06	0.00E+00	0.00E+00	7.71E-06	0.00E+00	0.00E+00	3.72E-07	7.34E-06	0.00E+00	0.00E+00	1.54E-05
Co-58	2.24E-05	1.54E-05	5.44E-05	8.43E-03	1.28E-04	7.46E-05	8.72E-03	3.37E-05	4.09E-05	4.82E-06	3.81E-03	5.12E-04	2.41E-04	1.34E-02
Co-60	4.54E-05	8.77E-05	1.21E-04	3.21E-03	4.13E-05	3.52E-05	3.54E-03	4.16E-05	7.39E-05	3.16E-05	3.36E-04	1.28E-04	2.29E-05	4.17E-03
Ni-63	4.46E-04	5.58E-04	7.45E-04	4.50E-04	2.19E-05	1.17E-04	2.34E-03	3.06E-05	1.54E-04	0.00E+00	7.48E-06	9.97E-05	6.86E-05	2.70E-03
Zn-65	0.00E+00	0.00E+00	0.00E+00	3.21E-05	0.00E+00	0.00E+00	3.21E-05	0.00E+00	0.00E+00	0.00E+00	0.00E+00	0.00E+00	0.00E+00	3.21E-05
Se-75	0.00E+00	0.00E+00	2.55E-06	8.49E-06	0.00E+00	0.00E+00	1.10E-05	0.00E+00	0.00E+00	0.00E+00	0.00E+00	0.00E+00	0.00E+00	1.10E-05
As-76	0.00E+00	0.00E+00	1.02E-05	2.65E-05	0.00E+00	0.00E+00	3.67E-05	0.00E+00	0.00E+00	0.00E+00	4.33E-05	4.00E-05	0.00E+00	1.20E-04
Sr-90	0.00E+00	0.00E+00	0.00E+00	0.00E+00	0.00E+00	0.00E+00	0.00E+00	0.00E+00	0.00E+00	0.00E+00	0.00E+00	0.00E+00	0.00E+00	0.00E+00
Sr-92	0.00E+00	0.00E+00	1.49E-06	0.00E+00	0.00E+00	0.00E+00	1.49E-06	0.00E+00	0.00E+00	0.00E+00	0.00E+00	0.00E+00	0.00E+00	1.49E-06
Nb-95	0.00E+00	0.00E+00	0.00E+00	1.99E-03	1.05E-05	1.00E-05	2.01E-03	1.33E-06	1.97E-06	0.00E+00	5.65E-05	0.00E+00	0.00E+00	2.07E-03
Nb-97	0.00E+00	0.00E+00	0.00E+00	0.00E+00	0.00E+00	0.00E+00	0.00E+00	0.00E+00	0.00E+00	0.00E+00	0.00E+00	0.00E+00	0.00E+00	0.00E+00
Zr-95	0.00E+00	0.00E+00	0.00E+00	1.09E-03	0.00E+00	0.00E+00	1.09E-03	0.00E+00	0.00E+00	0.00E+00	2.83E-05	0.00E+00	0.00E+00	1.12E-03
Tc-99	8.39E-06	2.60E-05	7.09E-06	3.99E-05	4.99E-06	4.77E-06	9.12E-05	5.25E-06	2.57E-05	8.58E-06	2.46E-05	0.00E+00	2.41E-05	1.79E-04
Ag-110m	0.00E+00	0.00E+00	3.63E-05	1.39E-04	0.00E+00	0.00E+00	1.75E-04	1.63E-05	0.00E+00	0.00E+00	3.21E-05	0.00E+00	0.00E+00	2.23E-04
Sn-113	0.00E+00	0.00E+00	0.00E+00	1.43E-04	0.00E+00	0.00E+00	1.43E-04	1.30E-06	0.00E+00	0.00E+00	0.00E+00	0.00E+00	0.00E+00	1.44E-04
Sn-117m	9.86E-06	2.23E-05	1.79E-05	5.21E-03	1.53E-04	1.21E-04	5.54E-03	6.07E-05	3.58E-05	5.36E-06	1.21E-03	8.62E-04	1.14E-04	7.83E-03
Sb-122	0.00E+00	0.00E+00	1.89E-06	1.66E-05	0.00E+00	8.78E-07	1.94E-05	0.00E+00	0.00E+00	0.00E+00	4.24E-05	0.00E+00	0.00E+00	6.18E-05
Sb-124	0.00E+00	0.00E+00	6.19E-06	4.99E-04	5.84E-06	1.04E-04	6.15E-04	0.00E+00	6.15E-05	2.84E-06	1.04E-04	0.00E+00	2.58E-05	8.09E-04
Sb-125	2.21E-04	2.06E-04	4.76E-04	3.63E-03	0.00E+00	5.29E-05	4.59E-03	0.00E+00	1.20E-04	4.06E-06	2.12E-04	0.00E+00	7.74E-05	5.00E-03
I-131	0.00E+00	0.00E+00	0.00E+00	0.00E+00	0.00E+00	0.00E+00	0.00E+00	0.00E+00	0.00E+00	0.00E+00	0.00E+00	0.00E+00	0.00E+00	0.00E+00
I-132	0.00E+00	0.00E+00	0.00E+00	0.00E+00	0.00E+00	0.00E+00	0.00E+00	0.00E+00	0.00E+00	0.00E+00	0.00E+00	0.00E+00	0.00E+00	0.00E+00
Te-132	0.00E+00	0.00E+00	0.00E+00	3.51E-60	0.00E+00	0.00E+00	3.51E-60	0.00E+00	0.00E+00	0.00E+00	4.40E-05	5.82E-06	0.00E+00	4.98E-05
Cs-137	0.00E+00	2.78E-05	6.89E-05	9.12E-05	9.74E-06	0.00E+00	1.98E-04	3.30E-06	0.00E+00	0.00E+00	0.00E+00	0.00E+00	0.00E+00	2.01E-04
Xe-131m	0.00E+00	3.01E-04	0.00E+00	0.00E+00	0.00E+00	0.00E+00	3.01E-04	0.00E+00	0.00E+00	0.00E+00	0.00E+00	0.00E+00	0.00E+00	3.01E-04
Xe-133	9.33E-04	1.95E-03	7.64E-04	5.41E-03	8.97E-04	1.30E-03	1.13E-02	1.68E-03	8.03E-03	1.70E-03	5.37E-04	3.51E-04	1.36E-03	1.37E-02
Xe-133m	0.00E+00	0.00E+00	0.00E+00	0.00E+00	0.00E+00	0.00E+00	0.00E+00	8.97E-06	1.11E-04	1.22E-05	0.00E+00	0.00E+00	0.00E+00	1.32E-04
Xe-135	1.64E-05	5.50E-05	1.63E-05	2.46E-04	3.37E-06	1.24E-05	3.50E-04	1.51E-05	3.73E-04	1.08E-05	1.12E-05	9.49E-05	9.81E-06	5.15E-04

Note: The dissolved noble gases detected in liquid effluents (e.g., Xe-133, Xe-135, etc.) also are added to the atmospheric release summaries. "-" = no analysis

Table 2-4
Subsoil System Drains - Tritium Summary
 January 1, 2017, through December 31, 2017

	S-1	S-3	S-7	S-8	S-9	S-10	S-11	S-12	S-13
1st Qtr									
H-3 (Ci)	0.00E+00	0.00E+00	0.00E+00	0.00E+00	0.00E+00	0.00E+00	0.00E+00	0.00E+00	0.00E+00
Flow (gal)	3.89E+05	8.93E+04	0.00E+00	0.00E+00	0.00E+00	0.00E+00	0.00E+00	0.00E+00	0.00E+00
2nd Qtr									
H-3 (Ci)	0.00E+00	0.00E+00	0.00E+00	0.00E+00	0.00E+00	0.00E+00	0.00E+00	0.00E+00	0.00E+00
Flow (gal)	1.38E+06	0.00E+00	0.00E+00	0.00E+00	0.00E+00	0.00E+00	2.77E+05	8.93E+04	0.00E+00
3rd Qtr									
H-3 (Ci)	0.00E+00	0.00E+00	0.00E+00	0.00E+00	0.00E+00	0.00E+00	0.00E+00	0.00E+00	0.00E+00
Flow (gal)	4.44E+05	8.93E+04	0.00E+00	0.00E+00	0.00E+00	0.00E+00	0.00E+00	0.00E+00	0.00E+00
4th Qtr									
H-3 (Ci)	0.00E+00	0.00E+00	0.00E+00	0.00E+00	0.00E+00	0.00E+00	0.00E+00	0.00E+00	0.00E+00
Flow (gal)	3.11E+05	6.70E+04	0.00E+00	0.00E+00	0.00E+00	0.00E+00	0.00E+00	0.00E+00	0.00E+00

2.6 Land Application of Sewage Sludge and Wastewater

In 1988, pursuant to 10 CFR 20.302(a), Point Beach received NRC approval for the disposal of sewage sludge, which may contain trace amounts of radionuclides, by land application on acreage within the site. Land application of sewage sludge is regulated by the Wisconsin Department of Natural Resources. Point Beach has not land applied sewage sludge for over a decade. Therefore, Point Beach has not renewed its WI DNR permit to dispose of sewage sludge in this manner.

There were no sludge or equalization basin disposals by land application during 2017. All disposals from the PBNP sewage treatment plant (STP) were done at the Manitowoc Sewage Treatment Plant. A total of 208,400 gallons in 36 shipments were made to Manitowoc. All sludge and equalization basin discharges were analyzed for environmental LLDs. Naturally occurring radionuclides such as Ra-226 and K-40 were present in all samples. For the 36 shipments in 2017 the total Ra-226 and K-40 were 145 µCi and 141 µCi, respectively. Small concentrations of H-3 (95 – 867 pCi/l) were found in thirty-three (33) of the shipments for a total of 241 µCi. Based on the daily flow at the Manitowoc plant, the H-3 discharge concentration would be on the order of 0.3 pCi/L or 60,000 times lower than the EPA drinking water limit of 20,000 pCi/L.

The STP H-3 is attributable to groundwater in-leakage at the STP lift station whose volume is known to increase after a heavy rain or snow melt event. The STP is in the groundwater flow path from the retention pond area and the lake. The STP H-3 concentrations are comparable to those found in the retention pond area monitoring wells.

2.7 Carbon-14

Carbon-14 (C-14) is a naturally occurring radionuclide. Nuclear weapons testing of the 1950s and 1960s significantly increased the amount of C-14 in the atmosphere. Small amounts of C-14 also are produced by nuclear reactors, but the amounts produced are less than C-14 produced by weapons testing or that occurs naturally. Based on information from the NRC obtained at industry sponsored workshops, NextEra Point Beach began evaluating C-14 liquid discharges in 2009, prior to the issuance of Regulatory Guide 1.21 [RG 1.21], Rev 2 in June of 2009. Point Beach continues to analyze batch liquid waste discharges for C-14 and reporting the results in the Annual Monitoring Report.

The NRC requested that all nuclear plants report C-14 emissions beginning with the 2010 monitoring reports. Pursuant to NRC guidance in RG 1.21(Rev 2), evaluation of C-14 in liquid wastes is not required because the quantity released via this pathway is much less than that contributed by gaseous emissions. However, as stated above, Point Beach began C-14 analyses and reporting prior to the issuance of RG 1.21 (Rev 2). RG 1.21 states that a radionuclide is a principal effluent component if it contributes greater than 1% of the Appendix I design objective dose compared to the other radionuclides in the effluent type, or, if it is greater than 1% of the activity of all radionuclides in the effluent type. In this case, C-14 is compared to other (non-tritium or noble gases) radionuclides discharged in liquids.

For 2017, the monthly and total C-14 ($2.22\text{E-}02$ Ci) in liquid discharges is documented in Table 2-3. The 2017 amount of C-14 released makes up about 25% of the non-tritium radionuclides released in liquids ($2.22\text{E-}02/8.82\text{E-}02$).

The liquid C-14 dose contribution is included in the doses calculated for the hypothetically, maximally exposed individual (Table 2-1). Under the parameters and pathways used for the dose calculations, the C-14 dose contribution to the infant age group ranges from 0.074 to 0.076% of the dose to the whole body and the applicable organs except for bone, for which C-14 contributes 18.9% of the total dose. For the remaining age groups, the C-14 contributes roughly 73% of the bone dose and 2 – 12% of the dose to the whole body and to other organs specified in RG 1.109.

3.0 RADIOACTIVE AIRBORNE RELEASES

The release paths to the environment contributing to radioactive airborne release totals during this reporting period were the auxiliary building vent stack, the drumming area vent stack, the letdown gas stripper, the Unit 1 containment purge stack, and the Unit 2 containment purge stack. A gaseous radioactive effluent treatment system in conjunction with administrative controls is used to minimize the impact on the environment from the airborne releases and maintain doses to the public ALARA.

3.1 Doses from Airborne Effluent

Doses from airborne effluent are calculated for the maximum exposed individual (MEI) following the methodology contained in the PBNP ODCM. These calculated doses use parameters such as the amount of radioactive material released, the concentration at and beyond the site boundary, the average site weather conditions, and usage factors (e.g., breathing rates, food consumption). In addition to the MEI doses, the energy deposited in the air by noble gas beta particles and gamma rays is calculated and compared to the corresponding Appendix I design objectives. A comparison of the annual Appendix I design objectives for atmospheric effluents to the highest organ dose and the noble gas doses calculated using ODCM methodology is listed in Table 3-1. C-14 is not included in the Appendix I calculations because it is not an Appendix I radionuclide. The C-14 dose calculation has been required since 2010 (see Sections 3.4 through 3.6, below, for a more detailed description) and is treated separately. The comparison between airborne effluent doses with and without C-14 is shown in Table 3-4. The highest Appendix I dose is $1.83\text{E-}02$ mrem for the child age group thyroid. Had C-14 been included, the child-bone dose would have been the highest at $2.41\text{E-}01$ mrem. Even with the inclusion of C-14 the doses demonstrate that releases from PBNP to the atmosphere continue to be ALARA at 0.8% dose objective.

3.2 Radioactive Airborne Release Summary

Radioactivity released in airborne effluents for 2017 is summarized in Table 3-2. The particulate total increased from $8.82\text{E-}05$ Ci in 2016 to $2.33\text{E-}04$ in 2017. H-3 increased from 64.4 to 148 Ci. Noble gases increased from $5.82\text{E-}01$ to $6.15\text{E-}01$ Ci.

3.3 Isotopic Airborne Releases

The monthly isotopic airborne releases for 2017, from which the airborne doses were calculated, are presented in Table 3-3. Carbon-14 is not included in Table 3-3 because it was calculated and not measured. C-14 is discussed in the following sections.

As in previous years the outage impact of the isotopic mixture is demonstrated in the comparison of the non-outage particulate releases. Eight different particulates were identified in the airborne effluent during March and nine in October, whereas in the non-outage months, two at the most were found. Most were released via the open hatch on the 66-foot elevation of containment. The convective flow through the open hatch during purge is unfiltered. Although the flow is into the façade, there are two circumferential gaps around the façade. It is

assumed that the release into façade is transferred to the outside and therefore is treated as a release to the environment.

3.4 Carbon-14

C-14 is a naturally occurring radionuclide. Nuclear weapons testing of the 1950s and 1960s significantly increased the amount of C-14 in the atmosphere. Small amounts of C-14 also are produced by nuclear reactors as neutrons interact with the dissolved oxygen and nitrogen in the primary coolant. However, the amount produced by nuclear reactors is much less than that produced by weapons testing or that occur naturally.

The NRC has requested that nuclear plants report C-14 emissions. C-14 is a hard-to-detect radionuclide. It is not a gamma emitter and must be chemically separated from the effluent stream before it can be measured. Because nuclear plants currently are not equipped to perform this type of sampling, RG 1.21 allows for calculating C-14 discharges based on fission rates.

The Electric Power Research Institute (EPRI) developed the methodology for calculating C-14 generation and releases for the nuclear industry. The results were published as Technical Report 1021106 (December 2010), "Estimation of Carbon-14 in Nuclear Power Plant Gaseous Effluents." In addition to neutron flux, the percent oxygen and nitrogen in the VCTs is used in the C-14 calculation as both gases contribute to the generation of C-14. Pursuant to NRC guidance (Regulatory Guide 1.21, Rev 2, p. 16, June 2009), most of the C-14 emissions from nuclear plant occur in the gaseous phase.

The Point Beach C-14 generation for 2017 was calculated using the EPRI guidance and the current core parameters resulting from the power uprate. The calculated amounts were 5.88 Ci for Unit 1 and 5.86 Ci for Unit 2 yielding a total of 11.74 Ci which is the same as 2016. The 2017 calculated total 11.74 Ci is roughly 500 times higher than the 2.43E-02 Ci of C-14 determined by analyses of composites from liquid waste batch discharges, steam generator blowdown, and other waste streams.

3.5 C-14 Airborne Effluent Dose Calculation

The dose from the airborne C-14 is dependent on its chemical form. The C-14 released to the atmosphere consists of both organic and inorganic species. Both the inorganic and organic C-14 contribute to the inhalation dose. Only the inorganic $^{14}\text{CO}_2$ species contributes to the dose from the ingestion of photosynthetically incorporated C-14. The organic forms such as methane, CH_4 , are not photosynthetically active. For PWRs such as PBNP most of the gaseous C-14 occurs as methane, $^{14}\text{CH}_4$, not as carbon dioxide, $^{14}\text{CO}_2$.

The amount of $^{14}\text{CO}_2$ present in the PBNP airborne effluent has not been measured. However, such measurements have been made at a comparable PWR sites similar to the PBNP design. The Ginna nuclear generating station is of similar design to PBNP. It is a Westinghouse 2-loop PWR of the same vintage as PBNP and approximately the same power (prior to the PBNP power uprate). Measurements at Ginna for 18 months in 1980 - 1981 (Kunz, "Measurement of

¹⁴C Production and Discharge From the Ginna Nuclear Power Reactor," 1982) found that ten percent of the C-14 was discharged as ¹⁴CO₂. Therefore, 10% of the 11.74 Ci of the calculated C-14 for PBNP will be used in the ingestion dose calculations.

C-14 dose calculations were made using the dose factors and the methodology of Regulatory Guide 1.109. The inhalation dose was calculated using all of the C-14 calculated to be released. All the C-14 is used because whether the C-14 is in the form of ¹⁴CO₂ or one of the organic forms, such as CH₄, both would be inhaled and contribute to a lung dose.

For the other existing pathways, milk, meat, and produce, the dose depends upon the amount incorporated into biomass consumed by cattle and people: forage for cattle and produce for humans. Incorporation only occurs via photosynthesis. Photosynthesis only incorporates ¹⁴CO₂ and hence the use of only the 10% fraction of the total C-14 release for these pathways.

The airborne effluent C-14 dose calculations were made as described above. They were made for the MEI as explained in Section 2.1. This approach utilizes all the pathways that are applicable to a hypothetical person residing at the site boundary. Because C-14 is present as a gas, the pathways are milk, meat, and produce (vegetables, fruit, and grain) and the Regulatory Guide 1.109, Table E-5 usage factors applied to the calculation. As such, the resulting dose will be conservative in that the produce usage factor includes grain and fruit and these pathways do not exist in the vicinity of the point for which the C-14 doses are calculated. Furthermore, because leafy vegetables are included in the produce pathway, they are not used as a separate pathway because that would result in double accounting for leafy vegetable dose contribution.

Carbon-14 is not an Appendix I radionuclide. Therefore, airborne C-14 is not summed with the other airborne radioactive effluents for comparison of airborne effluent dose to the Appendix I dose objectives. However, the C-14 doses are presented and compared to the other radionuclide doses in Table 3-4.

3.6 C-14 Measurements

No C-14 measurements were made of PBNP airborne effluents. In 2010, C-14 was measured in crops grown on fields in the owner controlled area located in the highest χ/Q sector at the site's south boundary. One field is leased for feed corn by a dairy south of the plant. That dairy is part of the REMP. In an adjacent field soybeans are grown by another farmer. These two crops were sampled in this sector and as well as in a background location about 17 miles SW of the plant. Based on the measurement error, there was no statistical difference between the results obtained on site in the highest χ/Q sector as compared to the background site some 17 miles away (2013 AMR, Table 10-3). These results demonstrated that the dose from C-14 in Point Beach airborne effluents should not measurably increase the C-14 dose compared to that received from naturally occurring C-14 in plants (1 mrem: NCRP Report 93, Ionizing Radiation Exposure of the Population of the United States, 1987, p.12).

Table 3-1
Comparison of 2017 Airborne Effluent Calculated Doses to 10 CFR 50 Appendix I Design Objectives

Category	Annual Appendix I Design Objective	January-December Calculated Dose	Percent of Appendix I Design Objective
Particulate	30 mrem/organ	0.0183 mrem	0.061
Noble gas	40 mrad (beta air)	0.0000379 mrad	0.00010
Noble gas	20 mrad (gamma air)	0.0000984 mrad	0.00049
Noble gas	30 mrem (skin)	0.000137 mrem	0.00046
Noble gas	10 mrem (whole body)	0.0000932 mrem	0.00093

Table 3-2
Radioactive Airborne Effluent Release Summary
 January 1, 2017, through December 31, 2017

	Jan	Feb	Mar	Apr	May	Jun	Total Jan-Jun	Jul	Aug	Sep	Oct	Nov	Dec	Total
Total NG from Liq (Ci)	9.49E-04	2.31E-03	7.80E-04	5.66E-03	9.01E-04	1.31E-03	1.19E-02	1.70E-03	8.52E-03	1.72E-03	5.48E-04	4.46E-04	1.37E-03	2.62E-02
Total Noble Gas (Ci)¹	5.82E-02	5.07E-02	5.64E-02	6.34E-02	5.20E-02	4.42E-02	3.25E-01	5.32E-02	6.03E-02	4.98E-02	3.05E-02	5.05E-02	4.56E-02	6.15E-01
Total Radioiodines (Ci)²	0.00E+00	0.00E+00	0.00E+00	1.37E-06	1.39E-05	4.49E-06	1.98E-05	0.00E+00	0.00E+00	0.00E+00	0.00E+00	0.00E+00	0.00E+00	1.98E-05
Total Particulate (Ci)³	0.00E+00	0.00E+00	1.77E-05	2.02E-10	0.00E+00	0.00E+00	1.77E-05	8.39E-06	0.00E+00	5.19E-09	9.55E-06	1.98E-04	0.00E+00	2.33E-04
Alpha (Ci)	0.00E+00	0.00E+00	0.00E+00	0.00E+00	0.00E+00	0.00E+00	0.00E+00	0.00E+00	0.00E+00	0.00E+00	0.00E+00	0.00E+00	0.00E+00	0.00E+00
Strontium(Ci)	0.00E+00	0.00E+00	0.00E+00	0.00E+00	0.00E+00	0.00E+00	0.00E+00	0.00E+00	0.00E+00	0.00E+00	0.00E+00	0.00E+00	0.00E+00	0.00E+00
All other beta + gamma (Ci)	0.00E+00	0.00E+00	1.77E-05	2.02E-10	0.00E+00	0.00E+00	1.77E-05	8.39E-06	0.00E+00	5.19E-09	9.55E-06	1.98E-04	0.00E+00	2.33E-04
Total Tritium (Ci)	2.17E+01	7.84E+00	8.20E+00	5.92E+01	5.50E+00	4.17E+00	1.07E+02	3.60E+00	5.13E+00	4.49E+00	7.03E+00	1.23E+01	9.12E+00	1.48E+02
Max NG H'rly Rel.(Ci/sec)	7.51E-08	8.01E-08	7.60E-08	7.35E-08	6.40E-08	5.54E-09		6.34E-08	4.80E-07	5.03E-08	4.39E-05	5.54E-08	5.69E-08	

¹ Total noble gas (airborne + liquid releases) and activation gas A-41. It does not include the activation gas F-18 because of its short T_{1/2} and because it is not an Appendix I radionuclide.

² Airborne radioiodines only include I-131 and I-133. Although for dose calculations iodines are grouped with particulates, for this reporting table they are separated from the particulate group.

³ Total Particulate is the sum of alpha, strontium, and others. It does not include radioiodines or C-14. C-14 was calculated for the year and no monthly values are available.

TABLE 3-3
Isotopic Composition of Airborne Releases
 January 1, 2017 through December 31, 2017

Nuclide	Jan (Ci)	Feb (Ci)	Mar (Ci)	Apr (Ci)	May (Ci)	Jun (Ci)	Semi- Annual	Jul (Ci)	Aug (Ci)	Sep (Ci)	Oct (Ci)	Nov (Ci)	Dec (Ci)	Total (Ci)
H-3	2.17E+01	7.84E+00	8.20E+00	5.92E+01	5.50E+00	4.17E+00	1.07E+02	3.60E+00	5.13E+00	4.49E+00	7.03E+00	1.23E+01	9.12E+00	1.48E+02
F-18	1.05E+00	5.94E-05	0.00E+00	9.62E-08	0.00E+00	0.00E+00	1.05E+00	8.39E-06	0.00E+00	5.19E-09	0.00E+00	1.98E-04	0.00E+00	1.05E+00
Ar-41	4.63E-02	3.89E-02	4.02E-02	3.70E-02	4.55E-02	3.96E-02	2.47E-01	4.49E-02	3.44E-02	4.17E-02	2.25E-02	3.34E-02	3.61E-02	4.61E-01
Kr-85	0.00E+00	0.00E+00	0.00E+00	0.00E+00	0.00E+00	0.00E+00	0.00E+00	0.00E+00	0.00E+00	0.00E+00	0.00E+00	0.00E+00	0.00E+00	0.00E+00
Kr-85m	0.00E+00	0.00E+00	0.00E+00	0.00E+00	0.00E+00	0.00E+00	0.00E+00	0.00E+00	0.00E+00	0.00E+00	0.00E+00	0.00E+00	0.00E+00	0.00E+00
Kr-87	0.00E+00	0.00E+00	0.00E+00	0.00E+00	0.00E+00	0.00E+00	0.00E+00	0.00E+00	0.00E+00	0.00E+00	0.00E+00	0.00E+00	0.00E+00	0.00E+00
Kr-88	0.00E+00	0.00E+00	0.00E+00	0.00E+00	0.00E+00	0.00E+00	0.00E+00	0.00E+00	0.00E+00	0.00E+00	0.00E+00	0.00E+00	0.00E+00	0.00E+00
Xe-131m	0.00E+00	3.01E-04	0.00E+00	0.00E+00	0.00E+00	0.00E+00	3.01E-04	0.00E+00	2.32E-04	0.00E+00	0.00E+00	1.67E-04	0.00E+00	7.00E-04
Xe-133	1.19E-02	9.51E-03	1.62E-02	2.62E-02	6.48E-03	4.60E-03	7.49E-02	8.32E-03	2.51E-02	8.05E-03	7.84E-03	1.67E-02	9.45E-03	1.50E-01
Xe-133m	0.00E+00	1.95E-03	0.00E+00	0.00E+00	0.00E+00	0.00E+00	1.95E-03	0.00E+00	1.56E-04	1.22E-05	0.00E+00	1.12E-04	0.00E+00	2.23E-03
Xe-135	1.64E-05	5.50E-05	1.63E-05	2.46E-04	3.37E-06	1.24E-05	3.49E-04	0.00E+00	3.73E-04	1.08E-05	1.44E-04	1.63E-04	9.81E-06	1.05E-03
Xe-135m	0.00E+00	0.00E+00	0.00E+00	0.00E+00	0.00E+00	0.00E+00	0.00E+00	0.00E+00	0.00E+00	0.00E+00	0.00E+00	0.00E+00	0.00E+00	0.00E+00
Xe-138	0.00E+00	0.00E+00	0.00E+00	0.00E+00	0.00E+00	0.00E+00	0.00E+00	0.00E+00	0.00E+00	0.00E+00	0.00E+00	0.00E+00	0.00E+00	0.00E+00
Cr-51	0.00E+00	0.00E+00	4.83E-06	0.00E+00	0.00E+00	0.00E+00	4.83E-06	0.00E+00	0.00E+00	0.00E+00	0.00E+00	0.00E+00	0.00E+00	4.83E-06
Mn-54	0.00E+00	0.00E+00	0.00E+00	0.00E+00	0.00E+00	0.00E+00	0.00E+00	0.00E+00	0.00E+00	0.00E+00	2.33E-08	0.00E+00	0.00E+00	2.33E-08
Fe-59	0.00E+00	0.00E+00	0.00E+00	0.00E+00	0.00E+00	0.00E+00	0.00E+00	0.00E+00	0.00E+00	0.00E+00	0.00E+00	0.00E+00	0.00E+00	0.00E+00
Co-57	0.00E+00	0.00E+00	0.00E+00	0.00E+00	0.00E+00	0.00E+00	0.00E+00	0.00E+00	0.00E+00	0.00E+00	0.00E+00	0.00E+00	0.00E+00	0.00E+00
Co-58	0.00E+00	0.00E+00	1.16E-06	0.00E+00	0.00E+00	0.00E+00	1.16E-06	0.00E+00	0.00E+00	0.00E+00	7.97E-06	0.00E+00	0.00E+00	9.13E-06
Co-60	0.00E+00	0.00E+00	7.97E-07	0.00E+00	0.00E+00	0.00E+00	7.97E-07	0.00E+00	0.00E+00	0.00E+00	2.49E-07	0.00E+00	0.00E+00	1.05E-06
Zn-65	0.00E+00	0.00E+00	0.00E+00	0.00E+00	0.00E+00	0.00E+00	0.00E+00	0.00E+00	0.00E+00	0.00E+00	0.00E+00	0.00E+00	0.00E+00	0.00E+00
Nb-95	0.00E+00	0.00E+00	1.71E-06	2.02E-10	0.00E+00	0.00E+00	1.71E-06	0.00E+00	0.00E+00	0.00E+00	2.84E-07	0.00E+00	0.00E+00	1.99E-06
Zr-95	0.00E+00	0.00E+00	1.47E-06	0.00E+00	0.00E+00	0.00E+00	1.47E-06	0.00E+00	0.00E+00	0.00E+00	0.00E+00	0.00E+00	0.00E+00	1.47E-06
I-131	0.00E+00	0.00E+00	1.09E-06	0.00E+00	2.30E-06	0.00E+00	3.40E-06	0.00E+00	0.00E+00	0.00E+00	0.00E+00	0.00E+00	0.00E+00	3.40E-06
I-132	0.00E+00	0.00E+00	0.00E+00	0.00E+00	0.00E+00	0.00E+00	0.00E+00	0.00E+00	0.00E+00	0.00E+00	0.00E+00	0.00E+00	0.00E+00	0.00E+00
I-133	0.00E+00	0.00E+00	0.00E+00	1.37E-06	1.16E-05	4.49E-06	1.75E-05	0.00E+00	0.00E+00	0.00E+00	0.00E+00	0.00E+00	0.00E+00	1.75E-05
Sb-124	0.00E+00	0.00E+00	6.12E-06	0.00E+00	0.00E+00	0.00E+00	6.12E-06	0.00E+00	0.00E+00	0.00E+00	0.00E+00	0.00E+00	0.00E+00	6.12E-06
Sb-125	0.00E+00	0.00E+00	1.18E-06	0.00E+00	0.00E+00	0.00E+00	1.18E-06	0.00E+00	0.00E+00	0.00E+00	0.00E+00	0.00E+00	0.00E+00	1.18E-06
Cs-137	0.00E+00	0.00E+00	0.00E+00	0.00E+00	0.00E+00	0.00E+00	0.00E+00	0.00E+00	0.00E+00	0.00E+00	2.37E-07	0.00E+00	0.00E+00	2.37E-07
Fe-55	0.00E+00	0.00E+00	0.00E+00	0.00E+00	0.00E+00	0.00E+00	0.00E+00	0.00E+00	0.00E+00	0.00E+00	0.00E+00	0.00E+00	0.00E+00	0.00E+00
Ni-63	0.00E+00	0.00E+00	0.00E+00	0.00E+00	0.00E+00	0.00E+00	0.00E+00	0.00E+00	0.00E+00	0.00E+00	7.87E-07	0.00E+00	0.00E+00	7.87E-07
Tc-99	0.00E+00	0.00E+00	0.00E+00	0.00E+00	0.00E+00	0.00E+00	0.00E+00	0.00E+00	0.00E+00	0.00E+00	0.00E+00	0.00E+00	0.00E+00	0.00E+00
Sr-89	0.00E+00	0.00E+00	0.00E+00	0.00E+00	0.00E+00	0.00E+00	0.00E+00	0.00E+00	0.00E+00	0.00E+00	0.00E+00	0.00E+00	0.00E+00	0.00E+00
Sr-90	0.00E+00	0.00E+00	0.00E+00	0.00E+00	0.00E+00	0.00E+00	0.00E+00	0.00E+00	0.00E+00	0.00E+00	0.00E+00	0.00E+00	0.00E+00	0.00E+00
Sn-113	0.00E+00	0.00E+00	0.00E+00	0.00E+00	0.00E+00	0.00E+00	0.00E+00	0.00E+00	0.00E+00	0.00E+00	0.00E+00	0.00E+00	0.00E+00	0.00E+00
Sn-117m	0.00E+00	0.00E+00	4.78E-07	0.00E+00	0.00E+00	0.00E+00	4.78E-07	0.00E+00	0.00E+00	0.00E+00	0.00E+00	0.00E+00	0.00E+00	4.78E-07

Note: The Noble Gases listed above include the liquid contribution

**Table 3-4
Comparison of Airborne Effluent Doses (Appendix I and C-14)**

2017 Appendix I (Airborne Particulate + Tritium) Dose (mrem)

	Bone	Liver	T-WB	Thyroid	Kidney	Lung	GI-LLI	Skin
Adult	1.33E-05	1.17E-02	1.17E-02	1.17E-02	1.17E-02	1.17E-02	1.17E-02	1.07E-08
Teen	1.50E-05	1.29E-02	1.29E-02	1.29E-02	1.29E-02	1.29E-02	1.29E-02	1.07E-08
Child	2.47E-05	1.82E-02	1.82E-02	1.83E-02	1.82E-02	1.82E-02	1.82E-02	1.07E-08
Infant	1.41E-05	7.90E-03	7.89E-03	7.95E-03	7.89E-03	7.89E-03	7.89E-03	1.07E-08
Ann.Limit				3.00E+01				
% Ann Lim				6.09E-02				

2017 Carbon-14 Dose (mrem)

	Bone	Liver	T. Body	Thyroid	Kidney	Lungs	GI-LLI	Skin
Adult	6.65E-02	1.32E-02	1.32E-02	1.32E-02	1.32E-02	1.32E-02	1.32E-02	0.00E+00
Teen	1.04E-01	2.08E-02	2.08E-02	2.08E-02	2.08E-02	2.08E-02	2.08E-02	0.00E+00
Child	2.41E-01	4.81E-02	4.81E-02	4.81E-02	4.81E-02	4.81E-02	4.81E-02	0.00E+00
Infant	1.23E-01	2.61E-02	2.61E-02	2.61E-02	2.61E-02	2.61E-02	2.61E-02	0.00E+00

2017 Total Airborne Non-Noble Gas Dose [Particulate + H-3 + C-14 (mrem)]

	Bone	Liver	T-WB	Thyroid	Kidney	Lung	GI-LLI	Skin
Adult	6.65E-02	2.49E-02	2.49E-02	2.49E-02	2.49E-02	2.49E-02	2.49E-02	1.07E-08
Teen	1.04E-01	3.36E-02	3.36E-02	3.37E-02	3.36E-02	3.36E-02	3.37E-02	1.07E-08
Child	2.41E-01	6.63E-02	6.63E-02	6.64E-02	6.63E-02	6.63E-02	6.63E-02	1.07E-08
Infant	1.23E-01	3.40E-02	3.40E-02	3.40E-02	3.40E-02	3.40E-02	3.40E-02	1.07E-08

Ann.Limit 3.00E+01
% Limit 8.04E-01

The percent of limit is calculated using the highest total dose, the Child Age Group.

4.0 RADIOACTIVE SOLID WASTE SHIPMENTS

4.1 Types, Volumes, and Activity of Shipped Solid Waste

The following types, volumes, and activity of solid waste were shipped from PBNP for offsite disposal or burial during 2017. No Types C or D wastes were shipped. No irradiated fuel was shipped offsite. The volume, activity and type of waste are listed in Table 4-1.

**Table 4-1
Quantities and Types of Waste Shipped from PBNP in 2017**

A. Spent resins, filter sludge, evaporator bottoms, etc.	9.4 m ³	180.030 Ci
	332.6 ft ³	
B. Dry compressible waste, contaminated equipment, etc	368.1 m ³	0.285 Ci
	13000.0 ft ³	
C. Irradiated components, control rods, etc.	0.00 m ³	N/A Ci
	ft ³	
D. Other	0.0 m ³	N/A Ci
	0 ft ³	

4.2 Solid Waste Disposition

There were eight solid waste shipments from PBNP during 2017. The dates and destinations are shown in Table 4-2.

Table 4-2

2017 PBNP Radioactive Waste Shipments	
Date	Destination
01/26/17	Oak Ridge, TN
03/13/17	Clive, Utah
3/20/2017	Oak Ridge, TN
04/03/17	Oak Ridge, TN
07/21/17	Andrews, TX
10/06/17	Oak Ridge, TN
10/23/17	Oak Ridge, TN
10/31/17	Oak Ridge, TN

4.3 Major Nuclide Composition (by Type of Waste)

The major radionuclide content of the 2017 solid waste was determined by gamma isotopic analysis and the application of scaling factors for certain indicator radionuclides based on the measured isotopic content of representative waste stream samples. The estimated isotopic content is presented in Table 4-3. Only those radionuclides with detectable activity are listed.

**Table 4-3
2017 Estimated Solid Waste Major Radionuclide Composition**

TYPE A			TYPE B		
	Percent	Activity		Percent	Activity
Nuclide	Abundance	(mCi)	Nuclide	Abundance	(mCi)
Total	100.00%	1.81E+05	Total	100.00%	2.93E+02
Ni-63	66.87%	1.21E+05	Co-60	40.57%	1.19E+02
Co-60	14.43%	2.61E+04	Fe-55	25.55%	7.49E+01
Co-58	9.28%	1.68E+04	Co-58	8.43%	2.47E+01
Cs-137	2.27%	4.10E+03	Ni-63	5.80%	1.70E+01
Fe-55	2.04%	3.69E+03	Cr-51	4.42%	1.30E+01
Sb-125	1.97%	3.55E+03	Sb-125	3.63%	1.06E+01
Mn-54	1.40%	2.53E+03	Nb-95	2.27%	6.64E+00
Ni-59	0.73%	1.31E+03	Zr-95	1.75%	5.14E+00
Co-57	0.49%	8.91E+02	Mn-54	1.41%	4.14E+00
Zn-65	0.11%	2.03E+02	Fe-59	1.26%	3.69E+00
Ag-110m	0.08%	1.43E+02	Zn-65	1.03%	3.03E+00
Pu-241	0.08%	1.42E+02	Sb-124	0.79%	2.31E+00
Sr-90	0.06%	1.01E+02	Sn-113	0.44%	1.28E+00
H-3	0.05%	9.08E+01	Ag-110m	0.43%	1.25E+00
C-14	0.05%	8.17E+01	Co-57	0.33%	9.78E-01
Sn-113	0.03%	4.99E+01	Cs-137	0.32%	9.42E-01
Sb-124	0.03%	4.60E+01	Ni-59	0.32%	9.36E-01
Sr-89	0.01%	2.66E+01	H-3	0.29%	8.62E-01
Nb-95	0.01%	1.61E+01	Nb-94	0.26%	7.48E-01
Tc-99	0.01%	1.22E+01	Ce-144	0.25%	7.23E-01
Ce-144	0.00%	8.39E+00	Tc-99	0.15%	4.37E-01
Zr-95	0.00%	6.17E+00	Sn-117m	0.11%	3.27E-01
Cr-51	0.00%	3.89E+00	C-14	0.06%	1.81E-01
Pu-238	0.00%	1.54E+00	Sr-90	0.05%	1.35E-01
Pu-239	0.00%	9.93E-01	Pu-241	0.03%	9.27E-02
Am-241	0.00%	6.58E-01	Am-241	0.01%	4.27E-02
Cm-243	0.00%	1.10E-01	Pu-239	0.01%	2.62E-02
Cm-242	0.00%	2.57E-02	Pu-238	0.01%	2.18E-02
Eu-154	0.00%	9.75E-04	Cm-243	0.01%	1.72E-02
Th-230	0.00%	6.83E-05	Cm-242	0.00%	3.18E-03
Ba-133	0.00%	3.41E-05	Pu-242	0.00%	0.00E+00

5.0 NONRADIOACTIVE CHEMICAL RELEASES

5.1 Scheduled Chemical Waste Releases

There were no scheduled chemical releases of neutralized wastewater to the circulating water system from January 1, 2017, to June 30, 2017.

There were no scheduled chemical releases of neutralized wastewater to the circulating water system from July 1, 2017, to December 31, 2017.

Scheduled chemical waste releases are based on the average analytical results obtained from sampling a representative number of neutralizing tanks.

5.2 Miscellaneous Chemical Waste Releases

Miscellaneous chemical waste releases from the wastewater effluent (based on effluent analyses) to the circulating water for January 1, 2017, to June 30, 2017, included 2.06E+07 gallons of clarified effluent. The wastewater contained 2.20E+03 lbs. of suspended solids.

Miscellaneous chemical waste releases from the wastewater effluent (based on effluent analyses) to the circulating water for July 1, 2017, to December 31, 2017, included 2.05E+07 gallons of clarified effluent. The wastewater contained 1.62+03 lbs. of suspended solids.

Miscellaneous chemical waste released directly to the circulating water, based on amount of chemicals used from January 1, 2017, to June 30, 2017, included 3.28E+05 lbs. of sodium bisulfite solution (1.25E+05 lbs. sodium bisulfite), 2.85E+05 lbs. of Sodium Hypochlorite Solution (3.56E+04 lbs. sodium hypochlorite), 1.02E+03 lbs. Acti-Brom 1338 (4.61E+02 lbs. sodium bromide), 1.33E+02 lbs. of biodetergent, and 6.86E+02 lbs. of silt dispersant.

Miscellaneous chemical waste released directly to the circulating water, based on amount of chemicals used from July 1, 2017, to December 31, 2017, included 9.50E+05 lbs. of sodium bisulfite solution (3.61E+05 lbs. sodium bisulfite), 8.06E+05 lbs. Sodium Hypochlorite Solution (1.01E+05 lbs. sodium hypochlorite), 4.02E+04 lbs. Acti-Brom 1338 (1.81E+04 lbs. sodium bromide), 1.35E+03 lbs. of biodetergent, and 7.08E+04 lbs. of silt dispersant..

6.0 CIRCULATING WATER SYSTEM OPERATION

The circulating water system operation during this reporting period for periods of plant operation is described in Table 6-1.

**Table 6-1
Circulating Water System Operation for 2017**

	UNIT	JAN	FEB	MAR**	APR	MAY	JUN
Average Volume Cooling	1	346.7	346.7	356.5	489.8	542.5	544.3
Water Discharge [million gal/day]*	2	346.7	346.7	201.3	284.6	548.3	548.5
Average Cooling Water	1	37.7	38.3	36.0	43.3	47.9	50.2
Intake Temperature [°F]	2	38.3	38.8	36.5	45.3	48.3	50.6
Average Cooling Water	1	69.5	69.9	66.8	65.9	67.0	70.1
Discharge Temperature [°F]	2	68.5	68.1	62.7	56.0	63.4	66.3
Average Ambient Lake Temperature [°F]		34.8	35.4	34.1	40.6	44.3	45.9

* For days with cooling water discharge flow.

**U2 outage March 18 – April 13

**Table 6-1(continued)
Circulating Water System Operation for 2017**

	UNIT	JUL	AUG	SEP	OCT**	NOV	DEC
Average Volume Cooling*	1	549.7	549.7	549.7	157.5	534.3	422.6
Water Discharge [million gal/day]	2	551.1	551.1	551.1	566.0	550.4	429.6
Average Cooling Water	1	62.6	66.7	59.4	50.5	43.0	38.8
Intake Temperature [°F]	2	63.1	67.2	59.9	50.4	43.2	39.2
Average Cooling Water	1	83.4	87.7	79.8	60.3	62.9	67.5
Discharge Temperature [°F]	2	78.9	83.2	75.8	66.4	59.2	63.5
Average Ambient Lake Temperature [°F]		57.3	62.1	55.4	46.6	40.3	36.8

* For days with cooling water discharge flow.

**U1 outage October 7 – October 31

Part B

Miscellaneous Reporting Requirements

7.0 ADDITIONAL REPORTING REQUIREMENTS

7.1 Revisions to the PBNP Effluent and Environmental Programs

The ODCM (attached) was revised in its entirety in 2017. The Radiological Effluent Control Manual (RECM) and Environmental Manual, formerly separate documents incorporated by reference, were physically incorporated into the ODCM to align with the industry standard.

Changes to the ODCM include new liquid and airborne RMS setpoints that conform to the Technical Specification (TS) limits. Liquid setpoints are based on ten times the 10CFR20, Appendix B, Table 2, Col. 2 effluent concentrations, while the airborne setpoints are based on complying with the TS site boundary dose rate values. The setpoint calculation methodology also uses an updated source term based on the effluent distribution from 2000-2010.

Dose factors were revised by eliminating effluent dose pathways which do not exist for PBNP. The meteorological factors, χ/Q and D/Q , were updated to reflect more current data. New airborne dose factors were calculated in a manner to allow the option of using sector specific χ/Q and D/Q data to be used in addition to using the highest annual average χ/Q and D/Q .

EPRI methodology for calculating C-14, as well as the dose factor and dose calculation methodology, has been included. Definitions important to effluents and environmental monitoring were added to the ODCM. Additionally some material was eliminated or transferred to other site documents to conform to the standard format.

Information concerning the land application of sewage sludge was reinserted in the ODCM per NRC letter, NPC-30250, which stipulates the permanent incorporation of the letter into the ODCM. PBNP no longer disposes of sewage sludge by land application. This information was added to comply with the requirements of NPC-30250.

7.2 Interlaboratory Comparison Program

ATI Environmental, Inc, Midwest Laboratory, the analytical laboratory contracted to perform the radioanalyses of the PBNP environmental samples, participated in the Department of Energy's Mixed Analyte Performance Evaluation Program (MAPEP) as well as in the interlaboratory comparison studies administered by Environmental Resources Associates (ERA) during 2017. The ERA environmental crosscheck program replaces the Environmental Measurements Laboratory (EML) Quality Assessment Program which was discontinued. The

results of these comparisons can be found in Appendix A of the attached final report for 2017, January – December 2017 from ATI Environmental Inc.

7.3 Special Circumstances

No special circumstances report regarding operation of the explosive gas monitor for the waste gas holdup system was needed during 2017.

Part C

RADIOLOGICAL ENVIRONMENTAL MONITORING

8.0 INTRODUCTION

The objective of the PBNP Radiological Environmental Monitoring Program (REMP) is to determine whether the operation of PBNP or the ISFSI has radiologically impacted the environment. To accomplish this, the REMP collects and analyzes air, water, milk, soil, vegetation (grasses, weeds, and crops), and fish samples for radionuclides and uses thermoluminescent dosimeters (TLDs) to determine the ambient radiation background. The analyses of the various environmental media provide data on measurable levels of radiation and radioactive materials in the principal pathways of environmental exposure. These measurements also serve as a check of the efficacy of PBNP effluent controls.

The REMP fulfills the requirements of 10 CFR 20.1302, PBNP General Design Criterion (GDC) 17, GDC 64 of Appendix A to 10 CFR 50, and Sections IV.B.2 and IV.B.3 of Appendix I to 10 CFR 50 for the operation of the plant. A subset of the PBNP REMP samples, consisting of air, soil and vegetation also fulfills 10 CFR 72.44(d)(2) for operation of the ISFSI. Additionally, TLDs provide the means to measure changes in the ambient environmental radiation levels at sites near the ISFSI and at the PBNP site boundary to ensure that radiation levels from the ISFSI are maintained within the dose limits of 10 CFR 72.104. Because the ISFSI is within the PBNP site boundary, radiation doses from PBNP and the ISFSI, combined, must be used to assess compliance with 10 CFR 72.122 and 40 CFR 190. Therefore, radiological environmental monitoring for the ISFSI is provided by selected sampling sites, which are part of the PBNP REMP.

For the aquatic environment, the samples include water as well as the biological integrators, such as fish and filamentous algae. Because of their migratory behavior, fish are wide area integrators. In contrast, the filamentous algae periphyton is attached to shoreline rocks and concentrate nuclides from the water flowing by their point of attachment. Grab samples of lake water provide a snapshot of radionuclide concentrations at the time the sample is taken; whereas analysis of fish and filamentous algae yield concentrations integrated over time.

The air-grass-cow-milk exposure pathway unites the terrestrial and atmospheric environments. This pathway is important because of the many dairy farms around PBNP. Therefore, the REMP includes samples of air, general grasses, and milk from the PBNP environs. An annual land use survey is made to determine whether the assumptions on the location of dairy cattle remain conservative with respect to dose calculations for PBNP effluents. The dose calculations assume that the dairy cattle are located at the south site boundary, the highest depositional sector. In addition, soil samples are collected and analyzed in order to monitor the potential for long-term buildup of radionuclides in the vicinity of PBNP.

For the measurement of ambient environmental radiation levels that may be affected by direct radiation from PBNP or by noble gas effluents, the REMP employs a series of TLDs situated around PBNP and the ISFSI.

9.0 PROGRAM DESCRIPTION

9.1 Results Reporting Convention

The vendor used by PBNP to analyze the environmental samples is directed to report analysis results as measured by a detector, which can meet the required lower limit of detection (LLD) as specified in Table 12-1 of the ODCM for each sample. The report provided by the vendor (see Appendix 1) contains values, which can be either negative, positive or zero plus/minus the two sigma counting uncertainty, which provide the 95% confidence level for the measured value.

The LLD is an *a priori* concentration value that specifies the performance capability of the counting system used in the analyses of the REMP samples. The parameters for the *a priori* LLD are chosen such that only a five percent chance exists of falsely concluding a specific radionuclide is present when it is not present at the specified LLD. Based on detector efficiency and average background activity, the time needed to count the sample in order to achieve the desired LLD depends upon the sample size. Hence, the desired LLD may be achieved by adjusting various parameters. When a suite of radionuclides are required to be quantified in an environmental sample such as lake water, the count time used is that required to achieve the LLD for the radionuclide with the longest counting time. Therefore, in fulfilling the requirement for the most difficult to achieve radionuclide LLD, the probability of detecting the other radionuclides is increased because the counting time used is longer than that required to achieve the remaining radionuclide LLDs.

The REMP results in this report are reported as averages of the measurements made throughout the calendar year plus/minus the associated standard deviation. If all net sample concentrations are equal to or less than zero, the result is reported as "Not Detectable" (ND), indicating no detectable level of activity present in the sample. If any of the net sample concentrations indicate a positive result statistically greater than zero, all of the data reported are used to generate the reported statistics. Because of the statistical nature of radioactive decay, when the radionuclide of interest is not present in the sample, negative and positive results centered about zero will be seen. Excluding validly measured concentrations, whether negative or as small positive values below the LLD, artificially inflates the calculated average value. Therefore, all generated data are used to calculate the statistical values (i.e., average, standard deviation) presented in this report. The calculated average may be a negative number.

As mentioned above, radioactive decay is a statistical process which has an inherent uncertainty in the analytical result. No two measurements will yield exactly the same result. However, the results are considered equal if the results fall within a certain range based upon the statistical parameters involved in the process. The REMP analytical results are reported at the 95% confidence limit in which the true result may be two standard deviations above or below the reported result. This means that there is only a 5% chance of concluding that the identified radioactive atom is not there when it really is present in the sample. A false positive is an analytical result which statistically shows that the radionuclide is present in the sample when it really is not there. Typically, if the 95% confidence interval for a positive does not include zero, the radionuclide is

considered to be present. For example, the result is reported as 100 ± 90 . One hundred minus 90 yields a positive result and therefore may be considered to be present. However, this may be a false positive. If the radionuclide was not in the plant effluent, this result would fall into that category which 5% of the time it is falsely concluded that the radionuclide is present when in actuality it is not. This usually happens at low concentrations at or near the LLD where fluctuations in the background during the counting process skew the results to produce a positive result.

In interpreting the data, effects due to the plant must be distinguished from those due to other sources. A key interpretive aid in assessment of these effects is the design of the PBNP REMP, which is based upon the indicator-control concept. Most types of samples are collected at both indicator locations and at control locations. A plant effect would be indicated if the radiation level at an indicator location was significantly larger than that at the control location. The difference would have to be greater than could be accounted for by typical fluctuation in radiation levels arising from other sources.

9.2 Sampling Parameters

Samples are collected and analyzed at the frequency indicated in Table 9-1 from the locations described in Table 9-2 and shown in Figures 9-1, 9-2 and 9-3. (The latter two figures show sampling locations not shown in preceding figures due to space limitations. The location of the former retention pond, retired and remediated to NRC unrestricted access criteria, is indicated in Figure 9-3). The list of PBNP REMP sampling sites used to determine environmental impact around the ISFSI is found in Table 9-3. The minimum acceptable sample size is found in Table 9-4. In addition, Table 9-1 indicates the collection and analysis frequency of the ISFSI fence TLDs.

9.3 Deviations from Required Collection Frequency

Deviations from the collection frequency given in Table 9-1 are allowed because of hazardous conditions, automatic sampler malfunction, seasonal unavailability, and other legitimate reasons (Section 12.2.2.e of the ODCM). Table 9-5 lists the deviations from the scheduled sampling frequency that occurred during the reporting period.

9.4 Assistance to the State of Wisconsin

The Radiation Protection Unit of the Wisconsin Department of Health and Family Services maintains a radiological environmental monitoring program to confirm the results from the PBNP REMP. As a courtesy to the State of Wisconsin, PBNP personnel collect certain environmental samples (Table 9-6) for the State from sites that are near PBNP sampling sites, or are co-located.

9.5 Program Modifications

No new sampling sites or other modifications were made to the REMP in 2017.

**Table 9-1
PBNP REMP Sample Analysis and Frequency**

Sample Type	Sample Codes	Analyses	Frequency
Environmental Radiation Exposure	E-01, -02, -03, -04, -05 -06, -07, -08, -09, -12 -14, -15, -16B, -17, -18, 20, -22, -23, -24, -25, -26B, -27, -28 -29, -30, 31, -32, -38, -39,-41, -42,-43, -TC -	TLD	Quarterly
Vegetation	E-01, -02, -03, -04, -06, -08, -09, -20,	Gross Beta Gamma Isotopic Analysis	3x/yr as available
Algae	E-05, -12	Gross Beta Gamma Isotopic Analysis	3x/yr as available
Fish	E-13	Gross Beta Gamma Isotopic Analysis (Analysis of edible portions only)	3x/yr as available
Well Water	E-10	Gross Beta, H-3 Sr-89, 90, I-131 Gamma Isotopic Analysis	Quarterly
Lake Water	E-01, -05, -06, -33	Gross Beta, Sr-89/90, H-3 I-131 Gamma Isotopic Analysis	Monthly / Quarterly composite of monthly collections Monthly Monthly
Milk	E-11, -40, -21	Sr-89, 90 I-131 Gamma Isotopic Analysis	Monthly
Air Filters	E-01, -02, -03, -04, -08, -20	Gross Beta I-131 Gamma Isotopic Analysis	Weekly (particulate) Weekly (charcoal) Quarterly (on composite particulate filters)
Soil	E-01, -02, -03, -04, -06, -08, -09, -20,	Gross Beta Gamma Isotopic Analysis	2x/yr
Shoreline Sediment	E-01, -05, -06, -12, -33,	Gross Beta Gamma Isotopic Analysis	2x/yr
ISFSI Ambient Radiation Exposure	North, East, South, West Fence Sections	TLD	Quarterly

**Table 9-2
PBNP REMP Sampling Locations**

Location Code	Location Description
E-01	Primary Meteorological Tower South of the Plant
E-02	Site Boundary Control Center - East Side of Building
E-03	Tapawingo Road, about 0.4 Miles West of Lakeshore Road
E-04	North Boundary
E-05	Two Creeks Park
E-06	Point Beach State Park - Coast Guard Station; TLD located South of the Lighthouse on Telephone pole
E-07	WPSC Substation on County V, about 0.5 Miles West of Hwy 42
E-08	G.J. Francar Property at Southeast Corner of the Intersection of Cty. B and Zander Road
E-09	Nature Conservancy
E-10	PBNP Site Well
E-11	Dairy Farm about 3.75 Miles West of Site
E-12	Discharge Flume/Pier
E-13	Pumphouse
E-14	South Boundary, about 0.2 miles East of Site Boundary Control Center
E-15	Southwest Corner of Site
E-16B	WSW, Hwy 42, a residence about 0.25 miles North of Nuclear Road
E-17	North of Mishicot, Cty. B and Assman Road, Northeast Corner of Intersection
E-18	Northwest of Two Creeks at Zander and Tannery Roads
E-20	Reference Location, 17 miles Southwest, at Silver Lake College
E-21	Local Dairy Farm just South of Site on Lakeshore and Irish Roads
E-22	West Side of Hwy 42, about 0.25 miles North of Johanek Road
E-23	Greenfield Lane, about 4.5 Miles South of Site, 0.5 Miles East of Hwy 42
E-24	North Side of County Rt. V, near intersection of Saxonburg Road
E-25	South Side of County Rt. BB, about 0.5 miles West of Norman Road
E-26B	804 Tapawingo Road, about 0.4 miles East of Cty. B, North Side of Road
E-27	Intersection of Saxonburg and Nuclear Roads, Southwest Corner, about 4 Miles WSW
E-28	TLD site on western most pole between the 2 nd and 3 rd parking lots.
E-29	Area of North Meteorological Tower.
E-30	NE corner at Intersection of Tapawingo and Lakeshore Roads.
E-31	On utility pole North side of Tapawingo Road closest to the gate at the West property line.
E-32	On a tree located at the junction of property lines, as indicated by trees and shrubs, about 500 feet east of the west gate on Tapawingo Road and about 1200 feet south of Tapawingo Road. The location is almost under the power lines between the blue and gray transmission towers.
E-33	Lake Michigan shoreline accessed from the SE corner of KNPP parking lot. Sample South of creek.
E-38	Tree located at the West end of the area previously containing the Retention Pond.
E-39	Tree located at the East end of the area previously containing the Retention Pond.
E-40	Local Dairy Farm, W side of Hwy 42, about 1.8 miles north of the Nuclear Rd intersection
E-41	NW corner of Woodside and Nuclear Rds (Kewaunee County)
E-42	NW corner of Church and Division, East of Mishicot
E-43	West side of Tannery Rd south of Elmwood (7th utility pole south of Elmwood)
E-TC	Transportation Control; Reserved for TLDs

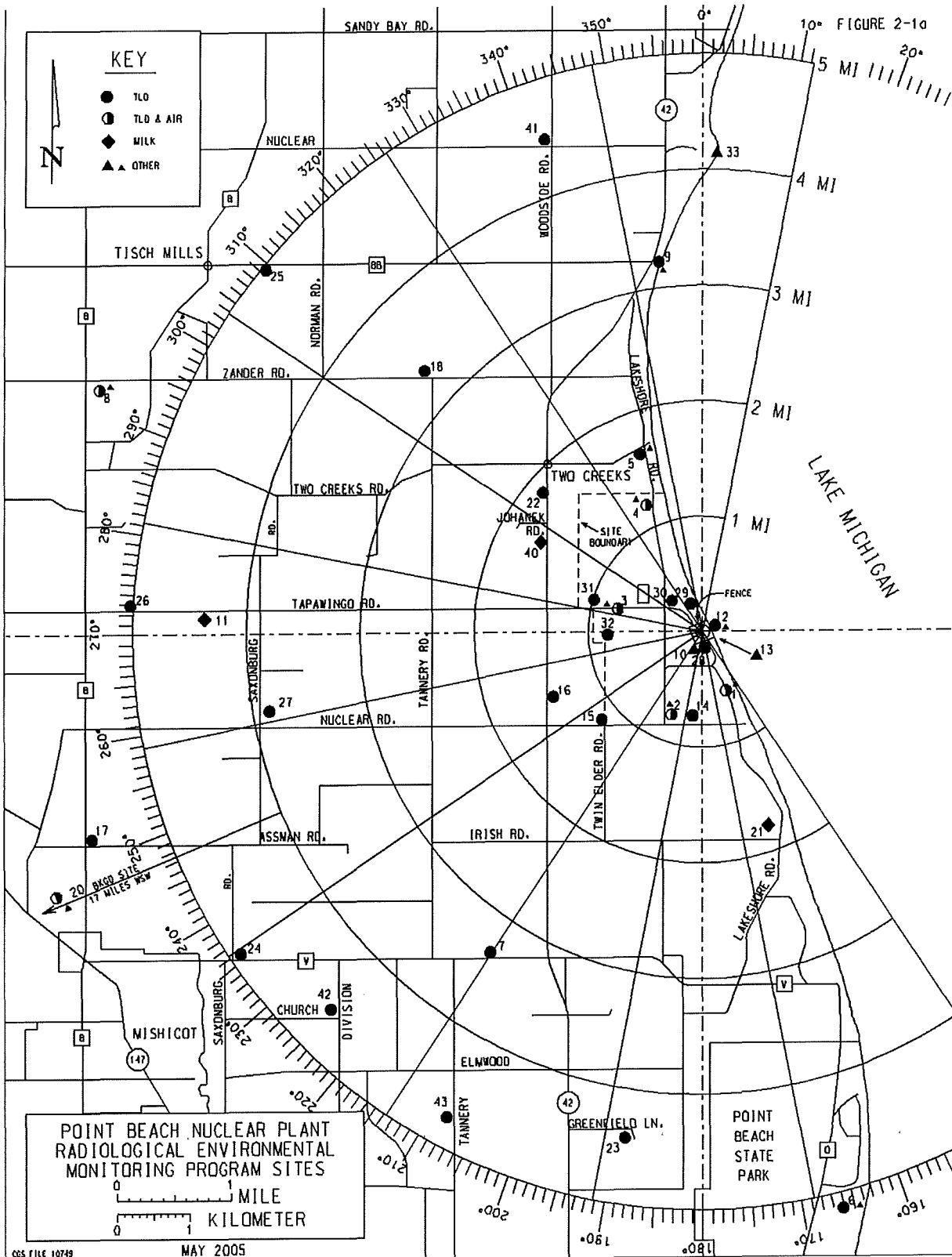

Figure 9-1
PBNP REMP Sampling Sites

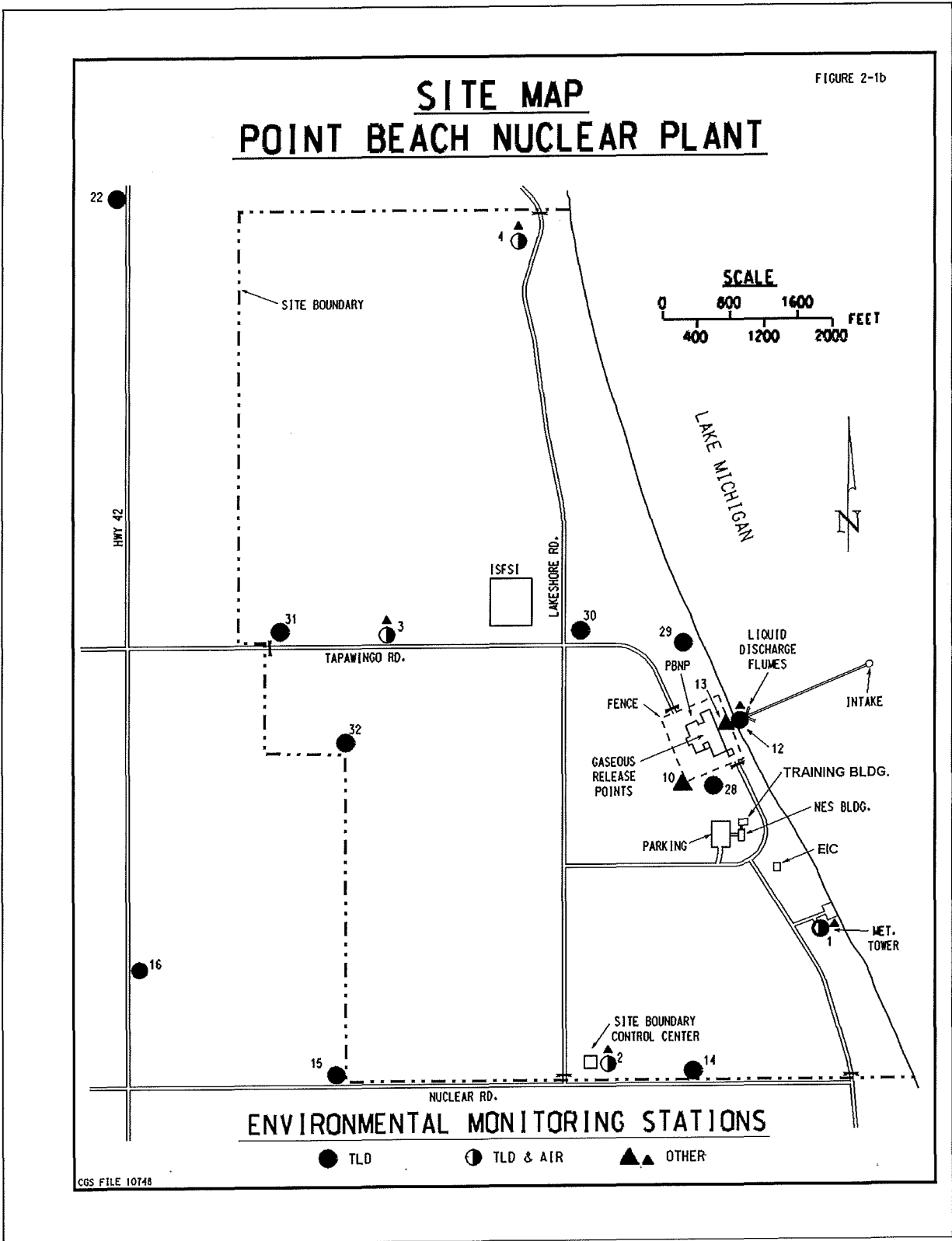

Figure 9-2
Map of REMP Sampling Sites Located Around PBNP

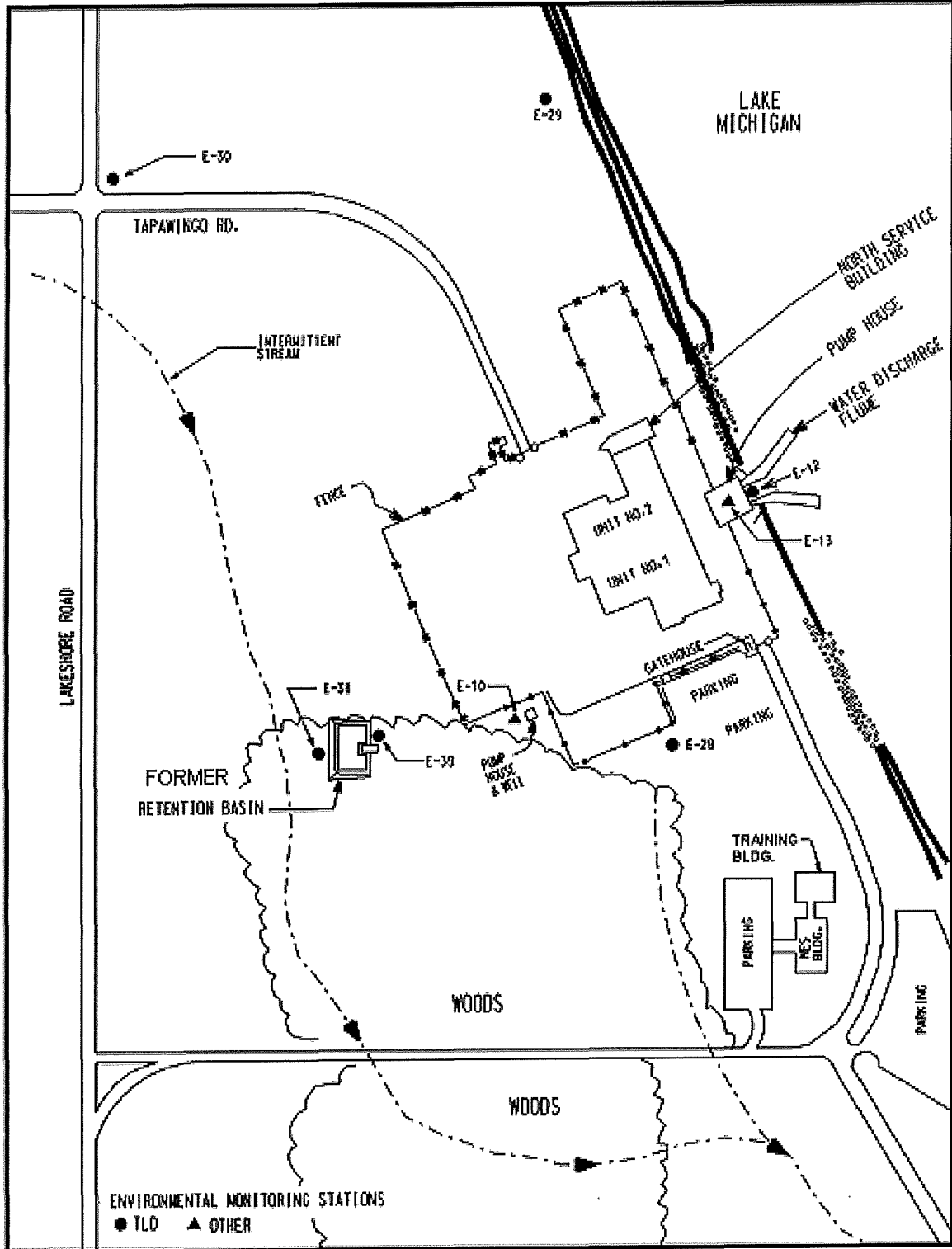

Figure 9-3
Enhanced Map Showing REMP Sampling Sites Closest to PBNP

**Table 9-3
ISFSI Sampling Sites**

Ambient Radiation Monitoring (TLD)	Soil, Vegetation and Airborne Monitoring
E-03	E-02
E-28	E-03
E-29	E-04
E-30	
E-31	
E-32	

**Table 9-4
Minimum Acceptable Sample Size**

Sample Type	Size
Vegetation	100-1000 grams
Lake Water	8 liters
Air Filters	250 m ³ (volume of air)
Well Water	8 liters
Milk	8 liters
Algae	100-1000 grams
Fish (edible portions)	1000 grams
Soil	500-1000 grams
Shoreline Sediment	500-1000 grams

**Table 9-5
Deviations from Scheduled Sampling and Frequency During 2017**

Sample Type	Location	Collection Date	Reason for not conducting REMP as required	Plans for Preventing Recurrence
LW	E-01	1/30/2017	Icy conditions at the shore	Natural occurrence
LW	E-05	1/30/2017	Icy conditions at the shore	Natural occurrence
LW	E-06	1/30/2017	Icy conditions at the shore	Natural occurrence
LW	E-33	1/30/2017	Icy conditions at the shore	Natural occurrence
AP/AI	E-02	2/1/2017	GFI failure	Unknown cause
AP/AI	E-02	2/22/2017	Loss of power	Unknown cause
AP/AI	E-02	3/1/2017	Loss of power	Circuit breaker tripped after 5 hrs
AP/AI	E-04	4/19/2017	Loss of power	Loss of power due to storm
Algae	E-05	6/30/2017	No algae found growing	Natural occurrence
Algae	E-12	6/30/2017	No algae found growing	Natural occurrence
Algae	E-05	8/2/2017	No algae found growing	Natural occurrence
LW	E-06	12/4/2017	Icy conditions at the shore	Natural occurrence
LW	E-33	12/4/2017	Icy conditions at the shore	Natural occurrence

**Table 9-6
Sample Collections for State of Wisconsin**

Sample Type	Location	Frequency
Lake Water	E-01	Monthly
Air Filters	E-07 E-08	Weekly
Fish	E-13	Quarterly, As Available
Precipitation	E-04 E-08	Twice a month, As Available
Milk	E-11 E-21	Monthly
Well Water	E-10	Twice per year

9.6 Analytical Parameters

The types of analyses and their frequencies are given in Table 9-1. The LLDs for the various analyses are found in Table 10-1 with the summary of the REMP results. All environmental LLDs listed in Table 12-2 of the ODCM (also in Table 10-1) were achieved during 2017.

9.7 Description of Analytical Parameters in Table 9-1

9.7.1 Gamma isotopic analysis

Gamma isotopic analysis consists of a computerized scan of the gamma ray spectrum from 80 keV to 2048 keV. Specifically included in the scan are Mn-54, Fe-59, Co-58, Co-60, Zr-95, Nb-95, Ru-103, Ru-106, I-131, Ba-La-140, Cs-134, Cs-137, Ce-141, and Ce-144. However, other detected nuclear power plant produced radionuclides also are noted. The above radionuclides detected by gamma isotopic analysis are decay corrected to the time of collection. Frequently detected, but not normally reported in the Annual Monitoring Report, are the naturally occurring radionuclides Ra-226, Bi-214, Pb-212, Tl-208, Ac-228, Be-7, and K-40.

9.7.2 Gross Beta Analysis

Gross beta analysis is a non-specific analysis that consists of measuring the total beta activity of the sample. No individual radionuclides are identifiable by this method. Gross beta analysis is a quick method of screening samples for the presence of elevated activity that may require additional, immediate analyses.

9.7.3 Water Samples

Water samples include both Lake Michigan and well water. The Lake Michigan samples are collected along the shoreline at two locations north and two locations south of PBNP. The well water is sampled from the on-site PBNP well. Gross beta measurements are made on the solids remaining after evaporation of the unfiltered sample to dryness. Gamma isotopic analyses are performed using 1-liter liquid samples. Strontium is determined by chemical separation and beta counting.

9.7.4 Air Samples

Particulate air filters are allowed to decay at least 72 hours before gross beta measurements are made in order for naturally occurring radionuclides to become a negligible part of the total activity. Gross beta measurements serve as a quick check for any unexpected activity that may require immediate investigation. Quarterly composites of the particulate air filters are analyzed for long-lived radionuclides such as Cs-134 and Cs-137. Charcoal cartridges for radioiodine are counted as soon as possible so the I-131 will undergo only minimal decay prior to analyses. The weekly charcoal cartridges are screened for I-131 by

counting them all at the same time to achieve a lower LLD. If a positive result is obtained, each cartridge is counted individually.

In order to ensure that the air sampling pumps are operating satisfactorily, a gross leak check is performed weekly. The pumps are changed out annually for calibration and maintenance beyond what can be accomplished in the field.

9.7.5 Vegetation

Vegetation samples consist predominantly of green, growing plant material (grasses and weeds most likely to be eaten by cattle if they were present at the sampling site). Care is taken not to include dirt associated with roots by cutting the vegetation off above the soil line.

No special vegetation samples were obtained for C-14 analyses in 2017.

9.7.6 Environmental Radiation Exposure

The 2017 environmental radiation exposure measurements were made using TLD cards. The TLD card is a small passive detector, which integrates radiation exposure. Each TLD consists of a Teflon sheet coated with a crystalline, phosphorus material (calcium sulfate containing dysprosium) which absorbs the gamma ray energy deposited in them. Each TLD is read in four distinct areas to yield four exposure values which are averaged. Prior to the third quarter of 2001, exposure data was obtained using three lithium fluoride (LiF) TLD chips sealed in black plastic. The difference in material types can impact the amount of exposure measured. An evaluation of the response difference between the two types of TLD in 2001 demonstrated that the TLD cards produced a 14% higher response than the LiF chips (2011 AMR, Table 9-7, p. 36).

The reported field exposure is the arithmetic average of the measured exposure values at each location minus the exposure transportation control TLD (exposure received while the field TLD is in storage and transit). The gamma rays may originate from PBNP produced radionuclides or from naturally occurring radionuclides. The TLDs remain at the monitoring site for roughly three months prior to analyses and the results are reported as mrem per seven days. Because the TLDs are constantly bombarded by naturally occurring gamma radiation, even during shipment to and from PBNP, the amount of exposure during transportation is measured using transportation controls with each shipment of TLDs to and from the laboratory. The doses recorded on the transportation controls are subtracted from the monitoring TLDs in order to obtain the net *in situ* dose.

9.7.7 ISFSI Ambient Radiation Exposure

The ISFSI fence TLDs are part of the 10CFR72.44 monitoring and are not considered part of the REMP. However, their results can be used indirectly to determine whether the operation of the ISFSI is having an impact on the ambient environmental radiation beyond the site boundary. Impacts are determined by comparison of fence TLD results to the results of the monitoring at PBNP site boundary and other selected locations. These results are used as part of the 40CFR190 compliance demonstration.

10.0 RESULTS

10.1 Summary of 2017 REMP Results

Radiological environmental monitoring conducted at PBNP from January 1, 2017, through December 31, 2017, consisted of analysis of air filters, milk, lake water, well water, soil, fish, shoreline sediments, algae, and vegetation as well as TLDs. The results are summarized, averages and high values, in Table 10-1 which contain the following information:

Sample:	Type of the sample medium
Description:	Type of measurement
N:	Number of samples analyzed
LLD:	<i>a priori</i> lower limit of detection
Average:	Average value \pm the standard deviation of N samples
High:	Highest measured value \pm its associated 2 sigma counting error
Units:	Units of measurement

For certain analyses, an LLD, which is lower than that required by REMP, is used because the lower value derives from the counting time required to obtain the LLDs for radionuclides that are more difficult to detect. For these analyses, both LLDs are listed with the tech spec required REMP LLD given in parentheses. The results are discussed in the narrative portion of this report (Section 11). Blank values have not been subtracted from the results presented in Table 10-1. A listing of all the individual results obtained from the contracted analytical laboratory and the laboratory's radioanalytical quality assurance results and Interlaboratory Crosscheck Program results are presented in the Appendix.

In Table 10-1 no results are reported as less than LLD (<LLD). All results are reported to Point Beach by the contracted radioanalytical laboratory "as measured" whether positive or negative (see Section 9-1). Based on these results, a radionuclide is considered detected if it meets the criterion that the measured value minus its 2σ counting error is greater than zero ($x-2\sigma > 0$). An "ND" entry in Table 10-1 means that for this radionuclide the criterion was not satisfied for any of the measurements. If one analysis fulfilled the criterion, then all of the reported results, both positive and negative, were used in calculating the average shown in Table 10-1.

The method of determining averages based on "as measured" results follows the recommendations made in NUREG-0475 (1978), "Radiological Environmental Monitoring by NRC Licensees for Routine Operations of Nuclear Facilities Task Force Report," and in Health Physics Society Committee Report HPSR-1 (1980) "Upgrading Environmental Radiation Data" released as document EPA 520/1-80-012 and in more recent documents such as ANSI N42.23-1996, "Instrument Quality Assurance for Radioassay Laboratories;" ANSI N13.30-1996, "Performance Criteria for Radiobioassay;" DE91-013607, "Environmental Regulatory Guide for Radiological Effluent Monitoring and Environmental Surveillance" and NUREG-1576, "Multi-Agency Radiological Laboratory Analytical Protocols Manual."

In addition to the required radionuclides for each medium analyzed, Table 10-1 also has an additional radionuclide listed known to originate with nuclear power plants. This radionuclide is either Co-60, Ru-103, or any other radionuclide which has the lowest LLD based on the analytical parameters needed to meet the LLDs required for radionuclides specified for the medium being analyzed. The radionuclide is identified by parentheses.

During the analyses for those radionuclides specifically required to be identified, naturally occurring radionuclides such as Ra-226, Be-7 and K-40 are detected in many samples. Their concentrations are presented in Table 10-1 for a comparison to those radionuclides for which specific analyses are required by the regulations. There are no regulatory required LLDs for naturally occurring radionuclides.

Finally, Point Beach reports the results for soil analyses. There is no regulatory requirement for soil analyses in standard RETS (NUREG-0472 and NUREG-1301). Point Beach includes soil analyses in the REMP to be able to compare current results to the historical record.

The crop sampling initiated in 2015 continued in 2017 and is incorporated into the REMP via HPIP 3.58.1. Approximately 60% of the 1260 acres (FSAR 2.1) comprising the NextERA Point Beach site is licensed to farmers who use the land to grow various crops. These crops consist of corn, hay, and soy beans and appear to be for cattle feed. Ten samples were obtained from the nine separate plots and gamma scanned for radionuclides representative of Point Beach effluents and for naturally occurring radionuclides. Results are reported in Table 10-2.

Table 10-3 contains the ISFSI fence TLD results.

**Table 10-1
Summary of Radiological Environmental Monitoring Results for 2017**

Sample	Description	N	LLD (a)	Average \pm 1 Std.		Units
				Deviation (b)	High \pm 2 sigma	
TLD	Environmental Radiation	124	1 mrem	1.11 \pm 0.17	1.48 \pm 0.06	mR/7days
	Control (E-20)	4	1 mrem	1.21 \pm 0.17	1.37 \pm 0.05	mR/7days
Air	Gross Beta	261	0.01	0.024 \pm 0.007	0.046 \pm 0.004	pCi/m3
	Control (E-20) Gross beta	53	0.01	0.025 \pm 0.007	0.042 \pm 0.004	pCi/m3
	I-131	261	0.030 (0.07)	ND	-	pCi/m3
	Control (E-20) I-131	53	0.030 (0.07)	ND	-	pCi/m3
	Cs-134	20	0.01(0.05)	ND	-	pCi/m3
	Control (E-20) Cs-134	4	0.01(0.05)	ND	-	pCi/m3
	Cs-137	20	0.01(0.06)	0.0001 \pm 0.0003	0.0007 \pm 0.0005	pCi/m3
	Control (E-20) Cs-137	4	0.01(0.06)	ND	-	pCi/m3
	Other γ emitters (Co-60)	20	0.1	0.0000 \pm 0.0004	0.0007 \pm 0.0006	pCi/m3
	Control (E-20) Other (Co-60)	4	0.1	0.0000 \pm 0.0005	0.0007 \pm 0.0006	pCi/m3
	Natural Be-7	20	-	0.074 \pm 0.014	0.100 \pm 0.016	pCi/m3
	Control (E-20) Natural Be-7	4	-	0.078 \pm 0.022	0.097 \pm 0.015	pCi/m3
Milk	Sr-89	36	5	ND	-	pCi/L
	Sr-90	36	1	0.5 \pm 0.2	1.1 \pm 0.3	pCi/L
	I-131	36	0.5	ND	-	pCi/L
	Cs-134	36	5 (15)	ND	-	pCi/L
	Cs-137	36	5 (18)	0.5 \pm 0.8	2.4 \pm 1.9	pCi/L
	Ba-La-140	36	5 (15)	ND	-	pCi/L
	Other gamma emitters(Co-60)	36	15	0 \pm 1.2	3.4 \pm 2.2	pCi/L
	Natural K-40	36	-	1401 \pm 73	1548 \pm 112	pCi/L
Well Water	Gross beta	4	4	1.6 \pm 0.8	2.6 \pm 0.8	pCi/L
	H-3	4	200 (3000)	ND	-	pCi/L
	Sr-89	4	5(10)	ND	-	pCi/L
	Sr-90	4	1 (2)	ND	-	pCi/L
	I-131	4	0.5 (2)	ND	-	pCi/L
	Mn-54	4	10 (15)	ND	-	pCi/L
	Fe-59	4	30	-0.1 \pm 1.9	2.5 \pm 2.0	pCi/L
	Co-58	4	10(15)	0.4 \pm 1.1	1.6 \pm 1.4	pCi/L
	Co-60	4	10(15)	ND	-	pCi/L
	Zn-65	4	30	0.6 \pm 2.1	3.5 \pm 3.0	pCi/L
	Zr-Nb-95	4	15	ND	-	pCi/L
	Cs-134	4	10(15)	ND	-	pCi/L
	Cs-137	4	10(18)	ND	-	pCi/L
	Ba-La-140	4	15	0.1 \pm 2.7	3.4 \pm 1.6	pCi/L
Other gamma emitters(Ru-103)	4	30	ND	-	pCi/L	
Algae	Gross beta	3	0.25	1.47 \pm 0.60	2.05 \pm 0.13	pCi/g
	Co-58	3	0.25	ND	-	pCi/g
	Co-60	3	0.25	0.005 \pm 0.006	0.003 \pm 0.002	pCi/g
	Cs-134	3	0.25	ND	-	pCi/g
	Cs-137	3	0.25	0.011 \pm 0.006	0.008 \pm 0.003	pCi/g
	Natural Be-7	3	-	0.59 \pm 0.78	1.49 \pm 0.11	pCi/g
	Natural K-40	3	-	2.40 \pm 2.11	4.83 \pm 0.11	pCi/g

Table 10-1 (continued)
Summary of Radiological Environmental Monitoring Results for 2017

Sample	Description	N	LLD (a)	Average \pm 1 Std. Deviation (b)	High \pm 2 sigma	Units
Lake Water	Gross beta	42	4	1.4 \pm 0.9	5.4 \pm 0.8	pCi/L
	I-131	42	0.5 (2)	ND	-	pCi/L
	Mn-54	42	10 (15)	0.0 \pm 0.8	1.3 \pm 1.2	pCi/L
	Fe-59	42	30	0.2 \pm 1.9	5.2 \pm 3.4	pCi/L
	Co-58	42	10(15)	-0.1 \pm 0.8	1.8 \pm 1.6	pCi/L
	Co-60	42	10(15)	0.2 \pm 0.8	2.5 \pm 1.6	pCi/L
	Zn-65	42	30	0.1 \pm 1.4	3.3 \pm 3.1	pCi/L
	Zr-Nb-95	42	15	0.1 \pm 1.3	4.4 \pm 1.9	pCi/L
	Cs-134	42	10 (15)	ND	-	pCi/L
	Cs-137	42	10 (18)	0.2 \pm 0.8	2.3 \pm 2.0	pCi/L
	Ba-La-140	42	15	-0.3 \pm 2.8	7.8 \pm 1.4	pCi/L
	Other gamma (Ru-103)	42	30	-0.6 \pm 1.1	2.9 \pm 1.8	pCi/L
	Sr-89	16	5(10)	ND	-	pCi/L
Sr-90	16	1 (2)	0.15 \pm 0.15	0.41 \pm 0.37	pCi/L	
H-3	16	200 (3000)	2254 \pm 8490	34083 \pm 543	pCi/L	
Fish	Gross beta	15	0.5	3.10 \pm 1.14	4.17 \pm 0.13	pCi/g
	Mn-54	15	0.13	0.002 \pm 0.006	0.013 \pm 0.011	pCi/g
	Fe-59	15	0.26	0.002 \pm 0.011	0.020 \pm 0.012	pCi/g
	Co-58	15	0.13	0.002 \pm 0.007	0.012 \pm 0.008	pCi/g
	Co-60	15	0.13	-0.001 \pm 0.008	0.016 \pm 0.012	pCi/g
	Zn-65	15	0.26	-0.010 \pm 0.021	0.024 \pm 0.022	pCi/g
	Cs-134	15	0.13	0.000 \pm 0.007	0.012 \pm 0.009	pCi/g
	Cs-137	15	0.15	0.013 \pm 0.008	0.031 \pm 0.018	pCi/g
	Other gamma (Ru-103)	15	0.5	-0.001 \pm 0.006	0.010 \pm 0.006	pCi/g
Natural K-40	15	-	2.46 \pm 0.88	3.45 \pm 0.42	pCi/g	
Shoreline Sediment	Gross beta	10	2	6.98 \pm 3.02	10.84 \pm 0.93	pCi/g
	Cs-134	10	0.18	ND	-	pCi/g
	Cs-137	10	0.15	0.014 \pm 0.009	0.028 \pm 0.016	pCi/g
	Natural Be-7	10	-	0.057 \pm 0.059	0.184 \pm 0.065	pCi/g
	Natural K-40	10	-	4.66 \pm 1.15	6.35 \pm 0.42	pCi/g
	Natural Ra-226	10	-	0.35 \pm 0.07	0.46 \pm 0.18	pCi/g
Soil	Gross beta	16	2	24.15 \pm 6.36	35.61 \pm 2.33	pCi/g
	Cs-134	16	0.15	ND	-	pCi/g
	Cs-137	16	0.15	0.15 \pm 0.13	0.58 \pm 0.04	pCi/g
	Natural Be-7	16	-	0.08 \pm 0.14	0.44 \pm 0.20	pCi/g
	Natural K-40	16	-	14.44 \pm 3.82	19.53 \pm 0.63	pCi/g
	Natural Ra-226	16	-	0.92 \pm 0.30	1.49 \pm 0.72	pCi/g
Vegetation	Gross beta	24	0.25	6.06 \pm 1.42	8.28 \pm 0.30	pCi/g
	I-131	24	0.06	0.000 \pm 0.008	0.017 \pm 0.009	pCi/g
	Cs-134	24	0.06	ND	-	pCi/g
	Cs-137	24	0.08	0.003 \pm 0.008	0.029 \pm 0.013	pCi/g
	Other gamma emitters (Co-60)	24	0.25	ND	-	pCi/g
	Natural Be-7	24	-	2.73 \pm 1.40	4.86 \pm 0.32	pCi/g
Natural K-40	24	-	5.48 \pm 1.37	7.79 \pm 0.54	pCi/g	

(a) When two LLD values are listed, the required LLD per the PBNP REMP is enclosed in the parentheses. Whenever possible, PBNP uses the lower value to obtain greater sensitivity.
(b) "ND" indicates that the sample result is Not Detectable, i.e., sample concentrations were statistically equal to zero or <MDA.

**Table 10-2
Feed Crops Grown on Point Beach Land**

	Number	Average		Max	
		pCi/g	1 σ	pCi/g	2 σ
Gross Beta	10	3.95	± 1.56	7.26	± 0.14
Be-7	10	0.35	± 0.47	1.31	± 0.18
K-40	10	3.42	± 1.77	6.53	± 0.45
Co-60	10	ND		-	
I-131	10	0.001	± 0.050	0.013	± 0.008
Cs-134	10	ND		-	
Cs-137	10	ND		-	

ND = Not detected

**Table 10-3
Average ISFSI Fence TLD Results for 2017**

Fence Location	Average	±	Standard Deviation	Units
North	2.21	±	0.38	mR/7 days
East	3.84	±	0.08	mR/7 days
South	1.30	±	0.08	mR/7 days
West	4.25	±	0.16	mR/7 days

11.0 DISCUSSION

11.1 TLD Cards

The ambient radiation was measured in the general area of the site boundary, at an outer ring four – five miles from the plant, at special interest areas, and at one control location, roughly 17 miles southwest of the plant. The average indicator TLD is 1.11 ± 0.17 mR/7-days compared to 1.21 ± 0.17 mR/7-days at the background location. These two values are not significantly different from each other. Neither are the indicator TLD values significantly different from those observed from 2001 through 2017 for the same type of TLD (tabulated below in Table 11-1). Prior to third quarter of 2001 TLD LiF chips were used versus the current TLD cards, see Section 9.7.6 for additional information. The response difference between the two types of TLDs is evident in Table 11-1. Prior to 2001 all of the annual averages are <1 mrem/7-days. Beginning in 2001, all are >1 mrem/7-days.

Table 11-1
Average Indicator TLD Results from 1993 – 2017

Year	mR/7-days	±	St. Dev*
1993	0.82	±	0.15
1994	0.90	±	0.12
1995	0.87	±	0.13
1996	0.85	±	0.12
1997	0.87	±	0.11
1998	0.79	±	0.13
1999	0.79	±	0.21
2000	0.91	±	0.15
2001	1.06	±	0.19
2002	1.17	±	0.21
2003	1.10	±	0.20
2004	1.10	±	0.22
2005	1.04	±	0.21
2006	1.14	±	0.21
2007	1.08	±	0.20
2008	1.05	±	0.17
2009	1.08	±	0.17
2010	1.11	±	0.15
2011	1.14	±	0.25
2012	1.17	±	0.17
2013	1.14	±	0.20
2014	1.07	±	0.19
2015	1.18	±	0.20
2016	1.19	±	0.21
2017	1.11	±	0.17

*St. Dev = Standard Deviation

No new loaded casks were added to the ISFSI in 2017. Five new empty casks were staged on the pad for the 2018 campaign. The west fence TLDs continue to record higher exposures followed by the east, north, and south fence locations (Table 1-2). This sequence has been observed for the last five years.

There is no significant change in the exposure on the TLD monitoring locations around the ISFSI (Table 11-3). The results at E-03 and E-31 (W of the ISFSI) and E-32 (SW of the ISFSI) are similar to previous years (1.36, 1.21, and 1.44 respectively) and continue to be higher than E-30 (1.01) on the east side and closest to the ISFSI. E-03, about equidistant between the ISFSI and the site boundary location E-31, continues to be slightly higher than the site boundary location but the difference is not statistically different. (See Figs. 9-1 and 9-2 for locations).

**Table 11-2
Average ISFSI Fence TLD Results (mR/7 days)**

TLD FENCE LOCATION				
	North	East	South	West
1995	1.29	1.28	1.10	1.26
1996	2.12	1.39	1.10	1.68
1997	2.05	1.28	1.00	1.66
1998	2.08	1.37	1.02	1.86
1999	2.57	1.84	1.11	3.26
2000	2.72	2.28	1.25	5.05
2001	2.78	2.54	1.36	6.08
2002	2.79	2.74	1.42	6.46
2003	2.70	2.60	1.50	6.88
2004	2.61	2.12	1.41	6.50
2005	2.54	2.05	1.44	5.63
2006	2.73	2.35	1.38	5.80
2007	2.72	2.73	1.34	5.47
2008	2.64	2.37	1.36	5.36
2009	2.36	2.35	1.20	4.63
2010	2.64	3.02	1.41	5.05
2011	2.44	2.62	1.31	4.75
2012	2.59	3.27	1.40	4.92
2013	2.62	3.66	1.15	4.28
2014	2.45	3.35	1.14	4.24
2015	2.31	3.24	1.17	4.36
2016	2.30	3.34	1.33	4.35
2017	2.21	3.84	1.30	4.25

Although the mR/7-day results for the three TLD locations nearest the site boundary (E-03 1.36 ± 0.14 ; E-31, 1.21 ± 0.19 ; E-32, 1.44 ± 0.07) are higher than at the background site E-20 (1.21 ± 0.34), they are comparable at the 95% confidence level, indicating a small, but not significant, increase in ambient gamma radiation at the site boundary due to the operation of the ISFSI.

Further data supporting this conclusion is the comparison of the TLD results at selected locations around the ISFSI before and after the storage of spent fuel at the ISFSI (Figure 11-1). As stated in Section 9.7.6, the TLD values increased by about 14% in the second half of 2001 when the TLD monitoring devices were changed from LiF chips in the first half of the 2001 to calcium sulfate impregnated TLD cards. After that initial change, the measured radiation exposure, as measured by the TLD cards, has remained fairly constant with a slight increase with the addition of stored fuel at the ISFSI. Each year the variations in the TLD results appear to move in concert with each other and with the background site, E-20, which is 17 miles south west of the ISFSI.

Comparing the ISFSI TLD results to results from surrounding REMP indicator and background TLDs reveals minimal impact of the ISFSI on the surrounding radiation levels (Figure 11-2). As previously discussed, the small increase is more related to the switch from the LiF chips to the calcium sulfate impregnated Teflon TLD cards as evidenced by the synchronicity with E-20, the background site.

LiF TLD chips were replaced with calcium sulfate impregnated Teflon TLD cards in the third quarter of 2001 resulting in a higher measured background values.

Figure 11-1 ISFSI AREA TLD RESULTS

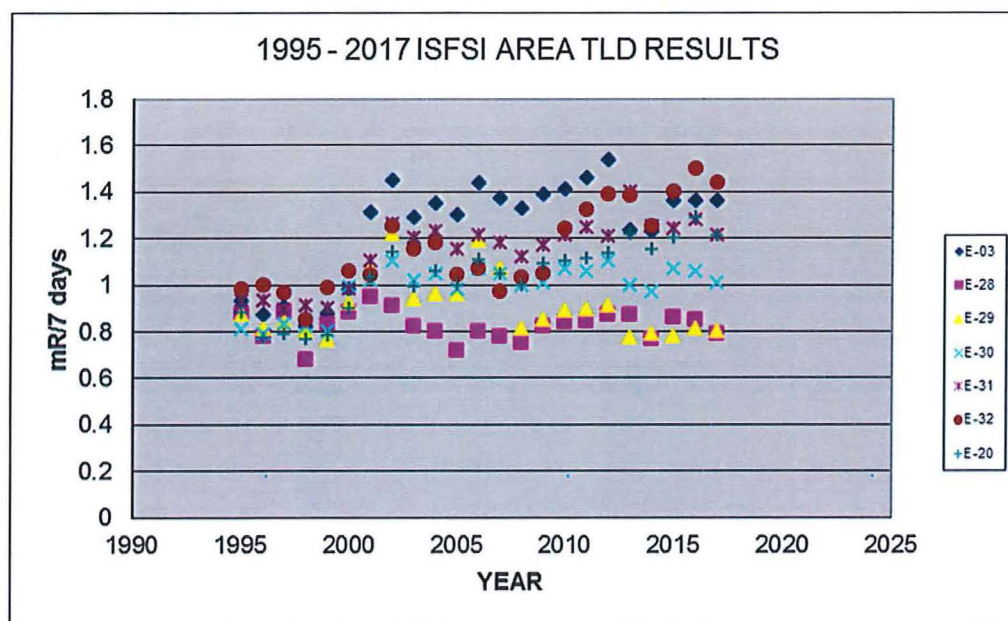
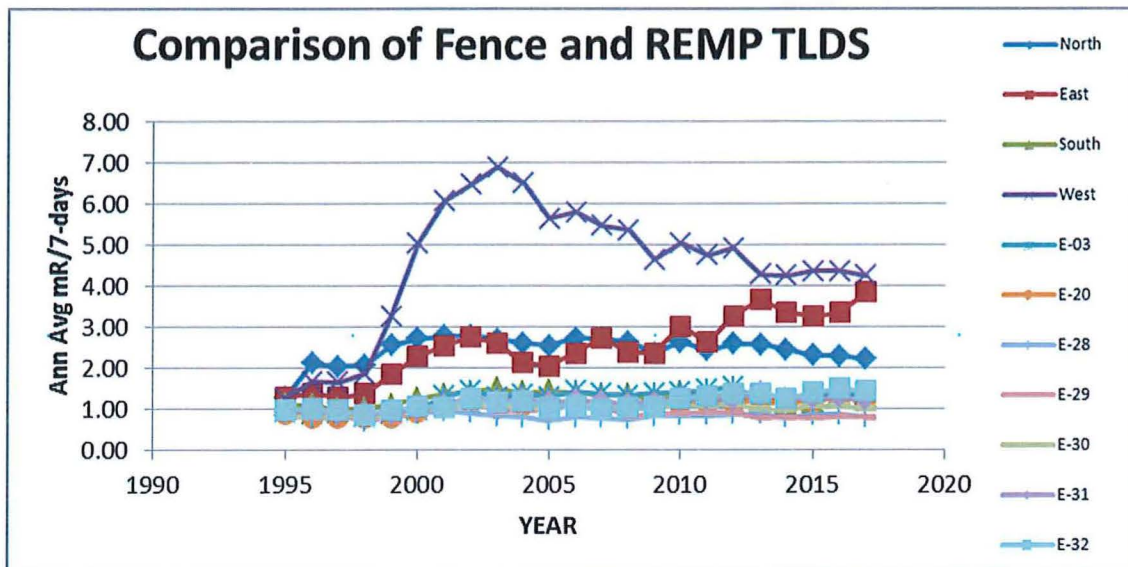

**Table 11-3
Average TLD Results Surrounding the ISFSI (mR/7 days)**

	Sampling Site						
	E-03	E-28	E-29	E-30	E-31**	E-32**	E-20***
Pre-Operation*	0.93	0.87	0.87	0.81	0.93	0.98	0.88
1996	0.87	0.78	0.81	0.79	0.93	1.00	0.78
1997	0.91	0.89	0.84	0.84	0.89	0.97	0.79
1998	0.82	0.68	0.80	0.82	0.91	0.85	0.77
1999	0.88	0.83	0.76	0.80	0.90	0.99	0.78
2000	0.98	0.88	0.92	0.99	0.98	1.06	0.90
2001	1.31	0.95	1.07	1.02	1.10	1.04	1.03
2002	1.45	0.91	1.22	1.10	1.26	1.25	1.14
2003	1.29	0.82	0.94	1.02	1.20	1.15	0.99
2004	1.35	0.80	0.96	1.05	1.23	1.18	1.06
2005	1.30	0.72	0.96	0.98	1.15	1.04	1.00
2006	1.44	0.80	1.19	1.07	1.21	1.07	1.11
2007	1.37	0.78	1.07	1.05	1.18	0.97	1.05
2008	1.33	0.75	0.81	1.00	1.12	1.03	1.00
2009	1.39	0.82	0.85	1.01	1.17	1.05	1.09
2010	1.41	0.84	0.89	1.07	1.21	1.24	1.10
2011	1.46	0.85	0.90	1.06	1.25	1.32	1.12
2012	1.54	0.87	0.91	1.10	1.21	1.39	1.14
2013	1.23	0.87	0.77	1.00	1.40	1.38	1.22
2014	1.23	0.77	0.79	0.97	1.25	1.25	1.15
2015	1.36	0.86	0.78	1.07	1.24	1.40	1.20
2016	1.35	0.85	0.81	1.06	1.28	1.50	1.25
2017	1.36	0.79	0.80	1.01	1.21	1.44	1.21

*Pre-Operational data are the averages of the years 1992 through 3rd quarter of 1995.
 **Sites E-31 and E-32 are located at the Site Boundary to the West and South-West of the ISFSI.
 ***E-20 is located approximately 17 miles WSW of the ISFSI.

Figure 11-2 Comparison of ISFSI Fence TLDs to Selected REMP TLDs



11.2 Milk

Naturally occurring potassium-40 (1401 ± 73 pCi/l) continues to be the most prevalent radionuclide measured in milk at concentrations roughly 1300 times higher than the only potential plant related radionuclide, Sr-90 (1.1 ± 0.3 pCi/l), detected in milk. The annual average Sr-90 concentrations in milk continue to be similar to previous years. No positive results for Ba-La-140, I-131, Cs-134, or Sr-89 were obtained in 2017.

Some low positive Cs-137 (4 of 36) results were obtained. In the last two years, Cs-137 was discharged from PBNP only in March 2016 and October 2017. All the Cs-137 values also are <MDC limit and therefore may be false positive. Another possibility is residual Cs-137 recycling through the environment from the 1960's atmospheric weapons tests and events such as Chernobyl and Fukushima. No Cs-134 was discharged and no positive Cs-134 results were obtained.

Several (3 of 36) positive Co-60 values were obtained from site E-11 west of the plant. Only one was greater than the MDC, 2.6 vs 2.4 pCi/L. Also, the highest value occurred in February when the cattle would not be on pasture. It is concluded that these Co-60 results are false positives.

Approximately 3.4 μ Ci of airborne I-131 were discharged in the spring during and shortly after the U2 refueling outage. No I-131 was detected in any of the milk samples.

The 2017 average Sr-90 concentrations have not changed much over the last few years (Figure 11-3). Over the past twenty years, the average has decreased from 1.2 ± 0.5 pCi/L in 1997 to 0.5 ± 0.2 pCi/L in 2017. The graph of the annual averages displays a logarithmic decrease over time.

The annual averages are from the monthly Sr-90 measurements from three different dairies (Figure 9-1). The only dairy that has been in the monitoring program over the entire 1997 – 2017 timespan under consideration is located at site E-21. It is located south of the plant. The other two, E-40 and E-11, are replacements for dairies which had dropped out of the program at various times during this time interval. The replacements were chosen to maintain, to the extent possible, the former sampling sites west and north of Point Beach.

The decrease by about one-half from 1997 to 2017 indicates a Sr-90 removal half-life of about 20 years which is lower than its radiological half-life of 28.6 years. However, given the standard deviation of the annual averages, the actual decrease probably is not much different from the radiological half-life.

Point Beach discharged no airborne Sr-90 in 2017. Since 1997, PBNP has discharged airborne Sr-90 only in 3 years: 1999, $2.4E-08$ Ci; 2004, $3.2E-08$ Ci; and 2011, $1.6 E-08$ Ci. It is interesting to note that nine of highest Sr-90 results occur at E-11 located about 4.4 miles west of PBNP (Fig. 9-1). If the observed Sr-90 activity were from Point Beach the highest Sr-90 concentrations would occur at E-21, the dairy south of the site boundary in the highest X/Q and D/Q meteorological sector. This dairy grows feed corn on site and in a field across the road from the site

boundary in the highest D/Q sectors. Feed crops are the dominant source of food for dairy cattle. No cattle have been seen grazing for many years.

The major Sr-90 input to the environment is from fallout from atmospheric weapons testing during the early 1960s with minor inputs during the 50's, 70's and later contributions from the Chernobyl accident in the late 1980s and from Fukushima in 2011. The Sr-90 in milk persists due to its 28.6 year half-life and to cycling in the biosphere. With little or no atmospheric input to the environment, the mode of entry into cattle feed must be root uptake by forage crops and transfer into the milk. Over the time period of this graph (1997 – 2017), these low discharges do not appear to impact the decreasing concentrations as they continue to decrease over time.

It is concluded that the milk data for 2017 show no radiological effects of the plant operation.

Figure 11-3
Sr-90 Concentration in Milk (1997 – 2017)

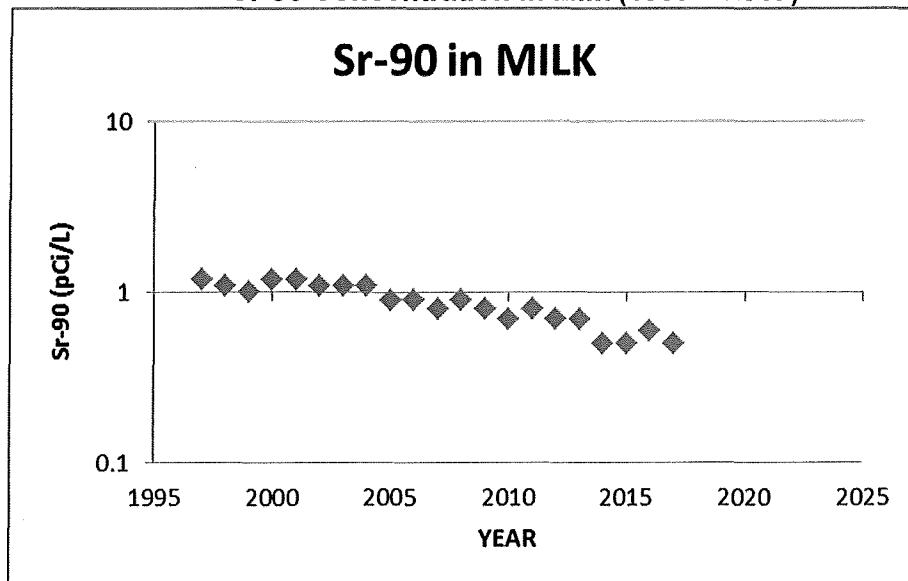

11.3 Air

The average annual gross beta concentrations (plus/minus the 2σ uncertainty) in weekly airborne particulates at the indicator and control locations were 0.024 ± 0.015 pCi/m³ and 0.025 ± 0.015 pCi/m³, respectively, and are similar to levels observed from 1993 through 2017 (Figure 11-4).

The 2017 weekly gross beta concentrations reveal higher winter values and lower summer values (Figure 11-5). This is a repeat of the patterns seen in 2006 - 2016. As in 2016, the slight August – September peak is not as well defined as it was in 2015 (Figure 11-6). The August-September peak is observed throughout the US and believed to result from weather patterns impacting with naturally occurring airborne radionuclides. This would explain why the control and indicators are moving in concert. Therefore, a plant effect can be ruled out.

Figure 11-4 Annual Average Air Gross β (1993 – 2017)

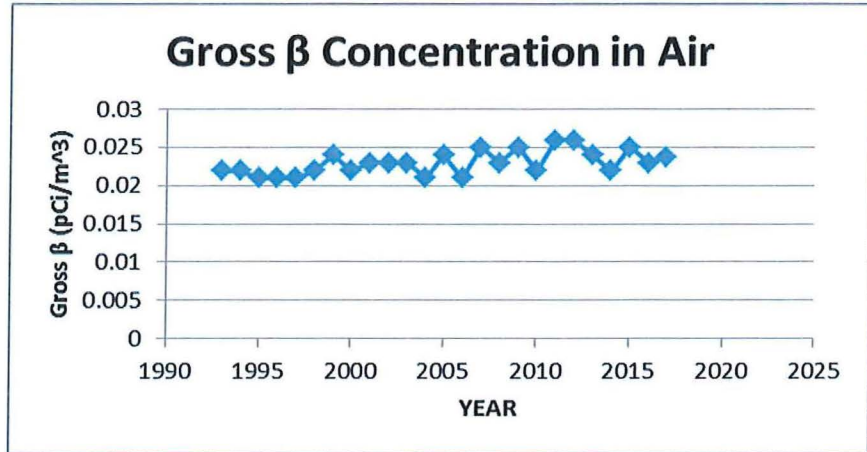

Figure 11-5 2017 Airborne Gross Beta

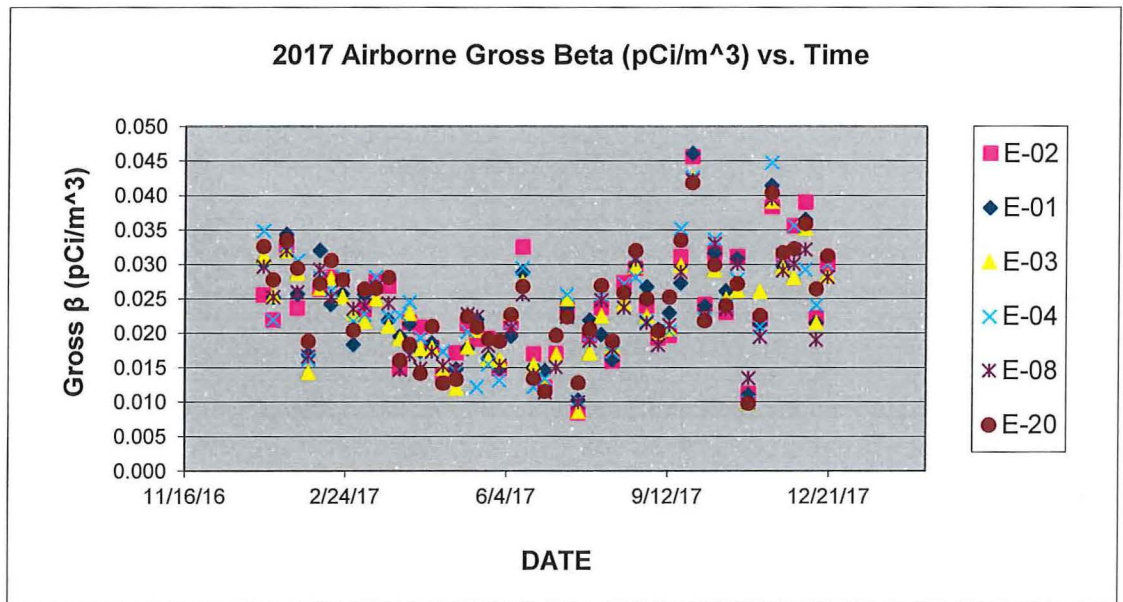
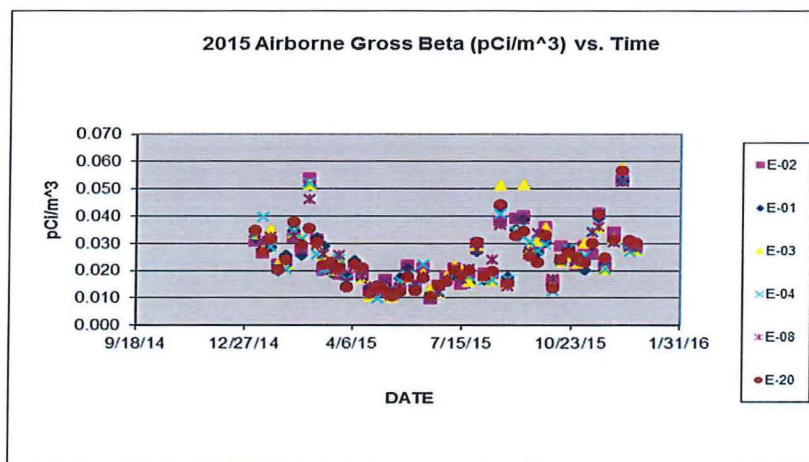

Figure 11-6 2015 Airborne Gross Beta



No I-131 was detected during 2017. In 2005, the new method of evaluating airborne I-131 was instituted. Instead of counting each charcoal cartridge separately, all six cartridges for the week are counted as one sample in a predetermined geometry to screen the samples for I-131. If any airborne radioiodine is detected, each sample cartridge is counted individually. With no detectable I-131, the reported analytical result is the minimum detectable activity (MDA) conservatively calculated using the smallest of the six sample volumes. The reported MDAs ranged from 0.005 to 0.016 pCi/m³. Because the analysis LLD is based on counting only one cartridge, the use of six cartridges or roughly six times the sample volume with the same count time as would be needed to achieve the desired LLD for only one sample, the actual LLD is about six times lower than the programmatic value given in Table 10-1. Similarly, the actual MDA is about one-sixth of that reported, in the range of 0.001 to 0.003 pCi/m³.

At each sampling location, the particulate filters are composited quarterly and analyzed for Cs-134, Cs-137 and any other (Co-60) detectable gamma emitters. As summarized in Table 10-1, several gamma emitters were detected but all were <MDC. By contrast, naturally occurring Beryllium-7 was found in all of the quarterly composites at concentrations ranging from 5.6E-02 to 1.0E-01 pCi/m³. Be-7 (T_{1/2} = 53.3 days) is produced in the atmosphere by the interaction of cosmic rays with oxygen and nitrogen nuclei. Its half-life is long enough to allow for it to be detected in the quarterly composited filters.

In summary, the 2017 air gamma data from quarterly composites do not indicate an environmental impact from the operation of PBNP.

11.4 Lake Water

Lake water results are summarized in Table 10-1. The gross beta results for June were higher than expected, 5.4±0.8 pCi/L. A recount resulted with a similar result, 5.5±0.9 pCi/L. After thorough mixing, a 200 ml aliquot was filtered through a 0.8 micron filter. The gross beta analyses showed 19.2±1.8 pCi/L for the suspended solids and 7.3±1.0 pCi/L for the dissolved solids. The filter was gamma scanned

revealing high amounts of K-40 (470 ± 47 pCi/L) and Ra-226 (153 ± 40 pCi/L). No plant radionuclides were identified on the filter. It is concluded that the observed high gross beta result was not due to plant discharges.

For the REMP-specified gamma emitting radionuclides listed in Table 10-1, the reported concentrations continue to occur as small, negative and positive values scattered around zero, indicating no radiological impact from the operation of PBNP. Only 29 of the results were positive, of which, about half (15) are from north of the plant, sites E-33 and E-05 (see Figure 9-1).

Only two of the 29 slightly positive results are >MDC. Both occurrences are within the site boundary at site E-01, about 2800 feet from the Unit 1 discharge. Both are concluded to be false positives for the following reasons. During 2017 PBNP discharged Co-58 and Co-60 in about the same amounts. Only the Co-60 showed up as >MDC. If the Co-60 result were real, Co-58 also should have been detected. The other positive result >MDC was for Ba-La-140. However, no Ba-140 or La-140 was discharged during in 2017. A review of discharges going back to 2012 also found no Ba-la-140 being discharged. Given the short Ba-La-140 half-life of 12.8 days, it is unlikely that the value is a valid positive result. Therefore, based on these comparisons, it is concluded that the positive results are false positives and not indications of PBNP effluents in Lake Michigan during 2017.

A false positive is concluding an isotope is present when it isn't. False positives occur most often at the detection limit when the random fluctuations of the background result in lower than normal background activity. The result is a higher net count and hence falsely concluding an isotope is present when it isn't because the value is statistically above zero.

In conclusion, based on the results of the gamma scans of Lake Michigan water, there is no measureable impact on the lake from PBNP discharges.

Aliquots of the monthly samples are composited quarterly and analyzed for Sr-89/90 and for tritium. Small amounts of Sr-90 were detected in three of the sixteen quarterly composites, two north and one south of the plant. All the results were below their statistically calculated minimum detectable concentrations (MDCs). No Sr-90 was discharged in 2017 or in 2012 – 2015. A small amount was discharged in March of 2016. Sr-90 has a 28.6 year half-life and, like Cs-137, is a remnant of atmospheric weapons testing in the '50s and '60s. Therefore, positive Sr-90 concentrations could be indicative of fallout being recycled in Lake Michigan. However, because the concentrations are below their MDCs, they most likely are false positives and there for unlikely to be the result of past PBNP discharges.

Tritium, in addition to being produced by water-cooled reactors such as PBNP, also is a naturally occurring radionuclide. It also was produced by atmospheric weapons testing. However, due to its mobility, any H-3 now found in Lake Michigan at the concentrations typically found in monitoring programs cannot be from that time period. It is the result of power plant discharges. Point Beach discharges on the order of 700 - 800 Ci of tritium per year.

Sixteen quarterly lake water composites were generated from the monthly samples. Of the six quarterly composites with positive H-3 indications, four were greater than

the MDC. Two of these occurred in the samples obtained at the site of the shut-down Kewaunee nuclear plant. Analysis of the individual monthly samples indicated that PBNP sampled shortly after a Kewaunee discharge in the months of June, August, and September.

The second quarter results were slightly elevated. The H-3 concentration was 661 ± 114 at E-33 (the Kewaunee site 5 miles north of PBNP), 276 ± 89 at E-05 (Two Creeks boat ramp 3 miles north of PBNP), 119 ± 82 at E-01 (PBNP met tower ~0.7 miles south of the plant), and 422 ± 96 at E-06 (Rawley Point light house six miles south of PBNP). Based on these results, the individual June samples were analyzed for H-3. The June sample from E-33 was 1402 ± 135 pCi/l. E-05 H-3 concentration was 625 ± 103 pCi/L. The on-site location, E-01, was 104 ± 85 pCi/l of H-3. E-06 was 651 ± 104 pCi/L.

Although Kewaunee is retired from service, it still makes discharges. Kewaunee made three H-3 discharges on June 7-13th. Point Beach had three H-3 discharges June 6 – 13th at concentrations of $2.2\text{E}+03$ pCi/L – $9.2\text{E}+04$ pCi/L. Point Beach sampled on June 14th. Based on higher discharge concentrations and the location of the higher lake water H-3 concentrations, it is concluded that the higher concentrations north of PBNP are not the result of PBNP effluent. The H-3 concentrations at E-06 may indicate an impact from both Kewaunee and Point Beach.

The third quarter composite from location E-33 at the Kewaunee site had the highest H-3, 34083 ± 543 pCi/L. The other location composites had H-3 concentrations ranging from 41 ± 74 to 71 ± 76 pCi/l, all below the MDC of 150 pCi/L. As with the analysis of the second quarter results, the individual months were analyzed for each location with emphasis on the samples from E-33. No H-3 was detected in the E-33 July sample. However, the August sample had H-3 at 4680 ± 211 pCi/L and the September H-3 concentration was $100,062 \pm 848$ pCi/L. For those two months it was determined that Point Beach had sampled on the day of or two days after Kewaunee had discharged H-3. None of the other three sites had detectable H-3 for the month of September. A review of the Point Beach discharges reveals that they were made 2- 4 days prior to the June, August, and September sampling dates. Based on these results, it is unlikely that PBNP discharges had an impact on the observed elevated H-3 concentrations.

11.5 Algae

Filamentous algae attached to rocks along the Lake Michigan shoreline are known to concentrate radionuclides from the water. Samples are obtained at Two Creeks Park and at the PBNP discharge (locations 5 and 12 in Figure 9-1). In order to allow the algae time to grow, typically no samples are collected until June and then again in August and October. This is done to ensure that there is enough new growth to provide a sample.

In 2017 no algae samples were available in June. In August algae were available only on site. In October, algae were available at both locations.

Algae sampling is not called for in either NUREG-0472 or 1301 the standard RETS documents. However, PBNP has continued to collect algae as a good practice to provide continuity between the current REMP and the pre-operational REMP.

The only PBNP related radionuclide with positive results above the MDC is Cs-137. PBNP released μCi amounts of Cs-137 from February to June of 2017. Therefore, the 0.008 ± 0.003 pCi/g of Cs-137 could be the results of PBNP discharges. The other possibility is the recycling of weapons testing fallout in Lake Michigan. In either case, the results indicate a minimal environmental impact from PBNP.

11.6 Fish

Fifteen fish were analyzed in 2017 with eleven exhibiting detectable amounts of plant related activity. Of these, eight were positive for Cs-137 with 3 Cs-137 results $>\text{MDC}$. No other radionuclide has a positive result $>\text{MDC}$. The positive Cs-137 concentrations ranged from 0.011 ± 0.008 to 0.031 ± 0.018 pCi/g. In 2017 PBNP released μCi amounts of Cs-137 from February – June. This may be a source of the Cs-137 in the fish. The other Cs-137 source is the recycling of Cs-137 that entered Lake Michigan as fallout from atmospheric weapons testing in the '50s and '60s with lesser amounts from events at Chernobyl and Fukushima.

Positive results below their MDCs were found also for Mn-54, Fe-59, Co-58, Co-60, Zn-65, Ru-103 and Cs-134. It is concluded that these results are false positives.

The highest radionuclide concentration in fish is naturally occurring K-40 with an average concentration of 2.46 ± 0.88 pCi/g.

Based on these results, it is concluded that there is little impact of PBNP discharges on Lake Michigan fish.

11.7 Well Water

Small, positive values of Fe-59, Co-58, Zn-65, and Ba-La-140 were detected in the main plant well water (E-10) during 2017. All values were below their minimum detectable concentrations of 5.5, 2.4, 5.7, and 7.8 pCi/L. It is concluded that these slightly positive values are false positives. Therefore, there is no evidence of PBNP effluents getting into the aquifer supplying drinking water to PBNP.

11.8 Soil

Cs-137 is present in the soils throughout North America and the world resulting from the atmospheric nuclear weapons testing in the 1950s, 1960s, and 1970s and from the 1986 Chernobyl accident, and more recently, from the Fukushima event. Soil is an integrating sample media, in that it is a better indicator of long term buildup of Cs-137 as opposed to current deposition for local sources. In addition to erosion and radioactive decay, human activities can modify the soil Cs-137 concentrations.

In 2017, Cs-137 was detected in all 16 soil samples. The concentrations ranged from 0.040 ± 0.016 to 0.58 ± 0.04 and all were $>\text{MDC}$. As in previous years, the highest value was found at E-06, Point Beach State Park which lies in the highest x/Q meteorological sector some 6 miles south of PBNP. During 2017 the only

airborne Cs-137 release occurred in October, for a total of 0.237 μCi at a concentration of $1.96\text{E-}08$ pCi/cc. The dilution at the site boundary would reduce this by approximately $1\text{E-}06$ for a concentration of $1.96\text{E-}14$ pCi/cc at the south boundary with the highest χ/Q . Further dilution would occur by the time this Cs-137 would have reached the highest concentration location, Point Beach State Park, some 6 miles further south.

Therefore, it seems unlikely that the observed soil Cs-137 is attributable to PBNP effluent. The most likely source is recycling of fallout from atmospheric weapons testing in the 50s and 60 as well as the Chernobyl and Fukushima events and subsequently being bound to the soil.

The remaining soil Cs-137 results range from 0.04 ± 0.02 to 0.19 ± 0.03 pCi/g. Based on the rather uniform distribution of Cs-137 in soils at various locations, no plant based effect is indicated.

By comparison to naturally occurring radionuclides, Cs-137 continues to be present in soil samples at well below the levels of naturally occurring Be-7, K-40, and Ra-226 (see Table 10-1).

11.9 Shoreline Sediment

Shoreline sediment consists of sand and other sediments washed up on the Lake Michigan shore. As in soil samples, the only non-naturally occurring radionuclide found in these samples is Cs-137. Seven of the ten samples have Cs-137 concentrations statistically different from zero with five results being >MDC. The one positive Cs-134 is below its MDC. Since no Cs-134 was released in 2017, this result is a false positive.

Shoreline sediment Cs-137 concentrations continue to be about one-tenth of that found in soils (Table 10-1). This is expected because Cs-137 in the geological media is bound to fine particles, such as clay, as opposed to the sand found on the beach. Lake Michigan sediments are a known reservoir of fallout Cs-137. Wave action suspends lake sediments depositing them on the beach. The fine particles deposited on the beach eventually are winnowed from the beach leaving the heavier sand; hence the lower Cs-137 concentrations in beach samples. In contrast to Cs-137, K-40, which is actually part of the minerals making up the clay and sand, is at a concentration about several hundred times higher than the Cs-137 that is attached to particle surfaces. Therefore, it is not surprising that Cs-137 is present at concentrations 1% or less of the naturally occurring concentrations of K-40.

The most likely source of the observed Cs-137 is the cycling of fallout from atmospheric weapons tests and event such as Chernobyl and Fukushima in the Lake Michigan environment and not current PBNP discharges. As with soil, the naturally occurring radionuclides such as K-40 and Ra-226 are found in the shoreline sediment samples. Therefore, the shoreline sediment data indicate no radiological effects from current plant operation.

11.10 Vegetation and Crops

The REMP collects two general types of vegetation within the site. The first consists of general vegetation, non-cultivated plants which would be consumed by grazing cattle. The second consists of crops grown on site acreage licensed to farmers, about half the site's 1400 acres, for growing feed crops for cattle. Ten samples of cultivated crops (corn, hay, alfalfa, and soybeans) grown on this acreage were obtained for analyses.

The naturally occurring radionuclides Be-7 and K-40 were found in all of the general vegetation and crop samples (Tables 10-1 and 10-2). The source of Be-7 is atmospheric deposition. It is continuously formed in the atmosphere by cosmic ray spallation of oxygen, carbon, and nitrogen atoms. (Spallation is a process whereby a cosmic ray breaks up the target atom's nucleus producing a radionuclide of lower mass.) Be-7 was lower in the crop samples with an average of 0.35 ± 0.47 pCi/g, with only one result being greater than 1 pCi/g. In general vegetation Be-7 concentrations were higher and ranged from 0.39 ± 0.11 to 4.86 ± 0.32 pCi/g or about a factor of 12 difference with the average concentrations increasing from May (1.28 ± 0.89 pCi/g) to October (3.67 ± 0.94). In contrast, K-40 is a primordial radionuclide which is incorporated into vegetation from the soil during the growing process. By not being dependent upon seasonal atmospheric variations and plant surface to capture deposition, the K-40 concentrations from root uptake are more uniform with a range of 3.01 ± 0.24 to 7.79 ± 0.54 , or about a factor of 2.5 difference. In crops, as in general vegetation, the K-40 is higher than Be-7.

Cs-137 can be present in vegetation via both pathways. Fresh Cs-137 fallout is associated, like Be-7, with deposition on the plant surface. Old fallout from the '50s and '60s is now being incorporated into growing plants in the same manner as potassium because it is in the same chemical family as potassium. This fallout Cs-137 has been found in firewood ash at many locations in the United States that are far from any nuclear plants (S. Farber, "Cesium-137 in Wood Ash, Results of a Nationwide Survey," 5th Ann. Nat. Biofuels Conf., 10/21/1992).

No Cs-137 was detected in the crop samples. In 2017 three of the twenty-four vegetation samples had a positive indication for Cs-137 and only E-06 (0.029 ± 0.013) was above the MDC of 0.021 pCi/g. Typically, only the vegetation collected at monitoring site E-06, in the Point Beach State Park south of PBNP, has detectable levels of Cs-137. Both the positive 2016 results were from E-06 and only one was >MDC. These occurrences were attributed to the above described mechanism. The only 2016 airborne Cs-137 discharged by PBNP occurred in March when there was no fresh vegetation. In 2017 the airborne Cs-137 release occurred in October after the vegetation and crops were collected. Therefore, the Cs-137 has to be the result of uptake via roots. In this case, it is not possible to distinguish between plant effluent and radioactive fallout as previously mentioned. Given that only one of the 2017 positive results is above the MDC, and that one is not much above the MDC, both results could be false positives. Therefore, it is unlikely that the Cs-137 results indicate an impact from PBNP releases.

The only other radionuclide having positive indication was I-131, 0.017 ± 0.009 pCi/g in general vegetation and 0.013 ± 0.008 pCi/g in crops. I-131 releases occurred only in March ($1.47 \mu\text{Ci}$) and in May ($2.3 \mu\text{Ci}$). Based on its 8-day half-life,

this I-131 would have decreased by 15 half-lives by the time of the September sample or about 1/300,000th of its original value. Factoring in the dispersion coefficients, it is unlikely that it would be detected in any vegetation. Additionally, the I-131 result was below the calculated MDC. Therefore the I-131 results are considered to be false positives.

Based on the 2017 crop and general vegetation sampling results, it is concluded that there is little or no effect from PBNP effluents.

11.11 Land Use Census

In accordance with the requirements of Section 12.2.5 of the ODCM, a visual verification of animals grazing in the vicinity of the PBNP site boundary was completed in 2017. No significant change in the use of pasturelands or grazing herds was noted. Therefore, the existing milk-sampling program continues to be acceptable. The nearest dairy (E-21) lies in the SSE sector and it is one of the Point Beach REMP milk sampling sites. This dairy leases land in the S and SSE sectors at the PBNP site boundary for growing feed corn. Also, the highest χ/Q (1.09E-06) and D/Q (6.23E-09) values occur in these sectors. As demonstrated from the analyses of feed crops, there is no measureable plant impact on the crops grown on site by this dairy. Therefore, dose calculations to the maximum exposed hypothetical individual, assumed to reside at the site boundary in the S sector, continues to be conservative for the purpose of calculating doses via the grass-cow-milk and the other ingestion pathways. The 2017 LUC revealed no changes that would necessitate changes to the current REMP, such as the addition of new sampling locations.

11.12 Long Term TLD Trending

To put the 2017 REMP TLD results in perspective, it is instructive to look at long term trends. The following examines the TLD results from 1971 to 2017. The ANSI standard (ANSI/HPS N13.37-2014 "Environmental Dosimetry) states that the data from early vintage dosimetry systems (c. 1970 – 1990) should not be considered comparable to current dosimetry systems in establishing a baseline for environmental TLD results. These problems are evident from the review of our early data as discussed below.

The pre-operational data, 1968 – 1970, are not included. The pre-operational ambient radiation monitoring sites were E-01 (the met tower area) through E-04 (the north boundary). They were monitored using TLDs and ionization chambers. E-04 was used as a background location until E-08 (see Figure 9-1) was added for the operational REMP in 1971. Prior to 1975, a control TLD stored in a lead pig was used for a comparison to those placed in the field. In the pre-operational data, the control TLD could be equal to or higher than the field results and both the field and control TLD results appear erratic compared to the ion-chamber results. Also, the reported TLD results do not have transportation exposures from New Mexico to Wisconsin subtracted. Therefore, only the TLD results beginning in 1971, with the transportation caveat, are used in this analysis of long-term trends.

The trend at E-01(Figure 11-7) shows slowly decreasing trend from 1971 to 1979. This is may be an artifact. The cause is not known. As previously mentioned, no transportation controls were used until the 4th quarter of 1975 so no transport dose corrections were made prior to that quarter. There is a small increase in 1980 when the current contracted REMP lab began. A slowly decreasing exposure rate occurs from 1980 – 1992 except for the 1984 - 1988 time segments. The erratic results from 1984 – 1988 were traced to a faulty connection in the TLD reader.

Figure 11-7 E-01 Results 1971 – 2017

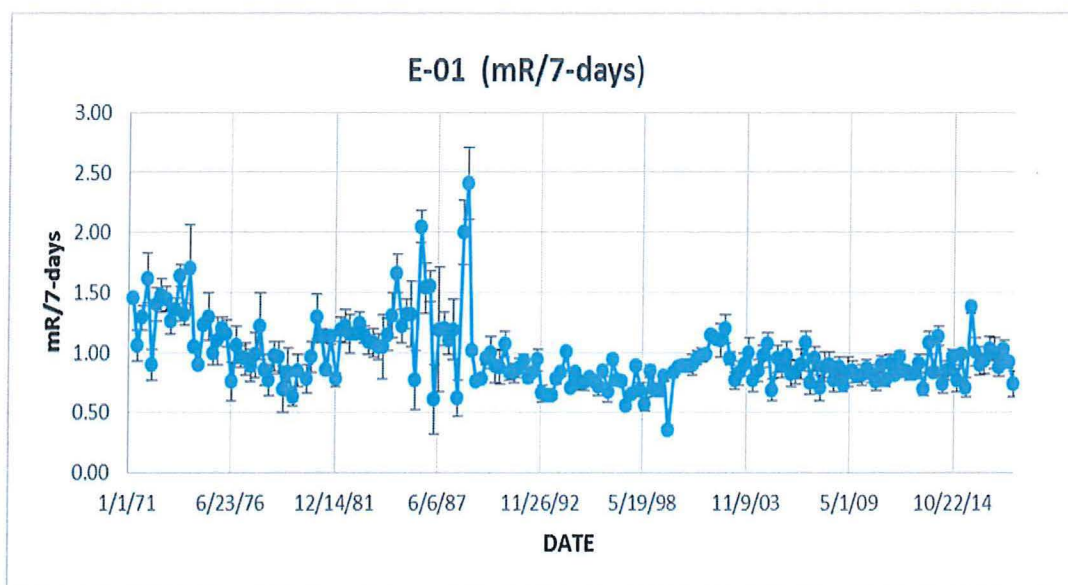

The TLD package from 1980 to 2001 consisted of three LiF chips sealed in a black plastic bag. The magnitude of the error bars indicates the degree of variability of the 1984 - 1988 results from the three chips due to a fault in the TLD reader. The results appear much the same for the E-03 and E-20 results (Figure 11-8). Note that E-20 did not begin until 1976. Again, there is an increase in both the E-20 (the background site) and E-03 (the location nearest the ISFSI) which coincides with the switch from the LiF chips to the Teflon TLD cards. Given that the first twelve casks were loaded December 1995 to September 2000 in which there were no increases in the TLD results, the increase in 2001 indicates that this change is the result of the different response of the new TLDs and not of any effluents or shine from the plant.

Figure 11-8 Comparison of E-03 and E-20 Results 1971 – 2017

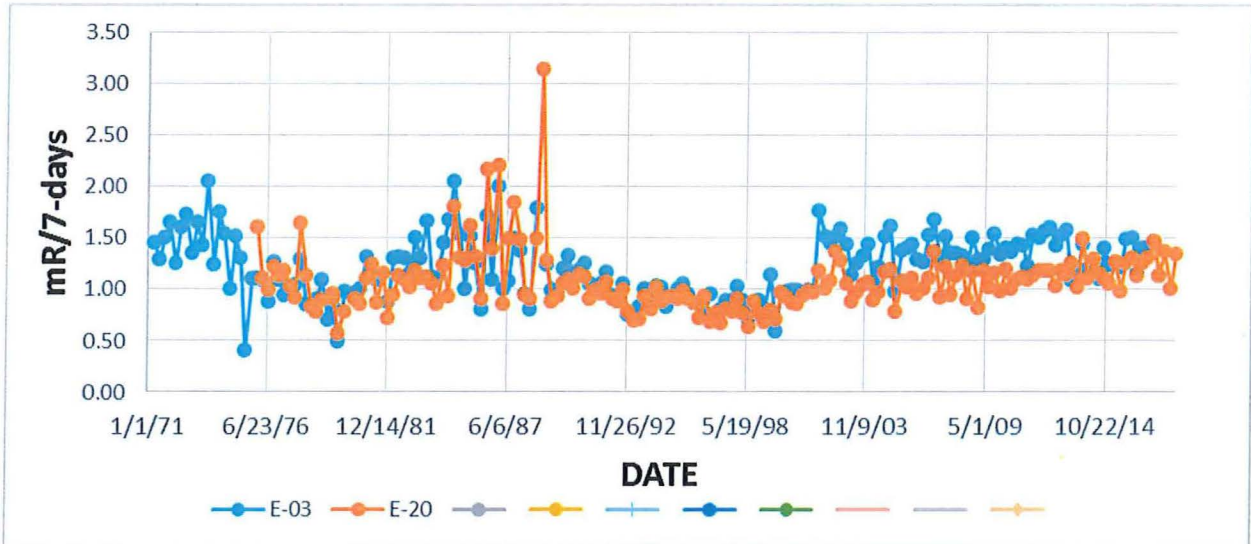

Narrowing the time window for the TLD results from 1992 to the present allows for a comparison among the for original four TLD locations since the introduction of the ISFSI (Figure 11-9) without the interference by the faulty TLD reader in the mid-1980s. Sites E-01 and E-02 are about 1 mile south of the ISFSI. E-03 is 1200 feet west and E-04 is 4300 feet north.

Figure 11-9 Comparison of E-01, E-02, E-03 and E-04 (1992 –2017)

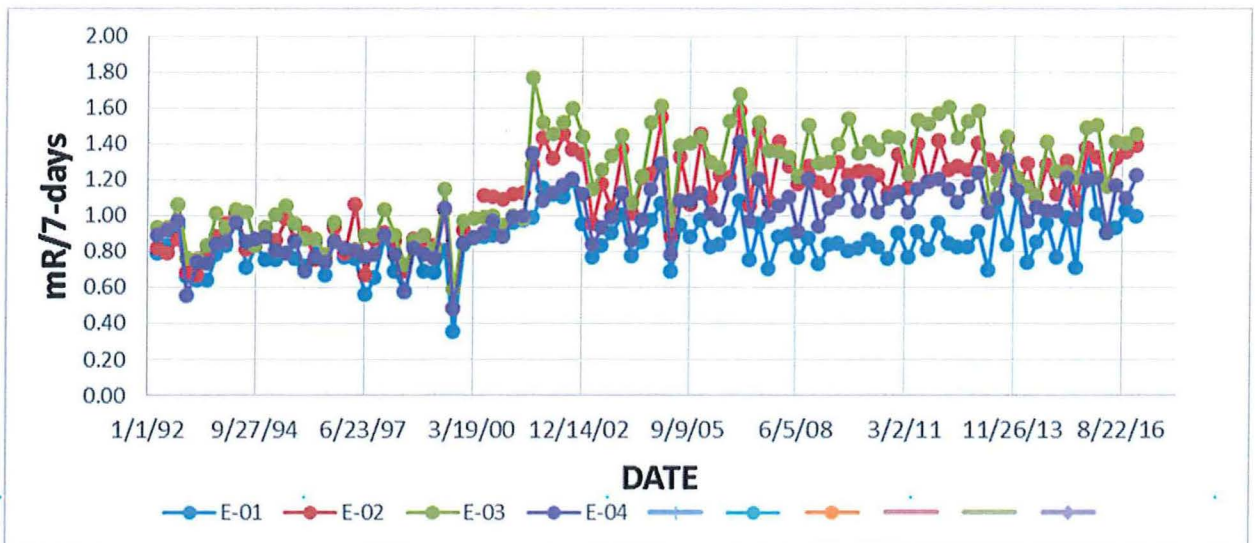

The comparison shows a definite difference between E-01 and the other three locations. E-01, although approximately the same distance from the ISFSI as E-02 and further away than either E-03 or E-04, is lower than the other three sites.

Therefore, distance is not the determining factor in the difference among the measured exposures. There are two factors which could cause the observed difference. The first difference is that E-02, E-3, and E-04 are surrounded by plowed fields whereas the area around E-01 is uncultivated. Second, E-01 is within 100 feet of the lake. Therefore, about 50% of the area contributing natural radiation to the location is a combination of sandy soil, beach sand, and lake water. As seen from the REMP soil and beach analyses, the soil at E-01 has lower average Ra-226 content (0.90 pCi/g) than the soil at E-02, -03, -04 (1.30 pCi/g). Similar results are obtained for K-40, 12.6 pCi/g at E-01 vs. 15.3 pCi/g (E-02, -03, -04). Furthermore, the beach sands at E-01 have lower Ra-226 (0.31 pCi/g) and K-40 (5.75 pCi/g) concentrations than the soil at E-01. So, in effect, half the radiation field at E-01 is about a third of that of E-02, -03, and -04.

The impact of the ISFSI on the ambient radiation levels at its nearest site boundary, the west boundary is shown in Figure 11-10. The ISFSI impact on ambient exposure levels was addressed briefly in Section 11.1 (see Figure 11-2).

Figure 11-10 E-03, E-31, and Background Site E-20 Results 1992 to 2017

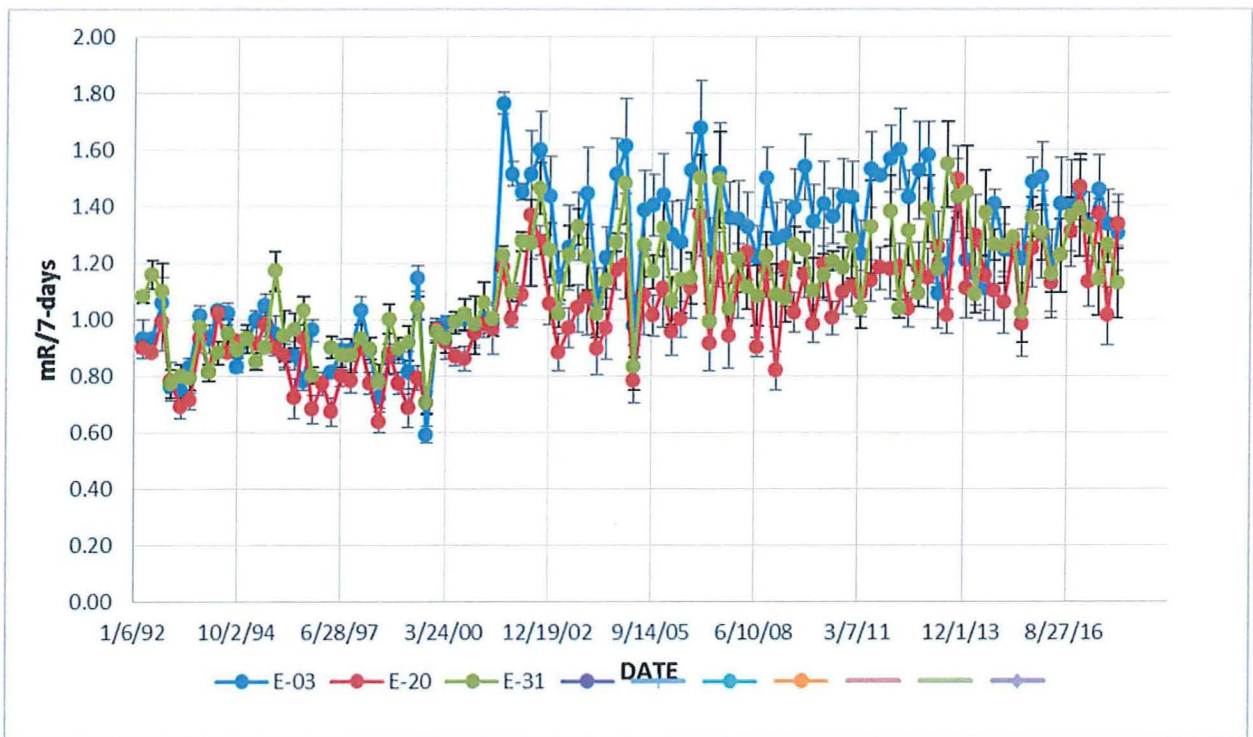

Figure 11-2 shows that beginning with the use of the Teflon TLD cards in the fourth quarter of 2000, the measured exposure levels at E-03 are 2 – 5 mR/7-days lower than the exposures at the west fence of the ISFSI. Figure 11-10 shows that although their individual 95% confidence levels overlap indicating no statistical difference, the quarterly exposures at E-03 (about 1200 feet from the ISFSI) are consistently higher than the exposure at E-31 (at the site boundary about 1400 feet west of E-03). Therefore, the lower values at E-31 compared to E-03 appear to be a real difference as the distance from the ISFSI increases at the west boundary. Because land usage and location are similar at E-03 and E-31, the cause of the

previously identified response differences between E-03 and E-01 are not applicable. Therefore, the lower results at the site boundary location E-31 show that the exposures from the ISFSI are dropping off and approaching the lower readings found at the background site E-20.

12.0 REMP CONCLUSION

Based on the analytical results from the 828 environmental samples (788 individual samples with an additional 24 quarterly air particulate composites and 16 quarterly lake water composites) together with 128 REMP + 16 ISFSI sets of TLDs that comprised the PBNP REMP for 2017, PBNP effluents had no discernable effect on the surrounding environs. The calculated effluent doses are below the 10 CFR 50, Appendix I dose objectives demonstrate that PBNP continues to have good controls on effluent releases. The control of effluents from PBNP continues to be acceptable pursuant to the ALARA criteria of 10 CFR 50.34a. Additionally, when the TLD results are factored in to the overall exposure, the resulting doses are lower than the ISFSI (10 CFR 72.104) and EPA (40 CFR 190) limits of 25 mrem whole body, 75 mrem thyroid, and 25 mrem any other organ.

From the long-term analysis of TLD results, there is no evidence of elevated ambient radiation levels from the operation of Point Beach and the ISFSI except for the slightly higher exposures measured at the site boundary (E-31) compared to the background reference site (E-20) [see Figure 11-10].

Part D

GROUNDWATER MONITORING

13.0 PROGRAM DESCRIPTION

PBNP monitors groundwater for tritium as part of the Groundwater Protection Program (GWPP). The GWPP supports NEI 07-07, the nuclear industry's groundwater protection initiative. The GWPP also fulfills the requirement of 10 CFR 20.1501(a) to make surveys of areas, including to subsurface in order to comply with Part 20. During 2017 the sampling program consisted of beach drains, intermittent stream and bog locations, drinking water wells, façade wells, yard electrical manholes, ground water monitoring wells, and the subsurface drainage (SSD) system sump located in the U-2 façade.

In the late 1970s, the beach drains entering Lake Michigan were found to contain tritium. The beach drains are the discharge points for yard drainage system, which carries storm water runoff, and are known to be infiltrated by groundwater as observed by discharges even when no rain has occurred. In the 1980s, the source of H-3 for this pathway was postulated to be spent fuel pool leakage into the groundwater under the plant. Based on this observation, modifications were made to the pool, and the tritium concentrations decreased below the effluent LLDs. Beach drain effluents continue to be monitored and are accounted for in the monthly effluent quantification process. Because the beach drains are susceptible to groundwater in-leakage from other sources such as the area around the former retention pond which is known to contain H-3, the beach drains are monitored as part of the groundwater monitoring program. In addition to H-3, groundwater beach drain samples also are gamma scanned for the same suite of radionuclides as lake water using the lake water LLDs.

Three intermittent stream locations and the Energy Information Center (EIC) well were added to the groundwater monitoring program in the late 1990s when it was discovered that tritium diffusion from the then operable, earthen retention pond was observable in the intermittent streams which transverse the site in a NW to SE direction. A fourth stream location closer to the plant was added in 2008. These streams pass on the east and west sides of the former retention pond and empty into Lake Michigan about half a mile south of the plant near the meteorological tower. The intermittent stream samples track H-3 in the surface groundwater.

The groundwater monitoring program also includes two bogs / ponds on site. One is located about 400 feet SSE of the former retention pond; the other, about 1500 feet N between Warehouses 6 and 7.

In addition to the main plant well, four other drinking water wells also are monitored. The Site Boundary Control Center well, located at the plant entrance, the Warehouse 6 well, on the north side of the plant, and the EIC well, located south of the plant. In 2012, a new building (Warehouse 7) was constructed for radwaste. The well for this building was added to the GWPP. These wells do not draw water from the top 20 - 30 feet of soil which is known to contain H-3. These wells monitor the deeper (200 - 600 feet), drinking water aquifer from which the main plant well draws its water. The two soil layers are separated by a gray, very dense till layer of low permeability identified by hydrological studies.

Manholes in the plant yard and for the subsurface drainage (SSD) system under the plant are available for obtaining ground water samples. The plant yard manholes for accessing electrical conduits are susceptible to ground water in-leakage. Therefore, a number of these were sampled. The SSD system was designed to lessen hydrostatic pressure on the foundation by controlling the flow of water under the plant and around the perimeter of the foundation walls. The SSD system flows to a sump in the Unit 2 facade. The sump was sampled twelve times during 2017.

Due to flooding concerns, man-holes and clean-outs for the SSD were sealed in 2014. Therefore, only the SSD sump now is used for sampling.

In the 1990s, two wells were sunk in each unit's façade to monitor the groundwater levels and look for evidence of concrete integrity as part of the ISI IWE Containment Inspection Program. These wells are stand pipes which are sampled periodically for chemical analyses. Façade well sampling has been part of the GWPP since 2007. These wells are sampled quarterly.

Rising lake levels and rip-rap added for flooding protection have impacted beach drain sampling. Beach drain S-1 has been sampled most frequently, eleven out of twelve months. High lake levels have washed away the access to beach drain S-3 south of the U2 discharge allowing sampling only three times during 2017. S-7, -8, and -10 were available but had no flow. S-9 has been buried under sand and when accessible, there was no flow. Although two samples were obtained at S-11, high lake levels and rip-rap made sampling impossible during the rest of the year. S-12 and S-13 are impacted by high lake levels and rip-rap. However, two samples were available from S-12. Only three samples have been available in 2017. Because of rip-rap added for flooding concerns and of high lake water levels, beach drains S-7, S-8, S-9, and S-10 could not be sampled during 2017. Beach drains S-11 and S-12 were sampled only twice due to lake levels and rip-rap concerns.

The groundwater sampling sites (other than the beach drains, SSDs and manholes) are shown in Figure 13.1.

Figure 13-1 Groundwater Monitoring Locations

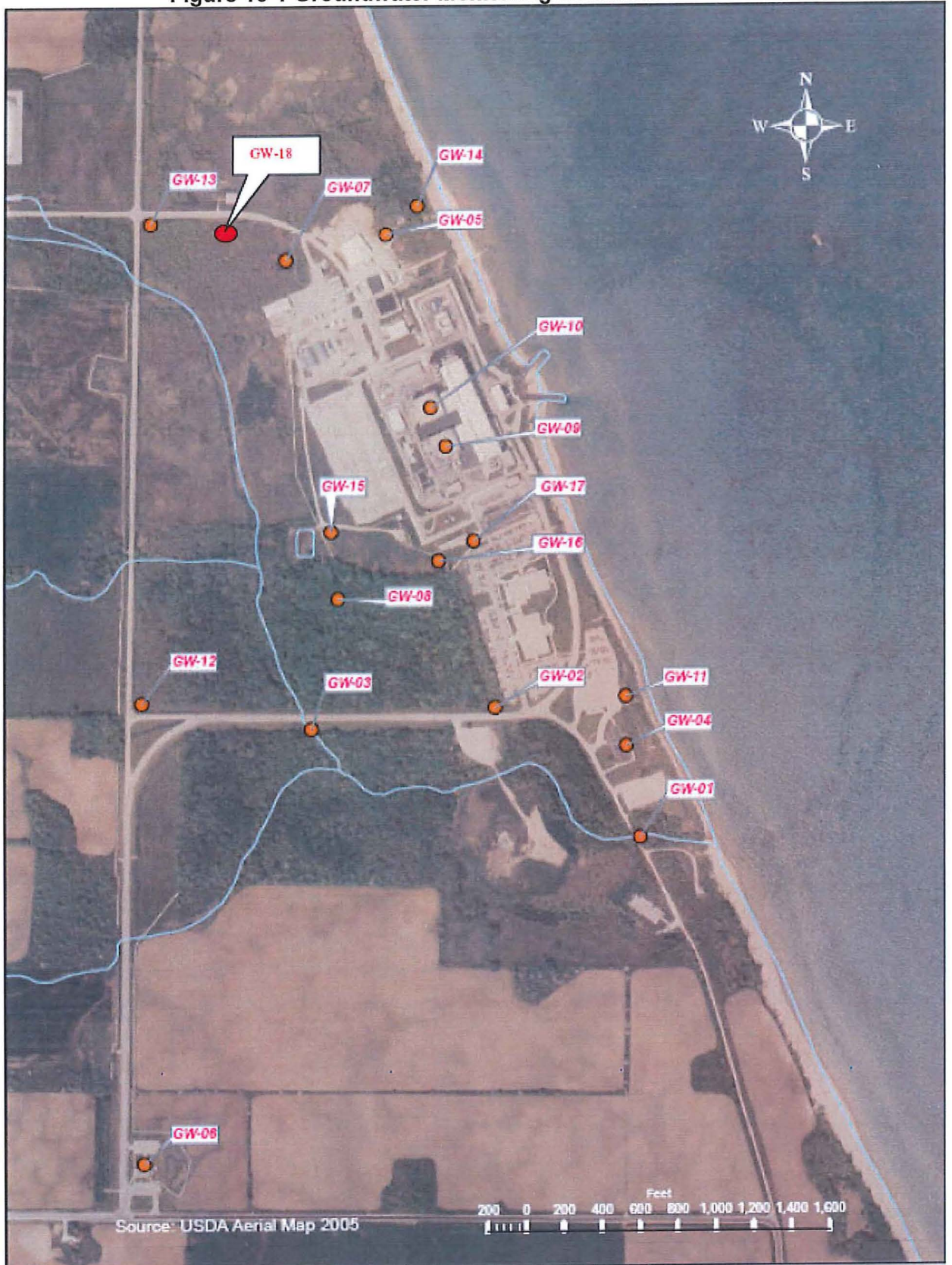

14.0 RESULTS AND DISCUSSION

14.1 Streams and Bogs

The results from the surface groundwater monitoring associated with the former retention pond are presented in Table 14-1. For the most part, the creek results are barely above the detection level and less than the MDC. The highest averages are for the East Creek and STP which are in the groundwater flow path from the retention pond area to Lake Michigan. The West Creek is west of the former retention pond, an upstream location with respect to the groundwater flow. The H-3 concentration at GW-08, close to the former retention pond, is about one-tenth of the H-3 concentrations it had prior to the remediation of the retention pond.

**Table 14-1 Intermittent Streams and Bogs
H-3 Concentration (pCi/l)**

Month	GW-01(E-01)	GW-02	GW-03	GW-17	BOGS		MDC
	Creek Confluence	E. Creek	W. Creek	STP	GW-07	GW-08	
Jan	ND ±	225 ± 99	ND ±	278 ± 102			169
Feb	179 ± 86	342 ± 94	ND ±	314 ± 93			146
Mar	130 ± 78	284 ± 86	111 ± 77	461 ± 95			150
Apr	ND ±	318 ± 90	ND ±	231 ± 86			153
May	129 ± 94	360 ± 104	ND ±	306 ± 102	ND ±	ND ±	145
Jun	ND ±	141 ± 81	ND ±	155 ± 82			149
Jul	142 ± 83	115 ± 82	95 ± 81	122 ± 82			158
Aug	146 ± 78	NS ±	ND ±	317 ± 87			149
Sep	79 ± 72	156 ± 77	110 ± 74	NS ±			144
Oct	158 ± 118	246 ± 87	80 ± 78	273 ± 88			186
Nov	ND ±	231 ± 85	ND ±	178 ± 82			154
Dec	NS	NS ±	NS ±	NS ±			
Average	118 ± 40	244 ± 90	76 ± 27	262 ± 104			

A blank indicates no sample was scheduled. Streams are sampled monthly; bogs, annually.

NS = no sample due to dry or frozen. Values are presented as the measured value and the 95% confidence level counting error. The LLD = 200 pCi/l. ND = measured value minus 2σ is less than zero and <MDC. To be statistically correct, the measured, actual values for the NDs are used in calculating the average (i.e. 64±77, the 64 is used to calculate the average). STP is the north end of the E. Creek at the SE corner of the sewage treatment plant.

The analyses of these surface water samples show low concentrations of H-3. Although seven small positive H-3 concentrations occur in samples from the confluence of the two creeks (GW-01), only the February concentration is above its MDC. None of the West Creek (GW-03) samples had H-3 above its MDC. In contrast, there are more positive results from GW-02 (south end of the East Creek) and GW-17 (located at the north end of the East Creek). GW-17 is east of the former retention pond area in the groundwater flow path to Lake Michigan. Except for the February and May sample results, the East Creek concentrations are generally lower than the 300 - 350 pCi/l found before the retention pond was remediated in 2002. It should be noted that the East Creek, in addition to being in the path of the west to east groundwater flow from the old retention pond, also is fed by yard runoff from the west side of the yard which may account for the higher values.

Tritium was not detected at the bog (GW-08, measured value of 81 ± 92) SE of the former retention and the bog (GW-07) north of the former retention pond. The GW-08 result is in conformance with the west to east groundwater flow described in the Site Conceptual Model and the FSAR. The non-detection of H-3 at GW-08, the bog closest to the former retention pond, is in contrast to the 3200 - 3900 pCi/l seen in 1999 before the retention pond was remediated and the 297 ± 89 pCi/L seen in 2012.

14.2 Beach Drains

The 2017 results for the beach drains that were sampled are presented in Table 14-2. Beach drain S-9 was inaccessible due to high lake level and rip-rap placed due to flooding concerns. S-1 collects yard drainage from the north part of the site yard. S-3 collects yard drainage from the south part of the site yard. Drains S-8 and S-9 carry water from the lake side yard drains whereas drains S-7 and S-10 are from the turbine building roof. S-11 is not connected to any yard drain system and mainly carries groundwater flow and runoff from a small lawn area south of the plant. S-12 is a drain from the external SSD which run along the outside northern half of the foundation wall. It is not connected to the internal SSD under the plant which drains to a sump in the U2 façade. S-13, the south external SSD drain cannot be samples because it is buried under rip rap.

Table 14-2
2017 Beach Drain H-3 Concentration (pCi/l)

Month	S-1	S-12	S-3	S-11	MDC
Jan	NF ±	NF	NS ±	NF ±	
Feb	293 ± 90	NF	NS ±	NF ±	146
Mar	350 ± 89	NF	201 ± 81	NF ±	150
Apr	309 ± 88	245 ± 84	NS ±	NS ±	152
May	339 ± 103	216 ± 81	NS ±	558 ± 98	157
Jun	319 ± 108	NF	NS ±	280 ± 106	147
Jul	204 ± 93	NF	264 ± 96	NF ±	146
Aug	175 ± 88	NF	NS ±	NF ±	149
Sep	215 ± 95	NF	NS ±	NF ±	151
Oct	529 ± 94	NF	NS ±	NF ±	177
Nov	224 ± 94	NF	NS ±	NF ±	158
Dec	376 ± 91	NF	332 ± 89	NF ±	155
Avg =	304 ± 106	231 ± 21	266 ± 66	419 ± 197	

ND = not detected and \leq MDC

NS = no sample

NF = no sample due to no flow

The H-3 concentrations at S-1 are consistent with results from previous years. Because high lake levels and the addition of rip-rap around some of the beach drains to prevent shoreline erosion and to address flooding concerns, it is not possible to sample from the other beach drains most of the year. However, the results from available samples are consistent with other groundwater results from various streams and manholes.

Gamma scans were performed on the beach drain samples at the LLD used for lake water. A few indications of small, positive concentration values below their MDCs

were found for Ba-La-140, Co-58, Co-60, Fe-59, and Zr-Nb-95. No Ba-La-140 was released via liquid or airborne effluents in 2017. Also, all the positive results were below their MDCs. Therefore, it is concluded that all the gamma results are false positives. This leaves H-3 as the only PBNP radionuclide positively found in the beach drains.

14.3 Electrical Vaults and Other Manholes

Manholes for access to below ground electrical facilities are susceptible to groundwater in-leakage. The manholes east side of the plant, between the Turbine building and Lake Michigan have low H-3 concentrations (Table 14-3). Z-065A and Z-065B are located on the west side of the pump house. Manholes, Z-066A and Z-067A through Z-066D and Z-067D are between the pump house and the turbine building and run in parallel in the NE section of the yard beginning just north of the Unit 2 truck bay and run from the Unit 2 truck bay north to the EDG building. Z-068 is located just west of the EDG building and north of Z-066/067D. Z-493F is near Z-068. Each of the two A, B, C, and D vaults is side by side. Based on being side-by-side, it is expected that the each pair of manholes 66A/67A, etc. would have similar H-3 concentrations. This appears to hold for all the paired vaults. The similarity of the April Z-068 H-3 value to the S-1 beach drain was noted in the previous section.

**Table 14-3
2017 East Yard Area Manhole Tritium (pCi/l)**

MH	9/11-12/2017
Z-065A(M-1)	184 ± 82
Z-065B(M-2)	239 ± 85
Z-066A	192 ± 83
Z-067A	186 ± 82
Z-066B	141 ± 80
Z-067B	186 ± 82
Z-066C	148 ± 80
Z-067C	99 ± 78
Z-066D	218 ± 84
Z-067D	230 ± 85
Z-068	232 ± 78
Z-493F	218 ± 84
MDC	150

14.4 Façade Wells and Subsurface Drainage System

There are two methods of sampling the groundwater under the plant foundation. The first is a set of four shallow wells, two in each façade. The other is a subsurface drainage system (SSD). The façade wells were installed to monitor for groundwater conditions which may be detrimental to the integrity of the concrete and rebar of each unit's foundation. The SSD was designed to relieve hydrostatic pressure on each unit's foundation as well as the Auxiliary and Turbine buildings.

The façade wells are not located symmetrically in the two units. The Unit 1 façade wells are east of the containment in the SE (1Z-361A) and NE (1Z-361B) corners of the façade. However, in Unit 2, there is one well in the NW corner (2Z-361A) and

the other rotated approximately 180° in the SW corner (2Z-361B). In each the well cap is level with the floor.

The 2017 façade well results are shown in Table 14-4. The Unit 1 wells continue to have higher H-3 concentrations than the U2 wells with 1Z-361A, in the SE corner of the Unit 1 façade, having the highest H-3 concentrations. The 2017 highest results are in line with the 2016 results but a lower than the 2007 and 2008 highs of 1169 - 1331 pCi/l. Based on the 2017 façade well results, the conclusion is that H-3 remains unevenly distributed in the soil beneath the facades and that the concentrations remain low compared to the 2007 – 2008 results.

**Table 14-4
2017 Facade Well Water Tritium (pCi/l)**

Month	UNIT 1		UNIT 2		MDC
	1Z-361A	*1Z-361B	*2Z-361A	*2Z-361B	
January	252 ± 84	177 ± 80	NS ±	ND ±	147
May	266 ± 91	104 ± 83	ND ±	167 ± 86	156
July	271 ± 88	ND ±	ND ±	229 ± 103	*158
October	271 ± 86	125 ± 78	83 ± 76	216 ± 83	150

*The July samples had an MDC = 190 pCi/L

To relieve hydrostatic pressure on the foundation, Point Beach has an external and an internal subsurface drainage system (SSD) to drain groundwater away from the foundation.

The internal SSD consist of perforated piping which drains groundwater by gravity to a sump located in the Unit 2 façade. A comparison of the 2016 and 2017 SSD results are presented in Table 14-5. The 2017 concentrations are higher than those seen in 2016. Why the H-3 concentration increase by an order of magnitude in October 2017 is not known. There are no known system leaks. The decreasing concentrations for the months of November and December have continued into 2018 with the January concentration being 2634 ± 168 pCi/L.

**Table 14-5
2016 and 2017 Unit 2 Facade SSD Sump H-3 (pCi/l)**

Date	2016		2017	
	pCi/l	2σ	pCi/l	2σ
Jan	499 ±	102	1058 ±	122
Feb	510 ±	102	776 ±	107
Mar	507 ±	99	765 ±	111
Apr	572 ±	102	1635 ±	142
May	1018 ±	133	1503 ±	134
Jun	1230 ±	125	854 ±	112
Jul	1333 ±	128	907 ±	115
Aug	929 ±	116	1035 ±	115
Sep	615 ±	104	737 ±	105
Oct	966 ±	119	8772 ±	284
Nov	1616 ±	140	7478 ±	265
Dec	1523 ±	136	4165 ±	203
Average	943 ±	410	2474 ±	2815

The SSD system and the façade wells sample the groundwater under the plant foundation. Again in 2017, as in 2016, the SSD sump has higher H-3 concentrations than the façade wells. Why the façade wells have lower H-3 is not known. The difference does illustrate that the groundwater H-3 was not uniformly distributed under the foundation.

The SSD sump samples are scanned for gamma emitters. A few slightly positive values were found for Mn-54, Co-58, Fe-59, Zn-65, Cs-134, and Ba-La-140, all results were below the MDC. Additional analyses for hard-to-detect radionuclides were made on the SSD sump samples with elevated H-3 for the months of April, October, and November. No Fe-55, Ni-63, Sr-89, Sr-90, or Tc-99 was found.

The H-3 in the SSD system sump is discharged via the wastewater effluent system.

The external SSD system runs along the external foundation walls for the Unit 1 and Unit 2 facades, the Auxiliary Building, the North Service Building, and the Turbine Hall. It is not connected to the internal SSD system. During 2014, work to mitigate the possibility of external flooding events uncovered the N (S-12) and S (S-13) external SSD outfalls. Both the north and south halves of the external SSD system drain toward the beach. No samples from SSD S-13 were obtained in 2016 and 2017 because it is buried under rip-rap. The two H-3 2017 results from S-12 are comparable to the 236 ± 93 m pCi/L found in 2016 as well as the concentrations found in various manholes (Table 14-3) on the east side of the plant during 2017.

In addition to H-3 analysis, the façade wells were gamma scanned. As in lake water samples, small positive values below their calculated, minimum detectable concentrations were found for Mn-54, Fe-59, Zr-Nb-95, Cs-134, Cs-137, and Ba-La-140. Because all values were less than or equal to the MDC, it is concluded that this result is a false positives.

14.5 Potable Water and Monitoring Wells

Outside of the protected area, ten wells, in addition to the main plant well (Section 11.7), are used for monitoring H-3 in groundwater: the four potable water wells, GW-04 (Energy Information Center or EIC), GW-05 (Warehouse 6), GW-18 (Warehouse 7), GW-06 (Site Boundary Control Center), and six H-3 groundwater monitoring wells, GW-11 through GW-16 (Figure 13-1). The potable water wells monitor the deep, drinking water aquifer whereas the monitoring wells penetrate less than 30 feet to monitor the top soil layer. The potable water aquifer is separated from the shallow, surface water aquifer by a thick, clay layer with very low permeability. The one, slightly positive H-3 result from a potable water well was below the MDC. It was determined to be a false positive. The other potable water wells had no detectable H-3 (Table 14-6).

The monitoring well results are similar to that obtained in 2016. The two monitoring wells showing higher and consistently detectable H-3 (GW-15, GW-16) are in the flow path from the retention pond area to the lake (Table 14-7). Similar results were obtained in 2016.

**Table 14-6
2017 Potable Well Water Tritium Concentration (pCi/l)**

Month	EIC WELL GW-04	EIC MDC	Warehouse 6 Well GW-05	SBCC Well GW-06	WH 7 GW-18	GW-05, 06, 18 MDC
Jan	ND	169	ND	ND	ND	176
Feb	ND	146				
Mar	ND	150				
Apr	ND	153	ND	ND	ND	147
May	ND	145				
Jun	ND	149				
Jul	ND	158	ND	ND	ND	149
Aug	77 ± 74	149				
Sep	ND	144				
Oct	ND	154	ND	ND	ND	149
Nov	ND	154				
Dec	ND	158				

ND= not detected

In summary, the results from monitoring wells GW-15 and GW-16 as well as results from the nearby surface water sample locations (GW-03, the east creek; GW-08, the bog to the SE of the former pond; and GW-17, the surface water on the SE corner of the STP) show that the area around and in the groundwater flow from the former retention pond remain impacted by the H-3 that diffused from the pond into the soil while it was in use.

Table 14-7 2017 Quarterly Monitoring Well Tritium (pCi/l)

Q	MW-01 GW-11	MW-02 GW-12	MW-06 GW-13	MW-05 GW-14	MW-04 *GW-15	MW-03 *GW-16	MDC
1	ND ±	ND ±	ND ±	ND ±	ND	ND	169
2	98 ± 75	ND ±	ND ±	126 ± 76	188 ± 80	199 ± 80	148
3	113 ± 82	ND ±	ND ±	139 ± 83	184 ± 86	256 ± 89	158
4	ND ±	ND ±	ND ±	121 ± 90	125 ± 90	119 ± 89	159

ND= not statistically different from zero and <MDC.

NS = no sample available

*Duplicate samples taken, highest value reported.

15.0 GROUNDWATER SUMMARY

Groundwater monitoring indicates that low levels of tritium continue to occur in the upper soil layer but not in the deep, drinking water aquifer. These results also indicate that the low levels of tritium are restricted to a small, well defined area close to the plant. Results from precipitation analyses (2011 AMR) show that airborne H-3 concentrations are higher close to the plant as compared to results at the site boundaries. The observed tritium concentrations in the yard manholes can be explained by the higher H-3 in precipitation close to the plant. In addition to tritium captured by precipitation, the beach drains also

receive the H-3 captured in the AC condensate because the condensate drainage is connected to the yard drain system.

Tritium continues in the soil below the plant foundation as evidenced by results from the subsurface drainage system and from the façade wells.

In conclusion, the groundwater H-3 concentrations observed at Point Beach are below the EPA drinking water standards prior to emptying into Lake Michigan where they will undergo further dilution. All analyses to date indicate that the drinking water contains no tritium. None of the H-3 in the upper soil layer is migrating off-site toward the surrounding population. This is based on the known west-to-east groundwater flow toward Lake Michigan and the negative results from the two monitoring wells west of the plant (GW-12 and GW-13, Figure 13-1). Additionally, because no H-3 is detected in either of the four on-site drinking water wells close to the power block or from the drinking water well at the site boundary, none of the H-3 observed in the upper soil layer has penetrated into the drinking water aquifer to impact either on-site or off-site personnel.

APPENDIX 1

Environmental, Inc. Midwest Laboratory
Final Report for the Point Beach Nuclear Plant
and
Other Analyses
Reporting Period: January – December 2017

103 pages follow



700 Landwehr Road • Northbrook, IL 60062-2310
phone (847) 564-0700 • fax (847) 564-4517

FINAL REPORT
TO
NextEra Energy

RADIOLOGICAL ENVIRONMENTAL MONITORING PROGRAM (REMP)
FOR
THE POINT BEACH NUCLEAR PLANT
TWO RIVERS, WISCONSIN

PREPARED AND SUBMITTED
BY
ENVIRONMENTAL INCORPORATED MIDWEST LABORATORY

Project Number: 8006

Reporting Period: January-December, 2017

Reviewed and
Approved by _____

B. Grob, M.S.
Laboratory Manager

Date 02-15-2018

corrected copy
Received 2/27/18
Reviewed 2/28/18

Distribution: K. Johansen, 1 hardcopy, 1 e-mail
S. Bartels, 1 hardcopy, 1 email

POINT BEACH NUCLEAR PLANT

TABLE OF CONTENTS

<u>Section</u>		<u>Page</u>
	List of Tables	iii
1.0	INTRODUCTION	iv
2.0	LISTING OF MISSED SAMPLES	v
3	DATA TABLES	vi
<u>Appendices</u>		
A	Interlaboratory Comparison Program Results	A-1
B	Data Reporting Conventions	B-1
C	Sampling Program and Locations	C-1
D	Graphs of Data Trends	D-1
E	Supplemental Analyses	E-1
F	Special Analyses	F-1

POINT BEACH NUCLEAR PLANT

LIST OF TABLES

<u>Title</u>	<u>Page</u>
Airborne Particulates and Iodine-131	
Location E-01, Meteorological Tower	1-1
Location E-02, Site Boundary Control Center	1-2
Location E-03, West Boundary	1-3
Location E-04, North Boundary	1-4
Location E-08, G. J. Francar Residence	1-5
Location E-20, Silver Lake College	1-6
Airborne Particulates, Gamma Isotopic Analyses	2-1
Milk	3-1
Well Water	4-1
Lake Water	5-1
Lake Water, Analyses on Quarterly Composites	6-1
Fish	7-1
Shoreline Sediments	8-1
Soil	9-1
Vegetation (Grass).....	10-1
Aquatic Vegetation	11-1
Gamma Radiation, as Measured by TLDs	12-1
Groundwater Monitoring Program.....	13-1
Vegetation (Corn/Alfaifa).....	14-1

POINT BEACH NUCLEAR PLANT

1.0 INTRODUCTION

The following constitutes the final 2017 Monthly Progress Report for the Environmental Radiological Monitoring Program conducted at the Point Beach Nuclear Plant, Two Rivers, Wisconsin. Results of analyses are presented in the attached tables. Data tables reflect sample analysis results for both Technical Specification requirements and Special Interest locations and samples are randomly selected within the Program monitoring area to provide additional data for cross-comparisons.

For gamma isotopic analyses, the spectrum covers an energy range from 80 to 2048 KeV. Specifically included are Mn-54, Fe-59, Co-58, Co-60, Zn-65, Zr-95, Nb-95, Ru-103, Ru-106, I-131, Ba-La-140, Cs-134, Cs-137, Ce-141, and Ce-144. Naturally occurring gamma-emitters, such as K-40 and Ra daughters, are frequently detected in soil and sediment samples. Specific isotopes listed are K-40, Tl-208, Pb-212, Bi-214, Ra-226 and Ac-228. Unless noted otherwise, the results reported under "Other Gammas" are for Co-60 and may be higher or lower for other radionuclides.

All concentrations, except gross beta, are decay corrected.

All samples were collected within the scheduled period unless noted otherwise in the Listing of Missed Samples.

POINT BEACH NUCLEAR PLANT
2.0 LISTING OF MISSED SAMPLES

Sample Type	Location	Expected Collection Date	Reason
LW	E-001	01-30-17	No sample due to icy conditions.
LW	E-005	01-30-17	No sample due to icy conditions.
LW	E-006	01-30-17	No sample due to icy conditions.
LW	E-033	01-30-17	No sample due to icy conditions.
AP/AI	E-02	02-01-17	Loss of power.
AP/AI	E-02	02-22-17	Loss of power.
AP/AI	E-02	03-01-17	Breaker tripped after 5 hours.
AP/AI	E-04	04-19-17	Loss of power due to storm.
SL	E-05, 12	06-30-17	Samples not available.
SL	E-05	08-02-17	Sample not available.
LW	E-006	12-14-17	No sample due to icy conditions.
LW	E-033	12-14-17	No sample due to icy conditions.

POINT BEACH NUCLEAR PLANT

3.0 Data Tables

POINT BEACH NUCLEAR PLANT

Table 1. Airborne particulates and charcoal canisters, analyses for gross beta and iodine-131.

Location: E-01, Meteorological Tower

Units: pCi/m³

Collection: Continuous, weekly exchange.

Date Collected	Vol. (m ³)	Gross Beta	I-131	Date Collected	Vol. (m ³)	Gross Beta	I-131
<u>Required LLD</u>		<u>0.010</u>	<u>0.030</u>	<u>Required LLD</u>		<u>0.010</u>	<u>0.030</u>
01-04-17	304	0.030 ± 0.004	< 0.006	07-05-17	292	0.020 ± 0.003	< 0.010
01-10-17	257	0.025 ± 0.004	< 0.010	07-12-17	290	0.024 ± 0.004	< 0.010
01-18-17	361	0.034 ± 0.004	< 0.006	07-19-17	290	0.010 ± 0.003	< 0.012
01-25-17	292	0.026 ± 0.004	< 0.009	07-26-17	302	0.022 ± 0.003	< 0.007
02-01-17	308	0.017 ± 0.003	< 0.010	08-02-17	302	0.020 ± 0.003	< 0.010
02-08-17	313	0.032 ± 0.004	< 0.008	08-09-17	300	0.016 ± 0.003	< 0.010
02-15-17	292	0.024 ± 0.004	< 0.008	08-16-17	298	0.026 ± 0.004	< 0.008
02-22-17	289	0.026 ± 0.004	< 0.008	08-23-17	302	0.030 ± 0.004	< 0.009
03-01-17	303	0.018 ± 0.003	< 0.005	08-30-17	300	0.027 ± 0.004	< 0.009
03-08-17	306	0.026 ± 0.004	< 0.007	09-06-17	300	0.020 ± 0.003	< 0.006
03-15-17	299	0.026 ± 0.004	< 0.007	09-13-17	300	0.023 ± 0.003	< 0.008
03-23-17	336	0.022 ± 0.003	< 0.008	09-20-17	306	0.027 ± 0.004	< 0.006
03-30-17	298	0.020 ± 0.003	< 0.009	09-27-17	305	0.046 ± 0.004	< 0.009
<u>1st Quarter</u>				<u>3rd Quarter</u>			
Mean ± s.d.		0.025 ± 0.005	< 0.008	Mean ± s.d.		0.024 ± 0.008	< 0.009
04-05-17	252	0.021 ± 0.004	< 0.010	10-05-17	365	0.024 ± 0.003	< 0.007
04-12-17	296	0.017 ± 0.003	< 0.011	10-11-17	260	0.032 ± 0.004	< 0.019
04-19-17	299	0.019 ± 0.003	< 0.005	10-18-17	297	0.026 ± 0.004	< 0.007
04-26-17	302	0.013 ± 0.003	< 0.010	10-25-17	300	0.031 ± 0.004	< 0.005
05-04-17	345	0.015 ± 0.003	< 0.010	11-01-17	306	0.011 ± 0.003	< 0.009
05-11-17	314	0.018 ± 0.003	< 0.008	11-08-17	301	0.021 ± 0.003	< 0.010
05-17-17	254	0.022 ± 0.004	< 0.011	11-15-17	312	0.041 ± 0.004	< 0.007
05-24-17	314	0.016 ± 0.003	< 0.010	11-22-17	307	0.030 ± 0.004	< 0.007
05-31-17	297	0.015 ± 0.003	< 0.009	11-29-17	301	0.032 ± 0.004	< 0.004
06-07-17	297	0.020 ± 0.003	< 0.009	12-06-17	295	0.036 ± 0.004	< 0.008
06-14-17	306	0.029 ± 0.004	< 0.006	12-13-17	301	0.022 ± 0.003	< 0.008
06-21-17	314	0.015 ± 0.003	< 0.010	12-20-17	312	0.031 ± 0.004	< 0.006
06-28-17	300	0.015 ± 0.003	< 0.009	12-28-17	349	0.030 ± 0.004	< 0.009
<u>2nd Quarter</u>				<u>4th Quarter</u>			
Mean ± s.d.		0.018 ± 0.004	< 0.009	Mean ± s.d.		0.029 ± 0.007	< 0.008
<u>Cumulative Average</u>						0.024 ± 0.007	< 0.008

POINT BEACH NUCLEAR PLANT

Table 1. Airborne particulates and charcoal canisters, analyses for gross beta and iodine-131.
 Location: E-02, Site Boundary Control Center
 Units: pCi/m³
 Collection: Continuous, weekly exchange.

Date Collected	Vol. (m ³)	Gross Beta	I-131	Date Collected	Vol. (m ³)	Gross Beta	I-131
<u>Required LLD</u>		<u>0.010</u>	<u>0.030</u>	<u>Required LLD</u>		<u>0.010</u>	<u>0.030</u>
01-04-17	303	0.026 ± 0.004	< 0.006	07-05-17	296	0.017 ± 0.003	< 0.010
01-10-17	267	0.022 ± 0.004	< 0.010	07-12-17	300	0.023 ± 0.003	< 0.010
01-18-17	362	0.033 ± 0.004	< 0.006	07-19-17	300	0.008 ± 0.003	< 0.011
01-25-17	296	0.024 ± 0.004	< 0.009	07-26-17	298	0.020 ± 0.003	< 0.008
02-01-17		ND ^a		08-02-17	297	0.024 ± 0.003	< 0.010
02-08-17	302	0.026 ± 0.004	< 0.008	08-09-17	303	0.016 ± 0.003	< 0.010
02-15-17	297	0.028 ± 0.004	< 0.008	08-16-17	304	0.027 ± 0.004	< 0.007
02-22-17		ND ^a		08-23-17	302	0.029 ± 0.004	< 0.009
03-01-17		ND ^a		08-30-17	302	0.024 ± 0.003	< 0.009
03-08-17	303	0.023 ± 0.004	< 0.007	09-06-17	303	0.019 ± 0.003	< 0.006
03-15-17	302	0.027 ± 0.004	< 0.007	09-13-17	303	0.020 ± 0.003	< 0.008
03-23-17	342	0.027 ± 0.003	< 0.008	09-20-17	303	0.031 ± 0.004	< 0.007
03-30-17	298	0.015 ± 0.003	< 0.009	09-27-17	296	0.046 ± 0.005	< 0.009
<u>1st Quarter</u>				<u>3rd Quarter</u>			
Mean ± s.d.		0.025 ± 0.005	< 0.008	Mean ± s.d.		0.023 ± 0.009	< 0.009
04-05-17	256	0.022 ± 0.004	< 0.009	10-05-17	348	0.024 ± 0.003	< 0.008
04-12-17	305	0.021 ± 0.003	< 0.011	10-11-17	262	0.032 ± 0.004	< 0.019
04-19-17	302	0.018 ± 0.003	< 0.005	10-18-17	292	0.023 ± 0.003	< 0.007
04-26-17	302	0.014 ± 0.003	< 0.010	10-25-17	288	0.031 ± 0.004	< 0.005
				11-01-17	303	0.011 ± 0.003	< 0.009
05-04-17	342	0.017 ± 0.003	< 0.010				
05-11-17	309	0.021 ± 0.003	< 0.008	11-08-17	305	0.022 ± 0.003	< 0.010
05-17-17	252	0.019 ± 0.004	< 0.012	11-15-17	306	0.038 ± 0.004	< 0.007
05-24-17	314	0.019 ± 0.003	< 0.010	11-22-17	302	0.031 ± 0.004	< 0.008
05-31-17	296	0.015 ± 0.003	< 0.009	11-29-17	298	0.036 ± 0.004	< 0.004
06-07-17	296	0.022 ± 0.003	< 0.009	12-06-17	301	0.039 ± 0.004	< 0.007
06-14-17	304	0.033 ± 0.004	< 0.007	12-13-17	306	0.022 ± 0.003	< 0.007
06-21-17	300	0.017 ± 0.003	< 0.010	12-20-17	303	0.030 ± 0.004	< 0.006
06-28-17	301	0.012 ± 0.003	< 0.009	12-28-17	353	0.028 ± 0.003	< 0.008
				01-03-18	258	0.035 ± 0.005	< 0.010
<u>2nd Quarter</u>				<u>4th Quarter</u>			
Mean ± s.d.		0.019 ± 0.005	< 0.009	Mean ± s.d.		0.029 ± 0.008	< 0.008
<u>Cumulative Average</u>						0.024 ± 0.008	< 0.009

^a "ND" = No data; see Table 2.0, Listing of Missed Samples.

POINT BEACH NUCLEAR PLANT

Table 1. Airborne particulates and charcoal canisters, analyses for gross beta and iodine-131.
 Location: E-03, West Boundary
 Units: pCi/m³
 Collection: Continuous, weekly exchange.

Date Collected	Vol. (m ³)	Gross Beta	I-131	Date Collected	Vol. (m ³)	Gross Beta	I-131
<u>Required LLD</u>		<u>0.010</u>	<u>0.030</u>	<u>Required LLD</u>		<u>0.010</u>	<u>0.030</u>
01-04-17	304	0.031 ± 0.004	< 0.006	07-05-17	293	0.017 ± 0.003	< 0.010
01-10-17	268	0.026 ± 0.004	< 0.010	07-12-17	292	0.025 ± 0.004	< 0.010
01-18-17	362	0.032 ± 0.004	< 0.006	07-19-17	292	0.009 ± 0.003	< 0.011
01-25-17	300	0.029 ± 0.004	< 0.009	07-26-17	299	0.017 ± 0.003	< 0.007
02-01-17	306	0.014 ± 0.003	< 0.010	08-02-17	301	0.023 ± 0.003	< 0.010
02-08-17	305	0.027 ± 0.004	< 0.008	08-09-17	300	0.018 ± 0.003	< 0.010
02-15-17	298	0.028 ± 0.004	< 0.008	08-16-17	303	0.024 ± 0.003	< 0.007
02-22-17	294	0.025 ± 0.004	< 0.008	08-23-17	296	0.030 ± 0.004	< 0.009
03-01-17	314	0.023 ± 0.003	< 0.005	08-30-17	308	0.022 ± 0.003	< 0.009
03-08-17	311	0.022 ± 0.003	< 0.007	09-06-17	304	0.020 ± 0.003	< 0.006
03-15-17	310	0.025 ± 0.004	< 0.007	09-13-17	304	0.021 ± 0.003	< 0.008
03-23-17	343	0.021 ± 0.003	< 0.008	09-20-17	297	0.030 ± 0.004	< 0.007
03-30-17	304	0.019 ± 0.003	< 0.009	09-27-17	289	0.042 ± 0.004	< 0.009
<u>1st Quarter Mean ± s.d.</u>		<u>0.025 ± 0.005 < 0.008</u>		<u>3rd Quarter Mean ± s.d.</u>		<u>0.023 ± 0.008 < 0.009</u>	
04-05-17	255	0.023 ± 0.004	< 0.009	10-05-17	346	0.022 ± 0.003	< 0.008
04-12-17	301	0.018 ± 0.003	< 0.011	10-11-17	266	0.029 ± 0.004	< 0.019
04-19-17	303	0.018 ± 0.003	< 0.005	10-18-17	294	0.025 ± 0.004	< 0.007
04-26-17	306	0.015 ± 0.003	< 0.010	10-25-17	304	0.026 ± 0.004	< 0.005
05-04-17	348	0.012 ± 0.003	< 0.009	11-01-17	304	0.010 ± 0.003	< 0.009
05-11-17	306	0.018 ± 0.003	< 0.008	11-08-17	304	0.026 ± 0.004	< 0.010
05-17-17	258	0.020 ± 0.004	< 0.011	11-15-17	305	0.039 ± 0.004	< 0.007
05-24-17	313	0.016 ± 0.003	< 0.010	11-22-17	305	0.030 ± 0.004	< 0.008
05-31-17	297	0.016 ± 0.003	< 0.009	11-29-17	293	0.028 ± 0.004	< 0.004
06-07-17	297	0.023 ± 0.003	< 0.009	12-06-17	296	0.035 ± 0.004	< 0.008
06-14-17	302	0.027 ± 0.004	< 0.007	12-13-17	304	0.022 ± 0.003	< 0.007
06-21-17	295	0.015 ± 0.003	< 0.011	12-20-17	312	0.028 ± 0.004	< 0.006
06-28-17	294	0.012 ± 0.003	< 0.009	12-28-17	355	0.030 ± 0.003	< 0.008
<u>2nd Quarter Mean ± s.d.</u>		<u>0.018 ± 0.004 < 0.009</u>		01-03-18	259	0.036 ± 0.005	< 0.010
				<u>4th Quarter Mean ± s.d.</u>		<u>0.028 ± 0.007 < 0.008</u>	
<u>Cumulative Average</u>						<u>0.023 ± 0.007</u>	<u>< 0.008</u>

POINT BEACH NUCLEAR PLANT

Table 1. Airborne particulates and charcoal canisters, analyses for gross beta and iodine-131.

Location: E-04, North Boundary

Units: pCi/m³

Collection: Continuous, weekly exchange.

Date Collected	Vol. (m ³)	Gross Beta	I-131	Date Collected	Vol. (m ³)	Gross Beta	I-131
<u>Required LLD</u>		<u>0.010</u>	<u>0.030</u>	<u>Required LLD</u>		<u>0.010</u>	<u>0.030</u>
01-04-17	306	0.035 ± 0.004	< 0.006	07-05-17	300	0.015 ± 0.003	< 0.010
01-10-17	271	0.022 ± 0.004	< 0.010	07-12-17	297	0.026 ± 0.004	< 0.010
01-18-17	358	0.033 ± 0.004	< 0.006	07-19-17	297	0.010 ± 0.003	< 0.011
01-25-17	296	0.031 ± 0.004	< 0.009	07-26-17	302	0.020 ± 0.003	< 0.007
02-01-17	304	0.016 ± 0.003	< 0.010	08-02-17	308	0.026 ± 0.003	< 0.010
02-08-17	308	0.028 ± 0.004	< 0.008	08-09-17	299	0.017 ± 0.003	< 0.010
02-15-17	298	0.026 ± 0.004	< 0.008	08-16-17	297	0.027 ± 0.004	< 0.008
02-22-17	296	0.028 ± 0.004	< 0.008	08-23-17	300	0.028 ± 0.004	< 0.009
03-01-17	314	0.022 ± 0.003	< 0.005	08-30-17	300	0.022 ± 0.003	< 0.009
03-08-17	308	0.023 ± 0.003	< 0.007	09-06-17	305	0.018 ± 0.003	< 0.006
03-15-17	310	0.028 ± 0.004	< 0.007	09-13-17	305	0.020 ± 0.003	< 0.008
03-23-17	340	0.022 ± 0.003	< 0.008	09-20-17	297	0.035 ± 0.004	< 0.007
03-30-17	303	0.023 ± 0.003	< 0.009	09-27-17	306	0.043 ± 0.004	< 0.008
<u>1st Quarter</u>				<u>3rd Quarter</u>			
Mean ± s.d.		0.026 ± 0.005 < 0.008		Mean ± s.d.		0.024 ± 0.009 < 0.009	
04-05-17	255	0.025 ± 0.004	< 0.009	10-05-17	356	0.022 ± 0.003	< 0.008
04-12-17	305	0.019 ± 0.003	< 0.011	10-11-17	260	0.034 ± 0.004	< 0.019
04-19-17		ND ^a		10-18-17	293	0.024 ± 0.004	< 0.007
04-26-17	294	0.017 ± 0.003	< 0.010	10-25-17	301	0.028 ± 0.004	< 0.005
05-04-17	357	0.014 ± 0.003	< 0.009	11-01-17	307	0.010 ± 0.003	< 0.009
05-11-17	313	0.020 ± 0.003	< 0.008	11-08-17	305	0.021 ± 0.003	< 0.010
05-17-17	196	0.012 ± 0.004	< 0.015	11-15-17	309	0.045 ± 0.004	< 0.007
05-24-17	304	0.016 ± 0.003	< 0.011	11-22-17	302	0.031 ± 0.004	< 0.008
05-31-17	294	0.013 ± 0.003	< 0.009	11-29-17	300	0.036 ± 0.004	< 0.004
06-07-17	294	0.022 ± 0.003	< 0.009	12-06-17	302	0.029 ± 0.004	< 0.007
06-14-17	301	0.030 ± 0.004	< 0.007	12-13-17	309	0.024 ± 0.004	< 0.007
06-21-17	294	0.012 ± 0.003	< 0.011	12-20-17	309	0.030 ± 0.004	< 0.006
06-28-17	299	0.013 ± 0.003	< 0.009	12-28-17	352	0.027 ± 0.003	< 0.009
<u>2nd Quarter</u>				01-03-18	264	0.040 ± 0.005	< 0.010
Mean ± s.d.		0.018 ± 0.005 < 0.010		<u>4th Quarter</u>			
				Mean ± s.d.		0.029 ± 0.009 < 0.008	
<u>Cumulative Average</u>						0.024 ± 0.008	< 0.009

^a"ND" = No data; see Table 2.0, Listing of Missed Samples.

POINT BEACH NUCLEAR PLANT

Table 1. Airborne particulates and charcoal canisters, analyses for gross beta and iodine-131.
 Location: E-08, G.J. Francar Residence
 Units: pCi/m³
 Collection: Continuous, weekly exchange.

Date Collected	Vol. (m ³)	Gross Beta	I-131	Date Collected	Vol. (m ³)	Gross Beta	I-131
<u>Required LLD</u>		<u>0.010</u>	<u>0.030</u>	<u>Required LLD</u>		<u>0.010</u>	<u>0.030</u>
01-04-17	313	0.030 ± 0.004	< 0.006	07-05-17	299	0.015 ± 0.003	< 0.010
01-10-17	273	0.025 ± 0.004	< 0.010	07-12-17	302	0.022 ± 0.003	< 0.010
01-18-17	361	0.032 ± 0.004	< 0.006	07-19-17	302	0.010 ± 0.003	< 0.011
01-25-17	304	0.026 ± 0.004	< 0.009	07-26-17	301	0.019 ± 0.003	< 0.007
02-01-17	311	0.017 ± 0.003	< 0.010	08-02-17	303	0.025 ± 0.003	< 0.010
02-08-17	309	0.029 ± 0.004	< 0.008	08-09-17	295	0.018 ± 0.003	< 0.011
02-15-17	297	0.025 ± 0.004	< 0.008	08-16-17	301	0.024 ± 0.003	< 0.007
02-22-17	289	0.028 ± 0.004	< 0.008	08-23-17	299	0.031 ± 0.004	< 0.009
03-01-17	308	0.024 ± 0.004	< 0.005	08-30-17	304	0.021 ± 0.003	< 0.009
03-08-17	307	0.024 ± 0.004	< 0.007	09-06-17	309	0.018 ± 0.003	< 0.006
03-15-17	314	0.027 ± 0.004	< 0.007	09-13-17	309	0.021 ± 0.003	< 0.008
03-23-17	349	0.024 ± 0.003	< 0.008	09-20-17	304	0.029 ± 0.004	< 0.006
03-30-17	300	0.015 ± 0.003	< 0.009	09-27-17	304	0.042 ± 0.004	< 0.009
<u>1st Quarter</u>				<u>3rd Quarter</u>			
Mean ± s.d.		0.025 ± 0.005 < 0.008		Mean ± s.d.		0.023 ± 0.008 < 0.009	
04-05-17	257	0.017 ± 0.004	< 0.009	10-05-17	359	0.023 ± 0.003	< 0.008
04-12-17	300	0.015 ± 0.003	< 0.011	10-11-17	254	0.033 ± 0.004	< 0.020
04-19-17	299	0.017 ± 0.003	< 0.005	10-18-17	291	0.024 ± 0.004	< 0.007
04-26-17	296	0.015 ± 0.003	< 0.010	10-25-17	301	0.030 ± 0.004	< 0.005
05-04-17	351	0.015 ± 0.003	< 0.009	11-01-17	300	0.013 ± 0.003	< 0.009
05-11-17	303	0.023 ± 0.003	< 0.008	11-08-17	302	0.019 ± 0.003	< 0.010
05-17-17	257	0.022 ± 0.004	< 0.011	11-15-17	309	0.039 ± 0.004	< 0.007
05-24-17	317	0.018 ± 0.003	< 0.010	11-22-17	310	0.029 ± 0.004	< 0.007
05-31-17	298	0.015 ± 0.003	< 0.009	11-29-17	299	0.030 ± 0.004	< 0.004
06-07-17	298	0.021 ± 0.003	< 0.009	12-06-17	295	0.032 ± 0.004	< 0.008
06-14-17	297	0.026 ± 0.004	< 0.007	12-13-17	301	0.019 ± 0.003	< 0.008
06-21-17	287	0.014 ± 0.003	< 0.011	12-20-17	313	0.028 ± 0.004	< 0.006
06-28-17	299	0.011 ± 0.003	< 0.009	12-28-17	352	0.025 ± 0.003	< 0.009
<u>2nd Quarter</u>				<u>4th Quarter</u>			
Mean ± s.d.		0.018 ± 0.004 < 0.009		Mean ± s.d.		0.027 ± 0.007 < 0.008	
Cumulative Average						0.023 ± 0.007	< 0.008
Indicator Locations Annual Mean ± s.d.						0.024 ± 0.007	< 0.009

POINT BEACH NUCLEAR PLANT

Table 1. Airborne particulates and charcoal canisters, analyses for gross beta and iodine-131.

Location: E-20, Silver Lake

Units: pCi/m³

Collection: Continuous, weekly exchange.

Date Collected	Vol. (m ³)	Gross Beta	I-131	Date Collected	Vol. (m ³)	Gross Beta	I-131
<u>Required LLD</u>		<u>0.010</u>	<u>0.030</u>	<u>Required LLD</u>		<u>0.010</u>	<u>0.030</u>
01-04-17	308	0.033 ± 0.004	< 0.006	07-05-17	299	0.020 ± 0.003	< 0.010
01-10-17	263	0.028 ± 0.004	< 0.010	07-12-17	296	0.022 ± 0.003	< 0.010
01-18-17	366	0.034 ± 0.004	< 0.006	07-19-17	296	0.013 ± 0.003	< 0.011
01-25-17	301	0.029 ± 0.004	< 0.009	07-26-17	294	0.021 ± 0.003	< 0.008
02-01-17	308	0.019 ± 0.003	< 0.010	08-02-17	290	0.027 ± 0.004	< 0.010
02-08-17	311	0.027 ± 0.004	< 0.008	08-09-17	302	0.019 ± 0.003	< 0.010
02-15-17	302	0.031 ± 0.004	< 0.008	08-16-17	302	0.026 ± 0.004	< 0.007
02-22-17	295	0.028 ± 0.004	< 0.008	08-23-17	300	0.032 ± 0.004	< 0.009
03-01-17	317	0.020 ± 0.003	< 0.005	08-30-17	304	0.025 ± 0.003	< 0.009
03-08-17	315	0.026 ± 0.004	< 0.007	09-06-17	313	0.020 ± 0.003	< 0.006
03-15-17	320	0.027 ± 0.004	< 0.007	09-13-17	313	0.025 ± 0.003	< 0.008
03-23-17	342	0.028 ± 0.003	< 0.008	09-20-17	300	0.034 ± 0.004	< 0.007
03-30-17	302	0.016 ± 0.003	< 0.009	09-27-17	298	0.042 ± 0.004	< 0.009
1st Quarter				3rd Quarter			
Mean ± s.d.		0.027 ± 0.005 < 0.008		Mean ± s.d.		0.025 ± 0.007 < 0.009	
04-05-17	257	0.018 ± 0.004	< 0.009	10-05-17	360	0.022 ± 0.003	< 0.008
04-12-17	304	0.014 ± 0.003	< 0.011	10-11-17	258	0.030 ± 0.004	< 0.019
04-19-17	297	0.021 ± 0.004	< 0.005	10-18-17	300	0.024 ± 0.003	< 0.006
04-26-17	302	0.013 ± 0.003	< 0.010	10-25-17	302	0.027 ± 0.004	< 0.005
05-04-17	355	0.013 ± 0.003	< 0.009	11-01-17	306	0.010 ± 0.003	< 0.009
05-11-17	312	0.022 ± 0.003	< 0.008	11-08-17	311	0.023 ± 0.003	< 0.009
05-17-17	258	0.021 ± 0.004	< 0.011	11-15-17	308	0.040 ± 0.004	< 0.007
05-24-17	318	0.019 ± 0.003	< 0.010	11-22-17	306	0.032 ± 0.004	< 0.008
05-31-17	296	0.019 ± 0.003	< 0.009	11-29-17	304	0.032 ± 0.004	< 0.004
06-07-17	296	0.023 ± 0.003	< 0.009	12-06-17	298	0.036 ± 0.004	< 0.007
06-14-17	300	0.027 ± 0.004	< 0.007	12-13-17	300	0.026 ± 0.004	< 0.008
06-21-17	293	0.013 ± 0.003	< 0.011	12-20-17	317	0.031 ± 0.004	< 0.006
06-28-17	297	0.012 ± 0.003	< 0.009	12-28-17	356	0.030 ± 0.004	< 0.008
2nd Quarter				4th Quarter			
Mean ± s.d.		0.018 ± 0.005 < 0.009		Mean ± s.d.		0.029 ± 0.008 < 0.008	
Cumulative Average						0.025 ± 0.007	< 0.008
Control Annual Mean ± s.d.						0.025 ± 0.007	< 0.008

POINT BEACH NUCLEAR PLANT

Table 2. Gamma emitters in quarterly composites of air particulate filters

Units: pCi/m³

Location	Lab Code Req. LLD	Be-7 -	Be-7 MDC	Cs-134 0.01	Cs-134 MDC	Cs-137 0.01	Cs-137 MDC	(Other) Co-60 (0.10)	(Other) (Co-60) MDC	Volume m ³
<u>1st Quarter</u>										
E-01	EAP- 1693	0.072 ± 0.013	-	0.0000 ± 0.0005	< 0.0010	0.0005 ± 0.0006	< 0.0007	-0.0005 ± 0.0006	< 0.0006	3956
E-02	- 1694	0.068 ± 0.016	-	0.0002 ± 0.0005	< 0.0008	-0.0003 ± 0.0005	< 0.0007	0.0006 ± 0.0005	< 0.0006	3073
E-03	- 1695	0.061 ± 0.014	-	-0.0002 ± 0.0003	< 0.0007	0.0001 ± 0.0004	< 0.0006	-0.0002 ± 0.0004	< 0.0005	4018
E-04	- 1696	0.066 ± 0.018	-	-0.0001 ± 0.0005	< 0.0009	-0.0003 ± 0.0005	< 0.0007	-0.0003 ± 0.0006	< 0.0004	4012
E-08	- 1697	0.065 ± 0.016	-	0.0003 ± 0.0005	< 0.0008	0.0001 ± 0.0005	< 0.0007	0.0004 ± 0.0006	< 0.0008	4035
E-20	- 1698	0.061 ± 0.015	-	-0.0002 ± 0.0006	< 0.0010	0.0000 ± 0.0006	< 0.0010	-0.0001 ± 0.0006	< 0.0004	4049
<u>2nd Quarter</u>										
E-01	EAP- 3707	0.090 ± 0.016		0.0002 ± 0.0004	< 0.0007	-0.0001 ± 0.0005	< 0.0007	0.0003 ± 0.0004	< 0.0007	3889
E-02	- 3708	0.100 ± 0.016		0.0000 ± 0.0004	< 0.0008	0.0001 ± 0.0004	< 0.0007	0.0001 ± 0.0004	< 0.0005	3878
E-03	- 3709	0.093 ± 0.014		0.0001 ± 0.0004	< 0.0006	0.0002 ± 0.0004	< 0.0006	-0.0003 ± 0.0004	< 0.0003	3873
E-04	- 3710	0.090 ± 0.018		-0.0005 ± 0.0006	< 0.0010	0.0004 ± 0.0006	< 0.0010	0.0003 ± 0.0008	< 0.0012	3508
E-08	- 3711	0.089 ± 0.016		0.0003 ± 0.0005	< 0.0010	-0.0004 ± 0.0005	< 0.0008	0.0007 ± 0.0006	< 0.0008	3857
E-20	- 3712	0.097 ± 0.015		-0.0003 ± 0.0004	< 0.0008	0.0001 ± 0.0004	< 0.0006	0.0001 ± 0.0005	< 0.0005	3885
<u>3rd Quarter</u>										
E-01	EAP- 5570	0.080 ± 0.011		-0.0001 ± 0.0003	< 0.0004	0.0003 ± 0.0003	< 0.0006	0.0001 ± 0.0003	< 0.0004	3885
E-02	- 5571	0.091 ± 0.014		0.0001 ± 0.0004	< 0.0007	0.0003 ± 0.0004	< 0.0008	-0.0001 ± 0.0005	< 0.0008	3905
E-03	- 5572	0.075 ± 0.014		-0.0001 ± 0.0004	< 0.0008	0.0002 ± 0.0004	< 0.0006	0.0000 ± 0.0004	< 0.0007	3879
E-04	- 5574	0.076 ± 0.012		0.0000 ± 0.0004	< 0.0007	0.0002 ± 0.0004	< 0.0007	0.0002 ± 0.0003	< 0.0004	3911
E-08	- 5575	0.077 ± 0.018		-0.0002 ± 0.0005	< 0.0010	-0.0001 ± 0.0006	< 0.0008	-0.0004 ± 0.0006	< 0.0007	3932
E-20	- 5576	0.097 ± 0.020		-0.0018 ± 0.0007	< 0.0010	0.0003 ± 0.0006	< 0.0008	0.0007 ± 0.0006	< 0.0008	3906
<u>4th Quarter</u>										
E-01	EAP- 6818	0.061 ± 0.012		-0.0001 ± 0.0005	< 0.0009	0.0003 ± 0.0005	< 0.0007	-0.0004 ± 0.0006	< 0.0005	4260
E-02	- 6819	0.063 ± 0.015		0.0001 ± 0.0005	< 0.0007	0.0007 ± 0.0005	< 0.0008	-0.0006 ± 0.0006	< 0.0004	4225
E-03	- 6820	0.056 ± 0.010		0.0000 ± 0.0003	< 0.0007	0.0002 ± 0.0004	< 0.0007	0.0001 ± 0.0004	< 0.0005	4247
E-04	- 6821	0.056 ± 0.009		0.0000 ± 0.0003	< 0.0006	0.0001 ± 0.0003	< 0.0005	-0.0001 ± 0.0004	< 0.0005	4269
E-08	- 6822	0.058 ± 0.012		-0.0002 ± 0.0004	< 0.0007	-0.0001 ± 0.0005	< 0.0005	0.0004 ± 0.0005	< 0.0007	4248
E-20	- 6823	0.056 ± 0.013		0.0001 ± 0.0004	< 0.0004	0.0001 ± 0.0004	< 0.0006	-0.0005 ± 0.0005	< 0.0005	4288
Annual Means ± s.d.		0.075 ± 0.015		-0.0001 ± 0.0004	< 0.0008	0.0001 ± 0.0002	< 0.0007	0.0000 ± 0.0004	< 0.0006	

POINT BEACH NUCLEAR PLANT

Table 3. Radioactivity in milk samples

Collection: Monthly

Sample Description and Concentration (pCi/L)							
<u>E-11 Lambert Dairy Farm</u>							
Collection Date	01-18-17	MDC	02-08-17	MDC	03-08-17	MDC	Required LLD
Lab Code	EMI- 227		EMI- 504		EMI- 915		
Sr-89	-0.4 ± 0.7	< 0.7	0.6 ± 0.7	< 0.8	0.0 ± 0.8	< 0.8	5.0
Sr-90	0.8 ± 0.3	< 0.6	0.4 ± 0.3	< 0.5	0.5 ± 0.3	< 0.6	1.0
I-131	0.22 ± 0.22	< 0.42	0.10 ± 0.19	< 0.35	0.00 ± 0.13	< 0.23	0.5
K-40	1405 ± 103	-	1391 ± 104	-	1481 ± 101	-	
Cs-134	-1.0 ± 1.6	< 3.4	-0.9 ± 1.9	< 3.9	0.1 ± 1.7	< 3.0	5.0
Cs-137	1.5 ± 2.0	< 3.1	-0.1 ± 2.3	< 4.0	0.9 ± 1.9	< 3.1	5.0
Ba-La-140	1.3 ± 1.7	< 4.5	0.9 ± 1.4	< 2.5	0.9 ± 1.8	< 2.6	5.0
Other (Co-60)	-1.2 ± 1.9	< 1.9	3.4 ± 2.2	< 3.9	1.0 ± 1.8	< 3.0	15.0
Collection Date	04-12-17		05-10-17		06-14-17		
Lab Code	EMI- 1492		EMI- 2093		EMI- 2896		
Sr-89	0.5 ± 0.7	< 0.6	-0.4 ± 0.7	< 0.7	-0.7 ± 0.8	< 0.7	5.0
Sr-90	0.6 ± 0.3	< 0.5	0.6 ± 0.3	< 0.5	1.1 ± 0.3	< 0.5	1.0
I-131	-0.12 ± 0.34	< 0.34	0.04 ± 0.13	< 0.23	-0.03 ± 0.19	< 0.34	0.5
K-40	1367 ± 90	-	1405 ± 41	-	1422 ± 40	-	
Cs-134	-0.1 ± 1.6	< 2.8	-0.3 ± 0.7	< 1.2	-0.3 ± 0.7	< 1.2	5.0
Cs-137	-0.4 ± 1.9	< 3.3	0.4 ± 0.8	< 1.6	0.6 ± 0.7	< 1.4	5.0
Ba-La-140	-0.4 ± 1.8	< 2.8	-1.0 ± 0.7	< 3.5	-0.6 ± 0.6	< 1.1	5.0
Other (Co-60)	-1.5 ± 1.8	< 2.2	0.1 ± 0.8	< 1.2	0.1 ± 0.8	< 1.4	15.0

POINT BEACH NUCLEAR PLANT

Table 3. Radioactivity in milk samples

Collection: Monthly

Sample Description and Concentration (pCi/L)							
Collection Date	E-11 Lambert Dairy Farm						Required LLD
	07-12-17	MDC	08-09-17	MDC	09-13-17	MDC	
Lab Code	EMI- 3358		EMI- 4072		EMI- 4671		
Sr-89	0.8 ± 0.8	< 0.7	-0.2 ± 0.8	< 0.8	0.0 ± 0.6	< 0.7	5.0
Sr-90	0.9 ± 0.3	< 0.5	0.8 ± 0.3	< 0.5	0.5 ± 0.3	< 0.5	1.0
I-131	0.04 ± 0.19	< 0.39	0.06 ± 0.12	< 0.21	0.07 ± 0.20	< 0.39	0.5
K-40	1416 ± 49	-	1341 ± 101	-	1283 ± 118	-	
Cs-134	-0.1 ± 0.8	< 1.6	-0.9 ± 1.8	< 3.3	0.7 ± 2.1	< 3.8	5.0
Cs-137	0.1 ± 1.0	< 1.8	1.7 ± 1.9	< 2.9	0.6 ± 2.4	< 4.0	5.0
Ba-La-140	-0.3 ± 0.8	< 4.1	1.4 ± 1.5	< 3.0	-2.5 ± 1.8	< 1.4	5.0
Other (Co-60)	1.0 ± 0.9	< 1.6	-2.5 ± 2.3	< 2.0	-0.5 ± 2.6	< 3.2	15.0
Collection Date	10-11-17		11-08-17		12-13-17		Required LLD
Lab Code	EMI- 5276		EMI- 5940		EMI- 6475		
Sr-89	0.4 ± 0.8	< 0.8	-0.2 ± 0.7	< 0.7	0.2 ± 0.8	< 0.8	5.0
Sr-90	0.6 ± 0.3	< 0.5	0.6 ± 0.3	< 0.5	0.5 ± 0.3	< 0.6	1.0
I-131	0.06 ± 0.08	< 0.10	0.03 ± 0.20	< 0.40	-0.04 ± 0.19	< 0.34	0.5
K-40	1280 ± 101	-	1282 ± 108	-	1242 ± 106	-	
Cs-134	-0.3 ± 1.6	< 2.6	0.0 ± 1.8	< 3.4	-0.5 ± 2.0	< 3.7	5.0
Cs-137	-0.5 ± 1.8	< 2.4	-0.1 ± 1.9	< 2.8	0.2 ± 2.3	< 3.0	5.0
Ba-La-140	0.3 ± 1.9	< 3.2	-1.1 ± 1.7	< 3.0	1.4 ± 1.7	< 2.7	5.0
Other (Co-60)	2.6 ± 2.0	< 2.4	-0.5 ± 2.1	< 3.1	0.8 ± 2.1	< 2.2	15.0

POINT BEACH NUCLEAR PLANT

Table 3. Radioactivity in milk samples

Collection: Monthly

Sample Description and Concentration (pCi/L)							
Collection Date	01-18-17		02-08-17		03-08-17		Required LLD
	EMI- 228	MDC	EMI- 505	MDC	EMI- 916	MDC	
Sr-89	-0.1 ± 0.8	< 0.7	-0.4 ± 0.7	< 0.8	-0.2 ± 0.7	< 0.8	5.0
Sr-90	0.4 ± 0.3	< 0.5	0.5 ± 0.3	< 0.5	0.3 ± 0.3	< 0.6	1.0
I-131	0.16 ± 0.18	< 0.32	-0.03 ± 0.15	< 0.22	0.21 ± 0.22	< 0.43	0.5
K-40	1509 ± 97	-	1433 ± 94	-	1383 ± 86	-	
Cs-134	-0.9 ± 1.4	< 2.9	2.0 ± 1.7	< 3.5	-0.8 ± 1.4	< 2.6	5.0
Cs-137	1.9 ± 1.8	< 3.6	1.0 ± 1.9	< 2.9	0.1 ± 1.8	< 2.0	5.0
Ba-La-140	0.7 ± 1.4	< 2.7	-1.2 ± 1.7	< 3.1	-1.3 ± 1.4	< 2.7	5.0
Other (Co-60)	-1.5 ± 1.8	< 1.8	-0.9 ± 2.0	< 3.2	1.3 ± 1.8	< 2.5	15.0

Collection Date	04-12-17		05-10-17		06-14-17		Required LLD
	EMI- 1493	MDC	EMI- 2094	MDC	EMI- 2897	MDC	
Sr-89	-0.5 ± 0.6	< 0.7	-0.3 ± 0.7	< 0.8	-0.4 ± 0.9	< 1.0	5.0
Sr-90	0.6 ± 0.3	< 0.5	0.3 ± 0.3	< 0.6	0.6 ± 0.4	< 0.7	1.0
I-131	0.10 ± 0.12	< 0.21	-0.06 ± 0.13	< 0.24	-0.26 ± 0.20	< 0.39	0.5
K-40	1501 ± 91	-	1466 ± 42	-	1364 ± 45	-	
Cs-134	1.4 ± 1.6	< 2.9	0.2 ± 0.7	< 1.3	0.2 ± 0.7	< 1.3	5.0
Cs-137	-1.4 ± 1.8	< 2.4	-0.3 ± 0.7	< 1.1	0.4 ± 0.8	< 1.5	5.0
Ba-La-140	-2.2 ± 1.6	< 4.1	-0.2 ± 0.6	< 2.4	-0.9 ± 0.7	< 1.8	5.0
Other (Co-60)	1.1 ± 1.9	< 3.1	0.3 ± 0.8	< 1.3	-0.1 ± 0.8	< 1.3	15.0

POINT BEACH NUCLEAR PLANT

Table 3. Radioactivity in milk samples

Collection: Monthly

Sample Description and Concentration (pCi/L)							
E-21 Strutz Dairy Farm							
Collection Date	07-12-17	MDC	08-09-17	MDC	09-13-17	MDC	Required LLD
Lab Code	EMI- 3359		EMI- 4073		EMI- 4673		
Sr-89	-0.2 ± 0.7	< 0.9	-0.1 ± 0.7	< 0.8	0.1 ± 0.8	< 0.7	5.0
Sr-90	0.4 ± 0.3	< 0.5	0.5 ± 0.3	< 0.5	0.7 ± 0.3	< 0.5	1.0
I-131	-0.01 ± 0.12	< 0.22	0.06 ± 0.15	< 0.26	-0.11 ± 0.14	< 0.27	0.5
K-40	1452 ± 46	-	1548 ± 112	-	1349 ± 111	-	
Cs-134	0.0 ± 0.7	< 1.4	-0.4 ± 1.9	< 3.8	-0.6 ± 1.6	< 2.8	5.0
Cs-137	0.7 ± 0.9	< 1.6	1.4 ± 1.9	< 3.1	1.9 ± 2.1	< 3.9	5.0
Ba-La-140	-0.6 ± 0.7	< 2.9	-1.2 ± 1.5	< 4.0	0.6 ± 1.8	< 3.0	5.0
Other (Co-60)	-0.6 ± 0.9	< 1.5	-0.3 ± 2.3	< 3.2	-0.4 ± 2.5	< 3.8	15.0
Collection Date	10-11-17		11-08-17		12-13-17		Required LLD
Lab Code	EMI- 5277		EMI- 5941		EMI- 6476		
Sr-89	-0.1 ± 0.8	< 1.0	0.1 ± 0.7	< 0.8	0.0 ± 0.7	< 0.8	5.0
Sr-90	0.1 ± 0.3	< 0.6	0.2 ± 0.3	< 0.5	0.2 ± 0.3	< 0.5	1.0
I-131	0.08 ± 0.13	< 0.23	0.17 ± 0.21	< 0.36	-0.07 ± 0.16	< 0.30	0.5
K-40	1449 ± 120	-	1436 ± 109	-	1238 ± 104	-	
Cs-134	-1.5 ± 1.9	< 3.5	0.9 ± 1.7	< 3.2	1.2 ± 1.9	< 3.4	5.0
Cs-137	-0.5 ± 2.1	< 3.0	0.7 ± 1.9	< 3.4	0.3 ± 2.3	< 3.8	5.0
Ba-La-140	-0.3 ± 1.8	< 3.5	-1.8 ± 1.6	< 2.8	1.5 ± 2.1	< 4.7	5.0
Other (Co-60)	1.8 ± 2.8	< 2.9	-1.0 ± 2.2	< 2.6	-1.7 ± 2.1	< 2.3	15.0

POINT BEACH NUCLEAR PLANT

Table 3. Radioactivity in milk samples

Collection: Monthly

Sample Description and Concentration (pCi/L)							
Collection Date	01-18-17		<u>E-40 Barta</u>		03-08-17		Required LLD
	Lab Code	MDC	02-08-17	MDC	03-08-17	MDC	
	EMI- 229		EMI- 506		EMI- 917		
Sr-89	0.0 ± 0.8	< 0.8	0.5 ± 0.6	< 0.7	-0.2 ± 0.7	< 0.7	5.0
Sr-90	0.7 ± 0.4	< 0.7	0.1 ± 0.2	< 0.5	0.4 ± 0.3	< 0.5	1.0
I-131	0.14 ± 0.25	< 0.50	0.07 ± 0.19	< 0.37	-0.03 ± 0.15	< 0.27	0.5
K-40	1406 ± 104	-	1422 ± 89	-	1493 ± 93	-	
Cs-134	-0.1 ± 1.7	< 3.2	-0.2 ± 1.5	< 2.8	-1.5 ± 1.4	< 3.1	5.0
Cs-137	0.7 ± 1.7	< 2.9	0.0 ± 1.5	< 2.8	-0.1 ± 1.6	< 3.0	5.0
Ba-La-140	0.6 ± 1.6	< 3.7	-2.1 ± 1.4	< 1.8	0.7 ± 1.3	< 3.3	5.0
Other (Co-60)	1.1 ± 1.9	< 2.6	-1.0 ± 2.0	< 2.8	1.5 ± 1.5	< 2.0	15.0
Collection Date	04-12-17		05-10-17		06-14-17		
Lab Code	EMI- 1494		EMI- 2095		EMI- 2898		
Sr-89	0.3 ± 0.6	< 0.6	-0.6 ± 0.7	< 0.7	-0.6 ± 0.7	< 0.7	5.0
Sr-90	0.3 ± 0.3	< 0.5	0.5 ± 0.3	< 0.6	0.7 ± 0.3	< 0.5	1.0
I-131	0.00 ± 0.10	< 0.19	0.03 ± 0.12	< 0.21	-0.13 ± 0.19	< 0.36	0.5
K-40	1460 ± 42	-	1461 ± 43	-	1445 ± 43	-	
Cs-134	-0.2 ± 0.7	< 1.2	-0.2 ± 0.7	< 1.4	-0.1 ± 0.7	< 1.3	5.0
Cs-137	0.3 ± 0.8	< 1.3	1.0 ± 0.8	< 1.6	0.0 ± 0.8	< 1.5	5.0
Ba-La-140	-1.5 ± 0.7	< 1.7	-1.2 ± 0.7	< 2.5	-2.3 ± 0.7	< 2.0	5.0
Other (Co-60)	-0.1 ± 0.8	< 1.2	0.6 ± 0.9	< 1.8	-0.1 ± 0.8	< 1.5	15.0

POINT BEACH NUCLEAR PLANT

Table 3. Radioactivity in milk samples

Collection: Monthly

Sample Description and Concentration (pCi/L)							
Collection Date	07-12-17		<u>E-40 Barta</u>		09-13-17		Required LLD
		MDC	08-09-17	MDC		MDC	
Lab Code	EMI- 3360		EMI- 4074		EMI- 4674		
Sr-89	0.1 ± 0.7	< 0.7	0.1 ± 0.6	< 0.7	0.2 ± 0.7	< 0.7	5.0
Sr-90	0.5 ± 0.3	< 0.4	0.3 ± 0.3	< 0.5	0.6 ± 0.3	< 0.5	1.0
I-131	-0.02 ± 0.10	< 0.18	0.03 ± 0.14	< 0.24	0.02 ± 0.12	< 0.21	0.5
K-40	1406 ± 46	-	1365 ± 109	-	1377 ± 118	-	
Cs-134	-0.5 ± 0.7	< 1.5	-0.9 ± 1.7	< 3.1	-2.4 ± 2.0	< 3.9	5.0
Cs-137	1.1 ± 0.9	< 1.6	0.9 ± 1.9	< 3.4	0.2 ± 2.2	< 3.4	5.0
Ba-La-140	-1.3 ± 0.8	< 2.5	-0.7 ± 1.4	< 3.3	-0.7 ± 2.1	< 1.9	5.0
Other (Co-60)	0.3 ± 0.9	< 1.2	0.8 ± 2.1	< 2.7	-1.1 ± 2.1	< 2.5	15.0
Collection Date	10-11-17		11-08-17		12-13-17		Required LLD
Lab Code	EMI- 5278		EMI- 5942		EMI- 6477		
Sr-89	0.2 ± 0.8	< 0.8	-0.5 ± 0.7	< 0.7	-0.3 ± 0.6	< 0.7	5.0
Sr-90	0.6 ± 0.3	< 0.5	0.4 ± 0.3	< 0.5	0.4 ± 0.3	< 0.5	1.0
I-131	0.09 ± 0.12	< 0.21	0.19 ± 0.20	< 0.34	0.04 ± 0.16	< 0.29	0.5
K-40	1408 ± 100	-	1362 ± 107	-	1383 ± 105	-	
Cs-134	-1.2 ± 1.7	< 3.0	0.8 ± 1.8	< 3.3	-1.6 ± 1.7	< 3.0	5.0
Cs-137	2.4 ± 1.9	< 3.4	0.0 ± 2.0	< 3.2	-0.2 ± 2.1	< 2.9	5.0
Ba-La-140	-0.1 ± 1.5	< 2.1	-2.0 ± 1.5	< 1.5	0.8 ± 1.8	< 1.9	5.0
Other (Co-60)	-0.4 ± 2.3	< 3.6	-0.3 ± 2.2	< 2.1	-1.7 ± 2.4	< 2.9	15.0

Sr-89 Annual Mean + s.d. -0.1 ± 0.4
Sr-90 Annual Mean + s.d. 0.5 ± 0.2
I-131 Annual Mean + s.d. 0.03 ± 0.10
K-40 Annual Mean + s.d. 1401 ± 73
Cs-134 Annual Mean + s.d. -0.3 ± 0.9
Cs-137 Annual Mean + s.d. 0.5 ± 0.8
Ba-La Annual Mean + s.d. -0.5 ± 1.2
Co-60 Annual Mean + s.d. 0.0 ± 1.2

POINT BEACH NUCLEAR PLANT

Table 4. Radioactivity in Well Water Samples, E-10
 Collection: Quarterly
 Units: pCi/L

	1st Qtr.	2nd Qtr.	3rd Qtr.	4th Qtr.	Req. LLD	Annual Mean \pm s.d
Collection Date	01-11-17	04-13-17	07-13-17	10-11-17		
Lab Code	EWV- 133	EWV- 1540	EWV- 3496	EWV- 5306		
Gross Beta	1.6 \pm 1.1	0.6 \pm 1.0	1.4 \pm 1.1	2.6 \pm 0.8	4.0	1.6 \pm 0.8
H-3	88 \pm 96	55 \pm 79	34 \pm 73	-6 \pm 69	500	42.8 \pm 39.4
Sr-89	-0.1 \pm 0.4	0.2 \pm 0.3	0.0 \pm 0.4	-0.1 \pm 0.5	5.0	0.0 \pm 0.1
Sr-90	0.0 \pm 0.2	-0.2 \pm 0.2	0.1 \pm 0.2	0.0 \pm 0.2	1.0	0.0 \pm 0.1
I-131	0.12 \pm 0.19	0.04 \pm 0.14	0.17 \pm 0.33	0.05 \pm 0.22	0.5	0.10 \pm 0.06
Mn-54	1.1 \pm 1.4	-0.9 \pm 1.6	0.6 \pm 1.1	-0.2 \pm 1.5	10	0.1 \pm 0.9
Fe-59	-1.5 \pm 2.8	-1.5 \pm 2.7	2.5 \pm 2.0	0.4 \pm 2.9	30	-0.1 \pm 1.9
Co-58	0.3 \pm 1.4	1.6 \pm 1.4	-1.1 \pm 1.1	0.9 \pm 1.4	10	0.4 \pm 1.1
Co-60	0.3 \pm 1.7	0.2 \pm 2.0	-0.2 \pm 1.3	0.1 \pm 1.4	10	0.1 \pm 0.2
Zn-65	-1.3 \pm 2.6	3.5 \pm 3.0	-0.7 \pm 1.9	1.1 \pm 3.2	30	0.6 \pm 2.1
Zr-Nb-95	-0.8 \pm 1.8	-1.5 \pm 1.6	-0.4 \pm 1.2	-4.7 \pm 1.9	15	-1.8 \pm 1.9
Cs-134	-1.4 \pm 1.5	0.6 \pm 1.5	-1.7 \pm 1.1	-0.9 \pm 1.9	10	-0.8 \pm 1.0
Cs-137	-0.9 \pm 1.6	0.1 \pm 1.8	-0.4 \pm 1.4	-0.3 \pm 2.0	10	-0.4 \pm 0.4
Ba-La-140	1.3 \pm 1.5	-2.6 \pm 2.1	3.4 \pm 1.6	-1.5 \pm 1.9	15	0.1 \pm 2.7
Other (Ru-103)	-0.2 \pm 1.4	0.1 \pm 1.5	-0.4 \pm 1.2	-0.6 \pm 1.5	30	-0.3 \pm 0.3

MDC Data

	01-11-17	04-13-17	07-13-17	10-11-17		
Collection Date	01-11-17	04-13-17	07-13-17	10-11-17		
Lab Code	EWV- 133	EWV- 1540	EWV- 3496	EWV- 5306		
Gross Beta	< 2.0	< 2.0	< 1.9	< 1.2	4.0	< 1.8
H-3	< 176	< 144	< 149	< 149	500	< 154.6
Sr-89	< 0.5	< 0.5	< 0.5	< 0.6	5.0	< 0.5
Sr-90	< 0.5	< 0.4	< 0.4	< 0.5	1.0	< 0.5
I-131	< 0.37	< 0.26	< 0.50	< 0.44	0.5	< 0.39
Mn-54	< 2.3	< 2.4	< 2.5	< 2.0	10	< 2.3
Fe-59	< 4.7	< 3.5	< 5.5	< 5.5	30	< 4.8
Co-58	< 2.4	< 2.4	< 1.8	< 2.1	10	< 2.2
Co-60	< 2.7	< 2.0	< 1.3	< 2.4	10	< 2.1
Zn-65	< 4.0	< 5.7	< 2.3	< 5.9	30	< 4.5
Zr-Nb-95	< 3.3	< 2.1	< 4.0	< 1.8	15	< 2.8
Cs-134	< 2.7	< 2.6	< 2.2	< 3.3	10	< 2.7
Cs-137	< 2.1	< 3.6	< 2.2	< 2.7	10	< 2.7
Ba-La-140	< 2.4	< 3.4	< 7.8	< 2.5	15	< 4.0
Other (Ru-103)	< 2.8	< 3.4	< 2.9	< 2.8	30	< 3.0

POINT BEACH

Table 5. Lake water, analyses for gross beta, iodine-131 and gamma emitting isotopes.
 Location: E-01 (Meteorological Tower)
 Collection: Monthly composites

Units: pCi/L

	MDC		MDC		MDC		MDC		
Lab Code	NS ^a	ELW- 513	ELW- 513	ELW- 945	ELW- 945	ELW- 1536	ELW- 1536		
Date Collected	01-30-17	02-08-17	02-08-17	03-08-17	03-08-17	04-12-17	04-12-17		Req. LLD
Gross beta	-	1.5 ± 0.9	< 1.7	3.1 ± 0.7	< 0.9	1.5 ± 0.6	< 0.9		4.0
I-131	-	0.13 ± 0.14	< 0.24	-0.06 ± 0.14	< 0.27	0.04 ± 0.21	< 0.42		0.5
Be-7	-	2.1 ± 12.6	< 28.5	6.2 ± 18.9	< 37.0	5.8 ± 8.5	< 22.0		
Mn-54	-	0.4 ± 1.6	< 2.2	-0.2 ± 1.6	< 2.7	0.2 ± 1.0	< 1.7		10
Fe-59	-	2.3 ± 2.7	< 4.4	5.2 ± 3.4	< 7.2	-1.3 ± 1.6	< 3.0		30
Co-58	-	-0.3 ± 1.4	< 1.6	-0.4 ± 1.7	< 2.8	-0.6 ± 1.0	< 1.5		10
Co-60	-	1.2 ± 1.2	< 1.6	0.1 ± 1.9	< 2.0	0.4 ± 1.1	< 1.7		10
Zn-65	-	0.4 ± 2.9	< 3.9	0.3 ± 4.0	< 4.9	-0.5 ± 2.1	< 4.0		30
Zr-Nb-95	-	0.1 ± 1.6	< 3.8	-0.7 ± 1.8	< 3.2	0.7 ± 1.0	< 2.3		15
Cs-134	-	-0.1 ± 1.4	< 2.8	-1.1 ± 1.9	< 3.8	-0.8 ± 1.0	< 1.9		10
Cs-137	-	0.4 ± 1.4	< 2.8	1.0 ± 2.1	< 3.5	0.7 ± 1.0	< 2.1		10
Ba-La-140	-	-1.2 ± 1.5	< 3.3	-0.9 ± 1.8	< 3.2	-1.4 ± 1.2	< 2.0		15
Other (Ru-103)	-	-2.2 ± 1.5	< 2.4	0.4 ± 2.0	< 4.7	0.8 ± 0.9	< 2.5		30

Lab Code	ELW- 2103	ELW- 2103	ELW- 2899	ELW- 2899	ELW- 3385	ELW- 3385	ELW- 4075	ELW- 4075	
Date Collected	05-10-17	05-10-17	06-14-17	06-14-17	07-12-17	07-12-17	08-09-17	08-09-17	Req. LLD
Gross beta	0.3 ± 0.5	< 0.9	5.4 ± 0.8 ^b	< 0.9	2.0 ± 0.7	< 1.0	0.6 ± 0.5	< 0.9	4.0
I-131	-0.02 ± 0.21	< 0.38	0.00 ± 0.23	< 0.45	-0.04 ± 0.13	< 0.23	-0.08 ± 0.23	< 0.48	0.5
Be-7	4.4 ± 13.8	< 32.3	5.1 ± 14.8	< 34.1	7.1 ± 11.4	< 38.7	-3.8 ± 15.7	< 34.8	
Mn-54	0.1 ± 1.6	< 2.4	-1.2 ± 2.0	< 3.0	-0.8 ± 1.4	< 1.9	0.6 ± 1.6	< 2.7	10
Fe-59	-1.3 ± 2.5	< 3.5	2.4 ± 3.0	< 4.2	-3.0 ± 2.2	< 4.2	-2.2 ± 2.8	< 7.4	30
Co-58	0.1 ± 1.6	< 2.6	-0.9 ± 1.9	< 3.1	-0.3 ± 1.2	< 2.0	0.1 ± 1.7	< 2.2	10
Co-60	0.3 ± 1.6	< 1.9	1.0 ± 1.9	< 2.6	-0.2 ± 1.2	< 1.4	1.2 ± 1.7	< 2.8	10
Zn-65	0.3 ± 3.2	< 4.3	1.4 ± 3.6	< 5.3	-0.2 ± 2.6	< 3.7	-0.6 ± 3.0	< 4.0	30
Zr-Nb-95	4.4 ± 1.9	< 5.2	2.1 ± 2.0	< 4.9	0.8 ± 1.3	< 4.2	0.7 ± 1.7	< 3.1	15
Cs-134	-0.3 ± 1.4	< 2.8	-0.4 ± 1.6	< 3.1	1.0 ± 1.3	< 2.3	0.0 ± 1.5	< 3.4	10
Cs-137	0.3 ± 1.7	< 3.3	0.2 ± 2.1	< 3.5	-1.0 ± 1.6	< 1.4	1.4 ± 1.9	< 3.8	10
Ba-La-140	4.3 ± 1.5	< 3.6	0.5 ± 2.1	< 5.0	-0.4 ± 1.7	< 11.0	2.3 ± 2.0	< 13.2	15
Other (Ru-103)	0.0 ± 1.5	< 3.5	-1.9 ± 1.7	< 2.5	-0.2 ± 1.2	< 4.7	-2.3 ± 1.8	< 3.3	30

Lab Code	ELW- 4699	ELW- 4699	ELW- 5302	ELW- 5302	ELW- 5976	ELW- 5976	ELW- 6478	ELW- 6478	
Date Collected	09-13-17	09-13-17	10-11-17	10-11-17	11-08-17	11-08-17	12-12-17	12-12-17	Req. LLD
Gross beta	1.2 ± 0.6	< 0.9	1.6 ± 0.6	< 0.9	1.3 ± 0.6	< 0.9	1.3 ± 0.6	< 0.9	4.0
I-131	0.15 ± 0.16	< 0.27	-0.01 ± 0.16	< 0.29	0.10 ± 0.17	< 0.29	0.08 ± 0.15	< 0.27	0.5
Be-7	-3.2 ± 14.2	< 30.9	19.7 ± 17.9	< 37.9	-2.2 ± 14.9	< 28.0	6.7 ± 16.4	< 32.4	
Mn-54	0.7 ± 1.5	< 2.7	-0.9 ± 1.8	< 3.0	-1.0 ± 1.6	< 2.7	1.3 ± 1.7	< 2.9	10
Fe-59	0.6 ± 3.1	< 5.9	2.7 ± 3.0	< 6.1	-2.7 ± 2.8	< 4.8	2.4 ± 2.9	< 5.7	30
Co-58	0.6 ± 1.6	< 3.1	-0.8 ± 1.9	< 1.9	-0.1 ± 1.3	< 2.0	1.5 ± 1.5	< 2.8	10
Co-60	1.4 ± 1.5	< 2.2	-0.6 ± 1.8	< 2.0	2.5 ± 1.6	< 2.1	-0.9 ± 1.5	< 1.9	10
Zn-65	-0.3 ± 3.1	< 4.2	-0.7 ± 2.4	< 1.7	3.3 ± 3.1	< 4.3	-0.7 ± 2.4	< 2.9	30
Zr-Nb-95	0.6 ± 1.7	< 3.3	1.4 ± 1.9	< 4.0	-1.1 ± 1.3	< 1.8	0.2 ± 1.7	< 3.2	15
Cs-134	1.1 ± 1.5	< 3.0	-1.1 ± 1.8	< 3.3	-0.3 ± 1.5	< 3.0	0.3 ± 1.5	< 2.5	10
Cs-137	-0.5 ± 1.7	< 2.4	0.3 ± 2.1	< 2.2	-0.1 ± 1.6	< 1.2	-0.1 ± 1.9	< 2.7	10
Ba-La-140	1.2 ± 1.2	< 5.5	-2.0 ± 2.0	< 2.6	-2.6 ± 1.7	< 4.7	-1.9 ± 1.7	< 1.9	15
Other (Ru-103)	-1.8 ± 1.7	< 2.8	-0.2 ± 1.9	< 2.0	-1.7 ± 1.4	< 2.4	2.9 ± 1.8	< 2.8	30

^a"NS" = No sample; see Table 2.0, Listing of Missed Samples.

^bGross beta recounted with a result of 5.5±0.9 pCi/L. Sample being reanalyzed at time of report. Results after mixing well and filtering = beta(ss) = 19.2±1.8pCi/L, beta(ds) = 7.3±1.0 pCi/L.

POINT BEACH

Table 5. Lake water, analyses for gross beta, iodine-131 and gamma emitting isotopes.
 Location: E-05 (Two Creeks Park)
 Collection: Monthly composites

Lab Code	MDC		MDC		MDC		MDC		Req. LLD
	NS ^a		ELW- 514		ELW- 946		ELW- 1537		
Date Collected	01-30-17		02-09-17		03-08-17		04-13-17		
Gross beta	-		2.1 ± 1.0	< 1.7	1.7 ± 0.6	< 0.9	1.5 ± 0.6	< 0.9	4.0
I-131	-		0.03 ± 0.13	< 0.23	0.00 ± 0.15	< 0.27	-0.05 ± 0.14	< 0.26	0.5
Be-7	-		7.8 ± 10.6	< 24.9	0.6 ± 14.6	< 30.5	2.4 ± 17.7	< 34.4	
Mn-54	-		-1.1 ± 1.3	< 2.1	0.2 ± 1.6	< 2.2	0.1 ± 1.5	< 2.9	10
Fe-59	-		1.5 ± 2.2	< 4.6	-1.8 ± 3.2	< 3.9	-0.2 ± 3.3	< 6.0	30
Co-58	-		-0.2 ± 1.1	< 2.0	0.6 ± 1.6	< 2.5	0.0 ± 1.5	< 1.8	10
Co-60	-		0.3 ± 1.3	< 1.8	-0.7 ± 1.7	< 2.3	0.6 ± 1.7	< 1.9	10
Zn-65	-		-0.7 ± 2.1	< 2.8	-1.1 ± 3.4	< 3.3	-0.2 ± 2.9	< 2.8	30
Zr-Nb-95	-		-0.2 ± 1.4	< 2.7	-0.2 ± 1.7	< 4.1	0.7 ± 1.7	< 3.2	15
Cs-134	-		-0.2 ± 1.5	< 2.7	0.7 ± 1.3	< 3.0	1.5 ± 1.8	< 3.6	10
Cs-137	-		0.9 ± 1.4	< 2.3	-0.1 ± 1.8	< 2.5	-0.5 ± 1.9	< 2.2	10
Ba-La-140	-		1.9 ± 1.5	< 4.5	2.9 ± 1.7	< 4.2	1.2 ± 1.9	< 2.9	15
Other (Ru-103)	-		-1.2 ± 1.2	< 1.9	0.3 ± 1.8	< 3.7	-1.1 ± 2.1	< 3.4	30
Lab Code	ELW- 2104		ELW- 2900		ELW- 3386		ELW- 4076		Req. LLD
Date Collected	05-10-17		06-14-17		07-12-17		08-09-17		
Gross beta	1.2 ± 0.5	< 0.8	3.3 ± 0.7	< 0.9	0.6 ± 0.5	< 0.9	0.5 ± 0.5	< 0.9	4.0
I-131	0.17 ± 0.21	< 0.36	0.08 ± 0.22	< 0.42	0.08 ± 0.12	< 0.21	0.19 ± 0.20	< 0.36	0.5
Be-7	1.2 ± 11.0	< 27.3	9.1 ± 12.1	< 30.4	5.4 ± 11.0	< 27.5	15.2 ± 11.0	< 32.4	
Mn-54	0.2 ± 1.4	< 2.3	-1.0 ± 1.4	< 1.8	-0.3 ± 1.3	< 1.4	-0.1 ± 1.3	< 1.8	10
Fe-59	-1.3 ± 2.2	< 5.0	0.2 ± 2.3	< 3.4	-3.8 ± 2.3	< 4.5	0.5 ± 2.3	< 5.9	30
Co-58	0.1 ± 1.2	< 2.4	-0.9 ± 1.2	< 1.9	0.0 ± 1.4	< 2.0	-0.6 ± 1.4	< 3.5	10
Co-60	0.8 ± 1.3	< 1.9	0.2 ± 1.4	< 1.9	0.9 ± 1.3	< 2.3	-0.3 ± 1.5	< 1.9	10
Zn-65	1.0 ± 2.8	< 4.9	0.7 ± 2.7	< 4.1	-0.7 ± 2.2	< 2.3	2.2 ± 2.9	< 5.6	30
Zr-Nb-95	-2.4 ± 1.4	< 2.4	-1.0 ± 1.6	< 2.8	-0.5 ± 1.6	< 4.9	-0.8 ± 1.4	< 3.7	15
Cs-134	0.5 ± 1.4	< 2.6	0.0 ± 1.4	< 2.7	-0.6 ± 1.3	< 2.3	0.8 ± 1.4	< 2.5	10
Cs-137	0.0 ± 1.6	< 2.1	1.9 ± 1.7	< 3.1	-0.5 ± 1.4	< 2.2	-1.1 ± 1.5	< 2.1	10
Ba-La-140	0.3 ± 1.6	< 8.6	-1.7 ± 1.9	< 6.1	7.8 ± 1.4	< 8.5	2.4 ± 1.1	< 3.7	15
Other (Ru-103)	-0.7 ± 1.4	< 2.7	0.8 ± 1.3	< 3.0	0.2 ± 1.3	< 4.2	-1.2 ± 1.3	< 3.2	30
Lab Code	ELW- 4700		ELW- 5303		ELW- 5977		ELW- 6479		Req. LLD
Date Collected	09-14-17		10-12-17		11-08-17		12-14-17		
Gross beta	1.0 ± 0.5	< 0.8	1.3 ± 0.6	< 0.9	0.0 ± 0.4	< 0.9	1.8 ± 0.6	< 0.9	4.0
I-131	0.00 ± 0.14	< 0.26	-0.08 ± 0.14	< 0.26	0.03 ± 0.18	< 0.32	-0.03 ± 0.13	< 0.24	0.5
Be-7	-3.2 ± 9.4	< 21.3	-12.2 ± 11.7	< 18.3	-0.2 ± 19.0	< 43.2	-0.9 ± 12.4	< 23.0	
Mn-54	1.2 ± 1.1	< 2.1	1.0 ± 1.5	< 2.6	-1.6 ± 1.8	< 1.7	0.3 ± 1.7	< 2.2	10
Fe-59	2.7 ± 2.3	< 5.5	2.5 ± 2.8	< 2.9	-1.7 ± 2.4	< 4.8	0.7 ± 2.8	< 4.3	30
Co-58	-1.2 ± 1.2	< 2.3	1.6 ± 1.7	< 3.3	-0.3 ± 1.7	< 2.9	0.5 ± 1.6	< 2.8	10
Co-60	-0.5 ± 1.4	< 1.8	-0.3 ± 1.5	< 1.5	0.4 ± 2.3	< 3.5	1.4 ± 2.0	< 3.1	10
Zn-65	2.4 ± 2.3	< 4.1	-1.2 ± 2.6	< 1.7	-0.7 ± 3.4	< 3.9	0.4 ± 2.9	< 3.3	30
Zr-Nb-95	0.2 ± 1.2	< 3.2	1.2 ± 1.8	< 2.7	-1.4 ± 1.5	< 3.0	-1.3 ± 1.8	< 2.7	15
Cs-134	-0.1 ± 1.1	< 2.2	-0.3 ± 1.6	< 3.0	0.3 ± 1.6	< 3.1	0.5 ± 1.9	< 3.1	10
Cs-137	0.2 ± 1.4	< 2.4	0.3 ± 1.6	< 2.7	0.7 ± 1.8	< 2.4	-0.6 ± 1.9	< 2.6	10
Ba-La-140	3.0 ± 1.6	< 10.7	-0.3 ± 1.7	< 3.3	-6.3 ± 2.1	< 3.9	-0.7 ± 1.6	< 2.1	15
Other (Ru-103)	-2.1 ± 1.1	< 2.5	-1.3 ± 1.5	< 2.4	-1.7 ± 2.1	< 3.4	0.9 ± 1.6	< 3.6	30

^a "NS" = No sample; see Table 2.0, Listing of Missed Samples.

POINT BEACH

Table 5. Lake water, analyses for gross beta, iodine-131 and gamma emitting isotopes.
 Location: E-06 (Coast Guard Station)
 Collection: Monthly composites

Lab Code	MDC		MDC		MDC		MDC		Req. LLD
	NS ^a		ELW- 515		ELW- 947		ELW- 1538		
Date Collected	01-30-17		02-09-17		03-09-17		04-13-17		
Gross beta	-		1.9 ± 0.9	< 1.6	2.6 ± 0.7	< 0.9	1.2 ± 0.6	< 0.9	4.0
I-131	-		-0.04 ± 0.25	< 0.37	0.14 ± 0.19	< 0.33	0.17 ± 0.18	< 0.31	0.5
Be-7	-		-1.0 ± 4.8	< 9.5	-0.3 ± 14.2	< 24.7	2.5 ± 8.3	< 16.6	
Mn-54	-		-0.2 ± 0.6	< 0.8	-0.4 ± 1.6	< 2.7	-0.2 ± 1.0	< 1.7	10
Fe-59	-		0.2 ± 1.0	< 1.6	-0.2 ± 2.9	< 4.8	1.5 ± 1.8	< 2.2	30
Co-58	-		0.5 ± 0.5	< 1.2	-0.6 ± 1.5	< 1.8	-0.5 ± 1.0	< 1.4	10
Co-60	-		0.0 ± 0.6	< 1.2	-0.4 ± 1.6	< 1.8	0.3 ± 1.0	< 1.7	10
Zn-65	-		0.2 ± 1.1	< 1.7	3.0 ± 3.6	< 5.9	-0.7 ± 1.8	< 2.0	30
Zr-Nb-95	-		-0.5 ± 0.6	< 0.8	0.1 ± 1.8	< 3.1	-0.4 ± 1.0	< 1.7	15
Cs-134	-		-0.2 ± 0.6	< 1.1	0.0 ± 1.5	< 3.2	0.3 ± 1.0	< 1.8	10
Cs-137	-		1.0 ± 0.7	< 1.4	-0.9 ± 1.8	< 3.5	1.8 ± 1.1	< 1.9	10
Ba-La-140	-		-1.9 ± 0.7	< 1.0	0.4 ± 1.9	< 3.5	0.3 ± 1.2	< 3.0	15
Other (Ru-103)	-		0.1 ± 0.5	< 1.5	-1.9 ± 1.8	< 3.3	0.3 ± 0.9	< 1.5	30
Lab Code	ELW- 2105		ELW- 2901		ELW- 3387		ELW- 4077		Req. LLD
Date Collected	05-10-17		06-14-17		07-12-17		08-09-17		
Gross beta	0.9 ± 0.5	< 0.9	0.7 ± 0.5	< 0.9	1.2 ± 0.6	< 0.9	1.1 ± 0.6	< 0.9	4.0
I-131	-0.04 ± 0.23	< 0.42	-0.14 ± 0.18	< 0.27	0.01 ± 0.12	< 0.22	-0.02 ± 0.16	< 0.25	0.5
Be-7	-8.3 ± 10.6	< 21.9	5.0 ± 11.1	< 34.7	0.2 ± 9.2	< 28.9	5.1 ± 10.1	< 28.8	
Mn-54	0.6 ± 1.2	< 1.8	0.6 ± 1.6	< 3.1	-0.4 ± 1.2	< 2.0	1.3 ± 1.2	< 2.3	10
Fe-59	3.0 ± 2.6	< 4.0	1.9 ± 2.3	< 4.9	0.7 ± 1.9	< 3.8	-0.2 ± 2.2	< 6.0	30
Co-58	-0.4 ± 1.2	< 2.0	-1.5 ± 1.4	< 1.9	-1.1 ± 1.1	< 2.1	1.6 ± 1.1	< 2.5	10
Co-60	-0.6 ± 1.5	< 1.6	1.4 ± 1.5	< 1.7	-0.5 ± 1.1	< 0.9	-0.1 ± 1.4	< 1.5	10
Zn-65	-0.6 ± 2.5	< 4.1	1.1 ± 2.7	< 3.4	-0.2 ± 2.2	< 3.0	-0.3 ± 2.6	< 3.8	30
Zr-Nb-95	1.6 ± 1.3	< 3.4	-0.9 ± 1.4	< 2.7	-1.1 ± 1.2	< 2.9	1.9 ± 1.3	< 4.3	15
Cs-134	0.0 ± 1.4	< 2.6	0.5 ± 1.6	< 2.7	0.9 ± 1.1	< 2.3	0.1 ± 1.2	< 2.3	10
Cs-137	0.0 ± 1.5	< 2.2	0.4 ± 1.7	< 3.2	-1.1 ± 1.4	< 1.7	0.2 ± 1.5	< 2.9	10
Ba-La-140	-2.0 ± 1.6	< 6.3	-6.1 ± 2.0	< 5.5	-5.3 ± 1.3	< 6.0	0.5 ± 1.4	< 9.6	15
Other (Ru-103)	-0.4 ± 1.2	< 2.8	-1.1 ± 1.2	< 2.3	-0.5 ± 1.1	< 2.1	-1.6 ± 1.0	< 2.3	30
Lab Code	ELW- 4701		ELW- 5304		ELW- 5978		NS ^a		Req. LLD
Date Collected	09-14-17		10-12-17		11-08-17		12-14-17		
Gross beta	0.6 ± 0.5	< 0.9	1.3 ± 0.5	< 0.8	1.7 ± 0.6	< 0.9	-		4.0
I-131	-0.08 ± 0.14	< 0.26	0.16 ± 0.19	< 0.32	0.16 ± 0.18	< 0.31	-		0.5
Be-7	6.1 ± 9.2	< 26.6	-7.8 ± 17.8	< 31.6	3.9 ± 12.4	< 24.5	-		
Mn-54	0.3 ± 1.2	< 2.0	1.4 ± 1.6	< 2.6	0.0 ± 1.2	< 2.2	-		10
Fe-59	1.4 ± 2.3	< 5.5	1.8 ± 3.1	< 3.7	0.2 ± 3.0	< 5.8	-		30
Co-58	-0.8 ± 1.2	< 1.6	0.4 ± 1.9	< 3.1	-1.2 ± 1.2	< 1.7	-		10
Co-60	-0.8 ± 1.3	< 1.3	-0.2 ± 2.3	< 2.9	0.7 ± 1.6	< 2.4	-		10
Zn-65	0.2 ± 2.1	< 4.2	-1.6 ± 2.6	< 2.0	-0.5 ± 2.5	< 3.1	-		30
Zr-Nb-95	0.4 ± 1.3	< 4.4	1.7 ± 1.9	< 3.4	-1.7 ± 1.6	< 2.4	-		15
Cs-134	0.1 ± 1.2	< 2.1	-1.1 ± 1.7	< 3.1	-1.4 ± 1.5	< 2.9	-		10
Cs-137	0.3 ± 1.4	< 3.0	2.3 ± 2.0	< 3.1	0.6 ± 1.5	< 2.5	-		10
Ba-La-140	-4.1 ± 1.5	< 8.8	1.4 ± 2.1	< 3.0	0.9 ± 1.1	< 4.3	-		15
Other (Ru-103)	-0.9 ± 1.1	< 2.5	-2.7 ± 2.1	< 1.7	-1.1 ± 1.2	< 3.0	-		30

^a "NS" = No sample; see Table 2.0, Listing of Missed Samples.

POINT BEACH

Table 5. Lake water, analyses for gross beta, iodine-131 and gamma emitting isotopes.

Location: E-33 (Kewaunee)

Collection: Monthly composites

Units: pCi/L

	MDC		MDC		MDC		MDC		
Lab Code	NS ^a		ELW- 516		ELW- 948		ELW- 1539		
Date Collected	01-13-16		02-09-17		03-09-17		04-13-17		Req. LLD
Gross beta	-		2.1 ± 1.0	< 1.8	1.7 ± 0.6	< 0.8	0.8 ± 0.5	< 0.9	4.0
I-131	-		0.07 ± 0.13	< 0.23	0.05 ± 0.20	< 0.40	-0.05 ± 0.15	< 0.27	0.5
Be-7	-		11.8 ± 13.7	< 30.6	-3.9 ± 12.5	< 25.6	-9.2 ± 13.6	< 20.8	
Mn-54	-		0.6 ± 1.6	< 2.3	1.3 ± 1.5	< 2.7	-0.4 ± 1.4	< 2.7	10
Fe-59	-		0.7 ± 2.6	< 5.2	1.0 ± 2.5	< 4.4	-1.0 ± 2.7	< 5.1	30
Co-58	-		1.8 ± 1.6	< 2.8	0.0 ± 1.3	< 2.4	-0.5 ± 1.2	< 1.5	10
Co-60	-		0.9 ± 1.5	< 2.2	-0.1 ± 1.7	< 2.5	-0.2 ± 1.6	< 2.9	10
Zn-65	-		0.7 ± 3.5	< 3.6	1.6 ± 2.7	< 3.7	-1.0 ± 3.0	< 4.8	30
Zr-Nb-95	-		1.6 ± 1.5	< 3.4	-1.2 ± 1.5	< 2.5	0.8 ± 1.4	< 2.6	15
Cs-134	-		0.2 ± 1.4	< 2.6	-0.7 ± 1.5	< 2.5	-0.5 ± 1.5	< 2.6	10
Cs-137	-		0.8 ± 1.6	< 2.4	-0.5 ± 1.6	< 1.7	-0.3 ± 1.5	< 2.4	10
Ba-La-140	-		-2.9 ± 1.5	< 3.3	-3.6 ± 2.0	< 3.3	-2.0 ± 1.8	< 3.8	15
Other (Ru-103)	-		-0.8 ± 1.6	< 2.7	1.0 ± 1.3	< 3.3	0.5 ± 1.5	< 2.8	30
Lab Code	ELW- 2106		ELW- 2902		ELW- 3388		ELW- 4078		
Date Collected	05-10-17		06-14-17		07-12-17		08-09-17		Req. LLD
Gross beta	0.6 ± 0.5	< 0.9	0.6 ± 0.5	< 0.8	0.9 ± 0.5	< 0.8	0.7 ± 0.5	< 0.9	4.0
I-131	-0.09 ± 0.21	< 0.40	0.04 ± 0.16	< 0.29	0.01 ± 0.11	< 0.19	0.07 ± 0.19	< 0.36	0.5
Be-7	-13.1 ± 12.7	< 21.6	6.2 ± 12.8	< 39.3	-7.6 ± 9.3	< 19.9	-14.9 ± 11.6	< 20.7	
Mn-54	-1.1 ± 1.5	< 1.8	0.4 ± 1.3	< 1.5	-0.4 ± 1.0	< 1.4	-0.3 ± 1.5	< 2.8	10
Fe-59	-1.6 ± 3.3	< 3.3	-4.1 ± 2.8	< 5.1	-0.4 ± 2.2	< 3.7	-0.8 ± 2.4	< 5.2	30
Co-58	0.9 ± 1.5	< 2.9	-1.6 ± 1.5	< 2.3	0.5 ± 1.0	< 2.5	-0.7 ± 1.3	< 2.4	10
Co-60	0.3 ± 1.2	< 1.6	-0.9 ± 1.6	< 1.7	-1.2 ± 1.1	< 1.1	-0.4 ± 1.5	< 1.8	10
Zn-65	-4.4 ± 3.1	< 2.5	0.5 ± 3.0	< 3.2	0.6 ± 2.3	< 4.2	1.4 ± 2.8	< 4.1	30
Zr-Nb-95	1.8 ± 1.7	< 4.4	-2.5 ± 1.5	< 2.4	-0.3 ± 1.0	< 2.6	0.2 ± 1.2	< 3.4	15
Cs-134	-0.6 ± 1.4	< 2.8	0.2 ± 1.2	< 2.5	0.0 ± 1.3	< 2.4	-0.5 ± 1.5	< 2.5	10
Cs-137	-0.1 ± 1.6	< 2.7	0.2 ± 1.6	< 2.6	0.6 ± 1.4	< 2.2	0.1 ± 1.7	< 2.2	10
Ba-La-140	2.8 ± 2.1	< 7.9	-1.5 ± 1.6	< 5.1	-0.3 ± 1.5	< 7.2	2.0 ± 1.5	< 8.7	15
Other (Ru-103)	-0.3 ± 1.5	< 3.1	-1.5 ± 1.4	< 2.8	0.1 ± 1.1	< 3.1	-1.1 ± 1.2	< 2.8	30
Lab Code	ELW- 4702		ELW- 5305		ELW- 5979		NS ^a		
Date Collected	09-14-17		10-12-17		11-08-17		12-14-17		Req. LLD
Gross beta	1.4 ± 0.6	< 0.8	1.6 ± 0.6	< 0.9	1.5 ± 0.6	< 0.9	-		4.0
I-131	-0.01 ± 0.16	< 0.29	-0.04 ± 0.15	< 0.27	-0.08 ± 0.22	< 0.46	-		0.5
Be-7	-1.2 ± 8.9	< 22.2	-0.5 ± 13.6	< 24.9	-17.2 ± 14.5	< 21.8	-		
Mn-54	0.0 ± 1.1	< 1.6	-1.2 ± 1.7	< 2.2	0.9 ± 1.5	< 2.9	-		10
Fe-59	-1.6 ± 2.2	< 6.4	3.0 ± 3.2	< 4.8	-2.6 ± 2.4	< 5.6	-		30
Co-58	0.0 ± 1.2	< 2.6	-0.5 ± 1.6	< 2.4	0.9 ± 1.5	< 2.2	-		10
Co-60	0.8 ± 1.4	< 2.0	-0.7 ± 1.7	< 1.5	0.5 ± 1.7	< 1.9	-		10
Zn-65	0.4 ± 2.3	< 2.8	-1.8 ± 3.2	< 2.4	1.1 ± 3.1	< 3.8	-		30
Zr-Nb-95	0.1 ± 1.2	< 3.3	-0.3 ± 2.1	< 2.7	0.0 ± 1.5	< 2.2	-		15
Cs-134	-0.7 ± 1.0	< 2.2	0.8 ± 1.4	< 2.9	-0.9 ± 1.6	< 2.8	-		10
Cs-137	0.2 ± 1.2	< 2.2	0.9 ± 2.0	< 3.2	-0.9 ± 1.7	< 2.2	-		10
Ba-La-140	1.3 ± 1.2	< 8.1	0.9 ± 1.8	< 3.1	-1.9 ± 1.8	< 4.3	-		15
Other (Ru-103)	0.0 ± 1.1	< 3.2	0.0 ± 1.6	< 2.9	0.2 ± 1.7	< 3.6	-		30

^a"NS" = No sample; see Table 2.0, Listing of Missed Samples.

POINT BEACH NUCLEAR PLANT

Table 6. Lake water, analyses for tritium, strontium-89 and strontium-90.
Collection: Quarterly composites of weekly grab samples
Units: pCi/L

Location		E-01 (Meteorological Tower)						
Period	1st Qtr.	MDC	2nd Qtr.	MDC	3rd Qtr.	MDC	4th Qtr.	MDC
Lab Code	ELW- 958		ELW- 2922		ELW- 4721		ELW- 6626	
H-3	14 ± 75	< 154	119 ± 82	< 152 ^a	71 ± 76	< 150 ^b	65 ± 86	< 158
Sr-89	0.23 ± 0.51	< 0.58	0.22 ± 0.77	< 0.75	0.55 ± 0.64	< 0.75	0.41 ± 0.70	< 0.76
Sr-90	0.32 ± 0.28	< 0.54	0.10 ± 0.36	< 0.75	0.07 ± 0.24	< 0.51	0.21 ± 0.28	< 0.54

Location		E-05 (Two Creeks Park)						
Period	1st Qtr.		2nd Qtr.		3rd Qtr.		4th Qtr.	
Lab Code	ELW- 959		ELW- 2923		ELW- 4722		ELW- 6627	
H-3	-27 ± 72	< 154	276 ± 89	< 152 ^a	58 ± 75	< 150 ^c	27 ± 85	< 158
Sr-89	-0.14 ± 0.42	< 0.50	0.06 ± 0.85	< 0.82	0.47 ± 0.65	< 0.98	0.61 ± 0.61	< 0.77
Sr-90	0.22 ± 0.25	< 0.48	0.24 ± 0.40	< 0.80	-0.02 ± 0.21	< 0.46	-0.05 ± 0.23	< 0.50

Location		E-06 (Coast Guard Station)						
Period	1st Qtr.		2nd Qtr.		3rd Qtr.		4th Qtr.	
Lab Code	ELW- 960		ELW- 2924		ELW- 4723		ELW- 6628	
H-3	87 ± 79	< 154	422 ± 96	< 152 ^a	41 ± 74	< 150 ^d	57 ± 86	< 159
Sr-89	-0.02 ± 0.42	< 0.51	0.40 ± 0.65	< 0.68	0.32 ± 0.66	< 0.77	0.91 ± 1.05	< 1.44
Sr-90	0.15 ± 0.24	< 0.47	0.26 ± 0.27	< 0.52	0.13 ± 0.26	< 0.52	-0.15 ± 0.25	< 0.57

Location		E-33 (Kewaunee)						
Period	1st Qtr.		2nd Qtr.		3rd Qtr.		4th Qtr.	
Lab Code	ELW- 961		ELW- 2925		ELW- 4724		ELW- 6629	
H-3	23 ± 75	< 154	661 ± 114	< 152 ^a	34083 ± 543	< 150 ^e	93 ± 88	< 159
Sr-89	0.08 ± 0.46	< 0.49	0.38 ± 0.54	< 0.66	0.26 ± 0.80	< 0.64	-0.18 ± 0.97	< 1.12
Sr-90	0.26 ± 0.27	< 0.51	0.00 ± 0.22	< 0.47	0.41 ± 0.37	< 0.65	0.27 ± 0.25	< 0.47

^a Tritium analysis on June sample requested by station. Results: E-01 = 104±85; E-05 = 625±103; E-06 = 651±104; E-33 = 1,402±135 pCi/L.

^b August tritium = 155±77 pCi/L, September = 35±70 pCi/L (MDC = <145 pCi/L).

^c August tritium = 69±72 pCi/L, September = 81±73 pCi/L (MDC = <145 pCi/L).

^d August tritium = 143±76 pCi/L, September = 92±73 pCi/L (MDC = <145 pCi/L).

^e Tritium repeated with a result of 35416±533 pCi/L. Monthly breakdown = July - 80±110 pCi/L; August - 4680±211 pCi/L; September - 100062±848 pCi/L.

Tritium Annual Mean ± s.d.	2254 ± 8490
Sr-89 Annual Mean ± s.d.	0.29 ± 0.29
Sr-90 Annual Mean ± s.d.	0.15 ± 0.15

POINT BEACH NUCLEAR PLANT

Table 7. Fish, analyses for gross beta and gamma emitting isotopes.

Location: E-13

Collection: 2x / year

Units: pCi/g wet

	Sample Description and Concentration						Req. LLD
	MDC		MDC		MDC		
Collection Date	01-19-17		01-31-17		02-08-17		
Lab Code	EF- 595		EF- 596		EF- 597		
Type	Chinook		Brown Trout		Rainbow Trout		
Ratio (wet/dry wt.)	4.93		5.04		3.41		
Gross Beta	0.77 ± 0.02	< 0.008	3.78 ± 0.07	< 0.023	4.03 ± 0.09	< 0.032	0.5
K-40	0.56 ± 0.17	-	3.45 ± 0.42	-	2.61 ± 0.28	-	
Mn-54	0.000 ± 0.005	< 0.010	0.002 ± 0.007	< 0.014	0.010 ± 0.006	< 0.012	0.13
Fe-59	0.007 ± 0.008	< 0.027	-0.007 ± 0.013	< 0.026	-0.004 ± 0.012	< 0.026	0.26
Co-58	0.003 ± 0.005	< 0.012	0.008 ± 0.006	< 0.016	0.004 ± 0.005	< 0.011	0.13
Co-60	0.001 ± 0.006	< 0.009	-0.005 ± 0.008	< 0.007	0.000 ± 0.006	< 0.007	0.13
Zn-65	-0.009 ± 0.011	< 0.024	-0.029 ± 0.015	< 0.017	-0.019 ± 0.014	< 0.026	0.26
Cs-134	-0.001 ± 0.005	< 0.010	-0.007 ± 0.006	< 0.013	-0.006 ± 0.007	< 0.011	0.13
Cs-137	0.006 ± 0.006	< 0.012	0.016 ± 0.009	< 0.013	0.011 ± 0.008	< 0.013	0.15
Other (Ru-103)	0.006 ± 0.004	< 0.015	-0.001 ± 0.007	< 0.018	0.003 ± 0.005	< 0.013	0.5
Collection Date	02-21-17		02-24-17		03-05-17		
Lab Code	EF- 1550		EF- 1551		EF- 1552		
Type	Brown Trout		Rainbow Trout		Catfish		
Ratio (wet/dry wt.)	5.41		5.08		5.15		
Gross Beta	3.34 ± 0.07	< 0.021	3.78 ± 0.07	< 0.024	3.11 ± 0.06	< 0.020	0.5
K-40	2.44 ± 0.35	-	3.16 ± 0.38	-	2.19 ± 0.33	-	
Mn-54	-0.004 ± 0.009	< 0.019	-0.001 ± 0.007	< 0.013	0.003 ± 0.009	< 0.014	0.13
Fe-59	-0.018 ± 0.015	< 0.055	0.005 ± 0.015	< 0.065	0.020 ± 0.012	< 0.028	0.26
Co-58	0.002 ± 0.008	< 0.022	0.008 ± 0.008	< 0.024	0.012 ± 0.008	< 0.020	0.13
Co-60	0.003 ± 0.010	< 0.014	0.007 ± 0.008	< 0.008	-0.004 ± 0.009	< 0.011	0.13
Zn-65	0.002 ± 0.018	< 0.033	0.002 ± 0.019	< 0.032	0.005 ± 0.017	< 0.024	0.26
Cs-134	0.004 ± 0.008	< 0.015	-0.009 ± 0.007	< 0.014	-0.012 ± 0.008	< 0.016	0.13
Cs-137	0.011 ± 0.011	< 0.018	0.019 ± 0.011	< 0.019	0.018 ± 0.010	< 0.019	0.15
Other (Ru-103)	-0.005 ± 0.007	< 0.036	0.010 ± 0.006	< 0.033	0.002 ± 0.008	< 0.026	0.5

POINT BEACH NUCLEAR PLANT

Table 7. Fish, analyses for gross beta and gamma emitting isotopes.

Location: E-13

Collection: 2x / year

Units: pCi/g wet

	Sample Description and Concentration (pCi/g wet)						Req. LLD
	05-01-17		08-02-17		08-03-17		
	MDC		MDC		MDC		
Collection Date	05-01-17		08-02-17		08-03-17		
Lab Code	EF- 2270		EF- 4238		EF- 4239		
Type	Lake Trout		Brown Trout		Lake Trout		
Ratio (wet/dry wt.)	5.09		3.23		3.65		
Gross Beta	2.96 ± 0.06	< 0.023	4.17 ± 0.13	< 0.042	3.77 ± 0.12	< 0.043	0.5
K-40	2.24 ± 0.38	-	3.08 ± 0.42	-	2.92 ± 0.41		
Mn-54	0.005 ± 0.010	< 0.020	-0.004 ± 0.009	< 0.014	-0.006 ± 0.010	< 0.010	0.13
Fe-59	0.012 ± 0.020	< 0.044	0.005 ± 0.017	< 0.041	-0.008 ± 0.021	< 0.067	0.26
Co-58	0.001 ± 0.009	< 0.019	-0.005 ± 0.007	< 0.011	0.004 ± 0.009	< 0.028	0.13
Co-60	-0.001 ± 0.009	< 0.011	-0.011 ± 0.009	< 0.010	-0.013 ± 0.012	< 0.016	0.13
Zn-65	-0.012 ± 0.025	< 0.021	0.016 ± 0.021	< 0.029	0.024 ± 0.022	< 0.042	0.26
Cs-134	0.012 ± 0.009	< 0.017	-0.001 ± 0.008	< 0.014	0.004 ± 0.009	< 0.018	0.13
Cs-137	0.010 ± 0.013	< 0.018	0.016 ± 0.010	< 0.013	0.020 ± 0.013	< 0.024	0.15
Other (Ru-103)	0.005 ± 0.010	< 0.024	-0.010 ± 0.007	< 0.020	-0.001 ± 0.009	< 0.036	0.5
Collection Date	10-08-17		11-04-17		11-04-17		
Lab Code	EF- 5939		EF- 5937		EF- 5938		
Type	Brown Trout		Chinook Salmon		Burbot		
Ratio (wet/dry wt.)	4.08		4.81		5.11		
Gross Beta	3.89 ± 0.11	< 0.034	2.65 ± 0.08	< 0.026	0.21 ± 0.02	< 0.012	0.5
K-40	3.05 ± 0.42	-	2.11 ± 0.37	-	0.51 ± 0.21	< 0.38	
Mn-54	0.002 ± 0.011	< 0.025	0.012 ± 0.010	< 0.020	-0.002 ± 0.010	< 0.015	0.13
Fe-59	0.001 ± 0.024	< 0.069	-0.011 ± 0.023	< 0.042	-0.001 ± 0.016	< 0.029	0.26
Co-58	-0.014 ± 0.011	< 0.021	-0.005 ± 0.011	< 0.020	-0.003 ± 0.010	< 0.014	0.13
Co-60	-0.008 ± 0.013	< 0.020	-0.009 ± 0.012	< 0.017	0.001 ± 0.011	< 0.009	0.13
Zn-65	-0.049 ± 0.030	< 0.045	-0.017 ± 0.024	< 0.029	-0.017 ± 0.018	< 0.016	0.26
Cs-134	0.000 ± 0.010	< 0.019	0.004 ± 0.009	< 0.018	-0.006 ± 0.011	< 0.021	0.13
Cs-137	0.005 ± 0.013	< 0.024	0.010 ± 0.011	< 0.018	0.000 ± 0.012	< 0.014	0.15
Other (Ru-103)	-0.009 ± 0.011	< 0.032	-0.003 ± 0.010	< 0.022	-0.004 ± 0.009	< 0.021	0.5

POINT BEACH NUCLEAR PLANT

Table 7. Fish, analyses for gross beta and gamma emitting isotopes.

Location: E-13

Collection: 2x / year

Units: pCi/g wet

	Sample Description and Concentration (pCi/g wet)						Req. LLD
	11-18-17		11-29-17		11-29-17		
	MDC		MDC		MDC		
Collection Date	11-18-17		11-29-17		11-29-17		
Lab Code	EF- 6472		EF- 6473		EF- 6474		
Type	Chinook Salmon		Brown Trout		Lake Trout		
Ratio (wet/dry wt.)	5.91		5.53		4.67		
Gross Beta	3.26 ± 0.06	< 0.020	3.49 ± 0.07	< 0.023	3.35 ± 0.06	< 0.020	0.5
K-40	3.02 ± 0.41	-	3.06 ± 0.41	-	2.55 ± 0.36	-	
Mn-54	0.003 ± 0.008	< 0.014	0.013 ± 0.011	< 0.022	0.003 ± 0.008	< 0.015	0.13
Fe-59	0.011 ± 0.020	< 0.043	0.014 ± 0.025	< 0.055	0.011 ± 0.014	< 0.032	0.26
Co-58	0.012 ± 0.009	< 0.023	0.003 ± 0.011	< 0.018	0.003 ± 0.008	< 0.017	0.13
Co-60	-0.001 ± 0.009	< 0.008	0.016 ± 0.012	< 0.019	0.008 ± 0.010	< 0.014	0.13
Zn-65	0.005 ± 0.020	< 0.029	-0.046 ± 0.033	< 0.047	-0.009 ± 0.019	< 0.033	0.26
Cs-134	0.001 ± 0.009	< 0.020	0.009 ± 0.011	< 0.021	0.000 ± 0.008	< 0.015	0.13
Cs-137	0.002 ± 0.011	< 0.020	0.031 ± 0.018	< 0.022	0.015 ± 0.010	< 0.017	0.15
Other (Ru-103)	0.001 ± 0.010	< 0.021	-0.007 ± 0.012	< 0.019	0.004 ± 0.006	< 0.018	0.5
Collection Date	Annual						
Lab Code	Annual						
Type	Annual						
Ratio (wet/dry wt.)	Mean ± s.d.						
Gross Beta	3.10 ± 1.14						
K-40	2.46 ± 0.88						
Mn-54	0.002 ± 0.006						
Fe-59	0.002 ± 0.011						
Co-58	0.002 ± 0.007						
Co-60	-0.001 ± 0.008						
Zn-65	-0.010 ± 0.021						
Cs-134	0.000 ± 0.007						
Cs-137	0.013 ± 0.008						
Other (Ru-103)	-0.001 ± 0.006						

POINT BEACH NUCLEAR PLANT

Table 8. Radioactivity in shoreline sediment samples

Collection: Semiannual

Sample Description and Concentration (pCi/g dry)							
Collection Date Lab Code	MDC		MDC		MDC		LLD
	4/13/2017 ESS- 1553		4/13/2017 ESS- 1555		4/13/2017 ESS- 1556		
Location	E-01		E-05		E-06		
Gross Beta	6.09 ± 0.91	< 1.23	5.39 ± 0.90	< 1.25	8.44 ± 1.03	< 1.35	2.0
Be-7	0.075 ± 0.041	< 0.11	-0.006 ± 0.051	< 0.12	-0.008 ± 0.042	< 0.11	
K-40	4.84 ± 0.34	-	3.93 ± 0.33	-	4.82 ± 0.36	-	-
Cs-134	0.000 ± 0.005	< 0.010	-0.003 ± 0.005	< 0.008	0.001 ± 0.006	< 0.011	0.15
Cs-137	0.015 ± 0.006	< 0.011	0.002 ± 0.007	< 0.009	0.014 ± 0.007	< 0.012	0.15
Tl-208	0.032 ± 0.011	-	0.043 ± 0.014	-	0.034 ± 0.013	-	-
Pb-212	0.10 ± 0.015	-	0.11 ± 0.019	-	0.12 ± 0.017	-	-
Bi-214	0.109 ± 0.022	-	0.16 ± 0.026	-	0.11 ± 0.023	-	-
Ra-226	0.35 ± 0.12	< 0.23	0.29 ± 0.17	-	0.33 ± 0.13	< 0.25	-
Ac-228	0.11 ± 0.046	-	0.14 ± 0.057	-	0.15 ± 0.044	-	-
Collection Date Lab Code	4/13/2017 ESS- 1557		4/13/2017 ESS- 1558				
Location	E-12		E-33				
Gross Beta	7.71 ± 0.95	< 1.25	10.37 ± 1.11	< 1.42			2.0
Be-7	0.059 ± 0.054	< 0.12	0.038 ± 0.056	< 0.14			
K-40	4.69 ± 0.34	-	6.35 ± 0.42	-			-
Cs-134	-0.007 ± 0.006	< 0.007	0.001 ± 0.006	< 0.012			0.15
Cs-137	0.023 ± 0.013	< 0.013	0.013 ± 0.008	< 0.013			0.15
Tl-208	0.040 ± 0.016	-	0.038 ± 0.016	-			-
Pb-212	0.11 ± 0.018	-	0.095 ± 0.018	-			-
Bi-214	0.093 ± 0.022	-	0.079 ± 0.024	-			-
Ra-226	0.28 ± 0.14	< 0.27	0.28 ± 0.17	-			-
Ac-228	0.11 ± 0.044	-	0.10 ± 0.050	-			-

POINT BEACH NUCLEAR PLANT

Table 8. Radioactivity in shoreline sediment samples

Collection: Semiannual

Sample Description and Concentration (pCi/g dry)							
Collection Date Lab Code	MDC		MDC		MDC		Req. LLD
	10/12/2017 ESS- 5341		10/12/2017 ESS- 5342		10/12/2017 ESS- 5343		
Location	E-01		E-05		E-06		
Gross Beta	4.15 ± 0.81	< 1.11	0.80 ± 0.80	< 1.19	8.90 ± 0.90	< 1.09	2.0
Be-7	0.12 ± 0.056	< 0.17	0.047 ± 0.040	< 0.13	0.014 ± 0.042	< 0.13	
K-40	2.97 ± 0.34	-	2.78 ± 0.28	-	5.26 ± 0.37	-	-
Cs-134	-0.004 ± 0.007	< 0.010	0.004 ± 0.005	< 0.007	-0.001 ± 0.006	< 0.010	0.15
Cs-137	0.010 ± 0.008	< 0.013	0.006 ± 0.007	< 0.012	0.006 ± 0.008	< 0.012	0.15
Tl-208	0.047 ± 0.018	-	0.032 ± 0.012	-	0.039 ± 0.014	-	-
Pb-212	0.11 ± 0.020	-	0.12 ± 0.017	-	0.12 ± 0.018	-	-
Bi-214	0.13 ± 0.027	-	0.11 ± 0.022	-	0.10 ± 0.022	-	-
Ra-226	0.31 ± 0.15	< 0.31	0.44 ± 0.12	< 0.25	0.41 ± 0.13	< 0.26	-
Ac-228	0.13 ± 0.045	-	0.13 ± 0.038	-	0.13 ± 0.047	-	-

Collection Date Lab Code	10/12/2017 ESS- 5344		10/12/2017 ESS- 5345		Annual Mean ±s.d.	
	E-12		E-33			
Gross Beta	7.07 ± 0.91	< 1.17	10.84 ± 0.93	< 1.09	2.0	6.98 ± 3.02
Be-7	0.18 ± 0.065	< 0.21	0.043 ± 0.048	< 0.15		0.057 ± 0.059
K-40	4.98 ± 0.39	-	5.94 ± 0.41	-	-	4.66 ± 1.15
Cs-134	-0.006 ± 0.007	< 0.011	-0.006 ± 0.006	< 0.009	0.15	0.00 ± 0.00
Cs-137	0.028 ± 0.016	< 0.016	0.024 ± 0.013	< 0.013	0.15	0.014 ± 0.009
Tl-208	0.046 ± 0.017	-	0.051 ± 0.015	-	-	0.04 ± 0.01
Pb-212	0.10 ± 0.021	-	0.13 ± 0.020	-	-	0.11 ± 0.01
Bi-214	0.14 ± 0.032	-	0.21 ± 0.037	-	-	0.12 ± 0.04
Ra-226	0.30 ± 0.16	< 0.33	0.46 ± 0.18	-	-	0.35 ± 0.07
Ac-228	0.12 ± 0.046	-	0.18 ± 0.050	-	-	0.13 ± 0.02

POINT BEACH NUCLEAR PLANT

Table 9. Radioactivity in soil samples

Collection: Semiannual

Sample Description and Concentration (pCi/g dry)							
	MDC		MDC		MDC		
Collection Date	5/25/2017		5/25/2017		5/25/2017		Req.
Lab Code	ESO- 2450		ESO- 2451		ESO- 2452		LLD
Location	E-01		E-02		E-03		
Gross Beta	26.69 ± 1.18	< 1.10	25.17 ± 1.19	< 1.17	20.54 ± 1.07	< 1.07	2.0
Be-7	0.047 ± 0.11	< 0.24	0.22 ± 0.10	< 0.25	-0.004 ± 0.096	< 0.17	
K-40	15.70 ± 0.76	-	14.27 ± 0.70	-	15.39 ± 0.80	-	-
Cs-134	-0.005 ± 0.011	< 0.017	0.010 ± 0.011	< 0.021	0.000 ± 0.012	< 0.023	0.15
Cs-137	0.17 ± 0.035	< 0.031	0.074 ± 0.023	< 0.023	0.088 ± 0.024	< 0.025	0.15
Tl-208	0.19 ± 0.032	-	0.15 ± 0.028	-	0.15 ± 0.034	-	-
Pb-212	0.58 ± 0.041	-	0.41 ± 0.034	-	0.39 ± 0.040	-	-
Bi-214	0.37 ± 0.047	-	0.29 ± 0.042	-	0.27 ± 0.047	-	-
Ra-226	1.19 ± 0.33	-	0.69 ± 0.22	< 0.48	1.49 ± 0.72	-	-
Ac-228	0.56 ± 0.095	-	0.49 ± 0.076	-	0.52 ± 0.10	-	-
Collection Date	5/25/2017		5/25/2017		5/25/2017		
Lab Code	ESO- 2453		ESO- 2455		ESO- 2456		
Location	E-04		E-06		E-08		
Gross Beta	15.70 ± 1.06	< 1.17	16.84 ± 1.04	< 1.13	24.80 ± 1.09	< 0.96	2.0
Be-7	-0.073 ± 0.083	< 0.17	0.008 ± 0.090	< 0.18	-0.013 ± 0.068	< 0.13	
K-40	9.19 ± 0.57	-	8.60 ± 0.54	-	13.47 ± 0.69	-	-
Cs-134	-0.002 ± 0.009	< 0.018	-0.006 ± 0.009	< 0.016	0.001 ± 0.009	< 0.017	0.15
Cs-137	0.18 ± 0.035	< 0.028	0.58 ± 0.040	< 0.024	0.19 ± 0.027	< 0.022	0.15
Tl-208	0.10 ± 0.025	-	0.080 ± 0.024	-	0.088 ± 0.022	-	-
Pb-212	0.30 ± 0.032	-	0.23 ± 0.029	-	0.25 ± 0.029	-	-
Bi-214	0.18 ± 0.037	-	0.16 ± 0.036	-	0.21 ± 0.036	-	-
Ra-226	0.62 ± 0.27	-	0.56 ± 0.20	< 0.42	0.59 ± 0.23	-	-
Ac-228	0.28 ± 0.076	-	0.29 ± 0.082	-	0.35 ± 0.085	-	-
Collection Date	5/25/2017		5/25/2017				
Lab Code	ESO- 2457		ESO- 2458				
Location	E-09		E-20				
Gross Beta	31.52 ± 1.32	< 1.25	24.87 ± 1.27	< 1.29			2.0
Be-7	-0.034 ± 0.084	< 0.22	0.22 ± 0.083	< 0.26			
K-40	18.23 ± 0.86	-	16.17 ± 0.78	-			-
Cs-134	-0.005 ± 0.012	< 0.022	-0.001 ± 0.011	< 0.020			0.15
Cs-137	0.17 ± 0.030	< 0.026	0.055 ± 0.018	< 0.021			0.15
Tl-208	0.18 ± 0.035	-	0.15 ± 0.026	-			-
Pb-212	0.47 ± 0.039	-	0.48 ± 0.038	-			-
Bi-214	0.37 ± 0.050	-	0.38 ± 0.049	-			-
Ra-226	1.11 ± 0.31	-	0.94 ± 0.31	-			-
Ac-228	0.52 ± 0.10	-	0.57 ± 0.091	-			-

POINT BEACH NUCLEAR PLANT

Table 9. Radioactivity in soil samples

Collection: Semiannual

	Sample Description and Concentration (pCi/g dry)						Req. LLD
	MDC		MDC		MDC		
Collection Date	10/25/2017		10/25/2017		10/25/2017		
Lab Code	ESO- 5704		ESO- 5706		ESO- 5707		
Location	E-01		E-02		E-03		
Gross Beta	16.50 ± 1.03	< 1.11	25.29 ± 1.20	< 1.18	35.61 ± 2.33	< 1.89	2.0
Be-7	0.019 ± 0.063	< 0.16	0.038 ± 0.10	< 0.17	0.20 ± 0.083	< 0.22	
K-40	9.57 ± 0.56	-	17.08 ± 0.77	-	18.80 ± 0.83	-	-
Cs-134	-0.004 ± 0.009	< 0.013	0.000 ± 0.011	< 0.018	0.001 ± 0.011	< 0.021	0.15
Cs-137	0.040 ± 0.016	< 0.018	0.092 ± 0.028	< 0.028	0.19 ± 0.032	< 0.028	0.15
Tl-208	0.093 ± 0.022	-	0.15 ± 0.027	-	0.19 ± 0.030	-	-
Pb-212	0.27 ± 0.027	-	0.41 ± 0.037	-	0.56 ± 0.041	-	-
Bi-214	0.27 ± 0.036	-	0.31 ± 0.047	-	0.43 ± 0.049	-	-
Ra-226	0.59 ± 0.22	-	1.00 ± 0.30	-	1.20 ± 0.32	-	-
Ac-228	0.31 ± 0.071	-	0.59 ± 0.11	-	0.65 ± 0.081	-	-
Collection Date	10/25/2017		10/25/2017		10/25/2017		
Lab Code	ESO- 5708		ESO- 5709		ESO- 5710		
Location	E-04		E-06		E-08		
Gross Beta	27.05 ± 1.18	< 1.09	12.56 ± 1.01	< 1.17	23.26 ± 1.12	< 1.09	2.0
Be-7	0.11 ± 0.090	< 0.23	0.055 ± 0.058	< 0.17	0.15 ± 0.092	< 0.27	
K-40	17.23 ± 0.75	-	7.58 ± 0.46	-	13.62 ± 0.69	-	-
Cs-134	-0.008 ± 0.011	< 0.016	0.001 ± 0.007	< 0.013	0.009 ± 0.009	< 0.018	0.15
Cs-137	0.11 ± 0.027	< 0.026	0.13 ± 0.018	< 0.015	0.13 ± 0.023	< 0.020	0.15
Tl-208	0.14 ± 0.025	-	0.10 ± 0.023	-	0.096 ± 0.030	-	-
Pb-212	0.41 ± 0.032	-	0.26 ± 0.024	-	0.23 ± 0.031	-	-
Bi-214	0.30 ± 0.042	-	0.29 ± 0.033	-	0.17 ± 0.039	-	-
Ra-226	0.96 ± 0.29	-	0.71 ± 0.23	-	0.64 ± 0.29	-	-
Ac-228	0.53 ± 0.093	-	0.32 ± 0.062	-	0.29 ± 0.076	-	-
Collection Date	10/25/2017		10/25/2017		Annual		
Lab Code	ESO- 5711		ESO- 5712				
Location	E-09		E-20		Mean ± s.d.		
Gross Beta	31.15 ± 1.18	< 0.95	28.89 ± 1.30	< 1.26	24.15 ± 6.36		2.0
Be-7	-0.075 ± 0.060	< 0.12	0.44 ± 0.20	-	0.082 ± 0.14		
K-40	19.53 ± 0.63	-	16.71 ± 0.64	-	14.44 ± 3.82		-
Cs-134	-0.003 ± 0.008	< 0.016	-0.003 ± 0.008	< 0.015	-0.001 ± 0.01		0.15
Cs-137	0.093 ± 0.015	< 0.019	0.077 ± 0.018	< 0.020	0.15 ± 0.13		0.15
Tl-208	0.18 ± 0.022	-	0.16 ± 0.026	-	0.14 ± 0.04		-
Pb-212	0.51 ± 0.029	-	0.46 ± 0.030	-	0.39 ± 0.12		-
Bi-214	0.40 ± 0.035	-	0.37 ± 0.038	-	0.30 ± 0.09		-
Ra-226	1.26 ± 0.24	-	1.16 ± 0.23	-	0.92 ± 0.30		-
Ac-228	0.60 ± 0.065	-	0.57 ± 0.068	-	0.46 ± 0.13		-

POINT BEACH NUCLEAR PLANT

Table 10. Radioactivity in vegetation samples
Collection: Tri-annual

Sample Description and Concentration (pCi/g wet)							
Location	E-01	MDC	E-02	MDC	E-03	MDC	
Collection Date	05-24-17		05-24-17		05-24-17		
Lab Code	EG- 2459		EG- 2460		EG- 2461		Req. LLD
Ratio (wet/dry)	8.08		7.43		6.92		-
Gross Beta	6.89 ± 0.17	< 0.051	4.12 ± 0.12	< 0.042	2.50 ± 0.11	< 0.049	0.25
Be-7	0.43 ± 0.14	-	0.39 ± 0.11	-	1.25 ± 0.16	-	-
K-40	5.91 ± 0.43	-	3.37 ± 0.28	-	4.76 ± 0.29	-	-
I-131	-0.007 ± 0.008	< 0.031	-0.006 ± 0.005	< 0.017	-0.001 ± 0.005	< 0.015	0.060
Cs-134	0.001 ± 0.007	< 0.015	0.001 ± 0.005	< 0.009	0.001 ± 0.005	< 0.010	0.060
Cs-137	-0.001 ± 0.009	< 0.010	0.000 ± 0.005	< 0.009	-0.002 ± 0.006	< 0.006	0.080
Other (Co-60)	-0.002 ± 0.007	< 0.007	0.000 ± 0.006	< 0.008	0.003 ± 0.005	< 0.008	0.060
Location	E-04		E-06		E-08		
Collection Date	05-24-17		05-24-17		05-24-17		
Lab Code	EG- 2462		EG- 2463		EG- 2464		Req. LLD
Ratio (wet/dry)	5.64		4.04		5.14		-
Gross Beta	6.26 ± 0.18	< 0.059	6.56 ± 0.19	< 0.065	4.27 ± 0.12	< 0.036	0.25
Be-7	0.73 ± 0.14	-	3.02 ± 0.28	-	2.07 ± 0.16	-	-
K-40	3.91 ± 0.30	-	3.88 ± 0.37	-	3.01 ± 0.24	-	-
I-131	0.005 ± 0.006	< 0.027	-0.008 ± 0.008	< 0.024	0.003 ± 0.004	< 0.020	0.060
Cs-134	0.002 ± 0.005	< 0.009	-0.005 ± 0.007	< 0.014	0.004 ± 0.004	< 0.007	0.060
Cs-137	0.004 ± 0.005	< 0.008	0.010 ± 0.009	< 0.017	0.001 ± 0.006	< 0.010	0.080
Other (Co-60)	-0.003 ± 0.006	< 0.007	0.001 ± 0.005	< 0.006	-0.001 ± 0.005	< 0.005	0.060
Location	E-09		E-20				
Collection Date	05-24-17		05-24-17				
Lab Code	EG- 2465		EG- 2466				Req. LLD
Ratio (wet/dry)	6.22		7.78				-
Gross Beta	5.86 ± 0.15	< 0.050	4.12 ± 0.12	< 0.037			0.25
Be-7	1.07 ± 0.16	-	1.18 ± 0.13	-			-
K-40	5.15 ± 0.35	-	4.64 ± 0.28	-			-
I-131	0.007 ± 0.005	< 0.025	-0.002 ± 0.004	< 0.023			0.060
Cs-134	0.000 ± 0.005	< 0.010	0.002 ± 0.005	< 0.009			0.060
Cs-137	0.001 ± 0.006	< 0.010	0.001 ± 0.005	< 0.008			0.080
Other (Co-60)	0.005 ± 0.006	< 0.010	0.004 ± 0.005	< 0.009			0.060

POINT BEACH NUCLEAR PLANT

Table 10. Radioactivity in vegetation samples
Collection: Tri-annual

Sample Description and Concentration (pCi/g wet)							
Location	E-01		E-02		E-03		
Collection Date	07-27-17		07-27-17		07-27-17		
Lab Code	EG- 3800		EG- 3801		EG- 3802		Req. LLD
Ratio (wet/dry)	3.43		5.63		2.82		-
Gross Beta	6.34 ± 0.19	< 0.062	5.79 ± 0.17	< 0.057	7.29 ± 0.28	< 0.110	0.25
Be-7	3.34 ± 0.37	-	1.23 ± 0.21	-	4.30 ± 0.39	-	-
K-40	6.48 ± 0.56	-	4.30 ± 0.41	-	6.99 ± 0.60	-	-
I-131	-0.009 ± 0.011	< 0.039	0.002 ± 0.009	< 0.036	-0.012 ± 0.011	< 0.033	0.060
Cs-134	-0.002 ± 0.012	< 0.021	0.006 ± 0.007	< 0.015	-0.005 ± 0.011	< 0.019	0.060
Cs-137	-0.007 ± 0.012	< 0.015	0.006 ± 0.009	< 0.017	0.002 ± 0.013	< 0.021	0.080
Other (Co-60)	-0.002 ± 0.012	< 0.019	0.005 ± 0.009	< 0.010	0.008 ± 0.013	< 0.016	0.060
Location	E-04		E-06		E-08		
Collection Date	07-27-17		07-27-17		07-27-17		
Lab Code	EG- 3803		EG- 3804		EG- 3806		Req. LLD
Ratio (wet/dry)	2.90		2.79		2.95		-
Gross Beta	5.30 ± 0.21	< 0.099	4.63 ± 0.18	< 0.078	7.18 ± 0.24	< 0.097	0.25
Be-7	3.59 ± 0.29	-	3.47 ± 0.40	-	4.24 ± 0.39	-	-
K-40	4.70 ± 0.43	-	4.46 ± 0.52	-	6.96 ± 0.57	-	-
I-131	0.006 ± 0.009	< 0.041	-0.018 ± 0.012	< 0.076	0.006 ± 0.011	< 0.048	0.060
Cs-134	-0.006 ± 0.010	< 0.017	-0.002 ± 0.011	< 0.020	-0.006 ± 0.011	< 0.020	0.060
Cs-137	-0.001 ± 0.010	< 0.014	0.015 ± 0.016	< 0.027	0.000 ± 0.012	< 0.019	0.080
Other (Co-60)	-0.005 ± 0.010	< 0.011	0.006 ± 0.011	< 0.013	0.001 ± 0.013	< 0.016	0.060
Location	E-09		E-20				
Collection Date	07-27-17		07-27-17				
Lab Code	EG- 3807		EG- 3808				Req. LLD
Ratio (wet/dry)	3.04		3.93				-
Gross Beta	6.23 ± 0.23	< 0.098	7.31 ± 0.22	< 0.078			0.25
Be-7	4.63 ± 0.32	-	2.99 ± 0.27	-			-
K-40	6.89 ± 0.50	-	6.14 ± 0.49	-			-
I-131	0.004 ± 0.010	< 0.035	-0.005 ± 0.009	< 0.037			0.060
Cs-134	0.001 ± 0.010	< 0.018	-0.009 ± 0.009	< 0.015			0.060
Cs-137	-0.002 ± 0.011	< 0.021	-0.002 ± 0.010	< 0.019			0.080
Other (Co-60)	0.004 ± 0.010	< 0.017	0.005 ± 0.011	< 0.018			0.060

POINT BEACH NUCLEAR PLANT

Table 10. Radioactivity in vegetation samples
Collection: Tri-annual

Sample Description and Concentration (pCi/g wet)							
Location	E-01	MDC	E-02	MDC	E-03	MDC	
Collection Date	09-27-17		09-27-17		09-27-17		
Lab Code	EG- 4979		EG- 4980		EG- 4981		Req. LLD
Ratio (wet/dry)	2.82		3.61		2.87		-
Gross Beta	7.55 ± 0.25	< 0.091	6.58 ± 0.22	< 0.090	8.28 ± 0.30	< 0.12	0.25
Be-7	3.64 ± 0.26	-	2.91 ± 0.23	-	3.10 ± 0.25	-	-
K-40	5.27 ± 0.39	-	6.13 ± 0.41	-	6.85 ± 0.46	-	-
I-131	0.006 ± 0.008	< 0.037	-0.002 ± 0.008	< 0.034	0.001 ± 0.008	< 0.036	0.060
Cs-134	0.006 ± 0.007	< 0.014	0.002 ± 0.007	< 0.014	-0.010 ± 0.008	< 0.013	0.060
Cs-137	-0.004 ± 0.009	< 0.013	0.009 ± 0.008	< 0.016	0.009 ± 0.008	< 0.016	0.080
Other (Co-60)	-0.002 ± 0.008	< 0.011	-0.003 ± 0.009	< 0.013	0.005 ± 0.009	< 0.015	0.060
Location	E-04		E-06		E-08		
Collection Date	09-27-17		09-27-17		09-27-17		
Lab Code	EG- 4982		EG- 4983		EG- 4984		Req. LLD
Ratio (wet/dry)	3.04		2.33		2.18		-
Gross Beta	5.96 ± 0.23	< 0.11	4.53 ± 0.19	< 0.088	7.65 ± 0.28	< 0.12	0.25
Be-7	3.18 ± 0.30	-	3.85 ± 0.34	-	4.86 ± 0.32	-	-
K-40	6.13 ± 0.45	-	3.85 ± 0.45	-	7.79 ± 0.54	-	-
I-131	0.002 ± 0.008	< 0.043	-0.006 ± 0.010	< 0.042	0.017 ± 0.009	< 0.039	0.060
Cs-134	-0.011 ± 0.009	< 0.016	-0.018 ± 0.010	< 0.018	-0.003 ± 0.009	< 0.017	0.060
Cs-137	0.007 ± 0.010	< 0.020	0.029 ± 0.013	< 0.021	0.010 ± 0.011	< 0.020	0.080
Other (Co-60)	-0.003 ± 0.009	< 0.011	0.004 ± 0.011	< 0.012	-0.003 ± 0.008	< 0.009	0.060
Location	E-09		E-20				
Collection Date	09-27-17		09-27-17				
Lab Code	EG- 4985		EG- 4986				Req. LLD
Ratio (wet/dry)	2.64		3.90				-
Gross Beta	7.40 ± 0.28	< 0.13	6.92 ± 0.23	< 0.076			0.25
Be-7	4.18 ± 0.23	-	1.74 ± 0.23	-			-
K-40	6.74 ± 0.37	-	7.11 ± 0.48	-			-
I-131	0.001 ± 0.006	< 0.026	0.006 ± 0.007	< 0.032			0.060
Cs-134	0.000 ± 0.006	< 0.012	0.007 ± 0.007	< 0.012			0.060
Cs-137	-0.002 ± 0.007	< 0.011	-0.003 ± 0.010	< 0.019			0.080
Other (Co-60)	0.003 ± 0.007	< 0.011	0.005 ± 0.008	< 0.013			0.060

Beta Annual Mean ± s.d. 6.06 ± 1.42
Be-7 Annual Mean ± s.d. 2.73 ± 1.40
K-40 Annual Mean ± s.d. 5.48 ± 1.37
I-131 Annual Mean ± s.d. 0.000 ± 0.008
Cs-134 Annual Mean ± s.d. -0.002 ± 0.006
Cs-137 Annual Mean ± s.d. 0.003 ± 0.008
Co-60 Annual Mean ± s.d. 0.005 ± 0.004

POINT BEACH NUCLEAR PLANT

Table 11. Aquatic Vegetation, analyses for gross beta and gamma emitting isotopes.

Collection: Triannual

Units: pCi/g wet

Sample Description and Concentration						
Collection Date	06-30-17	MDC	06-30-17	MDC	Req.	
Lab Code	NS ^a		NS ^a		LLD	
Location	E-05		E-12			
Ratio (wet wt./dry wt.)						
Gross Beta	-		-		0.25	
Be-7	-		-		-	
K-40	-		-		-	
Co-58	-		-		0.25	
Co-60	-		-		0.25	
Cs-134	-		-		0.25	
Cs-137	-		-		0.25	
Collection Date	08-02-17		08-02-17		Req.	
Lab Code	NS ^a		ESL- 3956		LLD	
Location	E-05		E-12			
Ratio (wet wt./dry wt.)			6.84			
Gross Beta	-		1.49 ± 0.10	< 0.070	0.25	
Be-7	-		1.49 ± 0.11	-	-	
K-40	-		1.08 ± 0.10	-	-	
Co-58	-		0.001 ± 0.003	< 0.006	0.25	
Co-60	-		-0.001 ± 0.003	< 0.005	0.25	
Cs-134	-		0.000 ± 0.003	< 0.005	0.25	
Cs-137	-		0.008 ± 0.003	< 0.007	0.25	
Collection Date	10-05-17		10-05-17		Req.	
Lab Code	ESL- 5140		ESL- 5141 ^b		LLD	Annual
Location	E-05		E-12			Mean ± s.d.
Ratio (wet wt./dry wt.)	8.73		1.94			
Gross Beta	2.05 ± 0.13	< 0.070	0.86 ± 0.05	< 0.042	0.25	1.47 ± 0.60
Be-7	0.18 ± 0.13	< 0.37	0.085 ± 0.029	-	-	0.59 ± 0.78
K-40	1.27 ± 1.27	-	4.83 ± 0.11	-	-	2.40 ± 2.11
Co-58	-0.014 ± 0.016	< 0.031	0.000 ± 0.002	< 0.003	0.25	-0.004 ± 0.008
Co-60	0.011 ± 0.021	< 0.040	0.003 ± 0.002	< 0.004	0.25	0.005 ± 0.006
Cs-134	-0.020 ± 0.017	< 0.036	-0.001 ± 0.001	< 0.003	0.25	-0.007 ± 0.011
Cs-137	0.017 ± 0.020	< 0.031	0.008 ± 0.003	< 0.003	0.25	0.011 ± 0.006

^a "NS" = No sample. See Table 2.0, Listing of Missed Samples.

^b Sample contained sand and shells. After sieving to remove sand and shell particles, gross beta on ashed sample low compared to K-40 result on gamma isotopic scan. Reanalysis = 0.57±0.05 pCi/g wet.

POINT BEACH NUCLEAR PLANT

Table 12. Ambient Gamma Radiation^a
LLD/7days: < 1mR/TLD

1st. Quarter, 2017

Location	Days in Field	Total mR	Net mR	mR/Std Qtr (91 days)	Net mR per 7 days
<u>Indicator</u>					
E-1	99	16.9 ± 1.0	12.4 ± 1.1	11.4 ± 1.0	0.88 ± 0.08
E-2	99	23.3 ± 1.0	18.8 ± 1.1	17.2 ± 1.0	1.33 ± 0.07
E-3	99	23.3 ± 1.7	18.8 ± 1.7	17.3 ± 1.6	1.33 ± 0.12
E-4	99	19.7 ± 1.6	15.2 ± 1.6	13.9 ± 1.5	1.07 ± 0.11
E-5	99	20.8 ± 0.8	16.3 ± 0.9	15.0 ± 0.8	1.15 ± 0.06
E-6	99	18.7 ± 1.0	14.2 ± 1.0	13.0 ± 0.9	1.00 ± 0.07
E-7	99	18.6 ± 1.0	14.1 ± 1.0	12.9 ± 0.9	1.00 ± 0.07
E-8	99	19.1 ± 1.0	14.6 ± 1.0	13.4 ± 0.9	1.03 ± 0.07
E-9	99	21.4 ± 0.9	16.9 ± 0.9	15.6 ± 0.8	1.20 ± 0.06
E-12	99	16.5 ± 1.1	12.0 ± 1.1	11.0 ± 1.1	0.85 ± 0.08
E-14	99	21.5 ± 0.8	17.0 ± 0.8	15.6 ± 0.7	1.20 ± 0.06
E-15	99	20.8 ± 0.6	16.3 ± 0.7	15.0 ± 0.6	1.15 ± 0.05
E-16B	99	21.3 ± 0.8	16.8 ± 0.9	15.5 ± 0.8	1.19 ± 0.08
E-17	99	21.3 ± 1.0	16.8 ± 1.1	15.4 ± 1.0	1.19 ± 0.08
E-18	99	22.8 ± 0.9	18.3 ± 0.9	16.8 ± 0.8	1.29 ± 0.07
E-22	99	22.7 ± 1.7	18.3 ± 1.8	16.8 ± 1.6	1.29 ± 0.12
E-23	99	23.4 ± 0.7	18.9 ± 0.7	17.4 ± 0.7	1.34 ± 0.05
E-24	99	20.4 ± 1.0	16.0 ± 1.1	14.7 ± 1.0	1.13 ± 0.07
E-25	99	20.6 ± 0.4	16.1 ± 0.5	14.8 ± 0.5	1.14 ± 0.04
E-26B	99	18.8 ± 1.1	14.3 ± 1.2	13.1 ± 1.1	1.01 ± 0.08
E-27	99	22.0 ± 0.7	17.5 ± 0.8	16.1 ± 0.7	1.24 ± 0.06
E-28	99	16.0 ± 0.9	11.5 ± 0.9	10.6 ± 0.8	0.81 ± 0.06
E-29	99	16.0 ± 1.2	11.6 ± 1.3	10.6 ± 1.2	0.82 ± 0.09
E-30	99	19.3 ± 1.4	14.8 ± 1.4	13.6 ± 1.3	1.04 ± 0.10
E-31	99	23.1 ± 0.7	18.7 ± 0.8	17.2 ± 0.7	1.32 ± 0.05
E-32	99	24.2 ± 0.8	19.8 ± 0.8	18.2 ± 0.7	1.40 ± 0.06
E-38	99	22.9 ± 1.9	18.4 ± 2.0	16.9 ± 1.8	1.30 ± 0.14
E-39	99	22.8 ± 1.4	18.3 ± 1.4	16.8 ± 1.3	1.29 ± 0.10
E-41	99	21.2 ± 1.1	16.7 ± 1.1	15.3 ± 1.0	1.18 ± 0.08
E-42	99	22.1 ± 1.0	17.6 ± 1.1	16.2 ± 1.0	1.25 ± 0.08
E-43	99	22.4 ± 1.8	18.0 ± 1.9	16.5 ± 1.7	1.27 ± 0.13
<u>Control</u>					
E-20	99	20.5 ± 1.2	16.0 ± 1.2	14.7 ± 1.1	1.13 ± 0.09
Mean±s.d.		20.8 ± 2.3	16.3 ± 2.3	15.0 ± 2.1	1.15 ± 0.15
<u>In-Transit Exposure</u>					
		<u>Date Annealed</u>	<u>Date Read</u>	<u>ITC-1</u>	<u>ITC-2</u>
		12-07-16	01-04-17	4.8 ± 0.3	4.9 ± 0.3
		03-15-17	04-11-17	4.5 ± 0.3	4.8 ± 0.3

^a The CaSO₄:Dy dosimeter cards provide four separate readout areas. Values listed represent the mean and standard deviation of the average of the four readings.

POINT BEACH NUCLEAR PLANT

Table 12. Ambient Gamma Radiation ^a
LLD/7days: < 1mR/TLD

2nd Quarter, 2017

Location	Days in Field	Total mR	Net mR	mR/Std Qtr (91 days)	Net mR per 7 days
Date Annealed: 03-15-17		Days in the field		90	
Date Placed: 04-07-17		Days from Annealing to Readout:		118	
Date Removed: 07-06-17		Date Read: 07-11-17			
<u>Indicator</u>					
E-1	90	17.4 ± 0.9	13.1 ± 1.1	13.3 ± 1.1	1.02 ± 0.08
E-2	90	20.9 ± 1.2	16.6 ± 1.3	16.8 ± 1.3	1.29 ± 0.10
E-3	90	23.0 ± 1.4	18.8 ± 1.5	19.0 ± 1.5	1.46 ± 0.12
E-4	90	19.0 ± 0.8	14.8 ± 0.9	14.9 ± 0.9	1.15 ± 0.07
E-5	90	18.3 ± 0.3	14.1 ± 0.6	14.2 ± 0.6	1.09 ± 0.05
E-6	90	16.5 ± 0.1	12.3 ± 0.5	12.4 ± 0.5	0.95 ± 0.04
E-7	90	17.5 ± 0.8	13.2 ± 1.0	13.4 ± 1.0	1.03 ± 0.08
E-8	90	17.7 ± 0.8	13.5 ± 1.0	13.6 ± 1.0	1.05 ± 0.08
E-9	90	17.6 ± 0.4	13.3 ± 0.7	13.5 ± 0.7	1.04 ± 0.05
E-12	90	13.8 ± 0.6	9.5 ± 0.8	9.6 ± 0.8	0.74 ± 0.06
E-14	90	19.9 ± 0.7	15.7 ± 0.9	15.8 ± 0.9	1.22 ± 0.07
E-15	90	20.1 ± 2.0	15.8 ± 2.1	16.0 ± 2.1	1.23 ± 0.16
E-16B	90	18.2 ± 0.6	14.0 ± 0.8	14.1 ± 0.8	1.09 ± 0.06
E-17	90	21.1 ± 0.3	16.8 ± 0.6	17.0 ± 0.6	1.31 ± 0.05
E-18	90	20.6 ± 1.0	16.4 ± 1.1	16.6 ± 1.1	1.27 ± 0.09
E-22	90	19.1 ± 0.9	14.9 ± 1.0	15.1 ± 1.0	1.16 ± 0.08
E-23	90	20.6 ± 0.4	16.4 ± 0.7	16.5 ± 0.7	1.27 ± 0.05
E-24	90	19.1 ± 0.6	14.9 ± 0.8	15.1 ± 0.8	1.16 ± 0.06
E-25	90	18.8 ± 0.6	14.6 ± 0.8	14.7 ± 0.8	1.13 ± 0.06
E-26B	90	18.7 ± 0.7	14.5 ± 0.9	14.6 ± 0.9	1.13 ± 0.07
E-27	90	21.1 ± 0.9	16.9 ± 1.1	17.1 ± 1.1	1.31 ± 0.08
E-28	90	15.2 ± 0.3	10.9 ± 0.6	11.0 ± 0.6	0.85 ± 0.05
E-29	90	15.2 ± 0.5	11.0 ± 0.7	11.1 ± 0.7	0.85 ± 0.06
E-30	90	16.9 ± 0.7	12.7 ± 0.9	12.8 ± 0.9	0.99 ± 0.07
E-31	90	18.9 ± 1.5	14.6 ± 1.6	14.8 ± 1.7	1.14 ± 0.13
E-32	90	23.2 ± 0.5	19.0 ± 0.7	19.2 ± 0.8	1.48 ± 0.06
E-38	90	17.5 ± 0.4	13.2 ± 0.7	13.4 ± 0.7	1.03 ± 0.05
E-39	90	17.9 ± 0.9	13.6 ± 1.1	13.8 ± 1.1	1.06 ± 0.08
E-41	90	17.4 ± 0.4	13.2 ± 0.6	13.3 ± 0.7	1.03 ± 0.05
E-42	90	19.7 ± 0.8	15.4 ± 0.9	15.6 ± 0.9	1.20 ± 0.07
E-43	90	18.9 ± 0.7	14.6 ± 0.9	14.8 ± 0.9	1.14 ± 0.07
<u>Control</u>					
E-20	90	<u>21.9 ± 0.5</u>	<u>17.6 ± 0.7</u>	<u>17.8 ± 0.7</u>	<u>1.37 ± 0.05</u>
Mean±s.d.		18.8 ± 2.2	14.6 ± 2.2	14.7 ± 2.2	1.13 ± 0.17
<u>In-Transit Exposure</u>					
		<u>Date Annealed</u>	<u>Date Read</u>	<u>ITC-1</u>	<u>ITC-2</u>
		03-15-17	04-11-17	4.5 ± 0.3	4.8 ± 0.3
		06-12-17	07-11-17	4.0 ± 0.3	3.7 ± 0.1

^a The CaSO₄:Dy dosimeter cards provide four separate readout areas. Values listed represent the mean and standard deviation of the average of the four readings.

POINT BEACH NUCLEAR PLANT

Table 12. Ambient Gamma Radiation ^a
LLD/7days: < 1mR/TLD

3rd Quarter, 2017

Location	Days in Field	Total mR	Net mR	mR/Std Qtr (91 days)	Net mR per 7 days
Date Annealed: 06-12-17		Days in the field		89	
Date Placed: 07-06-17		Days from Annealing to Readout:		117	
Date Removed: 10-03-17		Date Read: 10-07-17			
<u>Indicator</u>					
E-1	89	15.8 ± 0.2	11.7 ± 0.6	11.9 ± 0.6	0.92 ± 0.05
E-2	89	21.4 ± 1.6	17.3 ± 1.7	17.6 ± 1.7	1.36 ± 0.13
E-3	89	21.1 ± 1.4	17.0 ± 1.5	17.4 ± 1.6	1.34 ± 0.12
E-4	89	16.6 ± 1.2	12.5 ± 1.4	12.7 ± 1.4	0.98 ± 0.11
E-5	89	17.6 ± 1.0	13.4 ± 1.1	13.7 ± 1.1	1.06 ± 0.09
E-6	89	15.8 ± 0.9	11.6 ± 1.1	11.9 ± 1.1	0.92 ± 0.09
E-7	89	16.0 ± 0.7	11.8 ± 0.9	12.1 ± 1.0	0.93 ± 0.07
E-8	89	16.6 ± 0.8	12.5 ± 1.0	12.7 ± 1.0	0.98 ± 0.08
E-9	89	18.6 ± 0.9	14.5 ± 1.1	14.8 ± 1.1	1.14 ± 0.09
E-12	89	14.4 ± 1.0	10.2 ± 1.2	10.4 ± 1.2	0.80 ± 0.09
E-14	89	18.1 ± 0.7	14.0 ± 0.9	14.3 ± 0.9	1.10 ± 0.07
E-15	89	18.6 ± 0.4	14.4 ± 0.7	14.8 ± 0.7	1.14 ± 0.06
E-16B	89	18.2 ± 0.6	14.1 ± 0.9	14.4 ± 0.9	1.11 ± 0.07
E-17	89	18.5 ± 1.1	14.3 ± 1.3	14.7 ± 1.3	1.13 ± 0.10
E-18	89	19.6 ± 1.0	15.4 ± 1.1	15.8 ± 1.2	1.21 ± 0.09
E-22	89	20.7 ± 1.5	16.6 ± 1.6	16.9 ± 1.6	1.30 ± 0.12
E-23	89	20.8 ± 0.6	16.6 ± 0.9	17.0 ± 0.9	1.31 ± 0.07
E-24	89	17.9 ± 1.4	13.7 ± 1.5	14.0 ± 1.5	1.08 ± 0.12
E-25	89	18.0 ± 0.5	13.9 ± 0.8	14.2 ± 0.8	1.09 ± 0.06
E-26B	89	17.3 ± 0.7	13.1 ± 0.9	13.4 ± 0.9	1.03 ± 0.07
E-27	89	21.8 ± 0.5	17.7 ± 0.8	18.1 ± 0.8	1.39 ± 0.06
E-28	89	13.6 ± 0.6	9.5 ± 0.9	9.7 ± 0.9	0.74 ± 0.07
E-29	89	13.8 ± 1.0	9.7 ± 1.2	9.9 ± 1.2	0.76 ± 0.09
E-30	89	17.2 ± 0.9	13.0 ± 1.1	13.3 ± 1.1	1.02 ± 0.09
E-31	89	20.2 ± 0.5	16.0 ± 0.8	16.4 ± 0.8	1.26 ± 0.06
E-32	89	22.3 ± 0.8	18.1 ± 1.0	18.5 ± 1.0	1.42 ± 0.08
E-38	89	20.9 ± 0.7	16.8 ± 0.9	17.1 ± 0.9	1.32 ± 0.07
E-39	89	20.1 ± 1.2	15.9 ± 1.3	16.3 ± 1.4	1.25 ± 0.11
E-41	89	18.8 ± 1.0	14.7 ± 1.2	15.0 ± 1.2	1.15 ± 0.09
E-42	89	19.4 ± 0.8	15.2 ± 1.0	15.6 ± 1.1	1.20 ± 0.08
E-43	89	21.2 ± 1.5	17.1 ± 1.6	17.5 ± 1.6	1.34 ± 0.13
<u>Control</u>					
E-20	89	17.0 ± 1.2	12.8 ± 1.3	13.1 ± 1.3	1.01 ± 0.10
Mean±s.d.		18.4 ± 2.3	14.2 ± 2.3	14.5 ± 2.4	1.12 ± 0.18
<u>In-Transit Exposure</u>					
		<u>Date Annealed</u>	<u>Date Read</u>	<u>ITC-1</u>	<u>ITC-2</u>
		06-12-17	07-11-17	4.0 ± 0.3	3.7 ± 0.1
		09-08-17	10-07-17	4.3 ± 0.3	4.6 ± 0.4

^a The CaSO₄:Dy dosimeter cards provide four separate readout areas. Values listed represent the mean and standard deviation of the average of the four readings.

POINT BEACH NUCLEAR PLANT

Table 12. Ambient Gamma Radiation ^a
LLD/7days: < 1mR/TLD

4th Quarter, 2017

Location	Days in Field	Total mR	Net mR	mR/Std Qtr (91 days)	Net mR per 7 days
<u>Indicator</u>					
E-1	94	14.7 ± 1.2	9.9 ± 1.4	9.5 ± 1.4	0.73 ± 0.11
E-2	94	19.8 ± 1.0	14.9 ± 1.3	14.5 ± 1.2	1.11 ± 0.10
E-3	94	22.4 ± 1.6	17.5 ± 1.8	17.0 ± 1.7	1.30 ± 0.13
E-4	94	18.4 ± 0.7	13.5 ± 1.1	13.1 ± 1.0	1.01 ± 0.08
E-5	94	17.9 ± 0.3	13.1 ± 0.8	12.7 ± 0.8	0.97 ± 0.06
E-6	94	15.8 ± 0.3	10.9 ± 0.8	10.6 ± 0.8	0.82 ± 0.06
E-7	94	17.0 ± 0.8	12.2 ± 1.1	11.8 ± 1.0	0.91 ± 0.08
E-8	94	17.3 ± 1.1	12.5 ± 1.4	12.1 ± 1.3	0.93 ± 0.10
E-9	94	17.2 ± 0.4	12.3 ± 0.9	11.9 ± 0.9	0.92 ± 0.07
E-12	94	16.9 ± 0.8	12.0 ± 1.1	11.7 ± 1.1	0.90 ± 0.08
E-14	94	20.0 ± 0.8	15.1 ± 1.1	14.6 ± 1.1	1.13 ± 0.08
E-15	94	20.3 ± 1.8	15.4 ± 1.9	14.9 ± 1.9	1.15 ± 0.15
E-16B	94	19.3 ± 0.7	14.4 ± 1.1	14.0 ± 1.0	1.08 ± 0.08
E-17	94	21.0 ± 0.3	16.2 ± 0.8	15.7 ± 0.8	1.20 ± 0.06
E-18	94	20.5 ± 1.0	15.7 ± 1.3	15.2 ± 1.2	1.17 ± 0.09
E-22	94	19.5 ± 1.0	14.6 ± 1.2	14.2 ± 1.2	1.09 ± 0.09
E-23	94	21.2 ± 0.5	16.3 ± 0.9	15.8 ± 0.9	1.21 ± 0.07
E-24	94	19.3 ± 1.0	14.4 ± 1.3	14.0 ± 1.2	1.07 ± 0.09
E-25	94	19.0 ± 0.3	14.2 ± 0.8	13.7 ± 0.8	1.06 ± 0.06
E-26B	94	17.3 ± 0.4	12.4 ± 0.9	12.0 ± 0.9	0.92 ± 0.07
E-27	94	21.9 ± 0.4	17.0 ± 0.9	16.5 ± 0.8	1.27 ± 0.06
E-28	94	14.7 ± 0.2	9.9 ± 0.8	9.6 ± 0.8	0.74 ± 0.06
E-29	94	15.4 ± 1.6	10.5 ± 1.8	10.2 ± 1.7	0.78 ± 0.13
E-30	94	17.8 ± 1.1	13.0 ± 1.3	12.6 ± 1.3	0.97 ± 0.10
E-31	94	20.0 ± 1.5	15.1 ± 1.7	14.7 ± 1.6	1.13 ± 0.12
E-32	94	24.4 ± 0.6	19.5 ± 1.0	18.9 ± 1.0	1.46 ± 0.07
E-38	94	19.0 ± 0.4	14.1 ± 0.9	13.7 ± 0.8	1.05 ± 0.06
E-39	94	20.3 ± 1.6	15.5 ± 1.7	15.0 ± 1.7	1.15 ± 0.13
E-41	94	18.2 ± 0.3	13.4 ± 0.8	13.0 ± 0.8	1.00 ± 0.06
E-42	94	20.6 ± 0.9	15.8 ± 1.2	15.2 ± 1.1	1.17 ± 0.09
E-43	94	19.6 ± 0.8	14.7 ± 1.1	14.3 ± 1.1	1.10 ± 0.08
<u>Control</u>					
E-20	94	22.8 ± 0.7	17.9 ± 1.0	17.4 ± 1.0	1.34 ± 0.08
Mean±s.d.		20.1 ± 1.5	14.2 ± 2.3	19.7 ± 1.5	1.06 ± 0.17
<u>In-Transit Exposure</u>					
		<u>Date Annealed</u>	<u>Date Read</u>	<u>ITC-1</u>	<u>ITC-2</u>
		09-08-17	10-07-17	4.3 ± 0.3	4.6 ± 0.4
		12-06-17	01-10-18	5.1 ± 0.3	5.4 ± 0.5
^a The CaSO ₄ :Dy dosimeter cards provide four separate readout areas. Values listed represent the mean and standard deviation of the average of the four readings.					
Annual Indicator Mean±s.d.		19.2 ± 2.4	14.8 ± 2.4	14.4 ± 2.2	1.1 ± 0.2
Annual Control Mean±s.d.		20.5 ± 2.5	16.1 ± 2.3	15.8 ± 2.2	1.2 ± 0.2
Annual Indicator/Control Mean±s.d.		19.2 ± 2.4	14.8 ± 2.4	14.5 ± 2.2	1.1 ± 0.2

POINT BEACH NUCLEAR PLANT

Table 13. Groundwater Tritium Monitoring Program
(Monthly Collections)
Units = pCi/L

Intermittent Streams							
Sample ID		GW-01		GW-02			
Collection Date	Lab Code	Tritium	MDC	Collection Date	Lab Code	Tritium	MDC
01-26-17	EWV- 309	3 ± 89	< 169	01-26-17	EWV- 310	225 ± 99	< 169
03-02-17	EWV- 841	179 ± 86	< 146	03-02-17	EWV- 842	342 ± 94	< 146
03-30-17	EWV- 1289	130 ± 78	< 150	03-30-17	EWV- 1290	284 ± 86	< 150
04-25-17	EWV- 1781	64 ± 77	< 153	04-25-17	EWV- 1782	318 ± 90	< 153
05-03-17	EWV- 1989	129 ± 94	< 145	05-03-17	EWV- 1990	360 ± 104	< 145
06-29-17	EWV- 3154	78 ± 78	< 149	06-29-17	EWV- 3155	141 ± 81	< 149
07-26-17	EWV- 3809	142 ± 83	< 158	07-26-17	EWV- 3810	115 ± 82	< 158
08-23-17	EWV- 4354	146 ± 78	< 149	08-23-17		NS ^a	
09-27-17	EWV- 4994	79 ± 72	< 144	09-27-17	EWV- 4996	156 ± 77	< 144
10-25-17	EWV- 5713	158 ± 118	< 186	10-25-17	EWV- 5714	246 ± 87	< 154
11-30-17	EWV- 6250	76 ± 77	< 154	11-30-17	EWV- 6251	231 ± 85	< 154
12-28-17		NS ^b		12-28-17		NS ^b	
Mean ± s.d.		108 ± 52		Mean ± s.d.		242 ± 85	

Sample ID		GW-03		GW-17			
Collection Date	Lab Code	Tritium	MDC	Collection Date	Lab Code	Tritium	MDC
01-26-17	EWV- 311	5 ± 89	< 169	01-26-17	EWV- 313	278 ± 102	< 169
03-02-17	EWV- 843	79 ± 81	< 146	03-02-17	EWV- 845	314 ± 93	< 146
03-30-17	EWV- 1291	111 ± 77	< 150	03-30-17	EWV- 1293	461 ± 95	< 150
04-25-17	EWV- 1783	49 ± 76	< 153	04-25-17	EWV- 1785	231 ± 86	< 153
05-03-17	EWV- 1991	88 ± 92	< 145	05-03-17	EWV- 1996	306 ± 102	< 145
06-29-17	EWV- 3157	38 ± 76	< 149	06-29-17	EWV- 3159	155 ± 82	< 149
07-26-17	EWV- 3811	95 ± 81	< 158	07-26-17	EWV- 3813	122 ± 82	< 158
08-23-17	EWV- 4357	41 ± 72	< 149	08-23-17	EWV- 4359	317 ± 87	< 149
09-27-17	EWV- 4997	110 ± 74	< 144	09-27-17		NS ^a	
10-25-17	EWV- 5715	80 ± 78	< 154	10-25-17	EWV- 5717	273 ± 88	< 154
11-30-17	EWV- 6252	71 ± 76	< 154	11-30-17	EWV- 6254	178 ± 82	< 154
12-28-17		NS ^b		12-28-17		NS ^b	
Mean ± s.d.		70 ± 33		Mean ± s.d.		264 ± 98	

Wells			
Sample ID		GW-04 (EIC Well)	
Collection Date	Lab Code	Tritium	MDC
01-26-17	EWV- 312	-128 ± 82	< 169
03-02-17	EWV- 844	76 ± 81	< 146
03-30-17	EWV- 1292	68 ± 75	< 150
04-25-17	EWV- 1784	9 ± 74	< 153
05-03-17	EWV- 1992	32 ± 90	< 145
06-29-17	EWV- 3158	9 ± 74	< 149
07-26-17	EWV- 3812	16 ± 77	< 158
08-23-17	EWV- 4358	77 ± 74	< 149
09-27-17	EWV- 4998	12 ± 68	< 144
10-25-17	EWV- 5716	-13 ± 73	< 154
11-30-17	EWV- 6253	-27 ± 71	< 154
12-28-17	EWV- 6604	-61 ± 80	< 158
Mean ± s.d.		6 ± 59	

^a"NS" = No sample; no water available.

^b"NS" = No sample; creeks frozen.

POINT BEACH NUCLEAR PLANT

Table 13. Groundwater Tritium Monitoring Program
(Monthly Collections)
Units = pCi/L

Beach Drains							
S-1				S-3			
Collection Date	Lab Code	Tritium	MDC	Collection Date	Lab Code	Tritium	MDC
01-10-17		NF ^a		01-10-17		NF ^a	
02-16-17	EW- 611	293 ± 90	< 154	02-16-17		NF ^a	
03-09-17	EW- 1041	350 ± 89	< 145	03-09-17	EW- 1042	201 ± 81	< 145
04-05-17	EW- 1381	309 ± 88	< 150	04-05-17		NF ^a	
05-03-17	EW- 1997	339 ± 103	< 145	05-03-17		NF ^a	
06-08-17	EW- 2781	319 ± 108	< 155	06-08-17		NF ^a	
07-05-17	EW- 3253	204 ± 93	< 178	07-05-17	EW- 3254	264 ± 96	< 178
08-03-17	EW- 3947	175 ± 88	< 159	08-03-17		NF ^a	
09-07-17	EW- 4531	215 ± 95	< 187	09-07-17		NF ^a	
10-03-17	EW- 5142	529 ± 94	< 143	10-03-17		NF ^a	
10-31-17	EW- 5801	224 ± 94	< 158	11-30-17		NF ^a	
11-30-17		NF ^a		12-06-17	EW- 6381	332 ± 89	< 148
12-06-17	EW- 6380	376 ± 91	< 148				
Mean ± s.d.		303 ± 100		Mean ± s.d.		266 ± 65	

S-7				S-8			
Collection Date	Lab Code	Tritium	MDC	Collection Date	Lab Code	Tritium	MDC
01-10-17		NF ^a		01-10-17		NF ^a	
02-16-17		NF ^a		02-16-17		NF ^a	
03-09-17		NF ^a		03-09-17		NF ^a	
04-05-17		NF ^a		04-05-17		NF ^a	
05-03-17		NF ^a		05-03-17		NF ^a	
06-08-17		NF ^a		06-08-17		NF ^a	
07-05-17		NF ^a		07-05-17		NF ^a	
08-03-17		NF ^a		08-03-17		NF ^a	
09-07-17		NF ^a		09-07-17		NF ^a	
10-03-17		NF ^a		10-03-17		NF ^a	
11-30-17		NF ^a		11-30-17		NF ^a	
Mean ± s.d.				Mean ± s.d.			

S-9				S-10			
Collection Date	Lab Code	Tritium	MDC	Collection Date	Lab Code	Tritium	MDC
01-10-17		NF ^a		01-10-17		NF ^a	
02-16-17		NF ^a		02-16-17		NF ^a	
03-09-17		NF ^a		03-09-17		NF ^a	
04-05-17		NF ^a		04-05-17		NF ^a	
05-03-17		NF ^a		05-03-17		NF ^a	
06-08-17		NF ^a		06-08-17		NF ^a	
07-05-17		NF ^a		07-05-17		NF ^a	
08-03-17		NF ^a		08-03-17		NF ^a	
09-07-17		NF ^a		09-07-17		NF ^a	
10-03-17		NF ^a		10-03-17		NF ^a	
11-30-17		NF ^a		11-30-17		NF ^a	
Mean ± s.d.				Mean ± s.d.			

^a "NF" = No flow.

POINT BEACH NUCLEAR PLANT

Table 13. Groundwater Tritium Monitoring Program
(Monthly Collections)
Units = pCi/L

Beach Drains (cont.)							
S-11				S-12			
Sample ID							
Collection Date	Lab Code	Tritium	MDC	Collection Date	Lab Code	Tritium	MDC
01-10-17		NF ^a		01-10-17		NF ^a	
02-16-17		NF ^a		02-16-17		NF ^a	
03-09-17		NF ^a		03-09-17		NF ^a	
04-05-17		NF ^a		04-05-17	EW- 1383	245 ± 84	< 150
05-03-17	EW- 1998	558 ± 98	< 148	05-03-17	EW- 1999	216 ± 81	< 148
06-08-17	EW- 2782	280 ± 106	< 155	06-08-17		NF ^a	
07-05-17		NF ^a		07-05-17		NF ^a	
08-03-17		NF ^a		08-03-17		NF ^a	
09-07-17		NF ^a		09-07-17		NF ^a	
10-03-17		NF ^a		10-03-17		NF ^a	
11-30-17		NF ^a		11-30-17		NF ^a	
Mean ± s.d.		419 ± 196		Mean ± s.d.		230 ± 20	

U2 Façade Subsurface Drain Sump							
Collection Date	Lab Code	Tritium	MDC	Collection Date	Lab Code	Tritium	MDC
01-31-17	EW- 500	1058 ± 122	< 156				
02-28-17	EW- 1038	776 ± 107	< 146				
03-31-17	EW- 1384	765 ± 111	< 145				
04-30-17	EW- 2191	1635 ± 142	< 156				
05-31-17	EW- 2903	1503 ± 134	< 153				
06-30-17	EW- 3361	854 ± 112	< 149				
07-31-17	EW- 3958	907 ± 115	< 158				
08-31-17	EW- 4999	1035 ± 115	< 145				
09-30-17	EW- 5333	737 ± 105	< 149				
10-31-17	EW- 6129	8772 ± 284	< 153				
11-30-17	EW- 6513	7478 ± 265	< 157				
12-31-17	EW- 6719	4165 ± 203	< 152				
Mean ± s.d.		2474 ± 2815					

^a "NF" = No flow.

POINT BEACH NUCLEAR PLANT

Beach Drains

Units: = pCi/L			Gamma isotopic analysis					
Location	S-1		S-3		S-7		S-8	
Collection Date	01-31-17		01-31-17		01-31-17		01-31-17	
Lab Code	NF ^a	MDC	NF ^a	MDC	NF ^a	MDC	NF ^a	MDC
Be-7	-		-		-		-	
Mn-54	-		-		-		-	
Fe-59	-		-		-		-	
Co-58	-		-		-		-	
Co-60	-		-		-		-	
Zn-65	-		-		-		-	
Zr-Nb-95	-		-		-		-	
Cs-134	-		-		-		-	
Cs-137	-		-		-		-	
Ba-La-140	-		-		-		-	
Location	S-9		S-10		S-11		S-12	
Collection Date	01-31-17		01-31-17		01-31-17		01-31-17	
Lab Code	NF ^a		NF ^a		NF ^a		NF ^a	
Be-7	-		-		-		-	
Mn-54	-		-		-		-	
Fe-59	-		-		-		-	
Co-58	-		-		-		-	
Co-60	-		-		-		-	
Zn-65	-		-		-		-	
Zr-Nb-95	-		-		-		-	
Cs-134	-		-		-		-	
Cs-137	-		-		-		-	
Ba-La-140	-		-		-		-	
Location	S-1		S-3		S-7		S-8	
Collection Date	02-16-17		02-16-17		02-16-17		02-16-17	
Lab Code	EW- 611		NF ^a		NF ^a		NF ^a	
Be-7	1.1 ± 16.1	< 29.4	-		-		-	
Mn-54	-0.5 ± 1.5	< 2.5	-		-		-	
Fe-59	-0.6 ± 2.9	< 4.4	-		-		-	
Co-58	0.5 ± 1.7	< 2.5	-		-		-	
Co-60	0.2 ± 1.6	< 2.6	-		-		-	
Zn-65	0.7 ± 3.0	< 4.1	-		-		-	
Zr-Nb-95	0.5 ± 1.5	< 2.6	-		-		-	
Cs-134	0.7 ± 1.6	< 3.5	-		-		-	
Cs-137	-2.3 ± 1.9	< 3.8	-		-		-	
Ba-La-140	0.6 ± 1.7	< 3.2	-		-		-	

^a "NF" = No flow.

POINT BEACH NUCLEAR PLANT

Beach Drains (cont.)

Units: = pCi/L		Gamma isotopic analysis							
Location	S-9		S-10		S-11		S-12		
Collection Date	02-16-17		02-16-17		02-16-17		02-16-17		
Lab Code	NF ^a	MDC	NF ^a	MDC	NF ^a	NF ^a			
Be-7	-		-		-	-			
Mn-54	-		-		-	-			
Fe-59	-		-		-	-			
Co-58	-		-		-	-			
Co-60	-		-		-	-			
Zn-65	-		-		-	-			
Zr-Nb-95	-		-		-	-			
Cs-134	-		-		-	-			
Cs-137	-		-		-	-			
Ba-La-140	-		-		-	-			
Location	S-1		S-3		S-7		S-8		
Collection Date	03-09-17		03-09-17		03-09-17		03-09-17		
Lab Code	EW- 1041		EW- 1042		NF ^a		NF ^a		
Be-7	2.9 ± 11.2	< 23.6	3.3 ± 19.0	< 41.1	-	-			
Mn-54	-0.6 ± 1.3	< 1.9	1.1 ± 1.6	< 3.1	-	-			
Fe-59	-2.8 ± 2.3	< 2.4	0.5 ± 4.1	< 8.2	-	-			
Co-58	-0.5 ± 1.3	< 2.4	0.3 ± 1.8	< 3.6	-	-			
Co-60	1.5 ± 1.7	< 2.7	0.0 ± 2.4	< 3.1	-	-			
Zn-65	-0.7 ± 2.9	< 3.9	-2.8 ± 4.3	< 1.5	-	-			
Zr-Nb-95	0.2 ± 1.5	< 2.5	2.1 ± 1.9	< 4.0	-	-			
Cs-134	0.7 ± 1.3	< 2.7	-0.6 ± 1.9	< 3.5	-	-			
Cs-137	-0.1 ± 1.5	< 2.7	0.3 ± 2.1	< 3.7	-	-			
Ba-La-140	-0.3 ± 1.5	< 2.4	-1.4 ± 2.3	< 3.5	-	-			
Location	S-9		S-10		S-11		S-12		
Collection Date	03-09-17		03-09-17		03-09-17		03-09-17		
Lab Code	NF ^a	MDC	NF ^a	MDC	NF ^a	NF ^a			
Be-7	-		-		-	-			
Mn-54	-		-		-	-			
Fe-59	-		-		-	-			
Co-58	-		-		-	-			
Co-60	-		-		-	-			
Zn-65	-		-		-	-			
Zr-Nb-95	-		-		-	-			
Cs-134	-		-		-	-			
Cs-137	-		-		-	-			
Ba-La-140	-		-		-	-			

^a "NF" = No flow.

POINT BEACH NUCLEAR PLANT

Beach Drains (cont.)

Units: = pCi/L		Gamma isotopic analysis						
Location	S-1		S-3		S-7		S-8	
Collection Date	04-05-17		04-05-17		04-05-17		04-05-17	
Lab Code	EW- 1381	MDC	NF ^a	MDC	NF ^a	NF ^a	MDC	
Be-7	-1.1 ± 16.1	< 29.2	-		-		-	
Mn-54	-0.8 ± 1.5	< 2.8	-		-		-	
Fe-59	-1.9 ± 3.6	< 5.2	-		-		-	
Co-58	-0.2 ± 1.9	< 3.4	-		-		-	
Co-60	2.1 ± 1.6	< 1.5	-		-		-	
Zn-65	-0.2 ± 3.8	< 5.5	-		-		-	
Zr-Nb-95	0.2 ± 1.7	< 4.6	-		-		-	
Cs-134	1.5 ± 1.9	< 3.2	-		-		-	
Cs-137	1.4 ± 1.9	< 3.2	-		-		-	
Ba-La-140	3.8 ± 1.6	< 6.2	-		-		-	
Location	S-9		S-10		S-11		S-12	
Collection Date	04-05-17		04-05-17		04-05-17		04-05-17	
Lab Code	NF ^a		NF ^a		NF ^a		EW- 1383	
Be-7	-		-		-		3.9 ± 14.7	< 28.1
Mn-54	-		-		-		1.5 ± 1.6	< 2.6
Fe-59	-		-		-		2.6 ± 2.8	< 4.2
Co-58	-		-		-		1.8 ± 1.6	< 2.8
Co-60	-		-		-		0.2 ± 2.0	< 2.1
Zn-65	-		-		-		-4.2 ± 3.6	< 3.1
Zr-Nb-95	-		-		-		0.3 ± 1.7	< 3.7
Cs-134	-		-		-		0.7 ± 1.6	< 3.5
Cs-137	-		-		-		0.1 ± 1.8	< 3.6
Ba-La-140	-		-		-		-0.4 ± 1.2	< 3.4
Location	S-1		S-3		S-7		S-8	
Collection Date	05-03-17		05-03-17		05-03-17		05-03-17	
Lab Code	EW- 1997		NF ^a		NF ^a		NF ^a	
Be-7	-9.3 ± 9.9	< 23.6	-		-		-	
Mn-54	0.2 ± 1.1	< 2.2	-		-		-	
Fe-59	-3.0 ± 2.0	< 3.1	-		-		-	
Co-58	-0.2 ± 1.2	< 2.4	-		-		-	
Co-60	1.0 ± 1.4	< 2.2	-		-		-	
Zn-65	-1.0 ± 2.4	< 3.5	-		-		-	
Zr-Nb-95	-1.3 ± 1.2	< 2.5	-		-		-	
Cs-134	0.3 ± 1.3	< 2.3	-		-		-	
Cs-137	-0.2 ± 1.4	< 2.4	-		-		-	
Ba-La-140	-2.0 ± 1.7	< 4.0	-		-		-	

^a "NF" = No flow.

POINT BEACH NUCLEAR PLANT

Beach Drains (cont.)

Units: = pCi/L					Gamma isotopic analysis			
Location	S-9		S-10		S-11		S-12 ^b	
Collection Date	05-03-17		05-03-17		05-03-17		05-03-17	
Lab Code	NF ^a	MDC	NF ^a	MDC	EW- 1998	MDC	EW- 1999	MDC
Be-7	-		-		-2.6 ± 13.1	< 23.1	-71.4 ± 76.1	< 94.2
Mn-54	-		-		0.5 ± 1.7	< 2.4	7.7 ± 9.2	< 19.7
Fe-59	-		-		2.7 ± 2.6	< 6.2	-16.4 ± 17.0	< 38.4
Co-58	-		-		-0.4 ± 1.5	< 2.3	-1.0 ± 9.4	< 17.9
Co-60	-		-		-0.5 ± 1.6	< 2.3	5.5 ± 10.2	< 20.5
Zn-65	-		-		-1.6 ± 2.8	< 3.8	9.6 ± 20.0	< 38.6
Zr-Nb-95	-		-		1.3 ± 1.4	< 4.0	1.8 ± 10.6	< 25.1
Cs-134	-		-		0.7 ± 1.5	< 2.8	-4.7 ± 10.0	< 19.3
Cs-137	-		-		0.1 ± 1.9	< 3.2	5.5 ± 10.9	< 16.5
Ba-La-140	-		-		-6.1 ± 1.7	< 6.0	-7.9 ± 10.1	< 16.1
Location	S-1		S-3		S-7		S-8	
Collection Date	06-08-17		06-08-17		06-08-17		06-08-17	
Lab Code	EW- 2781		NF ^a		NF ^a		NF ^a	
Be-7	4.5 ± 10.4	< 31.8	-		-		-	
Mn-54	0.4 ± 1.3	< 1.3	-		-		-	
Fe-59	-0.1 ± 2.4	< 2.4	-		-		-	
Co-58	-0.2 ± 1.4	< 2.8	-		-		-	
Co-60	-1.4 ± 1.5	< 1.3	-		-		-	
Zn-65	-1.3 ± 2.9	< 4.1	-		-		-	
Zr-Nb-95	-0.3 ± 1.5	< 4.1	-		-		-	
Cs-134	-0.9 ± 1.3	< 3.0	-		-		-	
Cs-137	-1.6 ± 1.5	< 1.5	-		-		-	
Ba-La-140	-0.8 ± 1.7	< 4.7	-		-		-	
Location	S-9		S-10		S-11		S-12	
Collection Date	06-08-17		06-08-17		06-08-17		06-08-17	
Lab Code	NF ^a		NF ^a		EW- 2782	MDC	NF ^a	
Be-7	-		-		6.7 ± 12.4	< 32.9	-	
Mn-54	-		-		-0.7 ± 1.7	< 2.1	-	
Fe-59	-		-		-1.7 ± 2.9	< 3.1	-	
Co-58	-		-		-0.6 ± 1.4	< 2.1	-	
Co-60	-		-		-0.5 ± 1.4	< 1.5	-	
Zn-65	-		-		-1.0 ± 2.9	< 3.4	-	
Zr-Nb-95	-		-		-0.4 ± 1.4	< 3.4	-	
Cs-134	-		-		-0.7 ± 1.4	< 2.8	-	
Cs-137	-		-		0.8 ± 1.6	< 2.9	-	
Ba-La-140	-		-		0.6 ± 1.3	< 4.4	-	

^a "NF" = No flow.

^b LLDs not reached due to small sample size (0.1 L). Sample counted 60,000 seconds.

POINT BEACH NUCLEAR PLANT

Beach Drains (cont.)

Units: = pCi/L					Gamma isotopic analysis				
Location	S-1		S-3		S-7		S-8		
Collection Date	07-05-17		07-05-17		07-05-17		07-05-17		
Lab Code	EW- 3253	MDC	EW- 3254	MDC	NF ^a		NF ^a		
Be-7	1.5 ± 11.3	< 32.3	-6.8 ± 10.6	< 32.8	-		-		
Mn-54	-1.8 ± 1.5	< 1.8	1.1 ± 1.2	< 2.1	-		-		
Fe-59	5.0 ± 2.4	< 5.3	-1.3 ± 2.6	< 4.8	-		-		
Co-58	-0.8 ± 1.3	< 2.3	0.1 ± 1.1	< 1.9	-		-		
Co-60	0.1 ± 1.5	< 1.8	-0.1 ± 1.7	< 1.7	-		-		
Zn-65	1.9 ± 2.1	< 3.7	-0.6 ± 2.6	< 2.9	-		-		
Zr-Nb-95	0.7 ± 1.2	< 3.7	-2.3 ± 1.3	< 3.3	-		-		
Cs-134	-1.1 ± 1.4	< 2.8	-0.2 ± 1.4	< 2.8	-		-		
Cs-137	1.1 ± 1.3	< 2.1	0.1 ± 1.7	< 1.7	-		-		
Ba-La-140	6.6 ± 1.7	< 8.6	-4.5 ± 1.4	< 5.8	-		-		
Location	S-9		S-10		S-11		S-12		
Collection Date	07-05-17		07-05-17		07-05-17		07-05-17		
Lab Code	NF ^a		NF ^a		NF ^a		NF ^a		
Be-7	-		-		-		-		
Mn-54	-		-		-		-		
Fe-59	-		-		-		-		
Co-58	-		-		-		-		
Co-60	-		-		-		-		
Zn-65	-		-		-		-		
Zr-Nb-95	-		-		-		-		
Cs-134	-		-		-		-		
Cs-137	-		-		-		-		
Ba-La-140	-		-		-		-		
Location	S-1		S-3		S-7		S-8		
Collection Date	08-03-17		08-03-17		08-03-17		08-03-17		
Lab Code	EW- 3947		NF ^a		NF ^a		NF ^a		
Be-7	6.9 ± 9.8	< 31.6	-		-		-		
Mn-54	1.0 ± 1.3	< 2.4	-		-		-		
Fe-59	-3.1 ± 2.3	< 4.1	-		-		-		
Co-58	1.3 ± 1.0	< 2.1	-		-		-		
Co-60	-1.2 ± 1.6	< 2.2	-		-		-		
Zn-65	1.3 ± 2.3	< 2.6	-		-		-		
Zr-Nb-95	-2.7 ± 1.3	< 3.3	-		-		-		
Cs-134	-1.0 ± 1.3	< 2.3	-		-		-		
Cs-137	-0.4 ± 1.4	< 1.5	-		-		-		
Ba-La-140	3.8 ± 1.2	< 9.2	-		-		-		

^a "NF" = No flow.

POINT BEACH NUCLEAR PLANT

Beach Drains (cont.)

Units: = pCi/L		Gamma isotopic analysis							
Location	S-9		S-10		S-11		S-12		
Collection Date	08-03-17		08-03-17		08-03-17		08-03-17		
Lab Code	NF ^a	MDC	NF ^a	MDC	NF ^a	MDC	NF ^a	MDC	
Be-7	-		-		-		-		
Mn-54	-		-		-		-		
Fe-59	-		-		-		-		
Co-58	-		-		-		-		
Co-60	-		-		-		-		
Zn-65	-		-		-		-		
Zr-Nb-95	-		-		-		-		
Cs-134	-		-		-		-		
Cs-137	-		-		-		-		
Ba-La-140	-		-		-		-		
Location	S-1		S-3		S-7		S-8		
Collection Date	09-07-17		09-07-17		09-07-17		09-07-17		
Lab Code	EW- 4531		NF ^a		NF ^a		NF ^a		
Be-7	1.6 ± 13.0	< 30.4	-		-		-		
Mn-54	0.8 ± 1.3	< 2.4	-		-		-		
Fe-59	0.3 ± 2.8	< 7.2	-		-		-		
Co-58	-0.6 ± 1.2	< 1.7	-		-		-		
Co-60	0.6 ± 1.7	< 2.8	-		-		-		
Zn-65	-3.4 ± 3.0	< 4.3	-		-		-		
Zr-Nb-95	-1.3 ± 1.3	< 2.5	-		-		-		
Cs-134	-0.8 ± 1.4	< 2.6	-		-		-		
Cs-137	-0.4 ± 1.6	< 2.8	-		-		-		
Ba-La-140	-3.3 ± 1.5	< 4.2	-		-		-		
Location	S-9		S-10		S-11		S-12		
Collection Date	09-07-17		09-07-17		09-07-17		09-07-17		
Lab Code	NF ^a	MDC	NF ^a	MDC	NF ^a	MDC	NF ^a	MDC	
Be-7	-		-		-		-		
Mn-54	-		-		-		-		
Fe-59	-		-		-		-		
Co-58	-		-		-		-		
Co-60	-		-		-		-		
Zn-65	-		-		-		-		
Zr-Nb-95	-		-		-		-		
Cs-134	-		-		-		-		
Cs-137	-		-		-		-		
Ba-La-140	-		-		-		-		

^a "NF" = No flow.

POINT BEACH NUCLEAR PLANT

Beach Drains (cont.)

Units: = pCi/L			Gamma isotopic analysis					
Location	S-1		S-3		S-7		S-8	
Collection Date	10-03-17		10-03-17		10-03-17		10-03-17	
Lab Code	EW- 5142	MDC	NF ^a	MDC	NF ^a	MDC	NF ^a	MDC
Be-7	13.0 ± 12.1	< 31.2	-	-	-	-	-	-
Mn-54	-0.5 ± 1.5	< 1.7	-	-	-	-	-	-
Fe-59	2.4 ± 3.1	< 5.5	-	-	-	-	-	-
Co-58	-0.3 ± 1.6	< 2.6	-	-	-	-	-	-
Co-60	1.0 ± 1.9	< 3.0	-	-	-	-	-	-
Zn-65	-0.4 ± 2.6	< 3.3	-	-	-	-	-	-
Zr-Nb-95	-2.1 ± 1.9	< 3.8	-	-	-	-	-	-
Cs-134	-1.3 ± 1.8	< 2.6	-	-	-	-	-	-
Cs-137	0.3 ± 2.0	< 3.5	-	-	-	-	-	-
Ba-La-140	1.2 ± 1.1	< 3.1	-	-	-	-	-	-
Location	S-9		S-10		S-11		S-12	
Collection Date	10-03-17		10-03-17		10-03-17		10-03-17	
Lab Code	NF ^a		NF ^a		NF ^a		NF ^a	
Be-7	-	-	-	-	-	-	-	-
Mn-54	-	-	-	-	-	-	-	-
Fe-59	-	-	-	-	-	-	-	-
Co-58	-	-	-	-	-	-	-	-
Co-60	-	-	-	-	-	-	-	-
Zn-65	-	-	-	-	-	-	-	-
Zr-Nb-95	-	-	-	-	-	-	-	-
Cs-134	-	-	-	-	-	-	-	-
Cs-137	-	-	-	-	-	-	-	-
Ba-La-140	-	-	-	-	-	-	-	-
Location	S-1		S-3		S-7		S-8	
Collection Date	10-31-17		10-31-17		10-31-17		10-31-17	
Lab Code	EW- 5801		NF ^a		NF ^a		NF ^a	
Be-7	1.3 ± 19.2	< 30.5	-	-	-	-	-	-
Mn-54	-0.9 ± 1.7	< 1.6	-	-	-	-	-	-
Fe-59	2.6 ± 3.2	< 6.7	-	-	-	-	-	-
Co-58	-0.8 ± 1.7	< 2.5	-	-	-	-	-	-
Co-60	-1.3 ± 2.0	< 2.3	-	-	-	-	-	-
Zn-65	-3.4 ± 3.5	< 2.7	-	-	-	-	-	-
Zr-Nb-95	0.3 ± 1.9	< 3.5	-	-	-	-	-	-
Cs-134	-0.1 ± 2.1	< 4.1	-	-	-	-	-	-
Cs-137	-0.8 ± 1.9	< 2.1	-	-	-	-	-	-
Ba-La-140	0.6 ± 2.4	< 8.8	-	-	-	-	-	-

^a "NF" = No flow.

POINT BEACH NUCLEAR PLANT

Beach Drains (cont.)

Units: = pCi/L		Gamma isotopic analysis			
Location	S-9	S-10	S-11	S-12	
Collection Date	10-31-17	10-31-17	10-31-17	10-31-17	
Lab Code	NF ^a	NF ^a	NF ^a	NF ^a	MDC
Be-7	-	-	-	-	
Mn-54	-	-	-	-	
Fe-59	-	-	-	-	
Co-58	-	-	-	-	
Co-60	-	-	-	-	
Zn-65	-	-	-	-	
Zr-Nb-95	-	-	-	-	
Cs-134	-	-	-	-	
Cs-137	-	-	-	-	
Ba-La-140	-	-	-	-	
Location	S-1	S-3	S-7	S-8	
Collection Date	11-30-17	11-30-17	11-30-17	11-30-17	
Lab Code	NF ^a	NF ^a	NF ^a	NF ^a	
Be-7	-	-	-	-	
Mn-54	-	-	-	-	
Fe-59	-	-	-	-	
Co-58	-	-	-	-	
Co-60	-	-	-	-	
Zn-65	-	-	-	-	
Zr-Nb-95	-	-	-	-	
Cs-134	-	-	-	-	
Cs-137	-	-	-	-	
Ba-La-140	-	-	-	-	
Location	S-9	S-10	S-11	S-12	
Collection Date	11-30-17	11-30-17	11-30-17	11-30-17	
Lab Code	NF ^a	NF ^a	NF ^a	NF ^a	
Be-7	-	-	-	-	
Mn-54	-	-	-	-	
Fe-59	-	-	-	-	
Co-58	-	-	-	-	
Co-60	-	-	-	-	
Zn-65	-	-	-	-	
Zr-Nb-95	-	-	-	-	
Cs-134	-	-	-	-	
Cs-137	-	-	-	-	
Ba-La-140	-	-	-	-	

POINT BEACH NUCLEAR PLANT

Beach Drains (cont.)

Units: = pCi/L		Gamma isotopic analysis				
Location	S-1	S-3	S-7	S-8		
Collection Date	12-06-17	12-06-17	12-06-17	12-06-17		
Lab Code	EW- 6380	EW- 6381	NF ^a	NF ^a	MDC	
Be-7	8.7 ± 20.1	< 22.9	-3.2 ± 13.1	< 29.9	-	
Mn-54	1.7 ± 1.8	< 3.3	-0.1 ± 1.6	< 3.1	-	
Fe-59	-3.2 ± 4.8	< 6.1	-0.9 ± 2.7	< 4.2	-	
Co-58	2.2 ± 2.2	< 4.0	-0.9 ± 1.5	< 1.6	-	
Co-60	-0.3 ± 2.5	< 2.4	-0.8 ± 1.7	< 2.2	-	
Zn-65	1.8 ± 5.1	< 4.9	-0.3 ± 3.1	< 3.3	-	
Zr-Nb-95	-2.4 ± 2.6	< 4.6	0.3 ± 1.6	< 2.3	-	
Cs-134	-1.3 ± 2.0	< 3.9	0.5 ± 1.5	< 2.7	-	
Cs-137	1.3 ± 2.7	< 5.1	-0.4 ± 1.8	< 2.7	-	
Ba-La-140	-0.6 ± 2.9	< 5.0	0.5 ± 1.5	< 2.4	-	
Location	S-9	S-10	S-11	S-12		
Collection Date	12-06-17	12-06-17	12-06-17	12-06-17		
Lab Code	NF ^a	NF ^a	NF ^a	NF ^a		
Be-7	-	-	-	-		
Mn-54	-	-	-	-		
Fe-59	-	-	-	-		
Co-58	-	-	-	-		
Co-60	-	-	-	-		
Zn-65	-	-	-	-		
Zr-Nb-95	-	-	-	-		
Cs-134	-	-	-	-		
Cs-137	-	-	-	-		
Ba-La-140	-	-	-	-		
Annual						
All locations	Mean ± s.d.	Mean ± s.d.	Mean ± s.d.	Mean ± s.d.	Mean ± s.d.	
Be-7	-2.2 ± 18.1	Co-58 0.0 ± 0.9	Zr/Nb-95 -0.3 ± 1.4	Ba/La-140 -0.5 ± 3.5		
Mn-54	0.6 ± 2.0	Co-60 0.3 ± 1.6	Cs-134 -0.4 ± -1.3			
Fe-59	-1.0 ± 4.5	Zn-65 -0.3 ± 3.0	Cs-137 0.3 ± 1.6			

POINT BEACH NUCLEAR PLANT

Table 13. Groundwater Tritium Monitoring Program
(Quarterly Collections)
Units = pCi/L

Quarterly Wells							
GW-05 (WH 6 Well)				GW-06 (SBCC Well)			
Collection Date	Lab Code	Tritium	MDC	Collection Date	Lab Code	Tritium	MDC
01-11-17	EW-134	80 ± 96	< 176	01-11-17	EW-135	-8 ± 92	< 176
04-13-17	EW-1544	28 ± 72	< 147	04-13-17	EW-1545	4 ± 71	< 147
07-13-17	EW-3492	-9 ± 71	< 149	07-13-17	EW-3494	2 ± 71	< 149
10-12-17	EW-5307	-48 ± 66	< 149	10-12-17	EW-5308	22 ± 70	< 149
Mean ± s.d.		13 ± 55		Mean ± s.d.		5 ± 13	
GW-11 (MW-1)				GW-12 (MW-2)			
Collection Date	Lab Code	Tritium	MDC	Collection Date	Lab Code	Tritium	MDC
01-24-17	EW-314	-45 ± 86	< 169	01-24-17	EW-315	-128 ± 82	< 169
04-24-17	EW-1829	98 ± 75	< 148	04-24-17	EW-1830	-8 ± 68	< 148
07-18-17	EW-3822	113 ± 82	< 158	07-18-17	EW-3823	-19 ± 75	< 158
10-17-17	EW-5772	39 ± 85	< 159	10-17-17	EW-5773	67 ± 87	< 159
Mean ± s.d.		51 ± 72		Mean ± s.d.		-22 ± 81	
GW-13 (MW-6)				GW-14A (MW-05A)			
Collection Date	Lab Code	Tritium	MDC	Collection Date	Lab Code	Tritium	MDC
01-24-17	EW-316	-27 ± 87	< 169	01-24-17	EW-317	43 ± 91	< 169
04-24-17	EW-1831	59 ± 72	< 148	04-24-17	EW-1832	126 ± 76	< 148
07-18-17	EW-3824	23 ± 77	< 158	07-18-17	EW-3826	139 ± 83	< 158
10-17-17	EW-5774	30 ± 85	< 159	10-17-17	EW-5776	121 ± 90	< 159
Mean ± s.d.		21 ± 36		Mean ± s.d.		107 ± 44	
GW-15A (MW-4)				GW-15B (MW-4)			
Collection Date	Lab Code	Tritium	MDC	Collection Date	Lab Code	Tritium	MDC
01-24-17	EW-318	19 ± 90	< 169	01-24-17	EW-319	41 ± 91	< 169
04-24-17	EW-1833	188 ± 80	< 148	04-24-17	EW-1834	179 ± 79	< 148
07-18-17	EW-3827	184 ± 86	< 158	07-18-17		NS ^a	
10-17-17	EW-5777	82 ± 88	< 159	10-17-17	EW-5778	125 ± 90	< 159
Mean ± s.d.		118 ± 82		Mean ± s.d.		115 ± 70	
GW-16A (MW-3)				GW-16B (MW-3)			
Collection Date	Lab Code	Tritium	MDC	Collection Date	Lab Code	Tritium	MDC
01-24-17	EW-320	91 ± 93	< 169	01-24-17		NS ^a	
04-24-17	EW-1835	199 ± 80	< 148	04-24-17		NS ^a	
07-18-17	EW-3828	164 ± 85	< 158	07-18-17	EW-3829	256 ± 89	< 158
10-17-17	EW-5779	119 ± 89	< 159	10-17-17		NS ^a	
Mean ± s.d.		143 ± 48					

^a"NS" = No sample.

POINT BEACH NUCLEAR PLANT

Table 13. Groundwater Tritium Monitoring Program
(Quarterly Collections)
Units = pCi/L

Quarterly Wells (cont.)

Sample ID	GW-18 (WH 7 Well)		
Collection Date	Lab Code	Tritium	MDC
01-11-17	EWV- 136	-26 ± 92	< 176
04-13-17	EWV- 1546	-19 ± 69	< 147
07-13-17	EWV- 3495	51 ± 74	< 149
10-12-17	EWV- 5309	47 ± 72	< 149
Mean ± s.d.		13 ± 42	

Façade Wells

Sample ID				Sample ID			
GW-09 1Z-361A				GW-09 1Z-361B			
Collection Date	Lab Code	Tritium	MDC	Collection Date	Lab Code	Tritium	MDC
01-14-17	EWV- 1043	252 ± 84	< 147	01-14-17	EWV- 1044	177 ± 80	< 147
05-05-17	EWV- 2186	266 ± 91	< 156	05-05-17	EWV- 2187	104 ± 83	< 156
07-27-17	EWV- 4096	271 ± 88	< 158	07-27-17	EWV- 4097	88 ± 98	< 190
10-08-17	EWV- 5802	271 ± 86	< 150	10-08-17	EWV- 5803	125 ± 78	< 150
Mean ± s.d.		265 ± 9		Mean ± s.d.		123 ± 39	

Sample ID				Sample ID			
GW-10 2Z-361A				GW-10 2Z-361B			
Collection Date	Lab Code	Tritium	MDC	Collection Date	Lab Code	Tritium	MDC
01-14-17		NS ^a		01-14-17	EWV- 1046	26 ± 72	< 147
05-05-17	EWV- 2189	-58 ± 74	< 156	05-05-17	EWV- 2190	167 ± 86	< 156
07-27-17	EWV- 4098	-19 ± 94	< 190	07-27-17	EWV- 4099	229 ± 103	< 190
10-08-17	EWV- 5804	83 ± 76	< 150	10-08-17	EWV- 5805	216 ± 83	< 150
Mean ± s.d.		2 ± 73		Mean ± s.d.		160 ± 93	

(Annual Collections)
Units = pCi/L

Bogs

Sample ID				Sample ID			
GW-07 (North Bog)				GW-08 EIC Bog			
Collection Date	Lab Code	Tritium	MDC	Collection Date	Lab Code	Tritium	MDC
05-03-17	EWV- 1993	19 ± 89	< 145	05-03-17	EWV- 1994	81 ± 92	< 145

^a"NS" = No sample; water frozen.

POINT BEACH NUCLEAR PLANT

Table 13. Groundwater Tritium Monitoring Program

Units = pCi/L

Manholes

MH Z-065A				MH Z-065B			
Sample ID	Lab Code	Tritium	MDC (pCi/L)	Collection Date	Lab Code	Tritium	MDC (pCi/L)
09-11-17	EW- 4734	184 ± 82	< 150	09-11-17	EW- 4735	239 ± 85	< 150
Mean ± s.d.				Mean ± s.d.			
MH Z-065C				MH Z-065D			
Sample ID	Lab Code	Tritium	MDC (pCi/L)	Collection Date	Lab Code	Tritium	MDC (pCi/L)
09-11-17		NS ^a		09-11-17		NS ^a	
Mean ± s.d.				Mean ± s.d.			
MH Z-066A				MH Z-066B			
Sample ID	Lab Code	Tritium	MDC (pCi/L)	Collection Date	Lab Code	Tritium	MDC (pCi/L)
09-11-17	EW- 4736	192 ± 83	< 150	09-12-17	EW- 4737	141 ± 80	< 150
Mean ± s.d.				Mean ± s.d.			
MH Z-066C				MH Z-066D			
Sample ID	Lab Code	Tritium	MDC (pCi/L)	Collection Date	Lab Code	Tritium	MDC (pCi/L)
09-12-17	EW- 4739	148 ± 80	< 150	09-12-17	EW- 4740	218 ± 84	< 150
Mean ± s.d.				Mean ± s.d.			
MH Z-067A				MH Z-067B			
Sample ID	Lab Code	Tritium	MDC (pCi/L)	Collection Date	Lab Code	Tritium	MDC (pCi/L)
09-11-17	EW- 4741	186 ± 82	< 150	09-12-17	EW- 4742	186 ± 82	< 150
Mean ± s.d.				Mean ± s.d.			

^a "NS" = No sample; not sent.

POINT BEACH NUCLEAR PLANT

Table 14. Radioactivity in vegetation samples
Collection: Annual

Sample Description and Concentration (pCi/g wet)							
Location	E-F1A	MDC	E-F1B	MDC	E-F2	MDC	
Collection Date	09-20-17		09-20-17		09-20-17		
Lab Code	EVE- 4839		EVE- 4840		EVE- 4841		Req. LLD
Type	Alfalfa		Soybeans		Soybeans		
Ratio (wet/dry)	6.72		3.82		3.65		-
Gross Beta	7.26 ± 0.14	< 0.041	4.83 ± 0.11	< 0.041	4.15 ± 0.10	< 0.038	0.25
Be-7	0.034 ± 0.052	< 0.094	0.97 ± 0.23	-	0.64 ± 0.13	-	-
K-40	6.53 ± 0.45	-	4.65 ± 0.48	-	4.38 ± 0.32	-	-
I-131	-0.004 ± 0.005	< 0.012	0.000 ± 0.010	< 0.055	0.001 ± 0.006	< 0.032	0.060
Cs-134	0.003 ± 0.006	< 0.013	-0.005 ± 0.009	< 0.017	-0.001 ± 0.005	< 0.011	0.060
Cs-137	0.006 ± 0.007	< 0.013	-0.009 ± 0.011	< 0.011	-0.005 ± 0.006	< 0.006	0.080
Other (Co-60)	-0.003 ± 0.009	< 0.014	0.003 ± 0.010	< 0.016	0.005 ± 0.006	< 0.011	0.060
Location	E-F3		E-F4		E-F5		
Collection Date	09-21-17		09-21-17		09-21-17		
Lab Code	EVE- 4842		EVE- 4843		EVE- 4844		Req. LLD
Type	Corn		Corn		Corn		
Ratio (wet/dry)	2.50		2.80		4.12		-
Gross Beta	4.18 ± 0.10	< 0.036	3.61 ± 0.08	< 0.030	2.24 ± 0.07	< 0.021	0.25
Be-7	0.34 ± 0.11	-	0.063 ± 0.051	< 0.091	0.026 ± 0.037	< 0.086	-
K-40	2.03 ± 0.23	-	2.45 ± 0.23	-	1.88 ± 0.21	-	-
I-131	0.002 ± 0.005	< 0.022	0.004 ± 0.006	< 0.027	0.000 ± 0.005	< 0.018	0.060
Cs-134	0.001 ± 0.005	< 0.009	-0.003 ± 0.005	< 0.009	0.000 ± 0.004	< 0.007	0.060
Cs-137	-0.002 ± 0.006	< 0.009	0.000 ± 0.005	< 0.008	-0.001 ± 0.006	< 0.010	0.080
Other (Co-60)	-0.005 ± 0.006	< 0.006	0.001 ± 0.005	< 0.004	0.000 ± 0.004	< 0.005	0.060
Location	E-F6		E-F7		E-F8		
Collection Date	09-21-17		09-21-17		09-21-17		
Lab Code	EVE- 4846		EVE- 4847		EVE- 4848		Req. LLD
Type	Corn		Corn		Rye grass/clover		
Ratio (wet/dry)	3.13		4.79		7.50		-
Gross Beta	2.63 ± 0.07	< 0.075 ^a	2.77 ± 0.08	< 0.025	5.31 ± 0.17	< 0.060	0.25
Be-7	0.004 ± 0.050	< 0.11	0.020 ± 0.042	< 0.088	1.31 ± 0.18	-	-
K-40	2.46 ± 0.27	-	1.91 ± 0.25	-	5.83 ± 0.45	-	-
I-131	-0.005 ± 0.005	< 0.027	0.003 ± 0.005	< 0.026	0.013 ± 0.008	< 0.031	0.060
Cs-134	0.002 ± 0.006	< 0.011	-0.005 ± 0.005	< 0.009	0.001 ± 0.008	< 0.016	0.060
Cs-137	0.005 ± 0.007	< 0.013	-0.003 ± 0.006	< 0.008	-0.001 ± 0.009	< 0.015	0.080
Other (Co-60)	0.003 ± 0.006	< 0.009	-0.001 ± 0.006	< 0.010	-0.001 ± 0.008	< 0.011	0.060

^a Gross beta reanalyzed.

POINT BEACH NUCLEAR PLANT

Table 14. Radioactivity in vegetation samples
Collection: Annual

Sample Description and Concentration (pCi/g wet)		MDC	MDC	MDC
Location	E-F9			
Collection Date	09-21-17			
Lab Code	EVE- 4849			Req. LLD
Type	Corn			
Ratio (wet/dry)	3.84			-
Gross Beta	2.52 ± 0.07	< 0.022		0.25
Be-7	0.097 ± 0.051	< 0.12		-
K-40	2.11 ± 0.24	-		-
I-131	-0.002 ± 0.005	< 0.026		0.060
Cs-134	-0.003 ± 0.005	< 0.010		0.060
Cs-137	0.001 ± 0.006	< 0.011		0.080
Other (Co-60)	0.002 ± 0.007	< 0.010		0.060

Beta Annual Mean ± s.d. 3.95 ± 1.56
Be-7 Annual Mean ± s.d. 0.35 ± 0.47
K-40 Annual Mean ± s.d. 3.42 ± 1.77
I-131 Annual Mean ± s.d. 0.001 ± 0.005
Cs-134 Annual Mean ± s.d. -0.001 ± 0.003
Cs-137 Annual Mean ± s.d. -0.001 ± 0.004
Co-60 Annual Mean ± s.d. 0.000 ± 0.003



APPENDIX A

INTERLABORATORY COMPARISON PROGRAM RESULTS AND INTRALABORATORY COMPARISON PROGRAM RESULTS

NOTE: Appendix A is updated four times a year. The complete appendix is included in March, June, September and December monthly progress reports only.

January, 2017 through December, 2017

Appendix A

Interlaboratory/ Intralaboratory Comparison Program Results

Environmental, Inc., Midwest Laboratory has participated in interlaboratory comparison (crosscheck) programs since the formulation of its quality control program in December 1971. These programs are operated by agencies which supply environmental type samples containing concentrations of radionuclides known to the issuing agency but not to participant laboratories. The purpose of such a program is to provide an independent check on a laboratory's analytical procedures and to alert it of any possible problems.

Participant laboratories measure the concentration of specified radionuclides and report them to the issuing agency. Several months later, the agency reports the known values to the participant laboratories and specifies control limits. Results consistently higher or lower than the known values or outside the control limits indicate a need to check the instruments or procedures used.

Results in Table A-1 were obtained through participation in the RAD PT Study Proficiency Testing Program administered by Environmental Resources Associates, serving as a replacement for studies conducted previously by the U.S. EPA Environmental Monitoring Systems Laboratory, Las Vegas, Nevada.

Table A-2 lists results for thermoluminescent dosimeters (TLDs), via irradiation and evaluation by the University of Wisconsin-Madison Radiation Calibration Laboratory at the University of Wisconsin Medical Radiation Research Center.

Table A-3 lists results of the analyses on in-house "spiked" samples for the past twelve months. All samples are prepared using NIST traceable sources. Data for previous years available upon request.

Table A-4 lists results of the analyses on in-house "blank" samples for the past twelve months. Data for previous years available upon request.

Table A-5 lists analytical results from the in-house "duplicate" program for the past twelve months. Acceptance is based on the difference of the results being less than the sum of the errors. Complete analytical data for duplicate analyses is available upon request.

The results in Table A-6 were obtained through participation in the Mixed Analyte Performance Evaluation Program.

Results in Table A-7 were obtained through participation in the MRAD PT Study Proficiency Testing Program administered by Environmental Resources Associates, serving as a replacement for studies conducted previously by the Environmental Measurement Laboratory Quality Assessment Program (EML).

Attachment A lists the laboratory precision at the 1 sigma level for various analyses. The acceptance criteria in Table A-3 is set at ± 2 sigma.

Out-of-limit results are explained directly below the result.

Attachment A

ACCEPTANCE CRITERIA FOR "SPIKED" SAMPLES

LABORATORY PRECISION: ONE STANDARD DEVIATION VALUES FOR VARIOUS ANALYSES^a

Analysis	Level	One standard deviation for single determination
Gamma Emitters	5 to 100 pCi/liter or kg > 100 pCi/liter or kg	5.0 pCi/liter 10% of known value
Strontium-89 ^b	5 to 50 pCi/liter or kg > 50 pCi/liter or kg	5.0 pCi/liter 10% of known value
Strontium-90 ^b	2 to 30 pCi/liter or kg > 30 pCi/liter or kg	5.0 pCi/liter 10% of known value
Potassium-40	≥ 0.1 g/liter or kg	10% of known value
Gross alpha	≤ 20 pCi/liter > 20 pCi/liter	5.0 pCi/liter 25% of known value
Gross beta	≤ 100 pCi/liter > 100 pCi/liter	5.0 pCi/liter 10% of known value
Tritium	≤ 4,000 pCi/liter > 4,000 pCi/liter	± 1σ = 169.85 x (known) ^{0.0933} 10% of known value
Radium-226,-228	≥ 0.1 pCi/liter	15% of known value
Plutonium	≥ 0.1 pCi/liter, gram, or sample	10% of known value
Iodine-131, Iodine-129 ^b	≤ 55 pCi/liter > 55 pCi/liter	6 pCi/liter 10% of known value
Uranium-238, Nickel-63 ^b Technetium-99 ^b	≤ 35 pCi/liter > 35 pCi/liter	6 pCi/liter 15% of known value
Iron-55 ^b	50 to 100 pCi/liter > 100 pCi/liter	10 pCi/liter 10% of known value
Other Analyses ^b	---	20% of known value

^a From EPA publication, "Environmental Radioactivity Laboratory Intercomparison Studies Program", Fiscal Year, 1981-1982, EPA-600/4-81-004.

^b Laboratory limit.

TABLE A-1. Interlaboratory Comparison Crosscheck program, Environmental Resource Associates (ERA)^a.
RAD study

Lab Code	Date	Analysis	Concentration (pCi/L)			Acceptance
			Laboratory Result	ERA Result	Control Limits	
ERW-95	1/9/2017	Sr-89	51.9 ± 4.6	55.5	44.3 - 63.2	Pass
ERW-95	1/9/2017	Sr-90	43.6 ± 2.4	43.1	31.8 - 49.5	Pass
ERW-97	1/9/2017	Ba-133	78.2 ± 4.1	85.6	72.0 - 94.2	Pass
ERW-97	1/9/2017	Cs-134	53.9 ± 3.8	52.6	42.4 - 57.9	Pass
ERW-97	1/9/2017	Cs-137	122 ± 6	112	101 - 126	Pass
ERW-97	1/9/2017	Co-60	117 ± 4	113	102 - 126	Pass
ERW-97	1/9/2017	Zn-65	208 ± 13	189	170 - 222	Pass
ERW-99	1/9/2017	Gr. Alpha	48.9 ± 2.4	52.3	27.3 - 65.5	Pass
ERW-99	1/9/2017	Gr. Beta	37.1 ± 1.3	41.6	27.7 - 49.0	Pass
ERW-101	1/9/2017	I-131	22.3 ± 0.6	24.3	20.2 - 28.8	Pass
ERW-103	1/9/2017	Ra-226	11.3 ± 0.4	12.7	9.5 - 14.7	Pass
ERW-103	1/9/2017	Ra-228	6.10 ± 0.90	6.20	3.8 - 8.1	Pass
ERW-103	1/9/2017	Uranium	11.8 ± 0.8	12.6	9.9 - 14.4	Pass
ERW-106	1/9/2017	H-3	12,600 ± 300	12,500	10,900 - 13,800	Pass
ERW-3344	7/10/2017	Sr-89	29.0 ± 10.0	26.4	18.4 - 32.9	Pass
ERW-3344	7/10/2017	Sr-90	33.8 ± 3.3	36.0	26.4 - 41.5	Pass
ERW-3346	7/10/2017	Ba-133	66.4 ± 4.1	66.3	55.2 - 72.9	Pass
ERW-3346	7/10/2017	Cs-134	27.0 ± 4.3	24.4	18.7 - 27.2	Pass
ERW-3346	7/10/2017	Cs-137	57.4 ± 4.5	51.6	46.4 - 59.6	Pass
ERW-3346	7/10/2017	Co-60	92.6 ± 4.4	88.6	79.7 - 99.8	Pass
ERW-3346	7/10/2017	Zn-65	32.4 ± 6.0	32.7	27.3 - 41.6	Pass
ERW-3348	7/10/2017	Gr. Alpha	23.7 ± 1.9	25.7	13.0 - 34.1	Pass
ERW-3348	7/10/2017	Gr. Beta	54.6 ± 1.6	63.0	43.5 - 69.6	Pass
ERW-3350	7/10/2017	I-131	25.4 ± 1.3	25.5	21.2 - 30.1	Pass
ERW-3352	7/10/2017	Ra-226	1.38 ± 0.15	1.29	1.07 - 1.95	Pass
ERW-3352	7/10/2017	Ra-228	6.70 ± 0.93	5.66	3.45 - 7.47	Pass
ERW-3352	7/10/2017	Uranium	58.4 ± 0.9	66.7	54.3 - 73.9	Pass
ERW-3354	7/10/2017	H-3	5,254 ± 224	5,060	4,340 - 5,570	Pass

^a Results obtained by Environmental, Inc., Midwest Laboratory as a participant in the crosscheck program for proficiency testing in drinking water conducted by Environmental Resources Associates (ERA).

TABLE A-2. Thermoluminescent Dosimetry, (TLD, CaSO₄: Dy Cards). ^a

Lab Code	Irradiation Date	Description	Delivered Dose	mrem		Performance ^c Quotient (P)	
				Reported ^b Dose			
<u>Environmental, Inc.</u>		Group 1					
2017-1	10/16/2017	Spike 1	59.0	49.3		-0.16	
2017-1	10/16/2017	Spike 2	59.0	53.2		-0.10	
2017-1	10/16/2017	Spike 3	59.0	52.7		-0.11	
2017-1	10/16/2017	Spike 4	59.0	53.4		-0.09	
2017-1	10/16/2017	Spike 5	59.0	51.8		-0.12	
2017-1	10/16/2017	Spike 6	59.0	54.0		-0.08	
2017-1	10/16/2017	Spike 7	59.0	52.0		-0.12	
2017-1	10/16/2017	Spike 8	59.0	52.6		-0.11	
2017-1	10/16/2017	Spike 9	59.0	54.6		-0.07	
2017-1	10/16/2017	Spike 10	59.0	50.4		-0.15	
2017-1	10/16/2017	Spike 11	59.0	53.9		-0.09	
2017-1	10/16/2017	Spike 12	59.0	55.7		-0.06	
2017-1	10/16/2017	Spike 13	59.0	50.2		-0.15	
2017-1	10/16/2017	Spike 14	59.0	52.4		-0.11	
2017-1	10/16/2017	Spike 15	59.0	54.3		-0.08	
2017-1	10/16/2017	Spike 16	59.0	53.2		-0.10	
2017-1	10/16/2017	Spike 17	59.0	50.1		-0.15	
2017-1	10/16/2017	Spike 18	59.0	52.3		-0.11	
2017-1	10/16/2017	Spike 19	59.0	50.3		-0.15	
2017-1	10/16/2017	Spike 20	59.0	50.7		-0.14	
2017-1	10/16/2017	Spike 21	59.0	53.1		-0.10	
2017-1	10/16/2017	Spike 22	59.0	51.5		-0.13	
2017-1	10/16/2017	Spike 23	59.0	54.4		-0.08	
2017-1	10/16/2017	Spike 24	59.0	53.3		-0.10	
2017-1	10/16/2017	Spike 25	59.0	53.7		-0.09	
2017-1	10/16/2017	Spike 26	59.0	51.6		-0.13	
2017-1	10/16/2017	Spike 27	59.0	51.5		-0.13	
2017-1	10/16/2017	Spike 28	59.0	51.6		-0.13	
2017-1	10/16/2017	Spike 29	59.0	49.9		-0.15	
2017-1	10/16/2017	Spike 30	59.0	55.3		-0.06	
Mean (Spike 1-30)				52.4		-0.11	Pass ^d
Standard Deviation (Spike 1-30)				1.7		0.03	Pass ^d

a TLD's were irradiated by the University of Wisconsin-Madison Radiation Calibration Laboratory following ANSI N13.37 protocol from a known air kerma rate. TLD's were read and the results were submitted by Environmental Inc. to the University of Wisconsin-Madison Radiation Calibration Laboratory for comparison to the delivered dose.

b Reported dose was converted from exposure (R) to Air Kerma (cGy) using a conversion of 0.876. Conversion from air kerma to ambient dose equivalent for Cs-137 at the reference dose point $H^*(10)K_a = 1.20$. mrem/cGy = 1000.

c Performance Quotient (P) is calculated as ((reported dose - conventionally true value) ÷ conventionally true value) where the conventionally true value is the delivered dose.

d Acceptance is achieved when neither the absolute value of mean of the P values, nor the standard deviation of the P values exceed 0.15.

TABLE A-2. Thermoluminescent Dosimetry, (TLD, CaSO₄: Dy Cards). ^a

Lab Code	Irradiation Date	Description	Delivered Dose	mrem		Performance ^c Quotient (P)	
				Reported ^b Dose			
<u>Environmental, Inc.</u>		Group 2					
2017-2	10/16/2017	Spike 31	186.0	164.7		-0.11	
2017-2	10/16/2017	Spike 32	186.0	172.0		-0.08	
2017-2	10/16/2017	Spike 33	186.0	167.3		-0.10	
2017-2	10/16/2017	Spike 34	186.0	160.6		-0.14	
2017-2	10/16/2017	Spike 35	186.0	171.7		-0.08	
2017-2	10/16/2017	Spike 36	186.0	177.0		-0.05	
2017-2	10/16/2017	Spike 37	186.0	176.7		-0.05	
2017-2	10/16/2017	Spike 38	186.0	165.5		-0.11	
2017-2	10/16/2017	Spike 39	186.0	174.6		-0.06	
2017-2	10/16/2017	Spike 40	186.0	172.7		-0.07	
2017-2	10/16/2017	Spike 41	186.0	167.8		-0.10	
2017-2	10/16/2017	Spike 42	186.0	161.0		-0.13	
2017-2	10/16/2017	Spike 43	186.0	166.3		-0.11	
2017-2	10/16/2017	Spike 44	186.0	172.4		-0.07	
2017-2	10/16/2017	Spike 45	186.0	173.0		-0.07	
2017-2	10/16/2017	Spike 46	186.0	169.5		-0.09	
2017-2	10/16/2017	Spike 47	186.0	169.0		-0.09	
2017-2	10/16/2017	Spike 48	186.0	166.9		-0.10	
2017-2	10/16/2017	Spike 49	186.0	165.9		-0.11	
2017-2	10/16/2017	Spike 50	186.0	166.7		-0.10	
2017-2	10/16/2017	Spike 51	186.0	161.1		-0.13	
2017-2	10/16/2017	Spike 52	186.0	173.4		-0.07	
2017-2	10/16/2017	Spike 53	186.0	173.1		-0.07	
2017-2	10/16/2017	Spike 54	186.0	160.0		-0.14	
2017-2	10/16/2017	Spike 55	186.0	166.1		-0.11	
2017-2	10/16/2017	Spike 56	186.0	164.5		-0.12	
2017-2	10/16/2017	Spike 57	186.0	163.8		-0.12	
2017-2	10/16/2017	Spike 58	186.0	159.9		-0.14	
2017-2	10/16/2017	Spike 59	186.0	165.6		-0.11	
2017-2	10/16/2017	Spike 60	186.0	165.0		-0.11	
Mean (Spike 31-60)				167.8		-0.10	Pass ^d
Standard Deviation (Spike 31-60)				5.0		0.03	Pass ^d

a TLD's were irradiated by the University of Wisconsin-Madison Radiation Calibration Laboratory following ANSI N13.37 protocol from a known air kerma rate. TLD's were read and the results were submitted by Environmental Inc. to the University of Wisconsin-Madison Radiation Calibration Laboratory for comparison to the delivered dose.

b Reported dose was converted from exposure (R) to Air Kerma (cGy) using a conversion of 0.876. Conversion from air kerma to ambient dose equivalent for Cs-137 at the reference dose point $H^*(10)K_a = 1.20$. mrem/cGy = 1000.

c Performance Quotient (P) is calculated as ((reported dose - conventionally true value) ÷ conventionally true value) where the conventionally true value is the delivered dose.

d Acceptance is achieved when neither the absolute value of mean of the P values, nor the standard deviation of the P values exceed 0.15.

TABLE A-3. In-House "Spiked" Samples

Lab Code ^b	Date	Analysis	Concentration ^a			Acceptance
			Laboratory results 2s, n=1 ^c	Known Activity	Control Limits ^d	
W-010417	4/29/2016	Cs-134	38.2 ± 8.1	36.2	29.0 - 43.4	Pass
W-010417	4/29/2016	Cs-137	78.0 ± 8.8	71.9	57.5 - 86.3	Pass
SPW-306	1/4/2017	Ra-226	18.1 ± 0.4	16.7	13.4 - 20.1	Pass
SPW-32	1/6/2017	H-3	17,849 ± 393	17,243	10,346 - 24,140	Pass
SPW-46	1/9/2017	Gr. Alpha	20.0 ± 0.4	20.1	16.1 - 24.1	Pass
SPW-46	1/9/2017	Gr. Beta	29.0 ± 0.3	28.9	23.1 - 34.6	Pass
SPW-92	1/11/2017	H-3	18,095 ± 397	17,243	10,346 - 24,140	Pass
SPW-142	1/12/2017	Sr-90	39.4 ± 2.3	36.6	29.3 - 43.9	Pass
SPW-155	1/19/2017	H-3	17,974 ± 400	17,243	10,346 - 24,140	Pass
SPW-186	1/23/2017	H-3	17,383 ± 366	17,243	10,346 - 24,140	Pass
SPW-232	1/19/2017	H-3	17,542 ± 368	17,243	10,346 - 24,140	Pass
SPW-304	1/26/2017	H-3	17,782 ± 400	17,243	10,346 - 24,140	Pass
SPW-333	1/30/2017	H-3	17,910 ± 406	17,243	10,346 - 24,140	Pass
SPW-353	2/2/2017	U-234	47.8 ± 2.3	41.7	33.4 - 50.0	Pass
SPW-353	2/2/2017	U-238	50.4 ± 2.4	41.7	33.4 - 50.0	Pass
W-020217	4/29/2016	Cs-134	33.7 ± 6.1	36.2	29.0 - 43.4	Pass
W-020217	4/29/2016	Cs-137	78.4 ± 7.3	71.9	57.5 - 86.3	Pass
SPW-412	2/6/2017	Sr-90	36.2 ± 2.4	36.6	29.3 - 43.9	Pass
SPW-465	2/8/2017	H-3	17,573 ± 396	17,243	10,346 - 24,140	Pass
SPW-561	2/15/2017	H-3	17,358 ± 395	17,243	10,346 - 24,140	Pass
SPW-605	2/16/2017	H-3	17,820 ± 401	17,243	10,346 - 24,140	Pass
SPW-657	2/17/2017	H-3	17,614 ± 376	17,243	10,346 - 24,140	Pass
SPW-714	2/23/2017	H-3	17,662 ± 400	17,243	10,346 - 24,140	Pass
SPW-737	2/28/2017	H-3	17,196 ± 395	17,243	10,346 - 24,140	Pass
SPAP-740	2/28/2017	Gr. Beta	38.9 ± 0.1	41.5	33.2 - 49.8	Pass
SPAP-742	2/24/2017	Cs-134	1.05 ± 0.60	0.98	0.78 - 1.18	Pass
SPAP-742	2/24/2017	Cs-137	90.4 ± 2.5	92.9	74.3 - 111.5	Pass
SPW-746	2/28/2017	Sr-90	42.8 ± 2.5	36.6	29.3 - 43.9	Pass
SPW-748	2/28/2017	C-14	4270 ± 17	4735	3788 - 5682	Pass
SPW-750	2/28/2017	Ni-63	463 ± 4	400	240 - 560	Pass
SPF-752	2/28/2017	Cs-134	1033 ± 38	1090	870 - 1300	Pass
SPF-752	2/28/2017	Cs-137	3071 ± 61	2820	2250 - 3380	Pass
SPW-781	3/1/2017	Ra-226	18.1 ± 0.4	16.7	13.4 - 20.1	Pass
SPW-783	3/1/2017	H-3	17,653 ± 400	17,243	13,794 - 20,692	Pass
W-030517	4/29/2016	Cs-134	38.0 ± 9.0	36.2	29.0 - 43.4	Pass
W-030517	4/29/2016	Cs-137	80.9 ± 9.2	71.9	57.5 - 86.3	Pass
SPW-1010	3/14/2017	H-3	17,312 ± 395	17,243	13,794 - 20,692	Pass
SPW-1026	3/16/2017	Gr. Alpha	22.4 ± 0.5	20.1	12.0 - 28.1	Pass
SPW-1026	3/16/2017	Gr. Beta	29.2 ± 0.3	28.9	17.3 - 40.4	Pass
SPW-1092	3/21/2017	H-3	17,252 ± 390	17,243	13,794 - 20,692	Pass
SPW-1151	3/24/2017	H-3	17,009 ± 388	17,243	13,794 - 20,692	Pass
SPW-1163	3/28/2017	Sr-90	39.0 ± 2.3	36.3	29.0 - 43.5	Pass
SPW-1178	3/29/2017	Ra-228	15.1 ± 1.9	16.0	9.6 - 22.4	Pass

TABLE A-3. In-House "Spiked" Samples

Lab Code ^b	Date	Analysis	Concentration ^a			Acceptance
			Laboratory results 2s, n=1 ^c	Known Activity	Control Limits ^d	
SPW-1232	3/30/2017	H-3	17,150 ± 390	17,243	13,794 - 20,692	Pass
SPW-1246	3/31/2017	I-131(G)	33.0 ± 7.3	36.6	29.3 - 43.9	Pass
SPW-1246	3/31/2017	Cs-134	28.9 ± 4.6	26.6	21.3 - 31.9	Pass
SPW-1246	3/31/2017	Cs-137	80.6 ± 8.2	70.4	56.3 - 84.5	Pass
SPMI-1248	3/31/2017	I-131(G)	39.8 ± 7.0	36.6	29.3 - 43.9	Pass
SPMI-1248	3/31/2017	Cs-134	26.9 ± 5.9	26.6	21.3 - 31.9	Pass
SPMI-1248	3/31/2017	Cs-137	70.4 ± 6.9	70.4	56.3 - 84.5	Pass
SPMI-1248	3/31/2017	I-131	36.2 ± 0.6	36.6	29.3 - 43.9	Pass
SPW-1295	3/31/2017	Ra-226	17.9 ± 0.4	16.7	13.4 - 20.1	Pass
SPW-1304	4/4/2017	H-3	17,741 ± 398	17,243	13,794 - 20,692	Pass
SPW-1359	4/5/2017	I-131	44.3 ± 0.5	47.6	38.1 - 57.1	Pass
SPW-1378	4/7/2017	H-3	17,528 ± 395	17,243	13,794 - 20,692	Pass
SPW-1391	4/7/2017	Gr. Alpha	21.1 ± 0.4	20.1	12.0 - 28.1	Pass
SPW-1391	4/7/2017	Gr. Beta	27.8 ± 0.3	28.2	17.3 - 40.4	Pass
SPW-1480	4/12/2017	H-3	17,399 ± 392	17,243	13,794 - 20,692	Pass
W-041317	4/29/2016	Cs-134	34.6 ± 5.6	36.2	29.0 - 43.4	Pass
W-041317	4/29/2016	Cs-137	81.9 ± 8.0	71.9	57.5 - 86.3	Pass
SPW-1480	4/12/2017	H-3	17,399 ± 392	17,243	13,794 - 20,692	Pass
SPW-1575	4/18/2017	H-3	17,419 ± 393	17,243	13,794 - 20,692	Pass
SPW-1626	4/20/2017	Sr-90	37.2 ± 2.4	36.3	29.0 - 43.5	Pass
SPW-1658	4/21/2017	H-3	17,194 ± 391	17,243	13,794 - 20,692	Pass
SPW-1776	4/26/2017	H-3	16,609 ± 386	17,243	13,794 - 20,692	Pass
SPW-1806	4/27/2017	H-3	17,203 ± 390	17,243	13,794 - 20,692	Pass
SPW-1937	5/3/2017	H-3	16,690 ± 385	17,243	13,794 - 20,692	Pass
SPW-1971	5/5/2017	Sr-90	41.5 ± 2.2	36.3	29.0 - 43.5	Pass
SPW-2033	5/8/2017	H-3	16,780 ± 386	17,243	13,794 - 20,692	Pass
SPW-2420	5/9/2017	Ra-226	16.3 ± 0.5	16.7	13.4 - 20.1	Pass
W-051517	4/29/2016	Cs-134	36.3 ± 5.0	36.2	29.0 - 43.4	Pass
W-051517	4/29/2016	Cs-137	68.9 ± 6.6	71.9	57.5 - 86.3	Pass
SPW-2284	5/22/2017	H-3	16,935 ± 389	16,703	13,362 - 20,043	Pass
SPW-2354	5/23/2017	H-3	17,006 ± 390	16,700	13,360 - 20,040	Pass
SPW-2891	5/23/2017	Ra-226	17.5 ± 0.4	16.7	13.4 - 20.1	Pass
SPW-2418	5/23/2017	Ra-228	14.0 ± 1.8	16.0	11.2 - 20.8	Pass
SPW-2439	5/25/2017	Ra-228	13.0 ± 1.8	16.0	11.2 - 20.8	Pass
SPMI-2378	5/24/2017	Sr-89	83.7 ± 4.9	98.4	78.7 - 118.1	Pass
SPMI-2378	5/24/2017	Sr-90	39.5 ± 1.5	36.1	28.9 - 43.4	Pass
SPW-2468	5/26/2017	H-3	17,065 ± 391	16,692	13,354 - 20,031	Pass
SPW-2848	5/26/2017	I-131	56.4 ± 0.6	58.3	46.6 - 70.0	Pass
SPW-2502	6/1/2017	H-3	17,596 ± 396	16,677	13,342 - 20,012	Pass
SPW-2659	6/5/2017	H-3	17,027 ± 390	16,677	13,342 - 20,012	Pass
SPW-2790	6/9/2017	H-3	17,101 ± 392	17,101	13,325 - 19,988	Pass

TABLE A-3. In-House "Spiked" Samples

Lab Code ^b	Date	Analysis	Concentration ^a			Acceptance
			Laboratory results 2s, n=1 ^c	Known Activity	Control Limits ^d	
SPW-2798	6/12/2017	H-3	16,683 ± 364	16,649	13,319 - 19,978	Pass
SPW-2943	6/19/2017	Sr-90	39.2 ± 2.3	36.1	28.9 - 43.4	Pass
SPW-3509	6/15/2017	Ra-226	17.6 ± 0.5	16.7	13.4 - 20.1	Pass
W-061317	4/29/2016	Cs-134	35.0 ± 6.2	36.2	29.0 - 43.4	Pass
W-061317	4/29/2016	Cs-137	77.4 ± 7.8	71.9	57.5 - 86.3	Pass
SPW-3041	6/23/2017	H-3	16,419 ± 378	16,620	13,296 - 19,945	Pass
SPW-3511	6/23/2017	Ra-226	15.5 ± 0.6	16.7	13.4 - 20.1	Pass
SPW-3103	6/28/2017	H-3	16,507 ± 380	16,507	13,286 - 19,929	Pass
SPW-3117	6/29/2017	Tc-99	112.7 ± 1.9	107.8	86.2 - 129.4	Pass
SPW-3513	6/29/2017	Ra-226	17.8 ± 0.5	16.7	13.4 - 20.1	Pass
SPW-3188	7/3/2017	Sr-90	38.1 ± 2.2	36.1	28.9 - 43.4	Pass
SPW-3283	7/11/2017	H-3	16,057 ± 347	16,649	13,319 - 19,978	Pass
SPW-4054	7/11/2017	Ra-226	17.7 ± 0.4	16.0	11.2 - 20.8	Pass
SPW-3467	7/14/2017	Gr. Alpha	22.3 ± 0.5	20.1	12.0 - 28.1	Pass
SPW-3467	7/14/2017	Gr. Beta	29.1 ± 0.3	28.2	17.3 - 40.4	Pass
SPW-3449	7/15/2017	H-3	17,196 ± 393	16,507	13,286 - 19,929	Pass
SPW-3548	7/19/2017	H-3	16,764 ± 386	16,507	13,286 - 19,929	Pass
SPW-3728	7/24/2017	H-3	16,117 ± 354	16,507	13,286 - 19,929	Pass
SPW-3794	7/28/2017	H-3	16,645 ± 384	16,507	13,286 - 19,929	Pass
W-072817	4/29/2016	Cs-134	38.6 ± 5.6	36.2	29.0 - 43.4	Pass
W-072817	4/29/2016	Cs-137	76.5 ± 7.6	71.9	57.5 - 86.3	Pass
SPW-3905	8/3/2017	Gr. Alpha	22.3 ± 0.5	20.1	12.0 - 28.1	Pass
SPW-3905	8/3/2017	Gr. Beta	27.6 ± 0.3	28.2	17.3 - 40.4	Pass
SPW-4030	8/9/2017	H-3	17,636 ± 403	16,507	13,286 - 19,929	Pass
SPW-4086	8/14/2017	H-3	17,472 ± 401	16,507	13,286 - 19,929	Pass
SPW-4207	8/17/2017	H-3	17,013 ± 393	16,507	13,286 - 19,929	Pass
W-083017	4/29/2016	Cs-134	34.7 ± 6.4	36.2	29.0 - 43.4	Pass
W-083017	4/29/2016	Cs-137	78.2 ± 6.7	71.9	57.5 - 86.3	Pass
SPW-4241	8/19/2017	H-3	17,222 ± 371	16,507	13,286 - 19,929	Pass
SPW-4458	9/1/2017	Ra-226	14.1 ± 1.8	16.7	13.4 - 20.1	Pass
SPW-4466	9/6/2017	Sr-89	22.8 ± 8.5	26.4	21.1 - 31.7	Pass
SPW-4466	9/6/2017	Sr-90	32.5 ± 2.1	33.8	27.0 - 40.6	Pass
SPW-4512	9/8/2017	Gr. Alpha	19.2 ± 0.4	20.1	10.1 - 30.2	Pass
SPW-4512	9/8/2017	Gr. Beta	27.8 ± 0.3	27.9	22.3 - 33.5	Pass
SPW-4586	9/9/2017	H-3	16,586 ± 362	16,507	13,286 - 19,929	Pass
SPW-4720	9/16/2017	H-3	16,439 ± 362	16,507	13,286 - 19,929	Pass
SPW-4834	9/22/2017	H-3	16,238 ± 378	16,507	13,286 - 19,929	Pass
SPW-4935	9/27/2017	H-3	16,595 ± 381	16,507	13,286 - 19,929	Pass
SPW-4937	9/27/2017	Ra-228	5.7 ± 0.9	5.8	4.1 - 7.5	Pass
W-092717	4/29/2016	Cs-134	36.0 ± 5.9	36.2	29.0 - 43.4	Pass
W-092717	4/29/2016	Cs-137	82.6 ± 8.5	71.9	57.5 - 86.3	Pass
SPW-5001	9/29/2017	H-3	16,446 ± 358	16,507	13,286 - 19,929	Pass

TABLE A-3. In-House "Spiked" Samples

Lab Code ^b	Date	Analysis	Concentration ^a			Acceptance
			Laboratory results 2s, n=1 ^c	Known Activity	Control Limits ^d	
SPW-5134	10/6/2017	H-3	16,128 ± 373	16,507	13,286 - 19,929	Pass
SPW-5274	10/12/2017	H-3	16,108 ± 374	16,507	13,286 - 19,929	Pass
W-101217S	10/12/2017	Fe-55	1,491 ± 77	1,482	1,186 - 01,778	Pass
SPW-5408	10/18/2017	Ni-63	203 ± 3	199	159 - 238	Pass
SPW-5430	10/19/2017	H-3	16,453 ± 380	16,507	13,286 - 19,929	Pass
W-102017	4/29/2016	Cs-134	31.3 ± 4.9	36.2	29.0 - 43.4	Pass
W-102017	4/29/2016	Cs-137	80.4 ± 6.9	71.9	57.5 - 86.3	Pass
SPW-5674	10/25/2017	H-3	16,313 ± 380	16,507	13,286 - 19,929	Pass
SPW-5719	10/27/2017	H-3	16,113 ± 350	16,507	13,286 - 19,929	Pass
SPW-5730	10/31/2017	H-3	16,776 ± 387	16,507	13,286 - 19,929	Pass
SPW-5944	10/27/2017	Ra-226	16.4 ± 0.5	16.7	13.4 - 20.1	Pass
SPW-5915	11/9/2017	H-3	16,930 ± 390	16,507	13,286 - 19,929	Pass
SPW-5989	11/11/2017	H-3	16,084 ± 352	16,507	13,286 - 19,929	Pass
W-111417	4/29/2016	Cs-134	38.1 ± 6.2	36.2	29.0 - 43.4	Pass
W-111417	4/29/2016	Cs-137	74.0 ± 7.5	71.9	57.5 - 86.3	Pass
SPW-6121	11/16/2017	H-3	16,276 ± 378	16,507	13,286 - 19,929	Pass
SPW-6132	11/20/2017	H-3	15,897 ± 374	16,507	13,286 - 19,929	Pass
SPW-6249	11/30/2017	Ra-226	12.2 ± 0.4	12.3	9.8 - 14.8	Pass
SPW-6226	12/1/2017	H-3	16,164 ± 378	16,507	13,286 - 19,929	Pass
SPW-6318	12/7/2017	H-3	15,779 ± 372	16,507	13,286 - 19,929	Pass
W-120817	4/29/2016	Cs-134	29.5 ± 5.6	36.2	29.0 - 43.4	Pass
W-120817	4/29/2016	Cs-137	78.8 ± 9.6	71.9	57.5 - 86.3	Pass
SPW-65	12/11/2017	Ra-226	12.5 ± 0.4	12.3	9.8 - 14.8	Pass
SPW-6437	12/13/2017	Gr. Alpha	19.6 ± 0.4	20.1	10.1 - 30.2	Pass
SPW-6437	12/13/2017	Gr. Beta	28.2 ± 0.3	27.9	22.3 - 33.5	Pass
SPW-6463	12/15/2017	H-3	15,560 ± 372	16,507	13,286 - 19,929	Pass

^a Liquid sample results are reported in pCi/Liter, air filters (pCi/m3), charcoal (pCi/charcoal canister), and solid samples (pCi/kg).

^b Laboratory codes : W (Water), Ml (milk), AP (air filter), SO (soil), VE (vegetation), CH (charcoal canister), F (fish), U (urine).

^c Results are based on single determinations.

^d Control limits are established from the precision values listed in Attachment A of this report, adjusted to ± 2s.

NOTE: For fish, gelatin is used for the spike matrix. For vegetation, cabbage is used for the spike matrix.

TABLE A-4. In-House "Blank" Samples

Lab Code	Sample Type	Date	Analysis ^b	Concentration ^a		Acceptance Criteria (4.66 σ)
				Laboratory results (4.66 σ)		
				LLD	Activity ^c	
SPW-31	Water	1/6/2017	H-3	143	71 ± 75	200
SPW-45	Water	1/9/2017	Gr. Alpha	0.41	0.09 ± 0.30	2
SPW-45	Water	1/9/2017	Gr. Beta	0.74	-0.56 ± 0.50	4
SPW-91	Water	1/11/2017	H-3	151	-23 ± 71	200
SPW-141	Water	1/12/2017	Sr-89	0.55	0.29 ± 0.47	5
SPW-141	Water	1/12/2017	Sr-90	0.67	-0.02 ± 0.31	1
SPW-154	Water	1/19/2017	H-3	155	-17 ± 73	200
SPW-185	Water	1/23/2017	H-3	176	44 ± 94	200
SPW-231	Water	1/19/2017	H-3	179	26 ± 87	200
SPW-303	Water	1/26/2017	H-3	160	8 ± 77	200
SPW-305	Water	1/4/2017	Ra-226	0.02	0.02 ± 0.01	2
SPW-307	Water	1/27/2017	I-131	0.21	0.01 ± 0.11	1.00
SPW-332	Water	1/30/2017	H-3	169	-52 ± 86	200
SPW-352	Water	2/2/2017	U-234	0.14	0.00 ± 0.08	1
SPW-352	Water	2/2/2017	U-238	0.14	0.12 ± 0.15	1
SPW-411	Water	2/6/2017	Sr-89	0.49	0.30 ± 0.35	5
SPW-411	Water	2/6/2017	Sr-90	0.52	-0.22 ± 0.21	1
SPW-464	Water	2/8/2017	H-3	155	2 ± 74	200
SPW-560	Water	2/15/2017	H-3	156	38 ± 77	200
SPW-604	Water	2/16/2017	H-3	154	59 ± 77	200
SPW-656	Water	2/17/2017	H-3	187	28 ± 94	200
SPW-713	Water	2/23/2017	H-3	161	20 ± 81	200
SPW-736	Water	2/28/2017	H-3	161	-75 ± 76	200
SPAP-739	AP	2/28/2017	Gr. Beta	0.002	0.004 ± 0.001	0.01
SPAP-741	AP	2/24/2017	Cs-134	2.27	-0.95 ± 1.29	100
SPAP-741	AP	2/24/2017	Cs-137	2.65	0.17 ± 1.67	100
SPW-747	Water	2/28/2017	C-14	161	-28 ± 97	200
SPW-749	Water	2/28/2017	Ni-63	17	-3 ± 10	200
SPF-751	Fish	2/28/2017	Cs-134	0.008	0.002 ± 0.004	100
SPF-751	Fish	2/28/2017	Cs-137	0.008	0.000 ± 0.005	100
SPW-780	Water	3/1/2017	Ra-226	0.02	0.02 ± 0.01	2
SPW-782	Water	3/1/2017	H-3	154	35 ± 78	200
SPW-3506	Water	3/1/2017	Ra-226	0.03	0.02 ± 0.02	2
SPW-836	Water	3/3/2017	I-131	0.38	0.04 ± 0.18	1
SPW-1009	Water	3/14/2017	H-3	154	-31 ± 72	200
SPW-1025	Water	3/16/2017	Gr. Alpha	0.43	-0.16 ± 0.28	2
SPW-1025	Water	3/16/2017	Gr. Beta	0.75	-0.24 ± 0.52	4
SPW-1091	Water	3/21/2017	H-3	145	60 ± 73	200
SPW-1150	Water	3/24/2017	H-3	152	-31 ± 71	200
SPW-1162	Water	3/28/2017	Sr-89	0.61	-0.39 ± 0.45	5
SPW-1162	Water	3/28/2017	Sr-90	0.52	0.18 ± 0.27	1

^a Liquid sample results are reported in pCi/Liter, air filters (pCi/m³), charcoal (pCi/charcoal canister), and solid samples (pCi/g).

^b I-131(G); iodine-131 as analyzed by gamma spectroscopy.

^c Activity reported is a net activity result.

TABLE A-4. In-House "Blank" Samples

Lab Code	Sample Type	Date	Analysis ^b	Concentration ^a		Acceptance Criteria (4.66 σ)
				Laboratory results (4.66 σ)		
				LLD	Activity ^c	
SPW-1177	Water	3/29/2017	Ra-228	0.83	-0.14 ± 0.36	2
SPW-1231	Water	3/30/2017	H-3	150	24 ± 73	200
SPW-1245	Water	3/31/2017	Cs-134	3.73	0.43 ± 2.18	100
SPW-1245	Water	3/31/2017	Cs-137	3.01	-1.23 ± 2.12	100
SPW-1245	Water	3/31/2017	I-131(G)	5.39	0.92 ± 2.15	100
SPW-1245	Water	3/31/2017	I-131	0.32	0.03 ± 0.18	1
SPMI-1247	Milk	3/31/2017	Cs-134	3.70	1.23 ± 1.96	100
SPMI-1247	Milk	3/31/2017	Cs-137	3.62	-0.84 ± 2.15	100
SPMI-1247	Milk	3/31/2017	I-131(G)	4.42	0.39 ± 2.14	100
SPW-1294	Water	3/31/2017	Ra-226	0.02	0.18 ± 0.02	2
SPW-1303	Water	4/4/2017	H-3	151	8 ± 75	200
SPW-1377	Water	4/7/2017	H-3	150	29 ± 72	200
SPW-1390	Water	4/7/2017	Gr. Alpha	0.42	0.15 ± 0.31	2
SPW-1390	Water	4/7/2017	Gr. Beta	0.73	-0.17 ± 0.51	4
SPW-1479	Water	4/12/2017	H-3	151	89 ± 77	200
SPW-1574	Water	4/18/2017	H-3	144	55 ± 79	200
SPW-1625	Water	4/20/2017	Sr-89	0.59	-0.01 ± 0.50	5
SPW-1625	Water	4/20/2017	Sr-90	0.71	0.16 ± 0.35	1
SPW-1657	Water	4/21/2017	H-3	147	34 ± 73	200
SPW-1775	Water	4/26/2017	H-3	155	67 ± 80	200
SPW-1805	Water	4/27/2017	H-3	153	15 ± 74	200
SPW-1936	Water	5/3/2017	H-3	148	33 ± 71	200
SPW-1970	Water	5/5/2017	Sr-89	0.66	0.34 ± 0.54	5
SPW-1970	Water	5/5/2017	Sr-90	0.62	-0.08 ± 0.28	1
SPW-2032	Water	5/8/2017	H-3	147	66 ± 73	200
SPW-2419	Water	5/9/2017	Ra-226	0.03	0.01 ± 0.03	2
SPW-2283	Water	5/22/2017	H-3	155	24 ± 78	200
SPW-2353	Water	5/23/2017	H-3	151	56 ± 76	200
SPW-2890	Water	5/23/2017	Ra-226	0.03	-0.01 ± 0.02	2
SPMI-2377	Milk	5/24/2017	Sr-89	0.78	0.86 ± 0.93	5
SPMI-2377	Milk	5/24/2017	Sr-90	0.49	0.95 ± 0.33	1
SPW-2438	Water	5/25/2017	Ra-228	0.90	-0.28 ± 0.38	2
SPW-2467	Water	5/26/2017	H-3	152	27 ± 77	200
SPW-2417	Water	5/26/2017	Ra-228	0.80	1.58 ± 0.54	2
SPW-2447	Water	5/26/2017	I-131	0.21	-0.05 ± 0.12	1
SPW-2501	Water	6/1/2017	H-3	151	-23 ± 70	200
SPW-2658	Water	6/5/2017	H-3	152	107 ± 78	200
SPW-2789	Water	6/9/2017	H-3	150	52 ± 77	200
SPW-2797	Water	6/12/2017	H-3	177	7 ± 93	200
SPW-2847	Water	6/14/2017	I-131	0.18	0.03 ± 0.10	1

^a Liquid sample results are reported in pCi/Liter, air filters (pCi/m³), charcoal (pCi/charcoal canister), and solid samples (pCi/g).

^b I-131(G); iodine-131 as analyzed by gamma spectroscopy.

^c Activity reported is a net activity result.

TABLE A-4. In-House "Blank" Samples

Lab Code	Sample Type	Date	Analysis ^b	Concentration ^a		Acceptance Criteria (4.66 σ)
				Laboratory results (4.66 σ)		
				LLD	Activity ^c	
SPW-3508	Water	6/15/2017	Ra-226	0.03	0.00 ± 0.02	2
SPW-2942	Water	6/19/2017	Sr-89	0.58	0.80 ± 0.53	5
SPW-2942	Water	6/19/2017	Sr-90	0.50	0.15 ± 0.25	1
SPW-3042	Water	6/23/2017	H-3	146	25 ± 74	200
SPW-3510	Water	6/23/2017	Ra-226	0.02	0.03 ± 0.02	2
SPW-3102	Water	6/28/2017	H-3	148	-7 ± 73	200
SPW-3116	Water	6/29/2017	Tc-99	5.91	-0.39 ± 3.58	10
SPW-3512	Water	6/29/2017	Ra-226	0.02	-0.01 ± 0.02	2
SPW-3187	Water	7/3/2017	Sr-89	0.62	0.00 ± 0.48	5
SPW-3187	Water	7/3/2017	Sr-90	0.48	0.07 ± 0.23	1
SPW-3282	Water	7/11/2017	H-3	178	-37 ± 84	200
SPW-4053	Water	7/11/2017	Ra-226	0.03	0.02 ± 0.02	2
SPW-3466	Water	7/14/2017	Gr. Alpha	0.42	-0.09 ± 0.28	2
SPW-3466	Water	7/14/2017	Gr. Beta	0.76	-0.18 ± 0.53	4
SPW-3448	Water	7/15/2017	H-3	150	54 ± 77	200
SPW-3727	Water	7/27/2017	Ni-63	90	18 ± 55	200
SPW-3793	Water	7/28/2017	H-3	151	47 ± 82	200
SPW-3904	Water	8/3/2017	Gr. Alpha	0.47	-0.02 ± 0.33	2
SPW-3904	Water	8/3/2017	Gr. Beta	0.75	-0.11 ± 0.52	4
SPW-4029	Water	8/9/2017	H-3	159	11 ± 79	200
SPW-4206	Water	8/17/2017	H-3	157	55 ± 76	200
SPW-4241	Water	8/19/2017	H-3	190	61 ± 96	200
SPW-4085	Water	8/14/2017	H-3	159	-28 ± 77	200
SPW-4206	Water	8/17/2017	H-3	157	55 ± 76	200
SPW-4241	Water	8/19/2017	H-3	190	61 ± 96	200
SPW-4457	Water	9/1/2017	Ra-228	0.78	-0.02 ± 0.36	2
SPW-4465	Water	9/6/2017	Sr-89	0.51	0.30 ± 0.37	5
SPW-4465	Water	9/6/2017	Sr-90	0.46	-0.09 ± 0.20	1
SPW-4585	Water	9/9/2017	H-3	187	-86 ± 83	200
SPW-5720	Water	9/13/2017	Ra-226	0.02	0.13 ± 0.02	2
SPW-4703	Water	9/15/2017	I-131	0.17	0.10 ± 0.10	1
SPW-4719	Water	9/16/2017	H-3	184	-86 ± 93	200
SPW-4833	Water	9/22/2017	H-3	150	5 ± 72	200
SPW-4934	Water	9/27/2017	H-3	148	5 ± 70	200
SPW-4936	Water	9/27/2017	Ra-228	0.80	0.55 ± 0.44	2
SPW-5000	Water	9/29/2017	H-3	183	-13 ± 90	200
SPW-5133	Water	10/6/2017	H-3	144	64 ± 71	200
SPW-5273	Water	10/12/2017	H-3	142	106 ± 72	200

^a Liquid sample results are reported in pCi/Liter, air filters (pCi/m³), charcoal (pCi/charcoal canister), and solid samples (pCi/g).

^b I-131(G); iodine-131 as analyzed by gamma spectroscopy.

^c Activity reported is a net activity result.

TABLE A-4. In-House "Blank" Samples

Lab Code	Sample Type	Date	Analysis ^b	Concentration ^a		Acceptance Criteria (4.66 σ)
				Laboratory results (4.66 σ)		
				LLD	Activity ^c	
SPW-5407	Water	10/18/2017	Ni-63	69	43 \pm 43	200
SPW-5429	Water	10/19/2017	H-3	148	54 \pm 72	200
SPW-5603	Water	10/23/2017	Sr-89	0.57	0.16 \pm 0.47	5
SPW-5603	Water	10/23/2017	Sr-90	0.70	-0.12 \pm 0.31	1
SPW-5673	Water	10/25/2017	H-3	156	-36 \pm 71	200
SPW-5718	Water	10/27/2017	H-3	182	45 \pm 92	200
SPW-5943	Water	10/27/2017	Ra-226	0.02	0.08 \pm 0.02	2
SPW-5723	Water	10/30/2017	I-131	0.10	0.03 \pm 0.07	1
SPW-5914	Water	11/09/17	H-3	149	-39 \pm 68	200
SPW-5988	Water	11/11/2017	H-3	183	-8 \pm 88	200
SPW-6120	Water	11/16/2017	H-3	146	83 \pm 75	200
SPW-6131	Water	11/20/2017	H-3	151	16 \pm 72	200
SPW-6197	Water	11/29/2017	I-131	0.38	0.01 \pm 0.18	1
SPW-6248	Water	11/30/2017	Ra-226	0.03	0.15 \pm 0.03	2
SPW-6225	Water	12/1/2017	H-3	154	-10 \pm 72	200
SPW-6317	Water	12/7/2017	H-3	148	44 \pm 74	200
SPW-64	Water	12/11/2017	Ra-226	0.03	0.18 \pm 0.03	2
SPW-6436	Water	12/13/2017	Gr. Alpha	0.54	-0.17 \pm 0.37	2
SPW-6436	Water	12/13/2017	Gr. Beta	0.74	0.12 \pm 0.52	4
SPW-6464	Water	12/15/2017	H-3	148	31 \pm 75	200

^a Liquid sample results are reported in pCi/Liter, air filters (pCi/m³), charcoal (pCi/charcoal canister), and solid samples (pCi/g).

^b I-131(G); iodine-131 as analyzed by gamma spectroscopy.

^c Activity reported is a net activity result.

TABLE A-5. In-House "Duplicate" Samples

Lab Code	Date	Analysis	Concentration ^a		Averaged Result	Acceptance
			First Result	Second Result		
AP-7178,7179	1/3/2017	Be-7	0.047 ± 0.015	0.062 ± 0.017	0.054 ± 0.012	Pass
SW-6986,6987	1/3/2017	Gr. Beta	1.39 ± 0.41	0.77 ± 0.41	1.08 ± 0.29	Pass
E-66,67	1/3/2017	Gr. Beta	1.62 ± 0.05	1.45 ± 0.04	1.54 ± 0.11	Pass
E-66,67	1/3/2017	K-40	1.26 ± 0.14	1.39 ± 0.16	1.32 ± 0.11	Pass
CF-87,88	1/3/2017	Be-7	0.25 ± 0.11	0.30 ± 0.12	0.28 ± 0.08	Pass
CF-87,88	1/3/2017	K-40	7.77 ± 0.39	6.84 ± 0.37	7.31 ± 0.27	Pass
AP-011217	1/12/2017	Be-7	0.137 ± 0.078	0.139 ± 0.082	0.138 ± 0.056	Pass
MI-212,213	1/16/2017	K-40	1,515 ± 98	1,347 ± 107	1,431 ± 73	Pass
WW-321,322	1/19/2017	H-3	675 ± 118	506 ± 133	590 ± 89	Pass
WW-674,675	1/20/2017	H-3	7,326 ± 254	7,717 ± 259	7,522 ± 181	Pass
AP-012317	1/23/2017	Gr. Beta	0.034 ± 0.005	0.038 ± 0.005	0.036 ± 0.004	Pass
WW-298,299	1/24/2017	H-3	5,916 ± 239	5764 ± 237	5840 ± 168	Pass
AP-013117	1/30/2017	Gr. Beta	0.027 ± 0.004	0.028 ± 0.004	0.028 ± 0.003	Pass
WW-500,501	1/31/2017	H-3	1,058 ± 122	1,054 ± 121	1,056 ± 86	Pass
SW-391,392	1/31/2017	Gr. Beta	1.40 ± 0.56	1.62 ± 0.61	1.51 ± 0.41	Pass
SPS-370,371	2/1/2017	K-40	23.47 ± 0.66	23.11 ± 0.72	23.29 ± 0.49	Pass
AP-456,457	2/2/2017	Be-7	0.129 ± 0.076	0.167 ± 0.092	0.148 ± 0.060	Pass
AP-020217	2/2/2017	Gr. Beta	0.021 ± 0.004	0.027 ± 0.004	0.024 ± 0.003	Pass
SPS-414,415	2/3/2017	K-40	19.45 ± 1.85	21.58 ± 1.99	20.52 ± 1.36	Pass
AP-020617	2/6/2017	Gr. Beta	0.023 ± 0.004	0.023 ± 0.004	0.023 ± 0.003	Pass
AP-021417A	2/14/2017	Gr. Beta	0.031 ± 0.004	0.030 ± 0.004	0.030 ± 0.003	Pass
SPW-543	2/14/2017	Gr. Beta	7.99 ± 0.82	9.45 ± 0.88	8.72 ± 0.60	Pass
AP-021417B	2/14/2017	Gr. Beta	0.024 ± 0.004	0.028 ± 0.004	0.026 ± 0.003	Pass
WW-718,719	2/14/2017	H-3	737 ± 113	643 ± 110	690 ± 79	Pass
AP-022017	2/20/2017	Gr. Beta	0.018 ± 0.005	0.021 ± 0.005	0.020 ± 0.004	Pass
WW-755,756	2/22/2017	H-3	3,709 ± 196	3,823 ± 198	3,766 ± 139	Pass
AP-022717	2/27/2017	Gr. Beta	0.021 ± 0.004	0.019 ± 0.004	0.020 ± 0.003	Pass
SPDW-80011,2	3/2/2017	Ra-226	7.29 ± 0.32	6.76 ± 0.30	7.03 ± 0.22	Pass
SPDW-80011,2	3/2/2017	Ra-228	4.68 ± 0.82	6.29 ± 1.03	5.49 ± 0.66	Pass
SPDW-80013,4	3/2/2017	Gr. Alpha	13.57 ± 1.43	12.44 ± 1.37	13.01 ± 0.99	Pass
WW-845,846	3/2/2017	H-3	314 ± 93	249 ± 90	281 ± 65	Pass
AP-030617	3/6/2017	Gr. Beta	0.022 ± 0.004	0.019 ± 0.004	0.020 ± 0.003	Pass
WW-1050,1051	3/8/2017	H-3	14,994 ± 364	14,745 ± 362	14,870 ± 257	Pass
SPS-920,921	3/9/2017	K-40	23.30 ± 1.76	23.13 ± 1.64	23.21 ± 1.20	Pass
WW-1004,1005	3/13/2017	H-3	182 ± 80	158 ± 79	170 ± 56	Pass
SPS-1029,1030	3/15/2017	K-40	11.82 ± 0.68	12.01 ± 0.68	11.92 ± 0.48	Pass
AP-031517	3/15/2017	Gr. Beta	0.020 ± 0.003	0.020 ± 0.003	0.020 ± 0.002	Pass
SPDW-80037,8	3/20/2017	Gr. Alpha	4.54 ± 0.82	5.29 ± 0.91	4.91 ± 0.61	Pass
AP-032017	3/20/2017	Gr. Beta	0.021 ± 0.006	0.021 ± 0.006	0.021 ± 0.005	Pass
WW-1094,1095	3/20/2017	H-3	1,571 ± 137	1,595 ± 138	1,583 ± 175	Pass

TABLE A-5. In-House "Duplicate" Samples

Lab Code	Date	Analysis	Concentration ^a		Averaged Result	Acceptance
			First Result	Second Result		
WW-1175,1176	3/20/2017	H-3	218 ± 84	211 ± 84	214 ± 59	Pass
WW-1129,1130	3/21/2017	Gr. Beta	3.51 ± 1.24	2.99 ± 1.17	3.25 ± 0.85	Pass
WW-1219,1220	3/22/2017	H-3	11,467 ± 322	11,516 ± 323	11,492 ± 200	Pass
SPS-1152,1153	3/27/2017	Ac-228	20.39 ± 0.75	20.43 ± 0.88	20.41 ± 0.58	Pass
SPS-1152,1153	3/27/2017	Pb-214	17.22 ± 0.50	16.44 ± 0.52	16.83 ± 0.36	Pass
SPDW-80047,8	3/28/2017	Ra-226	2.06 ± 0.23	1.60 ± 0.32	1.83 ± 0.20	Pass
SPDW-80047,8	3/28/2017	Ra-228	0.53 ± 0.48	0.78 ± 0.49	0.66 ± 0.34	Pass
SWU-1242,1243	3/28/2017	Gr. Beta	2.04 ± 0.81	2.47 ± 0.69	2.26 ± 0.53	Pass
SPS-1198,1199	3/29/2017	K-40	16.95 ± 1.85	18.33 ± 1.71	17.64 ± 1.26	Pass
SPDW-80050,1	3/29/2017	Gr. Alpha	3.19 ± 0.80	3.39 ± 0.78	3.29 ± 0.56	Pass
SPDW-80050,1	3/29/2017	Gr. Beta	1.58 ± 0.60	2.08 ± 0.63	1.83 ± 0.44	Pass
AP-1706,1707	3/30/2017	Be-7	0.068 ± 0.018	0.072 ± 0.017	0.070 ± 0.012	Pass
SW-1381,1382	4/5/2017	H-3	402 ± 92	309 ± 88	356 ± 64	Pass
WW-1446,1447	4/6/2017	H-3	305 ± 89	358 ± 91	332 ± 64	Pass
WW-1532,1533	4/10/2017	H-3	19,124 ± 412	18,991 ± 410	19,058 ± 291	Pass
WW-1618,1619	4/12/2017	H-3	4,187 ± 203	4,305 ± 205	4,246 ± 144	Pass
SS-1553,1554	4/13/2017	Gr. Beta	7.16 ± 0.99	6.09 ± 0.91	6.63 ± 0.67	Pass
SS-1553,1554	4/13/2017	K-40	4.60 ± 0.32	4.84 ± 0.34	4.72 ± 0.23	Pass
SS-1553,1554	4/13/2017	Tl-208	0.038 ± 0.016	0.032 ± 0.011	0.035 ± 0.010	Pass
SS-1553,1554	4/13/2017	Pb-212	0.101 ± 0.015	0.096 ± 0.015	0.098 ± 0.010	Pass
SS-1553,1554	4/13/2017	Bi-214	0.094 ± 0.032	0.109 ± 0.022	0.101 ± 0.019	Pass
SS-1553,1554	4/13/2017	Ac-228	0.089 ± 0.042	0.111 ± 0.046	0.100 ± 0.031	Pass
P-2015,2016	5/4/2017	H-3	189 ± 80	212 ± 81	200 ± 57	Pass
WW-2336,2337	5/8/2017	H-3	422 ± 97	298 ± 91	360 ± 66	Pass
AP-051117	5/11/2017	Gr. Beta	0.018 ± 0.003	0.025 ± 0.004	0.021 ± 0.002	Pass
WW-2497,2498	5/23/2017	H-3	1,268 ± 127	1,247 ± 126	1,257 ± 89	Pass
WW-2583,2584	5/23/2017	H-3	5,159 ± 224	5,223 ± 126	5,191 ± 129	Pass
WW-2732,2733	5/23/2017	H-3	8,559 ± 282	8,570 ± 283	8,564 ± 200	Pass
XW-1218,1219	5/23/2017	H-3	11,467 ± 282	11,516 ± 283	11,492 ± 200	Pass
MI-2428,2429	5/24/2017	K-40	1,752 ± 137	1,805 ± 132	1,778 ± 95	Pass
SO-2562,2563	5/24/2017	K-40	7.87 ± 0.50	8.64 ± 0.49	8.25 ± 0.35	Pass
WW-3023,3024	5/24/2017	H-3	27,398 ± 486	27,733 ± 489	27,565 ± 344	Pass
SO-2453,2454	5/25/2017	Gr. Beta	14.38 ± 0.93	15.70 ± 1.06	15.04 ± 0.70	Pass
SO-2453,2454	5/25/2017	Cs-137	0.17 ± 0.03	0.18 ± 0.03	0.17 ± 0.02	Pass
SO-2453,2454	5/25/2017	K-40	9.80 ± 0.50	9.19 ± 0.57	9.50 ± 0.38	Pass
SO-2453,2454	5/25/2017	Tl-208	0.09 ± 0.02	0.10 ± 0.03	0.09 ± 0.02	Pass
SO-2453,2454	5/25/2017	Pb-212	0.29 ± 0.03	0.30 ± 0.03	0.29 ± 0.02	Pass
SO-2453,2454	5/25/2017	Bi-214	0.24 ± 0.03	0.18 ± 0.04	0.21 ± 0.03	Pass
SO-2453,2454	5/25/2017	Ra-226	0.82 ± 0.22	0.62 ± 0.27	0.72 ± 0.17	Pass
SO-2453,2454	5/25/2017	Ac-228	0.32 ± 0.07	0.28 ± 0.08	0.30 ± 0.05	Pass

TABLE A-5. In-House "Duplicate" Samples

Lab Code	Date	Analysis	Concentration ^a		Averaged Result	Acceptance
			First Result	Second Result		
SWT-2625,2626	5/30/2017	Gr. Beta	0.64 ± 0.53	1.08 ± 0.55	0.86 ± 0.38	Pass
AP-053117	5/31/2017	Gr. Beta	0.013 ± 0.003	0.011 ± 0.003	0.012 ± 0.002	Pass
G-2646,2647	6/1/2017	Be-7	1.02 ± 0.17	1.06 ± 0.26	1.04 ± 0.15	Pass
G-2646,2647	6/1/2017	K-40	7.51 ± 0.49	6.55 ± 0.51	7.03 ± 0.36	Pass
SL-2669,70	6/1/2017	Be-7	0.34 ± 0.06	0.30 ± 0.06	0.32 ± 0.04	Pass
SL-2669,70	6/1/2017	K-40	4.35 ± 0.14	4.39 ± 0.15	4.37 ± 0.10	Pass
F-2711,2712	6/2/2017	K-40	2.56 ± 0.32	2.77 ± 0.44	2.66 ± 0.27	Pass
AP-060617	6/6/2017	Gr. Beta	0.026 ± 0.005	0.027 ± 0.005	0.027 ± 0.004	Pass
SW-2849,50	6/8/2017	H-3	8,178 ± 273	8,563 ± 279	8,371 ± 195	Pass
AP-061217	6/12/2017	Gr. Beta	0.027 ± 0.005	0.027 ± 0.005	0.027 ± 0.004	Pass
BS-3446,3447	6/12/2017	K-40	8.30 ± 0.47	8.57 ± 0.47	8.44 ± 0.33	Pass
VE-2870,2871	6/13/2017	K-40	3.65 ± 0.25	3.90 ± 0.26	3.77 ± 0.18	Pass
AP-2914,5	6/15/2017	Be-7	0.269 ± 0.146	0.212 ± 0.123	0.240 ± 0.095	Pass
AP-3067,8	6/15/2017	Be-7	0.204 ± 0.113	0.328 ± 0.126	0.266 ± 0.085	Pass
AP-061917	6/19/2017	Gr. Beta	0.020 ± 0.004	0.019 ± 0.004	0.020 ± 0.003	Pass
AP-3610,1	6/26/2017	Be-7	0.107 ± 0.015	0.116 ± 0.021	0.111 ± 0.013	Pass
AP-062617	6/26/2017	Gr. Beta	0.017 ± 0.004	0.021 ± 0.004	0.019 ± 0.003	Pass
AP-3673,3674	7/3/2017	Be-7	0.087 ± 0.008	0.078 ± 0.008	0.083 ± 0.006	Pass
AP-3287,3288	7/6/2017	Be-7	0.207 ± 0.112	0.244 ± 0.096	0.226 ± 0.074	Pass
WW-3308,3309	7/7/2017	H-3	549 ± 108	501 ± 107	525 ± 76	Pass
VE-3362,3363	7/12/2017	K-40	2.32 ± 0.17	2.40 ± 0.16	2.36 ± 0.12	Pass
VE-3589,3590	7/18/2017	K-40	5.25 ± 0.33	4.64 ± 0.33	4.94 ± 0.23	Pass
SG-3631,3632	7/18/2017	Pb-214	3.03 ± 0.11	2.97 ± 0.11	3.00 ± 0.08	Pass
SG-3631,3632	7/18/2017	Ac-228	2.47 ± 0.22	2.56 ± 0.23	2.52 ± 0.16	Pass
WW-3846,3847	7/25/2017	H-3	505 ± 101	446 ± 98	475 ± 70	Pass
F-4509,4510	7/26/2017	K-40	0.85 ± 0.25	1.00 ± 0.25	0.93 ± 0.18	Pass
F-4509,4510	7/26/2017	Gr. Beta	1.19 ± 0.03	1.18 ± 0.03	1.18 ± 0.02	Pass
G-3804,3805	7/27/2017	Be-7	3.72 ± 0.39	3.47 ± 0.40	3.59 ± 0.28	Pass
G-3804,3805	7/27/2017	K-40	4.21 ± 0.52	4.46 ± 0.52	4.34 ± 0.33	Pass
SL-3888,3889	8/1/2017	Be-7	0.77 ± 0.04	0.73 ± 0.07	0.75 ± 0.04	Pass
SL-3888,3889	8/1/2017	K-40	0.94 ± 0.04	0.87 ± 0.08	0.90 ± 0.23	Pass
WW-4158,4159	8/8/2017	H-3	321 ± 90	270 ± 88	295 ± 63	Pass
VE-4179,4180	8/14/2017	K-40	1.84 ± 0.18	1.90 ± 0.21	1.87 ± 0.14	Pass
AP-4289,4290	8/17/2017	Be-7	0.212 ± 0.095	0.162 ± 0.080	0.187 ± 0.062	Pass
F-4333,4334	8/18/2017	K-40	3.22 ± 0.41	3.62 ± 0.42	3.42 ± 0.29	Pass
CF-4310,4311	8/21/2017	K-40	10.94 ± 0.74	11.48 ± 0.50	11.21 ± 0.45	Pass
DW-80161,80162	8/22/2017	Ra-226	1.22 ± 0.15	1.19 ± 0.17	1.21 ± 0.11	Pass
DW-80161,80162	8/22/2017	Ra-228	1.99 ± 0.63	0.70 ± 0.49	1.35 ± 0.40	Pass
VE-4398,4399	8/28/2017	Be-7	0.13 ± 0.07	0.13 ± 0.08	0.13 ± 0.05	Pass

TABLE A-5. In-House "Duplicate" Samples

Lab Code	Date	Analysis	Concentration ^a		Averaged Result	Acceptance
			First Result	Second Result		
VE-4398,4399	8/28/2017	K-40	3.32 ± 0.22	3.48 ± 0.25	3.40 ± 0.17	Pass
SW-4463,4464	8/29/2017	H-3	495 ± 106	491 ± 106	493 ± 75	Pass
LW-4486,4487	8/31/2017	Gr. Beta	0.425 ± 0.471	1.358 ± 0.571	0.892 ± 0.370	Pass
VE-4561,4562	9/6/2017	Be-7	5.89 ± 0.29	5.76 ± 0.25	5.83 ± 0.19	Pass
VE-4561,4562	9/6/2017	K-40	3.73 ± 0.34	3.77 ± 0.29	3.75 ± 0.22	Pass
BO-5122,5123	9/8/2017	K-40	4.50 ± 0.36	4.50 ± 0.36	4.50 ± 0.25	Pass
VE-4692,4693	9/12/2017	K-40	5.16 ± 0.13	5.31 ± 0.36	5.24 ± 0.19	Pass
SS-4650,4651	9/12/2017	K-40	10.55 ± 0.51	10.41 ± 0.54	10.48 ± 0.37	Pass
MI-4671,4672	9/13/2017	K-40	1,347 ± 115	1,283 ± 118	1,315 ± 82	Pass
MI-4671,4672	9/13/2017	Sr-90	0.7 ± 0.3	0.5 ± 0.3	0.6 ± 0.2	Pass
VE-4973,4974	9/17/2017	K-40	1.11 ± 0.15	1.17 ± 0.13	1.14 ± 0.10	Pass
F-4928,4929	9/19/2017	K-40	1.84 ± 0.31	1.68 ± 0.34	1.76 ± 0.23	Pass
S-4865,4866	9/20/2017	K-40	21.07 ± 2.39	19.09 ± 2.51	20.08 ± 1.73	Pass
VE-4907,4908	9/20/2017	K-40	3.83 ± 0.44	4.28 ± 0.31	4.05 ± 0.27	Pass
VE-4844,4845	9/21/2017	K-40	1.81 ± 0.22	1.88 ± 0.21	1.84 ± 0.15	Pass
AP-5572,5573	9/27/2017	Be-7	0.082 ± 0.015	0.075 ± 0.014	0.078 ± 0.010	Pass
LW-5145,5146	9/28/2017	Gr. Beta	0.84 ± 0.49	1.47 ± 0.57	1.16 ± 0.38	Pass
AP-092917	9/29/2017	Gr. Beta	0.038 ± 0.004	0.031 ± 0.004	0.035 ± 0.003	Pass
WW-5080,5081	10/2/2017	H-3	208 ± 79	223 ± 80	215 ± 56	Pass
AP-100217	10/2/2017	Gr. Beta	0.025 ± 0.005	0.028 ± 0.005	0.026 ± 0.003	Pass
AP-100317	10/3/2017	Gr. Beta	0.037 ± 0.004	0.033 ± 0.004	0.035 ± 0.003	Pass
S-5165,5166	10/4/2017	K-40	15.93 ± 2.30	20.34 ± 3.15	18.14 ± 1.95	Pass
VE-5228,5229	10/5/2017	K-40	3.25 ± 0.25	2.82 ± 0.24	3.04 ± 0.17	Pass
AP-100917	10/9/2017	Gr. Beta	0.021 ± 0.004	0.025 ± 0.004	0.023 ± 0.003	Pass
VE-5293,5294	10/10/2017	K-40	3.89 ± 0.30	4.08 ± 0.34	3.99 ± 0.22	Pass
DW-80184,80185	10/11/2017	Gr. Alpha	2.17 ± 0.81	2.50 ± 0.81	2.34 ± 0.57	Pass
DW-80184,80185	10/11/2017	Gr. Beta	9.45 ± 0.79	10.20 ± 0.83	9.83 ± 0.57	Pass
S-5421,5422	10/12/2017	K-40	8.82 ± 1.94	7.97 ± 0.72	8.40 ± 1.03	Pass
AP-101617	10/16/2017	Gr. Beta	0.025 ± 0.005	0.022 ± 0.004	0.024 ± 0.003	Pass
F-5658,5659	10/19/2017	K-40	2.44 ± 0.41	2.57 ± 0.39	2.51 ± 0.28	Pass
SO-5704,5705	10/25/2017	Cs-137	0.05 ± 0.02	0.04 ± 0.02	0.04 ± 0.01	Pass
SO-5704,5705	10/25/2017	K-40	10.08 ± 0.51	9.57 ± 0.56	9.83 ± 0.38	Pass
SO-5704,5705	10/25/2017	Tl-208	0.10 ± 0.02	0.09 ± 0.02	0.10 ± 0.01	Pass
SO-5704,5705	10/25/2017	Bi-214	0.34 ± 0.04	0.27 ± 0.04	0.30 ± 0.03	Pass
SO-5704,5705	10/25/2017	Pb-212	0.28 ± 0.03	0.27 ± 0.03	0.27 ± 0.02	Pass
SO-5704,5705	10/25/2017	Ra-226	1.15 ± 0.52	0.59 ± 0.22	0.87 ± 0.28	Pass
SO-5704,5705	10/25/2017	Ac-228	0.33 ± 0.05	0.31 ± 0.07	0.32 ± 0.04	Pass
SO-5704,5705	10/25/2017	Gr. Beta	18.34 ± 1.80	16.50 ± 1.03	17.42 ± 1.04	Pass
AP-5732,5733	10/26/2017	Be-7	0.139 ± 0.064	0.175 ± 0.075	0.157 ± 0.049	Pass

TABLE A-5. In-House "Duplicate" Samples

Lab Code	Date	Analysis	Concentration ^a		Averaged Result	Acceptance
			First Result	Second Result		
SW-5753,5754	10/31/2017	H-3	220 ± 83	279 ± 86	249 ± 60	Pass
SWU-5816,5817	10/31/2017	Gr. Beta	1.51 ± 1.00	2.02 ± 1.02	1.76 ± 0.71	Pass
AP-103117	10/31/2017	Gr. Beta	0.015 ± 0.004	0.014 ± 0.004	0.015 ± 0.003	Pass
SO-5923,5924	11/1/2017	Cs-137	0.30 ± 0.04	0.31 ± 0.04	0.31 ± 0.03	Pass
SO-5923,5924	11/1/2017	K-40	10.52 ± 0.61	10.56 ± 0.67	10.54 ± 0.45	Pass
AP-5858,5859	11/2/2017	Be-7	0.145 ± 0.075	0.146 ± 0.084	0.145 ± 0.056	Pass
AP-110717	11/7/2017	Be-7	0.026 ± 0.004	0.030 ± 0.004	0.028 ± 0.003	Pass
WW-6032,6033	11/7/2017	H-3	204 ± 86	298 ± 80	251 ± 59	Pass
WW-6074,6075	11/8/2017	H-3	72,247 ± 786	73,062 ± 791	72,655 ± 558	Pass
BS-6053,6054	11/13/2017	K-40	7.99 ± 0.62	9.20 ± 0.68	8.60 ± 0.46	Pass
BS-6053,6054	11/13/2017	Cs-137	0.07 ± 0.03	0.08 ± 0.03	0.07 ± 0.02	Pass
DW-80211,80212	11/14/2017	Gr. Alpha	2.30 ± 0.80	3.60 ± 1.00	2.95 ± 0.64	Pass
DW-80211,80212	11/14/2017	Gr. Beta	9.32 ± 0.81	8.99 ± 0.81	9.16 ± 0.57	Pass
DW-80214,80215	11/14/2017	Ra-226	1.36 ± 0.22	1.35 ± 0.15	1.355 ± 0.13	Pass
DW-80214,80215	11/14/2017	Ra-228	1.41 ± 0.51	0.90 ± 0.45	1.16 ± 0.34	Pass
WW-6152,6153	11/15/2017	H-3	416 ± 94	328 ± 90	372 ± 65	Pass
SWU-6219,6220	11/28/2017	Gr. Beta	1.04 ± 0.54	1.75 ± 0.58	1.39 ± 0.39	Pass
SS-6242,6243	11/29/2017	K-40	24.17 ± 1.05	22.31 ± 1.03	23.24 ± 0.74	Pass
SS-6242,6243	11/29/2017	Cs-137	0.11 ± 0.03	0.08 ± 0.03	0.10 ± 0.02	Pass
SG-6938,6939	11/28/2017	Pb-214	15.28 ± 0.34	14.96 ± 0.43	15.12 ± 0.27	Pass
SG-6938,6939	11/28/2017	Ac-228	18.99 ± 0.59	19.92 ± 0.79	19.46 ± 0.49	Pass
AP-112817	11/28/2017	Gr. Beta	0.026 ± 0.004	0.030 ± 0.004	0.028 ± 0.003	Pass
SQ-6286,6287	12/1/2017	Gr. Alpha	70.6 ± 6.2	60.9 ± 6.0	65.8 ± 4.3	Pass
SQ-6286,6287	12/1/2017	Gr. Beta	48.9 ± 2.7	53.7 ± 2.8	51.3 ± 1.9	Pass
SQ-6286,6287	12/1/2017	Ra-226	11.3 ± 0.4	10.7 ± 0.5	11.0 ± 0.3	Pass
SQ-6286,6287	12/1/2017	Ra-228	13.5 ± 0.9	13.2 ± 1.0	13.4 ± 0.7	Pass
SG-6286,6287	12/1/2017	K-40	5.10 ± 1.82	6.65 ± 1.53	5.88 ± 1.19	Pass
AP-120417	12/4/2017	Gr. Beta	0.037 ± 0.006	0.035 ± 0.005	0.036 ± 0.004	Pass
WW-6548,6549	12/19/2017	H-3	8,428 ± 280	8,604 ± 282	8,516 ± 199	Pass
AP-122717	12/27/2017	Gr. Beta	0.047 ± 0.004	0.043 ± 0.004	0.045 ± 0.003	Pass
XAP-6762,6763	12/31/2017	Co-60	2.43 ± 1.30	2.24 ± 0.82	2.34 ± 0.77	Pass
XAP-6762,6763	12/31/2017	Cs-137	4.21 ± 1.11	4.05 ± 0.96	4.14 ± 0.73	Pass

Note: Duplicate analyses are performed on every twentieth sample received in-house. Results are not listed for those analyses with activities that measure below the LLD.

^a Results are reported in units of pCi/L, except for air filters (pCi/Filter or pCi/m³), food products, vegetation, soil and sediment (pCi/g).

TABLE A-6. Department of Energy's Mixed Analyte Performance Evaluation Program (MAPEP).

Lab Code ^b	Reference Date	Analysis	Laboratory result	Concentration ^a		Acceptance
				Known Activity	Control Limits ^c	
MASO-903	2/1/2017	Am-241	60.9 ± 6.9	67.0	46.9 - 87.1	Pass
MASO-903	2/1/2017	Cs-134	1360 ± 14	1550	1085 - 2015	Pass
MASO-903	2/1/2017	Cs-137	678 ± 13	611	428 - 794	Pass
MASO-903	2/1/2017	Co-57	1.63 ± 1.69	0.00	NA ^c	Pass
MASO-903	2/1/2017	Co-60	909 ± 12	891	624 - 1158	Pass
MASO-903	2/1/2017	Mn-54	1052 ± 17	967	677 - 1257	Pass
MASO-903	2/1/2017	K-40	657 ± 68	607	425 - 789	Pass
MASO-903	2/1/2017	Zn-65	-0.52 ± 7.40	0.00	NA ^c	Pass
MASO-903	2/1/2017	Ni-63	3.25 ± 7.17	0.00	NA ^c	Pass
MASO-903	2/1/2017	Pu-238	0.46 ± 0.69	0.41	NA ^e	Pass
MASO-903	2/1/2017	Pu-239/240	56.8 ± 5.9	59.8	41.9 - 77.7	Pass
MASO-903	2/1/2017	Sr-90	501 ± 17	624	437 - 811	Pass
MASO-903	2/1/2017	Tc-99	748 ± 16	656	459 - 853	Pass
MAW-849	2/1/2017	I-129	-0.05 ± 0.12	0.00	NA ^c	Pass
MAVE-905	2/1/2017	Cs-134	6.61 ± 0.16	6.95	4.87 - 9.04	Pass
MAVE-905	2/1/2017	Cs-137	4.97 ± 0.18	4.60	3.22 - 5.98	Pass
MAVE-905	2/1/2017	Co-57	-0.01 ± 0.03	0.00	NA ^c	Pass
MAVE-905	2/1/2017	Co-60	9.51 ± 0.17	8.75	6.13 - 11.38	Pass
MAVE-905	2/1/2017	Mn-54	3.67 ± 0.17	3.28	2.30 - 4.26	Pass
MAVE-905	2/1/2017	Zn-65	6.12 ± 0.44	5.39	3.77 - 7.01	Pass
MAW-847	2/1/2017	Am-241	0.679 ± 0.079	0.846	0.592 - 1.100	Pass
MAW-847	2/1/2017	Cs-134	0.03 ± 0.10	0.00	NA ^c	Pass
MAW-847	2/1/2017	Cs-137	12.7 ± 0.4	11.1	7.8 - 14.4	Pass
MAW-847 ^d	2/1/2017	Co-57	2.7 ± 0.3	28.5	20.0 - 37.1	Fail
MAW-847	2/1/2017	Co-60	13.5 ± 0.3	12.3	8.6 - 16.0	Pass
MAW-847	2/1/2017	Mn-54	16.5 ± 0.4	14.9	10.4 - 19.4	Pass
MAW-847	2/1/2017	K-40	287 ± 6	254	178 - 330	Pass
MAW-847	2/1/2017	Zn-65	-0.15 ± 0.23	0.00	NA ^c	Pass
MAW-847	2/1/2017	H-3	275 ± 10	249	174 - 324	Pass
MAW-847	2/1/2017	Fe-55	2.4 ± 13.6	1.7	NA ^e	Pass
MAW-847	2/1/2017	Ni-63	10.1 ± 2.8	12.2	8.5 - 15.9	Pass
MAW-847	2/1/2017	Pu-238	0.729 ± 0.097	0.703	0.492 - 0.914	Pass
MAW-847	2/1/2017	Pu-239/240	0.866 ± 0.102	0.934	0.654 - 1.214	Pass
MAW-847	2/1/2017	Ra-226	0.506 ± 0.053	0.504	0.353 - 0.655	Pass
MAW-847	2/1/2017	Sr-90	10.0 ± 0.8	10.1	7.1 - 13.1	Pass

TABLE A-6. Department of Energy's Mixed Analyte Performance Evaluation Program (MAPEP).

Lab Code ^b	Reference Date	Analysis	Laboratory result	Concentration ^a		Acceptance
				Known Activity	Control Limits ^c	
MAW-847	2/1/2017	Tc-99	4.77 ± 0.62	6.25	4.38 - 8.13	Pass
MAW-847	2/1/2017	U-234/233	1.19 ± 0.10	1.16	0.81 - 1.51	Pass
MAW-847	2/1/2017	U-238	1.15 ± 0.10	1.20	0.84 - 1.56	Pass
MAAP-907 ^f	2/1/2017	Am-241	0.0540 ± 0.0140	0.0376	0.0263 - 0.0489	Fail
MAAP-907	2/1/2017	Cs-134	1.31 ± 0.06	1.42	0.99 - 1.85	Pass
MAAP-907	2/1/2017	Cs-137	0.797 ± 0.080	0.685	0.480 - 0.891	Pass
MAAP-907	2/1/2017	Co-57	1.86 ± 0.06	1.70	1.19 - 2.21	Pass
MAAP-907	2/1/2017	Co-60	0.86 ± 0.05	0.78	0.55 - 1.01	Pass
MAAP-907	2/1/2017	Mn-54	0.01 ± 0.03	0.00	NA ^c	Pass
MAAP-907	2/1/2017	Zn-65	1.62 ± 0.13	1.29	0.90 - 1.68	Pass
MAAP-907	2/1/2017	Pu-238	0.0530 ± 0.0190	0.0598	0.0419 - 0.0777	Pass
MAAP-907	2/1/2017	Pu-239/240	0.0490 ± 0.0160	0.0460	0.0322 - 0.0598	Pass
MAAP-907	2/1/2017	Sr-90	0.648 ± 0.120	0.651	0.456 - 0.846	Pass
MAAP-907	2/1/2017	U-234/233	0.086 ± 0.024	0.104	0.073 - 0.135	Pass
MAAP-907	2/1/2017	U-238	0.097 ± 0.024	0.107	0.075 - 0.139	Pass
MASO-4515	8/1/2017	Am-241	45.9 ± 7.0	58.8	41.2 - 76.4	Pass ^g
MASO-4515	8/1/2017	Cs-134	409 ± 7	448	314 - 582	Pass ^g
MASO-4515	8/1/2017	Cs-137	798 ± 12	722	505 - 939	Pass ^g
MASO-4515	8/1/2017	Co-57	1572 ± 10	1458	1021 - 1895	Pass ^g
MASO-4515	8/1/2017	Co-60	0.2 ± 1.4	0.00	NA ^c	Pass ^g
MASO-4515	8/1/2017	Mn-54	934 ± 13	825	578 - 1073	Pass ^g
MASO-4515	8/1/2017	K-40	704 ± 53	592	414 - 770	Pass ^g
MASO-4515	8/1/2017	Zn-65	667 ± 17	559	391 - 727	Pass ^g
MASO-4515	8/1/2017	Pu-238	101 ± 9	92	64 - 120	Pass ^g
MASO-4515	8/1/2017	Pu-239/240	74.8 ± 7.7	68.8	48.2 - 89.4	Pass ^g
MASO-4515	8/1/2017	Sr-90	252 ± 7	289	202 - 376	Pass ^g
MAW-4494	8/1/2017	I-129	2.31 ± 0.10	2.31	1.62 - 3.00	Pass
MAVE-4517	8/1/2017	Cs-134	2.40 ± 0.10	2.32	1.62 - 3.02	Pass
MAVE-4517	8/1/2017	Cs-137	-0.002 ± 0.048	0.000	NA ^c	Pass
MAVE-4517	8/1/2017	Co-57	3.3 ± 0.1	2.8	2.0 - 3.6	Pass
MAVE-4517	8/1/2017	Co-60	2.10 ± 0.10	2.07	1.45 - 2.69	Pass
MAVE-4517	8/1/2017	Mn-54	3.00 ± 0.20	2.62	1.83 - 3.41	Pass
MAVE-4517	8/1/2017	Zn-65	5.90 ± 0.30	5.37	3.76 - 6.98	Pass

TABLE A-6. Department of Energy's Mixed Analyte Performance Evaluation Program (MAPEP).

Lab Code ^b	Reference Date	Analysis	Laboratory result	Concentration ^a		Acceptance
				Known Activity	Control Limits ^c	
MAW-4513	8/1/2017	Am-241	0.820 ± 0.220	0.892	0.624 - 1.160	Pass
MAW-4513	8/1/2017	Cs-134	10.3 ± 0.3	11.5	8.1 - 15.0	Pass
MAW-4513	8/1/2017	Cs-137	17.2 ± 0.5	16.3	11.4 - 21.2	Pass
MAW-4513	8/1/2017	Co-57	12.7 ± 0.4	12.1	8.5 - 15.7	Pass
MAW-4513	8/1/2017	Co-60	10.6 ± 0.3	10.7	7.5 - 13.9	Pass
MAW-4513	8/1/2017	Mn-54	15.6 ± 0.4	14.9	10.4 - 19.4	Pass
MAW-4513	8/1/2017	Zn-65	15.9 ± 0.7	15.5	10.9 - 20.2	Pass
MAW-4513	8/1/2017	H-3	255 ± 9	258	181 - 335	Pass
MAW-4513	8/1/2017	Fe-55	21.6 ± 6.6	19.4	13.6 - 25.2	Pass
MAW-4513	8/1/2017	Ni-63	-0.1 ± 2.0	0.0	NA ^c	Pass
MAW-4513	8/1/2017	Pu-238	0.590 ± 0.080	0.603	0.422 - 0.784	Pass
MAW-4513	8/1/2017	Pu-239/240	0.740 ± 0.090	0.781	0.547 - 1.015	Pass
MAW-4513	8/1/2017	Ra-226	1.000 ± 0.100	0.858	0.601 - 1.115	Pass
MAW-4513	8/1/2017	Sr-90	7.80 ± 0.60	7.77	5.44 - 10.10	Pass
MAW-4513	8/1/2017	Tc-99	6.70 ± 0.40	6.73	4.71 - 8.75	Pass
MAW-4513	8/1/2017	U-2344/233	0.94 ± 0.06	1.01	0.71 - 1.31	Pass
MAW-4513	8/1/2017	U-238	0.97 ± 0.07	1.04	0.73 - 1.35	Pass
MAAP-4519 ^h	8/1/2017	Am-241	0.0400 ± 0.0100	0.0612	0.0428 - 0.0796	Fail
MAAP-4519	8/1/2017	Cs-134	0.90 ± 0.10	1.00	0.70 - 1.30	Pass
MAAP-4519	8/1/2017	Cs-137	0.90 ± 0.10	0.82	0.57 - 1.07	Pass
MAAP-4519	8/1/2017	Co-57	0.01 ± 0.01	0.00	NA ^c	Pass
MAAP-4519	8/1/2017	Co-60	0.70 ± 0.10	0.68	0.48 - 0.88	Pass
MAAP-4519	8/1/2017	Mn-54	1.50 ± 0.10	1.30	0.91 - 1.69	Pass
MAAP-4519	8/1/2017	Zn-65	1.30 ± 0.10	1.08	0.76 - 1.40	Pass
MAAP-4519	8/1/2017	Pu-238	0.0300 ± 0.0100	0.0298	0.0209 - 0.0387	Pass
MAAP-4519	8/1/2017	Pu-239/240	0.0400 ± 0.0200	0.0468	0.0328 - 0.0608	Pass
MAAP-4519	8/1/2017	Sr-90	0.800 ± 0.100	0.801	0.561 - 1.041	Pass
MAAP-4519	8/1/2017	U-234/233	0.070 ± 0.010	0.084	0.059 - 0.109	Pass
MAAP-4519	8/1/2017	U-238	0.090 ± 0.010	0.087	0.061 - 0.113	Pass

^a Results are reported in units of Bq/kg (soil), Bq/L (water) or Bq/total sample (filters, vegetation).

^b Laboratory codes as follows: MAW (water), MAAP (air filter), MASO (soil), MAVE (vegetation).

^c MAPEP results are presented as the known values and expected laboratory precision (1 sigma, 1 determination) and control limits as defined by the MAPEP. A known value of "zero" indicates an analysis was included in the testing series as a "false positive". MAPEP does not provide control limits.

^d Decimal point was misplaced while performing a unit conversion. The result is within control limits when the proper unit conversion is performed.

^e Provided in the series for "sensitivity evaluation". MAPEP does not provide control limits.

^f Sample was reanalyzed in duplicate with acceptable results. Original plating was inferior to platings obtained during reanalysis. It is believed that isotopic tracer was not accurately quantified due to poor resolution of its peak.

^g Data were erroneously submitted in units of Bq/g. All results pass MAPEP criteria when evaluated in units of Bq/Kg.

^h Laboratory is not currently offering analysis for Am-241 in Air Particulate samples.

TABLE A-7. Interlaboratory Comparison Crosscheck Program, Environmental Resource Associates (ERA)^a.

MRAD Study						
Lab Code ^b	Date	Analysis	Concentration ^a		Control Limits ^c	Acceptance
			Laboratory Result	ERA Result		
ERAP-1112	3/20/2017	Am-241	55.3 ± 2.8	76.4	47.1 - 103.0	Pass
ERAP-1112	3/20/2017	Co-60	1,230 ± 8	1030	797 - 1290	Pass
ERAP-1112	3/20/2017	Cs-134	1,110 ± 9	1100	700 - 1360	Pass
ERAP-1112	3/20/2017	Cs-137	1,810 ± 12	1,390	1,040 - 1,830	Pass
ERAP-1112 ^d	3/20/2017	Fe-55	590 ± 385	256	79.4 - 500	Fail
ERAP-1112	3/20/2017	Mn-54	< 5.14	< 50.0	0.00 - 50.0	Pass
ERAP-1112	3/20/2017	Pu-238	54.6 ± 2.8	54.3	37.2 - 71.4	Pass
ERAP-1112	3/20/2017	Pu-239/240	63.6 ± 3.0	62.0	44.9 - 81.0	Pass
ERAP-1112	3/20/2017	Sr-90	55.3 ± 8.3	52.4	25.6 - 78.5	Pass
ERAP-1112	3/20/2017	U-233/234	65.7 ± 3.0	73.1	45.3 - 110	Pass
ERAP-1112	3/20/2017	U-238	67.3 ± 3.0	72.4	46.8 - 100	Pass
ERAP-1112	3/20/2017	Zn-65	1,355 ± 16	984	705 - 1,360	Pass
ERAP-1114	3/20/2017	Gr. Alpha	106 ± 5	85.5	28.6 - 133	Pass
ERAP-1114 ^e	3/20/2017	Gr. Beta	67.6 ± 3.0	45.2	28.6 - 65.9	Fail
ERSO-1116	3/20/2017	Am-241	418 ± 98	448	262 - 582	Pass
ERSO-1116	3/20/2017	Ac-228	1,540 ± 260	1,240	795 - 1,720	Pass
ERSO-1116	3/20/2017	Bi-212	1,550 ± 90	1,240	330 - 1,820	Pass
ERSO-1116	3/20/2017	Bi-214	2,560 ± 20	2,750	1,660 - 3,960	Pass
ERSO-1116	3/20/2017	Co-60	4,620 ± 100	4,430	3,000 - 6,100	Pass
ERSO-1116	3/20/2017	Cs-134	8,340 ± 100	8,860	5,790 - 10,600	Pass
ERSO-1116	3/20/2017	Cs-137	8,420 ± 100	7,500	5,750 - 9,650	Pass
ERSO-1116	3/20/2017	K-40	13,600 ± 900	10,600	7,740 - 14,200	Pass
ERSO-1116	3/20/2017	Mn-54	< 68.1	< 1000	0.00 - 1,000	Pass
ERSO-1116	3/20/2017	Pb-212	1,060 ± 70	1,240	812 - 1,730	Pass
ERSO-1116	3/20/2017	Pb-214	2,620 ± 160	2,890	1,690 - 4,310	Pass
ERSO-1116	3/20/2017	Pu-238	424 ± 154	648	390 - 894	Pass
ERSO-1116 ^f	3/20/2017	Pu-239/240	252 ± 112	484	316 - 669	Fail
ERSO-1116 ^g	3/20/2017	Pu-239/240	436 ± 106	484	316 - 669	Pass
ERSO-1116	3/20/2017	Sr-90	7,930 ± 250	9,150	3,490 - 14,500	Pass
ERSO-1116	3/20/2017	Th-234	1,820 ± 200	1,940	614 - 3,650	Pass
ERSO-1116 ^h	3/20/2017	U-233/234	1,030 ± 130	1,950	1,190 - 2,500	Fail
ERSO-1116 ⁱ	3/20/2017	U-233/234	1,820 ± 200	1,950	1,190 - 2,500	Pass
ERSO-1116	3/20/2017	U-238	1,240 ± 140	1,940	1,200 - 2,460	Pass
ERSO-1116 ^j	3/20/2017	U-238	1,930 ± 200	1,940	1,200 - 2,460	Pass
ERSO-1116	3/20/2017	Zn-65	7,190 ± 240	6,090	4,850 - 8,090	Pass
ERW-1122	3/20/2017	Gr. Alpha	65.3 ± 2.4	89.5	31.8 - 139	Pass
ERW-1122	3/20/2017	Gr. Beta	54.8 ± 1.5	61.0	34.9 - 90.4	Pass
ERW-1124	3/20/2017	H-3	19,000 ± 410	19,400	13,000 - 27,700	Pass

TABLE A-7. Interlaboratory Comparison Crosscheck Program, Environmental Resource Associates (ERA)^a.

MRAD Study						
Lab Code ^b	Date	Analysis	Concentration ^a		Control Limits ^c	Acceptance
			Laboratory Result	ERA Result		
ERVE-1118	3/20/2017	Am-241	1,560 ± 140	1,860	1,140 - 2,470	Pass
ERVE-1118	3/20/2017	Cm-244	530 ± 80	734	360 - 1,140	Pass
ERVE-1118	3/20/2017	Co-60	1,400 ± 350	1,390	959 - 1,940	Pass
ERVE-1118	3/20/2017	Cs-134	1,650 ± 460	1,830	1,180 - 2,380	Pass
ERVE-1118	3/20/2017	Cs-137	2,580 ± 540	2,500	1,810 - 3,480	Pass
ERVE-1118	3/20/2017	K-40	32,100 ± 700	30,900	22,300 - 43,400	Pass
ERVE-1118	3/20/2017	Mn-54	< 27.3	< 300	0.00 - 300	Pass
ERVE-1118	3/20/2017	Zn-65	889 ± 64	853	615 - 1,200	Pass
ERVE-1118	3/20/2017	Pu-238	3,250 ± 210	3,250	1,940 - 4,450	Pass
ERVE-1118	3/20/2017	Pu-239/240	2,180 ± 170	2,150	1,320 - 2,960	Pass
ERVE-1118	3/20/2017	Sr-90	665 ± 135	726	414 - 963	Pass
ERVE-1118	3/20/2017	U-233/234	2,840 ± 200	3,090	2,030 - 3,970	Pass
ERVE-1118	3/20/2017	U-238	2,990 ± 200	3,060	2,040 - 3,890	Pass
ERW-1120	3/20/2017	Am-241	108 ± 7	140	94.3 - 188	Pass
ERW-1120	3/20/2017	Co-60	2,600 ± 198	2,540	2,210 - 2,970	Pass
ERW-1120	3/20/2017	Cs-134	2,380 ± 250	2,510	1,840 - 2880	Pass
ERW-1120	3/20/2017	Cs-137	1,470 ± 243	1,400	1,190 - 1,680	Pass
ERW-1120	3/20/2017	Mn-54	< 12.3	< 100	0.00 - 100	Pass
ERW-1120	3/20/2017	Pu-238	117 ± 4	128	94.7 - 159	Pass
ERW-1120	3/20/2017	Pu-239/240	74.8 ± 3.3	85.8	66.6 - 108	Pass
ERW-1120	3/20/2017	U-233/234	75.3 ± 3.2	90.3	67.8 - 116	Pass
ERW-1120	3/20/2017	U-238	76.4 ± 3.2	89.5	68.2 - 110	Pass
ERW-1120	3/20/2017	Zn-65	2,130 ± 378	1,960	1630 - 2,470	Pass
ERW-1120 ^j	3/20/2017	Fe-55	1,400 ± 403	984	587 - 1,340	Fail
ERW-1120 ^k	3/20/2017	Fe-55	1,081 ± 383	984	587 - 1,340	Pass
ERW-1120	3/20/2017	Sr-90	652 ± 12	714	465 - 944	Pass

^a Results obtained by Environmental, Inc., Midwest Laboratory as a participant in the crosscheck program for proficiency testing administered by Environmental Resources Associates, serving as a replacement for studies conducted previously by the Environmental Measurements Laboratory Quality Assessment Program (EML).

^b Laboratory codes as follows: ERW (water), ERAP (air filter), ERSO (soil), ERVE (vegetation). Results are reported in units of pCi/L, except for air filters (pCi/Filter), vegetation and soil (pCi/kg).

^c Results are presented as the known values, expected laboratory precision (2 sigma, 1 determination) and control limits as provided by ERA.

^d Fe-55 analysis result was outside the acceptable range. Recounting the sample disk for 1000 minutes resulted in 254 ± 364 with an LLD calculation of < 342. Insufficient sample was available after performing other required analyses on the sample to quantify the activity with an uncertainty less than the activity.

^e ERA appears to have applied the standard material to the filter in a pattern closer to the center of the filter compared to previous studies and different from the filter efficiency utilized by the laboratory. This likely caused the efficiency used the calculation to be understated and the result obtained by the laboratory to be overstated. For comparison the in-house spike for gross beta in AP (table A-3 SPAP-740 2/28/17) was acceptable with a ratio of 0.94 of lab result to known.

^f Analysis result for Plutonium-239/240 was below the lower limit of acceptance.

^g Samples were reanalyzed in duplicate with acceptable results for each. Original analysis had poor resolution possibly due to a poor electroplating and is suspected in contributing to poor results.

^h Analysis result for U-233/234 was below the lower limit of acceptance.

ⁱ The reanalysis result for U-233/234 was within the acceptance limits and U-238 reanalysis result was closer to the known value. Original analysis had poor resolution possibly due to a poor electroplating and is suspected in contributing to poor results.

^j Fe-55 analysis result was outside acceptable range.

^k Result of recounting was acceptable. Using available aliquot after dividing sample for other analyses leaves insufficient sample to reliably determine the activity present in sample.

APPENDIX B

DATA REPORTING CONVENTIONS

Data Reporting Conventions

1.0. All activities, except gross alpha and gross beta, are decay corrected to collection time or the end of the collection period.

2.0. Single Measurements

Each single measurement is reported as follows: $x \pm s$
where: x = value of the measurement;
 s = 2σ counting uncertainty (corresponding to the 95% confidence level).

In cases where the activity is less than the lower limit of detection L , it is reported as: $< L$,
where L = the lower limit of detection based on 4.66σ uncertainty for a background sample.

3.0. Duplicate analyses

If duplicate analyses are reported, the convention is as follows. :

- 3.1. Individual results: For two analysis results; $x_1 \pm s_1$ and $x_2 \pm s_2$
Reported result: $x \pm s$; where $x = (1/2)(x_1 + x_2)$ and $s = (1/2)\sqrt{s_1^2 + s_2^2}$
- 3.2. Individual results: $< L_1, < L_2$ Reported result: $< L$, where L = lower of L_1 and L_2
- 3.3. Individual results: $x \pm s, < L$ Reported result: $x \pm s$ if $x \geq L$; $< L$ otherwise.

4.0. Computation of Averages and Standard Deviations

4.1 Averages and standard deviations listed in the tables are computed from all of the individual measurements over the period averaged; for example, an annual standard deviation would not be the average of quarterly standard deviations. The average \bar{x} and standard deviation "s" of a set of n numbers x_1, x_2, \dots, x_n are defined as follows:

$$\bar{x} = \frac{1}{n} \sum x \qquad s = \sqrt{\frac{\sum (x - \bar{x})^2}{n-1}}$$

- 4.2 Values below the highest lower limit of detection are not included in the average.
- 4.3 If all values in the averaging group are less than the highest LLD, the highest LLD is reported.
- 4.4 If all but one of the values are less than the highest LLD, the single value x and associated two sigma error is reported.
- 4.5 In rounding off, the following rules are followed:
- 4.5.1. If the number following those to be retained is less than 5, the number is dropped, and the retained numbers are kept unchanged. As an example, 11.443 is rounded off to 11.44.
- 4.5.2. If the number following those to be retained is equal to or greater than 5, the number is dropped and the last retained number is raised by 1. As an example, 11.445 is rounded off to 11.45.

POINT BEACH NUCLEAR PLANT

APPENDIX C

Sampling Program and Locations

POINT BEACH NUCLEAR PLANT

Sample Type	Locations		Collection Type (and Frequency) ^b	Analysis (and Frequency) ^b
	No.	Codes (and Type) ^a		
Airborne Filters	6	E-1-4, 8, 20	Weekly	GB, GS, on QC for each location
Airborne Iodine	6	E-1-4, 8, 20	Weekly	I-131
Ambient Radiation (TLD's)	22	E-1-9, 12, 14-18, 20, 22-32, 34-36, 38,39	Quarterly	Ambient Gamma
Lake Water	5	E-1, 5, 6, 33	Monthly	GB, GS, I-131 on MC H-3, Sr-89-90 on QC
Well Water	1	E-10	Quarterly	GB, GS, H-3, Sr-89-90, I-131
Vegetation	8	E-1-4, 6, 9, 20	3x / year as available	GB, GS
Shoreline Silt	5	E-1, 5, 6, 12, 33	2x / year	GB, GS
Soil	8	E-1-4, 6, 8, 9, 20	2x / year	GB, GS
Milk	3	E-11, 40, 21	Monthly	GS, I-131, Sr-89-90
Algae	2	E-5, 12	3x / year as available	GB, GS
Fish	1	E-13	2x / year as available	GB, GS (in edible portions)

^a Locations codes are defined in Table 2. Control Stations are indicated by (C). All other stations are indicators.

^b Analysis type is coded as follows: GB = gross beta, GA = gross alpha, GS = gamma spectroscopy, H-3 = tritium, Sr-89 = strontium-89, Sr-90 = strontium-90, I-131 = iodine-131. Analysis frequency is coded as follows: MC = monthly composite, QC = quarterly composite.

POINT BEACH NUCLEAR PLANT

APPENDIX D

Graphs of Data Trends

POINT BEACH

Air Particulates - Gross Beta

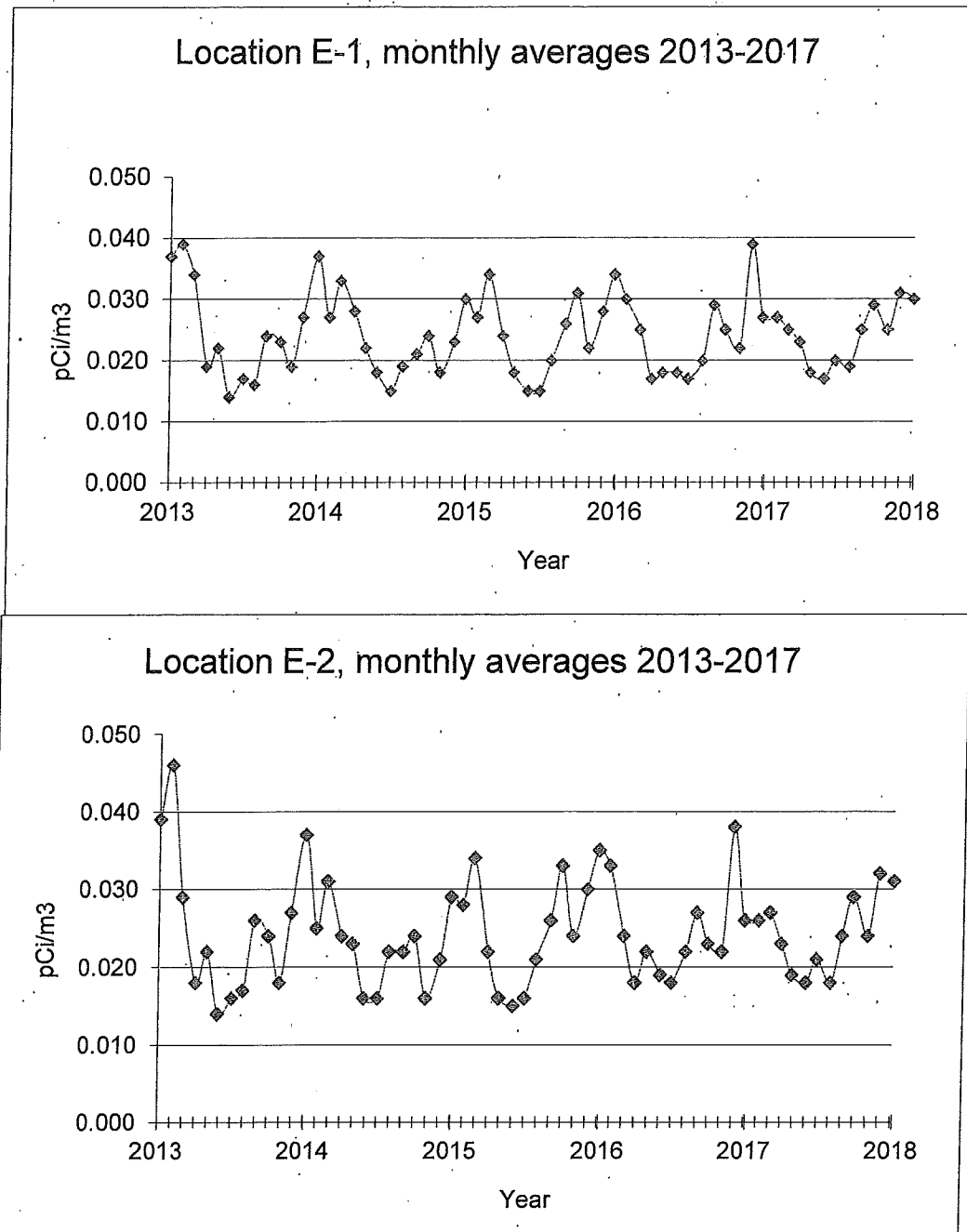

POINT BEACH

Air Particulates - Gross Beta

Location E-3, monthly averages 2013-2017

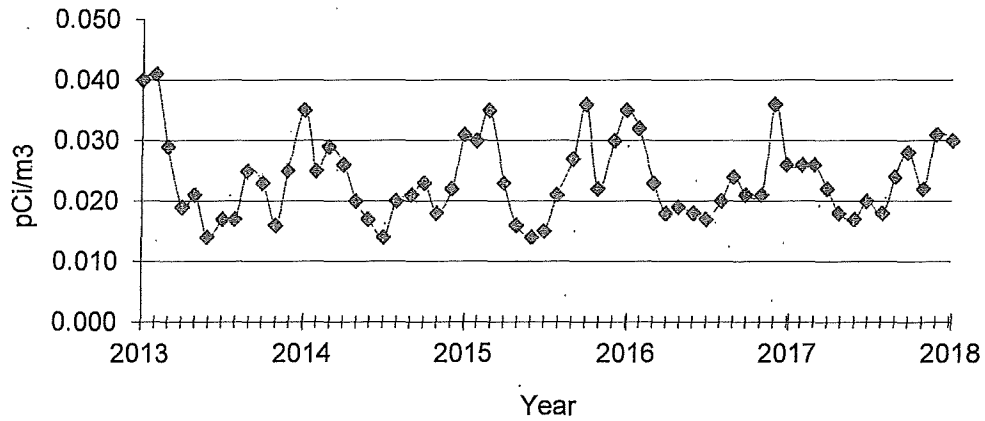

Location E-4, monthly averages 2013-2017

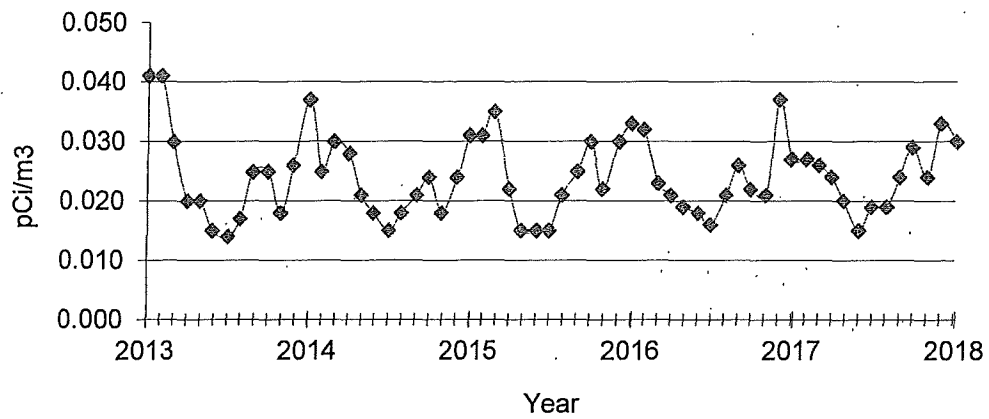

POINT BEACH

Air Particulates - Gross Beta

Location E-8, monthly averages 2013-2017

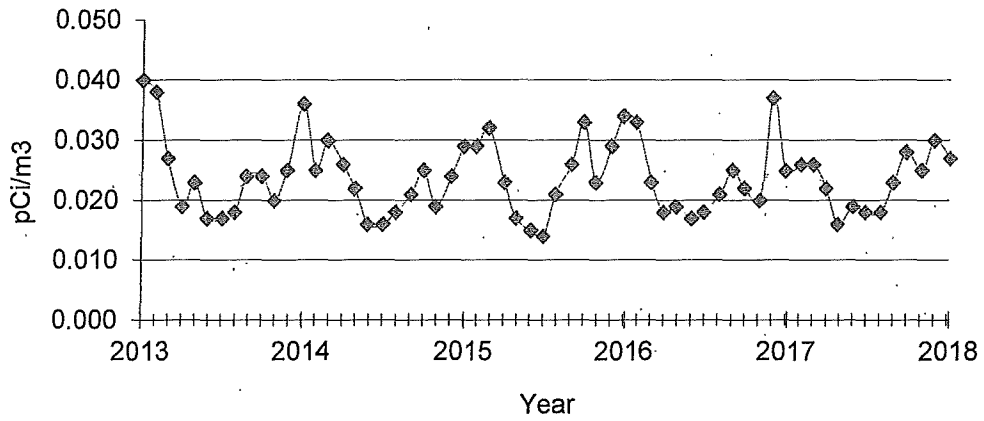

Location E-20, monthly averages 2013-2017

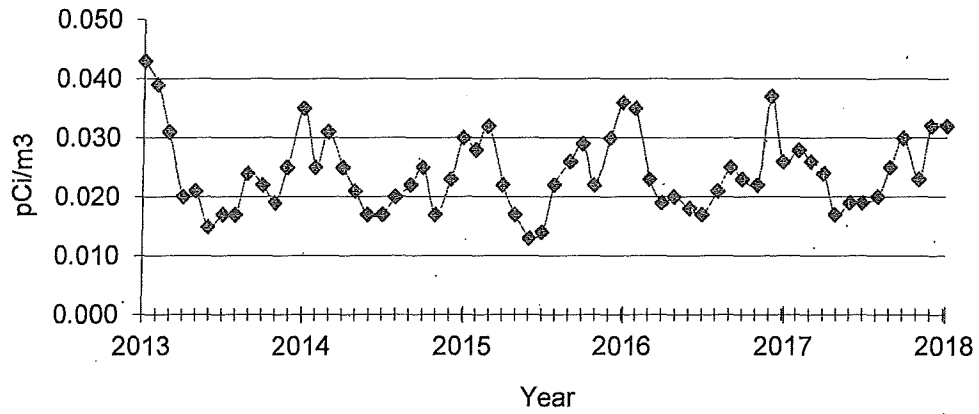

POINT BEACH NUCLEAR PLANT

APPENDIX E
Supplemental Analyses

POINT BEACH NUCLEAR PLANT

Facade Wells

Units: = pCi/L		Gamma isotopic analysis							
Location	GW-09 1Z-361A		GW-09 1Z-361B		GW-10 2Z-361A		GW-10 2Z-361B		
Collection Date	01-14-17		01-14-17		01-14-17		01-14-17		
Lab Code	EW-1043	MDC	EW-1044	MDC	NS ^b	MDC	EW-1046	MDC	
Be-7	27.0 ± 12.5	< 31.3	14.4 ± 12.5	< 32.2			6.5 ± 9.9	< 40.9	
Mn-54	0.4 ± 1.6	< 2.1	3.0 ± 1.5	< 2.3			0.3 ± 1.2	< 2.8	
Fe-59	-2.2 ± 2.8	< 9.2	-4.1 ± 3.1	< 10.0			-1.4 ± 2.3	< 11.1	
Co-58	-1.2 ± 1.5	< 3.2	0.7 ± 1.3	< 2.8			-0.4 ± 1.2	< 4.4	
Co-60	-0.3 ± 1.6	< 2.3	0.5 ± 1.5	< 2.0			0.2 ± 1.4	< 2.8	
Zn-65	-0.6 ± 3.3	< 4.3	1.9 ± 3.3	< 4.7			-1.7 ± 2.4	< 4.7	
Zr-Nb-95	-2.8 ± 1.5	< 6.5	-4.1 ± 1.5	< 6.6			-6.3 ± 1.4	< 7.9	
Cs-134	1.1 ± 1.4	< 2.1	1.3 ± 1.4	< 3.0			-1.1 ± 1.3	< 2.4	
Cs-137	1.3 ± 1.7	< 2.0	1.6 ± 1.7	< 2.1			0.8 ± 1.5	< 2.2	
Ba-La-140	-65.7 ± 1.8	< 53.8 ^a	22.3 ± 1.6	< 65.1 ^a			-7.7 ± 1.3	< 68.6 ^a	

Location	GW-09 1Z-361A		GW-09 1Z-361B		GW-10 2Z-361A		GW-10 2Z-361B	
Collection Date	05-05-17		05-05-17		05-05-17		05-05-17	
Lab Code	EW-2186		EW-2187		EW-2189		EW-2190	
Be-7	-10.3 ± 13.6	< 24.8	-1.0 ± 9.9	< 26.0	-7.0 ± 10.4	< 23.7	-3.1 ± 9.8	< 22.0
Mn-54	0.1 ± 1.3	< 2.3	-1.4 ± 1.2	< 1.7	0.0 ± 1.3	< 2.5	0.8 ± 1.3	< 2.6
Fe-59	-1.1 ± 2.8	< 3.3	1.0 ± 2.2	< 4.7	-0.8 ± 2.4	< 6.3	-1.6 ± 2.1	< 3.5
Co-58	0.2 ± 1.3	< 2.7	-1.9 ± 1.2	< 1.9	-0.3 ± 1.2	< 2.4	-0.3 ± 1.2	< 2.7
Co-60	-0.1 ± 1.5	< 2.8	0.1 ± 1.4	< 2.5	-0.2 ± 1.4	< 1.8	0.4 ± 1.2	< 1.7
Zn-65	-0.1 ± 3.0	< 4.8	0.5 ± 2.3	< 3.2	0.5 ± 2.6	< 5.2	-0.2 ± 2.4	< 4.3
Zr-Nb-95	1.8 ± 1.3	< 3.2	0.6 ± 1.2	< 3.3	-0.3 ± 1.4	< 2.4	-0.6 ± 1.3	< 3.3
Cs-134	-0.6 ± 1.4	< 2.8	-0.5 ± 1.3	< 2.5	-0.9 ± 1.3	< 2.5	-0.5 ± 1.3	< 2.4
Cs-137	0.7 ± 1.6	< 2.8	1.6 ± 1.5	< 2.8	-1.1 ± 1.5	< 2.1	0.7 ± 1.4	< 2.6
Ba-La-140	-2.2 ± 1.5	< 4.7	-1.0 ± 1.5	< 4.6	-3.2 ± 1.4	< 4.1	-2.4 ± 1.5	< 5.8

Location	GW-09 1Z-361A		GW-09 1Z-361B		GW-10 2Z-361A		GW-10 2Z-361B	
Collection Date	07-27-17		07-27-17		07-27-17		07-27-17	
Lab Code	EW-4096		EW-4097		EW-4098		EW-4099	
Be-7	-2.4 ± 9.7	< 20.9	5.6 ± 10.6	< 31.8	-0.9 ± 9.6	< 26.2	7.4 ± 13.6	< 39.4
Mn-54	-0.2 ± 1.2	< 2.2	1.6 ± 1.2	< 2.4	-0.9 ± 1.3	< 2.3	0.2 ± 1.4	< 2.8
Fe-59	-1.5 ± 2.4	< 5.2	0.3 ± 2.4	< 7.2	1.8 ± 2.3	< 6.3	-2.3 ± 2.9	< 6.5
Co-58	0.4 ± 1.2	< 1.5	0.4 ± 1.3	< 2.1	-1.4 ± 1.2	< 2.5	0.9 ± 1.3	< 3.1
Co-60	-0.7 ± 1.3	< 2.2	0.7 ± 1.4	< 2.0	-0.2 ± 1.3	< 2.4	0.3 ± 1.5	< 2.7
Zn-65	-1.5 ± 2.4	< 4.3	-1.3 ± 2.4	< 5.1	-1.4 ± 2.5	< 3.9	-2.5 ± 3.1	< 4.8
Zr-Nb-95	-0.5 ± 1.3	< 3.6	-0.8 ± 1.3	< 3.1	-1.7 ± 1.4	< 3.4	-0.5 ± 1.4	< 4.4
Cs-134	1.4 ± 1.2	< 2.4	-1.4 ± 1.3	< 2.5	-1.1 ± 1.3	< 2.4	-0.5 ± 1.5	< 2.8
Cs-137	0.8 ± 1.5	< 2.4	-0.3 ± 1.5	< 3.0	0.8 ± 1.5	< 2.4	-0.7 ± 1.5	< 2.3
Ba-La-140	-4.0 ± 1.5	< 5.7	-8.2 ± 1.5	< 7.2	-2.7 ± 1.5	< 7.5	0.1 ± 1.6	< 10.6

^a LLD for La-140 not reached due to age of sample and/or smaller sample size; samples counted for 60,000 seconds.

^b "NS" = No sample; water frozen.

POINT BEACH NUCLEAR PLANT

Facade Wells

Units: = pCi/L

Gamma isotopic analysis

Location	GW-09 1Z-361A		GW-09 1Z-361B		GW-10 2Z-361A		GW-10 2Z-361B	
	Collection Date	10-08-17	10-08-17	10-08-17	10-08-17	10-08-17	10-08-17	10-08-17
Lab Code	EW- 5802	MDC	EW- 5803	MDC	EW- 5804	MDC	EW- 5805	MDC
Be-7	-2.1 ± 10.3	< 26.9	-13.4 ± 12.1	< 27.7	-3.3 ± 9.7	< 21.4	3.9 ± 13.2	< 29.9
Mn-54	-0.5 ± 1.3	< 2.6	1.2 ± 1.4	< 2.5	-0.2 ± 1.2	< 2.0	0.0 ± 1.3	< 2.8
Fe-59	3.7 ± 2.2	< 6.0	-0.1 ± 2.7	< 4.3	-2.2 ± 2.1	< 3.3	-0.3 ± 2.7	< 5.2
Co-58	-0.6 ± 1.2	< 2.5	0.0 ± 1.4	< 2.4	-0.5 ± 1.2	< 1.7	-0.8 ± 1.3	< 2.2
Co-60	-0.1 ± 1.4	< 1.9	-0.8 ± 1.3	< 2.3	-0.3 ± 1.3	< 2.1	0.5 ± 1.4	< 3.1
Zn-65	1.4 ± 2.4	< 4.4	1.0 ± 2.7	< 4.5	-0.9 ± 2.6	< 4.7	-1.1 ± 2.9	< 2.6
Zr-Nb-95	-0.9 ± 1.4	< 4.5	1.7 ± 1.4	< 4.5	-0.3 ± 1.3	< 2.9	0.1 ± 1.5	< 4.3
Cs-134	-1.6 ± 1.3	< 2.4	-1.2 ± 1.3	< 2.8	0.4 ± 1.2	< 2.6	-0.6 ± 1.4	< 2.7
Cs-137	0.1 ± 1.5	< 1.8	-0.5 ± 1.4	< 2.7	0.8 ± 1.5	< 2.5	-0.2 ± 1.6	< 2.7
Ba-La-140	1.2 ± 1.4	< 4.7	7.3 ± 1.6	< 8.7	-5.6 ± 1.5	< 9.8	-1.8 ± 1.5	< 7.1

**Annual Average
All Locations**

Be-7	1.3 ± 9.7
Mn-54	0.3 ± 1.0
Fe-59	-0.7 ± 1.9
Co-58	-0.3 ± 0.8
Co-60	0.0 ± 0.4
Zn-65	-0.4 ± 1.2
Zr-Nb-95	-0.9 ± 2.0
Cs-134	-0.4 ± 1.0
Cs-137	0.4 ± 0.8
Ba-La-140	-4.59 ± 17.76

POINT BEACH NUCLEAR PLANT

Supplemental Analyses

Units: = pCi/L

Gamma isotopic analysis

Location	U2FSSDS		U2FSSDS		U2FSSDS	
Collection Date	01-31-17		02-28-17		03-31-17	
Lab Code	EW- 500	MDC	EW- 1038	MDC	EW- 1384	MDC
Be-7	-3.3 ± 10.1	< 22.6	-19.3 ± 17.1	< 40.3	5.6 ± 9.8	< 23.8
Mn-54	0.2 ± 1.3	< 2.2	-0.5 ± 1.7	< 3.6	1.3 ± 1.2	< 2.7
Fe-59	-0.6 ± 2.3	< 3.2	1.5 ± 3.2	< 4.6	-0.9 ± 2.2	< 4.9
Co-58	0.8 ± 1.2	< 2.5	1.7 ± 1.5	< 4.3	-0.7 ± 1.2	< 1.5
Co-60	0.1 ± 1.3	< 1.9	1.1 ± 1.7	< 3.4	0.3 ± 1.3	< 2.6
Zn-65	-1.4 ± 2.5	< 3.2	-4.4 ± 3.9	< 4.0	1.4 ± 2.4	< 3.9
Zr-Nb-95	-0.5 ± 1.3	< 2.8	-1.2 ± 1.7	< 3.8	0.2 ± 1.2	< 2.9
Cs-134	-0.6 ± 1.2	< 2.5	-0.9 ± 1.7	< 3.4	-0.9 ± 1.3	< 2.4
Cs-137	1.2 ± 1.4	< 2.8	0.3 ± 2.0	< 3.7	1.4 ± 1.4	< 2.6
Ba-La-140	-0.9 ± 1.4	< 3.2	-2.8 ± 2.0	< 7.5	-0.4 ± 1.4	< 3.3
Location	U2FSSDS		U2FSSDS		E-04	
Collection Date	04-30-17		05-31-17		04-25-17	
Lab Code	EW- 2191		EW- 2903		EW- 1784	
Sr-89	-1.0 ± 3.8	< 4.5				
Sr-90	0.6 ± 1.2	< 2.5				
Tc-99	0.2 ± 3.6	< 5.9				
Fe-55	-274 ± 491	< 833				
Ni-63	-2.3 ± 11.5	< 18.9				
Be-7	-4.6 ± 10.5	< 19.8	-13.3 ± 13.5	< 18.0	6.6 ± 4.8	< 18.5
Mn-54	0.2 ± 1.3	< 2.5	0.2 ± 1.6	< 1.9	0.1 ± 0.6	< 1.1
Fe-59	-1.6 ± 2.4	< 6.2	-1.8 ± 3.0	< 4.4	-0.8 ± 1.0	< 3.5
Co-58	0.0 ± 1.2	< 2.5	-1.8 ± 1.5	< 2.5	0.2 ± 0.6	< 1.5
Co-60	-1.2 ± 1.3	< 1.7	1.0 ± 1.8	< 2.7	-0.7 ± 0.6	< 1.1
Zn-65	-0.3 ± 2.6	< 5.6	-2.1 ± 3.3	< 3.4	0.3 ± 1.2	< 1.9
Zr-Nb-95	-0.5 ± 1.3	< 3.5	-1.1 ± 1.6	< 3.3	-0.1 ± 0.6	< 2.4
Cs-134	0.2 ± 1.3	< 2.6	0.3 ± 1.5	< 3.0	-0.1 ± 0.6	< 1.1
Cs-137	0.4 ± 1.5	< 2.7	0.7 ± 1.7	< 2.0	-0.2 ± 0.7	< 1.3
Ba-La-140	-1.9 ± 1.5	< 5.2	-1.5 ± 1.8	< 5.4	-0.9 ± 0.7	< 4.5
Location	GW-15A,B		U2FSSDS		E-04	
Collection Date	04-24-17		06-30-17		06-29-17	
Lab Code	EW- 2500		EW- 3361		EWW- 3158	
Be-7	5.9 ± 11.0	< 41.2	10.3 ± 12.8	< 18.4	-2.2 ± 11.6	< 27.3
Mn-54	2.0 ± 1.3	< 3.0	-0.7 ± 1.6	< 2.4	0.0 ± 1.3	< 2.1
Fe-59	0.7 ± 2.4	< 9.8	3.8 ± 2.8	< 4.7	-2.6 ± 2.4	< 2.7
Co-58	-1.9 ± 1.3	< 2.2	-0.7 ± 1.6	< 2.2	-0.7 ± 1.4	< 1.7
Co-60	-2.0 ± 1.4	< 1.5	-0.3 ± 1.7	< 2.1	-0.4 ± 1.4	< 1.7
Zn-65	-0.9 ± 2.6	< 4.1	1.4 ± 3.1	< 3.9	-3.1 ± 2.6	< 1.7
Zr-Nb-95	-2.5 ± 1.4	< 4.1	0.1 ± 1.4	< 2.4	-1.3 ± 1.3	< 1.9
Cs-134	-0.3 ± 1.4	< 2.8	-0.8 ± 1.5	< 2.9	0.6 ± 1.4	< 2.7
Cs-137	1.7 ± 1.6	< 3.4	1.4 ± 1.7	< 2.0	1.5 ± 1.5	< 2.5
Ba-La-140	-5.2 ± 1.5	< 22.1	-3.0 ± 1.9	< 4.5	1.3 ± 1.6	< 1.7

POINT BEACH NUCLEAR PLANT

Supplemental Analyses

Units: = pCi/L

Gamma isotopic analysis

Location	U2FSSDS		GW-16A,B		E-04	
Collection Date	07-31-17		07-18-17		08-23-17	
Lab Code	EW- 3958	MDC	EW- 3831	MDC	EW- 4358	MDC
Be-7	3.1 ± 10.1	< 26.6	-6.8 ± 12.6	< 38.4	4.5 ± 7.6	< 18.7
Mn-54	0.4 ± 1.3	< 2.3	1.0 ± 1.5	< 3.4	-0.4 ± 1.0	< 1.6
Fe-59	-1.5 ± 2.3	< 6.2	0.7 ± 2.7	< 6.9	0.9 ± 1.9	< 4.4
Co-58	-0.9 ± 1.3	< 1.7	-1.3 ± 1.4	< 2.3	0.6 ± 0.8	< 1.7
Co-60	-1.5 ± 1.4	< 2.0	-1.0 ± 1.6	< 2.4	-0.3 ± 1.0	< 1.2
Zn-65	-0.6 ± 2.4	< 4.9	-1.2 ± 2.9	< 6.3	-0.9 ± 1.6	< 2.1
Zr-Nb-95	-1.7 ± 1.4	< 4.0	-0.9 ± 1.6	< 4.3	1.0 ± 0.9	< 2.2
Cs-134	-0.6 ± 1.2	< 2.5	-1.2 ± 1.5	< 3.0	0.8 ± 1.0	< 2.0
Cs-137	-0.8 ± 1.5	< 2.3	1.1 ± 1.7	< 3.0	0.7 ± 1.1	< 1.8
Ba-La-140	-3.1 ± 1.4	< 5.2	-3.6 ± 1.7	< 11.9	-2.2 ± 1.1	< 2.8
Location	U2FSSDS		U2FSSDS		E-04	
Collection Date	08-31-17		09-30-17		09-27-17	
Lab Code	EW- 4999		EW- 5333		EW- 4998	
Be-7	-11.2 ± 13.0	< 22.3	10.8 ± 12.4	< 31.3	8.2 ± 17.8	< 40.8
Mn-54	0.5 ± 1.3	< 2.2	1.6 ± 1.4	< 3.1	0.3 ± 1.7	< 2.7
Fe-59	-1.6 ± 2.7	< 5.2	0.4 ± 2.8	< 5.8	0.4 ± 2.6	< 4.2
Co-58	0.1 ± 1.3	< 3.5	0.6 ± 1.5	< 2.6	-0.4 ± 1.7	< 2.5
Co-60	-0.1 ± 1.4	< 2.1	-0.6 ± 1.5	< 2.6	-0.5 ± 1.5	< 1.6
Zn-65	-1.8 ± 3.1	< 5.9	2.4 ± 2.6	< 5.2	0.6 ± 3.5	< 5.7
Zr-Nb-95	-0.6 ± 1.4	< 5.1	0.1 ± 1.6	< 3.5	-0.7 ± 1.9	< 3.6
Cs-134	1.6 ± 1.3	< 2.8	0.9 ± 1.4	< 3.0	0.4 ± 1.8	< 3.4
Cs-137	0.4 ± 1.6	< 3.1	1.0 ± 1.5	< 3.0	0.3 ± 2.1	< 3.0
Ba-La-140	1.9 ± 1.3	< 9.7	-2.1 ± 1.6	< 6.2	-1.3 ± 2.4	< 8.1
Location	GW-15A,B		U2FSSDS		U2FSSDS	
Collection Date	10-17-17		10-31-17		11-30-17	
Lab Code	EW- 5780		EW- 6129		EW- 6513	
Sr-90			-0.2 ± 0.4	< 0.9	-0.1 ± 1.3	< 2.9
Fe-55			24 ± 216	< 354	-150 ± 448	< 752
Ni-63					49 ± 42	< 67
Tc-99					1.0 ± 3.9	< 6.3
Be-7	-2.7 ± 10.6	< 26.4	4.8 ± 10.1	< 31.6	-5.7 ± 10.3	< 22.4
Mn-54	1.1 ± 1.4	< 2.4	-1.1 ± 1.3	< 1.8	1.0 ± 1.3	< 3.0
Fe-59	3.1 ± 2.3	< 5.8	-2.2 ± 2.3	< 4.2	-2.4 ± 2.3	< 5.4
Co-58	-0.4 ± 1.3	< 3.0	0.2 ± 1.3	< 2.9	-0.9 ± 1.3	< 1.9
Co-60	0.8 ± 1.4	< 2.2	-0.5 ± 1.4	< 1.8	0.4 ± 1.5	< 3.0
Zn-65	0.7 ± 2.7	< 4.2	0.1 ± 2.6	< 5.4	2.7 ± 2.4	< 4.8
Zr-Nb-95	-1.6 ± 1.4	< 2.8	-1.1 ± 1.3	< 3.7	0.1 ± 1.4	< 3.6
Cs-134	1.5 ± 1.3	< 2.9	0.2 ± 1.4	< 2.6	0.0 ± 1.3	< 2.4
Cs-137	1.3 ± 1.6	< 3.5	0.3 ± 1.5	< 2.7	0.2 ± 1.4	< 2.8
Ba-La-140	-1.4 ± 1.6	< 8.5	-0.6 ± 1.4	< 5.5	-0.4 ± 1.6	< 8.4

POINT BEACH NUCLEAR PLANT

Supplemental Analyses

Units: = pCi/L

Gamma isotopic analysis

Location	U2FSSDS		GW-04	
Collection Date	12-31-17		12-28-17	
Lab Code	EW- 6719	MDC	EW- 6604	MDC
Be-7	7.0 ± 10.0	< 26.9	1.9 ± 11.1	< 27.7
Mn-54	0.5 ± 1.2	< 2.5	-0.5 ± 1.4	< 2.2
Fe-59	1.6 ± 2.2	< 5.6	-1.4 ± 2.4	< 2.6
Co-58	0.6 ± 1.2	< 2.8	0.9 ± 1.4	< 1.8
Co-60	0.7 ± 1.3	< 2.6	0.6 ± 1.4	< 2.3
Zn-65	-0.6 ± 2.4	< 3.6	1.1 ± 2.7	< 4.5
Zr-Nb-95	-0.8 ± 1.2	< 2.6	-0.3 ± 1.4	< 2.6
Cs-134	-0.9 ± 1.2	< 2.5	-1.9 ± 1.5	< 2.9
Cs-137	1.3 ± 1.4	< 2.2	0.5 ± 1.5	< 3.0
Ba-La-140	-0.4 ± 1.5	< 4.4	-1.9 ± 1.9	< 2.8

Annual	Mean ± s.d.
Be-7	0.0 ± 8.3
Mn-54	0.4 ± 0.8
Fe-59	-0.2 ± 1.8
Co-58	-0.2 ± 0.9
Co-60	-0.2 ± 0.8
Zn-65	-0.2 ± 1.6
Zr-Nb-95	-0.7 ± 0.8
Cs-134	0.0 ± 1.0
Cs-137	0.0 ± 1.7
Ba-La-140	-1.3 ± 1.5

POINT BEACH NUCLEAR PLANT

APPENDIX F
Special Analyses

Dr. Kjell Johansen
NextEra Energy
Point Beach Nuclear Plant
6610 Nuclear Road
Two Rivers, Wisconsin 54241

LABORATORY REPORT NO.: 8006-100-1233
DATE: 04-19-2017
SAMPLES RECEIVED: 03-26-2017
PURCHASE ORDER NO.: _____

Below is the result of the analysis for tritium in one groundwater sample.

Sample Location	Collection Date	Lab Code	Concentration / MDC (pCi/L) H-3
Z-493F	03-20-17	EWV-1175	218 ± 84 / < 150

The error given is the probable counting error at the 95% confidence level. The less than (<) value, is based on 4.66 sigma counting error for the background sample.

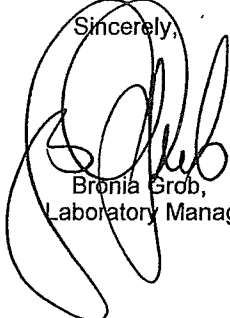
Sincerely,

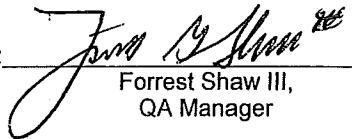
Bronia Grob,
Laboratory Manager

APPROVED BY:  4/20/17
Forrest Shaw III,
QA Manager

Mr. Richard Welty
 Radiation Protection Mgr.
 Point Beach Nuclear Plant
 NextEraEnergy
 6610 Nuclear Road
 Two Rivers, WI 54241

LABORATORY REPORT NO.: 8006-100-1239
 DATE: 05-10-17
 SAMPLES RECEIVED: 04-10-17
 PURCHASE ORDER NO.: _____

Below are the corrected results of the readout of supplemental TLDs deployed during the first quarter, 2017.

Period:	1st Quarter, 2017
Date Annealed:	12/07/16
Date Placed:	12/29/16
Date Removed:	04/07/17
Date Read:	04/11/17
Days in the Field:	99
Days from Annealing to Readout:	125
In-transit exposure:	4.05 ± 0.26

Location	Total mR	Net mR	Net mR Std Qtr	Net mR per 7 days
SGSF-North	20.0 ± 1.6	16.0 ± 1.7	14.7 ± 1.5	1.13 ± 0.12
SGSF-East	18.5 ± 0.6	14.5 ± 0.7	13.3 ± 0.6	1.02 ± 0.05
SGSF-South	20.3 ± 0.4	16.2 ± 0.5	14.9 ± 0.4	1.15 ± 0.03
SGSF-West	19.2 ± 0.7	15.2 ± 0.8	13.9 ± 0.7	1.07 ± 0.06
ISFSI-North	41.7 ± 0.9	37.7 ± 1.0	34.6 ± 0.9	2.66 ± 0.07
ISFSI-East	59.4 ± 1.8	55.3 ± 1.8	50.9 ± 1.6	3.91 ± 0.13
ISFSI-South	23.7 ± 1.3	19.7 ± 1.4	18.1 ± 1.2	1.39 ± 0.10
ISFSI-West	66.7 ± 3.4	62.7 ± 3.4	57.6 ± 3.2	4.43 ± 0.24
Control	25.1 ± 1.0	21.0 ± 1.0	19.3 ± 0.9	1.49 ± 0.07

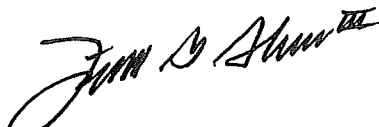
 Forrest G. Shaw III
 Quality Assurance

APPROVED 
 Bronia Grob
 Laboratory Manager

Mr. Richard Welty
 Radiation Protection Mgr.
 Point Beach Nuclear Plant
 NextEraEnergy
 6610 Nuclear Road
 Two Rivers, WI 54241

LABORATORY REPORT NO.: 8006-100-1247
 DATE: 08-01-17
 SAMPLES RECEIVED: 07-07-17
 PURCHASE ORDER NO.: _____

Below are the results of the readout of supplemental TLDs deployed during the second quarter, 2017.

Period:	2nd Quarter, 2017
Date Annealed:	03/15/17
Date Placed:	04/07/17
Date Removed:	07/06/17
Date Read:	07/11/17
Days in the Field:	90
Days from Annealing to Readout:	118
In-transit exposure:	4.41 ± 0.29

Location	Total mR	Net mR	Net mR Std Qtr	Net mR per 7 days
SGSF-North	16.4 ± 0.7	12.0 ± 0.8	12.1 ± 0.8	0.93 ± 0.06
SGSF-East	16.3 ± 0.3	11.9 ± 0.4	12.0 ± 0.4	0.93 ± 0.03
SGSF-South	16.1 ± 0.6	11.7 ± 0.7	11.9 ± 0.7	0.91 ± 0.05
SGSF-West	17.6 ± 1.2	13.2 ± 1.2	13.4 ± 1.2	1.03 ± 0.09
ISFSI-North	28.6 ± 1.3	24.2 ± 1.4	24.5 ± 1.4	1.88 ± 0.11
ISFSI-East	53.5 ± 0.7	49.1 ± 0.8	49.6 ± 0.8	3.82 ± 0.06
ISFSI-South	21.7 ± 1.2	17.3 ± 1.3	17.4 ± 1.3	1.34 ± 0.10
ISFSI-West	59.4 ± 2.0	55.0 ± 2.0	55.6 ± 2.1	4.28 ± 0.16
Control	19.5 ± 0.5	15.1 ± 0.6	15.3 ± 0.6	1.18 ± 0.05

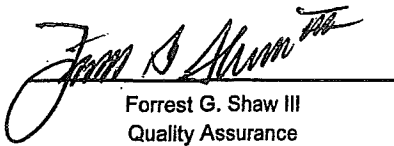
 Forrest G. Shaw III
 Quality Assurance

APPROVED  08/01/17
 Bronja Grob
 Laboratory Manager

Mr. Richard Welty
 Radiation Protection Mgr.
 Point Beach Nuclear Plant
 NextEraEnergy
 6610 Nuclear Road
 Two Rivers, WI 54241

LABORATORY REPORT NO.: 8006-100-1261
 DATE: 11-09-17
 SAMPLES RECEIVED: 10-06-17
 PURCHASE ORDER NO.:

Below are the results of the readout of supplemental TLDs deployed during the third quarter, 2017.

Period:	3rd Quarter, 2017
Date Annealed:	06/12/17
Date Placed:	07/06/17
Date Removed:	10/03/17
Date Read:	10/06/17
Days in the Field:	89
Days from Annealing to Readout:	116
In-transit exposure:	3.98 ± 0.38

Location	Total mR	Net mR	Net mR Std Qtr	Net mR per 7 days
SGSF-North	16.2 ± 0.8	12.2 ± 0.9	12.4 ± 0.9	0.96 ± 0.07
SGSF-East	17.0 ± 0.7	13.0 ± 0.8	13.3 ± 0.8	1.02 ± 0.06
SGSF-South	17.1 ± 0.4	13.2 ± 0.5	13.5 ± 0.6	1.03 ± 0.04
SGSF-West	16.3 ± 0.9	12.3 ± 1.0	12.6 ± 1.0	0.97 ± 0.08
ISFSI-North	34.2 ± 1.1	30.3 ± 1.2	30.9 ± 1.2	2.38 ± 0.10
ISFSI-East	51.4 ± 1.1	47.5 ± 1.2	48.5 ± 1.2	3.73 ± 0.09
ISFSI-South	19.5 ± 0.8	15.5 ± 0.9	15.9 ± 1.0	1.22 ± 0.07
ISFSI-West	55.4 ± 2.8	51.4 ± 2.8	52.6 ± 2.9	4.05 ± 0.22
Control	22.0 ± 0.7	18.1 ± 0.8	18.5 ± 0.9	1.42 ± 0.07



Forrest G. Shaw III
 Quality Assurance

APPROVED

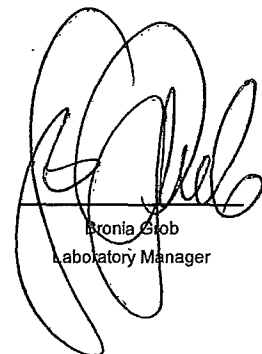
 11/09/17
 Bronia Glob
 Laboratory Manager

Jerri Walters
 Radiation Protection Mgr.
 Point Beach Nuclear Plant
 NextEraEnergy
 6610 Nuclear Road
 Two Rivers, WI 54241

LABORATORY REPORT NO.: 8006-100-1273
 DATE: 02-16-18
 SAMPLES RECEIVED: 01-08-18
 PURCHASE ORDER NO.: _____

Below are the results of the readout of supplemental TLDs deployed during the fourth quarter, 2017.

Period:	4th Quarter, 2017
Date Annealed:	09/08/17
Date Placed:	10/03/17
Date Removed:	01/05/18
Date Read:	01/10/18
Days in the Field:	94
Days from Annealing to Readout:	124
In-transit exposure:	4.50 ± 0.52

Location	Total mR	Net mR	Net mR Std Qtr	Net mR per 7 days
SGSF-North	16.0 ± 0.7	11.5 ± 0.9	11.2 ± 0.9	0.86 ± 0.07
SGSF-East	17.6 ± 0.4	13.1 ± 0.6	12.7 ± 0.6	0.98 ± 0.05
SGSF-South	17.2 ± 0.8	12.7 ± 0.9	12.3 ± 0.9	0.95 ± 0.07
SGSF-West	17.5 ± 1.4	13.0 ± 1.5	12.6 ± 1.4	0.97 ± 0.11
ISFSI-North	30.1 ± 1.9	25.6 ± 2.0	24.8 ± 1.9	1.90 ± 0.15
ISFSI-East	56.8 ± 1.4	52.3 ± 1.5	50.7 ± 1.5	3.90 ± 0.11
ISFSI-South	21.5 ± 0.7	17.0 ± 0.9	16.4 ± 0.9	1.26 ± 0.07
ISFSI-West	61.1 ± 2.0	56.6 ± 2.1	54.8 ± 2.0	4.22 ± 0.15
Control	19.5 ± 0.9	15.0 ± 1.0	14.6 ± 1.0	1.12 ± 0.07

 Forrest G. Shaw III
 Quality Assurance

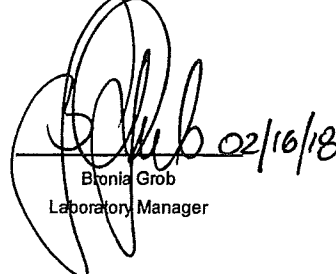
APPROVED 
 Bronia Grob
 Laboratory Manager



Dr. Kjell Johansen
Point Beach Nuclear Plant
6610 Nuclear Road
Two Rivers, Wisconsin 54241

LABORATORY REPORT NO.: 8006-100 -1275
DATE: 03-09-18
SAMPLES RECEIVED:

Analyses for gamma emitting isotopes on the suspended solids. The aliquot of 200 ml was filtered through 47 mm Millipore filter 0.8 μ m and the filter was analyzed on September 5, 2017.

Lab Code ELW-2899
Date Collected 06-14-17
Location E-01

Isotope	MDC / Concentration (pCi/L)	
K-40	< 108.7	469.9 \pm 47
Mn-54	< 4.0	1.0 \pm 2.1
Co-58	< 7.6	2.0 \pm 1.9
Co-60	< 4.2	3.3 \pm 2.2
Fe-59	< 20.9	14.1 \pm 4.0
Zn-65	< 11.7	2.7 \pm 4.4
Zr-Nb-95	< 23.1	-9.1 \pm 2.2
Ru-103	< 12.9	-0.7 \pm 2.0
Cs-134	< 5.0	0.4 \pm 2.4
Cs-137	< 4.1	1.0 \pm 2.3
Ba-La-140	< 217.9	-264.5 \pm 2.6
Ce-141	< 29.4	-21.1 \pm 2.5
Ce-144	< 25.3	6.8 \pm 10.8
Tl-208	< 5.9	6.1 \pm 2.5
Bi-212	< 57.9	6.4 \pm 28.7
Bi-214	---	19.1 \pm 6.9
Pb-212	< 7.7	15.4 \pm 3.4
Pb-214	---	23.7 \pm 7.2
Ra-226	< 94.3	153 \pm 40
Ac-228	< 19.5	14.2 \pm 8.6
U-235	< 3.9	-7.8 \pm 2.5

Less than (<), value is based on a 4.66 sigma counting error for the background sample and it's the MDC value for this measurement. The error given is the probable counting error at 95% confidence level.

E-mail: Kjell.Johansen@nee.com
E-mail: Sophia.Bartels@nee.com

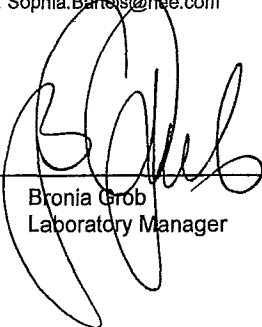
Bronia Grob
Laboratory Manager

Approved:

Forrest G. Shaw III
QA Manager

3/9/18

APPENDIX 2

NextEra Energy Point Beach, LLC

Offsite Dose Calculation Manual

Revision 19

Issued 03/08/2017

279 pages follow

ODCM

OFFSITE DOSE CALCULATION MANUAL

DOCUMENT TYPE: Controlled Reference

CLASSIFICATION: N/A

REVISION: 19

REVIEWER: Onsite Review Group

APPROVAL AUTHORITY: Plant Manager

PROCEDURE OWNER (title): Group Head

OWNER GROUP: Chemistry

Verified Current Copy: _____
Signature Date Time

List pages used for Partial Performance

Controlling Work Document Numbers

TABLE OF CONTENTS

SECTION	TITLE	PAGE
1.0	RECORD OF REVISIONS	7
2.0	INTRODUCTION	8
2.1	Purpose.....	8
2.2	Guidance	8
2.3	General Responsibilities	9
2.4	Audits.....	9
2.5	Definitions.....	9
3.0	REPORTING REQUIREMENTS	14
3.1	Annual Monitoring Report.....	14
3.2	Record Retention Requirements	16
4.0	RADIATION MONITORING SYSTEM AND RELEASE ACCOUNTING	17
5.0	SPECIFICATIONS AND SURVEILLANCE REQUIREMENTS	22
5.1	Specifications	22
5.2	Surveillance Requirements	22
6.0	LIQUID EFFLUENT SPECIFICATIONS AND SURVEILLANCE REQUIREMENTS.....	23
6.1	Concentration.....	23
6.2	Dose	26
6.3	Liquid Radwaste Treatment System	27
6.4	Liquid Effluent Monitoring Instrumentation	28
7.0	GASEOUS EFFLUENT SPECIFICATIONS AND SURVEILLANCE REQUIREMENTS.....	32
7.1	Dose Rate	32
7.2	Dose – Noble Gases	35
7.3	Dose – I-131, I-133, H-3 and Radionuclides in Particulate Form	36
7.4	Gaseous Radwaste Treatment System	38
7.5	Gaseous Effluent Monitoring Instrumentation	40

TABLE OF CONTENTS

SECTION	TITLE	PAGE
8.0	TOTAL DOSE	44
8.1	Specification	44
8.2	Applicability	44
8.3	Action.....	44
8.4	Surveillance Requirements	44
9.0	LIQUID EFFLUENT CALCULATIONS	46
9.1	Monitor Alarm Setpoint Determination.....	46
9.2	Liquid Dose Calculations.....	51
9.3	Dose Projections	55
10.0	GASEOUS EFFLUENT CALCULATIONS	56
10.1	Monitor Alarm Setpoint Determination.....	56
10.2	Carbon-14	61
10.3	Dose Rate Calculations – Noble Gases.....	63
10.4	Dose Rate Calculations – Radioiodine, Tritium, Particulates.....	64
10.5	Dose Calculations – Noble Gases	65
10.6	Dose Calculations – Radioiodine, Tritium, Particulates.....	66
10.7	Gaseous Dose Projection	67
11.0	DETERMINATION OF TOTAL DOSE.....	120
12.0	RADIOLOGICAL ENVIRONMENTAL MONITORING PROGRAM.....	121
12.1	REMP Administration	121
12.2	REMP Implementation	126
13.0	RADIOLOGICAL EFFLUENT CONTROLS PROGRAM	140
13.1	Radiological Effluent Controls Program	140
13.2	Radioactive Effluent Control and Accountability.....	144
13.3	Radioactive Effluent Monitoring Instrumentation Functionality Requirements	145
13.4	Solid Radioactive Waste	146
14.0	REFERENCES	147

TABLE OF CONTENTS

SECTION	TITLE	PAGE
Appendix A	Liquid Pathway EMEC For Use In Setpoint Calculations	148
Appendix B	Liquid Dose Factors Technical Basis	153
Appendix C	Gaseous Pathway Setpoint Calculations	158
Appendix D	Gaseous Dose Factors Technical Basis.....	162
Appendix E	Derivation of Dilution Factors Using Regulatory Guide 1.113	177
Appendix F	Radiological Impact Of Sewage Treatment Sludge Disposal.....	182
Appendix G	187
Appendix H	Modification #1 To NRC Submittal	239
Appendix I	Modification #2 To NRC Submittal	241
Appendix J	Modification #3 To NRC Submittal	244
Appendix K	Liquid Effluent Dose Conversion Factors	246
Appendix L	Gaseous Effluent Dose Conversion Factors	262
 <u>TABLES</u>		
Table 4-1	Radioactive Liquid Waste Effluent Monitors	18
Table 4-2	Radioactive Gaseous Waste Effluent Monitors	19
Table 6-1	Radioactive Liquid Waste Sampling And Analysis Program.....	25
Table 6-2	Radioactive Liquid Effluent Monitoring Instrumentation	30
Table 6-3	Radioactive Liquid Effluent Monitoring Instrumentation Surveillance Requirements	31
Table 7-1	Radioactive Gaseous Waste Sampling And Analysis Program.....	34
Table 7-2	Gaseous Effluent Monitoring Instrumentation	42
Table 7-3	Radioactive Gaseous Effluent Monitoring Instrumentation Surveillance Requirements	43

TABLE OF CONTENTS

SECTION	TITLE	PAGE
Table 9-1	Liquid Effluent Pathways	50
Table 9-2	Liquid Effluent Sub-Pathways	52
Table 9-3	PBNP Site-Specific Liquid Dose Commitment Factors, <i>Aio</i>	53
Table 10-1	Gaseous Effluent Pathways.....	59
Table 10-2	Controlling Locations, Pathways And Atmospheric Dispersion For Dose Calculations.....	60
Table 10-3	Dose Factors For Noble Gases.....	64
Table 10-4	<i>Rio</i> , Inhalation Pathway Dose Factors – Adult.....	68
Table 10-5	<i>Rio</i> , Inhalation Pathway Dose Factors – Teen.....	71
Table 10-6	<i>Rio</i> , Inhalation Pathway Dose Factors – Child.....	74
Table 10-7	<i>Rio</i> , Inhalation Pathway Dose Factors – Infant.....	77
Table 10-8	<i>Rio</i> , Grass-Cow-Milk Pathway Dose Factors – Adult.....	80
Table 10-9	<i>Rio</i> , Grass-Cow-Milk Pathway Dose Factors – Teen.....	83
Table 10-10	<i>Rio</i> , Grass-Cow-Milk Pathway Dose Factors – Child.....	86
Table 10-11	<i>Rio</i> , Grass-Cow-Milk Pathway Dose Factors – Infant.....	89
Table 10-12	<i>Rio</i> , Grass-Cow-Meat Pathway Dose Factors – Adult.....	92
Table 10-13	<i>Rio</i> , Grass-Cow-Meat Pathway Dose Factors – Teen.....	95
Table 10-14	<i>Rio</i> , Grass-Cow-Meat Pathway Dose Factors – Child.....	98
Table 10-15	<i>Rio</i> , Produce Pathway Dose Factors – Adult.....	101
Table 10-16	<i>Rio</i> , Produce Pathway Dose Factors – Teen.....	104
Table 10-17	<i>Rio</i> , Produce Pathway Dose Factors – Child.....	107
Table 10-18	<i>Rio</i> , Leafy Vegetable Pathway Dose Factors – Adult.....	110
Table 10-19	<i>Rio</i> , Leafy Vegetable Pathway Dose Factors – Teen.....	113
Table 10-20	<i>Rio</i> , Leafy Vegetable Pathway Dose Factors – Child.....	116
Table 10-21	<i>Rio</i> , Ground Plane Pathway Dose Factors.....	119
Table 12-1	Sample Types And Associated Lower Level Of Detection (LLD) And Notification Level Values.....	132
Table 12-2	Radiological Environmental Sampling Locations.....	134
Table 12-3	PBNP Radiological Environmental Sample Collection And Analysis Frequency.....	136

TABLE OF CONTENTS

SECTION	TITLE	PAGE
Table A-1	Liquid Effluent Volumes	149
Table A-2	Liquid Effluent Releases.....	149
Table A-3	Liquid Effluent Concentrations.....	151
Table A-4	Beta Corrected Setpoints.....	152
Table C-1	Noble Gas Releases.....	159
Table C-2	Average Annual Discharge Volume.....	159
Table C-3	Noble Gas Setpoint Parameter Calculation.....	160
Table C-4	RMS AIRBORNE ALARM SETPOINTS	161
Table E-1	Surface Dilution Factors For Liquid Effluents In A Large Lake.....	177

OFFSITE DOSE CALCULATION MANUAL

Table E-2 Dilution Factors181

FIGURES

Figure 4-1 Radioactive Liquid Waste Effluent Monitors20
Figure 4-2 Radioactive Gaseous Waste Effluent Monitors21
Figure 12-1 Radioactive Environmental Sampling Locations.....137
Figure 12-2 Radiological Environmental Sampling Locations138
Figure 12-3 Radiological Environmental Sampling Locations139

1.0 RECORD OF REVISIONS

Per TS 5.5.1.C, licensee initiated changes to the Offsite Dose Calculation Manual (ODCM) shall be documented and records of reviews performed shall be retained. This documentation shall contain sufficient information to support the changes(s) together with the appropriate analyses or evaluations justifying the changes(s), and a determination that the change(s) maintain the levels of radioactive effluent control required by 10 CFR 20.1302, 40 CFR 190, 10 CFR 50.36a, and 10 CFR 50, Appendix I, and do not adversely impact the accuracy or reliability of effluent, dose, or setpoint calculations. These changes shall become effective after receiving concurrence from the Onsite Review Group (ORG)* and approval of the Plant General Manager, and shall be submitted to the NRC in the form of a complete, legible copy of the entire ODCM as a part of or concurrent with the Annual Monitoring Report for the period of the report in which any change in the ODCM was made. Each change shall be identified by markings in the affected pages, clearly indicating the area of the page that was changed, and shall indicate the date (i.e. month and year) the change was implemented.

***NOTE: Pursuant to the Procedure, Plan and Program Review Matrix approved by the Plant General Manager, changes that have been determined to be editorial do not need ORG approval.**

OFFSITE DOSE CALCULATION MANUAL

2.0 INTRODUCTION

2.1 Purpose

The PBNP Offsite Dose Calculation Manual contains the current methodology and parameters for the calculation of offsite doses due to radioactive gaseous and liquid effluents. This manual describes a methodology for demonstrating compliance with 10 CFR 50, Appendix I dose limits. Compliance with Appendix I is demonstrated by periodic calculation of offsite doses based on actual plant releases and comparison to Appendix I dose limits.

The manual also details the methodology for the determination of gaseous and liquid effluent monitor alarm setpoints. The PBNP Radiation Monitoring System (RMS) effluent monitor alarm setpoints are established to ensure that controlled releases of liquid and gaseous radioactive effluents are maintained as low as is reasonably achievable. The setpoints also are established to ensure that the dose rate from radioactive material released in effluents to the atmosphere do not exceed 500 mrem/yr at the site boundary and to ensure that the concentrations of radioactive materials released in liquid effluents to the unrestricted area conform to (do not exceed) 10 times the concentration values in Table 2, Column 2 of Appendix B to 10 CFR 20 as specified in TS 5.5.4.g.

The manual also details the methodology for evaluating the radiological impact of sewage treatment sludge disposal. This methodology addresses the commitments made to the United States Nuclear Regulatory Commission in our application dated October 8, 1987 (NRC-87-104) and accepted by the USNRC in a letter dated January 13, 1988 (NPC-30260). This application was submitted in accordance with the provisions of 10 CFR 20.302(a). Dose limits are established in the application to ensure the health and safety of the maximally exposed member of the general public and the inadvertent intruder. 10 CFR 50, Appendix I dose limits do not apply to sewage treatment sludge disposal.

2.2 Guidance

The following sources provided guidance for this document:

U. S. Nuclear Regulatory Commission, Regulatory Guide 1.109, "Calculation of Annual Doses to Man from Routine Releases of Reactor Effluents for the Purpose of Evaluating Compliance with 10CFR50, Appendix I", Revision 1, October 1977.

U.S. Nuclear Regulatory Commission, Regulatory Guide 1.113, "Estimating Aquatic Dispersion of Effluents from Accidental and Routine Reactor Releases for the Purpose of Implementing Appendix I", Revision 1, April 1977.

U.S. Nuclear Regulatory Commission, Regulatory Guide 1.21, "Measuring, Evaluating, and Reporting Radioactive Material in Liquid and Gaseous Effluents and Solid Waste", Revision 2, June 2009.

OFFSITE DOSE CALCULATION MANUAL

U. S. Nuclear Regulatory Commission, NUREG-0133, "Preparation of Radiological Effluent Technical Specifications for Nuclear Power Plants", Revision 2, May 1982.

U.S. Nuclear Regulatory Commission, NUREG-1301, "Offsite Dose Calculation Manual Guidance: Standard Radiological Effluent Controls for Pressurized Water Reactors", April 1991.

2.3 General Responsibilities

The primary responsibility for the implementation of the PBNP offsite dose calculation program and for any actions required by the program resides with Chemistry. Chemistry will provide the technical, regulatory, licensing, and administrative support necessary to fulfill the requirements of this manual. The calculation of offsite doses and analysis of data are Chemistry responsibilities.

The Plant General Manager, PBNP is responsible for assuring that Radiation Monitoring System alarm setpoints are established and maintained in accordance with the methodologies outlined in this manual. The Plant General Manager, PBNP is also responsible for assuring the performance of periodic release summaries for the purpose of demonstrating compliance with PBNP effluent release limits.

2.4 Audits

Audits of the activities encompassed by the ODCM, the Radiological Effluent Control Program (Section 13.0 of this manual), and the Radiological Environmental Monitoring Program (Section 12.0 of this manual) and its implementing procedures shall be scheduled, performed, and reported in accordance with the Quality Assurance Topical Report.

2.5 Definitions

ABNORMAL RELEASE

An ABNORMAL RELEASE is an unplanned or uncontrolled emission of an effluent containing plant related, licensed radioactive material.

ACTION

ACTION shall be that part of a specification that prescribes remedial measures required under designated conditions.

BATCH RELEASE

A BATCH RELEASE is a release of a discrete liquid volume from a tank or any isolatable containment containing radionuclide(s) whose inputs to the volume were secured prior to sampling for discharge and remains secured until the discharge is completed.

OFFSITE DOSE CALCULATION MANUAL

CHANNEL CALIBRATION

A CHANNEL CALIBRATION is the adjustment, as necessary, of the channel such that it responds within the required range and accuracy to known values of input. The CHANNEL CALIBRATION SHALL encompass the entire channel including the sensors and alarm, interlock and/or trip functions and may be performed by any series of sequential, overlapping, or total channel steps such that the entire channel is calibrated.

CHANNEL CHECK

CHANNEL CHECK is a qualitative determination of acceptable FUNCTIONALITY made by observing channel behavior during operation. This shall include, where possible, comparison of the channel with other independent instrumentation channels measuring the same parameter.

CONTINUOUS RELEASE

A CONTINUOUS RELEASE is a discharge of liquid or gaseous radioactive effluents of a non-discrete volume from a source containing radionuclide(s) that usually has make-up flow during the release.

DISCHARGE

A DISCHARGE is a radioactive effluent that enters an unrestricted area.

FUNCTIONAL – FUNCTIONALITY

FUNCTIONALITY is an attribute of an SSC(s) that is not controlled by TSs. An SSC not controlled by TSs is FUNCTIONAL or has FUNCTIONALITY when it is capable of performing its function(s) as set forth in the CLB. These CLB function(s) may include the capability to perform a necessary and related support function for an SSC(s) controlled by TSs.

FUNCTIONAL TEST

FUNCTIONAL TEST is the injection of a simulated signal into the channel to verify that it is FUNCTIONAL, including alarm and/or trip initiating action. This shall include, where possible, a comparison of the channel with other independent channels measuring the same variable.

GASEOUS RADWASTE TREATMENT SYSTEM

The GASEOUS RADWASTE TREATMENT SYSTEM consists of those components or devices utilized to reduce radioactive material in effluents released to the atmosphere. The system consists of the following:

- Gas decay tanks,
- Drumming area ventilation exhaust duct filter assembly (F-26),
- Unit 1 and 2 containment purge exhaust filter assemblies (1/2 F-11A/B),
- Air ejector decay duct filter assembly (F-30),
- Auxiliary building ventilation filter assembly (F-25, nominal 11,214 CFM exhaust pathway),
- Chemistry laboratory exhaust duct filter assembly (F-21),
- Service building ventilation exhaust duct filter assembly (F-20),
- Auxiliary building ventilation filter assemblies (F-23, F-29, nominal 34,150 CFM exhaust pathway).

LIQUID RADWASTE TREATMENT SYSTEM

The LIQUID RADWASTE TREATMENT SYSTEM consists of those components or devices used to reduce radioactive material in liquid effluent. The system consists of the following:

- Blowdown evaporator or waste evaporator,
- Polishing demineralizers,
- Advanced Liquid Processing System (ALPS)
- Boric acid evaporator feed and condensate demineralizers

MEMBER OF THE PUBLIC (10 CFR 20)

MEMBER OF THE PUBLIC as defined by 10 CFR 20.1003: Means any individual except when that individual is receiving an occupational dose. (TRM 4.1)

MEMBER OF THE PUBLIC (40 CFR 190)

MEMBER OF THE PUBLIC as defined by 40 CFR 190.02: Means any individual that can receive a radiation dose in the general environment, whether he may or may not also be exposed to radiation in an occupation associated with a nuclear fuel cycle. However, an individual is not considered a member of the public during any period in which the individual is engaged in carrying out any operation which is part of the nuclear fuel cycle. (TRM 4.1)

OFFSITE DOSE CALCULATION MANUAL

NUCLEAR FUEL CYCLE

NUCLEAR FUEL CYCLE as defined by 40 CFR 190.02: Means the operations defined to be associated with the production of electrical power for public use by any fuel cycle through the use of nuclear energy.

OPERABLE-OPERABILITY

A system, subsystem, train, component or device shall be OPERABLE or have OPERABILITY when it is capable of performing its *specified safety function(s)*, and when all necessary attendant instrumentation, controls, normal or emergency electrical power, cooling or seal water, lubrication and other auxiliary equipment that are required for the system, subsystem, train, component or device to perform its specified safety function(s) are also capable of performing their related support function(s).

PURGE-PURGING

PURGE or PURGING is any controlled process of discharging air or gas from a confinement to maintain temperature, pressure, humidity, concentration or other operating condition, in such a manner that replacement air or gas is required to purify the confinement.

RELEASE

A RELEASE is an effluent from the plant regardless of where the effluent is deposited.

SITE BOUNDARY

The SITE BOUNDARY shall be that line beyond which the land is neither owned, nor leased, nor otherwise controlled by the licensee.

SOURCE CHECK

A SOURCE CHECK shall be the qualitative assessment of channel response when the channel sensor is exposed to a source of increased radioactivity.

SPECIFIED FUNCTION/SPECIFIED SAFETY FUNCTION

The definition of operability refers to the capability to perform the "specified function" at non-improved TSs plants or "specified safety function" at improved TSs plants. The specified safety function(s) in the CLB for the facility.

In addition to providing the specified safety function, an SSC is expected to perform as designed, tested and maintained. When system capability is degraded to a point where it cannot perform with reasonable expectation or reliability, the SSC should be judged inoperable, even if at this instantaneous point in time the SSC(s) could provide the specified safety function.

UNRESTRICTED AREA

An UNRESTRICTED AREA is any area at or beyond the SITE BOUNDARY access to which is not controlled by the licensee for purposes of protection of individuals from exposure to radiation and radioactive materials. (TRM 4.1)

URANIUM FUEL CYCLE

The URANIUM FUEL CYCLE is defined in 40 CFR Part 190.02(b) as: "The operation of milling of uranium ore, chemical conversion of uranium, isotopic enrichment of uranium, fabrication of uranium fuel, generation of electricity by a light-water-cooled nuclear power plant using uranium fuel, and reprocessing of spent uranium fuel, to the extent that these directly support the production of electrical power for public use utilizing nuclear energy, but excludes mining operations, operations at wasted disposal sites, transportation of any radioactive material in support of these operations, and the use of recovered non-uranium special nuclear and by-product materials from the cycle".

VENTILATION EXHAUST TREATMENT SYSTEM

A VENTILATION EXHAUST TREATMENT SYSTEM is any system designed and installed to reduce gaseous radioiodine or radioactive material in particulate form in effluents by passing ventilation or vent exhaust gases through charcoal absorbers and/or HEPA filters for the purpose of removing iodines or particulates from the gaseous exhaust stream prior to the release to the environment. Such a system is not considered to have any effect on noble gas effluents. Engineered Safety Features Atmospheric Cleanup Systems are not considered to be VENTILATION EXHAUST TREATMENT SYSTEM components.

VENTING

VENTING is the controlled process of discharging air or gas from a confinement to maintain temperature, pressure, humidity, concentration, or other operating condition, in such a manner that replacement air or gas is not provided or required during VENTING. Vent, used in system names, does not imply a VENTING process.

OFFSITE DOSE CALCULATION MANUAL

3.0 REPORTING REQUIREMENTS

3.1 Annual Monitoring Report

In accordance with TS 5.6.2 and 5.6.3, the Annual Monitoring Report covering the operation of the units shall be submitted in accordance with 10 CFR 50.36a. The annual monitoring report shall be submitted by April 30 of each calendar year to the administrator of the appropriate Regional NRC office or designee and shall include:

- a. A summary of the quantities of radioactive liquid and gaseous effluents released from the plant with data summarized on a semi-annual basis. The material provided shall be consistent with the objectives outlined in Sections 6.2, 7.2 and 7.3 of the ODCM and in conformance with 10 CFR 50, Appendix I, Section IV.B.1. In the event that some results are not available for inclusion with the report, the report shall be submitted noting and explaining the reasons for the missing results. The missing data shall be submitted as an addendum in the next Annual Monitoring Report.
- b. An assessment of the radiation doses from radioactive effluents released from the plant during the previous calendar year. All assumptions used in making these assessments (i.e., specific activity, exposure time and location) shall be included in the report.
- c. The air doses and the doses to the hypothetical maximum exposed individual calculated following the ODCM methodology shall be reported.
- d. The following information for solid waste shipped offsite during the report period:
 - Total amount of solid waste shipped, buried or stored (in cubic feet)
 - Estimated total isotopic content (in curies) determined by scaling factors, gamma isotopic and/or other suitable analyses
 - Dates of shipment and burial site, if applicable quantity
 - Type of waste (e.g., spent resin, dry activated waste, evaporator bottoms, filters, scrap metal, asbestos, etc.),
 - Type of container (e.g., LSA, Type A, Type B, Large Quantity), and
 - Solidification agent (e.g., cement, urea formaldehyde), if applicable
- e. The following information for liquid releases during the report period.
 - Total radioactivity in curies released and average diluted discharge concentrations of the following release categories: gamma isotopic, gross alpha, tritium, and strontium (beta emitters other than tritium).
 - Total volume (in gallons) of liquid waste released into circulating water discharge.

OFFSITE DOSE CALCULATION MANUAL

- Total volume (in gallons) of dilution water used.
 - The maximum concentration of tritium and gross gamma radioactivity released (averaged over the period of a single release).
 - Estimated monthly total radioactivity in curies of individual radionuclides released based on representative isotopic analyses.
 - Semiannual and annual totals of monthly quantities of individual radionuclides, as determined by isotopic analyses.
- f. The following information for gaseous releases during the report period.
- Total gross radioactivity (in Curies), by month, released of:
 - Noble Gases
 - Halogens
 - Particulates, subdivided into beta emitters (strontium, etc.), gross alpha, and gamma emitters
 - Tritium
 - Maximum release rate (for any one-hour period).
 - Estimated monthly total radioactivity (in Curies) released, by nuclide, for I-131, I-133, H-3, and radioactive particulates with half-lives greater than eight days, based on representative analyses performed by beta and by gamma isotopic analyses.
 - Semiannual and annual totals of monthly isotopic radionuclide quantities.
- g. Identification of ABNORMAL RELEASES from the site in gaseous and liquid effluents in the AMR.
- h. Summaries, interpretations, and analyses of trends of the results of the radiological environmental monitoring program for the reporting period. The material provided shall be consistent with the objectives outlined in ODCM Section 12.0 and in 10 CFR 50, Appendix I, Sections IV.B.2, IV.B.3, and IV.C. See Section 12.1.2.a.6 for REMP specific reporting requirements.
- i. If the calculated dose from the release of radioactive materials in liquid or gaseous effluents exceeds twice the limits of 10 CFR 50, Appendix I, the Annual Monitoring Report shall also include an assessment of radiation doses to the most likely exposed member of the general public from reactor releases and other nearby uranium fuel cycle sources (including doses from primary effluent pathways and direct radiation) for the previous 12 consecutive months to show compliance with 40 CFR 190, Environmental Radiation Protection Standards for Nuclear Power Operation.

OFFSITE DOSE CALCULATION MANUAL

- j. A description (including cause, response and prevention of reoccurrence) of occurrences and circumstances when fewer than the sampling frequency, minimum analysis frequency, or lower limit of detection requirement specified in Table 6-2 and Table 7-1 are met.
- k. The Annual Monitoring Report shall include a description of all deviations from the radiological environmental sample collection and analysis frequency contained in Table 12-3.
- l. The Annual Monitoring Report shall include a description of occurrences when fewer than the minimum required radioactive liquid and/or gaseous effluent monitoring instrumentation channels were FUNCTIONAL OR OPERABLE as required in Table 6-2 and Table 7-2.
- m. The quantity of each of the principal radionuclides released to the environment in liquid and gaseous effluents during the previous 12 months of operation for the ISFSI. Other information required by the Commission to estimate maximum potential radiation dose commitment to the public resulting from effluent releases should be included in the report.
- n. Licensee initiated changes to the ODCM in the form of a complete legible copy of the entire ODCM as a part of or concurrent with the Annual Monitoring Report for the period of the report in which the change in the ODCM was made. Each change shall be identified by markings in the margin of the affected pages clearly indicating the area of the page that was changed.

3.2 Record Retention Requirements

Records of reviews performed for changes made to the ODCM shall be kept for the duration of the operating licenses of Units 1 and 2 of the Point Beach Nuclear Plant. (TS 5.5.1)

Meteorological data shall be kept on file, on site for review by the NRC, upon request. The data available will include wind speed, wind direction and atmospheric stability. The data will be in the form of hour-by-hour averages stored in electronic form for each of the parameters.

4.0 RADIATION MONITORING SYSTEM AND RELEASE ACCOUNTING

A computerized Radiation Monitoring System (RMS) is installed at Point Beach Nuclear Plant (PBNP). The RMS includes area, process, and effluent monitors. A description of those monitors used for liquid and gaseous effluents is presented in Table 4-1 and Table 4-2. The liquid and gaseous waste processing flow paths, equipment, and monitoring systems are depicted in Figure 4-1 and Figure 4-2. Calibration of the RMS detectors is accomplished in accordance with the PBNP instrument and control procedures. The setpoint methodology is described in Section 9.1 and Section 10.1 of the ODCM.

The RMS is designed to detect and measure liquid and gaseous releases from the plant effluent pathways. The RMS will initiate isolation and control functions on certain effluent streams identified in Table 4-1 and Table 4-2. Complete monitoring and accounting of nuclides released in liquid and gaseous effluents is accomplished with the RMS together with the characterization of nuclide distributions by laboratory analysis of grab samples. Sampling frequencies and analysis requirements are described for liquids in Table 6-1 and gases in Table 7-1.

The RMS is not used for normal operational release quantification. Release quantification is based on the analysis of actual samples and the known discharge rate. The main liquid releases (Ci) occur via batch releases. The continuous releases via SGBD and waste water effluents have a greater volume but very little licensed material. The major continuous release points are the vents from the Auxiliary Building, the Drumming Area, and the Gas Stripper. The Combined Air Ejector is a minor release source in terms of activity and volume during normal operation. The batch releases from the gas decay tanks occur through the Aux. Building vent stack.

OFFSITE DOSE CALCULATION MANUAL

TABLE 4-1
RADIOACTIVE LIQUID WASTE EFFLUENT MONITORS

CHANNEL NUMBER	NAME	CONTROL FUNCTION	DETECTOR TYPE
1 (2) RE-216	Containment Fan Coolers Liquid Monitors	None	Scintillation
RE-218	Waste Disposal System Liquid Monitor	Shuts waste liquid overboard	Scintillation
1 (2) RE-219	Steam Generator Blowdown Line Liquid Monitors	Shuts steam generator blowdown isolation valves, blowdown tank outlet valves and steam generator sample valves	Scintillation
RE-220	Spent Fuel Pool Liquid Monitor	None	Scintillation
1 (2) RE-222	Steam Generator Blowdown Tank Outlet Monitor	Shuts steam generator blowdown isolation valves and blowdown tank outlet valves	GM Tube
RE-223	Waste Distillate Overboard Liquid Monitor	Shuts waste distillate overboard isolation valve	Scintillation
1 (2) RE-229	Service Water Discharge Monitors	None	Scintillation
RE-230	Waste Water Effluent Monitor	None	Scintillation

OFFSITE DOSE CALCULATION MANUAL

TABLE 4-2
RADIOACTIVE GASEOUS WASTE EFFLUENT MONITORS

CHANNEL NUMBER	NAME	CONTROL FUNCTION	DETECTOR TYPE
1 (2) RE-212	Containment Noble Gas Monitor	Actuates containment ventilation isolation	Scintillation
RE-214	Auxiliary Building Exhaust Ventilation Noble Gas Monitor	Shuts gas release valve and shifts auxiliary building exhaust through carbon filters	Scintillation
1 (2) RE-215	Condenser Air Ejector Noble Gas Monitors	None	Scintillation
RE-221	Drumming Area Vent Noble Gas Monitor	None	Scintillation
RE-224	Gas Stripper Building Exhaust Noble Gas Monitor	None	Scintillation
RE-225	Combined Air Ejector Low-Range Noble Gas Monitor	None	Scintillation
1 (2) RE-305	Unit 1 and 2 Purge Exhaust Noble Gas Monitors (Channel 5 on SPING Units No. 21 and No. 22)	Containment ventilation isolation	Scintillation
RE-315	Auxiliary Building Exhaust Ventilation Noble Gas Monitor (Channel 5 on SPING Unit No. 23)	None	Scintillation
RE-325	Drumming Area Ventilation Noble Gas Monitor (Channel 5 on SPING Unit No. 24)	None	Scintillation

FIGURE 4-1
 RADIOACTIVE LIQUID WASTE EFFLUENT MONITORS

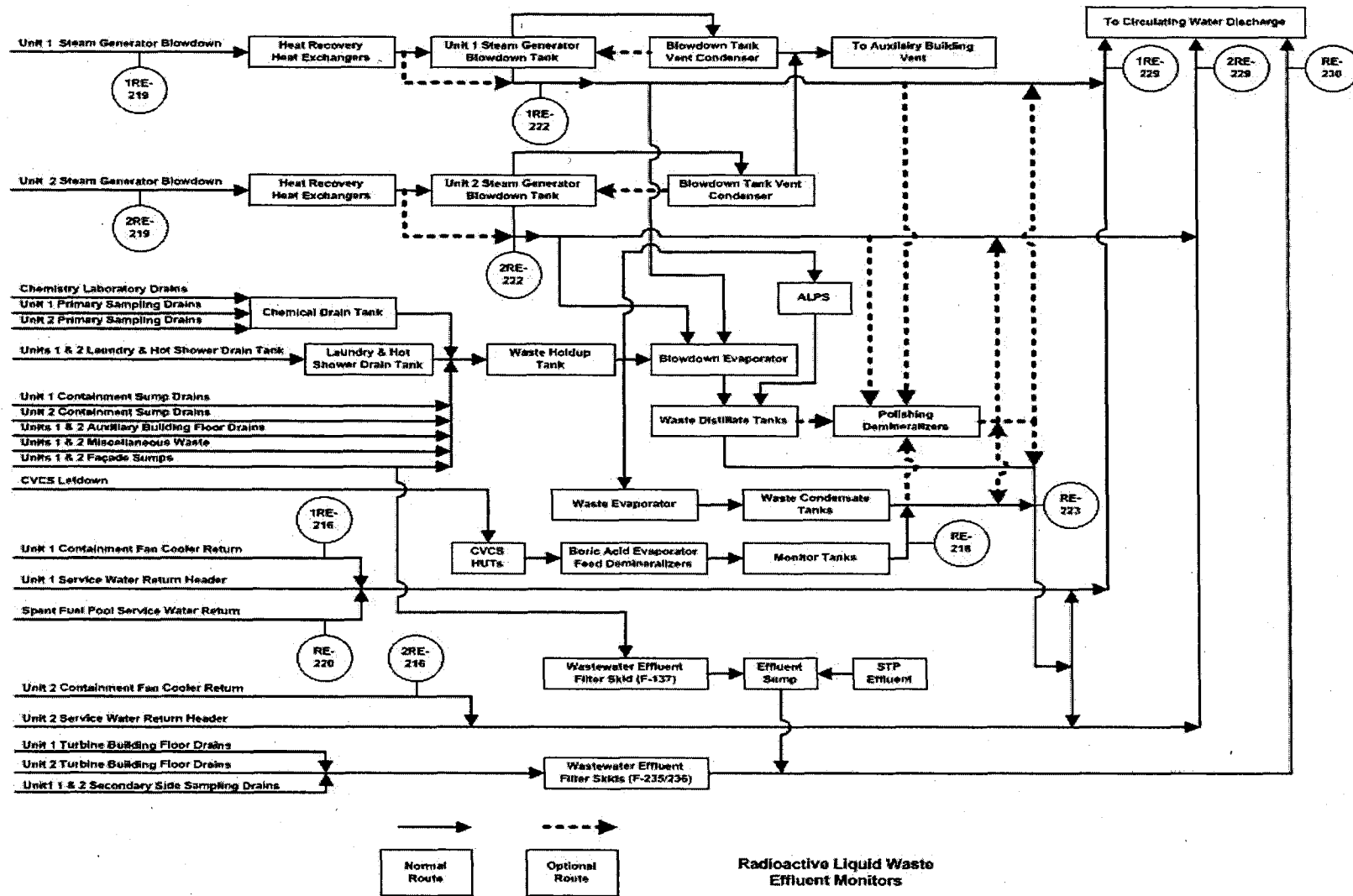
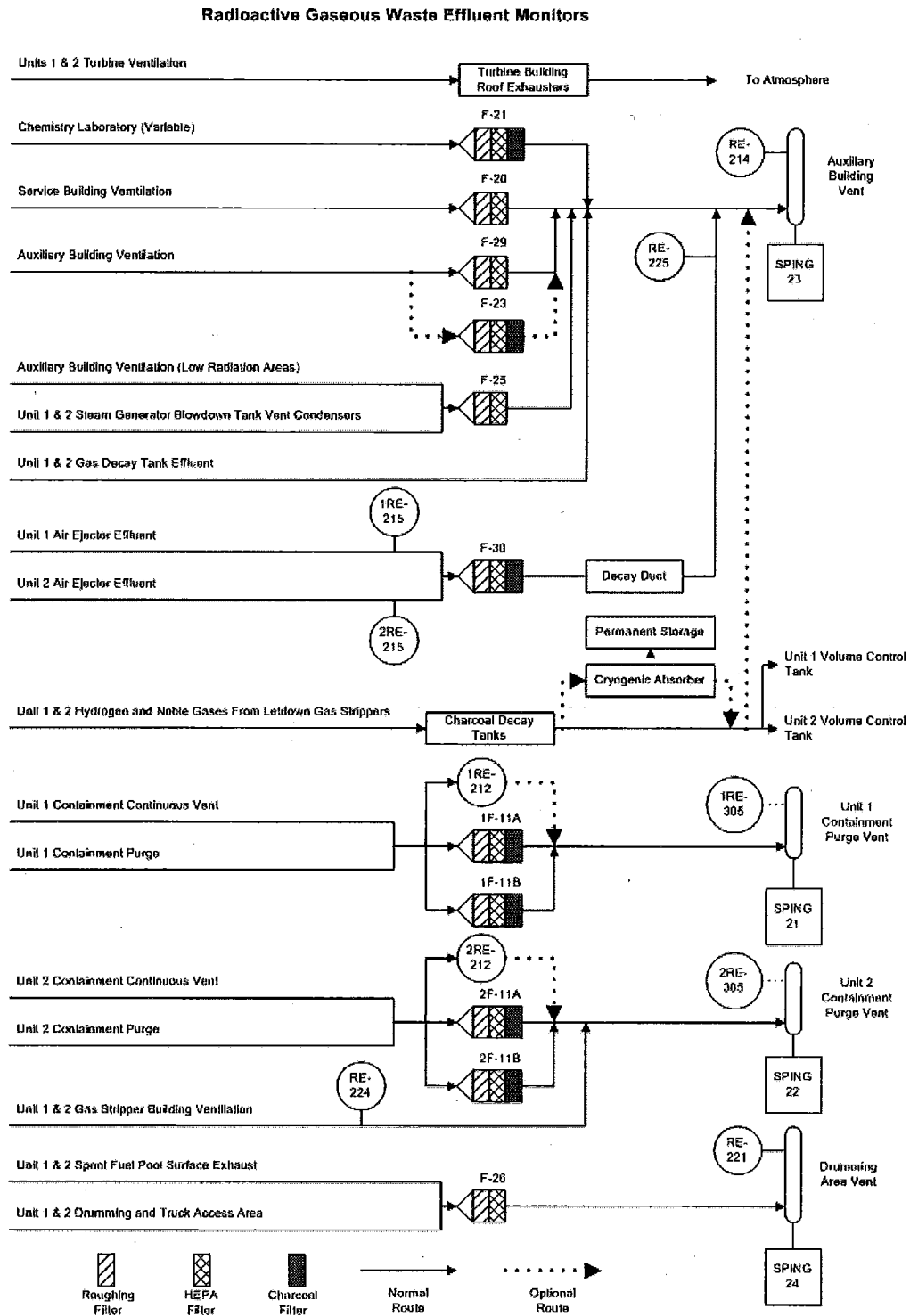

FIGURE 4-2
RADIOACTIVE GASEOUS WASTE EFFLUENT MONITORS



OFFSITE DOSE CALCULATION MANUAL

5.0 SPECIFICATIONS AND SURVEILLANCE REQUIREMENTS

5.1 Specifications

Compliance with the specifications contained in the succeeding text is required during the conditions specified therein. Upon failure to meet the specification, either during the performance of the surveillance, or between performances, the associated ACTION requirement shall be met.

Noncompliance with a specification shall exist when its requirements and associated ACTION requirements are not met within the specified time period. If the specification is restored prior to expiration of the specified time intervals, completion of the ACTION requirements is not required.

5.2 Surveillance Requirements

Surveillance Requirements shall be met during the conditions specified for individual specifications unless otherwise stated in an individual surveillance requirement. The provisions of SR 3.0.2 and 3.0.3 are applicable to the surveillance frequency of the Radioactive Effluent Controls Program in accordance with TS 5.5.4.

OFFSITE DOSE CALCULATION MANUAL

6.0 LIQUID EFFLUENT SPECIFICATIONS AND SURVEILLANCE REQUIREMENTS

6.1 Concentration

6.1.1 Specifications

In accordance with PBNP TS 5.5.4.b, the concentration of radioactive materials in liquid effluents to the unrestricted area is limited to ten times the concentration value in Appendix B, Table 2, Column 2 to 10 CFR 20. For dissolved and entrained noble gases, the concentration shall be limited to 2.0 E-04 $\mu\text{Ci/mL}$ total activity.

6.1.2 Applicability

At all times

6.1.3 Action

- a. During release of radioactive liquid effluents, at least one condenser circulating water pump shall be in operation and the service water return header shall be lined up only to the unit whose circulating water pump is operating.
- b. When the concentration of radioactive material released in liquid effluents to UNRESTRICTED AREAS exceeds the limits identified in Section 6.1.1, immediately restore the concentration to within the above limits.
- c. Report all deviations in the Annual Monitoring Report

6.1.4 Surveillance Requirement

- a. The concentration of radioactivity in liquid waste shall be determined by sampling and analysis in accordance with Table 6-1.
- b. The results of radioactive analysis shall be used in accordance with the methodology of Section 9.1 to assure that the concentrations at the point of release are maintained within the limits of Section 6.1.1.

OFFSITE DOSE CALCULATION MANUAL

6.1.5 Basis

This specification is provided to ensure that the concentration of radioactive materials released in liquid waste effluents from the site to UNRESTRICTED AREAS will be less than 10X the concentration levels specified in 10 CFR Part 20, Appendix B, Table 2, Column 2. This limitation provides additional assurance that the levels of radioactive materials in bodies of water outside the site will not result in exposures exceeding (1) the Section II.A design objectives of Appendix I, 10 CFR Part 50, to a MEMBER OF THE PUBLIC and (2) the limits of 10 CFR Part 20.1301(a)(1) to the population. The concentration limit for dissolved or entrained noble gases is based upon the NRC's evaluation and assumption that Xe-135 is the controlling radioisotope and its limit in air (submersion) has been converted to an equivalent concentration in water using the methods described in International Commission on Radiological Protection (ICRP) Publication 2. The required detection capabilities for radioactive materials in liquid waste samples are tabulated in terms of the lower limits of detection (LLDs). Detailed discussion of the LLD, and other detection limits can be found in Currie, L. A., "Lower Limit of Detection: Definition and Elaboration of a Proposed Position for Radiological Effluent and Environmental Measurements," NUREG/CR-4007 (September 1984).

Note: Hard-to-detect (HTD) radionuclides are radionuclides, such as alpha emitters and pure beta emitters which can be detected only by chemical extraction followed by alpha or beta counting, and therefore cannot be detected before a release using gamma spectroscopy. Analyses for HTDs are accomplished by obtaining aliquots of sample streams and sending the samples to a contracted laboratory for analyses. Their release quantities and doses are assessed after analytical results are obtained and then included in the monthly effluent quantification. The HTDs specifically identified by the Point Beach RETS were Sr-89/90 and alpha emitters. Fe-55 identified in NUREG-0472 was not included in the Point Beach RETS. Pursuant to regulatory guidance, reviews of the Part 61 analyses have been undertaken and, as a good practice, the following HTDs (other than the ones specifically required) have been added to the analytical list: C-14, Fe-55, Ni-63, and Tc-99. NRC guidance (Reg Guide 1.21, Rev 2, June 2009) does not require analysis for C-14 in liquids because the airborne C-14 far outweighs the amount discharged in liquids. Therefore, C-14 analyses may be discontinued in the future based on the results from the Part 61 analyses. The list of required radionuclides and the additional HTDs are listed in Table 6-1.

OFFSITE DOSE CALCULATION MANUAL

TABLE 6-1
RADIOACTIVE LIQUID WASTE SAMPLING AND ANALYSIS PROGRAM

LIQUID RELEASE TYPE ⁶	SAMPLING FREQUENCY	MINIMUM ANALYSIS FREQUENCY	TYPE OF ACTIVITY ANALYSIS ⁵	LOWER LEVEL OF DETECTION ¹ (μCi/CC)
1. Batch Releases ² a. Waste Condensate Tank b. Waste Distillate Tank c. Monitor Tanks d. Other tanks containing radioactivity to be discharged	Prior to release	Prior to release	Gamma emitters	5 E-07
			I-131	1 E-06
			Tritium	1 E-05
		Monthly on composites obtained from batches released during the current month	Gross alpha	1 E-07
			Fe-55, Ni-63, Tc-99, C-14	1E-06 1E-06
Quarterly on composites obtained from batches released during the current quarter	Sr-89/90	5 E-08		
2. Continuous Releases ^{3, 6} a. Steam Generator Blowdown b. Service Water	Grab samples twice weekly	Twice weekly	Gamma emitters	5E-07
			I-131	1E-06
			Tritium	1E-05
		Monthly on grab composites	Gross alpha	1E-07
			Fe-55, Ni-63, Tc-99, C-14	1E-06 1E-06
Quarterly on grab composites	Sr-89/90	5E-08		
3. Waste Water Effluent	Continuous Composite ⁴	Weekly	Gamma emitters	5E-07
			I-131	1E-06
			Tritium	1E-05
		Monthly on weekly composite	Gross alpha	1E-07
			Fe-55, Ni-63, Tc-99, C-14	1E-06 1E-06
Quarterly on monthly composite	Sr-89/90	5E-08		

- NOTE 1:** The principal gamma emitter for which the gamma isotopic LLD applies is Cs-137. Because gamma isotopic analyses are performed, the LLDs for all other gamma emitters are inherently determined by the operating characteristics of the counting system. All positively identified gamma emitters will be reported in the Annual Monitoring Report
- NOTE 2:** A BATCH RELEASE is defined in Section 2.5. Prior to sampling for analysis, each batch shall be isolated and mixed to assure representative sampling.
- NOTE 3:** A CONTINUOUS RELEASE is defined in Section 2.5.
- NOTE 4:** A continuous composite is one in which the method of sampling employed results in a specimen that is representative of the liquids released.
- NOTE 5:** Identified entrained noble gases shall be reported as gaseous effluents.
- NOTE 6:** For compensatory analyses required by Table 6-2 only the analyses performed by the out-of-service monitor need to be performed.

OFFSITE DOSE CALCULATION MANUAL

6.2 Dose

6.2.1 Specifications

In accordance with PBNP TS 5.5.4.d, the dose or dose commitment to a MEMBER OF THE PUBLIC from radioactive materials in liquid effluents released to UNRESTRICTED AREAS shall not exceed:

- a. 3 mrem to the total body or 10 mrem to any organ, total from both units, during any calendar quarter, and
- b. 6 mrem to the total body or 20 mrem to any organ, total from both units, during any calendar year.

6.2.2 Applicability

At all times

6.2.3 Action

If the calculated dose from radioactive material actually released in liquid effluents exceeds any of the above limits, a special report shall be prepared and submitted to the Commission within 30 days of determination of the release quantity. The report shall include, as appropriate:

- The cause(s) for exceeding the limits,
- The corrective action(s) taken to reduce the release, and
- The proposed corrective action(s) to be taken to assure that subsequent releases will be in compliance with the above limits.

If the dose to any MEMBER OF THE PUBLIC exceeds 75 mrem to the thyroid or 25 mrem to the whole body or an organ other than the thyroid, pursuant to 40 CFR 190, the report shall also contain a request for a variance from this standard pursuant to 40 CFR 190.11.

6.2.4 Surveillance Requirement

Cumulative dose contributions from radioactive effluents shall be determined for the current calendar quarter and current calendar year in accordance with the methodology described in Section 9.2 at least once every 31 days.

6.2.5 Basis

This specification is provided to implement the requirements of Sections II.A, III.A, and IV.A of Appendix I, 10 CFR Part 50. The Limiting Condition for Operation implements the guides set forth in Section II.A of Appendix I. The ACTION statements provide operating flexibility and at the same time implement the guides set forth in Section IV.A of Appendix I to assure that the releases of radioactive material in liquid effluents to UNRESTRICTED AREAS will be kept "as low as is reasonably achievable". Also, for fresh water sites with drinking water supplies that can be potentially affected by plant operations, there is reasonable assurance that the operation of the facility will not result in radionuclide concentrations in the finished drinking water that are in excess of the requirements of 40 CFR Part 141. The dose calculation methodology in Section 9.2 implements the requirements of Section III.A of Appendix I that conformance with the guides of Appendix I be shown by calculational procedures based on models and data such that the actual exposure of a MEMBER OF THE PUBLIC through appropriate pathways is unlikely to be substantially underestimated. The equations specified in Section 9.2 for calculating the doses due to the actual release rates of radioactive materials in liquid effluents are consistent with the methodology provided in Regulatory Guide 1.109 and Regulatory Guide 1.113.

6.3 Liquid Radwaste Treatment System

6.3.1 Specifications

In accordance with PBNP TS 5.5.4.f, the LIQUID RADWASTE TREATMENT SYSTEM shall be used to reduce the radioactive materials in liquid wastes prior to discharge when the projected doses, due to the liquid effluent, to UNRESTRICTED AREAS would exceed 0.12 mrem to the total body or 0.4 mrem to any organ (2% of the annual Appendix I dose objective) in a 31 day period.

6.3.2 Applicability

At all times

OFFSITE DOSE CALCULATION MANUAL

6.3.3 Action

With radioactive liquid waste being discharged without treatment and in excess of the above limits and any portion of the LIQUID RADWASTE TREATMENT SYSTEM not in operation, prepare and submit to the Commission within 30 days a special report that includes the following information:

- Identification of the non-functional equipment or subsystem and the reason for non-functionality.
- Actions taken to restore the non-functional equipment to FUNCTIONAL status.
- Summary description of actions taken to prevent a recurrence.

6.3.4 Surveillance Requirement

Doses due to liquid releases shall be projected at least once per 31 days in accordance with the methodology and parameters in Section 9.3.

6.3.5 Basis

The requirement that the appropriate portions of this system be used, when specified, provides assurance that the releases of radioactive materials in liquid effluents will be kept "as low as is reasonably achievable". This specification implements the requirements of 10 CFR Part 50.36a, General Design Criterion 60 of Appendix A to 10 CFR Part 50 and the design objective given in Section II.D of Appendix I to 10 CFR Part 50. The specified limits governing the use of appropriate portions of the LIQUID RADWASTE TREATMENT SYSTEM were specified as a suitable fraction of the dose design objectives set forth in Section II.A of Appendix I, 10 CFR Part 50, for liquid effluents.

6.4 Liquid Effluent Monitoring Instrumentation

6.4.1 Specifications

- a. In accordance with PBNP TS 5.5.4, the radioactive liquid monitoring instrumentation channels listed in Table 6-2 shall be FUNCTIONAL and alarm or trip setpoints established such that effluent releases do not exceed the values described in Section 6.1.1.
- b. The alarm or trip setpoints of the monitoring instrumentation channels shall be determined in accordance with the methodology in Section 9.1.

OFFSITE DOSE CALCULATION MANUAL

6.4.2 Applicability

During releases using the monitored pathway

6.4.3 Action

- a. If a radioactive effluent monitoring instrumentation channel alarm or trip setpoint is found less conservative than required by Section 6.4.1, immediately suspend the release of radioactive liquid effluents monitored by the affected channel, or declare the channel non-functional, or change the setpoint so it is acceptably conservative.
- b. If fewer than the minimum number of radioactive effluent monitoring channels is FUNCTIONAL, the appropriate ACTION should be taken for the instrument as listed in Table 6-2. Best effort shall be made to return the non-functional channel to a FUNCTIONAL status within 30 days. If this cannot be accomplished, the circumstances of the instrument failure and schedule for repair shall be reported in the Annual Monitoring Report.
- c. Report all deviations in the Annual Monitoring Report.

6.4.4 Surveillance Requirement

Each radioactive effluent monitoring instrumentation channel shall be demonstrated FUNCTIONAL by performance of the CHANNEL CHECK, calibration, FUNCTIONAL TEST, and SOURCE CHECK at the frequencies described in Table 6-3.

6.4.5 Basis

The radioactive liquid effluent monitoring instrumentation is provided to monitor and control, as applicable, the releases of radioactive materials in liquid effluents during actual or potential releases of liquid effluents. The Alarm/Trip Setpoint for these instruments SHALL be calculated and adjusted in accordance with the methodologies and parameters in Section 9.1 of the ODCM to ensure that the alarm/trip will occur prior to exceeding the limits of TS 5.5.4.6. The FUNCTIONALITY and use of the instrumentation is consistent with the requirements of General Design Criteria 60, 63, and 64 of Appendix A to 10 CFR Part 50 and Point Beach General Design Criteria 17 and 70.

OFFSITE DOSE CALCULATION MANUAL

TABLE 6-2
RADIOACTIVE LIQUID EFFLUENT MONITORING INSTRUMENTATION

INSTRUMENT	MINIMUM CHANNELS FUNCTIONAL	ACTION
1. Liquid Radwaste System		
a. RE-223, Waste Distillate Tank Discharge	1	Note 1
b. RE-218, Waste Condensate Tank Discharge	1	Note 1
c. Waste Condensate Tank Discharge Flow Meter	1	Note 2
d. Waste Distillate Tank Flow Rate Recorder	1	Note 2
2. Steam Generator Blowdown System		
a. For each unit: RE-219, Steam Generator Blowdown Liquid Discharge, or RE-222, Blowdown Tank Monitor, or RE-229, Service Water Discharge	1	Note 3
b. Steam Generator Blowdown Flow Indicating Transmitters (1 per steam generator)	1	Note 4
3. Service Water System		
a. RE-229, Service Water Discharge (for applicable unit)	1	Note 5
b. For each unit: RE-216, Containment Cooling Fan Service Water Return, or RE-229, Service Water Discharge	1	Note 5
c. RE-220, Spent Fuel Pool Heat Exchanger Service Water Outlet or RE-229, Service Water Discharge (for applicable unit)	1	Note 5
4. Waste Water Effluent		
a. RE-230, Waste Water Effluent	1	Note 5
b. Waste Water Effluent Composite Sampler	1	Note 6
c. Waste Water Effluent Flow Determination	N/A	Note 7

NOTE 1: If the number of channels FUNCTIONAL is fewer than the minimum required, effluent releases via this pathway shall be discontinued immediately (reference TRM 3.3.1).

NOTE 2: If the number of channels FUNCTIONAL is fewer than the minimum required, effluent releases via this pathway may continue provided the flow rate is estimated at least once every four hours during actual liquid batch releases.

NOTE 3: If the number of channels FUNCTIONAL is fewer than the minimum required, effluent releases via this pathway may continue provided grab samples are analyzed for gamma radioactivity in accordance with Table 6-1 at least once every 24 hours when the secondary coolant specific activity is less than 0.01 $\mu\text{Ci/cc}$ dose equivalent I-131 or once every 12 hours when the activity is greater than 0.01 $\mu\text{Ci/cc}$ dose equivalent I-131.

NOTE 4: If the number of channels FUNCTIONAL is fewer than the minimum required, effluent releases via this pathway may continue provided the flow is estimated or determined with auxiliary indication at least once every 24 hours.

NOTE 5: If the number of channels FUNCTIONAL is fewer than the minimum required, effluent releases via this pathway may continue provided that at least once every 12 hours grab samples are collected and analyzed in accordance with Table 6-1.

NOTE 6: If the number of channels FUNCTIONAL is fewer than the minimum required, effluent releases via this pathway may continue provided grab samples are collected twice per week and analyzed in accordance with Table 6-1.

NOTE 7: Waste water effluent flow may be determined from the waste water effluent flow meter

TABLE 6-3
RADIOACTIVE LIQUID EFFLUENT MONITORING INSTRUMENTATION SURVEILLANCE
REQUIREMENTS

INSTRUMENT DESCRIPTION	CHANNEL CHECK	CALIB.	FUNCTION TEST	SOURCE CHECK
1. Liquid Radwaste System				
a. RE-223, Waste Distillate Tank	D	R	Q	P
b. RE-218, Waste Condensate Tank Discharge	D	R	Q	P
c. Waste Condensate Tank Discharge Flow Meter	P/D	R	N/A	N/A
d. Waste Distillate Tank Flow Rate Recorder	P/D	R	N/A	N/A
2. Steam Generator Blowdown System				
a. RE-219, Steam Generator Blowdown Liquid Discharge (1 per unit)	D	R	Q	M
b. RE-222, Blowdown Tank Monitor (1 per unit)	D	R	Q	M
c. Steam Generator Blowdown Flow Indicating Transmitters (1 per steam generator)	D	R	N/A	N/A
3. Service Water System				
a. RE-229, Service Water Discharge (1 per unit)	D	R	Q	M
b. RE-216, Containment Cooling Fan Service Water Return	D	R	Q	M
c. RE-220, Spent Fuel Pool Heat Exchanger Service Water Outlet	D	R	Q	M
4. Waste Water Effluent				
a. RE-230, Waste Water Effluent	D	R	Q	M
b. Waste Water Effluent Composite Sampler	W	N/A	N/A	N/A
c. Waste Water Effluent Flow Meter	W	R	N/A	N/A

Legend:

D = Daily

W = Weekly

M = Monthly

Q = Quarterly

R = Once per 18 months, typically during refueling

P/D = Prior to or immediately upon initiation of a release or daily if a release continues for more than one day

N/A = Not applicable

OFFSITE DOSE CALCULATION MANUAL

7.0 GASEOUS EFFLUENT SPECIFICATIONS AND SURVEILLANCE REQUIREMENTS

7.1 Dose Rate

7.1.1 Specifications

In accordance with PBNP TS 5.5.4.g, the dose rate resulting from radioactive material released in gaseous effluents from the site areas at or beyond the SITE BOUNDARY shall be limited to the following:

- a. For noble gases: a dose rate ≤ 500 mrem/yr to the whole body and a dose rate ≤ 3000 mrem/yr to the skin, and
- b. For iodine-131, iodine-133, tritium, and all radionuclides in particulate form with half-lives greater than eight days: a dose rate ≤ 1500 mrem/yr to any organ.

7.1.2 Applicability

At all times.

7.1.3 Action

With the dose rate(s) exceeding the above limits, immediately restore the release rate within the above limit(s).

7.1.4 Surveillance Requirement

- a. The dose rate due to noble gases in gaseous effluents shall be determined to be within the above limits in accordance with the methodology and parameters in Section 10.3 of this manual.
- b. The dose rate due to iodine-131, iodine-133, tritium, and all radionuclides in particulate form with half-lives greater than 8 days in gaseous effluents shall be determined to be within the above limits in accordance with the methodology and parameters in Section 10.4 of this manual by obtaining representative samples and performing analyses in accordance with the sampling and analysis program specified in Table 7-1.

OFFSITE DOSE CALCULATION MANUAL

7.1.5 Basis

This specification is provided to ensure that the dose rate at the SITE BOUNDARY averaged over a time period of no greater than one hour due to gaseous effluents from all units on the site will be within the annual dose limits of 10 CFR Part 20 for UNRESTRICTED AREAS. These limits provide reasonable assurance that radioactive material discharged in gaseous effluents will not result in the exposure of a MEMBER OF THE PUBLIC in an UNRESTRICTED AREA, either within or outside the SITE BOUNDARY, to annual average concentrations exceeding the limits specified in Appendix B, Table 2 of 10 CFR Part 20. For MEMBERS OF THE PUBLIC who may at times be within the SITE BOUNDARY, the occupancy of the MEMBER OF THE PUBLIC will usually be sufficiently low to compensate for any increase in the atmospheric diffusion factor above that for the SITE BOUNDARY. The specified release rate limits restrict, at all times, the corresponding gamma and beta dose rates above background to a MEMBER OF THE PUBLIC at or beyond the SITE BOUNDARY to less than or equal to 500 mrem/yr to the total body or to less than or equal to 3000 mrem/year to the skin. These release rate limits also restrict, at all times, the corresponding thyroid dose rate above background to less than or equal to 1500 mrem/year. The required detection capabilities for radioactive material in gaseous waste samples are tabulated in terms of the lower limits of detection (LLDs). Detailed discussion of the LLD, and other detection limits can be found in Currie, L. A., "Lower Limit of Detection: Definition and Elaboration of a Proposed Position for Radiological Effluent and Environmental Measurements," NUREG/CR-4007 (September 1984).

Hard-to-detect (HTD) radionuclides are radionuclides, such as alpha emitters and pure beta emitters which can be detected only by chemical extraction followed by alpha or beta counting. HTD analyses are accomplished by a contracted laboratory on representative waste stream samples. Their release quantities and doses are assessed after analytical results are obtained and then included in the monthly effluent quantification. The HTDs specifically identified by the Point Beach RETS were Sr-89/90 and alpha emitters. Fe-55 identified in NUREG-0472 was not included in the Point Beach RETS. Pursuant to regulatory guidance, reviews of the Part 61 analyses have been undertaken, and, as a good practice, the following HTDs (other than the ones specifically required) have been added to the analytical list: Fe-55, Ni-63, and Tc-99. Airborne C-14 is calculated. The list of required radionuclides and the additional HTDs are listed in Table 7-1.

OFFSITE DOSE CALCULATION MANUAL

TABLE 7-1
RADIOACTIVE GASEOUS WASTE SAMPLING AND ANALYSIS PROGRAM

GASEOUS RELEASE TYPE	SAMPLING FREQUENCY	MINIMUM FREQUENCY ANALYSIS	TYPE OF ACTIVITY ANALYSIS	LOWER LEVEL OF DETECTION ¹ (µCi/cc)
1. Gas Decay Tank	Prior to release	Prior to release	Gamma emitters	1E-04
2. Containment Purge or Continuous Vent	Prior to Purge ² or vent	Prior to purge or vent	Gamma emitters	1E-04
			Tritium	1E-06
3. Continuous Releases	Continuous ³	Weekly analysis of charcoal and particulate samples	Gamma emitters	1E-11
a. Unit 1 Containment Purge and Vent			I-131	1E-12
b. Unit 2 Containment Purge and Vent		Monthly composite of particulate sample	Gross alpha	1E-11
c. Drumming Area vent		Quarterly composite of particulate sample	Sr-89/90	1E-11
d. Gas Stripper Building Vent			Fe-55, Ni-63, Tc-99	Per industry standards ⁵
e. Auxiliary Building Vent		Noble gas monitor	Noble gases – gross beta or gamma	1E-06
		Monthly ⁴ (grab)	Monthly	Gamma emitters
	Tritium			1E-06

NOTE 1: The principal gamma emitters for which LLD specification applies are Cs-137 in particulates and Xe-133 in gases. Because gamma isotopic analyses are performed, the LLDs for all other gamma emitters are inherently determined by the operating characteristics of the counting system. All identifiable gamma emitters will be reported in the Annual Monitoring Report.

NOTE 2: Tritium grab samples will be taken every 24 hours when the refueling cavity is flooded.

NOTE 3: The ratio of the sample flow rate to the release flow rate shall be known or estimated for the time period covered by each sampling interval. (Reference RAM 5.2)

NOTE 4: Tritium grab samples will be taken every seven days from the drumming area ventilation exhaust/spent fuel pool area whenever there is spent fuel in the spent fuel pool.

NOTE 5: LLDs for Fe-55, Ni-63 and Tc-99 are not prescribed in NUREG 1301. LLDs should be consistent with laboratory capabilities and industry standards for nuclide detection.

OFFSITE DOSE CALCULATION MANUAL

7.2 Dose – Noble Gases

7.2.1 Specifications

In accordance with PBNP TS 5.5.4.e & 5.5.4.h, the air dose from noble gases released in gaseous effluents to areas beyond the SITE BOUNDARY shall not exceed:

- a. 10 mrad for gamma radiation or 20 mrad for beta radiation, per calendar quarter, and
- b. 20 mrad for gamma radiation or 40 mrad for beta radiation, per calendar year.

7.2.2 Applicability

At all times.

7.2.3 Action

If the calculated air dose from radioactive noble gases actually released in gaseous effluents exceeds any of the above limits, a special report shall be prepared and submitted to the Commission within 30 days of determination of the release quantity. The report shall include, as appropriate:

- The cause(s) for exceeding the limits,
- The corrective action(s) taken to reduce the release, and
- The proposed corrective action(s) to be taken to assure that subsequent releases will be in compliance with the above limits.

If the dose to any MEMBER OF THE PUBLIC exceeds 75 mrem to the thyroid or 25 mrem to the whole body or an organ other than the thyroid, pursuant to 40 CFR 190, the report shall also contain a request for a variance from this standard pursuant to 40 CFR 190.11.

7.2.4 Surveillance Requirement

Cumulative dose contributions from noble gases in radioactive effluents shall be determined for the current calendar quarter and current calendar year in accordance with the methodology described in Section 10.5, at least every 31 days.

OFFSITE DOSE CALCULATION MANUAL

7.2.5 Basis

This specification is provided to implement the requirements of Section II.B, III.A and IV.A of Appendix I, 10 CFR Part 50. The Limiting Conditions for Operation implement the guides set forth in Section II.B of Appendix I. The ACTION statement provides the required operating flexibility and at the same time implements the guides set forth in Section IV.A of Appendix I to assure that the release of radioactive material in gaseous effluents will be kept "as low as reasonably achievable". The Surveillance Requirements implement the requirements of Section III.A of Appendix I that conformance with the guides of Appendix I be shown by calculational procedures based on models and data such that the actual exposure of a MEMBER OF THE PUBLIC through appropriate pathways is unlikely to be substantially underestimated. The dose calculation methodology of Section 10.3 for calculating the doses due to the actual release rate of radioactive noble gases in gaseous effluents are consistent with the methodology provided in Regulatory Guide 1.109 and Regulatory Guide 1.111. The equations of Section 10.5 provided for determining the air doses at and beyond the SITE BOUNDARY are based upon the historical average atmospheric conditions.

Consistent with the approach for limiting gaseous effluents in 10CFR50 App. I, meeting the air dose limits for gamma and beta radiation under most all site conditions provides a *de facto* compliance with the total body (5 mrem per unit) and skin (15 mrem per unit) dose limits. For PBNP, the air dose limits are met at the site boundary at the location with the highest γ/Q , which is a very conservative assessment when compared to the location of any real person. Furthermore, PBNP TS section 5.5.4.h. requires compliance with only the air dose limits. Therefore, compliance with the gamma and beta air dose limits provides for compliance with the total body and skin dose limits.

7.3 Dose – I-131, I-133, H-3 and Radionuclides in Particulate Form

7.3.1 Specifications

In accordance with PBNP TS 5.5.4.i, the annual or quarterly dose to a MEMBER OF THE PUBLIC from iodine-131, iodine-133, tritium, and all radionuclides in particulate form with half-lives greater than eight days in gaseous effluents release to areas beyond the SITE BOUNDARY shall be limited to:

- a. ≤ 15 mrem to any organ per calendar quarter, and
- b. ≤ 30 mrem to any organ per calendar year.

7.3.2 Applicability

At all times.

7.3.3 Action

If the calculated dose from the release of iodine-131, iodine-133, tritium, and radionuclides in particulate form with half-lives greater than eight days, in gaseous effluents exceeds any of the above limits, a special report shall be prepared and submitted to the Commission within 30 days of determination of the release quantity. The report shall include, as appropriate:

- The cause(s) for exceeding the limits,
- The corrective action(s) taken to reduce the release, and
- The proposed corrective action(s) to be taken to assure that subsequent releases will be in compliance with the above limits.

If the dose to any MEMBER OF THE PUBLIC exceeds 75 mrem to the thyroid or 25 mrem to the whole body or an organ other than the thyroid, pursuant to 40 CFR 190, the report shall also contain a request for a variance from this standard pursuant to 40 CFR 190.11.

7.3.4 Surveillance Requirement

Cumulative dose contributions from iodine-131, iodine-133, tritium, and particulates with half-lives greater than eight days in radioactive effluents shall be determined for the current calendar quarter and current calendar year in accordance with the methodology described in Section 10.6, at least every 31 days.

7.3.5 Basis

This specification is provided to implement the requirements of Section II.C, III.A and IV.A of Appendix I, 10 CFR Part 50. The Limiting Conditions for Operation are the guides set forth in Section II.C of Appendix I. The ACTION statements provide the required operating flexibility and at the same time implement the guides set forth in Section IV.A of Appendix I to assure that the release of radioactive materials in gaseous effluents to UNRESTRICTED AREAS will be kept "as low as is reasonably achievable". The Surveillance Requirements implement the requirements of Section III.A of Appendix I that conformance with the guides of Appendix I be shown by calculational procedures based on models and data such that the actual exposure of a MEMBER OF THE PUBLIC through appropriate pathways is unlikely to be substantially underestimated. The dose calculation methodology of Section 10.4 for calculating the doses due to the actual release rates of the subject materials are consistent with the methodology provided in Regulatory Guide 1.109 and Regulatory Guide 1.111. These equations also provide for determining the actual doses based upon the historical average atmospheric conditions. The release rate controls for iodine-131, iodine-133, tritium, and radionuclides in particulate form with half-lives greater than eight days are dependent upon the existing radionuclide pathways to man at and beyond the SITE BOUNDARY. The pathways that were examined in the development of the calculations were: (1) individual inhalation of airborne radionuclides, (2) deposition of radionuclides onto green leafy vegetation with subsequent consumption by man, (3) deposition onto grassy areas where milk animals and meat producing animals graze with consumption of the milk and meat by man, and (4) deposition on the ground with subsequent exposure of man.

7.4 Gaseous Radwaste Treatment System

7.4.1 Specifications

In accordance with PBNP TS 5.5.4.f, the GASEOUS RADWASTE TREATMENT SYSTEM shall be used to reduce radioactive materials in gaseous waste prior to discharge when the 31-day projected gaseous effluent air doses due to the gaseous effluents to UNRESTRICTED AREAS would exceed 0.4 mrad from noble gas gamma radiation, 0.8 mrad from noble gas beta radiation, and 0.6 mrem to any organ from I-131, I-133, H-3 and radioactive material in particulate form whose half-life is > 8 days, from both units (2% of the Appendix I annual dose objectives).

7.4.2 Applicability

At all times.

7.4.3 Action

If radioactive gases are being discharged for a period of 31 consecutive days without use of the effluent treatment system to meet the release limits specified above, a special report shall be prepared and submitted to the Commission within thirty days which includes the following information:

- Identification of the non-functional equipment or subsystem and the reason for non-functionality.
- Actions taken to restore the non-functional equipment to FUNCTIONAL status.
- Summary description of actions taken to prevent a recurrence.

The following portions of the gaseous radioactive effluent treatment system shall be used to reduce the release of radioactivity:

- For noble gases, a gas decay tank(s) (GDTs) shall be operated when required to maintain gaseous releases within the specified limits, described above.
- During a GDT discharge through the Auxiliary Building vent, at least one exhaust fan shall be in operation (FSAR 11.2.3).
- For iodine-131, iodine-133, tritium, and particulates with half-lives greater than eight days, the auxiliary building ventilation exhaust charcoal filter and/or air ejector charcoal filter shall be operated when required to maintain gaseous releases within the specified limits, described above.

7.4.4 Surveillance Requirement

Projected dose contributions from radioactive effluents shall be determined for the current calendar quarter and current calendar year in accordance with the methodology described Sections 9.3 and 10.7 at least every 31 days.

7.4.5 Basis

The requirement that the appropriate portions of these systems be used, when specified, provides reasonable assurance that the release of radioactive materials in gaseous effluents will be kept "as low as is reasonably achievable". This specification implements the requirements of PBNP GDC 70, 10 CFR Part 50.36a, General Design Criterion 60 of Appendix A to 10 CFR Part 50 and the design objective given in Section II.D of Appendix I to 10 CFR Part 50. The specified limits governing the use of appropriate portions of the GASEOUS RADWASTE TREATMENT SYSTEM were specified as a suitable fraction (2%) of the annual dose design objectives set forth in Sections II.B and II.C of Appendix I, 10 CFR Part 50, for gaseous effluents.

OFFSITE DOSE CALCULATION MANUAL

7.5 Gaseous Effluent Monitoring Instrumentation

7.5.1 Specification

- a. In accordance with PBNP TS 5.5.4.a, the radioactive gaseous monitoring instrumentation channels listed in Table 7-2 shall be FUNCTIONAL and alarm or trip setpoints established such that effluent releases do not exceed the values described in Section 7.1.1.
 1. All monitors are defined by the term FUNCTIONAL – FUNCTIONALITY, **EXCEPT** 1(2) RE-212 Containment Noble Gas Monitor which is defined by the term OPERABLE – OPERABILITY.
 2. **IF** the ability of 1(2) RE-212, Containment Noble Gas Monitor, to perform its function is questioned, **THEN** the Operability Determination process is applicable. (LCO 3.4.15, RCS Leakage Detection Instrumentation)
- b. The alarm or trip setpoints of the monitoring instrumentation channels shall be determined in accordance with the methodology in Section 10.1 of the ODCM.

7.5.2 Applicability

During releases via the monitored pathway.

7.5.3 Action

- a. If a radioactive effluent monitoring instrumentation channel alarm or trip setpoint is found less conservative than required by Section 7.5.1, immediately suspend the release of radioactive gaseous effluents monitored by the affected channel, or declare the channel non-functional, or change the setpoint so it is acceptably conservative.
- b. If fewer than the minimum number of radioactive effluent monitoring channels is FUNCTIONAL, the appropriate ACTION should be taken for the instrument as listed in. Best effort shall be made to return the non-functional channel to a FUNCTIONAL status within 30 days. If the number of channels FUNCTIONAL is not restored to the minimum required for any release pathway within 30 days, the circumstances of the instrument failures and schedule for repair shall be reported in the Annual Monitoring Report.
- c. Report all deviations in the Annual Monitoring Report

7.5.4 Surveillance Requirement

Each radioactive effluent monitoring instrumentation channel shall be demonstrated FUNCTIONAL by performance of the CHANNEL CHECK, calibration, FUNCTIONAL TEST, and SOURCE CHECK at the frequencies described in Table 7-3.

7.5.5 Basis

The radioactive gaseous effluent monitoring instrumentation is provided to monitor and control, as applicable, the releases of radioactive materials in gaseous effluents during actual or potential releases of gaseous effluents. The Alarm/Trip Setpoint for these instruments SHALL be calculated and adjusted in accordance with the methodologies and parameters in the ODCM to ensure that the alarm/trip will occur prior to exceeding the limits of 10 CFR Part 20. The FUNCTIONALITY and use of the instrumentation is consistent with the requirements of Point Beach General Design Criteria 17 and 70 and General Design Criteria 60, 63, and 64 of Appendix A to 10 CFR Part 50.

OFFSITE DOSE CALCULATION MANUAL

TABLE 7-2
GASEOUS EFFLUENT MONITORING INSTRUMENTATION

INSTRUMENT	MINIMUM CHANNELS FUNCTIONAL	ACTION
1. Gas Decay Tank System		
a. RE-214, Noble Gas (Auxiliary Building Vent Stack), or RE-315, Noble Gas (Auxiliary Building Vent SPING)	1	Note 1
b. Gas Decay Tank Flow Measuring Meter	1	Note 2
2. Auxiliary Building Ventilation		
a. RE-214, Noble Gas (Auxiliary Building Vent Stack), or RE-315, Noble Gas (Auxiliary Building Vent SPING)	1	Note 3
b. Isokinetic Iodine and Particulate Continuous Air Sampling System or SPING 23	1	Note 4
3. Condenser Air Ejector System		
a. RE-225, Noble Gas (Combined Air Ejector Discharge Monitor), or RE-215, Noble Gas (Air Ejector Monitors – 1 per unit), or RE-214, Noble Gas (Auxiliary Building Vent Stack); or RE-315, Noble Gas (Auxiliary Building Vent SPING)	1	Note 3
b. Flow Rate Monitor – Air Ejectors	1	Note 5
4. Containment Purge and Vent System		
a. RE-212, Noble Gas Monitors (1 per unit); or RE-305, Noble Gas (Purge Exhaust SPING – 1 per unit)	1	Note 3
b. 30 cfm Forced Vent Path Flow Indicators	1	Note 5
c. Iodine and Particulate – Continuous Air Samplers	1	Note 4
d. Sampler Flow Rate Measuring Device	1	Note 5
5. Fuel Storage and Drumming Area Ventilation		
a. RE-221, Noble Gas (Drumming Area Stack), or RE-325, Noble Gas (Drumming Area SPING)	1	Note 3
b. Isokinetic Iodine and Particulate Continuous Air Sampling System or SPING 24	1	Note 4
6. Gas Stripper Building Ventilations		
a. RE-224, Noble Gas (Gas Stripper Building), or RE-305, Unit 2 Purge Exhaust SPING	1	Note 3
b. Iodine and Particulate – Continuous Air Sampler or SPING 22	1	Note 4
c. Sampler Flow Rate Measuring Device	1	Note 5

NOTE 1: If the number of channels FUNCTIONAL is fewer than the minimum required, effluent releases via this pathway may continue provided that prior to initiating a release, two separate samples are analyzed by two technically qualified people in accordance with the applicable part of Table 7-1 and the release rate is reviewed by two technically qualified people.

NOTE 2: If the number of channels FUNCTIONAL is fewer than the minimum required, effluent releases via this pathway may continue provided the flow rate is estimated at least once every four hours during actual gaseous releases.

NOTE 3: If the number of channels FUNCTIONAL is fewer than the minimum required, effluent releases via this pathway may continue provided grab samples are collected at least once per 12 hours and are analyzed in accordance with Table 7-1. (Reference Step 7.5.1 for additional information regarding RE-212)

NOTE 4: If the number of channels FUNCTIONAL is fewer than the minimum required, effluent releases via the affected pathway may continue provided samples are continuously collected with auxiliary sampling equipment, (e.g., any low volume sampler which meets the requirements of Table 7-1).

NOTE 5: If the number of channels FUNCTIONAL is fewer than the minimum required, effluent releases via this pathway may continue provided the flow is estimated or determined with auxiliary indication at least once every 24 hours.

OFFSITE DOSE CALCULATION MANUAL

TABLE 7-3
RADIOACTIVE GASEOUS EFFLUENT MONITORING INSTRUMENTATION SURVEILLANCE
REQUIREMENTS

INSTRUMENT DESCRIPTION	CHANNEL CHECK	CALIB.	FUNCT. TEST	SOURCE CHECK
1. Gas Decay Tank System				
a. RE-214, Noble Gas (Auxiliary Building Vent Stack)	D	R	Q	M
b. Gas Decay Tank Flow Measuring Device	P	R	N/A	N/A
2. Auxiliary Building Ventilation System				
a. RE-214, Noble Gas (Auxiliary Building Vent Stack)	D	R	Q	M
b. RE-315, Noble Gas (Auxiliary Building SPING)	D	R	Q	M
c. Isokinetic Iodine and Particulate Continuous Air Sampling System	W	R	N/A	N/A
3. Condenser Air Ejector System				
a. RE-225, Noble Gas (Combined Air Ejector Discharge)	D	R	Q	M
b. RE-215, Noble Gas (Air Ejectors – 1 per unit)	D	R	Q	M
c. Flow Rate Monitor – Air Ejectors (1 per unit)	D	R	N/A	N/A
4. Containment Purge and Vent System				
a. RE-212, Noble Gas (1 per unit)	D	R	Q	M ¹
b. 30 cfm Vent Path Flow Indication	P/D	R	N/A	N/A
c. RE-305, Noble Gas (Purge Exhaust SPING – 1 per unit)	D	R	Q	M ¹
d. Iodine and Particulate Continuous Air Sampler	P/W	N/A	N/A	N/A
e. Sampler Flow Rate Measuring Device	P/D	R	N/A	N/A
5. Fuel Storage and Drumming Area Ventilation Stack				
a. RE-221, Noble Gas (Drumming Area Vent Stack)	D	R	Q	M
b. RE-325, Noble Gas (Drumming Area SPING)	D	R	Q	M
c. Isokinetic Iodine and Particulate Continuous Air Sampling System	W	R	N/A	N/A
6. Gas Stripper Building Ventilation System				
a. RE-224, Noble Gas	D	R	Q	M
b. Iodine and Particulate Continuous Air Sampler	W	N/A	N/A	N/A
c. Sampler Flow Rate Measuring Device	W	R	N/A	N/A

Legend: D = Daily R = Once per 18 months, typically during refueling
W = Weekly P/D(W) = Prior to or immediately upon initiation of a release or daily (weekly) if a release continues for more than one day (week)
M = Monthly Q = Quarterly N/A = Not applicable

NOTE 1: SOURCE CHECK required prior to containment purge

OFFSITE DOSE CALCULATION MANUAL

8.0 TOTAL DOSE

8.1 Specification

The annual (calendar year) dose or dose commitment to any MEMBER OF THE PUBLIC due to releases of radioactivity and to radiation from URANIUM FUEL SOURCES shall be limited to less than or equal to 25 mrem to the total body or any organ, except the thyroid, which shall be limited to less than or equal to 75 mrem.

8.2 Applicability

At all times.

8.3 Action

- a. With the calculated doses from the release or radioactive materials in liquid or gaseous effluents exceeding twice the limits of Sections 6.2.1, 7.2.1, or 7.3.1, calculations should be made including direct radiation contributions from the site to determine whether the above limits have been exceeded. If the limits are exceeded, a special report shall be prepared and submitted to the Commission within 30 days in lieu of a License Event Report, that includes the following:
- the corrective action(s) taken to reduce subsequent releases to prevent recurrence of exceeding the above limits and includes the schedule for achieving conformance with the above limits.
 - An analysis that estimates the radiation exposure (dose) to a MEMBER OF THE PUBLIC from URANIUM FUEL CYCLE sources, including all effluent pathways and direct radiation, for the calendar year that includes the release(s) covered by this report, as defined in 10 CFR 20.2203.
 - A description of the levels of radiation and concentrations of radioactive material involved, and the cause of the exposure levels or concentrations.
- b. If the estimated dose(s) exceeds the above limits, and if the release condition resulting in violation of 40 CFR Part 190 has not already been corrected, a request for a variance in accordance with the provisions of 40 CFR Part 190 shall be made. Submittal of the report is considered a timely request, and a variance is granted until staff action on the request is complete.

8.4 Surveillance Requirements

- 8.4.1 Cumulative dose contributions from liquid and gaseous effluents shall be determined in accordance with Surveillance Requirements 6.2.4, 7.2.4, and 7.3.4 and in accordance with the methodology of Sections 9.2, 10.5, and 10.6, respectively.

- 8.4.2 Cumulative dose contributions from direct radiation from the reactor units shall be determined using the procedure outlined in Section 11.0. This application is applicable only under the conditions set forth in ACTION 7.1.3.

8.5 Basis

This specification is provided to meet the dose limitations of 40 CFR Part 190 that have been incorporated into 10 CFR Part 20 by 46 FR 18525. The specification requires the preparation and submittal of a special report whenever the calculated doses due to releases of radioactivity and to radiation from the URANIUM FUEL CYCLE sources exceed 25 mrem to the whole body or any organ, except the thyroid, which shall be limited to less than or equal to 75 mrem. For sites containing up to four reactors, it is highly unlikely that the resultant dose to a MEMBER OF THE PUBLIC will exceed the dose limits of 40 CFR 190 if the individual reactors remain within twice the dose design objectives of Appendix I and if direct radiation doses from the units (including outside storage tanks, the ISFSI, etc.) are kept small. The special report will describe a course of action that should result in the limitation of the annual dose to a MEMBER OF THE PUBLIC to within 40 CFR 190 limits. For the purposes of the special report, it may be assumed that the dose commitment to a MEMBER OF THE PUBLIC from other URANIUM FUEL CYCLE sources is negligible, with the exception that dose contributions from other nuclear fuel cycle facilities at the same site or within a radius of 8 km must be considered.

The Kewaunee Nuclear Power Plant (KNPP) is within a radius of 8 Km of Point Beach. KNPP is now shut down. However, should there be any stored licensed material on that site which is released to the environment; the dose contribution from that release would have to be considered when evaluating Point Beach compliance with 40 CFR 190 limits.

If the dose to any MEMBER OF THE PUBLIC is estimated to exceed the requirements of 40CFR190, the special report with a request for a variance (provided the release conditions resulting in violation of 40CFR190 have not already been corrected), in accordance with the provisions of 40CFR190.11 and 10CFR20.2203(a)(4), is considered to be a timely request and fulfills the requirements of 40CFR190 until NRC staff action is completed. The variance only relates to the limits of 40CFR190, and does not apply in any way to the other requirements for dose limitation of 10CFR20, as addressed in Sections 6.2, 7.2 and 7.3. An individual is not considered a MEMBER OF THE PUBLIC during any period in which he/she is engaged in carrying out any operation that is part of the nuclear fuel cycle.

OFFSITE DOSE CALCULATION MANUAL

9.0 LIQUID EFFLUENT CALCULATIONS

9.1 Monitor Alarm Setpoint Determination

The effluent monitor setpoints are established to ensure that controlled releases of liquid radioactive effluents are maintained as low as is reasonably achievable, to ensure releases result in concentrations to unrestricted areas within the limits specified in Section 6.1 and to ensure that the dose limits of 10 CFR 50, Appendix I are not exceeded.

The computerized PBNP Radiation Monitoring System (RMS) permits each effluent radiation monitor to be programmed to alarm at two distinct setpoints. The alert setpoint, typically twice the steady-state reading, is intended to delineate a changing plant condition, and is established for evaluation purposes only. The high alarm or trip setpoint either will actuate a control function as applicable or will require corrective action to be initiated.

Alert Setpoint Guidelines

The alert setpoint of each effluent monitor normally will be set to alarm at two times the established steady-state reading. The alert setpoint is normally set at concentrations well below the alarm setpoint value and is never to be set in excess of the alarm setpoint. Certain situations during the course of plant operations may require a deviation from the two times steady-state value. The intent of this setpoint is to warn of changing plant conditions, which may warrant an evaluation to determine the cause of the increased reading. If the increased level is actually due to an increased radiation inventory within the system being monitored, as opposed to an increased background radiation field in the vicinity of the detector, an evaluation should be made to determine the impact of the release. The alert setpoint may be adjusted with prior approval. Alert setpoint adjustments are to be made in accordance with the PBNP RMS Alarm Setpoint and Response Book (Ref. OM 4.1.7).

High Alarm or Trip Setpoint Guidelines

In accordance with TS 5.5.4 and as stated in Section 6.1, the high alarm or trip setpoint for effluent monitors shall be established to annunciate at concentrations that would result in an UNRESTRICTED AREA concentration equal to or greater than 10x the applicable maximum effluent concentration (MEC) for a single radionuclide. For a mixture of radionuclides, the setpoint shall be established so that the sum of fractions (SOF), as defined in Appendix B of 10 CFR 20, is less than or equal to one. If the setpoints listed in Table 9-1 exceed the monitor's saturation or fail high level, the setpoint may be set at a value $\leq 70\%$ of the fail high level (MSSM No. 93-01). These monitors are indicated by an asterisk (*) in Table 9-1. The appropriate detailed response to an effluent alarm is described in the PBNP RMS Alarm Setpoint and Response Book.

The effluent monitor setpoints are established to ensure that controlled releases of liquid radioactive effluent are maintained as low as is reasonably achievable, to ensure releases result in concentrations to UNRESTRICTED AREAS within the specified limits described in Section 6.1.1 and to ensure that the dose limits of 10 CFR50, Appendix 1 are not exceeded.

The following equation must be satisfied to meet the liquid effluent restriction:

$$c \leq \frac{C(F + f)}{f} \quad [9-1]$$

- Where:
- c = The setpoint of the radioactivity monitor measuring the radioactivity concentration in the effluent line prior to dilution and subsequent release; the setpoint, which is inversely proportional to the volumetric flow of the dilution stream plus the effluent stream, represents a value which, if exceeded, would result in concentration exceeding the TS limits of 10x the 10 CFR 20 values in the UNRESTRICTED AREA ($\mu\text{Ci/mL}$)
 - C = 10x the effluent concentration limit from 10 CFR 20, Appendix B, Table 2 Column 2 (see section 6.1.1) ($\mu\text{Ci/mL}$)
 - f = the flow rate at the radiation monitor location (volume/time)
 - F = The dilution water flow rate as measured prior to the release point (volume/time)

Note: If no dilution is provided, then $c \leq C$. Also if F is large compared to f , then $(F+f) \approx F$

The liquid monitor setpoints are based on 10x the 10CFR20, Appendix B, Table 2, Column 2 maximum effluent concentration (MEC) values as allowed by the Point Beach TS. For a mixture of radionuclides, the setpoint is calculated so that the summation of fractions (SOF) will not exceed unity, i.e.

$$SOF = \sum \frac{C_i}{MEC_i} \leq 1 \quad [9-2]$$

- Where:
- C_i = The concentration of radionuclide i in the liquid effluent ($\mu\text{Ci/mL}$)
 - MEC_i = 10 times the Maximum Effluent Concentration value corresponding to radionuclide " i " from 10 CFR Part 20, Appendix B, Column 2 ($\mu\text{Ci/mL}$),

The SOF meeting the ≤ 1 criterion means that the discharge concentration could have been higher by a factor of $1/\text{SOF}$ such that the effective maximum effluent concentration (EMEC) for the mixture could have been

$$EMEC = \frac{\sum C_i}{\sum \frac{C_i}{MEC_i}} \quad [9-3]$$

The setpoints for liquid effluent monitors are determined by the following equation:

$$SP \leq \frac{\sum(C_i) \times CW}{\sum \frac{C_i}{MEC_i} \times RR} \quad [9-4]$$

$$SP \leq \frac{EMEC \times CW}{RR} \beta_{cf} \quad [9-5]$$

Where:

<i>SP</i>	=	Setpoint of the radiation monitor (cpm or $\mu\text{Ci/mL}$, depending upon the specific monitor),
<i>EMEC</i>	=	The effective MEC value for the mixture of radionuclides in the effluent stream ($\mu\text{Ci/mL}$)
<i>CW</i>	=	the circulating water flow rate (dilution water flow) at the time of the release (gpm)
<i>C_i</i>	=	The concentration of radionuclide <i>i</i> in the liquid effluent ($\mu\text{Ci/mL}$)
<i>RR</i>	=	The liquid effluent release rate (gpm)
β_{cf}	=	Beta correction factor to account for pure beta emitters such as H-3 which are not detected by the monitors

Note: The *EMEC* includes pure beta emitting radionuclides that may not be detected by the monitors (i.e., non-gamma emitters). See Appendix A for a discussion of this factor.

If the nuclide specific sensitivity is unavailable, the default sensitivity based upon system calibration should be used. The default sensitivity is based upon the monitor response to the 2000 – 2010 average liquid isotopic distribution, as presented in Appendix A.

$$\text{Sensitivity} = \frac{\text{Monitor Response}}{\sum (\mu\text{Ci/cc}_i)} \quad [9-6]$$

Where:

<i>Monitor Response</i>	=	the counts per minute registered by the monitor exposed to a calibration source
$\sum (\mu\text{Ci/cc}_i)$	=	total concentration of radionuclides in the 2000 - 2010 average liquid effluent isotopic distribution.

In the event that an alarm setpoint, based upon the concentration limits of Section 6.1.1, is exceeded during any release of liquid effluents, an evaluation of compliance with the concentration limits may be performed using the following equation:

$$\sum \left[\frac{C_i}{MEC_i} \times \frac{RR}{CW} \right] \leq 1 \quad [9-7]$$

Where:

<i>C_i</i>	=	the concentration of radionuclide "i" in the liquid effluent ($\mu\text{Ci/mL}$),
<i>RR</i>	=	the liquid effluent release rate (gpm)
<i>CW</i>	=	the circulating water flow rate (dilution water flow) at the time of the release (gpm),

Default Monitor Setpoints

A default alarm setpoint for each liquid monitor is based upon the 2000 – 2010 average radionuclide concentration in the effluent discharged to the UNRESTRICTED AREA. The concentration in the release is calculated assuming a minimum circulating water flow rate of 243,000 gpm and the physical maximum flow rate of the individual liquid effluent waste stream. Maximum waste discharge flow rates, the monitors associated with each liquid effluent pathway and the maximum TS default setpoints are listed in Table 9-1. The isotopic distribution of the waste system is obtained from the historical PBNP release data for the eleven years mentioned above. This information can be found in Appendix A.

As indicated in Table 9-1, several liquid RMS monitors fail high before reaching the TS high alarm setpoint. For these monitors, as described above, the $\leq 70\%$ of the fail high value will be applied to the monitor in lieu of the calculated default setpoint.

Additionally, RE-230, Waste Water Effluent Monitor, is impacted by a PBNP EP requirement for EAL declaration, therefore the application of the $\leq 70\%$ of the fail high value is not an acceptable option. To fulfill the EAL requirement, RE-230 must be capable of reading 2x the ODCM setpoint on the liquid radiation monitor. As a result, the alarm setpoint as described in this section cannot be implemented for RE-230, Waste Water Effluent Monitor.

Therefore, instead of utilizing the TS limit of 10x the 10 CFR 20, Appendix B, Table 2, Column 2, concentrations, the ODCM (Revision 18) RE-230 setpoint of $1.03\text{E-}03 \mu\text{Ci/cc}$ value will be used as the basis for the new setpoint. This setpoint is based on 1x the current 10 CFR 20, Appendix B, Table 2, Column 2, concentrations AND the old circulating water minimum flow rate of 206 Kgal/min. The ODCM (Revision 18) setpoint will be modified by the ratio of the current minimum circulating water flow rate of 243 Kgal/min to the old minimum circulating water flow rate. The flow augmentation factor is $1.18\text{E}+00$ ($243/206 = 1.18\text{E}+00$). The application of this flow factor results in an RE-230 setpoint of $1.22\text{E-}03 \mu\text{Ci/cc}$.

OFFSITE DOSE CALCULATION MANUAL

TABLE 9-1
LIQUID EFFLUENT PATHWAYS

LIQUID EFFLUENT PATHWAY	PATHWAY MONITOR ³		DISCHARGE FLOWRATE (GPM)	CALCULATED DEFAULT SETPOINT ¹ (µCi/cc)
Recirculation Water	None	1 pump, either unit	243,000	N/A
		2 pumps, either unit	394,000	N/A
		1 pump, each unit	484,000	N/A
		1 pump, one unit & 2 pumps, other unit	619,000	N/A
		2 pumps, each unit	744,000	N/A
Service Water Return (normal cool down per pump)	1(2)RE-229	2 pumps @ 7500 gpm	15,000	
		3 pumps @ 6300 gpm	18,900	
		4 pumps @ 5100 gpm	20,400	
		5 pumps @ 4300 gpm	21,500	
		6 pumps @ 3700 gpm	22,200	1.14E-03
Steam Generator Blowdown	1(2)RE-219* & 1 (2)RE-222	Max Flow Rate	200	1.26E-01
Waste Water Effluent ²	RE-230	Max Flow Rate (both filter skids running in parallel)	700	1.22E-03
Spent Fuel Pool	RE-220*	Max Flow Rate	700	3.61E-02
Waste Distillate & Condensate Storage Tank Discharge	RE-218* & RE-223*	Max Flow Rate	100	2.53E-01
Containment Fan Cooler Return	1(2)RE-216*	Max Flow Rate (per Containment)	4000	6.32E-03

NOTE 1: Setpoints except for RE-230 are based on 10x the MEC values listed in 10CFR20, Appendix B, Table 2, Column 2. PBNP TS Section 5.5.4.b allows concentrations of radioactive material released to unrestricted areas to be 10x the MEC values.

NOTE 2: RE-230 setpoint explanation can be found in section 9.1, Default Monitor Setpoints.

NOTE 3: Monitors marked with an asterisk (*) have a calculated default alarm setpoint above the monitors fail high or saturation level. See section 9.1, High Alarm or Trip Setpoint Guidelines for further explanation.

9.2 Liquid Dose Calculations

Section 6.2.1 establishes dose or dose commitment limits to members of the public from radioactive materials in liquid effluents.

The following equation may be used to determine the dose or dose commitment to members of the public due to these releases:

$$D_o = \frac{1.67E - 02 * Vol}{CW} * \sum (C_i * A_{io}) \quad [9-8]$$

Where:

- D_o = dose or dose commitment for the release or release period evaluated, to organ "o", including total body (mrem)
- Vol = volume of liquid effluent released for the release or release period evaluated (gal),
- CW = average circulating water discharge rate during the release period (gpm)
- C_i = average concentration of radionuclide "i", in undiluted liquid effluent representative of the waste volume Vol ($\mu Ci/mL$),
- A_{io} = ingestion dose factor to the total body or any organ "o" for radionuclide "i" (mrem/hr per $\mu Ci/mL$)
- $1.67E-02$ = Conversion factor (hr/min)

The default PBNP site-specific liquid dose commitment factors (A_{io}), presented in Table 9-3, have been derived using guidance from Regulatory Guide 1.109 and NUREG-0133. NUREG-0133 states that the maximum exposed individual's cumulative dose contribution should consider consumption of fish, invertebrates (not applicable to Point Beach) and potable water as appropriate. The NUREG goes on to state that the adult is normally the maximum exposed individual. Therefore, the default factors contained in Table 9-3 are based on adult dose conversion factors, fish consumption from Lake Michigan plus potable water consumption from the Two Rivers facility. The derivation of these factors is described in detail in Appendix B. Dose conversion factors for other age ranges are provided in Appendix K. A summary of the liquid effluent sub-pathways applicable to Point Beach is described below in Table 9-2.

TABLE 9-2
LIQUID EFFLUENT SUB-PATHWAYS

LIQUID EFFLUENT SUB-PATHWAY	APPLICABLE	JUSTIFICATION	LOCATION
Aquatic Foods (fish)	Yes	Fish assumed to be caught at PBNP discharge	PBNP discharge
Aquatic Foods (invertebrates)	No	No invertebrates are consumed from Lake Michigan	N/A
Irrigated Foods (meat from watered cattle)	No	In the area of PBNP, only well water is used to irrigate crops or water animals. Lake Michigan water is not used.	N/A
Irrigated Foods (milk from watered cattle)	No	In the area of PBNP, only well water is used to irrigate crops or water animals. Lake Michigan water is not used.	N/A
Potable Water	Yes	Assumed drinking water obtained from Two Rivers facility, 11 miles south of PBNP.	Two Rivers
Shoreline Deposits	No	Although shoreline deposits could be considered, NUREG-0133 provides guidance that the dose consequence of this pathway is generally negligible.	N/A

TABLE 9-3
PBNP SITE-SPECIFIC LIQUID DOSE COMMITMENT FACTORS, A_{io}

(mrem/hr per $\mu\text{Ci/mL}$)

NUCLIDE	BONE	LIVER	T.BODY	THYROID	KIDNEY	LUNG	GI-LLI
H-3	0.00E+00	2.06E-01	2.06E-01	2.06E-01	2.06E-01	2.06E-01	2.06E-01
C-14	3.56E+03	7.13E+02	7.13E+02	7.13E+02	7.13E+02	7.13E+02	7.13E+02
F-18	1.80E-02	0.00E+00	2.00E-03	0.00E+00	0.00E+00	0.00E+00	5.34E-04
Na-22	5.29E+02	5.29E+02	5.29E+02	5.29E+02	5.29E+02	5.29E+02	5.29E+02
Na-24	2.71E+01	2.71E+01	2.71E+01	2.71E+01	2.71E+01	2.71E+01	2.71E+01
P-32	5.13E+06	3.19E+05	1.98E+05	0.00E+00	0.00E+00	0.00E+00	5.76E+05
Sc-46	2.03E-02	3.95E-02	1.15E-02	0.00E+00	3.68E-02	0.00E+00	1.92E+02
Cr-51	0.00E+00	0.00E+00	1.51E-01	9.03E-02	3.33E-02	2.00E-01	3.80E+01
Mn-54	0.00E+00	5.11E+02	9.76E+01	0.00E+00	1.52E+02	0.00E+00	1.57E+03
Mn-56	0.00E+00	4.97E-01	8.82E-02	0.00E+00	6.31E-01	0.00E+00	1.59E+01
Fe-55	8.36E+01	5.78E+01	1.35E+01	0.00E+00	0.00E+00	3.22E+01	3.31E+01
Fe-59	1.31E+02	3.07E+02	1.18E+02	0.00E+00	0.00E+00	8.58E+01	1.02E+03
Co-57	0.00E+00	2.93E+00	4.88E+00	0.00E+00	0.00E+00	0.00E+00	7.45E+01
Co-58	0.00E+00	1.24E+01	2.78E+01	0.00E+00	0.00E+00	0.00E+00	2.52E+02
Co-60	0.00E+00	3.60E+01	7.93E+01	0.00E+00	0.00E+00	0.00E+00	6.75E+02
Ni-63	3.95E+03	2.74E+02	1.33E+02	0.00E+00	0.00E+00	0.00E+00	5.72E+01
Ni-65	5.28E-01	6.85E-02	3.13E-02	0.00E+00	0.00E+00	0.00E+00	1.74E+00
Cu-64	0.00E+00	6.08E-01	2.86E-01	0.00E+00	1.53E+00	0.00E+00	5.18E+01
Zn-65	2.65E+03	8.42E+03	3.80E+03	0.00E+00	5.63E+03	0.00E+00	5.30E+03
Zn-69m	5.06E+01	1.21E+02	1.11E+01	0.00E+00	7.35E+01	0.00E+00	7.41E+03
Zn-69	7.56E-04	1.45E-03	1.00E-04	0.00E+00	9.39E-04	0.00E+00	2.17E-04
As-76	8.45E+00	2.46E+01	1.23E+02	7.37E+00	3.00E+01	7.68E+00	1.08E+03
Br-82	0.00E+00	0.00E+00	2.07E+02	0.00E+00	0.00E+00	0.00E+00	2.37E+02
Br-83	0.00E+00	0.00E+00	1.44E-01	0.00E+00	0.00E+00	0.00E+00	2.07E-01
Br-84	0.00E+00	0.00E+00	9.10E-07	0.00E+00	0.00E+00	0.00E+00	7.14E-12
Br-85	0.00E+00	0.00E+00	0.00E+00	0.00E+00	0.00E+00	0.00E+00	0.00E+00
Rb-86	0.00E+00	1.13E+04	5.28E+03	0.00E+00	0.00E+00	0.00E+00	2.23E+03
Rb-88	0.00E+00	1.87E-11	9.93E-12	0.00E+00	0.00E+00	0.00E+00	0.00E+00
Rb-89	0.00E+00	1.84E-13	1.29E-13	0.00E+00	0.00E+00	0.00E+00	0.00E+00
Sr-89	3.46E+03	0.00E+00	9.92E+01	0.00E+00	0.00E+00	0.00E+00	5.54E+02
Sr-90	9.90E+04	0.00E+00	1.33E+03	0.00E+00	0.00E+00	0.00E+00	2.49E+03
Sr-91	1.98E+01	0.00E+00	8.01E-01	0.00E+00	0.00E+00	0.00E+00	9.44E+01
Sr-92	8.15E-01	0.00E+00	3.53E-02	0.00E+00	0.00E+00	0.00E+00	1.62E+01
Y-90	7.58E-02	0.00E+00	2.03E-03	0.00E+00	0.00E+00	0.00E+00	8.04E+02
Y-91m	2.84E-08	0.00E+00	1.10E-09	0.00E+00	0.00E+00	0.00E+00	8.36E-08
Y-91	1.39E+00	0.00E+00	3.73E-02	0.00E+00	0.00E+00	0.00E+00	7.67E+02
Y-92	5.49E-04	0.00E+00	1.60E-05	0.00E+00	0.00E+00	0.00E+00	9.61E+00
Y-93	8.40E-03	0.00E+00	2.32E-04	0.00E+00	0.00E+00	0.00E+00	2.66E+02
Zr-95	1.22E-01	3.92E-02	2.65E-02	0.00E+00	6.15E-02	0.00E+00	1.24E+02
Zr-97	1.66E-03	3.35E-04	1.53E-04	0.00E+00	5.06E-04	0.00E+00	1.04E+02

OFFSITE DOSE CALCULATION MANUAL

TABLE 9-3
PBNP SITE-SPECIFIC LIQUID DOSE COMMITMENT FACTORS, A_{io}

NUCLIDE	BONE	LIVER	T.BODY	THYROID	KIDNEY	LUNG	GI-LLI
Nb-95	5.03E+01	2.80E+01	1.50E+01	0.00E+00	2.77E+01	0.00E+00	1.70E+05
Nb-97	4.93E-04	1.25E-04	4.55E-05	0.00E+00	1.45E-04	0.00E+00	4.60E-01
Mo-99	0.00E+00	1.87E+01	3.55E+00	0.00E+00	4.23E+01	0.00E+00	4.33E+01
Tc-99m	2.56E-04	7.23E-04	9.21E-03	0.00E+00	1.10E-02	3.54E-04	4.28E-01
Tc-99	9.10E-01	1.35E+00	3.65E-01	0.00E+00	1.70E+01	1.15E-01	4.43E+01
Tc-101	5.94E-19	8.56E-19	8.39E-18	0.00E+00	1.54E-17	4.37E-19	0.00E+00
Ru-103	1.07E+00	0.00E+00	4.61E-01	0.00E+00	4.08E+00	0.00E+00	1.25E+02
Ru-105	6.46E-03	0.00E+00	2.55E-03	0.00E+00	8.35E-02	0.00E+00	3.95E+00
Ru-106	1.62E+01	0.00E+00	2.05E+00	0.00E+00	3.14E+01	0.00E+00	1.05E+03
Rh-105	4.12E-01	3.01E-01	1.98E-01	0.00E+00	1.28E+00	0.00E+00	4.80E+01
Ag-110m	6.09E-01	5.63E-01	3.34E-01	0.00E+00	1.11E+00	0.00E+00	2.30E+02
Sn-113	7.87E+02	1.33E+02	2.21E+03	6.96E+01	1.82E+02	8.17E+01	2.42E+04
Sn-117m	1.48E+03	5.03E+01	2.10E+03	1.01E+01	7.69E+01	1.60E+01	2.37E+04
Sb-122	1.44E+00	7.92E-01	1.36E+01	1.68E-01	5.60E-01	2.16E-01	1.44E+02
Sb-124	9.51E+00	1.80E-01	3.77E+00	2.31E-02	0.00E+00	7.40E+00	2.70E+02
Sb-125	6.20E+00	6.93E-02	1.48E+00	6.31E-03	0.00E+00	4.78E+00	6.83E+01
Te-125m	2.98E+02	1.08E+02	4.00E+01	8.97E+01	1.21E+03	0.00E+00	1.19E+03
Te-127m	7.56E+02	2.70E+02	9.21E+01	1.93E+02	3.07E+03	0.00E+00	2.53E+03
Te-127	4.95E+00	1.78E+00	1.07E+00	3.67E+00	2.02E+01	0.00E+00	3.91E+02
Te-129m	1.27E+03	4.75E+02	2.02E+02	4.38E+02	5.32E+03	0.00E+00	6.42E+03
Te-129	2.63E-03	9.88E-04	6.40E-04	2.02E-03	1.10E-02	0.00E+00	1.98E-03
Te-131m	1.45E+02	7.07E+01	5.89E+01	1.12E+02	7.16E+02	0.00E+00	7.02E+03
Te-131	4.59E-09	1.92E-09	1.45E-09	3.77E-09	2.01E-08	0.00E+00	6.50E-10
Te-132	2.51E+02	1.63E+02	1.53E+02	1.80E+02	1.57E+03	0.00E+00	7.69E+03
I-130	1.74E+00	5.13E+00	2.02E+00	4.35E+02	8.00E+00	0.00E+00	4.41E+00
I-131	2.75E+01	3.93E+01	2.25E+01	1.29E+04	6.73E+01	0.00E+00	1.04E+01
I-132	2.16E-02	5.77E-02	2.02E-02	2.02E+00	9.19E-02	0.00E+00	1.08E-02
I-133	4.80E+00	8.35E+00	2.55E+00	1.23E+03	1.46E+01	0.00E+00	7.51E+00
I-134	3.28E-05	8.91E-05	3.19E-05	1.54E-03	1.42E-04	0.00E+00	7.76E-08
I-135	5.19E-01	1.36E+00	5.01E-01	8.96E+01	2.18E+00	0.00E+00	1.53E+00
Cs-134	3.40E+04	8.10E+04	6.62E+04	0.00E+00	2.62E+04	8.70E+03	1.42E+03
Cs-134m	6.59E-01	1.39E+00	7.08E-01	0.00E+00	7.51E-01	1.18E-01	4.88E-01
Cs-136	3.47E+03	1.37E+04	9.86E+03	0.00E+00	7.62E+03	1.04E+03	1.56E+03
Cs-137	4.36E+04	5.97E+04	3.91E+04	0.00E+00	2.03E+04	6.73E+03	1.16E+03
Cs-138	5.58E-06	1.10E-05	5.46E-06	0.00E+00	8.10E-06	8.00E-07	4.70E-11
Ba-139	2.73E-04	1.94E-07	7.99E-06	0.00E+00	1.82E-07	1.10E-07	4.84E-04
Ba-140	7.97E+01	1.00E-01	5.22E+00	0.00E+00	3.41E-02	5.73E-02	1.64E+02
Ba-141	7.35E-14	5.55E-17	2.48E-15	0.00E+00	5.16E-17	3.15E-17	0.00E+00
Ba-142	0.00E+00	0.00E+00	0.00E+00	0.00E+00	0.00E+00	0.00E+00	0.00E+00
La-140	1.73E-02	8.74E-03	2.31E-03	0.00E+00	0.00E+00	0.00E+00	6.41E+02
La-142	3.93E-06	1.79E-06	4.45E-07	0.00E+00	0.00E+00	0.00E+00	1.30E-02

TABLE 9-3
PBNP SITE-SPECIFIC LIQUID DOSE COMMITMENT FACTORS, A_{io}

NUCLIDE	BONE	LIVER	T.BODY	THYROID	KIDNEY	LUNG	GI-LLI
Ce-141	3.12E-02	2.11E-02	2.39E-03	0.00E+00	9.80E-03	0.00E+00	8.07E+01
Ce-143	2.28E-03	1.68E+00	1.86E-04	0.00E+00	7.41E-04	0.00E+00	6.29E+01
Ce-144	1.69E+00	7.05E-01	9.05E-02	0.00E+00	4.18E-01	0.00E+00	5.70E+02
Pr-143	8.76E-02	3.51E-02	4.34E-03	0.00E+00	2.03E-02	0.00E+00	3.84E+02
Pr-144	5.87E-17	2.44E-17	2.98E-18	0.00E+00	1.37E-17	0.00E+00	0.00E+00
Nd-147	5.92E-02	6.84E-02	4.09E-03	0.00E+00	4.00E-02	0.00E+00	3.28E+02
Eu-152	1.97E+00	4.44E-01	3.90E-01	0.00E+00	2.75E+00	0.00E+00	2.56E+02
W-187	2.38E+01	1.99E+01	6.96E+00	0.00E+00	0.00E+00	0.00E+00	6.52E+03
U-235	2.56E+03	0.00E+00	1.55E+02	0.00E+00	5.98E+02	0.00E+00	2.50E+02
U-238	2.45E+03	0.00E+00	1.45E+02	0.00E+00	5.60E+02	0.00E+00	1.76E+02
Np-239	4.91E-03	4.83E-04	2.66E-04	0.00E+00	1.51E-03	0.00E+00	9.90E+01
Am-241	8.19E+03	2.88E+03	5.41E+02	0.00E+00	4.07E+03	0.00E+00	7.42E+02

NOTE: A_{io} factors listed above are for the controlling (adult) age group, per NUREG-0133 guidance. The pathways included are fish and potable water, the only significant, applicable pathways present at Point Beach.

9.3 Dose Projections

As required by TS 5.5.4.e and TS 5.5.4.f dose projections shall be made at least once every 31 days. As described in Section 6.3.1, when the projected doses in a period of 31 days would exceed 2% of the guidelines for the annual dose or dose commitment, appropriate portions of the liquid effluent treatment system should be used to reduce releases of radioactivity to within the allowable limits. The following equations should be used to perform dose projections:

$$D_{tbp} = D_{tb} \left(\frac{31}{d} \right) \quad [9-9]$$

$$D_{maxp} = D_{max} \left(\frac{31}{d} \right) \quad [9-10]$$

Where: D_{tbp} = total body dose projection for the current calendar month (mrem)

D_{tb} = total body dose to date for the current calendar month as determined by Equation 9-7 (mrem)

D_{maxp} = maximum organ dose projection for the current calendar month (mrem)

D_{max} = maximum organ dose to date for the current calendar month as determined by Equation 9-7 (mrem)

d = number of days to date for the current calendar month

31 = number of days in projection

OFFSITE DOSE CALCULATION MANUAL

10.0 GASEOUS EFFLUENT CALCULATIONS

10.1 Monitor Alarm Setpoint Determination

The computerized PBNP radiation monitoring system permits each effluent radiation monitor to be programmed to alarm at two distinct setpoints. The alert setpoint, typically twice the steady state reading, is intended to delineate a changing plant condition, and is established for evaluation purposes only. The high alarm or trip setpoint either will actuate a control function as applicable or will require corrective action to be initiated.

Alert Setpoint Guidelines

The alert setpoint of each effluent monitor will normally be set to alarm at two times the established steady-state reading. The alert setpoint is normally set at concentrations well below the alarm setpoint value and is never to be set in excess of the alarm setpoint. Certain situations during the course of plant operations may require a deviation from the two times steady-state value. The intent of this setpoint is to warn of changing plant conditions, which may warrant an evaluation to determine the cause of the increased reading. If the increased level is actually due to an increased radiation inventory with the system being monitored, as opposed to an increased background radiation field in the vicinity of the detector, an evaluation should be made to determine the impact of the release. The alert setpoint may be adjusted with prior approval. Alert setpoint adjustments are to be made in accordance with the PBNP RMS Alarm Setpoint and Response Book (Ref. OM 4.1.7). The appropriate detailed response to an effluent alarm also is described in the PBNP RMS Alarm Setpoint and Response Book.

High Alarm or Trip Setpoint Guidelines

In accordance with PBNP TS 5.5.4.a, alarm setpoints shall be established for the gaseous effluent monitoring instrumentation to ensure that the release rate of noble gases does not exceed the instantaneous dose rate limits of Section 7.1.1. These limits correspond to a dose rate at or beyond the SITE BOUNDARY of 500 mrem/yr to the total body or 3000 mrem/yr to the skin.

Certain airborne effluent monitors cannot reach the calculated setpoint because they fail high at a lower value. These monitors are indicated by an asterisk (*) in Table 10-1. It is plant operational practice to set these monitors at $\leq 70\%$ of the fail high value (MSSM No. 93-01). The following mid-range SPING monitors can read the calculated default setpoints: SPING 21, 1RE-307; SPING22, 2RE-307; SPING 23, RE-317; and SPING 24, RE-327.

OFFSITE DOSE CALCULATION MANUAL

The radiation monitoring alarm setpoints are established using the following equations:

$$SP_{TB} \leq \frac{\sum Ci * 500}{472 * \chi / Q_{NG} * VF * \sum (Ci * Ki)} * AF$$

$$SP_S \leq \frac{\sum Ci * 3000}{472 * \chi / Q_{NG} * VF * \sum [Ci * (Li + 1.1Mi)]} * AF \quad [10-1]$$

- Where:
- SP_{TB} = monitor setpoint corresponding to the release rate limit for the total body dose rate of 500 mrem/yr ($\mu\text{Ci/cc}$)
 - SP_S = monitor setpoint corresponding to the release rate limit for the skin dose rate of 3000 mrem/yr ($\mu\text{Ci/cc}$)
 - 500 = total body dose rate limit (mrem/yr)
 - 3000 = skin dose rate limit (mrem/yr)
 - χ / Q_{NG} = atmospheric dispersion for direct exposure to noble gas at or beyond the SITE BOUNDARY (sec/m^3 see Table 10-2)
 - VF = ventilation flow rate for the applicable release point and monitor (ft^3/min)
 - C_i = concentration of noble gas radionuclide "i" as determined by radioanalysis of grab sample ($\mu\text{Ci/cc}$)
 - K_i = total body dose conversion factor for noble gas radionuclide "i" (mrem/yr per $\mu\text{Ci/m}^3$, see Table 10-3)
 - L_i = beta skin dose conversion factor for noble gas radionuclide "i" (mrem/yr per $\mu\text{Ci/m}^3$, see Table 10-3)
 - M_i = gamma air dose conversion factor for noble gas radionuclide "i" (mrad/yr per $\mu\text{Ci/m}^3$, see Table 10-3)
 - 1.1 = mrem skin dose per mrad gamma air dose (mrem/mrad),
 - 472 = $28317 (\text{cc/ft}^3) \times 1/60 (\text{min/sec})$
 - AF = additional reduction factor of 0.25 applied to the four release point monitors (RE-214, -221, -224, and -225) to ensure that the maximum allowable SITE BOUNDARY dose rates will not be exceeded in the event simultaneous release from these points occur

The lesser value of SP_{TB} and SP_S is used to establish the monitor setpoint.

OFFSITE DOSE CALCULATION MANUAL

Default Monitor Setpoints

Default setpoints are established to eliminate the potential of periodically having to adjust the setpoint to reflect slight variations in the radionuclide distribution and variations in release flow rates. Using activities obtained from the 2000-2010 average annual atmospheric releases (see Appendix C for a detailed discussion), the highest annual χ/Q , and the maximum ventilation flow rates for each pathway, default setpoints can be determined using Equations 10-1 and 10-2.

Gaseous effluent pathway discharge flow rates, the monitors associated with each pathway and default setpoints are listed in Table 10-1. If the default setpoints listed in Table 10-1 exceed the monitors' saturation or fail high levels, the MSS has approved (MSSM No. 93-01) the use of a setpoint which is set at $\leq 70\%$ of that monitor's fail high level. The current alarm levels are recorded in the RMS Alarm Setpoint and Response Book.

Adjustments may be made to the alarm setpoints for release periods if actual flow rates are reduced to less than the maximum values or the actual χ/Q values are calculated. This is not typical under conditions with elevated levels in containment or the waste gas decay tank. Alarm setpoint adjustments which result in values higher than the default values are to be made in accordance with the provisions and methodologies of the PBNP RMS Alarm Setpoint and Response Book.

To maintain the inequality of Equations 10-1 and 10-2 during the release, the release rate (or release of gaseous effluents) may be adjusted. If at any time the monitor response is greater than that anticipated for the gaseous release (i.e., above the alert alarm setpoint), the activity should be re-evaluated. This re-evaluation will may include resampling of the applicable waste stream.

With the setpoints being calculated based on TS release limits, some monitors fail high below the calculated default alarm setpoint. This value is the TS limit that will be reached at the sector of the site boundary with the highest X/Q and D/Q values. For the current airborne monitors, one of the associated SPING monitors has the range required to encompass the default alarm setpoint.

TABLE 10-1
GASEOUS EFFLUENT PATHWAYS

GASEOUS EFFLUENT PATHWAY	MONITORS	DISCHARGE FLOW RATE (cfm)	CALCULATED DEFAULT SETPOINT ($\mu\text{Ci/cc}$)
1. Auxiliary Building Vent	RE-214* & SPING 23	66,400 (1500 ¹)	6.75E-04
2. Combined Air Ejector	RE-225*	20	2.24E+00
3. Unit Air Ejector	1(2) RE-215*	10	1.79E+01
4. Containment Purge/Vent			
Unit 1	1RE-212* & SPING 21	25,000 ²	7.17E-03
Unit 2	2RE-212* & SPING 22	38,000 ³	4.72E-03
Unit 1(2)	1(2) RE-212*	35 ⁴	5.12E+00
5. Gas Stripper Building	RE-224*	13,000 (250 ¹)	3.45E-03
6. Drumming Area Vent	RE-221* & SPING 24	43,100 (500 ¹)	1.04E-03

NOTE 1: From RAM 5.1, Radioactive Airborne Effluent Releases, Table 2, convective flow with fans off

NOTE 2: Two fans of 12,500 cfm

NOTE 3: Two fans + 13,000 cfm from gas stripper bldg.

NOTE 4: Forced vent with nominal 35 cfm flow rate

NOTE 5: Monitors marked with an asterisk (*) have a calculated default alarm setpoint above the monitors fail high or saturation level. See section 10.1, High Alarm or Trip Setpoint Guidelines for further explanation and designation of SPING monitors that can be set at the calculated default setpoint.

OFFSITE DOSE CALCULATION MANUAL

TABLE 10-2
CONTROLLING LOCATIONS, PATHWAYS AND ATMOSPHERIC DISPERSION FOR DOSE
CALCULATIONS

ODCM SECTION	LOCATION	DISTANCE AND DIRECTION	PATHWAY(S)	χ/Q^1 (sec/m ³)	D/Q (m ⁻²)
7.1.1.a	Site boundary	SSE, 1220 meters ²	Noble gases Direct exposure	1.09E-06	N/A
7.1.1.b	Site boundary	SSE, 1220 meters	Inhalation	1.09E-06	N/A
7.2.1	Site boundary	SSE, 1220 meters	Gamma-air Beta-air	1.09E-06	N/A
7.3.1	Residence/dairy	SSW, 1290 meters ³	Inhalation, milk, meat, produce, leafy vegetables and ground plane.	7.15E-07	5.90E-9

NOTE 1: Atmospheric dispersion and deposition data taken from *Point Beach Annual Meteorological and Atmospheric Dispersion Report for 2009*, Report No. R-2330244-001, December 2010.

NOTE 2: Location corresponds to site boundary distance and sector with the greatest χ/Q and D/Q values.

NOTE 3: The nearest residence/dairy is in the SSW sector. The distance is conservatively assumed to be at the site boundary.

OFFSITE DOSE CALCULATION MANUAL

10.2 Carbon-14

Carbon-14 is a constituent of a nuclear power plants atmospheric effluent that requires specific attention and evaluation. ^{14}C is a pure, low-energy beta emitter (0.156 MeV) that historically has not been a focus of ODCM and nuclear power plant radiological effluent evaluations. The low beta energy means that ^{14}C is not detected by installed effluent monitors, and can only be quantified with sensitive, in-laboratory equipment. Historically, ^{14}C has not been identified as a significant contributor to the effluent source term, on either an activity or dose basis. However, the continued reduction in total effluent releases has increased the relative importance of ^{14}C , with respect to both the activity released and dose consequence. The PBNP methodology for estimating the activity of ^{14}C released and the dose consequence of the release is described in the sections below.

10.2.1 Carbon-14 Effluent Activity

The annual release rate of ^{14}C in gaseous effluents is calculated in accordance with the methodology described in EPRI Technical Report 1021106 "Estimation of Carbon-14 in Nuclear Power Plant Gaseous Effluents" (EPRI, 2010). ^{14}C is primarily generated in a nuclear power plant by one of 2 reactions:

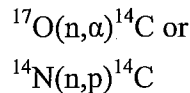

The ^{14}C production rate is determined by the following equation:

$$\text{Prod. Rate} = \frac{N \times (\sigma_{th} \times \varphi_{th} + \sigma_{i+f} \times \varphi_{i+f}) \times 1.0E - 24 \times \lambda}{3.7E - 04} \quad [10-2]$$

Where:

Prod. Rate = Production rate of C-14 production ($\mu\text{Ci/s-kg}$ from ^{17}O and $\mu\text{Ci/s-kg-ppm}$ N from ^{14}N)

N = Atoms
 $^{17}\text{O} = 1.27E+22$ atoms $^{17}\text{O/kg}$ H_2O
 $^{14}\text{N} = 4.284E+19$ atoms $^{14}\text{N/kg-ppm}$ N

σ_{th} = "effective" thermal cross-section (b)
 $^{17}\text{O} = 0.121$
 $^{14}\text{N} = 0.951$ (from EPRI TR-1021106)

φ_{th} = Thermal neutron flux ($\text{n/cm}^2\text{-s}$)
 $= 3.55E13$ $\text{n/cm}^2\text{-s}$ at BOC (from EPRI TR-1021106)

σ_{i+f} = "effective" intermediate + fast cross-section (b)
 $^{17}\text{O} = 0.0479$
 $^{14}\text{N} = 0.0392$ (from EPRI TR-1021106)

φ_{i+f} = Intermediate + fast neutron flux ($\text{n/cm}^2\text{-s}$)
 $= 3.51E17$ $\text{n/cm}^2\text{-s}$ at BOC (from EPRI TR-1021106)

$1.0E-24$ = (cm^2/b)

λ = ^{14}C decay constant, $3.833E-12$ s^{-1}

$3.7E-04$ = $\text{d/s-}\mu\text{Ci}$

OFFSITE DOSE CALCULATION MANUAL

Using the above formula and example PWR data values (for neutron flux, water mass in the active core and nitrogen content) from the EPRI report, the calculated ^{14}C generation rate is $0.349 \mu\text{Ci/s}$ from the ^{17}O reaction and $2.96\text{E-}3 \mu\text{Ci/s}$ from the ^{14}N reaction. This results in a total ^{14}C production rate of 11.1 Ci/year . According to the EPRI report, the atmospheric release rate is approximately 90-98% of the production rate. The remainder is effectively released via solid waste. For PWRs virtually all of the released C-14 is in the non- CO_2 form, a form which does not contribute to ingestion dose. Based on measurements at Ginna (a Westinghouse plant the same vintage as PBNP), approximately 10% is released as CO_2 (Kunz, "Measurement of ^{14}C Production and Discharge From the Ginna Nuclear Power Plant, June 1982, p. 20)

The neutron flux values listed in the formulae above are based on an assumed $3548 \text{ MW}_{\text{th}}$ Westinghouse PWR operating continuously at full power. Annual ^{14}C production and release values can be determined based on actual reactor operating performance at PBNP. As needed, the neutron flux data are obtained from ENG-Fuel/JB each year to estimate the year's ^{14}C production. An evaluation of plant conditions and operating data will be considered to determine if adjustments are needed to the assumed production rate of ^{14}C .

10.2.2 Carbon-14 Vegetation Concentration

The concentration of ^{14}C incorporated in vegetation from ^{14}CO or $^{14}\text{CO}_2$ is calculated as described in Regulatory Guide 1.109 (Rev 1) Appendix C, equation C-8:

$$C_{C-14}^V(r, \theta) = 3.17\text{E} + 07 \times p \times Q_{C-14} \left[\frac{X}{Q} \right] (r, \theta) \frac{0.11}{0.16} \quad [10-3]$$

Where:

$C_{C-14}^V(r, \theta)$ = the concentration of carbon-14 in vegetation grown at location (r, θ) in pCi/kg

$3.17\text{E}+07$ = conversion factor equivalent to $(1\text{E}+12 \text{ pCi/Ci})(1 \times 10^3 \text{ g/kg}) / (3.15\text{E}+07 \text{ sec/year})$

p = the fractional equilibrium ratio defined as the total annual release time (for ^{14}C atmospheric releases) to the total annual release time during which photosynthesis occurs (assumed to be 4400 hours) with $p \leq 1.0$.

$0.11/0.16$ = total plant mass as natural carbon (0.11) divided the concentration of natural carbon in the atmosphere (0.16 g/m^3)

Q_{C-14} = the annual release rate of ^{14}C (Ci/year)

$X/Q(r, \theta)$ = the annual average atmospheric dispersion factor, in sec/m^3 for the point of interest defined by (r, θ) .

The concentration calculated above is then used to determine the concentration in meat and milk, no different from other radionuclides. The resultant dose is calculated in the same fashion as listed in the applicable sections below.

OFFSITE DOSE CALCULATION MANUAL

10.3 Dose Rate Calculations – Noble Gases

PBNP TS 5.5.4.g limits the instantaneous dose rate at the SITE BOUNDARY due to noble gas releases to:

- ≤ 500 mrem/yr to the total body
- ≤ 3000 mrem/yr to the skin

Radiation monitor alarm setpoints are established to ensure that these release limits are not exceeded. If the alarm setpoint is exceeded by any gaseous release from the station, and evaluation of the SITE BOUNDARY dose rate resulting from the release shall be performed using the following equations:

$$\dot{D}_{tb} = \chi/Q * \sum_i (K_i * \dot{Q}_i) \quad [10-4]$$

$$\dot{D}_s = \chi/Q * \sum_i [(L_i + 1.1M_i) * \dot{Q}_i] \quad [10-5]$$

- Where:
- \dot{D}_{tb} = the total body dose rate (mrem/yr),
 - \dot{D}_s = the skin dose rate (mrem/yr),
 - χ/Q = the atmospheric dispersion to the controlling SITE BOUNDARY location (sec/m³, see Table 10-2)
 - \dot{Q}_i = the average release rate of radionuclide "i" over the release period under evaluation, not to exceed one hour (μ Ci/sec)
 - K_i = total body dose conversion factor for noble gas radionuclide "i" (mrem/yr per μ Ci/m³ see Table 10-3)
 - L_i = beta skin dose conversion factor for noble gas radionuclide "i" (mrem/yr per μ Ci/m³ see Table 10-3)
 - M_i = gamma air dose conversion factor for noble gas radionuclide "i" (mrad/yr per μ Ci/m³ see Table 10-3)
 - 1.1 = mrem skin dose per mrad gamma air dose (mrem/mrad)

OFFSITE DOSE CALCULATION MANUAL

TABLE 10-3
DOSE FACTORS FOR NOBLE GASES

RADIONUCLIDE	TOTAL BODY DOSE FACTOR K_i (mrem/yr per $\mu\text{Ci}/\text{m}^3$)	SKIN DOSE FACTOR L_i (mrem/yr per $\mu\text{Ci}/\text{m}^3$)	GAMMA AIR DOSE FACTOR M_i (mrad/yr per $\mu\text{Ci}/\text{m}^3$)	BETA AIR DOSE FACTOR N_i (mrad/yr per $\mu\text{Ci}/\text{m}^3$)
Kr-83m	7.56E-02	---	1.93 E+01	2.88 E+02
Kr-85m	1.17 E+03	1.46 E+03	1.23 E+03	1.97 E+03
Kr-85	1.61 E+01	1.34 E+03	1.72 E+01	1.95 E+03
Kr-87	5.92 E+03	9.73 E+03	6.17 E+03	1.03 E+04
Kr-88	1.47 E+04	2.37 E+03	1.52 E+04	2.93 E+03
Kr-89	1.66 E+04	1.01 E+04	1.73 E+04	1.06 E+04
Kr-90	1.56 E+04	7.29 E+03	1.63 E+04	7.83 E+03
Xe-131m	9.15 E+01	4.76 E+02	1.56 E+02	1.11 E+03
Xe-133m	2.51 E+02	9.94 E+02	3.27 E+02	1.48 E+03
Xe-133	2.94 E+02	3.06 E+02	3.53 E+02	1.05 E+03
Xe-135m	3.12 E+03	7.11 E+02	3.36 E+03	7.39 E+02
Xe-135	1.81 E+03	1.86 E+03	1.92 E+03	2.46 E+03
Xe-137	1.42 E+03	1.22 E+04	1.51 E+03	1.27 E+04
Xe-138	8.83 E+03	4.13 E+03	9.21 E+03	4.75 E+03
Ar-41	8.84 E+03	2.69 E+03	9.30 E+03	3.28 E+03

Source: Reg. Guide 1.109, Table B-1

10.4 Dose Rate Calculations – Radioiodine, Tritium, Particulates

PBNP TS 5.5.4.g limits the instantaneous dose rate to 1500 mrem/yr to any organ for I-131, I-133, tritium, and particulates with half-lives greater than eight days. To demonstrate compliance with this limit, an evaluation may be performed at a frequency no greater than that corresponding to the sampling and analysis time period for CONTINUOUS RELEASES and for BATCH RELEASES on the time period over which any BATCH RELEASE is to occur when conditions depart from bounding conditions of the previous year. The following equation shall be used for the dose rate evaluation:

$$\dot{D}_o = \chi/Q * \sum_i (R_{io} * \dot{Q}_i) \quad [10-6]$$

- Where:
- \dot{D}_o = the average organ dose rate over the sampling time period (mrem/yr)
 - χ/Q = the atmospheric dispersion to the controlling SITE BOUNDARY location (sec/m^3 , see Table 10-2)
 - R_{io} = the dose parameter for radionuclide "i", for the child inhalation pathway (mrem/yr per $\mu\text{Ci}/\text{m}^3$ see Table 10-6)
 - \dot{Q}_i = the average release rate over the appropriate sampling period and analysis frequency for radionuclide "i", I-131, I-133, tritium, or other radionuclide in particulate form with a half-life greater than 8 days ($\mu\text{Ci}/\text{sec}$)

10.5 Dose Calculations – Noble Gases

PBNP TS 5.5.4.h requires that dose contributions due to the release of noble gases should be determined at least once every 31 days in order to evaluate compliance with the quarterly dose limits of < 5 mrad, gamma-air and < 10 mrad, beta-air and annual dose limits of < 10 mrad, gamma-air and < 20 mrad, beta-air. The following equations shall be used to calculate the gamma-air and beta-air doses:

$$D_{\gamma} = 3.17E - 08 * \chi/Q * \sum_i (M_i * Q_i) \quad [10-7]$$

$$D_{\beta} = 3.17E - 08 * \chi/Q * \sum_i (N_i * Q_i) \quad [10-8]$$

Where:

D_{γ} = air dose due to gamma emissions for noble gas radionuclides (mrad),

D_{β} = air dose due to beta emissions for noble gas radionuclides (mrad),

χ/Q = atmospheric dispersion to the controlling SITE BOUNDARY location (sec/m³, see Table 10-2)

Q_i = cumulative release of noble gas radionuclide "i" over the period of interest (μ Ci)

M_i = air dose factor due to gamma emissions form noble gas radionuclide "i" (mrad/yr per μ Ci /m³, see Table 10-3)

N_i = air dose factor due to beta emissions form noble gas radionuclide "i" (mrad/yr per μ Ci /m³, see Table 10-3)

3.17E-08 = yr/sec

OFFSITE DOSE CALCULATION MANUAL

10.6 Dose Calculations – Radioiodine, Tritium, Particulates

PBNP TS 5.5.4.i requires that dose contributions due to the release of I-131, I-133, tritium, and/or particulates with half-lives greater than eight days should be determined at least once every 31 days in order to evaluate compliance with the quarterly dose limit of < 7.5 mrem and annual dose limit of < 15 mrem to any organ, per unit. For the two unit PBNP site, the limit is 15 mrem per quarter and 30 mrem per year. The following equation shall be used to evaluate the maximum organ dose:

$$D_{aop} = 3.17E - 08 \times W \times \sum_i (R_{io} * Q_i) \quad [10-9]$$

- Where:
- D_{aop} = dose for age group "a" to organ "o", including the total body, via pathway "p" (mrem),
 - W = atmospheric dispersion factor to the controlling location(s) as identified in Table 10-2
 = χ/Q (sec/m³) for inhalation pathway and C-14 or H-3 in food pathways
 = D/Q (m⁻²) for ground plane and food pathways (except C-14 and H-3).
 - R_{io} = dose factor for radionuclide "i" to organ "o" for each age group "a" and the applicable pathway "p" (mrem/yr per $\mu\text{Ci}/\text{m}^3$ or m²-mrem/yr per $\mu\text{Ci}/\text{sec}$, see Table 10-4 through Table 10-21)
 - Q_i = cumulative release for radionuclide "i" (μCi),
 - 3.17E-08 = conversion factor for yr/sec

In general, the infant or child is expected to be the controlling age group for gaseous exposures.

OFFSITE DOSE CALCULATION MANUAL

10.7 Gaseous Dose Projection

As required by TS 5.5.4.e and TS 5.5.4.f dose projections shall be made at least once every 31 days. As described in Section 7.4.1, when the projected doses in a period of 31 days would exceed 2% of the guidelines for the annual dose or dose commitment, appropriate portions of the gaseous effluent treatment system should be used to reduce releases of radioactivity to within the allowable limits. The following equations should be used to perform dose projections:

$$D_{\gamma p} = D_{\gamma}(31/d) \quad [10-10]$$

$$D_{\beta p} = D_{\beta}(31/d) \quad [10-11]$$

$$D_{maxp} = D_{max}(31/d) \quad [10-12]$$

- Where:
- $D_{\gamma p}$ = projected 31-day gamma-air dose (mrad)
 - D_{γ} = gamma-air dose for current calendar month (mrad)
 - $D_{\beta p}$ = projected 31-day beta-air dose (mrad)
 - D_{β} = beta-air dose for current calendar month (mrad)
 - D_{maxp} = maximum organ dose projection for the current calendar month (mrem)
 - d = number of days to date for the current month (days)
 - 31 = number of days in projection (days)

OFFSITE DOSE CALCULATION MANUAL

TABLE 10-4
 R_{io} , INHALATION PATHWAY DOSE FACTORS – ADULT

(mrem/yr per $\mu\text{Ci}/\text{m}^3$)

NUCLIDE	BONE	LIVER	T. BODY	THYROID	KIDNEY	LUNG	G-LLI
H-3	0.00E+00	7.18E+02	7.18E+02	7.18E+02	7.18E+02	7.18E+02	7.18E+02
C-14	1.82E+04	3.41E+03	3.41E+03	3.41E+03	3.41E+03	3.41E+03	3.41E+03
F-18	3.77E+03	0.00E+00	4.15E+02	0.00E+00	0.00E+00	0.00E+00	7.39E+01
Na-22	1.04E+05	1.04E+05	1.04E+05	1.04E+05	1.04E+05	1.04E+05	1.04E+05
Na-24	1.02E+04	1.02E+04	1.02E+04	1.02E+04	1.02E+04	1.02E+04	1.02E+04
Sc-46	4.41E+05	8.56E+05	2.49E+05	0.00E+00	7.99E+05	0.00E+00	2.15E+05
P-32	1.32E+06	7.71E+04	5.01E+04	0.00E+00	0.00E+00	0.00E+00	8.64E+04
Cr-51	0.00E+00	0.00E+00	1.00E+02	5.95E+01	2.28E+01	1.44E+04	3.32E+03
Mn-54	0.00E+00	3.96E+04	6.30E+03	0.00E+00	9.84E+03	1.40E+06	7.74E+04
Mn-56	0.00E+00	1.24E+00	1.83E-01	0.00E+00	1.30E+00	9.44E+03	2.02E+04
Fe-55	2.46E+04	1.70E+04	3.94E+03	0.00E+00	0.00E+00	7.21E+04	6.03E+03
Fe-59	1.18E+04	2.78E+04	1.06E+04	0.00E+00	0.00E+00	1.02E+06	1.88E+05
Co-57	0.00E+00	6.92E+02	6.71E+02	0.00E+00	0.00E+00	3.70E+05	3.14E+04
Co-58	0.00E+00	1.58E+03	2.07E+03	0.00E+00	0.00E+00	9.28E+05	1.06E+05
Co-60	0.00E+00	1.15E+04	1.48E+04	0.00E+00	0.00E+00	5.97E+06	2.85E+05
Ni-63	4.32E+05	3.14E+04	1.45E+04	0.00E+00	0.00E+00	1.78E+05	1.34E+04
Ni-65	1.54E+00	2.26E-01	9.12E-02	0.00E+00	0.00E+00	5.60E+03	1.23E+04
Cu-64	0.00E+00	1.46E+00	6.15E-01	0.00E+00	4.62E+00	6.78E+03	4.90E+04
Zn-65	3.24E+04	1.03E+05	4.66E+04	0.00E+00	6.90E+04	8.64E+05	5.34E+04
Zn-69m	8.16E+00	1.96E+01	1.79E+00	0.00E+00	1.18E+01	1.90E+04	1.37E+05
Zn-69	3.38E-02	6.51E-02	4.52E-03	0.00E+00	4.22E-02	9.20E+02	1.63E+01
As-76	9.78E+02	2.61E+03	2.19E+04	9.48E+02	2.90E+03	1.01E+05	8.59E+04
Br-82	0.00E+00	0.00E+00	1.35E+04	0.00E+00	0.00E+00	0.00E+00	1.04E+04
Br-83	0.00E+00	0.00E+00	2.41E+02	0.00E+00	0.00E+00	0.00E+00	2.32E+02
Br-84	0.00E+00	0.00E+00	3.13E+02	0.00E+00	0.00E+00	0.00E+00	1.64E-03
Br-85	0.00E+00	0.00E+00	1.28E+01	0.00E+00	0.00E+00	0.00E+00	0.00E+00
Rb-86	0.00E+00	1.35E+05	5.90E+04	0.00E+00	0.00E+00	0.00E+00	1.66E+04
Rb-88	0.00E+00	3.87E+02	1.93E+02	0.00E+00	0.00E+00	0.00E+00	3.34E-09
Rb-89	0.00E+00	2.56E+02	1.70E+02	0.00E+00	0.00E+00	0.00E+00	9.28E-12
Sr-89	3.04E+05	0.00E+00	8.72E+03	0.00E+00	0.00E+00	1.40E+06	3.50E+05
Sr-90	2.87E+07	0.00E+00	5.77E+05	0.00E+00	0.00E+00	9.60E+06	7.22E+05
Sr-91	6.19E+01	0.00E+00	2.50E+00	0.00E+00	0.00E+00	3.65E+04	1.91E+05
Sr-92	6.74E+00	0.00E+00	2.91E-01	0.00E+00	0.00E+00	1.65E+04	4.30E+04
Y-90	2.09E+03	0.00E+00	5.61E+01	0.00E+00	0.00E+00	1.70E+05	5.06E+05
Y-91m	2.61E-01	0.00E+00	1.02E-02	0.00E+00	0.00E+00	1.92E+03	1.33E+00
Y-91	4.62E+05	0.00E+00	1.24E+04	0.00E+00	0.00E+00	1.70E+06	3.85E+05

OFFSITE DOSE CALCULATION MANUAL

TABLE 10-4
 R_{io} , INHALATION PATHWAY DOSE FACTORS – ADULT

NUCLIDE	BONE	LIVER	T. BODY	THYROID	KIDNEY	LUNG	GI-LLI
Y-92	1.03E+01	0.00E+00	3.02E-01	0.00E+00	0.00E+00	1.57E+04	7.35E+04
Y-93	9.44E+01	0.00E+00	2.61E+00	0.00E+00	0.00E+00	4.85E+04	4.22E+05
Zr-95	1.07E+05	3.44E+04	2.33E+04	0.00E+00	5.42E+04	1.77E+06	1.50E+05
Zr-97	9.68E+01	1.96E+01	9.04E+00	0.00E+00	2.97E+01	7.87E+04	5.23E+05
Nb-95	1.41E+04	7.82E+03	4.21E+03	0.00E+00	7.74E+03	5.05E+05	1.04E+05
Nb-97	2.22E-01	5.62E-02	2.05E-02	0.00E+00	6.54E-02	2.40E+03	2.42E+02
Mo-99	0.00E+00	1.21E+02	2.30E+01	0.00E+00	2.91E+02	9.12E+04	2.48E+05
Tc-99m	1.03E-03	2.91E-03	3.70E-02	0.00E+00	4.42E-02	7.64E+02	4.16E+03
Tc-99	2.50E+02	3.71E+02	1.00E+02	0.00E+00	4.68E+03	8.08E+05	6.03E+04
Tc-101	4.18E-05	6.02E-05	5.90E-04	0.00E+00	1.08E-03	3.99E+02	1.09E-11
Ru-103	1.53E+03	0.00E+00	6.58E+02	0.00E+00	5.83E+03	5.05E+05	1.10E+05
Ru-105	7.90E-01	0.00E+00	3.11E-01	0.00E+00	1.02E+00	1.10E+04	4.82E+04
Ru-106	6.91E+04	0.00E+00	8.72E+03	0.00E+00	1.34E+05	9.36E+06	9.12E+05
Rh-105	7.39E+00	5.38E+00	3.54E+00	0.00E+00	2.29E+01	1.93E+04	8.72E+04
Ag-110m	1.08E+04	1.00E+04	5.94E+03	0.00E+00	1.97E+04	4.63E+06	3.02E+05
Sn-113	2.70E+04	1.01E+04	8.00E+04	5.63E+03	5.33E+03	5.63E+05	6.22E+04
Sn-117m	2.79E+04	1.48E+03	7.11E+04	7.11E+02	7.11E+02	5.63E+05	5.33E+04
Sb-122	1.90E+03	1.48E+03	2.96E+04	6.52E+02	7.70E+02	1.63E+05	1.16E+05
Sb-124	3.12E+04	5.89E+02	1.24E+04	7.55E+01	0.00E+00	2.48E+06	4.06E+05
Sb-125	5.34E+04	5.95E+02	1.26E+04	5.40E+01	0.00E+00	1.74E+06	1.01E+05
Te-125m	3.42E+03	1.58E+03	4.67E+02	1.05E+03	1.24E+04	3.14E+05	7.06E+04
Te-127m	1.26E+04	5.77E+03	1.57E+03	3.29E+03	4.58E+04	9.60E+05	1.50E+05
Te-127	1.40E+00	6.42E-01	3.10E-01	1.06E+00	5.10E+00	6.51E+03	5.74E+04
Te-129m	9.76E+03	4.67E+03	1.58E+03	3.44E+03	3.66E+04	1.16E+06	3.83E+05
Te-129	4.98E-02	2.39E-02	1.24E-02	3.90E-02	1.87E-01	1.94E+03	1.57E+02
Te-131m	6.99E+01	4.36E+01	2.90E+01	5.50E+01	3.09E+02	1.46E+05	5.56E+05
Te-131	1.11E-02	5.95E-03	3.59E-03	9.36E-03	4.37E-02	1.39E+03	1.84E+01
Te-132	2.60E+02	2.15E+02	1.62E+02	1.90E+02	1.46E+03	2.88E+05	5.10E+05
I-130	4.58E+03	1.34E+04	5.28E+03	1.14E+06	2.09E+04	0.00E+00	7.69E+03
I-131	2.52E+04	3.58E+04	2.05E+04	1.19E+07	6.13E+04	0.00E+00	6.28E+03
I-132	1.16E+03	3.26E+03	1.16E+03	1.14E+05	5.18E+03	0.00E+00	4.06E+02
I-133	8.64E+03	1.48E+04	4.52E+03	2.15E+06	2.58E+04	0.00E+00	8.88E+03
I-134	6.44E+02	1.73E+03	6.15E+02	2.98E+04	2.75E+03	0.00E+00	1.01E+00
I-135	2.68E+03	6.98E+03	2.57E+03	4.48E+05	1.11E+04	0.00E+00	5.25E+03
Cs-134	3.73E+05	8.48E+05	7.28E+05	0.00E+00	2.87E+05	9.76E+04	1.04E+04
Cs-134m	1.27E+02	2.56E+02	1.38E+02	0.00E+00	1.46E+02	2.34E+01	6.34E+01
Cs-136	3.90E+04	1.46E+05	1.10E+05	0.00E+00	8.56E+04	1.20E+04	1.17E+04

OFFSITE DOSE CALCULATION MANUAL

TABLE 10-4
 R_{io} , INHALATION PATHWAY DOSE FACTORS – ADULT

NUCLIDE	BONE	LIVER	T. BODY	THYROID	KIDNEY	LUNG	GI-LLI
Cs-137	4.78E+05	6.21E+05	4.28E+05	0.00E+00	2.22E+05	7.52E+04	8.40E+03
Cs-138	3.31E+02	6.21E+02	3.24E+02	0.00E+00	4.80E+02	4.86E+01	1.86E-03
Ba-139	9.36E-01	6.66E-04	2.74E-02	0.00E+00	6.22E-04	3.76E+03	8.96E+02
Ba-140	3.90E+04	4.90E+01	2.57E+03	0.00E+00	1.67E+01	1.27E+06	2.18E+05
Ba-141	1.00E-01	7.53E-05	3.36E-03	0.00E+00	7.00E-05	1.94E+03	1.16E-07
Ba-142	2.63E-02	2.70E-05	1.66E-03	0.00E+00	2.29E-05	1.19E+03	1.57E-16
La-140	3.44E+02	1.74E+02	4.58E+01	0.00E+00	0.00E+00	1.36E+05	4.58E+05
La-142	6.83E-01	3.10E-01	7.72E-02	0.00E+00	0.00E+00	6.33E+03	2.11E+03
Ce-141	1.99E+04	1.35E+04	1.53E+03	0.00E+00	6.26E+03	3.62E+05	1.20E+05
Ce-143	1.86E+02	1.38E+02	1.53E+01	0.00E+00	6.08E+01	7.98E+04	2.26E+05
Ce-144	3.43E+06	1.43E+06	1.84E+05	0.00E+00	8.48E+05	7.78E+06	8.16E+05
Pr-143	9.36E+03	3.75E+03	4.64E+02	0.00E+00	2.16E+03	2.81E+05	2.00E+05
Pr-144	3.01E-02	1.25E-02	1.53E-03	0.00E+00	7.05E-03	1.02E+03	2.15E-08
Nd-147	5.27E+03	6.10E+03	3.65E+02	0.00E+00	3.56E+03	2.21E+05	1.73E+05
Eu-152	1.90E+06	4.33E+05	3.81E+05	0.00E+00	2.68E+06	2.74E+06	1.27E+05
W-187	8.48E+00	7.08E+00	2.48E+00	0.00E+00	0.00E+00	2.90E+04	1.55E+05
U-235	8.00E+07	0.00E+00	4.86E+06	0.00E+00	1.87E+07	3.92E+08	3.87E+05
U-238	7.66E+07	0.00E+00	4.54E+06	0.00E+00	1.74E+07	3.66E+08	2.73E+05
Np-239	2.30E+02	2.26E+01	1.24E+01	0.00E+00	7.00E+01	3.76E+04	1.19E+05
Am-241	8.08E+09	2.87E+09	5.37E+08	0.00E+00	4.03E+09	4.85E+08	3.68E+05

OFFSITE DOSE CALCULATION MANUAL

TABLE 10-5
 R_{io} , INHALATION PATHWAY DOSE FACTORS – TEEN

(mrem/yr per $\mu\text{Ci}/\text{m}^3$)

NUCLIDE	BONE	LIVER	T. BODY	THYROID	KIDNEY	LUNG	GI-LLI
H-3	0.00E+00	7.25E+02	7.25E+02	7.25E+02	7.25E+02	7.25E+02	7.25E+02
C-14	2.60E+04	4.87E+03	4.87E+03	4.87E+03	4.87E+03	4.87E+03	4.87E+03
F-18	5.22E+03	0.00E+00	5.68E+02	0.00E+00	0.00E+00	0.00E+00	3.11E+02
Na-22	1.04E+05	1.04E+05	1.04E+05	1.04E+05	1.04E+05	1.04E+05	1.04E+05
Na-24	1.38E+04	1.38E+04	1.38E+04	1.38E+04	1.38E+04	1.38E+04	1.38E+04
Sc-46	5.79E+05	1.13E+06	3.34E+05	0.00E+00	1.08E+06	0.00E+00	2.38E+05
P-32	1.89E+06	1.10E+05	7.16E+04	0.00E+00	0.00E+00	0.00E+00	9.28E+04
Cr-51	0.00E+00	0.00E+00	1.35E+02	7.50E+01	3.07E+01	2.10E+04	3.00E+03
Mn-54	0.00E+00	5.11E+04	8.40E+03	0.00E+00	1.27E+04	1.98E+06	6.68E+04
Mn-56	0.00E+00	1.70E+00	2.52E-01	0.00E+00	1.79E+00	1.52E+04	5.74E+04
Fe-55	3.34E+04	2.38E+04	5.54E+03	0.00E+00	0.00E+00	1.24E+05	6.39E+03
Fe-59	1.59E+04	3.70E+04	1.43E+04	0.00E+00	0.00E+00	1.53E+06	1.78E+05
Co-57	0.00E+00	9.44E+02	9.20E+02	0.00E+00	0.00E+00	5.86E+05	3.14E+04
Co-58	0.00E+00	2.07E+03	2.78E+03	0.00E+00	0.00E+00	1.34E+06	9.52E+04
Co-60	0.00E+00	1.51E+04	1.98E+04	0.00E+00	0.00E+00	8.72E+06	2.59E+05
Ni-63	5.80E+05	4.34E+04	1.98E+04	0.00E+00	0.00E+00	3.07E+05	1.42E+04
Ni-65	2.18E+00	2.93E-01	1.27E-01	0.00E+00	0.00E+00	9.36E+03	3.67E+04
Cu-64	0.00E+00	2.03E+00	8.48E-01	0.00E+00	6.41E+00	1.11E+04	6.14E+04
Zn-65	3.86E+04	1.34E+05	6.24E+04	0.00E+00	8.64E+04	1.24E+06	4.66E+04
Zn-69m	1.15E+01	2.71E+01	2.49E+00	0.00E+00	1.65E+01	3.14E+04	1.71E+05
Zn-69	4.83E-02	9.20E-02	6.46E-03	0.00E+00	6.02E-02	1.58E+03	2.85E+02
As-76	1.16E+03	3.26E+03	2.61E+04	1.10E+03	3.56E+03	1.19E+05	1.04E+05
Br-82	0.00E+00	0.00E+00	1.82E+04	0.00E+00	0.00E+00	0.00E+00	0.00E+00
Br-83	0.00E+00	0.00E+00	3.44E+02	0.00E+00	0.00E+00	0.00E+00	0.00E+00
Br-84	0.00E+00	0.00E+00	4.33E+02	0.00E+00	0.00E+00	0.00E+00	0.00E+00
Br-85	0.00E+00	0.00E+00	1.83E+01	0.00E+00	0.00E+00	0.00E+00	0.00E+00
Rb-86	0.00E+00	1.90E+05	8.40E+04	0.00E+00	0.00E+00	0.00E+00	1.77E+04
Rb-88	0.00E+00	5.46E+02	2.72E+02	0.00E+00	0.00E+00	0.00E+00	2.92E-05
Rb-89	0.00E+00	3.52E+02	2.33E+02	0.00E+00	0.00E+00	0.00E+00	3.38E-07
Sr-89	4.34E+05	0.00E+00	1.25E+04	0.00E+00	0.00E+00	2.42E+06	3.71E+05
Sr-90	3.31E+07	0.00E+00	6.66E+05	0.00E+00	0.00E+00	1.65E+07	7.65E+05
Sr-91	8.80E+01	0.00E+00	3.51E+00	0.00E+00	0.00E+00	6.07E+04	2.59E+05
Sr-92	9.52E+00	0.00E+00	4.06E-01	0.00E+00	0.00E+00	2.74E+04	1.19E+05
Y-90	2.98E+03	0.00E+00	8.00E+01	0.00E+00	0.00E+00	2.93E+05	5.59E+05
Y-91m	3.70E-01	0.00E+00	1.42E-02	0.00E+00	0.00E+00	3.20E+03	3.02E+01
Y-91	6.61E+05	0.00E+00	1.77E+04	0.00E+00	0.00E+00	2.94E+06	4.09E+05

TABLE 10-5
 R_{io} , INHALATION PATHWAY DOSE FACTORS – TEEN

NUCLIDE	BONE	LIVER	T. BODY	THYROID	KIDNEY	LUNG	GI-LLI
Y-92	1.47E+01	0.00E+00	4.29E-01	0.00E+00	0.00E+00	2.68E+04	1.65E+05
Y-93	1.35E+02	0.00E+00	3.72E+00	0.00E+00	0.00E+00	8.32E+04	5.79E+05
Zr-95	1.46E+05	4.58E+04	3.15E+04	0.00E+00	6.74E+04	2.69E+06	1.49E+05
Zr-97	1.38E+02	2.72E+01	1.26E+01	0.00E+00	4.12E+01	1.30E+05	6.30E+05
Nb-95	1.86E+04	1.03E+04	5.66E+03	0.00E+00	1.00E+04	7.51E+05	9.68E+04
Nb-97	3.14E-01	7.78E-02	2.84E-02	0.00E+00	9.12E-02	3.93E+03	2.17E+03
Mo-99	0.00E+00	1.69E+02	3.22E+01	0.00E+00	4.11E+02	1.54E+05	2.69E+05
Tc-99m	1.38E-03	3.86E-03	4.99E-02	0.00E+00	5.76E-02	1.15E+03	6.13E+03
Tc-99	3.58E+02	5.26E+02	1.43E+02	0.00E+00	6.68E+03	1.39E+06	6.39E+04
Tc-101	5.92E-05	8.40E-05	8.24E-04	0.00E+00	1.52E-03	6.67E+02	8.72E-07
Ru-103	2.10E+03	0.00E+00	8.96E+02	0.00E+00	7.43E+03	7.83E+05	1.09E+05
Ru-105	1.12E+00	0.00E+00	4.34E-01	0.00E+00	1.41E+00	1.82E+04	9.04E+04
Ru-106	9.84E+04	0.00E+00	1.24E+04	0.00E+00	1.90E+05	1.61E+07	9.60E+05
Rh-105	1.06E+01	7.58E+00	4.99E+00	0.00E+00	3.23E+01	3.27E+04	9.84E+04
Ag-110m	1.38E+04	1.31E+04	7.99E+03	0.00E+00	2.50E+04	6.75E+06	2.73E+05
Sn-113	2.81E+04	1.24E+04	9.48E+04	6.52E+03	6.52E+03	6.81E+03	7.41E+04
Sn-117m	2.73E+04	1.87E+03	9.19E+04	8.59E+02	9.19E+02	7.11E+05	6.22E+04
Sb-122	2.01E+03	1.84E+03	3.85E+04	7.41E+02	9.48E+02	1.99E+05	1.39E+05
Sb-124	4.30E+04	7.94E+02	1.68E+04	9.76E+01	0.00E+00	3.85E+06	3.98E+05
Sb-125	7.38E+04	8.08E+02	1.72E+04	7.04E+01	0.00E+00	2.74E+06	9.92E+04
Te-125m	4.88E+03	2.24E+03	6.67E+02	1.40E+03	0.00E+00	5.36E+05	7.50E+04
Te-127m	1.80E+04	8.16E+03	2.18E+03	4.38E+03	6.54E+04	1.66E+06	1.59E+05
Te-127	2.01E+00	9.12E-01	4.42E-01	1.42E+00	7.28E+00	1.12E+04	8.08E+04
Te-129m	1.39E+04	6.58E+03	2.25E+03	4.58E+03	5.19E+04	1.98E+06	4.05E+05
Te-129	7.10E-02	3.38E-02	1.76E-02	5.18E-02	2.66E-01	3.30E+03	1.62E+03
Te-131m	9.84E+01	6.01E+01	4.02E+01	7.25E+01	4.39E+02	2.38E+05	6.21E+05
Te-131	1.58E-02	8.32E-03	5.04E-03	1.24E-02	6.18E-02	2.34E+03	1.51E+01
Te-132	3.60E+02	2.90E+02	2.19E+02	2.46E+02	1.95E+03	4.49E+05	4.63E+05
I-130	6.24E+03	1.79E+04	7.17E+03	1.49E+06	2.75E+04	0.00E+00	9.12E+03
I-131	3.54E+04	4.91E+04	2.64E+04	1.46E+07	8.40E+04	0.00E+00	6.49E+03
I-132	1.59E+03	4.38E+03	1.58E+03	1.51E+05	6.92E+03	0.00E+00	1.27E+03
I-133	1.22E+04	2.05E+04	6.22E+03	2.92E+06	3.59E+04	0.00E+00	1.03E+04
I-134	8.88E+02	2.32E+03	8.40E+02	3.95E+04	3.66E+03	0.00E+00	2.04E+01
I-135	3.70E+03	9.44E+03	3.49E+03	6.21E+05	1.49E+04	0.00E+00	6.95E+03
Cs-134	5.02E+05	1.13E+06	5.49E+05	0.00E+00	3.75E+05	1.46E+05	9.76E+03
Cs-134m	1.76E+02	3.48E+02	1.88E+02	0.00E+00	2.03E+02	3.65E+01	1.62E+02
Cs-136	5.15E+04	1.94E+05	1.37E+05	0.00E+00	1.10E+05	1.78E+04	1.09E+04

OFFSITE DOSE CALCULATION MANUAL

TABLE 10-5
 R_{io} , INHALATION PATHWAY DOSE FACTORS – TEEN

NUCLIDE	BONE	LIVER	T. BODY	THYROID	KIDNEY	LUNG	GI-LLI
Cs-137	6.70E+05	8.48E+05	3.11E+05	0.00E+00	3.04E+05	1.21E+05	8.48E+03
Cs-138	4.66E+02	8.56E+02	4.46E+02	0.00E+00	6.62E+02	7.87E+01	2.70E-01
Ba-139	1.34E+00	9.44E-04	3.90E-02	0.00E+00	8.88E-04	6.46E+03	6.45E+03
Ba-140	5.47E+04	6.70E+01	3.52E+03	0.00E+00	2.28E+01	2.03E+06	2.29E+05
Ba-141	1.42E-01	1.06E-04	4.74E-03	0.00E+00	9.84E-05	3.29E+03	7.46E-04
Ba-142	3.70E-02	3.70E-05	2.27E-03	0.00E+00	3.14E-05	1.91E+03	4.79E-10
La-140	4.79E+02	2.36E+02	6.26E+01	0.00E+00	0.00E+00	2.14E+05	4.87E+05
La-142	9.60E-01	4.25E-01	1.06E-01	0.00E+00	0.00E+00	1.02E+04	1.20E+04
Ce-141	2.84E+04	1.90E+04	2.17E+03	0.00E+00	8.88E+03	6.14E+05	1.26E+05
Ce-143	2.66E+02	1.94E+02	2.16E+01	0.00E+00	8.64E+01	1.30E+05	2.55E+05
Ce-144	4.89E+06	2.02E+06	2.62E+05	0.00E+00	1.21E+06	1.34E+07	8.64E+05
Pr-143	1.34E+04	5.31E+03	6.62E+02	0.00E+00	3.09E+03	4.83E+05	2.14E+05
Pr-144	4.30E-02	1.76E-02	2.18E-03	0.00E+00	1.01E-02	1.75E+03	2.35E-04
Nd-147	7.86E+03	8.56E+03	5.13E+02	0.00E+00	5.02E+03	3.72E+05	1.82E+05
Eu-152	2.37E+06	5.75E+05	5.04E+05	0.00E+00	2.67E+06	4.01E+06	1.08E+05
W-187	1.20E+01	9.76E+00	3.43E+00	0.00E+00	0.00E+00	4.74E+04	1.77E+05
U-235	1.14E+08	0.00E+00	6.94E+06	0.00E+00	2.67E+07	6.75E+08	4.10E+05
U-238	1.09E+08	0.00E+00	6.48E+06	0.00E+00	2.50E+07	6.31E+08	2.90E+05
Np-239	3.38E+02	3.19E+01	1.77E+01	0.00E+00	1.00E+02	6.49E+04	1.32E+05
Am-241	8.48E+09	3.26E+09	5.68E+08	0.00E+00	4.26E+09	8.40E+08	3.90E+05

TABLE 10-6
 R_{io} , INHALATION PATHWAY DOSE FACTORS – CHILD

(mrem/yr per $\mu\text{Ci}/\text{m}^3$)

NUCLIDE	BONE	LIVER	T. BODY	THYROID	KIDNEY	LUNG	GLETT
H-3	0.00E+00	6.40E+02	6.40E+02	6.40E+02	6.40E+02	6.40E+02	6.40E+02
C-14	3.59E+04	6.73E+03	6.73E+03	6.73E+03	6.73E+03	6.73E+03	6.73E+03
F-18	6.96E+03	0.00E+00	6.85E+02	0.00E+00	0.00E+00	0.00E+00	1.25E+03
Na-22	1.63E+05	1.63E+05	1.63E+05	1.63E+05	1.63E+05	1.63E+05	1.63E+05
Na-24	1.61E+04	1.61E+04	1.61E+04	1.61E+04	1.61E+04	1.61E+04	1.61E+04
Sc-46	7.29E+05	9.99E+05	3.85E+05	0.00E+00	8.84E+05	0.00E+00	9.07E+04
P-32	2.60E+06	1.14E+05	9.88E+04	0.00E+00	0.00E+00	0.00E+00	4.22E+04
Cr-51	0.00E+00	0.00E+00	1.54E+02	8.55E+01	2.43E+01	1.70E+04	1.08E+03
Mn-54	0.00E+00	4.29E+04	9.51E+03	0.00E+00	1.00E+04	1.58E+06	2.29E+04
Mn-56	0.00E+00	1.66E+00	3.12E-01	0.00E+00	1.67E+00	1.31E+04	1.23E+05
Fe-55	4.74E+04	2.52E+04	7.77E+03	0.00E+00	0.00E+00	1.11E+05	2.87E+03
Fe-59	2.07E+04	3.34E+04	1.67E+04	0.00E+00	0.00E+00	1.27E+06	7.07E+04
Co-57	0.00E+00	9.03E+02	1.07E+03	0.00E+00	0.00E+00	5.07E+05	1.32E+04
Co-58	0.00E+00	1.77E+03	3.16E+03	0.00E+00	0.00E+00	1.11E+06	3.44E+04
Co-60	0.00E+00	1.31E+04	2.26E+04	0.00E+00	0.00E+00	7.07E+06	9.62E+04
Ni-63	8.21E+05	4.63E+04	2.80E+04	0.00E+00	0.00E+00	2.75E+05	6.33E+03
Ni-65	2.99E+00	2.96E-01	1.64E-01	0.00E+00	0.00E+00	8.18E+03	8.40E+04
Cu-64	0.00E+00	1.99E+00	1.07E+00	0.00E+00	6.03E+00	9.58E+03	3.67E+04
Zn-65	4.26E+04	1.13E+05	7.03E+04	0.00E+00	7.14E+04	9.95E+05	1.63E+04
Zn-69m	1.58E+01	2.69E+01	3.18E+00	0.00E+00	1.56E+01	2.72E+04	1.00E+05
Zn-69	6.70E-02	9.66E-02	8.92E-03	0.00E+00	5.85E-02	1.42E+03	1.02E+04
As-76	1.64E+03	4.11E+03	3.01E+04	1.51E+03	4.11E+03	9.32E+04	1.64E+05
Br-82	0.00E+00	0.00E+00	2.09E+04	0.00E+00	0.00E+00	0.00E+00	0.00E+00
Br-83	0.00E+00	0.00E+00	4.74E+02	0.00E+00	0.00E+00	0.00E+00	0.00E+00
Br-84	0.00E+00	0.00E+00	5.48E+05	0.00E+00	0.00E+00	0.00E+00	0.00E+00
Br-85	0.00E+00	0.00E+00	2.53E+01	0.00E+00	0.00E+00	0.00E+00	0.00E+00
Rb-86	0.00E+00	1.98E+05	1.14E+05	0.00E+00	0.00E+00	0.00E+00	7.99E+03
Rb-88	0.00E+00	5.62E+02	3.66E+02	0.00E+00	0.00E+00	0.00E+00	1.72E+01
Rb-89	0.00E+00	3.45E+02	2.90E+02	0.00E+00	0.00E+00	0.00E+00	1.89E+00
Sr-89	5.99E+05	0.00E+00	1.72E+04	0.00E+00	0.00E+00	2.16E+06	1.67E+05
Sr-90	3.85E+07	0.00E+00	7.66E+05	0.00E+00	0.00E+00	1.48E+07	3.43E+05
Sr-91	1.21E+02	0.00E+00	4.59E+00	0.00E+00	0.00E+00	5.33E+04	1.74E+05
Sr-92	1.31E+01	0.00E+00	5.25E-01	0.00E+00	0.00E+00	2.40E+04	2.42E+05
Y-90	4.11E+03	0.00E+00	1.11E+02	0.00E+00	0.00E+00	2.62E+05	2.68E+05
Y-91m	5.07E-01	0.00E+00	1.84E-02	0.00E+00	0.00E+00	2.81E+03	1.72E+03
Y-91	9.14E+05	0.00E+00	2.44E+04	0.00E+00	0.00E+00	2.63E+06	1.84E+05

OFFSITE DOSE CALCULATION MANUAL

TABLE 10-6
R_{io}, INHALATION PATHWAY DOSE FACTORS – CHILD

NUCLIDE	BONE	LIVER	T. BODY	THYROID	KIDNEY	LUNG	GI-LI
Y-92	2.04E+01	0.00E+00	5.81E-01	0.00E+00	0.00E+00	2.39E+04	2.39E+05
Y-93	1.86E+02	0.00E+00	5.11E+00	0.00E+00	0.00E+00	7.44E+04	3.89E+05
Zr-95	1.90E+05	4.18E+04	3.70E+04	0.00E+00	5.96E+04	2.23E+06	6.11E+04
Zr-97	1.88E+02	2.72E+01	1.60E+01	0.00E+00	3.89E+01	1.13E+05	3.51E+05
Nb-95	2.35E+04	9.18E+03	6.55E+03	0.00E+00	8.62E+03	6.14E+05	3.70E+04
Nb-97	4.29E-01	7.70E-02	3.60E-02	0.00E+00	8.55E-02	3.42E+03	2.78E+04
Mo-99	0.00E+00	1.72E+02	4.26E+01	0.00E+00	3.92E+02	1.35E+05	1.27E+05
Tc-99m	1.78E-03	3.48E-03	5.77E-02	0.00E+00	5.07E-02	9.51E+02	4.81E+03
Tc-99	4.96E+02	5.51E+02	1.98E+02	0.00E+00	6.48E+03	1.25E+06	2.87E+04
Tc-101	8.10E-05	8.51E-05	1.08E-03	0.00E+00	1.45E-03	5.85E+02	1.63E+01
Ru-103	2.79E+03	0.00E+00	1.07E+03	0.00E+00	7.03E+03	6.62E+05	4.48E+04
Ru-105	1.53E+00	0.00E+00	5.55E-01	0.00E+00	1.34E+00	1.59E+04	9.95E+04
Ru-106	1.36E+05	0.00E+00	1.69E+04	0.00E+00	1.84E+05	1.43E+07	4.29E+05
Rh-105	1.45E+01	7.77E+00	6.62E+00	0.00E+00	3.10E+01	2.89E+04	4.92E+04
Ag-110m	1.69E+04	1.14E+04	9.14E+03	0.00E+00	2.12E+04	5.48E+06	1.00E+05
Sn-113	3.56E+04	1.18E+04	7.95E+04	7.67E+03	6.99E+03	5.21E+05	1.12E+05
Sn-117m	4.11E+04	1.78E+03	6.30E+04	1.04E+03	1.06E+03	4.39E+05	9.87E+04
Sb-122	2.60E+03	2.06E+03	3.84E+04	8.63E+02	1.11E+03	1.37E+05	2.33E+05
Sb-124	5.74E+04	7.40E+02	2.00E+04	1.26E+02	0.00E+00	3.24E+06	1.64E+05
Sb-125	9.84E+04	7.59E+02	2.07E+04	9.10E+01	0.00E+00	2.32E+06	4.03E+04
Te-125m	6.73E+03	2.33E+03	9.14E+02	1.92E+03	0.00E+00	4.77E+05	3.38E+04
Te-127m	2.49E+04	8.55E+03	3.03E+03	6.07E+03	6.36E+04	1.48E+06	7.14E+04
Te-127	2.77E+00	9.51E-01	6.11E-01	1.96E+00	7.07E+00	1.00E+04	5.62E+04
Te-129m	1.92E+04	6.85E+03	3.04E+03	6.33E+03	5.03E+04	1.76E+06	1.82E+05
Te-129	9.77E-02	3.50E-02	2.38E-02	7.14E-02	2.57E-01	2.93E+03	2.55E+04
Te-131m	1.34E+02	5.92E+01	5.07E+01	9.77E+01	4.00E+02	2.06E+05	3.08E+05
Te-131	2.17E-02	8.44E-03	6.59E-03	1.70E-02	5.88E-02	2.05E+03	1.33E+03
Te-132	4.81E+02	2.72E+02	2.63E+02	3.17E+02	1.77E+03	3.77E+05	1.38E+05
I-130	8.18E+03	1.64E+04	8.44E+03	1.85E+06	2.45E+04	0.00E+00	5.11E+03
I-131	4.81E+04	4.81E+04	2.73E+04	1.62E+07	7.88E+04	0.00E+00	2.84E+03
I-132	2.12E+03	4.07E+03	1.88E+03	1.94E+05	6.25E+03	0.00E+00	3.20E+03
I-133	1.66E+04	2.03E+04	7.70E+03	3.85E+06	3.38E+04	0.00E+00	5.48E+03
I-134	1.17E+03	2.16E+03	9.95E+02	5.07E+04	3.30E+03	0.00E+00	9.55E+02
I-135	4.92E+03	8.73E+03	4.14E+03	7.92E+05	1.34E+04	0.00E+00	4.44E+03
Cs-134	6.51E+05	1.01E+06	2.25E+05	0.00E+00	3.30E+05	1.21E+05	3.85E+03
Cs-134m	2.34E+02	3.30E+02	2.26E+02	0.00E+00	1.83E+02	3.09E+01	2.93E+02
Cs-136	6.51E+04	1.71E+05	1.16E+05	0.00E+00	9.55E+04	1.45E+04	4.18E+03

OFFSITE DOSE CALCULATION MANUAL

TABLE 10-6
 R_{io} , INHALATION PATHWAY DOSE FACTORS – CHILD

NUCLIDE	BONE	LIVER	T. BODY	THYROID	KIDNEY	LUNG	G.I.-I
Cs-137	9.07E+05	8.25E+05	1.28E+05	0.00E+00	2.82E+05	1.04E+05	3.62E+03
Cs-138	6.33E+02	8.40E+02	5.55E+02	0.00E+00	6.22E+02	6.81E+01	2.70E+02
Ba-139	1.84E+00	9.84E-04	5.37E-02	0.00E+00	8.62E-04	5.77E+03	5.77E+04
Ba-140	7.40E+04	6.48E+01	4.33E+03	0.00E+00	2.11E+01	1.74E+06	1.02E+05
Ba-141	1.96E-01	1.09E-04	6.36E-03	0.00E+00	9.47E-05	2.92E+03	2.75E+02
Ba-142	5.00E-02	3.60E-05	2.79E-03	0.00E+00	2.91E-05	1.64E+03	2.74E+00
La-140	6.44E+02	2.25E+02	7.55E+01	0.00E+00	0.00E+00	1.83E+05	2.26E+05
La-142	1.30E+00	4.11E-01	1.29E-01	0.00E+00	0.00E+00	8.70E+03	7.59E+04
Ce-141	3.92E+04	1.95E+04	2.90E+03	0.00E+00	8.55E+03	5.44E+05	5.66E+04
Ce-143	3.66E+02	1.99E+02	2.87E+01	0.00E+00	8.36E+01	1.15E+05	1.27E+05
Ce-144	6.77E+06	2.12E+06	3.61E+05	0.00E+00	1.17E+06	1.20E+07	3.89E+05
Pr-143	1.85E+04	5.55E+03	9.14E+02	0.00E+00	3.00E+03	4.33E+05	9.73E+04
Pr-144	5.96E-02	1.85E-02	3.00E-03	0.00E+00	9.77E-03	1.57E+03	1.97E+02
Nd-147	1.08E+04	8.73E+03	6.81E+02	0.00E+00	4.81E+03	3.28E+05	8.21E+04
Eu-152	2.75E+06	5.07E+05	5.96E+05	0.00E+00	2.12E+06	3.33E+06	4.22E+04
W-187	1.63E+01	9.66E+00	4.33E+00	0.00E+00	0.00E+00	4.11E+04	9.10E+04
U-235	1.58E+08	0.00E+00	9.58E+06	0.00E+00	2.59E+07	6.03E+08	1.84E+05
U-238	1.51E+08	0.00E+00	8.95E+06	0.00E+00	2.42E+07	5.66E+08	1.30E+05
Np-239	4.66E+02	3.34E+01	2.35E+01	0.00E+00	9.73E+01	5.81E+04	6.40E+04
Am-241	6.44E+09	2.90E+09	4.59E+08	0.00E+00	2.82E+09	7.47E+08	1.75E+05

OFFSITE DOSE CALCULATION MANUAL

TABLE 10-7
 R_{io} , INHALATION PATHWAY DOSE FACTORS – INFANT

(mrem/yr per $\mu\text{Ci}/\text{m}^3$)

NUCLIDE	BONE	LIVER	T. BODY	THYROID	KIDNEY	LUNG	GI-LLI
H-3	0.00E+00	3.68E+02	3.68E+02	3.69E+02	3.68E+02	3.68E+02	3.68E+02
C-14	2.65E+04	5.31E+03	5.31E+03	5.31E+03	5.31E+03	5.31E+03	5.31E+03
F-18	5.49E+03	0.00E+00	4.66E+02	0.00E+00	0.00E+00	0.00E+00	8.54E+02
Na-22	1.03E+05	1.03E+05	1.03E+05	1.03E+05	1.03E+05	1.03E+05	1.03E+05
Na-24	1.06E+04	1.06E+04	1.06E+04	1.06E+04	1.06E+04	1.06E+04	1.06E+04
Sc-46	5.25E+05	7.57E+05	2.37E+05	0.00E+00	4.98E+05	0.00E+00	3.07E+04
P-32	2.03E+06	1.12E+05	7.74E+04	0.00E+00	0.00E+00	0.00E+00	1.61E+04
Cr-51	0.00E+00	0.00E+00	8.92E+01	5.75E+01	1.32E+01	1.28E+04	3.57E+02
Mn-54	0.00E+00	2.53E+04	4.98E+03	0.00E+00	4.98E+03	1.00E+06	7.06E+03
Mn-56	0.00E+00	1.54E+00	2.21E-01	0.00E+00	1.10E+00	1.25E+04	7.17E+04
Fe-55	1.97E+04	1.17E+04	3.33E+03	0.00E+00	0.00E+00	8.69E+04	1.09E+03
Fe-59	1.36E+04	2.35E+04	9.48E+03	0.00E+00	0.00E+00	1.02E+06	2.48E+04
Co-57	0.00E+00	6.51E+02	6.41E+02	0.00E+00	0.00E+00	3.79E+05	4.86E+03
Co-58	0.00E+00	1.22E+03	1.82E+03	0.00E+00	0.00E+00	7.77E+05	1.11E+04
Co-60	0.00E+00	8.02E+03	1.18E+04	0.00E+00	0.00E+00	4.51E+06	3.19E+04
Ni-63	3.39E+05	2.04E+04	1.16E+04	0.00E+00	0.00E+00	2.09E+05	2.42E+03
Ni-65	2.39E+00	2.84E-01	1.23E-01	0.00E+00	0.00E+00	8.12E+03	5.01E+04
Cu-64	0.00E+00	1.88E+00	7.74E-01	0.00E+00	3.98E+00	9.30E+03	1.50E+04
Zn-65	1.93E+04	6.26E+04	3.11E+04	0.00E+00	3.25E+04	6.47E+05	5.14E+04
Zn-69m	1.26E+01	2.58E+01	2.34E+00	0.00E+00	1.04E+01	2.67E+04	4.09E+04
Zn-69	5.39E-02	9.67E-02	7.18E-03	0.00E+00	4.02E-02	1.47E+03	1.32E+04
As-76	3.58E+03	9.33E+03	2.64E+04	3.58E+03	9.33E+03	7.78E+04	9.85E+04
Br-82	0.00E+00	0.00E+00	1.33E+04	0.00E+00	0.00E+00	0.00E+00	0.00E+00
Br-83	0.00E+00	0.00E+00	3.81E+02	0.00E+00	0.00E+00	0.00E+00	0.00E+00
Br-84	0.00E+00	0.00E+00	4.00E+02	0.00E+00	0.00E+00	0.00E+00	0.00E+00
Br-85	0.00E+00	0.00E+00	2.04E+01	0.00E+00	0.00E+00	0.00E+00	0.00E+00
Rb-86	0.00E+00	1.90E+05	8.82E+04	0.00E+00	0.00E+00	0.00E+00	3.04E+03
Rb-88	0.00E+00	5.57E+02	2.87E+02	0.00E+00	0.00E+00	0.00E+00	3.39E+02
Rb-89	0.00E+00	3.21E+02	2.06E+02	0.00E+00	0.00E+00	0.00E+00	6.82E+01
Sr-89	3.98E+05	0.00E+00	1.14E+04	0.00E+00	0.00E+00	2.03E+06	6.40E+04
Sr-90	1.55E+07	0.00E+00	3.12E+05	0.00E+00	0.00E+00	1.12E+07	1.31E+05
Sr-91	9.56E+01	0.00E+00	3.46E+00	0.00E+00	0.00E+00	5.26E+04	7.34E+04
Sr-92	1.05E+01	0.00E+00	3.91E-01	0.00E+00	0.00E+00	2.38E+04	1.40E+05
Y-90	3.29E+03	0.00E+00	8.82E+01	0.00E+00	0.00E+00	2.69E+05	1.04E+05
Y-91m	4.07E-01	0.00E+00	1.39E-02	0.00E+00	0.00E+00	2.79E+03	2.35E+03
Y-91	5.88E+05	0.00E+00	1.57E+04	0.00E+00	0.00E+00	2.45E+06	7.03E+04

OFFSITE DOSE CALCULATION MANUAL

TABLE 10-7
 R_{io} , INHALATION PATHWAY DOSE FACTORS – INFANT

NUCLIDE	BONE	LIVER	T. BODY	THYROID	KIDNEY	LUNG	GI-LLI
Y-92	1.64E+01	0.00E+00	4.61E-01	0.00E+00	0.00E+00	2.45E+04	1.27E+05
Y-93	1.50E+02	0.00E+00	4.07E+00	0.00E+00	0.00E+00	7.64E+04	1.67E+05
Zr-95	1.15E+05	2.79E+04	2.03E+04	0.00E+00	3.11E+04	1.75E+06	2.17E+04
Zr-97	1.50E+02	2.56E+01	1.17E+01	0.00E+00	2.59E+01	1.10E+05	1.40E+05
Nb-95	1.57E+04	6.43E+03	3.78E+03	0.00E+00	4.72E+03	4.79E+05	1.27E+04
Nb-97	3.42E-01	7.29E-02	2.63E-02	0.00E+00	5.70E-02	3.32E+03	2.69E+04
Mo-99	0.00E+00	1.65E+02	3.23E+01	0.00E+00	2.65E+02	1.35E+05	4.87E+04
Tc-99m	1.40E-03	2.88E-03	3.72E-02	0.00E+00	3.11E-02	8.11E+02	2.03E+03
Tc-99	2.93E+02	3.75E+02	1.24E+02	0.00E+00	3.49E+03	9.48E+05	1.09E+04
Tc-101	6.51E-05	8.23E-05	8.12E-04	0.00E+00	9.79E-04	5.84E+02	8.44E+02
Ru-103	2.02E+03	0.00E+00	6.79E+02	0.00E+00	4.24E+03	5.52E+05	1.61E+04
Ru-105	1.22E+00	0.00E+00	4.10E-01	0.00E+00	8.99E-01	1.57E+04	4.84E+04
Ru-106	8.68E+04	0.00E+00	1.09E+04	0.00E+00	1.07E+05	1.16E+07	1.64E+05
Rh-105	1.16E+01	7.57E+00	5.08E+00	0.00E+00	2.10E+01	2.91E+04	1.92E+04
Ag-110m	9.98E+03	7.22E+03	5.00E+03	0.00E+00	1.09E+04	3.67E+06	3.30E+04
Sn-113	2.80E+04	9.33E+03	6.74E+04	6.22E+03	6.22E+03	3.99E+05	1.45E+05
Sn-117m	3.27E+04	1.66E+03	5.19E+04	9.85E+02	1.09E+03	3.32E+05	1.35E+05
Sb-122	2.39E+03	2.13E+03	4.30E+04	8.30E+02	1.14E+03	1.14E+05	3.16E+05
Sb-124	3.79E+04	5.56E+02	1.20E+04	1.01E+02	0.00E+00	2.65E+06	5.91E+04
Sb-125	5.17E+04	4.77E+02	1.09E+04	6.23E+01	0.00E+00	1.64E+06	1.47E+04
Te-125m	4.76E+03	1.99E+03	6.58E+02	1.62E+03	0.00E+00	4.47E+05	1.29E+04
Te-127m	1.67E+04	6.90E+03	2.07E+03	4.87E+03	3.75E+04	1.31E+06	2.73E+04
Te-127	2.23E+00	9.53E-01	4.89E-01	1.85E+00	4.86E+00	1.03E+04	2.44E+04
Te-129m	1.41E+04	6.09E+03	2.23E+03	5.47E+03	3.18E+04	1.68E+06	6.90E+04
Te-129	7.88E-02	3.47E-02	1.88E-02	6.75E-02	1.75E-01	3.00E+03	2.63E+04
Te-131m	1.07E+02	5.50E+01	3.63E+01	8.93E+01	2.65E+02	1.99E+05	1.19E+05
Te-131	1.74E-02	8.22E-03	5.00E-03	1.58E-02	3.99E-02	2.06E+03	8.22E+03
Te-132	3.72E+02	2.37E+02	1.76E+02	2.79E+02	1.03E+03	3.40E+05	4.41E+04
I-130	6.36E+03	1.39E+04	5.57E+03	1.60E+06	1.53E+04	0.00E+00	1.99E+03
I-131	3.79E+04	4.44E+04	1.96E+04	1.48E+07	5.18E+04	0.00E+00	1.06E+03
I-132	1.69E+03	3.54E+03	1.26E+03	1.69E+05	3.95E+03	0.00E+00	1.90E+03
I-133	1.32E+04	1.92E+04	5.60E+03	3.56E+06	2.24E+04	0.00E+00	2.16E+03
I-134	9.21E+02	1.88E+03	6.65E+02	4.45E+04	2.09E+03	0.00E+00	1.29E+03
I-135	3.86E+03	7.60E+03	2.77E+03	6.96E+05	8.47E+03	0.00E+00	1.83E+03
Cs-134	3.96E+05	7.03E+05	7.45E+04	0.00E+00	1.90E+05	7.97E+04	1.33E+03
Cs-134m	1.85E+02	2.94E+02	1.55E+02	0.00E+00	1.19E+02	2.80E+01	1.62E+02
Cs-136	4.83E+04	1.35E+05	5.29E+04	0.00E+00	5.64E+04	1.18E+04	1.43E+03

TABLE 10-7
 R_{io} , INHALATION PATHWAY DOSE FACTORS – INFANT

NUCLIDE	BONE	LIVER	T. BODY	THYROID	KIDNEY	LUNG	GI-LLI
Cs-137	5.49E+05	6.12E+05	4.55E+04	0.00E+00	1.72E+05	7.13E+04	1.33E+03
Cs-138	5.05E+02	7.81E+02	3.98E+02	0.00E+00	4.10E+02	6.54E+01	8.76E+02
Ba-139	1.48E+00	9.84E-04	4.30E-02	0.00E+00	5.92E-04	5.95E+03	5.10E+04
Ba-140	5.60E+04	5.60E+01	2.90E+03	0.00E+00	1.34E+01	1.60E+06	3.84E+04
Ba-141	1.57E-01	1.08E-04	4.97E-03	0.00E+00	6.50E-05	2.97E+03	4.75E+03
Ba-142	3.98E-02	3.30E-05	1.96E-03	0.00E+00	1.90E-05	1.55E+03	6.93E+02
La-140	5.05E+02	2.00E+02	5.15E+01	0.00E+00	0.00E+00	1.68E+05	8.48E+04
La-142	1.03E+00	3.77E-01	9.04E-02	0.00E+00	0.00E+00	8.22E+03	5.95E+04
Ce-141	2.77E+04	1.67E+04	1.99E+03	0.00E+00	5.25E+03	5.17E+05	2.16E+04
Ce-143	2.93E+02	1.93E+02	2.21E+01	0.00E+00	5.64E+01	1.16E+05	4.97E+04
Ce-144	3.19E+06	1.21E+06	1.76E+05	0.00E+00	5.38E+05	9.84E+06	1.48E+05
Pr-143	1.40E+04	5.24E+03	6.99E+02	0.00E+00	1.97E+03	4.33E+05	3.72E+04
Pr-144	4.79E-02	1.85E-02	2.41E-03	0.00E+00	6.72E-03	1.61E+03	4.28E+03
Nd-147	7.94E+03	8.13E+03	5.00E+02	0.00E+00	3.15E+03	3.22E+05	3.12E+04
Eu-152	1.10E+06	2.48E+05	2.41E+05	0.00E+00	8.32E+05	2.07E+06	1.38E+04
W-187	1.30E+01	9.02E+00	3.12E+00	0.00E+00	0.00E+00	3.96E+04	3.56E+04
U-235	7.01E+07	0.00E+00	4.93E+06	0.00E+00	1.41E+07	4.59E+08	7.03E+04
U-238	6.71E+07	0.00E+00	4.61E+06	0.00E+00	1.32E+07	4.28E+08	4.96E+04
Np-239	3.71E+02	3.32E+01	1.88E+01	0.00E+00	6.62E+01	5.95E+04	2.49E+04
Am-241	2.58E+09	1.18E+09	1.83E+08	0.00E+00	1.11E+09	5.68E+08	6.69E+04

OFFSITE DOSE CALCULATION MANUAL

TABLE 10-8
 R_{io} , GRASS-COW-MILK PATHWAY DOSE FACTORS – ADULT

{ m^2 -mrem/yr per $\mu Ci/s$ (mrem/yr per $\mu Ci/m^3$ for 3H and ^{14}C)}

NUCLIDE	BONE	LIVER	T. BODY	THYROID	KIDNEY	LUNG	G-I-LI
H-3	0.00E+00	6.33E+02	6.33E+02	6.33E+02	6.33E+02	6.33E+02	6.33E+02
C-14	3.63E+05	7.26E+04	7.26E+04	7.26E+04	7.26E+04	7.26E+04	7.26E+04
F-18	1.16E-03	0.00E+00	1.28E-04	0.00E+00	0.00E+00	0.00E+00	3.43E-05
Na-22	4.18E+09	4.18E+09	4.18E+09	4.18E+09	4.18E+09	4.18E+09	4.18E+09
Na-24	6.05E+05	6.05E+05	6.05E+05	6.05E+05	6.05E+05	6.05E+05	6.05E+05
Sc-46	8.96E+01	1.74E+02	5.06E+01	0.00E+00	1.62E+02	0.00E+00	8.47E+05
P-32	4.34E+09	2.70E+08	1.68E+08	0.00E+00	0.00E+00	0.00E+00	4.88E+08
Cr-51	0.00E+00	0.00E+00	8.39E+03	5.02E+03	1.85E+03	1.11E+04	2.11E+06
Mn-54	0.00E+00	5.80E+06	1.11E+06	0.00E+00	1.73E+06	0.00E+00	1.78E+07
Mn-56	0.00E+00	1.05E-03	1.86E-04	0.00E+00	1.33E-03	0.00E+00	3.35E-02
Fe-55	1.87E+07	1.29E+07	3.01E+06	0.00E+00	0.00E+00	7.20E+06	7.40E+06
Fe-59	1.11E+07	2.60E+07	9.97E+06	0.00E+00	0.00E+00	7.27E+06	8.67E+07
Co-57	0.00E+00	8.59E+05	1.43E+06	0.00E+00	0.00E+00	0.00E+00	2.18E+07
Co-58	0.00E+00	2.20E+06	4.93E+06	0.00E+00	0.00E+00	0.00E+00	4.46E+07
Co-60	0.00E+00	1.27E+07	2.80E+07	0.00E+00	0.00E+00	0.00E+00	2.38E+08
Ni-63	5.68E+09	3.94E+08	1.90E+08	0.00E+00	0.00E+00	0.00E+00	8.21E+07
Ni-65	9.23E-02	1.20E-02	5.47E-03	0.00E+00	0.00E+00	0.00E+00	3.04E-01
Cu-64	0.00E+00	5.99E+03	2.81E+03	0.00E+00	1.51E+04	0.00E+00	5.10E+05
Zn-65	1.03E+09	3.26E+09	1.47E+09	0.00E+00	2.18E+09	0.00E+00	2.05E+09
Zn-69m	4.52E+04	1.08E+05	9.91E+03	0.00E+00	6.56E+04	0.00E+00	6.62E+06
Zn-69	7.14E-13	1.36E-12	9.49E-14	0.00E+00	8.87E-13	0.00E+00	2.05E-13
As-76	9.68E+04	2.82E+05	1.41E+06	8.45E+04	3.43E+05	8.80E+04	1.23E+07
Br-82	0.00E+00	0.00E+00	8.19E+06	0.00E+00	0.00E+00	0.00E+00	9.38E+06
Br-83	0.00E+00	0.00E+00	2.66E-02	0.00E+00	0.00E+00	0.00E+00	3.83E-02
Br-84	0.00E+00	0.00E+00	0.00E+00	0.00E+00	0.00E+00	0.00E+00	0.00E+00
Br-85	0.00E+00	0.00E+00	0.00E+00	0.00E+00	0.00E+00	0.00E+00	0.00E+00
Rb-86	0.00E+00	6.67E+08	3.11E+08	0.00E+00	0.00E+00	0.00E+00	1.32E+08
Rb-88	0.00E+00	0.00E+00	0.00E+00	0.00E+00	0.00E+00	0.00E+00	0.00E+00
Rb-89	0.00E+00	0.00E+00	0.00E+00	0.00E+00	0.00E+00	0.00E+00	0.00E+00
Sr-89	5.78E+08	0.00E+00	1.66E+07	0.00E+00	0.00E+00	0.00E+00	9.27E+07
Sr-90	4.45E+10	0.00E+00	8.93E+08	0.00E+00	0.00E+00	0.00E+00	1.52E+09
Sr-91	7.26E+03	0.00E+00	2.93E+02	0.00E+00	0.00E+00	0.00E+00	3.46E+04
Sr-92	1.24E-01	0.00E+00	5.36E-03	0.00E+00	0.00E+00	0.00E+00	2.45E+00
Y-90	1.77E+01	0.00E+00	4.75E-01	0.00E+00	0.00E+00	0.00E+00	1.88E+05
Y-91m	1.55E-20	0.00E+00	0.00E+00	0.00E+00	0.00E+00	0.00E+00	4.56E-20
Y-91	3.67E+03	0.00E+00	9.82E+01	0.00E+00	0.00E+00	0.00E+00	2.02E+06

OFFSITE DOSE CALCULATION MANUAL

TABLE 10-8
 R_{io} , GRASS-COW-MILK PATHWAY DOSE FACTORS – ADULT

NUCLIDE	BONE	LIVER	T. BODY	THYROID	KIDNEY	LUNG	GI-LLI
Y-92	1.41E-05	0.00E+00	4.12E-07	0.00E+00	0.00E+00	0.00E+00	2.47E-01
Y-93	5.85E-02	0.00E+00	1.61E-03	0.00E+00	0.00E+00	0.00E+00	1.85E+03
Zr-95	4.21E+02	1.35E+02	9.13E+01	0.00E+00	2.12E+02	0.00E+00	4.28E+05
Zr-97	1.07E-01	2.15E-02	9.84E-03	0.00E+00	3.25E-02	0.00E+00	6.67E+03
Nb-95	2.72E+04	1.51E+04	8.12E+03	0.00E+00	1.49E+04	0.00E+00	9.17E+07
Nb-97	1.64E-12	4.16E-13	1.52E-13	0.00E+00	4.85E-13	0.00E+00	1.53E-09
Mo-99	0.00E+00	6.20E+06	1.18E+06	0.00E+00	1.40E+07	0.00E+00	1.44E+07
Tc-99m	8.30E-01	2.34E+00	2.99E+01	0.00E+00	3.56E+01	1.15E+00	1.39E+03
Tc-99	4.26E+07	6.33E+07	1.71E+07	0.00E+00	7.97E+08	5.38E+06	2.07E+09
Tc-101	0.00E+00	0.00E+00	0.00E+00	0.00E+00	0.00E+00	0.00E+00	0.00E+00
Ru-103	3.57E+02	0.00E+00	1.54E+02	0.00E+00	1.36E+03	0.00E+00	4.16E+04
Ru-105	2.16E-04	0.00E+00	8.54E-05	0.00E+00	2.79E-03	0.00E+00	1.32E-01
Ru-106	1.45E+04	0.00E+00	1.84E+03	0.00E+00	2.81E+04	0.00E+00	9.42E+05
Rh-105	1.05E+05	7.70E+04	5.07E+04	0.00E+00	3.27E+05	0.00E+00	1.23E+07
Ag-110m	4.05E+07	3.74E+07	2.22E+07	0.00E+00	7.36E+07	0.00E+00	1.53E+10
Sn-113	9.13E+06	1.54E+06	2.56E+07	8.07E+05	2.11E+06	9.48E+05	2.81E+08
Sn-117m	3.90E+06	1.33E+05	5.54E+06	2.65E+04	2.03E+05	4.21E+04	6.24E+07
Sb-122	1.89E+05	1.04E+05	1.78E+06	2.20E+04	7.34E+04	2.83E+04	1.89E+07
Sb-124	1.12E+07	2.11E+05	4.43E+06	2.71E+04	0.00E+00	8.69E+06	3.17E+08
Sb-125	1.54E+07	1.72E+05	3.67E+06	1.57E+04	0.00E+00	1.19E+07	1.70E+08
Te-125m	7.74E+06	2.80E+06	1.04E+06	2.33E+06	3.15E+07	0.00E+00	3.09E+07
Te-127m	3.02E+07	1.08E+07	3.68E+06	7.71E+06	1.23E+08	0.00E+00	1.01E+08
Te-127	1.71E+02	6.15E+01	3.70E+01	1.27E+02	6.97E+02	0.00E+00	1.35E+04
Te-129m	2.08E+07	7.77E+06	3.30E+06	7.16E+06	8.70E+07	0.00E+00	1.05E+08
Te-129	7.44E-11	2.79E-11	1.81E-11	5.71E-11	3.13E-10	0.00E+00	5.61E-11
Te-131m	1.07E+05	5.26E+04	4.38E+04	8.32E+04	5.32E+05	0.00E+00	5.22E+06
Te-131	0.00E+00	0.00E+00	0.00E+00	0.00E+00	0.00E+00	0.00E+00	0.00E+00
Te-132	6.01E+05	3.89E+05	3.65E+05	4.29E+05	3.74E+06	0.00E+00	1.84E+07
I-130	5.27E+04	1.55E+05	6.13E+04	1.32E+07	2.42E+05	0.00E+00	1.34E+05
I-131	3.64E+07	5.20E+07	2.98E+07	1.70E+10	8.92E+07	0.00E+00	1.37E+07
I-132	1.82E-02	4.88E-02	1.71E-02	1.71E+00	7.77E-02	0.00E+00	9.16E-03
I-133	4.85E+05	4.83E+05	2.57E+05	1.24E+08	1.47E+06	0.00E+00	7.58E+05
I-134	2.63E-13	7.16E-13	2.56E-13	1.24E-11	1.14E-12	0.00E+00	6.24E-16
I-135	1.56E+03	4.07E+03	1.50E+03	2.69E+05	6.53E+03	0.00E+00	4.60E+03
Cs-134	4.19E+09	9.97E+09	8.15E+09	0.00E+00	3.23E+09	1.07E+09	1.74E+08
Cs-134m	4.40E-02	9.25E-02	4.73E-02	0.00E+00	5.02E-02	7.91E-03	3.26E-02
Cs-136	6.44E+07	2.54E+08	1.83E+08	0.00E+00	1.42E+08	1.94E+07	2.89E+07

OFFSITE DOSE CALCULATION MANUAL

TABLE 10-8
 R_{io} , GRASS-COW-MILK PATHWAY DOSE FACTORS – ADULT

NUCLIDE	BONE	LIVER	T. BODY	THYROID	KIDNEY	LUNG	GI-LLI
Cs-137	5.94E+09	8.12E+09	5.32E+09	0.00E+00	2.76E+09	9.16E+08	1.57E+08
Cs-138	0.00E+00	0.00E+00	0.00E+00	0.00E+00	0.00E+00	0.00E+00	0.00E+00
Ba-139	1.38E-08	9.86E-12	4.05E-10	0.00E+00	9.21E-12	5.89E-12	2.45E-08
Ba-140	6.56E+06	8.23E+03	4.30E+05	0.00E+00	2.80E+03	4.71E+03	1.35E+07
Ba-141	0.00E+00	0.00E+00	0.00E+00	0.00E+00	0.00E+00	0.00E+00	0.00E+00
Ba-142	0.00E+00	0.00E+00	0.00E+00	0.00E+00	0.00E+00	0.00E+00	0.00E+00
La-140	1.11E+00	5.70E-01	1.51E-01	0.00E+00	0.00E+00	0.00E+00	4.19E+04
La-142	2.34E-12	1.06E-12	2.65E-13	0.00E+00	0.00E+00	0.00E+00	7.76E-09
Ce-141	1.54E+03	1.04E+03	1.18E+02	0.00E+00	4.83E+02	0.00E+00	3.97E+06
Ce-143	1.04E+01	7.71E+03	8.54E-01	0.00E+00	3.40E+00	0.00E+00	2.88E+05
Ce-144	2.41E+05	1.01E+05	1.29E+04	0.00E+00	5.98E+04	0.00E+00	8.15E+07
Pr-143	3.87E+01	1.55E+01	1.92E+00	0.00E+00	8.96E+00	0.00E+00	1.70E+05
Pr-144	0.00E+00	0.00E+00	0.00E+00	0.00E+00	0.00E+00	0.00E+00	0.00E+00
Nd-147	2.30E+01	2.66E+01	1.59E+00	0.00E+00	1.55E+01	0.00E+00	1.27E+05
Eu-152	5.87E+03	1.32E+03	1.16E+03	0.00E+00	8.20E+03	0.00E+00	7.63E+05
W-187	1.64E+03	1.37E+03	4.80E+02	0.00E+00	0.00E+00	0.00E+00	4.50E+05
U-235	2.43E+09	0.00E+00	1.47E+08	0.00E+00	5.66E+08	0.00E+00	2.36E+08
U-238	2.32E+09	0.00E+00	1.37E+08	0.00E+00	5.30E+08	0.00E+00	1.67E+08
Np-239	9.19E-01	9.03E-02	4.98E-02	0.00E+00	2.82E-01	0.00E+00	1.85E+04
Am-241	2.45E+07	8.62E+06	1.62E+06	0.00E+00	1.22E+07	0.00E+00	2.22E+06

TABLE 10-9
 R_{io} , GRASS-COW-MILK PATHWAY DOSE FACTORS – TEEN

{ m^2 -mrem/yr per μ Ci/s (mrem/yr per μ Ci/ m^3 for 3H and ^{14}C)}

NUCLIDE	BONE	LIVER	T. BODY	THYROID	KIDNEY	LUNG	GI-LLI
H-3	0.00E+00	8.23E+02	8.23E+03	8.23E+03	8.23E+03	8.23E+03	8.23E+03
C-14	6.70E+05	1.34E+05	1.34E+05	1.34E+05	1.34E+05	1.34E+05	1.34E+05
F-18	2.07E-03	0.00E+00	2.26E-04	0.00E+00	0.00E+00	0.00E+00	1.86E-04
Na-22	7.26E+09	7.26E+09	7.26E+09	7.26E+09	7.26E+09	7.26E+09	7.26E+09
Na-24	1.06E+06	1.06E+06	1.06E+06	1.06E+06	1.06E+06	1.06E+06	1.06E+06
Sc-46	1.52E+02	2.96E+02	8.77E+01	0.00E+00	2.83E+02	0.00E+00	1.01E+06
P-32	8.02E+09	4.97E+08	3.11E+08	0.00E+00	0.00E+00	0.00E+00	6.74E+08
Cr-51	0.00E+00	0.00E+00	1.47E+04	8.14E+03	3.21E+03	2.09E+04	2.46E+06
Mn-54	0.00E+00	9.67E+06	1.92E+06	0.00E+00	2.88E+06	0.00E+00	1.98E+07
Mn-56	0.00E+00	1.86E-03	3.31E-04	0.00E+00	2.36E-03	0.00E+00	1.23E-01
Fe-55	3.31E+07	2.35E+07	5.48E+06	0.00E+00	0.00E+00	1.49E+07	1.02E+07
Fe-59	1.93E+07	4.51E+07	1.74E+07	0.00E+00	0.00E+00	1.42E+07	1.07E+08
Co-57	0.00E+00	1.51E+06	2.53E+06	0.00E+00	0.00E+00	0.00E+00	2.81E+07
Co-58	0.00E+00	3.71E+06	8.54E+06	0.00E+00	0.00E+00	0.00E+00	5.11E+07
Co-60	0.00E+00	2.15E+07	4.84E+07	0.00E+00	0.00E+00	0.00E+00	2.80E+08
Ni-63	9.98E+09	7.05E+08	3.38E+08	0.00E+00	0.00E+00	0.00E+00	1.12E+08
Ni-65	1.69E-01	2.16E-02	9.84E-03	0.00E+00	0.00E+00	0.00E+00	1.17E+00
Cu-64	0.00E+00	1.07E+04	5.02E+03	0.00E+00	2.70E+04	0.00E+00	8.27E+05
Zn-65	1.57E+09	5.47E+09	2.55E+09	0.00E+00	3.50E+09	0.00E+00	2.31E+09
Zn-69m	8.23E+04	1.94E+05	1.78E+04	0.00E+00	1.18E+05	0.00E+00	1.07E+07
Zn-69	9.70E-13	1.85E-12	1.29E-13	0.00E+00	1.21E-12	0.00E+00	3.41E-12
As-76	1.48E+05	4.65E+05	2.27E+06	1.36E+05	5.45E+05	1.36E+05	2.04E+07
Br-82	0.00E+00	0.00E+00	1.42E+07	0.00E+00	0.00E+00	0.00E+00	0.00E+00
Br-83	0.00E+00	0.00E+00	4.89E-02	0.00E+00	0.00E+00	0.00E+00	0.00E+00
Br-84	0.00E+00	0.00E+00	0.00E+00	0.00E+00	0.00E+00	0.00E+00	0.00E+00
Br-85	0.00E+00	0.00E+00	0.00E+00	0.00E+00	0.00E+00	0.00E+00	0.00E+00
Rb-86	0.00E+00	1.22E+09	5.71E+08	0.00E+00	0.00E+00	0.00E+00	1.80E+08
Rb-88	0.00E+00	0.00E+00	0.00E+00	0.00E+00	0.00E+00	0.00E+00	0.00E+00
Rb-89	0.00E+00	0.00E+00	0.00E+00	0.00E+00	0.00E+00	0.00E+00	0.00E+00
Sr-89	1.07E+09	0.00E+00	3.05E+07	0.00E+00	0.00E+00	0.00E+00	1.27E+08
Sr-90	6.72E+10	0.00E+00	1.34E+09	0.00E+00	0.00E+00	0.00E+00	2.08E+09
Sr-91	1.33E+04	0.00E+00	5.31E+02	0.00E+00	0.00E+00	0.00E+00	6.05E+04
Sr-92	2.27E-01	0.00E+00	9.66E-03	0.00E+00	0.00E+00	0.00E+00	5.78E+00
Y-90	3.25E+01	0.00E+00	8.77E-01	0.00E+00	0.00E+00	0.00E+00	2.68E+05
Y-91m	2.85E-20	0.00E+00	0.00E+00	0.00E+00	0.00E+00	0.00E+00	1.34E-18
Y-91	6.76E+03	0.00E+00	1.81E+02	0.00E+00	0.00E+00	0.00E+00	2.77E+06
Y-92	2.61E-05	0.00E+00	7.54E-07	0.00E+00	0.00E+00	0.00E+00	7.15E-01

OFFSITE DOSE CALCULATION MANUAL

TABLE 10-9
 R_{io} , GRASS-COW-MILK PATHWAY DOSE FACTORS – TEEN

NUCLIDE	BONE	LIVER	T. BODY	THYROID	KIDNEY	LUNG	GI-LLI
Y-93	1.08E-01	0.00E+00	2.96E-03	0.00E+00	0.00E+00	0.00E+00	3.29E+03
Zr-95	7.35E+02	2.32E+02	1.60E+02	0.00E+00	3.41E+02	0.00E+00	5.36E+05
Zr-97	1.94E-01	3.84E-02	1.77E-02	0.00E+00	5.82E-02	0.00E+00	1.04E+04
Nb-95	4.63E+04	2.57E+04	1.41E+04	0.00E+00	2.49E+04	0.00E+00	1.10E+08
Nb-97	3.00E-12	7.44E-13	2.72E-13	0.00E+00	8.70E-13	0.00E+00	1.78E-08
Mo-99	0.00E+00	1.12E+07	2.13E+06	0.00E+00	2.56E+07	0.00E+00	2.00E+07
Tc-99m	1.44E+00	4.01E+00	5.20E+01	0.00E+00	5.98E+01	2.23E+00	2.63E+03
Tc-99	7.87E+07	1.16E+08	3.15E+07	0.00E+00	1.47E+09	1.20E+07	2.83E+09
Tc-101	0.00E+00	0.00E+00	0.00E+00	0.00E+00	0.00E+00	0.00E+00	0.00E+00
Ru-103	6.34E+02	0.00E+00	2.71E+02	0.00E+00	2.24E+03	0.00E+00	5.30E+04
Ru-105	3.95E-04	0.00E+00	1.53E-04	0.00E+00	4.98E-03	0.00E+00	3.19E-01
Ru-106	2.68E+04	0.00E+00	3.37E+03	0.00E+00	5.16E+04	0.00E+00	1.28E+06
Rh-105	1.94E+05	1.40E+05	9.21E+04	0.00E+00	5.96E+05	0.00E+00	1.79E+07
Ag-110m	6.69E+07	6.33E+07	3.85E+07	0.00E+00	1.21E+08	0.00E+00	1.78E+10
Sn-113	1.27E+07	2.54E+06	4.17E+07	1.22E+06	3.31E+06	1.49E+06	4.48E+08
Sn-117m	5.13E+06	2.21E+05	8.86E+06	4.13E+04	3.12E+05	7.55E+04	9.97E+07
Sb-122	2.57E+05	1.76E+05	2.84E+06	3.52E+04	1.15E+05	4.74E+04	2.98E+07
Sb-124	1.99E+07	3.67E+05	7.77E+06	4.52E+04	0.00E+00	1.74E+07	4.01E+08
Sb-125	2.76E+07	3.01E+05	6.44E+06	2.63E+04	0.00E+00	2.42E+07	2.14E+08
Te-125m	1.43E+07	5.14E+06	1.91E+06	3.99E+06	0.00E+00	0.00E+00	4.21E+07
Te-127m	5.56E+07	1.97E+07	6.62E+06	1.32E+07	2.26E+08	0.00E+00	1.39E+08
Te-127	3.17E+02	1.12E+02	6.83E+01	2.19E+02	1.29E+03	0.00E+00	2.45E+04
Te-129m	3.81E+07	1.41E+07	6.03E+06	1.23E+07	1.59E+08	0.00E+00	1.43E+08
Te-129	1.37E-10	5.10E-11	3.33E-11	9.78E-11	5.74E-10	0.00E+00	7.49E-10
Te-131m	1.96E+05	9.38E+04	7.82E+04	1.41E+05	9.78E+05	0.00E+00	7.53E+06
Te-131	0.00E+00	0.00E+00	0.00E+00	0.00E+00	0.00E+00	0.00E+00	0.00E+00
Te-132	1.07E+06	6.80E+05	6.40E+05	7.17E+05	6.52E+06	0.00E+00	2.15E+07
I-130	9.26E+04	2.68E+05	1.07E+05	2.18E+07	4.13E+05	0.00E+00	2.06E+05
I-131	6.60E+07	9.24E+07	4.96E+07	2.70E+10	1.59E+08	0.00E+00	1.83E+07
I-132	3.23E-02	8.46E-02	3.04E-02	2.85E+00	1.33E-01	0.00E+00	3.69E-02
I-133	8.85E+05	1.50E+06	4.58E+05	2.10E+08	2.63E+06	0.00E+00	1.14E+06
I-134	4.68E-13	1.24E-12	4.46E-13	2.17E-11	1.96E-12	0.00E+00	1.64E-14
I-135	2.76E+03	7.12E+03	2.64E+03	4.58E+05	1.12E+04	0.00E+00	7.89E+03
Cs-134	7.27E+09	1.71E+10	7.94E+09	0.00E+00	5.44E+09	2.08E+09	2.13E+08
Cs-134m	7.84E-02	1.62E-01	8.34E-02	0.00E+00	9.03E-02	1.59E-02	1.08E-01
Cs-136	1.10E+08	4.32E+08	2.90E+08	0.00E+00	2.35E+08	3.70E+07	3.47E+07
Cs-137	1.08E+10	1.43E+10	4.99E+09	0.00E+00	4.87E+09	1.89E+09	2.04E+08
Cs-138	0.00E+00	0.00E+00	0.00E+00	0.00E+00	0.00E+00	0.00E+00	0.00E+00

OFFSITE DOSE CALCULATION MANUAL

TABLE 10-9
 R_{io} , GRASS-COW-MILK PATHWAY DOSE FACTORS – TEEN

NUCLIDE	BONE	LIVER	T. BODY	THYROID	KIDNEY	LUNG	GI-LLI
Ba-139	2.56E-08	1.80E-11	7.45E-10	0.00E+00	1.70E-11	1.24E-11	2.28E-07
Ba-140	1.18E+07	1.45E+04	7.63E+05	0.00E+00	4.92E+03	9.75E+03	1.83E+07
Ba-141	0.00E+00	0.00E+00	0.00E+00	0.00E+00	0.00E+00	0.00E+00	0.00E+00
Ba-142	0.00E+00	0.00E+00	0.00E+00	0.00E+00	0.00E+00	0.00E+00	0.00E+00
La-140	2.03E+00	9.99E-01	2.66E-01	0.00E+00	0.00E+00	0.00E+00	5.73E+04
La-142	4.22E-12	1.87E-12	4.66E-13	0.00E+00	0.00E+00	0.00E+00	5.70E-08
Ce-141	2.82E+03	1.88E+03	2.16E+02	0.00E+00	8.85E+02	0.00E+00	5.38E+06
Ce-143	1.92E+01	1.40E+04	1.56E+00	0.00E+00	6.26E+00	0.00E+00	4.19E+05
Ce-144	4.43E+05	1.84E+05	2.38E+04	0.00E+00	1.10E+05	0.00E+00	1.12E+08
Pr-143	7.11E+01	2.84E+01	3.54E+00	0.00E+00	1.65E+01	0.00E+00	2.34E+05
Pr-144	0.00E+00	0.00E+00	0.00E+00	0.00E+00	0.00E+00	0.00E+00	0.00E+00
Nd-147	4.42E+01	4.81E+01	2.88E+00	0.00E+00	2.82E+01	0.00E+00	1.73E+05
Eu-152	9.42E+03	2.27E+03	2.00E+03	0.00E+00	1.05E+04	0.00E+00	8.35E+05
W-187	3.00E+03	2.45E+03	8.58E+02	0.00E+00	0.00E+00	0.00E+00	6.63E+05
U-235	4.45E+09	0.00E+00	2.71E+08	0.00E+00	1.04E+09	0.00E+00	3.23E+08
U-238	4.26E+09	0.00E+00	2.54E+08	0.00E+00	9.77E+08	0.00E+00	2.28E+08
Np-239	1.75E+00	1.65E-01	9.19E-02	0.00E+00	5.19E-01	0.00E+00	2.66E+04
Am-241	3.33E+07	1.27E+07	2.22E+06	0.00E+00	1.66E+07	0.00E+00	3.04E+06

OFFSITE DOSE CALCULATION MANUAL

TABLE 10-10
 R_{io} , GRASS-COW-MILK PATHWAY DOSE FACTORS – CHILD

{ m^2 -mrem/yr per μ Ci/s (mrem/yr per μ Ci/ m^3 for 3H and ^{14}C)}

NUCLIDE	BONE	LIVER	T. BODY	THYROID	KIDNEY	LUNG	GI-LLI
H-3	0.00E+00	1.30E+03	1.30E+03	1.30E+03	1.30E+03	1.30E+03	1.30E+03
C-14	1.65E+06	3.29E+05	3.29E+05	3.29E+05	3.29E+05	3.29E+05	3.29E+05
F-18	4.91E-03	0.00E+00	4.87E-04	0.00E+00	0.00E+00	0.00E+00	1.33E-03
Na-22	1.50E+10	1.50E+10	1.50E+10	1.50E+10	1.50E+10	1.50E+10	1.50E+10
Na-24	2.20E+06	2.20E+06	2.20E+06	2.20E+06	2.20E+06	2.20E+06	2.20E+06
Sc-46	3.41E+02	4.67E+02	1.80E+02	0.00E+00	4.14E+02	0.00E+00	6.84E+05
P-32	1.98E+10	9.25E+08	7.62E+08	0.00E+00	0.00E+00	0.00E+00	5.46E+08
Cr-51	0.00E+00	0.00E+00	2.99E+04	1.66E+04	4.54E+03	3.03E+04	1.59E+06
Mn-54	0.00E+00	1.45E+07	3.85E+06	0.00E+00	4.05E+06	0.00E+00	1.21E+07
Mn-56	0.00E+00	3.25E-03	7.33E-04	0.00E+00	3.93E-03	0.00E+00	4.71E-01
Fe-55	8.31E+07	4.41E+07	1.37E+07	0.00E+00	0.00E+00	2.49E+07	8.17E+06
Fe-59	4.48E+07	7.25E+07	3.61E+07	0.00E+00	0.00E+00	2.10E+07	7.55E+07
Co-57	0.00E+00	2.58E+06	5.21E+06	0.00E+00	0.00E+00	0.00E+00	2.11E+07
Co-58	0.00E+00	5.66E+06	1.73E+07	0.00E+00	0.00E+00	0.00E+00	3.30E+07
Co-60	0.00E+00	3.34E+07	9.85E+07	0.00E+00	0.00E+00	0.00E+00	1.85E+08
Ni-63	2.50E+10	1.34E+09	8.51E+08	0.00E+00	0.00E+00	0.00E+00	9.02E+07
Ni-65	4.13E-01	3.89E-02	2.27E-02	0.00E+00	0.00E+00	0.00E+00	4.77E+00
Cu-64	0.00E+00	1.87E+04	1.13E+04	0.00E+00	4.53E+04	0.00E+00	8.80E+05
Zn-65	3.09E+09	8.23E+09	5.12E+09	0.00E+00	5.19E+09	0.00E+00	1.45E+09
Zn-69m	2.01E+05	3.42E+05	4.05E+04	0.00E+00	1.99E+05	0.00E+00	1.11E+07
Zn-69	3.23E-12	4.67E-12	4.31E-13	0.00E+00	2.83E-12	0.00E+00	2.94E-10
As-76	3.37E+05	9.37E+05	5.43E+06	3.18E+05	1.03E+06	3.18E+05	4.87E+07
Br-82	0.00E+00	0.00E+00	2.91E+07	0.00E+00	0.00E+00	0.00E+00	0.00E+00
Br-83	0.00E+00	0.00E+00	1.20E-01	0.00E+00	0.00E+00	0.00E+00	0.00E+00
Br-84	0.00E+00	0.00E+00	0.00E+00	0.00E+00	0.00E+00	0.00E+00	0.00E+00
Br-85	0.00E+00	0.00E+00	0.00E+00	0.00E+00	0.00E+00	0.00E+00	0.00E+00
Rb-86	0.00E+00	2.26E+09	1.39E+09	0.00E+00	0.00E+00	0.00E+00	1.45E+08
Rb-88	0.00E+00	0.00E+00	0.00E+00	0.00E+00	0.00E+00	0.00E+00	0.00E+00
Rb-89	0.00E+00	0.00E+00	0.00E+00	0.00E+00	0.00E+00	0.00E+00	0.00E+00
Sr-89	2.64E+09	0.00E+00	7.53E+07	0.00E+00	0.00E+00	0.00E+00	1.02E+08
Sr-90	1.39E+11	0.00E+00	2.80E+09	0.00E+00	0.00E+00	0.00E+00	1.24E+09
Sr-91	3.27E+04	0.00E+00	1.24E+03	0.00E+00	0.00E+00	0.00E+00	7.23E+04
Sr-92	5.54E-01	0.00E+00	2.22E-02	0.00E+00	0.00E+00	0.00E+00	1.05E+01
Y-90	8.06E+01	0.00E+00	2.16E+00	0.00E+00	0.00E+00	0.00E+00	2.29E+05
Y-91m	6.95E-20	0.00E+00	0.00E+00	0.00E+00	0.00E+00	0.00E+00	1.36E-16
Y-91	1.67E+04	0.00E+00	4.46E+02	0.00E+00	0.00E+00	0.00E+00	2.22E+06
Y-92	6.40E-05	0.00E+00	1.83E-06	0.00E+00	0.00E+00	0.00E+00	1.85E+00

TABLE 10-10
 R_{io} , GRASS-COW-MILK PATHWAY DOSE FACTORS – CHILD

NUCLIDE	BONE	LIVER	T. BODY	THYROID	KIDNEY	LUNG	GI-LLI
Y-93	2.65E-01	0.00E+00	7.27E-03	0.00E+00	0.00E+00	0.00E+00	3.95E+03
Zr-95	1.71E+03	3.76E+02	3.34E+02	0.00E+00	5.38E+02	0.00E+00	3.92E+05
Zr-97	4.72E-01	6.83E-02	4.03E-02	0.00E+00	9.80E-02	0.00E+00	1.03E+04
Nb-95	1.05E+05	4.07E+04	2.91E+04	0.00E+00	3.82E+04	0.00E+00	7.53E+07
Nb-97	7.28E-12	1.31E-12	6.14E-13	0.00E+00	1.46E-12	0.00E+00	4.06E-07
Mo-99	0.00E+00	2.04E+07	5.04E+06	0.00E+00	4.35E+07	0.00E+00	1.68E+07
Tc-99m	3.30E+00	6.47E+00	1.07E+02	0.00E+00	9.40E+01	3.29E+00	3.68E+03
Tc-99	1.94E+08	2.16E+08	7.76E+07	0.00E+00	2.54E+09	1.91E+07	2.27E+09
Tc-101	0.00E+00	0.00E+00	0.00E+00	0.00E+00	0.00E+00	0.00E+00	0.00E+00
Ru-103	1.50E+03	0.00E+00	5.77E+02	0.00E+00	3.78E+03	0.00E+00	3.88E+04
Ru-105	9.64E-04	0.00E+00	3.50E-04	0.00E+00	8.47E-03	0.00E+00	6.29E-01
Ru-106	6.59E+04	0.00E+00	8.22E+03	0.00E+00	8.90E+04	0.00E+00	1.02E+06
Rh-105	4.76E+05	2.56E+05	2.19E+05	0.00E+00	1.02E+06	0.00E+00	1.58E+07
Ag-110m	1.45E+08	9.80E+07	7.83E+07	0.00E+00	1.83E+08	0.00E+00	1.17E+10
Sn-113	2.95E+07	6.35E+06	9.71E+07	2.54E+06	6.73E+06	3.18E+06	1.08E+09
Sn-117m	1.33E+07	6.31E+05	2.08E+07	9.97E+04	6.40E+05	1.83E+05	2.41E+08
Sb-122	6.14E+05	3.69E+05	6.81E+06	8.04E+04	2.23E+05	1.05E+05	7.37E+07
Sb-124	4.71E+07	6.11E+05	1.65E+07	1.04E+05	0.00E+00	2.61E+07	2.95E+08
Sb-125	6.56E+07	5.06E+05	1.37E+07	6.08E+04	0.00E+00	3.66E+07	1.57E+08
Te-125m	3.51E+07	9.50E+06	4.67E+06	9.84E+06	0.00E+00	0.00E+00	3.38E+07
Te-127m	1.37E+08	3.69E+07	1.63E+07	3.28E+07	3.91E+08	0.00E+00	1.11E+08
Te-127	7.80E+02	2.10E+02	1.67E+02	5.40E+02	2.22E+03	0.00E+00	3.05E+04
Te-129m	9.39E+07	2.62E+07	1.46E+07	3.03E+07	2.76E+08	0.00E+00	1.15E+08
Te-129	3.38E-10	9.43E-11	8.02E-11	2.41E-10	9.88E-10	0.00E+00	2.10E-08
Te-131m	4.76E+05	1.65E+05	1.75E+05	3.39E+05	1.59E+06	0.00E+00	6.68E+06
Te-131	0.00E+00	0.00E+00	0.00E+00	0.00E+00	0.00E+00	0.00E+00	0.00E+00
Te-132	2.56E+06	1.13E+06	1.37E+06	1.65E+06	1.05E+07	0.00E+00	1.14E+07
I-130	2.17E+05	4.38E+05	2.25E+05	4.82E+07	6.564E+05	0.00E+00	2.05E+05
I-131	1.60E+08	1.61E+08	9.15E+07	5.32E+10	2.64E+08	0.00E+00	1.43E+07
I-132	7.65E-02	1.41E-01	6.46E-02	6.52E+00	2.15E-01	0.00E+00	1.65E-01
I-133	2.15E+06	2.66E+06	1.01E+06	4.94E+08	4.43E+06	0.00E+00	1.07E+06
I-134	1.11E-12	2.06E-12	9.47E-13	4.73E-11	3.15E-12	0.00E+00	1.36E-12
I-135	6.54E+03	1.18E+04	5.57E+03	1.04E+06	1.81E+04	0.00E+00	8.97E+03
Cs-134	1.68E+10	2.75E+10	5.81E+09	0.00E+00	8.53E+09	3.06E+09	1.48E+08
Cs-134m	1.86E-01	2.75E-01	1.79E-01	0.00E+00	1.45E-01	2.39E-02	3.47E-01
Cs-136	2.48E+08	6.80E+08	4.40E+08	0.00E+00	3.62E+08	5.40E+07	2.39E+07
Cs-137	2.59E+10	2.48E+10	3.66E+09	0.00E+00	8.09E+09	2.91E+09	1.55E+08

OFFSITE DOSE CALCULATION MANUAL

TABLE 10-10
 R_{io} , GRASS-COW-MILK PATHWAY DOSE FACTORS – CHILD

NUCLIDE	BONE	LIVER	T. BODY	THYROID	KIDNEY	LUNG	G-LLI
Cs-138	0.00E+00	0.00E+00	0.00E+00	0.00E+00	0.00E+00	0.00E+00	0.00E+00
Ba-139	6.29E-08	3.36E-11	1.82E-09	0.00E+00	2.93E-11	1.97E-11	3.63E-06
Ba-140	2.86E+07	2.50E+04	1.67E+06	0.00E+00	8.15E+03	1.49E+04	1.45E+07
Ba-141	0.00E+00	0.00E+00	0.00E+00	0.00E+00	0.00E+00	0.00E+00	0.00E+00
Ba-142	0.00E+00	0.00E+00	0.00E+00	0.00E+00	0.00E+00	0.00E+00	0.00E+00
La-140	4.87E+00	1.70E+00	5.73E-01	0.00E+00	0.00E+00	0.00E+00	4.74E+04
La-142	1.02E-11	3.25E-12	1.02E-12	0.00E+00	0.00E+00	0.00E+00	6.43E-07
Ce-141	6.94E+03	3.46E+03	5.14E+02	0.00E+00	1.52E+03	0.00E+00	4.32E+06
Ce-143	4.70E+01	2.55E+04	3.69E+00	0.00E+00	1.07E+01	0.00E+00	3.74E+05
Ce-144	1.09E+06	3.43E+05	5.84E+04	0.00E+00	1.90E+05	0.00E+00	8.94E+07
Pr-143	1.76E+02	5.28E+01	8.73E+00	0.00E+00	2.86E+01	0.00E+00	1.90E+05
Pr-144	0.00E+00	0.00E+00	0.00E+00	0.00E+00	0.00E+00	0.00E+00	0.00E+00
Nd-147	1.08E+02	8.79E+01	6.80E+00	0.00E+00	4.82E+01	0.00E+00	1.39E+05
Eu-152	1.95E+04	3.55E+03	4.22E+03	0.00E+00	1.50E+04	0.00E+00	5.84E+05
W-187	7.28E+03	4.31E+03	1.94E+03	0.00E+00	0.00E+00	0.00E+00	6.06E+05
U-235	1.10E+10	0.00E+00	6.67E+08	0.00E+00	1.81E+09	0.00E+00	2.59E+08
U-238	1.05E+10	0.00E+00	6.25E+08	0.00E+00	1.69E+09	0.00E+00	1.82E+08
Np-239	4.32E+00	3.10E-01	2.18E-01	0.00E+00	8.96E-01	0.00E+00	2.29E+04
Am-241	4.55E+07	2.04E+07	3.25E+06	0.00E+00	1.98E+07	0.00E+00	2.43E+06

TABLE 10-11
 R_{io} , GRASS-COW-MILK PATHWAY DOSE FACTORS – INFANT

{m²-mrem/yr per μ Ci/s (mrem/yr per μ Ci/m³ for ³H and ¹⁴C)}

NUCLIDE	BONE	LIVER	T. BODY	THYROID	KIDNEY	LUNG	GI-LLI
H-3	0.00E+00	1.98E+03	1.98E+03	1.98E+03	1.98E+03	1.98E+03	1.98E+03
C-14	3.23E+06	6.89E+05	6.89E+05	6.89E+05	6.89E+05	6.89E+05	6.89E+05
F-18	1.02E-02	0.00E+00	8.74E-04	0.00E+00	0.00E+00	0.00E+00	2.41E-03
Na-22	2.52E+10	2.52E+10	2.52E+10	2.52E+10	2.52E+10	2.52E+10	2.52E+10
Na-24	3.83E+06	3.83E+06	3.83E+06	3.83E+06	3.83E+06	3.83E+06	3.83E+06
Sc-46	6.49E+02	9.36E+02	2.93E+02	0.00E+00	6.16E+02	0.00E+00	6.11E+05
P-32	4.07E+10	2.40E+09	1.58E+09	0.00E+00	0.00E+00	0.00E+00	5.51E+08
Cr-51	0.00E+00	0.00E+00	4.74E+04	3.09E+04	6.75E+03	6.01E+04	1.38E+06
Mn-54	0.00E+00	2.69E+07	6.10E+06	0.00E+00	5.96E+06	0.00E+00	9.88E+06
Mn-56	0.00E+00	7.96E-03	1.37E-03	0.00E+00	6.84E-03	0.00E+00	7.23E-01
Fe-55	1.00E+08	6.49E+07	1.73E+07	0.00E+00	0.00E+00	3.17E+07	8.24E+06
Fe-59	8.36E+07	1.46E+08	5.76E+07	0.00E+00	0.00E+00	4.32E+07	6.98E+07
Co-57	0.00E+00	6.01E+06	9.77E+06	0.00E+00	0.00E+00	0.00E+00	2.05E+07
Co-58	0.00E+00	1.13E+07	2.82E+07	0.00E+00	0.00E+00	0.00E+00	2.82E+07
Co-60	0.00E+00	6.82E+07	1.61E+08	0.00E+00	0.00E+00	0.00E+00	1.62E+08
Ni-63	2.95E+10	1.82E+09	1.02E+09	0.00E+00	0.00E+00	0.00E+00	9.07E+07
Ni-65	8.75E-01	9.90E-02	4.51E-02	0.00E+00	0.00E+00	0.00E+00	7.54E+00
Cu-64	0.00E+00	4.66E+04	2.16E+04	0.00E+00	7.88E+04	0.00E+00	9.57E+05
Zn-65	4.15E+09	1.42E+10	6.56E+09	0.00E+00	6.90E+09	0.00E+00	1.20E+10
Zn-69m	4.24E+05	8.66E+05	7.89E+04	0.00E+00	3.51E+05	0.00E+00	1.20E+07
Zn-69	6.88E-12	1.24E-11	9.22E-13	0.00E+00	5.15E-12	0.00E+00	1.01E-09
As-76	2.06E+06	5.43E+06	9.37E+06	2.06E+06	5.71E+06	2.06E+06	5.99E+07
Br-82	0.00E+00	0.00E+00	4.90E+07	0.00E+00	0.00E+00	0.00E+00	0.00E+00
Br-83	0.00E+00	0.00E+00	2.55E-01	0.00E+00	0.00E+00	0.00E+00	0.00E+00
Br-84	0.00E+00	0.00E+00	0.00E+00	0.00E+00	0.00E+00	0.00E+00	0.00E+00
Br-85	0.00E+00	0.00E+00	0.00E+00	0.00E+00	0.00E+00	0.00E+00	0.00E+00
Rb-86	0.00E+00	5.72E+09	2.83E+09	0.00E+00	0.00E+00	0.00E+00	1.46E+08
Rb-88	0.00E+00	0.00E+00	0.00E+00	0.00E+00	0.00E+00	0.00E+00	0.00E+00
Rb-89	0.00E+00	0.00E+00	0.00E+00	0.00E+00	0.00E+00	0.00E+00	0.00E+00
Sr-89	5.02E+09	0.00E+00	1.44E+08	0.00E+00	0.00E+00	0.00E+00	1.03E+08
Sr-90	1.54E+11	0.00E+00	3.12E+09	0.00E+00	0.00E+00	0.00E+00	1.26E+09
Sr-91	6.82E+04	0.00E+00	2.47E+03	0.00E+00	0.00E+00	0.00E+00	8.07E+04
Sr-92	1.18E+00	0.00E+00	4.37E-02	0.00E+00	0.00E+00	0.00E+00	1.27E+01
Y-90	1.70E+02	0.00E+00	4.57E+00	0.00E+00	0.00E+00	0.00E+00	2.35E+05
Y-91m	1.47E-19	0.00E+00	0.00E+00	0.00E+00	0.00E+00	0.00E+00	4.91E-16
Y-91	3.13E+04	0.00E+00	8.35E+02	0.00E+00	0.00E+00	0.00E+00	2.25E+06
Y-92	1.36E-04	0.00E+00	3.82E-06	0.00E+00	0.00E+00	0.00E+00	2.59E+00

OFFSITE DOSE CALCULATION MANUAL

TABLE 10-11
 R_{io} , GRASS-COW-MILK PATHWAY DOSE FACTORS – INFANT

NUCLIDE	BONE	LIVER	T. BODY	THYROID	KIDNEY	LUNG	GI-LLI
Y-93	5.64E-01	0.00E+00	1.54E-02	0.00E+00	0.00E+00	0.00E+00	4.46E+03
Zr-95	3.03E+03	7.39E+02	5.24E+02	0.00E+00	7.97E+02	0.00E+00	3.68E+05
Zr-97	1.00E+00	1.72E-01	7.84E-02	0.00E+00	1.73E-01	0.00E+00	1.09E+04
Nb-95	1.95E+05	8.04E+04	4.65E+04	0.00E+00	5.76E+04	0.00E+00	6.79E+07
Nb-97	1.54E-11	3.28E-12	1.18E-12	0.00E+00	2.57E-12	0.00E+00	1.04E-06
Mo-99	0.00E+00	5.21E+07	1.02E+07	0.00E+00	7.78E+07	0.00E+00	1.71E+07
Tc-99m	6.86E+00	1.42E+01	1.82E+02	0.00E+00	1.52E+02	7.32E+00	4.11E+03
Tc-99	3.92E+08	5.29E+08	1.65E+08	0.00E+00	4.46E+09	5.15E+07	2.29E+09
Tc-101	0.00E+00	0.00E+00	0.00E+00	0.00E+00	0.00E+00	0.00E+00	0.00E+00
Ru-103	3.04E+03	0.00E+00	1.02E+03	0.00E+00	6.32E+03	0.00E+00	3.69E+04
Ru-105	2.03E-03	0.00E+00	6.84E-04	0.00E+00	1.49E-02	0.00E+00	8.08E-01
Ru-106	1.36E+05	0.00E+00	1.70E+04	0.00E+00	1.60E+05	0.00E+00	1.03E+06
Rh-105	1.01E+06	6.61E+05	4.44E+05	0.00E+00	1.83E+06	0.00E+00	1.64E+07
Ag-110m	2.68E+08	1.96E+08	1.29E+08	0.00E+00	2.80E+08	0.00E+00	1.01E+10
Sn-113	1.08E+08	2.17E+07	2.91E+08	1.16E+07	2.17E+07	1.46E+07	3.21E+09
Sn-117m	4.73E+07	1.91E+06	6.40E+07	5.40E+05	1.66E+06	7.81E+05	7.31E+08
Sb-122	2.35E+06	1.56E+06	2.01E+07	4.69E+05	7.48E+05	5.36E+05	2.12E+08
Sb-124	9.08E+07	1.34E+06	2.81E+07	2.41E+05	0.00E+00	5.69E+07	2.80E+08
Sb-125	1.13E+08	1.09E+06	2.32E+07	1.41E+05	0.00E+00	7.08E+07	1.50E+08
Te-125m	7.16E+07	2.40E+07	9.69E+06	2.41E+07	0.00E+00	0.00E+00	3.41E+07
Te-127m	2.78E+08	9.21E+07	3.36E+07	8.02E+07	6.84E+08	0.00E+00	1.12E+08
Te-127	1.66E+03	5.55E+02	3.56E+02	1.35E+03	4.04E+03	0.00E+00	3.48E+04
Te-129m	1.93E+08	6.61E+07	2.97E+07	7.41E+07	4.82E+08	0.00E+00	1.15E+08
Te-129	7.16E-10	2.47E-10	1.67E-10	6.00E-10	1.78E-09	0.00E+00	5.72E-08
Te-131m	1.01E+06	4.05E+05	3.34E+05	8.20E+05	2.78E+06	0.00E+00	6.81E+06
Te-131	0.00E+00	0.00E+00	0.00E+00	0.00E+00	0.00E+00	0.00E+00	0.00E+00
Te-132	5.28E+06	2.61E+06	2.44E+06	3.86E+06	1.63E+07	0.00E+00	9.67E+06
I-130	4.45E+05	9.79E+05	3.93E+05	1.10E+08	1.08E+06	0.00E+00	2.10E+05
I-131	3.34E+08	3.94E+08	1.73E+08	1.29E+11	4.60E+08	0.00E+00	1.41E+07
I-132	1.59E-01	3.22E-01	1.15E-01	1.51E+01	3.59E-01	0.00E+00	2.61E-01
I-133	4.54E+06	6.61E+06	1.94E+06	1.20E+09	7.77E+06	0.00E+00	1.12E+06
I-134	2.30E-12	4.71E-12	1.67E-12	1.10E-10	5.26E-10	0.00E+00	4.87E-12
I-135	1.36E+04	2.71E+04	9.87E+03	2.43E+06	3.02E+04	0.00E+00	9.80E+03
Cs-134	2.70E+10	5.04E+10	5.09E+09	0.00E+00	1.30E+10	5.32E+09	1.37E+08
Cs-134m	3.87E-01	6.44E-01	3.25E-01	0.00E+00	2.48E-01	5.72E-02	5.10E-01
Cs-136	4.84E+08	1.42E+09	5.31E+08	0.00E+00	5.67E+08	1.16E+08	2.16E+07
Cs-137	4.14E+10	4.84E+10	3.43E+09	0.00E+00	1.30E+10	5.26E+09	1.51E+08

TABLE 10-11
 R_{io} , GRASS-COW-MILK PATHWAY DOSE FACTORS – INFANT

NUCLIDE	BONE	LIVER	T. BODY	THYROID	KIDNEY	LUNG	GI-LLI
Cs-138	0.00E+00	0.00E+00	0.00E+00	0.00E+00	0.00E+00	0.00E+00	0.00E+00
Ba-139	1.34E-07	8.87E-11	3.87E-09	0.00E+00	5.33E-11	5.38E-11	8.474E-06
Ba-140	5.88E+07	5.88E+04	3.03E+06	0.00E+00	1.40E+04	3.61E+04	1.44E+07
Ba-141	0.00E+00	0.00E+00	0.00E+00	0.00E+00	0.00E+00	0.00E+00	0.00E+00
Ba-142	0.00E+00	0.00E+00	0.00E+00	0.00E+00	0.00E+00	0.00E+00	0.00E+00
La-140	1.02E+01	4.01E+00	1.03E+00	0.00E+00	0.00E+00	0.00E+00	4.71E+04
La-142	2.14E-11	7.85E-12	1.88E-12	0.00E+00	0.00E+00	0.00E+00	1.33E-06
Ce-141	1.38E+04	8.39E+03	9.87E+02	0.00E+00	2.59E+03	0.00E+00	4.33E+06
Ce-143	9.96E+01	6.61E+04	7.54E+00	0.00E+00	1.92E+01	0.00E+00	3.86E+05
Ce-144	1.57E+06	6.41E+05	8.78E+04	0.00E+00	2.59E+05	0.00E+00	8.99E+07
Pr-143	3.64E+02	1.36E+02	1.80E+01	0.00E+00	5.06E+01	0.00E+00	1.92E+05
Pr-144	0.00E+00	0.00E+00	0.00E+00	0.00E+00	0.00E+00	0.00E+00	0.00E+00
Nd-147	2.15E+02	2.21E+02	1.35E+01	0.00E+00	8.52E+01	0.00E+00	1.40E+05
Eu-152	2.14E+04	5.68E+03	4.79E+03	0.00E+00	1.59E+04	0.00E+00	5.05E+05
W-187	1.53E+04	1.07E+04	3.68E+03	0.00E+00	0.00E+00	0.00E+00	6.27E+05
U-235	1.51E+10	0.00E+00	1.15E+09	0.00E+00	3.20E+09	0.00E+00	2.61E+08
U-238	1.44E+10	0.00E+00	1.07E+09	0.00E+00	2.99E+09	0.00E+00	1.84E+08
Np-239	9.12E+00	8.16E-01	4.61E-01	0.00E+00	1.63E+00	0.00E+00	2.36E+04
Am-241	4.87E+07	2.29E+07	3.47E+06	0.00E+00	2.09E+07	0.00E+00	2.45E+06

OFFSITE DOSE CALCULATION MANUAL

TABLE 10-12
 R_{io} , GRASS-COW-MEAT PATHWAY DOSE FACTORS – ADULT

{ m^2 -mrem/yr per $\mu Ci/s$ (mrem/yr per $\mu Ci/m^3$ for 3H and ^{14}C)}

NUCLIDE	BONE	LIVER	T. BODY	THYROID	KIDNEY	LUNG	GI-ILI
H-3	0.00E+00	2.69E+02	2.69E+02	2.69E+02	2.69E+02	2.69E+02	2.69E+02
C-14	3.33E+05	6.66E+04	6.66E+04	6.66E+04	6.66E+04	6.66E+04	6.66E+04
F-18	0.00E+00	0.00E+00	0.00E+00	0.00E+00	0.00E+00	0.00E+00	0.00E+00
Na-22	1.10E+09	1.10E+09	1.10E+09	1.10E+09	1.10E+09	1.10E+09	1.10E+09
Na-24	3.22E-04	3.22E-04	3.22E-04	3.22E-04	3.22E-04	3.22E-04	3.22E-04
Sc-46	8.77E+04	1.70E+05	4.95E+04	0.00E+00	1.59E+05	0.00E+00	8.29E+08
P-32	1.18E+09	7.36E+07	4.58E+07	0.00E+00	0.00E+00	0.00E+00	1.33E+08
Cr-51	0.00E+00	0.00E+00	2.07E+03	1.24E+03	4.56E+02	2.75E+03	5.21E+05
Mn-54	0.00E+00	6.33E+06	1.21E+06	0.00E+00	1.88E+06	0.00E+00	1.94E+07
Mn-56	0.00E+00	0.00E+00	0.00E+00	0.00E+00	0.00E+00	0.00E+00	0.00E+00
Fe-55	2.18E+08	1.51E+08	3.51E+07	0.00E+00	0.00E+00	8.41E+07	8.65E+07
Fe-59	9.89E+07	2.33E+08	8.91E+07	0.00E+00	0.00E+00	6.50E+07	7.75E+08
Co-57	0.00E+00	3.78E+06	6.29E+06	0.00E+00	0.00E+00	0.00E+00	9.60E+07
Co-58	0.00E+00	8.51E+06	1.91E+07	0.00E+00	0.00E+00	0.00E+00	1.73E+08
Co-60	0.00E+00	5.82E+07	1.28E+08	0.00E+00	0.00E+00	0.00E+00	1.09E+09
Ni-63	1.59E+10	1.10E+09	5.34E+08	0.00E+00	0.00E+00	0.00E+00	2.30E+08
Ni-65	0.00E+00	0.00E+00	0.00E+00	0.00E+00	0.00E+00	0.00E+00	0.00E+00
Cu-64	0.00E+00	7.00E-08	3.29E-08	0.00E+00	1.77E-07	0.00E+00	5.97E-06
Zn-65	2.66E+08	8.46E+08	3.82E+08	0.00E+00	5.66E+08	0.00E+00	5.33E+08
Zn-69m	4.37E-06	1.05E-05	9.58E-06	0.00E+00	6.34E-06	0.00E+00	6.39E-04
Zn-69	0.00E+00	0.00E+00	0.00E+00	0.00E+00	0.00E+00	0.00E+00	0.00E+00
As-76	1.30E-01	3.78E-01	1.89E+00	1.13E-01	4.61E-01	1.18E-01	1.65E+01
Br-82	0.00E+00	0.00E+00	3.01E+02	0.00E+00	0.00E+00	0.00E+00	3.59E+02
Br-83	0.00E+00	0.00E+00	0.00E+00	0.00E+00	0.00E+00	0.00E+00	0.00E+00
Br-84	0.00E+00	0.00E+00	0.00E+00	0.00E+00	0.00E+00	0.00E+00	0.00E+00
Br-85	0.00E+00	0.00E+00	0.00E+00	0.00E+00	0.00E+00	0.00E+00	0.00E+00
Rb-86	0.00E+00	1.25E+08	5.84E+07	0.00E+00	0.00E+00	0.00E+00	2.47E+07
Rb-88	0.00E+00	0.00E+00	0.00E+00	0.00E+00	0.00E+00	0.00E+00	0.00E+00
Rb-89	0.00E+00	0.00E+00	0.00E+00	0.00E+00	0.00E+00	0.00E+00	0.00E+00
Sr-89	1.20E+08	0.00E+00	3.45E+06	0.00E+00	0.00E+00	0.00E+00	1.93E+07
Sr-90	1.18E+10	0.00E+00	2.37E+08	0.00E+00	0.00E+00	0.00E+00	2.97E+08
Sr-91	3.96E-11	0.00E+00	1.60E-12	0.00E+00	0.00E+00	0.00E+00	1.88E-10
Sr-92	0.00E+00	0.00E+00	0.00E+00	0.00E+00	0.00E+00	0.00E+00	0.00E+00
Y-90	2.70E+01	0.00E+00	7.25E-01	0.00E+00	0.00E+00	0.00E+00	2.86E+05
Y-91m	0.00E+00	0.00E+00	0.00E+00	0.00E+00	0.00E+00	0.00E+00	0.00E+00
Y-91	4.83E+05	0.00E+00	1.29E+04	0.00E+00	0.00E+00	0.00E+00	2.67E+08
Y-92	0.00E+00	0.00E+00	0.00E+00	0.00E+00	0.00E+00	0.00E+00	0.00E+00

TABLE 10-12
 R_{io} , GRASS-COW-MEAT PATHWAY DOSE FACTORS – ADULT

NUCLIDE	BONE	LIVER	T. BODY	THYROID	KIDNEY	LUNG	GI-LLI
Y-93	1.70E-12	0.00E+00	4.69E-14	0.00E+00	0.00E+00	0.00E+00	5.39E-08
Zr-95	8.35E+05	2.68E+05	1.81E+05	0.00E+00	4.28E+05	0.00E+00	8.49E+08
Zr-97	4.67E-06	9.43E-05	4.31E-07	0.00E+00	1.42E-06	0.00E+00	2.92E-01
Nb-95	7.55E+05	4.20E+05	2.26E+05	0.00E+00	4.15E+05	0.00E+00	2.55E+09
Nb-97	0.00E+00	0.00E+00	0.00E+00	0.00E+00	0.00E+00	0.00E+00	0.00E+00
Mo-99	0.00E+00	2.50E+04	4.76E+03	0.00E+00	5.67E+04	0.00E+00	5.80E+04
Tc-99m	0.00E+00	0.00E+00	3.90E-20	0.00E+00	4.65E-20	0.00E+00	1.81E-18
Tc-99	2.42E+08	3.60E+08	9.71E+07	0.00E+00	4.52E+09	3.05E+07	1.18E+10
Tc-101	0.00E+00	0.00E+00	0.00E+00	0.00E+00	0.00E+00	0.00E+00	0.00E+00
Ru-103	3.68E+07	0.00E+00	1.59E+07	0.00E+00	1.41E+08	0.00E+00	4.30E+09
Ru-105	0.00E+00	0.00E+00	0.00E+00	0.00E+00	0.00E+00	0.00E+00	0.00E+00
Ru-106	2.00E+09	0.00E+00	2.53E+08	0.00E+00	3.86E+09	0.00E+00	1.29E+11
Rh-105	1.19E+00	8.69E-01	5.73E-01	0.00E+00	3.69E+00	0.00E+00	1.38E+02
Ag-110m	4.64E+06	4.30E+06	2.55E+06	0.00E+00	8.44E+06	0.00E+00	1.75E+09
Sn-113	9.30E+07	1.57E+07	2.61E+08	8.22E+06	2.15E+07	9.65E+06	2.86E+09
Sn-117m	1.77E+07	6.08E+05	2.51E+07	1.20E+05	9.20E+05	1.91E+05	2.83E+08
Sb-122	1.82E+03	1.00E+03	1.72E+04	2.12E+02	7.08E+02	2.73E+02	1.82E+05
Sb-124	8.59E+06	1.62E+05	3.40E+06	2.08E+04	0.00E+00	6.69E+06	2.44E+08
Sb-125	1.44E+07	1.61E+05	3.43E+06	1.46E+04	0.00E+00	1.11E+07	1.59E+08
Te-125m	1.71E+08	6.18E+07	2.28E+07	5.13E+07	6.94E+08	0.00E+00	6.81E+08
Te-127m	7.36E+08	2.63E+08	8.96E+07	1.88E+08	2.99E+09	0.00E+00	2.47E+09
Te-127	6.85E-11	2.46E-11	1.48E-11	5.07E-11	2.79E-10	0.00E+00	5.40E-09
Te-129m	3.93E+08	1.46E+08	6.21E+07	1.35E+08	1.64E+09	0.00E+00	1.98E+09
Te-129	0.00E+00	0.00E+00	0.00E+00	0.00E+00	0.00E+00	0.00E+00	0.00E+00
Te-131m	2.84E+02	1.39E+02	1.16E+02	2.20E+02	1.41E+03	0.00E+00	1.38E+04
Te-131	0.00E+00	0.00E+00	0.00E+00	0.00E+00	0.00E+00	0.00E+00	0.00E+00
Te-132	3.33E+05	2.15E+05	2.02E+05	2.38E+05	2.07E+06	0.00E+00	1.02E+07
I-130	1.72E-07	8.02E-07	3.17E-07	6.80E-05	1.25E-06	0.00E+00	6.91E-07
I-131	1.32E+06	1.88E+06	1.08E+06	6.17E+08	3.23E+06	0.00E+00	4.97E+05
I-132	0.00E+00	0.00E+00	0.00E+00	0.00E+00	0.00E+00	0.00E+00	0.00E+00
I-133	4.65E-02	8.09E-02	2.47E-02	1.19E+01	1.41E-01	0.00E+00	7.27E-02
I-134	0.00E+00	0.00E+00	0.00E+00	0.00E+00	0.00E+00	0.00E+00	0.00E+00
I-135	4.29E-18	1.12E-17	4.15E-18	7.41E-16	1.80E-17	0.00E+00	1.27E-17
Cs-134	4.87E+08	1.16E+09	9.48E+08	0.00E+00	3.75E+08	1.25E+08	2.03E+07
Cs-134m	0.00E+00	0.00E+00	0.00E+00	0.00E+00	0.00E+00	0.00E+00	0.00E+00
Cs-136	2.95E+06	1.17E+07	8.39E+06	0.00E+00	6.49E+06	8.89E+05	1.32E+06
Cs-137	7.01E+08	9.59E+08	6.28E+08	0.00E+00	3.26E+08	1.08E+08	1.86E+07

OFFSITE DOSE CALCULATION MANUAL

TABLE 10-12
 R_{io} , GRASS-COW-MEAT PATHWAY DOSE FACTORS – ADULT

NUCLIDE	BONE	LIVER	T. BODY	THYROID	KIDNEY	LUNG	G-LLI
Cs-138	0.00E+00	0.00E+00	0.00E+00	0.00E+00	0.00E+00	0.00E+00	0.00E+00
Ba-139	0.00E+00	0.00E+00	0.00E+00	0.00E+00	0.00E+00	0.00E+00	0.00E+00
Ba-140	6.99E+06	8.79E+03	4.58E+05	0.00E+00	2.99E+03	5.03E+03	1.44E+07
Ba-141	0.00E+00	0.00E+00	0.00E+00	0.00E+00	0.00E+00	0.00E+00	0.00E+00
Ba-142	0.00E+00	0.00E+00	0.00E+00	0.00E+00	0.00E+00	0.00E+00	0.00E+00
La-140	9.48E-03	4.78E-03	1.26E-03	0.00E+00	0.00E+00	0.00E+00	3.51E+02
La-142	0.00E+00	0.00E+00	0.00E+00	0.00E+00	0.00E+00	0.00E+00	0.00E+00
Ce-141	4.46E+03	3.01E+03	3.42E+02	0.00E+00	1.40E+03	0.00E+00	1.15E+07
Ce-143	5.16E-03	3.81E+00	4.22E-04	0.00E+00	1.68E-03	0.00E+00	1.43E+02
Ce-144	9.82E+05	4.11E+05	5.27E+04	0.00E+00	2.44E+05	0.00E+00	3.32E+08
Pr-143	5.15E+03	2.06E+03	2.55E+02	0.00E+00	1.19E+03	0.00E+00	2.26E+07
Pr-144	0.00E+00	0.00E+00	0.00E+00	0.00E+00	0.00E+00	0.00E+00	0.00E+00
Nd-147	1.73E+03	2.00E+03	1.19E+02	0.00E+00	1.17E+03	0.00E+00	9.58E+06
Eu-152	2.00E+06	4.50E+05	3.95E+05	0.00E+00	2.79E+06	0.00E+00	2.59E+08
W-187	5.49E-03	4.59E-03	1.60E-03	0.00E+00	0.00E+00	0.00E+00	1.50E+00
U-235	5.85E+08	0.00E+00	3.55E+07	0.00E+00	1.37E+08	0.00E+00	5.71E+07
U-238	5.60E+08	0.00E+00	3.32E+07	0.00E+00	1.28E+08	0.00E+00	4.02E+07
Np-239	6.52E-02	6.41E-03	3.54E-03	0.00E+00	2.00E-02	0.00E+00	1.32E+03
Am-241	3.48E+08	1.22E+08	2.30E+07	0.00E+00	1.73E+08	0.00E+00	3.15E+07

TABLE 10-13
 R_{io} , GRASS-COW-MEAT PATHWAY DOSE FACTORS – TEEN

{ m^2 -mrem/yr per μ Ci/s (mrem/yr per μ Ci/ m^3 for 3H and ^{14}C)}

NUCLIDE	BONE	LIVER	T. BODY	THYROID	KIDNEY	LUNG	GI-LLI
H-3	0.00E+00	1.60E+02	1.60E+02	1.60E+02	1.60E+02	1.60E+02	1.60E+02
C-14	2.81E+05	5.62E+04	5.62E+04	5.62E+04	5.62E+04	5.62E+04	5.62E+04
F-18	0.00E+00	0.00E+00	0.00E+00	0.00E+00	0.00E+00	0.00E+00	0.00E+00
Na-22	8.73E+08	8.73E+08	8.73E+08	8.73E+08	8.73E+08	8.73E+08	8.73E+08
Na-24	2.58E-04	2.58E-04	2.58E-04	2.58E-04	2.58E-04	2.58E-04	2.58E-04
Sc-46	6.81E+04	1.33E+05	3.93E+04	0.00E+00	1.27E+05	0.00E+00	4.51E+08
P-32	1.00E+09	6.20E+07	3.88E+07	0.00E+00	0.00E+00	0.00E+00	8.41E+07
Cr-51	0.00E+00	0.00E+00	1.66E+03	9.20E+02	3.63E+02	2.37E+03	2.78E+05
Mn-54	0.00E+00	4.83E+06	9.58E+05	0.00E+00	1.44E+06	0.00E+00	9.90E+06
Mn-56	0.00E+00	0.00E+00	0.00E+00	0.00E+00	0.00E+00	0.00E+00	0.00E+00
Fe-55	1.77E+08	1.26E+08	2.93E+07	0.00E+00	0.00E+00	7.97E+07	5.44E+07
Fe-59	7.91E+07	1.85E+08	7.13E+07	0.00E+00	0.00E+00	5.82E+07	4.36E+08
Co-57	0.00E+00	3.04E+06	5.10E+06	0.00E+00	0.00E+00	0.00E+00	5.67E+07
Co-58	0.00E+00	6.56E+06	1.51E+07	0.00E+00	0.00E+00	0.00E+00	9.05E+07
Co-60	0.00E+00	4.51E+07	1.02E+08	0.00E+00	0.00E+00	0.00E+00	5.88E+08
Ni-63	1.28E+10	9.06E+08	4.35E+08	0.00E+00	0.00E+00	0.00E+00	1.44E+08
Ni-65	0.00E+00	0.00E+00	0.00E+00	0.00E+00	0.00E+00	0.00E+00	0.00E+00
Cu-64	0.00E+00	5.71E-08	2.69E-08	0.00E+00	1.45E-07	0.00E+00	4.43E-06
Zn-65	1.87E+08	6.49E+08	3.03E+08	0.00E+00	4.15E+08	0.00E+00	2.75E+08
Zn-69m	3.64E-06	8.59E-06	7.88E-07	0.00E+00	5.22E-06	0.00E+00	4.72E-04
Zn-69	0.00E+00	0.00E+00	0.00E+00	0.00E+00	0.00E+00	0.00E+00	0.00E+00
As-76	9.08E-02	2.86E-01	1.40E+00	8.35E-02	3.35E-01	8.38E-02	1.26E+01
Br-82	0.00E+00	0.00E+00	2.49E+02	0.00E+00	0.00E+00	0.00E+00	0.00E+00
Br-83	0.00E+00	0.00E+00	0.00E+00	0.00E+00	0.00E+00	0.00E+00	0.00E+00
Br-84	0.00E+00	0.00E+00	0.00E+00	0.00E+00	0.00E+00	0.00E+00	0.00E+00
Br-85	0.00E+00	0.00E+00	0.00E+00	0.00E+00	0.00E+00	0.00E+00	0.00E+00
Rb-86	0.00E+00	1.05E+08	4.91E+07	0.00E+00	0.00E+00	0.00E+00	1.55E+07
Rb-88	0.00E+00	0.00E+00	0.00E+00	0.00E+00	0.00E+00	0.00E+00	0.00E+00
Rb-89	0.00E+00	0.00E+00	0.00E+00	0.00E+00	0.00E+00	0.00E+00	0.00E+00
Sr-89	1.01E+08	0.00E+00	2.91E+06	0.00E+00	0.00E+00	0.00E+00	1.21E+07
Sr-90	8.18E+09	0.00E+00	1.64E+08	0.00E+00	0.00E+00	0.00E+00	1.87E+08
Sr-91	3.33E-11	0.00E+00	1.32E-12	0.00E+00	0.00E+00	0.00E+00	1.51E-10
Sr-92	0.00E+00	0.00E+00	0.00E+00	0.00E+00	0.00E+00	0.00E+00	0.00E+00
Y-90	2.27E+01	0.00E+00	6.12E-01	0.00E+00	0.00E+00	0.00E+00	1.88E+05
Y-91m	0.00E+00	0.00E+00	0.00E+00	0.00E+00	0.00E+00	0.00E+00	0.00E+00
Y-91	4.08E+05	0.00E+00	1.09E+04	0.00E+00	0.00E+00	0.00E+00	1.67E+08

OFFSITE DOSE CALCULATION MANUAL

TABLE 10-13
 R_{io} , GRASS-COW-MEAT PATHWAY DOSE FACTORS – TEEN

NUCLIDE	BONE	LIVER	T. BODY	THYROID	KIDNEY	LUNG	G-LLI
Y-92	0.00E+00	0.00E+00	0.00E+00	0.00E+00	0.00E+00	0.00E+00	0.00E+00
Y-93	1.43E-12	0.00E+00	3.93E-14	0.00E+00	0.00E+00	0.00E+00	4.38E-08
Zr-95	6.69E+05	2.11E+05	1.45E+05	0.00E+00	3.10E+05	0.00E+00	4.87E+08
Zr-97	3.90E-06	7.71E-07	3.55E-07	0.00E+00	1.17E-06	0.00E+00	2.09E-01
Nb-95	5.90E+05	3.27E+05	1.80E+05	0.00E+00	3.17E+05	0.00E+00	1.40E+09
Nb-97	0.00E+00	0.00E+00	0.00E+00	0.00E+00	0.00E+00	0.00E+00	0.00E+00
Mo-99	0.00E+00	2.07E+04	3.94E+03	0.00E+00	4.73E+04	0.00E+00	3.70E+04
Tc-99m	0.00E+00	0.00E+00	3.11E-20	0.00E+00	3.58E-20	0.00E+00	1.58E-18
Tc-99	2.05E+08	3.00E+08	8.19E+07	0.00E+00	3.82E+09	3.11E+07	7.36E+09
Tc-101	0.00E+00	0.00E+00	0.00E+00	0.00E+00	0.00E+00	0.00E+00	0.00E+00
Ru-103	3.00E+07	0.00E+00	1.28E+07	0.00E+00	1.06E+08	0.00E+00	2.51E+09
Ru-105	0.00E+00	0.00E+00	0.00E+00	0.00E+00	0.00E+00	0.00E+00	0.00E+00
Ru-106	1.68E+09	0.00E+00	2.12E+08	0.00E+00	3.24E+09	0.00E+00	8.07E+10
Rh-105	1.00E+00	7.25E-01	4.76E-01	0.00E+00	3.08E+00	0.00E+00	9.23E+01
Ag-110m	3.52E+06	3.33E+06	2.02E+06	0.00E+00	6.34E+06	0.00E+00	9.35E+08
Sn-113	5.92E+07	1.18E+07	1.94E+08	5.71E+06	1.54E+07	6.97E+06	2.09E+09
Sn-117m	1.07E+07	4.60E+05	1.84E+07	8.58E+04	6.48E+05	1.57E+05	2.07E+08
Sb-122	1.13E+03	7.76E+02	1.25E+04	1.55E+02	5.08E+02	2.09E+02	1.31E+05
Sb-124	7.01E+06	1.29E+05	2.74E+06	1.59E+04	0.00E+00	6.13E+06	1.41E+08
Sb-125	1.18E+07	1.29E+05	2.76E+06	1.13E+04	0.00E+00	1.04E+07	9.18E+07
Te-125m	1.44E+08	5.19E+07	1.93E+07	4.02E+07	0.00E+00	0.00E+00	4.25E+08
Te-127m	6.21E+08	2.20E+08	7.38E+07	1.48E+08	2.52E+09	0.00E+00	1.55E+09
Te-127	5.81E-11	2.06E-11	1.25E-11	4.01E-11	2.35E-10	0.00E+00	4.49E-09
Te-129m	3.29E+08	1.22E+08	5.21E+07	1.07E+08	1.38E+09	0.00E+00	1.23E+09
Te-129	0.00E+00	0.00E+00	0.00E+00	0.00E+00	0.00E+00	0.00E+00	0.00E+00
Te-131m	2.37E+02	1.14E+02	9.48E+01	1.71E+02	1.19E+03	0.00E+00	9.12E+03
Te-131	0.00E+00	0.00E+00	0.00E+00	0.00E+00	0.00E+00	0.00E+00	0.00E+00
Te-132	2.72E+05	1.72E+05	1.62E+05	1.82E+05	1.65E+06	0.00E+00	5.46E+06
I-130	2.19E-07	6.33E-07	2.53E-07	5.16E-05	9.76E-07	0.00E+00	4.87E-07
I-131	1.09E+06	1.53E+06	8.23E+05	4.47E+08	2.64E+06	0.00E+00	3.03E+05
I-132	0.00E+00	0.00E+00	0.00E+00	0.00E+00	0.00E+00	0.00E+00	0.00E+00
I-133	3.89E-02	6.60E-02	2.01E-02	9.21E+00	1.16E-01	0.00E+00	4.99E-02
I-134	0.00E+00	0.00E+00	0.00E+00	0.00E+00	0.00E+00	0.00E+00	0.00E+00
I-135	3.49E-18	8.99E-18	3.33E-18	5.78E-16	1.42E-17	0.00E+00	9.96E-18
Cs-134	3.87E+08	9.12E+08	4.23E+08	0.00E+00	2.90E+08	1.11E+08	1.13E+07
Cs-134m	0.00E+00	0.00E+00	0.00E+00	0.00E+00	0.00E+00	0.00E+00	0.00E+00
Cs-136	2.30E+06	9.06E+06	6.08E+06	0.00E+00	4.93E+06	7.77E+05	7.29E+05
Cs-137	5.82E+08	7.75E+08	2.70E+08	0.00E+00	2.64E+08	1.02E+08	1.10E+07

TABLE 10-13
 R_{io} , GRASS-COW-MEAT PATHWAY DOSE FACTORS – TEEN

NUCLIDE	BONE	LIVER	T. BODY	THYROID	KIDNEY	LUNG	GI-ILI
Cs-138	0.00E+00	0.00E+00	0.00E+00	0.00E+00	0.00E+00	0.00E+00	0.00E+00
Ba-139	0.00E+00	0.00E+00	0.00E+00	0.00E+00	0.00E+00	0.00E+00	0.00E+00
Ba-140	5.78E+06	7.09E+03	3.73E+05	0.00E+00	2.40E+03	4.76E+03	8.92E+06
Ba-141	0.00E+00	0.00E+00	0.00E+00	0.00E+00	0.00E+00	0.00E+00	0.00E+00
Ba-142	0.00E+00	0.00E+00	0.00E+00	0.00E+00	0.00E+00	0.00E+00	0.00E+00
La-140	7.79E-03	3.83E-03	1.02E-03	0.00E+00	0.00E+00	0.00E+00	2.20E+02
La-142	0.00E+00	0.00E+00	0.00E+00	0.00E+00	0.00E+00	0.00E+00	0.00E+00
Ce-141	3.74E+03	2.50E+03	2.87E+02	0.00E+00	1.18E+03	0.00E+00	7.15E+06
Ce-143	4.34E-03	3.16E+00	3.53E-04	0.00E+00	1.42E-03	0.00E+00	9.50E+01
Ce-144	8.28E+05	3.43E+05	4.45E+04	0.00E+00	2.05E+05	0.00E+00	2.08E+08
Pr-143	4.33E+03	1.73E+03	2.16E+02	0.00E+00	1.01E+03	0.00E+00	1.43E+07
Pr-144	0.00E+00	0.00E+00	0.00E+00	0.00E+00	0.00E+00	0.00E+00	0.00E+00
Nd-147	1.52E+03	1.65E+03	9.91E+01	0.00E+00	9.72E+02	0.00E+00	5.97E+06
Eu-152	1.47E+06	3.53E+05	3.11E+05	0.00E+00	1.64E+06	0.00E+00	1.30E+08
W-187	4.60E-03	3.75E-03	1.31E-03	0.00E+00	0.00E+00	0.00E+00	1.01E+00
U-235	4.92E+08	0.00E+00	3.00E+07	0.00E+00	1.15E+08	0.00E+00	3.57E+07
U-238	4.71E+08	0.00E+00	2.80E+07	0.00E+00	1.08E+08	0.00E+00	2.52E+07
Np-239	5.70E-02	5.38E-03	2.99E-03	0.00E+00	1.69E-02	0.00E+00	8.65E+02
Am-241	2.16E+08	8.26E+07	1.44E+07	0.00E+00	1.08E+08	0.00E+00	1.97E+07

OFFSITE DOSE CALCULATION MANUAL

TABLE 10-14
 R_{io} , GRASS-COW-MEAT PATHWAY DOSE FACTORS – CHILD

{ m^2 -mrem/yr per $\mu Ci/s$ (mrem/yr per $\mu Ci/m^3$ for 3H -3 and ^{14}C)}

NUCLIDE	BONE	LIVER	T. BODY	THYROID	KIDNEY	LUNG	GI-LLI
H-3	0.00E+00	1.94E+02	1.94E+02	1.94E+02	1.94E+02	1.94E+02	1.94E+02
C-14	5.29E+05	1.06E+05	1.06E+05	1.06E+05	1.06E+05	1.06E+05	1.06E+05
F-18	0.00E+00	0.00E+00	0.00E+00	0.00E+00	0.00E+00	0.00E+00	0.00E+00
Na-22	1.38E+09	1.38E+09	1.38E+09	1.38E+09	1.38E+09	1.38E+09	1.38E+09
Na-24	4.10E-04	4.10E-04	4.10E-04	4.10E-04	4.10E-04	4.10E-04	4.10E-04
Sc-46	1.17E+05	1.60E+05	6.17E+04	0.00E+00	1.42E+05	0.00E+00	2.34E+08
P-32	1.89E+09	8.83E+07	7.27E+07	0.00E+00	0.00E+00	0.00E+00	5.21E+07
Cr-51	0.00E+00	0.00E+00	2.58E+03	1.43E+03	3.92E+02	2.62E+03	1.37E+05
Mn-54	0.00E+00	5.52E+06	1.47E+06	0.00E+00	1.55E+06	0.00E+00	4.64E+06
Mn-56	0.00E+00	0.00E+00	0.00E+00	0.00E+00	0.00E+00	0.00E+00	0.00E+00
Fe-55	3.40E+08	1.80E+08	5.59E+07	0.00E+00	0.00E+00	1.02E+08	3.34E+07
Fe-59	1.40E+08	2.27E+08	1.13E+08	0.00E+00	0.00E+00	6.58E+07	2.36E+08
Co-57	0.00E+00	3.97E+06	8.04E+06	0.00E+00	0.00E+00	0.00E+00	3.26E+07
Co-58	0.00E+00	7.67E+06	2.35E+07	0.00E+00	0.00E+00	0.00E+00	4.47E+07
Co-60	0.00E+00	5.36E+07	1.58E+08	0.00E+00	0.00E+00	0.00E+00	2.97E+08
Ni-63	2.46E+10	1.32E+09	8.36E+08	0.00E+00	0.00E+00	0.00E+00	8.86E+07
Ni-65	0.00E+00	0.00E+00	0.00E+00	0.00E+00	0.00E+00	0.00E+00	0.00E+00
Cu-64	0.00E+00	7.68E-08	4.64E-08	0.00E+00	1.86E-07	0.00E+00	3.60E-06
Zn-65	2.80E+08	7.47E+08	4.65E+08	0.00E+00	4.71E+08	0.00E+00	1.31E+08
Zn-69m	6.80E-06	1.16E-05	1.37E-06	0.00E+00	6.73E-06	0.00E+00	3.77E-04
Zn-69	0.00E+00	0.00E+00	0.00E+00	0.00E+00	0.00E+00	0.00E+00	0.00E+00
As-76	1.59E-01	4.41E-01	2.56E+00	1.50E-01	4.85E-01	1.50E-01	2.29E+01
Br-82	0.00E+00	0.00E+00	3.90E+02	0.00E+00	0.00E+00	0.00E+00	0.00E+00
Br-83	0.00E+00	0.00E+00	0.00E+00	0.00E+00	0.00E+00	0.00E+00	0.00E+00
Br-84	0.00E+00	0.00E+00	0.00E+00	0.00E+00	0.00E+00	0.00E+00	0.00E+00
Br-85	0.00E+00	0.00E+00	0.00E+00	0.00E+00	0.00E+00	0.00E+00	0.00E+00
Rb-86	0.00E+00	1.48E+08	9.12E+07	0.00E+00	0.00E+00	0.00E+00	9.54E+06
Rb-88	0.00E+00	0.00E+00	0.00E+00	0.00E+00	0.00E+00	0.00E+00	0.00E+00
Rb-89	0.00E+00	0.00E+00	0.00E+00	0.00E+00	0.00E+00	0.00E+00	0.00E+00
Sr-89	1.92E+08	0.00E+00	5.48E+06	0.00E+00	0.00E+00	0.00E+00	7.43E+06
Sr-90	1.29E+10	0.00E+00	2.60E+08	0.00E+00	0.00E+00	0.00E+00	1.16E+08
Sr-91	6.24E-11	0.00E+00	2.36E-12	0.00E+00	0.00E+00	0.00E+00	1.38E-10
Sr-92	0.00E+00	0.00E+00	0.00E+00	0.00E+00	0.00E+00	0.00E+00	0.00E+00
Y-90	4.30E+01	0.00E+00	1.15E+00	0.00E+00	0.00E+00	0.00E+00	1.22E+05
Y-91m	0.00E+00	0.00E+00	0.00E+00	0.00E+00	0.00E+00	0.00E+00	0.00E+00
Y-91	7.71E+05	0.00E+00	2.06E+04	0.00E+00	0.00E+00	0.00E+00	1.03E+08

OFFSITE DOSE CALCULATION MANUAL

TABLE 10-14
 R_{io} , GRASS-COW-MEAT PATHWAY DOSE FACTORS – CHILD

NUCLIDE	BONE	LIVER	T. BODY	THYROID	KIDNEY	LUNG	GI-LLI
Y-92	0.00E+00	0.00E+00	0.00E+00	0.00E+00	0.00E+00	0.00E+00	0.00E+00
Y-93	2.69E-12	0.00E+00	7.39E-14	0.00E+00	0.00E+00	0.00E+00	4.02E-08
Zr-95	1.19E+06	2.61E+05	2.32E+05	0.00E+00	3.74E+05	0.00E+00	2.72E+08
Zr-97	7.25E-06	1.05E-06	6.18E-07	0.00E+00	1.50E-06	0.00E+00	1.59E-01
Nb-95	1.02E+06	3.97E+05	2.83E+05	0.00E+00	3.73E+05	0.00E+00	7.33E+08
Nb-97	0.00E+00	0.00E+00	0.00E+00	0.00E+00	0.00E+00	0.00E+00	0.00E+00
Mo-99	0.00E+00	2.88E+04	7.12E+03	0.00E+00	6.14E+04	0.00E+00	2.38E+04
Tc-99m	0.00E+00	0.00E+00	4.91E-20	0.00E+00	4.30E-20	0.00E+00	1.68E-18
Tc-99	3.86E+08	4.29E+08	1.54E+08	0.00E+00	5.06E+09	3.80E+07	4.50E+09
Tc-101	0.00E+00	0.00E+00	0.00E+00	0.00E+00	0.00E+00	0.00E+00	0.00E+00
Ru-103	5.43E+07	0.00E+00	2.09E+07	0.00E+00	1.37E+08	0.00E+00	1.40E+09
Ru-105	0.00E+00	0.00E+00	0.00E+00	0.00E+00	0.00E+00	0.00E+00	0.00E+00
Ru-106	3.17E+09	0.00E+00	3.95E+08	0.00E+00	4.28E+09	0.00E+00	4.93E+10
Rh-105	1.88E+00	1.01E+00	8.64E-01	0.00E+00	4.03E+00	0.00E+00	6.26E+01
Ag-110m	5.83E+06	3.94E+06	3.15E+06	0.00E+00	7.33E+06	0.00E+00	4.68E+08
Sn-113	1.05E+08	2.27E+07	3.47E+08	9.06E+06	2.40E+07	1.13E+07	3.87E+09
Sn-117m	2.11E+07	1.00E+06	3.30E+07	1.58E+05	1.02E+06	2.90E+05	3.83E+08
Sb-122	2.07E+03	1.24E+03	2.30E+04	2.71E+02	7.54E+02	3.54E+02	2.49E+05
Sb-124	1.27E+07	1.65E+05	4.45E+06	2.80E+04	0.00E+00	7.04E+06	7.93E+07
Sb-125	2.15E+07	1.66E+05	4.50E+06	1.99E+04	0.00E+00	1.20E+07	5.13E+07
Te-125m	2.70E+08	7.33E+07	3.61E+07	7.59E+07	0.00E+00	0.00E+00	2.61E+08
Te-127m	1.17E+09	3.15E+08	1.39E+08	2.84E+08	3.34E+09	0.00E+00	9.48E+08
Te-127	1.09E-10	2.95E-11	2.34E-11	7.56E-11	3.11E-10	0.00E+00	4.27E-09
Te-129m	6.20E+08	1.73E+08	9.62E+07	2.00E+08	1.82E+09	0.00E+00	7.56E+08
Te-129	0.00E+00	0.00E+00	0.00E+00	0.00E+00	0.00E+00	0.00E+00	0.00E+00
Te-131m	4.41E+02	1.53E+02	1.62E+02	3.14E+02	1.48E+03	0.00E+00	6.19E+03
Te-131	0.00E+00	0.00E+00	0.00E+00	0.00E+00	0.00E+00	0.00E+00	0.00E+00
Te-132	4.97E+05	2.20E+05	2.66E+05	3.20E+05	2.04E+06	0.00E+00	2.21E+06
I-130	3.91E-07	7.91E-07	4.08E-07	8.71E-05	1.18E-06	0.00E+00	3.70E-07
I-131	2.03E+06	2.04E+06	1.16E+06	6.75E+08	3.35E+06	0.00E+00	1.82E+05
I-132	0.00E+00	0.00E+00	0.00E+00	0.00E+00	0.00E+00	0.00E+00	0.00E+00
I-133	7.23E-02	8.94E-02	3.38E-02	1.66E+01	1.49E-01	0.00E+00	3.60E-02
I-134	0.00E+00	0.00E+00	0.00E+00	0.00E+00	0.00E+00	0.00E+00	0.00E+00
I-135	6.32E-18	1.14E-17	5.38E-18	1.01E-15	1.74E-17	0.00E+00	8.67E-18
Cs-134	6.83E+08	1.12E+09	2.36E+08	0.00E+00	3.47E+08	1.25E+08	6.04E+06
Cs-134m	0.00E+00	0.00E+00	0.00E+00	0.00E+00	0.00E+00	0.00E+00	0.00E+00
Cs-136	3.97E+06	1.09E+07	7.07E+06	0.00E+00	5.82E+06	8.67E+05	3.84E+05

OFFSITE DOSE CALCULATION MANUAL

TABLE 10-14
 R_{io} , GRASS-COW-MEAT PATHWAY DOSE FACTORS – CHILD

NUCLIDE	BONE	LIVER	T. BODY	THYROID	KIDNEY	LUNG	GI-LI
Cs-137	1.07E+09	1.03E+09	1.52E+08	0.00E+00	3.34E+08	1.20E+08	6.43E+06
Cs-138	0.00E+00	0.00E+00	0.00E+00	0.00E+00	0.00E+00	0.00E+00	0.00E+00
Ba-139	0.00E+00	0.00E+00	0.00E+00	0.00E+00	0.00E+00	0.00E+00	0.00E+00
Ba-140	1.07E+07	9.35E+03	6.23E+05	0.00E+00	3.04E+03	5.57E+03	5.41E+06
Ba-141	0.00E+00	0.00E+00	0.00E+00	0.00E+00	0.00E+00	0.00E+00	0.00E+00
Ba-142	0.00E+00	0.00E+00	0.00E+00	0.00E+00	0.00E+00	0.00E+00	0.00E+00
La-140	1.43E-02	4.99E-03	1.68E-03	0.00E+00	0.00E+00	0.00E+00	1.39E+02
La-142	0.00E+00	0.00E+00	0.00E+00	0.00E+00	0.00E+00	0.00E+00	0.00E+00
Ce-141	7.04E+03	3.51E+03	5.22E+02	0.00E+00	1.54E+03	0.00E+00	4.38E+06
Ce-143	8.15E-03	4.42E+00	6.40E-04	0.00E+00	1.85E-03	0.00E+00	6.47E+01
Ce-144	1.56E+06	4.89E+05	8.33E+04	0.00E+00	2.71E+05	0.00E+00	1.28E+08
Pr-143	8.20E+03	2.46E+03	4.07E+02	0.00E+00	1.33E+03	0.00E+00	8.84E+06
Pr-144	0.00E+00	0.00E+00	0.00E+00	0.00E+00	0.00E+00	0.00E+00	0.00E+00
Nd-147	2.86E+03	2.31E+03	1.79E+02	0.00E+00	1.27E+03	0.00E+00	3.66E+06
Eu-152	2.32E+06	4.23E+05	5.02E+05	0.00E+00	1.79E+06	0.00E+00	6.95E+07
W-187	8.52E-03	5.04E-03	2.26E-03	0.00E+00	0.00E+00	0.00E+00	7.09E-01
U-235	9.31E+08	0.00E+00	5.64E+07	0.00E+00	1.53E+08	0.00E+00	2.19E+07
U-238	8.90E+08	0.00E+00	5.28E+07	0.00E+00	1.43E+08	0.00E+00	1.54E+07
Np-239	1.07E-01	7.70E-03	5.41E-03	0.00E+00	2.23E-02	0.00E+00	5.70E+02
Am-241	2.26E+08	1.01E+08	1.61E+07	0.00E+00	9.86E+07	0.00E+00	1.21E+07

TABLE 10-15
 R_{io} , PRODUCE PATHWAY DOSE FACTORS – ADULT

{ m^2 -mrem/yr per μ Ci/s (mrem/yr per μ Ci/ m^3 for 3H -3 and ^{14}C)}

NUCLIDE	BONE	LIVER	T. BODY	THYROID	KIDNEY	LUNG	GI-LLI
H-3	0.00E+00	1.60E+03	1.60E+03	1.60E+03	1.60E+03	1.60E+03	1.60E+03
C-14	7.72E+05	1.54E+05	1.54E+05	1.54E+05	1.54E+05	1.54E+05	1.54E+05
F-18	0.00E+00	0.00E+00	0.00E+00	0.00E+00	0.00E+00	0.00E+00	0.00E+00
Na-22	1.24E+09	1.24E+09	1.24E+09	1.24E+09	1.24E+09	1.24E+09	1.24E+09
Na-24	0.00E+00	0.00E+00	0.00E+00	0.00E+00	0.00E+00	0.00E+00	0.00E+00
Sc-46	1.92E+05	3.73E+05	1.08E+05	0.00E+00	3.48E+05	0.00E+00	1.82E+09
P-32	3.98E+08	2.48E+07	1.54E+07	0.00E+00	0.00E+00	0.00E+00	4.48E+07
Cr-51	0.00E+00	0.00E+00	2.69E+04	1.60E+04	5.92E+03	3.56E+04	6.75E+06
Mn-54	0.00E+00	2.60E+08	4.95E+07	0.00E+00	7.73E+07	0.00E+00	7.95E+08
Mn-56	0.00E+00	0.00E+00	0.00E+00	0.00E+00	0.00E+00	0.00E+00	0.00E+00
Fe-55	1.71E+08	1.18E+08	2.75E+07	0.00E+00	0.00E+00	6.59E+07	6.78E+07
Fe-59	8.77E+07	2.06E+08	7.90E+07	0.00E+00	0.00E+00	5.76E+07	6.87E+08
Co-57	0.00E+00	9.50E+06	1.58E+07	0.00E+00	0.00E+00	0.00E+00	2.41E+08
Co-58	0.00E+00	2.32E+07	5.21E+07	0.00E+00	0.00E+00	0.00E+00	4.71E+08
Co-60	0.00E+00	1.43E+08	3.15E+08	0.00E+00	0.00E+00	0.00E+00	2.68E+09
Ni-63	1.03E+10	7.15E+08	3.46E+08	0.00E+00	0.00E+00	0.00E+00	1.49E+08
Ni-65	0.00E+00	0.00E+00	0.00E+00	0.00E+00	0.00E+00	0.00E+00	0.00E+00
Cu-64	0.00E+00	0.00E+00	0.00E+00	0.00E+00	0.00E+00	0.00E+00	0.00E+00
Zn-65	3.36E+08	1.07E+09	4.84E+08	0.00E+00	7.16E+08	0.00E+00	6.74E+08
Zn-69m	0.00E+00	0.00E+00	0.00E+00	0.00E+00	0.00E+00	0.00E+00	0.00E+00
Zn-69	0.00E+00	0.00E+00	0.00E+00	0.00E+00	0.00E+00	0.00E+00	0.00E+00
As-76	6.72E-11	1.96E-10	9.78E-10	5.87E-11	2.38E-10	6.11E-11	8.56E-09
Br-82	0.00E+00	0.00E+00	8.08E-06	0.00E+00	0.00E+00	0.00E+00	9.26E-06
Br-83	0.00E+00	0.00E+00	0.00E+00	0.00E+00	0.00E+00	0.00E+00	0.00E+00
Br-84	0.00E+00	0.00E+00	0.00E+00	0.00E+00	0.00E+00	0.00E+00	0.00E+00
Br-85	0.00E+00	0.00E+00	0.00E+00	0.00E+00	0.00E+00	0.00E+00	0.00E+00
Rb-86	0.00E+00	9.00E+07	4.19E+07	0.00E+00	0.00E+00	0.00E+00	1.77E+07
Rb-88	0.00E+00	0.00E+00	0.00E+00	0.00E+00	0.00E+00	0.00E+00	0.00E+00
Rb-89	0.00E+00	0.00E+00	0.00E+00	0.00E+00	0.00E+00	0.00E+00	0.00E+00
Sr-89	7.16E+09	0.00E+00	2.06E+08	0.00E+00	0.00E+00	0.00E+00	1.15E+09
Sr-90	6.64E+11	0.00E+00	1.33E+10	0.00E+00	0.00E+00	0.00E+00	1.67E+10
Sr-91	0.00E+00	0.00E+00	0.00E+00	0.00E+00	0.00E+00	0.00E+00	0.00E+00
Sr-92	0.00E+00	0.00E+00	0.00E+00	0.00E+00	0.00E+00	0.00E+00	0.00E+00
Y-90	1.83E-02	0.00E+00	4.90E-04	0.00E+00	0.00E+00	0.00E+00	1.94E+02
Y-91m	0.00E+00	0.00E+00	0.00E+00	0.00E+00	0.00E+00	0.00E+00	0.00E+00
Y-91	3.76E+06	0.00E+00	1.01E+05	0.00E+00	0.00E+00	0.00E+00	2.07E+09
Y-92	0.00E+00	0.00E+00	0.00E+00	0.00E+00	0.00E+00	0.00E+00	0.00E+00

OFFSITE DOSE CALCULATION MANUAL

TABLE 10-15
 R_{io} , PRODUCE PATHWAY DOSE FACTORS – ADULT

NUCLIDE	BONE	LIVER	T. BODY	THYROID	KIDNEY	LUNG	GULLI
Y-93	0.00E+00	0.00E+00	0.00E+00	0.00E+00	0.00E+00	0.00E+00	0.00E+00
Zr-95	8.75E+05	2.80E+05	1.90E+05	0.00E+00	4.40E+05	0.00E+00	8.89E+08
Zr-97	0.00E+00	0.00E+00	0.00E+00	0.00E+00	0.00E+00	0.00E+00	5.43E-18
Nb-95	9.19E+04	5.11E+04	2.75E+04	0.00E+00	5.06E+04	0.00E+00	3.10E+08
Nb-97	0.00E+00	0.00E+00	0.00E+00	0.00E+00	0.00E+00	0.00E+00	0.00E+00
Mo-99	0.00E+00	1.31E+01	2.49E+00	0.00E+00	2.97E+01	0.00E+00	3.03E+01
Tc-99m	0.00E+00	0.00E+00	0.00E+00	0.00E+00	0.00E+00	0.00E+00	0.00E+00
Tc-99	3.25E+07	4.84E+07	1.31E+07	0.00E+00	6.09E+08	4.11E+06	1.58E+09
Tc-101	0.00E+00	0.00E+00	0.00E+00	0.00E+00	0.00E+00	0.00E+00	0.00E+00
Ru-103	3.23E+06	0.00E+00	1.39E+06	0.00E+00	1.23E+07	0.00E+00	3.77E+08
Ru-105	0.00E+00	0.00E+00	0.00E+00	0.00E+00	0.00E+00	0.00E+00	0.00E+00
Ru-106	1.65E+08	0.00E+00	2.09E+07	0.00E+00	3.19E+08	0.00E+00	1.07E+10
Rh-105	7.23E-07	5.29E-07	3.48E-07	0.00E+00	2.25E-06	0.00E+00	8.42E-05
Ag-110m	9.51E+06	8.79E+06	5.22E+06	0.00E+00	1.73E+07	0.00E+00	3.59E+09
Sn-113	3.98E+07	6.74E+06	1.12E+08	3.52E+06	9.19E+06	4.14E+06	1.23E+09
Sn-117m	2.95E+06	1.00E+05	4.19E+06	2.01E+04	1.53E+05	3.19E+04	4.72E+07
Sb-122	1.71E+00	9.42E-01	1.62E+01	2.00E-01	6.66E-01	2.57E-01	1.71E+02
Sb-124	7.67E+07	1.45E+06	3.04E+07	1.86E+05	0.00E+00	5.97E+07	2.18E+09
Sb-125	1.15E+08	1.28E+06	2.73E+07	1.17E+05	0.00E+00	8.86E+07	1.26E+09
Te-125m	9.11E+07	3.30E+07	1.22E+07	2.74E+07	3.71E+08	0.00E+00	3.64E+08
Te-127m	4.07E+08	1.46E+08	4.96E+07	1.04E+08	1.65E+09	0.00E+00	1.37E+09
Te-127	0.00E+00	0.00E+00	0.00E+00	0.00E+00	0.00E+00	0.00E+00	0.00E+00
Te-129m	1.90E+08	7.08E+07	3.01E+07	6.52E+07	7.93E+08	0.00E+00	9.56E+08
Te-129	0.00E+00	0.00E+00	0.00E+00	0.00E+00	0.00E+00	0.00E+00	0.00E+00
Te-131m	4.64E-07	2.27E-07	1.89E-07	3.60E-07	2.30E-06	0.00E+00	2.25E-05
Te-131	0.00E+00	0.00E+00	0.00E+00	0.00E+00	0.00E+00	0.00E+00	0.00E+00
Te-132	7.82E+01	5.06E+01	4.75E+01	5.59E+01	4.87E+02	0.00E+00	2.39E+03
I-130	0.00E+00	0.00E+00	0.00E+00	0.00E+00	0.00E+00	0.00E+00	0.00E+00
I-131	1.46E+06	2.09E+06	1.20E+06	6.86E+08	3.59E+06	0.00E+00	5.52E+05
I-132	0.00E+00	0.00E+00	0.00E+00	0.00E+00	0.00E+00	0.00E+00	0.00E+00
I-133	2.06E-14	3.58E-14	1.09E-14	5.27E-12	6.26E-14	0.00E+00	3.22E-14
I-134	0.00E+00	0.00E+00	0.00E+00	0.00E+00	0.00E+00	0.00E+00	0.00E+00
I-135	0.00E+00	0.00E+00	0.00E+00	0.00E+00	0.00E+00	0.00E+00	0.00E+00
Cs-134	3.88E+09	9.24E+09	7.55E+09	0.00E+00	2.99E+09	9.93E+08	1.62E+08
Cs-134m	0.00E+00	0.00E+00	0.00E+00	0.00E+00	0.00E+00	0.00E+00	0.00E+00
Cs-136	9.22E+06	3.64E+07	2.62E+07	0.00E+00	2.02E+07	2.77E+06	4.13E+06
Cs-137	5.71E+09	7.81E+09	5.12E+09	0.00E+00	2.65E+09	8.82E+08	1.51E+08

OFFSITE DOSE CALCULATION MANUAL

TABLE 10-15
 R_{io} , PRODUCE PATHWAY DOSE FACTORS – ADULT

NUCLIDE	BONE	LIVER	T. BODY	THYROID	KIDNEY	LUNG	GI-LLI
Cs-138	0.00E+00	0.00E+00	0.00E+00	0.00E+00	0.00E+00	0.00E+00	0.00E+00
Ba-139	0.00E+00	0.00E+00	0.00E+00	0.00E+00	0.00E+00	0.00E+00	0.00E+00
Ba-140	2.55E+07	3.21E+04	1.67E+06	0.00E+00	1.09E+04	1.84E+04	5.26E+07
Ba-141	0.00E+00	0.00E+00	0.00E+00	0.00E+00	0.00E+00	0.00E+00	0.00E+00
Ba-142	0.00E+00	0.00E+00	0.00E+00	0.00E+00	0.00E+00	0.00E+00	0.00E+00
La-140	3.18E-07	1.60E-07	4.23E-08	0.00E+00	0.00E+00	0.00E+00	1.18E-02
La-142	0.00E+00	0.00E+00	0.00E+00	0.00E+00	0.00E+00	0.00E+00	0.00E+00
Ce-141	1.24E+05	8.37E+04	9.49E+03	0.00E+00	3.89E+04	0.00E+00	3.20E+08
Ce-143	7.79E-10	5.76E-07	6.37E-11	0.00E+00	2.53E-10	0.00E+00	2.15E-05
Ce-144	2.66E+07	1.11E+07	1.43E+06	0.00E+00	6.58E+06	0.00E+00	8.98E+09
Pr-143	1.45E+04	5.83E+03	7.21E+02	0.00E+00	3.37E+03	0.00E+00	6.37E+07
Pr-144	0.00E+00	0.00E+00	0.00E+00	0.00E+00	0.00E+00	0.00E+00	0.00E+00
Nd-147	4.31E+03	4.99E+03	2.98E+02	0.00E+00	2.92E+03	0.00E+00	2.39E+07
Eu-152	1.30E+07	2.93E+06	2.58E+06	0.00E+00	1.82E+07	0.00E+00	1.69E+09
W-187	3.44E-13	2.88E-13	1.01E-13	0.00E+00	0.00E+00	0.00E+00	9.42E-11
U-235	5.40E+10	0.00E+00	3.28E+09	0.00E+00	1.26E+10	0.00E+00	5.26E+09
U-238	5.17E+10	0.00E+00	3.06E+09	0.00E+00	1.18E+10	0.00E+00	3.71E+09
Np-239	2.53E-04	2.49E-05	1.37E-05	0.00E+00	7.76E-05	0.00E+00	5.10E+00
Am-241	5.37E+10	1.89E+10	3.55E+09	0.00E+00	2.67E+10	0.00E+00	4.87E+09

OFFSITE DOSE CALCULATION MANUAL

TABLE 10-16
 R_{io} , PRODUCE PATHWAY DOSE FACTORS – TEEN

{ m^2 -mrem/yr per μ Ci/s (mrem/yr per μ Ci/ m^3 for 3H -3 and ^{14}C)}

NUCLIDE	BONE	LIVER	T. BODY	THYROID	KIDNEY	LUNG	GI-LLI
H-3	0.00E+00	1.95E+03	1.95E+03	1.95E+03	1.95E+03	1.95E+03	1.95E+03
C-14	1.34E+06	2.67E+05	2.67E+05	2.67E+05	2.67E+05	2.67E+05	2.67E+05
F-18	0.00E+00	0.00E+00	0.00E+00	0.00E+00	0.00E+00	0.00E+00	0.00E+00
Na-22	2.02E+09	2.02E+09	2.02E+09	2.02E+09	2.02E+09	2.02E+09	2.02E+09
Na-24	0.00E+00	0.00E+00	0.00E+00	0.00E+00	0.00E+00	0.00E+00	0.00E+00
Sc-46	3.06E+05	5.96E+05	1.77E+05	0.00E+00	5.70E+05	0.00E+00	2.03E+09
P-32	6.90E+08	4.27E+07	2.67E+07	0.00E+00	0.00E+00	0.00E+00	5.80E+07
Cr-51	0.00E+00	0.00E+00	4.40E+04	2.45E+04	9.65E+03	6.29E+04	7.40E+06
Mn-54	0.00E+00	4.06E+08	8.05E+07	0.00E+00	1.21E+08	0.00E+00	8.33E+08
Mn-56	0.00E+00	0.00E+00	0.00E+00	0.00E+00	0.00E+00	0.00E+00	0.00E+00
Fe-55	2.85E+08	2.02E+08	4.71E+07	0.00E+00	0.00E+00	1.28E+08	8.74E+07
Fe-59	1.44E+08	3.35E+08	1.29E+08	0.00E+00	0.00E+00	1.06E+08	7.93E+08
Co-57	0.00E+00	1.56E+07	2.62E+07	0.00E+00	0.00E+00	0.00E+00	2.92E+08
Co-58	0.00E+00	3.67E+07	8.47E+07	0.00E+00	0.00E+00	0.00E+00	5.06E+08
Co-60	0.00E+00	2.27E+08	5.12E+08	0.00E+00	0.00E+00	0.00E+00	2.96E+09
Ni-63	1.70E+10	1.20E+09	5.77E+08	0.00E+00	0.00E+00	0.00E+00	1.91E+08
Ni-65	0.00E+00	0.00E+00	0.00E+00	0.00E+00	0.00E+00	0.00E+00	0.00E+00
Cu-64	0.00E+00	0.00E+00	0.00E+00	0.00E+00	0.00E+00	0.00E+00	0.00E+00
Zn-65	4.85E+08	1.68E+09	7.86E+08	0.00E+00	1.08E+09	0.00E+00	7.13E+08
Zn-69m	0.00E+00	0.00E+00	0.00E+00	0.00E+00	0.00E+00	0.00E+00	0.00E+00
Zn-69	0.00E+00	0.00E+00	0.00E+00	0.00E+00	0.00E+00	0.00E+00	0.00E+00
As-76	9.62E-11	3.04E-10	1.48E-09	8.88E-11	3.55E-10	8.88E-11	1.33E-08
Br-82	0.00E+00	0.00E+00	1.32E-05	0.00E+00	0.00E+00	0.00E+00	0.00E+00
Br-83	0.00E+00	0.00E+00	0.00E+00	0.00E+00	0.00E+00	0.00E+00	0.00E+00
Br-84	0.00E+00	0.00E+00	0.00E+00	0.00E+00	0.00E+00	0.00E+00	0.00E+00
Br-85	0.00E+00	0.00E+00	0.00E+00	0.00E+00	0.00E+00	0.00E+00	0.00E+00
Rb-86	0.00E+00	1.54E+08	7.24E+07	0.00E+00	0.00E+00	0.00E+00	2.28E+07
Rb-88	0.00E+00	0.00E+00	0.00E+00	0.00E+00	0.00E+00	0.00E+00	0.00E+00
Rb-89	0.00E+00	0.00E+00	0.00E+00	0.00E+00	0.00E+00	0.00E+00	0.00E+00
Sr-89	1.24E+10	0.00E+00	3.55E+08	0.00E+00	0.00E+00	0.00E+00	1.48E+09
Sr-90	9.42E+11	0.00E+00	1.88E+10	0.00E+00	0.00E+00	0.00E+00	2.15E+10
Sr-91	0.00E+00	0.00E+00	0.00E+00	0.00E+00	0.00E+00	0.00E+00	0.00E+00
Sr-92	0.00E+00	0.00E+00	0.00E+00	0.00E+00	0.00E+00	0.00E+00	0.00E+00
Y-90	3.15E-02	0.00E+00	8.49E-04	0.00E+00	0.00E+00	0.00E+00	2.60E+02
Y-91m	0.00E+00	0.00E+00	0.00E+00	0.00E+00	0.00E+00	0.00E+00	0.00E+00
Y-91	6.49E+06	0.00E+00	1.74E+05	0.00E+00	0.00E+00	0.00E+00	2.66E+09
Y-92	0.00E+00	0.00E+00	0.00E+00	0.00E+00	0.00E+00	0.00E+00	0.00E+00

OFFSITE DOSE CALCULATION MANUAL

TABLE 10-16
 R_{io} , PRODUCE PATHWAY DOSE FACTORS – TEEN

NUCLIDE	BONE	LIVER	T. BODY	THYROID	KIDNEY	LUNG	GI-LLI
Y-93	0.00E+00	0.00E+00	0.00E+00	0.00E+00	0.00E+00	0.00E+00	0.00E+00
Zr-95	1.44E+06	4.53E+05	3.12E+05	0.00E+00	6.66E+05	0.00E+00	1.05E+09
Zr-97	0.00E+00	0.00E+00	0.00E+00	0.00E+00	0.00E+00	0.00E+00	7.96E-18
Nb-95	1.47E+05	8.17E+04	4.50E+04	0.00E+00	7.92E+04	0.00E+00	3.49E+08
Nb-97	0.00E+00	0.00E+00	0.00E+00	0.00E+00	0.00E+00	0.00E+00	0.00E+00
Mo-99	0.00E+00	2.22E+01	4.23E+00	0.00E+00	5.08E+01	0.00E+00	3.97E+01
Tc-99m	0.00E+00	0.00E+00	0.00E+00	0.00E+00	0.00E+00	0.00E+00	0.00E+00
Tc-99	5.65E+07	8.29E+07	2.26E+07	0.00E+00	1.05E+09	8.58E+06	2.03E+09
Tc-101	0.00E+00	0.00E+00	0.00E+00	0.00E+00	0.00E+00	0.00E+00	0.00E+00
Ru-103	5.49E+06	0.00E+00	2.31E+06	0.00E+00	1.90E+07	0.00E+00	4.51E+08
Ru-105	0.00E+00	0.00E+00	0.00E+00	0.00E+00	0.00E+00	0.00E+00	0.00E+00
Ru-106	2.86E+08	0.00E+00	3.60E+07	0.00E+00	5.51E+08	0.00E+00	1.37E+10
Rh-105	1.25E-06	9.05E-07	5.94E-07	0.00E+00	3.84E-06	0.00E+00	1.15E-04
Ag-110m	1.48E+07	1.40E+07	8.49E+06	0.00E+00	2.66E+07	0.00E+00	3.92E+09
Sn-113	5.20E+07	1.04E+07	1.71E+08	5.01E+06	1.35E+07	6.12E+06	1.84E+09
Sn-117m	3.65E+06	1.57E+05	6.29E+06	2.93E+04	2.22E+05	5.36E+04	7.08E+07
Sb-122	2.19E+00	1.50E+00	2.42E+01	3.00E-01	9.80E-01	4.04E-01	2.54E+02
Sb-124	1.28E+08	2.37E+06	5.01E+07	2.91E+05	0.00E+00	1.12E+08	2.59E+09
Sb-125	1.93E+08	2.11E+06	4.51E+07	1.84E+05	0.00E+00	1.70E+08	1.50E+09
Te-125m	1.58E+08	5.68E+07	2.11E+07	4.41E+07	0.00E+00	0.00E+00	4.66E+08
Te-127m	7.05E+08	2.50E+08	8.38E+07	1.68E+08	2.86E+09	0.00E+00	1.76E+09
Te-127	0.00E+00	0.00E+00	0.00E+00	0.00E+00	0.00E+00	0.00E+00	0.00E+00
Te-129m	3.26E+08	1.21E+08	5.15E+07	1.05E+08	1.36E+09	0.00E+00	1.22E+09
Te-129	0.00E+00	0.00E+00	0.00E+00	0.00E+00	0.00E+00	0.00E+00	0.00E+00
Te-131m	7.93E-07	3.80E-07	3.17E-07	5.72E-07	3.97E-06	0.00E+00	3.05E-05
Te-131	0.00E+00	0.00E+00	0.00E+00	0.00E+00	0.00E+00	0.00E+00	0.00E+00
Te-132	1.31E+02	8.31E+01	7.82E+01	8.76E+01	7.97E+02	0.00E+00	2.63E+03
I-130	0.00E+00	0.00E+00	0.00E+00	0.00E+00	0.00E+00	0.00E+00	0.00E+00
I-131	2.49E+06	3.49E+06	1.87E+06	1.02E+09	6.01E+06	0.00E+00	6.90E+05
I-132	0.00E+00	0.00E+00	0.00E+00	0.00E+00	0.00E+00	0.00E+00	0.00E+00
I-133	3.53E-14	6.00E-14	1.83E-14	8.37E-12	1.05E-13	0.00E+00	4.54E-14
I-134	0.00E+00	0.00E+00	0.00E+00	0.00E+00	0.00E+00	0.00E+00	0.00E+00
I-135	0.00E+00	0.00E+00	0.00E+00	0.00E+00	0.00E+00	0.00E+00	0.00E+00
Cs-134	6.33E+09	1.49E+10	6.91E+09	0.00E+00	4.74E+09	1.81E+09	1.85E+08
Cs-134m	0.00E+00	0.00E+00	0.00E+00	0.00E+00	0.00E+00	0.00E+00	0.00E+00
Cs-136	1.47E+07	5.80E+07	3.89E+07	0.00E+00	3.16E+07	4.97E+06	4.66E+06
Cs-137	9.73E+09	1.29E+10	4.51E+09	0.00E+00	4.40E+09	1.71E+09	1.84E+08

OFFSITE DOSE CALCULATION MANUAL

TABLE 10-16
 R_{io} , PRODUCE PATHWAY DOSE FACTORS – TEEN

NUCLIDE	BONE	LIVER	T. BODY	THYROID	KIDNEY	LUNG	GI-LLI
Cs-138	0.00E+00	0.00E+00	0.00E+00	0.00E+00	0.00E+00	0.00E+00	0.00E+00
Ba-139	0.00E+00	0.00E+00	0.00E+00	0.00E+00	0.00E+00	0.00E+00	0.00E+00
Ba-140	4.33E+07	5.30E+04	2.79E+06	0.00E+00	1.80E+04	3.57E+04	6.67E+07
Ba-141	0.00E+00	0.00E+00	0.00E+00	0.00E+00	0.00E+00	0.00E+00	0.00E+00
Ba-142	0.00E+00	0.00E+00	0.00E+00	0.00E+00	0.00E+00	0.00E+00	0.00E+00
La-140	5.36E-07	2.63E-07	7.01E-08	0.00E+00	0.00E+00	0.00E+00	1.51E-02
La-142	0.00E+00	0.00E+00	0.00E+00	0.00E+00	0.00E+00	0.00E+00	0.00E+00
Ce-141	2.13E+05	1.42E+05	1.63E+04	0.00E+00	6.70E+04	0.00E+00	4.07E+08
Ce-143	1.34E-09	9.78E-07	1.09E-10	0.00E+00	4.39E-10	0.00E+00	2.94E-05
Ce-144	4.59E+07	1.90E+07	2.47E+06	0.00E+00	1.13E+07	0.00E+00	1.15E+10
Pr-143	2.51E+04	1.00E+04	1.25E+03	0.00E+00	5.82E+03	0.00E+00	8.25E+07
Pr-144	0.00E+00	0.00E+00	0.00E+00	0.00E+00	0.00E+00	0.00E+00	0.00E+00
Nd-147	7.80E+03	8.48E+03	5.08E+02	0.00E+00	4.98E+03	0.00E+00	3.06E+07
Eu-152	1.96E+07	4.72E+06	4.16E+06	0.00E+00	2.19E+07	0.00E+00	1.74E+09
W-187	5.91E-13	4.82E-13	1.69E-13	0.00E+00	0.00E+00	0.00E+00	1.30E-10
U-235	9.31E+10	0.00E+00	5.67E+09	0.00E+00	2.18E+10	0.00E+00	6.76E+09
U-238	8.90E+10	0.00E+00	5.30E+09	0.00E+00	2.04E+10	0.00E+00	4.76E+09
Np-239	4.53E-04	4.27E-05	2.37E-05	0.00E+00	1.34E-04	0.00E+00	6.88E+00
Am-241	6.85E+10	2.62E+10	4.57E+09	0.00E+00	3.43E+10	0.00E+00	6.26E+09

TABLE 10-17
 R_{io} , PRODUCE PATHWAY DOSE FACTORS – CHILD

{ m^2 -mrem/yr per μ Ci/s (mrem/yr per μ Ci/ m^3 for 3H -3 and ^{14}C)}

NUCLIDE	BONE	LIVER	T. BODY	THYROID	KIDNEY	LUNG	GI-LLI
H-3	0.00E+00	3.10E+03	3.10E+03	3.10E+03	3.10E+03	3.10E+03	3.10E+03
C-14	3.29E+06	6.58E+05	6.58E+05	6.58E+05	6.58E+05	6.58E+05	6.58E+05
F-18	0.00E+00	0.00E+00	0.00E+00	0.00E+00	0.00E+00	0.00E+00	0.00E+00
Na-22	4.20E+09	4.20E+09	4.20E+09	4.20E+09	4.20E+09	4.20E+09	4.20E+09
Na-24	0.00E+00	0.00E+00	0.00E+00	0.00E+00	0.00E+00	0.00E+00	0.00E+00
Sc-46	6.87E+05	9.42E+05	3.63E+05	0.00E+00	8.33E+05	0.00E+00	1.38E+09
P-32	1.70E+09	7.96E+07	6.56E+07	0.00E+00	0.00E+00	0.00E+00	4.70E+07
Cr-51	0.00E+00	0.00E+00	8.98E+04	4.99E+04	1.36E+04	9.10E+04	4.76E+06
Mn-54	0.00E+00	6.08E+08	1.62E+08	0.00E+00	1.70E+08	0.00E+00	5.10E+08
Mn-56	0.00E+00	0.00E+00	0.00E+00	0.00E+00	0.00E+00	0.00E+00	0.00E+00
Fe-55	7.15E+08	3.79E+08	1.17E+08	0.00E+00	0.00E+00	2.14E+08	7.02E+07
Fe-59	3.33E+08	5.39E+08	2.69E+08	0.00E+00	0.00E+00	1.56E+08	5.62E+08
Co-57	0.00E+00	2.68E+07	5.42E+07	0.00E+00	0.00E+00	0.00E+00	2.19E+08
Co-58	0.00E+00	5.62E+07	1.72E+08	0.00E+00	0.00E+00	0.00E+00	3.28E+08
Co-60	0.00E+00	3.53E+08	1.04E+09	0.00E+00	0.00E+00	0.00E+00	1.96E+09
Ni-63	4.27E+10	2.29E+09	1.45E+09	0.00E+00	0.00E+00	0.00E+00	1.54E+08
Ni-65	0.00E+00	0.00E+00	0.00E+00	0.00E+00	0.00E+00	0.00E+00	0.00E+00
Cu-64	0.00E+00	0.00E+00	0.00E+00	0.00E+00	0.00E+00	0.00E+00	0.00E+00
Zn-65	9.52E+08	2.54E+09	1.58E+09	0.00E+00	1.60E+09	0.00E+00	4.46E+08
Zn-69m	0.00E+00	0.00E+00	0.00E+00	0.00E+00	0.00E+00	0.00E+00	0.00E+00
Zn-69	0.00E+00	0.00E+00	0.00E+00	0.00E+00	0.00E+00	0.00E+00	0.00E+00
As-76	2.20E-10	6.11E-10	3.54E-09	2.08E-10	6.72E-10	2.08E-10	3.18E-08
Br-82	0.00E+00	0.00E+00	2.70E-05	0.00E+00	0.00E+00	0.00E+00	0.00E+00
Br-83	0.00E+00	0.00E+00	0.00E+00	0.00E+00	0.00E+00	0.00E+00	0.00E+00
Br-84	0.00E+00	0.00E+00	0.00E+00	0.00E+00	0.00E+00	0.00E+00	0.00E+00
Br-85	0.00E+00	0.00E+00	0.00E+00	0.00E+00	0.00E+00	0.00E+00	0.00E+00
Rb-86	0.00E+00	2.86E+08	1.76E+08	0.00E+00	0.00E+00	0.00E+00	1.84E+07
Rb-88	0.00E+00	0.00E+00	0.00E+00	0.00E+00	0.00E+00	0.00E+00	0.00E+00
Rb-89	0.00E+00	0.00E+00	0.00E+00	0.00E+00	0.00E+00	0.00E+00	0.00E+00
Sr-89	3.07E+10	0.00E+00	8.77E+08	0.00E+00	0.00E+00	0.00E+00	1.19E+09
Sr-90	1.95E+12	0.00E+00	3.92E+10	0.00E+00	0.00E+00	0.00E+00	1.74E+10
Sr-91	0.00E+00	0.00E+00	0.00E+00	0.00E+00	0.00E+00	0.00E+00	0.00E+00
Sr-92	0.00E+00	0.00E+00	0.00E+00	0.00E+00	0.00E+00	0.00E+00	0.00E+00
Y-90	7.81E-02	0.00E+00	2.09E-03	0.00E+00	0.00E+00	0.00E+00	2.22E+02
Y-91m	0.00E+00	0.00E+00	0.00E+00	0.00E+00	0.00E+00	0.00E+00	0.00E+00
Y-91	1.61E+07	0.00E+00	4.29E+05	0.00E+00	0.00E+00	0.00E+00	2.14E+09
Y-92	0.00E+00	0.00E+00	0.00E+00	0.00E+00	0.00E+00	0.00E+00	0.00E+00

TABLE 10-17
 R_{io} , PRODUCE PATHWAY DOSE FACTORS – CHILD

NUCLIDE	BONE	LIVER	T. BODY	THYROID	KIDNEY	LUNG	GI-LLI
Y-93	0.00E+00	0.00E+00	0.00E+00	0.00E+00	0.00E+00	0.00E+00	0.00E+00
Zr-95	3.34E+06	7.34E+05	6.53E+05	0.00E+00	1.05E+06	0.00E+00	7.65E+08
Zr-97	0.00E+00	0.00E+00	0.00E+00	0.00E+00	0.00E+00	0.00E+00	7.92E-18
Nb-95	3.33E+05	1.29E+05	9.25E+04	0.00E+00	1.22E+05	0.00E+00	2.39E+08
Nb-97	0.00E+00	0.00E+00	0.00E+00	0.00E+00	0.00E+00	0.00E+00	0.00E+00
Mo-99	0.00E+00	4.04E+01	9.99E+00	0.00E+00	8.63E+01	0.00E+00	3.34E+01
Tc-99m	0.00E+00	0.00E+00	0.00E+00	0.00E+00	0.00E+00	0.00E+00	0.00E+00
Tc-99	1.39E+08	1.55E+08	5.55E+07	0.00E+00	1.83E+09	1.37E+07	1.63E+09
Tc-101	0.00E+00	0.00E+00	0.00E+00	0.00E+00	0.00E+00	0.00E+00	0.00E+00
Ru-103	1.28E+07	0.00E+00	4.91E+06	0.00E+00	3.21E+07	0.00E+00	3.30E+08
Ru-105	0.00E+00	0.00E+00	0.00E+00	0.00E+00	0.00E+00	0.00E+00	0.00E+00
Ru-106	7.04E+08	0.00E+00	8.78E+07	0.00E+00	9.50E+08	0.00E+00	1.09E+10
Rh-105	3.07E-06	1.65E-06	1.41E-06	0.00E+00	6.57E-06	0.00E+00	1.02E-04
Ag-110m	3.20E+07	2.16E+07	1.73E+07	0.00E+00	4.03E+07	0.00E+00	2.57E+09
Sn-113	1.21E+08	2.60E+07	3.98E+08	1.04E+07	2.76E+07	1.30E+07	4.44E+09
Sn-117m	9.44E+06	4.48E+05	1.48E+07	7.08E+04	4.54E+05	1.30E+05	1.71E+08
Sb-122	5.23E+00	3.14E+00	5.81E+01	6.84E-01	1.80E+00	8.95E-01	6.28E+02
Sb-124	3.04E+08	3.94E+06	1.07E+08	6.71E+05	0.00E+00	1.69E+08	1.90E+09
Sb-125	4.60E+08	3.54E+06	9.63E+07	4.26E+05	0.00E+00	2.56E+08	1.10E+09
Te-125m	3.88E+08	1.05E+08	5.17E+07	1.09E+08	0.00E+00	0.00E+00	3.74E+08
Te-127m	1.74E+09	4.68E+08	2.06E+08	4.16E+08	4.96E+09	0.00E+00	1.41E+09
Te-127	0.00E+00	0.00E+00	0.00E+00	0.00E+00	0.00E+00	0.00E+00	0.00E+00
Te-129m	8.04E+08	2.25E+08	1.25E+08	2.59E+08	2.36E+09	0.00E+00	9.81E+08
Te-129	0.00E+00	0.00E+00	0.00E+00	0.00E+00	0.00E+00	0.00E+00	0.00E+00
Te-131m	1.93E-06	6.68E-07	7.11E-07	1.37E-06	6.47E-06	0.00E+00	2.71E-05
Te-131	0.00E+00	0.00E+00	0.00E+00	0.00E+00	0.00E+00	0.00E+00	0.00E+00
Te-132	3.14E+02	1.39E+02	1.68E+02	2.02E+02	1.29E+03	0.00E+00	1.40E+03
I-130	0.00E+00	0.00E+00	0.00E+00	0.00E+00	0.00E+00	0.00E+00	0.00E+00
I-131	6.05E+06	6.08E+06	3.46E+06	2.01E+09	9.99E+06	0.00E+00	5.42E+05
I-132	0.00E+00	0.00E+00	0.00E+00	0.00E+00	0.00E+00	0.00E+00	0.00E+00
I-133	8.49E-14	1.06E-13	4.02E-14	1.97E-11	1.77E-13	0.00E+00	4.28E-14
I-134	0.00E+00	0.00E+00	0.00E+00	0.00E+00	0.00E+00	0.00E+00	0.00E+00
I-135	0.00E+00	0.00E+00	0.00E+00	0.00E+00	0.00E+00	0.00E+00	0.00E+00
Cs-134	1.46E+10	2.40E+10	5.06E+09	0.00E+00	7.43E+09	2.67E+09	1.29E+08
Cs-134m	0.00E+00	0.00E+00	0.00E+00	0.00E+00	0.00E+00	0.00E+00	0.00E+00
Cs-136	3.33E+07	9.14E+07	5.92E+07	0.00E+00	4.87E+07	7.26E+06	3.21E+06
Cs-137	2.34E+10	2.24E+10	3.31E+09	0.00E+00	7.31E+09	2.63E+09	1.41E+08

OFFSITE DOSE CALCULATION MANUAL

TABLE 10-17
 R_{io} , PRODUCE PATHWAY DOSE FACTORS – CHILD

NUCLIDE	BONE	LIVER	T. BODY	THYROID	KIDNEY	LUNG	GI-LLI
Cs-138	0.00E+00	0.00E+00	0.00E+00	0.00E+00	0.00E+00	0.00E+00	0.00E+00
Ba-139	0.00E+00	0.00E+00	0.00E+00	0.00E+00	0.00E+00	0.00E+00	0.00E+00
Ba-140	1.05E+08	9.16E+04	6.10E+06	0.00E+00	2.98E+04	5.46E+04	5.29E+07
Ba-141	0.00E+00	0.00E+00	0.00E+00	0.00E+00	0.00E+00	0.00E+00	0.00E+00
Ba-142	0.00E+00	0.00E+00	0.00E+00	0.00E+00	0.00E+00	0.00E+00	0.00E+00
La-140	1.28E-06	4.49E-07	1.51E-07	0.00E+00	0.00E+00	0.00E+00	1.25E-02
La-142	0.00E+00	0.00E+00	0.00E+00	0.00E+00	0.00E+00	0.00E+00	0.00E+00
Ce-141	5.25E+05	2.62E+05	3.89E+04	0.00E+00	1.15E+05	0.00E+00	3.27E+08
Ce-143	3.30E-09	1.79E-06	2.59E-10	0.00E+00	7.51E-10	0.00E+00	2.62E-05
Ce-144	1.13E+08	3.55E+07	6.04E+06	0.00E+00	1.96E+07	0.00E+00	9.25E+09
Pr-143	6.21E+04	1.87E+04	3.08E+03	0.00E+00	1.01E+04	0.00E+00	6.70E+07
Pr-144	0.00E+00	0.00E+00	0.00E+00	0.00E+00	0.00E+00	0.00E+00	0.00E+00
Nd-147	1.91E+04	1.55E+04	1.20E+03	0.00E+00	8.51E+03	0.00E+00	2.46E+07
Eu-152	4.06E+07	7.40E+06	8.78E+06	0.00E+00	3.12E+07	0.00E+00	1.22E+09
W-187	1.43E-12	8.49E-13	3.81E-13	0.00E+00	0.00E+00	0.00E+00	1.22E-10
U-235	2.30E+11	0.00E+00	1.39E+10	0.00E+00	3.78E+10	0.00E+00	5.41E+09
U-238	2.20E+11	0.00E+00	1.31E+10	0.00E+00	3.53E+10	0.00E+00	3.81E+09
Np-239	1.12E-03	8.01E-05	5.63E-05	0.00E+00	2.32E-04	0.00E+00	5.93E+00
Am-241	9.38E+10	4.20E+10	6.69E+09	0.00E+00	4.09E+10	0.00E+00	5.01E+09

TABLE 10-18
 R_{i0} , LEAFY VEGETABLE PATHWAY DOSE FACTORS – ADULT

{ m^2 -mrem/yr per $\mu\text{Ci/s}$ (mrem/yr per $\mu\text{Ci/m}^3$ for $^3\text{H-3}$ and ^{14}C)}

NUCLIDE	BONE	LIVER	T. BODY	THYROID	KIDNEY	LUNG	GILLI
H-3	0.00E+00	2.61E+02	2.61E+02	2.61E+02	2.61E+02	2.61E+02	2.61E+02
C-14	1.25E+05	2.50E+04	2.50E+04	2.50E+04	2.50E+04	2.50E+04	2.50E+04
F-18	4.24E+00	0.00E+00	4.71E-01	0.00E+00	0.00E+00	0.00E+00	1.26E-01
Na-22	2.10E+08	2.10E+08	2.10E+08	2.10E+08	2.10E+08	2.10E+08	2.10E+08
Na-24	2.66E+05	2.66E+05	2.66E+05	2.66E+05	2.66E+05	2.66E+05	2.66E+05
Sc-46	5.07E+04	9.84E+04	2.86E+04	0.00E+00	9.19E+04	0.00E+00	4.79E+08
P-32	1.13E+09	7.03E+07	4.37E+07	0.00E+00	0.00E+00	0.00E+00	1.27E+08
Cr-51	0.00E+00	0.00E+00	1.90E+04	1.14E+04	4.19E+03	2.53E+04	4.79E+06
Mn-54	0.00E+00	4.79E+07	9.15E+06	0.00E+00	1.43E+07	0.00E+00	1.47E+08
Mn-56	0.00E+00	1.54E+01	2.74E+00	0.00E+00	1.96E+01	0.00E+00	4.92E+02
Fe-55	2.88E+07	1.99E+07	4.65E+06	0.00E+00	0.00E+00	1.11E+07	1.14E+07
Fe-59	3.56E+07	8.36E+07	3.21E+07	0.00E+00	0.00E+00	2.34E+07	2.79E+08
Co-57	0.00E+00	1.79E+06	2.97E+06	0.00E+00	0.00E+00	0.00E+00	4.54E+07
Co-58	0.00E+00	6.70E+06	1.50E+07	0.00E+00	0.00E+00	0.00E+00	1.36E+08
Co-60	0.00E+00	2.36E+07	5.21E+07	0.00E+00	0.00E+00	0.00E+00	4.44E+08
Ni-63	1.67E+09	1.16E+08	5.61E+07	0.00E+00	0.00E+00	0.00E+00	2.42E+07
Ni-65	5.91E+01	7.68E+00	3.51E+00	0.00E+00	0.00E+00	0.00E+00	1.95E+02
Cu-64	0.00E+00	9.19E+03	4.31E+03	0.00E+00	2.32E+04	0.00E+00	7.84E+05
Zn-65	6.44E+07	2.05E+08	9.26E+07	0.00E+00	1.37E+08	0.00E+00	1.29E+08
Zn-69m	2.27E+04	5.44E+04	4.98E+03	0.00E+00	3.30E+04	0.00E+00	3.32E+06
Zn-69	5.89E-06	1.13E-05	7.83E-07	0.00E+00	7.31E-06	0.00E+00	1.69E-06
As-76	1.76E+05	5.11E+05	2.55E+06	1.53E+05	6.22E+05	1.60E+05	2.23E+07
Br-82	0.00E+00	0.00E+00	1.55E+06	0.00E+00	0.00E+00	0.00E+00	1.78E+06
Br-83	0.00E+00	0.00E+00	3.21E+00	0.00E+00	0.00E+00	0.00E+00	4.62E+00
Br-84	0.00E+00	0.00E+00	2.21E-11	0.00E+00	0.00E+00	0.00E+00	1.73E-16
Br-85	0.00E+00	0.00E+00	0.00E+00	0.00E+00	0.00E+00	0.00E+00	0.00E+00
Rb-86	0.00E+00	1.31E+08	6.09E+07	0.00E+00	0.00E+00	0.00E+00	2.58E+07
Rb-88	0.00E+00	0.00E+00	0.00E+00	0.00E+00	0.00E+00	0.00E+00	0.00E+00
Rb-89	0.00E+00	0.00E+00	0.00E+00	0.00E+00	0.00E+00	0.00E+00	0.00E+00
Sr-89	2.61E+09	0.00E+00	7.48E+07	0.00E+00	0.00E+00	0.00E+00	4.18E+08
Sr-90	1.08E+11	0.00E+00	2.17E+09	0.00E+00	0.00E+00	0.00E+00	2.71E+09
Sr-91	3.02E+05	0.00E+00	1.22E+04	0.00E+00	0.00E+00	0.00E+00	1.44E+06
Sr-92	4.15E+02	0.00E+00	1.79E+01	0.00E+00	0.00E+00	0.00E+00	8.22E+03
Y-90	1.33E+04	0.00E+00	3.56E+02	0.00E+00	0.00E+00	0.00E+00	1.41E+08
Y-91m	4.74E-09	0.00E+00	1.83E-10	0.00E+00	0.00E+00	0.00E+00	1.39E-08
Y-91	1.22E+06	0.00E+00	3.28E+04	0.00E+00	0.00E+00	0.00E+00	6.74E+08
Y-92	8.96E-01	0.00E+00	2.62E-02	0.00E+00	0.00E+00	0.00E+00	1.57E+04

TABLE 10-18
 R_{io} , LEAFY VEGETABLE PATHWAY DOSE FACTORS – ADULT

NUCLIDE	BONE	LIVER	T. BODY	THYROID	KIDNEY	LUNG	GI-LLI
Y-93	1.73E+02	0.00E+00	4.77E+00	0.00E+00	0.00E+00	0.00E+00	5.48E+06
Zr-95	2.68E+05	8.60E+04	5.82E+04	0.00E+00	1.35E+05	0.00E+00	2.73E+08
Zr-97	3.32E+02	6.70E+01	3.06E+01	0.00E+00	1.01E+02	0.00E+00	2.07E+07
Nb-95	4.79E+04	2.67E+04	1.43E+04	0.00E+00	2.64E+04	0.00E+00	1.62E+08
Nb-97	2.84E-06	7.19E-07	2.63E-07	0.00E+00	8.39E-07	0.00E+00	2.65E-03
Mo-99	0.00E+00	6.17E+06	1.17E+06	0.00E+00	1.40E+07	0.00E+00	1.43E+07
Tc-99m	3.08E+00	8.69E+00	1.11E+02	0.00E+00	1.32E+02	4.26E+00	5.14E+03
Tc-99	5.27E+06	7.84E+06	2.12E+06	0.00E+00	9.86E+07	6.66E+05	2.56E+08
Tc-101	0.00E+00	0.00E+00	0.00E+00	0.00E+00	0.00E+00	0.00E+00	0.00E+00
Ru-103	1.48E+06	0.00E+00	6.38E+05	0.00E+00	5.66E+06	0.00E+00	1.73E+08
Ru-105	5.30E+01	0.00E+00	2.09E+01	0.00E+00	6.85E+02	0.00E+00	3.24E+04
Ru-106	2.99E+07	0.00E+00	3.78E+06	0.00E+00	5.77E+07	0.00E+00	1.94E+09
Rh-105	1.29E+05	9.41E+04	6.20E+04	0.00E+00	4.00E+05	0.00E+00	1.50E+07
Ag-110m	1.81E+06	1.68E+06	9.96E+05	0.00E+00	3.30E+06	0.00E+00	6.84E+08
Sn-113	9.20E+06	1.56E+06	2.58E+07	8.14E+05	2.12E+06	9.56E+05	2.83E+08
Sn-117m	9.66E+06	3.29E+05	1.37E+07	6.57E+04	5.03E+05	1.04E+05	1.55E+08
Sb-122	9.39E+05	5.17E+05	8.87E+06	1.10E+05	3.65E+05	1.41E+05	9.39E+07
Sb-124	2.45E+07	4.63E+05	9.71E+06	5.94E+04	0.00E+00	1.91E+07	6.96E+08
Sb-125	1.94E+07	2.17E+05	4.61E+06	1.97E+04	0.00E+00	1.49E+07	2.13E+08
Te-125m	2.99E+07	1.08E+07	4.00E+06	8.98E+06	1.21E+08	0.00E+00	1.19E+08
Te-127m	9.59E+07	3.43E+07	1.17E+07	2.45E+07	3.90E+08	0.00E+00	3.22E+08
Te-127	6.01E+03	2.16E+03	1.30E+03	4.46E+03	2.45E+04	0.00E+00	4.75E+05
Te-129m	1.04E+08	3.87E+07	1.64E+07	3.57E+07	4.33E+08	0.00E+00	5.23E+08
Te-129	7.52E-04	2.83E-04	1.83E-04	5.77E-04	3.16E-03	0.00E+00	5.68E-04
Te-131m	1.08E+06	5.27E+05	4.39E+05	8.34E+05	5.34E+06	0.00E+00	5.23E+07
Te-131	1.32E-15	5.49E-16	4.15E-16	1.08E-15	5.76E-15	0.00E+00	1.86E-16
Te-132	4.50E+06	2.91E+06	2.73E+06	3.21E+06	2.80E+07	0.00E+00	1.38E+08
I-130	1.95E+05	5.75E+05	2.27E+05	4.87E+07	8.98E+05	0.00E+00	4.95E+05
I-131	3.88E+07	5.55E+07	3.18E+07	1.82E+10	9.51E+07	0.00E+00	1.46E+07
I-132	2.59E+01	6.93E+01	2.42E+01	2.42E+03	1.10E+02	0.00E+00	1.30E+01
I-133	1.04E+06	1.81E+06	5.51E+05	2.66E+08	3.15E+06	0.00E+00	1.62E+06
I-134	4.42E-05	1.20E-04	4.30E-05	2.08E-03	1.91E-04	0.00E+00	1.05E-07
I-135	1.89E+04	4.94E+04	1.82E+04	3.26E+06	7.92E+04	0.00E+00	5.58E+04
Cs-134	6.64E+08	1.58E+09	1.29E+09	0.00E+00	5.11E+08	1.70E+08	2.76E+07
Cs-134m	6.57E+00	1.38E+01	7.06E+00	0.00E+00	7.50E+00	1.18E+00	4.87E+00
Cs-136	3.34E+07	1.32E+08	9.49E+07	0.00E+00	7.33E+07	1.00E+07	1.50E+07
Cs-137	9.29E+08	1.27E+09	8.32E+08	0.00E+00	4.31E+08	1.43E+08	2.46E+07

OFFSITE DOSE CALCULATION MANUAL

TABLE 10-18
 R_{io} , LEAFY VEGETABLE PATHWAY DOSE FACTORS – ADULT

NUCLIDE	BONE	LIVER	T. BODY	THYROID	KIDNEY	LUNG	GI-LLI
Cs-138	3.39E-11	6.70E-11	3.32E-11	0.00E+00	4.92E-11	4.86E-12	2.86E-16
Ba-139	2.99E-02	2.13E-05	8.77E-04	0.00E+00	1.99E-05	1.21E-05	5.31E-02
Ba-140	1.02E+08	1.28E+05	6.70E+06	0.00E+00	4.36E+04	7.35E+04	2.10E+08
Ba-141	0.00E+00	0.00E+00	0.00E+00	0.00E+00	0.00E+00	0.00E+00	0.00E+00
Ba-142	0.00E+00	0.00E+00	0.00E+00	0.00E+00	0.00E+00	0.00E+00	0.00E+00
La-140	1.98E+03	9.97E+02	2.63E+02	0.00E+00	0.00E+00	0.00E+00	7.32E+07
La-142	1.33E-04	6.04E-05	1.50E-05	0.00E+00	0.00E+00	0.00E+00	4.41E-01
Ce-141	7.05E+04	4.77E+04	5.41E+03	0.00E+00	2.22E+04	0.00E+00	1.82E+08
Ce-143	9.98E+02	7.38E+05	8.16E+01	0.00E+00	3.25E+02	0.00E+00	2.76E+07
Ce-144	4.96E+06	2.08E+06	2.67E+05	0.00E+00	1.23E+06	0.00E+00	1.68E+09
Pr-143	4.80E+04	1.92E+04	2.38E+03	0.00E+00	1.11E+04	0.00E+00	2.10E+08
Pr-144	0.00E+00	0.00E+00	0.00E+00	0.00E+00	0.00E+00	0.00E+00	0.00E+00
Nd-147	2.90E+04	3.35E+04	2.00E+03	0.00E+00	1.96E+04	0.00E+00	1.61E+08
Eu-152	2.12E+06	4.79E+05	4.21E+05	0.00E+00	2.97E+06	0.00E+00	2.76E+08
W-187	3.81E+04	3.19E+04	1.11E+04	0.00E+00	0.00E+00	0.00E+00	1.04E+07
U-235	8.74E+09	0.00E+00	5.30E+08	0.00E+00	2.04E+09	0.00E+00	8.52E+08
U-238	8.37E+09	0.00E+00	4.95E+08	0.00E+00	1.91E+09	0.00E+00	6.00E+08
Np-239	1.43E+03	1.40E+02	7.73E+01	0.00E+00	4.37E+02	0.00E+00	2.88E+07
Am-241	8.70E+09	3.06E+09	5.75E+08	0.00E+00	4.33E+09	0.00E+00	7.89E+08

TABLE 10-19
 R_{io} , LEAFY VEGETABLE PATHWAY DOSE FACTORS – TEEN

{m²-mrem/yr per μ Ci/s (mrem/yr per μ Ci/m³ for ³H-3 and ¹⁴C)}

NUCLIDE	BONE	LIVER	T. BODY	THYROID	KIDNEY	LUNG	GI-LLI
H-3	0.00E+00	1.73E+02	1.73E+02	1.73E+02	1.73E+02	1.73E+02	1.73E+02
C-14	1.17E+05	2.34E+04	2.34E+04	2.34E+04	2.34E+04	2.34E+04	2.34E+04
F-18	3.86E+00	0.00E+00	4.23E-01	0.00E+00	0.00E+00	0.00E+00	3.47E-01
Na-22	1.85E+08	1.85E+08	1.85E+08	1.85E+08	1.85E+08	1.85E+08	1.85E+08
Na-24	2.37E+05	2.37E+05	2.37E+05	2.37E+05	2.37E+05	2.37E+05	2.37E+05
Sc-46	4.37E+04	8.51E+04	2.52E+04	0.00E+00	8.15E+04	0.00E+00	2.90E+08
P-32	1.06E+09	6.57E+07	4.11E+07	0.00E+00	0.00E+00	0.00E+00	8.91E+07
Cr-51	0.00E+00	0.00E+00	1.69E+04	9.39E+03	3.70E+03	2.41E+04	2.84E+06
Mn-54	0.00E+00	4.06E+07	8.05E+06	0.00E+00	1.21E+07	0.00E+00	8.33E+07
Mn-56	0.00E+00	1.39E+01	2.47E+00	0.00E+00	1.76E+01	0.00E+00	9.16E+02
Fe-55	2.60E+07	1.84E+07	4.30E+06	0.00E+00	0.00E+00	1.17E+07	7.98E+06
Fe-59	3.16E+07	7.37E+07	2.85E+07	0.00E+00	0.00E+00	2.32E+07	1.74E+08
Co-57	0.00E+00	1.60E+06	2.67E+06	0.00E+00	0.00E+00	0.00E+00	2.98E+07
Co-58	0.00E+00	5.74E+06	1.32E+07	0.00E+00	0.00E+00	0.00E+00	7.91E+07
Co-60	0.00E+00	2.04E+07	4.59E+07	0.00E+00	0.00E+00	0.00E+00	2.65E+08
Ni-63	1.50E+09	1.06E+08	5.07E+07	0.00E+00	0.00E+00	0.00E+00	1.68E+07
Ni-65	5.51E+01	7.03E+00	3.21E+00	0.00E+00	0.00E+00	0.00E+00	3.82E+02
Cu-64	0.00E+00	8.33E+03	3.92E+03	0.00E+00	2.11E+04	0.00E+00	6.46E+05
Zn-65	5.03E+07	1.75E+08	8.15E+07	0.00E+00	1.12E+08	0.00E+00	7.40E+07
Zn-69m	2.10E+04	4.96E+04	4.54E+03	0.00E+00	3.01E+04	0.00E+00	2.72E+06
Zn-69	5.51E-06	1.05E-05	7.35E-07	0.00E+00	6.86E-06	0.00E+00	1.93E-05
As-76	1.36E+05	4.29E+05	2.09E+06	1.26E+05	5.03E+05	1.26E+05	1.89E+07
Br-82	0.00E+00	0.00E+00	1.37E+06	0.00E+00	0.00E+00	0.00E+00	0.00E+00
Br-83	0.00E+00	0.00E+00	3.01E+00	0.00E+00	0.00E+00	0.00E+00	0.00E+00
Br-84	0.00E+00	0.00E+00	2.01E-11	0.00E+00	0.00E+00	0.00E+00	0.00E+00
Br-85	0.00E+00	0.00E+00	0.00E+00	0.00E+00	0.00E+00	0.00E+00	0.00E+00
Rb-86	0.00E+00	1.21E+08	5.69E+07	0.00E+00	0.00E+00	0.00E+00	1.79E+07
Rb-88	0.00E+00	0.00E+00	0.00E+00	0.00E+00	0.00E+00	0.00E+00	0.00E+00
Rb-89	0.00E+00	0.00E+00	0.00E+00	0.00E+00	0.00E+00	0.00E+00	0.00E+00
Sr-89	2.44E+09	0.00E+00	7.00E+07	0.00E+00	0.00E+00	0.00E+00	2.91E+08
Sr-90	8.29E+10	0.00E+00	1.66E+09	0.00E+00	0.00E+00	0.00E+00	2.57E+09
Sr-91	2.83E+05	0.00E+00	1.12E+04	0.00E+00	0.00E+00	0.00E+00	1.28E+06
Sr-92	3.86E+02	0.00E+00	1.65E+01	0.00E+00	0.00E+00	0.00E+00	9.84E+03
Y-90	1.24E+04	0.00E+00	3.34E+02	0.00E+00	0.00E+00	0.00E+00	1.02E+08
Y-91m	4.41E-09	0.00E+00	1.69E-10	0.00E+00	0.00E+00	0.00E+00	2.08E-07
Y-91	1.15E+06	0.00E+00	3.07E+04	0.00E+00	0.00E+00	0.00E+00	4.70E+08
Y-92	8.42E-01	0.00E+00	2.43E-02	0.00E+00	0.00E+00	0.00E+00	2.31E+04

OFFSITE DOSE CALCULATION MANUAL

TABLE 10-19
 R_{io} , LEAFY VEGETABLE PATHWAY DOSE FACTORS – TEEN

NUCLIDE	BONE	LIVER	T. BODY	THYROID	KIDNEY	LUNG	GI-LLI
Y-93	1.62E+02	0.00E+00	4.44E+00	0.00E+00	0.00E+00	0.00E+00	4.95E+06
Zr-95	2.39E+05	7.53E+04	5.18E+04	0.00E+00	1.11E+05	0.00E+00	1.74E+08
Zr-97	3.07E+02	6.08E+01	2.80E+01	0.00E+00	9.22E+01	0.00E+00	1.65E+07
Nb-95	4.16E+04	2.31E+04	1.27E+04	0.00E+00	2.24E+04	0.00E+00	9.86E+07
Nb-97	2.64E-06	6.55E-07	2.39E-07	0.00E+00	7.65E-07	0.00E+00	1.56E-02
Mo-99	0.00E+00	5.67E+06	1.08E+06	0.00E+00	1.30E+07	0.00E+00	1.02E+07
Tc-99m	2.71E+00	7.57E+00	9.81E+01	0.00E+00	1.13E+02	4.20E+00	4.97E+03
Tc-99	4.95E+06	7.28E+06	1.98E+06	0.00E+00	9.24E+07	7.52E+05	1.78E+08
Tc-101	0.00E+00	0.00E+00	0.00E+00	0.00E+00	0.00E+00	0.00E+00	0.00E+00
Ru-103	1.34E+06	0.00E+00	5.73E+05	0.00E+00	4.73E+06	0.00E+00	1.12E+08
Ru-105	4.93E+01	0.00E+00	1.91E+01	0.00E+00	6.22E+02	0.00E+00	3.98E+04
Ru-106	2.80E+07	0.00E+00	3.52E+06	0.00E+00	5.39E+07	0.00E+00	1.34E+09
Rh-105	1.21E+05	8.73E+04	5.72E+04	0.00E+00	3.71E+05	0.00E+00	1.11E+07
Ag-110m	1.52E+06	1.44E+06	8.78E+05	0.00E+00	2.75E+06	0.00E+00	4.05E+08
Sn-113	6.50E+06	1.30E+06	2.14E+07	6.27E+05	1.70E+06	7.66E+05	2.30E+08
Sn-117m	6.47E+06	2.79E+05	1.12E+07	5.20E+04	3.93E+05	9.51E+04	1.26E+08
Sb-122	6.51E+05	4.45E+05	7.19E+06	8.90E+04	2.91E+05	1.20E+05	7.53E+07
Sb-124	2.22E+07	4.09E+05	8.67E+06	5.04E+04	0.00E+00	1.94E+07	4.48E+08
Sb-125	1.76E+07	1.93E+05	4.12E+06	1.68E+04	0.00E+00	1.55E+07	1.37E+08
Te-125m	2.80E+07	1.01E+07	3.74E+06	7.83E+06	0.00E+00	0.00E+00	8.26E+07
Te-127m	8.99E+07	3.19E+07	1.07E+07	2.14E+07	3.65E+08	0.00E+00	2.24E+08
Te-127	5.67E+03	2.01E+03	1.22E+03	3.91E+03	2.30E+04	0.00E+00	4.38E+05
Te-129m	9.66E+07	3.59E+07	1.53E+07	3.12E+07	4.04E+08	0.00E+00	3.63E+08
Te-129	7.04E-04	2.63E-04	1.71E-04	5.03E-04	2.96E-03	0.00E+00	3.85E-03
Te-131m	9.97E+05	4.78E+05	3.99E+05	7.19E+05	4.99E+06	0.00E+00	3.84E+07
Te-131	1.22E-15	5.04E-16	3.82E-16	9.42E-16	5.34E-15	0.00E+00	1.00E-16
Te-132	4.09E+06	2.59E+06	2.44E+06	2.73E+06	2.48E+07	0.00E+00	8.20E+07
I-130	1.74E+05	5.04E+05	2.01E+05	4.11E+07	7.77E+06	0.00E+00	3.88E+05
I-131	3.58E+07	5.01E+07	2.69E+07	1.46E+10	8.63E+07	0.00E+00	9.92E+06
I-132	2.34E+01	6.11E+01	2.19E+01	2.06E+03	9.63E+01	0.00E+00	2.66E+01
I-133	9.65E+05	1.64E+06	4.99E+05	2.29E+08	2.87E+06	0.00E+00	1.24E+06
I-134	4.00E-05	1.06E-04	3.80E-05	1.77E-03	1.67E-04	0.00E+00	1.40E-06
I-135	1.70E+04	4.39E+04	1.63E+04	2.82E+06	6.93E+04	0.00E+00	4.86E+04
Cs-134	5.86E+08	1.38E+09	6.40E+08	0.00E+00	4.39E+08	1.67E+08	1.72E+07
Cs-134m	5.95E+00	1.23E+01	6.34E+00	0.00E+00	6.86E+00	1.20E+00	8.20E+00
Cs-136	2.89E+07	1.14E+08	7.64E+07	0.00E+00	6.19E+07	9.76E+06	9.15E+06
Cs-137	8.56E+08	1.14E+09	3.97E+08	0.00E+00	3.88E+08	1.51E+08	1.62E+07

TABLE 10-19
 R_{io} , LEAFY VEGETABLE PATHWAY DOSE FACTORS – TEEN

NUCLIDE	BONE	LIVER	T. BODY	THYROID	KIDNEY	LUNG	GI-LLI
Cs-138	3.13E-11	6.01E-11	3.01E-11	0.00E+00	4.44E-11	5.16E-12	2.73E-14
Ba-139	2.82E-02	1.98E-05	8.20E-04	0.00E+00	1.87E-05	1.37E-05	2.51E-01
Ba-140	9.38E+07	1.15E+05	6.05E+06	0.00E+00	3.90E+04	7.73E+04	1.45E+08
Ba-141	0.00E+00	0.00E+00	0.00E+00	0.00E+00	0.00E+00	0.00E+00	0.00E+00
Ba-142	0.00E+00	0.00E+00	0.00E+00	0.00E+00	0.00E+00	0.00E+00	0.00E+00
La-140	1.81E+03	8.88E+02	2.36E+02	0.00E+00	0.00E+00	0.00E+00	5.10E+07
La-142	1.22E-04	5.41E-05	1.35E-05	0.00E+00	0.00E+00	0.00E+00	1.65E+00
Ce-141	6.58E+04	4.39E+04	5.04E+03	0.00E+00	2.07E+04	0.00E+00	1.26E+08
Ce-143	9.32E+02	6.79E+05	7.58E+01	0.00E+00	3.04E+02	0.00E+00	2.04E+07
Ce-144	4.65E+06	1.92E+06	2.50E+05	0.00E+00	1.15E+06	0.00E+00	1.17E+09
Pr-143	4.48E+04	1.79E+04	2.23E+03	0.00E+00	1.04E+04	0.00E+00	1.47E+08
Pr-144	0.00E+00	0.00E+00	0.00E+00	0.00E+00	0.00E+00	0.00E+00	0.00E+00
Nd-147	2.83E+04	3.08E+04	1.85E+03	0.00E+00	1.81E+04	0.00E+00	1.11E+08
Eu-152	1.73E+06	4.17E+05	3.68E+05	0.00E+00	1.94E+06	0.00E+00	1.54E+08
W-187	3.55E+04	2.89E+04	1.01E+04	0.00E+00	0.00E+00	0.00E+00	7.82E+06
U-235	8.16E+09	0.00E+00	4.97E+08	0.00E+00	1.91E+09	0.00E+00	5.93E+08
U-238	7.81E+09	0.00E+00	4.65E+08	0.00E+00	1.79E+09	0.00E+00	4.17E+08
Np-239	1.38E+03	1.31E+02	7.25E+01	0.00E+00	4.10E+02	0.00E+00	2.10E+07
Am-241	6.01E+09	2.29E+09	4.01E+08	0.00E+00	3.01E+09	0.00E+00	5.49E+08

OFFSITE DOSE CALCULATION MANUAL

TABLE 10-20
 R_{io} , LEAFY VEGETABLE PATHWAY DOSE FACTORS – CHILD

{m²-mrem/yr per μ Ci/s (mrem/yr per μ Ci/m³ for ³H-3 and ¹⁴C)}

NUCLIDE	BONE	LIVER	T. BODY	THYROID	KIDNEY	LUNG	GI-LLI
H-3	0.00E+00	2.06E+02	2.06E+02	2.06E+02	2.06E+02	2.06E+02	2.06E+02
C-14	2.16E+05	4.33E+04	4.33E+04	4.33E+04	4.33E+04	4.33E+04	4.33E+04
F-18	6.88E+00	0.00E+00	6.83E-01	0.00E+00	0.00E+00	0.00E+00	1.86E+00
Na-22	2.88E+08	2.88E+08	2.88E+08	2.88E+08	2.88E+08	2.88E+08	2.88E+08
Na-24	3.69E+05	3.69E+05	3.69E+05	3.69E+05	3.69E+05	3.69E+05	3.69E+05
Sc-46	7.36E+04	1.01E+05	3.89E+04	0.00E+00	8.93E+04	0.00E+00	1.48E+08
P-32	1.96E+09	9.18E+07	7.56E+07	0.00E+00	0.00E+00	0.00E+00	5.42E+07
Cr-51	0.00E+00	0.00E+00	2.59E+04	1.44E+04	3.92E+03	2.62E+04	1.37E+06
Mn-54	0.00E+00	4.56E+07	1.21E+07	0.00E+00	1.28E+07	0.00E+00	3.83E+07
Mn-56	0.00E+00	1.82E+01	4.11E+00	0.00E+00	2.20E+01	0.00E+00	2.64E+03
Fe-55	4.90E+07	2.60E+07	8.05E+06	0.00E+00	0.00E+00	1.47E+07	4.81E+06
Fe-59	5.50E+07	8.89E+07	4.43E+07	0.00E+00	0.00E+00	2.58E+07	9.26E+07
Co-57	0.00E+00	2.05E+06	4.14E+06	0.00E+00	0.00E+00	0.00E+00	1.68E+07
Co-58	0.00E+00	6.58E+06	2.01E+07	0.00E+00	0.00E+00	0.00E+00	3.84E+07
Co-60	0.00E+00	2.37E+07	7.00E+07	0.00E+00	0.00E+00	0.00E+00	1.31E+08
Ni-63	2.81E+09	1.51E+08	9.57E+07	0.00E+00	0.00E+00	0.00E+00	1.01E+07
Ni-65	1.01E+02	9.51E+00	5.55E+00	0.00E+00	0.00E+00	0.00E+00	1.16E+03
Cu-64	0.00E+00	1.10E+04	6.64E+03	0.00E+00	2.65E+04	0.00E+00	5.16E+05
Zn-65	7.41E+07	1.97E+08	1.23E+08	0.00E+00	1.24E+08	0.00E+00	3.47E+07
Zn-69m	3.85E+04	6.56E+04	7.75E+03	0.00E+00	3.81E+04	0.00E+00	2.14E+06
Zn-69	1.02E-05	1.47E-05	1.36E-06	0.00E+00	8.91E-06	0.00E+00	9.26E-04
As-76	2.33E+05	6.48E+05	3.76E+06	2.20E+05	7.13E+05	2.20E+05	3.37E+07
Br-82	0.00E+00	0.00E+00	2.10E+06	0.00E+00	0.00E+00	0.00E+00	0.00E+00
Br-83	0.00E+00	0.00E+00	5.55E+00	0.00E+00	0.00E+00	0.00E+00	0.00E+00
Br-84	0.00E+00	0.00E+00	3.41E-11	0.00E+00	0.00E+00	0.00E+00	0.00E+00
Br-85	0.00E+00	0.00E+00	0.00E+00	0.00E+00	0.00E+00	0.00E+00	0.00E+00
Rb-86	0.00E+00	1.69E+08	1.04E+08	0.00E+00	0.00E+00	0.00E+00	1.08E+07
Rb-88	0.00E+00	0.00E+00	0.00E+00	0.00E+00	0.00E+00	0.00E+00	0.00E+00
Rb-89	0.00E+00	0.00E+00	0.00E+00	0.00E+00	0.00E+00	0.00E+00	0.00E+00
Sr-89	4.54E+09	0.00E+00	1.30E+08	0.00E+00	0.00E+00	0.00E+00	1.76E+08
Sr-90	1.29E+11	0.00E+00	2.59E+09	0.00E+00	0.00E+00	0.00E+00	1.15E+09
Sr-91	5.20E+05	0.00E+00	1.96E+04	0.00E+00	0.00E+00	0.00E+00	1.15E+06
Sr-92	7.08E+02	0.00E+00	2.84E+01	0.00E+00	0.00E+00	0.00E+00	1.34E+04
Y-90	2.30E+04	0.00E+00	6.17E+02	0.00E+00	0.00E+00	0.00E+00	6.56E+07
Y-91m	8.09E-09	0.00E+00	2.940E-10	0.00E+00	0.00E+00	0.00E+00	1.58E-05
Y-91	2.12E+06	0.00E+00	5.68E+04	0.00E+00	0.00E+00	0.00E+00	2.83E+08
Y-92	1.55E+00	0.00E+00	4.44E-02	0.00E+00	0.00E+00	0.00E+00	4.48E+04

OFFSITE DOSE CALCULATION MANUAL

TABLE 10-20
 R_{io} , LEAFY VEGETABLE PATHWAY DOSE FACTORS -- CHILD

NUCLIDE	BONE	LIVER	T. BODY	THYROID	KIDNEY	LUNG	GI-LLI
Y-93	2.98E+02	0.00E+00	8.19E+00	0.00E+00	0.00E+00	0.00E+00	4.45E+06
Zr-95	4.16E+05	9.14E+04	8.14E+04	0.00E+00	1.31E+05	0.00E+00	9.54E+07
Zr-97	5.61E+02	8.11E+01	4.78E+01	0.00E+00	1.16E+02	0.00E+00	1.23E+07
Nb-95	7.05E+04	2.74E+04	1.96E+04	0.00E+00	2.58E+04	0.00E+00	5.07E+07
Nb-97	4.80E-06	8.68E-07	4.05E-07	0.00E+00	9.63E-07	0.00E+00	2.68E-01
Mo-99	0.00E+00	7.74E+06	1.91E+06	0.00E+00	1.65E+07	0.00E+00	6.40E+06
Tc-99m	4.67E+00	9.16E+00	1.52E+02	0.00E+00	1.33E+02	4.65E+00	5.21E+03
Tc-99	9.16E+06	1.02E+07	3.66E+06	0.00E+00	1.20E+08	9.00E+05	1.07E+08
Tc-101	0.00E+00	0.00E+00	0.00E+00	0.00E+00	0.00E+00	0.00E+00	0.00E+00
Ru-103	2.38E+06	0.00E+00	9.14E+05	0.00E+00	5.99E+06	0.00E+00	6.15E+07
Ru-105	9.02E+01	0.00E+00	3.27E+01	0.00E+00	7.93E+02	0.00E+00	5.89E+04
Ru-106	5.17E+07	0.00E+00	6.45E+06	0.00E+00	6.98E+07	0.00E+00	8.04E+08
Rh-105	2.22E+05	1.19E+05	1.02E+05	0.00E+00	4.75E+05	0.00E+00	7.39E+06
Ag-110m	2.48E+06	1.68E+06	1.34E+06	0.00E+00	3.12E+06	0.00E+00	1.99E+08
Sn-113	1.14E+07	2.44E+06	3.74E+07	9.78E+05	2.59E+06	1.22E+06	4.17E+08
Sn-117m	1.26E+07	5.97E+05	1.96E+07	9.42E+04	6.05E+05	1.73E+05	2.28E+08
Sb-122	1.17E+06	7.00E+05	1.29E+07	1.53E+05	4.24E+05	1.99E+05	1.40E+08
Sb-124	3.95E+07	5.12E+05	1.38E+07	8.71E+04	0.00E+00	2.19E+07	2.47E+08
Sb-125	3.15E+07	2.43E+05	6.60E+06	2.92E+04	0.00E+00	1.76E+07	7.52E+07
Te-125m	5.16E+07	1.40E+07	6.88E+06	1.45E+07	0.00E+00	0.00E+00	4.98E+07
Te-127m	1.66E+08	4.48E+07	1.97E+07	3.98E+07	4.74E+08	0.00E+00	1.35E+08
Te-127	1.05E+04	2.82E+03	2.24E+03	7.24E+03	2.98E+04	0.00E+00	4.09E+05
Te-129m	1.79E+08	4.99E+07	2.77E+07	5.76E+07	5.25E+08	0.00E+00	2.18E+08
Te-129	1.30E-03	3.64E-04	3.09E-04	9.30E-04	3.81E-03	0.00E+00	8.12E-02
Te-131m	1.82E+06	6.30E+05	6.70E+05	1.30E+06	6.10E+06	0.00E+00	2.56E+07
Te-131	2.25E-15	6.86E-16	6.70E-16	1.72E-15	6.81E-15	0.00E+00	1.18E-14
Te-132	7.32E+06	3.24E+06	3.91E+06	4.72E+06	3.01E+07	0.00E+00	3.26E+07
I-130	3.06E+05	6.18E+05	3.19E+05	6.81E+07	9.24E+05	0.00E+00	2.89E+05
I-131	6.52E+07	6.56E+07	3.73E+07	2.17E+10	1.08E+08	0.00E+00	5.84E+06
I-132	4.15E+01	7.62E+01	3.50E+01	3.54E+03	1.17E+02	0.00E+00	8.97E+01
I-133	1.76E+06	2.18E+06	8.23E+05	4.04E+08	3.63E+06	0.00E+00	8.77E+05
I-134	7.10E-05	1.32E-04	6.07E-05	3.03E-03	2.02E-04	0.00E+00	8.74E-05
I-135	3.03E+04	5.45E+04	2.58E+04	4.83E+06	8.35E+04	0.00E+00	4.15E+04
Cs-134	1.01E+09	1.67E+09	3.51E+08	0.00E+00	5.16E+08	1.85E+08	8.98E+06
Cs-134m	1.06E+01	1.57E+01	1.02E+01	0.00E+00	8.26E+00	1.37E+00	1.98E+01
Cs-136	4.90E+07	1.35E+08	8.71E+07	0.00E+00	7.17E+07	1.07E+07	4.73E+06
Cs-137	1.55E+09	1.48E+09	2.19E+08	0.00E+00	4.83E+08	1.74E+08	9.28E+06
Cs-138	5.69E-11	7.92E-11	5.02E-11	0.00E+00	5.57E-11	5.99E-12	3.65E-11

TABLE 10-20
 R_{io} , LEAFY VEGETABLE PATHWAY DOSE FACTORS – CHILD

NUCLIDE	BONE	LIVER	T. BODY	THYROID	KIDNEY	LUNG	GI-LIN
Ba-139	5.19E-02	2.77E-05	1.50E-03	0.00E+00	2.42E-05	1.63E-05	3.00E+00
Ba-140	1.70E+08	1.49E+05	9.92E+06	0.00E+00	4.85E+04	8.88E+04	8.61E+07
Ba-141	0.00E+00	0.00E+00	0.00E+00	0.00E+00	0.00E+00	0.00E+00	0.00E+00
Ba-142	0.00E+00	0.00E+00	0.00E+00	0.00E+00	0.00E+00	0.00E+00	0.00E+00
La-140	3.25E+03	1.13E+03	3.82E+02	0.00E+00	0.00E+00	0.00E+00	3.16E+07
La-142	2.21E-04	7.04E-05	2.20E-05	0.00E+00	0.00E+00	0.00E+00	1.39E+01
Ce-141	1.22E+05	6.06E+04	9.00E+03	0.00E+00	2.66E+04	0.00E+00	7.56E+07
Ce-143	1.72E+03	9.31E+05	1.35E+02	0.00E+00	3.91E+02	0.00E+00	1.36E+07
Ce-144	8.60E+06	2.69E+06	4.59E+05	0.00E+00	1.49E+06	0.00E+00	7.03E+08
Pr-143	8.32E+04	2.50E+04	4.13E+03	0.00E+00	1.35E+04	0.00E+00	8.97E+07
Pr-144	0.00E+00	0.00E+00	0.00E+00	0.00E+00	0.00E+00	0.00E+00	0.00E+00
Nd-147	5.22E+04	4.23E+04	3.27E+03	0.00E+00	2.32E+04	0.00E+00	6.70E+07
Eu-152	2.69E+06	4.91E+05	5.83E+05	0.00E+00	2.07E+06	0.00E+00	8.06E+07
W-187	6.45E+04	3.82E+04	1.71E+04	0.00E+00	0.00E+00	0.00E+00	5.37E+06
U-235	1.52E+10	0.00E+00	9.18E+08	0.00E+00	2.49E+09	0.00E+00	3.56E+08
U-238	1.45E+10	0.00E+00	8.60E+08	0.00E+00	2.32E+09	0.00E+00	2.51E+08
Np-239	2.56E+03	1.84E+02	1.29E+02	0.00E+00	5.31E+02	0.00E+00	1.36E+07
Am-241	6.17E+09	2.76E+09	4.40E+08	0.00E+00	2.69E+09	0.00E+00	3.30E+08

TABLE 10-21
 R_{io} , GROUND PLANE PATHWAY DOSE FACTORS

(m^2 -mrem/yr per μ Ci/s)

NUCLIDE	TOTAL BODY AND ORGANS	NUCLIDE	TOTAL BODY AND ORGANS	NUCLIDE	TOTAL BODY AND ORGANS
H-3	0.00E+00	Y-90	4.49E+03	I-132	1.24E+06
C-14	0.00E+00	Y-91m	1.00E+05	I-133	2.45E+06
F-18	7.87E+05	Y-91	1.07E+06	I-134	4.47E+05
Na-22	2.00E+10	Y-92	1.81E+05	I-135	2.51E+06
Na-24	1.19E+07	Y-93	1.85E+05	Cs-134	6.88E+09
Sc-46	1.65E+09	Zr-95	2.45E+08	Cs-134m	3.19E+04
P-32	0.00E+00	Zr-97	2.94E+06	Cs-136	1.51E+08
Cr-51	4.66E+06	Nb-95	1.36E+08	Cs-137	1.03E+10
Mn-54	1.38E+09	Nb-97	3.37E+05	Cs-138	3.59E+05
Mn-56	9.04E+05	Mo-99	3.99E+06	Ba-139	1.07E+05
Fe-55	0.00E+00	Tc-99m	1.84E+05	Ba-140	2.05E+07
Fe-59	2.72E+08	Tc-99	3.02E+06	Ba-141	4.18E+04
Co-57	3.18E+08	Tc-101	2.04E+04	Ba-142	4.49E+04
Co-58	3.79E+08	Ru-103	1.08E+08	La-140	1.93E+07
Co-60	2.16E+10	Ru-105	6.37E+05	La-142	7.36E+05
Ni-63	0.00E+00	Ru-106	4.27E+08	Ce-141	1.37E+07
Ni-65	2.97E+05	Rh-105	1.15E+06	Ce-143	2.32E+06
Cu-64	6.07E+05	Ag-110m	3.44E+09	Ce-144	6.97E+07
Zn-65	7.46E+08	Sn-113	2.50E+07	Pr-143	0.00E+00
Zn-69m	2.41E+06	Sn-117m	2.09E+07	Pr-144	1.84E+03
Zn-69	0.00E+00	Sb-122	1.21E+07	Nd-147	8.40E+06
As-76	4.74E+06	Sb-124	1.05E+09	Eu-152	2.98E+10
Br-82	3.83E+07	Sb-125	4.27E+09	W-187	2.36E+06
Br-83	4.90E+03	Te-125m	1.55E+06	U-235	5.72E+09
Br-84	2.03E+05	Te-127m	9.17E+04	U-238	2.13E+07
Br-85	0.00E+00	Te-127	3.00E+03	Np-239	1.71E+06
Rb-86	8.99E+06	Te-129m	1.98E+07	Am-241	1.05E+09
Rb-88	3.29E+04	Te-129	2.62E+04		
Rb-89	1.23E+05	Te-131m	8.67E+06		
Sr-89	2.16E+04	Te-131	2.92E+04		
Sr-90	9.24E+06	Te-132	4.16E+06		
Sr-91	2.15E+06	I-130	5.51E+06		
Sr-92	7.77E+05	I-131	1.72E+07		

OFFSITE DOSE CALCULATION MANUAL

11.0 DETERMINATION OF TOTAL DOSE

The purpose of this section is to describe the method used to calculate the cumulative dose contributions from liquid and gaseous effluents in accordance with PBNP Technical Specifications for total dose. This method can also be used to demonstrate compliance with the Environmental Protection Agency (EPA) 40CFR190, "Environmental Standards for the Uranium Fuel Cycle".

Compliance with the PBNP Technical Specification dose objectives for the maximum individual demonstrates compliance with the EPA limits to any MEMBER OF THE PUBLIC, since the design dose objectives from 10CFR50, Appendix I are much lower than the 40CFR190 dose limits to the general public. With the calculated doses from the releases of radioactive materials in liquid or gaseous effluents exceeding twice the limits outlined in Sections 6.2.1, 7.2.1 and 7.3.1, a special analysis shall be performed. The purpose of this analysis is to demonstrate if the total dose to any MEMBER OF THE PUBLIC (real individual) from all URANIUM FUEL CYCLE sources (including direct radiation contributions from the reactor units and from outside storage areas and from all real pathways) is limited to less than or equal to 25 mrem per year to the total body or any organ, except the thyroid, which is limited to 75 mrem per year.

If required, the total dose to a MEMBER OF THE PUBLIC will be calculated for all significant effluent release points for all real pathways including direct radiation. As necessary, effluent releases from Kewaunee Nuclear Power Plant must also be considered due to its proximity. Calculations will be based on the equations in Sections 9.2, 10.5, 10.6 with the exception that usage factors and other site specific parameters may be modified using more realistic assumptions, where appropriate.

The direct radiation component from the facility can be determined using environmental TLD results. These results will be corrected for natural background and for actual occupancy time of any areas accessible to the general public at the location of maximum direct radiation. It is recognized that by including the results from the environmental TLDs into the sum of total dose component, the direct radiation dose may be overestimated. The TLD measurements may include the exposure from noble gases, ground plane deposition, and shoreline deposition, which have already been included in the summation of the significant dose pathways to the general public. However, this conservative method can be used, if required, as well as any other method for estimating the direct radiation dose from contained radioactive sources within the facility. The methodology used to incorporate the direct radiation component into total dose estimates will be outlined whenever total doses are reported.

Therefore, the total dose will be determined based on the most realistic site specific data and parameters to assess the real dose to any MEMBER OF THE PUBLIC.

OFFSITE DOSE CALCULATION MANUAL

12.0 RADIOLOGICAL ENVIRONMENTAL MONITORING PROGRAM

12.1 REMP Administration

12.1.1 Definition and Basis

Radiological environmental monitoring is the measurement of radioactivity in samples collected from the atmospheric, aquatic and terrestrial environment around the Point Beach Nuclear Plant (PBNP). Monitoring radioactivity in effluent streams at or prior to the point of discharge to the environment is not part of the Radiological Environmental Monitoring Program (REMP).

The REMP is designed to fulfill the requirements of 10 CFR 20.1302, PBNP GDC 17, and Sections IV.B.2 and IV.B.3 of Appendix I to 10 CFR 50. Technical Specification 5.5.1.b requires the Offsite Dose Calculation Manual (ODCM) to contain the radiological environmental monitoring activities.

No significant radionuclide concentrations of plant origin are expected in the plant environs because radioactivity in plant effluent is continuously monitored to ensure that releases are well below levels which are considered safe upper limits. The REMP is conducted to demonstrate compliance with applicable standards, to assess the radiological environmental impact of PBNP operations, and to monitor the efficacy of in plant effluent controls. The REMP, as outlined in Table 12-2 through Table 12-3 is designed to provide sufficient sample types and locations to detect and to evaluate changes in environmental radioactivity.

Radioactivity is released in liquid and gaseous effluents. Air samplers and thermoluminescent dosimeters placed at various locations provide means of detecting changes in environmental radioactivity as a result of plant releases to the atmosphere. Because the land area around PBNP is used primarily for farming and dairy operations, sampling of vegetation is conducted to detect changes in radiological conditions at the base of the food chain. Sampling of area-produced milk is conducted because dairy farming is a major industry in the area.

Water, periphyton, and fish are analyzed to monitor radionuclide levels in Lake Michigan in the vicinity of PBNP. Periphyton, attached algae, along with lake water samples, provide a means of detecting changes which may have a potential impact on the radionuclide concentrations in Lake Michigan fish. Because of the migratory behavior of fish, fish sampling is of minimal value for determining radiological impact specifically related to the operation of the Point Beach Nuclear Plant. However, fish sampling is carried out in order to monitor the status of radioactivity in fish in the vicinity of Point Beach.

Vegetation, algae, and fish sampling frequencies are qualified on an "as available" basis recognizing that certain biological samples may occasionally be unavailable due to environmental conditions.

OFFSITE DOSE CALCULATION MANUAL

12.1.2 Responsibilities

a. Chemistry Functions

Chemistry together with Regulatory Affairs (RA) provides the Plant Manager with the technical, regulatory, licensing, and administrative support necessary for the implementation of the program. The Chemistry administrative functions relating to the REMP fall into the six broad areas outlined below.

1. Program Scope

The scope of the REMP is determined by the cognizant Chemist based on radiological principles for the fulfillment of PBNP Technical Specifications (TS) and the applicable Federal Regulations. Based on the scope, the ODCM is written to accomplish the collection and analyses of the necessary environmental samples, and revised as necessary to conform to changes in procedures and scope. Chemistry monitors the REMP effectiveness and compliance with TS and with the procedures and directives in the ODCM. In order to verify compliance with TS, Nuclear Oversight arranges for program audits and Supplier Assessments of the contracted radioanalytical laboratory. Chemistry reviews the REMP annually via the Annual Monitoring Report.

2. Record Keeping

The monthly radioanalytical results from the contracted laboratory are reviewed by Chemistry and one copy of the monthly radioanalytical results from the contracted laboratory is kept for the lifetime of the plant. The vendors monthly reports are cumulative (e.g. The September report contains all the results from January-September). The cognizant Chemist reviews the current months results, signs and dates the cover page, and sends the reviewed report to plants records for retention.

3. Data Monitoring

Chemistry reviews the monthly analytical results from the vendor. Trends, if any, are noted. Any resulting corrections, modifications and additions to the data are made by Chemistry. Inconsistencies are investigated by Chemistry with the cooperation of Radiation Protection (RP) and contractor personnel, as required. Radioactivity levels in excess of administrative notification levels would be evaluated and notifications made, as appropriate, in accordance with applicable fleet policies and procedures (LI-AA-102-1001).

4. Data Summary

Pursuant to TS 5.6.2, REMP results shall be summarized annually for inclusion in the PBNP Annual Monitoring Report. This summary advises the Plant Manager of the radiological status of the environment in the vicinity of PBNP. The summary shall include the numbers and types of samples as well as the averages, statistical confidence limits and the ranges of analytical results. Methods used in summarizing data are at the discretion of Chemistry.

5. Contractor Communications

Communication with the contractor regarding data, analytical procedures, lower limits of detection, notification levels and contractual matters are normally conducted by Chemistry. Communication regarding sample shipment may be done by either RP or Chemistry as appropriate.

6. Reportable Items

Chemistry shall generate reports related to the operation of the REMP. The material included shall be sufficient to fulfill the objectives outlined in Sections IV.B.2 and IV.B.3 of Appendix I to 10 CFR 50. The following items specific to the REMP are required to be reported in the PBNP Annual Monitoring Report:

- (a) Summary and discussion of monitoring results including number and type of samples and measurements, and all detected radionuclides, except for naturally occurring radionuclides;
- (b) Unavailable, missing, and lost samples and plans to prevent recurrence and comments on any significant portion of the REMP not conducted as indicated in Table 12-3.
- (c) New or relocated sampling locations and reason for change;
- (d) LLDs that are higher than specified in Table 12-1 and factors contributing to inability to achieve specified LLDs;
- (e) Notification that the analytical laboratory does not participate in an interlaboratory comparison program and corrective action taken to preclude a recurrence; and

- (f) Results of the annual milk sampling program land use census "milk survey" to visually verify that the location of grazing animals in the vicinity of the PBNP site boundary so as to ensure that the milk sampling program remains as conservative as practicable.
- (g) The annual results from the contracted REMP analytical laboratory as well as the laboratory's analytical QA/QC results, in-house blanks, interlaboratory comparisons, etc., shall be submitted to the NRC, via the Annual Monitoring Report.

b. Non-Chemistry Functions

The primary responsibility for the implementation of the PBNP REMP and for any actions to be taken at PBNP, based on the results of the program, resides with the Plant Manager.

1. Manual control and distribution

The distribution of the PBNP Environmental Manual is the responsibility of Document Control.

2. Program coordination

The daily operation of the program is conducted by PBNP Radiation Protection personnel, and other qualified personnel as required, under the supervision of an RP staff member who consults, as needed, with Chemistry. The daily administrative functions of the RP Management Employee address those functions required for the effective operation of the PBNP Radiological Environmental Monitoring Program. These administrative functions include the following:

- (a) Ensuring that samples are obtained in accordance with the type and frequency in Table 12-3 following procedures outlined in this manual;
- (b) Ensuring adequate sampling supplies and calibrated, functional equipment are available at all times;
- (c) Ensuring that air sampling pumps are maintained, repaired and calibrated as required and that an adequate number of backup pumps are readily available at all times;

- (d) Reporting lost or unavailable samples as well as other potential deviations from the sampling regime in Table 12-3 via the Corrective Action Program (CAP) and notifying the cognizant Chemist.
- (e) As a courtesy to the State of Wisconsin, Point Beach assists in obtaining samples at co-located and other sampling sites (this is not a TS requirement); and
- (f) Assisting Chemistry, as necessary, with investigations into elevated radioactivity levels in environmental samples.

12.1.3 Quality Assurance / Quality Control

Quality assurance is an integral part of PBNP's Radiological Environmental Monitoring Program. The QATR commits PBNP to Reg. Guide 4.15, Quality Assurance for Radiological Monitoring Programs (Inception through Normal Operation to License Termination) – Effluent Streams and the Environment. The REMP involves the interaction of Chemistry and the contracted analytical laboratory. The contracted vendor shall participate in an interlaboratory comparison program. The laboratory is audited periodically, either by PBNP or by an independent third party.

Quality control for the PBNP portion of the Radiological Environmental Monitoring Program is achieved by following the procedures contained in this manual. Radiation Protection Technologists (RPTs) collect, package and ship environmental samples under the supervision of Radiation Protection supervisors. They are advised by Radiation Protection Management who has immediate responsibility for the overall technical operation of the environmental sampling functions. The RPTs receive classroom training as well as on-the-job training in carrying out these procedures.

An audit of the PBNP Radiological Environmental Monitoring Program and its results shall be completed periodically as a means of monitoring program effectiveness and assuring compliance with program directives. The audit shall be performed in accordance with Section 2.4.

OFFSITE DOSE CALCULATION MANUAL

12.2 REMP Implementation

12.2.1 Program Overview

a. Purpose

No significant or unexpected radionuclide concentrations of plant origin are expected because each normal effluent pathway at PBNP is monitored at or before the release point. However, the REMP is conducted to verify that plant operations produce no significant radiological impact on the environment and to demonstrate compliance with applicable standards.

b. Samples

Samples for the REMP are obtained from the aquatic, terrestrial and atmospheric environment. The sample types represent key indicators or critical pathways which have been identified by applying radiological principles from NRC and other guidance documents to the PBNP environment.

c. Monitoring Sensitivity

The effectiveness of the REMP in fulfilling its purpose depends upon the ability to accurately determine the nature and origins of fluctuations in low levels of environmental radioactivity. This requires a high degree of sensitivity so that it is possible to correctly discriminate between fluctuations in background radiation levels and levels of radioactivity that may be attributable to the operation of PBNP. Therefore, personnel actively participating in the monitoring program should make every effort to minimize the possibility of contaminating environmental samples and to obtain samples of the appropriate size.

12.2.2 Program Parameters

a. Contamination Avoidance

Contamination prevents the accurate quantification of environmental radioactivity and the correct differentiation between fluctuating background radioactivity and levels of radioactivity attributable to the operation of PBNP. Therefore, it is necessary that all personnel associated with collecting and handling radiological environmental samples take the appropriate precautions to minimize the possibility of contaminating the samples. Some of the precautions that should be taken and which will help to minimize contamination are listed below:

1. Equipment which has been in the radiologically controlled area, even if released clean, should not normally be used in conjunction with radiological environmental monitoring. An exception to this is the Health Physics Test Instrument (HPTI) equipment used to calibrate the air flow calibrator.
2. Store sampling equipment in radiologically clean areas only;
3. Store radiological environmental samples only in radiologically clean areas when samples cannot be shipped to the contractor on the same day they are collected;
4. Treat each sample as a possible source of contamination for other samples so as to minimize the possibility of cross-contamination;
5. Radiological environmental monitoring equipment should be repaired in clean-side shops;
6. Avoid entering contaminated areas prior to collecting environmental samples.

b. Lower Limit of Detection

The sensitivity required for a specific analysis of an environmental sample is defined in terms of the lower limit of detection (LLD). The LLD is the smallest concentration of radioactive material in a sample that will yield a net count, above system background, that will be detected with a 95% probability and have only a 5% probability of falsely concluding that a blank observation represents a real signal. Mathematically, the LLD is defined by the formula:

$$LLD = \frac{4.66S_b}{E \times V \times 2.22 \times Y \times e^{-\lambda\Delta T}} \quad [12-1]$$

- Where:
- LLD* = The a priori lower limit of detection in picocuries per unit volume or mass, as applicable
 - S_b* = The standard deviation of the background counting rate or the counting rate of a blank sample, as appropriate, in counts per minutes
 - E* = counting efficiency in counts per disintegration;
 - V* = sample size in units of volume or mass, as applicable;
 - 2.22* = number of disintegrations per minute per picocurie;
 - Y* = the fractional chemical yield as applicable;
 - λ* = the radioactive decay constant for the particular radionuclide; and
 - ΔT* = the elapsed time between sample collection, or the end of the collection period, and the time of counting.

Typical values of E, V, Y, and ΔT are used to calculate the LLD. As defined, the LLD is an *a priori* limit representing the capability of a measuring system and not an *a posteriori* limit for a particular measurement.

The required analysis for each environmental sample and the highest acceptable LLD associated with each analysis are listed in Table 12-1. Whenever LLD values lower than those specified in Table 12-1 are reasonably achievable, the analytical contractor for the radiological environmental samples will do so. When the LLDs listed in Table 12-1 are not achieved, a description of the factors contributing to the higher LLD shall be reported in the next PBNP Annual Monitoring Report.

c. Notification Levels

The Notification Level (NL) is that measured quantity of radioactivity in an environmental sample which, when exceeded, requires a notification of such an occurrence be made to the appropriate party. Regulatory and administrative notification levels are listed in Table 12-1.

1. Regulatory notification levels

The regulatory notification levels listed in Table 12-1 represent the concentration levels at which NRC notification is required. If a measured level of radioactivity in any radiological environmental monitoring program sample exceeds the regulatory notification level listed in Table 12-1, resampling and/or reanalysis for confirmation shall be completed within 30 days of the determination of the anomalous result. If the confirmed measured level of radioactivity remains above the notification level, a written report shall be submitted to the NRC. If more than one of the radionuclides listed in Table 12-1 are detected in any environmental medium, a weighted sum calculation shall be performed if the measured concentration of a detected radionuclide is greater than 25% of the notification levels. For those radionuclides with LLDs in excess of 25% of the notification level, a weighted sum calculation needs to be performed only if the reported value exceeds the LLD. Radionuclide concentration levels, called Weighted Sum Action Levels, which trigger a weighted sum calculation, are listed in Table 12-1.

The weighted sum is calculated as follows:

$$\frac{\text{concentration (1)}}{\text{notification level (1)}} + \frac{\text{concentration (2)}}{\text{notification level (2)}} + \dots = \text{weighted sum} \quad [12-2]$$

OFFSITE DOSE CALCULATION MANUAL

If the calculated weighted sum is equal to or greater than 1, resampling and/or reanalysis for confirmation shall be completed within 30 days of the determination of the anomalous result. If the confirmed calculated weighted sum remains equal to or greater than 1, see Section 12.1.2.a.3 for notification guidance. This calculation requirement and report is not required if the measured level of radioactivity was not the result of plant effluents.

2. Administrative notification levels

The administrative notification levels are the concentration levels at which the contracted analytical laboratory promptly notifies the cognizant Chemistry Specialist by phone, followed by a formal written communication. The administrative notification levels are lower than the NRC regulatory notification levels and lower than, or equal to, the weighted sum action levels so the nature and origin of the increased level of environmental radioactivity may be ascertained and corrective actions taken, if required.

d. Sampling Locations

A list of sampling locations and the corresponding location codes appear in Table 12-2. The locations are shown in Figure 12-1 through Figure 12-3. If samples become unavailable from specified sample locations, new locations for obtaining replacement samples shall be identified and added to the Radiological Environmental Monitoring Program. If milk or vegetation samples become unavailable from the specified sampling locations, new sampling locations will be identified within 30 days. The specific locations where samples were unavailable may be deleted from the monitoring program in accordance with established provisions for assessing changes. Any significant changes in existing sampling location and the criteria for the change shall be reported in the Annual Monitoring Report for the period in which the change occurred. Additional sampling locations may be designated if deemed necessary by cognizant company personnel. Figures and tables in this manual shall be revised to reflect the changes.

e. Sampling Media and Frequency

The sampling frequency for the environmental media required by the PBNP REMF is found in Table 12-3. Included is algae which is not a NUREG-0472 requirement. Additionally, the REMF also includes the sampling of soil and shoreline sediment, which were not part of the PBNP RETS but kept for continuity with the preoperational monitoring program. Samples are collected pursuant to HPIP 3.58.1, Radiological Environmental Sampling, which uses a monthly checklist to ensure that all the samples for the month are collected. The checklists also identify the schedule for the annual milk survey.

It is recognized that on occasions samples will be lost or that samples cannot be collected at the specified frequency because of hazardous conditions, seasonable unavailability, automatic sampling equipment malfunctions and other legitimate reasons. Reasonable efforts will be made to recover lost or missed samples if warranted and appropriate. If samples are not obtained at the indicated frequency or location, the reasons or explanations for deviations from the sampling frequency specified in Table 12-3 shall be documented in an AR and reported in the AMR.

f. Sample Analyses and Frequency

The PBNP REMF samples shall be analyzed for designated parameters at the frequency listed in Table 12-3. Gamma isotopic analysis means the identification and quantification of gamma-emitting radionuclides that may be attributable to effluents from PBNP. Typically, this entails the scanning of the spectrum from 80 to 2048 KeV and decay correcting identified radionuclides to the time of collection. The analysis specifically includes, but is not limited to, Mn-54, Fe-59, Zn-65, Co-58, Co-60, Zr/Nb-95, Ru-103, I-131, Cs-134, Cs-137, Ba/La-140, Ce-141, and Ce-144.

g. Analytical Laboratory

The contracted laboratory performs the analyses in such a manner as to attain the desired LLDs. The contracted laboratory participates in an inter-laboratory comparison crosscheck program.

The laboratory is responsible for providing prompt notification to the cognizant Chemist regarding any samples found to exceed the administrative notification levels as identified in Table 12-1.

12.2.3 Assistance to the State of Wisconsin (Non-Technical Specification Activity)

As a courtesy and convenience, PBNP personnel obtain certain environmental samples for the Section of Radiation Protection, Department of Health and Family Services of the State of Wisconsin. A checklist is used. In addition, a State of Wisconsin air sampling data sheet is submitted with each sample obtained at Wisconsin air sampling locations serviced by PBNP personnel.

12.2.4 Specification of Sampling Procedures

General radiological environmental sampling procedures follow the directives presented in Sections 12.1 and 12.2. Station procedures provide the specific information for the collection of the following samples:

- Vegetation
- Thermoluminescent Dosimeters (TLDs)
- Lake water
- Well water
- Air
- Milk
- Algae (part of PBNP RETS,10-3-1985)
- Fish
- Soil (not part of PBNP RETS,10-3-1985)
- Shoreline sediment (not part of PBNP RETS,10-3-1985)

12.2.5 Milk Survey

The milk sampling program is reviewed annually, including a visual verification of animal grazing in the vicinity of the site boundary, to ensure that sampling locations remain as conservative as practicable. The verification is conducted each summer by cognizant PBNP personnel. Because it is already assumed that milk animals may graze up to the site boundary, it is only necessary to verify that these animals have not moved onto the site. No animal census is required. Upon completion of the visual check, a memo will be generated to document the review and the memo sent to file. To ensure performance of the annual verification, "milk review" is identified on the sampling checklist.

OFFSITE DOSE CALCULATION MANUAL

TABLE 12-1
SAMPLE TYPES AND ASSOCIATED LOWER LEVEL OF DETECTION (LLD) AND
NOTIFICATION LEVEL VALUES

SAMPLE TYPE	REPORTING UNIT	PARAMETER	LLD ¹	NOTIFICATION LEVELS	
				NRC	PBNP ² (ADMIN.)
Vegetation	pCi/g (wet)	Gross beta ⁵	0.25	---	60
		Cs-137	0.08	2	0.40
		Cs-134	0.06	1	0.20
		I-131	0.06	0.1	0.06
		Other ³	0.25	---	2.0
Shoreline Sediment and Soil ⁵	pCi/g (dry)	Gross beta	2.0	---	100
		Cs-137/134	0.15/0.18	---	20
		Other ³	0.15	---	20
Algae ⁵	pCi/g (wet)	Gross beta	0.25	---	12
		Cs-137	0.25	10	1
		Cs-134	0.25	10	1
		Co-58	0.25	10	1
		Co-60	0.25	10	1
		Other ³	0.25	---	1
Fish	pCi/g (wet)	Gross beta ⁵	0.5	---	125
		Cs-137	0.15	2	0.40
		Cs-134	0.13	1	0.20
		Co-58	0.13	30	3
		Co-60	0.13	10	1
		Mn-54	0.13	30	3
		Fe-59	0.26	10	1
		Zn-65	0.26	20	2
		Other ³	0.5	---	6
Milk	pCi/L	Sr-89 ⁵	5	---	100
		Sr-90 ⁵	1	---	100
		I-131	0.5 ⁷	3	0.5
		Cs-134	15 (5)	60	15
		Cs-137	18 (5)	70	18
		Ba-La-140	15 (5)	300	30
		Other ³	15	---	30
Air Filter ⁶	pCi/m ³	Gross beta	0.01	---	1.0
		I-131	0.07 (0.03)	0.9	0.09
		Cs-137	0.06	20	2.0
		Cs-134	0.05	10	1.0
		Other ³	0.1	---	1.0
TLDs	mR/7 days	Gamma	1mR/TLD	---	5mR/7 days

TABLE 12-1
SAMPLE TYPES AND ASSOCIATED LOWER LEVEL OF DETECTION (LLD) AND
NOTIFICATION LEVEL VALUES

SAMPLE TYPE	REPORTING UNIT	PARAMETER	LLD ¹	NOTIFICATION LEVELS	
				NRC	PBNP ² (ADMIN.)
Lakewater ⁴ and Well Water	pCi/L from Total Solids	Gross beta ⁵	4	---	100
	pCi/L	Cs-134	15 (10)	30	15
		Cs-137	18 (10)	50	18
		Fe-59	30	400	40
		Zn-65	30	300	30
		Zr-Nb-95	15	400	40
		Ba-La-140	15	200	20
		Co-58	15 (10)	1,000	100
		Co-60	15 (10)	300	30
		Mn-54	15 (10)	1,000	100
		I-131	1 (0.5)	2	2
		Other ³	30	---	100
		H-3 ⁴ (Lakewater)	3,000 (200)	30,000	3,000
		H-3 (Well Water)	2,000 (200)	20,000	3,000
		Sr-89 ⁵	10 (5)	---	50
Sr-90 ⁵	2 (1)	---	20		

NOTE 1: The LLDs in this column are the maximum acceptable values. The values in parentheses are the administrative LLDs.

NOTE 2: Values in this column are not technical specifications

NOTE 3: "Other" refers to non-specified identifiable gamma emitters resulting from the operation of PBNP. Naturally occurring radionuclides are not included.

NOTE 4: No drinking water

NOTE 5: Items not required by PBNP RETS (10-3-1985) or NUREG-1301 but kept in the REMP for comparison to pre-operational and historical data.

NOTE 6: All particulate filters shall be allowed to decay for at least 24 hours after sampling to allow for radon and radon-daughter decay prior to gross β analysis.

NOTE 7: Lower than NUREG-1301 value 1 pCi/L to support PBNP's sampling frequency.

TABLE 12-2
RADIOLOGICAL ENVIRONMENTAL SAMPLING LOCATIONS

LOCATION CODE	LOCATION DESCRIPTION
E-01	Primary Meteorological Tower, South of the plant
E-02	Site Boundary Control Center - East Side of Building
E-03	Tapawingo Road, about 0.4 Miles West of Lakeshore Road
E-04	North Boundary
E-05	Two Creeks Park, the TLD is on South side of Two Creeks Road, West of Lakeshore Road on first pole West of Lakeshore.
E-06	Point Beach State Park - Water and shoreline sediment samples at the Coast Guard Station; soil and vegetation from the Point Beach State Park campground area N of the Coast Guard Station and on the West side of County Road O; TLD located South of lighthouse on telephone pole.
E-07	WPSC Substation on County Rt. V, about 0.5 Miles West of Hwy. 42
E-08	G. J. Francar Property, at the SE Corner of the Intersection of Cty. B and Zander Road
E-09	Nature Conservancy, East side of Hwy 42. Corner of Hwy 42 and Cty. BB. On pole North side of Entrance.
E-10	PBNP Site Well
E-11	Lambert Dairy Farm, 1523 Tapawingo Road, 0.5 miles West of Saxonburg Road
E-12	Discharge Flume / Pier, U-1 side
E-13	Pumphouse
E-14	South Boundary, about 0.2 miles East of Site Boundary Control Center
E-15	SW Corner of Site, N side of Nuclear Rd at junction with Twin Elder Rd.
E-16b	Pole #2124 23L17, Third pole (beside white underground cable post) N of old E-16 pole at residence 14427 Hwy 42
E-17	North of Mishicot, Cty. B and Assman Road, NE Corner of Intersection
E-18	NW of Two Creeks at Zander and Tannery Roads
E-20	Reference Location, 17 miles SW, at Silver Lake College
E-21	Local Dairy Farm just South of Site (R. Strutz) on Lakeshore and Irish Roads
E-22	West Side of Hwy. 42, about 0.25 miles North of Johaneck Road
E-23	Greenfield Lane, about 4.5 Miles South of Site, 0.5 Miles East of Hwy. 42
E-24	North Side of County Rt. V, near intersection of Saxonburg Road
E-25	South Side of County Rt. BB, about 0.5 miles West of Norman/Saxonberg Road

TABLE 12-2
RADIOLOGICAL ENVIRONMENTAL SAMPLING LOCATIONS

LOCATION CODE	LOCATION DESCRIPTION
E-26b	804 Tapawingo Road, Pole #2124 18L17, Second Pole East of Cty. B. North Side of Road
E-27	NE corner of Saxonburg and Nuclear Roads, about 4 Miles WSW
E-28	TLD on westernmost pole between the 2nd and 3rd parking lots,
E-29	On microwave tower fence
E-30	NE corner at Intersection of Tapawingo and Lakeshore Roads.
E-31	On utility pole North side of Tapawingo Road closest to the gate at the West property line
E-32	On a conduit/pole located near the junction of property lines, about 500 feet east of the west gate in line with first designated treeline on Tapawingo Road and about 1200 feet south of Tapawingo Road. The location is almost under the power lines between the blue and gray transmission towers. (The conduit/pole is about 6 feet high).
E-33	Lake Michigan shoreline accessed from area just S of KPS discharge.
E-38	On tree West of former Retention Pond site
E-39	On tree East of former Retention Pond site
E-40	Local Dairy Farm (Barta), about 1.8 miles north of intersection of Highway 42 and Nuclear Road (Manitowoc County), on West side of Highway 42.
E-41	NW corner of Woodside and Nuclear Roads (Kewaunee Co.)
E-42	NW corner of Church and Division, East of Mishicot
E-43	West Side of Tannery Road South of Elmwood (7th pole South of Elmwood)
E-TC	Transportation Control; Reserved for TLDs
E-F1a	Field ENE of E-14
E-F1b	Field immediately N of SBCC
E-F2	Field NW corner of Nuclear Rd and Lakeshore Rd, 200' W of Lakeshore Rd
E-F3	Field approximately 400 ft. E of E-15
E-F4	Field approximately 600 ft. W of Lakeshore Rd
E-F5	Field approximately 600 ft. W of Lakeshore Rd
E-F6	Field approximately 600 ft. W of Lakeshore Rd (West of marshy area)
E-F7	Field N of ISFSI and W of Lakeshore Rd, approximately 600 ft. W of Lakeshore Rd
E-F8	Field approximately 400 ft. NE of E-31
E-F9	Field approximately 1000 ft. W of E-04

OFFSITE DOSE CALCULATION MANUAL

TABLE 12-3
PBNP RADIOLOGICAL ENVIRONMENTAL SAMPLE COLLECTION AND ANALYSIS
FREQUENCY

SAMPLE TYPE	SAMPLE CODES	ANALYSES	FREQUENCY
Environmental Radiation Exposure	E-01, -02, -03, -04, -05, -06, -07, -08, -09, -12, -14, -15, -16, -17, -18, -20, -22, -23, -24, -25, -26, -27, -28, -29, -30, -31, -32, -38, -39, -41, -42, -43, -TC	TLD	Quarterly
Vegetation (Grass and Weeds)	E-01, -02, -03, -04, -06, -08, -09, -20,	Gross beta	3x/yr as available
		Gamma isotopic	
Vegetation (Crops)	E-F1a, -F1b, -F2, -F3, -F4, -F5, -F6, -F7, -F8, -F9	Gamma isotopic analysis	1x/yr as available
Algae	E-05, -12	Gross beta	3x/yr as available
		Gamma isotopic	
Fish (edible portions only)	E-13	Gross beta	2x/yr as available
		Gamma isotopic	
Well Water	E-10	Gross beta, H-3	Quarterly
		Sr-89, 90, I-131	
		Gamma isotopic	
Lake Water	E-01, -05, -06, -33	Gross beta	Monthly
		H-3, Sr-89, 90	Quarterly composite of monthly collections
		I-131	Monthly
		Gamma isotopic	Monthly
Milk	E-11, -21, -40	Sr-89, 90	Monthly
		I-131	
		Gamma isotopic	
Air Filters	E-01, -02, -03, -04, -08, -20	Gross beta	Weekly (particulate)
		I-131	Weekly (charcoal)
		Gamma isotopic	Quarterly (on composite particulate filters)
Soil	E-01, -02, -03, -04, -06, -08, -09, -20,	Gross beta	2x/yr
		Gamma isotopic	
Shoreline Sediment	E-01, -05, -06, -12, -33	Gross beta	2x/yr
		Gamma isotopic Analysis	

FIGURE 12-1
RADIOACTIVE ENVIRONMENTAL SAMPLING LOCATIONS

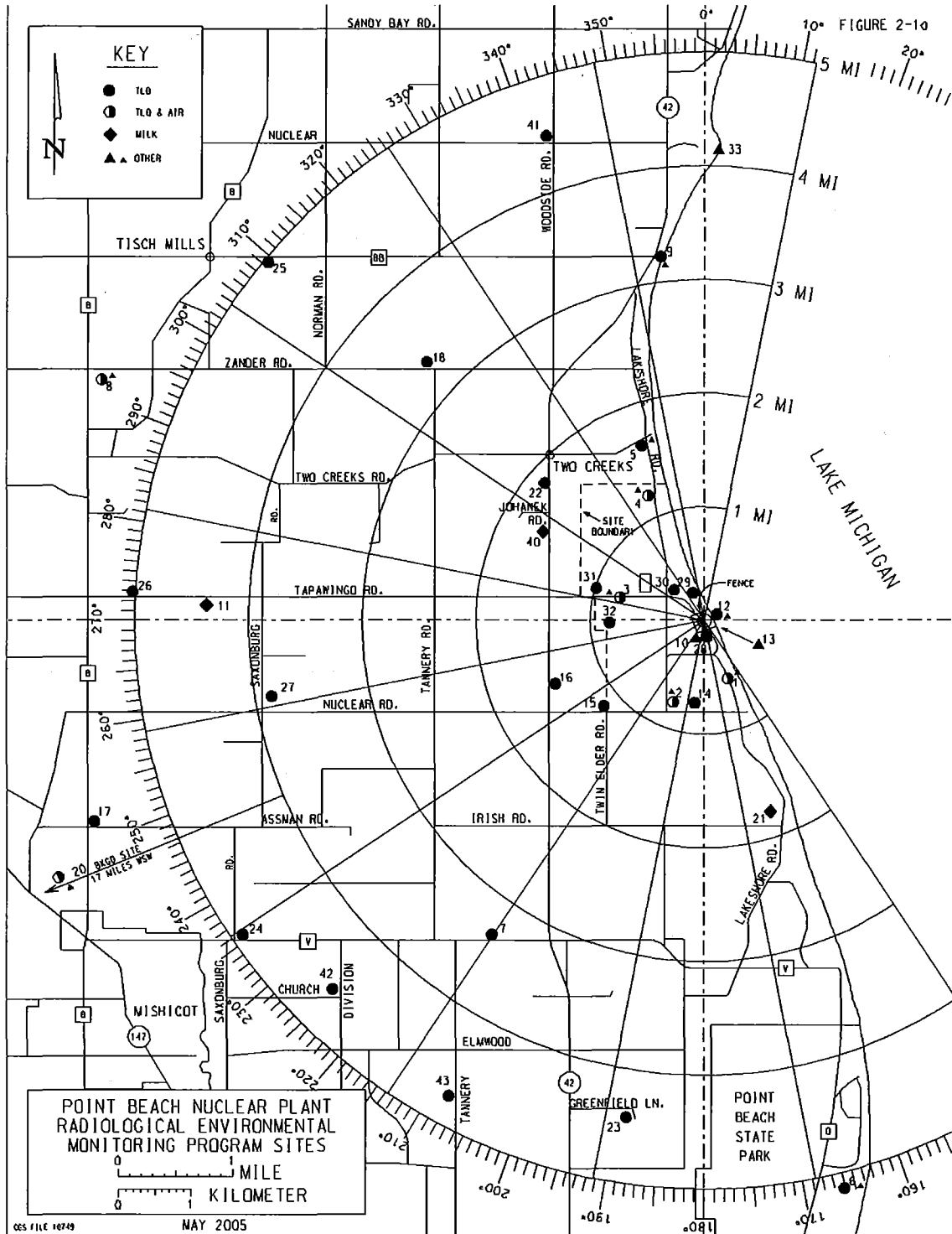

FIGURE 12-2
 RADIOLOGICAL ENVIRONMENTAL SAMPLING LOCATIONS

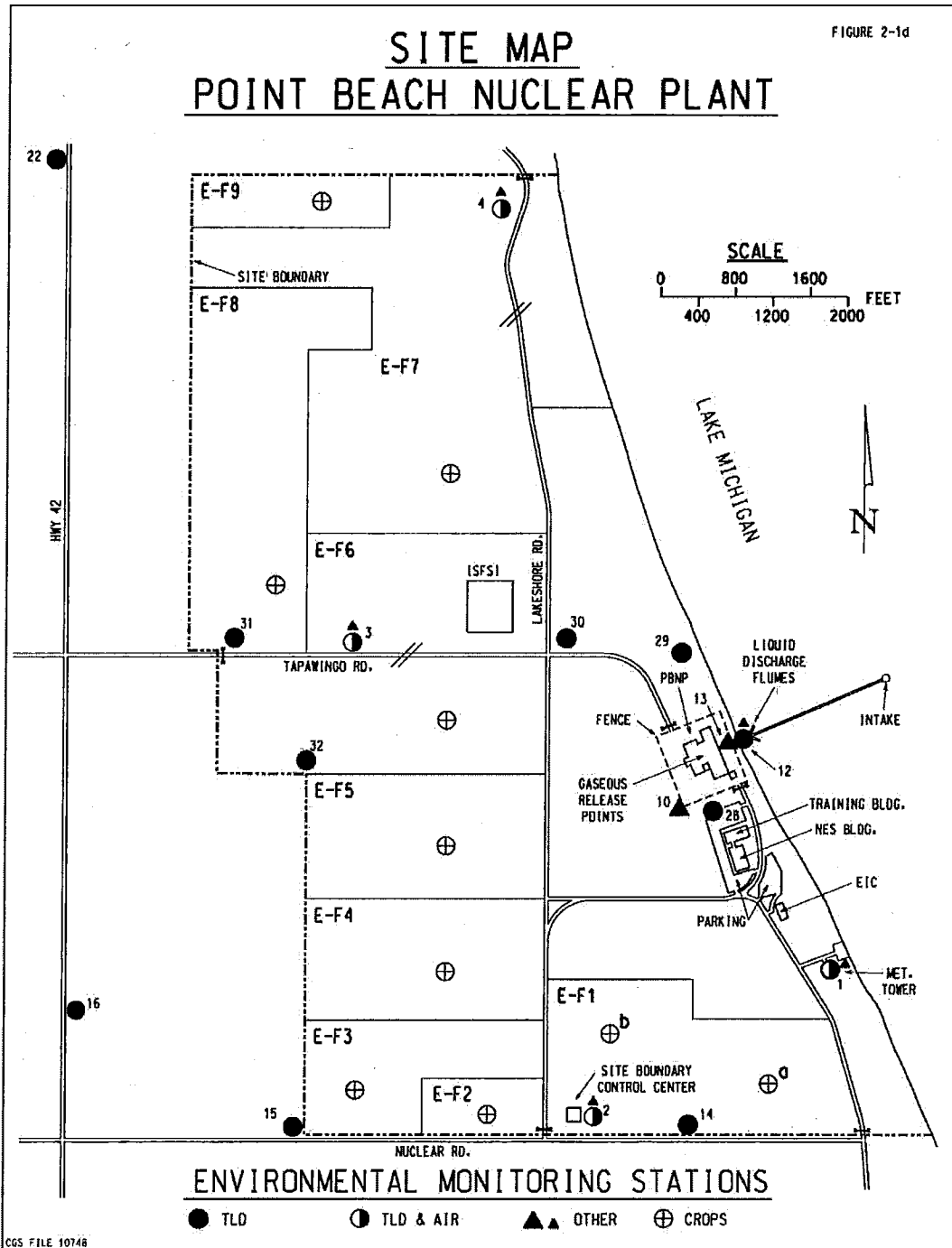
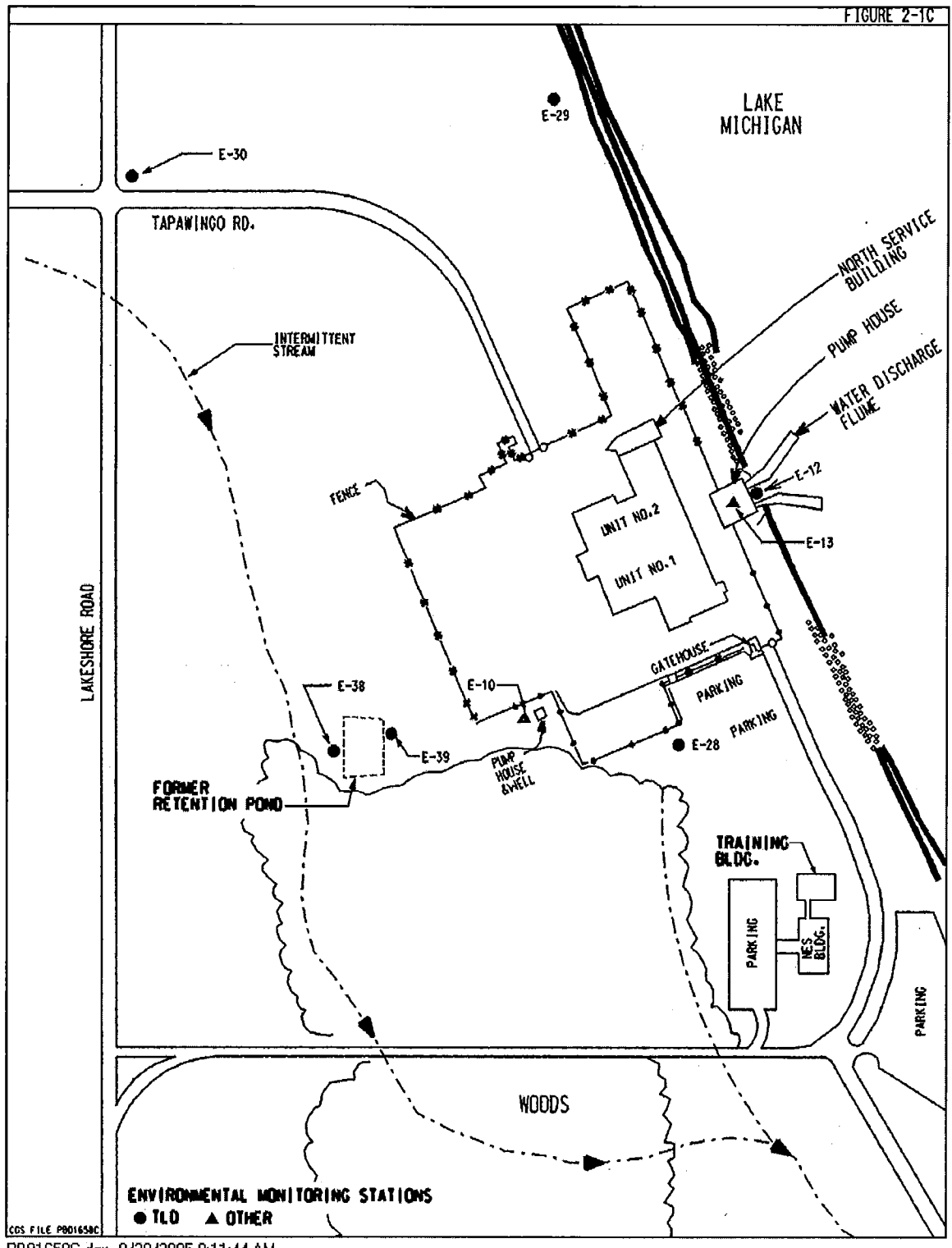

FIGURE 12-3
RADIOLOGICAL ENVIRONMENTAL SAMPLING LOCATIONS



OFFSITE DOSE CALCULATION MANUAL

13.0 RADIOLOGICAL EFFLUENT CONTROLS PROGRAM

13.1 Radiological Effluent Controls Program

13.1.1 Basis

The Radiological Effluent Control Program (RECP) shall conform to 10 CFR 50.36a for the control of radioactive effluents and maintaining doses to members of the public from radioactive effluents as low as reasonably achievable (ALARA). The RECP also is established to control the amount and concentrations of radioactivity in PBNP effluent pursuant to the following documents:

- 10 CFR 50.34a-Design objectives for equipment to control releases of radioactive material in effluents-nuclear power reactors,
- 10 CFR 50, Appendix A, Criterion 60-Control of releases of radioactive material to the environment,
- 10 CFR 50, Appendix A, Criterion 63-Monitoring fuel and waste storage,
- 10 CFR 50, Appendix A, Criterion 64-Monitoring radioactivity releases,
- 10 CFR 20.1302-Compliance with dose limits for individual members of the public,
- 10 CFR 20.1501-General,
- PBNP General Design Criterion 17-Monitoring Radioactivity Releases, and
- PBNP General Design Criterion 70-Control of releases of radioactivity to the environment

13.1.2 Basis Statement

Liquid effluent from the radioactive waste disposal system is diluted by the circulating water system prior to release to Lake Michigan. With two pumps operating per unit, the flow of the circulating water system is approximately 390,000 gpm per unit. Operation of a single circulating water pump per unit reduces the nominal flow rate by about 35%. Liquid waste from the waste disposal system may be discharged to the circulating water system of either unit via the service water return header. Because of the low radioactivity levels in the circulating water discharge, the concentrations of liquid radioactive effluents at this point are not measured directly. Instead, the concentrations in the circulating water discharge are calculated from the measured concentration of the liquid effluent, the discharge flow rate of the effluent and the nominal flow in the circulating water system.

The release of radioactive materials in liquid effluents to unrestricted areas is monitored and controlled to conform to the dose objectives in Section II.A of Appendix I to 10 CFR 50 and will be ALARA in accordance with the requirements of 10 CFR Parts 50.34a and 50.36a. The monitoring and control also is undertaken to keep the concentrations of radionuclides in PBNP liquid effluent released to unrestricted areas conforming to ten times the maximum effluent concentration (MEC) values specified in Table 2, Column 2 of Appendix B to 10 CFR 20. Furthermore, the appropriate portions of the liquid radwaste treatment systems will be used as required to keep the releases ALARA.

These actions provide reasonable assurance that the resulting average annual dose or dose commitment from liquid effluent from each unit of the Point Beach Nuclear Plant for any individual in an unrestricted area from all pathways of exposure will not exceed the 10 CFR 50, Appendix I dose objectives. Thus, discharge of liquid wastes not exceeding these release limits will not result in significant exposure to members of the public because of consumption of drinking water from the lake, even if the effect of potable water treatment systems on reducing radioactive concentrations of the water supply is conservatively neglected.

Prior to release to the atmosphere, gaseous wastes are mixed in the auxiliary building vent with the flow from at least one of two auxiliary building exhaust fans. Further dilution then occurs in the atmosphere. Release of radionuclides to the atmosphere is monitored and controlled so that effluents to unrestricted areas conform to the dose objectives of Sections II.B and C of Appendix I to 10 CFR 50. Monitoring and control also is undertaken to ensure that at the point of maximum ground concentration at the site boundary, the radionuclide concentrations in the atmosphere will conform to the limits specified in Table 2, Column 1 of Appendix B to 10 CFR 20. Furthermore, the appropriate portions of the gaseous radwaste treatment system are used as required to keep the radioactive releases to the atmosphere ALARA.

In order to achieve the dose objectives of Appendix I to 10 CFR 50 and the aforementioned concentration limits, the setpoints for releases to the atmosphere and to Lake Michigan utilize the methodology found in the Offsite Dose Calculation Manual. Setpoints for releases to the atmosphere are based on conforming to the TS instantaneous dose rate limits using the dilution provided by building vents as well as the highest annual average χ/Q at the site boundary. Setpoints for releases to Lake Michigan are based only on dilution by circulation water. Together, control and monitoring provide reasonable assurance that the annual dose from each unit's effluents, to an individual in an unrestricted area will not exceed the dose objectives of Appendix I to 10 CFR 50.

OFFSITE DOSE CALCULATION MANUAL

Implementation of the RECP will keep average annual releases of radioactive material in PBNP effluents and their resultant committed effective dose equivalents at small percentages of the dose limits specified in 10 CFR 20.1301. At the same time, the methodology of implementing the RECP permits the flexibility of operation, compatible with considerations of health and safety, to assure that the public is provided with a dependable source of power even under unusual operating conditions which may temporarily result in releases higher than such numerical guides for design objectives set forth in Appendix I but still within levels that assure that the average population exposure is equivalent to small fractions of doses from natural background radiation.

Compliance with the provisions of Appendix I to 10 CFR Part 50 constitutes adequate demonstration of conformance to the standards set forth in 40 CFR Part 190 regarding the dose commitment to individuals from the uranium fuel cycle.

13.1.3 Other RECP Reportable Events

a. Radioactive Effluent Non-Treatment

If the effluent treatment system for radioactive liquids or for releases to the atmosphere is non-functional and effluents are being discharged for 31 consecutive days without the treatment required to meet the release limits specified in Section 6.1 and Section 7.1, a special report shall be prepared and submitted to the Commission within thirty days which includes the following information:

1. Identification of the non-functional equipment or subsystem and the reason for non-functionality.
2. Actions taken to restore the non-functional equipment to FUNCTIONAL status.
3. Summary description of actions taken to prevent a recurrence.

b. Exceeding Radioactive Effluent Release Limits

If the quantity of radioactive material actually released in liquid or gaseous effluents during any calendar quarter exceeds twice the quarterly limit as specified in Sections 6.2, 7.2 or 7.3, a special report shall be prepared and submitted to the Commission within thirty days of determination of the release quantity.

OFFSITE DOSE CALCULATION MANUAL

The report must describe the extent of exposure of individuals to radiation and radioactive material, including as appropriate:

1. corrective action(s) to be taken to reduce subsequent releases to prevent recurrence of exceeding the limits, including the schedule for achieving conformance with applicable limits, ALARA constraints, generally applicable environmental standards, and associated license conditions,
2. estimates of exposures to a member of the public, including the dose from any external storage units, such as the ISFSI and the SGSF, for compliance with 40 CFR 190 limits,
3. levels of radiation and concentrations of radioactive materials involved, and
4. cause of the elevated exposures, dose rates, or concentrations.

If the dose to any member of the public exceeds 75 mrem to the thyroid or 25 mrem to the whole body or any organ other than the thyroid, pursuant to 40 CFR 190, the report shall also contain a request for a variance from this standard pursuant to 40 CFR 190.11.

c. Major Change to Radioactive Liquid, Gaseous and Solid Waste Treatment Systems

Licensee initiated major changes to the radioactive waste treatment systems (liquid, gaseous, and solid) shall be reported to the U.S. Nuclear Regulatory Commission with the periodic update to the FSAR for the period for which the updates are submitted. The discussion of each change shall include:

1. A summary of the evaluation that led to the determination that the change could be made in accordance with 10 CFR Part 50.59;
2. Information necessary to support the reason for the change;
3. A description of the equipment, components and processes involved and the interfaces with other plant systems;
4. An evaluation of the change, which shows how the predicted releases of radioactive materials in liquid effluents and gaseous effluents and/or quantity of solid waste will differ from those previously predicted in the license application and amendments thereto;

OFFSITE DOSE CALCULATION MANUAL

5. An evaluation of the change, which shows the expected maximum exposures to an individual in the unrestricted area and to the general population that differ from those previously estimated in the license application and amendments thereto;
6. An estimate of the exposure to plant operating personnel because of the change

d. Audits

The activities of the Radiological Effluent Controls Program as described in this manual and its implementing procedures shall be audited in accordance with Section 2.4.

13.2 Radioactive Effluent Control and Accountability

13.2.1 Radiation Monitoring System

a. Description

The computerized Radiation Monitoring System (RMS) at Point Beach Nuclear Plant consists of area and process monitors. The effluent monitors are those process monitors that are designed to detect and measure radioactivity in liquid and gaseous releases from PBNP. A description of the liquid and gaseous effluent monitors and associated isolation and control functions are presented in ODCM Sections 9.1 and 10.1.

b. Calibration

Calibration of the RMS detectors is accomplished according to the PBNP instrument and control procedures.

c. Setpoints

The methodology for determining effluent RMS detector setpoints is described in the ODCM Sections 9.1 and 10.1.

d. Alarms

Response to alarms received from RMS effluent detectors is described in the PBNP RMS Alarm Setpoint and Response Book.

e. Effluent Detector Functionality and Surveillance

Detector functionality and surveillance requirements are addressed in Sections 6.0 and 7.0 of this manual.

13.2.2 Release Accountability

Control and accountability of radioactivity in PBNP effluents is accomplished by the RMS in conjunction with the characterization of radionuclide distributions by laboratory analyses of grab samples from the various waste streams. Sampling frequencies and analysis requirements are set forth in Sections 6.1.4 and 7.1.4 of this manual. Additional aspects of grab sampling and release accountability are described in the PBNP Release Accountability Manual

13.3 Radioactive Effluent Monitoring Instrumentation Functionality Requirements

13.3.1 Objective

The functionality of detectors is specified in order to ensure that liquid and gaseous radioactive effluents are adequately monitored and to ensure that alarm or trip setpoints are established such that effluent releases do not exceed the values cited in Sections 6.1.1, 6.2.1, 7.1.1, 7.2.1, 7.3.1 and 8.1.

13.3.2 Functionality Specifications

- a. The radioactive effluent monitoring instrumentation channels listed in Table 6-2 and Table 7-2 shall be functional. The alarm or trip setpoints of these channels shall be determined and adjusted in accordance with the methodology and parameters in the ODCM.
 1. All monitors are defined by the term FUNCTIONAL – FUNCTIONALITY, EXCEPT 1(2) RE-212 Containment Noble Gas Monitor which is defined by the term OPERABLE – OPERABILITY.
 2. **IF** the ability of 1(2) RE-212, Containment Noble Gas Monitor, to perform its function is questioned, **THEN** the Operability Determination process is applicable. (LCO 3.4.15, RCS Leakage Detection Instrumentation)
- b. If fewer than the minimum number of radioactive effluent monitoring channels are functional, the action statement listed in either Table 6-2 or Table 7-2 shall be taken. Best effort shall be made to return a non-functional channel to functional status within 30 days.
- c. If the channel is not returned to a functional status within 30 days, the circumstances of the instrument failure and schedule for repair shall be reported to the NRC Resident Inspector.

- d. If a radioactive effluent monitoring instrumentation channel alarm or trip setpoint is found less conservative than required by the ODCM, the channel shall be declared non-functional
OR the setpoint shall be changed to the ODCM value or a more conservative value.

13.4 Solid Radioactive Waste

The solid radwaste system shall be used in accordance with the Process Control Program to process radioactive wastes to meet all shipping and burial ground requirements. If the provisions of the Process Control Program are not satisfied, shipments of defectively processed or defectively packaged radioactive waste from the site will be suspended. The Process Control Program shall be used to verify solidification of radwaste.

OFFSITE DOSE CALCULATION MANUAL

14.0 REFERENCES

- 14.1 10 CFR Part 50, "Domestic Licensing of Production and Utilization Facilities," U.S. Nuclear Regulatory Commission, Washington DC.
- 14.2 Regulatory Guide 1.109, "Calculation of Annual Doses to Man from Routine Releases of Reactor Effluents for the Purpose of Demonstrating Compliance with 10 CFR Part 50, Appendix I," U.S. Nuclear Regulatory Commission, Washington, DC.
- 14.3 Regulatory Guide 1.113, "Estimating Aquatic Dispersion of Effluents from Accidental and Routine Reactor Releases for the Purpose of Implementing Appendix I," U.S. Nuclear Regulatory Commission, Washington, DC.
- 14.4 Regulatory Guide 1.21, "Measuring, Evaluating, and Reporting Radioactive Material in Liquid and Gaseous Effluents and Solid Waste," U.S. Nuclear Regulatory Commission, Washington, DC.
- 14.5 NUREG-0133, "Preparation of Radiological Effluent Technical Specifications for Nuclear Power Plants," October 1978.
- 14.6 NUREG-1301, "Offsite Dose Calculation Manual Guidance: Standard Radiological Effluent Controls for Pressurized Water Reactors," April 1991.
- 14.7 EPRI Technical Report 1021106 "Estimation of Carbon-14 in Nuclear Power Plant Gaseous Effluents", 2010.
- 14.8 Report No. R-2330244-001, Point Beach Annual Meteorological and Atmospheric Dispersion Report for 2009, December 2010.
- 14.9 Regulatory Guide 4.1, "Radiological Environmental Monitoring for Nuclear Power Plants," June 2008, Rev. 2, USNRC, Washington, DC.

NOTE: The NRC documents (references 14.2 - 14.6, and 14.9) are presented for informational purposes and do not constitute a NextEra Energy Point Beach commitment to these documents.

APPENDIX A
LIQUID PATHWAY EMEC FOR USE IN SETPOINT CALCULATIONS

The effective maximum effluent concentration (EMEC) is calculated from the annual liquid releases for the years 2000 through 2010 (Table A-1). The EMEC is the total concentration of radionuclides which can be discharged without having the summation of concentration fractions exceed unity. To obtain this value, the average annual total radionuclide concentration is divided by the sum of the ratio of each average individual radionuclide concentration divided by 10x its maximum effluent concentration listed in 10CFR20, Appendix B, Table 2, Col 2. The EMEC formula (Equation 9-3) is:

$$EMEC = \frac{\sum C_i}{\sum \frac{C_i}{MEC_i}} \text{ or } EMEC = \frac{\sum C_i}{SOF} \quad [A-1]$$

Where: *SOF* = Sum of fractions
C_i = Annual average concentration of radionuclide "i"
MEC_i = 10x the maximum effluent concentration from 10CFR20, Appendix B, Table 2, Column 2. Also referred to as the Effluent Concentration Limit (ECL)

The 2000 – 2010 liquid effluent data are used for calculating the annual averages and EMEC (see Table A-1). C-14, Ni-63 and Tc-99 were added to the analytical requirements for liquid wastes in 2009, so each of these three radionuclides is averaged only over the two years of available data.

The annual average concentration is based on the volume for all of the eleven years. In calculating the annual average concentrations, the annual liquid waste effluent volumes were not used because they were four orders of magnitude lower than the dilution volume and would have but a minor effect on the resulting concentrations.

The calculated value for the EMEC is 9.89E-03 μCi/cc. The NaI detectors do not measure pure β-emitters such as H-3, C-14, Fe-55, Ni-63, Sr-90, and Tc-99. Therefore, a β-correction factor (βCF) is used to correct for these radionuclides to correct for these isotopes not being detected by the monitors. Additional conservatism is realized when calculating individual liquid effluent monitor setpoints because the minimum dilution flow is used. PBNP technical specifications allow liquid discharge concentrations at ten times the concentrations set forth in 10CFR20, Appendix B, Table 2, Column 2.

The EMEC is the maximum concentration allowed at the point of discharge. Therefore, in addition to a βCF, a dilution scaling factor (SF) is applied to determine the monitor setpoint which is the maximum allowable discharge concentration. The SF is the ratio of the circ water flow rate (CW) to the release rate (RR) [ODCM formula 9-5]. Therefore the SP = EMEC * SF * βCF. The SF is calculated from the minimum circ water flow (243,000 gpm) and the maximum effluent release rate (Table 9-1).

OFFSITE DOSE CALCULATION MANUAL

TABLE A-1
LIQUID EFFLUENT VOLUMES

	2000	2001	2002	2003	2004	2005	2006	2007	2008	2009	2010	TOTAL	AVE.
Discharge Vol. (cc)	4.94E+11	4.15E+11	4.72E+11	3.96E+11	4.15E+11	3.59E+11	3.77E+11	3.84E+11	4.12E+11	4.80E+11	6.24E+11	4.83E+12	4.39E+11
Dilution Vol. (cc)	1.06E+15	1.04E+15	1.03E+15	1.00E+15	1.04E+15	8.64E+14	1.12E+15	1.10E+15	1.70E+15	1.07E+15	1.11E+15	1.21E+16	1.103E+15

TABLE A-2
LIQUID EFFLUENT RELEASES

	MEC (μ Ci/cc)	2000 (Ci/yr)	2001 (Ci/yr)	2002 (Ci/yr)	2003 (Ci/yr)	2004 (Ci/yr)	2005 (Ci/yr)	2006 (Ci/yr)	2007 (Ci/yr)	2008 (Ci/yr)	2009 (Ci/yr)	2010 (Ci/yr)	Total (Ci)	Ave. (Ci/yr)
H-3	1.00E-03	8.04E+02	5.88E+02	5.60E+02	7.48E+02	6.08E+02	5.53E+02	6.07E+02	5.88E+02	5.34E+02	6.37E+02	5.59E+02	6.79E+03	6.17E+02
C-14	3.00E-05										1.97E-02	3.39E-03	2.31E-02	1.15E-02
F-18	7.00E-04	2.26E-04	9.90E-04	3.31E-04	1.08E-03	1.30E-03	1.20E-03	2.52E-03	2.45E-03	1.97E-03	3.81E-03	5.66E-03	2.15E-02	1.96E-03
Na-22	6.00E-06										5.58E-06		5.58E-06	5.07E-07
Na-24	5.00E-05									5.50E-06			5.50E-06	5.00E-07
Cr-51	5.00E-04	8.24E-03	9.08E-03	1.41E-02	8.23E-03	4.25E-04	2.55E-03	7.82E-03	3.10E-03	2.06E-02	8.63E-03	4.88E-03	8.77E-02	7.97E-03
Mn-54	3.00E-05	4.53E-04	1.52E-03	4.42E-04	1.06E-03	1.21E-04	6.97E-04	4.39E-04	1.24E-04	6.62E-04	9.10E-04	1.42E-04	6.57E-03	5.97E-04
Mn-56	7.00E-05							1.92E-06					1.92E-06	1.75E-07
Fe-55	1.00E-04	1.12E-02	8.80E-03	6.82E-03	7.21E-03	3.85E-03	3.23E-03	3.06E-03	6.22E-03	5.50E-03	4.62E-03	4.92E-03	6.54E-02	5.95E-03
Fe-59	1.00E-05	1.23E-04	2.18E-04	1.85E-03	3.11E-04	5.61E-05	1.04E-05	1.09E-04	1.93E-04	5.21E-04	1.49E-04	3.66E-04	3.91E-03	3.55E-04
Ni-63	1.00E-04										9.94E-03	2.26E-03	1.22E-02	6.10E-03
Co-57	6.00E-05	1.29E-04	1.03E-03	1.11E-04	1.29E-04	1.06E-05	3.04E-05	5.50E-06		2.72E-04	9.13E-05	5.60E-05	1.86E-03	1.69E-04
Co-58	2.00E-05	5.56E-02	9.01E-02	3.39E-02	1.04E-01	4.12E-03	4.92E-03	3.58E-03	6.26E-03	3.70E-02	1.36E-02	4.28E-02	3.96E-01	3.60E-02
Co-60	3.00E-06	7.33E-03	1.35E-02	3.61E-03	1.27E-02	2.13E-03	8.02E-03	9.94E-03	5.45E-03	1.10E-02	2.17E-02	3.96E-03	9.93E-02	9.03E-03
Zn-65	5.00E-06	1.44E-04	1.76E-04	4.57E-05	6.35E-05	3.73E-06	8.13E-05	4.38E-05	4.62E-06	1.55E-04	3.50E-04	9.33E-06	1.08E-03	9.79E-05
As-76	1.00E-05				2.07E-05	1.27E-05	1.97E-05	1.84E-05	1.99E-05	7.09E-06	9.33E-05	8.59E-09	1.92E-04	1.74E-05
Sr-89	8.00E-06	3.41E-06									7.69E-05		8.03E-05	7.30E-06
Sr-90	5.00E-07	3.04E-04	8.79E-05	2.14E-04	1.57E-05			1.71E-06	9.36E-05	1.03E-05	1.95E-05		7.47E-04	6.79E-05
Sr-92	4.00E-05		1.36E-06	4.25E-05	5.54E-06						1.76E-06	1.61E-06	5.27E-05	4.79E-06
Nb-95	3.00E-05	1.07E-03	3.86E-03	1.67E-03	1.73E-03	1.83E-04	1.62E-03	9.38E-04	2.71E-04	3.92E-03	1.57E-03	6.09E-04	1.74E-02	1.59E-03
Nb-97	3.00E-04	2.93E-05	1.92E-05	9.20E-06	1.92E-05	1.50E-05	7.07E-06	9.10E-06	1.83E-06	1.50E-05	6.36E-06	1.13E-05	1.43E-04	1.30E-05

OFFSITE DOSE CALCULATION MANUAL

TABLE A-2
LIQUID EFFLUENT RELEASES

	MEC ($\mu\text{Ci/cc}$)	2000 (Ci/yr)	2001 (Ci/yr)	2002 (Ci/yr)	2003 (Ci/yr)	2004 (Ci/yr)	2005 (Ci/yr)	2006 (Ci/yr)	2007 (Ci/yr)	2008 (Ci/yr)	2009 (Ci/yr)	2010 (Ci/yr)	Total (Ci)	Ave. (Ci/yr)
Zr-95	2.00E-05	5.11E-04	1.69E-03	7.02E-03	8.89E-04	5.26E-05	6.85E-04	4.97E-04	4.53E-05	2.12E-03	8.17E-04	3.38E-04	1.47E-02	1.33E-03
Zr-97	9.00E-06		1.65E-06	5.31E-08	7.14E-06	0.00E+00	0.00E+00	2.86E-06				6.67E-06	1.84E-05	1.67E-06
Mo-99	2.00E-05		1.96E-06		8.72E-06								1.07E-05	9.71E-07
Tc-99	6.00E-05										6.46E-04	6.60E-04	1.31E-03	6.53E-04
Tc-99m	1.00E-03		6.34E-06		8.45E-06								1.48E-05	1.34E-06
Ru-103	3.00E-05			9.58E-06					2.68E-06	2.05E-05			3.28E-05	2.98E-06
Ru-105	7.00E-05			1.68E-05									1.68E-05	1.52E-06
Ru-106	3.00E-06			2.31E-05	3.13E-05				2.49E-04				3.03E-04	2.76E-05
Ag-110m	6.00E-06	2.92E-03	4.66E-03	2.80E-03	3.85E-03	5.45E-04	3.29E-03	2.46E-03	4.74E-03	2.67E-03	1.06E-03	2.95E-03	3.19E-02	2.90E-03
Sn-113	3.00E-05	1.20E-04	3.51E-04	6.91E-04	4.17E-04	3.23E-05	1.64E-04	7.81E-05	1.17E-04	1.22E-03	4.34E-04	2.88E-04	3.91E-03	3.56E-04
Sn-117m	3.00E-05	3.47E-04	5.83E-04	1.32E-03	1.45E-03	1.29E-03	2.45E-03	1.24E-03	2.27E-03	4.34E-03	3.68E-03	1.70E-03	2.07E-02	1.88E-03
Sb-122	1.00E-05	5.90E-06		3.14E-06	4.25E-06		5.75E-06	3.49E-06	1.33E-05		5.66E-07		3.64E-05	3.31E-06
Sb-124	7.00E-06	2.03E-04	4.31E-04	6.09E-04	4.71E-04	1.76E-03	4.76E-05	2.01E-04	2.90E-04	1.20E-03	7.59E-04	1.06E-03	7.03E-03	6.39E-04
Sb-125	3.00E-05	5.70E-03	6.65E-04	2.06E-03	1.30E-02	6.69E-03	2.40E-02	9.15E-04	4.88E-02	2.64E-02	8.90E-03	1.57E-03	1.39E-01	1.26E-02
Te-131	8.00E-05							3.49E-06					3.49E-06	3.17E-07
Te-132	9.00E-06	2.73E-05		3.73E-05	1.17E-04	1.07E-05			2.32E-05	1.38E-05			2.29E-04	2.09E-05
I-131	1.00E-06	1.65E-04		9.30E-05	1.97E-06	2.50E-06			3.74E-05	9.32E-07		1.21E-05	3.13E-04	2.85E-05
I-132	1.00E-04									1.10E-05			1.10E-05	1.00E-06
I-133	7.00E-06	2.68E-06					1.74E-05	4.22E-05	2.06E-05	1.53E-06		2.10E-05	1.05E-04	9.58E-06
Cs-134	9.00E-07							2.70E-06					2.70E-06	2.45E-07
Cs-134m	2.00E-03			4.09E-06									4.09E-06	3.72E-07
Cs-136	6.00E-06	1.73E-05	1.60E-05	6.94E-06	6.83E-06		1.51E-06				5.67E-06	2.42E-06	5.67E-05	5.15E-06
Cs-137	1.00E-06	9.15E-04	9.31E-05	2.84E-05	7.83E-05	3.57E-05	2.62E-04	5.13E-04	1.04E-04	9.35E-05	2.45E-03	1.17E-05	4.58E-03	4.16E-04
Ba-139	2.00E-04	5.37E-07											5.37E-07	4.88E-08
Ba-140	8.00E-06		9.31E-06					3.66E-05	1.79E-05				6.38E-05	5.80E-06
La-140	9.00E-06	1.45E-04		8.21E-06									1.53E-04	1.39E-05
Ce-141	3.00E-05	0.00E+00	2.18E-06										2.18E-06	1.99E-07
W-187	3.00E-05							1.12E-05					1.12E-05	1.02E-06

TABLE A-3
LIQUID EFFLUENT CONCENTRATIONS
(The pure β emitters are highlighted)

	MEC ($\mu\text{Ci/cc}$)	Ann. Average ($\mu\text{Ci/cc}$)	$C_i/10xMEC_i$
H-3	1.00E-03	5.59E-07	5.59E-05
C-14	3.00E-05	1.05E-11	3.49E-08
F-18	7.00E-04	1.77E-12	2.54E-10
Na-22	6.00E-06	4.60E-16	7.66E-12
Na-24	5.00E-05	4.53E-16	9.07E-13
Cr-51	5.00E-04	7.23E-12	1.45E-09
Mn-54	3.00E-05	5.41E-13	1.80E-09
Mn-56	3.00E-05	1.58E-16	2.26E-13
Fe-55	1.00E-04	5.39E-12	5.39E-09
Fe-59	1.00E-05	3.22E-13	3.22E-09
Ni-63	1.00E-04	5.53E-12	5.53E-09
Co-57	6.00E-05	1.53E-13	2.56E-10
Co-58	2.00E-05	3.26E-11	1.63E-07
Co-60	3.00E-06	8.19E-12	2.73E-07
Zn-65	5.00E-06	8.87E-14	1.77E-09
As-76	1.00E-05	1.58E-14	1.58E-10
Sr-89	8.00E-06	6.62E-15	8.27E-11
Sr-90	5.00E-07	6.16E-14	1.23E-08
Sr-92	4.00E-05	4.35E-15	1.09E-11
Nb-95	3.00E-05	1.44E-12	4.79E-09
Nb-97	3.00E-04	1.18E-14	3.92E-12
Zr-95	2.00E-05	1.21E-12	6.04E-09
Zr-97	9.00E-06	1.51E-15	1.68E-11
Mo-99	2.00E-05	8.80E-16	4.40E-12
Tc-99	6.00E-05	5.92E-13	9.86E-10
Tc-99m	1.00E-03	1.22E-15	1.22E-13
Ru-103	3.00E-05	2.70E-15	9.00E-12
Ru-105	7.00E-05	1.38E-15	1.97E-12
Ru-106	3.00E-06	2.50E-14	8.33E-10
Ag-110m	6.00E-06	2.63E-12	4.39E-08
Sn-113	3.00E-05	3.22E-13	1.07E-09
Sn-117m	3.00E-05	1.70E-12	5.68E-09
Sb-122	1.00E-05	3.00E-15	3.00E-11
Sb-124	7.00E-06	5.80E-13	8.28E-09
Sb-125	3.00E-05	1.14E-11	3.81E-08
Te-131	8.00E-08	2.88E-16	3.60E-13
Te-132	9.00E-06	1.89E-14	2.10E-10
I-131	1.00E-06	2.58E-14	2.58E-09
I-132	1.00E-04	9.07E-16	9.07E-13

TABLE A-3(CONT'D)
LIQUID EFFLUENT CONCENTRATIONS

	MEC ($\mu\text{Ci/cc}$)	Ann. Average ($\mu\text{Ci/cc}$)	$C_i/10xMEC_i$
I-133	7.00E-06	8.69E-15	1.24E-10
Cs-134	9.00E-07	2.23E-16	2.47E-11
Cs-134m	2.00E-03	3.37E-16	1.69E-14
Cs-136	6.00E-06	4.67E-15	7.79E-11
Cs-137	1.00E-06	3.77E-13	3.77E-08
Ba-139	2.00E-04	4.43E-17	2.21E-14
Ba-140	8.00E-06	5.26E-15	6.57E-11
La-140	9.00E-06	1.26E-14	1.40E-10
Ce-141	3.00E-05	1.80E-16	6.00E-13
W-187	3.00E-05	9.23E-16	3.08E-12
TOTAL		5.59E-07	5.66E-05
TOTAL γ		7.07E-11	5.95E-07
Total β		5.59E-07	5.60E-05

The β CF is based on the condition that the total summation of fraction or $\Sigma\text{SOF} \leq 1$. Therefore, at the setpoint, the β and γ SOF fractions of the total SOF (ΣSOF) must satisfy the condition

$$1 = \text{SOF}\beta / \Sigma\text{SOF} + \text{SOF}\gamma / \Sigma\text{SOF}.$$

Because the monitors detect only the gamma fraction of the ΣSOF , the EMEC is multiplied by the ratio $\text{SOF}\gamma / \Sigma\text{SOF}$ which is the β CF. Using the above Table A-3 SOF values, the

$$\beta\text{CF} = \text{SOF}\gamma / \Sigma\text{SOF} = 5.95\text{E-}07 / 5.66\text{E-}05 = 1.05\text{E-}02.$$

TABLE A-4
BETA CORRECTED SETPOINTS

Beta Corrected Set Point = EMEC x SF x β CF			
Monitor	MAX GPM	SF (CW/RR)	β -Corrected SP($\mu\text{Ci/cc}$)
1/2RE-229	22200	1.09E+01	1.14E-03
1/2RE-219/222	200	1.22E+03	1.26E-01
RE-230	700	3.47E+02	3.61E-02
RE-220	700	3.47E+02	3.61E-02
RE-218/223	100	2.43E+03	2.53E-01
1/2RE-216	4000	6.08E+01	6.32E-03

APPENDIX B
LIQUID DOSE FACTORS TECHNICAL BASIS

TECHNICAL BASIS FOR PBNP-SITE-SPECIFIC LIQUID DOSE FACTORS

The site-specific liquid dose factors, presented in Table 9-2, have been extracted from the liquid dose equations outlined in Regulatory Guide 1.109, Section C.1, along with the guidance of NUREG-0133. To obtain the liquid dose factors, all variables specific to each release of liquid effluents have been removed from the liquid dose equations of Regulatory Guide 1.109, Section C.1. These include the dilution flow rate and the average release rate of the effluent. The dose factors for each liquid effluent pathway are calculated using the following equations:

Aquatic Foods (Fish)

$$A_{io} = 114000 \times M_p \times U_{ap} \times \sum_i B_{ip} D_{aio} e^{-\lambda_i t_p} \quad [B-1]$$

- Where:
- A_{io} = Ingestion dose factor to the total body or any organ "o" for radionuclide "i" (mrem/hr per $\mu\text{Ci/mL}$)
 - M_p = the mixing ratio (reciprocal of the dilution factor) at the point of harvest of aquatic food
= 0.1136 (Point of harvest of the fresh fish is taken at a point 1000m downstream. The plume centerline dilution factor at this location is 8.8 using RG 1.113 methodology. The factor of 2 allowed for current reversals was not used. See Appendix E.)
 - U_{ap} = annual fish consumption rate for age group "a" and meat pathway "p" (kg/yr)
= 0 kg/yr for infant
= 6.9 kg/yr for child
= 16 kg/yr for teen
= 21 kg/yr for adult (see RG 1.109, Table E-5 for maximum exposed individual)
 - B_{ip} = the equilibrium bioaccumulation factor for radionuclide "i" in pathway "p", expressed as the ratio of the concentration in biota (in pCi/kg) to the radionuclide concentration in water (pCi/l). (L/kg, see RG 1.109, Table A-1)
 - D_{aio} = ingestion dose factor for age group "a", radionuclide "i" and organ "o", from Reg. Guide 1.109 (mrem/pCi)
 - λ_i = the radioactive decay constant of nuclide "i", in day^{-1}
 - t_p = the average transit time required for nuclides to reach the point of exposure. For internal dose, t_p is the total time elapsed between release of the nuclides and the ingestion of the water
= 0.5 d
 - 114000 = conversion factor (pCi/ μCi * mL/L per hr/yr)

OFFSITE DOSE CALCULATION MANUAL

Irrigated Foods (Meat From Watered Cattle)

$$A_{io} = 114000 \times M_p \times U_{ap} \times Q_{Aw} \times \sum_i F_f D_{aio} e^{-\lambda_i t_s} \quad [B-2]$$

- Where:
- M_p = the mixing ratio (reciprocal of the dilution factor) at the point of harvest of aquatic food
= 0.1111 (Point at which water is taken from the lake is plume centerline 1 mile downstream. The plume centerline dilution factor at this location is 9 using RG 1.113 methodology. See Appendix E.)
 - U_{ap} = annual meat consumption rate for age group "a" and meat pathway "p" (kg/yr)
= 0 kg/yr for infant
= 41 kg/yr for child
= 65 kg/yr for teen
= 110 kg/yr for adult (see RG 1.109, Table E-5 for maximum exposed individual)
 - Q_{Aw} = consumption rate of contaminated water by an animal (L/d)
= 60 L/day (see RG 1.109, Table E-3)
 - F_f = stable element transfer coefficients (d/kg, see RG 1.109, Table E-1)
 - D_{aio} = ingestion dose factor for age group "a", radionuclide "i" and organ "o", from Reg. Guide 1.109 (mrem/pCi)
 - λ_i = the radioactive decay constant of nuclide "i", in day⁻¹
 - t_s = time from slaughter to consumption (d)
= 20d (see RG 1.109, Table E-15)
 - 114000 = conversion factor (pCi/μCi * mL/L per hr/yr)

Irrigated Foods (Milk From Watered Cattle)

$$A_{io} = 114000 \times M_p \times U_{ap} \times Q_{Aw} \times \sum_i F_m D_{aio} e^{-\lambda_i t_f} \quad [B-3]$$

- Where:
- M_p = the mixing ratio (reciprocal of the dilution factor) at the point of harvest of aquatic food;
= 0.1111 (Point at which water is taken as plume centerline 1 mile downstream. The plume centerline dilution factor at this location is 9 using RG 1.113 methodology. See Appendix E.)
 - U_{ap} = annual cow's milk consumption rate for age group "a" and milk pathway "p" (L/yr)
= 330 L/yr for infant
= 330 L/yr for child
= 400 L/yr for teen
= 310 L/yr for adult (from RG 1.109, Table E-5 for maximum exposed individual)
 - Q_{Aw} = consumption rate of contaminated water by an animal (L/d)
= 60 L/day (see RG 1.109, Table E-3)
 - F_m = stable element transfer coefficients (d/L, from RG 1.109, Table E-1)
 - D_{aio} = ingestion dose factor for age group "a", radionuclide "i" and organ "o", from Reg. Guide 1.109 (mrem/pCi)
 - λ_i = the radioactive decay constant of nuclide "i", in day⁻¹
 - t_f = transport time from pasture to cow, to milk, to receptor (d)
= 2 d (see RG 1.109, Table E-15)
 - 114000 = conversion factor (pCi/μCi * mL/L per hr/yr)

OFFSITE DOSE CALCULATION MANUAL

Potable Water

$$A_{io} = 114000 \times M_p \times U_{ap} \times \sum_i D_{aio} e^{-\lambda_i t_p} \quad [B-4]$$

Where:

- M_p = mixing ratio (reciprocal of the dilution factor) at the point of withdrawal of drinking water
= 0.0384 (Withdrawal point is taken as the Two Rivers municipal water intake located a distance of 12 miles downstream. The plume centerline dilution factor at this location is 26 using RG 1.113 methodology.)
- U_{ap} = a usage factor that specifies the drinking water intake rate for an individual of age group "a" associated with pathway "p";
= 330 L/yr for infant
= 510 L/yr for child
= 510 L/yr for teen
= 730 L/yr for adult (see RG 1.109, Table E-5)
- D_{aio} = ingestion dose factor for age group "a", radionuclide "i" and organ "o", from Reg. Guide 1.109 (mrem/pCi)
- λ_i = radioactive decay constant of nuclide "i", in day⁻¹
- t_p = average transit time required for nuclides to reach the point of exposure. (d)
= 2 d (12.2 cm/s plus 12 hours to reflect the transport of the water through the water purification plant and distribution system)
- 114000 = conversion factor (pCi/μCi * mL/L per hr/yr)

OFFSITE DOSE CALCULATION MANUAL

Shoreline Deposits

$$A_{io} = 1.14E + 07 \times M_p \times U_{ap} \times W \times \sum_i T_i D_i e^{-\lambda_i t_p} (1 - e^{-\lambda_i t_b}) \quad [B-5]$$

Where:

M_p = the mixing ratio (reciprocal of the dilution factor) at the point of harvest of aquatic food;
= 0.01821 (Point of exposure is taken as the Point Beach State Park beach which is located 8000 meters downstream. The plume shoreline dilution factor at this location is 54.9 using RG 1.113 methodology. The factor of 2 allowed for current reversals was not used. See Appendix E)

U_{ap} = annual drinking water consumption for age group "a" and pathway "p" (L/yr)
= 0 hr/yr for infant
= 14 hr/yr for child
= 67 hr/yr for teen
= 12 hr/yr for adult (from RG 1.109, Table E-5 for maximum exposed individual)

W = the shoreline width factor;
= 0.3 (from RG 1.109, Table A-2)

T_i = radioactive half-life of radionuclide "i" (d)

D_i = the external dose factor for nuclide "i", in mrem/hr per pCi/m², taken from Table E-6 of RG 1.109

λ_i = the radioactive decay constant of nuclide "i", in day⁻¹

t_p = the average transit time required for nuclides to reach the point of exposure (d)
= 0.5 d

t_b = time period of long-term buildup for activity in sediment or soil (d)
= 5.47E+03 d (15 yr, see RG 1.109, Table E-15)

1.14E+07 = conversion factor (pCi/μCi * mL/kg per hr/yr) and to account for the proportionality constant used in the sediment radioactivity model

Following the guidance of NUREG-0133, the adult age group represents the maximum exposed individual. Evaluation of doses for other age groups is not required for demonstrating compliance with the dose criteria of Section 6.2. To obtain a composite dose factor, the factors are summed for each liquid effluent pathway. (Reference Appendix K)

APPENDIX C
GASEOUS PATHWAY SETPOINT CALCULATIONS

The calculation of the setpoints for airborne effluents is based on the tech spec requirement that the noble gas dose rate at the site boundary nearest the closest residence must be ≤ 500 mrem/yr total body or ≤ 3000 mrem/yr to the skin of the whole body. The calculation proceeds in a manner similar to the liquid EMEC calculation. First the average noble gas emission rate for each identified noble gas is calculated from the average annual effluent discharge. Next, the site boundary concentrations are calculated by multiplying the release rates by the dispersion coefficient, χ/Q . Then the product of the individual noble gas concentrations and its dose factor is summed to determine the total dose rate from this noble gas mixture. Dividing this dose rate into the dose rate limit determines factor by which the average total site boundary noble concentration must be multiplied in order to achieve the concentration which will yield the limiting dose rate. Finally, based on the flow rate of an individual stack and applying the dispersion factor, the alarm setpoint for that stack monitor is calculated.

The parameters for calculating the setpoints are shown in the spreadsheet below and the setpoints are calculated using either equation 10-1(total body) or equation 10-2 (skin).

OFFSITE DOSE CALCULATION MANUAL

TABLE C-1
NOBLE GAS RELEASES

	2000 (Ci/yr)	2001 (Ci/yr)	2002 (Ci/yr)	2003 (Ci/yr)	2004 (Ci/yr)	2005 (Ci/yr)	2006 (Ci/yr)	2007 (Ci/yr)	2008 (Ci/yr)	2009 (Ci/yr)	2010 (Ci/yr)	Avg. (Ci/yr)
Ar-41	1.35E+00	9.28E-01	1.87E+00	7.77E-01	8.47E-01	4.61E-01	5.45E-01	4.98E-01	1.55E+00	7.67E-01	7.74E-01	8.52E-01
Kr-85	0.00E+00	0.00E+00	4.87E-03	3.95E-04	0.00E+00	2.63E-04	0.00E+00	0.00E+00	1.37E-03	8.66E-03	0.00E+00	1.41E-03
Kr-85m	1.47E-02	4.42E-04	4.67E-02	0.00E+00	2.84E-03	3.71E-03	1.43E-04	2.07E-04	8.47E-04	7.60E-03	9.73E-03	7.90E-03
Kr-87	3.51E-02	1.76E-03	1.68E-01	0.00E+00	7.27E-03	8.80E-03	0.00E+00	4.64E-04	2.10E-03	1.86E-02	2.35E-02	2.41E-02
Kr-88	3.52E-02	2.02E-03	1.61E-01	0.00E+00	7.62E-03	9.12E-03	0.00E+00	2.02E-02	6.50E-03	1.80E-02	2.33E-02	2.57E-02
Xe-131m	0.00E+00	1.15E-04	0.00E+00	7.00E-05	0.00E+00	0.00E+00	0.00E+00	0.00E+00	1.70E-03	8.04E-04	0.00E+00	2.44E-04
Xe-133	9.86E-01	4.95E-01	2.37E-01	1.12E-01	3.70E-01	9.14E-02	4.13E-02	9.95E-02	3.32E-04	5.43E-02	2.83E-01	2.52E-01
Xe-133m	2.89E-03	4.72E-04	0.00E+00	8.37E-04	9.67E-04	5.19E-04	3.65E+00	3.74E-04	2.77E-01	9.40E-04	2.11E-03	3.58E-01
Xe-135	1.75E-01	3.20E-02	4.10E-01	1.59E-04	1.97E-02	2.26E-02	9.32E-02	4.79E-03	4.05E-03	4.28E-02	6.14E-02	7.88E-02
Xe-135m	6.07E-02	0.00E+00	1.79E-01	3.46E-04	1.18E-02	1.74E-02	1.48E-02	9.53E-04	0.00E+00	3.36E-02	5.38E-02	3.38E-02
Xe-138	1.50E-01	8.77E-03	7.57E-01	0.00E+00	3.25E-02	4.43E-02	3.89E-02	2.17E-03	1.14E-02	9.17E-02	1.16E-01	1.14E-01

TABLE C-2
AVERAGE ANNUAL DISCHARGE VOLUME

MONITOR	VENT/STACK	CFM	CC/MIN	CC/YR
RE-214	ABVS	66,400	1.880E+09	9.883E+14
RE-225	CAE	20	5.663E+05	2.977E+11
1/2RE-215	CAE	10	2.832E+05	1.488E+11
1RE-212	U1	25,000	7.079E+08	
2RE-212	U2	38,000	1.076E+09	
1/2RE-212	U1/2	35	9.911E+05	5.209E+11
RE-224	GSVS	13,000	3.681E+08	1.935E+14
RE-221	DAVS	43,100	1.220E+09	6.415E+14
			Total (cc/yr)	1.823E+15

OFFSITE DOSE CALCULATION MANUAL

The average annual discharge volume is based on the flow from the four pathways monitored by RE-214, RE-221, RE-224, and RE-225. A random check of monthly effluent calculations show that over a span of one year, only the Aux. Bldg. Vent Stack, the Gas Stripper, and the Drumming Area Vent are important. The containment vents typically are about 35 cfm. The purges at 25,000 cfm occur during outages at a time when there no noble gas is detected in containment as all results are <MDA. Therefore, including the purge volumes would result in a less conservative calculated concentration by adding to the total volume at a time when no noble gases would be contributed to the total annual noble gas discharge. Also, not included are the GDT discharges. Their volumes are negligible in comparison to the main stack discharge volumes.

TABLE C-3
NOBLE GAS SETPOINT PARAMETER CALCULATION

	Avg. (Ci/yr)	C _i (μCi/cc)	K _i (Whole Body)	L _i (skin)	M _i (γ-air)	C _i × K _i	C _i × (L _i + 1.1M _i)
Ar-41	8.52E-01	4.670E-10	8.84E+03	2.69E+03	9.30E+03	4.129E-06	6.034E-08
Kr-85	1.41E-03	7.758E-13	1.61E+01	1.34E+03	1.72E+01	1.249E-11	1.054E-09
Kr-85m	7.90E-03	4.335E-12	1.17E+03	1.46E+03	1.23E+03	5.072E-09	1.219E-08
Kr-87	2.41E-02	1.324E-11	5.92E+03	9.73E+03	6.17E+03	7.839E-08	2.187E-07
Kr-88	2.57E-02	1.411E-11	1.47E+04	2.37E+03	1.52E+04	2.074E-07	2.694E-07
Xe-131m	2.44E-04	1.341E-13	9.15E+01	4.76E+02	1.56E+02	1.227E-11	6.613E-11
Xe-133	2.52E-01	1.383E-10	2.94E+02	3.06E+02	3.53E+02	4.065E-08	9.600E-08
Xe-133m	3.58E-01	1.963E-10	2.51E+02	9.94E+02	3.27E+02	4.927E-08	2.657E-07
Xe-135	7.88E-02	4.319E-11	1.81E+03	1.86E+03	1.92E+03	7.818E-08	1.716E-07
Xe-135m	3.38E-02	1.857E-11	3.12E+03	7.11E+02	3.36E+03	5.792E-08	8.182E-08
Xe-138	1.14E-01	6.247E-11	8.83E+03	4.13E+03	9.21E+03	5.516E-07	8.909E-07
TOTAL						5.197E-06	8.042E-06

Inserting these calculated totals and this sector's χ/Q into equations 10-1 and 10-2, the equations reduce to the following:

$$SP_{TB} (\mu Ci/cc) = 1.79E+02 AF/VF \quad \text{and} \quad SP_S (\mu Ci/cc) = 6.95E+03 AF/VF, \text{ or}$$

$$SP_{TB} (\mu Ci/cc) = 1.95E-04 AF/(VF * \chi/Q) \quad \text{and} \quad SP_S (\mu Ci/cc) = 7.58E-04 AF/(VF * \chi/Q)$$

From this it is seen that the limiting setpoints are derived using the total body dose rate restriction. The resulting setpoints are shown in Table C-4 where AF is applied only to RE-214, RE-221, RE-224, and RE-225.

TABLE C-4
 RMS AIRBORNE ALARM SETPOINTS

GASEOUS EFFLUENT PATHWAY	MONITORS	DISCHARGE FLOW RATE (cfm)	DEFAULT SETPOINT ($\mu\text{Ci/cc}$)
1. Auxiliary Building Vent	RE-214 & SPING 23	66,400	6.75E-04
2. Combined Air Ejector	RE-225	20	2.24E+00
3. Unit Air Ejector	1(2) RE-215	10	1.79E+01
4. Containment Purge Vent			
Unit 1	1RE-212 & SPING 21	25,000 ¹	7.17E-03
Unit 2	2RE-212 & SPING 22	38,000 ²	4.72E-03
Unit 1(2)	1(2) RE-212	35 ³	5.12E+00
5. Gas Stripper Building	RE-224	13,000	3.45E-03
6. Drumming Area Vent	RE-221 & SPING 24	43,100	1.04E-03

Note 1: Two fans of 12,500 cfm

Note 2: Two fans + 13,000 cfm from gas stripper bldg.

Note 3: Forced vent with nominal 35 cfm flow rate

APPENDIX D
GASEOUS DOSE FACTORS TECHNICAL BASIS

TECHNICAL BASIS FOR PBNP SITE-SPECIFIC GASEOUS DOSE FACTORS

The site-specific gaseous dose factors, presented in Chapter 10, have been extracted from the gaseous effluent dose equations outlined in Regulatory Guide 1.109, Section C.2, along with the guidance of NUREG-0133, Section 5.3.

To obtain the gaseous dose factors, all variables specific to each release of gaseous effluents have been removed from the gaseous dose equations of Regulatory Guide 1.109. The dose factors for each gaseous effluent pathway are calculated using the following equations:

Inhalation Pathway (see NUREG-0133, section 5.3.1.1)

$$R_{io} = 1 \times 10^6 \times BR_a \times D_{aio} \quad [D-1]$$

Where:

- R_{io} = dose factor for each identified radionuclide "i" and organ "o" ($m^2(mrem/yr)$ per $\mu Ci/s$ or $mrem/yr$ per $\mu Ci/m^3$)
- BR_a = breathing rate for age group "a" (m^3/yr):
 - Infant = 1400
 - Child = 3700
 - Teen & Adult = 8000 (from RG 1.109, Table E-5 for maximum exposed individual)
- D_{aio} = Inhalation dose factor for age group "a", radionuclide "i" and organ "o", from Reg. Guide 1.109 ($mrem/pCi$)
- $1E+06$ = Conversion factor for $pCi/\mu Ci$

Ground Plane Pathway (see NUREG-0133, section 5.3.1.2)

$$R_{io} = 8.76 \times 10^9 \times SF \times D_{aio} \times \frac{(1 - e^{-\lambda_i t_b})}{\lambda_i} \quad [D-2]$$

Where:

- R_{io} = dose factor for each identified radionuclide "i" and organ "o" ($m^2(mrem/yr)$ per $\mu Ci/s$ or $mrem/yr$ per $\mu Ci/m^3$)
- D_{aio} = ground plane dose factor for age group "a", radionuclide "i" and organ "o", (see RG 1.109, Table E-6)
- λ_i = the radioactive decay constant of nuclide "i", in sec^{-1}
- t_b = the exposure period (sec)
 - = $4.73E+08$ s (15 yr, from RG 1.109, App. C.1)
- $8.76E+09$ = conversion factor for $pCi/\mu Ci$ and hr/yr
- SF = shielding factor
 - = 0.7 (see RG 1.109, Table E-15 for maximum exposed individual)

OFFSITE DOSE CALCULATION MANUAL

Grass-Cow-Milk Pathway

The dose from the grass-cow-milk pathway is determined according to Equation 10-11. The produce R_{io} dose factor is calculated according to the following equation for all particulates and iodines, EXCEPT H-3 and C-14:

$$R_{io} = 1E + 06 \times Q_f U_{ap} F_m D_{aio} e^{-\lambda_i t_f} \times \{f_p f_s + (1 - f_p f_s) e^{-\lambda_i t_h}\} \times \left\{ \frac{r(1 - e^{-(\lambda_i + \lambda_w)t_e}}{Y_V(\lambda_i + \lambda_w)} + \frac{B_{iv}(1 - e^{-\lambda_i t_b})}{P\lambda_i} \right\} \quad [D-3]$$

- Where:
- R_{io} = dose factor for each identified radionuclide "i" and organ "o" (m^2 -mrem/yr per μ Ci/s or mrem/yr per μ Ci/ m^3)
 - Q_f = cow feed consumption rate (kg/d)
= 50 kg/d (from RG 1.109, Table E-3)
 - U_{ap} = annual cow's milk consumption rate for age group "a" and milk pathway "p" (L/yr)
= 330 L/yr for infant
= 330 L/yr for child
= 400 L/yr for teen
= 310 L/yr for adult (from RG 1.109, Table E-5 for maximum exposed individual)
 - F_m = stable element transfer coefficients (d/L, from RG 1.109, Table E-1)
 - D_{aio} = ingestion dose factor for age group "a", radionuclide "i" and organ "o", from Reg. Guide 1.109 (mrem/pCi)
 - λ_i = decay constant of radionuclide "i" (sec^{-1})
 - t_f = transport time from pasture to cow, to milk, to receptor (sec)
= $1.73E+05$ s (2d, from RG 1.109, Table E-15)
 - f_p = fraction of the year that cow is on pasture
= 0.5 (from June 1976 Appendix I submittal to NRC. Doc. Number NPC-27397)
 - f_s = fraction of cow feed that is pasture grass while cow is on pasture
= 0.5 (from June 1976 Appendix I submittal to NRC. Doc. Number NPC-27397)
 - r = fraction of deposited activity retained on cow's feed grass
= 1.0 for radioiodines
= 0.2 for particulates (see RG 1.109, Table E-15)
 - t_h = transport time from pasture, to harvest, to cow, to milk to receptor (sec)
= $7.78E+06$ s (90d, see RG 1.109, Table E-15)

OFFSITE DOSE CALCULATION MANUAL

- λ_w = decay constant for removal of activity on leaf and plant surfaces by weathering (sec^{-1})
= $5.73\text{E-}07 \text{ sec}^{-1}$ (corresponds to a 14 day half-life, see RG 1.109, Table E-15)
- Y_v = agricultural productivity by unit area of pasture feed grass (kg/m^2)
= 0.7 kg/m^2 (from RG 1.109, Table E-15)
- t_e = time period that crops are exposed to contamination during the growing season (s)
= $2.59\text{E+}06 \text{ s}$ (30d, see RG 1.109, Table E-15)
- B_{iv} = concentration factor for the uptake of radionuclide "I", expressed as the ratio of the concentration in biota (pCi/kg) to the concentration in water (pCi/L) (see RG 1.109, Table E-1)
- t_b = time period of long-term buildup for activity in sediment or soil (s)
= $4.72\text{E+}8 \text{ s}$ (15 yr, see RG 1.109, Table E-15)
- P = effective surface density for soil (kg/m^2)
= 240 kg/m^2 (see RG 1.109, Table E-15)
- $1\text{E+}06$ = conversion factor for pCi/ μ Ci. This factor should be reduced to $5\text{E+}05$ when calculating the dose factors for radioiodines. This accounts for the fraction of deposited elemental iodine that is accounted for in the dose modeling. See Reg. Guide 1.109, Appendix C, Section 3.a.

For carbon-14, the milk pathway R_{io} dose factor is calculated according to the following equation:

$$R_{io} = 1E + 09 \times \frac{0.11}{0.16} \times F_m U_{ap} \times p \times Q_f D_{aio} e^{-\lambda_i t_h} \quad [D-4]$$

Where:

- R_{io} = dose factor for radionuclide "i" (C-14) and organ "o" (mrem/yr per $\mu\text{Ci}/\text{m}^3$)
- 0.11 = fraction of plant mass that is natural carbon (see RG 1.109, eqn. C-8)
- 0.16 = concentration of natural carbon in the atmosphere (see RG 1.109, eqn. C-8)
- F_m = stable element transfer coefficients (d/L, from RG 1.109, Table E-1)
- U_{ap} = annual cow's milk consumption rate for age group "a" and milk pathway "p" (L/yr)
= 330 L/yr for infant
= 330 L/yr for child
= 400 L/yr for teen
= 310 L/yr for adult (from RG 1.109, Table E-5 for maximum exposed individual)
- p = Fractional equilibrium ratio
= 1 for continuous releases (from RG 1.109, page 26)
- D_{aio} = ingestion dose factor for age group "a", radionuclide "i" and organ "o", (mrem/pCi) (from Reg. Guide 1.109, Table E-11)
- Q_f = cow feed consumption rate (kg/d)
= 50 kg/d (from RG 1.109, Table E-3)
- 1E+09 = conversion factor for pCi/ μCi and g/kg.
- λ_i = decay constant of radionuclide "i" (C-14) (sec^{-1})
= $3.84E-12 \text{ sec}^{-1}$
- t_h = time interval between harvest and consumption of food (sec)
= $1.73E+05 \text{ sec}$ (2 d, RG 1.109, Table E-15)

OFFSITE DOSE CALCULATION MANUAL

For hydrogen-3, the milk pathway R_{io} dose factor is calculated according to the following equation:

$$R_{io} = 1E + 09 \times 0.75 \times \frac{0.5}{H} F_m U_{ap} Q_f D_{aio} e^{-\lambda_i t_h} \quad [D-5]$$

- Where:
- R_{io} = dose factor for radionuclide "i" (H-3) and organ "o" (mrem/yr per $\mu\text{Ci}/\text{m}^3$)
 - 0.75 = fraction of plant mass that is water (see RG 1.109, eqn. C-9)
 - 0.5 = ratio of tritium concentration in plant water to tritium concentration in atmospheric water (see RG 1.109, eqn. C-9)
 - H = absolute humidity at the location of interest (g/m^3)
= $5.5 \text{ g}/\text{m}^3$ (from E. L. Entier (1980), Health Physics 39:318-320)
 - F_m = stable element transfer coefficients (d/L, from RG 1.109, Table E-1)
 - U_{ap} = annual cow's milk consumption rate for age group "a" and milk pathway "p" (L/yr)
= 330 L/yr for infant
= 330 L/yr for child
= 400 L/yr for teen
= 310 L/yr for adult (from RG 1.109, Table E-5 for maximum exposed individual)
 - Q_f = cow feed consumption rate (kg/d)
= 50 kg/d (from RG 1.109, Table E-3)
 - D_{aio} = ingestion dose factor for age group "a", radionuclide "i" (H-3) and organ "o", (mrem/pCi) (from Reg. Guide 1.109, Table E-11)
 - 1E+09 = conversion factor for pCi/ μCi and g/kg.
 - λ_i = decay constant of radionuclide "i" (H-3) (sec^{-1})
= $1.78\text{E}-09 \text{ sec}^{-1}$
 - t_h = time interval between harvest and consumption of milk (sec)
= $1.73\text{E}+05 \text{ sec}$ (2 d, RG 1.109, Table E-15)

OFFSITE DOSE CALCULATION MANUAL

Grass-Cow-Meat Pathway

The dose from the grass-cow-meat pathway is determined according to Equation 10-11. The produce R_{io} dose factor is calculated according to the following equation for all particulates and iodines, EXCEPT H-3 and C-14:

$$R_{io} = 1E + 06 \times Q_f U_{ap} F_f D_{aio} e^{-\lambda_i t_s} \times \{f_p f_s + (1 - f_p f_s) e^{-\lambda_i t_h}\} \times \left\{ \frac{r(1 - e^{-(\lambda_i + \lambda_w) t_e})}{Y_V(\lambda_i + \lambda_w)} + \frac{B_{iv}(1 - e^{-\lambda_i t_b})}{P\lambda_i} \right\} \quad [D-6]$$

Where:

- R_{io} = dose factor for each identified radionuclide "i" and organ "o" ($m^2(mrem/yr)$ per $\mu Ci/s$ or $mrem/yr$ per $\mu Ci/m^3$)
- Q_f = cow's consumption rate (kg/day)
- U_{ap} = annual meat consumption rate for age group "a" and meat pathway "p" (kg/yr)
= 0 kg/yr for infant
= 41 kg/yr for child
= 65 kg/yr for teen
= 110 kg/yr for adult (see RG 1.109, Table E-5 for maximum exposed individual)
- F_f = stable element transfer coefficients (d/kg, see RG 1.109, Table E-1)
- D_{aio} = ingestion dose factor for age group "a", radionuclide "i" and organ "o", from Reg. Guide 1.109 (mrem/pCi)
- λ_i = decay constant of radionuclide "i" (sec^{-1})
- t_s = time from slaughter to consumption (sec)
= $1.73E+06$ s (20d, see RG 1.109, Table E-15)
- f_p = fraction of the year that cow is on pasture
= 0.5 (from June 1976 Appendix I submittal to NRC. Doc. Number NPC-27397)
- f_s = fraction of cow feed that is pasture grass while cow is on pasture
= 0.5 (from June 1976 Appendix I submittal to NRC. Doc. Number NPC-27397)
- r = fraction of deposited activity retained on cow's feed grass
= 1.0 for radioiodines
= 0.2 for particulates (see RG 1.109, Table E-15)
- t_h = transport time from pasture, to harvest, to cow, to milk to receptor (sec)
= $7.77E+06$ s (90d, see RG 1.109, Table E-15)
- λ_w = decay constant for removal of activity on leaf and plant surfaces by weathering (sec^{-1})
= $5.73E-07$ sec^{-1} (corresponds to a 14 day half-life, see RG 1.109, Table E-15)

OFFSITE DOSE CALCULATION MANUAL

- Y_v = agricultural productivity by unit area of pasture feed grass (kg/m^2)
= $0.7 \text{ kg}/\text{m}^2$ (from RG 1.109, Table E-15)
- t_e = time period that crops are exposed to contamination during the growing season (s)
= $2.59\text{E}+06 \text{ s}$ (30d, see RG 1.109, Table E-15)
- B_{iv} = concentration factor for the uptake of radionuclide "I", expressed as the ratio of the concentration in biota (pCi/kg) to the concentration in water (pCi/L) (see RG 1.109, Table E-1)
- t_b = time period of long-term buildup for activity in sediment or soil (s)
= $4.72\text{E}+8 \text{ s}$ (15 yr, see RG 1.109, Table E-15)
- P = effective surface density for soil (kg/m^2)
= $240 \text{ kg}/\text{m}^2$ (see RG 1.109, Table E-15)
- $1\text{E}+06$ = conversion factor for $\text{pCi}/\mu\text{Ci}$

OFFSITE DOSE CALCULATION MANUAL

For carbon-14, the meat pathway R_{io} dose factor is calculated according to the following equation:

$$R_{io} = 1E + 09 \times \frac{0.11}{0.16} \times F_f U_{ap} \times p \times Q_f D_{aio} e^{-\lambda_i t_s} \quad [D-7]$$

- Where:
- R_{io} = dose factor for radionuclide "i" (C-14) and organ "o" (mrem/yr per $\mu\text{Ci}/\text{m}^3$)
 - 0.11 = fraction of plant mass that is natural carbon (see RG 1.109, eqn. C-8)
 - 0.16 = concentration of natural carbon in the atmosphere (see RG 1.109, eqn. C-8)
 - F_f = stable element transfer coefficients (d/kg, see RG 1.109, Table E-1)
 - U_{ap} = annual meat consumption rate for age group "a" and meat pathway "p" (kg/yr)
 - = 0 kg/yr for infant
 - = 41 kg/yr for child
 - = 65 kg/yr for teen
 - = 110 kg/yr for adult (see RG 1.109, Table E-5 for maximum exposed individual)
 - p = Fractional equilibrium ratio
 - = 1 for continuous releases (from RG 1.109, page 26)
 - D_{aio} = ingestion dose factor for age group "a", radionuclide "i" and organ "o", (mrem/pCi) (from Reg. Guide 1.109, Table E-11)
 - Q_f = cow feed consumption rate (kg/d)
 - = 50 kg/d (from RG 1.109, Table E-3)
 - 1E+09 = conversion factor for pCi/ μCi and g/kg.
 - λ_i = decay constant of radionuclide "i" (C-14) (sec^{-1})
 - = $3.84E-12 \text{ sec}^{-1}$
 - t_s = time from slaughter to consumption (sec)
 - = $1.73E+06 \text{ s}$ (20d, see RG 1.109, Table E-15)

OFFSITE DOSE CALCULATION MANUAL

For hydrogen-3, the meat pathway R_{io} dose factor is calculated according to the following equation:

$$R_{io} = 1E + 09 \times 0.75 \times \frac{0.5}{H} F_f U_{ap} Q_f D_{aio} e^{-\lambda_i t_s} \quad [D-8]$$

- Where:
- R_{io} = dose factor for radionuclide "i" (H-3) and organ "o" (mrem/yr per $\mu\text{Ci}/\text{m}^3$)
 - 0.75 = fraction of plant mass that is water (see RG 1.109, eqn. C-9)
 - 0.5 = ratio of tritium concentration in plant waer to tritium concentration in atmospheric water (see RG 1.109, eqn. C-9)
 - H = absolute humidity at the location of interest (g/m^3)
= $5.5 \text{ g}/\text{m}^3$ (from E. L. Entier (1980), Health Physics 39:318-320)
 - F_f = stable element transfer coefficients (d/kg, see RG 1.109, Table E-1)
 - U_{ap} = annual meat consumption rate for age group "a" and meat pathway "p" (kg/yr)
= 0 kg/yr for infant
= 41 kg/yr for child
= 65 kg/yr for teen
= 110 kg/yr for adult (see RG 1.109, Table E-5 for maximum exposed individual)
 - Q_f = cow feed consumption rate (kg/d)
= 50 kg/d (from RG 1.109, Table E-3)
 - D_{aio} = ingestion dose factor for age group "a", radionuclide "i" (H-3) and organ "o", (mrem/pCi) (from Reg. Guide 1.109, Table E-11)
 - 1E+09 = conversion factor for pCi/ μCi and g/kg.
 - λ_i = decay constant of radionuclide "i" (H-3) (sec^{-1})
= $1.78E-09 \text{ sec}^{-1}$
 - t_s = time from slaughter to consumption (sec)
= $1.73E+06 \text{ s}$ (20d, see RG 1.109, Table E-15)

OFFSITE DOSE CALCULATION MANUAL

Fruit, Grain, Non-Leafy Vegetable (Produce) Pathway

The dose from the fruit, grain, non-leafy vegetable (produce) pathway is determined according to Equation 10-11. The produce R_{io} dose factor is calculated according to the following equation for all particulates and iodines, EXCEPT H-3 and C-14:

$$R_{io} = 1E + 06 \times \left\{ \frac{r(1 - e^{-(\lambda_i + \lambda_w)t_e})}{Y_v(\lambda_i + \lambda_w)} + \frac{B_{iv}(1 - e^{-\lambda_i t_b})}{P\lambda_i} \right\} f_g U_{ap} D_{aio} e^{-\lambda_i t_h} \quad [D-9]$$

- Where:
- R_{io} = dose factor for each identified radionuclide "i" and organ "o" (m^2 -mrem/yr per μ Ci/s or mrem/yr per μ Ci/ m^3)
 - r = fraction of deposited activity remaining on crops
= 1.0 for iodines
= 0.2 for other particulates (from RG 1.109, Table E-15)
 - λ_i = decay constant of radionuclide "i" (sec^{-1})
 - λ_w = decay constant for removal of activity on leaf and plant surfaces by weathering, (sec^{-1})
= $5.73E-07 sec^{-1}$ (14 day half-life, from RG 1.109, Table E-15)
 - D_{aio} = ingestion dose factor for age group "a", radionuclide "i" and organ "o", (mrem/pCi) (from Reg. Guide 1.109, Table E-11)
 - t_e = growing season (sec)
= $5.18E+06 sec$ (60 days, from RG 1.109, Table E-15)
 - t_b = time that soil is exposed to the effluent (hr).
= $4.72E+08 sec$ (15 yr, from RG 1.109, Table E-15)
 - t_h = time interval between harvest and consumption of food (sec)
= $5.18E+06 sec$ (60 d, RG 1.109, Table E-15)
 - Y_v = agricultural productivity by unit area (kg/m^2)
= $2.0 kg/m^2$ (from RG 1.109, Table E-15)
 - P = effective surface density of soil (kg/m^2)
= $240 kg/m^2$ (from RG 1.109, Table E-15)
 - B_{iv} = concentration factor for uptake of radionuclide "i" from soil by edible parts of crops (pCi/kg, see RG 1.109, Table E-1)
 - f_g = fraction of ingestion taken from the garden of interest
= 0.76 (from NUREG-0133, page 36)
 - U_{ap} = annual produce usage rate (consumption rate) for age group "a" and produce pathway "p" (kg/yr)
= 0 kg/yr for infant
= 520 kg/yr for child
= 630 kg/yr for teen
= 520 kg/yr for adult (from RG 1.109, Table E-5 for maximum exposed individual)
 - $1E+06$ = conversion factor for pCi/ μ Ci. This factor is reduced by 50% to $5E+05$ for iodines. (see RG 1.109, eqn. C-7)

OFFSITE DOSE CALCULATION MANUAL

For carbon-14, the produce R_{io} dose factor is calculated according to the following equation:

$$R_{io} = 1E + 09 \times \frac{0.11}{0.16} \times f_g U_{ap} \times p \times D_{aio} e^{-\lambda_i t_h} \quad [D-10]$$

Where:

- R_{io} = dose factor for radionuclide "i" (C-14) and organ "o" (mrem/yr per $\mu\text{Ci}/\text{m}^3$)
- 0.11 = fraction of plant mass that is natural carbon (see RG 1.109, eqn. C-8)
- 0.16 = concentration of natural carbon in the atmosphere (see RG 1.109, eqn. C-8)
- f_g = fraction of ingestion taken from the garden of interest
= 0.76 (from NUREG-0133, page 36)
- U_{ap} = annual produce usage rate (consumption rate) for age group "a" and produce pathway "p" (kg/yr)
= 0 kg/yr for infant
= 520 kg/yr for child
= 630 kg/yr for teen
= 520 kg/yr for adult (from RG 1.109, Table E-5 for maximum exposed individual)
- p = Fractional equilibrium ratio
= 1 for continuous releases (from RG 1.109, page 26)
- D_{aio} = ingestion dose factor for age group "a", radionuclide "i" and organ "o", (mrem/pCi) (from Reg. Guide 1.109, Table E-11)
- 1E+09 = conversion factor for pCi/ μCi and g/kg.
- λ_i = decay constant of radionuclide "i" (C-14) (sec^{-1})
= $3.84E-12 \text{ sec}^{-1}$
- t_h = time interval between harvest and consumption of food (sec)
= $5.18E+06 \text{ sec}$ (60 d, RG 1.109, Table E-15)

For hydrogen-3, the produce R_{io} dose factor is calculated according to the following equation:

$$R_{io} = 1E + 09 \times 0.75 \times \frac{0.5}{H} f_g U_{ap} D_{aio} e^{-\lambda_i t_h} \quad [D-11]$$

- Where:
- R_{io} = dose factor for radionuclide "i" (H-3) and organ "o" (mrem/yr per $\mu\text{Ci}/\text{m}^3$)
 - 0.75 = fraction of plant mass that is water (see RG 1.109, eqn. C-9)
 - 0.5 = ratio of tritium concentration in plant waer to tritium concentration in atmospheric water (see RG 1.109, eqn. C-9)
 - H = absolute humidity at the location of interest (g/m^3)
= $5.5 \text{ g}/\text{m}^3$ (from E. L. Entier (1980), Health Physics 39:318-320)
 - f_g = fraction of ingestion taken from the garden of interest
= 0.76 (from NUREG-0133, page 36)
 - U_{ap} = annual produce usage rate (consumption rate) for age group "a" and produce pathway "p" (kg/yr)
= 0 kg/yr for infant
= 520 kg/yr for child
= 630 kg/yr for teen
= 520 kg/yr for adult (from RG 1.109, Table E-5 for maximum exposed individual)
 - D_{aio} = ingestion dose factor for age group "a", radionuclide "i" (H-3) and organ "o", (mrem/pCi) (from Reg. Guide 1.109, Table E-11)
 - 1E+09 = conversion factor for pCi/ μCi and g/kg.
 - λ_i = decay constant of radionuclide "i" (H-3) (sec^{-1})
= $1.78\text{E}-09 \text{ sec}^{-1}$
 - t_h = time interval between harvest and consumption of food (sec)
= $5.18\text{E}+06 \text{ sec}$ (60 d, RG 1.109, Table E-15)

OFFSITE DOSE CALCULATION MANUAL

Leafy Vegetable Pathway

The dose from the leafy vegetable pathway is determined according to Equation 10-11. The leafy vegetable R_{io} dose factor is calculated according to the following equation for all particulates and iodines, EXCEPT H-3 and C-14:

$$R_{io} = 1E + 06 \times \left\{ \frac{r(1 - e^{-(\lambda_i + \lambda_w)t_e})}{Y_v(\lambda_i + \lambda_w)} + \frac{B_{iv}(1 - e^{-\lambda_i t_b})}{P\lambda_i} \right\} f_g U_{ap} D_{aio} e^{-\lambda_i t_h} \quad [D-12]$$

- Where:
- R_{io} = dose factor for each identified radionuclide "i" and organ "o" (m^2 -mrem/yr per $\mu\text{Ci/s}$ or mrem/yr per $\mu\text{Ci/m}^3$)
 - r = fraction of deposited activity remaining on crops
= 1.0 for iodines
= 0.2 for other particulates (from RG 1.109, Table E-15)
 - λ_i = decay constant of radionuclide "i" (sec^{-1})
 - λ_w = decay constant for removal of activity on leaf and plant surfaces by weathering, (sec^{-1})
= $5.73E-07 \text{ sec}^{-1}$ (14 day half-life, from RG 1.109, Table E-15)
 - D_{aio} = ingestion dose fact or for age group "a", radionuclide "i" and organ "o", from Reg. Guide 1.109
 - t_e = growing season (sec)
= $5.18E+06 \text{ sec}$ (60 days, from RG 1.109, Table E-15)
 - t_b = time that soil is exposed to the effluent (hr).
= $4.72E+08 \text{ sec}$ (15 yr, from RG 1.109, Table E-15)
 - t_h = time interval between harvest and consumption of food (sec)
= $8.64E+04 \text{ sec}$ (1 d, from RG 1.109, Table E-15)
 - Y_v = agricultural productivity by unit area (kg/m^2)
= 2.0 kg/m^2 (from RG 1.109, Table E-15)
 - P = effective surface density of soil (kg/m^2)
= 240 kg/m^2
 - B_{iv} = concentration factor for uptake of radionuclide "i" from soil by edible parts of crops (pCi/kg) (from RG 1.109, Table E-1)
 - f_g = fraction of ingestion taken from the garden of interest
= 1.0 (from NUREG-0133, page 36)

OFFSITE DOSE CALCULATION MANUAL

- U_{ap} = annual produce usage rate (consumption rate) for age group "a" and produce pathway "p" (kg/yr)
 = 0 kg/yr for infant
 = 26 kg/yr for child
 = 42 kg/yr for teen
 = 64 kg/yr for adult (from RG 1.109, Table E-5 for maximum exposed individual)
- $1E+06$ = conversion factor for pCi/ μ Ci. This factor is reduced by 50% to $5E+05$ for iodines. (see RG 1.109, eqn. C-7)

For carbon-14, the leafy vegetable R_{io} dose factor is calculated according to the following equation:

$$R_{io} = 1E + 09 \times \frac{0.11}{0.16} \times f_g U_{ap} D_{aio} e^{-\lambda_i t_h} \quad [D-13]$$

- Where:
- R_{io} = dose factor for radionuclide "i" (C-14) and organ "o" (mrem/yr per μ Ci/ m^3)
- 0.11 = fraction of plant mass that is natural carbon (see RG 1.109, eqn. C-8)
- 0.16 = concentration of natural carbon in the atmosphere (see RG 1.109, eqn. C-8)
- f_g = fraction of ingestion taken from the garden of interest = 1.0 (from NUREG-0133, page 36)
- U_{ap} = annual produce usage rate (consumption rate) for age group "a" and produce pathway "p" (kg/yr)
 = 0 kg/yr for infant
 = 26 kg/yr for child
 = 42 kg/yr for teen
 = 64 kg/yr for adult (from RG 1.109, Table E-5 for maximum exposed individual)
- D_{aio} = ingestion dose factor for age group "a", radionuclide "i" and organ "o", (mrem/pCi) (from Reg. Guide 1.109, Table E-11)
- $1E+09$ = conversion factor for pCi/ μ Ci and g/kg.
- λ_i = decay constant of radionuclide "i" (C-14) (sec^{-1})
 = $3.84E-12 sec^{-1}$
- t_h = time interval between harvest and consumption of food (sec)
 = $8.64E+04 sec$ (1 d, RG 1.109, Table E-15)

OFFSITE DOSE CALCULATION MANUAL

For hydrogen-3, the leafy vegetable R_{io} dose factor is calculated according to the following equation:

$$R_{io} = 1E + 09 \times 0.75 \times \frac{0.5}{H} f_g U_{ap} D_{aio} e^{-\lambda_i t_h} \quad [D-14]$$

- Where:
- R_{io} = dose factor for radionuclide "i" (H-3) and organ "o" (mrem/yr per $\mu\text{Ci}/\text{m}^3$)
 - 0.75 = fraction of plant mass that is water (see RG 1.109, eqn. C-9)
 - 0.5 = ratio of tritium concentration in plant waer to tritium concentration in atmospheric water (see RG 1.109, eqn. C-9)
 - H = absolute humidity at the location of interest (g/m^3)
= $5.5 \text{ g}/\text{m}^3$ (from E. L. Entier (1980), Health Physics 39:318-320)
 - f_g = fraction of ingestion taken from the garden of interest
= 1.0 (from NUREG-0133, page 36)
 - U_{ap} = annual produce usage rate (consumption rate) for age group "a" and produce pathway "p" (kg/yr)
= 0 kg/yr for infant
= 26 kg/yr for child
= 42 kg/yr for teen
= 64 kg/yr for adult (from RG 1.109, Table E-5 for maximum exposed individual)
 - D_{aio} = ingestion dose factor for age group "a", radionuclide "i" (H-3) and organ "o", (mrem/pCi) (from Reg. Guide 1.109, Table E-11)
 - 1E+09 = conversion factor for pCi/ μCi and g/kg.
 - λ_i = decay constant of radionuclide "i"(H-3) (sec^{-1})
= $1.78E-09 \text{ sec}^{-1}$
 - t_h = time interval between harvest and consumption of food (sec)
= $8.64E+04 \text{ sec}$ (1 d, RG 1.109, Table E-15)

APPENDIX E
 DERIVATION OF DILUTION FACTORS USING REGULATORY GUIDE 1.113

E.1 Liquid Effluent Dilution Factor Calculations

E.1.1 Methodology

The dilution factors used for calculating the doses from liquid effluent released to Lake Michigan were calculated using the methodology of Regulatory Guide 1.113, "Estimating Aquatic Dispersion of Effluents from Accidental and Routine Reactor Releases for the Purpose of Implementing Appendix I." The parameters used in the calculation and the results of the calculation are given in Table E-1. The results are presented graphically in Figure E-1.

The centerline and shoreline values were calculated using Reg Guide 1.113 formulae 17 and 18 which apply to discharges to the Great Lakes. (The formulae are not presented here. See Section 5 of the PBNP FSAR for the formulae and origin of values used.) These results are applied as calculated for fish caught near PBNP. But for other pathways, an extra factor of two (2) is applied to account for current reversals which occur in Lake Michigan as described in the Appendix I, Section 5, of the PBNP FSAR.

TABLE E-1
 SURFACE DILUTION FACTORS FOR LIQUID EFFLUENTS IN A LARGE LAKE

DOWNSTREAM DISTANCE (meters)	PLUME CENTERLINE	SHORELINE
10	8.81	
20	8.81	
30	8.81	
40	8.81	
50	8.81	
60	8.81	
70	8.81	
80	8.81	
90	8.81	
100	8.81	
200	8.81	
300	8.81	
400	8.81	
500	8.81	
600	8.81	
700	8.81	
800	8.81	

TABLE E-1
SURFACE DILUTION FACTORS FOR LIQUID EFFLUENTS IN A LARGE LAKE

DOWNSTREAM DISTANCE (meters)	PLUME CENTERLINE	SHORELINE
900	8.81	
1000	8.81	122000
2000	8.86	1758
3000	9.01	401
4000	9.25	186
5000	9.53	116
6000	9.85	83.8
7000	10.2	65.9
8000	10.5	54.9
9000	10.8	47.4
10000	11.1	42.1
20000	14.0	24.0
30000	16.1	20.1
40000	17.7	18.7
50000	18.8	18.3
60000	19.6	18.2
70000	20.3	18.3
80000	20.9	18.6
90000	21.4	18.9
100000	21.9	19.2
200000	25.9	23.2
300000	29.2	26.9
400000	32.3	30.3
500000	35.2	33.3
600000	37.8	36.0
700000	40.2	38.6
800000	42.6	41.0
900000	44.8	43.3
1000000	46.9	45.5

NOTE 1: These values were calculated using the equation described in Section 5.2 of the PBNP FSAR and the following values:

$$\begin{aligned}
 \epsilon_y &= 900 \text{ cm}^2/\text{sec} & z_s &= 0 \text{ meters} \\
 \epsilon_z &= 2 \text{ cm}^2/\text{sec} & d &= 10 \text{ meters} \\
 U &= 12.2 \text{ cm/sec} & h &= 10 \text{ meters} \\
 y_s &= 152.5 \text{ meters} & b &= 305 \text{ meters} \\
 \text{Discharge rate} &= 42.2 \text{ m}^3/\text{sec}
 \end{aligned}$$

FIGURE E-1
 DILUTION FACTORS AT SURFACE

Dilution Factor at Surface Liquid Effluents in a Large Lake

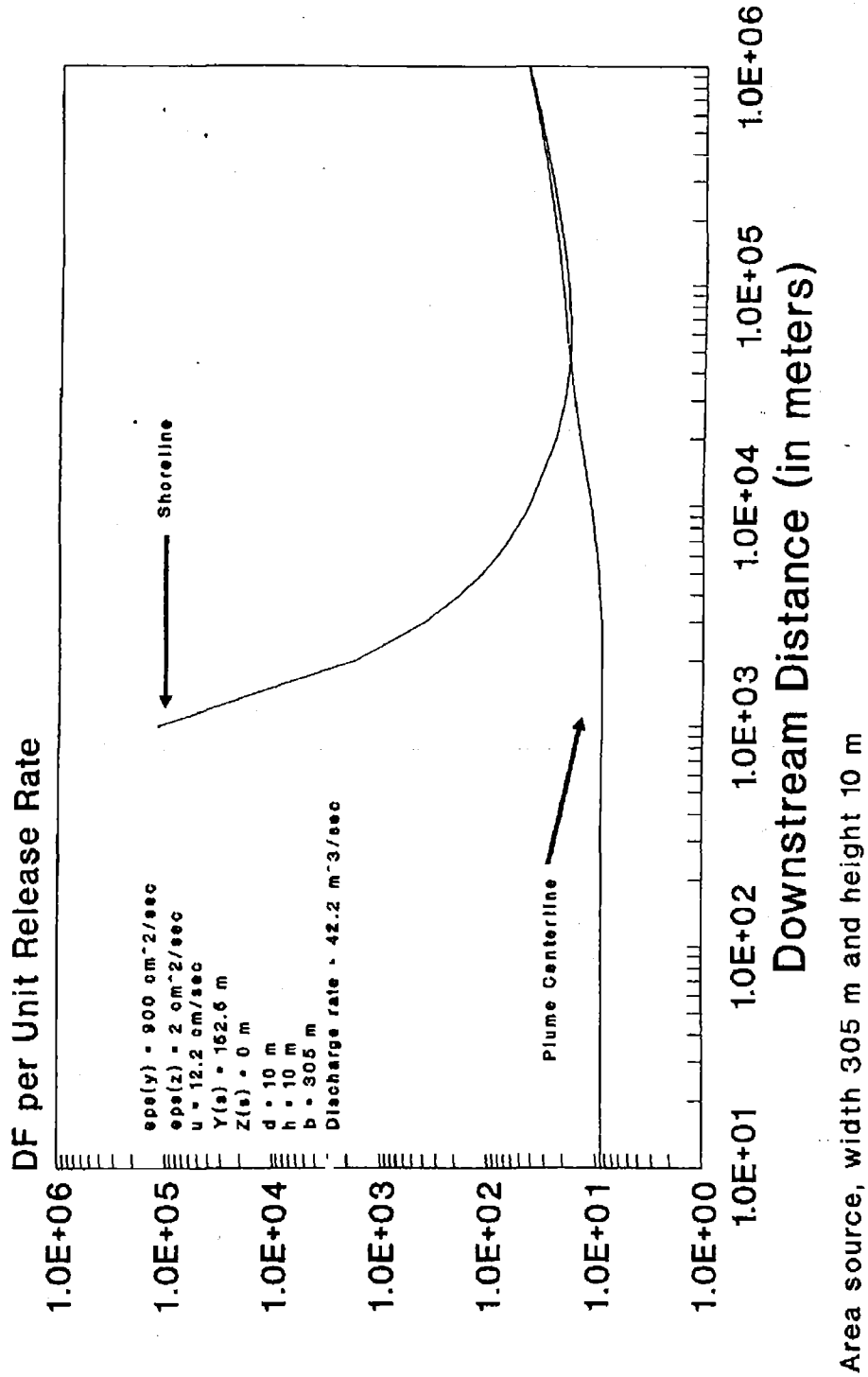

OFFSITE DOSE CALCULATION MANUAL

E.1.2 Dilution Factor Twelve Miles Downstream: Two Rivers Water Intake

The dilution factors used at the Two Rivers water intake twelve miles downstream from PBNP included the factor of two described in Section D1.1. However, instead of using the straight centerline dilution factor shown in Table 1, the weighted average dilution factor calculated over the width of the plume was used.

The approach was used for the following reasons. First, the path that the current takes to reach the Two Rivers water intake is not straight. In order to reach Two Rivers, the water must flow southeast around Point Beach State Park, which juts into Lake Michigan, and then curves back 90 degrees towards Two Rivers. As a result of this deviation from straight line flow, any part of the plume or possibly none of the plume would impinge upon the intake structure.

Second, there is a difference in the distance offshore of the PBNP discharge and the Two Rivers water intake. The Two Rivers water intake is located 5080 feet offshore. By contrast, PBNP discharges close to the shoreline through two flumes, one directed north and one directed south, and is modeled as a source that extends 1000 feet out into the lake from the shoreline.

Based on these two considerations, it was concluded that the weighted average dilution across the width of the plume as it diverges while flowing south would constitute a better estimate of the dilution factor instead of the calculated for the centerline of an area source as is assumed for the FSAR calculation. The calculation and the values used are shown below.

The average dilution factor at 12 miles downstream was calculated in the following manner:

The standard deviation of the radionuclide concentration in the y direction at 12 miles downstream on the surface of the lake is 168.8 meters. This calculation used the following formula:

$$\sigma_y = \sqrt{\frac{2 \times \epsilon_y \times x}{u}} \quad [E-1]$$

- Where:
- σ_y = Standard deviation of the radionuclide concentration in the y direction
 - ϵ_y = Lateral turbulent diffusion coefficient (cm²/sec)
= 900 cm²/sec
 - x = Downstream distance (cm)
= 1.93E+06 cm
 - u = Current (cm/sec)
= 12.2 cm/sec

At distances of 0.1σ, 0.2σ, etc. off the plume centerline, the dilution factor was calculated using the equation shown in Section 5.2 of the PBNP FSAR. The distances off the plume centerline, the calculated dilution factor, and the fraction of the area under the normal distribution curve is listed below.

TABLE E-2
DILUTION FACTORS

STANDARD DEVIATION	DISTANCE (meters)	FRACTION OF AREA UNDER CURVE ¹	DILUTION FACTOR
0.1σ	16.9	0.080	13.8
0.2σ	33.8	0.080	14.0
0.3σ	50.6	0.078	14.3
0.4σ	67.5	0.075	14.7
0.5σ	84.4	0.072	15.2
0.6σ	101.3	0.068	15.8
0.7σ	118.1	0.065	16.6
0.8σ	135.0	0.060	17.6
0.9σ	151.9	0.056	18.8
1.0σ	168.8	0.051	20.2
1.1σ	185.6	0.046	21.9
1.2σ	202.5	0.042	23.9
1.3σ	219.4	0.037	26.3
1.4σ	236.3	0.032	29.2
1.5σ	253.2	0.028	32.6
1.75σ	295.4	0.053	44.7
2.0σ	337.6	0.035	64.7
2.25σ	379.8	0.021	98.4
2.5σ	421.9	0.012	158.4
3.0σ	506.3	0.010	482
TOTAL		1.000	

NOTE: It is assumed that the standard deviation of the radionuclide concentrations across the plume can be represented by a normal distribution curve. The fraction of the total area under the curve is that fraction of the area under the curve that lies between, for example, the interval 0.1σ and 0.2σ which also includes the area of the curve in the interval -0.1σ and -0.2σ. The average dilution factor over the width of the plume was calculated by multiplying the dilution factor at each of the locations off of the plume centerline by the fraction of the total area of the curve occupied by that interval and then summing over all the intervals. An average dilution factor of 29 was calculated.

APPENDIX F
RADIOLOGICAL IMPACT OF SEWAGE TREATMENT SLUDGE DISPOSAL

NOTE: Appendix F is for historical reference. Land disposal of sewage sludge is no longer used at Point Beach

The methodology for determining the radiological impact of land application of contaminated sewage treatment sludge is presented in this section. The evaluation must be made prior to every land application of sewage treatment plant (STP) sludge that contains licensed material. Sludge and other STP material which does not contain licensed material may be disposed of by any legal method without prior radiological analysis.

F.1 Basis, Commitments and Actions

F.1.1 Basis

With the discovery that the PBNP STP sludge contained licensed material, Wisconsin Electric applied for NRC approval to dispose of the sludge by land application on land within the PBNP site boundary pursuant to 10 CFR 20.302(a). Wisconsin Electric committed to gamma isotopic analysis (GIA) of the sludge to measure the concentrations of licensed material in the STP sludge and to compare the results to concentration limits prior to each disposal [letter dated October 8, 1987 (VPNPD-87-430, NRC-87-104)] (See Appendix G). In addition, the dose to the maximally exposed individual of the general public and to the inadvertent intruder would be evaluated for the appropriate exposure pathways.

F.1.2 Basis for NRC Commitment Modification

Pursuant to NRC guidance, the sludge is clean if no licensed materials are found when analyzed under conditions necessary to achieve the environmental LLDs (NRC HPPOS 221). Clean sludge is not under NRC jurisdiction and may be disposed of by any legal method without prior radioanalyses. Therefore, if the sludge is clean and there is no pathway to the STP from the RCA, or pathways are administratively controlled to prevent the transfer of licensed materials to the STP, there is no need to analyze the sludge prior to any disposal.

Since the 1987 commitment, engineering modifications and administrative controls have eliminated the pathways from the RCA to the STP. Three subsequent sludge GIAs (a total of eight STP samples) utilizing the analytical parameters required to achieve environmental lower limit of detection (LLD) found only naturally occurring radionuclides. In each analysis, the licensed materials were below the minimum detectable activity for the particular measurement and below the required LLDs. These results verify the efficiency of the modifications and administrative controls in eliminating pathways from the RCA to the STP. Therefore, because there is no longer any reason to believe that the PBNP STP sewage contains licensed material and there are no pathways from the RCA to the STP, the sewage may be disposed of by any legal method without GIA prior to each disposal.

F.1.3 Modification

Periodic gamma isotopic analyses (GIA) of the STP sludge shall occur at a frequency set forth in the Chemistry Analytical Methods & Procedures (CAMP). This may include analyses prior to disposal depending on the results from the periodic analyses. The GIA of the STP sludge shall meet the LLD criteria of normal liquid effluents. The detection of any licensed material in the sludge during the periodic GIA shall necessitate returning to the GIA prior to disposal in order to evaluate the radiological consequences of the disposal. The GIA prior to each disposal shall continue until such time that the sludge can be shown, using environmental LLD criteria, not to contain licensed material.

Also, re-initiation of the 1987 commitment to analyze the STP sludge prior to each disposal shall be required if plant conditions change in a manner which would lead one to believe that the STP sludge may be contaminated. An example of such a condition is the opening of valve STP-009 which is controlled by a tag. Again, reversion to a CAMP controlled frequency can occur only upon verification that no licensed material is in the sludge pursuant to the environmental LLD criteria.

F.1.4 Exposure Evaluations

If the sludge contains licensed material, the 1987 commitment requires that the appropriate exposure pathways be evaluated prior to each application of sludge to insure that the dose to the maximally exposed member of the general public is maintained at less than 1 mrem/year and that to the inadvertent intruder, at less than 5 mrem/year. Also, the measured concentration shall be compared to the liquid maximum effluent concentrations of Appendix B to 10 CFR 20.

The exposure pathways evaluated for the maximally exposed individual are the following:

1. External whole body exposure due to a ground plane source of radionuclides.
2. Milk ingestion pathway from cows fed alfalfa grown on plot.
3. Meat ingestion pathway from cows fed alfalfa grown on plot.
4. Vegetable ingestion pathway from vegetables grown on plot.
5. Inhalation of radioactivity resuspended in air above plot.
6. Pathways associated with a release to Lake Michigan. These pathways are ingestion of potable water at the Two Rivers, Wisconsin municipal water supply, ingestion of fish from edge of initial mixing zone of radionuclide release, ingestion of fresh and stored vegetables irrigated with water from Lake Michigan, ingestion of milk and meat from cows utilizing Lake Michigan as drinking water source, swimming and boating activities at the edge of the initial mixing zone, and shoreline deposits.

The exposure pathways evaluated for the inadvertent intruder are the same as items 1, 4, 5, and 6 identified above for the maximally exposed individual.

OFFSITE DOSE CALCULATION MANUAL

F.2 Procedure

The following steps are to be performed by the responsible Chemistry Specialist for each contaminated sewage treatment sludge disposal.

1. Determine the radionuclide concentrations in each representative sewage treatment sludge sample. The minimum number of representative samples required is three from each sludge storage tank. The average of all statistically valid concentration determinations will be utilized in determining the sludge storage tank concentration values.
2. Verify that the concentration of each radionuclide meets the concentration and activity limit criteria. The methodology for determining compliance with the concentration and activity limit criteria are contained in Wisconsin Electric letter VPMPD 87-430.
3. Verify that the proposed disposal of the sewage treatment sludge will maintain doses within the applicable limits. This calculation will include radionuclides disposed of in previous sludge applications. The activity from these prior disposals will be corrected for radiological decay prior to performing dose calculations for the meat, milk, and vegetable ingestion pathways, the inhalation of resuspended radionuclides, and all pathways associated with a potential release to Lake Michigan. The residual radioactivity will be corrected, if applicable, for the mixing of radionuclides in the soil prior to performing external exposure calculations.

Microshield, a nationally recognized computer code, will be used to calculate the dose rate due to standing on a plot of land utilized for sludge disposal in which the radionuclides from prior disposals have been incorporated into the plot by plowing. This calculated dose rate will be used to assess the radiological consequences from prior disposals with the consequences of proposed future disposals. The total radiological dose consequence of the past and the proposed disposal will be compared to the applicable limits to insure the dose is maintained at or below the limits.

The methodology for calculating the radiological impact of the sewage treatment sludge disposal is contained in Wisconsin Electric letter VPMPD 87-430.

4. Inform the appropriate Chemistry Specialist that the sewage treatment sludge disposal may proceed after verifying that the sewage treatment sludge meets the concentration, activity, and dose limits.
5. All calculations shall be included with the sewage treatment sludge disposal record.

OFFSITE DOSE CALCULATION MANUAL

F.3 Administrative Requirements

The following steps are to be performed by the responsible Chemistry Specialist for each contaminated sewage treatment sludge disposal.

1. Complete records of each contaminated disposal shall be kept as follows:
 - a. Radionuclide concentration of the sludge
 - b. Total volume of the sludge disposed
 - c. The identity of the plot used for the disposal
 - d. Dose calculation results
 - e. Results of annual chemical composition determination
2. Modifications to the WE application as documented in the October 8, 1987, letter shall be processed in accordance with NP 5.1.7, Regulatory Commitment Management. (CCE 001-013)

a. Commitment Change - 1

Section 3.2 of Attachment II of the submittal states that physical and chemical properties of the sludge would be determined prior the each land application. Pursuant to a change in the PBNP WPDES Permit, non-radiological properties are now determined annually instead of per application. The frequency for radiological characterization did not change. (See Appendix H and CCE 2002-002)

b. Commitment Change - 2

In Section 3.3 of Attachment II of the submittal letter, the annual disposal rate was..." limited to 4,000 gallons/acre, provided WDNR chemical composition, NRC dose guidelines and activity limits are maintained..." Modification 2 removes the 4,000 gallon limit and makes the application unlimited provided the WDNR and NRC constraints are met. (See Appendix I and CCE 2002-004)

c. Commitment Change - 3

In Section 3.2 of Attachment II of NRC submittal letter dated October 8, 1987, Wisconsin Electric committed to gamma isotopic analysis (GIA) to determine the concentration of licensed material in sewage treatment plant (STP) sludge prior to each disposal. Pursuant to NRC HPPOS-221 guidance, the sludge has been shown to be clean on three different occasions after pathways from the RCA to the STP were eliminated by plant modifications and administrative controls. Pursuant to HPPOS, the sludge analyses were done under the conditions necessary to achieve the environmental LLDs. Only naturally occurring radionuclides were found and licensed material was below the minimum detectable concentration. This indicates that the former pathways from the RCA to the STP had been eliminated. Therefore, there is no need to continue the analyses because there is no RCA to STP pathway and there is no reason to believe that the sewage contains licensed material. Hence, the commitment to analyze STP sludge prior to every disposal is modified and replaced with periodic analyses at a frequency set by CAMP 914. However, if plant conditions change in a manner which places the STP sewage outside the guidance parameters which allowed for the discontinuance of analyses, the sewage must be analyzed prior to each disposal until it again is shown not to contain licensed material. (See Appendix J and CCE-2002-3)

APPENDIX G
VPNPD-87-430, NRC-87-104

Wisconsin Electric submittal to the United States Nuclear Regulatory Commission, dated October 8, 1987 (VPNPD-87-430, NRC-87-104)

The submittal consists of the letter and two Attachments. Attachment II contains Appendices A-G.

Pursuant to the NRC letter of January 13, 1988 (NPC-30260), a copy of the submittal (VPNPD-87-430, NRC-87-104) must be permanently incorporated into the ODCM as an Appendix and future modifications of the letter be reported to the NRC in accordance with commitments regarding ODCM changes.

OFFSITE DOSE CALCULATION MANUAL

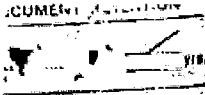

Wisconsin Electric POWER COMPANY
231 W. MICHIGAN, P. O. BOX 2046, MILWAUKEE, WI 53201

(414) 277-2345

VPNPD-87-430
NRC-87-104

October 8, 1987

U.S. NUCLEAR REGULATORY COMMISSION
Document Control Desk
Washington, D.C. 20555

Gentlemen:

DOCKET NOS. 50-266 AND 50-301
RESPONSE TO REQUEST FOR ADDITIONAL INFORMATION
FOR 10 CFR 20.302 APPLICATION
POINT BEACH NUCLEAR PLANT

*Plant 12010100 gen.
(cc. 05160000)
commitment made for
additional sampling
& analysis prior to
discharge of tank B,
page 2.)*

*JFB
JFK
JFK
JFK
JFK
JFK*

On July 14, 1987, Wisconsin Electric Power Company submitted an application, under the provisions of 10 CFR 20.302, for approval of a proposed procedure to dispose of sewage treatment sludge containing minute quantities of radioactive materials. Subsequent to the application, Mr. Ted Quay of the NRC staff requested additional information regarding the environmental characteristics of the area surrounding the Point Beach Nuclear Plant. The responses to this request were furnished in our submittal dated August 6, 1987.

By letter dated September 9, 1987, the NRC has requested Wisconsin Electric supply additional information in order to complete the review of our application. This Request for Additional Information (RAI) contains ten specific items which require responses or commitments from Wisconsin Electric. In addition, the NRC requests the previously submitted information and the information supplied in response to the RAI be compiled into "one complete, extensive, and self-contained package". To facilitate your review, Attachment I is included to provide direct responses to the ten items contained in the RAI. Attachment II is provided as the complete application, including the information from our letters dated July 14, 1987, and August 6, 1987, and information supplied in response to the NRC RAI.

We request that you complete your review of this complete, self-contained package and issue an approval of our application

RECEIVED

OCT 12 1987

POINT BEACH

OFFSITE DOSE CALCULATION MANUAL

NRC Document Control Desk

October 8, 1987

Page 2

as soon as possible. In order to facilitate your review and to expedite processing, we would be pleased to discuss these matters or provide additional information by telephone. Please feel free to contact us.

Very truly yours,

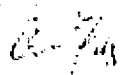
C. W. Fay
Vice President
Nuclear Power

bjm

Attachments

Copies to NRC Resident Inspector
NRC Regional Administrator, Region III

Blind copies to Britt/Gorske/Finke, Burstein, Charnoff,
Fay, Krieser, Lipke, Newton, Zick

ATTACHMENT I

RESPONSES TO QUESTIONS CONTAINED IN THE
REQUEST FOR ADDITIONAL INFORMATION (RAI)
ON POINT BEACH 1 AND 2 REQUEST
FOR DISPOSAL OF LOW LEVEL RADIOACTIVITY
CONTAMINATED SEWAGE SLUDGE BY LAND APPLICATION
WISCONSIN ELECTRIC POWER COMPANY
UNDER 10 CFR 20.302(a)

OFFSITE DOSE CALCULATION MANUAL

The numbering system used in these responses corresponds directly to numbering used in the NRC RAI, dated September 9, 1987.

1. a. This request is for multiple applications, approximately 2 to 4 per year.
- b. This request is for multiple years, expiration to coincide with conclusion of decommissioning activities associated with retirement of PBNP Units 1 & 2.
- c. Please refer to the response to question number 10.

2. The pathways used to determine doses to both the maximally exposed individual and the inadvertent intruder are documented in Attachment II, Appendices D and E.

Due to the extremely low concentrations of radionuclides in the sewage sludge and the associated low doses, Wisconsin Electric will control access to the disposal sites by conditions of use defined in lease agreements with the lease. Use of the land is not controlled beyond the conditions of the lease, thereby not restraining a casual visitor from the disposal site. However continuous occupancy would be readily observed, and remedial action would be taken.

3. Information contained in previous submittals has been included in Attachment II with modifications to provide specific commitments to the NRC.
4. Please refer to the response to question number 10.
5. Site maps have been updated and are included in Attachment II, Appendix C.
6. The direct grazing of cattle on the proposed disposal sites is controlled by restrictions contained in the lease agreement.

There will be no restrictions placed on fishermen on Lake Michigan. Calculations of doses due to all pathways associated with a release to Lake Michigan (Attachment II, Appendix E) do not indicate a need to apply restrictions to fishermen.

7. Please refer to revised site maps included in Attachment II, Appendix C. Site number 5 is located on company owned land beyond the PBNP site boundary. All other sites are within the PBNP site boundary area.
8. a. Please refer to Attachment II, Section 3.2, Disposal Procedure.
- b. Please refer to Attachment II, Section 3.2, Disposal Procedure.
- c. Please refer to Attachment II, Section 3.2, Disposal Procedure.
- d. Please refer to Attachment II, Appendix A.
9. Please refer to Attachment II, including Appendix D and Appendix E for additional pathways analyzed for this submittal. These identified pathways will be analyzed prior to all subsequent disposals to insure doses are maintained within prescribed limits, i.e., 1 mrem/year to the maximally exposed individual and 5 mrem/year to the inadvertent intruder.
10. A limiting concentration level for the sludge contained in the storage tank is discussed, in Attachment II, Appendix F. Since this application is for multiple applications over multiple years, Attachment II, Appendix F also addresses an activity limit.

ATTACHMENT II

COMPLETE ANALYSIS AND EVALUATION

POINT BEACH NUCLEAR PLANT

10 CFR 20.302(a) APPLICATION

OFFSITE DOSE CALCULATION MANUAL

1.0 Purpose

By this submittal Wisconsin Electric Power Company requests approval of the U.S. Nuclear Regulatory Commission for a proposed procedure to dispose of sewage treatment sludge containing trace quantities of radionuclides generated at the Point Beach Nuclear Plant. This request is submitted in accordance with the provisions of 10 CFR 20.302(a).

2.0 Waste Description

The waste involved in this disposal process consists of the residual solids remaining in solution upon completion of the aerobic digestion sewage treatment process utilized at PBNP. The PBNP sewage treatment plant is used to process waste water from the plant sanitary and potable water systems. These systems produce non-radioactive waste streams with the possible exception of wash basins located in the radiologically controlled area of the plant. These wash basins are believed to be the primary source of the extremely small quantities of radionuclides in the sludge.

The sewage sludge generated at PBNP is allowed to accumulate in the sewage plant digester and aeration basin. Two to four times annually, depending on work activities and corresponding work force at PBNP, the volume of the sludge in the digester and aeration basin needs to be reduced to allow continued efficient operation of the treatment facility. The total volume of sludge removed during each disposal operation is typically on the order of 15,000 gallons. The maximum capacity for the entire PBNP treatment facility and hence the maximum disposal volume is about 30,000 gallons. In the case of a maximum capacity disposal, doses would not necessarily increase in proportion to the volume, since more than one disposal site may be used.

Trace amounts of radionuclides have been identified in PBNP sludge currently being stored awaiting disposal. The radionuclides identified and their concentrations in the sludge are summarized below:

<u>Nuclide</u>	<u>Concentration ($\mu\text{Ci/cc}$)</u>
Co-60	2.33E-07
Cs-137	1.50E-07

The total activity of the radionuclides in the stored sludge, based on the identified concentrations and a total volume of 15,000 gallons of sewage sludge, are as follows:

<u>Nuclide</u>	<u>Activity (μCi)</u>
Co-60	13.2
Cs-137	8.5

These concentrations and activities are consistent with expected values based on prior analyses of sewage sludge. The radionuclide concentration in the sewage sludge has remained relatively constant during sampling conducted since December 30, 1993. A detailed summary of the results of this sampling program are contained in Appendix A for your review.

OFFSITE DOSE CALCULATION MANUAL

In addition to monitoring for the radionuclide content of the sludge, the WDNR requires several other physical and chemical properties of the sludge to be determined. These properties are the percent total solids, percent total nitrogen, percent ammonium nitrogen, pH, percent total phosphorus, percent total potassium, cadmium, copper, lead, nickel, mercury, zinc, and boron. An example of a typical sludge sample analysis is included in Appendix B

3.0 Disposal Method

In the context of this application, Wisconsin Electric commits to the following methodology. No distinction is made or intended between "shall" or "will", as used in the descriptions contained in this section.

3.1 Transport of Sludge

The method used to dispose of the sludge shall utilize a technique approved by the WDNR. The process of transporting the sewage sludge for disposal involves pumping the sludge from the PBNP sewage treatment plant storage tanks into a truck mounted tank. The truck mounted tank shall be required to be maintained tightly closed to prevent spillage while in transit to the disposal site. The sludge shall be transported to one or more of the six sites approved by the WDNR for land application of the sewage sludge from PBNP.

3.2 Disposal Procedure

The radionuclide concentrations in the sludge shall be determined prior to each disposal by obtaining three representative samples from each of the sludge storage tanks. The sludge contained in the sludge tanks is prevented from going septic by a process known as complete mix and continuous aeration. This process completely mixes the sludge allowing for representative samples to be obtained.

The samples shall be counted utilizing a GeLi detector and multi-channel analyzer with appropriate geometry. The detection system is routinely calibrated and checked to ensure the lower limits of detection are within values specified in the Radiological Effluent Technical Specifications (RETS).

To insure the samples are representative of the overall concentration in the storage tanks, the radionuclide concentration determination for each of the three samples shall be analyzed to insure each sample is within two standard deviations of the average value of the three samples. If this criteria is not met, additional samples will be obtained and analyzed to insure a truly representative radionuclide concentration is utilized for dose calculations and concentration limit determinations. The average of all statistically valid concentration determinations will be utilized in determining the storage tank concentration values.

OFFSITE DOSE CALCULATION MANUAL

Prior to disposal the waste stream will be monitored to determine the physical and chemical properties of the sludge, as discussed in the last paragraph of Section 2.0, Waste Description. The results will be compared to State of Wisconsin limits to insure the sludge does not pose a chemical hazard to people or to the environment.

The radionuclides identified in the sludge, along with their respective concentrations, will be compared to concentration limits prior to disposal. The methodology discussed in Appendix F will be used in determining compliance with the proposed concentration limit. The total activity of the proposed disposal will be compared to the proposed activity limit as described in Appendix F.

If the concentration and activity limit criteria are met, the appropriate exposure pathways (as described in Appendix D) will be evaluated prior to each application of sludge. These exposures will be evaluated to insure the dose to the maximally exposed individual will be maintained less than 1 mrem/year and the dose to the inadvertent intruder is maintained less than 5 mrem/year. The exposures will be calculated utilizing the methodology used in Appendix E, including the current activity to be landspread along with the activity from all prior disposal. The remaining radioactivity from prior disposals will be corrected for radiological decay prior to performing dose calculations for the meat, milk, and vegetable ingestion pathways, the inhalation of resuspended radionuclides, and all pathways associated with a release to Lake Michigan. The residual radioactivity will be corrected for radiological decay and, if appropriate, the mixing of the radionuclides in the soil by plowing prior to performing external exposure calculations.

The sewage sludge is applied on the designated area of land utilizing the WDNR approved technique and adhering to the following requirements of WPOES Permit Number WI-0000957-3.

- ° Discharge to the land disposal system shall be limited so that during surface spreading all of the sludge and any precipitation falling onto or flowing onto the disposal field shall not overflow the perimeter of the system.
- ° Sludge shall not be land spread on land with a slope greater than 12%. During the period from December 15 through March 31 sludge shall not be land spread on land with a slope greater than 6% unless the wastes are injected immediately into the soil.
- ° Sludge shall not be surface spread closer than 500 feet from the nearest inhabited dwelling except that this distance may be reduced ~~with the dwelling owner's written consent.~~
- ° Sludge shall not be spread closer than 1,000 feet from a public water supply well or 250 feet from a private water supply well.
- ° Sludge shall not be land spread within 200 feet of any surface water unless a vegetative buffer strip is maintained between the surface watercourse and the land spreading system, in which case a minimum separation distance of at least 100 feet is required between the system and the surface watercourse.

OFFSITE DOSE CALCULATION MANUAL

- Depth to groundwater and bedrock shall be greater than 3 feet from the land surface elevation during use of any site.
- Sludge shall not be land spread in a floodway.
- Sludge shall not be land spread within 50 feet of a property line road or ditch unless the sludge is incorporated with the soil, in which case a minimum separation distance of at least 25 feet is required.
- The pH of the sludge-soil mixture shall be maintained at 6.5 or higher.
- Low areas of the approved fields, subject to seasonally high groundwater levels, are excluded from the sludge application.
- Crops for human consumption shall not be grown on the land for up to one year following the application of the sludge.
- The sludge shall be plowed, disked, injected or otherwise incorporated into the surface soil layer at appropriate intervals.

The flexibility implied in the latter provision for soil incorporation is intended to allow for crops which require more than a one year cycle. For the Point Beach disposal sites, alfalfa is a common crop which is harvested for several years after a single planting. Sludge disposal on an alfalfa plot constitutes good fertilization, but the plot cannot be plowed without destroying the crop. The alfalfa in this case aids in binding the layer of sludge on the surface of the plot. At a minimum, however, plowing (or disking or other method of injection and mixing to a nominal depth of 6 inches) shall be done prior to planting any new crop, regardless of the crop.

3.3 Administrative Procedures

Complete records of each disposal will be maintained. These records will include the concentration of radionuclides in the sludge, the total volume of sludge disposed, the total activity, the plot on which the sludge was applied, the results of the chemical composition determinations, and all dose calculations.

The annual disposal rate for each of the approved land spread sites will be limited to 4,000 gallons/acre, provided WDNR chemical composition, NRC dose guidelines, and concentration and activity limits are maintained within the appropriate values.

The farmer leasing the site used for the disposal will be notified of the applicable restrictions placed on the site due to the land spreading of sewage sludge.

4.0 Evaluation of Environmental Impact

4.1 Site Characteristics

4.1.1 Site Topography

The disposal sites are located in the Town of Two Creeks in the northeast corner of Manitowoc County, Wisconsin, or the

OFFSITE DOSE CALCULATION MANUAL

west shore of Lake Michigan about 30 miles southeast of the center of the city of Green Bay, and 90 miles MNE of Milwaukee. This site is located at longitude 87° 32.5'W and latitude 44° 17.0'N. The six sites are on property owned and controlled by Wisconsin Electric and are within or directly adjacent to the Point Beach site boundary. The sites are described below and are outlined on the map contained in Appendix C as Figure 3.

Site No. PB-01 - The approximately 15 acres located in the NE 1/4 of the NE 1/4 of Section 23, T. 21N - R. 24E.

Site No. PB-02 - The approximately 20 acres located in the SE 1/4 of the SE 1/4 of Section 14, T. 21N - R. 24E.

Site No. PB-03 - The approximately 5 acres located in the NW 1/4 of Section 24, T. 21N - R. 24E.

Site No. PB-04 - The approximately 5 acres located in the NW 1/4 of the SW 1/4 of Section 24, T. 21N - R. 24E.

Site No. PB-05 - The approximately 5 acres located in the NE 1/4 of the NW 1/4 of Section 25, T. 21N - R. 24E.

Site No. PB-06 - The approximately 5 acres located in the NE 1/4 of the SW 1/4 of Section 14, T. 21N - R. 24E.

The overall ground surface at the site of the Point Beach Nuclear Plant is gently rolling to flat with elevations varying from 5 to 60 feet above the level of Lake Michigan. Subdued knob and kettle topography is visible from aerial photographs. The land surface slopes gradually toward the lake from the higher glacial moraine areas west of the site. Higher ground adjacent to the lake, however, diverts the drainage to the north and south.

The major surface drainage features are two small creeks which drain to the north and south. One creek discharges into the lake about 1500 feet above the northern corner of the site and the other near the center of the site. During the spring, ponds of water may occupy the shallow depressions. As mentioned in Section 3.2, Disposal Procedure, these low areas are excluded from the sludge application.

A site topographic map covering details out to a 5 mile radius may be found in the FSAR at Figure 2.2-3 and is included in Appendix C as Figure 2.

The disposal of sewage sludge at these six sites will have no impact on the topography of this area.

4.1.2 Site Geology

Prior to construction of the Point Beach Nuclear Plant, an evaluation of the geological characteristics of the area in and surrounding the site was made. The geologic structure of the region is essentially simple. Gently dipping sedimentary rock

OFFSITE DOSE CALCULATION MANUAL

strata of Paleozoic age outcrop in a horseshoe pattern around a shield of Precambrian crystalline rock which occupies the western part of the region. The site is located on the western flank of the Michigan Basin, which is a broad downwarp ringed by discontinuous outcrops of more resistant formations. The bedrock formations are principally limestones, dolomites, and sandstones with subordinate shale layers. The rocks form a succession of extensive layers that are relatively uniform in thickness. The bedrock strata dip very gently towards Lake Michigan at rates from 15 to 35 feet per mile.

The uppermost bedrock under the site is Niagara Dolomite. Bedrock does not outcrop on the site but is covered by glacial till and lake deposits. The soils contain expansive clay minerals and have moderately high base exchange capacity.

In the area of the site, the overburden soils are approximately 70 to 100 feet in thickness. Although the character of the glacial deposits may vary greatly within relatively short distances, a generalized section through the overburden soils adjacent to Lake Michigan at the site consists of the following sequence:

1. An upper layer of brown clay silt topsoil underlain with several feet of brown silty clay with layers of silty sand;
2. A layer of 20 feet of reddish-brown silty clay with some sand and gravel and occasional lenses of silt;
3. A layer of 25 feet of reddish-brown silty clay with layers of silty sand and lenses of silt;
4. A layer of 50 feet of reddish-brown silty clay with some sand and gravel, the lower portion of which contains gravels, cobbles, and boulders resting on a glacial eroded surface of Niagara dolomite bedrock.

Site drainage is poor due to the high clay content of the soil combined with the pock-marked surface. Additional information on site geology may be found in Section 2.8 of the FSAR.

The use of these sites for disposal of sewage sludge will not impact the geology of the area.

4.2 Area Characteristics

4.2.1 Meteorology

The climate of the site region is influenced by the general storms which move eastward along the northern tier of the United States and by those which move northeastward from the southwestern part of the country to the Great Lakes. This continental type of climate is modified by Lake Michigan. During spring, summer, and fall months the lake temperature differs markedly from the air temperature. Wind shifts from westerly to easterly directions produce marked cooling of day-time

temperatures in spring and summer. In autumn the relatively warm water to the lake prevents night-time temperatures from falling as low as they do a few miles inland from the shoreline. Summer time temperatures exceed 90°F for six days on the average. Freezing temperatures occur 147 days and below zero on 14 days of the winter on the average. Rainfall averages about 28 inches per year with 55 percent falling in the months of May through September. Snowfall averages about 45 inches per year. Sludge spreading shall be managed such that the surface spreading together with any precipitation falling on the field shall not overflow the perimeter of the field. Additional information on site meteorology may be found in Section 2.6 of the FSAR.

There will be no impact on the meteorology of the area due to the disposal of the sewage sludge.

4.2.2 Hydrology

The dominant hydrological feature of this site is Lake Michigan, one of the largest of the Great Lakes. The normal water level in Lake Michigan is approximately 580 feet above mean sea level. In the general vicinity of the site, the 30 foot depth contour is between 1 and 1-1/2 miles offshore and the 60 foot contour is 3 to 3-1/2 miles off shore. The disposal sites are twenty or more feet above the normal lake level. There is no record that the sites have been flooded by the lake during modern times. There are no rivers or large streams which could create a flood hazard at or near the sites.

The subsurface water table at the Point Beach site has a definite slope eastward toward the lake. The gradient indicated by test drilling on the site is approximately 30 feet per mile. It is therefore extremely unlikely that any release of radioactivity on the site could spread inland. Furthermore, the rate of subsurface flow is small due to the relative impervious nature of the soil and will not promote the spread of releases. Further information on site hydrology is detailed in the PBNP FSAR Section 2.5.

There will be no adverse impact on hydrology of the area due to disposal of sewage sludge by land spreading.

4.3 Water Usage

4.3.1 Surface Water

Lake Michigan is used as the source of potable water supplies in the vicinity of the site for the cities of Two Rivers (12 miles south), Manitowoc (16 miles south), Sheboygan (40 miles south), and Green Bay (intake at Rostok 1 mile north of Kewaunee, 13 miles north). No other potable water uses are recorded within 50 miles of the site along the lake shore. All public water supplies drawn from Lake Michigan are treated in purification plants. The nearest surface water used for drinking other than Lake Michigan are the Fox River 30 miles NW and

OFFSITE DOSE CALCULATION MANUAL

Lake Winnebago 40 miles W of the site.

Lake Michigan is also utilized by various recreational activities, including fishing, swimming and boating.

There will be no impact on surface water usage due to the disposal of sewage sludge.

4.3.2 Ground Water

Ground water provides the remaining population with potable supplies. Public ground water supplies within a 20 mile radius of the site are listed in Table 2.5-3 of the FSAR. Additional wells for private use are in existence throughout the region. The location of private wells within a two mile radius of PBNP are indicated on Figure 3, Appendix C.

The potable water for use at the Point Beach Nuclear Plant is drawn from a 257 feet deep well located at the southwest corner of the plant yard. Water from this well is routinely sampled as part of the environmental monitoring program.

There will be no adverse impact on ground water usage due to the disposal of sewage sludge.

4.4 Land Usage

Manitowoc County, in which the site is located, and the adjacent counties of Kewaunee, Brown, Calumet, and Sheboygan are predominantly rural. Agricultural pursuits account for approximately 90% of the total county acreage. With the exception of the Kewaunee Nuclear Plant located 4.5 miles north, the region within a radius of five miles of the site is presently devoted exclusively to agriculture. Dairy products and livestock account for 85% of the counties' farm production, with field crops and vegetables accounting for most of the remainder. The principal crops are grain corn, silage corn, oats, barley, hay, potatoes, green peas, lima beans, snap beans, beets, cabbage, sweet corn, cucumbers, and cranberries. Within the township of Two Creeks surrounding the site (15 sq. miles), there are about 800 producing cows on about 40 dairy farms. Some beef cattle are raised 2.5 miles north of the site. Cows are on pasture from the first of June to late September or early October. During the winter, cows are fed on locally produced hay and silage. Of the milk produced in this area, about 25 percent is consumed as fluid milk and 50 percent is converted to cheese, with the remainder being used in butter making and other by-products.

It has been the policy of Wisconsin Electric to permit the controlled use of crop land and pasture land on company owned property. No direct grazing of dairy or beef cattle or other animals is permitted on these company owned properties. Crops intended for human consumption shall not be grown on the disposal sites for at least one year following the application of the sludge.

The proposed land application of sewage sludge will not have any direct effect on the adjacent facilities. Additional land use

OFFSITE DOSE CALCULATION MANUAL

information may be found in Section 2.4 of the FSAR.

4.5 Radiological Impact

The rate of sewage sludge application on each of the six proposed sites will be monitored to insure doses are maintained within applicable limits. These limits are based on NRC Nuclear Reactor Regulation (NRR) staff proposed guidance (described in AIF/NESP-037, August, 1986). These limits require doses to the maximally exposed member of the general public to be maintained less than 1 mrem/year due to the disposal material. In addition, NRR guidance requires doses of less than 5 mrem/year to an inadvertent intruder.

To assess the doses received by the maximally exposed individual and the inadvertent intruder, six credible pathways have been identified for the maximally exposed individual and four credible pathways for the inadvertent intruder. The identified credible pathways are described in Appendix D.

Calculations detailed in Appendix E demonstrate the disposal of the currently stored PBNP sewage sludge would remain below these limits. The total annual exposure to the maximally exposed individual based on the identified exposure pathways is equal to 0.072 mrem. The dose to a hypothetical intruder assuming an overly conservative occupancy factor of 100% is calculated to be 0.115 mrem/year. By definition, the inadvertent intruder would not be exposed to the processed food pathways (meat and milk).

The calculational methodology used in determining doses for the proposed disposal of sludge stored at PBNP shall be utilized prior to each additional land application to insure doses are maintained less than those proposed by NRR. This calculation will include radionuclides disposed of in previous sludge applications. The activity from these prior disposals will be corrected for radiological decay prior to performing dose calculations for the meat, milk, and vegetable ingestion pathways, the inhalation of resuspended radionuclides, and all pathways associated with a potential release to Lake Michigan. The residual radioactivity will be corrected for radiological decay and, if applicable, the mixing of radionuclides in the soil prior to performing external exposure calculations. In addition, the dose to a farmer potentially leasing more than one application site will be addressed by summing the doses received from the external exposure from a ground plane source and resuspension inhalation pathways for each leased site. In addition, the maximum site specific dose due to the other pathways identified in Appendix D, will be utilized in the total exposure estimation.

5.0 Radiation Protection

The disposal operation will follow the applicable PBNP procedures to maintain doses as low as reasonably achievable. Technical review and guidance will be provided by the PBNP Superintendent - Health Physics.

APPENDIX A

SUMMARY OF RADIOLOGICAL ANALYSES
OF SEWAGE SLUDGE SINCE DECEMBER 30, 1983

OFFSITE DOSE CALCULATION MANUAL

<u>Sample Date</u>	<u>Tank</u>	<u>Tank Volume (Gallons)</u>	<u>Radionuclide</u>	<u>Concentration (µCi/cc)</u>
12-30-83	Digester	8400	Co-58	5.58E-07
			Co-60	1.87E-06
			Cr-51	4.88E-07
			Cs-134	1.59E-07
			Cs-137	3.57E-07
4-05-84	Digester	7560	Co-60	7.89E-07
	Aeration	6667	Co-60	1.87E-07
12-05-84	Digester	7560	Co-58	1.75E-07
	Aeration	6667	Co-60	8.29E-07
6-03-85	Digester	7560	Co-60	8.29E-07
			Cs-137	2.46E-07
	Aeration	6700	Co-60	3.27E-07
			Cs-137	1.33E-07
4-10-86	Digester	7560	Co-60	6.79E-07
			Cs-137	1.72E-07
			Mn-54	4.91E-08
			Co-60	1.65E-07
11-04-86	Digester	7560	Co-58	8.04E-08
			Aeration & Clarifier	
		25100	Co-58	1.37E-07
			Co-60	2.18E-07
			Cs-137	1.64E-07

APPENDIX B

CHEMICAL COMPOSITION ANALYSIS
OF SEWAGE SLUDGE

OFFSITE DOSE CALCULATION MANUAL

STATE OF WISCONSIN
DEPARTMENT OF NATURAL RESOURCES

SLUDGE CHARACTERISTIC
Wisconsin Statute 147.02(1) and
Wisconsin Administrative Code NR 110.27(6)
FORM 3400-49 REV. 10-80

Sewage Treatment Plant Sludge

Please complete this form and send to the Department of Natural Resources appropriate District/Area Office. Keep one copy for your records.
For additional forms, please contact your appropriate District/Area Office.

PERMITTEE Wisconsin Electric Power Company	WPDNR PERMIT NUMBER WI 00 0 0 9 5 7
STREET OR ROUTE 231 W. Michigan Street	COUNTY Milwaukee
CITY, STATE, ZIP CODE Milwaukee, WI 53203	TELEPHONE NUMBER (INCLUDE AREA CODE) 414-277-2153

1. Please report laboratory testing results for the following parameters:

*Parameter	Abbreviation	Result	*Parameter	Abbreviation	Result
Total Solids, %	-	<u>1.85</u>	Chromium, ppm	Cr	<u>7</u>
Total Nitrogen, %	TOT N	<u>1.0</u>	Copper, ppm	Cu	<u>2200</u>
Ammonium Nitrogen, %	NH ₄ ⁺ -N	<u>0.34</u>	Lead, ppm	Pb	<u>120</u>
Total Phosphorous, %	P	<u>< 0.01</u>	Mercury, ppm	Hg	<u>5.6</u>
Total Potassium, %	K	<u>0.25</u>	Nickel, ppm	Ni	<u>12</u>
Arsenic, ppm	As	<u>1.0</u>	Zinc, ppm	Zn	<u>2300</u>
Cadmium, ppm	Cd	<u>12</u>	pH	-	<u>7.0</u>

*Suggested analysis procedures for the above parameters can be found in NR 219, analytical tests and procedures, Wisconsin Administrative Code. All parameters other than percent solids and pH shall be reported on a dry weight basis.

2. What is the name of the laboratory that did the analysis and when was it performed?

Laboratory Name Wisconsin Electric Power Co. Laboratory Services Division Date sent to lab April 12, 1983

Where at the treatment plant was the sample taken? From sludge holding tank prior to hauling

4. When was the sample taken? April 12, 1983

SIGNATURE <u>[Signature]</u>	TITLE <u>Water Quality Engineer</u>	DATE <u>4/12/83</u>
---------------------------------	--	------------------------

APPENDIX C

SITE MAPS

OFFSITE DOSE CALCULATION MANUAL

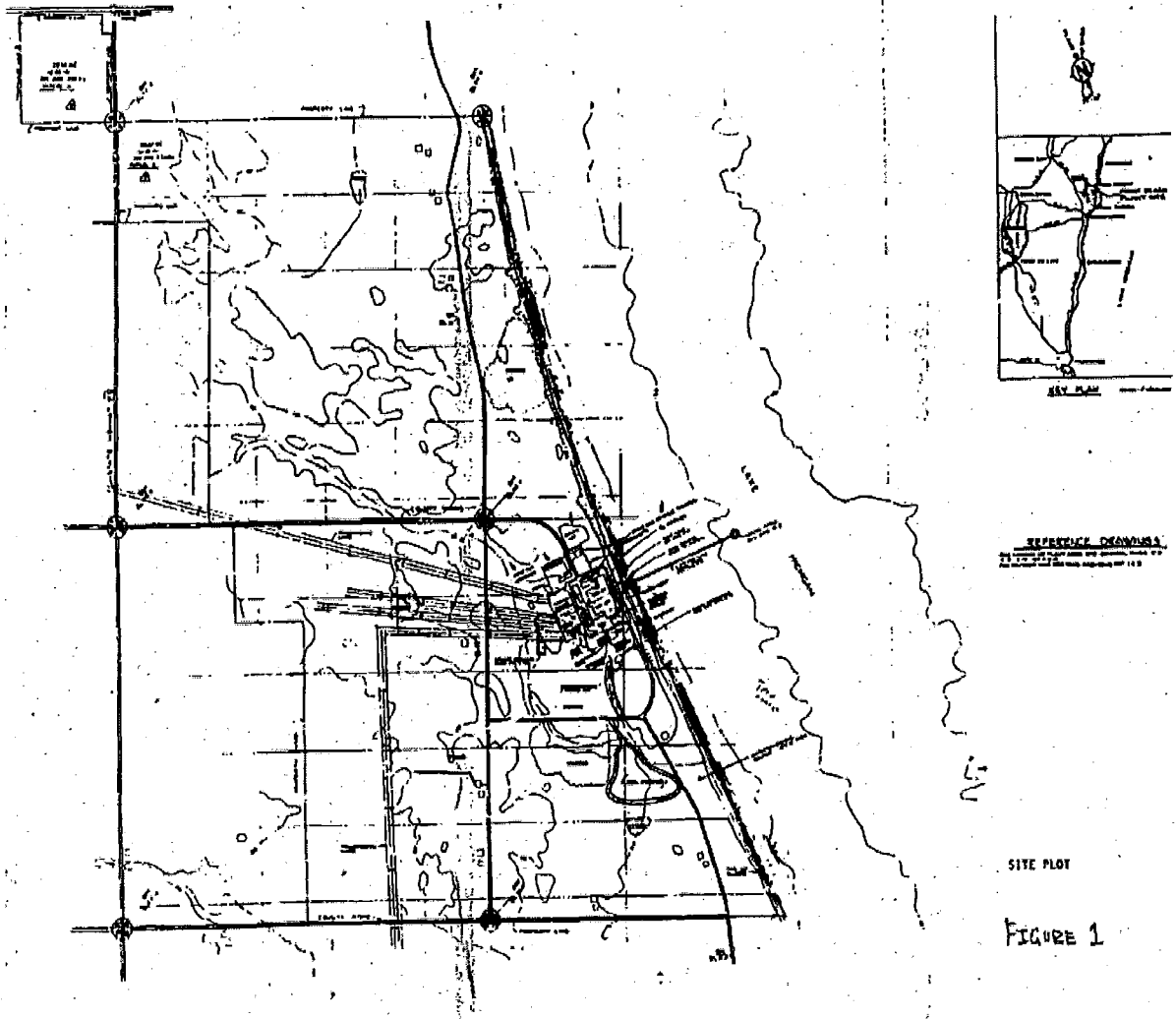

OFFSITE DOSE CALCULATION MANUAL

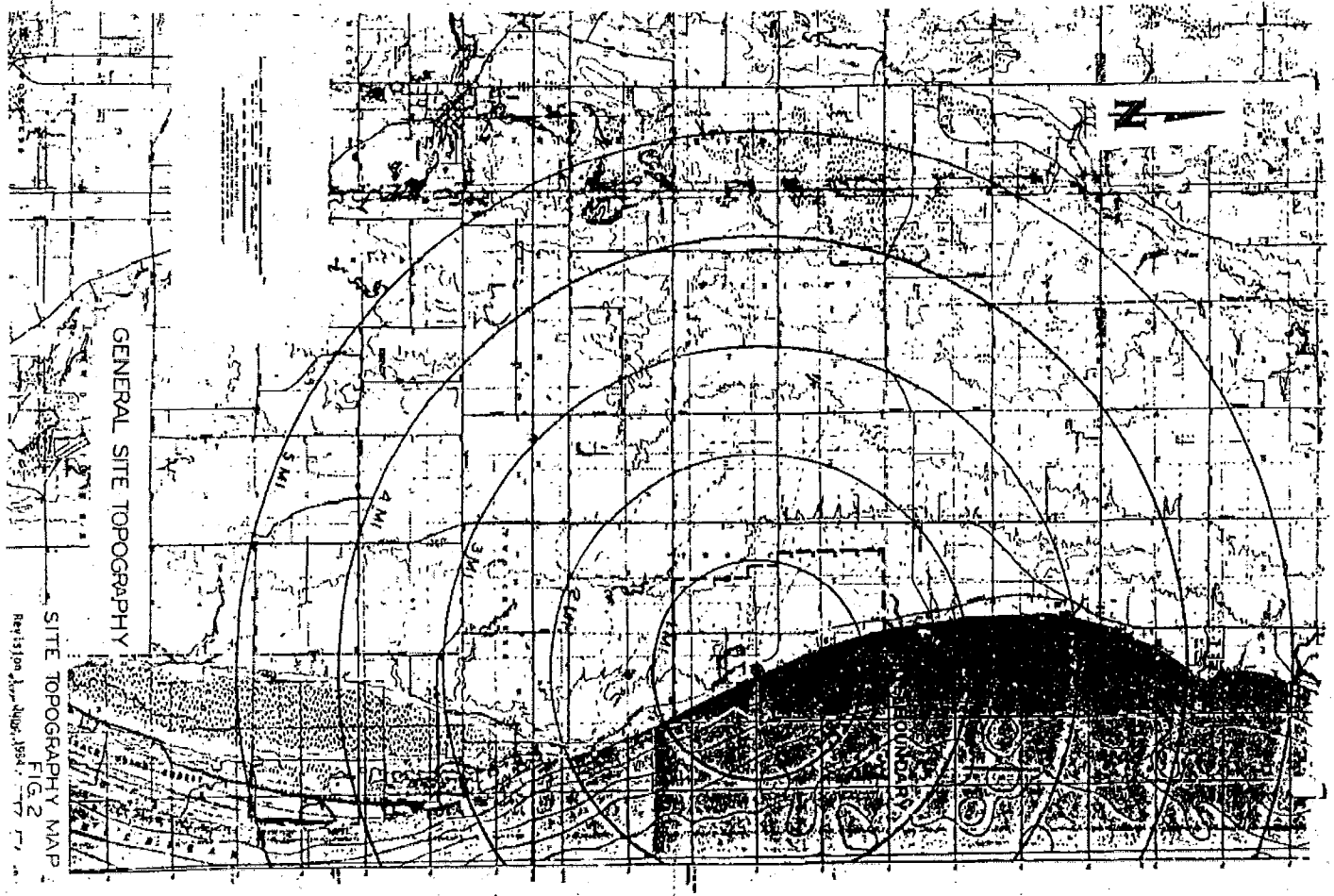

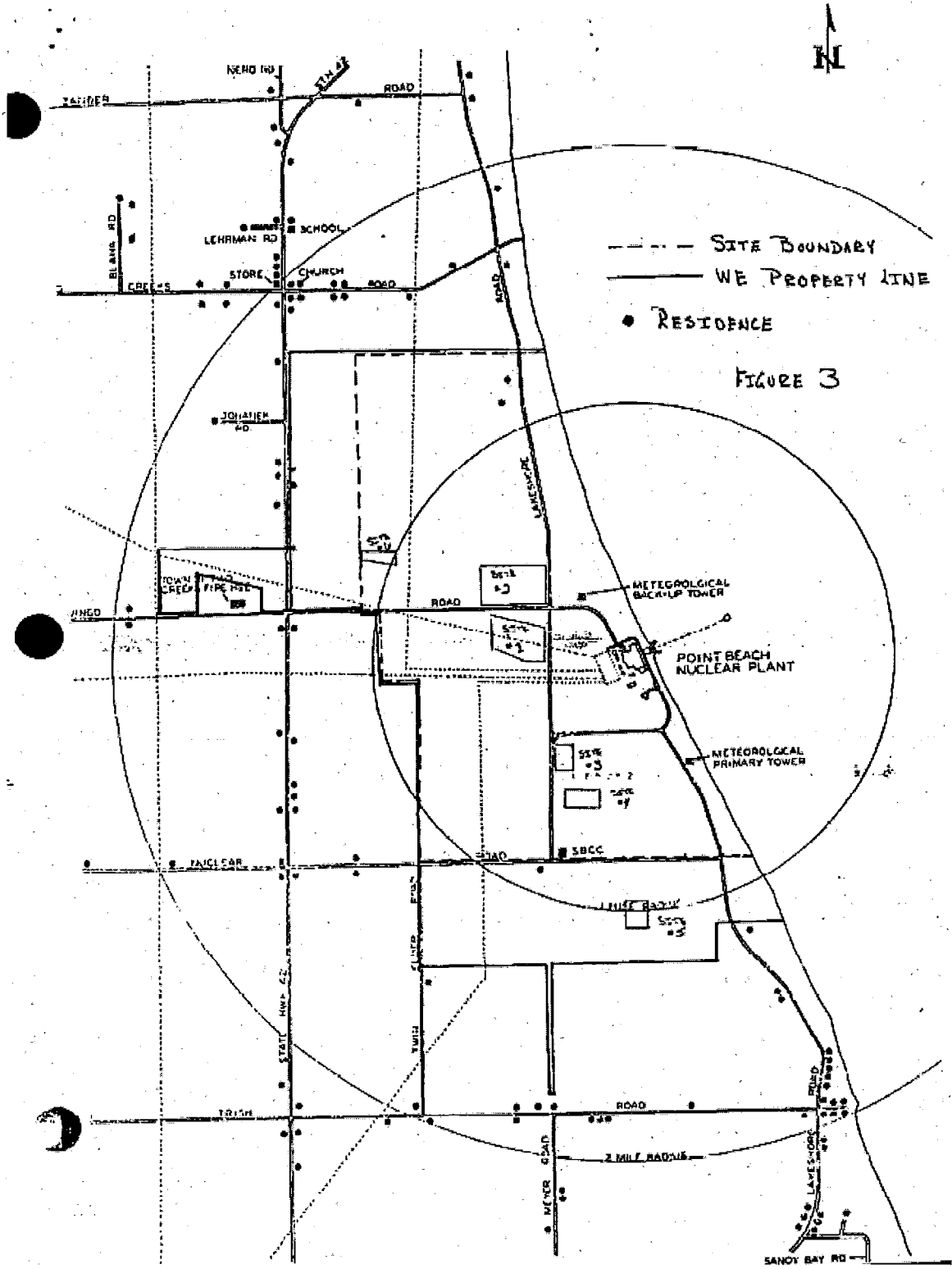

APPENDIX D

EXPOSURE PATHWAYS

OFFSITE DOSE CALCULATION MANUAL

I. EXPOSURE PATHWAYS - MAXIMALLY EXPOSED INDIVIDUAL

1. External whole body exposure due to a ground plane source of radionuclides.
2. Milk ingestion pathway from cows fed alfalfa grown on plot.
3. Meat ingestion pathway from cows fed alfalfa grown on plot.
4. Vegetable ingestion pathway from vegetables grown on plot.
5. Inhalation of radioactivity resuspended in air above application site.
6. Pathways associated with a release to Lake Michigan. Ingestion of potable water at Two Rivers, Wisconsin municipal water supply, ingestion of fish from edge of initial mixing zone of radionuclide release, ingestion of fresh and stored vegetables irrigated with water source as Lake Michigan, ingestion of milk and meat from cows utilizing Lake Michigan as drinking water source, swimming and boating activities at edge of initial mixing zone, and shoreline deposits.

II. EXPOSURE PATHWAYS - INADVERTENT INTRUDER

1. External whole body exposure due to ~~to~~ ground plane source of ~~to the body and~~ radionuclides.
2. Vegetable ingestion pathway from vegetables grown on plot.
3. Inhalation of radioactivity resuspended in air above application site.
4. Pathways associated with a release to Lake Michigan. Ingestion of potable water at Two Rivers, Wisconsin municipal water supply, ingestion of fish from edge of initial mixing zone of radionuclide release, ingestion of fresh and stored vegetables irrigated with water source as Lake Michigan, ingestion of milk and meat from cows utilizing Lake Michigan as drinking water source, swimming and boating activities at edge of initial mixing zone, and shoreline deposits.

The milk and meat pathways are not included in calculating the dose to the inadvertent intruder. The doses due to these pathways are calculated based on feeding the cows alfalfa grown on the sludge applied land. Since direct grazing on these lands is prohibited, the alfalfa must be cropped prior to being used as feed. This effectively removes the availability of these pathways to the inadvertent intruder, who by definition occupies the sludge applied land continuously.

OFFSITE DOSE CALCULATION MANUAL

III. GROUND WATER PATHWAY

The ingestion of groundwater is not a credible exposure pathway. The two factors contributing to this determination are as follows:

1. The site map in Appendix C, Figure 3 details the spatial relationship between the proposed disposal sites and the local ground water wells. The flow gradient of ground water was determined for the PBNP FSAR to be towards Lake Michigan. Reviewing the sites and local wells shows no private well located in the path of radionuclide migration towards Lake Michigan.

The PBNP site well is located on the plant site, potentially in a path of radionuclide migration. The PBNP well is routinely sampled as a requirement of the PBNP environmental monitoring program.

2. The cation exchange capacity (CEC) of the soils at each site has been determined.

<u>Site</u>	<u>Cation Exchange Capacity (MEQ/100g)</u>
1	16
2	11
3	11
4	10
5	8
6	9

The cation exchange capacity of soil is dependent on the valance of the radionuclides and is determined by the relation:

$$MEQ = \frac{ATOMIC\ WEIGHT}{VALANCE} * 1.0E-03$$

<u>Radionuclide</u>	<u>Valance</u>	<u>CEC (MEQ/100g)</u>
Co-60	+2	3.00E-02
Co-58	+2	2.90E-02
Cs-137	+1	1.37E-01
Mn-54	+2	2.70E-02
Cr-51	+3	1.70E-02
Cs-134	+1	1.34E-01

Using the values for Cs-137 and site 5 which has the lowest CEC, the total exchange capacity of the soil is

$$\frac{1.10 \text{ grams of Cs-137}}{100 \text{ grams of soil}}$$

Calculating the specific activity of Cs-137,

$$\text{Specific Activity} = \frac{3.578E+05}{T_{1/2}(\text{yrs.}) \cdot ATOMIC\ MASS} = \frac{3.578E+05}{30 \cdot 137}$$

$$= 87.1 \text{ Ci/gram}$$

The cation exchange capacity of the soil expressed in the number of Curies of radionuclide per 100 grams of soil is

$$\frac{95.8 \text{ Ci Cs-137}}{100 \text{ grams of soil}}$$

Since the proposed disposal of sewage sludge contains quantities of radionuclides on the order of 10-100 μCi the soil at each site has the capacity to effectively eliminate the migration of the radionuclide to ground water.

APPENDIX E

EXPOSURE ANALYSIS

OFFSITE DOSE CALCULATION MANUAL

GENERAL ASSUMPTIONS

1. Sewage sludge is uniformly applied over plot acreage.
2. Sewage sludge is applied to one of the 5 acre plots, site PB-03, PB-04, PB-05, or PB-06. (Assuming the smallest site size is conservative for the calculation methodology herein.)
3. Based on the sewage sludge currently stored at PBNP, the following data is used in the calculations.

<u>Radionuclide</u>	<u>Sludge Volume (Gallons)</u>	<u>Sludge Volume (cm³)</u>	<u>Activity (μCi)</u>	<u>Concentration (μCi/cm³)</u>	<u>Ground Plane Concentration (μCi/cm²)</u>
Co-60	15,000	5.68E+07	13.2	2.33E-07	6.53E-08
Cs-137	15,000	5.68E+07	8.5	1.50E-07	4.21E-08

I. CALCULATION OF EXTERNAL EXPOSURES

A. Specific Assumptions

1. Conservatively assume radioactivity remains on surface of land plot. Calculation ignores any plowing or mixing of radioactivity within soil. Calculations for the proposed disposal will therefore ignore self absorption or shielding from soil.

The external exposure at the application site due to prior disposals will be calculated utilizing the methodology in Appendix G and added to that calculated for the proposed disposal.

2. The plots are owned by Wisconsin Electric and have been approved by the Wisconsin Department of Natural Resources (DNR) as disposal sites. The land is leased and potentially farmed. Occupancy of the land can be realistically expected only during plowing, planting and harvesting. Occupancy has been estimated to be 64 hours per year.

B. Summary of Calculational Methodology

1. Calculate ground plane radionuclide concentrations in pCi/cm².
2. The dose from a plane of uniformly deposited radionuclides is calculated using Regulatory Guide 1.109, Revision 1, Appendix C, Formula C-2.
3. Dose rates were calculated assuming continuous occupancy then adjusted for realistic occupancy factors.

OFFSITE DOSE CALCULATION MANUAL

C. External Exposure Rate Calculations

The dose from a plane of uniformly deposited radionuclides is calculated using Regulatory Guide 1.109, Revision 1, Appendix C, formula C-2

$$D_j^G(r,\theta) = 8760 S_F \sum_i C_i^G(r,\theta) DFG_{ij}$$

where

$D_j^G(r,\theta)$ = yearly dose

8760 = hours per year

S_F = 1.0, since no dose reduction due to residential shielding is applicable.

$C_i^G(r,\theta)$ = ground plane radionuclide concentration (pCi/m²)

$DFG(i,j)$ = external dose factor for standing on contaminated ground as given in Table E-6 of Regulatory Guide 1.109, Revision 1.

Radionuclide	γ Dose Factor (mrem/hr per pCi/m ²)	Ground Plane Concentration (μ Ci/cm ²)	Ground Plane Concentration (pCi/m ²)	γ Dose Rate (mrem/yr)
Co-60	1.70E-08	6.53E-08	6.53E+02	9.72E-02
Cs-137	4.20E-09	4.21E-08	4.21E+02	1.55E-02

TOTAL: 1.13E-01 mrem/year

These calculated dose rates assume continuous occupancy. In reality, these sites will be occupied only during plowing, planting, and harvesting. Assuming an occupancy of 2 hours per day, 1 day per week, and 32 weeks (8 month growing season) per year, the occupancy factor becomes

$$2 \text{ hr/day} * 1 \text{ day/week} * 32 \text{ weeks/yr} * 1/8760 \text{ hours/yr} = 7.3E-03.$$

EXTERNAL EXPOSURE DOSE RATE (mrem/year)

Radionuclide	Continuous Occupancy	Realistic Occupancy
Co-60	9.72E-02	7.10E-04
Cs-137	1.55E-02	1.13E-04
TOTAL:	1.13E-01	8.23E-04

OFFSITE DOSE CALCULATION MANUAL

II. CALCULATION OF MEAT AND MILK INGESTION PATHWAY EXPOSURES

A. Specific Assumptions

1. All feed consumed by cow is grown on sludge applied acreage.
2. All meat and milk consumed by human is from cattle exclusively fed feed from sludge applied land.
3. Stable element transfer coefficients (B_{iv}) are utilized from Regulatory Guide 1.109 to estimate the fraction of radioactivity which is transferred from the soil to the feed.

Radionuclide	B_{iv}
Co-60	9.4E-03
Cs-137	1.0E-02

4. Alfalfa has typically been grown on the plots. Soil tests have indicated a minimum alfalfa yield of 4.1 tons per acre can be expected.

B. Summary of Calculational Methodology

1. The concentration of radionuclides in feed grown on the disposal plots is estimated. Transfer coefficients (B_{iv}) from Table E-1 of Regulatory Guide 1.109 were used to estimate the fraction of radionuclide which may be expected to transfer to the feed from the soil.
2. Concentrations of radionuclides in milk and meat were estimated using Formula A-11 from Regulatory Guide 1.109.
3. Ingestion dose rates were estimated using Formula A-12 from Regulatory Guide 1.109.

C. Milk and Meat Ingestion Pathway Dose Rate Calculation

1. Concentration in feed.

$$\text{Activity in Feed} = B_{iv} * \text{Activity in Soil}$$

$$\text{Concentration in Feed} = \text{Activity in Feed} / \left(\frac{\text{kg of Feed}}{\text{Acre}} * 5 \text{ Acres} \right)$$

Radionuclide	Activity in Soil (μCi)	Activity in Feed (μCi)	Radionuclide Concentration in Feed (pCi/kg)
Co-60	13.2	1.24E-01	6.67E+00
Cs-137	8.5	8.50E-02	4.57E+00

2. Concentration in Milk and Meat

Calculate concentrations of radionuclides in milk and meat using

OFFSITE DOSE CALCULATION MANUAL

Formula A-11 in Regulatory Guide 1.109, Revision 1 which is

$$C_{iA} = F_{iA} * C_{iF} * Q_F$$

where C_{iA} = radionuclide concentration of i in component A
 F_{iA} = stable element transfer coefficient whose values are in Table E-1 of the Regulatory Guide
 C_{iF} = radionuclide concentration in feed
 Q_F = consumption rate of feed = 50 kg/d (wet weight) from Regulatory Guide 1.109

Use the following Regulatory Guide 1.109 values for F_{iA}

Element	F_{iA_m} (d/l) for milk	F_{iA_f} (d/kg) for meat
Co	1.0E-03	1.3E-02
Cs	1.2E-02	4.0E-03

Radionuclide	Concentration in Milk (pCi/l)	Concentration in Meat (pCi/kg)
Co-60	3.34E-01	4.34E+00
Cs-137	2.74E+00	9.14E-01

3. Calculated Dose rates

The formula for total dose from eating animal products fed vegetation (alfalfa) grown on PBNP sludge applied land is given by Regulatory Guide 1.109, Revision 1, Formula A-12, page 1-109-16. But, as noted following equation A-13, it is necessary to compute separately the milk and meat portions of the dose.

$$DOSE = \sum (U_{ap} * D_{iapg} * \exp(-\lambda_i t_s))$$

where U_{ap} = consumption rate of animal product
 C_{iA} = conc of radionuclide i in animal product A
 D_{iapg} = dose factor
 t_s = average time between milking or slaughtering and consumption

	U_{ap} by Age Group			
	Infant	Child	Teenager	Adult
Milk (l/yr)	330	330	400	310
Meat (kg/yr)	-	41	65	110

C_{iA} = concentration calculated above
 D_{iapg} = DF whole body dose factors, Regulatory Guide 1.109, Revision 1.

Whole Body Dose Factors (mrem/pCi Ingested)

<u>Nuclide</u>	<u>Infant Ingestion</u>	<u>Child Ingestion</u>	<u>Teenager Ingestion</u>	<u>Adult Ingestion</u>
Co-60	2.55E-05	1.56E-05	6.33E-06	4.72E-06
Cs-137	4.33E-05	4.62E-05	5.19E-05	7.14E-05

T₅ = 0 for milk (assume consumption on farm)
T₅ = 20 days for meat (Regulatory Guide 1.109, Revision 1, Table E-15)

MILK INGESTION DOSE RATE (mrem/year)

<u>Radionuclide</u>	<u>Infant</u>	<u>Child</u>	<u>Teenager</u>	<u>Adult</u>
Co-60	2.81E-03	1.72E-03	8.46E-04	4.89E-04
Cs-137	3.92E-02	4.18E-02	5.69E-02	6.06E-02
TOTALS:	4.20E-02	4.35E-02	5.77E-02	6.11E-02

MEAT INGESTION DOSE RATE (mrem/year)

<u>Radionuclide</u>	<u>Infant</u>	<u>Child</u>	<u>Teenager</u>	<u>Adult</u>
Co-60	-	2.76E-03	1.77E-03	2.24E-03
Cs-137	-	1.73E-03	3.08E-03	7.18E-03
TOTALS:	-	4.49E-03	4.85E-03	9.42E-03

MEAT AND MILK INGESTION PATHWAY DOSE RATES (mrem/year)

Infant	- 4.20E-02
Child	- 4.80E-02
Teenager	- 6.26E-02
Adult	- 7.05E-02

III. CALCULATION OF VEGETABLE INGESTION PATHWAY EXPOSURES

A. Specific Assumptions

- The WPDES permit issued to PBNP for the disposal of sewage sludge prohibits the growing of crops for human consumption for one year following the application of the sewage sludge. Therefore, prior to planting vegetables on the application site, the soil would be plowed. Plowing is assumed to uniformly mix the top 6 inches of soil.

OFFSITE DOSE CALCULATION MANUAL

2. The soil density is assumed to be 1.3 grams/cm³.
3. All vegetables consumed by the individual of interest are grown on the sludge applied acreage.
4. Stable element transfer coefficients (B_{iv}) from Regulatory Guide 1.109 are used to estimate the fraction of radioactivity transferred from the soil to the vegetables.

<u>Radionuclide</u>	<u>B_{iv}</u>
Co-60	9.4E-03
Cs-137	1.0E-02

5. The consumption factors of food medium (U_{ap}) and the mass basis distributions from Regulatory Guide 1.109, Table E-5 are used to determine annual consumption of vegetables.

U_{ap} by Age Group*

<u>Infant</u>	<u>Child</u>	<u>Teen</u>	<u>Adult</u>
-	280 kg/yr	340 kg/yr	280 kg/yr

*Based on 54% vegetable consumption by mass of fruit, vegetable, and grain.

6. The Ingestion Dose Factors by age group are from Regulatory Guide 1.109, Tables E-11, E-12, E-13, and E-14.

Whole Body Ingestion Dose Factors (mrem/pCi ingested)

<u>Radionuclide</u>	<u>Infant</u>	<u>Child</u>	<u>Teen</u>	<u>Adult</u>
Co-60	2.55E-05	1.56E-05	6.33E-06	4.72E-06
Cs-137	4.33E-05	4.62E-05	5.19E-05	7.14E-05

7. Radiological decay of the radionuclides applied to the plot is not taken into account in these calculations.

B. Summary of Computational Methodology

1. The radionuclide concentration in the soil is calculated in units of pCi/kg based on uniform application over 5 acre plot, plowing to a depth of 6 inches, and a soil density of 1.3 g/cm³.
2. The B_{iv} values are applied to the soil concentration values to obtain the radionuclide concentration in the vegetables.
3. The consumption factors (U_{ap}) for each age group are then used to determine the annual radionuclide intake by age group due to eating these vegetables.

OFFSITE DOSE CALCULATION MANUAL

4. Finally, the age dependent ingestion dose factors are used to obtain annual doses by age group.

C. Vegetable Pathway Ingestion Dose Rate Calculations

1. Concentration in soil

Radionuclide	Activity Applied (μCi)	Soil Volume (cm^3)	Soil Mass (kg)	Concentration In Soil (pCi/kg)
Co-60	13.2	3.08E+09	4.00E+06	3.30E+00
Cs-137	8.5	3.08E+09	4.00E+06	2.13E+00

2. Concentration in vegetables

Radionuclide	Concentration In Soil (pCi/kg)	B_{iv}	Concentration In Vegetables (pCi/kg)
Co-60	3.30E+00	9.4E-03	3.10E-02
Cs-137	2.13E+00	1.0E-02	2.13E-02

3. Calculated Dose Rates

The dose rate for direct ingestion of vegetables grown on the sludge applied land is given by the equation.

$$\text{DOSE RATE} = \sum U_{ap} * D_{iapj} * \text{EXP}(-\lambda_i t) * C_i$$

where

- U_{ap} = consumption rate of food medium
- D_{iapj} = dose factor for radionuclide, i
- λ_i = radiological decay constant
- t = time between harvest and consumption
- C_i = concentration of radionuclide, i, in food medium.

t, the time between harvest and ingestion, is assumed to be zero for this calculation.

VEGETABLE INGESTION DOSE RATE (mrem/year)

Radionuclide	Infant	Child	Teen	Adult
Co-60	-	1.35E-04	6.67E-05	4.10E-05
Cs-137	-	2.76E-04	3.76E-04	4.26E-04
TOTAL	-	4.11E-04	4.43E-04	4.67E-04

OFFSITE DOSE CALCULATION MANUAL

IV. CALCULATION OF INHALATION OF RESUSPENDED RADIONUCLIDES PATHWAY EXPOSURE

A. Specific Assumptions

1. The model used to determine the radionuclide concentration in air above the sludge applied land is taken from WASH-1400, USNRC, Reactor Safety Study - An Assessment of Accident Risks in Commercial Nuclear Power Plants, Appendix VI.
2. The radionuclide concentration in air remains constant for year of interest, i.e., radiological decay and decrease in resuspension factor are not taken into account for this calculation.
3. The maximally exposed member of the general public is assumed to be the farmer using the plot of land with an occupancy of 64 hours per year.
4. The inadvertent intruder is assumed to occupy the plot of land for the entire year.
5. The Inhalation Dose Factors by age group are from Regulatory Guide 1.109, Tables E-7, E-8, E-9, and E-10.

WHOLE BODY INHALATION DOSE FACTORS (mrem/pCi inhaled)

<u>Radionuclide</u>	<u>Infant</u>	<u>Child</u>	<u>Teen</u>	<u>Adult</u>
Co-60	8.41E-06	6.12E-06	2.48E-06	1.85E-06
Cs-137	3.25E-05	3.47E-05	3.89E-05	5.35E-05

LUNG INHALATION DOSE FACTORS (mrem/pCi inhaled)

<u>Radionuclide</u>	<u>Infant</u>	<u>Child</u>	<u>Teen</u>	<u>Adult</u>
Co-60	3.22E-03	1.91E-03	1.09E-03	7.46E-04
Cs-137	5.09E-05	2.81E-05	1.51E-05	9.40E-06

6. The age dependent inhalation rates are obtained from Regulatory Guide 1.109, Table E-5.

Inhalation Rates (m³/yr)

<u>Infant</u>	<u>Child</u>	<u>Teen</u>	<u>Adult</u>
1400	3700	8000	8000

OFFSITE DOSE CALCULATION MANUAL

B. Summary of Computational Methodology

1. The ground plane radionuclide concentrations in pCi/m².
2. Calculate the resuspension factor utilizing equation given in WASH-1400.
3. Obtain the radionuclide concentration in air (pCi/m³) above plot utilizing methodology in WASH-1400.
4. Using parameters contained in Regulatory Guide 1.109, calculate annual dose for continuous occupancy and for realistic occupancy.

C. Inhalation of Resuspended Radionuclides in Air Pathway Dose Rate Calculations - Resuspension of Radionuclide in Air

1. Ground plane radionuclide concentration

<u>Radionuclide</u>	<u>Ground Plane Concentration (μCi/cm²)</u>	<u>Ground Plane Concentration (pCi/m²)</u>
Co-60	6.53E-08	6.53E+02
Cs-137	4.21E-08	4.21E+02

2. Calculation of resuspension factor, K (m⁻¹)

From WASH-1400, $K(t) = 1.0E-09 + 1.0E-05 * \text{EXP} [-0.6769 * t]$

where t = time since radionuclides were deposited on ground surface.

t is assumed to be 0 for these calculation, thereby maximizing the resuspension factor.

Therefore,

$$K = 1.0E-05 \text{ m}^{-1}$$

3. Calculate radionuclide concentration (pCi/m³) in air.

From WASH-1400,

$$K(\text{m}^{-1}) = \frac{\text{air concentration (pCi/m}^3\text{)}}{\text{surface deposit (pCi/m}^2\text{)}}$$

or

$$\text{Air Concentration (pCi/m}^3\text{)} = \text{surface deposit (pCi/m}^2\text{)} * K(\text{m}^{-1})$$

AIR CONCENTRATIONS

<u>Radionuclide</u>	<u>Air Concentrations (pCi/m³)</u>
Co-60	6.53E-03
Cs-137	4.21E-03

OFFSITE DOSE CALCULATION MANUAL

4. Dose Rate Calculations

$$\text{Dose Rate (mrem/yr)} = \text{Inhalation Rate (m}^3\text{/yr)} * \text{Air Conc. (pCi/m}^3\text{)} * \text{Dose Conversion Factor (mrem/pCi)}$$

WHOLE BODY INHALATION DOSE RATE (mrem/year)

<u>Radionuclide</u>	<u>Infant</u>	<u>Child</u>	<u>Teen</u>	<u>Adult</u>
Co-60	7.69E-05	1.48E-04	1.30E-04	9.66E-05
Cs-137	1.92E-04	5.41E-04	1.31E-03	1.80E-03
TOTAL	2.69E-04	6.89E-04	1.44E-03	1.90E-03

LUNG INHALATION DOSE RATE (mrem/year)

<u>Radionuclide</u>	<u>Infant</u>	<u>Child</u>	<u>Teen</u>	<u>Adult</u>
Co-60	2.94E-02	4.61E-02	5.69E-02	3.90E-02
Cs-137	3.00E-04	4.38E-04	5.09E-04	3.17E-04
TOTAL	2.97E-02	4.65E-02	5.74E-02	3.93E-02

INHALATION OF RESUSPENDED RADIONUCLIDES IN AIR DOSE RATES (mrem/year)

WHOLE BODY DOSE RATE (mrem/year)

<u>Occupancy</u>	<u>Infant</u>	<u>Child</u>	<u>Teen</u>	<u>Adult</u>
Continuous	2.69E-04	6.89E-04	1.44E-03	1.90E-03
Realistic	1.96E-06	5.03E-06	1.05E-05	1.39E-05

LUNG DOSE RATE (mrem/year)

<u>Occupancy</u>	<u>Infant</u>	<u>Child</u>	<u>Teen</u>	<u>Adult</u>
Continuous	2.97E-02	4.65E-02	5.74E-02	3.93E-02
Realistic	2.17E-04	3.39E-04	4.19E-04	2.87E-04

V. CALCULATION OF WHOLE BODY EXPOSURES DUE TO RELEASE TO LAKE MICHIGAN

A. Specific Assumptions

1. The methodology contained in the PBNP Offsite Dose Calculation Manual (ODCM) is used to perform this calculation.

OFFSITE DOSE CALCULATION MANUAL

2. The entire activity contained in the sludge is released into Lake Michigan.
3. The exposure pathways addressed by the ODCM methodology are ingestion of potable water from Two Rivers, WI water supply, ingestion of fish at edge of initial mixing zone, ingestion of fresh and stored vegetables, irrigated with Lake Michigan as source of water, ingestion of milk and meat from cows utilizing Lake Michigan as drinking water source, swimming and boating activities at edge of initial mixing zone, and shoreline deposits.

B. Summary of Calculational Methodology

1. The activity released in the sludge is converted into Co-60 dose equivalent Curies.
2. The annual design release limit from the ODCM is 94.7 Co-60 equivalent curies.
3. The annual design release limit is based on a limiting dose of 6 mrem adult whole body. The annual dose due to sewage sludge is calculated by a ratio of calculated release compared to release limit.

C. Whole Body Exposure Calculations

1. Co-60 equivalent Curies

Radionuclide	Activity (μCi)	DF _i /DF _{Co-60}	Co-60 eq. Activity (μCi)
Co-60	13.2	1.00E+00	13.2
Cs-137	8.5	1.51E+01	128.4
TOTAL			141.6 μCi Co-60 equivalent

2. Ratio of dose limit to annual design release limit

$$\frac{6 \text{ mrem}}{94.7 \text{ Co-60 equivalent curies}}$$

3. Whole Body Dose Calculation

$$\frac{\text{Dose}}{141.6 \mu\text{Ci}} = \frac{6 \text{ mrem}}{94.7 \times 10^6 \mu\text{Ci}}$$

$$\text{Dose} = 8.97\text{E-}06 \text{ mrem}$$

WHOLE BODY DOSE RATE (mrem/year)

8.97E-06

OFFSITE DOSE CALCULATION MANUAL

DOSE SUMMARY

Maximally Exposed Individual

The identified credible exposure pathways for the maximally exposed individual are:

- 1.) External exposure from ground plane source (realistic occupancy)
- 2.) Milk ingestion pathway
- 3.) Meat ingestion pathway
- 4.) Vegetable ingestion pathway
- 5.) Resuspension inhalation pathway (realistic occupancy)
- 6.) Pathways identified due to release to Lake Michigan.

<u>Pathway</u>	<u>AGE GROUP</u>			
	<u>Infant</u>	<u>Child</u>	<u>Teen</u>	<u>Adult</u>
External	8.23E-04	8.23E-04	8.23E-04	8.23E-04
Milk	4.20E-02	4.35E-02	5.77E-02	6.11E-02
Meat	-	4.49E-03	4.85E-03	9.42E-03
Vegetable	-	4.11E-04	4.43E-04	4.67E-04
Inhalation	1.96E-06	5.03E-06	1.05E-05	1.39E-05
Water	8.97E-06	8.97E-06	8.97E-06	8.97E-06
TOTAL: (mrem/year)	0.043	0.049	0.064	0.072

Inadvertent Intruder

The identified credible exposure pathways for the inadvertent intruder are:

- 1.) External exposure from ground plane source (continuous occupancy)
- 2.) Vegetable ingestion pathway
- 3.) Resuspension inhalation pathway (continuous occupancy)
- 4.) Pathways identified due to release to Lake Michigan.

<u>Pathway</u>	<u>AGE GROUP</u>			
	<u>Infant</u>	<u>Child</u>	<u>Teen</u>	<u>Adult</u>
External	1.13E-01	1.13E-01	1.13E-01	1.13E-01
Vegetable	-	4.11E-04	4.43E-04	4.67E-04
Inhalation	2.96E-04	6.89E-04	1.44E-03	1.90E-03
Water	8.97E-06	8.97E-06	8.97E-06	8.97E-06
TOTAL: (mrem/year)	0.113	0.114	0.115	0.115

Reviewing these tables, the calculated limiting doses for both the maximally exposed individual and the inadvertent intruder occur for the adult age group. These doses are:

Maximally Exposed Individual: 0.072 mrem/year
Inadvertent Intruder: 0.115 mrem/year

APPENDIX F

BASIS FOR SETTING CONCENTRATION LIMITS AND ACTIVITY LIMIT
FOR DISPOSAL OF SLUDGE

OFFSITE DOSE CALCULATION MANUAL

Analyses of previously disposed sewage sludge have identified six different radionuclides in the sludge. All six radionuclides did not occur in each disposal. Therefore, it is difficult to determine a single concentration limit for regulating the disposal of the sludge from the storage tanks.

To provide a basis to regulate the disposal of the sewage sludge based on identified radionuclide concentrations, the following relation is proposed.

$$\sum_{i=1}^N \frac{C_i}{0.1 * MPC_i} \leq 1$$

where

- N = number of different radionuclides identified in the sewage sludge.
- C_i = concentration of the ith radionuclide in the sewage sludge.
- MPC_i = the MPC value of the ith radionuclide in the sewage sludge, as listed in 10 CFR Part 20 Appendix B, Table II, Column 2.

If this criteria is met, the sewage sludge may be disposed of by land spreading provided the dose calculations (as identified in Appendix E) indicate dose rates within the prescribed limits.

The attachment to this Appendix details calculations performed to determine doses from four radionuclides identified in the sludge. The calculations are based on an identified concentration equal to 10% of the 10 CFR Part 20, Appendix B, Table II, Column 2 values. The calculations use the methodology in Appendix E along with the exposure pathways identified in Appendix D to determine the dose rates. These calculations indicate the use of this methodology will maintain radiation doses within the appropriate limits.

The maximum allowable activity disposed of per year per acre is calculated utilizing 10% of the MPC value, 10 CFR Part 20, Appendix B, Table II, Column 2, for Co-58. Volume limit per acre has been proposed at 4,000 gallons/acre/year. Then,

$$\begin{aligned} &1.0E-05 \text{ } \mu\text{Ci/cc} * 4,000 \text{ gallons/acre/year} * 3.785.43 \text{ cc/gallon} \\ &= 151.4 \text{ } \mu\text{Ci/acre/year} \end{aligned}$$

OFFSITE DOSE CALCULATION MANUAL

Cs-134

Concentration in Sludge: 9.0E-07 mCi/ml

Sludge Volume (Gallons)	Sludge Volume (cm ³)	Concentration (μ Ci/cm ³)	Activity (μ Ci)	Ground Plane Concentration (μ Ci/cm ²)
15000	5.68E+07	9.00E-07	5.11E+01	2.53E-07

External Exposure

γ Dose Factor (mrem/hr. per μ Ci/m ²)	Ground Plane Concentration (μ Ci/m ²)	γ Dose Rate (mrem/year)
1.20E-08	2.53E+03	2.66E-01

Continuous Occupancy: 2.66E-01 mrem/year
Realistic Occupancy: 1.94E-03 mrem/year

Meat & Milk Pathway

Activity in Soil (μ Ci)	Activity in Feed (μ Ci)	Concentration in Feed (μ Ci/Kg)	Concentration in Milk (μ Ci/l)	Concentration in Meat (μ Ci/kg)
5.22E+01	5.11E-01	2.75E+01	1.65E+01	5.50E+00

Milk Dose Rates (mrem/year)

Infant	Child	Teenager	Adult
3.87E-01	4.41E-01	6.03E-01	6.19E-01

Meat Dose Rate (mrem/year)

Infant	Child	Teenager	Adult
-	1.83E-02	3.27E-02	7.32E-02

Vegetable Pathway

Activity (μ Ci)	Soil Volume (Cm ³)	Soil Mass (Kg)	Concentration in Soil (μ Ci/Kg)	Concentration in Vegetables (μ Ci/Kg)
5.11E+01	3.08E+09	4.00E+06	1.28E+01	1.28E-01

Cs-134-1

OFFSITE DOSE CALCULATION MANUAL

Vegetable Pathway Dose Rates (mrem/year)

<u>Infant</u>	<u>Child</u>	<u>Teenager</u>	<u>Adult</u>
-	2.90E-03	3.98E-03	4.34E-03

Inhalation Pathway

<u>Ground Plane Concentration (pCi/m²)</u>	<u>K₁ (m⁻¹)</u>	<u>Air Concentration (pCi/m³)</u>
2.53E+03	1.0E-05	2.53E-02

Inhalation Pathway Dose Rates (mrem/year)

	<u>Infant</u>	<u>Child</u>	<u>Teenager</u>	<u>Adult</u>
Continuous Occupancy	1.88E-03	5.68E-03	1.39E-02	1.84E-02
Realistic Occupancy	1.38E-05	4.15E-05	1.01E-04	1.35E-04

Release to Lake Michigan

<u>Activity (μCi)</u>	<u>DF₁/DF_{Co-60}</u>	<u>Co-60 eq. activity (μCi)</u>
5.11E+01	2.56E+01	1.31E+03

$$\frac{6 \text{ mrem}}{94.7 \text{ Ci}} * 1.31E+03 * \frac{1 \text{ Ci}}{1.0E+06 \text{ } \mu\text{Ci}} = 8.29E-05 \text{ mrem}$$

Maximally Exposed Individual

	<u>Infant</u>	<u>Child</u>	<u>Teenager</u>	<u>Adult</u>
External	1.94E-03	1.94E-03	1.94E-03	1.94E-03
Milk	3.87E-01	4.41E-01	6.03E-01	6.19E-01
Meat	-	1.83E-02	3.27E-02	7.32E-02
Vegetable	-	2.90E-03	3.98E-03	4.34E-03
Inhalation	1.38E-05	4.15E-05	1.01E-04	1.35E-04
Water	8.29E-05	8.29E-05	8.29E-05	8.29E-05
Totals:	3.89E-01	4.64E-01	6.42E-01	6.99E-01

Inadvertent Intruder

	<u>Infant</u>	<u>Child</u>	<u>Teenager</u>	<u>Adult</u>
External	2.66E-01	2.66E-01	2.66E-01	2.66E-01
Vegetable	-	2.90E-03	3.98E-03	4.34E-03
Inhalation	1.88E-03	5.68E-03	1.39E-02	1.84E-02
Water	8.29E-05	8.29E-05	8.29E-05	8.29E-05
Totals:	2.68E-01	2.75E-01	2.84E-01	2.89E-01

Cs-134-2

OFFSITE DOSE CALCULATION MANUAL

Cs-137

Concentration in Sludge: 2.0E-06 $\mu\text{Ci}/\text{ml}$

Sludge Volume (Gallons)	Sludge Volume (cm^3)	Concentration ($\mu\text{Ci}/\text{cm}^3$)	Activity (μCi)	Ground Plane Concentration ($\mu\text{Ci}/\text{cm}^2$)
15000	5.68E+07	2.00E-06	1.14E+02	5.62E-07

External Exposure

γ Dose Factor ($\text{mrem}/\text{hr. per pCi}/\text{m}^2$)	Ground Plane Concentration (pCi/m^2)	γ Dose Rate (mrem/year)
4.20E-09	5.62E+03	2.07E-01

Continuous Occupancy: 2.07E-01 mrem/year
Realistic Occupancy: 1.51E-03 mrem/year

Meat & Milk Pathway

Activity in Soil (μCi)	Activity in Feed (μCi)	Concentration in Feed (pCi/Kg)	Concentration in Milk (pCi/ℓ)	Concentration in Meat (pCi/kg)
1.14E+02	1.14E+00	6.13E+01	3.68E+01	1.23E+01

Milk Dose Rates (mrem/year)

Infant	Child	Teenager	Adult
5.26E-00	5.61E-01	7.64E-01	8.15E-01

Meat Dose Rate (mrem/year)

Infant	Child	Teenager	Adult
-	2.33E-02	4.15E-02	9.66E-02

Vegetable Pathway

Activity (μCi)	Soil Volume (Cm^3)	Soil Mass (Kg)	Concentration in Soil (pCi/Kg)	Concentration in Vegetables (pCi/Kg)
1.14E+02	3.08E+09	4.00E+06	2.85E+01	2.85E-01

Cs-137-1

OFFSITE DOSE CALCULATION MANUAL

Vegetable Pathway Dose Rates (mrem/year)

<u>Infant</u>	<u>Child</u>	<u>Teenager</u>	<u>Adult</u>
-	3.69E-03	5.03E-03	5.70E-03

Inhalation Pathway

<u>Ground Plane Concentration (pCi/m²)</u>	<u>K₁ (m⁻¹)</u>	<u>Air Concentration (pCi/m³)</u>
5.62E+03	1.0E-05	5.62E-02

Inhalation Pathway Dose Rates (mrem/year)

	<u>Infant</u>	<u>Child</u>	<u>Teenager</u>	<u>Adult</u>
Continuous Occupancy	2.56E-03	7.22E-03	1.75E-02	2.41E-02
Realistic Occupancy	1.87E-05	5.27E-05	1.28E-04	1.76E-04

Release to Lake Michigan

<u>Activity (μCi)</u>	<u>DF_i/DF_{Co-60}</u>	<u>Co-60 eq. activity (μCi)</u>
1.14E+02	1.51E+01	1.72E+03

$$\frac{6 \text{ mrem}}{94.7 \text{ Ci}} * 1.72E+03 * \frac{1 \text{ Ci}}{1.0E+06 \text{ } \mu\text{Ci}} = 1.09E-04 \text{ mrem}$$

Maximally Exposed Individual

	<u>Infant</u>	<u>Child</u>	<u>Teenager</u>	<u>Adult</u>
External	1.51E-03	1.51E-03	1.51E-03	1.51E-03
Milk	5.26E-01	5.61E-01	7.64E-01	8.15E-01
Meat	-	2.33E-02	4.15E-02	5.70E-03
Vegetable	-	3.69E-03	5.03E-03	5.70E-03
Inhalation	1.87E-05	5.27E-05	1.28E-04	1.76E-04
Water	1.09E-04	1.09E-04	1.09E-04	1.09E-04
Totals:	5.28E-01	5.90E-01	8.12E-01	9.19E-01

Inadvertent Intruder

	<u>Infant</u>	<u>Child</u>	<u>Teenager</u>	<u>Adult</u>
External	2.07E-01	2.07E-01	2.07E-01	2.07E-01
Vegetable	-	3.69E-03	5.03E-03	5.70E-03
Inhalation	2.56E-03	7.22E-03	1.75E-02	2.41E-02
Water	1.09E-04	1.09E-04	1.09E-04	1.09E-04
Totals:	2.10E-01	2.18E-01	2.30E-01	2.37E-01

Cs-137-2

OFFSITE DOSE CALCULATION MANUAL

Co-58

Concentration in Sludge: 1.00E-05 $\mu\text{Ci}/\text{ml}$

<u>Sludge Volume (Gallons)</u>	<u>Sludge Volume (cm^3)</u>	<u>Concentration ($\mu\text{Ci}/\text{cm}^3$)</u>	<u>Activity (μCi)</u>	<u>Ground Plane Concentration ($\mu\text{Ci}/\text{cm}^2$)</u>
15000	5.68E+07	1.00E-05	5.68E+02	2.81E-06

External Exposure

<u>γ Dose Factor (mrem/hr. per pCi/m^2)</u>	<u>Ground Plane Concentration (pCi/m^2)</u>	<u>γ Dose Rate (mrem/year)</u>
7.00E-09	2.81E+04	1.72E+00

Continuous Occupancy: 1.72E+00 mrem/year
Realistic Occupancy: 1.26E-02 mrem/year

Meat & Milk Pathway

<u>Activity in Soil (μCi)</u>	<u>Activity in Feed (μCi)</u>	<u>Concentration in Feed (pCi/Kg)</u>	<u>Concentration in Milk (pCi/ℓ)</u>	<u>Concentration in Meat (pCi/kg)</u>
5.68E+02	5.34E+00	2.87E+02	1.44E+01	1.87E+02

Milk Dose Rates (mrem/year)

<u>Infant</u>	<u>Child</u>	<u>Teenager</u>	<u>Adult</u>
4.27E-02	2.62E-02	1.29E-02	7.45E-03

Meat Dose Rate (mrem/year)

<u>Infant</u>	<u>Child</u>	<u>Teenager</u>	<u>Adult</u>
-	4.22E-02	2.72E-02	3.44E-02

Vegetable Pathway

<u>Activity (μCi)</u>	<u>Soil Volume (cm^3)</u>	<u>Soil Mass (Kg)</u>	<u>Concentration in Soil (pCi/Kg)</u>	<u>Concentration in Vegetables (pCi/Kg)</u>
5.68E+02	3.08E+09	4.00E+06	1.42E-04	1.33E+00

Co-58-1

OFFSITE DOSE CALCULATION MANUAL

Vegetable Pathway Dose Rates (mrem/year)

<u>Infant</u>	<u>Child</u>	<u>Teenager</u>	<u>Adult</u>
-	2.05E-03	1.01E-03	6.22E-04

Inhalation Pathway

<u>Ground Plane Concentration (pCi/m²)</u>	<u>K₁ (m⁻¹)</u>	<u>Air Concentration (pCi/m³)</u>
2.81E+04	1.0E-05	2.81E-01

Inhalation Pathway Dose Rates (mrem/year)

	<u>Infant</u>	<u>Child</u>	<u>Teenager</u>	<u>Adult</u>
Continuous Occupancy	5.11E-04	8.89E-04	7.80E-04	5.82E-04
Realistic Occupancy	3.74E-06	6.49E-06	5.70E-06	4.25E-06

Release to Lake Michigan

<u>Activity (μCi)</u>	<u>DF_i/DF_{Co-60}</u>	<u>Co-60 eq. activity (μCi)</u>
5.68E+02	3.54E-01	2.01E+02

$$6 \text{ mrem} \times \frac{2.01E+02 \text{ } \mu\text{Ci}}{94.7 \text{ Ci}} \times \frac{1 \text{ Ci}}{1.0E+06 \text{ } \mu\text{Ci}} = 1.27E-05 \text{ mrem}$$

Maximally Exposed Individual

	<u>Infant</u>	<u>Child</u>	<u>Teenager</u>	<u>Adult</u>
External	1.26E-02	1.26E-02	1.26E-02	1.26E-02
Milk	4.27E-02	2.62E-02	1.29E-02	7.45E-03
Meat	-	4.22E-02	2.72E-02	3.44E-02
Vegetable	-	2.05E-03	1.01E-03	6.22E-04
Inhalation	3.74E-06	6.49E-06	5.70E-06	4.25E-06
Water	1.27E-05	1.27E-05	1.27E-05	1.27E-05
Totals:	5.53E-02	8.31E-02	5.37E-02	5.51E-02

Inadvertent Intruder

	<u>Infant</u>	<u>Child</u>	<u>Teenager</u>	<u>Adult</u>
External	1.72E+00	1.72E+00	1.72E+00	1.72E+00
Vegetable	-	2.05E-03	1.01E-03	6.22E-04
Inhalation	5.11E-04	8.89E-04	7.80E-04	5.82E-04
Water	1.27E-05	1.27E-05	1.27E-05	1.27E-05
Totals:	1.72E+00	1.72E+00	1.72E+00	1.72E+00

Co-58-2

OFFSITE DOSE CALCULATION MANUAL

Co-60

Concentration in Sludge: 5.0E-06 $\mu\text{Ci}/\text{ml}$

<u>Sludge Volume (Gallons)</u>	<u>Sludge Volume (cm^3)</u>	<u>Concentration ($\mu\text{Ci}/\text{cm}^3$)</u>	<u>Activity (μCi)</u>	<u>Ground Plane Concentration ($\mu\text{Ci}/\text{cm}^2$)</u>
15000	5.68E+07	5.00E-06	2.84E+02	1.41E-06

External Exposure

<u>y Dose Factor (mrem/hr. per pCi/m^2)</u>	<u>Ground Plane Concentration (pCi/m^2)</u>	<u>y Dose Rate (mrem/year)</u>
1.70E-08	1.41E+04	2.09E+00

Continuous Occupancy: 2.09E+00 mrem/year
Realistic Occupancy: 1.53E-02 mrem/year

Meat & Milk Pathway

<u>Activity in Soil (μCi)</u>	<u>Activity in Feed (μCi)</u>	<u>Concentration in Feed (pCi/Kg)</u>	<u>Concentration in Milk (pCi/L)</u>	<u>Concentration in Meat (pCi/kg)</u>
2.84E+02	2.67E+00	1.44E+02	7.18E+00	9.33E+01

Milk Dose Rates (mrem/year)

<u>Infant</u>	<u>Child</u>	<u>Teenager</u>	<u>Adult</u>
6.04E-02	3.70E-02	1.82E-02	1.05E-02

Meat Dose Rate (mrem/year)

<u>Infant</u>	<u>Child</u>	<u>Teenager</u>	<u>Adult</u>
-	5.97E-02	3.84E-02	4.84E-02

Vegetable Pathway

<u>Activity (μCi)</u>	<u>Soil Volume (Cm^3)</u>	<u>Soil Mass (Kg)</u>	<u>Concentration in Soil (pCi/Kg)</u>	<u>Concentration in Vegetables (pCi/Kg)</u>
2.84E+02	3.08E+09	4.00E+06	7.10E+01	6.67E-01

Co-60-1

OFFSITE DOSE CALCULATION MANUAL

Vegetable Pathway Dose Rates (mrem/year)

<u>Infant</u>	<u>Child</u>	<u>Teenager</u>	<u>Adult</u>
-	2.91E-03	1.44E-03	8.82E-04

Inhalation Pathway

<u>Ground Plane Concentration (pCi/m²)</u>	<u>K₁ (m⁻¹)</u>	<u>Air Concentration (pCi/m³)</u>
1.41E+04	1.0E-05	1.41E-01

Inhalation Pathway Dose Rates (mrem/year)

	<u>Infant</u>	<u>Child</u>	<u>Teenager</u>	<u>Adult</u>
Continuous Occupancy	1.66E-03	3.19E-03	2.80E-03	2.09E-03
Realistic Occupancy	1.21E-05	2.33E-05	2.05E-05	1.53E-05

Release to Lake Michigan

<u>Activity (μCi)</u>	<u>DF_i/DF_{Co-60}</u>	<u>Co-60 eq. activity (μCi)</u>
-----------------------	--	---------------------------------

$$\frac{6 \text{ mrem}}{94.7 \text{ Ci}} * 2.84E+02 \mu\text{Ci} * \frac{1 \text{ Ci}}{1.0E+06 \mu\text{Ci}} = 1.80E-05 \text{ mrem}$$

Maximally Exposed Individual

	<u>Infant</u>	<u>Child</u>	<u>Teenager</u>	<u>Adult</u>
External	1.53E-02	1.53E-02	1.53E-02	1.53E-02
Milk	6.04E-02	3.70E-02	1.82E-02	1.05E-02
Meat	-	5.97E-02	3.84E-02	4.84E-02
Vegetable	-	2.91E-03	1.44E-03	8.82E-04
Inhalation	1.21E-05	2.33E-05	2.05E-05	1.53E-05
Water	1.80E-05	1.80E-05	1.80E-05	1.80E-05
Totals:	7.57E-02	1.15E-01	7.34E-02	7.51E-02

Inadvertent Intruder

	<u>Infant</u>	<u>Child</u>	<u>Teenager</u>	<u>Adult</u>
External	2.09E+00	2.09E+00	2.09E+00	2.09E+00
Vegetable	-	2.91E-03	1.44E-03	8.82E-04
Inhalation	1.66E-03	3.19E-03	2.80E-03	2.09E-03
Water	1.80E-05	1.80E-05	1.80E-03	1.80E-03
Totals:	2.09E+00	2.10E+00	2.10E+00	2.09E+00

Co-60-2

APPENDIX G

CALCULATIONAL METHODOLOGY FOR DETERMINING
EXTERNAL DOSE RATES FROM RADIONUCLIDES
AFTER INCORPORATION INTO SOIL

OFFSITE DOSE CALCULATION MANUAL

Wisconsin Electric utilizes QAD, a nationally recognized computer code, to perform shielding and dose rate analyses. The QAD computer code utilizes a point kernel methodology to calculate the dose rate at a specified point due to a given source of radiation.

QAD will be used to calculate the dose rate due to standing on a plot of land utilized for sludge disposal after the radionuclides have been incorporated into the plot by plowing. The following parameters will be used in the calculation:

- ° The total activity from all previous disposals will be corrected for radiological decay and used as the radionuclide source term.
- ° Appropriate values will be used to represent the surface area of the plot.
- ° The radionuclides will be assumed to be incorporated uniformly into the top six inches of soil.
- ° The dose rate will be calculated at a height of 1 meter above the ground plane at a depth of 5 centimeters in tissue. (Regulatory Guide 1.109 values).

The density of the soil will be assumed to be 1.3 grams per cubic centimeter.

This calculated dose rate will be used to assess the radiological consequences of past disposals in conjunction with the consequences of proposed future disposals. The total radiological dose consequence of the past and the proposed disposal will be compared to the applicable limits to insure the dose is maintained at or below the limits.

APPENDIX H
MODIFICATION #1 TO NRC SUBMITTAL

Modifications to the Wisconsin Electric submittal to the United States Nuclear Regulatory Commission dated October 8, 1987 (VPNPD-87-430, NRC-87-104), Disposal by Land Application of Sewage Sludge Containing Minute Quantities Of Radioactive Material.

MODIFICATION #1 TO NRC SUBMITTAL

CHANGE TO ORIGINAL SUBMITTAL

Section 3.2, Disposal Procedure (page 3)

Section 3.3, Administrative Procedure (page 4)

The requirements for sludge characterization (the determination of the chemical and physical properties of the sludge) contained in the sections referenced above are modified to allow characterization of the sludge on an annual basis.

BASIS/EXPLANATION

The October 8, 1987 submittal to the USNRC for permission to dispose of sewage treatment sludge containing minute quantities of radioactive material requires that, "prior to disposal the waste stream will be monitored to determine the physical and chemical properties of the sludge...". Subsequent to the submittal and the approval by the NRC, a new Wisconsin Pollutant Discharge Elimination System (WPDES) permit was issued to the Point Beach Nuclear Plant by the Wisconsin Department of Natural Resources on November 30, 1988. Both the new WPDES permit and the Point Beach Nuclear Plant Sludge Management Plan specify an annual required frequency for the evaluation of the sludge characteristics.

The original requirement to perform the characterization of the chemical and physical properties of the sewage sludge prior to each disposal has proven time consuming and costly for Wisconsin Electric Lab Services. Preparation of special analytical standards are required to complete the characterization study. The preparation of these standards, sample preparation, and the actual analyses are all manpower intensive and difficult to perform on a timely basis. This has led to requiring overtime for Lab Services personnel and support from outside companies. In order to better utilize the resources of Lab Services while maintaining the requirements of the WPDES permit, the frequency of sludge characterization in the October 8, 1987 submittal to the NRC should be changed to an annual requirement.

This change in the required frequency for determination of the sludge characteristics does not change the requirement to analyze the sewage sludge for radionuclide content or perform dose evaluations prior to each disposal.

APPENDIX I
MODIFICATION #2 TO NRC SUBMITTAL

Modifications to the Wisconsin Electric submittal to the United States Nuclear Regulatory Commission dated October 8, 1987 (VPNPD-87-430, NRC-87-104), Disposal by Land Application of Sewage Sludge Containing Minute Quantities Of Radioactive Material.

MODIFICATION #2

CHANGE TO ORIGINAL SUBMITTAL

Section 3.3, Administrative Procedures (Page E-10)

The limitation on the annual volume of sludge disposal per acre contained in the section referenced above is modified to allow unlimited disposal provided the other requirements of this submittal are met.

BASIS/EXPLANATION

The October 8, 1987, submittal to the USNRC for permission to dispose of sewage treatment sludge containing minute quantities of radioactive material requires that "the annual disposal rate for each of the approved land spread sites will be limited to 4,000 gallons/acre, provided WDNR chemical composition, NRC dose guidelines, and concentration and activity limits are maintained with the appropriate values".

The original requirement to limit sewage sludge disposal to 4,000 gallons per acre is based on the assumption that the sewage sludge is contaminated with Co-58 at a concentration that is ten percent of the 10 CFR Part 20 Appendix B Table 2 Column 2 value. Past sewage sludge disposal experience has shown that the sludge may or may not be contaminated and, if it is, at concentrations far below ten percent of the performed prior to each sewage sludge disposal. With the removal of some of the land spread sites due to their use as a storage site for dry storage of spent fuel, this requirement is limiting our ability to dispose of the sewage sludge on the remaining approved land spread sites.

This removal of the annual volume of sewage sludge that may be disposed of per acre on approved land spread sites does not change the requirement to analyze the sewage sludge for radionuclide content or perform dose evaluation prior to each disposal.

This change was evaluation under SER 95-057, "Removal of licensee Commitment Involved With Sewage Sludge Disposal", 4/20/95.

OFFSITE DOSE CALCULATION MANUAL

MODIFICATION #2

- Depth to groundwater and bedrock shall be greater than 3 feet from the land surface elevation during use of any site.
- Sludge shall not be land spread in a floodway.
- Sludge shall not be land spread within 50 feet of a property line road or ditch unless the sludge is incorporated with the soil, in which case a minimum separation distance of at least 25 feet is required.
- The pH of the sludge-soil mixture shall be maintained at 6.5 or higher.
- Low areas of the approved fields, subject to seasonally high groundwater levels, are excluded from the sludge application.
- Crops for human consumption shall not be grown on the land for up to one year following the application of the sludge.
- The sludge shall be plowed, disked, injected or otherwise incorporated into the surface soil layer at appropriate intervals.

The flexibility implied in the latter provision for soil incorporation is intended to allow for crops which require more than a one year cycle. For the Point Beach disposal sites, alfalfa is a common crop which is harvested for several years after a single planting. Sludge disposal on an alfalfa plot constitutes good fertilization, but the plot cannot be plowed without destroying the crop. The alfalfa in this case aids in binding the layer of sludge on the surface of the plot. At a minimum, however, plowing (or disking or other method of injection and mixing to a nominal depth of 6 inches) shall be done prior to planting any new crop, regardless of the crop.

3.3 Administrative Procedures

Complete records of each disposal will be maintained. These records will include the concentration of radionuclides in the sludge, the total volume of sludge disposed, the total activity, the plot on which the sludge was applied, the results of the chemical composition determinations, and all dose calculations.

The annual ^{per acre} disposal rate for each of the approved land spread sites will be limited to 4,000 gallons/acre, provided WDNR chemical composition, MRC dose guidelines, and concentration and activity limits are maintained within the appropriate values.

The farmer leasing the site used for the disposal will be notified of the applicable restrictions placed on the site due to the land spreading of sewage sludge.

4.0 Evaluation of Environmental Impact

4.1 Site Characteristics

4.1.1 Site Topography

The disposal sites are located in the Town of Two Creeks in the northeast corner of Manitowoc County, Wisconsin, on the

APPENDIX J
MODIFICATION #3 TO NRC SUBMITTAL

Modifications to the Wisconsin Electric submittal to the United States Nuclear Regulatory Commission dated October 8, 1987 (VPNPD-87-430, NRC-87-104), Disposal by Land Application of Sewage Sludge Containing Minute Quantities Of Radioactive Material.

MODIFICATION #3 TO NRC SUBMITTAL

CHANGE TO ORIGINAL SUBMITTAL

Section 3.2 of Attachment II of the October 8, 1987 letter to the NRC contains the commitment to perform a gamma isotopic analysis of sewage sludge samples prior to every sludge disposal on land surrounding PBNP. The analytical results are to be used to evaluate the dose consequences of the radionuclides entering the environment via this disposal pathway. As described in ODCM Section 7, the requirement for a radioisotopic analysis of the sewage sludge prior to every disposal on land surrounding PBNP is modified if the sludge has been shown to be clean and there is no reason to believe that the sludge is contaminated.

BASIS/EXPLANATION

Small μCi quantities of PBNP licensed materials (Co-58/60, Cs-134/137, Cr-51, and Mn-54) were found in PBNP sewage treatment plant (STP) sludge. Pursuant to 10 CFR 20.302(a), Wisconsin Electric applied to the NRC for permission to dispose of the licensed material by applying the sludge to Wisconsin Electric land surrounding PBNP. In the October 8, 1987 application letter, Wisconsin Electric committed to gamma isotopic analysis of the sludge prior to every disposal in order to evaluate the dose consequences of this disposal and to compare radionuclide concentrations to the 10 CFR 20, Appendix B, maximum effluent concentrations. However, such analysis are not required if the sludge does not contain licensed material. If there is no reason to believe that the sludge is contaminated and if there is no pathway from the RCA to the STP, then there is no reason to analyze the sludge for radionuclides once it has been shown to be clean. Administrative controls and engineering modifications to PBNP have removed the pathway from the RCA to the STP as verified by subsequent analyses of the sludge under conditions required to obtain the environmental LLDs. These analyses have not revealed radionuclides attributable to PBNP. Pursuant to NRC HPPOS-221, a substance is clean if analyses under analytical parameters necessary to achieve the environmental LLDs does not reveal any licensed material. These LLDs define how hard you have to look. Below this detection level, "...the probability of undetected radioactivity is negligible and can be disregarded when considering the practicality of detecting such potential radioactivity from natural background..." (Docket No. 50-206, letter to J. E. Dyer from L. J. Cunningham dated September 6, 1991). Therefore the NRC criteria are met and there is no longer any reason to believe that the STP sludge is contaminated. However if plant conditions should change in a manner compromising the NRC criteria, radiological analysis must be made prior to each STP sludge land application until such time that the clean criteria are satisfied pursuant to subsequent NRC guidance.

APPENDIX K
LIQUID EFFLUENT DOSE CONVERSION FACTORS

The tables below identify the expected dose to each of the four age ranges (adult, teen, child and infant) as a result of activity released via liquid effluents. These dose conversion factors are based on Reg. Guide 1.109 and NUREG-0133 assumptions. The pathways included in these DCFs are drinking water and fish. The other pathways (irrigated meat, irrigated milk, invertebrates and shoreline exposure) are either not applicable or contribute a negligible contribution to the dose. The dose conversion factors below assume a discharge flow of 6.77E+05 gpm. If actual plant conditions are significantly different, revised DCFs should be calculated and used.

H-3		Liquid release (mrem/Ci released)					
	Bone	Liver	T.Body	Thyroid	Kidney	Lung	GI-LLI
Adult	0.00E+00	1.34E-06	1.34E-06	1.34E-06	1.34E-06	1.34E-06	1.34E-06
Teen	0.00E+00	9.51E-07	9.51E-07	9.51E-07	9.51E-07	9.51E-07	9.51E-07
Child	0.00E+00	1.75E-06	1.75E-06	1.75E-06	1.75E-06	1.75E-06	1.75E-06
Infant	0.00E+00	1.65E-06	1.65E-06	1.65E-06	1.65E-06	1.65E-06	1.65E-06

C-14		Liquid release (mrem/Ci released)					
	Bone	Liver	T.Body	Thyroid	Kidney	Lung	GI-LLI
Adult	2.32E-02	4.64E-03	4.64E-03	4.64E-03	4.64E-03	4.64E-03	4.64E-03
Teen	2.52E-02	5.05E-03	5.05E-03	5.05E-03	5.05E-03	5.05E-03	5.05E-03
Child	3.25E-02	6.51E-03	6.51E-03	6.51E-03	6.51E-03	6.51E-03	6.51E-03
Infant	2.23E-04	4.76E-05	4.76E-05	4.76E-05	4.76E-05	4.76E-05	4.76E-05

F-18		Liquid release (mrem/Ci released)					
	Bone	Liver	T.Body	Thyroid	Kidney	Lung	GI-LLI
Adult	1.17E-07	0.00E+00	1.30E-08	0.00E+00	0.00E+00	0.00E+00	3.47E-09
Teen	1.24E-07	0.00E+00	1.35E-08	0.00E+00	0.00E+00	0.00E+00	1.11E-08
Child	1.54E-07	0.00E+00	1.52E-08	0.00E+00	0.00E+00	0.00E+00	4.16E-08
Infant	6.17E-13	0.00E+00	5.27E-14	0.00E+00	0.00E+00	0.00E+00	1.45E-13

Na-22		Liquid release (mrem/Ci released)					
	Bone	Liver	T.Body	Thyroid	Kidney	Lung	GI-LLI
Adult	3.44E-03	3.44E-03	3.44E-03	3.44E-03	3.44E-03	3.44E-03	3.44E-03
Teen	3.49E-03	3.49E-03	3.49E-03	3.49E-03	3.49E-03	3.49E-03	3.49E-03
Child	4.27E-03	4.27E-03	4.27E-03	4.27E-03	4.27E-03	4.27E-03	4.27E-03
Infant	9.23E-04	9.23E-04	9.23E-04	9.23E-04	9.23E-04	9.23E-04	9.23E-04

Na-24		Liquid release (mrem/Ci released)					
	Bone	Liver	T.Body	Thyroid	Kidney	Lung	GI-LLI
Adult	1.76E-04	1.76E-04	1.76E-04	1.76E-04	1.76E-04	1.76E-04	1.76E-04
Teen	1.81E-04	1.81E-04	1.81E-04	1.81E-04	1.81E-04	1.81E-04	1.81E-04
Child	2.02E-04	2.02E-04	2.02E-04	2.02E-04	2.02E-04	2.02E-04	2.02E-04
Infant	1.03E-05	1.03E-05	1.03E-05	1.03E-05	1.03E-05	1.03E-05	1.03E-05

APPENDIX K
LIQUID EFFLUENT DOSE CONVERSION FACTORS

P-32		Liquid release (mrem/Ci released)					
	Bone	Liver	T.Body	Thyroid	Kidney	Lung	GI-LLI
Adult	3.33E+01	2.07E+00	1.29E+00	0.00E+00	0.00E+00	0.00E+00	3.75E+00
Teen	3.63E+01	2.25E+00	1.41E+00	0.00E+00	0.00E+00	0.00E+00	3.05E+00
Child	4.68E+01	2.19E+00	1.81E+00	0.00E+00	0.00E+00	0.00E+00	1.29E+00
Infant	1.45E-02	8.53E-04	5.62E-04	0.00E+00	0.00E+00	0.00E+00	1.96E-04

Sc-46		Liquid release (mrem/Ci released)					
	Bone	Liver	T.Body	Thyroid	Kidney	Lung	GI-LLI
Adult	1.32E-07	2.57E-07	7.46E-08	0.00E+00	2.40E-07	0.00E+00	1.25E-03
Teen	1.23E-07	2.39E-07	7.10E-08	0.00E+00	2.29E-07	0.00E+00	8.15E-04
Child	3.04E-07	4.17E-07	1.61E-07	0.00E+00	3.69E-07	0.00E+00	6.10E-04
Infant	3.47E-07	5.00E-07	1.56E-07	0.00E+00	3.29E-07	0.00E+00	3.26E-04

Cr-51		Liquid release (mrem/Ci released)					
	Bone	Liver	T.Body	Thyroid	Kidney	Lung	GI-LLI
Adult	0.00E+00	0.00E+00	9.82E-07	5.87E-07	2.16E-07	1.30E-06	2.47E-04
Teen	0.00E+00	0.00E+00	1.01E-06	5.60E-07	2.21E-07	1.44E-06	1.70E-04
Child	0.00E+00	0.00E+00	1.15E-06	6.36E-07	1.74E-07	1.16E-06	6.07E-05
Infant	0.00E+00	0.00E+00	1.26E-07	8.23E-08	1.80E-08	1.60E-07	3.68E-06

Mn-54		Liquid release (mrem/Ci released)					
	Bone	Liver	T.Body	Thyroid	Kidney	Lung	GI-LLI
Adult	0.00E+00	3.33E-03	6.35E-04	0.00E+00	9.90E-04	0.00E+00	1.02E-02
Teen	0.00E+00	3.26E-03	6.47E-04	0.00E+00	9.74E-04	0.00E+00	6.69E-03
Child	0.00E+00	2.64E-03	7.03E-04	0.00E+00	7.40E-04	0.00E+00	2.22E-03
Infant	0.00E+00	1.86E-04	4.22E-05	0.00E+00	4.13E-05	0.00E+00	6.84E-05

Mn-56		Liquid release (mrem/Ci released)					
	Bone	Liver	T.Body	Thyroid	Kidney	Lung	GI-LLI
Adult	0.00E+00	3.23E-06	5.73E-07	0.00E+00	4.10E-06	0.00E+00	1.03E-04
Teen	0.00E+00	3.38E-06	6.02E-07	0.00E+00	4.28E-06	0.00E+00	2.23E-04
Child	0.00E+00	3.08E-06	6.96E-07	0.00E+00	3.73E-06	0.00E+00	4.47E-04
Infant	0.00E+00	1.91E-11	3.29E-12	0.00E+00	1.64E-11	0.00E+00	1.73E-09

Fe-55		Liquid release (mrem/Ci released)					
	Bone	Liver	T.Body	Thyroid	Kidney	Lung	GI-LLI
Adult	5.44E-04	3.76E-04	8.76E-05	0.00E+00	0.00E+00	2.10E-04	2.15E-04
Teen	5.64E-04	4.00E-04	9.33E-05	0.00E+00	0.00E+00	2.54E-04	1.73E-04
Child	8.35E-04	4.43E-04	1.37E-04	0.00E+00	0.00E+00	2.51E-04	8.21E-05
Infant	1.30E-04	8.43E-05	2.25E-05	0.00E+00	0.00E+00	4.12E-05	1.07E-05

APPENDIX K
LIQUID EFFLUENT DOSE CONVERSION FACTORS

Fe-59		Liquid release (mrem/Ci released)					
	Bone	Liver	T.Body	Thyroid	Kidney	Lung	GI-LLI
Adult	8.50E-04	2.00E-03	7.66E-04	0.00E+00	0.00E+00	5.58E-04	6.66E-03
Teen	8.68E-04	2.03E-03	7.82E-04	0.00E+00	0.00E+00	6.39E-04	4.79E-03
Child	1.18E-03	1.92E-03	9.55E-04	0.00E+00	0.00E+00	5.56E-04	2.00E-03
Infant	2.81E-04	4.90E-04	1.93E-04	0.00E+00	0.00E+00	1.45E-04	2.34E-04

Co-57		Liquid release (mrem/Ci released)					
	Bone	Liver	T.Body	Thyroid	Kidney	Lung	GI-LLI
Adult	0.00E+00	1.91E-05	3.17E-05	0.00E+00	0.00E+00	0.00E+00	4.84E-04
Teen	0.00E+00	1.95E-05	3.26E-05	0.00E+00	0.00E+00	0.00E+00	3.63E-04
Child	0.00E+00	2.14E-05	4.34E-05	0.00E+00	0.00E+00	0.00E+00	1.76E-04
Infant	0.00E+00	1.08E-05	1.75E-05	0.00E+00	0.00E+00	0.00E+00	3.67E-05

Co-58		Liquid release (mrem/Ci released)					
	Bone	Liver	T.Body	Thyroid	Kidney	Lung	GI-LLI
Adult	0.00E+00	8.08E-05	1.81E-04	0.00E+00	0.00E+00	0.00E+00	1.64E-03
Teen	0.00E+00	7.91E-05	1.82E-04	0.00E+00	0.00E+00	0.00E+00	1.09E-03
Child	0.00E+00	7.77E-05	2.38E-04	0.00E+00	0.00E+00	0.00E+00	4.53E-04
Infant	0.00E+00	3.32E-05	8.28E-05	0.00E+00	0.00E+00	0.00E+00	8.27E-05

Co-60		Liquid release (mrem/Ci released)					
	Bone	Liver	T.Body	Thyroid	Kidney	Lung	GI-LLI
Adult	0.00E+00	2.34E-04	5.16E-04	0.00E+00	0.00E+00	0.00E+00	4.39E-03
Teen	0.00E+00	2.30E-04	5.19E-04	0.00E+00	0.00E+00	0.00E+00	3.00E-03
Child	0.00E+00	2.31E-04	6.80E-04	0.00E+00	0.00E+00	0.00E+00	1.28E-03
Infant	0.00E+00	1.01E-04	2.40E-04	0.00E+00	0.00E+00	0.00E+00	2.41E-04

Ni-63		Liquid release (mrem/Ci released)					
	Bone	Liver	T.Body	Thyroid	Kidney	Lung	GI-LLI
Adult	2.57E-02	1.78E-03	8.62E-04	0.00E+00	0.00E+00	0.00E+00	3.72E-04
Teen	2.64E-02	1.87E-03	8.96E-04	0.00E+00	0.00E+00	0.00E+00	2.97E-04
Child	3.91E-02	2.09E-03	1.33E-03	0.00E+00	0.00E+00	0.00E+00	1.41E-04
Infant	5.96E-03	3.69E-04	2.07E-04	0.00E+00	0.00E+00	0.00E+00	1.83E-05

Ni-65		Liquid release (mrem/Ci released)					
	Bone	Liver	T.Body	Thyroid	Kidney	Lung	GI-LLI
Adult	3.43E-06	4.46E-07	2.03E-07	0.00E+00	0.00E+00	0.00E+00	1.13E-05
Teen	3.71E-06	4.74E-07	2.16E-07	0.00E+00	0.00E+00	0.00E+00	2.57E-05
Child	4.74E-06	4.46E-07	2.60E-07	0.00E+00	0.00E+00	0.00E+00	5.47E-05
Infant	8.03E-11	9.09E-12	4.13E-12	0.00E+00	0.00E+00	0.00E+00	6.92E-10

APPENDIX K
LIQUID EFFLUENT DOSE CONVERSION FACTORS

Cu-64		Liquid release (mrem/Ci released)					
	Bone	Liver	T.Body	Thyroid	Kidney	Lung	GI-LLI
Adult	0.00E+00	3.96E-06	1.86E-06	0.00E+00	9.97E-06	0.00E+00	3.37E-04
Teen	0.00E+00	4.15E-06	1.95E-06	0.00E+00	1.05E-05	0.00E+00	3.22E-04
Child	0.00E+00	3.96E-06	2.39E-06	0.00E+00	9.57E-06	0.00E+00	1.86E-04
Infant	0.00E+00	4.17E-07	1.93E-07	0.00E+00	7.05E-07	0.00E+00	8.56E-06

Zn-65		Liquid release (mrem/Ci released)					
	Bone	Liver	T.Body	Thyroid	Kidney	Lung	GI-LLI
Adult	1.72E-02	5.48E-02	2.47E-02	0.00E+00	3.66E-02	0.00E+00	3.45E-02
Teen	1.56E-02	5.42E-02	2.53E-02	0.00E+00	3.47E-02	0.00E+00	2.29E-02
Child	1.61E-02	4.29E-02	2.67E-02	0.00E+00	2.70E-02	0.00E+00	7.54E-03
Infant	1.72E-04	5.90E-04	2.72E-04	0.00E+00	2.86E-04	0.00E+00	4.98E-04

Zn-69m		Liquid release (mrem/Ci released)					
	Bone	Liver	T.Body	Thyroid	Kidney	Lung	GI-LLI
Adult	3.29E-04	7.90E-04	7.22E-05	0.00E+00	4.78E-04	0.00E+00	4.82E-02
Teen	3.54E-04	8.34E-04	7.65E-05	0.00E+00	5.07E-04	0.00E+00	4.59E-02
Child	4.52E-04	7.70E-04	9.11E-05	0.00E+00	4.48E-04	0.00E+00	2.51E-02
Infant	1.26E-06	2.56E-06	2.34E-07	0.00E+00	1.04E-06	0.00E+00	3.55E-05

Zn-69		Liquid release (mrem/Ci released)					
	Bone	Liver	T.Body	Thyroid	Kidney	Lung	GI-LLI
Adult	4.91E-09	9.40E-09	6.54E-10	0.00E+00	6.11E-09	0.00E+00	1.41E-09
Teen	5.34E-09	1.02E-08	7.12E-10	0.00E+00	6.65E-09	0.00E+00	1.88E-08
Child	6.87E-09	9.92E-09	9.17E-10	0.00E+00	6.02E-09	0.00E+00	6.25E-07
Infant	2.89E-22	5.21E-22	3.88E-23	0.00E+00	2.17E-22	0.00E+00	4.25E-20

As-76		Liquid release (mrem/Ci released)					
	Bone	Liver	T.Body	Thyroid	Kidney	Lung	GI-LLI
Adult	5.50E-05	1.60E-04	7.99E-04	4.80E-05	1.95E-04	5.00E-05	6.99E-03
Teen	4.93E-05	1.55E-04	7.58E-04	4.55E-05	1.82E-04	4.55E-05	6.83E-03
Child	6.20E-05	1.72E-04	9.99E-04	5.85E-05	1.89E-04	5.85E-05	8.95E-03
Infant	2.16E-05	5.70E-05	9.83E-05	2.16E-05	5.99E-05	2.16E-05	6.29E-04

Br-82		Liquid release (mrem/Ci released)					
	Bone	Liver	T.Body	Thyroid	Kidney	Lung	GI-LLI
Adult	0.00E+00	0.00E+00	1.35E-03	0.00E+00	0.00E+00	0.00E+00	1.54E-03
Teen	0.00E+00	0.00E+00	1.38E-03	0.00E+00	0.00E+00	0.00E+00	0.00E+00
Child	0.00E+00	0.00E+00	1.50E-03	0.00E+00	0.00E+00	0.00E+00	0.00E+00
Infant	0.00E+00	0.00E+00	4.65E-05	0.00E+00	0.00E+00	0.00E+00	0.00E+00

APPENDIX K
LIQUID EFFLUENT DOSE CONVERSION FACTORS

Br-83		Liquid release (mrem/Ci released)					
	Bone	Liver	T.Body	Thyroid	Kidney	Lung	GI-LLI
Adult	0.00E+00	0.00E+00	9.34E-07	0.00E+00	0.00E+00	0.00E+00	1.35E-06
Teen	0.00E+00	0.00E+00	1.02E-06	0.00E+00	0.00E+00	0.00E+00	0.00E+00
Child	0.00E+00	0.00E+00	1.31E-06	0.00E+00	0.00E+00	0.00E+00	0.00E+00
Infant	0.00E+00	0.00E+00	3.25E-12	0.00E+00	0.00E+00	0.00E+00	0.00E+00

Br-84		Liquid release (mrem/Ci released)					
	Bone	Liver	T.Body	Thyroid	Kidney	Lung	GI-LLI
Adult	0.00E+00	0.00E+00	5.92E-12	0.00E+00	0.00E+00	0.00E+00	4.65E-17
Teen	0.00E+00	0.00E+00	6.25E-12	0.00E+00	0.00E+00	0.00E+00	0.00E+00
Child	0.00E+00	0.00E+00	7.39E-12	0.00E+00	0.00E+00	0.00E+00	0.00E+00
Infant	0.00E+00	0.00E+00	0.00E+00	0.00E+00	0.00E+00	0.00E+00	0.00E+00

Br-85		Liquid release (mrem/Ci released)					
	Bone	Liver	T.Body	Thyroid	Kidney	Lung	GI-LLI
Adult	0.00E+00	0.00E+00	0.00E+00	0.00E+00	0.00E+00	0.00E+00	0.00E+00
Teen	0.00E+00	0.00E+00	0.00E+00	0.00E+00	0.00E+00	0.00E+00	0.00E+00
Child	0.00E+00	0.00E+00	0.00E+00	0.00E+00	0.00E+00	0.00E+00	0.00E+00
Infant	0.00E+00	0.00E+00	0.00E+00	0.00E+00	0.00E+00	0.00E+00	0.00E+00

Rb-86		Liquid release (mrem/Ci released)					
	Bone	Liver	T.Body	Thyroid	Kidney	Lung	GI-LLI
Adult	0.00E+00	7.37E-02	3.43E-02	0.00E+00	0.00E+00	0.00E+00	1.45E-02
Teen	0.00E+00	7.93E-02	3.73E-02	0.00E+00	0.00E+00	0.00E+00	1.17E-02
Child	0.00E+00	7.74E-02	4.76E-02	0.00E+00	0.00E+00	0.00E+00	4.98E-03
Infant	0.00E+00	1.48E-03	7.33E-04	0.00E+00	0.00E+00	0.00E+00	3.80E-05

Rb-88		Liquid release (mrem/Ci released)					
	Bone	Liver	T.Body	Thyroid	Kidney	Lung	GI-LLI
Adult	0.00E+00	1.22E-16	6.46E-17	0.00E+00	0.00E+00	0.00E+00	0.00E+00
Teen	0.00E+00	1.31E-16	6.96E-17	0.00E+00	0.00E+00	0.00E+00	1.12E-23
Child	0.00E+00	1.26E-16	8.73E-17	0.00E+00	0.00E+00	0.00E+00	6.16E-18
Infant	0.00E+00	0.00E+00	0.00E+00	0.00E+00	0.00E+00	0.00E+00	0.00E+00

Rb-89		Liquid release (mrem/Ci released)					
	Bone	Liver	T.Body	Thyroid	Kidney	Lung	GI-LLI
Adult	0.00E+00	1.20E-18	8.42E-19	0.00E+00	0.00E+00	0.00E+00	0.00E+00
Teen	0.00E+00	1.25E-18	8.84E-19	0.00E+00	0.00E+00	0.00E+00	0.00E+00
Child	0.00E+00	1.15E-18	1.02E-18	0.00E+00	0.00E+00	0.00E+00	1.00E-20
Infant	0.00E+00	0.00E+00	0.00E+00	0.00E+00	0.00E+00	0.00E+00	0.00E+00

APPENDIX K
LIQUID EFFLUENT DOSE CONVERSION FACTORS

Sr-89		Liquid release (mrem/Ci released)					
	Bone	Liver	T.Body	Thyroid	Kidney	Lung	GI-LLI
Adult	2.25E-02	0.00E+00	6.45E-04	0.00E+00	0.00E+00	0.00E+00	3.60E-03
Teen	2.39E-02	0.00E+00	6.84E-04	0.00E+00	0.00E+00	0.00E+00	2.85E-03
Child	4.15E-02	0.00E+00	1.19E-03	0.00E+00	0.00E+00	0.00E+00	1.61E-03
Infant	2.30E-02	0.00E+00	6.59E-04	0.00E+00	0.00E+00	0.00E+00	4.72E-04

Sr-90		Liquid release (mrem/Ci released)					
	Bone	Liver	T.Body	Thyroid	Kidney	Lung	GI-LLI
Adult	6.44E-01	0.00E+00	1.29E-02	0.00E+00	0.00E+00	0.00E+00	1.62E-02
Teen	5.61E-01	0.00E+00	1.12E-02	0.00E+00	0.00E+00	0.00E+00	1.28E-02
Child	8.19E-01	0.00E+00	1.65E-02	0.00E+00	0.00E+00	0.00E+00	7.32E-03
Infant	2.66E-01	0.00E+00	5.40E-03	0.00E+00	0.00E+00	0.00E+00	2.17E-03

Sr-91		Liquid release (mrem/Ci released)					
	Bone	Liver	T.Body	Thyroid	Kidney	Lung	GI-LLI
Adult	1.29E-04	0.00E+00	5.21E-06	0.00E+00	0.00E+00	0.00E+00	6.14E-04
Teen	1.40E-04	0.00E+00	5.55E-06	0.00E+00	0.00E+00	0.00E+00	6.33E-04
Child	1.85E-04	0.00E+00	6.98E-06	0.00E+00	0.00E+00	0.00E+00	4.08E-04
Infant	1.42E-05	0.00E+00	5.13E-07	0.00E+00	0.00E+00	0.00E+00	1.68E-05

Sr-92		Liquid release (mrem/Ci released)					
	Bone	Liver	T.Body	Thyroid	Kidney	Lung	GI-LLI
Adult	5.30E-06	0.00E+00	2.29E-07	0.00E+00	0.00E+00	0.00E+00	1.05E-04
Teen	5.73E-06	0.00E+00	2.44E-07	0.00E+00	0.00E+00	0.00E+00	1.46E-04
Child	7.32E-06	0.00E+00	2.93E-07	0.00E+00	0.00E+00	0.00E+00	1.39E-04
Infant	8.41E-10	0.00E+00	3.12E-11	0.00E+00	0.00E+00	0.00E+00	9.06E-09

Y-90		Liquid release (mrem/Ci released)					
	Bone	Liver	T.Body	Thyroid	Kidney	Lung	GI-LLI
Adult	4.93E-07	0.00E+00	1.32E-08	0.00E+00	0.00E+00	0.00E+00	5.23E-03
Teen	5.24E-07	0.00E+00	1.41E-08	0.00E+00	0.00E+00	0.00E+00	4.32E-03
Child	8.80E-07	0.00E+00	2.36E-08	0.00E+00	0.00E+00	0.00E+00	2.51E-03
Infant	4.86E-07	0.00E+00	1.30E-08	0.00E+00	0.00E+00	0.00E+00	6.71E-04

Y-91m		Liquid release (mrem/Ci released)					
	Bone	Liver	T.Body	Thyroid	Kidney	Lung	GI-LLI
Adult	1.75E-13	0.00E+00	6.78E-15	0.00E+00	0.00E+00	0.00E+00	5.15E-13
Teen	1.89E-13	0.00E+00	7.24E-15	0.00E+00	0.00E+00	0.00E+00	8.94E-12
Child	2.42E-13	0.00E+00	8.80E-15	0.00E+00	0.00E+00	0.00E+00	4.74E-10
Infant	0.00E+00	0.00E+00	0.00E+00	0.00E+00	0.00E+00	0.00E+00	9.13E-23

APPENDIX K
LIQUID EFFLUENT DOSE CONVERSION FACTORS

Y-91		Liquid release (mrem/Ci released)					
	Bone	Liver	T.Body	Thyroid	Kidney	Lung	GI-LLI
Adult	9.07E-06	0.00E+00	2.42E-07	0.00E+00	0.00E+00	0.00E+00	4.99E-03
Teen	9.59E-06	0.00E+00	2.57E-07	0.00E+00	0.00E+00	0.00E+00	3.93E-03
Child	1.72E-05	0.00E+00	4.61E-07	0.00E+00	0.00E+00	0.00E+00	2.30E-03
Infant	1.04E-05	0.00E+00	2.76E-07	0.00E+00	0.00E+00	0.00E+00	7.44E-04

Y-92		Liquid release (mrem/Ci released)					
	Bone	Liver	T.Body	Thyroid	Kidney	Lung	GI-LLI
Adult	3.57E-09	0.00E+00	1.04E-10	0.00E+00	0.00E+00	0.00E+00	6.25E-05
Teen	3.89E-09	0.00E+00	1.13E-10	0.00E+00	0.00E+00	0.00E+00	1.07E-04
Child	5.00E-09	0.00E+00	1.43E-10	0.00E+00	0.00E+00	0.00E+00	1.44E-04
Infant	5.96E-12	0.00E+00	1.67E-13	0.00E+00	0.00E+00	0.00E+00	1.14E-07

Y-93		Liquid release (mrem/Ci released)					
	Bone	Liver	T.Body	Thyroid	Kidney	Lung	GI-LLI
Adult	5.46E-08	0.00E+00	1.51E-09	0.00E+00	0.00E+00	0.00E+00	1.73E-03
Teen	5.93E-08	0.00E+00	1.62E-09	0.00E+00	0.00E+00	0.00E+00	1.81E-03
Child	7.97E-08	0.00E+00	2.19E-09	0.00E+00	0.00E+00	0.00E+00	1.19E-03
Infant	8.76E-09	0.00E+00	2.38E-10	0.00E+00	0.00E+00	0.00E+00	6.92E-05

Zr-95		Liquid release (mrem/Ci released)					
	Bone	Liver	T.Body	Thyroid	Kidney	Lung	GI-LLI
Adult	7.95E-07	2.55E-07	1.73E-07	0.00E+00	4.00E-07	0.00E+00	8.09E-04
Teen	7.68E-07	2.42E-07	1.67E-07	0.00E+00	3.56E-07	0.00E+00	5.59E-04
Child	1.87E-06	4.11E-07	3.66E-07	0.00E+00	5.89E-07	0.00E+00	4.29E-04
Infant	1.90E-06	4.62E-07	3.28E-07	0.00E+00	4.98E-07	0.00E+00	2.30E-04

Zr-97		Liquid release (mrem/Ci released)					
	Bone	Liver	T.Body	Thyroid	Kidney	Lung	GI-LLI
Adult	1.08E-08	2.18E-09	9.97E-10	0.00E+00	3.29E-09	0.00E+00	6.75E-04
Teen	1.12E-08	2.21E-09	1.02E-09	0.00E+00	3.35E-09	0.00E+00	5.99E-04
Child	2.22E-08	3.21E-09	1.89E-09	0.00E+00	4.60E-09	0.00E+00	4.86E-04
Infant	1.92E-08	3.30E-09	1.51E-09	0.00E+00	3.32E-09	0.00E+00	2.10E-04

Nb-95		Liquid release (mrem/Ci released)					
	Bone	Liver	T.Body	Thyroid	Kidney	Lung	GI-LLI
Adult	3.27E-04	1.82E-04	9.78E-05	0.00E+00	1.80E-04	0.00E+00	1.10E+00
Teen	3.29E-04	1.83E-04	1.01E-04	0.00E+00	1.77E-04	0.00E+00	7.81E-01
Child	3.89E-04	1.51E-04	1.08E-04	0.00E+00	1.42E-04	0.00E+00	2.80E-01
Infant	3.80E-07	1.56E-07	9.04E-08	0.00E+00	1.12E-07	0.00E+00	1.32E-04

APPENDIX K
LIQUID EFFLUENT DOSE CONVERSION FACTORS

Nb-97		Liquid release (mrem/Ci released)					
	Bone	Liver	T.Body	Thyroid	Kidney	Lung	GI-LLI
Adult	3.21E-09	8.11E-10	2.96E-10	0.00E+00	9.46E-10	0.00E+00	2.99E-06
Teen	3.45E-09	8.56E-10	3.13E-10	0.00E+00	1.00E-09	0.00E+00	2.04E-05
Child	4.38E-09	7.91E-10	3.69E-10	0.00E+00	8.78E-10	0.00E+00	2.44E-04
Infant	7.72E-21	1.65E-21	5.94E-22	0.00E+00	1.29E-21	0.00E+00	5.20E-16

Mo-99		Liquid release (mrem/Ci released)					
	Bone	Liver	T.Body	Thyroid	Kidney	Lung	GI-LLI
Adult	0.00E+00	1.21E-04	2.31E-05	0.00E+00	2.75E-04	0.00E+00	2.81E-04
Teen	0.00E+00	1.25E-04	2.38E-05	0.00E+00	2.85E-04	0.00E+00	2.23E-04
Child	0.00E+00	1.85E-04	4.57E-05	0.00E+00	3.95E-04	0.00E+00	1.53E-04
Infant	0.00E+00	1.93E-04	3.76E-05	0.00E+00	2.88E-04	0.00E+00	6.36E-05

Tc-99m		Liquid release (mrem/Ci released)					
	Bone	Liver	T.Body	Thyroid	Kidney	Lung	GI-LLI
Adult	1.66E-09	4.70E-09	5.99E-08	0.00E+00	7.14E-08	2.30E-09	2.78E-06
Teen	1.70E-09	4.75E-09	6.15E-08	0.00E+00	7.07E-08	2.63E-09	3.12E-06
Child	2.07E-09	4.06E-09	6.73E-08	0.00E+00	5.90E-08	2.06E-09	2.31E-06
Infant	7.05E-11	1.47E-10	1.89E-09	0.00E+00	1.58E-09	7.67E-11	4.26E-08

Tc-99		Liquid release (mrem/Ci released)					
	Bone	Liver	T.Body	Thyroid	Kidney	Lung	GI-LLI
Adult	5.92E-06	8.81E-06	2.38E-06	0.00E+00	1.11E-04	7.48E-07	2.88E-04
Teen	6.22E-06	9.14E-06	2.49E-06	0.00E+00	1.16E-04	9.45E-07	2.24E-04
Child	1.24E-05	1.39E-05	4.98E-06	0.00E+00	1.63E-04	1.23E-06	1.45E-04
Infant	1.02E-05	1.37E-05	4.28E-06	0.00E+00	1.16E-04	1.33E-06	5.93E-05

Tc-101		Liquid release (mrem/Ci released)					
	Bone	Liver	T.Body	Thyroid	Kidney	Lung	GI-LLI
Adult	3.86E-24	5.57E-24	5.46E-23	0.00E+00	1.00E-22	2.84E-24	0.00E+00
Teen	4.17E-24	5.93E-24	5.83E-23	0.00E+00	1.07E-22	3.61E-24	0.00E+00
Child	5.35E-24	5.60E-24	7.09E-23	0.00E+00	9.54E-23	2.96E-24	1.78E-23
Infant	0.00E+00	0.00E+00	0.00E+00	0.00E+00	0.00E+00	0.00E+00	0.00E+00

Ru-103		Liquid release (mrem/Ci released)					
	Bone	Liver	T.Body	Thyroid	Kidney	Lung	GI-LLI
Adult	6.96E-06	0.00E+00	3.00E-06	0.00E+00	2.66E-05	0.00E+00	8.13E-04
Teen	6.99E-06	0.00E+00	2.99E-06	0.00E+00	2.46E-05	0.00E+00	5.83E-04
Child	1.45E-05	0.00E+00	5.56E-06	0.00E+00	3.64E-05	0.00E+00	3.74E-04
Infant	1.34E-05	0.00E+00	4.49E-06	0.00E+00	2.80E-05	0.00E+00	1.63E-04

OFFSITE DOSE CALCULATION MANUAL

APPENDIX K
LIQUID EFFLUENT DOSE CONVERSION FACTORS

Ru-105		Liquid release (mrem/Ci released)					
	Bone	Liver	T.Body	Thyroid	Kidney	Lung	GI-LLI
Adult	4.20E-08	0.00E+00	1.66E-08	0.00E+00	5.43E-07	0.00E+00	2.57E-05
Teen	4.53E-08	0.00E+00	1.76E-08	0.00E+00	5.72E-07	0.00E+00	3.66E-05
Child	5.81E-08	0.00E+00	2.11E-08	0.00E+00	5.11E-07	0.00E+00	3.79E-05
Infant	7.12E-10	0.00E+00	2.40E-10	0.00E+00	5.23E-09	0.00E+00	2.83E-07

Ru-106		Liquid release (mrem/Ci released)					
	Bone	Liver	T.Body	Thyroid	Kidney	Lung	GI-LLI
Adult	1.06E-04	0.00E+00	1.34E-05	0.00E+00	2.04E-04	0.00E+00	6.84E-03
Teen	1.10E-04	0.00E+00	1.38E-05	0.00E+00	2.11E-04	0.00E+00	5.25E-03
Child	2.37E-04	0.00E+00	2.96E-05	0.00E+00	3.20E-04	0.00E+00	3.69E-03
Infant	2.26E-04	0.00E+00	2.82E-05	0.00E+00	2.67E-04	0.00E+00	1.71E-03

Rh-105		Liquid release (mrem/Ci released)					
	Bone	Liver	T.Body	Thyroid	Kidney	Lung	GI-LLI
Adult	2.68E-06	1.96E-06	1.29E-06	0.00E+00	8.32E-06	0.00E+00	3.12E-04
Teen	2.83E-06	2.04E-06	1.34E-06	0.00E+00	8.68E-06	0.00E+00	2.60E-04
Child	5.28E-06	2.84E-06	2.42E-06	0.00E+00	1.13E-05	0.00E+00	1.76E-04
Infant	4.00E-06	2.62E-06	1.76E-06	0.00E+00	7.27E-06	0.00E+00	6.50E-05

Ag-110m		Liquid release (mrem/Ci released)					
	Bone	Liver	T.Body	Thyroid	Kidney	Lung	GI-LLI
Adult	3.96E-06	3.66E-06	2.18E-06	0.00E+00	7.20E-06	0.00E+00	1.49E-03
Teen	3.60E-06	3.40E-06	2.07E-06	0.00E+00	6.49E-06	0.00E+00	9.56E-04
Child	8.51E-06	5.75E-06	4.59E-06	0.00E+00	1.07E-05	0.00E+00	6.83E-04
Infant	9.31E-06	6.80E-06	4.50E-06	0.00E+00	9.72E-06	0.00E+00	3.52E-04

Sn-113		Liquid release (mrem/Ci released)					
	Bone	Liver	T.Body	Thyroid	Kidney	Lung	GI-LLI
Adult	5.12E-03	8.66E-04	1.44E-02	4.53E-04	1.18E-03	5.31E-04	1.57E-01
Teen	4.20E-03	8.40E-04	1.38E-02	4.05E-04	1.09E-03	4.95E-04	1.48E-01
Child	5.13E-03	1.10E-03	1.69E-02	4.42E-04	1.17E-03	5.52E-04	1.88E-01
Infant	9.98E-05	2.00E-05	2.68E-04	1.07E-05	2.00E-05	1.34E-05	2.96E-03

Sn-117m		Liquid release (mrem/Ci released)					
	Bone	Liver	T.Body	Thyroid	Kidney	Lung	GI-LLI
Adult	9.62E-03	3.27E-04	1.37E-02	6.54E-05	5.00E-04	1.04E-04	1.54E-01
Teen	7.47E-03	3.22E-04	1.29E-02	6.01E-05	4.54E-04	1.10E-04	1.45E-01
Child	1.02E-02	4.82E-04	1.59E-02	7.62E-05	4.89E-04	1.40E-04	1.84E-01
Infant	1.79E-04	7.23E-06	2.42E-04	2.04E-06	6.29E-06	2.96E-06	2.77E-03

APPENDIX K
LIQUID EFFLUENT DOSE CONVERSION FACTORS

Sb-122		Liquid release (mrem/Ci released)					
	Bone	Liver	T.Body	Thyroid	Kidney	Lung	GI-LLI
Adult	9.37E-06	5.15E-06	8.85E-05	1.09E-06	3.64E-06	1.41E-06	9.37E-04
Teen	6.98E-06	4.77E-06	7.71E-05	9.55E-07	3.12E-06	1.29E-06	8.08E-04
Child	1.88E-05	1.13E-05	2.09E-04	2.46E-06	6.84E-06	3.22E-06	2.26E-03
Infant	4.39E-05	2.93E-05	3.76E-04	8.78E-06	1.40E-05	1.00E-05	3.97E-03

Sb-124		Liquid release (mrem/Ci released)					
	Bone	Liver	T.Body	Thyroid	Kidney	Lung	GI-LLI
Adult	6.18E-05	1.17E-06	2.45E-05	1.50E-07	0.00E+00	4.81E-05	1.76E-03
Teen	6.01E-05	1.11E-06	2.35E-05	1.36E-07	0.00E+00	5.25E-05	1.21E-03
Child	1.64E-04	2.13E-06	5.75E-05	3.62E-07	0.00E+00	9.10E-05	1.03E-03
Infant	1.97E-04	2.89E-06	6.09E-05	5.22E-07	0.00E+00	1.23E-04	6.06E-04

Sb-125		Liquid release (mrem/Ci released)					
	Bone	Liver	T.Body	Thyroid	Kidney	Lung	GI-LLI
Adult	4.03E-05	4.51E-07	9.60E-06	4.10E-08	0.00E+00	3.11E-05	4.44E-04
Teen	3.93E-05	4.30E-07	9.20E-06	3.76E-08	0.00E+00	3.46E-05	3.06E-04
Child	1.08E-04	8.33E-07	2.26E-05	1.00E-07	0.00E+00	6.02E-05	2.58E-04
Infant	1.15E-04	1.12E-06	2.38E-05	1.45E-07	0.00E+00	7.25E-05	1.54E-04

Te-125m		Liquid release (mrem/Ci released)					
	Bone	Liver	T.Body	Thyroid	Kidney	Lung	GI-LLI
Adult	1.94E-03	7.03E-04	2.60E-04	5.84E-04	7.89E-03	0.00E+00	7.75E-03
Teen	2.11E-03	7.60E-04	2.82E-04	5.89E-04	0.00E+00	0.00E+00	6.22E-03
Child	2.80E-03	7.58E-04	3.73E-04	7.85E-04	0.00E+00	0.00E+00	2.70E-03
Infant	2.14E-04	7.15E-05	2.89E-05	7.20E-05	0.00E+00	0.00E+00	1.02E-04

Te-127m		Liquid release (mrem/Ci released)					
	Bone	Liver	T.Body	Thyroid	Kidney	Lung	GI-LLI
Adult	4.92E-03	1.76E-03	5.99E-04	1.26E-03	2.00E-02	0.00E+00	1.65E-02
Teen	5.34E-03	1.89E-03	6.35E-04	1.27E-03	2.16E-02	0.00E+00	1.33E-02
Child	7.12E-03	1.92E-03	8.45E-04	1.70E-03	2.03E-02	0.00E+00	5.76E-03
Infant	5.43E-04	1.80E-04	6.57E-05	1.57E-04	1.34E-03	0.00E+00	2.19E-04

Te-127		Liquid release (mrem/Ci released)					
	Bone	Liver	T.Body	Thyroid	Kidney	Lung	GI-LLI
Adult	3.22E-05	1.16E-05	6.97E-06	2.39E-05	1.31E-04	0.00E+00	2.54E-03
Teen	3.52E-05	1.25E-05	7.58E-06	2.43E-05	1.43E-04	0.00E+00	2.72E-03
Child	4.54E-05	1.22E-05	9.74E-06	3.14E-05	1.29E-04	0.00E+00	1.77E-03
Infant	2.73E-07	9.14E-08	5.87E-08	2.22E-07	6.66E-07	0.00E+00	5.73E-06

APPENDIX K
LIQUID EFFLUENT DOSE CONVERSION FACTORS

Te-129m		Liquid release (mrem/Ci released)					
	Bone	Liver	T.Body	Thyroid	Kidney	Lung	GI-LLI
Adult	8.29E-03	3.09E-03	1.31E-03	2.85E-03	3.46E-02	0.00E+00	4.17E-02
Teen	8.93E-03	3.31E-03	1.41E-03	2.88E-03	3.74E-02	0.00E+00	3.35E-02
Child	1.19E-02	3.32E-03	1.85E-03	3.83E-03	3.49E-02	0.00E+00	1.45E-02
Infant	9.02E-04	3.09E-04	1.39E-04	3.46E-04	2.26E-03	0.00E+00	5.39E-04

Te-129		Liquid release (mrem/Ci released)					
	Bone	Liver	T.Body	Thyroid	Kidney	Lung	GI-LLI
Adult	1.71E-08	6.42E-09	4.16E-09	1.31E-08	7.19E-08	0.00E+00	1.29E-08
Teen	1.86E-08	6.93E-09	4.52E-09	1.33E-08	7.80E-08	0.00E+00	1.02E-07
Child	2.40E-08	6.69E-09	5.69E-09	1.71E-08	7.01E-08	0.00E+00	1.49E-06
Infant	9.33E-19	3.22E-19	2.18E-19	7.82E-19	2.32E-18	0.00E+00	7.46E-17

Te-131m		Liquid release (mrem/Ci released)					
	Bone	Liver	T.Body	Thyroid	Kidney	Lung	GI-LLI
Adult	9.40E-04	4.60E-04	3.83E-04	7.28E-04	4.66E-03	0.00E+00	4.56E-02
Teen	1.01E-03	4.84E-04	4.04E-04	7.28E-04	5.05E-03	0.00E+00	3.88E-02
Child	1.30E-03	4.51E-04	4.80E-04	9.27E-04	4.36E-03	0.00E+00	1.83E-02
Infant	4.71E-05	1.90E-05	1.57E-05	3.85E-05	1.31E-04	0.00E+00	3.19E-04

Te-131		Liquid release (mrem/Ci released)					
	Bone	Liver	T.Body	Thyroid	Kidney	Lung	GI-LLI
Adult	2.98E-14	1.25E-14	9.42E-15	2.45E-14	1.31E-13	0.00E+00	4.23E-15
Teen	3.22E-14	1.33E-14	1.01E-14	2.48E-14	1.41E-13	0.00E+00	2.64E-15
Child	4.13E-14	1.26E-14	1.23E-14	3.16E-14	1.25E-13	0.00E+00	2.17E-13
Infant	0.00E+00	0.00E+00	0.00E+00	0.00E+00	0.00E+00	0.00E+00	0.00E+00

Te-132		Liquid release (mrem/Ci released)					
	Bone	Liver	T.Body	Thyroid	Kidney	Lung	GI-LLI
Adult	1.63E-03	1.06E-03	9.93E-04	1.17E-03	1.02E-02	0.00E+00	5.00E-02
Teen	1.72E-03	1.09E-03	1.03E-03	1.15E-03	1.05E-02	0.00E+00	3.45E-02
Child	2.20E-03	9.75E-04	1.18E-03	1.42E-03	9.05E-03	0.00E+00	9.82E-03
Infant	1.27E-04	6.28E-05	5.86E-05	9.27E-05	3.93E-04	0.00E+00	2.32E-04

I-130		Liquid release (mrem/Ci released)					
	Bone	Liver	T.Body	Thyroid	Kidney	Lung	GI-LLI
Adult	1.13E-05	3.33E-05	1.32E-05	2.83E-03	5.20E-05	0.00E+00	2.87E-05
Teen	1.16E-05	3.37E-05	1.35E-05	2.75E-03	5.19E-05	0.00E+00	2.59E-05
Child	1.59E-05	3.22E-05	1.65E-05	3.53E-03	4.79E-05	0.00E+00	1.50E-05
Infant	3.82E-06	8.41E-06	3.38E-06	9.43E-04	9.24E-06	0.00E+00	1.80E-06

APPENDIX K
LIQUID EFFLUENT DOSE CONVERSION FACTORS

I-131		Liquid release (mrem/Ci released)					
	Bone	Liver	T.Body	Thyroid	Kidney	Lung	GI-LLI
Adult	1.79E-04	2.55E-04	1.46E-04	8.37E-02	4.38E-04	0.00E+00	6.74E-05
Teen	1.85E-04	2.59E-04	1.39E-04	7.55E-02	4.45E-04	0.00E+00	5.12E-05
Child	3.54E-04	3.56E-04	2.02E-04	1.18E-01	5.84E-04	0.00E+00	3.17E-05
Infant	2.84E-04	3.35E-04	1.47E-04	1.10E-01	3.91E-04	0.00E+00	1.19E-05

I-132		Liquid release (mrem/Ci released)					
	Bone	Liver	T.Body	Thyroid	Kidney	Lung	GI-LLI
Adult	1.40E-07	3.75E-07	1.31E-07	1.31E-05	5.98E-07	0.00E+00	7.05E-08
Teen	1.47E-07	3.85E-07	1.38E-07	1.30E-05	6.06E-07	0.00E+00	1.67E-07
Child	1.82E-07	3.34E-07	1.54E-07	1.55E-05	5.11E-07	0.00E+00	3.93E-07
Infant	7.18E-12	1.46E-11	5.19E-12	6.83E-10	1.63E-11	0.00E+00	1.18E-11

I-133		Liquid release (mrem/Ci released)					
	Bone	Liver	T.Body	Thyroid	Kidney	Lung	GI-LLI
Adult	3.12E-05	5.43E-05	1.66E-05	7.98E-03	9.48E-05	0.00E+00	4.88E-05
Teen	3.31E-05	5.62E-05	1.72E-05	7.85E-03	9.86E-05	0.00E+00	4.25E-05
Child	5.20E-05	6.43E-05	2.43E-05	1.19E-02	1.07E-04	0.00E+00	2.59E-05
Infant	2.37E-05	3.45E-05	1.01E-05	6.29E-03	4.06E-05	0.00E+00	5.85E-06

I-134		Liquid release (mrem/Ci released)					
	Bone	Liver	T.Body	Thyroid	Kidney	Lung	GI-LLI
Adult	2.13E-10	5.79E-10	2.07E-10	1.00E-08	9.21E-10	0.00E+00	5.05E-13
Teen	2.24E-10	5.93E-10	2.13E-10	9.88E-09	9.35E-10	0.00E+00	7.82E-12
Child	2.77E-10	5.14E-10	2.37E-10	1.18E-08	7.86E-10	0.00E+00	3.41E-10
Infant	2.69E-22	5.51E-22	1.96E-22	1.29E-20	6.16E-22	0.00E+00	5.70E-22

I-135		Liquid release (mrem/Ci released)					
	Bone	Liver	T.Body	Thyroid	Kidney	Lung	GI-LLI
Adult	3.37E-06	8.84E-06	3.26E-06	5.83E-04	1.42E-05	0.00E+00	9.98E-06
Teen	3.53E-06	9.10E-06	3.37E-06	5.85E-04	1.44E-05	0.00E+00	1.01E-05
Child	4.46E-06	8.04E-06	3.80E-06	7.12E-04	1.23E-05	0.00E+00	6.12E-06
Infant	2.16E-07	4.30E-07	1.57E-07	3.86E-05	4.79E-07	0.00E+00	1.56E-07

Cs-134		Liquid release (mrem/Ci released)					
	Bone	Liver	T.Body	Thyroid	Kidney	Lung	GI-LLI
Adult	2.21E-01	5.27E-01	4.31E-01	0.00E+00	1.70E-01	5.66E-02	9.22E-03
Teen	2.27E-01	5.34E-01	2.48E-01	0.00E+00	1.70E-01	6.48E-02	6.64E-03
Child	2.75E-01	4.52E-01	9.53E-02	0.00E+00	1.40E-01	5.03E-02	2.44E-03
Infant	3.54E-03	6.60E-03	6.66E-04	0.00E+00	1.70E-03	6.96E-04	1.79E-05

APPENDIX K
LIQUID EFFLUENT DOSE CONVERSION FACTORS

Cs-134m		Liquid release (mrem/Ci released)					
	Bone	Liver	T.Body	Thyroid	Kidney	Lung	GI-LLI
Adult	4.28E-06	9.01E-06	4.60E-06	0.00E+00	4.89E-06	7.70E-07	3.18E-06
Teen	4.50E-06	9.33E-06	4.79E-06	0.00E+00	5.19E-06	9.11E-07	6.20E-06
Child	5.58E-06	8.26E-06	5.39E-06	0.00E+00	4.35E-06	7.20E-07	1.04E-05
Infant	1.72E-11	2.87E-11	1.45E-11	0.00E+00	1.11E-11	2.54E-12	2.27E-11

Cs-136		Liquid release (mrem/Ci released)					
	Bone	Liver	T.Body	Thyroid	Kidney	Lung	GI-LLI
Adult	2.26E-02	8.91E-02	6.41E-02	0.00E+00	4.96E-02	6.79E-03	1.01E-02
Teen	2.27E-02	8.92E-02	5.99E-02	0.00E+00	4.86E-02	7.66E-03	7.18E-03
Child	2.69E-02	7.40E-02	4.79E-02	0.00E+00	3.94E-02	5.88E-03	2.60E-03
Infant	3.88E-04	1.14E-03	4.26E-04	0.00E+00	4.55E-04	9.31E-05	1.73E-05

Cs-137		Liquid release (mrem/Ci released)					
	Bone	Liver	T.Body	Thyroid	Kidney	Lung	GI-LLI
Adult	2.84E-01	3.88E-01	2.54E-01	0.00E+00	1.32E-01	4.38E-02	7.51E-03
Teen	3.04E-01	4.04E-01	1.41E-01	0.00E+00	1.37E-01	5.34E-02	5.75E-03
Child	3.85E-01	3.69E-01	5.44E-02	0.00E+00	1.20E-01	4.32E-02	2.31E-03
Infant	4.91E-03	5.74E-03	4.07E-04	0.00E+00	1.54E-03	6.24E-04	1.80E-05

Cs-138		Liquid release (mrem/Ci released)					
	Bone	Liver	T.Body	Thyroid	Kidney	Lung	GI-LLI
Adult	3.63E-11	7.17E-11	3.55E-11	0.00E+00	5.27E-11	5.20E-12	3.06E-16
Teen	3.89E-11	7.46E-11	3.73E-11	0.00E+00	5.51E-11	6.41E-12	3.39E-14
Child	4.93E-11	6.85E-11	4.34E-11	0.00E+00	4.82E-11	5.18E-12	3.15E-11
Infant	0.00E+00	0.00E+00	0.00E+00	0.00E+00	0.00E+00	0.00E+00	0.00E+00

Ba-139		Liquid release (mrem/Ci released)					
	Bone	Liver	T.Body	Thyroid	Kidney	Lung	GI-LLI
Adult	1.77E-09	1.26E-12	5.20E-11	0.00E+00	1.18E-12	7.17E-13	3.15E-09
Teen	1.94E-09	1.36E-12	5.65E-11	0.00E+00	1.29E-12	9.40E-13	1.73E-08
Child	2.49E-09	1.33E-12	7.21E-11	0.00E+00	1.16E-12	7.81E-13	1.44E-07
Infant	3.69E-16	2.45E-19	1.07E-17	0.00E+00	1.47E-19	1.48E-19	2.34E-14

Ba-140		Liquid release (mrem/Ci released)					
	Bone	Liver	T.Body	Thyroid	Kidney	Lung	GI-LLI
Adult	5.19E-04	6.51E-07	3.40E-05	0.00E+00	2.21E-07	3.73E-07	1.07E-03
Teen	5.19E-04	6.36E-07	3.35E-05	0.00E+00	2.16E-07	4.28E-07	8.01E-04
Child	1.27E-03	1.11E-06	7.42E-05	0.00E+00	3.63E-07	6.64E-07	6.44E-04
Infant	1.44E-03	1.44E-06	7.43E-05	0.00E+00	3.42E-07	8.85E-07	3.54E-04

APPENDIX K
LIQUID EFFLUENT DOSE CONVERSION FACTORS

Ba-141		Liquid release (mrem/Ci released)					
	Bone	Liver	T.Body	Thyroid	Kidney	Lung	GI-LLI
Adult	4.78E-19	3.61E-22	1.61E-20	0.00E+00	3.36E-22	2.05E-22	0.00E+00
Teen	5.19E-19	3.87E-22	1.73E-20	0.00E+00	3.59E-22	2.65E-22	1.11E-24
Child	6.67E-19	3.73E-22	2.17E-20	0.00E+00	3.23E-22	2.19E-21	3.80E-19
Infant	0.00E+00	0.00E+00	0.00E+00	0.00E+00	0.00E+00	0.00E+00	0.00E+00

Ba-142		Liquid release (mrem/Ci released)					
	Bone	Liver	T.Body	Thyroid	Kidney	Lung	GI-LLI
Adult	0.00E+00	0.00E+00	0.00E+00	0.00E+00	0.00E+00	0.00E+00	0.00E+00
Teen	0.00E+00	0.00E+00	0.00E+00	0.00E+00	0.00E+00	0.00E+00	0.00E+00
Child	0.00E+00	0.00E+00	0.00E+00	0.00E+00	0.00E+00	0.00E+00	0.00E+00
Infant	0.00E+00	0.00E+00	0.00E+00	0.00E+00	0.00E+00	0.00E+00	0.00E+00

La-140		Liquid release (mrem/Ci released)					
	Bone	Liver	T.Body	Thyroid	Kidney	Lung	GI-LLI
Adult	1.13E-07	5.68E-08	1.50E-08	0.00E+00	0.00E+00	0.00E+00	4.17E-03
Teen	1.17E-07	5.78E-08	1.54E-08	0.00E+00	0.00E+00	0.00E+00	3.32E-03
Child	1.84E-07	6.42E-08	2.16E-08	0.00E+00	0.00E+00	0.00E+00	1.79E-03
Infant	8.68E-08	3.42E-08	8.81E-09	0.00E+00	0.00E+00	0.00E+00	4.02E-04

La-142		Liquid release (mrem/Ci released)					
	Bone	Liver	T.Body	Thyroid	Kidney	Lung	GI-LLI
Adult	2.56E-11	1.16E-11	2.89E-12	0.00E+00	0.00E+00	0.00E+00	8.48E-08
Teen	2.72E-11	1.21E-11	3.01E-12	0.00E+00	0.00E+00	0.00E+00	3.68E-07
Child	3.44E-11	1.10E-11	3.43E-12	0.00E+00	0.00E+00	0.00E+00	2.17E-06
Infant	4.28E-18	1.57E-18	3.77E-19	0.00E+00	0.00E+00	0.00E+00	2.67E-13

Ce-141		Liquid release (mrem/Ci released)					
	Bone	Liver	T.Body	Thyroid	Kidney	Lung	GI-LLI
Adult	2.03E-07	1.37E-07	1.56E-08	0.00E+00	6.37E-08	0.00E+00	5.25E-04
Teen	2.03E-07	1.35E-07	1.56E-08	0.00E+00	6.38E-08	0.00E+00	3.88E-04
Child	5.76E-07	2.87E-07	4.26E-08	0.00E+00	1.26E-07	0.00E+00	3.58E-04
Infant	7.09E-07	4.32E-07	5.09E-08	0.00E+00	1.33E-07	0.00E+00	2.23E-04

Ce-143		Liquid release (mrem/Ci released)					
	Bone	Liver	T.Body	Thyroid	Kidney	Lung	GI-LLI
Adult	1.48E-08	1.09E-05	1.21E-09	0.00E+00	4.82E-09	0.00E+00	4.09E-04
Teen	1.49E-08	1.09E-05	1.21E-09	0.00E+00	4.88E-09	0.00E+00	3.27E-04
Child	4.03E-08	2.18E-05	3.16E-09	0.00E+00	9.16E-09	0.00E+00	3.20E-04
Infant	5.08E-08	3.37E-05	3.85E-09	0.00E+00	9.82E-09	0.00E+00	1.97E-04

OFFSITE DOSE CALCULATION MANUAL

APPENDIX K
LIQUID EFFLUENT DOSE CONVERSION FACTORS

Ce-144		Liquid release (mrem/Ci released)					
	Bone	Liver	T.Body	Thyroid	Kidney	Lung	GI-LLI
Adult	1.10E-05	4.58E-06	5.89E-07	0.00E+00	2.72E-06	0.00E+00	3.71E-03
Teen	1.10E-05	4.55E-06	5.91E-07	0.00E+00	2.72E-06	0.00E+00	2.77E-03
Child	3.13E-05	9.81E-06	1.67E-06	0.00E+00	5.43E-06	0.00E+00	2.56E-03
Infant	2.79E-05	1.14E-05	1.56E-06	0.00E+00	4.61E-06	0.00E+00	1.60E-03

Pr-143		Liquid release (mrem/Ci released)					
	Bone	Liver	T.Body	Thyroid	Kidney	Lung	GI-LLI
Adult	5.70E-07	2.28E-07	2.82E-08	0.00E+00	1.32E-07	0.00E+00	2.49E-03
Teen	6.02E-07	2.40E-07	3.00E-08	0.00E+00	1.40E-07	0.00E+00	1.98E-03
Child	1.07E-06	3.22E-07	5.32E-08	0.00E+00	1.74E-07	0.00E+00	1.16E-03
Infant	6.90E-07	2.58E-07	3.42E-08	0.00E+00	9.59E-08	0.00E+00	3.64E-04

Pr-144		Liquid release (mrem/Ci released)					
	Bone	Liver	T.Body	Thyroid	Kidney	Lung	GI-LLI
Adult	3.82E-22	1.59E-22	1.94E-23	0.00E+00	8.94E-23	0.00E+00	0.00E+00
Teen	4.16E-22	1.70E-22	2.11E-23	0.00E+00	9.75E-23	0.00E+00	4.58E-25
Child	5.38E-22	1.66E-22	2.70E-23	0.00E+00	8.79E-23	0.00E+00	3.58E-19
Infant	0.00E+00	0.00E+00	0.00E+00	0.00E+00	0.00E+00	0.00E+00	0.00E+00

Nd-147		Liquid release (mrem/Ci released)					
	Bone	Liver	T.Body	Thyroid	Kidney	Lung	GI-LLI
Adult	3.85E-07	4.45E-07	2.66E-08	0.00E+00	2.60E-07	0.00E+00	2.14E-03
Teen	4.27E-07	4.64E-07	2.78E-08	0.00E+00	2.72E-07	0.00E+00	1.67E-03
Child	7.50E-07	6.08E-07	4.71E-08	0.00E+00	3.33E-07	0.00E+00	9.63E-04
Infant	4.58E-07	4.71E-07	2.88E-08	0.00E+00	1.81E-07	0.00E+00	2.98E-04

Eu-152		Liquid release (mrem/Ci released)					
	Bone	Liver	T.Body	Thyroid	Kidney	Lung	GI-LLI
Adult	1.28E-05	2.89E-06	2.54E-06	0.00E+00	1.79E-05	0.00E+00	1.66E-03
Teen	1.18E-05	2.85E-06	2.51E-06	0.00E+00	1.32E-05	0.00E+00	1.05E-03
Child	1.79E-05	3.26E-06	3.87E-06	0.00E+00	1.37E-05	0.00E+00	5.35E-04
Infant	6.33E-06	1.68E-06	1.42E-06	0.00E+00	4.72E-06	0.00E+00	1.49E-04

W-187		Liquid release (mrem/Ci released)					
	Bone	Liver	T.Body	Thyroid	Kidney	Lung	GI-LLI
Adult	1.55E-04	1.30E-04	4.53E-05	0.00E+00	0.00E+00	0.00E+00	4.24E-02
Teen	1.67E-04	1.36E-04	4.78E-05	0.00E+00	0.00E+00	0.00E+00	3.69E-02
Child	2.13E-04	1.26E-04	5.66E-05	0.00E+00	0.00E+00	0.00E+00	1.77E-02
Infant	2.11E-06	1.47E-06	5.07E-07	0.00E+00	0.00E+00	0.00E+00	8.62E-05

APPENDIX K
LIQUID EFFLUENT DOSE CONVERSION FACTORS

U-235 Liquid release (mrem/Ci released)							
	Bone	Liver	T.Body	Thyroid	Kidney	Lung	GI-LLI
Adult	1.67E-02	0.00E+00	1.01E-03	0.00E+00	3.89E-03	0.00E+00	1.62E-03
Teen	1.66E-02	0.00E+00	1.01E-03	0.00E+00	3.88E-03	0.00E+00	1.20E-03
Child	4.97E-02	0.00E+00	3.01E-03	0.00E+00	8.15E-03	0.00E+00	1.17E-03
Infant	4.39E-02	0.00E+00	3.35E-03	0.00E+00	9.34E-03	0.00E+00	7.62E-04

U-238 Liquid release (mrem/Ci released)							
	Bone	Liver	T.Body	Thyroid	Kidney	Lung	GI-LLI
Adult	1.60E-02	0.00E+00	9.44E-04	0.00E+00	3.64E-03	0.00E+00	1.14E-03
Teen	1.58E-02	0.00E+00	9.43E-04	0.00E+00	3.63E-03	0.00E+00	8.47E-04
Child	4.75E-02	0.00E+00	2.82E-03	0.00E+00	7.61E-03	0.00E+00	8.22E-04
Infant	4.20E-02	0.00E+00	3.13E-03	0.00E+00	8.72E-03	0.00E+00	5.37E-04

Np-239 Liquid release (mrem/Ci released)							
	Bone	Liver	T.Body	Thyroid	Kidney	Lung	GI-LLI
Adult	3.19E-08	3.14E-09	1.73E-09	0.00E+00	9.79E-09	0.00E+00	6.44E-04
Teen	3.47E-08	3.27E-09	1.82E-09	0.00E+00	1.03E-08	0.00E+00	5.26E-04
Child	6.87E-08	4.93E-09	3.46E-09	0.00E+00	1.43E-08	0.00E+00	3.65E-04
Infant	5.79E-08	5.18E-09	2.93E-09	0.00E+00	1.03E-08	0.00E+00	1.50E-04

Am-241 Liquid release (mrem/Ci released)							
	Bone	Liver	T.Body	Thyroid	Kidney	Lung	GI-LLI
Adult	5.33E-02	1.87E-02	3.52E-03	0.00E+00	2.65E-02	0.00E+00	4.83E-03
Teen	4.16E-02	1.59E-02	2.77E-03	0.00E+00	2.08E-02	0.00E+00	3.80E-03
Child	4.16E-02	1.86E-02	2.96E-03	0.00E+00	1.81E-02	0.00E+00	2.22E-03
Infant	1.44E-02	6.75E-03	1.02E-03	0.00E+00	6.16E-03	0.00E+00	7.24E-04

OFFSITE DOSE CALCULATION MANUAL

APPENDIX L
GASEOUS EFFLUENT DOSE CONVERSION FACTORS

The tables below identify the expected dose to each of the four age ranges (adult, teen, child and infant) as a result of activity released via gaseous effluents. These dose conversion factors are the summation of the expected exposures based on Reg. Guide 1.109 and NUREG-0133 assumptions. The pathways considered are inhalation, ground plane, milk, meat, leafy vegetables and produce. The assumed values for γ/Q and D/Q are those referenced in Table 10-2.

The total body, skin and air dose factors for noble gas releases are contained at the end of the tables below.

H-3 Gaseous release (mrem/Ci released)							
	Bone	Liver	T.Body	Thyroid	Kidney	Lung	GI-LLI
Adult	0.00E+00	7.89E-05	7.89E-05	7.89E-05	7.89E-05	7.89E-05	7.89E-05
Teen	0.00E+00	8.69E-05	8.69E-05	8.69E-05	8.69E-05	8.69E-05	8.69E-05
Child	0.00E+00	1.23E-04	1.23E-04	1.23E-04	1.23E-04	1.23E-04	1.23E-04
Infant	0.00E+00	5.32E-05	5.32E-05	5.32E-05	5.32E-05	5.32E-05	5.32E-05

C-14 Gaseous release (mrem/Ci released)							
	Bone	Liver	T.Body	Thyroid	Kidney	Lung	GI-LLI
Adult	3.65E-02	7.30E-03	7.30E-03	7.30E-03	7.30E-03	7.30E-03	7.30E-03
Teen	5.51E-02	1.10E-02	1.10E-02	1.10E-02	1.10E-02	1.10E-02	1.10E-02
Child	1.30E-01	2.59E-02	2.59E-02	2.59E-02	2.59E-02	2.59E-02	2.59E-02
Infant	7.37E-02	1.57E-02	1.57E-02	1.57E-02	1.57E-02	1.57E-02	1.57E-02

F-18 Gaseous release (mrem/Ci released)							
	Bone	Liver	T.Body	Thyroid	Kidney	Lung	GI-LLI
Adult	2.33E-04	1.47E-04	1.57E-04	1.47E-04	1.47E-04	1.47E-04	1.49E-04
Teen	2.65E-04	1.47E-04	1.60E-04	1.47E-04	1.47E-04	1.47E-04	1.54E-04
Child	3.05E-04	1.47E-04	1.63E-04	1.47E-04	1.47E-04	1.47E-04	1.75E-04
Infant	2.72E-04	1.47E-04	1.58E-04	1.47E-04	1.47E-04	1.47E-04	1.67E-04

Na-22 Gaseous release (mrem/Ci released)							
	Bone	Liver	T.Body	Thyroid	Kidney	Lung	GI-LLI
Adult	5.00E+00	5.00E+00	5.00E+00	5.00E+00	5.00E+00	5.00E+00	5.00E+00
Teen	5.68E+00	5.68E+00	5.68E+00	5.68E+00	5.68E+00	5.68E+00	5.68E+00
Child	7.66E+00	7.66E+00	7.66E+00	7.66E+00	7.66E+00	7.66E+00	7.66E+00
Infant	8.45E+00	8.45E+00	8.45E+00	8.45E+00	8.45E+00	8.45E+00	8.45E+00

OFFSITE DOSE CALCULATION MANUAL

APPENDIX L
GASEOUS EFFLUENT DOSE CONVERSION FACTORS

Na-24		Gaseous release (mrem/Ci released)					
	Bone	Liver	T.Body	Thyroid	Kidney	Lung	GI-LLI
Adult	2.62E-03	2.62E-03	2.62E-03	2.62E-03	2.62E-03	2.62E-03	2.62E-03
Teen	2.78E-03	2.78E-03	2.78E-03	2.78E-03	2.78E-03	2.78E-03	2.78E-03
Child	3.07E-03	3.07E-03	3.07E-03	3.07E-03	3.07E-03	3.07E-03	3.07E-03
Infant	3.18E-03	3.18E-03	3.18E-03	3.18E-03	3.18E-03	3.18E-03	3.18E-03

P-32		Gaseous release (mrem/Ci released)					
	Bone	Liver	T.Body	Thyroid	Kidney	Lung	GI-LLI
Adult	3.18E-01	3.28E-01	3.14E-01	3.08E-01	3.26E-01	3.08E-01	8.98E-01
Teen	3.21E-01	3.34E-01	3.16E-01	3.08E-01	3.33E-01	3.08E-01	8.31E-01
Child	3.25E-01	3.31E-01	3.17E-01	3.08E-01	3.28E-01	3.08E-01	6.39E-01
Infant	3.20E-01	3.25E-01	3.13E-01	3.08E-01	3.19E-01	3.08E-01	3.09E-01

Sc-46		Gaseous release (mrem/Ci released)					
	Bone	Liver	T.Body	Thyroid	Kidney	Lung	GI-LLI
Adult	1.35E+00	8.38E-02	5.21E-02	0.00E+00	0.00E+00	0.00E+00	1.50E-01
Teen	2.06E+00	1.27E-01	7.97E-02	0.00E+00	0.00E+00	0.00E+00	1.71E-01
Child	4.79E+00	2.24E-01	1.85E-01	0.00E+00	0.00E+00	0.00E+00	1.32E-01
Infant	7.66E+00	4.51E-01	2.97E-01	0.00E+00	0.00E+00	0.00E+00	1.03E-01

Cr-51		Gaseous release (mrem/Ci released)					
	Bone	Liver	T.Body	Thyroid	Kidney	Lung	GI-LLI
Adult	8.72E-04	8.72E-04	8.85E-04	8.79E-04	8.75E-04	1.21E-03	3.60E-03
Teen	8.72E-04	8.72E-04	8.89E-04	8.82E-04	8.76E-04	1.37E-03	3.37E-03
Child	8.72E-04	8.72E-04	9.03E-04	8.89E-04	8.77E-04	1.28E-03	2.37E-03
Infant	8.72E-04	8.72E-04	8.83E-04	8.79E-04	8.73E-04	1.17E-03	1.14E-03

Mn-54		Gaseous release (mrem/Ci released)					
	Bone	Liver	T.Body	Thyroid	Kidney	Lung	GI-LLI
Adult	2.59E-01	3.20E-01	2.71E-01	2.59E-01	2.77E-01	2.91E-01	4.44E-01
Teen	2.59E-01	3.46E-01	2.76E-01	2.59E-01	2.85E-01	3.04E-01	4.37E-01
Child	2.59E-01	3.86E-01	2.93E-01	2.59E-01	2.95E-01	2.95E-01	3.65E-01
Infant	2.59E-01	2.65E-01	2.60E-01	2.59E-01	2.60E-01	2.82E-01	2.61E-01

Mn-56		Gaseous release (mrem/Ci released)					
	Bone	Liver	T.Body	Thyroid	Kidney	Lung	GI-LLI
Adult	1.69E-04	1.69E-04	1.69E-04	1.69E-04	1.69E-04	3.83E-04	6.28E-04
Teen	1.69E-04	1.69E-04	1.69E-04	1.69E-04	1.69E-04	5.14E-04	1.47E-03
Child	1.69E-04	1.69E-04	1.69E-04	1.69E-04	1.69E-04	4.67E-04	2.96E-03
Infant	1.69E-04	1.69E-04	1.69E-04	1.69E-04	1.69E-04	4.53E-04	1.79E-03

OFFSITE DOSE CALCULATION MANUAL

APPENDIX L
GASEOUS EFFLUENT DOSE CONVERSION FACTORS

Fe-55		Gaseous release (mrem/Ci released)					
	Bone	Liver	T.Body	Thyroid	Kidney	Lung	GI-LLI
Adult	8.22E-02	5.68E-02	1.32E-02	0.00E+00	0.00E+00	3.31E-02	3.25E-02
Teen	9.82E-02	6.96E-02	1.62E-02	0.00E+00	0.00E+00	4.66E-02	3.00E-02
Child	2.23E-01	1.18E-01	3.67E-02	0.00E+00	0.00E+00	6.91E-02	2.19E-02
Infant	1.92E-02	1.24E-02	3.32E-03	0.00E+00	0.00E+00	7.91E-03	1.57E-03

Fe-59		Gaseous release (mrem/Ci released)					
	Bone	Liver	T.Body	Thyroid	Kidney	Lung	GI-LLI
Adult	9.48E-02	1.54E-01	9.05E-02	5.09E-02	5.09E-02	1.03E-01	3.97E-01
Teen	1.02E-01	1.71E-01	9.74E-02	5.09E-02	5.09E-02	1.23E-01	3.37E-01
Child	1.59E-01	2.25E-01	1.38E-01	5.09E-02	5.09E-02	1.30E-01	2.33E-01
Infant	6.69E-02	7.88E-02	6.19E-02	5.09E-02	5.09E-02	8.20E-02	6.46E-02

Co-57		Gaseous release (mrem/Ci released)					
	Bone	Liver	T.Body	Thyroid	Kidney	Lung	GI-LLI
Adult	5.95E-02	6.25E-02	6.45E-02	5.95E-02	5.95E-02	6.79E-02	1.36E-01
Teen	5.95E-02	6.36E-02	6.63E-02	5.95E-02	5.95E-02	7.28E-02	1.36E-01
Child	5.95E-02	6.61E-02	7.29E-02	5.95E-02	5.95E-02	7.10E-02	1.14E-01
Infant	5.95E-02	6.06E-02	6.13E-02	5.95E-02	5.95E-02	6.81E-02	6.34E-02

Co-58		Gaseous release (mrem/Ci released)					
	Bone	Liver	T.Body	Thyroid	Kidney	Lung	GI-LLI
Adult	7.10E-02	7.86E-02	8.81E-02	7.10E-02	7.10E-02	9.20E-02	2.28E-01
Teen	7.10E-02	8.09E-02	9.38E-02	7.10E-02	7.10E-02	1.01E-01	2.09E-01
Child	7.10E-02	8.52E-02	1.15E-01	7.10E-02	7.10E-02	9.61E-02	1.55E-01
Infant	7.10E-02	7.31E-02	7.63E-02	7.10E-02	7.10E-02	8.86E-02	7.65E-02

Co-60		Gaseous release (mrem/Ci released)					
	Bone	Liver	T.Body	Thyroid	Kidney	Lung	GI-LLI
Adult	4.03E+00	4.08E+00	4.13E+00	4.03E+00	4.03E+00	4.17E+00	4.87E+00
Teen	4.03E+00	4.09E+00	4.16E+00	4.03E+00	4.03E+00	4.23E+00	4.80E+00
Child	4.03E+00	4.12E+00	4.29E+00	4.03E+00	4.03E+00	4.19E+00	4.51E+00
Infant	4.03E+00	4.04E+00	4.06E+00	4.03E+00	4.03E+00	4.13E+00	4.06E+00

Ni-63		Gaseous release (mrem/Ci released)					
	Bone	Liver	T.Body	Thyroid	Kidney	Lung	GI-LLI
Adult	6.30E+00	4.36E-01	2.11E-01	0.00E+00	0.00E+00	4.04E-03	9.12E-02
Teen	7.74E+00	5.47E-01	2.62E-01	0.00E+00	0.00E+00	6.96E-03	8.72E-02
Child	1.78E+01	9.53E-01	6.06E-01	0.00E+00	0.00E+00	6.23E-03	6.43E-02
Infant	5.52E+00	3.41E-01	1.92E-01	0.00E+00	0.00E+00	4.73E-03	1.70E-02

APPENDIX L
GASEOUS EFFLUENT DOSE CONVERSION FACTORS

Ni-65		Gaseous release (mrem/Ci released)					
	Bone	Liver	T.Body	Thyroid	Kidney	Lung	GI-LLI
Adult	5.56E-05	5.55E-05	5.55E-05	5.55E-05	5.55E-05	1.82E-04	3.35E-04
Teen	5.56E-05	5.55E-05	5.55E-05	5.55E-05	5.55E-05	2.68E-04	8.88E-04
Child	5.56E-05	5.55E-05	5.55E-05	5.55E-05	5.55E-05	2.41E-04	1.96E-03
Infant	5.56E-05	5.55E-05	5.55E-05	5.55E-05	5.55E-05	2.40E-04	1.19E-03

Cu-64		Gaseous release (mrem/Ci released)					
	Bone	Liver	T.Body	Thyroid	Kidney	Lung	GI-LLI
Adult	1.14E-04	1.16E-04	1.15E-04	1.14E-04	1.21E-04	2.67E-04	1.47E-03
Teen	1.14E-04	1.17E-04	1.15E-04	1.14E-04	1.23E-04	3.66E-04	1.78E-03
Child	1.14E-04	1.19E-04	1.17E-04	1.14E-04	1.27E-04	3.31E-04	1.21E-03
Infant	1.14E-04	1.22E-04	1.18E-04	1.14E-04	1.28E-04	3.24E-04	6.32E-04

Zn-65		Gaseous release (mrem/Ci released)					
	Bone	Liver	T.Body	Thyroid	Kidney	Lung	GI-LLI
Adult	4.57E-01	1.15E+00	5.96E-01	1.40E-01	8.14E-01	1.59E-01	7.75E-01
Teen	5.70E-01	1.63E+00	8.37E-01	1.40E-01	1.10E+00	1.68E-01	7.72E-01
Child	9.63E-01	2.33E+00	1.50E+00	1.40E-01	1.52E+00	1.62E-01	5.25E-01
Infant	9.16E-01	2.80E+00	1.37E+00	1.40E-01	1.43E+00	1.54E-01	2.39E+00

Zn-69m		Gaseous release (mrem/Ci released)					
	Bone	Liver	T.Body	Thyroid	Kidney	Lung	GI-LLI
Adult	4.63E-04	4.81E-04	4.53E-04	4.50E-04	4.69E-04	8.82E-04	5.41E-03
Teen	4.70E-04	4.96E-04	4.54E-04	4.50E-04	4.78E-04	1.16E-03	6.83E-03
Child	4.95E-04	5.27E-04	4.59E-04	4.50E-04	4.95E-04	1.07E-03	5.21E-03
Infant	5.30E-04	6.12E-04	4.65E-04	4.50E-04	5.16E-04	1.06E-03	3.62E-03

Zn-69		Gaseous release (mrem/Ci released)					
	Bone	Liver	T.Body	Thyroid	Kidney	Lung	GI-LLI
Adult	7.67E-10	1.48E-09	1.02E-10	0.00E+00	9.56E-10	2.09E-05	3.70E-07
Teen	1.10E-09	2.09E-09	1.46E-10	0.00E+00	1.37E-09	3.59E-05	6.46E-06
Child	1.52E-09	2.19E-09	2.02E-10	0.00E+00	1.33E-09	3.22E-05	2.31E-04
Infant	1.22E-09	2.19E-09	1.63E-10	0.00E+00	9.11E-10	3.33E-05	3.00E-04

As-76		Gaseous release (mrem/Ci released)					
	Bone	Liver	T.Body	Thyroid	Kidney	Lung	GI-LLI
Adult	9.59E-04	1.09E-03	2.12E-03	9.52E-04	1.13E-03	3.22E-03	9.32E-03
Teen	9.65E-04	1.13E-03	2.29E-03	9.60E-04	1.16E-03	3.62E-03	1.06E-02
Child	1.03E-03	1.28E-03	3.29E-03	1.02E-03	1.31E-03	3.10E-03	2.00E-02
Infant	1.35E-03	2.11E-03	3.24E-03	1.35E-03	2.17E-03	3.03E-03	1.43E-02

APPENDIX L
GASEOUS EFFLUENT DOSE CONVERSION FACTORS

Br-82		Gaseous release (mrem/Ci released)					
	Bone	Liver	T.Body	Thyroid	Kidney	Lung	GI-LLI
Adult	7.15E-03	7.15E-03	9.28E-03	7.15E-03	7.15E-03	7.15E-03	9.48E-03
Teen	7.15E-03	7.15E-03	1.05E-02	7.15E-03	7.15E-03	7.15E-03	7.15E-03
Child	7.15E-03	7.15E-03	1.35E-02	7.15E-03	7.15E-03	7.15E-03	7.15E-03
Infant	7.15E-03	7.15E-03	1.66E-02	7.15E-03	7.15E-03	7.15E-03	7.15E-03

Br-83		Gaseous release (mrem/Ci released)					
	Bone	Liver	T.Body	Thyroid	Kidney	Lung	GI-LLI
Adult	9.16E-07	9.16E-07	6.37E-06	9.16E-07	9.16E-07	9.16E-07	6.17E-06
Teen	9.16E-07	9.16E-07	8.71E-06	9.16E-07	9.16E-07	9.16E-07	9.16E-07
Child	9.16E-07	9.16E-07	1.17E-05	9.16E-07	9.16E-07	9.16E-07	9.16E-07
Infant	9.16E-07	9.16E-07	9.55E-06	9.16E-07	9.16E-07	9.16E-07	9.16E-07

Br-84		Gaseous release (mrem/Ci released)					
	Bone	Liver	T.Body	Thyroid	Kidney	Lung	GI-LLI
Adult	3.79E-05	3.79E-05	4.50E-05	3.79E-05	3.79E-05	3.79E-05	3.79E-05
Teen	3.79E-05	3.79E-05	4.77E-05	3.79E-05	3.79E-05	3.79E-05	3.79E-05
Child	3.79E-05	3.79E-05	5.03E-05	3.79E-05	3.79E-05	3.79E-05	3.79E-05
Infant	3.79E-05	3.79E-05	4.70E-05	3.79E-05	3.79E-05	3.79E-05	3.79E-05

Br-85		Gaseous release (mrem/Ci released)					
	Bone	Liver	T.Body	Thyroid	Kidney	Lung	GI-LLI
Adult	0.00E+00	0.00E+00	2.90E-07	0.00E+00	0.00E+00	0.00E+00	0.00E+00
Teen	0.00E+00	0.00E+00	4.15E-07	0.00E+00	0.00E+00	0.00E+00	0.00E+00
Child	0.00E+00	0.00E+00	5.74E-07	0.00E+00	0.00E+00	0.00E+00	0.00E+00
Infant	0.00E+00	0.00E+00	4.63E-07	0.00E+00	0.00E+00	0.00E+00	0.00E+00

Rb-86		Gaseous release (mrem/Ci released)					
	Bone	Liver	T.Body	Thyroid	Kidney	Lung	GI-LLI
Adult	1.68E-03	1.94E-01	9.13E-02	1.68E-03	1.68E-03	1.68E-03	3.94E-02
Teen	1.68E-03	3.04E-01	1.44E-01	1.68E-03	1.68E-03	1.68E-03	4.62E-02
Child	1.68E-03	5.41E-01	3.33E-01	1.68E-03	1.68E-03	1.68E-03	3.62E-02
Infant	1.68E-03	1.08E+00	5.32E-01	1.68E-03	1.68E-03	1.68E-03	2.91E-02

Rb-88		Gaseous release (mrem/Ci released)					
	Bone	Liver	T.Body	Thyroid	Kidney	Lung	GI-LLI
Adult	6.15E-06	1.49E-05	1.05E-05	6.15E-06	6.15E-06	6.15E-06	6.15E-06
Teen	6.15E-06	1.86E-05	1.23E-05	6.15E-06	6.15E-06	6.15E-06	6.15E-06
Child	6.15E-06	1.89E-05	1.45E-05	6.15E-06	6.15E-06	6.15E-06	6.55E-06
Infant	6.15E-06	1.88E-05	1.27E-05	6.15E-06	6.15E-06	6.15E-06	1.38E-05

APPENDIX L
GASEOUS EFFLUENT DOSE CONVERSION FACTORS

Rb-89 Gaseous release (mrem/Ci released)							
	Bone	Liver	T.Body	Thyroid	Kidney	Lung	GI-LLI
Adult	2.29E-05	2.88E-05	2.68E-05	2.29E-05	2.29E-05	2.29E-05	2.29E-05
Teen	2.29E-05	3.09E-05	2.82E-05	2.29E-05	2.29E-05	2.29E-05	2.29E-05
Child	2.29E-05	3.08E-05	2.95E-05	2.29E-05	2.29E-05	2.29E-05	2.30E-05
Infant	2.29E-05	3.02E-05	2.76E-05	2.29E-05	2.29E-05	2.29E-05	2.45E-05

Sr-89 Gaseous release (mrem/Ci released)							
	Bone	Liver	T.Body	Thyroid	Kidney	Lung	GI-LLI
Adult	1.96E+00	4.05E-06	5.64E-02	4.05E-06	4.05E-06	3.17E-02	3.23E-01
Teen	3.00E+00	4.05E-06	8.60E-02	4.05E-06	4.05E-06	5.48E-02	3.65E-01
Child	7.13E+00	4.05E-06	2.04E-01	4.05E-06	4.05E-06	4.89E-02	2.79E-01
Infant	9.47E-01	4.05E-06	2.72E-02	4.05E-06	4.05E-06	4.60E-02	2.07E-02

Sr-90 Gaseous release (mrem/Ci released)							
	Bone	Liver	T.Body	Thyroid	Kidney	Lung	GI-LLI
Adult	1.55E+02	1.73E-03	3.13E+00	1.73E-03	1.73E-03	2.19E-01	5.30E+00
Teen	2.06E+02	1.73E-03	4.13E+00	1.73E-03	1.73E-03	3.75E-01	6.39E+00
Child	4.18E+02	1.73E-03	8.41E+00	1.73E-03	1.73E-03	3.36E-01	3.74E+00
Infant	2.91E+01	1.73E-03	5.92E-01	1.73E-03	1.73E-03	2.57E-01	2.39E-01

Sr-91 Gaseous release (mrem/Ci released)							
	Bone	Liver	T.Body	Thyroid	Kidney	Lung	GI-LLI
Adult	4.61E-04	4.02E-04	4.04E-04	4.02E-04	4.02E-04	1.23E-03	5.01E-03
Teen	4.59E-04	4.02E-04	4.04E-04	4.02E-04	4.02E-04	1.78E-03	6.53E-03
Child	5.08E-04	4.02E-04	4.06E-04	4.02E-04	4.02E-04	1.61E-03	4.57E-03
Infant	4.17E-04	4.02E-04	4.03E-04	4.02E-04	4.02E-04	1.60E-03	2.08E-03

Sr-92 Gaseous release (mrem/Ci released)							
	Bone	Liver	T.Body	Thyroid	Kidney	Lung	GI-LLI
Adult	1.46E-04	1.45E-04	1.45E-04	1.45E-04	1.45E-04	5.19E-04	1.12E-03
Teen	1.46E-04	1.45E-04	1.45E-04	1.45E-04	1.45E-04	7.67E-04	2.85E-03
Child	1.46E-04	1.45E-04	1.45E-04	1.45E-04	1.45E-04	6.90E-04	5.64E-03
Infant	1.46E-04	1.45E-04	1.45E-04	1.45E-04	1.45E-04	6.85E-04	3.32E-03

Y-90 Gaseous release (mrem/Ci released)							
	Bone	Liver	T.Body	Thyroid	Kidney	Lung	GI-LLI
Adult	5.07E-05	8.40E-07	2.18E-06	8.40E-07	8.40E-07	3.84E-03	3.79E-02
Teen	7.08E-05	8.40E-07	2.72E-06	8.40E-07	8.40E-07	6.64E-03	3.19E-02
Child	9.83E-05	8.40E-07	3.46E-06	8.40E-07	8.40E-07	5.93E-03	1.84E-02
Infant	7.54E-05	8.40E-07	2.84E-06	8.40E-07	8.40E-07	6.09E-03	2.40E-03

OFFSITE DOSE CALCULATION MANUAL

APPENDIX L
GASEOUS EFFLUENT DOSE CONVERSION FACTORS

Y-91m		Gaseous release (mrem/Ci released)					
	Bone	Liver	T.Body	Thyroid	Kidney	Lung	GI-LLI
Adult	1.88E-05	1.88E-05	1.88E-05	1.88E-05	1.88E-05	6.23E-05	1.88E-05
Teen	1.88E-05	1.88E-05	1.88E-05	1.88E-05	1.88E-05	9.13E-05	1.94E-05
Child	1.88E-05	1.88E-05	1.88E-05	1.88E-05	1.88E-05	8.25E-05	5.77E-05
Infant	1.88E-05	1.88E-05	1.88E-05	1.88E-05	1.88E-05	8.19E-05	7.21E-05

Y-91		Gaseous release (mrem/Ci released)					
	Bone	Liver	T.Body	Thyroid	Kidney	Lung	GI-LLI
Adult	1.17E-02	2.01E-04	5.09E-04	2.01E-04	2.01E-04	3.88E-02	5.72E-01
Teen	1.67E-02	2.01E-04	6.42E-04	2.01E-04	2.01E-04	6.67E-02	6.27E-01
Child	2.45E-02	2.01E-04	8.48E-04	2.01E-04	2.01E-04	5.97E-02	4.77E-01
Infant	1.35E-02	2.01E-04	5.56E-04	2.01E-04	2.01E-04	5.57E-02	2.21E-03

Y-92		Gaseous release (mrem/Ci released)					
	Bone	Liver	T.Body	Thyroid	Kidney	Lung	GI-LLI
Adult	3.40E-05	3.38E-05	3.38E-05	3.38E-05	3.38E-05	3.89E-04	1.70E-03
Teen	3.41E-05	3.38E-05	3.38E-05	3.38E-05	3.38E-05	6.41E-04	3.77E-03
Child	3.42E-05	3.38E-05	3.38E-05	3.38E-05	3.38E-05	5.76E-04	5.46E-03
Infant	3.41E-05	3.38E-05	3.38E-05	3.38E-05	3.38E-05	5.89E-04	2.90E-03

Y-93		Gaseous release (mrem/Ci released)					
	Bone	Liver	T.Body	Thyroid	Kidney	Lung	GI-LLI
Adult	3.68E-05	3.47E-05	3.47E-05	3.47E-05	3.47E-05	1.13E-03	1.06E-02
Teen	3.77E-05	3.47E-05	3.47E-05	3.47E-05	3.47E-05	1.92E-03	1.41E-02
Child	3.89E-05	3.47E-05	3.48E-05	3.47E-05	3.47E-05	1.72E-03	9.67E-03
Infant	3.74E-04	3.47E-05	3.47E-05	3.47E-05	3.47E-05	1.77E-03	3.81E-03

Zr-95		Gaseous release (mrem/Ci released)					
	Bone	Liver	T.Body	Thyroid	Kidney	Lung	GI-LLI
Adult	4.86E-02	4.67E-02	4.64E-02	4.58E-02	4.72E-02	8.59E-02	4.25E-01
Teen	4.95E-02	4.70E-02	4.66E-02	4.58E-02	4.75E-02	1.07E-01	3.68E-01
Child	5.10E-02	4.69E-02	4.68E-02	4.58E-02	4.75E-02	9.64E-02	2.59E-01
Infant	4.84E-02	4.64E-02	4.63E-02	4.58E-02	4.65E-02	8.55E-02	4.64E-02

Zr-97		Gaseous release (mrem/Ci released)					
	Bone	Liver	T.Body	Thyroid	Kidney	Lung	GI-LLI
Adult	5.53E-04	5.51E-04	5.51E-04	5.51E-04	5.51E-04	2.33E-03	1.63E-02
Teen	5.54E-04	5.51E-04	5.51E-04	5.51E-04	5.52E-04	3.49E-03	1.79E-02
Child	5.55E-04	5.51E-04	5.51E-04	5.51E-04	5.52E-04	3.12E-03	1.08E-02
Infant	5.54E-04	5.51E-04	5.51E-04	5.51E-04	5.51E-04	3.05E-03	3.73E-03

APPENDIX L
GASEOUS EFFLUENT DOSE CONVERSION FACTORS

Nb-95		Gaseous release (mrem/Ci released)					
	Bone	Liver	T.Body	Thyroid	Kidney	Lung	GI-LLI
Adult	2.60E-02	2.58E-02	2.57E-02	2.55E-02	2.59E-02	3.70E-02	6.10E-01
Teen	2.61E-02	2.59E-02	2.57E-02	2.55E-02	2.59E-02	4.25E-02	3.94E-01
Child	2.63E-02	2.59E-02	2.58E-02	2.55E-02	2.59E-02	3.94E-02	2.32E-01
Infant	2.59E-02	2.57E-02	2.56E-02	2.55E-02	2.56E-02	3.64E-02	3.85E-02

Nb-97		Gaseous release (mrem/Ci released)					
	Bone	Liver	T.Body	Thyroid	Kidney	Lung	GI-LLI
Adult	6.31E-05	6.31E-05	6.31E-05	6.31E-05	6.31E-05	1.17E-04	6.85E-05
Teen	6.31E-05	6.31E-05	6.31E-05	6.31E-05	6.31E-05	1.52E-04	1.12E-04
Child	6.31E-05	6.31E-05	6.31E-05	6.31E-05	6.31E-05	1.40E-04	6.94E-04
Infant	6.31E-05	6.31E-05	6.31E-05	6.31E-05	6.31E-05	1.38E-04	6.72E-04

Mo-99		Gaseous release (mrem/Ci released)					
	Bone	Liver	T.Body	Thyroid	Kidney	Lung	GI-LLI
Adult	7.47E-04	3.07E-03	1.19E-03	7.47E-04	6.00E-03	2.81E-03	1.17E-02
Teen	7.47E-04	3.91E-03	1.35E-03	7.47E-04	7.98E-02	4.23E-03	1.25E-02
Child	7.47E-04	6.01E-03	2.05E-03	7.47E-04	1.20E-02	3.82E-03	7.97E-03
Infant	7.47E-04	1.05E-02	2.65E-03	7.47E-04	1.53E-02	3.80E-03	5.06E-03

Tc-99m		Gaseous release (mrem/Ci released)					
	Bone	Liver	T.Body	Thyroid	Kidney	Lung	GI-LLI
Adult	3.44E-05	3.44E-05	3.44E-05	3.44E-05	3.44E-05	5.17E-05	1.30E-04
Teen	3.44E-05	3.44E-05	3.44E-05	3.44E-05	3.44E-05	6.05E-05	1.75E-04
Child	3.44E-05	3.44E-05	3.44E-05	3.44E-05	3.44E-05	5.59E-05	1.45E-04
Infant	3.44E-05	3.44E-05	3.44E-05	3.44E-05	3.44E-05	5.28E-05	8.12E-05

Tc-99		Gaseous release (mrem/Ci released)					
	Bone	Liver	T.Body	Thyroid	Kidney	Lung	GI-LLI
Adult	6.08E-02	9.02E-02	2.48E-02	5.65E-04	1.13E+00	2.65E-02	2.93E+00
Teen	6.50E-02	9.52E-02	2.64E-02	5.65E-04	1.20E+00	4.19E-02	2.32E+00
Child	1.37E-01	1.52E-01	5.50E-02	5.65E-04	1.79E+00	4.22E-02	1.59E+00
Infant	7.38E-02	9.96E-02	3.14E-02	5.65E-04	8.35E-01	3.17E-02	4.29E-01

Tc-101		Gaseous release (mrem/Ci released)					
	Bone	Liver	T.Body	Thyroid	Kidney	Lung	GI-LLI
Adult	3.81E-06	3.81E-06	3.81E-06	3.81E-06	3.81E-06	1.29E-05	3.81E-06
Teen	3.81E-06	3.81E-06	3.81E-06	3.81E-06	3.81E-06	1.89E-05	3.81E-06
Child	3.81E-06	3.81E-06	3.81E-06	3.81E-06	3.81E-06	1.71E-05	4.18E-06
Infant	3.81E-06	3.81E-06	3.81E-06	3.81E-06	3.81E-06	1.70E-05	2.29E-05

APPENDIX L
GASEOUS EFFLUENT DOSE CONVERSION FACTORS

Ru-103 Gaseous release (mrem/Ci released)							
	Bone	Liver	T.Body	Thyroid	Kidney	Lung	GI-LLI
Adult	2.80E-02	2.02E-02	2.36E-02	2.02E-02	5.00E-02	3.17E-02	9.30E-01
Teen	2.71E-02	2.02E-02	2.32E-02	2.02E-02	4.46E-02	3.80E-02	5.97E-01
Child	3.33E-02	2.02E-02	2.52E-02	2.02E-02	5.31E-02	3.52E-02	3.57E-01
Infant	2.03E-02	2.02E-02	2.02E-02	2.02E-02	2.03E-02	3.27E-02	2.06E-02

Ru-105 Gaseous release (mrem/Ci released)							
	Bone	Liver	T.Body	Thyroid	Kidney	Lung	GI-LLI
Adult	1.19E-04	1.19E-04	1.19E-04	1.19E-04	1.19E-04	3.68E-04	1.22E-03
Teen	1.19E-04	1.19E-04	1.19E-04	1.19E-04	1.19E-04	5.31E-04	2.18E-03
Child	1.19E-04	1.19E-04	1.19E-04	1.19E-04	1.19E-04	4.80E-04	2.39E-03
Infant	1.19E-04	1.19E-04	1.19E-04	1.19E-04	1.19E-04	4.74E-04	1.22E-03

Ru-106 Gaseous release (mrem/Ci released)							
	Bone	Liver	T.Body	Thyroid	Kidney	Lung	GI-LLI
Adult	4.92E-01	7.99E-02	1.32E-01	7.99E-02	8.75E-01	2.92E-01	2.66E+01
Teen	4.55E-01	7.99E-02	1.27E-01	7.99E-02	8.04E-01	4.44E-01	1.80E+01
Child	8.17E-01	7.99E-02	1.72E-01	7.99E-02	1.07E+00	4.04E-01	1.15E+01
Infant	8.19E-02	7.99E-02	8.02E-02	7.99E-02	8.24E-02	3.42E-01	8.38E-02

Rh-105 Gaseous release (mrem/Ci released)							
	Bone	Liver	T.Body	Thyroid	Kidney	Lung	GI-LLI
Adult	2.59E-04	2.47E-04	2.36E-04	2.15E-04	3.52E-04	6.52E-04	7.29E-03
Teen	2.74E-04	2.58E-04	2.43E-04	2.15E-04	3.97E-04	9.57E-04	7.86E-03
Child	3.46E-04	2.85E-04	2.75E-04	2.15E-04	4.95E-04	8.71E-04	5.67E-03
Infant	4.04E-04	3.39E-04	2.98E-04	2.15E-04	5.59E-04	8.75E-04	3.72E-03

Ag-110m Gaseous release (mrem/Ci released)							
	Bone	Liver	T.Body	Thyroid	Kidney	Lung	GI-LLI
Adult	6.54E-01	6.53E-01	6.49E-01	6.43E-01	6.63E-01	7.48E-01	4.66E+00
Teen	6.60E-01	6.59E-01	6.53E-01	6.43E-01	6.73E-01	7.96E-01	4.97E+00
Child	6.78E-01	6.67E-01	6.62E-01	6.43E-01	6.87E-01	7.67E-01	3.44E+00
Infant	6.94E-01	6.80E-01	6.68E-01	6.43E-01	6.96E-01	7.26E-01	2.54E+00

Sn-113 Gaseous release (mrem/Ci released)							
	Bone	Liver	T.Body	Thyroid	Kidney	Lung	GI-LLI
Adult	3.36E-02	9.69E-03	8.58E-02	7.30E-03	1.13E-02	2.04E-02	8.76E-01
Teen	2.97E-02	9.83E-03	8.69E-02	7.17E-03	1.12E-02	2.30E-02	8.68E-01
Child	5.55E-02	1.57E-02	1.71E-01	9.15E-03	1.62E-02	2.19E-02	1.84E+00
Infant	2.56E-02	8.94E-03	6.07E-02	6.98E-03	8.87E-03	1.65E-02	6.09E-01

APPENDIX L
GASEOUS EFFLUENT DOSE CONVERSION FACTORS

Sn-117m		Gaseous release (mrem/Ci released)					
	Bone	Liver	T.Body	Thyroid	Kidney	Lung	GI-LLI
Adult	1.09E-02	4.16E-03	1.46E-02	3.97E-03	4.26E-03	1.67E-02	1.08E-01
Teen	9.38E-03	4.16E-03	1.44E-02	3.97E-03	4.23E-03	2.01E-02	9.94E-02
Child	1.54E-02	4.45E-03	2.18E-02	4.01E-03	4.44E-03	1.40E-02	1.97E-01
Infant	1.35E-02	4.31E-03	1.70E-02	4.03E-03	4.25E-03	1.16E-02	1.44E-01

Sb-122		Gaseous release (mrem/Ci released)					
	Bone	Liver	T.Body	Thyroid	Kidney	Lung	GI-LLI
Adult	2.52E-03	2.41E-03	4.93E-03	2.30E-03	2.36E-03	5.99E-03	2.60E-02
Teen	2.48E-03	2.42E-03	5.02E-03	2.30E-03	2.36E-03	6.79E-03	2.51E-02
Child	2.65E-03	2.51E-03	6.83E-03	2.32E-03	2.41E-03	5.42E-03	4.75E-02
Infant	2.75E-03	2.60E-03	7.00E-03	2.37E-03	2.43E-03	4.95E-03	4.91E-02

Sb-124		Gaseous release (mrem/Ci released)					
	Bone	Liver	T.Body	Thyroid	Kidney	Lung	GI-LLI
Adult	2.20E-01	1.97E-01	2.06E-01	1.96E-01	1.96E-01	2.70E-01	8.48E-01
Teen	2.31E-01	1.97E-01	2.10E-01	1.96E-01	1.96E-01	3.13E-01	8.75E-01
Child	2.73E-01	1.97E-01	2.23E-01	1.97E-01	1.96E-01	3.12E-01	6.72E-01
Infant	2.14E-01	1.97E-01	2.02E-01	1.96E-01	1.96E-01	2.77E-01	2.50E-01

Sb-125		Gaseous release (mrem/Ci released)					
	Bone	Liver	T.Body	Thyroid	Kidney	Lung	GI-LLI
Adult	8.30E-01	7.99E-01	8.06E-01	7.98E-01	7.98E-01	8.61E-01	1.14E+00
Teen	8.47E-01	7.99E-01	8.10E-01	7.98E-01	7.98E-01	9.01E-01	1.16E+00
Child	9.09E-01	7.99E-01	8.21E-01	7.98E-01	7.98E-01	9.11E-01	1.06E+00
Infant	8.21E-01	7.98E-01	8.03E-01	7.98E-01	7.98E-01	8.32E-01	8.27E-01

Te-125m		Gaseous release (mrem/Ci released)					
	Bone	Liver	T.Body	Thyroid	Kidney	Lung	GI-LLI
Adult	5.63E-02	2.06E-02	7.80E-03	1.71E-02	2.28E-01	7.40E-03	2.25E-01
Teen	6.48E-02	2.35E-02	8.91E-03	1.83E-02	2.90E-04	1.24E-02	1.92E-01
Child	1.40E-01	3.81E-02	1.89E-02	3.94E-02	2.90E-04	1.11E-02	1.35E-01
Infant	1.38E-02	4.82E-03	2.12E-03	4.84E-03	2.90E-04	1.04E-02	6.97E-03

Te-127m		Gaseous release (mrem/Ci released)					
	Bone	Liver	T.Body	Thyroid	Kidney	Lung	GI-LLI
Adult	2.38E-01	8.50E-02	2.90E-02	6.07E-02	9.65E-01	2.18E-02	7.99E-01
Teen	2.76E-01	9.78E-02	3.28E-02	6.56E-02	1.12E+00	3.76E-02	6.89E-01
Child	6.01E-01	1.62E-01	7.14E-02	1.44E-01	1.71E+00	3.36E-02	4.88E-01
Infant	5.23E-02	1.74E-02	6.35E-03	1.51E-02	1.29E-01	2.97E-02	2.16E-02

OFFSITE DOSE CALCULATION MANUAL

APPENDIX L
GASEOUS EFFLUENT DOSE CONVERSION FACTORS

Te-127		Gaseous release (mrem/Ci released)					
	Bone	Liver	T.Body	Thyroid	Kidney	Lung	GI-LLI
Adult	1.75E-06	9.90E-07	8.18E-07	1.44E-06	5.39E-06	1.48E-04	1.39E-03
Teen	1.73E-06	9.78E-07	8.11E-07	1.36E-06	5.26E-06	2.54E-04	1.92E-03
Child	2.73E-06	1.15E-06	1.02E-06	2.06E-06	6.70E-06	2.28E-04	1.36E-03
Infant	9.22E-07	6.86E-07	6.38E-07	8.54E-07	1.43E-06	2.35E-04	5.59E-04

Te-129m		Gaseous release (mrem/Ci released)					
	Bone	Liver	T.Body	Thyroid	Kidney	Lung	GI-LLI
Adult	1.36E-01	5.32E-02	2.47E-02	4.92E-02	5.57E-01	3.00E-02	6.78E-01
Teen	1.52E-01	5.87E-02	2.71E-02	5.15E-02	6.23E-01	4.85E-02	5.67E-01
Child	3.21E-01	9.25E-02	5.30E-02	1.06E-01	9.37E-01	4.36E-02	3.95E-01
Infant	4.01E-02	1.62E-02	9.31E-03	1.77E-02	9.46E-02	4.18E-02	2.68E-02

Te-129		Gaseous release (mrem/Ci released)					
	Bone	Liver	T.Body	Thyroid	Kidney	Lung	GI-LLI
Adult	4.91E-06	4.91E-06	4.91E-06	4.91E-06	4.91E-06	4.88E-05	8.46E-06
Teen	4.91E-06	4.91E-06	4.91E-06	4.91E-06	4.92E-06	7.96E-05	4.15E-05
Child	4.91E-06	4.91E-06	4.91E-06	4.91E-06	4.91E-06	7.14E-05	5.83E-04
Infant	4.91E-06	4.91E-06	4.91E-06	4.91E-06	4.91E-06	7.28E-05	6.01E-04

Te-131m		Gaseous release (mrem/Ci released)					
	Bone	Liver	T.Body	Thyroid	Kidney	Lung	GI-LLI
Adult	1.85E-03	1.73E-03	1.71E-03	1.80E-03	2.73E-03	4.92E-03	2.50E-02
Teen	1.85E-03	1.73E-03	1.71E-03	1.78E-03	2.75E-03	7.01E-03	2.43E-02
Child	2.06E-03	1.77E-03	1.78E-03	1.93E-03	3.07E-03	6.28E-03	1.46E-02
Infant	1.81E-03	1.70E-03	1.69E-03	1.78E-03	2.15E-03	6.13E-03	5.60E-03

Te-131		Gaseous release (mrem/Ci released)					
	Bone	Liver	T.Body	Thyroid	Kidney	Lung	GI-LLI
Adult	5.46E-06	5.46E-06	5.46E-06	5.46E-06	5.46E-06	3.70E-05	5.88E-06
Teen	5.46E-06	5.46E-06	5.46E-06	5.46E-06	5.47E-06	5.84E-05	5.81E-06
Child	5.46E-06	5.46E-06	5.46E-06	5.46E-06	5.47E-06	5.20E-05	3.57E-05
Infant	5.46E-06	5.46E-06	5.46E-06	5.46E-06	5.46E-06	5.21E-05	1.92E-04

Te-132		Gaseous release (mrem/Ci released)					
	Bone	Liver	T.Body	Thyroid	Kidney	Lung	GI-LLI
Adult	1.80E-03	1.44E-03	1.40E-03	1.51E-03	7.14E-03	7.31E-03	4.34E-02
Teen	1.80E-03	1.43E-03	1.39E-03	1.46E-03	7.00E-03	1.10E-02	3.17E-02
Child	2.73E-03	1.64E-03	1.82E-03	2.04E-03	8.80E-03	9.33E-03	1.26E-02
Infant	1.77E-03	1.27E-03	1.24E-03	1.51E-03	3.86E-03	8.49E-03	3.59E-03

APPENDIX L
GASEOUS EFFLUENT DOSE CONVERSION FACTORS

I-130 Gaseous release (mrem/Ci released)							
	Bone	Liver	T.Body	Thyroid	Kidney	Lung	GI-LLI
Adult	1.18E-03	1.47E-03	1.21E-03	3.84E-02	1.72E-03	1.03E-03	1.32E-03
Teen	1.22E-03	1.58E-03	1.25E-03	4.65E-02	1.88E-03	1.03E-03	1.35E-03
Child	1.31E-03	1.60E-03	1.32E-03	6.46E-02	1.88E-03	1.03E-03	1.24E-03
Infant	1.26E-03	1.53E-03	1.23E-03	5.77E-02	1.58E-03	1.03E-03	1.12E-03

I-131 Gaseous release (mrem/Ci released)							
	Bone	Liver	T.Body	Thyroid	Kidney	Lung	GI-LLI
Adult	1.84E-02	2.49E-02	1.56E-02	7.11E+00	4.03E-02	3.21E-03	8.86E-03
Teen	2.37E-02	3.19E-02	1.86E-02	8.39E+00	5.26E-02	3.21E-03	8.82E-03
Child	4.79E-02	4.82E-02	2.88E-02	1.49E+01	7.71E-02	3.21E-03	7.18E-03
Infant	6.66E-02	7.78E-02	3.60E-02	2.45E+01	9.04E-02	3.21E-03	5.86E-03

I-132 Gaseous release (mrem/Ci released)							
	Bone	Liver	T.Body	Thyroid	Kidney	Lung	GI-LLI
Adult	2.57E-04	3.05E-04	2.57E-04	2.82E-03	3.49E-04	2.31E-04	2.40E-04
Teen	2.67E-04	3.30E-04	2.67E-04	3.66E-03	3.88E-04	2.31E-04	2.60E-04
Child	2.79E-04	3.23E-04	2.74E-04	4.62E-03	3.73E-04	2.31E-04	3.04E-04
Infant	2.69E-04	3.11E-04	2.60E-04	4.07E-03	3.21E-04	2.31E-04	2.74E-04

I-133 Gaseous release (mrem/Ci released)							
	Bone	Liver	T.Body	Thyroid	Kidney	Lung	GI-LLI
Adult	9.40E-04	1.29E-03	7.12E-04	1.22E-01	1.91E-03	4.59E-04	1.11E-03
Teen	1.08E-03	1.51E-03	7.79E-04	1.49E-01	2.30E-03	4.59E-04	1.14E-03
Child	1.57E-03	1.82E-03	9.75E-04	2.56E-01	2.73E-03	4.59E-04	9.47E-04
Infant	1.61E-03	2.13E-03	9.48E-04	3.06E-01	2.42E-03	4.59E-04	7.17E-04

I-134 Gaseous release (mrem/Ci released)							
	Bone	Liver	T.Body	Thyroid	Kidney	Lung	GI-LLI
Adult	9.82E-05	1.23E-04	9.76E-05	7.60E-04	1.46E-04	8.36E-05	8.36E-05
Teen	1.04E-04	1.36E-04	1.03E-04	9.79E-04	1.67E-04	8.36E-05	8.41E-05
Child	1.10E-04	1.33E-04	1.06E-04	1.23E-03	1.58E-04	8.36E-05	1.05E-04
Infant	1.04E-04	1.26E-04	9.87E-05	1.09E-03	1.31E-04	8.36E-05	1.13E-04

I-135 Gaseous release (mrem/Ci released)							
	Bone	Liver	T.Body	Thyroid	Kidney	Lung	GI-LLI
Adult	5.34E-04	6.38E-04	5.32E-04	1.13E-02	7.38E-04	4.70E-04	6.00E-04
Teen	5.57E-04	6.93E-04	5.53E-04	1.52E-02	8.22E-04	4.70E-04	6.38E-04
Child	5.88E-04	6.80E-04	5.70E-04	1.95E-02	7.93E-04	4.70E-04	5.80E-04
Infant	5.60E-04	6.47E-04	5.35E-04	1.67E-02	6.68E-04	4.70E-04	5.13E-04

OFFSITE DOSE CALCULATION MANUAL

APPENDIX L
GASEOUS EFFLUENT DOSE CONVERSION FACTORS

Cs-134		Gaseous release (mrem/Ci released)					
	Bone	Liver	T.Body	Thyroid	Kidney	Lung	GI-LLI
Adult	3.02E+00	5.41E+00	4.66E+00	1.29E+00	2.62E+00	1.73E+00	1.36E+00
Teen	4.02E+00	7.73E+00	4.28E+00	1.29E+00	3.33E+00	2.07E+00	1.37E+00
Child	7.49E+00	1.15E+01	3.43E+00	1.29E+00	4.44E+00	2.42E+00	1.34E+00
Infant	6.35E+00	1.07E+01	2.24E+00	1.29E+00	3.72E+00	2.28E+00	1.31E+00

Cs-134m		Gaseous release (mrem/Ci released)					
	Bone	Liver	T.Body	Thyroid	Kidney	Lung	GI-LLI
Adult	8.85E-06	1.18E-05	9.08E-06	5.96E-06	9.28E-06	6.50E-06	7.40E-06
Teen	9.95E-06	1.39E-05	1.02E-05	5.96E-06	1.06E-05	6.79E-06	9.63E-06
Child	1.13E-05	1.34E-05	1.11E-05	5.96E-06	1.01E-05	6.66E-06	1.26E-05
Infant	1.02E-05	1.26E-05	9.49E-06	5.96E-06	8.66E-06	6.60E-06	9.64E-06

Cs-136		Gaseous release (mrem/Ci released)					
	Bone	Liver	T.Body	Thyroid	Kidney	Lung	GI-LLI
Adult	4.97E-02	1.13E-01	8.92E-02	2.82E-02	7.54E-02	3.47E-02	3.77E-02
Teen	5.85E-02	1.47E-01	1.08E-01	2.82E-02	9.31E-02	3.85E-02	3.77E-02
Child	9.21E-02	2.04E-01	1.42E-01	2.82E-02	1.22E-01	4.22E-02	3.44E-02
Infant	1.20E-01	2.97E-01	1.29E-01	2.82E-02	1.36E-01	5.02E-02	3.23E-02

Cs-137		Gaseous release (mrem/Ci released)					
	Bone	Liver	T.Body	Thyroid	Kidney	Lung	GI-LLI
Adult	4.42E+00	5.34E+00	4.16E+00	1.93E+00	3.09E+00	2.31E+00	2.00E+00
Teen	6.05E+00	7.40E+00	3.84E+00	1.93E+00	3.79E+00	2.65E+00	2.01E+00
Child	1.17E+01	1.13E+01	3.31E+00	1.93E+00	4.97E+00	3.02E+00	1.99E+00
Infant	9.68E+00	1.10E+01	2.57E+00	1.93E+00	4.36E+00	2.92E+00	1.96E+00

Cs-138		Gaseous release (mrem/Ci released)					
	Bone	Liver	T.Body	Thyroid	Kidney	Lung	GI-LLI
Adult	7.47E-05	8.12E-05	7.45E-05	6.72E-05	7.81E-05	6.83E-05	6.72E-05
Teen	7.77E-05	8.66E-05	7.73E-05	6.72E-05	8.22E-05	6.90E-05	6.72E-05
Child	8.15E-05	8.62E-05	7.98E-05	6.72E-05	8.13E-05	6.87E-05	7.33E-05
Infant	7.86E-05	8.49E-05	7.62E-05	6.72E-05	7.65E-05	6.87E-05	8.70E-05

Ba-139		Gaseous release (mrem/Ci released)					
	Bone	Liver	T.Body	Thyroid	Kidney	Lung	GI-LLI
Adult	2.00E-05	2.00E-05	2.00E-05	2.00E-05	2.00E-05	1.05E-04	4.03E-05
Teen	2.00E-05	2.00E-05	2.00E-05	2.00E-05	2.00E-05	1.66E-04	1.66E-04
Child	2.00E-05	2.00E-05	2.00E-05	2.00E-05	2.00E-05	1.51E-04	1.33E-03
Infant	2.00E-05	2.00E-05	2.00E-05	2.00E-05	2.00E-05	1.55E-04	1.18E-03

APPENDIX L
GASEOUS EFFLUENT DOSE CONVERSION FACTORS

Ba-140		Gaseous release (mrem/Ci released)					
	Bone	Liver	T.Body	Thyroid	Kidney	Lung	GI-LLI
Adult	3.11E-02	3.86E-03	5.62E-03	3.83E-03	3.84E-03	3.27E-02	6.32E-02
Teen	3.40E-02	3.87E-03	5.77E-03	3.83E-03	3.84E-03	4.99E-02	5.36E-02
Child	6.42E-02	3.88E-03	7.35E-03	3.83E-03	3.85E-03	4.34E-02	3.59E-02
Infant	1.61E-02	3.84E-03	4.46E-03	3.83E-03	3.83E-03	4.00E-02	7.40E-03

Ba-141		Gaseous release (mrem/Ci released)					
	Bone	Liver	T.Body	Thyroid	Kidney	Lung	GI-LLI
Adult	7.82E-06	7.82E-06	7.82E-06	7.82E-06	7.82E-06	5.17E-05	7.82E-06
Teen	7.82E-06	7.82E-06	7.82E-06	7.82E-06	7.82E-06	8.23E-05	7.82E-06
Child	7.82E-06	7.82E-06	7.82E-06	7.82E-06	7.82E-06	7.40E-05	1.41E-05
Infant	7.82E-06	7.82E-06	7.82E-06	7.82E-06	7.82E-06	7.51E-05	1.15E-04

Ba-142		Gaseous release (mrem/Ci released)					
	Bone	Liver	T.Body	Thyroid	Kidney	Lung	GI-LLI
Adult	8.40E-06	8.40E-06	8.40E-06	8.40E-06	8.40E-06	3.54E-05	8.40E-06
Teen	8.40E-06	8.40E-06	8.40E-06	8.40E-06	8.40E-06	5.17E-05	8.40E-06
Child	8.40E-06	8.40E-06	8.40E-06	8.40E-06	8.40E-06	4.56E-05	8.46E-06
Infant	8.40E-06	8.40E-06	8.40E-06	8.40E-06	8.40E-06	4.36E-05	2.41E-05

La-140		Gaseous release (mrem/Ci released)					
	Bone	Liver	T.Body	Thyroid	Kidney	Lung	GI-LLI
Adult	3.61E-03	3.60E-03	3.60E-03	3.60E-03	3.60E-03	6.68E-03	2.77E-02
Teen	3.61E-03	3.61E-03	3.60E-03	3.60E-03	3.60E-03	8.46E-03	2.42E-02
Child	3.62E-03	3.61E-03	3.60E-03	3.60E-03	3.60E-03	7.74E-03	1.46E-02
Infant	3.61E-03	3.61E-03	3.60E-03	3.60E-03	3.60E-03	7.41E-03	5.53E-03

La-142		Gaseous release (mrem/Ci released)					
	Bone	Liver	T.Body	Thyroid	Kidney	Lung	GI-LLI
Adult	1.38E-04	1.38E-04	1.38E-04	1.38E-04	1.38E-04	2.81E-04	1.86E-04
Teen	1.38E-04	1.38E-04	1.38E-04	1.38E-04	1.38E-04	3.68E-04	4.10E-04
Child	1.38E-04	1.38E-04	1.38E-04	1.38E-04	1.38E-04	3.35E-04	1.86E-03
Infant	1.38E-04	1.38E-04	1.38E-04	1.38E-04	1.38E-04	3.24E-04	1.49E-03

Ce-141		Gaseous release (mrem/Ci released)					
	Bone	Liver	T.Body	Thyroid	Kidney	Lung	GI-LLI
Adult	3.05E-03	2.89E-03	2.59E-03	2.56E-03	2.71E-03	1.08E-02	1.02E-01
Teen	3.25E-03	3.02E-03	2.61E-03	2.56E-03	2.78E-03	1.65E-02	1.07E-01
Child	3.57E-03	3.06E-03	2.63E-03	2.56E-03	2.78E-03	1.49E-02	8.07E-02
Infant	3.19E-03	2.94E-03	2.60E-03	2.56E-03	2.68E-03	1.43E-02	3.86E-03

APPENDIX L
GASEOUS EFFLUENT DOSE CONVERSION FACTORS

Ce-143		Gaseous release (mrem/Ci released)					
	Bone	Liver	T.Body	Thyroid	Kidney	Lung	GI-LLI
Adult	4.38E-04	5.76E-04	4.33E-04	4.33E-04	4.35E-04	2.24E-03	1.08E-02
Teen	4.40E-04	5.67E-04	4.34E-04	4.33E-04	4.35E-04	3.39E-03	1.01E-02
Child	4.42E-04	6.17E-04	4.34E-04	4.33E-04	4.35E-04	3.05E-03	5.94E-03
Infant	4.40E-04	4.50E-04	4.34E-04	4.33E-04	4.35E-04	3.07E-03	1.63E-03

Ce-144		Gaseous release (mrem/Ci released)					
	Bone	Liver	T.Body	Thyroid	Kidney	Lung	GI-LLI
Adult	9.69E-02	4.80E-02	1.75E-02	1.30E-02	3.38E-02	1.89E-01	2.10E+00
Teen	1.34E-01	6.29E-02	1.95E-02	1.30E-02	4.28E-02	3.16E-01	2.47E+00
Child	1.90E-01	6.83E-02	2.25E-02	1.30E-02	4.37E-02	2.84E-01	1.92E+00
Infant	8.57E-02	4.06E-02	1.70E-02	1.30E-02	2.53E-02	2.36E-01	3.32E-02

Pr-143		Gaseous release (mrem/Ci released)					
	Bone	Liver	T.Body	Thyroid	Kidney	Lung	GI-LLI
Adult	2.25E-04	9.01E-05	1.11E-05	0.00E+00	5.19E-05	6.36E-03	6.00E-02
Teen	3.17E-04	1.26E-04	1.57E-05	0.00E+00	7.32E-05	1.10E-02	5.06E-02
Child	4.47E-04	1.34E-04	2.21E-05	0.00E+00	7.27E-05	9.81E-03	3.32E-02
Infant	3.17E-04	1.19E-04	1.58E-05	0.00E+00	4.48E-05	9.81E-03	8.80E-04

Pr-144		Gaseous release (mrem/Ci released)					
	Bone	Liver	T.Body	Thyroid	Kidney	Lung	GI-LLI
Adult	3.44E-07	3.44E-07	3.43E-07	3.43E-07	3.44E-07	2.34E-05	3.43E-07
Teen	3.44E-07	3.44E-07	3.43E-07	3.43E-07	3.44E-07	4.01E-05	3.43E-07
Child	3.45E-07	3.44E-07	3.43E-07	3.43E-07	3.44E-07	3.58E-05	4.80E-06
Infant	3.44E-07	3.44E-07	3.43E-07	3.43E-07	3.44E-07	3.68E-05	9.74E-05

Nd-147		Gaseous release (mrem/Ci released)					
	Bone	Liver	T.Body	Thyroid	Kidney	Lung	GI-LLI
Adult	1.70E-03	1.72E-03	1.58E-03	1.57E-03	1.66E-03	6.58E-03	4.18E-02
Teen	1.76E-03	1.77E-03	1.58E-03	1.57E-03	1.69E-03	1.00E-02	3.34E-02
Child	1.83E-03	1.78E-03	1.59E-03	1.57E-03	1.69E-03	9.01E-03	2.13E-02
Infant	1.75E-03	1.76E-03	1.58E-03	1.57E-03	1.64E-03	8.87E-03	2.30E-03

Eu-152		Gaseous release (mrem/Ci released)					
	Bone	Liver	T.Body	Thyroid	Kidney	Lung	GI-LLI
Adult	5.62E+00	5.59E+00	5.58E+00	5.57E+00	5.64E+00	5.64E+00	5.99E+00
Teen	5.63E+00	5.59E+00	5.59E+00	5.57E+00	5.64E+00	5.67E+00	5.95E+00
Child	5.65E+00	5.59E+00	5.59E+00	5.57E+00	5.63E+00	5.65E+00	5.83E+00
Infant	5.60E+00	5.58E+00	5.58E+00	5.57E+00	5.59E+00	5.62E+00	5.57E+00

APPENDIX L
GASEOUS EFFLUENT DOSE CONVERSION FACTORS

W-187 Gaseous release (mrem/Ci released)							
	Bone	Liver	T.Body	Thyroid	Kidney	Lung	GI-LLI
Adult	4.49E-04	4.48E-04	4.44E-04	4.42E-04	4.42E-04	1.10E-03	6.00E-03
Teen	4.49E-04	4.48E-04	4.44E-04	4.42E-04	4.42E-04	1.52E-03	6.04E-03
Child	4.55E-04	4.50E-04	4.45E-04	4.42E-04	4.42E-04	1.37E-03	3.62E-03
Infant	4.45E-04	4.44E-04	4.42E-04	4.42E-04	4.42E-04	1.34E-03	1.36E-03

U-235 Gaseous release (mrem/Ci released)							
	Bone	Liver	T.Body	Thyroid	Kidney	Lung	GI-LLI
Adult	1.52E+01	1.07E+00	1.93E+00	1.07E+00	4.36E+00	9.96E+00	2.28E+00
Teen	2.35E+01	1.07E+00	2.44E+00	1.07E+00	6.33E+00	1.64E+01	2.52E+00
Child	5.28E+01	1.07E+00	4.20E+00	1.07E+00	9.56E+00	1.47E+01	2.21E+00
Infant	5.48E+00	1.07E+00	1.40E+00	1.07E+00	1.99E+00	1.15E+01	1.12E+00

U-238 Gaseous release (mrem/Ci released)							
	Bone	Liver	T.Body	Thyroid	Kidney	Lung	GI-LLI
Adult	1.35E+01	3.99E-03	8.04E-01	3.99E-03	3.09E+00	8.31E+00	8.54E-01
Teen	2.15E+01	3.99E-03	1.28E+00	3.99E-03	4.93E+00	1.43E+01	1.03E+00
Child	4.95E+01	3.99E-03	2.94E+00	3.99E-03	7.93E+00	1.28E+01	8.04E-01
Infant	4.22E+00	3.99E-03	3.09E-01	3.99E-03	8.62E-01	9.71E+00	3.95E-02

Np-239 Gaseous release (mrem/Ci released)							
	Bone	Liver	T.Body	Thyroid	Kidney	Lung	GI-LLI
Adult	3.26E-04	3.21E-04	3.20E-04	3.20E-04	3.22E-04	1.17E-03	8.40E-03
Teen	3.28E-04	3.21E-04	3.20E-04	3.20E-04	3.22E-04	1.79E-03	7.24E-03
Child	3.31E-04	3.21E-04	3.21E-04	3.20E-04	3.22E-04	1.64E-03	4.32E-03
Infant	3.28E-04	3.21E-04	3.20E-04	3.20E-04	3.22E-04	1.67E-03	8.89E-04

Am-241 Gaseous release (mrem/Ci released)							
	Bone	Liver	T.Body	Thyroid	Kidney	Lung	GI-LLI
Adult	1.95E+02	6.94E+01	1.31E+01	1.97E-01	9.74E+01	1.12E+01	1.27E+00
Teen	2.06E+02	7.93E+01	1.40E+01	1.97E-01	1.04E+02	1.92E+01	1.48E+00
Child	1.65E+02	7.44E+01	1.19E+01	1.97E-01	7.24E+01	1.71E+01	1.20E+00
Infant	5.86E+01	2.70E+01	4.35E+00	1.97E-01	2.54E+01	1.31E+01	1.99E-01

ACTIVITY RELEASED TO DOSE CONVERSION FACTORS FOR NOBLE GASES

RADIONUCLIDE	TOTAL BODY DOSE (mrem/Ci)	SKIN DOSE (mrem/Ci)	GAMMA AIR DOSE (mrad/Ci)	BETA AIR DOSE (mrad/Ci)
Kr-83m	1.71E-09	4.81E-07	4.37E-07	6.53E-06
Kr-85m	2.65E-05	6.37E-05	2.79E-05	4.46E-05
Kr-85	3.65E-07	3.08E-05	3.90E-07	4.42E-05
Kr-87	1.34E-04	3.74E-04	1.40E-04	2.33E-04
Kr-88	3.33E-04	4.33E-04	3.44E-04	6.64E-05
Kr-89	3.76E-04	6.60E-04	3.92E-04	2.40E-04
Kr-90	3.53E-04	5.71E-04	3.69E-04	1.77E-04
Xe-131m	2.07E-06	1.47E-05	3.53E-06	2.51E-05
Xe-133m	5.69E-06	3.07E-05	7.41E-06	3.35E-05
Xe-133	6.66E-06	1.57E-05	8.00E-06	2.38E-05
Xe-135m	7.07E-05	9.98E-05	7.61E-05	1.67E-05
Xe-135	4.10E-05	9.00E-05	4.35E-05	5.57E-05
Xe-137	3.22E-05	3.14E-04	3.42E-05	2.88E-04
Xe-138	2.00E-04	3.23E-04	2.09E-04	1.08E-04
Ar-41	2.00E-04	2.93E-04	2.11E-04	7.43E-05