

2807 West County Road 75  
Monticello, MN 55362

800.895.4999  
xcelenergy.com



July 6, 2017

L-MT-17-047  
10 CFR 2.202

ATTN: Document Control Desk  
U.S. Nuclear Regulatory Commission  
Washington, DC 20555-0001

Monticello Nuclear Generating Plant  
Docket No. 50-263  
Renewed Facility Operating License No. DPR-22

Monticello Nuclear Generating Plant: Notification of Full Compliance of Required Action for NRC Order EA-12-049 Mitigation Strategies for Beyond-Design-Basis External Events (TAC No. MF0923)

- References:
- 1) NRC Order EA-12-049, "Issuance of Order to Modify Licenses with Regard to Requirements for Mitigation Strategies for Beyond-Design-Basis External Events," dated March 12, 2012. (ADAMS Accession No. ML12054A735)
  - 2) Letter from K. Fili (NSPM) to Document Control Desk (NRC), "Request for Relaxation from NRC Order EA-12-049, "Order Modifying Licenses with Regard to Requirements for Mitigation Strategies for Beyond-Design-Basis External Events" - Monticello Nuclear Generating Plant," L-MT-14-083, dated October 1, 2014. (ADAMS Accession No. ML14289A512)
  - 3) Letter from W. Dean (NRC) to K. Fili (NSPM), "Subject: Monticello Nuclear Generating Plant - Relaxation of Certain Schedule Requirements for Order EA-12-049 'Issuance of Order to Modify Licenses With Regard to Requirements for Mitigation Strategies for Beyond Design Basis External Events' (TAC No. MF0923)," dated November 21, 2014. (ADAMS Accession No. ML14294A061)
  - 4) NRC Order EA-13-109, "Issuance of Order to Modify Licenses with Regard to Reliable Hardened Containment Vents Capable of Operation under Severe Accident Conditions," dated June 6, 2013. (ADAMS Accession No. ML13143A334)

- 5) Letter from P. Gardner (NSPM) to Document Control Desk (NRC), "Monticello Nuclear Generating Plant: Update of Information Related to NRC Order EA-12-049 Mitigation Strategies for Beyond-Design-Basis External Events (TAC No. MF0923)," L-MT-15-047, dated October 12, 2015. (ADAMS Accession No. ML15288A132)
- 6) Letter from P. Gardner (NSPM) to Document Control Desk (NRC), "Monticello Nuclear Generating Plant's Eighth Six-Month Status Report in Response to March 12, 2012 Commission Order Modifying Licenses with Regard to Requirements for Mitigation Strategies for Beyond-Design-Basis External Events (Order Number EA-12-049) (TAC No. MF0923)," L-MT-17-006, dated February 20, 2017. (ADAMS Accession No. ML17051A009)
- 7) NEI 12-06, Revision 2, "Diverse and Flexible Coping Strategies (FLEX) Implementation Guide," December 2015. (ADAMS Accession No. ML16005A625)

The purpose of this letter is to provide the notification required by Item IV.C.3 of Order EA-12-049 that full compliance with the requirements described in Attachment 2 of the Order EA-12-049 was achieved for Monticello Nuclear Generating Plant (MNGP) on May 11, 2017.

On March 12, 2012, the Nuclear Regulatory Commission (NRC) staff issued Order EA-12-049, "Issuance of Order to Modify Licenses with Regard to Requirements for Mitigation Strategies for Beyond-Design-Basis External Events," (Reference 1) to all NRC power reactor licensees and holders of construction permits in active or deferred status. Reference 1 was effective immediately and directed Northern States Power Company, a Minnesota corporation (NSPM), doing business as Xcel Energy, to develop, implement, and maintain guidance and strategies to maintain or restore core cooling, containment, and spent fuel pool cooling capabilities following a beyond-design-basis external event for the MNGP. Specific requirements are outlined in Attachment 2 of Reference 1.

In Reference 2, NSPM requested relaxation of Order EA-12-049 for the MNGP. NSPM requested relaxation of the completion of the Order from startup from the Spring 2015 refueling outage (RFO) to startup from the Spring 2017 RFO. The reason for the relaxation was to permit NSPM to design and install the severe accident capable hardened containment wetwell vent in accordance with Order EA-13-109 (Reference 4) and to integrate it into the mitigating strategies required for Order EA-12-049. Reference 2 stipulated that the relaxation request only applied to the hardened containment vent portion of Order EA-12-049 and further stipulated that other requirements of Order EA-12-049 would be completed prior to startup from the Spring 2015 RFO.

In Reference 3, the NRC approved NSPM's relaxation request and accepted both the justification and the stipulations regarding completion of the balance of Order EA-12-049 by the completion of the 2015 RFO.

In Reference 5, NSPM informed the NRC that the equipment and modifications required to implement the mitigating strategies required by Order EA-12-049 were implemented and were available for use in accordance with the original implementation schedule requirements, except for installation of a severe accident capable hardened containment wetwell vent as required by NRC Order EA-13-109, and integration of its operation into the mitigating strategies required for Order EA-12-049. In Reference 5, Enclosure 2, NSPM provided updates to NRC information requests to demonstrate implementation of Order EA-12-049 to the extent described in Reference 3.

In Reference 6, NSPM provided its most recent status report on accomplishments related to Order EA-12-049 and provided a response to the final open item related to the Order.

Enclosure 1 of this letter summarizes the MNGP compliance with Order EA-12-049. Enclosure 2 contains the MNGP Final Integrated Plan (FIP), which provides strategies to maintain or restore core cooling, containment, and spent fuel pool cooling capabilities in the event of a beyond-design basis external event.

The MNGP FIP is based on demonstrating compliance with NEI 12-06, Rev. 2 (Reference 7) with the exception of Appendix E, which was finalized after the validation process was completed. Other aspects of NEI 12-06, Rev. 2, while not applicable to Order EA-12-049 compliance, were utilized for other related submittals (e.g., use of reevaluated hazards, Appendix G and Appendix H). Finally, references to drills/exercises using the guidance of NEI 13-06 and NEI 14-01 will be performed consistent with 10 CFR 50.155 requirements, including the schedule required for implementation of the final rule.

Please contact John Fields at 763-271-6707, if additional information or clarification is required.

### Summary of Commitments

This letter makes no new commitments and no revisions to existing commitments.

I declare under penalty of perjury that the foregoing is true and correct.

Executed on July 6, 2017.

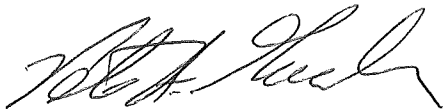
A handwritten signature in black ink, appearing to read "Peter A. Gardner". The signature is fluid and cursive, with a large initial "P" and "G".

Peter A. Gardner  
Site Vice President, Monticello Nuclear Generating Plant  
Northern States Power Company – Minnesota

Enclosures (2)

cc: Administrator, Region III, USNRC  
Project Manager, Monticello Nuclear Generating Plant, USNRC  
Resident Inspector, Monticello Nuclear Generating Plant, USNRC

## ENCLOSURE 1

### Monticello Nuclear Generating Plant

#### Implementation of Required Action by NRC Order EA-12-049 Mitigation Strategies for Beyond-Design-Basis External Events

## 1.0 Background

### Introduction

On March 12, 2012, the Nuclear Regulatory Commission (NRC) staff issued Order EA-12-049, "Issuance of Order to Modify Licenses with Regard to Requirements for Mitigation Strategies for Beyond-Design-Basis External Events," (Reference 1), to all NRC power reactor licensees and holders of construction permits in active or deferred status. Reference 1 was effective immediately and directed Northern States Power Company, a Minnesota corporation (NSPM), doing business as Xcel Energy, to develop, implement and maintain guidance and strategies to maintain or restore core cooling, containment, and spent fuel pool cooling capabilities following a beyond-design-basis external event for the Monticello Nuclear Generating Plant (MNGP). Specific requirements are outlined in Attachment 2 of Reference 1.

NSPM submitted the MNGP Overall Integrated Plan (OIP) for compliance of Order EA-12-049 by letter dated February 28, 2013 (Reference 2). By letter dated November 25, 2013 (Reference 3), the NRC provided its interim staff evaluation of the OIP and requested additional information necessary for completion of the review.

In Reference 4, NSPM requested relaxation of Order EA-12-049 for the MNGP. NSPM requested relaxation of the completion of the Order from startup from the Spring 2015 refueling outage (RFO) to startup from the Spring 2017 RFO. The reason for the relaxation was to permit NSPM to design and install the severe accident capable hardened containment wetwell vent in accordance with Order EA-13-109 and to integrate it into the mitigating strategies required for Order EA-12-049. Reference 4 stipulated that the relaxation request only applied to the hardened containment vent (HCV) portion of Order EA-12-049, and further stipulated that other requirements of Order EA-12-049 would be completed prior to startup from the Spring 2015 RFO.

In Reference 5, the NRC approved NSPMs relaxation request and accepted both the justification and the stipulations regarding completion of the balance of Order EA-12-049 by the completion of the 2015 RFO.

**Open Item Resolution**

In References 8 and 9, NSPM provided a response to all NRC open items related to NRC Order EA-12-049. This includes Confirmatory Items (CIs), Open Items (OIs), Audit Questions (AQs), and Safety Evaluation Items (SEs). Separately, NSPM responded to Spent Fuel Pool Instrument Order (EA-12-051) Requests for Additional Information (RAIs) in Reference 10. An additional clarification to an SFPI Order response was provided in Reference 9.

**Milestone Schedule – Items Complete**

<b>MNGP Milestone</b>	<b>Completion Date</b>
Submit 60 Day Status Report	October 2012
Submit Overall Integrated Plan	February 2013
Submit First Six-Month Status Report	August 2013
Commence Engineering Modification Design – Phase 2 & 3	January 2014
Submit Second Six-Month Status Report	February 2014
Submit Third Six-Month Status Update	August 2014
Commence Installation for Online Modifications – Phase 2 and 3	October 2014
Submit Staffing Assessment	December 2014
Complete Communication Recommendations	December 2014
Submit Fourth Six-Month Status Report	February 2015
National SAFER Response Center Operational (MNGP)	March 2015
Issue Maintenance Procedures	March 2015
Procure Equipment	April 2015
Implement Storage	April 2015
Implement Training	April 2015
Validation Walk-throughs	April 2015
Issue Procedures Updated for FLEX strategies	May 2015
Implementation Outage	May 2015
Submit Fifth Six-Month Status Report	August 2015
Submit Sixth Six-Month Status Report	February 2016
Submit Seventh Six-Month Status Report	August 2016
Submit Eighth Six-Month Status Report	February 2017
Hardened Containment Vent Upgrades – Phase 1 Complete (Reference 11)	May 2017

MNGP Milestone	Completion Date
Submit Completion Report	July 2017

## 2.0 Implementation

### STRATEGIES - COMPLETE

MNGP strategies are in compliance with Order EA-12-049. There are no strategy related Open Items, Confirmatory Items, or Audit Questions/Audit Report Open Items.

### MODIFICATIONS - COMPLETE

The modifications required to support the FLEX strategies for MNGP have been fully implemented in accordance with the station design control process.

### EQUIPMENT – PROCURED AND MAINTENANCE & TESTING - COMPLETE

The equipment required to implement the FLEX strategies for MNGP has been procured in accordance with NEI 12-06, Section 11.1 and 11.2, received at MNGP, initially tested/performance verified as identified in NEI 12-06 (Reference 12), Section 11.5, and is available for use.

Maintenance and testing will be conducted through the use of the MNGP Preventative Maintenance program such that equipment reliability is achieved and maintained. All maintenance and testing activities have been identified. All six month or less PM's have been developed and performed. Greater than six month PMs have been developed and will be performed on their scheduled due date.

### PROTECTED STORAGE - COMPLETE

The storage facilities required to implement the FLEX strategies for MNGP have been completed and provide protection from the applicable site hazards. The equipment required to implement the FLEX strategies for MNGP is stored in its protected configuration.

### PROCEDURES - COMPLETE

FLEX Support Guidelines (FSGs) for MNGP have been developed and integrated with existing procedures, except as permitted by the NRC approved Order relaxation. The implemented FSGs and affected existing procedures have been verified and are available for use in accordance with the site procedure control program.

**TRAINING - COMPLETE**

Training for MNGP personnel has been completed in accordance with an accepted training process as recommended in NEI 12-06 (Reference 12), Section 11.6.

**STAFFING - COMPLETE**

The Phase 2 staffing study for MNGP has been completed in accordance with 10CFR50.54(f), "Request for Information Pursuant to Title 10 of the Code of Federal Recommendations 2.1, 2.3, and 9.3, of the Near-Term Task Force review of Insights from the Fukushima Dai-ichi Accident," Recommendation 9.3, dated March 12, 2012 (Reference 6), as documented in a letter to the NRC dated April 30, 2015 (Reference 7). The staffing study concluded that no additional staff is required to mitigate the extended loss of alternating current (ac) power (ELAP) event.

**COMMUNICATIONS - COMPLETE**

NSPM committed to compliance with the communications capabilities in accordance with the 10-CFR 50.54(f) letter (Reference 6). NSPM completed communications systems upgrades, including the integration of satellite communications into selected portions of the site telephone system (Reference 8).

**NATIONAL SAFER RESPONSE CENTERS - COMPLETE**

NSPM has established a contract with Pooled Equipment Inventory Company (PEICo) and has joined the Strategic Alliance for FLEX Emergency Response (SAFER) Team Equipment Committee for off-site facility coordination. It has been confirmed that PEICo is ready to support MNGP with Phase 3 equipment stored in the National SAFER Response Centers in accordance with the site specific SAFER Response Plan.

**VALIDATION - COMPLETE**

NSPM has completed performance of validation in accordance with industry developed guidance to assure required tasks, manual actions, and decisions for FLEX strategies are feasible and may be executed within the constraints identified in the Final Integrated Plan (Enclosure 2 of this letter) and Request for Additional Information Responses (i.e. the Open Items, Confirmatory Items, Audit Questions and Safety Evaluation questions provided in References 8 and 9) for Order EA-12-049.

**FLEX PROGRAM DOCUMENT - ESTABLISHED**

The NSPM FLEX Program Document for MNGP has been developed in accordance with the requirements of NEI 12-06 (Reference 12).



### 3.0 References

1. NRC Order EA-12-049, "Issuance of Order to Modify Licenses with Regard to Requirements for Mitigation Strategies for Beyond-Design-Basis External Events," dated March 12, 2012. (ADAMS Accession No. ML12054A735)
2. Letter from M. Schimmel (NSPM) to Document Control Desk (NRC), "Monticello Nuclear Generating Plant's Overall Integrated Plan in Response to March 12, 2012 Commission Order Modifying Licenses with Regard to Requirements for Mitigation Strategies for Beyond-Design-Basis External Events (Order Number EA-12-049)," L-MT-13-017, dated February 28, 2013. (ADAMS Accession No. ML13066A066)
3. Letter from J. Bowen (NRC) to K. Fili (NSPM), "Monticello Nuclear Generating Plant – Interim Staff Evaluation Relating to Overall Integrated Plan in Response to Order EA-12-049 (Mitigation Strategies) (TAC No. MF0923)," dated November 25, 2013. (ADAMS Accession No. ML13220A139)
4. Letter from K. Fili (NSPM) to Document Control Desk (NRC), "Request for Relaxation from NRC Order EA-12-049, "Order Modifying Licenses with Regard to Requirements for Mitigation Strategies for Beyond-Design-Basis External Events" - Monticello Nuclear Generating Plant," L-MT-14-083, dated October 1, 2014. (ADAMS Accession No. ML14289A512)
5. Letter from W. Dean (NRC) to K. Fili (NSPM), "Subject: Monticello Nuclear Generating Plant - Relaxation of Certain Schedule Requirements for Order EA-12-049 'Issuance of Order to Modify Licenses With Regard to Requirements for Mitigation Strategies for Beyond Design Basis External Events' (TAC No. MF0923)," dated November 21, 2014. (ADAMS Accession No. ML14294A061)
6. Letter from E. Leeds/M. Johnson (NRC), to Licensees, "Request for Information Pursuant to Title 10 of the Code of Federal Regulations 50.54(f), Regarding Recommendations 2.1, 2.3, and 9.3, of the Near-Term Task Force Review of Insights from the Fukushima Dai-ichi Accident," dated March 12, 2012. (ADAMS Accession No. ML12053A340)
7. Letter from P. Gardner (NSPM) to Document Control Desk (NRC), "Monticello Nuclear Generating Plant Phase 2 Staffing Assessment Revised - Onsite and Augmented Staffing Assessment Considering Functions Related to Near-Term Task Force (NTTF) Recommendation 4.2," L-MT-15-027, dated April 30, 2015. (ADAMS Accession No. ML15128A264)
8. Letter from P. Gardner (NSPM) to Document Control Desk (NRC), "Monticello Nuclear Generating Plant: Update of Information Related to NRC Order EA-12-049 Mitigation Strategies for Beyond-Design-Basis External Events (TAC No. MF0923)," L-MT-15-047, dated October 12, 2015. (ADAMS Accession No. ML15288A132)
9. Letter from P. Gardner (NSPM) to Document Control Desk (NRC), "Monticello Nuclear Generating Plant's Eighth Six-Month Status Report in Response to March 12, 2012 Commission Order Modifying Licenses with Regard to Requirements for Mitigation Strategies for Beyond-Design-Basis External Events (Order Number EA-12-049) (TAC

No. MF0923),” L-MT-17-006, dated February 20, 2017. (ADAMS Accession No. ML17051A009)

10. Letter from P. Gardner (NSPM) to Document Control Desk (NRC), “Monticello Nuclear Generating Plant Completion of Required Action by NRC Order EA-12-051 Reliable Spent Fuel Pool Instrumentation (TAC No. MF0924),” L-MT-15-046, dated July 28, 2015. (ADAMS Accession No. ML15212A114)
11. Letter from P. Gardner (NSPM) to Document Control Desk (NRC), “Monticello Nuclear Generating Plant: Sixth Six-Month Status Report in Response to June 6, 2013 Commission Order Modifying Licenses with Regard to Reliable Hardened Containment Vents Capable of Operation Under Severe Accident Conditions (Order EA-13-109), Phases 1 and 2 (TAC No. MF4376),” L-MT-17-042, dated June 14, 2017.
12. NEI 12-06, Revision 2, “Diverse and Flexible Coping Strategies (FLEX) Implementation Guide,” December 2015. (ADAMS Accession No. ML16005A625)

**ENCLOSURE 2**

**MONTICELLO NUCLEAR GENERATING PLANT**

**NOTIFICATION OF FULL COMPLIANCE OF REQUIRED ACTION FOR**

**NRC ORDER EA-12-049  
MITIGATION STRATEGIES FOR BEYOND-DESIGN-BASIS EXTERNAL EVENTS**

**FINAL INTEGRATED PLAN**

**Final Integrated Plan for  
Mitigating Strategies for Beyond-Design-  
Basis External Events and Reliable  
Spent Fuel Pool Instrumentation for  
Monticello Nuclear Generating Plant**

Revision 0

July 2017

**Final Integrated Plan  
for Mitigating Strategies for Beyond-Design-Basis External Events and  
Reliable Spent Fuel Pool Instrumentation  
for Monticello Nuclear Generating Plant**

## Table of Contents

1.0	Background .....	1
2.0	NRC Order EA-12-049 – Mitigation Strategies (FLEX) .....	3
2.1	General Elements .....	3
2.1.1	Boundary Conditions.....	3
2.1.2	Plant Initial Conditions .....	3
2.1.3	Key Assumptions .....	4
3.0	Strategies .....	6
3.1	Reactor Core Cooling and Heat Removal Strategy .....	7
3.1.1	Phase 1 Strategy .....	8
3.1.2	Phase 2 Strategy .....	9
3.1.3	Phase 3 Strategy .....	14
3.1.4	Structures, Systems and Components.....	15
3.1.5	FLEX Strategy Connections.....	20
3.1.6	Key Parameters .....	21
3.1.7	Thermal Hydraulic Analyses .....	22
3.1.8	FLEX Pump and Water Supplies.....	23
3.1.9	Electrical Analysis .....	24
3.2	Spent Fuel Pool (SFP) Cooling/Inventory.....	25
3.2.1	Phase 1 Strategy .....	25
3.2.2	Phase 2 Strategy .....	25
3.2.3	Phase 3 Strategy .....	26
3.2.4	Structures, Systems and Components.....	28
3.2.5	Key Parameters .....	29
3.2.6	Thermal-Hydraulic Analyses .....	31
3.2.7	FLEX Pump and Water Supplies.....	32
3.2.8	Electrical Analysis .....	32
3.3	Containment Integrity.....	32
3.3.1	Phase 1 Strategy .....	33
3.3.2	Phase 2 Strategy .....	33
3.3.3	Phase 3 Strategy .....	34
3.3.4	Structures, Systems and Components.....	34
3.3.5	Key Parameters .....	34
3.3.6	Thermal-Hydraulic Analyses .....	34
3.3.7	FLEX Pump and Water Supplies.....	35
3.3.8	Electrical Analysis .....	35
4.0	Characterization of External Hazards .....	36
4.1	Seismic.....	36

**Final Integrated Plan  
for Mitigating Strategies for Beyond-Design-Basis External Events and  
Reliable Spent Fuel Pool Instrumentation  
for Monticello Nuclear Generating Plant**

4.1.1	Protection of FLEX equipment .....	36
4.1.2	Considerations in Utilizing Off-site Resources.....	36
4.2	External Flooding .....	37
4.2.1	Protection of FLEX equipment .....	37
4.2.2	Considerations in Utilizing Off-site Resources.....	37
4.3	Severe Storms with High Winds Assessment.....	38
4.3.1	Protection of FLEX Equipment.....	38
4.3.2	Considerations in Utilizing Off-site Resources.....	38
4.4	Ice, Snow and Extreme Cold Assessment .....	39
4.4.1	Protection of FLEX Equipment.....	39
4.4.2	Considerations in Utilizing Off-site Resources.....	39
4.5	High Temperatures .....	39
4.5.1	Protection of FLEX Equipment.....	39
4.5.2	Considerations in Utilizing Off-site Resources.....	40
5.0	Protection and Deployment of FLEX Equipment.....	41
5.1	Protection of FLEX Equipment.....	41
5.2	Planned Deployment of FLEX Equipment.....	43
5.2.1	Haul Paths .....	43
5.2.2	Accessibility .....	49
5.2.3	Debris/Snow Removal .....	50
5.3	Deployment of Strategies.....	51
5.3.1	Reactor Pressure Vessel Makeup Strategy.....	51
5.3.2	SFP Injection Makeup Strategy.....	54
5.3.3	Electrical Strategy.....	54
5.3.4	Refueling of FLEX Equipment Strategy.....	55
6.0	Offsite Resources.....	57
6.1	National SAFER Response Center .....	57
6.2	Equipment List.....	57
6.3	NSRC Connections.....	60
6.4	Offsite Storage of NSRC Equipment.....	60
6.5	Deployment of NSRC Equipment.....	60
7.0	Equipment Operating Conditions.....	62
7.1	Ventilation.....	62

**Final Integrated Plan  
for Mitigating Strategies for Beyond-Design-Basis External Events and  
Reliable Spent Fuel Pool Instrumentation  
for Monticello Nuclear Generating Plant**

7.2	Heat Tracing .....	64
8.0	Habitability Analysis.....	65
8.1	Habitability .....	65
8.2	Lighting .....	66
8.3	Communications .....	67
8.4	Water Sources .....	68
8.4.1	Ultimate Heat Sink Sources .....	68
8.4.2	Condensate Storage Tanks .....	69
9.0	Shutdown and Refueling Modes Analysis.....	70
10.0	Sequence of Events .....	71
11.0	FLEX Program Items .....	75
11.1	FLEX Program Document.....	75
11.2	Procedural Guidance .....	76
11.3	Staffing Analysis .....	79
11.4	Training.....	80
11.5	Equipment List.....	81
11.6	N+1 Equipment Requirement.....	84
11.7	FLEX Equipment Maintenance and Testing .....	84
11.8	FLEX Equipment Unavailability.....	86
11.9	FLEX Program Supporting Analyses.....	87
12.0	References.....	89

**Final Integrated Plan  
for Mitigating Strategies for Beyond-Design-Basis External Events and  
Reliable Spent Fuel Pool Instrumentation  
for Monticello Nuclear Generating Plant**

## List of Figures and Tables

### Figures

Figure 3.1.2-1	Monticello FLEX Primary Water Delivery Strategy .....	11
Figure 3.1.2-2	Monticello FLEX Alternate Water Delivery Strategy .....	12
Figure 3.1.2-3	Monticello FLEX 480 V Electrical Delivery Strategy .....	13
Figure 3.1.3-1	SAFER 4kV Electrical Generator Connections.....	15
Figure 3.2.3-1	Monticello FLEX SFP Water Delivery Strategy .....	27
Figure 3.2.5.1-1	Spent Fuel Pool Instrument Levels .....	31
Figure 5.1-1	BDBEE Storage Building Locations .....	42
Figure 5.2.1-1	FLEX Portable Diesel Pump Deployment Paths and Staging Areas .....	45
Figure 5.2.1-2	FLEX 480V Diesel Generator Deployment Paths and Staging Areas.....	46
Figure 5.3.1-1	Phase 2 & 3 Reactor Vessel Water Supply .....	52
Figure 5.3.1-2	FLEX Hose and Cable Deployment Paths .....	53
Figure 10.0-1	FLEX Sequence of Events Timeline .....	71
Figure 11.2-1	Procedure Hierarchy.....	77

### Tables

Table 6.2-1	Portable Equipment from NSRC .....	58
Table 7.1-1	Equipment Operating Conditions .....	63
Table 8.1-1	Habitability Conditions .....	65
Table 10.0-1	Sequence of Events Timeline .....	72
Table 11.2-1	FLEX Support Guidelines .....	78
Table 11.2-2	FLEX Interface and Support Procedures .....	79
Table 11.5-1	Portable Equipment Stored in MNGP BDBEE Storage Buildings.....	82
Table 11.9-1	FLEX Supporting Analyses and Key Calculations.....	87



**Final Integrated Plan  
for Mitigating Strategies for Beyond-Design-Basis External Events and  
Reliable Spent Fuel Pool Instrumentation  
for Monticello Nuclear Generating Plant**

## **1.0 Background**

In 2011, an earthquake-induced tsunami caused beyond-design-basis (BDB) flooding at the Fukushima Dai-Ichi Nuclear Power Station in Japan. The flooding caused the emergency power supplies and electrical distribution systems to be inoperable, resulting in an extended loss of alternating current power (ELAP) in five of the six units on the site. The ELAP led to (1) the loss of core cooling, (2) loss of spent fuel pool cooling capabilities, and (3) a significant challenge to maintaining Containment Integrity. All direct current (DC) power was lost early in the event on Units 1 & 2 and after some period of time at the other units. Core damage occurred in three of the units along with a loss of Containment Integrity resulting in a release of radioactive material to the surrounding environment.

The US Nuclear Regulatory Commission (NRC) assembled a Near-Term Task Force (NTTF) to advise the Commission on actions the US nuclear industry should take to preclude core damage and a release of radioactive material after a natural disaster such as that seen at Fukushima. The NTTF report (Reference 1) contained many recommendations to fulfill this charter, including assessing extreme external event hazards and strengthening station capabilities for responding to BDB external events (BDBEEs).

Based on NTTF Recommendation 4.2, the NRC issued Order EA-12-049 (Reference 2) on March 12, 2012 to implement mitigation strategies for BDBEEs. The order provided the following requirements for strategies to mitigate BDBEEs:

1. Licensees shall develop, implement, and maintain guidance and strategies to maintain or restore core cooling, Containment, and Spent Fuel Pool (SFP) cooling capabilities following a BDBEE.
2. Licensees shall develop strategies that are capable of mitigating a simultaneous loss of all AC power and loss of normal access to the ultimate heat sink (LUHS) and have adequate capacity to address challenges to core cooling, Containment and SFP cooling capabilities at all units on a site subject to the Order.
3. Licensees must provide reasonable protection for the associated equipment from external events. Such protection must demonstrate that there is adequate capacity to address challenges to core cooling, Containment, and SFP cooling capabilities at all units on a site subject to the Order.
4. Licensees must be capable of implementing the strategies in all modes.
5. Full compliance shall include procedures, guidance, training, and acquisition, staging or installing of equipment needed for the strategies.

The order specifies a three-phase approach for strategies to mitigate BDBEEs:

**Final Integrated Plan  
for Mitigating Strategies for Beyond-Design-Basis External Events and  
Reliable Spent Fuel Pool Instrumentation  
for Monticello Nuclear Generating Plant**

- Phase 1 - The initial phase requires the use of installed equipment and resources to maintain or restore core cooling, Containment and SFP cooling capabilities.
- Phase 2 - The transition phase requires providing sufficient, portable, onsite equipment and consumables to maintain or restore these functions until they can be accomplished with resources brought from off site.
- Phase 3 - The final phase requires obtaining sufficient offsite resources to sustain those functions indefinitely.

NRC Order EA-12-049 (Reference 2) required licensees of operating reactors to submit an overall integrated plan, including a description of how compliance with these requirements would be achieved by February 28, 2013. The Order also required licensees to complete implementation of the requirements no later than two refueling cycles after submittal of the overall integrated plan or December 31, 2016, whichever comes first. NSPM subsequently received NRC permission (Reference 27) to delay complete implementation of EA-12-049 requirements until the Monticello Nuclear Generating Plant (MNGP) 2017 refueling outage.

The Nuclear Energy Institute (NEI) developed NEI 12-06, Rev. 0 (Reference 3), which provides guidelines for nuclear stations to assess extreme external event hazards and implement the mitigation strategies specified in NRC Order EA-12-049. The NRC issued Interim Staff Guidance JLD-ISG-2012-01 (Reference 4), dated August 29, 2012, which endorsed NEI 12-06 with clarifications on determining baseline coping capability and equipment quality. Subsequently, NEI 12-06, Rev. 2 (Reference 25) was provided to the NRC and was endorsed by the NRC in JLD-ISG-2012-01, Rev. 1 (Reference 26). NSPM used NEI 12-06, Rev. 2 as the basis for the MNGP compliance with NRC Order EA-12-049, with the exception of Appendix E.

NRC Order EA-12-051 (Reference 5) required licensees to install reliable SFP instrumentation with specific design features for monitoring SFP water level. This order was prompted by NTF Recommendation 7.1 (Reference 1).

NEI 12-02 (Reference 6) provided guidance for compliance with Order EA-12-051. The NRC determined that, with the exceptions and clarifications provided in JLD-ISG-2012-03 (Reference 7), conformance with the guidance in NEI 12-02 is an acceptable method for satisfying the requirements in Order EA-12-051.

**Final Integrated Plan  
for Mitigating Strategies for Beyond-Design-Basis External Events and  
Reliable Spent Fuel Pool Instrumentation  
for Monticello Nuclear Generating Plant**

## **2.0 NRC Order EA-12-049 – Mitigation Strategies (FLEX)**

### **2.1 General Elements**

The following Boundary Condition assumptions, Plant Initial Conditions and Key Assumptions used for the evaluations of the MNGP ELAP/Loss of the Ultimate Heat Sink (LUHS) event and the development of diverse and flexible coping strategies (FLEX) strategies are stated below.

#### **2.1.1 Boundary Conditions**

Boundary conditions consistent with NEI 12-06, Rev. 2, Section 3.2.1, *General Criteria and Baseline Assumptions* are established to support development of FLEX strategies, as follows:

- The BDBEE occurs impacting the site.
- The reactor is initially operating at power, unless there are procedural requirements to shut down due to the impending event. The reactor has been operating at 100 percent power for the past 100 days.
- The reactor is successfully shut down when required (i.e. all rods inserted, no Anticipated Transient Without Scram (ATWS) conditions are present). Following the loss of AC power, the main steam system valves and safety/relief valves (SRV) are assumed to operate normally following the automatic trip of the reactor and insertion of control rods. No independent failures, other than those causing the ELAP/LUHS event, are assumed to occur in the course of the transient.
- On-site staff is at site administrative minimum shift staffing levels.
- No independent, concurrent events, e.g., no active security threat.
- All personnel on-site are available to support site response.
- The reactor and supporting plant equipment are either operating within normal ranges for pressure, temperature and water level, or available to operate, at the time of the event consistent with the design and licensing basis.

#### **2.1.2 Plant Initial Conditions**

The following plant initial conditions and assumptions are established for the purpose of defining FLEX strategies and are consistent with NEI 12-06, Rev. 2, Section 3.2.1, *General Criteria and Baseline Assumptions*:

- No specific initiating event is used. The initial condition is assumed to be a loss of off-site power (LOOP) with installed sources of emergency on-site AC power and station blackout (SBO) alternate AC power sources unavailable with no prospect for recovery.

**Final Integrated Plan  
for Mitigating Strategies for Beyond-Design-Basis External Events and  
Reliable Spent Fuel Pool Instrumentation  
for Monticello Nuclear Generating Plant**

- Cooling and makeup water inventories contained in systems or structures with designs that are robust with respect to seismic events, floods, and high winds and associated missiles are available. Permanent plant equipment that is contained in structures with designs that are robust with respect to seismic events, floods, and high winds and associated missiles, are available.
- Normal access to the UHS is lost, but the water inventory in the Ultimate Heat Sink (UHS) remains available and robust piping connecting the UHS to plant systems remains intact. The motive force for UHS flow, i.e., pumps, is assumed to be lost with no prospect for recovery.
- Fuel for FLEX equipment stored in structures with designs that are robust with respect to seismic events, floods and high winds and associated missiles, remains available.
- Installed Class 1E electrical distribution systems, including inverters and battery chargers, remain available since they are protected.
- No additional accidents, events, or failures are assumed to occur immediately prior to or during the event, including security events.
- Reactor coolant inventory loss consists of leakage from recirculation seals and other primary coolant leakage.
- For the SFP, the heat load is assumed to be the maximum design basis heat load. In addition, inventory loss from sloshing during a seismic event does not preclude access to the pool area.

**2.1.3 Key Assumptions**

Additionally, key assumptions associated with implementation of FLEX Strategies are as follows:

- Site access is impeded for the first six hours, consistent with NEI 12-01 (Reference 8). Additional resources are assumed to begin arriving at hour 6 with limited site access up to 24 hours. By 24 hours and beyond, near-normal site access is restored allowing augmented resources to deliver supplies and personnel to the site.
- This plan defines strategies capable of mitigating a simultaneous loss of all AC power and loss of normal access to the UHS resulting from a BDBEE by providing adequate capability to maintain or restore core cooling, Containment, and SFP cooling capabilities at MNGP. Though specific strategies have been developed, due to the inability to anticipate all possible scenarios, the strategies are also diverse and flexible to encompass a wide range of possible conditions. These pre-planned strategies developed to protect the public health and safety have been coordinated with the unit emergency operating procedures (EOPs) in accordance with the established EOP change

**Final Integrated Plan  
for Mitigating Strategies for Beyond-Design-Basis External Events and  
Reliable Spent Fuel Pool Instrumentation  
for Monticello Nuclear Generating Plant**

processes, and their impact to the design basis capabilities of the unit evaluated under 10 CFR 50.59, *Changes, Tests and Experiments*.

- The plant Technical Specifications (TS) contain the limiting conditions for normal unit operations to ensure that design safety features are available to respond to a design basis accident and direct the required actions to be taken when the limiting conditions are not met. The result of the BDBEE may place the plant in a condition where it cannot comply with certain TSs and/or with its Security Plan, and, as such, may warrant invocation of 10 CFR 50.54(x), *Conditions of Licenses* and/or 10 CFR 73.55(p), *Suspension of Security Measures*. This position is consistent with the previously documented Task Interface Agreement (TIA) 2004-04, *Acceptability of Proceduralized Departures from Technical Specifications (TSs) Requirements at the Surry Power Station*, (TAC Nos. MC4331 and MC4332), dated September 12, 2006 (Accession No. ML060590273).
- No alternatives to NEI 12-06 Rev. 2 are being utilized.

**Final Integrated Plan  
for Mitigating Strategies for Beyond-Design-Basis External Events and  
Reliable Spent Fuel Pool Instrumentation  
for Monticello Nuclear Generating Plant**

### **3.0 Strategies**

The objective of the FLEX strategies is to establish an indefinite coping capability in order to 1) prevent damage to the fuel in the reactor, 2) maintain the Containment function and 3) maintain cooling and prevent damage to fuel in the SFP using installed equipment, on-site portable equipment, and pre-staged off-site resources. This indefinite coping capability will address an ELAP – loss of off-site power, EDGs and any alternate AC source, but not the loss of AC power to buses fed by station batteries through inverters – with a simultaneous LUHS. This condition could arise following external events that are within the existing design basis with additional failures and conditions that could arise from a BDBEE.

The plant's indefinite coping capability is attained through the implementation of pre-determined strategies (FLEX strategies) that are focused on maintaining or restoring key plant safety functions. The FLEX strategies are not tied to any specific damage state or mechanistic assessment of external events. Rather, the strategies are developed to maintain the key plant safety functions based on the evaluation of plant response to the coincident ELAP/LUHS event. A safety function-based approach provides consistency with, and allows coordination with, existing plant EOPs. FLEX strategies are implemented in support of EOPs using FLEX Support Guidelines (FSGs).

The strategies for coping with the plant conditions that result from an ELAP/LUHS event involve a three-phase approach:

- Phase 1 – Initially cope by relying on installed plant equipment and on-site resources.
- Phase 2 – Transition from installed plant equipment to on-site BDBEE equipment.
- Phase 3 – Obtain additional capability and redundancy from off-site equipment and resources until power, water, and coolant injection systems are restored.

The duration of each phase is specific to the installed and portable equipment utilized for the particular FLEX strategy employed to mitigate the plant condition.

The FLEX strategies described below are capable of mitigating an ELAP/LUHS resulting from a BDBEE by providing adequate capability to maintain or restore core cooling, Containment, and SFP cooling capabilities at MNGP. Though specific strategies have been developed, due to the inability to anticipate all possible scenarios, the FLEX strategies are also diverse and flexible to encompass a wide range of possible conditions. These pre-planned strategies, which have been developed to protect the public health and safety, are coordinated with the MNGP EOPs in accordance with established EOP change

**Final Integrated Plan  
for Mitigating Strategies for Beyond-Design-Basis External Events and  
Reliable Spent Fuel Pool Instrumentation  
for Monticello Nuclear Generating Plant**

processes, and their impact to the design basis capabilities of the unit evaluated under 10 CFR 50.59.

An overall diagram of the following FLEX strategies showing the staging locations of BDBEE equipment and general hose routing is provided in Figures 5.2.1-1, 5.2.1-2 and 5.3.1-2.

**3.1 Reactor Core Cooling and Heat Removal Strategy**

Reactor core cooling, as defined in NEI 12-06, Rev. 2 requirements, involves:

- Use of plant equipment for initial coping,
- A means to depressurize the Reactor Pressure Vessel (RPV), and
- Use of an alternate water supply to support core heat removal and makeup by use of primary and alternate connections points for the FLEX pumps.

The FLEX strategy for reactor core cooling and decay heat removal is achieved using the Reactor Core Isolation Cooling (RCIC) and High Pressure Coolant Injection (HPCI) systems to provide high pressure makeup to the reactor, with automatic initiation on low-low reactor water level. The normal suction supply for both RCIC and HPCI is the non-seismically qualified CST. The CST is the preferred source, if available. Operators are directed to secure HPCI soon after the initiation of the event. If the CST is unavailable, suction will automatically transfer to the Safety-Related Suppression Pool (Torus) on a low CST level signal. Manual alignment to the CST is also available. The Torus is used as the heat sink for SRV discharge, heat sink for RCIC and HPCI exhaust, and makeup water to the reactor.

The FLEX strategy for reactor core cooling and decay heat removal is to run the RCIC system and provide makeup to the RPV for as long as conditions support RCIC operation. The RCIC injection source will be maintained for as long as possible, since it is a closed loop system using relatively clean suppression pool water (called wetwell or Torus).

RPV cooldown will be initiated within the first hour following a BDBEE that initiates an ELAP/LUHS event.

The strategy for cooling the reactor core includes releasing steam from the RPV using the SRVs to initially reduce reactor pressure and using the RCIC system to replace the reactor water inventory with water from the Torus. DC bus load shedding is started in hour 1, completed by hour 2, and is used to extend the station battery availability to 12 hours which provides sufficient time to deploy an on-site portable generator (FLEX 480V Generator). The FLEX 480V Generator is used to repower instrumentation prior to battery depletion.

**Final Integrated Plan  
for Mitigating Strategies for Beyond-Design-Basis External Events and  
Reliable Spent Fuel Pool Instrumentation  
for Monticello Nuclear Generating Plant**

The SRV steam discharge and RCIC exhaust into the Torus will raise the temperature of the water in the pool. The Hard Pipe Vent (HPV) system will pass steam to the environment, removing the reactor decay heat from the Torus.

Core cooling continues after the initial phase by providing a flow of water from a FLEX Pump that is aligned to inject to the RPV. Primary and alternate sources of water for the FLEX pump are from the CSTs and the MNGP intake and discharge canal.

### **3.1.1 Phase 1 Strategy**

The event is initiated by a loss of offsite power coincident with the non-recoverable failure of the EDGs (i.e. initially appears as an SBO event). The reactor will scram automatically on loss of AC power. Following a reactor scram, steam generation will continue at a reduced rate due to core fission product decay heat. The main steam isolation valves and primary and secondary Containment Isolation Valves close. The main steam SRVs will automatically control reactor pressure. The reactor water level will drop due to continued steam generation from decay heat discharged to the Torus via the SRVs. The control room (CR) operators enter the EOPs and the SBO/ELAP procedure. The RCIC and HPCI system pumps automatically start on reaching low-low reactor water level (Level 2). The turbines for these pumps are driven with steam from the reactor. The steam exhausts from the RCIC or HPCI turbine to the Torus.

After determination that installed EDGs cannot be restarted and off-site power cannot be restored for a period greater than 60 minutes, the operating crew declares the event is an ELAP and enters the FSGs. It is assumed that ELAP declaration is made less than or equal to one hour into the event.

It is assumed that the CSTs are unavailable and that the RCIC suction is realigned to the Torus early in the event. In that alignment, the RCIC system is able to maintain adequate core cooling by providing the reactor with makeup, while steam flows through SRVs and the RCIC steam discharge to the Torus removing decay heat from the reactor.

The reactor will be depressurized and maintained within a pressure range of 150 to 300 psig using SRVs at a rate not to exceed 100°F per hour. This pressure range will facilitate long term RCIC operation.

The operator takes the following initial actions in accordance with the SBO/ELAP procedures:

- Open SRVs to control reactor pressure and feed the reactor using RCIC to maintain reactor level.

The operator will initiate reactor depressurization to the lower pressure band required for RCIC operation (150 to 300 psig). If emergency depressurization



## **Final Integrated Plan for Mitigating Strategies for Beyond-Design-Basis External Events and Reliable Spent Fuel Pool Instrumentation for Monticello Nuclear Generating Plant**

is required and RCIC is the only injection source to the reactor, the operator will depressurize the reactor, but stop the depressurization above 150 psig reactor pressure to maintain a steam supply to the RCIC turbine (see RCIC System – Section 3.1.4.1 for details).

Procedures and equipment currently exist and are staged to allow RCIC to be started locally in the event there is no electrical power available.

- Begin DC Load shedding to ensure DC power from the batteries is available until a portable generator is available to repower the battery chargers (See Electrical Systems – Section 3.1.4.5 for details),
- Bypass RCIC trips to ensure reliability of injection source for the event,
- Take actions to maximize RCIC room cooling, and
- Perform actions to address the loss of power to security doors.

The plant telephone system or sound powered phone system is used as necessary to maintain communications between personnel in the CR and in the plant.

### **3.1.2 Phase 2 Strategy**

The Phase 2 strategy transitions from permanently installed plant equipment to portable FLEX equipment designed to support BDBEE mitigation.

The Phase 2 FLEX strategy for reactor core cooling and heat removal provides an indefinite supply of water for feeding the RPV using the portable FLEX Pump capable of drawing water from the MNGP intake or discharge canal.

RPV makeup will be initiated within 11 hours of the ELAP/LUHS event using a FLEX Pump to replenish RCS inventory and re-establish RCS level in the RPV.

During Phase 1, RPV makeup is provided from RCIC and RPV pressure control is provided from RCIC and the SRVs. SRVs continue to maintain reactor pressure from 150 to 300 psig.

When RCIC operation is no longer possible, the operators will fully depressurize the reactor using the SRVs. A FLEX Pump is aligned to the RPV to maintain reactor water level. The FLEX pumps draw water from either the discharge canal or the plant intake (both considered ultimate heat sink), either ensures an indefinite supply of cooling water. The primary injection path is through a connection that has been added to the A Residual Heat Removal (RHR) loop via Residual Heat Removal Service Water (RHRSW) to deliver water to the RPV. See Figure 3.1.2-1 below for the primary injection path. Alternate paths are also available. See Figure 3.1.2-2 below for the alternate injection paths.

At the beginning of Phase 2, station batteries continue to supply power to RCIC and other required components.

**Final Integrated Plan  
for Mitigating Strategies for Beyond-Design-Basis External Events and  
Reliable Spent Fuel Pool Instrumentation  
for Monticello Nuclear Generating Plant**

Before the station batteries are no longer capable of supporting the equipment, a FLEX 480V Generator will be staged and started to repower the battery chargers to ensure a continuous DC power supply. The battery chargers were modified with connections to permit the FLEX 480V Generators to be plugged in. See Figure 3.1.2-3 below for the FLEX 480V Generator connection strategy.

FLEX 120V Generators are used to supply power for the following plant equipment:

- Plant Telephone System (after hour 12),
- Temporary ventilation (after hour 10) for the Battery Room, RCIC Room and the Main Control Room,
- Temporary heating or temporary ventilation for the Emergency Filtration Train (EFT) Building, and
- Temporary lighting, as needed.

# Final Integrated Plan for Mitigating Strategies for Beyond-Design-Basis External Events and Reliable Spent Fuel Pool Instrumentation for Monticello Nuclear Generating Plant

Figure 3.1.2-1

## Monticello FLEX Primary Water Delivery Strategy

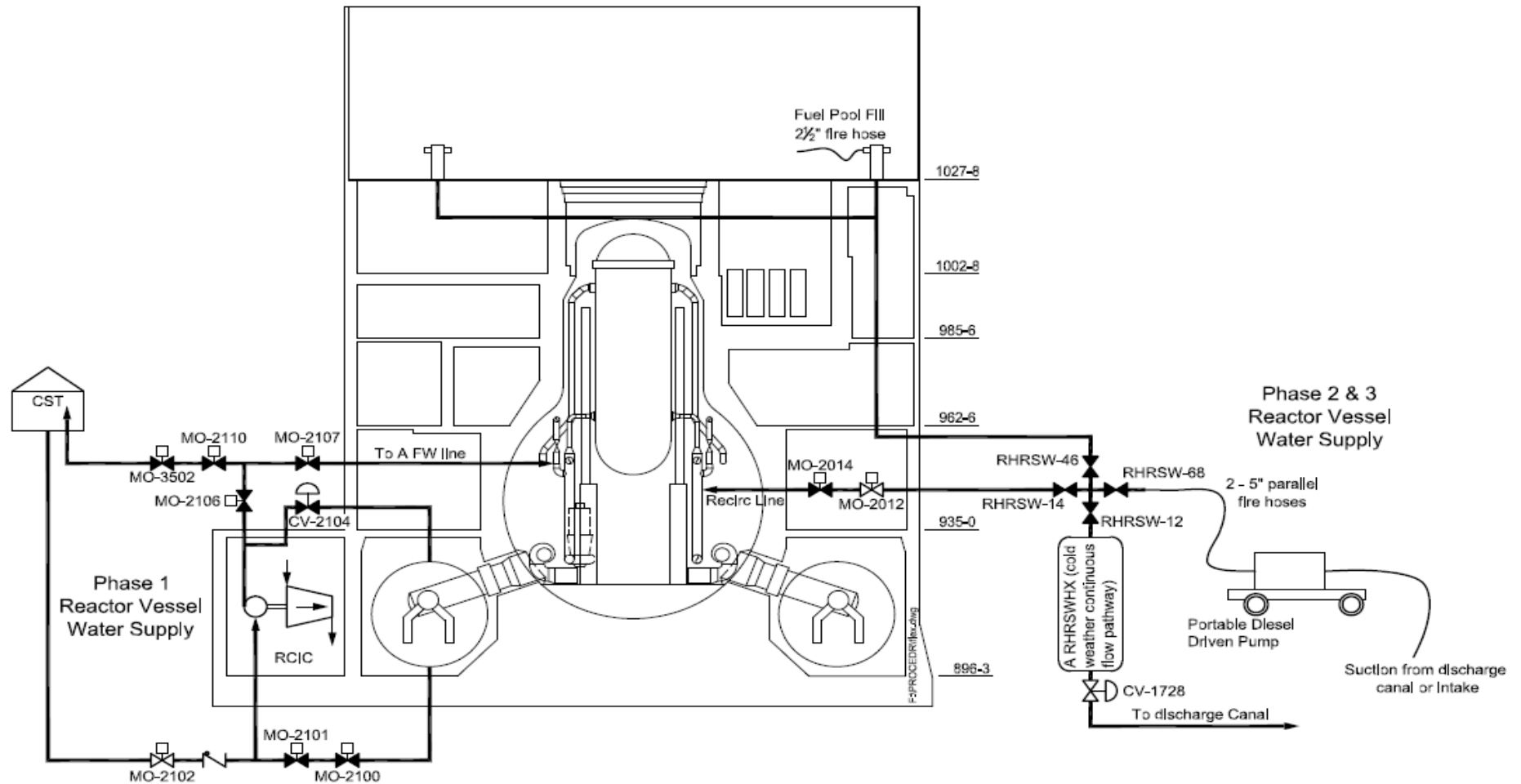

# Final Integrated Plan for Mitigating Strategies for Beyond-Design-Basis External Events and Reliable Spent Fuel Pool Instrumentation for Monticello Nuclear Generating Plant

Figure 3.1.2-2

## Monticello FLEX Alternate Water Delivery Strategy

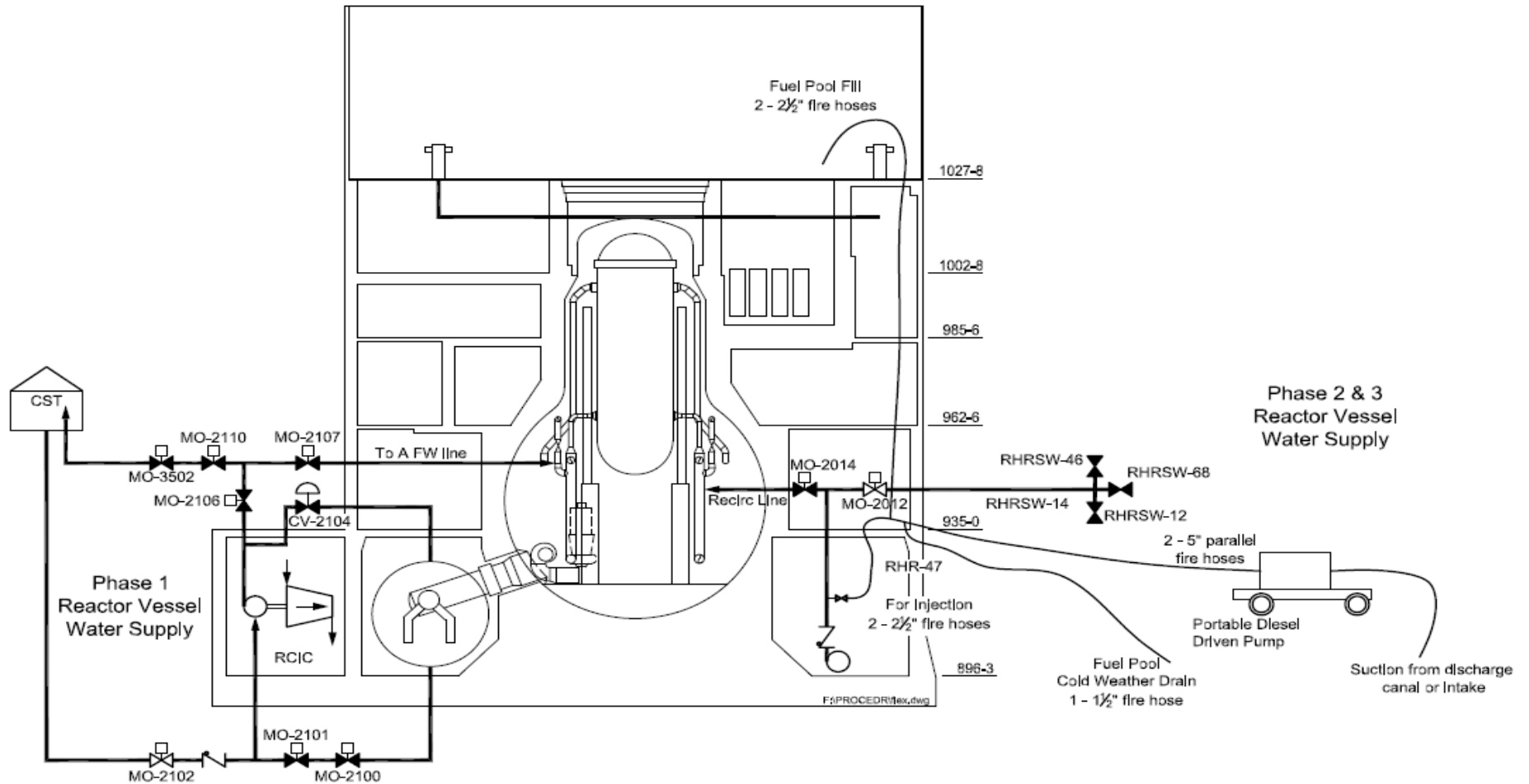

**Final Integrated Plan  
for Mitigating Strategies for Beyond-Design-Basis External Events and Reliable Spent Fuel Pool  
Instrumentation for Monticello Nuclear Generating Plant**

Figure 3.1.2-3

# Monticello FLEX 480 V Electrical Delivery Strategy

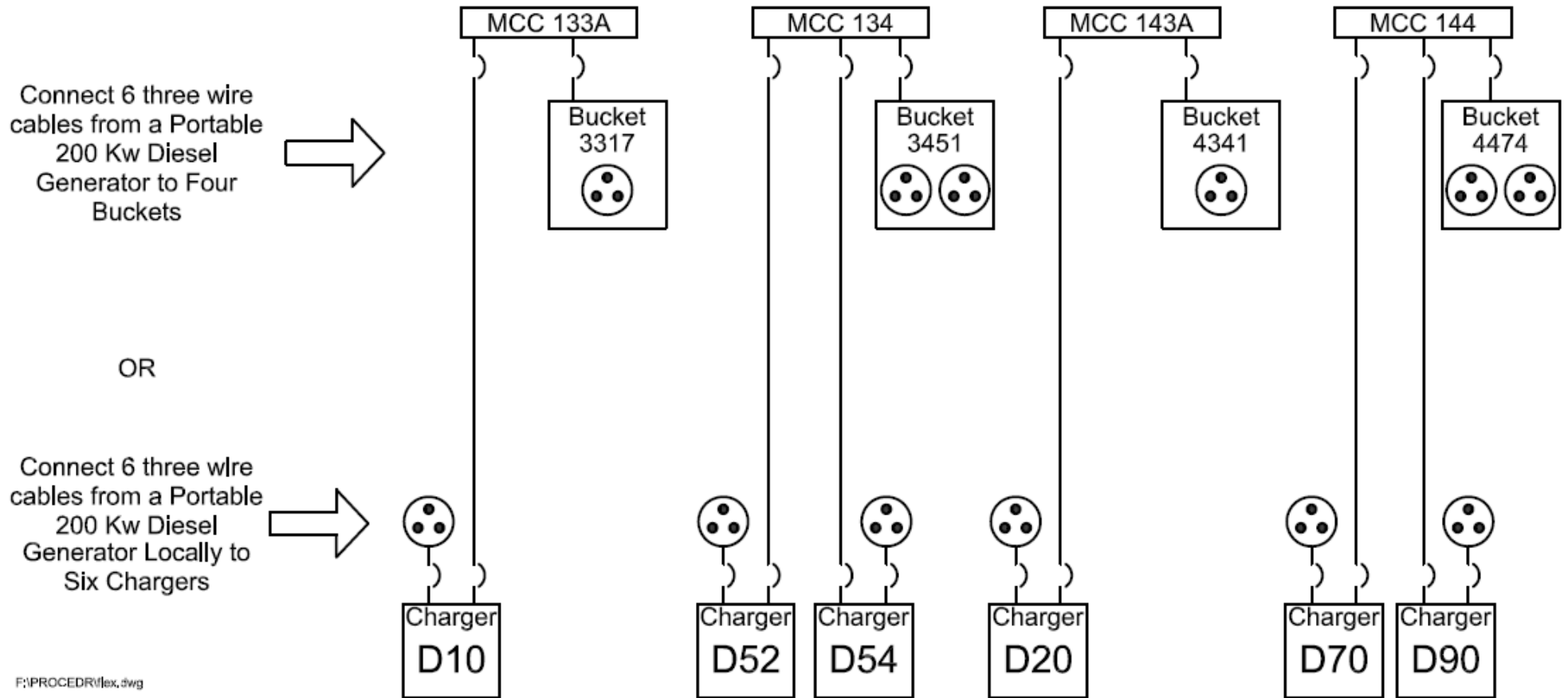

F:\PROCEDR\Flex.dwg

**Final Integrated Plan  
for Mitigating Strategies for Beyond-Design-Basis External Events and  
Reliable Spent Fuel Pool Instrumentation for Monticello Nuclear Generating  
Plant**

**3.1.3 Phase 3 Strategy**

The Phase 3 strategy for core cooling and decay heat removal includes additional equipment available from the National SAFER Response Center (NSRC) to provide backup to the FLEX Pumps, and the FLEX 480V Generators as well as other support equipment. Additionally, a water treatment system will be provided from the NSRC to provide a method to remove impurities from raw water supplies to the RPV.

Due to the multitude of possible damage scenarios and the availability of plant equipment, pre-planning of recovery actions for Phase 3 prior to the event is not practical. The Phase 3 strategy is to continue to use the Phase 2 strategy. Phase 2 equipment can continue to provide cooling and electrical power for an indefinite period. The Phase 3 equipment, from NSRC will act as backup or redundant equipment to the Phase 2 portable equipment and is deployed from an offsite facility and delivered to MNGP.

The Phase 3 equipment also includes the ability to repower a safeguard 4KV bus. Portable 4160 VAC generators will be provided from the NSRC in order to supply power to either of the two Class 1E 4KV buses. This would allow restoration of a 4KV pump to further cool down the RPV. The Phase 3 4KV generator would be connected to the plant through a spare breaker to energize the appropriate safeguards division. See Figure 3.1.3-1 for details. Additionally, by restoring the Class 1E 4KV bus, power can be restored to the Class 1E 480 VAC boards via the 4160/480 VAC transformers to power selected 480 VAC loads.

The off-site facility supplying this equipment is the NSRC through executed contractual agreements with Pooled Equipment Inventory Company (PEICo). The NSRC will support initial portable FLEX equipment delivery to the site within 24 hours of a request for deployment per the MNGP SAFER Response Plan (Reference 9). The MNGP SAFER Response Plan defines the actions necessary to deliver pre-specified equipment to MNGP. Designated local staging areas have been selected to support deliveries of requested SAFER equipment from the NSRC to MNGP. Resources will be available, and are sufficient, at the times required for Phase 3 implementation.

The emergency response organization will develop the appropriate recovery strategy using plant, FLEX and NSRC equipment.

**Final Integrated Plan  
for Mitigating Strategies for Beyond-Design-Basis External Events and  
Reliable Spent Fuel Pool Instrumentation for Monticello Nuclear Generating  
Plant**

**Figure 3.1.3-1**

**SAFER 4kV Electrical Generator Connections**

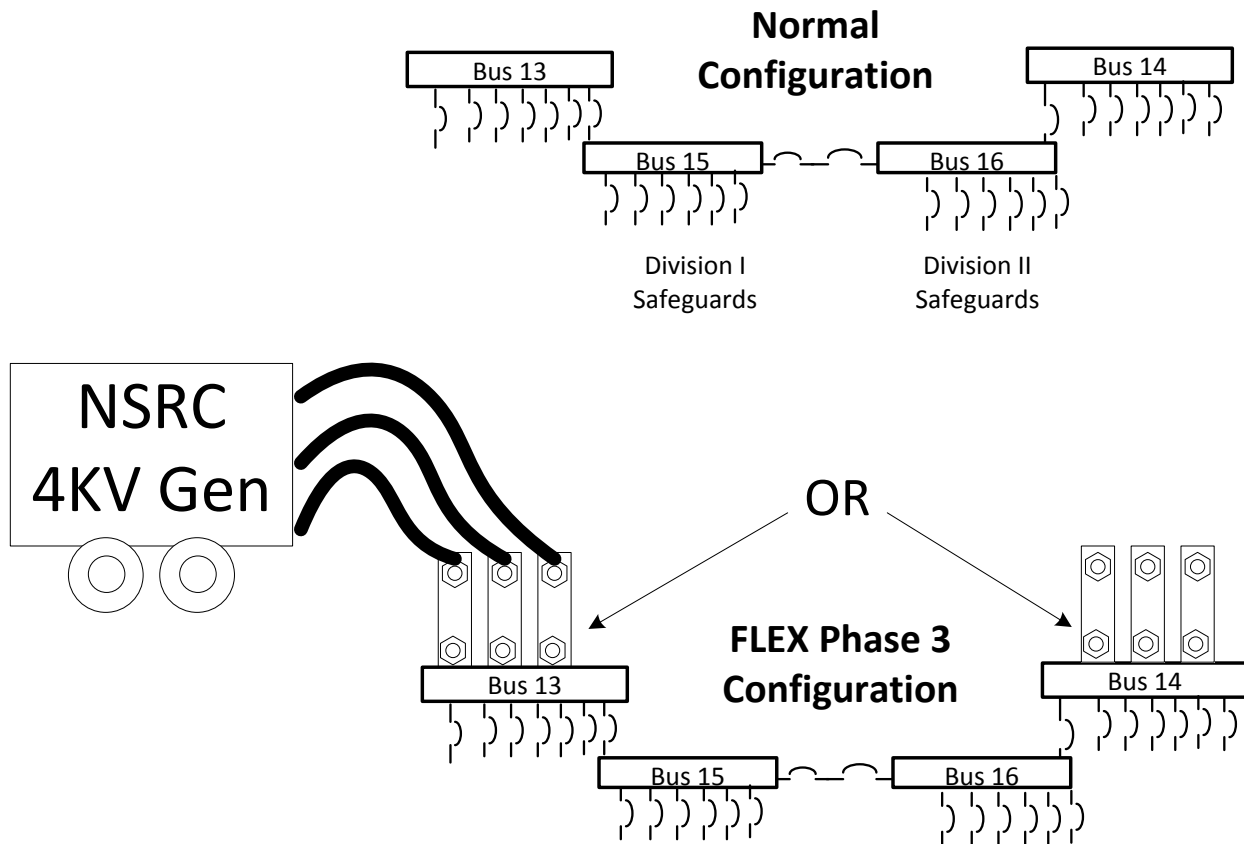

**3.1.4 Structures, Systems and Components**

This section describes the key permanently installed Structures, Systems and Components (SSCs) that are used to support the FLEX strategies described in Section 3.1. This section provides the bases and analyses used to determine the acceptability of the key SSCs that support the Reactor Core Cooling and Heat Removal strategy.

**3.1.4.1 Reactor Core Isolation Cooling (RCIC) System**

The RCIC system provides makeup water to the reactor vessel when the vessel is isolated. The RCIC system uses a steam-driven turbine-pump unit and operates with sufficient coolant flow to maintain adequate water level in the reactor vessel.

RCIC can take suction from the CST or Torus and is normally aligned to the CST. In the FLEX event, the CST is assumed to be unavailable (not qualified for

**Final Integrated Plan  
for Mitigating Strategies for Beyond-Design-Basis External Events and  
Reliable Spent Fuel Pool Instrumentation for Monticello Nuclear Generating  
Plant**

seismic or high wind events). RCIC suction is assumed to be realigned to the Torus. The RCIC pump is sized to deliver 400 gpm or more at a reactor pressure down to 150 psig.

Currently installed reactor level indication instrumentation is available to ensure adequate core cooling is provided.

The operator will initiate reactor depressurization to the lower pressure band required for RCIC operation (150 to 300 psig). If emergency depressurization is required and RCIC is the only injection source to the reactor, the operator will emergency depressurize the reactor, but stop the depressurization above 150 psig reactor pressure to maintain a steam supply to the RCIC turbine

RCIC net positive suction head available (NPSHa) is greater than the required NPSH for the flow rates necessary for continuous RCIC operation. The RCIC pump is sized to provide more than the design basis flow requirements and is located in a structure designed for protection from applicable design basis external hazards.

**3.1.4.2 Main Steam Safety/Relief Valves (SRVs)**

During an ELAP/LUHS event with the loss of all AC power and instrument air, reactor core cooling and decay heat will be removed from the RPV for an indefinite time period by manually opening/throttling the SRVs, which are equipped with backup air bottles. SRVs provide pressure relief for the reactor and discharge steam into the Torus. The SRVs are installed so that each valve discharge is piped through its own discharge line to a point below the minimum water level in the Torus to permit the steam to condense in the Torus. The SRVs are Safety-Related, missile protected, seismically qualified valves. The valves can be manually opened by solenoid valves which supply nitrogen gas to open the SRV. The AC solenoid valves are powered from the Safety-Related batteries.

If normal SRV operations are lost due to loss of AC power, then operations with two remaining SRVs can be maintained using the accumulators. Two SRVs (RV-2-71D and RV-2-71G) are provided with Safety-Related pneumatic accumulators which are charged by the Instrument Nitrogen or Instrument Air systems. The accumulators are located in the Drywell and configured into two separate banks of four accumulators each for a total of eight. Each bank is connected to its respective SRV pneumatic supply line between the SRV actuator solenoid valve(s) and check valve which isolates the Instrument Nitrogen and Instrument Air makeup supplies from the SRV.

The Monticello MAAP analysis show that reactor pressure is controlled with less than 100 SRV openings. The maximum Containment temperature is less than 300°F, ensuring SRV solenoid operability.



**Final Integrated Plan  
for Mitigating Strategies for Beyond-Design-Basis External Events and  
Reliable Spent Fuel Pool Instrumentation for Monticello Nuclear Generating  
Plant**

The reactor will be depressurized and maintained within a pressure range of 150 to 300 psig using SRVs at a rate not to exceed 100°F per hour. This pressure range is used to facilitate long term RCIC operation.

**3.1.4.3 Torus**

The Torus (also called suppression pool) is the heat sink for reactor vessel (MNGP Updated Safety Analysis Report (USAR) Sections 5.2.2.3 and 5.2.3.1) SRV discharges and RCIC turbine steam exhaust following a BDBEE. It is also the credited suction source for the RCIC pump for providing core cooling prior to transition to ELAP phase 2 (i.e. the first 10 - 11 hours after shutdown caused by the BDBEE). The CSTs are the preferred suction source. However, the CSTs may not be available after a seismic or tornado event, as the CSTs are not designed with protection for either event.

The design basis for the Torus is to initially serve as the heat sink for any postulated transient or accident condition in which the normal heat sink, main condenser, or Shutdown Cooling System is unavailable. Energy is transferred to the Torus by the discharge piping from the SRVs. The relief valve discharge piping is used as the energy transfer path for any condition which requires the operation of the relief valves.

The Torus receives this flow, condenses the steam portion of this flow, and releases the non-condensable gases and any fission products not removed by the water to the Torus air space. The condensed steam and any water carryover cause an increase in Torus volume and temperature. Energy can be removed from the Torus when the Residual Heat Removal System (RHR) is operating in the suppression pool cooling mode. During a BDBEE energy is removed from the Torus by utilization of the HPV System which vents the Torus to the atmosphere.

The water level and temperature of the Torus are continuously displayed in the main CR. Torus water level is provided at the Alternate Shutdown System (ASDS) Panel.

**3.1.4.4 Hard Pipe Vent System**

The HPV System consists of an 8 inch pipe off the top of the Torus. Two air operated valves provide Containment isolation. The air operated valves are spring to close and opened by a dedicated pneumatic system via solenoid valves. The DC solenoid valves are powered from dedicated batteries. Downstream of the Containment isolation valves, the pipe increases to a 10 inch pipe. A rupture disc provides secondary Containment Isolation. Another dedicated HPV pneumatic system is used to rupture the rupture disc. The vent line exits the plant buildings, up the outside of the reactor building to a point above the top of the reactor building.

## **Final Integrated Plan for Mitigating Strategies for Beyond-Design-Basis External Events and Reliable Spent Fuel Pool Instrumentation for Monticello Nuclear Generating Plant**

The system is operated at the ASDS panel. The portion of the HPV system as it comes out the HPCI building roof up to 30 ft above grade is protected from tornado missiles.

The HPV system is used to vent non-condensable gases and steam out of the Torus to the atmosphere. Procedures direct the operator to begin the containment venting when the Containment Pressure is  $\geq 10$  psig and the suppression pool temperature is  $\geq 212^\circ\text{F}$ . HPV is closed if drywell pressure drops to 5 psig. Venting is repeated as necessary throughout the ELAP event.

### **3.1.4.5 Electrical Systems**

The ELAP event assumes that a complete loss of all AC power sources occurs on the site, except for those derived from inverted DC systems.

The batteries and associated DC distribution systems support FLEX operations by powering the SRVs, RCIC, the HPV System, the telephone system and instrumentation needed for FLEX.

The safety related batteries and associated DC distribution systems are located within safety related structures designed to meet applicable design basis external hazards and will be used to initially power required key instrumentation and applicable DC components.

The shift manager will declare an ELAP event has occurred, by procedure, within 60 minutes of the event occurring. Once the declaration is made, load shedding will be performed on the Division I and Division II station batteries to extend the time station batteries can be used to operate equipment and instruments used to provide core cooling. The battery calculations have been performed using the remaining loads to demonstrate that the batteries life was extended to 12 hours.

When an ELAP is declared, the DC load shed is completed within 2 hours<sup>1</sup> from the onset of the event. Within 11 hours the batteries are re-powered using the FLEX 480V Generator.

Safety-Related battery (Division 1 and II 125VDC and 250 VDC batteries) coping time was calculated in accordance with IEEE-485 methodology using manufacturer published data for Safety-Related cells as outlined in the NEI white paper on *Battery Life Issues* and endorsed by the NRC (Reference 10). A 12 hour coping time was determined from the calculations. Non-Safety-Related battery (Battery D7 used for communications) coping time was calculated in accordance with IEEE-485 methodology using manufacturer published data with manufacturer recommended extrapolation from 8 to 12 hours.

---

<sup>1</sup> The one exception is that the Emergency Seal Oil Pump remains in operation to support main generator purging. This load will be shed in hour six.

**Final Integrated Plan  
for Mitigating Strategies for Beyond-Design-Basis External Events and  
Reliable Spent Fuel Pool Instrumentation for Monticello Nuclear Generating  
Plant**

During Phase 2 each battery will be recharged from its associated battery charger. The battery chargers will be repowered by a FLEX 480V Generator output being connected to the battery charger (or its associated Motor Control Center (MCC)).

Each station battery charger required following an ELAP event was modified to install a 480V receptacle and an input breaker for the receptacle. A mechanical interlock was added to each battery charger that allows either the normal AC input breaker to be closed or the input breaker from the 480V receptacle to be closed, but not both. With only one input breaker closed, the 480V receptacle is isolated from the normal AC input to the battery charger.

If access to the battery chargers is not available, the FLEX 480V Generator is used to supply the associated MCC. The procedures provide instructions for connecting the FLEX 480V Generator to the associated MCC. In each case, prior to connecting the FLEX 480V Generator to the MCC, the MCC feeder breaker at the Load Center is verified to be in the OPEN position.

In Phase 3, the 480V generator supplied from the NSRC will be used as a backup to the Phase 2, FLEX 480V Generators. It is not necessary to remove a Phase 2 generator from service to install the Phase 3 generator. It is only necessary to keep refueling the Phase 2 generators. For this reason, the Phase 3 generator is considered a further backup to the Phase 2 generators.

Hydrogen generation in the battery rooms was found to be acceptable without the battery room exhaust fan running for the first 24 hours.

**3.1.4.6 Pneumatic Supply**

The AN2 system is a Safety-Related backup automatic pneumatic supply pressure to the SRV actuators upon loss of the Instrument Nitrogen System. The AN2 system has two trains, A and B, which ensures that redundant SRVs will be available in an event.

During an ELAP event, the AN2 system will provide a pneumatic supply to the SRVs for at least 25 hours using installed nitrogen bottles. After that nitrogen bottles will need to be replaced. The HPV System (used for FLEX venting) has its own pneumatic system that supports its operation. The HPV pneumatic system has been determined to support at least 24 hours of operation of the HPV system.

Spare N<sub>2</sub> bottles are available and will be used to ensure a continuous supply of nitrogen to operate needed SRVs and the HPV system. Operators monitor nitrogen status every six hours.

**Final Integrated Plan  
for Mitigating Strategies for Beyond-Design-Basis External Events and  
Reliable Spent Fuel Pool Instrumentation for Monticello Nuclear Generating  
Plant**

### **3.1.5 FLEX Strategy Connections**

#### ***3.1.5.1 Connection for Cooling Water Supply to the Reactor***

The primary FLEX coolant connection is located in the RHR to RHRSW crosstie line in the Turbine Building (See Figure 3.1.2-1). Flexible hoses will be routed from the FLEX Pump discharge to the primary RPV cooling water connection (RHRSW-68) located inside the Turbine Building. Flow to the RPV will be manually controlled by operating hose manifold valves and reading flow indications on the attached flow meter. Hydraulic analysis of the flow path from the FLEX Pump connection to the primary RPV cooling water connection has confirmed that applicable performance requirements are met. This connection is located in a seismically robust structure (Class I).

#### ***3.1.5.2 Alternate Connection for Cooling Water Supply to the Reactor***

In the event that the primary RPV cooling water connection is not available, an alternate connection location is provided. Flexible hoses will be routed from the FLEX Pump discharge to the alternate RPV cooling water connection in the Division I RHR room in the Reactor Building (RHR-47) (See Figure 3.1.2-2). Flow to the RPV will be manually controlled by operating hose manifold valves and reading flow indications on the attached flow meter. Hydraulic analysis of the flow path from the FLEX Pump connection to the alternate RPV cooling water connection has confirmed that applicable performance requirements are met. This connection is located in a seismically robust structure (Class I).

#### ***3.1.5.3 Tertiary Connection for Cooling Water Supply to the Reactor***

In the event that the primary and alternate RPV cooling water connections are not available, a third option exists to connect to the Fire System at the 12 Cooling Tower. A flexible hose will be routed from the FLEX Pump located at the discharge canal to the Fire System connection near the north end of 12 Cooling Tower. Flow is controlled by opening Fire System Header valve FP-24 and reading flow indications on the attached flow meter. Hydraulic analysis of the flow path from the FLEX Pump connection to the alternate RPV cooling water connection has confirmed that applicable performance requirements are met.

#### ***3.1.5.4 Primary 480 Volt Electrical Connections***

The primary 480V connection points are located near the Safety-Related battery chargers. A modification was performed which added an inlet receptacle near each of the Safety-Related battery chargers; D10, D20, D52, D54, D70 and D90 (See Figure 3.1.2-3). Each receptacle is connected via conduit and cable to a breaker installed in each battery charger to receive power from the FLEX 480V Generator. The 480VAC inlet receptacle circuits will provide the means to re-power the 125VDC / 250VDC battery chargers from a FLEX 480V Generator in support of Phase II of the MNGP FLEX strategy. The receptacles, cabling and

## **Final Integrated Plan for Mitigating Strategies for Beyond-Design-Basis External Events and Reliable Spent Fuel Pool Instrumentation for Monticello Nuclear Generating Plant**

connections are installed seismically and are located in a seismically robust structure which also provides protection from missiles, flood, snow and ice.

### ***3.1.5.5 Alternate 480 Volt Electrical Connections***

The alternate 480V connection is located at the MCCs that feed the battery chargers. Using the safety related MCCs connected to safety related battery chargers D10, D20, D52, D54, D70 and D90, modified spare breaker connections were fabricated to be able to connect the MCCs to FLEX 480V Generator (See Figure 3.1.2-3). Each receptacle uses a spare breaker connection in the MCC to backfeed the associated battery charger. Each connection will receive power from the FLEX 480V Generator. The MCC spare breaker circuits will provide the means to re-power the 125VDC / 250VDC battery chargers from FLEX 480V Generator in support of Phase II of the MNGP FLEX strategy. The MCCs are installed seismically and are located in a seismically robust structure which also provides protection from missiles, flood, snow and ice.

### ***3.1.5.6 4160V Electrical Connections***

Two (2) 1-MW 4160V Generators and one 4160V Distribution Panel will be delivered to the site from the NSRC in order to meet the required Phase 3, 4160V load requirements for MNGP. Modifications have been made to switchgear cubicles 152-304 and 152-404 to connect the 4160V Generators to the plant switchgear (See Figure 3.1.3-1). The 4160V Generators will be used to power one division of essential power to support continued core cooling functions.

Due to the multitude of possible damage scenarios and the availability of plant equipment, pre-planning of recovery actions for Phase 3 prior to the event is not practical. The MNGP Emergency Response Organization (ERO) will need to develop plans for deployment and priorities for restoration of plant systems.

## **3.1.6 Key Parameters**

### ***3.1.6.1 Reactor Vessel Essential Instrumentation:***

Instrumentation providing the following key parameters is credited for all phases of the reactor core cooling and decay heat removal strategy:

- LT-2-3-85A/B – RPV Level instrumentation is available in the control room.
- LT-2-3-112A/B – RPV Level instrumentation is available in the control room and the ASDS panel.
- LT-2-3-61 – RPV Level instrumentation is available in the control room and the ASDS panel.
- PT-6-53A/B – RPV Pressure instrumentation is available on the ASDS Panel.

Portable FLEX equipment is supplied with the local instrumentation needed to operate the equipment. The use of these instruments is detailed in the associated

## **Final Integrated Plan for Mitigating Strategies for Beyond-Design-Basis External Events and Reliable Spent Fuel Pool Instrumentation for Monticello Nuclear Generating Plant**

FSGs for use of the equipment. These procedures are based on inputs from the equipment suppliers, operating experience, and expected equipment function in an ELAP event.

### **3.1.7 Thermal Hydraulic Analyses**

#### **3.1.7.1 MAAP Analysis**

The MNGP FLEX Strategy Timeline is based on a detailed evaluation using a comprehensive Modular Accident Analysis Program (MAAP4) Analysis performed to provide validation of the assumptions and steps in the FLEX Strategy Timeline.

MAAP Analysis results are used as input for other analyses such as GOTHIC.

The Reactor Core Cooling and Heat Removal strategy results show that:

- RPV water level remains above the top of active fuel (TAF)
- Torus temperature reaches 250°F in approximately 11.5 hours
- Torus temperature decreases after reaching ~250°F
- Torus Level does not need water addition or removal for at least 48 hours while maintaining the HPV System functional
- Drywell Temperature does not exceed the SRV solenoid operating temperature
- Containment pressure does not exceed the design pressure
- RCIC supplemented with the FLEX pump ensures core cooling

A net positive suction head evaluation was performed for RCIC operation when drawing from the Torus. Once the nitrogen is vented from the Torus, RCIC flow needs to remain below ~ 300 gpm to ensure sufficient net positive suction head is available.

#### **3.1.7.2 Reactor Coolant System Losses**

Sources of water loss from the reactor coolant system, other than steam to the SRVs and RCIC/HPCI operation, are reactor recirculation pump seal leakage due to the event and existing identified/unidentified leakage existing prior to the event. MAAP analyses assumed a range of leakages between 30 and 165 gpm. The maximum leakage from the failure of both seals for each reactor recirculation pump is 70 gpm. The maximum leakage for both reactor recirculation pumps plus the TS primary system boundary leakage of 25 gpm, equals a total primary system leakage of up to 165 gpm.

The RCIC system or the FLEX pumps will provide sufficient cooling flow to make-up for any reactor coolant lost in addition to maintaining sufficient reactor coolant in the reactor.

**Final Integrated Plan  
for Mitigating Strategies for Beyond-Design-Basis External Events and  
Reliable Spent Fuel Pool Instrumentation for Monticello Nuclear Generating  
Plant**

**3.1.7.3 RCIC Pump Performance**

BWROG documentation (Reference 11), supported by RCIC operation at Fukushima Unit 2 for approximately 70 hours, support RCIC operation with a Torus temperature up to 250°F when run in a continuous mode. As shown at Fukushima Unit 2, RCIC supplied water to the reactor with a Torus temperature up to 300°F. Based on this, the MNGP analysis determined that RCIC operation is assumed to be unavailable when the torus temperature reaches 250°F.

In the Monticello MAAP analysis, the Torus reaches approximately 250°F in 11.5 hours from the beginning of the ELAP. The FLEX pump will be available for injecting cooling water just after 10 hours. Procedures direct the FLEX portable diesel pump to be used, when RCIC is no longer available and when the FLEX portable diesel pump is available for injection.

**3.1.8 FLEX Pump and Water Supplies****3.1.8.1 FLEX Pumps**

One portable diesel-driven pump is available in all BDBEE scenarios to deliver cooling water to the reactor when RCIC is no longer functional. Two portable diesel-driven pumps (P-506 and P-507) are stored on-site. Each pump is rated for a maximum flow of 1000 gpm and discharge head of 455 ft.

The FLEX pump is a trailer-mounted, diesel driven, centrifugal pump that is stored in one of the BDBEE Storage Buildings. The pump is deployed by towing the trailer to a designated draft location near the selected water source. One FLEX pump is required to implement the reactor core cooling and heat removal strategy. Two FLEX pumps are available to satisfy the N+1 requirement.

Analysis has shown that the FLEX pump will be able to add the water necessary to maintain constant reactor water level when RCIC is not available. The FLEX pumps have been sized such that injection into the RPV and SFP can occur simultaneously (through throttling). Sufficient pump suction and discharge head has been determined for each pumping and injection configuration. A calculation confirmed that a minimum of 300 gpm of makeup water can be delivered to the RPV simultaneously with makeup water (200 gpm) supplied to the SFP. Flow paths to both the RPV and SFP are through a combination of existing piping systems RHR, RHRSW, Fuel Pool Cooling (FPC), and Fire Protection (FP) and interconnecting hoses in conjunction with a FLEX pump.

The pumps will be staged and ready for use prior to 11 hours after the onset of the event.

**Final Integrated Plan  
for Mitigating Strategies for Beyond-Design-Basis External Events and  
Reliable Spent Fuel Pool Instrumentation for Monticello Nuclear Generating  
Plant**

**3.1.8.2 Water Sources**

The water supplies for the FLEX Pump are the MNGP intake and discharge canal – the Ultimate Heat Sink sources – and the Condensate Storage Tanks (CSTs). See Section 8.4 for details.

**3.1.9 Electrical Analysis**

The Class 1E battery duty cycle of 12 hours for MNGP was calculated in accordance with the IEEE-485 methodology using manufacturer discharge test data applicable to the FLEX strategy as outlined in the NEI white paper on Extended Battery Duty Cycles (Reference 10). The time margin between the calculated battery duration for the FLEX strategy and the expected deployment time for FLEX equipment to supply the DC loads is approximately one hour for MNGP.

The strategy to re-power the stations vital AC/DC buses requires the use of diesel powered generators. For this purpose, MNGP requires one FLEX 480V Generator as the re-powering option. In addition one FLEX 120V Generator is used to support temporary ventilation, portable heaters (if required), temporary lighting and communications.

The FLEX 480V Generators (G-506 and G-507) are 200 KW (182 kW continuous rating), 3-phase generators that are trailer mounted with a 350 gallon diesel fuel tank built into the trailer. One portable 480V, 3-phase, diesel-driven generator is available beginning in Phase 2 for all BDBEE scenarios to repower the Safety-Related battery chargers. Two portable 480V FLEX Generators are stored on-site. Repowering the Safety-Related battery chargers will maintain continuous availability of the Division I 125V and 250V batteries as well as the Division II 125V and 250V batteries.

The 480V FLEX Generator has a capability to generate 182 KW continuous rating and is sufficient to supply the necessary chargers for the 125V and 250V batteries when the chargers are current limited. The engineering evaluation determined that a generator with a continuous rating in the range of 175 kW and 200 kW is recommended.

The FLEX 120V Generators (G-101 and G-102) are 12 KW, single phase, 60Hz generators that are trailer-mounted with a 56 gallon double-walled diesel fuel tank built into the trailer. One portable 120V, single-phase, 12 Kw diesel-driven-generator is available beginning in Phase 2 for all scenarios to repower portable lights, portable fans, portable heaters and the telephone system service in the power block. Two portable FLEX 120V Generators are stored on-site.

Additional replacement 480V generators and 4160 V generators are available from the NSRC for the Phase 3 strategy. The specifications and ratings for this equipment are listed in Table 6.2-1.



## **Final Integrated Plan for Mitigating Strategies for Beyond-Design-Basis External Events and Reliable Spent Fuel Pool Instrumentation for Monticello Nuclear Generating Plant**

Calculations show that the FLEX 480V Generators have ample capacity to supply the six battery chargers described in Section 3.1.5.4. The two, 1 MWe, 4kV NSRC generators have ample capacity to supply one RHR pump, one RHRSW pump, related valves, and miscellaneous required loads when the NSRC generators are connected in parallel.

### **3.2 Spent Fuel Pool (SFP) Cooling/Inventory**

The MNGP SFP is a wet spent-fuel storage facility located on the top floor of the MNGP Reactor Building inside the Secondary Containment. It provides specially designed underwater storage space for the reactor spent fuel assemblies which require shielding and cooling during storage and handling. Normal makeup water source to the SFP is from Condensate System via the Fuel Pool Cooling System.

The basic FLEX strategy for maintaining SFP cooling is to monitor SFP level and provide makeup water to the SFP sufficient to maintain substantial radiation shielding for a person standing on the SFP operating deck and cooling for the spent fuel. The strategy for all phases for spent fuel pool cooling includes monitoring spent fuel pool level using the instrumentation installed as required by NRC Order EA-12-051 (Reference 5).

#### **3.2.1 Phase 1 Strategy**

Evaluations estimate that with no operator action following a loss of SFP cooling at the normal heat load ( $5.55 \times 10^6$  Btu/hr) for the Spent Fuel Pool (SFP), the SFP will reach 212°F in approximately 36.9 hours, and the evaporation rate would be 11.9 gpm (715 gal/hr). The Spent Fuel Pool has 7,769 gallons per foot of depth. Once boiling begins, it would take more than 20 hours for the SFP level to drop by less than two feet.

Based on the above information, there are no Phase 1 actions required. The Phase 1 coping strategy for spent fuel pool cooling and makeup is to monitor spent fuel pool level using instrumentation installed as required by NRC Order EA-12-051 (Reference 5).

#### **3.2.2 Phase 2 Strategy**

As noted in Phase 1 section above, the SFP level would drop by less than two feet in approximately 57 hours (36.9 hours to boiling plus 20 hours to drop two feet). Therefore, makeup is not necessary for the SFP for at least 57 hours.

The FLEX pump staged for providing water to the reactor to maintain core cooling also has the capacity to maintain SFP level. The FLEX Pump would be deployed from either of the BDBEE Storage Buildings to either the discharge canal or the intake (Figure 5.2.1-1). The discharge of the pump would be connected to the SFP makeup hose connection outside of the Reactor Building (Figure 5.2.1-1).

**Final Integrated Plan  
for Mitigating Strategies for Beyond-Design-Basis External Events and  
Reliable Spent Fuel Pool Instrumentation for Monticello Nuclear Generating  
Plant**

See Section 3.2.4 for a complete description of the SFP deployment paths and options.

Required hose lengths and fittings are also located in the BDBEE Storage Buildings. The FLEX Pump is trailer mounted and will be towed to the predetermined deployment position, along with the necessary hoses and fittings, by tow vehicles also located within the protected BDBEE Storage Buildings.

See Figure 3.2.3-1 for the FLEX SFP injection paths.

**3.2.3 Phase 3 Strategy**

For Phase 3, one of the FLEX Pumps used in Phase 2 will continue to be used as the primary pump for makeup water to the SFP, as well as maintain reactor water level. The NSRC will provide an additional diesel driven pump that will be used to back up the FLEX Pump.

# Final Integrated Plan for Mitigating Strategies for Beyond-Design-Basis External Events and Reliable Spent Fuel Pool Instrumentation for Monticello Nuclear Generating Plant

Figure 3.2.3-1

## Monticello FLEX SFP Water Delivery Strategy

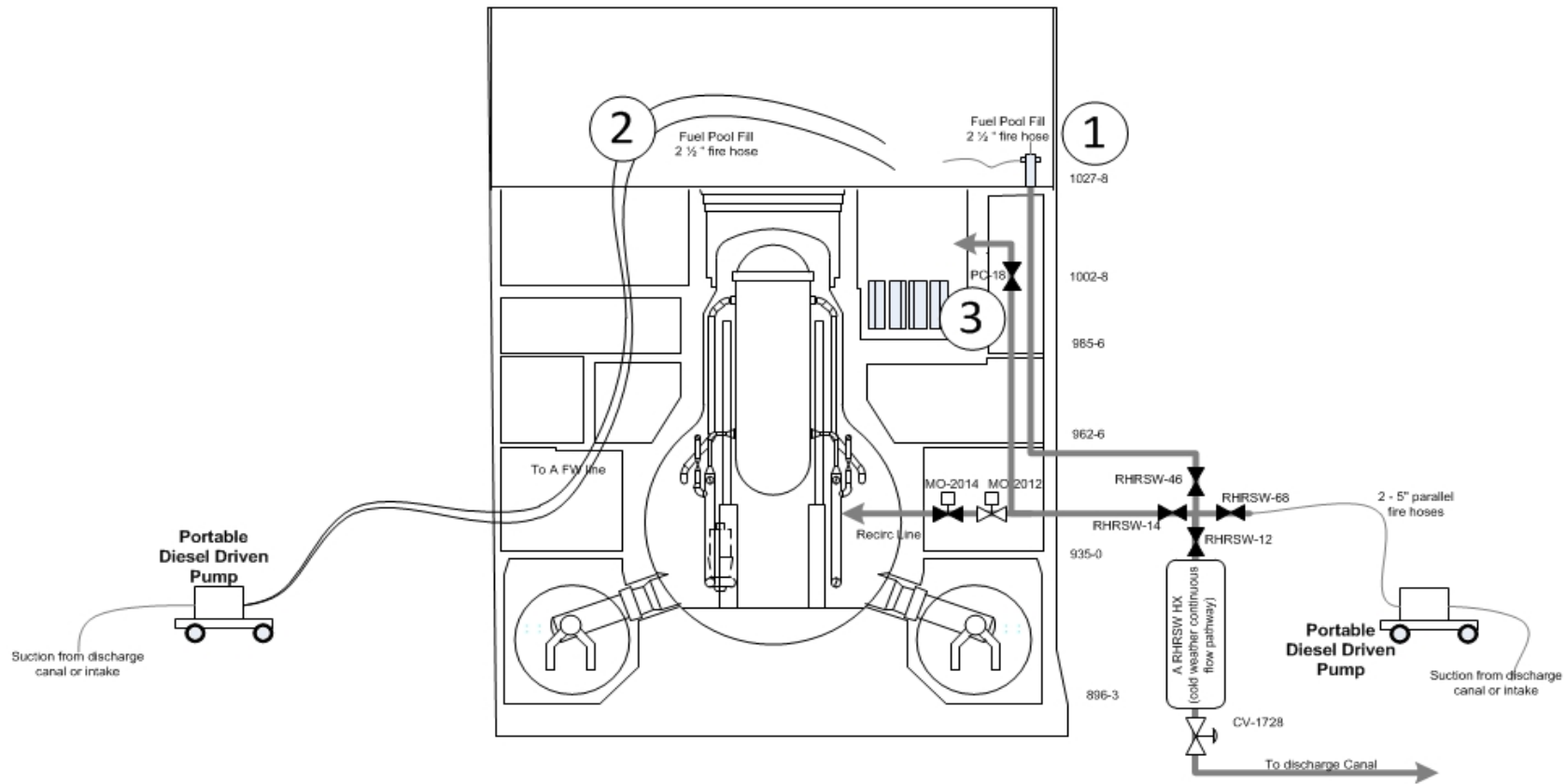

Valve position is show in normal-at-power line-up

**Final Integrated Plan  
for Mitigating Strategies for Beyond-Design-Basis External Events and  
Reliable Spent Fuel Pool Instrumentation  
for Monticello Nuclear Generating Plant**

### **3.2.4 Structures, Systems and Components**

If the SFP is damaged or a considerable amount of water is lost due to sloshing during a seismic event, three specific paths have been assessed for providing makeup to the SFP.

- Path 1 routes a fire hose from a FLEX portable diesel driven pump to the FLEX connection (see Figure 3.2.3-1) at RHRSW-68 to the refueling floor fire hose station located near the SFP. From the local fire hose stations, water can be supplied to the SFP.
- Path 2 routes a fire hose directly from a FLEX portable diesel driven pump up the equipment hatch to the refueling floor. From there, the hose can be supplied to the SFP.
- Path 3 routes a fire hose directly from a FLEX portable diesel driven pump supplies water through RHRSW-68 to RHRSW-14 to fill the SFP directly using the RHR to SFP emergency return line.

#### **3.2.4.1 Primary Connection**

Path 1 - The primary connection for the SFP makeup is located in the MNGP Turbine Building (TB), utilizing the RHRSW-68 FLEX connection that is used for the Reactor Cooling strategy. From RHRSW-68 flow is directed to the fire header on the refueling floor by opening RHRSW-46. The fire header connects to the seven fire hose stations on the refuel floor. From the fire hose stations, at least two, 1 ½" fire hoses are used to refill the SFP. The FLEX SFP makeup connection is sufficiently sized to restore SFP level long-term after the loss of SFP cooling at a makeup rate of 200 gpm of makeup water for SFP boil off.

#### **3.2.4.2 Alternate Connection**

Path 2 – The alternate connection for SFP refilling is to route hoses from the FLEX pump into the reactor building railway and up the equipment hatch directly to the refuel floor. Two, 2 ½" hoses are routed from the 5" hose manifold located outside the Reactor Building (RB). This path utilizes no permanently installed plant equipment. The FLEX SFP makeup connection is sufficiently sized to restore SFP level long-term after the loss of SFP cooling at a makeup rate of 200 gpm of makeup water for SFP boil off.

#### **3.2.4.3 Tertiary Connection**

Path 3 – The tertiary connection for SFP refilling is located in the MNGP TB, utilizing the RHRSW-68 FLEX connection that is used for the Reactor Cooling strategy. From RHRSW-68, flow is directed to the SFP emergency return line connection by opening RHRSW-14 and PC-18. The advantage of this path is that no entry to the refueling floor is required to make initial connections or throttle the flow to the SFP. The FLEX SFP makeup connection is sufficiently sized to restore

**Final Integrated Plan  
for Mitigating Strategies for Beyond-Design-Basis External Events and  
Reliable Spent Fuel Pool Instrumentation  
for Monticello Nuclear Generating Plant**

SFP level long-term after the loss of SFP cooling at a makeup rate of 200 gpm of makeup water for SFP boil off.

#### ***3.2.4.4 Spray Option***

The SFP cooling strategies do not include a spray capability via portable monitor nozzles from refueling floor using FLEX Pump. While the spray capability was included in the MNGP Overall Integrated Plan for compliance with Order EA-12-049, the requirement for this capability was removed consistent with NRC endorsed NEI guidance contained in NEI 12-06, Revision 2. In Reference 28 NSPM provided an analysis that confirmed that the MNGP SFP is seismically adequate in accordance with NTTF 2.1 Seismic evaluation criteria.

#### ***3.2.4.5 SFP Area Ventilation***

Ventilation requirements to prevent excessive steam accumulation on the Refuel floor are included in the FSGs. The FSGs direct operators to disconnect and open four Refuel floor dampers and operators are directed to open up the Reactor Building Railroad doors to establish a natural circulation flow path. Airflow through these dampers and doors provides adequate vent pathways through which steam generated by SFP boiling can exit the Refuel Floor. The FSGs also provide additional guidance to open other doors to further enhance the natural circulation.

### **3.2.5 Key Parameters**

#### ***3.2.5.1 Spent Fuel Pool Essential Instrumentation:***

The key parameter for the SFP Make-up strategy is the SFP water level. The SFP water level is monitored by the instrumentation that has been installed in response to Order EA-12-051, Reliable Spent Fuel Pool level Instrumentation (Reference 5) and complies with the industry guidance provided by the Nuclear Energy Institute guidance document NEI 12-02 (Reference 6). Instrumentation providing the following key parameters is credited for all phases of the SFP cooling strategy:

- Spent Fuel Pool Level: LI-2789A and LI-2789B

NSPM installed two MOHR Test and Measurement LLC (MOHR), independent, wide range level monitors in the MNGP SFP to meet Order EA-12-051. Each monitor train consists of a Signal Processor, Battery Enclosure, and Level Probe Assembly.

The SFP levels of interest are listed below. These are not setpoints, but instead are meant to correlate the indicated water levels to the amount of coverage of fuel assemblies in the pool.

- Level 1 - This is the level that is adequate to support operation of the normal fuel pool cooling system. At MNGP, Level 1 represents a water level of 37'-3"

**Final Integrated Plan  
for Mitigating Strategies for Beyond-Design-Basis External Events and  
Reliable Spent Fuel Pool Instrumentation  
for Monticello Nuclear Generating Plant**

in the SFP. This corresponds to a water level that is 22'-6" above the top of the SFP rack.

- Level 2 - This is the level that is adequate to provide substantial radiation shielding for a person standing on the spent fuel pool operating deck. NEI 12-02 indicates that selection of 10 feet between level 2 and the highest point of any fuel rack assures a range of water level where any necessary operations in the vicinity of the spent fuel pool can be completed without significant dose consequences from direct gamma radiation from the stored spent fuel. At MNGP, Level 2 represents a water level of 24'-9" in the SFP. This corresponds to a water level that is 10'-0" above the top of the SFP rack.
- Level 3 - This is the level where fuel remains covered and actions to implement make-up water addition should no longer be deferred. At MNGP, Level 3 corresponds to a water level of 15'-3" in the SFP. This corresponds to a water level that is approximately 6" above the top of the SFP rack. This level meets NEI 12-02 criteria which require that Level 3 be nominally +/- 1 foot from the highest point of any fuel rack seated in the SFP.

SFP Level instruments can be read in the CR or in the ASDS Panel area. Qualification of the instrumentation and further details on the design, operation and maintenance of the instruments can be found in Reference 12. See Figure 3.2.5.1-1 for further information.

**Final Integrated Plan  
for Mitigating Strategies for Beyond-Design-Basis External Events and  
Reliable Spent Fuel Pool Instrumentation  
for Monticello Nuclear Generating Plant**

**Figure 3.2.5.1-1**

**Spent Fuel Pool Instrument Levels**

(not to scale)

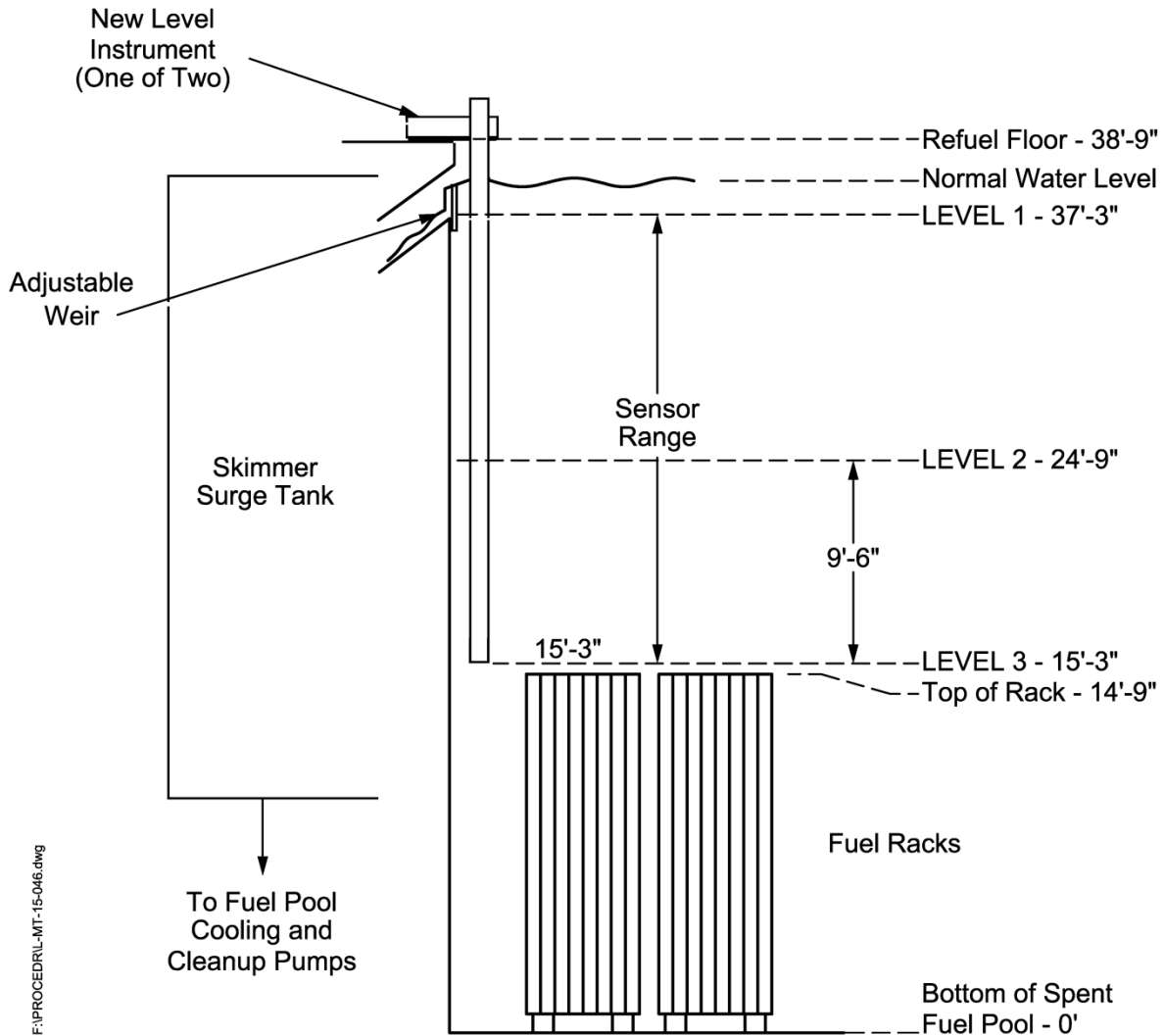

**3.2.6 Thermal-Hydraulic Analyses**

The MNGP USAR describes that assuming the maximum expected SFP heat load immediately following a core offload, that the SFP will reach a bulk boiling temperature of 212°F in approximately 8.3 hours. The peak boil off rate would be 53 gpm. At this rate, and assuming the pool begins at Level 1 (which is conservative) it would take approximately 63.2 hours to drop the SFP 22.5 ft (from

**Final Integrated Plan  
for Mitigating Strategies for Beyond-Design-Basis External Events and  
Reliable Spent Fuel Pool Instrumentation  
for Monticello Nuclear Generating Plant**

Level 1 to the top of the fuel rack). A flow exceeding 53 gpm will replenish the water lost due to boiling.

A calculation confirmed that makeup water (200 gpm) can be supplied to the SFP simultaneously with a minimum of 300 gpm of makeup water delivered to the RPV. Deployment of the SFP hose connection from the FLEX Pump within 24 hours with a design flow of 200 gpm for filling the SFP will provide for adequate makeup to restore the SFP level and maintain an acceptable level of water for shielding purposes.

### **3.2.7 FLEX Pump and Water Supplies**

#### **3.2.7.1 FLEX Pump**

The FLEX Pump is a nominal 1000 gpm pump with a discharge head of 455 ft. that provides both RPV and SFP makeup. The FLEX Pump is a trailer-mounted, diesel driven centrifugal pump. Two of these pumps are located on the MNGP site and are stored (1 each) in the BDBEE Storage Buildings. A pump is deployed by towing the trailer to a designated location near the selected water source. Each FLEX Pump is sized to provide 300 gpm makeup water to the RPV and 200 gpm makeup water to SFP Fuel Pool makeup simultaneously. Refer to Section 3.1.8.1 for further information.

#### **3.2.7.2 Water Supplies**

The water supplies for the FLEX Pump are the MNGP intake and discharge canal – the Ultimate Heat Sink sources – and the CSTs. See Section 8.4 for details.

### **3.2.8 Electrical Analysis**

The SFP will be monitored by instrumentation installed in response to Order EA-12-051. Two separate and independent channels monitor SFP level. The power for each channel has independent battery capacity for 7 days. Alternative power supplies can be provided beyond 7 days using onsite portable generators, or other means, to provide power to the instrumentation and display panels and to recharge the backup battery.

### **3.3 Containment Integrity**

With an ELAP initiated while MNGP is in Modes 1-4, Containment cooling is also lost for an extended period of time. Therefore, Containment temperature and pressure will slowly increase.

During the BDBEE, Containment Integrity is maintained by normal design features of the Containment, such as the Containment Isolation Valves and the HPV System. As the Torus heats up due to RCIC operation and SRV operation, the Containment will begin to heat up and pressurize. The MNGP FLEX Strategy is



**Final Integrated Plan  
for Mitigating Strategies for Beyond-Design-Basis External Events and  
Reliable Spent Fuel Pool Instrumentation  
for Monticello Nuclear Generating Plant**

based on performing Torus Venting for Containment heat removal when the Drywell or Torus pressure is  $\geq 10$  psig and the Torus water temperature is  $\geq 212^\circ\text{F}$ . The HPV is closed prior to Containment Pressure decreasing to 5 psig.

Using this strategy, the maximum pressure achieved is approximately 38 psia, which is well below the Primary Containment Pressure Limit (PCPL) of 62 psig. Permanently installed plant equipment/features are used to maintain Containment Integrity throughout the duration of the event. The permanent plant equipment is supported by FLEX electrical power and replacement of nitrogen bottles as necessary during the event.

### **3.3.1 Phase 1 Strategy**

The Phase 1 coping strategy for Containment involves verifying Containment isolation, and monitoring Containment temperature and pressure using installed instrumentation. The Containment will be pressurized by the steam going to the Torus from RCIC/HPCI and the SRVs. Reactor coolant leakage into the drywell and loss of forced cooling in the drywell will also increase drywell temperature and pressure.

Maintaining Containment Integrity will be achieved by the removal of energy from the Torus by opening the HPV. The vent will be operated in accordance with the EOPs. The vent will be opened after the water in the Torus reaches  $212^\circ\text{F}$  and Containment Pressure is  $\leq 10$  psig. This occurs approximately 7 hours after the ELAP event begins.

Once the HPV is opened, Torus water temperature will peak at approximately  $250^\circ\text{F}$  and will slowly decrease over the next several days. After the release of the nitrogen overpressure, the Containment Pressure will rise to the saturation pressure associated with  $250^\circ\text{F}$  ( $\sim 30$  psig), and then decrease as the energy removed from the Containment exceeds the energy added. After 48 hours, the Containment Temperature will have lowered to  $\sim 240^\circ\text{F}$ .

Monitoring of Containment Drywell Pressure, Torus Level, Drywell Temperature and Torus Temperature will be available via normal plant instrumentation.

### **3.3.2 Phase 2 Strategy**

The strategy for Phase 2 is to continue to maintain Containment using Torus venting through the HPV to maintain drywell and Torus temperatures and pressures within allowable limits. This is a continuation of Phase 1 strategy with the addition of FLEX electrical power and nitrogen gas. Therefore, there is no defined end time for the Phase 1 and 2 periods for maintaining Containment integrity. In addition to the instruments identified for Phase 1 Containment integrity, the power supply for the HPV will be repowered in Phase 2 using a FLEX 480V Generator.

**Final Integrated Plan  
for Mitigating Strategies for Beyond-Design-Basis External Events and  
Reliable Spent Fuel Pool Instrumentation  
for Monticello Nuclear Generating Plant**

**3.3.3 Phase 3 Strategy**

Due to the multitude of possible damage scenarios and the availability of plant equipment, pre-planning of recovery actions for Phase 3 prior to the event is not practical. Phase 2 equipment is able to remove decay heat past 24 hours. The HPV line will be used to remove heat until off-site resources provided by the NSRC arrive on site and the ERO develops a plan to restore plant systems.

**3.3.4 Structures, Systems and Components**

Cooling of the Containment utilizes the FLEX Pump and the HPV system together. As the core is cooled, steam is vented to the Torus. The Containment pressure and temperature is lowered through venting the Torus to keep Containment pressure and temperature within design limits.

The HPV system is the key system for maintaining the Containment function and is discussed further in Section 3.1.4.4.

**3.3.5 Key Parameters**

Instrumentation providing the following key parameters is credited for all phases of the Containment integrity strategy:

- Drywell Pressure: PT-7251A/B – Instrumentation is available in the Control Room and the ASDS Panel.
- Torus Level: LT-7338A/B – Instrumentation is available in the Control Room and the ASDS Panel.
- Drywell Air Temperature: TE-4247 A1/A2/B1/B2/C1/C2/D1/D2/E1/E2/F1/F2/G1/G2/H1/H2 through TR 23-115 – Instrumentation is available in the Control Room.
- HPV Radiation Monitor: RE/RM-4544 – Instrumentation is available at the ASDS Panel.
- HPV System Valve Position Indication: AO-4539 and AO-4540 - Instrumentation is available at the ASDS Panel.
- HPV temperature: Vent temperature readout on RR-4544 at the ASDS Panel.

**3.3.6 Thermal-Hydraulic Analyses**

Evaluations have concluded that Containment temperature and pressure will remain below Containment design limits and that key parameter instruments subject to the Containment environment will remain functional during a BDBEE. The Containment pressure and temperature will be procedurally monitored and, will be reduced using the HPV system to ensure that key Containment parameters will remain within their analyzed limits. The Containment Integrity analysis confirms that:

**Final Integrated Plan  
for Mitigating Strategies for Beyond-Design-Basis External Events and  
Reliable Spent Fuel Pool Instrumentation  
for Monticello Nuclear Generating Plant**

- Torus pressure and drywell pressure remain acceptable, if Containment venting is initiated per procedural guidance.
- Suppression pool remains acceptable for Containment venting, even if the CST is used to maintain reactor water level.
- Suppression pool temperature rises above 250°F after ~11.7 hours, allowing time for FLEX pump setup.
- Containment pressure does not exceed the design pressure.

**3.3.7 FLEX Pump and Water Supplies**

Under Phase 2 conditions a FLEX Pump is utilized to supply water to the RPV to achieve core cooling. The heat from the RPV is transferred to the Containment including the Torus through opening the SRVs and is removed through opening the HPV system. See Section 3.1.8.1 for a description of the FLEX pump capabilities.

In Phase 3 the Containment pressure and temperature monitoring remains unchanged. However, after NSRC delivery and setup of the 4160V Generator, additional cooling options for Containment may be utilized. For example, an RHR pump and RHRSW pump may be started for torus cooling. In addition, Containment cooling through starting of Containment fans and a cooling water source may also be initiated. Due to the multitude of possible damage scenarios and the availability of plant equipment, pre-planning of recovery actions for Phase 3 prior to the event is not practical. The MNGP ERO will need to develop plans for deployment and priorities for restoration of plant systems.

Water supplies are as described in Section 8.4.

**3.3.8 Electrical Analysis**

In Phase 1, after the shift manager declares an ELAP event has occurred, by procedure, load shedding will be performed on the Division I and Division II station batteries to extend the time station batteries can be used to operate equipment used to provide core cooling and instruments used to monitor core, SFP and containment parameters. See Section 3.1.4.5 for details.

In Phase 2, one of the two FLEX 480V Generators is required to repower the Containment pressure and temperature monitoring and Containment heat removal functions described above. See Section 3.1.9 for further details on the FLEX 480V Generators.

The 4160V equipment (two 1 - MW 4160V Generators and a distribution panel - including cable and connectors) being supplied from the NSRC will provide an additional resource of power to perform additional Phase 3 Containment cooling strategies.

**Final Integrated Plan  
for Mitigating Strategies for Beyond-Design-Basis External Events and  
Reliable Spent Fuel Pool Instrumentation  
for Monticello Nuclear Generating Plant**

## **4.0 Characterization of External Hazards**

### **4.1 Seismic**

NEI 12-06, Rev. 2, Section 5.2, *Approach to Seismically-Induced Challenges*, requires that all plants address seismic considerations in the implementation of FLEX strategies. The plant design basis safe shutdown earthquake (SSE) is 0.12g. The associated spectra are included in Updated Safety Analysis Report (USAR) Section 2, Figure 2.6-5 (Reference 13).

In accordance with the NRC Request For Information Pursuant to 10 CFR 50.54(f) Regarding the Seismic Aspects of Recommendation 2.1 of the Near-Term Task Force Review of Insights from the Fukushima Dai-Ichi Accident (Reference 14), a seismic hazard and screening evaluation was performed for MNGP (Reference 15). A Ground Motion Response Spectra (GMRS) was developed solely for purpose of screening for additional evaluations in accordance with NRC endorsed EPRI Report 1025287, "Screening, Prioritization and Implementation Details (SPID) for the Resolution of Fukushima Near-Term Task Force Recommendation 2.1: Seismic." Based on the results of the screening evaluation, MNGP screens-in for a risk evaluation, a SFP evaluation, and a High Frequency Confirmation.

For the FLEX strategies, the earthquake is assumed to occur without warning and result in damage to non-seismically designed structures and equipment. Non-seismic structures and equipment may fail in a manner that would prevent accomplishment of FLEX-related activities (normal access to plant equipment, functionality of non-seismic plant equipment, deployment of FLEX equipment, restoration of normal plant services, etc.). The diverse nature of the FLEX strategies has been discussed. The ability to clear haul routes from seismic debris to facilitate the deployment of the FLEX Phase 2 equipment is addressed in Section 5.2.1.1.

#### **4.1.1 Protection of FLEX equipment**

Storage of FLEX equipment is provided in structures designed or evaluated to be equivalent to the standard American Society of Civil Engineers (ASCE) 7-10, *Minimum Design Loads for Buildings and Other Structures*. A calculation determined that high wind loading was the limiting event, even more than using the MNGP Safe Shutdown Earthquake loads or the newly developed Ground Motion Response Spectra loads.

#### **4.1.2 Considerations in Utilizing Off-site Resources**

Implementation of Phase 3 strategies, which use offsite resources, considers the impacts from the seismic event when selecting staging areas for NSRC equipment. The MNGP SAFER Response plan identifies primary and alternate routes to the site from the staging areas.

**Final Integrated Plan  
for Mitigating Strategies for Beyond-Design-Basis External Events and  
Reliable Spent Fuel Pool Instrumentation  
for Monticello Nuclear Generating Plant**

## **4.2 External Flooding**

NEI 12-06, Rev. 2, Section 6.2.1, *Susceptibility to External Flooding*, requires plants that are not dry sites to perform a flood-induced challenge evaluation. A dry site is one that is built above design basis flood level. The design bases flood for the plant is a Probable Maximum Flood (PMF) on the Mississippi River. The flood is a relatively slow developing event with actions based on forecasts of river water level. Maximum predicted flood water level is 939.2 ft and there are about 12 days available until the peak stage would be reached. The peak flood is a result of the worst combination of hydro-meteorological, hydrological, and climatic conditions. Site grade would be flooded for approximately 11 days. MNGP screens in for the external flood hazard and is not considered a dry site.

Site procedures provide for flood protection of all Class I structures and all Class II structures housing Class I equipment.

In accordance with the NRC Request For Information Pursuant to 10 CFR 50.54(f) Regarding the Flooding Aspects of Recommendation 2.1 of the Near-Term Task Force Review of Insights from the Fukushima Dai-Ichi Accident (Reference 14), a flood hazard reevaluation report (FHRR) was performed for MNGP (Reference 16) and provided to the NRC. The results of the FHRR indicated that the reevaluated flooding from streams and rivers, including wave run-up, was below the top elevation of the existing flood protection system required to support the current design basis probable maximum flood (PMF) of 939.2'. In addition, new flooding mechanisms were evaluated including local intense precipitation (LIP). Finally, the effects of groundwater ingress were discussed in the FHRR and were determined not to be credible. An assessment of the FHRR results determined that no interim actions are necessary.

### **4.2.1 Protection of FLEX equipment**

Protection of the FLEX equipment from flooding is provided by pre-staging of the Phase 2 FLEX equipment within the flood-protected area before the design basis flood level is reached. Flood level predictions provide sufficient time to accomplish this prior to the water levels impacting the storage buildings.

### **4.2.2 Considerations in Utilizing Off-site Resources**

Phase 3 equipment from the NSRC can be requested prior to flooding of the main access road or can be brought in on the temporary access road and set up on site in advance of the PMF. During an external flood event, the FLEX equipment would be relocated within the flood protected area of the site. During the peak period of a PMF, a FLEX pump is pre-staged at the CSTs.

**Final Integrated Plan  
for Mitigating Strategies for Beyond-Design-Basis External Events and  
Reliable Spent Fuel Pool Instrumentation  
for Monticello Nuclear Generating Plant**

The PMF response plan includes elements for restocking of consumables and alternate routes for access to the site during peak flooding conditions.

**4.3 Severe Storms with High Winds Assessment**

NEI 12-06, Rev. 2, Section 7.2.1, *Applicability of High Wind Conditions*, contains a screening process to identify whether sites should address high wind hazards as a result of hurricanes and tornadoes. USAR Section 2.2.1, *Location*, states that the plant is located at 45° 20' North latitude and 93° 50' West longitude. Using NEI 12-06, Rev. 2, Figure 7-1 the plant screens out for hurricanes. Using NEI 12-06, Rev. 2, Figure 7-2, the plant high wind speed expected to occur at a rate of 1 in 1 million chance per year is 184 mph. Therefore, the plant needs to address storms involving high winds and tornados, including missiles produced by these events.

The USAR identifies tornadoes are not a frequent occurrence near MNGP. The latitude of the plant places it at the northern edge of the region of maximum tornado frequency in the US. USAR Table 2.3-21 records the maximum wind velocities recorded in the vicinity of MNGP. The highest recorded wind velocity was 92 mph on July 20, 1951 and was associated with a tornado. Wind frequency distribution tables are provided in Section 2.3 of the MNGP USAR.

Class I and Class II Station structures are designed to withstand the effects of 100 mph winds at 30-feet above ground with a gust factor of 1.1. Structures and systems which are necessary for a safe shutdown of the reactor and maintaining a shutdown condition are designed to withstand tornado wind loadings of 300 mph.

**4.3.1 Protection of FLEX Equipment**

Storage of FLEX equipment is provided in structures designed or evaluated to meet ASCE 7-10. Physical separation of the redundant sets of equipment provides assurance that one set will survive the impact of tornado winds and missiles..

**4.3.2 Considerations in Utilizing Off-site Resources**

The Phase 3 response strategy considers the path from the staging area to the site after a high wind event. Debris removal equipment for deployment of FLEX equipment would be used to clear a path for the offsite resources. It is expected that if any other vehicle is available to remove debris, it will be used, if necessary.

**Final Integrated Plan  
for Mitigating Strategies for Beyond-Design-Basis External Events and  
Reliable Spent Fuel Pool Instrumentation  
for Monticello Nuclear Generating Plant**

#### **4.4 Ice, Snow and Extreme Cold Assessment**

NEI 12-06, Rev. 2, Section 8.2.1, *Applicability of Snow, Ice and Extreme Cold*, requires all plants consider the temperature ranges and weather conditions for locations above the 35<sup>th</sup> parallel, which includes MNGP which is located at 45° 20' North latitude and 93° 50' West longitude. The USAR Table 2.3-1 identifies the extreme minimum temperature for MNGP as -38°F. The minimum monthly average low temperature is 3°F in January.

MNGP is located within the region characterized by EPRI as ice severity level 4 (NEI 12-06, Rev. 2, Figure 8-2, Maximum Ice Storm Severity Maps). Consequently, MNGP is subject to severe damage to power lines and/or existence of large amounts of ice. Therefore, NSPM must consider the impacts of ice storms and snow on the FLEX strategies. The USAR identifies in Table 2.3-3 that the maximum 24 hour snow fall in the vicinity of MNGP is 16.2". The maximum average snowfall for a month is 11.5" in March. The USAR also identifies that snowfall totals for a season have ranged from as little as 6" to as much as 88".

##### **4.4.1 Protection of FLEX Equipment**

Storage of FLEX equipment is provided in structures designed or evaluated to meet ASCE 7-10. The storage buildings are heated and provide protection from ice, snow, and extreme cold.

##### **4.4.2 Considerations in Utilizing Off-site Resources**

Implementation of FLEX strategies during Phase 3 addresses how severe snow and ice storms can affect site access and impact staging areas for receipt of off-site materials and equipment.

#### **4.5 High Temperatures**

NEI 12-06, Rev. 2, Section 9.2, *Approach to Extreme High Temperature Challenges*, requires all plants to consider the high temperature conditions for the site in storing and deploying the FLEX equipment. USAR Table 2.3-1 identifies an extreme maximum air temperature for MNGP of 107°F. The maximum monthly average high is 83°F in July.

##### **4.5.1 Protection of FLEX Equipment**

The FLEX storage locations have adequate ventilation to maintain reasonable storage temperatures. Backup ventilation cooling is not required if power is lost since FLEX equipment was procured to be suitable for use in peak temperatures for the region. High temperature will not affect the deployment of FLEX equipment.

**Final Integrated Plan  
for Mitigating Strategies for Beyond-Design-Basis External Events and  
Reliable Spent Fuel Pool Instrumentation  
for Monticello Nuclear Generating Plant**

**4.5.2 Considerations in Utilizing Off-site Resources**

Extreme heat is not expected to impact the utilization of offsite resources because extreme heat is not expected to impact accessibility to the site or impact equipment operation.



**Final Integrated Plan  
for Mitigating Strategies for Beyond-Design-Basis External Events and  
Reliable Spent Fuel Pool Instrumentation  
for Monticello Nuclear Generating Plant**

## **5.0 Protection and Deployment of FLEX Equipment**

### **5.1 Protection of FLEX Equipment**

A complete set of FLEX portable equipment, vehicles and tools are maintained in the FLEX Building and in Warehouse #6 (collectively called the BDBEE storage buildings), with each location providing “N” equipment sets. The two buildings are spatially separated FLEX equipment storage areas, over 900 feet apart, which exceeds the minimum separation criterion of 850.5 ft, based on meeting a 90<sup>th</sup> percentile tornado width as determined by data from the National Oceanic and Atmospheric Administration’s (NOAA’s) Storm Prediction Center for 1950 - 2012. The North – South orientation minimizes the probability that a tornado would directly impact both structures.

The FLEX equipment staged in these areas is redundant. Either storage area may be lost to a BDBEE, leaving the second area with adequate equipment (N Set) to implement the FLEX Strategy. The axis of separation between the storage areas considers the predominant path of tornadoes in the region (i.e. North-South alignment). The two (north and south) BDBEE storage buildings are located within the owner controlled area. See Figure 5.1-1 for the location of the BDBEE Storage buildings. The equipment is sheltered, maintained dry, and protected from seismic events, high wind events (redundant sets of equipment, stored in each building, with standoff distance determined, one set will be available), ice-snow-cold events and high temperature events.

Approximately 2,400 square feet of storage is available in each building. Both areas are heated and have doors that can be opened manually with no need for electrical power. Fire protection is provided by sprinkler systems. The buildings are located within 1,000 ft of the power block to provide prompt FLEX equipment access. Both buildings are located outside the protected area.

The FLEX building is a new dedicated building for FLEX equipment. The stand-alone FLEX Building has been designed to ASCE 7-10 seismic requirements. The storage building is located outside of the site design basis flood protection so equipment will be deployed from this location prior to the flood event. The FLEX building was evaluated to determine the limiting event (i.e. which event establishes the design limits for the building). A calculation determined that high wind loading was the limiting event, even more than using the MNGP Safe Shutdown Earthquake loads or the newly developed Ground Motion Response Spectra loads. Only the FLEX building was evaluated as only one of the two structures is required following a seismic event.

Warehouse #6 has been evaluated to ASCE 7-10 seismic requirements and modifications made to address loading due to high winds. This location is outside of the site design basis flood protection so equipment will be deployed from this

**Final Integrated Plan  
for Mitigating Strategies for Beyond-Design-Basis External Events and  
Reliable Spent Fuel Pool Instrumentation  
for Monticello Nuclear Generating Plant**

location prior to the flood event. A 40 ft by 60 ft section of Warehouse #6 is used for FLEX equipment. Warehouse #6 is attached to the Site Administration Building (SAB).

The debris removal equipment required to support the implementation of the FLEX strategies is also stored inside the BDBEE Storage Buildings in order to protect them from the applicable external hazards. Therefore, the equipment will remain functional and deployable to clear obstructions from the pathway between the FLEX equipment's storage location and its deployment location(s). This debris removal equipment includes mobile equipment such as a front end loader and a fork lift.

**Figure 5.1-1**

**BDBEE Storage Building Locations**



**Final Integrated Plan  
for Mitigating Strategies for Beyond-Design-Basis External Events and  
Reliable Spent Fuel Pool Instrumentation  
for Monticello Nuclear Generating Plant**

## **5.2 Planned Deployment of FLEX Equipment**

### **5.2.1 Haul Paths**

Multiple pre-determined haul paths from either BDBEE storage building are available for FLEX equipment. A FLEX Pump must be moved to the discharge canal or the intake structure during non-flood events. For a flooding event a FLEX Pump is moved near the CST or a suction hose is laid over the flood berm. The FLEX 480V Generator needs to be moved inside the protected area to either of two locations near the plant administrative building. The FLEX pump deployment paths are shown on Figure 5.2.1-1 and the FLEX 480V Generator deployment paths are shown on Figure 5.2.1-2.

Deployment of the FLEX equipment or debris removal equipment from storage locations does not depend on off-site power or on-site emergency AC power (e.g., to operate roll up doors, lifts, elevators, etc.).

The entire MNGP site has been reviewed for potential soil liquefaction and has been determined to be stable following a seismic event as described in the MNGP USAR. Therefore, the haul paths for FLEX equipment deployment are not subject to soil liquefaction.

Additionally, the preferred haul paths minimize travel through areas with trees, power lines, narrow passages, etc. to the extent practical. However, high winds can cause debris from distant sources to interfere with planned haul paths. Debris removal equipment is stored inside each BDBEE Storage Building and is protected from the severe storm and high wind hazards such that the equipment remains functional and deployable to clear obstructions from the pathway between the applicable BDBEE Storage Building and the FLEX equipment deployment locations.

The deployment of onsite FLEX equipment in Phase 2 requires that pathways between the BDBEE Storage Building(s) and various deployment locations be clear of debris resulting from BDB seismic, or high wind (tornado) or ice, snow events. The stored debris removal equipment includes a front end loader equipped with front end bucket and a large forklift vehicle. Each vehicle has rear tow connections in order to move or remove debris from the needed travel paths.

One of the key assumptions in the MNGP FLEX strategy is that offsite resources are available to begin arriving at hour six and fully staffed by 24 hours. This is in agreement with NEI 12-01, Section 2.2. This assumption, along with the assumption that on-shift personnel will not have the qualification to use the heavy debris removal equipment (front-end loader and large forklift), delays the onset of heavy debris removal for 6 hours. Thus, on-shift personnel will perform light debris removal and perform hose/cable layout. Heavy debris removal will

**Final Integrated Plan  
for Mitigating Strategies for Beyond-Design-Basis External Events and  
Reliable Spent Fuel Pool Instrumentation  
for Monticello Nuclear Generating Plant**

commence at hour 6 and can be completed in 2 hours, but does not have to be completed until hour 10 for FLEX equipment deployment.

Phase 3 of the FLEX strategies involves the receipt of equipment from offsite sources including the NSRC and various commodities such as fuel and supplies. Transportation of these deliveries can be through airlift or via ground transportation. Debris removal for the pathway between the site and the NSRC receiving location, and from the various plant access routes may be required. The same debris removal equipment used for on-site pathways could be used to support debris removal to facilitate road access to the site.

Deployment paths internal to site structures traverse through areas that are designed Class I with respect to postulated environmental and accident loading, include design basis earthquake or have been evaluated to Class I requirements. Specific considerations for deployment during each BDBEE are discussed below.

**Final Integrated Plan  
for Mitigating Strategies for Beyond-Design-Basis External Events and Reliable Spent Fuel Pool  
Instrumentation  
for Monticello Nuclear Generating Plant**

Figure 5.2.1-1

**FLEX  
PORTABLE DIESEL PUMP  
DEPLOYMENT PATHS AND STAGING AREAS**

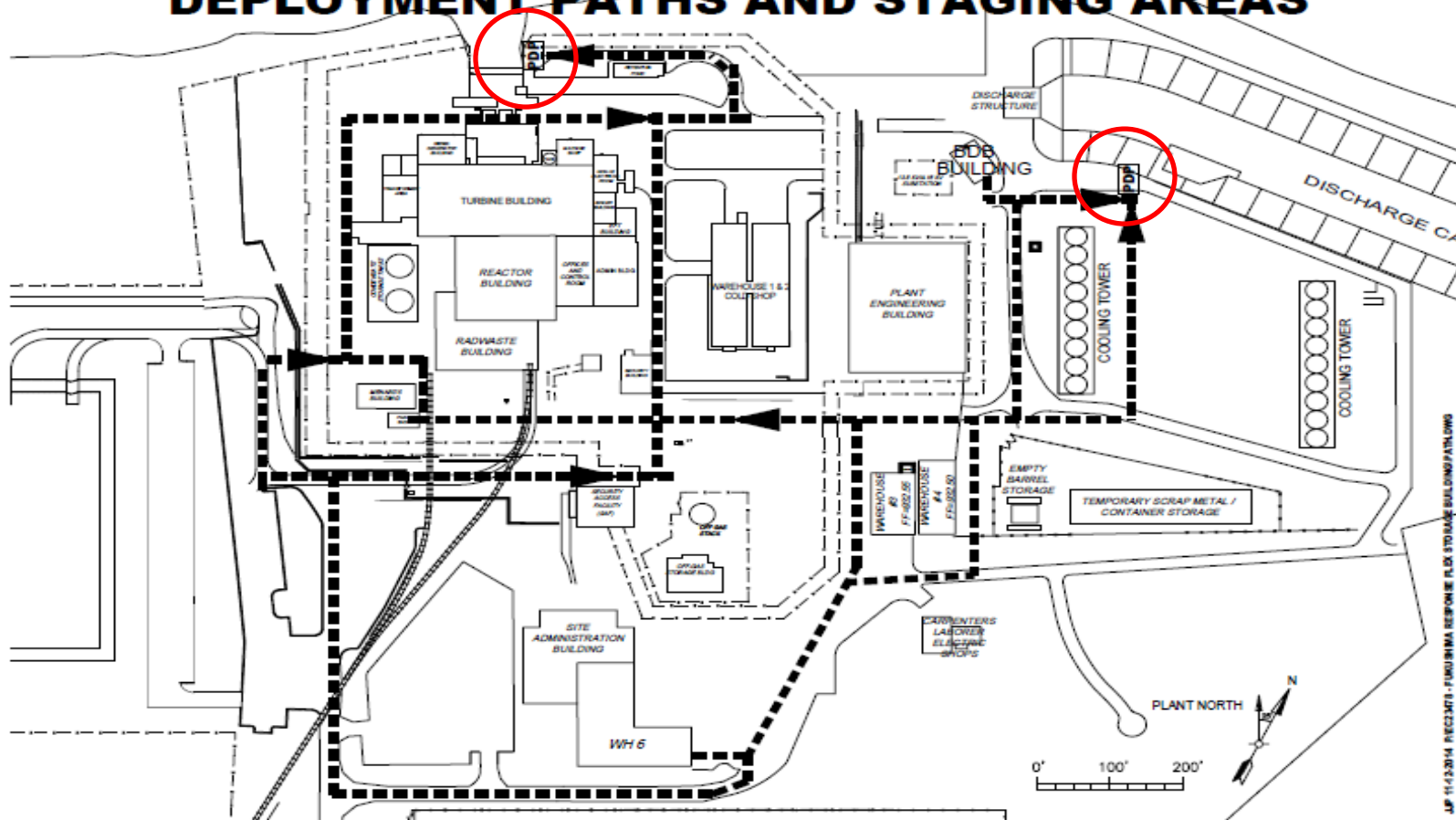

**Final Integrated Plan  
for Mitigating Strategies for Beyond-Design-Basis External Events and Reliable Spent Fuel Pool  
Instrumentation  
for Monticello Nuclear Generating Plant**

Figure 5.2.1-2

**FLEX  
480V DIESEL GENERATOR  
DEPLOYMENT PATHS AND STAGING AREAS**

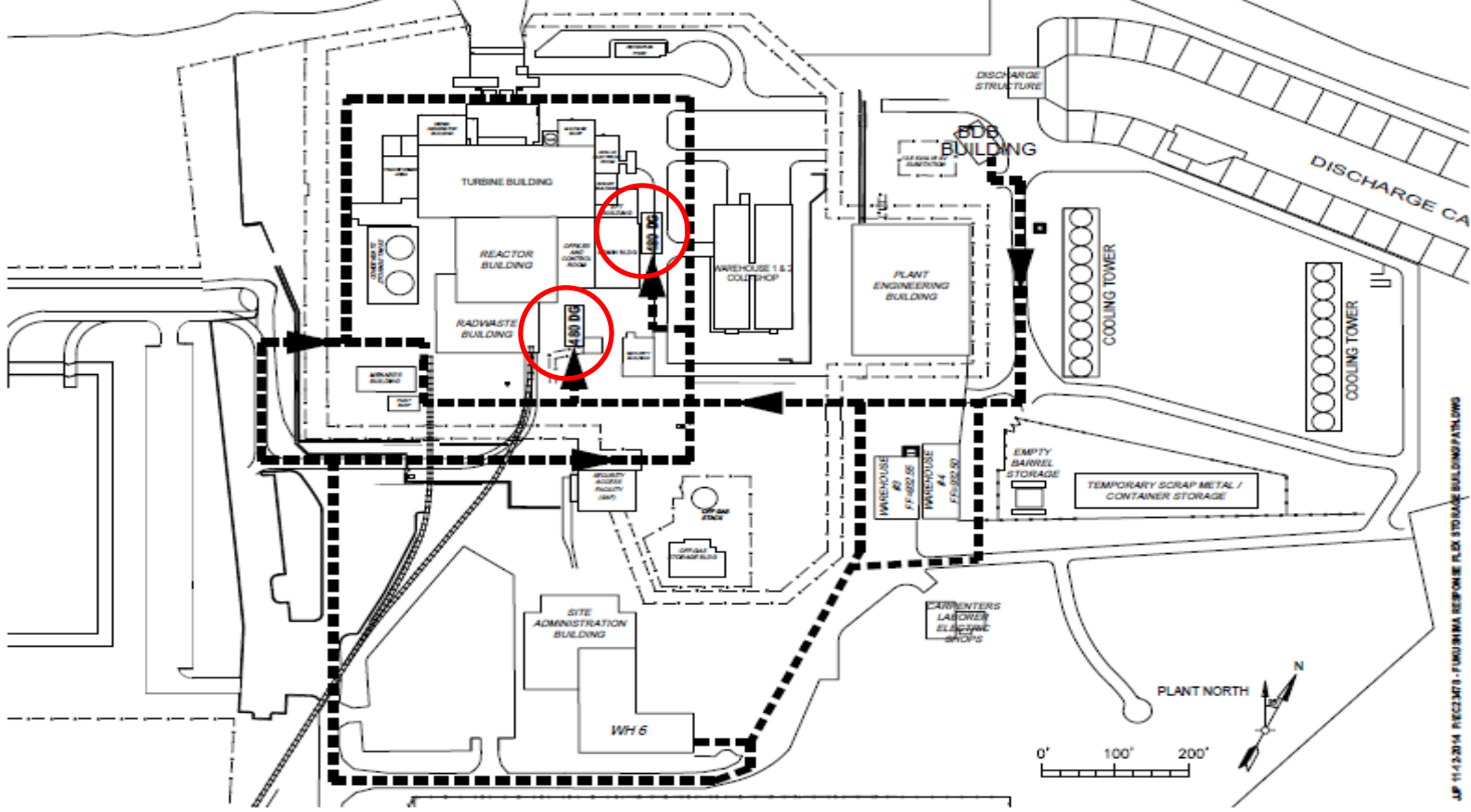

**Final Integrated Plan  
for Mitigating Strategies for Beyond-Design-Basis External Events and  
Reliable Spent Fuel Pool Instrumentation  
for Monticello Nuclear Generating Plant**

**5.2.1.1 Seismic**

FLEX equipment is provided with a storage and deployment strategy based on the use of seismically rugged, diverse, spatially separated locations to meet the requirements of NEI 12-06, Rev. 2.

Deployment pathways of FLEX equipment from the storage locations include the potential for debris due to non-seismically designed structures. Debris removal equipment onsite is capable of clearing pathways for deployment. As long as the deployment equipment is accessible after a seismic event it is considered available.

Cable and hose deployment includes pathways through non-seismic and non-tornado protected structures. Deployment in these areas will be done manually and hoses and cables can be maneuvered through areas of debris. Analysis was performed to show that the pathways through the PAB are seismically robust.

As described in the USAR, Section 2.5.5, the site is not considered susceptible to liquefaction based on the soil properties and design basis earthquake accelerations. Site borings used in this evaluation, as shown in USAR Figure 2.5-2, cover the deployment paths.

Debris removal equipment onsite is capable of clearing pathways for deployment. FLEX connection points are located in seismically robust structures and at least one seismically robust pathway exists to the connection points.

No external power supply is required to deploy FLEX equipment. The FLEX building structures utilize roll-up doors that do not require power to actuate.

The towing vehicles used to move FLEX equipment are reasonably protected in the same FLEX structures that contain the portable equipment.

**Procedural Interfaces**

Procedures are provided which contain methods to read essential plant parameters when normal instrumentation is not available.

Seismic forces could cause pipe failure leading to drainage of the CSTs or a fire protection line in the turbine building basement. Either of these failures could cause the flooding of turbine building basement, which could make one of the alternate battery charger repowering options not available. However, internal flooding does not affect the primary FLEX electrical connections. Procedures exist that provide operations with guidance for internal flooding events.

**5.2.1.2 Flooding**

Storage of FLEX equipment is provided in structures located below the design basis flood level. River level predictions allow sufficient time for FLEX equipment to be moved to an area protected from the flood.

**Final Integrated Plan  
for Mitigating Strategies for Beyond-Design-Basis External Events and  
Reliable Spent Fuel Pool Instrumentation  
for Monticello Nuclear Generating Plant**

There is sufficient time for pre-staging of the Phase 2 FLEX equipment within the flood-protected area before the design basis flood level is reached. The main access road to the site will not be available in the design basis flood and so an alternate access road will be constructed as part of the flood preparations.

The fuel for the FLEX equipment is located in tanks protected inside the berm erected for the flood.

FLEX connection points are located inside the flood protected area.

Materials required to provide plant flood protection are located on site. Construction of the flood protection measures have been evaluated to provide reasonable assurance that they could be deployed to provide the required protection.

Current procedures require the plant to shut down when the river level is predicted to exceed elevation 918'. When the river level is predicted to exceed 919', plant procedures require one FLEX Pump and one FLEX 480V Generator and associated support equipment to be moved to higher ground as part of the flood response. If a river level of 930' is predicted, an alternate road to the plant is constructed.

No other beyond design basis event is assumed to occur with the flood; therefore makeup from the CSTs will be available for makeup functions because they will be inside the flood protection features. The FLEX pumps will be moved as necessary to ensure that they are protected from the flood, but also have access to a water supply. The CSTs are the preferred source, as it is cleaner water.

**5.2.1.3 High Winds**

Following a high wind event, deployment of FLEX equipment could be impaired by large debris. Debris removal equipment is stored and protected with the FLEX equipment in the BDBEE storage buildings to ensure a clear path for deployment of FLEX equipment is available.

Debris removal equipment is available to remove debris interfering with deployment of FLEX equipment. Each storage building houses debris removal equipment. Procedures direct debris removal following any event interfering with deployment.

**5.2.1.4 Ice, Snow, Extreme Cold**

Snow removal is a normal activity at the plant site because of the climate. Reasonable access to FLEX equipment is maintained prior to and throughout a snow event. Ice management is performed as required such that large FLEX equipment can be moved by vehicles. Debris removal equipment will move through any snow accumulations and can also be used to move portable equipment, if needed. Snow removal is addressed by plant procedure.



**Final Integrated Plan  
for Mitigating Strategies for Beyond-Design-Basis External Events and  
Reliable Spent Fuel Pool Instrumentation  
for Monticello Nuclear Generating Plant**

Ice management is performed as a normal plant activity. Ice melting chemicals and equipment are maintained on site.

The FLEX response uses the discharge canal (ultimate heat sink) as the makeup water source for core and Spent Fuel Pool Cooling operations in Phase 2 and 3. This canal is unlikely to have any significant ice buildup because it is the discharge path for normal plant cooling operations, and therefore, warm water is constantly being discharged into it from plant equipment cooling, prior to onset of loss of offsite of power.

Flow bypass pathways are provided to allow for continuous flow to prevent freezing in the hoses.

Since ice build-up can cause problems for power lines, the FLEX building locations were selected so that equipment does not need to travel under any overhead power lines.

FLEX equipment is stored in buildings that maintain a minimum temperature of 40°F. This ensures that equipment will start when called upon to function. In addition, heaters and canvas materials are available on site and can be used to keep equipment running during extreme cold conditions.

**5.2.1.5 High temperature**

High temperature does not impact the deployment of FLEX equipment because high temperature does not create obstacles for deployment paths. All FLEX equipment was procured to be suitable for use in peak temperatures for the region.

No hazard specific procedures are required for FLEX deployment or operation during high temperature conditions. However, the FSG procedures address high temperatures inside the power block and are used under any ELAP condition, regardless of the hazard. These procedures direct setting up temporary ventilation (e.g. opening doors and installing portable fans) for the reactor building, CR, plant administration building and the EFT building to support long term operation in an ELAP.

**5.2.2 Accessibility**

The potential impairments to required access are: 1) doors and gates, and 2) site debris blocking personnel or equipment access. The coping strategy to maintain site accessibility through doors and gates is applicable to all phases of the FLEX coping strategies, but is required as part of the immediate activities required during Phase 1.

Doors and gates serve a variety of barrier functions on the site. One primary function is security and is discussed below. However, other barrier functions include fire, flood, radiation, ventilation, tornado, and HELB. As barriers, these

**Final Integrated Plan  
for Mitigating Strategies for Beyond-Design-Basis External Events and  
Reliable Spent Fuel Pool Instrumentation  
for Monticello Nuclear Generating Plant**

doors and gates are typically administratively controlled to maintain their function as barriers during normal operations. Following a BDBEE and subsequent ELAP event, FLEX coping strategies require the routing of hoses and cables to be run through various barriers in order to connect FLEX equipment to station fluid and electric systems. For this reason, certain barriers (gates and doors) will be opened and remain open. Access to the Protected Area during a BDBEE is addressed in the FSGs and FSG Support Procedures.

The ability to open doors for ingress and egress, ventilation, or temporary cables/hoses routing is necessary to implement the FLEX coping strategies. Security doors and gates that rely on electric power to operate opening and/or locking mechanisms are barriers of concern. The Security force will initiate an access contingency upon loss of the Security Diesel and all ac/dc power as part of the Security Plan. Access to the Owner Controlled Area, site Protected Area, and areas within the plant structures will be controlled under this access contingency as implemented by security personnel.

Vehicle access to the Protected Area is via the double gated enclosure at the Security Access Facility (SAF). As part of the Security access contingency, the enclosure gates will be manually controlled to allow delivery of FLEX equipment (e.g., generators, pumps) and other vehicles such as debris removal equipment into the Protected Area.

If the normal vehicle entry point cannot be cleared for access, then site resources will remove security perimeter blocks at alternate east side or west side entry gates. The perimeter block removal requires use of the heavy equipment (i.e. forklift or front-end loader) stored in the BDBEE Storage Buildings.

### **5.2.3 Debris/Snow Removal**

Debris removal equipment will clear the FLEX haul paths as necessary. The primary entry into the protected area is a double gated enclosure at the SAF. If an alternate path is needed, the debris removal equipment can move existing obstacles.

The primary tow vehicle for the FLEX pumps, hose trailers and generators is a truck stored in each BDBEE Storage Building.

Snow removal is a normal activity at the plant site in the winter season. Haul paths will be cleared of significant snow accumulations. The truck can tow equipment through small snow accumulations.

Ice management/removal is performed as a normal plant activity. Ice melting chemicals are maintained on site and used frequently.

**Final Integrated Plan  
for Mitigating Strategies for Beyond-Design-Basis External Events and  
Reliable Spent Fuel Pool Instrumentation  
for Monticello Nuclear Generating Plant**

### **5.3 Deployment of Strategies**

#### **5.3.1 Reactor Pressure Vessel Makeup Strategy**

The FLEX Pumps are stored in the BDBEE Storage Buildings and are protected against all external hazards described in Section 5.1.

There are many possible combinations of FLEX Pump suction sources and injection locations. The longest run of hose required to transfer water from the discharge canal to the RHR/RHRSW cross-tie (located on the 931' east elevation of the TB) utilizes the following route. From the pump discharge, two 5" hoses are routed south between the cooling towers. From there the hoses are routed over the security barricade, through the security fence at the east gate just south of the Plant Engineering Building (PEB)), then west toward the Plant Administration Building (PAB).

At the hose run closest to the Reactor Building railroad doors, a splitter is attached to each hose. The splitter has a 5" inlet, a 5" outlet, and at least one 2½" outlet (used for SFP injection). The 5" outlet is used to continue to route the 5" hose on the east end of the PAB, around the Compressed Air Building, and into the Turbine Building through the north door of the 13.8 kV room.

Near the entrance to the Turbine Building, the two 5" hoses are connected to the double end of a Y-fitting. The single 5" hose from the outlet of the Y-fitting is then connected to a flow meter. The outlet of the flow meter is connected to a single 5" hose, which is then connected to the RHR/RHRSW cross-tie through RHRSW-68 and into the RPV. The preferred FLEX connection station is shown on Figure 5.3.1-1 below.

The portable diesel pump can also be connected to the Division 1 (or A train) RHR – system (using the intake or discharge canal as water source), or the 12 Cooling Tower Fire connection (using the discharge canal as the water source) as well as alternate routes to the RHRSW-68 connection (using the intake or discharge canal as water source).

FLEX hose deployment paths in plant buildings are indicated on Figure 5.3.1-2.

**Final Integrated Plan  
for Mitigating Strategies for Beyond-Design-Basis External Events and  
Reliable Spent Fuel Pool Instrumentation  
for Monticello Nuclear Generating Plant**

Figure 5.3.1-1

**Phase 2 & 3  
Reactor Vessel  
Water Supply**

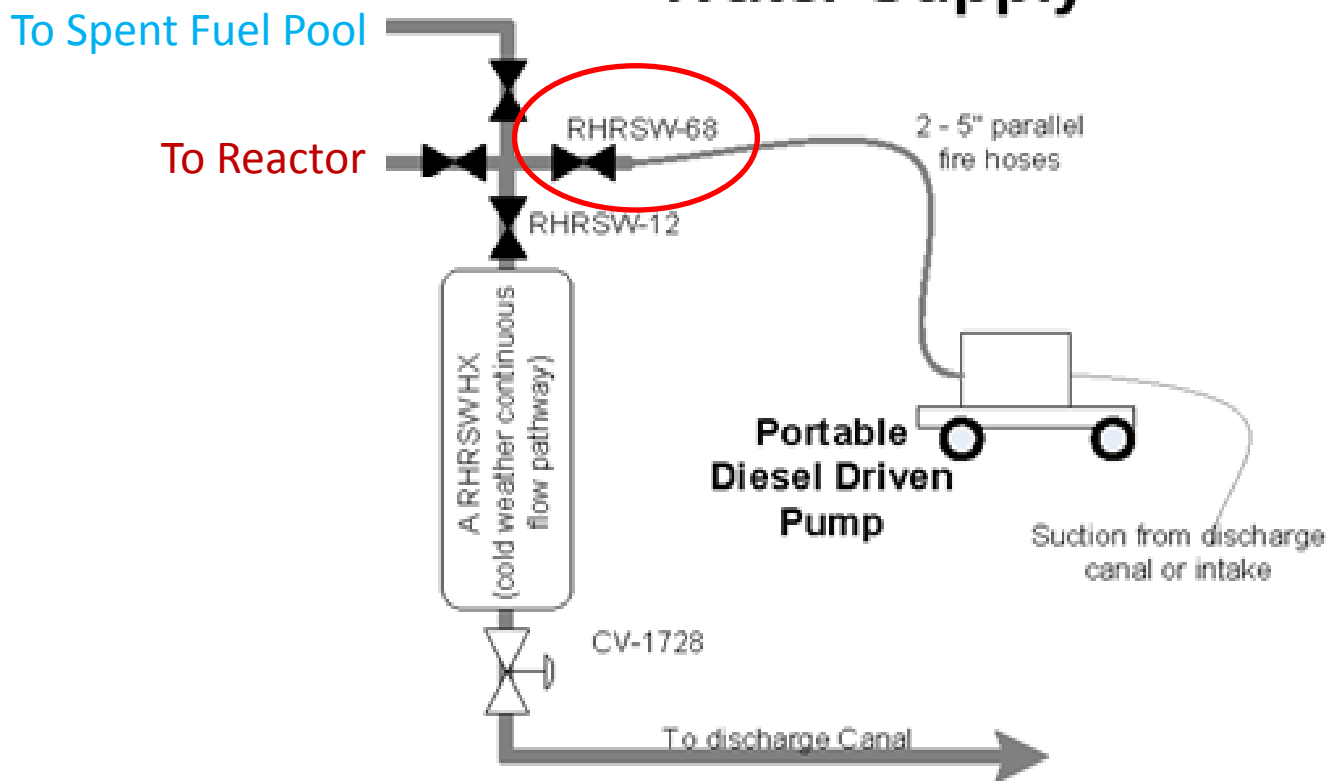

**Final Integrated Plan  
for Mitigating Strategies for Beyond-Design-Basis External Events and  
Reliable Spent Fuel Pool Instrumentation  
for Monticello Nuclear Generating Plant**

Figure 5.3.1-2

**FLEX Hose and Cable Deployment Paths**

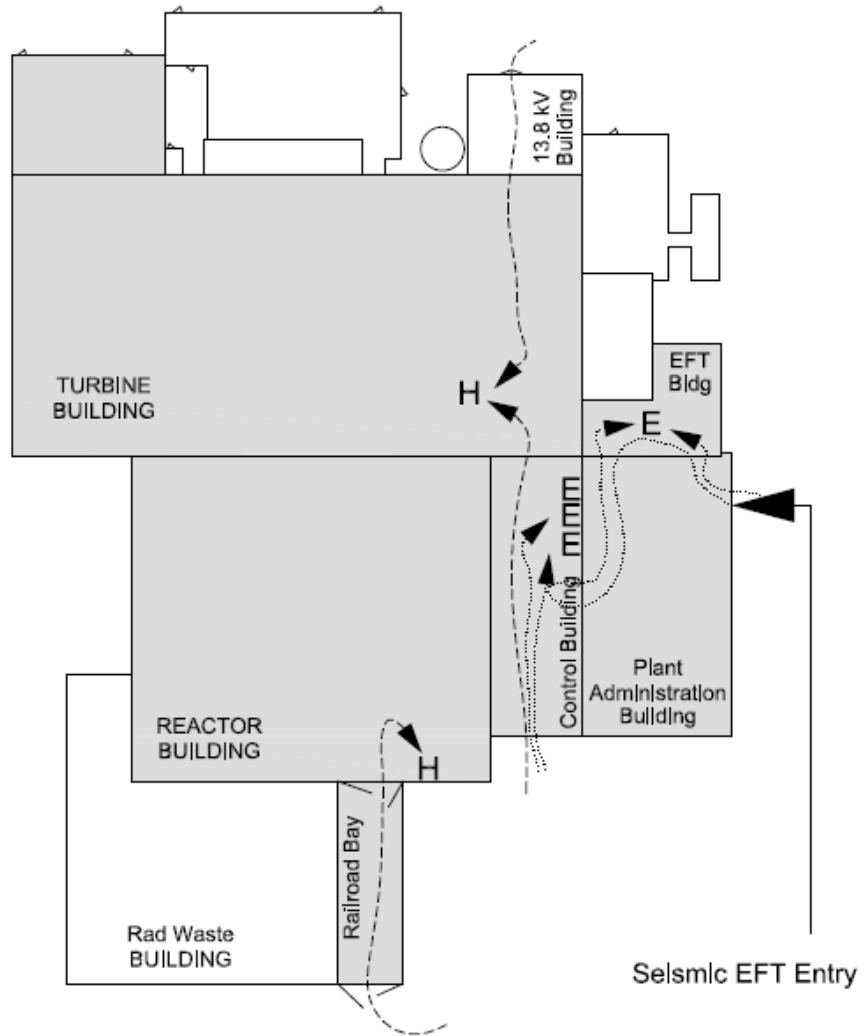

Legend

- H Hose connection location
- E Electrical connection location
- Seismic | Hose connection Path
- ..... Seismic | Electrical connection Path
- Seismic | Building or demonstrated to meet Design Basis Earthquake forces

F:\PROCEDR\flex.dwg

**Final Integrated Plan  
for Mitigating Strategies for Beyond-Design-Basis External Events and  
Reliable Spent Fuel Pool Instrumentation  
for Monticello Nuclear Generating Plant**

**5.3.2 SFP Injection Makeup Strategy**

The SFP makeup strategy will initiate makeup by deploying a FLEX Pump from one of the BDBEE Storage Buildings.

Multiple injection paths also exist for moving water to the SFP. These paths consist of:

- Hoses to the SFP:
  - Pump through 5" hoses, to RHRSW-68, to RHRSW-46, through Fire Protection piping, through 1½" hoses on the refuel floor, or
  - Each of the two 2½" outlets from the flow splitters described in Section 5.3.1 are used to route 2½" fire hoses through the reactor building railroad doors, up to 1027' elevation of the reactor building.
- RHR: Pump through 5" hoses, to RHRSW-68, to RHRSW-14, to PC-18 directly to the SFP.

FLEX hose deployment paths in plant buildings are indicated on Figure 5.3.1-2.

The SFP cooling strategies do not include a spray capability via portable monitor nozzles from refueling floor using the FLEX Pump. While the spray capability was included in the MNGP Overall Integrated Plan for compliance with Order EA-12-049, the requirement for this capability was removed consistent with NRC endorsed NEI guidance contained in NEI 12-06, Rev. 2.

**5.3.3 Electrical Strategy**

The FLEX 480V Generators are stored in the BDBEE Storage Buildings and are, therefore, protected from the BDBEES identified in Section 5.1.

One FLEX 480V Generator will be deployed to the specified locations shown on Figure 5.2.1-2.

A FLEX 480V Generator discussed in Section 3.1.9 will be staged and ready for use prior to 11 hours after the beginning of the event. This occurs prior to the depletion of the station batteries, so that the generator can power the station battery chargers. This will ensure the key instrumentation discussed in Sections 3.1.6, 3.2.5 and 3.3.5 remains powered. The FLEX 480V generators are trailer mounted with sufficient cabling available so either generator can be connected to either connection points shown in Figure 3.1.2-3.

FLEX 480V generator cable deployment paths are indicated on Figure 5.3.1-2 above.

The FLEX 480V Generators each have a set of cables which connect from the deployed generator to a receptacle located on specific battery chargers located in the associated Battery Room to charge the station batteries. As an alternate the

**Final Integrated Plan  
for Mitigating Strategies for Beyond-Design-Basis External Events and  
Reliable Spent Fuel Pool Instrumentation  
for Monticello Nuclear Generating Plant**

cables also connect to specific MCCs which can then power the station battery chargers as well.

The protection for the FLEX 480V Generator connections is provided by the Class 1 Control Building location and the EFT building. The FLEX 480V Generator cables are stored in the BDBEE Storage Buildings with the FLEX 480V Generators and are, therefore, protected from the BDBEE hazards identified in Section 5.1.

**5.3.4 Refueling of FLEX Equipment Strategy**

FLEX equipment is stored in a fueled condition. The minimum expected time for refueling the FLEX equipment is 22.2 hours. Once deployed after a BDBEE, a fuel transfer truck will refuel this equipment on an as needed basis.

The FLEX strategies for maintenance and/or support of safety functions involve several elements including the supply of fuel to necessary diesel powered generators, pumps, hauling vehicles, etc. The general coping strategy for supplying fuel oil to diesel driven portable equipment, i.e., pumps and generators, being utilized to cope with an ELAP / LUHS, is to draw fuel oil out of existing diesel fuel oil tanks on the MNGP site.

All major FLEX equipment runs on diesel fuel and is maintained with fuel in their tanks. The FLEX diesel-driven pump, FLEX 480V Generator and FLEX 120V Generator can run fully loaded in excess of 22 hours when started with the diesel fuel tank full.

Diesel fuel in the fuel oil storage tanks is routinely sampled and tested to assure fuel oil quality is maintained to ASTM standards (Technical Specification SR 3.8.3.3, and Section 5.5.8, Reference 17). This sampling and testing surveillance program also assures the fuel oil quality is maintained for operation of the station Emergency Diesel generators. Fuel oil in the fuel tanks of portable diesel engine driven FLEX equipment is maintained in the Preventative Maintenance program in accordance with the EPRI maintenance templates.

Refueling is accomplished in one of many ways:

- Obtain fuel from the MNGP emergency diesel generator (EDG) day tanks,
- Or obtain fuel from an offsite supplier.

The installed EDG day tanks have a capacity of 1500 gallons each; two tanks total. Both day tanks are located in a Class I seismic structure and would be located inside the licensee constructed PMF levee and thus protected from flood waters.

Fuel can be obtained using the EDG day tank drain valve and a flexible hose. Fuel can be pumped to suitable fuel containers for transport to FLEX equipment. Fuel is transported in either 5 gallon safety containers (for refueling small

**Final Integrated Plan  
for Mitigating Strategies for Beyond-Design-Basis External Events and  
Reliable Spent Fuel Pool Instrumentation  
for Monticello Nuclear Generating Plant**

generators and other small equipment) or using fuel storage cubes (TransCubes) mounted on the FLEX towing vehicles.

When empty, the TransCube can be refilled from one of two EDG Day Tanks. A DC transfer pump on the TransCube can refill the TransCube from a Day Tank and also transfer fuel from the TransCube to the FLEX equipment. The refueling requirements for 72 hour operation of a FLEX diesel driven pump, a FLEX 480V Generator and a FLEX 120V Generator combined will require less than 1,800 gallons from the day tanks. This assumes the FLEX equipment is fully loaded from time zero.

Depending on the design of the diesel powered equipment, the equipment may require fuel additives to prevent fuel from gelling in extreme cold conditions. The additives are stored with the equipment, and it is recommended that if the equipment is stored with fuel in the tank, the additive be premixed. Procedures are provided with instructions on the use of additives.

The BDBEE response strategy includes small support equipment that is powered by gasoline engines (e.g., chain saws, chop saws, and small electrical generator units). These components will be re-fueled using portable containers of fuel. Gasoline – oil mix is stored in flammable cabinets in the BDBEE Storage buildings.



**Final Integrated Plan  
for Mitigating Strategies for Beyond-Design-Basis External Events and  
Reliable Spent Fuel Pool Instrumentation  
for Monticello Nuclear Generating Plant**

## **6.0 Offsite Resources**

### **6.1 National SAFER Response Center**

The industry has established two (2) National SAFER Response Centers (NSRCs) to support utilities during BDBEE. NSPM has established contracts with the Pooled Equipment Inventory Company (PEICo) to participate in the process for support of the NSRCs as required. Each NSRC holds five (5) sets of equipment, four (4) of which are able to be fully deployed when requested, the fifth set will have equipment in a maintenance cycle. The SAFER team is an alliance between AREVA, Inc. and PEICo which was contracted by the nuclear industry to establish and operate two NSRCs - one in Memphis, TN and one in Phoenix, AZ. SAFER also purchases, stores, and delivers emergency response equipment in accordance with the FLEX Phase 3 strategies. In addition, onsite FLEX equipment hose and cable end fittings are standardized with the equipment supplied from the NSRC.

In the event of a BDBEE and subsequent ELAP/LUHS condition, equipment will be moved from an NSRC to a local assembly area established by the Strategic Alliance for FLEX Emergency Response (SAFER) team. From there, equipment can be taken to the MNGP site and staged at the SAFER onsite Staging Area "B" near the plant access by helicopter if ground transportation is unavailable. Communications will be established between the MNGP plant site and the SAFER team via satellite phones and required equipment moved to the site as needed. First arriving equipment will be delivered to the site within 24 hours from the initial request. The order in which equipment is delivered is identified in the MNGP *SAFER Response Plan* (Reference 9).

SAFER maintains a generic set of equipment that is applicable to greater than 70% of the nuclear power plants. SAFER also maintains a non-generic (or site specific) set of equipment that will be provided to a specific plant when SAFER is requested to respond to a BDBEE.

### **6.2 Equipment List**

The equipment stored and maintained at the NSRC for transportation to the local assembly area to support the response to a BDBEE at MNGP is listed in Table 6.2-1. Table 6.2-1 identifies the equipment that is specifically credited in the FLEX strategies for MNGP, and also lists the equipment that will be available for backup/replacement should onsite equipment become unavailable. Since all the equipment will be located at the site area, the time needed for the replacement of a failed component will be minimal.

**Final Integrated Plan  
for Mitigating Strategies for Beyond-Design-Basis External Events and Reliable Spent Fuel Pool  
Instrumentation  
for Monticello Nuclear Generating Plant**

<b>Table 6.2-1 – Portable Equipment From NSRC</b>										
<b>Portable Equipment</b>	<b>Quantity Required</b>	<b>Quantity Provided</b>	<b>Power</b>	<b>Performance Criteria</b>				<b>Performance Criteria</b>		<b>Notes</b>
				Core Cooling	Containment Integrity	Instrumentation	RPV Inventory			
High Pressure pump	0	1	Diesel					2000 psi	60 gpm	1,4
Low Pressure – Medium flow pump	0	1	Diesel					300 psi	2500 gpm	1,4
RPV Makeup Pump	1	1	Diesel	X			X	500 psi	500 gpm	1,4
Low Pressure – High flow pump	0	1	Diesel					150 psi	5000 gpm	1,4
Suction Booster Lift Pump	0	2	Diesel					26 ft	5000 gpm	1
Low Voltage Generator	0	1	Diesel	X	X	X	X	480V	1100 KWe	2,4
Medium Voltage Generator	2	2	Diesel	X			X	4kV	1 MWe	2,4
Mobile Lighting Tower	0	3	Diesel					440,000 Lumens	30 Ft high	3,4
Diesel Fuel Transfer Cube	0	2	Diesel					264 gallons	25 gpm (DC)	4
Fuel Air-Lift Container	0	1	NA					500 gallons		4

**Final Integrated Plan  
for Mitigating Strategies for Beyond-Design-Basis External Events and Reliable Spent Fuel Pool  
Instrumentation  
for Monticello Nuclear Generating Plant**

<b>Table 6.2-1 – Portable Equipment From NSRC</b>										
Portable Equipment	Quantity Required	Quantity Provided	Power	Performance Criteria				Performance Criteria		Notes
				Core Cooling	Containment Integrity	Instrumentation	RPV Inventory			
On-Site Diesel Transfer Pump	0	1	Diesel	X	X	X	X	60 gpm		1
Distribution System Panel	0	1	NA					4Kv	1200 Amp	4
Water Treatment Pre-filter	0	1	NA	X				500 gpm		
Water Treatment Reverse Osmosis	0	1	Diesel	X				250 gpm		
Water Storage Tank	0	1	NA					20,000 gallons		

Note 1: The pumps come with associated equipment such as suction and discharge hoses, connections and external fuel tanks.

Note 2: The generators come with associated equipment such as cables and external fuel tanks.

Note 3: Lighting is used where needed to support operations of equipment.

Note 4: NSRC Generic Equipment – Not required for FLEX strategy – Provided for Defense-in-Depth

**Final Integrated Plan  
for Mitigating Strategies for Beyond-Design-Basis External Events and  
Reliable Spent Fuel Pool Instrumentation  
for Monticello Nuclear Generating Plant**

**6.3 NSRC Connections**

4160 Volt Electrical Connections

One connection point is located in the Division I 4kV switchgear room. The other is located in the Division II 4kV switchgear room. The connection will consist of bolting cables to the bus bar. The switchgear is located in a seismic (Class I) section of the Turbine Building.

Connection for Cooling Water Supply to the Reactor

Connections used for offsite portable equipment are the same as that used for on-site portable equipment. For details, see Section 3.1.5.1, "*Connection for Cooling Water Supply to the Reactor.*"

**6.4 Offsite Storage of NSRC Equipment**

Storage of the NSRC equipment to be delivered by SAFER is provided at the NSRC sites located in Memphis, Tennessee and Phoenix, Arizona. These sites are fully redundant and are both capable of delivering equipment within 24 hours of being activated. The Institute of Nuclear Power Operations (INPO) is available to coordinate additional offsite equipment that may be provided by another nuclear plant in the U.S.

Each NSRC holds five (5) sets of equipment, four (4) of which will be able to be fully deployed when requested, the fifth set will have equipment in a maintenance cycle. In addition, on-site FLEX equipment hose and cable end fittings are standardized with the equipment supplied from the NSRC.

Details of the off-site storage strategy are included in the MNGP SAFER Response Plan.

**6.5 Deployment of NSRC Equipment**

SAFER is responsible for the transportation services for the Phase 3 equipment stored at the NSRCs. In accordance with the site specific SAFER Response Plan, equipment delivery will begin 24 hours after the initial request. SAFER will also start and initially run the equipment on site to ensure it is operating properly. Once the equipment is up and running, its operation will be turned over to site personnel.

Site personnel are responsible for setting up the onsite staging areas for the equipment and verifying that the over land travel routes are passable from the staging areas to the final location at the nuclear plant. Phase 3 equipment from the NSRC will be requested prior to the flooding of the main access road or can be brought in on the temporary access road and set up on site in advance of the PMF and expected loss of offsite power.

**Final Integrated Plan  
for Mitigating Strategies for Beyond-Design-Basis External Events and  
Reliable Spent Fuel Pool Instrumentation  
for Monticello Nuclear Generating Plant**

A Memorandum of Understanding (MOU) has been signed with the Xcel Energy Maple Grove Service Center to establish agreement for use of this facility as the SAFER designated Staging Area in the event that the normal site access has not been restored within 24 hours. A MOU with the Three Rivers Park District has been established to permit helicopter operations in the Elm Creek Park Reserve, if necessary.

**Final Integrated Plan  
for Mitigating Strategies for Beyond-Design-Basis External Events and  
Reliable Spent Fuel Pool Instrumentation  
for Monticello Nuclear Generating Plant**

## **7.0 Equipment Operating Conditions**

### **7.1 Ventilation**

Following a BDBEE and subsequent ELAP/LUHS event at MNGP, ventilation providing cooling to occupied areas and areas containing FLEX strategy equipment will be lost. Per the guidance in NEI 12-06, Rev. 2, FLEX strategies must be capable of execution under the adverse conditions (unavailability of installed plant lighting, ventilation, etc.) expected following a BDBEE resulting in an ELAP/LUHS. The primary concern with regard to ventilation is the heat buildup which occurs when forced ventilation is lost in areas that continue to have heat loads. Loss of ventilation analyses were performed to quantify the maximum steady state temperatures expected in specific areas related to FLEX implementation to ensure the environmental conditions remain acceptable for personnel habitability and within equipment qualification limits.

The ELAP will cause loss of ventilation to the plant and heat to be added to the Torus. Temperature analyses have been performed to determine the actions required for the FLEX strategies to be successful. Elevated temperature analyses for the ELAP scenario were performed for areas necessary of access or occupation during the event. See Table 7.1-1 below for Equipment Operating Conditions.

Portable FLEX fans, door openings/damper openings will be used as necessary to reduce temperatures in key areas. Procedures require a portable fan to be used within 10 hours in the RCIC room to ensure the room temperature remains below 130°F. Ventilation to the battery charger rooms is established concurrently with the repowering of the battery chargers.

During Phase 2, supplemental ventilation is provided for the operating personnel using portable ducting and fans for air circulation, as necessary. Portable fans are to be powered by a FLEX 120V Generator. The 250V and 125V battery charger rooms require cooling when the battery charger is energized. Ventilation is provided by staging portable fans to circulate air through the rooms for cooling and to mitigate the potential for hydrogen buildup.

Ventilation to the reactor building (to support the SFP Cooling strategy) will be via natural circulation by opening the reactor building railroad doors and manually opening the inlet dampers of the refuel floor air handling units.

Procedures require that within one hour the decision is made to declare an ELAP. After 10 hours, portable FLEX fans will be staged and powered by the FLEX 120V Generators to provide cooling to the Battery Rooms, RCIC Room and the Control Room.

**Final Integrated Plan  
for Mitigating Strategies for Beyond-Design-Basis External Events and  
Reliable Spent Fuel Pool Instrumentation  
for Monticello Nuclear Generating Plant**

The analyses conclude that adequate ventilation is available to support operating FLEX equipment if high temperatures occur inside plant buildings.

In extreme cold conditions, the ASDS panel area in the EFT building requires the addition of a heating source to ensure that the ASDS Panel equipment and the HPV battery remains functional. Operators are instructed to add portable heaters as needed within 15 hours upon initiation of an ELAP to maintain EFT building third floor temperatures above 40°F.

<b>Table 7.1-1 - Equipment Operating Conditions</b>			
<b>Building</b>	<b>Room</b>	<b>Equipment in the Area</b>	<b>Procedure Actions</b>
Drywell	Drywell	SRVs, RPV Instruments	Note 1
Reactor Building	RCIC Room	RCIC pump skid	Note 2
	Torus Room	Torus, Hard Pipe Vent Containment Isolation Valves, Torus Instruments	Note 1
Control and Administration Building	Control Room	Plant Indication and Operator controls	Note 2
	Battery Rooms	Access for FLEX Load shedding and Primary Electrical connection – Divisions I and II 125 V and Division I 250V	Note 2
EFT Building	Battery Charger Room	Access for FLEX Load shedding and Primary Electrical connection – Division II 250 V, Access to DC-AC Inverters	Note 2
	ASDS Panel Area	Operation of HPV equipment	Note 3

Notes:

1 – No actions required for this area. Post-LOCA environment is considered bounding.

2 - Doors opened and fans deployed.

3 – Heaters are deployed in extreme cold conditions to ensure the ASDS Panel and the HPV battery remain functional.

**Final Integrated Plan  
for Mitigating Strategies for Beyond-Design-Basis External Events and  
Reliable Spent Fuel Pool Instrumentation  
for Monticello Nuclear Generating Plant**

**7.2 Heat Tracing**

As stated in NEI 12-06, Rev. 2, Section 3.2.2, *Minimum Baseline Capabilities*, Guideline 12, heat tracing is used to ensure cold weather conditions do not result in freezing important piping and instrumentation systems with small diameter piping. The primary source of water for Phase 1 FLEX strategy is the Torus. No heat traced components or systems are required for operation using the FLEX strategies. Therefore, no specific action is required to compensate for a loss of heat trace during ELAP.



**Final Integrated Plan  
for Mitigating Strategies for Beyond-Design-Basis External Events and  
Reliable Spent Fuel Pool Instrumentation  
for Monticello Nuclear Generating Plant**

## 8.0 Habitability Analysis

Following a BDBEE, ventilation providing cooling to occupied areas and areas containing FLEX strategy equipment will be lost. The guidance given in NEI 12-06, Rev. 2, FLEX states that the strategies must be capable of execution under the adverse conditions (unavailability of installed plant lighting, ventilation, etc.) expected following an event. The primary concern with regard to ventilation is the heat buildup which occurs with the loss of forced ventilation in areas that continue to have heat loads.

GOTHIC analyses were performed to quantify the maximum steady state temperatures expected in specific areas related to FLEX implementation to ensure the environmental conditions remain acceptable for personnel habitability limits.

## 8.1 Habitability

Critical areas with major FLEX activities that require access are provided in Table 8.1-1 below.

<b>Table 8.1-1 - Habitability Conditions</b>			
<b>Building</b>	<b>Room</b>	<b>Reason for Operator Action</b>	<b>Procedure Action</b>
Reactor Building	East or West Shutdown Cooling Room	RHR valves require opening for FLEX injection path	Note 1
	Train "A" RHR Room	Alternate FLEX water injection connection	Note 2
Control and Administration Building	Control Room	Plant Indication and Operator controls	Note 3
	Cable Spreading Room	Access for FLEX Load stripping	Note 1
	Battery Rooms	Access for FLEX Load shedding and Primary Electrical connection – Divisions I and II 125 V and Division I 250V	Note 3
EFT Building	Battery Charger Room	Access for FLEX Load shedding and Primary Electrical connection – Division II 250 V	Note 3

**Final Integrated Plan  
for Mitigating Strategies for Beyond-Design-Basis External Events and  
Reliable Spent Fuel Pool Instrumentation  
for Monticello Nuclear Generating Plant**

<b>Table 8.1-1 - Habitability Conditions</b>			
<b>Building</b>	<b>Room</b>	<b>Reason for Operator Action</b>	<b>Procedure Action</b>
		Alternate Electrical connection	Note 3
	ASDS Panel Area	HPV controls at ASDS Panel	Note 4
Turbine Building	General Area	Remote control/isolation for pneumatic supply to the HPV system	Note 2
		Primary FLEX water injection connection	Note 2
		Alternate Electrical connection	Note 2

**Notes**

1 – Operator entry to this area is only required early in the event when ambient conditions are suitable for habitability. Later entry would require evaluation on an event specific basis.

2 – Area is located in an area that is not susceptible to significant temperature changes.

3 – Per procedures, doors are opened and fans deployed.

4 –Per procedure, either heating or fans can be added to the ASDS Panel area to mitigate habitability concerns.

Temperature profiles were obtained to provide procedural guidance for the use of FLEX portable ventilation in areas with significant heat sources. These procedures ensure the necessary equipment will run and personnel access will be available as long as necessary. With the use of FLEX portable ventilation, all areas remained functional when access is required.

Cold temperatures inside the plant were also considered and determined not to be a concern early in the event. The reactor building will have a significant heat source in the Torus. Other buildings are massive structures not subject to rapid temperature changes. The ASDS Panel Area in the EFT building may be provided with portable heaters to support habitability during periods of extreme cold weather.

## **8.2 Lighting**

Following the BDBEE, emergency lighting for the CR and other critical areas is accomplished with wall mounted-battery powered lighting units that are designed to last for a minimum of 8 hours. Lighting powered from station batteries is shed as part of the FLEX load shed, but can be repowered after battery chargers are fed from the FLEX 480V Generator. After 11 - 12 hours, the battery chargers are

**Final Integrated Plan  
for Mitigating Strategies for Beyond-Design-Basis External Events and  
Reliable Spent Fuel Pool Instrumentation  
for Monticello Nuclear Generating Plant**

powered from a FLEX 480V Generator which carries the DC loads and will restart emergency lighting.

Several emergency lights are located throughout the plant, including the CR, to illuminate pathways and ASDS Panels. As a backup, operations personnel are instructed by procedure to have a flashlight as a backup in the event the emergency lights are not operating.

Temporary lighting using a portable generator is also available to be installed and used during BDBEE.

There are no emergency lighting fixtures in the yard outside of the protected area to provide necessary lighting in those areas where portable FLEX equipment is to be deployed. For this reason, portable lights are included in the BDBEE Storage Buildings. These portable battery powered lights can be deployed as needed to support night time operations.

The BDBEE Storage Buildings also contain a stock of flashlights and head lights to further assist the staff responding to a BDBEE during low light conditions.

### **8.3 Communications**

In the event of a BDBEE and subsequent ELAP/LUHS, communications systems functionality could be challenged. A standard set of assumptions for a BDBEE is identified in NEI 12-01, *“Guideline for Assessing Beyond Design Basis Accident Response Staffing and Communications Capabilities,”* April 2012 (Reference 8).

Communications necessary to provide onsite command and control of the FLEX strategies and offsite notifications at MNGP can be effectively implemented with a combination of the power block Private Branch Exchange (PBX), sound powered phones, satellite phones, and hand-held radios.

#### Power Block PBX

The Power Block PBX has a battery backup from a non-safety related battery. The battery will supply the power block phone system until the PBX can be repowered by a FLEX 120V Generator. For example, internal continuous communications between the CR and the RCIC room, the AN2 system Train “B”, and the primary FLEX pump connection area will be available.

#### Sound Powered Phones

In addition to the installed sound powered phone system, portable sound powered phones are available in each of the BDBEE Storage Buildings to provide a backup communication system.

#### Satellite Phone System

The Satellite Phone System consists of three uninterruptible power systems supplying power to multiple docking stations, with an antenna and analog

**Final Integrated Plan  
for Mitigating Strategies for Beyond-Design-Basis External Events and  
Reliable Spent Fuel Pool Instrumentation  
for Monticello Nuclear Generating Plant**

telephone handsets for each docking station. Analog telephone handsets are located in the:

- Control Room,
- Operational Support Center,
- Near the ASDS Panel in the EFT Building,
- Technical Support Center, and the
- Emergency Operations Facility.

The system will work for at least 24 hours following the loss of its normal power supply. Plant personnel will use the analog telephone handsets to communicate offsite in the event that local telephones service is lost.

Some of the analog telephone handsets can communicate with the station PBXs.

Hand Held Radios

The site 800 MHz radio equipment is located at the neighboring Sherco Power Plant (a coal plant owned and operated by Xcel Energy Inc., Northern States Power- Minnesota) and is supplied by normal off-site power and backed up by a dedicated liquid propane generator. MNGP also has local repeaters for the radio system which are supplied by the security batteries and security diesel generator. This system is a backup method of communication described in the MNGP emergency plan.

## **8.4 Water Sources**

There are two water sources used for response during Phase 2 of an ELAP event. The credited source is from the Ultimate Heat Sink (the Mississippi River) through the discharge canal or intake structure. The preferred source is through the MNGP CSTs. Because the FLEX Pump is designed to supply water to the RPV and SFP concurrently, the water sources below do not differentiate on the direction of the flow.

### **8.4.1 Ultimate Heat Sink Sources**

A FLEX pump will be used during Phase 2 to supply water from the intake or discharge canal in all events except the beyond-design-basis flooding event. A FLEX portable diesel driven pump will be deployed near the discharge canal or intake structure and take suction directly from the canal or river, with a strainer installed at the suction to prevent large debris from entering the pump.

The FLEX pump will draw water from the discharge canal (behind the traveling screens) or from the intake structure after water has traversed through the travelling screens. The travelling screens stop debris larger than 3/8". The traveling screens would not have power during an ELAP and would be stationary.

**Final Integrated Plan  
for Mitigating Strategies for Beyond-Design-Basis External Events and  
Reliable Spent Fuel Pool Instrumentation  
for Monticello Nuclear Generating Plant**

When the FLEX Pump is injecting water from the intake structure or the discharge canal, reactor fuel is adequately cooled if the reactor water level outside the shroud is maintained above the steam separator return elevation of approximately +48 inches. If fuel blockage occurs, the fuel can be cooled from water spilling over in the core through the steam separators. Procedures direct maintaining reactor water level from +55" to + 100".

**8.4.2 Condensate Storage Tanks**

The CSTs are the preferred source of water for response to the ELAP event simply because the water is cleaner. However, the CSTs may not be available after a seismic or tornado events, as the CSTs are not designed with protection for either event.

During Phase 1, the CSTs are preferred because they provide a cleaner and cooler source of water for RPV injection. A cooler source of water is beneficial as the RCIC pump uses suction flow to cool the pump. A cooler source of water will lengthen the timeframe for operation of the RCIC pump and provide margin to the event response.

During the BDB flooding event, suction for core cooling and SFP cooling will be taken from the CSTs. In a flooding event the CST is used as a water source since the FLEX Pump would be brought inside the flood berm and there is ample time to pre-stage the FLEX Pump to use the CST source.

**Final Integrated Plan  
for Mitigating Strategies for Beyond-Design-Basis External Events and  
Reliable Spent Fuel Pool Instrumentation  
for Monticello Nuclear Generating Plant**

**9.0 Shutdown and Refueling Modes Analysis**

NSPM has adopted the BWROG paper TP-15-019, *BWR-Specific Shutdown Refueling Mode Guidance*, Rev. 0 (Reference 18) as the basis for the MNGP FLEX strategy in Shutdown and Refueling modes. This paper addresses FLEX implementation during plant shutdown and refueling modes, specifically hot shutdown (Mode 3), cold shutdown (Mode 4) and refueling (Mode 5).

The analysis utilizes the risk management concepts described and NRC endorsed in NEI position paper: *Shutdown/Refueling Modes*, (Reference 19). TP-15-019 (Reference 18) expands upon the guidance provided in Reference 19 by defining specific BWR shutdown refueling mode conditions that pose a higher risk of challenges to decay heat removal functions. For each such condition, specific actions are identified that should be considered as part of the outage risk management program that are commensurate with the risk and applicable for a given plant state.

MNGP procedures require one FLEX pump to be available during an outage and also an injection path to the RPV. By procedure the FLEX pump will be staged if the time to uncover the core is less than two hours or if the decay heat removal safety function risk is unacceptably high or if the inventory control safety function risk is unacceptably high.

**Final Integrated Plan  
for Mitigating Strategies for Beyond-Design-Basis External Events and  
Reliable Spent Fuel Pool Instrumentation  
for Monticello Nuclear Generating Plant**

**10.0 Sequence of Events**

Figure 10.0-1 below shows the initial response timeline (first 12 hours) for a FLEX event. The timeline shows only the basic elements of the FLEX strategy.

**Figure 10.0-1**

**FLEX Sequence of Events Timeline**

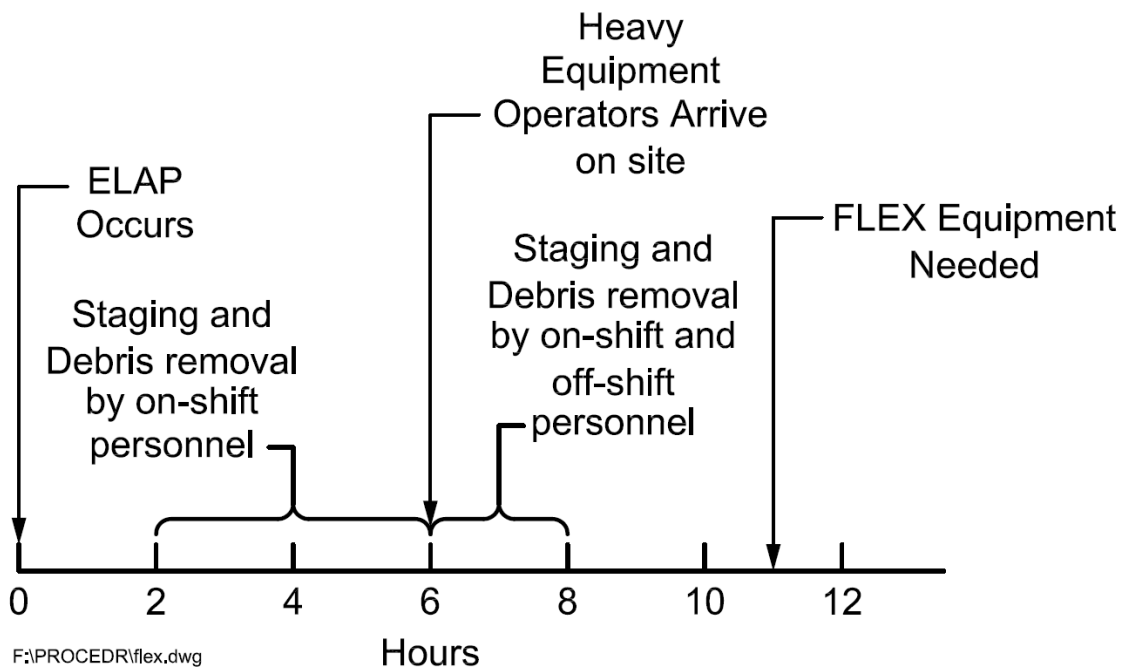

Table 10.0-1 below presents a Sequence of Events (SOE) Timeline for an ELAP/LUHS event at MNGP. Validation of each of the FLEX time constraint actions has been completed in accordance with the FLEX Validation Process document issued by NEI and includes consideration for staffing. The time to clear debris to allow equipment deployment could start as early as hour 2 after the event starts and could occur over 9 hours while simultaneously staging the FLEX equipment. The sequence of events timeline assumes that debris removal is completed by hour 8. This time is considered to be reasonable based on site reviews and the location of the BDBEE Storage Buildings. Debris removal equipment is stored inside the BDBEE Storage Buildings and is, therefore, protected from the external hazards described in Section 4.0.

The sequence of events timeline shows the integrated strategy to provide the capability to indefinitely maintain core cooling, Containment integrity, and spent fuel pool cooling at MNGP.

**Final Integrated Plan  
for Mitigating Strategies for Beyond-Design-Basis External Events and  
Reliable Spent Fuel Pool Instrumentation  
for Monticello Nuclear Generating Plant**

<b>Table 10.0-1 - Sequence of Events Timeline</b>				
<b>Action item</b>	<b>Elapsed Time</b>	<b>Action</b>	<b>FLEX Time Constraint Y/N</b>	<b>Remarks / Applicability</b>
	0	BDBEE occurs	NA	Plant at 100% power
1	A few minutes	Immediate Operator Actions	NA	Verify HPCI and RCIC start at -47". Dispatch operator to investigate EDG.
2	1 hr	Declare ELAP	Y	In order to ensure that follow-on actions are completed consistent with the timelines identified, a timely decision must be made that the SBO condition is an ELAP. From event initiation, operations have one hour to attempt to restart the EDGs and evaluate site conditions prior to making the determination that the condition is an ELAP and entering appropriate procedures and FLEX strategies.
3	2 hrs	Complete DC load shed	Y	This action ensures Safety-Related battery power can be extended through Phase 1. A deep load shed is driven by procedure for the Division I and Division II 125 Vdc and 250 Vdc batteries. Loads are shed by manipulating individual circuit breakers at the distribution panels. A specific sequence of loads to shed has been proceduralized based on priority and efficiency of execution. Individual circuits to be shed are labeled with reflective FLEX labels so they are easy for operators to identify. DC panels are readily accessible and familiar to operators.
4	As directed by procedure	Depressurize Reactor using SRVs to a range that will support continued operation of RCIC	N	Reactor depressurization is secured in a range that will enable continued RCIC operation. Reactor depressurization is not time critical. Depressurization is required prior to venting the Torus. This range has been determined to be 150-300 psig.



**Final Integrated Plan  
for Mitigating Strategies for Beyond-Design-Basis External Events and  
Reliable Spent Fuel Pool Instrumentation  
for Monticello Nuclear Generating Plant**

<b>Table 10.0-1 - Sequence of Events Timeline</b>				
<b>Action item</b>	<b>Elapsed Time</b>	<b>Action</b>	<b>FLEX Time Constraint Y/N</b>	<b>Remarks / Applicability</b>
5	6 hrs	Off-site staffing resources begin to arrive	NA	NA - not a time constraint; included for reference only.
6	6 - 8 hrs	Complete large debris removal	N	Performed by augmented personnel.
7	Per procedure when Torus temperature $\geq 212^{\circ}\text{F}$ and Torus pressure $\geq 10$ psig.	Initiate use of HPV System	Y	The HPV must be opened per the EOPs. Opening the HPV provides a path for heat removal from the Torus which extends time that the Torus is able to function as a heat sink and makeup water source. The vent is powered by a dedicated battery and supplied with Nitrogen from a dedicated pneumatic system. Controls for the HPV are on the ASDS panel outside of the CR but are readily accessible and familiar to operators.
8	8 - 10 hrs	Stage portable diesel driven FLEX pumps for use	N	The FLEX Pump will be staged after hour 8 and before end of hour 10.
9	After 10 hrs	Provide Battery Room ventilation	Y	Necessary for continued qualification and operation of batteries and equipment. Portable FLEX fans are staged and powered by the FLEX 120V Generator and provide cooling to the battery room when the chargers are energized.
10	After 10 hrs	Provide RCIC room cooling	N	Necessary for continued qualification and operation of RCIC equipment. Portable FLEX fans are staged and powered by the FLEX 120V Generator and provide cooling.
11	After 10 hrs	Provide Main CR cooling	N	Necessary for continued Main CR habitability. Portable FLEX fans are staged and powered by the FLEX 120V Generator and provide cooling to the main CR.

**Final Integrated Plan  
for Mitigating Strategies for Beyond-Design-Basis External Events and  
Reliable Spent Fuel Pool Instrumentation  
for Monticello Nuclear Generating Plant**

<b>Table 10.0-1 - Sequence of Events Timeline</b>				
<b>Action item</b>	<b>Elapsed Time</b>	<b>Action</b>	<b>FLEX Time Constraint Y/N</b>	<b>Remarks / Applicability</b>
12	11 hrs or before	Begin FLEX Pump injection to the RPV	Y	Necessary for continued cooling and inventory makeup for the RPV.
13	11 hrs or before	Repower batteries using portable FLEX 480V Diesel Generator	Y	Necessary for continued DC power. Portable FLEX 480V Generator and necessary deployment equipment will be stored in a protected structure.
14	11 hrs	Repower PBX	N	Necessary for continued operation of plant phone system. FLEX 120V Generators will maintain the phone system powered and available for use.
15	After 22 hrs	Refuel portable equipment	Y	Procedures direct the refueling requirements for the portable equipment.
16	24 hr or before	Supplement HPV equipment	N	Provide additional nitrogen to support sustained operation of the HPV through the replacement of bottles. Transfer HPV loads from the HPV Battery to the station batteries that are repowered using the portable FLEX 480V Generator.
17	25 hr or before	Supplement Alternate Nitrogen	Y	Provide additional nitrogen supply to the Alternate Nitrogen System to support continued SRV operation. Bottles are staged in accessible areas.
18	25 - 72 hrs	Supplement on-site equipment with equipment from the NSRC	Y	The NSRC equipment will provide a reliable backup to the on-site portable equipment for extended operation. It will restore power to a 4160 V AC bus and restore water make up from the UHS per the direction of the fully staffed ERO.
19	57 hours or before	Begin FLEX Pump injection to the SFP	Y	Necessary for continued cooling and inventory makeup of the SFP.

**Final Integrated Plan  
for Mitigating Strategies for Beyond-Design-Basis External Events and  
Reliable Spent Fuel Pool Instrumentation  
for Monticello Nuclear Generating Plant**

## **11.0 FLEX Program Items**

### **11.1 FLEX Program Document**

The program document satisfies the requirement of NEI 12-06, Diverse and Flexible Coping Strategies (FLEX) Implementation Guide, Rev. 2. The program document also contains elements of the following Nuclear Energy Institute (NEI) guidance documents necessary to meet and implement the FLEX strategies.

- NEI 12-01, Guideline for Assessing Beyond Design Basis Accident Response Staffing and Communications Capabilities (Reference 8).
- NEI 12-02, Industry Guidance for Compliance with NRC Order EA-12-051, “To Modify Licenses with Regard to Reliable Spent Fuel Pool Instrumentation” (Reference 6).

The MNGP FLEX Program document contains the following key elements:

- Description of FLEX strategies and basis
- Maintenance of the FSGs including any impacts on the interfacing procedures (EOPs, AOPs, etc.)
- Maintenance and testing of FLEX equipment (i.e., SFP level instrumentation, emergency communications equipment, portable FLEX equipment, FLEX support equipment, and FLEX support vehicles)
- Portable equipment deployment routes, staging areas, and connections to existing mechanical and electrical systems
- Validation of time sensitive operator actions
- The BDBEE Storage Buildings and the National SAFER Response Center
- Hazards considerations (Flooding, Seismic, High Winds, etc.)
- References to supporting evaluations, calculations and drawings
- Tracking of commitments and equipment unavailability
- Staffing, Training, and Emergency Drills
- Configuration Management
- Program Maintenance

In addition, the program description references:

- (1) a list of the BDBEE FLEX and SFPI basis documents and MNGP procedures,
- (2) a historical record of previous strategies and their bases, and
- (3) the bases for ongoing maintenance and testing activities for the FLEX equipment.

**Final Integrated Plan  
for Mitigating Strategies for Beyond-Design-Basis External Events and  
Reliable Spent Fuel Pool Instrumentation  
for Monticello Nuclear Generating Plant**

The instructions required to implement the various elements of the FLEX Program and thereby ensure readiness in the event of a BDBEE, are contained in fleet procedures.

Existing design control procedures have been revised to ensure that changes to the plant design, physical plant layout, roads, buildings, and miscellaneous structures will not adversely impact the approved FLEX strategies.

Future changes to the FLEX strategies may be made without prior NRC approval provided:

- The revised FLEX strategies meets:
  1. The requirements of NEI 12-06, Rev. 2, or
  2. The change to the strategies and guidance implement an alternative or exception approved by the NRC, provided that the bases of the NRC approval are applicable to MNGP, or
  3. An evaluation demonstrates that the provisions of Order EA-12-049 continue to be met,

And,

- An engineering basis is documented that ensures that the change in FLEX strategies continues to ensure the key safety functions (Containment, core and SFP cooling) are met.

## **11.2 Procedural Guidance**

The inability to predict actual plant conditions that require the use of FLEX equipment makes it impossible to provide specific procedural guidance. As such, the FLEX Support Guidelines (FSGs) provide guidance that can be employed for a variety of conditions. Clear criteria for entry into FSGs ensures that FLEX strategies are used only as directed for BDBEE conditions, and are not used inappropriately in lieu of existing procedures. When FLEX equipment is needed to supplement EOPs or Abnormal Operating Procedures (AOPs) strategies, the EOP or AOP directs the entry into and exit from the appropriate FSG procedure.

The overall plant response to an ELAP will be accomplished through normal plant command and control procedures and practices. The plant EOPs (C.5s) or abnormal operating procedures (C.4s) govern the operational response. The FLEX strategies are deployed using a separate set of procedures called FSGs. The FSGs provide direction for using FLEX equipment in maintaining or restoring key safety functions. The hierarchy shown in Figure 11.2-1 below illustrates the relationship between the FSGs and other plant procedures.

## Final Integrated Plan for Mitigating Strategies for Beyond-Design-Basis External Events and Reliable Spent Fuel Pool Instrumentation for Monticello Nuclear Generating Plant

Figure 11.2-1

### Procedure Hierarchy

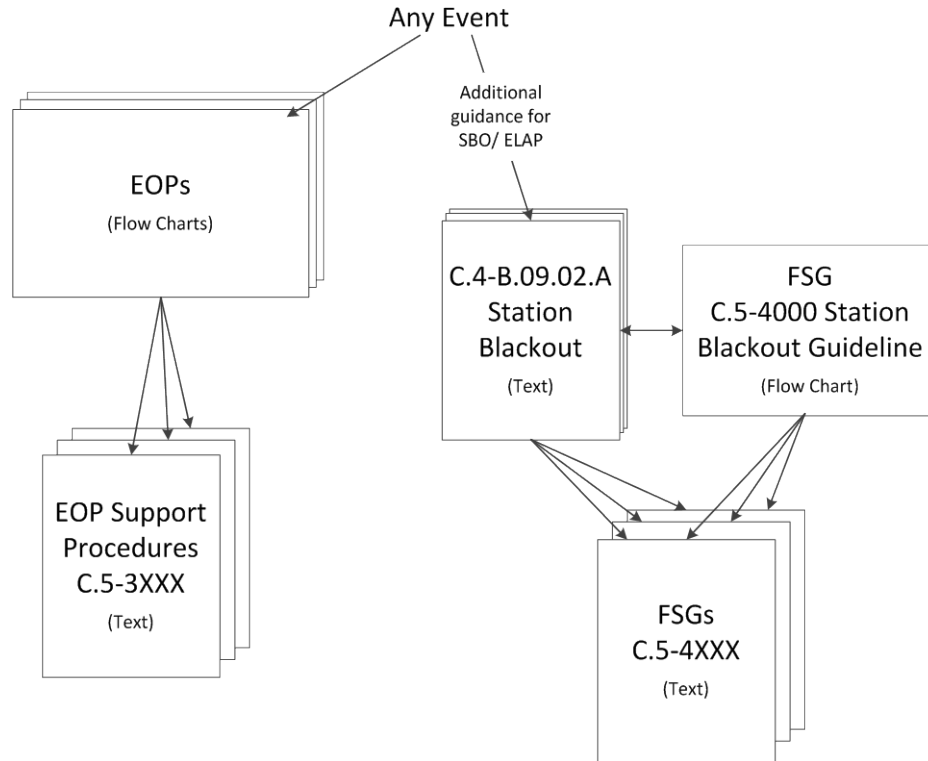

FSG maintenance is performed by the Station Procedures group via the Procedure Change Request in the NSPM nuclear fleet procedures. In accordance with fleet corporate directives, NEI 96-07, Revision 1 (Reference 20) is to be used to evaluate changes to current procedures, including the FSGs, to determine the need for prior NRC approval. However, per the guidance and examples provided in NEI 96-07, Revision 1, changes to procedures (EOPs, AOPs, or FSGs) that perform actions in response events that exceed a site's design-basis should screen out. Therefore, procedure steps which recognize the BDBEE ELAP/LUHS has occurred and which direct FLEX strategy actions to ensure core cooling, Containment, or SFP cooling should not require prior NRC approval.

FSGs have been reviewed and validated by the involved groups to the extent necessary to ensure that implementation of the associated FLEX strategy is feasible. Specific FSG validation was accomplished via table top evaluations and walk-throughs of the guidelines, when appropriate.

**Final Integrated Plan  
for Mitigating Strategies for Beyond-Design-Basis External Events and  
Reliable Spent Fuel Pool Instrumentation  
for Monticello Nuclear Generating Plant**

A listing of FSG procedures used to perform mitigation strategies associated with an ELAP/LUHS event is provided in Table 11.2-1. Other procedures that interface with and support FLEX operations are identified in Table 11.2-2.

**Table 11.2-1 - FLEX Support Guidelines**

<b>Document No.</b>	<b>Title</b>
C.5-4000	Station Blackout Guideline
C.5-4101	FLEX Site Assessment
C.5-4102	FLEX Debris Removal
C.5-4103	FLEX Response During External Flooding
C.5-4201	FLEX Portable Diesel Pump Staging and Hose Connection
C.5-4202	FLEX Portable Diesel Pump (PDP) Operation
C.5-4203	RCIC Operation with High Level Trip Bypassed
C.5-4204	HPCI Operation with High Level Trip Bypassed
C.5-4301	Spent Fuel Pool Makeup with FLEX Portable Diesel Pump
C.5-4401	FLEX DC Load Shed
C.5-4402	Stage and Connect FLEX 480V Portable Diesel Generator
C.5-4403	FLEX Portable Generator Operation
C.5-4404	Operate Essential Battery Chargers from FLEX Portable Diesel Generator
C.5-4405	Backfeed MCCs from 480V Portable Diesel Generator
C.5-4406	Stage 120V Portable Diesel Generator
C.5-4410	FLEX 4kV Generator Installation
C.5-4453	Energize Hard Pipe Vent During SBO
C.5-4501	Reactor Building Ventilation During FLEX Conditions
C.5-4502	Control Room and PAB Ventilation During FLEX Conditions
C.5-4503	EFT Ventilation During FLEX Conditions
C.5-4504	Temporary Lighting During FLEX Conditions

**Final Integrated Plan  
for Mitigating Strategies for Beyond-Design-Basis External Events and  
Reliable Spent Fuel Pool Instrumentation  
for Monticello Nuclear Generating Plant**

**Table 11.2-2 - FLEX Interface and Support Procedures**

Document No.	Title
A.6	Acts of Nature
8300-02	External Flooding Protection Implementation to Support A.6 Acts of Nature
A.8-02.01	Spent Fuel Pool (SFP) Strategies
A.8-06.02	Repower PAB PBX Phone System with Portable Generator
A.8-06.03	Refueling Emergency Portable Diesel Powered Equipment
A.8-06.04	Alternate Methods for Monitoring RX Vessel and Containment Parameters
C.4-B.09.02.A	Station Blackout
C.5-2002	Emergency RPV Depressurization
C.5-3201	Defeat RCIC Isolations
C.5-3202	Defeat HPCI Signals
C.5-3203	Use of Alternate Injection Systems for RPV Makeup
C.5-3302	Alternate Pressure Control
C.5-3505	Venting Primary Containment
E.4-01	Backfeed Bus 13 from 13 DG
FP-BDB-IP-01	SAFER Response Staging Area Procedure
FP-BDB-EQP-01	Equipment Important to BDB Compliance
FP-BDB-CHNG-01	FLEX Strategy Change Process
OSP-FIR-1489	B.5.B/FLEX Equipment Inventory
4 AWI-08.15.03	Risk Management for Outages

### 11.3 Staffing Analysis

Using the methodology of NEI 12-01, *Guideline for Assessing Beyond Design Basis Accident Response Staffing and Communications Capabilities*, (Reference 8) an assessment of the capability of the MNGP on-shift staff to respond to a BDBEE was performed (Reference 21). The results were provided to the NRC (Reference 22).

The assumptions for the NEI 12-01 Phase 2 scenario postulate that the BDBEE involves a large-scale external event that results in:

- an ELAP has occurred

**Final Integrated Plan  
for Mitigating Strategies for Beyond-Design-Basis External Events and  
Reliable Spent Fuel Pool Instrumentation  
for Monticello Nuclear Generating Plant**

- a hostile action directed at the site does not occur during the period that the site is responding the BDBEE.
- impact on the unit (unit is operating at full power at the time of the event)
- impeded access to the unit by off-site responders as follows:
  - 0 to 6 Hours Post Event- No site access.
  - 6 to 24 Hours Post Event - Limited site access. Individuals may access the site by walking, personal vehicle or via alternate transportation capabilities (e.g., private resource providers or public sector support).
  - 24+ Hours Post Event - Improved site access. Site access is restored to a near-normal status and/or augmented transportation resources are available to deliver equipment, supplies and large numbers of personnel.

The current shift complement for MNGP consisting of 12 operations personnel and one security officer for a total of 13 personnel perform FLEX responses. As described above, the study assumed that only onsite personnel respond to the event for the first six hours. The security officer fills the role of Shift Emergency Communicator for non-FLEX events. After six hours, additional personnel arrive on site to assist the on-site staff.

The Phase 2 Staffing Assessment concluded that the current minimum on-shift staffing as defined in the MNGP Emergency Plan is sufficient to support the implementation of the mitigating strategies (FLEX strategies), with no unacceptable collateral tasks assigned to the on-shift personnel during the first six hours.

The staffing assessments noted above were performed in conjunction with the development of procedures and guidelines that address NRC Order EA-12-049. Once the FSGs were developed, a validation assessment of the FSGs was performed using the staff deemed available per the staffing studies. The validation process was performed and documented in accordance with NEI Guidance (Reference 23).

#### **11.4 Training**

MNGP's Nuclear Training Program has been revised to assure personnel proficiency in the mitigation of BDBEEs is adequate and maintained. These programs and controls were developed and have been implemented in accordance with the Systematic Approach to Training (SAT) Process.

Initial training has been provided and periodic training will be provided to site emergency response leaders on BDBEE emergency response strategies and implementing guidelines. Personnel assigned to direct the execution of mitigation strategies for BDBEEs have received the necessary training to ensure familiarity



**Final Integrated Plan  
for Mitigating Strategies for Beyond-Design-Basis External Events and  
Reliable Spent Fuel Pool Instrumentation  
for Monticello Nuclear Generating Plant**

with the associated tasks, considering available job aids, instructions, and mitigating strategy time constraints.

Care has been taken to not give undue weight (in comparison with other training requirements) for Operator training for BDBEE accident mitigation. The testing/evaluation of operator knowledge and skills in this area have been similarly weighted. ANSI/ANS 3.5, "Nuclear Power Plant Simulators for use in Operator Training" certification of simulator fidelity is considered to be sufficient for the initial stages of the BDBEE scenario.

The Full Scope Simulator has been modified to reflect the changes and modifications performed as part of the mitigating strategies implementation. These modifications include, as examples, enhanced DC modeling to reflect the load shed procedure as well as back-feeding of 4KV busses, a SFP Level Indicator, and flow dynamics to align with planned injection with external water sources.

Validation demonstrations were performed as part of the FLEX order compliance. The validation demonstrated that the FLEX strategies would work within the timeframes allotted. As part of the validation, connections to plant SSCs were accomplished, when available. Therefore, it is not required to connect/operate permanently installed equipment during the FLEX drills.

It is NSPM's intention to comply with drill/exercise performance requirements consistent the final BDBEE rulemaking language. NSPM will continue to utilize the guidance of NEI 13-06 and NEI 14-01 insofar as it is consistent with the regulatory requirements promulgated in the final rulemaking.

## **11.5 Equipment List**

The equipment stored and maintained in the MNGP BDBEE Storage Buildings necessary for the implementation of the FLEX strategies in response to a BDBEE is listed in Table 11.5-1. Table 11.5-1 identifies the quantity, applicable strategy, and capacity/rating for the major FLEX equipment components only, as well as various clarifying notes. Specific details regarding fittings, tools, hose lengths, consumable supplies, etc. are not provided in Table 11.5-1.

**Final Integrated Plan  
for Mitigating Strategies for Beyond-Design-Basis External Events and Reliable Spent Fuel Pool  
Instrumentation  
for Monticello Nuclear Generating Plant**

<b>Table 11.5-1 – Portable Equipment Stored in MNGP BDBEE Storage Buildings</b>						
<b>Portable Equipment</b>	<b>FLEX Strategy Use</b>					<b>Performance Criteria</b>
	<b>Core</b>	<b>Containment</b>	<b>SFP</b>	<b>Instrumentation</b>	<b>Accessibility</b>	
FLEX Pumps (2) and associated hoses and fittings	X	X	X			1000 gpm at 455 ft
FLEX 480V Generators (2) and associated cables and connectors		X		X		200 Kw
FLEX 120V Generators (2) and associated cables and connectors				X	X	12 Kw
Front End Loader (1)					X	Debris removal equipment redundant to fork lift. Note 5
Fork Lift (1)					X	Debris removal equipment redundant to front end loader. Note 5
Tow Vehicles (2)	X	X	X		X	Notes 1, 5
Hose Trailers (2)	X	X	X		X	Note 2

**Final Integrated Plan  
for Mitigating Strategies for Beyond-Design-Basis External Events and Reliable Spent Fuel Pool  
Instrumentation  
for Monticello Nuclear Generating Plant**

<b>Table 11.5-1 – Portable Equipment Stored in MNGP BDBEE Storage Buildings</b>						
<b>Portable Equipment</b>	<b>FLEX Strategy Use</b>					<b>Performance Criteria</b>
	<b>Core</b>	<b>Containment</b>	<b>SFP</b>	<b>Instrumentation</b>	<b>Accessibility</b>	
Fans/Blowers (8) and ducting					X	
Light Units (18)					X	
Communications Equipment	X	X	X	X	X	Note 3
Misc. Debris Removal Equipment					X	Note 4
Misc. Support Equipment					X	Note 4

**Notes:**

- 1 – Contains 5” and 2 ½” supply hoses and fittings, 480V Cable reel, and Fuel Transfer Cube with hose.
- 2 – Contains 5”, 2 ½” and 1 ½” supply hoses.
- 3 – Sound-Powered phones, headsets and cords, and portable radios (Warehouse #6 only).
- 4 – Includes chain saws, chop saws, extension cords, ladders, tow chains, portable shelters, tools, instruments, etc.
- 5 – Towing and debris removal vehicles are intended for multi-purpose use. A front end loader and a large fork lift are designated for debris removal. The debris removal vehicles are also capable of performing towing functions for deployment of equipment, if necessary. This equipment is not dedicated to FLEX and therefore, may be used for non-FLEX work. Non-FLEX use of the equipment is controlled by site procedures.

**Final Integrated Plan  
for Mitigating Strategies for Beyond-Design-Basis External Events and  
Reliable Spent Fuel Pool Instrumentation  
for Monticello Nuclear Generating Plant**

### **11.6 N+1 Equipment Requirement**

NEI 12-06, Rev. 2, invokes an N+1 requirement for the major FLEX equipment that directly performs a FLEX mitigation strategy for core cooling, Containment, or SFP cooling in order to assure reliability and availability of the FLEX equipment required to meet the FLEX strategies. Sufficient equipment has been purchased to address all functions at MNGP, plus one additional spare, i.e., an N+1 capability, where "N" is the number of equipment required by FLEX strategies to accomplish the FLEX mitigation function. Therefore, where a single resource is sized to support multiple functions a second resource has been purchased to meet the +1 capability. In addition, where multiple strategies to accomplish a function have been developed, the equipment associated with each strategy does not require N+1 capability.

The N+1 capability applies to the portable FLEX equipment that directly supports maintenance of the key safety functions identified in Table 3-1 of NEI 12-06, Rev. 2. Other FLEX support equipment provided for mitigation of BDBEEs, but not directly supporting a credited FLEX strategy, is not required to have N+1 capability.

In the case of hoses and cables associated with FLEX equipment required for FLEX strategies, MNGP requires that one full set of cables and hoses be provided with the major piece of equipment (generator and pump). Additional cables and hoses are stored in the BDBEE storage buildings beyond that required to support one full set of FLEX equipment.

The N+1 requirement does not apply to the FLEX support equipment, vehicles, and tools. However, these items are covered by an administrative procedure and are subject to inventory checks, requirements, and any maintenance and testing that are needed to ensure they can perform their required functions.

### **11.7 FLEX Equipment Maintenance and Testing**

Initial Component Level Testing, consisting of Factory Acceptance Testing and Site Acceptance Testing, was conducted to ensure the portable FLEX equipment can perform its required FLEX strategy design functions. Factory Acceptance Testing verified that the portable equipment performance conformed to the manufacturers rating for the equipment as specified in the Purchase Order. Verification of the vendor test documentation was performed as part of the receipt inspection process for each of the affected pieces of equipment and included in the applicable Vendor Technical Manuals. Site Acceptance Testing confirmed Factory Acceptance Testing to ensure portable FLEX equipment delivered to the site performed in accordance with the FLEX strategy functional design requirements.

**Final Integrated Plan  
for Mitigating Strategies for Beyond-Design-Basis External Events and  
Reliable Spent Fuel Pool Instrumentation  
for Monticello Nuclear Generating Plant**

The portable FLEX equipment that directly performs a FLEX mitigation strategy for the core cooling, Containment, or SFP cooling is subject to periodic maintenance and testing in accordance with NEI 12-06, Rev. 2, (Reference 25) and INPO AP-913, *Equipment Reliability Process*, (Reference 24), to verify proper function. This is included in the NSPM Preventive Maintenance program, as described below, to ensure it will perform its required functions during a BDBEE.

Maintenance and testing of FLEX equipment is governed by the NSPM Preventive Maintenance (PM) Program. The NSPM PM Program is consistent with INPO AP-913 and utilizes the EPRI Preventive Maintenance Basis Database as an input in development of fleet specific MNGP PM Basis Templates. Based on this, the NSPM fleet PM program for FLEX equipment follows the guidance NEI 12-06, Rev. 2, Section 11.5.

Maintenance and testing procedures have been developed for FLEX equipment using the following guidance:

- Credited FLEX equipment with existing EPRI Preventive Maintenance (PM) Template - PMs are developed using the EPRI template as guidance or justifying deviations in the program document.
- Credited equipment that has no EPRI PM Template - PMs are developed using manufacturer's recommendations and the knowledge that the FLEX equipment will have few operating hours and deviations to the manufacturer's guidance will be required.

The NSPM FLEX equipment PM Basis Templates include activities such as:

- Periodic Static Inspections
- Fluid analysis
- Operational Inspections
- Periodic functional verifications
- Periodic performance verification tests

FLEX support equipment (i.e. trailers, Fuel transfer Cubes, chainsaws, chopsaws, etc.) and vehicles also require maintenance and testing to ensure they will perform their required functions during a BDBEE. The performance of the PMs and test procedures are controlled through the MNGP work order process. In addition, all the FLEX equipment is verified to be in place for use quarterly and its condition inspected annually.

Equipment stored with SAFER also have PM and testing programs developed to ensure that equipment will function when called upon to operate.

**Final Integrated Plan  
for Mitigating Strategies for Beyond-Design-Basis External Events and  
Reliable Spent Fuel Pool Instrumentation  
for Monticello Nuclear Generating Plant**

**11.8 FLEX Equipment Unavailability**

The unavailability of equipment and applicable connections that directly performs a FLEX mitigation strategy for core, Containment, and SFP (including SFP level instruments) are managed such that risk to mitigating strategy capability is minimized. Maintenance/risk guidance conforms to the guidance of NEI 12-06, Rev. 2, as follows:

- Portable FLEX equipment and SFP instruments may be unavailable for up to 90 days provided that the site FLEX capability (N set) is available.
- Connections to permanent equipment required for FLEX strategies can be unavailable for 90 days provided alternate capabilities remain functional.
- Portable equipment that is expected to be unavailable for more than 90 days or expected to be unavailable during forecasted site specific external events (e.g., flooding) should be supplemented with alternate suitable equipment.
- The short duration of equipment unavailability, discussed above, does not constitute a loss of reasonable protection from a diverse storage location protection strategy perspective.
- If portable equipment becomes unavailable such that the site FLEX capability (N) is not maintained, initiate actions within 24 hours to restore the site FLEX capability (N) and implement compensatory measures (e.g., repair equipment, use of alternate suitable equipment or supplemental personnel) within 72 hours.

Temporary compensatory measures may be used to offset a loss of function of FLEX equipment. Compensatory measures may include use of alternate suitable equipment or supplemental personnel. NSPM Work Management procedures reflect the permitted out of service times as outlined above.

For the generic SAFER equipment, SAFER maintains one additional unit or set of units at each NSRC beyond the minimum equipment needed to support four reactor units at one time. This allows for one unit to be out of service for maintenance at any time. The SAFER program uses this additional equipment to minimize the risk of required equipment being out of service for greater than 90 days.

PEIco procedures are in place for tracking equipment out of service, handling nonconformance reports, informing the SAFER participants, and developing a recovery plan, which will include replacing the equipment or making equivalent equipment available within 90 days. These procedures apply to the generic and the non-generic equipment.

**Final Integrated Plan  
for Mitigating Strategies for Beyond-Design-Basis External Events and  
Reliable Spent Fuel Pool Instrumentation  
for Monticello Nuclear Generating Plant**

**11.9 FLEX Program Supporting Analyses**

Table 11.9-1 below provides a listing of the calculations and analyses performed to support the implementation of the FLEX strategies for MNGP.

<b>Table 11.9-1 - FLEX Supporting Analyses and Key Calculations</b>		
<b>Document Type</b>	<b>Document Number</b>	<b>Title</b>
EC	23419	Fukushima Response Spent Fuel Pool Instrumentation
EC	23475	Fukushima Response Portable Diesel Generator Connections
EC	23477	Fukushima Response Satellite Phone Communications
EC	23478	Fukushima Response FLEX Storage Building
EC	23479	Fukushima Response RPV Injection Point
EC	24147	Fukushima Implementation EC
EC	26081	Tornado Missile Barrier for Hardened Containment Venting System
EC	26083	Hardened Containment Venting System NRC Order EA-13-109 Phase 1
EC	28516	FLEX – Time to Bottle Replacement for AN2
Calculation	90-038	Control Room Space Temperature Evaluation During Station Blackout
Calculation	96-074	Station Blackout (SBO) Heat-up of the EFT Building
Calculation	14-009	FLEX Alternate Nitrogen Requirements
Calculation	14-010	FLEX Tornado Missile Separation
Calculation	14-023	Monticello B5b Scenario Hydraulic Analysis SPF Makeup
Calculation	14-024	Monticello B5b Pump P-506/P-507 Hydraulic Analysis
Calculation	14-036	250V D7 Battery FLEX Coping Time Analysis
Calculation	14-080	External Flooding Timeline
Calculation	14-099	125V D1 Battery FLEX Coping Time Analysis
Calculation	14-100	125V D2 Battery FLEX Coping Time Analysis
Calculation	14-101	250V D3 Battery FLEX Coping Time Analysis
Calculation	14-102	250V D6 Battery FLEX Coping Time Analysis
Calculation	14-112	Reactor Building Heat-up During an Extended Loss of AC Power (ELAP)
Calculation	15-004	FLEX Pump Simultaneous SFP/RPV Flow
Calculation	15-017	PAB/ELAP Battery Rooms Heat-up During a SBO and ELAP
Calculation	15-038	Monticello Seismic & Tornado Analysis of the Plant Admin Building

**Final Integrated Plan  
for Mitigating Strategies for Beyond-Design-Basis External Events and  
Reliable Spent Fuel Pool Instrumentation  
for Monticello Nuclear Generating Plant**

<b>Table 11.9-1 - FLEX Supporting Analyses and Key Calculations</b>		
<b>Document Type</b>	<b>Document Number</b>	<b>Title</b>
Calculation	16-002	Evaluation of HPV Missile Barrier – Upper & Intermediate Frames
Calculation	16-003	Evaluation of HPV Missile Barrier – Lower Frame
Calculation	16-006	Hard Pipe Vent D8 Battery HCVS 125VDC Battery Calculation
Calculation	16-011	Calculation of HPV System Dedicated Nitrogen Supply and Pressure Requirements



**Final Integrated Plan  
for Mitigating Strategies for Beyond-Design-Basis External Events and  
Reliable Spent Fuel Pool Instrumentation  
for Monticello Nuclear Generating Plant**

**12.0 References**

1. USNRC, "Recommendations for Enhancing Reactor Safety in the 21st Century; The Near-Term Task Force Review of Insights from the Fukushima Dai-Ichi Accident," July 12, 2011. (ADAMS Accession No. ML111861807)
2. NRC Order EA-12-049, "Issuance of Order to Modify Licenses with Regard to Requirements for Mitigation Strategies for Beyond-Design-Basis External Events," dated March 12, 2012. (ADAMS Accession No. ML12054A735)
3. NEI 12-06, "Diverse and Flexible Coping Strategies (FLEX) Implementation Guide," Revision 0, dated August 2012. (ADAMS Accession No. ML12242A378)
4. NRC Interim Staff Guidance JLD-ISG-2012-01, "Compliance with Order EA-12-049, Order Modifying Licenses with Regard to Requirements for Mitigation Strategies for Beyond-Design-Basis External Events," Revision 0, dated August 29, 2012. (ADAMS Accession No. ML12229A174)
5. NRC Order EA-12-051, "Issuance of Order to Modify Licenses with Regard to Reliable Spent Fuel Pool Instrumentation," dated March 12, 2012. (ADAMS Accession No. ML12054A682)
6. NEI 12-02, "Industry Guidance for Compliance with NRC Order EA-12-051, 'To Modify Licenses with Regard to Reliable Spent Fuel Pool Instrumentation,'" Revision 1, dated August 2012. (ADAMS Accession No. ML12240A307)
7. NRC Interim Staff Guidance JLD-ISG-2012-03, "Compliance with Order EA-12-051, Reliable Spent Fuel Pool Instrumentation," Revision 0, dated August 29, 2012. (ADAMS Accession No. ML12221A339)
8. NEI 12-01, "Guideline for Assessing Beyond Design Basis Accident Response Staffing and Communications Capabilities," Revision 0, dated April 2012. (ADAMS Accession No. ML12110A204)
9. AREVA 38-9233760-000, "SAFER Response Plan for Monticello Nuclear Generating Plant," Revision 001, dated January 23, 2015.
10. Letter N. Pappas (NEI) to J. Davis (NRC), "Subject: EA-12-049 Mitigating Strategies Resolution of Extended Battery Duty Cycles Generic Concern," dated August 27, 2013, contains NEI White Paper: Battery Life Issues, dated August 21, 2013. (ADAMS Accession No. ML13239A339)
11. 0000-0155-1545-R0, "BWROG – RCIC Pump and Turbine Durability Evaluation – Pinch Point Study," February 2013.

**Final Integrated Plan  
for Mitigating Strategies for Beyond-Design-Basis External Events and  
Reliable Spent Fuel Pool Instrumentation  
for Monticello Nuclear Generating Plant**

12. Letter from P. Gardner (NSPM) to Document Control Desk (NRC), "Monticello Nuclear Generating Plant Completion of Required Action by NRC Order EA-12-051 Reliable Spent Fuel Pool Instrumentation (TAC No. MF0924)," L-MT-15-046, dated July 28, 2015. (ADAMS Accession No. ML15212A114)
13. "Monticello Nuclear Generating Plant, Updated Final Safety Analysis Report," Revision 34.
14. USNRC, "Request for Information Pursuant to Title of the Code of Federal Regulations 50.54(f) Regarding Recommendations 2.1, 2.3, and 9.3 of the Near Term Task Force Review of Insights from the Fukushima Dai-Ichi Accident," dated March 12, 2012. (ADAMS Accession No. ML12056A046)
15. Letter from K. Fili (NSPM) to Document Control Desk (NRC), "MNGP Seismic Hazard and Screening Report (CEUS Sites), Response to NRC Request for Information Pursuant to Title 10 of the *Code of Federal Regulations* 50.54(f) Regarding Recommendation 2.1 of the Near-Term Task Force Review of Insights from the Fukushima Dai-Ichi Accident," L-MT-14-045, dated May 14, 2014. (ADAMS Accession No. ML14136A288)
16. Letter from P. Gardner (NSPM) to Document Control Desk (NRC), "Monticello Nuclear Generating Plant: Response to Post-Fukushima Near-Term Task Force (NTTF) Recommendation 2.1, Flooding – Flood Hazard Reevaluation Report," L-MT-16-024, dated May 12, 2016. (ADAMS Accession Nos. ML16145A179 and ML16145A180)
17. "Monticello Nuclear Generating Plant, Technical Specifications," through Amendment 193.
18. BWROG-TP-15-019, "BWR-Specific Shutdown Refueling Mode Guidance," Revision 0, dated December 2015.
19. NEI Position Paper, "Shutdown/Refueling Modes," Revision 0, dated September 18, 2013. (ADAMS Accession No. ML13190A152)
20. NEI 96-07, "Guidelines for 10CFR50.59 Implementation," Revision 1, November 2000.
21. "Monticello Nuclear Generating Plant, Fukushima Response NEI 12-01 Phase 2 Staffing Assessment Report," dated April 15, 2015
22. Letter from P. Gardner (NSPM) to Document Control Desk (NRC), "Monticello Nuclear Generating Plant Phase 2 Staffing Assessment Revised - Onsite and Augmented Staffing Assessment Considering Functions Related to Near-Term Task Force (NTTF) Recommendation 4.2," L-MT-15-027, dated April 30, 2015. (ADAMS Accession No. ML15128A264)

**Final Integrated Plan  
for Mitigating Strategies for Beyond-Design-Basis External Events and  
Reliable Spent Fuel Pool Instrumentation  
for Monticello Nuclear Generating Plant**

23. NEI guidance document, "FLEX (Beyond Design Basis) Validation Process."
24. INPO AP 913, "Equipment Reliability Process Description, Institute of Nuclear Power Operations," Revision 3, March 2011.
25. NEI 12-06, "Diverse and Flexible Coping Strategies (FLEX) Implementation Guide," Revision 2, dated December 2015. (ADAMS Accession No. ML16005A625)
26. NRC Interim Staff Guidance JLD-ISG-2012-01, "Compliance with Order EA-12-049, Order Modifying Licenses with Regard to Requirements for Mitigation Strategies for Beyond-Design-Basis External Events," Revision 1, dated January 22, 2016. (ADAMS Accession No. ML15357A163)
27. Letter W. Dean (NRC) to K. Fili (NSPM), "Subject: Monticello Nuclear Generating Plant – Relaxation of Certain Schedule Requirements for Order EA-12-049 'Issuance of Order to Modify Licenses with Regard to Requirements for Mitigation Strategies for Beyond Design Basis External Events' (TAC No. MF0923)," dated November 21, 2014. (ADAMS Accession No. ML14294A061)
28. Letter from P. Gardner (NSPM) to Document Control Desk (NRC), "Spent Fuel Pool Evaluation Supplemental Report, Response to NRC Request for Information Pursuant to 10 CFR 50.54(f) Regarding Recommendation 2.1 of the Near-Term Task Force Review of Insights from the Fukushima Dai-Ichi Accident," L-MT-16-053, dated October 28, 2016. (ADAMS Accession No. ML16302A246)