

Open Secondary Testing of Window-Type Current Transformers

AVAILABILITY OF REFERENCE MATERIALS IN NRC PUBLICATIONS

NRC Reference Material

As of November 1999, you may electronically access NUREG-series publications and other NRC records at the NRC's Public Electronic Reading Room at <http://www.nrc.gov/reading-rm.html>. Publicly released records include, to name a few, NUREG-series publications; *Federal Register* notices; applicant, licensee, and vendor documents and correspondence; NRC correspondence and internal memoranda; bulletins and information notices; inspection and investigative reports; licensee event reports; and Commission papers and their attachments.

NRC publications in the NUREG series, NRC regulations, and Title 10, "Energy," in the *Code of Federal Regulations* may also be purchased from one of these two sources.

1. The Superintendent of Documents

U.S. Government Publishing Office
Mail Stop SSOP
Washington, DC 20402-0001
Internet: <http://bookstore.gpo.gov>
Telephone: 1-866-512-1800
Fax: (202) 512-2104

2. The National Technical Information Service

5301 Shawnee Road
Alexandria, VA 22161-0002
<http://www.ntis.gov>
1-800-553-6847 or, locally, (703) 605-6000

A single copy of each NRC draft report for comment is available free, to the extent of supply, upon written request as follows:

U.S. Nuclear Regulatory Commission

Office of Administration
Publications Branch
Washington, DC 20555-0001
E-mail: distribution_resource@nrc.gov
Facsimile: (301) 415-2289

Some publications in the NUREG series that are posted at the NRC's Web site address <http://www.nrc.gov/reading-rm/doc-collections/nuregs> are updated periodically and may differ from the last printed version. Although references to material found on a Web site bear the date the material was accessed, the material available on the date cited may subsequently be removed from the site.

Non-NRC Reference Material

Documents available from public and special technical libraries include all open literature items, such as books, journal articles, transactions, *Federal Register* notices, Federal and State legislation, and congressional reports. Such documents as theses, dissertations, foreign reports and translations, and non-NRC conference proceedings may be purchased from their sponsoring organization.

Copies of industry codes and standards used in a substantive manner in the NRC regulatory process are maintained at—

The NRC Technical Library

Two White Flint North
11545 Rockville Pike
Rockville, MD 20852-2738

These standards are available in the library for reference use by the public. Codes and standards are usually copyrighted and may be purchased from the originating organization or, if they are American National Standards, from—

American National Standards Institute

11 West 42nd Street
New York, NY 10036-8002
<http://www.ansi.org>
(212) 642-4900

Legally binding regulatory requirements are stated only in laws; NRC regulations; licenses, including technical specifications; or orders, not in NUREG-series publications. The views expressed in contractor-prepared publications in this series are not necessarily those of the NRC.

The NUREG series comprises (1) technical and administrative reports and books prepared by the staff (NUREG-XXXX) or agency contractors (NUREG/CR-XXXX), (2) proceedings of conferences (NUREG/CP-XXXX), (3) reports resulting from international agreements (NUREG/IA-XXXX), (4) brochures (NUREG/BR-XXXX), and (5) compilations of legal decisions and orders of the Commission and Atomic and Safety Licensing Boards and of Directors' decisions under Section 2.206 of NRC's regulations (NUREG-0750).

DISCLAIMER: This report was prepared as an account of work sponsored by an agency of the U.S. Government. Neither the U.S. Government nor any agency thereof, nor any employee, makes any warranty, expressed or implied, or assumes any legal liability or responsibility for any third party's use, or the results of such use, of any information, apparatus, product, or process disclosed in this publication, or represents that its use by such third party would not infringe privately owned rights.

Open Secondary Testing of Window-Type Current Transformers

Manuscript Completed: July 2016

Date Published: May 2017

Prepared by:

M. Subudhi, P. Joshi¹, S. Dimaiuta¹ and W. Gunther²

Department of Nuclear Science and Technology
Brookhaven National Laboratory
Upton, New York 11973

¹ Superconducting Magnet Division

² Retired BNL Staff

G. Taylor, NRC Project Manager

ABSTRACT

Two AMRAN Current Transformers (CTs) were tested to characterize the propensity of an open-circuited CT secondary to cause a fire in a location remote to the open circuit. Also evaluated was the magnitude of the secondary winding peak (crest) voltage¹ when the CT's secondary circuit transitioned to an open circuit condition, and its dependencies on the primary voltage, primary current and the CT's turn ratio². Parameters identified as having an effect on the CT's open secondary crest voltage include:

- Material and construction of the CT's magnetic core,
- CT's primary voltage,
- CT's primary current, and,
- CT's turn ratio.

The primary objective of this testing, however, was to better understand the following scenario:

Will fire-induced open circuit in the secondary circuit of a wound-type CT, which is operating within its rated continuous primary current limits, result in an excessively high voltage in the secondary circuit sufficient to start a fire in the form of explosion or arcing in the circuit's insulation at the location of the CT itself or at some other location in the secondary circuit?

For the configurations tested, the results indicated that an open circuited CT was incapable of starting a secondary fire based on the criteria established in the test plan. This observation applies to the CT, CT taps, cabling, and burden devices. Additionally, when an arc was deliberately initiated in the secondary circuit, it was observed that the crest voltage diminished significantly.

The test results provide supplemental information to the JACQUE-FIRE Volume 3 working group for developing technical recommendations to possibly extend the limit on the 1200:5 CT turns ratio limit as stated in the NUREG/CR-7150, Volume 1

¹ Throughout this report the open secondary "peak voltage" is identified as open secondary "crest voltage" consistent with the IEEE Standard C57.13-2008.

² Turn ratio is defined as the ratio of the number of secondary coil turns to primary coil turns around the magnetic core.

TABLE OF CONTENTS

ABSTRACT	iii
LIST OF FIGURES	vii
LIST OF TABLES	ix
EXECUTIVE SUMMARY	xi
ACKNOWLEDGMENTS	xiii
ACRONYMS	xv
1 INTRODUCTION	1
2 CURRENT TRANSFORMER CHARACTERISTICS UNDER OPEN SECONDARY CONDITION	3
3 TESTING APPROACH	7
3.1 Test Objectives	7
3.2 Test Configuration and Setup	9
3.2.1 Testing Facility	9
3.2.2 CT Test Circuit Configuration	10
3.2.3 Periodic Monitoring of the CT	13
3.2.4 Periodic Monitoring of the Secondary Cable	15
3.2.5 Test Equipment Functionality Check	16
3.3 Assumptions and Limitations	17
3.4 Baseline CT Tests (No Secondary Open Circuit)	17
3.5 Open Secondary Tests	18
4 TEST RESULTS	23
4.1 Baseline Test Results	23
4.2 Open Secondary Tests	27
5 EVALUATION OF TEST RESULTS	35
5.1 Effect of Primary Voltage/Current	35
5.2 Effect of Primary Voltage and Turn Ratio	36
5.3 Effect of Primary Voltage/Current and Turn Ratio	36
5.4 Impact of Arcing and Intermittent Opening	37
5.5 Other Effects	39
5.6 Evaluation of Data to Test Plan Criteria	40
6 SUMMARY OF TEST RESULTS	41
7 REFERENCES	43
APPENDIX A OPEN SECONDARY TESTING OF WINDOW-TYPE CURRENT TRANSFORMERS – TEST PLAN	A-1
APPENDIX B DATA FROM ALL TESTS PERFORMED	B-1

LIST OF FIGURES

Figure 2-1:	Application of Window-Type CTs in Nuclear Power Plants.....	3
Figure 2-2:	Excitation Curve for a Typical Current Transformer	4
Figure 3-1:	Voltage versus Air Flash Gap	8
Figure 3-2:	Test Power Supply Configuration	10
Figure 3-3:	Photograph of 2000:5 CT (Left), and 4000:5 CT (Right).....	10
Figure 3-4:	Secondary Circuit Layout of the CT Testing	12
Figure 3-5:	CT Testing Configuration and Data Logger	13
Figure 3-6:	DC Resistance Testing of CT's Secondary Winding	14
Figure 3-7:	ECG-Kokusai Model DWX-05 Impulse Tester	15
Figure 3-8:	Example of Turn-To-Turn Short Indicating Compromised Insulation in the Winding	15
Figure 3-9:	HiPot Testing of Cable Insulation.....	16
Figure 3-10:	Typical Test Duration at 10,000 Steps/Sec	22
Figure 4-1:	AM4CT - Secondary Voltage Under Normal CT Operation	23
Figure 4-2:	Inductance of Secondary Coil	25
Figure 4-3:	CT 2000:5 (X1-X2) Impulse Test Signature	25
Figure 4-4:	CT 4000:5 (X1-X5) Impulse Test Signature	26
Figure 4-5:	AM4CT01 Test – Primary Voltage at 500V (Typical)	28
Figure 4-6:	AM4CT01 Test – Primary Current Approximately at 400A RMS (Typical)	28
Figure 4-7:	AM4CT01 Test – RMS Primary Current Approx. at 400A (Typical).....	29
Figure 4-8:	AM4CT01 Test – Typical Secondary Current Harmonics for an Approximate Primary Current of 400A (or 4000AT)	30
Figure 4-9:	AM2CT01 Test – Open Secondary Crest Voltage (Typical)	30
Figure 4-10:	AM4CT01 Test – Open Secondary Crest Voltage (Typical)	31
Figure 4-11:	AM4CT01 Test – CT Temperature Rise Over 10 Minutes	34
Figure 5-1:	AM2CT - Open Secondary Crest Voltage Versus Primary Voltage/Current with Turn Ratio Fixed at 2000:5	35
Figure 5-2:	AM4CT - Open Secondary Crest Voltage with Varying Primary Voltage and Rated Turn Ratio.....	36
Figure 5-3:	AM4CT - Open Secondary Crest Voltage with Varying Primary Current at 500V	37
Figure 5-4:	Secondary Crest Voltage Characteristics Under Various Conditions	38
Figure 5-5:	AM2CT03: Secondary Crest Voltage Under Intermittent Arcing.....	39
Figure 5-6:	Secondary Crest Voltage in Tests AM2CT01 and AM4CT05	40

LIST OF TABLES

Table 3-1:	Specification for Current Transformers Used in Testing	11
Table 3-2:	Maximum Current Achievable in the CT's Primary Circuit	18
Table 3-3:	Test Matrix for AMRAN 2000:5 CT Tests	18
Table 3-4:	Test Matrix for AMRAN 4000:5 CT Tests	19
Table 4-1:	Sample Data Sheet for Open Secondary Tests	24
Table 4-2:	Baseline HiPot Test Results of Instrument Cables.....	27
Table 4-3:	Test Results for AM2CT Test Series Given in Table 3-3	31
Table 4-4:	Test Results for AM4CT Test Series Given in Table 3-4	32

EXECUTIVE SUMMARY

In October 2012, the Phenomena Identification and Ranking Table (PIRT) panel of the Joint Assessment of Cable Damage and Quantification of Effects from Fire (JACQUE-FIRE) program published NUREG/CR-7150, Volume 1 documenting an exercise conducted to better understand the state of knowledge related to fire-induced electrical circuit failures. As part of the work, the panel of technical experts reached a consensus on several long-standing fire protection circuit analysis issues. These recommendations were based on experts' knowledge, experience, and insights from the PIRT and technical information (data) presented to the panel. One of those topics was the need to consider a fire-induced open-circuit on the secondary circuit of a CT that could result in a second fire at a different location than the initial fire that caused the damage. The PIRT panel recommended in Volume 1 of NUREG/CR-7150 that the secondary fires of those CTs with a turn ratio of 1200:5 or lower in power distribution systems are not a credible risk when the secondary circuit is opened. The PIRT panel also felt that the risk to fire safety is low for CT's with higher turn ratios. The data to support this position, however, was not available. To resolve this concern, the PIRT panel recommended that additional testing be performed.

Under the guidance of the JACQUE-FIRE Volume 3 working group, Brookhaven National Laboratory (BNL) performed testing on two AMRAN CTs, one rated at 2000:5 fixed-ratio and the other rated at 4000:5 multi-ratios, to characterize the propensity of an open-circuited CT secondary to cause a fire at a location remote to the open circuit. It was expected that the test results would provide a sound technical justification for treatment of CTs with higher turn ratios (>1200:5) in post-fire safe shutdown analysis.

To address the above concern, BNL evaluated the test results associated with the magnitude of the secondary winding crest voltage when the CT's secondary circuit transitioned to an open circuit condition, and its dependencies on the primary voltage, primary current and the CT's turn ratio. Parameters that affect the *open secondary crest voltage* include the following:

- The material and construction of the CT's magnetic core It varies between manufacturers and even between different models from the same manufacturer.
- Primary voltage source Crest voltage increases with increasing primary voltage under open secondary circuited conditions. This is contrary to CTs under normal operating condition, where primary voltage has little effect on secondary voltage.
- Primary current level Crest voltage increases with increasing primary current under open circuited secondary conditions.
- CT's turn ratio Crest voltage increases with increasing CT's turn ratio.

The primary objective of this testing, however, was to better understand the following scenario:

Will fire-induced open circuiting of the secondary circuit of a wound-type CT, which is operating within its rated continuous primary current limits, result in an excessively high voltage in the secondary circuit sufficient to start a fire in the form of explosion or arcing in the circuit's insulation at the location of the CT itself or at some other location in the secondary circuit?

Engineering principles and testing confirm that as long as current is flowing in the primary circuit, an open-circuit in CT's secondary can cause high crest voltage on the secondary circuit as the CT

attempts to maintain the current relationship dictated by the transformer's winding turn ratio. This condition, in addition to shock hazard to personnel, can result in CT damage, potentially can generate voltages that may exceed the dielectric strength of the CT's insulating materials, and may cause arcing to connected or nearby components.

Additionally, high voltage induced on the secondary winding of a CT as a result of open-circuiting the CT's secondary circuit due to a fire has the potential to cause the CT and/or the connected components to fail in a manner that could potentially start a secondary fire. A secondary fire, as used in this report, refers to a fire at a location remote from the original fire that is responsible for the initial open-circuit in the CT's secondary circuit.

From the CT's physical location in the plant to the main control room instrument indications, the secondary circuit may consist of long (e.g., hundreds of feet) instrument wires whose insulation is susceptible to both initial and secondary fires. The resulting high voltage condition in the secondary from an open-circuited CT introduces a potential concern for fire protection strategies in nuclear power plants. Since the post-fire safe shutdown analysis is based on postulating a fire in one fire area at a time, the possibility of a second fire in a separate fire area can impact the final outcome of the fire protection strategies.

For the configurations tested, the results indicated that an open circuited CT was incapable of starting a secondary fire based on the criteria established in the test plan. This observation applies to the CT, CT taps, cabling, and burden devices. Additionally, when an arc was deliberately initiated in the secondary circuit, it was observed that the crest voltage diminished significantly. This report describes the testing performed by BNL and documents the results. The data and video are available in electronic format in the CD-ROM provided with this publication. The information contained in this report is expected to support a technical recommendation by the working group for treatment of higher turn ratio CTs in post-fire safe shutdown analysis.

ACKNOWLEDGMENTS

This test program was completed under the technical guidance of the Joint Assessment of Cable Damage and Quantification of Effects from Fire (JACQUE-FIRE) Volume 3 working group, which included staff from Brookhaven National Laboratory (BNL), the U.S. Nuclear Regulatory Commission (NRC), and the Electric Power Research Institute (EPRI). This project was sponsored by the NRC's Office of Nuclear Regulatory Research (NRC-RES) with support from EPRI under a collaborative research agreement termed in the NRC-RES/EPRI Memorandum of Understanding (MOU).

The authors thank the members of the working group, Harold Barrett, Robert Daley, Daniel Funk, Thomas Gorman, Shannon Lovvorn, Steven Nowlen, Andy Ratchford, and Gabriel Taylor for their technical guidance. We are grateful for the support of working group members' organizations who cooperatively shared some or all of the cost and time for their participation in this study.

We appreciate public comments on our test plan from Exelon Generation Company and Nuclear Energy Institute (NEI).

Other participants of the working group who deserve a special mention include Gabriel Taylor (NRC Contracting Officer Representative), Mark Henry Salley, Tammie Rivera, and Mark Jeffers of NRC, and Ashley Lindeman of EPRI. We appreciate that the CTs tested were supplied by EPRI under the NRC-RES/EPRI memorandum of understanding for cooperative research.

We thank the following BNL staff for their administrative and technical support: William Horak, James Higgins, Peter Kohut, Peter Wanderer, Glenn Jochen, Domenick Milidantri, Mary Chuc, and the safety committee members.

Finally, we appreciate BNL's Maria Anzaldi and Avril Woodhead for assistance in preparing and technical editing the report.

ACRONYMS

A or Amps	Ampere(s)
AC	Alternating Current
AM2CT	AMRAN Fixed-Ratio CT 2000:5
AM4CT	AMRAN Multi-Ratio CT 4000:5
ANSI	American National Standards Institute
AT	Ampere-Turn
AWG	American Wire Gauge
BIL	Basic Insulation Level
BNL	Brookhaven National Laboratory
CFR	Code of Federal Regulations
CT	Current Transformer
CD	Compact Disc
DC	Direct Current
EMF	Electro-Motive Force
EPRI	Electric Power Research Institute
EQ	Equipment (or Environmental) Qualification
FR	Federal Register
H	Henry
IEEE	Institute of Electrical and Electronics Engineers
JACQUE-FIRE	Joint Assessment of Cable Damage and Quantification of Effects from Fire
kV	Kilovolt
kW	Kilowatt
mH	Millihenry
MOU	Memorandum of Understanding
MMF	Magneto-Motive Force
MR	Multi-Ratio
NEI	Nuclear Energy Institute
NPP	Nuclear Power Plant
NRC	Nuclear Regulatory Commission
PIRT	Phenomena Identification and Ranking Table
PT	Potential Transformer
RES	Office of Nuclear Regulatory Research
RMS	Root Mean Square
STD	Standard
V	Volt(s)
VA	Volt-Ampere
VT	Voltage Transformer

1 INTRODUCTION

Current transformers (CTs), a sub-group of instrument transformers, are used throughout alternating current (AC) electrical distribution systems in nuclear power plants (NPPs). These devices monitor current levels at select locations and provide a signal from their secondary winding that is proportional to the current flowing through the main (primary) winding (e.g., cable, bus bar). CTs measure the primary current through magnetic coupling and thus do not have a physical connection between the primary and secondary circuits. Therefore, CTs provide isolation from the high voltage and high current in the primary circuit that being monitored.

The CT's secondary current signal is commonly used for relay protection and indication circuits (both local and remote). In many cases the protective relays and/or indicators associated with the CT are located at the same locations as the CT. For these cases, the secondary circuit is typically confined to the switchgear/equipment containing the CT. In other instances, the secondary circuit of the CT may provide a signal to remotely located protective relay(s) or indicator(s), e.g., differential protective relays and remote ammeters. As such, the secondary circuit may span numerous compartments within a NPP. These latter cases present a potential safety concern, as discussed below.

Safety Concern

Engineering principles and testing confirm that as long as current is flowing in the primary circuit, an open-circuit in CT's secondary can cause high crest (or peak) voltage on the secondary circuit as the CT attempts to maintain the current relationship dictated by the transformer's winding turn ratio. This condition, in addition to shock hazard to personnel, can result in CT damage, potentially can generate voltages that may exceed the dielectric strength of the CT's insulating materials, and may cause arcing to connected or nearby components.

In a letter to the NRC dated July 21, 1983 (Ref. 1), Brookhaven National Laboratory (BNL) raised a potential concern associated with fire-induced open-circuit in a CT's secondary circuit. The letter postulated the scenario in which potentially high voltage induced on the secondary winding of a CT as a result of open-circuiting the CT's secondary circuit due to a fire, ultimately causing the CT and/or the connected components to fail in a manner that could potentially start a secondary fire. A secondary fire, as used in this report, refers to a fire at a location remote from the original fire that is responsible for the initial open-circuit in the CT's secondary circuit.

From the CT's physical location in the plant to the main control room instrument indications, the secondary circuit may consist of long (e.g., hundreds of feet) instrument wires whose insulation is susceptible to both initial and secondary fires. The resulting high voltage condition in the secondary from an open-circuited CT introduces a potential concern for fire protection strategies in NPPs. Since the post-fire safe shutdown analysis is based on postulating a fire in one fire area at a time, the possibility of a second fire in a separate fire area can impact the final outcome of the fire protection strategies. Currently NRC-endorsed (Ref. 2) industry guidance¹ (Ref. 3) for conducting a post-fire safe shutdown circuit analysis identifies circuit failures due to an open circuit. An example provided in Section 3.5.2.1 of NEI 00-01, Rev. 2 (Ref. 3) includes:

¹ When used in conjunction with RG 1.189, "Fire Protection for Nuclear Power Plants," industry guidance document NEI 00-01, "Guidance for Post Fire Safe Shutdown Circuit Analysis," Rev. 2, provides one acceptable method for conducting a post-fire safe shutdown circuit analysis.

Open circuits on a high voltage (e.g., 4.16 kV) ammeter current transformer (CT) circuit may result in secondary damage, possibly resulting in occurrence of an additional fire in the location of the CT itself.

In October 2012, the Phenomena Identification and Ranking Table (PIRT) panel of the Joint Assessment of Cable Damage and Quantification of Effects from Fire (JACQUE-FIRE) program published NUREG/CR-7150, Volume 1 (Ref. 4) documenting an exercise conducted to better understand the state of knowledge related to fire-induced electrical circuit failures. As part of the work, the panel of technical experts reached a consensus on several long-standing fire protection circuit analysis issues. These recommendations were based on experts' knowledge, experience, and insights from the PIRT and technical information (data) presented to the panel. One of those topics was the need to consider a fire-induced open-circuit on the secondary circuit of a CT that could result in a second fire at a different location than the initial fire that caused the damage. The PIRT panel recommended in Volume 1 of NUREG/CR-7150 (Ref. 4) that the secondary fires of those CTs with a turn ratio of 1200:5 or lower in power distribution systems are not a credible risk when the secondary circuit is opened. CTs with a higher turn ratio the PIRT panel felt that the risk to fire safety is low. However, this may experience damage to their insulation, and conceivably could fail. Such failure would involve the breakdown of insulation due to arcing, as is evidenced in higher voltage power distribution lines in a plant's switchyard.

Based on the experts' judgement, the PIRT panel also determined that the concern was more theoretical than real for the types of CTs (i.e., open window type) found within the AC electrical distribution system of NPPs. However, the data available to support this recommendation did not cover the range commonly encountered within NPPs. Although the panel believed this to be true for higher than 1200:5 turn ratio CTs, the lack of data along with the concern of the phenomena becoming more pronounced as turn ratios increase, resulted in the panel's conclusion that this concern could not be excluded for CTs with turn ratios greater than 1200:5. To resolve this concern, the PIRT panel recommended that additional testing be performed.

This report describes the testing that was performed under the guidance of the JACQUE-FIRE Volume 3 working group and documents the results. All data from the testing program is publically available without restriction on the CD-ROM provided with this publication and on the NRC website (www.NRC.gov). The information contained in this report is expected to support a technical recommendation for treatment of higher turn ratio CTs in post-fire safe shutdown analysis.

2 CURRENT TRANSFORMER CHARACTERISTICS UNDER OPEN SECONDARY CONDITION

Different types of current transformers (CTs) are used in nuclear power plants (NPPs), including wound, bar, window, bushing, auxiliary, and ground sensor types. However, the window-type dominates the types of CTs used in NPP's AC power distribution system applications and is the focus of this research. The window-type CTs considered here have a laminated core of high permeability steel with a secondary winding insulated from and permanently assembled on the core. The window-type CTs have no primary winding as an integral part of the CT structure. The primary winding (bus bar or cable) is located through the window of the CT. Figure 2-1 below shows the different applications of window-type CTs around conductors or bus bars inside electrical enclosures.



Figure 2-1: Application of Window-Type CTs in Nuclear Power Plants

Under normal operating conditions, a CT reproduces a scaled-down current waveform of the current flowing in the primary circuit (e.g., based on the specific phase of the three-phase AC power distribution system being monitored) at the point of measurement. This scaled-down current can then be used by protective relays, metering, and other applications. The alternating current in the primary winding (known as excitation current) produces an alternating magnetic field in the core, which then induces an alternating current in the secondary winding circuit. The primary and secondary circuits are magnetically coupled so that the secondary current is linearly proportional to the primary current over an intended normal operational range.

Since the coupling between the primary circuit and the secondary is via CT's magnetic core, it is important that the operation of the CT in the excitation curve, shown in Figure 2-2, defines its behavior. Normally the CT operates in the linear portion (Non-saturated Zone 1) of the excitation curve (i.e., primary current = secondary current x turn ratio); while under open secondary condition it operates near or above its knee (Intermediate Zone 2 or Saturated Zone 3), the nonlinear portion of the excitation curve that is closely similar to that of a voltage transformer (VT). However, under this abnormal condition the CT still attempts to maintain the current ratio (i.e., primary \div secondary).

Excitation Curve

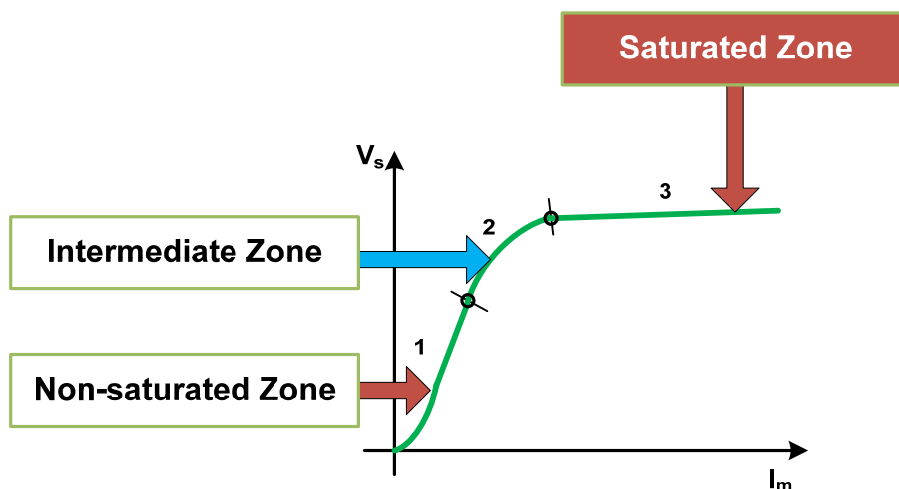

Figure 2-2: Excitation Curve for a Typical Current Transformer

With current flowing in both primary and secondary circuits, the CT's exciting current (and hence the corresponding inductive reactance or impedance of the primary coil) typically is very small under the normal operating conditions (Refs. 5, 6 & 7). The secondary current's magneto-motive force (mmf) keeps in check the magnetizing flux in the CT's core. The secondary voltage depends upon the secondary current, and the impedance (burden) of the meter and relaying circuitry. The secondary circuit of the CT functions as a current source; thus, as the burden on the secondary side of the CT increases, the secondary voltage of the CT increases proportional to the burden.

When the secondary circuit opens, the impedance essentially will be infinite. An ideal CT would have an infinite secondary voltage. In reality, normal losses (such as core loss, core saturation, leakage inductance, and finite insulation resistance) will limit the actual voltage. Under open-circuited secondary conditions, the total primary current becomes the exciting current, comprising a magnetizing current plus any additional current necessary to overcome core (iron) loss, consisting of losses caused by eddy currents and hysteresis. Thus, the primary current's magneto-motive force (mmf) produces an exciting current "orders of magnitude" greater than that under normal conditions. The resultant large increase in flux density produces a high voltage in the secondary circuit and will likely raise the density of the core flux to saturation. As long as the primary current is present, the CT operates near the knee (i.e., the magnetizing saturation) of the excitation curve at 60 Hz, similar to a voltage transformer.

The turn ratio of a CT was considered as one of the influencing parameters that affect the amplitude of the voltage spike during open circuit conditions. The higher the turn ratio the greater the voltage spike at a fixed AC frequency (e.g., 60 Hz line current)¹. In accordance with IEEE Standard C57.13-2008 (Ref. 8), Section 6.7.1, Operation with Secondary Circuit Open,

¹ The open secondary voltage spike is increased by higher operating frequency. In all our testing, we kept this constant at the line frequency of 60 Hz.

“... Transformers conforming to this standard shall be capable of operating under emergency conditions for 1 minute with rated primary current times the rating factor with the secondary circuit open if the open-circuit voltage does not exceed 3500 V crest.

When the open circuit voltage exceeds 3500 V peak, the secondary winding terminals should be provided with voltage limiting devices (varistors or spark gaps).

...”

Once the secondary circuit's cable conductors have opened, a high voltage in terms of voltage spikes is assumed to exist on the CT's secondary. Under the postulated fire event the cable's insulation and conductor are assumed to have been damaged by the fire and resulted in an open circuit. This location where the postulated fire damage causes the open circuit, along with the connections at the CT's secondary terminals, are the most likely points of failure (least resistance) in the circuit. Other potential failure locations in the secondary circuit may include the burden (e.g., the ammeter, relay) and degraded insulation locations due to the influence of aging or other deleterious effects². Since any arcing that may occur as a result of the high voltage is assumed to occur at these points of least resistance (weak link), the most probable locations for arcing are assumed to occur at these points.

² Note that this testing did not consider degraded insulation or physical damage in the secondary circuit, which could have compounded the potential for secondary fire ignition source.

3 TESTING APPROACH

3.1 Test Objectives

The objective of this testing was to develop data that could be used to inform technical decisions regarding the necessity to postulate secondary fires due to fire damage of current transformers (CTs). The purpose of this test program is to better understand the following scenario:

Will fire-induced open circuiting of the secondary circuit of a wound-type CT, which is operating within its rated continuous primary current limits, result in an excessively high voltage in the secondary circuit sufficient to start a fire in the form of explosion or arcing in the circuit's insulation at the location of the CT itself or at some other location in the secondary circuit?

To evaluate the plausibility of this scenario, the testing focused on evaluating the transient characteristics¹ of the core's magnetic behavior, along with the effects of primary voltage and current at 60 Hz line frequency on the secondary voltage peaks (or crests) as it transitioned from normal conditions to an abnormal open secondary condition.

To accomplish the objective of this research, the tests focused on characterizing the transition of the exciting (or magnetizing) current from the very low magnitude under normal operating conditions to an open secondary condition with no current in the secondary but high voltages that could act as a fire ignition source. The testing assumed that an open-circuit condition of an energized CT occurred (due to fire damage). The open-circuit is expected to cause abnormally high voltages in the secondary circuit, provided that the flow of the primary current continues. The desired outcome of this testing is to determine whether the possibility exists for the high voltage to cause sustained arcing or a catastrophic failure of the CT (or other secondary circuit elements) that is sufficiently energetic to initiate a secondary fire that damages components or equipment beyond the CT's circuit and its components.

Therefore, we postulated the following two specific conditions that could be affected by the saturation of the CT's magnetic core and the high voltage in the open secondary circuit:

- The CT itself gets overheated after being exposed to a very long core saturation period or an arcing occurs at the CT's secondary taps which may need over 20-40 kV crest voltage² for an air gap of 1-2 inches (Ref. 9). The data presented in Figure 3-1 correspond to ionization voltage levels of air gap distance for alternating current (AC) and direct current (DC) circuits. These failures are postulated to create a localized secondary fire at the CT's cabinet or location.

¹ A small portion of normal rated primary current is sufficient to saturate the core. However, there is a very short interval in each half cycle as the current passes through zero when the magnetic flux is very rapidly whisked from saturation value in one direction to saturation value in the other direction. It is this exceedingly rapid rate of change of flux during the short interval is responsible for the high open secondary voltage (Ref. Kaufmann and Camilli, Transactions of the AIEE, Vol. 62, July 1943).

² This voltage range is based on Figure 3-1, which is replotted from "A Basic Stun Gun Concept," Chemlec © 2007 & 2011.

- The open secondary crest voltage in the secondary circuit exceeds the breakdown voltage of the cable's insulating system.³

A draft test plan was prepared and the NRC requested public comments in the Federal Register 80FR46061, dated August 3, 2015 [Docket NRC-2015-0183/FR-2015-18997]. A final version of this test plan after addressing all public comments received is provided in Appendix A.

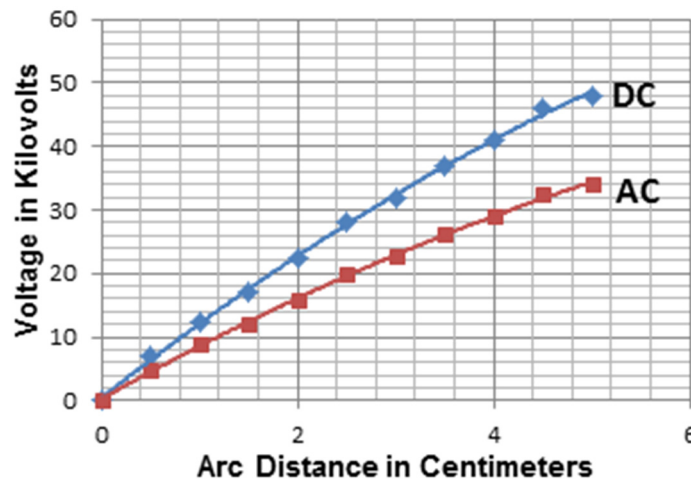

Figure 3-1: Voltage versus Air Flash Gap

As stated in the Test Plan, to achieve the overall objective in this test program (i.e., excessively high voltage in the secondary circuit sufficient to start a fire in the form of explosion or arcing in the circuit's insulation at the location of the CT itself or at some other location in the secondary circuit), the following test conditions were considered:

- Primary Voltages⁴: 500V, 250V, 125V
- Two AMRAN CT Types: Fixed-Ratio 2000:5 CT; Multi-Ratio 4000:5 CT
- For the Fixed-Ratio of 2000:5: Varied primary current of 60A to 4000A
- For the Multi-Ratio CT: Varied turn ratios of 500:5 to 4000:5 (or primary current ratings) and primary current for fixed turn ratios at 2000:5 and 4000:5
- Open secondary mode: Fast open; Intermittent opening; Arcing simulations
- Thermal measurements of CT surface and electrical enclosure air space.

Note that the performance of subsequent tests, as stated in Section A.4.3 of the Test Plan were not undertaken due to lack of funding.

³ Insulation failure (breakdown) could potentially occur at lower voltage if the cable insulation system contains a latent defect or has been damaged. However, no tests were performed to investigate this variable.

⁴ Test voltage was limited to 500V due to 1) limitations of the power supply available, 2) test personnel safety concerns, and 3) logistical burden of high energy testing. The working group judged that the voltage limitation would not preclude obtaining representative data for higher voltage applications.

3.2 Test Configuration and Setup

A series of tests were conducted to demonstrate the impact of an open circuit on a CT's secondary has on the secondary crest voltage. This is important in determining if the crest voltages on the secondary are high and energetic enough to damage the insulation and pose a potential fire ignition source to other components. Thus, a total of 63 tests in 51 different test configurations involving two CTs (AM2CT – 29 configurations and AM4CT– 34 configurations) were completed.

3.2.1 Testing Facility

The CT testing was conducted in the high bay area of the Brookhaven National Laboratory Superconducting Magnet Division test facility. The test facility has various AC- and DC-controlled power sources ranging from 480 Volts, 1,600 Amps AC to 30 Volts, 30,000 Amps DC. Associated with these power sources, each test facility has a state-of-the-art high speed multi-channel data acquisition system with the sampling frequency of up to 1 MHz and 16 bit resolution.

Figure 3-2 shows the power supply circuit for the CT tests. The primary current for the CT under test was supplied by a three-phase (delta/wye) source connected to a three-phase delta connected variable load bank. The power source was configured to a nominal voltage of 125VAC, 250VAC or 500VAC, through a 1600 Amp switch and a remotely controlled 700 Amp circuit breaker. The CT being tested connected to one of the legs (Leg A) and the supply current to the primary circuit can be adjusted to get the required value by manipulating the resistance of the load bank⁵. Due to limitations on the available current from the power supply, the leg of the power supply acting as the primary circuit of the CT was wrapped around and through the CT window 10 times. Theoretically, this configuration should accurately simulate the higher current; however it is not representative of a typical installation. Baseline tests of the test configuration indicated expected system behavior. Current in one phase will be used to generate the necessary Ampere-Turns in the primary of the CT under test. For example, to test a 4000:5 CT, ten (10) turns of Ultraflex 500MCM cable was wrapped around the core of the CT to obtain an almost 4000 ampere-turn in the primary. Exact current in that phase was measured and recorded using three in-house 800:5 CTs.

⁵ Originally-planned load bank discussed in the test plan was replaced with a new modern portable load bank with resistance switches for easier manipulation of resistors.

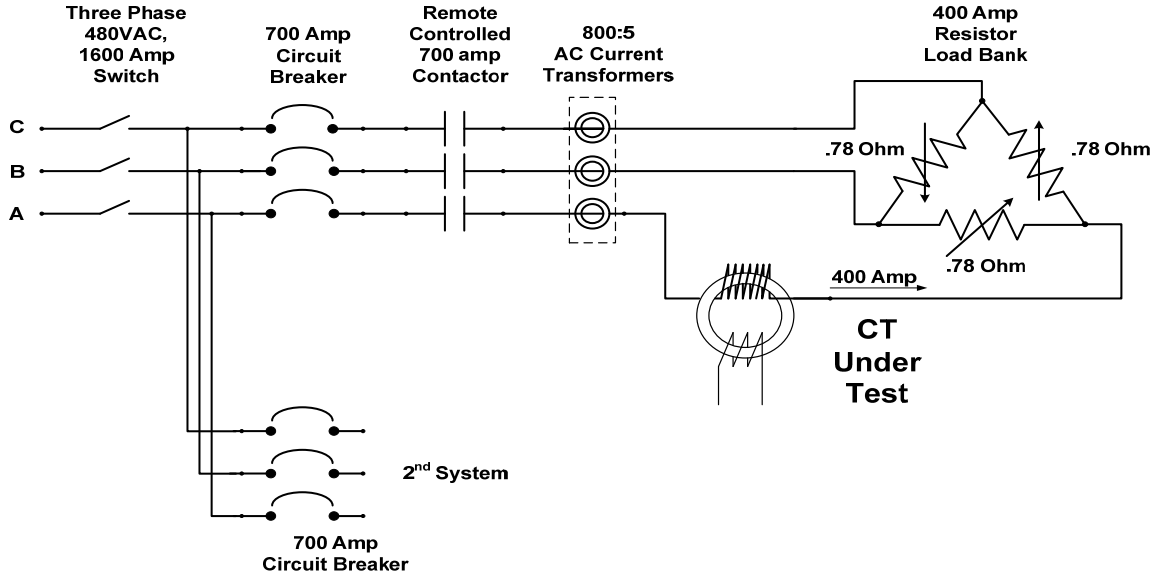

Figure 3-2: Test Power Supply Configuration

3.2.2 CT Test Circuit Configuration

Two different models of AMRAN CTs were provided under the cooperative research agreement [Memorandum of Understanding (MOU)] between the US Nuclear Regulatory Commission (NRC) Office of Nuclear Regulatory Research (RES) and the Electric Power Research Institute (EPRI). Six units of each model were provided, for a total of 12 CTs. Figure 3-3 shows a photograph of the actual CTs tested. The 2000:5 CTs (identified as “AM2CT”) are of the fixed-ratio type, while the 4000:5 CTs (identified as “AM4CT”) are multi-ratio. Both CTs meet the ANSI/IEEE C57.13 Standard, and their outer encapsulations were enclosed in plastic-cases. Table 3-1 provides the specifications of the CTs tested.

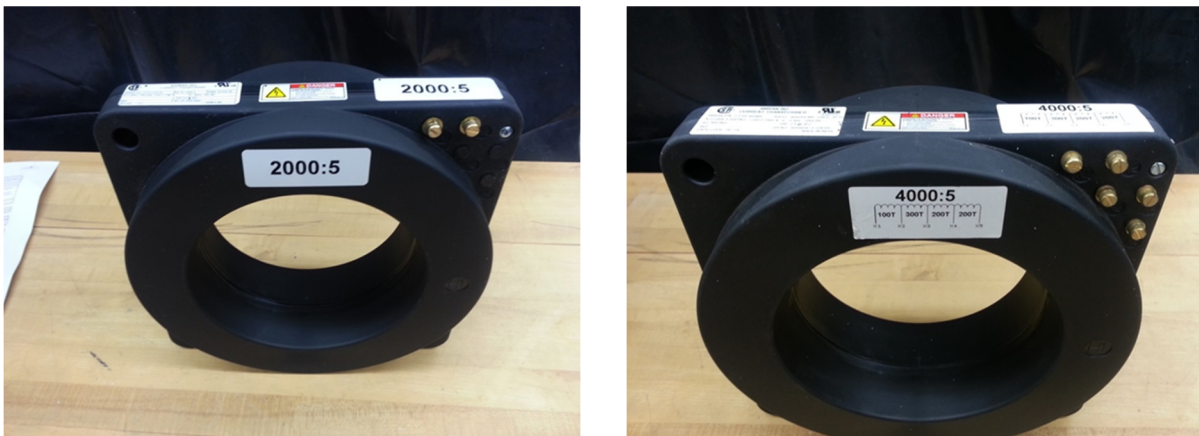

Figure 3-3: Photograph of 2000:5 CT (Left), and 4000:5 CT (Right)

Table 3-1: Specification for Current Transformers Used in Testing

Parameter	AM2CT	AM4CT
Serial #	AMRAN 019591	AMRAN 605A419/F226114
Part #	CT101-202-04	CT102-402MR
Insulation Level	600V; Basic Insulation Level (BIL) 10kV Full Wave	600V; BIL 10kV Full Wave
DC Resistance	0.3329 Ω @ 24°C (measured) 0.375 Ω @ 75°C (rated)	0.1268 to 0.8684 Ω @ 24°C (measured) 0.0015 Ω /Turn @ 75°C (rated)
AC Inductance @ 60Hz	3.9938 henry (H) (Measured)	183.82mH to 7.621 H (Measured)
AC Inductance @ 1kHz	500 mH (Measured)	26.161mH to 1.54H (Measured)
Turn Ratio(s)	2000:5	500:5 1000:5 1500:5 2000:5 2500:5 3000:5 3500:5 4000:5

The circuit diagram in Figure 3-4 illustrates the actual⁶ test setup for obtaining the characteristics of an open-circuited CT. As stated above, the test power supply feeds the CT's primary side to represent the typical current flow in a power circuit. Approximately 100 feet of secondary cable with a burden resistor (i.e., an ammeter) was used to simulate an actual plant's typical configuration. The CT's secondary side was instrumented with a relay⁷ for intermittently opening the circuit or an instantaneous circuit break. The increase in the secondary voltage and decrease in secondary current was recorded via high voltage isolation modules. A computerized high speed data acquisition system was used to capture the CT secondary voltage and current. Other parameters monitored during testing included primary current (I1 for Harmonics and I3 for its RMS values in Figure 3-4) and primary voltage (V2 in Figure 3-4)⁸, and the surface temperature of the CT. A high speed video camera (D2 in Figure 3-4) also was used to capture the arcing and fire formation (if any) at several strategic locations. These cameras were synchronized with the high speed data acquisition system to get secondary circuit characteristics during the arcing process (if any).

⁶ Figure 3-4 represents a modified circuit diagram of Figure A-7 presented in the test plan. Additional parameters V2 for primary voltage, I3 for RMS primary current, and D2 for digital camera were added to the data logger.

⁷ This is a high voltage relay, with automatic delay but positive closing or opening after turn on, turn-off or loss of power, manufactured by Ross Engineering Corp (Model EV40-NC-40).

⁸ V2: Primary voltage for the 4000:5 CT testing, while the same input was used for Temperature of the test cabinet environment for the 2000:5 CT testing. Primary voltage of 125V, 250V, or 500V and line frequency of 60 Hz were kept fixed and monitored from the load bank meters as well.

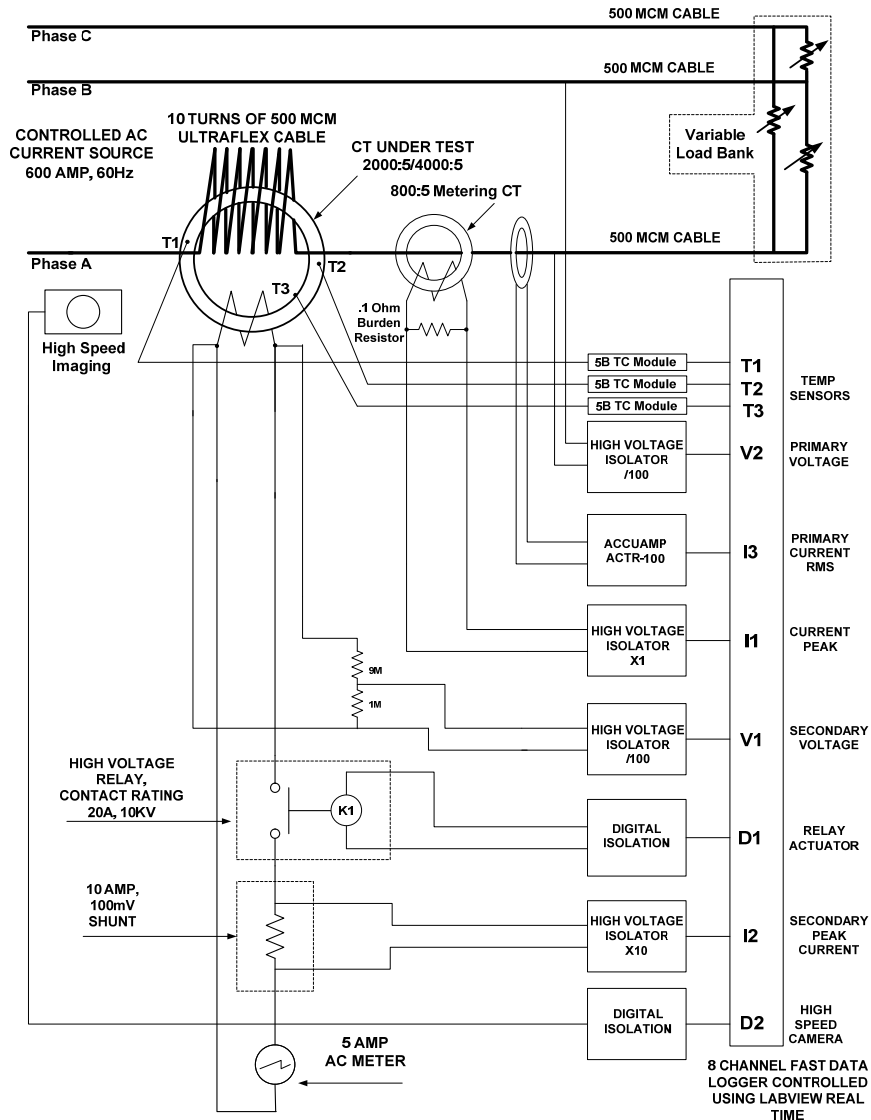

Figure 3-4: Secondary Circuit Layout of the CT Testing

For safety reasons, the CTs under evaluation were placed inside a metal enclosure (i.e., test cabinet), as shown in Figure 3-5. The data logger used for these tests is also shown in this figure. The data logger used separate National Instrument Cards: for slow log (Model NIPXI-6123, S.N. 013E2CA7, Calibration 11/3/14) and for fast log (Model NIPXI-4300, S.N. 0197E732, Calibration 7/8/14). At BNL, the National Instrument Data Acquisition Channels for capturing signals are calibrated against Agilent 34410A Multimeter on a 2-year calibration cycle. The recent Certificate of Calibration dated 6/30/16 (on file at BNL) indicates these components within calibration.

The test plan in Appendix A provides a complete description of the data acquisition system.



Figure 3-5: CT Testing Configuration and Data Logger

3.2.3 Periodic Monitoring of the CT

During each test we observed the secondary tap connections for any electrical arcing or fire damage and the CT's core for its temperature rise. The high speed camera also was taking video clips of the CT's secondary taps for the entire test duration. Since each video clip needed a file size of the order of 900 megabytes to 1 gigabyte, it was not saved unless some sort of damage was noted during the test. For those test cases simulating arcing video clips of shorter duration of significance were saved.

In addition, the following two types of condition monitoring tests (Refs. 10, 11, 12) were performed periodically to assess the condition of the CT's secondary winding after it had been subjected to crest voltages during several open secondary tests.

1. DC Resistance Test

Figure 3-6 shows the DC resistance test setup of a new CT. This test also was performed in situ on the CT's secondary winding to examine if any turn of the winding was shorted or degraded due to high crest voltage distributed among all turns during open secondary tests. This was achieved if the DC resistance of the secondary winding had changed from its baseline value.

To obtain the DC resistance of the secondary coil, one ampere of current from a precision current source (HP Model 6634A, S.N. 31451A02586) was injected into the secondary winding of the CT via its secondary taps. Voltage drop across the secondary winding was then measured with a digital precision volt meter (HP Model 34401A, S.N. 3146A24334). These instruments were calibrated on 2/8/16 and are within calibration per the BNL 2-year calibration cycle.

The resistance value thus obtained was compared with the baseline DC resistance value included in Table 3-1. If no significant change in the resistance value was noted, the CT's secondary winding was assumed to be in good condition.

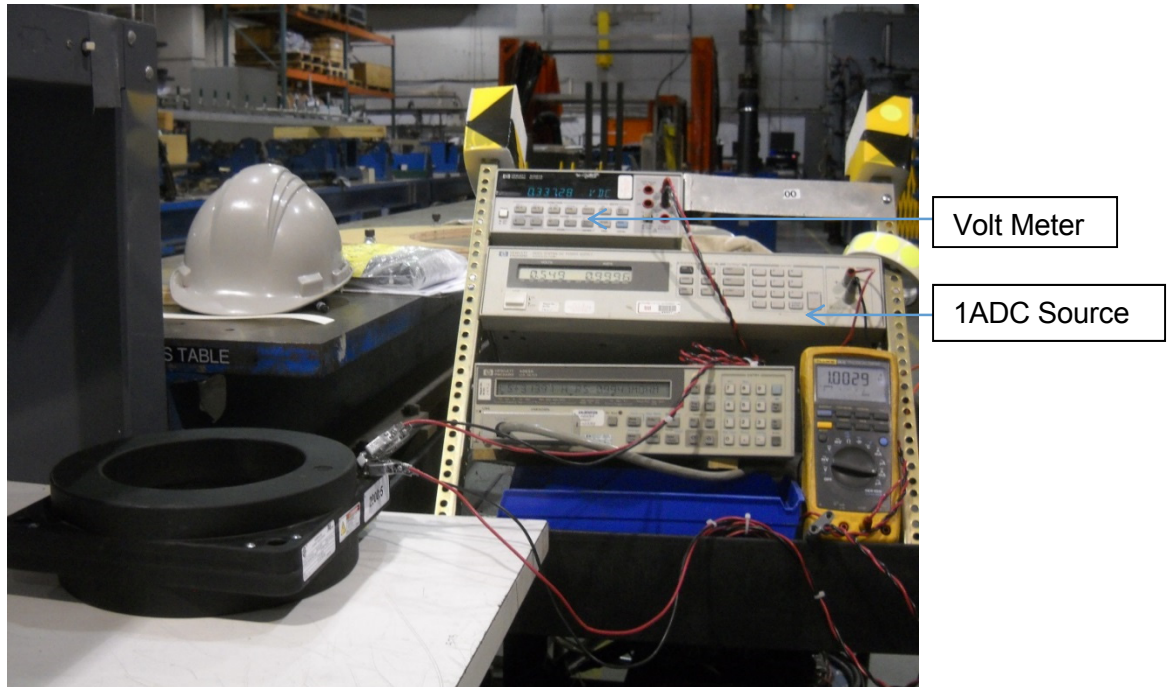

Figure 3-6: DC Resistance Testing of CT's Secondary Winding

2. Impulse Test

CT's secondary winding was periodically impulse-tested to determine if degradation had occurred. This testing was performed using an ECG-Kokusai Model DWX-05 Impulse Tester (S.N. 2004321) shown in Figure 3-7. Recent calibration dated 4/1/16 indicates that this instrument was within calibration.

A capacitor charged to high voltage of 1kV (a set value) is discharged into the CT's winding or coil under test. This voltage sets up a nonlinear voltage distribution in the coil that creates a turn-to-turn voltage difference (Ref. 13). The voltage decay waveform is generated in response to the impulse, related to the Q-factor⁹ and inductance of the coil. The resulting waveform is captured by high speed data logger and displayed on the screen. This waveform is compared with an internally-stored baseline (or master) waveform obtained from the original condition of the coil. If the error between the original and the resulting test waveform is less than 5% (a set value), then it passes the winding test, otherwise it fails. Thus, the output of this test is either "pass" or "fail" indication on the screen.

Figure 3-8 illustrates an example of a compromised winding that failed the impulse test. Spike(s) in the signal indicates turn-to-turn short (highlighted inside a rectangular box) compromising the insulation in the winding.

In case of the AM2CT, this test was performed by connecting the Impulse Tester to the two secondary taps (X1-X2). For the multi-ratio AM4CT, the impulse test was performed by connecting to the two secondary taps (X1-X5), which includes the entire secondary winding.

⁹ Q-factor generally is a measure of the ratio of stored versus lost energy per unit time.

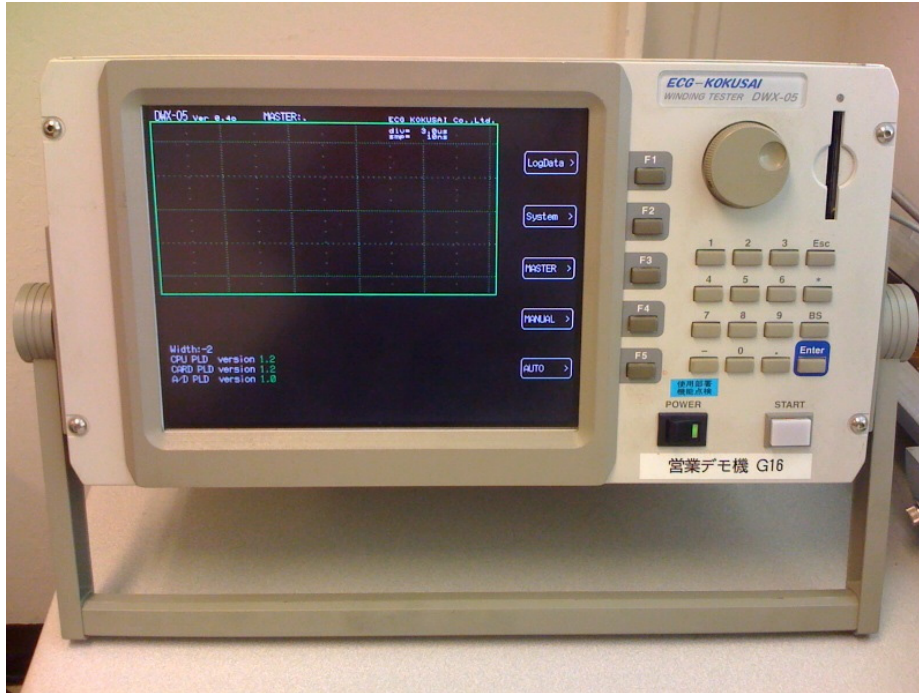

Figure 3-7: ECG-Kokusai Model DWX-05 Impulse Tester

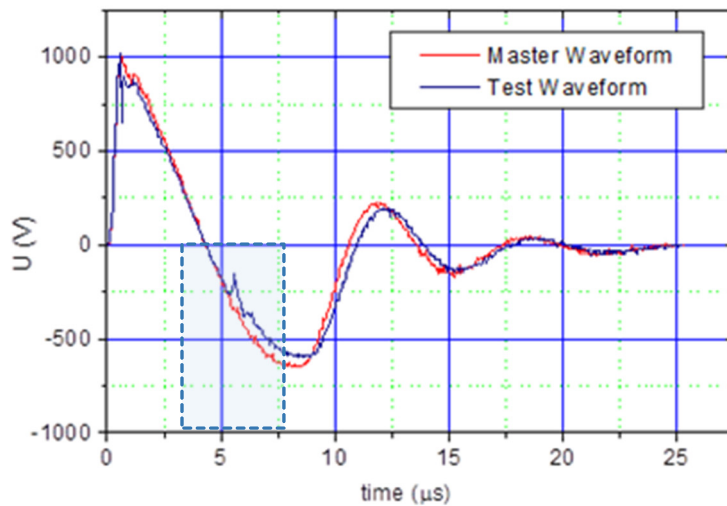

Figure 3-8: Example of Turn-To-Turn Short Indicating Compromised Insulation in the Winding

3.2.4 Periodic Monitoring of the Secondary Cable

During each test we observed for any electrical arcing or damage to the entire length of the secondary cable and its connection points to the relay, ammeter, and other components.

In addition, the secondary cable also was periodically high potential (HiPot) tested (also known as the dielectric withstand test) at 10 kV using HiPot Testers (Associated Research Inc. S.N. 50245

for 5kV and S.N. 2090 for 15 kV, Calibration 1/19/15), shown in Figure 3-9, and the leakage currents were recorded for assessing the condition of its insulating system.

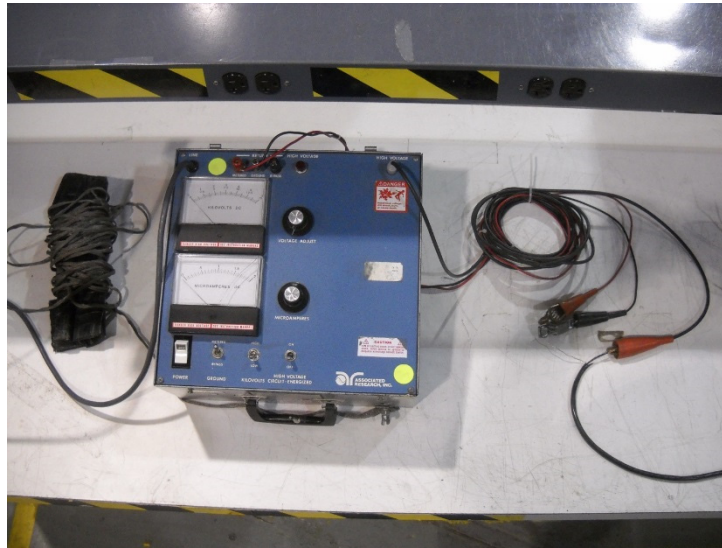

Figure 3-9: HiPot Testing of Cable Insulation

Three different conductor configurations were included in this testing: (1) white conductor and black conductor/shield together, (2) shield and black/white together, and (3) shield/black/white together against the steel plate on which the cable was lying. The former two configurations yield leakage currents for the two conductors (white and black) of the secondary cable in reference to the shield. The third configuration provides the leakage current across the jacket of the cable in reference to the steel plate which was grounded.

High voltage was applied between the two test terminals in steps and then held at that voltage for a minute or so until the leakage current stabilized. The leakage current was then recorded and compared with baseline values recorded earlier. Higher values of the leakage current when compared to their baseline values would have been an indication of damaged insulation in the cable.

3.2.5 Test Equipment Functionality Check

Several shakedown tests on the 2000:5 CT were conducted before the actual tests outlined in the test plan. This was done to ensure that the entire test set up as discussed in the test plan (see Appendix A) was complete and functional, and to ensure that the data logging instrumentation was accurately calibrated for collecting the expected information. These shakedown tests included evaluating the following:

Primary circuit line's current flow level, as appropriate, by adjusting the load bank resistors

Secondary circuit maximum current flow of 5 amps through the ammeter

Data logger appropriately collecting current/voltage of the primary and secondary circuits, and temperatures from the four thermal probes mounted on the CT or the test cabinet

Secondary side open circuit mechanism working (i.e., high voltage relay)

Camera setup taking high speed videos of the targeted locations and synchronizing the collection of data by the data logger

DC insulation resistance of the CT's secondary winding (see Section 3.2.3)

CTs tested for secondary winding resistance and subjected to impulse tests to determine the shape of the impulse voltage for comparisons. Any distortion in the wave shape is the criterion of a CT's winding failure. (see Section 3.2.3)

HiPot testing of the secondary cable's insulations (see Section 3.2.4)

3.3 Assumptions and Limitations

No known test program, excluding an in-situ testing, possibly could simulate an actual real-life plant condition or event. In conducting the open secondary testing to characterize CT's behavior, certain assumptions were made that could limit or contribute to uncertainties in the final test outcome.

- a. The two CTs tested were manufactured by AMRAN, with an insulating system rated at 600V, BIL of 10kV. Their construction and application represent CTs that typically are used in both low and medium voltage AC power distribution systems of nuclear power plants.
- b. Since the testing was focused on characterizing the propensity of an open-circuited CT secondary to cause a fire in a location remote to the open circuit, no effort was made to characterize the magnetic saturation that occurs during open secondary condition.
- c. A high voltage relay was used to cleanly open the secondary circuit. We also postulated that fire-induced open circuits could be intermittent. We, therefore, modified our programming to simulate intermittent opening of the high voltage relay for determining the differences in test results between clean and intermittent opening.
- d. Once the secondary circuit was open, the relay chattering or arcing between two adjacent conductors (i.e., intermittent opening) was simulated by using two conductors at the relay opening with a gap of 2 mm (0.1 inch) or smaller.
- e. CTs were fully functional and operating without any degradation from previous tests. Dielectric conditions of the CT under test and the secondary cabling were monitored periodically using dielectric strength and impulse test equipment when there was indication of potential degradation (e.g., high temperature rise or arcing).
- f. Because of the limitations in resistor combinations in the load bank used in the primary circuit, the primary or line current of 200 amperes at 250V and 100 amperes at 125V could not be increased up to 400 amperes line current available.
- g. The determination made related to secondary fires relied primarily upon visual observation of the test specimens.

3.4 Baseline CT Tests (No Secondary Open Circuit)

The primary circuit consisting of a 60 Hz, Delta 3- Φ , AC source was connected to a Simplex dynamITE 300 Portable Load Bank, rated 315 kW at 480V and 289 kW at 240V. The load bank is configured for 250V and 500V and therefore, was manipulated to determine the maximum line current achievable in each phase of the circuit at the Auto Transformer power supply voltages for the power supply voltage levels. For 125V, the load bank switches were manipulated to assure to the degree possible that the desired levels of primary current were achieved.

These tests defined the limits in the maximum AC line current in each phase as listed in Table 3-2. With 10-loops¹⁰ of the primary cable around the magnetic core of the CT under test, this line current would exhibit a maximum primary current in the CT's core equal to 10 times this maximum line current in ampere-turns (ATs).

Table 3-2: Maximum Current Achievable in the CT's Primary Circuit

Voltage Range	Maximum Line Current	Maximum CT Primary Current
110-125 V	~100 A	~1000 AT
220-250 V	~200 A	~2000 AT
480-500 V	~400 A	~4000 AT

Baseline tests were then performed using the setup of a 2000:5 CT to simulate its in-plant configuration. This did not involve opening the secondary circuit. In addition, the data logger, the camera, and tests of the insulation resistance of the secondary cable were not used during these tests. During each of the tests the desired voltage level and current was verified. This was achieved by using the resistance load combination switches in the load bank determined in an earlier set of tests. The actual and expected currents and voltages in both the primary and secondary circuits were obtained via the high speed data logger for each test set up. The multi-channel fast data logger was controlled via LabVIEW real-time programming for fast-open and intermittent-open of the secondary.

3.5 Open Secondary Tests

Because of the limitations on the maximum primary current, the number of open secondary tests at each source voltage range was limited. Tables 3-3 and 3-4 present the test matrices for the AMRAN 2000:5 CT (AM2CT) and AMRAN 4000:5 CT (AM4CT), respectively. Note that all values indicated in these tables are the root mean square (RMS) values of their parameter harmonic signals. For example, 500V primary voltage is the RMS value of a voltage signal that has a peak value of around 707VAC (i.e., $1.414 \times 500V$).

Table 3-3: Test Matrix for AMRAN 2000:5 CT Tests

Test Identification	Primary Voltage (Volts)	Primary Current (Amps)	CT's Turn Ratio	Secondary Current (Amps)	Secondary CT Taps
AM2CT01	480-500	2000	2000:5	5.00	X1-X2
AM2CT02	480-500	1500	2000:5	3.75	X1-X2
AM2CT03	480-500	1000	2000:5	2.50	X1-X2
AM2CT04	480-500	500	2000:5	1.25	X1-X2
AM2CT05	480-500	250	2000:5	0.62	X1-X2

¹⁰ The test plan indicated 7-loops based on an expected 600A line current. With the limitation of 400A found in each phase of power supply, this was changed to 10-loops to obtain our expected 4000 amperes maximum in the primary circuit. Based on this, Figure 3-5 was updated to indicate 10-loops.

Table 3-3: Test Matrix for AMRAN 2000:5 CT Tests

Test Identification	Primary Voltage (Volts)	Primary Current (Amps)	CT's Turn Ratio	Secondary Current (Amps)	Secondary CT Taps
AM2CT06	480-500	125	2000:5	0.31	X1-X2
AM2CT07	220-250	2000	2000:5	5.00	X1-X2
AM2CT08	220-250	1500	2000:5	3.75	X1-X2
AM2CT09	220-250	1000	2000:5	2.50	X1-X2
AM2CT10	220-250	500	2000:5	1.25	X1-X2
AM2CT11	220-250	250	2000:5	0.62	X1-X2
AM2CT12	220-250	125	2000:5	0.31	X1-X2
AM2CT13	220-250	62	2000:5	0.15	X1-X2
AM2CT14	110-125	1000	2000:5	2.50	X1-X2
AM2CT15	110-125	500	2000:5	1.25	X1-X2
AM2CT16	110-125	250	2000:5	0.62	X1-X2
AM2CT17	110-125	125	2000:5	0.31	X1-X2
AM2CT18	110-125	62	2000:5	0.16	X1-X2
AM2CT19	480-500	2500	2000:5	6.25	X1-X2
AM2CT20	480-500	3000	2000:5	7.50	X1-X2
AM2CT21	480-500	4000	2000:5	10.0	X1-X2

In Table 3-4, the first 14 tests were originally planned. At the request of the working group members, 16 additional tests were conducted to collect data supporting comparison between the two different CTs tested.

Table 3-4: Test Matrix for AMRAN 4000:5 CT Tests (

Test Identification	Primary Voltage (Volts)	Primary Current (Amps)	CT's Turn Ratio	Secondary Current (Amps)	Secondary CT Taps
AM4CT01	480-500	4000	4000:5	5.00	X1-X5
AM4CT02	480-500	3500	3500:5	5.00	X2-X5

Table 3-4: Test Matrix for AMRAN 4000:5 CT Tests (Continued)

Test Identification	Primary Voltage (Volts)	Primary Current (Amps)	CT's Turn Ratio	Secondary Current (Amps)	Secondary CT Taps
AM4CT03	480-500	3000	3000:5	5.00	X1-X4
AM4CT04	480-500	2500	2500:5	5.00	X2-X4
AM4CT05	480-500	2000	2000:5	5.00	X1-X3
AM4CT06	480-500	1500	1500:5	5.00	X2-X3
AM4CT07	480-500	1000	1000:5	5.00	X3-X4
AM4CT08	480-500	500	500:5	5.00	X1-X2
AM4CT09	220-250	2000	2000:5	5.00	X1-X3
AM4CT10	220-250	1500	1500:5	5.00	X2-X3
AM4CT11	220-250	1000	1000:5	5.00	X3-X4
AM4CT12	220-250	500	500:5	5.00	X1-X2
AM4CT13	110-125	1000	1000:5	5.00	X3-X4
AM4CT14	110-125	500	500:5	5.00	X1-X2
AM4CT15	480-500	4000	4000:5	5.00	X1-X5
AM4CT16	480-500	3000	4000:5	3.75	X1-X5
AM4CT17	480-500	2000	4000:5	2.50	X1-X5
AM4CT18	480-500	1000	4000:5	1.25	X1-X5
AM4CT19	480-500	500	4000:5	0.625	X1-X5
AM4CT20	480-500	250	4000:5	0.31	X1-X5
AM4CT21	480-500	125	4000:5	0.155	X1-X5
AM4CT22	480-500	62	4000:5	0.08	X1-X5
AM4CT23	480-500	4000	2000:5	10.0	X1-X3
AM4CT24	480-500	3000	2000:5	7.5	X1-X3

Table 3-4: Test Matrix for AMRAN 4000:5 CT Tests (Continued)

Test Identification	Primary Voltage (Volts)	Primary Current (Amps)	CT's Turn Ratio	Secondary Current (Amps)	Secondary CT Taps
AM4CT25	480-500	2000	2000:5	5.00	X1-X3
AM4CT26	480-500	1000	2000:5	2.50	X1-X3
AM4CT27	480-500	500	2000:5	1.25	X1-X3
AM4CT28	480-500	250	2000:5	0.625	X1-X3
AM4CT29	480-500	125	2000:5	0.31	X1-X3
AM4CT30	480-500	62	2000:5	0.155	X1-X3

Fifty-one open secondary test configurations were tested using both fixed-ratio CT 2000:5 (AM2CT) and multi-ratio CT 4000:5 (AM4CT) as listed in the test matrices given in Tables 3-3 and 3-4. Additional tests of certain test configurations were performed to simulate the effects of long duration, test repeatability, intermittent relay opening, time step optimization, and other conditions such as arcing. Thus, a total of 63 tests involving two CTs were performed.

Each open secondary test typically lasted for 30 seconds. The opening relay remained open for about 5-6 seconds during which the data logger registered the "TRANSIENT" data for 10,000 time steps per second (i.e., each step being 100 microseconds). The first 1000 steps simulate the normal condition, followed by opening of the secondary circuit for the remaining 9000 time steps. As soon as the secondary circuit was opened, the secondary current becomes zero and the secondary voltage increases. The primary circuit remained constant for the entire 30 seconds. Another set of "CONTINUOUS" data also was recorded each second for the entire 30 seconds (or 10 minutes, in a few tests) to capture the temperature rise in the CT. Figure 3-10 presents the timeline of a typical test cycle and the data collection sequences. All relay opening and data collection sequences were automated using LabVIEW real-time programming computer code.

Several additional tests were repeated varying other test parameters, for example, with the relay open in the secondary for about 5 and 10 minutes to obtain the effect of the high secondary voltage and core saturation on the secondary cable's insulation resistance, the temperature rise in the CT, and the change in the CT's winding resistance. The sampling rate of 10,000 steps per second was used so that the spikes of the open secondary voltage were captured. Based on the shake down test results, doubling the sampling rate (from 5,000 to 10,000 steps per second) increased the open secondary crest voltage by a few volts (e.g., AM2CT07: 2,874V to 2,880V). Nevertheless, all baseline and open secondary tests were performed at 10,000 steps sampling rate (i.e., 100 Microsecond steps). Several other tests involved arcing simulation at the relay opening, intermittent opening of the relay, and examining the repeatability of each test.

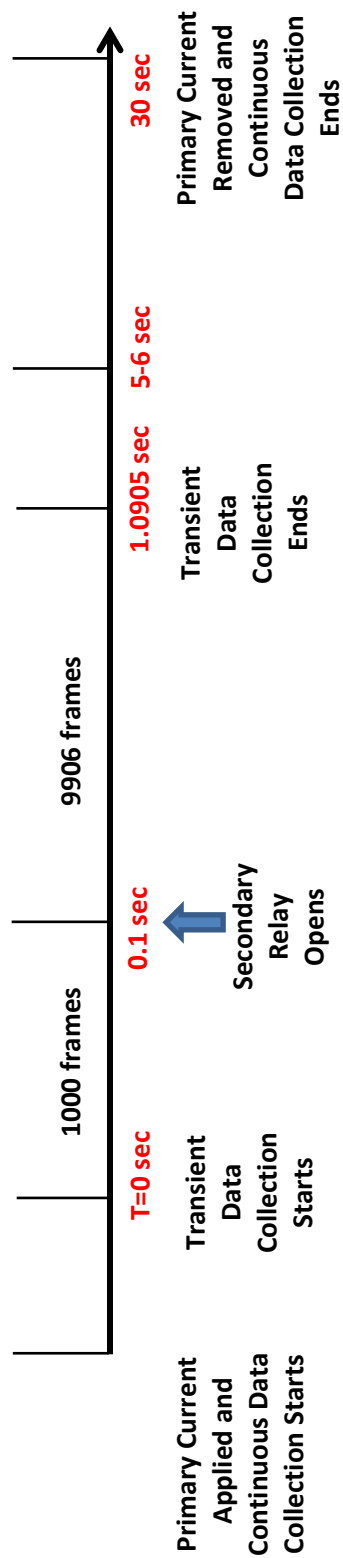

Figure 3-10: Typical Test Duration at 10,000 Steps/Sec

4 TEST RESULTS

Test results for each test setup were hand-written in a data sheet as shown in RED in Table 4-1. The data logger records the unique date and time of each test. In addition to the eight entries' peak values from the data logger, each sheet contains any deviation from the test matrices that are listed in Tables 3-3 and 3-4, and any visual observations and video recordings. Also, included were the periodic HiPot results of the secondary cable's insulation and the DC resistance of the CT's secondary coil along with the pass/fail results of impulse testing. Arcing simulation video clips, and data logger files in EXCEL format involving all 63 tests are provided in the attached compact disc (CD). See Appendix B.

4.1 Baseline Test Results

Baseline tests were conducted first on a 2000:5 CT to ensure that the test setup simulated the plant's normal operating condition. That is, at 2000 amps primary current the secondary current ammeter reading was 5 amps and the crest secondary voltages were around 20V¹. Similar tests were made on the 4000:5 CT's set up; they exhibited the expected results as shown in Figure 4-1 below, indicating no dependence on the primary voltage levels. Note that since all test results presented in Figure 4-1 correspond to a secondary current at 5 amperes, the horizontal axis also represents the CT's turn ratios (e.g., 500:5 through 4000:5).

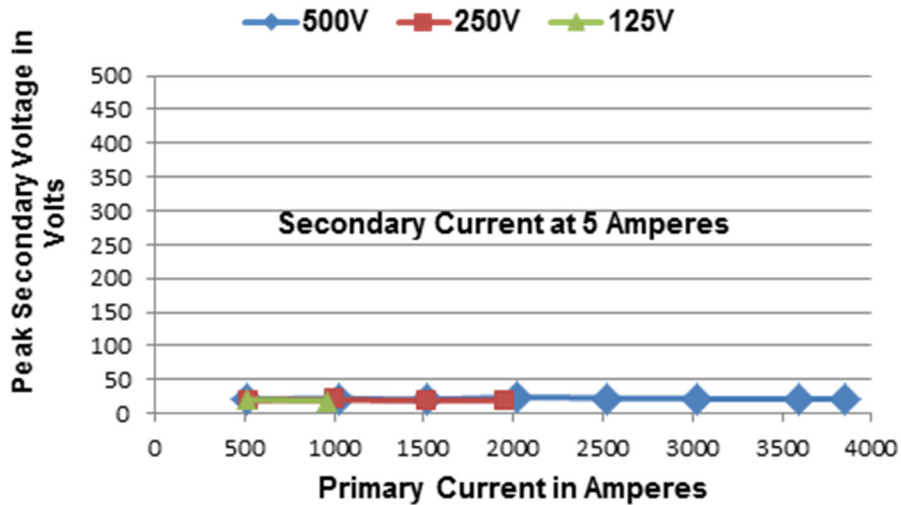

Figure 4-1: AM4CT - Secondary Voltage Under Normal CT Operation

¹ In the normal configuration of AM2CT and AM4CT, the secondary voltage was found to be independent of the primary voltage levels (i.e., 500V, 250V, and 125V), and dependent on the primary current levels. For example, at rated current of 2000:5 for the AM2CT, the peak secondary voltage was around 20V depending on the current and the impedance of the meter and the relay circuit in the secondary, while at lower secondary current level (i.e., <2000A) the peak secondary voltage was as low as 15V and at higher secondary current level (i.e., >2000A) the peak secondary voltage was as high as 25V.

Table 4-1: Sample Data Sheet for Open Secondary Tests

TEST DATA SHEET

SHEET # **28**

CT TEST IDENTIFICATION: AM2CT21; CT Serial Number: AM019591; CT Winding Resistance: 0.375 Ohms @ 75 °C
 DATE PERFORMED: **1-4-16**; OPEN SECONDARY MODE: **FAST**; TURN RATIO: **2000:5**
TIME TEST WAS PERFORMED: 1602.05

Nominal Primary Voltage Source V _p (Volts)	Primary Current RMS/Peak I _p (Amps/Turn)	Secondary Voltage V _s (+/-) Spikes (Volts)	Peak Secondary Current I _s (Amps)*	Final Temperature Readings in °C				Secondary Cable Insulation Leakage Current at 10 kV (Micro-amp)
				T ₁ at Outside CT (0 degree)	T ₂ at Outside CT (180 degrees)	T ₃ at Inside CT (90 degrees)	T ₄ Inside CT Cabinet	
500 Nominal	3808/4494 (~4000) Nominal	3717/(-3755) 3736 Average	13.64 (~10RMS)	23.69	22.86	24.11	20.87	B+W to GND 0.5 B to W+GND 0.2 B+W+GND to PLATE 0.65
CT Secondary Winding Resistance (Ohms)				Video Camera Observations and Frames Recorded				Remarks
0.33527 Impulse Test "PASSED"				None				OK

* Note that the secondary current becomes zero soon after opening the secondary

Data Input By: **MSubudhi**; Initials: **MS** Test Duration: 1000 | 9000 ~1 Sec
 Checked By: Data Logger Record Load Bank Setting: **315 kW**

Reference Document/File on Data Records:

Testing of CT's Secondary Winding

Figure 4-2 presents the inductance of the secondary coil in each of the tested CTs. This component is responsible for keeping the magnetic flux in the core in check. The DC resistance of each CT's secondary coil also was measured for its normal condition and the values are included in Table 3-1 along with the manufacturer's rated values for the tested CTs. The DC resistance values were compared with the baseline data given in Table 3-1 to periodically evaluate the condition of the insulation of the CT's secondary winding.

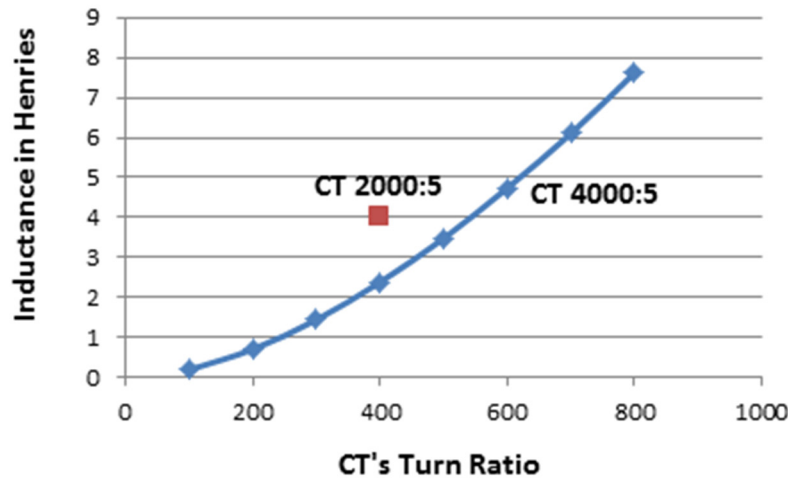

Figure 4-2: Inductance of Secondary Coil

Figure 4-3 for AM2CT and Figure 4-4 for AM4CT present the baseline voltage signatures of the impulse tester. To monitor the condition of the secondary winding, as stated earlier in Section 3.2.3, 1kV voltage pulse was introduced into the CT's winding periodically and the impulse tester compared within 5% error in the impulse signature with the baseline signature to determine whether the winding was in good condition for the subsequent tests.

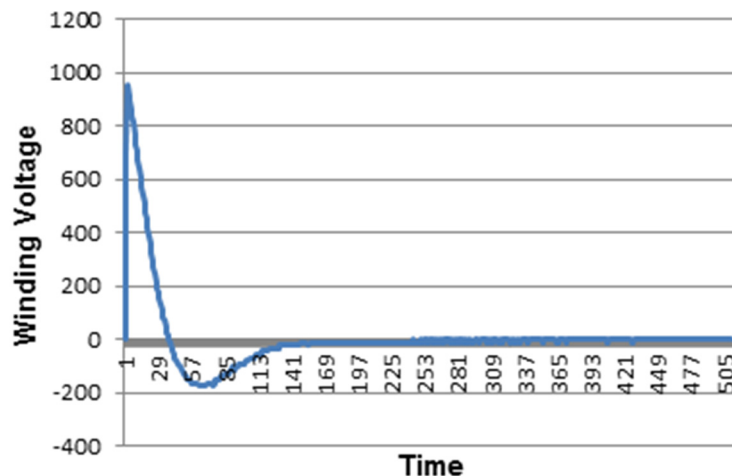

Figure 4-3: CT 2000:5 (X1-X2) Impulse Test Signature

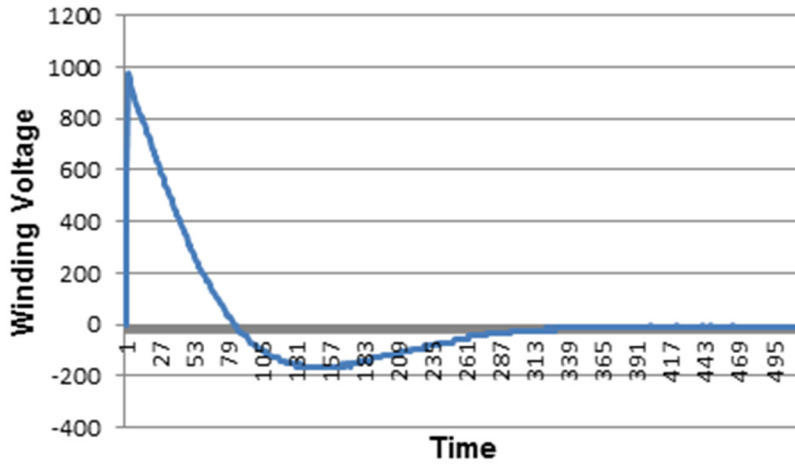

Figure 4-4: CT 4000:5 (X1-X5) Impulse Test Signature

Secondary Cable Insulation Test Parameters

Table 4-2 presents the HiPot testing results of three different instrument cables known to be used in nuclear power plants. One of them was used in the CT testing and the other two were taken from BNL's storage from the environmental qualification (EQ) test on cables performed for NRC during the late 90's.

Table 4-2: Baseline HiPot Test Results of Instrument Cables

Cable Used in CT Testing	Cable Used in EQ Testing	
Commercial-Grade, General Cable, PVC/Nylon/PVC, Shielded, AWG 16, 2/C, 600V (No Drain or Ground Wire)	Samuel Moore, 20 mil Dekorad (EPDM)/10 mil Dekorad (CSPE) Bonded Jacket/45 mil Dekorad (CSPE) Jacket, 600V, 2/C, AWG 16, Shielded and Ground, Manufactured 1982	Rockbestos, 30mil XLPE/45 mil Neoprene Jacket, 600V, 2/C, AWG 14, Firewall III, Manufactured 1979
White (W) Wire to Black (B) Wire/Shield (S)*	Red Wire to Violet Wire/Shield	Wire to Wire
5kV: 0.0 microampere	5kV: 0.0 microampere	5kV: 0.0 microampere
10kV: 1.0 microampere	10kV: 0.25 microampere	10kV: 0.05 microampere
15kV: 3.5 microampere	15kV: 6.0 microampere	15kV: 1.4 microampere
W/B to Shield**	Red/Violet Wire to Shield	No Shield Wire
5kV: 0.0 microampere	5kV: 0.0 microampere	-
10kV: 0.1 microampere	10kV: 1.5 microampere	-
15kV: 7.0 microampere	15kV: 10.0 microampere	-
W/B/S to Metal Plate***	W/B/S to Metal Plate	W/B/S to Metal Plate
5kV: 0.0 microampere	5kV: 0.0 microampere	5kV: 0.0 microampere
10kV: 5.5 microampere	10kV: 0.5 microampere	10kV: 2.0 microampere
15kV: 20.0 microampere	15kV: 3.0 microampere	15kV: 13.0 microampere

* White conductor and black/shield shorted together

** Shield and white/black shorted together

*** Metal plate on which the cable was placed and White/black/shield shorted together for jacket integrity

Leakage currents in Table 4-2 demonstrate that the instrument cables typically used in NPPs have very high dielectric strength even at 15 kV and can withstand higher voltage levels even after 40 years. In-between the open secondary tests, periodically the secondary cable used in this testing was disconnected from the CT and the burden ammeter followed by high potential (HiPot) testing of the cable's insulating system. The DC leakage current at 10 kV was closely monitored to assess the condition of the cable's insulation.

New secondary cable was used from the start of all open secondary tests performed on each CT's test configuration. The primary cable configuration remained the same for both CT configurations with ten turns around each CT.

4.2 Open Secondary Tests

Open secondary tests were performed on both 2000:5 and 4000:5 CTs as outlined in the test matrices listed in Tables 3-3 and 3-4. The data sheet shown in Table 4-1 was used to register each set of test data obtained from the instrumentation including the data logger. Also included were physical and visual evidences gathered during each test. Any deviations in the test, such as longer duration, intermediate opening of the secondary circuit, different sampling rate by the data logger, simulation of arcing in the secondary circuit, also were detailed in these data sheets.

Out of fifty-one test conditions, twenty-one tests on 2000:5 CT (AM2CT) and thirty test conditions on 4000:5 CT (AM4CT) were conducted. In each test, the primary voltage and primary current remained constant and independent of what was happening in the secondary circuit (i.e., from a closed secondary circuit to an open secondary configuration). Figures 4-5 and 4-6 present the typical harmonic signatures of the primary voltage and current for the open secondary Test # AM4CT01 in Table 3-4. Similar primary voltage and current profiles typically were seen in all AM2CT and AM4CT open secondary tests listed in Tables 3-3 and 3-4 for all three source voltage levels (i.e., 125V, 250V, and 500V). There was no change in these signatures even though the entire primary current became the excitation current in an open secondary configuration. The primary voltage remained unchanged from its set value for all of the transition period.

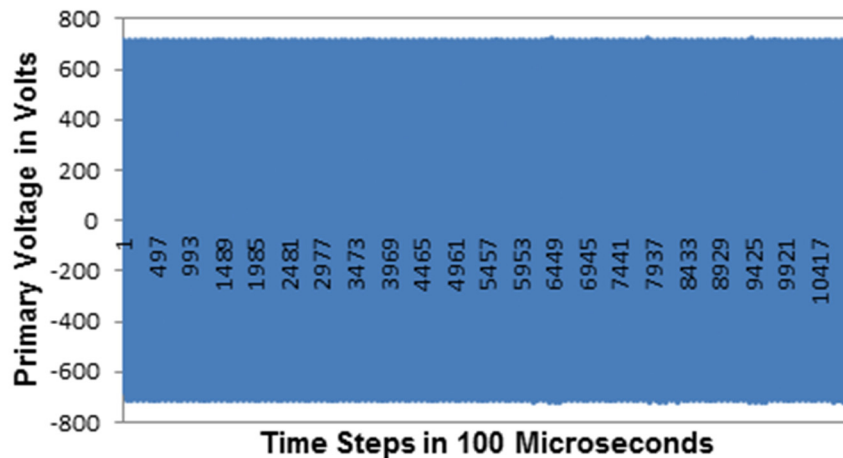

Figure 4-5: AM4CT01 Test – Primary Voltage at 500V (Typical)

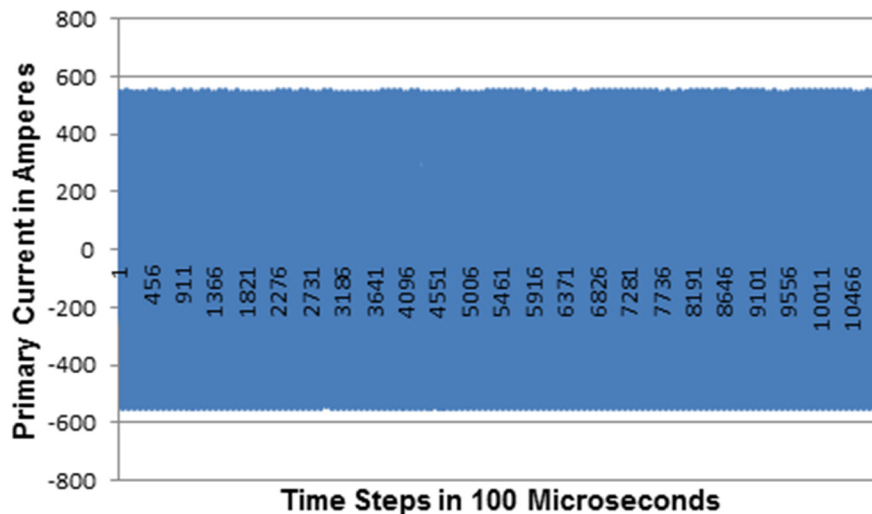

Figure 4-6: AM4CT01 Test – Primary Current Approximately at 400A RMS (Typical)

Figure 4-7 presents the root mean square (RMS)² value of the primary current in Figure 4-6 set for each open secondary test. This value was used in setting the level of the primary current by manipulating the load bank resistors in the primary circuit. Once set at a value closer to a pre-set value as listed in Tables 3-3 and 3-4, this parameter was monitored for its transient behavior during the opening of the secondary circuit. As shown in Figure 4-7, the primary current remained unchanged during the transient from closed secondary configuration to open secondary one, even though under the latter, the entire primary current became the excitation current for the core's magnetics.

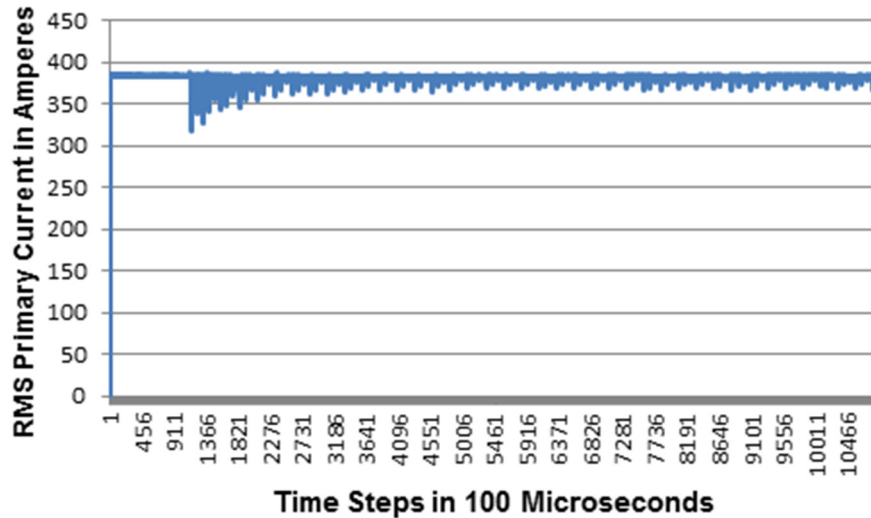

Figure 4-7: AM4CT01 Test – RMS Primary Current Approx. at 400A (Typical)

For the first 1000 time steps, Figure 4-8 presents the typical secondary current under a normal operating configuration in a nuclear power plant. This represents a secondary current of 5 amperes RMS corresponding to a turn ratio of 4000:5. Once the relay was opened to simulate an open secondary condition, the secondary current dropped to zero for the remaining ~9000 time steps.

² This is the only test parameter whose RMS value was recorded by the data logger. All other test parameter data are peak values, unless it is noted otherwise.

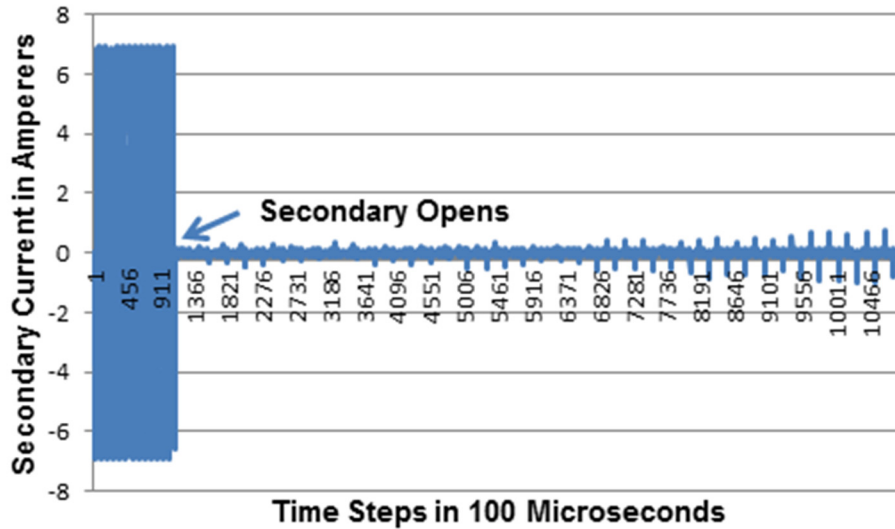

Figure 4-8: AM4CT01 Test – Typical Secondary Current Harmonics for an Approximate Primary Current of 400A (or 4000AT)

Figures 4-9 and 4-10 illustrate typical secondary crest voltages for the AM2CT and AM4CT at their rated turn ratios (i.e., 2000:5 and 4000:5) and primary voltage of 500V, respectively.

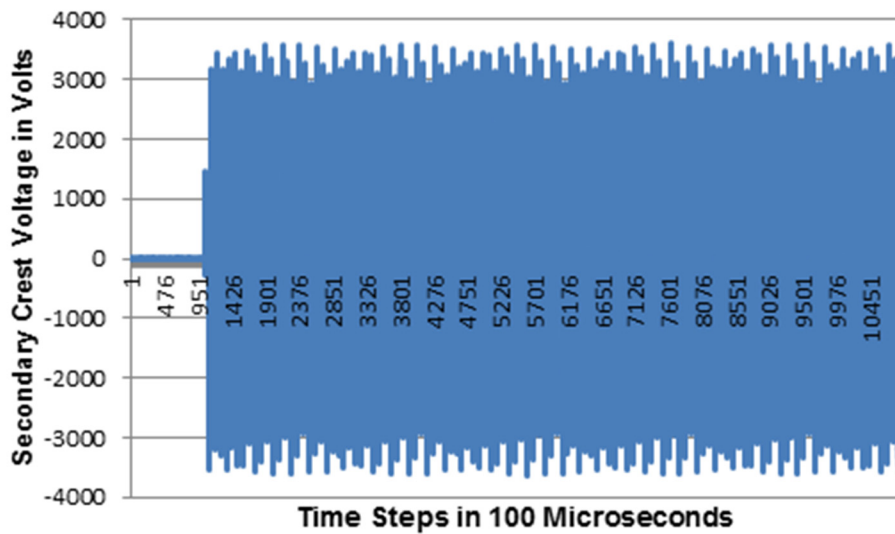

Figure 4-9: AM2CT01 Test – Open Secondary Crest Voltage (Typical)

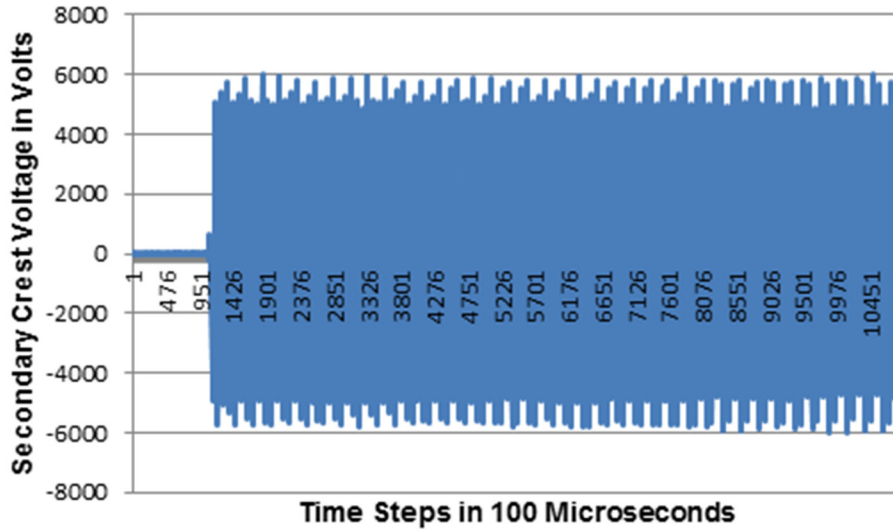

Figure 4-10: AM4CT01 Test – Open Secondary Crest Voltage (Typical)

Table 4-3 lists the results from the series of tests (21) performed on 2000:5 Fixed-Ratio CT (AM2CT), while Table 4-4 those from 4000:5 Multi-Ratio CT (AM4CT). Each open secondary crest voltage presented in these tables is the average of the plus-side peak and the minus-side peak values. The typical difference between these two peaks is less than 2% of the mean value. Out of the 30 tests on AM4CT, the first 14 were performed at their rated turn ratios and the remaining 16 tests were performed at constant turn ratios of 4000:5 and 2000:5, while varying the primary current levels.

Table 4-3: Test Results for AM2CT Test Series Given in Table 3-3 (

Test Identification	Nominal* Primary Voltage in Volts	RMS Primary Current in Ampere-Turns	CT Turn Ratio	Closed Secondary Peak Current in Amperes	Opened Secondary Crest Voltage in Volts
AM2CT01	500	1953	2000:5	7.07	3612
AM2CT02	500	1445	2000:5	5.27	3489
AM2CT03	500	976	2000:5	3.55	3299
AM2CT04	500	450	2000:5	2.41	2947
AM2CT05	500	260	2000:5	1.10	2672
AM2CT06	500	147	2000:5	0.67	2265
AM2CT07	250	2003	2000:5	7.35	2880
AM2CT08	250	1521	2000:5	5.57	2808
AM2CT09	250	1010	2000:5	3.77	2684

Table 4-3: Test Results for AM2CT Test Series Given in Table 3-3 (Continued)

Test Identification	Nominal* Primary Voltage in Volts	RMS Primary Current in Ampere-Turns	CT Turn Ratio	Closed Secondary Peak Current in Amperes	Opened Secondary Crest Voltage in Volts
AM2CT10	250	527	2000:5	2.05	2479
AM2CT11	250	257	2000:5	1.14	2212
AM2CT12	250	129	2000:5	0.57	1842
AM2CT13	250	69	2000:5	0.33	1588
AM2CT14	125	961	2000:5	3.58	2053
AM2CT15	125	514	2000:5	2.01	1948
AM2CT16	125	266	2000:5	1.09	1796
AM2CT17	125	120	2000:5	0.58	1591
AM2CT18	125	76	2000:5	0.32	1312
AM2CT19	500	2505	2000:5	8.97	3584
AM2CT20	500	3049	2000:5	10.9	3628
AM2CT21	500	3808	2000:5	13.64	3736

*Transient data was not recorded. Load bank voltage input data recorded instead.

Table 4-4: Test Results for AM4CT Test Series Given in Table 3-4 (

Test Identification	Peak/Nominal Primary Voltage in Volts	RMS Primary Current in Ampere-Turns	CT Turn Ratio	Closed Secondary Peak Current in Amperes	Opened Secondary Crest Voltage in Volts
AM4CT01	718/500	3848	4000:5	6.94	6138
AM4CT02	718/500	3590	3500:5	7.17	5262
AM4CT03	722/500	3022	3000:5	7.25	4436
AM4CT04	722/500	2526	2500:5	7.30	3612
AM4CT05	719/500	2016	2000:5	7.35	2745
AM4CT06	724/500	1517	1500:5	7.41	2025
AM4CT07	724/500	1027	1000:5	7.62	1342
AM4CT08	724/500	513	500:5	7.98	625

Table 4-4: Test Results for AM4CT Test Series Given in Table 3-4 (Continued)

Test Identification	Peak/Nominal Primary Voltage in Volts	RMS Primary Current in Ampere-Turns	CT Turn Ratio	Closed Secondary Peak Current in Amperes	Opened Secondary Crest Voltage in Volts
AM4CT09	356/250	1948	2000:5	7.12	2200
AM4CT10	357/250	1513	1500:5	7.43	1625
AM4CT11	359/250	1009	1000:5	7.53	1085
AM4CT12	360/250	528	500:5	8.13	522
AM4CT13	179/125	955	1000:5	7.14	828
AM4CT14	180/125	515	500:5	7.92	410
AM4CT15	715/500	3864	4000:5	6.89	6127
AM4CT16	720/500	3141	4000:5	5.29	5912
AM4CT17	721/500	2047	4000:5	3.67	5611
AM4CT18	726/500	1034	4000:5	1.90	5098
AM4CT19	729/500	527	4000:5	1.01	4576
AM4CT20	729/500	260	4000:5	0.55	4034
AM4CT21	728/500	145	4000:5	0.34	3379
AM4CT22	728/500	60	4000:5	0.12	2346
AM4CT23	715/500	3856	2000:5	13.77	3013
AM4CT24	717/500	3011	2000:5	10.79	2920
AM4CT25	720/500	2027	2000:5	7.33	2773
AM4CT26	725/500	1026	2000:5	3.80	2526
AM4CT27	727/500	522	2000:5	2.01	2260
AM4CT28	726/500	269	2000:5	1.10	2012
AM4CT29	727/500	146	2000:5	0.55	1696
AM4CT30	728/500	70	2000:5	0.16	1176

Temperature measurements of the CT's core were monitored throughout the entire duration of each test performed on AM2CT and AM4CT. In all cases the temperature remained unchanged at room temperature shown in Figure 4-11 and therefore, they are not included in Tables 4-3 or 4-4.

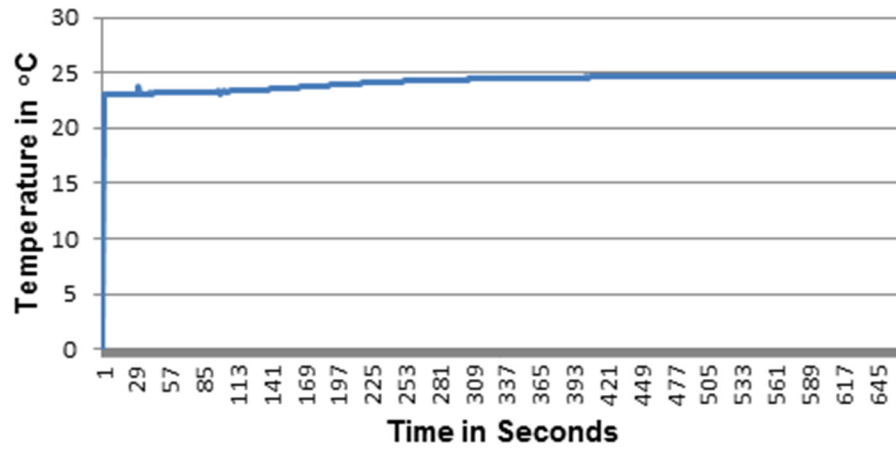

Figure 4-11: AM4CT01 Test – CT Temperature Rise Over 10 Minutes

Several special cases involving a longer duration, intermittent opening of the secondary, and arcing simulation in the secondary circuit are discussed in Section 5.

5 EVALUATION OF TEST RESULTS

5.1 Effect of Primary Voltage/Current

Unlike a voltage transformer (VT), under normal condition CT's primary voltage has minimal effect on its operation (see Figure 4-1). However, the primary current level, because of the CT's inherent turn ratio, has significant effect on the instrumentation readout of the secondary current.

The primary voltage, along with the primary current and the turn ratio, has an effect on the CT's behavior under an abnormal open secondary condition. Figure 5-1 illustrates the dependencies of the open secondary crest voltage with the primary voltage and primary current levels keeping the turn ratio constant. The results presented here are taken from the AM2CT testing given in Table 4-3. This clearly indicates that the open secondary crest voltage is dependent on the primary current as well as the primary voltage.

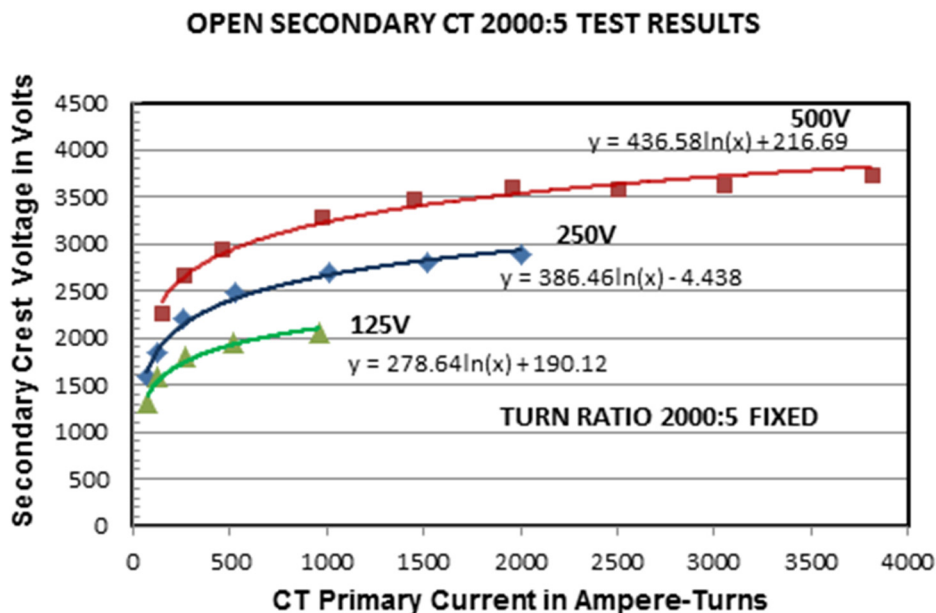

Figure 5-1: AM2CT - Open Secondary Crest Voltage Versus Primary Voltage/Current with Turn Ratio Fixed at 2000:5

Figure 5-1 shows three plots for primary voltage levels of 500V, 250V, and 125V. At each primary voltage level, the primary current level was varied from 500 Amp-Turn (AT) through 4000 AT where possible. In all cases at its rated turn ratio value of 2000:5, as the secondary is opened the crest voltage increases instantly to a value higher than 1000V and then as the primary current continues to increase it starts flattening. This flattening is likely due to the core saturation effect on the CT's magnetic core.

5.2 Effect of Primary Voltage and Turn Ratio

A similar observation on the dependence of the primary voltage also is evident from the test results presented in Table 4-4 on AM4CT keeping turn ratio at its rated values from 500:5 through 4000:5 where possible. Since the AM4CT has multi-ratio secondary taps, in the first 14 test cases presented in Table 4-4 the secondary current was maintained at 5 amperes under normal condition as the primary current was changed from 500 AT through 4000 AT. This also corresponds to changing the turn ratio from 500:5 through 4000:5.

Interestingly, it clearly is illustrated in Figure 5-2 that the open secondary crest voltage is dependent on the primary voltage when the test results of the 4000:5 CT were plotted from Table 4-4. At each primary voltage level of 500V, 250V, and 125V, the open secondary crest voltage is linearly dependent on their rated values for a multi-ratio CT. Because of the limitations in the primary line current level at 125V, only two data points are plotted and therefore, the linear regression has higher uncertainty. However, it does indicate linear relationship taking the zero as one additional data point, consistent in all three voltage classes.

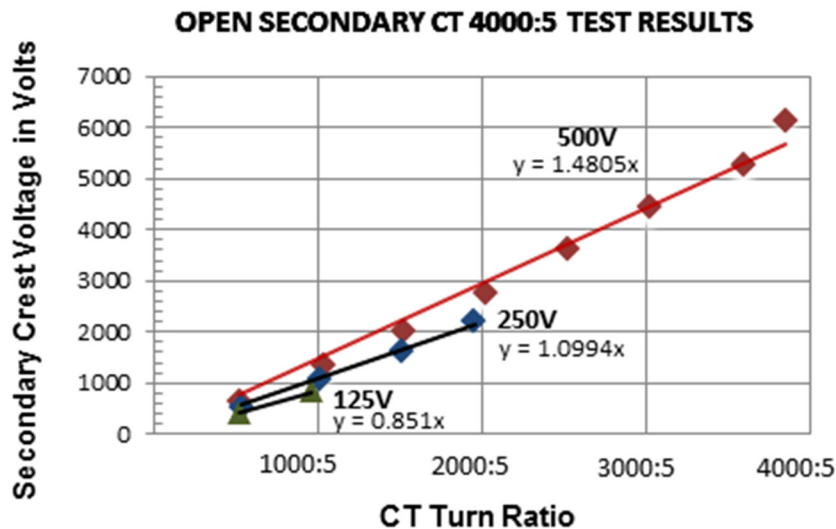

Figure 5-2: AM4CT - Open Secondary Crest Voltage with Varying Primary Voltage and Rated Turn Ratio

Figure 4-1 presents the results corresponding to normal operating condition of the 4000:5 CT at three primary voltage levels. The same three cases corresponding to an open secondary condition are plotted in Figure 5-2. Comparing both figures one can conclude that primary voltage, while has no effect during normal operation of a CT, has significant effect on the open secondary crest voltage.

5.3 Effect of Primary Voltage/Current and Turn Ratio

Figure 5-3 presents similar characteristics shown in Figure 5-1 when the CT's turn ratios were kept fixed at 4000:5 and 2000:5 in the multi-ratio CT (AM4CT). When results from Figure 5-2 are compared for the primary voltage level of 500V, Figure 5-3 illustrates the independent behavior of

the open secondary crest voltage when operated at their rated conditions versus at a constant turn ratio.

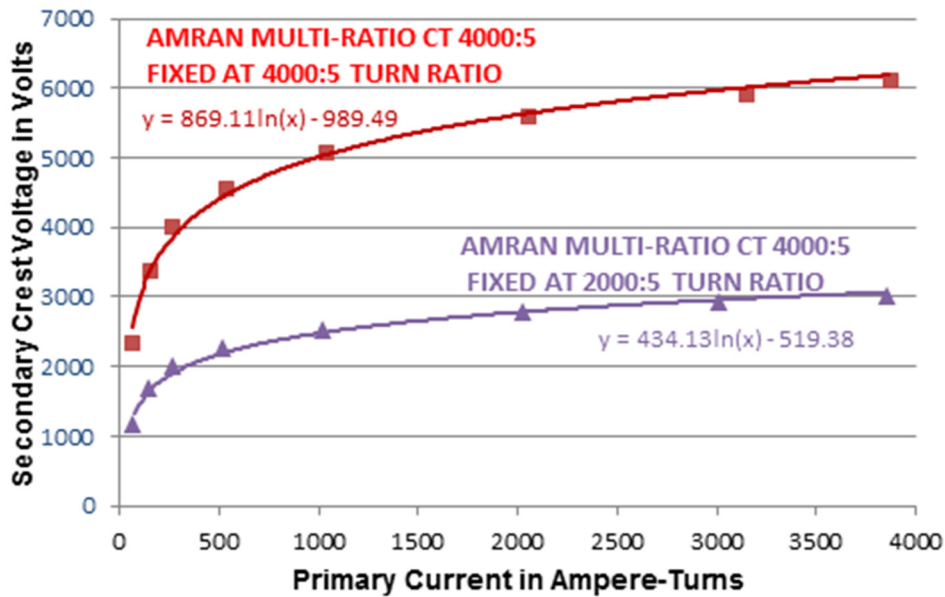

Figure 5-3: AM4CT - Open Secondary Crest Voltage with Varying Primary Current at 500V

One additional and important conclusion observed in all tests is that we did not have any secondary fire or evidence for an arc occurring either at the CT's secondary taps or within the secondary cable's insulating system. The temperature probes on the CT indicated no significant change even under a saturated core (see Figure 4-11). As indicated in Table 4-2, the insulating system of the secondary cable could withstand 10kV or higher without any significant leakage current. Therefore, the worst cases with open secondary crest voltage of nearly 6,000V crest would not have broken down the cable's insulating system.

5.4 Impact of Arcing and Intermittent Opening

Additional tests of the AM4CT01 were performed to examine the effects of arcing at the opening relay (or relay chattering) and to simulate an intermittent relay opening on the crest secondary voltage. Figure 5-4 presents a comparison of these results with a normal case of open secondary (see Top Plot).

If electrical arcing, persistent or intermittent, occurred in the open secondary circuit then the secondary crest voltage diminished significantly during the sustained arcing period (see Middle Plot). This also was postulated by the PIRT panel¹ (Ref. 4). However, the crest voltage always bounced back to its peak value for the duration when the secondary remained in the open

¹ The PIRT panel stated that as soon as an arc forms at a location in the cable, the voltage of the CT's circuit will drop because of the secondary flux that develops, opposing the primary current. With this decline in the voltage, the arc will be extinguished, allowing the process to repeat itself. This fault condition will continue until the CT's associated load is de-energized.

condition without arcing (see Figure 5-5²). Similar behavior also was noted when clean (or controlled) intermittent opening of the secondary circuit occurred (see Bottom Plot).

Based on the above, for a secondary location to become an ignition source for fire it would require a crest secondary voltage high enough to cause immediate damage to the secondary cable's insulating system. There will be insufficient energy to cause a secondary fire once arcing starts at any location in the secondary circuit. We did not observe insulation failure of the secondary cable in any of our tests.

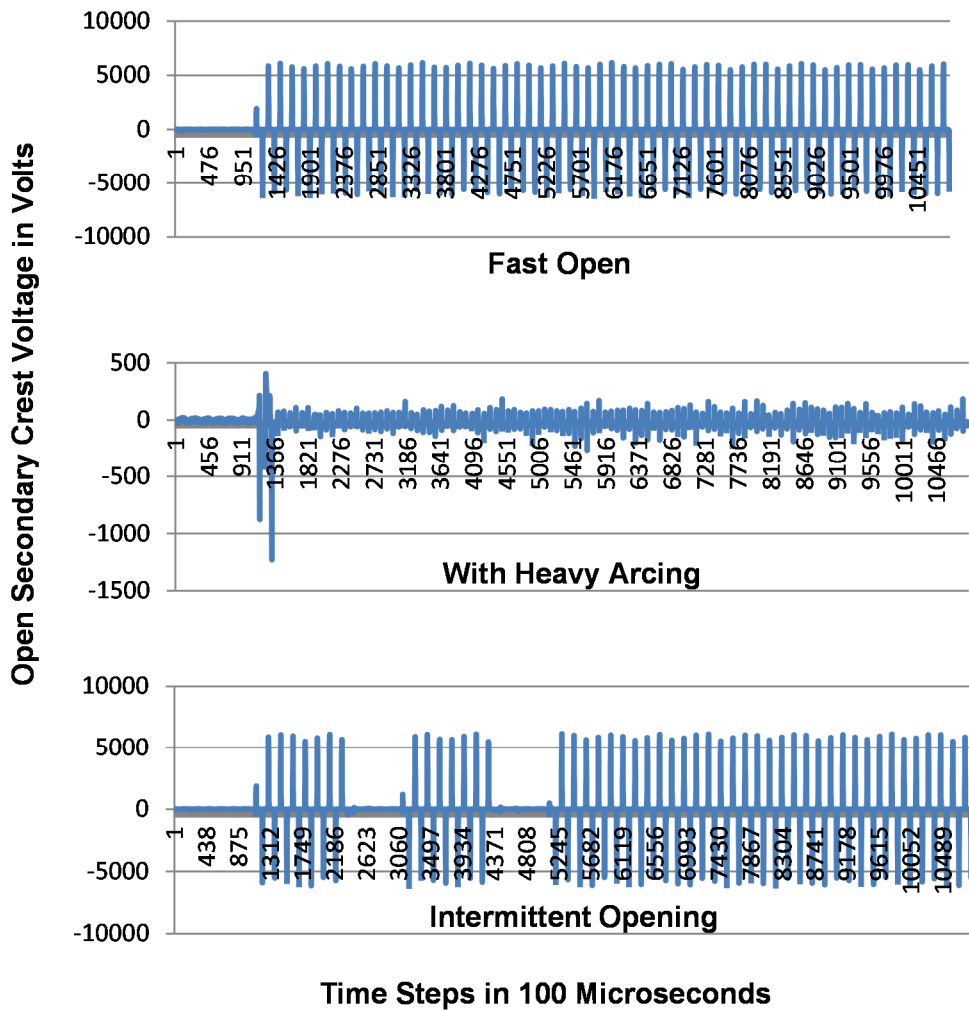

Figure 5-4: Secondary Crest Voltage Characteristics Under Various Conditions

² Figure 5-5 represents the test data for Test AM2CT03 and the crest voltage for this case is 3,299V (see Table 4-3). This Figure simulates relay chattering or random arcing contacts at the opening of the secondary.

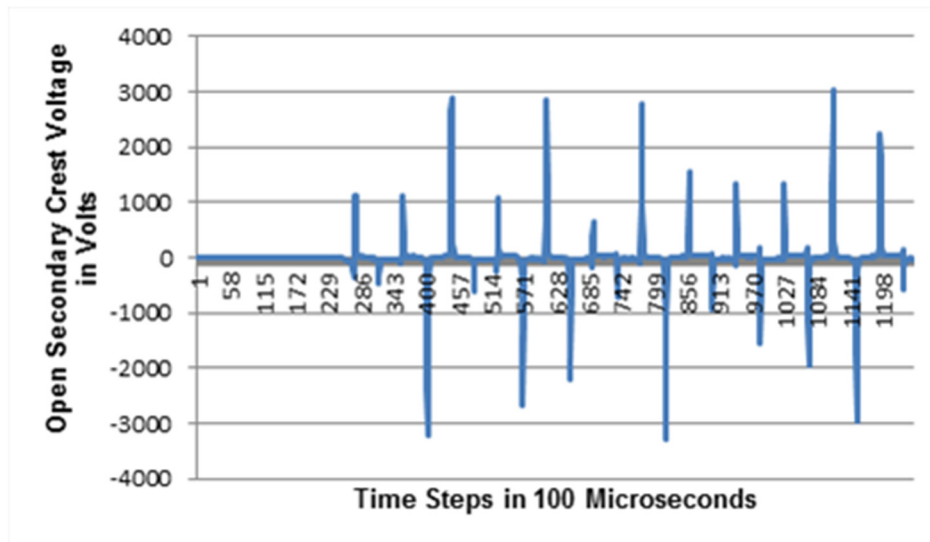

Figure 5-5: AM2CT03: Secondary Crest Voltage Under Intermittent Arcing

5.5 Other Effects

Test Repeatability

Several cases were repeated to understand if the same test conditions exhibit similar results. In all of them it was found that all tests are repeatable with results within less than 5% experimental bias of the crest secondary voltage.

Test Duration Effect on CT's Temperature

To better understand the effect of long duration open secondary condition on the CT's temperature, several tests of AM2CT01 and AM4CT01 were performed for 5 or 10 minutes. Even for this long duration at a secondary crest voltage of over 6 kV, no evidence of significant temperature change was noted.

Effect of Magnetics

Figure 5-6 compares the secondary crest voltage for two cases involving AM2CT and AM4CT from the same manufacturer when the primary voltage at 500V, the primary current at 2000 ATs, and the turn ratio of 2000:5 were kept the same. It clearly indicates that the open secondary crest voltage values are very different while the trend remains similar. This difference indicates the magnetics of the CT's construction may have contributed and significantly affects the open secondary crest voltage. This is consistent with the difference in the inductance values of the secondary winding shown in Figure 4-2. This inductive component is responsible for keeping magnetizing flux in the core in check during CT's operation.

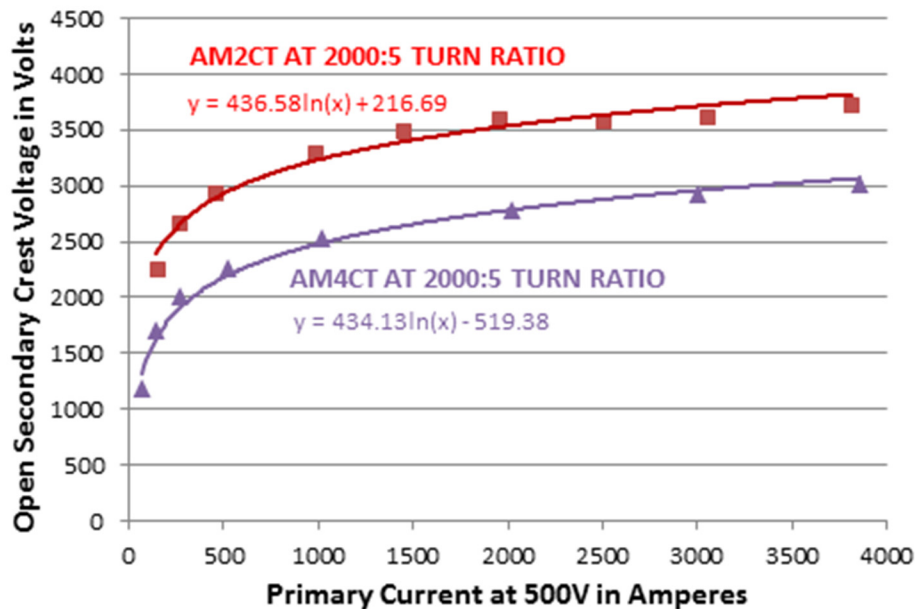

Figure 5-6: Secondary Crest Voltage in Tests AM2CT01 and AM4CT05

5.6 Evaluation of Data to Test Plan Criteria

The test plan (Appendix A.5) identified the following three criteria to support the working groups assessment of test data developed here. Those criteria are:

Neither the CT nor its secondary circuit shows any signs of arcing or explosive failure.

Either the CT or its secondary circuit does show signs of arcing, but the duration is short and near the CT, or the arc is of insufficient intensity to ignite surrounding materials farther from the CT.

The CT does exhibit explosive failure, but the explosive behavior is near the CT and insufficient to damage surrounding materials. The explosive failure is not accompanied by subsequent arcing of the CT or its secondary circuit.

Based on the 63 tests performed there was not a single observance of any one of these criteria.

6 SUMMARY OF TEST RESULTS

The primary objective of this testing was to better understand the following scenario: Will fire-induced open circuiting of the secondary circuit of a wound-type CT, which is operating within its rated continuous primary current limits, result in an excessively high voltage in the secondary circuit sufficient to start a fire in the form of explosion or arcing in the circuit's insulation at the location of the CT itself or at some other location in the secondary circuit?

The CTs tested at BNL are typically used for low and medium voltage applications. The most important conclusion observed in all tests is that we did not have any secondary fire or evidence for an arc occurring either at the CT's secondary taps or within the secondary cable's insulating system. The temperature probes on the CT indicated no significant change even under a saturated core (see Figure 4-11). As indicated in Table 4-2, the insulating system of the secondary cable could withstand 10kV or higher without any significant leakage current. Therefore, the worst cases with open secondary crest voltage of nearly 6,000V crest would not have broken down the cable's insulating system. When an arc was deliberately initiated in the secondary circuit at the high voltage relay, it was observed that the crest voltage diminished significantly. For the configurations tested, the results from 63 individual tests indicated that an open circuited CT was incapable of starting a secondary fire based on the criteria established in the test plan. This observation applies to the CT, CT taps, cabling, and burden devices.

Based on the results discussed in previous sections, the following findings either were observed or are derived from the test results. These results may be of use to the working group in developing guidelines on the question of secondary fires resulting from open circuits in CT's secondary, including extending the limit on the 1200:5 CTs as stated in the NUREG/CR-7150, Volume 1 (Ref. 4).

Parameters that affect the open secondary crest voltage include the following:

The material and construction of the CT's magnetic core.

It varies between manufacturers and even between different models from the same manufacturer (see Figure 5-6, where the primary voltage was at 500V and the turn ratio was constant at 2000:5 while the primary current was varied).

Primary voltage source (see Figures 5-1 & 5-2).

Crest voltage increases with increasing primary voltage under open secondary circuited conditions. This is contrary to CTs under normal operating condition, where primary voltage has little effect on secondary voltage (see Figure 4-1).

Primary current level (see Figures 5-1 & 5-3).

Crest voltage increases with increasing primary current under open circuited secondary conditions.

CT's turn ratio (see Figure 5-2).

Crest voltage increases with increasing CT's turn ratio.

The open secondary crest voltage rises to 1000V or higher immediately after opening the secondary circuit.

To capture the crest voltage the minimum time step needed is above a 5,000 steps/second. Both test series used 10,000 steps per second in almost all open secondary tests.

Intermittent opening/closing via a relay (i.e., clean open/close) or via arcing over a small gap does not affect the magnitude of the crest voltage (see Figures 5-4 & 5-5).

Electrical arcing, however, diminishes the magnitude of the open secondary crest voltage (see Figures 5-4 & 5-5).

No degradation of the CT's secondary coil insulation was found during any tests. The temperature rise of the CT was insignificant (<5 °C per test).

The insulation of the secondary cable did not indicate any degradation. The periodic HiPot tests indicated no leakage current at 10 kV.

The repeatability of each test was excellent based on the open secondary crest voltage and the deviations noted were well below 5%.

7 REFERENCES

- [1] Brookhaven National Laboratory Letter from Mr. E. A. MacDougall to Nicholas S. Fiorante of NRC, dated July 21, 1983.
- [2] Regulatory Guide 1.189, Fire Protection for Nuclear Power Plants, Revision 2, October 2009.
- [3] NEI 00-01, Guidance for Post-Fire Safe Shutdown Circuit Analysis, Revision 2, May 2009.
- [4] NUREG/CR-7150 and EPRI 1026424, "Joint Assessment of Cable Damage and Quantification of Effects from Fire (JACQUE-FIRE) - *Phenomena Identification and Ranking Table (PIRT) Exercise for Nuclear Power Plant Fire-Induced Electrical Circuit Failure*," BNL-NUREG-98204-2012, Volume 1, October 2012.
- [5] https://www.eiseverywhere.com/file_uploads/389f38b2dff8bcc3c58da78777e4d71_Current_Transformers.pdf
- [6] <http://sound.westhost.com/xfmr2.htm> , Chapter 17.
- [7] <http://www.allaboutcircuits.com/textbook/alternating-current/chpt-9/mutual-inductance-and-basic-operation/>, Mutual Inductance and Basic Operation, Chapter 9 - Transformers
- [8] IEEE Std. C57.13-2008, "IEEE Standard Requirements for Instrument Transformers," IEEE Power Engineering Society, July 2008.
- [9] "A Basic Stun Gun Concept," Chemlec © 2007 & 2011.
- [10] IEEE Std. C57.13.2-2005, "IEEE Standard Conformance Test Procedure for Instrument Transformers," IEEE Power Engineering Society, September 2005.
- [11] NETA WORLD, Back to Basics – Current Transformer Testing, http://www.netaworld.org/netaworld-journal/archived-articles/468_Fall-Winter_2004.
- [12] Current Transformers: A Tester Survival Guide. <http://www.docfoc.com/current-transformers-a-tester-survival-guide-bryan-shannon-abb-inc-coral>
- [13] Wiedenbrug, E., Frey, G. and Wilson, J., "Impulse Testing as a Predictive Maintenance Tool," <http://www.reliabilityweb.com>.

APPENDIX A

OPEN SECONDARY TESTING OF WINDOW-TYPE CURRENT TRANSFORMERS – TEST PLAN

A.1 Introduction

A.1.1 Basic Principles of Current Transformer

The design and construction of a window-type (or donut-type) current transformer (CT) consist of two separate windings on a common laminated iron or steel core [Refs. A1, A2]. The primary winding is made out of more than one turn of heavy gauge wire capable of carrying a large primary current from a power distribution system, where the secondary winding uses many turns of smaller gauge wire with a continuous current carrying capacity of 1 amp or 5 amps, depending on the instrumentation design. Under normal operation, the alternating current (AC) in the primary winding (known as excitation current) produces an alternating magnetic field in the core, which then induces an alternating current in the secondary winding circuit. The primary and secondary circuits are magnetically coupled so that the secondary current is linearly proportional to the primary current over the intended range of the CT.

The linear proportionality between the primary and secondary currents ceases when the excitation current increases to a certain level, depending on the magnetic saturation in the CT's iron core. At this point, an increase in the excitation current produces a significantly smaller increase in the secondary current.

CTs rated 1200:5 current ratio will produce 5 amps continuous secondary current when 1,200 amps of current flow in the primary. The relationship between primary current and secondary current is based on the ratio of their turns in the windings of the CT's core. In fact, the Amperes-Turns (i.e., current multiplied by number of turns) in the primary winding is maintained equal to the Amperes-Turns in the secondary. Theoretically, the secondary voltage increases or decreases as required for maintaining a constant primary-to-secondary current ratio.

CTs, a specific type of instrument transformers, are widely used in the electric power industry, including nuclear power plants (NPPs), to monitor the current at strategic locations in electrical power distribution systems. These CTs provide isolation from the high voltage primary, and step-down the magnitude of the measured current to a value that can be safely handled by the monitoring instruments. Thus, they are designed to measure the current in AC power systems (generally three-phase systems) in their primary winding and transform this current into a representative low secondary current for instrumentation used for remote readout of the current.

A.1.2 Potential Fire Due to Open-Circuited Secondary

In a letter to the NRC dated July 21, 1983, Brookhaven National Laboratory (BNL) raised a potential concern for fire-induced open circuits on a CT's secondary [Ref. A3]. The BNL letter postulated the scenario in which potentially high voltages induced on the secondary winding of a CT as a result of open circuiting the CT secondary due to fire-induced failure of the CT or its connected components. The postulated failure mode could potentially start a secondary fire at a location remote from the initiating fire area. However, the Auxiliary Systems Branch (ASB) of the NRC concluded at the time that the BNL's concerns were overly conservative and recommended no further action on this issue [Ref. A4]. Differing opinions on the validity of the fault mode have persisted for decades. Although identified in regulatory and industry guidance as a potential

concern, agreement has not existed on treatment within both performance-based and deterministic approaches. Based on the substantial increase in knowledge of fire-induced circuit failures, the JACQUE-FIRE Phenomena Identification and Ranking Table (PIRT) panel elected to further investigate the open circuit CT issue. Upon further review of this failure mode, the PIRT Panel concluded that CTs with turn ratio 1200:5 or less pose no risk of a secondary fire. [Ref. A7] It was the PIRT Panels judgement that this conclusion could not be extended beyond this turn ratio limitation without further supporting data.

It has been recognized that as long as current is flowing in the primary winding of a CT, an open-circuit in a CT's secondary can cause high voltages on the secondary circuit as the CT attempts to maintain the current relationship dictated by the transformer's winding turns ratio [Ref. A8]. This condition can result in CT damage and potentially generate voltages that may exceed the dielectric strength of the current transformer insulating materials or other CT circuit conductors, which may cause arcing to connected components.

The resulting high voltage condition in the secondary circuit from an open-circuited CT introduces a potential failure mode that warrants further investigation as part of the final resolution of circuit failure issues associated with the fire protection strategies at nuclear power plants. The secondary circuit from the CT location in the plant to the main control room instrument indications may consist of long (e.g., hundreds of feet) instrument wires, whose insulations are susceptible to secondary fires. Since the safe shutdown analysis and the fire probability risk assessment (Fire PRA) are based on one fire area (safe shutdown) or one scenario at a time, the possibility of a second fire in a separate location fire area can significantly impact the final outcome of the analysis results, and subsequent fire protection strategies.

IEEE Std. C57.13-2008 [Ref. A9], § 6.7.1, Operation with Secondary Circuit Open, states: "Current transformers should never be operated with the secondary circuit open because hazardous crest voltages may result. Transformers conforming to this standard shall be capable of operating under emergency conditions for 1 min with rated primary current times the rating factor with the secondary circuit open if the open-circuit voltage does not exceed 3500 V crest.

When the open circuit voltage exceeds 3500 V peak, the secondary winding terminals should be provided with voltage limiting devices (varistors or spark gaps). The voltage limiting device should be able to withstand an open-circuit situation for a period of 1 min without damage to the secondary circuit. The voltage limiting device may need to be replaced after such an abnormal condition."

A.2 Objective

A.2.1 Purpose and Scope

The purpose of this test program is to better understand the following scenario: Will fire-induced open circuiting of the secondary circuit of a wound-type CT, which is operating within its rated continuous primary current limits, result in an excessively high voltage in the secondary circuit sufficient to start a fire in the form of explosion or arcing in the circuit's insulation at the location of the CT itself or at some other location in the secondary circuit? The test results are expected to provide technical justifications to the working group for developing guidelines on this subject area, including the limit on the 1200:5 CTs as stated in the NUREG/CR-7150, Volume 1 [Ref. A7].

Because the secondary open-circuit voltage is limited by saturation of the CT's iron core, the root-mean-square (RMS) value measured by a voltmeter may not appear to be dangerous. However, as the current cyclically passes through zero (e.g., a sinusoidal AC current at a power frequency of 60 Hz), the rate of change of flux at current zero is not limited by saturation, and is raised to a higher than normal magnitude. This induces high peaks or pulses of voltage in the secondary circuit. These high peaks can exceed the rated dielectric strength of the instrumentation cable insulation (i.e., 3,500 V per IEEE Std. C57.13-2008), potentially causing break down of the insulation and arcing to adjacent electrical components.

Influencing parameters, the primary voltage and the turn ratio, are expected to impact the secondary voltage spikes under open secondary condition of a CT. The test plan includes a set of preliminary testing of CTs with primary voltages 120V, 240V, and 480V, while it also includes turn ratios from 100 (500:5) to 800 (4000:5). If these first set of CT testing will indicate any fire, arcing or any degradation of the secondary cable, subsequent causal analysis would determine all other influencing parameters. Based on the findings, additional CTs and test configurations will be considered for subsequent testing. Testing of higher voltage CTs, different-manufacturer CTs, bush-type CTs, and other considerations such as longer secondary cabling, influence of inductive loads will depend on the results from this preliminary set of tests and future funding.

A.2.2 Recent CT Test Results

Based on a presentation given by Steve Laslo of the Bonneville Power Administration in March 2012, the response of a 3000:5 CT¹ to an open secondary can be illustrated in Figures A-1 and A-2 below [Ref. A10]. Figure A-1 is a composite summary of the CT's response in terms of flux in the core, primary current, and induced secondary voltage (E_s) changes under open secondary condition.

Of interest to this program is the ability to measure the magnitude and duration of the secondary voltage spike that is induced by opening the secondary side of an energized CT. In the same presentation, the secondary "peak" voltage is plotted as a function of the magnitude of the primary current for the 3000:5 CT (see Figure A-2). In the test program, this simplified response will be more accurately quantified in magnitude and time response using high-speed data acquisition equipment described in Section A.3.1.

The presentation also indicates that moderate to high voltage spikes up to 2,220 volts in the secondary were observed for the low primary current flow below 813 amps and the CT flux behaved sinusoidal with some minor distortions at higher current levels. Above 813 amps up to 2,337 amps (i.e., 80% of the 3,000 amps) of primary current the CT started making significant noise and the flux reached to a fully saturated waveform with 3,600 volts secondary voltage spikes. The testing continued to a primary current level of 6,487 amps for the 3000:5 CT, the secondary voltage spikes became progressively higher and narrower, and the extremely high secondary voltage spikes of 8,000 volts were observed with excessively high CT noise levels.

¹ CT used was from a retired 500kV ITE SF6 PCB – BCT 3000/5 (Full Winding). CTs used in nuclear safety systems are smaller and typically at low voltage ratings (600V-6kV).

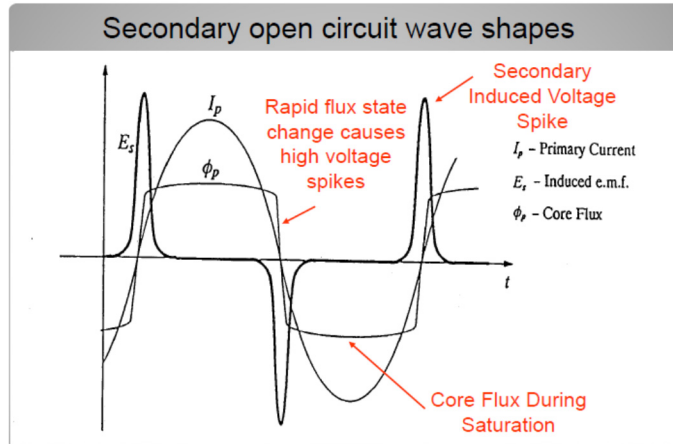

Figure A-1: CT Response - Open Secondary Circuit [Ref. A10]

Since the presentation was intended for training purposes it does not provide any test data or photos of arcing or damage to the secondary circuit or its components. However, it concluded that CTs with very high turn ratios can produce very high voltages on the open-circuited secondary even at low levels of primary current flow.

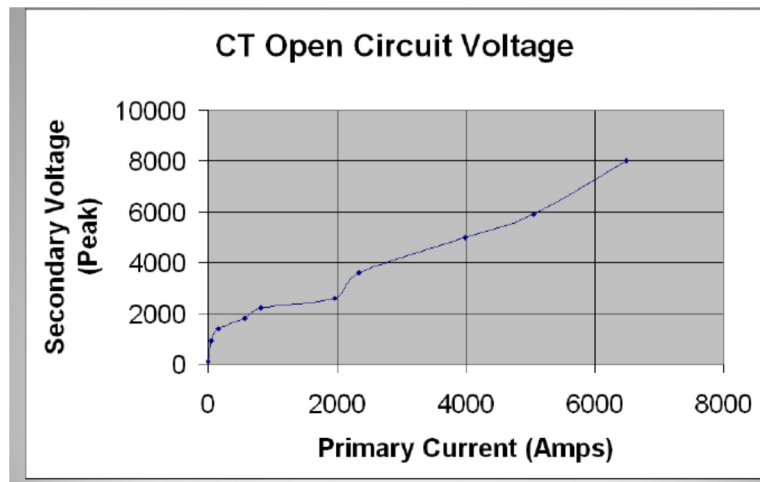

Figure A-2: Secondary Peak Voltage Achieved During

Open Circuit on the Secondary of a CT [Ref. A10]

References A11 and A12 present similar open secondary CT testing. Unlike Reference A10 presentation, no specific test data are available from these programs, just videos showing the test profiles. Both indicated no secondary wiring failure with some explanations given in Reference A11. Reference A12 showed that with intermittent shorting of the secondary terminals its insulation could be compromised with arcing at the CT connecting location. It appears that the size and application of CTs under the purview of nuclear power plant's fire safety are smaller (i.e., typically for a line voltage up to 6 kV or less) from those used in these test programs.

Based on the above test characteristics and many other similar test videos seen on the internet, high secondary voltage spikes are expected during the testing in the form of arcing or insulation damage in the secondary circuit. Since the insulation of the CT's secondary is typically designed to

withstand voltages between 2,500 – 4,000 Volts [Refs. A9 & A13], it is unlikely that we will observe any such damage scenarios without exceeding this voltage threshold or inducing a failure by some other means. However, it should be noted that the sole purpose of this testing is to obtain adequate information that would form the technical basis for assessing the propensity of a secondary fire or damage to the secondary side circuit or components under an open-circuited CT secondary.

A.3 TESTING Approach

For this test program, we will simulate the effects of a fire that damage the secondary side conductors of an energized CT that are typically used in the safety and applicable non-safety systems of nuclear power plants, causing an open circuit on the secondary windings. As discussed earlier, the open circuit is expected to cause abnormally high secondary voltages when primary current flow is present. This testing will evaluate the potential effects of these high voltage spikes on an open-circuited CT secondary circuit. Specifically considered is whether the possibility exists for the high voltage to cause sustained arcing or a catastrophic failure of the CT (or other secondary circuit elements) that is sufficiently energetic to initiate a secondary fire that damages components or equipment beyond the CT's circuit and its components. A secondary fire here is a fire at a location remote from the original fire that is responsible for the initial open-circuit in the CT secondary circuitry.

A series of tests will be conducted to demonstrate the impact of the primary current values on the secondary peak voltage. This is important in determining if the peak voltages on the secondary are high enough to damage the insulation and create a potential fire source.

A.3.1 BNL Superconducting Magnet Test Facility

The Superconducting Magnet Division at BNL has been involved in testing various superconducting magnets for use in both particle accelerators and experimental facilities. Capabilities include:

- Superconductor materials development/test facility
- Magnetic structure design
- Superconducting magnet fabrication
- Vertical and horizontal cryogenic testing
- Magnetic field measurements

The CT testing will be carried out in the high bay area of the Superconducting Magnet Division test facility. Magnet Division routinely assembles and tests very high current, high field superconducting electromagnets for particle accelerators like Relativistic Heavy Ion Collider (RHIC) at BNL and Large Hadron Collider (LHC) at the European Organization for Nuclear Research (CERN). The test facility has various AC- and DC-controlled power sources ranging from 480 Volts, 1,600 Amps AC to 30 Volts, 30,000 Amps DC. Associated with these power sources, each test facility has a state-of-the-art high speed multi-channel data acquisition system with the sampling frequency of up to 1 MHz and 16 bit resolution. Many other monitoring systems, sensors and equipment required to do such specialized measurements are also available for this test program. Available equipment includes isolation and buffer amplifiers for high voltage measurement, voltage and current transformers, high current controlled switches and circuit breakers, and deionized water supply for cooling the load banks.

Laboratory Space

Figure A-3 shows an aerial view of the high bay area at the BNL Superconducting Magnet test facility. All CT tests will be carried out at the barricaded area (right).



Figure A-3: Aerial View of the Test Facility

As shown in a close-up photo in Figure A-4, its present configuration has the required AC current source and the spacing around it to set up an enclosed cabinet with each CT under test and to locate the data acquisition racks.

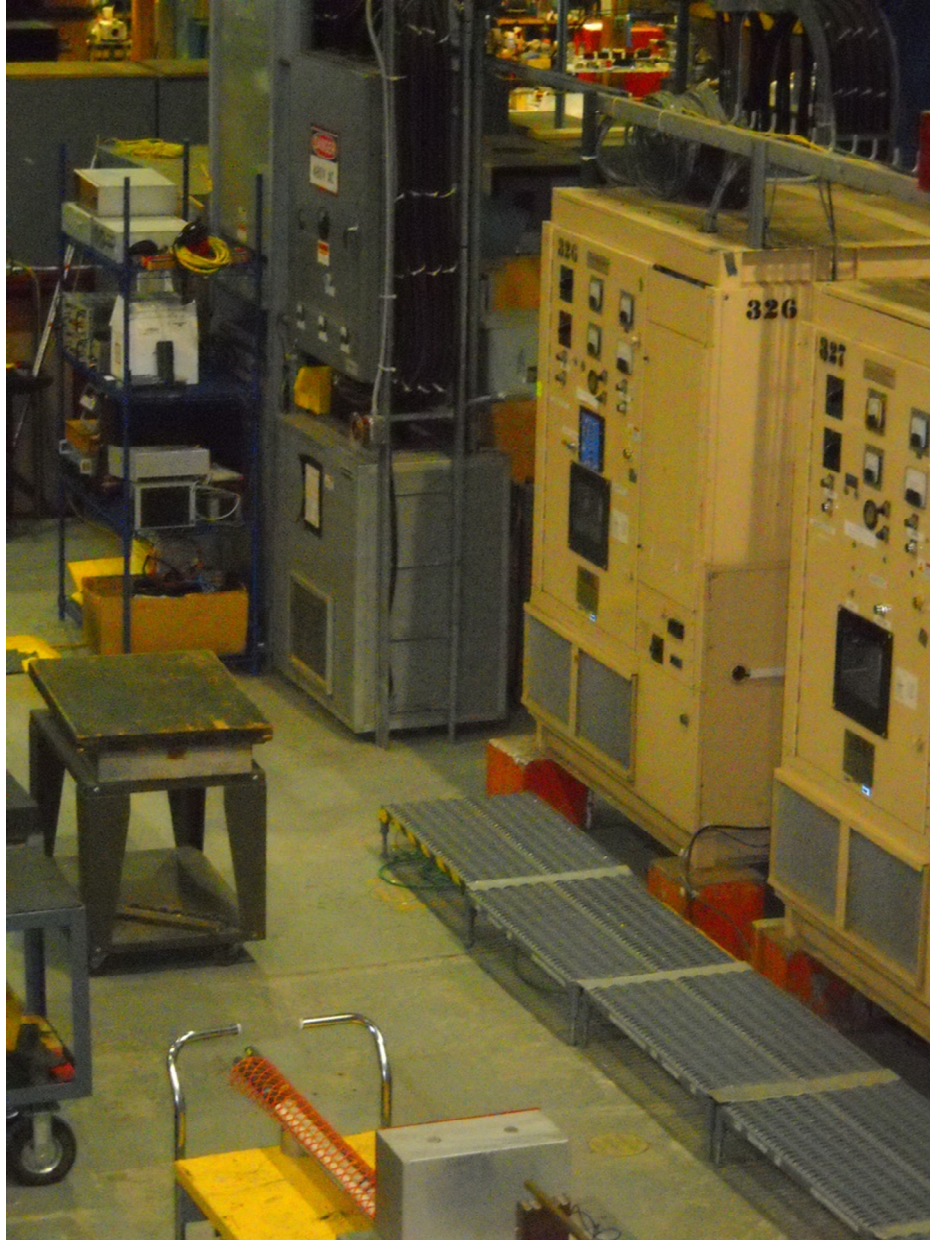

Figure A-4: Close-up Photo of the Proposed CT Test Area

CT Test Setup

At this time six CTs with 2000:5 and six other CTs with 4000:5 current ratios, as shown in Figure A-5, are available to BNL for testing. These twelve CTs have been supplied by the NRC and if needed, additional units with different current ratios will be acquired for testing. Some of these new ones may include different CT manufacturers.

The 4000:5 CTs have secondary terminals for eight different turn ratios from 100 through 800. They include 500:5 (X1-X2), 1000:5 (X3-X4), 1500:5 (X2-X3), 2000:5 (X1-X3), 2500:5 (X2-X4), 3000:5 (X1-X4), 3500:5 (X2-X5), and 4000:5 (X1-X5) current ratio ratings, where X's are secondary taps of the CT.



Fixed-Ratio Design: 2000:5

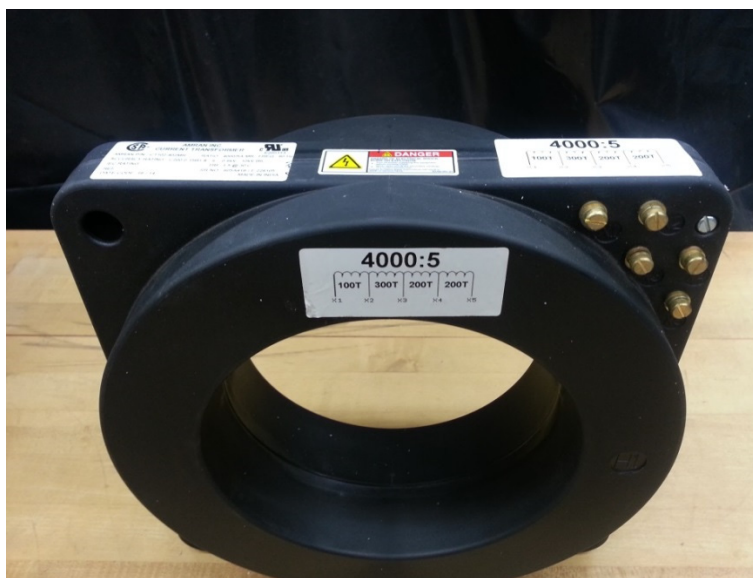

Multi-Ratio Design: (500, 1000, 1500, 2000, 2500, 3000, 3500, and 4000):5

Figure A-5: AMRAN Current Transformers

Figure A-6 shows the power supply circuit for the proposed CT tests. The primary current for the CT under test will be set up from a three-phase delta connected water-cooled load bank of 0.78 ohms each leg connected to a 480V, AC power source through 700 Amps circuit breaker and remotely controlled contactor. These will give about 600 Amps in each phase of the circuit which will be measured by three 800:5 CTs. The supply current to the primary circuit can be adjusted to get the required value by manipulating the resistance of the load bank. As shown in Figure A-6, current in one phase will be used to generate the necessary Ampere-Turns in the primary of the CT under test. For example, to test a 4000:5 CT, seven (7) turns of Ultraflex 500MCM cable will

be wrapped around the core of the CT. Exact current in that phase will be measured and recorded using three in-house 800:5 CTs.

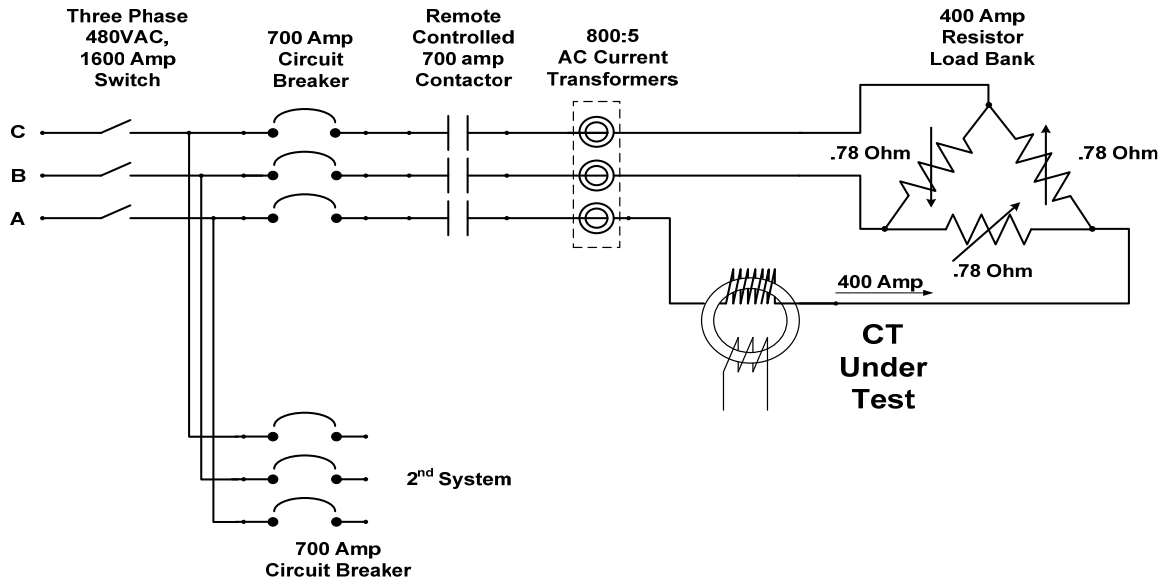

Figure A-6: Test Power Supply Setup

The circuit diagram in Figure A-7 illustrates the test setup for obtaining the characteristics of an open-circuited CT. As stated above, a test current source feeds the CT's primary side to represent the normal current flow in a power circuit. Approximately 100 feet of secondary cable with a burden resistor (or ammeter) will be used to simulate an actual plant's normal configuration. The CT secondary side will be instrumented with a relay for intermittently opening the circuit or a very low current fuse link (e.g. 1 amp) for an instantaneous circuit break. The increase in the secondary voltage and decrease in secondary current will be recorded via high voltage isolation modules. A computerized high speed data acquisition system will be used to capture the CT secondary voltage and current. Other parameters to be monitored during testing include primary current and voltage, magnetic flux, and the temperature of the CT magnetic elements. A high speed video camera and a thermal imaging infra-red camera will also be used to capture the arcing and fire formation (if any) at several strategic locations. These cameras will be synchronized with the high speed data acquisition system to get secondary circuit characteristics during the arcing process.

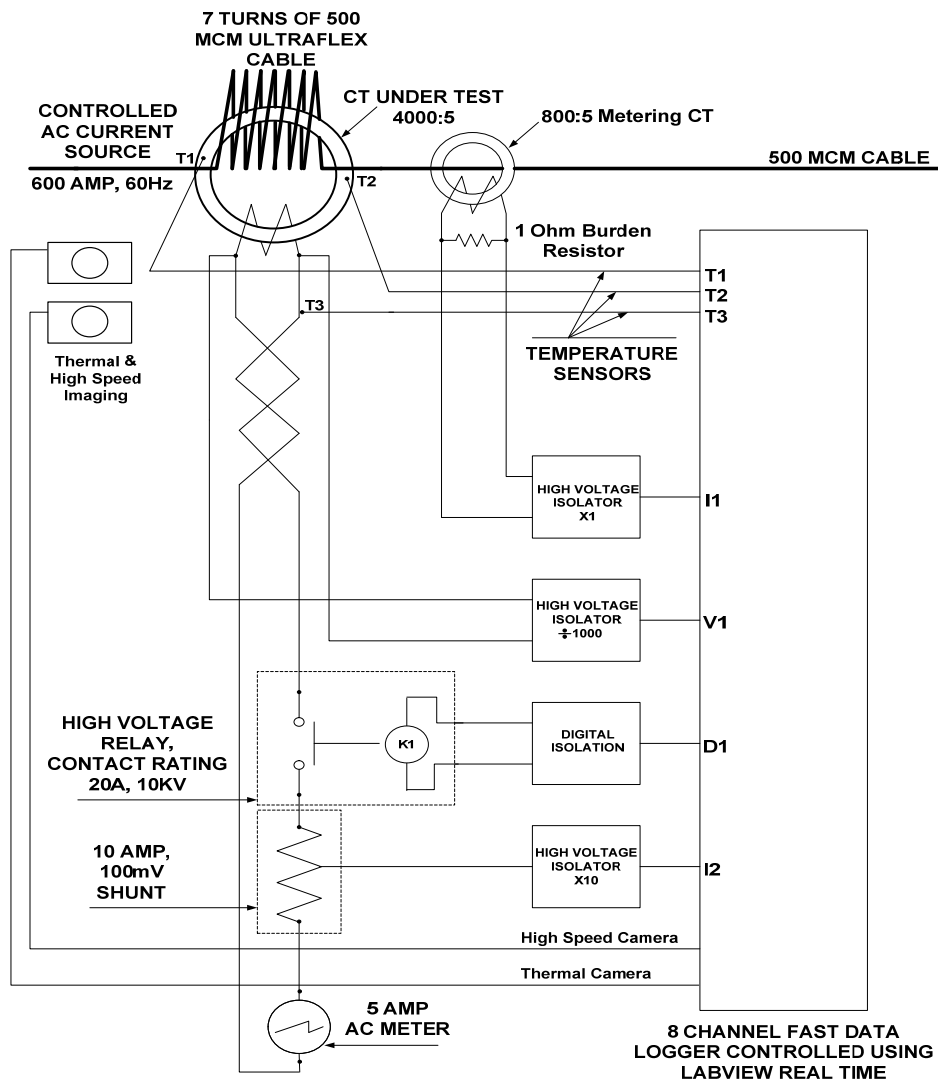

Figure A-7: Proposed Secondary Circuit Layout of the CT Testing

Data Acquisition Equipment

Figure A-7 above shows the instrumentation and data acquisition connections on secondary side of the CT under test. This setup will capture the high secondary voltage spikes and the profile of arcing current at the instance of opening of the secondary of a CT along with images from high speed and thermal cameras. Opening of the secondary of CT will also be simulated.

Details of the instrumentation are as follows:

High Speed Data Logger: The 8-channel high speed data logger has a sampling rate of 100K Samples/sec per channel, sampled simultaneously. This logger is programmed using LabVIEW® Real Time graphical programming software and uses digital to analog converter hardware from National Instruments.

HV Isolators: These isolator modules manufactured by VeriVolt Inc. provide fast response and isolation between channel to channel and channel to ground in excess of 10,000V. They have programmable gain to maintain output voltage within +/- 10V range for data logger.

High Voltage Relay: A high voltage (HV) relay is used to provide clean opening (or instantaneous break) of the secondary circuit of the CT under test. It has contact ratings of 20 Amps at 10 kV. The relay ratings are intended to prevent contact fusing and excessive arcing during high voltages generated when the circuit is opened.

Shunt-10A, 100mV: The voltage signal across this shunt will be used to capture the characteristic and duration of the arcing current at the instant of opening of the secondary of CT under test. Arcing current can last up to few AC cycles and its profile can give good correlation between arcing duration and igniting of a fire.

The following parameters will be measured and logged using high speed data logger:

T1, T2: Temperature of the CT's magnetic core at two opposite ends of the outside perimeter

T3: Temperature of the CT's magnetic core at the inside perimeter 90 degrees off the outside ones

V1: Secondary voltage of the CT under test. Because of the high voltage generated during opening of the secondary, this voltage is isolated and divided by 1000 before being fed to the data logger

I1: Primary current of the CT under test by measuring voltage across 1ohm burden resistor

I2: Secondary current of the CT under test by measuring voltage across 10A, 100mV shunt. Isolator for this signal provides the gain of 10 so that with 5A RMS flowing in the circuit, data logger sees 500mV RMS

D1: Relay for opening the secondary circuit

High speed digital camera

All the above parameters will be captured for duration of 5-10 seconds, <5 sec before trigger and <5 sec after trigger. Data capture trigger and the opening of secondary through high voltage relay is done using isolated digital output of the data logger.

Captured data will be logged as an excel file and its time stamp will be synchronized with that of camera images.

A.3.2 Quality Control and Safety

Existing BNL quality control procedures will be used to ensure all results are reproducible and accurate. Instruments will be calibrated using standards that are traceable to a national standard. Any new equipment will be field tested and calibrated as needed to ensure it is operating properly.

Since the CT testing involves high voltage and potential for high energy arcing and/or explosion of insulations, approval (if required) from the BNL safety committee after reviewing the test plan and all safety requirements will be obtained.

Project reports will receive a BNL technical review and will be reviewed and approved by the NRC/RES Project Manager.

A.4 Test Matrix

A.4.1 Test Configurations

CTs to be Tested: Amran 2000:5 and 4000:5 (with multiple turn ratios from 100, 200, 300, 400, 500, 600, 700, 800) shown in Figure A-5

Primary Voltages: 125V, 250V, 500V

Primary Current Levels: 500A, 1000A, 1500A, 2000A, 2500A, 3000A, 3500A, 4000A

Open Secondary Simulations: Fast Open using Fuse Link (for Open Circuit Fault); Intermittent Open using a Relay (for Arcing Fault)

Maximum Duration of Test: 10 minutes (subject to change based on test results)

Secondary Cable: Commercial-Grade General Cable, PVC/Nylon/PVC, shielded, 100 feet of AWG 16, 2 conductor 600V (no drain or ground wire) for instrument wiring application

Insulation Resistance (Megger Test) of the secondary cable will be monitored at the beginning and ending of each test set up for its insulation integrity

Locations Subject to Visual Monitoring (Camera and Thermal Imaging) for Secondary Fire (or Arcing): CT, 50 feet from the CT (Another Fire Area) including the open circuit simulations, and 100 feet from the CT (Ammeter or Protective Relay Location)

For each test set up, the following data will be obtained:

Primary Voltage

Primary Current

Secondary Voltage

Secondary Current (Prior to Open Circuit Fault)

Temperatures at three locations (see Figure A-7)

Magnetic flux density (if needed)

For each test set up, the following locations will have Visual and Thermal Imaging:

CT Location

Open Secondary Fault Location

Ammeter Location

High Speed data will be obtained for the first couple of minutes, followed by slower speed data acquisition for remaining of test duration for capturing any arcing fault in the secondary cable.

A.4.2 CT Preliminary Tests

The following tests are planned to be performed first:

Baseline Performance

Prior to conducting the open circuit testing of the CT, it will be operated to obtain baseline performance information including core temperature, and primary to secondary current and voltage response between 500 and 4000 amps (primary). Two separate test fixtures corresponding to two Amran CTs will be used to run these tests to verify all data acquisitions and other circuit parameters.

Fast Open Secondary Response

Using a time delay fuse link (not shown in Figure A-7) on the secondary circuit, the secondary voltage response will be obtained with primary current values ranging from 500 to 4000 amps. The results of this series of tests will yield information on the CT's voltage response to a single initiating open circuit event as a function of primary current values.

Intermittent Open Secondary Response

Using a mechanical switch or relay that interrupts the secondary circuit at 1 second intervals for 10 seconds (10 circuit interruptions), the CT's response will be recorded to determine the repeatability of its response and the potential additional degradation that results to the secondary side cable insulation.

Repeat this with modifications as necessary for the different sizes of CTs to be tested.

The following relationships or conditions will be examined from this series of tests:

Effect of primary voltage (i.e., 120V, 240V, 480V) on the secondary voltage peaks.

Effect of turn ratio (i.e., 100 thru 800) or primary current (i.e., 500 thru 4000 amps) on the secondary voltage peaks.

Effect of fast open and intermittent open conditions on the secondary voltage peaks.

Comparison of secondary voltage response at 2000:5 current ratios for the fixed and multi-tap CTs.

Examine the repeatability of test results.

In addition, during each test visual and thermal imaging of the CT location, open secondary location and the ammeter location will be monitored.

A.4.3 CT Subsequent Tests

Depending on the results of the above preliminary tests, additional tests will be performed to meet the objectives of this test program.

If the secondary voltage spikes demonstrate secondary fire or arcing in the secondary cabling, then additional tests will be performed to evaluate all influencing parameters that are important to this scenario.

If the secondary voltage spikes indicate no secondary fire or arcing, then the testing will be extended to determine the threshold condition at which arcing in the secondary circuit could be observed.

Ammeters or protective relays will be added to the secondary circuit. Failures will be assessed based on the following: CT fails or ammeter/relay fails or cable fails. A technical basis will be derived from the test for developing guidelines for open secondary CT scenarios.

If necessary, other tests will be carried out on CTs from several manufacturers. Tests at higher voltage levels up to 4.1 or 13 kV may require special laboratory facilities. Some of these tests will require support from the NRC COR.

A.5 DATA Evaluation

The testing will indicate the potential for a secondary fire occurring away from the CT location in a nuclear power plant set up. All test data will be collected directly from the Data Logger.

If the open circuited CT secondary is considered to be incapable of starting a secondary fire, this testing will provide the technical basis for the working group for assessing the following conditions:

Neither the CT nor its secondary circuit shows any signs of arcing or explosive failure.

Either the CT or its secondary circuit does show signs of arcing, but the duration is short and near the CT, or the arc is of insufficient intensity to ignite surrounding materials farther from the CT.

The CT does exhibit explosive failure, but the explosive behavior is near the CT and insufficient to damage surrounding materials. The explosive failure is not accompanied by subsequent arcing of the CT or its secondary circuit.

If the testing does accompany the explosion or arcing failure, it will be evaluated further by the working group for further testing or studies.

A.6 Documentation

Comments and their dispositions on this test plan were documented in the Attachment 1 to this document.

A technical test report (or NUREG/CR) will document the test procedures and details of the testing that will include all assumptions and limitations. The test results will be summarized for the working group so that the CT's secondary fire issue can be technically assessed and appropriate guidelines are developed for circuit analysis in the fire protection program.

A.7 References

- [A1] "Instrument Transformer Basic Technical Information and Application," GE Digital Energy – ITI, www.gedigitalenergy.com/products/manuals/geh-230af.pdf
- [A2] "Instrument Transformers – Technical Information and application Guide," ABB Field Engineering Services Instrument Transformers On-site Testing.
- [A3] BNL Letter from Mr. E. A. MacDougall to Nicholas S. Fiorante of NRC, dated July 21, 1983.
- [A4] Memorandum from Olan D. Parr, Chief, Auxiliary Systems Branch to its members on "Fire Protection Review Guidance," November 30, 1984.

- [A5] Regulatory Guide 1.189, Fire Protection for Nuclear Power Plants, Revision 2, October 2009.
- [A6] NEI 00-01, Guidance for Post-Fire Safe Shutdown Circuit Analysis, Revision 2, May 2009.
- [A7] “Joint Assessment of Cable Damage and Quantification of Effects from Fire (JACQUE-FIRE) – Phenomena Identification and Ranking Table (PIRT) Exercise for Nuclear Power Plant Fire-Induced Electrical Circuit Failure,” Volume 1, NUREG/CR-7150, EPRI 1026424, October 2012.
- [A8] Kaufmann, R. H. and Camilli, G., “Overvoltage Protection of Current Transformer Secondary Windings and Associated Circuits,” Transactions of the AIEE, Vol. 62, July 1943, pp. 467-472.
- [A9] IEEE Std. C57.13-2008, IEEE Standard Requirements for Instrument Transformers.
- [A10] Bonneville Power Administration Presentation of CT’s Safety Hazards for Class Room Lecture by Steve Leslo (2/20/2013):
https://www.eiseverywhere.com/file_uploads/dbb5ba3a17812e8cea24ddf2aeebfa2d_Current_Transformers_for_HORS_2013-2.pdf
- [A11] NGK (a Japanese Manufacturer) CT Open Circuit Test:
<https://www.youtube.com/watch?v=TGEcBCR4DV0>
- [A12] CT Fails When Leads Open Circuited: <https://www.youtube.com/watch?v=j6v0ybdhGk0>
- [A13] UL 61010B-1, “Electrical Measuring and Test Equipment; Part 1: General Requirements.

APPENDIX B DATA FROM ALL TESTS PERFORMED

All test scoring sheets in the format shown in Table 4-1 are taken from the Data Logger records in its first eight columns. These data sheets were hand written and contain raw information regarding each test condition. Since there was no abnormal condition noted during any of the 63 tests, the data presented in these sheets are those taken from the data logger. Also the HiPot test data of the secondary cable and other information on the CT's DC resistance test and impulse test are included as per Table 4-1. Since there was no abnormal measured data significantly different from those given in Table 3-1 and Table 4-2, we do not include them here.

Two types of test data are included in the attached compact disc (CD):

- I. EXCEL Worksheet files contain all 63 tests in the following three folders:
 1. AM2CT Test Data Files (3 Files Containing All Tests Performed Under 125V, 250V, 500V Levels) – A Total of 29 Worksheets
 - i. AM2CT01 through AM2CT21: 21 Tests per Table 4-3
 - ii. 8 Additional Tests for Initial Trial Runs, Repeatability, Scanning Rate and Long Duration
 - a. AM2CT04 and AM2CT03 Trial Tests
 - b. AM2CT01 and AM2CT02 for Repeatability and AM2CT01 for Long Duration Tests
 - c. AM2CT07 for Scanning Rate and Two Long Duration Tests
 2. AM4CT Test Data Files (3 Files Containing All Tests Performed Under 125V, 250V, 500V Levels) – A Total of 18 Worksheets
 - i. AM4CT01 through AM4CT14: 14 tests per Table 4-4
 - ii. AM4CT01 for Repeatability, Arcing, Intermittent and Long Duration Tests
 3. Additional CT 4000 Test Data Worksheets – A Total of 16 Tests (16 Tests AM4CT15 through AM4CT30 in Table 4-4) Contains 2 Files – One for 2000:5 and the Other for 4000:5 Turn Ratios)

Each EXCEL worksheet presents one out of 63 tests and contains 9 columns as marked:

1. Time (Sampling Time in Seconds)
 2. T1 (Temperature Outside CT in °C)
 3. T2 (Temperature Outside CT – Opposite Side in °C)
 4. T3 (Temperature Inside CT – 90 degrees Off Outside Probes in °C)
 5. Phase A Sine via 800:5 CT (Primary Current in Phase A of the Power Source in Amperes)
 6. CT Sec Open Voltage (Secondary Voltage in Volts)
 7. Shunt in CT Sec (Secondary Current in Amperes)
 8. Phase A RMS (Primary Current RMS Value in Amperes)
 9. T4 (Temperature of the Cabinet Housing in °C for CT 2000 Tests or
 - Primary Voltage A-B (Primary Voltage in Volts for CT 4000 Tests)
 -
- II. Video clip of arcing simulation at the opening relay.

BIBLIOGRAPHIC DATA SHEET

(See instructions on the reverse)

NUREG/CR-7228

2. TITLE AND SUBTITLE

Open Secondary Testing of Window-Type Current Transformers

3. DATE REPORT PUBLISHED

MONTH

May

YEAR

2017

4. FIN OR GRANT NUMBER

5. AUTHOR(S)

M. Subudhi, P. Joshi¹, S. Dimaiuta¹ and W. Gunther²

6. TYPE OF REPORT

Technical

7. PERIOD COVERED (Inclusive Dates)

8. PERFORMING ORGANIZATION - NAME AND ADDRESS (If NRC, provide Division, Office or Region, U. S. Nuclear Regulatory Commission, and mailing address; if contractor, provide name and mailing address.)

Department of Nuclear Science and Technology
Brookhaven National Laboratory
Upton, New York 11973

¹ Superconducting Magnet Division

² Retired BNL Staff

9. SPONSORING ORGANIZATION - NAME AND ADDRESS (If NRC, type "Same as above", if contractor, provide NRC Division, Office or Region, U. S. Nuclear Regulatory Commission, and mailing address.)

Division of Risk Analysis
Office of Nuclear Regulatory Research
U.S. Nuclear Regulatory Commission
Washington, D.C. 20555-0001

10. SUPPLEMENTARY NOTES

G. Taylor, NRC Contracting Officer Representative

11. ABSTRACT (200 words or less)

Two AMRAN Current Transformers (CTs) were tested to characterize the propensity of an open-circuited CT secondary to cause a fire in a location remote to the open circuit. Also evaluated was the magnitude of the secondary winding peak (crest) voltage when the CT's secondary circuit transitioned to an open circuit condition, and its dependencies on the primary voltage, primary current and the CT's turn ratio. Parameters identified as having an effect on the CT's open secondary crest voltage include:

- Material and construction of the CT's magnetic core,
- CT's primary voltage,
- CT's primary current, and,
- CT's turn ratio.

The primary objective of this testing, however, was to better understand the following scenario:

Will fire-induced open circuit in the secondary circuit of a wound-type CT, which is operating within its rated continuous primary current limits, result in an excessively high voltage in the secondary circuit sufficient to start a fire in the form of explosion or arcing in the circuit's insulation at the location of the CT itself or at some other location in the secondary circuit?

For the configurations tested, the results indicated that an open circuited CT was incapable of starting a secondary fire based on the criteria established in the test plan. This observation applies to the CT, CT taps, cabling, and burden devices. Additionally, when an arc was deliberately initiated in the secondary circuit, it was observed that the crest voltage diminished significantly.

The test results provide supplemental information to the JACQUE-FIRE Volume 3 working group for developing technical recommendations to possibly extend the limit on the 1200:5 CT turns ratio limit as stated in the NUREG/CR-7150, Volume 1

12. KEY WORDS/DESCRIPTORS (List words or phrases that will assist researchers in locating the report.)

associated circuits	instrument transformer
circuit analysis	nuclear power plant (NPP)
crest voltage	open CT secondary
current transformer	Phenomena Identification and Ranking Table (PIRT)
fire probabilistic	risk assessment power distribution system
fire protection	secondary fire
fire safety	voltage transformer
fire safe-shutdown	

13. AVAILABILITY STATEMENT

unlimited

14. SECURITY CLASSIFICATION

(This Page)

unclassified

(This Report)

unclassified

15. NUMBER OF PAGES

16. PRICE

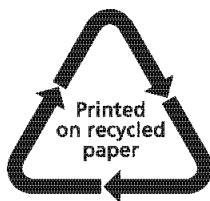

Federal Recycling Program



UNITED STATES
NUCLEAR REGULATORY COMMISSION
WASHINGTON, DC 20555-0001

OFFICIAL BUSINESS



NUREG/CR-7228

Open Secondary Testing of Window-Type Current Transformers

May 2017