



International Agreement Report

TRACE/SNAP Model Establishment of Chinshan Nuclear Power Plant for Ultimate Response Guideline

Prepared by:

Jong-Rong Wang*, Chunkuan Shih*, Jung-Hua Yang*, Hsiung-Chih Chen*, Shao-Wen Chen*, Show-Chyuan Chiang**, Tzu-Yao Yu**

*Institute of Nuclear Engineering and Science, National Tsing Hua University; Nuclear and New Energy Education and Research Foundation
101 Section 2, Kuang Fu Rd., HsinChu, Taiwan

**Department of Nuclear Safety, Taiwan Power Company
242, Section 3, Roosevelt Rd., Zhongzheng District, Taipei, Taiwan

K. Tien, NRC Project Manager

**Division of Systems Analysis
Office of Nuclear Regulatory Research
U.S. Nuclear Regulatory Commission
Washington, DC 20555-0001**

Manuscript Completed: February 2016
Date Published: May 2017

Prepared as part of
The Agreement on Research Participation and Technical Exchange
Under the Thermal-Hydraulic Code Applications and Maintenance Program (CAMP)

**Published by
U.S. Nuclear Regulatory Commission**

AVAILABILITY OF REFERENCE MATERIALS IN NRC PUBLICATIONS

NRC Reference Material

As of November 1999, you may electronically access NUREG-series publications and other NRC records at the NRC's Public Electronic Reading Room at <http://www.nrc.gov/reading-rm.html>. Publicly released records include, to name a few, NUREG-series publications; *Federal Register* notices; applicant, licensee, and vendor documents and correspondence; NRC correspondence and internal memoranda; bulletins and information notices; inspection and investigative reports; licensee event reports; and Commission papers and their attachments.

NRC publications in the NUREG series, NRC regulations, and Title 10, "Energy," in the *Code of Federal Regulations* may also be purchased from one of these two sources.

1. The Superintendent of Documents

U.S. Government Publishing Office
Mail Stop SSOP
Washington, DC 20402-0001
Internet: <http://bookstore.gpo.gov>
Telephone: 1-866-512-1800
Fax: (202) 512-2104

2. The National Technical Information Service

5301 Shawnee Road
Alexandria, VA 22161-0002
<http://www.ntis.gov>
1-800-553-6847 or, locally, (703) 605-6000

A single copy of each NRC draft report for comment is available free, to the extent of supply, upon written request as follows:

U.S. Nuclear Regulatory Commission

Office of Administration
Publications Branch
Washington, DC 20555-0001
E-mail: distribution.resource@nrc.gov
Facsimile: (301) 415-2289

Some publications in the NUREG series that are posted at the NRC's Web site address <http://www.nrc.gov/reading-rm/doc-collections/nuregs> are updated periodically and may differ from the last printed version. Although references to material found on a Web site bear the date the material was accessed, the material available on the date cited may subsequently be removed from the site.

Non-NRC Reference Material

Documents available from public and special technical libraries include all open literature items, such as books, journal articles, transactions, *Federal Register* notices, Federal and State legislation, and congressional reports. Such documents as theses, dissertations, foreign reports and translations, and non-NRC conference proceedings may be purchased from their sponsoring organization.

Copies of industry codes and standards used in a substantive manner in the NRC regulatory process are maintained at—

The NRC Technical Library

Two White Flint North
11545 Rockville Pike
Rockville, MD 20852-2738

These standards are available in the library for reference use by the public. Codes and standards are usually copyrighted and may be purchased from the originating organization or, if they are American National Standards, from—

American National Standards Institute

11 West 42nd Street
New York, NY 10036-8002
<http://www.ansi.org>
(212) 642-4900

Legally binding regulatory requirements are stated only in laws; NRC regulations; licenses, including technical specifications; or orders, not in NUREG-series publications. The views expressed in contractor-prepared publications in this series are not necessarily those of the NRC.

The NUREG series comprises (1) technical and administrative reports and books prepared by the staff (NUREG-XXXX) or agency contractors (NUREG/CR-XXXX), (2) proceedings of conferences (NUREG/CP-XXXX), (3) reports resulting from international agreements (NUREG/IA-XXXX), (4) brochures (NUREG/BR-XXXX), and (5) compilations of legal decisions and orders of the Commission and Atomic and Safety Licensing Boards and of Directors' decisions under Section 2.206 of NRC's regulations (NUREG-0750).

DISCLAIMER: This report was prepared under an international cooperative agreement for the exchange of technical information. Neither the U.S. Government nor any agency thereof, nor any employee, makes any warranty, expressed or implied, or assumes any legal liability or responsibility for any third party's use, or the results of such use, of any information, apparatus, product or process disclosed in this publication, or represents that its use by such third party would not infringe privately owned rights.



International Agreement Report

TRACE/SNAP Model Establishment of Chinshan Nuclear Power Plant for Ultimate Response Guideline

Prepared by:

Jong-Rong Wang*, Chunkuan Shih*, Jung-Hua Yang*, Hsiung-Chih Chen*, Shao-Wen Chen*, Show-Chyuan Chiang**, Tzu-Yao Yu**

*Institute of Nuclear Engineering and Science, National Tsing Hua University; Nuclear and New Energy Education and Research Foundation
101 Section 2, Kuang Fu Rd., HsinChu, Taiwan

**Department of Nuclear Safety, Taiwan Power Company
242, Section 3, Roosevelt Rd., Zhongzheng District, Taipei, Taiwan

K. Tien, NRC Project Manager

**Division of Systems Analysis
Office of Nuclear Regulatory Research
U.S. Nuclear Regulatory Commission
Washington, DC 20555-0001**

Manuscript Completed: February 2016
Date Published: May 2017

Prepared as part of
The Agreement on Research Participation and Technical Exchange
Under the Thermal-Hydraulic Code Applications and Maintenance Program (CAMP)

**Published by
U.S. Nuclear Regulatory Commission**

ABSTRACT

In this research, the TRACE/SNAP model of Chinshan BWR/4 nuclear power plant (NPP) was established for the simulation and analysis of ultimate response guideline (URG). The main actions of URG are the depressurization and low pressure water injection of the reactor and containment venting. This research focuses to assess the URG utility of Chinshan NPP under Fukushima-like conditions. This study consists of three steps. The first step is the establishment of Chinshan NPP TRACE/SNAP model. In order to evaluate the system response of TRACE/SNAP model, startup tests and FSAR data were used to compare with the results of TRACE. The second step is the URG simulation and analysis under Fukushima-like conditions by using Chinshan NPP TRACE/SNAP model. In this step, the no URG case was also performed in order to evaluate the URG effectiveness of Chinshan NPP. In addition, the sensitivity study of URG and the required raw water injection were also performed. According to TRACE analysis results, the URG can keep the peak cladding temperature (PCT) below the criteria 1088.7 K under Fukushima-like conditions. It indicates that Chinshan NPP can be controlled in a safe situation. If Chinshan NPP does not perform the URG under Fukushima-like conditions, the water level may drop lower than TAF (top of active fuel) which means a safety issue about the fuel rods may be generated. In order to confirm the mechanical property and integrity of fuel rods, the final step is the analysis of FRAPTRAN.

FOREWORD

The U.S. NRC (United States Nuclear Regulatory Commission) is developing an advanced thermal hydraulic code named TRACE for nuclear power plant safety analysis. The development of TRACE is based on TRAC, integrating RELAP5 and other programs. NRC has determined that in the future, TRACE will be the main code used in thermal hydraulic safety analysis, and no further development of other thermal hydraulic codes such as RELAP5 and TRAC will be continued. A graphic user interface program, SNAP which processes inputs and outputs for TRACE is also under development. One of the features of TRACE is its capacity to model the reactor vessel with 3-D geometry. It can support a more accurate and detailed safety analysis of nuclear power plants. TRACE usually used in the nuclear power plants analysis.

Taiwan and the United States have signed an agreement on CAMP (Code Applications and Maintenance Program) which includes the development and maintenance of TRACE. To meet this responsibility, the TRACE/SNAP model of Chinshan NPP was established. In this report, the TRACE/SNAP model of Chinshan NPP was used to evaluate the utility of URG.

TABLE OF CONTENTS

ABSTRACT	iii
FOREWORD	v
LIST OF FIGURES	ix
LIST OF TABLES	xi
EXECUTIVE SUMMARY	xiii
ABBREVIATIONS	xv
1 INTRODUCTION	1
2 ULTIMATE RESPONSE GUIDELINE (URG)	3
3 CHINSHAN NPP TRACE/SNAP MODEL	5
4 RESULTS	7
4.1 Load Rejection Transient	7
4.2 Turbine Trip without Bypass Valve Transient	11
4.3 URG Simulation and Analysis	14
5 CONCLUSIONS	47
6 REFERENCES	49

LIST OF FIGURES

Figure 1	Correspondent Relation between NPP Operating States and Operating Procedures ..2
Figure 2	URG Flowchart.....4
Figure 3	Chinshan NPP TRACE Model.....6
Figure 4	The Power of Startup Test and TRACE for Load Rejection Transient.....8
Figure 5	The Steam Flow of Startup Test and TRACE for Load Rejection Transient9
Figure 6	The Dome Pressure of Startup Test and TRACE for Load Rejection Transient10
Figure 7	The NRWL of Startup Test and TRACE for Load Rejection Transient.....11
Figure 8	The Power of FSAR and TRACE for Turbine Trip without Bypass Valve Transient ...12
Figure 9	The Dome Pressure of FSAR and TRACE for Turbine Trip without Bypass Valve Transient13
Figure 10	The Core Flow of FSAR and TRACE for Turbine Trip without Bypass Valve Transient14
Figure 11	The Dome Pressure Comparison of Case 1 and 218
Figure 12	The Water Level Comparison of Case 1 and 219
Figure 13	The PCT Comparison of Case 1 and 220
Figure 14	The DRYWELL PRESSURE Comparison of Case 1 and 221
Figure 15	The Wetwell Pressure Comparison of Case 1 and 222
Figure 16	The Drywell Temperature Comparison of Case 1 and 223
Figure 17	The Suppression Pool Temperature Comparison of Case 1 and 2.....24
Figure 18	The Dome Pressure Comparison of Case 1, 3 and 425
Figure 19	The Water Level Comparison of Case 1, 3 and 426
Figure 20	The PCT Comparison of Case 1, 3 and 427
Figure 21	The Drywell Pressure Comparison of Case 1, 3 and 428
Figure 22	The Wetwell Pressure Comparison of Case 1, 3 and 429
Figure 23	The Drywell Temperature Comparison of Case 1, 3 and 430
Figure 24	The Suppression Pool Temperature Comparison of Case 1, 3 and 4.....31
Figure 25	The Dome Pressure Comparison of Case 1, 5 and 632
Figure 26	The Water Level Comparison of Case 1, 5 and 633
Figure 27	The PCT Comparison of Case 1, 5 and 634
Figure 28	The Drywell Pressure Comparison of Case 1, 5 and 635
Figure 29	The Drywell Temperature Comparison of Case 1, 5 and 636
Figure 30	The Wetwell Pressure Comparison of Case 1, 5 and 637
Figure 31	The Suppression Pool Temperature Comparison of Case 1, 5 and 6.....38
Figure 32	The Water Level Results for The Sensitivity Study39
Figure 33	The Water Metal Reaction Energy Result of FRAPTRAN for Case 240
Figure 34	The Oxide Thickness Result of FRAPTRAN for Case 241
Figure 35	The STRUCTURAL RADIAL GAP RESULT of FRAPTRAN for Case 242
Figure 36	The Gap Gas Pressure Result of FRAPTRAN for Case 243
Figure 37	The Cladding Hoop Strain Result of FRAPTRAN for Case 244
Figure 38	The Cladding Hoop Stress Result of FRAPTRAN for Case 245
Figure 39	The Fuel Enthalpy Result of FRAPTRAN for Case 246

LIST OF TABLES

Table 1	The Comparison of Initial Conditions of FSAR and TRACE	5
Table 2	The Sequences of Startup Test and TRACE Data for Load Rejection Transient	7
Table 3	The Sequences of FSAR and TRACE Data for Turbine Trip without Bypass Valve Transient	12
Table 4	The Sequences of URG Case (Case 1).....	17
Table 5	The Sensitivity Study of URG	17

EXECUTIVE SUMMARY

According to the user manual, TRACE is the product of a long term effort to combine the capabilities of the NRC's four main systems codes (TRAC-P, TRAC-B, RELAP5 and RAMONA) into one modernized computational tool. NRC has ensured that TRACE will be the main code used in thermal hydraulic safety analysis in the future without further development of other thermal hydraulic codes, such as RELAP5 and TRAC. Besides, the 3-D geometry model of reactor vessel, which is one of the representative features of TRACE, can support a more accurate and detailed safety analysis of NPPs. On the whole TRACE provides greater simulation capability than the previous codes, especially for events like LOCA.

FRAPTRAN is a Fortran language computer code that calculates the transient performance of light-water reactor fuel rods during reactor transients and hypothetical accidents such as loss-of-coolant accidents, anticipated transients without scram, and reactivity-initiated accidents.

SNAP is an interface of NPP analysis codes which developed by U.S. NRC and Applied Programming Technology, Inc. Different from the traditional input deck in ASCII files, the graphical control blocks and thermal hydraulic connections make researches comprehend the whole power plant and control system more easily. Due to these advantages, the TRACE/SNAP and FRAPTRAN/SNAP models of Chinshan NPP was developed in this research.

Chinshan NPP was building in 1970. It is the first NPP in Taiwan which is the BWR/4 plant and the original rated power for each unit is 1775 MWt. In addition, Chinshan NPP finished the project of SPU (stretch power uprated) and the operating power is 1840 MWt now. The safety analysis of the NPP is very important work in the NPP safety. The importance of NPP safety analysis has been raised and there is more concern for the safety of the NPPs in Taiwan after the Fukushima NPP disaster occurred. Therefore, with regard to this fact, Taiwan Power Company developed an additional URG to prevent BWR, PWR and ABWR from encountering core damage for events beyond design basis.

The aim of this study is to use multiple computer codes to evaluate the URG effectiveness for Chinshan NPP. This study consists of three steps. The first step is the establishment of Chinshan NPP TRACE/SNAP model. In order to evaluate the system response of TRACE/SNAP model, startup tests and FSAR data were used to compare with the results of TRACE. The second step is the URG simulation and analysis under Fukushima-like conditions by using Chinshan NPP TRACE/SNAP model. In this step, the no URG case was also performed in order to evaluate the URG effectiveness of Chinshan NPP. In addition, the sensitivity study of URG and the required raw water injection were also performed. According to TRACE analysis results, the URG can keep the PCT below the criteria 1088.7 K under Fukushima-like conditions. It indicates that Chinshan NPP can be controlled in a safe situation. If Chinshan NPP does not perform the URG under Fukushima-like conditions, the water level may drop lower than TAF which means a safety issue about the fuel rods may be generated. In order to confirm the mechanical property and integrity of fuel rods, the final step is the analysis of FRAPTRAN.

ABBREVIATIONS

AOPs	Abnormal Operating Procedures
BPV	Bypass valve
BWR	Boiling-Water Reactor
CAMP	Code Applications and Maintenance Program
EOPs	Emergency Operating Procedures
MSIV	Main Steamline Isolation Valve
NPP	Nuclear Power Plant
OPs	Operating Procedures
PCT	Peak Cladding Temperature
RPV	Reactor pressure vessel
SAMPs	Severe Accident Management Procedures
SNAP	Symbolic Nuclear Analysis Program
SPU	Stretch Power Up rated
SRV	Safety Relief Valves
TAF	Top of Active Fuel
TBV	Turbine Bypass Valve
TCV	Turbine Control Valve
TRACE	TRAC/RELAP Advanced Computational Engine
TSV	Turbine Stop Valve
URG	Ultimate Response Guideline
U.S. NRC	United States Nuclear Regulatory Commission

1 INTRODUCTION

Chinshan NPP was building in 1970. It is the first NPP in Taiwan which is the BWR/4 plant and the original rated power for each unit is 1775 MWt. In addition, Chinshan NPP finished the project of SPU and the operating power is 1840 MWt now. The safety analysis of the NPP is very important work in the NPP safety. The importance of NPP safety analysis has been raised and there is more concern for the safety of the NPPs in Taiwan after the Fukushima NPP disaster occurred.

In general, there are four categories for the NPP operating state, which involve normal operation, abnormal events/transients, accidents and severe accidents. For each operating state, there are corresponding procedures to follow to secure NPPs safety and integrity. Figure 1 shows the correspondent relationship between NPP operating states and procedures. The first level is operating procedures (OPs) which focus on the NPP operation within an acceptable range. The second level is abnormal operating procedures (AOPs) which aim at restoring the function of NPP systems that could impact the NPP operating margins. The third level is emergency operating procedures (EOPs) which focus on bringing the NPP to a safe and stable state by following a reactor trip or safety injection signal. The fourth level is severe accident management procedures (SAMPS). Uncertainties may exist in both NPP status and in the outcome of actions for severe accidents. Therefore, SAMPS propose a range of possible actions and should allow for additional evaluation and alternative actions. However, EOP or SAMP is generally the symptom-based procedures to mitigate transients/accidents consequence and restore the NPP, depending on the real-time operational parameters of the NPP. For the compound severe accidents, such as Fukushima NPP disaster, its impact to NPP is relatively broad, rather than focus on one system or one area influence. Therefore, with regard to this fact, Taiwan Power Company developed an additional URG to prevent BWR, PWR and ABWR from encountering core damage for events beyond design basis [1]-[3].

The aim of this study is to use multiple computer codes to evaluate the URG effectiveness for Chinshan NPP. The advanced thermal hydraulic code named TRACE has been developed by U.S. NRC for NPP safety analysis. According to the user manual [4], TRACE is the product of a long term effort to combine the capabilities of the NRC's four main systems codes (TRAC-P, TRAC-B, RELAP5 and RAMONA) into one modernized computational tool. The development of TRACE is based on TRAC, combining with the capabilities of RELAP5 and other programs. SNAP, a graphic user interface program that processes the inputs and outputs of TRACE, has also been developing. One of the features of TRACE is its capacity to model the reactor vessel with 3-D geometry. It could support a more accurate and detailed safety analysis for nuclear power plants. According to the user and assessment manual [4]-[5], TRACE also provides greater simulation capability than the previous codes (TRAC-P, TRAC-B, RELAP5 and RAMONA), especially for events like LOCA.

Accordingly, an increasing number of researchers are using TRACE code to analyze test facilities and nuclear power plants. F. Mascari et al. [6] established a TRACE model for OSU-MASLWR test facility and performed a preliminary analysis, aiming at the evaluation of the code capability in predicting natural circulation phenomena and heat exchange from primary to secondary side by helical SG in superheated condition. J. Freixa and A. Manera [7] used TRACE to develop a model of Olkiluoto-3 NPP. They performed the SBLOCA simulation and analysis by this model. In addition, they also used the ROSA large scale test facility experimental data to test the nodalization for transient analyses. Konstantin Nikitin and Annalisa Manera [8] developed a TRACE model of BWR/6 NPP and performed the analysis of an ADS spurious opening event. Their paper depicted that TRACE results were in good agreement with the plant data. Anthony Pollman et al. [9] used TRACE to establish a model of MANOTEA facility. The analysis of rapid-condensation transient was performed by this TRACE model. They used the MANOTEA facility experimental data to compare the results of TRACE. Ovidiu-Adrian Berar et al. [10] performed the RELAP5 and TRACE

assessment of Achilles natural reflood experiment. Their paper indicated that both TRACE and RELAP5 are capable of reproducing the reflood phenomena at a satisfactory level. But some discrepancies between the predicted variables and the experimental data suggested further investigation of the TRACE reflood model. Davide Papini et al. [11] used the tests data carried out on a passive containment condenser unit in the PANDA large-scale thermal-hydraulic facility to assess the predictions of GOTHIC and TRACE. Their paper illustrated that both the GOTHIC and TRACE were able to reasonably predict the heat transfer capability of the PCC as well as the influence of non-condensable gas on the system. However, a slight underestimation of the condenser performance was obtained with both codes. Blaž Mikulec et al. [12] established a TRACE model for TOPFLOW facility. The main component of TOPFLOW facility was about 8 m long vertical tube with an inner diameter of 195.3 mm. The evaporation of liquid water to steam caused by depressurization was simulated using two different procedures: from stagnant water and during circulating of water in tubes. They also performed the simulation and analysis of the decompression experiments by using this TRACE model. The TRACE simulations of the first procedure (stagnant water at beginning) were in a good agreement with experimental data. The TRACE simulations of the second procedure (circulating water in a loop) correctly predicted the pressure and temperature decrease, but underpredicted the void fraction.

There were three main steps in this study. First, Chinshan NPP TRACE/SNAP model was established in this research. In order to assess the system response of TRACE/SNAP model, the startup tests and FSAR data were used to compare with the results of TRACE [13]-[14]. Second, by using the above TRACE/SNAP model, the URG simulation and analysis under Fukushima-like conditions was performed. In this step, the no URG case was also performed. Subsequently, we compared the results of these two cases in order to evaluate the URG effectiveness for Chinshan NPP. Third, in order to confirm the mechanical property and integrity of fuel rods, the analysis of FRAPTRAN is performed.

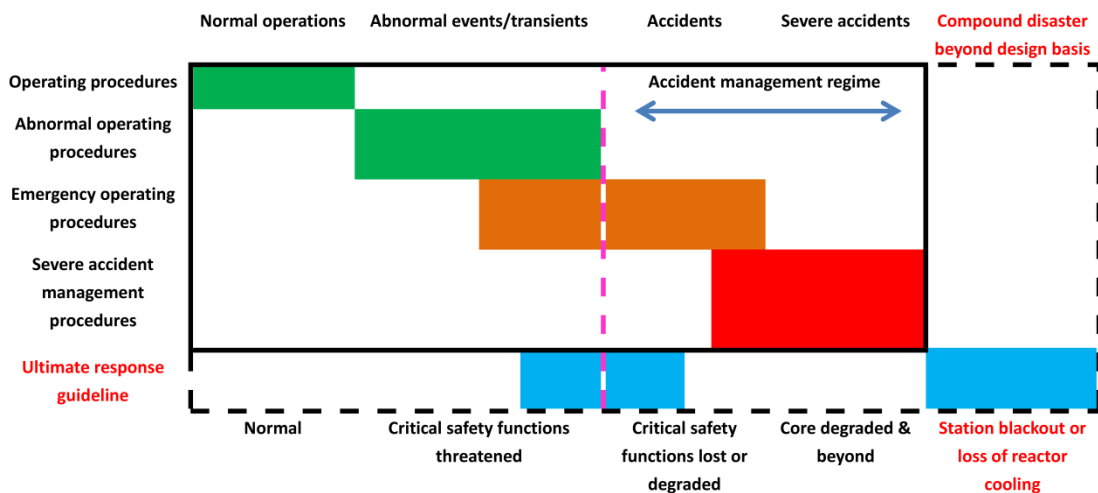

Figure 1 Correspondent Relation between NPP Operating States and Operating Procedures

2 ULTIMATE RESPONSE GUIDELINE (URG)

According to URG, the core concept is treating compound disaster beyond design basis (blue blocks in Figure 1). When Chinshan NPP meets a Fukushima-like accident (the accident with loss of all AC power or reactor cooling conditions), EOP/SAMP and URG will be initiated at the same time. EOP and SAMP focus on maintaining the reactor core cooling, preventing the release of radioactive material, and protecting the property of NPP. The main difference among EOP, SAMP and URG is that when the NPP status does not recovery in time, URG must be executed without most information of NPP. URG may result in the permanent damage on the reactor of NPP and is an irreversible choice, so it needs the senior manager such as the vice president or the plant manager to make this decision. The following are the main objectives of URG:

- Maintain the reactor core cooling.
- Maintain the monitoring functions of the control room.
- Prevent the release of radioactive material.
- Remove the amount of cumulated hydrogen in building.
- Maintain the spent fuel pool cooling and water level.

When NPP encounters the Fukushima-like accident, URG will be activated to prevent reactor core from being damaged. Once entering the procedure of URG, the NPP reactor will be depressurized first, and if the electrical power cannot be recovered before passive reactor core isolation cooling (RCIC) becomes inoperable, any water available will be injected into the reactor vessel. Figure 2 depicts the URG procedure. The URG procedure includes several measures to be performed:

- Perform the controlled depressurization for the reactor to bring down the dome pressure to 35 kg/cm² by opening one ADS (automatic depressurization system) when the NPP meets the situation “3” (RCIC is available).
- Perform the controlled depressurization for the reactor to bring down the dome pressure to 15 kg/cm² by opening one ADS when the NPP meets the situation “3 + 1” or “3 + 2” (RCIC is available).
- Prepare alternative water supply which might include service fresh water, reservoir gravity injection, fire engine creek, or sea water within the first hour.
- If NPP status cannot be restored before RCIC is unavailable, perform the fully depressurization to 3 kg/cm² by opening all ADS. The set-up of alternative water supply must be finished before the fully depressurization is performed.
- Inject the low pressure water into the reactor vessel after the system fully depressurizes.

Perform the containment venting if the containment pressure is beyond design to maintain containment integrity.

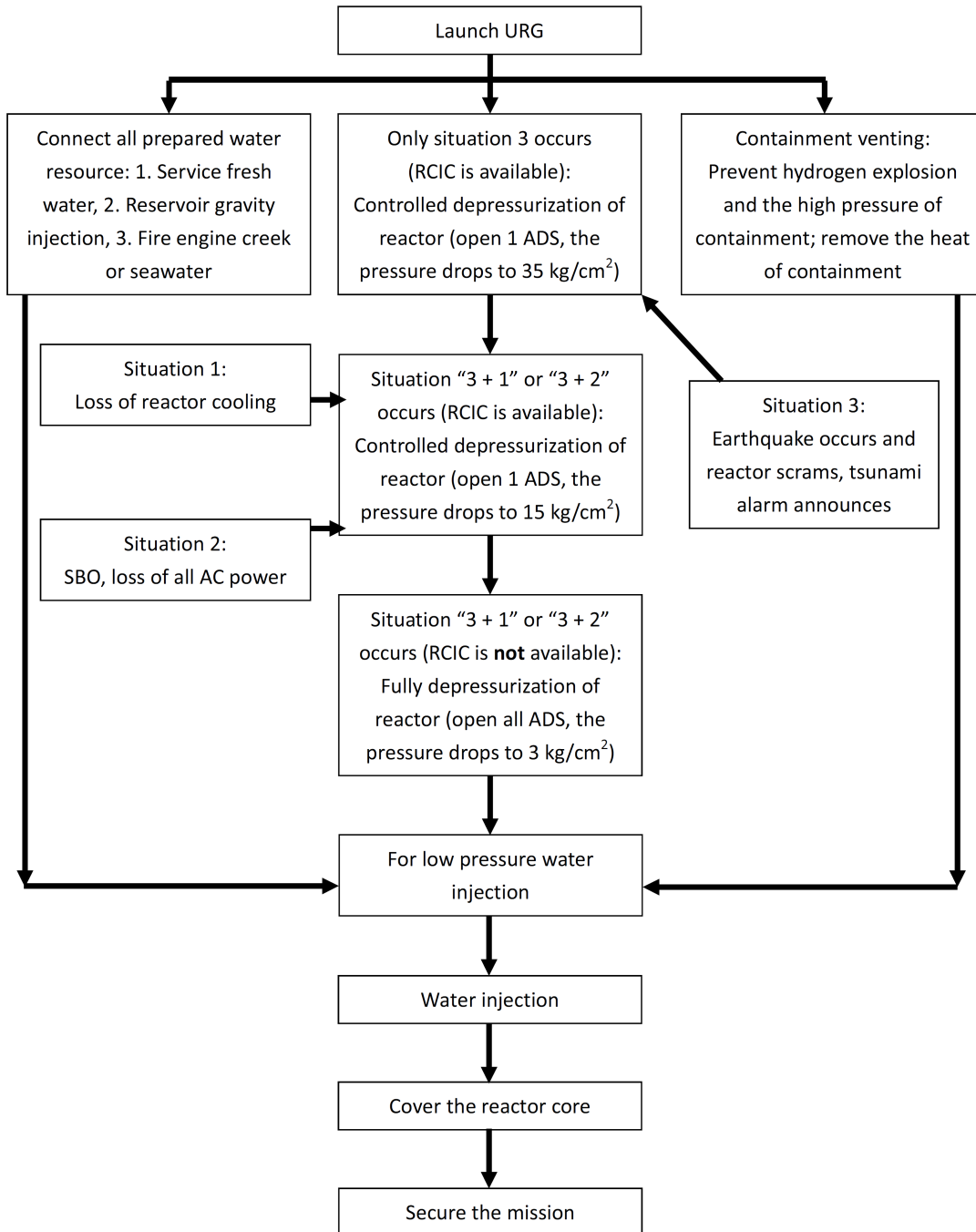

Figure 2 URG Flowchart

3 CHINSHAN NPP TRACE/SNAP MODEL

SNAP v 2.2.9 and TRACE v 5.0 patch4 are used in this research. The process of Chinshan NPP TRACE/SNAP model development is as follows: First, the system and operating data for the startup tests and FSAR of Chinshan NPP were collected. Second, several important control systems such as recirculation flow control system, pressure control system and feedwater flow control system etc. were established by SNAP and TRACE. Next, other necessary components (e.g., RPV (Reactor pressure vessel) and main steam piping) were added into the model to complete the TRACE/SNAP model of Chinshan NPP. Finally, Chinshan TRACE/SNAP model was verified with the cases of startup tests and FSAR. The TRACE/SNAP model of Chinshan NPP is presented in Figure 3.

The reactor vessel is divided into 9 axial levels, 4 radial rings, and 2 azimuthal sectors. Six channels are used to modeling 408 fuel rods and connect to the vessel's level 3~4. There are 27 axial nodes and 6 radial nodes in one channel. The water rods and partial length rods are also simulated in the channels. Six separators connect to the level 6~8 of the vessel. Two recirculation loops are set outside the vessel, with a recirculation pump in each loop. In the TRACE model, 10 injection pumps are merged into an equal injection pump. We use valve components to simulate the SRV (safety relief valve), MSIV (main steamline isolation valve), TSV (turbine stop valve), TCV (turbine control valve) and BPV (bypass valve). The critical flow models for the MSIV, SRV, TCV, TSV, and BPV have been considered in our analysis. The reactor vessel connects with four steamlines. Every steamline has MSIV, TCV/TSV, and SRVs. The break components are used to simulate the turbines (boundary conditions). We also build bypass pipeline. Moreover, the break component at the end of bypass valve is used to simulate the condenser. In addition, the containment is composed of drywell, wetwell (included suppression pool) and vent header (shown in Figure 3). In Chinshan NPP TRACE/SNAP model, "point kinetic" parameters such as delay neutron fraction, Doppler reactivity coefficient, and void reactivity coefficient are provided as TRACE input for power calculations. These data are set in the power component. In the Chinshan NPP TRACE/SNAP model, there are three simulation control systems included (1) feedwater flow control system, (2) pressure control system and (3) recirculation flow control system. Currently, these three control systems have been built by the signal variables, control blocks, trips components of TRACE.

Before the transient calculation of Chinshan TRACE/SNAP model begins, it is necessary to carry out the steady state calculation and make sure that the system parameters (such as the feedwater flow, steam flow, dome pressure, and core flow, etc.) are in agreement with FSAR data under the steady state condition. The time step of this model was 0.01 sec and the steady state convergence was 1×10^{-4} . The results of analysis of TRACE are clearly consistent with FSAR data under the steady state condition (See Table 1).

Table 1 The Comparison of Initial Conditions of FSAR and TRACE

Parameter	FSAR	TRACE	Difference (%)
Power (MWt)	1840	1840	0
Dome pressure (MPa)	6.96	6.96	0
Narrow range water level (m)	0.9	0.9	0
Steam flow (kg/sec)	989.92	989.7	-0.02
Feedwater flow (kg/sec)	987.02	990.6	0.36
Core flow (kg/sec)	6676.74	6665.8	-0.16

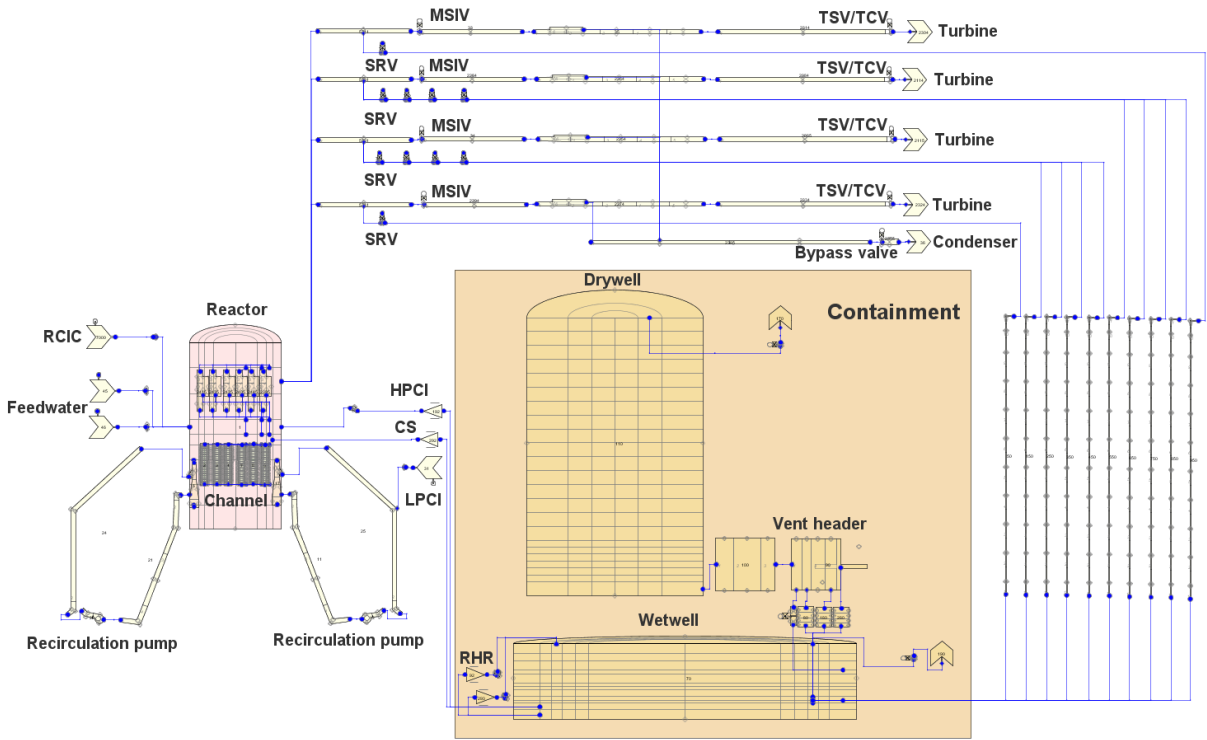

Figure 3 Chinshan NPP TRACE Model

4 RESULTS

4.1 Load Rejection Transient

The purpose of this test is to verify the response of the reactor system and the capability of the protection system under the transient. The load rejection test was initiated by manually opening both generator breakers in April 11, 1978, while the plant was steadily operated at 1775 MWt. Such loss of load caused the fast closure of TCV within 0.4 sec. At the same time, the bypass valves were activated to open. Closure of the TCV to 90% opening initiated reactor scram with 0.1 second delay. In response to fast closure of TCV, the system pressure quickly increased to open one of the SRVs. No recirculation pump trip occurred as designed and no RCIC/HPCI initiation was observed.

Table 2 compares the load rejection transient's sequences of NPP test data with TRACE. Their sequences are similar. Figure 4~7 show the comparison of results of startup test and TRACE. Figure 4 depicts the power curves of startup test and TRACE. The trends of the curves are approximately in agreement. As a result, the power calculated from TRACE includes decay heat, and stays at a level higher than the neutron flux-determined power from NPP after 3 sec. Figure 5 shows the steam flow results of startup test and TRACE. Because the TCV closed and the reactor scrammed, the steam flow decreased after 1.5 sec. Figure 6 illustrates the dome pressure results of startup test and TRACE. The pressure increased because the TCV closed. When the pressure was larger than 7.3 MPa, the SRVs opened until the pressure decreased to 7.1 MPa. Figure 7 compares the NRWL of startup test and TRACE. The result of TRACE is similar to startup test data. In summary, the trends of TRACE prediction are consistent with startup test data for this transient

Table 2 The Sequences of Startup Test and TRACE Data for Load Rejection Transient

Action	Time (sec)	
	Startup test	TRACE
TCV initiated closure	1.5	1.5
Bypass valve open	1.5	1.5
Reactor scram	1.6	1.6
TCV totally closure	1.9	1.9
Bypass valve totally open	2.1	2.1
SRV open	3.1	3.4
SRV closure	9.9	10.8
End	16	16

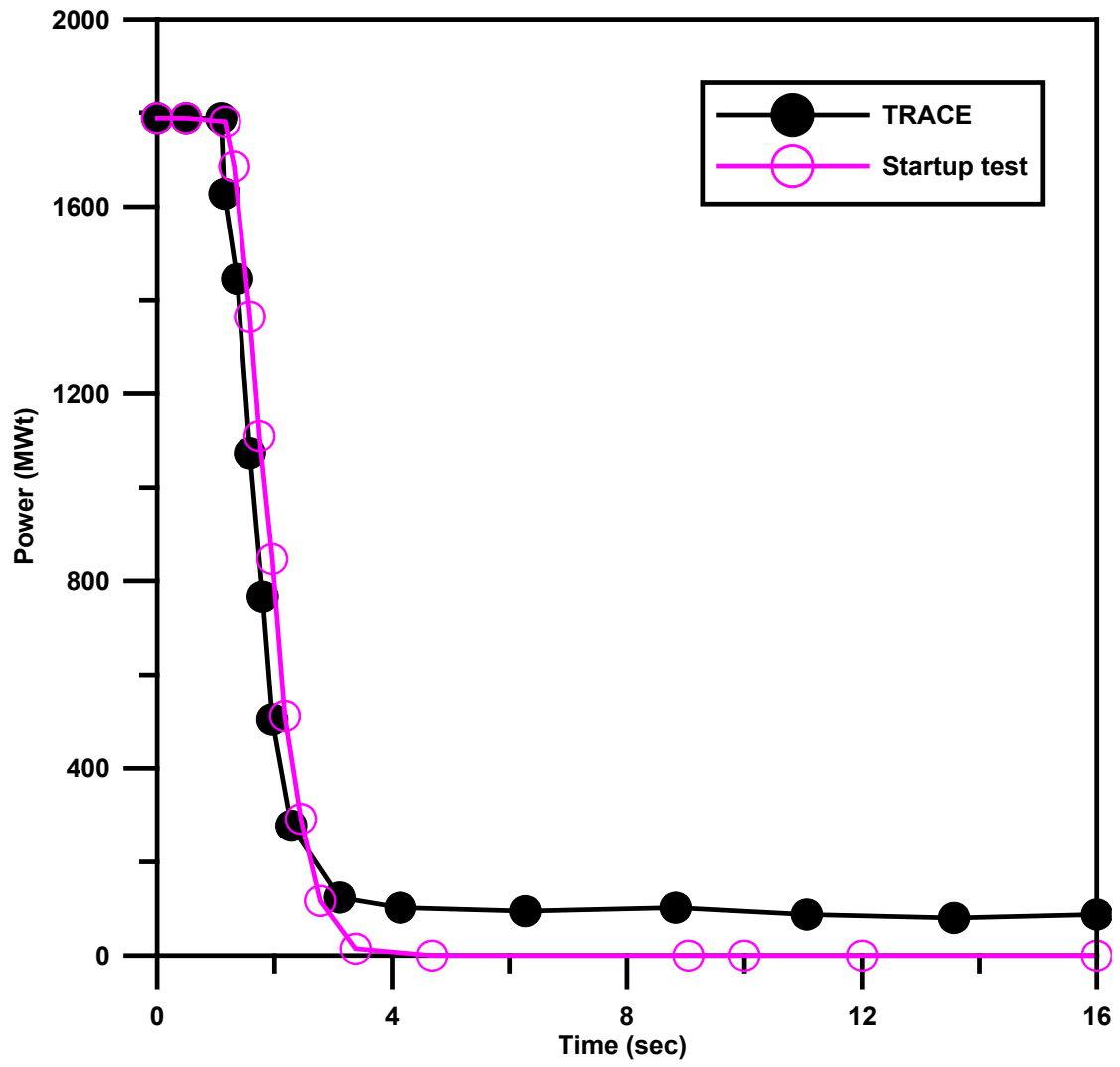

Figure 4 The Power of Startup Test and TRACE for Load Rejection Transient

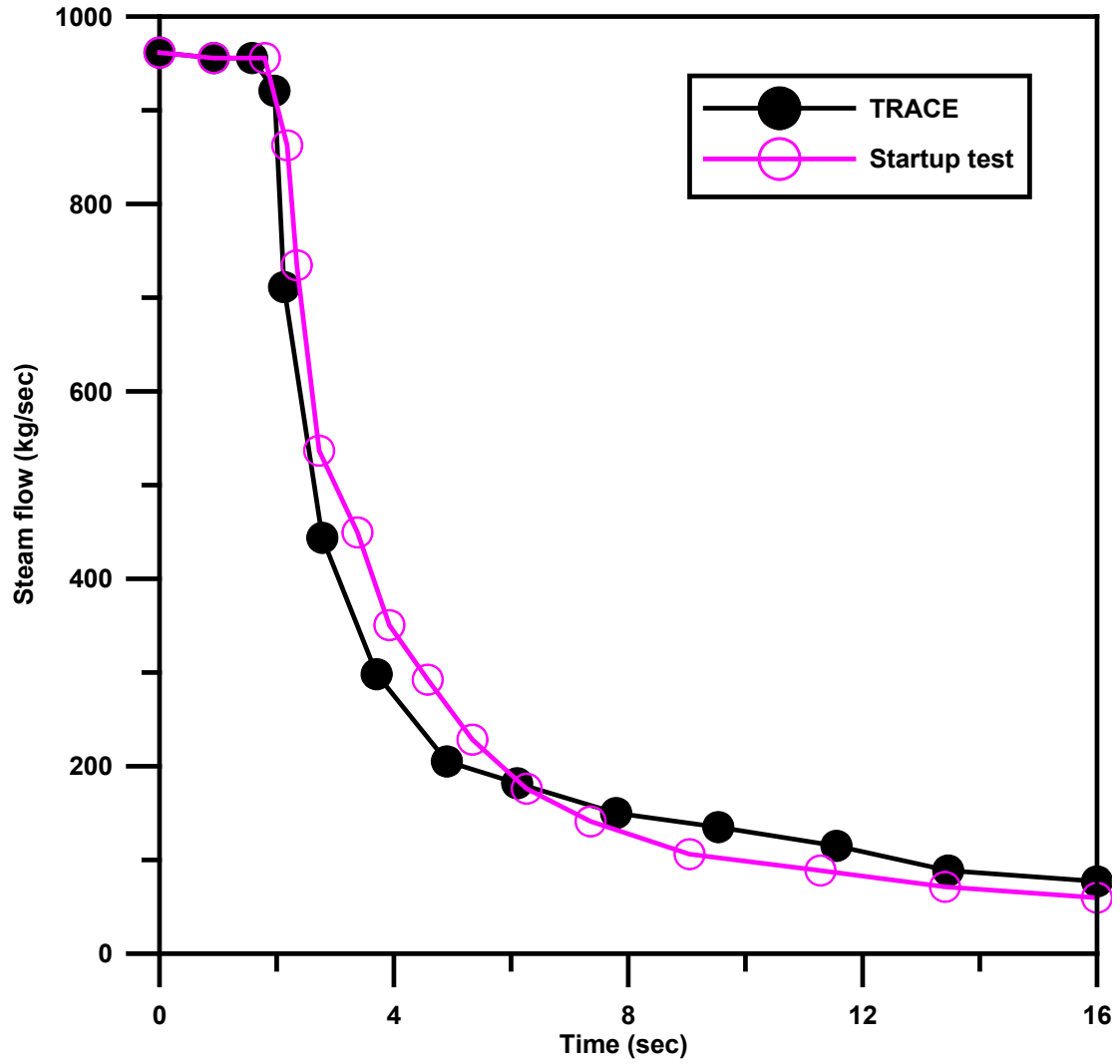

Figure 5 The Steam Flow of Startup Test and TRACE for Load Rejection Transient

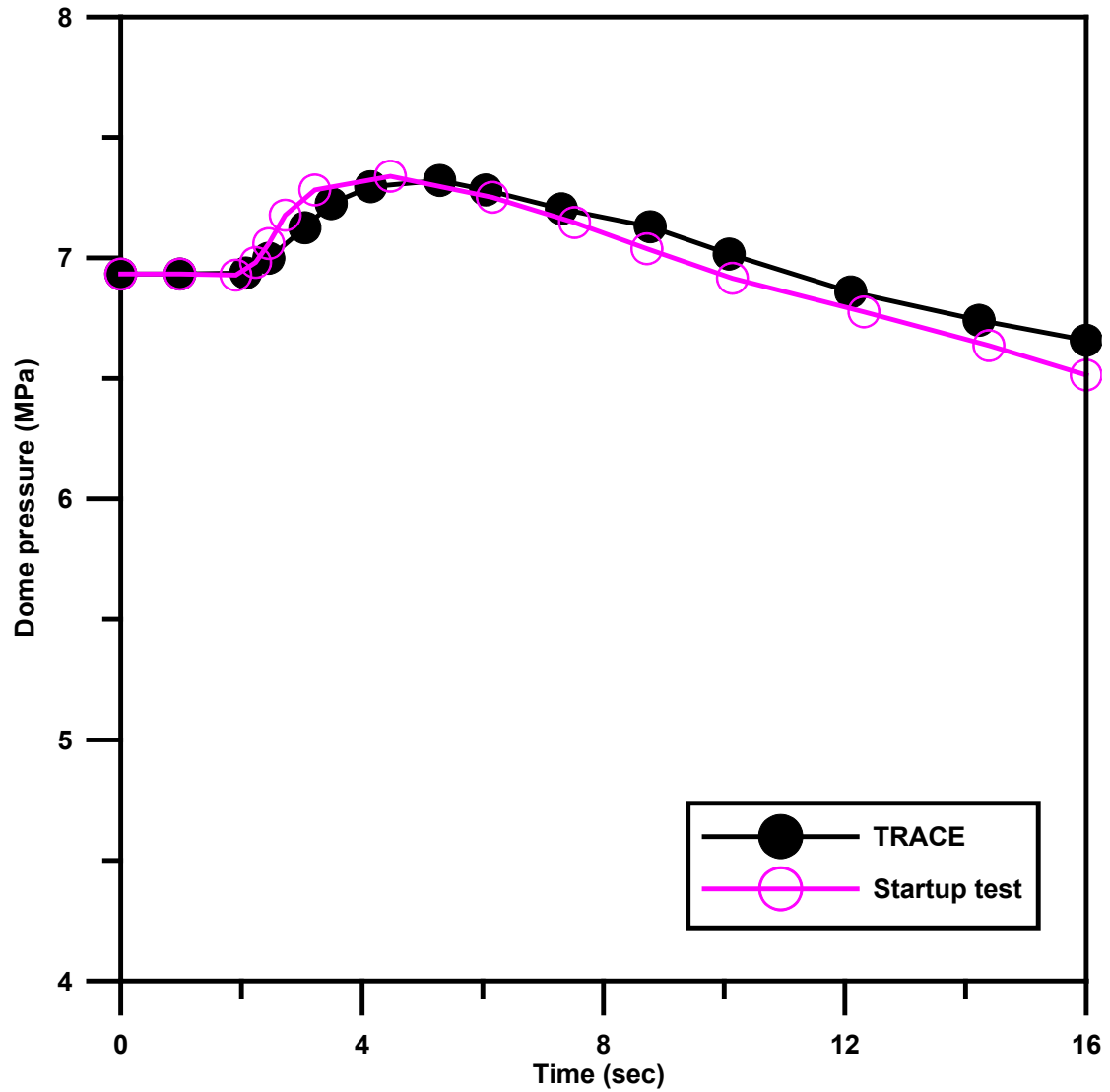

Figure 6 The Dome Pressure of Startup Test and TRACE for Load Rejection Transient

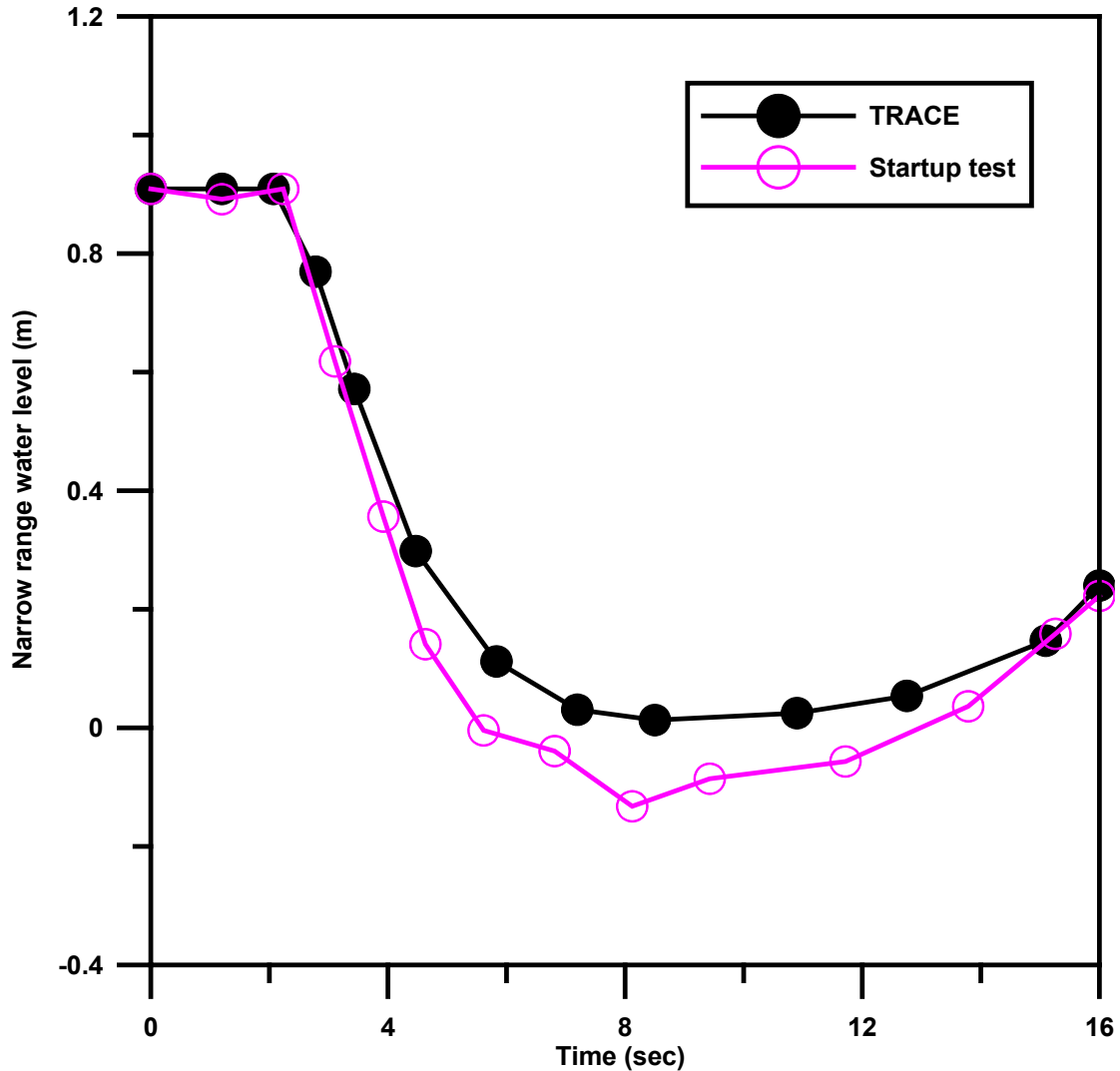

Figure 7 The NRWL of Startup Test and TRACE for Load Rejection Transient

4.2 Turbine Trip without Bypass Valve Transient

According to FSAR data, the reactor is initially operating at 1864 MWt. Table 3 shows the turbine trip transient’s sequences of FSAR and TRACE. Their sequences are the same. In this transient, the reactor scram and recirculation pump trip is initiated by position switches on the TSV when the valves are less than 90% open. The turbine bypass valve system is assumed failure in this transient.

Figure 8~10 show the results of FSAR and TRACE. Figure 8 illustrates the power curves of FSAR and TRACE. The trends of their curves are similar. The increase of the power was caused by TSV closing. The TSV closing decreased the reactor’s void fraction which generated the positive reactivity. Subsequently, the scram initiated and the power dropped. Figure 9 compares the dome pressure of FSAR and TRACE. The trends of the curves are approximately in agreement. The TSV closing caused the dome pressure to rise. Subsequently, SRVs opened and the dome pressure declined. Figure 10 shows the comparison of core flow between FSAR and TRACE. The curve of TRACE is similar to FSAR data. Due to the dome pressure increase, it resulted in the core flow rising during 0.5~1.5 sec. The decrease of core inlet flow was caused by recirculation pumps trip after 1.5 sec.

Table 3 The Sequences of FSAR and TRACE Data for Turbine Trip without Bypass Valve Transient

Action	Time (sec)	
	FSAR	TRACE
TSV initiated closure	0.1	0.1
Recirculation pump initiated trip	0.6	0.6
Reactor scram	1.0	1.0
End	6	6

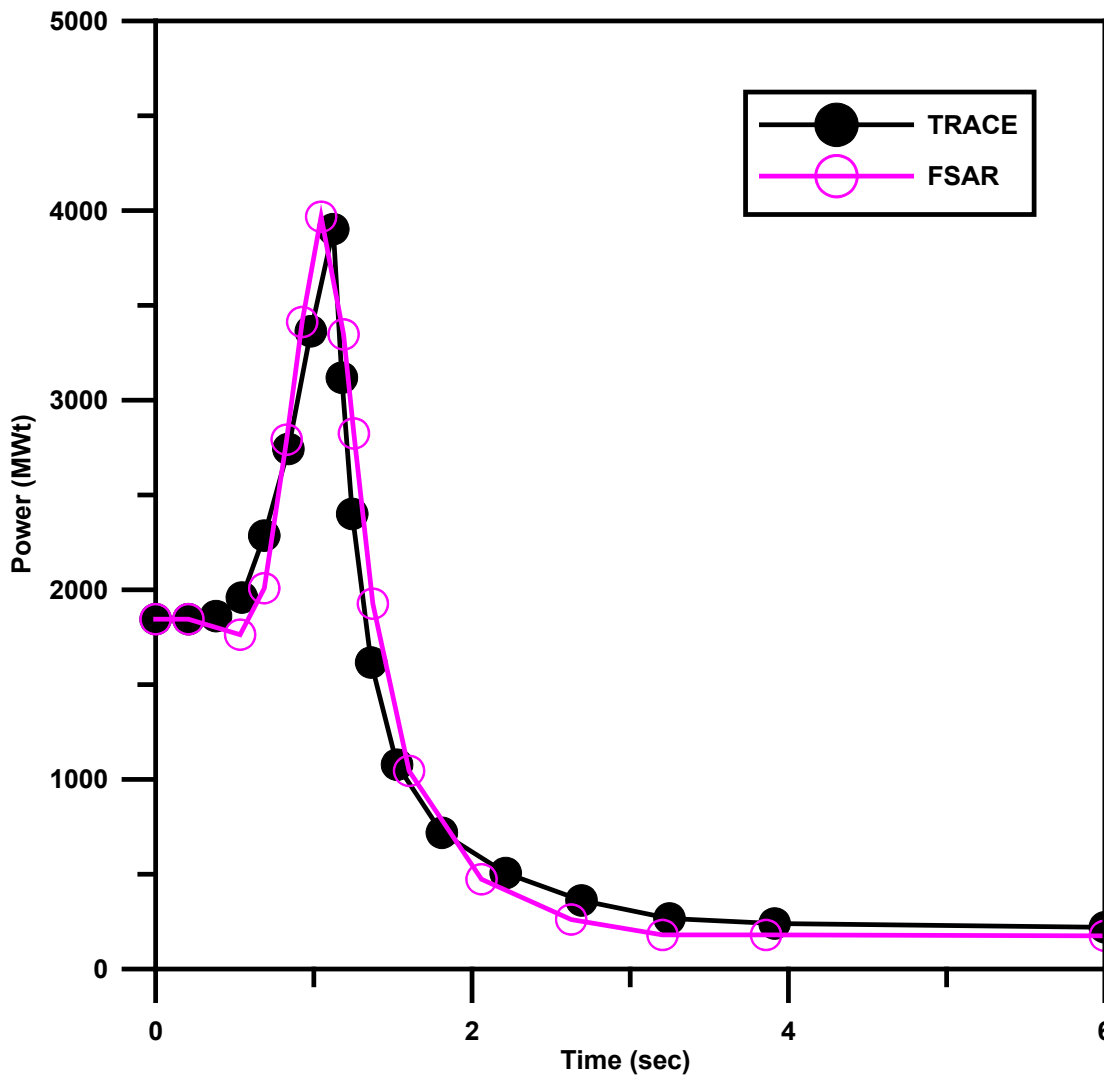

Figure 8 The Power of FSAR and TRACE for Turbine Trip without Bypass Valve Transient

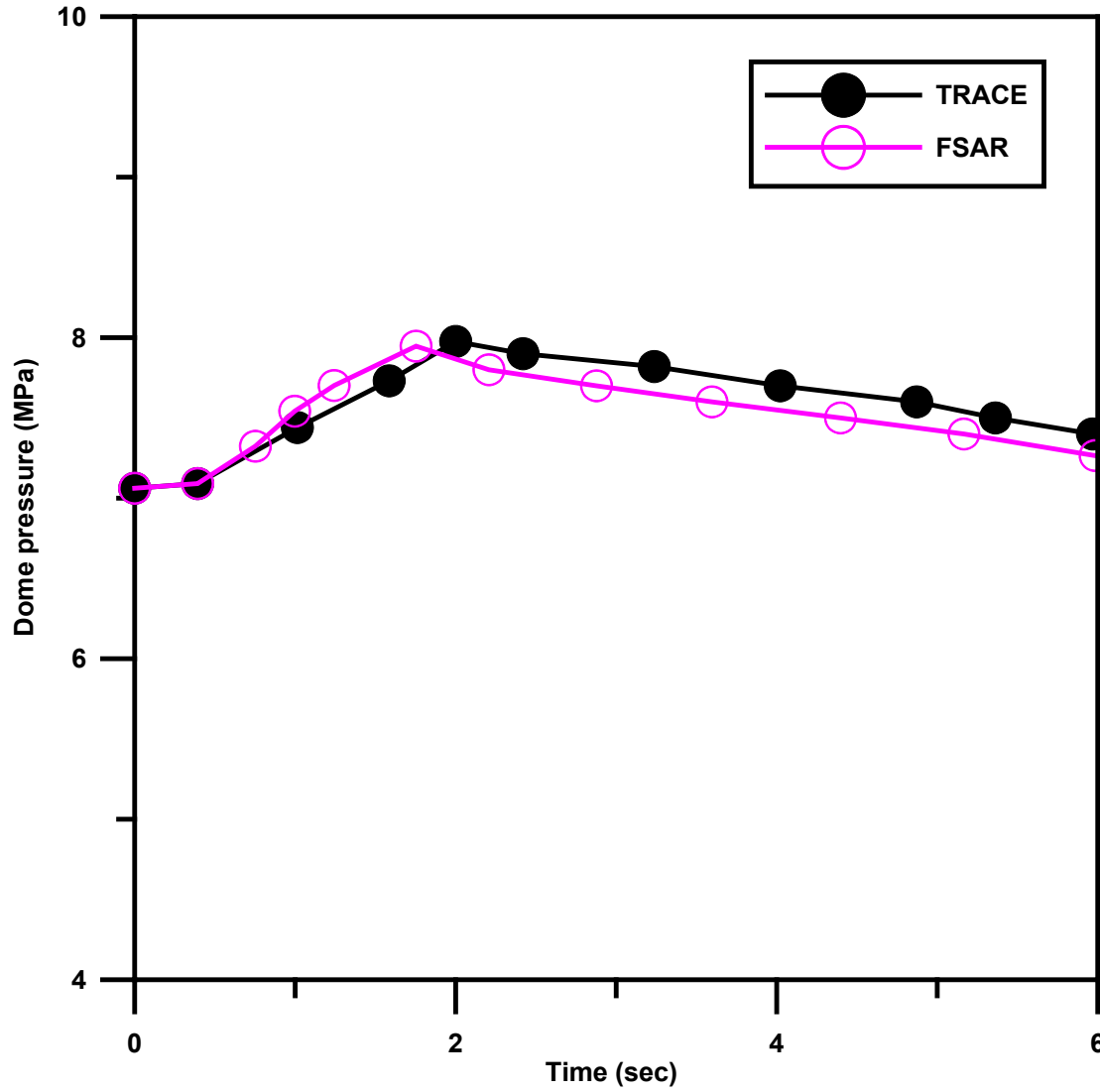

Figure 9 The Dome Pressure of FSAR and TRACE for Turbine Trip without Bypass Valve Transient

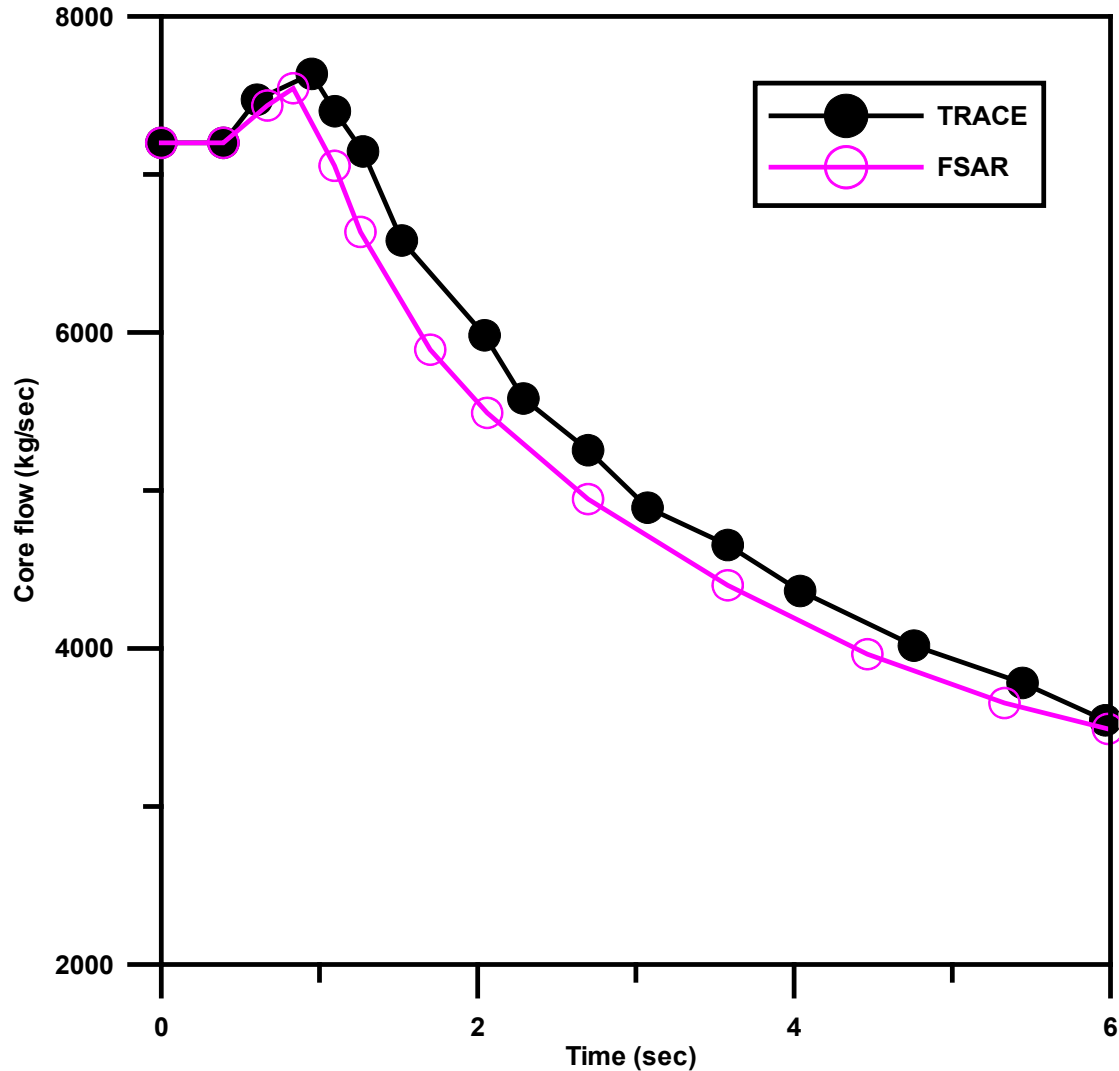

Figure 10 The Core Flow of FSAR and TRACE for Turbine Trip without Bypass Valve Transient

4.3 URG Simulation and Analysis

In order to estimate the URG efficiency under Fukushima-like conditions and perform the sensitivity study of depressurization and low pressure water injection, there are six cases in this paper. Table 4 lists the sequence of URG simulation of TRACE under Fukushima-like conditions (base case, Case 1). In addition, there are some assumptions have been made in this analysis: (1) the SRVs activate in this transient; (2) the decay heat model ANS-73 is used in this transient simulation; (3) the low pressure water injection is 28.35 kg/sec. The main actions of URG are the depressurization and low pressure water injection of the reactor and containment venting. However, we focus on the sensitivity study of depressurization and low pressure water injection, shown in Table 5. Additionally, the depressurization of reactor consists of controlled and fully depressurization.

For Case 1 (base case), the simulation of steady state was first performed during 0~300 sec. Because the earthquake occurred and tsunami alarm announced (assumed conditions), the reactor scrammed at 300 sec. Controlled depressurization of reactor, MSIV closure, recirculation pumps

trip and feedwater trip were also performed at 300 sec. In this controlled depressurization step, 1 ADS opened which caused that the dome pressure dropped to 35 kg/cm² and kept at this level (shown in Figure 11). RCIC was available at this step which controlled the water level between level 2 and level 8 during 300~3905 sec (see Figure 12). Subsequently, station blackout (SBO) was assumed to occur at 2100 sec. At this step, controlled depressurization of reactor was performed again. Therefore, 1 ADS opened and the dome pressure dropped to 15 kg/cm² (see Figure 11). We assumed RCIC failure at 3905 sec. Because RCIC failed, fully depressurization of reactor was performed in order to start low pressure water injection. At this step, 5 ADS opened and the dome pressure dropped to 3 kg/cm² which caused the water level decrease (see Figure 11 and 12). Subsequently, low pressure water injected to the reactor at 5000 sec. The sources of low pressure water were assumed from service fresh water, reservoir gravity injection, fire engine creek or seawater (see Figure 2). The water level went up and PCT decreased after the low pressure water injection (see Figure 12 and 13). Finally, the transient finished at 8000 sec. The above results show that the URG can keep the PCT below the criteria 1088.7 K under Fukushima-like conditions (shown in Figure 13). Figure 14~17 show the containment parameters results of TRACE. According to the FSAR, the pressure and temperature of containment should be lower than 0.487 MPa and 444.26 K. In this case, the results of TRACE didn't reach these criteria. The pressure of drywell and wetwell went up due to the large amount of steam was released into suppression pool (see Figure 14 and 15). The large amount of steam also caused that the temperature of containment rose (see Figure 16 and 17). In addition, due to containment venting was performed at 3905 sec, the pressure and temperature of drywell and wetwell dropped at this time (shown in Figure 14 ~ 16).

No URG case is Case 2. The dome pressure of Case 2 was kept at about 6.8~7.6 MPa and there was an oscillation in Case 2 due to SRVs activated (see Figure 11). After RCIC failure, the water level started to decrease and was lower than TAF at about 7500 sec (shown in Figure 12). The PCT started to increase after the water level lower than TAF and reached 1088.7 K at 16225 sec. It indicated that the zirconium-water reaction was able to generate. The above results depicted that Chinshan NPP was not at the safe situation. Furthermore, the pressure and temperature of containment were lower than 0.487 MPa and 444.26 K in this case (see Figure 14~17). It indicates that the safety issue may occur in the reactor core and not in the containment before 18000 sec. In the comparison of Case 1 and 2, it shows clearly that URG can keep Chinshan NPP at the safe situation under Fukushima-like conditions.

Figure 18~24 depict the comparison of Case 1, 3 and 4. Because there was no controlled depressurization for Case 3 and 4, the SRVs were activated during 300~3905 sec (shown in Figure 18). If there was only the fully depressurization of reactor in URG (no controlled depressurization), TRACE results depicted that the water level dropping was larger (see Figure 19) than the controlled depressurization cases. It indicates that PCT increases faster. Furthermore, if no water injection was also in the above cases, the PCT was larger than 1088.7 K (see Case 4, Figure 20) which indicated that Chinshan NPP was not at the safety situation. Figure 21~24 illustrate the containment parameters results of TRACE. In Case 3 and 4, the results of TRACE didn't reach the criteria (0.487 MPa and 444.26 K). The pressure of drywell and wetwell went up due to the large amount of steam was released into suppression pool (see Figure 21 and 22). Subsequently, the large amount of steam caused that the temperature of containment rose (see Figure 23 and 24). Additionally, due to containment venting was performed at 3905 sec, the pressure and temperature of drywell and wetwell dropped at this time (shown in Figure 21 ~ 23). In the comparison of Case 1, 3 and 4, due to no controlled depressurization in Case 3 and 4, the pressure and temperature of containment for Case 1 were larger than Case 3 and 4 during 300~3905 sec.

Figure 25~31 illustrate the comparison of Case 1, 5 and 6. Comparing Case 1 and 5, if there was only the controlled depressurization of reactor in URG (no fully depressurization and low pressure

water injection), TRACE results presented that the water level was lower than TAF at 7700 sec and the PCT was larger than 1088.7 K at 14030 sec. Comparing Case 1 and 6, if there was no water injection in URG, TRACE results indicated that PCT went up after the depressurization of reactor (see Case 6, Figure 27). It presented that the zirconium-water reaction generated and Chinshan NPP was not at the safe situation. The above results also indicated that if the NPP want to be at the safe situation, the low pressure injection must be performed after the depressurization of reactor finishes. Figure 28~31 show the containment parameters results of TRACE. In Case 5 and 6, the results of TRACE didn't reach the criteria (0.487 MPa and 444.26 K). The pressure of drywell and wetwell went up due to the large amount of steam was released into suppression pool (see Figure 28 and 29). Subsequently, the large amount of steam caused that the temperature of containment increased (see Figure 30 and 31). In addition, due to containment venting for Case 6 was performed at 3905 sec, the pressure and temperature of drywell and wetwell dropped at this time (shown in Figure 28 ~ 30). In the comparison of Case 1, 5 and 6, due to no fully depressurization in Case 5, the temperature of suppression pool for Case 1 and 6 were larger than Case 5 after 3905 sec (see Figure 31).

In summary, Table 5 shows the time point of Case 1~6 for the water level lower than TAF and the PCT larger than 1088.7 K. It indicates clearly that Case 4 is the most severe case.

Additionally, the sensitivity study of the required raw water injection for URG was performed in this research. The low pressure water injection is 28.35 kg/sec for Case 1. Therefore, we assumed that the low pressure water injection is 14.18 kg/sec for Case 1-1; 10.63 kg/sec for Case 1-2; 7.09 kg/sec for Case 1-3. Figure 32 depicts the water level of Case 1, 1-1, 1-2, and 1-3. It shows that the water level of Case 1-3 was always lower than TAF after the water injection. The water level of Case 1-2 reached the TAF after 8000 sec. But its water level was lower than TAF during 4620~8000 sec. The water level of Case 1-1 was kept at TAF after the water injection and was larger than TAF after 6500 sec. Therefore, we think that the required raw water injection must be larger than 14.18 kg/sec.

In order to study the mechanical property and integrity of fuel rods, FRAPTRAN analysis was performed in this study. In this step, we only analyzed the no URG case. The URG case is not considered in this step because its PCT is lower than 1088.7 K. Figure 33~39 depict the results of FRAPTRAN. FRAPTRAN output file depicted that the max PCT was in the axial node 15. Hence, Figure 33~39 only present the results of the axial node 15. The zirconium-water reaction occurred at about 16000 sec (shown in Figure 33). At this time, the core water level was lower than bottom of active fuel (BAF) and PCT reached 1088.7 K. Because zirconium-water reaction occurred, the oxide thickness of cladding went up. According to 10 CFR 50.46 rule [15], the increasing oxide thickness of cladding should be less than 17%, Figure 34 shows the cladding oxide thickness is over the critical value (0.103 mm). Figure 35 and 36 present the structural radial gap and gap gas pressure results of FRAPTRAN. The structural radial gap became zero at about 14500 sec. It indicated that PCMI (Pellet Cladding Mechanical Interaction) generated. The gap gas pressure increases when structural radial gap decreases. Figure 37 and 38 illustrates the cladding hoop strain and stress results of FRAPTRAN. When the water level was lower than TAF, there was the variation in the cladding hoop strain and stress. As PCT increased, cladding hoop strain and stress also went up initially. Furthermore, when PCMI occurred, cladding hoop strain and stress had the more variation. According to NUREG-0800 Standard Review Plan [16], the fuel enthalpy should be lower than 7.11×10^5 J/kg. The result of FRAPTRAN did not reach this criterion (see Figure 39) but was close to this value.

Table 4 The Sequences of URG Case (Case 1)

Action	Time (sec)
Start	0
Reactor scrams (because earthquake occurs and tsunami alarm announces), MSIV closes, Recirculation pumps trip, Feedwater trip, Controlled depressurization of reactor (open 1 ADS, the pressure drops to 35 kg/cm ²) (RCIC is available)	300
SBO (loss of all AC power), Controlled depressurization of reactor (open 1 ADS, the pressure drops to 15 kg/cm ²)	2100
RCIC is not available, Fully depressurization of reactor (open 5 ADS, the pressure drops to 3 kg/cm ²), Containment venting	3905
Low pressure water injection	5000

Table 5 The Sensitivity Study of URG

	Case 1	Case 2	Case 3	Case 4	Case 5	Case 6
Controlled depressurization of the reactor	○	x	x	x	○	○
Fully depressurization of the reactor	○	x	○	○	x	○
Low pressure water injection	○	x	○	x	x	x
The water level lower than TAF	4620~ 5060 sec	7500~ 18000 sec	4030~ 8000 sec	4030~ 6880 sec	7700~ 15000 sec	4680~ 12100 sec
The PCT larger than 1088.7 K	---	16225~ 18000 sec	5620~ 6740 sec	5700~ 6880 sec	14030~ 15000 sec	9865~ 12100 sec
Transient end	8000 sec	18000 sec	8000 sec	6880 sec	15000 sec	12100 sec

○: Perform this action

x: Don't perform this action

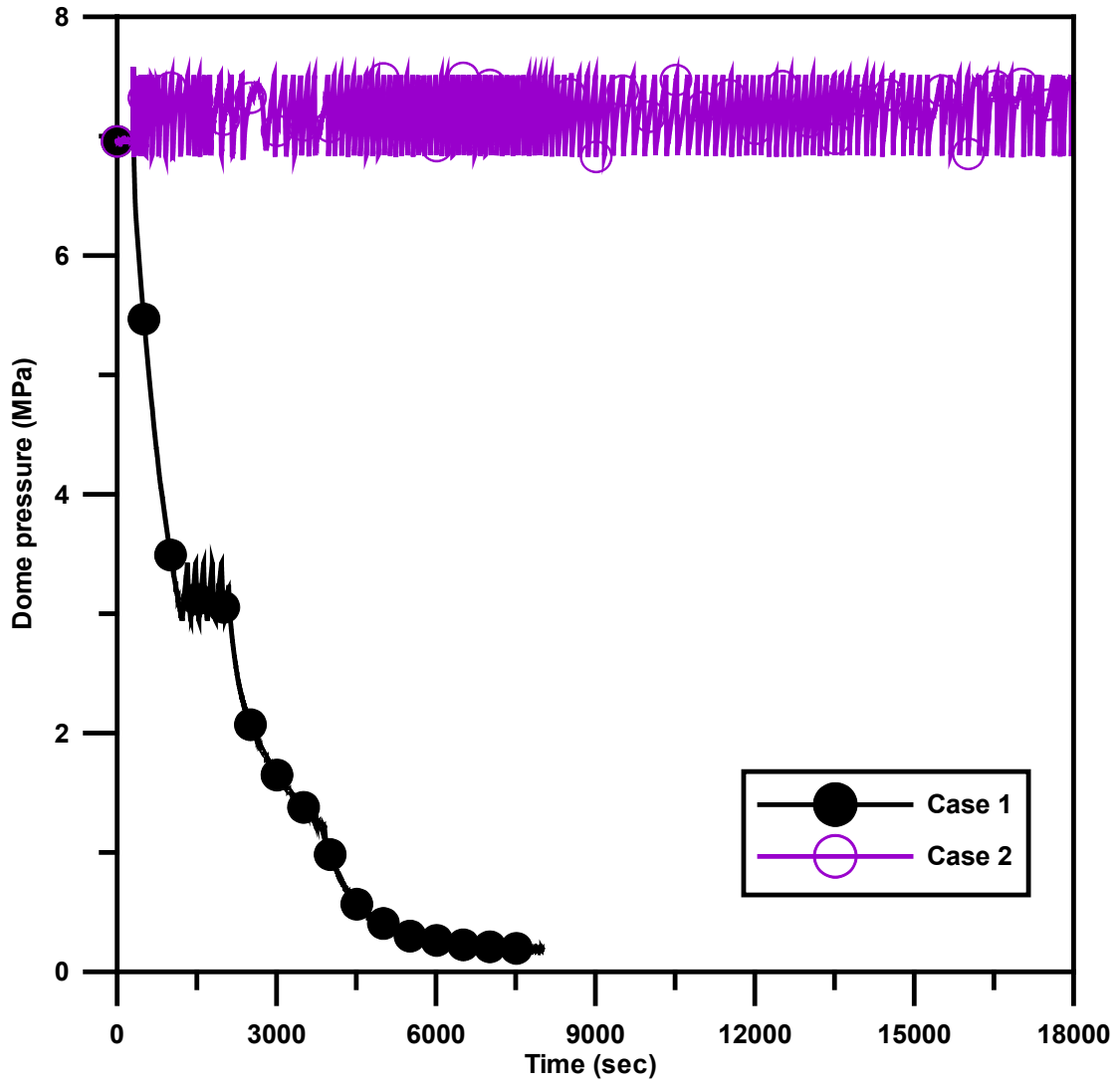

Figure 11 The Dome Pressure Comparison of Case 1 and 2

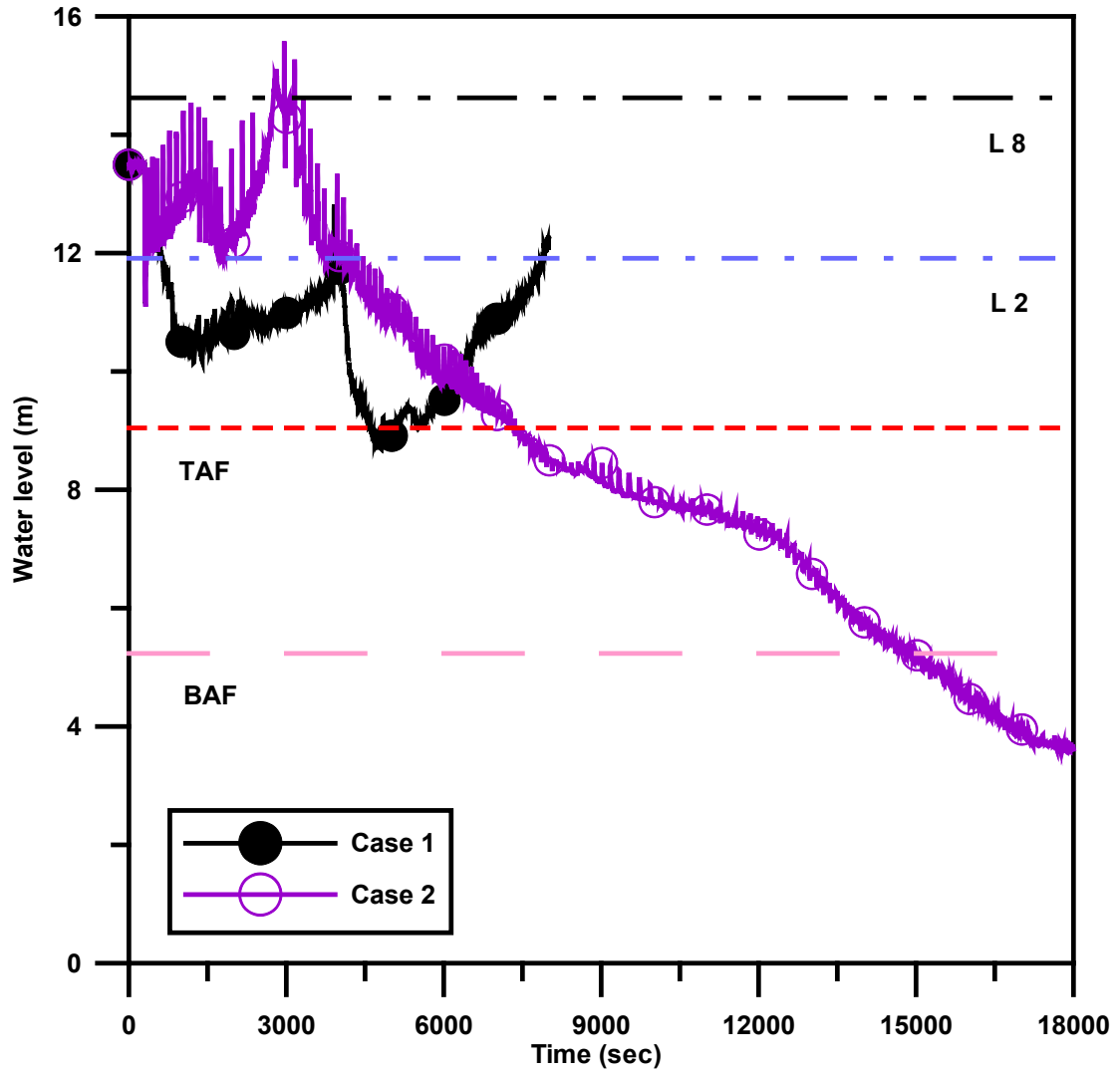

Figure 12 The Water Level Comparison of Case 1 and 2

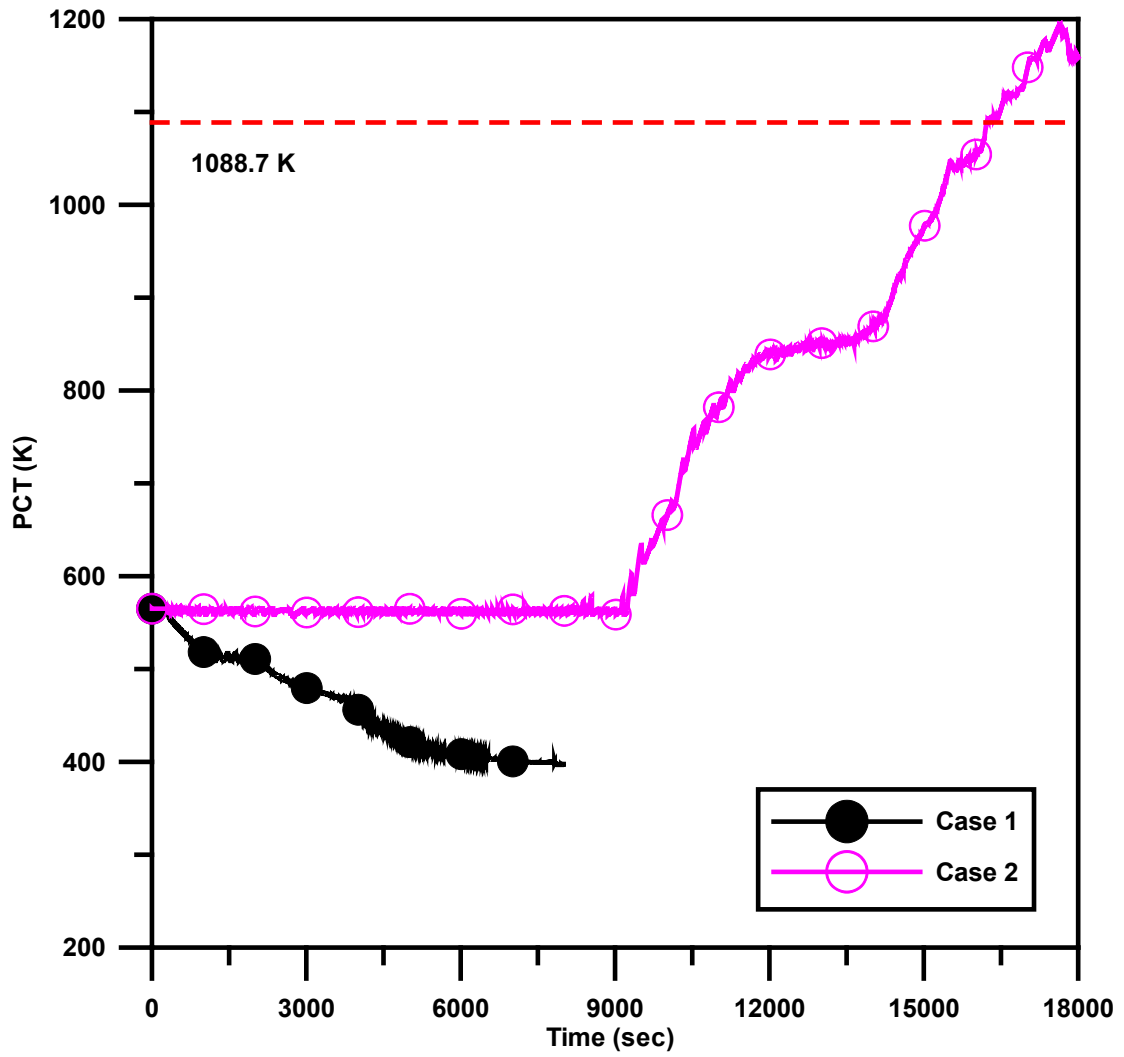

Figure 13 The PCT Comparison of Case 1 and 2

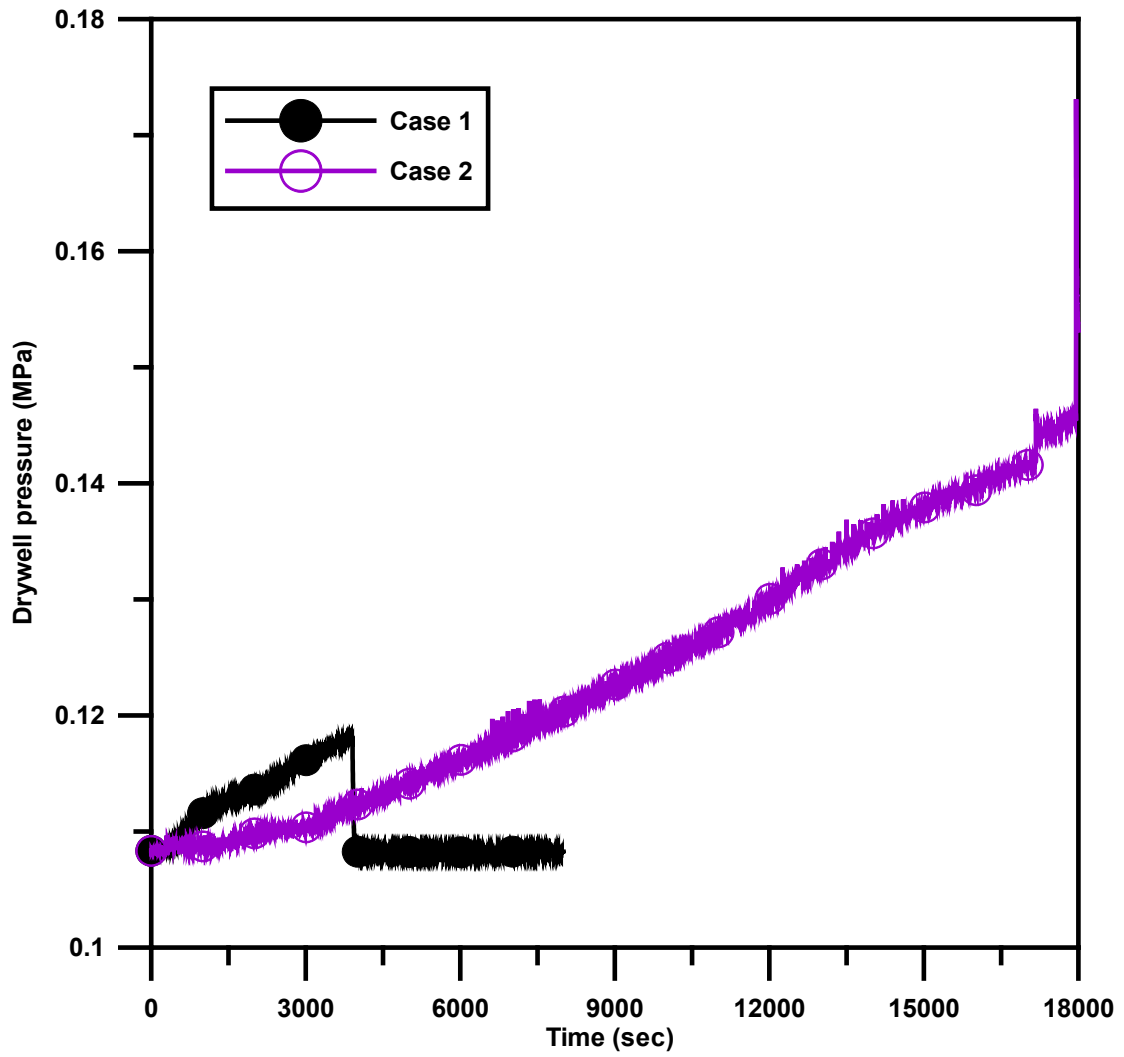

Figure 14 The DRYWELL PRESSURE Comparison of Case 1 and 2

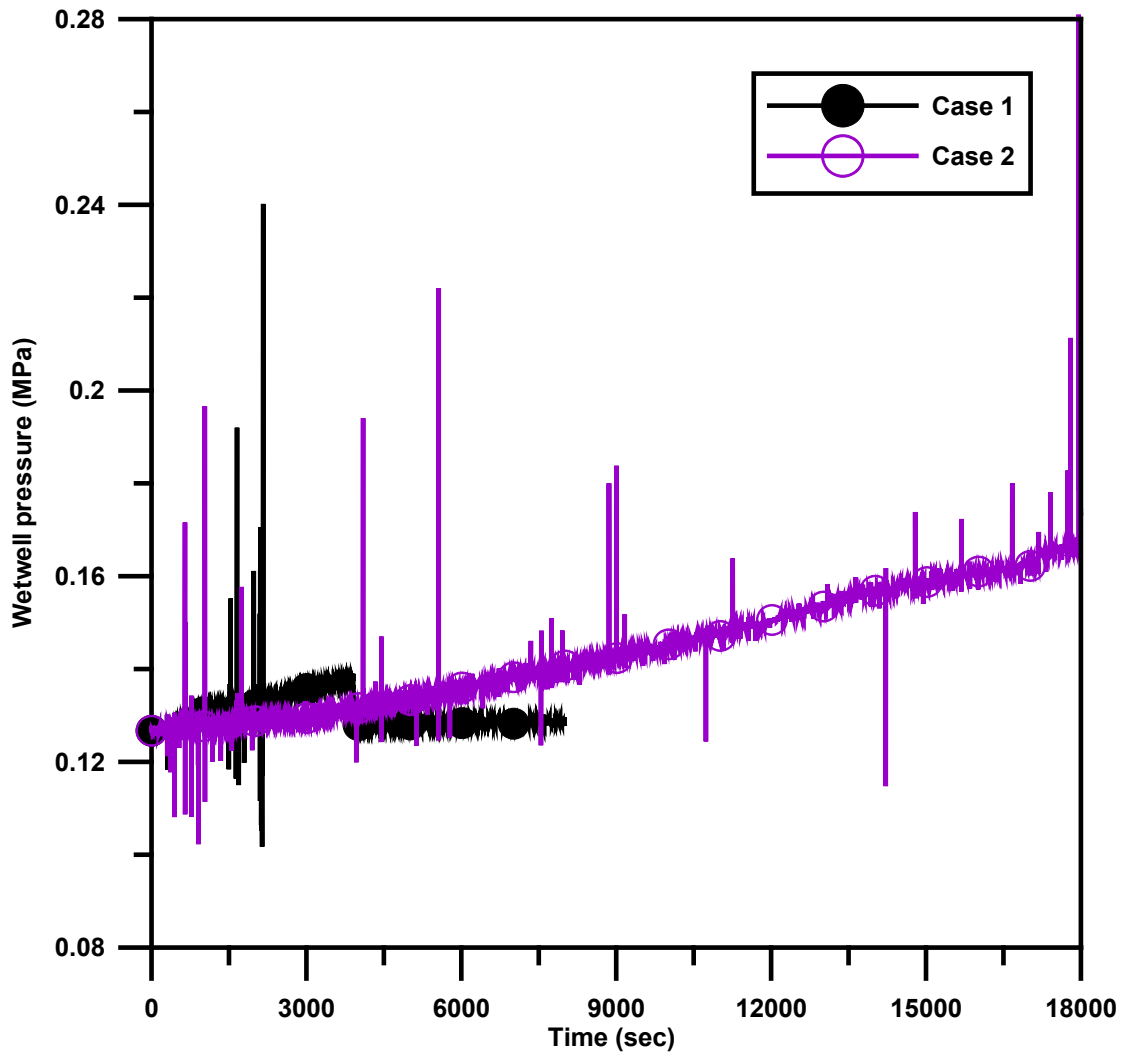

Figure 15 The Wetwell Pressure Comparison of Case 1 and 2

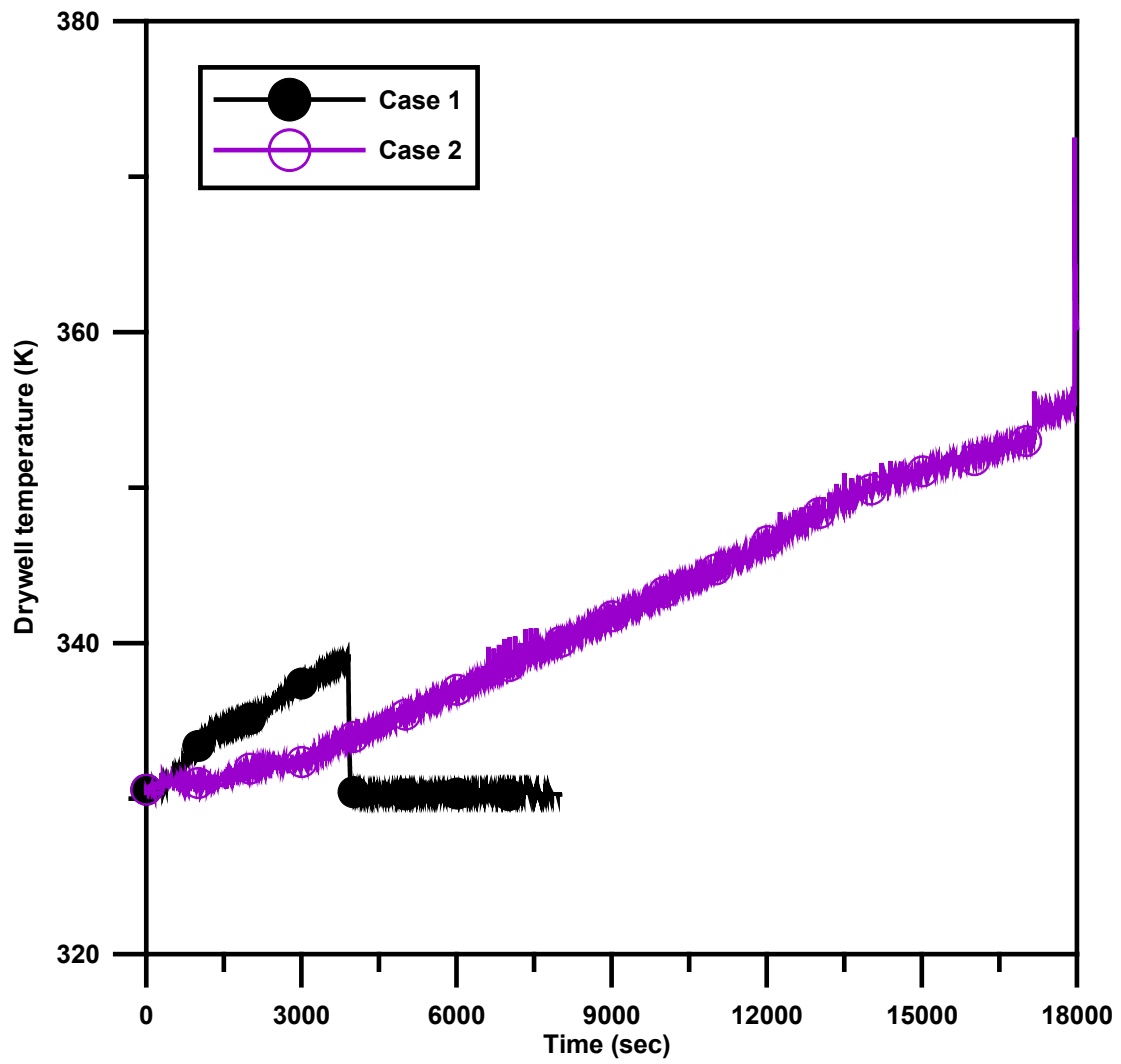

Figure 16 The Drywell Temperature Comparison of Case 1 and 2

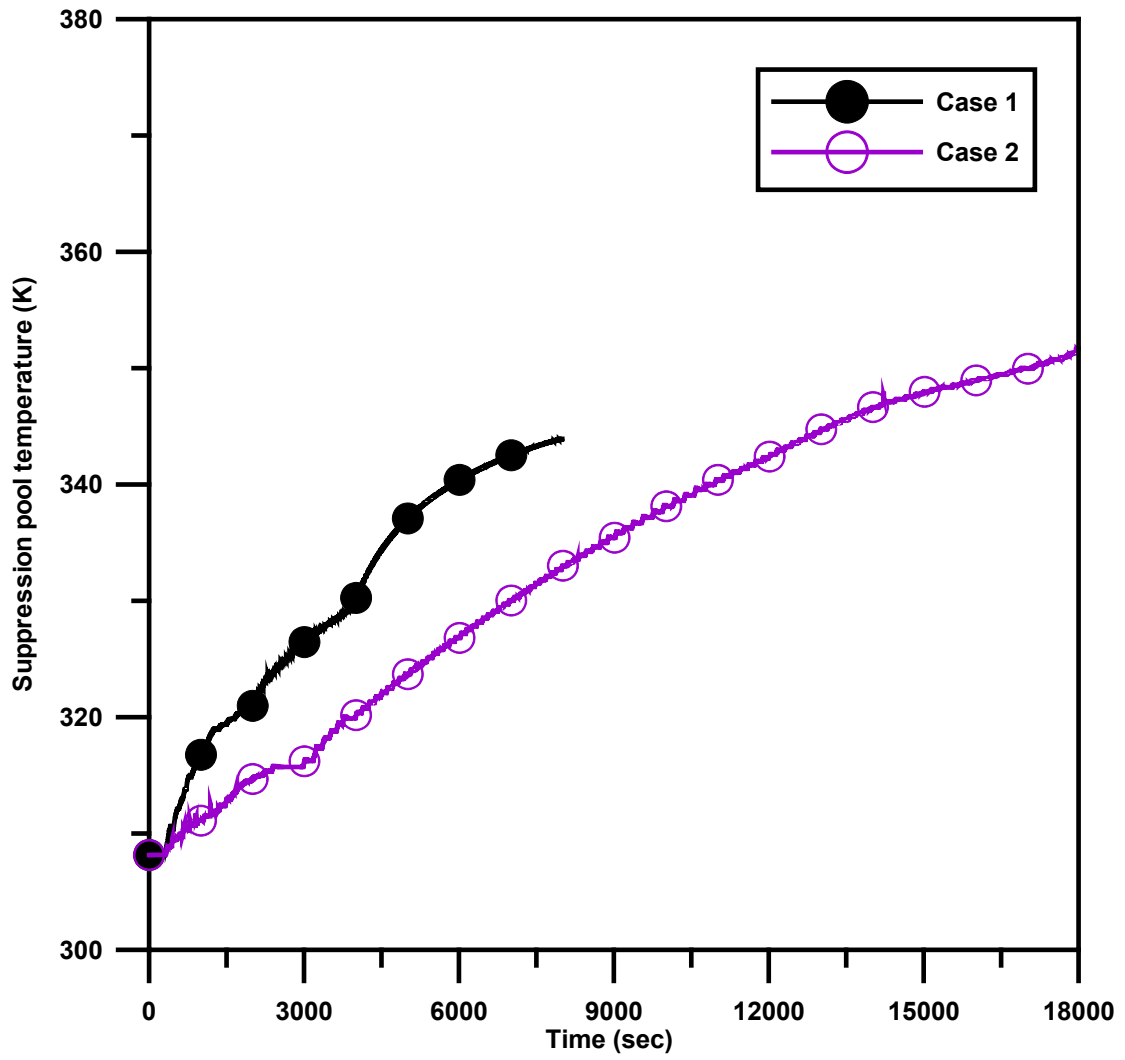

Figure 17 The Suppression Pool Temperature Comparison of Case 1 and 2

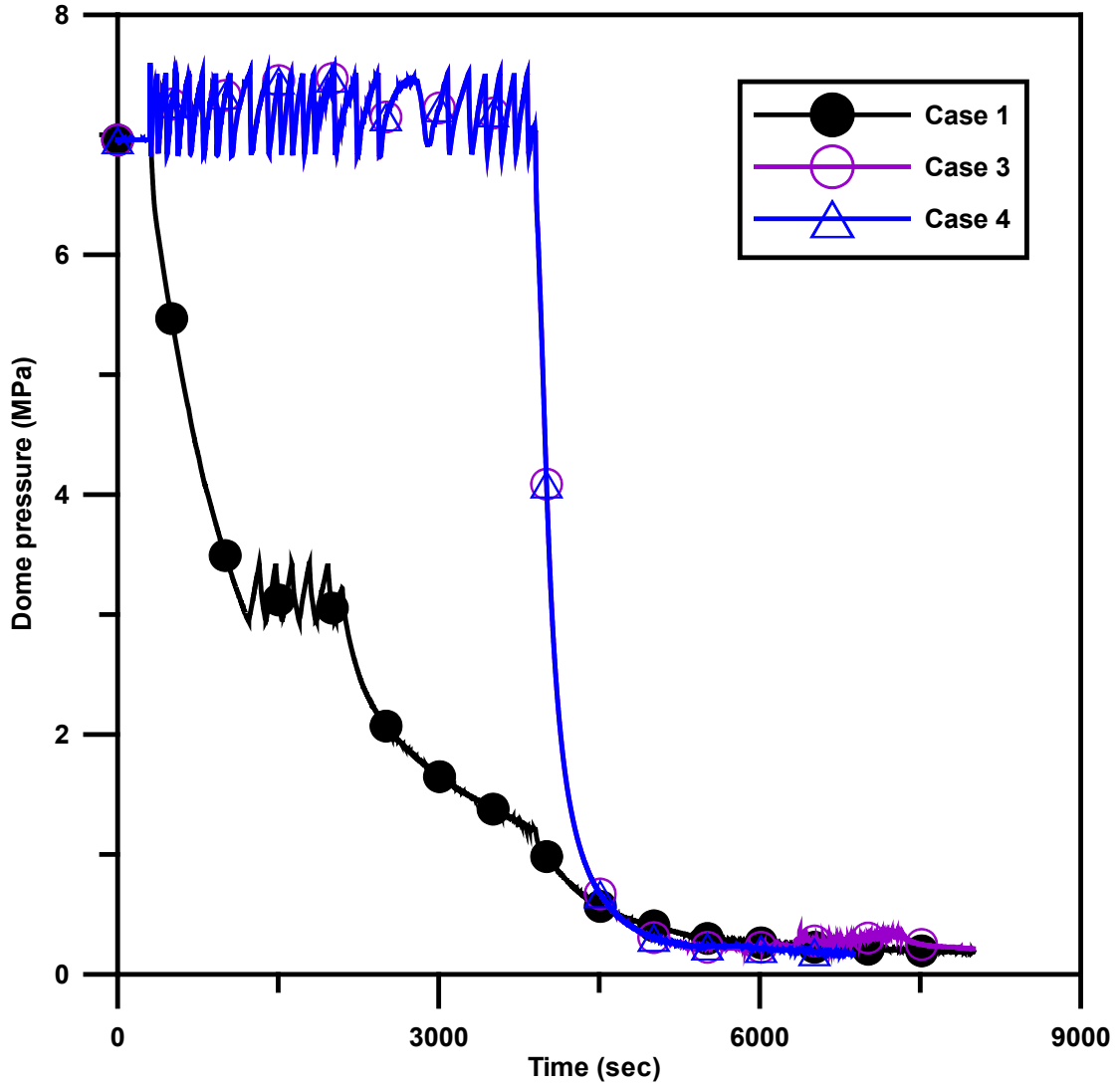

Figure 18 The Dome Pressure Comparison of Case 1, 3 and 4

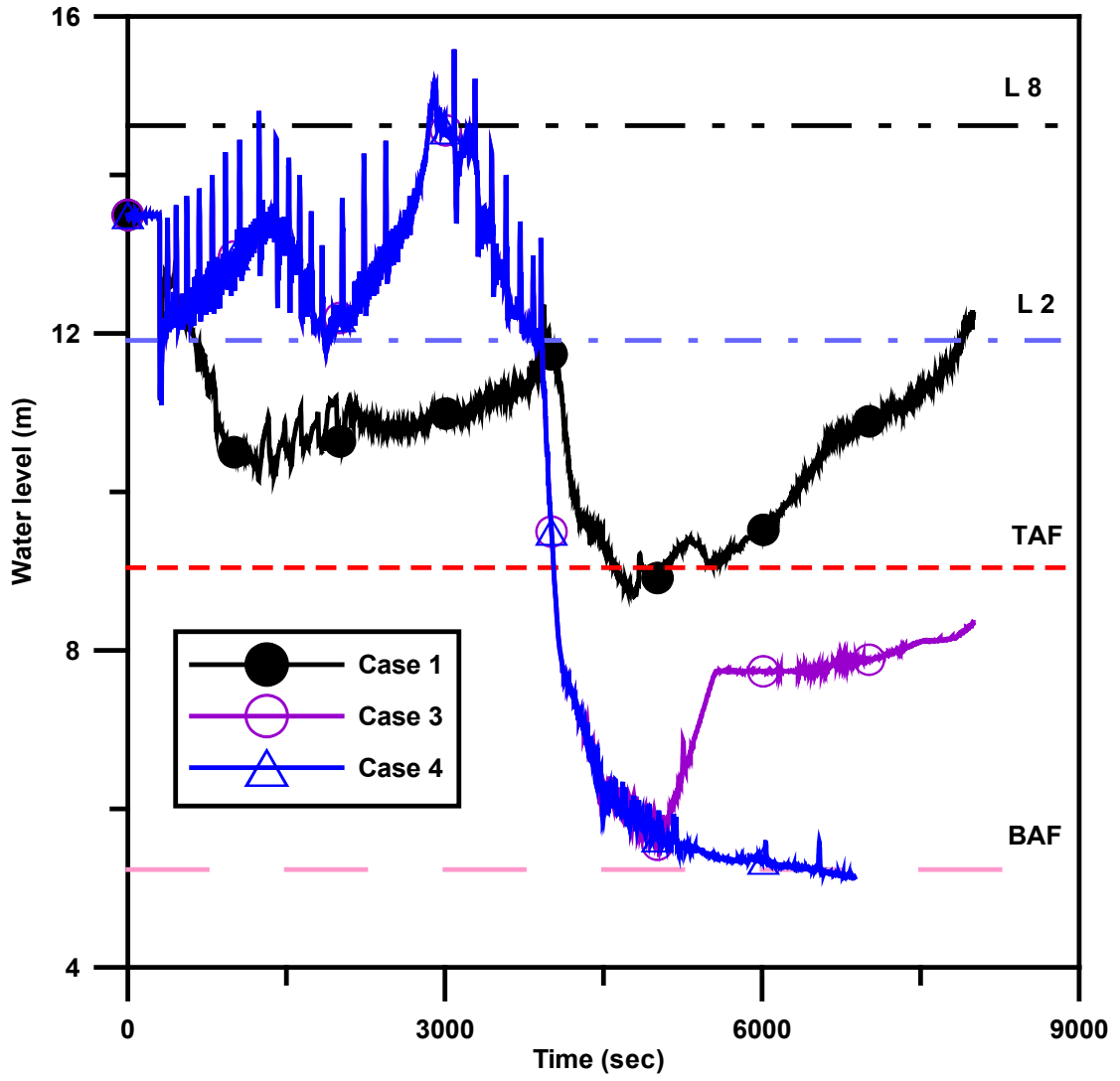

Figure 19 The Water Level Comparison of Case 1, 3 and 4

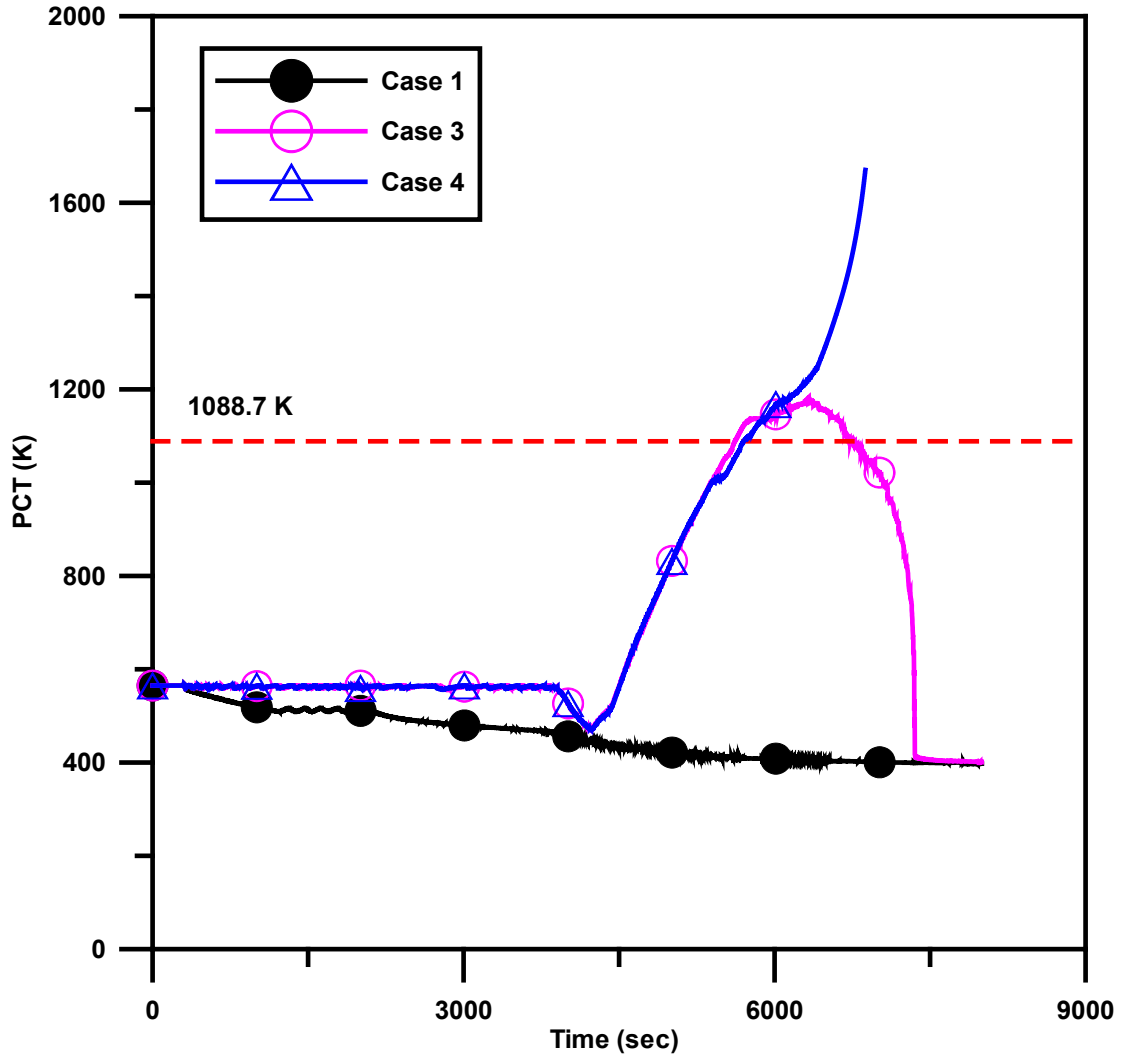

Figure 20 The PCT Comparison of Case 1, 3 and 4

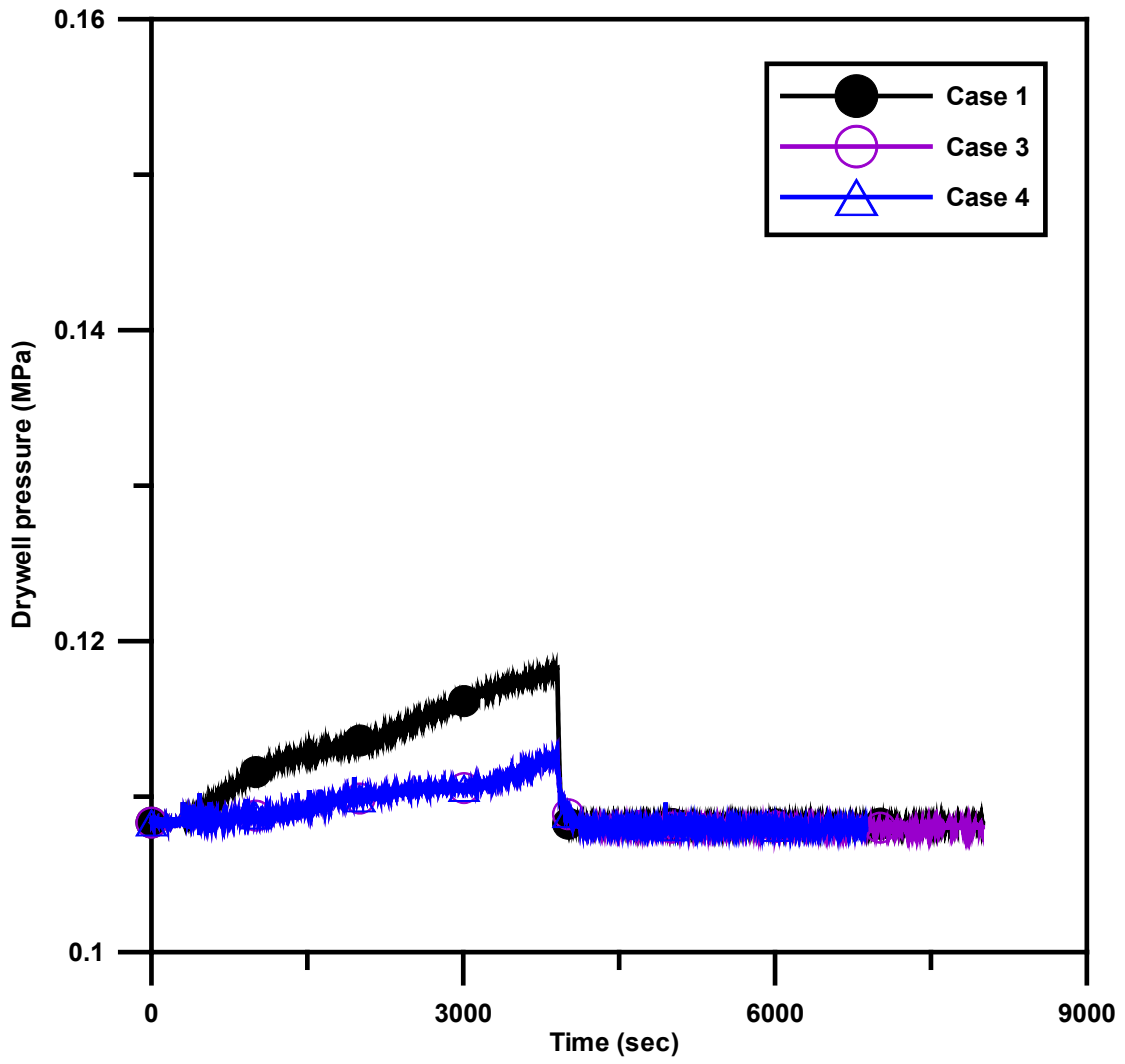

Figure 21 The Drywell Pressure Comparison of Case 1, 3 and 4

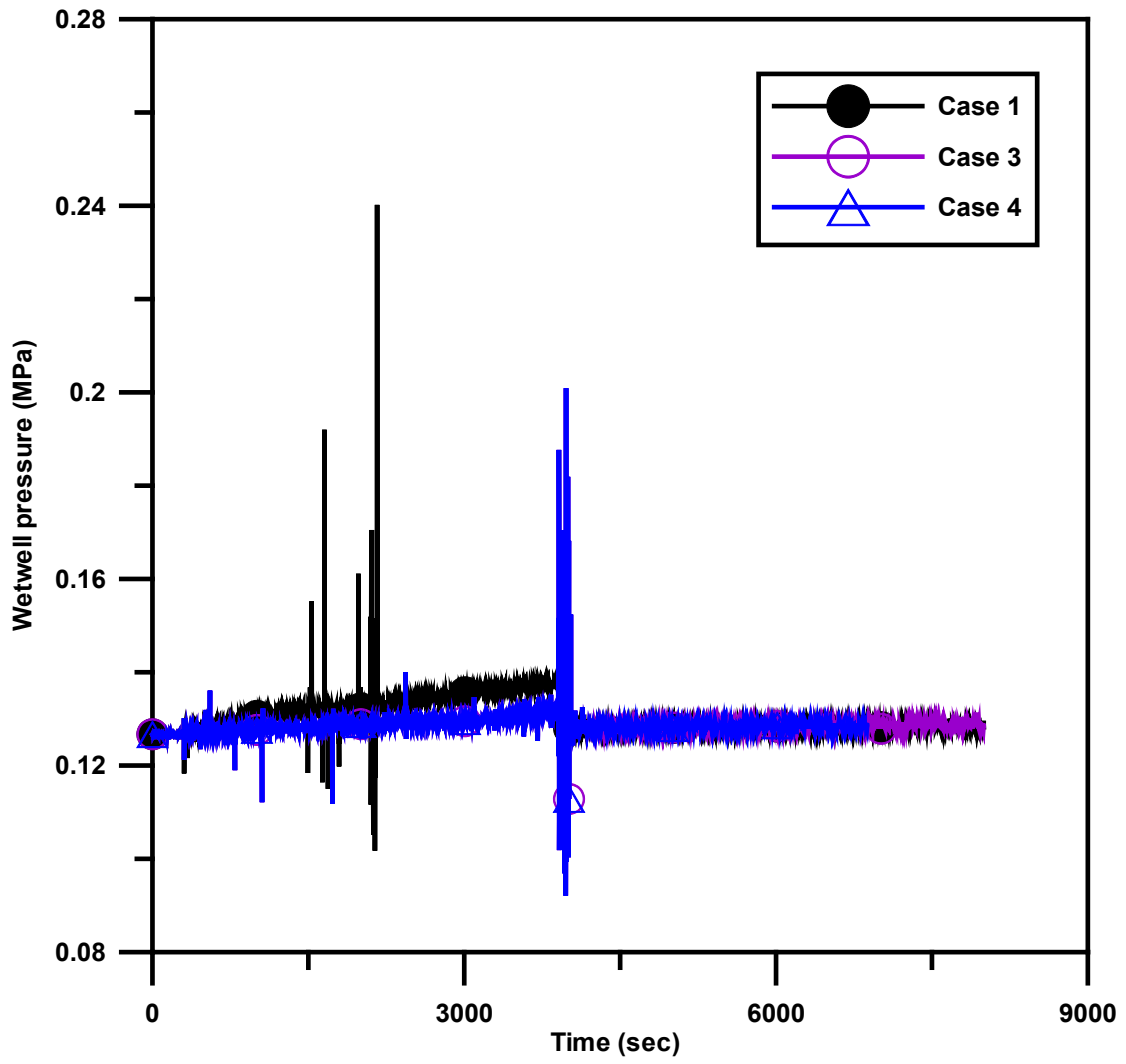

Figure 22 The Wetwell Pressure Comparison of Case 1, 3 and 4

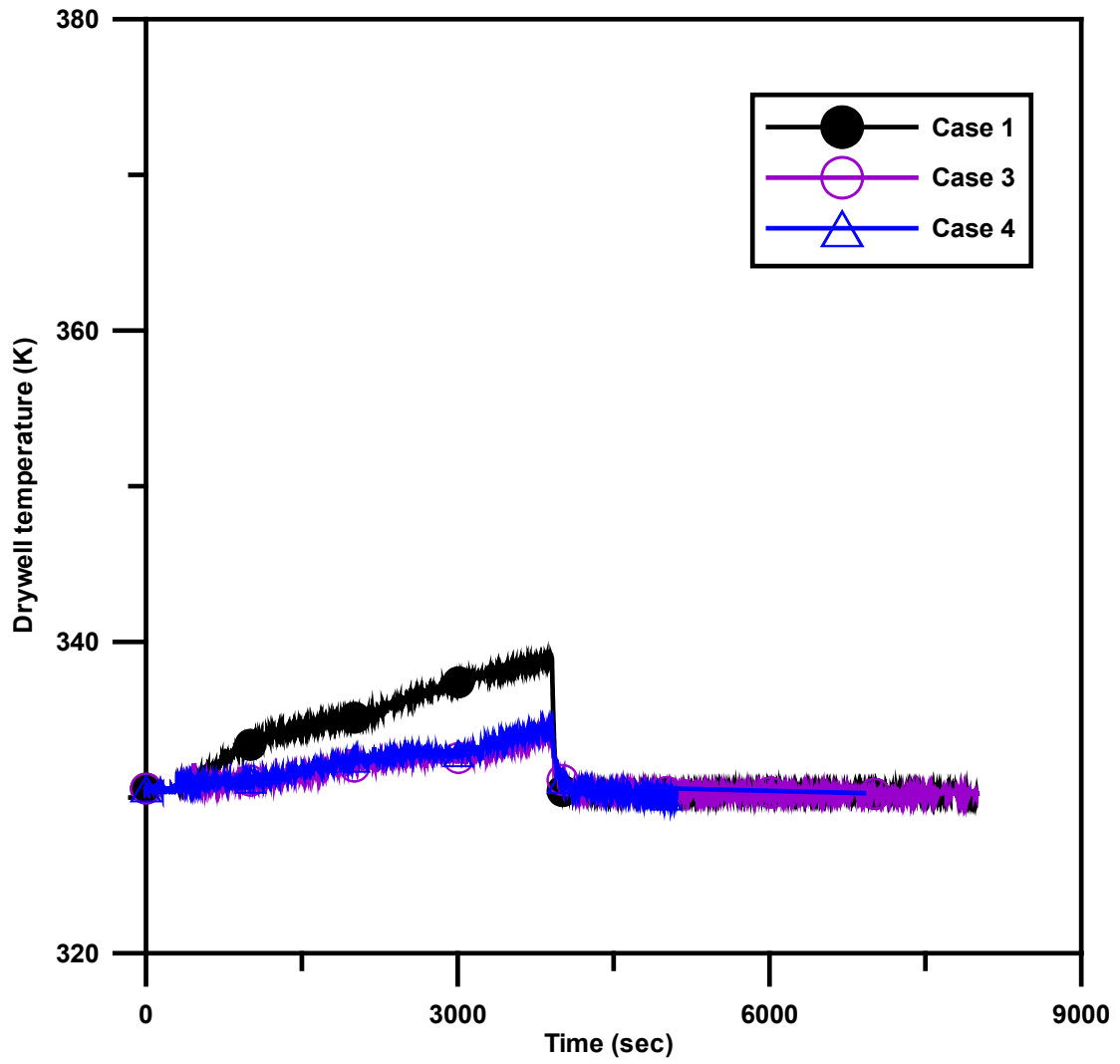

Figure 23 The Drywell Temperature Comparison of Case 1, 3 and 4

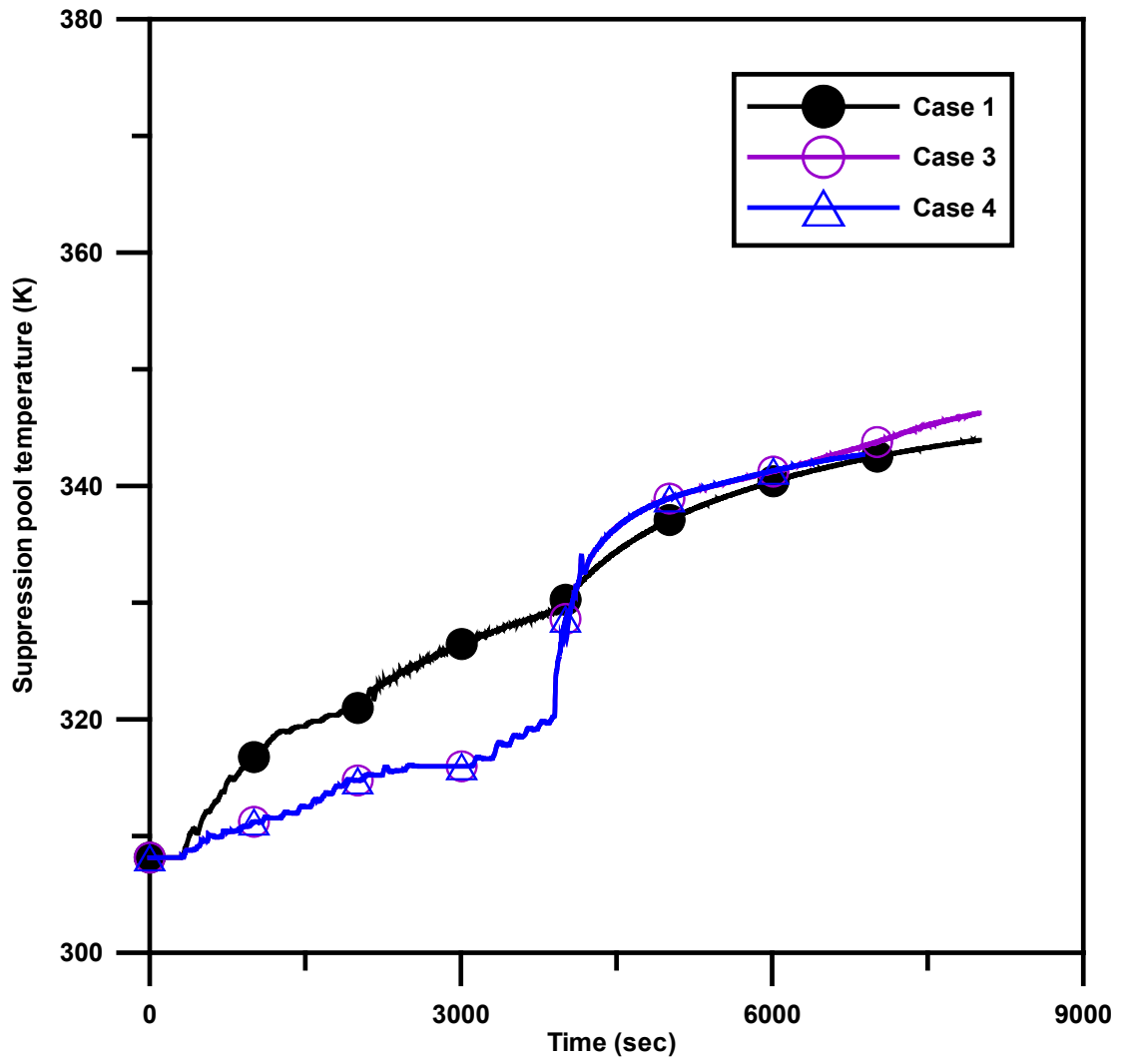

Figure 24 The Suppression Pool Temperature Comparison of Case 1, 3 and 4

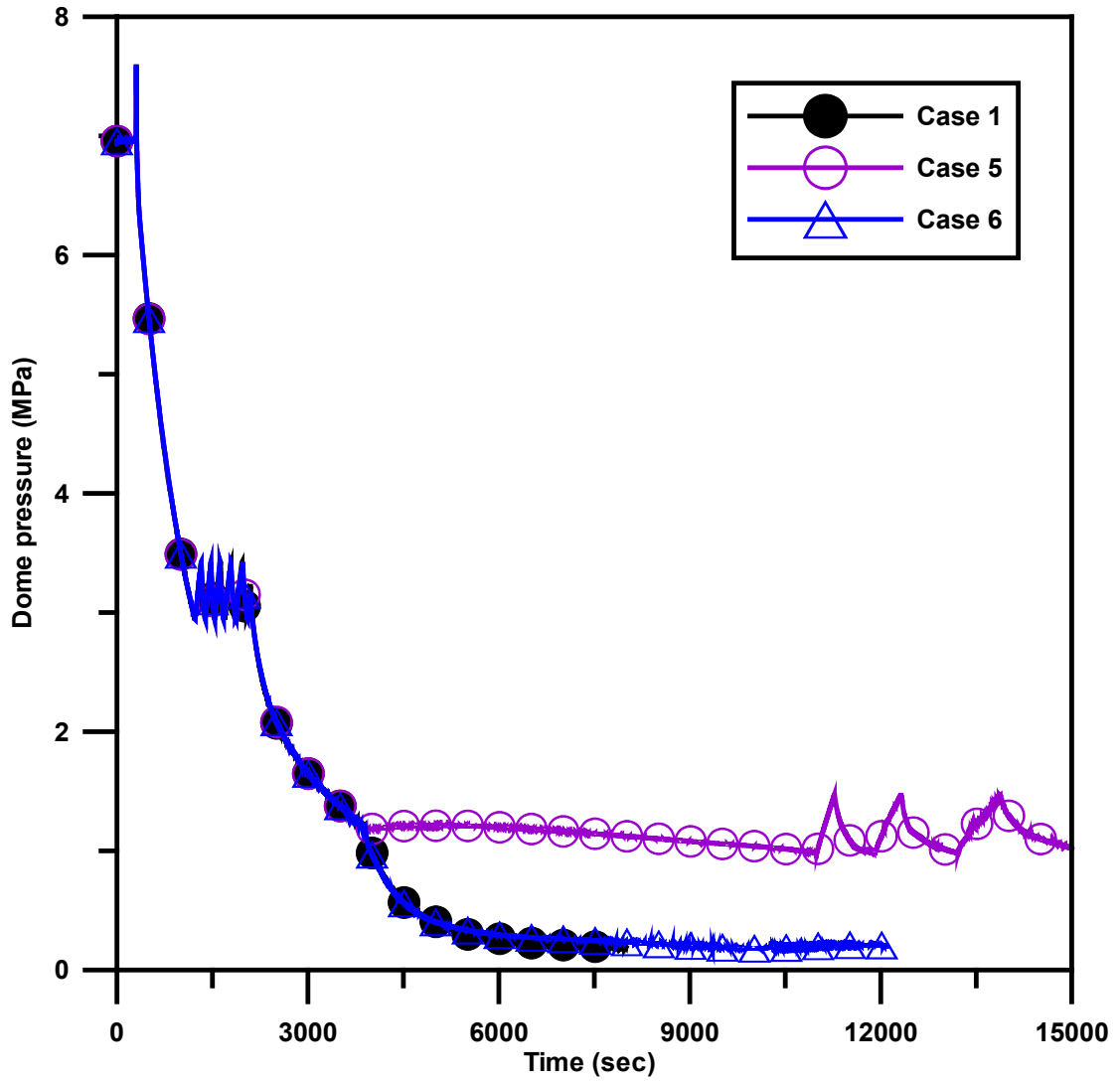

Figure 25 The Dome Pressure Comparison of Case 1, 5 and 6

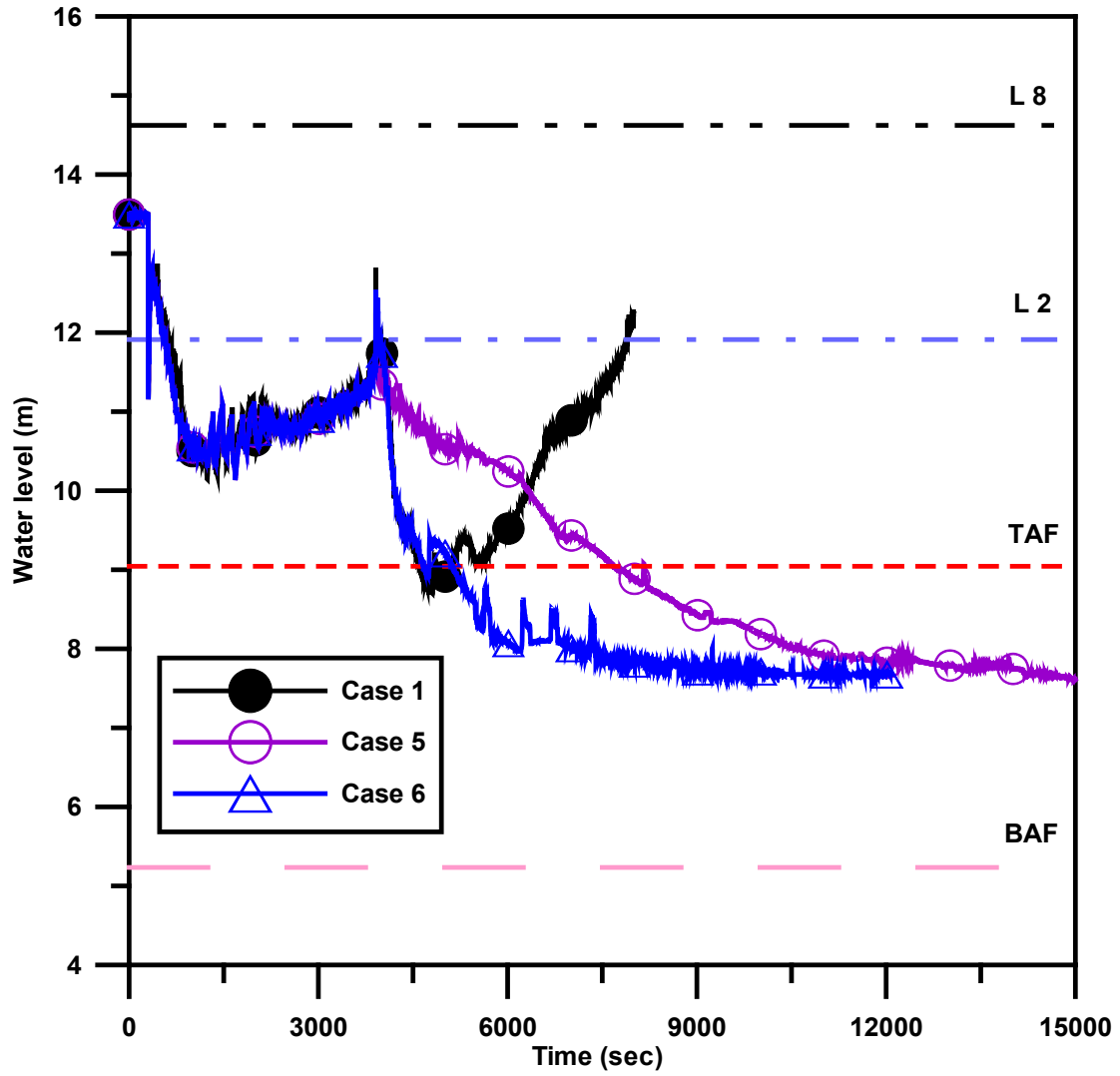

Figure 26 The Water Level Comparison of Case 1, 5 and 6

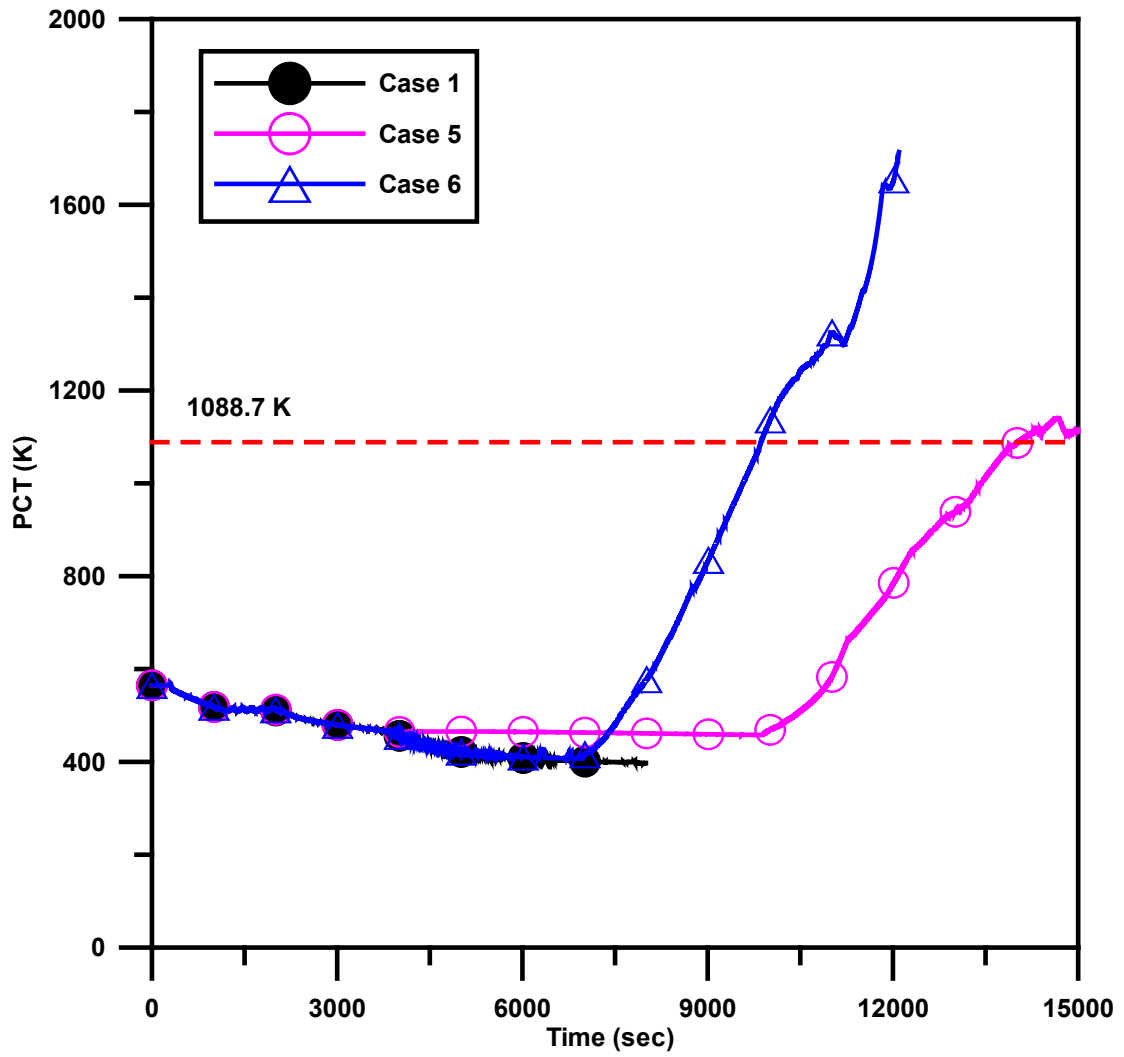

Figure 27 The PCT Comparison of Case 1, 5 and 6

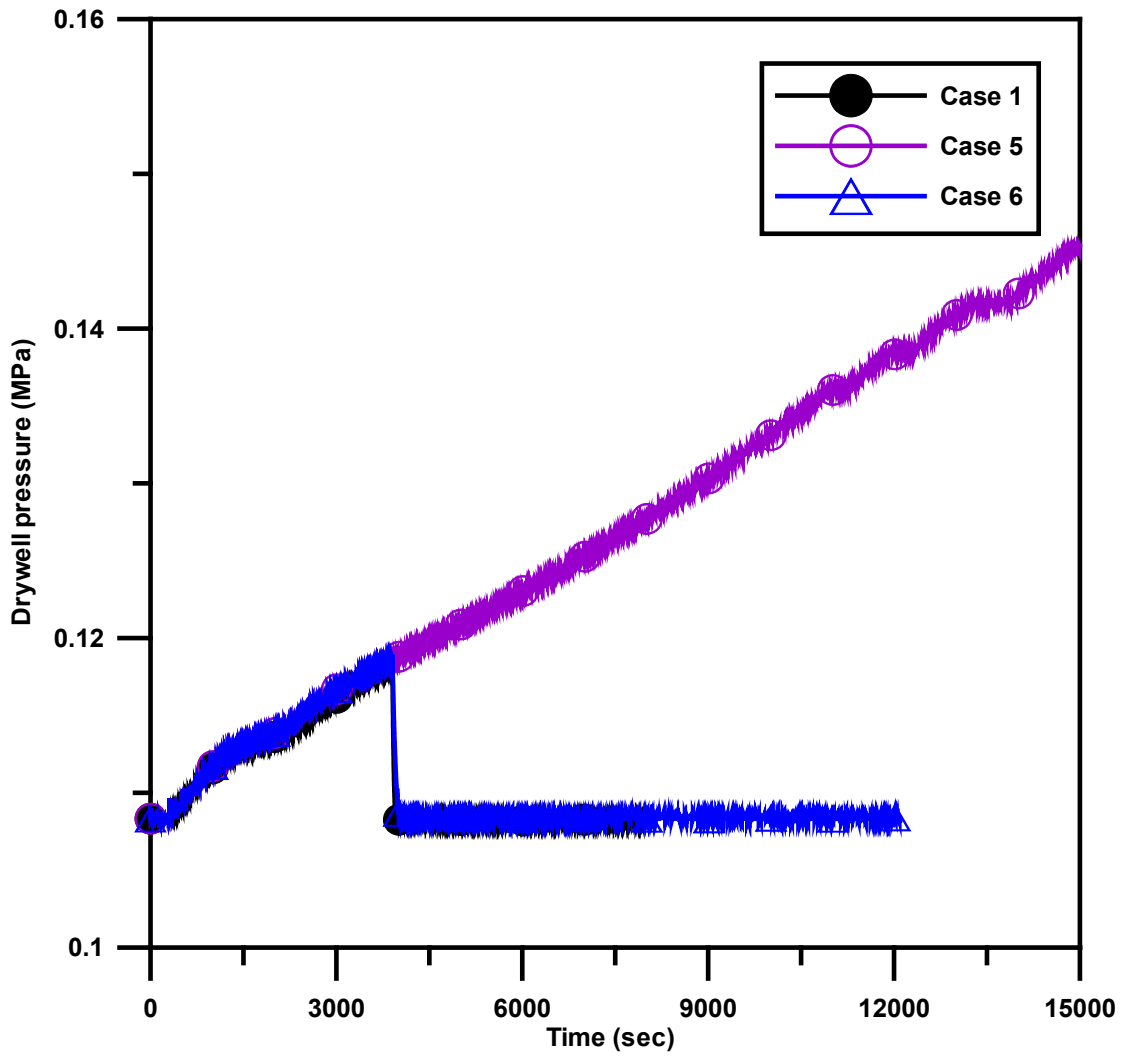

Figure 28 The Drywell Pressure Comparison of Case 1, 5 and 6

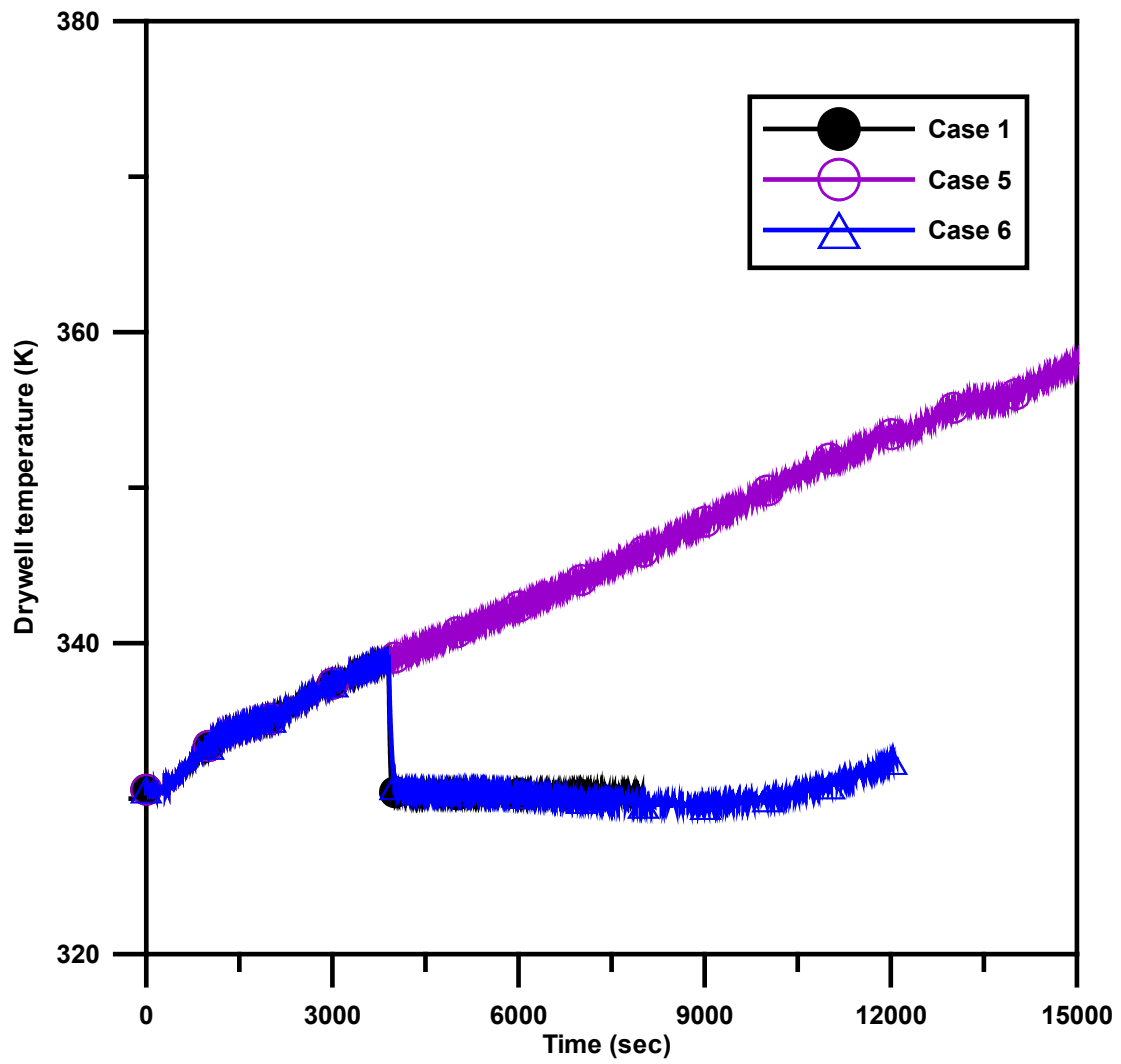

Figure 29 The Drywell Temperature Comparison of Case 1, 5 and 6

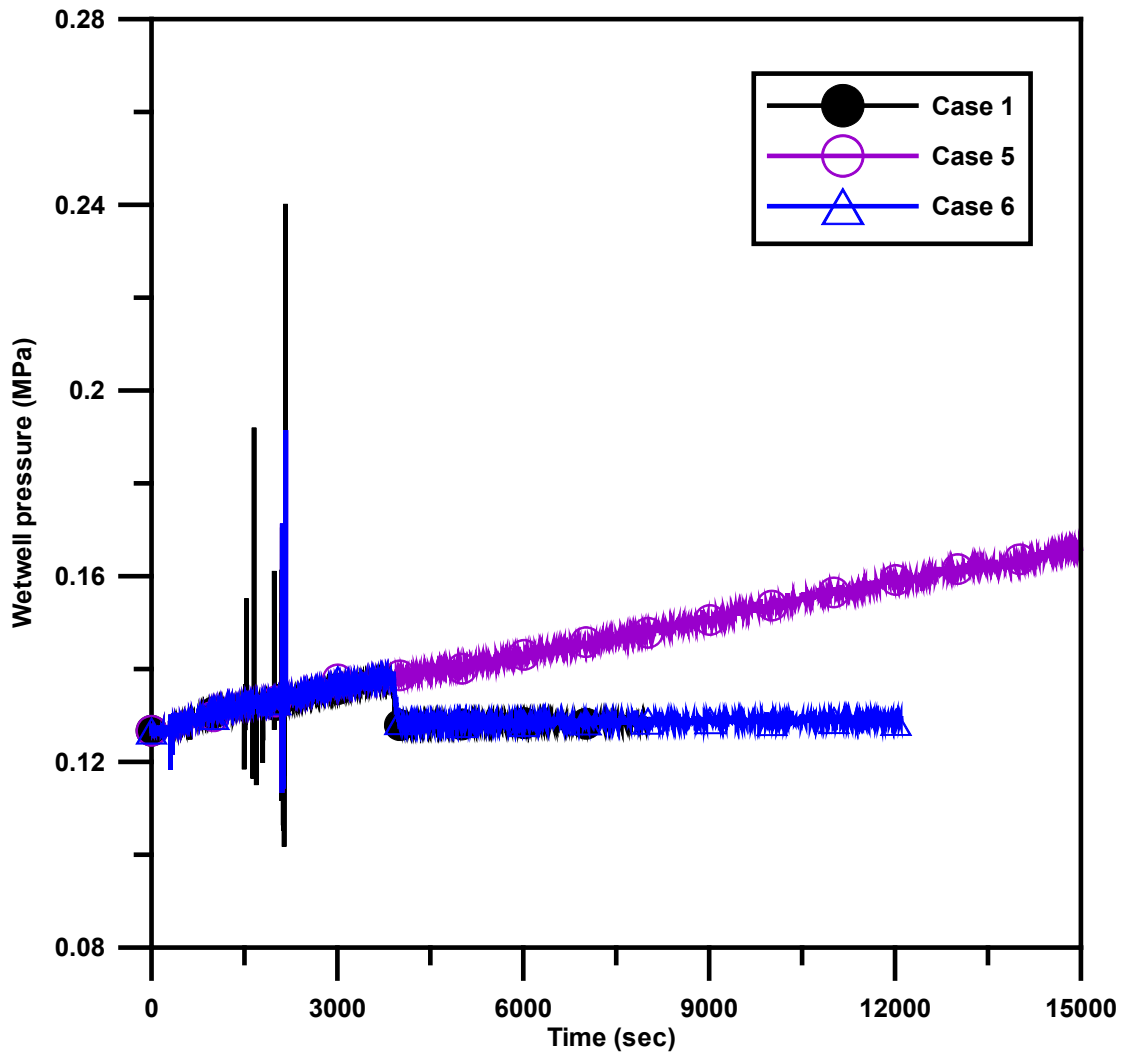

Figure 30 The Wetwell Pressure Comparison of Case 1, 5 and 6

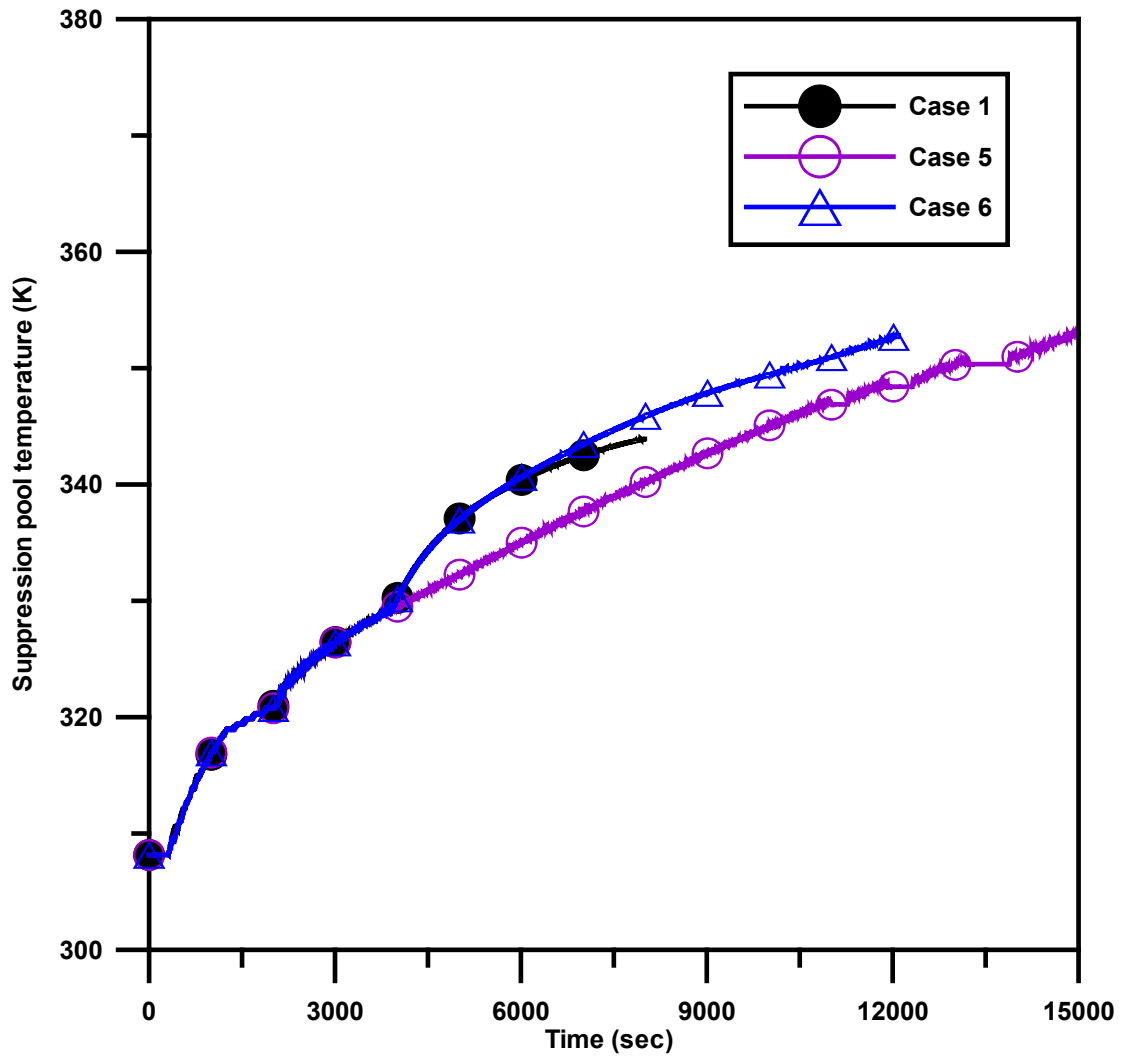

Figure 31 The Suppression Pool Temperature Comparison of Case 1, 5 and 6

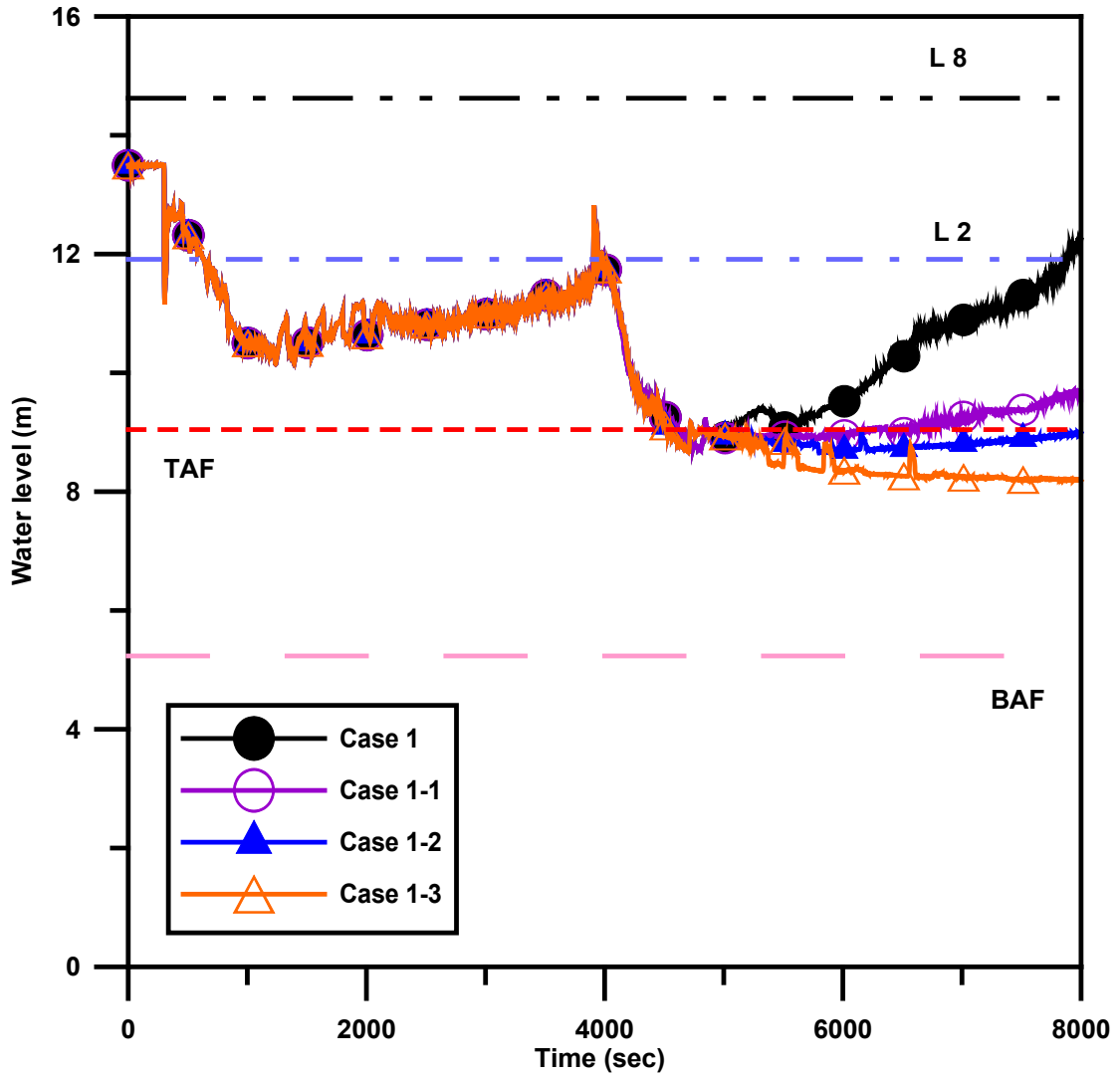

Figure 32 The Water Level Results for The Sensitivity Study

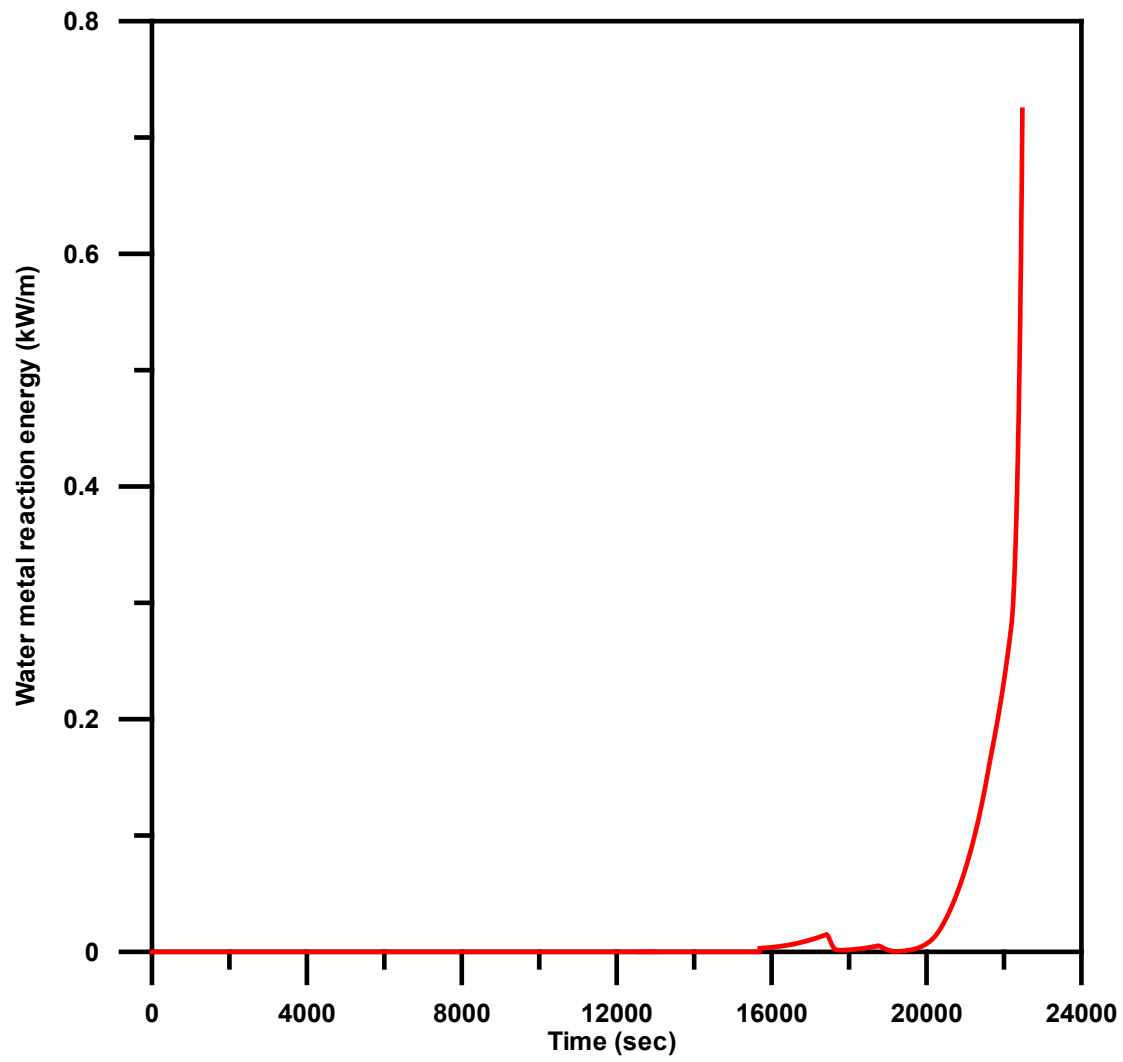

Figure 33 The Water Metal Reaction Energy Result of FRAPTRAN for Case 2

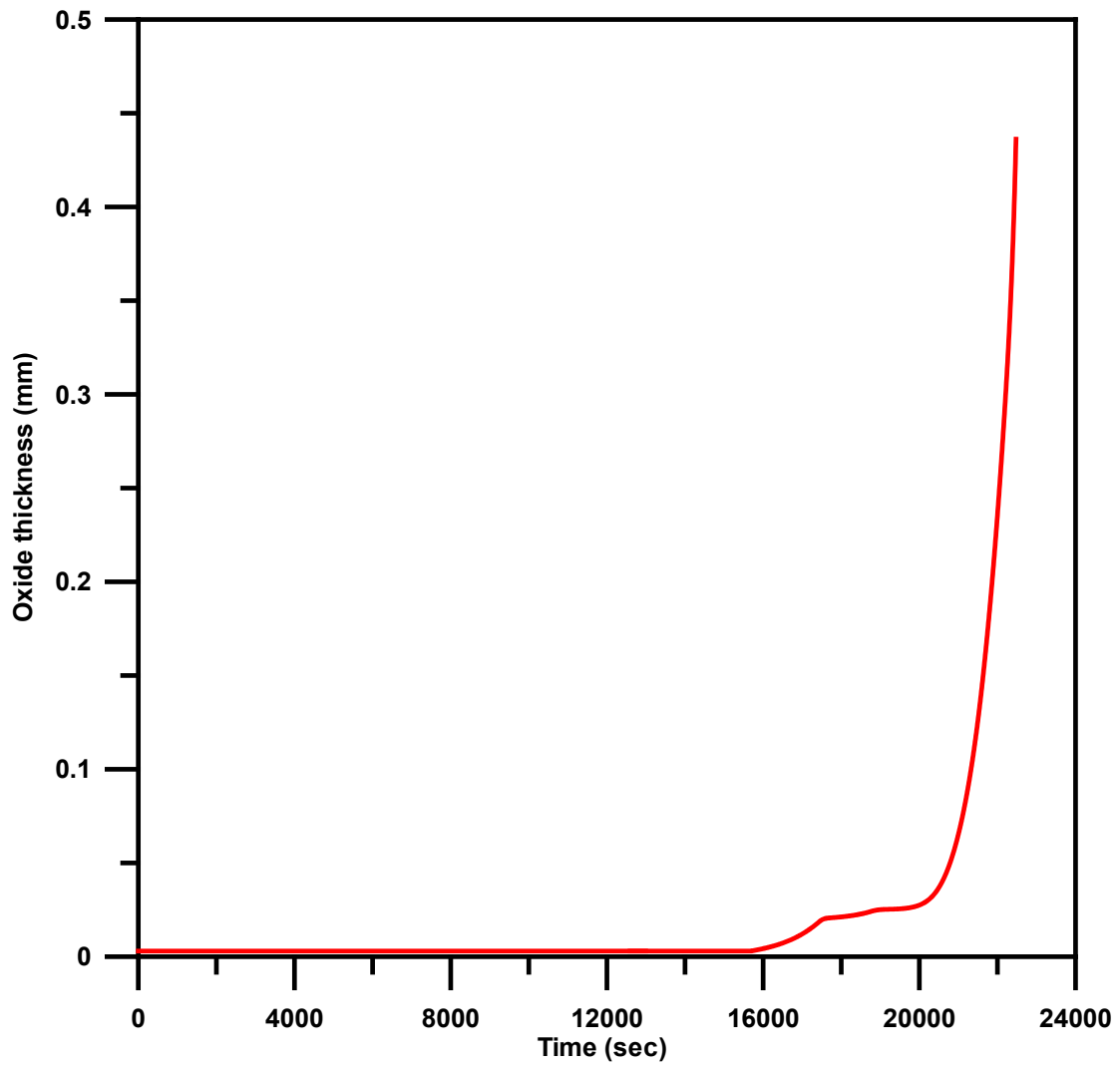

Figure 34 The Oxide Thickness Result of FRAPTRAN for Case 2

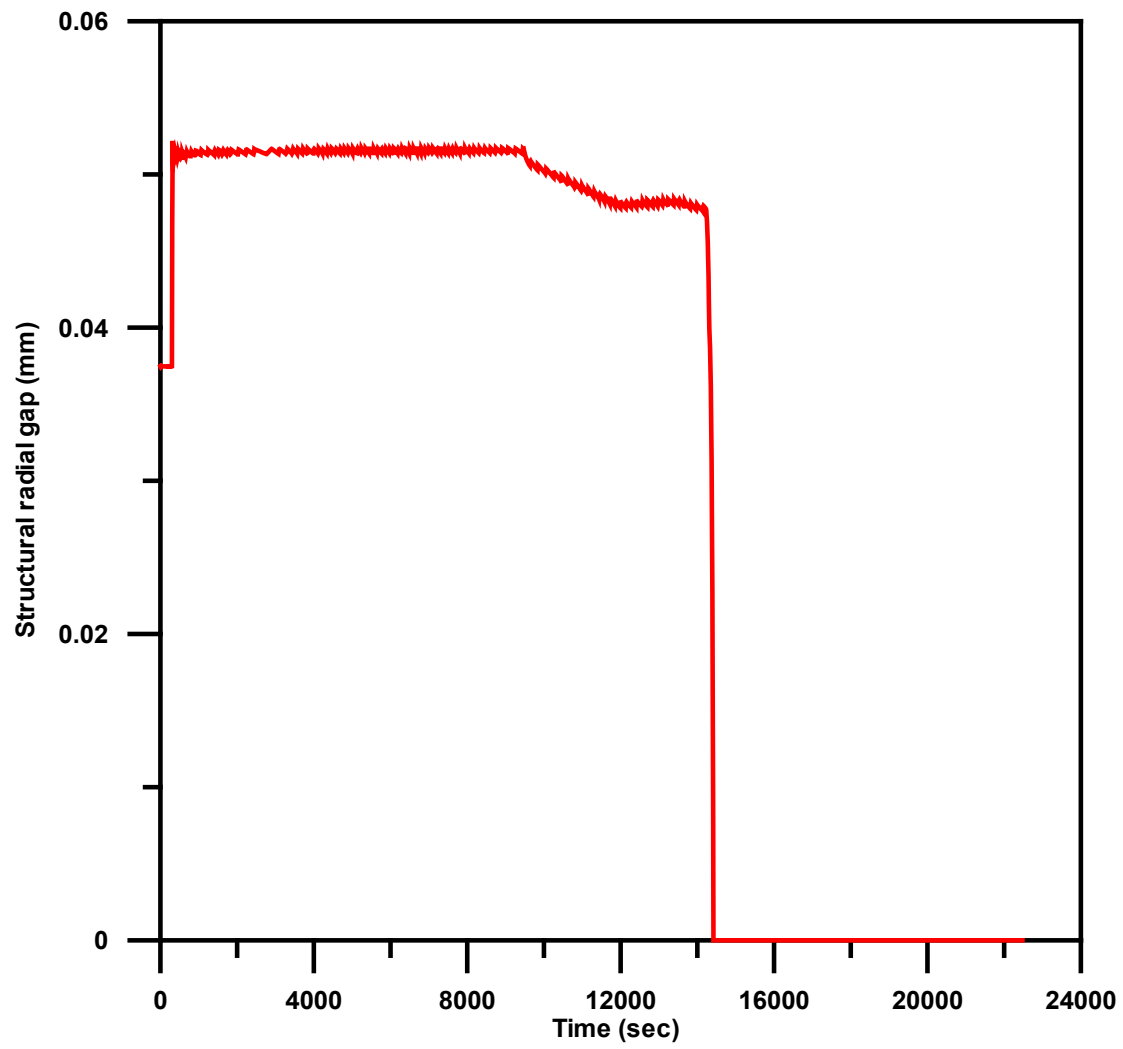

Figure 35 The Structural Radial Gap Result of Fraptran for Case 2

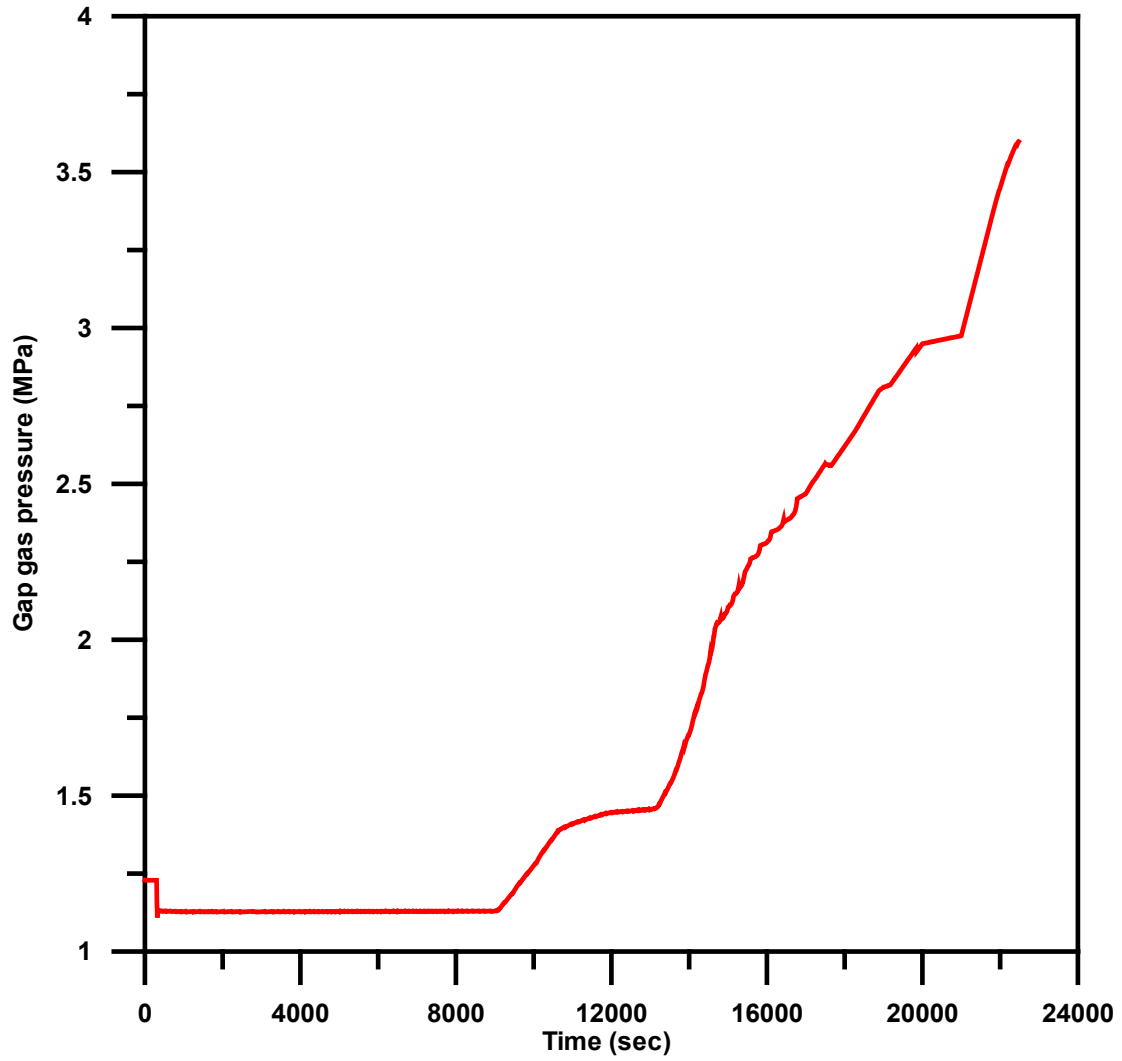

Figure 36 The Gap Gas Pressure Result of FRAPTRAN for Case 2

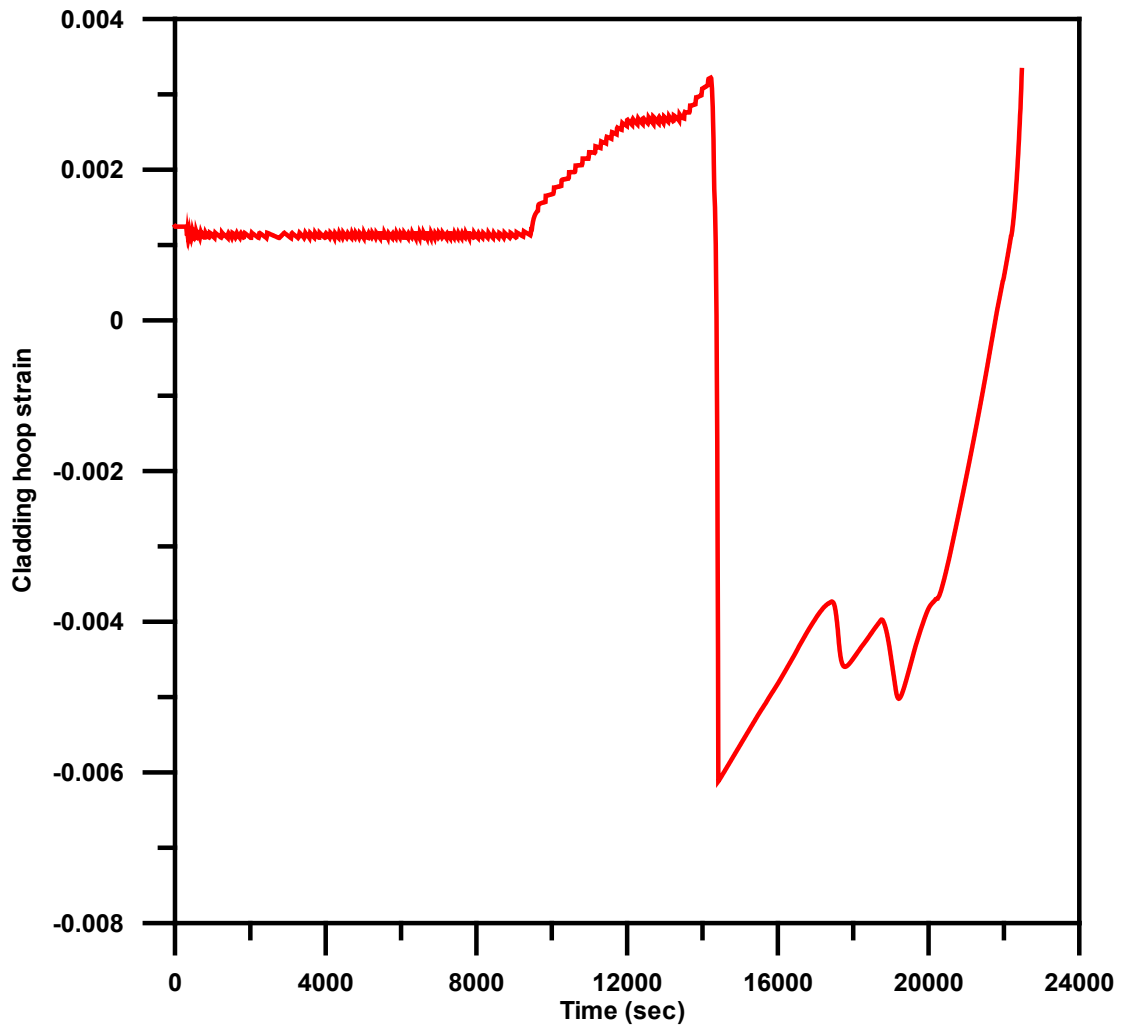

Figure 37 The Cladding Hoop Strain Result of FRAPTRAN for Case 2

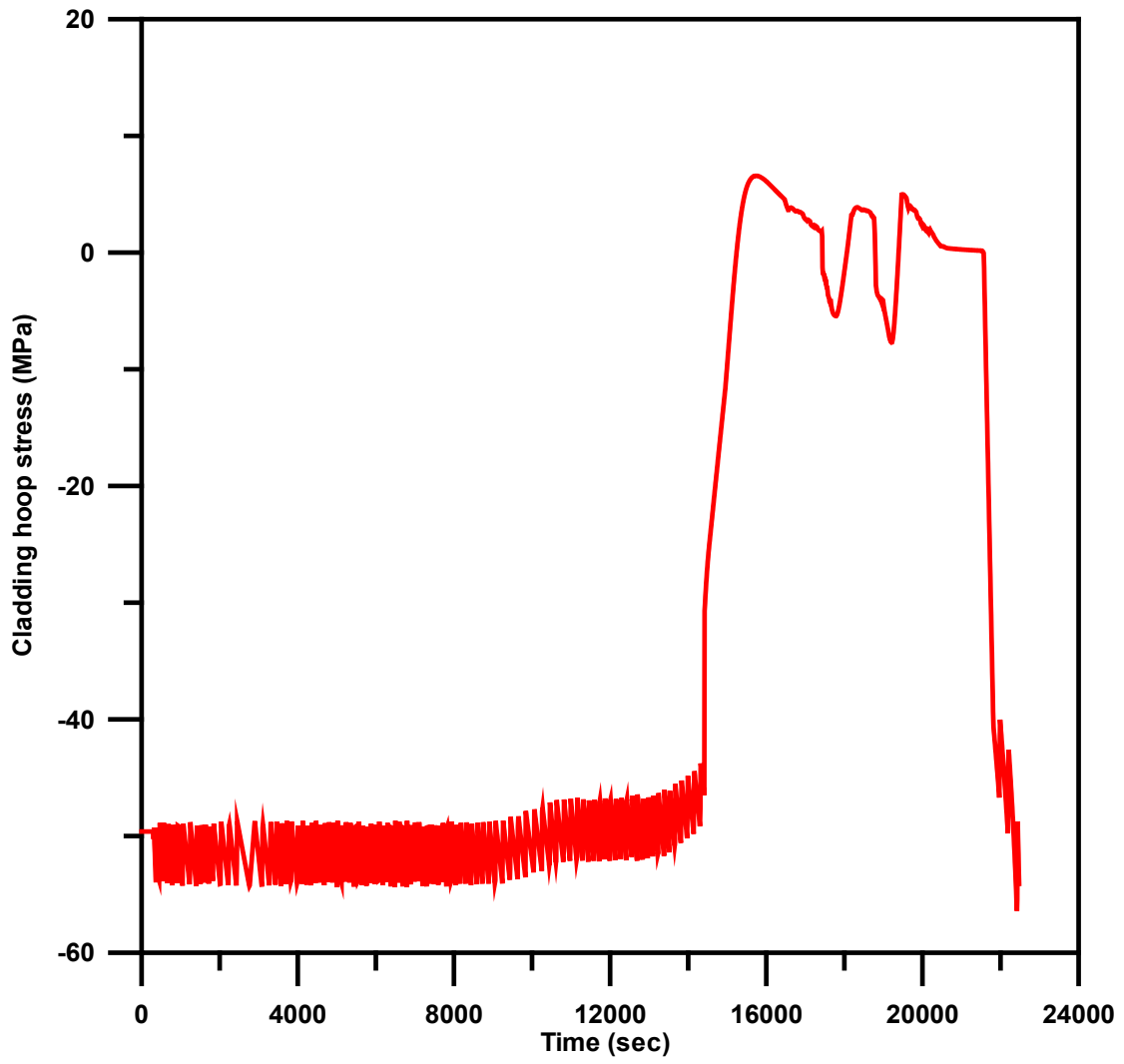

Figure 38 The Cladding Hoop Stress Result of FRAPTRAN for Case 2

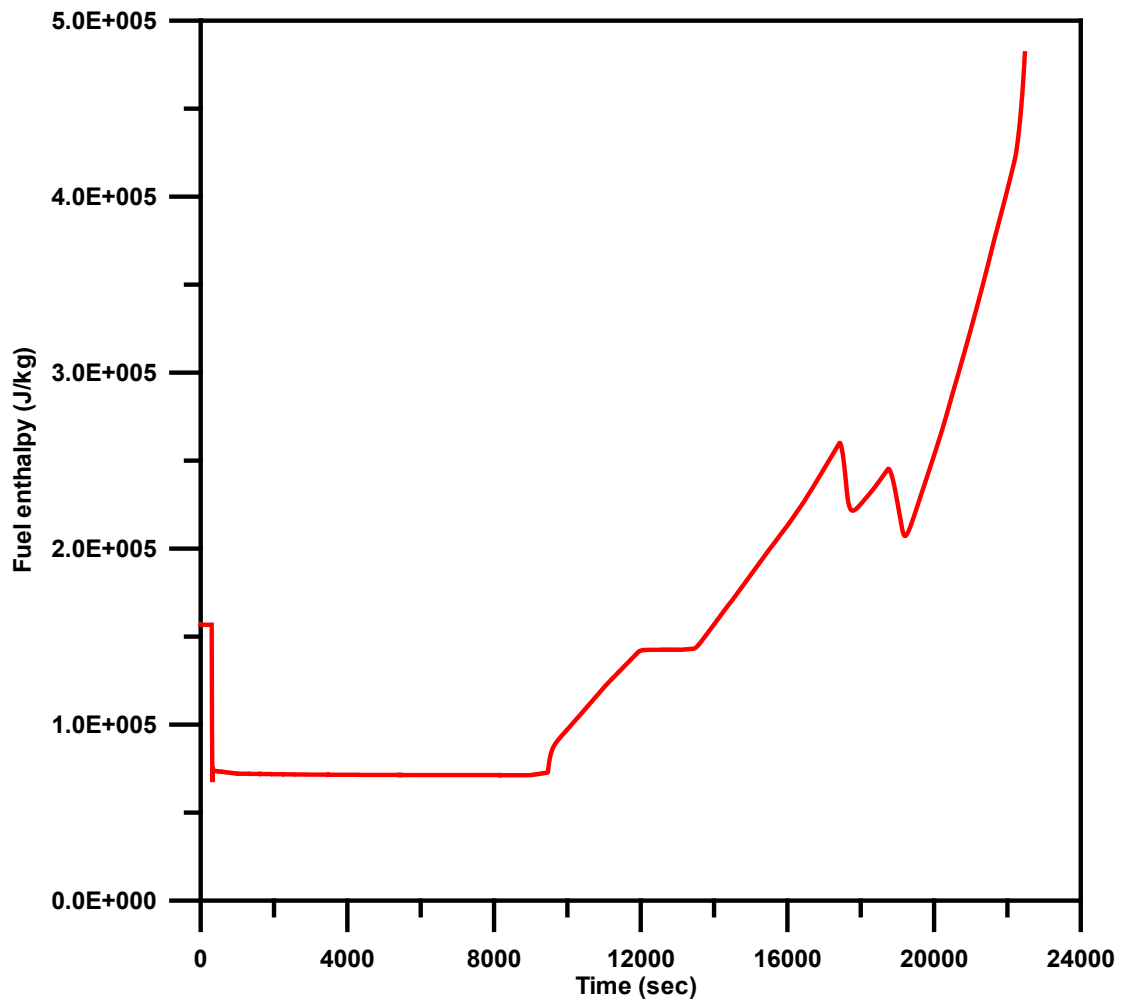

Figure 39 The Fuel Enthalpy Result of FRAPTRAN for Case 2

5 CONCLUSIONS

This research focuses on the establishment of the Chinshan NPP TRACE/SNAP model. The startup test (load rejection transient) and FSAR (turbine trip without bypass valve transient) data were used to compare with the results of TRACE. The compared results indicate that the trends of parameters are similar. By the above compared results, it depicts that there is a respectable accuracy in Chinshan NPP TRACE/SNAP model and it also shows that Chinshan NPP TRACE/SNAP model is satisfying for the purpose of Chinshan NPP safety analyses with confidence.

This study used the above model to estimate the effectiveness of URG for Chinshan NPP. TRACE analysis results show that the URG can keep the PCT below the criteria 1088.7 K under Fukushima-like conditions. It indicates that Chinshan NPP is at the safe situation. On the sensitivity study of URG, the summary is as follows:

- In no water injection cases, if the controlled and fully depressurization of reactor are both performed, its PCT will increase faster than the no depressurization case.
- The set-up of raw water must be finished as fast as possible. If RCIC is unavailable, Chinshan NPP can perform the fully depressurization of the reactor immediately and inject the low pressure water to the reactor.
- The controlled depressurization should be performed before the fully depressurization. It can mitigate the dropping of the water level when Chinshan NPP runs the fully depressurization.
- The required raw water injection must be larger than 14.18 kg/sec.
- In all cases, the results of TRACE did not reach the criteria (0.487 MPa and 444.26 K) of containment. It indicates that the safety issue may occur in the reactor core earlier than in the containment.

Additionally, the results of FRAPTRAN also show that the integrity of fuel was not kept for Case 2.

6 REFERENCES

- [1] Taiwan Power Company, 2012. Chinshan nuclear power plant ultimate response guideline, No. 1451.
- [2] Liang, K.S., Chiang, S.C., Hsu, Y.F., Young, H.J., Pei, B.S., Wang, L.C., 2012. The ultimate emergency measures to secure a NPP under an accidental condition with no designed power or water supply. Nucl. Eng. Des. 253, 259-268.
- [3] Liu, K.H., Hwang, S.L., 2012. Human performance evaluation: The procedures of ultimate response guideline for nuclear power plants. Nucl. Eng. Des. 253, 259-268.
- [4] U.S. NRC, 2014. TRACE V5.840 user's manual.
- [5] U.S. NRC, 2010. TRACE V5.0 assessment manual.
- [6] Mascari, F., Vella, G., Woods, B.G., Welter, K., Pottorf, J., Young, E., Adorni, M., D'auria, F., 2011. Sensitivity analysis of the MASLWR helical coil steam generator using TRACE. Nucl. Eng. Des. 241, 1137-1144.
- [7] Freixa, J., Manera, A., 2011. Verification of a TRACE EPRTM model on the basis of a scaling calculation of an SBLOCA ROSA test. Nucl. Eng. Des. 241, 888-896.
- [8] Nikitin, K., Manera, A., 2011. Analysis of an ADS spurious opening event at a BWR/6 by means of the TRACE code. Nucl. Eng. Des. 241, 2240-2247.
- [9] Pollman, A., Vierow, K., di Marzo, M., 2012. Analysis of rapid-condensation transient using TRACE. Nucl. Eng. Des. 250, 512-519.
- [10] Berar, O.-A., Prošek, A., Mavko, B., 2013. RELAP5 and TRACE assessment of the Achilles natural reflood experiment. Nucl. Eng. Des. 261, 306-316.
- [11] Papini, D., Adamsson, C., Andreani, M., Prasser, H.-M., 2014. Assessment of GOTHIC and TRACE codes against selected PANDA experiments on a passive containment condenser. Nucl. Eng. Des. 278, 542-557.
- [12] Mikuž, B., Tiselj, I., Beyer, M., Lucas, D., 2015. Simulations of flashing experiments in TOPFLOW facility with TRACE code. Nucl. Eng. Des. 283, 60-70.
- [13] Taiwan Power Company, 1999. Final safety analysis report for Chinshan nuclear power station units 1&2.
- [14] Wang, J.R., Jang, S.C., Chen, B.S., Wang S.F., 1989. Chinshan nuclear power plant startup test documentation. INER report, INER-T1322.
- [15] U.S. NRC, 2011. 10CFR50.46c, ML110970044.
- [16] U.S. NRC, 2007. Standard review plan, NUREG-0800.

<p>NRC FORM 335 (12-2010) NRCMD 3.7</p> <p style="text-align: center;">U.S. NUCLEAR REGULATORY COMMISSION</p> <p style="text-align: center;">BIBLIOGRAPHIC DATA SHEET <i>(See instructions on the reverse)</i></p>	<p>1. REPORT NUMBER (Assigned by NRC, Add Vol., Supp., Rev., and Addendum Numbers, if any.)</p> <p style="text-align: center;">NUREG/IA-0478</p>				
<p>2. TITLE AND SUBTITLE</p> <p style="text-align: center;">TRACE/SNAP Model Establishment of Chinshan Nuclear Power Plant for Ultimate Response Guideline</p>	<p>3. DATE REPORT PUBLISHED</p> <table border="1" style="width: 100%;"> <tr> <td style="width: 50%;">MONTH</td> <td style="width: 50%;">YEAR</td> </tr> <tr> <td style="text-align: center;">May</td> <td style="text-align: center;">2017</td> </tr> </table> <p>4. FIN OR GRANT NUMBER</p>	MONTH	YEAR	May	2017
MONTH	YEAR				
May	2017				
<p>5. AUTHOR(S)</p> <p>Jong-Rong Wang*, Chunkuan Shih*, Jung-Hua Yang*, Hsiung-Chih Chen*, Shao-Wen Chen*, Show-Chyuan Chiang**, Tzu-Yao Yu**</p>	<p>6. TYPE OF REPORT</p> <p style="text-align: center;">Technical</p> <p>7. PERIOD COVERED (Inclusive Dates)</p>				
<p>8. PERFORMING ORGANIZATION - NAME AND ADDRESS (If NRC, provide Division, Office or Region, U. S. Nuclear Regulatory Commission, and mailing address; if contractor, provide name and mailing address.)</p> <table style="width: 100%;"> <tr> <td style="width: 50%;"> <p>*Institute of Nuclear Engineering and Science, National Tsing Hua University; Nuclear and New Energy Education and Research Foundation 101 Section 2, Kuang Fu Rd., HsinChu, Taiwan</p> </td> <td style="width: 50%;"> <p>**Department of Nuclear Safety, Taiwan Power Company 242, Section 3, Roosevelt Rd., Zhongzheng District, Taipei, Taiwan</p> </td> </tr> </table>		<p>*Institute of Nuclear Engineering and Science, National Tsing Hua University; Nuclear and New Energy Education and Research Foundation 101 Section 2, Kuang Fu Rd., HsinChu, Taiwan</p>	<p>**Department of Nuclear Safety, Taiwan Power Company 242, Section 3, Roosevelt Rd., Zhongzheng District, Taipei, Taiwan</p>		
<p>*Institute of Nuclear Engineering and Science, National Tsing Hua University; Nuclear and New Energy Education and Research Foundation 101 Section 2, Kuang Fu Rd., HsinChu, Taiwan</p>	<p>**Department of Nuclear Safety, Taiwan Power Company 242, Section 3, Roosevelt Rd., Zhongzheng District, Taipei, Taiwan</p>				
<p>9. SPONSORING ORGANIZATION - NAME AND ADDRESS (If NRC, type "Same as above", if contractor, provide NRC Division, Office or Region, U. S. Nuclear Regulatory Commission, and mailing address.)</p> <p>Division of Systems Analysis Office of Nuclear Regulatory Research U.S. Nuclear Regulatory Commission Washington, DC 20555-0001</p>					
<p>10. SUPPLEMENTARY NOTES</p> <p>K. Tien, NRC Project Manager</p>					
<p>11. ABSTRACT (200 words or less)</p> <p>In this research, the TRACE/SNAP model of Chinshan BWR/4 nuclear power plant (NPP) was established for the simulation and analysis of ultimate response guideline (URG). The main actions of URG are the depressurization and low pressure water injection of the reactor and containment venting. This research focuses to assess the URG utility of Chinshan NPP under Fukushima-like conditions. This study consists of three steps. The first step is the establishment of Chinshan NPP TRACE/SNAP model. In order to evaluate the system response of TRACE/SNAP model, startup tests and FSAR data were used to compare with the results of TRACE. The second step is the URG simulation and analysis under Fukushima-like conditions by using Chinshan NPP TRACE/SNAP model. In this step, the no URG case was also performed in order to evaluate the URG effectiveness of Chinshan NPP. In addition, the sensitivity study of URG and the required raw water injection were also performed. According to TRACE analysis results, the URG can keep the peak cladding temperature (PCT) below the criteria 1088.7 K under Fukushima-like conditions. It indicates that Chinshan NPP can be controlled in a safe situation. If Chinshan NPP does not perform the URG under Fukushima-like conditions, the water level may drop lower than TAF (top of active fuel) which means a safety issue about the fuel rods may be generated. In order to confirm the mechanical property and integrity of fuel rods, the final step is the analysis of FRAPTRAN.</p>					
<p>12. KEY WORDS/DESCRIPTORS (List words or phrases that will assist researchers in locating the report.)</p> <p>Ultimate Response Guideline (URG) Fukushima-like Events TRACE/SNAP/FRAPTRAN Peak Cladding Temperature (PCT) Top of Active Fuel (TAF) Chinshan Nuclear Power Plant (NPP)</p>	<p>13. AVAILABILITY STATEMENT</p> <p style="text-align: center;">unlimited</p> <p>14. SECURITY CLASSIFICATION</p> <p style="text-align: center;"><i>(This Page)</i> unclassified</p> <p style="text-align: center;"><i>(This Report)</i> unclassified</p> <p>15. NUMBER OF PAGES</p> <p>16. PRICE</p>				

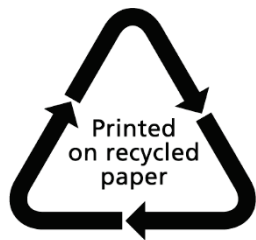

Federal Recycling Program



UNITED STATES
NUCLEAR REGULATORY COMMISSION
WASHINGTON, DC 20555-0001

OFFICIAL BUSINESS



NUREG/IA-0478

**TRACE/SNAP Model Establishment of Chinshan Nuclear Power Plant for Ultimate Response
Guideline**

May 2017