



April 28, 2017
Docket No. 50-443
SBK-L-17072

U.S. Nuclear Regulatory Commission
Attn.: Document Control Desk
Washington, DC 20555-0001

Seabrook Station
2016 Annual Radioactive Effluent Release Report

Pursuant to 10CFR 50.36a (a).2 and Technical Specification 6.8.1.4, NextEra Energy Seabrook, LLC submits the Annual Radioactive Effluent Release Report for 2016. A copy of the Offsite Dose Calculation Manual (ODCM) is also provided pursuant to Technical Specification 6.13.c. A summary of the changes to the ODCM is included in Enclosure 1, Appendix A.

The following information is provided in the enclosures:

- | | |
|-------------|--|
| Enclosure 1 | Effluent release data as required by Regulatory Guide 1.21 |
| Enclosure 2 | Joint frequency distributions of wind speed, wind direction, and atmospheric stability |
| Enclosure 3 | Radiation dose assessment |
| Enclosure 4 | Offsite Dose Calculation Manual (ODCM), Revision 37 |

Should you have any questions regarding this letter, please contact David Robinson, Chemistry Department Manager, at (603) 773-7496.

Sincerely,

NextEra Energy Seabrook, LLC

A handwritten signature in blue ink, appearing to be "KB", written over a horizontal line.

Kenneth Browne
Licensing Manager

cc: NRC Region I Administrator
NRC Project Manager, Project Directorate I-2
NRC Senior Resident Inspector
B. Dionne, Region I Inspector
Seth Breitmaier, American Nuclear Insurers

Enclosure 1

Effluent Release Data
as Required by Regulatory Guide 1.21

EFFLUENT AND WASTE DISPOSAL ANNUAL REPORT
Supplemental Information 2016

Facility: Seabrook Station Unit 1 Licensee: NextEra Energy
Seabrook, LLC

1. Regulatory Limits

A. Gaseous Effluents

- a. 5.0 mrad per quarter gamma air dose.
- b. 10.0 mrad per quarter beta air dose.
- c. 7.5 mrem per quarter to any organ.

B. Liquid Effluents

- a. 1.5 mrem per quarter total body.
- b. 5.0 mrem per quarter any organ.
- c. 2.0 E-04 $\mu\text{Ci/ml}$ dissolved or entrained gas.

2. Effluent Concentration Limits

Provide the ECL's used in determining allowable release rates or concentrations.

- a. Fission and activation gases: 10 ECL
- b. Iodines: 10 ECL
- c. Particulates, half-lives >8 days: 10 ECL
- d. Liquid Effluents: 10 ECL

3. Average Energy

Not applicable

4. Measurements and Approximations of Total Radioactivity

Provide the methods used to measure or approximate the total radioactivity in effluents and the methods used to determine radionuclide composition.

- A. Fission and activation gases: Determined by gamma spectroscopy. Total error is based on stack flow error, analytical error, and calculated sampling error.
- B. Iodines: Determined by collection on charcoal with subsequent gamma spectroscopy analysis. Total error is based on stack flow error, analytical error, and calculated sampling error.

- C. Particulates: Determined by collection on fixed filter with subsequent gamma spectroscopy analysis. Strontium is determined by composite analysis of filters by liquid scintillation, gross alpha by proportional counter and iron 55 by liquid scintillation. Total error is based on stack flow error, analytical error, and calculated sampling error.
- D. Liquid Effluents: Determined by gamma spectroscopy. A composite sample is analyzed for strontium by liquid scintillation, tritium by liquid scintillation, gross alpha by proportional counter and iron 55 by liquid scintillation. Total error is based on the volume discharge error and analytical error.
- E. ND: None Detected or No Detectable Activity

5. Batch Releases

Provide the following information relating to batch releases of radioactive materials in liquid and gaseous effluents.

A. Liquid

- a. Number of batch releases: 76
- b. Total time for batch releases: 16517 minutes
- c. Maximum time period for batch release: 574 minutes
- d. Average time period for batch release: 217 minutes
- e. Minimum time period for batch release: 64 minutes
- f. Average stream flow during periods of release of effluents into a flowing stream: 1.68 E+06 liters per minute

B. Gaseous

- a. Number of batch releases: 26
- b. Total time for batch releases: 6045 minutes
- c. Maximum time period for batch release: 5283 minutes
- d. Average time period for batch release: 233 minutes
- e. Minimum time period for batch release: 4 minute

6. Abnormal Releases

A. Liquid

- a. Number of releases: 0
- b. Total activity released: N/A

B. Gaseous

- a. Number of releases: 0
- b. Total activity released: N/A

TABLE 1A
EFFLUENT AND WASTE DISPOSAL ANNUAL REPORT 2016
GASEOUS EFFLUENTS-SUMMATION OF ALL RELEASES

Unit	Quarter 1	Quarter 2	Quarter 3	Quarter 4	Est. Total Error, %
------	-----------	-----------	-----------	-----------	---------------------

A. Fission and activation gases

1. Total releases	Ci	3.99E-03	3.14E-03	2.74E-03	2.83E-03	1.70E+01
2. Average release rate for period	uCi/sec	5.07E-04	4.00E-04	3.45E-04	3.56E-04	
3. Percent of applicable Technical Specification limit	%	1.27E-04	1.09E-04	5.14E-05	2.98E-05	

B. Iodines

1. Total release	Ci	ND	ND	ND	ND	1.50E+01
2. Average release rate for period	uCi/sec	N/A	N/A	N/A	N/A	
3. Percent of applicable Technical Specification limit	%	N/A	N/A	N/A	N/A	

C. Particulates

1. Total release	Ci	2.05E+00	5.02E+00	3.13E+00	1.86E+00	1.80E+01
2. Average release rate for period	uCi/sec	2.61E-01	6.38E-01	3.94E-01	2.34E-01	
3. Percent of applicable Technical Specification limit	%	1.44E-01	2.04E-01	1.79E-01	4.33E-01	
4. Total alpha radioactivity	Ci	ND	ND	ND	ND	

D. Tritium

1. Total release	Ci	9.76E+00	1.49E+01	1.32E+01	3.21E+01	1.60E+01
2. Average release rate for period	uCi/sec	1.24E+00	1.89E+00	1.66E+00	4.03E+00	
3. Percent of applicable Technical Specification limit	%	1.44E-01	2.04E-01	1.79E-01	4.33E-01	

TABLE 1B
EFFLUENT AND WASTE DISPOSAL ANNUAL REPORT 2016
GASEOUS EFFLUENTS-ELEVATED RELEASES
BATCH

Nuclides Released	Unit	Quarter 1	Quarter 2	Quarter 3	Quarter 4
-------------------	------	--------------	--------------	--------------	--------------

1. Fission and activation gases

argon-41	Ci	3.69E-03	3.13E-03	2.70E-03	2.68E-03
krypton-85	Ci	ND	ND	ND	ND
krypton-85m	Ci	ND	ND	ND	ND
krypton-87	Ci	ND	ND	ND	ND
krypton-88	Ci	ND	ND	ND	ND
xenon-131m	Ci	ND	ND	ND	ND
xenon-133	Ci	ND	1.20E-05	ND	ND
xenon-133m	Ci	ND	ND	ND	ND
xenon-135	Ci	ND	ND	3.97E-05	1.52E-04
xenon-135m	Ci	3.01E-04	ND	ND	ND
xenon-138	Ci	ND	ND	ND	ND
	Ci				
unidentified	Ci	ND	ND	ND	ND
Total for period	Ci	3.99E-03	3.14E-03	2.74E-03	2.83E-03

2. Iodines

iodine-131	Ci	ND	ND	ND	ND
iodine-132	Ci	ND	ND	ND	ND
iodine-133	Ci	ND	ND	ND	ND
iodine-135	Ci	ND	ND	ND	ND
Total for period	Ci	0.00E+00	0.00E+00	0.00E+00	0.00E+00

3. Particulates

strontium-89	Ci	ND	ND	ND	ND
strontium-90	Ci	ND	ND	ND	ND
cesium-134	Ci	ND	ND	ND	ND
cesium-137	Ci	ND	ND	ND	ND
barium-lanthanum-140	Ci	ND	ND	ND	ND
	Ci				
unidentified	Ci	ND	ND	ND	ND
Total for period	Ci	0.00E+00	0.00E+00	0.00E+00	0.00E+00

TABLE 1B
EFFLUENT AND WASTE DISPOSAL ANNUAL REPORT 2016
GASEOUS EFFLUENTS-ELEVATED RELEASES
CONTINUOUS

Nuclides Released	Unit	Quarter 1	Quarter 2	Quarter 3	Quarter 4
-------------------	------	--------------	--------------	--------------	--------------

1. Fission and activation gases

argon-41	Ci	ND	ND	ND	ND
krypton-85	Ci	ND	ND	ND	ND
krypton-85m	Ci	ND	ND	ND	ND
krypton-87	Ci	ND	ND	ND	ND
krypton-88	Ci	ND	ND	ND	ND
xenon-131m	Ci	ND	ND	ND	ND
xenon-133	Ci	ND	ND	ND	ND
xenon-133m	Ci	ND	ND	ND	ND
xenon-135	Ci	ND	ND	ND	ND
xenon-135m	Ci	ND	ND	ND	ND
xenon-138	Ci	ND	ND	ND	ND
	Ci				
	Ci				
unidentified	Ci	ND	ND	ND	ND
Total for period	Ci	0.00E+00	0.00E+00	0.00E+00	0.00E+00

2. Iodines

iodine-131	Ci	ND	ND	ND	ND
iodine-132	Ci	ND	ND	ND	ND
iodine-133	Ci	ND	ND	ND	ND
iodine-135	Ci	ND	ND	ND	ND
Total for period	Ci	0.00E+00	0.00E+00	0.00E+00	0.00E+00

3. Particulates

strontium-89	Ci	ND	ND	ND	ND
strontium-90	Ci	ND	ND	ND	ND
cesium-134	Ci	ND	ND	ND	ND
cesium-137	Ci	ND	ND	ND	ND
barium-lanthanum-140	Ci	ND	ND	ND	ND
cobalt-58	Ci	ND	ND	ND	ND
cobalt-60	Ci	ND	ND	ND	ND
chromium-51	Ci	ND	ND	ND	ND
manganese-54	Ci	ND	ND	ND	ND
niobium-95	Ci	ND	ND	ND	ND
iron-59	Ci	ND	ND	ND	ND
carbon-14	Ci	2.05E+00	5.02E+00	3.13E+00	1.86E+00
unidentified	Ci	ND	ND	ND	ND
Total for period	Ci	2.05E+00	5.02E+00	3.13E+00	1.86E+00

TABLE 1C
EFFLUENT AND WASTE DISPOSAL ANNUAL REPORT 2016
GASEOUS EFFLUENTS-GROUND LEVEL RELEASES

BATCH

Nuclides Released	Unit	Quarter 1	Quarter 2	Quarter 3	Quarter 4
-------------------	------	--------------	--------------	--------------	--------------

1. Fission and activation gases

argon-41	Ci	ND	ND	ND	ND
krypton-85	Ci	ND	ND	ND	ND
krypton-85m	Ci	ND	ND	ND	ND
krypton-87	Ci	ND	ND	ND	ND
krypton-88	Ci	ND	ND	ND	ND
xenon-131m	Ci	ND	ND	ND	ND
xenon-133m	Ci	ND	ND	ND	ND
xenon-133	Ci	ND	ND	ND	ND
xenon-135	Ci	ND	ND	ND	ND
xenon-135m	Ci	ND	ND	ND	ND
xenon-138	Ci	ND	ND	ND	ND
	Ci				
	Ci				
unidentified	Ci	ND	ND	ND	ND
Total for period	Ci	0.00E+00	0.00E+00	0.00E+00	0.00E+00

2. Iodines

iodine-131	Ci	ND	ND	ND	ND
iodine-132	Ci	ND	ND	ND	ND
iodine-133	Ci	ND	ND	ND	ND
iodine-135	Ci	ND	ND	ND	ND
Total for period	Ci	0.00E+00	0.00E+00	0.00E+00	0.00E+00

3. Particulates

strontium-89	Ci	ND	ND	ND	ND
strontium-90	Ci	ND	ND	ND	ND
cesium-134	Ci	ND	ND	ND	ND
cesium-136	Ci	ND	ND	ND	ND
cesium-137	Ci	ND	ND	ND	ND
barium-lanthanum-140	Ci	ND	ND	ND	ND
cobalt-57	Ci	ND	ND	ND	ND
cobalt-58	Ci	ND	ND	ND	ND
cobalt-60	Ci	ND	ND	ND	ND
manganese-54	Ci	ND	ND	ND	ND
iron-59	Ci	ND	ND	ND	ND
niobium/zirconium-95	Ci	ND	ND	ND	ND
chromium-51	Ci	ND	ND	ND	ND
technetium-99m	Ci	ND	ND	ND	ND
bromine-82	Ci	ND	ND	ND	ND
unidentified	Ci	ND	ND	ND	ND
Total for period	Ci	0.00E+00	0.00E+00	0.00E+00	0.00E+00

TABLE 1C
 EFFLUENT AND WASTE DISPOSAL ANNUAL REPORT 2016
 GASEOUS EFFLUENTS-GROUND LEVEL RELEASES
 CONTINUOUS

Nuclides Released	Unit	Quarter 1	Quarter 2	Quarter 3	Quarter 4
-------------------	------	--------------	--------------	--------------	--------------

1. Fission and activation gases

argon-41	Ci	ND	ND	ND	ND
krypton-85	Ci	ND	ND	ND	ND
krypton-85m	Ci	ND	ND	ND	ND
krypton-87	Ci	ND	ND	ND	ND
krypton-88	Ci	ND	ND	ND	ND
xenon-133	Ci	ND	ND	ND	ND
xenon-135	Ci	ND	ND	ND	ND
xenon-135m	Ci	ND	ND	ND	ND
xenon-138	Ci	ND	ND	ND	ND
	Ci				
	Ci				
unidentified	Ci	ND	ND	ND	ND
Total for period	Ci	0.00E+00	0.00E+00	0.00E+00	0.00E+00

2. Iodines

iodine-131	Ci	ND	ND	ND	ND
iodine-133	Ci	ND	ND	ND	ND
	Ci				
Total for period	Ci	0.00E+00	0.00E+00	0.00E+00	0.00E+00

3. Particulates

strontium-89	Ci	ND	ND	ND	ND
strontium-90	Ci	ND	ND	ND	ND
cesium-134	Ci	ND	ND	ND	ND
cesium-136	Ci	ND	ND	ND	ND
cesium-137	Ci	ND	ND	ND	ND
barium-lanthanum-140	Ci	ND	ND	ND	ND
cobalt-58	Ci	ND	ND	ND	ND
cobalt-60	Ci	ND	ND	ND	ND
chromium-51	Ci	ND	ND	ND	ND
unidentified	Ci	ND	ND	ND	ND
Total for period	Ci	0.00E+00	0.00E+00	0.00E+00	0.00E+00

TABLE 2A
 EFFLUENT AND WASTE DISPOSAL ANNUAL REPORT 2016
 LIQUID EFFLUENTS-SUMMATION OF ALL RELEASES

Unit	Quarter 1	Quarter 2	Quarter 3	Quarter 4	Est. Total Error, %
------	-----------	-----------	-----------	-----------	---------------------

A. Fission and activation products

1. Total releases	Ci	6.04E-03	3.41E-03	2.40E-03	1.21E-03	7.00E+00
2. Average diluted concentration during period	uCi/ml	2.86E-11	1.52E-11	1.19E-11	5.76E-12	
3. Percent of applicable limit	%	5.58E-03	4.83E-03	3.57E-03	3.67E-03	

B. Tritium

1. Total release	Ci	1.96E+02	1.93E+02	1.36E+02	1.69E+02	9.00E+00
2. Average diluted concentration during period	uCi/ml	9.28E-07	8.59E-07	6.75E-07	8.08E-07	
3. Percent of applicable limit	%	3.48E-03	1.96E-03	1.36E-03	1.26E-03	

C. Dissolved and entrained gases

1. Total release	Ci	ND	ND	ND	ND	1.90E+01
2. Average diluted concentration during period	uCi/ml	N/A	N/A	N/A	N/A	
3. Percent of applicable limit	%	N/A	N/A	N/A	N/A	

D. Gross alpha radioactivity

1. Total release	Ci	ND	ND	ND	ND	1.00E+01
------------------	----	----	----	----	----	----------

E. Volume of waste released (prior to dilution)	liters	2.97E+07	2.40E+07	1.55E+07	1.49E+07	1.30E+00
F. Volume of dilution water used during period	liters	2.11E+11	2.24E+11	2.02E+11	2.09E+11	9.00E+00

TABLE 2B
EFFLUENT AND WASTE DISPOSAL ANNUAL REPORT 2016
LIQUID EFFLUENTS
CONTINUOUS MODE

Nuclides Released	Unit	Quarter 1	Quarter 2	Quarter 3	Quarter 4
strontium-89	Ci	ND	ND	ND	ND
strontium-90	Ci	ND	ND	ND	ND
cesium-134	Ci	ND	ND	ND	ND
cesium-137	Ci	ND	ND	ND	ND
iodine-131	Ci	ND	ND	ND	ND
iodine-133	Ci	ND	ND	ND	ND
cobalt-57	Ci	ND	ND	ND	ND
cobalt-58	Ci	ND	ND	ND	ND
cobalt-60	Ci	ND	ND	ND	ND
iron-55	Ci	ND	ND	ND	ND
iron-59	Ci	ND	ND	ND	ND
zinc-65	Ci	ND	ND	ND	ND
manganese-54	Ci	ND	ND	ND	ND
chromium-51	Ci	ND	ND	ND	ND
zirconium-niobium-95	Ci	ND	ND	ND	ND
molybdenum-99	Ci	ND	ND	ND	ND
technetium-99m	Ci	ND	ND	ND	ND
barium-lanthanum-140	Ci	ND	ND	ND	ND
cerium-141	Ci	ND	ND	ND	ND
unidentified	Ci	ND	ND	ND	ND
Total for period(above)	Ci	0.00E+00	0.00E+00	0.00E+00	0.00E+00
xenon-131m	Ci	ND	ND	ND	ND
xenon-133m	Ci	ND	ND	ND	ND
xenon-133	Ci	ND	ND	ND	ND
xenon-135	Ci	ND	ND	ND	ND

TABLE 2B
EFFLUENT AND WASTE DISPOSAL ANNUAL REPORT 2016
LIQUID EFFLUENTS
BATCH MODE

Nuclides Released	Unit	Quarter 1	Quarter 2	Quarter 3	Quarter 4
strontium-89	Ci	ND	ND	ND	ND
strontium-90	Ci	ND	ND	ND	ND
cesium-134	Ci	ND	ND	ND	ND
cesium-137	Ci	ND	ND	ND	ND
iodine-131	Ci	ND	ND	ND	ND
iodine-133	Ci	ND	ND	ND	ND
cobalt-57	Ci	2.52E-06	5.10E-06	2.35E-06	1.33E-06
cobalt-58	Ci	4.76E-03	1.19E-03	5.32E-04	2.62E-04
cobalt-60	Ci	1.34E-04	7.43E-05	9.15E-05	6.61E-05
chromium-51	Ci	1.41E-04	ND	ND	ND
iron-55	Ci	ND	ND	ND	ND
iron-59	Ci	1.34E-05	ND	ND	ND
zinc-65	Ci	ND	ND	ND	ND
manganese-54	Ci	8.40E-06	ND	6.68E-07	ND
zirconium-niobium-95	Ci	9.03E-06	ND	ND	ND
molybdenum-99	Ci	ND	ND	ND	ND
technetium-99m	Ci	ND	ND	ND	ND
silver-110m	Ci	1.16E-05	ND	ND	ND
barium-lanthanum-140	Ci	ND	ND	ND	ND
cerium-141	Ci	ND	ND	ND	ND
antimony-122	Ci	ND	ND	ND	ND
antimony-124	Ci	1.35E-05	ND	ND	ND
antimony-125	Ci	9.51E-04	2.14E-03	1.77E-03	8.78E-04
antimony-126	Ci	ND	ND	ND	ND
niobium-97	Ci	ND	ND	ND	ND
tin-117m	Ci	ND	ND	ND	ND
sodium-24	Ci	ND	ND	ND	ND
Tellurium-129m	Ci	ND	ND	ND	ND
Tellurium-132	Ci	ND	ND	ND	ND
unidentified	Ci	ND	ND	ND	ND
Total for period(above)	Ci	6.04E-03	3.41E-03	2.40E-03	1.21E-03
xenon-133	Ci	ND	ND	ND	ND
xenon-135	Ci	ND	ND	ND	ND

**EFFLUENT AND WASTE DISPOSAL ANNUAL REPORT 2016
SOLID WASTE AND IRRADIATED FUEL SHIPMENTS**

A. SOLID WASTE SHIPPED OFFSITE FOR BURIAL OR DISPOSAL (Not irradiated fuel)

1. Type of waste	Unit	1 year Period	Est. Total Error, %
a. Spent resins, filter sludges, evaporator Bottoms, etc.	m ³ Ci	8.04E+00 3.21E+02	2.50E+01
b. Dry compressible waste, contaminated Equip, etc.	m ³ Ci	2.31E+02 6.26E-01	2.50E+01
c. Irradiated components, control Rods, etc.	m ³ Ci	N/A	N/A
d. Other (describe)	m ³ Ci	N/A	N/A

2. Estimate of major nuclide composition (by type of waste)

a.	Ni-63	%	8.18E+01
	Co-60	%	8.17E+00
	Fe-55	%	4.00E+00
	Co-58	%	2.04E+00
	Mn-54	%	1.13E+00
	Ni-59	%	1.01E+00
	Co-57	%	6.24E-01
	Sb-125	%	6.19E-01
	Cs-137	%	4.36E-01
	H-3	%	1.02E-01
	C-14	%	9.59E-02
	Sr-90	%	2.93E-03
		%	
		%	
b.	Fe-55	%	6.24E+01
	Ni-63	%	1.37E+01
	Co-58	%	1.16E+01
	Co-60	%	5.55E+00
	Cs-137	%	2.63E+00
	H-3	%	1.55E+00
	Zr-95	%	1.01E+00
	Nb-95	%	8.96E-01
	Mn-54	%	5.31E-01
	Sb-125	%	9.88E-02
	Co-57	%	3.28E-02
	Be-7	%	5.26E-03
	Cr-51	%	2.09E-03
	Sn-113	%	2.08E-03
		%	
		%	
		%	
c.	N/A	%	N/A
d.	N/A	%	N/A

3. Solid Waste Disposition

<u>Number of Shipments</u>	<u>Waste Class</u>	<u>Container Type</u>	<u>Solidification Agent</u>	<u>Mode of Transportation</u>	<u>Destination</u>
1	A	General Design	N/A	Truck	EnergySolutions, Kingston, TN
4	A	General Design	N/A	Truck	EnergySolutions, Oak Ridge, TN
3	B	Type A	N/A	Truck	Waste Control Specialists, Andrews, TX

B. IRRADIATED FUEL SHIPMENTS (Disposition)

<u>Number of Shipments</u>	<u>Mode of Transportation</u>	<u>Destination</u>
N/A	N/A	N/A

C. REVIEW AND APPROVAL

Prepared By: Fred Haniffy Date: 4/18/17
Reviewed By: Andrew A. Gesta Date: 4/24/17
Approved By: David A. DeLeon Date: 04/24/2017

LIST OF APPENDICES

<u>Appendix</u>	<u>Title</u>
A	Offsite Dose Calculation Manual
B	Process Control Program
C	Liquid Holdup Tanks
D	Radwaste Treatment Systems
E	Unplanned Releases

Appendix A

Offsite Dose Calculation Manual

Requirement: Technical Specification 6.13.2c requires that licensee initiated changes to the Offsite Dose Calculation Manual be submitted to the Commission in the Annual Radioactive Effluent Release Report for the period in which the change(s) was made effective. Include in this changes to the Radiological Environmental Program in accordance with Offsite Dose Calculation Manual (ODCM) - C.9.1.1 and - C.9.2.1.

Response: Changes were made to the ODCM in 2016.

Changes to the Seabrook ODCM to be included under Revision 37 include the following items:

- Expanded critical organ dose equations for offsite receptors to include dose impact from the ingestion and inhalation exposure pathways for C-14 projected to be emitted from the station over a full year of power operations.
- Expanded critical organ dose equations for on-site receptors to include the dose impact from the inhalation exposure pathway (no food ingestion pathway exist) of C-14 projected to be emitted from the station over a full year of power operations.
- Added new reference to the re-located “Fitness Center” now located in the ground floor of the Hi-Rise office building. This includes dose factors and meteorology specific to the new location.
- Added new reference to the “Firing Range” for security personnel (include local member of law enforcement who are considered members of the public). This includes the development of dose factors and meteorological dispersion estimates specific to this new location.
- Removed unsupported statement referencing the Station Management Manual (SSMM) policy for radiation monitors rendered inoperable for testing.
- Added clarification in Table A.6.1-1 on liquid effluent sampling by identify that minimum analysis frequencies applied to “composite samples” collected at the identified sampling frequencies should be stated in accordance with NUREG-1301.
- Added clarification to Table A.6.1-1 on the application of the liquid radiation monitor located on the yard drain system is for trending only (not under control of RETS or REMP surveillance, testing or calibration requirements).
- Added clarification that certain analyses (gross alpha, Sr-89, Sr-90, Fe-55 [and H-3 for Service water]) are only required to be performed when water samples taken from Neutralization Tank, Low Conductivity Tank, Turbine Building Sump, SGBD Flash Tank, Condensate Polishing/SGBD Demin. Mega-rinse, Service Water, Subsurface Dewatering, and Storm Drains show positives for gamma analysis as an indication of contamination of secondary side water.

- Added reference to Table A.7.1-1 footnote 3 to the plant Vent monthly grab sample and the Containment Purge analysis frequency of “each Purge” to reflect statements in NUREG-1301.
- Removed all dose and dose rate equations from the ODCM that apply to on-site special receptors where members of the public could be present for short periods of time (low occupancy factors), with the exception of the critical organ dose methods for on-site special receptors in order to provide dose characterization information as required by the ODCM Section A.10.2, Annual Radioactive Effluent Release Report. ODCM Controls C.7.1.1 and C.7.2.1 apply at and beyond the site boundary, not to on-site locations inside the site boundary.
- Updated distance and direction information for REMP aquatic sampling locations (Table B.4-1) as measured by recent GPS measurements taken by Normandeau Associates.
- Re-located TLD position of TL-10 on Tables B.4-1 and B.4-2. (The TLD was moved a short distance due to its interference with on-going quarry operations near the SSW site boundary [maintained position criteria for TLD coverage in the SSW sector from the plant near the site boundary]).
- Removed location information for TLD locations TL-67 and SB-35 which have been taken out of the field due to the re-location of the old Fitness Center south of the DFS pad to the ground floor of the Hi-Rise Office Building. Add reference in the ODCM monitoring with respect to the DFS TLD locations SB-32 and SB-33 which are in the Hi-Rise Office Building and provide exposure monitoring of the new Fitness Center.
- Added new radionuclide dose conversion factors for new on-site receptors at the Firing Range and new Fitness Center.
- Removed dose factors and all references to the on-site boat launching ramp known as the “Rocks”. This was due to its close proximity to the Protected Area Boundary which has precipitated security to exercise restricted access to the site for the public, and thereby eliminating the location from any exposure pathways to members of the public. In addition, the need for TL-43 to monitor direct radiation for public exposures at the “Rock” is eliminated and the TLD at this location can be permanently removed.
- Removed from Figure B.4-2 reference to an old milk sampling location (TM-09), along with milk location TM-20 on Figure B.4-3, since both locations have gone out of business and have been dropped from the REMP sampling program. Shell-fish sampling location MU-59 is added to Figure B.4-3 to illustrate its placement as a control location.
- Revised and added new location atmospheric dispersion factors used in the assessment of dose impacts at the site boundary and on-site receptors (Science and Nature Center, Firing Range, new Fitness Center).
- Updated time dependent (t^{-a}) meteorological factors for the maximum off-site dose receptor location and on-site Science & Nature Center to account for small changes in computational precision identified between the original derivation of these factors and re-calculation of the same factors on current computer operating platforms.

Appendix B

Process Control Program

Requirement: The Offsite Dose Calculation Manual requires that licensee initiated changes to the Process Control Program be submitted to the Commission in the Annual Radioactive Effluent Release Report for the period in which the change(s) was made.

Response: No changes were made to the process control program in 2016.

Appendix C

Liquid Holdup Tanks

Requirement: Technical Specification 3.11.1.4 limits the quantity of radioactive material contained in any outside temporary tank. With the quantity of radioactive material in any outside temporary tank exceeding the limits of Technical Specification 3.11.1.4, a description of the events leading to this condition is required in the next Annual Effluent Release Report in accordance with Tech. Spec. 6.8.1.4.

Response: From January 1, 2016 to December 31, 2016, there was no radioactive material stored in any temporary outdoor tank that exceeded the limits of T. S. 3.11.1.4.

Appendix D

Radwaste Treatment Systems

Requirement: Technical Specification 6.14.1a requires that licensee initiated changes to the Radwaste Treatment Systems (liquid, gaseous, and solid) be submitted to the Commission in the Annual Radioactive Effluent Release Report for the period in which the change was made.

Response: For 2016 NextEra Energy Seabrook LLC, will submit any changes to the Radwaste Treatment Systems (liquid, gaseous and solid) as part of the FSAR update.

Appendix E

Unplanned Releases

Requirement: Technical Specification 6.8.1.4 requires a list and description of unplanned releases from the site to UNRESTRICTED AREAS of radioactive materials in gaseous and liquid effluents made during the reporting period.

- Submit all groundwater monitoring well sample results and a description of any significant onsite leaks/spills that impact groundwater

Response: A review of the January 1, 2016 to December 31, 2016 time period indicated there were no unplanned, unanticipated or abnormal releases from the site to unrestricted areas of radioactive materials of gaseous or liquid effluents. See next sheet for groundwater monitoring well results.

2016 Ground Water Monitoring Well Tritium Data

Date/Time	BD-1	BD-2	BD-3	BD-4	BD-5	BD-6	BU-1	SC-1	SD-1	SD-2	SD-3	SD-4	SD-5	SU-1	SW-1	SW-2	SW-3	SW-4	SW-5	SW-6	SU-10	SU-11	BU-10	BU-11	TW-1	TW-2	TW-3	
	(pCi/L)	(pCi/L)	(pCi/L)	(pCi/L)	(pCi/L)	(pCi/L)	(pCi/L)	(pCi/L)	(pCi/L)	(pCi/L)	(pCi/L)	(pCi/L)	(pCi/L)	(pCi/L)	(pCi/L)	(pCi/L)	(pCi/L)	(pCi/L)	(pCi/L)	(pCi/L)	(pCi/L)	(pCi/L)	(pCi/L)	(pCi/L)	(pCi/L)	(pCi/L)	(pCi/L)	(pCi/L)
03/30/16															1730													
03/31/16		618							<590								<595											
06/23/16		598							<576						2080		<593											
09/08/16		<432							652																			
09/09/16															1820													
09/14/16																<601	<572											
09/15/16																		<572			<570	<578	<572	<570				
09/16/16						<569	<570							<569	<572													
12/14/16															1960		<580											
12/15/16		<580							<580																			

Paired well locations:

- SD-1 / BD-2 South of plant near seawall inside PA fence
- SD-2 / BD-3 East of plant inside owner controlled area
- SD-3 / BD-4 Northeast of plant inside owner controlled area
- SD-4 / BD-5 Southwest of plant, south of cooling tower inside owner controlled area
- SD-5 / BD-6 South of Unit 2 containment equipment hatch outside PA fence
- SU-1 / BU-1 Northwest of plant (Background location) inside owner controlled area
- SU-10 / BU-10 North / northwest of plant inside PA fence
- SU-11 / BU-11 North of plant inside PA fence

Selected well locations:

- SW-1 South of Fuel Storage Building (Indicator location) inside PA fence
- SW-2 East of plant near Service Water Pump House inside PA fence
- SW-3 Southwest of plant near Unit 1 to Unit 2 tunnel inside PA fence
- SW-4 South of waste process building / steam generator blowdown room inside PA fence
- SW-5 West of service water building inside PA fence
- SW-6 Southwest of demineralized tank 259 inside PA fence
- TW-1 Southeast of plant inside owner controlled area outside PA fence
- TW-2 Southeast of plant inside owner controlled area outside PA fence
- TW-3 Southeast of plant inside owner controlled area outside PA fence

Note: All sample results in pCi/L

Definitions:

- S = Shallow
- C = Cross gradient
- U = up gradient
- W = well
- B = Bedrock
- D = down gradient
- T = temporary

Enclosure 2

Joint Frequency Distributions of Wind Speed,
Wind Direction, and Atmospheric Stability

SEABROOK JAN16-DEC16 MET DATA JOINT FREQUENCY DISTRIBUTION (210-FOOT TOWER)

43.0 FT WIND DATA STABILITY CLASS A CLASS FREQUENCY (PERCENT) = 19.12

WIND DIRECTION FROM

SPEED MPH	N	NNE	NE	ENE	E	ESE	SE	SSE	S	SSW	SW	WSW	W	WNW	NW	NNW	VRBL	TOTAL
CALM	1	0	0	0	0	0	1	0	0	0	0	0	0	0	0	0	0	2
(1)	.06	.00	.00	.00	.00	.00	.06	.00	.00	.00	.00	.00	.00	.00	.00	.00	.00	.12
(2)	.01	.00	.00	.00	.00	.00	.01	.00	.00	.00	.00	.00	.00	.00	.00	.00	.00	.02
C-3	7	6	6	6	7	4	2	5	8	8	8	15	15	20	28	11	0	156
(1)	.42	.36	.36	.36	.42	.24	.12	.30	.48	.48	.48	.90	.90	1.21	1.69	.66	.00	9.40
(2)	.08	.07	.07	.07	.08	.05	.02	.06	.09	.09	.09	.17	.17	.23	.32	.13	.00	1.80
4-7	34	29	15	17	42	22	35	18	25	30	36	79	71	70	96	41	0	660
(1)	2.05	1.75	.90	1.02	2.53	1.33	2.11	1.08	1.51	1.81	2.17	4.76	4.28	4.22	5.79	2.47	.00	39.78
(2)	.39	.33	.17	.20	.48	.25	.40	.21	.29	.35	.41	.91	.82	.81	1.11	.47	.00	7.61
8-12	4	5	25	46	32	29	48	25	4	15	38	74	64	107	94	13	0	623
(1)	.24	.30	1.51	2.77	1.93	1.75	2.89	1.51	.24	.90	2.29	4.46	3.86	6.45	5.67	.78	.00	37.55
(2)	.05	.06	.29	.53	.37	.33	.55	.29	.05	.17	.44	.85	.74	1.23	1.08	.15	.00	7.18
13-18	0	0	20	16	10	5	0	2	0	4	21	20	10	46	47	6	0	207
(1)	.00	.00	1.21	.96	.60	.30	.00	.12	.00	.24	1.27	1.21	.60	2.77	2.83	.36	.00	12.48
(2)	.00	.00	.23	.18	.12	.06	.00	.02	.00	.05	.24	.23	.12	.53	.54	.07	.00	2.39
19-24	0	0	0	2	3	2	0	0	0	0	0	0	0	0	4	0	0	11
(1)	.00	.00	.00	.12	.18	.12	.00	.00	.00	.00	.00	.00	.00	.00	.24	.00	.00	.66
(2)	.00	.00	.00	.02	.03	.02	.00	.00	.00	.00	.00	.00	.00	.00	.05	.00	.00	.13
GT 24	0	0	0	0	0	0	0	0	0	0	0	0	0	0	0	0	0	0
(1)	.00	.00	.00	.00	.00	.00	.00	.00	.00	.00	.00	.00	.00	.00	.00	.00	.00	.00
(2)	.00	.00	.00	.00	.00	.00	.00	.00	.00	.00	.00	.00	.00	.00	.00	.00	.00	.00
ALL SPEEDS	46	40	66	87	94	62	86	50	37	57	103	188	160	243	269	71	0	1659
(1)	2.77	2.41	3.98	5.24	5.67	3.74	5.18	3.01	2.23	3.44	6.21	11.33	9.64	14.65	16.21	4.28	.00	100.00
(2)	.53	.46	.76	1.00	1.08	.71	.99	.58	.43	.66	1.19	2.17	1.84	2.80	3.10	.82	.00	19.12

(1)=PERCENT OF ALL GOOD OBSERVATIONS FOR THIS PAGE
 (2)=PERCENT OF ALL GOOD OBSERVATIONS FOR THIS PERIOD
 C= CALM (WIND SPEED LESS THAN OR EQUAL TO .95 MPH)

SEABROOK JAN16-DEC16 MET DATA JOINT FREQUENCY DISTRIBUTION (210-FOOT TOWER)

43.0 FT WIND DATA STABILITY CLASS B CLASS FREQUENCY (PERCENT) = 4.71

WIND DIRECTION FROM

SPEED MPH	N	NNE	NE	ENE	E	ESE	SE	SSE	S	SSW	SW	WSW	W	WNW	NW	NNW	VRBL	TOTAL
CALM	0	0	0	0	1	0	0	0	0	0	0	0	0	0	0	0	0	1
(1)	.00	.00	.00	.00	.24	.00	.00	.00	.00	.00	.00	.00	.00	.00	.00	.00	.00	.24
(2)	.00	.00	.00	.00	.01	.00	.00	.00	.00	.00	.00	.00	.00	.00	.00	.00	.00	.01
C-3	2	0	0	1	1	2	1	1	2	2	3	2	3	2	4	1	0	27
(1)	.49	.00	.00	.24	.24	.49	.24	.24	.49	.49	.73	.49	.73	.49	.98	.24	.00	6.60
(2)	.02	.00	.00	.01	.01	.02	.01	.01	.02	.02	.03	.02	.03	.02	.05	.01	.00	.31
4-7	8	2	0	1	1	4	11	2	2	2	6	31	18	12	17	5	0	122
(1)	1.96	.49	.00	.24	.24	.98	2.69	.49	.49	.49	1.47	7.58	4.40	2.93	4.16	1.22	.00	29.83
(2)	.09	.02	.00	.01	.01	.05	.13	.02	.02	.02	.07	.36	.21	.14	.20	.06	.00	1.41
8-12	2	0	3	20	19	14	20	9	2	10	22	22	24	25	16	2	0	210
(1)	.49	.00	.73	4.89	4.65	3.42	4.89	2.20	.49	2.44	5.38	5.38	5.87	6.11	3.91	.49	.00	51.34
(2)	.02	.00	.03	.23	.22	.16	.23	.10	.02	.12	.25	.25	.28	.29	.18	.02	.00	2.42
13-18	0	0	2	7	2	0	0	0	0	0	5	2	3	7	7	2	0	37
(1)	.00	.00	.49	1.71	.49	.00	.00	.00	.00	.00	1.22	.49	.73	1.71	1.71	.49	.00	9.05
(2)	.00	.00	.02	.08	.02	.00	.00	.00	.00	.00	.06	.02	.03	.08	.08	.02	.00	.43
19-24	0	0	0	0	0	0	0	0	0	0	5	0	0	4	3	0	0	12
(1)	.00	.00	.00	.00	.00	.00	.00	.00	.00	.00	1.22	.00	.00	.98	.73	.00	.00	2.93
(2)	.00	.00	.00	.00	.00	.00	.00	.00	.00	.00	.06	.00	.00	.05	.03	.00	.00	.14
GT 24	0	0	0	0	0	0	0	0	0	0	0	0	0	0	0	0	0	0
(1)	.00	.00	.00	.00	.00	.00	.00	.00	.00	.00	.00	.00	.00	.00	.00	.00	.00	.00
(2)	.00	.00	.00	.00	.00	.00	.00	.00	.00	.00	.00	.00	.00	.00	.00	.00	.00	.00
ALL SPEEDS	12	2	5	29	24	20	32	12	6	14	41	57	48	50	47	10	0	409
(1)	2.93	.49	1.22	7.09	5.87	4.89	7.82	2.93	1.47	3.42	10.02	13.94	11.74	12.22	11.49	2.44	.00	100.00
(2)	.14	.02	.06	.33	.28	.23	.37	.14	.07	.16	.47	.66	.55	.58	.54	.12	.00	4.71

(1)=PERCENT OF ALL GOOD OBSERVATIONS FOR THIS PAGE
 (2)=PERCENT OF ALL GOOD OBSERVATIONS FOR THIS PERIOD
 C= CALM (WIND SPEED LESS THAN OR EQUAL TO .95 MPH)

SEABROOK JAN16-DEC16 MET DATA JOINT FREQUENCY DISTRIBUTION (210-FOOT TOWER)

43.0 FT WIND DATA STABILITY CLASS C CLASS FREQUENCY (PERCENT) = 6.33

WIND DIRECTION FROM

SPEED MPH	N	NNE	NE	ENE	E	ESE	SE	SSE	S	SSW	SW	WSW	W	WNW	NW	NNW	VRBL	TOTAL
CALM	0	0	0	0	0	0	0	0	0	0	0	0	0	0	0	0	0	0
(1)	.00	.00	.00	.00	.00	.00	.00	.00	.00	.00	.00	.00	.00	.00	.00	.00	.00	.00
(2)	.00	.00	.00	.00	.00	.00	.00	.00	.00	.00	.00	.00	.00	.00	.00	.00	.00	.00
C-3	4	0	2	3	1	0	0	0	3	0	0	3	7	5	1	2	0	31
(1)	.73	.00	.36	.55	.18	.00	.00	.00	.55	.00	.00	.55	1.28	.91	.18	.36	.00	5.65
(2)	.05	.00	.02	.03	.01	.00	.00	.00	.03	.00	.00	.03	.08	.06	.01	.02	.00	.36
4-7	9	3	1	1	8	7	16	8	5	6	12	38	23	20	11	18	0	186
(1)	1.64	.55	.18	.18	1.46	1.28	2.91	1.46	.91	1.09	2.19	6.92	4.19	3.64	2.00	3.28	.00	33.88
(2)	.10	.03	.01	.01	.09	.08	.18	.09	.06	.07	.14	.44	.27	.23	.13	.21	.00	2.14
8-12	3	4	7	27	33	20	22	4	1	3	29	22	14	29	34	5	0	257
(1)	.55	.73	1.28	4.92	6.01	3.64	4.01	.73	.18	.55	5.28	4.01	2.55	5.28	6.19	.91	.00	46.81
(2)	.03	.05	.08	.31	.38	.23	.25	.05	.01	.03	.33	.25	.16	.33	.39	.06	.00	2.96
13-18	0	0	4	6	4	1	0	0	0	1	6	3	4	20	17	2	0	68
(1)	.00	.00	.73	1.09	.73	.18	.00	.00	.00	.18	1.09	.55	.73	3.64	3.10	.36	.00	12.39
(2)	.00	.00	.05	.07	.05	.01	.00	.00	.00	.01	.07	.03	.05	.23	.20	.02	.00	.78
19-24	0	0	1	0	0	0	0	0	0	0	1	0	0	2	3	0	0	7
(1)	.00	.00	.18	.00	.00	.00	.00	.00	.00	.00	.18	.00	.00	.36	.55	.00	.00	1.28
(2)	.00	.00	.01	.00	.00	.00	.00	.00	.00	.00	.01	.00	.00	.02	.03	.00	.00	.08
GT 24	0	0	0	0	0	0	0	0	0	0	0	0	0	0	0	0	0	0
(1)	.00	.00	.00	.00	.00	.00	.00	.00	.00	.00	.00	.00	.00	.00	.00	.00	.00	.00
(2)	.00	.00	.00	.00	.00	.00	.00	.00	.00	.00	.00	.00	.00	.00	.00	.00	.00	.00
ALL SPEEDS	16	7	15	37	46	28	38	12	9	10	48	66	48	76	66	27	0	549
(1)	2.91	1.28	2.73	6.74	8.38	5.10	6.92	2.19	1.64	1.82	8.74	12.02	8.74	13.84	12.02	4.92	.00	100.00
(2)	.18	.08	.17	.43	.53	.32	.44	.14	.10	.12	.55	.76	.55	.88	.76	.31	.00	6.33

(1)=PERCENT OF ALL GOOD OBSERVATIONS FOR THIS PAGE
 (2)=PERCENT OF ALL GOOD OBSERVATIONS FOR THIS PERIOD
 C= CALM (WIND SPEED LESS THAN OR EQUAL TO .95 MPH)

SEABROOK JAN16-DEC16 MET DATA JOINT FREQUENCY DISTRIBUTION (210-FOOT TOWER)

43.0 FT WIND DATA STABILITY CLASS D CLASS FREQUENCY (PERCENT) = 39.82

WIND DIRECTION FROM

SPEED MPH	N	NNE	NE	ENE	E	ESE	SE	SSE	S	SSW	SW	WSW	W	WNW	NW	NNW	VRBL	TOTAL
CALM	1	1	0	1	0	1	0	0	0	0	0	0	0	2	0	0	0	6
(1)	.03	.03	.00	.03	.00	.03	.00	.00	.00	.00	.00	.00	.00	.06	.00	.00	.00	.17
(2)	.01	.01	.00	.01	.00	.01	.00	.00	.00	.00	.00	.00	.00	.02	.00	.00	.00	.07
C-3	22	20	16	29	22	10	15	18	25	23	18	27	32	29	34	19	0	359
(1)	.64	.58	.46	.84	.64	.29	.43	.52	.72	.67	.52	.78	.93	.84	.98	.55	.00	10.39
(2)	.25	.23	.18	.33	.25	.12	.17	.21	.29	.27	.21	.31	.37	.33	.39	.22	.00	4.14
4-7	72	44	54	104	90	78	84	72	60	87	106	139	98	131	144	103	0	1466
(1)	2.08	1.27	1.56	3.01	2.60	2.26	2.43	2.08	1.74	2.52	3.07	4.02	2.84	3.79	4.17	2.98	.00	42.42
(2)	.83	.51	.62	1.20	1.04	.90	.97	.83	.69	1.00	1.22	1.60	1.13	1.51	1.66	1.19	.00	16.89
8-12	47	21	93	80	87	57	32	45	32	75	169	75	111	167	150	41	0	1282
(1)	1.36	.61	2.69	2.31	2.52	1.65	.93	1.30	.93	2.17	4.89	2.17	3.21	4.83	4.34	1.19	.00	37.09
(2)	.54	.24	1.07	.92	1.00	.66	.37	.52	.37	.86	1.95	.86	1.28	1.92	1.73	.47	.00	14.77
13-18	0	0	31	15	27	2	1	6	2	15	29	5	27	92	60	2	0	314
(1)	.00	.00	.90	.43	.78	.06	.03	.17	.06	.43	.84	.14	.78	2.66	1.74	.06	.00	9.09
(2)	.00	.00	.36	.17	.31	.02	.01	.07	.02	.17	.33	.06	.31	1.06	.69	.02	.00	3.62
19-24	0	0	2	1	1	1	0	0	1	0	4	0	0	12	6	0	0	28
(1)	.00	.00	.06	.03	.03	.03	.00	.00	.03	.00	.12	.00	.00	.35	.17	.00	.00	.81
(2)	.00	.00	.02	.01	.01	.01	.00	.00	.01	.00	.05	.00	.00	.14	.07	.00	.00	.32
GT 24	0	0	0	0	0	0	0	0	1	0	0	0	0	0	0	0	0	1
(1)	.00	.00	.00	.00	.00	.00	.00	.00	.03	.00	.00	.00	.00	.00	.00	.00	.00	.03
(2)	.00	.00	.00	.00	.00	.00	.00	.00	.01	.00	.00	.00	.00	.00	.00	.00	.00	.01
ALL SPEEDS	142	86	196	230	227	149	132	141	121	200	326	246	268	433	394	165	0	3456
(1)	4.11	2.49	5.67	6.66	6.57	4.31	3.82	4.08	3.50	5.79	9.43	7.12	7.75	12.53	11.40	4.77	.00	100.00
(2)	1.64	.99	2.26	2.65	2.62	1.72	1.52	1.62	1.39	2.30	3.76	2.83	3.09	4.99	4.54	1.90	.00	39.82

(1)=PERCENT OF ALL GOOD OBSERVATIONS FOR THIS PAGE
 (2)=PERCENT OF ALL GOOD OBSERVATIONS FOR THIS PERIOD
 C= CALM (WIND SPEED LESS THAN OR EQUAL TO .95 MPH)

SEABROOK JAN16-DEC16 MET DATA JOINT FREQUENCY DISTRIBUTION (210-FOOT TOWER)

43.0 FT WIND DATA STABILITY CLASS E CLASS FREQUENCY (PERCENT) = 18.69

WIND DIRECTION FROM

SPEED MPH	N	NNE	NE	ENE	E	ESE	SE	SSE	S	SSW	SW	WSW	W	WNW	NW	NNW	VRBL	TOTAL
CALM	2	1	0	1	0	1	1	0	0	0	1	0	0	0	1	2	0	10
(1)	.12	.06	.00	.06	.00	.06	.06	.00	.00	.00	.06	.00	.00	.00	.06	.12	.00	.62
(2)	.02	.01	.00	.01	.00	.01	.01	.00	.00	.00	.01	.00	.00	.00	.01	.02	.00	.12
C-3	27	17	21	18	13	17	3	17	27	40	44	64	87	67	49	37	0	548
(1)	1.66	1.05	1.29	1.11	.80	1.05	.18	1.05	1.66	2.47	2.71	3.95	5.36	4.13	3.02	2.28	.00	33.79
(2)	.31	.20	.24	.21	.15	.20	.03	.20	.31	.46	.51	.74	1.00	.77	.56	.43	.00	6.31
4-7	14	11	10	13	28	12	20	25	14	37	90	170	143	130	125	39	0	881
(1)	.86	.68	.62	.80	1.73	.74	1.23	1.54	.86	2.28	5.55	10.48	8.82	8.01	7.71	2.40	.00	54.32
(2)	.16	.13	.12	.15	.32	.14	.23	.29	.16	.43	1.04	1.96	1.65	1.50	1.44	.45	.00	10.15
8-12	1	0	7	17	11	5	7	8	4	15	35	26	5	9	19	0	0	169
(1)	.06	.00	.43	1.05	.68	.31	.43	.49	.25	.92	2.16	1.60	.31	.55	1.17	.00	.00	10.42
(2)	.01	.00	.08	.20	.13	.06	.08	.09	.05	.17	.40	.30	.06	.10	.22	.00	.00	1.95
13-18	0	0	1	2	6	0	0	1	0	0	2	0	0	0	1	0	0	13
(1)	.00	.00	.06	.12	.37	.00	.00	.06	.00	.00	.12	.00	.00	.00	.06	.00	.00	.80
(2)	.00	.00	.01	.02	.07	.00	.00	.01	.00	.00	.02	.00	.00	.00	.01	.00	.00	.15
19-24	0	0	0	0	0	1	0	0	0	0	0	0	0	0	0	0	0	1
(1)	.00	.00	.00	.00	.00	.06	.00	.00	.00	.00	.00	.00	.00	.00	.00	.00	.00	.06
(2)	.00	.00	.00	.00	.00	.01	.00	.00	.00	.00	.00	.00	.00	.00	.00	.00	.00	.01
GT 24	0	0	0	0	0	0	0	0	0	0	0	0	0	0	0	0	0	0
(1)	.00	.00	.00	.00	.00	.00	.00	.00	.00	.00	.00	.00	.00	.00	.00	.00	.00	.00
(2)	.00	.00	.00	.00	.00	.00	.00	.00	.00	.00	.00	.00	.00	.00	.00	.00	.00	.00
ALL SPEEDS	44	29	39	51	58	36	31	51	45	92	172	260	235	206	195	78	0	1622
(1)	2.71	1.79	2.40	3.14	3.58	2.22	1.91	3.14	2.77	5.67	10.60	16.03	14.49	12.70	12.02	4.81	.00	100.00
(2)	.51	.33	.45	.59	.67	.41	.36	.59	.52	1.06	1.98	3.00	2.71	2.37	2.25	.90	.00	18.69

(1)=PERCENT OF ALL GOOD OBSERVATIONS FOR THIS PAGE
 (2)=PERCENT OF ALL GOOD OBSERVATIONS FOR THIS PERIOD
 C= CALM (WIND SPEED LESS THAN OR EQUAL TO .95 MPH)

SEABROOK JAN16--DEC16 MET DATA JOINT FREQUENCY DISTRIBUTION (210-FOOT TOWER)

43.0 FT WIND DATA STABILITY CLASS F CLASS FREQUENCY (PERCENT) = 6.61

WIND DIRECTION FROM

SPEED MPH	N	NNE	NE	ENE	E	ESE	SE	SSE	S	SSW	SW	WSW	W	WNW	NW	NNW	VRBL	TOTAL
CALM	2	0	1	0	1	0	0	0	0	0	1	0	0	1	1	1	0	8
(1)	.35	.00	.17	.00	.17	.00	.00	.00	.00	.00	.17	.00	.00	.17	.17	.17	.00	1.39
(2)	.02	.00	.01	.00	.01	.00	.00	.00	.00	.00	.01	.00	.00	.01	.01	.01	.00	.09
C-3	13	7	10	13	6	7	4	2	3	9	28	52	87	71	49	13	0	374
(1)	2.26	1.22	1.74	2.26	1.05	1.22	.70	.35	.52	1.57	4.88	9.06	15.16	12.37	8.54	2.26	.00	65.16
(2)	.15	.08	.12	.15	.07	.08	.05	.02	.03	.10	.32	.60	1.00	.82	.56	.15	.00	4.31
4-7	2	0	1	3	5	2	6	0	3	3	7	30	34	30	44	14	0	184
(1)	.35	.00	.17	.52	.87	.35	1.05	.00	.52	.52	1.22	5.23	5.92	5.23	7.67	2.44	.00	32.06
(2)	.02	.00	.01	.03	.06	.02	.07	.00	.03	.03	.08	.35	.39	.35	.51	.16	.00	2.12
8-12	0	0	0	0	2	0	2	0	0	1	0	0	0	0	2	1	0	8
(1)	.00	.00	.00	.00	.35	.00	.35	.00	.00	.17	.00	.00	.00	.00	.35	.17	.00	1.39
(2)	.00	.00	.00	.00	.02	.00	.02	.00	.00	.01	.00	.00	.00	.00	.02	.01	.00	.09
13-18	0	0	0	0	0	0	0	0	0	0	0	0	0	0	0	0	0	0
(1)	.00	.00	.00	.00	.00	.00	.00	.00	.00	.00	.00	.00	.00	.00	.00	.00	.00	.00
(2)	.00	.00	.00	.00	.00	.00	.00	.00	.00	.00	.00	.00	.00	.00	.00	.00	.00	.00
19-24	0	0	0	0	0	0	0	0	0	0	0	0	0	0	0	0	0	0
(1)	.00	.00	.00	.00	.00	.00	.00	.00	.00	.00	.00	.00	.00	.00	.00	.00	.00	.00
(2)	.00	.00	.00	.00	.00	.00	.00	.00	.00	.00	.00	.00	.00	.00	.00	.00	.00	.00
GT 24	0	0	0	0	0	0	0	0	0	0	0	0	0	0	0	0	0	0
(1)	.00	.00	.00	.00	.00	.00	.00	.00	.00	.00	.00	.00	.00	.00	.00	.00	.00	.00
(2)	.00	.00	.00	.00	.00	.00	.00	.00	.00	.00	.00	.00	.00	.00	.00	.00	.00	.00
ALL SPEEDS	17	7	12	16	14	9	12	2	6	13	36	82	121	102	96	29	0	574
(1)	2.96	1.22	2.09	2.79	2.44	1.57	2.09	.35	1.05	2.26	6.27	14.29	21.08	17.77	16.72	5.05	.00	100.00
(2)	.20	.08	.14	.18	.16	.10	.14	.02	.07	.15	.41	.94	1.39	1.18	1.11	.33	.00	6.61

(1)=PERCENT OF ALL GOOD OBSERVATIONS FOR THIS PAGE
 (2)=PERCENT OF ALL GOOD OBSERVATIONS FOR THIS PERIOD
 C= CALM (WIND SPEED LESS THAN OR EQUAL TO .95 MPH)

SEABROOK JAN16-DEC16 MET DATA JOINT FREQUENCY DISTRIBUTION (210-FOOT TOWER)

43.0 FT WIND DATA STABILITY CLASS G CLASS FREQUENCY (PERCENT) = 4.71

WIND DIRECTION FROM

SPEED MPH	N	NNE	NE	ENE	E	ESE	SE	SSE	S	SSW	SW	WSW	W	WNW	NW	NNW	VRBL	TOTAL
CALM	0	1	1	0	0	0	1	0	0	0	1	2	0	0	1	0	0	7
(1)	.00	.24	.24	.00	.00	.00	.24	.00	.00	.00	.24	.49	.00	.00	.24	.00	.00	1.71
(2)	.00	.01	.01	.00	.00	.00	.01	.00	.00	.00	.01	.02	.00	.00	.01	.00	.00	.08
C-3	3	2	6	10	7	3	1	1	1	5	18	54	79	101	45	7	0	343
(1)	.73	.49	1.47	2.44	1.71	.73	.24	.24	.24	1.22	4.40	13.20	19.32	24.69	11.00	1.71	.00	83.86
(2)	.03	.02	.07	.12	.08	.03	.01	.01	.01	.06	.21	.62	.91	1.16	.52	.08	.00	3.95
4-7	0	0	0	1	5	0	0	0	0	0	0	4	14	11	22	2	0	59
(1)	.00	.00	.00	.24	1.22	.00	.00	.00	.00	.00	.00	.98	3.42	2.69	5.38	.49	.00	14.43
(2)	.00	.00	.00	.01	.06	.00	.00	.00	.00	.00	.00	.05	.16	.13	.25	.02	.00	.68
8-12	0	0	0	0	0	0	0	0	0	0	0	0	0	0	0	0	0	0
(1)	.00	.00	.00	.00	.00	.00	.00	.00	.00	.00	.00	.00	.00	.00	.00	.00	.00	.00
(2)	.00	.00	.00	.00	.00	.00	.00	.00	.00	.00	.00	.00	.00	.00	.00	.00	.00	.00
13-18	0	0	0	0	0	0	0	0	0	0	0	0	0	0	0	0	0	0
(1)	.00	.00	.00	.00	.00	.00	.00	.00	.00	.00	.00	.00	.00	.00	.00	.00	.00	.00
(2)	.00	.00	.00	.00	.00	.00	.00	.00	.00	.00	.00	.00	.00	.00	.00	.00	.00	.00
19-24	0	0	0	0	0	0	0	0	0	0	0	0	0	0	0	0	0	0
(1)	.00	.00	.00	.00	.00	.00	.00	.00	.00	.00	.00	.00	.00	.00	.00	.00	.00	.00
(2)	.00	.00	.00	.00	.00	.00	.00	.00	.00	.00	.00	.00	.00	.00	.00	.00	.00	.00
GT 24	0	0	0	0	0	0	0	0	0	0	0	0	0	0	0	0	0	0
(1)	.00	.00	.00	.00	.00	.00	.00	.00	.00	.00	.00	.00	.00	.00	.00	.00	.00	.00
(2)	.00	.00	.00	.00	.00	.00	.00	.00	.00	.00	.00	.00	.00	.00	.00	.00	.00	.00
ALL SPEEDS	3	3	7	11	12	3	2	1	1	5	19	60	93	112	68	9	0	409
(1)	.73	.73	1.71	2.69	2.93	.73	.49	.24	.24	1.22	4.65	14.67	22.74	27.38	16.63	2.20	.00	100.00
(2)	.03	.03	.08	.13	.14	.03	.02	.01	.01	.06	.22	.69	1.07	1.29	.78	.10	.00	4.71

(1)=PERCENT OF ALL GOOD OBSERVATIONS FOR THIS PAGE
 (2)=PERCENT OF ALL GOOD OBSERVATIONS FOR THIS PERIOD
 C= CALM (WIND SPEED LESS THAN OR EQUAL TO .95 MPH)

SEABROOK JAN16-DEC16 MET DATA JOINT FREQUENCY DISTRIBUTION (210-FOOT TOWER)

43.0 FT WIND DATA STABILITY CLASS ALL CLASS FREQUENCY (PERCENT) = 100.00

WIND DIRECTION FROM

SPEED MPH	N	NNE	NE	ENE	E	ESE	SE	SSE	S	SSW	SW	WSW	W	WNW	NW	NNW	VRBL	TOTAL
CALM	6	3	2	2	2	2	3	0	0	0	3	2	0	3	3	3	0	34
(1)	.07	.03	.02	.02	.02	.02	.03	.00	.00	.00	.03	.02	.00	.03	.03	.03	.00	.39
(2)	.07	.03	.02	.02	.02	.02	.03	.00	.00	.00	.03	.02	.00	.03	.03	.03	.00	.39
C-3	78	52	61	80	57	43	26	44	69	87	119	217	310	295	210	90	0	1838
(1)	.90	.60	.70	.92	.66	.50	.30	.51	.80	1.00	1.37	2.50	3.57	3.40	2.42	1.04	.00	21.18
(2)	.90	.60	.70	.92	.66	.50	.30	.51	.80	1.00	1.37	2.50	3.57	3.40	2.42	1.04	.00	21.18
4-7	139	89	81	140	179	125	172	125	109	165	257	491	401	404	459	222	0	3558
(1)	1.60	1.03	.93	1.61	2.06	1.44	1.98	1.44	1.26	1.90	2.96	5.66	4.62	4.66	5.29	2.56	.00	41.00
(2)	1.60	1.03	.93	1.61	2.06	1.44	1.98	1.44	1.26	1.90	2.96	5.66	4.62	4.66	5.29	2.56	.00	41.00
8-12	57	30	135	190	184	125	131	91	43	119	293	219	218	337	315	62	0	2549
(1)	.66	.35	1.56	2.19	2.12	1.44	1.51	1.05	.50	1.37	3.38	2.52	2.51	3.88	3.63	.71	.00	29.37
(2)	.66	.35	1.56	2.19	2.12	1.44	1.51	1.05	.50	1.37	3.38	2.52	2.51	3.88	3.63	.71	.00	29.37
13-18	0	0	58	46	49	8	1	9	2	20	63	30	44	165	132	12	0	639
(1)	.00	.00	.67	.53	.56	.09	.01	.10	.02	.23	.73	.35	.51	1.90	1.52	.14	.00	7.36
(2)	.00	.00	.67	.53	.56	.09	.01	.10	.02	.23	.73	.35	.51	1.90	1.52	.14	.00	7.36
19-24	0	0	3	3	4	4	0	0	1	0	10	0	0	18	16	0	0	59
(1)	.00	.00	.03	.03	.05	.05	.00	.00	.01	.00	.12	.00	.00	.21	.18	.00	.00	.68
(2)	.00	.00	.03	.03	.05	.05	.00	.00	.01	.00	.12	.00	.00	.21	.18	.00	.00	.68
GT 24	0	0	0	0	0	0	0	0	1	0	0	0	0	0	0	0	0	1
(1)	.00	.00	.00	.00	.00	.00	.00	.00	.01	.00	.00	.00	.00	.00	.00	.00	.00	.01
(2)	.00	.00	.00	.00	.00	.00	.00	.00	.01	.00	.00	.00	.00	.00	.00	.00	.00	.01
ALL SPEEDS	280	174	340	461	475	307	333	269	225	391	745	959	973	1222	1135	389	0	8678
(1)	3.23	2.01	3.92	5.31	5.47	3.54	3.84	3.10	2.59	4.51	8.58	11.05	11.21	14.08	13.08	4.48	.00	100.00
(2)	3.23	2.01	3.92	5.31	5.47	3.54	3.84	3.10	2.59	4.51	8.58	11.05	11.21	14.08	13.08	4.48	.00	100.00

(1)=PERCENT OF ALL GOOD OBSERVATIONS FOR THIS PAGE
 (2)=PERCENT OF ALL GOOD OBSERVATIONS FOR THIS PERIOD
 C= CALM (WIND SPEED LESS THAN OR EQUAL TO .95 MPH)

SEABROOK JAN16-DEC16 MET DATA JOINT FREQUENCY DISTRIBUTION (210-FOOT TOWER)

209.0 FT WIND DATA STABILITY CLASS A CLASS FREQUENCY (PERCENT) = 23.95

WIND DIRECTION FROM

SPEED MPH	N	NNE	NE	ENE	E	ESE	SE	SSE	S	SSW	SW	WSW	W	WNW	NW	NNW	VRBL	TOTAL
CALM	0	0	0	0	0	0	0	0	0	0	0	0	0	0	0	0	0	0
(1)	.00	.00	.00	.00	.00	.00	.00	.00	.00	.00	.00	.00	.00	.00	.00	.00	.00	.00
(2)	.00	.00	.00	.00	.00	.00	.00	.00	.00	.00	.00	.00	.00	.00	.00	.00	.00	.00
C-3	2	2	2	4	2	2	2	3	5	2	2	5	5	11	7	6	0	62
(1)	.13	.13	.13	.25	.13	.13	.13	.19	.32	.13	.13	.32	.32	.70	.45	.38	.00	3.95
(2)	.03	.03	.03	.06	.03	.03	.03	.05	.08	.03	.03	.08	.08	.17	.11	.09	.00	.95
4-7	21	16	5	10	22	13	13	10	9	17	19	23	15	39	28	36	0	296
(1)	1.34	1.02	.32	.64	1.40	.83	.83	.64	.57	1.08	1.21	1.46	.96	2.48	1.78	2.29	.00	18.85
(2)	.32	.24	.08	.15	.34	.20	.20	.15	.14	.26	.29	.35	.23	.59	.43	.55	.00	4.52
8-12	30	24	22	15	24	20	31	11	21	27	39	47	57	82	81	20	0	551
(1)	1.91	1.53	1.40	.96	1.53	1.27	1.97	.70	1.34	1.72	2.48	2.99	3.63	5.22	5.16	1.27	.00	35.10
(2)	.46	.37	.34	.23	.37	.31	.47	.17	.32	.41	.59	.72	.87	1.25	1.24	.31	.00	8.41
13-18	3	12	34	22	13	9	23	10	5	10	27	71	68	115	51	6	0	479
(1)	.19	.76	2.17	1.40	.83	.57	1.46	.64	.32	.64	1.72	4.52	4.33	7.32	3.25	.38	.00	30.51
(2)	.05	.18	.52	.34	.20	.14	.35	.15	.08	.15	.41	1.08	1.04	1.75	.78	.09	.00	7.31
19-24	1	3	9	4	8	2	3	2	1	2	17	23	25	40	17	4	0	161
(1)	.06	.19	.57	.25	.51	.13	.19	.13	.06	.13	1.08	1.46	1.59	2.55	1.08	.25	.00	10.25
(2)	.02	.05	.14	.06	.12	.03	.05	.03	.02	.03	.26	.35	.38	.61	.26	.06	.00	2.46
GT 24	0	0	1	3	3	4	0	0	0	0	1	1	2	4	2	0	0	21
(1)	.00	.00	.06	.19	.19	.25	.00	.00	.00	.00	.06	.06	.13	.25	.13	.00	.00	1.34
(2)	.00	.00	.02	.05	.05	.06	.00	.00	.00	.00	.02	.02	.03	.06	.03	.00	.00	.32
ALL SPEEDS	57	57	73	58	72	50	72	36	41	58	105	170	172	291	186	72	0	1570
(1)	3.63	3.63	4.65	3.69	4.59	3.18	4.59	2.29	2.61	3.69	6.69	10.83	10.96	18.54	11.85	4.59	.00	100.00
(2)	.87	.87	1.11	.88	1.10	.76	1.10	.55	.63	.88	1.60	2.59	2.62	4.44	2.84	1.10	.00	23.95

(1)=PERCENT OF ALL GOOD OBSERVATIONS FOR THIS PAGE
 (2)=PERCENT OF ALL GOOD OBSERVATIONS FOR THIS PERIOD
 C= CALM (WIND SPEED LESS THAN OR EQUAL TO .95 MPH)

SEABROOK JAN16-DEC16 MET DATA JOINT FREQUENCY DISTRIBUTION (210-FOOT TOWER)

209.0 FT WIND DATA STABILITY CLASS B CLASS FREQUENCY (PERCENT) = 4.24

WIND DIRECTION FROM

SPEED MPH	N	NNE	NE	ENE	E	ESE	SE	SSE	S	SSW	SW	WSW	W	WNW	NW	NNW	VRBL	TOTAL
CALM	0	0	0	0	0	0	0	0	0	0	0	0	0	0	0	0	0	0
(1)	.00	.00	.00	.00	.00	.00	.00	.00	.00	.00	.00	.00	.00	.00	.00	.00	.00	.00
(2)	.00	.00	.00	.00	.00	.00	.00	.00	.00	.00	.00	.00	.00	.00	.00	.00	.00	.00
C-3	0	1	1	0	0	0	0	0	0	0	0	0	0	0	0	0	0	2
(1)	.00	.36	.36	.00	.00	.00	.00	.00	.00	.00	.00	.00	.00	.00	.00	.00	.00	.72
(2)	.00	.02	.02	.00	.00	.00	.00	.00	.00	.00	.00	.00	.00	.00	.00	.00	.00	.03
4-7	1	0	0	0	1	3	3	0	5	3	5	0	4	4	3	4	0	36
(1)	.36	.00	.00	.00	.36	1.08	1.08	.00	1.80	1.08	1.80	.00	1.44	1.44	1.08	1.44	.00	12.95
(2)	.02	.00	.00	.00	.02	.05	.05	.00	.08	.05	.08	.00	.06	.06	.05	.06	.00	.55
8-12	6	2	1	8	7	7	10	1	3	4	7	17	17	10	13	5	0	118
(1)	2.16	.72	.36	2.88	2.52	2.52	3.60	.36	1.08	1.44	2.52	6.12	6.12	3.60	4.68	1.80	.00	42.45
(2)	.09	.03	.02	.12	.11	.11	.15	.02	.05	.06	.11	.26	.26	.15	.20	.08	.00	1.80
13-18	2	0	1	3	2	2	3	3	1	3	19	20	20	21	5	0	0	105
(1)	.72	.00	.36	1.08	.72	.72	1.08	1.08	.36	1.08	6.83	7.19	7.19	7.55	1.80	.00	.00	37.77
(2)	.03	.00	.02	.05	.03	.03	.05	.05	.02	.05	.29	.31	.31	.32	.08	.00	.00	1.60
19-24	0	0	1	1	0	0	0	0	0	0	1	1	0	3	1	0	0	8
(1)	.00	.00	.36	.36	.00	.00	.00	.00	.00	.00	.36	.36	.00	1.08	.36	.00	.00	2.88
(2)	.00	.00	.02	.02	.00	.00	.00	.00	.00	.00	.02	.02	.00	.05	.02	.00	.00	.12
GT 24	0	0	0	0	0	0	0	0	0	1	4	0	0	3	1	0	0	9
(1)	.00	.00	.00	.00	.00	.00	.00	.00	.00	.36	1.44	.00	.00	1.08	.36	.00	.00	3.24
(2)	.00	.00	.00	.00	.00	.00	.00	.00	.00	.02	.06	.00	.00	.05	.02	.00	.00	.14
ALL SPEEDS	9	3	4	12	10	12	16	4	9	11	36	38	41	41	23	9	0	278
(1)	3.24	1.08	1.44	4.32	3.60	4.32	5.76	1.44	3.24	3.96	12.95	13.67	14.75	14.75	8.27	3.24	.00	100.00
(2)	.14	.05	.06	.18	.15	.18	.24	.06	.14	.17	.55	.58	.63	.63	.35	.14	.00	4.24

(1)=PERCENT OF ALL GOOD OBSERVATIONS FOR THIS PAGE
 (2)=PERCENT OF ALL GOOD OBSERVATIONS FOR THIS PERIOD
 C= CALM (WIND SPEED LESS THAN OR EQUAL TO .95 MPH)

SEABROOK JAN16-DEC16 MET DATA JOINT FREQUENCY DISTRIBUTION (210-FOOT TOWER)

209.0 FT WIND DATA STABILITY CLASS C CLASS FREQUENCY (PERCENT) = 5.90

WIND DIRECTION FROM

SPEED MPH	N	NNE	NE	ENE	E	ESE	SE	SSE	S	SSW	SW	WSW	W	WNW	NW	NNW	VRBL	TOTAL
CALM	0	0	0	0	0	0	0	0	0	0	0	0	0	0	0	0	0	0
(1)	.00	.00	.00	.00	.00	.00	.00	.00	.00	.00	.00	.00	.00	.00	.00	.00	.00	.00
(2)	.00	.00	.00	.00	.00	.00	.00	.00	.00	.00	.00	.00	.00	.00	.00	.00	.00	.00
C-3	1	1	1	0	0	0	1	0	0	0	0	0	0	0	0	2	0	6
(1)	.26	.26	.26	.00	.00	.00	.26	.00	.00	.00	.00	.00	.00	.00	.00	.52	.00	1.55
(2)	.02	.02	.02	.00	.00	.00	.02	.00	.00	.00	.00	.00	.00	.00	.00	.03	.00	.09
4-7	1	2	0	0	2	1	3	0	3	1	4	3	10	2	2	5	0	39
(1)	.26	.52	.00	.00	.52	.26	.78	.00	.78	.26	1.03	.78	2.58	.52	.52	1.29	.00	10.08
(2)	.02	.03	.00	.00	.03	.02	.05	.00	.05	.02	.06	.05	.15	.03	.03	.08	.00	.59
8-12	17	5	5	14	16	12	8	9	3	5	12	27	15	21	17	3	0	189
(1)	4.39	1.29	1.29	3.62	4.13	3.10	2.07	2.33	.78	1.29	3.10	6.98	3.88	5.43	4.39	.78	.00	48.84
(2)	.26	.08	.08	.21	.24	.18	.12	.14	.05	.08	.18	.41	.23	.32	.26	.05	.00	2.88
13-18	2	2	3	3	2	2	2	4	0	1	21	17	14	28	13	2	0	116
(1)	.52	.52	.78	.78	.52	.52	.52	1.03	.00	.26	5.43	4.39	3.62	7.24	3.36	.52	.00	29.97
(2)	.03	.03	.05	.05	.03	.03	.03	.06	.00	.02	.32	.26	.21	.43	.20	.03	.00	1.77
19-24	0	0	1	1	1	1	1	0	0	1	3	1	3	15	4	0	0	32
(1)	.00	.00	.26	.26	.26	.26	.26	.00	.00	.26	.78	.26	.78	3.88	1.03	.00	.00	8.27
(2)	.00	.00	.02	.02	.02	.02	.02	.00	.00	.02	.05	.02	.05	.23	.06	.00	.00	.49
GT 24	0	0	0	0	0	0	0	0	0	0	1	0	1	3	0	0	0	5
(1)	.00	.00	.00	.00	.00	.00	.00	.00	.00	.00	.26	.00	.26	.78	.00	.00	.00	1.29
(2)	.00	.00	.00	.00	.00	.00	.00	.00	.00	.00	.02	.00	.02	.05	.00	.00	.00	.08
ALL SPEEDS	21	10	10	18	21	16	15	13	6	8	41	48	43	69	36	12	0	387
(1)	5.43	2.58	2.58	4.65	5.43	4.13	3.88	3.36	1.55	2.07	10.59	12.40	11.11	17.83	9.30	3.10	.00	100.00
(2)	.32	.15	.15	.27	.32	.24	.23	.20	.09	.12	.63	.73	.66	1.05	.55	.18	.00	5.90

(1)=PERCENT OF ALL GOOD OBSERVATIONS FOR THIS PAGE
 (2)=PERCENT OF ALL GOOD OBSERVATIONS FOR THIS PERIOD
 C= CALM (WIND SPEED LESS THAN OR EQUAL TO .95 MPH)

SEABROOK JAN16-DEC16 MET DATA JOINT FREQUENCY DISTRIBUTION (210-FOOT TOWER)

209.0 FT WIND DATA STABILITY CLASS D CLASS FREQUENCY (PERCENT) = 37.33

WIND DIRECTION FROM

SPEED MPH	N	NNE	NE	ENE	E	ESE	SE	SSE	S	SSW	SW	WSW	W	WNW	NW	NNW	VRBL	TOTAL
CALM	0	0	0	0	0	0	0	0	0	0	0	0	0	0	0	0	0	0
(1)	.00	.00	.00	.00	.00	.00	.00	.00	.00	.00	.00	.00	.00	.00	.00	.00	.00	.00
(2)	.00	.00	.00	.00	.00	.00	.00	.00	.00	.00	.00	.00	.00	.00	.00	.00	.00	.00
C-3	6	2	13	6	4	0	4	7	2	4	1	3	5	4	5	8	0	74
(1)	.25	.08	.53	.25	.16	.00	.16	.29	.08	.16	.04	.12	.20	.16	.20	.33	.00	3.02
(2)	.09	.03	.20	.09	.06	.00	.06	.11	.03	.06	.02	.05	.08	.06	.08	.12	.00	1.13
4-7	26	17	33	23	28	28	25	19	12	16	23	25	26	20	41	25	0	387
(1)	1.06	.69	1.35	.94	1.14	1.14	1.02	.78	.49	.65	.94	1.02	1.06	.82	1.68	1.02	.00	15.82
(2)	.40	.26	.50	.35	.43	.43	.38	.29	.18	.24	.35	.38	.40	.31	.63	.38	.00	5.90
8-12	82	29	33	23	42	39	29	44	42	66	85	94	72	121	122	57	0	980
(1)	3.35	1.19	1.35	.94	1.72	1.59	1.19	1.80	1.72	2.70	3.47	3.84	2.94	4.94	4.99	2.33	.00	40.05
(2)	1.25	.44	.50	.35	.64	.59	.44	.67	.64	1.01	1.30	1.43	1.10	1.85	1.86	.87	.00	14.95
13-18	48	23	20	21	9	8	11	27	17	61	105	58	85	134	68	17	0	712
(1)	1.96	.94	.82	.86	.37	.33	.45	1.10	.69	2.49	4.29	2.37	3.47	5.48	2.78	.69	.00	29.10
(2)	.73	.35	.31	.32	.14	.12	.17	.41	.26	.93	1.60	.88	1.30	2.04	1.04	.26	.00	10.86
19-24	9	9	8	9	17	0	1	10	2	19	11	8	57	72	15	0	0	247
(1)	.37	.37	.33	.37	.69	.00	.04	.41	.08	.78	.45	.33	2.33	2.94	.61	.00	.00	10.09
(2)	.14	.14	.12	.14	.26	.00	.02	.15	.03	.29	.17	.12	.87	1.10	.23	.00	.00	3.77
GT 24	0	1	2	0	0	3	1	2	3	1	2	0	6	25	1	0	0	47
(1)	.00	.04	.08	.00	.00	.12	.04	.08	.12	.04	.08	.00	.25	1.02	.04	.00	.00	1.92
(2)	.00	.02	.03	.00	.00	.05	.02	.03	.05	.02	.03	.00	.09	.38	.02	.00	.00	.72
ALL SPEEDS	171	81	109	82	100	78	71	109	78	167	227	188	251	376	252	107	0	2447
(1)	6.99	3.31	4.45	3.35	4.09	3.19	2.90	4.45	3.19	6.82	9.28	7.68	10.26	15.37	10.30	4.37	.00	100.00
(2)	2.61	1.24	1.66	1.25	1.53	1.19	1.08	1.66	1.19	2.55	3.46	2.87	3.83	5.74	3.84	1.63	.00	37.33

(1)=PERCENT OF ALL GOOD OBSERVATIONS FOR THIS PAGE
 (2)=PERCENT OF ALL GOOD OBSERVATIONS FOR THIS PERIOD
 C= CALM (WIND SPEED LESS THAN OR EQUAL TO .95 MPH)

SEABROOK JAN16-DEC16 MET DATA JOINT FREQUENCY DISTRIBUTION (210-FOOT TOWER)

209.0 FT WIND DATA STABILITY CLASS E CLASS FREQUENCY (PERCENT) = 18.72

WIND DIRECTION FROM

SPEED MPH	N	NNE	NE	ENE	E	ESE	SE	SSE	S	SSW	SW	WSW	W	WNW	NW	NNW	VRBL	TOTAL
CALM	0	0	0	0	0	0	0	0	0	0	0	0	0	0	0	0	0	0
(1)	.00	.00	.00	.00	.00	.00	.00	.00	.00	.00	.00	.00	.00	.00	.00	.00	.00	.00
(2)	.00	.00	.00	.00	.00	.00	.00	.00	.00	.00	.00	.00	.00	.00	.00	.00	.00	.00
C-3	8	2	5	4	8	4	3	1	5	8	2	3	3	1	0	3	0	60
(1)	.65	.16	.41	.33	.65	.33	.24	.08	.41	.65	.16	.24	.24	.08	.00	.24	.00	4.89
(2)	.12	.03	.08	.06	.12	.06	.05	.02	.08	.12	.03	.05	.05	.02	.00	.05	.00	.92
4-7	19	18	8	6	6	5	9	17	18	22	20	8	16	22	15	12	0	221
(1)	1.55	1.47	.65	.49	.49	.41	.73	1.39	1.47	1.79	1.63	.65	1.30	1.79	1.22	.98	.00	18.01
(2)	.29	.27	.12	.09	.09	.08	.14	.26	.27	.34	.31	.12	.24	.34	.23	.18	.00	3.37
8-12	50	7	12	9	4	2	10	25	20	50	77	79	72	117	78	30	0	642
(1)	4.07	.57	.98	.73	.33	.16	.81	2.04	1.63	4.07	6.28	6.44	5.87	9.54	6.36	2.44	.00	52.32
(2)	.76	.11	.18	.14	.06	.03	.15	.38	.31	.76	1.17	1.21	1.10	1.78	1.19	.46	.00	9.79
13-18	8	4	2	8	9	0	0	8	4	21	43	56	37	46	32	3	0	281
(1)	.65	.33	.16	.65	.73	.00	.00	.65	.33	1.71	3.50	4.56	3.02	3.75	2.61	.24	.00	22.90
(2)	.12	.06	.03	.12	.14	.00	.00	.12	.06	.32	.66	.85	.56	.70	.49	.05	.00	4.29
19-24	0	0	0	4	5	0	2	4	0	1	2	0	0	1	0	0	0	19
(1)	.00	.00	.00	.33	.41	.00	.16	.33	.00	.08	.16	.00	.00	.08	.00	.00	.00	1.55
(2)	.00	.00	.00	.06	.08	.00	.03	.06	.00	.02	.03	.00	.00	.02	.00	.00	.00	.29
GT 24	0	0	0	0	2	1	0	1	0	0	0	0	0	0	0	0	0	4
(1)	.00	.00	.00	.00	.16	.08	.00	.08	.00	.00	.00	.00	.00	.00	.00	.00	.00	.33
(2)	.00	.00	.00	.00	.03	.02	.00	.02	.00	.00	.00	.00	.00	.00	.00	.00	.00	.06
ALL SPEEDS	85	31	27	31	34	12	24	56	47	102	144	146	128	187	125	48	0	1227
(1)	6.93	2.53	2.20	2.53	2.77	.98	1.96	4.56	3.83	8.31	11.74	11.90	10.43	15.24	10.19	3.91	.00	100.00
(2)	1.30	.47	.41	.47	.52	.18	.37	.85	.72	1.56	2.20	2.23	1.95	2.85	1.91	.73	.00	18.72

(1)=PERCENT OF ALL GOOD OBSERVATIONS FOR THIS PAGE
 (2)=PERCENT OF ALL GOOD OBSERVATIONS FOR THIS PERIOD
 C= CALM (WIND SPEED LESS THAN OR EQUAL TO .95 MPH)

SEABROOK JAN16--DEC16 MET DATA JOINT FREQUENCY DISTRIBUTION (210-FOOT TOWER)

209.0 FT WIND DATA STABILITY CLASS F CLASS FREQUENCY (PERCENT) = 6.24

WIND DIRECTION FROM

SPEED MPH	N	NNE	NE	ENE	E	ESE	SE	SSE	S	SSW	SW	WSW	W	WNW	NW	NNW	VRBL	TOTAL
CALM	0	0	0	0	0	0	0	0	0	0	0	0	0	0	0	0	0	0
(1)	.00	.00	.00	.00	.00	.00	.00	.00	.00	.00	.00	.00	.00	.00	.00	.00	.00	.00
(2)	.00	.00	.00	.00	.00	.00	.00	.00	.00	.00	.00	.00	.00	.00	.00	.00	.00	.00
C-3	0	1	0	4	0	0	1	2	4	2	7	4	1	1	1	2	0	30
(1)	.00	.24	.00	.98	.00	.00	.24	.49	.98	.49	1.71	.98	.24	.24	.24	.49	.00	7.33
(2)	.00	.02	.00	.06	.00	.00	.02	.03	.06	.03	.11	.06	.02	.02	.02	.03	.00	.46
4-7	7	6	4	5	1	2	8	13	13	9	8	6	3	7	9	2	0	103
(1)	1.71	1.47	.98	1.22	.24	.49	1.96	3.18	3.18	2.20	1.96	1.47	.73	1.71	2.20	.49	.00	25.18
(2)	.11	.09	.06	.08	.02	.03	.12	.20	.20	.14	.12	.09	.05	.11	.14	.03	.00	1.57
8-12	14	4	2	1	1	0	0	7	12	15	14	26	36	46	35	10	0	223
(1)	3.42	.98	.49	.24	.24	.00	.00	1.71	2.93	3.67	3.42	6.36	8.80	11.25	8.56	2.44	.00	54.52
(2)	.21	.06	.03	.02	.02	.00	.00	.11	.18	.23	.21	.40	.55	.70	.53	.15	.00	3.40
13-18	9	3	0	1	0	0	0	2	1	1	2	7	8	5	11	3	0	53
(1)	2.20	.73	.00	.24	.00	.00	.00	.49	.24	.24	.49	1.71	1.96	1.22	2.69	.73	.00	12.96
(2)	.14	.05	.00	.02	.00	.00	.00	.03	.02	.02	.03	.11	.12	.08	.17	.05	.00	.81
19-24	0	0	0	0	0	0	0	0	0	0	0	0	0	0	0	0	0	0
(1)	.00	.00	.00	.00	.00	.00	.00	.00	.00	.00	.00	.00	.00	.00	.00	.00	.00	.00
(2)	.00	.00	.00	.00	.00	.00	.00	.00	.00	.00	.00	.00	.00	.00	.00	.00	.00	.00
GT 24	0	0	0	0	0	0	0	0	0	0	0	0	0	0	0	0	0	0
(1)	.00	.00	.00	.00	.00	.00	.00	.00	.00	.00	.00	.00	.00	.00	.00	.00	.00	.00
(2)	.00	.00	.00	.00	.00	.00	.00	.00	.00	.00	.00	.00	.00	.00	.00	.00	.00	.00
ALL SPEEDS	30	14	6	11	2	2	9	24	30	27	31	43	48	59	56	17	0	409
(1)	7.33	3.42	1.47	2.69	.49	.49	2.20	5.87	7.33	6.60	7.58	10.51	11.74	14.43	13.69	4.16	.00	100.00
(2)	.46	.21	.09	.17	.03	.03	.14	.37	.46	.41	.47	.66	.73	.90	.85	.26	.00	6.24

(1)=PERCENT OF ALL GOOD OBSERVATIONS FOR THIS PAGE
 (2)=PERCENT OF ALL GOOD OBSERVATIONS FOR THIS PERIOD
 C= CALM (WIND SPEED LESS THAN OR EQUAL TO .95 MPH)

SEABROOK JAN16-DEC16 MET DATA JOINT FREQUENCY DISTRIBUTION (210-FOOT TOWER)

209.0 FT WIND DATA STABILITY CLASS G CLASS FREQUENCY (PERCENT) = 3.62

WIND DIRECTION FROM

SPEED MPH	N	NNE	NE	ENE	E	ESE	SE	SSE	S	SSW	SW	WSW	W	WNW	NW	NNW	VRBL	TOTAL
CALM	0	0	0	0	0	0	0	0	0	0	0	0	1	0	0	0	0	1
(1)	.00	.00	.00	.00	.00	.00	.00	.00	.00	.00	.00	.00	.42	.00	.00	.00	.00	.42
(2)	.00	.00	.00	.00	.00	.00	.00	.00	.00	.00	.00	.00	.02	.00	.00	.00	.00	.02
C-3	3	2	1	2	1	1	0	1	1	2	1	1	3	4	2	3	0	28
(1)	1.27	.84	.42	.84	.42	.42	.00	.42	.42	.84	.42	.42	1.27	1.69	.84	1.27	.00	11.81
(2)	.05	.03	.02	.03	.02	.02	.00	.02	.02	.03	.02	.02	.05	.06	.03	.05	.00	.43
4-7	5	4	7	2	2	1	3	2	5	8	13	14	8	4	13	6	0	97
(1)	2.11	1.69	2.95	.84	.84	.42	1.27	.84	2.11	3.38	5.49	5.91	3.38	1.69	5.49	2.53	.00	40.93
(2)	.08	.06	.11	.03	.03	.02	.05	.03	.08	.12	.20	.21	.12	.06	.20	.09	.00	1.48
8-12	7	2	2	1	0	0	1	3	7	6	16	9	12	18	6	7	0	97
(1)	2.95	.84	.84	.42	.00	.00	.42	1.27	2.95	2.53	6.75	3.80	5.06	7.59	2.53	2.95	.00	40.93
(2)	.11	.03	.03	.02	.00	.00	.02	.05	.11	.09	.24	.14	.18	.27	.09	.11	.00	1.48
13-18	3	2	0	0	0	0	0	0	0	1	0	3	3	1	1	0	0	14
(1)	1.27	.84	.00	.00	.00	.00	.00	.00	.00	.42	.00	1.27	1.27	.42	.42	.00	.00	5.91
(2)	.05	.03	.00	.00	.00	.00	.00	.00	.00	.02	.00	.05	.05	.02	.02	.00	.00	.21
19-24	0	0	0	0	0	0	0	0	0	0	0	0	0	0	0	0	0	0
(1)	.00	.00	.00	.00	.00	.00	.00	.00	.00	.00	.00	.00	.00	.00	.00	.00	.00	.00
(2)	.00	.00	.00	.00	.00	.00	.00	.00	.00	.00	.00	.00	.00	.00	.00	.00	.00	.00
GT 24	0	0	0	0	0	0	0	0	0	0	0	0	0	0	0	0	0	0
(1)	.00	.00	.00	.00	.00	.00	.00	.00	.00	.00	.00	.00	.00	.00	.00	.00	.00	.00
(2)	.00	.00	.00	.00	.00	.00	.00	.00	.00	.00	.00	.00	.00	.00	.00	.00	.00	.00
ALL SPEEDS	18	10	10	5	3	2	4	6	13	17	30	27	27	27	22	16	0	237
(1)	7.59	4.22	4.22	2.11	1.27	.84	1.69	2.53	5.49	7.17	12.66	11.39	11.39	11.39	9.28	6.75	.00	100.00
(2)	.27	.15	.15	.08	.05	.03	.06	.09	.20	.26	.46	.41	.41	.41	.34	.24	.00	3.62

(1)=PERCENT OF ALL GOOD OBSERVATIONS FOR THIS PAGE
 (2)=PERCENT OF ALL GOOD OBSERVATIONS FOR THIS PERIOD
 C= CALM (WIND SPEED LESS THAN OR EQUAL TO .95 MPH)

SEABROOK JAN16-DEC16 MET DATA JOINT FREQUENCY DISTRIBUTION (210-FOOT TOWER)

209.0 FT WIND DATA STABILITY CLASS ALL CLASS FREQUENCY (PERCENT) = 100.00

WIND DIRECTION FROM

SPEED MPH	N	NNE	NE	ENE	E	ESE	SE	SSE	S	SSW	SW	WSW	W	WNW	NW	NNW	VRBL	TOTAL
CALM	0	0	0	0	0	0	0	0	0	0	0	0	1	0	0	0	0	1
(1)	.00	.00	.00	.00	.00	.00	.00	.00	.00	.00	.00	.00	.02	.00	.00	.00	.00	.02
(2)	.00	.00	.00	.00	.00	.00	.00	.00	.00	.00	.00	.00	.02	.00	.00	.00	.00	.02
C-3	20	11	23	20	15	7	11	14	17	18	13	16	17	21	15	24	0	262
(1)	.31	.17	.35	.31	.23	.11	.17	.21	.26	.27	.20	.24	.26	.32	.23	.37	.00	4.00
(2)	.31	.17	.35	.31	.23	.11	.17	.21	.26	.27	.20	.24	.26	.32	.23	.37	.00	4.00
4-7	80	63	57	46	62	53	64	61	65	76	92	79	82	98	111	90	0	1179
(1)	1.22	.96	.87	.70	.95	.81	.98	.93	.99	1.16	1.40	1.21	1.25	1.50	1.69	1.37	.00	17.99
(2)	1.22	.96	.87	.70	.95	.81	.98	.93	.99	1.16	1.40	1.21	1.25	1.50	1.69	1.37	.00	17.99
8-12	206	73	77	71	94	80	89	100	108	173	250	299	281	415	352	132	0	2800
(1)	3.14	1.11	1.17	1.08	1.43	1.22	1.36	1.53	1.65	2.64	3.81	4.56	4.29	6.33	5.37	2.01	.00	42.72
(2)	3.14	1.11	1.17	1.08	1.43	1.22	1.36	1.53	1.65	2.64	3.81	4.56	4.29	6.33	5.37	2.01	.00	42.72
13-18	75	46	60	58	35	21	39	54	28	98	217	232	235	350	181	31	0	1760
(1)	1.14	.70	.92	.88	.53	.32	.59	.82	.43	1.50	3.31	3.54	3.59	5.34	2.76	.47	.00	26.85
(2)	1.14	.70	.92	.88	.53	.32	.59	.82	.43	1.50	3.31	3.54	3.59	5.34	2.76	.47	.00	26.85
19-24	10	12	19	19	31	3	7	16	3	23	34	33	85	131	37	4	0	467
(1)	.15	.18	.29	.29	.47	.05	.11	.24	.05	.35	.52	.50	1.30	2.00	.56	.06	.00	7.12
(2)	.15	.18	.29	.29	.47	.05	.11	.24	.05	.35	.52	.50	1.30	2.00	.56	.06	.00	7.12
GT 24	0	1	3	3	5	8	1	3	3	2	8	1	9	35	4	0	0	86
(1)	.00	.02	.05	.05	.08	.12	.02	.05	.05	.03	.12	.02	.14	.53	.06	.00	.00	1.31
(2)	.00	.02	.05	.05	.08	.12	.02	.05	.05	.03	.12	.02	.14	.53	.06	.00	.00	1.31
ALL SPEEDS	391	206	239	217	242	172	211	248	224	390	614	660	710	1050	700	281	0	6555
(1)	5.96	3.14	3.65	3.31	3.69	2.62	3.22	3.78	3.42	5.95	9.37	10.07	10.83	16.02	10.68	4.29	.00	100.00
(2)	5.96	3.14	3.65	3.31	3.69	2.62	3.22	3.78	3.42	5.95	9.37	10.07	10.83	16.02	10.68	4.29	.00	100.00

(1)=PERCENT OF ALL GOOD OBSERVATIONS FOR THIS PAGE
 (2)=PERCENT OF ALL GOOD OBSERVATIONS FOR THIS PERIOD
 C= CALM (WIND SPEED LESS THAN OR EQUAL TO .95 MPH)

Enclosure 3

Radiation Dose Assessment

**Seabrook Station
Radiological Effluent Impact Assessment For 2016
(Annual Radioactive Effluent Release Report)**

I. Summary

Seabrook Technical Specification Sections 6.7.6.g.4 & 9 require that limitations be placed on the quarterly and annual doses or dose commitments to Members of the Public from radioactive materials in liquid and gaseous effluents released from the station to Unrestricted Areas at or beyond the site boundary conforming to the dose objectives of Appendix I to 10 CFR Part 50. Technical Specification 6.7.6.g.8 requires that limitations on the quarterly and annual air doses resulting from noble gases released in gaseous effluents to areas beyond the site boundary also conform to Appendix I to 10 CFR Part 50. In a similar fashion, Technical Specification 6.7.6.g.11 requires limitations on the annual dose or dose commitment to any Member of the Public due to radioactivity and radiation from uranium fuel cycle sources conforming to the EPA Radiation Standards in 40 CFR Part 190. The following table details the above referenced effluent dose limits.

DOSE OBJECTIVE CRITERIA FOR COMPLIANCE

EFFLUENT TYPE	DOSE TYPE	QUARTERLY LIMITS	ANNUAL LIMITS
LIQUIDS (10CFR50, APP. I)	Total Body	1.5 mrem	3 mrem
	Max. Organ	5 mrem	10 mrem
NOBLE GAS (10CFR50, APP. I)	Gamma Air	5 mrad	10 mrad
	Beta Air	10 mrad	20 mrad
GAS PARTICULATE (10CFR50, APP. I)	Max. Organ	7.5 mrem	15 mrem
TOTAL DOSE (40CFR190) [liquids, gas, direct]	Total Body & organ		25 mrem
	Thyroid	---	75 mrem

Technical Specification 6.8.1.4 and the Seabrook Offsite Dose Calculation Manual (ODCM) Part A, Section 10.2, provide that the Station's Annual Radioactive Effluent Release Report include a demonstration of compliance with the above off-site dose limitations, as well as the determination of dose impacts to Members of the Public who may be associated with permitted activities inside the site boundary.

Doses resulting from actual liquid and gaseous effluents from Seabrook Station during 2016 were calculated in accordance with Method II as defined in the Station ODCM. The calculation methods follow the models in Regulatory Guide 1.109 (Reference 1). The assessments included maximum whole body doses and organ doses from all liquid releases, maximum offsite organ doses resulting from airborne Iodine, Tritium, Carbon-14 and particulate radionuclides with half-lives greater than eight days, and maximum offsite beta air and gamma air doses from airborne noble gases. Calculated dose impacts from airborne effluents included atmospheric dispersion estimates utilizing concurrent meteorology recorded by the Station's on-site meteorological tower. In addition, the potential direct dose from fixed radiation

sources from both plant operations and dry fuel storage were evaluated as part of the assessment required under 40 CFR Part 190 for doses from the uranium fuel cycle.

Doses were also calculated for three special receptor locations inside the site boundary where the public might be granted access for recreational or educational purposes. The Science and Nature Center is located in the southwest portion of the site and offers educational opportunities on nuclear power and the environment. The Fitness Center located in the Hi-Rise office building, approximately 384 meters WSW from the plant vent stack. A third on-site location considered is the Firing Range for security force training (including local law enforcement), which straddles the West site boundary at approximately 974 meters from the plant vent stack. Another location which had been included in the past was the “Rocks” boat launching ramp in an area northeast of the main plant facilities with access to Brown’s Creek and the tidal marsh that borders the site. This location has been dropped from consideration of public on-site activities due to restricted public access limitation as a result of security and safety concerns and abandonment of the boat launching ramp.

All calculated liquid and gaseous pathway doses for the 2016 reporting period are well below the dose criteria of 10 CFR Part 50, Appendix I, and the dose limits for effluent releases stated in the ODCM. In addition, the total dose to the most limiting Member of the Public due to the combined exposure to plant liquid and gaseous effluents and direct radiation from fixed plant and dry fuel storage sources was below the dose standards of 40 CFR Part 190.

II. Method for Calculating the Total Body and Maximum Organ Doses Resulting from Liquid Releases

Liquid waste generated during plant operations is processed and discharged to the environment via the station's circulating water cooling system. The cooling system utilizes an offshore-submerged multi-port diffuser discharge for rapid dissipation and mixing of liquid effluents in the ocean environment. A 22-port diffuser section of the discharge system is located in approximately 50 to 60 feet of water with each nozzle 7 to 10 feet above the sea floor. Eleven riser shafts, with two discharge nozzles for each diffuser, are spaced about 100 feet apart over a distance of about 1000 feet. Water is discharged in a generally eastward direction away from the shoreline through the multiport diffuser, beginning at a location over one mile offshore. During power operations, these high velocity jets passively entrain about ten volumes of fresh water into the near field jet-mixing region before the plume reaches the water surface. This arrangement also effectively prevents the discharge plume (at least to the 1 degree or 40 to 1 dilution isopleth) from impacting the shoreline over the tidal cycle.

During shutdown periods, the high velocity jet mixing created by the normal circulating water flow at the diffuser nozzles is reduced. However, mixing within the discharge tunnel water volume is significantly increased due to the long transit time for batch discharges to travel the three miles from the plant through the 19-foot diameter tunnels to the diffuser nozzles. Additional mixing of the effluent in the near field assures that an equivalent overall 10 to 1 dilution occurs by the time the effluent reaches the ocean surface.

The exposure pathways considered in the calculations of total body and maximum organ doses resulting from liquid discharges from Seabrook Station are limited to ingestion of aquatic foods and exposure to shoreline deposits. The dose calculations do not include the ingestion of potable water or irrigated vegetation as potential exposure pathways because the liquid effluents from the plant are discharged into salt water.

The dose assessment models utilized in the Offsite Dose Calculation Manual (Reference 2) are taken from Regulatory Guide 1.109 (Reference 1). The total body and organ doses are evaluated for each of the four age groups (i.e., infant, child, teen and adult) to determine the maximum total body dose and maximum organ dose via all existing exposure pathways (i.e., fish and aquatic invertebrate ingestion, and shoreline exposure) to an age-dependent individual from all detected radionuclides in plant releases. The values for the various factors considered in the model equations are provided in Regulatory Guide 1.109 and the ODCM (see Table D). The flow rate (F) of the liquid effluent and the radionuclide activities (Q_i) are measured specifically prior to each liquid release. The values for half-lives for radionuclides ($T_{1/2}$) and their radioactive decay constants (λ_i) have been taken from Kocher (Reference 3).

Table A presents the calculated liquid pathway doses for each calendar quarter and total for the year. The calculated annual doses as a percent of the applicable regulatory limits are shown in Table C. The estimated quarterly and annual doses resulting from liquid effluents to members of the public are well below all dose limit criteria.

III. Method for Calculating the Gamma and Beta Air Doses from Noble Gases

Gamma and beta air doses due to noble gases in gaseous effluents are calculated for several receptor locations when noble gases are recorded in effluents. Those locations include the points in each of the sixteen principle compass directions of estimated highest off-site ground level air concentration of radioactive material, site boundary (or closest point on the opposite shoreline in directions which are bordered by the tidal marsh), nearest resident, nearest vegetable garden, and nearest milk animal within five miles. The special on-site receptor locations (Science and Nature Center, the Fitness Center and the Firing Range) are evaluated for whole body dose to an individual from the noble gas component of effluents predicted to pass nearby.

Atmospheric dispersion factors (i.e., X/Q factors) calculated from recorded concurrent site meteorological data (i.e., meteorological data measurements taken during the time of the release) are used in the estimation of receptor specific air concentrations due to station effluents. The atmospheric dispersion estimations utilize methodology generally consistent with US NRC Regulatory Guide 1.111 (Reference 4). Beta air doses use undepleted X/Qs and assume a semi-infinite plume at the point of exposure. Gamma air doses are calculated using the finite cloud model presented in “Meteorology and Atomic Energy – 1968” (Reference 5). That model is implemented through the definition of an effective gamma atmospheric dispersion factor $[X/Q^\gamma]$ (Reference 6) and the replacement of the undepleted X/Q in the infinite cloud dose equation by $[X/Q^\gamma]$.

The release point of effluents is also considered in the atmospheric dispersion calculation. The primary vent stack is treated as a “mixed-mode” release, as defined in Regulatory Guide 1.111 (Reference 4). These effluents are considered to be part-time ground level / part-time elevated releases, depending on the ratio of primary vent stack exit velocity relative to the speed of prevailing wind. All other release points (e.g., Turbine Building and Chemistry lab hoods) are considered ground-level releases. The beta air and gamma air dose calculations are consistent with the models presented in Regulatory Guide 1.109 (Reference 1). The values for the dose factors, DF_i^γ and DF_i^β , have been taken from Table B-1 in Regulatory Guide 1.109.

Table A presents the calculated maximum off-site gamma air and beta air doses for each calendar quarter and year. The calculated annual doses as a percent of the applicable regulatory limit are shown in Table C. The estimated quarterly and annual air doses resulting from noble gas effluents are well below all dose limit criteria.

IV. Method for Calculating the Critical Organ Dose Resulting from Iodines, Tritium, Carbon-14 and Particulates with T_{1/2} Greater than 8 Days in Gaseous Releases

Regulatory Guide 1.109 (Reference 1) dose models are applied in the calculation of the critical organ doses from Iodines, Tritium, Carbon-14 and particulate radionuclides released into the atmosphere during the reporting period. Atmospheric dispersion and deposition factors (i.e., depleted X/Q and D/Q factors) calculated with concurrent meteorological data (i.e., meteorological data measurements taken during the time of the release) are used in the determination of gaseous pathway doses. The dispersion models are described in Section B.7.3.2 & B.7.3.3 of the Seabrook ODCM.

Potential exposure pathways associated with gaseous effluent are (i) external irradiation from radioactivity deposited on the ground surface, (ii) inhalation, and (iii) ingestion of vegetables (both fresh leafy and stored) and milk. Dose estimates were determined for the site boundary and for the locations of the nearest resident, vegetable garden, and milk animal in each of the sixteen principle compass directions. The locations of the nearest resident, vegetable garden and milk animal in each sector were identified by the 2016 Annual Land Use Census as required by ODCM Control C.9.2.1 (see Table F). Conservatism in the dose estimates was maintained by assuming that the vegetable garden pathway was active at each milk animal location. Milk animals were assumed to receive their entire intake from pasture during the second and third quarters. This is a conservative assumption because most dairy operations utilize supplemental feeding when animals are on pasture, or actually restrict animals to full time silage feeding throughout the entire year. Table E provides the reference sources for dose model parameter assumptions used in the dose assessment.

In June 2009, the NRC issued Revision 2 of Regulatory Guide 1.21 (Reference 7) which introduced the term “principal radionuclide” in a risk informed or dose context. A radionuclide can be considered a principal radionuclide if it contributes either (1) greater than 1 percent of the 10 CFR Part 50, Appendix I design objective dose for all radionuclides in the type of effluent being considered, or (2) greater than 1 percent of the activity of all radionuclides in the type of effluent being considered. In addition to natural production in the environment, Carbon-14 is also produced in nuclear reactors as a function of power output, but at amounts much less than those generated naturally or from past weapons testing. Since the time of the earlier publication of Regulatory Guide 1.21 (Revision 1) in 1974, commercial nuclear power plants have decreased total radioactive effluents (other than Carbon-14) through improved fuel performance and waste management practices to the point today that Carbon-14 could be considered a principal radionuclide under today’s definition, and therefore has been included in the assessment of dose to the public from gaseous effluent releases for 2016.

The primary exposure pathways associated with Carbon-14 include inhalation and ingestion of food products that have incorporated Carbon-14 (in the form of CO₂) via photosynthesis. A full year’s consumption of food products are assumed to be grown from the highest impacted garden during the growing season (2nd and 3rd quarters). It is also assumed that the garden grows sufficient mass to support ingestion throughout the year (i.e., the annual dose to the individual is from consumption during all four quarters).

The maximum organ doses from all radionuclides in this category of gaseous effluents were determined by summing the contributions from all exposure pathways at each location, and sorting in descending order.

Doses were calculated for the whole body, GI-LLI, bone, liver, kidney, thyroid, lung, and skin for adults, teenagers, children, and infants. The estimated quarterly and annual organ doses at the location of the maximally exposed individual are reported in Table A.

The estimated organ doses from Iodines, Tritium, Carbon-14 and Particulates in gaseous effluents are well below the 10 CFR Part 50, Appendix I dose criteria for the reporting period. (See Table C for calculated dose as a percentage of annual limits.)

V. Total Dose (40 CFR Part 190)

40 CFR 190 states that the annual dose equivalent should not exceed 25 mrem to the whole body, 75 mrem to the Thyroid, or 25 mrem to any other organ of any Member of the Public at and beyond the site boundary from all uranium fuel cycle sources. To show compliance with this standard, the maximum doses for both the liquid and gaseous pathways from Seabrook Station are added together with the whole body dose from noble gas releases and any direct radiation component attributed to station fixed sources to the maximum receptor location. This includes the addition of spent fuel storage in a Dry Fuel Storage (DFS) facility that began operations in July 2008 with the first transfer of spent fuel assemblies into storage arrays. A second transfer of spent fuel assemblies to the DFS occurred between August and September, 2013. The DFS facility is located on Seabrook Station property approximately 0.38 miles West-Southwest of the Unit 1 Containment Building. Since there are no other uranium fuel cycle facilities within five miles of Seabrook Station, no additional impacts from sources beyond Seabrook Station need be considered.

The sum of the maximum annual whole body doses to Members of the Public from all exposure pathways for liquid and gaseous effluents, plus the direct external dose from plant and dry fuel storage fixed sources, was 5.86E-02 mrem to a hypothetical individual at or beyond the site boundary. The maximum organ dose (including the thyroid) to any age group from all exposure pathways including direct radiation was 2.58E-01 mrem.

Table B illustrates the total dose projections from all station sources to the maximum potential off-site individual for the year 2016 and demonstrates compliance with the EPA's environmental radiation standard for the uranium fuel cycle per 40 CFR Part 190. (See Table C for total dose as a percentage of annual limits.)

VI. References

1. Regulatory Guide 1.109, Revision 1, "Calculation of Annual Doses to Man from Routine Releases of Reactor Effluents for the Purposes of Evaluating Compliance with 10CFR Part 50, Appendix I", USNRC, October 1977.
2. Seabrook Station Program Manual: Offsite Dose Calculation Manual (ODCM), Revision 37.
3. Kocher, D.C., "Dose-Rate Conversion Factors for Exposure to Photons and Electrons", Health Physics, Vol. 45, No. 3, Sept. 1983.
4. Regulatory Guide 1.111, Revision 1, "Method for Estimating Atmospheric Transport and Dispersion of Gaseous Effluents in Routine Releases from Light-Water Cooled Reactors", USNRC, July 1977.
5. Slade, D.H., "Meteorology and Atomic Energy – 1968", USAEC, July 1968.
6. Hamawi, J.N., "AEOLUS-2 A Computer Code for the Determination of Continuous and Intermittent-Release Atmospheric Dispersion and Deposition of Nuclear Power Plant Effluents in Open-Terrain Sites, Coastal Sites, and Deep-River Valleys for the Assessment of Ensuing Doses and Finite-Cloud Gamma Radiation Exposures", Entech Engineering, Inc., March 1988.
7. Regulatory Guide 1.21, Revision 2, "Measuring, Evaluating, and Reporting Radioactive Material in Liquid and Gaseous Effluents and Solid Waste", USNRC, June 2009.

Table A

Seabrook Station
2016 Annual Radioactive Effluent Release Report

Maximum^(a) Off-Site Doses and Dose Commitments to Members of the Public

Release Type	Dose (mrem) ^(b)				
	1st Quarter	2nd Quarter	3rd Quarter	4th Quarter	Year ^(c) 2016
Liquid Effluents:					
Total Body Dose	6.72E-05 (1)	5.59E-05 (1)	3.91E-05 (1)	4.67E-05 (1)	2.09E-04
Max Organ Dose	1.54E-04 (2)	7.44E-05 (2)	5.04E-05 (2)	5.28E-05 (2)	3.32E-04
Airborne Effluents:					
Organ Dose from Carbon-14, Iodines, Tritium, and Particulates ($T_{1/2} > 8$ days)	6.32E-02 (3)	6.80E-02 (3)	6.38E-02 (3)	6.25E-02 (3)	2.58E-01
Noble Gases					
Beta Air (mrad)	4.82E-07 (4)	5.46E-07 (5)	6.16E-07 (6)	1.18E-07 (7)	1.76E-06
Gamma Air (mrad)	1.05E-06 (4)	2.26E-06 (5)	1.58E-06 (6)	3.34E-07 (7)	5.22E-06
Direct Dose Offsite From Station Operation ^(e)	0	0	0	0	0
Doses (mrem) at Receptor Locations Inside Site Boundary ^(d) :					
Science and Nature Center (SW, 488m): Max Organ Dose (mrem)	3.91E-06	1.26E-05	7.86E-06	1.22E-06	2.56E-05
The Firing Range (W, 974m) Max Organ Dose	7.69E-05	2.23E-04	1.18E-04	3.07E-05	4.49E-04
The Fitness Center (WSW, 384m): Max Organ Dose (mrem)	2.96E-04	6.67E-04	4.25E-04	8.52E-05	1.47E-03

Table A (continued)

Seabrook Station
2016 Annual Radioactive Effluent Release Report

Maximum^(a) Off-Site Doses and Dose Commitments to Members of the Public

NOTES:

- (a) "Maximum" means the largest fraction of corresponding 10CFR50, Appendix I, dose design objective.
- (b) The numbered footnotes indicate the age group, organ, and location (compass sector and distance from the primary vent in meters) of the critical receptor, where appropriate, based on the most limiting radionuclide dose contributor (C-14).
- (1) Adult
 - (2) GI-LLI of an Adult
 - (3) Bone of a child, NW 1178 m
 - (4) ESE 2276 m
 - (5) WSW 1022 m
 - (6) WNW 930 m
 - (7) SSE 914m
- (c) "Maximum" dose for the year is the sum of the maximum doses for each quarter. This results in a conservative yearly dose estimate, but still well within the limits of 10CFR50.
- (d) For each special receptor location, the whole body and organ doses calculated for the airborne effluent releases were adjusted by the occupancy factors (i.e., 0.0014 for the Science and Nature Center and 0.0416 for the Fitness Center and Firing Range). The most limiting on-site location with respect to dose is estimated to be the Fitness Center located in the Hi-Rise office building due to relatively close location to the plant vent stack. An alternate TLD assessment method from National Standard ANSI/HPS N13.37-2014 did detect a statistical positive TLD related dose in the third quarter at the on-site Fitness Center of 4.8 mR, corrected for occupancy time to 0.05 mR for the quarter. For the annual period the statistical dose above background was calculated to be 14.8 mR, corrected for annual occupancy time to 0.6 mR.
- (e) Only station sources (both plant and dry fuel storage) are considered since there are no other fuel cycle facilities within five miles of Seabrook Station site. Dosimeter data collected in 2016 for the closest off-site environmental TLD locations in each sector (as listed in Tables B.4-1 and B.4-2 of Seabrook's ODCM) were compared to preoperational data for the same locations. No statistical difference above random background variability which could be attributed to station sources was identified.

Table B
 Seabrook Station
 2016 Annual Radioactive Effluent Release Report

Total Dose to Maximum Off-Site Individual
(40CFR190)

Release Source	Total Body (mrem)	Maximum Organ ^(a) (mrem)
Liquids	2.09E-04	3.32E-04
Noble Gases	3.47E-06	3.47E-06
Gaseous Iodines, Tritium, C-14 & Particulates ($T_{1/2} > 8$ days)	5.84E-02	2.58E-01
Direct Radiation	0	0
Annual Total	5.86E-02	2.58E-01

(a) Maximum organ includes consideration of the thyroid.

Table C

Seabrook Station
2016 Annual Radioactive Effluent Release Report

Calculated 2016 Maximum Doses versus Applicable Limits

Receptor	Applicable ODCM Control	ODCM Annual Limit	Calculated Annual (2016) Dose	Percent of Limit
Offsite				
Liquid Effluents				
Whole Body Dose	C.6.2.1	3 mrem	2.09E-04 mrem	0.0070%
Organ Dose	C.6.2.1	10 mrem	3.32E-04 mrem	0.0033%
Airborne Effluents				
Organ Dose (iodines, H-3, C-14 and part.)	C.7.3.1	15 mrem	2.58E-01 mrem	1.72%
Gamma Air Dose (noble gases)	C.7.2.1	10 mrad	5.22E-06 mrad	0.0001%
Beta Air Dose (noble gases)	C.7.2.1	20 mrad	1.76E-06 mrad	0.00001%
All Station Sources ^(a)				
Whole Body Dose	C.8.1.1	25 mrem	5.86E-02 mrem	0.234%
Organ Dose	C.8.1.1	25 mrem	2.58E-01 mrem	1.03%
Onsite (Science & Nature Center, 488m SW)				
Organ Dose (iodines, H-3, C-14 and part.)	C.7.3.1 ^(b)	15 mrem	2.56E-05 mrem	0.00017%
Onsite (The Firing Range, 974m W)				
Organ Dose (iodines, H-3, C-14 and part.)	C.7.3.1 ^(b)	15 mrem	4.49E-04 mrem	0.0030%
Onsite (Fitness Center, 384m WSW)				
Organ Dose (iodines, H-3, C-14 and part.)	C.7.3.1 ^(b)	15 mrem	1.47E-03 mrem	0.0098%

(a) The "all station sources" doses are the sum of the whole body doses and maximum organ doses from liquid, noble gas, and gaseous iodines/tritium/carbon-14/particulate releases as well as direct radiation from fixed station sources (both plant facilities and dry fuel storage).

(b) ODCM Part A, Section 10.2 states that the annual effluent report shall include an assessment of the radiation doses from radioactive liquids and gaseous effluents to members of the public due to their activities inside the site boundary during the report period. The referenced limits (C.7.2.1 & C.7.3.1) are the acceptable doses from liquid and gaseous effluents to areas at and beyond the site boundary and are considered to be appropriate for comparison purposes.

Table D
 Seabrook Station
 2016 Annual Radioactive Effluent Release Report
Sources of the Values of Factors Used in Liquid Dose Equations

Factor	Definition	Source
U_{ap}	Usage factor	Table B.7-1, Station ODCM
M_p	Mixing ratio	Section B.7.1, Station ODCM (value=0.1 for aquatic foods and 0.025 for shoreline)
B_{ip}	Equilibrium bioaccumulation factor	Table A-1, Reg. Guide 1.109
D_{aipj}	Dose factor	Tables E-11 through E-14, R.G. 1.109
t_p	Nuclide transit time	Table E-15, Reg. Guide 1.109
K_c	Transfer coefficient from water to sediment	Reg. Guide 1.109
t_b	Period of activity buildup in sediment or soil	Table B.7-2, Station ODCM
W	Shoreline width factor	Table A-2, Reg. Guide 1.109 (value = 0.5)

Table E

Seabrook Station
2016 Annual Radioactive Effluent Release Report

Sources of Values for the Factors Used in Dose Equations for Gaseous Releases

Factor	Definition	Source
t_b	Period of activity buildup in sediment or soil	Table B.7-2, Station ODCM
λ_i	Nuclide decay constant	Kocher (Reference 3)
DFG_{ij}	Ground plane dose factor	Table E-6, Reg. Guide 1.109
$[X/Q]$	Atmospheric dispersion factor (non-depleted)	Calculated following Reg. Guide 1.111
$[X/Q]^D$	Atmospheric dispersion factor (depleted)	Calculated following Reg. Guide 1.111
R_a	Breathing rate	Table B.7-3, Station ODCM
DFA_{ija}	Inhalation dose factor	Tables E-7 through E-10, Reg. Guide 1.109
d_i	Nuclide deposition rate	Reg. Guide 1.109
P	Soil surface density	Table B.7-2, Station ODCM
t_e	Crop, leafy vegetable, or pasture grass exposure period	Table B.7-2, Station ODCM
t_h	Average time from crop harvest to consumption	Table B.7-2, Station ODCM
Y_v	Agricultural productivity by unit area	Table B.7-2, Station ODCM
r	Fraction of deposited activity retained on crops, leafy vegetables, or pasture grass	Table E-15, Reg. Guide 1.109
B_{iv}	Stable element transfer coefficient from soil to produce, leafy vegetable, or pasture grass	Table E-1, Reg. Guide 1.109
p	Fractional equilibrium ratio	Reg. Guide 1.109
H	Ambient absolute humidity	Table B.7-2, Station ODCM

Table E (continued)

Seabrook Station
2016 Annual Radioactive Effluent Release Report

Sources of Values for the Factors Used in Dose Equations for Gaseous Releases

Factor	Definition	Source
F_m	Stable element transfer coefficient from feed to milk	Tables E-1 and E-2, Reg. Guide 1.109
t_f	Average time from feed to milk to consumption	Reg. Guide 1.109
f_p	Fraction of the year that animals graze on pasture	Table B.7-2, Station ODCM
f_s	Fraction daily feed pasture grass	Table B.7-2, Station ODCM
F_f	Stable element transfer coefficient from feed to meat	Table E-1, Reg. Guide 1.109
t_s	Average time from meat animal slaughter to consumption	Table E-15, Reg. Guide 1.109
DFI_{ija}	Ingestion dose factor	Tables E-11 through E-14, R.G.1.109
U_a^v	Annual intake of produce	Table B.7-3, Station ODCM
U_a^m	Annual intake of milk	Table B.7-3, Station ODCM
U_a^F	Annual intake of meat	Table B.7-3, Station ODCM
U_a^L	Annual intake of leafy vegetables	Table B.7-3, Station ODCM
f_g	Ingestion rate fractions for garden produce	Reg. Guide 1.109
f_l	Ingestion rate fractions for garden leafy vegetables	Reg. Guide 1.109
λ_w	Rate constant for activity removal from plant and leaf surfaces by weathering	Table E-15, Reg. Guide 1.109
Q_F	Animal consumption rate	Table E-3, Reg. Guide 1.109

Table F
 Seabrook Station
 2016 Annual Radioactive Effluent Release Report

Receptor Locations* for Seabrook Station

Sector	Nearest Resident km (miles)	Nearest Garden km (miles)	Milk Animals within 5 Mile Radius km (miles)
N	2.78 (1.73)	3.99 (2.48)	---
NNE	3.09 (1.92)	3.08 (1.91)	---
NE	2.92 (1.82)	4.20 (2.61)	---
ENE	2.31 (1.44)	2.44 (1.52)	---
E	2.56 (1.59)	---	---
ESE	2.43 (1.51)	2.76 (1.71)	---
SE	2.36 (1.46)	4.69 (2.91)	---
SSE	1.65 (1.02)	---	---
S	1.21(0.75)	1.25 (0.77)	---
SSW	1.12 (0.69)	1.22 (0.76)	---
SW	1.13 (0.70)	1.57 (0.97)	4.52 (2.81)
WSW	1.87 (1.16)	2.33 (1.45)	---
W	1.25 (0.78)	1.55 (0.96)	---
WNW	1.11 (0.69)	1.52 (0.94)	---
NW	1.22 (0.76)	2.35 (1.46)	6.93 (4.30)
NNW	1.04 (0.64)	1.07 (0.67)	5.32 (3.31) ¹

¹ Owner could not be contacted to determine if goats were milking.

* Locations based on 2016 Land Use Census.

Enclosure 4

Offsite Dose Calculation Manual (ODCM), Revision 37

**SEABROOK STATION
PROGRAM MANUAL**

Offsite Dose Calculation Manual

ODCM
Rev. 37

Manual Owner:
D. A. Robinson

ABSTRACT

The Offsite Dose Calculation Manual (ODCM) contains details to implement the requirements of Technical Specifications 6.7.6g and 6.7.6h.

The Offsite Dose Calculation Manual (ODCM) is divided into two parts: (1) the Radioactive Effluent Controls Program for both in-plant radiological effluent monitoring of liquids and gases, along with the Radiological Environmental Monitoring Program (REMP) (Part A); and (2) approved methods to determine effluent monitor setpoint values and estimates of doses and radionuclide concentrations occurring beyond the boundaries of Seabrook Station resulting from normal Station operation (Part B).

The sampling and analysis requirements of the Radioactive Effluent Controls Program, specified in Part A, provide the inputs for the models of Part B in order to calculate offsite doses and radionuclide concentrations necessary to determine compliance with the dose and concentration requirements of the Station Technical Specification 6.7.6g. The REMP required by Technical Specification 6.7.6h, and as specified within this manual, provides the means to determine that measurable concentrations of radioactive materials released as a result of the operation of Seabrook Station are not significantly higher than expected.

Revisions to the ODCM require an interdisciplinary review documented on the following page as well as a SORC review prior to implementing the change. An interdisciplinary review includes as a minimum the potential impact the change has on the respective departments' programs and procedures. The interdisciplinary review shall involve the following departments: Chemistry, Radiation Protection, I&C, and Operations. The Originator shall ensure the interdisciplinary reviews are completed prior to the SORC meeting.

OFFSITE DOSE CALCULATION MANUAL
(ODCM)

TABLE OF CONTENTS

<u>CONTENT</u>	<u>PAGE</u>
PART A: RADIOLOGICAL EFFLUENT CONTROL AND ENVIRONMENTAL MONITORING PROGRAMS	
1.0 INTRODUCTION	A.1-1
2.0 RESPONSIBILITIES (PART A)	A.2-1
3.0 DEFINITIONS	A.3-1
4.0 CONTROL AND APPLICABILITY	A.4-1
5.0 RADIOACTIVE EFFLUENT MONITORING INSTRUMENTATION	A.5-1
5.1 Liquids	A.5-1
5.2 Radioactive Gaseous Effluent Monitoring Instrumentation	A.5-11
6.0 RADIOACTIVE LIQUID EFFLUENTS	A.6-1
6.1 Concentration	A.6-1
6.2 Dose	A.6-9
6.3 Liquid Radwaste Treatment System	A.6-11
7.0 RADIOACTIVE GASEOUS EFFLUENTS	A.7-1
7.1 Dose Rate	A.7-1
7.2 Dose - Noble Gases	A.7-7
7.3 Dose - Iodine-131, Iodine-133, Tritium, and Radioactive Material in Particulate Form	A.7-9
7.4 Gaseous Radwaste Treatment System	A.7-11
8.0 TOTAL DOSE	A.8-1
9.0 RADIOLOGICAL ENVIRONMENTAL MONITORING	A.9-1
9.1 Plant Operations Monitoring Program	A.9-1
9.2 Land Use Census	A.9-11

<u>CONTENT</u>	<u>PAGE</u>
9.3 Interlaboratory Comparison Program	A.9-13
9.4 Dry Fuel Storage Facility Monitoring Program	A.9-14
10.0 REPORTS	A.10-1
10.1 Annual Radiological Environmental Operating Report	A.10-1
10.2 Annual Radioactive Effluent Release Report	A.10-2
PART B: RADIOLOGICAL CALCULATIONAL METHODS AND PARAMETERS	
1.0 INTRODUCTION	B.1-1
1.1 Responsibilities for Part B	B.1-1
1.2 Summary of Methods, Dose Factors, Limits, Constants, Variables and Definitions	B.1-2
2.0 METHOD TO CALCULATE OFF-SITE LIQUID CONCENTRATIONS	B.2-1
2.1 Method to Determine F_1^{ENG} and C_1^{NG}	B.2-1
2.2 Method to Determine Radionuclide Concentration for Each Liquid Effluent Source	B.2-2
2.2.1 Waste Test Tanks	B.2-2
2.2.2 Turbine Building Sump	B.2-3
2.2.3 Steam Generator Blowdown Flash Tank	B.2-3
2.2.4 Primary Component Cooling Water (PCCW) System	B.2-3
2.2.5 Water Treatment System (Condensate Polishing System)	B.2-3
3.0 OFF-SITE DOSE CALCULATION METHODS	B.3-1
3.1 Introductory Concepts	B.3-2
3.2 Method to Calculate the Total Body Dose from Liquid Releases	B.3-4
3.2.1 Method I	B.3-4
3.2.2 Method II	B.3-5
3.3 Method to Calculate Maximum Organ Dose from Liquid Releases	B.3-6
3.3.1 Method I	B.3-6
3.3.2 Method II	B.3-7
3.4 Method to Calculate the Total Body Dose Rate from Noble Gases	B.3-8
3.4.1 Method I	B.3-8

<u>CONTENT</u>	<u>PAGE</u>
3.4.2 Method II	B.3-9
3.5 Method to Calculate the Skin Dose Rate from Noble Gases	B.3-10
3.5.1 Method I	B.3-10
3.5.2 Method II	B.3-11
3.6 Method to Calculate the Critical Organ Dose Rate from Iodines, Tritium and Particulates with $T_{1/2}$ Greater than 8 Days, (Including Carbon-14)	B.3-12
3.6.1 Method I	B.3-12
3.6.2 Method II	B.3-14
3.7 Method to Calculate the Gamma Air Dose from Noble Gases	B.3-15
3.7.1 Method I	B.3-15
3.7.2 Method II	B.3-16
3.8 Method to Calculate the Beta Air Dose from Noble Gases	B.3-17
3.8.1 Method I	B.3-17
3.8.2 Method II	B.3-18
3.9 Method to Calculate the Critical Organ Dose from Iodines, Tritium and Particulates, (Including Carbon-14)	B.3-19
3.9.1 Method I	B.3-19
3.9.2 Method II	B.3-22
3.10 Method to Calculate Direct Dose from Site Operations	B.3-23
3.10.1 Method	B.3-23
3.11 Dose Projections	B.3-25
3.11.1 Liquid Dose Projections	B.3-25
3.11.2 Gaseous Dose Projections	B.3-26
3.12 Method to Calculate Total Dose from Plant Operations	B.3-29
3.12.1 Method	B.3-29
4.0 RADIOLOGICAL ENVIRONMENTAL MONITORING PROGRAM	B.4-1
4.1 Plant Operations REMP	B.4-1
4.2 Dry Fuel Storage Facility Monitoring Program	B.4-1
5.0 SETPOINT DETERMINATIONS	B.5-1

<u>CONTENT</u>	<u>PAGE</u>
5.1 Liquid Effluent Instrumentation Setpoints	B.5-1
5.1.1 Liquid Waste Test Tank Monitor (RM-6509)	B.5-1
5.1.1.1 Method to Determine the Setpoint of the Liquid Waste Test Tank Monitor (RM-6509)	B.5-1
5.1.1.2 Liquid Waste Test Tank Monitor Setpoint Example	B.5-5
5.1.2 Turbine Building Drains Liquid Effluent Monitor (RM-6521)	B.5-7
5.1.3 Steam Generator Blowdown Liquid Sample Monitor (RM-6519)	B.5-8
5.1.4 PCCW Head Tank Rate-of-Change Alarm Setpoint	B.5-8
5.1.5 PCCW Radiation Monitor	B.5-9
5.1.6 Water Treatment Liquid Effluent (CPS Rad Monitor RM-6473)	B.5-10
5.2 Gaseous Effluent Instrumentation Setpoints	B.5-11
5.2.1 Plant Vent Wide-Range Gas Monitors (RM-6528-1, 2 and 3)	B.5-11
5.2.1.1 Method to Determine the Setpoint of the Plant Vent Wide Range Gas Monitors (RM-6528-1, 2 and 3)	B.5-11
5.2.1.2 Plant Vent Wide Range Gas Monitor Setpoint Example for Limiting Case	B.5-13
5.2.2 Waste Gas System Monitors (RM-6504 and RM-6503)	B.5-16
5.2.3 Main Condenser Air Evacuation Monitor (RM-6505)	B.5-16
6.0 LIQUID AND GASEOUS EFFLUENT STREAMS, RADIATION MONITORS AND RADWASTE TREATMENT SYSTEMS	B.6-1
7.0 BASES FOR DOSE CALCULATION METHODS	B.7-1
7.1 Liquid Release Dose Calculations	B.7-1
7.1.1 Dose to the Total Body	B.7-4
7.1.2 Dose to the Critical Organ	B.7-4
7.2 Gaseous Release Dose Calculations	B.7-7
7.2.1 Total Body Dose Rate from Noble Gases	B.7-7
7.2.2 Skin Dose Rate from Noble Gases	B.7-8
7.2.3 Critical Organ Dose Rate from Iodines, Tritium and Particulates with Half-Lives Greater Than Eight Days, (Including Carbon-14)	B.7-11
7.2.4 Gamma Dose to Air from Noble Gases	B.7-13
7.2.5 Beta Dose to Air from Noble Gases	B.7-14

<u>CONTENT</u>	<u>PAGE</u>
7.2.6 Dose to Critical Organ from Iodines, Tritium and Particulates with Half-Lives Greater Than Eight Days, (including Carbon-14)	B.7-16
7.2.7 Special Receptor Gaseous Release Dose Calculations	B.7-19
7.2.7.1 -Deleted-	B.7-20
7.2.7.2 -Deleted-	B.7-20
7.2.7.3 -Deleted-	B.7-20
7.2.7.4 -Deleted-	B.7-20
7.2.7.5 -Deleted-	B.7-20
7.2.7.6 Critical Organ Dose from Iodines, Tritium and Particulates with Half-Lives Greater Than Eight Days, (Including Carbon-14)	B.7-21
7.3 Receptor Points and Average Atmospheric Dispersion Factors for Important Exposure Pathways	B.7-28
7.3.1 Receptor Locations	B.7-28
7.3.2 Seabrook Station Atmospheric Dispersion Model	B.7-29
7.3.3 Average Atmospheric Dispersion Factors for Receptors	B.7-29
8.0 BASES FOR LIQUID AND GASEOUS MONITOR SETPOINTS	B.8-1
8.1 Basis for the Liquid Waste Test Tank Monitor Setpoint	B.8-1
8.2 Basis for the Plant Vent Wide Range Gas Monitor Setpoints	B.8-5
8.3 Basis for PCCW Head Tank Rate-of-Change Alarm Setpoint	B.8-10
8.4 Basis for Waste Gas Processing System Monitors (RM-6504 and RM-6503)	B.8-11
8.5 Basis for the Main Condenser Air Evacuation Monitor Setpoint (RM-6505)	B.8-13
8.5.1 Limiting Example for the Air Evacuation Monitor Setpoint During Normal Operations	B.8-13
8.5.2 Example for the Air Evacuation Monitor Setpoint During Start Up (Hogging Mode)	B.8-15
References	R-1
Appendix A: Dose Conversion Factors	A-1
Appendix B: Annual Average Effluent Concentration Limits Taken From 10 CFR 20, Appendix B	B-1
Appendix C: EMS Software Documentation	C-1

LIST OF TABLES AND FIGURES**PART A TABLES**

A.5.1-1	Radioactive Liquid Effluent Monitoring Instrumentation	A.5-5
A.5.1-2	Radioactive Liquid Effluent Monitoring Instrumentation Surveillance Requirements	A.5-8
A.5.2-1	Radioactive Gaseous Effluent Monitoring Instrumentation	A.5-17
A.5.2-2	Radioactive Gaseous Effluent Monitoring Instrumentation Surveillance Requirements	A.5-19
A.6.1-1	Radioactive Liquid Waste Sampling and Analysis Program	A.6-3
A.7.1-1	Radioactive Gaseous Waste Sampling and Analysis Program	A.7-3
A.9.1-1	Radiological Environmental Monitoring Program	A.9-3
A.9.1-2	Detection Capabilities for Environmental Sample Analysis	A.9-7
A.9.1-3	Reporting Levels for Radioactivity Concentrations in Environmental Samples	A.9-10
A.9.4-1	Dry Fuel Storage Facility Radiological Environmental Monitoring Program	A.9-15

PART B TABLES

B.1-1	Summary of Radiological Effluent Part A Controls and Implementing Equations	B.1-3
B.1-2	Summary of Method I Equations to Calculate Unrestricted Area Liquid Concentrations	B.1-6
B.1-3	Summary of Method I Equations to Calculate Off-Site Doses from Liquid Releases	B.1-7
B.1-4	Summary of Method I Equations to Calculate Dose Rates	B.1-8
B.1-5	Summary of Method I Equations to Calculate Doses to Air from Noble Gases	B.1-11
B.1-6	Summary of Method I Equations to Calculate Dose to an Individual from Tritium, Iodine, Carbon-14 and Particulates	B.1-13
B.1-7	Summary of Methods for Setpoint Determinations	B.1-14
B.1-8	Summary of Variables	B.1-15

<u>CONTENT</u>	<u>PAGE</u>	
B.1-9	Definition of Terms	B.1-21
B.1-10	Dose Factors Specific for Seabrook Station for Noble Gas Releases	B.1-22
B.1-11	Dose Factors Specific for Seabrook Station for Liquid Releases	B.1-23
B.1-12	Dose and Dose Rate Factors Specific for Seabrook Station for Iodines, Tritium and Particulate Releases	B.1-24
B.1-13	-Deleted-	B.1-25
B.1-14	Dose Factors Specific for the Science and Nature Center and Fitness Center for Iodine, Tritium, and Particulate Releases	B.1-26
B.1-15	Dose Factors Specific for the Firing Range for Iodine, Tritium, and Particulate Releases	B.1-27
B.4-1	Radiological Environmental Monitoring Stations	B.4-2
B.4-2	Dry Fuel Storage Radiological Environmental Monitoring Stations	B.4-6
B.7-1	Usage Factors for Various Liquid Pathways at Seabrook Station	B.7-6
B.7-2	Environmental Parameters for Gaseous Effluents at Seabrook Station	B.7-25
B.7-3	Usage Factors for Various Gaseous Pathways at Seabrook Station	B.7-27
B.7-4	Seabrook Station Long-Term Average Dispersion Factors* Primary Vent Stack	B.7-31
B.7-5	Seabrook Station Long-Term Average Dispersion Factors for Special Receptors Primary Vent Stack	B.7-32
B.7-6	Seabrook Station Long-Term Average Dispersion Factors for Special Receptors Ground-Level Release Pathway	B.7-33
B.7-7	Seabrook Station Growing Season Diffusion for Carbon-14 Elevated-Level Release Pathway	B.7-34
PART B FIGURES		
B.4-1	Radiological Environmental Monitoring Locations within 4 Kilometers of Seabrook Station	B.4-7
B.4-2	Radiological Environmental Monitoring Locations Between 4 Kilometers and 12 Kilometers from Seabrook Station	B.4-8
B.4-3	Radiological Environmental Monitoring Locations Outside 12 Kilometers of Seabrook Station	B.4-9

<u>CONTENT</u>	<u>PAGE</u>
B.4-4 Direct Radiation Monitoring Locations within 4 Kilometers of Seabrook Station	B.4-10
B.4-5 Direct Radiation Monitoring Locations Between 4 Kilometers and 12 Kilometers from Seabrook Station	B.4-11
B.4-6 Direct Radiation Monitoring Locations Outside 12 Kilometers of Seabrook Station	B.4-12
B.4-7 Dry Fuel Storage Radiological Environmental Monitoring Stations	B.4-13
B.6-1 Liquid Effluent Streams, Radiation Monitors, and Radwaste Treatment System at Seabrook Station	B.6-2
B.6-2 Gaseous Effluent Streams, Radiation Monitors, and Radwaste Treatment System at Seabrook Station	B.6-3

LIST OF EFFECTIVE PAGES

<u>PAGE</u>	<u>REV.</u>	<u>PAGE</u>	<u>REV.</u>	<u>PAGE</u>	<u>REV.</u>
<i>Cover</i>	37				
Abstract 1&2	30	A-1 thru A-15	21		
<i>TOC 1 - 8</i>	37	B-1 thru B-52	25		
<i>LOEP 1</i>	37	C-1	28		
A.1-1	33	C-2	28		
A.2-1	24	C-3	16		
A.3-1	24	C-4	16		
A.4-1 thru A.4-5	32	C-5	16		
<i>A.5-1 thru A.5-20</i>	36	C-6	28		
<i>A.6-1 thru A.6-12</i>	36				
<i>A.7-1 thru A.7-12</i>	36				
A.8-1 and A.8-2	32				
<i>A.9-1 thru A.9-15</i>	36				
A.10-1 thru A.10-3	29				
<i>B.1-0 thru B.1-27</i>	35				
B.2-1 thru B.2-3	32				
<i>B.3-1 thru B.3-29</i>	35				
<i>B.4-1 thru B.4-13</i>	35				
<i>B.5-1 thru B.5-19</i>	35				
B.6-1 thru B.6-3	28				
<i>B.7-1 thru B.7-34</i>	35				
<i>B.8-1 thru B.8-18</i>	35				
<i>R-1</i>	28				

PART A
RADIOLOGICAL EFFLUENT CONTROL AND ENVIRONMENTAL MONITORING PROGRAMS

1.0 INTRODUCTION

The Offsite Dose Calculation Manual (ODCM) contains details to implement the Radioactive Effluent Controls and Environmental Monitoring Programs” of Technical Specifications 6.7.6g and 6.7.6h.

The purpose of this manual is to contain details for the implementation of the Radioactive Effluent Technical Requirement Program (RETRP) and the Radiological Environmental Monitoring Program (REMP). These programs are required by Technical Specifications 6.7.6g and 6.7.6h.

Part A of this manual defines specific concentrations, sampling regimes and frequencies for both the RETRP and the REMP. These activities are the defined surveillances for radiological releases. Part A also defines specific sampling locations for the RETRP. The information contained in Part A is used as input into the models that are used in Part B. The Part B models identify the calculational methods for determining radiation monitor setpoints, offsite doses and effluent concentrations of radionuclides. Part B also defines sampling locations for the REMP. The data resulting from the surveillance and monitoring programs described in Part A provide a means to confirm that concentrations of radioactive material released, as a result of routine Seabrook Station operations, do not contribute to effluent dose significantly different than as postulated in Part B.

An ODCM Surveillance Requirement may be considered met if surveillance is performed within 1.25 times the stated surveillance interval. This 25% extension facilitates surveillance scheduling and considers plant operating conditions that may not be suitable for conducting the surveillance test. This provision is not intended to be used repeatedly merely as an operational convenience to extend surveillance intervals beyond those specified.

2.0 RESPONSIBILITIES (PART A)

All changes to the ODCM shall be reviewed by the Station Operation Review Committee (SORC), approved by the Station Director, and documented per Administrative Control 6.13 of the Technical Specifications. The change process is controlled by the Applicability Determination Process as controlled by the 10 CFR 50.59 Resource Manual (5059RM). Changes made to Part A shall be submitted to the NRC for its information in the Annual Radioactive Effluent Release Report for the period in which the change(s) was made effective, pursuant to T.S. 6.13.

It shall be the responsibility of the Station Director to ensure that the ODCM is used in the performance of the Radioactive Effluent Control and Environmental Monitoring Program implementation requirements, as identified under Administrative Controls 6.7.6g and 6.7.6h of the Technical Specifications.

3.0 DEFINITIONS

The defined terms of this section appear in capitalized type and are applicable throughout these Controls. Terms used in these Controls and not defined herein have the same definition as listed in the Technical Specifications.

4.0 CONTROL AND APPLICABILITY

This section provides a summary listing of the Controls and Applicability requirements of the ODCM.

The RECP conforms with 10 CFR 50.36a for the control of radioactive effluents and for maintaining the doses to MEMBERS OF THE PUBLIC from radioactive effluents as low as reasonably achievable. The REMP provides for monitoring the radiation and radionuclides in the environs of the plant.

The specific implementation details for the RECP and REMP are located in the OFFSITE DOSE CALCULATION MANUAL (ODCM). Contained within the ODCM are the following CONTROLS:

C.5.1 - RADIOACTIVE EFFLUENT MONITORING INSTRUMENTATION – LIQUIDS

CONTROL - At All Times

The radioactive liquid effluent monitoring instrumentation channels shown in Table A.5.1-1 shall be OPERABLE with their Alarm/Trip Setpoints set to ensure that the limits of Control C.6.1.1 are not exceeded. The Alarm/Trip Setpoints of these channels shall be determined and adjusted in accordance with the methodology and parameters in the OFFSITE DOSE CALCULATION MANUAL (ODCM), Part B.

C.5.2 - RADIOACTIVE GASEOUS EFFLUENT MONITORING INSTRUMENTATION

CONTROL- As Shown on ODCM Table A.5.2-1

The radioactive gaseous effluent monitoring instrumentation channels shown in Table A.5.2-1 shall be OPERABLE with their Alarm/Trip Setpoints set to ensure that the limits of Control C.7.1.1 are not exceeded. The Alarm/Trip Setpoints of these channels meeting Control C.7.1.1 shall be determined and adjusted in accordance with the methodology and parameters in the ODCM (Part B).

C.6.1.1 - RADIOACTIVE LIQUID EFFLUENTS – CONCENTRATION

CONTROL - At All Times

The concentration of radioactive material released in liquid effluents at the point of discharge from the multiport diffuser (see Technical Specifications Figure 5.1-3) shall be limited to not more than ten times the concentrations specified in 10 CFR Part 20, Appendix B, Table 2, Column 2, for radionuclides other than dissolved or entrained noble gases. For dissolved or entrained noble gases, the concentration shall be limited to 2×10^{-4} microCurie/ml total activity.

C.6.2.1 – DOSE

CONTROL – At All Times

The dose or dose commitment to a MEMBER OF THE PUBLIC from radioactive materials in liquid effluents released, from each unit, to UNRESTRICTED AREAS (see Technical Specification Figure 5.1-3) shall be limited

- During any calendar quarter to less than or equal to 1.5 mrem to the whole body and to less than or equal to 5 mrem to any organ, and
 - During any calendar year to less than or equal to 3 mrem to the whole body and to less than or equal to 10 mrem to any organ.
-

C.6.3.1 – LIQUID RADWASTE TREATMENT SYSTEM

CONTROL – At All Times

The Liquid Radwaste Treatment System shall be OPERABLE and appropriate portions of the system shall be used to reduce releases of radioactivity when the projected doses due to the liquid effluent to UNRESTRICTED AREAS (see Technical Specification Figure 5.1-3) would exceed 0.06 mrem to the whole body or 0.2 mrem to any organ in a 31-day period.

C.7.1.1 – RADIOACTIVE GASEOUS EFFLUENTS – DOSE RATE

CONTROL - At All Times

The dose rate due to radioactive materials released in gaseous effluents from the site to areas at and beyond the SITE BOUNDARY (see Technical Specification Figure 5.1-1) shall be limited to the following:

- For noble gases: Less than or equal to 500 mrem/yr to the whole body and less than or equal to 3000 mrem/yr to the skin, and
 - For Iodine-131, for Iodine-133, for tritium, and for all radionuclides in particulate form with half-lives greater than 8 days: Less than or equal to 1500 mrem/yr to any organ.
-

C.7.2.1 – DOSE – NOBLE GASES

CONTROL - At All Times

The air dose due to noble gases released in gaseous effluents to areas at and beyond the SITE BOUNDARY (see Technical Specification Figure 5.1-1) shall be limited to the following:

- During any calendar quarter: Less than or equal to 5 mrad for gamma radiation and less than or equal to 10 mrad for beta radiation, and
 - During any calendar year: Less than or equal to 10 mrad for gamma radiation and less than or equal to 20 mrad for beta radiation.
-

C.7.3.1 – DOSE – IODINE-131, TRITIUM, AND RADIOACTIVE MATERIAL IN PARTICULATE FORM

CONTROL- At All Times

The dose to a MEMBER OF THE PUBLIC from Iodine-131, Iodine-133, tritium, and all radionuclides in particulate form with half-lives greater than 8 days in gaseous effluents released to areas at and beyond the SITE BOUNDARY (see Technical Specification Figure 5.1-1) shall be limited to the following:

- During any calendar quarter: Less than or equal to 7.5 mrems to any organ, and
 - During any calendar year: Less than or equal to 15 mrems to any organ.
-

C.7.4.1 - GASEOUS RADWASTE TREATMENT SYSTEM

CONTROL – At All Times

The VENTILATION EXHAUST TREATMENT SYSTEM and the GASEOUS RADWASTE TREATMENT SYSTEM shall be OPERABLE and appropriate portions of these system shall be used to reduce releases of radioactivity when the projected doses in 31 days due to gaseous effluent releases to areas at and beyond the SITE BOUNDARY (see Technical Specification Figure 5.1-1) would exceed

- 0.2 mrad to air from gamma radiation, or
 - 0.4 mrad to air from beta radiation, or
 - 0.3 mrem to any organ of a MEMBER OF THE PUBLIC.
-

C.8.1.1 - TOTAL DOSE

CONTROL- At All Times

The annual (calendar year) dose or dose commitment to any MEMBER OF THE PUBLIC due to releases of radioactivity and to radiation from uranium fuel cycle sources shall be limited to less than or equal to 25 mrem to the whole body or any organ, except the thyroid, which shall be limited to less than or equal to 75 mrem.

C.9.1.1 - RADIOLOGICAL ENVIRONMENTAL MONITORING – MONITORING PROGRAM

CONTROL – At All Times

The Radiological Environmental Monitoring Program (REMP) shall be conducted as specified in Table A.9.1-1.

C.9.2.1 – LAND USE CENSUS

CONTROL - At All Times

A Land Use Census shall be conducted and shall identify within a distance of 8 km (5 miles) the location in each of the 16 meteorological sectors of the nearest milk animal, the nearest residence, and the nearest garden** of greater than 50 m² (500 ft²) producing broad leaf vegetation.

C.9.3.1 – INTERLABORATORY COMPARISON PROGRAM

CONTROL - At All Times

In accordance with Technical Specification 6.7.6.h.3, analyses shall be performed on all radioactive materials supplied as part of an Interlaboratory Comparison Program, that has been approved by the Commission, that correspond to samples required by REMP.

**Broad leaf vegetation sampling of at least three different kinds of vegetation may be performed at the SITE BOUNDARY in each of two different direction sectors with the highest predicted relative deposition values (D/Qs) in lieu of the garden census. Specifications for broad leaf vegetation sampling in the REMP shall be followed, including analysis of control samples.

C.9.4.1 DRY FUEL STORAGE FACILITY MONITORING PROGRAM

CONTROL - At All Times

The Dry Fuel Storage Facility Radiological Environmental Monitoring Program shall be conducted as specified in Table A.9.4-1.

MONITORING INSTRUMENTATION

5.0 RADIOACTIVE EFFLUENT MONITORING INSTRUMENTATION

5.1 Liquids

CONTROLS

C.5.1 The radioactive liquid effluent monitoring instrumentation channels shown in Table A.5.1-1 shall be OPERABLE with their Alarm/Trip Setpoints set to ensure that the limits of Control C.6.1.1 are not exceeded. The Alarm/Trip Setpoints of these channels shall be determined and adjusted in accordance with the methodology and parameters in the OFFSITE DOSE CALCULATION MANUAL (ODCM), Part B.

APPLICABILITY: At all times.

ACTION:

- a. With a radioactive liquid effluent monitoring instrumentation channel Alarm/Trip Setpoint less conservative than required by the above specification, immediately suspend the release of radioactive liquid effluents monitored by the affected channel, or declare the channel inoperable.
- b. With less than the minimum number of radioactive liquid effluent monitoring instrumentation channels OPERABLE, take the ACTION shown in Table A.5.1-1. Restore the inoperable instrumentation to OPERABLE status within a time period determined by an evaluation conducted in accordance with the requirements of the Corrective Action Program. An evaluation is not required if the noncompliance is a consequence of surveillance testing or planned maintenance.

SURVEILLANCE REQUIREMENTS

S.5.1 Each radioactive liquid effluent monitoring instrumentation channel shall be demonstrated OPERABLE by performance of the CHANNEL CHECK, SOURCE CHECK, CHANNEL CALIBRATION, and CHANNEL OPERATIONAL TEST at the frequencies shown in Table A.5.1-2.

BASES

The radioactive liquid effluent instrumentation is provided to monitor and control, as applicable, the releases of radioactive materials in liquid effluents during actual or potential releases of liquid effluents. The Alarm/Trip Setpoints for these instruments shall be calculated and adjusted in accordance with the methodology and parameters in the ODCM to ensure that the alarm/trip will occur prior to exceeding the limits of 10 CFR Part 20. The OPERABILITY and use of this instrumentation is consistent with the requirements of General Design Criteria 60, 63, and 64 of Appendix A to 10 CFR Part 50.

Table A.5.1-2 Item 3a of Control C.5.1 requires that a Channel Operational Test be performed on the radioactivity monitors (RM-R-6515 and RM-R-6516) for the PCCW System. This channel operational test is a digital channel operational test and requires that it shall demonstrate automatic isolation of the pathway and control room alarm annunciation.

For Seabrook Station, these two radioactivity monitoring channels provide control room annunciation, but do not provide automatic isolation of the release pathway. This particular item was discussed in detail with the NRC staff reviewers. For this particular reason, the words "But Not Termination of Release" were added to Item 3 of Table A.5.1-2. The purpose of adding the above words to Item 3 was to preclude the addition of another Table Notation to Table A.5.1-2. Therefore, the channel operational test for these monitors only requires that they provide control room alarm annunciation.

The CHANNEL CHECK for Flow Rate Measurement Devices (Table A.5.1-2, items 2.a., 2.b. and 2.d.) is required "at least once per 24 hours on **days when continuous, periodic, or batch releases are made.**" Additionally, ACTION 31 of Table A.5.1-1 is only applicable during actual releases.

Based on the above requirements, these instruments are only required to be OPERABLE during actual releases. Therefore, the CHANNEL CHECK is only required during periods when continuous, periodic, or batch releases are being made.

The Primary Component Cooling Water (PCCW) System is monitored by radiation monitors, which are required by Technical Specifications 3.3.3.1 and ODCM C.5.1 to be OPERABLE, or sampling of the PCCW and Service Water (SW) Systems is required. Clarification of this requirement needs to be made for certain PCCW System conditions. Below is a list of 3 conditions and their corresponding requirements.

- 1) If the PCCW System is shut down but not drained, grab samples shall be taken of PCCW and SW, as required in Technical Specification Table 3.3-6, Items 6a and 6b (Action 28).
- 2) During transition times when the PCCW system is in the process of being drained, grab samples, as required by Technical Specification Table 3.3-6 and ODCM C.5.1, shall be taken until such time as sampling of PCCW is no longer possible. At this time neither PCCW nor SW need to be sampled. During transition times when the PCCW system is being filled, the taking of grab samples shall commence as soon as physically possible and continue in accordance with the requirements of Technical Specifications 3.3.3.1 and ODCM C.5.1 until PCCW is in service, the pumps are operating, and monitors are operable.
- 3) When PCCW is drained, there are no sampling requirements.

The above statements are consistent with the Technical Specification definition of OPERABILITY and with the Bases for Technical Specification 3.3.3.1.

The following actions are required when the Service Water side of the Primary Component Cooling Water (PCCW) Heat Exchanger is drained and grab samples of the Service Water System are required:

- a. Grab samples from the Service Water System will be obtained at the frequencies specified in Technical Specification 3.3.3.1 and ODCM C.5.1 as the Service Water System is being drained until obtaining these samples is not physically possible.
- b. Grab samples are not required once the Service Water System is drained such that it is not physically possible to obtain the samples.
- c. When refilling the Service Water System, grab samples shall resume as soon as physically possible, at the intervals specified in the aforementioned sources, and continue until the PCCW radiation monitors (1-RM-6515 and 1-RM-6516) are OPERABLE.

Sampling of the PCCW system with the Service Water system drained and the PCCW system in operation shall continue per the requirements of Technical Specification 3.3.3.1 and this Control.

The purpose of the plant radiation monitors is to sense radiation levels in selected plant systems and locations and determine whether or not predetermined limits are being exceeded. In the case of the Primary Component Cooling Water (PCCW) loops, the radiation monitors (1-RM-6515 and 1-RM-6516) sense radiation in the PCCW system which could leak into the Service Water System and be discharged to the environment via the multiport diffuser. Per Control C.6.1.1, the concentration of radioactive material released in liquid effluents at the point of discharge from the multiport diffuser must be within specified limits. This limitation provides assurance that the levels of radioactive materials in unrestricted areas will not pose a threat to the health and safety of the public.

Based on the importance of maintaining radioactive effluent releases within limits that guarantee the health and safety of the public will not be at risk, the PCCW radiation monitors are required to be in operation at all times. When a radiation monitor is inoperable, grab samples from the PCCW and Service Water systems must be obtained and analyzed as a compensatory measure in accordance with Technical Specification 3.3.3.1, Table 3.3-6 Action 28 and this Control. If the service water system is drained, there is no potential for inadvertent radioactive liquid effluent release through the service water system to the environment via the multiport diffuser. Thus, when the system is drained there is no need to obtain the grab sample. However, when the system is being filled, grab samples must be obtained as soon as possible to ensure that the water discharged to the environment is in compliance with Control C.6.1.1.

The purpose of the PCCW monitors is to detect radioactivity indicative of a leak from the Reactor Coolant System or from one of the other radioactive systems which exchange with the PCCW System. These monitors are required to be operable at all times. Grab samples of PCCW are required when the PCCW monitors are not operable. Since the purpose of obtaining the PCCW samples is to provide an indication of a leak of radioactive liquid into the PCCW system, draining of the Service Water system does not remove the reason for obtaining the PCCW grab samples. These samples shall be obtained as specified in Technical Specification 3.3.3.1 and this Control. This determination is consistent with the Bases for Technical Specification 3.3.3.1.

The temporary lowering of an RDMS channel setpoint, by RDMS data base manipulation to verify alarm/trip functions, does not prevent the channel from continuously monitoring radiation levels (except for the WRGM DCOT due to low and high activity sample flow paths). Additionally, when the setpoint is lowered below background radiation levels the associated trip functions will actuate equipment in their required operating mode as if a high radiation condition exists. The channel remains OPERABLE because monitoring and associated trip functions are not inhibited.

When the SGBD demineralizers are being rinsed to the ocean using SGBD water, the SGBD flash tank radiation monitor (RM-6519) may become inoperable in this alignment from decreased backpressure to run the monitor sample pump. If this happens, the sampling requirements of Table A.5.1-1 ACTION 30 must be performed.

RM-6509, although in the flowpath of the SGBD demineralizer rinse, cannot perform the function of RM-6519 because it cannot achieve the same sensitivity to radiation. However, RM-6509 shall have its setpoints established per plant procedures since the discharge flow path is through the SGBD demineralizers (where a potential to acquire radioactivity exists), but after RM-6519.

If RM-6509 is inoperable, then in addition to the periodic sampling requirements of Table A.5.1-1 ACTION 30 for RM-6519, the batch sample and lineup verification of ACTION 29 would also have to be complied with, for RM-6509.

It should be noted that, during a SGBD demineralizer rinse to the discharge transition structure with SB liquid, SB-FE-1918 is not in the flow path. It is acceptable to use a flow monitoring device in the final flow path (such as WL-FIT-1458) so that Table A.5.1-1 ACTION 31 does **NOT** have to be entered.

During power operations, SGBD demineralizer effluent is normally aligned to the Main Condenser Hotwell for water recovery. However, following SGBD / SGBD demineralizer system maintenance, or for plant operational requirements, the system effluent can be aligned to the Turbine Building Sump to maintain secondary chemistry and plant related parameters. When SGBD demineralizer effluent is aligned to the Turbine Building Sump, the effluent to Outfall 001 is monitored by RM-6521. The Turbine Sump Radiation Monitor RM-6521, although in the flow path of the SGBD demineralizer effluent, cannot perform the alarm and trip function of the SGBD Flash Tank Monitor RM-6519 because it cannot achieve the same sensitivity to radiation. However, RM-6521 shall have its set points established per plant procedures since the discharge flow path is through the SGBD demineralizers (where a potential to acquire radioactivity exist), but after passing through RM-6519. If either RM-6519 or RM-6521 is inoperable, then the periodic sampling requirements of Table A.5.1-1 Action 30 apply. It should be noted that when SGBD demineralizer effluent is aligned to the Turbine Building Sump, flow indicator SB-FE-1918 is not in the flow path. It is acceptable to use a flow monitoring device in the final flow path (such as DF-FT-5957) so that Table A.5.1-1 ACTION 31 does **NOT** have to be met.

Steam generators may be drained using the wet lay-up pumps directly to the circulating water system, if no secondary steam pressure is available **and** provided the steam generator(s) liquid radioactivity is less than **both** 10 CFR 20 (Appendix B, Table 2, Column 2 instantaneous release); **and** 10 CFR 50 Appendix I (annual release). Table A.5.1-1 Actions 30 and 31 apply in this case as both the radiation monitor (RM-RM-6519) and the flow rate monitor (SB-FE-1918) are bypassed.

The Note which corresponds to Table A.5.1-1 "***" states that pump performance curves generated in place "should" be used to estimate flow. Hence, there is no requirement to use the pump curves as described in these tables.

TABLE A.5.1-1

RADIOACTIVE LIQUID EFFLUENT MONITORING INSTRUMENTATION

INSTRUMENT	MINIMUM CHANNELS OPERABLE	ACTION
1. Radioactivity Monitors Providing Alarm and Automatic Termination of Release		
a. Liquid Radwaste Test Tank Discharge	1	29
b. Steam Generator Blowdown Flash Tank Drain	1*	30
c. Turbine Building Sump Effluent Line	1	30
d. Water Treatment Liquid Effluent Discharge	1	29
2. Flow Rate Measurement Devices		
a. Liquid Radwaste Test Tank Discharge	1	31
b. Steam Generator Blowdown Flash Tank Drain	1*	31
c. Circulating Water Discharge	1**	N.A.
d. Water Treatment Liquid Effluent Discharge	1	31

*Only applicable when steam generator blowdown is directed to the discharge transition structure without intermediate collection. The required radiation monitoring channel is RM-6519. The flow path must include a flow indicator which can be used to provide total flow discharged during period of interest.

**Pump performance curves generated in place should be used to estimate flow.

TABLE A.5.1-1

RADIOACTIVE LIQUID EFFLUENT MONITORING INSTRUMENTATION

(Continued)

INSTRUMENT	MINIMUM CHANNELS OPERABLE	ACTION
3. Radioactivity Monitors Providing Alarm but Not Termination of Release		
a. Primary Component Cooling Water System (in lieu of service water monitors)	1	32
4. Rate of Change Monitor		
a. Primary Component Cooling Water System Head Tank (in lieu of service water monitors)	1	33

TABLE A.5.1-1

(Continued)

ACTION STATEMENTS

- ACTION 29 - With the number of channels OPERABLE less than the Minimum Channels OPERABLE requirement, effluent releases via this pathway may continue provided that prior to initiating a release
- a. At least two independent samples are analyzed in accordance with Surveillance S.6.1.1, and
 - b. At least two technically qualified members of the station staff independently verify the release rate calculations and discharge line valving.
- Otherwise, suspend release of radioactive effluents via this pathway.
- ACTION 30 - With the number of channels OPERABLE less than the Minimum Channels OPERABLE requirement, effluent releases via this pathway may continue provided grab samples are analyzed for radioactivity at a lower limit of detection of no more than 10^{-7} microCurie/ml
- a. At least once per 12 hours when the specific activity of the secondary coolant is greater than 0.01 microCurie/gram DOSE EQUIVALENT I-131, or
 - b. At least once per 24 hours when the specific activity of the secondary coolant is less than or equal to 0.01 microCurie/gram DOSE EQUIVALENT I-131.
- ACTION 31 - With the number of channels OPERABLE less than the Minimum Channels OPERABLE requirement, effluent releases via this pathway may continue provided the flow rate is estimated at least once per 4 hours during actual releases. Pump performance curves generated in place may be used to estimate flow.
- ACTION 32 - With the number of channels OPERABLE less than required by the Minimum Channels OPERABLE requirement, collect grab samples daily from the Primary Component Cooling Water System and the Service Water System and analyzed for radioactivity until the inoperable channel(s) is restored to OPERABLE status.
- ACTION 33 - With the number of channels OPERABLE less than required by the Minimum Channels OPERABLE requirement, effluent releases via this pathway may continue provided the radioactivity level is determined at least once per 12 hours during actual releases.

TABLE A.5.1-2

RADIOACTIVE LIQUID EFFLUENT MONITORING INSTRUMENTATION SURVEILLANCE REQUIREMENTS

INSTRUMENT	CHANNEL CHECK	SOURCE CHECK	CHANNEL CALIBRATION	CHANNEL OPERATIONAL TEST
1. Radioactivity Monitors Providing Alarm and Automatic Termination of Release				
a. Liquid Radwaste Test Tank Discharge	D	P	R(2)	P(1)
b. Steam Generator Blowdown Flash Tank Drain	D	M	R(2)	Q(1)
c. Turbine Building Sumps Effluent Line	D	M	R(2)	Q(1)
d. Water Treatment Liquid Effluent Discharge	D	P	R(2)	P(1)
2. Flow Rate Measurement Devices				
a. Liquid Radwaste Test Tank Discharge*	D(3)	N.A.	R	N.A.
b. Steam Generator Blowdown Flash Tank Drain***	D(3)	N.A.	R	N.A.
c. Circulating Water Discharge	D(3)	N.A.	N.A.	N.A.
d. Water Treatment Liquid Effluent Discharge	D(3)	N.A.	R	N.A.

*Isolation of the flow path is accomplished by the Waste Test Tank Discharge Pump Trip Circuitry.

**Pump curves may be used to estimate flow.

***Applies to the flow indicator used in the discharge path when steam generator blowdown is directed to the discharge transition structure without intermediate collection.

TABLE A.5.1-2

RADIOACTIVE LIQUID EFFLUENT MONITORING INSTRUMENTATION SURVEILLANCE REQUIREMENTS

(Continued)

INSTRUMENT	CHANNEL CHECK	SOURCE CHECK	CHANNEL CALIBRATION	CHANNEL OPERATIONAL TEST
3. Radioactivity Monitor Providing Alarm but Not Termination of Release				
a. Primary Component Cooling Water System (in lieu of service water monitors)	D	M	R(2)	Q(1)
4. Rate of Change Monitor				
a. Primary Component Cooling Water System (in lieu of service water monitors)	D(4)	N.A.	R	N.A

TABLE A.5.1-2

(Continued)

TABLE NOTATIONS

- (1) The DIGITAL CHANNEL OPERATIONAL TEST shall also demonstrate that automatic isolation of this pathway and Control Room alarm annunciation occurs if the instrument indicates measured levels above the normal or Surveillance test Alarm/Trip Setpoint.
- (2) The initial channel calibration for radioactivity measurement instrumentation shall include the use of a known (traceable to National Institute for Standards and Technology) liquid radioactive source positioned in a reproducible geometry with respect to the sensor. These standards shall permit calibrating the system over its normal operating range of energy and rate. For subsequent channel calibrations, sources that have been related to the initial calibration shall be used.
- (3) CHANNEL CHECK shall consist of verifying indication of flow during periods of release. CHANNEL CHECK shall be made at least once per 24 hours on days on which continuous, periodic, or batch releases are made.
- (4) CHANNEL CHECK shall consist of verifying indication of tank level during periods of release. CHANNEL CHECK shall be made at least once per 24 hours.

5.2 Radioactive Gaseous Effluent Monitoring Instrumentation

CONTROLS

C.5.2 The radioactive gaseous effluent monitoring instrumentation channels shown in Table A.5.2-1 shall be OPERABLE with their Alarm/Trip Setpoints set to ensure that the limits of Control C.7.1.1 are not exceeded. The Alarm/Trip Setpoints of these channels meeting Control C.7.1.1 shall be determined and adjusted in accordance with the methodology and parameters in the ODCM (Part B).

APPLICABILITY: As shown in Table A.5.2-1.

ACTION:

- a. With a radioactive gaseous effluent monitoring instrumentation channel Alarm/Trip Setpoint less conservative than required by the above specification, immediately suspend the release of radioactive gaseous effluents monitored by the affected channel, or declare the channel inoperable.
- b. With the number of OPERABLE radioactive gaseous effluent monitoring instrumentation channels less than the Minimum Channels OPERABLE, take the ACTION shown in Table A.5.2-1. Restore the inoperable instrumentation to OPERABLE status within a time period determined by an evaluation conducted in accordance with the requirements of the Corrective Action Program. An evaluation is not required if the noncompliance is a consequence of surveillance testing or planned maintenance.

SURVEILLANCE REQUIREMENTS

S.5.2 Each radioactive gaseous effluent monitoring instrumentation channel shall be demonstrated OPERABLE by performance of the CHANNEL CHECK, SOURCE CHECK, CHANNEL CALIBRATION and CHANNEL OPERATIONAL TEST at the frequencies shown in Table A.5.2-2.

BASES

The radioactive gaseous effluent instrumentation is provided to monitor and control, as applicable, the releases of radioactive materials in gaseous effluents during actual or potential releases of gaseous effluents. The Alarm/Trip Setpoints for these instruments shall be calculated and adjusted in accordance with the methodology and parameters in the ODCM (Part B) to ensure that the alarm/trip will occur prior to exceeding the limits of 10 CFR Part 20. The OPERABILITY and use of this instrumentation is consistent with the requirements of General Design Criteria 60, 63, and 64 of Appendix A to 10 CFR Part 50. The sensitivity of any noble gas activity monitors used to show compliance with the gaseous effluent release requirements of Control C.7.2.1 shall be such that concentrations as low as 1×10^{-6} $\mu\text{Ci/cc}$ are measurable.

The main condenser air evacuation radiation monitor, RM-6505, is included with the Turbine Gland Seal Condenser Exhaust in Tables A.5.2-1 and A.5.2-2. Table A.5.2-1 defines the minimum channels operable and the required actions for the radioactive gaseous effluent monitoring instrumentation. Table A.5.2-2 lists the surveillance requirements for this instrumentation.

The Plant Vent Wide Range Gas Monitor (WRGM) design includes three ranges of noble gas monitors and two ranges of iodine and particulate sampling filters. The noble gas monitor, the equipment necessary to provide flow through three ranges of the noble gas monitors, and the iodine and particulate sample filters all affect the operability of the WRGM. The various combinations of out-of-service components are addressed in this clarification.

The WRGM noble gas activity monitor has three overlapping detector ranges: low, mid, and high.

UFSAR Table 12.3-15 lists the following ranges for the WRGM:

Low Range	10^{-7} - 10^{-1}	$\mu\text{Ci/cc}$
Mid Range	10^{-3} - 10^3	
High Range	10^{-1} - 10^5	

The minimum number of operable channels for the noble gas activity monitor, the flow rate monitors and the iodine sampler and particulate sampler is one, respectively.

The Controls do not list the specific WRGM noble gas activity monitor, the iodine/particulate sampler or the flow rate monitor channels separately by an instrumentation identification tag number.

Heat tracing of the sample lines, from the plant vent to the WRGM, is not listed as a specific requirement for WRGM operability. However, these circuits are necessary to ensure that the particulate and iodine concentration of the sample reaching the WRGM is representative of the effluent. The purpose of heat tracing is to ensure that the sample lines are free of moisture due to condensation. The low temperature alarm setpoint is variable based on outside ambient air temperature, and ensures that the sample line tubing metal temperature is high enough to prevent the moisture in the air from condensing inside of the sample line. The ability to detect of noble gases is not affected by the operational status of the heat tracing circuits.

The heat tracing on the sample lines within the PAB (CP 433, circuit 55) is not required for WRGM operation. (Engineering Evaluation, SS-EV-960017 and MMOD 02-0531)

The following equipment normally defines an operational WRGM:

During routine releases,

- Sample flow through one of the particulate and iodine (P&I) filters F-156-1,2,3 and channel 1 (low range) noble gas (NG) detectors using pump P-240-2, and
 - Sample flow through P&I filters F-156-7, 8 using pump RM-P-391.
- or in the event the noble gas activity is in the mid/high range,
- Sample flow through one of the particulate/iodine (P&I) filters F-156-4, 5, 6 and channels 2 or 3 (mid/high range) NG detectors using pump P-240-1, and
 - Sample flow bypassing P&I filters F-156-7, 8 using pump RM-P-391.

At all times,

-Heat tracing (HT) on the sample lines from the plant vent to the WRGM.

Note: Dewpoint measurements may be used if heat tracing is out of service. (See the following table)

-Vent stack flow rate monitor.

-WRGM sample flow rate for the channel(s) in service.

The table below lists the action required in the event that a WRGM component is out of service.

<u>Out of Service Component</u>	<u>Action</u>
Low range NG detector	Enter Action 33. Perform grab sampling as required.
High range NG detector	Enter Action 33. The actions required by Action 33 are satisfied provided the Low range NG detector provides continuous indication of the effluent concentrations, grab sampling not required. In the unlikely event that elevated effluent concentrations above the capability of the low range detector are present, then grab sampling or backup monitoring will/may be required.
Mid range NG detector	No action required, detection capability met by the overlapping ranges of the low and high NG detectors. (May need to ensure that the high range pump [RM-P-240-1] starts on increasing activity.)
RM-P-391	Enter Action 35. The mid and high range particulate and iodine sampling capability is lost. If a low range P&I filter F-156-1,2 or 3 is in service then no further action is required. If the low range P&I filters are out of service then comply with Action 35 within one hour.
P-240-1 (High range pump)	Enter Actions 32, 33 and 35. Action 33 is satisfied provided the low range NG detector provides continuous indication of the effluent concentrations, grab sampling is not required. Actions 32 and 35 are satisfied if P-240-2, and filters F-156-1,-2, or -3 are in service. If these P&I filters are out of service and the NG activity is in the low range, then ensure compliance with Actions 32 and 35 within one hour of identifying the out of service condition. In the unlikely event that elevated effluent concentrations above the capability of the low range detector are present, then, with P-391 operating, install a portable sample pump across valves V28 and V29 to facilitate P&I grab sampling using filters F-156-4,-5, or -6, and noble gas sampling using the medium and high range detectors.

P-240-2 (Low range pump)

Enter Actions 32, 33 and 35. Action 33 is satisfied by performing grab samples. Actions 32 and 35 are satisfied by ensuring one of the following sample configurations are in service within one hour of identifying the out-of-service condition; the operation of P-391 with filters F-156-7 & 8, or installing a portable sample pump across valves V2, and V5 to facilitate P&I grab sampling.

HT circuit:

Enter Action 36. Action 36 is satisfied and

CP-434 Ckt 28.

the WRGM may

(Sample line temperature less than 20°F above ambient as indicated by computer points B5946 / B5948.)

remain OPERABLE with CP-434 Ckt 28 out of service provided that CP-426 Ckt 46 is

energized within 1 hr of the out-of-service

condition. If the sample line temperature can not be maintained greater than or equal to 20°F above ambient, the particulate and iodine samples remain valid provided moisture is not present.

Action 36 provides moisture monitoring capability.

Flow rate monitor and/or sampler flow rate monitor.

Comply with Action 32.

Action Statement 35 provides no guidance with regard to time required to initiate auxiliary sampling upon failure of a monitor. A finite time is required to take the appropriate actions to initiate auxiliary sampling. An interval of 60 minutes is a reasonable period of time in which to accomplish these actions provided that no activity occurs during this period which could result in an increase in radiation release levels.

Since the intent of Action 35 is to allow continued release of gaseous effluents provided an alternate means of continuous monitoring/collection capability is on-going during the release of radioactive gaseous effluents, the 60 minute time frame for auxiliary sampling to be established is still a reasonable period of time to complete the necessary manual actions to establish auxiliary sampling. If auxiliary sampling cannot be established within 60 minutes then the initial action of immediately suspending the release of radioactive gaseous effluents should be done, as specified in Action a. of C.5.2. It should be noted that for lack of specified criteria the 60-minute time period is solely based on prudent engineering judgment for completion of manual actions in order to satisfy the intent of Action 35. Operation beyond 60 minutes without auxiliary sampling service would need to be justified by engineering calculation to ensure continued compliance with 10 CFR Part 20 limits.

When a surveillance test must be performed on the WRGM, rendering it inoperable, Action 35 cannot be fully satisfied because of the nature of testing is incompatible with the Action 35 required installation of auxiliary sampling equipment. However, because the performance of the WRGM surveillance renders it inoperable for only a short period of time (e.g., less than one hour), it is reasonable to allow the surveillance test to be performed without the installation of the auxiliary sampling equipment. It should be noted that neither C.5.2 Action a. nor Action b. requires the immediate establishment of auxiliary sampling. However, if there is concern that the results of surveillance testing activities will identify the instrumentation as inoperable then it would be prudent to set up the auxiliary sampling equipment prior to surveillance testing. The prudent action would prevent the potential situation of continued release of gaseous effluents beyond 60 minutes without continuous monitoring/collection capability.

A procedural method of collecting the grab sample from the plant vent release pathway may require the shutdown of the compensatory sampling equipment pump (for pressure equilibrium purposes) whenever a grab sample is to be withdrawn into the sample bottle. Shutting down the pump raises the question as to whether this action contradicts the "continuous collection" requirement of Action 35.

Action 35 allows effluent releases to continue provided samples are continuously collected (as required in Table A.7.1-1) with auxiliary equipment whenever the number of channels OPERABLE is less than the Minimum Channels OPERABLE requirement. Table A.7.1-1 requires that the sampling frequency be continuous for iodine and particulate and a monthly grab sample for noble gasses (Kr and Xe). Action 32 supports Action 35 by providing periodic sample flow rate monitoring for use in the iodine and particulate activity determinations. The ODCM also requires that the ratio of the sample flow rate to the sampled stream flow rate be known/determined for the time period covered by each dose or dose rate calculation made in accordance with C.7.1.1, C.7.2.1, and C.7.3.1 (i.e., weekly and/or monthly).

It must be noted that Actions 32 and 35 pertain to the iodine and particulate samplers. For noble gas collection, Action 33 is applicable which requires grab samples be taken once per 12 hours and analyzed for radioactivity within 24 hours. Action 33 does not specify that auxiliary sampling for noble gas must be continuous; therefore, the concern for "continuous" monitoring/collection is not applicable for auxiliary sampling of noble gas.

Whenever the station is operating under the auspices of Action 35 the process of collecting grab samples by the auxiliary sampling method necessitates, on occasions, the temporary disablement of permanent and/or temporary equipment (e.g., installation, and disconnection of auxiliary sampling equipment, pressure equalization, etc.) in order to achieve and comply with the requirements of Action 35. Therefore, actions required (e.g. temporarily shutting down the sample pump in order to install / remove / equalize sample bottles, thus interrupting continuous flow) to obtain a grab sample are not considered actions that are contrary in meeting the intent of Action 35.

The temporary lowering of an RDMS channel setpoint, by RDMS data base manipulation to verify alarm/trip functions, does not prevent the channel from continuously monitoring radiation levels (except WRGM). Additionally, when the setpoint is lowered below background radiation levels the associated trip functions will actuate equipment in their required operating mode as if a high radiation condition exists. The channel remains OPERABLE because monitoring and associated trip functions are not inhibited. Therefore, during performance of a RDMS channel DCOT, the LCO remains satisfied. Entering an ACTION statement is neither appropriate nor required (except for WRGM DCOT due to low and high activity sample flow paths). However, because the channel is in alarm status, increased operator vigilance is required to note any increase in radiation levels during the DCOT surveillance period and to take remedial actions if required.

C.5.2 ACTION Statement #33 is applied if RM-6504 is inoperable. The intent of the last sentence is that RM-6503 may be used instead of taking a grab sample. It is not intended that RM-6503 be used in place of or as an alternate to RM-6504 and ACTION Statement #33 not entered. If RM-6503 were considered an alternate for RM-6504 then operations could continue indefinitely without the ability to automatically terminate a radiological release. This is clearly not the intent of C.5.2 ACTION Statement #33.

RM-6504 monitors the radiation level of the gas stream at the outlet of the waste gas compressors. If a high radiation level is detected, RM-6504 automatically closes WG-FV-1602. The closing of WG-FV-1602 isolates a potential radiological release path to the environment. RM-6503, located at the inlet to the waste gas compressor, provides alarm and monitoring functions only. It does not have the ability to terminate a radiological release. Therefore, it cannot be used as a substitute for RM-6504.

Table A.5.2-1, Radioactive Gaseous Effluent Monitoring Instrumentation, specifically lists RM-6504 as the instrument required to satisfy the Limiting Condition for operation. This table also states that the monitor provide the functions of alarm and automatic termination of release.

TABLE A.5.2-1

RADIOACTIVE GASEOUS EFFLUENT MONITORING INSTRUMENTATION

INSTRUMENT	MINIMUM CHANNELS OPERABLE	APPLICABILITY	ACTION
1. (Not Used)			
2. PLANT VENT-WIDE RANGE GAS MONITOR			
a. Noble Gas Activity Monitor	1	*	33
b. Iodine Sampler	1	*	35
c. Particulate Sampler	1	*	35
d. Flow Rate Monitor	1	*	32
e. Sampler Flow Rate Monitor	1	*	32, 35
f. Sample Line Temperature	1	*	36
3. GASEOUS WASTE PROCESSING SYSTEM (Providing Alarm and Automatic Termination of Release - RM-6504)			
a. Noble Gas Activity Monitor (Process)	1	*	33
4. TURBINE GLAND SEAL CONDENSER EXHAUST			
a. Iodine Sampler	1	***	35
b. Particulate Sampler	1	***	35
c. Sampler Flow Rate Indicator	1	***	32, 35
d. Noble Gas Activity Monitor (RM 6505)	1	***	34

* At all times.

** (Not Used.)

*** When the gland seal exhauster is in operation.

TABLE A.5.2-1

(Continued)

ACTION STATEMENTS

- ACTION 32 - With the number of channels OPERABLE less than the Minimum Channels OPERABLE requirement, effluent releases via this pathway may continue provided the flow rate is estimated at least once per 4 hours.
- ACTION 33 - With the number of channels OPERABLE less than the Minimum Channels OPERABLE requirement, effluent releases via this pathway may continue provided grab samples are taken at least once per 12 hours and these samples are analyzed for radioactivity within 24 hours. For RM-6504, RM-6503 may be used instead of taking grab samples.
- ACTION 34 - With RM-6505 INOPERABLE and the gland seal exhaust in operation, effluent releases via the turbine gland seal condenser exhaust may continue provided grab samples from condenser air evacuation pump effluent are taken at least once per 12 hours, and analyzed for radioactivity within 24 hours.
- ACTION 35 - With the number of channels OPERABLE less than the Minimum Channels OPERABLE requirement, effluent releases via the affected pathway may continue provided samples are continuously collected with auxiliary sampling equipment as required in this document.

Auxiliary sampling must be initiated within 60 minutes. Additionally, the auxiliary sampling equipment need not be installed during surveillance activities provided the surveillance testing is completed in less than one hour. Actions required (e.g., temporarily shutting down the sample pump in order to install / remove / equalize sample bottles, thus interrupting continuous flow) to obtain a grab sample are not considered actions that are contrary in meeting the intent of this Action.

Auxiliary sample equipment includes sample flow monitoring to provide information used in the sample analysis.

- ACTION 36 - If, for any reason, the sample line temperature cannot be maintained greater than or equal to 20° F above outside ambient air temperature, the WRGM may remain OPERABLE provided dewpoint measurements are obtained every 12 hours verifying that conditions do not exist for condensation in the sample line with the inservice operating sample pump. (CX0901.38)

TABLE A.5.2-2

RADIOACTIVE GASEOUS EFFLUENT MONITORING INSTRUMENTATION SURVEILLANCE REQUIREMENTS

INSTRUMENT	CHANNEL CHECK	SOURCE CHECK	CHANNEL CALIBRATION	CHANNEL OPERATIONAL TEST	MODES FOR WHICH SURVEILLANCE IS REQUIRED
1 (Not Used)					
2. PLANT VENT-WIDE RANGE GAS MONITOR					
a. Noble Gas Activity Monitor	D	M	R(3)	Q(2)	*
b. Iodine Sampler	W	N.A.	N.A.	N.A.	*
c. Particulate Sampler	W	N.A.	N.A.	N.A.	*
d. Flow Rate Monitor	D	N.A.	R	Q****	*
e. Sampler Flow Rate Monitor	D	N.A.	R	Q****	*
f. Sample Line Temperature	N.A.	N.A.	240W	N.A.	*
3. GASEOUS WASTE PROCESSING SYSTEM (Providing Alarm and Automatic Termination of Release)					
a. Noble Gas Activity Monitor (Process)	D	N.A.	R(5)	Q(1)	*
4. TURBINE GLAND SEAL CONDENSER EXHAUST					
a. Iodine Sampler	W	N.A.	N.A.	N.A.	***
b. Particulate Sampler	W	N.A.	N.A.	N.A.	***
c. Sampler Flow Rate Indicator	D	N.A.	N.A.	N.A.	***
d. Noble Gas Activity Monitor (RM 6505)	D	M	R(3)	Q(2)	***

TABLE A.5.2-2
(Continued)

TABLE NOTATIONS

- * At all times.
 - ** (Not Used.)
 - *** When the gland seal exhauster is in operation.
 - **** The CHANNEL OPERATIONAL TEST for the flow rate monitor shall consist of a verification that the Radiation Data Management System (RDMS) indicated flow is consistent with the operational status of the plant.
- (1) The DIGITAL CHANNEL OPERATIONAL TEST shall also demonstrate that automatic isolation of this pathway and Control Room alarm annunciation occurs if the instrument indicates measured levels above the normal or Surveillance test Alarm/Trip Setpoint.
 - (2) The DIGITAL CHANNEL OPERATIONAL TEST shall also demonstrate that Control Room alarm annunciation occurs if the instrument indicates measured levels above the normal or Surveillance test Alarm Setpoint.
 - (3) The initial channel calibration for radioactivity measurement instrumentation shall include the use of a known (traceable to National Institute for Standards and Technology) radioactive source positioned in a reproducible geometry with respect to the sensor. These standards should permit calibrating the system over its normal operating range of rate capabilities. For subsequent channel calibrations, sources that have been related to the initial calibration shall be used.
 - (4) (Not Used).
 - (5) The CHANNEL CALIBRATION shall be performed using sources of various activities covering the measurement range of the monitor to verify that the response is linear. Sources shall be used to verify the monitor response only for the intended energy range.

6.0 RADIOACTIVE LIQUID EFFLUENTS

6.1 Concentration

CONTROLS

- C.6.1.1 The concentration of radioactive material released in liquid effluents at the point of discharge from the multiport diffuser (see Technical Specifications Figure 5.1-3) shall be limited to not more than ten times the concentrations specified in 10 CFR Part 20, Appendix B, Table 2, Column 2, for radionuclides other than dissolved or entrained noble gases. For dissolved or entrained noble gases, the concentration shall be limited to 2×10^{-4} $\mu\text{Ci/ml}$ total activity.

APPLICABILITY: At all times.

ACTION:

With the concentration of radioactive material released in liquid effluents at the point of discharge from the multiport diffuser exceeding the above limits, restore the concentration to within the above limits within 15 minutes.

SURVEILLANCE REQUIREMENTS

- S.6.1.1 Radioactive liquid wastes shall be sampled and analyzed according to the sampling and analysis program specified in Table A.6.1-1.
- S.6.1.2 The results of the radioactivity analyses shall be used in accordance with the methodology and parameters in Part B of the ODCM to assure that the concentrations at the point of release are maintained within the limits of Control C.6.1.1.

BASES

This Control is provided to ensure that the concentration of radioactive materials released in liquid waste effluents at the point of discharge from the multiport diffuser will be less than the concentration levels specified in 10 CFR Part 20, Appendix B to 20, Table 2, Column 2 (most restrictive). This limitation provides additional assurance that the levels of radioactive materials in bodies of water in UNRESTRICTED AREAS will result in exposures within (1) the Section II.A design objectives of Appendix I, 10 CFR Part 50, to a MEMBER OF THE PUBLIC, and (2) the limits of Appendix I, 10 CFR 20.1301 and 20.1302 to the population. Those values assure a continuous discharge at those concentrations (8760 hours per year). Pursuant to the requirements of 10 CFR 50.36a to maintain effluent concentrations as low as reasonably achievable (ALARA), Appendix I to 10 CFR 50 specifies dose values that are a small percentage of the dose limits in 10 CFR 20.1301. Consistent with Appendix I to 10 CFR 50, to allow operational flexibility, this specification in conjunction with the dose specification in Section C-6.2 permits an instantaneous concentration release rate up to a factor of ten times greater than specified in 10 CFR 20, Appendix B, Table 2, Column 2 while continuing to limit the total annual discharge to a small fraction of the allowable annual dose as specified in Appendix I.

The concentration limit for dissolved or entrained noble gases is based upon the assumption that Xe-135 is the controlling radioisotope and its MPC in air (submersion) was converted to an equivalent concentration in water using the methods described in International Commission on Radiological Protection (ICRP) Publication 2. For technical requirements associated with the release of liquid effluent, the method currently in use for controlling releases of dissolved and entrained noble gases is suitable for demonstrating conformance to the requirements of the "new" 10 CFR 20, Appendix B ECL concentration limits because the $2 \times 10^{-4} \mu\text{Ci/ml}$ criterion is based on the "old" MPC value for Xe-135 as the driving radionuclide. Controlling liquid effluent to within the MPC values based on an instantaneous release rate (i.e., no time averaging of effluent concentrations) is considered more conservative than the requirements of the new Part 20 which have limits stated as effluent concentrations averaged over a year. In other words, if discharged dissolved and entrained noble gas concentrations remain within the instantaneous concentration limit of $2 \times 10^{-4} \mu\text{Ci/ml}$ during the times that discharges actually take place, then there is reasonable confidence that the annual average limits established by the ECL values will also be met. This position is based on a June 30, 1993 letter from Thomas E. Murley (then Director, Office of Nuclear Reactor Regulation) to Thomas E. Tipton of NEI, in which the NRC responded to an industry inquiry on promulgation of a new Part 20.

Controls C.6.1.1 and C.5.1 provide controls to ensure that the concentration of radioactive materials released in liquid waste effluents at the point of discharge from the multiport diffuser will be less than the concentration levels specified in 10 CFR 20, Appendix B, Table 2, Column 2. As no LLD is specified for the compensatory samples taken for an inoperable PCCW Head Tank Rate of Change Monitor, the LLD for these samples must ensure that these limits are met.

Although the periodic Service Water System sample is counted to an LLD of $5 \times 10^{-7} \mu\text{Ci/cc}$, the compensatory samples for inoperable SGBD Flash Tank and Turbine Building Sump Monitors are required to be counted to an LLD of $1 \times 10^{-7} \mu\text{Ci/cc}$. This more restrictive limit will ensure that the limits of 10 CFR 20 are met during periods of PCCW Head Tank Rate of Change Monitor inoperability, thereby ensuring compliance with the requirements of the respective Controls.

Counting the required grab samples to an LLD of $1 \times 10^{-7} \mu\text{Ci/cc}$ is therefore an acceptable method of complying with these requirements; it is not necessary to meet the LLD of $1 \times 10^{-8} \mu\text{Ci/cc}$ specified as the equivalent sensitivity of the PCCW Head Tank Rate of Change Monitor.

TABLE A.6.1-1
RADIOACTIVE LIQUID WASTE SAMPLING AND ANALYSIS PROGRAM

Liquid Release Type	Sampling Frequency	Minimum Analysis Frequency	Type of Activity Analysis	Lower Limit of Detection (LLD) ⁽¹⁾ (μCi/ml)
A. 1. Liquid Radwaste Test Tanks (WL-TK-63A+B) (BRS-TK58A+B) SGBD Waste Holdup Sump 2. Neutralization Tank (TK-32) 3. Low Conductivity Tank (TK-274) 4. Steam Generator Drains (i.e. from wet lay-up) ⁽⁶⁾ 5. Temporary Tanks via CPS Discharge Line ⁽¹⁴⁾ (Batch Release) ⁽²⁾	P Each Batch	P Each Batch	Principal Gamma Emitters ⁽³⁾	5x10 ⁻⁷
			I-131	1x10 ⁻⁶
	P One Batch/M	M	Dissolved and Entrained Gases (Gamma Emitters)	1x10 ⁻⁵
	P Each Batch	M ⁽⁴⁾ Composite	H-3	1x10 ⁻⁵
			Gross Alpha ⁽¹⁶⁾	1x10 ⁻⁷
	P Each Batch	Q ⁽⁴⁾⁽⁹⁾ Composite	Sr-89, Sr-90 ⁽¹⁶⁾	5x10 ⁻⁸
			Fe-55 ⁽¹⁶⁾	1x10 ⁻⁶
B. 1. Turbine Building Sump Effluent ⁽⁸⁾ 2. Steam Generator Blowdown ⁽⁶⁾⁽⁸⁾ 3. Condensate Polishing / Steam Generator Blowdown Demineralizer Megarinse ⁽⁸⁾⁽¹²⁾ (Continuous Release) ⁽⁵⁾	W Grab Sample	W	Principal Gamma Emitters ⁽³⁾	5x10 ⁻⁷
			I-131	1x10 ⁻⁶
	W Grab Sample	M Composite	Dissolved and Entrained Gases (Gamma Emitters)	1x10 ⁻⁵

TABLE A.6.1-1
RADIOACTIVE LIQUID WASTE SAMPLING AND ANALYSIS PROGRAM
(Continued)

Liquid Release Type	Sampling Frequency	Minimum Analysis Frequency	Type of Activity Analysis	Lower Limit of Detection (LLD) ⁽¹⁾ (μCi/ml)
B. (Continued)	W Grab Sample	M Composite	H-3	1x10 ⁻⁵
			Gross Alpha ⁽¹⁵⁾	1x10 ⁻⁷
	W Grab Sample	Q ⁽⁹⁾ Composite	Sr-89, Sr-90 ⁽¹⁵⁾	5x10 ⁻⁸
			Fe-55 ⁽¹⁵⁾	1x10 ⁻⁶
C. Service Water ⁽⁷⁾⁽¹⁰⁾	W Grab Sample	W	Principal Gamma Emitters ⁽³⁾	5x10 ⁻⁷
			I-131	1x10 ⁻⁶
	W Grab Sample	M	Dissolved and Entrained Gases (Gamma Emitters)	1x10 ⁻⁵
	W Grab Sample	M Composite	H-3 ⁽¹⁵⁾	1x10 ⁻⁵
			Gross Alpha ⁽¹⁵⁾	1x10 ⁻⁷
	W Grab Sample	Q ⁽⁹⁾ Composite	Sr-89, Sr-90 ⁽¹⁵⁾	5x10 ⁻⁸
			Fe-55 ⁽¹⁵⁾	1x10 ⁻⁶

TABLE A.6.1-1
RADIOACTIVE LIQUID WASTE SAMPLING AND ANALYSIS PROGRAM
(Continued)

Liquid Release Type	Sampling Frequency	Minimum Analysis Frequency	Type of Activity Analysis	Lower Limit of Detection (LLD) ⁽¹⁾ ($\mu\text{Ci/ml}$)	
D. Subsurface Dewatering ⁽¹¹⁾	M Grab Sample	M	Principal Gamma Emitters ⁽³⁾	5×10^{-7}	
			H-3 ⁽¹⁵⁾	2×10^{-6}	
	M Grab Sample	M	Gross Alpha ⁽¹⁵⁾	1×10^{-7}	
			Q ⁽⁹⁾ Composite	Sr-89, Sr-90 ⁽¹⁵⁾	5×10^{-8}
				Fe-55 ⁽¹⁵⁾	1×10^{-6}
E. Storm Drains ⁽¹³⁾	W Composite Sample ⁽⁴⁾	W	Principal Gamma Emitters ⁽³⁾	5×10^{-7}	
			H-3	2×10^{-6}	
	W Composite Sample	M Composite	Gross Alpha ⁽¹⁵⁾	1×10^{-7}	
			Q ⁽⁹⁾ Composite	Sr-89, Sr-90 ⁽¹⁵⁾	5×10^{-8}
				Fe-55 ⁽¹⁵⁾	1×10^{-6}

P - Prior to Discharge

W - Weekly

M - Monthly

Q - Quarterly

TABLE A.6.1-1
RADIOACTIVE LIQUID WASTE SAMPLING AND ANALYSIS PROGRAM
 (Continued)

Notations

- (1) The LLD is defined, for purposes of these specifications, as the smallest concentration of radioactive material in a sample that will yield a net count, above system background, that will be detected with 95 percent probability with only 5 percent probability of falsely concluding that a blank observation represents a "real" signal.

For a particular measurement system, which may include radiochemical separation:

$$LLD = \frac{4.66 S_b}{E \times V \times 2.22 \times 10^6 \times Y \times \exp(-\lambda \Delta t)}$$

Where:

- LLD = the "a priori" lower limit of detection (microcurie per unit mass or volume),
- 4.66 = a constant derived from the K_{α} and K_{β} values for the 95% confidence level;
- S_b = the standard deviation of the background counting rate or of the counting rate of a blank sample as appropriate (counts per minute),
- E = the counting efficiency (counts per disintegration),
- V = the sample size (units of mass or volume),
- 2.22×10^6 = the number of disintegrations per minute per microcurie,
- Y = the fractional radiochemical yield, when applicable,
- λ = the radioactive decay constant for the particular radionuclide (s^{-1}), and
- Δt = the elapsed time between the midpoint of sample collection and the time of counting(s).

Typical values of E, V, Y, and Δt should be used in the calculation.

It should be recognized that the LLD is defined as an a priori (before the fact) limit representing the capability of a measurement system and not as an a posteriori (after the fact) limit for a particular measurement.

- (2) A batch release is the discharge of liquid wastes of a discrete volume. A batch discharge that is interrupted and reinitiated at a later time with no additional input (verified input isolated) is considered to be one release. Prior to sampling for analyses, each batch shall be isolated, and then thoroughly mixed to assure representative sampling.

TABLE A.6.1-1
RADIOACTIVE LIQUID WASTE SAMPLING AND ANALYSIS PROGRAM

(Continued)

Notations

(Continued)

- (3) The principal gamma emitters for which the LLD specification applies include the following radionuclides: Mn-54, Fe-59, Co-58, Co-60, Zn-65, Mo-99, Cs-134, Cs-137, Ce-141, and Ce-144. This list does not mean that only these nuclides are to be considered. Other gamma peaks that are identifiable, together with those of the above nuclides, shall also be analyzed and reported in the Annual Radioactive Effluent Release Report in accordance with Technical Specification 6.8.1.4. Isotopes which are not detected should be reported as "not detected." Values determined to be below detectable levels are not used in dose calculations.
- (4) A composite sample is one in which the quantity of liquid sampled is proportional to the quantity of liquid waste discharged and in which the method of sampling employed results in a specimen that is representative of the liquids released.
- (5) A continuous release is the discharge of liquid wastes of a nondiscrete volume, e.g., from a volume of a system that has an input flow during the continuous release.
- (6) Sampling and analysis is only required when Steam Generator Blowdown is directed to the discharge transition structure. During plant operation in Modes 1 through 4, Steam Generator Blowdown Flash Tank releases are considered continuous releases (sampled prior to or during the release) due to the potential input from primary to secondary system leakage during discharges. During plant outages (Modes 5 and 6), Steam Generator drains are considered as batch type releases (input isolated, recirculated and sampled prior to release).
- (7) Principal gamma emitters shall be analyzed weekly in Service Water. Sample and analysis requirements for dissolved and entrained gases, tritium, gross alpha, strontium 89 and 90, and Iron 55 shall only be required when analysis for principal gamma emitters exceeds the LLD for other than naturally occurring radioactivity.

The following are additional sampling and analysis requirements:

- a. PCCW sampled and analyzed weekly for principal gamma emitters.
- b. Sample Service Water System (SWS) daily for principal gamma emitters whenever primary component cooling water (PCCW) activity exceeds 1×10^{-3} $\mu\text{C}/\text{cc}$.
- c. With the PCCW System radiation monitor inoperable, sample PCCW and SWS daily for principal gamma emitters.
- d. With a confirmed PCCW/SWS leak and PCCW activity in excess of 1×10^{-4} $\mu\text{C}/\text{cc}$, sample SWS every 12 hours for principal gamma emitters.
- e. The setpoint on the PCCW head tank liquid rate-of-change alarm will be set to ensure that its sensitivity to detect a PCCW/SWS leak is equal to or greater than that of an SWS radiation monitor, located in the unit's combined SWS discharge, with an LLD of 1×10^{-8} $\mu\text{C}/\text{cc}$. If this sensitivity cannot be achieved, the SWS will be sampled once every 12 hours.

TABLE A.6.1-1
RADIOACTIVE LIQUID WASTE SAMPLING AND ANALYSIS PROGRAM

(Continued)

Notations

(Continued)

- (8) If the Turbine Building Sump, Steam Generator Blowdown Flash Tank, Steam Generator Blowdown Demineralizer Megarinse, or Condensate Polishing Demineralizer Megarinse discharges isolate due to high concentration of radioactivity, that liquid stream will be sampled and analyzed for Iodine-131 and principal gamma emitters prior to release.
- (9) Quarterly composite analysis requirements shall only be required when analysis for principal gamma emitters indicate positive radioactivity other than naturally occurring.
- (10) A grab sample can be considered as a combination of aliquots taken from each SW train during the same collection cycle or as individual samples taken from each train in service.
- (11) Principal gamma emitters and tritium shall be analyzed monthly in subsurface dewatering samples. Sample and analysis requirements for gross alpha, strontium 89 and 90, and Iron 55 shall only be required when analysis for principal gamma emitters exceeds the LLD for other than naturally occurring radioactivity.
- (12) Condensate Polishing Demineralizer or Steam Generator Blowdown Megarinse water shall be sampled and analyzed for principal gamma emitters and I-131 prior to initiation of the megarinse discharge to the circulating water system.
- (13) The Storm Drain System is not designed as a pathway for plant related liquid effluent waste releases. Storm drains are routinely used as the plant subsurface de-watering, secondary steam trap condensation and auxiliary boiler liquid release pathway to the circulating water system. Incidental releases from other sources that contain insignificant quantities of radioactivity may enter and use the storm drain system as a pathway to the circulating water system. Principal gamma emitters and tritium shall be analyzed for weekly. Sample and analysis requirements for gross alpha, strontium 89 and 90, and Iron 55 shall only be required when analysis for principal gamma emitters exceeds the LLD for other than naturally occurring radioactivity, from an unidentified source. The liquid radiation monitor located on the yard drain system outfall and associated with the liquid sampler for the Storm Drain System, is operated as a screening device for trending of response information that may be correlated with sample analysis results for the same flow path. As such, the radiation monitor is not part of either the RETS effluent control program or the REMP.
- (14) The Condensate Polishing System (CPS) has the provision to discharge temporary tanks as batch releases through the same discharge path as the Neutralization Tank (TK-32). The requirements for discharges from a temporary tank through this CPS pathway are equivalent to those of the Neutralization Tank.
- (15) This analysis shall only be required when a sample taken for gamma analysis contains positive activity, for other than naturally occurring isotopes.
- (16) For the Neutralization Tank (TK-32) and the Low Conductivity Tank (TK-274), this analysis shall only be required when a sample taken for gamma analysis contains positive activity, for other than naturally occurring isotopes.

6.2 Dose

CONTROLS

- C.6.2.1 The dose or dose commitment to a MEMBER OF THE PUBLIC from radioactive materials in liquid effluents released, from each unit, to UNRESTRICTED AREAS (see Technical Specification Figure 5.1-3) shall be limited
- a. During any calendar quarter to less than or equal to 1.5 mrems to the whole body and to less than or equal to 5 mrems to any organ, and
 - b. During any calendar year to less than or equal to 3 mrems to the whole body and to less than or equal to 10 mrems to any organ.

APPLICABILITY: At all times.

ACTION:

With the calculated dose from the release of radioactive materials in liquid effluents exceeding any of the above limits, prepare and submit to the Commission within 30 days, pursuant to Technical Specification 6.8.2, a Special Report that identifies the cause(s) for exceeding the limit(s) and defines the corrective actions that have been taken to reduce the releases and the proposed corrective actions to be taken to assure that subsequent releases will be in compliance with the above limits.

SURVEILLANCE REQUIREMENTS

- S.6.2.1 Cumulative dose contributions from liquid effluents for the current calendar quarter and the current calendar year shall be determined in accordance with the methodology and parameters in Part B of the ODCM at least once per 31 days.

BASES

This Control is provided to implement the requirements of Sections II.A, III.A, and IV.A of Appendix I to 10 CFR Part 50. The Control implements the guides set forth in Section II.A of Appendix I. The ACTION statements provide the required operating flexibility and at the same time implement the guides set forth in Section IV.A of Appendix I to assure that the releases of radioactive material in liquid effluents to UNRESTRICTED AREAS will be kept as low as is reasonably achievable. The dose calculation methodology and parameters in the ODCM implement the requirements in Section III.A of Appendix I that conformance with the guides of Appendix I be shown by calculational procedures based on models and data, such that the actual exposure of a MEMBER OF THE PUBLIC through appropriate pathways is unlikely to be substantially underestimated. The equations specified in the ODCM for calculating the doses due to the actual release rates of radioactive materials in liquid effluents are consistent with the methodology provided in Regulatory Guide 1.109, "Calculation of Annual Doses to Man from Routine Releases of Reactor Effluents for the Purpose of Evaluating Compliance with 10 CFR Part 50, Appendix I," Revision 1, October 1977 and Regulatory Guide 1.113, "Estimating Aquatic Dispersion of Effluents from Accidental and Routine Reactor Releases for the Purpose of Implementing Appendix I," April 1977.

6.3 Liquid Radwaste Treatment System

CONTROLS

- C.6.3.1 The Liquid Radwaste Treatment System shall be OPERABLE and appropriate portions of the system shall be used to reduce releases of radioactivity when the projected doses due to the liquid effluent to UNRESTRICTED AREAS (see Technical Specification Figure 5.1-3) would exceed 0.06 mrem to the whole body or 0.2 mrem to any organ in a 31-day period.

APPLICABILITY: At all times.

ACTION:

With radioactive liquid waste being discharged without treatment and in excess of the above limits and any portion of the Liquid Radwaste Treatment System which could reduce the radioactive liquid waste discharged not in operation, prepare and submit to the Commission within 30 days, pursuant to Specification 6.8.2, a Special Report that includes the following information:

- a. Explanation of why liquid radwaste was being discharged without treatment, identification of any inoperable equipment or subsystems, and the reason for the inoperability,
- b. Action(s) taken to restore the inoperable equipment to OPERABLE status, and
- c. Summary description of action(s) taken to prevent a recurrence.

SURVEILLANCE REQUIREMENTS

- S.6.3.1 Doses due to liquid releases from each unit to UNRESTRICTED AREAS shall be projected at least once per 31 days in accordance with the methodology and parameters in Part B of the ODCM when Liquid Radwaste Treatment Systems are not being fully utilized.
- S.6.3.2 The installed Liquid Radwaste Treatment System shall be considered OPERABLE by meeting Controls C.6.1.1 and C.6.2.1.

BASES

The OPERABILITY of the Liquid Radwaste Treatment System ensures that this system will be available for use whenever liquid effluents require treatment prior to release to the environment. The requirement that the appropriate portions of this system be used when specified provides assurance that the releases of radioactive materials in liquid effluents will be kept as low as is reasonably achievable. This specification implements the requirements of 10 CFR 50.36a, General Design Criterion 60 of Appendix A to 10 CFR Part 50, and the design objective given in Section II.D of Appendix I to 10 CFR Part 50. The specified limits governing the use of appropriate portions of the Liquid Radwaste Treatment System were specified as a suitable fraction of the dose design objectives set forth in Section II.A of Appendix A to 10 CFR Part 50 for liquid effluents.

7.0 RADIOACTIVE GASEOUS EFFLUENTS

7.1 Dose Rate

CONTROLS

- C.7.1.1 The dose rate due to radioactive materials released in gaseous effluents from the site to areas at and beyond the SITE BOUNDARY (see Technical Specification Figure 5.1-1) shall be limited to the following:
- a. For noble gases: Less than or equal to 500 mrem/yr to the whole body and less than or equal to 3000 mrem/yr to the skin, and
 - b. For Iodine-131, for Iodine-133, for tritium, and for all radionuclides in particulate form with half-lives greater than 8 days: Less than or equal to 1500 mrem/yr to any organ.

APPLICABILITY: At all times.

ACTION:

With the dose rate(s) exceeding the above limits, decrease the release rate within 15 minutes to within the above limit(s).

SURVEILLANCE REQUIREMENTS

- S.7.1.1 The dose rate due to noble gases in gaseous effluents shall be determined to be within the above limits in accordance with the methodology and parameters in Part B of the ODCM.
- S.7.1.2 The dose rate due to Iodine-131, Iodine-133, tritium, and all radionuclides in particulate form with half-lives greater than 8 days in gaseous effluents shall be determined to be within the above limits in accordance with the methodology and parameters in the ODCM by obtaining representative samples and performing analyses in accordance with the sampling and analysis program specified in Table A.7.1-1.

BASES

This Control is provided to ensure that the dose at any time at and beyond the SITE BOUNDARY from gaseous effluents from all units on the site will be within the annual dose limits of 10 CFR Part 20 to UNRESTRICTED AREAS. The annual dose limits are the doses associated with the concentrations of 10 CFR Part 20, Appendix B, Table 2, Column 1. These limits provide reasonable assurance that radioactive material discharged in gaseous effluents will not result in the exposure of a MEMBER OF THE PUBLIC in an UNRESTRICTED AREA, either within or outside the SITE BOUNDARY, to annual average concentrations exceeding the limits specified in Appendix B, Table 2 of 10 CFR Part 20 (10 CFR Part 20.1302[c]). For MEMBERS OF THE PUBLIC who may at times be within the SITE BOUNDARY, the occupancy of the MEMBER OF THE PUBLIC will usually be sufficiently low to compensate for any increase in the atmospheric diffusion factor above that for the SITE BOUNDARY. Examples of calculations for such MEMBERS OF THE PUBLIC, with the appropriate occupancy factors, shall be given in the ODCM. The specified release rate limits restrict, at all times, the corresponding gamma and beta dose rates above background to a MEMBER OF THE PUBLIC at or beyond the SITE BOUNDARY to less than or equal to 500 mrems/year to the whole body or to less than or equal to 3000 mrems/year to the skin. These release rate limits also restrict, at all times, the corresponding thyroid dose rate above background to a child via the inhalation pathway to less than or equal to 1500 mrems/year.

TABLE A.7.1-1
RADIOACTIVE GASEOUS WASTE SAMPLING
AND ANALYSIS PROGRAM

Gaseous Release Type	Sampling Frequency	Minimum Analysis Frequency	Type of Activity Analysis	Lower Limit of Detection ⁽¹⁾ (LLD) (μCi/cc)
1. Plant Vent	M ⁽³⁾⁽⁴⁾ Grab Sample	M ⁽³⁾	Principal Gamma Emitters ⁽²⁾	1x10 ⁻⁴
			H-3	1x10 ⁻⁶
	Continuous ⁽⁵⁾	W ⁽⁶⁾ Charcoal Sample	I-131	1x10 ⁻¹²
	Continuous ⁽⁵⁾	W ⁽⁶⁾ Particulate Sample	Principal Gamma Emitters ⁽²⁾	1x10 ⁻¹¹
	Continuous ⁽⁵⁾	M Composite Particulate Sample	Gross Alpha	1x10 ⁻¹¹
	Continuous ⁽⁵⁾	Q Composite Particulate Sample	Sr-89, Sr-90	1x10 ⁻¹¹
2. Condenser Air Removal Exhaust	M ⁽⁷⁾ Grab Sample	M ⁽⁷⁾ Noble Gases	Principal Gamma Emitters ⁽²⁾	1x10 ⁻⁴
			H-3	1x10 ⁻⁶

TABLE A.7.1-1
RADIOACTIVE GASEOUS WASTE SAMPLING
AND ANALYSIS PROGRAM
(Continued)

Gaseous Release Type	Sampling Frequency	Minimum Analysis Frequency	Type of Activity Analysis	Lower Limit of Detection ⁽¹⁾ (LLD) (μCi/cc)
3. Gland Steam Packing Exhauster	Continuous	W Particulate Sample	Principal Gamma Emitters ⁽²⁾	1x10 ⁻¹¹
	Continuous	W Charcoal Sample	I-131	1x10 ⁻¹²
	Continuous	M Composite Particulate Sample	Gross Alpha	1x10 ⁻¹¹
	Continuous	Q Composite Particulate Sample ⁽⁸⁾	Sr-89, Sr-90	1x10 ⁻¹¹
4. Containment Purge	P ⁽³⁾ Each Purge Grab Sample	P ⁽³⁾ Each Purge	Principal Gamma Emitters ⁽²⁾	1x10 ⁻⁴
			H-3 (oxide)	1x10 ⁻⁶

TABLE A.7.1-1
RADIOACTIVE GASEOUS WASTE SAMPLING
AND ANALYSIS PROGRAM
(Continued)

Notations

- (1) The LLD is defined, for purposes of these specifications, as the smallest concentration of radioactive material in a sample that will yield a net count, above system background, that will be detected with 95 percent probability with only 5 percent probability of falsely concluding that a blank observation represents a "real" signal.

For a particular measurement system, which may include radiochemical separation:

$$LLD = \frac{4.66 S_b}{E \times V \times 2.22 \times 10^6 \times Y \times \exp(-\lambda \Delta t)}$$

Where:

- LLD = the "a priori" lower limit of detection (microcurie per unit mass or volume),
- 4.66 = a constant derived from the K_{α} and K_{β} values for the 95% confidence level;
- S_b = the standard deviation of the background counting rate or of the counting rate of a blank sample as appropriate (counts per minute),
- E = the counting efficiency (counts per disintegration),
- V = the sample size (units of mass or volume),
- 2.22×10^6 = the number of disintegrations per minute per microcurie,
- Y = the fractional radiochemical yield, when applicable,
- λ = the radioactive decay constant for the particular radionuclide (s^{-1}), and
- Δt = the elapsed time between the midpoint of sample collection and the time of counting(s).

Typical values of E, V, Y, and Δt should be used in the calculation.

It should be recognized that the LLD is defined as an a priori (before the fact) limit representing the capability of a measurement system and not as an a posteriori (after the fact) limit for a particular measurement.

TABLE A.7.1-1
RADIOACTIVE GASEOUS WASTE SAMPLING
AND ANALYSIS PROGRAM
(Continued)

Notations
(Continued)

- (2) The principal gamma emitters for which the LLD specification applies include the following radionuclides: Kr-87, Kr-88, Xe-133, Xe-133m, Xe-135, and Xe-138 in noble gas releases and Mn-54, Fe-59, Co-58, Co-60, Zn-65, Mo-99, I-131, Cs-134, Cs-137, Ce-141 and Ce-144 in iodine and particulate releases. This list does not mean that only these nuclides are to be considered. Other gamma peaks that are identifiable, together with those of the above nuclides, shall also be analyzed and reported in the Annual Radioactive Effluent Release Report in accordance with Technical Specification 6.8.1.4 and Part A, Section 10.2 of the ODCM. Isotopes which are not detected should be reported as "not detected." Values determined to be below detectable levels are not used in dose calculations.
- (3) Sampling and analysis shall also be performed following shutdown, startup, or a THERMAL POWER change exceeding 15 percent of RATED THERMAL POWER within a one hour period unless; 1) analysis shows that the DOSE EQUIVALENT I-131 concentrations in the primary coolant has not increased more than a factor of 3; 2) the noble gas activity monitor for the plant vent has not increased by more than a factor of 3. For containment purge, requirements apply only when purge is in operation.
- (4) Tritium grab samples shall be taken at least once per 24 hours when the refueling canal is flooded.
- (5) The ratio of the sample flow rate to the sampled stream flow rate shall be known for the time period covered by each dose or dose rate calculation made in accordance with Controls C.7.1.1, C.7.2.1, and C.7.3.1.
- (6) Samples shall be changed at least once per seven (7) days and analyses shall be completed within 48 hours after changing, or after removal from sampler. Sampling shall also be performed at least once per 24 hours for at least seven (7) days following each shutdown, startup, or THERMAL POWER change exceeding 15 percent of RATED THERMAL POWER within a one-hour period and analyses shall be completed within 48 hours of changing. When samples collected for 24 hours are analyzed, the corresponding LLDs may be increased by a factor of 10. This requirement does not apply if 1) analysis shows that the DOSE EQUIVALENT I-131 concentration in the reactor coolant has not increased more than a factor of 3; and 2) the noble gas monitor shows that effluent activity has not increased more than a factor of 3.
- (7) Samples shall be taken prior to start-up of condenser air removal system when there have been indications of a primary to secondary leak.
- (8) Quarterly composite analysis requirements shall only be required when analysis for principal gamma emitters indicate positive radioactivity.

7.2 Dose - Noble Gases

CONTROLS

- C.7.2.1 The air dose due to noble gases released in gaseous effluents to areas at and beyond the SITE BOUNDARY (see Technical Specification Figure 5.1-1) shall be limited to the following:
- a. During any calendar quarter: Less than or equal to 5 mrad for gamma radiation and less than or equal to 10 mrad for beta radiation, and
 - b. During any calendar year: Less than or equal to 10 mrad for gamma radiation and less than or equal to 20 mrad for beta radiation.

APPLICABILITY: At all times.

ACTION:

With the calculated air dose from radioactive noble gases in gaseous effluents exceeding any of the above limits, prepare and submit to the Commission within 30 days, pursuant to Technical Specification 6.8.2, a Special Report that identifies the cause(s) for exceeding the limit(s) and defines the corrective actions that have been taken to reduce the releases and the proposed corrective actions to be taken to assure that subsequent releases will be in compliance with the above limits.

SURVEILLANCE REQUIREMENTS

- S.7.2.1 Cumulative dose contributions for the current calendar quarter and current calendar year for noble gases shall be determined in accordance with the methodology and parameters in Part B of the ODCM at least once per 31 days.

BASES

This Control is provided to implement the requirements of Sections II.B, III.A, and IV.A of Appendix I to 10 CFR Part 50. The Control implements the guides set forth in Section I.B of Appendix I. The ACTION statements provide the required operating flexibility and at the same time implement the guides set forth in Section IV.A of Appendix I at the SITE BOUNDARY that the releases of radioactive material in gaseous effluents to UNRESTRICTED AREAS will be kept as low as reasonably achievable. The Surveillance Requirements implement the requirements in Section III.A of Appendix I that conformance with the guides of Appendix I be shown by calculational procedures based on models and data such that the actual exposure of a MEMBER OF THE PUBLIC through appropriate pathways is unlikely to be substantially underestimated. The dose calculation methodology and parameters established in the ODCM for calculating the doses due to the actual release rates of radioactive noble gases in gaseous effluents are consistent with the methodology provided in Regulatory Guide 1.109, "Calculation of Annual Doses to Man from Routine Releases of Reactor Effluents for the Purpose of Evaluating Compliance with 10 CFR Part 50, Appendix I," Revision 1, October 1977, and Regulatory Guide 1.111, "Methods for Estimating Atmospheric Transport and Dispersion of Gaseous Effluents in Routine Releases from Light-Water Cooled Reactors," Revision 1, July 1977. The ODCM equations provided for determining the air doses at and beyond the SITE BOUNDARY are based upon the historical average atmospheric conditions.

7.3 Dose - Iodine-131, Iodine-133, Tritium, and Radioactive Material in Particulate Form

CONTROLS

- C.7.3.1 The dose to a MEMBER OF THE PUBLIC from Iodine-131, Iodine-133, tritium, and all radionuclides in particulate form with half-lives greater than 8 days in gaseous effluents released to areas at and beyond the SITE BOUNDARY (see Technical Specification Figure 5.1-1) shall be limited to the following:
- a. During any calendar quarter: Less than or equal to 7.5 mrems to any organ, and
 - b. During any calendar year: Less than or equal to 15 mrems to any organ.

APPLICABILITY: At all times.

ACTION:

With the calculated dose from the release of Iodine-131, Iodine-133, tritium, and radionuclides in particulate form with half-lives greater than 8 days, in gaseous effluents exceeding any of the above limits, prepare and submit to the Commission within 30 days, pursuant to Technical Specification 6.8.2, a Special Report that identifies the cause(s) for exceeding the limit(s) and defines the corrective actions that have been taken to reduce the releases and the proposed corrective actions to be taken to assure that subsequent releases will be in compliance with the above limits.

SURVEILLANCE REQUIREMENTS

- S.7.3.1 Cumulative dose contributions for the current calendar quarter and current calendar year for Iodine-131, Iodine-133, tritium, and radionuclides in particulate form with half-lives greater than 8 days shall be determined in accordance with the methodology and parameters in Part B of the ODCM at least once per 31 days.

BASES

This Control is provided to implement the requirements of Sections II.C, III.A, and IV.A of Appendix I to 10 CFR Part 50. The Controls are the guides set forth in Section II.C of Appendix I. The ACTION statements provide the required operating flexibility and at the same time implement the guides set forth in Section IV.A of Appendix I to assure that the releases of radioactive materials in gaseous effluents at the SITE BOUNDARY will be kept as low as reasonably achievable. The ODCM calculation methods specified in the Surveillance Requirements implement the requirements in Section III.A of Appendix I that conformance with the guides of Appendix I be shown by calculational procedures based on models and data such that the actual exposure of a MEMBER OF THE PUBLIC through appropriate pathways is unlikely to be substantially underestimated. The ODCM calculational methodology and parameters for calculating the doses due to the actual release rates of the subject materials are consistent with the methodology provided in Regulatory Guide 1.109, "Calculation of Annual Doses to Man from Routine Releases of Reactor Effluents for the Purpose of Evaluating Compliance with 10 CFR Part 50, Appendix I," Revision 1, October 1977, and Regulatory Guide 1.111, "Methods for Estimating Atmospheric Transport and Dispersion of Gaseous Effluents in Routine Releases from Light-Water Cooled Reactors," Revision 1, July 1977. These equations also provide for determining the actual doses based upon the historical Iodine-133, tritium, and radionuclides in particulate form with half-lives greater than 8 days are dependent upon the existing radionuclide pathways to man in the areas at and beyond the SITE BOUNDARY. The pathways that were examined in the development of the calculations were

- (1) Individual inhalation of airborne radionuclides,
- (2) Deposition of radionuclides onto green leafy vegetation with subsequent consumption by man,
- (3) Deposition of radionuclides onto grassy areas where milk animals and meat-producing animals graze followed by human consumption of that milk and meat, and
- (4) Deposition of radionuclides on the ground followed by subsequent human exposure.

7.4 Gaseous Radwaste Treatment System

CONTROLS

- C.7.4.1 The VENTILATION EXHAUST TREATMENT SYSTEM and the GASEOUS RADWASTE TREATMENT SYSTEM shall be OPERABLE and appropriate portions of these systems shall be used to reduce releases of radioactivity when the projected doses in 31 days due to gaseous effluent releases to areas at and beyond the SITE BOUNDARY (see Technical Specification Figure 5.1-1) would exceed
- a. 0.2 mrad to air from gamma radiation, or
 - b. 0.4 mrad to air from beta radiation, or
 - c. 0.3 mrem to any organ of a MEMBER OF THE PUBLIC.

APPLICABILITY: At all times.

ACTION:

With radioactive gaseous waste being discharged without treatment and in excess of the above limits, prepare and submit to the Commission within 30 days, pursuant to Specification 6.8.2, a Special Report that includes the following information:

- a. Identification of any inoperable equipment or subsystems, and the reason for the inoperability,
- b. Action(s) taken to restore the inoperable equipment to OPERABLE status, and
- c. Summary description of action(s) taken to prevent a recurrence.

SURVEILLANCE REQUIREMENTS

- S.7.4.1 Doses due to gaseous releases from each unit to areas at and beyond the SITE BOUNDARY shall be projected at least once per 31 days in accordance with the methodology and parameters in Part B of the ODCM when Gaseous Radwaste Treatment Systems are not being fully utilized.
- S.7.4.2 The installed VENTILATION EXHAUST TREATMENT SYSTEM and GASEOUS RADWASTE TREATMENT SYSTEM shall be considered OPERABLE by meeting Controls C.7.1.1, and C.7.2.1, or C.7.3.1.

BASES

The OPERABILITY of the GASEOUS RADWASTE TREATMENT SYSTEM and the VENTILATION EXHAUST TREATMENT SYSTEM ensures that the systems will be available for use whenever gaseous effluents require treatment prior to release to the environment. The requirement that the appropriate portions of these systems be used, when specified, provides reasonable assurance that the releases of radioactive materials in gaseous effluents will be kept as low as is reasonably achievable. This Control implements the requirements of 10 CFR 50.36a, General Design Criterion 60 of Appendix A to 10 CFR Part 50, and the design objectives given in Section II.D of Appendix I to 10 CFR Part 50. The specified limits governing the use of appropriate portions of the systems were specified as a suitable fraction of the dose design objectives set forth in Sections II.B and II.C of Appendix I to 10 CFR Part 50, for gaseous effluents.

8.0 TOTAL DOSE

CONTROL

- C.8.1.1 The annual (calendar year) dose or dose commitment to any MEMBER OF THE PUBLIC due to releases of radioactivity and to radiation from uranium fuel cycle sources shall be limited to less than or equal to 25 mrems to the whole body or any organ, except the thyroid, which shall be limited to less than or equal to 75 mrems.

APPLICABILITY: At all times.

ACTION:

With the calculated doses from the release of radioactive materials in liquid or gaseous effluents exceeding twice the limits of Controls C.6.2.1.a, C.6.2.1.b, C.7.2.1.a, C.7.2.1.b, C.7.3.1.a, or C.7.3.1.b, calculations shall be made including direct radiation contributions from the units and from outside storage tanks to determine whether the above limits of Control C.8.1.1 have been exceeded. If such is the case, prepare and submit to the Commission within 30 days, pursuant to Technical Specification 6.8.2, a Special Report that defines the corrective action to be taken to reduce subsequent releases to prevent recurrence of exceeding the above limits and includes the schedule for achieving conformance with the above limits. This Special Report, as defined in 10 CFR 20.2203(a)(4), shall include an analysis that estimates the radiation exposure (dose) to a MEMBER OF THE PUBLIC from uranium fuel cycle sources, including all effluent pathways and direct radiation, for the calendar year that includes the release(s) covered by this report. It shall also describe levels of radiation and concentrations of radioactive material involved, and the cause of the exposure levels or concentrations. If the estimated dose(s) exceeds the above limits, and if the release condition resulting in violation of 40 CFR Part 190 has not already been corrected, the Special Report shall include a request for a variance in accordance with the provisions of 40 CFR Part 190. Submittal of the report is considered a timely request, and a variance is granted until staff action on the request is complete.

SURVEILLANCE REQUIREMENTS

- S.8.1.1 Cumulative dose contributions from liquid and gaseous effluents shall be determined in accordance with Surveillance Requirement S.6.2.1, S.7.2.1, and S.7.3.1, and in accordance with the methodology and parameters in Part B of the ODCM.
- S.8.1.2 Cumulative dose contributions from direct radiation from plant facilities, including radwaste storage tanks and Dry Fuel Storage Facility, shall be determined in accordance with the methodology and parameters in Part B of the ODCM. This requirement is applicable only under conditions set forth in ACTION a. of Control C.8.1.1.

BASES

This Control is provided to meet the dose limitations of 40 CFR Part 190 that have been incorporated into 10 CFR Part 20 by 46FR18525. The specification requires the preparation and submittal of a Special Report whenever the calculated doses due to releases of radioactivity and to radiation from uranium fuel cycle sources exceed 25 mrems to the whole body or any organ, except the thyroid, which shall be limited to less than or equal to 75 mrems. For sites containing up to four reactors, it is highly unlikely that the resultant dose to a MEMBER OF THE PUBLIC will exceed the dose limits of 40 CFR Part 190 if the individual reactors remain within twice the dose design objectives of Appendix I, and if direct radiation doses from the units (including outside storage tanks, solid radwaste storage and dry fuel storage, etc.) are kept small. The Special Report will describe a course of action that should result in the limitation of the annual dose to a MEMBER OF THE PUBLIC to within the 40 CFR Part 190 limits. For the purposes of the Special Report, it may be assumed that the dose commitment to the MEMBER OF THE PUBLIC from other uranium fuel cycle sources is negligible, with the exception that dose contributions from other nuclear fuel cycle facilities at the same site are within a radius of 8 km must be considered. If the dose to any MEMBER OF THE PUBLIC is estimated to exceed the requirements of 40 CFR Part 190 [equivalent to 10 CFR 72.104(a) for Dry Fuel Storage considerations], the Special Report with a request for a variance (provided the release conditions resulting in violation of 40 CFR Part 190 have not already been corrected), in accordance with the provisions of 40 CFR 190.11 and 10 CFR 20.405c, is considered to be a timely request and fulfills the requirements of 40 CFR Part 190 until NRC staff action is completed. The variance only relates to the limits of 40 CFR Part 190, and does not apply in any way to the other requirements for dose limitation of 10 CFR Part 20, as addressed in Controls C.6.1.1 and C.7.1.1. An individual is not considered a MEMBER OF THE PUBLIC during any period in which he/she is engaged in carrying out any operation that is part of the nuclear fuel cycle.

9.0 RADIOLOGICAL ENVIRONMENTAL MONITORING

9.1 Plant Operations Monitoring Program

CONTROL

C.9.1.1 The Radiological Environmental Monitoring Program (REMP) shall be conducted as specified in Table A.9.1-1.

APPLICABILITY: At all times.

ACTION:

- a. With the REMP not being conducted as specified in Table A.9.1-1, prepare and submit to the Commission, in the Annual Radiological Environmental Operating Report required by Technical Specification 6.8.1.3 and Part A, Section 10.1 of the ODCM, a description of the reasons for not conducting the program as required and the plans for preventing a recurrence.
- b. With the level of radioactivity as the result of plant effluents in an environmental sampling medium at a specified location exceeding the reporting levels of Table A.9.1-3 when averaged over any calendar quarter, prepare and submit to the Commission within 30 days from receipt of the laboratory analyses, pursuant to Technical Specification 6.8.2, a Special Report that identifies the cause(s) for exceeding the limit(s) and defines the corrective actions to be taken to reduce radioactive effluents so that the potential annual dose* to a MEMBER OF THE PUBLIC is less than the calendar year limits of Control C.6.2.1, C.7.2.1, or C.7.3.1. When more than one of the radionuclides in the REMP are detected in the sampling medium, this report shall be submitted if

$$\frac{\text{concentration (1)}}{\text{reporting level (1)}} + \frac{\text{concentration (2)}}{\text{reporting level (2)}} + \dots \geq 1.0$$

When radionuclides other than those listed in the REMP are detected and are the result of plant effluents, this report shall be submitted if the potential annual dose* to a MEMBER OF THE PUBLIC from all radionuclides is equal to or greater than the calendar year limits of Control C.6.2.1, C.7.2.1, or C.7.3.1. This report is not required if the measured level of radioactivity was not the result of plant effluents; however, in such an event, the condition shall be reported and described in the Annual Radiological Environmental Operating Report required by Technical Specification 6.8.1.3 and Part A, Section 10.1 of the ODCM.

*The methodology and parameters used to estimate the potential annual dose to a MEMBER OF THE PUBLIC shall be indicated in this report.

ACTION: (Continued)

With milk or fresh leafy vegetable samples unavailable from one or more of the sample locations required by the REMP, identify specific locations for obtaining replacement samples and add them within 30 days to the REMP given in the ODCM. The specific locations from which samples were unavailable may then be deleted from the monitoring program. Pursuant to Technical Specification 6.13, and Part A, Section 10.2, of the ODCM, submit in the next Annual Radioactive Effluent Release Report documentation for a change in the ODCM including a revised figure(s) and table for the ODCM reflecting the new location(s) with supporting information identifying the cause of the unavailability of samples and justifying the selection of the new location(s) for obtaining samples.

SURVEILLANCE REQUIREMENTS

S.9.1.1 The radiological environmental monitoring samples shall be collected pursuant to Table A.9.1-1 from the specific locations given in the table and figure(s) in Part B of the ODCM, and shall be analyzed pursuant to the requirements of Table A.9.1-1 and the detection capabilities required by Table A.9.1-2.

BASES

The REMP required by this Control provides representative measurements of radiation and of radioactive materials in those exposure pathways and for those radionuclides that lead to the highest potential radiation exposures of MEMBERS OF THE PUBLIC resulting from the plant operation. This monitoring program implements Section IV.B.2 of Appendix I to 10 CFR Part 50, and thereby supplements the REMP by verifying that the measurable concentrations of radioactive materials and levels of radiation are not higher than expected on the basis of the effluent measurements and the modeling of the environmental exposure pathways. Guidance for this monitoring program is provided by the Radiological Assessment Branch Technical Position on Environmental Monitoring, Revision 1, November 1979. The initially specified monitoring program will be effective for at least the first 3 years of commercial operation. Following this period, program changes may be initiated based on operational experience.

Detailed discussion of the LLD and other detection limits can be found in Currie, L.A., "Lower Limit of Detection: Definition and Elaboration of a Proposed Position for Radiological Effluent and Environmental Measurements," NUREG/CR-4007 (September 1984).

TABLE A.9.1-1
RADIOLOGICAL ENVIRONMENTAL MONITORING PROGRAM

Exposure Pathway and/or Sample	Number of Representative Samples and Sample Locations ^a	Sampling and Collection Frequency	Type and Frequency of Analysis
1. DIRECT RADIATION ^b	<p>40 routine monitoring stations with two or more dosimeters placed as follows:</p> <p>An inner ring of stations, one in each meteorological sector in the general area of the SITE BOUNDARY;</p> <p>An outer ring of stations, one in each meteorological sector, generally in the 6 to 8-km range from the site;</p> <p>The balance of the stations to be placed in special interest areas such as population centers, nearby residences, schools, and control locations.</p>	Quarterly.	Gamma dose quarterly.
2. AIRBORNE Radioiodine and Particulates	<p>Samples from five locations^d:</p> <p>Three samples from close to the three SITE BOUNDARY locations, in different sectors, of high calculated long-term average ground-level D/Q.</p> <p>One sample from the vicinity of a community having the highest calculated long-term average ground-level D/Q.</p>	Continuous sampler operation with sample collection biweekly (approx. 14 days), or more frequently if required by dust loading.	<p><u>Radioiodine Canister:</u></p> <p>I-131 analysis biweekly (approx. 14 days).</p> <p><u>Particulate Sampler:</u></p> <p>Gross beta radioactivity analysis following filter change^c; Gamma isotopic analysis^e of composite (by location) quarterly.</p>

TABLE A.9.1-1
RADIOLOGICAL ENVIRONMENTAL MONITORING PROGRAM
(Continued)

Exposure Pathway and/or Sample	Number of Representative Samples and Sample Locations ^a	Sampling and Collection Frequency	Type and Frequency of Analysis
2. (Continued)	One sample from a control location, as for example 15-30 km distant and in the least prevalent wind direction.		
3. WATERBORNE a. Surface b. Sediment from shoreline	One sample in the discharge area. One sample from a control location. One sample from area with existing or potential recreational value.	Monthly grab sample. Semiannually.	Gamma isotopic analysis ^e monthly. Composite for tritium analysis quarterly. Gamma isotopic analysis ^e semiannually.
4. INGESTION a. Milk	Samples from milking animals in three locations within 5 km distance having the highest dose potential. If there are none, then, one sample from milking animals in each of three areas between 5 to 8 km distant where doses are calculated to be greater than 1 mrem per yr. ^f One sample from milking animals at a control location, as for example, 15-30 km distant and in the least prevalent wind direction.	Semimonthly when milking animals are on pasture, monthly at other times.	Gamma isotopic ^e and I-131 analysis on each sample.

TABLE A.9.1-1
RADIOLOGICAL ENVIRONMENTAL MONITORING PROGRAM
 (Continued)

Exposure Pathway and/or Sample	Number of Representative Samples and Sample Locations ^a	Sampling and Collection Frequency	Type and Frequency of Analysis
4. (Continued) b. Fish and Invertebrates c. Food Products	<p>One sample of each of three commercially and recreationally important species in vicinity of plant discharge area.</p> <p>One sample of similar species in areas not influenced by plant discharge.</p> <p>Samples of three (if practical) different kinds of broad leaf vegetation^g grown nearest each of two different off-site locations of highest predicted long-term average ground-level D/Q if milk sampling is not performed.^h</p> <p>One sample of each of the similar broad leaf vegetation^g grown at a control location, as for example 15-30 km distant in the least prevalent wind direction, if milk sampling is not performed.^h</p>	<p>Sample in season, or semiannually if they are not seasonal.</p> <p>Monthly, when available.</p> <p>Monthly, when available.</p>	<p>Gamma isotopic analysis^e on edible portions.</p> <p>Gamma isotopic^e and I-131 analysis.</p> <p>Gamma isotopic^e and I-131 analysis.</p>

TABLE A.9.1-1
RADIOLOGICAL ENVIRONMENTAL MONITORING PROGRAM
(Continued)

Table Notations

- a. Specific parameters of distance and direction sector from the centerline of the Unit 1 reactor, and additional description where pertinent, shall be provided for each and every sample location in Table B.4-1 in the ODCM, Part B. Deviations are permitted from the required sampling schedule if specimens are unobtainable due to circumstances such as hazardous conditions, seasonal unavailability and malfunction of automatic sampling equipment. If specimens are unobtainable due to sampling equipment malfunction, effort shall be made to complete corrective action prior to the end of the next sampling period. All deviations from the sampling schedule shall be documented in the Annual Radiological Environmental Operating Report as specified in Part A, Section 10.1. It is recognized that, at times, it may not be possible or practicable to continue to obtain samples of the media of choice at the most desired location or time. In these instances suitable alternative media and locations may be chosen for the particular pathway in question and appropriate substitutions made within 30 days in the Radiological Environmental Monitoring Program. Identify the cause of the unavailability of samples for that pathway and identify the new location(s), if available, for obtaining replacement samples in the next Semiannual Radioactive Effluent Release Report as specified in Part A, Section 10.2 and also include in the report a revised figure(s) and table for the ODCM reflecting the new location(s).
- b. A thermoluminescent dosimeter (TLD) is considered to be one phosphor; two or more phosphors in a packet are considered as two or more dosimeters.
- c. Airborne particulate sample filters shall be analyzed for gross beta radioactivity 24 hours or more after sampling to allow for radon and thoron daughter decay. If gross beta activity in air particulate samples is greater than ten times the yearly mean of control samples, gamma isotopic analysis shall be performed on the individual samples.
- d. Optimal air sampling locations are based not only on D/Q but on factors such as population in the area, year-round access to the site, and availability of power.
- e. Gamma isotopic analysis means the identification and quantification of gamma-emitting radionuclides that may be attributable to the effluents from the facility.
- f. The dose shall be calculated for the maximum organ and age group, using the methodology and parameters in the ODCM, Part B.
- g. If broad leaf vegetation is unavailable, other vegetation will be sampled.
- h. Vegetation samples may be taken in the general vicinity of the designated sample location, due to availability.

TABLE A.9.1-2
DETECTION CAPABILITIES FOR ENVIRONMENTAL SAMPLE ANALYSIS^{a,f,g}

Lower Limit of Detection (LLD)^b

Analysis	Water (pCi/kg)	Airborne Particulate or Gas (pCi/m ³)	Fish and Invertebrates (pCi/kg, wet)	Milk (pCi/kg)	Food Products (pCi/kg, wet)	Sediment (pCi/kg, dry)
Gross Beta	4	0.01				
H-3	3,000					
Mn-54	15		130			
Fe-59	30		260			
Co-58, 60	15		130			
Zn-65	30		260			
Zr-Nb-95	15 ^c					
I-131	15	0.07		1	60 ^e	
Cs-134	15	0.05	130	15	60	150
Cs-137	18	0.06	150	18	80	180
Ba-La-140	15 ^{c,d}			15 ^{c,d}		

TABLE A.9.1-2
DETECTION CAPABILITIES FOR ENVIRONMENTAL SAMPLE ANALYSIS
(Continued)

Table Notations

- a. This list does not mean that only these nuclides are to be considered. Other peaks that are identifiable, together with those of the above nuclides, shall also be analyzed and reported in the Annual Radiological Environmental Operating Report.
- b. The LLD is defined, for purposes of these specifications, as the smallest concentration of radioactive material in a sample that will yield a net count, above system background, that will be detected with 95% probability with only 5% probability of falsely concluding that a blank observation represents a "real" signal.

For a particular measurement system, which may include radiochemical separation:

$$LLD = \frac{4.66 S_b}{E \times V \times 2.22 \times 10^6 \times Y \times \exp(-\lambda \Delta t)}$$

Where:

LLD is the "a priori" lower limit of detection as defined above, as picocuries per unit mass or volume;

4.66 is a constant derived from the K_{α} and K_{β} values for the 95% confidence level;

s_b is the standard deviation of the background counting rate or of the counting rate of a blank sample as appropriate, as counts per minute;

E is the counting efficiency, as counts per disintegration;

V is the sample size in units of mass or volume;

2.22 is the number of disintegrations per minute per picocurie;

Y is the fractional radiochemical yield, when applicable;

λ is the radioactive decay constant for the particular radionuclide as per second; and

Δt for environmental samples is the elapsed time between sample collection and time of counting, as seconds.

Typical values of E, V, Y, and Δt should be used in the calculation.

In calculating the LLD for a radionuclide determined by gamma ray spectrometry, the background shall include the typical contributions of other radionuclides normally present in the samples (e.g., Potassium-40 in milk samples).

TABLE A.9.1-2
DETECTION CAPABILITIES FOR ENVIRONMENTAL SAMPLE ANALYSIS
(Continued)

Table Notations
(Continued)

It should be recognized that the LLD is defined as an a priori (before the fact) limit representing the capability of a measurement system and not as an a posteriori (after the fact) limit for a particular measurement. This does not preclude the calculation of an a posteriori LLD for a particular measurement based upon the actual parameters for the sample in question and appropriate decay correction parameters such as decay while sampling and during analysis. Analyses shall be performed in such a manner that the stated LLDs will be achieved under routine conditions. Occasionally background fluctuations, unavoidable small sample sizes, the presence of interfering nuclides, or other uncontrollable circumstances may render these LLDs unachievable. In such cases, the contributing factors shall be identified and described in the Annual Radiological Environmental Operating Report per Part A, Section 10.1.

- c. Parent only.
- d. The Ba-140 LLD and concentration can be determined by the analysis of its short-lived daughter product La-140 subsequent to an eight-day period following collection. The calculation shall be predicated on the normal ingrowth equations for a parent-daughter situation and the assumption that any unsupported La-140 in the sample would have decayed to an insignificant amount (at least 3.6% of its original value). The ingrowth equations will assume that the supported La-140 activity at the time of collection is zero.
- e. Broad leaf vegetation only.
- f. If the measured concentration minus the three standard deviation uncertainty is found to exceed the specified LLD, the sample does not have to be analyzed to meet the specified LLD.
- g. Required detection capabilities for thermoluminescent dosimeters used for environmental measurements shall be in accordance with recommendations of Regulatory Guide 4.13, Revision 1, July 1977.

TABLE A.9.1-3
REPORTING LEVELS FOR RADIOACTIVITY CONCENTRATIONS IN ENVIRONMENTAL SAMPLES

Analysis	Water (pCi/kg)	Airborne Particulate or Gas (pCi/m ³)	Fish and Invertebrates (pCi/kg, wet)	Milk (pCi/kg)	Food Products (pCi/kg, wet)
H-3	30,000***				
Mn-54	1,000		30,000		
Fe-59	400		10,000		
Co-58	1,000		30,000		
Co-60	300		10,000		
Zn-65	300		20,000		
Zr-Nb-95	400*				
I-131	100	0.9		3	100**
Cs-134	30	10	1,000	60	1,000
Cs-137	50	20	2,000	70	2,000
Ba-La-140	200*			300*	

* Parent only.

** Broad leaf vegetation only.

*** Drinking water reporting level = 20,000 pCi/kg (2E-05 µCi/ml)

9.2 Land Use Census

CONTROL

C.9.2.1 A Land Use Census shall be conducted and shall identify within a distance of 8 km (5 miles) the location in each of the 16 meteorological sectors of the nearest milk animal, the nearest residence, and the nearest garden** of greater than 50 m² (500 ft²) producing broad leaf vegetation.

APPLICABILITY: At all times.

ACTION

- a. With a Land Use Census identifying a location(s) that yields a calculated dose or dose commitment greater than the values currently being calculated in Surveillance S.7.3.1 pursuant to Technical Specification 6.8.1.4 and Part A, Section 10.2, of the ODCM, identify the new location(s) in the next Annual Radioactive Effluent Release Report.
- b. With a Land Use Census identifying a location(s) that yields a calculated dose or dose commitment (via the same exposure pathway) 20% greater than at a location from which samples are currently being obtained in accordance with Control C.9.1.1, add the new location(s) within 30 days to the REMP given in the ODCM, if permission from the owner to collect samples can be obtained and sufficient sample volume is available. The sampling location(s), excluding the Control station location, having the lowest calculated dose or dose commitment(s), via the same exposure pathway, may be deleted from this monitoring program after October 31 of the year in which this Land Use Census was conducted. Pursuant to Technical Specification 6.13 and Part A, Section 10.2 of the ODCM, submit in the next Annual Radioactive Effluent Release Report documentation for a change in the ODCM including a revised figure(s) and table(s) for the ODCM reflecting the new location(s) with information supporting the change in sampling locations.

SURVEILLANCE REQUIREMENTS

S.9.2.1 The Land Use Census shall be conducted during the growing season at least once per 12 months using a method such as by a door-to-door survey, aerial survey, or by consulting local agriculture authorities, as described in the ODCM. The results of the Land Use Census shall be included in the Annual Radiological Environmental Operating Report pursuant to Part A, Section 10.1 of the ODCM.

**Broad leaf vegetation sampling of at least three different kinds of vegetation may be performed at the SITE BOUNDARY in each of two different direction sectors with the highest predicted relative deposition values (D/Qs) in lieu of the garden census. Specifications for broad leaf vegetation sampling in the REMP shall be followed, including analysis of control samples.

BASES

This specification is provided to ensure that changes in the use of areas at and beyond the SITE BOUNDARY are identified and that modifications to the REMP given in the ODCM are made if required by the results of this census. Information from methods such as the door-to-door survey, from aerial survey, or from consulting with local agricultural authorities shall be used. This census satisfies the requirements of Section IV.B.3 of Appendix I to 10 CFR Part 50. Restricting the census to gardens of greater than 50 m² provides assurance that significant exposure pathways via leafy vegetables will be identified and monitored, since a garden of this size is the minimum required to produce the quantity (26 kg/year) of leafy vegetables assumed in Regulatory Guide 1.109 for consumption by a child. To determine this minimum garden size, the following assumptions were made: (1) 20% of the garden was used for growing broad-leaf vegetation (i.e., similar to lettuce and cabbage), and (2) there was a vegetation yield of 2 kg/m².

9.3 Interlaboratory Comparison Program

CONTROL

- C.9.3.1 In accordance with Technical Specification 6.7.6h.3, analyses shall be performed on all radioactive materials supplied as part of an Interlaboratory Comparison Program, that has been approved by the Commission, that correspond to samples required by REMP.

APPLICABILITY: At all times.

ACTION:

With analyses not being performed as required above, report the corrective actions taken to prevent a recurrence to the Commission in the Annual Radiological Environmental Operating Report pursuant to Part A, Section 10.1 of the ODCM.

SURVEILLANCE REQUIREMENTS

- S.9.3.1 The Interlaboratory Comparison Program shall be identified in Part B of the ODCM. A summary of the results obtained as part of the above required Interlaboratory Comparison Program shall be included in the Annual Radiological Environmental Operating Report pursuant to Part A, Section 10.1 of the ODCM.

BASES

The requirement for participation in an approved Interlaboratory Comparison Program is provided to ensure that independent checks on the precision and accuracy of the measurements of radioactive material in environmental sample matrices are performed as part of the Quality Assurance Program for environmental monitoring in order to demonstrate that the results are valid for the purposes of Section IV.B.2 of Appendix I to 10 CFR Part 50.

9.4 Dry Fuel Storage Facility Monitoring Program

CONTROL

C.9.4.1 The Dry Fuel Storage Facility radiological environmental monitoring program shall be conducted as specified in Table A.9.4-1

APPLICABILITY: At all times.

ACTION:

With the Dry Fuel Storage Facility radiological environmental measurements not being conducted as specified in Table A.9.4-1, prepare and submit to the Commission, in the Annual Radiological Environmental Operating Report required by Technical Specification 6.8.1.3 and Part A, Section 10.1 of the ODCM, a description of the reasons for not conducting the program as required and the plans for preventing a recurrence.

SURVEILLANCE REQUIREMENTS

S.9.4.1 The Dry Fuel Storage Facility radiological environmental measurements shall be performed pursuant to Table A.9.4-1 from the specific locations given in the table(s) and figure(s) in Part B of the ODCM, and shall be analyzed pursuant to the requirements of Table A.9.4-1.

BASES

The Dry Fuel Storage radiological environmental monitoring program required by this Control provides representative measurements of direct (including scattered) radiation exposure at those locations that have the highest potential for dose to MEMBERS OF THE PUBLIC resulting from dry fuel storage operations. The design of the storage facility is such that there are no liquid or gaseous effluents released to the environment from DFS and, therefore, no associated exposure pathways for liquids and gases requiring the collection and analysis of such sample media. As a result, only direct (including scattered) radiation from the DFS modules need to be monitored for integrated exposures in areas where doses to MEMBERS OF THE PUBLIC need to be limited. This measurement program provides information to support the determination of compliance with the dose criteria of 10 CFR 72.104(a), 40 CFR 190, and 10 CFR 20.1301(a)(1) for that portion of the total annual dose contributed by DFS.

TABLE A.9.4-1

DRY FUEL STORAGE FACILITY RADIOLOGICAL ENVIRONMENTAL MONITORING PROGRAM

Exposure Pathway	Number of Locations ^a	Collection Frequency	Type and Frequency of Analysis
1. DIRECT RADIATION ^b	<p>14 routine monitoring stations with two or more dosimeters placed at each station as follows:</p> <p>2 nearby locations on-site where MEMBERS OF THE PUBLIC can congregate.</p> <p>5 locations along the site boundary in areas of high potential for public exposure (shared TLD Locations with plant REMP, Table B.4-1).</p> <p>2 locations near the closest site boundary approach to the DFS in different sectors.</p> <p>5 locations beyond 15 km from the site (shared TLD locations with plant REMP, Table B.4-1).</p>	Quarterly.	Gamma dose quarterly.

a. Specific parameters of distance and direction sector from the centerline of the DFS Pad, and additional description where pertinent, shall be provided for each sample location in Table B.4-2 in the ODCM, Part B. Deviations are permitted from the required measurement schedule if dosimeters are unobtainable due to circumstances beyond the control of the licensee, such as lost of dosimeters resulting from unauthorized removal from the field. All deviations from the measurement schedule shall be documented in the Annual Radiological Environmental Operating Report as specified in Part A, Section 10.1.

b. A thermoluminescent dosimeter (TLD) is considered to be one phosphor; two or more phosphors in a packet are considered as two or more dosimeters.

10.0 REPORTS

10.1 Annual Radiological Environmental Operating Report

Routine Annual Radiological Environmental Operating Reports covering the operation of the station during the previous calendar year shall be submitted prior to May 1 of each year pursuant to Technical Specification 6.8.1.3.

The Annual Radiological Environmental Operating Reports shall include summaries, interpretations, and an analysis of trends of the results of the radiological environmental Surveillance activities for the report period, including a comparison with preoperational studies, with operational Controls, as appropriate, and with previous environmental Surveillance reports, and an assessment of the observed impacts of the plant operation on the environment. The reports shall also include the results of the Land Use Census required by Control C.9.2.1.

The Annual Radiological Environmental Operating Reports shall include the results of analysis of all radiological environmental samples and of all environmental radiation measurements taken during the period pursuant to the locations specified in the table and figures in Part B of the ODCM, as well as summarized and tabulated results of these analyses and measurements in the format of the table in the Radiological Assessment Branch Technical Position, Revision 1, November 1979. In the event that some individual results are not available for inclusion with the report, the report shall be submitted noting and explaining the reasons for the missing results. The missing data shall be submitted as soon as possible in a supplementary report.

The reports shall also include the following: a summary description of the Radiological Environmental Monitoring Program; at least two legible maps**** covering all sampling locations keyed to a table giving distances and directions from the centerline of one reactor; the results of licensee participation in the Interlaboratory Comparison Program and the corrective action taken if the specified program is not being performed as required by Control C.9.3.1; reason for not conducting the Radiological Environmental Monitoring Program as required by Control C.9.1.1, and discussion of all deviations from the sampling schedule; discussion of environmental sample measurements that exceed the reporting levels but are not the result of plant effluents, pursuant to ACTION b. of Control C.9.1.1; and discussion of all analyses in which the LLD required was not achievable.

****One map shall cover locations near the SITE BOUNDARY; the more distant locations shall be covered by one or more additional maps.

10.2 Annual Radioactive Effluent Release Report

A routine Annual Radioactive Effluent Release Report covering the operation of the station during the previous calendar year of operation shall be submitted by May 1 of each year, pursuant to Technical Specification 6.8.1.4.

The Annual Radioactive Effluent Release Reports shall include a summary of the quantities of radioactive liquid and gaseous effluents and solid waste released from the station as outlined in Regulatory Guide 1.21, "Measuring, Evaluating, and Reporting Radioactivity in Solid Wastes and Releases of Radioactive Materials in Liquid and Gaseous Effluents from Light-Water-Cooled Nuclear Power Plants," Revision 1, June 1974, with data summarized on a quarterly basis following the format of Appendix B thereof. For solid wastes, the format for Table 3 in Appendix B shall be supplemented with three additional categories: class of solid wastes (as defined by 10 CFR Part 61), type of container (e.g., LSA, Type A, Type B, Large Quantity) and SOLIDIFICATION agent or absorbent (e.g., cement).

The Annual Radioactive Effluent Release Report shall include an annual summary of hourly meteorological data collected over the previous year. This annual summary may be either in the form of an hour-by-hour listing on magnetic tape of wind speed, wind direction, atmospheric stability, and precipitation (if measured), or in the form of joint frequency distributions of wind speed, wind direction, and atmospheric stability.***** This same report shall include an assessment of the radiation doses due to the radioactive liquid and gaseous effluents released from the unit or station during the previous calendar year. This same report shall also include an assessment of the radiation doses from radioactive liquid and gaseous effluents to MEMBERS OF THE PUBLIC due to their activities inside the SITE BOUNDARY Technical Specification (Figure 5.1-3) during the report period. All assumptions used in making these assessments, i.e., specific activity, exposure time, and location, shall be included in these reports. The meteorological conditions concurrent with the time of release of radioactive materials in gaseous effluents, as determined by sampling frequency and measurement, shall be used for determining the gaseous pathway doses. The assessment of radiation doses shall be performed in accordance with the methodology and parameters in the OFFSITE DOSE CALCULATION MANUAL (ODCM).

The Annual Radioactive Effluent Release Report shall also include an assessment of radiation doses to the likely most exposed MEMBER OF THE PUBLIC from reactor releases and other nearby uranium fuel cycle sources, including doses from primary effluent pathways and direct radiation, for the previous calendar year to show conformance with 40 CFR Part 190, "Environmental Radiation Protection Standards for Nuclear Power Operation." Acceptable methods for calculating the dose contribution from liquid and gaseous effluents are given in Regulatory Guide 1.109, Rev. 1, October 1977.

*****In lieu of submission with the Annual Radioactive Effluent Release Report, the licensee has the option of retaining this summary of required meteorological data on site in a file that shall be provided to the NRC upon request.

The Annual Radioactive Effluent Release Report shall include a list and description of unplanned releases from the site to UNRESTRICTED AREAS of radioactive materials in gaseous and liquid effluents made during the reporting period.

The Annual Radioactive Effluent Release Report shall include any changes made during the reporting period to the PROCESS CONTROL PROGRAM and the ODCM, pursuant to Technical Specifications 6.12 and 6.13, respectively, as well as any major change to Liquid, Gaseous, or Solid Radwaste Treatment Systems pursuant to Control 11.0. It shall also include a listing of new locations for dose calculations and/or environmental monitoring identified by the Land Use Census pursuant to Control C.9.2.

The Annual Radioactive Effluent Release Report shall also include a description of the events leading to liquid holdup tanks or gas storage tanks exceeding the limits of Technical Specification 3.11.1.4.

SEABROOK STATION ODCM

PART B

RADIOLOGICAL CALCULATIONAL METHODS AND PARAMETERS

1.0 INTRODUCTION

The Offsite Dose Calculation Manual (ODCM) contains details to implement Radioactive Effluent Controls and Environmental Monitoring Program as required by Technical Specifications 6.7.6g and 6.7.6h.

Part B of the ODCM provides formal and approved methods for the calculation of off-site concentration, off-site doses and effluent monitor setpoints, and indicates the locations of environmental monitoring stations in order to comply with the Seabrook Station Radioactive Effluent Controls Program (RECP), and Radiological Environmental Monitoring Program (REMP) detailed in Part A of the manual. The ODCM forms the basis for station procedures which document the off-site doses due to station operation which are used to show compliance with the numerical guides for design objectives of Section II of Appendix I to 10CFR Part 50. The methods contained herein follow accepted NRC guidance, unless otherwise noted in the text.

The references to 10 CFR Part 20 in Part B of the ODCM refer to revisions of 10 CFR Part 20 published prior to 1 January 1993. The decision to continue the use of the "old" version of 10 CFR Part 20 is based on an NRC letter dated June 30, 1993, from Thomas E. Murley to Thomas E. Tipton. For the convenience of the plant staff a copy of 10 CFR Part 20 (Rev. 1, January 1992) has been included in Appendix B.

1.1 Responsibilities for Part B

All changes to the ODCM shall be reviewed by the Station Operation Review Committee (SORC), approved by the Station Director, and documented in accordance with Technical Specification 6.13. The change process is controlled by the Applicability Determination Process as controlled by the 10 CFR 50.59 Resource Manual (5059RM). Changes made to Part B shall be submitted to the Commission for their information in the Annual Radioactive Effluent Release Report for the period in which the change(s) was made effective.

It shall be the responsibility of the Station Director to ensure that the ODCM is used in the performance of surveillance requirements and administrative controls in accordance with Technical Specifications 6.7.6g and 6.7.6h, and Effluent Control Program and Radiological Environmental Monitoring Program detailed in Part A of the manual.

In addition to off-site dose calculations for the demonstration of compliance with Technical Specification dose limits at and beyond the site boundary, 10 CFR 20.1302 requires that compliance with the dose limits for individual members of the public (100 mrem/yr total effective dose equivalent) be demonstrated in controlled areas on-site. Demonstration of compliance with the dose limits to members of the public in controlled areas is implemented per Health Physics Department Procedures, and is outside the scope of the ODCM. However, calculations performed in accordance with the ODCM can be used as one indicator of the need to perform an assessment of exposure to members of the public within the site boundary. Since external direct exposure pathways are already subject to routine exposure rate surveys and measurements, only the inhalation pathway need be assessed. The accumulated critical organ dose at the site boundary, as calculated per ODCM Part B Sections 3.9 and 3.11, can be used as an indicator of when additional assessments of on-site exposure to members of the public is advisable (see Section 3.11.2). Off-site critical organ doses from station effluents should not, however, be the only indicator of potential on-site doses.

1.2 Summary of Methods, Dose Factors, Limits, Constants, Variables and Definitions

This section summarizes the Method I dose equations which are used as the primary means of demonstrating compliance with RECP. The concentration and setpoint methods are identified in Table B.1-2 through Table B.1-7. Appendix C provides documentation for an alternate computerized option, designated as Method IA in the ODCM, for calculating doses necessary to demonstrate compliance with RECP. The Effluent Management System (EMS) software package used for this purpose is provided by Canberra Industries, Inc. Where more refined dose calculations are needed, the use of Method II dose determinations are described in Sections 3.2 through 3.9 and 3.11. The dose factors used in the equations are in Tables B.1-10 through B.1-14 and the Regulatory Limits are summarized in Table B.1-1.

The variables and special definitions used in this ODCM, Part B, are in Tables B.1-8 and B.1-9.

TABLE B.1-1
SUMMARY OF RADIOLOGICAL EFFLUENT PART A CONTROLS AND IMPLEMENTING EQUATIONS

Part A Control	Category	Method I ⁽¹⁾	Limit
C.6.1.1	Liquid Effluent Concentration	Total Fraction of ECL Excluding Noble Gases	Eq. 2-1 ≤ 1.0
		Total Noble Gas Concentration	Eq. 2-2 $\leq 2 \times 10^{-4} \mu\text{Ci/ml}$
C.6.2.1	Liquid Effluent Dose	Total Body Dose	Eq. 3-1 $\leq 1.5 \text{ mrem in a qtr.}$ $\leq 3.0 \text{ mrem in a yr.}$
		Organ Dose	Eq. 3-2 $\leq 5 \text{ mrem in a qtr.}$ $\leq 10 \text{ mrem in a yr.}$
C.6.3.1	Liquid Radwaste Treatment Operability	Total Body Dose	Eq. 3-1 $\leq 0.06 \text{ mrem in a mo.}$
		Organ Dose	Eq. 3-2 $\leq 0.2 \text{ mrem in a mo.}$
C.7.1.1	Gaseous Effluents Dose Rate	Total Body Dose Rate from Noble Gases	Eq. 3-3 $\leq 500 \text{ mrem/yr.}$
		Skin Dose Rate from Noble Gases	Eq. 3-4 $\leq 3000 \text{ mrem/yr.}$
		Organ Dose Rate from I-131, I-133, Tritium, C-14 and Particulates with $T_{1/2} > 8 \text{ Days}$	Eq. 3-5 $\leq 1500 \text{ mrem/yr.}$

TABLE B.1-1
SUMMARY OF RADIOLOGICAL EFFLUENT PART A CONTROLS AND IMPLEMENTING EQUATIONS
(Continued)

Part A Control	Category	Method I ⁽¹⁾	Limit
C.7.2.1	Gaseous Effluents Dose from Noble Gases	Gamma Air Dose from Noble Gases	Eq. 3-6 ≤ 5 mrad in a qtr. ≤ 10 mrad in a yr.
		Beta Air Dose from Noble Gases	Eq. 3-7 ≤ 10 mrad in a qtr. ≤ 20 mrad in a yr.
C.7.3.1	Gaseous Effluents Dose from I-131, I-133, Tritium, and Particulates	Organ Dose from Iodines, Tritium and Particulates with T _{1/2} > 8 Days (Including Carbon-14)	Eq. 3-8 ≤ 7.5 mrem in a qtr. ≤ 15 mrem in a yr.
C.7.4.1	Ventilation Exhaust Treatment	Organ Dose	Eq. 3-8 ≤ 0.3 mrem in a mo.
C.8.1.1	Total Dose (from All Sources)	Total Body Dose	Footnote (2). ≤ 25 mrem in a yr.
		Organ Dose	≤ 25 mrem in a yr.
		Thyroid Dose	≤ 75 mrem in a yr.
C.5.1	Liquid Effluent Monitor Setpoint		
	Liquid Waste Test Tank Monitor	Alarm Setpoint	Eq. 5-1 Control C.6.1.1

TABLE B.1-1
SUMMARY OF RADIOLOGICAL EFFLUENT PART A CONTROLS AND IMPLEMENTING EQUATIONS
 (Continued)

Part A Controls	Category	Method I ⁽¹⁾	Limit
C.5.2	Gaseous Effluent Monitor Setpoint		
	Plant Vent Wide Range Gas Monitors	Alarm/Trip Setpoint For Total Body Dose Rate	Eq. 5-5
		Alarm/Trip Setpoint for Skin Dose Rate	Eq. 5-6
			Control C.7.1.1a (Total Body)
			Control C.7.1.1a (Skin)

(1) More accurate methods may be available (see subsequent chapters).

(2) Part A Control C.8.1.1a requires this evaluation only if twice the limit of equations 3-1, 3-2, 3-12, 3-15 or 3-18 is reached. If this occurs a Method II calculation, using actual release point parameters with annual average or concurrent meteorology and identified pathways for a real individual, shall be made.

TABLE B.1-2
SUMMARY OF METHOD I EQUATIONS TO CALCULATE
UNRESTRICTED AREA LIQUID CONCENTRATIONS

Equation Number	Category	Equation
2-1	Total Fraction of ECL in Liquids, Except Noble Gases	$F_i^{ENG} = \sum_p \sum_i \frac{C_{pi}}{ECL_i} \leq 10$
2-2	Total Activity of Dissolved and Entrained Noble Gases from all Station Sources	$C_i^{NG} \left(\frac{\mu Ci}{ml} \right) = \sum_i C_i^{NG} \leq 2E-04$

TABLE B.1-3
SUMMARY OF METHOD I EQUATIONS TO CALCULATE
OFF-SITE DOSES FROM LIQUID RELEASES

Equation Number	Category	Equation
3-1	Total Body Dose	$D_{tb} \text{ (mrem)} = k \sum_i Q_i \text{DFL}_{itb}$
3-2	Maximum Organ Dose	$D_{mo} \text{ (mrem)} = k \sum_i Q_i \text{DFL}_{imo}$

TABLE B.1-4
SUMMARY OF METHOD I EQUATIONS TO CALCULATE DOSE RATES

<u>Category</u>	<u>Equation Number</u>	<u>Receptor Location^a</u>	<u>Release Height^b</u>	<u>Equation</u>
Total Body Dose Rate From Noble Gases	3-3a	OS	E	$\dot{D}_{tb(e)} = 0.85 * \sum_i (\dot{Q}_i * DFB_i)$
	3-3b	OS	G	$\dot{D}_{tb(g)} = 3.4 * \sum_i (\dot{Q}_i * DFB_i)$

^aOS = Off-Site.

^bE = Elevated, G = Ground

TABLE B.1-4
SUMMARY OF METHOD I EQUATIONS TO CALCULATE DOSE RATES
 (Continued)

<u>Category</u>	<u>Equation Number</u>	<u>Receptor Location^a</u>	<u>Release Height^b</u>	<u>Equation</u>
Skin Dose Rate From Noble Gases	3-4a	OS	E	$\dot{D}_{\text{skin(e)}} = \sum_i (\dot{Q}_i * DF'_{i(e)})$
	3-4b	OS	G	$\dot{D}_{\text{skin(g)}} = \sum_i (\dot{Q}_i * DF'_{i(g)})$

^aOS = Off-Site.

^bE = Elevated, G = Ground

TABLE B.1-4
SUMMARY OF METHOD I EQUATIONS TO CALCULATE DOSE RATES
 (Continued)

<u>Category</u>	<u>Equation Number</u>	<u>Receptor Location^a</u>	<u>Release Height^b</u>	<u>Equation</u>
Critical Organ Dose Rate From I-131, I-133, H-3, C-14 and Particulate With $T_{1/2} > 8$ Days	3-5a	OS	E	$\dot{D}_{co(e)} = \sum_i (\dot{Q}_i * DFG'_{ico(e)}) \text{ plus } [0.611 \text{ mrem/yr}]_{C-14}$
	3-5b	OS	G	$\dot{D}_{co(g)} = \sum_i (\dot{Q}_i * DFG'_{ico(g)})$

^aOS = Off-Site.

^bE = Elevated, G = Ground

TABLE B.1-5
SUMMARY OF METHOD I EQUATIONS TO CALCULATE DOSES TO AIR FROM NOBLE GASES

<u>Category</u>	<u>Equation Number</u>	<u>Receptor Location^a</u>	<u>Release Height^b</u>	<u>Equation</u>
Gamma Dose to Air From Noble Gases	3-6a	OS	E	$D_{\text{air(e)}}^{\gamma} = 3.2 \text{E-} 07 * t^{-0.274} * \sum_i (Q_i * DF_i^{\gamma})$
	3-6b	OS	G	$D_{\text{air(g)}}^{\gamma} = 1.6 \text{E-} 06 * t^{-0.293} * \sum_i (Q_i * DF_i^{\gamma})$

^aOS = Off-Site.

^bE = Elevated, G = Ground

TABLE B.1-5
SUMMARY OF METHOD I EQUATIONS TO CALCULATE DOSES TO AIR FROM NOBLE GASES
 (Continued)

<u>Category</u>	<u>Equation Number</u>	<u>Receptor Location^a</u>	<u>Release Height^b</u>	<u>Equation</u>
Beta Dose to Air From Noble Gases	3-7a	OS	E	$D_{\text{air(e)}}^{\beta} = 4.0 \text{E-} 07 * t^{-0.302} * \sum_i (Q_i * DF_i^{\beta})$
	3-7b	OS	G	$D_{\text{air(g)}}^{\beta} = 6.1 \text{E-} 06 * t^{-0.320} * \sum_i (Q_i * DF_i^{\beta})$

^aOS = Off-Site.

^bE = Elevated, G = Ground

TABLE B.1-6
SUMMARY OF METHOD I EQUATIONS TO CALCULATE
DOSE TO AN INDIVIDUAL FROM TRITIUM, IODINE, CARBON-14 AND PARTICULATES

<u>Category</u>	<u>Equation Number</u>	<u>Receptor Location^a</u>	<u>Release Height^b</u>	<u>Equation</u>
Dose to Critical Organ From Iodines, Tritium, C-14 and Particulates	3-8a	OS	E	$D_{co(e)} = 15.0 * t^{-0.298} * \sum(Q_i * DFG_{ico(e)})$ plus [0.051 mrem/month] _{C-14}
	3-8b	OS	G	$D_{co(g)} = 17.7 * t^{-0.317} * \sum(Q_i * DFG_{ico(g)})$
	3-8c	EC	E	$D_{coE(e)} = 3.3E-02 * t^{-0.348} * \sum(Q_i * DFG_{icoE(e)})$ plus [2.58E-06 mrem/month] _{C-14}
	3-8d	EC	G	$D_{coE(g)} = 3.3E-02 * t^{-0.347} * \sum(Q_i * DFG_{icoE(g)})$
	3-8e	FR	E	$D_{coR(e)} = 1.15 * t^{-0.366} * \sum(Q_i * DFG_{icoR(e)})$ plus [2.60E-05 mrem/month] _{C-14}
	3-8f	FR	G	$D_{coR(g)} = 1.61 * t^{-0.403} * \sum(Q_i * DFG_{icoR(g)})$
	3-8g	FC	E	$D_{coFC(e)} = 1.08 * t^{-0.359} * \sum(Q_i * DFG_{icoFC(e)})$ plus [7.67E-05 mrem/month] _{C-14}
	3-8h	FC	G	$D_{coFC(g)} = 0.94 * t^{-0.344} * \sum(Q_i * DFG_{icoFC(g)})$

^aOS = Off-Site, FC = Fitness Center, EC = Science & Nature Center, formerly the Education Center, FR = Firing Range

^bE = Elevated, G = Ground

TABLE B.1-7
SUMMARY OF METHODS FOR
SETPOINT DETERMINATIONS

Equation Number	Category	Equation
5-1	<u>Liquid Effluents:</u> Liquid Waste Test Tank Monitor (RM-6509) ⁽¹⁾	$R_{\text{setpoint}} \left(\frac{\mu\text{Ci}}{\text{ml}} \right) = f_1 \frac{F_d}{F_m \times DF_{\text{min}_\gamma}} \sum C_{\gamma i}$
5-23	PCCW Rate-of-Change Alarm <u>Gaseous Effluents:</u> Plant Vent Wide Range Gas Monitors (RM-6528-1, 2, 3)	$RC_{\text{set}} (\text{gph}) = 1 \times 10^{-8} \cdot \text{SWF} \cdot \frac{1}{\text{PCC}}$
5-5	Total Body	$R_{\text{tb}} (\mu\text{Ci}/\text{sec}) = 588 \frac{1}{\text{DFB}_e} f_v$
5-6	Skin	$R_{\text{skin}} (\mu\text{Ci}/\text{sec}) = 3000 \frac{1}{\text{DF}'_e} f_v$

- (1) This equation maybe used for other effluent radiation monitors, such as the CPS Rad Monitor (RM-6473) where the fraction of total FCL (f_v) is administratively adjusted for the particular pathway.

TABLE B.1-8
SUMMARY OF VARIABLES

<u>Variable</u>	<u>Definition</u>	<u>Units</u>
C_{li}^{NG}	= Concentration at point of discharge and entrained noble gas "i" in liquid pathways from all station sources	$\mu\text{Ci/ml}$
C_i^{NG}	= Total activity of all dissolved and entrained noble gases in liquid pathways from all station sources	$\mu\text{Ci/ml}$
C_{di}	= Concentration of radionuclide "i" at the point of liquid discharge	$\mu\text{Ci/ml}$
C_i	= Concentration of radionuclide "i"	$\mu\text{Ci/ml}$
C_{pi}	= Concentration, exclusive of noble gases, of radionuclide "i" from tank "p" at point of discharge	$\mu\text{Ci/ml}$
$C_{\gamma i}$	= Concentration of radionuclide "i" in mixture at the monitor	$\mu\text{Ci/ml}$
$D_{air(e)}^{\beta}$	= Off-site beta dose to air due to noble gases in elevated release	mrad
$D_{air(g)}^{\beta}$	= Off-site beta dose to air due to noble gas in ground level release	mrad
$D_{air(e)}^{\gamma}$	= Off-site gamma dose to air due to noble gases in elevated release	mrad
$D_{air(g)}^{\gamma}$	= Off-site gamma dose to air due to noble gases in ground level release	mrad

TABLE B.1-8
SUMMARY OF VARIABLES
(Continued)

<u>Variable</u>	<u>Definition</u>	<u>Units</u>
$D_{co(e)}$	= Critical organ dose from an elevated release to an off-site receptor	mrem
$D_{co(g)}$	= Critical organ dose from a ground level release to an off-site receptor	mrem
$D_{coFC(e)}$	= Critical organ dose from an elevated release to a receptor at the Fitness Center (Hi-Rise Office Building)	mrem
$D_{coFC(g)}$	= Critical organ dose from a ground level release to a receptor at the Fitness Center (Hi-Rise Office Building)	mrem
$D_{coE(e)}$	= Critical organ dose from an elevated release to a receptor at the Science & Nature Center	mrem
$D_{coE(g)}$	= Critical organ dose from a ground level release to a receptor at the Science & Nature Center	mrem
$D_{coFR(e)}$	= Critical organ dose from an elevated release to a receptor at the Firing Range	mrem
$D_{coFR(g)}$	= Critical organ dose from a ground level release to a receptor at the Firing Range	mrem
D_d	= Direct dose	mrem
D_{finite}^γ	= Gamma dose to air, corrected for finite cloud	mrads
D_{mo}	= Dose to the maximum organ	mrem
D^S	= Dose to skin from beta and gamma	mrem
D_{tb}	= Dose to the total body	mrem
DF_{min}	= Minimum required dilution factor based on all (beta – emitting and gamma – emitting) radionuclides	ratio
DF_{min}^γ	= Minimum required dilution factor necessary to ensure that the sum of the ratios for the concentration of each gamma-emitting radionuclide to the respective ECL value is not greater than 1 (dimensionless).	
DF'_i	= Composite skin dose factor for off-site receptor	mrem-sec/ μ Ci-yr
DFB_i	= Total body gamma dose factor for nuclide "i" (Table B.1-10)	$\frac{\text{mrem}^3}{\text{pCi- yr}}$
DFB_c	= Composite total body dose factor	$\frac{\text{mrem}^3}{\text{pCi- yr}}$

TABLE B.1-8
SUMMARY OF VARIABLES
(Continued)

<u>Variable</u>	<u>Definition</u>	<u>Units</u>
DFL_{itb}	= Site-specific, total body dose factor for a liquid release of nuclide "i" (Table B.1-11)	mrem/ μ Ci1
DFL_{imo}	= Site-specific, maximum organ dose factor for a liquid release of nuclide "i" (Table B.1-11)	mrem/ μ Ci
$DFB_{ico(e)}$	= Site-specific, critical organ dose factor for an elevated gaseous release of nuclide "i" (Table B.1-12)	mrem/ μ Ci
$DFG_{ico(g)}$	= Site-specific critical organ dose factor for a ground level release of nuclide "i" (Table B.1-12)	mrem/ μ Ci
$DFG_{icoFC(e)}$	= Fitness Center (Hi-Rise Office Building) specific critical organ dose factor for an elevated release of nuclide "i".	mrem/ μ Ci
$DFG_{icoFC(g)}$	= Fitness Center (Hi-Rise Office Building) specific critical organ dose factor for a ground level release of nuclide "i".	mrem/ μ Ci
$DFG_{icoE(e)}$	= Science & Nature Center-specific critical organ dose factor for an elevated release of nuclide "i" (Table B.1-14)	mrem/ μ Ci
$DFG_{icoE(g)}$	= Science & Nature Center-specific critical organ dose factor for a ground level release of nuclide "i" (Table B.1-14)	mrem/ μ Ci
$DFG_{icoFR(e)}$	= The Firing Range-specific critical organ dose factor for an elevated release of nuclide "i" (Table B.1-15)	mrem/ μ Ci
$DFG_{icoFR(g)}$	= The Firing Range-specific critical dose factor for a ground level release of nuclide "i" (Table B.1-15)	mrem/ μ Ci
$DFG'_{ico(e)}$	= Site-specific critical organ dose rate factor for an elevated gaseous release of nuclide "i" (Table B.1-12)	mrem-sec/ μ Ci-yr
$DFG'_{ico(g)}$	= Site-specific critical organ dose rate factor for a ground level release of nuclide "i" (Table B.1-12)	mrem-sec/ μ Ci-yr
DFS_i	= Beta skin dose factor for nuclide "i" (Table B.1-10)	$\frac{\text{mrem- m}^3}{\text{pCi- yr}}$
DF'_i	= Combined skin dose factor for nuclide "i" (Table B.1-10)	mrem- sec/ μ Ci-yr
DF'_i	= Gamma air dose factor for nuclide "i" (Table B.1-10)	$\frac{\text{mrad- m}^3}{\text{pCi- yr}}$

TABLE B.1-8
SUMMARY OF VARIABLES
(Continued)

<u>Variable</u>	<u>Definition</u>	<u>Units</u>
DF_1^β	= Beta air dose factor for nuclide "i" (Table B.1-10)	$\frac{\text{mrad} \cdot \text{m}^3}{\text{pCi} \cdot \text{yr}}$
$\dot{D}_{\text{co}(e)}$	= Critical organ dose rate to an off-site receptor due to elevated release of iodines, tritium, carbon-14 and particulates	$\frac{\text{mrem}}{\text{yr}}$
$\dot{D}_{\text{co}(g)}$	= Critical organ dose rate to an off-site receptor due to ground level release of iodines, tritium, and particulates	$\frac{\text{mrem}}{\text{yr}}$
$\dot{D}_{\text{skin}(e)}$	= Skin dose rate to an off-site receptor due to noble gases in an elevated release	$\frac{\text{mrem}}{\text{yr}}$
$\dot{D}_{\text{skin}(g)}$	= Skin dose rate to an off-site receptor due to noble gases in a ground level release	$\frac{\text{mrem}}{\text{yr}}$
$\dot{D}_{\text{tb}(e)}$	= Total body dose rate to an off-site receptor due to noble gases in an elevated release	$\frac{\text{mrem}}{\text{yr}}$
$\dot{D}_{\text{tb}(g)}$	= Total body dose rate to an off-site receptor due to noble gases in a ground level release	$\frac{\text{mrem}}{\text{yr}}$
D/Q	= Deposition factor for dry deposition of elemental radioiodines and other particulates	$\frac{1}{\text{m}^2}$
ECL _i	= Effluent concentration limit (ECL) for radionuclide "i" (excluding dissolved and entrained noble gas) as specified in 10 CFR 20, Appendix B, Table 2.	$\mu\text{Ci}/\text{ml}$
f_v	= The fraction of the offsite limiting total body dose rate administratively assigned to the plant vent release	Dimensionless
F_d	= Actual or estimated flow rate out of discharge tunnel	gpm or ft^3/sec
F_m	= Flow rate past liquid waste test tank monitor	gpm
F_{max}	= Maximum allowable discharge flow rate from liquid test tanks based on all (beta – emitting and gamma – emitting) radionuclides	gpm
$F_{\text{max}\gamma}$	= Maximum allowable discharge flow rate from the test tank past the monitor which would equate to the control concentration limit for the gamma radioactivity mixture determined to be in the test tank	gpm
f_g	= The fraction of the offsite limiting total body dose rate administratively assigned to monitored ground level	Dimensionless

TABLE B.1-8
SUMMARY OF VARIABLES
(Continued)

<u>Variable</u>	<u>Definition</u>	<u>Units</u>
	release	
F	= Flow rate past plant vent monitor	$\frac{\text{cc}}{\text{sec}}$
f_{gland}	= Release reduction factor to be administratively assigned to account for potential unmonitored contributions from the Turbine Gland Seal Exhaust	Dimensionless
$f_1; f_2; f_3; f_4; f_5$	= Fraction of total ECL associated with Paths 1, 2, 3, 4, and 5, the sum of which is ≤ 1 .	Dimensionless
F_1^{ENG}	= Total fraction of ECL in liquid pathways (excluding noble gases)	Dimensionless
MPC_i	= Maximum permissible concentration for radionuclide "i" ("old" 10 CFR 20, Appendix B, Table II, Column 2)	$\mu\text{Ci/cc}$
Q_i	= Release to the environment for radionuclide "i"	curies, or μ curies
\dot{Q}_i	= Release rate to the environment for radionuclide "i"	$\mu\text{Ci/sec}$
R_{setpoint}	= Liquid monitor response for the limiting concentration at the point of discharge	$\mu\text{Ci/ml}$
R_{skin}	= Response of the noble gas monitor to limiting total body dose rate	cpm, or $\mu\text{Ci/sec}$
R_{tb}	= Response of the noble gas monitor to limiting total body dose rate	cpm, or $\mu\text{Ci/sec}$
S_F	= Shielding factor	Dimensionless
S_g	= Detector counting efficiency from the gas monitor calibration	$\frac{\text{cpm}}{\mu\text{Ci-cc}}$ or $\frac{\text{mR/hr}}{\mu\text{Ci/cc}}$
S_{gi}	= Detector counting efficiency for noble gas "i"	$\frac{\text{cpm}}{\mu\text{Ci-cc}}$ or $\frac{\text{mR/hr}}{\mu\text{Ci/cc}}$
S_l	= Detector counting efficiency from the liquid monitor calibration	$\text{cps}/\mu\text{Ci/ml}$
S_{li}	= Detector counting efficiency for radionuclide "i"	$\text{cps}/\mu\text{Ci/ml}$
X/Q	= Average long-term undepleted atmospheric dispersion factor (Tables B.7-4, B.7-5, and B.7-6)	$\frac{\text{sec}}{\text{m}^3}$
$[X/Q]_\gamma$	= Effective long-term average gamma atmospheric dispersion factor (Tables B.7-4, B.7-5, and B.7-6)	$\frac{\text{sec}}{\text{m}^3}$

TABLE B.1-8
SUMMARY OF VARIABLES
 (Continued)

<u>Variable</u>	<u>Definition</u>	<u>Units</u>
SWF	= Service Water System flow rate	gph
PCC	= Primary component cooling water measured (decay corrected) gross radioactivity concentration	μCi/ml
t ^a	= Unitless factor which adjusts the value of atmospheric dispersion factors for elevated or ground-level releases with a total release duration of t hours	Dimensionless
tc	= The C-14 release duration (hours) associated with the period of dose estimation being considered. Carbon-14 releases are considered continuous over the year from the plant vent stack.	hr

TABLE B.1-9
DEFINITION OF TERMS

Critical Receptor - A hypothetical or real individual whose location and behavior cause him or her to receive a dose greater than any other possible real individual.

Dose - As used in Regulatory Guide 1.109, the term "dose," when applied to individuals, is used instead of the more precise term "dose equivalent," as defined by the International Commission on Radiological Units and Measurements (ICRU). When applied to the evaluation of internal deposition or radioactivity, the term "dose," as used here, includes the prospective dose component arising from retention in the body beyond the period of environmental exposure, i.e., the dose commitment. The dose commitment is evaluated over a period of 50 years. The dose is measured in mrem to tissue or mrad to air.

Dose Rate - The rate for a specific averaging time (i.e., exposure period) of dose accumulation.

Liquid Radwaste Treatment System - The components or subsystems which comprise the available treatment system as shown in Figure B.6-1.

TABLE B.1-10
DOSE FACTORS SPECIFIC FOR SEABROOK STATION FOR NOBLE GAS RELEASES

Radio-nuclide	Gamma Total Body Dose Factor $DF_{Bi} (\frac{\text{mrem} \cdot \text{m}^3}{\text{pCi} \cdot \text{yr}})$	Beta Skin Dose Factor $DFS_i (\frac{\text{mrem} \cdot \text{m}^3}{\text{pCi} \cdot \text{yr}})$	Combined Skin Dose Factor for Elevated Release Points $DF_{i(e)} (\frac{\text{mrem} \cdot \text{sec}}{\mu \text{Ci} \cdot \text{yr}})$	Combined Skin Dose Factor for Ground Level Release Points $DF'_{i(g)} (\frac{\text{mrem} \cdot \text{sec}}{\mu \text{Ci} \cdot \text{yr}})$	Beta Air Dose Factor $DF_i^\beta (\frac{\text{mrad} \cdot \text{m}^3}{\text{pCi} \cdot \text{yr}})$	Gamma Air Dose Factor $DF_i^\gamma (\frac{\text{mrad} \cdot \text{m}^3}{\text{pCi} \cdot \text{yr}})$
Ar-41	8.84E-03	2.69E-03	1.09E-02	6.20E-02	3.28E-03	9.30E-03
Kr-83m	7.56E-08	-----	1.81E-05	7.28E-05	2.88E-04	1.93E-05
Kr-85m	1.17E-03	1.46E-03	2.35E-03	1.92E-02	1.97E-03	1.23E-03
Kr-85	1.61E-05	1.34E-03	1.11E-03	1.35E-02	1.95E-03	1.72E-05
Kr-87	5.92E-03	9.73E-03	1.38E-02	1.21E-01	1.03E-02	6.17E-03
Kr-88	1.47E-02	2.37E-03	1.62E-02	8.10E-02	2.93E-03	1.52E-02
Kr-89	1.66E-02	1.01E-02	2.45E-02	1.66E-01	1.06E-02	1.73E-02
Kr-90	1.56E-02	7.29E-03	2.13E-02	1.34E-01	7.83E-03	1.63E-02
Xe-131m	9.15E-05	4.76E-04	5.37E-04	5.35E-03	1.11E-03	1.56E-04
Xe-133m	2.51E-04	9.94E-04	1.12E-03	1.12E-02	1.48E-03	3.27E-04
Xe-133	2.94E-04	3.06E-04	5.83E-04	4.39E-03	1.05E-03	3.53E-04
Xe-135m	3.12E-03	7.11E-04	3.74E-03	1.98E-02	7.39E-04	3.36E-03
Xe-135	1.81E-03	1.86E-03	3.33E-03	2.58E-02	2.46E-03	1.92E-03
Xe-137	1.42E-03	1.22E-02	1.14E-02	1.28E-01	1.27E-02	1.51E-03
Xe-138	8.83E-03	4.13E-03	1.20E-02	7.60E-02	4.75E-03	9.21E-03

$8.84\text{E-}03 = 8.84 \times 10^{-3}$

TABLE B.1-11
DOSE FACTORS SPECIFIC FOR SEABROOK STATION
FOR
LIQUID RELEASES

<u>Radionuclide</u>	Total Body Dose Factor DFL _{itb} ($\frac{\text{mrem}}{\mu\text{Ci}}$)	Maximum Organ Dose Factor DFL _{imo} ($\frac{\text{mrem}}{\mu\text{Ci}}$)
H-3	3.02E-13	3.02E-13
Na-24	1.38E-10	1.42E-10
Cr-51	1.83E-11	1.48E-09
Mn-54	5.15E-09	2.68E-08
Fe-55	1.26E-08	7.67E-08
Fe-59	8.74E-08	6.66E-07
Co-58	2.46E-09	1.40E-08
Co-60	6.15E-08	9.22E-08
Zn-65	2.73E-07	5.49E-07
Br-83	1.30E-14	1.89E-14
Rb-86	4.18E-10	6.96E-10
Sr-89	2.17E-10	7.59E-09
Sr-90	3.22E-08	1.31E-07
Nb-95	5.25E-10	1.58E-06
Mo-99	3.72E-11	2.67E-10
Tc-99m	5.22E-13	1.95E-12
Ag-110m	1.01E-08	6.40E-07
Sb-124	1.71E-09	9.89E-09
Sb-125	6.28E-09	8.31E-09
Te-127m	7.07E-08	1.81E-06
Te-127	3.53E-10	9.54E-08
Te-129m	1.54E-07	3.46E-06
Te-129	7.02E-14	1.05E-13
Te-131m	3.16E-08	2.94E-06
Te-132	9.06E-08	3.80E-06
I-130	2.75E-11	3.17E-09
I-131	2.30E-10	1.00E-07
I-132	6.28E-11	6.36E-11
I-133	3.85E-11	1.15E-08
I-134	1.19E-12	1.41E-12
I-135	5.33E-11	4.69E-10
Cs-134	3.24E-08	3.56E-08
Cs-136	2.47E-09	3.27E-09
Cs-137	3.58E-08	4.03E-08
Ba-140	1.70E-10	3.49E-09
La-140	1.07E-10	4.14E-08
Ce-141	3.85E-11	9.31E-09
Ce-144	1.96E-10	6.46E-08
Other*	3.12E-08*	1.58E-06*

* Dose factors to be used in Method I calculation for any "other" detected gamma emitting radionuclide which is not included in the above list.

TABLE B.1-12
DOSE AND DOSE RATE FACTORS SPECIFIC FOR SEABROOK STATION
FOR
IODINES, TRITIUM AND PARTICULATE RELEASES

Radio-nuclide	Critical Organ Dose Factor for Elevated Release Point $DFG_{ico(e)} \left(\frac{\text{mrem}}{\mu\text{Ci}} \right)$	Critical Organ Dose Factor for Ground Level Release Point $DFG_{ico(g)} \left(\frac{\text{mrem}}{\mu\text{Ci}} \right)$	Critical Organ Dose Rate Factor for Elevated Release Point $DFG'_{ico(e)} \left(\frac{\text{mrem-sec}}{\text{yr-}\mu\text{Ci}} \right)$	Critical Organ Dose Rate Factor for Ground Level Release Point $DFG'_{ico(g)} \left(\frac{\text{mrem-sec}}{\text{yr-}\mu\text{Ci}} \right)$
H-3	3.08E-10	3.76E-09	9.71E-03	1.19E-01
Cr-51	8.28E-09	2.89E-08	2.91E-01	1.01E+00
Mn-54	1.11E-06	3.79E-06	4.38E+01	1.50E+02
Fe-59	1.06E-06	3.65E-06	3.53E+01	1.21E+02
Co-58	5.56E-07	1.91E-06	2.00E+01	6.88E+01
Co-60	1.21E-05	4.12E-05	5.42E+02	1.85E+03
Zn-65	2.33E-06	7.93E-06	7.82E+01	2.66E+02
Sr-89	1.98E-05	6.73E-05	6.24E+02	2.12E+03
Sr-90	7.21E-04	2.47E-03	2.27E+04	7.79E+04
Zr-95	1.10E-06	3.77E-06	3.63E+01	1.24E+02
Nb-95	2.01E-06	6.86E-06	6.40E+01	2.20E+02
Mo-99	1.63E-08	1.10E-07	5.39E-01	3.56E+00
Ru-103	3.03E-06	1.04E-05	9.62E+01	3.31E+02
Ag-110m	5.02E-06	1.72E-05	1.80E+02	6.15E+02
Sb-124	1.83E-06	6.28E-06	6.15E+01	2.11E+02
I-131	1.47E-04	5.04E-04	4.64E+03	1.59E+04
I-133	1.45E-06	5.72E-06	4.57E+01	1.80E+02
Cs-134	5.62E-05	1.91E-04	1.81E+03	6.18E+03
Cs-137	5.47E-05	1.86E-04	1.79E+03	6.09E+03
Ba-140	1.55E-07	6.39E-07	5.01E+00	2.06E+01
Ce-141	2.65E-07	9.28E-07	8.45E+00	2.96E+01
Ce-144	6.09E-06	2.09E-05	1.93E+02	6.62E+02
Other*	4.09E-06	1.39E-05	1.29E+02	4.38E+02

* Dose factors to be used in Method I calculations for any "other" detected gamma emitting radionuclide which is not included in the above list.

TABLE B.1-13
-Deleted-

|
|

TABLE B.1-14
DOSE FACTORS SPECIFIC FOR THE SCIENCE & NATURE CENTER AND FITNESS CENTER
FOR IODINE, TRITIUM, AND PARTICULATE RELEASES

Radio-nuclide	Science & Nature Critical Organ Dose Factor for Elevated Release Point	Science & Nature Critical Organ Dose Factor for Ground Level Release Point	Fitness Center Critical Organ Dose Factor for Elevated Release Point	Fitness Center Critical Organ Dose Factor for Ground Level Release Point
	$DFG_{icoE(e)} \left(\frac{\text{mrem}}{\mu\text{Ci}} \right)$	$DFG_{icoE(g)} \left(\frac{\text{mrem}}{\mu\text{Ci}} \right)$	$DFG_{icoFC(e)} \left(\frac{\text{mrem}}{\mu\text{Ci}} \right)$	$DFG_{icoFC(g)} \left(\frac{\text{mrem}}{\mu\text{Ci}} \right)$
H-3	6.49E-11	9.50E-10	6.51E-11	1.64E-09
Cr-51	4.93E-09	3.01E-08	4.06E-09	5.12E-08
Mn-54	1.37E-06	5.94E-06	1.06E-06	9.99E-06
Fe-59	3.06E-07	1.99E-06	2.54E-07	3.38E-06
Co-58	3.85E-07	2.20E-06	3.13E-07	3.73E-06
Co-60	2.14E-05	8.31E-05	1.65E-05	1.28E-05
Zn-65	7.25E-07	3.33E-06	5.60E-07	5.59E-06
Sr-89	1.16E-07	1.71E-06	1.17E-07	2.98E-06
Sr-90	5.18E-06	7.63E-05	5.25E-06	1.33E-04
Zr-95	3.36E-07	2.70E-06	2.91E-07	4.65E-06
Nb-95	1.52E-07	9.81E-07	1.26E-07	1.67E-06
Mo-99	1.63E-08	2.03E-07	1.57E-08	3.53E-07
Ru-103	1.29E-07	9.08E-07	1.09E-07	1.55E-06
Ag-110m	3.39E-06	1.61E-05	2.62E-06	2.70E-05
Sb-124	6.91E-07	4.69E-06	5.79E-07	8.01E-06
Sb-125	2.24E-06	9.61E-06	1.73E-06	1.62E-05
I-131	7.94E-07	1.16E-05	8.00E-07	2.01E-05
I-133	1.86E-07	2.73E-06	1.89E-07	4.75E-06
Cs-134	6.74E-06	2.62E-05	5.21E-06	4.35E-05
Cs-137	1.02E-05	3.94E-05	1.11E-07	1.06E-06
Ba-140	1.15E-07	1.51E-06	7.85E-06	6.55E-05
Ce-141	4.09E-08	4.78E-07	1.12E-07	2.61E-06
Ce-144	6.99E-07	9.67E-06	3.87E-08	8.30E-07
Other*	1.44E-07	6.30E-07	6.94E-07	1.69E-05

* Dose factors to be used in Method I calculations for any "other" detected gamma emitting radionuclide which is not included in the above list (i.e., based on Cs-136).

TABLE B.1-15
DOSE FACTORS SPECIFIC FOR THE FIRING RANGE
FOR IODINE, TRITIUM, AND PARTICULATE RELEASES

Radio-nuclide	Critical Organ Dose Factor for Elevated Release Point	Critical Organ Dose Factor for Ground Level Release Point
	$DFG_{iCOFR(e)} \left(\frac{\text{mrem}}{\mu\text{Ci}} \right)$	$DFG_{iCOFR(g)} \left(\frac{\text{mrem}}{\mu\text{Ci}} \right)$
H-3	2.21E-11	2.78E-10
Cr-51	1.62E-09	7.90E-09
Mn-54	4.50E-07	1.50E-06
Fe-59	1.01E-07	5.24E-07
Co-58	1.26E-07	5.72E-07
Co-60	7.03E-06	2.03E-05
Zn-65	2.38E-07	8.45E-07
Sr-89	3.84E-08	4.80E-07
Sr-90	1.72E-06	2.14E-05
Zr-95	1.11E-07	7.31E-07
Nb-95	5.00E-08	2.59E-07
Mo-99	5.38E-09	5.66E-08
Ru-103	4.24E-08	2.42E-07
Ag-110m	1.11E-06	4.10E-06
Sb-124	2.27E-07	1.25E-06
Sb-125	7.34E-07	2.42E-06
I-131	2.63E-07	3.23E-06
I-133	6.18E-08	7.66E-07
Cs-134	2.21E-06	6.40E-06
Cs-137	3.34E-06	9.65E-06
Ba-140	3.80E-08	4.19E-07
Ce-141	1.35E-08	1.33E-07
Ce-144	2.31E-07	2.71E-06
Other*	4.73E-08	1.59E-07

* Dose factors to be used in Method I calculations for any "other" detected gamma emitting radionuclide which is not included in the above list (i.e., based on Cs-136).

2.0 METHOD TO CALCULATE OFF-SITE LIQUID CONCENTRATIONS

Chapter 2 contains the basis for station procedures used to demonstrate compliance with ODCM Part A Control C.6.1.1, which limits the total fraction of ECL in liquid pathways, other than noble gases (denoted here as F_1^{ENG}) at the point of discharge from the station to the environment (see Figure B.6-1).

F_1^{ENG} is limited to less than or equal to ten, i.e.,

$$F_1^{ENG} \leq 10.$$

The total concentration of all dissolved and entrained noble gases at the point of discharge from the multiport diffuser from all station sources combined, denoted C_1^{NG} , is limited to 2E-04 $\mu\text{Ci/ml}$, i.e.,

$$C_1^{NG} \leq 2\text{E-}04 \mu\text{Ci/ml}.$$

Appendix C, Attachments 3 and 4, provide the option and bases for the use of the EMS determination of liquid concentration limits for plant discharges to the environment.

2.1 Method to Determine F_1^{ENG} AND C_1^{NG}

First, determine the total fraction of ECL (excluding noble gases), at the point of discharge from the station from all significant liquid sources denoted F_1^{ENG} ; and then separately determine the total concentration at the point of discharge of all dissolved and entrained noble gases from all station sources, denoted C_1^{NG} , as follows:

$$F_1^{ENG} = \sum_p \sum_i \frac{C_{pi}}{ECL_i} \leq 10 \quad (2-1)$$

$$\left(\frac{\mu\text{Ci} / \text{ml}}{\mu\text{Ci} / \text{ml}} \right)$$

and:

$$C_1^{NG} = \sum_i C_{li}^{NG} \leq 2\text{E-}04 \quad (2-2)$$

$$(\mu\text{Ci/ml}) \quad (\mu\text{Ci/ml}) \quad (\mu\text{Ci/ml})$$

where:

F_1^{ENG} = Total fraction of ECL in liquids, excluding noble gases, at the point of discharge from the multiport difuser.

- C_{pi} = Concentration at point of discharge from the multiport diffuser of radionuclide "i", except for dissolved and entrained noble gases, from all tanks and other significant sources, p, from which a discharge may be made (including the waste test tanks and any other significant source from which a discharge can be made). C_{pi} is determined by dividing the product of the measured radionuclide concentration in liquid waste test tanks, PCCW, steam generator blowdown, or other effluent streams times their discharge flow rate by the total available dilution water flow rate of circulating and service water at the time of release ($\mu\text{Ci/ml}$).
- ECL_i = Effluent concentration limit (ECL) for radionuclide "i" (except for dissolved and entrained noble gases) in $\mu\text{Ci/ml}$ as specified in 10 CFR 20, Appendix B, Table 2. See Appendix B for a list of ECL values.
- C_1^{NG} = Total concentration at point of discharge of all dissolved and entrained noble gases in liquids from all station sources ($\mu\text{Ci/ml}$)
- C_{li}^{NG} = Concentration at point of discharge of dissolved and entrained noble gas "i" in liquids from all station sources ($\mu\text{Ci/ml}$)

2.2 Method to Determine Radionuclide Concentration for Each Liquid Effluent Source

2.2.1 Waste Test Tanks

C_{pi} is determined for each radionuclide detected from the activity in a representative grab sample of any of the waste test tanks and the predicted flow at the point of discharge.

The batch releases are normally made from two 25,000-gallon capacity waste test tanks. These tanks normally hold liquid waste which may have been processed through the installed vendor equipment. The waste test tanks can also contain other waste such as liquid taken directly from the floor drain/chemical drain treatment tanks when that liquid does not require processing in the evaporator, from the installed vendor resin skid, distillate from the boron recovery evaporator when the BRS evaporator is substituting for the waste evaporator, or waste distillate from the Steam Generator Blowdown System when that system must discharge liquid off site.

If testing indicates that purification of the waste test tank contents is required prior to release, the liquid can be circulated through the waste demineralizer and filter.

The contents of the waste test tank may be reused in the Nuclear System if the sample test meets the purity requirements.

Prior to discharge, each waste test tank is analyzed for principal gamma emitters in accordance with the liquid sample and analysis program outlined in Part A to the ODCM.

2.2.2 Turbine Building Sump

The Turbine Building sump collects leakage from the Turbine Building floor drains and discharges the liquid unprocessed to the circulating water system.

Sampling of this potential source is normally done once per week for determining the radioactivity released to the environment (see Table A.6.1-1).

2.2.3 Steam Generator Blowdown Flash Tank

The primary method to process radioactive secondary liquid from the steam generators is to direct steam blowdown flash tank bottoms cooler discharge to the floor drain tanks. If no secondary pressure is available, the steam blowdown and wet lay-ups pumps can be used. From the floor drain tanks, processing through the installed vendor resin skid (WL-SKD-135) to the waste test tanks is the preferred method. Other methods may be used as defined below.

The steam generator blowdown evaporators may process the liquid from the steam generator blowdown flash tank when there is primary to secondary leakage. Distillate from the evaporators can be sent to the waste test tanks or recycled to the condensate system. When there is no primary to secondary leakage, flash tank liquid is processed through the steam generator blowdown demineralizers and returned to the secondary side.

Steam generator blowdown is only subject to sampling and analysis when all or part of the blowdown liquid is being discharged to the environment instead of the normal recycling process (see Table A.6.1-1).

2.2.4 Primary Component Cooling Water (PCCW) System

The PCCW System is used to cool selected primary components.

The system is normally sampled weekly to determine if there is any radwaste in-leakage. If leakage has been determined, the Service Water System is sampled to determine if any release to the environment has occurred.

2.2.5 Water Treatment System (Condensate Polishing System)

The addition to the plant design of a Condensate Polishing System (CPS) for secondary side water treatment creates the potential for radiological contaminated effluents to be discharge from the Mixed Bed or Cation Demineralizers (during Megarins) and from the Neutralization Tank (1-WT-TK-32) and the Low Conductivity Tank (1-CPS-TK-274) to the Circulating Water System via the Water Treatment System Piping following regeneration of the resin beds.

Prior to discharge, each tank or vessel to be processed is sampled and analyzed for principal gamma emitters in accordance with the Liquid Sample and Analysis Program outlined in Part A to the ODCM.

3.0 OFF-SITE DOSE CALCULATION METHODS

Chapter 3 provides the basis for station procedures required to meet the Radiological Effluent Control Program (RECP) dose and dose rate requirements contained in ODCM Part A Controls. A simple, conservative method (called Method I) is listed in Tables B.1-2 to B.1-7 for each of the requirements of the RECP. Each of the Method I equations is presented in Part B, Sections 3.2 through 3.9. As an alternate to Method I, the EMS computer program documented in Appendix C can be used to determine regulatory compliance for effluent doses and dose rates. The use of the EMS software is designated as Method IA in Chapter 3. In addition, those sections include more sophisticated methods (called Method II) for use when more refined results are needed. This chapter provides the methods, data, and reference material with which the operator can calculate the needed doses, dose rates and setpoints. For the requirements to demonstrate compliance with Part A off-site dose limits, the contribution from all measured ground level releases must be added to the calculated contribution from the vent stack to determine the Station's total radiological impact. The bases for the dose and dose rate equations are given in Chapter 7.0. Method IA bases and software verification documentation are contained in Appendix C.

The Annual Radioactive Effluent Release Report, to be filed after January 1 each year per Technical Specification 6.8.1.4, and Part A, Section 10.2, requires that meteorological conditions concurrent with the time of release of radioactive materials in gaseous effluents, as determined by sampling frequency and measurement, be used for determining the gaseous pathway doses. For continuous release sources (i.e., plant vent, condenser air removal exhaust, and gland steam packing exhaust), concurrent quarterly average meteorology will be used in the dose calculations along with the quarterly total radioactivity released. For batch releases or identifiable operational activities (i.e., containment purge or venting to atmosphere of the Waste Gas System), concurrent meteorology during the period of release will be used to determine dose if the total noble gas or iodine and particulates released in the batch exceeds five percent of the total quarterly radioactivity released from the unit; otherwise quarterly average meteorology will be applied. Quarterly average meteorology will also be applied to batch releases if the hourly met data for the period of batch release is unavailable.

Annual dose assessment reports prepared in accordance with the requirements of the ODCM will include a statement indicating that the appropriate portions of Regulatory Guide 1.109 (as identified in the individual subsections of the ODCM for each class of effluent exposure) have been used to determine dose impact from station releases. Any deviation from the methodology, assumptions, or parameters given in Regulatory Guide 1.109, and not already identified in the bases of the ODCM, will be explicitly described in the effluent report, along with the bases for the deviation.

3.1 Introductory Concepts

In Part A Controls, the RECP limits for dose or dose rate are stated. The term "dose" for ingested or inhaled radioactivity means the dose commitment, measured in mrem, which results from the exposure to radioactive materials that, because of uptake and deposition in the body, will continue to expose the body to radiation for some period of time after the source of radioactivity is stopped. The time frame over which the dose commitment is evaluated is 50 years. The phrases "annual dose" or "dose in one year" then refers to the 50-year dose commitment resulting from exposure to one year's worth of releases. "Dose in a quarter" similarly means the 50-year dose commitment resulting from exposure to one quarter's releases. The term "dose," with respect to external exposures, such as to noble gas clouds, refers only to the doses received during the actual time period of exposure to the radioactivity released from the plant. Once the source of the radioactivity is removed, there is no longer any additional accumulation to the dose commitment.

"Dose rate" is the total dose or dose commitment divided by exposure period. For example, an individual who is exposed via the ingestion of milk for one year to radioactivity from plant gaseous effluents and receives a 50-year dose commitment of 10 mrem is said to have been exposed to a dose rate of 10 mrem/year, even though the actual dose received in the year of exposure may be less than 10 mrem.

In addition to limits on dose commitment, gaseous effluents from the station are also controlled so that the maximum or peak dose rates at the site boundary at any time are limited to the equivalent annual dose limits of 10 CFR Part 20 to unrestricted areas (if it were assumed that the peak dose rates continued for one year). These dose rate limits provide reasonable assurance that members of the public, either inside or outside the site boundary, will not be exposed to annual averaged concentrations exceeding the limits specified in Appendix B, Table 2 of 10 CFR Part 20. See Appendix B for a listing of these concentration limits.

The quantities ΔD and \dot{D} are introduced to provide calculable quantities, related to off-site doses or dose rates that demonstrate compliance with the RETS.

Delta D, denoted ΔD , is the quantity calculated by the Part B, Chapter 3, Method I dose equations. It represents the conservative increment in dose. The ΔD calculated by Method I equations is not necessarily the actual dose received by a real individual, but usually provides an upper bound for a given release because of the conservative margin built into the dose factors and the selection and definition of critical receptors. The radionuclide specific dose factors in each Method I dose equation represent the greatest dose to any organ of any age group. (Organ dose is a function of age because organ mass and intake are functions of age.) The critical receptor assumed by "Method I" equations is then generally a hypothetical individual whose behavior - in terms of location and intake - results in a dose which is higher than any real individual is likely to receive. Method IA dose calculations using the EMS software evaluate each age group and organ combination to determine the maximum organ dose for each mix of radionuclides specified in a release period. Method II also allows for a more exact dose calculation for each individual if necessary.

D dot, denoted \dot{D} , is the quantity calculated in the Part B, Chapter 3 dose rate equations. It is calculated using the station's effluent monitoring system reading and an annual or long-term average atmospheric dispersion factor. \dot{D} predicts the maximum off-site annual dose if the peak observed radioactivity release rate from the plant stack continued for one entire year. Since peak release rates, or resulting dose rates, are usually of short time duration on the order of an hour or less, this approach then provides assurance that 10 CFR 20.106 limits will be met.

Each of the methods to calculate dose or dose rate is presented in the following subsections. Each dose type has two levels of complexity. Method I is the simplest and contains many conservative factors. As an alternate to Method I the EMS computer program documented in Appendix C can be used to determine regulatory compliance for effluent doses and dose rates. The use of the EMS system is designated as Method IA in Chapter 3 of Part B.

Method II is a more realistic analysis which makes use of the models in Regulatory Guide 1.109 (Revision 1), as noted in each subsection of Part B, Chapter 3 for the various exposure types. A detailed description of the methodology, assumptions, and input parameters to the dose models that are applied in each Method II calculation, if not already explicitly described in the ODCM, shall be documented and provided when this option is used for NRC reporting and ODCM, Part A RECP dose compliance.

3.2 Method to Calculate the Total Body Dose from Liquid Releases

Part A Control C.6.2.1 limits the total body dose commitment to a member of the public from radioactive material in liquid effluents to 1.5 mrem per quarter and 3 mrem per year per unit. Part A Control C.6.3.1 requires liquid radwaste treatment when the total body dose estimate exceeds 0.06 mrem in any 31-day period. Part A Control C.8.1.1 limits the total body dose commitment to any real member of the public from all station sources (including liquids) to 25 mrem in a year.

Use Method I or Method IA first to calculate the maximum total body dose from a liquid release from the station as it is simpler to execute and more conservative than Method II.

Use Method II if a more refined calculation of total body dose is needed, i.e., Method I or Method IA indicates the dose might be greater than Part A Control limits.

To evaluate the total body dose, use Equation 3-1 to estimate the dose from the planned release and add this to the total body dose accumulated from prior releases during the month. See Part B, Section 7.1.1 for basis.

3.2.1 Method I

The total body dose from a liquid release is:

$$D_{tb} = k \sum_i Q_i DFL_{itb} \quad (3-1)$$

$$(\text{mrem}) = () (\mu\text{Ci}) \left(\frac{\text{mrem}}{\mu\text{Ci}} \right)$$

where

DFL_{itb} = Site-specific total body dose factor (mrem/ μCi) for a liquid release. It is the highest of the four age groups. See Table B.1-11.

Q_i = Total activity (μCi) released for radionuclide "i". (For strontiums, use the most recent measurement available.)

k = $918/F_d$; where F_d is the average (typically monthly average) dilution flow of the Circulating Water System at the point of discharge from the multiport diffuser (in ft^3/sec). For normal operations with a cooling water flow of $918 \text{ ft}^3/\text{sec}$, k is equal to 1. During periods when no or low flow is recorded from the Discharge Transition Structure (DTS), a minimum dilution flow of $23 \text{ ft}^3/\text{sec}$ ($10,500 \text{ gpm}$ for one service water pump) can be used since this would be the minimum flow available when discharges to the tunnel are reestablished. Alternately, the monthly average discharge flow for the period in which the release occurs can be used when this value is available.

3.2 Method to Calculate the Total Body Dose from Liquid Releases (Continued)

3.2.1 Method I (Continued)

Equation 3-1 can be applied under the following conditions (otherwise, justify Method I or consider Method II):

1. Liquid releases via the multiport diffuser to unrestricted areas (at the edge of the initial mixing or prompt dilution zone that corresponds to a factor of 10 dilution), and
2. Any continuous or batch release over any time period up to 1 year. For annual dose estimates, the annual average discharge flow from the DTS should be used as the dilution flow estimate.

Method IA is implemented by the EMS software as described in Appendix C. Liquid release models are detailed in sections 2.1 - 2.6 of the EMS Technical Reference Manual (Attachment 4 of Appendix C).

3.2.2 Method II

Method II consists of the models, input data and assumptions (bioaccumulation factors, shore-width factor, dose conversion factors, and transport and buildup times) in Regulatory Guide 1.109, Rev. 1 (Reference A), except where site-specific data or assumptions have been identified in the ODCM. The general equations (A-3 and A-7) taken from Regulatory Guide 1.109, and used in the derivation of the simplified Method I approach as described in the Bases section, are also applied to Method II assessments, except that doses calculated to the whole body from radioactive effluents are evaluated for each of the four age groups to determine the maximum whole body dose of an age-dependent individual via all existing exposure pathways. Table B.7-1 lists the usage factors of Method II calculations. As noted in Section B.7.1, the mixing ratio associated with the edge of the 1°F surface isotherm above the multiport diffuser may be used in Method II calculations for the shoreline exposure pathway ($M_p = 0.025$). Aquatic food ingestion pathways shall limit credit taken for mixing zone dilution to the same value assumed in Method I ($M_p = 0.10$).

3.3 Method to Calculate Maximum Organ Dose from Liquid Releases

Part A Control C.6.2.1 limits the maximum organ dose commitment to a Member of the Public from radioactive material in liquid effluents to 5 mrem per quarter and 10 mrem per year per unit. Part A Control C.6.3.1 requires liquid radwaste treatment when the maximum organ dose projected exceeds 0.2 mrem in any 31 days (see Part B, Subsection 3.11 for dose projections). Part A Control C.8.1.1 limits the maximum organ dose commitment to any real member of the public from all station sources (including liquids) to 25 mrem in a year except for the thyroid, which is limited to 75 mrem in a year.

Use Method I or Method IA first to calculate the maximum organ dose from a liquid release to unrestricted areas (see Figure B.6-1) as it is simpler to execute and more conservative than Method II.

Use Method II if a more refined calculation of organ dose is needed, i.e., Method I or Method IA indicates the dose may be greater than the limit.

Use Equation 3-2 to estimate the maximum organ dose from individual or combined liquid releases. See Part B, Section 7.1.2 for basis.

3.3.1 Method I

The maximum organ dose from a liquid release is:

$$D_{mo} = k \sum_i Q_i \text{DFL}_{imo} \quad (3-2)$$
$$(\text{mrem}) = () (\mu\text{Ci}) \left(\frac{\text{mrem}}{\mu\text{Ci}} \right)$$

where

DFL_{imo} = Site-specific maximum organ dose factor (mrem/ μCi) for a liquid release. It is the highest of the four age groups. See Table B.1-11.

Q_i = Total activity (μCi) released for radionuclide "i". (For composited analyses of strontiums, use the most recent measurement available.)

k = $918/F_d$; where F_d is the average (typically monthly average) dilution flow of the Circulating Water System at the point of discharge from the multiport diffuser (in ft^3/sec). For normal operations with a cooling water flow of $918 \text{ ft}^3/\text{sec}$, k is equal to 1. During periods when no or low flow is recorded from the Discharge Transition Structure (DTS), a minimum dilution flow of $23 \text{ ft}^3/\text{sec}$ ($10,500 \text{ gpm}$ for one service water pump) can be used since this would be the minimum flow available when discharges to the tunnel are reestablished. Alternately, the monthly average discharge flow for the period in which the release occurs can be used when this value is available.

3.3 Method to Calculate Maximum Organ Dose from Liquid Releases (Continued)

3.3.1 Method I (Continued)

Equation 3-2 can be applied under the following conditions (otherwise, justify Method I or consider Method II):

1. Liquid releases via the multiport diffuser to unrestricted areas (at the edge of the initial mixing or prompt dilution zone that corresponds to a factor of 10 dilution), and
2. Any continuous or batch release over any time period up to 1 year. For annual dose estimates, the annual average discharge flow from the DTS should be used as the dilution flow estimate.

Method IA is implemented by the EMS software as described in Appendix C. Liquid release models are detailed in sections 2.1 - 2.6 of the EMS Technical Reference Manual (Attachment 4 of Appendix C).

3.3.2 Method II

Method II consists of the models, input data and assumptions (bioaccumulation factors, shore-width factor, dose conversion factors, and transport and buildup times) in Regulatory Guide 1.109, Rev. 1 (Reference A), except where site-specific data or assumptions have been identified in the ODCM. The general equations (A-3 and A-7) taken from Regulatory Guide 1.109, and used in the derivation of the simplified Method I approach as described in the Bases section, are also applied to Method II assessments, except that doses calculated to critical organs from radioactive effluents are evaluated for each of the four age groups to determine the maximum critical organ of an age-dependent individual via all existing exposure pathways. Table B.7-1 lists the usage factors for Method II calculations. As noted in Section B.7.1, the mixing ratio associated with the edge of the 1°F surface isotherm above the multiport diffuser may be used in Method II calculations for the shoreline exposure pathway ($M_p = 0.025$). Aquatic food ingestion pathways shall limit credit taken for mixing zone dilution to the same value assumed in Method I ($M_p = 0.10$).

3.4 Method to Calculate the Total Body Dose Rate from Noble Gases

Part A Control C.7.1.1 limits the dose rate at any time to the total body from noble gases at any location at or beyond the site boundary to 500 mrem/year. The Part A Control indirectly limits peak release rates by limiting the dose rate that is predicted from continued release at the peak rate. By limiting \dot{D}_{tb} to a rate equivalent to no more than 500 mrem/year, we assure that the total body dose accrued in any one year by any member of the general public is less than 500 mrem.

Use Method I or Method IA first to calculate the Total Body Dose Rate from the peak release rate via the station vents or ground level effluent release points. Method I applies at all release rates.

Use Method II if a more refined calculation of \dot{D}_{tb} is desired by the station (i.e., use of actual release point parameters with annual or actual meteorology to obtain release-specific X/Qs) or if Method I or Method IA predicts a dose rate greater than the Part A Control limit to determine if it had actually been exceeded during a short time interval. See Part B, Section 7.2.1 for basis.

Compliance with the dose rate limits for noble gases are continuously demonstrated when effluent release rates are below the plant vent noble gas activity monitor alarm setpoint by virtue of the fact that the alarm setpoint is based on a value which corresponds to the off-site dose rate limit, or a value below it. Determinations of dose rate for compliance with Part A Control are performed when the effluent monitor alarm setpoint is exceeded, or as required by the Action Statement (Part A Control C.5.2, Table A.5.2-1) when the monitor is inoperable.

3.4.1 Method I

The Total Body Dose Rate to an off-site receptor due to noble gases in effluents released via the plant vent can be determined as follows:

$$\dot{D}_{tb(e)} = 0.85 * \sum_i \left(\dot{Q}_i * DFB_i \right) \quad (3-3a)$$

$$\frac{\text{mrem}}{\text{yr}} = \left(\frac{\text{pCi} \cdot \text{sec}}{\mu\text{Ci} \cdot \text{m}^3} \right) \sum \left(\frac{\mu\text{Ci}}{\text{sec}} \right) \left(\frac{\text{mrem} \cdot \text{m}^3}{\text{pCi} \cdot \text{yr}} \right)$$

where

$\dot{D}_{tb(e)}$ \dot{D}_{tb} The off-site total body dose rate (mrem/yr) due to noble gases in elevated effluent releases,

\dot{Q}_i = the release rate at the station vents ($\mu\text{Ci}/\text{sec}$), for each noble gas radionuclide, "i", shown in Table B.1-10, and

DFB_i = total body gamma dose factor (see Table B.1-10).

The Total Body Dose Rate (to an off-site receptor) due to noble gas in ground level effluent releases can be determined as follows:

3.4 Method to Calculate the Total Body Dose Rate from Noble Gases (Continued)

3.4.1 Method I (Continued)

$$\dot{D}_{tb(g)} = 3.4 \sum_i (\dot{Q}_i * DFB_i) \quad (3-3b)$$

$$\frac{\text{mrem}}{\text{yr}} = \left(\frac{\text{pCi} \cdot \text{sec}}{\mu\text{Ci} \cdot \text{m}^3} \right) \sum \left(\frac{\mu\text{Ci}}{\text{sec}} \right) \left(\frac{\text{mrem} \cdot \text{m}^3}{\text{pCi} \cdot \text{yr}} \right)$$

where

$\dot{D}_{tb(g)}$ = The total off-site body dose rate (mrem/yr) due to noble gases in ground level equivalent effluent releases, and

\dot{Q}_i and DFB_i are as defined for Equation 3-3a.

Equations 3-3a and 3-3b can be applied under the following conditions (otherwise, justify Method I or consider Method II):

1. Normal operations (nonemergency event), and
2. Noble gas releases via any station vent to the atmosphere.

Method IA is implemented by the EMS software as described in Appendix C. Gaseous release models are detailed in Section 6.7.3 of the EMS Software Requirements Specification (Attachment 3 of Appendix C).

3.4.2 Method II

Method II consists of the model and input data (whole body dose factors) in Regulatory Guide 1.109, Rev. 1 (Reference A), except where site-specific data or assumptions have been identified in the ODCM. The general equation (B-8) taken from Regulatory Guide 1.109, and used in the derivation of the simplified Method I approach as described in the Bases section, is also applied to a Method II assessment. No credit for a shielding factor (S_F) associated with residential structures is assumed. Concurrent meteorology with the release period may be utilized for the gamma atmospheric dispersion factor identified in ODCM Equation 7-3 (Part B, Section 7.2.1), and determined as indicated in Part B, Section 7.3.2 for the release point (either ground level or vent stack) from which recorded effluents have been discharged.

3.5 Method to Calculate the Skin Dose Rate from Noble Gases

Part A Control C.7.1.1 limits the dose rate at any time to the skin from noble gases at any location at or beyond the site boundary to 3,000 mrem/year. The Part A Control indirectly limits peak release rates by limiting the dose rate that is predicted from continued release at the peak rate. By limiting \dot{D}_{skin} to a rate equivalent to no more than 3,000 mrem/year, we assure that the skin dose accrued in any one year by any member of the general public is less than 3,000 mrem. Since it can be expected that the peak release rate on which \dot{D}_{skin} is derived would not be exceeded without corrective action being taken to lower it, the resultant average release rate over the year is expected to be considerably less than the peak release rate.

Use Method I or Method IA first to calculate the Skin Dose Rate from peak release rate via station vents. Method I applies at all release rates.

Use Method II if a more refined calculation of \dot{D}_{skin} is desired by the station (i.e., use of actual release point parameters with annual or actual meteorology to obtain release-specific X/Qs) or if Method I or Method IA predicts a dose rate greater than the Part A Control limit to determine if it had actually been exceeded during a short time interval. See Part B, Section 7.2.2 for basis.

Compliance with the dose rate limits for noble gases are continuously demonstrated when effluent release rates are below the plant vent noble gas activity monitor alarm setpoint by virtue of the fact that the alarm setpoint is based on a value which corresponds to the off-site dose rate limit, or a value below it. Determinations of dose rate for compliance with Part A Controls are performed when the effluent monitor alarm setpoint is exceeded.

3.5.1 Method I

For an off-site receptor and elevated effluent release, the Skin Dose Rate due to noble gases is:

$$\dot{D}_{skin(e)} = \sum_i (\dot{Q}_i * DF'_{i(e)}) \quad (3-4a)$$

$$\frac{\text{mrem}}{\text{yr}} = \sum \left(\frac{\mu\text{Ci}}{\text{sec}} \right) \left(\frac{\text{mrem} \cdot \text{sec}}{\mu\text{Ci} \cdot \text{yr}} \right)$$

where

- $\dot{D}_{skin(e)}$ = the off-site skin dose rate (mrem/yr) due to noble gases in an effluent discharge from an elevated release point,
- \dot{Q}_i = as defined previously, and
- $DF'_{i(e)}$ = the combined skin dose factor for elevated discharges (see Table B.1-10).

3.5 Method to Calculate the Skin Dose Rate from Noble Gases (Continued)

3.5.1 Method I (Continued)

For an off-site receptor and ground level release, the skin dose rate due to noble gases is:

$$\dot{D}_{\text{skin(g)}} = \sum_i (\dot{Q}_i * DF'_{i(g)}) \quad (3-4b)$$

where

$\dot{D}_{\text{skin(g)}}$ = The off-site skin dose rate (mrem/yr) due to noble gases in an effluent discharge from a ground level release point,

\dot{Q}_i = as defined previously, and

$DF'_{i(g)}$ = The combined skin dose factor for ground level discharges (see Table B.1-10).

Equations 3-4a and 3-4b can be applied under the following conditions (otherwise, justify Method I or consider Method II).

1. Normal operations (nonemergency event), and
2. Noble gas releases via any station vent to the atmosphere.

Method IA is implemented by the EMS software as described in Appendix C. Gaseous release models are detailed in Section 6.7.3 of the EMS Software Requirements Specification (Attachment 3 of Appendix C).

3.5.2 Method II

Method II consists of the model and input data (skin dose factors) in Regulatory Guide 1.109, Rev. 1 (Reference A), except where site-specific data or assumptions have been identified in the ODCM. The general equation (B-9) taken from Regulatory Guide 1.109, and used in the derivation of the simplified Method I approach as described in the Bases section, is also applied to a Method II assessment, no credit for a shielding factor (S_F) associated with residential structures is assumed. Concurrent meteorology with the release period may be utilized for the gamma atmospheric dispersion factor and undepleted atmospheric dispersion factor identified in ODCM Equation 7-8 (Part B, Section 7.2.2), and determined as indicted in Part B, Sections 7.3.2 and 7.3.3 for the release point (either ground level or vent stack) from which recorded effluents have been discharged.

3.6 Method to Calculate the Critical Organ Dose Rate from Iodines, Tritium and Particulates with $T_{1/2}$ Greater Than 8 Days, (Including Carbon-14)

Part A Control C.7.1.1 limits the dose rate at any time to any organ from ^{131}I , ^{133}I , ^3H and radionuclides in particulate form with half lives greater than 8 days to 1500 mrem/year to any organ. In addition, Carbon-14 has been declared a principle radionuclide for Seabrook gaseous effluents and is included in the assessment of compliance with the Part A Control limit C.7.1.1. The Part A Control indirectly limits peak release rates by limiting the dose rate that is predicted from continued release at the peak rate. By limiting \dot{D}_{co} to a rate equivalent to no more than 1500 mrem/year, we assure that the critical organ dose accrued in any one year by any member of the general public is less than 1500 mrem.

Use Method I or Method IA first to calculate the Critical Organ Dose Rate from the peak release rate via the station vents. Method I applies at all release rates.

Use Method II if a more refined calculation of \dot{D}_{co} is desired by the station (i.e., use of actual release point parameters with annual or actual meteorology to obtain release-specific X/Qs) or if Method I or Method IA predicts a dose rate greater than the Part A Control limit to determine if it had actually been exceeded during a short time interval. See Part B, Section 7.2.3 for basis.

3.6.1 Method I

The Critical Organ Dose Rate to an off-site receptor and elevated release conditions can be determined as follows:

$$\dot{D}_{co(e)} = \sum_i (\dot{Q} * DFG'_{ico(e)}) \quad \text{plus } [0.611]_{C-14} \quad (3-5a)$$

$$\left(\frac{\text{mrem}}{\text{yr}} \right) = \sum \left(\frac{\mu\text{Ci}}{\text{sec}} \right) * \left(\frac{\text{mrem} - \text{sec}}{\mu\text{Ci} - \text{yr}} \right) + \left(\frac{\text{mrem}}{\text{yr}} \right)$$

where

$\dot{D}_{co(e)}$ = The off-site critical organ dose rate (mrem/yr) due to iodine, tritium, carbon-14, and particulates in an elevated release,

\dot{Q}_i = The activity release rate at the station vents of radionuclide "i" (except C-14) in $\mu\text{Ci}/\text{sec}$ (i.e., total activity measured of radionuclide "i" averaged over the time period for which the filter/charcoal sample collector was in the effluent stream. For $i = \text{Sr89}$ or Sr90 , use the best estimates, such as most recent measurements), and

$DFG'_{ico(e)}$ = the site-specific critical organ dose rate factor $\left(\frac{\text{mrem} - \text{sec}}{\mu\text{Ci} - \text{yr}} \right)$ for an elevated gaseous release (See Table B.1-12).

0.611 = The default annual dose rate contribution (inhalation and ingestion exposures) from Carbon-14 in elevated gaseous discharges (mrem/yr) used in lieu of surveillance measurements of Carbon-14 in effluents.

3.6 Method to Calculate the Critical Organ Dose Rate from Iodines, Tritium and Particulates with $T_{1/2}$ Greater Than 8 Days, (Including Carbon-14) (Continued)

3.6.1 Method I (Continued)

For an off-site receptor and ground level release, the critical organ dose rate can be determined as follows:

$$\dot{D}_{co(g)} = \sum_i (\dot{Q}_i DFG'_{ico(g)}) \quad (3-5b)$$

where

$\dot{D}_{co(g)}$ = the off-site critical organ dose rate (mrem/yr) due to iodine, tritium, and particulates in a ground level release (carbon-14 discharged via plant vent stack only),

\dot{Q}_i = as defined previously, and

$\frac{DFG'_{ico(g)}}{DFG_{ico(g)}}$ = the site-specific critical organ dose rate factor for a ground level gaseous discharge (see Table B.1-12).

Equations 3-5a and 3-5b can be applied under the following conditions (otherwise, justify Method I or consider Method II):

1. Normal operations (not emergency event), and
2. Tritium, I-131 and particulate releases via monitored station vents to the atmosphere.

Method IA is implemented by the EMS software as described in Appendix C. Gaseous release models are detailed in Section 6.7.3 of the EMS Software Requirements Specification (Attachment 3 of Appendix C).

3.6.2 Method II

Method II consists of the models, input data and assumptions in Appendix C of Regulatory Guide 1.109, Rev. 1 (Reference A), except where site-specific data or assumptions have been identified in the ODCM (see Tables B.7-2 and B.7-3). The critical organ dose rate will be determined based on the location (site boundary, nearest resident, or farm) of receptor pathways as identified in the most recent annual land use census, or by conservatively assuming the existence of all pathways (ground plane, inhalation, ingestion of stored and leafy vegetables, milk, and meat) at an off-site location of maximum potential dose. Concurrent meteorology with the release period may be utilized for determination of atmospheric dispersion factors in accordance with Part B, Sections 7.3.2 and 7.3.3 for the release point (either ground level or vent stack) from which recorded effluents have been discharged. The maximum critical organ dose rates will consider the four age groups independently, and take no credit for a shielding factor (S_F) associated with residential structures.

3.7 Method to Calculate the Gamma Air Dose from Noble Gases

Part A Control C.7.2.1 limits the gamma dose to air from noble gases at any location at or beyond the site boundary to 5 mrad in any quarter and 10 mrad in any year per unit. Dose evaluation is required at least once per 31 days.

Use Method I or Method IA first to calculate the gamma air dose from the station gaseous effluent releases during the period.

Use Method II if a more refined calculation is needed (i.e., use of actual release point parameter with annual or actual meteorology to obtain release-specific X/Qs), or if Method I or Method IA predicts a dose greater than the Part A Control limit to determine if it had actually been exceeded. See Part B, Section 7.2.4 for basis.

3.7.1 Method I

The general form of the gamma air dose equation is:

$$D_{\text{air}}^{\gamma} = 3.17\text{E}-02 * \left[\frac{X}{Q} \right]_{\text{1hr}}^{\gamma} * t^{-a} * \sum_i (Q_i * DF_i^{\gamma}) \quad (3-6)$$

$$(\text{mrad}) = \left(\frac{\text{pCi-yr}}{\mu\text{Ci-sec}} \right) * \left(\frac{\text{sec}}{\text{m}^3} \right) * () * \sum (\mu\text{Ci}) \left(\frac{\text{mrad-m}^3}{\text{pCi-yr}} \right)$$

where

D_{air}^{γ} is the gamma air dose.

3.17E-02 is the number of pCi per μCi divided by the number of second per year,

$\left[\frac{X}{Q} \right]_{\text{1hr}}^{\gamma}$ is the 1-hour gamma atmospheric dispersion factor,

t^{-a} is a unitless factor which adjusts the 1-hour $\left[\frac{X}{Q} \right]^{\gamma}$ value for a release with a total duration of t hours,

Q_i is the total activity in μCi of each radionuclide "i" released to the atmosphere from the station gaseous effluent release point during the period of interest, and

DF_i^{γ} is the gamma dose factor to air for radionuclide "i" (see Table B.1-10).

Incorporating receptor location-specific atmospheric dispersion factors ($\left[\frac{X}{Q} \right]^{\gamma}$), adjustment factors (t^{-a}) for elevated and ground-level effluent release conditions, and occupancy factors when applicable (see Section 7.2.7), yields a series of equations by which the gamma air dose can be determined.

3.7 Method to Calculate the Gamma Air Dose from Noble Gases (Continued)

3.7.1 Method I (Continued)

- a. Maximum off-site receptor location, elevated release conditions:

$$D_{\text{air(e)}}^{\gamma} = 3.2\text{E} - 07 * t^{-0.274} * \sum_i (Q_i * DF_i^{\gamma}) \quad (3-6a)$$

$$(\text{mrad}) = \left(\frac{\text{pCi} - \text{yr}}{\mu\text{Ci} - \text{m}^3} \right) * () * \sum (\mu\text{Ci}) \left(\frac{\text{mrad} - \text{m}^3}{\text{pCi} - \text{yr}} \right)$$

- b. Maximum off-site receptor location, ground-level release conditions:

$$D_{\text{air(g)}}^{\gamma} = 1.6\text{E} - 06 * t^{-0.293} * \sum_i (Q_i * DF_i^{\gamma}) \quad (3-6b)$$

$$(\text{mrad}) = \left(\frac{\text{pCi} - \text{yr}}{\mu\text{Ci} - \text{m}^3} \right) * () * \sum (\mu\text{Ci}) \left(\frac{\text{mrad} - \text{m}^3}{\text{pCi} - \text{yr}} \right)$$

Equations 3-6a and 3-6b can be applied under the following conditions (otherwise justify Method I or consider Method II):

1. Normal operations (nonemergency event), and
2. Noble gas releases via station vents to the atmosphere.

Method IA is implemented by the EMS software as described in Appendix C. Gaseous release models are detailed in Section 6.7.3 of the EMS Software Requirements Specification (Attachment 3 of Appendix C).

3.7.2 Method II

Method II consists of the models, input data (dose factors) and assumptions in Regulatory Guide 1.109, Rev. 1 (Reference A), except where site-specific data or assumptions have been identified in the ODCM. The general equations (B-4 and B-5) taken from Regulatory Guide 1.109, and used in the derivation of the simplified Method I approach as described in the Part B Bases Section 7.2.4 are also applied to Method II assessments. Concurrent meteorology with the release period may be utilized for the gamma atmospheric dispersion factor identified in ODCM Equation 7-14, and determined as indicated in Part B, Section 7.3.2 for the release point (either ground level or vent stack) from which recorded effluents have been discharged.

3.8 Method to Calculate the Beta Air Dose from Noble Gases

Part A Control C.7.2.1 limits the beta dose to air from noble gases at any location at or beyond the site boundary to 10 mrad in any quarter and 20 mrad in any year per unit. Dose evaluation is required at least once per 31 days.

Use Method I or Method IA first to calculate the beta air dose from gaseous effluent releases during the period. Method I applies at all dose levels.

Use Method II if a more refined calculation is needed (i.e., use of actual release point parameters with annual or actual meteorology to obtain release-specific X/Qs) or if Method I or Method IA predicts a dose greater than the Part A Control limit to determine if it had actually been exceeded. See Part B, Section 7.2.5 for basis.

3.8.1 Method I

The general form of the beta air dose equation is:

$$D_{\text{air}}^{\beta} = 3.17 \text{ E-} 02 * (X/Q)_{1\text{hr}} * t^{-a} * \sum (Q_i * DF_i^{\beta}) \quad (3-7)$$

$$(\text{mrad}) = \left(\frac{\text{pCi-yr}}{\mu\text{Ci- m}^3} \right) * \left(\frac{\text{sec}}{\text{m}^3} \right) * () * \sum \left(\mu\text{Ci} * \frac{\text{mrad- m}^3}{\text{pCi-yr}} \right)$$

where

D_{air}^{β} is the beta air dose,

3.17E-02 is the number of pCi per μCi divided by the number of seconds per year,

$(X/Q)_{1\text{hr}}$ is the 1-hour undepleted atmospheric dispersion factor,

t^{-a} is a unitless factor which adjusts the 1-hour X/Q value for a release with a total duration of t hours,

Q_i is the total activity (μCi) of each radionuclide "i" released to the atmosphere during the period of interest, and

DF_i^{β} is the beta dose factor to air for radionuclide "i" (see Table B.1-10).

Incorporating receptor location-specific atmospheric dispersion factor (X/Q), adjustment factors (t^{-a}) for elevated and ground-level effluent release conditions, and occupancy factors when applicable (see Section 7.2.7) yields a series of equations by which the Beta Air Dose can be determined.

3.8 Method to Calculate the Beta Air Dose from Noble Gases (Continued)

3.8.1 Method I (Continued)

- a. Maximum off-site receptor location, elevated release conditions:

$$D_{\text{air(e)}}^{\beta} = 4.0 \text{E-} 7 * t^{-0.302} * \sum_i (Q_i * DF_i^{\beta}) \quad (3-7a)$$

$$(\text{mrad}) = \left(\frac{\text{pCi-yr}}{\mu\text{Ci- m}^3} \right) * () \sum (\mu\text{Ci} * \frac{\text{mrad- m}^3}{\text{pCi-yr}})$$

- b. Maximum off-site receptor location, ground-level release conditions:

$$D_{\text{air(g)}}^{\beta} = 6.1 \text{E-} 06 * t^{-0.320} * \sum_i (Q_i * DF_i^{\beta}) \quad (3-7b)$$

$$(\text{mrad}) = \left(\frac{\text{pCi-yr}}{\mu\text{Ci- m}^3} \right) * () \sum (\mu\text{Ci} * \frac{\text{mrad- m}^3}{\text{pCi-yr}})$$

Equations 3-7a and 3-7b can be applied under the following conditions (otherwise justify Method I or consider Method II):

1. Normal operations (nonemergency event), and
2. Noble gas releases via station vents to the atmosphere.

Method IA is implemented by the EMS software as described in Appendix C. Gaseous release models are detailed in Section 6.7.3 of the EMS Software Requirements Specification (Attachment 3 of Appendix C).

3.8.2 Method II

Method II consists of the models, input data (dose factors) and assumptions in Regulatory Guide 1.109, Rev. 1 (Reference A), except where site-specific data or assumptions have been identified in the ODCM. The general equations (B-4 and B-5) taken from Regulatory Guide 1.109, and used in the derivation of the simplified Method I approach as described in the Part B Bases Section 7.2.5, are also applied to Method II assessments. Concurrent meteorology with the release period may be utilized for the atmospheric dispersion factor identified in ODCM Equation 7-15, and determined, as indicated in Part B, Sections 7.3.2 and 7.3.3 for the release point (either ground level or vent stack) from which recorded effluents have been discharged.

3.9 Method to Calculate the Critical Organ Dose from Iodines, Tritium and Particulates, (Including Carbon-14)

Part A Control C.7.3.1 limits the critical organ dose to a member of the public from radioactive iodines, tritium, and particulates with half-lives greater than 8 days in gaseous effluents to 7.5 mrem per quarter and 15 mrem per year per unit. In addition, Carbon-14 has been declared a principle radionuclide for Seabrook gaseous effluents and is included in the assessment of compliance with the Part A Control limit C.7.3.1. Part A Control C.7.3.1 limits the total body and organ dose to any real member of the public from all station sources (including gaseous effluents) to 25 mrem in a year except for the thyroid, which is limited to 75 mrem in a year.

Use Method I or Method IA first to calculate the critical organ dose from gaseous effluent releases as it is simpler to execute and more conservative than Method II.

Use Method II if a more refined calculation of critical organ dose is needed (i.e., Method I or Method IA indicates the dose is greater than the limit). See Part B, Section 7.2.6 for basis.

3.9.1 Method I

$$D_{co} = (X/Q)_{1hr}^{depl} / (X/Q)_{an}^{depl} * t^{-a} * \sum_i (Q_i * DFG_{ico}) \text{ plus } [6.97E-05 * tc]_{C-14} \quad (3-8)$$

$$(\text{mrem}) = \left(\frac{\text{sec}}{\text{m}^3} \right) / \left(\frac{\text{sec}}{\text{m}^3} \right) * () * \sum (\mu\text{Ci}) * \left(\frac{\text{mrem}}{\mu\text{Ci}} \right) + \left(\frac{\text{mrem}}{\text{hr}} \right) * \text{hr}$$

where

D_{co} is the critical organ dose from iodines, tritium, carbon-14 and particulates,

$(X/Q)_{1hr}^{depl}$ is the 1-hour depleted atmospheric dispersion factor.

$(X/Q)_{an}^{depl}$ is the annual average depleted atmospheric dispersion.

t^{-a} is a unitless adjustment factor to account for a release with a total duration of t hours,

Q_i is the total activity in μCi of radionuclide "i" (except C-14) released to the atmosphere during the period of interest (for strontiums, use the most recent measurement), and

DFG_{ico} is the site-specific critical organ dose factor for radionuclide "i", see Tables B.1-12, B.1-14, and B.1-15. (For each radionuclide, it is the age group and organ with the largest dose factor.)

6.97E-05 (mrem/hr) is the Carbon-14 default dose contribution to the maximum exposed member of the public based on a continuous release with an estimated annual discharge in gaseous effluent of 12.06 Curies of C-14. For a 1 month ($tc = 730$ hrs) release period, the C-14 dose contribution to the critical organ is estimated to be 5.1E-02 mrem/month.

tc is the C-14 release duration (hours) associated with the period of dose estimation being considered. Since the release of C-14 is considered to be continuous, the total tc for the year must account for 8760 hours of release regardless if any other radionuclide is detected to be present in the effluent stream.

3.9 Method to Calculate the Critical Organ Dose from Iodines, Tritium and Particulates, (Including Carbon-14) (Continued)

3.9.1 Method I (Continued)

Incorporating receptor location-specific atmospheric dispersion factors $((X/Q)_{\text{hr}}^{\text{depl}}$ and $(X/Q)_{\text{an}}^{\text{depl}}$) and adjustment factors (t^{-a}) for elevated and ground-level release conditions, and incorporating occupancy factors when applicable (see Section 7.2.7), yields a series of equations by which the critical organ dose can be determined.

- a. Maximum off-site receptor location, elevated release conditions:

$$D_{\text{co}(e)} = 15.0 * t^{-0.298} * \sum_i (Q_i * \text{DFG}_{\text{ico}(e)}) \quad \text{plus } [0.051 \text{ mrem/month}]_{\text{C-14}} \quad (3-8a)$$

$$(\text{mrem}) = () * () \sum (\mu \text{Ci} * \frac{\text{mrem}}{\mu \text{Ci}}) + (\text{mrem/mo.})$$

- b. Maximum off-site receptor location, ground-level release conditions:

$$D_{\text{co}(g)} = 17.7 * t^{-0.317} * \sum_i (Q_i * \text{DFG}_{\text{ico}(g)}) \quad (3-8b)$$

$$(\text{mrem}) = () * () \sum (\mu \text{Ci} * \frac{\text{mrem}}{\mu \text{Ci}})$$

- c. Science & Nature Center receptor; elevated release conditions:

$$D_{\text{coE}(e)} = 3.3\text{E-}02 * t^{-0.348} * \sum_i (Q_i * \text{DFG}_{\text{icoE}(e)}) \quad \text{plus } [2.58\text{E-}06 \text{ mrem/month}]_{\text{C-14}} \quad (3-8c)$$

$$(\text{mrem}) = () * () \sum (\mu \text{Ci} * \frac{\text{mrem}}{\mu \text{Ci}}) + (\text{mrem/mo.})$$

- d. Science & Nature Center receptor; ground-level release conditions:

$$D_{\text{coE}(g)} = 3.3\text{E-}02 * t^{-0.347} * \sum_i (Q_i * \text{DFG}_{\text{icoE}(g)}) \quad (3-8d)$$

$$(\text{mrem}) = () * () \sum (\mu \text{Ci} * \frac{\text{mrem}}{\mu \text{Ci}})$$

- e. Receptor at the "Firing Range"; elevated release conditions:

$$D_{\text{coFR}(e)} = 1.15 * t^{-0.366} * \sum_i (Q_i * \text{DFG}_{\text{icoFR}(e)}) \quad \text{plus } [2.60\text{E-}05 \text{ mrem/month}]_{\text{C-14}} \quad (3-8e)$$

$$(\text{mrem}) = () * () \sum (\mu \text{Ci} * \frac{\text{mrem}}{\mu \text{Ci}}) + (\text{mrem/mo.})$$

3.9 Method to Calculate the Critical Organ Dose from Iodines, Tritium and Particulates, (Including Carbon-14) (Continued)

3.9.1 Method I (Continued)

f. Receptor at the "Firing Range"; ground-level release conditions:

$$D_{coFR(g)} = 1.61 * t^{-0.403} * \sum_i (Q_i * DFG_{icoFR(g)}) \quad (3-8f)$$

$$(mrem) = () * () * \sum (\mu Ci * \frac{mrem}{\mu Ci})$$

g. Receptor at the Fitness Center; elevated release conditions:

$$D_{coFC(e)} = 1.08 * t^{-0.359} * \sum (Q_i * DFG_{icoFC(e)}) \text{ plus } [7.67E-05 \text{ mrem/month}]_{C-14} \quad (3-8g)$$

$$(mrem) = () * () * \sum (\mu Ci * \frac{(mrem)}{\mu Ci}) + \frac{(mrem)}{mo.}$$

h. Receptor at the Fitness Center; ground-level release conditions:

$$D_{coFC(g)} = 0.94 * t^{-0.344} * \sum (Q_i * DFG_{icoFC(g)}) \quad (3-8h)$$

$$(mrem) = () * () * \sum (\mu Ci * \frac{(mrem)}{\mu Ci})$$

Equations 3-8a through 3-8h can be applied under the following conditions (otherwise, justify Method I or consider Method II):

1. Normal operations (nonemergency event),
2. Iodine, tritium, and particulate releases via station vents to the atmosphere, and
3. Any continuous or batch release over any time period.

Method IA is implemented by the EMS software as described in Appendix C. Gaseous release models are detailed in Section 6.7.3 of the EMS Software Requirements Specification (Attachment 3 of Appendix C).

3.9.2 Method II

Method II consists of the models, input data and assumptions in Appendix C of Regulatory Guide 1.109, Rev. 1 (Reference A), except where site-specific data or assumptions have been identified in the ODCM (see Tables B.7-2 and B.7-3). The critical organ dose will be determined based on the location (site boundary, nearest resident, or farm) of receptor pathways, as identified in the most recent annual land use census, or by conservatively assuming the existence of all pathways (ground plane, inhalation, ingestion of stored and leafy vegetables, milk and meat) at an off-site location of maximum potential dose. Concurrent meteorology with the release period may be utilized for determination of atmospheric dispersion factors in accordance with Part B, Sections 7.3.2 and 7.3.3 for the release point (either ground level or vent stack) from which recorded effluents have been discharged. The maximum critical organ dose will consider the four age groups independently, and use a shielding factor (S_F) of 0.7 associated with residential structures.

3.10 Method to Calculate Direct Dose from Site Operations

Part A Control C.8.1.1 restricts the dose to the whole body or any organ to any member of the public from all uranium fuel cycle sources to 25 mrem in a calendar year (except the thyroid, which is limited to 75 mrem). Direct radiation from contained sources is required to be included in the assessment of compliance with this standard.

3.10.1 Method

The direct dose from the plant and Dry Fuel Storage (DFS) facilities will be determined by obtaining the dose from TLD locations situated on-site near potential sources of direct radiation, as well as those TLDs near the site boundary which are part of the plant operations and DFS environmental monitoring programs, and subtracting out the dose contribution from background. Realistic occupancy factors should be applied to the estimation of annual dose to MEMBERS OF THE PUBLIC from Seabrook site operations. Additional methods to calculate the direct dose may also be used to supplement the TLD information, such as high pressure ion chamber measurements, or analytical design calculations of direct dose from identified sources (such as solid waste storage facilities).

The dose determined from direct measurements or calculations will be related to the nearest real person off-site, as well as those individuals on-site involved in activities at either the Science and Nature Center or the Rocks boat landing, to assess the contribution of direct radiation to the total dose limits of Part A Control C.8.1.1 in conjunction with liquid and gaseous effluents.

For TLD assessments, the direct dose from plant area sources and DFS operations is determined by comparing the expected annual data for environmental TLD locations near the site boundary or public access areas to pre-operational data for the same locations.

The expected measurement for each indicator TLD location is determined as a function of the observed change in exposure rate at the control location TLD data (i.e., TLD locations more than 20 km from the site) for the current year and for the pre-operational monitoring program as follows:

$$X_e = X_p \frac{X_{mc}}{X_{pc}}$$

where:

X_e = the expected TLD measurement for a given location, independent of any direct radiation from station facilities,

X_p = the average pre-operational TLD¹ measurement response for the location of interest,

¹ For the DFS, the pre-operational period includes those DFS environmental monitoring program TLD measurements made prior to fuel assemblies being moved into the DFS facility.

3.10 Method to Calculate Direct Dose from Site Operations (Continued)

3.10.1 Method (Continued)

X_{mc} = the average TLD measurement for the control TLD locations (TL-36 through TL-38 and TL-40 through TL-42)² in the current year, and

X_{pc} = the average TLD measurement for the control TLD locations (TL-36 through TL-38 and TL-40 through TL-42) in the pre-operational period²

All doses are expressed in mR/91days. This is the length of a standard quarter which places all quarterly TLD field measurement on equivalent time intervals for comparisons.

The current year annual average measurement for each TLD location (X_o) is compared to the expected TLD measurement (X_e) by taking the difference between the current measurement value and the expected value ($X_o - X_e$). A direct dose component due to plant or DFS operations is assumed if the difference between the current annual average TLD measurement (X_o) and the calculated expected value for a TLD location (X_e) is greater than 20% (unless an evaluation can show that this difference is not plant related):

$$[(X_o - X_e)/X_e > 0.2]$$

For those measurements determined to reflect an increase due to plant or DFS operations, the net dose is estimated as the difference between the observed location value and the expected value ($X_o - X_e$).

The 20% criterion in increased dose is selected based on its similar use as a significance criterion in NUREG-1301 (Land Use Control 3/4.12.1, Action b). The 20% increase criteria is also related to the ability of the TLDs to differentiate a true positive increase above a fluctuating background in the low dose ranges associated with environmental TLD measurements (20% is in the range of the typical 3-sigma counting statistics on the TLD readouts).

² Control location TL-39 was not included since it has been moved from its original pre-operational location. Control locations can be added or removed from the assessment if their locations or nearby environments are altered from their baseline conditions.

3.11 Dose Projections

Part A Controls C.6.3.1 and C.7.4.1 require that appropriate portions of liquid and gaseous radwaste treatment systems, respectively, be used to reduce radioactive effluents when it is projected that the resulting dose(s) would exceed limits which represent small fractions of the "as low as reasonably achievable" criteria of Appendix I to 10 CFR Part 50. The surveillance requirements of these Part A Controls state that dose projections be performed at least once per 31 days when the liquid radwaste treatment systems or gaseous radwaste treatment systems are not being fully utilized.

Since dose assessments are routinely performed at least once per 31 days to account for actual releases, the projected doses shall be determined by comparing the calculated dose from the last (typical of expected operations) completed 31-day period to the appropriate dose limit for use of radwaste equipment, adjusted if appropriate for known or expected differences between past operational parameters and those anticipated for the next 31 days.

3.11.1 Liquid Dose Projections

The 31-day liquid dose projections are calculated by the following:

- a. Determine the total body D_{tb} and organ dose D_{mo} (Equations 3-1 and 3-2, respectively) for the last typical completed 31-day period. The last typical 31-day period should be one without significant identified operational differences from the period being projected to, such as full power operation vs. periods when the plant is shut down. For periods with identified operational differences, skip to subsection 3.11.1.e. below.
- b. Calculate the ratio (R_1) of the total estimated volume of batch releases expected to be released for the projected period to that actually released in the reference period.
- c. Calculate the ratio (R_2) of the estimated gross primary coolant activity for the projected period to the average value in the reference period. Use the most recent value of primary coolant activity as the projected value if no trend in decreasing or increasing levels can be determined.

- d. Determine the projected dose from:

$$\text{Total Body: } D_{tb\ pr} = D_{tb} \cdot R_1 \cdot R_2$$

$$\text{Max. Organ: } D_{mo\ pr} = D_{mo} \cdot R_1 \cdot R_2$$

- e. During periods when significant operational differences are identified, such as shutdowns vs. normal power operations, or when specific treatment components are expected to be bypassed or out of service for repair or maintenance, the projected dose should be based on an assessment of the expected amount of radioactivity that could be discharged, both through treated and any untreated pathways, over the next 31 days. Specific consideration should be given to effluent streams and treatment systems noted on Figure B.6-1. The volume of liquid to be released, the current or projected maximum radioactivity concentration in the effluent streams either prior to treatment or at the point of release to the environment, and the duration of expected release evaluations should be estimated as part of the projection of offsite dose.

For these periods outside the bounds of steps 3.11.1.a. when significant operational differences exist from the last reference period, the projected dose to the total body D_{tb} and organ dose D_{mo} shall use Equations 3-1 and 3-2, respectively to project dose for each definable time segment of release evolution and summed over the next 31 days. The radioactive release quantity, Q_i , in equations 3-1 and 3-2 represents the estimated quantity of radionuclide "i" estimated to be released over the next 31 days, or during short time periods for defined plant operational evaluations, based on expected volumes, concentrations and treatment options to be applied.

The EMS software can also be used to perform monthly projected dose calculations as described in Appendix C. The methodology applied by EMS in projecting liquid doses is outlined in Section 2.7 of Attachment 4 to Appendix C (EMS Technical Reference Manual).

3.11.2 Gaseous Dose Projections

1. For the gaseous radwaste treatment system, the 31-day dose projections are calculated by the following:
 - a. Determine the gamma air dose D_{air}^{γ} (Equation 3-6a), and the beta air dose D_{air}^{β} (Equation 3-7a) from the last typical 31-day operating period. The last typical 31-day period should be one without significant identified operational differences from the period being projected to, such as full power steady state operation vs. periods when the plant is shutdown. For periods with identified operational differences, skip to subsection 3.11.2.2.e. below.
 - b. Calculate the ratio (R3) of anticipated number of curies of noble gas to be released from the hydrogen surge tank to the atmosphere over the next 31 days to the number of curies released in the reference period on which the gamma and beta air doses are based. If no differences between the reference period and the next 31 days can be identified, set R3 to 1.

- c. Determine the projected dose from:

Gamma Air:
$$D_{air\ pr}^{\gamma} = D_{air}^{\gamma} \cdot R_3$$

Beta Air:
$$D_{air\ pr}^{\beta} = D_{air}^{\beta} \cdot R_3$$

2. For the ventilation exhaust treatment system, the critical organ dose from iodines, tritium, carbon-14 and particulates are projected for the next 31 days by the following:
 - a. Determine the critical organ dose D_{co} (Equation 3-8a) from the last typical 31-day operating period. (If the limit of Part A Control C.7.4.1.c (i.e., 0.3 mrem in 31 days) is exceeded, the projected controlled area annual total effective dose equivalent from all station sources should be assessed to assure that the 10 CFR 20.1301 dose limits to members of the public are not exceeded.)* . The last typical 31-day period should be one without significant identified operational differences from the period being projected to, such as full power steady state operation vs. periods when the plant is shutdown. For periods with identified operational differences, skip to subsection 3.11.2.2.e. below.

- b. Calculate the ratio (R_4) of anticipated primary coolant dose equivalent I-131 for the next 31 days to the average dose equivalent I-131 level during the reference period. Use the most current determination of DE I-131 as the projected value if no trend can be determined.
- c. Calculate the ratio (R_5) of anticipated primary system leakage rate to the average leakage rate during the reference period. Use the current value of the system leakage as an estimate of the anticipated rate for the next 31 days if no trend can be determined.
- d. Determine the projected dose from:

$$\text{Critical Organ: } D_{\text{co pr}} = [D_{\text{co}} - 5.09\text{E-}02] * (R_4) * (R_5) + 5.09\text{E-}02$$

Note: The value of 5.09E-02 (mrem) reflects the default CRITICAL ORGAN DOSE to the maximum exposed individual from Carbon-14 releases averaged over a 31-day (monthly) period. The value is based on the estimated annual Carbon-14 releases from the Station of 12.06 Curies (per HPSTID 11-004 which applies the methodology outlined in Reference G) and conservative atmospheric dispersion during the growing season to the limiting off-site receptor. For dose projection periods (continuous) other than monthly, the Carbon-14 dose contribution should be ratioed based on time duration in order to obtain a corrected default value.

- e. During periods when significant operational differences are identified, such as shutdowns vs. normal power operations, or when specific treatment components are expected to be bypassed or out of service for repair or maintenance, the projected dose should be based on an assessment of the expected amount of radioactivity that could be discharged, both through treated and any untreated pathways, over the next 31 days. Specific consideration should be given to effluent streams and treatment systems noted on Figure B.6-2. The volume or flow rate of gas to be released, the current or projected maximum radioactivity concentration in the effluent streams either prior to treatment or at the point of release to the environment, and the duration of expected release evaluations should be estimated as part of the projection of offsite dose.

For these periods outside the bounds of steps 3.11.2.1.a or 3.11.2.2.a. when significant operational differences exist from the last reference period, the projected air dose from gamma and beta emissions from noble gases (Equations 3-6 and Equations 3-7, respectively), or from iodines, tritium, carbon-14 and particulates (Equations 3-8) shall use the referenced equations to project dose for each definable time segment of release evolution and summed over the next 31 days. The radioactive release quantity, Q_i in the dose equations represents the estimated quantity of radionuclide "i" estimated to be released over the next 31 days, or during short time periods for defined plant operational evaluations, based on expected volumes, concentrations and treatment options to be applied.

3. Alternate Projection Method for Use with Containment Ventilation Exhaust Treatment System (Charcoal Filters)

During periods when the Containment Building air needs to be vented to the atmosphere, the decision to use the Containment charcoal filter train to exhaust Containment air can be based on dose conversion factors and critical organ dose equation that reflect only those real exposure pathways in the offsite environment as indicated by the annual Land Use Census. This reduces the excess conservatism associated with the standard Method I assumptions that all typical (potential) exposure pathways (including milk) may exist at the most limiting atmospheric dispersion point off site.

In place of the dose conversion factors found in Table B.1-12, and critical organ dose equation 3-8a for Dco, Chemistry Department technical evaluation CHSTID 02-004 contains the dose conversion factors (DFG) and critical organ dose equation which were developed in the same manner as the current Method I factors and time dependent dose equation, but which utilize the most recent Land Use Census data to define which exposure pathways and identified receptor locations exist. CHSTID 02-004 documents the development of this alternate dose projection method. After the Land Use Census is performed each year, and before application to any Containment venting evolution, CHSTID 02-004 will be reviewed to see if any new receptor location impacts the selection of controlling dose location.

The EMS software can also be used to perform monthly projected dose calculations as described in Appendix C. The methodology applied by EMS in projecting gaseous dose is outlined in Section 3.8 of Attachment 4 to Appendix C (EMS Technical Reference Manual).

*Note: This action is based on the assumption that tritium is the controlling nuclide for whole body exposures through the inhalation pathway. Maximum annual average on-site X/Q's for station effluent release points are approximately 100 times the values used for the site boundary dose calculations. However, the site boundary doses calculated by the ODCM for iodine, tritium, carbon-14 and particulates with half-lives greater than 8 days includes all potential off-site exposure pathways. For tritium, the inhalation pathway only accounts for about 5% of the total dose contribution being calculated. As a result, if the monthly calculation indicates that the site boundary maximum organ dose reached 0.3 mrem, the on-site maximum dose due to inhalation would be approximately 6 mrem for this period. If this were projected to continue for a year with a 2000 hour occupancy factor applied, the projected inhalation whole body dose would be approximately 16 mrem, or 16% of the 10 CFR 20.1301 limit. This is a reasonable trigger value for the need to consider the dose contribution from all station sources to members of the public in controlled areas.

3.12 Method to Calculate Total Dose From Plant Operations

ODCM Control C.8.1.1 restricts the annual dose to the whole body or any organ of a member of the public from all uranium fuel cycle sources (including direct radiation) to 25 mrem (except the thyroid, which is limited to 75 mrem). These cumulative dose contribution limits from liquids and gaseous effluents, and direct radiation, implement the Environmental Protection Agency (EPA) 40 CFR 190, "Environmental Standards for the Uranium Fuel Cycle."

3.12.1 Method

Compliance with the Seabrook Station Effluent Controls dose objectives for the maximum individual, as calculated by the methods described in sections B.3.2, B.3.3, B.3.7, B.3.8, B.3.9 of the ODCM also demonstrates compliance with the EPA limits to any member of the public. This indirect determination of compliance is based on the fact that the Effluent Control liquid and gaseous dose objectives are taken from 10 CFR 50, Appendix I, and represent lower values than the 40 CFR 190 dose limits. Direct radiation dose from contained sources is not expected to be a significant contributor to the total dose to areas beyond the site boundary. If the operational dose objectives in the Seabrook ODCM Effluent Controls C.6.2.1.a, C.6.2.1.b, C.7.2.1.a, C.7.2.1.b, C.7.3.1.a, or C.7.3.1.b are determined to be exceeded by a factor of two, a Special Report must be prepared. The purpose of this Special Report is to determine by direct assessment if the cumulative dose (calendar year) to any member of the public (real individual) from all sources is within the limits of the Total Dose Control C.8.1.1.

In addition, section A.10.2, "Annual Radioactive Effluent Release Report," requires that an assessment of radiation doses to the likely most exposed member of the public from all effluent and direct radiation sources be included for the previous calendar year to show compliance with 40 CFR 190 [equivalent limits to 10 CFR 72.104(a) when considering Dry Fuel Storage].

When required, the total dose to a member of the public will be calculated for all significant effluent release points for all real pathways, including direct radiation. Only effluent releases from Seabrook Station, including direct radiation from the Dry Fuel Storage facility, need be considered since no other uranium fuel cycle facilities exist within five miles. EPA has determined that for fuel cycle facilities separated by more than five miles, their contribution to each other's total dose would not be significant and cause dose Standard for the Uranium Fuel Cycle to be exceeded. The calculations will be based on the liquid and gaseous Methods II dose models as described in Section B.3, including usage factors and other documented site-specific parameters reflecting realistic assumptions, where appropriate. The liquid and gaseous effluent Method II models are derived from the methods given in Regulatory Guide 1.109, Rev. 1, October 1977.

The direct radiation component from the plant and the Dry Fuel Storage facility can be determined using environmental TLD results as noted in Section B.3.10.1 (or alternately, high pressure ion chamber measurements or analytical design calculations for estimating the direct radiation dose from identified contained radioactive sources within the facility).

4.0 RADIOLOGICAL ENVIRONMENTAL MONITORING PROGRAM (REMP)

The Radiological Environmental Monitoring Program consist of two interconnected sample collection and measurement schedules that look for environmental influences from: (1) plant operations which release to the environment radioactive materials in liquid and gaseous effluents, and direct radiation from plant facilities inside the power block Protected Area, and (2) direct radiation from used fuel placed in the Dry Fuel Storage (DFS) facility located in the West Southwest sector approximately 0.38 miles from the Containment Building. Several monitoring locations provide data that are shared or used in the assessment of both plant and DFS operations

4.1 Plant Operations REMP

The plant operations related radiological environmental monitoring stations are listed in Table B.4-1. The locations of the stations with respect to the Seabrook Station are shown on the maps in Figures B.4-1 to B.4-6.

All radiological analyses for environmental samples are performed at a contractor laboratory. The contractor laboratory participates in an Interlaboratory Comparison Program for all relevant species in an aqueous (water) matrix. An independent vendor (Analytics) supplies the remaining cross check samples. These samples are presented on an air filter and in milk and water matrices.

Pursuant to Part A Surveillance S.9.2.1, the Land Use Census will be conducted "during the growing season" at least once per 12 months. The growing season is defined, for the purposes of the Land Use Census, as the period from June 1 to October 1. The method to be used for conducting the census will consist of one or more of the following, as appropriate: door-to-door survey, visual inspection from roadside, aerial survey, or consulting with local agricultural authorities.

Technical Specification 6.8.1.3 and Part A, Section 10.1 of the ODCM require that the results of the Radiological Environmental Monitoring Program be summarized in the Annual Radiological Environmental Operating Report "in the format of the table in the Radiological Assessment Branch Technical Position, Revision 1, 1979." The general table format will be used with one exception and one clarification, as follows. The mean and range values will be based not upon detectable measurements only, as specified in the NRC Branch Technical Position, but upon all measurements. This will prevent the positive bias associated with the calculation of the mean and range based upon detectable measurements only. Secondly, the Lower Limit of Detection column will specify the LLD required by ODCM Table A.9.1-2 for that radionuclide and sample medium.

4.2 Dry Fuel Storage Facility Monitoring Program

The DFS radiological environmental monitoring stations are listed in Table B.4-2. The measurement locations with respect to the Seabrook site area are shown on Figures B.4-4 and B.4-7.

The results of the Dry Fuel Storage environmental monitoring are summarized and reported in the Annual Radiological Environmental Operating Report.

TABLE B.4-1
RADIOLOGICAL ENVIRONMENTAL MONITORING STATIONS^(a)

<u>Exposure Pathway and/or Sample</u>	<u>Sample Location and Designated Code</u>	<u>Approx. Distance From Unit 1 Containment (km)</u>	<u>Direction From the Plant</u>	
1. AIRBORNE (Particulate and Radioiodine)				
	AP/CF-01	PSNH Barge Landing Area	2.6	ESE
	AP/CF-02	Harbor Road	2.5	E
	AP/CF-03	SW Boundary	1.0	SW
	AP/CF-04	W. Boundary	1.2	W
	AP/CF-05	Winnacunnet H.S. ^(b)	4.0	NNE
	AP/CF-07	(PSNH Substation)	5.7	NNW
	AP/CF-08	E&H Substation ^(b)	3.4	SSE
	AP/CF-09	Georgetown Electric Light (Control)	21.4	SSW
2. WATERBORNE				
a. Surface	WS-01	Hampton-Discharge Area	5.1	E
	WS-51	Ipswich Bay (Control)	26.2	SSE
b. Sediment	SE-02	Hampton-Discharge Area ^(b)	5.2	E
	SE-07	Hampton Beach ^(b)	3.3	E
	SE-08	Seabrook Beach	3.3	ESE
	SE-52	Ipswich Bay (Control) ^(b)	26.2	SSE
	SE-57	Plum Island Beach (Control) ^(b)	22.4	SSE
3. INGESTION				
a. Milk	TM-15	Hampton Falls, NH ^(d)	6.9	NW
b. Fish and Invertebrates ^(c)				
	FH-03	Hampton - Discharge Area	5.0	ESE
	FH-53	Ipswich Bay (Control)	23.3	SSE
	HA-04	Hampton - Discharge Area	5.1	E
	HA-54	Ipswich Bay (Control)	27.9	SSE
	MU-06	Hampton - Discharge Area	5.2	E
	MU-09	Hampton Harbor ^(b)	2.5	E
	MU-56	Ipswich Bay (Control)	28.6	SSE
	MU-59	Plum Island ^(b)	22.0	SSE

TABLE B.4-1
RADIOLOGICAL ENVIRONMENTAL MONITORING STATIONS^(a)
(Continued)

<u>Exposure Pathway and/or Sample</u>	<u>Sample Location and Designated Code</u>	<u>Approx. Distance From Unit 1 Containment (km)</u>	<u>Direction From the Plant</u>	
c. Food Products				
	TG-08	Site Boundary	1.05	W
	TG-09	Site Boundary	.97	SW
	TG-10	Georgetown Light	21.4	SSW
4. DIRECT RADIATION				
	TL-1	Brimmer's Lane, Hampton Falls	.97	N
	TL-2	Landing Rd., Hampton	3.0	NNE
	TL-3	Glade Path, Hampton Beach	2.9	NE
	TL-4	Island Path, Hampton Beach	2.3	ENE
	TL-5	Harbor Rd., Hampton Beach	2.5	E
	TL-6	PSNH Barge Landing Area	2.7	ESE
	TL-7	Cross Rd., Seabrook Beach	2.6	SE
	TL-8	Farm Lane, Seabrook	1.3	SSE
	TL-9	Farm Lane, Seabrook	1.3	S
	TL-10	Site Boundary Fence ^(e)	1.1	SSW
	TL-11	Site Boundary Fence ^(e)	1.0	SW
	TL-12	Site Boundary Fence ^(e)	1.2	WSW
	TL-13	Inside Site Boundary ^(e)	1.2	W
	TL-14	Trailer Park, Seabrook ^(e)	1.3	WNW
	TL-15	Brimmer's Lane, Hampton Falls	1.4	NW
	TL-16	Brimmer's Lane, Hampton Falls	1.2	NNW
	TL-17	South Rd., N. Hampton	7.8	N
	TL-18	Mill Rd., N. Hampton	7.6	NNE
	TL-19	Appledore Ave., N. Hampton	7.7	NE
	TL-20	Ashworth Ave., Hampton Beach	3.2	ENE
	TL-21	Route 1A, Seabrook Beach	3.7	SE
	TL-22	Cable Ave., Salisbury Beach	7.6	SSE

TABLE B.4-1
RADIOLOGICAL ENVIRONMENTAL MONITORING STATIONS^(a)
(Continued)

<u>Exposure Pathway and/or Sample</u>	<u>Sample Location and Designated Code</u>	<u>Approx. Distance From Unit 1 Containment (km)</u>	<u>Direction From the Plant</u>
	TL-23 Ferry Rd., Salisbury	8.1	S
	TL-24 Ferry Lots Lane, Salisbury	7.2	SSW
	TL-25 Elm St., Amesbury	7.6	SW
	TL-26 Route 107A, Amesbury	8.1	WSW
	TL-27 Highland St., S. Hampton	7.5	W
	TL-28 Route 150, Kensington	7.5	WNW
	TL-29 Frying Pan Lane, Hampton Falls	7.2	NW
	TL-30 Route 27, Hampton	7.6	NNW
	TL-31 Alumni Drive, Hampton	3.8	NNE
	TL-32 Seabrook Elementary School	2.0	S
	TL-33 Dock Area, Newburyport	9.8	S
	TL-34 Bow St., Exeter	12.0	NW
	TL-35 Lincoln Ackerman School	2.3	NNW
	TL-36 Route 97, Georgetown (Control) ^(e)	22.6	SSW
	TL-37 Plaistow, NH (Control) ^(e)	21.5	WSW
	TL-38 Hampstead, NH (Control) ^(e)	27.7	W
	TL-39 Fremont, NH (Control) ^(e)	27.0	WNW
	TL-40 Newmarket, NH (Control) ^(e)	21.6	NNW
	TL-41 Portsmouth, NH, (Control) ^{(b)(e)}	21.0	NNE
	TL-42 Ipswich, MA (Control) ^{(b)(e)}	22.8	SSE

TABLE B.4-1
RADIOLOGICAL ENVIRONMENTAL MONITORING STATIONS^(a)
(Continued)

- (a) Sample locations are shown on Figures B.4-1 to B.4-6.
- (b) This sample location is not required by monitoring program defined in Part A of ODCM; program requirements specified in Part A do not apply to samples taken at this location.
- (c) Samples will be collected pursuant to ODCM Table A.9.1-1. Samples are not required from all stations listed during any sampling interval (FH = Fish; HA = Lobsters; MU = Mussels). Table A.9.1-1 specifies that "one sample of three commercially and recreationally important species" be collected in the vicinity of the plant discharge area, with similar species being collected at a control location. (This wording is consistent with the NRC Final Environmental Statement for Seabrook Station.) Since the discharge area is off-shore, there is a great number of fish species that could be considered commercially or recreationally important. Some are migratory (such as striped bass), making them less desirable as an indicator of plant-related radioactivity. Some pelagic species (such as herring and mackerel) tend to school and wander throughout a large area, sometimes making catches of significant size difficult to obtain. Since the collection of all species would be difficult or impossible, and would provide unnecessary redundancy in terms of monitoring important pathways to man, three fish and invertebrate species have been specified as a minimum requirement. Samples may include marine fauna such as lobsters, clams, mussels, and bottom-dwelling fish, such as flounder or hake. Several similar species may be grouped together into one sample if sufficient sample mass for a single species is not available after a reasonable effort has been made (e.g., yellowtail flounder and winter flounder)
- (d) Monitoring program defined in Part A of ODCM does not require this sample location; food product sampling is being implemented in lieu of an insufficient number of milk locations.
- (e) Indicates locations shared with DFS monitoring.

TABLE B.4-2

DRY FUEL STORAGE RADIOLOGICAL ENVIRONMENTAL MONITORING STATIONS

<u>Exposure Pathway</u>	<u>Sample Location and Designated Code</u>	<u>Approx. Distance From DFS Pad (km)</u>	<u>Direction From DFS Pad</u>
DIRECT RADIATION			
	TL-44 On-site, outside Science & Nature Center ⁽¹⁾	0.21	ESE
	SB-36 On-site, inside Science & Nature Center	0.24	SE
	SB-32 Hi-Rise Office Building, 3 rd floor	0.23	E
	SB-33 Hi-Rise Office Building, 1 st floor (Fitness Center)	0.23	E
	TL-68 Nearby site boundary (dump) to DFS	0.45	W
	TL-69 Nearby site boundary (Rocks Rd) to DFS	0.47	W
	TL-10 Site Boundary Fence ⁽²⁾	0.77	S
	TL-11 Site Boundary Fence ⁽²⁾	0.52	SSW
	TL-12 Site Boundary fence ⁽²⁾	0.53	WSW
	TL-13 Inside Site Boundary ⁽²⁾	0.61	WNW
	TL-14 Trailer Park, Seabrook ⁽²⁾	0.94	NW
	TL-36 Rt 97, Georgetown (Control) ⁽²⁾	22	SSW
	TL-37 Plaistow, NH (Control) ⁽²⁾	21	WSW
	TL-38 Hampstead, NH (Control) ⁽²⁾	27	W
	TL-39 Fremont, NH (Control) ⁽²⁾	27	WNW
	TL-40 Newmarket, NH (Control) ⁽²⁾	22	NNW
	TL-41 Portsmouth, NH (Control) ⁽¹⁾⁽²⁾	22	NNE
	TL-42 Ipswich, MA (Control) ⁽¹⁾⁽²⁾	22	SSE

(1) This location is not part of the required DFS radiological monitoring program defined in Table A.9.4-1 of the ODCM.

(2) Shared environmental monitoring locations for both plant REMP (see Table B.4-1) and DFS monitoring.

FIGURE B.4-1
RADIOLOGICAL ENVIRONMENTAL MONITORING LOCATIONS
WITHIN 4 KILOMETERS OF SEABROOK STATION

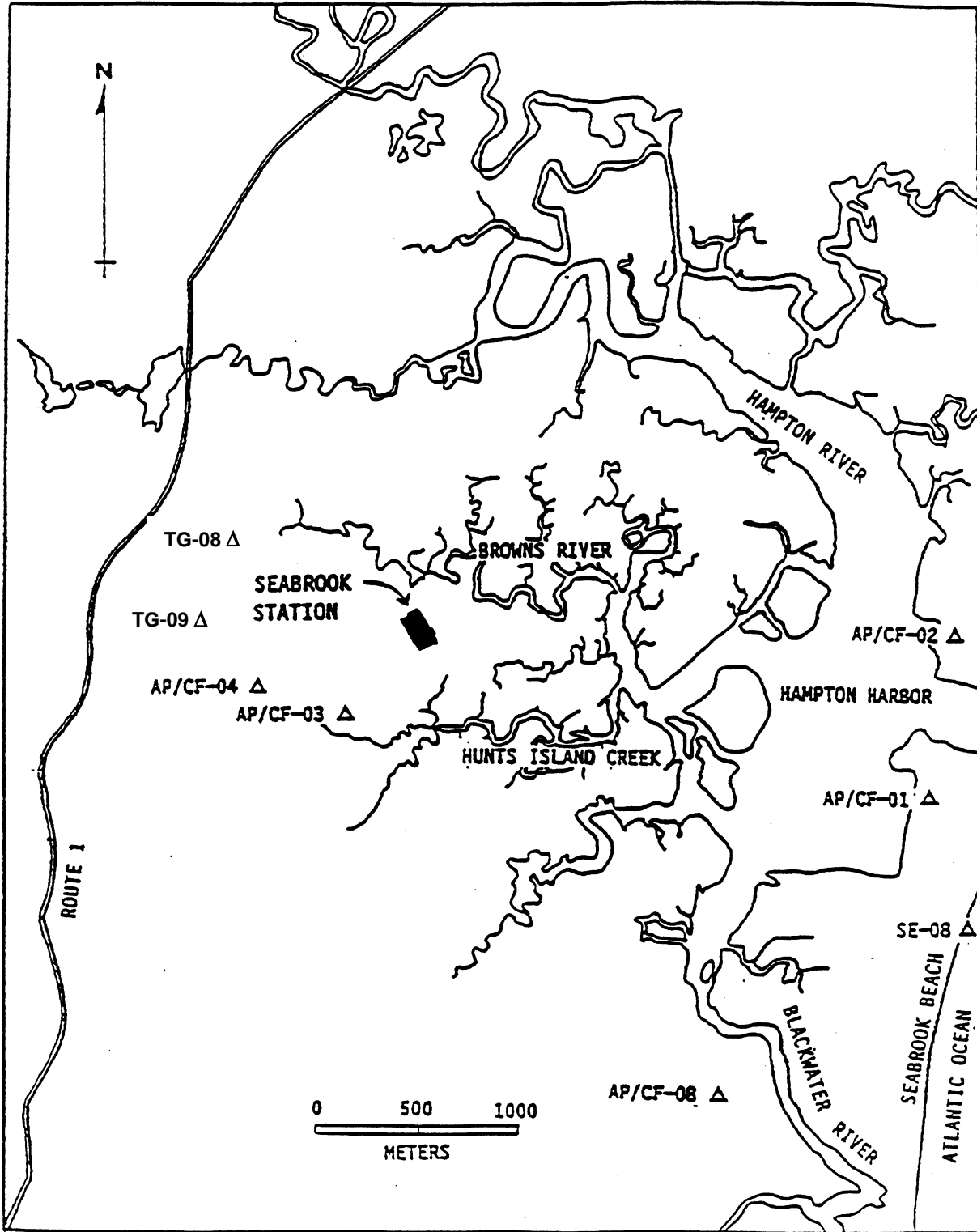

FIGURE B.4-2
RADIOLOGICAL ENVIRONMENTAL MONITORING LOCATIONS
BETWEEN 4 KILOMETERS AND 12 KILOMETERS FROM SEABROOK STATION

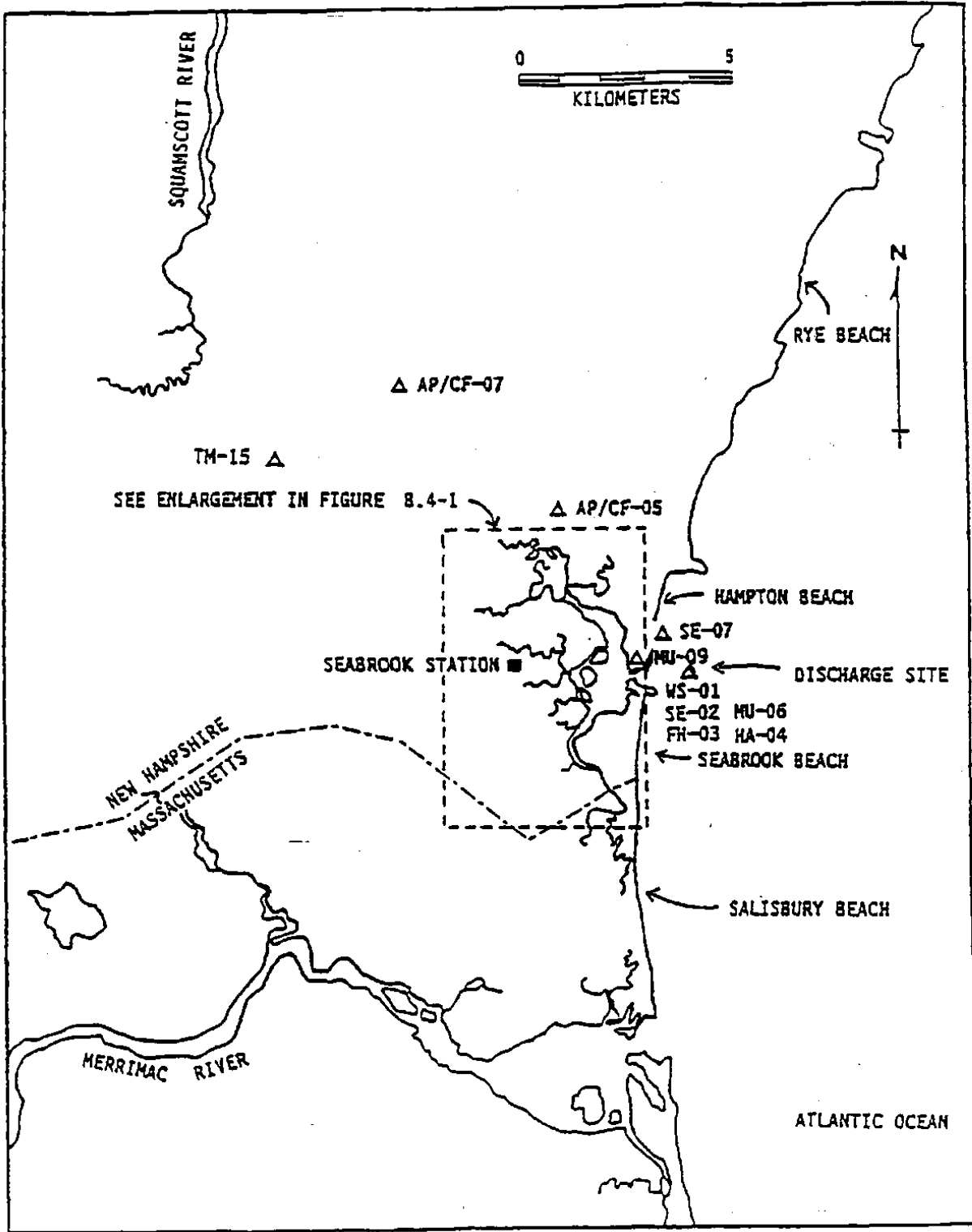

FIGURE B.4-3
RADIOLOGICAL ENVIRONMENTAL MONITORING LOCATIONS
OUTSIDE 12 KILOMETERS OF SEABROOK STATION

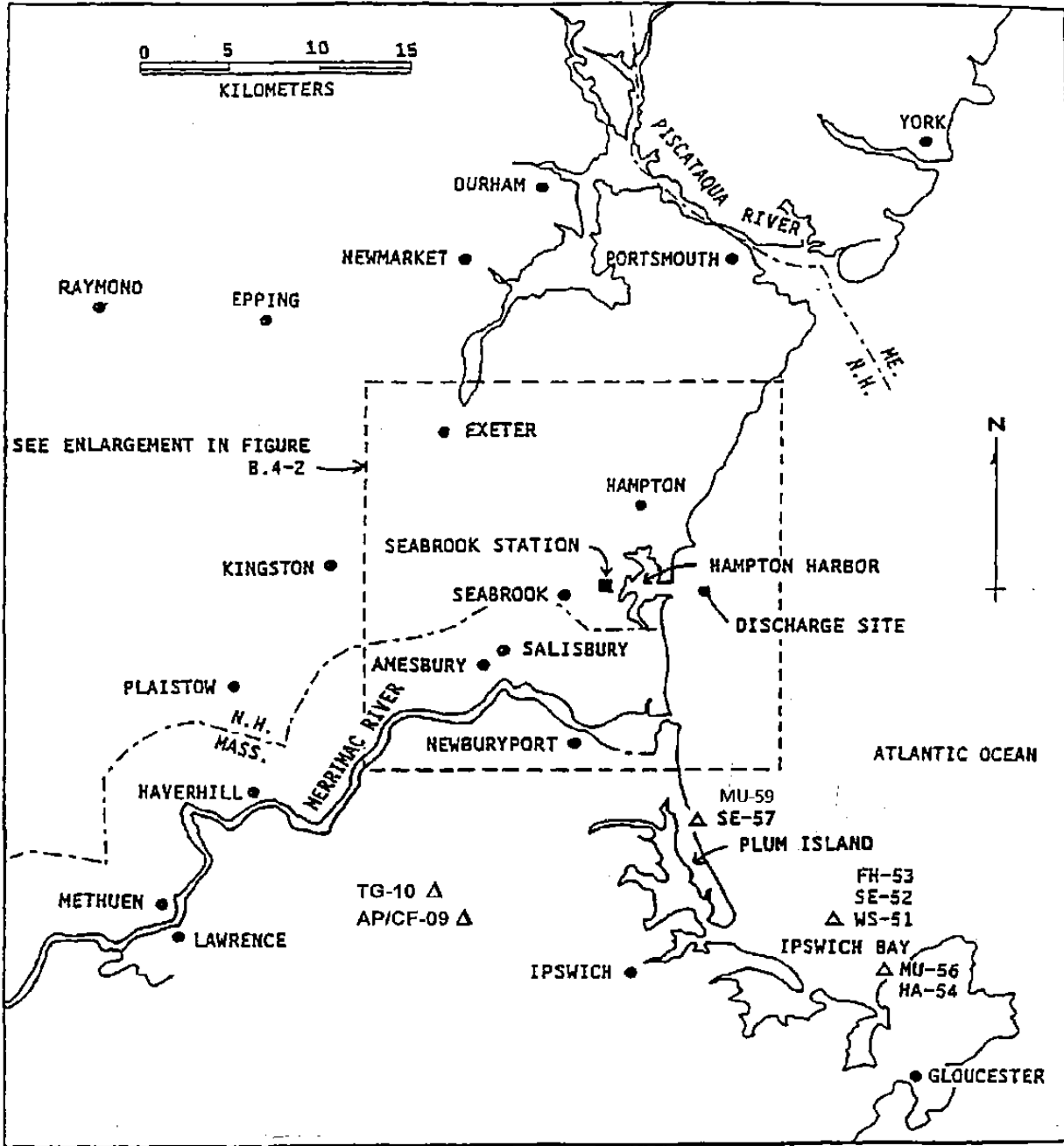

FIGURE B.4-4
DIRECT RADIATION MONITORING LOCATIONS WITHIN
4 KILOMETERS OF SEABROOK STATION

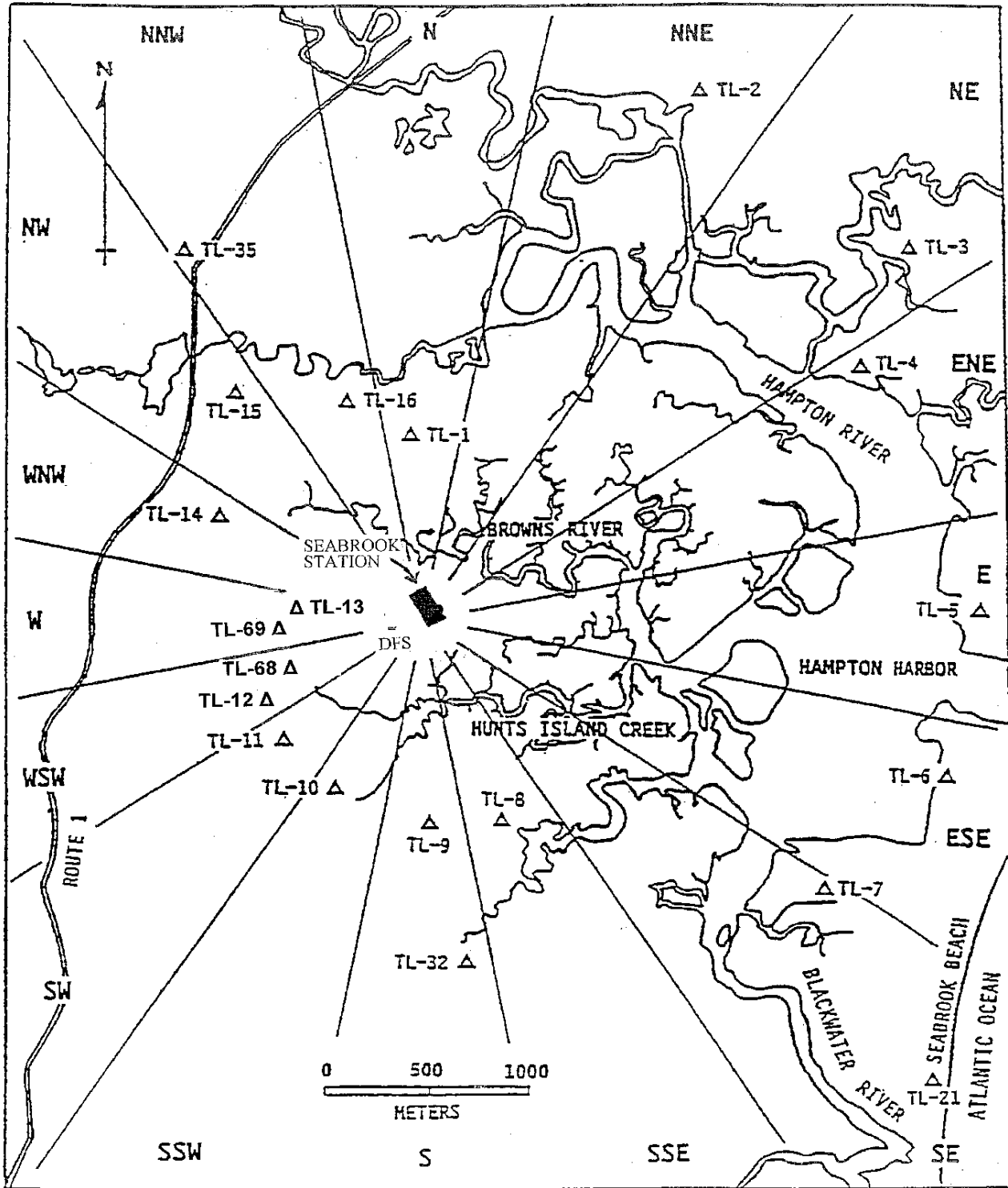

FIGURE B.4-5
DIRECT RADIATION MONITORING LOCATIONS BETWEEN
4 KILOMETERS AND 12 KILOMETERS FROM SEABROOK STATION

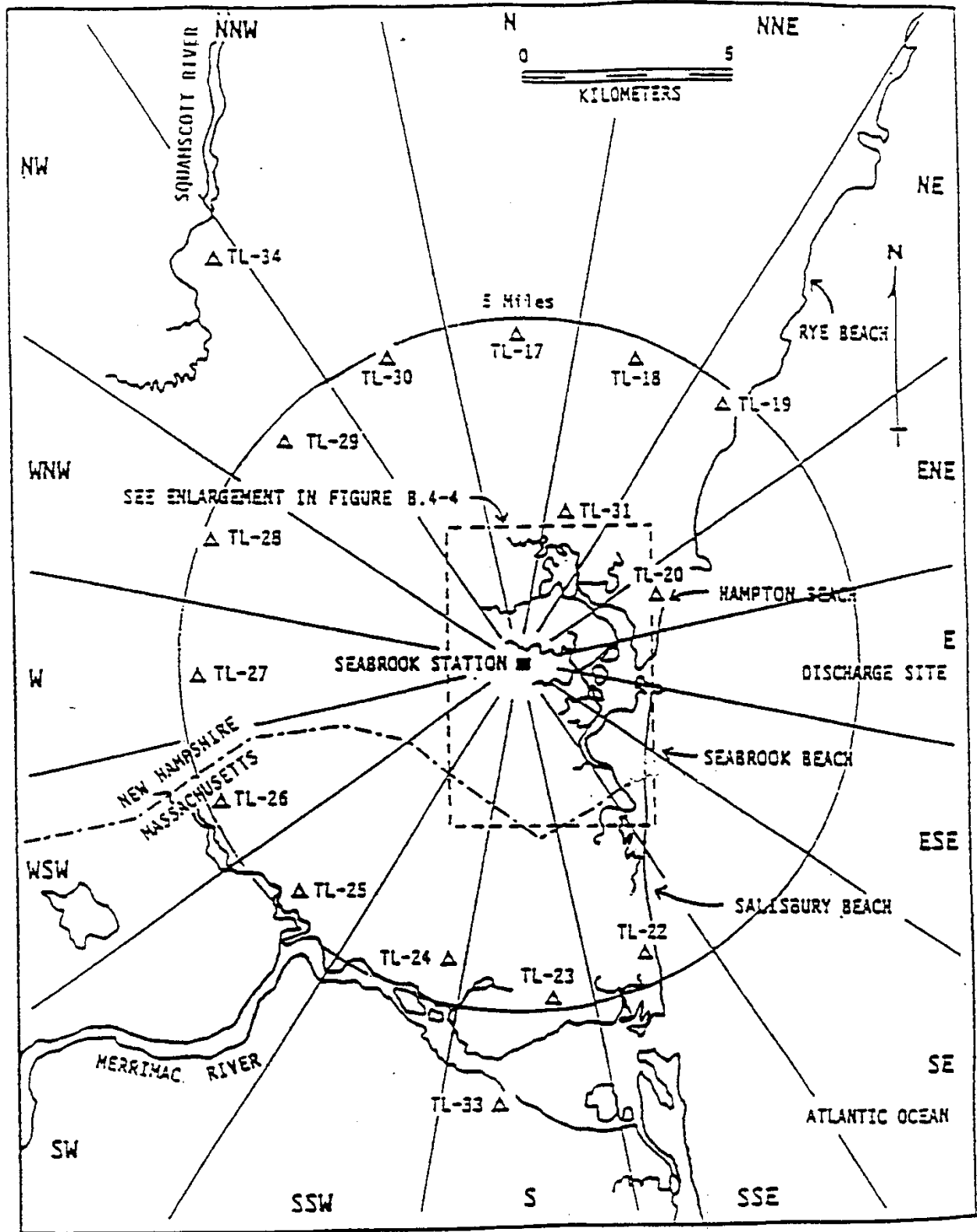

FIGURE B.4-6
DIRECT RADIATION MONITORING LOCATIONS OUTSIDE
12 KILOMETERS OF SEABROOK STATION

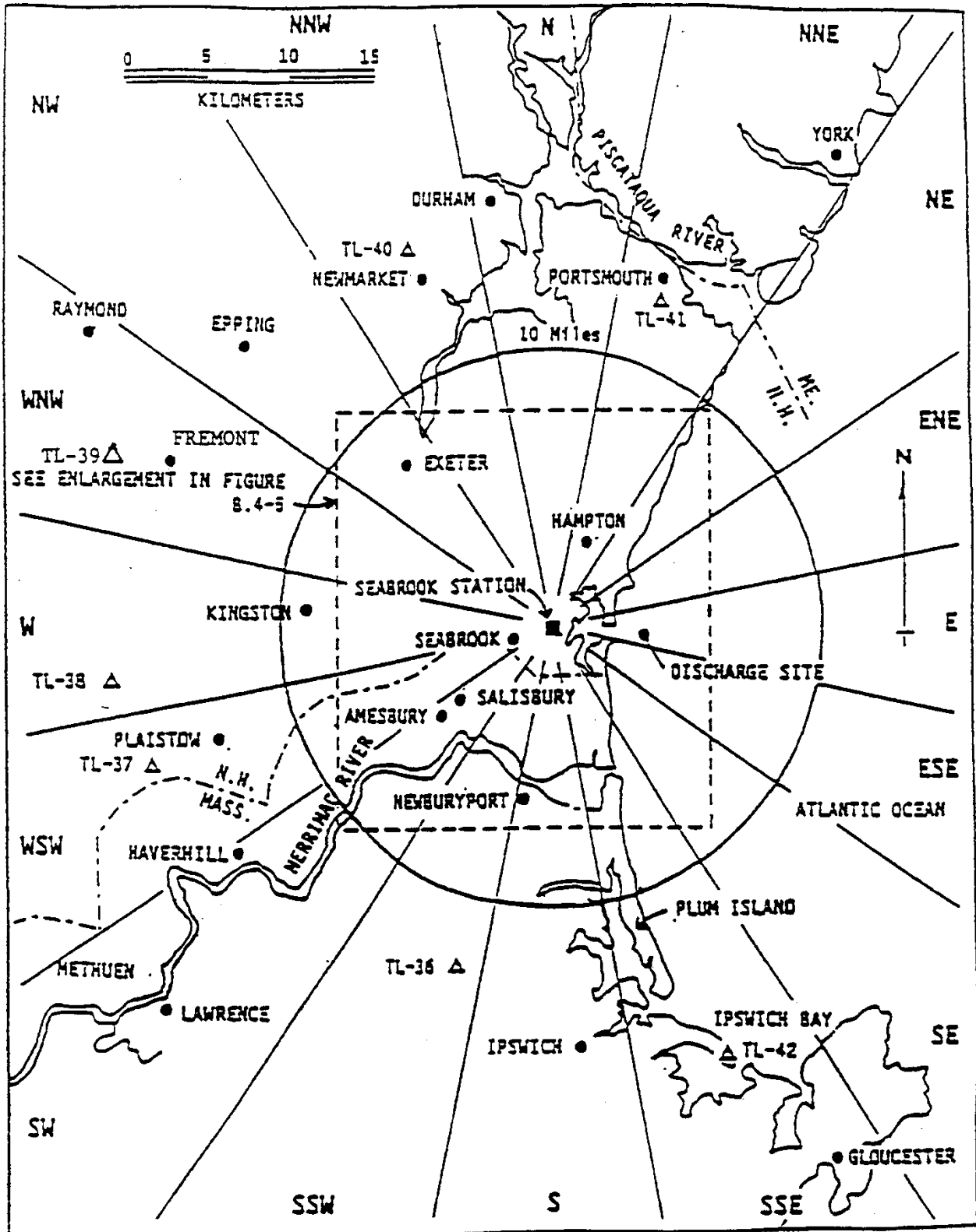
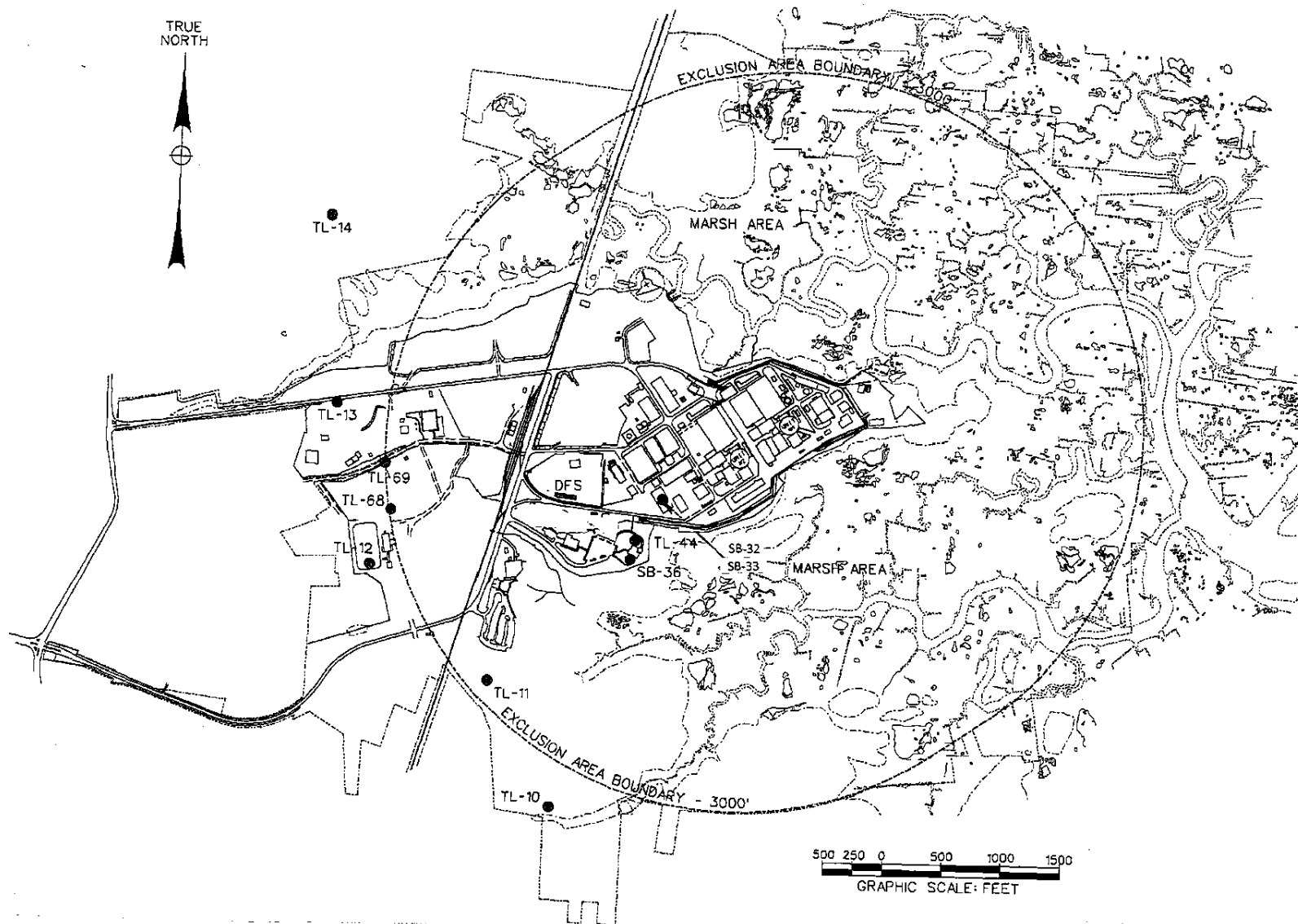

FIGURE B.4-7
DRY FUEL STORAGE RADIOLOGICAL ENVIRONMENTAL MONITORING STATIONS



5.0 SETPOINT DETERMINATIONS

Chapter 5 contains the methodology for the calculation of effluent monitor setpoints to implement the requirements of the radioactive effluent monitoring systems Part A Controls C.5.1 and C.5.2 for liquids gases, respectively.

Example setpoint calculations are provided for each of the required effluent monitors.

5.1 Liquid Effluent Instrumentation Setpoints

Part A Control C.5.1 requires that the radioactive liquid effluent instrumentation in Table A.5.1-1 of Part A have alarm setpoints in order to ensure that Part A Control C.6.1.1 is not exceeded. Part A Control C.6.1.1 limits the activity concentration in liquid effluents to ten times the ECL values in 10 CFR 20, Appendix B, Table 2, and a total noble gas MPC.

5.1.1 Liquid Waste Test Tank Monitor (RM-6509)

The liquid waste test tank effluent monitor provides alarm and automatic termination of release prior to exceeding ten times the concentration limits specified in 10 CFR 20, Appendix B, Table 2, Column 2 to the environment. It is also used to monitor discharges from various waste sumps to the environment.

5.1.1.1 Method to Determine the Setpoint of the Liquid Waste Test Tank Monitor (RM-6509)

The alarm setpoint is based on ensuring that radioactive effluents in liquid waste are in compliance with Control limits which are based on the concentration limits in Appendix B to 10 CFR 20. The alarm point depends on available dilution flow through the discharge tunnel, radwaste discharge flow rate from the test tanks, the isotopic composition of the liquid waste, and the monitor response efficiency and background count rate applicable at the time of the discharge. The alarm/trip setpoint is determined prior to each batch release taking into account current values for each variable parameter. The following steps are used in determining the monitor setpoint:

First, the minimum required dilution factor is determined by evaluating the isotopic analysis of each test tank to be released along with ECL requirements for each radionuclide. The most recent analysis data for tritium and other beta emitters that are analyzed only monthly or quarterly on composite samples can be used as an estimate of activity concentration in the tank to be released. For noble gases, the Control limit (C.6.1.1) is defined as 2E-04 $\mu\text{Ci/ml}$ total for all dissolved and entrained gases. Therefore,

$$DF_{\min} = \sum \frac{C_i}{10ECL_i} \quad \text{or} \quad \sum \frac{C_{\text{NG}}}{2E-04}, \text{ whichever is larger.} \quad (5-3)$$

Where:

DF_{\min} = Minimum required dilution factor necessary to ensure that the sum of the ratios for each nuclide concentration divided by its ECL value is not greater than 10 (dimensionless).

- C_i = Activity concentration of each radionuclide "i" (except noble gases) determined to be in the test tank ($\mu\text{Ci/ml}$). This includes tritium and other non gamma emitting isotopes either measured or estimated from the most recent composite analysis.
- C_{ng} = The sum of all dissolved and entrained noble gases identified in each test tank ($\mu\text{Ci/ml}$).
- ECL_i = Effluent concentration limit (ECL) for radionuclide "i" (except for dissolved and entrained noble gas) in $\mu\text{Ci/ml}$ as specified in 10 CFR 20, Appendix B, Table 2.
- See ODCM, Appendix B, for a listing. In the event that no activity is expected to be discharged, or can be measured in the system, the liquid monitor setpoint should be based on the most restrictive ECL for an "unidentified" mixture or a mixture known not to contain certain radionuclides as given in 10 CFR 20, Appendix B, notes.
- 2E-04 = The total dissolved and entrained noble gas Technical Specification concentration limit in liquid effluents from the plant ($\mu\text{Ci/ml}$).

Next, the available dilution flow through the discharge tunnel (F_d), or a conservative estimate for it, is divided by the minimum dilution factor (DF_{min}) to determine the maximum allowable discharge flow rate (F_{max}) that the test tanks could be released at without exceeding the ECL limits, assuming no additional radioactive flow paths are discharging at the time of release of the test tanks. Therefore,

$$F_{max} = \frac{F_d}{DF_{min}}$$

Where:

- F_{max} = The maximum allowable discharge flow rate from the test tank past the monitor which would equate to the Control concentration limit for the radioactivity mixture determined to be in the test tank (gpm).
- F_d = The actual or conservative estimate of the flow rate out of the discharge tunnel (gpm).

For Waste Test Tank (WTT) releases, tritium is expected to be the radionuclide with the highest concentration, and therefore requires the highest dilution flow in order to satisfy the discharge concentration limits. Unlike concentrations of other dissolved or suspended radionuclides, tritium concentrations are not expected to vary because they are unaffected by plant cleanup systems used to reduce or control waste radioactivity levels. As such, events that cause sudden increases in the concentrations of other dissolved or suspended radionuclides, such as changes in waste cleanup efficiencies, crud bursts or failed fuel fractions would not change the tritium concentrations. As long as the minimum required dilution factor (DF_{min}) for all radionuclides present in the liquid waste is satisfied, the alarm setpoint for the Waste Test Tank monitor need only consider the potential changes to the concentrations of detectable gamma-emitting radionuclides. Therefore, the required dilution for detectable activity by the WTT monitor can be determined by applying the definition of DF_{min} (given in equation (5-3)) to only the gamma-emitting radionuclides present in the waste.

$$DF_{min\gamma} = \sum (C_{i\gamma}/10ECL_i) \quad (5-3a)$$

Where:

$DF_{min\gamma}$ = Minimum required dilution factor necessary to ensure that the sum of the ratios for the concentration of each gamma-emitting radionuclide to the respective ECL value is not greater than 10 (dimensionless).

$C_{i\gamma}$ = Activity concentration of each detectable gamma-emitting radionuclide "i" in the mixture ($\mu\text{Ci/ml}$).

ECL_i = As defined previously.

As in the determination of F_{max} for the total radioactivity mixture, the maximum allowable discharge flow rate that the waste from the test tanks could be released at without exceeding the concentration limit for gamma-emitters, $F_{max\gamma}$, is obtained by dividing the discharge tunnel flow, F_d , by $DF_{min\gamma}$. This determination is based on the assumption that there are no additional discharges of liquid waste at the time of release from the test tanks. Therefore,

$$F_{max\gamma} = F_d / DF_{min\gamma}$$

Where:

$F_{max\gamma}$ = The maximum allowable discharge flow rate from the test tank past the monitor which would equate to the control concentration limit for the gamma radioactivity mixture determined to be in the test tank (gpm).

F_d = The actual or conservative estimate of the flow rate out of the discharge tunnel (gpm).

The selection of the actual discharge flow rate (F_m) from the test tanks compared to the maximum allowable discharge rate based on all radionuclides that are present (F_{max}) and the maximum allowable discharge rate based on only gamma-emitting radionuclides that are present ($F_{max\gamma}$) must satisfy the following:

$$F_m \leq F_{max} * f_{tt} \leq F_{max\gamma} * f_{tt}$$

Where the f_{tt} represents an administrative fraction of the maximum allowable discharge flow from the test tanks. This fraction provides additional margin in meeting ECL limits for non-gamma emitters (such as tritium) at the discharge point to the ocean when other flow paths may contribute to the total site release at the time of tank discharges and minimum dilution flow conditions exist.

With the above conditions on discharge and dilution flow rates satisfied, the alarm/trip setpoint for the monitor which corresponds to the maximum allowable concentration at the point of discharge is determined as follows:

$$R_{setpoint} = f_1 \times \frac{F_d}{F_m \times DF_{min\gamma}} \times \sum C\gamma_i \quad (5-1)$$

Where:

- $R_{setpoint}$ = The maximum allowable alarm/trip setpoint for an instrument response ($\mu\text{Ci/ml}$) that ensures the limiting concentration at the point of discharge is not exceeded.
- f_1 = The fraction of the total contribution of ECL at the discharge point to be associated with the test tank effluent pathway, where f_2 , f_3 , f_4 , and f_5 , are the fractions for the Turbine Building Sump, Steam Generator Blowdown, Primary Component Cooling and Water Treatment Effluent (Condensate Polishing System) pathways contribution to the total, respectively ($f_1+f_2+f_3+f_4+f_5 \leq 1$). Each of the fractions may be conservatively set administratively such that the sum of the fractions is less than 1. This additional margin can be used to account for the uncertainty in setpoint parameters such as estimated concentration of non gamma emitters that are based on previous composite analyses of the waste stream.

5.1.1.2 Liquid Waste Test Tank Monitor Setpoint Example

The radioactivity concentration of each radionuclide, C_i , in the waste test tank is determined by analysis of a representative grab sample obtained at the radwaste sample sink, and analyzed prior to release for gamma emitters, or as part of a composite analysis for non gamma emitters. The maximum allowable instantaneous effluent concentrations (i.e., ten time the ECL values in 10 CFR 20, Appendix B, Table 2) are used to illustrate a monitor setpoint determination. This setpoint example is based on the following data:

i	C_i ($\mu\text{Ci/ml}$)	ECL_i ($\mu\text{Ci/ml}$)	Ten Times ECL_i ($\mu\text{Ci/ml}$)
Cs-134	2.15E-05	9E-07	9E-06
Cs-137	7.48E-05	1E-06	1E-05
Co-60	2.56E-05	3E-06	3E-05
H-3	1.50E-01	1E-03	1E-02

The minimum required dilution factor for this mix of radionuclides (including beta-emitters) is:

$$\text{DF}_{\min} = \sum \frac{C_i}{10\text{ECL}_i} = \frac{2.15\text{E} - 05}{9\text{E} - 06} + \frac{7.48\text{E} - 05}{1\text{E} - 05} + \frac{2.56\text{E} - 05}{3\text{E} - 05} + \frac{1.50\text{E} - 01}{1\text{E} - 02} = 26$$

The release flow rate (F_m) from the waste test tanks can be set between 10 and 150 gpm. The cooling water tunnel discharge dilution flow rate (F_d) can typically vary from approximately 8,800 to 412,000 gpm depending on the operating status of the plant. In this example, if the dilution flow (F_d) is taken as 412,000 gpm, the maximum allowable discharge rate (F_{\max}) is:

$$\begin{aligned} F_{\max} &= \frac{F_d}{\text{DF}_{\min}} \\ &= \frac{412,000}{26} \text{ gpm} \\ &= 15,846 \text{ gpm} \end{aligned}$$

Next, the required dilution factor for only gamma emitters in the mix is:

$$\text{DF}_{\min\gamma} = \sum (C_{i\gamma} / 10\text{ECL}_i) = \frac{2.15\text{E} - 05}{9\text{E} - 06} + \frac{7.48\text{E} - 05}{1\text{E} - 05} + \frac{2.56\text{E} - 05}{3\text{E} - 05} = 11$$

The maximum allowable discharge flow rate ($F_{\max\gamma}$) considering only gamma emitters is given as:

$$F_{\max\gamma} = \frac{F_d}{\text{DF}_{\min\gamma}} = \frac{412,000}{11} \text{ gpm} = 37,455 \text{ gpm}$$

With the selected release rate from the test tank set at 150 gpm, and the administrative flow fraction (f_{tt}) assumed in this example to be 0.7, the condition for the control concentration limits is met since:

$$F_m \text{ (equal to 150)} < F_{\max} \text{ (equal to 15,846 gpm)} \times f_{tt} \text{ (set at 0.7)}$$

$$< F_{\max\gamma} \text{ (equal to 37,455 gpm)} \times F_{tt} \text{ (set at 0.7)}$$

$$150 < 11092 < 26219$$

and the monitor response due to the mix of the gamma emitters is:

i	$C_{\gamma i}$ ($\mu\text{Ci/ml}$)
Cs-134	2.15E-05
Cs-137	7.48E-05
Co-60	2.56E-05
$\Sigma C_{\gamma i} = 1.22\text{E} - 04 \mu\text{Ci/ml}$	

Under these conditions, the alarm/trip setpoint for the liquid radwaste discharge monitor is:

$$R_{\text{setpoint}} = f_l \times \frac{F_d}{F_m \times DF_{\min\gamma}} \times \Sigma C_{\gamma i} \quad (5-1)$$

$$\begin{aligned} \mu\text{Ci/ml} \quad () \quad () \quad \mu\text{Ci/ml} \\ R_{\text{setpoint}} &= 0.4 \times \frac{412,000}{150 \times 11} \times 1.22\text{E} - 04 \\ &= 1.22\text{E} - 02 \mu\text{Ci/ml} \end{aligned}$$

In this example, the alarm/trip setpoint of the liquid radwaste discharge monitor can be put at 1.22E-02 $\mu\text{Ci/ml}$ above background. For the example, it is assumed that the test tank release pathway will be limited to only 40% of the total site discharge allowable concentration.

5.1.2 Turbine Building Drains Liquid Effluent Monitor (RM-6521)

The Turbine Building drains liquid effluent monitor continuously monitors the Turbine Building sump effluent line. The only sources to the Sump Effluent System are from the secondary steam system. Activity is expected in the Turbine Building Sump Effluent System only if a significant primary-to-secondary leak is present. If a primary-to-secondary leak is present, the activity in the sump effluent system would be comprised of only those radionuclides found in the secondary system, with reduced activity from decay and dilution.

The Turbine Building drains liquid effluent monitor provides alarm and automatic termination of release prior to exceeding ten times the concentration limits specified in 10 CFR 20, Appendix B, Table 2, Column 2 to the environment. The alarm setpoint for this monitor will be determined using the same method as that of the liquid waste test tank monitor if the total sump activity is greater than the ECL, as determined by the most recent grab sample isotopic analysis. If the total activity is less than the ECL, the setpoints of RM-6521 are calculated as follows:

$$\text{High Trip Monitor Setpoint } (\mu\text{Ci/ml}) = f_2 (DF') (\text{"unidentified mix ECL"} (\mu\text{Ci/ml})) \quad (5-21)$$

where:

$$DF' = \frac{\text{Circulating water flow rate (gpm)}}{\text{Flow rate pass-monitor (gpm)}}$$

$$\text{unidentified mix ECL} = \text{most restrictive ECL value } (\mu\text{Ci/ml}) \text{ for an unidentified mixture or a mixture known not to contain certain radionuclides as given in 10 CFR 20, Appendix B, Notes.}$$

$$f_2 = 1 - (f_1 + f_3 + f_4 + f_5); \text{ where the f values are described above.}$$

In addition, a warning alarm setpoint can be determined by multiplying the high trip alarm point by an administratively selected fraction (as an example, 0.25).

$$\left(\begin{array}{c} \text{Warning Alarm} \\ \text{Monitor Setpoint} \\ (\mu\text{Ci/ml}) \end{array} \right) = \left(\begin{array}{c} \text{High Trip} \\ \text{Monitor Setpoint} \end{array} \right) (0.25)$$

5.1.3 Steam Generator Blowdown Liquid Sample Monitor (RM-6519)

The steam generator blowdown liquid sample monitor is used to detect abnormal activity concentrations in the steam generator blowdown flash tank liquid discharge.

The alarm setpoint for the steam generator blowdown liquid sample monitor, when liquid is to be discharged from the site, will be determined using the same approach as the Turbine Building drains liquid effluent monitor.

For any liquid monitor, in the event that no activity is expected to be discharged, or can be measured in the system, the liquid monitor setpoint should be based on the most restrictive ECL for an "unidentified" mixture or a mixture known not to contain certain radionuclides given in 10 CFR 20, Appendix B notes.

5.1.4 PCCW Head Tank Rate-of-Change Alarm Setpoint

A rate-of-change alarm on the liquid level in the Primary Component Cooling Water (PCCW) head tank will work in conjunction with the PCCW radiation monitor to alert the operator in the Main Control Room of a leak to the Service Water System from the PCCW System. For the rate-of-change alarm, a setpoint is selected based on detection of an activity level equivalent to 10^{-8} $\mu\text{Ci/ml}$ in the discharge of the Service Water System. The activity in the PCCW is determined in accordance with the liquid sampling and analysis program described in Part A, Table A.6.1-1 of the ODCM and is used to determine the setpoint.

The rate-of-change alarm setpoint is calculated from:

$$RC_{\text{set}} = 1 \times 10^{-8} \cdot \text{SWF} \cdot \frac{1}{\text{PCC}} \quad (5-23)$$

$$\left(\frac{\text{gal}}{\text{hr}} \right) = \left(\frac{\mu\text{Ci}}{\text{ml}} \right) \left(\frac{\text{gal}}{\text{hr}} \right) \left(\frac{\text{ml}}{\mu\text{Ci}} \right)$$

where:

- RC_{set} = The setpoint for the PCCW head tank rate-of-change alarm (in gallons per hour).
- 1×10^{-8} = The minimum detectable activity level in the Service Water System due to a PCCW to SWS leak ($\mu\text{Ci/ml}$).
- SWF = Service Water System flow rate (in gallons per hour).
- PCC = Primary Component Cooling Water measured (decay corrected) gross radioactivity level ($\mu\text{Ci/ml}$).

As an example, assume a PCCW activity concentration of $1 \times 10^{-5} \mu\text{Ci/ml}$ with a service water flow rate of only 80 percent of the normal flow of 21,000 gpm. The rate-of-change setpoint is then:

$$RC_{\text{set}} = 1 \times 10^{-8} \frac{\mu\text{Ci}}{\text{ml}} \bullet 1.0 \times 10^6 \text{ gph } (1/1 \times 10^{-5} \frac{\mu\text{Ci}}{\text{ml}})$$

$$RC_{\text{set}} = 1000 \text{ gph}$$

As a result, for other PCCW activities, the RC_{set} which would also relate to a detection of a minimum service water concentration of $1 \times 10^{-8} \mu\text{Ci/ml}$ can be found from:

$$RC_{\text{set}} = \frac{1 \times 10^{-5} \times \mu\text{Ci/ml} \times 1000 \text{ gph}}{\text{PCC}} \quad (5-24)$$

5.1.5 PCCW Radiation Monitor

The PCCW radiation monitor will alert the operator in the Main Control Room of a leak to the PCCW System from a radioactively contaminated system.

The PCCW radiation monitor alarm is based on a trend of radiation levels in the PCCW System. The background radiation of the PCCW is determined by evaluating the radiation levels over a finite time period. The alert alarm setpoint is set at 1.5 x background, and the high alarm setpoint is set at 2 x background, per Technical Specification Table 3.3-6.

5.1.6 Water Treatment Liquid Effluent (CPS Rad Monitor RM-6473)

The Water Treatment Liquid Effluent monitor is used to detect abnormal activity concentrations in waste liquid discharges to the Transition Structure from tank Tk-32 (CPS Neutralization Tank or equivalent¹), tank Tk-274 (Low Conductivity Tank) and megarinse wash water from the Condensate Polishing System (CPS) demineralizer regeneration cycle.

The CPS Rad monitor provides alarm and automatic termination of release prior to exceeding the concentration limits specified in 10CFR20, Appendix B, Table 2, Column 2 to the environment. The alarm setpoint for this monitor will be determined using the same method as that of the Liquid Waste Test Tank Monitor (see Section 5.1.1.1) if the total activity expected to be discharged is greater than 10 percent of ECL, as determined by the most recent grab sample isotopic analysis. If the total activity is less than 10 percent of ECL, the setpoints of RM-6473 can be calculated as follows:

$$\text{High Trip Monitor Setpoint } (\mu\text{Ci/ml}) = f_5 (DF') (\text{"unidentified mix ECL" } (\mu\text{Ci/ml}))$$

where:

$$DF' = \frac{\text{Circulating water flow rate (gpm)}}{\text{Flow rate pass - monitor (gpm)}}$$

unidentified mix ECL = most restrictive ECL value ($\mu\text{Ci/ml}$) for an unidentified mixture or a mixture known not to contain certain radionuclides as given in 10CFR20, Appendix B, Notes.

$$f_5 = 1 - (f_1 + f_2 + f_3 + f_4); \text{ where the f values are described in Section 5.1.1.1 above.}$$

In addition, a warning alarm setpoint can be determined by multiplying the high trip alarm point by an administratively selected fraction (as an example, 0.25).

$$\left(\begin{array}{c} \text{Warning Alarm} \\ \text{MonitorSetpoint} \\ (\mu\mu\text{Ci/ml}) \end{array} \right) = \left(\begin{array}{c} \text{High Trip} \\ \text{MonitorSepoint} \end{array} \right) (0.25)$$

¹ The Condensate Polishing System (CPS) has the provision to discharge temporary tanks as batch releases through the same discharge path as the Neutralization Tank (TK-32). The requirements for discharges from a temporary tank through this CPS pathway are equivalent to those of the Neutralization Tank.

5.2 Gaseous Effluent Instrumentation Setpoints

Part A Control C.5.2 requires that the radioactive gaseous effluent instrumentation in Table A.5.2-1 of Part A have their alarm setpoints set to insure that Part A Control C.7.1.1 is not exceeded.

5.2.1 Plant Vent Wide-Range Gas Monitors (RM-6528-1, 2 and 3)

The plant vent wide-range gas monitors are shown on Figure B.6-2.

5.2.1.1 Method to Determine the Setpoint of the Plant Vent Wide Range Gas Monitors (RM-6528-1, 2 and 3)

The maximum allowable setpoint for the plant vent wide-range gas monitor (readout response in $\mu\text{Ci}/\text{sec}$) is set by limiting the off-site noble gas dose rate to the total body or to the skin, and is denoted R_{setpoint} . R_{setpoint} is the lesser of:

$$R_{\text{tb}} = 588 \frac{1}{\text{DFB}_c} f_v \quad (5-5)$$

$$\mu\text{Ci}/\text{sec} = \left(\frac{\text{mrem} \cdot \mu\text{Ci} \cdot \text{m}^3}{\text{yr} \cdot \text{pCi} \cdot \text{sec}} \right) \left(\frac{\text{pCi} \cdot \text{yr}}{\text{mrem} \cdot \text{m}^3} \right)$$

and:

$$R_{\text{skin}} = 3,000 \frac{1}{\text{DF}'_c} f_v \quad (5-6)$$

$$\mu\text{Ci}/\text{sec} = \left(\frac{\text{mrem}}{\text{yr}} \right) \left(\frac{\mu\text{Ci} \cdot \text{yr}}{\text{mrem} \cdot \text{sec}} \right)$$

where:

R_{tb}	=	Response of the monitor at the limiting total body dose rate ($\mu\text{Ci}/\text{sec}$)
588	=	$\frac{500}{(1\text{E}+06) (8.5\text{E}-07)} \left(\frac{\text{mrem} \cdot \mu\text{Ci} \cdot \text{m}^3}{\text{yr} \cdot \text{pCi} \cdot \text{sec}} \right)$
500	=	The offsite limiting total body dose rate (mrem/yr) from all release points
1E+06	=	Number of pCi per μCi (pCi/ μCi)
8.5E-07	=	$[\text{X}/\text{Q}]^\gamma$, maximum off-site long-term average gamma atmospheric dispersion factor for primary vent stack releases (sec/m^3)

DFB_c = Composite total body dose factor (mrem-m³/pCi-yr)

$$= \frac{\sum \dot{Q}_i \text{DFB}_i}{\sum \dot{Q}_i} \quad (5-7)$$

f_v = The fraction of the offsite limiting total body dose rate to be administratively assigned to the plant vent (f_v ≤ 1 -f_g, where f_g is the fraction of the limiting dose rate to be assigned to monitored ground level releases)

\dot{Q}_i = The relative release rate of noble gas "i" in the mixture, for each noble gas identified or postulated to be in the off-gas (μCi/sec)

DFB_i = Total body dose factor (see Table B.1-10) (mrem-m³/pCi-yr)

R_{skin} = Response of the monitor at the limiting skin dose rate (μCi/sec)

3,000 = The offsite limiting skin dose rate (mrem/yr)

DF'_c = Composite skin dose factor (mrem-sec/μCi-yr)

$$= \frac{\sum \dot{Q}_i \text{DF}'_{i(e)}}{\sum \dot{Q}_i} \quad (5-8)$$

DF'_{i(e)} = Combined skin dose factor for elevated release point (see Table B.1-10) (mrem-sec/μCi-yr)

5.2.1.2 Plant Vent Wide Range Gas Monitor Setpoint Example for Limiting Case

The following setpoint example for the plant vent wide range gas monitors demonstrates the use of equations 5-5 and 5-6 for determining setpoints. Evaluations of potential releases rates associated with the limiting offsite dose rates (Control C.7.1.1.a) have been made considering different noble gas mixes related to normal operations, observed periods with fuel defects, and potential UFSAR accident conditions. The bounding noble gas mix case for setpoint alarm indications was found to be related to projected fuel gap activity at the time of shutdown from power operations (UFSAR Table 15.7-20). By setting the maximum alarm setpoint in accordance with this assumed mix, other potential or realistic release conditions will not create an effluent discharge at or above the limiting offsite dose rates without the monitor going into alarm.

This limiting setpoint example is based on the following data (see Table B.1-10 for $DFB_{i(e)}$ and $DF'_{i(e)}$):

i	\dot{Q}_i $(\frac{\mu Ci}{sec})$	DFB_i $(\frac{mrem \cdot m^3}{pCi \cdot yr})$	$DF'_{i(e)}$ $(\frac{mrem \cdot sec}{\mu Ci \cdot yr})$
Xe-138	2.52E+02	8.83E-03	1.20E-02
Kr-87	7.90E+01	5.92E-03	1.38E-02
Kr-88	1.15E+02	1.47E-02	1.62E-02
Kr-85m	4.49E+01	1.17E-03	2.35E-03
Xe-135	6.82E+01	1.81E-03	3.33E-03
Xe-133	3.23E+02	2.94E-04	5.83E-04
Kr-85	4.13E+00	1.61E-05	1.11E-03
Xe-131m	1.15E+00	9.15E-05	5.37E-04
Xe-133m	4.67E+01	2.51E-04	1.12E-03
Xe-135m	6.64E+01	3.12E-03	3.74E-03

$$DFB_c = \frac{\sum \dot{Q}_i DFB_i}{\sum \dot{Q}_i} \quad (5-7)$$

$$\begin{aligned} \sum \dot{Q}_i DFB_i &= (2.52E+02)(8.83E-03) + (7.90E+01)(5.92E-03) + (1.15E+02)(1.47E-02) \\ &\quad + (4.49E+01)(1.17E-03) + (6.82E+01)(1.81E-03) + (3.23E+02)(2.94E-04) \\ &\quad + (4.13E+00)(1.61E-05) + (1.15E+00)(9.15E-05) + (4.67E+01)(2.51E-04) \\ &\quad + (6.64E+01)(3.12E-03) \\ &= 4.86E+00 \text{ (}\mu\text{Ci-mrem-m}^3\text{/sec-pCi-yr)} \end{aligned}$$

$$\begin{aligned} \sum \dot{Q}_i &= 2.52E+02 + 7.90E+01 + 1.15E+02 + 4.49E+01 + 6.82E+01 \\ &\quad + 3.23E+02 + 4.14E+00 + 1.16E+00 + 4.67E+01 + 6.64E+01 \\ &= 1.00E+03 \text{ }\mu\text{Ci/sec} \end{aligned}$$

$$\begin{aligned} DFB_c &= \frac{4.86E+00}{1.00E+03} \\ &= 4.86E-03 \text{ (mrem-m}^3\text{/pCi-yr)} \end{aligned}$$

and therefore:

$$\begin{aligned} R_{tb} &= 588 \frac{1}{DFB_c} f_v \quad (5-5) \\ &= (588) \frac{1}{(4.86E-03)} 0.7 \\ &= 8.47E+04 \text{ }\mu\text{Ci/sec} \end{aligned}$$

and next;

$$DF'_c = \frac{\sum \dot{Q}_i DF'_i}{\sum \dot{Q}_i} \quad (5-8)$$

$$\begin{aligned} \sum \dot{Q}_i DF'_i &= (2.52E+02)(1.20E-02) + (7.90E+01)(1.38E-02) + (1.15E+02) (1.62E-02) \\ &+ (4.49E+01)(2.35E-03) + (6.82E+01)(3.33E-03) + (3.23E+02) (5.83E-04) \\ &+ (4.13E+00)(1.11E-03) + (1.15E+00)(5.37E-04) + (4.67E+01) (1.12E-03) \\ &+ (6.64E+01) (3.74E-03) \\ &= 6.80E+00 \text{ (}\mu\text{Ci-mrem-sec/sec-}\mu\text{Ci-yr)} \end{aligned}$$

$$\begin{aligned} DF'_c &= \frac{6.80E+00}{1.00E+03} \\ &= 6.80E-03 \text{ (mrem - sec/}\mu\text{Ci - yr)} \end{aligned}$$

and therefore:

$$\begin{aligned} R_{\text{skin}} &= 3,000 \frac{1}{DF'_c} f_v \quad (5-6) \\ &= (3,000) \left(\frac{1}{6.80E-03} \right) 0.7 \\ &= 3.09E+05 \text{ }\mu\text{Ci/sec} \end{aligned}$$

The setpoint, R_{setpoint} , is the lesser of R_{tb} and R_{skin} . For the limiting noble gas mixture, R_{tb} is less than R_{skin} , indicating that the total body dose rate is more restrictive. Therefore, the plant vent wide-range gas monitor should be set at no more than $8.47E+04 \mu\text{Ci/sec}$ above background, or at some administrative fraction of the above value.

5.2.2 Waste Gas System Monitors (RM-6504 and RM-6503)

Process radiation monitors in the waste gas system provide operational information on the performance of the system before its discharge is combined and diluted with other gas flows routed to the plant vent for release to the environment.

The setpoints for the waste gas system monitors are administratively set as small multiples of the expected activity concentration to provide operational control over unexpected changes in gas discharges from the system. Typically, the alert alarm setpoint for both monitors is placed at 1.5 times the expected activity concentration passing the monitor, with the high alarm trip set at 2.0 times the expected concentration flow.

Under all conditions, the maximum allowable alarm trip shall not exceed a concentration equivalent to $62.5 \mu\text{Ci}/\text{cm}^3$. This concentration limit, based on system design flow of 1.2 cfm, assures that any release from the waste gas system to the plant vent will not exceed the site boundary dose rate limits of Part A Control C.7.1.1.a.

5.2.3 Main Condenser Air Evacuation Monitor (RM-6505)

The process radiation monitor on the main condenser air evacuation system provides operational information about the air being discharged. The discharge typically occurs either directly from the turbine building during start up (hogging mode) or through the plant vent during normal operations. During maintenance activities or other temporary operational conditions, discharges to the turbine roof may also occur. This process monitor is also used as an indicator of potential releases from the Turbine Gland Seal Condenser exhaust. Early indications of a potential release (i.e., monitor count rate at twice the normal background) should be evaluated by collecting a grab sample of the exhausts from both the main condenser and the Turbine Gland Seal Condenser.

The condenser air evacuation monitor is the most sensitive indicator of a primary to secondary leak in the plant steam generators. Therefore, the operational setpoints for the air evacuation monitor are typically administratively set at small fractions of the values necessary to maintain the site boundary dose rate limits of Part A Control C.7.1.1. Station procedures for determining the condenser air evacuation monitor setpoints recognize the not to be exceeded ODCM determined maximum values. Typically when primary to secondary leakage is not present, the alert setpoint is 2 to 3 times background, with the high alarm set at $2.0\text{E}+03$ cpm or a higher value corresponding to 30 gallons per day of primary to secondary steam generator leakage.

Maximum allowable setpoint determinations assure that the site boundary dose rate limits of Part A Control C.7.1.1.a will not be exceeded. For the air evacuation detector an efficiency of $1.87\text{E} + 08 \text{ cpm}\cdot\text{cm}^3/\mu\text{Ci}$, (the AR-41 response value determined by HPSTID 00-021), flow rates of 10 to 50 cfm and 10,000 cfm for the normal and hogging modes of operation, respectively, and assuming that all the response is due to the most restrictive noble gas mixture associated with fuel gap activity inventory at the end of power operations (same mixture as used for the limiting mixture for the plant vent Wide Range Gas Monitor setpoint given in section 5.2.1.2), the following examples illustrate the calculation of the limiting setpoint for different operational conditions.

Case 1: For start-up operations (i.e., 10,000 cfm hogging flow to the Turbine Building roof), the maximum allowable alarm setpoint is calculated as:

$$R_{AE} = 147 \frac{1}{DFB_c} f_g f_{gland}$$

where :

R_{AE} = Release rate equivalent to the assigned fraction of the limiting offsite total body dose rate ($\mu\text{Ci}/\text{sec}$)

$$147 = \frac{500}{(1\text{E} + 06) (3.4\text{E} - 06)} \left(\frac{\text{mrem} - \mu\text{Ci} - \text{m}^3}{\text{yr} - \text{pCi} - \text{sec}} \right)$$

500 = The site boundary limiting total body dose rate (mrem/yr) from all release points

1E+06 = Number of pCi per μCi ($\text{pCi}/\mu\text{Ci}$)

3.4E-06 = Maximum off-site long-term average gamma atmospheric dispersion factor for ground level releases (sec/m^2)

DFB_c = Composite total body dose factor (defined for the WRGM in Section 5.2.1.2 to be equal to $4.86\text{E}-03$ [$\text{mrem}\text{-m}^3/\text{pCi}\text{-yr}$] for the limiting fuel gap activity mix)

f_g = The fraction of the site boundary total body dose rate limit to be administratively assigned to monitored ground level releases (for this illustration = 0.3) such that the combination of the plant vent fraction (f_v) and ground fraction (f_g) is less than or equal to 1 ($f_g \leq 1 - f_v$).

f_{gland} = Release reduction factor to be administratively assigned to account for potential unmonitored contributions from the Turbine Gland Seal Condenser exhaust (for this illustration = 0.7).

$$R_{AE} = 147 \frac{1}{4.86\text{E} - 03} (0.3) (0.7)$$

$$= 6.36\text{E}+03 \mu\text{Ci}/\text{sec} \text{ release rate limit}$$

and for the 10,000 cfm ($4.72\text{E}+06 \text{ cm}^3/\text{sec}$) exhaust flow, the count rate response of the air evacuation monitor would be:

$$\text{Monitor Response} = \frac{R_{AE}}{4.72\text{E} + 06 \text{ cm}^3/\text{sec}} 1.87\text{E} + 08 \text{ cpm}\text{-cm}^3/\mu\text{Ci}$$

$$= (6.36\text{E}+03) (1.87\text{E}+08) / (4.72\text{E}+06)$$

$$= 2.520\text{E} + 05 \text{ cpm}$$

Case 2: As an extension of Case 1 which assumed the full startup hogging flow was released to the Turbine Building roof, maintenance requirements could direct normal operating main condenser offgas flow (assume 50 cfm or equivalent $2.36\text{E}+04 \text{ cm}^3/\text{sec}$) to the Turbine Building Roof (ground level release point) instead of the elevated main plant vent. In this situation, the same release rate limit as calculated above (i.e., $6.36\text{E}+03 \text{ } \mu\text{Ci}/\text{sec}$) would apply. However, the reduced gas flow from 10,000 cfm down to 50 cfm would permit a higher alarm setpoint to be used.

$$\begin{aligned} \text{Monitor Response} &= \frac{R_{AE}}{2.36\text{E}+04 \text{ cm}^3/\text{sec}} \quad 1.87\text{E}+08 \text{ cpm-cm}^3/\mu\text{Ci} \\ &= (6.36\text{E}+03) (1.87\text{E}+08) / (2.36\text{E}+04) \\ &= 5.04\text{E}+07 \text{ cpm} \end{aligned}$$

Case 3: For normal operations which direct main condenser offgas flow (assume 50 cfm or equivalent $2.36\text{E}+04 \text{ cm}^3/\text{sec}$) to be released to the atmosphere via the main plant vent, the maximum allowable alarm setpoint would be:

$$R_{AE} = 588 \frac{1}{\text{DFBc}} f_v f_{\text{gland}}$$

where :

R_{AE} = Release rate equivalent to the assigned fraction of the limiting offsite total body dose rate ($\mu\text{Ci}/\text{sec}$)

$$588 = \frac{500}{(1\text{E}+06) (8.5\text{E}-07)} \left(\frac{\text{mrem} - \mu\text{Ci} - \text{m}^3}{\text{yr} - \text{pCi} - \text{sec}} \right)$$

$5.8\text{E}-07$ = Maximum off-site long-term average gamma atmospheric dispersion factor for elevated (mixed mode) releases (sec/m^2)

DFBc = Composite total body dose factor (defined for the WRGM in Section 5.2.1.2 to be equal to $4.86\text{E}-03$ [$\text{mrem-m}^3/\text{pCi-yr}$] for the limiting fuel gap activity mix)

f_{gland} = Same as listed above (i.e., 0.7)

f_v = The fraction of the site boundary total body dose rate limit to be administratively assigned to plant vent releases such that the combination of the plant vent fraction (f_v) and ground fraction (f_g) is less than or equal to 1 ($f_v \leq 1 - f_g$). For the case that main condenser offgas is discharged to the main plant vent, there is no ground release fraction to be assigned (i.e., $f_g = 0$), and f_v maybe set at 1.

$$\begin{aligned} R_{AE} &= 588 \frac{1}{4.86\text{E}-03} 0.7 \\ &= 8.47\text{E}+04 \text{ } \mu\text{Ci}/\text{sec} \text{ release rate limit} \end{aligned}$$

and for the 50 cfm (2.36E+06 cm³/sec) Main Condenser offgas exhaust flow, the count rate response of the air evacuation monitor would be:

$$\begin{aligned}\text{Monitor Response} &= \frac{R_{AE}}{2.36E + 06 \text{cm}^3 / \text{sec}} \quad 1.87E + 08 \text{ cpm-cm}^3/\mu\text{Ci} \\ &= (8.47E+04) (1.87E + 08) / (2.36E+04) \\ &= 6.71E + 08 \text{ cpm}\end{aligned}$$

The operation of the Main Condenser Evacuation System assumes 670 lbs./hour of steam flow through the Turbine Gland Seal Condenser exhaust (very small fraction of total steam flow), 1.5E+07 lbs./hour steam flow to the main condenser, and that the Turbine Gland Seal Condenser exhaust mostly air at a flow rate of 1,800 cfm which goes directly to the Turbine Building Vents (does not pass RM-6505). The main condenser offgas which goes past the Air Evacuation monitor during power operations is combined with other plant ventilation and process gas streams before being monitored by the WRGM and discharged to the atmosphere via the Plant Vent as a single release point.

The maximum allowable setpoints during startup and normal power operations may be recalculated based on identified changes in detector efficiency, discharge flow rate, radionuclide mix distribution, or administrative apportionment of potential contributions from the plant vent and ground level release points following the methods identified in Part B, Section 8.5.

6.0 LIQUID AND GASEOUS EFFLUENT STREAMS, RADIATION MONITORS AND RADWASTE TREATMENT SYSTEMS

Figure B.6-1 shows the liquid effluent streams, radiation monitors and the appropriate Liquid Radwaste Treatment System. Figure B.6-2 shows the gaseous effluent streams, radiation monitors and the appropriate Gaseous Radwaste Treatment System.

For more detailed information concerning the above, refer to the Seabrook Station Final Safety Analysis Report, Sections 11.2 (Liquid Waste System), 11.3 (Gaseous Waste System) and 11.5 (Process and Effluent Radiological Monitoring and Sampling System).

The turbine gland seal condenser exhaust iodine and particulate gaseous releases will be determined by continuously sampling the turbine gland seal condenser exhaust. The noble gas releases will be determined by periodic noble gas grab samples. A ratio of main condenser air evacuation exhaust and turbine gland seal condenser exhaust noble gas will be determined periodically.

Figure B.6-1
Liquid Effluent Streams, Radiation Monitors, and
Radwaste Treatment System at Seabrook Station

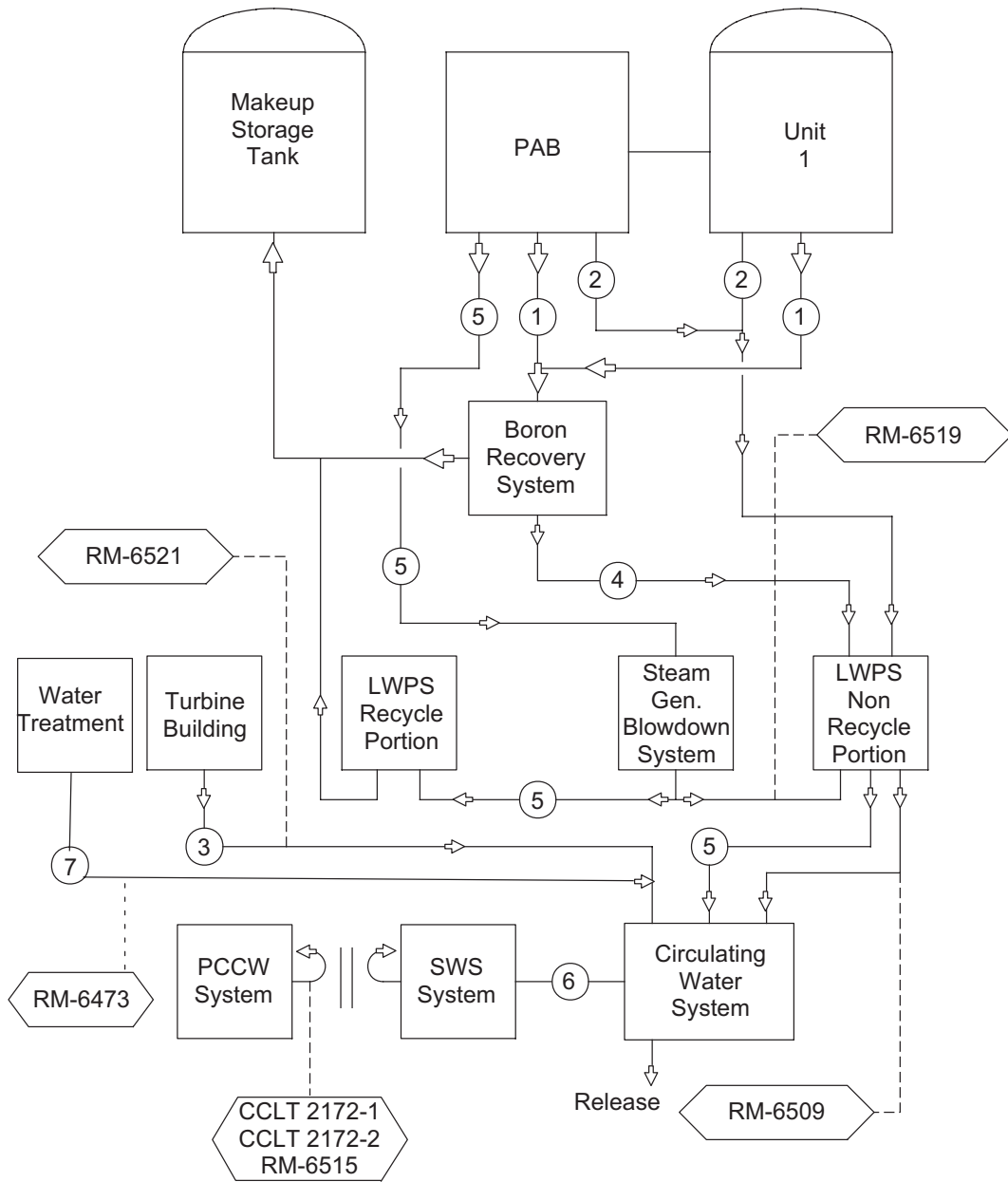

- | | |
|--|--|
| <ul style="list-style-type: none"> ① CVCS Letdown Diversion
Equipment Drainage
Equipment Leakage ② PAB Floor Drainage
Non-Recyclable and Misc Containment
Sumps Laboratory Drainage
Decontamination Water ③ Turbine Building Sump | <ul style="list-style-type: none"> ④ Tritium Control Release ⑤ Secondary Side Steam
Generator Blowdown ⑥ Service Water System ⑦ Water Treatment Liquid
Effluent (includes condensate
polishing system) |
|--|--|

RM Radiation Monitor

CCLT Level Transmitter

ODCM61 5/26/04

Figure B.6-2
Gaseous Effluent Streams, Radiation Monitors, and
Radwaste Treatment System at Seabrook Station

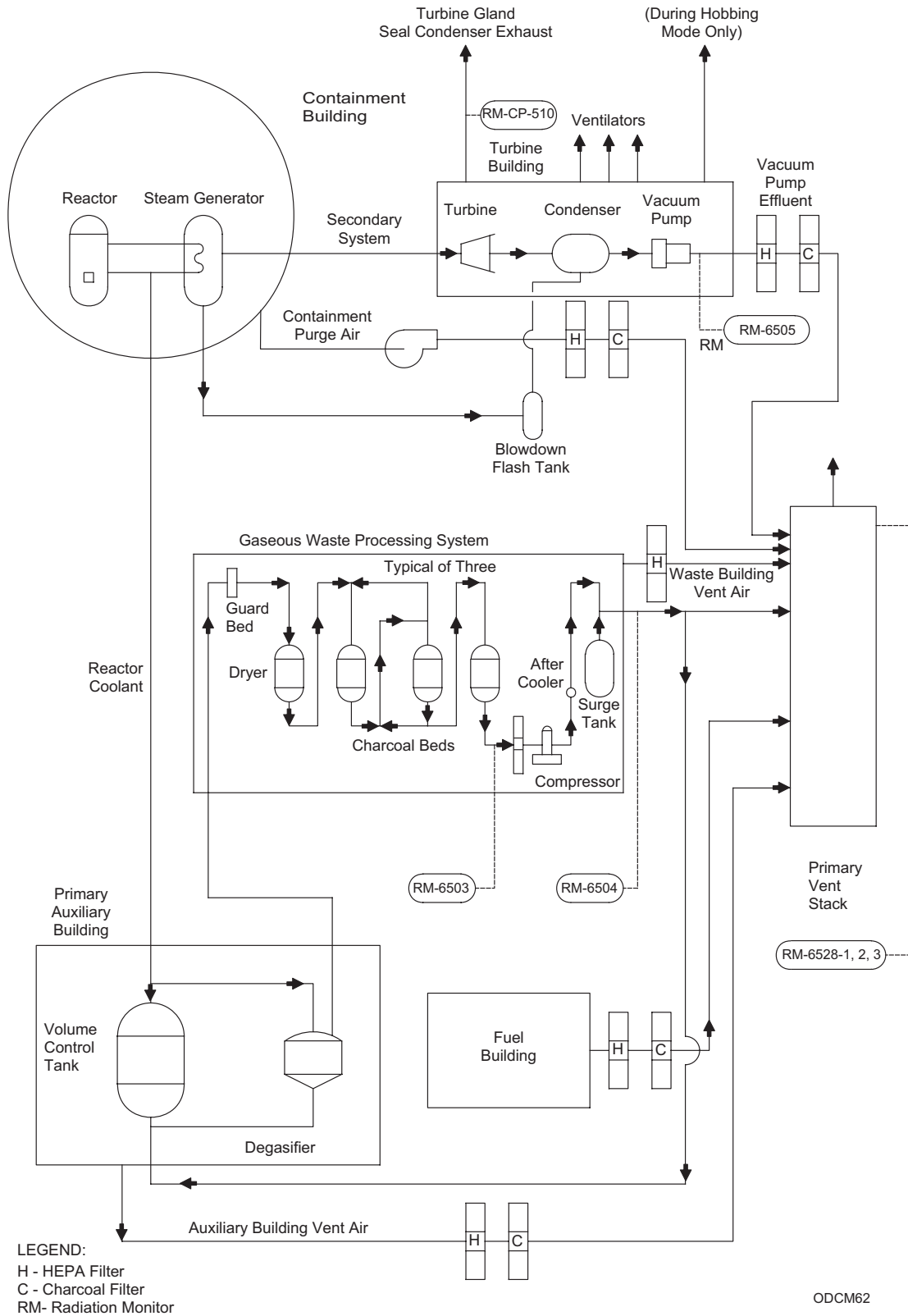

7.0 BASES FOR DOSE CALCULATION METHODS

7.1 Liquid Release Dose Calculations

This section serves: (1) to document the development and conservative nature of Method I equations to provide background information to Method I users, and (2) to identify the general equations, parameters and approaches to Method II-type dose assessments. Appendix C provides the bases for the EMS software which is used to implement the dose and dose rate calculations indicated as Method IA.

Method I may be used to show that the Part A RECP which limit off-site total body dose from liquids (C.6.2.1 and C.6.3.1) have been met for releases over the appropriate periods. The quarterly and annual dose limits in Part A Control C.6.2.1 are based on the ALARA design objectives in 10CFR50, Appendix I Subsection II A. The minimum dose values noted in Part A Control C.6.3.1 are "appropriate fractions," as determined by the NRC, of the design objective to ensure that radwaste equipment is used as required to keep off-site doses ALARA.

Method I was developed such that "the actual exposure of an individual ... is unlikely to be substantially underestimated" (10CFR50, Appendix I). The definition, below, of a single "critical receptor" (a hypothetical or real individual whose behavior results in a maximum potential dose) provides part of the conservative margin to the calculation of total body dose in Method I. Method II allows that actual individuals, associated with identifiable exposure pathways, be taken into account for any given release. In fact, Method I was based on a Method II analysis for a critical receptor assuming all principal pathways present instead of any real individual. That analysis was called the "base case;" it was then reduced to form Method I. The general equations used in the base case analysis are also used as the starting point in Method II evaluations. The base case, the method of reduction, and the assumptions and data used are presented below.

The steps performed in the Method I derivation follow. First, the dose impact to the critical receptor [in the form of dose factors DFL_{itb} (mrem/ μ Ci)] for a unit activity release of each radioisotope in liquid effluents was derived. The base case analysis uses the general equations, methods, data and assumptions in Regulatory Guide 1.109 (Equations A-3 and A-7, Reference A). The liquid pathways contributing to an individual dose are due to consumption of fish and invertebrates, shoreline activities, and swimming and boating near the discharge point. A nominal operating plant discharge flow rate of 918 ft³/sec was used with a mixing ratio of 0.10. The mixing ratio of 0.10 corresponds to the minimum expected prompt dilution or near-field mixing zone created at the ocean surface directly above the multiport diffusers. (Credit for additional dilution to the outer edge of the prompt mixing zone which corresponds to the 10F surface isotherm (mixing ratio .025) can be applied in the Method II calculation for shoreline exposures only since the edge of this isotherm typically does not reach the shoreline receptor points during the tidal cycle. The mixing ratio for aquatic food pathways in Method II assessments shall be limited to the same value (0.10) as applied in Method I for near-field mixing, or prompt dilution only.

The requirements for the determination of radiological impacts resulting from releases in liquid effluents is derived from 10CFR50, Appendix I. Section III.A.2 of Appendix I indicates that in making the assessment of doses to hypothetical receptors, "The Applicant may take account of any real phenomenon or factors actually affecting the estimate of radiation exposure, including the characteristics of the plant, modes of discharge of radioactive materials, physical processes tending to attenuate the quantity of radioactive material to which an individual would be exposed, and the effects of averaging exposures over time during which determining factors may fluctuate." In assessing the liquid exposure pathways that characterize Seabrook Station, the design and physical location of the Circulating Water Discharge System needs to be considered within the scope of Appendix I.

Seabrook utilizes an offshore submerged multiport diffuser discharger for rapid dissipation and mixing of thermal effluents in the ocean environment. The 22-port diffuser section of the Discharge System is located in approximately 50 to 60 feet of water with each nozzle 7 to 10 feet above the sea floor. Water is discharged in a generally eastward direction away from the shoreline through the multiport diffuser, beginning at a location over one mile due east of Hampton Harbor inlet. This arrangement effectively prevents the discharge plume (at least to the 1 degree or 40 to 1 dilution isopleth) from impacting the shoreline over the tidal cycle.

Eleven riser shafts with two diffuser nozzles each form the diffuser and are spaced about 100 feet apart over a distance of about 1,000 feet. The diffusers are designed to maintain a high exit velocity of about 7.5 feet per second during power operations. Each nozzle is angled approximately 20 degrees up from the horizontal plane to prevent bottom scour. These high velocity jets passively entrain about ten volumes of fresh ocean water into the near field jet mixing region before the plume reaches the water surface. This factor of 10 mixing occurs in a very narrow zone of less than 300 feet from the diffuser by the time the thermally buoyant plume reaches the ocean surface. This high rate of dilution occurs within about 70 seconds of discharge from the diffuser nozzles.

The design of the multiport diffuser to achieve a 10 to 1 dilution in the near field jet plume, and a 40 to 1 dilution in the near mixing zone associated with the 1 degree isotherm, has been verified by physical model tests (reference "Hydrothermal Studies of Bifurcated Diffuser Nozzles and Thermal Backwashing - Seabrook Station," Alden Research Laboratories, July 1977).

During shutdown periods, when the plant only requires service water cooling flow, the high velocity jet mixing created by the normal circulating water flow at the diffuser nozzles is reduced. However, mixing within the discharge tunnel water volume is significantly increased (factor of about 5) due to the long transit time (approximately 50 hours) for batch waste discharged from the plant to travel the three miles through the 19-foot diameter tunnels to the diffuser nozzles. Additional mixing of the thermally buoyant effluent in the near field mixing zone assures that an equivalent overall 10 to 1 dilution occurs by the time the plume reaches the ocean surface.

The dose assessment models utilized in the ODCM are taken from NRC Regulatory Guide 1.109. The liquid pathway equations include a parameter (M_p) to account for the mixing ratio (reciprocal of the dilution factor) of effluents in the environment at the point of exposure. Table 1, in Regulatory Guide 1.109, defines the point of exposure to be the location that is anticipated to be occupied during plant lifetime, or have potential land and water usage and food pathways as could actually exist during the term of plant operation. For Seabrook, the potable water and land irrigation pathways do not exist since saltwater is used as the receiving water body for the circulating water discharge. The three pathways that have been factored into the assessment models are shoreline exposures, ingestion of invertebrates, and fish ingestion.

With respect to shoreline exposures, both the mixing ratios of 0.1 and 0.025 are extremely conservative since the effluent plume which is discharged over one mile offshore never reaches the beach where this type of exposure could occur. Similarly, bottom dwelling invertebrates, either taken from mud flats near the shoreline or from the area of diffuser, are not exposed to the undiluted effluent plume. The shore area is beyond the reach of the surface plume of the discharge, and the design of the upward directed discharge nozzles along with the thermal buoyancy of the effluent, force the plume to quickly rise to the surface without affecting bottom organisms.

Consequentially, the only assumed exposure pathway which might be impacted by the near field plume of the circulating water discharge is finfish. However, the mixing ratio of 0.1 is very conservative because fish will avoid both the high exit velocity provided by the discharge nozzles and the high thermal temperature difference between the water discharged from the diffuser and the ambient water temperature in the near field. In addition, the dilution factor of 10 is achieved within 70 seconds of discharge and confined to a very small area, thus prohibiting any significant quantity of fish from reaching equilibrium conditions with radioactivity concentrations created in the water environment.

The mixing ratio of 0.025, which corresponds to the 1 degree thermal near field mixing zone, is a more realistic assessment of the dilution to which finfish might be exposed. However, even this dilution credit is conservative since it neglects the plant's operational design which discharges radioactivity by batch mode. Batch discharges are on the order of only a few hours in duration several times per week and, thus, the maximum discharge concentrations are not maintained in the environment long enough to allow fish to reach equilibrium uptake concentrations as assumed in the dose assessment modeling. Notwithstanding the above expected dilution credit afforded at the 1 degree isotherm, all Method II aquatic food pathway dose calculations shall conservatively assume credit for prompt dilution only with an $M_p = 0.10$. When dose impacts from the fish and invertebrate pathways are then added to the conservative dose impacts derived for shoreline exposures, the total calculated dose is very unlikely to have underestimated the exposure to any real individual.

The recommended value for dilution of 1.0 given in NUREG-0133 is a simplistic assumption provided so that a single model could be used with any plant design and physical discharge arrangement. For plants that utilize a surface canal-type discharge structure where little entrainment mixing in the environment occurs, a dilution factor of 1.0 is a reasonable assumption. However, in keeping with the guidance provided in Appendix I to 10CFR50, Seabrook has determine site-specific mixing ratios which factor in its plant design.

The transit time used for the aquatic food pathway was 24 hours, and for shoreline activity 0.0 hours. Table B.7-1 outlines the human consumption and use factors used in the analysis. The resulting, site-specific, total body dose factors appear in Table B.1-11. Appendix A provides an example of the development of a Method I liquid dose conversion factor for site-specific conditions at Seabrook.

7.1.1 Dose to the Total Body

For any liquid release, during any period, the increment in total body dose from radionuclide "i" is:

$$\Delta D_{tb} = k Q_i DFL_{itb} \quad (7-1)$$

(mrem) () (μCi) $\left(\frac{\text{mrem}}{\mu\text{Ci}} \right)$

where:

- DFL_{itb} = Site-specific total body dose factor (mrem/μCi) for a liquid release. It is the highest of the four age groups. See Table B.1-11.
- Q_i = Total activity (μCi) released for radionuclide "i".
- k = 918/F_d (dimensionless); where F_d is the average dilution flow of the Circulating Water System at the point of discharge from the multiport diffuser (in ft³/sec).

Method I is more conservative than Method II in the region of the Part A dose limits because the dose factors DFL_{itb} used in Method I were chosen for the base case to be the highest of the four age groups (adult, teen, child and infant) for that radionuclide. In effect each radionuclide is conservatively represented by its own critical age group.

7.1.2 Dose to the Critical Organ

The methods to calculate maximum organ dose parallel to the total body dose methods (see Part B, Section 7.1.1).

For each radionuclide, a dose factor (mrem/μCi) was determined for each of seven organs and four age groups. The largest of these was chosen to be the maximum organ dose factor (DFL_{imo}) for that radionuclide. DFL_{imo} also includes the external dose contribution to the critical organ.

For any liquid release, during any period, the increment in dose from radionuclide "i" to the maximum organ is:

$$\Delta D_{mo} = k Q_i DFL_{imo} \quad (7-2)$$

(mrem) () (μCi) $\left(\frac{\text{mrem}}{\mu\text{Ci}} \right)$

where:

- DFL_{imo} = Site-specific maximum organ dose factor (mrem/ μ Ci) for a liquid release. See Table B.1-11.
- Q_i = Total activity (μ Ci) released for radionuclide "i".
- k = $918/F_d$ (dimensionless); where F_d is the average dilution flow of the Circulating Water System at the point of discharge from the multiport diffuser (in ft^3/sec).

Table B.7-1
Usage Factors for Various Liquid Pathways at Seabrook Station

(From Reference A, Table E-5*, except as noted. Zero where no pathway exists)

AGE	VEG.	LEAFY VEG.	MILK	MEAT	FISH	INVERT.	POTABLE WATER	SHORELINE	SWIMMING**	BOATING**
	(KG/YR)	(KG/YR)	(LITER/YR)	(KG/YR)	(KG/YR)	(KG/YR)	(LITER/YR)	(HR/YR)	(HR/YR)	(HR/YR)
Adult	0.00	0.00	0.00	0.00	21.00	5.00	0.00	334.00***	8.00	52.00
Teen	0.00	0.00	0.00	0.00	16.00	3.80	0.00	67.00	45.00	52.00
Child	0.00	0.00	0.00	0.00	6.90	1.70	0.00	14.00	28.00	29.00
Infant	0.00	0.00	0.00	0.00	0.00	0.00	0.00	0.00	0.00	0.00

* Regulatory Guide 1.109.

** HERMES; "A Digital Computer Code for Estimating Regional Radiological Effects from Nuclear Power Industry," HEDL, December 1971. Note, for Method II analyses, these pathways need not be evaluated since they represent only a small fraction of the total dose contribution associated with the other pathways.

*** Regional shoreline use associated with mudflats - Maine Yankee Atomic Power Station Environmental Report.

7.2 Gaseous Release Dose Calculations

7.2.1 Total Body Dose Rate From Noble Gases

This section serves: (1) to document the development of the Method I equation, (2) to provide background information to Method I users, and (3) to identify the general equations, parameters and approaches to Method II-type dose rate assessments.

Method I may be used to show that the Part A Controls which limit total body dose rate from noble gases released to the atmosphere (Part A Control C.7.1.1) has been met for the peak noble gas release rate.

Method I was derived from general equation B-8 in Regulatory Guide 1.109 as follows:

$$\dot{D}_{tb} = 1E+06 [X/Q]^{\gamma} \sum_i \dot{Q}_i DFB_i \quad (7-3)$$

$$\left(\frac{\text{mrem}}{\text{yr}} \right) = \left(\frac{\text{pCi}}{\mu\text{Ci}} \right) \left(\frac{\text{sec}}{\text{m}^3} \right) \left(\frac{\mu\text{Ci}}{\text{sec}} \right) \left(\frac{\text{mrem} \cdot \text{m}^3}{\text{pCi} \cdot \text{yr}} \right)$$

where:

$[X/Q]^{\gamma}$ = Maximum off-site receptor location long-term average gamma atmospheric dispersion factor.

\dot{Q}_i = Release rate to the environment of noble gas "i" ($\mu\text{Ci}/\text{sec}$).

DFB_i = Gamma total body dose factor, $\left(\frac{\text{mrem} \cdot \text{m}^3}{\text{pCi} \cdot \text{yr}} \right)$. See Table B.1-10. (Regulatory Guide 1.109, Table B-1).

Elevated and ground level gaseous effluent release points are addressed separately through the use of specific $[X/Q]^{\gamma}$ For an elevated gaseous effluent release point and off-site receptor, Equation 7-3 takes the form:

$$\dot{D}_{tb(e)} = (1E+06) * (8.5E-07) * \sum_i (\dot{Q}_i * DFB_i)$$

$$\left(\frac{\text{mrem}}{\text{yr}} \right) = \left(\frac{\text{pCi}}{\mu\text{Ci}} \right) * \left(\frac{\text{sec}}{\text{m}^3} \right) * \sum \left(\frac{\mu\text{Ci}}{\text{sec}} * \frac{\text{mrem} \cdot \text{m}^3}{\text{pCi} \cdot \text{yr}} \right)$$

which reduces to:

$$\dot{D}_{tb(e)} = 0.85 * \sum_i (\dot{Q}_i * DFB_i) \quad (3-3a)$$

$$\left(\frac{\text{mrem}}{\text{yr}} \right) = \left(\frac{\text{pCi-sec}}{\mu\text{Ci-m}^3} \right) \sum \left(\frac{\mu\text{Ci}}{\text{sec}} \right) * \left(\frac{\text{mrem-m}^3}{\text{pCi-yr}} \right)$$

For a ground level gaseous effluent release point and off-site receptor, Equation 7-3 takes the form:

$$\dot{D}_{tb(g)} = (1E+06) * (3.4E-06) * \sum_i (\dot{Q}_i * DFB_i)$$

which reduces to:

$$\dot{D}_{tb(g)} = 3.4 * \sum_i (\dot{Q}_i * DFB_i) \quad (3-3b)$$

$$\left(\frac{\text{mrem}}{\text{yr}} \right) = \left(\frac{\text{pCi-sec}}{\mu\text{Ci-m}^3} \right) \sum \left(\frac{\mu\text{Ci}}{\text{sec}} \right) * \left(\frac{\text{mrem-m}^3}{\text{pCi-yr}} \right)$$

The selection of critical receptor, outlined in Part B, Section 7.3 is inherent in the derived Method I, since the maximum expected off-site long-term average atmospheric dispersion factor is used. The sum of doses from both plant vent stack and ground level releases must be considered for determination of Technical Specification compliance. All noble gases in Table B.1-10 should be considered.

A Method II analysis could include the use of actual concurrent meteorology to assess the dose rates as the result of a specific release.

7.2.2 Skin Dose Rate from Noble Gases

This section serves: (1) to document the development of the Method I equation, (2) to provide background information to Method I users, and (3) to identify the general equations parameters and approaches to Method II-type dose rate assessments. The methods to calculate skin dose rate parallel the total body dose rate methods in Part B, Section 7.2.1. Only the differences are presented here.

Method I may be used to show that the Part A Controls which limit skin dose rate from noble gases released to the atmosphere (Part A Control C.7.1.1) has been met for the peak noble gas release rate.

The annual skin dose limit is 3,000 mrem (from NBS Handbook 69, Reference D, pages 5 and 6, is 30 rem/10). The factor of 10 reduction is to account for non-occupational dose limits.

It is the skin dose commitment to the critical, or most limiting, off-site receptor assuming long-term site average meteorology and that the release rate reading remains constant over the entire year.

Method I was derived from the general equation B-9 in Regulatory Guide 1.109 as follows:

$$D^S = 1.11 D_{\text{air}}^{\gamma} + 3.17 \text{E}+04 \sum_i \dot{Q}_i [\text{X}/\text{Q}] \text{DFS}_i \quad (7-4)$$

$$\left(\frac{\text{mrem}}{\text{yr}} \right) = \left(\frac{\text{mrem}}{\text{mrad}} \right) \left(\frac{\text{mrad}}{\text{yr}} \right) \left(\frac{\text{pCi-yr}}{\text{Ci-sec}} \right) \frac{\text{Ci}}{\text{yr}} \left(\frac{\text{sec}}{\text{m}^3} \right) \left(\frac{\text{mrem- m}^3}{\text{pCi-yr}} \right)$$

where:

1.11 = Average ratio of tissue to air absorption coefficients (will convert mrad in air to mrem in tissue).

DFS_i = Beta skin dose factor for a semi-infinite cloud of radionuclide "i" which includes the attenuation by the outer "dead" layer of the skin.

$$D_{\text{air}}^{\gamma} = 3.17 \text{E}+04 \sum_i \dot{Q}_i [\text{X}/\text{Q}] \text{DF}_i^{\gamma} \quad (7-5)$$

$$\left(\frac{\text{mrad}}{\text{yr}} \right) = \left(\frac{\text{pCi-yr}}{\text{Ci-sec}} \right) \left(\frac{\text{Ci}}{\text{yr}} \right) \left(\frac{\text{sec}}{\text{m}^3} \right) \left(\frac{\text{mrad- m}^3}{\text{pCi-yr}} \right)$$

DF_i^γ = Gamma air dose factor for a uniform semi-infinite cloud of radionuclide "i".

Now it is assumed for the definition of (X/Q)^γ from Reference B that:

$$D_{\text{finite}}^{\gamma} = D_{\text{air}}^{\gamma} [\text{X}/\text{Q}]^{\gamma} / [\text{X}/\text{Q}] \quad (7-6)$$

$$\left(\frac{\text{mrad}}{\text{yr}} \right) = \left(\frac{\text{mrad}}{\text{yr}} \right) \left(\frac{\text{sec}}{\text{m}^3} \right) \left(\frac{\text{m}^3}{\text{sec}} \right)$$

and

$$Q_i = 31.54 \dot{Q}_i \quad (7-7)$$

$$\left(\frac{\text{Ci}}{\text{yr}} \right) = \left(\frac{\text{Ci-sec}}{\mu\text{Ci-yr}} \right) \left(\frac{\mu\text{Ci}}{\text{sec}} \right)$$

so:

$$\dot{D}_{skin} = 1.11 \cdot 10^6 \left[\frac{X}{Q} \right]^{\gamma} \sum_i \dot{Q}_i * DF_i^{\gamma} \quad (7-8)$$

$$\left(\frac{\text{mrem}}{\text{yr}} \right) = \left(\frac{\text{mrem}}{\text{mrad}} \right) \left(\frac{\text{pCi}}{\mu\text{Ci}} \right) \left(\frac{\text{sec}}{\text{m}^3} \right) \left(\frac{\mu\text{Ci}}{\text{sec}} \right) \left(\frac{\text{mrad} \cdot \text{m}^3}{\text{pCi} \cdot \text{yr}} \right)$$

$$+ 10^6 \frac{X}{Q} \sum_i \dot{Q}_i DFS_i$$

$$\left(\frac{\text{pCi}}{\mu\text{Ci}} \right) \left(\frac{\text{sec}}{\text{m}^3} \right) \left(\frac{\mu\text{Ci}}{\text{sec}} \right) \left(\frac{\text{mrem} \cdot \text{m}^3}{\text{pCi} \cdot \text{yr}} \right)$$

Substituting atmospheric dispersion factors for an elevated gaseous effluent release point, Equation 7-8 takes the following form:

$$\dot{D}_{skin(e)} = [1.11 * 10^6 * 8.5 \cdot 10^{-7} * \sum_i (\dot{Q}_i * DF_i^{\gamma})] + [10^6 * 8.2 \cdot 10^{-7} * \sum_i (\dot{Q}_i * DFS_i)]$$

which yields:

$$\dot{D}_{skin(e)} = [0.94 \sum_i (\dot{Q}_i * DF_i^{\gamma})] + [0.82 \sum_i (\dot{Q}_i * DFS_i)]$$

$$\left(\frac{\text{mrem}}{\text{yr}} \right) = \left(\frac{\text{pCi} \cdot \text{sec} \cdot \text{mrem}}{\mu\text{Ci} \cdot \text{m}^3 \cdot \text{mrad}} \right) \sum \left(\frac{\mu\text{Ci}}{\text{sec}} * \frac{\text{mrem} \cdot \text{m}^3}{\text{pCi} \cdot \text{yr}} \right) + \frac{\text{pCi} \cdot \text{sec}}{\mu\text{Ci} \cdot \text{m}^3} \sum \left(\frac{\mu\text{Ci}}{\text{sec}} * \frac{\text{mrem} \cdot \text{m}^3}{\text{pCi} \cdot \text{yr}} \right) \quad (7-9a)$$

defining:

$$DF_{i(e)}' = 0.94 DF_i^{\gamma} + 0.82 DFS_i \quad (7-10a)$$

Then the off-site skin dose rate equation for an elevated gaseous effluent release point is:

$$\dot{D}_{skin(e)} = \sum_i \dot{Q}_i * DF_{i(e)}' \quad (3-4a)$$

$$\left(\frac{\text{mrem}}{\text{yr}} \right) = \sum \left(\frac{\mu\text{Ci}}{\text{sec}} * \frac{\text{mrem} \cdot \text{sec}}{\mu\text{Ci} \cdot \text{yr}} \right)$$

For an off-site receptor and a ground level gaseous effluent release point, Equation 7-8 becomes:

$$\dot{D}_{skin(g)} = [1.11 * 10^6 * 3.4 \cdot 10^{-6} * \sum_i (\dot{Q}_i * DF_i^{\gamma})] + [10^6 * 1.0 \cdot 10^{-5} * \sum_i (\dot{Q}_i * DFS_i)]$$

which yields:

$$\begin{aligned} \dot{D}_{\text{skin(g)}} &= [3.8 \sum_i (\dot{Q}_i * DF_i^g)] + [10 \sum_i (\dot{Q}_{\text{ii}} * DFS_i)] \\ &= \sum_i \dot{Q}_i [3.8 DF_i^g + 10 DFS_i] \end{aligned} \quad (7-9b)$$

defining:

$$DF_{i(g)}^g = 3.8 DF_i^g + 10 DFS_i \quad (7-10b)$$

Then the off-site skin dose rate equation for ground level gaseous effluent release points is:

$$\dot{D}_{\text{skin(g)}} = \sum_i \dot{Q}_i * DF_{i(g)}^g \quad (3-4b)$$

The selection of critical receptor, outlined in Part B, Section 7.3, is inherent in the derived Method I, as it is based on the determined maximum expected off-site atmospheric dispersion factors. All noble gases in Table B.1-10 must be considered.

7.2.3 Critical Organ Dose Rate from Iodines, Tritium and Particulates With Half-Lives Greater Than Eight Days, (Including Carbon-14)

This section serves: (1) to document the development of the Method I equation, (2) to provide background information to Method I users, and (3) to identify the general equation's parameters and approach to Method II type dose rate assessments. The methods to calculate skin dose rate parallel the total body dose rate methods in Part B, Section 7.2.1.

Method I may be used to show that the Part A Controls which limit organ dose rate from iodines, tritium and radionuclides in particulate form with half lives greater than 8 days released to the atmosphere (Part A Control C.7.1.1) has been met for the peak above-mentioned release rates. The annual organ dose limit is 1500 mrem (from NBS Handbook 69, Reference D, pages 5 and 6). It is evaluated by looking at the critical organ dose commitment to the most limiting off-site receptor assuming long-term site average meteorology.

The equation for \dot{D}_{co} is derived from a form of Equation 3-8 in Part B, Section 3.9 by applying the conversion factor, 3.154E+07 (sec/yr) and converting Q to \dot{Q} $\mu\text{Ci}/\text{sec}$. To account for the dose rate contribution from C-14 when surveillance measurements of its concentration in plant effluents are not made, a default release rate value of 3.82E-01 $\mu\text{Ci}/\text{second}$ (12.06 Ci /yr per HPSTID 11-004 which applies the methodology outlined in Reference G) of total C-14 is used to estimate a site specific critical organ dose rate contribution from its continuous discharge of 0.611 mrem/year:

$$\begin{aligned} \dot{D}_{\text{co}} &= 3.15 \text{E}+ 07 * \sum_i (\dot{Q}_i * DFG_{i\text{co}}) + [0.611]_{\text{C-14}} \\ \left(\frac{\text{mrem}}{\text{yr}} \right) &= \left(\frac{\text{sec}}{\text{yr}} \right) \sum \left(\frac{\mu\text{Ci}}{\text{sec}} \right) * \left(\frac{\text{mrem}}{\mu\text{Ci}} \right) + \left(\frac{\text{mrem}}{\text{yr}} \right) \end{aligned} \quad (7-12)$$

Equation 7-12 is rewritten in the form:

$$\dot{D}_{co} = \sum_i (\dot{Q}_i * DFG'_{ico}) + [6.11E - 01]_{C - 14}$$

$$\left(\frac{\text{mrem}}{\text{yr}} \right) = \sum \left(\frac{\mu\text{Ci}}{\text{sec}} \right) * \left(\frac{\text{mrem- sec}}{\mu\text{Ci- yr}} \right) + \left(\frac{\text{mrem}}{\text{yr}} \right) \quad (7-12a)$$

where:

$$DFG'_{ico} = 3.154E+ 07 * DFG_{ico} \quad (7-13)$$

$$\left(\frac{\text{mrem- sec}}{\mu\text{Ci- yr}} \right) = \left(\frac{\text{sec}}{\text{yr}} \right) * \left(\frac{\text{mrem}}{\mu\text{Ci}} \right)$$

And

6.11E-01 (mrem/yr) is the fixed default dose rate contribution from the estimated annual release of C-14 at the location of the maximum exposed individual off-site (No direct surveillance measurements for C-14 are routinely performed on plant effluents).

The dose conversion factor, DFG_{ico} , has been developed for both elevated gaseous effluent release points and ground level gaseous effluent release points ($DFG_{ico(e)}$ and $DFG_{ico(g)}$), respectively. These dose factors are used to determine accumulated doses over extended periods and have been calculated with the Shielding Factor (SF) for ground plane exposure to gamma emitters set equal to 0.7, as referenced in Regulatory Guide 1.109. In the case of the dose rate conversion factors ($DFG'_{ico(e)}$ and $DFG'_{ico(g)}$), the dose conversion factors from which they were derived were calculated with the Shielding Factor (SF) for ground plane exposure set equal to 1.0.

For an off-site receptor and elevated effluent release point, the critical organ dose rate equation is:

$$\dot{D}_{co(e)} = \sum_i (\dot{Q}_i * DFG'_{ico(e)}) + [6.11E - 01]_{C - 14} \quad (3-5a)$$

$$\left(\frac{\text{mrem}}{\text{yr}} \right) = \sum \left(\frac{\mu\text{Ci}}{\text{sec}} * \frac{\text{mrem- sec}}{\mu\text{Ci- yr}} \right) + \left(\frac{\text{mrem}}{\text{yr}} \right)$$

For an off-site receptor and ground level effluent release point, the critical organ dose rate equation is:

$$\dot{D}_{co(g)} = \sum_i (\dot{Q}_i * DFG'_{ico(g)}) \quad (3-5b)$$

$$\left(\frac{\text{mrem}}{\text{yr}} \right) = \sum \left(\frac{\mu\text{Ci}}{\text{sec}} * \frac{\text{mrem- sec}}{\mu\text{Ci- yr}} \right)$$

Note: Gaseous C-14 from Reactor Coolant degassing is processed through the waste gas system, or discharged via Containment Building purges, and released to the plant vent stack (elevated release). As such, no significant contribution to C-14 releases is assumed via ground release points.

The selection of critical receptor, outlined in Part B, Section 7.3 is inherent in Method I, as are the expected atmospheric dispersion factors.

In accordance with the Basis Statement 3/4.11.2.1 in NUREG-0472, and the base's section for the organ dose rate limit given for Part A Control C.7.1.1 a Method II dose rate calculation, for compliance purposes, can be based on restricting the inhalation pathway to a child's thyroid to less than or equal to 1,500 mrem/yr. Concurrent meteorology with time of release may also be used to assess compliance for a Method II calculation.

7.2.4 Gamma Dose to Air from Noble Gases

This section serves: (1) to document the development and conservative nature of Method I equations to provide background information to Method I users, and (2) to identify the general equations, parameters and approaches to Method II-type dose assessments.

Method I may be used to show that the Part A Control C.7.2.1 which limits off-site gamma air dose from gaseous effluents has been met for releases over appropriate periods. This Part A Control is based on the objective in 10CFR50, Appendix I, Subsection B.1, which limits the estimated gamma air dose in off-site unrestricted areas.

NUREG/CR-2919 presents a methodology for determining atmospheric dispersion factors (CHI/Q values) for intermittent releases at user specified receptor locations (intermittent releases being defined as releases with durations between 1 and 8,760 hours). The CHI/Q values for intermittent releases are determined by linearly interpolating (on a log-log basis) between an hourly 15-percentile CHI/Q value and an annual average CHI/Q value as a function of release duration. This methodology has been adopted to produce a set of time-dependent atmospheric dispersion factors for Method I calculations.

For any noble gas release, in any period, the increment in dose is taken from Equations B-4 and B-5 of Regulatory Guide 1.109 with the added assumption that $D_{finite}^{\gamma} = D^{\gamma} [X/Q]^{\gamma} / [X/Q]$:

$$\Delta D_{air(e)}^{\gamma} = 3.17E+4 [X/Q]^{\gamma} \sum_i Q_i DF_i^{\gamma}$$

$$(\text{mrad}) = \left(\frac{\text{pCi} - \text{yr}}{\text{Ci} - \text{sec}} \right) \left(\frac{\text{sec}}{\text{m}^3} \right) (\text{Ci}) \left(\frac{\text{mrad} - \text{m}^3}{\text{pCi} - \text{yr}} \right) \quad (7-14)$$

where:

3.17E+04 = Number of pCi per Ci divided by the number of seconds per year.

$[X/Q]^{\gamma}$ = Annual average gamma atmospheric dispersion factor for the receptor location of interest.

Q_i = Number of curies of noble gas "i" released.

DF_i^{γ} = Gamma air dose factor for a uniform semi-infinite cloud of radionuclide "i".

Incorporating a unitless release duration adjustment term t^{-a} (where "a" is a constant and "t" is the total release duration in hours), and the conversion factor for Ci to μCi (to accommodate the use of a release rate Q in μCi), and substituting the 1-hour gamma atmospheric dispersion factor in place of the long term average gamma atmospheric dispersion factor in Equation 7-14 leads to:

$$D_{\text{air}}^{\gamma} = 3.17\text{E}-02 * [X/Q]_{\text{1hr}}^{\gamma} * t^{-a} * \sum_i \left(Q_i * DF_i^{\gamma} \right)$$

$$(\text{mrad}) = \left(\frac{\text{pCi-yr}}{\mu\text{Ci-sec}} \right) * \left(\frac{\text{sec}}{\text{m}^3} \right) * \sum \left(\mu\text{Ci} * \frac{\text{mrad-m}^3}{\text{pCi-yr}} \right) \quad (3-6)$$

For an elevated release, the equation used for an off-site receptor is:

$$D_{\text{air(e)}}^{\gamma} = 3.17\text{E}-02 * [1.0\text{E}-05] * t^{-0.274} * \sum_i \left(Q_i * DF_i^{\gamma} \right)$$

which leads to:

$$D_{\text{air(e)}}^{\gamma} = 3.2\text{E}-07 * t^{-0.274} * \sum_i \left(Q_i * DF_i^{\gamma} \right) \quad (3-6a)$$

$$(\text{mrad}) = \left(\frac{\text{pCi-yr}}{\mu\text{Ci-m}^3} \right) * \sum \left(\mu\text{Ci} * \frac{\text{mrad-m}^3}{\text{pCi-yr}} \right)$$

For a ground-level release, the equation used for an off-site receptor is:

$$D_{\text{air(g)}}^{\gamma} = 3.17\text{E}-02 * [4.9\text{E}-05] * t^{-0.293} * \sum_i \left(Q_i * DF_i^{\gamma} \right)$$

which leads to:

$$D_{\text{air(g)}}^{\gamma} = 1.6\text{E}-06 * t^{-0.293} * \sum_i \left(Q_i * DF_i^{\gamma} \right) \quad (3-6b)$$

$$(\text{mrad}) = \left(\frac{\text{pCi-yr}}{\mu\text{Ci-m}^3} \right) * \sum \left(\mu\text{Ci} * \frac{\text{mrad-m}^3}{\text{pCi-yr}} \right)$$

The major difference between Method I and Method II is that Method II would use actual or concurrent meteorology with a specific noble gas release spectrum to determine $[X/Q]^{\gamma}$ rather than use the site's long-term average meteorological dispersion values.

7.2.5 Beta Dose to Air from Noble Gases

This section serves: (1) to document the development and conservative nature of Method I equations to provide background information to Method I users, and (2) to identify the general equations, parameters and approaches to Method II-type dose assessments.

Method I may be used to show that Part A Control C.7.2.1, which limits off-site beta air dose from gaseous effluents, has been met for releases over appropriate periods. This Part A Control is based on the objective in 10CFR50, Appendix I, Subsection B.1, which limits the estimated beta air dose in off-site unrestricted area locations.

For any noble gas release, in any period, the increment in dose is taken from Equations B-4 and B-5 of Regulatory Guide 1.109:

$$\Delta D_{\text{air}}^{\beta} = 3.17\text{E} - 02 * X/Q \sum_i (Q_i * DF_i^{\beta}) \quad (7-15)$$

$$(\text{mrad}) = \left(\frac{\text{pCi} - \text{yr}}{\mu\text{Ci} - \text{sec}} \right) * \left(\frac{\text{sec}}{\text{m}^3} \right) (\mu\text{Ci}) \left(\frac{\text{mrad} - \text{m}^3}{\text{pCi} - \text{yr}} \right)$$

where:

DF_i^{β} = Beta air dose factors for a uniform semi-infinite cloud of radionuclide "i".

Incorporating the term t^{-a} into Equation 7-15 leads to:

$$D_{\text{air}}^{\beta} = 3.17\text{E} - 02 * X/Q_{1\text{hr}} * t^{-a} * \sum_i (Q_i * DF_i^{\beta}) \quad (3-7)$$

$$(\text{mrad}) = \left(\frac{\text{pCi} - \text{yr}}{\mu\text{Ci} - \text{sec}} \right) * \left(\frac{\text{sec}}{\text{m}^3} \right) * () * \sum \left(\mu\text{Ci} * \frac{\text{mrad} - \text{m}^3}{\text{pCi} - \text{yr}} \right)$$

Where $X/Q_{1\text{hr}}$ = average 1-hour undepleted atmospheric dispersion factor.

For an elevated release, the equation used for an off-site receptor is:

$$D_{\text{air(e)}}^{\beta} = 3.17\text{E} - 02 * 1.3\text{E} - 05 * t^{-0.302} * \sum_i (Q_i * DF_i^{\beta})$$

$$(\text{mrad}) = \left(\frac{\text{pCi} - \text{yr}}{\mu\text{Ci} - \text{sec}} \right) * \left(\frac{\text{sec}}{\text{m}^3} \right) * () * \sum \left(\mu\text{Ci} * \frac{\text{mrad} - \text{m}^3}{\text{pCi} - \text{yr}} \right)$$

which leads to:

$$D_{\text{air(e)}}^{\beta} = 4.0\text{E} - 07 * t^{-0.302} * \sum_i (Q_i * DF_i^{\beta}) \quad (3-7a)$$

$$(\text{mrad}) = \left(\frac{\text{pCi} - \text{yr}}{\mu\text{Ci} - \text{m}^3} \right) * () * \sum \left(\mu\text{Ci} * \frac{\text{mrad} - \text{m}^3}{\text{pCi} - \text{yr}} \right)$$

For a ground-level release, the equation used for an off-site receptor is:

$$D_{\text{air(g)}}^{\beta} = 3.17\text{E} - 02 * 1.9\text{E} - 04 * t^{-0.320} * \sum_i (Q_i * DF_i^{\beta})$$

$$(\text{mrad}) = \left(\frac{\text{pCi} - \text{yr}}{\mu\text{Ci} - \text{sec}} \right) * \left(\frac{\text{sec}}{\text{m}^3} \right) * () * \sum \left(\mu\text{Ci} * \frac{\text{mrad} - \text{m}^3}{\text{pCi} - \text{yr}} \right)$$

which leads to:

$$D_{\text{air(g)}}^{\beta} = 6.1\text{E}-06 * t^{-0.302} * \sum_i (Q_i * DF_i^{\beta}) \quad (3-7b)$$

$$(\text{mrad}) = \left(\frac{\text{pCi} \cdot \text{yr}}{\mu\text{Ci} \cdot \text{m}^3} \right) * () * \sum \left(\mu\text{Ci} * \frac{\text{mrad} \cdot \text{m}^3}{\text{pCi} \cdot \text{yr}} \right)$$

7.2.6 Dose to Critical Organ from Iodines, Tritium and Particulates with Half-Lives Greater Than Eight Days, (Including Carbon-14)

This section serves: (1) to document the development and conservative nature of Method I equations to provide background information to Method I users, and (2) to identify the general equations, parameters and approaches to Method II-type dose assessments.

Method I may be used to show that the Part A Controls which limit off-site organ dose from gases (C.7.3.1 and C.8.1.1) have been met for releases over the appropriate periods. Part A Control C.7.3.1 is based on the ALARA objectives in 10CFR50, Appendix I, Subsection II C. Part A Control C.8.1.1 is based on Environmental Standards for Uranium Fuel Cycle in 40CFR190, which applies to direct radiation as well as liquid and gaseous effluents. These methods apply only to iodine, tritium, and particulates in gaseous effluent contribution.

Method I was developed such that "the actual exposure of an individual ... is unlikely to be substantially underestimated" (10CFR50, Appendix I). The use below of a single "critical receptor" provides part of the conservative margin to the calculation of critical organ dose in Method I. Method II allows that actual individuals, associated with identifiable exposure pathways, be taken into account for any given release. In fact, Method I was based on a Method II analysis of a critical receptor assuming all pathways present. That analysis was called the "base case"; it was then reduced to form Method I. The base case, the method of reduction, and the assumptions and data used are presented below.

The steps performed in the Method I derivation follow. First, the dose impact to the critical receptor [in the form of dose factors DF_{ico} (mrem/ μCi)] for a unit activity release of each iodine, tritium, and particulate radionuclide with half lives greater than eight days to gaseous effluents was derived (Carbon-14 assessment is derived separately). Six exposure pathways (ground plane, inhalation, stored vegetables, leafy vegetables, milk, and meat ingestion) were assumed to exist at the site boundary (not over water or marsh areas) which exhibited the highest long-term X/Q. Doses were then calculated to six organs (bone, liver, kidney, lung, GI-LLL, and thyroid), as well as for the whole body and skin for four age groups (adult, teenager, child, and infant) due to the seven combined exposure pathways. For each radionuclide, the highest dose per unit activity release for any organ (or whole body) and age group was then selected to become the Method I site-specific dose factors. The base case, or Method I analysis, uses the general equations methods, data, and assumptions in Regulatory Guide 1.109 (Equation C-2 for doses resulting from direct exposure to contaminated ground plane; Equation C-4 for doses associated with inhalation of all radionuclides to different organs of individuals of different age groups; and Equation C-13 for doses to organs of individuals in different age groups resulting from ingestion of radionuclides in produce, milk, meat, and leafy vegetables in Reference A). Tables B.7-2 and B.7-3 outline human consumption and environmental parameters used in the analysis. It is conservatively assumed that the critical receptor lives at the "maximum off-site atmospheric dispersion factor location" as defined in Section 7.3.

The resulting site-specific dose factors are for the maximum organ which combine the limiting age group with the highest dose factor for any organ with each nuclide. These critical organ, critical age dose factors are given in Table B.1-12. Appendix A provides an example of the development of Method I gaseous dose conversion factor for site-specific conditions at Seabrook.

For any iodine, tritium, and particulate gas release, during any period, the increment in dose from radionuclide "i" is:

$$\Delta D_{iCO} = Q_i DFG_{iCO} \quad (7-16)$$

where DFG_{iCO} is the critical dose factor for radionuclide "i" and Q_i is the activity of radionuclide "i" released in microcuries.

Special Case: Carbon-14

Carbon-14 is handled as a separate case from that of other gaseous effluents (Noble gases, iodines, tritium and particulates) since the plant does not perform surveillance measurements of the amount of C-14 in plant systems / release point vents, but determines the amount of C-14 released over the year by calculation based on power level and other operating parameters using the methodology detailed in the EPRI Technical Report, "Estimation of Carbon-14 in Nuclear Power Plant Gaseous Effluents" (Reference G). The primary exposure pathways associated with Carbon-14 are ingestion of food products that have incorporated Carbon-14 (in the form of CO_2) via photosynthesis (off-site only) and inhalation. The fraction of total Carbon-14 that is CO_2 is set at 20% based on Seabrook design and industry experience. A full year's consumption of food products are assumed to be grown from the highest impacted garden during the growing season (2nd and 3rd quarters).

Doses from the ingestion of vegetation exposed to airborne Carbon-14 effluents during the growing season (second and third quarters) are considered. For inhalation doses, the total C-14 releases in all four calendar quarters is considered.

For 2010, the calculated reference total C-14 released (stack vent elevated release only) was 2.05 Curies, 1.86 curies, 3.13 Curies, and 5.02 Curies for the 1st, 2nd, 3rd, and 4th calendar quarters, respectively. As a conservative default set of values for estimating the maximum dose impact from Carbon-14, the quarterly release totals were reassigning such that the highest quarterly Carbon-14 releases were assumed to occur during the growing season periods with the most limiting dispersion estimates (see Table B.7-7). The following chart list the Carbon-14 curie releases by quarter and chemical form which are used in estimating the default dose impacts:

Carbon-14 Releases in Gaseous Effluents

Period	C-14 as CO_2 (Curies)	Total C-14
1 st Quarter	0.41	2.05
2 nd Quarter, (Max)	1.00	5.02
3 rd Quarter, (Growing)	0.63	3.13
4 th Quarter	0.37	1.86
Annual Totals	2.41	12.06

Regulatory Guide 1.109 (Reference A) provides default consumption rates for fruits and vegetable for the three age groups of interest. The concentration of C-14 in vegetation is calculated using equation C-8 (adjusted for time of release) from Regulatory Guide 1.109, while the ingestion dose impacts follow equation C-13. The inhalation dose impacts follow equation C-4 from Regulatory Guide 1.109. The resulting annual dose impact at the location of maximum off-site receptor is 6.11E-01 mrem. Reducing this quantity to an average dose rate by dividing by the number of hours in a year (8760 hrs) equals 6.97E-05 mrem/hour. This quantity can be multiplied by the duration of the release period (in hours) and added to the critical organ contribution from all measured radionuclides (iodines, tritium and particulates) recorded for a release period in order to account for the C-14 contribution during that period. Carbon-14 is normally treated as a continuous release such that all hours in a reporting period (such as 730 hours for a month) must be accounted for.

Applying this information, it follows that the general form for the critical organ dose equation is:

$$D_{co} = (X/Q)_{1hr}^{depl} / (X/Q)_{an}^{depl} * t^{-a} * \sum_i (Q_i * DFG_{ico}) + [DF_{C-14} * tc]_{C-14} \quad (3-8)$$

$$\text{mrem} = \left(\frac{\text{sec}}{\text{m}^3} \right) / \left(\frac{\text{sec}}{\text{m}^3} \right) * () * \sum \left(\mu\text{Ci} * \frac{\text{mrem}}{\mu\text{Ci}} \right) + (\text{mrem/hr}) * \text{hr}$$

Substituting specific values associated with the maximum off-site receptor location and elevated release condition yields:

$$D_{co(e)} = (1.13\text{E}-05) / (7.50\text{E}-07) * t^{-0.298} * \sum_i (Q_i * DFG_{ico(e)}) + [6.97\text{E}-05 * tc]_{C-14}$$

Where

6.97E-05 mrem/hr equals the site specific default dose factor (DF_{C-14}) contribution from Carbon-14 due to food ingestion and inhalation to the critical organ dose at the limiting off-site location, and tc reflects the duration of the release period (in hours) for all other radionuclides in the release class (iodines, tritium and particulates with half-lives greater than 8 days). Since the release of C-14 is considered to be continuous, the total tc for the year must account for 8760 hours of release regardless if any other radionuclide is detected to be present in the effluent stream.

And with tc = 730 hours (1 month), the equation reduces to:

$$D_{co(e)} = 15.0 * t^{-0.298} * \sum_i (Q_i * DFG_{ico(e)}) \text{ plus } [0.051 \text{ mrem/mo.}]_{C-14} \quad (3-8a)$$

For the maximum off-site receptor location and ground-level release conditions, the equation is:

$$D_{co(g)} = (1.71\text{E}-04) / (9.64\text{E}-06) * t^{-0.317} * \sum_i (Q_i * DFG_{ico(g)})$$

which reduces to:

$$D_{co(g)} = 17.7 * t^{-0.317} * \sum_i (Q_i * DFG_{ico(g)}) \quad (3-8b)$$

7.2.7 Special Receptor Gaseous Release Dose Calculations

Part A Section 10.2 requires that the doses to individuals involved in recreational activities within the site boundary are to be determined and reported in the Annual Radioactive Effluent Release Report.

For members of the public who may be at times within the Site Boundary, the occupancy time is expected to be sufficiently low to compensate for any increase in the atmospheric diffusion factor above that for the maximum impacted Site Boundary location. To illustrate this ranking of maximum Site Boundary to on-site locations where members of the public could be present, the following calculation provides the relative order of each of the receptor locations.

The general form of the dose equation can be shown as:

$$\text{Dose} = K \times U_{ap} \times X/Q_{pt} \times DF_{iap} \times OF_{pt}$$

Where:

K = Units conversion constant. This would be the same for all receptor points.

U_{ap} = Usage factor, such as inhalation rate or ingestion rate of food products by age group. This would include all pathways of exposure assumed at the Site Boundary, but only inhalation and ground plane exposure at each on-site receptor.

X/Q_{pt} = The atmospheric diffusion factor specific to a receptor point.

DF_{iap} = A dose conversion factor based on radionuclide, exposure pathways (inhalation, ground plane or ingestion) and age group. Site Boundary assumed to have all pathways present (conservative).

OF_{pt} = Occupancy factors which express the fraction of a year that a member of the public is exposed and is specific to each individual receptor point.

For all the factors considered in the dose estimate at each location (except the DF_{iap} which is conservatively set for the site boundary with all pathways possible), the X/Q_{pt} and the OF_{pt} are specific to a receptor location. As such, the ranking of dose importance of the maximum Site Boundary to each of the on-site receptors can be illustrated by multiply the location specific parameters together while cancelling out all the parameters which would common to each of the receptor sites. The following table shows this illustration:

Receptor location with respect to Unit 1 Containment	Long Term X/Q, undepleted (sec/m^3) (See Table B.7-5)	Occupancy Factor OF_{pt}	Relative Ranking (relative to Site B.)
Maximum Impacted Site Boundary (W 974 meters)	8.16E-07	1.0	8.16E-07 (1)
Fitness Center in Hi-Rise Bldg (WSW 384 meters)	1.61E-06	0.0416	6.70E-08 (0.082)
Firing Range (centered at W 1026 meters)	5.47E-07	0.0416	2.28E-08 (0.028)
Science & Nature Center (SW 488 meters)	1.61E-06	0.0014	2.25E-09 (0.0028)

As can be seen in the above illustration, the Site Boundary location has the highest dose ranking of any on-site receptor due to the effects of the occupancy factors applied to the on-site locations. For the site boundary location and beyond where the plant does not have right to exercise or limit access, occupancy is assumed to be full time (1.0). For both the Fitness Center and the Firing Range, a conservative assumption is applied that members of the public use the facilities 1 hour per day, 7 days per week, for 52 weeks per year, which when represented as a fraction of a year yields the occupancy factor of 0.0416. For the Science & Nature Center, it is assumed that education trips total 12.5 hours per year per individual (2.5 hours per trip x 5 trips per year, assumed) which on an annual basis gives a fraction of 0.0014.

As a result, dose rates and air dose estimates are bounded by those calculations that assess the maximum off-site location. Section B.7.2.7.6 does provide a methodology for estimating the dose impacts at the on-site receptors for consideration of the critical organ dose from Iodines, Tritium, Carbon-14 and particulates with half-lives greater than 8 days for purposes of providing information to users of these facilities.

7.2.7.1 -Deleted-

7.2.7.2 -Deleted-

7.2.7.3 -Deleted-

7.2.7.4 -Deleted-

7.2.7.5 -Deleted-

7.2.7.6 Critical Organ Dose from Iodines, Tritium and Particulates With Half-Lives Greater Than Eight Days, (Including Carbon-14)

Method I was derived as described in Part B, Section 7.2.3. The Critical Organ Dose equations for receptors at the Science & Nature Center, the "Fitness Center" and "Firing Range" were derived from Equation 3-8. The following general equation incorporates (i) a ratio of the average 1-hour depleted atmospheric dispersion factor to the average annual depleted atmospheric dispersion factor, (ii) the unitless t^{-a} term, and (iii) the OF:

$$D_{co} = (X/Q)_{1-hr}^{depl} / (X/Q)_{an}^{depl} * t^{-a} * OF * \sum_i (Q_i * DFG_{ico}) + OF * DF_{C-14} * tc$$

$$(mrem) = \left(\frac{sec}{m^3} \right) / \left(\frac{sec}{m^3} \right) * () * () * \sum \left(\mu Ci * \frac{mrem}{\mu Ci} \right) + () * (mrem/hr) * (hr)$$

Applying the Science & Nature Center-specific factors for elevated release conditions produces the equation:

$$D_{coE(e)} = (3.55E-05) / (1.51E-06) * t^{-0.348} * 0.0014 * \sum_i (Q_i * DFG_{icoE(e)}) + [0.0014 * 2.52E-06 * tc]_{C-14}$$

Where

2.52E-06 mrem/hr equals the site specific default dose factor (DF_{C-14E}) contribution from Carbon-14 due to inhalation to the critical organ dose at the Science and Nature Center for an annual release of 12.06 Curies of total C-14, and tc is the C-14 release duration (hours) associated with the period of dose estimation being considered, and 0.0014 is the occupancy fraction of a year that a member of the public is assumed to be present. This reduces to:

$$D_{coE(e)} = 3.3E-02 * t^{-0.348} * \sum_i (Q_i * DFG_{icoE(e)}) + [3.53E-09 * tc]_{C-14} \quad (3-8c)$$

$$(mrem) = () * () * \sum \left(\mu Ci * \frac{mrem}{\mu Ci} \right) + (mrem/hr) * (hr)$$

And with tc = 730 hrs. (1 month) to set the monthly dose contribution from C-14, the equation reduces to:

$$D_{coE(e)} = 3.3E-02 * t^{-0.348} * \sum (Q_i * DFG_{icoE(e)}) \text{ plus } [2.58E-06 \frac{(mrem)}{Month}]_{C-14} \quad (3-8c)$$

$$(mrem) = () () \left(\frac{\mu Ci * mrem}{\mu Ci} \right) \text{ plus } \left[\frac{() mrem}{month} \right]$$

where t defines the duration of releases for all radionuclides other than C-14 released during the month.

For a ground-level release, the equation for a receptor at the Science & Nature Center is:

$$D_{\text{coE(g)}} = (5.21\text{E-}04)/(2.23\text{E-}05) * t^{-0.347} * 0.0014 * \sum_i (Q_i * \text{DFG}_{\text{icoE(g)}})$$

which reduces to:

$$D_{\text{coE(g)}} = 3.3\text{E-}02 * t^{-0.347} * \sum_i (Q_i * \text{DFG}_{\text{icoE(g)}}) \quad (3-8d)$$

$$(\text{mrem}) = () * () * \sum \left(\mu\text{Ci} * \frac{\text{mrem}}{\mu\text{Ci}} \right)$$

The specific Critical Organ Dose equation for a receptor at the Firing Range under elevated release conditions is:

$$D_{\text{coFR(e)}} = (1.39\text{E-}05)/(5.01\text{E-}07) * t^{-0.366} * 0.0416 * \sum (Q_i * \text{DFG}_{\text{icoFR(e)}}) + [3.56\text{E-}08 * t\text{c}]_{\text{C-14}}$$

Where

1.39E-05 = the depleted 1 hour X/Q from elevated releases to the on-site Firing Range (sec/m³).

5.01E-07 = the long term average depleted X/Q from elevated releases to the on-site Firing Range (sec/m³).

3.56E-08 = the site specific default dose factor (DF_{C-14FR}) contribution from Carbon-14 due to inhalation to the critical organ dose at the Firing Range for an annual release of 12.06 Curies of total C-14 (mrem/hour). It includes the location specific occupancy correction factor (0.0416).

tc = the C-14 release duration (hours) associated with the period of dose estimation being considered. C-14 is treated as a continuous release such that the minimum required dose assessment period of monthly (730 hours) needs to be applied to estimate the monthly contribution to the dose credited to C-14.

0.0416 = the occupancy fraction of a year that a member of the public is assumed to be present at the firing range. It is conservatively assumed that an individual would spend 1 hour per day for each day of the year (i.e., 1 hour/day x 7 days/week x 52 weeks/year divided by 8760 hours/year).

This reduces to:

$$D_{\text{coFR(e)}} = 1.15 * t^{-0.366} * \sum (Q_i * \text{DFG}_{\text{icoFR(e)}}) \text{ plus } [2.60\text{E-}05]_{\text{C-14}} \quad (3-8e)$$

$$(\text{mrem}) = () * () * \sum (\mu\text{Ci} * \frac{(\text{mrem})}{\mu\text{Ci}}) + \frac{(\text{mrem})}{\text{mo.}}$$

where t defines the duration of releases for all other radionuclides released during the month.

For a ground-level release, the equation for a receptor at the Firing Range is:

$$D_{\text{coFR(g)}} = (2.43\text{E-}04)/(6.26\text{E-}06) * t^{-0.403} * 0.0416 * \sum (Q_i * \text{DFG}_{\text{icoFR(g)}})$$

which reduces to:

$$D_{\text{coFR(g)}} = 1.61 * t^{-0.403} * \sum (Q_i * \text{DFG}_{\text{icoFR(g)}}) \quad (3-8f)$$

$$(\text{mrem}) = () * () * \sum \left(\frac{\mu\text{Ci} * (\text{mrem})}{\mu\text{Ci}} \right)$$

The specific Critical Organ Dose equation for a receptor at the Fitness Center (at the Hi-Rise Office Building) under elevated release conditions is:

$$D_{\text{coFC(e)}} = (4.00 \text{E-} 05) / (1.533 \text{E-} 06) * t^{-0.359} * 0.0416 * \sum_i (Q_i * \text{DFG}_{\text{icoFC(e)}}) + (0.0416 * 2.52 \text{E-} 06 * \text{tc})_{\text{C-14}}$$

Where

2.52E-06 mrem/hr equals the site specific default dose factor ($\text{DF}_{\text{C-14FC}}$) contribution from Carbon-14 due to inhalation to the critical organ dose at the Fitness Center for an annual release of 12.06 Curies of total C-14, tc is the C-14 release duration (hours) associated with the period of dose estimation being considered, and 0.0416 is the occupancy fraction of a year that a member of the public is assumed to be present. It is conservatively assumed that an individual would spend 1 hour per day for each day of the year (i.e., 1 hour/day x 7 days/week x 52 weeks/year divided by 8760 hours/year). This reduces to:

$$D_{\text{coFC(e)}} = 1.08 * t^{-0.359} * \sum_i (Q_i * \text{DFG}_{\text{icoFC(e)}}) \text{ plus } [1.05 \text{E-} 07 * \text{tc}]_{\text{C-14}} \quad (3-8g)$$

$$(\text{mrem}) = () * () * \sum \left(\mu\text{Ci} * \frac{\text{mrem}}{\mu\text{Ci}} \right) + (\text{mrem/hr}) * \text{tc}$$

And with tc = 730 hrs. (1 month) to set the monthly dose contribution from C-14, the equation reduces to:

$$D_{\text{coFC(e)}} = 1.08 * t^{-0.359} * \sum (Q_i * \text{DFG}_{\text{icoFC(e)}}) \text{ plus } \left[\frac{7.67 \text{E-} 05 (\text{mrem})}{\text{month}} \right]_{\text{C-14}} \quad (3-8c)$$

$$(\text{mrem}) = () () \left(\frac{\mu\text{Ci} * \text{mrem}}{\mu\text{Ci}} \right) \text{ plus } \left[\frac{() \text{mrem}}{\text{month}} \right]$$

Where t defines the duration of releases for all radionuclides other than C-14 released during the month.

For a ground-level release, the equation for a receptor at the Fitness Center is:

$$D_{\text{coFC(g)}} = (8.84 \text{ E- } 04) / (3.89 \text{ E- } 05) * t^{-0.344} * 0.0416 * \sum_i (Q_i * \text{DFG}_{\text{icoFC(g)}})$$

which reduces to:

$$D_{\text{coFC(g)}} = 0.94 * t^{-0.344} * \sum_i (Q_i * \text{DFG}_{\text{icoFC(g)}}) \quad (3-8h)$$

$$(\text{mrem}) = () * () * \sum \left(\mu \text{Ci} * \frac{\text{mrem}}{\mu \text{Ci}} \right)$$

Note: Gaseous C-14 from Reactor Coolant degassing is processed through the waste gas system, or discharged via Containment Building purges, and released to the plant vent stack (elevated release). As such, no significant contribution to C-14 release is assumed via ground release points.

The special receptor equations can be applied under the following conditions (otherwise, justify Method I or consider Method II):

1. Normal operations (nonemergency event).
2. Applicable radionuclide releases via the station vents to the atmosphere.

If Method I cannot be applied, or if the Method I dose exceeds this limit, or if a more refined calculation is required, then Method II may be applied.

Table B.7-2
Environmental Parameters for Gaseous Effluents at Seabrook Station

(Derived from Reference A)*

Variable			Vegetables		Cow Milk		Goat Milk		Meat	
			Stored	Leafy	Pasture	Stored	Pasture	Stored	Pasture	Stored
YV	Agricultural Productivity	(Kg/M ²)	2.	2.	0.70	2.	0.70	2.	0.70	2.
P	Soil Surface Density	(Kg/M ²)	240.	240.	240.	240.	240.	240.	240.	240.
T	Transport Time to User	(HRS)			48.	48.	48.	48.	480.	480.
TB	Soil Exposure Time ⁽¹⁾	(HRS)	131400.	131400.	131400.	131400.	131400.	131400.	131400.	131400.
TE	Crop Exposure Time to Plume	(HRS)	1440.	1440.	720.	1440.	720.	1440.	720.	1440.
TH	Holdup After Harvest	(HRS)	1440.	24.	0.	2160.	0.	2160.	0.	2160.
QF	Animals Daily Feed	(Kg/DAY)			50.	50.	6.	6.	50.	50.
FP	Fraction of Year on Pasture ⁽²⁾				0.50		0.50		0.50	
FS	Fraction Pasture when on Pasture ⁽³⁾				1.		1.		1.	
FG	Fraction of Stored Veg. Grown in Garden		0.76							
FL	Fraction of Leafy Veg. Grown in Garden			1.0						
FI	Fraction Elemental Iodine = 0.5									
H	Absolute Humidity = 5.60 ⁽⁴⁾	(gm/m ³)								

* Regulatory Guide 1.109, Rev. 1

Table B.7-2
Environmental Parameters for Gaseous Effluents at Seabrook Station

Notes:

- (1) For Method II dose/dose rate analyses of identified radioactivity releases of less than one year, the soil exposure time for that release may be set at 8760 hours (1 year) for all pathways.
- (2) For Method II dose/dose rate analyses performed for releases occurring during the first or fourth calendar quarters, the fraction of time animals are assumed to be on pasture is zero (nongrowing season). For the second and third calendar quarters, the fraction of time on pasture (FP) will be set at 1.0. FP may also be adjusted for specific farm locations if this information is so identified and reported as part of the land use census.
- (3) For Method II analyses, the fraction of pasture feed while on pasture may be set to less than 1.0 for specific farm locations if this information is so identified and reported as part of the land use census.
- (4) For all Method II analyses, an absolute humidity value equal to 5.6 (gm/m³) shall be used to reflect conditions in the Northeast (Reference: Health Physics Journal, Vol. 39 (August), 1980; Page 318-320, Pergammon Press).

Table B.7-3
Usage Factors for Various Gaseous Pathways at Seabrook Station

(from Reference A, Table E-5)*

Maximum Receptor:

<u>Age Group</u>	<u>Vegetables</u> (kg/yr)	<u>Leafy Vegetables</u> (kg/yr)	<u>Milk</u> (1/yr)	<u>Meat</u> (kg/yr)	<u>Inhalation</u> (m ³ /yr)
Adult	520.00	64.00	310.00	110.00	8000.00
Teen	630.00	42.00	400.00	65.00	8000.00
Child	520.00	26.00	330.00	41.00	3700.00
Infant	0.00	0.00	330.00	0.00	1400.00

The Firing Range, Fitness Center and Science & Nature Center:

<u>Age Group</u>	<u>Vegetables</u> (kg/yr)	<u>Leafy Vegetables</u> (kg/yr)	<u>Milk</u> (1/yr)	<u>Meat</u> (kg/yr)	<u>Inhalation</u> (m ³ /yr)
Adult	0.00	0.00	0.00	0.00	8000.00
Teen	0.00	0.00	0.00	0.00	8000.00
Child	0.00	0.00	0.00	0.00	3700.00
Infant	0.00	0.00	0.00	0.00	1400.00

* Regulatory Guide 1.109

7.3 Receptor Points and Average Atmospheric Dispersion Factors for Important Exposure Pathways

The gaseous effluent dose equations (Method I) have been simplified by assuming an individual whose behavior and living habits inevitably lead to a higher dose than anyone else. The following exposure pathways to gaseous effluents listed in Regulatory Guide 1.109 (Reference A) have been considered:

1. Direct exposure to contaminated air;
2. Direct exposure to contaminated ground;
3. Inhalation of air;
4. Ingestion of vegetables;
5. Ingestion of goat's milk; and
6. Ingestion of meat.

Part B, Section 7.3.1 details the selection of important off-site and on-site locations and receptors. Part B, Section 7.3.2 describes the atmospheric model used to convert meteorological data into atmospheric dispersion factors. Part B, Section 7.3.3 presents the maximum atmospheric dispersion factors calculated at each of the off-site receptor locations.

7.3.1 Receptor Locations

The most limiting site boundary location in which individuals are, or likely to be located as a place of residence was assumed to be the receptor for all the gaseous pathways considered. This provides a conservative estimate of the dose to an individual from existing and potential gaseous pathways for the Method I analysis.

This point is the west sector, 974 meters from the center of the reactor units for undepleted, depleted, and gamma X/Q calculations, and the northwest section, 914 meters for calculations with D/Q the dispersion parameter.

The site boundary in the NNE through SE sectors is located over tidal marsh (e.g., over water), and consequently are not used as locations for determining maximum off-site receptors (Reference NUREG 0133).

Three other locations (on-site) were analyzed for direct ground plane exposure and inhalation only. They are the Science & Nature Center (SW, 488 meters from Unit 1 Containment), the Firing Range for security force training, including local law enforcement (W, 1026 meters from Containment), and the Fitness Center located on the ground floor of the Hi-Rise Office Building (WSW, 384 meters from Containment). These facilities provide access to members of the public involved in activities not associated with power generation.

7.3.2 Seabrook Station Atmospheric Dispersion Model

The time average atmospheric dispersion factors for use in both Method I and Method II are computed for routine releases using the AEOLUS-2 Computer Code (Reference B).

AEOLUS-2 produces the following average atmospheric dispersion factors for each location:

1. Undepleted X/Q dispersion factors for evaluating ground level concentrations of noble gases;
2. Depleted X/Q dispersion factors for evaluating ground level concentrations of iodines and particulates;
3. Gamma X/Q dispersion factors for evaluating gamma dose rates from a sector averaged finite noble gas cloud (multiple energy undepleted source); and
4. D/Q deposition factors for evaluating dry deposition of elemental radioiodines and other particulates.

Gamma dose rate is calculated throughout this ODCM using the finite cloud model presented in "Meteorology and Atomic Energy - 1968" (Reference E, Section 7-5.2.5). That model is implemented through the definition of an effective gamma atmospheric dispersion factor, $[X/Q^y]$ (Reference B, Section 6), and the replacement of X/Q in infinite cloud dose equations by the $[X/Q^y]$.

7.3.3 Average Atmospheric Dispersion Factors for Receptors

The calculation of Method I and Method II atmospheric diffusion factors (undepleted CHI/Q, depleted CHI/Q, D/Q, and gamma CHI/Q values) utilize a methodology generally consistent with US NRC Regulatory Guide 1.111 (Revision 1) criteria and the methodology for calculating routine release diffusion factors as represented by the XOQDOQ computer code (NUREG/CR-2919). The primary vent stack is treated as a "mixed-mode" release, as defined in Regulatory Guide 1.111. Effluents are considered to be part-time ground level/part-time elevated releases depending on the ratio of the primary vent stack effluent exit velocity relative to the speed of the prevailing wind. All other release points (e.g., Turbine Building and Chemistry lab hoods) are considered ground-level releases.

In addition, Regulatory Guide 1.111 discusses the concept that constant mean wind direction models like AEOLUS-2 do not describe spatial and temporal variations in airflow such as the recirculation of airflow which can occur during prolonged periods of atmospheric stagnation. For sites near large bodies of water like Seabrook, the onset and decay of sea breezes can also result in airflow reversals and curved trajectories. Consequently, Regulatory Guide 1.111 states that adjustments to constant mean wind direction model outputs may be necessary to account for such spatial and temporal variations in air flow trajectories. Recirculation correction factors have been applied to the diffusion factors. The recirculation correction factors used are compatible to the "default open terrain" recirculation correction factors used by the XOQDOQ computer code.

The relative deposition rates, D/Q values, were derived using the relative deposition rate curves presented in Regulatory Guide 1.111 (Revision 1). These curves provide estimates of deposition rates as a function of plume height, stability class, and plume travel distance.

Receptor Locations

For ground-level releases, the downwind location of the Fitness Center, Firing Range and the Science & Nature Center were taken as the distance from the nearest point on the Unit 1 Administrative Building/Turbine Building complex. For the site boundary, the minimum distances from the nearest point on the Administration Building/Turbine Building complex to the site boundary within a 45-degree sector centered on the compass direction of interest as measured from UFSAR Figure 2.1-4A were used (with the exception that the NE-NE-E-ENE-E-ESE-SE site boundary sectors were not used because of their over-water locations).

For primary vent stack releases, the distances from the Unit 1 primary vent stack to the Fitness Center, Firing Range and the Science & Nature Center as measured from a recent site aerial photograph were used. For the site boundary, the minimum distances from the Unit 1 primary vent stack to the site boundary within a 45-degree sector centered on the compass direction of interest as measured from UFSAR Figure 2.1-4A were used (with the exception that the NNE-NE-ENE-E-ESE-SE site boundary sectors were not used because of their over-water locations).

Meteorological Data Bases

For the Fitness Center, Firing Range and Science & Nature Center receptors, the diffusion factors represent six-year averages during the time period January 1980 through December 1983 and January 1987 through December 1988 (with the exception that, because of low data recovery, April 1979 and May 1979 were substituted for April 1980 and May 1980). For the site boundary receptors, both six-year average growing season (April through September) and year-round (January through December) diffusion factors were generated, with the higher of the two chosen to represent the site boundary.

The meteorological diffusion factor used in the development of the ODCM Method I dose models are summarized on Tables B.7-4 through B.7-6, for all radionuclides, except Carbon-14. For Carbon-14 assessments, the primary exposure pathway is ingestion of vegetables, fruits and grains grown near the plant site. A 15 year (1996 – 2010) meteorological data base was used to evaluate the diffusion factors by calendar quarter during the growing season (2nd and 3rd quarters) at the highest impacted local gardens as identified in the 2010 site are land use census. The maximum values for each quarter during the 15 year history were then averaged together. To the average was added three times the standard deviation of the variance of the average value in order to estimate a reasonable upper bound diffusion values to be used in the dose assessments. The resulting values are summarized on Table B.7-7.

Table B.7-4
Seabrook Station Long-Term Average Dispersion Factors*
Primary Vent Stack

Max Off-Site Location	Dose Rate to Individual			Dose to Air		Dose to Critical Organ
	Total Body	Skin	Critical Organ	Gamma	Beta	Thyroid
X/Q depleted $\left(\frac{\text{sec}}{\text{m}^3}\right)$	-	-	7.5E-07	-	-	7.5E-07
X/Q undepleted $\left(\frac{\text{sec}}{\text{m}^3}\right)$	-	8.2E-07	-	-	8.2E-07	-
D/Q $\left(\frac{1}{\text{m}^2}\right)$	-	-	1.5E-08**	-	-	1.5E-08
X/Q ^γ $\left(\frac{\text{sec}}{\text{m}^3}\right)$	8.5E-07	8.5E-07	-	8.5E-07	-	-

* West site boundary, 974 meters from Containment Building

** Northwest site boundary, 914 meters from Containment Building

Table B.7-5
Seabrook Station Long-Term Average Dispersion Factors
For Special Receptors
Primary Vent Stack

Diffusion Factor	RECEPTOR ^(a)			
	Hi-Rise Fitness Center	Firing Range	Science & Nature Center	Off-Site
Undepleted CHI/Q, sec/m ³	1.61 x 10 ⁻⁶ (384m WSW)	5.47 x 10 ⁻⁷ (1026m W)	1.61 x 10 ⁻⁶ (488m SW)	8.16 x 10 ⁻⁷ (974m W)
Depleted CHI/Q, sec/m ³	1.53 x 10 ⁻⁶ (384m WSW)	5.01 x 10 ⁻⁷ (1026m W)	1.51 x 10 ⁻⁶ (488m SW)	7.50 x 10 ⁻⁷ (974m W)
D/Q, m ⁻²	2.06 x 10 ⁻⁸ (284m WSW)	8.76 x 10 ⁻⁹ (1026m W)	2.67 x 10 ⁻⁸ (488m SW)	1.47 x 10 ⁻⁸ (914m NW)
Gamma CHI/Q, sec/m ³	1.06 x 10 ⁻⁶ (384m WSW)	5.49 x 10 ⁻⁷ (1026m W)	1.12 x 10 ⁻⁶ (488m SW)	8.49 x 10 ⁻⁷ (974m W)

^(a) The highest site boundary (off-site) diffusion and deposition factors occurred during the April through September growing season. Note that for the primary vent stack release pathway, none of the off-site receptor diffusion and deposition factors (located at 0.25-mile increments beyond the site boundary) exceeded the site boundary diffusion and deposition factors.

Table B.7-6
Seabrook Station Long-Term Average Dispersion Factors
For Special Receptors
Ground-Level Release Pathway

Diffusion Factor	RECEPTOR ^(a)			
	Hi-Rise Fitness Center	Firing Range	Science & Nature Center	Off-Site
Undepleted CHI/Q, sec/m ³	4.06 x 10 ⁻⁵ (288m SW)	6.90 x 10 ⁻⁶ (888m WSW)	2.36 x 10 ⁻⁵ (406m SW)	1.06 x 10 ⁻⁵ (823m W)
Depleted CHI/Q, sec/m ³	3.89 x 10 ⁻⁵ (288m SW)	6.26 x 10 ⁻⁶ (888m WSW)	2.23 x 10 ⁻⁵ (406m SW)	9.64 x 10 ⁻⁶ (823m W)
D/Q, m ⁻²	1.72 x 10 ⁻⁷ (288m SW)	2.53 x 10 ⁻⁸ (888m WSW)	1.04 x 10 ⁻⁷ (406m SW)	5.06 x 10 ⁻⁸ (823m NW)
Gamma CHI/Q, sec/m ³	8.15 x 10 ⁻⁶ (288m SW)	2.16 x 10 ⁻⁶ (888m WSW)	5.52 x 10 ⁻⁶ (406m SW)	3.45 x 10 ⁻⁶ (823m W)

^(a) The highest site boundary (off-site) diffusion and deposition factors occurred during the April through September growing season.

Table B.7-7
Seabrook Station
Growing Season Diffusion for Carbon-14
Elevated –Level Release Pathway

Exposure Pathway and Time Period	X/Q undepleted * (sec/m ³)
Inhalation (all quarters, site boundary)	2.33 x 10 ⁻⁶
Ingestion, 2 nd quarter growing season (gardens)	1.19 x 10 ⁻⁶
Ingestion, 3 rd quarter growing season (gardens)	8.91 x 10 ⁻⁷

* The off-site diffusion values represent the average for 15 years (1996 – 2010) of maximum values calculated for each year at the site boundaries and nearest gardens receptors (2010 Land Use Census) plus three standard deviations of the observed variance.

8.0 BASES FOR LIQUID AND GASEOUS MONITOR SETPOINTS

8.1 Basis for the Liquid Waste Test Tank Monitor Setpoint

The liquid waste test tank monitor setpoint must ensure that the limits of Part A Control C.5.1 are not exceeded in combination with any other site discharge pathways. The liquid waste test tank monitor is placed upstream of the major source of dilution flow.

The derivation of Equation 5-1 begins with the general equation for the response of a radiation monitor:

$$R = \sum C_{\gamma i} S_{li} \quad (8-1)$$

$$(\text{cps}) = \left(\frac{\mu\text{Ci}}{\text{ml}} \right) \left(\frac{\text{cps} \cdot \text{ml}}{\mu\text{Ci}} \right)$$

where:

R = Response of the monitor to radioactivity (cps).

S_{li} = Detector counting efficiency for radionuclide "i" (cps/(μCi/ml)).

C_{γi} = Activity concentration of each gamma emitting radionuclide "i" in the mixture that the monitor has a response efficiency sufficient to detect (μCi/ml).

The detector calibration procedure for the liquid waste test tank monitor at Seabrook Station establishes counting efficiency by use of a known calibration source standard and a linearity response check. Therefore, in Equation 8-1 one may substitute S_l for S_{li}, where S_l is the detector counting efficiency determined from the calibration procedure. Therefore, Equation 8-1 becomes:

$$R = S_l \sum C_{\gamma} \quad (8-2)$$

$$(\text{cps}) = \left(\frac{\text{cps} \cdot \text{ml}}{\mu\text{Ci}} \right) \left(\frac{\mu\text{Ci}}{\text{ml}} \right)$$

The ECL for a given radionuclide must not be exceeded at the point of discharge to the environment. When a mixture of radionuclides is present, 10 CFR 20 specifies that the concentration (excluding dissolved and entrained noble gases) at the point of discharge shall be limited as follows:

$$\sum \frac{C_{d_i}}{ECL_i} \leq 10 \quad (8-3)$$

where:

C_{d_i} = Activity concentration of radionuclide "i" determined to be present in the mixture at the point of discharge to the environment ($\mu\text{Ci/ml}$).

ECL_i = Effluent concentration limit (ECL) for radionuclide "i" (except for dissolved and entrained noble gas) in $\mu\text{Ci/ml}$ as specified in 10 CFR 20, Appendix B, Table 2. The limit for the sum of all noble gases in the waste discharge is $2\text{E-}04 \mu\text{Ci/ml}$. (See ODCM Appendix B for listing.)

The activity concentration of radionuclide "i" at the point of discharge is related to the activity concentration of each radionuclide at the monitor as follows:

$$C_{d_i} = \frac{F_m}{F_d} (C\gamma_i + C\beta_i)$$

$$\left(\frac{\mu\text{Ci}}{\text{ml}} \right) = \left(\frac{\text{gpm}}{\text{gpm}} \right) \left(\frac{\mu\text{Ci}}{\text{ml}} \right)$$

and with equivalence of $C_i = (C\gamma_i + C\beta_i)$, Equation 8-4 can be written as

$$C_{d_i} = \frac{F_m}{F_d} C_i \quad (8-4)$$

where:

F_m = Flow rate past monitor (gpm)

F_d = Flow rate out of discharge tunnel (gpm)

$C\beta_i$ = Activity concentration of non gamma emitting radionuclide "i" in the mixture at the monitor for which the monitor response is inefficient to detect ($\mu\text{Ci/ml}$).

C_i = The activity concentration of each radionuclide "i" in the waste stream. This includes both gamma and non gamma emitters, such as tritium.

Substituting the right half of Equation 8-4 for C_{di} in Equation 8-3, and solving for F_d/F_m yields the dilution factor needed to complete Equation 8-3:

$$DF_{\min} \leq \frac{F_d}{F_m} \geq \sum_i \frac{C_i}{10ECL_i} \quad (8-5)$$

$$\left(\frac{\text{gpm}}{\text{gpm}} \right) \left(\frac{\mu\text{Ci} - \text{ml}}{\text{ml} - \mu\text{Ci}} \right)$$

where:

ECL_i = Effluent concentration limit (ECL) for radionuclide "i" (except for dissolved and entrained noble gas) in $\mu\text{Ci}/\text{ml}$ as specified in 10 CFR 20, Appendix B, Table 2. For noble gases, a value of $2\text{E}-04 \mu\text{Ci}/\text{ml}$ is used for the limit of the sum of noble gases in the waste stream.

If F_d/F_m is less than DF_{\min} , then the tank may not be discharged until either F_d or F_m or both are adjusted such that:

$$DF_{\min} \leq \frac{F_d}{F_m} \quad (8-5)$$

The maximum allowable discharge flow rate past the monitor can be found by setting F_m to F_{\max} and its equivalents, i.e:

$$F_{\max} = \frac{F_d}{DF_{\min}}$$

Usually F_d/F_m is greater than DF_{\min} (i.e., there is more dilution than necessary to comply with Equation 8-3), but must be satisfied since the monitor can only detect the gamma emitting portion of the waste stream. The response of the liquid waste test tank monitor at the setpoint is therefore:

$$R_{\text{setpoint}} = f_1 \times \frac{F_d}{F_m \times DF_{\min}} \times S_1 \sum C \gamma_i$$

$$(\text{cps}) \left(\right) \left(\right) \left(\frac{\text{cps} - \text{ml}}{\mu\text{Ci}} \right) \left(\frac{\mu\text{Ci}}{\text{ml}} \right) \quad (8-6)$$

or with F_{\max} substituted into Equation 8-6 for the maximum allowable discharge flow rate

$\left(\frac{F_d}{DF_{\min}} \right)$, the setpoint equation can be stated also as:

$$R_{\text{setpoint}} = f_1 \times \frac{F_{\max}}{F_m} \times S_i \sum C \gamma_i$$

where f_1 is equal to the fraction of the total concentration of ECL at the discharge point to the environment to be associated with the test tank effluent pathway, such that the sum of the fractions of the five liquid discharge pathways is equal to or less than one ($f_1 + f_2 + f_3 + f_4 + f_5 \leq 1$). The five monitored liquid effluent pathways are derived from: (f_1) the Liquid Waste Test Tanks, (f_2) the Turbine Building Sump, (f_3) Steam Generator Blowdown, (f_4) Primary Component Cooling, and (f_5) Water Treatment Liquid Effluent (the Condensate Polishing System).

The monitoring system is designed to incorporate the detector efficiency, S_i , into its software. This results in an automatic readout in $\mu\text{Ci/ml}$ or $\mu\text{Ci/cc}$ for the monitor response. Since the conversion for changing cps to $\mu\text{Ci/ml}$ is inherently done by the system software, the monitor response setpoint can be calculated in terms of the total waste test tank activity concentration in $\mu\text{Ci/ml}$ determined by the laboratory analysis. Therefore, the setpoint calculation for the liquid waste test tank is:

$$R_{\text{setpoint}} = f_1 \times \frac{F_d}{F_m \times DF_{\min}} \times \sum C \gamma_i \quad (5-1)$$

$$\left(\frac{\mu\text{Ci}}{\text{ml}} \right) \quad () \quad () \quad \left(\frac{\mu\text{Ci}}{\text{ml}} \right)$$

All liquid effluent pathway monitors are similar to the Liquid Waste Test Tank Monitor in design and function as described above for ensuring the plant site's effluent concentration limits are not exceeded in combination with each other.

8.2 Basis for the Plant Vent Wide Range Gas Monitor Setpoints

The setpoints of the plant vent wide range gas monitors must ensure that Part A Control C.7.1.1.a is not exceeded. Part B, Sections 3.4 and 3.5 show that Equations 3-3 and 3-4 are acceptable methods for determining compliance with that Part A Control. Which equation (i.e., dose to total body or skin) is more limiting depends on the noble gas mixture. For the limiting setpoint case, the gas mixture associated with the fuel gap activity at time of shutdown (UFSAR Table 15.7-20) indicates that the total body dose rate to the maximum offsite receptor is the limiting dose rate type. The derivations of Equations 5-5 and 5-6 begin with the general equation for the response R of a radiation monitor:

$$R = \sum_i S_{gi} C_{mi} \quad (8-7)$$

$$(\text{cpm}) = \left(\frac{\text{cpm} \cdot \text{cm}^3}{\mu\text{Ci}} \right) \left(\frac{\mu\text{Ci}}{\text{cm}^3} \right)$$

where:

R = Response of the instrument (cpm)

S_{gi} = Detector counting efficiency for noble gas "i" (cpm/($\mu\text{Ci}/\text{cm}^3$))

C_{mi} = Activity concentration of noble gas "i" in the mixture at the noble gas activity monitor ($\mu\text{Ci}/\text{cm}^3$)

C_{mi} , the activity concentration of noble gas "i" at the noble gas activity monitor, may be expressed in terms of \dot{Q}_i by dividing by F, the appropriate flow rate. In the case of the plant vent noble gas activity monitors the appropriate flow rate is the plant vent flow rate.

$$C_{mi} = \dot{Q}_i \frac{1}{F} \quad (8-8)$$

$$\left(\frac{\mu\text{Ci}}{\text{cm}^3} \right) = \left(\frac{\mu\text{Ci}}{\text{sec}} \right) \left(\frac{\text{sec}}{\text{cm}^3} \right)$$

where:

\dot{Q}_i = The relative release rate of noble gas "i" identified or postulated to be in the mixture.

F = Appropriate flow rate (cm^3/sec)

Substituting the right half of Equation 8-8 into Equation 8-7 for C_{mi} yields:

$$R = \sum_i S_{gi} \dot{Q}_i \frac{1}{F} \quad (8-9)$$

$$(\text{cpm}) = \left(\frac{\text{cpm} \cdot \text{cm}^3}{\mu\text{Ci}} \right) \left(\frac{\mu\text{Ci}}{\text{sec}} \right) \left(\frac{\text{sec}}{\text{cm}^3} \right)$$

As in the case before, for the liquid waste test tank monitor, the plant vent wide range gas monitor establishes the detector counting efficiency by use of a calibration source. Therefore, S_g can be substituted for S_{gi} in Equation 8-9, where S_g is the detector counting efficiency determined from the calibration procedure. Therefore, Equation 8-9 becomes:

$$R = S_g \frac{1}{F} \sum_i \dot{Q}_i \quad (8-10)$$

$$(\text{cpm}) = \left(\frac{\text{cpm} \cdot \text{cm}^3}{\mu\text{Ci}} \right) \left(\frac{\text{sec}}{\text{cm}^3} \right) \left(\frac{\mu\text{Ci}}{\text{sec}} \right)$$

The total body dose rate due to noble gases is determined with Equation 3-3a:

$$\dot{D}_{\text{tb(e)}} = 0.85 * \sum_i (\dot{Q}_i * \text{DFB}_i) \quad (3-3a)$$

$$\left(\frac{\text{mrem}}{\text{yr}} \right) = \left(\frac{\text{pCi} \cdot \text{sec}}{\mu\text{Ci} \cdot \text{m}^3} \right) \left(\frac{\mu\text{Ci}}{\text{sec}} \right) \left(\frac{\text{mrem} \cdot \text{m}^3}{\text{pCi} \cdot \text{yr}} \right)$$

where:

$$\dot{D}_{\text{tb(e)}} = \text{Total body dose rate (mrem/yr)}$$

$$0.85 = (1.0\text{E}+06) \times (8.5\text{E}-07) (\text{pCi} \cdot \text{sec} / \mu\text{Ci} \cdot \text{m}^3)$$

$$1\text{E}+06 = \text{Number of pCi per } \mu\text{Ci} (\text{pCi} / \mu\text{Ci})$$

$$8.5\text{E}-07 = [X/Q]^y, \text{ maximum off-site average gamma atmospheric dispersion factor (sec/m}^3\text{) for primary vent stack releases}$$

$$\dot{Q}_i = \text{The relative release rate of noble gas "i" identified or postulated to be in the gas mix } (\mu\text{Ci/sec}).$$

$$\text{DFB}_i = \text{Total body dose factor (see Table B.1-10) (mrem} \cdot \text{m}^3 / \text{pCi} \cdot \text{yr)}$$

A composite total body gamma dose factor, DFB_c , may be defined such that:

$$DFB_c \sum_i \dot{Q}_i = \sum_i \dot{Q}_i DFB_i \quad (8-11)$$

$$\frac{\text{mrem} - \text{m}^3}{\text{pCi} - \text{yr}} \left(\frac{\mu\text{Ci}}{\text{sec}} \right) = \left(\frac{\mu\text{Ci}}{\text{sec}} \right) \left(\frac{\text{mrem} - \text{m}^3}{\text{pCi} - \text{yr}} \right)$$

Solving Equation 8-11 for DFB_c yields:

$$DFB_c = \frac{\sum_i \dot{Q}_i DFB_i}{\sum_i \dot{Q}_i} \quad (5-7)$$

Part A Control C.7.1.1.a limits the dose rate to the total body from noble gases at any location at or beyond the site boundary to 500 mrem/yr. By setting \dot{D}_{tb} equal to 500 mrem/yr and substituting DFB_c for DFB_i in Equation 3-3, one may solve for $\sum_i \dot{Q}_i$ at the limiting whole body noble gas dose rate:

$$\sum_i \dot{Q}_i = 588 \frac{1}{DFB_c} \quad (8-12)$$

$$\left(\frac{\mu\text{Ci}}{\text{sec}} \right) = \left(\frac{\text{mrem} - \mu\text{Ci} - \text{m}^3}{\text{yr} - \text{pCi} - \text{sec}} \right) \left(\frac{\text{pCi} - \text{yr}}{\text{mrem} - \text{m}^3} \right)$$

Substituting this result for $\sum_i \dot{Q}_i$ in Equation 8-10 yields R_{tb} , the response of the monitor at the limiting noble gas total body dose rate:

$$R_{tb} = 588 S_g \frac{1}{F} \frac{1}{DFB_c} \quad (8-13)$$

$$(\text{cpm}) = \left(\frac{\text{mrem} - \mu\text{Ci} - \text{m}^3}{\text{yr} - \text{pCi} - \text{sec}} \right) \left(\frac{\text{cpm} - \text{cm}^3}{\mu\text{Ci}} \right) \left(\frac{\text{sec}}{\text{cm}^3} \right) \left(\frac{\text{pCi} - \text{yr}}{\text{mrem} - \text{m}^3} \right)$$

The skin dose rate due to noble gases is determined with Equation 3-4a:

$$\dot{D}_{skin(e)} = \sum_i (\dot{Q}_i * DF'_{i(e)}) \quad (3-4a)$$

$$\frac{\text{mrem}}{\text{yr}} = \sum \left(\frac{\mu\text{Ci}}{\text{sec}} \right) \left(\frac{\text{mrem} - \text{sec}}{\mu\text{Ci} - \text{yr}} \right)$$

where:

$$\dot{D}_{skin(e)} = \text{Skin dose rate (mrem/yr)}$$

$$\dot{Q}_i = \text{As defined above.}$$

$$DF'_{i(e)} = \text{Combined skin dose factor (see Table B.1-10) (mrem-sec/\mu\text{Ci-yr)}$$

A composite combined skin dose factor, DF'_c , may be defined such that:

$$DF'_c * \sum_i \dot{Q}_i = \sum_i (\dot{Q}_i * DF'_{i(e)}) \quad (8-14)$$

$$\left(\frac{\text{mrem} - \text{sec}}{\mu\text{Ci} - \text{yr}} \right) \left(\frac{\mu\text{Ci}}{\text{sec}} \right) = \left(\frac{\mu\text{Ci}}{\text{sec}} \right) \left(\frac{\text{mrem} - \text{sec}}{\mu\text{Ci} - \text{yr}} \right)$$

Solving Equation 8-14 for DF'_c yields:

$$DF'_c = \frac{\sum_i \dot{Q}_i DF'_{i(e)}}{\sum_i \dot{Q}_i} \quad (5-8)$$

Part A Control C.7.1.1.a limits the dose rate to the skin from noble gases at any location at or beyond the site boundary to 3,000 mrem/yr. By setting \dot{D}_{skin} equal to 3,000 mrem/yr and substituting DF'_c for DF'_i in Equation 3-4 one may solve for $\sum_i \dot{Q}_i$ at the limiting skin noble gas dose rate:

$$\sum_i \dot{Q}_i = 3,000 \frac{1}{DF'_c} \quad (8-15)$$

$$\left(\frac{\mu\text{Ci}}{\text{sec}} \right) \left(\frac{\text{mrem}}{\text{yr}} \right) \left(\frac{\mu\text{Ci} - \text{yr}}{\text{mrem} - \text{sec}} \right)$$

Substituting this result for $\sum_i \dot{Q}_i$ in Equation 8-10 yields R_{skin} , the response of the monitor at the limiting noble gas skin dose rate:

$$R_{skin} = 3,000 \quad S_g \quad \frac{1}{F} \quad \frac{1}{DF'_c} \quad (8-16)$$

$$(\text{cpm}) \left(\frac{\text{mrem}}{\text{yr}} \right) \left(\frac{\text{cpm} - \text{cm}^3}{\mu\text{Ci}} \right) \left(\frac{\text{sec}}{\text{cm}^3} \right) \left(\frac{\mu\text{Ci} - \text{yr}}{\text{mrem} - \text{sec}} \right)$$

As with the liquid monitoring system, the gaseous monitoring system is also designed to incorporate the detector efficiency, S_g , into its software. The monitor also converts the response output to a release rate ($\mu\text{Ci}/\text{sec}$) by using a real time stack flow rate measurement input. Therefore, multiplying by the main plant vent flow rate measurement (F), the Equations 8-13 and 8-16 become:

$$R_{tb(e)} = 588 \frac{1}{DFB_c} \quad (5-5)$$

$$\left(\frac{\mu\text{Ci}}{\text{sec}} \right) = \left(\frac{\text{mrem} - \mu\text{Ci} - \text{m}^3}{\text{yr} - \text{pCi} - \text{sec}} \right) \left(\frac{\text{pCi} - \text{yr}}{\text{mrem} - \text{m}^3} \right)$$

$$R_{skin(e)} = 3,000 \frac{1}{DF'_c} \quad (5-6)$$

$$\left(\frac{\mu\text{Ci}}{\text{sec}} \right) = \left(\frac{\text{mrem}}{\text{yr}} \right) \left(\frac{\mu\text{Ci} - \text{yr}}{\text{mrem} - \text{sec}} \right)$$

These equations assume that the main plant vent is the only release point contributing to the determination of limiting offsite dose rate. The Control dose rate limits (500 mrem/yr and 3000 mrem/yr for total body and skin, respectively) apply to combination of all release points to the limiting offsite receptor. Administrative fractions (f) should be applied to main plant vent setpoint calculation as a multiplier, and any other release points, such that the summation of all fractions is less than or equal to 1. This provides for the combined impact of all release points to ensure that selected setpoints alarm at or before the site dose rate limits is exceeded.

8.3 Basis for PCCW Head Tank Rate-of-Change Alarm Setpoint

The PCCW head tank rate-of-change alarm will work in conjunction with the PCCW radiation monitor to alert the operator in the Main Control Room of a leak to the Service Water System from the PCCW System. For the rate-of-change alarm, a setpoint based on detection of an activity level of 10^{-8} $\mu\text{Ci/cc}$ in the discharge of the Service Water System has been selected. This activity level was chosen because it is the minimum detectable level of a service water monitor if such a monitor were installed. The use of rate-of-change alarm with information obtained from the liquid sampling and analysis commitments described in Table A.6.1-1 of Part A ensure that potential releases from the Service Water System are known. Sampling and analysis requirements for the Service Water System extend over various operating ranges with increased sampling and analysis at times when leakage from the PCCW to the service water is occurring and/or the activity level in the PCCW is high.

8.4 Basis for Waste Gas Processing System Monitors (RM-6504 and RM-6503)

The maximum allowable setpoint for the waste gas system monitors (response in $\mu\text{Ci}/\text{cm}^3$) can be determined by equating the limiting off-site noble gas dose rate from the plant vent to the total body or skin dose rate limits of Part A Control C.7.1.1.a, assuming that all the activity detected by the vent wide-range gas monitors is due to waste gas system discharges.

By evaluating the noble gas radionuclide with the most limiting dose factor as given on Table B.1-10, a conservative activity release rate from the plant vent for both whole body and skin dose rate conditions can be calculated. From Table B.1-10, Kr-89 is seen to be the most restrictive individual noble gas if it were present in the effluent discharge. Applying plant vent setpoint equation 5-5 for the whole body, and equation 5-6 for the skin, the maximum allowable plant vent stack release rate can be calculated as follows:

$$R_{\text{tb}} = 588 \ 1/\text{DFB}_c \quad (5-5)$$

where:

R_{tb} = plant vent maximum release rate ($\mu\text{Ci}/\text{sec}$) based on the whole body dose rate limit of 500 mrem/yr

DFB_c = $1.66\text{E-}02$ (mrem- $\text{m}^3/\mu\text{Ci-yr}$), whole body dose factor for Kr-89

588 = conversion factor (mrem- $\mu\text{Ci-}\text{m}^3/\text{yr-pCi-sec}$)

Therefore:

$$\begin{aligned} R_{\text{tb}} &= 588 \ 1/1.66\text{E-}02 \\ &= 35,421 \ \mu\text{Ci}/\text{sec} \text{ maximum release rate at plant vent} \end{aligned}$$

Next, the skin dose rate limit is evaluated from equation 5-6 in a similar fashion as follows:

$$R_{\text{skin}} = 3000 \ 1/\text{DF}'_c \quad (5-6)$$

where:

R_{skin} = plant vent maximum release rate ($\mu\text{Ci}/\text{sec}$) based on skin dose rate limit of 3000 mrem/yr.

DF'_c = $2.45\text{E-}02$ mrem-sec/ $\mu\text{Ci-yr}$ skin dose factor for Kr-89

3000 = Site boundary skin dose rate limit (mrem/yr)

therefore:

$$\begin{aligned} R_{\text{skin}} &= 3000 \text{ (mrem/yr)} \cdot 1/2.45\text{E-}02 \text{ (mrem-sec/}\mu\text{Ci-yr)} \\ &= 122,449 \mu\text{Ci/sec from the plant vent} \end{aligned}$$

Comparing the release rate limit for the whole body to that for the skin (i.e., 35,421 $\mu\text{Ci/sec}$ vs 122,449 $\mu\text{Ci/sec}$, respectively) it is determined that the release rate for the whole body is limiting.

Next, to get the maximum plant vent release rate from the waste gas system discharge, equate the plant vent maximum release rate limit for the whole body equal to the waste gas system activity concentration times its flow rate to the plant vent, i.e.:

$$R_{\text{tb}} = 35,421(\mu\text{Ci/sec}) = R_{\text{wg}}(\mu\text{Ci/cm}^3) F_{\text{wg}}(\text{cm}^3/\text{sec})$$

or solving for R_{wg} :

$$R_{\text{wg}}(\mu\text{Ci/cm}^3) = 35,421(\mu\text{Ci/sec}) / F_{\text{wg}}(\text{cm}^3/\text{sec})$$

where:

R_{wg} = maximum concentration (setpoint limit) at the waste gas system monitors

F_{wg} = waste gas design flow of 566.4 cm^3/sec (1.2 cfm)

therefore:

$$\begin{aligned} R_{\text{wg}}(\mu\text{Ci/cm}^3) &= 35,421(\mu\text{Ci/sec}) / 566.4(\text{cm}^3/\text{sec}) \\ &= 62.5 \mu\text{Ci/cm}^3 \end{aligned}$$

This represents the maximum waste gas discharge concentration which would equal the site boundary whole body dose rate limit for plant vent releases. Administrative controls may set alert alarm and high alarm (waste gas isolation) setpoints on the waste gas monitors as some multiple of expected activity concentration, such as 1.5 and 2 times, respectively, as long as the maximum setpoint does not exceed 62.5 $\mu\text{Ci/cm}^3$. This provides operational controls to be exercised before any waste gas discharges could equate to the Part A Control C.7.1.1.a.

The primary process monitor noted in Part A Control C.5.2 is RM-6504, which is downstream of the waste gas discharge compressor at the end of the process system. Monitor RM-6503 is on the inlet side of the compressor downstream of the charcoal delay beds, and is considered as an alternate monitor if RM-6504 is inoperable. For the purpose of setting the maximum discharge setpoint, RM-6503 is treated the same as RM-6504, which assumes no additional source reduction before discharge to the plant vent.

8.5 Basis for the Main Condenser Air Evacuation Monitor Setpoint (RM-6505)

The maximum allowable setpoint for the main condenser air evacuation monitor must be evaluated for two modes of operation. For normal operations the monitor is responding to a low flow rate that is typically released through the plant vent stack. During start-up (hogging mode), the monitor response must be related to a high flow rate that is being released from the turbine building which is considered a ground level release. In both instances, the setpoint can be determined by equating the limiting off-site noble gas dose rate from the release point to the total body or skin dose rates of Part A Control C.7.1.1.a. The most restrictive noble gas mixture has been found to be represented by the noble gases associated with the fuel gap activity at the time of plant shutdown. This mixture is listed on UFSAR Table 15.7-20, and provides a limiting setpoint calculation that bounds other potential or observed offgas mix conditions.

In addition to monitoring the main condenser air, the air evacuation monitor response is also used as an indicator for Turbine Gland Seal Condenser exhaust. Since this is a potential release pathway during both the normal and the hogging modes of operation, the impact is considered in the setpoint calculations.

8.5.1 Limiting Example for the Air Evacuation Monitor Setpoint During Normal Operations

During normal power operation, the maximum allowable setpoint for the air evacuation monitor is determined by applying plant vent setpoint equation 8-13 for the total body, and equation 8-16 for the skin. Therefore, the maximum allowable stack release rate can be calculated as follows:

$$R_{tb(e)} = (588) (S_g) (1/F) (1/DFB_c) \quad (8-13)$$

$$(cpm) = (mrem-\mu Ci-m^3/yr-pCi-sec) (cpm-cm^3/\mu Ci) (sec/cm^3)(pCi-yr/mrem-m^3)$$

where:

$R_{tb(e)}$ = count rate (cpm) for the plant vent maximum release rate based on the total body dose rate limit of 500-mrem/yr

588 = conversion factor (mrem- μ Ci- m^3 /yr-pCi-sec)

S_g = the detector response efficiency (cpm- cm^3 / μ Ci) as determined from monitor calibration. For the air evacuation monitor, a typical value is $1.87E+08$ cpm- cm^3 / μ Ci.

F = release flow rate. During normal operations, a typical flow value ranges from 10 to 50 cfm ($2.36E+04$ cc/sec maximum) for the air evacuation pathway.

DFB_c = the composite total body dose factor, (mrem- m^3 /pCi-yr). For different gas mixes, the composite can be found from:

$$DFB_c = \frac{\sum_i \dot{Q}_i DFB_i}{\sum_i \dot{Q}_i} \quad (5-7)$$

DFB_c for the limiting gas mixture is $4.86E-03$ mrem- m^3 /pCi-yr (See Section 5.2.1.2)

Therefore,

$$\begin{aligned} R_{tb(e)} &= 588 \cdot 1.87E+08 \cdot (1/2.36E+04) \cdot (1/4.86E-03) \\ &= 9.59E+08 \text{ cpm detector count rate for a maximum release rate at the plant vent based} \\ &\quad \text{on the total body dose rate.} \end{aligned}$$

Next, the off-site skin dose rate limit is evaluated from equation 8-16 in a similar fashion as follows:

$$\begin{aligned} R_{skin(e)} &= 3000 S_g (1/F) (1/DF'_c) && (8-16) \\ (\text{cpm}) &= (\text{mrem/yr}) (\text{cpm-cm}^3/\text{Ci}) (\text{sec/cm}^3) (\mu\text{Ci-yr/mrem-sec}) \end{aligned}$$

where:

$R_{skin(e)}$ = count rate (cpm) for a plant vent maximum release rate based on the skin dose rate limit of 3000 mrem/yr

DF'_c = the elevated release skin dose factor for the limiting noble gas mix associated with fuel gap activity at shutdown is calculated in the example provided in Section 5.2.1.2, and is equal to 6.80E-03 (mrem-sec/ μ Ci-yr).

Therefore,

$$\begin{aligned} R_{skin(e)} &= 3000 \cdot 1.87E+08 \cdot (1/2.36E+04) \cdot (1/6.80E-03) \\ &= 3.50E+09 \text{ cpm detector count rate for a maximum release rate at the plant vent based} \\ &\quad \text{on the skin dose rate.} \end{aligned}$$

Comparing the release rate limit for the total body to that of the skin (i.e., 9.59E+08 cpm versus 3.50E+09 cpm, respectively) it is determined that the release rate for the total body is limiting in this case.

Since during normal operations the Turbine Gland Seal Condenser exhaust has the potential to be a minor additional contribution to the total site release, the effective contribution from the main condenser exhaust must be limited to some fraction of the calculated value. The contribution from the Turbine Gland Seal Condenser exhaust is expected to be minor because this system handles only 670 lbs/hour of steam which is a very small fraction of the 1.5E+07 lbs/hour of secondary side steam that the main condenser handles. Therefore, the maximum alarm is set at 6.71E+08 cpm, which is 70% of the calculated value, to ensure that the contribution of the two does not exceed the dose rate limit of Part A Control C.7.1.1.a. During normal operations, this would represent the maximum allowable count rate on the air evacuation monitor that would equate to the site boundary total body dose rate limit or less.

8.5.2 Example for the Air Evacuation Monitor Setpoint During Startup (Hogging Mode)

During startup (hogging mode), the determination of the air evacuation setpoint must take into account a larger air flow rate that is also released as a ground level effluent. The flow rate must also include the contribution from the Turbine Gland Seal Condenser exhaust, which is a potential release pathway which the air evacuation monitor response must also take into account. For ground releases, the general equation 8-10 is used to represent the monitor count rate.

$$R = (S_g) (1/F) \sum_i \dot{Q}_i \quad (8-10)$$

$$(\text{cpm}) = (\text{cpm-cm}^3/\mu\text{Ci}) (\text{sec/cm}^3) (\mu\text{Ci/sec})$$

where:

R = detector count rate (cpm)

S_g = the detector efficiency (cpm-cm³/μCi)

F = release flow rate (cm³/sec)

\dot{Q}_i = the release rate of noble gas "i" in the mixture, for each noble gas listed in Table B.1-10.

For a ground release, the off-site total body dose rate is based on:

$$\dot{D}_{\text{tb(g)}} = 3.4 \sum_i (\dot{Q}_i \text{DFB}_i) \quad (3-3b)$$

A composite total body dose factor, DFB_c can be defined such that:

$$\text{DFB}_c \sum_i \dot{Q}_i = \sum_i (\dot{Q}_i \text{DFB}_i) \quad (8-11)$$

By substituting 8-11 into 3-3b and rearranging to solve for $\sum_i \dot{Q}_i$ the following equation is obtained:

$$\sum_i \dot{Q}_i = (\dot{D}_{(tb(g))} / 3.4) (1/DFB_c)$$

By inserting a limiting value of 500 mrem/yr as $\dot{D}_{(tb(g))}$ this simplifies to:

$$\sum_i \dot{Q}_i = 147 (1/DFB_c)$$

Insertion of this equation into equation 8-10 yields:

$$R_{(tb(g))} = 147 S_g (1/F) (1/DFB_c)$$

$$(\text{cpm}) = (\text{mrem-}\mu\text{Ci-m}^3/\text{yr-pCi-sec}) (\text{cpm-cm}^3/\mu\text{Ci}) (\text{sec/cm}^3) (\text{pCi-yr/mrem-m}^3)$$

where:

$R_{(tb(g))}$ = count rate (cpm) for the maximum ground release rate based on the total body dose rate limit of 500 mrem/yr.

147 = conversion factor (mrem- μ Ci- $\text{m}^3/\text{yr-pCi-sec}$)

S_g = the detector response efficiency for the air evacuation monitor (a typical value of $1.87\text{E}+08$ cpm- $\text{cm}^3/\mu\text{Ci}$ is applied in this example).

F = release flow rate. During the hogging mode of operation, a value of $4.72\text{E}+06$ cm^3/sec (10,000 cfm) is assumed. This represents the hogging flow that is discharged to the Turbine Building roof via the air evacuation monitor. An additional 1800 cfm is discharged from the Gland Seal Condenser exhaust directly to the Turbine Building roof without passing via the air evacuation monitor. To account for this unmonitored flow, an administrative fraction (f_{gland}) is applied to the setpoint calculation to ensure that the monitor would alarm before the dose rate limit for the combined release would be exceeded. One approach for determining a conservative fraction is to assume that the radioactivity concentration in the gland seal exhaust is equal to the main condenser offgas, even though the steam flow to the gland seal system is a very small fraction of the steam flow to the main condenser. Then the ratio of the Gland Seal Condenser exhaust flow to the total flow of hogging discharge and gland seal condenser provides for the relative flow of both sources. For the stated conditions, the unmonitored flow is about 15 % of the total (as additional conservatism, this could be doubled to 30% for the relative proportion assumed to be contributed by the unmonitored pathway). Therefore, $f_{\text{gland}} = 1-0.3$, or 0.7 as the fraction applied to the air evacuation monitor setpoint. An additional fraction (f_g) is also applied to account for the potential offsite dose rate contribution from this total ground source vs the plant main vent ($f_g \leq 1 - f_v$). The split for this illustration is set at 0.3 for ground sources and 0.7 for the plant vent.

DFBc = Composite total body dose factor which weights the combination of total body dose factors (from ODCM Table B.1-10) of each radionuclide assumed to be in the gas mix in accordance with the fraction that it makes up of the total release. For the limiting noble gas mix associated with fuel gap activity at shutdown (see example calculation provided in Section 5.2.1.2), the value is equal to 4.86E-03 (mrem-m³/pCi-yr).

In addition, two administrative fractions are applied to the general calculation to account for other release contributions to the site dose that do not go by the air evacuation monitor. The first (f_g) is the fraction of the site boundary total body dose rate limit to be administratively assigned to monitored ground level releases (for this illustration = 0.3) such that the combination of the plant vent fraction (f_v) and ground fraction (f_g) is less than or equal to 1 (f_g ≤ 1 - f_v). The second release reduction factor (f_{gland}) is administratively assigned to account for potential unmonitored contributions from the Turbine Gland Seal Condenser exhaust (for this illustration = 0.7) which discharges to the Turbine Building roof without going past the air evacuation monitor

Therefore:

$$R_{tb(g)} = (147) (1.87E+08) (1/4.72E+06) (1/4.86E-03) (0.3) (0.7)$$

$$= 2.52E+05 \text{ cpm detector count rate for a maximum ground release rate based on the total body dose rate.}$$

Next, the off-site skin dose rate limit for a ground release is evaluated from equation 3-4b in a similar fashion as follows:

$$\dot{D}_{skin(g)} = \sum_i (\dot{Q}_i DF_{i(g)}) \quad (3-4b)$$

A composite skin dose factor, DF'_{c(g)} can be defined such that:

$$DF'_{c(g)} \sum_i \dot{Q}_i = \sum_i (\dot{Q}_i DF_{i(g)}) \quad (8-17)$$

By substituting 8-17 into 3-4b and rearranging to solve for $\sum_i \dot{Q}_i$ the following equation is obtained:

$$\sum_i \dot{Q}_i = \dot{D}_{skin(g)} (1/DF'_{c(g)})$$

By inserting a limiting value of 3000 mrem/yr as $\dot{D}_{skin(g)}$ this simplifies to:

$$\sum_i \dot{Q}_i = 3000 (1/DF'_{c(g)})$$

Insertion of this equation into equation 8-10 yields:

$$R_{skin(g)} = 3000 S_g (1/F) (1/DF'_{c(g)})$$

$$(\text{cpm}) = (\text{mrem/yr}) (\text{cpm-cm}^3/\mu\text{Ci}) (\text{sec/cm}^3) (\mu\text{Ci-yr/mrem-sec})$$

where:

$R_{\text{skin}(g)}$ = Count rate (cpm) for the maximum ground release rate based on the skin dose rate limit of 3000 mrem/yr.

$DF'_{c(g)}$ = The composite ground release skin dose factors which weights the combination of the combined skin dose factors (from ODCM Table B.1-10) of each radionuclide assumed to be in the gas mix in accordance with the fraction that it makes up of the total release. For the limiting noble gas mix associated with fuel gap activity at shutdown (see example calculation provided in Section 5.2.1.2), the value is equal to $6.80E-03$ (mrem-sec/ $\mu\text{Ci-yr}$).

As with the whole body dose rate above, the same two administrative fractions, f_g and f_{gland} are also applied to the skin dose rate response.

Therefore:

$$\begin{aligned} R_{\text{skin}(g)} &= (3000) (1.87E+08) (1/4.72E+06) (1/6.80E-03) (0.3) (0.7) \\ &= 3.67E+06 \text{ cpm detector count rate for a maximum ground release rate based on the skin dose rate.} \end{aligned}$$

Comparing the release rate limit for the total body to that of the skin (i.e., $2.52E+05$ cpm versus $3.67E+06$ cpm, respectively) it is determined that the release rate for the total body is limiting in this case.

REFERENCES

- A. Regulatory Guide 1.109, "Calculation of Annual Doses to Man From Routine Releases of Reactor Effluents for the Purpose of Evaluating Compliance with 10CFR50, Appendix I", U.S. Nuclear Regulatory Commission, Revision 1, October 1977.
- B. Hamawi, J. N., "AEOLUS-2 - A Computer Code for the Determination of Continuous and Intermittent-Release Atmospheric Dispersion and Deposition of Nuclear Power Plant Effluents in Open-Terrain Sites, Coastal Sites, and Deep-River Valleys for Assessment of Ensuing Doses and Finite-Cloud Gamma Radiation Exposures," Entech Engineering, Inc., March 1988.
- C. Regulatory Guide 1.111, "Methods for Estimating Atmospheric Transport and Dispersion of Gaseous Effluents in Routine Releases From Light-Water Cooled Reactors", U.S. Nuclear Regulatory Commission, March 1976.
- D. National Bureau of Standards, "Maximum Permissible Body Burdens and Maximum Permissible Concentrations of Radionuclides in Air and in Water for Occupational Exposure", Handbook 69, June 5, 1959.
- E. Slade, D. H., "Meteorology and Atomic Energy - 1968", USAEC, July 1968.
- F. Seabrook Station Technical Specifications.
- G. "Estimation of Carbon-14 in Nuclear Power Plant Gaseous Effluents", Electric Power Research Institute (EPRI), Technical Report # 1021106, Final Report December 2010.

APPENDIX A

DOSE CONVERSION FACTORS

APPENDIX A
METHOD I DOSE CONVERSION FACTORS

I. LIQUID PATHWAYS - SEABROOK SITE SPECIFIC DCF'S

The models used to assess doses resulting from effluents into liquids is derived from Appendix A of Reg. Guide 1.109. Since Seabrook is a salt water site, the assumed pathways of exposure taken from Reg Guide 1.109 are Aquatic foods - fish; Aquatic foods -invertebrates; and dose from shoreline deposits (direct dose). No drinking water or irrigation pathways exist because of the salt water environment. In addition, exposures resulting from boating and swimming activities have been included for key radionuclides even though Reg. Guide 1.109 identifies these pathways as not contributing any significant contribution to the total dose, and therefore does not provide dose equations for them. For completeness, the swimming and boating pathways have been included using the dose models from the HERMES code (HEDL-TME-71-168, Dec. 1971) section G, Water Immersion.

The Method I dose conversion factors are derived by calculating the dose impact to individuals via the site specific pathways for a unit activity release (1 curie per nuclide). For each pathway, doses by radionuclide are calculated for each of the 7 organs (including whole body) for each of the four age groups (adult, teen, child, and infant). The Method I dose factor for each nuclide is then selected by taking the highest factor for any organ in any of the age groups for all the exposure pathways combined. The list of dose factors in the ODCM then represents a combination of different limiting organs and age groups which, when used to calculate a dose impact from a mix of radionuclides released in liquid effluents, gives a conservative dose since it combines the exposure to different organs and age groups as if there was a single critical organ-age group.

As an example of how the liquid dose conversion factors are developed, the following calculation for Co-60 is shown. The critical organ/age group is selected based on the full assessment of all organs and age groups.

Factor for fish Ingestion:

The general equation for ingestion doses in RG 1.109 is eq. A-3.

$$1119.7 * \frac{U_{ap} * M_p}{F} * \sum_i Q_i * B_{ip} * D_{aipj} * e^{-\lambda * t_p} 1$$

The full assessment for the ODCM dose factors indicated that for i = Co-60, the maximum dose (mrem/yr) is to the GI-LLI of an adult as the target organ and age group, therefore:

$$U_{ap} := 21 \quad \text{kg/yr adult usage factor for fish}$$

M_p	:=	0.1	mixing ratio for near field dilution provided by submerged multiport diffuser.
F	:=	918	cu. ft./sec effluent flow rate for circulating water system
Q_i	:=	1.0	curies/year released of Co-60 assumed
B_{ip}	:=	100	equilibrium bioaccumulation factor for Co-60 in salt water fish, in liters/kg
D_{aipj}	:=	$4.02 * 10^{-5}$	mrem/pCi. adult GI-LLI ingestion dose factor from RG-1.109, table E-11.
λ	:=	$1.501 * 10^{-5}$	decay constant for Co-60 in 1/hrs.
t_p	:=	24	time between release and ingestion, in hrs.
1119.7			is the factor to convert from Ci/yr per ft ³ /sec to pCi/liter. Note that RG 1.109 uses 1100 as a rounded approximation.

Therefore the dose from fish to adult GI-LLI is (mrem/yr):

$$1119.7 * \frac{U_{ap} * M_p}{F} * Q_i * B_{ip} * D_{aipj} * e^{-\lambda * t_p} = 0.01032$$

Factor for invertebrate ingestion:

Next, the dose from invertebrates to the adult GI-LLI is given by the same general equation but with the following variables changed:

U_{ap}	:=	5	kg/yr usage factor
B_{ip}	:=	1000	1/kg bioaccumulation factor

all other variables the same as above

therefore the dose from invertebrates is (mrem/yr):

$$1119.7 * \frac{U_{ap} * M_p}{F} * Q_i * B_{ip} * D_{aipj} * e^{-\lambda * t_p} = 0.02453$$

Factor for shoreline direct dose:

The general equation for direct dose from shoreline deposits is taken from equation A-7 in RG-1.109 as (mrem/yr):

$$111970 * \frac{U_{ap} * M_p * W}{F} * \sum_i Q_i * T * D_{aipj} * e^{-\lambda * t_p} * [1 - e^{-\lambda * t_b}]$$

It is assumed that all internal organ doses also receive exposure from direct external sources, therefore each organ dose due to ingestion must have an external component added. For the above equation, the site specific variables for an adult exposure to a 1 curie per year release of Co-60 are:

U_{ap}	:=	334	hrs/year usage factor used for assumed shoreline activities at Seabrook.
M_p	:=	0.1	mixing ratio for near field dilution provided by the submerged multiport diffuser and assume to be extended to the beach continuously.
W	:=	0.5	shorewidth factor for ocean sites, dimensionless
T	:=	$1.923 * 10^3$	radioactive half life in days for Co-60
D_{aipj}	:=	$1.70 * 10^{-8}$	dose factor for Co-60 due to deposits in sediments, units of (mrem/hr)/(pCi/m ²)
t_p	:=	0.0	transit time to point of exposure, hrs
t_b	:=	131400	period that sediment is assumed to be exposed to water contamination for long term buildup, set at 15 years for Method I DCF's
Q_i	:=	1.0	curies per year, Co-60 assumed
111970			conversion factor to convert (Ci/yr)/(ft ³ /sec) to pCi/liter and account for the proportionality constant used in sediment model

Therefore the dose to the whole body and each organ due to direct exposure to the shoreline (mrem/yr) is:

$$111970 * \frac{U_{ap} * M_p * W}{F} * Q_i * T * D_{aipj} * e^{-\lambda * t_p} * [1 - e^{-\lambda * t_b}] = 0.05735$$

Direct dose due to Swimming:

The dose due to immersion in water (swimming) is taken from the HERMES computer code. The original ODCM calculation was based on some preliminary dilution assumptions which gave

a near field prompt dilution factor for the multiport diffuser of 8. For single unit operation with both service water and circulating water flow (412,000 gpm), a value of 10 is more realistic. This surface area of the plume is restricted to a small area over the diffuser and does not touch the shoreline approx. 1 mile away. Since the over all impact from swimming is small when compared to the other exposure pathways, the original conservatism on dilution are kept here.

The dose from swimming is given by the following equation:

$$1.0 * 10^{12} * \frac{U_p}{F_a} * \sum_i Q_i * DF_{im} \quad (mrem/yr)$$

Where:

U_p	:=	45	hrs/yr, usage factor for swimming for maximum age group (teen) from HERMES.
F_a	:=	$6.56 * 10^{11}$	liters/yr, estimated annual dilution effluent flow in multiport diffuser
Q_i	:=	1.0	Curies/yr, assumed release rate of nuclide i.
DF_{im}	:=	$4.6 * 10^{-6}$	mrem-liters per hrs-pCi, dose factor for Co-60 for water immersion taken from HERMES.
$1.0 * 10^{12}$			constant for pCi/Ci

Therefore the swimming dose for a 1 curie release of Co-60 is (mrem/yr):

$$1.0 * 10^{12} * \frac{U_p}{F_a} * Q_i * DF_{im} = 3.155 * 10^{-5} \text{ 7}$$

As can be seen, the contribution of the swimming dose is only about one 30000ths of the total of the RG 1.109 pathways, and can be ignored in the case of Co-60. Similarly, the boating dose as given in HERMES is taken as half of the swimming dose, (and corrected for change in usage assumptions). The resulting dose is found to be less than the swimming dose and can also therefore be discounted in this case.

Total liquid Pathway dose:

The sum of the above liquid pathway doses can now be added to give the total maximum individual dose to the critical organ (adult-GI-LLI) for Co-60. This gives:

$$0.0103 + 0.0245 + 0.0573 = 0.0921 \text{ mrem/yr}$$

Since the internal doses given by the RG-1.109 methods actually are 50 yr dose commitments resulting from one year exposure to the quantity of activity assumed to be released into the water, and the direct dose represents the dose received for the period assumed to be exposed to the pathway, and the activity release was taken as a unit quantity (i.e. $Q = 1$ Ci), the above total liquid pathway dose can be stated as site specific committed dose factor in mrem/Ci released. For Method I in the ODCM, the critical organ dose factor is seen to be 0.0921 mrem/Ci, as shown above. The value reported on Table B.1-11 ($9.22 \text{ E-}08$ mrem/ μCi) was generated by a computational routine which gives rise to the round-off difference between it and the above example. The whole body site specific dose factor for the ODCM was calculated in the same way treating the whole body as a separate organ.

II. GASEOUS PATHWAYS - SEABROOK SITE SPECIFIC DCF'S

The models used to assess doses resulting from gaseous effluents in the form of iodines, tritium, and particulates are derived from Appendix C of Reg. Guide 1.109. For Seabrook, it is assumed that at the off site location which exhibits minimum atmospheric dilution for plant releases the following exposure pathways exist: inhalation, ground plane, ingestion of goats milk, meat, stored vegetables, and leafy vegetables.

The Method I dose and dose rate factors are derived by calculating the dose impact to all age group individuals via the site specific pathways for a unit activity release (1 curie per nuclide). For each pathway, doses by nuclide are calculated for each of 7 organs (including the whole body) for each of the 4 age groups. The Method I dose factor for each nuclide is then selected by taking the highest factor for any organ in any of the age groups for all exposure pathways combined. The list of dose factors in the ODCM then represents a combination of different limiting organs and age groups which, when used to calculate the dose impact from a mix of radionuclides released into the atmosphere, gives a conservative dose since it combines the exposure to different organs and age groups as if they were for all the same critical organ-age group.

As an example of how the gaseous particulate dose factors are developed, the following calculation for Mn-54 is shown. The critical organ/age group for Mn-54 was selected based on a full assessment of all organ and age group combinations. For elevated releases from the plant vent stack to the maximum site boundary (max. dose point due to meteorology), the critical organ and age group for Mn-54 was determined to be the GI-LLI for the adult.

PART A: INHALATION DOSE CONTRIBUTION

The general equations for inhalation doses in RG 1.109 are eq. C-3, and C-4 which together give:

$$3.17 * 10^4 * R_a * \left[\frac{X}{Q} \right] * \sum_i Q_i * DFA_{ija} = D_{ja} \quad 8$$

Where for the case of Mn-54 releases, the variables above are defined as:

$3.17 * 10^4$ is the number of pCi/Ci divided by the number of second per year

$R_a := 8000$ the breathing rate for age group a (adults) in m^3 / yr .

$\frac{X}{Q} := 7.5 * 10^{-7}$ the long term average depleted atmospheric dispersion factor, in sec/m^3 , at the maximum exposure point off site (S.B.)

$Q_i := 1$ the release rate of nuclide i to the atmosphere in Ci/yr

$DFA_{ija} := 9.67 * 10^{-6}$ the inhalation dose factor for nuclide i (Mn-54), organ j (GI-LLI), and age group a (adult) taken from RG 1.109, table E-7, in mrem/pCi inhaled.

Therefore, the inhalation dose to the maximum potential off site individual is given as:

$$3.17 * 10^4 * R_a * \left[\frac{X}{Q} \right] * Q_i * DFA_{ija} = 0.00184 \text{ mrem/yr per Ci } 10$$

PART B: GROUND PLANE DIRECT DOSE CONTRIBUTION

The general equations for ground plane external direct dose in RG 1.109 are equations C-1 and C-2 which together give the dose DG as:

$$8760 * 1.0 * 10^{12} * S_F * \left[\frac{D}{Q} \right] * \sum_i Q_i * \frac{1 - e^{-\lambda_i * t_b}}{\lambda_i} * DFG_{ij} \quad 11$$

Where for the case of Mn-54 releases, the variables in the above equation are defined as:

$1.0 * 10^{12}$ is the number of pCi per Ci

$S_F := 0.7$ the shielding factor provided by residential structures (dimensionless) for use in calculation accumulated doses over time. Note that for determination of dose rate factors (i.e. instantaneous dose rates) the shielding factor is set equal to 1.0, or in effect no credit for dose reduction is taken for determination of dose rates at points in time.

$\frac{D}{Q} := 1.5 * 10^{-8}$ the long term average relative deposition factor at the maximum site boundary location, in $1/m^2$

$\lambda_i := 0.8105$ is the radiological decay constant for Mn-54 (nuclide i in this case) in 1/yr.

$t_b := 15$ is the time in years over which accumulation is evaluated (approx. midpoint of plant operating life)

$DFG_{ij} := 5.80 * 10^{-9}$ external dose factor to the whole body, or any internal organ j, for standing on contaminated ground from Mn-54 (RG 1.109 Table E-6) in mrem/hr per pCi/ m^2

$Q_i := 1.0$ is the unit release quantity assumed for each nuclide i, in Ci/yr.

8760

is the number of hours in a year

Therefore, the contribution to the total dose made by exposure to the ground plane at the maximum off site exposure location for Mn-54 is given as:

$$8760 * 1.0 * 10^{12} * S_F * \left[\frac{D}{Q} \right] * Q_i * \frac{1 - e^{-\lambda_i * t_b}}{\lambda_i} * DFG_{ij} = 0.658 \text{ 13 mrem per yr per Ci}$$

PART C: INGESTION DOSE CONTRIBUTION:

As an initial step to determining the dose contribution from ingestion of milk, meat, stored vegetables, and leafy vegetables, we must first calculate the radionuclide concentration in forage, produce, and leafy vegetables resulting from atmospheric transfers of the activity to the surface of the vegetation and onto the soil for root uptake. For all radioiodines and particulate nuclides (except tritium and C-14), the concentration of nuclide i in and on the vegetation at a point of interest can be calculated using R.G. 1.109 equations C-5 and C-6, which combined gives:

$$1.14 * 10^8 * \left[\frac{D}{Q} \right] * Q_i * \left[r * \frac{1 - e^{-\lambda_{Ei} * t_e}}{Y_v * \lambda_{Ei}} + B_{iv} * \frac{1 - e^{-\lambda_i * t_b}}{P * \lambda_i} \right] * e^{-\lambda_i * t_h} \quad 14$$

PART C.1: Concentration in Produce (stored vegetables)

For the case of Mn-54 released in air emissions to the maximum site boundary, the concentration of Mn in produce grown in the hypothetical garden at that location can be calculated from the above equation where the variables are defined as:

$1.14 * 10^8$ is the number of pCi per Ci divided by the number of hours in a year (8760).

$\frac{D}{Q} = 1.5 * 10^{-8}$ is the relative deposition factor, in $1/m^2$, at the maximum exposure point off site (S. B.)

$Q_i := 1$ the release rate of nuclide i to the atmosphere in Ci/yr

$r := 0.2$ fraction of deposited activity retained on crops, leafy vegetables, or pasture grass (1.0 for iodines)

$\lambda_{Ei} := 0.00219$ effective removal rate constant for Mn-54 from crops due to decay and weathering, in hr^{-1}

$t_b := 131400$ soil exposure time to deposition, in (equal to 15 yrs, or mid plant life)

$Y_v := 2.0$ agricultural productivity (yield) for produce, in kg/m^2

$B_{iv} := 2.9 * 10^{-2}$ concentration factor for uptake of Mn-54 from soil by edible parts of crops in pCi/kg (wet weight) per pCi/kg dry soil

λ_i	:=	$9.252 \cdot 10^{-5}$	radioactive decay constant for Mn-54, in hrs-1
P	:=	240	effective surface density of soil, in kg/m ²
t_h	:=	1440	crop holdup time after harvest and before ingestion, in hrs
t_e	:=	1440	crop exposure time to plume, in hrs

Therefore, the concentration of Mn-54 in stored vegetables produced at the location of maximum deposition for a unit activity release is given as:

$$1.14 \cdot 10^8 * \left[\frac{D}{Q} \right] * Q_i * \left[r * \frac{1 - e^{-\lambda_{Ei} * t_e}}{Y_v * \lambda_{Ei}} + B_{iv} * \frac{1 - e^{-\lambda_i * t_b}}{P * \lambda_i} \right] * e^{-\lambda_i * t_h} = 67.37916 \quad \text{pCi/kg}$$

PART C.2: Leafy Vegetable Concentration

For leafy vegetables, the above equation is repeated with the value for t_h , crop holdup time after harvest is changed from 1440 hrs to 24 hrs, i.e.:

t_h	:=	24	crop holdup time after harvest, in hrs.
-------	----	----	---

Therefore the concentration of Mn-54 in leafy vegetables at the maximum deposition point due to a unit activity release is given as:

$$1.14 \cdot 10^8 * \left[\frac{D}{Q} \right] * Q_i * \left[r * \frac{1 - e^{-\lambda_{Ei} * t_e}}{Y_v * \lambda_{Ei}} + B_{iv} * \frac{1 - e^{-\lambda_i * t_b}}{P * \lambda_i} \right] * e^{-\lambda_i * t_h} = 76.81117 \quad \text{pCi/kg}$$

PART C.3.a: Animal Feed concentration (pasture): C_p

Next, we can repeat the above calculation to determine the concentration of Mn-54 in pasture grass used as animal feed. This will allow for the determination of dose contribution from milk and meat.

For pasture grass, all the above variables remain the same except for:

Y_v	:=	0.70	for agricultural productivity of pasture grasses, kg/m ²
t_e	:=	720	for grass exposure time to plume, hrs
t_h	:=	0.0	for holdup time after harvest

Using these variables in the above equation gives the concentration in pasture grass as:

$$1.14 * 10^8 * \left[\frac{D}{Q} \right] * Q_i * \left[r * \frac{1 - e^{-\lambda_{Ei} * t_e}}{Y_v * \lambda_{Ei}} + B_{iv} * \frac{1 - e^{-\lambda_i * t_b}}{P * \lambda_i} \right] * e^{-\lambda_i * t_h} = 179.227 \text{ 18} \quad \text{pCi/kg}$$

PART C.3.b: Animal Feed Concentration (stored feed): C_s

For stored feed that would be given to goats, or meat animals, the average concentration would be calculated by changing the following variables in the above calculation to:

- Y_v := 2.0 agricultural productivity for stored feed
- t_e := 1440 feed crop exposure time to plume in hrs
- t_h := 2160 feed crop holdup time after harvest, hrs

Putting these values back into the above equation gives the concentration in stored animal feed (goat and meat animal) of Mn-54 for a unit activity release to the maximum exposure point.

$$1.14 * 10^8 * \left[\frac{D}{Q} \right] * Q_i * \left[r * \frac{1 - e^{-\lambda_{Ei} * t_e}}{Y_v * \lambda_{Ei}} + B_{iv} * \frac{1 - e^{-\lambda_i * t_b}}{P * \lambda_i} \right] * e^{-\lambda_i * t_h} = 63.037 \text{ 19} \quad \text{pCi/kg}$$

PART C.3.c.: Concentration in Goat's Milk: C_m

The Mn-54 concentration in milk is dependent on the amount and contamination level of the feed consumed by the animal. The radionuclide concentration in milk is estimated from RG 1.109 general equation C-10 as:

$$F_m * C_v * Q_F * e^{-\lambda_i * t_f} 20 = \text{conc. in milk, pCi/liter}$$

where the variables are defined as:

- F_m := $2.5 * 10^{-4}$ average fraction of animal's daily intake of Mn-54 which appears in each liter of milk, in days/liter
- Q_F := 6.0 amount of feed consumed by a goat per day, in kg/day (50 kg/d for meat)
- t_f := 2.0 average transport time of activity from feed into milk and to receptor, in days.

$$\lambda_i := 2.22 \cdot 10^{-3} \quad \text{decay constant of Mn-54, in days}^{-1}$$

In addition, the C_v term for the concentration of a nuclide in the animal's feed is given from RG 1.109 general equation C-11 as:

$$C_v = f_p \cdot f_s \cdot C_p + [1 - f_p] \cdot C_s + f_p \cdot [1 - f_s] \cdot C_s \quad 21$$

where the following equals:

$$f_p := 0.5 \quad \text{fraction of the year that animals graze on pasture}$$

$$f_s := 1.0 \quad \text{fraction of daily feed that is pasture grass when the animal grazes on pasture}$$

$$C_p := 179.227 \quad \text{concentration of Mn-54 in pasture grass as calculated from above, pCi/kg}$$

$$C_s := 63.037 \quad \text{concentration of Mn-54 in stored feed as calculated from above, in pCi/kg}$$

Therefore, the concentration in the total animal's feed is estimated to be:

$$f_p \cdot f_s \cdot C_p + [1 - f_p] \cdot C_s + f_p \cdot [1 - f_s] \cdot C_s = 121.132 \text{ pCi/kg} \quad 22$$

When this value of 121.132 is put back into the above general equation for nuclide concentration in milk, we get:

$$[C_v := 121.132 \text{ pCi/kg}]$$

and

$$F_m \cdot C_v \cdot Q_F \cdot e^{-\lambda_i \cdot t_f} = 0.181 \text{ 23 pCi/liter of Mn-54 in goats milk}$$

PART C.3.d.: Concentration in Meat: C_f

Similar to milk, the concentration of the nuclide in animal meat is calculated. RG 1.109 general equation C-12 is given as:

$$C_f = F_f \cdot C_v \cdot Q_F \cdot e^{-\lambda_i \cdot t_s} \quad 24$$

Here the variables are set as:

$$F_f := 8.0 \cdot 10^{-4} \quad \text{fraction of animals daily intake of Mn-54 which appears in each kg of flesh, in days/kg}$$

$$Q_F := 50.0 \quad \text{animal's daily feed intake, in kg/day}$$

t_s	:=	20.0	average time from slaughter to consumption, in days
C_v	:=	121.132	concentration on Mn-54 in animal's feed, same as calculated above for goat, in pCi/kg

Therefore, the concentration of Mn-54 in animal meat is calculated to be:

$$F_f * C_v * Q_F * e^{-\lambda_i * t_s} = 4.635 \text{ 25 pCi/kg in meat for Mn-54}$$

PART D: DOSE FROM INGESTION OF FOODS PRODUCED AT MAXIMUM LOCATION

Now that we have calculated the concentration of Mn-54 in milk, meat, leafy vegetables, and stored vegetables produced at a location of maximum air deposition, the resulting dose to any organ j and age group a can be calculated from the following general equation C-13 taken from RG 1.109:

$$\sum_i DFI_{ija} * [U_{va} * f_g * C_v + U_{ma} * C_m + U_{Fa} * C_f + U_{La} * f_l * C_L] \text{ 26}$$

For Mn-54 set equal to i, we find that from the evaluation of all organs for all age groups for combination of all exposure pathways, the adults GI-LLI is the critical age group/organ. Therefore, the variables in the above dose equation can be defined as:

DFI_{ija}	:=	$1.40 * 10^{-5}$	ingestion dose factor for adults/GI-LLI for Mn-54, in mrem/pCi ingested (RG 1.109, Table E-11)
U_{va}	:=	520.0	vegetable ingestion rates for adults, kg/yr
f_g	:=	0.76	fraction of stored vegetables grown in the garden
f_l	:=	1.0	of leafy vegetables grown in the garden
U_{ma}	:=	310.0	milk ingestion rate for adults, liter/yr
U_{Fa}	:=	110.0	meat ingestion rate for adults, kg/yr
U_{La}	:=	64.0	leafy vegetable ingestion rate for adults, kg/yr
C_v	:=	67.379	concentration of Mn-54 in stored vegetables, in pCi/kg (from above)
C_m	:=	0.181	concentration of Mn-54 in milk, in pCi/liter (from above)
C_f	:=	4.635	concentration of Mn-54 in meat, in pCi/kg (from above)

C_L := 76.811 concentration of Mn-54 in leafy vegetables, in pCi/kg (from above)

The dose from the combination of ingestion pathways for this example is calculated by substituting the above listed variables back into the ingestion dose equation:

$$DFI_{ija} * [U_{va} * f_g * C_v + U_{ma} * C_m + U_{Fa} * C_f + U_{La} * f_l * C_L] = 0.449527 \quad \text{mrem-/yr per Ci}$$

By breaking the above dose equation down into the different pathways which combine to give the total ingestion dose, we can see the individual dose contribution made by each exposure pathway.

Therefore, we have:

Dose for ingestion of stored vegetables	$DFI_{ija} * U_{va} * f_g * C_v = 0.373$
Dose for ingestion of goat's milk	$DFI_{ija} * U_{ma} * C_m = 7.855 * 10^{-4}$
Dose for ingestion of meat	$DFI_{ija} * U_{Fa} * C_f = 0.00714$
Dose for ingestion of leafy vegetables	$DFI_{ija} * U_{La} * f_l * C_L = 0.0688$

PART E: TOTAL DOSE FROM ALL EXPOSURE PATHWAYS

The total dose from all exposure pathways assumed to be present at the maximum receptor location can be found by simply adding the individual pathway doses calculated above. Since all the calculations above assumed a unit activity release from the plant vent stack, the combined dose can be stated as dose factor per unit activity released. This then demonstrates the development of the Seabrook ODCM Method I dose factors for gaseous release of particulates from the vent stack.

Inhalation dose (Part A)	0.00184 mrem/yr per Ci
Ground plane dose (Part B)	0.658 mrem/yr per Ci
Ingestion dose total (Part D)	0.449 mrem/yr per Ci

Total dose all pathways (critical organ is GI-LLI of an adult for Mn-54)	1.11 mrem/yr per Ci

APPENDIX B

ANNUAL AVERAGE EFFLUENT CONCENTRATION LIMITS

TAKEN FROM

10 CFR 20, APPENDIX B

PART 20 • STANDARDS FOR PROTECTION AGAINST RADIATION

Atomic No.	Radionuclide	Class	Table 1 Occupational Values			Table 2 Effluent Concentrations		Table 3 Releases to Sewers
			Col. 1 Oral Ingestion ALI (μCi)	Inhalation		Col. 1 Air ($\mu\text{Ci}/\text{m}^3$)	Col. 2 Water ($\mu\text{Ci}/\text{m}^3$)	Monthly Average Concentration ($\mu\text{Ci}/\text{m}^3$)
				Col. 2 ALI (μCi)	Col. 3 DAC ($\mu\text{Ci}/\text{m}^3$)			
1	Hydrogen-3	Water, DAC includes skin absorption Gas (HT or T ₂)Submersion ¹	8E+4	8E+4	2E-5	1E-7	1E-3	1E-2
Use above values as HT and T ₂ oxidize in air and in the body to HTO.								
4	Beryllium-7	W, all compounds except those given for Y Y, oxides, halides, and nitrates	4E+4	2E+4	9E-6	3E-8	6E-4	6E-3
4	Beryllium-10	W, see ⁷ Be Y, see ⁷ Be	1E+3 LLI wall (1E+3)	2E+2	6E-8	2E-10	-	-
			-	1E+1	6E-9	2E-11	2E-5	2E-4
6	Carbon-11 ²	Monoxide Dioxide Compounds	-	1E+6 6E+5 4E+5	5E-4 3E-4 2E-4	2E-6 9E-7 6E-7	-	-
6	Carbon-14	Monoxide Dioxide Compounds	-	2E+6 2E+5 2E+3	7E-4 9E-5 1E-6	2E-6 3E-7 3E-9	-	-
9	Fluorine-18 ²	D, fluorides of H, Li, Na, K, Rb, Cs, and Fr W, fluorides of Be, Mg, Ca, Sr, Ba, Ra, Al, Ga, In, Tl, As, Sb, Bi, Fe, Ru, Os, Co, Ni, Pd, Pt, Cu, Ag, Au, Zn, Cd, Hg, Sc, Y, Ti, Zr, V, Nb, Ta, Mn, Tc, and Re Y, lanthanum fluoride	5E+4 St wall (5E+4)	7E+4	3E-5	1E-7	-	-
			-	9E+4	4E-5	1E-7	7E-4	7E-3
11	Sodium-22	D, all compounds	4E+2	6E+2	3E-7	9E-10	6E-6	6E-5
11	Sodium-24	D, all compounds	4E+3	5E+3	2E-6	7E-9	5E-5	5E-4
12	Magnesium-28	D, all compounds except those given for W W, oxides, hydroxides, carbides, halides, and nitrates	7E+2	2E+3	7E-7	2E-9	9E-6	9E-5
13	Aluminum-26	D, all compounds except those given for W W, oxides, hydroxides, carbides, halides, and nitrates	4E+2	6E+1	3E-8	9E-11	6E-6	6E-5
14	Silicon-31	D, all compounds except those given for W and Y W, oxides, hydroxides, carbides, and nitrates Y, aluminosilicate glass	9E+3	3E+4	1E-5	4E-8	1E-4	1E-3
14	Silicon-32	D, see ³¹ Si W, see ³¹ Si Y, see ³¹ Si	2E+3 LLI wall (3E+3)	2E+2	1E-7	3E-10	-	-
			-	3E+4	1E-5	5E-8	4E-5	4E-4
			-	1E+2	5E-8	2E-10	-	-
			-	5E+0	2E-9	7E-12	-	-
15	Phosphorus-32	D, all compounds except phosphates given for W W, phosphates of Zn ²⁺ , S ³⁺ , Mg ²⁺ , Fe ³⁺ , Bi ³⁺ , and lanthanides	6E+2	9E+2	4E-7	1E-9	9E-6	9E-5
15	Phosphorus-33	D, see ³² P W, see ³² P	6E+3	8E+3	4E-6	1E-8	8E-5	8E-4
			-	3E+3	1E-6	4E-9	-	-

58 FR 67657

PART 20 • STANDARDS FOR PROTECTION AGAINST RADIATION

Atomic No.	Radionuclide	Class	Table 1 Occupational Values			Table 2 Effluent Concentrations		Table 3 Releases to Sewers
			Col. 1 Oral Ingestion ALI (μCi)	Inhalation		Col. 1 Air (μCi/ml)	Col. 2 Water (μCi/ml)	Monthly Average Concentration (μCi/ml)
				Col. 2 ALI (μCi)	Col. 3 DAC (μCi/ml)			
16	Sulfur-35	Vapor	-	1E+4	6E-6	2E-8	-	-
		D, sulfides and sulfates except those given for W	1E+4 LLI wall (8E+3)	2E+4	7E-6	2E-8	-	-
		W, elemental sulfur, sulfides of Sr, Ba, Ge, Sn, Pb, As, Sb, Bi, Cu, Ag, Au, Zn, Cd, Hg, W, and Mo. Sulfates of Ca, Sr, Ba, Ra, As, Sb, and Bi	6E+3	-	-	-	1E-4	1E-3
17	Chlorine-36	D, chlorides of H, Li, Na, K, Rb, Cs, and Fr	2E+3	2E+3	1E-6	3E-9	2E-5	2E-4
		W, chlorides of lanthanides, Be, Mg, Ca, Sr, Ba, Ra, Al, Ga, In, Tl, Ge, Sn, Pb, As, Sb, Bi, Fe, Ru, Os, Co, Rh, Ir, Ni, Pd, Pt, Cu, Ag, Au, Zn, Cd, Hg, Sc, Y, Ti, Zr, Hf, V, Nb, Ta, Cr, Mo, W, Mn, Tc, and Re	-	2E+2	1E-7	3E-10	-	-
17	Chlorine-38 ²	D, see ³⁶ Cl	2E+4 St. wall (3E+4)	4E+4	2E-5	6E-8	-	-
		W, see ³⁶ Cl	-	5E+4	2E-5	6E-8	3E-4	3E-3
17	Chlorine-39 ²	D, see ³⁶ Cl	2E+4 St. wall (4E+4)	5E+4	2E-5	7E-8	-	-
		W, see ³⁶ Cl	-	6E+4	2E-5	8E-8	5E-4	5E-3
18	Argon-37	Submersion ¹	-	-	1E+0	6E-3	-	-
18	Argon-39	Submersion ¹	-	-	2E-4	8E-7	-	-
18	Argon-41	Submersion ¹	-	-	3E-6	1E-8	-	-
19	Potassium-40	D, all compounds	3E+2	4E+2	2E-7	6E-10	4E-6	4E-5
19	Potassium-42	D, all compounds	5E+3	5E+3	2E-6	7E-9	6E-5	6E-4
19	Potassium-43	D, all compounds	6E+3	9E+3	4E-6	1E-8	9E-5	9E-4
19	Potassium-44 ²	D, all compounds	2E+4 St. wall (4E+4)	7E+4	3E-5	9E-8	-	-
			-	-	-	5E-4	5E-3	
19	Potassium-45 ²	D, all compounds	3E+4 St. wall (5E+4)	1E+5	5E-5	2E-7	-	-
			-	-	-	7E-4	7E-3	
20	Calcium-41	W, all compounds	3E+3 Bone surf (4E+3)	4E+3 Bone surf (4E+3)	2E-6	-	-	-
			-	-	5E-9	6E-5	6E-4	
20	Calcium-45	W, all compounds	2E+3	8E+2	4E-7	1E-9	2E-5	2E-4
20	Calcium-47	W, all compounds	8E+2	9E+2	4E-7	1E-9	1E-5	1E-4
21	Scandium-43	Y, all compounds	7E+3	2E+4	9E-6	3E-8	1E-4	1E-3
21	Scandium-44m	Y, all compounds	5E+2	7E+2	3E-7	1E-9	7E-6	7E-5
21	Scandium-44	Y, all compounds	4E+3	1E+4	5E-6	2E-8	5E-5	5E-4
21	Scandium-46	Y, all compounds	9E+2	2E+2	1E-7	3E-10	1E-5	1E-4
21	Scandium-47	Y, all compounds	2E+3 LLI wall (3E+3)	3E+3	1E-6	4E-9	-	-
			-	-	-	4E-5	4E-4	
21	Scandium-48	Y, all compounds	8E+2	1E+3	6E-7	2E-9	1E-5	1E-4
21	Scandium-49 ²	Y, all compounds	2E+4	5E+4	2E-5	8E-8	3E-4	3E-3
22	Titanium-44	D, all compounds except those given for W and Y	3E+2	1E+1	5E-9	2E-11	4E-6	4E-5
		W, oxides, hydroxides, carbides, halides, and nitrates	-	3E+1	1E-8	4E-11	-	-
		Y, SrTiO ₃	-	6E+0	2E-9	8E-12	-	-

58 FR 67657

PART 20 STANDARDS FOR PROTECTION AGAINST RADIATION

Atomic No.	Radionuclide	Class	Table 1 Occupational Values			Table 2 Effluent Concentrations		Table 3 Releases to Sewers
			Col. 1 Oral Ingestion ALI (μCi)	Col. 2 Inhalation ALI (μCi)	Col. 3 DAC ($\mu\text{Ci}/\text{ml}$)	Col. 1 Air ($\mu\text{Ci}/\text{ml}$)	Col. 2 Water ($\mu\text{Ci}/\text{ml}$)	Monthly Average Concentration ($\mu\text{Ci}/\text{ml}$)
22	Titanium-45	D, see ⁴⁴ Ti W, see ⁴⁴ Ti Y, see ⁴⁴ Ti	9E+3 - -	3E+4 4E+4 3E+4	1E-5 1E-5 1E-5	3E-8 5E-8 4E-8	1E-4 -	1E-3 - -
23	Vanadium-47 ²	D, all compounds except those given for W	3E+4 St. wall (3E+4)	8E+4 -	3E-5 -	1E-7 -	- 4E-4	- 4E-3
		W, oxides, hydroxides, carbides, and halides	-	1E+5	4E-5	1E-7	-	-
23	Vanadium-48	D, see ⁴⁷ V W, see ⁴⁷ V	6E+2 -	1E+3 6E+2	5E-7 3E-7	2E-9 9E-10	9E-6 -	9E-5 -
23	Vanadium-49	D, see ⁴⁷ V W, see ⁴⁷ V	7E+4 LLI wall (9E+4) -	3E+4 Bone surf (3E+4) 2E+4	1E-5 - 8E-6	- 5E-8 2E-8	- 1E-3 -	- 1E-2 -
24	Chromium-48	D, all compounds except those given for W and Y	6E+3	1E+4	5E-6	2E-8	8E-5	8E-4
		W, halides and nitrates	-	7E+3	3E-6	1E-8	-	-
		Y, oxides and hydroxides	-	7E+3	3E-6	1E-8	-	-
24	Chromium-49 ²	D, see ⁴⁸ Cr W, see ⁴⁸ Cr Y, see ⁴⁸ Cr	3E+4 - -	8E+4 1E+5 9E+4	4E-5 4E-5 4E-5	1E-7 1E-7 1E-7	4E-4 -	4E-3 - -
24	Chromium-51	D, see ⁴⁸ Cr W, see ⁴⁸ Cr Y, see ⁴⁸ Cr	4E+4 - -	5E+4 2E+4 2E+4	2E-5 1E-5 8E-6	6E-8 3E-8 3E-8	5E-4 -	5E-3 - -
25	Manganese-51 ²	D, all compounds except those given for W	2E+4	5E+4	2E-5	7E-8	3E-4	3E-3
		W, oxides, hydroxides, halides, and nitrates	-	6E+4	3E-5	8E-8	-	-
25	Manganese-52m ²	D, see ⁵¹ Mn W, see ⁵¹ Mn	3E+4 St. wall (4E+4) -	9E+4 1E+5	4E-5 4E-5	1E-7 1E-7	- 5E-4	- 5E-3
25	Manganese-52	D, see ⁵¹ Mn W, see ⁵¹ Mn	7E+2 -	1E+3 9E+2	5E-7 4E-7	2E-9 1E-9	1E-5 -	1E-4 -
25	Manganese-53	D, see ⁵¹ Mn W, see ⁵¹ Mn	5E+4 -	1E+4 Bone surf (2E+4) 1E+4	5E-6 - 5E-6	- 3E-8 2E-8	7E-4 -	7E-3 - -
25	Manganese-54	D, see ⁵¹ Mn W, see ⁵¹ Mn	2E+3 -	9E+2 8E+2	4E-7 3E-7	1E-9 1E-9	3E-5 -	3E-4 -
25	Manganese-56	D, see ⁵¹ Mn W, see ⁵¹ Mn	5E+3 -	2E+4 2E+4	6E-6 9E-6	2E-8 3E-8	7E-5 -	7E-4 -

58 FR 67657

PART 20 STANDARDS FOR PROTECTION AGAINST RADIATION

58 FR 67657

Atomic No.	Radionuclide	Class	Table 1 Occupational Values			Table 2 Effluent Concentrations		Table 3 Releases to Sewers
			Col. 1 Oral Ingestion ALI (μCi)	Inhalation		Col. 1 Air ($\mu\text{Ci}/\text{ml}$)	Col. 2 Water ($\mu\text{Ci}/\text{ml}$)	Monthly Average Concentration ($\mu\text{Ci}/\text{ml}$)
				Col. 2 ALI (μCi)	Col. 3 DAC ($\mu\text{Ci}/\text{ml}$)			
26	Iron-52	D, all compounds except those given for W	9E+2	3E+3	1E-6	4E-9	1E-5	1E-4
		W, oxides, hydroxides, and halides	-	2E+3	1E-6	3E-9	-	-
26	Iron-55	D, see ^{52}Fe	9E+3	2E+3	8E-7	3E-9	1E-4	1E-3
		W, see ^{52}Fe	-	4E+3	2E-6	6E-9	-	-
26	Iron-59	D, see ^{52}Fe	8E+2	3E+2	1E-7	5E-10	1E-5	1E-4
		W, see ^{52}Fe	-	5E+2	2E-7	7E-10	-	-
26	Iron-60	D, see ^{52}Fe	3E+1	6E+0	3E-9	9E-12	4E-7	4E-6
		W, see ^{52}Fe	-	2E+1	8E-9	3E-11	-	-
27	Cobalt-55	W, all compounds except those given for Y	1E+3	3E+3	1E-6	4E-9	2E-5	2E-4
		Y, oxides, hydroxides, halides, and nitrates	-	3E+3	1E-6	4E-9	-	-
27	Cobalt-56	W, see ^{55}Co	5E+2	3E+2	1E-7	4E-10	6E-6	6E-5
		Y, see ^{55}Co	4E+2	2E+2	8E-8	3E-10	-	-
27	Cobalt-57	W, see ^{55}Co	8E+3	3E+3	1E-6	4E-9	6E-5	6E-4
		Y, see ^{55}Co	4E+3	7E+2	3E-7	9E-10	-	-
27	Cobalt-58m	W, see ^{55}Co	6E+4	9E+4	4E-5	1E-7	8E-4	8E-3
		Y, see ^{55}Co	-	6E+4	3E-5	9E-8	-	-
27	Cobalt-58	W, see ^{55}Co	2E+3	1E+3	5E-7	2E-9	2E-5	2E-4
		Y, see ^{55}Co	1E+3	7E+2	3E-7	1E-9	-	-
27	Cobalt-60m ²	W, see ^{55}Co	1E+6 St. wall (1E+6)	4E+6	2E-3	6E-6	-	-
		Y, see ^{55}Co	-	3E+6	1E-3	4E-6	2E-2	2E-1
27	Cobalt-60	W, see ^{55}Co	5E+2	2E+2	7E-8	2E-10	3E-6	3E-5
		Y, see ^{55}Co	2E+2	3E+1	1E-8	5E-11	-	-
27	Cobalt-61 ²	W, see ^{55}Co	2E+4	6E+4	3E-5	9E-8	3E-4	3E-3
		Y, see ^{55}Co	2E+4	6E+4	2E-5	8E-8	-	-
27	Cobalt-62m ²	W, see ^{55}Co	4E+4 St. wall (5E+4)	2E+5	7E-5	2E-7	-	-
		Y, see ^{55}Co	-	2E+5	6E-5	2E-7	7E-4	7E-3
28	Nickel-56	D, all compounds except those given for W	1E+3	2E+3	8E-7	3E-9	2E-5	2E-4
		W, oxides, hydroxides, and carbides Vapor	-	1E+3	5E-7	2E-9	-	-
28	Nickel-57	D, see ^{56}Ni	2E+3	5E+3	2E-6	7E-9	2E-5	2E-4
		W, see ^{56}Ni Vapor	-	3E+3	1E-6	4E-9	-	-
			-	6E+3	3E-6	9E-9	-	-

PART 20 STANDARDS FOR PROTECTION AGAINST RADIATION

Atomic No.	Radionuclide	Class	Table 1 Occupational Values			Table 2 Effluent Concentrations		Table 3 Releases to Sewers
			Col. 1 Oral Ingestion ALI (μCi)	Inhalation		Col. 1 Air ($\mu\text{Ci}/\text{m}^3$)	Col. 2 Water ($\mu\text{Ci}/\text{m}^3$)	Monthly Average Concentration ($\mu\text{Ci}/\text{m}^3$)
				Col. 2 ALI (μCi)	Col. 3 DAC ($\mu\text{Ci}/\text{m}^3$)			
28	Nickel-59	D, see ^{56}Ni	2E+4	4E+3	2E-6	5E-9	3E-4	3E-3
		W, see ^{56}Ni	-	7E+3	3E-6	1E-8	-	-
		Vapor	-	2E+3	8E-7	3E-9	-	-
28	Nickel-63	D, see ^{56}Ni	9E+3	2E+3	7E-7	2E-9	1E-4	1E-3
		W, see ^{56}Ni	-	3E+3	1E-6	4E-9	-	-
		Vapor	-	8E+2	3E-7	1E-9	-	-
28	Nickel-65	D, see ^{56}Ni	8E+3	2E+4	1E-5	3E-8	1E-4	1E-3
		W, see ^{56}Ni	-	3E+4	1E-5	4E-8	-	-
		Vapor	-	2E+4	7E-6	2E-8	-	-
28	Nickel-66	D, see ^{56}Ni	4E+2	2E+3	7E-7	2E-9	-	-
		W, see ^{56}Ni	(5E+2) LLI wall	-	-	-	6E-6	6E-5
		Vapor	-	6E+2	3E-7	9E-10	-	-
29	Copper-60 ²	D, all compounds except those given for W and Y	3E+4	9E+4	4E-5	1E-7	-	-
		W, sulfides, halides, and nitrates	(3E+4) St. wall	-	-	-	4E-4	4E-3
		Y, oxides and hydroxides	-	1E+5	5E-5	2E-7	-	-
29	Copper-61	D, see ^{60}Cu	1E+4	3E+4	1E-5	4E-8	2E-4	2E-3
		W, see ^{60}Cu	-	4E+4	2E-5	6E-8	-	-
		Y, see ^{60}Cu	-	4E+4	1E-5	5E-8	-	-
29	Copper-64	D, see ^{60}Cu	1E+4	3E+4	1E-5	4E-8	2E-4	2E-3
		W, see ^{60}Cu	-	2E+4	1E-5	3E-8	-	-
		Y, see ^{60}Cu	-	2E+4	9E-6	3E-8	-	-
29	Copper-67	D, see ^{60}Cu	5E+3	8E+3	3E-6	1E-8	6E-5	6E-4
		W, see ^{60}Cu	-	5E+3	2E-6	7E-9	-	-
		Y, see ^{60}Cu	-	5E+3	2E-6	6E-9	-	-
30	Zinc-62	Y, all compounds	1E+3	3E+3	1E-6	4E-9	2E-5	2E-4
30	Zinc-63 ²	Y, all compounds	2E+4	7E+4	3E-5	9E-8	-	-
			(3E+4) St. wall	-	-	-	3E-4	3E-3
30	Zinc-65	Y, all compounds	4E+2	3E+2	1E-7	4E-10	5E-6	5E-5
30	Zinc-69m	Y, all compounds	4E+3	7E+3	3E-6	1E-8	6E-5	6E-4
30	Zinc-69 ²	Y, all compounds	6E+4	1E+5	6E-5	2E-7	8E-4	8E-3
30	Zinc-71m	Y, all compounds	6E+3	2E+4	7E-6	2E-8	8E-5	8E-4
30	Zinc-72	Y, all compounds	1E+3	1E+3	5E-7	2E-9	1E-5	1E-4
31	Gallium-65 ²	D, all compounds except those given for W	5E+4	2E+5	7E-5	2E-7	-	-
		W, oxides, hydroxides, carbides, halides, and nitrates	(6E+4) St. wall	-	-	-	9E-4	9E-3
			-	2E+5	8E-5	3E-7	-	-

58 FR 67657

PART 20 STANDARDS FOR PROTECTION AGAINST RADIATION

58 FR 67657

Atomic No.	Radionuclide	Class	Table 1 Occupational Values			Table 2 Effluent Concentrations		Table 3 Releases to Sewers
			Col. 1 Oral Ingestion ALI (μCi)	Inhalation		Col. 1 Air ($\mu\text{Ci}/\text{m}^3$)	Col. 2 Water ($\mu\text{Ci}/\text{m}^3$)	Monthly Average Concentration ($\mu\text{Ci}/\text{m}^3$)
				Col. 2 ALI (μCi)	Col. 3 DAC ($\mu\text{Ci}/\text{m}^3$)			
31	Gallium-66	D, see ^{65}Ga W, see ^{65}Ga	1E+3 -	4E+3 3E+3	1E-6 1E-6	5E-9 4E-9	1E-5 -	1E-4 -
31	Gallium-67	D, see ^{65}Ga W, see ^{65}Ga	7E+3 -	1E+4 1E+4	6E-6 4E-6	2E-8 1E-8	1E-4 -	1E-3 -
31	Gallium-68 ²	D, see ^{65}Ga W, see ^{65}Ga	2E+4 -	4E+4 5E+4	2E-5 2E-5	6E-8 7E-8	2E-4 -	2E-3 -
31	Gallium-70 ²	D, see ^{65}Ga W, see ^{65}Ga	5E+4 (7E+4) -	2E+5 -	7E-5 -	2E-7 -	- 1E-3	- 1E-2
31	Gallium-72	D, see ^{65}Ga W, see ^{65}Ga	1E+3 -	4E+3 3E+3	1E-6 1E-6	5E-9 4E-9	2E-5 -	2E-4 -
31	Gallium-73	D, see ^{65}Ga W, see ^{65}Ga	5E+3 -	2E+4 2E+4	6E-6 6E-6	2E-8 2E-8	7E-5 -	7E-4 -
32	Germanium-66	D, all compounds except those given for W W, oxides, sulfides, and halides	2E+4 -	3E+4 2E+4	1E-5 8E-6	4E-8 3E-8	3E-4 -	3E-3 -
32	Germanium-67 ²	D, see ^{66}Ge W, see ^{66}Ge	3E+4 (4E+4) -	9E+4 -	4E-5 -	1E-7 -	- 6E-4	- 6E-3
32	Germanium-68	D, see ^{66}Ge W, see ^{66}Ge	5E+3 -	4E+3 1E+2	2E-6 4E-8	5E-9 1E-10	6E-5 -	6E-4 -
32	Germanium-69	D, see ^{66}Ge W, see ^{66}Ge	1E+4 -	2E+4 8E+3	6E-6 3E-6	2E-8 1E-8	2E-4 -	2E-3 -
32	Germanium-71	D, see ^{66}Ge W, see ^{66}Ge	5E+5 -	4E+5 4E+4	2E-4 2E-5	6E-7 6E-8	7E-3 -	7E-2 -
32	Germanium-75 ²	D, see ^{66}Ge W, see ^{66}Ge	4E+4 (7E+4) -	8E+4 8E+4	3E-5 -	1E-7 -	- 9E-4	- 9E-3
32	Germanium-77	D, see ^{66}Ge W, see ^{66}Ge	9E+3 -	1E+4 6E+3	4E-6 2E-6	1E-8 8E-9	1E-4 -	1E-3 -
32	Germanium-78 ²	D, see ^{66}Ge W, see ^{66}Ge	2E+4 (2E+4) -	2E+4 -	9E-6 -	3E-8 -	- 3E-4	- 3E-3

PART 20 STANDARDS FOR PROTECTION AGAINST RADIATION

58 FR 67657

Atomic No.	Radionuclide	Class	Table 1 Occupational Values			Table 2 Effluent Concentrations		Table 3 Releases to Sewers
			Col. 1 Oral Ingestion ALI (μCi)	Inhalation		Col. 1 Air ($\mu\text{Ci}/\text{m}^3$)	Col. 2 Water ($\mu\text{Ci}/\text{m}^3$)	Monthly Average Concentration ($\mu\text{Ci}/\text{m}^3$)
				Col. 2 ALI (μCi)	Col. 3 DAC ($\mu\text{Ci}/\text{m}^3$)			
33	Arsenic-69 ²	W, all compounds	3E+4 St. wall (4E+4)	1E+5	5E-5	2E-7	-	-
33	Arsenic-70 ²	W, all compounds	1E+4	5E+4	2E-5	7E-8	2E-4	2E-3
33	Arsenic-71	W, all compounds	4E+3	5E+3	2E-6	6E-9	5E-5	5E-4
33	Arsenic-72	W, all compounds	9E+2	1E+3	6E-7	2E-9	1E-5	1E-4
33	Arsenic-73	W, all compounds	8E+3	2E+3	7E-7	2E-9	1E-4	1E-3
33	Arsenic-74	W, all compounds	1E+3	8E+2	3E-7	1E-9	2E-5	2E-4
33	Arsenic-76	W, all compounds	1E+3	1E+3	6E-7	2E-9	1E-5	1E-4
33	Arsenic-77	W, all compounds	4E+3 LLI wall (5E+3)	5E+3	2E-6	7E-9	-	-
33	Arsenic-78 ²	W, all compounds	8E+3	2E+4	9E-6	3E-8	1E-4	1E-3
34	Selenium-70 ²	D, all compounds except those given for W	2E+4	4E+4	2E-5	5E-8	1E-4	1E-3
		W, oxides, hydroxides, carbides, and elemental Se	1E+4	4E+4	2E-5	6E-8	-	-
34	Selenium-73m ²	D, see ⁷⁰ Se W, see ⁷⁰ Se	6E+4 3E+4	2E+5 1E+5	6E-5 6E-5	2E-7 2E-7	4E-4 -	4E-3 -
34	Selenium-73	D, see ⁷⁰ Se W, see ⁷⁰ Se	3E+3 -	1E+4 2E+4	5E-6 7E-6	2E-8 2E-8	4E-5 -	4E-4 -
34	Selenium-75	D, see ⁷⁰ Se W, see ⁷⁰ Se	5E+2 -	7E+2 6E+2	3E-7 3E-7	1E-9 8E-10	7E-6 -	7E-5 -
34	Selenium-79	D, see ⁷⁰ Se W, see ⁷⁰ Se	6E+2 -	8E+2 6E+2	3E-7 2E-7	1E-9 8E-10	8E-6 -	8E-5 -
34	Selenium-81m ²	D, see ⁷⁰ Se W, see ⁷⁰ Se	4E+4 2E+4	7E+4 7E+4	3E-5 3E-5	9E-8 1E-7	3E-4 -	3E-3 -
34	Selenium-81 ²	D, see ⁷⁰ Se	6E+4 St. wall (8E+4)	2E+5	9E-5	3E-7	-	-
		W, see ⁷⁰ Se	-	2E+5	1E-4	3E-7	1E-3	1E-2
34	Selenium-83 ²	D, see ⁷⁰ Se W, see ⁷⁰ Se	4E+4 3E+4	1E+5 1E+5	5E-5 5E-5	2E-7 2E-7	4E-4 -	4E-3 -

PART 20 STANDARDS FOR PROTECTION AGAINST RADIATION

58 FR 67657

Atomic No.	Radionuclide	Class	Table 1 Occupational Values			Table 2 Effluent Concentrations		Table 3 Releases to Sewers
			Col. 1 Oral Ingestion ALI (μCi)	Inhalation		Col. 1 Air (μCi/ml)	Col. 2 Water (μCi/ml)	Monthly Average Concentration (μCi/ml)
				Col. 2 ALI (μCi)	Col. 3 DAC (μCi/ml)			
35	Bromine-74m ²	D, bromides of H, Li, Na, K, Rb, Cs, and Fr	1E+4 St. wall (2E+4)	4E+4	2E-5	5E-8	-	-
		W, bromides of lanthanides, Be, Mg, Ca, Sr, Ba, Ra, Al, Ga, In, Tl, Ge, Sn, Pb, As, Sb, Bi, Fe, Ru, Os, Co, Rh, Ir, Ni, Pd, Pt, Cu, Ag, Au, Zn, Cd, Hg, Sc, Y, Ti, Zr, Hf, V, Nb, Ta, Mn, Tc, and Re	-	4E+4	2E-5	6E-8	-	-
35	Bromine-74 ²	D, see ^{74m} Br	2E+4 St. wall (4E+4)	7E+4	3E-5	1E-7	-	-
		W, see ^{74m} Br	-	8E+4	4E-5	1E-7	5E-4	5E-3
35	Bromine-75 ²	D, see ^{74m} Br	3E+4 St. wall (4E+4)	5E+4	2E-5	7E-8	-	-
		W, see ^{74m} Br	-	5E+4	2E-5	7E-8	5E-4	5E-3
35	Bromine-76	D, see ^{74m} Br	4E+3	5E+3	2E-6	7E-9	5E-5	5E-4
		W, see ^{74m} Br	-	4E+3	2E-6	6E-9	-	-
35	Bromine-77	D, see ^{74m} Br	2E+4	2E+4	1E-5	3E-8	2E-4	2E-3
		W, see ^{74m} Br	-	2E+4	8E-6	3E-8	-	-
35	Bromine-80m	D, see ^{74m} Br	2E+4	2E+4	7E-6	2E-8	3E-4	3E-3
		W, see ^{74m} Br	-	1E+4	6E-6	2E-8	-	-
35	Bromine-80 ²	D, see ^{74m} Br	5E+4 St. wall (9E+4)	2E+5	8E-5	3E-7	-	-
		W, see ^{74m} Br	-	2E+5	9E-5	3E-7	1E-3	1E-2
35	Bromine-82	D, see ^{74m} Br	3E+3	4E+3	2E-6	6E-9	4E-5	4E-4
		W, see ^{74m} Br	-	4E+3	2E-6	5E-9	-	-
35	Bromine-83	D, see ^{74m} Br	5E+4 St. wall (7E+4)	6E+4	3E-5	9E-8	-	-
		W, see ^{74m} Br	-	6E+4	3E-5	9E-8	9E-4	9E-3
35	Bromine-84 ²	D, see ^{74m} Br	2E+4 St. wall (3E+4)	6E+4	2E-5	8E-8	-	-
		W, see ^{74m} Br	-	6E+4	3E-5	9E-8	4E-4	4E-3
36	Krypton-74 ²	Submersion ¹	-	-	3E-6	1E-8	-	-
36	Krypton-76	Submersion ¹	-	-	9E-6	4E-8	-	-
36	Krypton-77 ²	Submersion ¹	-	-	4E-6	2E-8	-	-
36	Krypton-79	Submersion ¹	-	-	2E-5	7E-8	-	-
36	Krypton-81	Submersion ¹	-	-	7E-4	3E-6	-	-

PART 20 STANDARDS FOR PROTECTION AGAINST RADIATION

58 FR 67657

Atomic No.	Radionuclide	Class	Table 1 Occupational Values			Table 2 Effluent Concentrations		Table 3 Releases to Sewers
			Col. 1 Oral Ingestion ALI (μ Ci)	Col. 2 ALI (μ Ci)	Col. 3 DAC (μ Ci/m)	Col. 1 Air (μ Ci/ml)	Col. 2 Water (μ Ci/ml)	Monthly Average Concentration (μ Ci/ml)
36	Krypton-83m ²	Submersion ¹	-	-	1E-2	5E-5	-	-
36	Krypton-85m	Submersion ¹	-	-	2E-5	1E-7	-	-
36	Krypton-85	Submersion ¹	-	-	1E-4	7E-7	-	-
36	Krypton-87 ²	Submersion ¹	-	-	5E-6	2E-8	-	-
36	Krypton-88	Submersion ¹	-	-	2E-6	9E-9	-	-
37	Rubidium-79 ²	D, all compounds	4E+4 St. wall (6E+4)	1E+5	5E-5	2E-7	-	8E-4
37	Rubidium-81m ²	D, all compounds	2E+5 St. wall (3E+5)	3E+5	1E-4	5E-7	-	4E-2
37	Rubidium-81	D, all compounds	4E+4	5E+4	2E-5	7E-8	5E-4	5E-3
37	Rubidium-82m	D, all compounds	1E+4	2E+4	7E-6	2E-8	2E-4	2E-3
37	Rubidium-83	D, all compounds	6E+2	1E+3	4E-7	1E-9	9E-6	9E-5
37	Rubidium-84	D, all compounds	5E+2	8E+2	3E-7	1E-9	7E-6	7E-5
37	Rubidium-86	D, all compounds	5E+2	8E+2	3E-7	1E-9	7E-6	7E-5
37	Rubidium-87	D, all compounds	1E+3	2E+3	6E-7	2E-9	1E-5	1E-4
37	Rubidium-88 ²	D, all compounds	2E+4 St. wall (3E+4)	6E+4	3E-5	9E-8	-	4E-4
37	Rubidium-89 ²	D, all compounds	4E+4 St. wall (6E+4)	1E+5	6E-5	2E-7	-	9E-4
38	Strontium-80 ²	D, all soluble compounds except SrTiO ₃ Y, all insoluble compounds and SrTiO ₃	4E+3	1E+4	5E-6	2E-8	6E-5	6E-4
38	Strontium-81 ²	D, see ⁸⁰ Sr Y, see ⁸⁰ Sr	3E+4 2E+4	8E+4 8E+4	3E-5 3E-5	1E-7 1E-7	3E-4	3E-3
38	Strontium-82	D, see ⁸⁰ Sr Y, see ⁸⁰ Sr	3E+2 LLI wall (2E+2) 2E+2	4E+2	2E-7	6E-10	-	3E-5
38	Strontium-83	D, see ⁸⁰ Sr Y, see ⁸⁰ Sr	3E+3 2E+3	7E+3 4E+3	3E-6 1E-6	1E-8 5E-9	3E-5	3E-4
38	Strontium-85m ²	D, see ⁸⁰ Sr Y, see ⁸⁰ Sr	2E+5	6E+5 8E+5	3E-4 4E-4	9E-7 1E-6	3E-3	3E-2
38	Strontium-85	D, see ⁸⁰ Sr Y, see ⁸⁰ Sr	3E+3	3E+3 2E+3	1E-6 6E-7	4E-9 2E-9	4E-5	4E-4
38	Strontium-87m	D, see ⁸⁰ Sr Y, see ⁸⁰ Sr	5E+4 4E+4	1E+5 2E+5	5E-5 6E-5	2E-7 2E-7	6E-4	6E-3

PART 20 STANDARDS FOR PROTECTION AGAINST RADIATION

Atomic No.	Radionuclide	Class	Table 1 Occupational Values			Table 2 Effluent Concentrations		Table 3 Releases to Sewers
			Col. 1 Oral Ingestion ALI (µCi)	Col. 2	Col. 3	Col. 1 Air (µCi/ml)	Col. 2 Water (µCi/ml)	Monthly Average Concentration (µCi/ml)
38	Strontium-89	D, see ⁸⁰ Sr	6E+2 LLI wall (6E+2)	8E+2	4E-7	1E-9	-	-
		Y, see ⁸⁰ Sr	5E+2	1E+2	6E-8	2E-10	8E-6	8E-5
38	Strontium-90	D, see ⁸⁰ Sr	3E+1 Bone surf (4E+1)	2E+1 Bone surf (2E+1)	8E-9	-	-	-
		Y, see ⁸⁰ Sr	-	4E+0	2E-9	3E-11 6E-12	5E-7	5E-6
38	Strontium-91	D, see ⁸⁰ Sr	2E+3	6E+3	2E-6	8E-9	2E-5	2E-4
		Y, see ⁸⁰ Sr	-	4E+3	1E-6	5E-9	-	-
38	Strontium-92	D, see ⁸⁰ Sr	3E+3	9E+3	4E-6	1E-8	4E-5	4E-4
		Y, see ⁸⁰ Sr	-	7E+3	3E-6	9E-9	-	-
39	Yttrium-86m ²	W, all compounds except those given for Y	2E+4	6E+4	2E-5	8E-8	3E-4	3E-3
		Y, oxides and hydroxides	-	5E+4	2E-5	8E-8	-	-
39	Yttrium-86	W, see ^{86m} Y	1E+3	3E+3	1E-6	5E-9	2E-5	2E-4
		Y, see ^{86m} Y	-	3E+3	1E-6	5E-9	-	-
39	Yttrium-87	W, see ^{86m} Y	2E+3	3E+3	1E-6	5E-9	3E-5	3E-4
		Y, see ^{86m} Y	-	3E+3	1E-6	5E-9	-	-
39	Yttrium-88	W, see ^{86m} Y	1E+3	3E+2	1E-7	3E-10	1E-5	1E-4
		Y, see ^{86m} Y	-	2E+2	1E-7	3E-10	-	-
39	Yttrium-90m	W, see ^{86m} Y	8E+3	1E+4	5E-6	2E-8	1E-4	1E-3
		Y, see ^{86m} Y	-	1E+4	5E-6	2E-8	-	-
39	Yttrium-90	W, see ^{86m} Y	4E+2 LLI wall (5E+2)	7E+2	3E-7	9E-10	-	-
		Y, see ^{86m} Y	-	6E+2	3E-7	9E-10	7E-6	7E-5
39	Yttrium-91m ²	W, see ^{86m} Y	1E+5	2E+5	1E-4	3E-7	2E-3	2E-2
		Y, see ^{86m} Y	-	2E+5	7E-5	2E-7	-	-
39	Yttrium-91	W, see ^{86m} Y	5E+2 LLI wall (6E+2)	2E+2	7E-8	2E-10	-	-
		Y, see ^{86m} Y	-	1E+2	5E-8	2E-10	8E-6	8E-5
39	Yttrium-92	W, see ^{86m} Y	3E+3	9E+3	4E-6	1E-8	4E-5	4E-4
		Y, see ^{86m} Y	-	8E+3	3E-6	1E-8	-	-
39	Yttrium-93	W, see ^{86m} Y	1E+3	3E+3	1E-6	4E-9	2E-5	2E-4
		Y, see ^{86m} Y	-	2E+3	1E-6	3E-9	-	-
39	Yttrium-94 ²	W, see ^{86m} Y	2E+4 St. wall (3E+4)	8E+4	3E-5	1E-7	-	-
		Y, see ^{86m} Y	-	8E+4	3E-5	1E-7	4E-4	4E-3
39	Yttrium-95 ²	W, see ^{86m} Y	4E+4 St. wall (5E+4)	2E+5	6E-5	2E-7	-	-
		Y, see ^{86m} Y	-	1E+5	6E-5	2E-7	7E-4	7E-3

58 FR 67857

PART 20 STANDARDS FOR PROTECTION AGAINST RADIATION

Atomic No.	Radionuclide	Class	Table 1 Occupational Values			Table 2 Effluent Concentrations		Table 3 Releases to Sewers
			Col. 1 Oral Ingestion ALI (μCi)	Inhalation		Col. 1 Air ($\mu\text{Ci}/\text{m}^3$)	Col. 2 Water ($\mu\text{Ci}/\text{m}^3$)	Monthly Average Concentration ($\mu\text{Ci}/\text{m}^3$)
				Col. 2 ALI (μCi)	Col. 3 DAC ($\mu\text{Ci}/\text{m}^3$)			
40	Zirconium-86	D, all compounds except those given for W and Y	1E+3	4E+3	2E-6	6E-9	2E-5	2E-4
		W, oxides, hydroxides, halides, and nitrates	-	3E+3	1E-6	4E-9	-	-
		Y, carbide	-	2E+3	1E-6	3E-9	-	-
40	Zirconium-88	D, see ^{86}Zr	4E+3	2E+2	9E-8	3E-10	5E-5	5E-4
		W, see ^{86}Zr	-	5E+2	2E-7	7E-10	-	-
		Y, see ^{86}Zr	-	3E+2	1E-7	4E-10	-	-
40	Zirconium-89	D, see ^{86}Zr	2E+3	4E+3	1E-6	5E-9	2E-5	2E-4
		W, see ^{86}Zr	-	2E+3	1E-6	3E-9	-	-
		Y, see ^{86}Zr	-	2E+3	1E-6	3E-9	-	-
40	Zirconium-93	D, see ^{86}Zr	1E+3	6E+0	3E-9	-	-	-
		W, see ^{86}Zr	Bone surf (3E+3)	Bone surf (2E+1)	-	2E-11	4E-5	4E-4
		Y, see ^{86}Zr	-	2E+1	1E-8	-	-	-
		-	Bone surf (6E+1)	-	9E-11	-	-	-
		-	6E+1	2E-8	-	-	-	-
40	Zirconium-95	D, see ^{86}Zr	1E+3	1E+2	5E-8	-	2E-5	2E-4
		W, see ^{86}Zr	-	Bone surf (3E+2)	-	4E-10	-	-
		Y, see ^{86}Zr	-	4E+2	2E-7	5E-10	-	-
		-	-	3E+2	1E-7	4E-10	-	-
		-	-	-	-	-	-	-
40	Zirconium-97	D, see ^{86}Zr	6E+2	2E+3	8E-7	3E-9	9E-6	9E-5
		W, see ^{86}Zr	-	1E+3	6E-7	2E-9	-	-
		Y, see ^{86}Zr	-	1E+3	5E-7	2E-9	-	-
41	Niobium-88 ²	W, all compounds except those given for Y	5E+4	2E+5	9E-5	3E-7	-	-
		Y, oxides and hydroxides	St. wall (7E+4)	-	-	-	1E-3	1E-2
		-	-	2E+5	9E-5	3E-7	-	-
41	Niobium-89m ² (66 min)	W, see ^{88}Nb	1E+4	4E+4	2E-5	6E-8	1E-4	1E-3
		Y, see ^{88}Nb	-	4E+4	2E-5	5E-8	-	-
41	Niobium-89 (122 min)	W, see ^{88}Nb	5E+3	2E+4	8E-6	3E-8	7E-5	7E-4
		Y, see ^{88}Nb	-	2E+4	6E-6	2E-8	-	-
41	Niobium-90	W, see ^{88}Nb	1E+3	3E+3	1E-6	4E-9	1E-5	1E-4
		Y, see ^{88}Nb	-	2E+3	1E-6	3E-9	-	-
41	Niobium-93m	W, see ^{88}Nb	9E+3	2E+3	8E-7	3E-9	-	-
		Y, see ^{88}Nb	LLI wall (1E+4)	-	-	-	2E-4	2E-3
41	Niobium-94	W, see ^{88}Nb	9E+2	2E+2	8E-8	3E-10	1E-5	1E-4
		Y, see ^{88}Nb	-	2E+1	6E-9	2E-11	-	-
41	Niobium-95m	W, see ^{88}Nb	2E+3	3E+3	1E-6	4E-9	-	-
		Y, see ^{88}Nb	LLI wall (2E+3)	-	-	-	3E-5	3E-4
-	-	-	2E+3	9E-7	3E-9	-	-	

58 FR 67657

PART 20 STANDARDS FOR PROTECTION AGAINST RADIATION

Atomic No.	Radionuclide	Class	Table 1 Occupational Values			Table 2 Effluent Concentrations		Table 3 Releases to Sewers
			Col. 1 Oral Ingestion ALI (μCi)	Inhalation		Col. 1 Air (μCi/ml)	Col. 2 Water (μCi/ml)	Monthly Average Concentration (μCi/ml)
				Col. 2 ALI (μCi)	Col. 3 DAC (μCi/ml)			
41	Niobium-95	W, see ⁸⁸ Nb Y, see ⁸⁸ Nb	2E+3 -	1E+3 1E+3	5E-7 5E-7	2E-9 2E-9	3E-5 -	3E-4 -
41	Niobium-96	W, see ⁸⁸ Nb Y, see ⁸⁸ Nb	1E+3 -	3E+3 2E+3	1E-6 1E-6	4E-9 3E-9	2E-5 -	2E-4 -
41	Niobium-97 ²	W, see ⁸⁸ Nb Y, see ⁸⁸ Nb	2E+4 -	8E+4 7E+4	3E-5 3E-5	1E-7 1E-7	3E-4 -	3E-3 -
41	Niobium-98 ²	W, see ⁸⁸ Nb Y, see ⁸⁸ Nb	1E+4 -	5E+4 5E+4	2E-5 2E-5	8E-8 7E-8	2E-4 -	2E-3 -
42	Molybdenum-90	D, all compounds except those given for Y Y, oxides, hydroxides, and MoS ₂	4E+3 2E+3	7E+3 5E+3	3E-6 2E-6	1E-8 6E-9	3E-5 -	3E-4 -
42	Molybdenum-93m	D, see ⁹⁰ Mo Y, see ⁹⁰ Mo	9E+3 4E+3	2E+4 1E+4	7E-6 6E-6	2E-8 2E-8	6E-5 -	6E-4 -
42	Molybdenum-93	D, see ⁹⁰ Mo Y, see ⁹⁰ Mo	4E+3 2E+4	5E+3 2E+2	2E-6 8E-8	8E-9 2E-10	5E-5 -	5E-4 -
42	Molybdenum-99	D, see ⁹⁰ Mo Y, see ⁹⁰ Mo	2E+3 (1E+3) 1E+3	3E+3 - 1E+3	1E-6 - 6E-7	4E-9 - 2E-9	- 2E-5 -	- 2E-4 -
42	Molybdenum-101 ²	D, see ⁹⁰ Mo Y, see ⁹⁰ Mo	4E+4 (5E+4) -	1E+5 - 1E+5	6E-5 - 6E-5	2E-7 - 2E-7	- 7E-4 -	- 7E-3 -
43	Technetium-93m ²	D, all compounds except those given for W W, oxides, hydroxides, halides, and nitrates	7E+4 -	2E+5 3E+5	6E-5 1E-4	2E-7 4E-7	1E-3 -	1E-2 -
43	Technetium-93	D, see ^{93m} Tc W, see ^{93m} Tc	3E+4 -	7E+4 1E+5	3E-5 4E-5	1E-7 1E-7	4E-4 -	4E-3 -
43	Technetium-94m ²	D, see ^{93m} Tc W, see ^{93m} Tc	2E+4 -	4E+4 6E+4	2E-5 2E-5	6E-8 8E-8	3E-4 -	3E-3 -
43	Technetium-94	D, see ^{93m} Tc W, see ^{93m} Tc	9E+3 -	2E+4 2E+4	8E-6 1E-5	3E-8 3E-8	1E-4 -	1E-3 -
43	Technetium-95m	D, see ^{93m} Tc W, see ^{93m} Tc	4E+3 -	5E+3 2E+3	2E-6 8E-7	8E-9 3E-9	5E-5 -	5E-4 -
43	Technetium-95	D, see ^{93m} Tc W, see ^{93m} Tc	1E+4 -	2E+4 2E+4	9E-6 8E-6	3E-8 3E-8	1E-4 -	1E-3 -
43	Technetium-96m ²	D, see ^{93m} Tc W, see ^{93m} Tc	2E+5 -	3E+5 2E+5	1E-4 1E-4	4E-7 3E-7	2E-3 -	2E-2 -
43	Technetium-96	D, see ^{93m} Tc W, see ^{93m} Tc	2E+3 -	3E+3 2E+3	1E-6 9E-7	5E-9 3E-9	3E-5 -	3E-4 -
43	Technetium-97m	D, see ^{93m} Tc W, see ^{93m} Tc	5E+3 -	7E+3 (7E+3) 1E+3	3E-6 - 5E-7	- 1E-8 2E-9	6E-5 -	6E-4 -

58 FR 67657

PART 20 STANDARDS FOR PROTECTION AGAINST RADIATION

58 FR 67657

Atomic No.	Radionuclide	Class	Table 1 Occupational Values			Table 2 Effluent Concentrations		Table 3 Releases to Sewers
			Col. 1 Oral Ingestion ALI (μ Ci)	Inhalation		Col. 1 Air (μ Ci/ml)	Col. 2 Water (μ Ci/ml)	Monthly Average Concentration (μ Ci/ml)
				Col. 2 ALI (μ Ci)	Col. 3 DAC (μ Ci/ml)			
43	Technetium-97	D, see ^{93m}Tc	4E+4	5E+4	2E-5	7E-8	5E-4	5E-3
		W, see ^{93m}Tc	-	6E+3	2E-6	8E-9	-	-
43	Technetium-98	D, see ^{93m}Tc	1E+3	2E+3	7E-7	2E-9	1E-5	1E-4
		W, see ^{93m}Tc	-	3E+2	1E-7	4E-10	-	-
43	Technetium-99m	D, see ^{93m}Tc	8E+4	2E+5	6E-5	2E-7	1E-3	1E-2
		W, see ^{93m}Tc	-	2E+5	1E-4	3E-7	-	-
43	Technetium-99	D, see ^{93m}Tc	4E+3	5E+3	2E-6	-	6E-5	6E-4
		W, see ^{93m}Tc	-	St. wall (6E+3) 7E+2	-	8E-9 9E-10	-	-
43	Technetium-101 ²	D, see ^{93m}Tc	9E+4 St. wall (1E+5)	3E+5	1E-4	5E-7	-	-
		W, see ^{93m}Tc	-	4E+5	2E-4	5E-7	2E-3	2E-2
43	Technetium-104 ²	D, see ^{93m}Tc	2E+4 St. wall (3E+4)	7E+4	3E-5	1E-7	-	-
		W, see ^{93m}Tc	-	9E+4	4E-5	1E-7	4E-4	4E-3
44	Ruthenium-94 ²	D, all compounds except those given for W and Y	2E+4	4E+4	2E-5	6E-8	2E-4	2E-3
		W, halides	-	6E+4	3E-5	9E-8	-	-
		Y, oxides and hydroxides	-	6E+4	2E-5	8E-8	-	-
44	Ruthenium-97	D, see ^{94}Ru	8E+3	2E+4	8E-6	3E-8	1E-4	1E-3
		W, see ^{94}Ru	-	1E+4	5E-6	2E-8	-	-
		Y, see ^{94}Ru	-	1E+4	5E-6	2E-8	-	-
44	Ruthenium-103	D, see ^{94}Ru	2E+3	2E+3	7E-7	2E-9	3E-5	3E-4
		W, see ^{94}Ru	-	1E+3	4E-7	1E-9	-	-
		Y, see ^{94}Ru	-	6E+2	3E-7	9E-10	-	-
44	Ruthenium-105	D, see ^{94}Ru	5E+3	1E+4	6E-6	2E-8	7E-5	7E-4
		W, see ^{94}Ru	-	1E+4	6E-6	2E-8	-	-
		Y, see ^{94}Ru	-	1E+4	5E-6	2E-8	-	-
44	Ruthenium-106	D, see ^{94}Ru	2E+2 LLI wall (2E+2)	9E+1	4E-8	1E-10	-	-
		W, see ^{94}Ru	-	5E+1	2E-8	8E-11	3E-6	3E-5
		Y, see ^{94}Ru	-	1E+1	5E-9	2E-11	-	-
45	Rhodium-99m	D, all compounds except those given for W and Y	2E+4	6E+4	2E-5	8E-8	2E-4	2E-3
		W, halides	-	8E+4	3E-5	1E-7	-	-
		Y, oxides and hydroxides	-	7E+4	3E-5	9E-8	-	-
45	Rhodium-99	D, see ^{99m}Rh	2E+3	3E+3	1E-6	4E-9	3E-5	3E-4
		W, see ^{99m}Rh	-	2E+3	2E-6	9E-7	-	-
		Y, see ^{99m}Rh	-	2E+3	8E-7	3E-9	-	-

PART 20 STANDARDS FOR PROTECTION AGAINST RADIATION

Atomic No.	Radionuclide	Class	Table 1 Occupational Values			Table 2 Effluent Concentrations		Table 3 Releases to Sewers
			Col. 1 Oral Ingestion ALI (μCi)	Inhalation		Col. 1 Air ($\mu\text{Ci}/\text{m}^3$)	Col. 2 Water ($\mu\text{Ci}/\text{m}^3$)	Monthly Average Concentration ($\mu\text{Ci}/\text{m}^3$)
				Col. 2 ALI (μCi)	Col. 3 DAC ($\mu\text{Ci}/\text{m}^3$)			
45	Rhodium-100	D, see $^{99\text{m}}\text{Rh}$	2E+3	5E+3	2E-6	7E-9	2E-5	2E-4
		W, see $^{99\text{m}}\text{Rh}$	-	4E+3	2E-6	6E-9	-	-
		Y, see $^{99\text{m}}\text{Rh}$	-	4E+3	2E-6	5E-9	-	-
45	Rhodium-101m	D, see $^{99\text{m}}\text{Rh}$	6E+3	1E+4	5E-6	2E-8	8E-5	8E-4
		W, see $^{99\text{m}}\text{Rh}$	-	8E+3	4E-6	1E-8	-	-
		Y, see $^{99\text{m}}\text{Rh}$	-	8E+3	3E-6	1E-8	-	-
45	Rhodium-101	D, see $^{99\text{m}}\text{Rh}$	2E+3	5E+2	2E-7	7E-10	3E-5	3E-4
		W, see $^{99\text{m}}\text{Rh}$	-	8E+2	3E-7	1E-9	-	-
		Y, see $^{99\text{m}}\text{Rh}$	-	2E+2	6E-8	2E-10	-	-
45	Rhodium-102m	D, see $^{99\text{m}}\text{Rh}$	1E+3	5E+2	2E-7	7E-10	-	-
		W, see $^{99\text{m}}\text{Rh}$	LLI wall (1E+3)	-	-	-	2E-5	2E-4
		Y, see $^{99\text{m}}\text{Rh}$	-	1E+2	5E-8	2E-10	-	-
45	Rhodium-102	D, see $^{99\text{m}}\text{Rh}$	6E+2	9E+1	4E-8	1E-10	8E-6	8E-5
		W, see $^{99\text{m}}\text{Rh}$	-	2E+2	7E-8	2E-10	-	-
		Y, see $^{99\text{m}}\text{Rh}$	-	6E+1	2E-8	8E-11	-	-
45	Rhodium-103m ²	D, see $^{99\text{m}}\text{Rh}$	4E+5	1E+6	5E-4	2E-6	6E-3	6E-2
		W, see $^{99\text{m}}\text{Rh}$	-	1E+6	5E-4	2E-6	-	-
		Y, see $^{99\text{m}}\text{Rh}$	-	1E+6	5E-4	2E-6	-	-
45	Rhodium-105	D, see $^{99\text{m}}\text{Rh}$	4E+3	1E+4	5E-6	2E-8	-	-
		W, see $^{99\text{m}}\text{Rh}$	LLI wall (4E+3)	-	-	-	5E-5	5E-4
		Y, see $^{99\text{m}}\text{Rh}$	-	6E+3	3E-6	9E-9	-	-
45	Rhodium-106m	D, see $^{99\text{m}}\text{Rh}$	8E+3	3E+4	1E-5	4E-8	1E-4	1E-3
		W, see $^{99\text{m}}\text{Rh}$	-	4E+4	2E-5	5E-8	-	-
		Y, see $^{99\text{m}}\text{Rh}$	-	4E+4	1E-5	5E-8	-	-
45	Rhodium-107 ²	D, see $^{99\text{m}}\text{Rh}$	7E+4	2E+5	1E-4	3E-7	-	-
		W, see $^{99\text{m}}\text{Rh}$	St. wall (9E+4)	-	-	-	1E-3	1E-2
		Y, see $^{99\text{m}}\text{Rh}$	-	3E+5	1E-4	4E-7	-	-
46	Palladium-100	D, all compounds except those given for W and Y	1E+3	1E+3	6E-7	2E-9	2E-5	2E-4
		W, nitrates	-	1E+3	5E-7	2E-9	-	-
		Y, oxides and hydroxides	-	1E+3	6E-7	2E-9	-	-
46	Palladium-101	D, see ^{100}Pd	1E+4	3E+4	1E-5	5E-8	2E-4	2E-3
		W, see ^{100}Pd	-	3E+4	1E-5	5E-8	-	-
		Y, see ^{100}Pd	-	3E+4	1E-5	4E-8	-	-
46	Palladium-103	D, see ^{100}Pd	6E+3	6E+3	3E-6	9E-9	-	-
		W, see ^{100}Pd	LLI wall (7E+3)	-	-	-	1E-4	1E-3
		Y, see ^{100}Pd	-	4E+3	2E-6	6E-9	-	-
46	Palladium-107	D, see ^{100}Pd	3E+4	2E+4	9E-6	-	-	-
		W, see ^{100}Pd	LLI wall (4E+4)	Kidneys (2E+4)	-	3E-8	5E-4	5E-3
		Y, see ^{100}Pd	-	7E+3	3E-6	1E-8	-	-
			-	4E+2	2E-7	6E-10	-	-

58 FR 67657

PART 20 STANDARDS FOR PROTECTION AGAINST RADIATION

58 FR 67657

Atomic No.	Radionuclide	Class	Table 1 Occupational Values			Table 2 Effluent Concentrations		Table 3 Releases to Sewers
			Col. 1 Oral Ingestion ALI (μCi)	Inhalation		Col. 1 Air (μCi/ml)	Col. 2 Water (μCi/ml)	Monthly Average Concentration (μCi/ml)
				Col. 2 ALI (μCi)	Col. 3 DAC (μCi/ml)			
46	Palladium-109	D, see ¹⁰⁰ Pd	2E+3	6E+3	3E-6	9E-9	3E-5	3E-4
		W, see ¹⁰⁰ Pd	-	5E+3	2E-6	8E-9	-	-
		Y, see ¹⁰⁰ Pd	-	5E+3	2E-6	6E-9	-	-
47	Silver-102 ²	D, all compounds except those given for W and Y	5E+4 St. wall (6E+4)	2E+5	8E-5	2E-7	-	-
		W, nitrates and sulfides	-	2E+5	9E-5	3E-7	-	-
		Y, oxides and hydroxides	-	2E+5	8E-5	3E-7	-	-
47	Silver-103 ²	D, see ¹⁰² Ag	4E+4	1E+5	4E-5	1E-7	5E-4	5E-3
		W, see ¹⁰² Ag	-	1E+5	5E-5	2E-7	-	-
		Y, see ¹⁰² Ag	-	1E+5	5E-5	2E-7	-	-
47	Silver-104m ²	D, see ¹⁰² Ag	3E+4	9E+4	4E-5	1E-7	4E-4	4E-3
		W, see ¹⁰² Ag	-	1E+5	5E-5	2E-7	-	-
		Y, see ¹⁰² Ag	-	1E+5	5E-5	2E-7	-	-
47	Silver-104 ²	D, see ¹⁰² Ag	2E+4	7E+4	3E-5	1E-7	3E-4	3E-3
		W, see ¹⁰² Ag	-	1E+5	6E-5	2E-7	-	-
		Y, see ¹⁰² Ag	-	1E+5	6E-5	2E-7	-	-
47	Silver-105	D, see ¹⁰² Ag	3E+3	1E+3	4E-7	1E-9	4E-5	4E-4
		W, see ¹⁰² Ag	-	2E+3	7E-7	2E-9	-	-
		Y, see ¹⁰² Ag	-	2E+3	7E-7	2E-9	-	-
47	Silver-106m	D, see ¹⁰² Ag	8E+2	7E+2	3E-7	1E-9	1E-5	1E-4
		W, see ¹⁰² Ag	-	9E+2	4E-7	1E-9	-	-
		Y, see ¹⁰² Ag	-	9E+2	4E-7	1E-9	-	-
47	Silver-106 ²	D, see ¹⁰² Ag	6E+4 St. wall (6E+4)	2E+5	8E-5	3E-7	-	-
		W, see ¹⁰² Ag	-	2E+5	9E-5	3E-7	9E-4	9E-3
		Y, see ¹⁰² Ag	-	2E+5	8E-5	3E-7	-	-
47	Silver-108m	D, see ¹⁰² Ag	6E+2	2E+2	8E-8	3E-10	9E-6	9E-5
		W, see ¹⁰² Ag	-	3E+2	1E-7	4E-10	-	-
		Y, see ¹⁰² Ag	-	2E+1	1E-8	3E-11	-	-
47	Silver-110m	D, see ¹⁰² Ag	5E+2	1E+2	5E-8	2E-10	6E-6	6E-5
		W, see ¹⁰² Ag	-	2E+2	8E-8	3E-10	-	-
		Y, see ¹⁰² Ag	-	9E+1	4E-8	1E-10	-	-
47	Silver-111	D, see ¹⁰² Ag	9E+2 LLI wall (1E+3)	2E+3 Liver (2E+3)	6E-7	-	-	-
		W, see ¹⁰² Ag	-	9E+2	4E-7	2E-9	2E-5	2E-4
		Y, see ¹⁰² Ag	-	9E+2	4E-7	1E-9	-	-
47	Silver-112	D, see ¹⁰² Ag	3E+3	8E+3	3E-6	1E-8	4E-5	4E-4
		W, see ¹⁰² Ag	-	1E+4	4E-6	1E-8	-	-
		Y, see ¹⁰² Ag	-	9E+3	4E-6	1E-8	-	-

PART 20 STANDARDS FOR PROTECTION AGAINST RADIATION

Atomic No.	Radionuclide	Class	Table 1 Occupational Values			Table 2 Effluent Concentrations		Table 3 Releases to Sewers
			Col. 1 Oral Ingestion ALI (μ Ci)	Col. 2 Inhalation ALI (μ Ci)	Col. 3 DAC (μ Ci/ml)	Col. 1 Air (μ Ci/ml)	Col. 2 Water (μ Ci/ml)	Monthly Average Concentration (μ Ci/ml)
47	Silver-115 ²	D, see ¹⁰² Ag	3E+4 St. wall (3E+4)	9E+4	4E-5	1E-7	-	-
		W, see ¹⁰² Ag	-	9E+4	4E-5	1E-7	4E-4	4E-3
		Y, see ¹⁰² Ag	-	8E+4	3E-5	1E-7	-	-
48	Cadmium-104 ²	D, all compounds except those given for W and Y	2E+4	7E+4	3E-5	9E-8	3E-4	3E-3
		W, sulfides, halides, and nitrates	-	1E+5	5E-5	2E-7	-	-
		Y, oxides and hydroxides	-	1E+5	5E-5	2E-7	-	-
48	Cadmium-107	D, see ¹⁰⁴ Cd	2E+4	5E+4	2E-5	8E-8	3E-4	3E-3
		W, see ¹⁰⁴ Cd	-	6E+4	2E-5	8E-8	-	-
		Y, see ¹⁰⁴ Cd	-	5E+4	2E-5	7E-8	-	-
48	Cadmium-109	D, see ¹⁰⁴ Cd	3E+2 Kidneys (4E+2)	4E+1 Kidneys (5E+1)	1E-8	-	-	-
		W, see ¹⁰⁴ Cd	-	1E+2 Kidneys	5E-8	7E-11	6E-6	6E-5
		Y, see ¹⁰⁴ Cd	-	1E+2	5E-8	2E-10	-	-
48	Cadmium-113m	D, see ¹⁰⁴ Cd	2E+1 Kidneys (4E+1)	2E+0 Kidneys (4E+0)	1E-9	-	-	-
		W, see ¹⁰⁴ Cd	-	8E+0 Kidneys (1E+1)	4E-9	5E-12	5E-7	5E-6
		Y, see ¹⁰⁴ Cd	-	1E+1	5E-9	2E-11	-	-
48	Cadmium-113	D, see ¹⁰⁴ Cd	2E+1 Kidneys (3E+1)	2E+0 Kidneys (3E+0)	9E-10	-	-	-
		W, see ¹⁰⁴ Cd	-	8E+0 Kidneys (1E+1)	3E-9	5E-12	4E-7	4E-6
		Y, see ¹⁰⁴ Cd	-	1E+1	6E-9	2E-11	-	-
48	Cadmium-115m	D, see ¹⁰⁴ Cd	3E+2	5E+1 Kidneys (8E+1)	2E-8	-	4E-6	4E-5
		W, see ¹⁰⁴ Cd	-	1E+2	5E-8	1E-10	-	-
		Y, see ¹⁰⁴ Cd	-	1E+2	6E-8	2E-10	-	-
48	Cadmium-115	D, see ¹⁰⁴ Cd	9E+2 LLI wall (1E+3)	1E+3	6E-7	2E-9	-	-
		W, see ¹⁰⁴ Cd	-	1E+3	5E-7	2E-9	1E-5	1E-4
		Y, see ¹⁰⁴ Cd	-	1E+3	6E-7	2E-9	-	-
48	Cadmium-117m	D, see ¹⁰⁴ Cd	5E+3	1E+4	5E-6	2E-8	6E-5	6E-4
		W, see ¹⁰⁴ Cd	-	2E+4	7E-6	2E-8	-	-
		Y, see ¹⁰⁴ Cd	-	1E+4	6E-6	2E-8	-	-

58 FR 67657

PART 20 STANDARDS FOR PROTECTION AGAINST RADIATION

58 FR 67657

Atomic No.	Radionuclide	Class	Table 1 Occupational Values			Table 2 Effluent Concentrations		Table 3 Releases to Sewers
			Col. 1 Oral Ingestion ALI (μCi)	Inhalation		Col. 1 Air (μCi/ml)	Col. 2 Water (μCi/ml)	Monthly Average Concentration (μCi/ml)
				Col. 2 ALI (μCi)	Col. 3 DAC (μCi/ml)			
48	Cadmium-117	D, see ¹⁰⁴ Cd	5E+3	1E+4	5E-6	2E-8	6E-5	6E-4
		W, see ¹⁰⁴ Cd	-	2E+4	7E-6	2E-8	-	-
		V, see ¹⁰⁴ Cd	-	1E+4	6E-6	2E-8	-	-
49	Indium-109	D, all compounds except those given for W	2E+4	4E+4	2E-5	6E-8	3E-4	3E-3
		W, oxides, hydroxides, halides, and nitrates	-	6E+4	3E-5	9E-8	-	-
49	Indium-110 ² (69.1 min)	D, see ¹⁰⁹ In W, see ¹⁰⁹ In	2E+4 -	4E+4 6E+4	2E-5 2E-5	6E-8 8E-8	2E-4 -	2E-3 -
49	Indium-110 (4.9 h)	D, see ¹⁰⁹ In W, see ¹⁰⁹ In	5E+3 -	2E+4 2E+4	7E-6 8E-6	2E-8 3E-8	7E-5 -	7E-4 -
49	Indium-111	D, see ¹⁰⁹ In W, see ¹⁰⁹ In	4E+3 -	6E+3 6E+3	3E-6 3E-6	9E-9 9E-9	6E-5 -	6E-4 -
49	Indium-112 ²	D, see ¹⁰⁹ In W, see ¹⁰⁹ In	2E+5 -	6E+5 7E+5	3E-4 3E-4	9E-7 1E-6	2E-3 -	2E-2 -
49	Indium-113m ²	D, see ¹⁰⁹ In W, see ¹⁰⁹ In	5E+4 -	1E+5 2E+5	6E-5 8E-5	2E-7 3E-7	7E-4 -	7E-3 -
49	Indium-114m	D, see ¹⁰⁹ In	3E+2 (4E+2)	6E+1	3E-8	9E-11	-	-
		W, see ¹⁰⁹ In	-	1E+2	4E-8	1E-10	5E-6	5E-5
49	Indium-115m	D, see ¹⁰⁹ In W, see ¹⁰⁹ In	1E+4 -	4E+4 5E+4	2E-5 2E-5	6E-8 7E-8	2E-4 -	2E-3 -
49	Indium-115	D, see ¹⁰⁹ In W, see ¹⁰⁹ In	4E+1 -	1E+0 5E+0	6E-10 2E-9	2E-12 8E-12	5E-7 -	5E-6 -
49	Indium-116m ²	D, see ¹⁰⁹ In W, see ¹⁰⁹ In	2E+4 -	8E+4 1E+5	3E-5 5E-5	1E-7 2E-7	3E-4 -	3E-3 -
49	Indium-117m ²	D, see ¹⁰⁹ In W, see ¹⁰⁹ In	1E+4 -	3E+4 4E+4	1E-5 2E-5	5E-8 6E-8	2E-4 -	2E-3 -
49	Indium-117 ²	D, see ¹⁰⁹ In W, see ¹⁰⁹ In	6E+4 -	2E+5 2E+5	7E-5 9E-5	2E-7 3E-7	8E-4 -	8E-3 -
49	Indium-119m ²	D, see ¹⁰⁹ In	4E+4 (5E+4)	1E+5	5E-5	2E-7	-	-
		W, see ¹⁰⁹ In	-	1E+5	6E-5	2E-7	7E-4	7E-3
50	Tin-110	D, all compounds except those given for W	4E+3	1E+4	5E-6	2E-8	5E-5	5E-4
		W, sulfides, oxides, hydroxides, halides, nitrates, and stannic phosphate	-	1E+4	5E-6	2E-8	-	-
50	Tin-111 ²	D, see ¹¹⁰ Sn W, see ¹¹⁰ Sn	7E+4 -	2E+5 3E+5	9E-5 1E-4	3E-7 4E-7	1E-3 -	1E-2 -

PART 20 STANDARDS FOR PROTECTION AGAINST RADIATION

Atomic No.	Radionuclide	Class	Table 1 Occupational Values			Table 2 Effluent Concentrations		Table 3 Releases to Sewers
			Col. 1 Oral Ingestion ALI (μCi)	Inhalation		Col. 1 Air (μCi/ml)	Col. 2 Water (μCi/ml)	Monthly Average Concentration (μCi/ml)
				Col. 2 ALI (μCi)	Col. 3 DAC (μCi/ml)			
50	Tin-113	D, see ¹¹⁰ Sn	2E+3 LLI wall	1E+3	5E-7	2E-9	-	-
		W, see ¹¹⁰ Sn	-	5E+2	2E-7	8E-10	3E-5	3E-4
50	Tin-117m	D, see ¹¹⁰ Sn	2E+3 LLI wall	1E+3 Bone surf	5E-7	-	-	-
		W, see ¹¹⁰ Sn	-	(2E+3) 1E+3	- 6E-7	3E-9 2E-9	3E-5	3E-4
50	Tin-119m	D, see ¹¹⁰ Sn	3E+3 LLI wall	2E+3	1E-6	3E-9	-	-
		W, see ¹¹⁰ Sn	(4E+3)	1E+3	4E-7	1E-9	6E-5	6E-4
50	Tin-121m	D, see ¹¹⁰ Sn	3E+3 LLI wall	9E+2	4E-7	1E-9	-	-
		W, see ¹¹⁰ Sn	(4E+3)	5E+2	2E-7	8E-10	5E-5	5E-4
50	Tin-121	D, see ¹¹⁰ Sn	6E+3 LLI wall	2E+4	6E-6	2E-8	-	-
		W, see ¹¹⁰ Sn	(6E+3)	1E+4	5E-6	2E-8	8E-5	8E-4
50	Tin-123m ²	D, see ¹¹⁰ Sn	5E+4	1E+5	5E-5	2E-7	7E-4	7E-3
		W, see ¹¹⁰ Sn	-	1E+5	6E-5	2E-7	-	-
50	Tin-123	D, see ¹¹⁰ Sn	5E+2 LLI wall	6E+2	3E-7	9E-10	-	-
		W, see ¹¹⁰ Sn	(6E+2)	2E+2	7E-8	2E-10	9E-6	9E-5
50	Tin-125	D, see ¹¹⁰ Sn	4E+2 LLI wall	9E+2	4E-7	1E-9	-	-
		W, see ¹¹⁰ Sn	(5E+2)	4E+2	1E-7	5E-10	6E-6	6E-5
50	Tin-126	D, see ¹¹⁰ Sn	3E+2	6E+1	2E-8	8E-11	4E-6	4E-5
		W, see ¹¹⁰ Sn	-	7E+1	3E-8	9E-11	-	-
50	Tin-127	D, see ¹¹⁰ Sn	7E+3	2E+4	8E-6	3E-8	9E-5	9E-4
		W, see ¹¹⁰ Sn	-	2E+4	8E-6	3E-8	-	-
50	Tin-128 ²	D, see ¹¹⁰ Sn	9E+3	3E+4	1E-5	4E-8	1E-4	1E-3
		W, see ¹¹⁰ Sn	-	4E+4	1E-5	5E-8	-	-
51	Antimony-115 ²	D, all compounds except those given for W	8E+4	2E+5	1E-4	3E-7	1E-3	1E-2
		W, oxides, hydroxides, halides, sulfides, sulfates, and nitrates	-	3E+5	1E-4	4E-7	-	-
51	Antimony-116m ²	D, see ¹¹⁵ Sb	2E+4	7E+4	3E-5	1E-7	3E-4	3E-3
		W, see ¹¹⁵ Sb	-	1E+5	6E-5	2E-7	-	-
51	Antimony-116 ²	D, see ¹¹⁵ Sb	7E+4 St. wall	3E+5	1E-4	4E-7	-	-
		W, see ¹¹⁵ Sb	(9E+4)	3E+5	1E-4	5E-7	1E-3	1E-2
51	Antimony-117	D, see ¹¹⁵ Sb	7E+4	2E+5	9E-5	3E-7	9E-4	9E-3
		W, see ¹¹⁵ Sb	-	3E+5	1E-4	4E-7	-	-

58 FR 67657

PART 20 STANDARDS FOR PROTECTION AGAINST RADIATION

58 FR 67657

Atomic No.	Radionuclide	Class	Table 1 Occupational Values			Table 2 Effluent Concentrations		Table 3 Releases to Sewers
			Col. 1 Oral Ingestion ALI (μCi)	Inhalation		Col. 1 Air ($\mu\text{Ci}/\text{ml}$)	Col. 2 Water ($\mu\text{Ci}/\text{ml}$)	Monthly Average Concentration ($\mu\text{Ci}/\text{ml}$)
				Col. 2 ALI (μCi)	Col. 3 DAC ($\mu\text{Ci}/\text{ml}$)			
51	Antimony-118m	D, see ^{115}Sb	6E+3	2E+4	8E-6	3E-8	7E-5	7E-4
		W, see ^{115}Sb	5E+3	2E+4	9E-6	3E-8	-	-
51	Antimony-119	D, see ^{115}Sb	2E+4	5E+4	2E-5	6E-8	2E-4	2E-3
		W, see ^{115}Sb	2E+4	3E+4	1E-5	4E-8	-	-
51	Antimony-120 ² (16 min)	D, see ^{115}Sb	1E+5 St. wall (2E+5)	4E+5	2E-4	6E-7	-	-
		W, see ^{115}Sb	-	5E+5	2E-4	7E-7	2E-3	2E-2
51	Antimony-120 (5.76 d)	D, see ^{115}Sb	1E+3	2E+3	9E-7	3E-9	1E-5	1E-4
		W, see ^{115}Sb	9E+2	1E+3	5E-7	2E-9	-	-
51	Antimony-122	D, see ^{115}Sb	8E+2 LLI wall	2E+3	1E-6	3E-9	-	-
		W, see ^{115}Sb	7E+2	1E+3	4E-7	2E-9	1E-5	1E-4
51	Antimony-124m ²	D, see ^{115}Sb	3E+5	8E+5	4E-4	1E-6	3E-3	3E-2
		W, see ^{115}Sb	2E+5	6E+5	2E-4	8E-7	-	-
51	Antimony-124	D, see ^{115}Sb	6E+2	9E+2	4E-7	1E-9	7E-6	7E-5
		W, see ^{115}Sb	5E+2	2E+2	1E-7	3E-10	-	-
51	Antimony-125	D, see ^{115}Sb	2E+3	2E+3	1E-6	3E-9	3E-5	3E-4
		W, see ^{115}Sb	-	5E+2	2E-7	7E-10	-	-
51	Antimony-126m ²	D, see ^{115}Sb	5E+4 St. wall (7E+4)	2E+5	8E-5	3E-7	-	-
		W, see ^{115}Sb	-	2E+5	8E-5	3E-7	9E-4	9E-3
51	Antimony-126	D, see ^{115}Sb	6E+2	1E+3	5E-7	2E-9	7E-6	7E-5
		W, see ^{115}Sb	5E+2	5E+2	2E-7	7E-10	-	-
51	Antimony-127	D, see ^{115}Sb	8E+2 LLI wall (8E+2)	2E+3	9E-7	3E-9	-	-
		W, see ^{115}Sb	7E+2	9E+2	4E-7	1E-9	1E-5	1E-4
51	Antimony-128 ² (10.4 min)	D, see ^{115}Sb	8E+4 St. wall (1E+5)	4E+5	2E-4	5E-7	-	-
		W, see ^{115}Sb	-	4E+5	2E-4	6E-7	1E-3	1E-2
51	Antimony-128 (9.01 h)	D, see ^{115}Sb	1E+3	4E+3	2E-6	6E-9	2E-5	2E-4
		W, see ^{115}Sb	-	3E+3	1E-6	5E-9	-	-
51	Antimony-129	D, see ^{115}Sb	3E+3	9E+3	4E-6	1E-8	4E-5	4E-4
		W, see ^{115}Sb	-	9E+3	4E-6	1E-8	-	-
51	Antimony-130 ²	D, see ^{115}Sb	2E+4	6E+4	3E-5	9E-8	3E-4	3E-3
		W, see ^{115}Sb	-	8E+4	3E-5	1E-7	-	-
51	Antimony-131 ²	D, see ^{115}Sb	1E+4 Thyroid (2E+4)	2E+4 Thyroid (4E+4)	1E-5	-	-	-
		W, see ^{115}Sb	-	2E+4 Thyroid (4E+4)	1E-5	6E-8	2E-4	2E-3
						6E-8	-	-

PART 20 STANDARDS FOR PROTECTION AGAINST RADIATION

58 FR 67657

Atomic No.	Radionuclide	Class	Table 1 Occupational Values			Table 2 Effluent Concentrations		Table 3 Releases to Sewers
			Col. 1 Oral Ingestion ALI (μCi)	Inhalation		Col. 1 Air ($\mu\text{Ci}/\text{m}^3$)	Col. 2 Water ($\mu\text{Ci}/\text{m}^3$)	Monthly Average Concentration ($\mu\text{Ci}/\text{m}^3$)
				Col. 2 ALI (μCi)	Col. 3 DAC ($\mu\text{Ci}/\text{m}^3$)			
52	Tellurium-116	D, all compounds except those given for W	8E+3	2E+4	9E-6	3E-8	1E-4	1E-3
		W, oxides, hydroxides, and nitrates	-	3E+4	1E-5	4E-8	-	-
52	Tellurium-121m	D, see ^{116}Te	5E+2 Bone surf (7E+2)	2E+2 Bone surf (4E+2)	8E-8	-	-	-
		W, see ^{116}Te	-	4E+2	2E-7	5E-10 6E-10	1E-5	1E-4
52	Tellurium-121	D, see ^{116}Te	3E+3	4E+3	2E-6	6E-9	4E-5	4E-4
		W, see ^{116}Te	-	3E+3	1E-6	4E-9	-	-
52	Tellurium-123m	D, see ^{116}Te	6E+2 Bone surf (1E+3)	2E+2 Bone surf (5E+2)	9E-8	-	-	-
		W, see ^{116}Te	-	5E+2	2E-7	8E-10 8E-10	1E-5	1E-4
52	Tellurium-123	D, see ^{116}Te	5E+2 Bone surf (1E+3)	2E+2 Bone surf (5E+2)	8E-8	-	-	-
		W, see ^{116}Te	-	4E+2 Bone surf (1E+3)	2E-7	7E-10	2E-5	2E-4
52	Tellurium-125m	D, see ^{116}Te	1E+3 Bone surf (1E+3)	4E+2 Bone surf (1E+3)	2E-7	-	-	-
		W, see ^{116}Te	-	7E+2	3E-7	1E-9	2E-5	2E-4
52	Tellurium-127m	D, see ^{116}Te	6E+2	3E+2	1E-7	-	9E-6	9E-5
		W, see ^{116}Te	-	(4E+2) 3E+2	- 1E-7	6E-10 4E-10	-	-
52	Tellurium-127	D, see ^{116}Te	7E+3	2E+4	9E-6	3E-8	1E-4	1E-3
		W, see ^{116}Te	-	2E+4	7E-6	2E-8	-	-
52	Tellurium-129m	D, see ^{116}Te	5E+2	6E+2	3E-7	9E-10	7E-6	7E-5
		W, see ^{116}Te	-	2E+2	1E-7	3E-10	-	-
52	Tellurium-129 ²	D, see ^{116}Te	3E+4	6E+4	3E-5	9E-8	4E-4	4E-3
		W, see ^{116}Te	-	7E+4	3E-5	1E-7	-	-
52	Tellurium-131m	D, see ^{116}Te	3E+2 Thyroid (6E+2)	4E+2 Thyroid (1E+3)	2E-7	-	-	-
		W, see ^{116}Te	-	4E+2 Thyroid (9E+2)	2E-7	2E-9	8E-6	8E-5
52	Tellurium-131 ²	D, see ^{116}Te	3E+3 Thyroid (6E+3)	5E+3 Thyroid (1E+4)	2E-6	-	-	-
		W, see ^{116}Te	-	5E+3 Thyroid (1E+4)	2E-6	2E-8	8E-5	8E-4

PART 20 STANDARDS FOR PROTECTION AGAINST RADIATION

Atomic No.	Radionuclide	Class	Table 1 Occupational Values			Table 2 Effluent Concentrations		Table 3 Releases to Sewers
			Col. 1 Oral Ingestion AI (μCi)	Inhalation		Col. 1 Air (μCi/ml)	Col. 2 Water (μCi/ml)	Monthly Average Concentration (μCi/ml)
				Col. 2 AI (μCi)	Col. 3 DAC (μCi/ml)			
52	Tellurium-132	D, see ¹¹⁶ Te	2E+2 Thyroid (7E+2)	2E+2 Thyroid (8E+2)	9E-8	-	-	-
		W, see ¹¹⁶ Te	-	2E+2 Thyroid (6E+2)	9E-8	1E-9	9E-6	9E-5
52	Tellurium-133m ²	D, see ¹¹⁶ Te	3E+3 Thyroid (6E+3)	5E+3 Thyroid (1E+4)	2E-6	-	-	-
		W, see ¹¹⁶ Te	-	5E+3 Thyroid (1E+4)	2E-6	2E-8	9E-5	9E-4
52	Tellurium-133 ²	D, see ¹¹⁶ Te	1E+4 Thyroid (3E+4)	2E+4 Thyroid (6E+4)	9E-6	-	-	-
		W, see ¹¹⁶ Te	-	2E+4 Thyroid (6E+4)	9E-6	8E-8	4E-4	4E-3
52	Tellurium-134 ²	D, see ¹¹⁶ Te	2E+4 Thyroid (2E+4)	2E+4 Thyroid (5E+4)	1E-5	-	-	-
		W, see ¹¹⁶ Te	-	2E+4 Thyroid (5E+4)	1E-5	7E-8	3E-4	3E-3
53	Iodine-120m ²	D, all compounds	1E+4 Thyroid (1E+4)	2E+4	9E-6	3E-8	-	-
53	Iodine-120 ²	D, all compounds	4E+3 Thyroid (8E+3)	9E+3 Thyroid (1E+4)	4E-6	-	2E-4	2E-3
			-	-	-	2E-8	1E-4	1E-3
53	Iodine-121	D, all compounds	1E+4 Thyroid (3E+4)	2E+4 Thyroid (5E+4)	8E-6	-	-	-
			-	-	-	7E-8	4E-4	4E-3
53	Iodine-123	D, all compounds	3E+3 Thyroid (1E+4)	6E+3 Thyroid (2E+4)	3E-6	-	-	-
			-	-	-	2E-8	1E-4	1E-3
53	Iodine-124	D, all compounds	5E+1 Thyroid (2E+2)	8E+1 Thyroid (3E+2)	3E-8	-	-	-
			-	-	-	4E-10	2E-6	2E-5
53	Iodine-125	D, all compounds	4E+1 Thyroid (1E+2)	6E+1 Thyroid (2E+2)	3E-8	-	-	-
			-	-	-	3E-10	2E-6	2E-5
53	Iodine-126	D, all compounds	2E+1 Thyroid (7E+1)	4E+1 Thyroid (1E+2)	1E-8	-	-	-
			-	-	-	2E-10	1E-6	1E-5
53	Iodine-128 ²	D, all compounds	4E+4 St. wall (6E+4)	1E+5	5E-5	2E-7	-	-
			-	-	-	-	8E-4	8E-3
53	Iodine-129	D, all compounds	5E+0 Thyroid (2E+1)	9E+0 Thyroid (3E+1)	4E-9	-	-	-
			-	-	-	4E-11	2E-7	2E-6

58 FR 67657

PART 20 STANDARDS FOR PROTECTION AGAINST RADIATION

58 FR 67657

Atomic No.	Radionuclide	Class	Table 1 Occupational Values			Table 2 Effluent Concentrations		Table 3 Releases to Sewers
			Col. 1 Oral Ingestion ALI (μCi)	Inhalation		Col. 1 Air (μCi/ml)	Col. 2 Water (μCi/ml)	Monthly Average Concentration (μCi/ml)
				Col. 2 ALI (μCi)	Col. 3 DAC (μCi/ml)			
53	Iodine-130	D, all compounds	4E+2 Thyroid (1E+3)	7E+2 Thyroid (2E+3)	3E-7	-	-	-
53	Iodine-131	D, all compounds	3E+1 Thyroid (9E+1)	5E+1 Thyroid (2E+2)	2E-8	-	-	-
53	Iodine-132m ²	D, all compounds	4E+3 Thyroid (1E+4)	8E+3 Thyroid (2E+4)	4E-6	-	-	-
53	Iodine-132	D, all compounds	4E+3 Thyroid (9E+3)	8E+3 Thyroid (1E+4)	3E-6	-	-	-
53	Iodine-133	D, all compounds	1E+2 Thyroid (5E+2)	3E+2 Thyroid (9E+2)	1E-7	-	-	-
53	Iodine-134 ²	D, all compounds	2E+4 Thyroid (3E+4)	5E+4	2E-5	6E-8	-	-
53	Iodine-135	D, all compounds	8E+2 Thyroid (3E+3)	2E+3 Thyroid (4E+3)	7E-7	-	-	-
54	Xenon-120 ²	Submersion ¹	-	-	1E-5	4E-8	-	-
54	Xenon-121 ²	Submersion ¹	-	-	2E-6	1E-8	-	-
54	Xenon-122	Submersion ¹	-	-	7E-5	3E-7	-	-
54	Xenon-123	Submersion ¹	-	-	6E-6	3E-8	-	-
54	Xenon-125	Submersion ¹	-	-	2E-5	7E-8	-	-
54	Xenon-127	Submersion ¹	-	-	1E-5	6E-8	-	-
54	Xenon-129m	Submersion ¹	-	-	2E-4	9E-7	-	-
54	Xenon-131m	Submersion ¹	-	-	4E-4	2E-6	-	-
54	Xenon-133m	Submersion ¹	-	-	1E-4	6E-7	-	-
54	Xenon-133	Submersion ¹	-	-	1E-4	5E-7	-	-
54	Xenon-135m ²	Submersion ¹	-	-	9E-6	4E-8	-	-
54	Xenon-135	Submersion ¹	-	-	1E-5	7E-8	-	-
54	Xenon-138 ²	Submersion ¹	-	-	4E-6	2E-8	-	-
55	Cesium-125 ²	D, all compounds	5E+4 St. wall (9E+4)	1E+5	6E-5	2E-7	-	-
55	Cesium-127	D, all compounds	6E+4	9E+4	4E-5	1E-7	9E-4	9E-3

PART 20 STANDARDS FOR PROTECTION AGAINST RADIATION

58 FR 67657

Atomic No.	Radionuclide	Class	Table 1 Occupational Values			Table 2 Effluent Concentrations		Table 3 Releases to Sewers
			Col. 1 Oral Ingestion ALI (μ Ci)	Col. 2 ALI (μ Ci)	Col. 3 DAC (μ Ci/ml)	Col. 1 Air (μ Ci/ml)	Col. 2 Water (μ Ci/ml)	Monthly Average Concentration (μ Ci/ml)
55	Cesium-129	D, all compounds	2E+4	3E+4	1E-5	5E-8	3E-4	3E-3
55	Cesium-130 ²	D, all compounds	6E+4 St. wall (1E+5)	2E+5	8E-5	3E-7	- 1E-3	- 1E-2
55	Cesium-131	D, all compounds	2E+4	3E+4	1E-5	4E-8	3E-4	3E-3
55	Cesium-132	D, all compounds	3E+3	4E+3	2E-6	6E-9	4E-5	4E-4
55	Cesium-134m	D, all compounds	1E+5 St. wall (1E+5)	1E+5	5E-5	2E-7	- 2E-3	- 2E-2
55	Cesium-134	D, all compounds	7E+1	1E+2	4E-8	2E-10	9E-7	9E-6
55	Cesium-135m ²	D, all compounds	1E+5	2E+5	8E-5	3E-7	1E-3	1E-2
55	Cesium-135	D, all compounds	7E+2	1E+3	5E-7	2E-9	1E-5	1E-4
55	Cesium-136	D, all compounds	4E+2	7E+2	3E-7	9E-10	6E-6	6E-5
55	Cesium-137	D, all compounds	1E+2	2E+2	6E-8	2E-10	1E-6	1E-5
55	Cesium-138 ²	D, all compounds	2E+4 St. wall (3E+4)	6E+4	2E-5	8E-8	- 4E-4	- 4E-3
56	Barium-126 ²	D, all compounds	6E+3	2E+4	6E-6	2E-8	8E-5	8E-4
56	Barium-128	D, all compounds	5E+2	2E+3	7E-7	2E-9	7E-6	7E-5
56	Barium-131m ²	D, all compounds	4E+5 St. wall (5E+5)	1E+6	6E-4	2E-6	- 7E-3	- 7E-2
56	Barium-131	D, all compounds	3E+3	8E+3	3E-6	1E-8	4E-5	4E-4
56	Barium-133m	D, all compounds	2E+3 LLI wall (3E+3)	9E+3	4E-6	1E-8	- 4E-5	- 4E-4
56	Barium-133	D, all compounds	2E+3	7E+2	3E-7	9E-10	2E-5	2E-4
56	Barium-135m	D, all compounds	3E+3	1E+4	5E-6	2E-8	4E-5	4E-4
56	Barium-139 ²	D, all compounds	1E+4	3E+4	1E-5	4E-8	2E-4	2E-3
56	Barium-140	D, all compounds	5E+2 LLI wall (6E+2)	1E+3	6E-7	2E-9	- 8E-6	- 8E-5
56	Barium-141 ²	D, all compounds	2E+4	7E+4	3E-5	1E-7	3E-4	3E-3
56	Barium-142 ²	D, all compounds	5E+4	1E+5	6E-5	2E-7	7E-4	7E-3
57	Lanthanum-131 ²	D, all compounds except those given for W	5E+4	1E+5	5E-5	2E-7	6E-4	6E-3
		W, oxides and hydroxides	-	2E+5	7E-5	2E-7	-	-

PART 20 STANDARDS FOR PROTECTION AGAINST RADIATION

58 FR 67657

Atomic No.	Radionuclide	Class	Table 1 Occupational Values			Table 2 Effluent Concentrations		Table 3 Releases to Sewers
			Col. 1 Oral Ingestion ALI (μCi)	Col. 2	Col. 3	Col. 1 Air ($\mu\text{Ci}/\text{ml}$)	Col. 2 Water ($\mu\text{Ci}/\text{ml}$)	Monthly Average Concentration ($\mu\text{Ci}/\text{ml}$)
			ALI (μCi)	DAC ($\mu\text{Ci}/\text{ml}$)				
57	Lanthanum-132	D, see ¹³¹ La	3E+3	1E+4	4E-6	1E-8	4E-5	4E-4
		W, see ¹³¹ La	-	1E+4	5E-6	2E-8	-	-
57	Lanthanum-135	D, see ¹³¹ La	4E+4	1E+5	4E-5	1E-7	5E-4	5E-3
		W, see ¹³¹ La	-	9E+4	4E-5	1E-7	-	-
57	Lanthanum-137	D, see ¹³¹ La	1E+4	6E+1	3E-8	-	2E-4	2E-3
		W, see ¹³¹ La	-	Liver (7E+1)	-	1E-10	-	-
			-	3E+2 Liver (3E+2)	1E-7	-	-	-
57	Lanthanum-138	D, see ¹³¹ La	9E+2	4E+0	1E-9	5E-12	1E-5	1E-4
		W, see ¹³¹ La	-	1E+1	6E-9	2E-11	-	-
57	Lanthanum-140	D, see ¹³¹ La	6E+2	1E+3	6E-7	2E-9	9E-6	9E-5
		W, see ¹³¹ La	-	1E+3	5E-7	2E-9	-	-
57	Lanthanum-141	D, see ¹³¹ La	4E+3	9E+3	4E-6	1E-8	5E-5	5E-4
		W, see ¹³¹ La	-	1E+4	5E-6	2E-8	-	-
57	Lanthanum-142 ²	D, see ¹³¹ La	8E+3	2E+4	9E-6	3E-8	1E-4	1E-3
		W, see ¹³¹ La	-	3E+4	1E-5	5E-8	-	-
57	Lanthanum-143 ²	D, see ¹³¹ La	4E+4	1E+5	4E-5	1E-7	-	-
		W, see ¹³¹ La	St. wall (4E+4)	-	-	-	5E-4	5E-3
			-	9E+4	4E-5	1E-7	-	-
58	Cerium-134	W, all compounds except those given for Y	5E+2	7E+2	3E-7	1E-9	-	-
		Y, oxides, hydroxides, and fluorides	LLI wall (6E+2)	-	-	-	8E-6	8E-5
			-	7E+2	3E-7	9E-10	-	-
58	Cerium-135	W, see ¹³⁴ Ce	2E+3	4E+3	2E-6	5E-9	2E-5	2E-4
		Y, see ¹³⁴ Ce	-	4E+3	1E-6	5E-9	-	-
58	Cerium-137m	W, see ¹³⁴ Ce	2E+3	4E+3	2E-6	6E-9	-	-
		Y, see ¹³⁴ Ce	LLI wall (2E+3)	-	-	-	3E-5	3E-4
58	Cerium-137	W, see ¹³⁴ Ce	5E+4	1E+5	6E-5	2E-7	7E-4	7E-3
		Y, see ¹³⁴ Ce	-	1E+5	5E-5	2E-7	-	-
58	Cerium-139	W, see ¹³⁴ Ce	5E+3	8E+2	3E-7	1E-9	7E-5	7E-4
		Y, see ¹³⁴ Ce	-	7E+2	3E-7	9E-10	-	-
58	Cerium-141	W, see ¹³⁴ Ce	2E+3	7E+2	3E-7	1E-9	-	-
		Y, see ¹³⁴ Ce	LLI wall (2E+3)	-	-	-	3E-5	3E-4
			-	6E+2	2E-7	8E-10	-	-
58	Cerium-143	W, see ¹³⁴ Ce	1E+3	2E+3	8E-7	3E-9	-	-
		Y, see ¹³⁴ Ce	LLI wall (1E+3)	-	-	-	2E-5	2E-4
			-	2E+3	7E-7	2E-9	-	-

PART 20 STANDARDS FOR PROTECTION AGAINST RADIATION

Atomic No.	Radionuclide	Class	Table 1 Occupational Values			Table 2 Effluent Concentrations		Table 3 Releases to Sewers
			Col. 1 Oral Ingestion ALI (μCi)	Col. 2 ALI (μCi)	Col. 3 Inhalation DAC (μCi/ml)	Col. 1 Air (μCi/ml)	Col. 2 Water (μCi/ml)	Monthly Average Concentration (μCi/ml)
58	Cerium-144	W, see ¹³⁴ Ce	2E+2	3E+1	1E-8	4E-11	-	-
		Y, see ¹³⁴ Ce	LLI wall (3E+2)	-	-	-	3E-6	3E-5
59	Praseodymium-136 ²	W, all compounds except those given for Y	5E+4	2E+5	1E-4	3E-7	-	-
		Y, oxides, hydroxides, carbides, and fluorides	St. wall (7E+4)	-	-	-	1E-3	1E-2
59	Praseodymium-137 ²	W, see ¹³⁶ Pr	4E+4	2E+5	6E-5	2E-7	5E-4	5E-3
		Y, see ¹³⁶ Pr	-	1E+5	6E-5	2E-7	-	-
59	Praseodymium-138m	W, see ¹³⁶ Pr	1E+4	5E+4	2E-5	8E-8	1E-4	1E-3
		Y, see ¹³⁶ Pr	-	4E+4	2E-5	6E-8	-	-
59	Praseodymium-139	W, see ¹³⁶ Pr	4E+4	1E+5	5E-5	2E-7	6E-4	6E-3
		Y, see ¹³⁶ Pr	-	1E+5	5E-5	2E-7	-	-
59	Praseodymium-142m ²	W, see ¹³⁶ Pr	8E+4	2E+5	7E-5	2E-7	1E-3	1E-2
		Y, see ¹³⁶ Pr	-	1E+5	6E-5	2E-7	-	-
59	Praseodymium-142	W, see ¹³⁶ Pr	1E+3	2E+3	9E-7	3E-9	1E-5	1E-4
		Y, see ¹³⁶ Pr	-	2E+3	8E-7	3E-9	-	-
59	Praseodymium-143	W, see ¹³⁶ Pr	9E+2	8E+2	3E-7	1E-9	-	-
		Y, see ¹³⁶ Pr	LLI wall (1E+3)	-	-	-	2E-5	2E-4
59	Praseodymium-144 ²	W, see ¹³⁶ Pr	3E+4	1E+5	5E-5	2E-7	-	-
		Y, see ¹³⁶ Pr	St. wall (4E+4)	-	-	-	6E-4	6E-3
59	Praseodymium-145	W, see ¹³⁶ Pr	3E+3	9E+3	4E-6	1E-8	4E-5	4E-4
		Y, see ¹³⁶ Pr	-	8E+3	3E-6	1E-8	-	-
59	Praseodymium-147 ²	W, see ¹³⁶ Pr	5E+4	2E+5	8E-5	3E-7	-	-
		Y, see ¹³⁶ Pr	St. wall (8E+4)	-	-	-	1E-3	1E-2
60	Neodymium-136 ²	W, all compounds except those given for Y	1E+4	6E+4	2E-5	8E-8	2E-4	2E-3
		Y, oxides, hydroxides, carbides, and fluorides	-	5E+4	2E-5	8E-8	-	-
60	Neodymium-138	W, see ¹³⁶ Nd	2E+3	6E+3	3E-6	9E-9	3E-5	3E-4
		Y, see ¹³⁶ Nd	-	5E+3	2E-6	7E-9	-	-
60	Neodymium-139m	W, see ¹³⁶ Nd	5E+3	2E+4	7E-6	2E-8	7E-5	7E-4
		Y, see ¹³⁶ Nd	-	1E+4	6E-6	2E-8	-	-

58 FR 67657

PART 20 STANDARDS FOR PROTECTION AGAINST RADIATION

Atomic No.	Radionuclide	Class	Table 1 Occupational Values			Table 2 Effluent Concentrations		Table 3 Releases to Sewers
			Col. 1 Oral Ingestion ALI (μCi)	Inhalation		Col. 1 Air ($\mu\text{Ci}/\text{m}^3$)	Col. 2 Water ($\mu\text{Ci}/\text{m}^3$)	Monthly Average Concentration ($\mu\text{Ci}/\text{m}^3$)
				Col. 2 ALI (μCi)	Col. 3 DAC ($\mu\text{Ci}/\text{m}^3$)			
60	Neodymium-139 ²	W, see ¹³⁶ Nd Y, see ¹³⁶ Nd	9E+4 -	3E+5 3E+5	1E-4 1E-4	5E-7 4E-7	1E-3	1E-2 -
60	Neodymium-141	W, see ¹³⁶ Nd Y, see ¹³⁶ Nd	2E+5 -	7E+5 6E+5	3E-4 3E-4	1E-6 9E-7	2E-3	2E-2 -
60	Neodymium-147	W, see ¹³⁶ Nd Y, see ¹³⁶ Nd	1E+3 LLI wall (1E+3) -	9E+2 8E+2	4E-7 4E-7	1E-9 1E-9	- 2E-5	- 2E-4
60	Neodymium-149 ²	W, see ¹³⁶ Nd Y, see ¹³⁶ Nd	1E+4 -	3E+4 2E+4	1E-5 1E-5	4E-8 3E-8	1E-4	1E-3 -
60	Neodymium-151 ²	W, see ¹³⁶ Nd Y, see ¹³⁶ Nd	7E+4 -	2E+5 2E+5	8E-5 8E-5	3E-7 3E-7	9E-4	9E-3 -
61	Promethium-141 ²	W, all compounds except those given for Y Y, oxides, hydroxides, carbides, and fluorides	5E+4 St. wall (6E+4) -	2E+5 - 2E+5	8E-5 - 7E-5	3E-7 - 2E-7	- 8E-4	- 8E-3
61	Promethium-143	W, see ¹⁴¹ Pm Y, see ¹⁴¹ Pm	5E+3 -	6E+2 7E+2	2E-7 3E-7	8E-10 1E-9	7E-5	7E-4 -
61	Promethium-144	W, see ¹⁴¹ Pm Y, see ¹⁴¹ Pm	1E+3 -	1E+2 1E+2	5E-8 5E-8	2E-10 2E-10	2E-5	2E-4 -
61	Promethium-145	W, see ¹⁴¹ Pm Y, see ¹⁴¹ Pm	1E+4 -	2E+2 Bone surf (2E+2) 2E+2	7E-8 - 8E-8	- 3E-10 3E-10	1E-4	1E-3 -
61	Promethium-146	W, see ¹⁴¹ Pm Y, see ¹⁴¹ Pm	2E+3 -	5E+1 4E+1	2E-8 2E-8	7E-11 6E-11	2E-5	2E-4 -
61	Promethium-147	W, see ¹⁴¹ Pm Y, see ¹⁴¹ Pm	4E+3 LLI wall (5E+3) -	1E+2 Bone surf (2E+2) 1E+2	5E-8 - 6E-8	- 3E-10 2E-10	- 7E-5	- 7E-4
61	Promethium-148m	W, see ¹⁴¹ Pm Y, see ¹⁴¹ Pm	7E+2 -	3E+2 3E+2	1E-7 1E-7	4E-10 5E-10	1E-5	1E-4 -
61	Promethium-148	W, see ¹⁴¹ Pm Y, see ¹⁴¹ Pm	4E+2 LLI wall (5E+2) -	5E+2 - 5E+2	2E-7 - 2E-7	8E-10 - 7E-10	- 7E-6	- 7E-5
61	Promethium-149	W, see ¹⁴¹ Pm Y, see ¹⁴¹ Pm	1E+3 LLI wall (1E+3) -	2E+3 - 2E+3	8E-7 - 8E-7	3E-9 - 2E-9	- 2E-5	- 2E-4
61	Promethium-150	W, see ¹⁴¹ Pm Y, see ¹⁴¹ Pm	5E+3 -	2E+4 2E+4	8E-6 7E-6	3E-8 2E-8	7E-5	7E-4 -
61	Promethium-151	W, see ¹⁴¹ Pm Y, see ¹⁴¹ Pm	2E+3 -	4E+3 3E+3	1E-6 1E-6	5E-9 4E-9	2E-5	2E-4 -

88 FR 67657

PART 20 STANDARDS FOR PROTECTION AGAINST RADIATION

Atomic No.	Radionuclide	Class	Table 1 Occupational Values			Table 2 Effluent Concentrations		Table 3 Releases to Sewers
			Col. 1 Oral Ingestion ALI (μCi)	Inhalation		Col. 1 Air (μCi/ml)	Col. 2 Water (μCi/ml)	Monthly Average Concentration (μCi/ml)
				Col. 2 ALI (μCi)	Col. 3 DAC (μCi/ml)			
62	Samarium-141m ²	W, all compounds	3E+4	1E+5	4E-5	1E-7	4E-4	4E-3
62	Samarium-141 ²	W, all compounds	5E+4 St. wall (6E+4)	2E+5	8E-5	2E-7	- 8E-4	- 8E-3
62	Samarium-142 ²	W, all compounds	8E+3	3E+4	1E-5	4E-8	1E-4	1E-3
62	Samarium-145	W, all compounds	6E+3	5E+2	2E-7	7E-10	8E-5	8E-4
62	Samarium-146	W, all compounds	1E+1 Bone surf (3E+1)	4E-2 Bone surf (6E-2)	1E-11	- 9E-14	- 3E-7	- 3E-6
62	Samarium-147	W, all compounds	2E+1 Bone surf (3E+1)	4E-2 Bone surf (7E-2)	2E-11	- 1E-13	- 4E-7	- 4E-6
62	Samarium-151	W, all compounds	1E+4 LLI wall (1E+4)	1E+2 Bone surf (2E+2)	4E-8	- 2E-10	- 2E-4	- 2E-3
62	Samarium-153	W, all compounds	2E+3 LLI wall (2E+3)	3E+3	1E-6	4E-9	- 3E-5	- 3E-4
62	Samarium-155 ²	W, all compounds	6E+4 St. wall (8E+4)	2E+5	9E-5	3E-7	- 1E-3	- 1E-2
62	Samarium-156	W, all compounds	5E+3	9E+3	4E-6	1E-8	7E-5	7E-4
63	Europium-145	W, all compounds	2E+3	2E+3	8E-7	3E-9	2E-5	2E-4
63	Europium-146	W, all compounds	1E+3	1E+3	5E-7	2E-9	1E-5	1E-4
63	Europium-147	W, all compounds	3E+3	2E+3	7E-7	2E-9	4E-5	4E-4
63	Europium-148	W, all compounds	1E+3	4E+2	1E-7	5E-10	1E-5	1E-4
63	Europium-149	W, all compounds	1E+4	3E+3	1E-6	4E-9	2E-4	2E-3
63	Europium-150 (12.62 h)	W, all compounds	3E+3	8E+3	4E-6	1E-8	4E-5	4E-4
63	Europium-150 (34.2 y)	W, all compounds	8E+2	2E+1	8E-9	3E-11	1E-5	1E-4
63	Europium-152m	W, all compounds	3E+3	6E+3	3E-6	9E-9	4E-5	4E-4
63	Europium-152	W, all compounds	8E+2	2E+1	1E-8	3E-11	1E-5	1E-4
63	Europium-154	W, all compounds	5E+2	2E+1	8E-9	3E-11	7E-6	7E-5
63	Europium-155	W, all compounds	4E+3	9E+1 Bone surf (1E+2)	4E-8	- 2E-10	5E-5	5E-4
63	Europium-156	W, all compounds	6E+2	5E+2	2E-7	6E-10	8E-6	8E-5

58 FR 67657

PART 20 STANDARDS FOR PROTECTION AGAINST RADIATION

Atomic No.	Radionuclide	Class	Table 1 Occupational Values			Table 2 Effluent Concentrations		Table 3 Releases to Sewers
			Col. 1 Oral Ingestion ALI (μCi)	Inhalation		Col. 1 Air ($\mu\text{Ci}/\text{m}^3$)	Col. 2 Water ($\mu\text{Ci}/\text{m}^3$)	Monthly Average Concentration ($\mu\text{Ci}/\text{m}^3$)
				Col. 2 ALI (μCi)	Col. 3 DAC ($\mu\text{Ci}/\text{m}^3$)			
63	Europium-157	W, all compounds	2E+3	5E+3	2E-6	7E-9	3E-5	3E-4
63	Europium-158 ²	W, all compounds	2E+4	6E+4	2E-5	8E-8	3E-4	3E-3
64	Gadolinium-145 ²	D, all compounds except those given for W	5E+4 St. wall (5E+4)	2E+5	6E-5	2E-7	-	-
		W, oxides, hydroxides, and fluorides	-	2E+5	7E-5	2E-7	-	6E-4
64	Gadolinium-146	D, see ¹⁴⁵ Gd	1E+3	1E+2	5E-8	2E-10	2E-5	2E-4
		W, see ¹⁴⁵ Gd	-	3E+2	1E-7	4E-10	-	-
64	Gadolinium-147	D, see ¹⁴⁵ Gd	2E+3	4E+3	2E-6	6E-9	3E-5	3E-4
		W, see ¹⁴⁵ Gd	-	4E+3	1E-6	5E-9	-	-
64	Gadolinium-148	D, see ¹⁴⁵ Gd	1E+1	8E-3	3E-12	-	-	-
		W, see ¹⁴⁵ Gd	Bone surf (2E+1)	Bone surf (2E-2)	-	2E-14	3E-7	3E-6
			-	3E-2	1E-11	-	-	-
			-	Bone surf (6E-2)	-	8E-14	-	-
64	Gadolinium-149	D, see ¹⁴⁵ Gd	3E+3	2E+3	9E-7	3E-9	4E-5	4E-4
		W, see ¹⁴⁵ Gd	-	2E+3	1E-6	3E-9	-	-
64	Gadolinium-151	D, see ¹⁴⁵ Gd	6E+3	4E+2	2E-7	-	9E-5	9E-4
		W, see ¹⁴⁵ Gd	-	Bone surf (6E+2)	-	9E-10	-	-
			-	1E+3	5E-7	2E-9	-	-
64	Gadolinium-152	D, see ¹⁴⁵ Gd	2E+1	1E-2	4E-12	-	-	-
		W, see ¹⁴⁵ Gd	Bone surf (3E+1)	Bone surf (2E-2)	-	3E-14	4E-7	4E-6
			-	4E-2	2E-11	-	-	-
			-	Bone surf (8E-2)	-	1E-13	-	-
64	Gadolinium-153	D, see ¹⁴⁵ Gd	5E+3	1E+2	6E-8	-	6E-5	6E-4
		W, see ¹⁴⁵ Gd	-	Bone surf (2E+2)	-	3E-10	-	-
			-	6E+2	2E-7	8E-10	-	-
64	Gadolinium-159	D, see ¹⁴⁵ Gd	3E+3	8E+3	3E-6	1E-8	4E-5	4E-4
		W, see ¹⁴⁵ Gd	-	6E+3	2E-6	8E-9	-	-
65	Terbium-147 ²	W, all compounds	9E+3	3E+4	1E-5	5E-8	1E-4	1E-3
65	Terbium-149	W, all compounds	5E+3	7E+2	3E-7	1E-9	7E-5	7E-4
65	Terbium-150	W, all compounds	5E+3	2E+4	9E-6	3E-8	7E-5	7E-4
65	Terbium-151	W, all compounds	4E+3	9E+3	4E-6	1E-8	5E-5	5E-4
65	Terbium-153	W, all compounds	5E+3	7E+3	3E-6	1E-8	7E-5	7E-4
65	Terbium-154	W, all compounds	2E+3	4E+3	2E-6	6E-9	2E-5	2E-4
65	Terbium-155	W, all compounds	6E+3	8E+3	3E-6	1E-8	8E-5	8E-4
65	Terbium-156m (5.0 h)	W, all compounds	2E+4	3E+4	1E-5	4E-8	2E-4	2E-3

58 FR 67657

PART 20 STANDARDS FOR PROTECTION AGAINST RADIATION

Atomic No.	Radionuclide	Class	Table 1 Occupational Values			Table 2 Effluent Concentrations		Table 3 Releases to Sewers
			Col. 1 Oral Ingestion ALI (μCi)	Col. 2 ALI (μCi)	Col. 3 DAC (μCi/ml)	Col. 1 Air (μCi/ml)	Col. 2 Water (μCi/ml)	Monthly Average Concentration (μCi/ml)
65	Terbium-156m (24.4 h)	W, all compounds	7E+3	8E+3	3E-6	1E-8	1E-4	1E-3
65	Terbium-156	W, all compounds	1E+3	1E+3	6E-7	2E-9	1E-5	1E-4
65	Terbium-157	W, all compounds	5E+4 LLI wall (5E+4)	3E+2 Bone surf (6E+2)	1E-7	-	-	-
65	Terbium-158	W, all compounds	1E+3	2E+1	8E-9	3E-11	2E-5	2E-4
65	Terbium-160	W, all compounds	8E+2	2E+2	9E-8	3E-10	1E-5	1E-4
65	Terbium-161	W, all compounds	2E+3 LLI wall (2E+3)	2E+3	7E-7	2E-9	-	-
66	Dysprosium-155	W, all compounds	9E+3	3E+4	1E-5	4E-8	1E-4	1E-3
66	Dysprosium-157	W, all compounds	2E+4	6E+4	3E-5	9E-8	3E-4	3E-3
66	Dysprosium-159	W, all compounds	1E+4	2E+3	1E-6	3E-9	2E-4	2E-3
66	Dysprosium-165	W, all compounds	1E+4	5E+4	2E-5	6E-8	2E-4	2E-3
66	Dysprosium-166	W, all compounds	6E+2 LLI wall (8E+2)	7E+2	3E-7	1E-9	-	-
67	Holmium-155 ²	W, all compounds	4E+4	2E+5	6E-5	2E-7	6E-4	6E-3
67	Holmium-157 ²	W, all compounds	3E+5	1E+6	6E-4	2E-6	4E-3	4E-2
67	Holmium-159 ²	W, all compounds	2E+5	1E+6	4E-4	1E-6	3E-3	3E-2
67	Holmium-161	W, all compounds	1E+5	4E+5	2E-4	6E-7	1E-3	1E-2
67	Holmium-162m ²	W, all compounds	5E+4	3E+5	1E-4	4E-7	7E-4	7E-3
67	Holmium-162 ²	W, all compounds	5E+5 St. wall (8E+5)	2E+6	1E-3	3E-6	-	-
67	Holmium-164m ²	W, all compounds	1E+5	3E+5	1E-4	4E-7	1E-3	1E-2
67	Holmium-164 ²	W, all compounds	2E+5 St. wall (2E+5)	6E+5	3E-4	9E-7	-	-
67	Holmium-166m	W, all compounds	6E+2	7E+0	3E-9	9E-12	9E-6	9E-5
67	Holmium-166	W, all compounds	9E+2 LLI wall (9E+2)	2E+3	7E-7	2E-9	-	-
67	Holmium-167	W, all compounds	2E+4	6E+4	2E-5	8E-8	2E-4	2E-3
68	Erbium-161	W, all compounds	2E+4	6E+4	3E-5	9E-8	2E-4	2E-3
68	Erbium-165	W, all compounds	6E+4	2E+5	8E-5	3E-7	9E-4	9E-3

58 FR 67657

PART 20 STANDARDS FOR PROTECTION AGAINST RADIATION

Atomic No.	Radionuclide	Class	Table 1 Occupational Values			Table 2 Effluent Concentrations		Table 3 Releases to Sewers
			Col. 1 Oral Ingestion ALI (μCi)	Inhalation		Col. 1 Air ($\mu\text{Ci}/\text{ml}$)	Col. 2 Water ($\mu\text{Ci}/\text{ml}$)	Monthly Average Concentration ($\mu\text{Ci}/\text{ml}$)
				Col. 2 ALI (μCi)	Col. 3 DAC ($\mu\text{Ci}/\text{ml}$)			
68	Erbium-169	W, all compounds	3E+3 LLI wall (4E+3)	3E+3	1E-6	4E-9	-	5E-4
68	Erbium-171	W, all compounds	4E+3	1E+4	4E-6	1E-8	5E-5	5E-4
68	Erbium-172	W, all compounds	1E+3 LLI wall (1E+3)	1E+3	6E-7	2E-9	-	2E-4
69	Thulium-162 ²	W, all compounds	7E+4 St. wall (7E+4)	3E+5	1E-4	4E-7	-	1E-2
69	Thulium-166	W, all compounds	4E+3	1E+4	6E-6	2E-8	6E-5	6E-4
69	Thulium-167	W, all compounds	2E+3 LLI wall (2E+3)	2E+3	8E-7	3E-9	-	3E-4
69	Thulium-170	W, all compounds	8E+2 LLI wall (1E+3)	2E+2	9E-8	3E-10	-	1E-4
69	Thulium-171	W, all compounds	1E+4 LLI wall (1E+4)	3E+2 Bone surf (6E+2)	1E-7	-	8E-10	2E-4
69	Thulium-172	W, all compounds	7E+2 LLI wall (8E+2)	1E+3	5E-7	2E-9	-	1E-4
69	Thulium-173	W, all compounds	4E+3	1E+4	5E-6	2E-8	6E-5	6E-4
69	Thulium-175 ²	W, all compounds	7E+4 St. wall (9E+4)	3E+5	1E-4	4E-7	-	1E-2
70	Ytterbium-162 ²	W, all compounds except those given for Y	7E+4	3E+5	1E-4	4E-7	1E-3	1E-2
		Y, oxides, hydroxides, and fluorides	-	3E+5	1E-4	4E-7	-	-
70	Ytterbium-166	W, see ¹⁶² Yb Y, see ¹⁶² Yb	1E+3	2E+3	8E-7	3E-9	2E-5	2E-4
70	Ytterbium-167 ²	W, see ¹⁶² Yb Y, see ¹⁶² Yb	3E+5	8E+5	3E-4	1E-6	4E-3	4E-2
70	Ytterbium-169	W, see ¹⁶² Yb Y, see ¹⁶² Yb	2E+3	8E+2	4E-7	1E-9	2E-5	2E-4
70	Ytterbium-175	W, see ¹⁶² Yb	3E+3 LLI wall (3E+3)	4E+3	1E-6	5E-9	-	-
		Y, see ¹⁶² Yb	-	3E+3	1E-6	5E-9	4E-5	4E-4
70	Ytterbium-177 ²	W, see ¹⁶² Yb Y, see ¹⁶² Yb	2E+4	5E+4	2E-5	7E-8	2E-4	2E-3
70	Ytterbium-178 ²	W, see ¹⁶² Yb Y, see ¹⁶² Yb	1E+4	4E+4	2E-5	6E-8	2E-4	2E-3

58 FR 67657

PART 20 STANDARDS FOR PROTECTION AGAINST RADIATION

58 FR 67657

Atomic No.	Radionuclide	Class	Table 1 Occupational Values			Table 2 Effluent Concentrations		Table 3 Releases to Sewers
			Col. 1 Oral Ingestion ALI (μCi)	Inhalation		Col. 1 Air ($\mu\text{Ci}/\text{ml}$)	Col. 2 Water ($\mu\text{Ci}/\text{ml}$)	Monthly Average Concentration ($\mu\text{Ci}/\text{ml}$)
				Col. 2 ALI (μCi)	Col. 3 DAC ($\mu\text{Ci}/\text{ml}$)			
71	Lutetium-169	W, all compounds except those given for Y	3E+3	4E+3	2E-6	6E-9	3E-5	3E-4
		Y, oxides, hydroxides, and fluorides	-	4E+3	2E-6	6E-9	-	-
71	Lutetium-170	W, see ¹⁶⁹ Lu Y, see ¹⁶⁹ Lu	1E+3 -	2E+3 2E+3	9E-7 8E-7	3E-9 3E-9	2E-5 -	2E-4 -
71	Lutetium-171	W, see ¹⁶⁹ Lu Y, see ¹⁶⁹ Lu	2E+3 -	2E+3 2E+3	8E-7 8E-7	3E-9 3E-9	3E-5 -	3E-4 -
71	Lutetium-172	W, see ¹⁶⁹ Lu Y, see ¹⁶⁹ Lu	1E+3 -	1E+3 1E+3	5E-7 5E-7	2E-9 2E-9	1E-5 -	1E-4 -
71	Lutetium-173	W, see ¹⁶⁹ Lu Y, see ¹⁶⁹ Lu	5E+3 -	3E+2 Bone surf (5E+2) 3E+2	1E-7 -	- 6E-10 4E-10	7E-5 -	7E-4 -
71	Lutetium-174m	W, see ¹⁶⁹ Lu Y, see ¹⁶⁹ Lu	2E+3 LLI wall (3E+3) -	2E+2 Bone surf (3E+2) 2E+2	1E-7 -	- 5E-10 3E-10	- 4E-5 -	- 4E-4 -
71	Lutetium-174	W, see ¹⁶⁹ Lu Y, see ¹⁶⁹ Lu	5E+3 -	1E+2 Bone surf (2E+2) 2E+2	5E-8 -	- 3E-10 2E-10	7E-5 -	7E-4 -
71	Lutetium-176m	W, see ¹⁶⁹ Lu Y, see ¹⁶⁹ Lu	8E+3 -	3E+4 2E+4	1E-5 9E-6	3E-8 3E-8	1E-4 -	1E-3 -
71	Lutetium-176	W, see ¹⁶⁹ Lu Y, see ¹⁶⁹ Lu	7E+2 -	5E+0 Bone surf (1E+1) 8E+0	2E-9 -	- 2E-11 1E-11	1E-5 -	1E-4 -
71	Lutetium-177m	W, see ¹⁶⁹ Lu Y, see ¹⁶⁹ Lu	7E+2 -	1E+2 Bone surf (1E+2) 8E+1	5E-8 -	- 2E-10 1E-10	1E-5 -	1E-4 -
71	Lutetium-177	W, see ¹⁶⁹ Lu Y, see ¹⁶⁹ Lu	2E+3 LLI wall (3E+3) -	2E+3 -	9E-7 -	3E-9 -	- 4E-5	- 4E-4
71	Lutetium-178m ²	W, see ¹⁶⁹ Lu Y, see ¹⁶⁹ Lu	5E+4 St. wall (6E+4) -	2E+5 -	8E-5 -	3E-7 -	- 8E-4	- 8E-3
71	Lutetium-178 ²	W, see ¹⁶⁹ Lu Y, see ¹⁶⁹ Lu	4E+4 St. wall (4E+4) -	1E+5 -	5E-5 -	2E-7 -	- 6E-4	- 6E-3
71	Lutetium-179	W, see ¹⁶⁹ Lu Y, see ¹⁶⁹ Lu	6E+3 -	2E+4 2E+4	8E-6 6E-6	3E-8 3E-8	9E-5 -	9E-4 -

PART 20 STANDARDS FOR PROTECTION AGAINST RADIATION

Atomic No.	Radionuclide	Class	Table 1 Occupational Values			Table 2 Effluent Concentrations		Table 3 Releases to Sewers
			Col. 1 Oral Ingestion ALI (μCi)	Col. 2 Inhalation ALI (μCi)	Col. 3 DAC ($\mu\text{Ci}/\text{ml}$)	Col. 1 Air ($\mu\text{Ci}/\text{ml}$)	Col. 2 Water ($\mu\text{Ci}/\text{ml}$)	Monthly Average Concentration ($\mu\text{Ci}/\text{ml}$)
72	Hafnium-170	D, all compounds except those given for W	3E+3	6E+3	2E-6	8E-9	4E-5	4E-4
		W, oxides, hydroxides, carbides, and nitrates	-	5E+3	2E-6	6E-9	-	-
72	Hafnium-172	D, see ^{170}Hf	1E+3	9E+0 Bone surf (2E+1)	4E-9	-	2E-5	2E-4
		W, see ^{170}Hf	-	4E+1 Bone surf (6E+1)	2E-8	3E-11	-	-
72	Hafnium-173	D, see ^{170}Hf	5E+3	1E+4	5E-6	2E-8	7E-5	7E-4
		W, see ^{170}Hf	-	1E+4	5E-6	2E-8	-	-
72	Hafnium-175	D, see ^{170}Hf	3E+3	9E+2 Bone surf (1E+3)	4E-7	-	4E-5	4E-4
		W, see ^{170}Hf	-	1E+3	5E-7	1E-9	-	-
72	Hafnium-177m ²	D, see ^{170}Hf	2E+4	6E+4	2E-5	8E-8	3E-4	3E-3
		W, see ^{170}Hf	-	9E+4	4E-5	1E-7	-	-
72	Hafnium-178m	D, see ^{170}Hf	3E+2	1E+0 Bone surf (2E+0)	5E-10	-	3E-6	3E-5
		W, see ^{170}Hf	-	5E+0 Bone surf (9E+0)	2E-9	3E-12	-	-
72	Hafnium-179m	D, see ^{170}Hf	1E+3	3E+2 Bone surf (6E+2)	1E-7	-	1E-5	1E-4
		W, see ^{170}Hf	-	6E+2	3E-7	8E-10	-	-
72	Hafnium-180m	D, see ^{170}Hf	7E+3	2E+4	9E-6	3E-8	1E-4	1E-3
		W, see ^{170}Hf	-	3E+4	1E-5	4E-8	-	-
72	Hafnium-181	D, see ^{170}Hf	1E+3	2E+2 Bone surf (4E+2)	7E-8	-	2E-5	2E-4
		W, see ^{170}Hf	-	4E+2	2E-7	6E-10	-	-
72	Hafnium-182m ²	D, see ^{170}Hf	4E+4	9E+4	4E-5	1E-7	5E-4	5E-3
		W, see ^{170}Hf	-	1E+5	6E-5	2E-7	-	-
72	Hafnium-182	D, see ^{170}Hf	2E+2 Bone surf (4E+2)	8E-1 Bone surf (2E+0)	3E-10	-	-	-
		W, see ^{170}Hf	-	3E+0 Bone surf (7E+0)	1E-9	2E-12	5E-6	5E-5
72	Hafnium-183 ²	D, see ^{170}Hf	2E+4	5E+4	2E-5	6E-8	3E-4	3E-3
		W, see ^{170}Hf	-	6E+4	2E-5	8E-8	-	-
72	Hafnium-184	D, see ^{170}Hf	2E+3	8E+3	3E-6	1E-8	3E-5	3E-4
		W, see ^{170}Hf	-	6E+3	3E-6	9E-9	-	-

58 FR 67657

PART 20 STANDARDS FOR PROTECTION AGAINST RADIATION

58 FR 67657

Atomic No.	Radionuclide	Class	Table 1 Occupational Values			Table 2 Effluent Concentrations		Table 3 Releases to Sewers
			Col. 1 Oral Ingestion ALI (μCi)	Inhalation		Col. 1 Air (μCi/ml)	Col. 2 Water (μCi/ml)	Monthly Average Concentration (μCi/ml)
				Col. 2 ALI (μCi)	Col. 3 DAC (μCi/ml)			
73	Tantalum-172 ²	W, all compounds except those given for Y Y, elemental Ta, oxides, hydroxides, halides, carbides, nitrates, and nitrides	4E+4	1E+5	5E-5	2E-7	5E-4	5E-3
73	Tantalum-173	W, see ¹⁷² Ta Y, see ¹⁷² Ta	7E+3	2E+4	8E-6	3E-8	9E-5	9E-4
73	Tantalum-174 ²	W, see ¹⁷² Ta Y, see ¹⁷² Ta	3E+4	1E+5	4E-5	1E-7	4E-4	4E-3
73	Tantalum-175	W, see ¹⁷² Ta Y, see ¹⁷² Ta	6E+3	2E+4	7E-6	2E-8	8E-5	8E-4
73	Tantalum-176	W, see ¹⁷² Ta Y, see ¹⁷² Ta	4E+3	1E+4	5E-6	2E-8	5E-5	5E-4
73	Tantalum-177	W, see ¹⁷² Ta Y, see ¹⁷² Ta	1E+4	2E+4	8E-6	3E-8	2E-4	2E-3
73	Tantalum-178	W, see ¹⁷² Ta Y, see ¹⁷² Ta	2E+4	9E+4	4E-5	1E-7	2E-4	2E-3
73	Tantalum-179	W, see ¹⁷² Ta Y, see ¹⁷² Ta	2E+4	5E+3	2E-6	8E-9	3E-4	3E-3
73	Tantalum-180m	W, see ¹⁷² Ta Y, see ¹⁷² Ta	2E+4	7E+4	3E-5	9E-8	3E-4	3E-3
73	Tantalum-180	W, see ¹⁷² Ta Y, see ¹⁷² Ta	1E+3	4E+2	2E-7	6E-10	2E-5	2E-4
73	Tantalum-182m ²	W, see ¹⁷² Ta	2E+5	5E+5	2E-4	8E-7	-	-
		Y, see ¹⁷² Ta	St. wall (2E+5)	4E+5	2E-4	6E-7	3E-3	3E-2
73	Tantalum-182	W, see ¹⁷² Ta Y, see ¹⁷² Ta	8E+2	3E+2	1E-7	5E-10	1E-5	1E-4
73	Tantalum-183	W, see ¹⁷² Ta	9E+2	1E+3	5E-7	2E-9	-	-
		Y, see ¹⁷² Ta	LLI wall (1E+3)	1E+3	4E-7	1E-9	2E-5	2E-4
73	Tantalum-184	W, see ¹⁷² Ta Y, see ¹⁷² Ta	2E+3	5E+3	2E-6	8E-9	3E-5	3E-4
73	Tantalum-185 ²	W, see ¹⁷² Ta Y, see ¹⁷² Ta	3E+4	7E+4	3E-5	1E-7	4E-4	4E-3
73	Tantalum-186 ²	W, see ¹⁷² Ta	5E+4	2E+5	1E-4	3E-7	-	-
		Y, see ¹⁷² Ta	St. wall (7E+4)	2E+5	9E-5	3E-7	1E-3	1E-2
74	Tungsten-176	D, all compounds	1E+4	5E+4	2E-5	7E-8	1E-4	1E-3
74	Tungsten-177	D, all compounds	2E+4	9E+4	4E-5	1E-7	3E-4	3E-3

PART 20 STANDARDS FOR PROTECTION AGAINST RADIATION

Atomic No.	Radionuclide	Class	Table 1 Occupational Values			Table 2 Effluent Concentrations		Table 3 Releases to Sewers	
			Col. 1 Oral Ingestion ALI (μCi)	Inhalation		Col. 1 Air (μCi/ml)	Col. 2 Water (μCi/ml)	Monthly Average Concentration (μCi/ml)	
				Col. 2 ALI (μCi)	Col. 3 DAC (μCi/ml)				
74	Tungsten-178	D, all compounds	5E+3	2E+4	8E-6	3E-8	7E-5	7E-4	
74	Tungsten-179 ²	D, all compounds	5E+5	2E+6	7E-4	2E-6	7E-3	7E-2	
74	Tungsten-181	D, all compounds	2E+4	3E+4	1E-5	5E-8	2E-4	2E-3	
74	Tungsten-185	D, all compounds	2E+3 LLI wall (3E+3)	7E+3	3E-6	9E-9	-	4E-5	4E-4
74	Tungsten-187	D, all compounds	2E+3	9E+3	4E-6	1E-8	3E-5	3E-4	
74	Tungsten-188	D, all compounds	4E+2 LLI wall (5E+2)	1E+3	5E-7	2E-9	-	7E-6	7E-5
75	Rhenium-177 ²	D, all compounds except those given for W	9E+4 St. wall (1E+5)	3E+5	1E-4	4E-7	-	2E-3	2E-2
		W, oxides, hydroxides, and nitrates	-	4E+5	1E-4	5E-7	-	-	-
75	Rhenium-178 ²	D, see ¹⁷⁷ Re	7E+4 St. wall (1E+5)	3E+5	1E-4	4E-7	-	-	-
		W, see ¹⁷⁷ Re	-	3E+5	1E-4	4E-7	1E-3	1E-2	-
75	Rhenium-181	D, see ¹⁷⁷ Re	5E+3	9E+3	4E-6	1E-8	7E-5	7E-4	-
		W, see ¹⁷⁷ Re	-	9E+3	4E-6	1E-8	-	-	-
75	Rhenium-182 (12.7 h)	D, see ¹⁷⁷ Re	7E+3	1E+4	5E-6	2E-8	9E-5	9E-4	-
		W, see ¹⁷⁷ Re	-	2E+4	6E-6	2E-8	-	-	-
75	Rhenium-182 (64.0 h)	D, see ¹⁷⁷ Re	1E+3	2E+3	1E-6	3E-9	2E-5	2E-4	-
		W, see ¹⁷⁷ Re	-	2E+3	9E-7	3E-9	-	-	-
75	Rhenium-184m	D, see ¹⁷⁷ Re	2E+3	3E+3	1E-6	4E-9	3E-5	3E-4	-
		W, see ¹⁷⁷ Re	-	4E+2	2E-7	6E-10	-	-	-
75	Rhenium-184	D, see ¹⁷⁷ Re	2E+3	4E+3	1E-6	5E-9	3E-5	3E-4	-
		W, see ¹⁷⁷ Re	-	1E+3	6E-7	2E-9	-	-	-
75	Rhenium-186m	D, see ¹⁷⁷ Re	1E+3 St. wall (2E+3)	2E+3 St. wall (2E+3)	7E-7	-	-	-	-
		W, see ¹⁷⁷ Re	-	2E+2	6E-8	3E-9	2E-5	2E-4	-
75	Rhenium-186	D, see ¹⁷⁷ Re	2E+3	3E+3	1E-6	4E-9	3E-5	3E-4	-
		W, see ¹⁷⁷ Re	-	2E+3	7E-7	2E-9	-	-	-
75	Rhenium-187	D, see ¹⁷⁷ Re	6E+5	8E+5	4E-4	-	8E-3	8E-2	-
		W, see ¹⁷⁷ Re	-	St. wall (9E+5)	-	1E-6	-	-	-
		W, see ¹⁷⁷ Re	-	1E+5	4E-5	1E-7	-	-	-
75	Rhenium-188m ²	D, see ¹⁷⁷ Re	8E+4	1E+5	6E-5	2E-7	1E-3	1E-2	-
		W, see ¹⁷⁷ Re	-	1E+5	6E-5	2E-7	-	-	-
75	Rhenium-188	D, see ¹⁷⁷ Re	2E+3	3E+3	1E-6	4E-9	2E-5	2E-4	-
		W, see ¹⁷⁷ Re	-	3E+3	1E-6	4E-9	-	-	-

58 FR 67657

PART 20 STANDARDS FOR PROTECTION AGAINST RADIATION

Atomic No.	Radionuclide	Class	Table 1 Occupational Values			Table 2 Effluent Concentrations		Table 3 Releases to Sewers
			Col. 1 Oral Ingestion ALI (μCi)	Inhalation		Col. 1 Air (μCi/ml)	Col. 2 Water (μCi/ml)	Monthly Average Concentration (μCi/ml)
				Col. 2 ALI (μCi)	Col. 3 DAC (μCi/ml)			
75	Rhenium-189	D, see ¹⁷⁷ Re W, see ¹⁷⁷ Re	3E+3 -	5E+3 4E+3	2E-6 2E-6	7E-9 6E-9	4E-5 -	4E-4 -
76	Osmium-180 ²	D, all compounds except those given for W and Y W, halides and nitrates Y, oxides and hydroxides	1E+5 - -	4E+5 5E+5 5E+5	2E-4 2E-4 2E-4	5E-7 7E-7 6E-7	1E-3 - -	1E-2 - -
76	Osmium-181 ²	D, see ¹⁸⁰ Os W, see ¹⁸⁰ Os Y, see ¹⁸⁰ Os	1E+4 - -	4E+4 5E+4 4E+4	2E-5 2E-5 2E-5	6E-8 6E-8 6E-8	2E-4 - -	2E-3 - -
76	Osmium-182	D, see ¹⁸⁰ Os W, see ¹⁸⁰ Os Y, see ¹⁸⁰ Os	2E+3 - -	6E+3 4E+3 4E+3	2E-6 2E-6 2E-6	8E-9 6E-9 6E-9	3E-5 - -	3E-4 - -
76	Osmium-185	D, see ¹⁸⁰ Os W, see ¹⁸⁰ Os Y, see ¹⁸⁰ Os	2E+3 - -	5E+2 8E+2 8E+2	2E-7 3E-7 3E-7	7E-10 1E-9 1E-9	3E-5 - -	3E-4 - -
76	Osmium-189m	D, see ¹⁸⁰ Os W, see ¹⁸⁰ Os Y, see ¹⁸⁰ Os	8E+4 - -	2E+5 2E+5 2E+5	1E-4 9E-5 7E-5	3E-7 3E-7 2E-7	1E-3 - -	1E-2 - -
76	Osmium-191m	D, see ¹⁸⁰ Os W, see ¹⁸⁰ Os Y, see ¹⁸⁰ Os	1E+4 - -	3E+4 2E+4 2E+4	1E-5 8E-6 7E-6	4E-8 3E-8 2E-8	2E-4 - -	2E-3 - -
76	Osmium-191	D, see ¹⁸⁰ Os W, see ¹⁸⁰ Os Y, see ¹⁸⁰ Os	2E+3 LLI wall (3E+3) -	2E+3 - 2E+3	9E-7 - 7E-7	3E-9 - 6E-7	- 3E-5 2E-9	- 3E-4 -
76	Osmium-193	D, see ¹⁸⁰ Os W, see ¹⁸⁰ Os Y, see ¹⁸⁰ Os	2E+3 LLI wall (2E+3) -	5E+3 - 3E+3	2E-6 - 1E-6	6E-9 - 4E-9	- 2E-5 4E-9	- 2E-4 -
76	Osmium-194	D, see ¹⁸⁰ Os W, see ¹⁸⁰ Os Y, see ¹⁸⁰ Os	4E+2 LLI wall (6E+2) -	4E+1 - 6E+1	2E-8 - 2E-8	6E-11 - 8E-11	- 8E-6 1E-11	- 8E-5 -
77	Iridium-182 ²	D, all compounds except those given for W and Y W, halides, nitrates, and metallic iridium Y, oxides and hydroxides	4E+4 St. wall (4E+4) -	1E+5 - 2E+5	6E-5 - 6E-5	2E-7 - 2E-7	- 6E-4 -	- 6E-3 -
77	Iridium-184	D, see ¹⁸² Ir W, see ¹⁸² Ir Y, see ¹⁸² Ir	8E+3 - -	2E+4 3E+4 3E+4	1E-5 1E-5 1E-5	3E-8 5E-8 4E-8	1E-4 - -	1E-3 - -

58 FR 67657

PART 20 STANDARDS FOR PROTECTION AGAINST RADIATION

Atomic No.	Radionuclide	Class	Table 1 Occupational Values			Table 2 Effluent Concentrations		Table 3 Releases to Sewers
			Col. 1 Oral Ingestion ALI (μCi)	Inhalation		Col. 1 Air ($\mu\text{Ci}/\text{m}^3$)	Col. 2 Water ($\mu\text{Ci}/\text{m}^3$)	Monthly Average Concentration ($\mu\text{Ci}/\text{m}^3$)
				Col. 2 ALI (μCi)	Col. 3 DAC ($\mu\text{Ci}/\text{m}^3$)			
77	Iridium-185	D, see ^{182}Ir W, see ^{182}Ir Y, see ^{182}Ir	5E+3 - -	1E+4 1E+4 1E+4	5E-6 5E-6 4E-6	2E-8 2E-8 1E-8	7E-5 -	7E-4 - -
77	Iridium-186	D, see ^{182}Ir W, see ^{182}Ir Y, see ^{182}Ir	2E+3 - -	8E+3 6E+3 6E+3	3E-6 3E-6 2E-6	1E-8 9E-9 8E-9	3E-5 -	3E-4 - -
77	Iridium-187	D, see ^{182}Ir W, see ^{182}Ir Y, see ^{182}Ir	1E+4 - -	3E+4 3E+4 3E+4	1E-5 1E-5 1E-5	5E-8 4E-8 4E-8	1E-4 -	1E-3 - -
77	Iridium-188	D, see ^{182}Ir W, see ^{182}Ir Y, see ^{182}Ir	2E+3 - -	5E+3 4E+3 3E+3	2E-6 1E-6 1E-6	6E-9 5E-9 5E-9	3E-5 -	3E-4 - -
77	Iridium-189	D, see ^{182}Ir W, see ^{182}Ir Y, see ^{182}Ir	5E+3 - -	5E+3 4E+3 4E+3	2E-6 2E-6 1E-6	7E-9 5E-9 5E-9	- 7E-5 -	- 7E-4 -
77	Iridium-190m ²	D, see ^{182}Ir W, see ^{182}Ir Y, see ^{182}Ir	2E+5 - -	2E+5 2E+5 2E+5	8E-5 9E-5 8E-5	3E-7 3E-7 3E-7	2E-3 -	2E-2 - -
77	Iridium-190	D, see ^{182}Ir W, see ^{182}Ir Y, see ^{182}Ir	1E+3 - -	9E+2 1E+3 9E+2	4E-7 4E-7 4E-7	1E-9 1E-9 1E-9	1E-5 -	1E-4 - -
77	Iridium-192m	D, see ^{182}Ir W, see ^{182}Ir Y, see ^{182}Ir	3E+3 - -	9E+1 2E+2 2E+1	4E-8 9E-8 6E-9	1E-10 3E-10 2E-11	4E-5 -	4E-4 - -
77	Iridium-192	D, see ^{182}Ir W, see ^{182}Ir Y, see ^{182}Ir	9E+2 - -	3E+2 4E+2 2E+2	1E-7 2E-7 9E-8	4E-10 6E-10 3E-10	1E-5 -	1E-4 - -
77	Iridium-194m	D, see ^{182}Ir W, see ^{182}Ir Y, see ^{182}Ir	6E+2 - -	9E+1 2E+2 1E+2	4E-8 7E-8 4E-8	1E-10 2E-10 1E-10	9E-6 -	9E-5 - -
77	Iridium-194	D, see ^{182}Ir W, see ^{182}Ir Y, see ^{182}Ir	1E+3 - -	3E+3 2E+3 2E+3	1E-6 9E-7 8E-7	4E-9 3E-9 3E-9	1E-5 -	1E-4 - -
77	Iridium-195m	D, see ^{182}Ir W, see ^{182}Ir Y, see ^{182}Ir	8E+3 - -	2E+4 3E+4 2E+4	1E-5 1E-5 9E-6	3E-8 4E-8 3E-8	1E-4 -	1E-3 - -
77	Iridium-195	D, see ^{182}Ir W, see ^{182}Ir Y, see ^{182}Ir	1E+4 - -	4E+4 5E+4 4E+4	2E-5 2E-5 2E-5	6E-8 7E-8 6E-8	2E-4 -	2E-3 - -
78	Platinum-186	D, all compounds	1E+4	4E+4	2E-5	5E-8	2E-4	2E-3
78	Platinum-188	D, all compounds	2E+3	2E+3	7E-7	2E-9	2E-5	2E-4
78	Platinum-189	D, all compounds	1E+4	3E+4	1E-5	4E-8	1E-4	1E-3
78	Platinum-191	D, all compounds	4E+3	8E+3	4E-6	1E-8	5E-5	5E-4

58 FR 67657

PART 20 STANDARDS FOR PROTECTION AGAINST RADIATION

Atomic No.	Radionuclide	Class	Table 1 Occupational Values			Table 2 Effluent Concentrations		Table 3 Releases to Sewers
			Col. 1 Oral Ingestion ALI (μCi)	Inhalation		Col. 1 Air ($\mu\text{Ci}/\text{ml}$)	Col. 2 Water ($\mu\text{Ci}/\text{ml}$)	Monthly Average Concentration ($\mu\text{Ci}/\text{ml}$)
				Col. 2 ALI (μCi)	Col. 3 DAC ($\mu\text{Ci}/\text{ml}$)			
78	Platinum-193m	D, all compounds	3E+3 LLI wall (3E+4)	6E+3	3E-6	8E-9	-	4E-4
78	Platinum-193	D, all compounds	4E+4 LLI wall (5E+4)	2E+4	1E-5	3E-8	-	6E-3
78	Platinum-195m	D, all compounds	2E+3 LLI wall (2E+3)	4E+3	2E-6	6E-9	-	3E-4
78	Platinum-197m ²	D, all compounds	2E+4	4E+4	2E-5	6E-8	2E-4	2E-3
78	Platinum-197	D, all compounds	3E+3	1E+4	4E-6	1E-8	4E-5	4E-4
78	Platinum-199 ²	D, all compounds	5E+4	1E+5	6E-5	2E-7	7E-4	7E-3
78	Platinum-200	D, all compounds	1E+3	3E+3	1E-6	5E-9	2E-5	2E-4
79	Gold-193	D, all compounds except those given for W and Y	9E+3	3E+4	1E-5	4E-8	1E-4	1E-3
		W, halides and nitrates	-	2E+4	9E-6	3E-8	-	-
		Y, oxides and hydroxides	-	2E+4	8E-6	3E-8	-	-
79	Gold-194	D, see ¹⁹³ Au	3E+3	8E+3	3E-6	1E-8	4E-5	4E-4
		W, see ¹⁹³ Au	-	5E+3	2E-6	8E-9	-	-
		Y, see ¹⁹³ Au	-	5E+3	2E-6	7E-9	-	-
79	Gold-195	D, see ¹⁹³ Au	5E+3	1E+4	5E-6	2E-8	7E-5	7E-4
		W, see ¹⁹³ Au	-	1E+3	6E-7	2E-9	-	-
		Y, see ¹⁹³ Au	-	4E+2	2E-7	6E-10	-	-
79	Gold-198m	D, see ¹⁹³ Au	1E+3	3E+3	1E-6	4E-9	1E-5	1E-4
		W, see ¹⁹³ Au	-	1E+3	5E-7	2E-9	-	-
		Y, see ¹⁹³ Au	-	1E+3	5E-7	2E-9	-	-
79	Gold-198	D, see ¹⁹³ Au	1E+3	4E+3	2E-6	5E-9	2E-5	2E-4
		W, see ¹⁹³ Au	-	2E+3	8E-7	3E-9	-	-
		Y, see ¹⁹³ Au	-	2E+3	7E-7	2E-9	-	-
79	Gold-199	D, see ¹⁹³ Au	3E+3 LLI wall (3E+3)	9E+3	4E-6	1E-8	-	-
		W, see ¹⁹³ Au	-	4E+3	2E-6	6E-9	4E-5	4E-4
		Y, see ¹⁹³ Au	-	4E+3	2E-6	5E-9	-	-
79	Gold-200m	D, see ¹⁹³ Au	1E+3	4E+3	1E-6	5E-9	2E-5	2E-4
		W, see ¹⁹³ Au	-	3E+3	1E-6	4E-9	-	-
		Y, see ¹⁹³ Au	-	2E+4	1E-6	3E-9	-	-
79	Gold-200 ²	D, see ¹⁹³ Au	3E+4	6E+4	3E-5	9E-8	4E-4	4E-3
		W, see ¹⁹³ Au	-	8E+4	3E-5	1E-7	-	-
		Y, see ¹⁹³ Au	-	7E+4	3E-5	1E-7	-	-
79	Gold-201 ²	D, see ¹⁹³ Au	7E+4 St. wall (9E+4)	2E+5	9E-5	3E-7	-	-
		W, see ¹⁹³ Au	-	2E+5	1E-4	3E-7	1E-3	1E-2
		Y, see ¹⁹³ Au	-	2E+5	9E-5	3E-7	-	-

58 FR 67657

PART 20 STANDARDS FOR PROTECTION AGAINST RADIATION

58 FR 67657

Atomic No.	Radionuclide	Class	Table 1 Occupational Values			Table 2 Effluent Concentrations		Table 3 Releases to Sewers
			Col. 1 Oral Ingestion ALI (μCi)	Inhalation		Col. 1 Air ($\mu\text{Ci}/\text{m}^3$)	Col. 2 Water ($\mu\text{Ci}/\text{m}^3$)	Monthly Average Concentration ($\mu\text{Ci}/\text{m}^3$)
				Col. 2 ALI (μCi)	Col. 3 DAC ($\mu\text{Ci}/\text{m}^3$)			
80	Mercury-193m	Vapor	-	8E+3	4E-6	1E-8	-	-
		Organic D	4E+3	1E+4	5E-6	2E-8	6E-5	6E-4
		D, sulfates	3E+3	9E+3	4E-6	1E-8	4E-5	4E-4
		W, oxides, hydroxides, halides, nitrates, and sulfides	-	8E+3	3E-6	1E-8	-	-
80	Mercury-193	Vapor	-	3E+4	1E-5	4E-8	-	-
		Organic D	2E+4	6E+4	3E-5	9E-8	3E-4	3E-3
		D, see ^{193m} Hg W, see ^{193m} Hg	2E+4	4E+4	2E-5	6E-8	2E-4	2E-3
		W, see ^{193m} Hg	-	4E+4	2E-5	6E-8	-	-
80	Mercury-194	Vapor	-	3E+1	1E-8	4E-11	-	-
		Organic D	2E+1	3E+1	1E-8	4E-11	2E-7	2E-6
		D, see ^{193m} Hg W, see ^{193m} Hg	8E+2	4E+1	2E-8	6E-11	1E-5	1E-4
		W, see ^{193m} Hg	-	1E+2	5E-8	2E-10	-	-
80	Mercury-195m	Vapor	-	4E+3	2E-6	6E-9	-	-
		Organic D	3E+3	6E+3	3E-6	8E-9	4E-5	4E-4
		D, see ^{193m} Hg W, see ^{193m} Hg	2E+3	5E+3	2E-6	7E-9	3E-5	3E-4
		W, see ^{193m} Hg	-	4E+3	2E-6	5E-9	-	-
80	Mercury-195	Vapor	-	3E+4	1E-5	4E-8	-	-
		Organic D	2E+4	5E+4	2E-5	6E-8	2E-4	2E-3
		D, see ^{193m} Hg W, see ^{193m} Hg	1E+4	4E+4	1E-5	5E-8	2E-4	2E-3
		W, see ^{193m} Hg	-	3E+4	1E-5	5E-8	-	-
80	Mercury-197m	Vapor	-	5E+3	2E-6	7E-9	-	-
		Organic D	4E+3	9E+3	4E-6	1E-8	5E-5	5E-4
		D, see ^{193m} Hg W, see ^{193m} Hg	3E+3	7E+3	3E-6	1E-8	4E-5	4E-4
		W, see ^{193m} Hg	-	5E+3	2E-6	7E-9	-	-
80	Mercury-197	Vapor	-	8E+3	4E-6	1E-8	-	-
		Organic D	7E+3	1E+4	6E-6	2E-8	9E-5	9E-4
		D, see ^{193m} Hg W, see ^{193m} Hg	6E+3	1E+4	5E-6	2E-8	8E-5	8E-4
		W, see ^{193m} Hg	-	9E+3	4E-6	1E-8	-	-
80	Mercury-199m ²	Vapor	-	8E+4	3E-5	1E-7	-	-
		Organic D	6E+4	2E+5	7E-5	2E-7	-	-
		D, see ^{193m} Hg W, see ^{193m} Hg	6E+4 (1E+5) St. wall	1E+5	6E-5	2E-7	8E-4	1E-2
		W, see ^{193m} Hg	-	2E+5	7E-5	2E-7	-	-
80	Mercury-203	Vapor	-	8E+2	4E-7	1E-9	-	-
		Organic D	5E+2	8E+2	3E-7	1E-9	7E-6	7E-5
		D, see ^{193m} Hg W, see ^{193m} Hg	2E+3	1E+3	5E-7	2E-9	3E-5	3E-4
		W, see ^{193m} Hg	-	1E+3	5E-7	2E-9	-	-
81	Thallium-194m ²	D, all compounds	5E+4 (7E+4) St. wall	2E+5	6E-5	2E-7	-	-
			-	-	-	1E-3	1E-2	

PART 20 STANDARDS FOR PROTECTION AGAINST RADIATION

58 FR 67657

Atomic No.	Radionuclide	Class	Table 1 Occupational Values			Table 2 Effluent Concentrations		Table 3 Releases to Sewers
			Col. 1 Oral Ingestion ALI (μCi)	Inhalation		Col. 1 Air (μCi/ml)	Col. 2 Water (μCi/ml)	Monthly Average Concentration (μCi/ml)
				Col. 2 ALI (μCi)	Col. 3 DAC (μCi/ml)			
81	Thallium-194 ²	D, all compounds	3E+5 St. wall (3E+5)	6E+5	2E-4	8E-7	-	4E-2
81	Thallium-195 ²	D, all compounds	6E+4	1E+5	5E-5	2E-7	9E-4	9E-3
81	Thallium-197	D, all compounds	7E+4	1E+5	5E-5	2E-7	1E-3	1E-2
81	Thallium-198m ²	D, all compounds	3E+4	5E+4	2E-5	8E-8	4E-4	4E-3
81	Thallium-198	D, all compounds	2E+4	3E+4	1E-5	5E-8	3E-4	3E-3
81	Thallium-199	D, all compounds	6E+4	8E+4	4E-5	1E-7	9E-4	9E-3
81	Thallium-200	D, all compounds	8E+3	1E+4	5E-6	2E-8	1E-4	1E-3
81	Thallium-201	D, all compounds	2E+4	2E+4	9E-6	3E-8	2E-4	2E-3
81	Thallium-202	D, all compounds	4E+3	5E+3	2E-6	7E-9	5E-5	5E-4
81	Thallium-204	D, all compounds	2E+3	2E+3	9E-7	3E-9	2E-5	2E-4
82	Lead-195m ²	D, all compounds	6E+4	2E+5	8E-5	3E-7	8E-4	8E-3
82	Lead-198	D, all compounds	3E+4	6E+4	3E-5	9E-8	4E-4	4E-3
82	Lead-199 ²	D, all compounds	2E+4	7E+4	3E-5	1E-7	3E-4	3E-3
82	Lead-200	D, all compounds	3E+3	6E+3	3E-6	9E-9	4E-5	4E-4
82	Lead-201	D, all compounds	7E+3	2E+4	8E-6	3E-8	1E-4	1E-3
82	Lead-202m	D, all compounds	9E+3	3E+4	1E-5	4E-8	1E-4	1E-3
82	Lead-202	D, all compounds	1E+2	5E+1	2E-8	7E-11	2E-6	2E-5
82	Lead-203	D, all compounds	5E+3	9E+3	4E-6	1E-8	7E-5	7E-4
82	Lead-205	D, all compounds	4E+3	1E+3	6E-7	2E-9	5E-5	5E-4
82	Lead-209	D, all compounds	2E+4	6E+4	2E-5	8E-8	3E-4	3E-3
82	Lead-210	D, all compounds	6E-1 Bone surf (1E+0)	2E-1 Bone surf (4E-1)	1E-10	-	-	-
82	Lead-211 ²	D, all compounds	1E+4	6E+2	3E-7	9E-10	2E-4	2E-3
82	Lead-212	D, all compounds	8E+1 Bone surf (1E+2)	3E+1	1E-8	5E-11	-	-
82	Lead-214 ²	D, all compounds	9E+3	8E+2	3E-7	1E-9	1E-4	1E-3
83	Bismuth-200 ²	D, nitrates W, all other compounds	3E+4 -	8E+4 1E+5	4E-5 4E-5	1E-7 1E-7	4E-4 -	4E-3 -
83	Bismuth-201 ²	D, see ²⁰⁰ Bi W, see ²⁰⁰ Bi	1E+4 -	3E+4 4E+4	1E-5 2E-5	4E-8 5E-8	2E-4 -	2E-3 -
83	Bismuth-202 ²	D, see ²⁰⁰ Bi W, see ²⁰⁰ Bi	1E+4 -	4E+4 8E+4	2E-5 3E-5	6E-8 1E-7	2E-4 -	2E-3 -

PART 20 STANDARDS FOR PROTECTION AGAINST RADIATION

Atomic No.	Radionuclide	Class	Table 1 Occupational Values			Table 2 Effluent Concentrations		Table 3 Releases to Sewers
			Col. 1 Oral Ingestion ALI (μCi)	Inhalation		Col. 1 Air ($\mu\text{Ci}/\text{ml}$)	Col. 2 Water ($\mu\text{Ci}/\text{ml}$)	Monthly Average Concentration ($\mu\text{Ci}/\text{ml}$)
				Col. 2 ALI (μCi)	Col. 3 DAC ($\mu\text{Ci}/\text{ml}$)			
83	Bismuth-203	D, see ^{200}Bi W, see ^{200}Bi	2E+3 -	7E+3 6E+3	3E-6 3E-6	9E-9 9E-9	3E-5 -	3E-4 -
83	Bismuth-205	D, see ^{200}Bi W, see ^{200}Bi	1E+3 -	3E+3 1E+3	1E-6 5E-7	3E-9 2E-9	2E-5 -	2E-4 -
83	Bismuth-206	D, see ^{200}Bi W, see ^{200}Bi	6E+2 -	1E+3 9E+2	6E-7 4E-7	2E-9 1E-9	9E-6 -	9E-5 -
83	Bismuth-207	D, see ^{200}Bi W, see ^{200}Bi	1E+3 -	2E+3 4E+2	7E-7 1E-7	2E-9 5E-10	1E-5 -	1E-4 -
83	Bismuth-210m	D, see ^{200}Bi W, see ^{200}Bi	4E+1 (6E+1) Kidneys	5E+0 (6E+0) 7E-1 Kidneys	2E-9 - 3E-10	- 9E-12 9E-13	- 8E-7	- 8E-6
83	Bismuth-210	D, see ^{200}Bi W, see ^{200}Bi	8E+2 -	2E+2 Kidneys (4E+2) 3E+1	1E-7 - 1E-8	- 5E-10 4E-11	1E-5 -	1E-4 -
83	Bismuth-212 ²	D, see ^{200}Bi W, see ^{200}Bi	5E+3 -	2E+2 3E+2	1E-7 1E-7	3E-10 4E-10	7E-5 -	7E-4 -
83	Bismuth-213 ²	D, see ^{200}Bi W, see ^{200}Bi	7E+3 -	3E+2 4E+2	1E-7 1E-7	4E-10 5E-10	1E-4 -	1E-3 -
83	Bismuth-214 ²	D, see ^{200}Bi W, see ^{200}Bi	2E+4 St. wall (2E+4)	8E+2 - 9E-2	3E-7 - 4E-7	1E-9 - 1E-9	- 3E-4	- 3E-3
84	Polonium-203 ²	D, all compounds except those given for W W, oxides, hydroxides, and nitrates	3E+4 -	6E+4 9E+4	3E-5 4E-5	9E-8 1E-7	3E-4 -	3E-3 -
84	Polonium-205 ²	D, see ^{203}Po W, see ^{203}Po	2E+4 -	4E+4 7E+4	2E-5 3E-5	5E-8 1E-7	3E-4 -	3E-3 -
84	Polonium-207	D, see ^{203}Po W, see ^{203}Po	8E+3 -	3E+4 3E+4	1E-5 1E-5	3E-8 4E-8	1E-4 -	1E-3 -
84	Polonium-210	D, see ^{203}Po W, see ^{203}Po	3E+0 -	6E-1 6E-1	3E-10 3E-10	9E-13 9E-13	4E-8 -	4E-7 -
85	Astatine-207 ²	D, halides W	6E+3 -	3E+3 2E+3	1E-6 9E-7	4E-9 3E-9	8E-5 -	8E-4 -
85	Astatine-211	D, halides W	1E+2 -	8E+1 5E+1	3E-8 2E-8	1E-10 8E-11	2E-6 -	2E-5 -
86	Radon-220	With daughters removed With daughters present	- -	2E+4 2E+1 (or 12 working level months)	7E-6 9E-9 (or 1.0 working level)	2E-8 3E-11	- -	- -

58 FR 67657

PART 20 STANDARDS FOR PROTECTION AGAINST RADIATION

58 FR 67657

Atomic No.	Radionuclide	Class	Table 1 Occupational Values			Table 2 Effluent Concentrations		Table 3 Releases to Sewers
			Col. 1 Oral Ingestion ALI (μCi)	Col. 2	Col. 3	Col. 1 Air ($\mu\text{Ci}/\text{ml}$)	Col. 2 Water ($\mu\text{Ci}/\text{ml}$)	Monthly Average Concentration ($\mu\text{Ci}/\text{ml}$)
				Inhalation				
86	Radon-222	With daughters removed	-	1E+4	4E-6	1E-8	-	-
		With daughters present	-	1E+2 (or 4 working level months)	3E-8 (or 0.33 working level)	1E-10	-	-
87	Francium-222 ²	D, all compounds	2E+3	5E+2	2E-7	6E-10	3E-5	3E-4
87	Francium-223 ²	D, all compounds	6E+2	8E+2	3E-7	1E-9	8E-6	8E-5
88	Radium-223	W, all compounds	5E+0 Bone surf (9E+0)	7E-1	3E-10	9E-13	-	1E-7 1E-6
88	Radium-224	W, all compounds	8E+0 Bone surf (2E+1)	2E+0	7E-10	2E-12	-	2E-7 2E-6
88	Radium-225	W, all compounds	8E+0 Bone surf (2E+1)	7E-1	3E-10	9E-13	-	2E-7 2E-6
88	Radium-226	W, all compounds	2E+0 Bone surf (5E+0)	6E-1	3E-10	9E-13	-	6E-8 6E-7
88	Radium-227 ²	W, all compounds	2E+4 Bone surf (2E+4)	1E+4 Bone surf (2E+4)	6E-6	-	3E-8 3E-4	- 3E-3
88	Radium-228	W, all compounds	2E+0 Bone surf (4E+0)	1E+0	5E-10	2E-12	-	6E-8 6E-7
89	Actinium-224	D, all compounds except those given for W and Y	2E+3 LLI wall (2E+3)	3E+1 Bone surf (4E+1)	1E-8	-	5E-11 3E-5	- 3E-4
		W, halides and nitrates	-	5E+1	2E-8	7E-11	-	-
		Y, oxides and hydroxides	-	5E+1	2E-8	6E-11	-	-
89	Actinium-225	D, see ²²⁴ Ac	5E+1 LLI wall (5E+1)	3E-1 Bone surf (5E-1)	1E-10	-	7E-13 7E-7	- 7E-6
		W, see ²²⁴ Ac	-	6E-1	3E-10	9E-13	-	-
		Y, see ²²⁴ Ac	-	6E-1	3E-10	9E-13	-	-
89	Actinium-226	D, see ²²⁴ Ac	1E+2 LLI wall (1E+2)	3E+0 Bone surf (4E+0)	1E-9	-	5E-12 2E-6	- 2E-5
		W, see ²²⁴ Ac	-	5E+0	2E-9	7E-12	-	-
		Y, see ²²⁴ Ac	-	5E+0	2E-9	6E-12	-	-
89	Actinium-227	D, see ²²⁴ Ac	2E-1 Bone surf (4E-1)	4E-4 Bone surf (8E-4)	2E-13	-	1E-15 5E-9	- 5E-8
		W, see ²²⁴ Ac	-	2E-3 Bone surf (3E-3)	7E-13	-	-	-
		Y, see ²²⁴ Ac	-	4E-3	2E-12	6E-15	-	-

PART 20 STANDARDS FOR PROTECTION AGAINST RADIATION

Atomic No.	Radionuclide	Class	Table 1 Occupational Values			Table 2 Effluent Concentrations		Table 3 Releases to Sewers
			Col. 1 Oral Ingestion ALI (μCi)	Inhalation		Col. 1 Air (μCi/ml)	Col. 2 Water (μCi/ml)	Monthly Average Concentration (μCi/ml)
				Col. 2 ALI (μCi)	Col. 3 DAC (μCi/ml)			
89	Actinium-228	D, see ²²⁴ Ac	2E+3	9E+0 Bone surf	4E-9	-	3E-5	3E-4
		W, see ²²⁴ Ac	-	(2E+1) 4E+1	-	2E-11	-	-
		Y, see ²²⁴ Ac	-	(6E+1) 4E+1	2E-8	8E-11 6E-11	-	-
90	Thorium-226 ²	W, all compounds except those given for Y	5E+3 St. wall (5E+3)	2E+2	6E-8	2E-10	-	7E-5 7E-4
		Y, oxides and hydroxides	-	1E+2	6E-8	2E-10	-	-
90	Thorium-227	W, see ²²⁶ Th	1E+2	3E-1	1E-10	5E-13	2E-6	2E-5
		Y, see ²²⁶ Th	-	3E-1	1E-10	5E-13	-	-
90	Thorium-228	W, see ²²⁶ Th	6E+0 Bone surf (1E+1)	1E-2 Bone surf (2E-2)	4E-12	-	-	-
		Y, see ²²⁶ Th	-	2E-2	7E-12	3E-14 2E-14	2E-7	2E-6
90	Thorium-229	W, see ²²⁶ Th	6E-1 Bone surf (1E+0)	9E-4 Bone surf (2E-3)	4E-13	-	-	-
		Y, see ²²⁶ Th	-	2E-3 Bone surf (3E-3)	1E-12	3E-15 4E-15	2E-8	2E-7
90	Thorium-230	W, see ²²⁶ Th	4E+0 Bone surf (9E+0)	6E-3 Bone surf (2E-2)	3E-12	-	-	-
		Y, see ²²⁶ Th	-	2E-2 Bone surf (2E-2)	6E-12	2E-14 3E-14	1E-7	1E-6
90	Thorium-231	W, see ²²⁶ Th	4E+3	6E+3	3E-6	9E-9	5E-5	5E-4
		Y, see ²²⁶ Th	-	6E+3	3E-6	9E-9	-	-
90	Thorium-232	W, see ²²⁶ Th	7E-1 Bone surf (2E+0)	1E-3 Bone surf (3E-3)	5E-13	-	-	-
		Y, see ²²⁶ Th	-	3E-3 Bone surf (4E-3)	1E-12	4E-15 6E-15	3E-8	3E-7
90	Thorium-234	W, see ²²⁶ Th	3E+2 LLI wall (4E+2)	2E+2	8E-8	3E-10	-	-
		Y, see ²²⁶ Th	-	2E+2	6E-8	2E-10	5E-6	5E-5
91	Protactinium-227 ²	W, all compounds except those given for Y	4E+3	1E+2	5E-8	2E-10	5E-5	5E-4
		Y, oxides and hydroxides	-	1E+2	4E-8	1E-10	-	-
91	Protactinium-228	W, see ²²⁷ Pa	1E+3	1E+1 Bone surf (2E+1)	5E-9	-	2E-5	2E-4
		Y, see ²²⁶ Pa	-	1E+1	5E-9	3E-11 2E-11	-	-

58 FR 67657

PART 20 STANDARDS FOR PROTECTION AGAINST RADIATION

58 FR 67657

Atomic No.	Radionuclide	Class	Table 1 Occupational Values			Table 2 Effluent Concentrations		Table 3 Releases to Sewers
			Col. 1 Oral Ingestion ALI (μCi)	Inhalation		Col. 1 Air ($\mu\text{Ci}/\text{m}^3$)	Col. 2 Water ($\mu\text{Ci}/\text{m}^3$)	Monthly Average Concentration ($\mu\text{Ci}/\text{m}^3$)
				Col. 2 ALI (μCi)	Col. 3 DAC ($\mu\text{Ci}/\text{m}^3$)			
91	Protactinium-230	W, see 227Pa	6E+2 Bone surf (9E+2)	5E+0	2E-9	7E-12	-	-
		Y, see 227Pa	-	4E+0	1E-9	5E-12	-	1E-4
91	Protactinium-231	W, see 227Pa	2E-1 Bone surf (5E-1)	2E-3 Bone surf (4E-3)	6E-13	-	-	-
		Y, see 226Pa	-	4E-3 Bone surf (6E-3)	2E-12	6E-15	6E-9	6E-8
91	Protactinium-232	W, see 227Pa	1E+3	2E+1 Bone surf (6E+1)	9E-9	-	2E-5	2E-4
		Y, see 227Pa	-	6E+1 Bone surf (7E+1)	2E-8	8E-11	-	-
91	Protactinium-233	W, see 227Pa	1E+3 LLI wall (2E+3)	7E+2	3E-7	1E-9	-	-
		Y, see 227Pa	-	6E+2	2E-7	8E-10	2E-5	2E-4
91	Protactinium-234	W, see 227Pa	2E+3	8E+3	3E-6	1E-8	3E-5	3E-4
		Y, see 227Pa	-	7E+3	3E-6	9E-9	-	-
92	Uranium-230	D, UF ₆ , UO ₂ F ₂ , UO ₂ (NO ₃) ₂	4E+0 Bone surf (6E+0)	4E-1 Bone surf (6E-1)	2E-10	-	-	-
		W, UO ₃ , UF ₄ , UC ₁₄	-	4E-1	1E-10	8E-13	8E-8	8E-7
		Y, UO ₂ , U ₃ O ₈	-	3E-1	1E-10	5E-13	-	-
92	Uranium-231	D, see 230U	5E+3 LLI wall (4E+3)	8E+3	3E-6	1E-8	-	-
		W, see 230U	-	6E+3	2E-6	8E-9	6E-5	6E-4
		Y, see 230U	-	5E+3	2E-6	6E-9	-	-
92	Uranium-232	D, see 230U	2E+0 Bone surf (4E+0)	2E-1 Bone surf (4E-1)	9E-11	-	-	-
		W, see 230U	-	4E-1	2E-10	6E-13	6E-8	6E-7
		Y, see 230U	-	8E-3	3E-12	5E-13	-	-
92	Uranium-233	D, see 230U	1E+1 Bone surf (2E+1)	1E+0 Bone surf (2E+0)	5E-10	-	-	-
		W, see 230U	-	7E-1	3E-10	3E-12	3E-7	3E-6
		Y, see 230U	-	4E-2	2E-11	1E-12	-	-
92	Uranium-234 ³	D, see 230U	1E+1 Bone surf (2E+1)	1E+0 Bone surf (2E+0)	5E-10	-	-	-
		W, see 230U	-	7E-1	3E-10	3E-12	3E-7	3E-6
		Y, see 230U	-	4E-2	2E-11	1E-12	-	-

PART 20 STANDARDS FOR PROTECTION AGAINST RADIATION

Atomic No.	Radionuclide	Class	Table 1 Occupational Values			Table 2 Effluent Concentrations		Table 3 Releases to Sewers
			Col. 1 Oral Ingestion ALI (μCi)	Col. 2 Inhalation AI (μCi)	Col. 3 DAC (μCi/ml)	Col. 1 Air (μCi/ml)	Col. 2 Water (μCi/ml)	Monthly Average Concentration (μCi/ml)
92	Uranium-235 ³	D, see ²³⁰ U	1E+1 Bone surf (2E+1)	1E+0 Bone surf (2E+0)	6E-10	-	-	-
		W, see ²³⁰ U	-	8E-1	3E-10	3E-12	3E-7	3E-6
		Y, see ²³⁰ U	-	4E-2	2E-11	6E-14	-	-
92	Uranium-235	D, see ²³⁰ U	1E+1 Bone surf (2E+1)	1E+0 Bone surf (2E+0)	5E-10	-	-	-
		W, see ²³⁰ U	-	8E-1	3E-10	3E-12	3E-7	3E-6
		Y, see ²³⁰ U	-	4E-2	2E-11	6E-14	-	-
92	Uranium-237	D, see ²³⁰ U	2E+3 LLI wall (2E+3)	3E+3	1E-6	4E-9	-	-
		W, see ²³⁰ U	-	2E+3	7E-7	2E-9	3E-5	3E-4
		Y, see ²³⁰ U	-	2E+3	6E-7	2E-9	-	-
92	Uranium-238 ³	D, see ²³⁰ U	1E+1 Bone surf (2E+1)	1E+0 Bone surf (2E+0)	6E-10	-	-	-
		W, see ²³⁰ U	-	8E-1	3E-10	3E-12	3E-7	3E-6
		Y, see ²³⁰ U	-	4E-2	2E-11	6E-14	-	-
92	Uranium-239 ²	D, see ²³⁰ U	7E+4	2E+5	8E-5	3E-7	9E-4	9E-3
		W, see ²³⁰ U	-	2E+5	7E-5	2E-7	-	-
		Y, see ²³⁰ U	-	2E+5	6E-5	2E-7	-	-
92	Uranium-240	D, see ²³⁰ U	1E+3	4E+3	2E-6	5E-9	2E-5	2E-4
		W, see ²³⁰ U	-	3E+3	1E-6	4E-9	-	-
		Y, see ²³⁰ U	-	2E+3	1E-6	3E-9	-	-
92	Uranium-natural ³	D, see ²³⁰ U	1E+1 Bone surf (2E+1)	1E+0 Bone surf (2E+0)	5E-10	-	-	-
		W, see ²³⁰ U	-	8E-1	3E-10	3E-12	3E-7	3E-6
		Y, see ²³⁰ U	-	5E-2	2E-11	9E-14	-	-
93	Neptunium-232 ²	W, all compounds	1E+5	2E+3 Bone surf (5E+2)	7E-7	-	2E-3	2E-2
		-	-	-	6E-9	-	-	
93	Neptunium-233 ²	W, all compounds	8E+5	3E+6	1E-3	4E-6	1E-2	1E-1
93	Neptunium-234	W, all compounds	2E+3	3E+3	1E-6	4E-9	3E-5	3E-4
93	Neptunium-235	W, all compounds	2E+4 LLI wall (2E+4)	8E+2 Bone surf (1E+3)	3E-7	-	-	-
93	Neptunium-236 (1.15E+5 y)	W, all compounds	3E+0 Bone surf (6E+0)	2E-2 Bone surf (5E-2)	9E-12	-	-	-
93	Neptunium-236m (22.5 h)	W, all compounds	3E+3 Bone surf (4E+3)	3E+1 Bone surf (7E+1)	1E-8	-	-	-
93	Neptunium-237	W, all compounds	5E-1 Bone surf (1E+0)	4E-3 Bone surf (1E-2)	2E-12	-	-	-
						1E-14	2E-8	2E-7

58 FR 67657

PART 20 STANDARDS FOR PROTECTION AGAINST RADIATION

Atomic No.	Radionuclide	Class	Table 1 Occupational Values			Table 2 Effluent Concentrations		Table 3 Releases to Sewers
			Col. 1 Oral Ingestion ALI (μCi)	Col. 2	Col. 3	Col. 1 Air ($\mu\text{Ci}/\text{ml}$)	Col. 2 Water ($\mu\text{Ci}/\text{ml}$)	Monthly Average Concentration ($\mu\text{Ci}/\text{ml}$)
93	Neptunium-238	W, all compounds	1E+3	6E+1 Bone surf (2E+2)	3E-8	-	2E-5	2E-4
93	Neptunium-239	W, all compounds	2E+3 LLI wall (2E+3)	2E+3	9E-7	3E-9	-	-
93	Neptunium-240 ²	W, all compounds	2E+4	8E+4	3E-5	1E-7	3E-4	3E-3
94	Plutonium-234	W, all compounds except PuO ₂ Y, PuO ₂	8E+3	2E+2 2E+2	9E-8 8E-8	3E-10 3E-10	1E-4	1E-3
94	Plutonium-235 ²	W, see ²³⁴ Pu Y, see ²³⁴ Pu	9E+5	3E+6 3E+6	1E-3 1E-3	4E-6 3E-6	1E-2	1E-1
94	Plutonium-236	W, see ²³⁴ Pu Y, see ²³⁴ Pu	2E+0 Bone surf (4E+0)	2E-2 Bone surf (4E-2) 4E-2	8E-12	-	-	-
94	Plutonium-237	W, see ²³⁴ Pu Y, see ²³⁴ Pu	1E+4	3E+3 3E+3	1E-6 1E-6	5E-9 4E-9	2E-4	2E-3
94	Plutonium-238	W, see ²³⁴ Pu Y, see ²³⁴ Pu	9E-1 Bone surf (2E+0)	7E-3 Bone surf (1E-2) 2E-2	3E-12	-	-	-
94	Plutonium-239	W, see ²³⁴ Pu Y, see ²³⁴ Pu	8E-1 Bone surf (1E+0)	6E-3 Bone surf (1E-2) 2E-2 Bone surf (2E-2)	3E-12	-	-	-
94	Plutonium-240	W, see ²³⁴ Pu Y, see ²³⁴ Pu	8E-1 Bone surf (1E+0)	6E-3 Bone surf (1E-2) 2E-2 Bone surf (2E-2)	3E-12	-	-	-
94	Plutonium-241	W, see ²³⁴ Pu Y, see ²³⁴ Pu	4E+1 Bone surf (7E+1)	3E-1 Bone surf (6E-1) 8E-1 Bone surf (1E+0)	1E-10	-	-	-
						8E-13	1E-6	1E-5
						1E-12	-	-

58 FR 67657

PART 20 STANDARDS FOR PROTECTION AGAINST RADIATION

Atomic No.	Radionuclide	Class	Table 1 Occupational Values			Table 2 Effluent Concentrations		Table 3 Releases to Sewers
			Col. 1	Col. 2	Col. 3	Col. 1	Col. 2	Monthly Average Concentration (µCi/ml)
			Oral Ingestion ALI (µCi)	Inhalation		Air (µCi/ml)	Water (µCi/ml)	
			ALI (µCi)	DAC (µCi/ml)				
94	Plutonium-242	W, see ²³⁴ Pu Y, see ²³⁴ Pu	8E-1 Bone surf (1E+0)	7E-3 Bone surf (1E-2) 2E-2 Bone surf (2E-2)	3E-12 - 7E-12 -	- 2E-14 -	- 2E-8 -	- 2E-7 -
94	Plutonium-243	W, see ²³⁴ Pu Y, see ²³⁴ Pu	2E+4 -	4E+4 4E+4	2E-5 2E-5	5E-8 5E-8	2E-4 -	2E-3 -
94	Plutonium-244	W, see ²³⁴ Pu Y, see ²³⁴ Pu	8E-1 Bone surf (2E+0)	7E-3 Bone surf (1E-2) 2E-2 Bone surf (2E-2)	3E-12 - 7E-12 -	- 2E-14 -	- 2E-8 -	- 2E-7 -
94	Plutonium-245	W, see ²³⁴ Pu Y, see ²³⁴ Pu	2E+3 -	5E+3 4E+3	2E-6 2E-6	6E-9 6E-9	3E-5 -	3E-4 -
94	Plutonium-246	W, see ²³⁴ Pu Y, see ²³⁴ Pu	4E+2 LLI wall (4E+2)	3E+2 - 3E+2	1E-7 - 1E-7	4E-10 - 4E-10	- 6E-6 -	- 6E-5 -
95	Americium-237 ²	W, all compounds	8E+4	3E+5	1E-4	4E-7	1E-3	1E-2
95	Americium-238 ²	W, all compounds	4E+4	3E+3 Bone surf (6E+3)	1E-6 -	- 9E-9	5E-4 -	5E-3 -
95	Americium-239	W, all compounds	5E+3	1E+4	5E-6	2E-8	7E-5	7E-4
95	Americium-240	W, all compounds	2E+3	3E+3	1E-6	4E-9	3E-5	3E-4
95	Americium-241	W, all compounds	8E-1 Bone surf (1E+0)	6E-3 Bone surf (1E-2)	3E-12 -	- 2E-14	- 2E-8	- 2E-7
95	Americium-242m	W, all compounds	8E-1 Bone surf (1E+0)	6E-3 Bone surf (1E-2)	3E-12 -	- 2E-14	- 2E-8	- 2E-7
95	Americium-242	W, all compounds	4E+3 -	8E+1 Bone surf (9E+1)	4E-8 -	- 1E-10	5E-5 -	5E-4 -
95	Americium-243	W, all compounds	8E-1 Bone surf (1E+0)	6E-3 Bone surf (1E-2)	3E-12 -	- 2E-14	- 2E-8	- 2E-7
95	Americium-244m ²	W, all compounds	6E+4 St. wall (8E+4)	4E+3 Bone surf (7E+3)	2E-6 -	- 1E-8	- 1E-3	- 1E-2
95	Americium-244	W, all compounds	3E+3 -	2E+2 Bone surf (3E+2)	8E-8 -	- 4E-10	4E-5 -	4E-4 -
95	Americium-245	W, all compounds	3E+4	8E+4	3E-5	1E-7	4E-4	4E-3

58 FR 67657

PART 20 STANDARDS FOR PROTECTION AGAINST RADIATION

Atomic No.	Radionuclide	Class	Table 1 Occupational Values			Table 2 Effluent Concentrations		Table 3 Releases to Sewers
			Col. 1 Oral Ingestion ALI (μCi)	Inhalation		Col. 1 Air (μCi/ml)	Col. 2 Water (μCi/ml)	Monthly Average Concentration (μCi/ml)
				Col. 2 ALI (μCi)	Col. 3 DAC (μCi/ml)			
95	Americium-246m ²	W, all compounds	5E+4 St. wall (6E+4)	2E+5	8E-5	3E-7	-	8E-3
95	Americium-246 ²	W, all compounds	3E+4	1E+5	4E-5	1E-7	4E-4	4E-3
96	Curium-238	W, all compounds	2E+4	1E+3	5E-7	2E-9	2E-4	2E-3
96	Curium-240	W, all compounds	5E+1 Bone surf (8E+1)	6E-1 Bone surf (6E-1)	2E-10	-	-	1E-5
96	Curium-241	W, all compounds	1E+3	3E+1 Bone surf (4E+1)	1E-8	-	2E-5	2E-4
96	Curium-242	W, all compounds	3E+1 Bone surf (5E+1)	3E-1 Bone surf (3E-1)	1E-10	-	-	-
96	Curium-243	W, all compounds	1E+0 Bone surf (2E+0)	9E-3 Bone surf (2E-2)	4E-12	-	-	-
96	Curium-244	W, all compounds	1E+0 Bone surf (3E+0)	1E-2 Bone surf (2E-2)	5E-12	-	-	-
96	Curium-245	W, all compounds	7E-1 Bone surf (1E+0)	6E-3 Bone surf (1E-2)	3E-12	-	-	-
96	Curium-246	W, all compounds	7E-1 Bone surf (1E+0)	6E-3 Bone surf (1E-2)	3E-12	-	-	-
96	Curium-247	W, all compounds	8E-1 Bone surf (1E+0)	6E-3 Bone surf (1E-2)	3E-12	-	-	-
96	Curium-248	W, all compounds	2E-1 Bone surf (4E-1)	2E-3 Bone surf (3E-3)	7E-13	-	-	-
96	Curium-249 ²	W, all compounds	5E+4	2E+4 Bone surf (3E+4)	7E-6	-	7E-4	7E-3
96	Curium-250	W, all compounds	4E-2 Bone surf (6E-2)	3E-4 Bone surf (5E-4)	1E-13	-	-	-
97	Berkelium-245	W, all compounds	2E+3	1E+3	5E-7	2E-9	3E-5	3E-4
97	Berkelium-246	W, all compounds	3E+3	3E+3	1E-6	4E-9	4E-5	4E-4
97	Berkelium-247	W, all compounds	5E-1 Bone surf (1E+0)	4E-3 Bone surf (9E-3)	2E-12	-	-	-
97	Berkelium-249	W, all compounds	2E+2 Bone surf (5E+2)	2E+0 Bone surf (4E+0)	7E-10	-	-	-

58 FR 67657

PART 20 STANDARDS FOR PROTECTION AGAINST RADIATION

Atomic No.	Radionuclide	Class	Table 1 Occupational Values			Table 2 Effluent Concentrations		Table 3 Releases to Sewers
			Col. 1 Oral Ingestion ALI (μCi)	Col. 2 Col. 3 Inhalation ALI (μCi) DAC (μCi/ml)	Col. 1 Air (μCi/ml)	Col. 2 Water (μCi/ml)	Monthly Average Concentration (μCi/ml)	
97	Berkelium-250	W, all compounds	9E+3	3E+2 Bone surf (7E+2)	1E-7	-	1E-4	1E-3
98	Californium-244 ²	W, all compounds except those given for Y	3E+4 St. wall (3E+4)	6E+2	2E-7	8E-10	-	-
		Y, oxides and hydroxides	-	6E+2	2E-7	8E-10	-	-
98	Californium-246	W, see ²⁴⁴ Cf Y, see ²⁴⁴ Cf	4E+2	9E+0 9E+0	4E-9 4E-9	1E-11 1E-11	5E-6	5E-5
98	Californium-248	W, see ²⁴⁴ Cf	8E+0 Bone surf (2E+1)	6E-2 Bone surf (1E-1)	3E-11	-	-	-
		Y, see ²⁴⁴ Cf	-	1E-1	4E-11	2E-13 1E-13	2E-7	2E-6
98	Californium-249	W, see ²⁴⁴ Cf	5E-1 Bone surf (1E+0)	4E-3 Bone surf (9E-3)	2E-12	-	-	-
		Y, see ²⁴⁴ Cf	-	1E-2 Bone surf (1E-2)	4E-12	1E-14	2E-8	2E-7
98	Californium-250	W, see ²⁴⁴ Cf	1E+0 Bone surf (2E+0)	9E-3 Bone surf (2E-2)	4E-12	-	-	-
		Y, see ²⁴⁴ Cf	-	3E-2	1E-11	3E-14 4E-14	3E-8	3E-7
98	Californium-251	W, see ²⁴⁴ Cf	5E-1 Bone surf (1E+0)	4E-3 Bone surf (9E-3)	2E-12	-	-	-
		Y, see ²⁴⁴ Cf	-	1E-2 Bone surf (1E-2)	4E-12	1E-14	2E-8	2E-7
98	Californium-252	W, see ²⁴⁴ Cf	2E+0 Bone surf (5E+0)	2E-2 Bone surf (4E-2)	8E-12	-	-	-
		Y, see ²⁴⁴ Cf	-	3E-2	1E-11	5E-14 5E-14	7E-8	7E-7
98	Californium-253	W, see ²⁴⁴ Cf	2E+2 Bone surf (4E+2)	2E+0	8E-10	3E-12	-	-
		Y, see ²⁴⁴ Cf	-	2E+0	7E-10	2E-12	5E-6	5E-5
98	Californium-254	W, see ²⁴⁴ Cf Y, see ²⁴⁴ Cf	2E+0	2E-2 2E-2	9E-12 7E-12	3E-14 2E-14	3E-8	3E-7
99	Einsteinium-250	W, all compounds	4E+4	5E+2 Bone surf (1E+3)	2E-7	-	6E-4	6E-3
99	Einsteinium-251	W, all compounds	7E+3	9E+2 Bone surf (1E+3)	4E-7	-	1E-4	1E-3
99	Einsteinium-253	W, all compounds	2E+2	1E+0	6E-10	2E-12	2E-6	2E-5

58 FR 67657

PART 20 STANDARDS FOR PROTECTION AGAINST RADIATION

58 FR 67657

Atomic No.	Radionuclide	Class	Table 1 Occupational Values			Table 2 Effluent Concentrations		Table 3 Releases to Sewers
			Col. 1 Oral Ingestion ALI (μCi)	Inhalation		Col. 1 Air (μCi/ml)	Col. 2 Water (μCi/ml)	Monthly Average Concentration (μCi/ml)
				Col. 2 ALI (μCi)	Col. 3 DAC (μCi/ml)			
99	Einsteinium-254m	W, all compounds	3E+2 LLI wall (3E+2)	1E+1	4E-9	1E-11	-	4E-5
99	Einsteinium-254	W, all compounds	8E+0 Bone surf (2E+1)	7E-2 Bone surf (1E-1)	3E-11	-	2E-13	2E-7
100	Fermium-252	W, all compounds	5E+2	1E+1	5E-9	2E-11	6E-6	6E-5
100	Fermium-253	W, all compounds	1E+3	1E+1	4E-9	1E-11	1E-5	1E-4
100	Fermium-254	W, all compounds	3E+3	9E+1	4E-8	1E-10	4E-5	4E-4
100	Fermium-255	W, all compounds	5E+2	2E+1	9E-9	3E-11	7E-6	7E-5
100	Fermium-257	W, all compounds	2E+1 Bone surf (4E+1)	2E-1 Bone surf (2E-1)	7E-11	-	3E-13	5E-7
101	Mendelevium-257	W, all compounds	7E+3	8E+1 Bone surf (9E+1)	4E-8	-	1E-10	1E-4
101	Mendelevium-258	W, all compounds	3E+1 Bone surf (5E+1)	2E-1 Bone surf (3E-1)	1E-10	-	5E-13	6E-7
-	Any single radionuclide not listed above with decay mode other than alpha emission or spontaneous fission and with radioactive half-life less than 2 hours		Submersion ¹	2E+2	1E-7	1E-9	-	-
-	Any single radionuclide not listed above with decay mode other than alpha emission or spontaneous fission and with radioactive half-life greater than 2 hours		-	2E-1	1E-10	1E-12	1E-8	1E-7
-	Any single radionuclide not listed above that decays by alpha emission or spontaneous fission, or any mixture for which either the identity or the concentration of any radionuclide in the mixture is not known		-	4E-4	2E-13	1E-15	2E-9	2E-8

PART 20 STANDARDS FOR PROTECTION AGAINST RADIATION

FOOTNOTES:

- ¹"Submersion" means that values given are for submersion in a hemispherical semi-infinite cloud of airborne material.
- ²These radionuclides have radiological half-lives of less than 2 hours. The total effective dose equivalent received during operations with these radionuclides might include a significant contribution from external exposure. The DAC values for all radionuclides, other than those designated Class "Submersion," are based upon the committed effective dose equivalent due to the intake of the radionuclide into the body and do NOT include potentially significant contributions to dose equivalent from external exposures. The licensee may substitute 1E-7 µCi/ml for the listed DAC to account for the submersion dose prospectively, but should use individual monitoring devices or other radiation measuring instruments that measure external exposure to demonstrate compliance with the limits. (See § 20.1203.)
- ³For soluble mixtures of U-238, U-234, and U-235 in air, chemical toxicity may be the limiting factor (see § 20.1201(e)). If the percent by weight (enrichment) of U-235 is not greater than 5, the concentration value for a 40-hour workweek is 0.2 milligrams uranium per cubic meter of air average. For any enrichment, the product of the average concentration and time of exposure during a 40-hour workweek shall not exceed 8E-3 (SA) µCi-hr/m, where SA is the specific activity of the uranium inhaled. The specific activity for natural uranium is 6.77E-7 curies per gram U. The specific activity for other mixtures of U-238, U-235, and U-234, if not known, shall be:

$$SA = 3.6E-7 \text{ curies/gram U} \quad \text{U-depleted}$$

$$SA = [0.4 + 0.38 (\text{enrichment}) + 0.0034 (\text{enrichment})^2] E-6, \quad \text{enrichment} \geq 0.72$$

where enrichment is the percentage by weight of U-235, expressed as percent.

NOTE:

1. If the identity of each radionuclide in a mixture is known but the concentration of one or more of the radionuclides in the mixture is not known, the DAC for the mixture shall be the most restrictive DAC of any radionuclide in the mixture.
2. If the identity of each radionuclide in the mixture is not known, but it is known that certain radionuclides specified in this appendix are not present in the mixture, the inhalation ALI, DAC, and effluent and sewage concentrations for the mixture are the lowest values specified in this appendix for any radionuclide that is not known to be absent from the mixture; or

Radionuclide	Table 1 Occupational Values			Table 2 Effluent Concentrations		Table 3 Releases to Sewers
	Col. 1 Oral Ingestion ALI (µCi)	Inhalation		Col. 1 Air (µCi/ml)	Col. 2 Water (µCi/ml)	Monthly Average Concentration (µCi/ml)
		Col. 2 ALI (µCi)	Col. 3 DAC (µCi/ml)			
If it is known that Ac-227-D and Cm-250-W are not present	-	7E-4	3E-13	-	-	-
If, in addition, it is known that Ac-227-W,Y, Th-229-W,Y, Th-230-W, Th-232-W,Y, Pa-231-W,Y, Np-237-W, Pu-239-W, Pu-240-W, Pu-242-W, Am-241-W, Am-242m-W, Am-243-W, Cm-245-W, Cm-246-W, Cm-247-W, Cm-248-W, Bk-247-W, Cf-249-W, and Cf-251-W are not present	-	7E-3	3E-12	-	-	-
If, in addition, it is known that Sm-146-W, Sm-147-W, Gd-148-D,W, Gd-152-D,W, Th-228-W,Y, Th-230-Y, U-232-Y, U-233-Y, U-234-Y, U-235-Y, U-236-Y, U-238-Y, Np-236-W, Pu-236-W,Y, Pu-238-W,Y, Pu-239-Y, Pu-240-Y, Pu-242-Y, Pu-244-W,Y, Cm-243-W, Cm-244-W, Cf-248-W, Cf-249-Y, Cf-250-W,Y, Cf-251-Y, Cf-252-W,Y, and Cf-254-W,Y are not present	-	7E-2	3E-11	-	-	-
If, in addition, it is known that Pb-210-D, Bi-210m-W, Po-210-D,W, Ra-223-W, Ra-225-W, Ra-226-W, Ac-225-D,W,Y, Th-227-W,Y, U-230-D,W,Y, U-232-D,W, Pu-241-W, Cm-240-W, Cm-242-W, Cf-248-Y, Es-254-W, Fm-257-W, and Md-258-W are not present	-	7E-1	3E-10	-	-	-

58 FR 67657

PART 20 STANDARDS FOR PROTECTION AGAINST RADIATION

58 FR 67657

Radionuclide	Table 1 Occupational Values			Table 2 Effluent Concentrations		Table 3 Releases to Sewers
	Col. 1 Oral Ingestion ALI (μCi)	Inhalation		Col. 1 Air ($\mu\text{Ci}/\text{ml}$)	Col. 2 Water ($\mu\text{Ci}/\text{ml}$)	Monthly Average Concentration ($\mu\text{Ci}/\text{ml}$)
		Col. 2 ALI (μCi)	Col. 3 DAC ($\mu\text{Ci}/\text{ml}$)			
If, in addition, it is known that Si-32-Y, Ti-44-Y, Fe-60-D, Sr-90-Y, Zr-93-D, Cd-113m-D, Cd-113-D, In-115-D,W, La-138-D, Lu-176-W, Hf-178m-D,W, Hf-182-D,W, Bi-210m-D, Ra-224-W, Ra-228-W, Ac-226-D,W,Y, Pa-230-W,Y, U-233-D,W, U-234-D,W, U-235-D,W, U-236-D,W, U-238-D,W, Pu-241-Y, Bk-249-W, Cf-253-W,Y, and Es-253-W are not present	-	7E+0	3E-9	-	-	-
If it is known that Ac-227-D,W,Y, Th-229-W,Y, Th-232-W,Y, Pa-231-W,Y, Cm-248-W, and Cm-250-W are not present -	-	-	-	1E-14	-	-
If, in addition, it is known that Sm-146-W, Gd-148-D,W, Gd-152-D, Th-228-W,Y, Th-230-W,Y, U-232-Y, U-233-Y, U-234-Y, U-235-Y, U-236-Y, U-238-Y, U-Nat-Y, Np-236-W, Np-237-W, Pu-236-W,Y, Pu-238-W,Y, Pu-239-W,Y, Pu-240-W,Y, Pu-242-W,Y, Pu-244-W,Y, Am-241-W, Am-242m-W, Am-243-W, Cm-243-W, Cm-244-W, Cm-245-W, Cm-246-W, Cm-247-W, Bk-247-W, Cf-249-W,Y, Cf-250-W,Y, Cf-251-W,Y, Cf-252-W,Y, and Cf-254-W,Y are not present	-	-	-	1E-13	-	-
If, in addition, it is known that Sm-147-W, Gd-152-W, Pb-210-D, Bi-210m-W, Po-210-D,W, Ra-223-W, Ra-225-W, Ra-226-W, Ac-225-D,W,Y, Th-227-W,Y, U-230-D,W,Y, U-232-D,W, U-Nat-W, Pu-241-W, Cm-240-W, Cm-242-W, Cf-248-W, Es-254-W, Fm-257-W, and Md-258-W are not present	-	-	-	1E-12	-	-
If, in addition it is known that Fe-60, Sr-90, Cd-113m, Cd-113, In-115, I-129, Cs-134, Sm-145, Sm-147, Gd-148, Gd-152, Hg-194 (organic), Bi-210m, Ra-223, Ra-224, Ra-225, Ac-225, Th-228, Th-230, U-233, U-234, U-235, U-236, U-238, U-Nat, Cm-242, Cf-248, Es-254, Fm-257, and Md-258 are not present	-	-	-	-	1E-6	1E-5

- If a mixture of radionuclides consists of uranium and its daughters in ore dust (10 μm AMAD particle distribution assumed) prior to chemical separation of the uranium from the ore, the following values may be used for the DAC of the mixture: 6E-11 μCi of gross alpha activity from uranium-238, uranium-234, thorium-230, and radium-226 per milliliter of air; 3E-11 μCi of natural uranium per milliliter of air; or 45 micrograms of natural uranium per cubic meter of air.
- If the identity and concentration of each radionuclide in a mixture are known, the limiting values should be derived as follows: determine, for each radionuclide in the mixture, the ratio between the concentration present in the mixture and the concentration otherwise established in Appendix B for the specific radionuclide when not in a mixture. The sum of such ratios for all of the radionuclides in the mixture may not exceed "1" (i.e., "unity").

Example: If radionuclides "A," "B," and "C" are present in concentrations C_A , C_B , and C_C , and if the applicable DACs are DAC_A , DAC_B , and DAC_C , respectively, then the concentrations shall be limited so that the following relationship exists:

$$\frac{C_A}{\text{DAC}_A} + \frac{C_B}{\text{DAC}_B} + \frac{C_C}{\text{DAC}_C} \leq 1$$

APPENDIX C

EMS SOFTWARE DOCUMENTATION

APPENDIX C
 EMS SOFTWARE DOCUMENTATION
TABLE OF CONTENTS

<u>CONTENTS</u>	<u>PAGES/REV.</u>
Attachment 1 Effluent Management System Software Test Report for Seabrook Station, May 1994	C-3 Cover ii 1-11
Attachment 2 Resolutions of EMS Software Test Report Discrepancies	C-4 1-2
Attachment 3 Software Requirements Specification for North Atlantic Energy Service Corporation, Seabrook Station, Effluent Management Systems, Revision 04, FP 75486	C-5 1-35
Attachment 4 Technical Reference Manual, Effluent Management System NAESCO Seabrook Station, July 1994, FP 75486	C-6 36 R28 37 R28 38 thru 93 R22

APPENDIX C: EMS SOFTWARE DOCUMENTATION

ATTACHMENT 1: EFFLUENT MANAGEMENT SYSTEM SOFTWARE TEST REPORT
FOR SEABROOK STATION, MAY 1994

EFFLUENT MANAGEMENT SYSTEM:
SOFTWARE TEST REPORT
FOR
SEABROOK STATION
MAY 1994

Prepared by Joseph Busion 5/26/94
Date
Matthew J. Scannell 5/27/94
Date
Reviewed by Mark S. Krum 5-31-94
Date
Approved by R.H. [Signature] 5/31/94
Date



Yankee Atomic Electric Company
Nuclear Services Division
580 Main Street
Bolton, Massachusetts 01740

Table of Contents

1.0 INTRODUCTION	1
1.1 Background	1
1.2 Acceptance Criteria	1
2.0 SUMMARY OF FINDINGS	2
2.1 EMS Dose and Dose Rate Conversion Factors	2
2.2 Liquid Release Testing	4
2.3 Gaseous Release Testing	4
3.0 TEST CONCLUSIONS	7
4.0 SUMMARY OF DISCREPANCIES	9
References	11

1.0 INTRODUCTION

Software testing as described in Reference [1] has been conducted for the Seabrook Station version of the Canberra Effluent Management System (EMS). The results and conclusions are presented in this report.

1.1 Background

Canberra Industries Inc. developed the EMS software to assist nuclear power plant personnel track effluent emissions and perform associated dose calculations. North Atlantic Energy Service Corporation purchased a Seabrook-specific version the Canberra EMS software which must meet specific requirements and incorporate site-specific information provided in the Offsite Dose Calculation Manual (ODCM) [2]. Software testing was conducted to provide assurances that the Seabrook EMS program produces results which are consistent with current ODCM assumptions and methods. All executions of the EMS program were performed at Seabrook Station on the target software. All executions of ODCM Method II were conducted at Yankee Atomic Electric Company in Bolton, Massachusetts.

1.2 Acceptance Criteria

The operability of the EMS software will be accepted if (i) information contained in the EMS data files is consistent with the ODCM, (ii) test results from the EMS program are consistent with results from ODCM methods, (iii) Technical Specifications requirements are met by the EMS software, and (iv) the EMS software meets design specifications.

Final user (Seabrook) acceptance is contingent on Seabrook approval of verification testing results and criteria established by user needs.

2.0 SUMMARY OF OBSERVATIONS

The EMS software testing included (i) identifying appropriate meteorological set up data, (ii) review of dose and dose rate conversion factor development, (iii) assessments for liquid releases, and (iv) assessments for gaseous releases. ODCM Method I was used initially to confirm dose results from the EMS program. However, the simplified nature of ODCM Method I made it difficult to change the values of various parameters or obtain meaningful comparisons (other than "bottom line" comparisons). The more adaptable ODCM method, Method II, was then used to confirm EMS doses. Observations made during the software testing are summarized below.

2.1 EMS Dose and Dose Rate Conversion Factors

The EMS software uses precalculated conversion factors which are contained in a data file. The dose conversion factors for both liquid and gaseous effluent releases were developed for four age groups (adult, teen, child and infant), and for specific organs (bone, liver, total body, kidney, lung, GI tract and skin). The liquid release dose conversion factors in the EMS program are the summation of the components for water recreation and ingestion of aquatic foods. The gaseous release dose conversion factors are exposure pathway-specific (e.g., inhalation, ground plane, milk ingestion, etc.).

Dose conversion factors are provided in the EMS program for all exposure pathways addressed in the ODCM. The development of all dose conversion factors in the EMS program followed the pathway-specific equations in the Effluent Management System Technical Reference Manual [3]. The EMS conversion factors for several radionuclides were examined to determine that the development process was consistent to the Technical Reference Manual and the ODCM.

2.1.1 Liquid Release Dose Conversion Factors

Although the individual components for the ingestion of aquatic foods were found to be consistent with the ODCM, a discrepancy was discovered in the water recreation component. The mixing ratio for shoreline activity used in the development of the EMS dose factors is equal to 0.025. While this value is inconsistent with ODCM Method I (which employs a mixing ratio of 0.1), it is consistent with ODCM Method II. It is identified as a discrepancy because it is unclear which set of ODCM assumptions (those for Method I or those for Method II) the EMS program is expected to adopt.

2.1.2 Gaseous Release Dose Conversion Factors

The EMS program uses dose conversion factors from Regulatory Guide 1.109 for assessment of noble gas releases. The dose factors in the EMS program were verified against and found to be consistent with Table B-1 of Regulatory Guide 1.109 [4].

The development methods for the other gaseous dose factors (i.e., for inhalation, ground plane, milk ingestion, meat ingestion, and ingestion of vegetables) were reviewed against applicable equations in the Technical Reference Manual and information in the ODCM. It is noted that the dose factors for ingestion of milk and meat are based on the fraction of year that animals are allowed to graze on pasture land (F_p) equal to 1.0. This is not consistent with the ODCM which calls for the use of an F_p value equal to 0.5.

The dose conversion factors in the EMS program for gaseous releases incorporate a shielding factor (SF) equal to 1.0. The EMS program is designed with a way of changing the value of SF (via use of the Options Table), but the factor is applied uniformly to both doses and dose rates. In contrast, the ODCM calls for the use of different values for SF in the calculations for doses and

dose rates.

2.2 Liquid Release Testing

Dose estimates from the EMS program for hypothetical liquid effluent discharges (containing single nuclide and radionuclide mixtures) are nearly identical to results from ODCM Method II when input data are based on the same mixing ratio value, indicating that the calculation method used in the EMS program is consistent with the ODCM. Additionally, the EMS routine(s) responsible for liquid effluent concentrations comparisons to MPC values and monitor set point determinations was observed to be operating properly.

2.3 Gaseous Release Testing

The agreement between estimates for total body dose rates, skin dose rates, and air (gamma and beta) doses due to emission of noble gases from the ODCM methods and the EMS program is excellent, indicating that the EMS calculation method is consistent with the ODCM.

There is also excellent agreement between inhalation doses from the EMS program and ODCM Method II indicating that, for the inhalation pathway, the calculational method and assumptions in the EMS program are consistent with those in the ODCM. The evaluation of the dose estimates via inhalation pathway included both long and short release durations for an elevated (mixed mode) and a ground level release point. The excellent agreement between the EMS and ODCM Method II also confirms that the release duration adjustment term, t^{-a} , is applied properly in the EMS program. However, an incorrect receptor location was reported on the EMS printout in the tests (D-2c and D-2d) in which the Plant Vent was changed to be recognized as a ground level release point.

Also noted during testing was that the EMS routine(s) responsible for calculating effluent concentration-to-MPC ratios and radionuclide release rates

appears to be operating properly for gaseous releases.

The EMS program incorporates the assumption that the fraction of elemental iodine is equal to 1.0 (consistent with NUREG-0133 [5]). In contrast, the fraction of elemental iodine is assumed equal to 0.5 in the ODCM methods (consistent with Regulatory Guide 1.109). Consequently, the EMS program produces dose estimates due to radiiodine that are at least a factor of two greater than doses from the ODCM methods. This difference increases to about a factor of 4 when the current values for Fp and SF assumed in the EMS program and ODCM methods are used in the dose calculations. The different assumptions for elemental iodine fractions should not present a problem because each program is based on NRC guidance: the EMS is based on NUREG-0133, the ODCM methods are based on Regulatory Guide 1.109. The EMS program takes the more conservative approach for determining doses from radioiodine.

Making appropriate adjustments for Fp, SF, and the fraction of elemental iodine (when radioiodine input was used) and comparing results for organ doses due to I131, H3, Co60 and Cs137 revealed that the calculational methods used in the EMS program are consistent with the ODCM for all exposure pathways (i.e., ground plane, inhalation, milk ingestion, meat ingestion, and vegetables ingestion).

Technical Specification 3.11.2.1 and the ODCM require the calculation of organ dose rates due to effluent discharges of I131, I133, H3 and particulates with a half-life greater than 8 days. However, in all test cases involving these types of nuclides, organ dose rate information did not appear on Page 4 of the EMS printout. Instead, the message "No calculations performed - check Sample & Receptors" appeared. The EMS set up data and input were reviewed with no apparent error identified. Since the test cases included Cs137, Co60, I131, and

H3, the missing dose rate information was unexpected. It is noted that organ dose rate information was provided on Page 4 of the EMS printout during a demonstration of the EMS program prior to testing.

3.0 TEST CONCLUSIONS

Although the dose conversion factors are based on information which is not completely consistent with the assumptions in the ODCM, the calculational methods used to determine doses from liquid and gaseous effluent discharges are consistent with the ODCM methods.

Other conclusions are:

1. As stated in Section 2.1.1, the development of the EMS liquid effluent dose factors is consistent with ODCM Method II, but not with Method I due to the mixing ratio value. If the EMS program is intended to be a hybrid method, the dose factors are consistent with the ODCM and are acceptable. On the other hand, if the EMS program is intended to provide automated ODCM Method I calculations, then the dose factor should be recalculated using a mixing ratio for shoreline activity equal to 0.1.
2. Since the EMS program is not designed to support the use of two shielding factors (one for dose rates and one for doses), use of a shielding factor equal to 1.0 is acceptable with the understanding that, although the dose rates produced by the EMS program will be consistent with the ODCM, the doses from the EMS program will be based on a more conservative assumption than doses from the ODCM methods.
3. Under the normal ODCM assumption for elemental iodine, the results from the EMS program will be at least a factor of two greater than results from the ODCM methods. The different assumptions regarding the elemental iodine fraction do not present a problem because each program is based on NRC guidance: the EMS program is based on NUREG-0133, and the ODCM is based on Regulatory Guide 1.109. Of the two methods, the EMS program takes the more conservative approach toward estimating doses from

radioiodine in gaseous effluent.

4. The radiation monitor set point determination method for liquid releases produces a set point value that is consistent the ODCM set point method.

5. The EMS routine that is responsible for comparison of liquid effluent concentrations and MPC values is operating properly.

6. The release duration adjustment term, t^{-a} , is used consistently to the ODCM.

4.0 SUMMARY OF DISCREPANCIES

Discrepancy	Area of Impact	Potential Solution(s)
Mixing ratio for shoreline activity used in EMS program.	Doses associated with liquid effluent discharges.	Clarify whether the EMS program is expected to follow ODCM assumptions for Method I or Method II. If determined to follow Method I, recalculate dose factors for liquid releases.
EMS dose factors based on Fp value which is not consistent with ODCM.	Doses due to ingestion of milk and meat.	Recalculate EMS dose factors for milk and meat ingestion pathways to incorporate Fp value consistent with the ODCM. Accept added conservatism in EMS in calculations of doses via milk and meat ingestion pathways.
Shielding factor (SF) applied uniformly to dose rates and doses in EMS program.	Doses associated with gaseous effluent discharges.	Accept use of SF = 1.0 and the added conservatism for doses. Modify EMS software to accommodate use of two values for SF (one for dose rates and one for doses).
Incorrect receptor location identified on EMS printout for ground level release point.	Potential assignment of doses to the wrong receptor.	Discuss with Canberra.
Assumed fraction of elemental iodine used in EMS program differs from ODCM methods.	Dose estimates due to iodine in gaseous effluents.	Accept added conservatism in doses due to iodine. Modify EMS software to use fraction for elemental iodine that is consistent with ODCM.

Discrepancy	Area of Impact	Potential Solution(s)
Missing organ dose rate information on EMS printout for effluent discharges containing I131, I133, H3, and particulates.	Technical Specification required dose rate not calculated.	Discuss with Canberra.

References

1. Yankee Atomic Electric Company, Effluent Monitoring System Software Test Plan for Seabrook Station, May, 1994.
2. NAESC, Station Offsite Dose Calculation Manual, Rev 13, 9/24/93.
3. Southern Nuclear Operating Company Effluent Management System Technical Reference Manual (07-0545), January 1993.
4. NRC Regulatory Guide 1.109, Calculation of Annual Doses to Man from Routine Releases of Reactor Effluents for the Purposes of Evaluating Compliance with 10CFR Part 50, Appendix I, Revision I, October 1977.
5. NRC NUREG-0133, Preparation of Radiological Effluent Technical Specifications for Nuclear Power Plants, October 1978.

APPENDIX C: EMS SOFTWARE DOCUMENTATION

ATTACHMENT 2: RESOLUTIONS OF EMS SOFTWARE TEST
REPORT DISCREPANCIES

2. Resolution of EMS Software Test Report Discrepancies

The following discrepancy resolutions apply to the findings contained in the "Effluent Management System Test Report for Seabrook Station, May 1994" as noted on pages 9 and 10 (see Attachment #1 of Appendix C of the ODCM). With the positive resolution of the discrepancies identified in the EMS dose code, use of EMS as a computerized alternative approach (designated as Method IA in the ODCM) to determine compliance with the radioactive effluent dose and dose rate limits is acceptable since the results are comparable with the currently approved dose methods.

Discrepancy:

Mixing ratio for shoreline activity used in EMS Program not equal to the value used in the ODCM Method I ($M_p = 1.0$).

Resolution:

The mixing ratio for the shoreline activity pathway in the EMS is consistent with the ODCM Method II approved value of 0.025, and therefore does provide for a calculated dose that is within the parameters already approved in the ODCM. The use of the EMS code (ODCM Method IA) for calculating liquid doses is acceptable for determining compliance with the dose limits of the Technical Specifications without the need to modify the assumption used for the shoreline mixing ratio.

Discrepancy:

EMS dose factors based on F_p (fraction of year animals are on pasture) value which is not consistent with ODCM.

Resolution:

ODCM Method I assumes that the pasture season in the North East is 6 months long each year ($F_p = 0.5$). Method II allows for the pasture fraction to be set equal to 0.0 for the first and fourth quarters which equates the non-growing period of the year. The second and third quarters correspond to the growing season where the pasture fraction is assumed to be 1.0. The EMS software assumes an F_p value of 1.0 for animal grazing (meat and milk pathways) for all conditions. This is a moderately conservative approach compared to Method I and the off grazing season conditions modeled in Method II. It is equal to the grazing season assumptions of Method II as applied in the second and third quarters. As a result, the added conservatism in the EMS calculations for doses via milk and meat pathways are within acceptable margins and guidance provided in NRC NUREG-0133 for demonstrating compliance with Technical Specification dose limits. No changes to the EMS software are necessary.

Discrepancy:

Shielding factors (SF) applied uniformly to dose rates and doses in the EMS program.

2. Resolution of EMS Software Test Report Discrepancies (Continued)

Resolution:

The EMS program for gaseous releases incorporates a shielding factor (SF) equal to 1.0 for both dose rate and total dose determinations. In contrast, both Method I and II use a SF value of 1.0 instantaneous dose rate calculations, but a value of 0.7 for integrated doses based on assumptions in NRC Reg. Guide 1.109. The use of a SF equal to 1.0 for the external ground plane exposure pathway for both dose rate and total dose is a moderately conservative assumption that is within the bounds already assumed in the ODCM dose modeling. As a result, no modification to the EMS code as an acceptable approach (Method IA) for demonstrating compliance with Technical Specification dose/dose rate limits is required for SF.

Discrepancy:

Incorrect receptor location identified on EMS printout for ground level release point.

Resolution:

Incorrect name is identified on report with no impact on dose or dose rate calculations which were verified to be correct.

Discrepancy:

Assumed fraction of elemental iodine used in EMS program differs from ODCM Methods I and II.

Resolution:

For ODCM Methods I and II, the fraction of elemental iodine assumed for gaseous releases is 0.5 based on the guidance in NRC Reg. Guide 1.109. The EMS code assumes an elemental iodine fraction of 1.0 based on the guidance in NUREG-0133. Consequently, the EMS program (Method IA) will produce a moderately conservative estimate of dose impact (factor of 2) for iodine radionuclides if present in the release estimations when compared to existing approved methods. As a result, no modification to the EMS code is necessary for use in the ODCM for determining compliance with Technical Specification dose limits.

Discrepancy:

Missing organ dose rate information on EMS printout for effluent discharges containing I-131, I-133, H-3, and particulates.

Resolution:

This required information is easily obtainable from the permit closure process with flashing indication if any dose or dose rate limits are exceeded.

APPENDIX C: EMS SOFTWARE DOCUMENTATION

ATTACHMENT 3: SOFTWARE REQUIREMENTS SPECIFICATION FOR NORTH ATLANTIC
ENERGY SERVICE CORPORATION, SEABROOK STATION,
EFFLUENT MANAGEMENT SYSTEMS, REVISION 04, FP 75486

Software Requirements Specification
for
North Atlantic Energy Services Corporation
Seabrook Station
Effluent Management Systems
48-8448

Revision 04

Nuclear Data Systems Division Software Product

Originator: David J. Honcar ^{wdw 9/15/93} Date: 9/14/93
Approved: Pete van der Heide Date: 9/15-93
Engineering (CI/NDS)
Approved: Geoff Zick Date: 9/20/93
Quality Assurance Manager(CI/NDS)
Approved: SAJ Date: 10/29/93
Project Manager (Seabrook Station)

page 1 of 92

Revision History

<u>Initials</u>	<u>Revision</u>	<u>Date</u>	<u>Description</u>
DJH	00	2/26/93	Initial version
DJH	01	3/22/93	Updated incorrect dose equation
DJH	02	4/30/93	Updated to include all dose and dose rate equations
DJH	03	8/3/93	Updated based on modifications to software and customer's requested modification to the use of the default nuclide for gaseous permit processing.
DJH	04	9/14/93	Updated based on customer's request to remove modification to the default nuclide for gaseous permit processing.

	<u>Page</u>
1. Scope	1
2. Applicable Documents	1
3. Interfaces	1
3.1 Hardware	1
3.2 Software	1
3.3 Human	2
3.4 Packaging	2
4. Definitions	2
5. Principal Changes from Existing Packages	2
6. EMS Functionality	4
6.1 Database Maintenance Transactions	4
6.2 Editing Values through INGRES QBF	7
6.3 Liquid Pre-Release Processing	8
6.3.1 User Interface and Functionality	8
6.3.2 Associated Reports	9
6.3.3 Underlying Calculations	10
6.4 Liquid Post-Release Processing	11
6.4.1 User Interface and Functionality	11
6.4.2 Associated Reports	12
6.4.3 Underlying Calculations	12
6.5 Liquid Permit Editing	13
6.5.1 User Interface and Functionality	13
6.5.2 Associated Reports	13
6.5.3 Underlying Calculations	13
6.6 Liquid Permit Deletion	13
6.7 Gaseous Pre-Release Processing	14
6.7.1 User Interface and Functionality	14
6.7.2 Associated Reports	15
6.7.3 Underlying Calculations	15
6.8 Gaseous Post-Release Processing	21
6.8.1 User Interface and Functionality	21
6.8.2 Associated Reports	21
6.8.3 Underlying Calculations	22
6.9 Gaseous Permit Editing	27
6.9.1 User Interface and Functionality	27
6.9.2 Associated Reports	27
6.9.3 Underlying Calculations	27
6.10 Gaseous Permit Deletion	27
6.11 Semi-Annual Reporting	28
6.11.1 User Interface and Functionality	28
6.11.2 EMS Trend Plots	30
6.12 End-of-the-Year Data Archiving	30
6.12.1 User Interface and Functionality	30

1. Scope

This document establishes the software requirements for the Effluent Management System (EMS) software to be installed at North Atlantic Energy Services Corporation's Seabrook Station.

2. Applicable Documents

2.1 The following two documents are included as part of this SRS, and this SRS refers to specific sections of them:

2.1.1 "Southern Nuclear Operating Company Effluent Management System Operator's Manual" (07-0544), Version 1, January 1993.

2.1.2 "Southern Nuclear Operating Company Effluent Management System Technical Reference Manual" (07-0545), Version 2, January 1993.

Note: The above documents contain material (including screens and report formats) imported from final manuals for other EMS packages. Utility and plant names shown on screens and reports in these manuals are not significant, since they are determined by database data that will be customized to fit the Seabrook Station's usage.

2.2 The following document is a reference source for calculation methods of the EMS software. This SRS may refer to specific sections.

2.2.1 "Seabrook Station Offsite Dose Calculation Manual," Revision 12, January 1993.

3. Interfaces

3.1 Hardware

The EMS software shall run on the following CPU model: DEC Microvax 3100, Model 80.

3.2 Software

The software shall be written under VMS version 5.4-2 or later, using INGRES version 6.4 or later. It shall be written in VAX/FORTRAN or VAX-DCL. Utility programs provided by INGRES that are installed on the hardware configuration may be used if applicable.

3.3 Human

The user may be expected to have received operator training from the system manager, Canberra/NDS, or the plant training department prior to using any part of the EMS software. Knowledge of INGRES or VMS shall not be assumed. The menus of operations are intended to be self-explanatory, but an Operator's Manual shall be developed.

The user may be expected to have enough knowledge of USNRC-regulated nuclear power plant effluent management to provide accurate and appropriate inputs, and to determine the validity of the software's results.

3.4 Packaging

A distribution kit will be produced for the customer. Any removable medium supported by the operating hardware delivered to the Seabrook Station is an acceptable distribution medium.

4. Definitions

EMS - Effluent Management System. Software for determining effluent monitor setpoints, tracking activity releases and dose impacts of individual releases, and generating semi-annual release reports.

SRS - Software Requirements Specification.

SNC - Southern Nuclear Operating Company

5. Principal Changes from Existing Package

The following paragraphs summarize the principal changes to the existing software that are required for the Seabrook Station system, and are intended only as introductory material. Specifics of the required Seabrook Station EMS functionality are presented in the following sections.

- 5.1 The EMS software will be developed by customizing the generic EMS package. In general, the most important changes from previous versions are as follows:
 - 5.1.1 Modification to Gaseous Permit Processing to allow scaling of nuclides for Plant Vent Spike release point.
 - 5.1.2 Modification of noble gas dose rate and dose calculation methods to use a third set of X/Q values.

- 5.1.3 Modification of noble gas dose rate and dose calculation methods to multiply X/Q and D/Q values by a factor depending on the release duration.
- 5.1.4 Modification to setpoint calculations to calculate setpoints for low gamma concentration releases.
- 5.1.5 Modification of Permit Processing to automatically correct the expected waste flow if it is greater than the calculated maximum waste flow.
- 5.1.6 Modification of Liquid Permit Processing to determine dilution flow rate based on the number of pumps operating.
- 5.1.7 Modification of the permit reports to include Month-to-Date Cumulative Doses and Alert Setpoints.
- 5.1.8 Modification of Post-Release Permit Processing to update the monitor response.
- 5.1.9 Addition of data to database to support and control the above operations.

page 6

6. EMS Functionality

6.1 Database Maintenance Transactions

The functionality of the EMS Database Maintenance transactions shall be described in section 2 of the EMS Operator's Manual (Reference 2.1.1), with the following revisions:

- 6.1.1 On the Release Point Setpoint transaction [EM-DM-RP (Form 2)], and the Discharge Point Setpoint transaction [EM-DM-DP (Form 2)], the following parameter shall be added to the list of those which can be entered, stored, and which appear on the printed report for these transactions:
- SCAL_NUC: For a gaseous release, a flag to denote that this release point will have nuclide concentrations scaled so that the total concentration matches a value entered by the user.
- 6.1.2 On the Release Point Setpoint transaction [EM-DM-RP (Form 2)] and the Discharge Point Setpoint transaction [EM-DM-DP (Form 2)], the following parameter shall be added to the list of those which can be entered, stored, and which appear on the printed report for these transactions:
- DILOOKUP: For a liquid release, a flag to denote that permits for this release point will have a selection screen appear for the user to select the proper dilution flow for the release based on the number of pumps operating.
- 6.1.3 On the Release Point Setpoint transaction [EM-DM-RP (Form 2)], and the Discharge Point Setpoint transaction [EM-DM-DP (Form 2)], the following parameter shall be added to the list of those which can be entered, stored, and which appear on the printed report for these transactions:
- DEF_NUC: For a liquid or gaseous release, this parameter will contain the default nuclide that will be used in setpoint calculations for low gamma concentration releases. This parameter is used in conjunction with the DEF_CONC parameter.
- 6.1.4 On the Release Point Setpoint transaction [EM-DM-RP (Form 2)], and the Discharge Point Setpoint transaction [EM-DM-DP (Form 2)], the following parameter shall be added to the list of those which can be entered, stored, and which appear on the printed report for these transactions:
- DEF_CONC: For a liquid or gaseous release, this parameter will contain the default concentration that will be used in setpoint calculations for low gamma concentration releases. This parameter is used in conjunction with the DEF_NUC parameter.

- 6.1.5 On the Release Point Setpoint transaction [EM-DM-RP (Form 2)], and the Discharge Point Setpoint transaction [EM-DM-DP (Form 2)], the following parameter shall be added to the list of those which can be entered, stored, and which appear on the printed report for these transactions:
- DEF_TYPE: For a liquid or gaseous release, this parameter will contain the default nuclide type that will be used in setpoint calculations for low gamma concentration releases. This parameter is used in conjunction with the DEF_NUC and DEF_CONC parameters. (Note: For a gaseous release, the default nuclide type shall determine which monitor setpoint should use the default nuclide and concentration.)
- 6.1.6 On the Release Point Setpoint transaction [EM-DM-RP (Form 2)], and the Discharge Point Setpoint transaction [EM-DM-DP (Form 2)], the following parameter shall be added to the list of those which can be entered, stored, and which appear on the printed report for these transactions:
- ALRT_SET: For a liquid or gaseous release, this parameter will contain the multiplier to be used in the calculation of Alert Alarm Setpoints for permit reports.
- 6.1.7 On the Release Point transaction [EM-DM-RP (Form 1)], the meaning of the Response Option will change. When set to "Y", this option will denote the display of a Monitor Response window during the Post-Release Permit Processing, rather than during the Pre-Release Permit Processing. The Response Option parameter, itself, will remain unchanged for this transaction, but the response entered should include the monitor background values.
- 6.1.8 On the Dilution Streams transaction [EM-DM-DS], the following parameters will be removed: the number of extra dilution flow rates and the four dilution flow rates.
- These parameters will be replaced with two column fields. One column will contain the dilution flow rate, while another will contain the pump configuration description (such as "Jockey Pump" or "5"). In this transaction, the dilution flow rate for particular pump configuration can be added.
- 6.1.9 On the Meteorological Data transaction [EM-DM-ME (Form 1)], several menu options will added to the list of MET DATA TABLES. These additional menu items are as follows:

- X/Q - Noble Gases (Gamma)
- "a" Factor - D/Q-Part/Iodines
- "a" Factor - Noble Gases
- "a" Factor - X/Q-Part/Iodines
- "a" Factor - Gamma Noble Gases

6.1.10 On the Meteorological Data transaction [EM-DM-ME (Form 1)], the following menu items will be used to store short-term (1 hour) D/Q and X/Q values.

- D/Q - Partics/Radioiodines
- X/Q - Partics/Radioiodines
- X/Q - Decayed Noble Gases
- X/Q - Noble Gases (Gamma)

Note: This specification item only denotes a change in the meaning for the values on this transaction and requires no further changes to the software.

6.1.11 On the Meteorological Data transaction [EM-DM-ME (Form 1)], the X/Q, D/Q, and "a" Factor values are defined for various elevations, distances, and directions from the plant vent or stack. This combination with the "mode of release" parameter on the Release Point transaction [EM-DM-RP (Form 1)], and the receptor definition on the Gas Receptors transaction [EM-DM-GR], allow the X/Q, D/Q, and "a" factors to be different for each receptor and/or release point.

Note: This specification item is only for clarification and no additional code changes need to be made to this transaction.

page 9

6.2 Editing Values through INGRES QBF

In addition to the interactive forms-based EMS Database Maintenance transactions, certain flags and values must be edited through INGRES QBF on the database tables which contain data not accessible through the forms-based transactions.

- 6.2.1 Some columns of the Quarterly Dilution Volume table (QDVOL), which has no other use in the Seabrook Station version of EMS, will be used for recording monthly dilution volume for use in semi-annual reports. Once per month, an authorized user will use QBF to append a record to the QDVOL table as follows:

sampleid	(sample ID)	0 [not used]
dvdate	(dilution volume date)	The first day of the month to which the volume applies (time not required).
tvol	(total volume)	Dilution volume for the month, in user units.
aflow	(average flowrate)	0 [not used]

6.3 Liquid Pre-Release Processing

6.3.1 User Interface and Functionality

Liquid Pre-Release Processing functionality for the EMS software shall be as described in section 3 of the EMS Operator's Manual (Reference 2.1.1), with the following revisions:

6.3.1.1 On the Liquid Permit Definition Screen (Screen 3.04):

Upon entering the permit definition screen, if the DILOOKUP parameter is set to "Y" for the release point associated with the current permit being processed, the Dilution Flow Rate parameter will default to zero.

If a user uses the "Tab" or "Return" key to exit the Dilution Flow Rate parameter on the Permit Definition Screen and the Dilution Flow Rate parameter has a value of zero, a selection screen with two columns of data will appear. One column will contain the pump configuration description, while the other will contain the dilution flow rate for each associated pump configuration.

Upon selection of the Dilution Flow Rate, the selection screen will disappear and the selected dilution flow rate will appear in the Dilution Flow Rate parameter on the Permit Definition Screen. The cursor will then automatically advance to the Dilution Volume Parameter.

6.3.1.2 On the Liquid Permit Definition Screen (Screen 3.04):

When a "Fill" (F14) or a "Save" (F10) without a "Fill" is executed, if the DILOOKUP parameter is set to "Y" for the release point associated with the current permit being processed and the Dilution Flow Rate parameter is set to zero, a selection screen, as described above will appear.

Once a selection of the Dilution Flow Rate is complete, the selection screen will disappear and the "Fill" operation will continue. Upon completion, the selected dilution flow rate will appear in the Dilution Flow Rate parameter on the Permit Definition Screen.

If the Dilution Flow Rate parameter on the Permit Definition Screen is not set to zero and the DILOOKUP parameter is set to "Y", the fill will proceed as normal without the dilution flow rate selection screen appearing.

6.3.1.3 Prior to entering the Liquid Permit Approval Screen (Screen 3.09):

If it is determined that the computed maximum waste flow is less than the anticipated waste flow, the anticipated waste flow will be changed to have the value of the computed maximum waste flow. If the anticipated waste flow is modified, setpoint, dose, and dose rate values will be recalculated based on the new value.

6.3.1.4 For releases with low or zero gamma emitter concentrations that result in a pre-diluted MPC ratio less than 10%, a default concentration will be used for setpoint calculations. This default concentration will not be used for updating curie, dose rates, or dose totals.

The default nuclide will be attained from the DEF_NUC parameter. The default concentration for this nuclide will be attained from the DEF_CONC parameter. The default type for this nuclide should be attained from the DEF_TYPE parameter.

6.3.1.5 The Monitor Response Screens for Release Points and Discharge Points (Screen 3.08) will no longer appear while processing a Pre-Release Permit when the Response Option is set to "Y" on the Release Point transaction [EM-DM-RP (Form 1)].**6.3.2 Associated Reports**

Liquid Pre-Release Permit Reports shall be as described in section 3 (pages 3-53 through 3-58) of the EMS Operator's Manual (Reference 2.1.1), with the following revisions:

6.3.2.1 On the Pre-Release Permit Report (3.01), the Cumulative Month-to-Date Doses will appear on the page with the report category of Cumulative Maximum Individual Dose for Controlling Age Group at Controlling Location. The Month-to-Date dose values will contain the summation of the doses for all "Open" and "Closed" permits including the permit for which the report is being generated. These dose values will appear immediately below the "This Release" row of doses.**6.3.2.2** On the Pre-Release Permit Report (3.01), an Alert Alarm Setpoint will appear below the Max Monitor Setpoint Value. The Alert Alarm Setpoint will be calculated by using the multiplying the release point setpoint value by a multiplier specified with the ALRT_SET parameter mentioned above.**6.3.2.3** On the Liquid Special Report (3.02), an Alert Alarm Setpoint will appear below the Release Point and Discharge Point Setpoint values in the Radiation Monitor(s) portion of the report.

6.3.2.4 On the Pre-Release Permit Report (3.01), the calculation of setpoint data for additional dilution flow rates (under Pre-Release Calculations) will use dilution flow rate values from the Dilution Streams transaction [EM-DM-DS] for a specific dilution stream. Up to four dilution flow rates which are larger than the dilution flow rate parameter entered on the Liquid Permit Definition Screen (3.06) will be used.

6.3.3 Underlying Calculations

The calculations performed by the EMS software for Liquid Pre-Release Permits shall produce the same results as those described in Chapter 2 (sections 2.1-2.6) of the EMS Technical Reference Manual (Reference 2.1.2), with no revisions.

6.4 Liquid Post-Release Processing

6.4.1 User Interface and Functionality

Liquid Post-Release Processing functionality for the EMS software shall be as described in section 3 of the EMS Operator's Manual (Reference 2.1.1), with the following revisions:

6.4.1.1 On the Liquid Permit Definition Screen (Screen 3.13):

If the DILOOKUP parameter is set to "Y" for the release point and a user uses the "Tab" or "Return" key to exit the Dilution Flow Rate parameter on the Permit Definition Screen and the Dilution Flow Rate parameter has a value of zero, a selection screen with two columns of data will appear. One column will contain the pump configuration description, while the other will contain the dilution flow rate for each associated pump configuration.

Upon selection of the Dilution Flow Rate, the selection screen will disappear and the selected dilution flow rate will appear in the Dilution Flow Rate parameter on the Permit Definition Screen. The cursor will then automatically advance to the Dilution Volume Parameter.

6.4.1.2 On the Liquid Permit Definition Screen (Screen 3.13):

When a "Fill" (F14) or a "Save" (F10) without a "Fill" is executed, if the DILOOKUP parameter is set to "Y" for the release point associated with the current permit being processed and the Dilution Flow Rate parameter is set to zero, a selection screen, as described above will appear.

Once a selection of the Dilution Flow Rate is complete, the selection screen will disappear and the "Fill" operation will continue. Upon completion, the selected dilution flow rate will appear in the Dilution Flow Rate parameter on the Permit Definition Screen.

If the Dilution Flow Rate parameter on the Permit Definition Screen is not set to zero and the DILOOKUP parameter is set to "Y", the fill will proceed as normal without the dilution flow rate selection screen appearing.

6.4.1.3 (Item removed since actual waste flow is known at time of post release processing.)

6.4.1.4 The Monitor Response Screens for Release Points and Discharge Points (Screen 3.08) will appear while processing a Post-Release Permit when the Response Option is set to "Y" on the Release Point transaction [EM-DM-RP (Form 1)]. These screens will appear following the Nuclide Concentration Screen (Screen 3.15). The monitor response values entered should include the monitor background values.

6.4.2 Associated Reports

Liquid Post-Release Permit Report shall be as described in section 3 (pages 3-59 through 3-62 of the EMS Operator's Manual (Reference 2.1.1), with the following revisions:

6.4.2.1 On the Post-Release Permit Report (3.03), the Cumulative Month-to-Date Doses will appear on the page with the report category of Cumulative Maximum Individual Dose for Controlling Age Group at Controlling Location. The Month-to-Date dose values will contain the summation of the doses for all "Open" and "Closed" permits including the permit for which the report is being generated. These dose values will appear immediately below the "This Release" row of doses.

6.4.3 Underlying Calculations

The calculations performed by the EMS software for Liquid Post-Release Permits shall produce the same results as those described in Chapter 2 (section 2.7) of the EMS Technical Reference Manual (Reference 2.1.2), with no revisions.

6.5 Liquid Permit Editing

6.5.1 User Interface and Functionality

Functionality for editing liquid permits through the EMS software shall be as described in section 3 of the EMS Operator's Manual (Reference 2.1.1), with the following revisions:

The appearance and functionality of the liquid permit definition screen and the monitor response screen shall be modified as described for the Pre-Release stage in sections 6.3.1 and 6.4.1 above.

6.5.2 Associated Reports

The permit report format and contents for edited open and closed liquid permits shall be as specified above for original permit reports, in sections 6.3.2 and 6.4.2, respectively.

6.5.3 Underlying Calculations

The calculation methods for editing open and closed liquid permits shall be as specified above for original calculations, in sections 6.3.3 and 6.4.3, respectively.

6.6 Liquid Permit Deletion

Functionality for deleting liquid permits through the EMS software shall be described section 3 or the EMS operator's Manual (Reference 2.1.1).

6.7 Gaseous Pre-Release Processing

6.7.1 User Interface and Functionality

Gaseous Pre-Release Processing functionality for the EMS software shall be as described in section 4 of the EMS Operator's Manual (Reference 2.1.1), with the following revisions:

6.7.1.1 On the Gaseous Permit Definition Screen (Screen 4.05):

The Initial Pressure and Final Pressure parameters shall be deleted.

6.7.1.2 On the Gaseous Nuclide Concentration Screen (Screen 4.06):

If the SCAL_NUC parameter is set to "Y", when exiting the Concentration Screen by hitting "Process" (Do), the user will be prompted for the total nuclide concentration of permit. The concentrations are then "scaled" and then stored internally. As a result, the concentrations displayed on the screen will remain unchanged. (See the Underlying Calculations section for Pre-Release Permit Processing for an explanation of the "scaling" of concentrations.)

NOTE: This method requires the VAX_GSP (F12) file transfer has occurred bringing the representative nuclide concentration values to the screen prior to "Save" of data.

6.7.1.3 For releases with low or zero gamma emitter concentrations that result in a pre-diluted MPC ratio less than 10%, a default concentration will be used for setpoint calculations. This default concentration will not be used for updating curie, dose rates, or dose totals.

The default nuclide will be attained from the DEF_NUC parameter. The default concentration for this nuclide will be attained from the DEF_CONC parameter. The default type for the default nuclide should be attained from the DEF_TYPE parameter.

6.7.1.4 The Monitor Response Screens for Release Points and Discharge Points (Screen 4.08) will no longer appear while processing a Pre-Release Permit when the Response Option is set to "Y" on the Release Point transaction [EM-DM-RP (Form 1)].

6.7.1.5 Prior to entering the Gaseous Permit Approval Screen (Screen 4.09):

If it is determined that the computed maximum waste flow is less than the anticipated waste flow, the anticipated waste flow will be changed to have the value of the computed maximum waste flow. If the anticipated waste flow is modified, setpoint, dose, and dose rate values will be recalculated based on the new value.

6.7.2 Associated Reports

Gaseous Pre-Release Permit Reports shall be as described in section 4 (pages 4-49 through 4-58) of the EMS Operator's Manual (Reference 2.1.1), with the following revisions:

- 6.7.2.1 On the Pre-Release Permit Report (4.01), the Cumulative Month-to-Date Doses will appear on the pages with the report category of Cumulative Dose at Site Boundary and Cumulative Maximum Individual Dose for Controlling Age Group at Controlling Location. The Month-to-Date dose values will contain the summation of the doses for all "Open" and "Closed" permits including the permit for which the report is being generated. These dose values will appear immediately below the "This Release" row of doses.
- 6.7.2.2 On the Pre-Release Permit Report (4.01), the "scaled" noble gas concentrations shall appear on the Isotopic Identification page of the report if the SCAL_NUC parameter is set to "Y" for the release point where the release is being made.
- 6.7.2.3 On the Pre-Release Permit Report (4.01), the Noble Gas Alert Alarm Setpoint will appear below the Max Monitor Setpoint values. The Alert Alarm Setpoint will be calculated by multiplying the noble gas monitor setpoint value by a multiplier specified with the ALRT_SET parameter mentioned above.
- 6.7.2.4 On the Gaseous Special Report (4.02), the Noble Gas Alert Alarm Setpoint will appear below the Release Point and Discharge Point Setpoint values in the Radiation Monitor(s) portion of the report. It will be calculated as mentioned above.
- 6.7.2.5 On the Pre-Release Permit Report (4.01), the Initial and Final Pressure parameters will be removed from the Pre-Release Data section of page one of the report.

6.7.3 Underlying Calculations

The calculations performed by the EMS software for Gaseous Pre-Release Permits shall produce the same results as those described in Chapter 3 (section 3.1-3.6) of the EMS Technical Reference Manual (Reference 2.1.2), with the following revisions and clarifications:

6.7.3.1 Dose Calculations will appear in the site specific technical reference manual as follows:

- For Noble Gas Total Body Dose Rate (for vents or stacks < 80 meters):

$$D_t = shf \cdot X/Q_g \cdot 8760^{-a} \cdot F_o \cdot \Sigma (K_i \cdot QR_{iV})$$

where

D_t = the total body dose rate due to gamma emissions by noble gas releases from vent v (mrem/yr)

shf = shielding factor (dimensionless)

QR_{iV} = release rate of noble gas radionuclides, i, in gaseous effluents from vent or stack v ($\mu\text{Ci}/\text{sec}$).

F_o = occupancy factor defined for the receptor at the given location (dimensionless)

K_i = total body dose factor due to gamma emissions for noble gas radionuclide i (mrem/yr per $\mu\text{Ci}/\text{m}^3$)

X/Q_g = highest value of the noble gas 1-hour X/Q for gamma radiation for vent or stack v at the site boundary, (sec/m^3)

8760^{-a} = adjustment factor used to convert the 1-hour X/Q value to an average 1 year X/Q value (dimensionless)

where

8760 = number of hours in a year

a = "a" factor for gamma noble gas X/Q

- For Noble Gas Total Body Dose (for vents or stacks < 80 meters):

$$D_{tb} = \frac{shf \cdot F_o \cdot \Sigma (K_i \cdot QR_{iV}) \cdot X/Q_g \cdot t^{-a}}{(5.256 \cdot 10^5 / \text{dur})}$$

where

D_{tb} = total body dose from gaseous effluents (mrem)

$5.256 \cdot 10^5$ = number of minutes in a year

dur = duration of the release (minutes)

t^{-a} = adjustment factor to convert the 1-hour X/Q value to the short term X/Q value for the release (dimensionless)

where

t = duration of release (hours)

a = "a" factor for gamma noble gas X/Q

- For Noble Gas Skin Dose Rate (for vents or stacks < 80 meters):

$$D_s = shf \cdot F_o \cdot \sum QR_{iv} \cdot [(L_i \cdot X/Q \cdot 8760^{-b}) + (1.11M_i \cdot X/Q_g \cdot 8760^{-a})]$$

where

D_s = skin dose rate from gaseous effluents (mrem/yr)

X/Q = highest value of the noble gas 1-hour X/Q for vent or stack v at the site boundary (sec/m^3)

M_i = air dose factor due to gamma emissions for noble gas radionuclide i (mrad/yr per $\mu\text{Ci}/\text{m}^3$)

1.11 = conversion factor from mrad to mrem

L_i = skin dose factor due to beta emissions for noble gas radionuclide i (mrem/yr per $\mu\text{Ci}/\text{m}^3$)

b = "a" factor for noble gas X/Q

- For Noble Gas Skin Dose (for vents or stacks < 80 meters):

$$D_{sk} = \frac{shf \cdot F_o \cdot \sum QR_{iv} \cdot [(L_i \cdot X/Q \cdot t^{-b}) + (1.11M_i \cdot X/Q_g \cdot t^{-a})]}{(5.256 \cdot 10^5 / \text{dur})}$$

where

D_{sk} = total skin dose from gaseous effluents (mrem)

- For Noble Gas Air Dose due to gamma radiation (for vents or stacks < 80 meters):

$$D_{\gamma} = (3.17 \cdot 10^{-8}) \cdot X/Q_g \cdot t^{-a} \cdot F_o \cdot \sum M_i \cdot Q_{iv}$$

where

$$D_{\gamma} = \text{total gamma air dose from gaseous effluents (mrad)}$$

$$3.17 \cdot 10^{-8} = \text{inverse of number of seconds in a year}$$

$$Q_{iv} = \text{release of noble gas radionuclides, i, in gaseous effluents from vent or stack v } (\mu\text{Ci})$$

$$Q_{iv} = QR_{iv} \cdot \text{dur} \cdot 60$$

where

$$60 = \text{number of seconds in a minute}$$

- For Noble Gas Air Dose due to beta radiation (for vents or stacks < 80 meters):

$$D_{\beta} = (3.17 \cdot 10^{-8}) \cdot X/Q \cdot t^{-b} \cdot F_o \cdot \sum N_i \cdot Q_{iv}$$

where

$$D_{\beta} = \text{total beta air dose from gaseous effluents (mrad)}$$

$$N_i = \text{air dose factor due to beta emissions for noble gas radionuclide i (mrad/yr per } \mu\text{Ci/m}^3\text{)}$$

- For Critical Organ Dose Rate--Inhalation Pathway and all Pathways for H-3, C-14 (for vents or stacks < 80 meters):

$$DR_{\tau a} = X/Q_r \cdot 8760^{-c} \cdot \sum P_{ip\tau a} \cdot QR_{iv}$$

where

$$DR_{\tau a} = \text{dose rate for age group a and organ } \tau \text{ from iodines and particulates with half lives greater than 8 days in gaseous effluents (mrem/yr)}$$

$$P_{ip\tau a} = \text{dose factor for each radionuclide i, pathway p, organ } \tau, \text{ and age group a (mrem/yr per } \mu\text{Ci/m}^3\text{)}$$

X/Q_r = highest value of the radioiodine/particulate 1-hour X/Q for vent or stack v at the site boundary (sec/m^3)

c = "a" factor for Radioiodine/Particulate X/Q

Note: It is assumed $P_{ip\tau a}$ will not contain long term X/Q or D/Q values.

- For Critical Organ Dose Rate--Ground and Food Pathways (for vents or stacks < 80 meters):

$$DR_{\tau a} = D/Q \cdot 8760^{-d} \cdot \sum R_{ip\tau a} \cdot QR_{iv}$$

where

D/Q = highest value of the 1-hour deposition factor at the distance of the site boundary ($1/\text{m}^2$)

d = "a" factor for D/Q

$R_{ip\tau a}$ = dose factor for each radionuclide i, pathway p, organ τ , and age group a ($\text{m}^2 \cdot \text{mrem}/\text{yr}$ per $\mu\text{Ci}/\text{sec}$)

Note: It is assumed $R_{ip\tau a}$ will not contain long term X/Q or D/Q values.

- For Critical Organ Dose-Inhalation Pathway and all Pathways for H-3, C-14 (for vents or stacks < 80 meters):

$$D_{\tau a} = (3.17 \cdot 10^{-8}) \cdot X/Q_r \cdot t^{-c} \cdot F_o \cdot \sum P_{ip\tau a} \cdot Q_{iv}$$

where

$D_{\tau a}$ = dose for age group a and organ τ from iodines and particulates with half lives greater than 8 days in gaseous effluents (mrem)

Note: It is assumed $P_{ip\tau a}$ will not contain long term X/Q or D/Q values.

- For Critical Organ Dose-Ground and Food Pathways (for vents or stacks < 80 meters):

$$D_{TA} = (3.17 \cdot 10^{-8}) \cdot D/Q \cdot t^d \cdot F_o \cdot \sum R_{ipTA} \cdot Q_{iv}$$

Note: It is assumed R_{ipTA} will not contain long term X/Q or D/Q values.

6.7.3.2 On the Nuclide Concentration Screen (Screen 4.06), nuclide concentrations will be "scaled" if the SCAL_NUC parameter is set properly for a Release Point. This "scaling" is described as follows:

$$C_{inew} = (t / s) \cdot C_i$$

where

C_{inew} = concentration (after "scaling") of nuclide_i
 s = sum of all nuclide concentrations on the Nuclide Concentration Screen.
 t = total nuclide concentration entered by the user
 C_i = concentration (before "scaling") of nuclide_i

6.8 Gaseous Post-Release Processing

6.8.1 User Interface and Functionality

Gaseous Post-Release Processing functionality for the EMS software shall be as described in section 4 of the EMS Operator's Manual (Reference 2.1.1), with the following revisions:

6.8.1.1 On the Gaseous Permit Definition Screen (Screen 4.14):

The Initial Pressure and Final Pressure parameters shall be deleted.

6.8.1.2 On the Gaseous Nuclide Concentration Screen (Screen 4.15):

If the SCAL_NUC parameter is set to "Y", when exiting the Concentration Screen by hitting "Process" (Do), the user will be prompted for the total nuclide concentration of permit. The value entered for the total nuclide concentration while opening the permit shall be displayed as a default value which can be modified. Once the value is entered/accepted the concentrations are then "scaled" and then stored internally. As a result, the concentrations displayed on the screen will remain unchanged. (See the Underlying Calculations section for Post-Release Permit Processing for an explanation of the "scaling" of concentrations.)

NOTE: This method requires the VAX_GSP (F12) file transfer has occurred bringing the representative nuclide concentration values to the screen prior to "Save" of data.

6.8.1.3 The Monitor Response Screens for Release Points and Discharge Points (Screen 4.08) will appear while processing a Post-Release Permit when the Response Option is set to "Y" on the Release Point transaction [EM-DM-RP (Form 1)]. These screens will appear following the Nuclide Concentration Screen (Screen 4.15). The monitor response values should include the monitor background values.

6.8.1.4 (Item removed since actual waste flow is known at time of post release processing.)

6.8.2 Associated Reports

Gaseous Post-Release Permit Reports shall be as described in section 4 (pages 4-58 through 4-63) of the EMS Operator's Manual (Reference 2.1.1), with the following revisions:

- 6.8.2.1 On the Post-Release Permit Report (4.03), the Cumulative Month-to-Date Doses will appear on the pages with the report category of Cumulative Dose at Site Boundary and Cumulative Maximum Individual Dose for Controlling Age Group at Controlling Location. The Month-to-Date dose values will contain the summation of the doses for all "Open" and "Closed" permits including the permit for which the report is being generated. These dose values will appear immediately below the "This Release" row of doses.
- 6.8.2.2 On the Post-Release Permit Report (4.03), the "scaled" noble gas concentrations shall appear on the Isotopic Identification page of the report if the SCAL_NUC parameter is set to "Y" for the release point where the release is being made.
- 6.8.2.3 On the Post-Release Permit Report (4.03), the Initial and Final Pressure parameters will be removed from the Pre-Release Data section of page one of the report.

6.8.3 Underlying Calculations

The calculations performed by the EMS software for Gaseous Post-Release Permits shall produce the same results as those described in Chapter 3 (section 3.7) of the EMS Technical Reference Manual (Reference 2.1.2), with the following revisions and clarifications:

- 6.8.3.1 Dose Calculations will appear in the site specific technical reference manual as follows:

- For Noble Gas Total Body Dose Rate (for vents or stacks < 80 meters):

$$D_t = shf \cdot X/Q_g \cdot 8760^a \cdot F_o \cdot \Sigma (K_i \cdot QR_{iv})$$

where

D_t = the total body dose rate due to gamma emissions by noble gas releases from vent v (mrem/yr)

shf = shielding factor (dimensionless)

QR_{iv} = release rate of noble gas radionuclides, i , in gaseous effluents from vent or stack v ($\mu\text{Ci}/\text{sec}$).

F_o = occupancy factor defined for the receptor at the given location (dimensionless)

K_i = total body dose factor due to gamma emissions for noble gas radionuclide i (mrem/yr per $\mu\text{Ci}/\text{m}^3$)

X/Q_g = highest value of the noble gas 1-hour X/Q for gamma radiation for vent or stack v at the site boundary, (sec/m^3)

8760^{-a} = adjustment factor used to convert the 1-hour X/Q value to an average 1 year X/Q value (dimensionless)

where

8760 = number of hours in a year

a = "a" factor for gamma noble gas X/Q

- For Noble Gas Total Body Dose (for vents or stacks < 80 meters):

$$D_{tb} = \frac{\text{shf} \cdot F_o \cdot \sum (K_i \cdot QR_{iv}) \cdot X/Q_g \cdot t^{-a}}{(5.256 \cdot 10^5 / \text{dur})}$$

where

D_{tb} = total body dose from gaseous effluents (mrem)

$5.256 \cdot 10^5$ = number of minutes in a year

dur = duration of the release (minutes)

t^{-a} = adjustment factor to convert the 1-hour X/Q value to the short term X/Q value for the release (dimensionless)

where

t = duration of release (hours)

a = "a" factor for gamma noble gas X/Q

- For Noble Gas Skin Dose Rate (for vents or stacks < 80 meters):

$$D_s = \text{shf} \cdot F_o \cdot \sum QR_{iv} \cdot [(L_i \cdot X/Q \cdot 8760^{-b}) + (1.11M_i \cdot X/Q_g \cdot 8760^{-a})]$$

where

D_s = skin dose rate from gaseous effluents (mrem/yr)

X/Q = highest value of the noble gas 1-hour X/Q for vent or stack v at the site boundary (sec/m^3)

- M_i = air dose factor due to gamma emissions for noble gas radionuclide i (mrad/yr per $\mu\text{Ci}/\text{m}^3$)
 1.11 = conversion factor from mrad to mrem
 L_i = skin dose factor due to beta emissions for noble gas radionuclide i (mrem/yr per $\mu\text{Ci}/\text{m}^3$)
 b = "a" factor for noble gas X/Q

- For Noble Gas Skin Dose (for vents or stacks < 80 meters):

$$D_{sk} = \frac{\text{shf} \cdot F_o \cdot \sum QR_{iv} \cdot [(L_i \cdot X/Q \cdot t^{-b}) + (1.11M_i \cdot X/Q_g \cdot t^{-a})]}{(5.256 \cdot 10^5 / \text{dur})}$$

where

D_{sk} = total skin dose from gaseous effluents (mrem)

- For Noble Gas Air Dose due to gamma radiation (for vents or stacks < 80 meters):

$$D_\gamma = (3.17 \cdot 10^{-8}) \cdot X/Q_g \cdot t^{-a} \cdot F_o \cdot \sum M_i \cdot Q_{iv}$$

where

D_γ = total gamma air dose from gaseous effluents (mrad)

$3.17 \cdot 10^{-8}$ = inverse of number of seconds in a year

Q_{iv} = release of noble gas radionuclides, i , in gaseous effluents from vent or stack v (μCi)

$Q_{iv} = QR_{iv} \cdot \text{dur} \cdot 60$

where

60 = number of seconds in a minute

- For Noble Gas Air Dose due to beta radiation (for vents or stacks < 80 meters):

$$D_{\beta} = (3.17 \cdot 10^{-8}) \cdot X/Q \cdot t^{-b} \cdot F_0 \cdot \sum N_i \cdot Q_{iv}$$

where

$$D_{\beta} = \text{total beta air dose from gaseous effluents (mrad)}$$

$$N_i = \text{air dose factor due to beta emissions for noble gas radionuclide } i \text{ (mrad/yr per } \mu\text{Ci/m}^3\text{)}$$

- For Critical Organ Dose Rate--Inhalation Pathway and all Pathways for H-3, C-14 (for vents or stacks < 80 meters):

$$DR_{\tau a} = X/Q_r \cdot 8760^{-c} \cdot \sum P_{ip\tau a} \cdot QR_{iv}$$

where

$$DR_{\tau a} = \text{dose rate for age group } a \text{ and organ } \tau \text{ from iodines and particulates with half lives greater than 8 days in gaseous effluents (mrem/yr)}$$

$$P_{ip\tau a} = \text{dose factor for each radionuclide } i, \text{ pathway } p, \text{ organ } \tau, \text{ and age group } a \text{ (mrem/yr per } \mu\text{Ci/m}^3\text{)}$$

$$X/Q_r = \text{highest value of the radioiodine/particulate 1-hour } X/Q \text{ for vent or stack } v \text{ at the site boundary (sec/m}^3\text{)}$$

$$c = \text{"a" factor for Radioiodine/Particulate } X/Q$$

Note: It is assumed $P_{ip\tau a}$ will not contain long term X/Q or D/Q values.

- For Critical Organ Dose Rate--Ground and Food Pathways (for vents or stacks < 80 meters):

$$DR_{\tau a} = D/Q \cdot 8760^{-d} \cdot \sum R_{ip\tau a} \cdot QR_{iv}$$

where

$$D/Q = \text{highest value of the 1-hour deposition factor at the distance of the site boundary (1/m}^2\text{)}$$

$$d = \text{"a" factor for } D/Q$$

$R_{ip\tau a}$ = dose factor for each radionuclide i , pathway p , organ τ , and age group a ($m^2 \cdot mrem/yr$ per $\mu Ci/sec$)

Note: It is assumed $R_{ip\tau a}$ will not contain long term X/Q or D/Q values.

- For Critical Organ Dose-Inhalation Pathway and all Pathways for H-3, C-14 (for vents or stacks < 80 meters):

$$D_{\tau a} = (3.17 \cdot 10^{-8}) \cdot X/Q_r \cdot t^{-c} \cdot F_o \cdot \sum P_{ip\tau a} \cdot Q_{iv}$$

where

$D_{\tau a}$ = dose for age group a and organ τ from iodines and particulates with half lives greater than 8 days in gaseous effluents (mrem)

Note: It is assumed $P_{ip\tau a}$ will not contain long term X/Q or D/Q values.

- For Critical Organ Dose-Ground and Food Pathways (for vents or stacks < 80 meters):

$$D_{\tau a} = (3.17 \cdot 10^{-8}) \cdot D/Q \cdot t^{-d} \cdot F_o \cdot \sum R_{ip\tau a} \cdot Q_{iv}$$

Note: It is assumed $R_{ip\tau a}$ will not contain long term X/Q or D/Q values.

- 6.8.3.2 On the Nuclide Concentration Screen (Screen 4.15), nuclide concentrations will be "scaled" if the SCAL_NUC parameter is set properly for a Release Point. This "scaling" is described as follows:

$$C_{i\text{new}} = (t/s) \cdot C_i$$

where

$C_{i\text{new}}$ = concentration (after "scaling") of nuclide _{i}
 s = sum of all nuclide concentrations on the Nuclide Concentration Screen.
 t = total nuclide concentration entered by the user
 C_i = concentration (before "scaling") of nuclide _{i}

6.9 Gaseous Permit Editing

6.9.1 User Interface and Functionality

Functionality for editing gaseous permits through the EMS software shall be described in section 4 of the EMS Operator's Manual (Reference 2.1.1), with the following revisions:

The appearance and functionality of the gaseous permit definition screen, the monitor response screen, and nuclide concentration shall be modified as described for the Pre- and Post-Release stages in sections 6.7.1 and 6.8.1 above.

6.9.2 Associated Reports

The permit report format and contents for edited open and closed gaseous permits shall be as specified above for original permit reports, in sections 6.7.2 and 6.8.2, respectively.

6.9.3 Underlying Calculations

The calculation methods for editing open and closed gaseous permits shall be specified for original calculations, in sections 6.7.3 and 6.8.3, respectively.

6.10 Gaseous Permit Deletion

Functionality for deleting gaseous permits through the EMS software shall be described section 4 or the EMS operator's Manual (Reference 2.1.1).

6.11 Semi-Annual Reporting

6.11.1 User Interface and Functionality

Semi-Annual Reporting functionality for the EMS software shall be as described in section 5 of the EMS Operator's Manual (Reference 2.1.1), with the following revisions:

6.11.1.1 On Report 5.01 (Gaseous Summation of All Releases):

- Compute each value on line A.3 of the report by taking

$$\text{the greater of } \left\{ \begin{array}{l} 100 \cdot D_{ag} / QL_{ag} \\ 100 \cdot D_{ab} / QL_{ab} \end{array} \right.$$

where

D_{ag} = the gamma air dose in the applicable quarter at the site boundary receptor due to noble gas emissions (mrem)

D_{ab} = the beta air dose in the applicable quarter at the site boundary due to noble gas emissions (mrem)

QL_{ag} = the quarterly limit on D_{ag} (mrem) [usually 5]

QL_{ab} = the quarterly limit on D_{ab} (mrem) [usually 10]

A note will be made at the bottom of the report stating whether the beta air dose and its associated limit or gamma air dose and its associated limit were used for the Percent of Applicable Limit of Fission and Activation Products..

- The values on lines B.3, C.3, and D.3 will be the equivalent. They will be calculated as follows:

$$\text{the greatest (over T) of } \left\{ 100 \cdot (\sum D_{i,T}) / QL_{TP} \right.$$

where

$D_{i,T}$ = the dose to organ T of the controlling receptor, in the applicable quarter, due to gaseous emissions of radionuclide i (mrem)

The summation is over all non-noble gas radionuclides with half-lives greater than 8 days, including radioiodines, particulates, and tritium.

QL_{rp} = the quarterly limit on the controlling receptor organ dose due to gaseous effluents (mrem) [usually 7.5]

6.11.1.2 On Report 5.02 (Liquid Summation of All Releases):

- For each quarter q in the report, calculate the reportable dilution volume (DV_{rq} , in liters) for the portion of the quarter that is within the report dates. It is the sum of the reportable monthly dilution volumes (DV_{rm}) in user units for all the months in the quarter that are within the report dates:

$$DV_{rq} = 28.31685 \cdot sd_lvol \cdot \sum DV_{rm}$$

The values DV_{rm} are from the column tvol of the QDVOL table. The value DV_{rq} is included in the report on line F, and is used in the calculations below. "sd_lvol" should be the user unit conversion factor to convert from user units to ft³. 28.31685 is a unit conversion factor from ft³ to liters.

- For each space on a line titled "AVERAGE DILUTED CONCENTRATION DURING PERIOD", the average concentration (C_q , in $\mu\text{Ci/ml}$) for the respective quarter is computed as follows (where i ranges over only the nuclides in the category):

$$C_q = \sum C_{iq} = \sum [Act_{iq} / (1000 \cdot DV_{rq})]$$

where

Act_{iq} = total activity of nuclide i released during the portion of the quarter q that is within the period (μCi)

DV_{rq} = reportable dilution flow for the portion of quarter q that is within the report period (liters), as calculated above.

- Compute each value on line A.3 and B.3 of the report by taking

the greater of $\left\{ \begin{array}{l} 100 \cdot D_{it} / QL_{it} \\ 100 \cdot D_{io} / QL_{io} \end{array} \right.$

where

D_{lt} = the liquid total body dose in the applicable quarter at the site boundary receptor (mrem)

D_{lo} = the liquid maximum organ dose in the applicable quarter at the site boundary (mrem)

QL_{lt} = the quarterly limit on D_{lt} (mrem) [usually 1.5]

QL_{lo} = the quarterly limit on D_{lo} (mrem) [usually 5]

A note will be made at the bottom of the report stating whether the liquid total body dose and its associated limit or maximum organ dose and its associated limit were used for the Percent of Applicable Limit.

- Compute each value on line C.3 of the report as follows:

$$P_q = 100 \cdot C_q / L_{dg}$$

where

C_q = sum of noble gas concentrations

P_q = Percentage applicable to a given quarter for dissolved and entrained gases

L_{dg} = Liquid dissolved gas limit ($\mu\text{Ci/ml}$) [usually $2.0\text{E-}04$]

6.11.2 EMS Trend Plots

Trend Plotting functionality for the EMS software shall be described in section 5 of the EMS Operator's Manual (Reference 2.1.1) with no revisions.

6.12 End-of-the-Year Data Archiving

6.12.1 User Interface and Functionality

End-of-the-Year Data Archiving functionality for the EMS software shall be described in section 6 of the EMS Operator's Manual (Reference 2.1.1) with no revisions.

Documentation Review Report

Document Reviewed SRS (25-8448-C4) SEABROOK LMS

Does the document meet the requirements? Yes or No

Is the document approved? Yes or No

If not please state the exceptions:

Signature: Lauren Lelotte

Date: 9/17/93

APPENDIX C: EMS SOFTWARE DOCUMENTATION

ATTACHMENT 4: TECHNICAL REFERENCE MANUAL, EFFLUENT MANAGEMENT SYSTEM
NAESCO SEABROOK STATION, JULY 1994, FP 75486

Canberra Industries, Inc.
800 Research Parkway
Meriden, CT 06450

July 1994

**NAESCO Seabrook Station
EMS Technical Reference Manual
07-0625**

Copyright 1994, Canberra Industries, Inc.
Printed in U.S.A.

Cover

ODCM Rev. 28
Page 36

THIS PAGE IS INTENTIONALLY BLANK

TABLE OF CONTENTS

Cover
A
i-ii

	Page
CHAPTER 1 INTRODUCTION	1-1
1.1 SETPOINT CALCULATIONS	1-2
1.2 RELEASE PROCESSING	1-3
1.3 COMPOSITE NUCLIDES	1-3 1-4
CHAPTER 2 LIQUID RELEASE CALCULATIONS	2-1
2.1 LIQUID PRE-RELEASE PERMIT	2-1
2.2 10CFR20 COMPLIANCE	2-1
Dissolved and Entrained Gases	2-4
2.3 MAXIMUM WASTE FLOW	2-4
2.4 MINIMUM DILUTION FLOW RATE	2-5
2.5 SETPOINT CALCULATIONS	2-5
Recommended Setpoint	2-8
Setpoint in $\mu\text{Ci/ml}$	2-8
Recommended Setpoint in User Units (e.g. cpm)	2-10
Setpoint for Discharge Point	2-11
Setpoints in $\mu\text{Ci/sec}$	2-13
2.6 DOSE CALCULATIONS FOR LIQUID RELEASES	2-13
2.7 31 DAY PROJECTED DOSE CALCULATIONS	2-17
2.8 POST-RELEASE PROCESSING	2-18
CHAPTER 3 GASEOUS RELEASE CALCULATIONS	3-1
3.1 GAS PRE-RELEASE PERMIT	3-1
3.2 RADIONUCLIDE ACTIVITIES AND COMPOSITE VALUES	3-1
Activity Released	3-2
3.3 10CFR20 COMPLIANCE	3-2
3.4 SETPOINT DETERMINATION	3-5
Noble Gases	3-5
Radioiodines and Particulates	3-6
3.4a SETPOINTS	3-6
3.4b REPORTED SETPOINTS	3-10
Setpoints in $\mu\text{Ci/sec}$	3-11
3.5 MAXIMUM WASTE FLOW	3-12
3.6 DOSE RATE AND CUMULATIVE DOSE CALCULATIONS	3-12
Noble Gas Dose and Dose Rate Calculations	3-12

Organ Dose Calculations	3-15
3.7 RESOLVING DOUBLE-COUNTING OF DOSE AND ACTIVITY	3-16
3.8 31 DAY PROJECTED DOSE CALCULATIONS	3-17
3.9 GAS POST-RELEASE PROCESSING	3-18
CHAPTER 4 LIQUID DOSE FACTOR EQUATIONS	4-1
4.1 POTABLE WATER	4-2
4.2 AQUATIC FOODS PATHWAYS	4-2
4.3 SHORELINE RECREATION PATHWAY	4-3
4.4 IRRIGATED VEGETABLE PATHWAY	4-4
4.5 REDUCTION TO NUREG-0133 EQUATIONS	4-5
CHAPTER 5 GAS DOSE FACTOR CALCULATIONS	5-1
5.1 INHALATION PATHWAY	5-1
5.2 GROUND PLANE PATHWAY	5-2
5.3 MILK PATHWAY	5-2
Carbon-14 in Milk	5-4
Tritium in Milk	5-4
5.4 MEAT PATHWAY	5-5
Carbon-14 in Meat	5-5
Tritium in Meat	5-6
5.5 VEGETABLE PATHWAY	5-6
Carbon-14 in Vegetables	5-7
Tritium in Vegetables	5-7
5.6 REDUCTION TO NUREG-0133 EQUATIONS	5-7
	5-8
APPENDIX A REFERENCES	A-1
	A-2

CHAPTER 1

INTRODUCTION

The Effluent Management System (EMS) Software implements the requirements for determining limits and doses for the routine liquid and gaseous releases from nuclear power plants. The calculations and methodology are based on those described in U. S. Nuclear Regulatory Commission Regulatory Guide 1.109 and references described therein. These equations reduce to those described in NUREG-0133 by proper selection of parameters.

This manual describes the calculations used in the LRW/GRW program for handling liquid and gaseous releases and preparing the semi-annual report, and the equations used in the DFP option for calculating the relevant dose factors.

This manual describes the new 10CFR20 (1992) as well as old 10CFR20 requirements.

For a nuclear power plant, the Off-Site Dose Calculation Manual (ODCM) describes the methods used at that plant for complying with the effluent release portions of the technical specifications and the requirements of 10CFR20 and Appendix I of 10CFR50.

The concentration and dose limits that are required to be met are:

- o For radioactive liquid effluents, the concentrations released to areas beyond the site boundary are limited to:

MPC values given in old 10CFR20, Appendix B, Table II.

OR

ECL values given in new 10CFR20, Appendix B, Table 2.

where ECL values are effluent concentration limit values.

- o For radioactive liquid effluents, the maximum dose to any member of the public will be less than the limits given in 10CFR50, Appendix I.
- o For gaseous effluents, the old 10CFR20 requires that the dose rate at any location beyond the site boundary will be limited to the annual dose limits given in the Technical Specifications and corresponding to the concentrations in Appendix B of the old 10CFR20. The old 10CFR20 approach for gaseous effluents has been accepted by the NRC for use under the new 10CFR20.

- o For gaseous effluents, the maximum dose to any member of the public will be less than the limits given in 10CFR50, Appendix I.
- o The maximum dose to any member of the public will not exceed the limits given in 40CFR190.

The equations employed for calculating the dose and dose factors are taken from NUREG-0133¹ and Regulatory Guide 1.109.²

For a particular nuclear plant, the ODCM describes the physical configuration of release sources and release points for routine and non-routine liquid and gaseous effluents, the monitor setpoint calculations, dose, and dose rate calculations.

1.1 SETPOINT CALCULATIONS

Calculations are made for the radiation monitors to determine the alarm/trip setpoint so that 10CFR20 compliance is met. For the old 10CFR20 compliance, liquid calculations use the maximum permissible concentrations from 10CFR20 App. B, Table 2, column 2, and the more conservative value (smaller) of the soluble and insoluble values while gas calculations use dose rate equations and limits from NUREG-0133. To comply with the new 10CFR20 requirements, the effluent concentration limits are used for liquid setpoint calculations. For gaseous setpoint calculations under the new 10CFR20, the NRC is still allowing the use of dose rate equations and limits from NUREG-0133..

In the terminology of EMS, individual sources of radiation, such as storage tanks, the containment building, etc., are defined as "release points." Several release points may lead to the same "discharge point."

Setpoint calculations produce monitor limiting values in activity units ($\mu\text{Ci/ml}$ or $\mu\text{Ci/cc}$). These are then converted to user units, e.g. counts per minute (cpm). For gaseous releases, setpoint can be reported as release rates ($\mu\text{Ci/sec}$). The reporting units for each monitor can be defined separately.

EMS allows setpoints to be set for both the release points and the discharge points. In the case that the release point and the discharge point are the same, or use the same physical monitor, the same discharge setpoint value is reported for both. This use of the same discharge setpoint value can be disabled.

EMS has a "nuclide specific" option. In this option only the nuclides listed in the monitor slope table are used in the setpoint calculations.

1.2 RELEASE PROCESSING

For batch releases, the processing of releases consists of sampling the tank or volume of air, analyzing the radionuclide content, then using the radionuclide concentrations and estimated release flows, volumes, etc. and calculating the doses and setpoints, comparing to the 10CFR20 limits, and comparing to the 10CFR50 limits. If the limits are not exceeded, the pre-release permit is signed off and the release can occur. After the release, post-release processing performs the same calculations (except the setpoints are not needed) and the database is updated with the actual values for the release.

For continuous releases, many installations prefer not to generate an actual pre-release permit, but for the sake of analogous operation, pre-release calculations must still be made in EMS. After review, the post-release calculations are made to update the database.

EMS does not allow more than one open release at a time for a single release point. However, multiple releases may be open for one discharge point. Also, for discharge points, the setpoint is calculated by summing over all open releases for the time period involved. An alternative approach if a new permit must be opened before the actual information for the previous permit are available is to go ahead and close the release using the pre-release values and then edit this closed release later when the actual information becomes available.

1.3 COMPOSITE NUCLIDES

The standard radionuclide analysis, with high-resolution germanium detectors, quantifies the gamma-emitting radionuclides. Pure beta emitters, nuclides that decay by K-capture, and alpha emitters are handled with other detection mechanisms. These are usually not tracked individually by sample, but as a composite of many samples over a month or quarter period. The concentrations of the composite nuclides are combined with the concentrations of the individual nuclides determined from gamma analysis for each sample.

For liquid releases, the composite nuclides are generally H-3, Fe-55, Sr-89, Sr-90, and gross alpha. For gaseous releases, Fe-55 is generally not included.

In EMS, these are contained in an editable file designated by the composite ID number. Each release point definition specifies which composite ID is used with the release point. These can be the composite nuclides, or any other nuclides desired.

Composite samples produced by taking portions of the samples from individual releases are analyzed after the releases are over. Since these generally do not vary much from one period to the next, it is common to use the most recent values. However, EMS provides the option of updating the composite values for the proper time period and recalculating the activity and dose values in the database.

The EMS composite update process processes only those nuclides listed in the Composite ID for the release point. For each nuclide, the curies and doses based on the previous value are subtracted from the cumulative totals and the curies and doses based on the correct value are added into the cumulative totals.

For the setting of flags to control options in the EMS code, see the NAESCO Seabrook Station EMS Operator's Manual 07-0589.

CHAPTER 2

LIQUID RELEASE CALCULATIONS

2.1 LIQUID PRE-RELEASE PERMIT

A liquid pre-release permit is generated with a program that uses the nuclide activities to determine the radiation monitor setpoint (for 10CFR20 compliance) and the potential doses for 10CFR50 compliance.

Continuous releases are treated similarly.

2.2 10CFR20 COMPLIANCE

10CFR20 compliance calculations are broken down into two paths. The first path calculates compliance with the old 10CFR20 in which the calculations are based on Maximum Permissible Concentrations. The second path complies with the new 10CFR20 and is Effluent Concentration Limits based.

10CFR20 requires that the sum of concentrations divided by MPC (old 10CFR20) or ECL (new 10CFR20) values must not exceed unity for MPCs or 10 for ECLs:

OLD 10CFR20

$$S = \sum_i C_i / MPC_i \leq 1$$

NEW 10CFR20

$$S = \sum_i C_i / ECL_i \leq 10$$

OR

for concentrations C_i released from the site. MPC_i is the maximum permissible concentration from the old 10CFR20, Appendix B, Table II, Column 2, for nuclide i and ECL_i is the effluent concentration limit from the new 10CFR20, Appendix B, Table 2, Column 2, for nuclide i .

If the summation is greater than the limit, then dilution is required. The required dilution factor is:

If the 10CFR20 option is OLD:

$$D_{req} = \frac{\sum_i \frac{C_i}{MPC_i}}{f \cdot R_{max}}$$

where

D_{req} = Total required dilution factor

C_i = Concentration of nuclide i in $\mu\text{Ci/mL}$

MPC_i = Maximum permissible concentration of nuclide i in $\mu\text{Ci/mL}$

f = Release point setpoint safety factor (usually equal to 0.5) from the release point definition.

R_{max} = The maximum MPC ratio from the release point setpoint definition.

If the 10CFR20 option is NEW:

$$D_{req,g} = \frac{\sum_{i=g} \frac{C_i}{ECL_i}}{f \cdot R_{max}}$$

$$D_{req,ng} = \frac{\sum_{i=ng} \frac{C_i}{ECL_i}}{f \cdot R_{max}}$$

$$D_{req} = D_{req,g} + D_{req,ng}$$

where

$D_{req,g}$ = Required dilution factor for gamma-emitters

$D_{req,ng}$ = Required dilution factor for non-gamma-emitters

ECL_i = Effluent concentration limit of nuclide i in $\mu\text{Ci/mL}$

and the sums extend over gamma-emitters (g) and non-gamma-emitters (ng), respectively.

Any nuclides with $MPC_i \leq 0$ are excluded from the sum.
Any nuclides with $ECL_i \leq 0$ are excluded from the sum.

The available dilution flow is the minimum dilution stream flow that can be ensured for the period of the release, corrected for other releases in process and any activity in the dilution stream, and reduced by a safety factor.

$$F_{avail} = F_{ant} (f_f/100) (1 - \sum C_i/XXX_i)$$

where

C_i = Concentration ($\mu\text{Ci/ml}$) for nuclide i for the dilution stream sample

XXX_i = MPC_i or ECL_i

f_f = Flow safety factor, in percent

F_{ant} = Anticipated dilution flow rate for the release.

The anticipated dilution factor is then

$$D_{ant} = (F_{waste} + f_{alloc} F_{avail}) / F_{waste}$$

where

F_{waste} = waste flow anticipated for this release

F_{avail} = available dilution flow

f_{alloc} = fraction of available dilution stream flow allocated to this release

Dissolved and Entrained Gases

To implement 10CFR20, it is also required that the total concentration of dissolved and entrained gases in liquid effluents be less than a specified value (normally, 2 E-04 $\mu\text{Ci/mL}$ under OLD 10CFR20, or 1 E-04 $\mu\text{Ci/mL}$ under NEW 10CFR20). EMS stores this limit in the Activity Limits transaction, checks this limit for each liquid permit, and indicates on the permit approval screen whether or not it is exceeded. To include dissolved noble gases in the D_{req} calculation, the database must also contain the same limiting value, as the liquid MPC or ECL for each noble gas nuclide.

2.3 MAXIMUM WASTE FLOW

The maximum waste flow calculation is based on the setting of the SET_OPT option in the WFLOW_M class of options in the Release Point Setpoint definition. This option can take on four values: NONE, NWS (no waste), CALC or DOSE. For liquid releases, NONE, NWS, and CALC are allowed.

For liquid releases,

W_{max} = the minimum of R_{wmax} and R_{cwmax}

where

W_{max} = Maximum permissible waste flow rate for this release

R_{wmax} = Release point maximum waste flow rate, as set in the release point definition

If the SET_OPT option = NONE:

R_{cwmax} = waste flow rate for the sample, F_{waste}

If the required dilution factor, D_{req} (section 2.2) for the sample is greater than 1, R_{cwmax} becomes:

$$R_{\text{cwmax}} = \frac{F_{\text{avail}} \cdot f_{\text{alloc}}}{D_{\text{req}} - 1.0}$$

If the SET_OPT option = CALC

$$R_{\text{cwmax}} = \frac{F_{\text{avail}} \cdot f_{\text{alloc}} + F_{\text{waste}}}{D_{\text{req}}}$$

If the SET_OPT option = NWAS

$$R_{\text{cwmax}} = \frac{F_{\text{avail}} \cdot f_{\text{alloc}}}{D_{\text{req}}}$$

2.4 MINIMUM DILUTION FLOW RATE

If $D_{\text{req}} > 1$, the minimum dilution flow rate is determined as follows:

If the SET_OPT option is NWAS:

$$\text{min_dflow} = \frac{F_{\text{waste}} \cdot D_{\text{req}}}{f_{\text{alloc}} \cdot (f_f / 100) \cdot \left[1 - \sum_i \frac{C_i}{\text{XXX}_i} \right]}$$

where XXX_i is MPC_i under OLD 10CFR20, and is ECL_i under NEW 10CFR20.

If the SET_OPT option is other than NWAS:

$$\text{min_dflow} = \frac{F_{\text{waste}} \cdot (D_{\text{req}} - 1.0)}{f_{\text{alloc}} \cdot (f_f / 100) \cdot \left[1 - \sum_i \frac{C_i}{\text{XXX}_i} \right]}$$

Otherwise:

$$\text{min_dflow} = 0.0$$

2.5 SETPOINT CALCULATIONS

Setpoints are calculated for individual release points, and for the discharge point that may combine several release points.

A setpoint adjustment factor, S_{adj} is determined from the value of D_{req} .

If $D_{req} > 1$ or the dilution factor option is N, and the setpoint equation is set to STD:

$$S_{adj} = D_{ant} / D_{req}$$

If the dilution factor option is Y, and $0 < D_{req} \leq 1.0$ or if the dilution factor option is Y, and the setpoint equation is set to NO_DIL, then no credit is taken for dilution, and the setpoint adjustment factor is:

$$S_{adj} = 1/D_{req}$$

If neither of these conditions is true, $S_{adj} = 0$.

After the above tests, further tests are made based on the setting of the setpoint equation option, SETP_EQN. These may change S_{adj} as follows:

If the SETP_EQN is set to DILUT, and $F_{waste} > 0$, then:

$$S_{adj} = \frac{F_{ant} + F_{waste}}{F_{waste}}$$

If the SETP_EQN is set to STD, and the SET_OPT option is set to NWAS, and $F_{waste} > 0$, then:

$$S_{adj} = \frac{f_{alloc} \cdot F_{avail}}{F_{waste} \cdot D_{req}}$$

Otherwise, if the SETP_EQN option is set to STD, and the SET_OPT option is set to other than NWAS, and $F_{waste} > 0$, then:

$$S_{adj} = \frac{(f_{alloc} \cdot F_{avail}) + F_{waste}}{F_{waste} \cdot D_{req}}$$

Otherwise, if the SETP_EQN option is set to LOW_ACT, and the SET_OPT option is set to NWAS, and $F_{waste} > 0$, then:

$$S_{adj} = \frac{\frac{(f_{alloc} \cdot F_{avail})}{F_{waste}} - D_{req,ng}}{D_{req,g}}$$

Otherwise, if the SETP_EQN option is set to LOW_ACT, and the SET_OPT option is set to other than NWSAS, and $F_{waste} > 0$, then:

$$S_{adj} = \frac{\frac{(f_{alloc} \cdot F_{avail}) + F_{waste}}{F_{waste}} - D_{req,ng}}{D_{req,g}}$$

Otherwise, S_{adj} is unchanged.

The setpoint adjustment factor is further tested against a limiting value ($S_{adj,lim}$ which is set using the Release Point transaction in Database Maintenance).

If $S_{adj} > S_{adj,lim}$ then $S_{adj} = S_{adj,lim}$

All of this leads to the maximum setpoint value, S_{max} , based on the gamma-emitting radionuclide mix:

$$S_{max} (\mu Ci/ml) = S_{adj} \sum C_i$$

where the sum extends over all gamma-emitting nuclides (nuclides of type other than 0) in which their concentrations are greater than 0.

In user units (cpm or other as set in the Flow Monitor Parameters transaction in Database Maintenance), the maximum setpoint is:

$$S_{max} (cpm) = S_{adj} (R_{mon} - B) + B$$

where

B = monitor background (cpm)

R_{mon} = monitor response (cpm)

$$= \text{offset} + \text{slope} \cdot \sum C_i + \text{quad} \cdot (\sum C_i)^2 + B$$

where offset, slope, and quad are the coefficients in a quadratic fit to the monitor response to nuclide activity.

EMS provides an option to calculate nuclide specific responses so that R_{mon} is the sum of responses for each nuclide, rather than the sum of the nuclide concentrations, as shown above. In the nuclide-specific case,

$$R_{\text{mon}} = \sum [\text{offset}_i + \text{slope}_i \cdot C_i + \text{quad}_i \cdot (C_i)^2] + B$$

where the sum extends over all nuclides which have response factors stored in the database for the monitor of interest.

Recommended Setpoint

The setpoint recommended for actual use is based on a comparison of the maximum setpoint calculated as above, to setpoints based on expected response time a tolerance factor (to allow for variations in monitor response during release) and to default values determined by the user. The user can restrict which setpoint value is usually reported by what values are used when setting these tolerance factors and default setpoint values.

The default setpoint in user units (e.g. cpm) can be defined with or without background included. If the cunitnopt parameter (defined in the release point and discharge point tables) equals 0, the default value does not include background; and the current background is added to the default value to get the reported default setpoint. Otherwise, the current background is not added to the default value.

Setpoint in $\mu\text{Ci/ml}$

Note: In this version of the software, the reported setpoint is the user units setpoint. The setpoint calculations using the original concentrations ($\mu\text{Ci/ml}$) is still being done by the software and stored in the sampledata table. To get reported setpoints in $\mu\text{Ci/ml}$, the monitor slope should be set to 1.0 in the Release Point transaction of Database Maintenance and the UNITS parameter for the monitor should be set to $\mu\text{Ci/ml}$ in the Activity Monitors transaction. If the Isotopic specific response option is turned on for the release point, then this individual nuclide slopes in the Monitor Slopes can be used to map the response from the nuclide to that of a monitor calibration source (e.g. Cs^{137} equivalent response)

A candidate setpoint is calculated based on the expected response:

$$S_{exp} = f_{tol} \sum C_i$$

where

f_{tol} = setpoint tolerance factor (can be set for the release point using QBF)

= 2 if not specified by the user

Now compare the S_{exp} value to the default table value S_{def} :

If $S_{exp} < S_{max}$

and if

$$S_{exp} < S_{def} \text{ and } S_{def} \leq S_{max}$$

then use S_{def}

Case 1

Otherwise use S_{exp} .

Case 2,5

If $S_{exp} \geq S_{max}$ use S_{max} .

Case 3

If $S_{max} = 0$, use S_{def}

Case 4

Case 4 occurs if no activity is detectable in the sample ($S_{adj} = 0$).

Case 1	Case 2	Case 3	Case 4	Case 5
		S _{exp} ----		S _{def} ----
S _{max} ----	S _{max} ----	S _{max} ----		S _{max} ----
	S _{exp} ----			S _{exp} ----
S _{def} ----	S _{def} ----	S _{def} ----	S _{def} ----	
S _{exp} ----				
0 ----	0 ----	0 ----	0 ----	0 ----
Use S _{def}	Use S _{exp}	Use S _{max}	Use S _{def}	Use S _{exp}

Schematic of Liquid Setpoint Cases

Recommended Setpoint in User Units (e.g. cpm)

The candidate setpoint based on expected monitor response is calculated as follows:

$$S_{exp} \text{ (cpm)} = f_{tol} \cdot (R_{mon} - B) + f_{Btol} \cdot B$$

where

f_{Btol} = background tolerance factor (set using QBF on the release table)

If the default setpoint value includes background:

$$B_{rp} = 0$$

If the default setpoint value does not include background:

$$B_{rp} = B$$

where B is the monitor background count rate and B_{rp} is used below.

If S_{exp} (cpm) < S_{max} (cpm)

and if

$$S_{exp} \text{ (cpm)} < S_{def} \text{ (cpm)} + B_{rp} \text{ and}$$

$$S_{def} \text{ (cpm)} + B_{rp} \leq S_{max} \text{ (cpm)}$$

then use S_{def} (cpm) + B_{rp} Case 1

Otherwise, use S_{exp} (cpm) Case 2, 5

If S_{exp} (cpm) > S_{max} (cpm)

use S_{max} (cpm) Case 3

If S_{max} (cpm) = 0, use $S_{def} + B_{rp}$ Case 4

NOTE: S_{max} is due to concentration only (i.e., excludes background) for Case 4

Setpoint for Discharge Point

For the discharge point, the total MPC/ECL fraction is:

$$\frac{(\sum C_i / MPC_i) \cdot F_o + (\sum C_i / MPC_i) \cdot F}{F_o + F}$$

OR

$$\frac{(\sum C_i / ECL_i) \cdot F_o + (\sum C_i / ECL_i) \cdot F}{F_o + F}$$

where

$(\sum C_i / MPC_i)_0$ = total MPC fraction for existing concurrent releases for this discharge point excluding this additional release.

$\sum C_i / MPC_i$ = total MPC fraction for the new release

$(\sum C_i / ECL_i)_0$ = total ECL fraction for existing concurrent releases for this discharge point excluding this additional release.

$\sum C_i / ECL_i$ = total ECL fraction for the new release

F_0 = discharge point waste flow excluding new the release point waste flow to be added.

F = projected waste flow for the new release point to be added

The radiation monitor for the discharge point has setpoint equations identical to those presented above for the release points with the following exceptions:

1. The LOW_ACT setpoint equation option is not supported.
2. For the nuclide-specific response, the concentrations are modified as in:

$$C_i^{dp} = C_i [F / (F + F_0)]$$

$$R_{dpmon} = [\sum (\text{offset}_i + \text{slope}_i \cdot C_i^{dp} + \text{quad}_i \cdot (C_i^{dp})^2)] + R_{dpmono}$$

where

C_i^{dp} = the discharge point isotope concentration from this release point

R_{dpmon} = the discharge monitor response in user units

R_{dpmono} = the discharge monitor response before the current release is added including the background

For non-isotope specific response:

$$R_{dpmon} = [\text{offset} + \text{slope} \cdot C^{dp} + \text{quad} \cdot (C^{dp})^2] + R_{dpmon_0}$$

where $C^{dp} = [\sum C_i] [F / (F + F_0)]$

Setpoints in $\mu\text{Ci}/\text{sec}$

Setpoints in units of $\mu\text{Ci}/\text{sec}$ can be obtained by setting the UNITS parameter for the monitor to " $\mu\text{Ci}/\text{s}$ " or " $\mu\text{Ci}/\text{sec}$ " (Case sensitive. 1st 5 characters must match) in the Activity Monitors transaction and setting the monitor slope to 1.0 as in the $\mu\text{Ci}/\text{ml}$ setpoint calculation. The user units setpoint, as calculated above for the setpoint in $\mu\text{Ci}/\text{ml}$ units, will be multiplied by the corresponding effluent flow rate (release point or discharge point) for the monitor to get a reported setpoint in $\mu\text{Ci}/\text{sec}$.

2.6 DOSE CALCULATIONS FOR LIQUID RELEASES

The EMS software calculates and stores the dose for each receptor, for each nuclide, and for each organ. The dose is the total over all pathways which apply to that receptor. A receptor is defined by receptor ID, age group (infant, child, teen, or adult), sector, and distance from the plant.

The equation used in the liquid permit processing to calculate the dose received by receptor r from a released nuclide i is:

$$D_{iTr} = A_{iTr} \sum \Delta t_s C_{is} F_{sr}$$

where:

The sum extends over all time periods.

D_{iTr} = the cumulative dose or dose commitment to the total body or an organ T by nuclide i for receptor r from the liquid effluents for the total time period of the release, in mrem.

A_{iTr} = site-related ingestion dose or dose commitment factor for receptor r to the total body or organ T for radionuclide i , in mrem/hr per $\mu\text{Ci}/\text{ml}$. A_{iTr} is available as an editable table, but can be recalculated with different parameters and pathways with the Dose Factor Processing (DFP) option. The

equations used are presented in Chapter 4 of this manual.

Δt_s = length of time period s , over which the concentration and F value are averaged, for all liquid releases, in hours.

C_{is} = the average concentration of radionuclide i in undiluted liquid effluent during time period Δt_s from any liquid release, in $\mu\text{Ci/ml}$.

F_{sr} = the near field average dilution factor for receptor r during any liquid effluent release.

$$F_{sr} = \frac{F_w}{\text{Denom}}$$

The value of Denom depends upon several variables and nested if statements. The derivation of the Denom value is shown in the logic and equations shown below.

If the STREAM_FLO option in the OPTIONS Table is set to Y, then

$$\text{Denom} = F_{\text{strm}} \cdot (U_f / 60) \cdot (1/R_{\text{mix}})$$

else (river stream flow is not used)

If the denom_typ option from the Options Table is 1, (dose from a dilution stream) then

$$\text{Denom} = (U_f / 60) \cdot (1/R_{\text{mix}})$$

Else if denom_typ is 2, (dilution flow includes waste flow) then

$$\text{Denom} = F_{\text{dil}} \cdot (U_f / 60) \cdot (1/R_{\text{mix}})$$

else (denom_typ is not 1 or 2)

if the QV_OPT option in the OPTIONS table is set to ON, (dilution flow is from the QDVOL table) then

$$\text{Denom} = (F_w + F_{\text{qv}}) \cdot (U_f / 60) \cdot (1/R_{\text{mix}})$$

else (the normal standard calculation)

$$\text{Denom} = (F_w + F_{\text{dil}}) \cdot (U_f / 60) \cdot (1/R_{\text{mix}})$$

end of if on QV_OPT option

end of if on denom_typ option

end of if on stream_flo option

If Denom is greater than 0.0 then

If Denom > 1000. and option to limit the denominator is Y, then

$$\text{Denom} = 1000.$$

end of if denom is too large

end of if denom is greater than 0.0

$$\text{Denom} = \text{Denom} / (U_f / 60)$$

Where:

F_{strm} = River stream flow past the site in user liquid flow rate units. The value used during permit processing is the value obtained from the STATIONDATA table. The value is entered into the STATIONDATA table using the QBF utility. If the value is to be changed often, it would be possible to write a command procedure which get the value from the user and write it into the table.

F_w = flow rate of undiluted waste effluent in user liquid flow rate units.

$U_f/60$ = Flow rate units conversion factor for liquid releases/60. U_f converts from user units to CFM so this factor converts to CFS.

F_{dil} = flow rate of the dilution flow in user liquid flow rate units.

R_{mix} = mixing ratio = fraction of the release that reaches the receptor. Separate mixing ratios are stored for each pathway for each receptor.

A mixing ratio of zero for a pathway receptor indicates that the pathway is not present for the receptor. The first non-zero value is used in the dose calculation.

The different mixing ratios for the pathways are incorporated into the composite A_i factors calculated by the dose factor processing (DFP) program.

F_{qvol} = Flow rate from user entered quarterly dilution flow rate. These values are from the AFLOW column of the QDVOL table for the release.

If stream flow option is being used and the average river stream flow is known at the time the liquid release is processed, then the command procedure which runs the liquid permit processing could be modified to ask for the stream flow value and put it into the stationdata table before the permit is processed. If the average river stream flow is not known at the time the liquid release is processed, then some other provision must be made for correcting the cumulative dose totals in the CUMDOSE table so that it is based on the correct stream flow value. If the average stream flow for

the month is used, then each liquid release point entry in the CUMDOSE table for the month could be multiplied by the ratio of the actual stream flow for the month divided by the default value contained in the STATIONDATA table. Caution: Since there is no record stored in the database of what stream flow value was used to calculate the dose values, the user must verify that no correction is applied more than once to each dose value.

2.7 31 DAY PROJECTED DOSE CALCULATIONS

The 31 Day Projected Dose values appear on the Standard and Special Permit Reports. The Projected Dose values are calculated as follows:

$$D_{PT} = (D_T \cdot p) + D_{AT}$$

where:

D_{PT} =the 31 Day Projected Dose by organ T, by reactor unit

D_T =the total dose in mrem by organ T, by reactor unit for the quarter containing the release start date from all closed and open releases when an answer of "Y" is specified for the "Update Totals" field on the release point definition screen.

p =the Projection Factor which is the result of 31 divided by the number of days from start of the quarter containing the release start date to the end of the release. The quarterly and annual projection values on the standard pre-release report use a projection factor with 92 days or 365 days instead of 31 days in the numerator and do not include the additional anticipated dose term.

D_{AT} =Additional Anticipated Dose for liquid releases by organ T and quarter of release by reactor unit.

NOTE: The 31 day dose projections on the Approval/Results screen is the site total for all units.

2.8 POST-RELEASE PROCESSING

After the release is made, actual concentrations are used to check 10CFR20 limits, and the actual dilution flow and waste flow are used instead of the anticipated dilution flow and waste flow.

For batch releases, the duration is determined from the start and end dates and times, and is used with the volume input to calculate the release rate.

Dose calculations are the same as for the pre-release, but with actual release flow rates and release duration.

Setpoint calculations are not performed at the post-release stage.

CHAPTER 3

GASEOUS RELEASE CALCULATIONS

The "annual average X/Q" method is used, in which fixed X/Q and D/Q values are used for each receptor for all dose calculations, regardless of actual wind direction and speed prevailing during a given release. Doses are calculated for each receptor location and age group specified in the Gas Receptors transaction. The controlling individual is the age group and location which receives the maximum organ dose.

3.1 GAS PRE-RELEASE PERMIT

The pre-release permit is produced by a program that uses user-entered estimates of flow rates and release times to calculate doses and activities. The dose rate from the potential release is added to the maximum dose rate occurring for all other releases during the duration of this release for 10CFR20 compliance. The noble gas or air doses and the organ doses are checked against the corresponding limits for 10CFR50 compliance.

3.2 RADIONUCLIDE ACTIVITIES AND COMPOSITE VALUES

The radionuclide results are read from one set of composite activity database records, and from three spectrum analysis result files, and saved in an activity array: If a nuclide appears in more than one spectrum, only the last value read for that nuclide is used. In case of duplication, the one not desired should be edited out of the nuclide list. The samples are read in the following order:

1. Composite Records
2. Particulate File
3. Radioiodine File
4. Noble Gas File

The activity (Q_i) and the activity release rate (\dot{Q}_i) are calculated for each nuclide i .

Activity Released

For the plant stack and turbine building vent:

$$Q_i = C_i \cdot V_v \cdot 28316.85 \cdot U_F \cdot 1e^{-6}$$

(μCi) = ($\mu\text{Ci/ml}$) (cubic feet) (ml/cubic feet)

where:

V_v = vent release volume in user units (usually FT^3)

C_i = concentration in $\mu\text{Ci/ml}$

U_F = the flow-rate units conversion factor which converts from user units to CFM

Note: The C_i value also includes the scaled noble gas nuclides for a release (if any exists).

The activity release rate in $\mu\text{Ci/sec}$ is

$$\dot{Q}_i = C_i \cdot V_f \cdot 28316.85 \cdot U_F / 60$$

For containment purge:

$$\dot{Q}_i = C_i \cdot \text{pump release rate (CFM)} \cdot 28316.85 \cdot U_F / 60$$

$$Q_i = \dot{Q}_i \cdot \text{duration of release (min)} \cdot 60$$

3.3 10CFR20 COMPLIANCE

The maximum dose rate during the release is determined by summing together the dose rates for this release, with all concurrent releases in the database for the time of the release.

The database contains all releases for which both pre- and post-release reports have been made (the post-release program enters the data into the cumulative totals). Pre-releases that have not been completed, and which occur during the release under consideration, are also added into the maximum dose rate to account for releases not yet added to the cumulative totals.

The three dose rates (whole body, skin, organ) are compared to the old 10CFR20 limits (old and new 10CFR20 are described below) as defined in the Dose Limits transaction in Database Maintenance.

The dose rate at or beyond the site boundary due to gaseous effluents from the site is limited to:

(a) Release rate limit for noble gases:

$$\sum_i K_i \text{ shf } \sum_v [(\overline{X/Q})_{vr} \dot{Q}_{iv}] < 500 \text{ mRem/yr} \cdot f_{\text{alloc}} \cdot f_s$$

OR

$$\sum_v \text{ shf } \sum_i [V_{ir} \dot{Q}_{iv}] < 500 \text{ mRem/yr} \cdot f_{\text{alloc}} \cdot f_s$$

Elevated Stack \geq 80m

$$\sum_i \text{ shf } (L_i + 1.1M_i) \sum_v [(\overline{X/Q})_{vr} \dot{Q}_{iv}] < 3000 \text{ mRem/yr} \cdot f_{\text{alloc}} \cdot f_s$$

OR

$$\sum_v \text{ shf } \sum_i [(L_i (\overline{X/Q})_{ir} + 1.1B_{ir}) \dot{Q}_{iv}] < 3000 \text{ mRem/yr} \cdot f_{\text{alloc}} \cdot f_s$$

Elevated Stack \geq 80m

where the terms are defined below.

(b) Release rate limit for all radionuclides and radioactive materials in particulate form, with half lives greater than 8 days:

$$\sum_i \sum_p \sum_v [f_p P_{ip} W_{mv} \dot{Q}_i] < 1500 \text{ mRem/yr} \cdot f_{\text{alloc}} \cdot f_s$$

where:

- i = index over all radionuclides
 v = index over all vents or stacks for the unit
 p = index over all pathways
 r = index for receptor locations
 K_i = the total body dose factor due to gamma emissions for noble gas radionuclide i , in mrem/yr per $\mu\text{Ci}/\text{m}^3$.
 L_i = the skin dose factor due to beta emissions for noble gas radionuclide i , in mrem/yr per $\mu\text{Ci}/\text{m}^3$.
 V_{ir} = the elevated plume gamma total body dose factor for nuclide i at receptor location r , in mrem/yr per $\mu\text{Ci}/\text{sec}$.
 M_i = the air dose factor due to gamma emissions for noble gas radionuclide i , in mrad/yr per $\mu\text{Ci}/\text{m}^3$.
 B_{ir} = the elevated plume gamma skin dose factor for nuclide i at receptor location r , in mrad/yr per $\mu\text{Ci}/\text{sec}$.
 1.1 = mrad to mrem conversion factor in mrem/mrad
 P_{ip} = the dose factor for the critical organ for nuclides other than noble gases for the inhalation pathway (in units of mrem/yr per $\mu\text{Ci}/\text{m}^3$) and for ground plane and food pathways (in units of m^2 (mrem/yr per $\mu\text{Ci}/\text{sec}$)). The most restrictive age group is used.
 f_p = factor to select which pathways are included in the calculation. Factor = 1 to include a pathway, 0 to exclude.
 W_{mv} = $\frac{(\overline{X/Q})_{mv}}{(D/Q)_{mv}}$ for tritium and the inhalation pathway and = $\frac{(\overline{X/Q})_{mv}}{(D/Q)_{mv}}$ for other nuclides and pathways.
 $(\overline{X/Q})_{vr}$ = the highest value of the annual average atmospheric dispersion factor at the site boundary, for all sectors, in sec/m^3 .
 $(\overline{X/Q})_{mv}$ = the highest value of the annual average atmospheric dispersion factor at the distance of the site boundary, for all sectors, in sec/m^3 .

$(\overline{D/Q})_{mv}$ = the highest value of the annual average deposition factor at the distance of the site boundary, for all sectors, in m^{-2} .

\dot{Q}_{iv} = the average release rate of nuclide i in gaseous effluent from release point v, in $\mu Ci/sec$. Noble gases may be averaged over a period of 1 hour, and any other nuclides may be averaged over a period of 1 week.

500 = site dose rate limit for whole body in mrem/year.

3000 = site dose rate limit for skin in mrem/year

1500 = site dose rate limit for any organ in mrem/year

shf = noble gas dose shielding factor

f_{alloc} = fraction of the dose limit allocated to this release point

f_s = safety factor for the release point

3.4 SETPOINT DETERMINATION

Setpoints are determined from Dose Rate Limits set forth in the Technical Specifications and stored in the Dose Limits Table.

The ratio of dose rate limit to dose rate for a single release point is given below for these three cases:

Noble Gases

$n_{ratio} = r_g$ = lesser of the ratios

(total body dose rate limit/total body dose rate) and
(skin dose rate limit/skin dose rate)

= for a vent release, lesser of

$$\frac{500 \text{ mrem/yr}}{shf \sum_i K_i \cdot \dot{Q}_{iv} \cdot (\overline{X/Q})_{mv}}$$

and

$$\frac{3000 \text{ mrem/yr}}{\text{shf } \Sigma (L_i + 1.1M_i) \cdot \dot{Q}_{iv} \cdot \overline{(X/Q)}_{mv}}$$

= for an Elevated Stack $\geq 80\text{m}$, lesser of

$$\frac{500 \text{ mrem/yr}}{\text{shf } \Sigma V_{ir} \cdot \dot{Q}_i}$$

and

$$\frac{3000 \text{ mrem/yr}}{\text{shf } \Sigma [L_i \cdot \overline{(X/Q)}_r + 1.1B_{ir}] \cdot \dot{Q}_i}$$

Radioiodines and Particulates

In these cases, the ratio is obtained by summing over the appropriate nuclide indices:

$$\text{rpratio} = \frac{1500 \text{ mrem/yr}}{\Sigma P_i \cdot \dot{Q}_{iv} \cdot W_{mv}} = \text{maximum organ dose rate}$$

When the sum is over nuclides and the inhalation, ground plane and cow's milk pathways are all turned on.

3.4a SETPOINTS

Setpoints are determined for radiation monitors on individual release points, and also for radiation monitors at the discharge points that may combine the effluent from several release points.

Calculations for the monitor response are made for noble gases, radioiodines, and particulates.

For a release point, the expected monitor response to a given nuclide concentration is:

$$R_{\text{mon}} = \text{monitor response (cpm)} + B$$
$$= \text{offset} + [\text{slope} \cdot \Sigma C_i] + [\text{quad} \cdot (\Sigma C_i)^2] + B$$

where offset, slope, and quad are the coefficients in a quadratic fit to the monitor response to nuclide activity, and B is the monitor background.

EMS provides an option to calculate nuclide specific responses so that R_{mon} is determined from the response for each nuclide, rather than the sum of the nuclide concentrations, as shown above. In that case,

$$R_{\text{mon}} = \sum (\text{offset}_i + [\text{slope}_i \cdot C_i] + [\text{quad}_i \cdot (C_i)^2]) + B$$

The expected response for discharge points is based on the sum of the expected response for releases already in progress plus the expected response due to release point being considered.

$$R_{\text{dpmon}} = R_{\text{dpmon}_o} + \sum [\text{offset}_i + \text{slope}_i \cdot C_i^{\text{dp}} + \text{quad}_i \cdot (C_i^{\text{dp}})^2]$$

where

$$C_i^{\text{dp}} = C_i \cdot (F_{\text{rp}} / F_{\text{dp}})$$

C_i = concentration for the release point

F_{rp} = flow rate for the release point

F_{dp} = flow rate for the discharge point

R_{dpmon} = discharge point monitor response for the release in progress

R_{dpmon_0} = the discharge monitor response before the current release is added including the background

and $offset_i$, $slope_i$ and $quad_i$ are the quadratic response coefficients of the discharge point monitor.

Non-isotope specific response:

$$R_{mon}^{dp} = offset + slope \cdot (\sum C_i^{dp}) + quad \cdot (\sum C_i^{dp})^2 + R_{dpmon_0}$$

All other equations are the same as for the individual release point, but use the discharge point monitor response and the discharge point allocation factor and safety factors.

EMS allows for setpoint calculations based on the standard or response method. Thus, each release point will have associated with it, a setpoint equation: STD or RESP. This can be set in the Release Point (Setpoint) transaction of Database Maintenance.

If the release point setpoint equation = STD :

The limiting setpoint for the monitor (in $\mu Ci/ml$) is given by:

$$S_{max} = f_s \cdot f_{alloc} \cdot ratio \cdot SUM$$

The limiting setpoint for the monitor (in user units, e.g., cpm) is given by:

$$SU_{max} = f_s \cdot f_{alloc} \cdot ratio \cdot (R_{mon} - B) + B$$

where

offset = 1. noble gas offset factor
2. radioiodine offset factor
3. particulate offset factor

slope = 1. noble gas slope factor
2. radioiodine slope factor
3. particulate slope factor

quad = 1. noble gas quadratic factor
2. radioiodine quadratic factor
3. particulate quadratic factor

f_s = safety factor for the release point

f_{alloc} = dose rate allocation factor for the release point

ratio = 1. nratio for noble gases
2. rpratio for radioiodines
3. rpratio for particulates

SUM = 1. Σ noble gas concentrations, for noble gases
2. Σ radioiodine concentrations, for radioiodines
3. Σ particulate concentrations, for particulates

R_{mon} = 1. noble gas monitor response
2. radioiodine monitor response
3. particulate monitor response

B = 1. observed background response for the noble gas monitor
2. observed background response for the radioiodine monitor
3. observed background response for the particulate monitor

NOTE :Separate calculations are made for noble gases, radioiodine, and particulates

The limiting setpoint for gaseous releases is determined separately for noble gases, radioiodines, and particulates for each release point and discharge point.

If the release point setpoint equation = RESP :

The reported setpoint for the monitor (in $\mu\text{Ci/ml}$) now becomes:

$$S_{\text{max}} = [\text{mrtol} \cdot (\text{SUM} - \text{B})] + (\text{mrtolb} \cdot \text{B})$$

The limiting setpoint for the monitor (in user units, e.g., cpm) now becomes:

$$\text{SU}_{\text{max}} = [\text{mrtol} \cdot (\text{R}_{\text{mon}} - \text{B})] + (\text{mrtolb} \cdot \text{B})$$

where.

mrtol = 1. monitor response tolerance factor (noble gas)
2. monitor response tolerance factor (radioiodine)
3. monitor response tolerance factor (particulate)

SUM = as defined above

B = as defined above

mrtolb = 1. monitor tolerance background factor (noble gas)
2. monitor tolerance background factor (radioiodine)
3. monitor tolerance background factor (particulate)

R_{mon} = as defined above

3.4b REPORTED SETPOINTS

The setpoint reported on the pre-release reports are in user defined units. If the release point setpoint equation is STD, then the maximum setpoint is compared with the response and default setpoints.

NOTE : The response setpoint as defined in this section is not necessarily the same as the maximum setpoint based on the RESP setpoint equation, as defined in the previous section. S_{response} is defined below.

The reported setpoint is as follows:

1. Reported = S_{response}
if $S_{\text{response}} < S_{\text{max}} < S_{\text{default}}$
OR
if $S_{\text{default}} < S_{\text{response}} < S_{\text{max}}$
2. Reported = S_{max}
if $S_{\text{response}} \geq S_{\text{max}}$
3. Reported = S_{default}
if $S_{\text{response}} < S_{\text{default}} < S_{\text{max}}$

where

S_{max} = as defined in the previous section

$S_{\text{response}} = \begin{cases} \text{mrtol} \cdot \text{SUM} & [\mu\text{Ci/ml}] \\ \text{[mrtol} \cdot (\text{Rmon} - \text{B})] + (\text{mrtolb} \cdot \text{B}) & [\text{User Units}] \end{cases}$

S_{default} = normal setpoint defined for the release point in units of $[\mu\text{Ci/ml}]$ and $[\text{User Units}]$.

NOTE : Separate checks are made for each setpoint in $[\mu\text{Ci/ml}]$ and $[\text{User Units}]$ for the noble gas, radioiodine, and particulate monitors.

Setpoints in $\mu\text{Ci/sec}$

Setpoints in units of $\mu\text{Ci/sec}$ can be obtained by setting the UNITS parameter for the monitor to " $\mu\text{Ci/s}$ " or " $\mu\text{Ci/sec}$ " (Case sensitive. 1st 5 characters must match) in the Activity Monitors transaction and setting the monitor slope to 1.0 as in the $\mu\text{Ci/ml}$ setpoint calculation. The user units setpoint, as calculated above for the setpoint in $\mu\text{Ci/ml}$ units, will be multiplied by the corresponding effluent flow rate (release point or discharge point) for the monitor to get a reported setpoint in $\mu\text{Ci/sec}$.

3.5 MAXIMUM WASTE FLOW

The maximum waste flow calculation is based on what the WFLOW_M option (release point setpoint calculation option) is set to. This option can take on one of three values: NONE, DOSE, and CALC. Gaseous release point setpoint WFLOW_M can be set to either NONE or DOSE.

For gaseous releases,

$$W_{max} = \text{the minimum of } R_{wmax} \text{ and } R_{cwmax}$$

where

R_{wmax} = Release point maximum waste flow rate as stored in the release point definition

If WFLOW_M option = NONE

R_{cwmax} = waste flow rate for the sample, V_f

If WFLOW_M option = DOSE

$$R_{cwmax} = \frac{f_s \cdot nratio \cdot V_f}{F_{wsfac}}$$

where

f_s = Safety factor for the release point

$nratio$ = $nratio$ as described in section 3.4

V_f = Waste flow rate for the release (sample)

F_{wsfac} = Waste flow rate DOSE setpoint safety factor

3.6 DOSE RATE AND CUMULATIVE DOSE CALCULATIONS

Noble Gas Dose and Dose Rate Calculations

The dose rate and dose contribution due to noble gases in gaseous effluents are calculated using the following expressions:

For Noble Gas Air Dose due to gamma radiation (for vents or stacks < 80 meters):

$$D_{\gamma} = (3.17 \cdot 10^{-8}) \cdot X/Q_g \cdot t^{-a} \cdot f_o \cdot \sum M_i \cdot Q_{iv}$$

For Noble Gas Air Dose due to beta radiation (for vents or stacks < 80 meters):

$$D_{\beta} = (3.17 \cdot 10^{-8}) \cdot X/Q \cdot t^{-b} \cdot f_o \cdot \sum N_i \cdot Q_{iv}$$

For Noble Gas Total Body Dose Rate (for vents or stacks < 80 meters):

$$D_t = shf \cdot X/Q_g \cdot 8760^{-a} \cdot f_o \cdot \sum (K_i \cdot QR_{iv})$$

For Noble Gas Total Body Dose (for vents or stacks < 80 meters):

$$D_{tb} = \frac{shf \cdot f_o \cdot \sum (K_i \cdot QR_{iv}) \cdot X/Q_g \cdot t^{-a}}{(5.256 \cdot 10^5 / \text{dur})}$$

For Noble Gas Skin Dose Rate (for vents or stacks < 80 meters):

$$D_s = shf \cdot f_o \cdot \sum QR_{iv} \cdot [(L_i \cdot X/Q \cdot 8760^{-b}) + (1.11M_i \cdot X/Q_g \cdot 8760^{-a})]$$

For Noble Gas Skin Dose (for vents or stacks < 80 meters):

$$D_{sk} = \frac{shf \cdot f_o \cdot \sum QR_{iv} \cdot [(L_i \cdot X/Q \cdot t^{-b}) + (1.11M_i \cdot X/Q_g \cdot t^{-a})]}{(5.256 \cdot 10^5 / \text{dur})}$$

where

D_{β} = total beta air dose from gaseous effluents (mrad)

D_{γ} = total gamma air dose from gaseous effluents (mrad)

D_t = the total body dose rate due to gamma emissions by noble gas releases from vent v (mrem/yr)

D_{tb} = total body dose from gaseous effluents (mrem)

D_s = skin dose rate from gaseous effluents (mrem/yr)

D_{sk} = skin dose from gaseous effluents (mrem)

1.11 = conversion factor from mrad to mrem

$3.17 \cdot 10^{-8}$ = inverse of number of seconds in a year
 $5.256 \cdot 10^5$ = number of minutes in a year
 8760^{-a} = adjustment factor used to convert the 1-hour X/Q value to an average 1 year X/Q value (dimensionless)
8760 = number of hours in a year
a = "a" factor for gamma noble gas X/Q
b = "a" factor for noble gas X/Q
 t^{-a} = adjustment factor to convert the 1-hour X/Q value to the short term X/Q value for the release (dimensionless)
t = duration of release (hours)
dur = duration of the release (minutes)
 f_o = occupancy factor defined for the receptor at the given location (dimensionless)
 K_i = total body dose factor due to gamma emissions for noble gas radionuclide i (mrem/yr per $\mu\text{Ci}/\text{m}^3$)
 L_i = skin dose factor due to beta emissions for noble gas radionuclide i (mrem/yr per $\mu\text{Ci}/\text{m}^3$)
 M_i = air dose factor due to gamma emissions for noble gas radionuclide i (mrad/yr per $\mu\text{Ci}/\text{m}^3$)
 N_i = air dose factor due to beta emissions for noble gas radionuclide i (mrad/yr per $\mu\text{Ci}/\text{m}^3$)
 $3.17 \cdot 10^{-8}$ = inverse of number of seconds in a year
 Q_{iv} = release of noble gas radionuclides, i, in gaseous effluents from vent or stack v (μCi)
 QR_{iv} = release rate of noble gas radionuclides, i, in gaseous effluents from vent or stack v ($\mu\text{Ci}/\text{sec}$).
shf = shielding factor (dimensionless)
X/Q = highest value of the noble gas 1-hour X/Q for vent or stack v at the site boundary (sec/m^3)

X/Q_g = highest value of the noble gas 1-hour X/Q for gamma radiation for vent or stack v at the site boundary, (sec/m³)

Organ Dose Calculations

For Critical Organ Dose Rate--Inhalation Pathway and all Pathways for H-3, C-14 (for vents or stacks < 80 meters):

$$DR_{Ta} = X/Q_r \cdot 8760^{-c} \cdot \sum P_{ipTa} \cdot QR_{iv}$$

For Critical Organ Dose Rate--Ground and Food Pathways (for vents or stacks < 80 meters):

$$DR_{Ta} = D/Q \cdot 8760^{-d} \cdot \sum R_{ipTa} \cdot QR_{iv}$$

For Critical Organ Dose-Inhalation Pathway and all Pathways for H-3, C-14 (for vents or stacks < 80 meters):

$$D_{Ta} = (3.17 \cdot 10^{-8}) \cdot X/Q_r \cdot t^{-c} \cdot f_o \cdot \sum P_{ipTa} \cdot Q_{iv}$$

For Critical Organ Dose-Ground and Food Pathways (for vents or stacks < 80 meters):

$$D_{Ta} = (3.17 \cdot 10^{-8}) \cdot D/Q \cdot t^{-d} \cdot f_o \cdot \sum R_{ipTa} \cdot Q_{iv}$$

where

DR_{Ta} = dose rate for age group a and organ T from iodines and particulates with half lives greater than 8 days in gaseous effluents (mrem/yr)

D_{Ta} = dose for age group a and organ T from iodines and particulates with half lives greater than 8 days in gaseous effluents (mrem)

c = "a" factor for Radioiodine/Particulate X/Q

d = "a" factor for D/Q

D/Q = highest value of the 1-hour deposition factor at the distance of the site boundary (1/m²)

P_{ipTa} = dose factor for each radionuclide i, pathway p, organ T, and age group a (mrem/yr per $\mu\text{Ci}/\text{m}^3$)

R_{ipTa} = dose factor for each radionuclide i, pathway p, organ T, and age group a (m² · mrem/yr per $\mu\text{Ci}/\text{sec}$)

X/Q_r = highest value of the radioiodine/particulate 1-hour X/Q for vent or stack v at the site boundary (sec/m^3)

Note: It is assumed P_{ipra} will not contain long term X/Q or D/Q values.

The maximum exposed individual is determined by the maximum dose received by any organ. The summation extends over all applicable nuclides and pathways.

3.7 RESOLVING DOUBLE-COUNTING OF DOSE AND ACTIVITY

Gaseous release points fall into three categories for double-counting of dose and activity. One, a release point will not have activity sampled twice. Two, a release point can have activity that is sampled again downstream and would be double-counted if no corrections were applied. Three, a release point can have samples containing activity already sampled once upstream which would be double-counted if no corrections were applied. The last two categories can be called the "CAUSE" release point and the "EFFECT" release point, respectively.

To avoid double-counting dose and activity, only the "EFFECT" release point will have its activity and concentrations corrected as follows. Corrected activity is calculated as follows:

$$A_{cei} = A_{ei} - A_{ci}$$

where:

A_{cei} = the corrected "EFFECT" release point activity for nuclide i which defaults to zero if its value is less than zero.

A_{ei} = the initial "EFFECT" release point activity for nuclide i

A_{ci} = the "CAUSE" release point activity for nuclide i

Corrected concentrations are calculated as follows:

$$C_{cei} = (A_{cei} / V_e) \cdot 35.315$$

where:

C_{cei} =the corrected "EFFECT" release point concentrations for nuclide i

V_e =the waste volume for the "EFFECT" release point

35.315 =conversion factor from Ci/ft^3 to $\mu Ci/ml$ ($Ci/ft^3 \cdot ft^3/1728 in^3 \cdot in^3/16.387 cm^3$)

3.8 31 DAY PROJECTED DOSE CALCULATIONS

The 31 Day Projected Dose values appear on the Standard and Special Permit Reports. The Projected Dose values are calculated as follows:

$$D_{p\tau} = (D_{\tau} \cdot p) + D_{at}$$

where:

$D_{p\tau}$ =the 31 Day Projected Dose by organ τ , by reactor unit

D_{τ} =the total dose in mrem by organ τ , by reactor unit for the quarter containing the release start date from all closed and open releases when an answer of "Y" is specified for the "Update Totals" field on the release point definition screen.

p =the Projection Factor which is the result of 31 divided by the number of days from the start of the quarter to the end of the release. The quarterly and annual projection values on the standard pre-release report use a projection factor with 92 days or 365 days instead of 31 days in the numerator and do not include the additional anticipated dose term.

D_{at} =Additional Anticipated Dose for gaseous releases by organ τ and quarter of release, by reactor unit.

NOTE: The 31 day dose projections on the Approval/Results screen is the site total for all units.

3.9 GAS POST-RELEASE PROCESSING

After a pre-release permit has been approved, the post-release program is run to:

- o Enter actual release start and stop times, flow rates, etc.
- o Check 10CFR20 limits
- o Check 10CFR50 limits
- o Add the dose and activity data into the cumulative totals.

Compliance with 10CFR20 limits is checked in the same way as described for the pre-release program.

Dose rates are calculated and compared to 10CFR20 limits. Monitor setpoints are not calculated at the post release stage.

CHAPTER 4

LIQUID DOSE FACTOR EQUATIONS

The DFP option is used to calculate the liquid dose factors described previously. Dose factors are calculated separately for each nuclide, organ, and age group. The age group, applied to a specific receptor's dose calculations, is part of the receptor specification.

For a particular receptor, the total dose factor (A_{iTR}) is a sum over each pathway p with its specific mixing ratio:

$$A_{iTR} = \frac{1}{R_{mix,r}} \sum R_{mix,r,p} A_{iT,r,p}$$

where

$A_{iT,r,p}$ = the dose factor for nuclide i , organ T , receptor age group r , and pathway p

$R_{mix,r,p}$ = mixing ratio for the pathway

$R_{mix,r}$ = mixing ratio for the receptor, which is the first non-zero value of $R_{mix,r,p}$ encountered during the calculation

The user specifies which pathways are included by setting the mixing ratios for the pathways desired to the correct non-zero value. If the receptor mixing ratio for a given pathway is zero, that term is not included in the sum.

The DFP option of EMS uses a more expanded form for liquid dose factors than is given in NUREG-0133. These equations are taken from R.G. 1.109, and account for nuclide decay as well as shoreline doses. If desired, parameters may be selected to reduce the calculations to match NUREG-0133 exactly.

Four different forms of equations are used for the dose factors.

4.1 POTABLE WATER

The dose factor for potable water is:

$$A_{i\tau,r,p} = k_0 \cdot (U_{r,p} / dw) \cdot N_i \cdot DF_{i\tau,r} \cdot e(-\lambda_i t_p)$$

where

$A_{i\tau,r,p}$ = dose parameter for organ τ , for the receptor age group r , for nuclide i , due to exposure pathway p , in mrem/hr per $\mu\text{Ci/ml}$

k_0 = units conversion factor, = $1.142E5 = 1E6(\text{pCi}/\mu\text{Ci}) \cdot 1000 (\text{ml}/\text{Kg}) / 8760 \text{ hr}/\text{yr}$

$U_{r,p}$ = usage factor for pathway p and age group r

dw = additional dilution factor for potable water

N_i = fraction of the radionuclide activity released to the water discharge path that reaches a specific receptor.

$DF_{i\tau,r}$ = ingestion dose conversion factor for nuclide i for receptor age group r in organ τ , in mrem/pCi (Tables E-7 to E-11 of R.G. 1.109)

λ_i = decay constant for nuclide i

t_p = average transit time in seconds

4.2 AQUATIC FOODS PATHWAYS

The liquid dose factor is

$$A_{i\tau,r,p} = k_0 \cdot U_{r,p} \cdot BF_{i,p} \cdot N_i \cdot DF_{i\tau,r} \cdot \exp(-\lambda_i t_p)$$

where

$BF_{i,p}$ = bioaccumulation factor for pathway p and nuclide i (from Reg. Guide 1.109, Table A-1). Other variables are as defined on the previous page.

4.3 SHORELINE RECREATION PATHWAY

The pathway-specific dose factors for shoreline deposition are given by:

$$A_{it,r,p} = k_s W_s N_i U_{f,r,p} \frac{1 - e^{-\lambda_i t_b}}{\lambda_i} e^{-\lambda_i t_{sd}} DFG_{it}$$

where

- W_s = shoreline width factor
- k_s = conversion factor = $k_o \cdot k_c \cdot \text{mtv}/3600$
- k_c = water to sediment transfer coefficient in L/kg hr
- mtv = Mass density of sediment in kg/m^2 , 40 kg/m^2
- 3600 = Seconds per hour units conversion factor
- t_b = length of time sediment is exposed to contaminated water, 4.716E8 sec
- t_{sd} = transit time to deposit activity on shoreline
- DFG_{it} = the dose conversion factor for standing on ground contaminated with nuclide i, in mrem/hr per pCi/m^2

4.4 IRRIGATED VEGETABLE PATHWAY

$$A_{i,r,p} = 1.14 \cdot 10^5 \cdot U_{f,r,p} \cdot CF_{iv} \cdot DF_{i,r}$$

where:

$1.14 \cdot 10^5$ = a units conversion factor

CF_{iv} = the concentration factor for radionuclide i in irrigated vegetables, as applicable to the vicinity of the plant site (pCi/kg)/(pCi/L).

Calculation of the Concentration Factor

The calculation of the concentration factor for radionuclide i in irrigated vegetables, CF_{iv} as used in the equation for $A_{i,r}$, is calculated as follows for all radionuclides other than Tritium:

$$CF_{iv} = N_i \cdot M \cdot I \left[\frac{r (1 - e^{-\lambda_{Ei} t})}{Y_V \lambda_{Ei}} + \frac{f_{I} B_{iv} (1 - e^{-\lambda_{i} t_b})}{P \lambda_i} \right] e^{-\lambda_i t}$$

For Tritium, the equation is as follows:

$$CF_{iv} = N_i \cdot M \cdot L_v$$

where

- M = the additional dilution factor from the near field of the discharge structure to the point of irrigation water usage.
- I = the average irrigation rate during the growing season (L/m²h).
- r = the fraction of irrigation-deposited activity retained on the edible portions of leafy vegetables. There are separate values available for radioiodines and particulates.
- Y_v = the agricultural productivity of irrigated leafy vegetables (kg/m²).

- f_i = the fraction of the year that vegetables are irrigated.
- B_{iv} = the crop to soil concentration factor applicable to radionuclide i . (pCi/kg vegetables)/(pCi/kg soil).
- P = the effective surface density of soil (kg/m^2).
- λ_i = the decay constant for radionuclide i (h^{-1}).
- λ_{Ei} = the effective removal rate for activity deposited on crop leaves (h^{-1}), calculated as $\lambda_{Ei} = \lambda_i + \lambda_w$
- λ_w = the rate constant for removal of activity from plant leaves by weathering (h^{-1}).
- t_e = the period of leafy vegetable exposure during the growing season (h).
- t_b = the period of long-term buildup of activity in soil (h).
- t_h = the time between harvest of vegetable and human consumption (h).
- L_v = the water content of leafy vegetable edible parts (L/kg).

4.5 REDUCTION TO NUREG-0133 EQUATIONS

NUREG-0133 does not have shoreline deposit equations, which can be eliminated by setting the Water Recreation Mixing Ratio to zero in the Liquid Receptor Transaction definition under EMS.

For the other equations, reduction to NUREG-0133 is obtained by setting:

$N_i = 1$ (this can be set in the definition of Fraction of Activity Reaching Receptor in DFP)

average transit time $t_p = 0$ (this can be set in the definition of Dose Calculation Parameters in DFP)

CHAPTER 5

GAS DOSE FACTOR CALCULATIONS

The DFP option is used to calculate the gas dose factors described previously. Dose factors are calculated separately for each nuclide, organ, and age group. The age group, applied to a specific receptor's dose calculations, is part of the receptor specification.

The same gas dose factors are used for both the site boundary dose rate calculations and for the maximum individual controlling location dose calculation.

The dose factor for each particulate or iodine nuclide i (or tritium) is given below. It is a function of pathway, organ, and age group. The pathways considered are:

1. Inhalation
2. Ground
3. Milk (Cow or Goat)
4. Meat
5. Vegetable

5.1 INHALATION PATHWAY

$$P_{iTa} = K' (BR)_a (DFA_{iT})_a \text{ (mrem/yr per } \mu\text{Ci/m}^3 \text{)}$$

$$K' = 1E6 \text{ pCi}/\mu\text{Ci}$$

$(BR)_a$ = breathing rate for age group a, in cubic m/yr

$(DFA_{i\tau})_a$ = inhalation dose factor for organ τ , for age group a, for nuclide i, in mrem/pCi

5.2 GROUND PLANE PATHWAY

$$R_{i\tau a} = K' K'' (SF) DFG_{i\tau} [(1 - e^{-\lambda_i t}) / \lambda_i]$$

(m² -mrem/yr per μ Ci/sec)

where

$$K' = 1E6 \text{ pCi}/\mu\text{Ci}$$

$$K'' = 8760 \text{ hr/yr}$$

$$\lambda_i = \text{decay constant for nuclide } i, \text{ in sec}^{-1}$$

$$t = \text{exposure time (sec)} = 4.73E8 \text{ (15 years)}$$

$DFG_{i\tau}$ = ground plane conversion factor for nuclide i, organ τ
 (The same $DFG_{i\tau}$ factors apply to all age groups. The factors labelled total body in the database are applied to all other organs)

SF = shielding factor

5.3 MILK PATHWAY

$$R_{i\tau a} = K' (DFL_{i\tau})_a e^{-\lambda_i t} f Q_F F_{mi} U_{ap}$$

$$\left[f_P f_s \left[\frac{r (1 - e^{-(\lambda_i + \lambda_w)t})}{Y_P (\lambda_i + \lambda_w)} + B_{iv} \frac{(1 - e^{-\lambda_i t})}{P \lambda_i} \right] \right]$$

$$+ (1-f_p f_s) e^{-\lambda_i t_h} \left[\frac{r (1-e^{-(\lambda_i + \lambda_w)t_e})}{Y_s (\lambda_i + \lambda_w)} + B_{iv} \frac{(1 - e^{-\lambda_i t_b})}{p \lambda_i} \right]$$

(m² - mrem/yr per μ Ci/sec)

where

$K' = 1E6 \text{ pCi}/\mu\text{Ci}$

$Q_F =$ feed consumption rate by the milk animal (cow or goat)
(Kg/day)

$U_{ap} =$ age group a milk consumption (cow or goat)

$Y_p =$ agricultural productivity by unit area of pasture feed
grass, in Kg/sq. m

$Y_s =$ agricultural productivity by unit area of stored feed,
in Kg/sq. m

$F_{mi} =$ stable element transfer coefficient for nuclide i,
from feed to milk, in days/liter

$B_{iv} =$ factor for uptake of radionuclides from soil by crops

$r =$ fraction of deposited activity retained on animal feed
grass (cow or milk). Separate values are used for
radiiodines than all other particulates.

$(DFL_{i\tau})_a =$ ingestion dose factor for organ τ , for nuclide i, for
receptor in age group a, in mrem/pCi

$\lambda_i =$ decay constant for nuclide i

$\lambda_w =$ decay constant for removal of activity on leaf and
plant surfaces by weathering, in sec⁻¹

$t_f =$ transport time from pasture to cow or goat to milk to
receptor, in sec.

$t_h =$ transport time from pasture to harvest to cow or goat
to milk to receptor, in sec.

$t_e =$ seasonal crop exposure time, in sec.

$f_p =$ fraction of year that animal is on pasture

f_s = fraction of animal feed that is pasture grass while animal is on pasture

Carbon-14 in Milk

$$R_{iTa} = K'K'' F_{mi} Q_F U_{ap} (DFL_{iT})_a P_c (0.11/0.16) e^{-\lambda_i t_f}$$

(m²-mrem/yr per μ Ci/sec)

where

$$K'' = 1E3 \text{ gm/Kg}$$

P_c = fractional equilibrium ratio

0.11 = fraction of total plant mass that is natural carbon

0.16 = concentration of natural carbon in the atmosphere (g/m³)

and all other parameters as defined above

Only Q_F and U_{ap} depend on cow or goat.

Tritium in Milk

$$R_{iTa} = K'K'' F_{mi} Q_F U_{ap} (DFL_{iT})_a \cdot (0.75) (0.5/H) e^{-\lambda_i t_f}$$

(m²-mrem/yr per μ Ci/sec)

where

$$K'' = 1E3 \text{ gm/Kg}$$

H = absolute humidity, gm/cubic meter

0.75 = fraction of total feed that is water

0.5 = ratio of specific activity of feed grass water to the atmospheric water

and all other parameters as defined above

Only Q_F and U_{ap} depend on cow or goat.

5.4 MEAT PATHWAY

$$R_{ira} = K' (DFL_{it})_a e^{-\lambda_i t_f} Q_F F_{fi} U_{ap} \cdot$$

$$\left[f_p f_s \left[\frac{r (1 - e^{-(\lambda_i + \lambda_w)t_e})}{Y_p (\lambda_i + \lambda_w)} + B_{iv} \frac{1 - e^{-\lambda_i t_b}}{p \lambda_i} \right] + (1 - f_p f_s) e^{-\lambda_i t_h} \left[\frac{r (1 - e^{-(\lambda_i + \lambda_w)t_e})}{Y_s (\lambda_i + \lambda_w)} + B_{iv} \frac{1 - e^{-\lambda_i t_b}}{p \lambda_i} \right] \right]$$

where

F_{fi} = stable element transfer coefficient for nuclide i , from feed to meat, in days/Kg

U_{ap} = receptor's meat consumption (Kg/yr)

t_h = transport time from crop field to receptor, in sec

t_f = transport time from pasture to receptor, in sec

and all other factors are as described for the cow-milk pathway

Carbon-14 in Meat

$$R_{ira} = K' K'' F_{fi} Q_F U_{ap} (DFL_{it})_a P_c (0.11/0.16) e^{-\lambda_i t_f} \\ (m^2\text{-mrem/yr per } \mu\text{Ci/sec})$$

where all terms are as defined above.

Tritium in Meat

$$R_{iTa} = K' K'' F_{fi} Q_F U_{ap} (DFL_{iT})_a \cdot (0.75) (0.5/H) e^{-\lambda_i t_f}$$

(m²-mrem/yr per μCi/sec)

where all terms are as defined above.

5.5 VEGETABLE PATHWAY

$$R_{iTa} = K' (DFL_{iT})_a \left\{ U_a^L f_L e^{-\lambda_i t_L} \cdot \left[\frac{r (1 - e^{-(\lambda_i + \lambda_w)t_e})}{Y_v (\lambda_i + \lambda_w)} + \frac{B_{iv} (1 - e^{-\lambda_i t_b})}{p \lambda_i} \right] + U_a^S f_g e^{-\lambda_i t_s} \cdot \left[\frac{r (1 - e^{-(\lambda_i + \lambda_w)t_e})}{Y_{sv} (\lambda_i + \lambda_w)} + \frac{B_{iv} (1 - e^{-\lambda_i t_b})}{p \lambda_i} \right] \right\}$$

(m²mrem/yr per μCi/sec)

where

U_a^L = consumption rate of fresh leafy vegetation for age group a, in Kg/yr

U_a^S = consumption rate of stored vegetation for age group a, in Kg/yr

f_L = fraction of annual intake of leafy vegetation grown locally

f_g = fraction of annual intake of stored vegetation grown locally

t_L = average time between harvest of leafy vegetation and consumption, in sec.

t_s = average time between harvest of stored vegetation and consumption, in sec.

t_b = long term sediment exposure time, in sec.

t_e = seasonal crop exposure time, in sec.

Y_v = vegetation areal density, in Kg/m²

Y_{sv} = stored vegetation areal density, in KG/m²

p = effective soil surface density

B_{iv} = soil to vegetation transfer factor for nuclide i

All other factors are as defined above.

Carbon-14 in Vegetables

$$R_{iTa} = K'K'' (U_a^L + U_a^S) (DFL_{iT})_a P_c (0.11/0.16) e^{-\lambda_i t_f}$$

(m²-mrem/yr per μ Ci/sec)

where all variables are as defined earlier.

Tritium in Vegetables

$$R_{iTa} = K'K'' (U_a^L + U_a^S) (DFL_{iT})_a \cdot (0.75) (0.5/H) e^{-\lambda_i t_f}$$

(m²-mrem/yr per μ Ci/sec)

where all variables are as defined earlier.

5.6 REDUCTION TO NUREG-0133 EQUATIONS

Inhalation and ground plane pathways are the same in R.G. 1.109 and NUREG-0133. For the other pathways (milk, meat, and vegetable), these equations reduce to the NUREG-0133 values by setting:

$$t_b = 0$$

$$t_e = 9.999E19$$

$$t_f = 0 \text{ (in tritium equations only)}$$

There are no C-14 equations in NUREG-0133, which can be obtained by setting $p_C = 0$.

APPENDIX A

REFERENCES

1. Boegli, J.S., R.R. Bellamy, W.L. Britz, and R.L. Waterfield, "Preparation of Radiological Effluent Technical Specifications for Nuclear Power Plants, "NUREG-0133" (October 1978).
2. Calculation of Annual Doses to Man from Routine Releases of Reactor Effluents for the Purpose of Evaluating Compliance with 10CFR Part 50, Appendix I, U.S. NRC Regulatory Guide 1.109, Rev. 1 (October 1977).