



**UNITED STATES
NUCLEAR REGULATORY COMMISSION**
REGION II
245 PEACHTREE CENTER AVENUE NE, SUITE 1200
ATLANTA, GEORGIA 30303-1257

October 26, 2016

EN 52090

Mr. Bruce Phillips
Interim Vice President, Columbia Fuel Operations
Westinghouse Electric Company
5801 Bluff Road
Hopkins, SC 29061

**SUBJECT: NUCLEAR REGULATORY COMMISSION AUGMENTED INSPECTION TEAM
REPORT NO. 70-1151/2016-007**

Dear Mr. Phillips:

On September 1, 2016, the U.S. Nuclear Regulatory Commission (NRC) completed an Augmented Inspection at your Westinghouse Electric Company facility. The enclosed report (Enclosure 1) documents the inspection results which were discussed with you and other members of your staff during a public exit meeting on September 27, 2016.

The Augmented Inspection Team (AIT) was established to inspect and assess the facts and circumstances surrounding the failure to meet the performance requirements of 10 CFR 70.61 due to exceeding the nuclear criticality safety (NCS) mass limit in a process off-gas scrubber. The team reviewed the record of activities that occurred, interviewed personnel, and conducted facility walkdowns. The inspection charter is included as Enclosure 2.

On May 28 through 29, 2016, Westinghouse conducted an annual inspection and cleanout of the S-1030 scrubber. When the scrubber was inspected and cleaned, a large mass of material was found inside the scrubber inlet transition. At the time, it was believed that the material removed from the scrubber was low in uranium content. The material was removed, and samples subsequently sent for analysis of the uranium content. Preliminary results of the analysis of the material indicated that uranium content may not be low. These results were not adequately pursued until much later when additional analysis was completed and revealed a concentration which indicated that the uranium mass limit was exceeded. The licensee reported the event on July 14, 2016, 24 Hour Event Notification (EN #52090) based on 10 CFR 70 Appendix A(b)(2) "Loss or degradation of IROFS that results in failure to meet the performance requirements of 10 CFR 70.61." On July 26, 2016, Westinghouse updated the EN to confirm that the mass limit for the scrubber inlet transition section was exceeded. On July 31, Westinghouse updated the event notification to report that clean-out material found in the S-1030 scrubber packing and floor also exceeded the uranium mass limit for the scrubber criticality safety evaluation (CSE). Westinghouse also upgraded the EN to a 1 Hour EN based on 10 CFR 70 Appendix A(a)(4).

The objectives of the Augmented Inspection were to: 1) review the facts surrounding the failure to maintain the mass controls in the S-1030 scrubber and the potential for similar failures in other production areas using the same mass control protocols; 2) assess the licensee's response to the failures; and 3) evaluate the licensee's immediate and planned long term corrective actions to prevent recurrence.

The AIT determined that items relied on for safety (IROFS) for the S-1030 scrubber did not ensure that a criticality accident was highly unlikely. The IROFS were not sufficient to prevent exceeding the NCS mass limit of the CSE. Westinghouse incorrectly assumed that only minor amounts of uranium were expected to accumulate in the S-1030 transition and scrubber vessel packing; that low uranium concentration would be present within the scrubber vessel; minimal amounts of small uranium particles were entrained within the intake ductwork; and that the scrubber would constantly dilute the uranium concentration with the addition of makeup water during normal operation and anticipated upsets. As a result, the controls and measures to protect against a criticality were not sufficient to assure subcriticality conditions. The AIT also determined that Westinghouse did not establish adequate management measures to ensure IROFS related to ventilation systems were designed, implemented, and maintained such that they were available and reliable to perform their function when needed.

The AIT also concluded that Westinghouse failed to provide adequate levels of oversight, enforcement, and accountability to the organizations directly involved with configuration management, operations, and maintenance of the wet ventilation systems. Specifically, the management team did not enforce procedure compliance and did not promote the importance of problem identification and resolution, even though established inspection criteria and procedure actions were available. Management did not drive corrective actions to be taken when action limits were exceeded, did not display accountability for monitoring criticality safety controls through management measures, and had a less than adequate questioning attitude that led to non-conservative decision making.

The Augmented Inspection was chartered as a fact finding effort. Therefore, the performance issues identified in this report will require additional NRC inspection follow-up and further review prior to determining what enforcement action, if any, is appropriate.

On August 11, 2016, the NRC issued Confirmatory Action Letter, EA-16-173, (ML16224B082) in response to a letter from David J. Precht dated August 9, 2016 (ML16223A003). The August 9 letter documented those actions (commitments) intended to ensure that the causes of the uranium buildup were adequately identified and evaluated and that appropriate corrective actions have been implemented to improve the performance of the NCS program. The NRC's oversight of the implementation of Westinghouse's commitments will include inspections of the completed actions.

In accordance with Title 10 of the Code of Federal Regulations (10 CFR) 2.390 of NRC's "Rules of Practice and Procedure," a copy of this letter and enclosures will be made available electronically for public inspection in the NRC Public Document Room, or from the NRC's Agencywide Documents Access and Management System (ADAMS), which is accessible from the NRC Website at <http://www.nrc.gov/reading-rm/adams.html>.

Should you have any questions concerning this inspection, please contact us.

Sincerely,

/RA/ L. Wert for

Catherine Haney
Regional Administrator

Docket No. 70-1151
License No. SNM-1107

Enclosures:

1. NRC Inspection Report No. 70-1151/2016-007 w/Attachments
Attachments:
 1. Supplemental Information
 2. Event Timeline
2. Augmented Inspection Team Charter dated July 28, 2016

cc: (See page 4)

cc:

John Howell
Manager
Environment, Health and Safety
Electronic Mail Distribution

Nancy Parr
Manager
Licensing
Electronic Mail Distribution

Christine Kneece
Manager
Industrial Safety
Electronic Mail Distribution

Susan E. Jenkins
Assistant Director, Division of Waste Management
Bureau of Land and Waste Management
Department of Health and Environmental Control
Electronic Mail Distribution

Should you have any questions concerning this inspection, please contact us.

Sincerely,

/RA/ L. Wert for

Catherine Haney
Regional Administrator

Docket No. 70-1151
License No. SNM-1107

Enclosures:

1. NRC Inspection Report No. 70-1151/2016-007 w/Attachments
Attachments:
 1. Supplemental Information
 2. Event Timeline
2. Augmented Inspection Team Charter dated July 28, 2016

cc: (See page 4)

DISTRIBUTION:

E. Michel, RII
T. Vukovinsky, RII
P. Startz, RII
R. Johnson, NMSS
C. Ryder, NMSS
M. Baker, NMSS
PUBLIC

PUBLICLY AVAILABLE NON-PUBLICLY AVAILABLE SENSITIVE NON-SENSITIVE
ADAMS: Yes ACCESSION NUMBER: ML16301A001 SUNSI REVIEW COMPLETE FORM 665 ATTACHED

OFFICE	RII:DFFI	RII:DFFI	RII:DFFI	RII:DFFI	RII:DFFI	RII:DFFI	FCSS
SIGNATURE	/RA/	/RA/	/RA/	/RA/	/RA/	OLópez-Santiago for	/RA/
NAME	MLesser	EMichel	OLópez-Santiago	TVukovinsky	DAnderson	PGlenn	CTripp
DATE	10/26/2016	10/21/2016	10/21/2016	10/24/2016	10/21/2016	10/25/2016	10/21/2016
E-MAIL COPY?	YES NO	YES NO	YES NO	YES NO	YES NO	YES NO	YES NO
OFFICE	FCSS	RII:DFFI	RII:ORA	RII:ORA			
SIGNATURE	/RA/	/RA/	/RA/	LWert for			
NAME	MDiaz	CEvans	LWert	CHaney			
DATE	10/21/2016	10/24/2016	10/26/2016	10/26/2016			
E-MAIL COPY?	YES NO	YES NO					

OFFICIAL RECORD COPY DOCUMENT NAME: G:\DFFI\REPORTS\FINAL
REPORTS\WESTINGHOUSE\2016\IR 2016007 REV 1.DOCX

U. S. NUCLEAR REGULATORY COMMISSION
REGION II
AUGMENTED INSPECTION TEAM

Docket No.: 70-1151

License No.: SNM-1107

Report No.: 70-1151/2016-007

Licensee: Westinghouse Electric Company

Facility: Columbia Fuel Fabrication Facility

Location: Hopkins, SC 29061

Dates: August 1 through September 2, 2016

Inspectors: O. López-Santiago – Team Leader, Chief, Safety Branch
T. Vukovinsky – Senior Fuel Facility Inspector
P. Glenn – Fuel Facility Inspector
D. Anderson – Fuel Facility Inspector
N. Pitoniak – Senior Fuel Facility Inspector
M. Díaz – Chemical Safety Engineer
C. Tripp – Senior Nuclear Process Engineer

Approved by: Catherine Haney
Regional Administrator

EXECUTIVE SUMMARY

Westinghouse Electric Company - Columbia Fuel Fabrication Facility NRC Inspection Report 70-1151/2016-007

The Augmented Inspection Team (AIT) was established to inspect and assess the facts and circumstances surrounding the failure to meet the performance requirements of 10 CFR 70.61 due to exceeding the nuclear criticality safety (NCS) mass limit in a process off-gas scrubber. The objectives of the inspection were to: 1) review the facts surrounding the failure to maintain the mass controls in the S-1030 scrubber and the potential for similar failures in other production areas using the same mass control protocols; 2) assess the licensee's response to the failures; and 3) evaluate the licensee's immediate and planned long term corrective actions to prevent recurrence.

On May 28 - 29, 2016, Westinghouse conducted an annual inspection and cleanout of the S-1030 scrubber. This scrubber is one of the main air scrubbers for the conversion process, with feeds from a multitude of processes. When the scrubber was inspected and cleaned, a large mass of material (approximately 197 kilograms (kg)) was found inside the scrubber. At the time, it was believed that the material removed from the scrubber was low uranium bearing in composition. The material was removed, and samples subsequently sent for analysis of the uranium content. The results of the initial analysis of material received on May 30 were not questioned until subsequent additional analyses were performed, the results of which were received on July 13, 2016. The final analysis indicated that the concentration of uranium was approximately 48%, resulting in 87.5 kg of uranium in the scrubber, which exceeded the mass limit of 29 kg. The licensee reported the event on July 14, 2016, 24 Hour Event Notification (EN 52090) based on 10 CFR 70 Appendix A(b)(2) "Loss or degradation of IROFS that results in failure to meet the performance requirements of 10CFR70.61." The scrubber was shut down on July 14, 2016 to facilitate a more thorough cleanout, and to determine the mass accumulation over the previous six week period since the last cleanout. The inlet transition and scrubber were thoroughly cleaned, and the uranium bearing solids were analyzed. The results of the previous six week run since the May cleanout resulted in approximately 5 kg of uranium accumulation. Based on the six week data, new items relied on for safety (IROFS) were developed to perform a monthly inspection of the scrubber transition area and also to remove the transition piece and conduct a thorough cleanout every six weeks to provide assurance that the mass limit in the scrubber would not be exceeded.

On July 20, 2016, Westinghouse authorized the restart of the S-1030 scrubber without investigating the potential accumulation of uranium in the scrubber packing and vessel. On July 26, 2016, Westinghouse updated the EN to confirm that the mass limit for the scrubber inlet transition section was exceeded. On July 28, 2016, while discussing extent of condition, the licensee decided to shut down the scrubber again and thoroughly inspect the entire scrubber to ensure that the scrubber was free of uranium accumulation. On July 31, 2016, Westinghouse provided an updated EN 52090 to document that cleanout material found in the S-1030 scrubber packing and floor also potentially exceeded the uranium mass limit for the scrubber criticality safety evaluation. The discovery convinced Westinghouse management that none of the IROFS in place for the scrubber would prevent the excessive accumulation of uranium in the scrubber. The event notification was upgraded to a 1 Hour EN based on 10 CFR 70 Appendix A(a)(4) for having no IROFS available to perform their safety function.

Westinghouse later confirmed that they had exceeded the mass limit for the packing section when they determined that 255.15 kg of material was removed.

On August 11, 2016, the NRC issued Confirmatory Action Letter, EA-16-173, (ML16224B082) in response to a letter from David J. Precht dated August 9, 2016 (ML16223A003). The letter documented actions (commitments) intended to ensure that the causes of the uranium buildup were adequately identified and evaluated and that appropriate corrective actions implemented to improve the performance of the NCS program.

In order to determine the safety implications and adequacy of the licensee's immediate corrective actions to address the issues which resulted in the event, the AIT focused on the following items:

Assessment of controls implemented, as documented in the licensee's integrated safety analysis (ISA), for the applicable accident sequences, were sufficient to limit the risk of criticality.

The IROFS credited for the S-1030 scrubber did not ensure that a criticality accident was highly unlikely. The IROFS were not sufficient to prevent exceeding the NCS mass limit as stated in the criticality safety evaluation (CSE). No other controls and process conditions were in place that could provide additional barriers or defense-in-depth to prevent a criticality.

Assessment of the licensee's decision process to restart the scrubber following the initial event (May 2016) and the effectiveness of the immediate corrective actions in response to the event.

Westinghouse's management was not aware of the initial exceedance of the mass limit, therefore, no restart criteria was imposed on the plant following the initial event in May 2016. The licensee did not demonstrate conservative decision making when the scrubber was authorized to restart and it was confirmed that the mass limit was exceeded for the transition section. In addition, the licensee made the decision to restart without identifying the presence of additional mass accumulation in the rest of the scrubber.

Evaluation of licensee's extent of condition for adequacy of scope, depth, identification of causal factors, and proposed corrective actions.

Westinghouse's extent of condition had the appropriate scope and depth to ensure that IROFS and the NCS safety basis for wet scrubbers and related ductwork had adequate technical basis and were properly implemented, and management measures were adequate to ensure availability and reliability of IROFS. In addition, proposed corrective actions appeared to be adequate to manage the accumulation of uranium in the scrubber.

Evaluate if there are other systems where the licensee made similar assumptions about uranium accumulation.

The AIT determined that Westinghouse made similar, un-validated assumptions for multiple CSEs related to ventilation systems. The un-validated assumptions included low uranium content, low particulate carryover, and small amounts of entrained uranium.

Adequacy of internal and external licensee event reporting.

The AIT determined that on June 2, 2016 Westinghouse had sufficient information to conclude that they had exceeded the scrubber mass limit and that IROFS were not sufficient to prevent a criticality. Based on the interviews and information reviewed, a 1-hour report should have been made in accordance with Appendix A(a)(4) of 10 CFR Part 70.

Evaluation of licensee's progress in their root cause analysis for adequacy of scope, depth, identification of contributing causes, and proposed corrective actions.

The licensee's root cause analysis was appropriate in scope, depth, identification of contributing causes, proposed corrective actions, and was determined to be thorough.

Review of safety culture aspects of the event, including conservative decision making and proceeding with actions in the face of uncertainty.

Westinghouse's actions and decisions leading up to, during, and after the event are potentially indicative of an organization that lacked, as an overriding priority, a commitment to emphasize the importance and significance of compliance with nuclear criticality safety limits.

Westinghouse failed to provide adequate levels of oversight, enforcement, and accountability to the organizations directly involved with configuration management, operations, and maintenance of the wet ventilation systems. Specifically, the management team did not enforce procedure compliance and did not promote the importance of problem identification and resolution, even though established inspection criteria (slight dusting of material on surfaces) and procedure actions were available.

Management did not drive corrective actions to be taken when action limits were exceeded, did not display accountability for monitoring criticality safety controls through management measures, and had a less than adequate questioning attitude that led to non-conservative decision making.

Determination of the process(es) and deposition rates involved in the accumulation of material in the scrubber.

The AIT determined that the frequency of scrubber clean outs was incorrectly determined because Westinghouse assumed low accumulation of uranium in the scrubber. In addition, design changes to the scrubber contributed to the precipitation of hardened uranium solids within the scrubber.

Review of analytical techniques used to determine uranium concentration, and chemical analysis of the deposits to verify any process theories. Develop an understanding of what drove different analysis times (e.g., the preliminary analysis completed on July 13, and the analysis of the six-week run of material).

No regulatory concerns were noted with the analytical techniques and chemical analyses used to determine uranium concentration. However, the AIT determined that a lack of understanding of scrubber chemistry and erroneous results from scrubber solution analysis contributed to a lack of confidence in the preliminary uranium concentration results.

Attachments:
Supplemental Information
Timeline

REPORT DETAILS

The Westinghouse facility is located near Columbia, South Carolina, and is situated on a 1,151 (approximate) acre site in Richland County, approximately eight miles southeast of the Columbia city limits, along State Highway 48 (Bluff Road). The facility fabricates fuel assemblies for pressurized water reactors and boiling water reactors using low enriched uranium. The facility uses a wet-chemical ammonium diuranate (ADU) process to convert uranium hexafluoride (UF_6) gas into uranium dioxide (UO_2) powder. The process consists of hydrolyzing vaporized UF_6 gas (which separates most of the fluorides from the uranium) and then precipitating the solution with ammonia followed by separation of liquid and solid phases. The solid phase (ADU) is then calcined and reduced to remove the ammonia and produce UO_2 powder. The powder is then pressed into pellets and sintered. These processes are followed by fuel rod loading and sealing, and fuel assembly fabrication. Westinghouse also performs recovery/disposal operations of scrap fuel produced during the fabrication process. Recovery operations can process a variety of fuel forms from this process.

BACKGROUND:

The S-1030 scrubber was installed in 2001, and began operations in 2002. The S-1030 scrubber replaced the S-1056 scrubbing system and combined vents that previously fed scrubbers S-1056 and 3A/B. In 2009, the feed streams that previously fed the 7A scrubber were routed to the S-1030 scrubber. The S-1030 scrubber operates as a cross flow horizontal packed bed scrubber where a recirculating scrubbing liquid is used to absorb soluble gas molecules and knock down suspended solids including uranium bearing particles vented from several processes in the Conversion area. The scrubber was originally designed to scrub acidic off-gas, however, many of the current feed streams contain ammoniated (basic) off-gas. The main process systems that vent to the S-1030 scrubber include: two nitrate storage columns, calciner off-gas scrubber condensers and various vent lines, decontamination room wet cleaning hood, scrap cage dissolver hood and filter press, S-1030 sump tanks, Blu-M Oxidation hoods/sifter enclosures, scrap cage washing machine, flexible hoses for the ADU holding tank, and various drain lines for conversion process equipment.

The feed streams all tie together through a network of duct work of various diameters to a large diameter section before entering the transition into the S-1030 scrubber. The large surface area reduces the linear velocity of the incoming stream as it enters the scrubber body. This speed reduction allows for greater reaction time between the scrubber solution and the incoming streams. The scrubber body contains a specialized packing to increase the surface area of the scrubber liquid. The increase in surface area allows for more absorption of gaseous contaminants into the scrubber liquid. The following diagram provides a visual representation of the S-1030 scrubber and related feed streams; this diagram does not show the inlet spray nozzles.

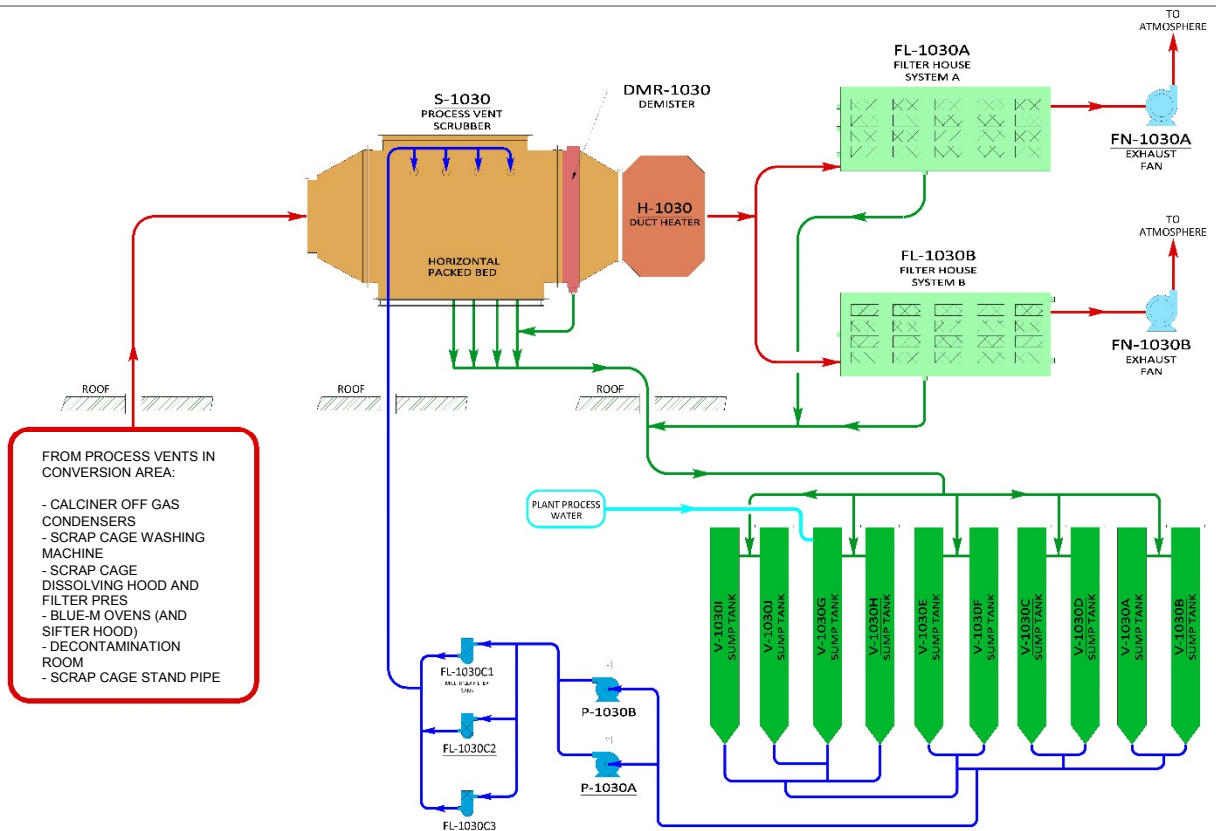

INSPECTION SCOPE:

The objectives of the Augmented Inspection Team (AIT) were to: 1) review the facts surrounding the failure to maintain the mass controls in the S-1030 scrubber and the potential for similar failures on other production areas using the same mass control protocols; 2) assess the licensee's response to the failures; and 3) evaluate the licensee's immediate and planned long term corrective actions to prevent recurrence. The inspection included a review of operating procedures, criticality safety evaluations (CSEs), integrated safety analyses (ISAs), configuration management and maintenance documents, and operational decision making to determine if the facility was operated safely and in compliance with its license. Areas examined during the inspection are identified in each charter item listed below. Within these areas, the inspection consisted of a selective examination of procedures and records, interviews with personnel, and observation of activities being performed by Westinghouse's staff following the event.

CHARTER ITEMS:**1. Develop a complete timeline and sequence of events related to the event.**

Through interviews of licensee personnel and review of licensee records, the AIT developed a sequence of events associated with the S-1030 scrubber event. The detailed sequence of events is included in this report as Attachment 2. The following figure represents an abbreviated timeline and sequence of events related to the S-1030 scrubber.

Sequence of S-1030 Scrubber Events

<u>Date</u>	<u>Activity</u>
~4/28/16	<ul style="list-style-type: none"> • Two operators pressure washed the S-1030 inlet transition • A portion of the slab (~20 kg) fell from the top section of the transition piece. • Operators notify the process engineer about the additional material. The process engineer instructs them to keep pressure washing, that the material will “dissolve.”
~5/12/16	<ul style="list-style-type: none"> • Operators pressure washed the scrubber. • Operators notify the process engineer that the material had not dissolved.
5/16/16	<ul style="list-style-type: none"> • Operator identified 0.5 inch of buildup in inlet duct to scrubber
~5/19/16	<ul style="list-style-type: none"> • Conversion operator pressure washed inlet transition in preparation for annual outage and to address high ammonia levels from the scrubber off-gas. • Slab of uranium bearing material fell into trough and process engineer viewed buildup
5/27/16	<ul style="list-style-type: none"> • Final approval of Radiation Work Permit (RWP) 2016-01 to clean out, inspect and/or replace packing and nozzles inside S-1030 scrubber. • Beginning of inspection and cleaning activities.
5/28/16	<ul style="list-style-type: none"> • Removed 6 - 7 buckets of material from the right and left side of the transition section. • Removed 2.5 additional 55 gallon bags of contaminated packing. Pressure washed the transition sections and some of the bottom of the packing. • Identified a buildup of material in the center section of the transition that needed to be cleaned out (~ 5-7 buckets worth of material.) Recommended dropping the elbow to gain access to the center. • Red Book item 71195 created to document 5-7 popcorn buckets in center section; criticality safety evaluated this accumulation and stated that it did not challenge the safety basis.
5/28/16	<ul style="list-style-type: none"> • Lid taken off the top of the scrubber and nuclear criticality safety (NCS) engineer looked in the top of the scrubber packing and transition ports.

5/29/16	<ul style="list-style-type: none"> • Pulled, inspected, and installed the S-1030 transition nozzles. • Removed another 55 gallon bag of packing and leveled packing in scrubber. • Weighed and sampled the S-1030 buckets (right and left side of the transition section) and turned in the samples to the Chemistry Laboratory
5/30/16	<ul style="list-style-type: none"> • Process engineer received uranium concentration results from first seven samples and the results indicated the previous assumption that the material was low uranium concentration was incorrect. • Process engineer provided weights and uranium concentration results of the first seven samples to NCS Engineer and NCS Manager.
5/31/16	<ul style="list-style-type: none"> • Westinghouse removed inlet elbow and began removing material from center section of inlet transition. • Meeting held with operations, maintenance, safety, criticality engineering (two NCS Engineers present) to brainstorm how to remove remaining material.
6/1/16	<ul style="list-style-type: none"> • A total of 36 popcorn buckets of material were removed from inlet transition for a total of 197 kgs (net weight) of wet, green sludge, and solid green chunks and 1 popcorn bucket of material removed from inlet elbow. • Process engineer received additional uranium concentration sample results.
6/2/16	<ul style="list-style-type: none"> • Process Engineer received the remaining uranium concentration sample results. • Discovery that popcorn buckets not dimensionally verified (failed IROFS) which resulted in NRC EN 51974 • S-1030 scrubber was restarted.
6/20/16	<ul style="list-style-type: none"> • Red Book 71195 was updated stating that the total accumulation removed weighed approximately 463 lbs (gross weight) • Material from 37 buckets placed in 22 cream cans to be dissolved for isotopic analysis.
6/27 - 7/8	<ul style="list-style-type: none"> • Informal meeting between two NCS Engineers, Environment, Health and Safety (EH&S) Manager, and Licensing Project Manager to discuss the potential exceedance of mass limit in S-1030
7/13/16	<ul style="list-style-type: none"> • Grab sample results from all 36 popcorn buckets indicate potential to exceed mass limit; misconception led to belief that material was low uranium and high fluorides. Data reviewed by NCS staff.
7/14/16	<ul style="list-style-type: none"> • Shut down of Conversion/scrubber operations • Westinghouse reported to the NRC EN 52090
7/15/16	<ul style="list-style-type: none"> • First attempt to dissolve the material from the transition cleanout (using water)
7/16/16	<ul style="list-style-type: none"> • After six weeks of operation, inlet transition was inspected and cleaned out, and 5.06 kgs of uranium was removed.
7/20/16	<ul style="list-style-type: none"> • A revised CSE for the S-1030 scrubber, with new IROFS, was implemented.

	<ul style="list-style-type: none"> Westinghouse completed initial Extent of Cause/Condition for other scrubbers. Restart of S-1030 scrubber.
7/26/16	<ul style="list-style-type: none"> Onsite chemical analysis confirmed that uranium mass limit for the scrubber transition piece was exceeded. The accumulated material contained 87 kgs of uranium. Westinghouse revised EN 52090 to confirm that mass limit was exceeded.
7/28/16	<ul style="list-style-type: none"> S-1030 scrubber and conversion process shutdown to perform additional extent of condition inspections of other scrubbers.
7/31/16	<ul style="list-style-type: none"> Westinghouse updated EN 52090 to report that clean-out material found in the S-1030 scrubber packing and floor also potentially exceeded the uranium mass limit for the scrubber CSE. EN 52090 was upgraded to a 1 Hour EN based on 10 CFR 70 Appendix A(a)(4).
8/9/16	<ul style="list-style-type: none"> Westinghouse submits commitment letter to the NRC

2. Assess whether the controls implemented, as documented in the licensee’s ISA for the applicable accident sequences, were sufficient to limit the risk of criticality to “highly unlikely” before the occurrence of any upsets, giving specific consideration to the potential dependence of the controls, common-mode failures, and the Double Contingency Principle. Assess if any other controls and/or process conditions were in place that could provide additional barriers or defense-in-depth to prevent a criticality.

The AIT reviewed the historic and current safety basis for the S-1030 scrubber to evaluate the technical basis for the established mass limit and safety controls, including IROFS. The AIT reviewed all revisions to Nuclear Criticality Safety Evaluation (CSE-1-E) for the S-1030 scrubber to identify the original safety basis and any potential changes that could negatively impact the safety basis. The AIT conducted walk downs of the S-1030 including the different inputs to the scrubber to understand system configuration and to verify process assumptions made in the CSEs. The AIT also conducted interviews of the NCS staff including those responsible for the scrubber and upstream processes to the scrubber. Additionally, the AIT reviewed procedures that implemented the NCS program at the facility, including RA 313, “Criticality Safety Evaluations,” RA-314, “Implementation of Criticality Safety Evaluations,” and RA-310, “Nuclear Criticality Safety Independent Technical Reviews.”

Failure to Ensure Criticality Accident Sequences Remain Highly Unlikely.

Introduction: An unresolved item (URI) was identified for the failure to implement adequate controls to the extent needed to reduce the likelihood of occurrence of a criticality so that, upon implementation of such controls, the event is highly unlikely as required by 10 CFR 70.61(b). Specifically, the licensee failed to ensure IROFS associated with criticality accident sequences with the S-1030 scrubber inlet ductwork, inlet transition area, vessel packing and vessel concentration, were sufficient to ensure a criticality was highly unlikely.

Description: On May 28, 2016, the licensee started the S-1030 scrubber inspection and cleanout activities which resulted in the removal of six - seven buckets of material from the right and left side of the inlet transition section. The licensee also pressure washed the transition sections and some of the bottom of the packing. The licensee completed the S-1030 scrubber cleanout activities on June 1, 2016. The licensee removed a total of 197 kilograms of material for a total of 36 popcorn buckets and an additional popcorn bucket from the inlet elbow. The scrubber was subsequently restarted following the maintenance outage on June 2, 2016. On July 13, 2016, the preliminary results of samples taken from the 36 containers all indicated a concentration of uranium (U) between 40-50% with an average of 47.8%. This equates to approximately 100kg of U in the scrubber, which is an unsafe geometry vessel. The mass limit in the CSE is 29kg U. The scrubber was shut down on July 14, 2016 when the determination was made by the licensee that the mass limit in the CSE had been exceeded. The licensee reported this event as EN 52090, a 24-hour event due to a high consequence event being "unlikely." The licensee also informed NRC inspectors who were on site and they conducted a preliminary inspection of the event. The licensee conducted a thorough inspection of the transition piece and cleaned out the scrubber. Material collected weighed 23.88 kgs and was 21.2%U, resulting in a mass of 5.06 kgs U after six weeks of operation. On July 31, 2016, as part of the extent of condition investigation, the scrubber packing section was inspected, and it was determined by the EH&S department that clean-out material found in the S-1030 scrubber packing and floor also potentially exceeded the uranium mass limit for the scrubber CSE. Over years of operations, the same mass prevention and inspection/clean-out IROFS did not prevent exceedance of the mass limit.

The AIT determined that CSE-1-E, Revision (Rev.) 7, "Criticality Safety Evaluation for the S-1030 Scrubber" incorrectly assumed that only minor amounts of uranium powder were expected to accumulate in the S-1030 transition and scrubber vessel packing; that low uranium concentration would be present within the scrubber vessel; minimal amounts of small uranium particles were entrained within the intake ductwork; and that the scrubber constantly diluted the uranium concentration with the addition of makeup water during normal operation and anticipated upsets. Additionally, the AIT noted that CSE-1-E established the following criticality safety limits for the S-1030 scrubber from June 2009 until present:

- a) 20.82 kg of uranium in the packing
- b) 263 g/liter of uranium in the recirculating spray water
- c) 29 kg of uranium in the transition
- d) 36.5 kg of uranium in the inlet elbow.

The primary contingency of CSE-1-E was that significant amounts of uranium can enter the ductwork leading to S-1030. The licensee established IROFS to prevent the primary contingency from occurring. The secondary contingency assumed the primary contingency had been challenged and additional measures were needed to prevent a criticality. Therefore, IROFS based on the secondary contingency assumed that significant amounts of uranium have entered the inlet to the S-1030 scrubber. The IROFS based on the secondary contingency were established to prevent the uranium from accumulating in a configuration with the mass, moderator, and geometry needed for a criticality. CSE-1-E listed seven credible criticality accident scenarios derived from the criticality hazard evaluation. Each of these seven accident scenarios identified the upset scenario and evaluated the resulting upset conditions for double contingency. Additionally, the upset evaluations identified any Safety Significant Controls (SSCs) necessary to provide double contingency and acceptable risk against a criticality accident. The IROFS for Double Contingency Protection listed in CSE-1-E were a combination

of passive engineered controls and administrative controls. The IROFS for primary contingency protection were passive features and IROFS for secondary protection were active and administrative. The license required that controls are verified to be reliable and effective as described below:

- a) Passive engineered controls are verified at time of installation and, where appropriate, are entered into the management measures programs for routine inspections and maintenance to ensure their reliability and availability.
- b) Administrative controls are implemented through approved procedures. The reliability and effectiveness of administrative controls are assured through procedure reviews, training, experience, and compliance audits.
- c) Active engineered controls undergo an operational verification process prior to first use in any system, to assure reliability of intended function, and are entered into the management measures programs for routine testing and maintenance to assure continued availability.

Based on the mass of material removed from the scrubber inlet, packing area, and scrubber vessel, four accident scenarios included in CSE-1-E were identified by the AIT to have controls which were inadequately implemented to prevent exceeding a mass limit in S-1030. These include:

- a) Uranium Accumulation in Scrubber Vessel Packing or Demister Section
- b) Uranium Concentration in Scrubber Vessel
- c) Uranium Accumulation in Scrubber Inlet Transition
- d) Uranium Accumulation in Scrubber Ductwork, Duct Heater, Scrap Cage Blue-M Duct Expansion, and Flex Hoses

The above referenced accident scenarios all credited four IROFS as the primary contingency to ensure that sufficient uranium was not available for a criticality accident. These IROFS were VENT-S1030-101, -102, -103, and -104. These IROFS included vacuum breaks prior to nonfavorable ventilation ducts, passive overflows at lower elevations than the ventilation ductwork, and a greater than 28 inch vertical rise prior to nonfavorable ducts and scrubber vessel. These IROFS were credited to prevent uranium bearing liquid entrainment into non-favorable ducts and the scrubber (VENT-S1030-101, 102, and 104). Another passive IROFS (VENT-S1030-103) was credited to prevent uranium particulate entrainment by physically separating the process and the ventilation ducts. As evidenced by the large accumulation of mass in the S1030 scrubber inlet transition and vessel packing, these IROFS were inadequate to prevent a significant amount of uranium from entering the ductwork leading to the S1030 scrubber.

The secondary contingencies for the above referenced accident sequences were as follows:

- a) Uranium Accumulation in Scrubber Vessel Packing. The first IROFS was Vent-S1030-105 which required that the packing section have a continuous liquid spray when the scrubber is operating. The assumption was that the spray would prevent material from accumulating on the packing both from the force of impacting water and because the uranium bearing material is mostly water soluble. The second IROFS was VENT-S1030-106 which consisted of a visual inspection of the vessel, packing, and demister and significant uranium concentration (greater than a surface coating) removed on an annual basis. Following the event, it was determined that the uranium bearing material

was mostly insoluble in water and that the visual inspections were inadequate in detecting and removing a significant uranium concentration from the scrubber vessel and packing areas which resulted in exceeding the mass limit in the CSE.

- b) Uranium Concentration in Scrubber Vessel. Two administrative IROFS were implemented as secondary contingencies for this accident sequence. IROFS-S1030-107 and -108. These IROFS consisted of a monthly (and an independent monthly) sample of the scrubber liquid for uranium concentration and reduction measures performed if the concentration was ≥ 1 gU/L (1000ppmU). The assumption for this accident sequence was that the uranium bearing material being scrubbed in the vessel would be dissolved by the scrubbing liquid and be entrained in solution which would be subsequently sampled for indication of uranium build up in the scrubber vessel. Due to the uranium bearing material being mostly insoluble, these controls were inadequate to detect and alert the operators that a uranium mass was accumulating in the scrubber which resulted in exceeding the mass limit of the CSE.
- c) Uranium Accumulation in Scrubber Inlet Transition. The first IROFS was Vent-S1030-109 which required that the inlet transition section have a continuous liquid spray when the scrubber was operating. The assumption was that the spray would prevent material from accumulating in the transition area both from the force of impacting water and because of the uranium bearing material is mostly water soluble. The second IROFS was VENT-S1030-110 which consisted of a visual inspection of the inlet transition and significant uranium concentration (greater than a surface coating) removed on an annual basis. Following the event, it was determined that the uranium bearing material was mostly insoluble in water and that the visual inspections were inadequate in detecting and removing significant uranium concentration from the scrubber transition area which resulted in exceeding the mass limit as stated in the CSE.
- d) Uranium Accumulation in Scrubber Ductwork, Duct Heater, Scrap Cage Blue-M Duct Expansion, and Flex Hoses. The first IROFS was VENT-S1030-111 which required a periodic visual inspection to detect uranium accumulations in ductwork greater than 10-inch diameter. The IROFS required a cleanout of ductwork for accumulations greater than a slight dusting. The second IROFS was VENT-901 which required a periodic gamma survey of ducting, piping, and equipment performed to detect uranium accumulations. The IROFS required a cleanout for accumulations greater than a slight dusting. The periodic inspections for these IROFS were being conducted and material was being detected, however, the licensee was not properly following procedures in that the material collected was not being weighed and sampled for uranium concentration as required. Due to this, the NCS department was not being informed of the potential migration of an excessive amount of material from upstream processes to the S-1030 scrubber. The assumption in CSE-1-E was that controls were in place to prevent large amounts of uranium from entering the ductwork and consequently transported to the S-1030 scrubber. The AIT noted that Control Forms (CFs) from the periodic visual inspections of the ductwork indicated that there was a large amount of uranium bearing material entering the ductwork and subsequently being transported to the S-1030 scrubber which resulted in exceeding the mass limit of the CSE. However, NCS was not notified of the amount of material identified and site management was not tracking and trending the information provided during these inspections.

10 CFR 70.61(b) requires, in part, that the risk of each credible high consequence event must be limited. Engineered controls, administrative controls, or both, shall be applied to the extent needed to reduce the likelihood of occurrence of the event so that, upon implementation of such controls, the event is highly unlikely. The above four accident sequences are potential criticality sequences, and as such, are required to have controls in place to ensure they are highly unlikely. Specifically, the AIT determined that the above listed controls, as implemented by the licensee, were not sufficient to prevent exceeding the mass limits as stated in the CSE. As such, the licensee failed to reduce the likelihood of occurrence of the event to “highly unlikely.” The licensee’s failure to ensure that the likelihood of each credible high consequence event was maintained “highly unlikely” is identified as Unresolved Item (URI) 70-1151/2016-007-01, Failure to ensure criticality accident sequences remain highly unlikely. This issue will require additional NRC review and will be further evaluated during a subsequent inspection to determine severity level.

Failure to Assure that all Nuclear Process were Subcritical

Introduction: A URI was identified for the failure to assure that under credible normal and abnormal conditions, all nuclear processes were subcritical including use of an approved margin of subcriticality as required by 70.61(d). Specifically, the licensee failed to assure that nuclear processes related to the S-1030 scrubber were controlled such that during operations, both normal and abnormal conditions were reasonably assured to remain subcritical.

Description: In June 2009, the licensee implemented CSE 1-E, Rev. 0 which established a new safety basis for the S-1030 scrubber. In September 2015, the licensee revised CSE-1-E to reflect a change in the scrubber supply water from the use of deionized water to process (city) water. This marked the seventh revision to CSE-1-E. From Rev. 0 through Rev. 7, there were no changes to the safety basis mass limits or assumptions used by the licensee. The CSE outlined multiple mass limits that were applied to various sections of the S-1030 scrubber (e.g. 20.82 kg of uranium in the scrubber vessel packing and 29 kg of uranium in the scrubber inlet transition). The mass limit of 20.82 kg is the minimum critical mass for a sphere of $\text{UO}_2/\text{C}_3\text{H}_6$ (uranium dioxide - polypropylene mixture) that is optimally moderated and fully reflected. The mass limit of 29 kg is the minimum critical mass required for a sphere of $\text{UO}_2/\text{H}_2\text{O}$ (uranium dioxide - water mixture) that is optimally moderated and fully reflected.

As part of the CSE development, the licensee conducted a “what-if criticality hazard analysis” to identify scenarios that have a potential criticality concern which would require some type of safeguard(s) to preclude a nuclear criticality. Through the process the licensee explored various scenarios that could lead to a criticality (i.e. changes in vessel packing spray, changes in transition spray, transition and vessel leaks, changes in pH level, acute uranium accumulation, etc.). The licensee’s analysis never considered that mass could accumulate in a chronic fashion within the scrubber.

The CSE documented the normal operating conditions and process flow that outlined pathways of the process off-gas to the S-1030 scrubber. For the normal case of the S-1030 scrubber, specifically the scrubber vessel, inlet transition, and vessel packing, the CSE repeatedly stated that “low uranium accumulation (<1gU/L) and/or minor amounts of uranium powder accumulation” were the normal condition. In regard to anticipated upsets, the CSE stated that minor concentration increases and/or minor uranium accumulation was anticipated; however, any mass accumulation was assumed to remain below the safety limit for the respective section (e.g. transition, scrubber vessel, and packing, etc.) For scenarios identified with a potential for criticality, the licensee conducted a double contingency analysis as required by the License

Application Section 6.1, "NCS Program Structure" which states, in part, that "the Double Contingency Principle is the basis for design and operation of processes using special nuclear material at the Columbia Fuel Fabrication Facility. Double Contingency Protection means that all process designs incorporate sufficient margins of safety to require at least two unlikely, independent, and concurrent changes in process conditions before a criticality accident is possible." Additionally, the licensee identified IROFS necessary to provide double contingency protection.

Within the Double Contingency Analysis the licensee incorporated several incorrect technical assumptions that were fundamental to establishing double contingency and assuring that under credible normal and abnormal conditions, all nuclear processes remain subcritical including use of an approved margin of subcriticality. Specifically, the licensee incorrectly assumed that only minor amounts of uranium powder were expected to accumulate in the S-1030 inlet transition and scrubber vessel packing; that low uranium concentration would be present within the scrubber vessel; that minimal amounts of small particle entrainment of uranium would be present within the intake ductwork; and that the scrubber constantly dilutes the uranium concentration with the addition of makeup water during normal operation and anticipated upsets. Section 6.1.3.c, "Controlled Parameters" of the License Application states, in part, that "all assumptions related to process, equipment, material theory, function and operation (including credible upset conditions) are justified, documented, and independently reviewed."

10 CFR 70.61(d) requires, in part, that the risk of nuclear criticality accidents must be limited to assure that under credible normal and abnormal conditions, all nuclear processes are subcritical including use of an approved margin of subcriticality. Given the licensee's incorrect assumptions which were used to support the double contingency analysis and identification of controls, the controls and measures to protect against a criticality were not sufficient to assure subcriticality conditions. Additionally, although, there was no actual safety consequence to the public, there was sufficient material available in the S-1030 scrubber for a criticality to occur. There were no other controls and/or processes identified to provide additional barriers or defense-in-depth to prevent a criticality. The failure to assure subcriticality is identified as URI 70-1151/2016-007-002. This issue will require additional NRC review and will be further evaluated in a subsequent inspection to determine severity level.

The AIT reviewed the licensee's nuclear criticality safety analysis, Atkins-NS-WDN-16-01, dated September 8, 2016, based on the "S-1030 Chemistry Analysis" White Paper, dated August 31, 2016. The analysis concluded that a realistic modeling of the as-found condition for the S-1030 scrubber event resulted in a k_{eff} value of ~0.89. The licensee also determined that an additional 310 kg of uranium accumulation would be need to exceed the k_{eff} license limit of 0.98.

The licensee concluded that approximately 310 kg of additional mass accumulation would be necessary to achieve a K_{eff} of 0.98. The AIT noted that there was large uncertainty in the calculation and did not agree that it properly characterized the event. The AIT performed independent calculations and modeling and determined that there was sufficient material present in the as-found condition to support a criticality. The AIT also determined that the material remained in a subcritical state due to the geometrically favorable configuration of a trough in the scrubber, where the majority of the material from the transition area was found. Given that sufficient moderator was also present, the as-found accumulation only needed to be configured in a different orientation to produce an environment where a criticality event was possible in the S-1030 scrubber.

The AIT reviewed the uncertainties and assumptions used in the licensee's as-found model. The licensee used an independent chemical laboratory to analyze the chemical composition of material found in the scrubber. As supported by the chemical analysis, the licensee assumed that the accumulated material in the S-1030 scrubber was ammonium uranyl fluoride (AUF) and used AUF as the chemical composition in the as-found NCS model. However, the margin to criticality for the as-found model is uncertain, primarily because of incomplete and/or conflicting data related to the composition of the fissionable material (e.g. chemical composition, density). For example, AUF is ~57 wt% uranium, but samples taken of the scrubber material averaged 41 wt% uranium. Additionally, AUF is 23 wt% fluorine, but the samples taken of the scrubber material averaged 11 wt%. Additionally, the energy dispersive x-ray spectroscopy (EDS) results of several samples showed that the material composition was variable. A variable composition is consistent with the stratified physical appearance of the material found in the S-1030 scrubber.

The AIT noted that the modeled geometry in the as-found model was conservative. However, the material was likely originally in a different configuration and was rearranged into the as-found configuration by power washing. Therefore, it is likely that the material fell or was pushed into the trench by luck and not by design resulting in a favorable geometric configuration for the as-found condition. The licensee used an enrichment of 4.1 wt% ^{235}U , which was lower than the documented plant nominal enrichment for 2016 of 4.391%. In addition, the facility is authorized to possess and process material up to 5 wt% ^{235}U (which is normally assumed in their safety basis analyses.)

Lastly, the AIT reviewed the latest NCS validation report at the facility and noted that AUF was not included in the report. Whether it was validated after the scrubber event is unknown, but there was no indication of this. A lack of validation calls into question the results of the model, given potentially non-validated nuclear cross sections used in the Monte Carlo code calculations. The AIT concluded that the material in the scrubber was subcritical in the as-found configuration, and would remain subcritical as long as most of it remained in the trench. There was sufficient material present that it could have gone critical if the material was removed from the trench and rearranged into a more compact configuration. (i.e. if mounded into a hemisphere)

3. Assess the licensee's decision process to restart the scrubber following the initial event (May 2016). Evaluate the effectiveness of the immediate corrective actions taken by the licensee in response to the event.

The AIT reviewed the licensee's activities leading up to, during, and after the event, the licensee's Safety Event Review Form titled Material Accumulation in S-1030 Transition Piece, procedure RA-107, Corrective Action Process for Regulatory Events, procedure RA-134, Columbia Plant Safety Event Response Guidelines and Procedure, and RA-121, Redbook Internal Reporting System. The AIT also interviewed licensee staff directly involved in the S-1030 scrubber inspection and cleanout, and follow-up activities.

Based on interviews and documentation review, the AIT determined that some plant personnel were aware of the amount of material removed from the scrubber and the concentration, however, this information was not provided to plant management. Thus, site management was not aware of the initial exceedance of the mass limit, therefore, no restart criteria was imposed on the plant following the initial event in May 2016.

On July 13, 2016, site management was made aware that Westinghouse had potentially exceeded the mass limit in the S-1030 scrubber. The decision was made at that time to shut down the scrubber and to conduct a thorough inspection. The scrubber was inspected after running for six weeks and approximately 5 kg of uranium was removed from the scrubber. The licensee used the data from this six-week run to revise the scrubber CSE. New IROFS were created to pressure wash the scrubber at a four-week frequency and to conduct a thorough cleanout of the transition area every six weeks. The mindset was to clean out the scrubber instead of ensuring the implementation of safety controls. Additionally, the licensee was under the assumption that the material accumulating in the scrubber was a high fluoride/low uranium blend and that the initial samples were not representative of the material that had deposited in the scrubber.

The licensee completed an extent of condition for the other scrubbers, however, they only reviewed the previous maintenance activities and did not re-inspect the other scrubbers. Additionally, the packing area of the S-1030 scrubber was not inspected as it was assumed that there was no material accumulated there since some of the packing had been inspected and the inlet face of the packing area was clean. The licensee issued a white paper describing how to measure %U in high fluoride material; and approved the area for restart with a training bulletin review at the start of each shift. Restart of the S-1030 scrubber was authorized by the management review required by procedure RA-134. This management review did not recognize the potential for accumulations in the scrubber packing to exceed mass limits even though the packing is immediately behind the transition.

On July 28, 2016, the S-1030 scrubber was again shutdown. While conducting the extent of condition for the water glass scrubber, site management determined that a thorough inspection of the scrubber internals had not been accomplished and the conservative decision would be to re-inspect the scrubber internals. On July 31, 2016, it was determined by the EH&S department that clean-out material found in the S-1030 scrubber packing and floor also potentially exceeded the uranium mass limit for the scrubber criticality safety evaluation. Over years of operations, the same mass prevention and inspection/clean-out IROFS did not prevent exceedance of the mass limit.

The AIT concluded that Westinghouse's management was not aware of the initial exceedance of the mass limit, therefore, no restart criteria was imposed on the plant following the initial event. The licensee did not establish clear expectations for staff to escalate important information that could negatively impact nuclear safety. The licensee also made the decision to restart without ensuring that the rest of the scrubber did not have additional mass accumulation. The licensee did not exhibit conservative decision making when the scrubber was authorized to restart and it was confirmed that the mass limit was exceeded for the transition section.

4. Review and evaluate the licensee's extent of condition for adequacy of scope, depth, identification of causal factors, and proposed corrective actions. Determine if there are other systems where the licensee made similar assumptions about uranium accumulation.

The AIT reviewed the licensee's extent of condition process and plan. Specifically, the AIT reviewed the Protocol process for organizing the extent of condition review and for identifying items that would require corrective actions. The Protocol process included, but was not limited to the following:

- 1) An independent review of the NCS safety basis for wet scrubbers with nonfavorable geometry components and related ductwork to ensure that there was an adequate technical basis for the systems and that IROFS were properly implemented;
- 2) A review of administrative IROFS related to visual inspection to verify that they were being implemented as required and are able to meet their intended safety function;
- 3) A management measures assessment to verify that measures credited were adequate to ensure availability and reliability of IROFS;
- 4) Review of the NCS safety basis for CSEs with nonfavorable geometry components and mass limits to ensure that there was an adequate technical basis and that IROFS were properly implemented; and
- 5) Review of out of service equipment with nonfavorable geometry components to verify that the systems were isolated and taken out of service in accordance with requirements.

The AIT conducted walkdowns and interviews; reviewed procedures, technical bases, training, and maintenance documents; and observed training, maintenance activities, pre-job briefings, turnover, corrective actions and status meetings. The AIT determined that the licensee's extent of condition process reviewed had an appropriate scope and that it contained sufficient depth. The AIT also determined that the licensee was identifying and documenting corrective actions. The observed items were consistent with the protocol process requirements and facility problem identification and resolution procedures.

The AIT also conducted an independent extent of condition that focused on aspects of the entire ventilation system at the facility. The AIT reviewed the safety basis and control schemes associated with 11 ventilation CSEs. The CSEs included ductwork, scrubber units, and components downstream of the scrubbers such as filter houses. The AIT noted that the control schemes were based on mass and moderator protection to ensure that either a safe mass was not exceeded or that moderator intrusion was prevented.

The AIT also inspected a select set of safety bases and control schemes for the Integral Fuel Burnable Absorber (IFBA) area which included the IFBA coaters, lathe, rework hood, vacuum, and miscellaneous operations. Additionally, the AIT reviewed honing booth operations in the low-level waste area and a selection of waste treatment tanks. Controls schemes for non-ventilation reviews were based on mass, moderator, geometry, and concentration- control. As a part of the independent review, the AIT also conducted walkdowns and interviews and reviewed procedures and records.

The AIT noted that Westinghouse used similar un-validated assumptions for multiple CSEs related to ventilation systems. The un-validated assumptions included low uranium content, low particulate carryover, and small amounts of entrained uranium. The AIT also noted similar issues with the implementation of periodic visual inspections and gamma surveys of ductwork as previously discussed. In addition to reviewing safety bases and control schemes, the AIT also looked at how controls were being implemented and maintained to ensure both availability and reliability.

Failure to Establish Adequate Management Measures to Ensure that IROFS to Perform Their Function When Needed

Introduction: The NRC identified an URI for the failure to establish adequate management measures to ensure that IROFS were designed, implemented, and maintained such that they were available and reliable to perform their function when needed as required by 10 CFR 70.62(d). Specifically, the configuration management program, procedures, training, audits, and corrective actions were not adequate to ensure that IROFS related to S-1030 and ventilation ductwork were available and reliable.

Description: During the AIT inspection, the team independently reviewed the causal factors in reference to the S-1030 scrubber event. In the course of reviewing the management measures for the associated S-1030 scrubber the AIT determined that Westinghouse did not establish adequate management measures (i.e., configuration management program, procedures, training, audits, and corrective actions) to ensure that IROFS related to ventilation systems were designed, implemented, and maintained such that they were available and reliable to perform their function when needed.

The AIT determined that the configuration management (CM) program did not ensure that facility changes and IROFS were properly designed and implemented to prevent adverse impact to the S-1030 safety basis. Those changes included the following:

- On May 28, 2002, the S-1056 scrubber was removed from service and replaced with the S-1030 scrubber. The licensee's CM program failed to ensure that S-1056 was free of uranium before taking the scrubber out of service.
- On June 2005, per CCF 05-334, Blue-M Vent Modification, Blue M Oven filters were removed without evaluating the potential impact on the S-1030 safety basis.
- On February 13, 2009, per COP-815020, Rev. 4, the continuous bleed directly to the Q-tanks was discontinued without considering impact on scrubber operations.
- On June 19, 2009, per CCF 09-505, Scrap Cage Blue M Oven Ventilation Modifications, the plenum hoods of the Blue M ovens were designed using a baseline document for particle carryover that was in error. This document incorrectly under predicted particle size carryover. An evaluation was not done regarding the potential for significant uranium entrainment.
- The S-1030 water spray system for transition piece was inadequate to prevent material uranium buildup because the nozzles were not pointing towards the transition as required by CSE-1-E and there was no documentation regarding the change in orientation of the nozzles.

The ventilation system at Westinghouse contained multiple administrative IROFS for ductwork inspection. In general, the requirements included visual inspections to ensure against fissile material build-up and gamma surveys to detect uranium accumulation. Material build up greater than a light dusting was required to be removed and the weight of the removed material needed to be reported to the NCS group. To accomplish these administrative IROFS, preventative maintenance (PM) and/or operating and maintenance procedures were established. These controls were established on a periodic frequency dependent on the system (i.e. 13 week, 26 week, or annual inspections). The AIT noted that there were discrepancies on how the implementing procedures instituted the above requirements. Specifically, it was noted that the requirement to notify NCS when accumulation was found was either not incorporated into the procedure or was not being performed by the operators. Most procedures reviewed required a

50 - 60 gram sample be collected to determine %U, %U235, and moisture content. These sample results were for Material Control & Accountability (MC&A) purposes and were not provided to the NCS department. The AIT also noted that the procedures only required NCS notification if a quantity in excess of 19 kg was discovered. This amount was considerably more than a "light dusting" which is specified in the administrative IROFS.

Additionally, the 13 week, 26 week and annual PMs required CFs to be filled out at each inspection location. These CFs provided the inspection location, who inspected it, date inspected, amount of material found, and its location within the ductwork. The AIT noted that on multiple occasions, material was identified by these inspections and was correctly annotated on the CFs, however, NCS was not notified of the amount of material identified and site management was not tracking and trending the information provided during these inspections. Specific examples are listed below:

- Quarterly PM of roof ventilation ducts/viewports per MCP-108218, documented on CF-84-007:
 - 5-20-15 – ¼ inch dusting on inlet duct to S-1030 scrubber
 - 2-19-15 – ¼ to 1 inch coating green crystals on inlet duct to S-1030 scrubber
 - 11-21-14 – Heavy build up dark green, yellow and white crystals on bottom of duct on inlet to S-1030 scrubber.
 - 8-19-14 – Wet green puddle 1.5 inches deep on bottom of inlet duct to S-1030 scrubber
- Quarterly PM for ventilation inspection in the Conversion area in accordance with COP-814321 and CF-81-922:
 - 3-9-15 – 64 kg material build up in ductwork leading to S-1030 scrubber
 - 8-25-14 – Sludge and build up (no specific amount) in ductwork leading to S-1030 scrubber
 - 8-27-13 – Build up (no specific amount) in ductwork leading to S-1030 scrubber

Westinghouse also uses periodic gamma surveys as a safety control to identify uranium buildup in the ventilation system. IROFS VENT-901 is an administrative control to conduct periodic gamma survey of ducts, piping, and equipment to detect uranium accumulations. A cleanout shall be performed for accumulations greater than a slight dusting. The inspectors reviewed the quarterly gamma survey results and noted that although these controls were being performed, they never tripped the threshold for required actions. The gamma surveys were dependent upon who was conducting the inspection and how they performed the survey. In addition, the results are only indicative of uranium being present and cannot be used to quantify the amount being accumulated. Corrective actions were taken following the S-1030 scrubber event to more readily identify where and how to conduct gamma surveys to enhance this IROFS.

The above PM results illustrate that a significant amount of material was being transported in the ventilation ductwork leading to the S-1030 scrubber. The PMs, procedures, and operator actions were not adequate in that the requirements of the CSEs and the administrative IROFS were not being accomplished. Material buildup was being identified; however, the CSE safety basis that little or no transportation of material to the S-1030 should be occurring was not being identified and corrected, and NCS was not being notified of the accumulation of material in the ductwork as required by the administrative IROFS. Had the NCS department and site management been cognizant of the routine identification of significant accumulation in the ductwork leading to the S-1030 scrubber, it may have prompted earlier actions by the site to correct the adverse condition leading to the excessive accumulation.

The AIT determined that procedures and training for the ventilation related administrative IROFS were inadequate because of the following:

- The inspections/cleanouts and gamma surveys did not identify / prevent significant uranium accumulation.
- Based upon interviews and a review of procedures, the training program did not assure that process engineers understood the S-1030 scrubber and ventilation safety basis as required by procedure RA-120-7, Regulatory Policy - Communicating Safety Significant Control Information.

The AIT determined that audits and corrective actions for the S-1030 scrubber and related ventilation were inadequate because of the following:

- Formal Compliance Audits and NCS Facility Walkthrough did not ensure that IROFS were available and reliable. The audits failed to ensure that CSE assumptions were valid and failed to verify that administrative IROFS were correctly implemented. As an example, the AIT reviewed EHS-Audit-14-1, Formal Compliance Audit, dated January 15, 2014, which audited, in part, the plant ventilation system. The AIT noted that for the ventilation IROFS that were audited, the licensee only verified that the IROFS were properly transcribed from the CSE to the ISA and to the procedures. The licensee did not verify that the IROFS were being properly implemented to validate effectiveness and reliability. The AIT also reviewed NCS Facility Walkthrough Assessment (FWA), dated March 31, 2016, which reviewed CSE-1-D, -E, -G, -H, -I, and -P. The AIT noted that the audit did not specify which IROFS were audited and did not specify what the responses were provided by the operators to verify that the operators understood the safety function of the IROFS. Also, the FWA did not provide any pass/fail criteria.
- The corrective action program (CAP) did not ensure the effectiveness of corrective actions related to the 2004 Incinerator event, which involved mass accumulation and higher than expected concentration of uranium material in the incinerator system. In addition, accumulation of mass in ductwork was not consistently reported or documented correctly and not entered into the CAP, which resulted in no trending of the issues.
- On May 28, 2016, a Redbook item (71195) was created documenting the material found in the center part of the transition piece (5 - 7 popcorn buckets), and Criticality Safety evaluated (5/31/16) this accumulation and determined it did not challenge the safety basis. However, the organization did not follow up to ensure that total material removed did not challenge the safety basis.
- A December 2009 CAP item documented a significant accumulation in the duct before the S-1030 scrubber. However, actions were not taken to ensure that S-1030 safety basis was not exceeded.

Title 10 CFR 70.62(d) requires, in part, that the licensee shall establish management measures to ensure compliance with the performance requirements of 10 CFR 70.61. The measures applied to a particular engineered or administrative control or control system may be graded commensurate with the reduction of the risk attributable to that control or control system. The management measures shall ensure that engineered and administrative controls and control systems that are identified as items relied on for safety pursuant to 10 CFR 70.61(e) of this subpart are designed, implemented, and maintained, as necessary, to ensure they are available and reliable to perform their function when needed, to comply with the performance

requirements of 10 CFR 70.61 of this subpart.

The AIT determined that on or before July 2016, the licensee failed to establish adequate management measures to ensure that IROFS were designed, implemented, and maintained such that they were available and reliable to perform their function when needed as required by 70.62(d). Specifically, the configuration management program, procedures, training, audits, and CAP were not adequate to ensure that IROFS related to S-1030 and ventilation ductwork were available and reliable. The licensee's failure to establish adequate management measures on or before July 2016 is identified as URI 70-1151/2016-007-03, Failure to establish adequate management measures to ensure that IROFS to perform their function when needed as required by 70.62(d). This issue will require additional NRC review and will be further evaluated in a subsequent inspection to determine the severity level.

5. Determine the adequacy of internal and external licensee event reporting.

The AIT reviewed the licensee's activities leading up to the event, the licensee's Safety Event Review Form titled Material Accumulation in S-1030 Transition Piece, procedure RA-107, Corrective Action Process for Regulatory Events, and procedure RA-121, Redbook Internal Reporting System. The AIT also interviewed licensee staff directly involved in the S-1030 scrubber inspection and cleanout, and follow-up activities. The AIT reviewed evaluation CSE-1-E, Criticality Safety Evaluation for the S-1030 Scrubber, Rev. 7 and ISA 01, Plant Ventilation System Summary, Rev. 10 to determine the safety basis and credited IROFS for the S-1030 scrubber.

Failure to make a 1 Hour Report

Introduction: The AIT identified an URI for the failure to report, within one hour, an event such that no IROFS, as documented in the ISA summary, remained available and reliable, to perform their function, and which resulted in the failure to meet the performance requirements of 10 CFR 70.61. Specifically, the licensee failed to report, within 1 hour, that it had exceeded the S-1030 scrubber inlet transition uranium mass limit and that IROFS were not sufficient to ensure a criticality was highly unlikely.

Description: On May 28, 2016, the licensee started the S-1030 scrubber inspection and cleanout activities which resulted in the removal of 6 - 7 packs of material from the right and left side of the inlet transition section. As part of the activities, the licensee identified a buildup of material in the center section of the inlet transition that needed to be cleaned out. Redbook Item 71195 was created to document that accumulation was found in the center transition section of the S-1030 scrubber and it was estimated that the amount of material was approximately enough to fill an additional 5 - 7 of the popcorn buckets. The Redbook item also stated that a plan was being developed to remove the inlet elbow to provide access to clean out the material. On May 30, 2016, a process engineer received the results from the grab samples taken from the material removed from the right and left side of the inlet transition section. The results ranged from 40.72 - 61.78 %U. The process engineer provided these results and the weights of the buckets of material (43.2 kilograms total) to the NCS engineer responsible for the scrubber system. He also stated that this was only the material from the left and right sections, and not the center section which was scheduled to be cleaned out on May 31.

On May 31, 2016, the responsible NCS engineer responded to the Redbook Item 71195 by stating that the inspection was performed as required and the accumulated material did not

challenge the safety basis of 29 kg of uranium. However, the NCS engineer did not consider the material that had already been removed from the left and right sections of the inlet transition, which the grab sample results indicated that the material ranged from 40.72 - 61.78 %U. Based on interviews and review of available information, the AIT determined that the licensee incorrectly assumed that the material removed from the inlet transition had a low uranium and high fluoride content, even though the grab samples taken from the left and right section of the inlet transaction showed that the assumption of low uranium content was incorrect. As a result, the licensee did not perform a detailed evaluation to determine whether the material discovered in the S-1030 scrubber could have exceeded the safety basis as documented in CSE-1-E, Criticality Safety Evaluation for the S-1030 Scrubber, Rev. 7 and ISA 01, Plant Ventilation System Summary, Rev. 10.

After completion of cleanout activities on June 1, 2016, the NCS engineer communicated to the process engineer that the NCS group did not have any issues with restarting the S-1030 scrubber. Based on interviews and reviews of available information, the AIT noted that the licensee took grab samples and weighed the popcorn buckets throughout the cleaning activities. The AIT determined that on June 2, 2016, the process engineer was knowledgeable of the grab sample and weight results from all the material that was removed from the S-1030 scrubber inlet transition. These results clearly indicated that the uranium mass limit for the S-1030 scrubber inlet transition had been exceeded and that a detailed evaluation of the credited IROFS needed to be performed to determine the reason that the IROFS did not prevent uranium accumulation in excess of the mass limit. However, the licensee did not use these results to evaluate the as-found condition in the scrubber and the response to Redbook Item 71195.

Appendix A(a)(4) of 10 CFR Part 70 requires, in part, a one hour report of any event or condition such that no IROFS, as documented in the ISA summary, remain available and reliable, in an accident sequence evaluated in the ISA, to perform their function, and which results in failing to meet the performance requirements of 10 CFR 70.61. The AIT determined that on June 2, 2016, the licensee failed to report an event such that no IROFS, as documented in the ISA summary, remained available and reliable, to perform their function, and which resulted in the failure to meet the performance requirements of 10 CFR 70.61. Specifically, the licensee failed to report that it had exceeded the S-1030 scrubber inlet transition uranium mass limit and that IROFS were not sufficient to ensure a criticality was highly unlikely. The licensee's failure to make a one hour report on June 2, 2016, is identified as URI 70-1151/2016-007-04, Failure to make a one hour report per Appendix A(a)(4) of 10 CFR Part 70. This issue will require additional NRC review and will be further evaluated in a subsequent inspection to determine severity level.

6. Review and evaluate the licensee's progress in their root cause analysis for adequacy of scope, depth, identification of contributing causes, and proposed corrective actions.

Westinghouse completed its Root Cause Analysis (RCA) on October 5, 2016, in accordance with W2-5.1-103, *Root Cause Analysis*, with the RCA being tracked as Issue Number 100397353. Westinghouse identified two root causes and two contributing causes for the S-1030 scrubber event:

- Root Cause 1: Programmatic controls for configuration management did not have the rigor to mitigate increased uranium accumulation in the S-1030 scrubber when design changes were made to the ventilation system and when operational requirements for the

- scrubber spray system were changed in procedure.
- Root Cause 2: Management did not scrutinize the content of CSE-1-E and as-found conditions in the S-1030 scrubber with the questioning attitude and conservative bias required for a healthy nuclear safety culture. Contributing to this, the management team did not ensure the organization had sufficient procedures and training to recognize and respond to deviations from the safety basis described in CSE-1-E.
- Contributing Cause 1: Operating experience and the corrective action processes were not effectively used to pursue the actions needed to detect, estimate, and mitigate deposited uranium in the S-1030 scrubber.
- Contributing Cause 2: The scope of audits and assessments performed per SNM-1107, §6.1.9 has not provided a comprehensive review of the NCS Program with an appropriate level of intrusiveness applied to higher risk activities.

The RCA also conducted an extent of condition and extent of cause evaluation. As part of the scope of the RCA, the investigation examined processes including, equipment design, criticality evaluation, operating experience, preventative maintenance, change management, uranium sampling, and configuration management aspects associated with the S-1030 scrubber. The RCA examined nuclear safety culture attributes as well as management oversight and determined how the extent of condition and extent of cause impacted other plant systems. The RCA team also reviewed the immediate actions taken and responses related to the operational safety aspects of this event.

The RCA team concluded the following: This event occurred due to long-standing weaknesses in the safety culture at the Columbia Fuel Fabrication Facility (CFFF). The organization did not exhibit the behaviors expected to recognize that nuclear work is unique and that complex technologies can fail in unpredictable ways, resulting in adverse latent conditions not being recognized. Weaknesses in this pattern of thinking contributed to invalid assumptions and non-conservative decisions not being challenged. As a result, mass limits were not well communicated and instructions for verifying the effectiveness of criticality controls were not well established. The following figure from the licensee's RCA illustrates how these latent organizational weaknesses led to error precursors and flawed defenses that allowed this unsatisfactory condition to exist since 2009.

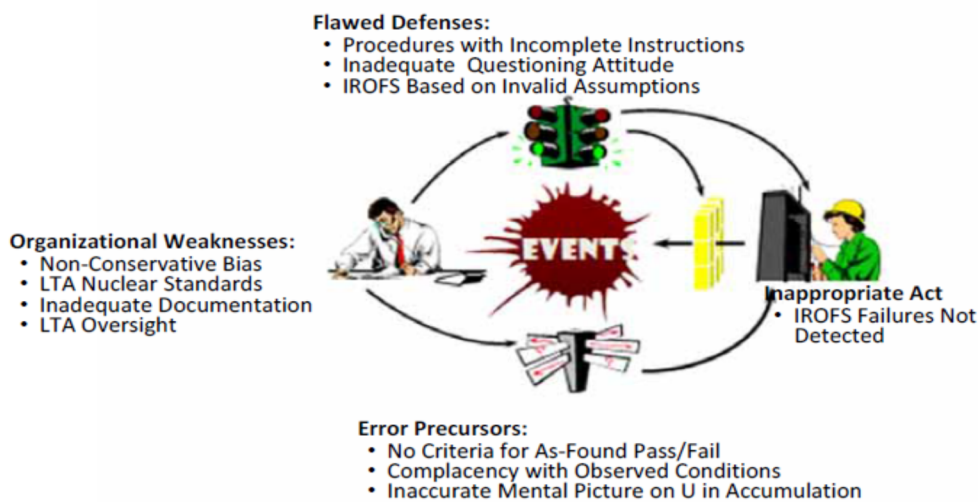

The RCA team identified six Corrective Action to Prevent Recurrence (CAPRs). Westinghouse defines a CAPR as a corrective action that results in a permanent defense that either prevents recurrence of a problem or prevents it from having significant consequences if it does occur. The identified CAPRs targeted several processes to prevent recurrence of the event and are listed below:

- Revising the configuration control procedure to require up-front planning between project, area, and criticality safety engineering. The purpose of the meeting would be to evaluate proposed changes to plant equipment or systems and obtain consensus regarding potential impact on the safety basis.
- Revising the electronic training system to implement a formal review for process changes with impact to safety aspects.
- Revising the configuration control procedure to require an independent technical review if a system or component that is described in a CSE is modified.
- Conduct a performance based assessment to identify needed improvements in design calculations and design packages.
- Revise the S-1030 scrubber inspection and cleanout procedure to clearly specify the recording of data needed to confirm the effectiveness of IROFS in maintaining uranium mass below the limits and to provide clear guidance for timely review and evaluating the data.
- Develop or revise applicable procedures to identify personnel who need training on the safety basis for CSEs.

These CAPRs include three interim actions to minimize the potential for recurrence until long-term corrective actions are implemented. These compensatory actions were directly related to the S-1030 scrubber corrective actions and the long-term corrective actions applied broadly to the entire site. In addition, 22 Corrective Actions, two Remedial Actions, and an Effectiveness Review were identified. All corrective actions have been entered and are being tracked in their corrective action database and Recovery Plan. The AIT reviewed the RCA and no issues were identified with the licensee's RCA for adequacy of scope, depth, identification of contributing causes, and proposed corrective actions, including the interim compensatory measures.

7. Review the safety culture aspects of the event, including conservative decision making and proceeding with actions in the face of uncertainty.

Westinghouse actions and decisions leading up to, during, and after the event were indicative of an organization that lacked as an overriding priority, a commitment to emphasize the importance and significance of compliance with nuclear criticality safety limits. The key cornerstones of the nuclear criticality safety program are mass, moderation, and geometry control. Workers at the facility were trained in these concepts and they were reinforced by the nuclear criticality safety department. The S-1030 scrubber was continuously sprayed with water, so moderation was present. The size of the scrubber was large enough that it was considered non-favorable geometry. Due to the presence of moderation and the geometry being unfavorable, the controls put in place relied upon mass control to prevent a criticality. Specific actions and decisions described below were indicative of an organization that lacked conservative decision making when faced with uncertainty regarding nuclear criticality safety limits.

Approximately one month before the scheduled annual cleanout of the S-1030 scrubber, operations personnel commenced pre-cleaning the scrubber by pressure washing the inlet transition area. During this time, a large slab of material (approximately 20 kg) fell from the center overhead section of the transition area. The operators notified the process engineer about the additional material, but were directed to continue working and not to worry because the material will “dissolve.” Approximately two weeks later while pressure washing the S-1030 scrubber, the operators notified the process engineer that the material previously identified had not dissolved. The operators were again directed to continue with their actions. Additionally, during the annual cleanout of the S-1030 scrubber, operators continued to pressure wash and move the material without knowing the uranium concentration in the material or what the scrubber’s mass limit was. These actions illustrate non-conservative decision making and proceeding in the face of uncertainty. Without knowing the mass and concentration in the material, taking actions to continue to add moderator or disturbing the geometry of the material (pressure washing) could have potentially led to a criticality accident.

Following the May 28 - 29, 2016 annual cleanout of the S-1030 scrubber, the system process engineer was made aware of the amount of material removed from the scrubber and the concentration of uranium in the removed material. These values were approximately three times the safety basis limit of 29 kg of uranium as specified in the CSE for the ventilation system. The process engineer shared with the NCS engineer the first set of sample results obtained from the initial material removed. The common understanding of the personnel involved was that the material being removed was high fluorine, low uranium concentration material even though sample results indicated that the uranium concentration was approximately 50%. The licensee had not established clear expectations for staff to escalate important information that could negatively impact nuclear safety, therefore Westinghouse site management was not made aware that the mass limit had potentially been exceeded, so no actions were taken.

Quarterly and semiannual inspections were conducted of the ventilation ductwork at Westinghouse. Numerous occasions were noted where accumulation of uranium bearing material was found. In most cases, the site failed to sample the material as required by procedure and to inform the criticality safety department of the accumulation. In addition to the ventilation ductwork inspections, previous annual inspections identified large accumulations of material in the S-1030 scrubber and transition area. The material found was assumed by the site to be low uranium bearing material, without truly understanding the source of material accumulation and how it was being transported throughout the ventilation system. Westinghouse failed to provide adequate levels of oversight, enforcement, and accountability to the organizations directly involved with configuration management, operations, and maintenance of the wet ventilation systems. Specifically, the management team did not enforce procedure compliance and did not promote the importance of problem identification and resolution, although established inspection criteria (slight dusting), and procedure actions were available. These accumulations were precursors that provided indications that significant amounts of uranium were being transported in the ventilation system to the S-1030 scrubber.

The AIT determined that the implementation of CSE-1-E was not scrutinized as needed to identify shortfalls in its implementation since June 2009. The shortfalls included:

- a. criticality safety reviewers did not ensure the validity of CSE secondary contingency statements that uranium masses were determined in the transition and packing sections during annual inspections,

- b. implementing procedures did not provide for consistent implementation of these secondary contingency statements,
- c. triennial audits reviewed only a small proportion of the CSEs and the implementation of CSE-1-E had not be done since it was implemented in June 2009, and
- d. management did not react with a sense of urgency on July 1, 2016, when confronted with the possibility that mass limits may have been exceeded in the transition; timely actions were not taken to ensure process engineers and criticality safety engineers scrutinized data from the clean-out.

The AIT determined that a lack of understanding of the scrubber chemistry and inadequate verification of the effectiveness of controls used to maintain uranium accumulation below mass limits in the S-1030 scrubber resulted in accumulations exceeding mass limits without recognition. In addition, Westinghouse's lack of reinforcement of the high performance standards required for a nuclear facility contributed to a less than adequate questioning attitude and a non-conservative bias that allowed operations to continue without reassessing the effectiveness of management measures used to prevent criticality. Management oversight did not drive corrective actions to be taken when action limits were exceeded, did not display accountability for monitoring criticality safety controls through management measures, and had a less than adequate questioning attitude that led to non-conservative decision making and proceeding in the face of uncertainty.

8. Determine the process(es) and deposition rates involved in the accumulation of material in the scrubber, especially as it relates to the scrubber clean out frequency IROFS, and the precipitation of hardened uranium solids within the scrubber.

The AIT reviewed information describing the S-1030 system operation with focus on the chemical and uranium inputs. This information included the licensee's documents on the system operation, material accumulation within ducts and the S-1030 scrubber, scrubber solution pH, and photographic and chemical analysis on scrubber deposits.

The S-1030 scrubber had various process offgas and residual particulates feeding into the system. The S-1030 scrubber system source feeds include the calciner off gas condensers, the scrap cage washing machine, the scrap cage dissolving hood and filter press, the Blue-M ovens (and sifter hood), the decontamination room, and the scrap cage stand pipe. The licensee determined that the primary uranium feed sources contributing to the deposition of material in the scrubber were the Blue M ovens and the calciner offgas. Chemicals identified by the licensee that may have been present in the feed streams are nitric acid, uranium oxides, ammonium diuranate, ammonium fluoride, ammonium bifluoride ammonium nitrate, ammonium hydroxide, uranyl nitrate, and other entrained fluorides. This mixture of chemicals created the opportunity for multiple chemical reactions to occur in the duct work and in the scrubber system. The qualitative analysis and photographs suggested that entrainment/settling; evaporative cooling; particle entrainment; solid phase reactions, gas-liquid adsorption reactions, and liquid-solid reactions were occurring in the scrubber system; none of which were at steady state.

Samples of removed material were sent to an external laboratory, Materials & Chemistry Laboratory, Inc. (MCL) for further material characterization. As confirmed by MCL, the material was a non-homogenous aggregate comprised of multiple phases and components. MCL identified one component as AUF ((NH₄)₃UO₂F₅), which is greenish-yellow crystalline solid that

is sparingly soluble in water. This specie was reported to form through the reaction of solid ammonium bifluoride and U_3O_8 , both of which were present in the calciner off-gas or by a reaction between uranium trioxide, ammonium bifluoride, and ammonium fluoride.

After receiving the external laboratory results, Westinghouse completed their Chemistry Analysis (PSEDOC-3270) on August 31, 2016, which provided an explanation for the formation and accumulation of the uranium bearing material found within the ductwork and the scrubber. The AIT reviewed the PSEDOC-3270, the S1030 CSE, process hazard analysis (PSEDOC-0003264) and analytical results from the licensee's internal chemical lab as well as those from the external laboratory (MCL). Westinghouse identified two main physical processes that had a role in the precipitation and accumulation of material in the S-1030 scrubber. Westinghouse determined that an increased in reaction time, due to a rapid drop in linear velocity in the inlet transition area, and lower temperatures in the scrubber contributed to the precipitation of uranium bearing solids including AUF.

The AIT also noted additional factors that may have contributed to the accumulation of material in the S-1030 scrubber, including modifications that might have reduced scrubber efficiency by increasing the amount of uranium carryover to the scrubber system. Other modifications such as the removal of the continuous feed and bleed of the spray water could have contributed to the accumulation of material. This modification resulted in the concentration of fluoride and ammonium ions in the scrubber process water further creating an environment for the generation of insoluble uranium compounds. Other modifications that may have contributed to the accumulation of material are discussed under item 4 of this report.

The licensee conducted annual cleanouts per COP-815021, "S-1030 Inspection and Clean Out." The frequency for the scrubber clean out was incorrectly determined because Westinghouse assumed low accumulation of uranium in the scrubber. The deposition rate was considered indeterminate because there was no data prior to the discovery of material in the S-1030 scrubber in May and July 2016. The only data point the licensee provided was based on a total of 23.88 kgs of material that was removed after 6 weeks of operation. Based on this data point, the licensee determined that every 6 weeks operators should perform an inspection and cleanout in the S1030 scrubber. The AIT determined that safe operations can be conducted using this inspection-cleanout frequency, particularly given that Westinghouse actions to reduce the entry of uranium into the ventilation system. Operation with this inspection-cleanout frequency will allow the collection of additional information that will support the identification of more appropriate inspection/cleanout frequencies.

9. Review the analytical techniques used to determine uranium concentration, and review the chemical analysis of the deposits to verify any process theories. Develop an understanding of what drove different analysis times (e.g., the preliminary analysis completed on July 13, and the analysis of the six-week run of material).

The AIT conducted interviews with licensee personnel and reviewed laboratory procedures as well as analytical results from the licensee's internal chemical laboratory to develop an understanding of the difficulties that the licensee experienced when trying to obtain uranium concentration results.

The AIT reviewed procedure COP-815021, S-1030 Inspection and Clean Out, which required grab samples to be taken from the material removed from the scrubber and sent to the chemistry lab to determine wt%U. The licensee obtained a grab sample from each bucket of

material. The initial seven samples were sent to the WEC chemistry lab and dissolved in nitric acid. The samples were analyzed per analytical laboratory procedure COCL-U01, Determination of Uranium by Potentiometric Titration, Rev. 35 and COCL-U02, Preparation of Samples for Uranium Analysis by Potentiometric Titration, Rev. 14.

The lab results were provided on May 30, 2016, and ranged from 41%- 62% uranium concentration. During the initial clean out additional material was found and it was determined that the cleanout scope was to be expanded. The material was removed and additional samples were analyzed from the inlet transition piece and elbow. The results were provided to cognizant personnel by June 2, 2016, and they ranged from 34%-54% wt%U.

Material Control and Accounting was informed regarding the material accumulation and the wt%U on June 1, 2016. Since the material was collected after inventory (i.e., May 27, 2016), it was determined that the material would be included as a miscellaneous receipt in the 2016 – 2017 Material Balance Period. The material was placed in storage and no further action was taken until the licensee determined that the amount of material in the scrubber had potentially exceeded the mass limit on July 13, 2016.

Despite the initial sample results analyzed by the Westinghouse lab indicating high uranium content, the licensee still continued to assume the material was low uranium. Because the licensee assumed the uranium concentrations were low, they incorrectly concluded that the samples were not homogenous and could not be trusted. Therefore when they received the results that showed a range of high uranium concentration results, they decided that a better method of analysis would yield an accurate result (i.e., one that conformed to their assumptions) for the amount of uranium removed from the scrubber inlet transition. Since, the licensee believed the material actually had a low uranium content they did not consider investigating it to be a high priority.

On July 19, 2016, the licensee developed procedure SOI-C-0665, Disposition of S-1030 Cleanout Material, to create a method for obtaining a more homogeneous representative sample of the material. The licensee quantified the material from the six week clean out and then proceeded with quantifying the material from the annual cleanout using the same method as the method used for the six week clean out. To ensure that a homogenous sample was obtained, the licensee took 15 samples from different locations throughout the same container. In addition, the licensee ensured that the samples were dry and uniformly mixed for consistency.

The AIT reviewed S-1030 Cleanout Material Analysis, dated July 21, 2016. On July 16, 2016, the intake to the S-1030 scrubber was pulled, and the licensee found additional accumulated material, so the inlet transition was cleaned. A total of 23.88 kg was removed. This time the licensee used the more robust established in SOI-C-0665 to analyze for wt%U. The results were 21.2 %U. All values were very similar, confirming that a sample taken anywhere in the container is representative of the container as a whole. Statistical analysis of the mixing and sampling technique was performed and showed that the results were statistically representative at a 3-sigma level. Re-analysis of the material from the initial clean out showed a uranium concentration of around 47.2%U, which fell within the range of the initial analysis.

The AIT did not identify regulatory concerns with the analytical techniques and chemical analysis used to determine uranium concentration. However, the AIT determined that a lack of understanding of the scrubber chemistry and results from scrubber solution analysis, which was not representative of the material in the scrubber, contributed to a lack of confidence in the preliminary laboratory results of uranium concentration.

EXIT MEETING:

During the course of the inspection, the team provided members of the plant staff and management summaries of inspection findings on a daily basis. During these discussions, licensee representatives identified some of the material examined during the inspection as proprietary. All proprietary information was returned to the licensee. The team presented the inspection results to members of the plant staff and management at a public meeting conducted on September 27, 2016, in Columbia, SC. The plant staff acknowledged the findings presented.

SUPPLEMENTAL INFORMATION

Key Points of Contact

M. Annacone	Vice President, Columbia Recovery
G. Byrd	Licensing Engineer
J. Coleman	Measurement Control Coordinator
C. Gantt	Senior Engineer, Pellet Operations
T. Graves	Conversion Engineer
J. Howell	Environment, Health and Safety (EH&S) Manager
F. Jackson	Director of Manufacturing, Standardization and Major Products
M. Krissingner	Senior Chemist
R. Likes	Safeguards Coordinator
G. McGehee	Senior NCS Engineer
C. Miller	Senior NCS Engineer
J. Nimmo	Conversion Team Manager
N. Parr	Licensing Manager
B. Phillips	Vice-President
B. Waskey	Analytical Services and Chemical Quality Control Manager
S. Weathers	Conversion Engineer
H. Whitaker	Principal Quality Engineer, Product Assurance Chemical Operations
J. Vining	Senior NCS Engineer

Other licensee employees contacted included engineers, technicians, production staff, and office personnel.

List of Items Opened

<u>Item Number</u>	<u>Status</u>	<u>Type/Description</u>
URI 70-1151/2016-007-01	Open	Failure to ensure criticality accident sequences remain highly unlikely
URI 70-1151/2016-007-02	Open	Failure to assure that under credible normal and abnormal conditions, all nuclear processes were subcritical including use of an approved margin of subcriticality
URI 70-1151/2016-007-03	Open	Failure to establish adequate management measures to ensure that IROFS to perform their function when needed
URI 70-1151/2016-007-04	Open	Failure to make a 1 hour report.

Inspection Procedures Used

IP 88003 Reactive Inspection for Events at Fuel Cycle Facilities
 IP 88015 Nuclear Criticality Safety
 IP 93800 Augmented Inspection Team

Key Documents ReviewedProcedures:

COP-801016, Inspection of Building Ventilation Ducts with Boroscope, Rev. 9
 COP-814321, Inspection of Ventilation Ducts, Rev. 15
 COP-815020, Scrap Recovery Scrubber S-1030, Rev(s). 0, 5, 6, and 7
 COP-815021, S-1030 Inspection and Clean Out, Rev(s). 0, 1, 2, 3, 4, 5, 6, 7, and 8
 COP-815023, S-2A and S-2B Inspection and Clean Out, Rev. 0
 COP-874086, Inspection of Ventilation Ducts, Rev. 3
 COCL-U01, Determination of Uranium by Potentiometric Titration, Rev. 35
 COCL-U02, Preparation of Samples for Uranium Analysis by Potentiometric Titration, Rev. 14
 MCP-108104, Changing Roof-Top (HEPA) Intermediate and Pre-Filters, Rev. 30
 MCP-108218, Inspection of Roof Ventilation Ducts with Boroscope, Revs. 7 and 8
 SOI-C-0665, Disposition of S-1030 Cleanout Material, Revs. 0, 1, 2, 3, and 4
 RA-120-7, Regulatory Policy - Communicating Safety Significant Control Information, Rev. 5
 RA 107, Corrective Action Process for Regulatory Events, Rev. 24
 SOI-C-0647, S-1030 Contaminated Demister Pads from the Roof to Chemical Area, Rev. 0

Records

QCF-810, Rev.1, Analytical Chemist Work Request –Miscellaneous Samples, S-1030 Solids %U for all 7 Individual Samples, dated May 30, 2016
 QCF-810, Rev.1, Analytical Chemist Work Request –Miscellaneous Samples, S-1030 Cleanout Material for %U and %U235, (Sample Nos.: S18067-1, S18067-2, S18484-1, S18484-2, S18482-1, S18482-2, S18483-1, S18483-2, S18486-1, S18486-2), dated July 22, 2016
 QCF-810, Rev.1, Analytical Chemist Work Request –Miscellaneous Samples, S-1030 Cleanout Material for %U and %U235, (Sample Nos.: S17614-1, S17614-2, S18065-1, S18065-2, S18062-1, S18062-2, S18064-1, S18064-2, S18063-1, S18063-2, S18066-1, S18066-2, S18061-1, S18061-2), dated July 22, 2016
 QCF-1203, COCL U-01 Uranium Titration Analysis Worksheet, Scrubber, dated July 18, 2016
 QCF-1203, COCL U-01 Uranium Titration Analysis Worksheet, Scrubber, dated July 19, 2016
 QCF-1203, COCL U-01 Uranium Titration Analysis Worksheet, Scrubber, dated July 20, 2016
 QCF-1203, COCL U-01 Uranium Titration Analysis Worksheet, Scrubber, dated July 21, 2016
 QCF-1203, COCL U-01 Uranium Titration Analysis Worksheet, Scrubber, dated July 23, 2016

Work Orders:

731203, 693528, 657563, 548326, 583812, 620717, 708931, 718347, 727840, 700116, 384730, 390126, 479924, 514354, 548326, 583812, 735546, 718347, 727840, 708931, 700116, 691105, 681632, 672485, 663724, 653890, 656234, 682549, 664341, 635992, 626287

CCFs:

CCF 05-334, CCF 09-505, CCF 01-152, CCF 09-471, CCF 09-516, CCF 09-248

PMs/Oms:

PM 81230, PM85160, PM85161, PM20319, PM83335, OM81801, OM81231, OM81000,
 OM81001, OM83102, OM83105, OM82004, OM81808, OM81807, OM81233, OM81805,
 OM81809, OM85027, OM85240, OM85243, OM85241 ,OM86003

Other Documents:

CAPAL 1003888517

CAPAL 100397353

RB 71195

RB 68119

RB 68202

RB 68245

RB 68951

RB 68963

RB 70415

RB 71124

RB 47190

RB 63910

RB 64633

RB 69796

IR 09-343-C007

IR 09-343-C007-C01

RAF-134-1, Safety Review Form, July 20, 2016

PSEDOC-3270 Rev.0, S-1030 Chemistry Analysis, dated August 31, 2016

Katz and Rabinowitch, Chemistry of Uranium, 1951

CF-81-914, Scrap Recovery S-1030 System

CSE 1-E, Rev. 0, "Criticality Safety Evaluation for the S-1030 Scrubber"

CSE 1-E, Rev. 7, "Criticality Safety Evaluation for the S-1030 Scrubber"

CSE 1-E, Rev. 8, "Criticality Safety Evaluation for the S-1030 Scrubber"

CSE 1-AA, Rev. 4, "Pellet Grinder Ventilation System"

CSE 1-AB, Rev. 1, "S-1008 Scrubber Filter Housing"

CSE 1-AC, Rev. 3, "Erbia Exhaust Ventilation"

CSE 1-AD, Rev. 2, "S-958 Scrubber Filter Housing"

CSE 1-AE, Rev. 3, "IFBA Scrubber"

CSE 1-AF, Rev. 3, "S-7159 Scrubber Filter Housing"

CSE 1-AN, Rev. 3, "IFBA DC-801 Torit Ventilation System"

CSE 1-AK, Rev. 4, "1A/1B Filter Housing"

CSE 1-AL, Rev. 3, "Chemical Lab Vent System FL-973 Filter House"

CSE 1-AJ, Rev. 2, "Chemical Development Lab Vent System"

CSE 12-D, Rev. 6, "Fuel Rod Manufacturing on Rod Line 5"

CSE 14-B, Rev. 6, "IFBA Coaters"

CSE 14-C, Rev. 12, "Miscellaneous Operations in IFBA Area"

CSE 13-C, Rev. 3, "CFFF Low Level Rad Waste Miscellaneous Operations"

CSE 15-A, Rev. 8, "Waste Treatment Tanks Various"

NRC – CAL Response Verification Documentation Flowchart, Rev. 1

Protocol Development and Execution Process Diagram

Protocol Master Template

LTR-EHS-16-36, "EH&S Regulatory Assignments", dated April 1, 2016

Atkins-NS-WDN-16-01, dated September 8, 2016

S-1030 Cleanout Material Analysis, dated July 21, 2016

MCL Lab Report WES003138A/WES003138B

EHS-AUDIT-09-003, March 18, 2009

EHS-AUDIT-12-07, July 2012

EHS-AUDIT-15-11

Various E-mail Correspondence between Westinghouse Staff

List of Acronyms Used

ADU	Ammonium Diuranate
AIT	Augmented Inspection Team
AUF	Ammonium Uranyl Fluoride
CAP	Corrective Action Program
CAPR	Corrective Action to Prevent Reoccurrence
CF	Control Form
CFFF	Columbia Fuel Fabrication Facility
CFR	Code of Federal Regulations
CM	Configuration Management
CSE	Criticality Safety Evaluation
EDS	Energy Dispersive X-ray Spectroscopy
EH&S	Environment, Health and Safety
EN	Event Notification
FAW	Facility Walkthrough Assessment
IFBA	Integral Fuel Burnable Absorber
IROFS	Items Relied on for Safety
ISA	Integrated Safety Analysis
Kg	Kilograms
MCL	Materials & Chemistry Laboratory, Inc.
NCS	Nuclear Criticality Safety
NRC	Nuclear Regulatory Commission
PM	Preventive Maintenance
RCA	Root Cause Analysis
Rev.	Revision
RWP	Radiation Work Permit
SNM	Special Nuclear Material
SSC	Safety Significance Controls
U	Uranium
URI	Unresolved Item
WT	Percent by Weight

S1030 – SCRUBBER EVENT TIMELINE

<u>DATE</u>	<u>ACTIVITY</u>
2001-2002 (5/28/02)	<ul style="list-style-type: none"> Removal of S-1056, 3A, and 3B scrubbers Installation of S-1030 to replace above scrubbers (CCF 01-152)
6/2005	<ul style="list-style-type: none"> Removed and replace Blue M filter box with straight 6" duct
5/30/06-6/7/06	<ul style="list-style-type: none"> S-1030 Transition Piece, inlet elbow and tellerettes Cleaned-out High U material was removed (WO 390126) 23kg of U removed from scrubber packing area. Transition section had significantly U accumulation >29kg.
	
2007	<ul style="list-style-type: none"> S-1030 Transition Piece and elbow removal Clean-out indicate significant build up



-
- 5/19/07**
- *Replaced fiberglass cover on S-1030 with clear PVC and installed additional viewports (CCF 07267 and CCF 07282)*
-

- 5/9/08**
- *Reinstalled fiberglass cover on S-1030 (CCF 08255)*
-

- 5/31/08**
- *Pressure washed S-1030, transition piece and inlet elbow (WO 418572)*
-

- 3/18/09**
- *EHS-Audit-09-003*
-

- *S-1030 Transition and inlet elbow cleanout*
- 5/5/09**
- *High U material was removed (but less than the 1956 kg U limit at the time)
(WO 479924)*



-
- 5/27/09**
- *Installed additional viewports on S-1030 (CCF 09471)*
-

- 6/18/09**
- *S-1030 CSE Creation: 29 kgU limit implemented (CSE-1-E, Rev. 0)*
-

6/19/09	<ul style="list-style-type: none"> The vent line of the Blue M Oven has expansion Plenums installed that were designed to reduce the amount of particulates that travel to scrubber S-1030. (CCF 09505)
9/17/09	<ul style="list-style-type: none"> COP-815020 revised to stop ammonia addition to the scrubber to reduce precipitation of U in the S-1030 scrubber
12/9/09	<ul style="list-style-type: none"> Issue Report Initiated for Significant Accumulation in the duct before S-1030 scrubber (IR 09-343-C007)
2/9/10	<ul style="list-style-type: none"> CCF 09-240 implemented to remove ammonia line to scrubber
4/22/10	<ul style="list-style-type: none"> In reference to IR 09-343-C007. Most of the build up comes from the calciner off gas scrubber vent based on the high fluoride content in the accumulated material in the duct. The following Actions were taken: <ol style="list-style-type: none"> Clean out the accumulation inside the calciner off gas scrubber. Replace tellerettes in S-1030 scrubber Change out spray nozzles of S-1030 scrubber. Train operators to leave the S-1030 scrubber water on at all time to stop the carry over. Implement 6 month clean out PM and OM of the calciner (IR 09-343-C007-C01)
5/5/10	<ul style="list-style-type: none"> Pressure washed S-1030 scrubber, transition and inlet elbow (WO 514354)
5/3/11	<ul style="list-style-type: none"> Pressure washed S-1030 scrubber, transition and inlet elbow (WO 548326)
5/7/12	<ul style="list-style-type: none"> Pressure washed S-1030 scrubber, transition and inlet elbow (WO 583812)
5/9/13	<ul style="list-style-type: none"> Pressure washed S-1030 scrubber, transition and inlet elbow (WO 620717)
4/23/15	<ul style="list-style-type: none"> COP-815021, S-1030 Inspection and Clean Out , Rev. 5 issued This revision included the following language: "From past experience the % U of the trapped powder is approximately 45.0-48.0 %."
5/7/15	<ul style="list-style-type: none"> Pressure washed S-1030 scrubber, transition, and inlet elbow; Replaced demister pads (WO 693528)

11/17/15	<ul style="list-style-type: none"> Operator Identifies .25 inch of buildup in inlet duct to the S-1030 scrubber
Periodically	<ul style="list-style-type: none"> Sporadic scrubber pressure wash to dissolve fluoride build-up and collect solids in bag filter
~4/28/16	<ul style="list-style-type: none"> Two operators pressure washed the S-1030 inlet transition A portion of the slab (~20 kg) fell from the top section of the transition piece. Operators notify the process engineer about the additional material. The process engineer instructs them to keep pressure washing that the material will “dissolve.”
~5/12/16	<ul style="list-style-type: none"> Operators pressure wash the scrubber. Operators notify the process engineer that the material had not dissolved.
5/16/16	<ul style="list-style-type: none"> Operator Identifies .5 inch of buildup in inlet duct to scrubber
~5/19/16	<ul style="list-style-type: none"> Conversion operator pressure washed inlet transition in preparation for annual outage and to address high ammonia levels from the scrubber off-gas. Slab of uranium bearing material fell into trough and process engineer viewed buildup
5/27/16	<ul style="list-style-type: none"> Final approval of Radiation Work Permit (RWP) 2016-01 to clean out, inspect and/or replace packing and nozzles inside S-1030 scrubber. Beginning of inspection and cleaning activities.
5/27/16	<ul style="list-style-type: none"> Removed S-1030 scrubber lid and demister pad view ports. Inspected demister pad and found acceptable. Inspected top of scrubber tellerettes. Pictures taken for reference and documentation. Removed piping and nozzles, inspected and reinstalled. Started removing grossly contaminated tellerettes. Noted that a lot of fluorides have been knocked down into the inlet transitions that will need to be removed. Started removing contaminated tellerettes. (WO 731203)



May 27, 2016 Inlet Transition Elbow

-
- Annual outage (Shutdown); planned annual scrubber clean-out;
 - Removed 6-7 polypacks of material from the right and left side of the transition section. Removed 2.5 additional 55 gallon bags of contaminated packing (tellerettes). Pressure washed the transition sections and some of the bottom of the packing. Identified a buildup of material in the center section of the transition that will need to be cleaned out – appears to be 5-7 polypaks worth of material. Recommend dropping the elbow to gain access to the center.
 - Red Book Item 71195 indicating 5-7 popcorn buckets; Criticality safety evaluated this accumulation and stated it did not challenge the safety basis.

5/28/16



Empty popcorn bucket

-
- 5/28/16**
- Lid taken off the top of the scrubber NCS engineer looked in the top of the scrubber packing and transition ports
-
- 5/29/16**
- Pulled, inspected and installed the S-1030 transition nozzles.
 - Removed another 55 gallon bag of packing and leveled packing in scrubber.
 - Weighed and sampled the S-1030 buckets (right and left side of the transition section) and turned in the samples to the Chemistry Laboratory.
-
- 5/30/16**
- Process engineer received uranium concentration results from first 7 samples and the results indicated the previous assumption that the material was low uranium concentration was incorrect.
 - Process engineer provided weights and uranium concentration results of the first 7 samples to NCS Engineer and NCS Manager.
-
- 5/31/16**
- Westinghouse removed inlet elbow and began removing material from center section of inlet transition.
 - Meeting held with operations, maintenance, safety, criticality engineering (2 NCS Engineers present) to brainstorm how to remove remaining material.
-





6/1/16	<ul style="list-style-type: none"> • A total of 36 popcorn buckets of material were removed from inlet transition for a total of 197 kgs (net weight) of wet, green sludge, and solid green chunks and 1 popcorn bucket of material removed from inlet elbow. • Process engineer received additional uranium concentration sample results.
6/2/16	<ul style="list-style-type: none"> • Process Engineer received the remaining uranium concentration sample results. • Discovery that “popcorn” buckets not dimensionally verified (failed IROFS) which resulted on NRC Event Notification (EN) 51974 • S-1030 scrubber was restarted.
6/20/16	<ul style="list-style-type: none"> • Red Book 71195 was updated stating that the total accumulation removed weighed approximately 463 lbs (gross weight) • Material from 37 buckets placed in 22 cream cans to be dissolved for isotopic analysis
6/21/16	<ul style="list-style-type: none"> • Personnel changes (New acting NCS manager)
(6/27) ~ (7/8)	<ul style="list-style-type: none"> • Informal meeting between 2 NCS Engineers, Environment, Health and Safety (EH&S) Manager, and Licensing Project Manager to discuss the potential exceedance of mass limit in S-1030
7/13/16	<ul style="list-style-type: none"> • Grab sample results from all 36 popcorn buckets indicate potential to exceed mass limit; misconception indicated material was low U fluorides. Data reviewed by NCS staff
7/14/16	<ul style="list-style-type: none"> • Shut down of Conversion/scrubber operations

-
- Westinghouse reported to the NRC EN 52090
 - Plan to cleanout scrubber after 6 weeks of operation delayed due to storms
 - First attempt to dissolve the material from the transition cleanout (using water)



7/15/16



Tellerette Removal

-
- 7/15/16**
- RWP 2016-03 (Final approval)
 - Inspection, cleanout and/or repair of S-1030 Scrubber. Gregg's Const. to remove elbow for operations.

-
- 7/16/16**
- After 6 weeks of operation, inlet transition was inspected and cleaned out, and 5.06 kgs of uranium was removed.
-

7/17/16	<ul style="list-style-type: none"> • Operators begin dissolution of material
7/20/16	<ul style="list-style-type: none"> • A revised CSE for the S-1030 scrubber, with new IROFS, was implemented. • Westinghouse completed initial Extent of Cause/Condition for other scrubbers. • Restart of S-1030 scrubber.
7/25/16	<ul style="list-style-type: none"> • Actual mass per SOI determined to be 87.2 kgs U; Once final verification is confirmed
7/26/16	<ul style="list-style-type: none"> • Onsite chemical analysis confirmed that uranium mass limit for the scrubber transition piece was exceeded. The accumulated material contained 87 kgs of uranium. • Westinghouse revised EN 52090 to confirm that mass limit was exceeded.
7/28/16	<ul style="list-style-type: none"> • S-1030 scrubber and conversion process shutdown to perform additional extent of condition inspections of other scrubbers.
7/31/16	<ul style="list-style-type: none"> • Westinghouse updated EN 52090 to report that clean-out material found in the S-1030 scrubber packing and floor also potentially exceeded the uranium mass limit for the scrubber CSE. • EN 52090 was upgraded to a 1 Hour Event Notification based on 10CFR70 Appendix A(a)(4).
8/9/16	<ul style="list-style-type: none"> • Westinghouse submits commitment letter to the NRC



UNITED STATES
NUCLEAR REGULATORY COMMISSION
REGION II
245 PEACHTREE CENTER AVENUE NE, SUITE 1200
ATLANTA, GEORGIA 30303-1257

July 28, 2016

MEMORANDUM TO: Omar R. López-Santiago, Team Leader
Westinghouse Electric Company, Augmented Inspection

FROM: Catherine Haney
Regional Administrator *Catherine Haney*

SUBJECT: AUGMENTED INSPECTION TEAM CHARTER FOR WESTINGHOUSE
ELECTRIC COMPANY, DOCKET NO. 70-1151 (INSPECTION
REPORT 70-1151/2016-007)

This memorandum confirms the establishment of an Augmented Inspection Team (AIT) at Westinghouse Electric Company (WEST) to inspect and assess the facts and circumstances surrounding the failure to meet the performance requirements of 10 CFR 70.61 due to exceeding the nuclear criticality safety (NCS) mass limit in a process off-gas scrubber. The S1030 scrubber was cleaned out on May 28-29, 2016, and a large amount of material was removed. Preliminary results of the analysis of the material, completed on July 13, showed a concentration of approximately 48% uranium, which indicated that the uranium mass limit was exceeded. WEST staff reported the occurrence to the Nuclear Regulatory Commission (NRC) Operations Center on July 14, 2014, as a 24-hour reportable event (Event #52090). There were no actual safety-related consequences resulting from exceeding the mass limit in the scrubber.

Regional Office Instruction No. 0704, "Documenting Management Directive 8.3, NRC Incident Investigation Program, Reactive Team Inspection Decisions in the Division of Fuel Facility Inspection," Revision 3, was used to evaluate the level of NRC response for this operational event. Based on the deterministic criteria, the staff concluded that this issue may have involved an event or condition which led to the loss of multiple barriers in systems used to mitigate an actual event, and that a high consequence event was "not unlikely." The NRC determined that the appropriate level of response was to conduct an Augmented Inspection to determine the facts surrounding this event.

The inspection will be performed in accordance with the guidance of Inspection Procedure (IP) 88003, "Reactive Inspection for Events at Fuel Cycle Facilities," and the applicable provisions of IP 93800, "Augmented Inspection," and Incident Response Manual Chapter 300, "Incident Investigation." The report will be issued within 30 days of the completion of the inspection.

CONTACTS: Eric Michel, RII/DFFI
404-997-4555

Mark Lesser, RII/DFFI
404-997-4700

Enclosure 2

A copy of the Charter is enclosed for your use. The objectives of the inspection are to gather information and make appropriate findings and conclusions in the areas listed in the Charter. These results will be used as a basis for any necessary follow-up and regulatory enforcement actions. It is not your responsibility to examine the regulatory process. As indicated in the Charter, the foremost objective is to determine the safety implications and adequacy of the licensee's immediate corrective actions for the issues which resulted in the event.

Before the end of the first day on site, you are to provide a recommendation to the Regional Administrator as to whether the AIT inspection should continue, be upgraded to an Incident Investigation Team (IIT) response or be downgraded to a Special Inspection. If appropriate, this recommendation may be made later in the inspection.

The team should notify Region II management of any potential generic issues identified as a result of this event for discussion with the Office of Nuclear Material Safety and Safeguards. Safety or security concerns identified that are not directly related to the event should be reported to the Region II office for appropriate action.

At the conclusion of the inspection you should provide lessons learned from the AIT. When appropriate, prepare a feedback form on recommendations for any needed program enhancements or changes.

This Charter may be modified should you develop significant new information that warrants review.

Enclosure: AIT Charter

**Augmented Inspection Team Charter
Westinghouse Electric Company
Exceeding Mass Limit in the S1030 Scrubber**

Event

On May 28-29, 2016, Westinghouse conducted an annual inspection and cleanout of the S1030 scrubber. The scrubber in question is one of the main air scrubbers for the conversion part of the facility. Exhaust air, from a multitude of processes, goes to this scrubber. When the scrubber was inspected and cleaned, a large mass of material was found inside the scrubber. At the time, Westinghouse believed that the material removed from the scrubber was low uranium bearing in composition. The material was removed, and samples subsequently sent for analysis of the uranium content. The preliminary results of the analysis were received on July 13, 2016, and indicated that the concentration of uranium was approximately 48%, which would exceed the mass limit of uranium in the scrubber. On July 14, 2016, Westinghouse reported to the NRC Operations Center a 24-Hour Event Notification (Event 52090) based on 10 CFR 70 Appendix A(b)(2) "*Loss or degradation of IROFS that results in failure to meet the performance requirements of 10CFR70.61.*" On July 26, 2016, the final analysis of the material was provided to Region II. It revealed that the amount of uranium in the scrubber was approximately three times the mass limit identified in the criticality safety evaluation.

Objectives

The objectives of the inspection are to: 1) review the facts surrounding the failure to maintain the mass controls in the S1030 scrubber and the potential for similar failures on other production areas using the same mass control protocols; 2) assess the licensee's response to the failures; and 3) evaluate the licensee's immediate and planned long term corrective actions to prevent recurrence. In order to determine the risk and safety significance of the event, the team should focus on the areas listed below.

1. Develop a complete timeline and sequence of events related to the event.
2. Assess whether the controls implemented, as documented in the licensee's integrated safety analysis (ISA) for the applicable accident sequences, were sufficient to limit the risk of criticality to "highly unlikely" before the occurrence of any upsets, giving specific consideration to the potential dependence of the controls, common-mode failures, and the Double Contingency Principle. Assess if any other controls and/or process conditions were in place that could provide additional barriers or defense-in-depth to prevent a criticality.
3. Assess the licensee's decision process to restart the scrubber following the initial event (May 2016). Evaluate the effectiveness of the immediate corrective actions taken by the licensee in response to the event.
4. Review and evaluate the licensee's extent of condition for adequacy of scope, depth, identification of causal factors, and proposed corrective actions. Determine if there are other systems where the licensee made similar assumptions about uranium accumulation.

5. Determine the adequacy of internal and external licensee event reporting.
6. Review and evaluate the licensee's progress in their root cause analysis for adequacy of scope, depth, identification of contributing causes, and proposed corrective actions.
7. Review the safety culture aspects of the event, including conservative decision making and proceeding with actions in the face of uncertainty.
8. Determine the process(es) and deposition rates involved in the accumulation of material in the scrubber, especially as it relates to the scrubber clean out frequency IROFS, and the precipitation of hardened uranium solids within the scrubber.
9. Review the analytical techniques used to determine uranium concentration, and review the chemical analysis of the deposits to verify any process theories. Develop an understanding of what drove different analysis times (e.g., the preliminary analysis completed on July 13, and the analysis of the six-week run of material).
10. Gather data/information to support the determination/assessment of the risk and safety significance of the event.

Documentation

Document the inspection findings and conclusions in Inspection Report 70-1151/2016-007 within 30 days of the completion of the inspection.

Team Composition

Omar Lopez, Chief, Safety Branch
Tom Vukovinsky, Senior Fuel Facility Inspector
Marilyn Diaz, Chemical Safety Engineer
Christopher Tripp, Senior Nuclear Process Engineer
Denise Anderson, Fuel Facility Inspector
Patricia Glenn, Fuel Facility Inspector