



Tennessee Valley Authority, 1101 Market Street, Chattanooga, Tennessee 37402

CNL-15-067

July 15, 2015

10 CFR 2.202  
10 CFR 50.4

ATTN: Document Control Desk  
U.S. Nuclear Regulatory Commission  
Washington, D.C. 20555-0001

Sequoyah Nuclear Plant, Unit 1 and Unit 2  
Facility Operating License No. DPR-77 and DPR-79  
NRC Docket No. 50-327 and 50-328

Subject: **Completion of Required Action by NRC Order EA-12-051, Reliable Spent Fuel Pool Instrumentation**

Reference: NRC Order Number EA-12-051, "Issuance of Order Modifying Licenses with Regard to Reliable Spent Fuel Pool Instrumentation," dated March 12, 2012 (ML12054A679)

On March 12, 2012, the Nuclear Regulatory Commission issued Order EA-12-051, Issuance of Order Modifying Licenses with Regard to Reliable Spent Fuel Pool Instrumentation (Referenced Letter), to Tennessee Valley Authority. This Order was effective immediately and directed the Sequoyah Nuclear Plant, Units 1 and 2, to install reliable spent fuel pool instrumentation as outlined in Attachment 2 of the Order. This letter, along with its enclosures, provides the notification required by § IV.C.3 of the Order that full compliance with the requirements described in Attachment 2 of the Order has been achieved for Sequoyah Nuclear Plant, Units 1 and 2.

This letter contains no new NRC commitments. If you have any questions, please contact Erin Henderson at (423) 843-7170.

I declare under penalty of perjury that the foregoing is true and correct. Executed on the 15th day of July 2015.

Respectfully,

A handwritten signature in black ink, appearing to read 'J. W. Shea', written over a horizontal line.

J. W. Shea  
Vice President, Nuclear Licensing

Enclosures  
cc: See Page 2

Enclosures:

1. Compliance with Order EA-12-051
2. Response to the NRC Request for Additional Information Regarding Overall Integrated Plan for Reliable Spent Fuel Pool Instrumentation

cc (Enclosures):

NRR Director - NRC Headquarters  
NRO Director - NRC Headquarters  
NRR JLD Director - NRC Headquarters  
NRC Regional Administrator - Region II  
NRC Project Manager - Sequoyah Nuclear Plant  
NRC JLD Project Manager - Sequoyah Nuclear Plant  
NRC Senior Resident Inspector - Sequoyah Nuclear Plant

**ENCLOSURE 1**

**SEQUOYAH NUCLEAR PLANT, UNITS 1 AND 2**

**COMPLIANCE WITH ORDER EA-12-051**

## **BACKGROUND**

On March 12, 2012, the Nuclear Regulatory Commission (NRC) issued Order EA-12-051, *Order Modifying Licenses with Regard to Reliable Spent Fuel Pool Instrumentation* (Reference 1) to Tennessee Valley Authority (TVA). This Order was effective immediately and directed Sequoyah Nuclear Plant (SQN), Units 1 and 2, to install reliable spent fuel pool instrumentation as outlined in Attachment 2 of the Order. The Order required compliance prior to plant startup from the second refueling outage following submittal of the Overall Integrated Plan (OIP), or by December 31, 2016, whichever comes first. The compliance date for SQN, Units 1 and 2, was May 16, 2015. The NRC staff requested that the compliance report be submitted within 60 days of the compliance date. The information provided herein documents full compliance for SQN, Units 1 and 2, in response to the Order.

## **COMPLIANCE**

Sequoyah Nuclear Plant has installed two independent full scale level monitors on the Spent Fuel Pool (SFP) in response to Reference 1. SQN is a two unit site with one SFP.

TVA submitted the SQN, Units 1 and 2 OIP by letter dated February 28, 2013 (Reference 2). By letter dated November 21, 2013, the NRC provided its interim staff evaluation (Reference 3) and requested additional information necessary for completion of the review. The information requested by NRC is included in Enclosure 2. NRC conducted an onsite audit at SQN from December 1 through 5, 2014, as documented in Reference 4. The NRC Audit Report did not identify additional information requests or develop new open items related to the SFP Level Instrumentation. As such this letter provides no additional information as a result of the NRC Audit Report.

Compliance with Order EA-12-051 was achieved using the guidance in Nuclear Energy Institute (NEI) document NEI 12-02 (Reference 5), which has been endorsed by the NRC (Reference 6).

## **REFERENCES**

1. NRC Order Number EA-12-051, "Issuance of Order Modifying Licenses with Regard to Reliable Spent Fuel Pool Instrumentation," dated March 12, 2012 (ML12054A679).
2. Letter from TVA to NRC, "Tennessee Valley Authority (TVA) - Overall Integrated Plan in Response to the March 12, 2012, Commission Order Modifying Licenses with Regard to Requirements for Reliable Spent Fuel Pool Instrumentation (Order Number EA-12-051) for Watts Bar Nuclear Plant," dated February 28, 2013 (ML13063A440).
3. Letter from NRC to TVA, "Sequoyah Nuclear Plant, Unit 1 and Unit 2 - Interim Staff Evaluation and Request for Additional Information Regarding the Overall Integrated Plan for Implementation of Order EA-12-051, Reliable Spent Fuel Pool Instrumentation (TAC Nos. MF0794 and MF0795)," dated November 21, 2013 (ML13312A415).
4. Letter from NRC to TVA, "Sequoyah Nuclear Plant, Units 1 and 2 - Report For The Onsite Audit Regarding Implementation Of Mitigating Strategies And Reliable Spent Fuel Instrumentation Related To Orders EA-12-049 and EA-12-051 (TAC NOS. MF0864, F0865, MF0794, and MF0795)," dated March 3, 2015.

Enclosure 1

5. NEI 12-02, "Industry Guidance for Compliance with NRC Order EA-12-051, 'To Modify Licenses with Regard to Reliable Spent Fuel Pool Instrumentation,'" Revision 1, dated August 2012 (ML12240A307).
6. NRC Interim Staff Guidance JLD-ISG-2012-03, "Compliance with Order EA-12-051, Reliable Spent Fuel Pool Instrumentation," Revision 0, dated August 29, 2012 (ML12221A339).

**ENCLOSURE 2  
SEQUOYAH NUCLEAR PLANT, UNITS 1 AND 2**

**RESPONSE TO THE NRC REQUEST FOR ADDITIONAL INFORMATION REGARDING  
OVERALL INTEGRATED PLAN FOR RELIABLE SPENT FUEL POOL INSTRUMENTATION**

## Enclosure 2

On November 21, 2013, NRC issued the Sequoyah Nuclear Plant (SQN) Interim Staff Evaluation (ISE) and Request for Additional Information (RAI) with regard to requirements for the Reliable Spent Fuel Pool Instrumentation (SFPI) Order EA-12-051 (Reference 1 of this Enclosure). The ISE identified NRC's RAI dated July 17, 2013 (Reference 2), and TVA's partial response to the request by letter dated August 16, 2013 (Reference 3), and August 28, 2013 (Reference 4). The responses to the final seven of the RAIs in the July 17, 2013, letter have not been available until now. The responses to the seven RAIs and the additional ISE RAIs are provided below.

NRC has conducted a vendor audit of the SFPI supplier for SQN (Reference 5). During the audit, a summary table was developed that includes key topics and parameters from the vendor testing and qualification documentation, and evaluation of the qualification/test results for a licensee using the Westinghouse level measurement technology. The responses to these RAIs are associated with the vendor audit results as identified on Attachment 1 of this Enclosure.

### **RAI #1**

*Please provide a clearly labeled sketch or marked-up plant drawing of the plan view of the SFP area, depicting the SFP inside dimensions, the planned locations/placement of the primary and back-up SFP level sensor and mounting brackets, and the proposed routing of the cables that will extend from the sensors toward the location of the read-out/display devices.*

*(This information was previously requested as RAI-2 in NRC letter dated July 17, 2013).*

### **TVA Response**

See Attachment 2 for plan view of the spent fuel pool (SFP) area, depicting the requested information.

### **RAI #2**

*Please provide the following:*

- a) The design criteria used to estimate the total loading on the mounting device(s), including static weight loads and dynamic loads. Describe the methodology that will be used to estimate the total loading, inclusive of design basis maximum seismic loads and the hydrodynamic loads that could result from pool sloshing or other effects that could accompany such seismic forces.*
- b) A description of the manner in which the level sensor will be attached to the refueling floor and/or other support structures for each planned point of attachment of the probe assembly. Indicate in a schematic the portions of the level sensor that will serve as points of attachment for mechanical/mounting or electrical connections.*
- c) A description of the manner by which the mechanical connections will attach the level instrument to permanent SFP structures to support the level sensor assembly.*

*(This information was previously requested as RAI-3 in NRC letter dated July 17, 2013).*

## TVA Response

- a) SFPI System (SFPI) equipment mounting is analyzed to maintain a minimum seismic capacity of high confidence of low probability failure (HCLPF) equal to or greater than a Review Level Ground Motion (RLGM) of two times (2x) the safe-shutdown earthquake (SSE). To achieve a minimum HCLPF of 2x SSE at SQN, SFPI SSCs are designed in accordance with plant Seismic Category I design requirements using 1.2 X SSE accelerations. Applicable TVA design criteria documents are referenced below in response to RAI #4. The vendor has performed calculations to evaluate the structural integrity of the mounting brackets at the SFP. The model considers load combinations for the dead load, live load and seismic load on the bracket, where seismic loading is for two-times the SSE. These loads are then compared to the allowable values of the applicable welds, bolts and members to determine the acceptability of the design.

### Seismic

The seismic loads are obtained from response spectra curves and damping values for the application. The following methodology was used in determining the stresses developed for the model.

- Frequency analysis is performed to obtain the natural frequencies of the structure in all three directions.
- SSE response spectra analysis is performed to obtain member stresses and support reactions due to the self weight of the bracket and associated components in a seismic event.
- Response spectra analysis results in each direction are combined using square root of the sum of the squares (SRSS) method. The seismic results in all three directions are combined using SRSS and then combined with the dead load results in absolute values. The combined results are compared with the allowable stress values.

### Sloshing

Because of the size and complexity of the spent fuel pool, and practical limitations in preparing a physical scale model suitable for seismic testing, the effects of water sloshing on the SFP level measurement are assessed with analytical methods. As part of work to address NRC Order EA-12-049, calculations were performed to determine plant-specific times for spent fuel pool boiling to begin. To establish initial post-seismic pool conditions, calculation methods from EPRI Report 1025287, "Seismic Evaluation Guidance," were used to estimate the amount of water sloshed out of the pool by seismic motion. Using this methodology, bounding results for the sloshing effect have been determined and supplemented with alternative analysis methods to make a qualitative assessment of the effects of seismic-induced fluid motion on the cable probe. **See Attachment 1, Item 9.** Because some water can be ejected from a pool, it is necessary to assume that the probe interconnecting cable will become wetted or submerged in borated water. Reliable operation of the level measurement sensor with a submerged interconnecting cable has been demonstrated by analysis of previous Westinghouse testing of the cable and vendor's cable qualification. Boron build up analysis has been performed to determine how boron build up on the probe would affect the sensor. **See Attachment 1, Item 11.**



## Enclosure 2

- b) The level sensor cable assembly is suspended from a support bracket, which is secured to the refueling floor and/or spent fuel pool curb using concrete anchor bolts. The level sensor cable suspended in the SFP is attached to a threaded coupling, which is secured to a support bracket. The cable leading to the transmitter is also attached to the threaded coupling. **See Attachment 1, Item 12.** The generic illustrations below depict these attachments.

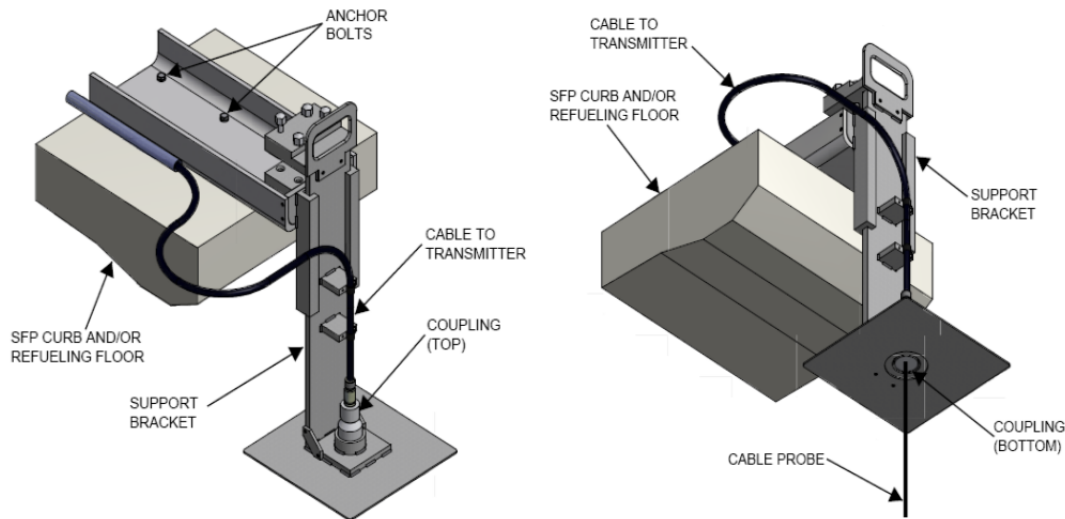

- c) See response to 2b above and **Attachment 1, Item 13.**

### **RAI #3**

*For RAI #2(a) above, please provide the results of the analyses used to verify the design criteria and methodology for seismic testing of the SFP instrumentation and the electronics units, including, design basis maximum seismic loads and the hydrodynamic loads that could result from pool sloshing or other effects that could accompany such seismic forces.*

### **TVA Response**

Seismic loads resulting from the analyses performed for the cable probe mounting brackets are documented in the referenced Westinghouse calculations. Seismic loads resulting from the analyses performed for mounting of the instrument enclosures and transmitters are documented in the referenced TVA calculations. Results of the seismic testing for the vendor supplied equipment are documented in Section 5.4 of the referenced Westinghouse summary report. No equipment failures were noted as a result of the seismic test runs. Section 7 of the referenced Westinghouse test strategy, provides methods used to demonstrate adequacy of the SFPIS under seismic conditions. Seismic test data has been documented in a seismic test report. **See Attachment 1, Items 8, 9, 12, and 13.**

References for RAI #3:

1. Westinghouse calculation CN-PEUS-14-12, Seismic Analysis of the SFP Pool-Side Brackets at SQN I & II, Rev. 2.
2. TVA calculation CDQ0000782014000114, Seismic Qualification for Mounting of Spent Fuel Pool Level Instrumentation for SQN.

## Enclosure 2

3. TVA calculation CDQ0000782014000204, Qualification of Typical Conduit Support, 1, 2-47A056-1091 for SQN Spent Fuel Pool (Design change Notice [DCN]23195).
4. TVA calculation CDQ0000782014000205, Qualification of Typical Conduit Support, 1, 2-47A056-1092 for SQN Spent Fuel Pool, R0 (DCN23195).
5. Request/Response Memo for Performing S/SQ – Design Changes, form NEDP-9-2, EDMS B85 140918 001.
6. Westinghouse Report EQ-QR-269, Design Verification Testing Summary Report for the Spent Fuel Pool Instrumentation System.
7. Westinghouse document WNA-PT-00188-GEN, SFPIS Standard Product Test Strategy.

TVA will make these documents available for review upon request.

### **RAI #4**

*For each of the mounting attachments required to attach SFP Level equipment to plant structures, please describe the design inputs, and the methodology used to qualify the structural integrity of the affected structures/equipment.*

### **TVA Response**

The design input and qualification methodology is consistent with TVA's current safety related seismic design. The design input and qualification methodology used for the mounting attachment of the instrument enclosures, transmitter and cable probe mounting brackets is documented in the referenced TVA calculation, TVA Civil Design Standard, and General Engineering Specification.

References for RAI #4:

1. TVA calculation CDQ0000782014000114, Seismic Qualification for Mounting of Spent Fuel Pool Level Instrumentation for SQN.
2. TVA General Engineering Specification G-32, Bolt Anchors Set in Hardened Concrete
3. TVA Design Standard DS-C1.7.1, General Anchorage to Concrete.
4. TVA Civil calculation CSG90CA01, Evaluation of HILTI KWIK-Bolt Wedge Bolt Concrete Anchors, Rev 5.
5. TVA General Specification Exception G-32-SQN-15, G-Spec Exception-Allow use of Stainless Steel Bolting, Rev. 0.

TVA will make these documents available for review upon request.

**RAI #5**

*Please provide the following:*

- a) A description of the specific method or combination of methods that will be used to demonstrate the reliability of the permanently installed equipment under BDB [beyond design basis] ambient temperature, humidity, shock, vibration, and radiation conditions.*
- b) A description of the testing and/or analyses that will be conducted to provide assurance the equipment will perform reliably under the worst-case credible design basis loading at the location where the equipment will be mounted. Include a discussion of this seismic reliability demonstration as it applies to a) the level sensor mounted in the SFP area, and b) any control boxes, electronics, or read-out and re-transmitting devices that will be employed to convey level information from the level sensor to the plant operators or emergency responders.*
- c) A description of the specific method or combination of methods that will be used to confirm the reliability of the permanently installed equipment such that following a seismic event the instrument will maintain its required accuracy.*

*(This information was previously requested as RAI-4 in the NRC letter dated July 17, 2013).*

**TVA Response**

- a) Harsh Environment: The nonmetallic materials of the SFPIS located in the SFP area were evaluated to confirm their behavior with respect to radiation aging mechanisms. Any materials for which radiation degradation effects cannot be determined were tested to demonstrate suitable resistance to radiation. Non-metallic components are rated for use in temperatures higher than 212 degrees Fahrenheit, which corresponds to the saturated steam environment of extended boiling in the spent fuel pool. The ability of the SFPIS to function properly at the expected temperature and steam environmental conditions is demonstrated by test. **See Attachment 1, Items 4, 5 and 6.**

Shock and Vibration: Components of both the primary and backup measurement channels are permanently installed and fixed to rigid, structural walls or floors of Seismic Category 1 structures, and will not be subject to anticipated shock or vibration inputs. The level sensor electronics are enclosed in a NEMA-4X housing. The electronics panel utilizes a NEMA-4X rated stainless steel housing. These housings will be mounted to a seismically qualified wall and aid in protecting the internal components from vibration induced damage. No additional vibration and shock testing is required. As provided by the NRC Order and the NEI guidance as clarified by the interim staff guidance, the probe, coaxial cable, and the mounting brackets are "inherently resistant to shock and vibration loadings." **See Attachment 1, Item 12, 13, and 14.**

Mild Environment: For equipment located in the mild environment, an assessment of equipment aging-related effects was performed to determine if aging has a significant effect on the ability of the equipment to perform following a plant design basis earthquake. Significant age-sensitive effects were identified for incorporation into technical manual recommendations for routine preventive maintenance. No beyond

## Enclosure 2

design basis conditions have been defined for mild-environment equipment. **See Attachment 1, Items 2, 3 and 5.** Environmental testing of the electronics cabinet will be in accordance with the following standards:

- IEEE-323-2003, Standard for Qualifying Class 1E Equipment for Nuclear Power Generating Stations.
  - NA 11.2, In-house Environmental Testing, Rev. 1, Westinghouse Electric Company LLC.
- b) The SFPIS seismic adequacy was demonstrated using the methodology defined in IEEE 344-2004 for Seismic Category 1, which allows for a combination of test and analysis. Seismic frequency and acceleration test parameters reflect an envelope of 2X the SQN design basis safe shutdown earthquake test response spectra with 5% critical damping. This equipment shall maintain functionality and physical integrity before and after five operating basis earthquakes and one safe shutdown earthquake. **See Attachment 1, Item 8.**

The seismic adequacy of the level sensor assembly in the SFP area, transmitter, transmitter bracket, electronics cabinets with indicators, and coaxial cable was demonstrated by vendor testing in accordance with the standards listed below.

The seismic adequacy of the sensor probe supporting bracket within the SFP area was demonstrated by analysis as discussed in the response to RAI #2a.

- IEEE 344-2004, IEEE Recommended Practice for Seismic Qualification of Class 1E Electrical Equipment for Nuclear Power Generating Stations.
  - IEEE-323-2003, Standard for Qualifying Class 1E Equipment for Nuclear Power Generating Stations.
  - USNRC Regulatory Guide 1.100, "Seismic Qualification of Electrical and Mechanical Equipment".
  - NA 11.1, In-house Seismic Testing, Rev. 1, Westinghouse Electric Company LLC.
- c) The methods described in the response to RAI #5b apply to RAI #5c. The acceptance criteria for these methods states that no degradation or loss of function below a performance level specified by the manufacturer is allowed, and that the system must provide reliable SFP level indication.

### **RAI #6**

*For RAI No. 5 above, please provide the results from the selected methods, tests and analyses used to demonstrate the qualification and reliability of the installed equipment in accordance with the Order requirements.*

### **TVA Response**

A summary of the test conditions for which the equipment is to be qualified is provided below as reported by the vendor. Current results of vendor tests and analysis demonstrating the qualification of the installed equipment have been provided by the vendor. **See Attachment 1, Items 3, 4, 5, 6, 7, and 8.**

## Enclosure 2

### Environmental Conditions for SFPIS Components in the Spent Fuel Pool Area

The coaxial cable, the coupler, the pool-side bracket and the probe in the spent fuel pool area are required to operate reliably in the service environmental conditions specified for the environmental conditions in the table below.

Parameter	Normal	BDB
Temperature	50-140°F	212°F
Pressure	Atmospheric	Atmospheric
Humidity	0-95% HR	100% HR (saturated steam)
Radiation (total integrated dose - TID)(above pool)	1E03 Rads $\gamma$	1E07 Rads $\gamma$
Radiation TID (12" above top of fuel rack)	1E07 Rads $\gamma$ (probe and weight only)	1E07 Rads $\gamma$

### Environmental Conditions Outside of the Spent Fuel Pool Area

The level sensor electronics, sensor electronics bracket, indicators and the electronics enclosures outside of the spent fuel pool area are required to operate reliably in the service environmental conditions specified for the environmental conditions in the table below.

Parameter	Normal	BDB	BDB (Level Sensor Electronics Only)
Temperature	50-120°F	140°F	140°F
Pressure	Atmospheric	Atmospheric	Atmospheric
Humidity	0-95% HR	0-95% HR (non-condensing)	0-100% HR (non-condensing)
Duration*	4 days	4 days	4 days
Radiation TID	$\leq 1E03 R \gamma$	$\leq 1E03 R \gamma$	$\leq 1E03 R \gamma$

\* Battery life limit if power is not restored.

### Thermal Aging

The SFPIS thermal aging process performed on the interconnecting cable and cable coupler inside the spent fuel pool area, followed by successful radiation aging and seismic testing of the components, has demonstrated a 10 year life for the level sensor after a beyond-design-basis event. **See Attachment 1, Item 6.**

### Seismic Cat-1 Testing/Analysis

The SFPIS Cat-1 seismic testing performed by the vendor and manufacturer, together with the technical evaluations performed by the vendor, confirm that the SFPIS is seismically acceptable for plant use and meets the seismic requirements of the vendor's design specification. The SFPIS seismic adequacy shall be demonstrated using the methodology defined in IEEE 344-2004 for Seismic Category I, and the equipment shall maintain

## Enclosure 2

functionality and physical integrity before and after five Operating Basis Earthquakes (OBEs) and one Safe Shutdown Earthquake (SSE). Vendor seismic testing profile exceeds 2x SSE for SQN.

### Vibration Justification

Refer to RAI #5a response.

### Sloshing Justification (With exception of Boron/Boric Acid)

During the SFPIS product development, a sloshing calculation was performed by the vendor to demonstrate that the probe would not be “sloshed” out of the spent fuel pool during a seismic event. This calculation concluded that, regardless of the construction, the probe will not be thrown out of the pool during a seismic event. **See Attachment 1, Item 9.**

### **RAI #7**

*Please provide the NRC staff with the final configuration of the power supply source for each channel so that the staff may conclude the two channels are independent from a power supply assignment perspective.*

### **TVA Response**

Power to the primary channel is supplied from 120 volt AC vital instrument power board 2-IV, which is train B. Power to the backup channel is supplied from 120 volt AC vital instrument power board 1-III, which is train A. The vital boards are supplied by the vital batteries and vital inverters, and will be backed up by the FLEX diesel generators. SQN FLEX diesel generator strategy provides two 225kva diesel generators on the roof of the Auxiliary Building to provide a direct connection to vital battery chargers and two 3MW diesel generators that provide an alternate approach to energize the battery chargers utilizing safety related shutdown power distribution. This approach is described in detail in response to Order EA-12-049.

Cable and conduit for each channel maintain trained separation from the power source to their respective instrument enclosures, which are mounted in separated areas of the plant. **See Attachment 2.**

### **RAI #8**

*Please provide the results of the calculation depicting the battery backup duty cycle requirements demonstrating battery capacity is sufficient to maintain the level indication function until offsite resource availability is reasonably assured.*

### **TVA Response**

The calculation concludes that the backup battery life is at least 4.22 days at full charge after loss of onsite alternating current power, based on maximum power consumption throughout the duration of the battery life. **See Attachment 1, Item 18.**

**RAI #9**

Please provide the following:

- a) *An estimate of the expected instrument channel accuracy performance (e.g., in % span) under both a) normal SFP level conditions (approximately Level 1 or higher) and b) at the BDB conditions (i.e., radiation, temperature, humidity, post-seismic and post-shock conditions) that would be present if the SFP level were at the Level 2 and Level 3 datum points.*
- b) *A description of the methodology to be used for determining the maximum allowed deviation from the instrument channel design accuracy under normal operating conditions. Staff understands this allowed deviation will serve as an acceptance criterion for a calibration procedure to alert operators and technicians that the channel requires adjustment to within normal design accuracy.*

*(This information was previously requested as RAI-7 in the NRC letter dated July 17, 2013).*

**TVA Response**

- a) Each instrument channel is expected to be accurate to within an estimated  $\pm 1\%$  of calibrated span during normal spent fuel pool level conditions. The instrument channels are expected to retain this estimated accuracy after being subjected to BDB conditions. This estimate is based on the vendor's specification documentation. **See Attachment 1, Item 17.**
- b) Technicians are required to perform an instrument channel calibration in the event that the instrument channel output lies outside the acceptance band established in the setpoint and scaling documents. The acceptance band or "as-left tolerance" is defined as the acceptable parameter variation limit above or below the desired output for a given input standard associated with the calibration of the instrument channel.

The instrument channel acceptance band, which may or may not be symmetrical, is calculated using the square root of the sum of the squares (SRSS) combination of the as-left tolerance for each component comprising the instrument loop. The as-left tolerance of each component is equal to or greater than the reference accuracy of the device being calibrated, but is not so large that it could prevent or mask detection of instrument degradation or failure. Note that the SRSS method is only used for uncertainty terms that are random, independent, and possess a normal (bell-shaped) distribution; otherwise, the uncertainty term is combined through summation, either within the SRSS (for dependent terms) or outside of the SRSS (for bias and non-normally distributed terms). **See Attachment 1, Item 20.**

**RAI #10**

*Please provide the following:*

- a) A further description of the capability and provisions the proposed level sensing equipment will have to enable periodic testing and calibration, including how this capability enables the equipment to be tested in situ.*
- b) Explain how such testing and calibration will enable the conduct of regular channel checks of each independent channel against the other, and against any other permanently-installed SFP level instrumentation.*
- c) Explain the calibration tests and functional checks to be performed and the frequency at which they will be conducted. Discuss how these surveillances will be incorporated into the plant surveillance program.*
- d) Describe the preventive maintenance tasks required to be performed during normal operation, and the planned maximum surveillance interval that is necessary to ensure that the channels are fully conditioned to accurately and reliably perform their functions when needed.*

*(This information was previously requested as RAI-8 in the NRC letter dated July 17, 2013).*

**TVA Response**

- a) The support bracket for the level sensor cable has been designed and manufactured with a sliding section. This sliding section will be raised 12 inches for calibration verification. The manufacturer has documented that the calibration is based on a linear time delay from transmission of the radar pulse to return of reflection on the surface of the water. Manufacturer documentation provides certification that raising the sensor a fixed distance and verifying that the indicator changes by this fixed amount confirms that the transmitter is in calibration. The system is designed to enable the removal of the sensor cable from the transmitter and attach a previously certified sensor cable with an adjustable metal target to allow a detailed multipoint calibration by mounting the target at different points along the cable for troubleshooting, if necessary. Each component in the instrument channel can be replaced (transmitter included) to restore the instrument loop to service in the event a component failure occurs.

In-situ testing will be performed by loosening the hold down bolts and raising the sensor assembly 12 inches and verifying that the indicator responds with a corresponding 12 inch change (allowed inaccuracy of change is documented in the scaling analysis). Upon completion of measurement, the technician will lower the mounting bracket and re-torque the slide assembly hold down bolts.

- b) Channel Check is not a specified requirement in NEI 12-02. Channel Check is specified in IEEE 338-1987 for Safety Systems. SFP level instrument channels are not safety-related and are not subject to testing requirements of safety-related instrumentation. If the plant staff determined a need to confirm that the two channels are performing as expected, then each channel may be read in its respective shutdown



## Enclosure 2

board room. While the SFP is operating within design basis and at normal level, the indicators may be compared to fixed marks within the SFP by visual observation to confirm indicated level.

- c) A description of channel calibration or functional test is shown in the response for RAI-10a. TVA will perform periodic calibration verification using a periodic maintenance procedure. The periodic calibration verification will be performed within 60 days of a refueling outage considering normal testing scheduling allowances (e.g., 25%). Calibration verification will not be required to be performed more than once per 12 months. These calibration requirements are consistent with the guidance provided in NEI 12-02 Section 4.3.
- d) Preventive Maintenance procedures are in place for periodic replacement of the backup batteries, uninterruptable power supply, level transmitters, and coaxial signal cable based on manufacturer recommendations and for calibration verification as identified in RAI #10c.

### **RAI #11**

*For the display location outside the MCR, please describe the evaluation used to validate the secondary display location can be accessed without unreasonable delay following a BDB event. Include the time available for personnel to access the display location as credited in the evaluation, as well as the actual time (e.g., based on walk-through) that it will take for personnel to access the display locations. Additionally, include a description of the radiological and environmental conditions on the paths personnel might take. Describe whether the secondary display location remains habitable for radiological, heat and humidity, and other environmental conditions following a BDB event. Describe whether personnel are continuously stationed at the secondary display location or monitor the display periodically.*

### **TVA Response**

SQN had proposed locating an indicator for the backup channel in the main control room. The backup channel has an indicator in an Auxiliary Building (AB) shutdown board room. **See Attachment 2.** SQN has eliminated the main control room (MCR) indicator because full compliance is achieved by having two independent channels of indication, physically separated and both located in the AB shutdown board room areas.

A shutdown board room and the path to the shutdown board room from the MCR is a mild environment during the extended loss of alternating current power (ELAP); is promptly accessible (2 minute walk) by MCR personnel; and is not subject to the environmental conditions associated with boiling in the SFP. Communication by radio or telephone is available if needed. The route to the shutdown board room area from the MCR will be the same route that is utilized during design basis events because the route is within safety-related, seismic structures (Control Building and Auxiliary Building). The pathway is expected to remain intact following a seismic event. .

**RAI #12**

*Please provide a list of the procedures addressing operation (both normal and abnormal response), calibration, test, maintenance, and inspection to be developed for use of the SFP instrumentation. Include a brief description of the specific technical objectives to be achieved within each procedure.*

*(This information was previously requested as RAI-10 in the NRC letter dated July 17, 2013. However, based on feedback from the licensees, it has been revised as above.)*

**TVA Response**

The following list of procedures is provided:

- 0-SO-78-1, "Spent Fuel Pit Cooling System." This system operating instruction describes the SFPIS and its operation.
- AOP-M.06, "Loss of Spent Fuel Cooling." This procedure provides the actions necessary to mitigate a loss of Spent Fuel Cooling or an abnormal lowering level in the Spent Fuel Pit.
- FSI-5.01, "Initial Assessment and FLEX Equipment Deployment." This Flex Support Instruction (FSI) provides actions for the initial assessment of plant equipment and system status.
- FSI-11, "Alternate SFP Makeup and Cooling." This Flex Support Instruction provides actions to make up to the Spent Fuel Pit from alternate sources.
- FSI-13, "Transition from FLEX Support Instructions," This Flex Support Instruction provides actions to transition from FLEX equipment to normal plant equipment when available.
- 0-LI-78-44 (Loop 1) and 0-LI-78-43 (Loop 2) Spent Fuel Pool Wide Range Level Calibration.
- Preventative Maintenance (PM) 960000034(Loop 1) / 960000039(Loop 2) Spent Fuel Pool Wide Level Loop 156 Week Battery Replacement.
- PM 960000035(Loop 1) / 960000040(Loop 2) Spent Fuel Pool Wide Range Level Transmitter Replacement.
- PM 960000036(Loop 1) / 960000041(Loop 2) Spent Fuel Pool Wide Range Level Loop 15 Year Replacement of Uninterruptable Power Supply.
- PM 960000037(Loop 1) / 960000042(Loop 2) Spent Fuel Pool Wide Range Level Element Coaxial Cable 0PV446 Replacement.

**RAI #13**

Please provide the following:

- a) *Further information describing the maintenance and testing program the licensee will establish and implement to ensure that regular testing and calibration is performed and verified by inspection and audit to demonstrate conformance with design and system readiness requirements. Include a description of plans to ensure that necessary channel checks, functional tests, periodic calibration, and maintenance will be conducted for the level measurement system and its supporting equipment.*
- b) *A description of the guidance in NEI 12-02 section 4.3 on compensatory actions for one or both non-functioning channels.*
- c) *A description of the compensatory actions to be taken in the event that one of the instrument channels cannot be restored to functional status within 90 days.*

*(This information was previously requested as RAI-11 in the NRC letter dated July 17, 2013).*

**TVA Response**

- a) The maintenance, testing and calibration program are in procedures and contain the elements listed below. The procedure(s) controlling maintenance, testing, and calibration of the SFPIS will be available for inspection.
  - Westinghouse provided instruction manuals and calibration procedures that were used to develop calibration procedures for the equipment.
  - Nuclear Engineering Setpoint and Scaling Documents NE-SSD-0-L-78-43 and -44, included in DCN 23195, were used in the development of the required calibration procedures.
  - Instrument loop calibration verification will be performed by a 2 point test using the adjustable mounting bracket to confirm the transmitter zero point has not drifted and the indicator correctly repeats the elevation change from the adjustable mounting bracket. Required loop accuracy from NE-SSD 0-L-78-43 and -44 is used in the calibration verification.
  - Westinghouse and K-Tek developed an in-situ detailed calibration method which will disconnect the probe cable assemblies and test the transmitter using a test cable probe assembly if calibration errors are identified during operation or testing.
  - The procurement specification contains adequate testing requirements in accordance with EA-12-051 and NEI-12-02, and requires that Westinghouse provide analysis certifying that a 2-point channel check is sufficient to maintain calibration of the full instrument range.
  - Calibration to validate the functionality of the installed instrument channels is required within 60 days of a planned refueling outage, considering normal testing scheduling allowances (e.g. +/- 25 percent), provided that the calibration has not been performed within the last 12 months.
  - Existing work control processes such as Surveillance Instructions (SI), Preventative Maintenance procedures and Work Orders will be utilized to perform testing and maintenance on the instrument channels.

## Enclosure 2

- Allowable channel out of service times and associated actions will be consistent with the guidance provided in NEI 12-02.
- b) NEI 12-02, Section 4.3 states "The primary or back-up instrument channel can be out of service for testing, maintenance and/or calibration for up to 90 days provided the other channel is functional. Additionally, compensatory actions must be taken if the instrumentation channel is not expected to be restored or is not restored within 90 days. If both channels become nonfunctioning then initiate actions within 24 hours to restore one of the channels of instrumentation and implement compensatory actions (e.g., use of alternate suitable equipment or supplemental personnel) within 72 hours."

SQN has received information from the part supplier indicating critical spare parts for the system, and the lead time and availability of spare parts. This information will be used in conjunction the site work control process to provide assurance that a channel can be restored to service within 90 days. An operating procedure is in place to track out of service time of the SFPIS. If one or both channels cannot be restored to service within 90 days, or if both channels become non-functioning, as a compensatory measure SQN will utilize AOP-M.06, "Loss of Spent Fuel Cooling" during any loss of spent fuel pool level or cooling event. This instruction requires the dispatch of operators to determine the spent fuel pool level and cooling system status and investigate for the cause of leakage and to take appropriate actions to restore the spent fuel pool level and cooling.

- c) See response to RAI #13b above.

### **RAI #14**

*Please provide a description of the in situ calibration process at the SFP location that will result in the channel calibration being maintained at its design accuracy.*

### **TVA Response**

See response to RAI #10 above.

### **References for Enclosure 2:**

1. Letter from NRC to TVA, "Sequoyah Nuclear Plant, Units 1 and 2 - Interim Staff Evaluation and Request for Additional Information Regarding the Overall Integrated Plan for Implementation of Order EA-12-051, Reliable Spent Fuel Pool Instrumentation (TAC Nos. MF0794 and MF0795)," dated November 21, 2013 (ML13312A415).
2. Letter from NRC to TVA, "Sequoyah Nuclear Plant, Units 1 and 2 - Request for Additional Information Regarding Overall Integrated Plan in Response to the Commission Order Modifying Licenses with Regard to Reliable Spent Fuel Pool Instrumentation (Order Number EA-12-051)," dated July 17, 2013 (ADAMS Accession No. ML13198A354).

Enclosure 2

3. Letter from TVA to NRC, "Response to NRC Request for Additional Information Regarding Overall Integrated Plan for Reliable Spent Fuel Pool Instrumentation (Order No. EA-12-051) (TAC Nos. MF0794 and MF0795)," dated August 16, 2013 (ADAMS Accession No. ML13235A007).
4. Letter from TVA to NRC, "First Six-Month Status Report in Response to the March 12, 2012, Commission Order Modifying Licenses with Regard to Reliable Spent Fuel Pool Instrumentation (Order Number EA-12-051) for Sequoyah Nuclear Plant," dated August 28, 2013 (ADAMS Accession No. ML 13247A291).
5. NRC letter to TVA, "Watts Bar Nuclear Plant, Units 1 and 2 - Report for the Westinghouse Audit in Support of Reliable Spent Fuel Instrumentation Related to Order EA-12-051 (TAC Nos. MF0951 and MF1178)" dated August 18, 2014.

Enclosure 2

#	Topic	Parameter Summary	Westinghouse Reference Document #	Additional Comment	Test or Analysis Results	Licensee Evaluation
1	Design Specification	SFPIS Requirements derived from References 1, 2, and 3	WNA-DS-02957-GEN	Contains technical SFPIS requirements based on NRC Order, NEI guidance, and the ISG listed above.	N/A	TVA has reviewed WNA-DS-02957-GEN Rev 3 and it bounds SQN requirements from References 1, 2 and 3 as discussed in the following responses, and is therefore acceptable. Refer to RAI #5 and #6 responses.
2	Test Strategy	Per Requirements.	WNA-PT-00188-GEN	Strategy for performing the testing and verification of the SFPIS and pool-side bracket.	N/A	TVA has reviewed WNA-PT-00188-GEN and found it to be acceptable for the current design. Refer to RAI #2, #3, #5 and #6 responses.
3	Environmental qualification for electronics enclosure with Display	<p>50<sup>0</sup> F to 140<sup>0</sup> F, 0 to 95% relative humidity (RH)</p> <p>TID ≤ 1E03 R <math>\gamma</math> normal (outside SFP area)</p> <p>TID ≤ 1E03 R <math>\gamma</math> abnormal (outside SFP area)</p>	EQ-QR-269 and WNA-TR-03149-GEN for all conditions.	<p>Results are summarized in EQ-QR-269 and WNA-TR-03149-GEN.</p> <p>Radiation Aging verification summarized in Section 5 of WNA-TR-03149-GEN.</p>	Test passed conditions described.	<p>The abnormal temperature and humidity values of 60°F to 104°F and 10 to 90% RH from SQN Design Criteria SQN-DC-V-21.0 (for Rooms A6 and A20 on AB Elev. 734.0) are bounded by the values in EQ-QR-269, Rev 4, which is acceptable.</p> <p>Section 4.4 of WNA-TR-03149-GEN Rev 2 states that the service life of electronics enclosure is 10 years. The normal 10 year TID of 4.5E02 R from SQN Design Criteria SQN-DC-V-21.0 (for Rooms A6 and A20 on AB Elev. 734.0 – ¼ of 40 year TID) is bounded by the qualification value of 1E3 rads, which is acceptable. Abnormal dose is not applicable.</p> <p>Refer to RAI #5 and #6 responses.</p>

Enclosure 2

#	Topic	Parameter Summary	Westinghouse Reference Document #	Additional Comment	Test or Analysis Results	Licensee Evaluation
4	Environmental Testing for Level Sensor components in SFP area – Saturated Steam & Radiation	50 <sup>0</sup> F to 212 <sup>0</sup> F and 100% humidity	EQ-QR-269, Rev. 4	Testing summarized in Section 5.7.	Passed	The temperature and humidity values of 212°F and 100% RH from TVA calculation NDQ0000782014000106 (for Volume 2) are bounded by the test results from EQ-QR-269 Rev 4 as described in Section 3.2 of WNA-TR-03149-GEN Rev 2, which is acceptable. Refer to RAI #5 and #6 responses.
1E03 R $\gamma$ normal (SFP area)		EQ-QR-269, Rev 4	Thermal Aging & radiation aging verification summarized in Sections 4.1 and 5 (entire system) of WNA-TR-03149-GEN.	Passed	Section 4.3 of EQ-QR-269 Rev 4 states that TID of components in SFP area will be 1000R. The normal 2.5 year TID of less than 1 R (for Room A13 with up to 4000 fuel assemblies at 4 days after shutdown) from SQNSQS2-0172 is bounded by EQ-QR-269 R4 and is insignificant in comparison to the BDB dose of 1E07 R from Section 4.3 of EQ-QR-269 Rev 4, and is assumed to be included in the 10% test margin, and therefore bounded by EQ-QR-269 Rev 4, which is acceptable.  TVA has reviewed the results of the additional testing documented in EQ-QR-269 Rev 4, Section 5.7.2.3, and concurs with the 10 year qualified life for the cable connectors.	
1E07 R $\gamma$ BDB (SFP area)		EQ-TP-354 (procedure)  Actual test report is in progress.	Additional thermal & radiation aging programs being conducted under test procedure EQ-TP-354.	Additional aging program is in progress to achieve longer life.	The BDB radiation value of 1.92E6 rem from TVA calculation NDQ0000782014000106 (Receiver Point 2) is bounded by Section 4.3 of EQ-QR-269, Rev 4 ( $\leq 1E7$ R), which is acceptable.	

Enclosure 2

#	Topic	Parameter Summary	Westinghouse Reference Document #	Additional Comment	Test or Analysis Results	Licensee Evaluation
						TVA has reviewed the results of the additional testing documented in EQ-QR-269 Rev 4, Section 5.7.1, and concurs with the 10 year qualified life for the cable connectors.  Refer to RAI #5 and #6 responses.
5	Environmental Testing for Level Sensor Electronics Housing – outside SFP	50 <sup>0</sup> F to 140 <sup>0</sup> F, 0 to 95% RH	EQ-QR-269, Rev. 2	Testing summarized in Section 5.5.	Passed	The BDB temperature and humidity values of 99°F to 140°F and 35% RH to 80% RH (for Volumes 3 and 4 up to 7 days) from TVA calculation NDQ0000782014000106 are bounded by Section 5.5 of EQ-QR-269, Rev. 4, which is acceptable. Refer to RAI #9, #5 and #6 responses.
		100% RH	WNA-TR-03149-GEN	100% humidity addressed in Section 7.5.	Passed	The BDB humidity value of 80% RH from TVA calculation NDQ0000782014000106 (for Volumes 3 and 4) is bounded by Section 7.5 of WNA-TR-03149-GEN Rev 2, which is acceptable. Refer to RAI #5 and #6 responses.
		TID ≤ 1E03 R $\gamma$ normal (outside SFP area)  TID ≤ 1E03 R $\gamma$ abnormal (outside SFP area)	WNA-TR-03149-GEN and EQ-QR-269, Rev 4	Radiation Aging verification summarized in Section 5.	Passed	Section 4.4 of WNA-TR-03149-GEN Rev 2 states that the service life of the level sensor will be a minimum of 10 years. Extrapolation of the worst-case dose rate of 3.00E-02 mrem/hr from TVA calculation NDQ0000782014000106 results in a 10 year TID of approximately 2.6R, which is bounded by EQ-QR-269, Rev 4 (≤1E3 R), which is acceptable.



Enclosure 2

#	Topic	Parameter Summary	Westinghouse Reference Document #	Additional Comment	Test or Analysis Results	Licensee Evaluation
						<p>The worst-case BDB dose value of 5.04E-03 rem for 7 days from TVA calculation NDQ0000782014000106 are bounded by EQ-QR-269, Rev 4 (<math>\leq 1E03 R \gamma</math> for 4 days per Section 4.5.2 of WNA-DS-02957-GEN), which is acceptable. Abnormal dose is not applicable. Refer to RAI #5 and #6 responses.</p> <p>TVA has reviewed the results of the additional testing documented in EQ-QR-269 Rev 4, and additional system calculated life documentation in WNA-TR-03149-GEN Rev 2 and concurs with the 10 year qualified life for the entire SFPIS.</p>
6	Thermal & Radiation Aging – organic components in SFP area	1E03 R $\gamma$ normal (SFP area)	EQ-QR-269 and WNA-TR-03149-GEN	Thermal Aging & radiation aging verification summarized in Sections 4.1 and 5 (entire system) of WNA-TR-03149-GEN.	Passed	TVA has reviewed EQ-QR-269 Rev 4 and WNA-TR-03149-GEN Rev 2 for this topic and found them acceptable for SQN. See responses to Item 4 above.
		1E07 R $\gamma$ BDB (SFP area)	EQ-TP-354 (procedure) Actual test report is in progress.	Additional thermal & radiation aging programs being conducted under test procedure EQ-TP-354.	Additional aging program is in progress to achieve longer life.	TVA has reviewed the results of the additional age testing documented in EQ-QR-269 Rev 4, and concurs with the 10 year qualified life for the cable connectors.
7	Basis for Dose Requirement	<u>SFP Normal Conditions:</u> 1E03 R $\gamma$ TID	LTR-SFPIS-13-35 and WNA-DS-02957-GEN	Explanation of Basis for Radiation Dose Requirement	Passed for all conditions	For normal and BDB conditions above the pool, see responses to Item 4 above. LTR-SFPIS-13-35 was not provided to TVA.

Enclosure 2

#	Topic	Parameter Summary	Westinghouse Reference Document #	Additional Comment	Test or Analysis Results	Licensee Evaluation
		(above pool)  1E09 R $\gamma$ TID (1' above fuel rack)  <u>SFP BDBE Conditions:</u>  1E07 R $\gamma$ TID (above pool)  < 1E07 R $\gamma$ TID (1' above fuel rack)		(includes the clarification of production equivalency of electronics enclosure used for Seismic and EMC Testing)		Section 4.5.1 of WNA-DS-02957-GEN Rev 3 states that only probe's stainless steel cable and weight are exposed at this location. EQ-QR-269, Rev 4 demonstrates the components are able to perform in the BDBE environment and is bounding for SQN, which is acceptable.  Refer to RAI #5 and #6 responses.
8	Seismic Qualification	Per Spectra in WNA-DS-02957-GEN	EQ-QR-269	EQ-QR-269 summarizes the testing performed by Westinghouse	Passed	TVA has reviewed the seismic qualification testing in EQ-QR-269 Rev 4 and WNA-TR-03149-GEN Rev 2 and finds them to be acceptable. Site-specific response spectra are appended to CN-PEUS-14-12 (see Item 12 below). Refer to RAI #2, #3, #4, #5 and #6 responses.
			WNA-TR-03149-GEN	WNA-TR-03149-GEN provides high level summary of the pool-side bracket analysis and optional RTD.	Passed	

Enclosure 2

#	Topic	Parameter Summary	Westinghouse Reference Document #	Additional Comment	Test or Analysis Results	Licensee Evaluation
			EQ-QR-269, Rev. 4	Seismic Pull test for new connectors documented in Section 4.4.	Passed	
9	Sloshing	N/A	LTR-SEE-II-13-47	Calculation to demonstrate that probe will not be sloshed out of the SFP.	Passed	TVA has reviewed LTR-SEE-II-13-47 and agrees with the conclusion that sloshing will not throw the instrument out of the pool.
			WNA-TR-03149-GEN	Sloshing is also addressed in Section 7.2.	Passed	TVA has reviewed Section 7.2 of WNA-TR-03149-GEN Rev 2 and found it to be acceptable. The SQN spent fuel pool level is sufficiently below the bracket such that sloshing will not impact the bracket. This is acceptable. Refer to RAI #2, #3 and #6 responses.
10	Spent Fuel Pool Instrumentation System Functionality Test Procedure	Acceptance Criteria for Performance during EQ testing	WNA-TP-04613-GEN	Test procedure used to demonstrate that SFPIS meet its operational and accuracy requirements during Equipment Qualification Testing programs.	See applicable EQ test.	WNA-TP-04613-GEN was not provided to TVA. SQN has reviewed WNA-TP-00189-GEN "Integrated Functional Test Plan" and found it acceptable, with the exception of EMC qualification to Performance Criteria A, which will be independently verified by TVA. Refer to RAI #9 and #10 responses.
11	Boron Build-Up	Per requirement in WNA-DS-02957-GEN	WNA-TR-03149-GEN	Boron build up demonstrated through Integrated Functional Test (IFT).	Passed	SQN has reviewed the justification in Section 7.4 of WNA-TR-03149-GEN Rev 2 and found it acceptable. Refer to RAI #2 and #6 response.
12	Pool-side Bracket	N/A	CN-PEUS-14-12	Also includes hydrodynamic forces, as	Passed	SQN seismic requirements for 2x SSE HCLPF are bounded by CN-PEUS-14-12,

Enclosure 2

#	Topic	Parameter Summary	Westinghouse Reference Document #	Additional Comment	Test or Analysis Results	Licensee Evaluation
	Seismic Analysis			appropriate.		which is acceptable. Refer to RAI #2, #3, #4, #5 and #6 responses.
13	Additional Brackets (Sensor Electronics and Electronics Enclosure)	N/A	WNA-DS-02957-GEN	Weights provided to licensees for their own evaluation.	N/A	Instrument panel mounting is qualified by TVA calculation CDQ0000782014000114 based on WNA-DS-02957-GEN Rev 3. TVA evaluates the seismic mounting requirements in accordance with SQN safety related requirements. Refer to RAI #2, #3, #4, #5 and #6 responses.
14	Shock & Vibration	WNA-DS-02957-GEN	WNA-TR-03149-GEN	Section 7 provides rationale and summary of RTD.	N/A	TVA concurs with the Westinghouse evaluation of shock and vibration in Section 7.1 of WNA-TR-03149-GEN Rev 2. Refer to RAI #5 and #9 responses.
15	Requirements Traceability Matrix	Maps Requirements to documentation / evidence that Requirement is met	WNA-VR-00408-GEN	The RTM maps the requirements of the NRC Order, NEI guidance, ISG to the applicable technical requirements in the SFPIS design specification and maps the design specification requirements to the documentation demonstrating the requirement is met.	Complete	Westinghouse issued WNA-DC-00247-WAT Rev 1 as a Requirements Matrix for TVA.
16	Westinghouse Factory Acceptance Test, including	IFT Functional Requirements from WNA-DS-02957-	WNA-TP-04752-GEN	The Integrated Functional Test (IFT) demonstrates functionality of the full system for each	Pilot IFT executed/passed	SQN has reviewed WNA-TP-04752-GEN and found it to be acceptable with the exception of any EMI/RFI tests that are being independently verified by TVA. Refer to RAI

Enclosure 2

#	Topic	Parameter Summary	Westinghouse Reference Document #	Additional Comment	Test or Analysis Results	Licensee Evaluation
	testing of dead-zones	GEN		customer's FAT, which includes calibration of each channel.	Sequoyah IFT executed/passed	#9 #10, #12 and #13 responses.
		12" dead-zone at top of probe  4" dead-zone at bottom of probe	WNA-TP-04752-GEN	Dead-zone tests are in Section 9.6.2.	N/A	The SQN instrument scaling from 701.06' to 728.44' from TVA setpoint and scaling documents 0-L-78-43 and 0-L-78-44 is bounded by the unmeasurable zones from Section 9.6.2 of WNA-TP-04752-GEN.
17	Channel Accuracy	+/- 3 inches per WNA-DS-02957-GEN	WNA-CN-00301-GEN	Channel accuracy from measurement to display.	Passed	TVA has reviewed the channel accuracy in WNA-DS-02957-GEN Rev 3 and WNA-CN-00301-GEN and found them to be acceptable. The SQN channel accuracy documented in TVA setpoint and scaling documents 0-L-78-43 and 0-L-78-44 is conservative and is bounded by WNA-CN-00301-GEN. Refer to RAI #9 response.
18	Power Consumption	3 day battery life (minimum)  0.257 Amps power consumption	WNA-CN-00300-GEN	N/A	Passed	TVA has reviewed WNA-CN-00300-GEN and concurs that battery life of 4.22 days from Table 5-7 is adequate for SQN. The 0.257A loading does not challenge the SQN distribution system per TVA calculations SQN-CPS-56 Rev 73, SQN-CPS-60 Rev84, and EDQ0009992014000102 Rev 0 which is acceptable. Refer to RAI #8 response.
19	Technical Manual	N/A	WNA-GO-00127-GEN	Information and instructions for Operation, Installation, use, etc. are	N/A	SQN has received WNA-GO-00127-GEN Rev 2 and will use it as input for procedure preparation. Refer to RAI #5 and #6

Enclosure 2

#	Topic	Parameter Summary	Westinghouse Reference Document #	Additional Comment	Test or Analysis Results	Licensee Evaluation
				included here.		responses.
20	Calibration	Routine Testing/calibration verification and Calibration method	WNA-TP-04709-GEN	Also, includes preventative maintenance actions such as those for Boron buildup and cable probe inspection.	N/A	SQN has utilized WNA-TP-04709-GEN as input for procedure preparation. The Acceptable As-Left calibration values listed in the SSD 0-L-78-43 and 0-L-78-44 were incorporated in the calibration procedures, which is conservative. Refer to RAI #9, #10, #12 and #13 responses.
21	Failure Modes and Effects Analysis (FMEA)	N/A	WNA-AR-00377-GEN	Addresses mitigations for the potential failure modes of the system.	N/A	Not required.
22	Emissions Testing	RG 1.180 R1 test conditions	EQ-QR-269, Rev. 2	Documented in Section 5.6.	Passed	TVA has reviewed the Westinghouse test report and found it meets requirements for radiated emissions limits and criteria B for susceptibility testing. In addition, TVA has conducted additional EMI testing (B43 140513 001) and has installed the channels such that Level A compliance exists around the transmitter and coax. Level A compliance at the probe cannot be obtained in the VHF frequency band (less than 200 MHZ), however VHF radios are being phased out from all plant organizations other than security. Security will only use VHF as a backup channel if the primary channel is

Enclosure 2

#	Topic	Parameter Summary	Westinghouse Reference Document #	Additional Comment	Test or Analysis Results	Licensee Evaluation
						unavailable, so the potential for spurious indication is extremely small and does not exist during BDB-EE when low water level (NEI 12-02 level 2) exists in SFP.

Open Items:

None

References:

- 1) ML12056A044, NRC Order EA-12-051, "ORDER MODIFYING LICENSES WITH REGARD TO RELIABLE SPENT FUEL POOL INSTRUMENTATION," Nuclear Regulatory Commission, March 12, 2012.
- 2) ML12240A307, NEI 12-02 (Revision 1), "Industry Guidance for Compliance with NRC Order EA-12-051, "To Modify Licenses with Regard to Reliable Spent Fuel Pool Instrumentation" August, 2012.
- 3) ML12221A339, Revision 0, JLD-ISG-2012-03, "Compliance with Order EA-12-051, Reliable Spent Fuel Pool Instrumentation", August 29, 2012, Nuclear Regulatory Commission Japan Lessons-Learned Project Directorate.
- 4) Westinghouse Proprietary Document, WNA-DS-02957-GEN, "Spent Fuel Pool Instrumentation System (SFPIS) Standard Product System Design Specification," Revision 3 reviewed by NRC in April 2014; current revision is Revision 3.
- 5) Westinghouse Proprietary Document, WNA-PT-00188-GEN, "Spent Fuel Pool Instrumentation System (SFPIS) Standard Product Test Strategy," Revision 1 reviewed by NRC in February 2014; current revision is Revision 2.
- 6) Westinghouse Proprietary Document, EQ-QR-269, "Design Verification Testing Summary Report for the Spent Fuel Pool Instrumentation," Revision 1 reviewed by NRC in April 2014; current revision is Revision 4.
- 7) Westinghouse Proprietary Document, WNA-TR-03149-GEN, "SFPIS Standard Product Final Summary Design Verification Report," Revision 1 reviewed by NRC in April 2014; current revision is Revision 2.

## Enclosure 2

- 8) Westinghouse Proprietary Document, EQ-TP-351, "Environmental Qualification Test Procedure for the Spent Fuel Pool Instrumentation System Coaxial Cable and Connectors Inside the Spent Fuel Pool Area," Revision 0 reviewed by the NRC in February 2014; current revision is Revision 0.
- 9) Westinghouse Proprietary Document, EQ-TP-354, "Mechanical Preconditioning, Thermal Aging, and Radiation Aging Procedure for the Spent Fuel Pool Instrumentation System Coaxial Cables and Couplers," Revision 0 reviewed by the NRC in February 2014; current revision is Revision 0.
- 10) Westinghouse Proprietary Document, EQ-TP-360, "Environmental Test Procedure for the Sensor Housing for Spent Fuel Pool Instrumentation System," Revision 0 reviewed by the NRC in February 2014; current revision is Revision 0.
- 11) Westinghouse Proprietary Document, LTR-SFPIS-13-35, "SFPIS: Basis for Dose Requirement and Clarification of Production Equivalency of Electronics Enclosure Used for Seismic Testing," Revision 0 reviewed by the NRC in February 2014; current revision is Revision 1.
- 12) Westinghouse Proprietary Document, LTR-SEE-II-13-47, "Determination if the Proposed Spent Fuel Pool Level Instrumentation can be Sloshed out of the Spent Fuel Pool during a Seismic Event," Revision 0 reviewed by the NRC in February 2014; current revision is Revision 0.
- 13) Westinghouse Proprietary Document, WNA-TP-04613-GEN, "Spent Fuel Pool Instrumentation System Functionality Test Procedure," Revision 5 reviewed by the NRC in February 2014; current revision is Revision 5.
- 14) Westinghouse Proprietary Document, CN-PEUS-14-12 Revision 2, "Seismic Analysis of the SFP Pool-Side Bracket at SQN I & II," CN-PEUS-13-20 and -21 Revision 1 for WBN reviewed by the NRC in February 2014.
- 15) Not Used
- 16) Not Used
- 17) Westinghouse Proprietary Document, WNA-TP-04752-GEN, "Spent Fuel Pool Instrumentation System Standard Product Integrated Functional Test Procedure," Revision 1 reviewed by the NRC in February 2014; current revision is Revision 2.
- 18) Westinghouse Proprietary Document, WNA-CN-00301-GEN, "Spent Fuel Pool Instrumentation System Channel Accuracy Analysis," Revision 0 reviewed by the NRC in February 2014; current revision is Revision 1.
- 19) Westinghouse Proprietary Document, WNA-CN-00300-GEN, "Spent Fuel Pool Instrumentation System Power Consumption Calculation," Revision 0 reviewed by the NRC in February 2014; current revision is Revision 1.
- 20) Westinghouse Proprietary Document, WNA-GO-00127-GEN, "Spent Fuel Pool Instrumentation System Standard Product Technical Manual," Revision 1 reviewed by the NRC in April 2014; current revision is Revision 3.
- 21) Westinghouse Proprietary Document, WNA-TP-04709-GEN, "Spent Fuel Pool Instrumentation System Calibration Procedure," Revision 3 was reviewed by the NRC in February 2014; current revision is Revision 4.
- 22) Westinghouse Proprietary Document, WNA-AR-00377-GEN, "Spent Fuel Pool Instrumentation System Failure Modes and Effect Analysis," Revision 2 was reviewed by the NRC in February 2014; current revision is Revision 3.



## Enclosure 2

### SQN References:

- 23) SQN Calculation NDQ0000782014000106, "Beyond Design Basis Dose Evaluation for Spent Fuel Pool Level Instrumentation", Revision 0.
  - a. TID is summarized on cover sheet and shown in section 7.0
- 24) SQN Design Criteria SQN-DC-V-21.0, "Environmental Design - EI 734 A6 & A20" Revision 23.
  - a. Shutdown Board Rooms 1B1 (A6) and 2A1 (A20)
- 25) SQN Design Criteria SQN-DC-V-21.0, "Environmental Design - EI 734 A13" Revision 23.
  - a. SFP Area
- 26) SQN Design Criteria SQN-DC-V-21.0, "Environmental Design - EI 734 A12 & A14" Revision 23.
  - a. Transmitter Mounting Locations
- 27) SQN Nuclear Engineering Setpoint and Scaling Documents 0-L-78-43 and 0-L-78-44, Revision 0.
- 28) SQN Calculation SQN-CPS-59, "120 VAC Vital Control Power System Loading Channel III and Continuous Loading Evaluation of Protective Devices in the Vital 120V AC Instrument Power Boards" Revision 73
- 29) SQN Calculation SQN-CPS-60, "120 VAC Vital Control Power System Loading Channel IV and Continuous Loading Evaluation of Protective Devices in the Vital 120V AC Instrument Power Boards" Revision 84
- 30) SQN Calculation 26D54EPMABBIMPFA, "SQN – Fire Hazard Analysis Calculation" Revision 95.
- 31) SQN Calculation SQN-VD-VAC-2, "120 VAC Vital Control Power System Design Verification" Revision 95.
- 32) SQN Calculation SQN-CPS-051, "Circuit Protective Device Evaluation" Revision 53.
- 33) SQN Calculation SQN-MS-TI09-003, "Electrical Equipment Heat Losses in Selected Areas Of The Auxiliary Building Control Building and ERCW Pumping Station" Revision 46.
- 34) SQN Calculation 26D54EPMABBIMP194, "SQN – Combustible Loading Calculation for Room 734.0-A06" Revision 1.
- 35) SQN Calculation 26D54EPMABBIMP208, "SQN – Combustible Loading Calculation for Room 734.0-A20" Revision 1.
- 36) TVA Test Report (B43 140513 001), "EMI/RFI Susceptibility Testing for the Westinghouse-Supplied SFPIS"
- 37) SQN Calculation NDQ0000782014000106, "Beyond Design Basis Dose Evaluation for Spent Fuel Pool Level Instrumentation" Revision 1.
- 38) SQN Calculation CDQ0000782014000114, "Seismic Qualification for Mounting of Spent Fuel Level Instrumentation for SQN" Revision 1.
- 39) SQN Calculation 31D53EPMGDF0103687, HVAC Cooling Load Calculation: Aux. Bldg. Board Room and Shutdown Board Room" Revision 7.
- 40) SQN Calculation SQS20077, "Station Blackout Temperature Transient Analysis for the Aux. Building and Main Control Room" Revision 16.
- 41) SQN Calculation MDQ00003120020121, "6.9kv AND 480v Board Room Transient Temperature Analysis" Revision 1.

## Enclosure 2

- 42) SQN Calculation MDQ0009992013000066, "Cooling of the Main Control Room and Auxiliary Building Elevation 734 During a Design Basis Flood Event" Revision 1.
- 43) SQN Calculation MDQ0009992013000085, "SQN ELAP Transient Temperature Analysis" Revision 2.
- 44) SQN Calculation CDQ0003602014000171, "Qualification of Typical Conduit Support 1, 2-47A056-1152" Revision 0.
- 45) SQN Calculation SQN-SQS2-0172, "Dose Rate at Refueling Pool Surface for a Depth of 23 ft of Water" Revision 0.

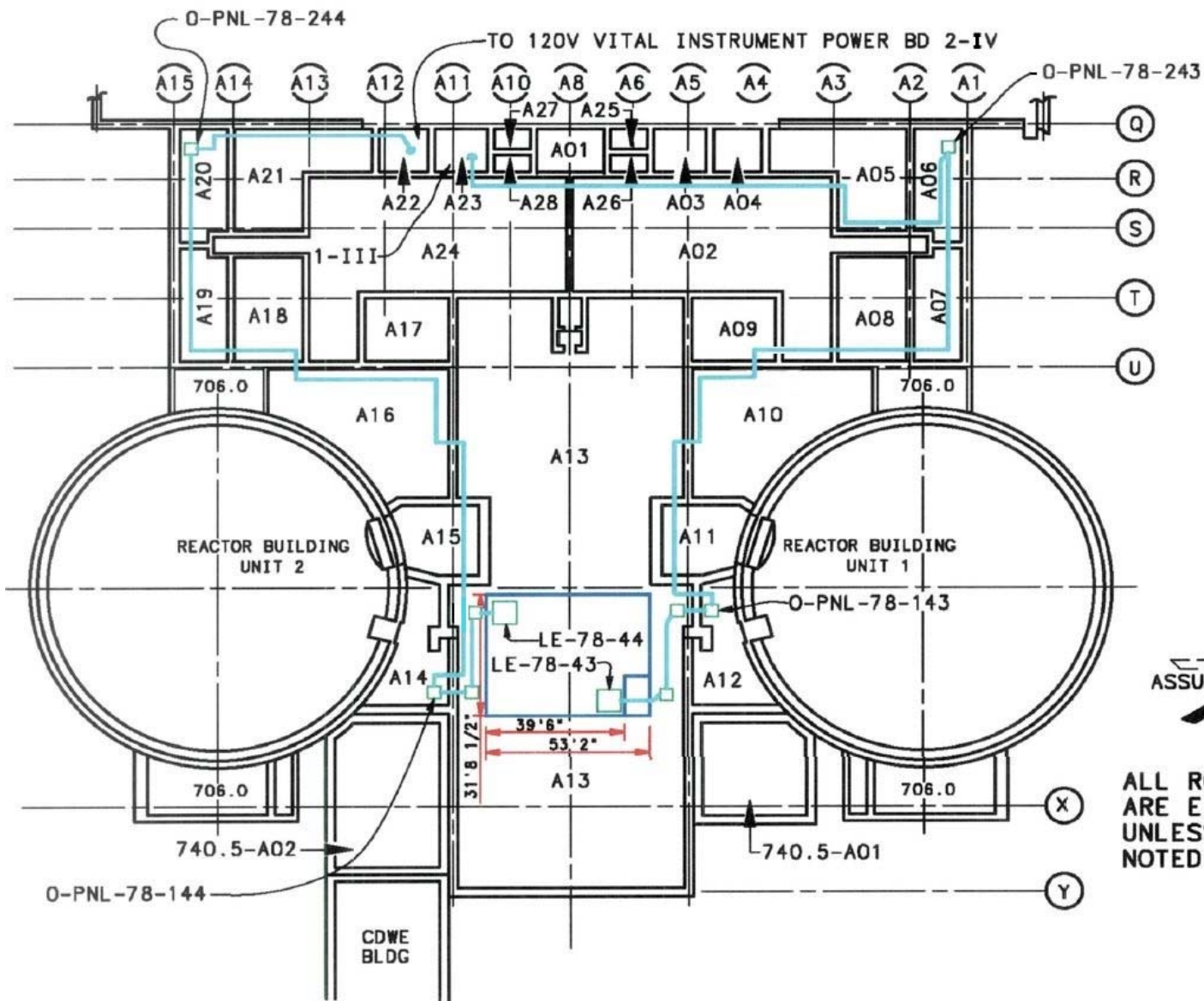
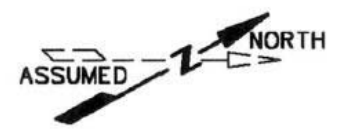

FIGURE 1.8

AUXILIARY BUILDING  
ELEVATION 734.0



ALL ROOM NUMBERS  
ARE ELEVATION 734.0  
UNLESS OTHERWISE  
NOTED

SQN Plan View of SFP Area - Response to RAI #1