

Rod Bundle Heat Transfer Facility Steam Cooling with Droplet Injection Experiments Data Report

AVAILABILITY OF REFERENCE MATERIALS IN NRC PUBLICATIONS

NRC Reference Material

As of November 1999, you may electronically access NUREG-series publications and other NRC records at NRC's Library at www.nrc.gov/reading-rm.html. Publicly released records include, to name a few, NUREG-series publications; *Federal Register* notices; applicant, licensee, and vendor documents and correspondence; NRC correspondence and internal memoranda; bulletins and information notices; inspection and investigative reports; licensee event reports; and Commission papers and their attachments.

NRC publications in the NUREG series, NRC regulations, and Title 10, "Energy," in the *Code of Federal Regulations* may also be purchased from one of these two sources.

1. The Superintendent of Documents

U.S. Government Publishing Office
Mail Stop IDCC
Washington, DC 20402-0001
Internet: bookstore.gpo.gov
Telephone: (202) 512-1800
Fax: (202) 512-2104

2. The National Technical Information Service

5301 Shawnee Rd., Alexandria, VA 22312-0002
www.ntis.gov
1-800-553-6847 or, locally, (703) 605-6000

A single copy of each NRC draft report for comment is available free, to the extent of supply, upon written request as follows:

Address: **U.S. Nuclear Regulatory Commission**
Office of Administration
Publications Branch
Washington, DC 20555-0001
E-mail: distribution.resource@nrc.gov
Facsimile: (301) 415-2289

Some publications in the NUREG series that are posted at NRC's Web site address www.nrc.gov/reading-rm/doc-collections/nuregs are updated periodically and may differ from the last printed version. Although references to material found on a Web site bear the date the material was accessed, the material available on the date cited may subsequently be removed from the site.

Non-NRC Reference Material

Documents available from public and special technical libraries include all open literature items, such as books, journal articles, transactions, *Federal Register* notices, Federal and State legislation, and congressional reports. Such documents as theses, dissertations, foreign reports and translations, and non-NRC conference proceedings may be purchased from their sponsoring organization.

Copies of industry codes and standards used in a substantive manner in the NRC regulatory process are maintained at—

The NRC Technical Library

Two White Flint North
11545 Rockville Pike
Rockville, MD 20852-2738

These standards are available in the library for reference use by the public. Codes and standards are usually copyrighted and may be purchased from the originating organization or, if they are American National Standards, from—

American National Standards Institute

11 West 42nd Street
New York, NY 10036-8002
www.ansi.org
(212) 642-4900

Legally binding regulatory requirements are stated only in laws; NRC regulations; licenses, including technical specifications; or orders, not in NUREG-series publications. The views expressed in contractor-prepared publications in this series are not necessarily those of the NRC.

The NUREG series comprises (1) technical and administrative reports and books prepared by the staff (NUREG-XXXX) or agency contractors (NUREG/CR-XXXX), (2) proceedings of conferences (NUREG/CP-XXXX), (3) reports resulting from international agreements (NUREG/IA-XXXX), (4) brochures (NUREG/BR-XXXX), and (5) compilations of legal decisions and orders of the Commission and Atomic and Safety Licensing Boards and of Directors' decisions under Section 2.206 of NRC's regulations (NUREG-0750).

DISCLAIMER: This report was prepared as an account of work sponsored by an agency of the U.S. Government. Neither the U.S. Government nor any agency thereof, nor any employee, makes any warranty, expressed or implied, or assumes any legal liability or responsibility for any third party's use, or the results of such use, of any information, apparatus, product, or process disclosed in this publication, or represents that its use by such third party would not infringe privately owned rights.

Rod Bundle Heat Transfer Facility Steam Cooling with Droplet Injection Experiments Data Report

Manuscript Completed: October 2014
Date Published: May 2015

Prepared by:
L.E. Hochreiter, F.B. Cheung, T.F. Lin, D.J. Miller, B.R. Lowery

The Pennsylvania State University
University Park, PA 16802

Division of Systems Analysis
Office of Nuclear Regulatory Research
U.S. Nuclear Regulatory Commission
Washington, DC 20555-0001

K. Tien, Project Manager

NRC Job Code N6154

Office of Nuclear Regulatory Research

ABSTRACT

As part of the Nuclear Regulatory Commission safety analysis computer code development efforts, the Rod Bundle Heat Transfer (RBHT) test facility has been designed and constructed at The Pennsylvania State University. The test series described in this report is the steam cooling tests with droplet injection. A total of 85 steady-state steam cooling experiments with prescribed droplet injection was performed in the RBHT. The purpose of the experiments was to examine steady-state dispersed flow film boiling in prototypical rod bundle geometry for computer code model development and validation.

The Rod Bundle Heat Transfer facility is a full length, 3.66 m (12 ft.), 7 by 7 rod array with typical Pressurized Water Reactor rod diameters of 9.49 mm (0.374 in.) and a rod pitch of 12.59 mm (0.496 in.). The heater rods have a top skewed power shape with a peak to average power of 1.5 at the 2.74 m (9 ft.) elevation. The RBHT facility has been designed using prototypical mixing vane spacer grids.

The bundle inlet steam Reynolds number ranged from 2000 to 15,000 with most of the experiments at the lower Reynolds number range. The droplets were injected upward in the center of the sub-channels at the 1.295 m (51 in.) elevation using two or four injection tubes. The injection tubes used a single row, linear hole pattern of four holes per sub-channel and four sub-channels per tube in the center of the bundle. One additional hole was located at the center of the rod gap location to minimize the chance of local boiling in the injection tube. The hole sizes used were 0.381 mm (0.015 in.) and 0.254 mm (0.01 in.). The injection tubes were bench tested before the bundle tests to optimize the performance of the liquid jets such that the injected droplets would flow upwards in the center of the sub-channel. The droplet sizes issuing from the holes were also measured. The selected hole sizes would produce drops that were typical of the drop sizes observed in the RBHT and FLECHT-SEASET reflood experiments.

FOREWORD

A loss-of-coolant accident (LOCA) is one of the primary postulated accidents that must be considered in the design of nuclear power plants. The plant response to such an accident, including the performance of safety systems that are designed to mitigate the accident, is mainly analyzed using computer codes. For effective analyses of accidents and operational transients, the U.S. Nuclear Regulatory Commission (NRC) consolidated earlier thermal-hydraulics analysis codes into one called TRACE.

The NRC is now assessing and improving the TRACE code as weaknesses are identified. One such weakness is inaccurate prediction of peak clad temperatures of fuel rods, particularly in the later stage of a large-break (LB) LOCA, called the reflood phase. Specifically, the reflood models currently employed in the TRACE code are not sufficiently accurate and, consequently, improved models must be developed to provide necessary support for risk-informed regulations. Accurate prediction of the consequences of an LBLOCA is important because this is one of the limiting postulated accidents used to determine whether plant design parameters (such as power densities, equipment sizes, etc.) have been appropriately selected to ensure safety. As the NRC places increasing emphasis on risk-informed regulations, the agency needs a more accurate and reliable computer code to obtain realistic (rather than conservative) predictions.

To develop better computer code models for an LBLOCA, we need detailed, fundamental data that show heat, mass, and momentum exchanges. Some of these detailed data have only recently become possible because of recent advances in instrumentation technology for two-phase flow measurements. Consequently, to acquire detailed, fundamental data for use in developing models for an LBLOCA, the NRC sponsored the construction of a rod bundle heat transfer (RBHT) test facility and completion of four test series; reflood tests, liquid-gas interfacial drag tests, steam cooling tests without liquid droplet injection, and steam cooling tests with liquid droplet injection.

This report presents the results of steam cooling with droplet injection tests. The data from these tests will be used to develop and assess the droplet model which is a component of a LOCA model for the TRACE code. The results of other test series will be reported in separate reports.

With improved data and code models for an LBLOCA, we can more accurately predict the consequences of LBLOCA accidents and provide better technical bases for regulations associated with such accidents. As a result, this study will help to achieve the NRC's strategic performance goals of making the agency's regulations more effective, efficient, and realistic.

TABLE OF CONTENTS

ABSTRACT	iii
FOREWORD.....	v
LIST OF FIGURES.....	ix
LIST OF TABLESxi
EXECUTIVE SUMMARY	xiii
1. INTRODUCTION.....	1-1
1.1 Introduction.....	1-1
2. TEST FACILITY DESCRIPTION FOR STEAM COOLING WITH DROPLET	
INJECTION EXPERIMENTS	2-1
2.1 General Facility Description	2-1
2.1.1 Test Section.....	2-3
2.1.2 Lower Plenum.....	2-13
2.1.3 Upper Plenum.....	2-13
2.1.4 Large and Small Carryover Tanks	2-15
2.1.5 Steam Separator and Collection Tanks	2-18
2.1.6 Pressure Oscillation Damping Tank.....	2-19
2.1.7 Exhaust Piping.....	2-21
2.1.8 Injection Water Supply Tank.....	2-22
2.1.9 Water Injection Line	2-23
2.1.10 Steam Supply.....	2-28
2.2 Facility Improvements Over Previous Tests	2-28
2.3 Instrumentation and Data Acquisition System.....	2-29
2.3.1 Loop Instrumentation and Controls.....	2-29
2.3.2 Test Section Instrumentation	2-32
2.3.3 Droplet Measuring System	2-44
2.3.4 Data Acquisition System.....	2-50
2.4 RBHT Steam Cooling with Droplet Injection Test Method.....	2-50
3. CALCULATIONAL METHODS USED FOR RBHT STEAM COOLING WITH	
DROPLET INJECTION EXPERIMENTS	3-1

3.1 Heat Transfer Coefficient Calculation (DATARH).....	3-1
3.1.1 Introduction.....	3-1
3.1.2 Mathematical Model.....	3-1
3.1.3 Structure of the source program DATARH.F	3-6
3.1.4 RBHT Rod Geometry and Materials	3-9
3.1.5 Input files required for executing the current version of the program.....	3-10
3.1.6 Calculation of the power factor at each thermocouple location.....	3-10
4. CONCLUSIONS.....	4-1
4.1 Conclusions.....	4-1
4.2 Recommendations for Future Work	4-1
5. REFERENCES.....	5-1
APPENDIX A: SAMPLE DATA PLOTS FOR INDIVIDUAL EXPERIMENTS.....	A-1
APPENDIX B: UNCERTAINTIES.....	B-1

LIST OF FIGURES

Figure 2-1:	RBHT Test Facility Schematic	2-2
Figure 2-2:	Test Facility Isometric View	2-2
Figure 2-3:	Test Section Isometric View	2-4
Figure 2-4:	Rod Bundle Cross Section View	2-5
Figure 2-5:	Heater Rod	2-6
Figure 2-6:	Heater Rod Axial Power Profile	2-7
Figure 2-7:	Mixing Vane Grid	2-9
Figure 2-8:	Low Melt Reservoir	2-9
Figure 2-9:	Flow Housing Cross Section View	2-10
Figure 2-10:	Low Mass Flow Housing	2-11
Figure 2-11:	Housing Window	2-12
Figure 2-12:	Lower Plenum	2-14
Figure 2-13:	Upper Plenum	2-14
Figure 2-14:	Exhaust Line Baffle	2-15
Figure 2-15:	Small Carryover Tank	2-16
Figure 2-16:	Large Carryover Tank	2-17
Figure 2-17:	Steam Separator	2-18
Figure 2-18:	Steam Separator Collection Tank	2-19
Figure 2-19:	Pressure Oscillation Damping Tank	2-20
Figure 2-20:	Exhaust Piping	2-21
Figure 2-21:	Injection Water Supply Tank	2-22
Figure 2-22:	Water Injection System Schematic	2-23
Figure 2-23:	Droplet Injection Plumbing Layout	2-25
Figure 2-24:	Droplet Injection Tube Design	2-26
Figure 2-25:	Droplet Injection Tubes During Flow Meter Calibration	2-27
Figure 2-26:	Sampled Subchannels for Droplet Size Measurements	2-27
Figure 2-27:	Loop Instrumentation Schematic	2-31
Figure 2-28:	Rod Bundle and Housing Instrumentation Axial Locations	2-33
Figure 2-29:	Mixing Vane Grid Instrumentation	2-34
Figure 2-30:	Grid No. 2 Instrumentation	2-35
Figure 2-31:	Grid No. 3 Instrumentation	2-36
Figure 2-32:	Grid No. 4 Instrumentation	2-37
Figure 2-33:	Grid No. 5 Instrumentation	2-38
Figure 2-34:	Grid No. 6 Instrumentation	2-39
Figure 2-35:	Grid No. 7 Instrumentation	2-40
Figure 2-36:	Instrumental Heater Rod Radial Location	2-41
Figure 2-37:	Traversing Steam Probe Rake Schematic	2-42
Figure 2-38:	Traversing Steam Probe Rake	2-43
Figure 2-39:	Digital Camera and Laser Instrumentation	2-45
Figure 2-40:	General Schematic of the Imaging System	2-47
Figure 2-41:	Typical VisiSizer Image through the Rod Bundle (no “in focus” droplets present)	2-48
Figure 2-42:	Linear Rails for Positioning High Speed Camera System	2-49

Figure 3-1:	Geometry, Materials and Dimensions of RBHT Heater Rod.....	3-9
Figure 3-2:	RBHT- Test Facility, Heater Rod Locations (Looking down from Top)...	3-11
Figure 3-3:	Axial Power Ratio for Rod F4, (Stern Heater number 2).....	3-13
Figure 3-4:	Power Factor as a function of length (beginning of heated length to PCT location)	3-14
Figure 3-5:	Power Factor as a function of length (from PCT location to the end of heater length)	3-15

LIST OF TABLES

Table 1-1:	Test Summary Table.....	1-3
Table 3-1:	Heater Number 1	3-11
Table 3-2:	Sample Power Factor Calculation for One Heater Rod.....	3-13
Table 3-3:	Axial Power Factors for the RBHT Heater Rods	3-16

EXECUTIVE SUMMARY

As part of the Nuclear Regulatory Commission safety analysis computer code development efforts, the Rod Bundle Heat Transfer (RBHT) test facility has been designed and constructed at The Pennsylvania State University to provide data and associated analysis to help support the code development efforts. This report describes one of the test series in the RBHT which included 85 steady-state steam cooling experiments with prescribed droplet injection. The purpose of the experiments was to examine steady-state dispersed flow film boiling in a prototypical rod bundle geometry for computer code model development and validation.

The Rod Bundle Heat Transfer (RBHT) facility is a full length simulation of a portion of a Pressurized Water Reactor (PWR) fuel assembly. The bundle is a 7 x 7 rod array with four unheated corner rods and 45 heated electrical rod which simulate a 17 x 17 PWR fuel assembly. The Rod Bundle Heat Transfer facility is full length, 3.66 m (12 ft.), with typical PWR rod diameters of 9.49 mm (0.374 in.) and a rod pitch of 12.59 mm (0.496 in.). The heater rods have a top skewed power shape with a peak to average power of 1.5 at the 2.74 m (9 ft.) elevation.

The droplet flow rates were estimated from examination of the RBHT and FLECHT-SEASET reflood experiments so as to obtain approximately the same two-phase quality behavior in the bundle with droplet injection. A droplet injector was designed and tested to provide the prescribed liquid flow rates at or very near the saturation temperature at the pressure of the experiments. It was found that the jet injection behavior was very sensitive to the temperature of the injection temperature or subcooling since high subcoolings would cause condensation and would collapse the droplet jet into a single stream.

The bundle inlet steam Reynolds number ranged from 2000 to 15,000 with most of the experiments at the lower Reynolds number range. The droplets were injected upward in the center of the sub-channels at the 1.295 m (51 in.) elevation using two or four injection tubes. The injection tubes used a single row, linear hole pattern of four holes per sub-channel and four sub-channels per tube such that the injection was in the center sub-channels of the bundle. One additional hole was located at the center of the rod gap location to minimize the chance of local boiling in the injection tube. The hole sizes used were 3.81 mm (0.015 in.) and 0.254 mm (0.01 in.). The injection tubes were bench tested before the bundle tests to optimize the performance of the liquid jets such that the injected droplets would flow upwards in the center of the sub-channel rather than impact the heater rods, causing early rod quench. The droplet sizes issuing from the holes were also measured. The selected hole sizes would produce drops that were typical of the drop sizes observed in the RBHT and FLECHT-SEASET reflood experiments.

The experiments were performed using a constant power rather than simulating the reactor decay power. The use of a constant bundle power enabled the bundle to reach a steady-state condition which then resulted in quasi-steady film boiling over the majority of the bundle length with droplet injection. There were approximately 500 channels of transient data recorded for each test including the bundle power, heater rod temperatures, upper plenum pressure, inlet flow rate, inlet water temperature, superheated vapor temperatures in the bundle, spacer grid temperatures, liquid carryout of the bundle, and the detailed axial bundle pressure drop. The experiments indicated the non-equilibrium behavior of the superheated steam with entrained saturated droplets. The experimental data has been qualified and submitted to the Nuclear Regulatory Data bank for analysis and computer code validation.

1. INTRODUCTION

1.1 Introduction

One of the objectives of the RBHT program has been to de-compose the dispersed flow film boiling heat transfer into its individual components such as single phase superheated steam convection, radiation effects, and the effects of the droplets on the superheated steam phase convection. The single phase steam convection experiments have been completed. The objective of the experiments given in this report was to achieve a steady-state experiments with injected droplets of prescribed diameters and mass flow rates to create a steady-state dispersed flow film boiling heat transfer situation in which different parameters could be varied in a separate-effects test manner. The data can then be analyzed in detail to calculate the individual heat flux components using the droplet measurements, non-equilibrium steam temperature measurements, heater rod surface measurements and the measured flow rates. A radiation network can also be used to estimate the radiation heat transfer effects to the steam, drops and structures. The convective heat transfer component in the dispersed flow film boiling can be calculated from the total measured wall heat flux and compared to the convective heat transfer obtained from the steam cooling only test data. This data will help support NRC best-estimate safety analysis computer code model development and validation.

A series of steady-state steam cooling with droplet injection experiments have been performed in the Pennsylvania State University and Nuclear Regulatory Commission Rod Bundle Heat Transfer (RBHT) Facility [1]. The range of conditions for these experiments were derived from the forced reflood experiments and the steady-state steam cooling experiments which were previously performed in the RBHT facility. The bundle inlet steam Reynolds numbers ranged from 2000 to 15,000, with most of the experiments at the lower Reynolds numbers. The inlet droplet injection flows ranges from 3.6 to 15 g/sec (0.008 to 0.033 lbm/sec) which would give a range of subchannel qualities of 0.115 to 0.795 and a range of bundle average qualities of 0.514 to 0.960. The experiments performed are given in Table 1-1 for the droplet injection experiments.

The droplet injection occurred at the 1.295 m (51 in.) elevation. Either two or four injector tubes were used to provide an upward liquid jet flow which then broke into a droplet stream in the center of the sub-channel in which the flow was injected. The liquid temperature for the liquid flow was at or very near the saturation temperature for the bundle pressure such that any effects of condensation was minimized. Earlier shakedown experiments indicated that the control of the liquid temperature was a critical parameter otherwise the individual liquid droplet streams would collapse into a single stream due to condensation. As a result, the liquid injection system had to be redesigned to insure that the liquid temperature was as close to saturation as possible. Bench-top experiments were performed as described in Section 2 to verify the droplet diameter as well as the spreading of the individual jet streams from the droplet injection. The objective was to obtain a droplet flow in the center of the injected sub-channel which could then interact with the spacer grid and spread between sub-channels without wetting the housing walls or the heater rods.

The experimental results indicate that the steam flow was superheated at the injection zone elevation (1.295 m, 51 in.) and would remain superheated throughout the length of the bundle for all but the highest droplet injection mass flow rates. Therefore, steady-state dispersed flow film boiling conditions were obtained within the bundle over the range of steam

and injected liquid flows. The injected droplets would evaporate, creating saturated vapor which then mixed with the superheated steam flow. The injected droplets would also interact with the spacer grids and would shatter on the blockage areas of the grids caused by the grid straps and the mixing vanes. The shattered droplets were of smaller diameter as compared to the incoming drop sizes such that a local heat transfer improvement would occur due to the increased evaporation as well as enhanced convection downstream of the spacer grids. The local steam temperature measurements indicate additional steam de-superheating downstream of the spacers due to the increased interaction of the entrained droplets and the superheated vapor.

It is believed that the RBHT steam cooling with droplet injection experiments will be very useful for NRC safety code model development and validation in the dispersed flow film boiling regime.

Table 1-1: Test Summary Table

Data File #	ARL Validated Test Designation	Test Date	NRC Test Matrix Test #	Window Start Time (seconds)	Window Stop Time (seconds)	UP Pressure (kPa (psia))	Bundle Power (kW)	Inlet Reynolds Number	Steam Flow (ACFM)	Steam Flow (kg/hr (lbm/hr))	Droplet Injection Mass Flow (kg/sec (lbm/sec))	Droplet Injection Fluid Temperature (K (°F))
4001		9/8/2005	shakedown	3600	4800	275.8 (40)	80.7	10000	2.27 (80)	198.7 (436)	0.007756 (0.0171)	392.6 (247)
4029		9/22/2005	shakedown									
	4029-A			9000	9900	275.8 (40)	80	10000	2.27 (80)	198.7 (436)	0.007575 (0.0167)	404.3 (268)
	4029-B			9900	10680	275.8 (40)	80	10000	2.27 (80)	198.7 (436)	0.01510 (0.0333)	404.3 (268)
	4029-C			10800	11700	275.8 (40)	75	8000	1.81 (64)	159.2 (351)	0.007575 (0.0167)	404.3 (268)
	4029-D			11760	12600	275.8 (40)	75	8000	1.81 (64)	159.2 (351)	0.01510 (0.0333)	404.3 (268)
	4029-E					275.8 (40)	60	6000	1.36 (48)	117.9 (260)	0.007575 (0.0167)	404.3 (268)
	4029-F			13500	13980	275.8 (40)	60	6000	1.36 (48)	117.9 (260)	0.01510 (0.0333)	404.3 (268)
4032		9/28/2005	shakedown									
	4032-A			10620	11400	275.8 (40)	80	10000	2.27 (80)	198.7 (436)	0.007303 (0.0161)	394.3 (250)
	4032-B			11640	12540	275.8 (40)	80	10000	2.27 (80.2)	198.7 (436)	0.01510 (0.0333)	394.8 (251)
	4032-C			12900	13920	275.8 (40)	72	8000	1.79 (63.1)	155.6 (343)	0.007348 (0.0162)	395.4 (252)
	4032-D			14040	14940	275.8 (40)	72	8000	1.81 (64)	159.2 (351)	0.01506 (0.0332)	400.9 (252)
	4032-E					275.8 (40)	65	6000	1.36 (48)	117.9 (260)	0.007575 (0.0167)	399.8 (260)
	4032-F			15360	16380	275.8 (40)	65	6000	1.36 (48)	117.9 (260)	0.01451 (0.032)	399.8 (260)
4035		10/4/2005	shakedown									
	4035-A			14100	15900	275.8 (40)	80	10000	2.27 (80)	201.8 (445)	0.007711 (0.017)	404.3 (268)
	4035-B			16200	18300	275.8 (40)	80	10000	2.27 (80)	200.5 (442)	0.01497 (0.033)	404.3 (268)
	4035-C			18540	19800	275.8 (40)	72	8000	1.81 (64)	156.5 (345)	0.007711 (0.017)	404.3 (268)
	4035-D			20040	21540	275.8 (40)	72	8000	1.81 (64)	156.9 (346)	0.01497 (0.033)	404.3 (268)
	4035-E			21600	23100	275.8 (40)	70	6000	1.36 (48)	117.5 (259)	0.007711 (0.017)	404.3 (268)
	4035-F			23340	25200	275.8 (40)	70	6000	1.36 (48)	117.9 (260)	0.01497 (0.033)	404.3 (268)
	4035-G					275.8 (40)	50	4000	0.906 (32)	78.47 (173)	0.007711 (0.017)	404.3 (268)
	4035-H					275.8 (40)	50	4000	0.906 (32)	78.47 (173)	0.01497 (0.033)	404.3 (268)
	4035-I					275.8 (40)	50	4000	0.906 (32)	78.47 (173)	0.02177 (0.048)	404.3 (268)
4037		10/11/2005										
	4037-A		17a	16440	17400	275.8 (40)	80	10000	2.27 (80)	199.6 (440)	0.003629 (0.008)	404.3 (268)
	4037-B		17b	17880	18540	275.8 (40)	80	10000	2.27 (80)	199.6 (440)	0.007257 (0.016)	404.3 (268)
	4037-C		17c	18660	19380	275.8 (40)	80	10000	2.27 (80)	199.6 (440)	0.01451 (0.032)	404.3 (268)
	4037-D		16a	21900	22980	275.8 (40)	72	8000	1.81 (64)	158.8 (350)	0.003629 (0.008)	404.3 (268)
	4037-E		16b	23400	24480	275.8 (40)	72	8000	1.81 (64)	158.8 (350)	0.007257 (0.016)	404.3 (268)
	4037-F		16c	24720	25320	275.8 (40)	72	8000	1.81 (64)	158.8 (350)	0.01089 (0.024)	404.3 (268)
	4037-G		15a			275.8 (40)	64	6000	1.36 (48)	117.9 (260)	0.003629 (0.008)	404.3 (268)
	4037-H		15b	26340	27120	275.8 (40)	64	6000	1.36 (48)	117.9 (260)	0.007257 (0.016)	404.3 (268)
	4037-I		15c			275.8 (40)	64	6000	1.36 (48)	117.9 (260)	0.01089 (0.024)	404.3 (268)

Table 1-1: Test Summary Table, continued

Data File #	ARL Validated Test Designation	Test Date	NRC Test Matrix Test #	Window Start Time (seconds)	Window Stop Time (seconds)	UP Pressure (kPa (psia))	Bundle Power (kW)	Inlet Reynolds Number	Steam Flow (ACFM)	Steam Flow (kg/hr (lbm/hr))	Droplet Injection Mass Flow (kg/sec (lbm/sec))	Droplet Injection Fluid Temperature (K (°F))
4041		10/26/2005										
	4041-A		9a	13320	14400	275.8 (40)	80	10000	2.27 (80)	199.6 (440)	0.003629 (0.008)	404.3 (268)
	4041-B		9b	17400	17940	275.8 (40)	80	10000	2.27 (80)	199.6 (440)	0.007257 (0.016)	404.3 (268)
	4041-C		9c	18060	18780	275.8 (40)	80	10000	2.27 (80)	199.6 (440)	0.01089 (0.024)	404.3 (268)
	4041-D		9d	19260	20100	275.8 (40)	80	10000	2.27 (80)	199.6 (440)	0.01451 (0.032)	404.3 (268)
	4041-E		8a	22500	23280	275.8 (40)	72	8000	1.81 (64)	158.8 (350)	0.003629 (0.008)	404.3 (268)
	4041-F		8b	23880	24300	275.8 (40)	72	8000	1.81 (64)	158.8 (350)	0.007257 (0.016)	404.3 (268)
	4041-G		8c	24660	25080	275.8 (40)	72	8000	1.81 (64)	158.8 (350)	0.01089 (0.024)	404.3 (268)
	4041-H		8d	25440	25680	275.8 (40)	72	8000	1.81 (64)	158.8 (350)	0.01451 (0.032)	404.3 (268)
	4041-I		7a	26460	27000	275.8 (40)	64	6000	1.36 (48)	117.9 (260)	0.003629 (0.008)	404.3 (268)
	4041-J		7b	27540	27840	275.8 (40)	64	6000	1.36 (48)	117.9 (260)	0.007257 (0.016)	404.3 (268)
	4041-K		7c	28620	28980	275.8 (40)	64	6000	1.36 (48)	117.9 (260)	0.01089 (0.024)	404.3 (268)
	4042			11/1/2005								
4042-A		3a	11940		13680	137.9 (20)	60	6000	2.75 (97)	121.6 (268)	0.003629 (0.008)	382.0 (228)
4042-B		3b	13920		14580	137.9 (20)	60	6000	2.83 (100)	122.5 (270)	0.007257 (0.016)	382.0 (228)
4042-C		3c	15060		15660	137.9 (20)	60	6000	2.83 (100)	122.5 (270)	0.01089 (0.024)	382.0 (228)
4042-D		3d	16200		16800	137.9 (20)	60	6000	2.83 (100)	122.5 (270)	0.01451 (0.032)	382.0 (228)
4042-E		2a				137.9 (20)	55	4000	1.90 (67)	83.46 (184)	0.003629 (0.008)	382.0 (228)
4042-F		2b	18300		19140	137.9 (20)	55	4000	1.90 (67)	83.46 (184)	0.007257 (0.016)	382.0 (228)
4042-G		2c	19620		20280	137.9 (20)	55	4000	1.90 (67)	81.65 (180)	0.01089 (0.024)	382.0 (228)
4042-H		2d	21180		21900	137.9 (20)	55	4000	1.90 (67)	81.65 (180)	0.01451 (0.032)	382.0 (228)
4042-I		1a				137.9 (20)	28.9	2000	0.963 (34)	40.82 (90)	0.003629 (0.008)	382.0 (228)
4042-J		1b				137.9 (20)	28.9	2000	0.963 (34)	40.82 (90)	0.007257 (0.016)	382.0 (228)
4042-K		1c	22860		23760	137.9 (20)	28.9	2000	0.963 (34)	42.64 (94)	0.01089 (0.024)	382.0 (228)
4042-L		1d				137.9 (20)	28.9	2000	0.963 (34)	42.64 (94)	0.01451 (0.032)	382.0 (228)
4049		11/9/2005										
	4049-A		6a	13320	14280	137.9 (20)	110	15000	5.95 (210)	301.6 (665)	0.003629 (0.008)	382.0 (228)
	4049-B		6b	15000	18240	137.9 (20)	110	15000	5.95 (210)	301.6 (665)	0.007257 (0.016)	382.0 (228)
	4049-C		6c	18720	19140	137.9 (20)	110	15000	5.95 (210)	301.6 (665)	0.01089 (0.024)	382.0 (228)
	4049-D		6d	19440	20040	137.9 (20)	110	15000	5.95 (210)	301.6 (665)	0.01451 (0.032)	382.0 (228)
	4049-E		5a	20820	21300	137.9 (20)	75	10000	3.96 (140)	181.4 (400)	0.003629 (0.008)	382.0 (228)
	4049-F		5b	21900	24000	137.9 (20)	75	10000	3.96 (140)	181.4 (400)	0.007257 (0.016)	382.0 (228)
	4049-G		5c	24600	24900	137.9 (20)	75	10000	3.96 (140)	181.4 (400)	0.01089 (0.024)	382.0 (228)
	4049-H		5d	25680	25920	137.9 (20)	75	10000	3.96 (140)	181.4 (400)	0.01451 (0.032)	382.0 (228)
	4049-I		4a	26940	27360	137.9 (20)	65	8000	3.17 (112)	144.2 (318)	0.003629 (0.008)	382.0 (228)
	4049-J		4b	28440	29760	137.9 (20)	65	8000	3.17 (112)	144.2 (318)	0.007257 (0.016)	382.0 (228)
	4049-K		4c	30420	30720	137.9 (20)	65	8000	3.17 (112)	144.2 (318)	0.01089 (0.024)	382.0 (228)
	4049-L		4d	31140	31440	137.9 (20)	65	8000	3.17 (112)	144.2 (318)	0.01451 (0.032)	382.0 (228)

Table 1-1: Test Summary Table, continued

Data File #	ARL Validated Test Designation	Test Date	NRC Test Matrix Test #	Window Start Time (seconds)	Window Stop Time (seconds)	UP Pressure (kPa (psia))	Bundle Power (kW)	Inlet Reynolds Number	Steam Flow (ACFM)	Steam Flow (kg/hr (lbm/hr))	Droplet Injection Mass Flow (kg/sec (lbm/sec))	Droplet Injection Fluid Temperature (K (°F))
4053		11/18/2005										
	4053-A		12a	11160	11820	137.9 (20)	60	6000	2.83 (100)	122.5 (270)	0.003629 (0.008)	382.0 (228)
	4053-B		12b	12300	13680	137.9 (20)	60	6000	2.83 (100)	122.5 (270)	0.007257 (0.016)	382.0 (228)
	4053-C		12c	14400	14880	137.9 (20)	60	6000	2.83 (100)	122.5 (270)	0.01089 (0.024)	382.0 (228)
	4053-D		12d	15780	16140	137.9 (20)	60	6000	2.83 (100)	122.5 (270)	0.01451 (0.032)	382.0 (228)
	4053-E		11a	18120	18900	137.9 (20)	55	4000	1.90 (67)	81.65 (180)	0.003629 (0.008)	382.0 (228)
	4053-F		11b	20100	21540	137.9 (20)	55	4000	1.90 (67)	81.65 (180)	0.007257 (0.016)	382.0 (228)
	4053-G		11c	22380	22920	137.9 (20)	55	4000	1.90 (67)	81.65 (180)	0.01089 (0.024)	382.0 (228)
	4053-H		11d	23940	24360	137.9 (20)	55	4000	1.90 (67)	81.65 (180)	0.01451 (0.032)	382.0 (228)
	4053-I		10a	25320	25920	137.9 (20)	29	2000	0.963 (34)	40.82 (90)	0.003629 (0.008)	382.0 (228)
	4053-J		10b	26400	27600	137.9 (20)	29	2000	0.963 (34)	40.82 (90)	0.007257 (0.016)	382.0 (228)
	4053-K		10c	28200	28560	137.9 (20)	29	2000	0.963 (34)	40.82 (90)	0.01089 (0.024)	382.0 (228)
	4053-L		10d	28800	29280	137.9 (20)	29	2000	0.963 (34)	40.82 (90)	0.01451 (0.032)	382.0 (228)
	4055			11/23/2005								
4055-D		13a	21600		23700	137.9 (20)	50	4000	1.90 (67)	81.65 (180)	0.003629 (0.008)	382.0 (228)
4055-A		13b	13980		15660	137.9 (20)	50	4000	1.90 (67)	81.65 (180)	0.007257 (0.016)	382.0 (228)
4055-B		13c	16800		17880	137.9 (20)	50	4000	1.90 (67)	81.65 (180)	0.01089 (0.024)	382.0 (228)
4055-C		13d	19260		20280	137.9 (20)	50	4000	1.90 (67)	81.65 (180)	0.01451 (0.032)	382.0 (228)
4076		12/13/2005										
	4076-A		14a	12120	18300	137.9 (20)	50	4000	1.90 (67)	85.28 (188)	0.003629 (0.008)	382.0 (228)
	4076-B		14b	19500	23700	137.9 (20)	50	4000	1.90 (67)	85.28 (188)	0.007257 (0.016)	382.0 (228)
	4076-C		14c	24420	27600	137.9 (20)	50	4000	1.90 (67)	85.28 (188)	0.01089 (0.024)	382.0 (228)
	4076-D		14d	28200	31620	137.9 (20)	50	4000	1.90 (67)	85.28 (188)	0.01451 (0.032)	382.0 (228)

2. TEST FACILITY DESCRIPTION FOR STEAM COOLING WITH DROPLET INJECTION EXPERIMENTS

The Rod Bundle Heat Transfer (RBHT) Test Facility is designed to conduct systematic separate-effects tests under well-controlled conditions in order to generate fundamental rod bundle heat transfer data from single phase steam cooling tests, low flow boiling tests, steam flow tests with and without injected droplets, and forced reflood tests which simulate inverted annular film boiling, and dispersed flow film boiling heat transfer. The facility is capable of operating in both forced and variable reflood modes covering wide ranges of flow and heat transfer conditions at pressures from 1.34 to 4.02 bars (20 to 60 psia).

2.1 General Facility Description

The test facility consists of the following major components shown schematically in Figure 2-1, and in an isometric view in Figure 2-2.

- A test section consisting of a lower plenum, a low-mass housing containing the heater rod bundle, and upper plenum
- Coolant injection and steam injection systems
- Closely coupled phase separation and liquid collection systems
- An injection system
- A pressure fluctuation damping tank and steam exhaust piping

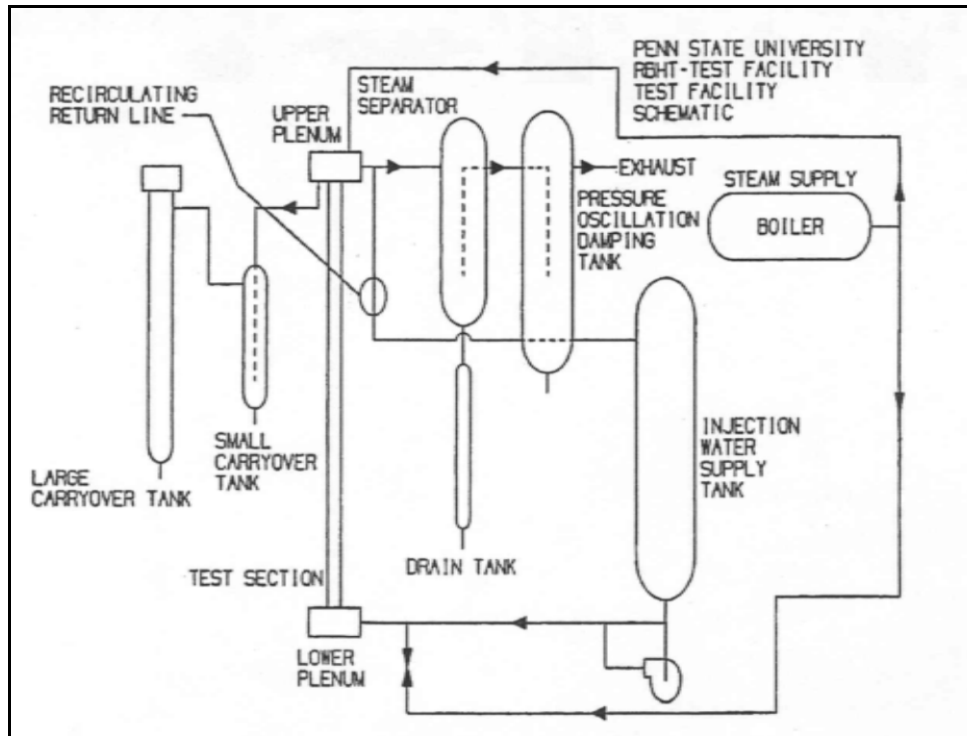

Figure 2-1: RBHT Test Facility Schematic

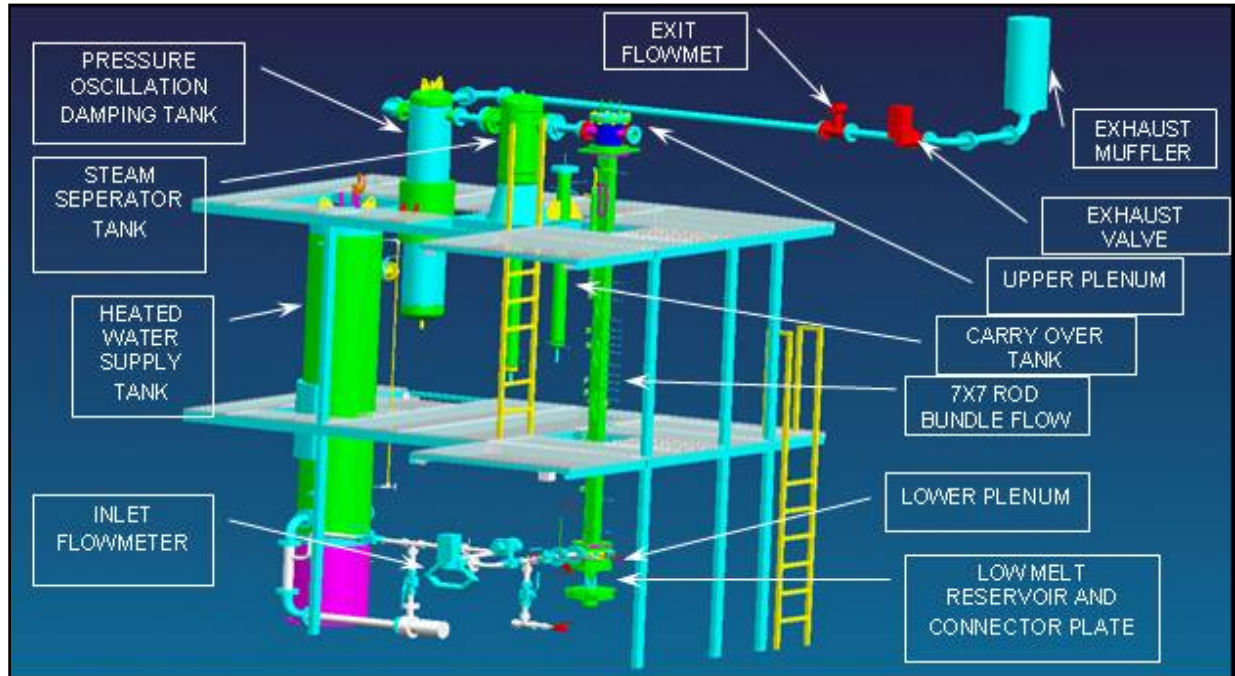

Figure 2-2: Test Facility Isometric View

2.1.1 Test Section

The test section consists of the heater rod bundle, the flow housing, and the lower and upper plenums, as shown in Figure 2-3. The heater rod bundle simulates a small portion of a 17 x 17 Pressurized Water Reactor (PWR) reactor fuel assembly. The electrically powered heater rods have a diameter of 9.5 mm (0.374 in.) arranged in a 7 x 7 array with a 12.6 mm (0.496 in.) pitch, as shown in Figure 2-4. The bundle has 45 heater rods and four unheated corner rods. The corner rods are used to support the bundle grid and fluid thermocouple leads. The support rods are made from Inconel 600 tubing having a diameter 9.525 mm (0.37 in.), a wall thickness of 2.108 mm (0.083 in.), and a total length of 3.9 m (156 in.). The heater rods are single ended and consist of a Monel 500 electrical resistance element filled and surrounded by hot pressed boron nitride (BN) insulation, and enclosed in a Inconel 600 cladding, as shown in Figure 2-5. This material was chosen for its high strength and low thermal expansion coefficient at high temperatures, which minimizes rod bowing and failure at high temperature operating conditions since it was desired to re-use the heater rods for multiple experiments. The heater rods have a 3.657 m (12 ft.) heated length with a skewed axial power profile, as shown in Figure 2-6, with the peak power located at the 2.74 m (9 ft.) elevation. The maximum-to-average power ratio (P_{\min}/P_{avg}) is 0.5 at both ends of the heated length. The bundle has a uniform radial power distribution.

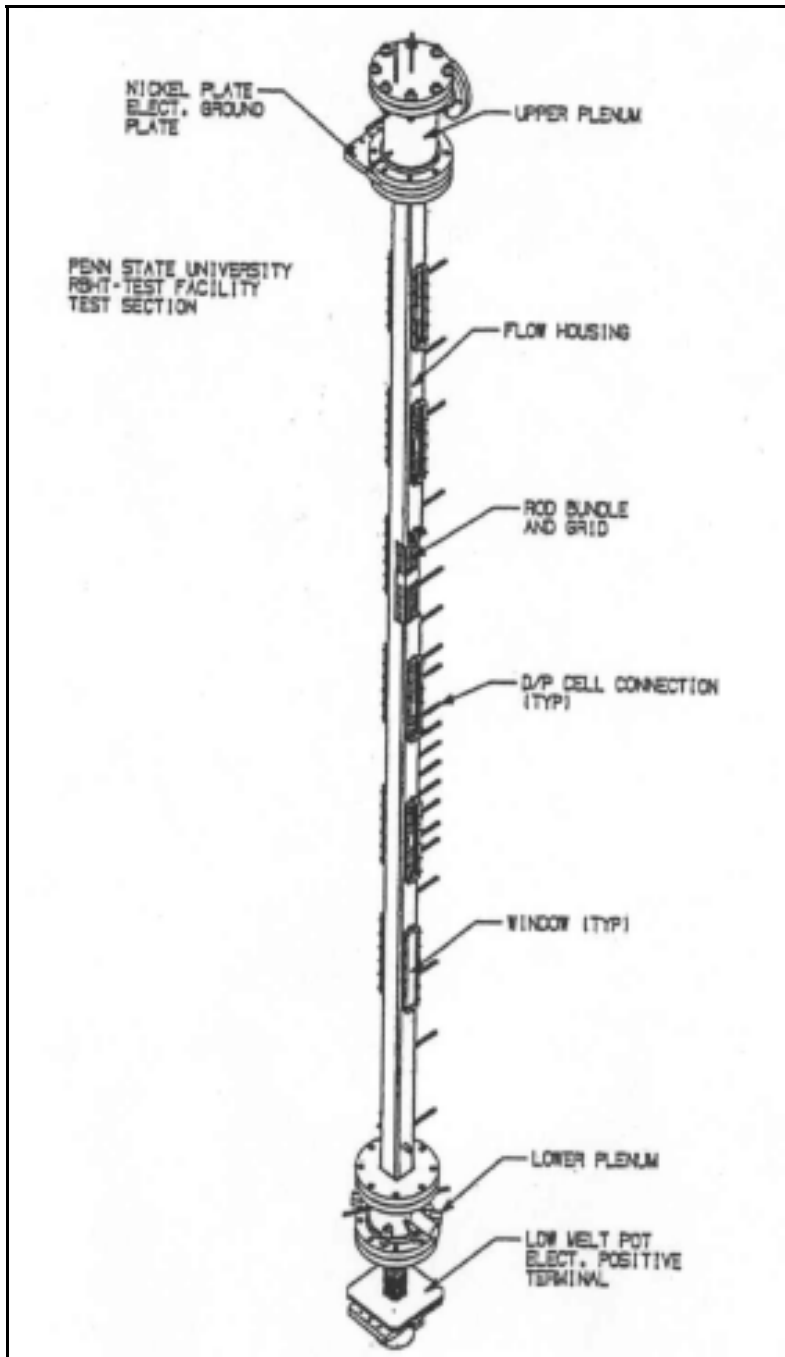

Figure 2-3: Test Section Isometric View

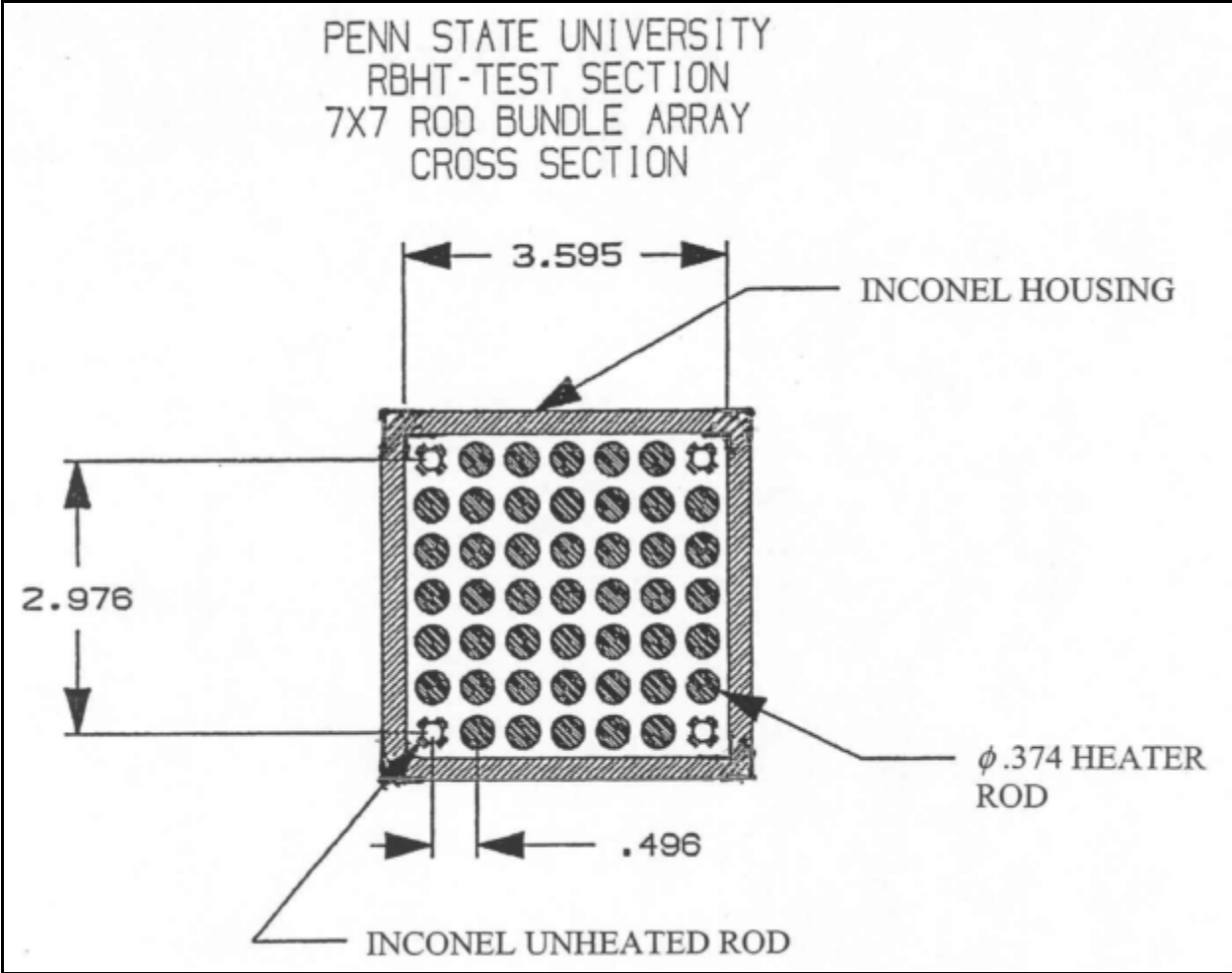

Figure 2-4: Rod Bundle Cross Section View

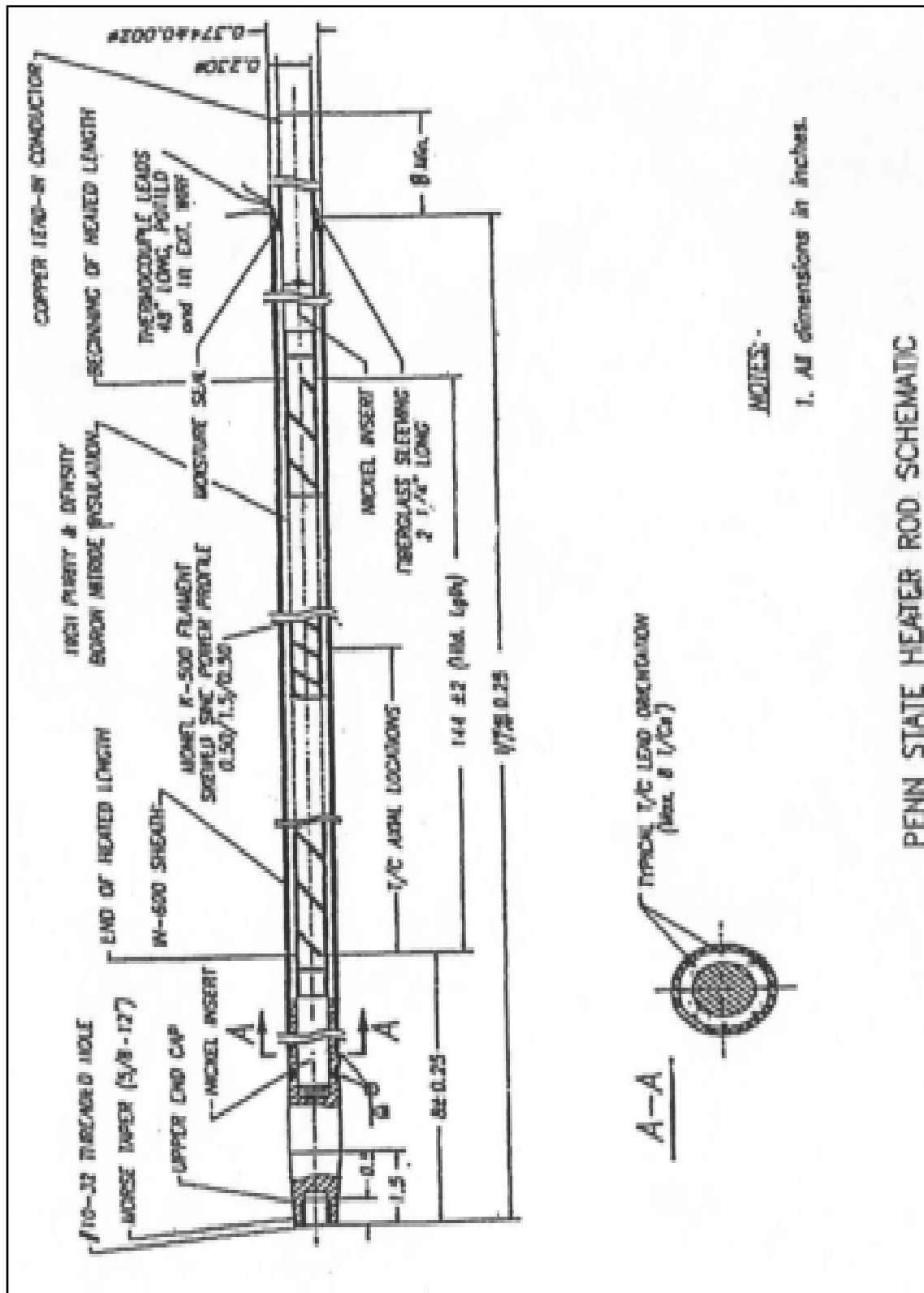

Figure 2-5: Heater Rod

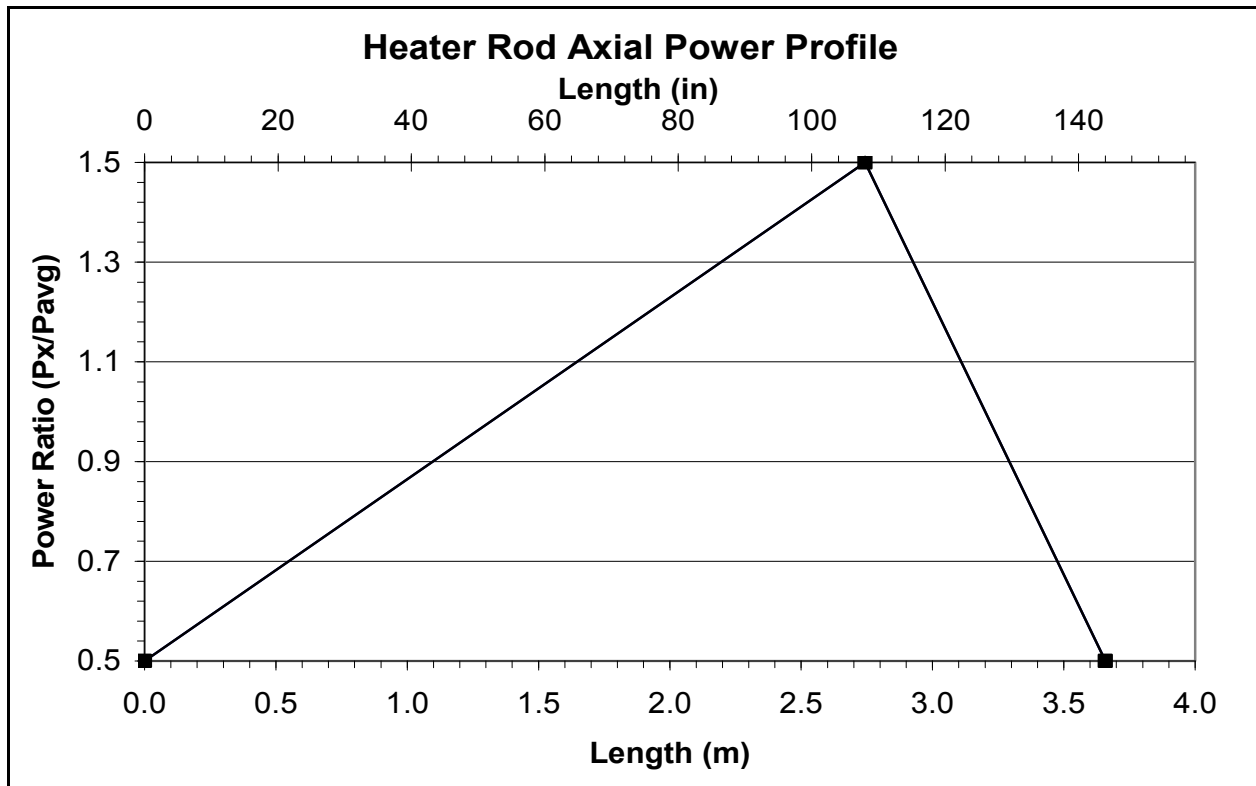

Figure 2-6: Heater Rod Axial Power Profile

Power to each rod is provided by a 60 volt, 12,600 amp, 750 kW DC power supply. Each rod is rated for 10 kW, and designed to operate at 13.8 bars (200 psig) at a maximum temperature of 1240 °C (2200 °F), but because of its solid construction it can be operated at up to 103.4 bars (1500 psig). Each rod is instrumented with eight (8) 0.508 mm (0.020 in.) diameter ungrounded thermocouples attached to the inside surface of the Inconel sheath at various locations. All of the thermocouple leads exit at the heater rod bottom end. The Inconel 600 thermocouple sheath is compatible with the heater rod cladding and housing material to reduce thermal expansion and minimize the possibility of causing thermocouple failure during the thermocycling operations.

The rod bundle has seven (7) mixing vane grids shown in Figure 2-7. These grids are similar in design of a PWR 17 x 17 fuel assembly, but instead of having dimples and springs, these grids have all dimples with a cold clearance of 0.127 mm (0.005 in.) around each heater rod in order to prevent bowing when the heater rods are linearly expanding at high temperatures. The grids straps are made out of Inconel 600 alloy sheets which are 0.508 mm (0.020 in.) thick and are 44.45 mm (1.75 in.) in height including the mixing vanes. The grids are located 522 mm (20.55 in.) apart except for the spacing between the first and second grid, which are 588.26 mm (23.26 in.) apart. The first grid is located 101.85 mm (4.01 in.) above the bottom of the heater length. The grids in conjunction with the corner rods form the heater rod bundle support structure. The grid locations are similar to the ones found in a 17 x 17 PWR fuel assembly. The heater rod top extensions are attached to the 25.4 mm (1 in.) thick nickel ground

plate by means of a Morse taper that provides a good electrical contact. The heater rod bottom extension and copper electrode extend through the lower plenum O-ring pressure seal plate.

The copper electrodes, which are 5.842 mm (0.023 in.) in diameter and 203 mm (8 in.) long, extend through holes drilled in the low-melt reservoir shown in Figure 2-8. This reservoir serves as the electrical power supply positive side connection. It contains a low temperature melting alloy at about 71.11 °C (160 °F) which is an excellent conductor, thus providing a good electrical contact and mechanical cushion allowing for rod thermal expansion to each heater rod.

The flow housing provides the pressure and flow boundary for the heater rod bundle. It has a square geometry. Its as-built inside dimensions are 91.3 mm x 91.3 mm (3.595 in. x 3.595 in.), and wall thickness 6.35 mm (0.25 in.) as shown in Figure 2-9. The housing is made out of Inconel 600 the same material used for the heater rod cladding and thermocouple sheaths. As pointed out previously, the high strength of Inconel 600 at elevated temperatures will minimize housing distortion during testing. The 6.35 mm (0.25 in.) wall thickness is the minimum allowable for operating at 4.02 bars (60 psig) and 537 °C (1000 °F), taking into consideration the cutouts to accommodate the large windows and numerous pressure and temperature penetrations through the walls, as shown in Figure 2-10. The empty housing has a flow area of 83.4 sq. cm (12.9 sq. in.). With the rod bundle in place, the flow area is 48.63 sq cm (7.5 sq. in.). This area is 7.21% larger than the ideal flow area of a 7 x 7 rod bundle configuration. The excess flow area is due to the flow housing inside dimensional tolerance and the space needed to insert the rod bundle in the housing. The gap between the outer rods and the flow housing inner wall is 3.12 mm (0.123 in.) wide.

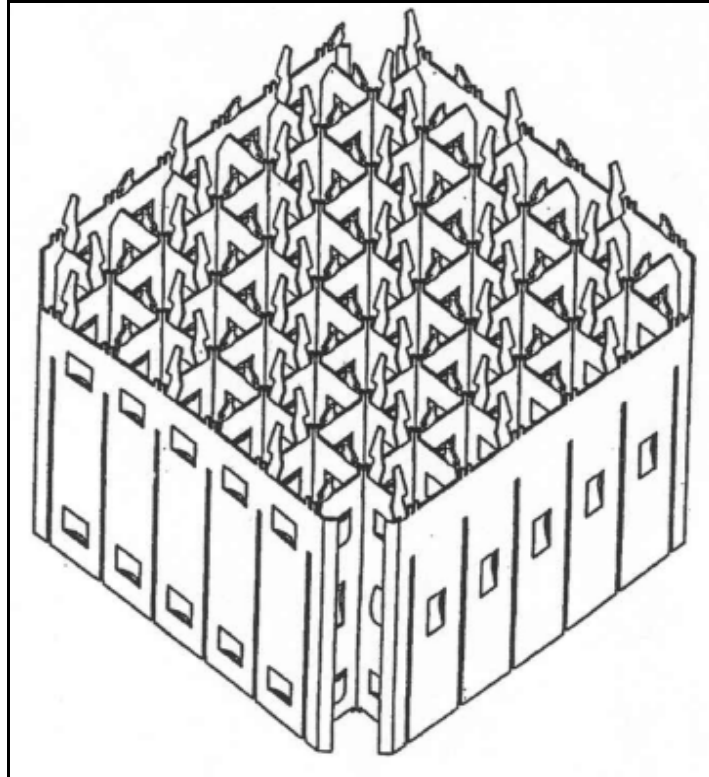

Figure 2-7: Mixing Vane Grid

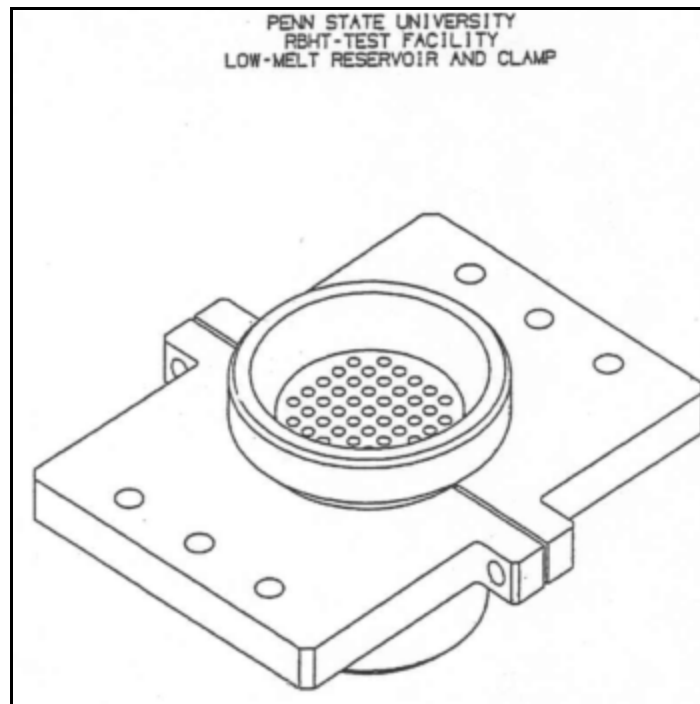

Figure 2-8: Low Melt Reservoir

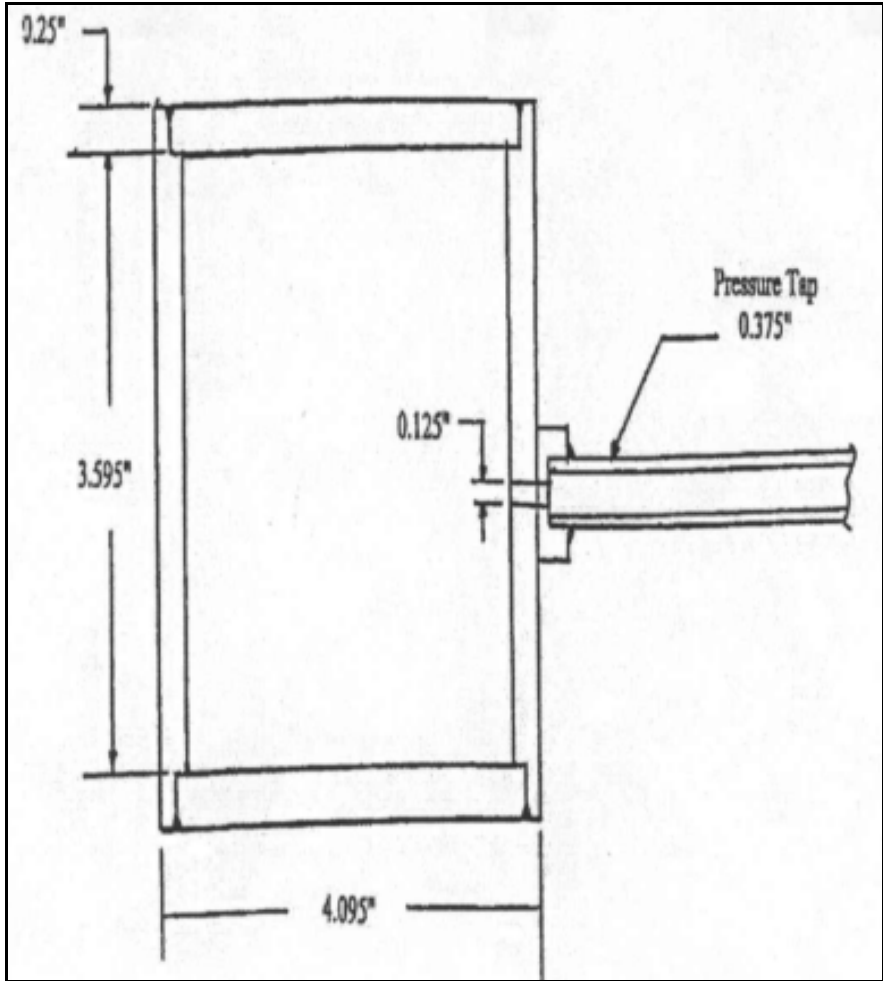

Figure 2-9: Flow Housing Cross Section View

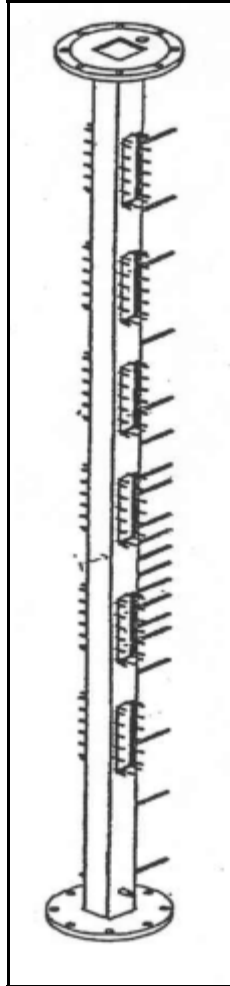

Figure 2-10: Low Mass Flow Housing

The flow housing has six pairs of windows. Each window provides a 50.8 mm x 292. mm (2 in. x 11.5 in.) viewing area. Each pair of windows is placed 180° apart and located axially at elevations overlapping rod bundle spacer grids, thus providing a viewing area about 88.9 mm (3.5 in.) below and 152.4 mm (6 in.) above the corresponding spacer grids. The windows will facilitate the measurement of droplet size and velocity using a Laser Illuminated Digital Camera System. In addition, high speed movies using diffused back lighting can be taken during the experiments for visualization and flow regime information. The windows are made out of optical grade fused quartz and are mounted on the housing by means of a bolted flange and Kemprofile high temperature gasket material, as shown in Figure 2-11.

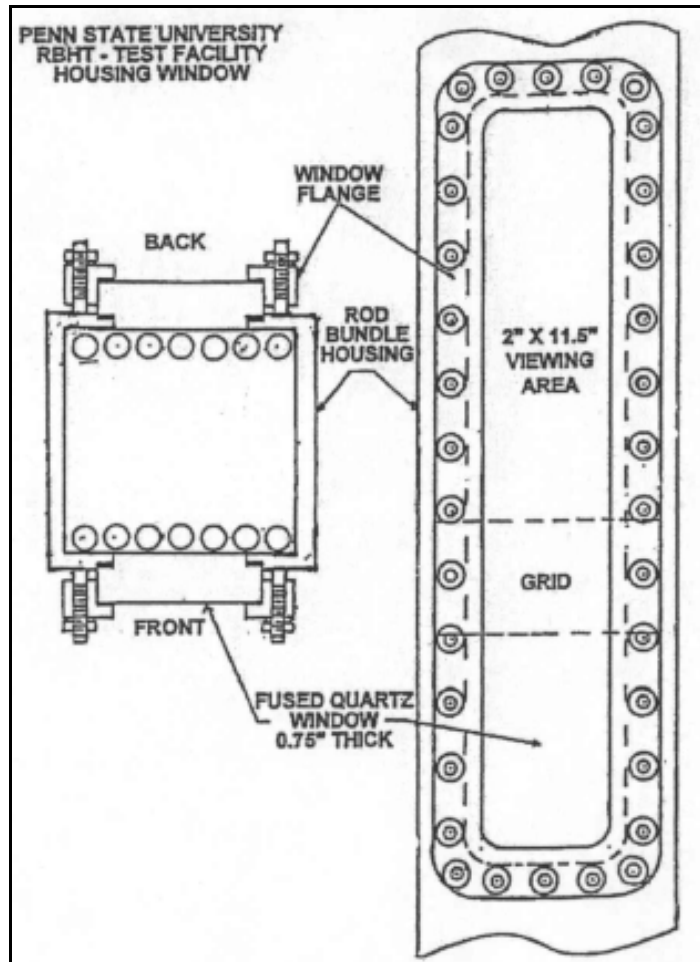

Figure 2-11: Housing Window

The flow housing is supported from the nickel plate and upper plenum, allowing it to freely expand downward, thus minimizing thermal buckling and distortion. The two-phase void fraction will be measured using sensitive differential pressure cells. The flow housing has twenty-three (23) pressure taps located at various elevations, as shown in Figure 2-10. The pressure taps are connected to sensitive differential pressure (D/P) cells providing measurements to calculate single-phase friction losses for determining base rod bundle and grid loss coefficients. Sixteen (16) of these pressure taps are located about 76.2 to 127 mm (3 to 5 in.) apart to provide detailed void fraction measurements in the froth region above the quench front.

The flow housing also has thirteen (13) stand-off penetrations at various elevations for the traversing Steam Probe Rakes which measure the superheated steam temperatures in the dispersed flow regime.

2.1.2 Lower Plenum

The lower plenum is attached to the bottom of the flow housing. The lower plenum is made out of nominal 203.2 mm (8 in.) sch. 40, 304 S.S. pipe with an inside diameter of 201.6 mm (7.937 in.), a height of 203.2 mm (8 in.), and a volume of 6569.5 cu. cm (0.232 cu. ft.), as shown in Figure 2-12. The lower plenum connects to the injection water line and steam cooling line. It has two penetrations for thermocouples monitoring the coolant temperature prior and during testing, and pressure taps for static and differential pressure measurements.

The lower plenum also has four Conax fittings with multiple probes sealing glands for the bundle grid, steam probes and support rod wall thermocouple extensions that are routed through the bottom of the rod bundle. It contains a flow baffle, which is attached to the flow housing bottom flange. The flow baffle has a square geometry, similar to the holes that act as a flow distributor and flow straightener to provide an even flow distribution into the rod bundle.

2.1.3 Upper Plenum

The upper plenum serves as the first stage for phase separation and liquid collection of the two-phase effluent exiting the rod bundle. The liquid phase separates due to the sudden expansion from the bundle to the larger plenum flow area. The de-entrained liquid is collected around the flow housing extension in the upper plenum. The extension acts as a weir preventing the separated liquid from falling back into the heater rod bundle. The upper plenum vessel configuration is shown in Figure 2-13. The vessel is made from a 203.2 mm (8 in.), 204 S. S. pipe with an inside diameter of 201.6 mm (7.937 in.) and a height of 304.8 mm (12 in.). It has a volume of 9872.5 cu. cm (0.347 cu ft.) The plenum has a 76.2 mm (3 in.) pipe flange connection to the steam separator and two penetrations for fluid thermocouples. It is covered with a 203.2 mm (8 in.), 304 S. S. blind flange. This flange has a 25.4 mm (1 in.) penetration for steam injection, venting, and connecting the safety relief valve and rupture disc assembly. It also has a pressure tap penetration for static and differential pressure measurements. In addition, the upper plenum contains an exhaust line baffle shown in Figure 2-14. The baffle is used to further de-entrain water from the steam and prevents water dripping from the upper plenum cover flange to be carried out by the exhaust steam. The baffle has a 76.2 mm (3 in.) flange connection at one end. It is inserted through the upper plenum exit nozzle, and it is bolted between the nozzle flange and the flange of the pipe going to the steam separator.

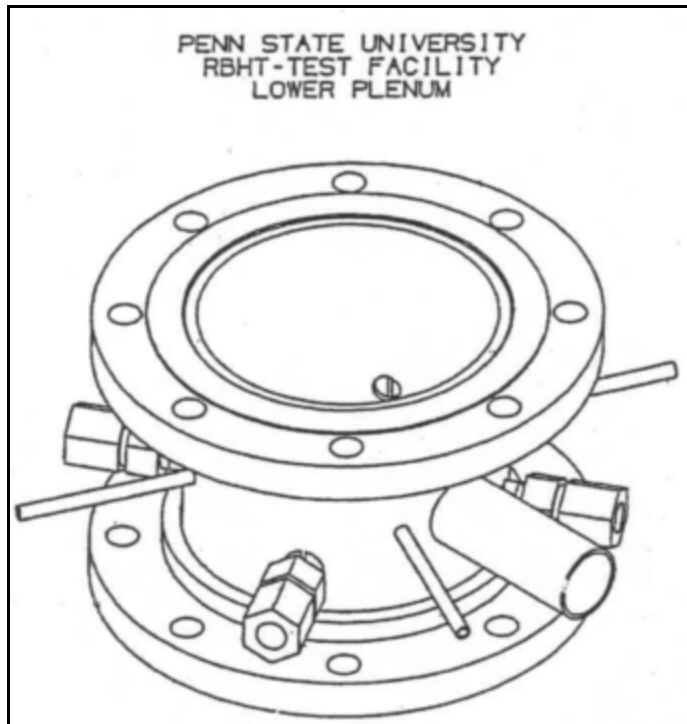

Figure 2-12: Lower Plenum

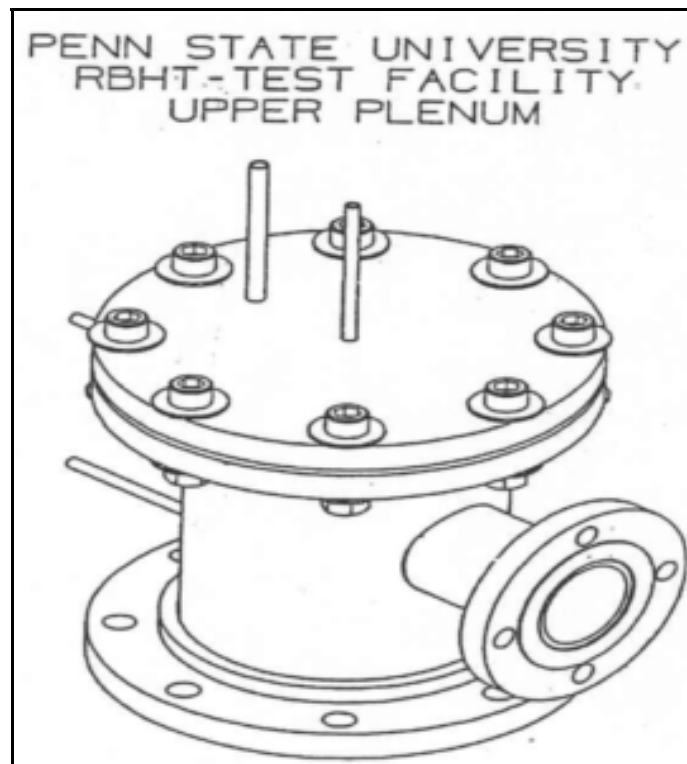

Figure 2-13: Upper Plenum

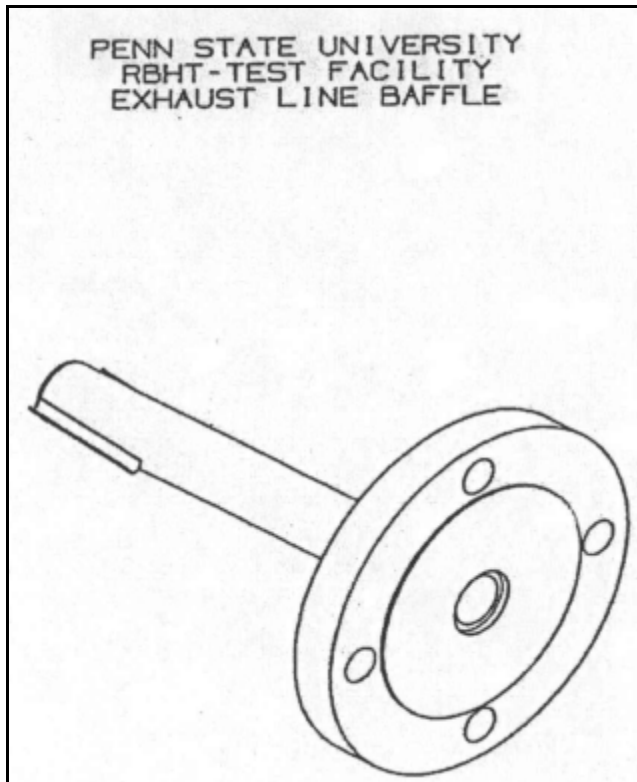

Figure 2-14: Exhaust Line Baffle

2.1.4 Large and Small Carryover Tanks

The de-entrained liquid from the upper plenum drains into the top of a 25.4 mm (1 in.) tube which extends inside a small carryover tank to detect and measure the carryover liquid as soon as possible. This tank, shown in Figure 2-15, is close-coupled in series with a larger carryover tank, shown in Figure 2-16, which collects and measures the amount of liquid overflow from the smaller carryover tank. The small carryover tank has a volume of about 1387.8 cu. cm (0.049 cu. ft.), and is used to more accurately measure the initial water being collected as a function of time. The smaller carry over tank is made from 76.2 mm (3 in.) schedule 40 stainless steel pipe having an overall length of 914.4 mm (36 in.) including the end caps. The large carryover tank is made from a 101.6 mm (4 in.) schedule 40 stainless steel pipe with a bottom end cap and top flanges having an overall length of 19.7 m (6 ft.) and a capacity of 15916.9 cu. cm. (0.562 cu ft.) Each tank is connected with 25.4 mm (1 in.) flexible hose, and has a 25.4 mm (1 in.) drain tube, and 9.5 mm (0.375 in.) tubes with wall penetration for installing fluid and level meter.

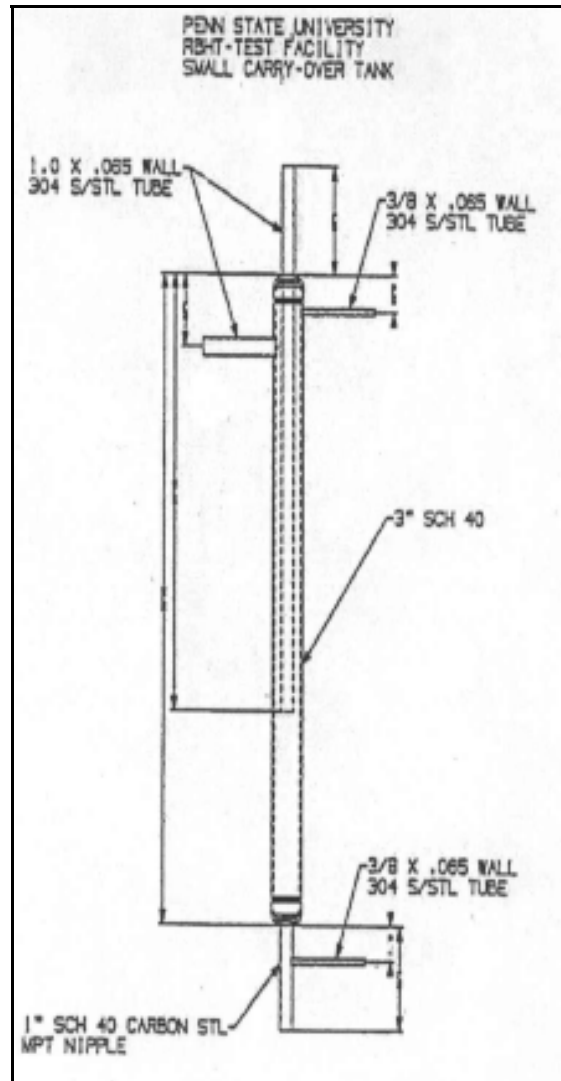

Figure 2-15: Small Carryover Tank

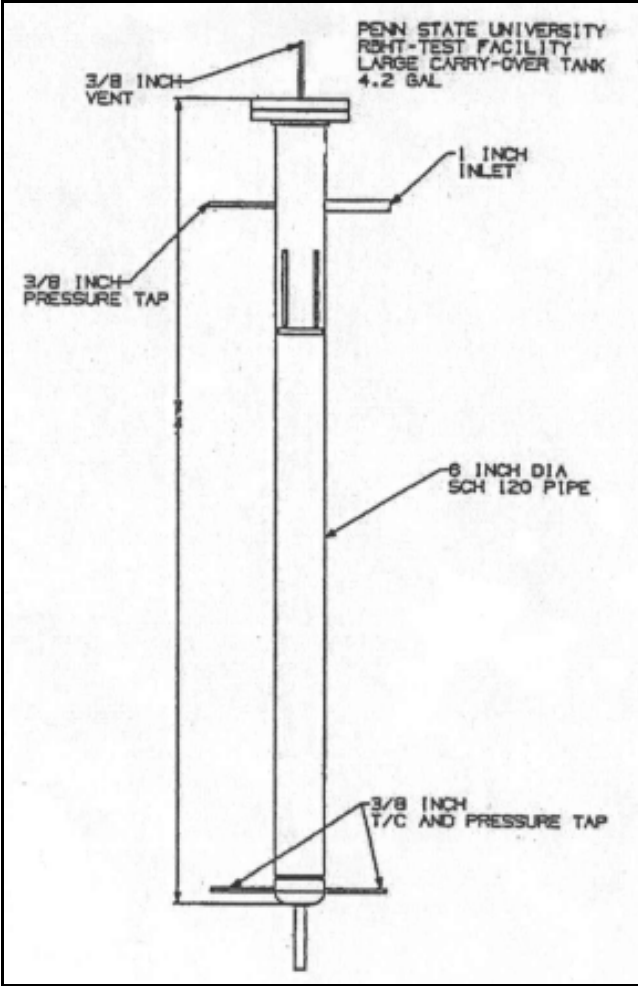

Figure 2-16: Large Carryover Tank

2.1.5 Steam Separator and Collection Tanks

The wet steam exhausted from the upper plenum flows through a steam separator (or dryer), shown in Figure 2-17, where carryover liquid droplets are further separated from the steam and collected in a small collection tank, shown in Figure 2-18, attached to the bottom of the steam separator. The steam separator relies on centrifugal force action to provide 99% dry steam. The separated liquid is drained into a collection tank where differential pressure cell is used as a level meter to measure liquid accumulation. The steam separator is fabricated from a 355.6 mm (14 in.) diameter, 316 stainless steel pipe and is 914.4 mm (36 in.) long. It has 50.8 mm (2 in.) connecting nozzles, a 25.4 mm (1 in.) drain, and a 12.7 mm (0.5 in.) top vent. It also has two pressure taps for liquid level measurements and two 38.1 mm (1.5 in.) side nozzle connections. The drain tank is a small vessel with a capacity of 11328.77 cu. cm. (0.4 cu. ft.). It is made from a 101.6 mm (4 in.) schedule 10, 304 stainless steel pipe with an overall length of 121.9 mm (48 in.), including both end caps. It has a 25.4 mm (1 in.) drain nozzle, a 25.4 mm (1 in.) pipe top connection to the steam separator, pressure taps and fluid thermocouple connections.

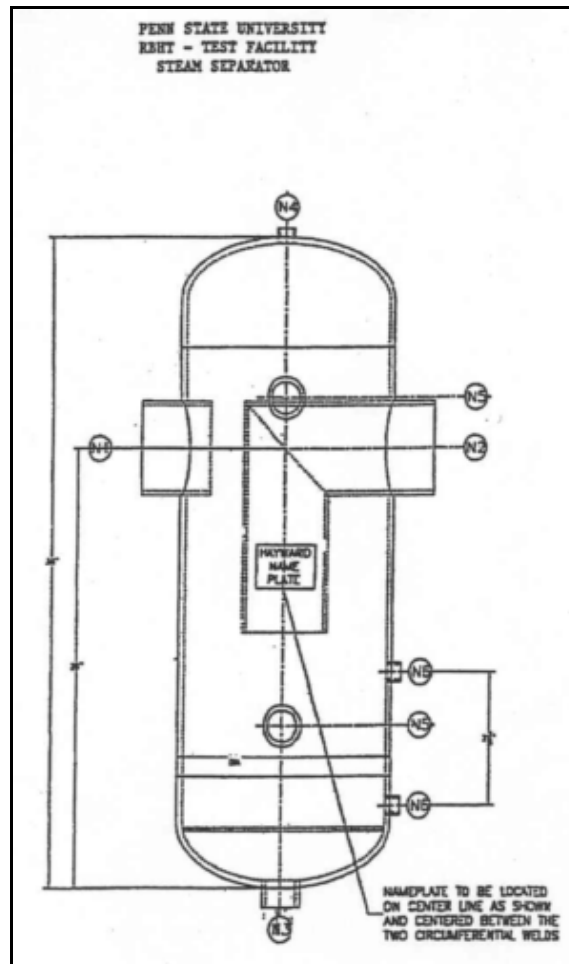

Figure 2-17: Steam Separator

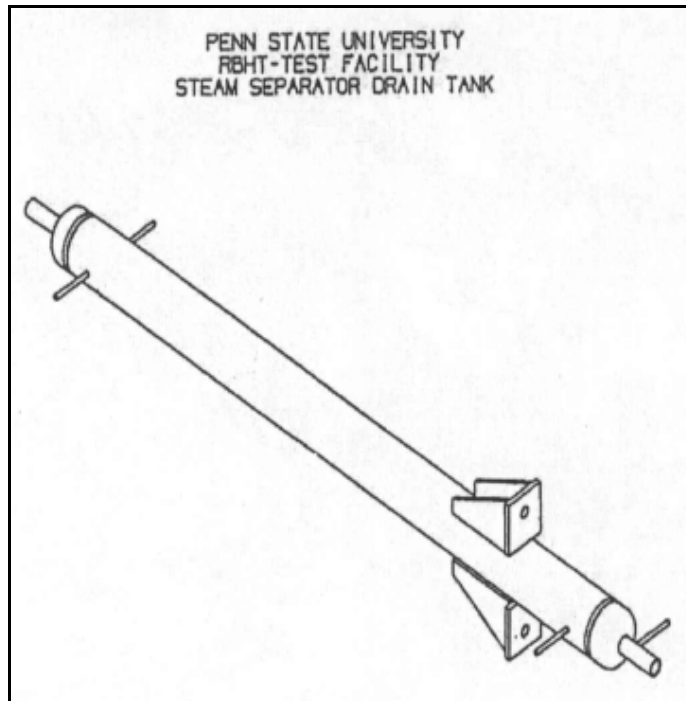

Figure 2-18: Steam Separator Collection Tank

2.1.6 Pressure Oscillation Damping Tank

The dry steam from the steam separator flows into a pressure oscillation-damping tank. As its name implies, it is used to dampen pressure oscillations at the upper plenum caused by rapidly oscillating steam generation rates in the heater rod bundle during testing. This effect is coupled to the characteristics of the pressure control valve, which is located downstream in the steam exhaust line. It is desirable to have a smooth pressure control in order to minimize uncertainties when calculating mass balances, steam generation rates, and heat transfer coefficients in the heater rod bundle, and avoid the pressure control valve causing oscillations in the bundle as it cycles. The tank has a volume of 0.209 cu. m (7.38 cu. ft.), which is approximately equal to the total volume of the rest of the test facility. The pressure tank is fabricated from 355.6 mm (14 in.), 304 stainless steel standard schedule pipe by 2.59 m (8.5 ft.) long, as shown in Figure 2-19. Inside the tank is a 76.2 mm (3 in.), schedule 40, 304 stainless steel pipe that provides a tortuous path for the steam flow to expand into a large volume, thus damping pressure oscillations. The inlet and outlet nozzles are 76.2 mm (3 in.) in diameter with flanges. The vent and drain lines are made of 25.4 mm (1 in.) stainless steel pipe. There are 95.3 mm (3.8 in.) tube penetrations for a fluid thermocouple and two static pressure taps. The tank walls are heated with clamp-on-strip heaters up to about 11 °C (20 °F) above saturation temperatures to prevent steam condensation.

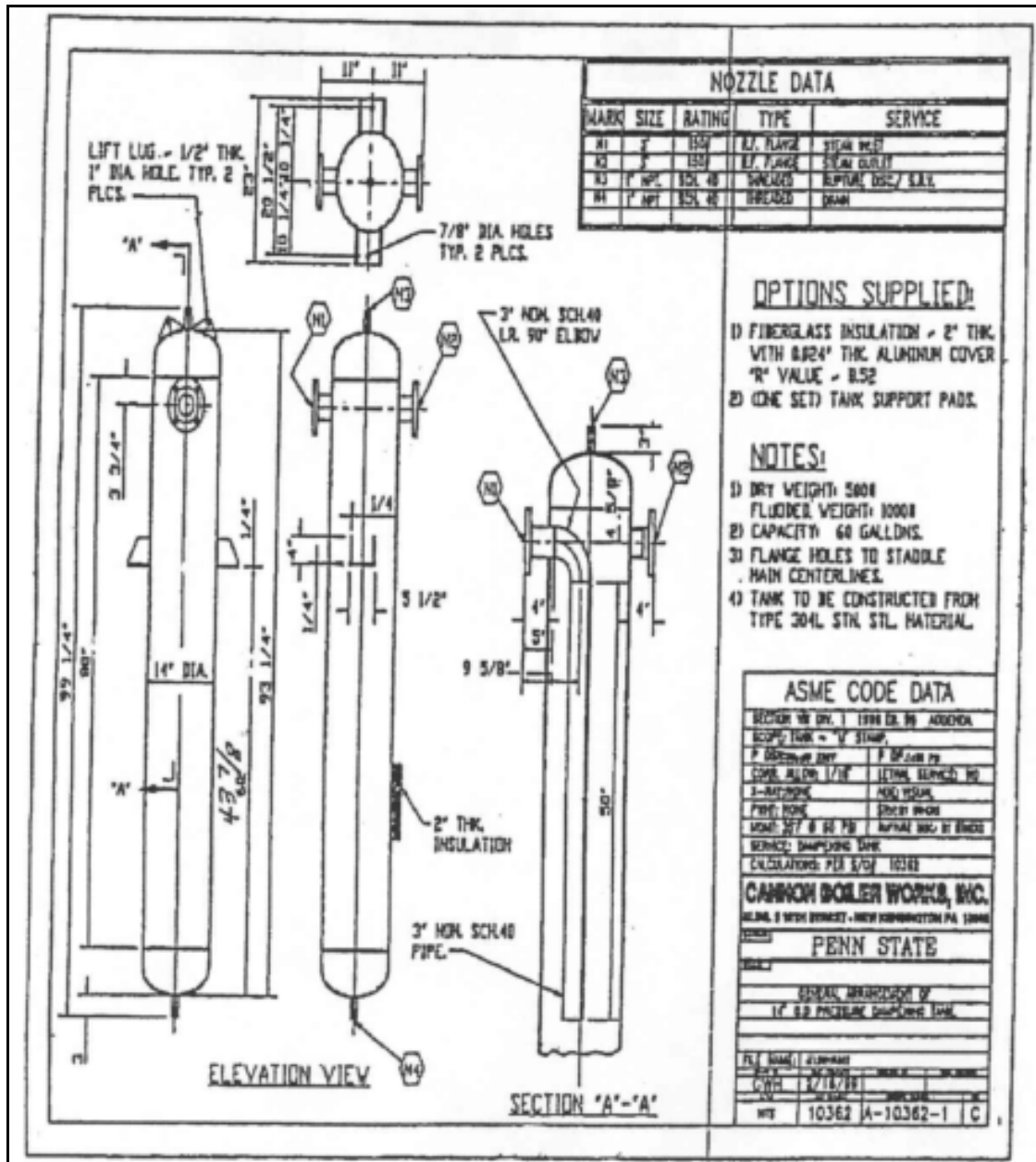

Figure 2-19: Pressure Oscillation Damping Tank

2.1.7 Exhaust Piping

The steam flows out of the pressure oscillation-damping through a 76.2 mm (3 in.) schedule 40, 304 stainless steel pipe shown schematically in Figure 2-20. The exhaust line has a Vortex flow meter, a 76.2 mm (3 in.) V-Ball pressure control valve, and a muffler at the exit to minimize the noise caused by steam blowing into the atmosphere. The pressure control valve is activated by a signal from a static pressure transmitter located on the upper plenum. The line is also instrumented with a static pressure transmitter, fluid thermocouples, and outer wall thermocouples. The 76.2 mm (3 in.) line has flow-straightening vanes which reduce the pipe length requirements upstream of the Vortex flow meter in order to obtain accurate flow measurements. This line has strapped-on electrical heaters to keep the wall temperatures about 11.11 °C (20 °F) above saturation to insure that single-phase steam flow measurements are made by the Vortex flow meter.

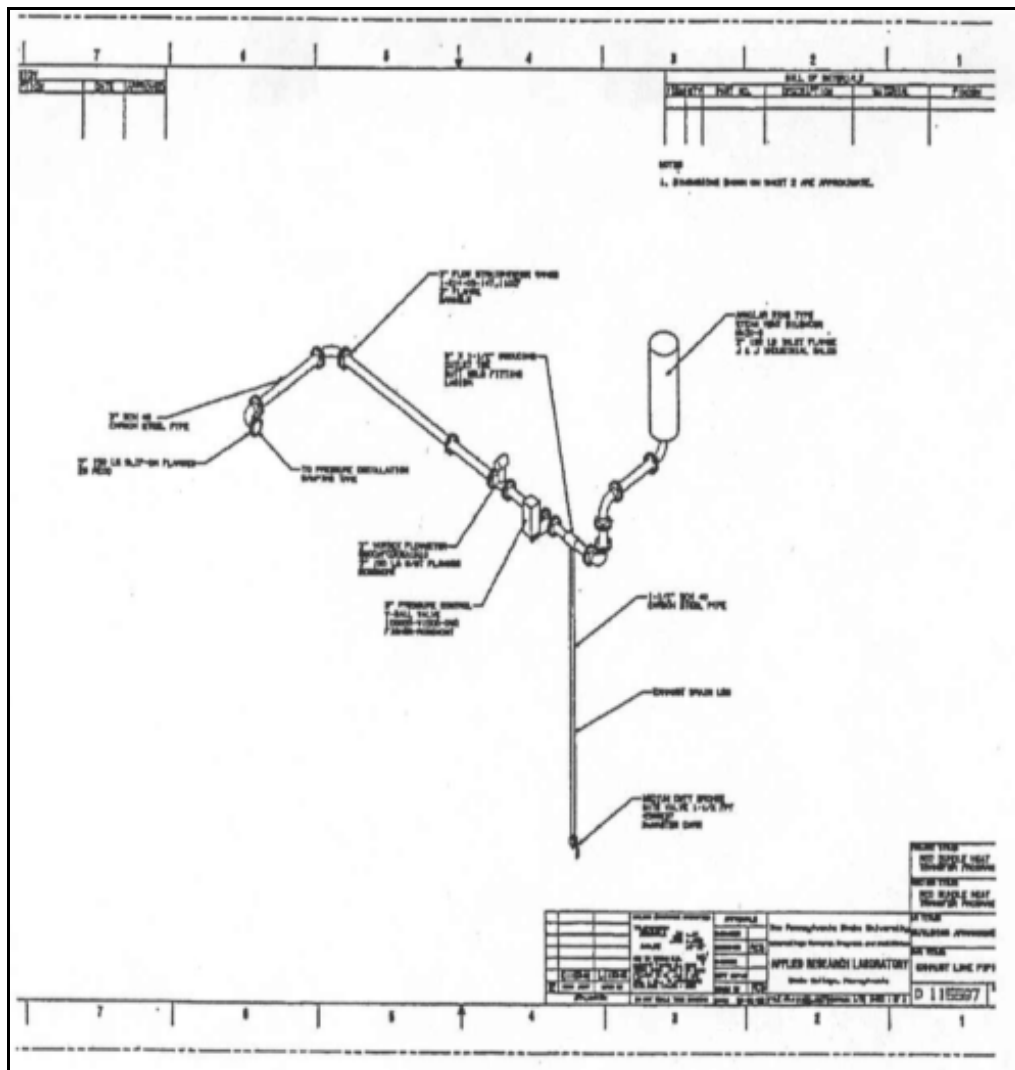

Figure 2-20: Exhaust Piping

2.1.8 Injection Water Supply Tank

The injection water system consists of a water supply tank, a circulation pump, and interconnecting lines to the test section lower plenum. The water supply tank shown in Figure 2-21, has a capacity of 0.953 cu. m. (251.75 gallons). It is designed for 4.14 bars (60 psig) and 154.4 °C (310 °F). The tank is equipped with a submersible electrical heater to heat the injection water to specified test temperatures. The tank is pressurized by a nitrogen supply system, which regulates the over-pressure needed for the forced flooding injection tests. The tank has inlet and outlet nozzles, pressure taps for level measurements, fluid and wall thermocouples. Water from the tank can be circulated through the test section by a centrifugal pump with a capacity up to 0.946 cu. m per minute (250 gallons per minutes) which are needed to perform liquid single-phase flow tests.

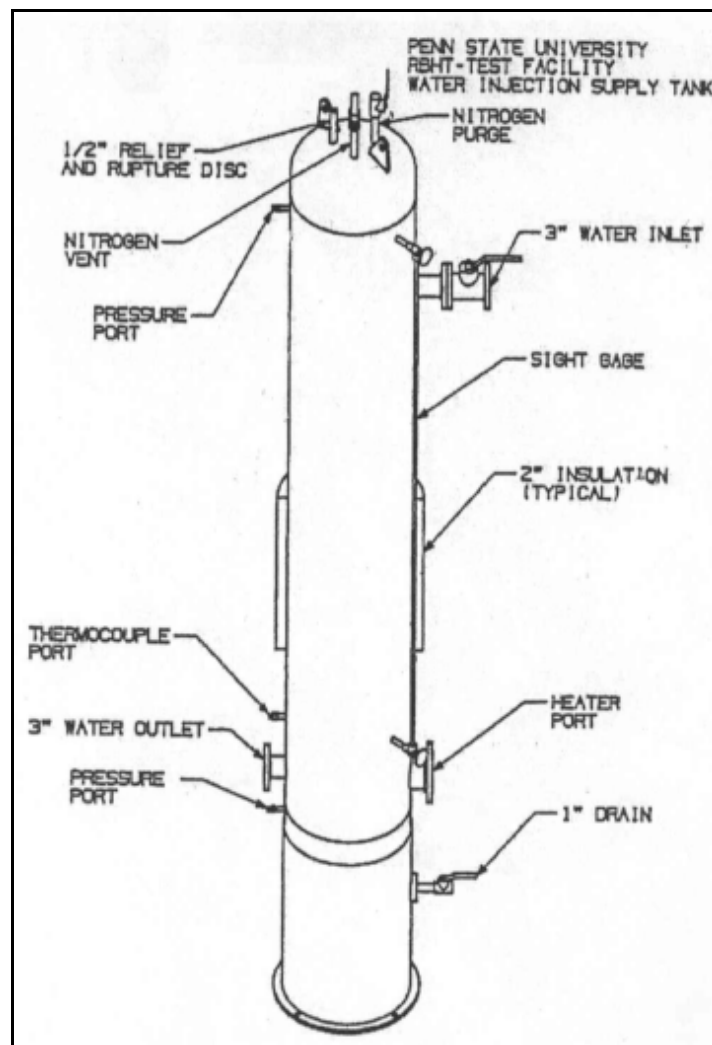

Figure 2-21: Injection Water Supply Tank

2.1.9 Water Injection Line

The water injection line, shown schematically in Figure 2-22, consists of a 50.8 mm (2 in.) diameter 304 stainless steel tubing with a 2.77 mm (0.109 in.) wall. It is rated for 4.14 bars (60 psi) and 154.4 °C (310 °F) service. This line has a Coriolis Effect type flow meter, a V-ball control valve, a quick opening solenoid valve, and a appropriate shut-off and drain valves. It also has penetrations for static pressure and fluid thermocouples, and outside wall thermocouples. The line has tracer electrical cable type heater to maintain the water being injected at the proper test inlet temperatures.

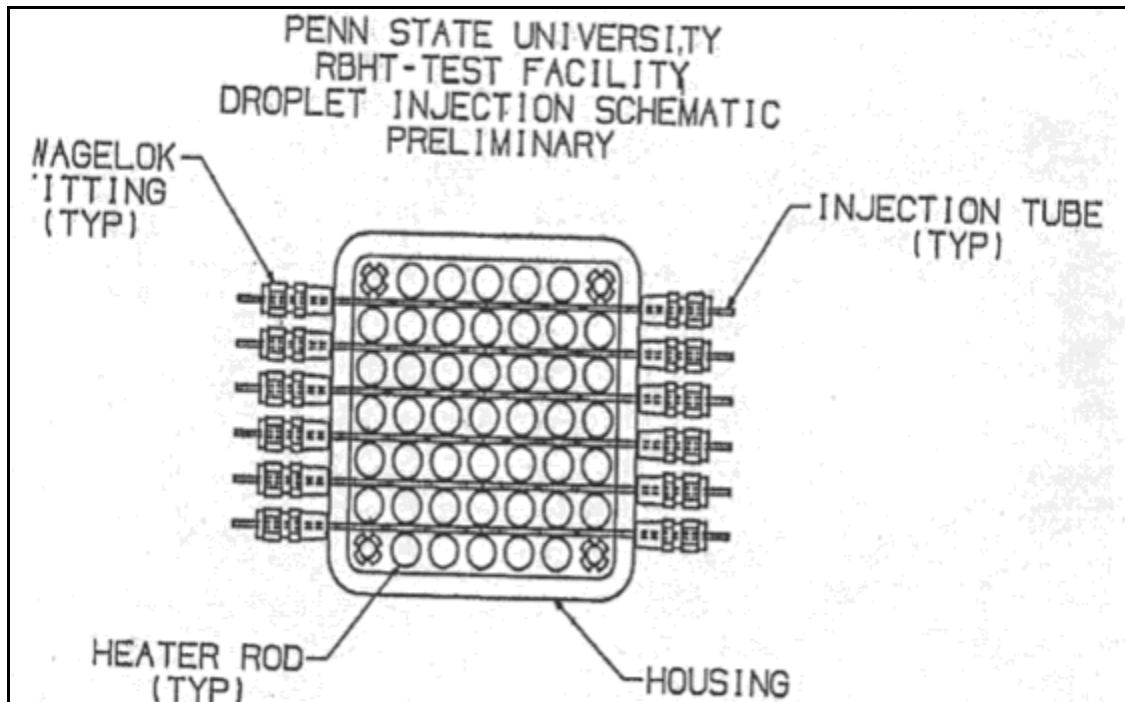
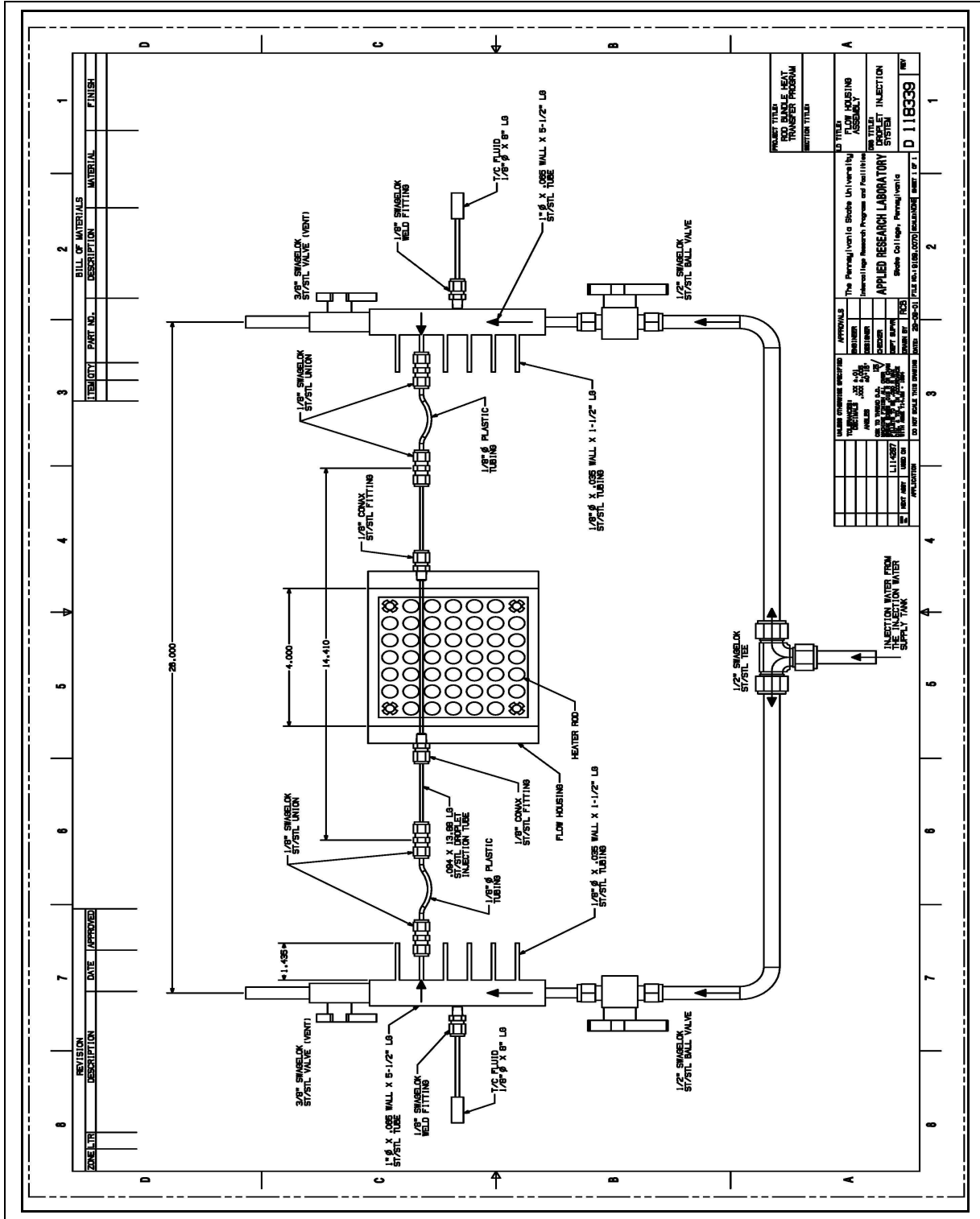

Figure 2-22: Water Injection System Schematic

In preparation for conducting the Steam Cooling with Droplet Injection tests, a number of modifications were made to the RBHT test setup to enable droplets of a controlled size, temperature and flow rate to be injected within the rod sub-channels of the test section.

A Coriolis Mass Flow meter, capable of measuring from 0 to 82 kg/hr (0 to 3 lbm/min) was installed to monitor the droplet injection water flow rate. The droplet injection water is supplied from the pressurized, heated supply tank and flows through 12.7 mm (0.5 in.) diameter stainless steel tubing to two manifolds located on either side of the flow housing shown in Figure 2-23. The supply lines are insulated and heated with external resistance heaters to maintain the droplet fluid temperature. Maintaining the droplet injection water temperature within approximately 1 °C (2 °F) of saturation temperature was found to be very important for steady flow of the Droplet Injection streams at the low flow rates and to minimize coalescence of the individual streams into larger combined streams, resulting in larger than desired drop size.

The Droplet Injection tubes, shown in Figure 2-24 and Figure 2-25, utilize a single row linear hole pattern of four holes per sub-channel and four sub-channels per tube. One additional hole is located at the center rod gap location to minimize the chance of local boiling since the flow is stagnant at this area. The hole sizes chosen for testing were 0.381 mm (0.015 in.) and 0.254 mm (0.010 in.) diameter, which is based on the average droplet diameter spectra as developed by Wallis [2]. Bench testing of the prototype Droplet Injection tubes fabricated from 2.381 mm (0.09375 in.) diameter, 304 stainless steel tubing with a 0.254 mm (0.010 in.) wall thickness revealed a problem with the droplet streams angling toward the center of the hole pattern rather than exiting perpendicular to the tube. This is not desirable since the drop stream would not be flowing directly in line with the rod sub-channels but rather at an angle toward the rod gaps, promoting localized drop impingement on the rods which could lead to localized cooling and rod wetting. A brief CFD analysis, shown in Appendix C, of the flow through the injector indicated that increasing the wall thickness from 0.254 to 0.508 mm (0.010 in. to 0.020 in.) would straighten the droplet streams. The Droplet Injection tubes are fabricated using an EDM hole drilling process which eliminates the occurrence of burrs at the hole edge which would distort the flow of the droplet streams.



PROJECT TITLE	ROD BUNDLE HEAT TRANSFER PROGRAM
SECTION TITLE	

DESIGNER	APPLIED RESEARCH LABORATORY
SCALE	AS SHOWN
DATE	11/11/87
BY	...
NO.	D 118339
REV.	

UNION	3/8\"/>
WELDED	...
FLANGES	...
VALVES	...
TEES	...
ELBOWS	...
ADAPTERS	...
COUPLERS	...
END CAPS	...
FLANGES	...
VALVES	...
TEES	...
ELBOWS	...
ADAPTERS	...
COUPLERS	...
END CAPS	...

APPROVALS	
DESIGNED BY	J. J. ...
CHECKED BY	...
DATE	...
BY	...
NO.	...
REV.	...

DATE	...
APPROVED	...

ZONE	
REVISION	
DATE	
APPROVED	

ITEM	
NO.	
DESCRIPTION	
DATE	
APPROVED	

DATE	...
APPROVED	...

Figure 2-23: Droplet Injection Plumbing Layout

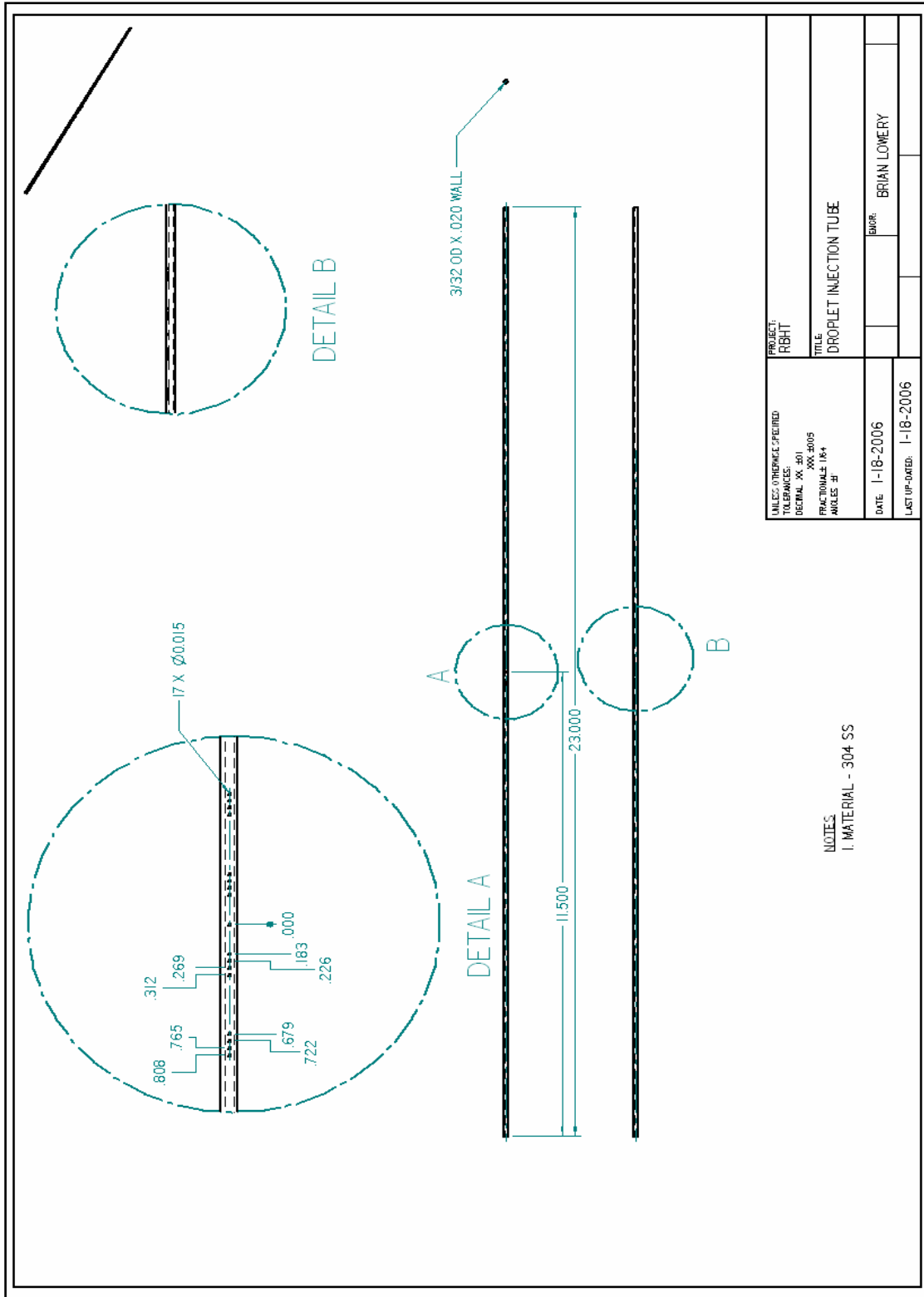

Figure 2-24: Droplet Injection Tube Design

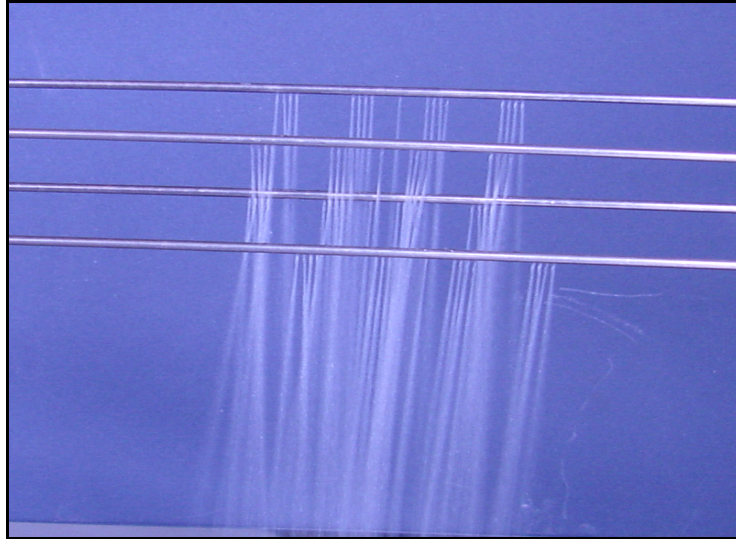

Figure 2-25: Droplet Injection Tubes During Flow Meter Calibration

Figure 2-26 presents the layout of the subchannels. When two injectors are used during the experiments, droplets are injected to the subchannels C4, D4, E4, F4, C5, D5, E5 and F5. When four injectors are used, C3, D3, E3, F3, C4, D4, E4, F4, C5, D5, E5, F5, C6, D6, E6 and F6 are the subchannels to which droplets are injected.

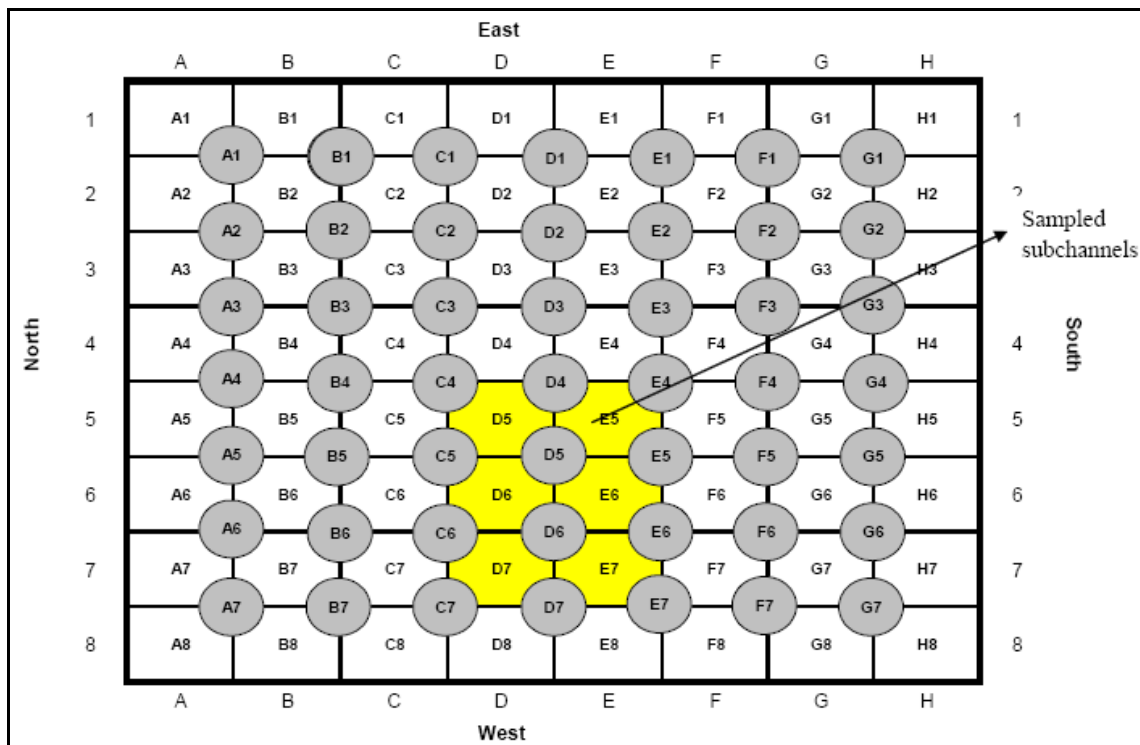

Figure 2-26: Sampled Subchannels for Droplet Size Measurements

2.1.10 Steam Supply

A Clayton oil-fired boiler with a capacity of 2613 kg (5760 lbs.) per hour at 10.3 bars (150 psig) provides steam for the single phase steam cooling, pressure drop and water droplet injection tests. It also provides steam for preheating the test components prior to testing. The boiler is connected to the lower plenum by means of a 50.8 mm (2 in.), 304 stainless steel tube. It is equipped with a Vortex flow meter to measure steam flows, fluid and wall thermocouples, a V-ball control valve, and a quick acting solenoid valve. The boiler is also connected to the upper plenum to provide steam for preheating the test components prior to testing.

2.2 Facility Improvements Over Previous Tests

Significant improvements related to other heater rod bundle testing programs, listed in Section 3.0 Literature Review of the Peer Review Report have been incorporated in the RBHT-Test Facility. These improvements are:

- A low mass square flow housing design which better fits a square rod bundle array and minimized the housing mass and excess rod bundle flow area.
- The six pairs of windows which provide large viewing areas below and above grid locations, making it possible to observe and make void fraction and droplet measurements during testing.
- The use of a laser illuminated Digital Camera system to measure entrained water droplets sizes, distribution, and velocities in the transition and disperse flow regions.
- The use of a traversing steam probe rake to measure simultaneously steam temperatures in the flow subchannel and in the rod-to-rod gap. They are specially designed such that they would not stay wet after having contacted by liquid droplets.
- Differential pressure transmitters axially located 76.2 to 127 mm (3 to 5 in.) apart in conjunction with heater rod and flow housing wall thermocouples to obtain detailed void fraction and heat transfer information.
- Water droplets injection system in conjunction with steam injection to study the droplet-steam cooling effects on heat transfer and grids.
- Addition of a large pressure oscillation-damping tank to minimize test section oscillations observed in the FLECHT and FLECHT-SEASET tests.
- The incorporation of close coupled entrained liquid collection tanks and piping to reduce delay times for liquid collection.

2.3 Instrumentation and Data Acquisition System

The test instrumentation is designed to measure temperatures, power, flows, liquid levels, pressures, void fractions, droplet sizes and distributions, and drop velocities. The vapor velocity cannot be directly measured in a two-phase dispersed flow, but it can be calculated at different axial positions from the data. Overall the transient mass and energy balances, mass inventories, carryover liquid and steam flow can be calculated as function of time. Heater rod power, heat rod temperature, and fluid temperature are used to calculate heat fluxes and heat transfer coefficients, quench times, rod bundle energy losses, convective and radiation heat transfer to steam, droplets, grids, support rods, and housing. Effects of grids, support rods and housing behavior during testing can be determined. The laser illuminated digital camera system measurements provide droplet size distribution and velocities during testing.

2.3.1 Loop Instrumentation and Controls

Loop instrumentation is shown schematically in Figure 2-27. One hundred twenty three (123) instrumentation channels are assigned to the collection of electrical power, fluid and wall temperatures, levels, flows differential pressures, and static pressure measurements. The injection water supply tank has three fluid and three wall thermocouples to monitor water and wall temperatures during heat-up prior to testing. It has a differential pressure transmitter used as a level meter to determine water mass in the tank and mass depletion during testing. It also has a static pressure transmitter that monitors the nitrogen over pressure and controls the nitrogen flow needed to maintain a constant pressure during tests. The water injection line is equipped with a Coriolis Effect Micromotion flow meter that directly measures mass flows up to 454 kg/min (1000 lbs./min) with an accuracy of plus or minus eleven hundredths of a percent ($\pm 0.11\%$) of rate. The steam line has a Rosemount Vortex shedding flow meter to measure flow up to 7.08 m³/min (250 ft³/min) with an accuracy of plus or minus sixty-five hundredths of a percent ($\pm 0.65\%$) of rate. Each flow meter is connected through a pneumatic controller to a V-ball flow control valve. Each line has a fluid thermocouple to measure water or steam temperature during heat-up and forced injection testing. They also have a static pressure transmitter which in conjunction with the thermocouples can determine the thermodynamic properties of the fluid. The injection line has three wall thermocouples to monitor wall temperatures during heat-up and during testing. One of these thermocouples in conjunction with a temperature controller regulates the power to an electrical heating cable wrapped around the injection line. The heating cable is used to heat-up the injection line wall and to maintain the injection water at the required injection temperature.

The small carryover tank has one (1) fluid and two (2) wall thermocouples. The large carryover tank instrumentation consists of one (1) fluid thermocouple, three (3) wall thermocouples. Both tanks have a liquid level meter, which measures the amount of carryover liquid being collected during testing. In addition, a differential pressure transmitter is connected from the top of the carryover tank to the upper plenum to determine the static pressure in the carryover tank.

The steam separator is instrumented with one (1) fluid and two (2) thermocouples. The drain tank is instrumented with two (2) fluid and two (2) wall thermocouples. The fluid thermocouple measures the water temperature de-entrained during testing. The wall

thermocouples monitor wall temperatures during heat-up. The volume of de-entrained water is measured with a level meter connected across the drain tank.

The pressure oscillation damping tank has two (2) fluid and three (3) wall thermocouples which are used to monitor vessel walls during heat-up, and to insure that the vessel wall is at a temperature above saturation to prevent condensation. One wall thermocouple in conjunction with a temperature controller monitors the power applied to clamp-on heaters that heat up the tank to the desired wall temperature.

The exhaust line is equipped with a Vortex flow meter which, in conjunction with a static pressure transmitter and a fluid thermocouple measurements are used to calculate steam volumetric flows up to 7.08 m³/min (250 ft³/min). The flow meter has an accuracy of plus or minus sixty-five hundredths of a percent ($\pm 0.65\%$) of the rate. The exhaust line also has three (3) wall thermocoupled to measure pipe wall temperatures. One wall thermocouple in conjunction with a temperature control regulates the power going to clamp-on-heaters which are used for heating the pipe walls up to a temperature about 11°C (20°F) above saturation to prevent steam condensation and to insure accurate single phase steam flow measurements. The exhaust line has V-ball pressure control valve. This valve is controlled by a static pressure transmitter through a pneumatic controller connected to the top of the upper plenum in order to maintain constant test section pressure during testing.

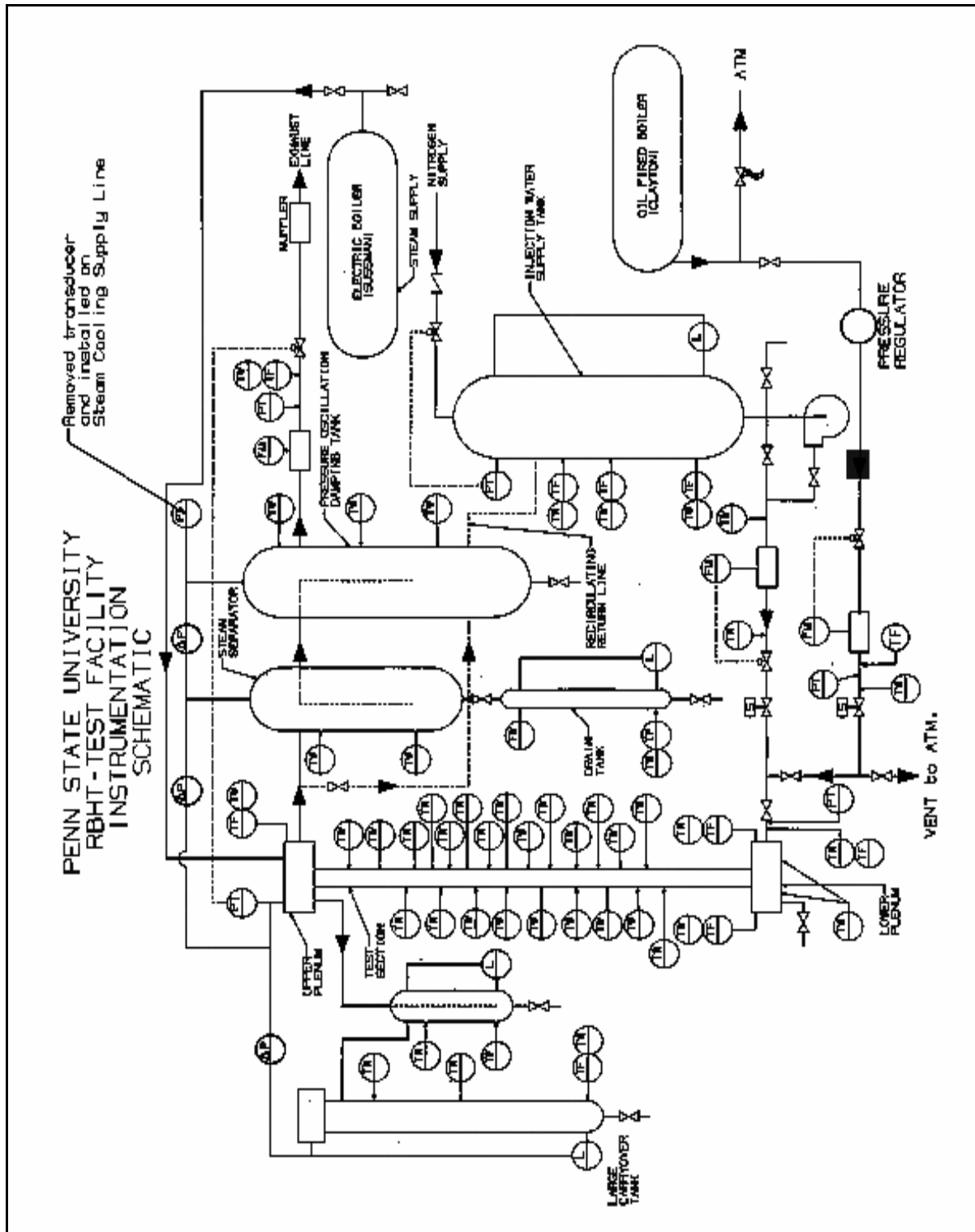

Figure 2-27: Loop Instrumentation Schematic

2.3.2 Test Section Instrumentation

The test section instrumentation consists of the heater rod bundle and flow housing, the low plenum, and the upper plenum groups. The heater rod bundle and flow housing instrumentation is shown schematically in Figure 2-28. This figure shows the instrumentation axial locations in relation to heater rod heated length, heater axial power profile, grids, steam probes and steam probe rakes, housing pressure taps and windows.

Six grids have thermocouples attached to their surfaces in order to determine behaviors during testing shown in Figure 2-29 through Figure 2-35. Grid and Steam Probes axial locations are shown schematically in Figure 2-28. Eight groups of heater rods have thermocouples at different elevations to cover, as much as possible, the entire rod bundle heated length. The radial location of each heater rod group is shown in Figure 2-36. The radial locations of instrumentation rods were chosen in order to be able to characterize heat transfer of hot rods simulated by the center rods, rod-to-rod and rod-to-housing radiation heat transfer. For this purpose, heater rod thermocouples, steam probes, and housing wall thermocouples are located at the same elevations. In addition, symmetrical location of the same group of instrumented heater rods will help in the data analysis and will determine any anomalies in the radial flow distribution through the heater rod bundle. Heater rod thermocouples are also placed at varying distances downstream from a grid to determine the decreasing heat transfer gradient between grid spans. The steam probes or fluid thermocouples are located at short distances upstream and downstream of a grid to determine the effect of water droplets being shattered by the grids on droplet size and distribution, and the desuperheating effect on the steam temperatures in the disperses flow regime.

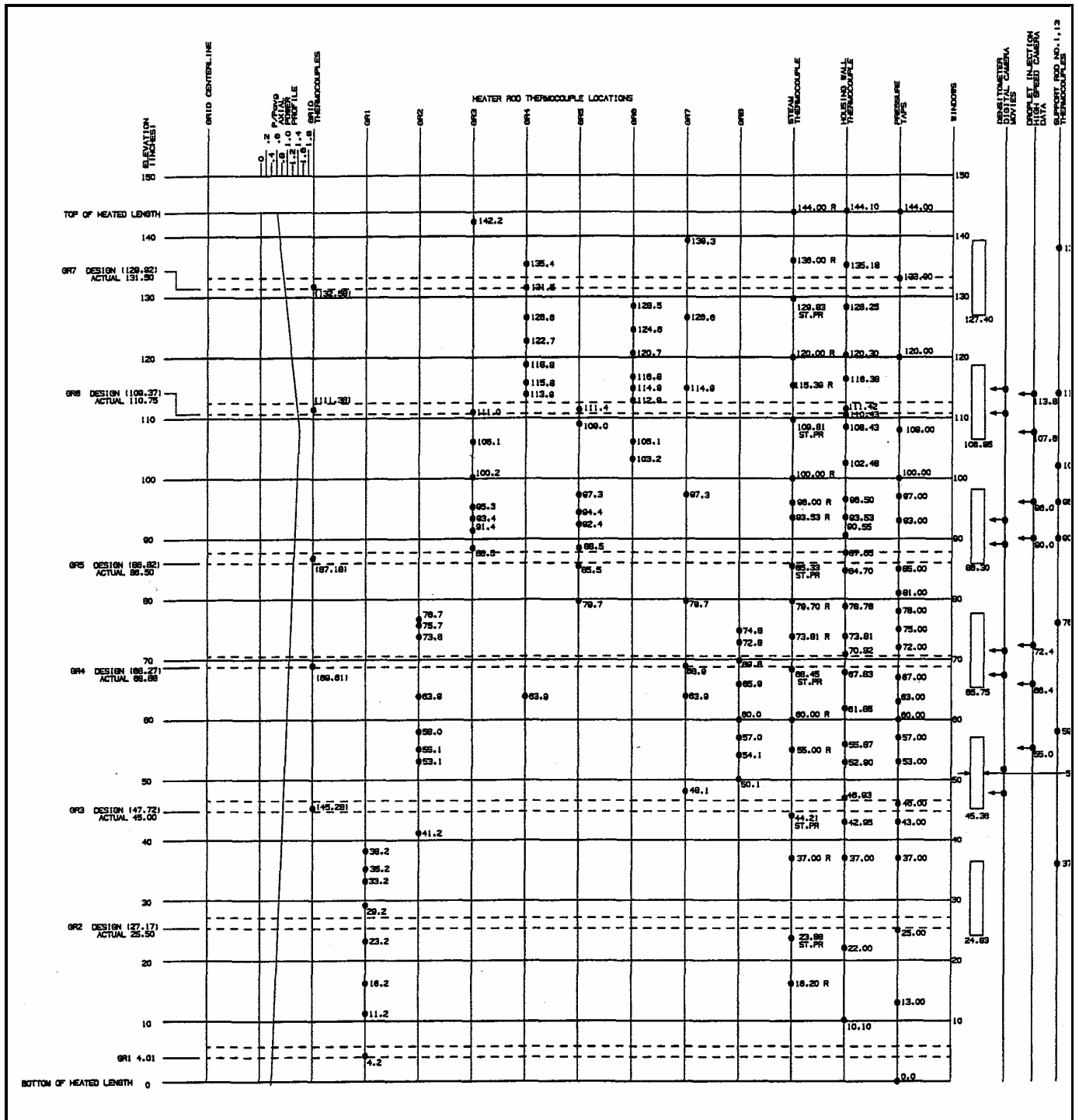

Figure 2-28: Rod Bundle and Housing Instrumentation Axial Locations

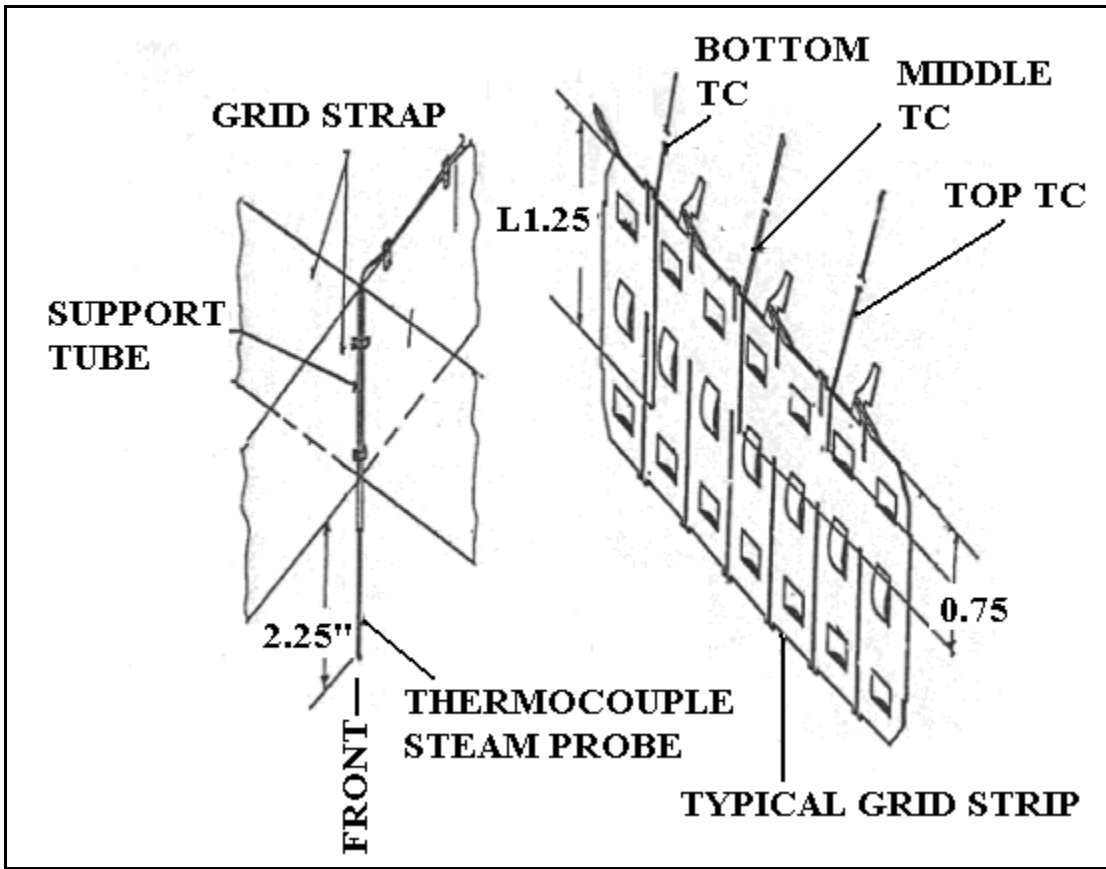

Figure 2-29: Mixing Vane Grid Instrumentation

Penn State University
 RBHT Test Facility
 Mixing Vane Grid Instrumentation
 Grid Strap and Steam Probe TCs

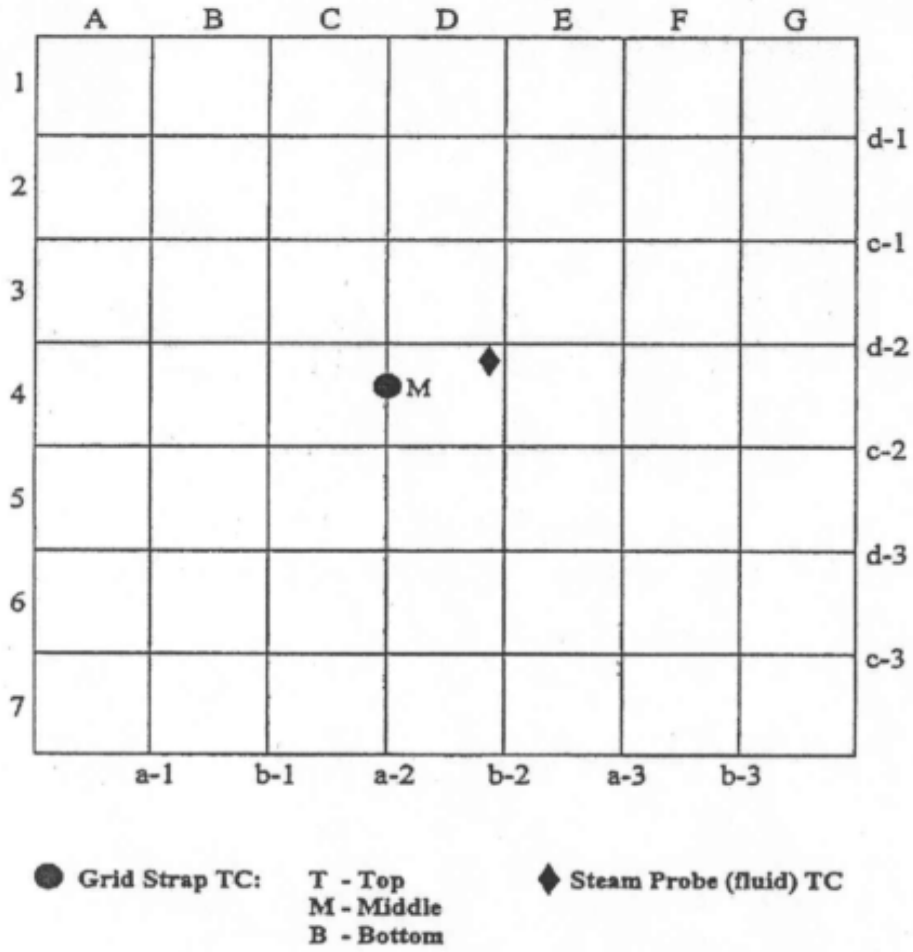

Figure 2-30: Grid No. 2 Instrumentation

Penn State University
 RBHT Test Facility
 Mixing Vane Grid Instrumentation
 Grid Strap and Steam Probe TCs

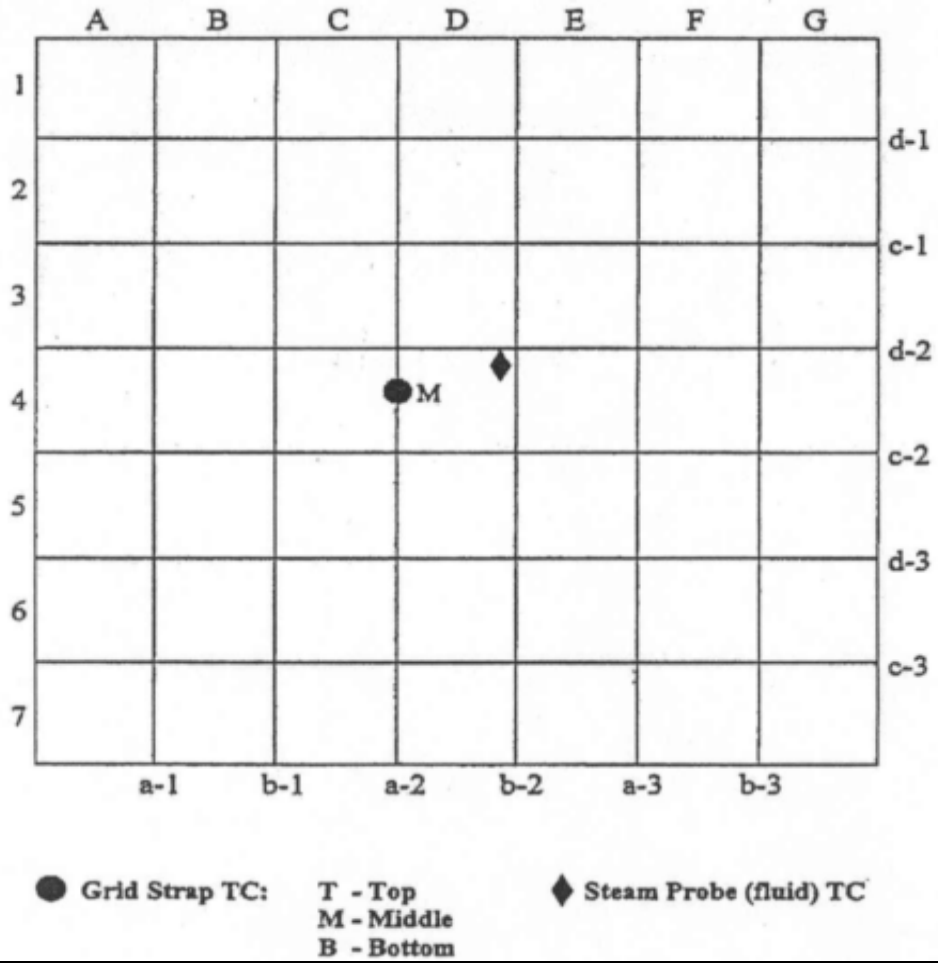

Figure 2-31: Grid No. 3 Instrumentation

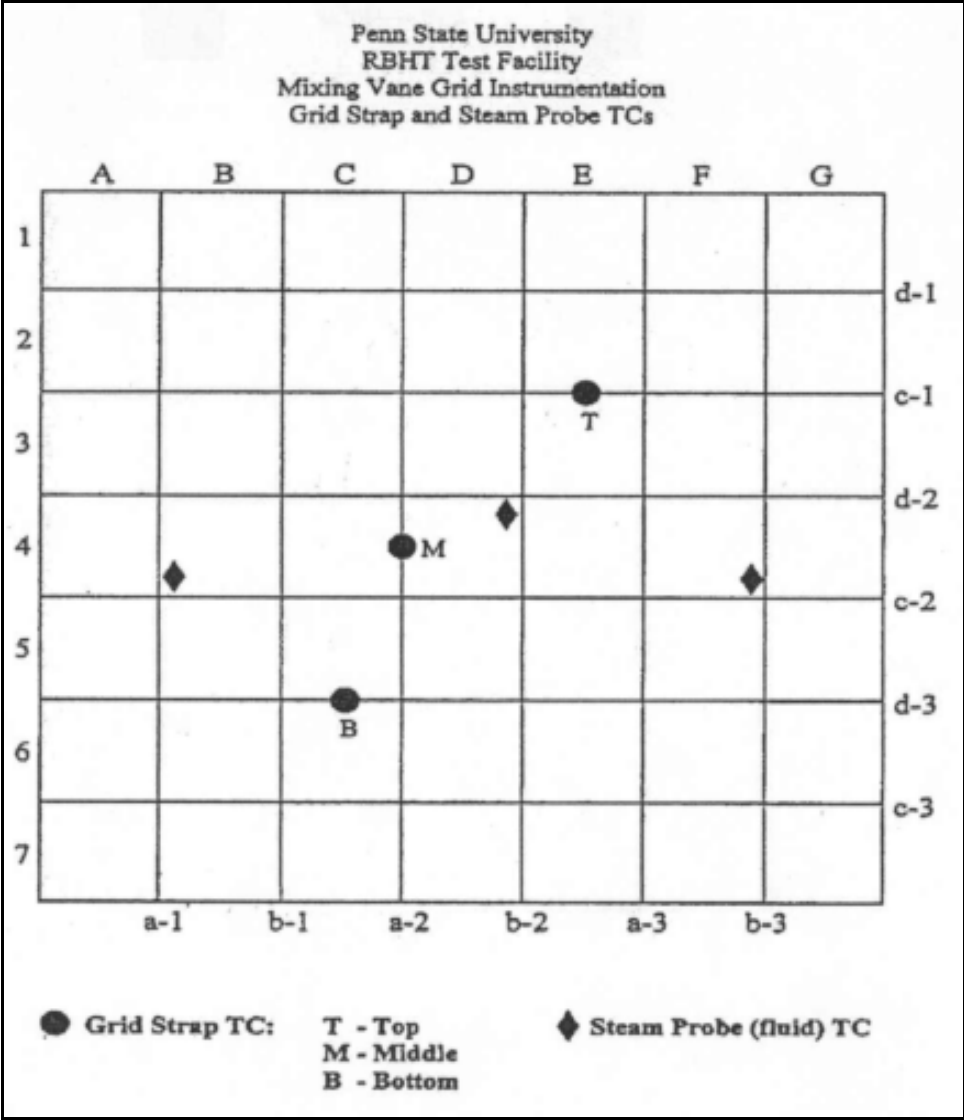

Figure 2-32: Grid No. 4 Instrumentation

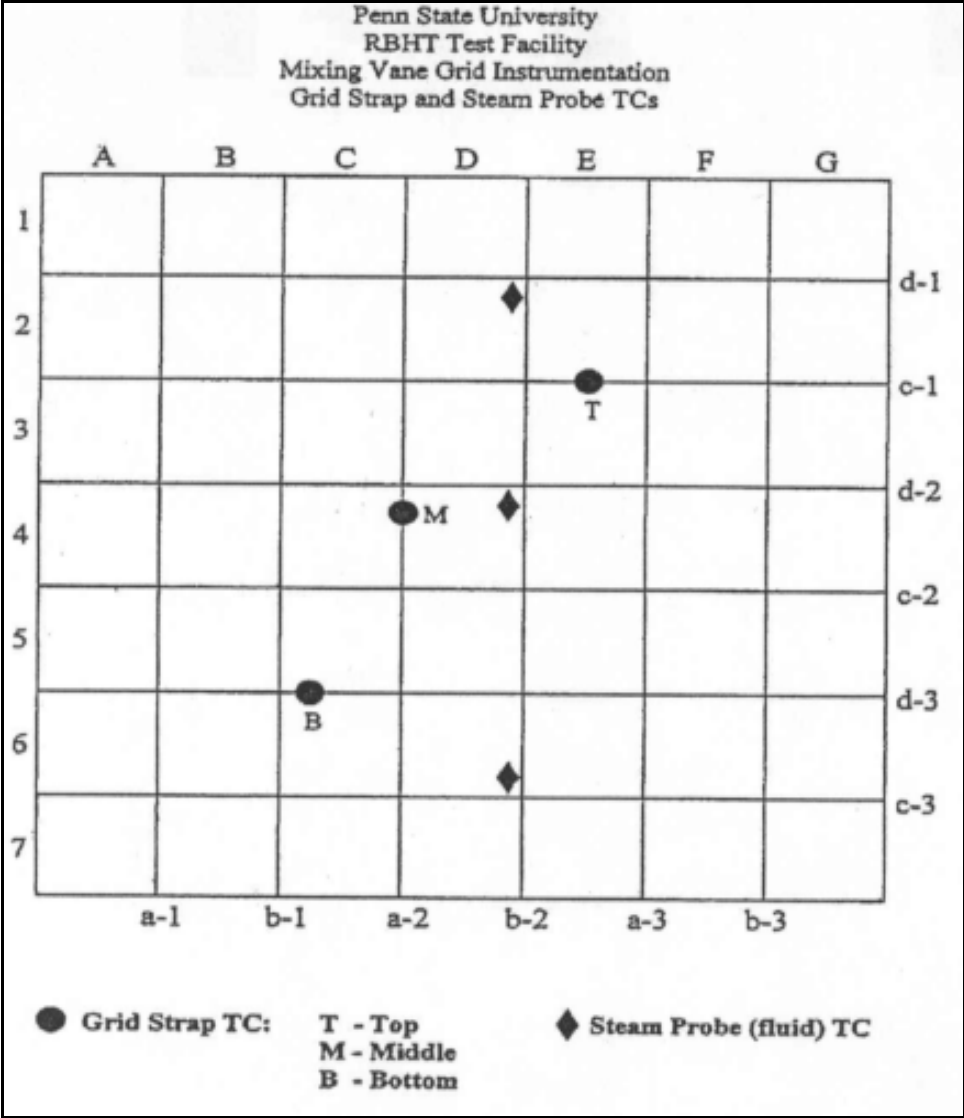

Figure 2-33: Grid No. 5 Instrumentation

Penn State University
 RBHT Test Facility
 Mixing Vane Grid Instrumentation
 Grid Strap and Steam Probe TCs

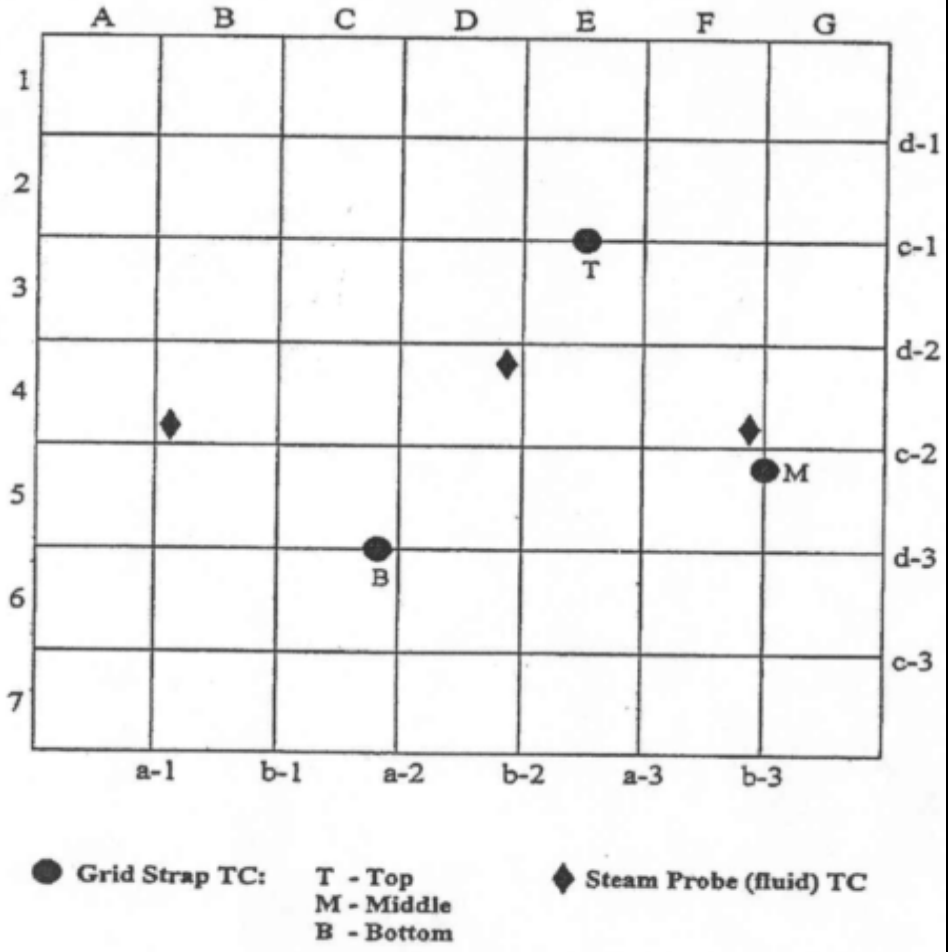

Figure 2-34: Grid No. 6 Instrumentation

Penn State University
 RBHT Test Facility
 Mixing Vane Grid Instrumentation
 Grid Strap and Steam Probe TCs

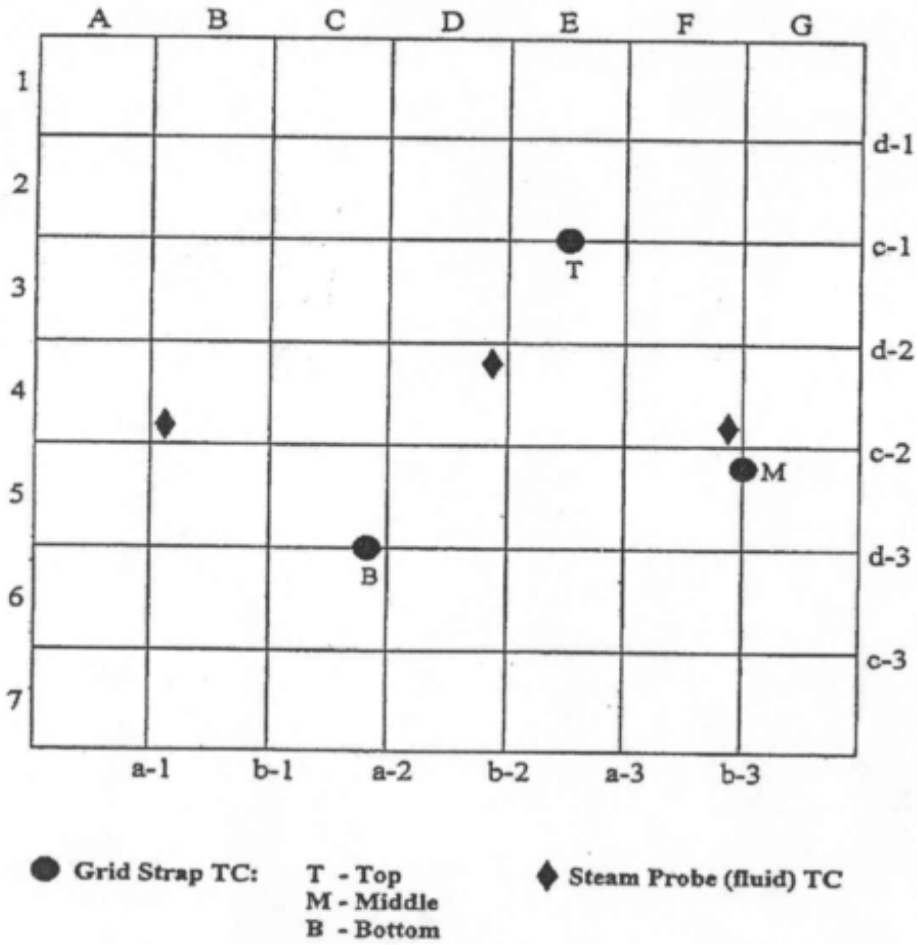

Figure 2-35: Grid No. 7 Instrumentation

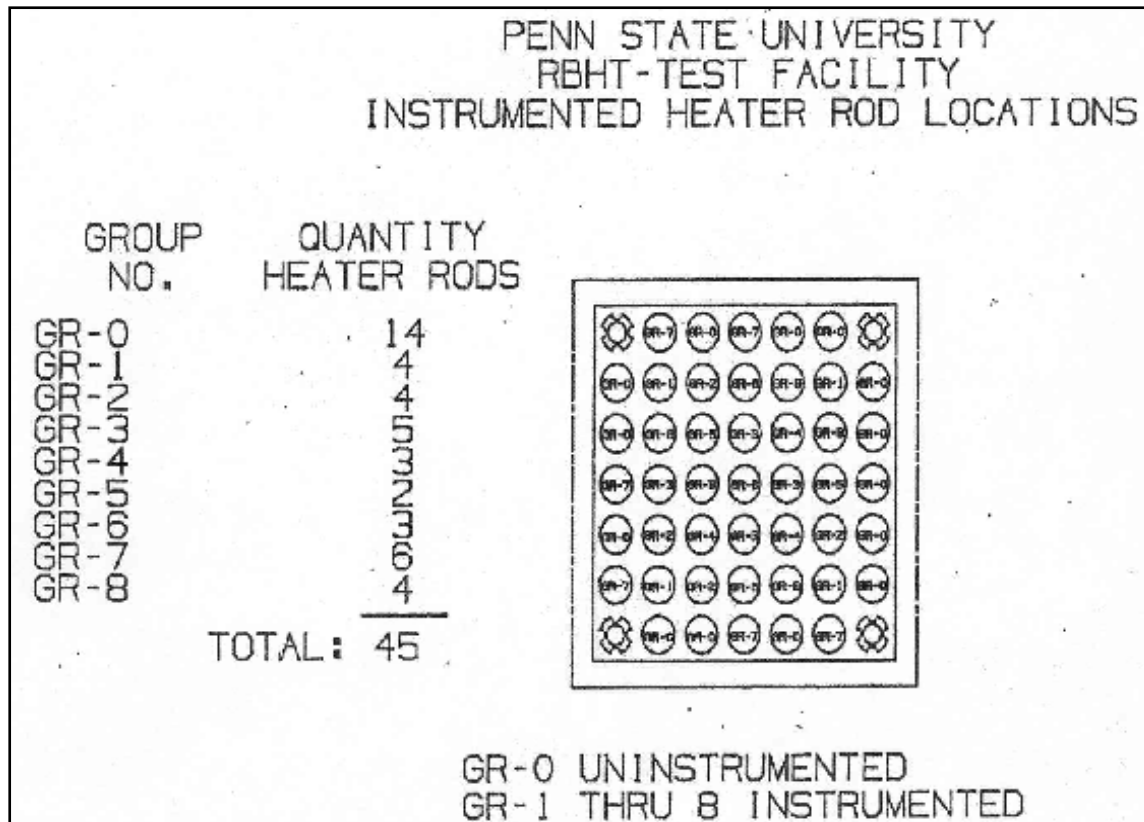

Figure 2-36: Instrumental Heater Rod Radial Location

The vapor or steam temperature will be measured using miniature thermocouples having a diameter of 0.813 mm (0.032 in.) which are attached to the spacer grids, as well as the traversing steam probe rakes having a diameter of 0.381 mm (0.015 in.). These are very small diameter thermocouples that have a fast response time such that they can follow the vapor temperature accurately in a dispersed, non-equilibrium, two-phase flow. As the froth front approaches, the number and sizes of the droplets increase which can lead to wetting of these thermocouples. Experiments performed as part of the FLECHT-SEASET program indicated that very small thermocouples would provide reliable vapor superheat ready for the longest time period until they quench as the froth region approached. While the Lehigh vapor probe was considered, it is too large and causes a flow distribution effect which is not typical of the bundle. The Lehigh probe would block 68% of the gap between adjacent heat rods. The effect of the probe would be to distort the data downstream of the sensing location. Such flow distribution effects were observed in the Lehigh data as well as the INEEL single tube data which used these probes.

The traversing steam probe rakes are located at the spans between the grids at the upper heater rod bundle elevations, as shown schematically in Figure 2-37. The traversing steam probe rakes will measure steam temperatures in the heater rod bundle flow subchannels and the gap between the heater rods during the dispersed flow regime. The traversing steam probe rake is shown in Figure 2-38. Each rake consists of three 0.381 mm (0.015 in.) diameter ungrounded thermocouples mounted on a 0.356 mm (0.014 in.) thick by 6.35 mm (0.25 in.) wide Inconel strip. The thermocouples are spaced 12.6 mm (0.496 in.) apart which correspond to the heater rod spacing in the bundle. The thermocouple tips are located facing the steam flow. A 2.39 mm (0.094 in.) diameter tube attached to the strip; is used to

traverse the steam probe rake across the rod bundle. This tube also carries the thermocouples leads outside the flow housing through an extension tube and a pressure seal arrangement. The tube is attached to an automated sliding mechanism shown in Figure 2-37. It consists of a sliding bar, a 24 DCV motor with a ball drive shaft, and a linear potentiometer provides a voltage input to the Data Acquisition which determines the rake thermocouple location and travel distances across the heater rod bundle.

Two fluid thermocouples are placed 25.4 mm (1 in.) below the bottom of the bundle heated length such that injection temperatures are monitored prior to and when testing is started. Twenty three (23) differential pressure transmitters are connected to the housing wall pressure taps providing measurements to calculate single phase flow heater rod bundle and grid friction losses, bundle mass inventory, and void fraction during testing. Nine (9) differential pressure cells are connected to pressure taps located 76.2 to 127 mm (3 to 5 in.) apart to provide detailed mass inventory, and void fraction data in the froth region above the quench front. In addition, heater rod and housing wall thermocouples are placed at these pressure tap mid spans locations to determine convective and radiant heat transfer coefficients in the froth region where the differential pressure cells will give the average void fraction.

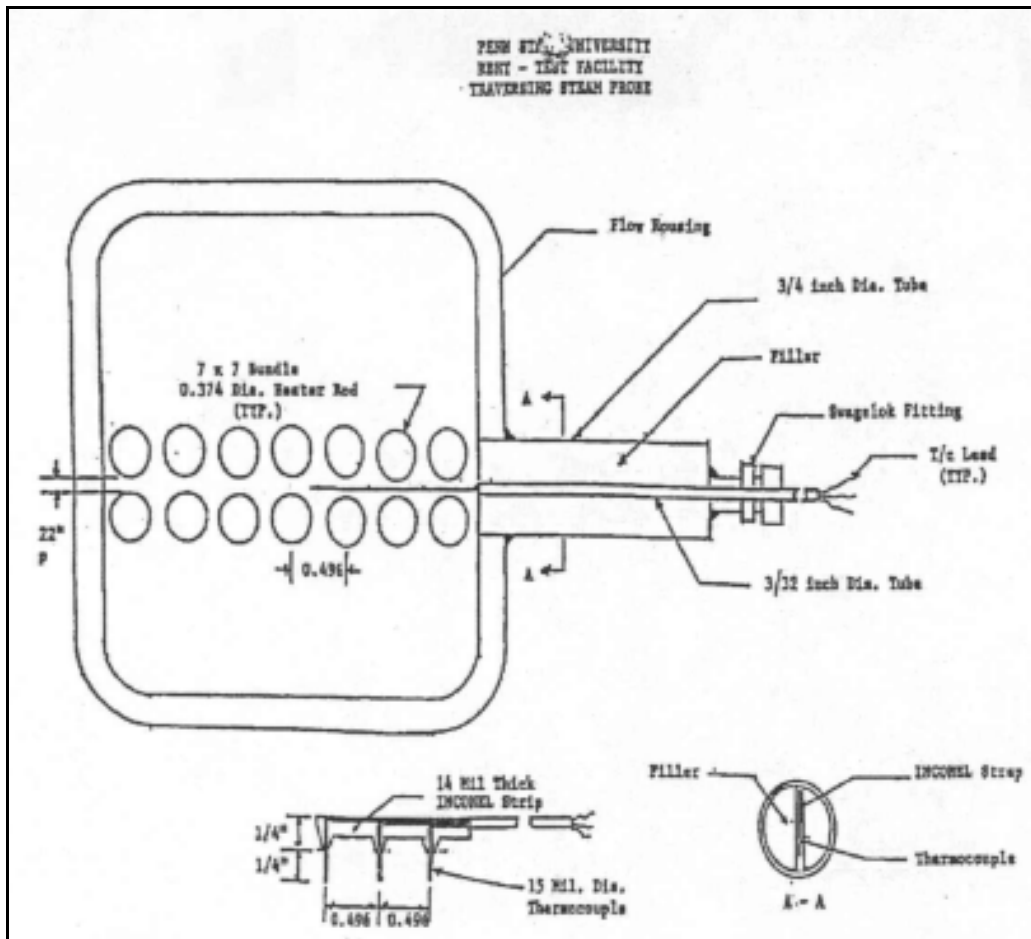

Figure 2-37: Traversing Steam Probe Rake Schematic

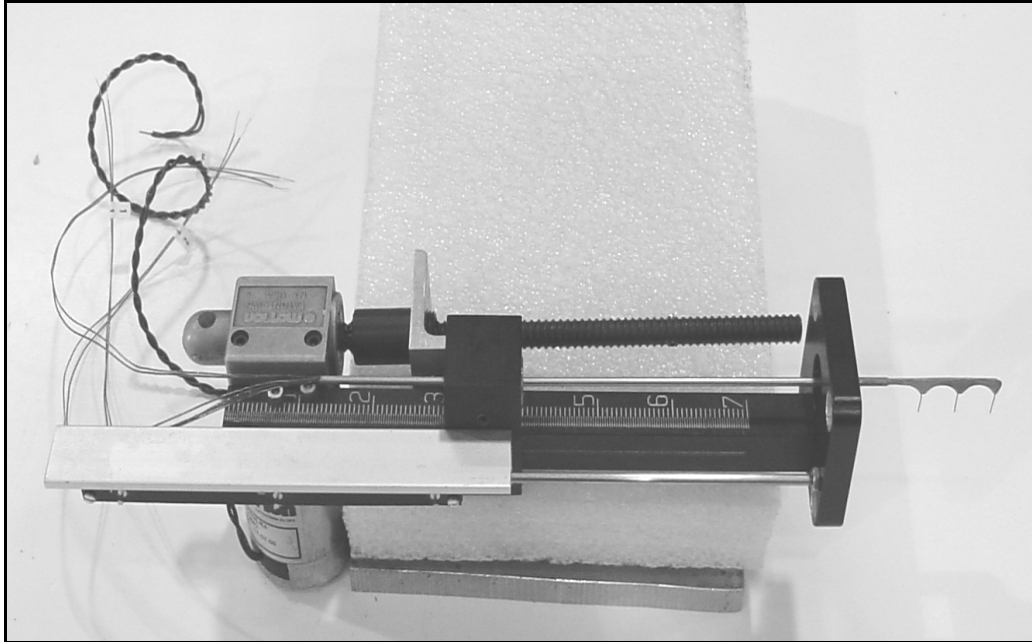

Figure 2-38: Traversing Steam Probe Rake

The flow housing has six pairs of windows at the following elevations: 61.39 cm (37.17 in.), 113.58 cm (44.72 in.), 165.8 cm (65.27 in.), 217.98 cm (85.82 in.), 270.18 cm (106.37 in.), and 322.4 cm (126.92 in.). Each pair of windows are one hundred eighty degrees (180°) apart. The window lenses are made from optical grade fused quartz and provide a viewing area of about 10.16 cm (4 in.) below and 15.24 cm (6 in.) above grids numbers 2 to 7. The windows are preheated to prevent wetting during the time when dispersed flow is occurring and LCDS measurements are being made using infrared heaters on each window and by pulsing the heater rod bundle when preheating the flow housing walls. The infrared heaters were removed just before a test is started. Droplet measurements above and below a grid can be made through the windows.

The four corner support rods are unheated, they are used to support the bundle grids and to support grid and steam probes thermocouple leads going out of the bundle. These rods are instrumented with eight (8) thermocouples attached at various elevations corresponding to heater rods and housing wall thermocouples. The purpose of this arrangement is to quantify radiation heat transfer losses to unheated surfaces and determine their behavior during testing.

The DC power supply can be controlled by regulating the voltage, current, or total power output. The voltage drop across the heater rod bundle is measured by a voltmeter connected to voltage taps at the Low-Melt pot and the Nickel Ground Plate. The electrical current is measured by a copper shunt calibrated for 15,000 amps proportional to an output signal of 0-50 milli-volts.

The Lower Plenum is instrumented with two (2) fluid and two (2) wall thermocouples. The fluid thermocouples monitor the injection water temperature prior to and during testing. The wall thermocouples measure the vessel wall during heat-up and testing. One of the wall thermocouples in conjunction with a temperature controller regulates electrical power to clamp-on-heater rods to maintain the vessel wall at inlet temperatures.

The Upper Plenum is also instrumented with two (2) fluid thermocouples and two (2) wall thermocouples. The fluid thermocouples measure steam and carryover liquid during testing. The wall thermocouples monitor vessel wall temperatures during heat-up and testing. The Upper Plenum is also instrumented with a static pressure transmitter which measures and controls the test section pressure during testing.

2.3.3 Droplet Measuring System

A droplet imaging system known as VisiSizer [3,4] has been developed in conjunction with Oxford Laser of Acton, Massachusetts to measure the size and velocity of water droplets entrained in the steam flow of the RBHT test section shown schematically in Figure 2-39. The drop sizes that are being captured are being viewed between the individual rods through the gap between the rods. VisiSizer used a pulsed infrared laser to image water droplets on a 1000 x 1000 pixel high-resolution black and white digital camera through a set of windows in the bundle housing. A digital system such as VisiSizer was chosen over conventional high-speed camera is capable of only a few seconds of imaging and speed of data acquisition. A high-speed camera that is capable of only a few seconds of imaging and is a tedious process that does not give instantaneous results. Each frame of a standard imaging technique would need to be analyzed by hand. The VisiSizer system is capable of analyzing 12 to 13 frames per second for an indefinite period of time. Film from the FLECHT-SEASET tests show poorer image quality than images taken with VisiSizer in the RBHT experiments. However, VisiSizer is incapable of measuring anything other than complete droplets. This makes it an inadequate tool for gathering information about the entrainment front where there are ligaments and other unusual water behavior.

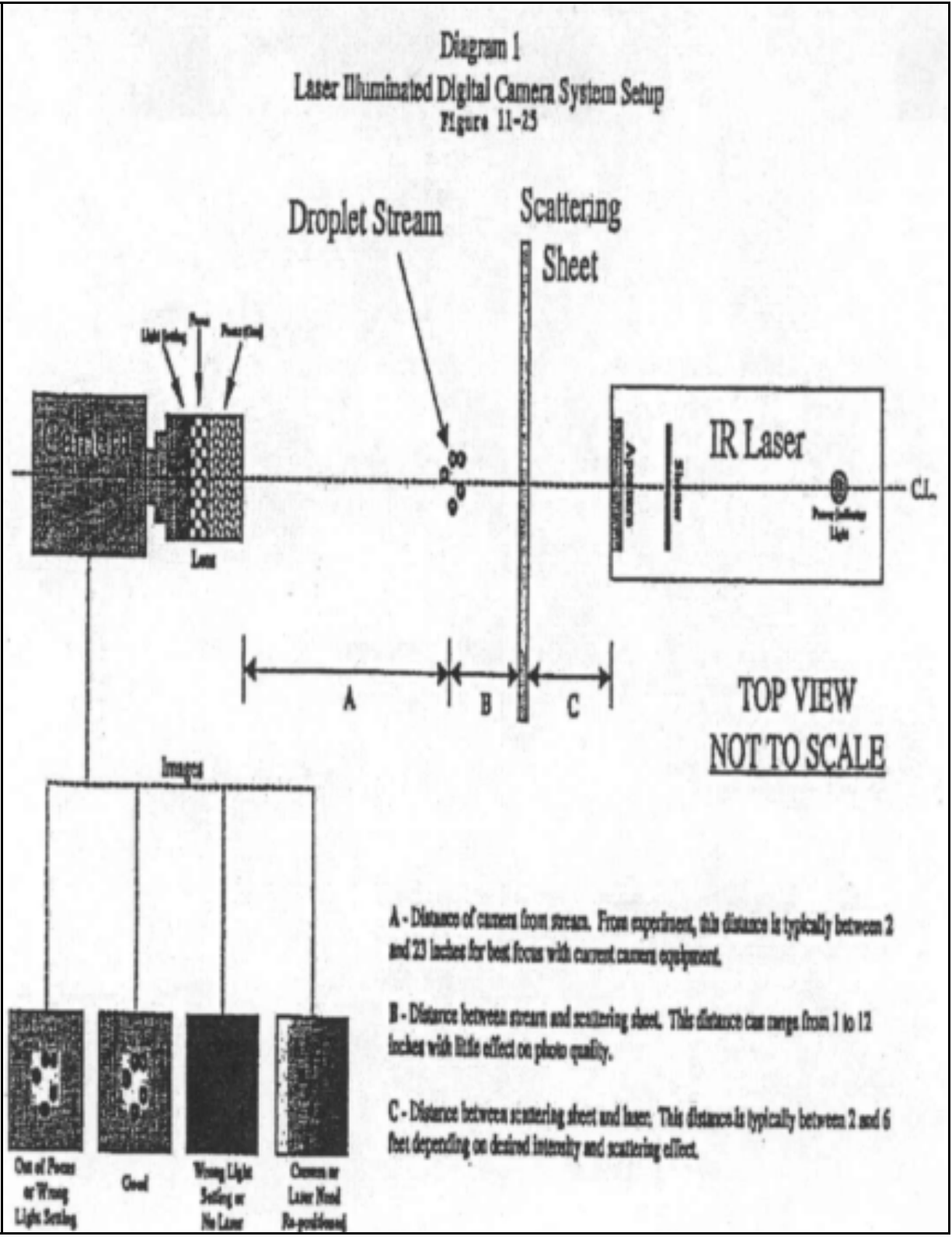

Figure 2-39: Digital Camera and Laser Instrumentation

The camera, a Kodak Megaplus™ digital camera, has a resolution of over 1.0 megapixels. The laser system incorporates an infrared beam of wavelength 805 nm and is capable of pulsing at frequencies up to 1000 Hz. The laser can also pulse twice during a single camera frame to produce a double image used in determining velocity information. The beam of the laser is scattered with an opaque sheet of plastic to produce uniform background lighting for imaging. The system captures high-resolution images of the injection streams and analyzes the images at a rate of about 7 frames per second, identifying droplets as dark images in front of the laser-illuminated scattering sheet. The diameter of each droplet is determined automatically by referencing the number of dark pixels in the droplet image to the pixel area of a calibration circle.

An infrared laser is used with the system because it is capable of passing through the quartz viewing windows and being absorbed by the water droplets entrained in the steam flow. Because the infrared rays are absorbed by the water droplets, the resulting droplet shadows can be recorded by the digital camera. There has been no effect of laser light scattering from rods to droplets. Pictures taken in and out of the rod bundle have the same imaging characteristics, droplet analyzing capability and clarity. A band pass laser light filter is placed in front of the digital camera to eliminate non-infrared light from other sources and an anti-glare attachment is used to eliminate any illumination interference from outside the viewing area. In addition, rod bundle geometry has little effect in the measurement of droplet distributions and velocities.

The frames captured by the camera are fed back to a PC at approximately 12 to 13 frames per second. The software can analyze each frame for droplet size and velocity and write the recorded data to a size and velocity data array. The software program determines droplet sizes by determining the area of black vs. white pixels in each droplet image. Once the droplet area is determined, the program calculates the perimeter of the droplet image to determine the sphericity of the droplet. The VisiSizer system is capable of determining the surface area based on diameter of any and all droplets. At any droplet concentration that is measurable with the system, an accurate measure of the total droplet surface area can be obtained. Up to 6 droplets per frame in velocity mode (12 droplet images) have been analyzed successfully with the droplets in a very narrow viewing area.

Operating the laser in a double pulse mode enables the VisiSizer system to measure both droplet diameter and velocity for a particular probe volume. The laser pulses twice with a known pulse delay (on the order of one (1) millisecond) while the camera shutter remains open, creating two images in the same frame of each droplet. The distance between images is then determined and the velocity calculated. These velocity characteristics are enough to characterize the behavior of the flow despite the fact that the droplets are only captured in a single frame.

The local distribution of droplets can be determined for a known probe volume governed by the software settings. Droplets that lie out of this probe volume on either side of the line of sight will be rejected based on focus. The opposite sides of the probe volume will be set by the spacing of the rods in the bundle. Each droplet is recorded in a two-dimensional array according to size and velocity. The droplet sizes are recorded in lognormal bins while the velocity bin size is user defined. Data for the experiments is recorded in user defined quasi-steady-state time periods. At the end of each time period the data is saved and a new array is opened.

The VisiSizer enables the experimenters to collect a vast amount of information about the droplet flow in the test section. The information was collected in an easy to handle data array and all information will be written to a CD-ROM to ensure the information will be available for later use.

The entrained droplets sizes from the droplet injection system were measured at several axial locations along the rod bundle. The objective was to measure the droplet diameter changes due to evaporation as well as due to the shattering effects of the spacer grids.

A variety of user-defined parameters control the counting of the droplets, including focus rejection and sphericity criteria. Focus rejection is determined by considering the sharpness of a droplet image, done by quantifying the intensity gradient at the outer edge of the droplet, described by Oxford Lasers [3]. In addition to this, the droplet analysis duration can be controlled by elapsed time, number of frames, or number of droplets counted. The software also calculates real-time statistics such as mean and sauter-mean droplet diameters as well as displays the droplet diameter distribution and, if applicable, the velocity distribution. Velocity is determined by double-pulsing the laser to capture the motion of a droplet. Analysis of the velocity is done automatically using criteria such as direction of motion, velocity range, and size matching.

The test setup for this analysis involves positioning the camera such that the view is through the quartz windows on the sides of the facility housing as shown in Figure 2-40.

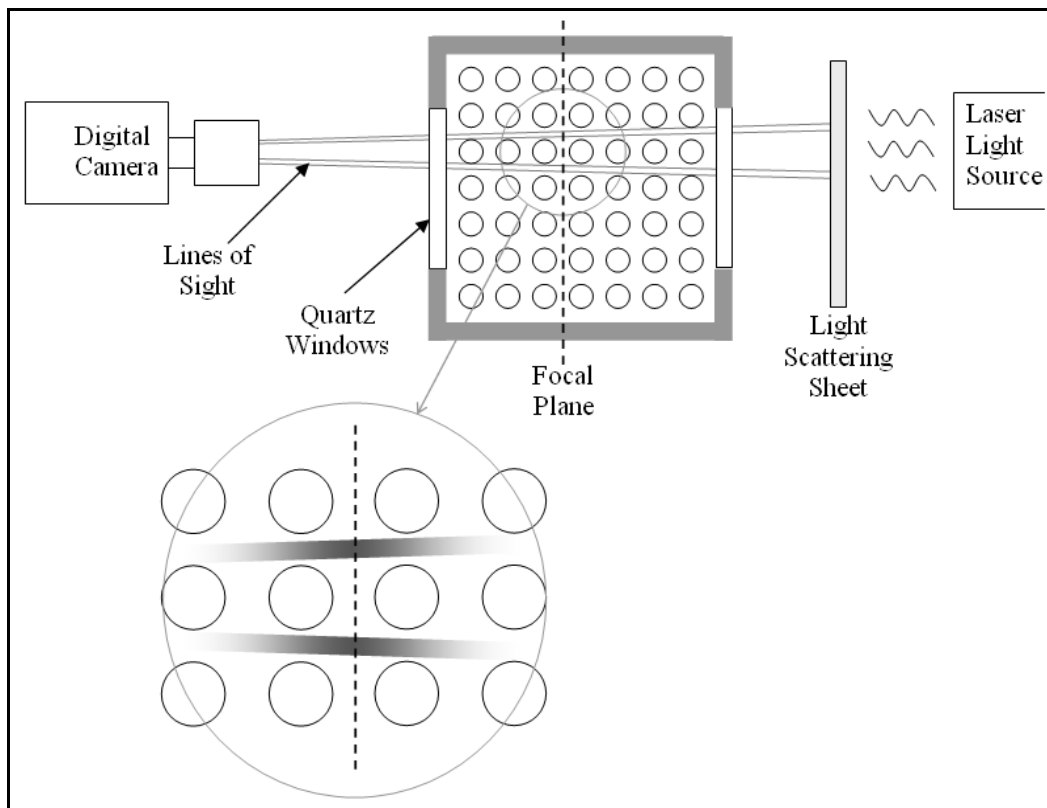

Figure 2-40: General Schematic of the Imaging System

It can also be seen in Figure 2-40 that the size of the sample volume is smaller than the heater rod gap size due to the parallax of viewing through the depth of the rod bundle. Figure 2-41 is an example of the image produced when viewing through the bundle. The center of the image is the row of rods directly in front of the camera and the white regions are the row of gaps on either side of the rod. The width of the sample volume will be a function of the distance of the camera from the rod bundle. It is also important to note that fuzzy borders produced by out-of-focus rods in the image decrease the effective width of the sample volume even more. The variation of the gap size in the image is due to the difficulty in aligning the camera to a high degree of precision. For the experiments presented here, the width of the focal plane is approximately 2.16 mm (0.085 in), which is about 70% of the 3.099 mm (0.122 inch) overall gap width.

The depth of the probe volume is also dependent on the distance of the camera from the bundle, but more directly on the focus rejection setting. The focus rejection setting is used to reject droplets that appear out-of-focus due to their distance from the focal plane. In the experiments presented in this paper this depth is approximately 5 mm (0.197 in.).

The imaging system has been calibrated using a small calibration reticule. The system is trained and focused on the reticule which is attached to a quartz window on the housing. Using the known size of the calibration circles on the reticule, the distance can be determined between the camera and the quartz window using a calibration curve that was developed. The camera can then be focused on the center of the desired subchannel in the bundle by adjusting the focus setting to the desired new distance from the camera.

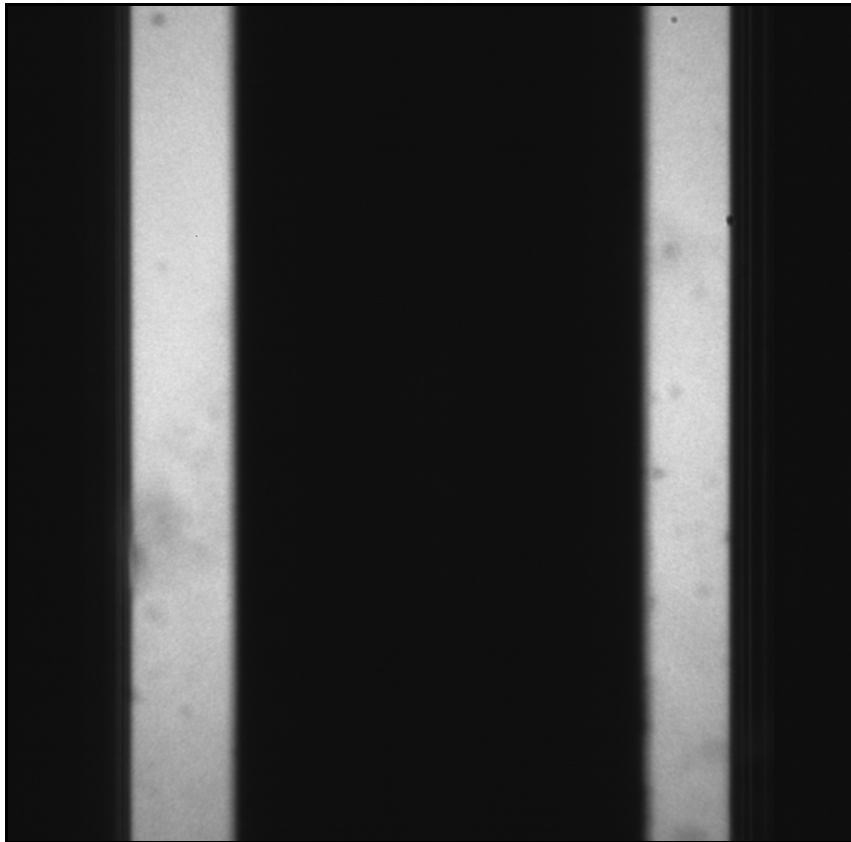

Figure 2-41: Typical VisiSizer Image through the Rod Bundle (no “in focus” droplets present).

To minimize the amount of time it would take to reposition the camera and laser between different axial locations in the bundle, a linear rail system was designed and installed which incorporated adjustable stops that could be pre-set prior to testing. This system, shown in Figure 2-42, is capable of traveling from the window opening at 1.143 m (45 inches) to the top of the window opening at 2.3 m (118 inches) and resulted in very efficient and accurate positioning of the camera system, minimizing testing time and allowing for more data to be collected within a fixed test period. With some additional modifications to the upper level floor grating, the camera system will be able to cover the highest window span at 3.23 to 3.51 m (127 to 138 inches) for future testing. The camera elevation stops were located at 1.397, 1.687, 1.839, 2.286, 2.438, 2.738, 2.891 m (55.0, 66.4, 72.4, 90.0, 96.0, 107.8, 113.8 inches) and injection is located at 1.295 m (51 inches).

In addition to the axial locations for the droplet measurements, the camera was re-focused for individual sub-channel measurements at selected elevations for a limited number of experiments. The sub-channels sampled were shown in Figure 2-26. These measurements examine the radial spreading of the injected droplets within the rod bundle.

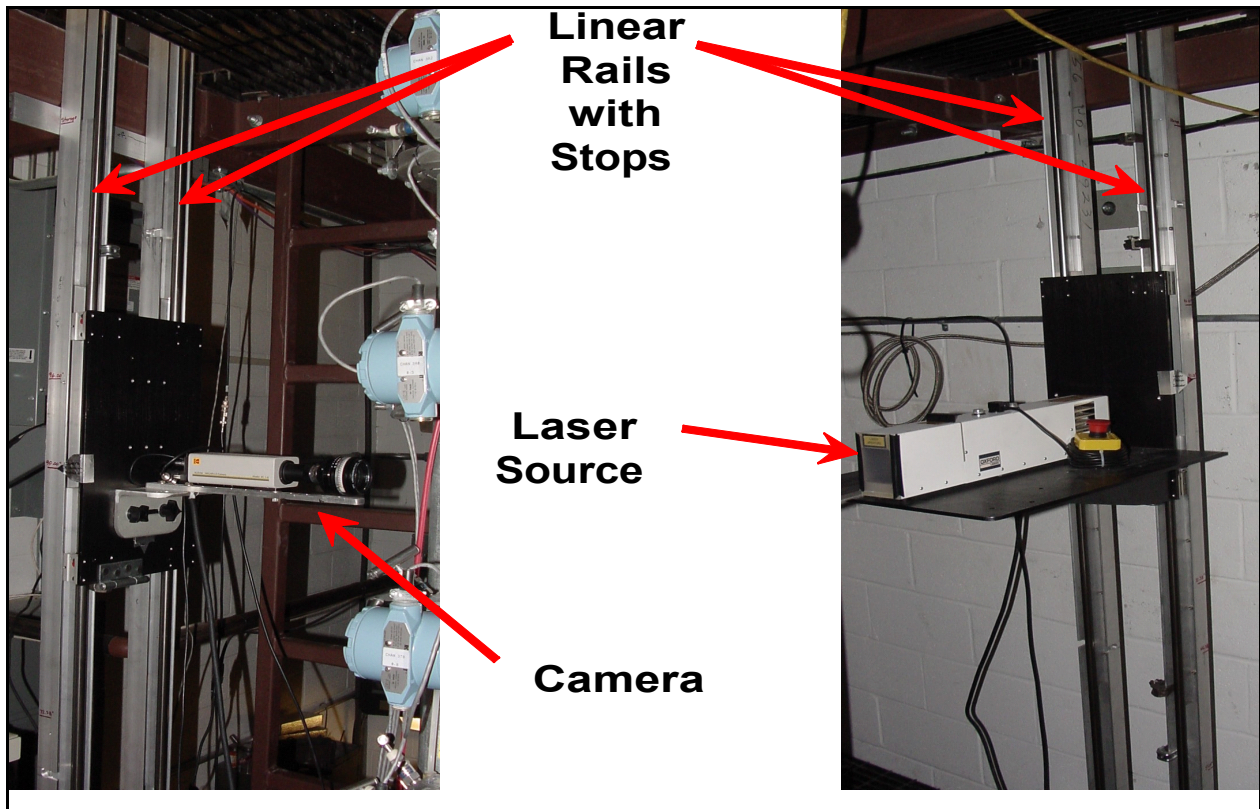

Figure 2-42: Linear Rails for Positioning High Speed Camera System

2.3.4 Data Acquisition System

The control and data acquisition system provides control functions and data collection functions for RBHT Test Facility. This system consists of two parts, the computer and display terminals residing in the control room and the VXI mainframe and terminal panels residing in the test facility. The two parts are connected via an industry standing IEEE 1394 (Firewire) serial control and data interface.

The computer provides the display, control, and data storage functions. It has the capability of displaying control function set points and process variables, and critical operating parameters during tests, along with selected variable such as various rod temperatures displayed in real-times during the experiment. This system will provide dial, meter, and strip-chart functions as required. The computer collects and saves data from the various instruments, such as voltage, current, pressure, level flow and temperature; and provides control functions such as heater rod power, injection water pressure, upper and low plenum temperatures, etc.

The instrumentation part of this system, residing in the test facility, consists of an industry standard VXI mainframe (Vme bus with extensions for Instrumentation) from Hewlett-Packard (HP-E8401AA), and a set of terminal panels (HP E1586A). The VXI mainframe contains a firewire controller card (HPE8491A) and several (currently seven) state-of-the art data acquisition and control cards (HP E1419A). The terminal panels provide the isothermal reference junctions needed for the thermocouples, as well as the voltage and current-loop input/output (i/o) interface to the RBHT Test Facility. These terminal panels are connected to the HP E1419A cards with SCSI cables. Seven cards yield a capability of 448 I/O. The VXI mainframe can hold up to twelve cards, and the firewire interface can support up to sixteen mainframes.

Each E1419A card can support up to eight signal conditioning plug-ons (scp's), conditioning eight channels each. Each E1509A scp contains low-pass anti-aliasing filters, fixed at 7 Hz. Because of this, the scan rate for each channel must be greater than or equal to the nyquist rate of 14 Hz. The maximum a/d conversion rate on each HP E1419A card is nominally 100kHz, but is controlled to rate the user requires. The seven cards can be synchronized to perform the scans simultaneously. The theoretical maximum scan rate for each channel (on any individual card) is $100,000/64 = 1,56235$ Hz, if all 64 channels are scanned. (Note, the actual scan rate would be less because of multiplexer switching, amplifier settling times due to gain changes, etc. There are different scp's available from HP providing different filter values to scan at these rates.) The normal data-scanning rate will be 2 Hz during the majority of the tests, but this rate can be increased to 10 Hz for specific times during testing.

2.4 RBHT Steam Cooling with Droplet Injection Test Method

Steam cooling with droplet injection experiments were performed with steam at superheated conditions. Steam entered the rod bundle through the lower plenum, passed through the heater rods, and exited via the upper plenum to the exhaust piping. The boiler steam injection rate was computer controlled and was verified for the correct pressure and temperature. The steam injection line was preheated to avoid any condensation. After approximately fifteen minutes of preheating the injection line, the inlet valve to the bundle was opened slightly to preheat the bundle and exit lines. The bypass lines around the rod bundle

were closed during this procedure. The lower plenum, carryover tanks, and steam separator tanks were also drained at this time. In order to account for any carryover from the boiler, the tanks had to be drained to accurately measure the liquid. Once the bundle was preheated to saturated vapor conditions, the bundle power was set at the desired power level. As the fluid flow stabilized for each matrix test condition, steady-state flow conditions were approached. At this time, droplet injection was started at desired flow rates which were monitored by computer. Droplet diameters near injection and additional elevations were measured by the VisiSizer computer. The droplet injection was stopped when wetting was observed to allow the bundle to dry and again approach steady-state conditions. Droplet injection was also stopped for adjustments to different steam flow and bundle power test conditions. Data was recorded for the entire length of the test duration, which included warm-up through shutdown.

3. CALCULATIONAL METHODS USED FOR RBHT STEAM COOLING WITH DROPLET INJECTION EXPERIMENTS

3.1 Heat Transfer Coefficient Calculation (DATARH)

3.1.1 Introduction

The DATARH program was used to calculate the heater rod outside surface temperature, the total surface heat flux and a FLECHT type heat transfer coefficient defined as

$$h_{FLECHT} = \frac{q_w''}{(T_w - T_{sat})} \quad (3-1)$$

which is referenced to the saturation temperature in the test bundle. Both the surface heat flux q_w'' and the FLECHT heat transfer coefficient represent a total heat transfer from the heater rod surface and would include radiation heat transfer as well as convection and flow boiling.

Program DATARH.F contains the source code to perform an inverse heat conduction calculation in an electrically heated rod, in which internal cladding thermocouples exist.

The purpose of the code is to calculate the surface temperature, the surface heat flux and the FLECHT type heat transfer coefficient for heater rods. The program uses experimental data and heater rod dimensions to perform calculations. The mathematical model for the calculations is described in Section 3.1.2 below.

The program described herein has been modified for the Rod Bundle Heat Transfer (RBHT) Experiments from the DATARH.F program used for the FLECHT-SEASET experiments [5]. Differences between heater rods used in the FLECHT-SEASET experiments and the RBHT experiments (e.g., rod dimensions, differences in rod internal materials) have been accounted for in this version of the program. Note that the steam cooling with droplet injection tests were done under quasi-steady conditions. As such, DATARH.F was used mainly to account for the resistance across the cladding in determining the surface temperature and to assure that steady-state conditions existed.

The sections that follow describe the structure of the DATARH program, RBHT rod geometry and materials, and the input files required for executing the current version of the program.

3.1.2 Mathematical Model

The DATARH program calculates the surface temperature, the surface heat flux and the transient heat transfer coefficient for heater rods by solving the "Inverse Heat Conduction Problem" (IHCP). The IHCP is basically the determination of the surface temperature, therefore the surface heat flux from the transient temperatures measured at an interior location of a

heated structure. In the problem solved by DATARH, the initial temperature distribution is known.

The IHCP is an illposed problem and in order to overcome the illposedness, several methods have been developed [6]. One method of solving IHCP problems is the Beck method which requires the knowledge of the initial temperature and proceeds sequentially. In this method, the equations are only solved for a few future times while the wall temperature and the wall heat flux is only taken up to the next time step, and the sequential procedure is started again by shifting it one time step further [6].

The finite difference approximation in implicit form of a one-dimensional heat conduction equation in cylindrical coordinates is typically [7]

$$B(n)T(n-1) + A(n)T(n) + C(n)T(n+1) = -T'(n) - Q(n); \quad 1 \leq n \leq N \quad (3-2)$$

where

$$B(n) = \frac{\Delta\theta}{(\Delta r)^2} \frac{r(n-1/2)}{r(n)} \cdot \frac{k(n-1/2)}{\rho(n)c(n)} \quad (3-3)$$

$$C(n) = \frac{\Delta\theta}{(\Delta r)^2} \frac{r(n+1/2)}{r(n)} \cdot \frac{k(n+1/2)}{\rho(n)c(n)} \quad (3-4)$$

$$A(n) = -B(n) - C(n) - 1 \quad (3-5)$$

$$Q(n) = \frac{q(n)\Delta\theta}{\rho(n)c(n)} \quad (3-6)$$

where $T(n)$ is the unknown temperature node point n

$T'(n)$ is the known temperature at node point n , which is also the "initial value".

r is the spatial variable.

Δr is the spatial increment.

and

$\Delta\theta$ is the time increment.

Here, k , ρ , and c are the thermal conductivity, density and heat capacity, respectively. Their numerical values are computed at T' . If values at half intervals are required, they are evaluated at the average of two adjacent temperatures.

q is the volumetric heat generation rate.

N is the number of internals. Hence, there are $N + 1$ node points.

For $n = 1$, the node point is at the center of the rod, $T(n-1) = T(n+1)$, since at this point the symmetry requires the flux be zero. At the point $n = M$, $T(n)$ is the known measured temperature and finally, at the outer boundary point, $n = N$, $T(n+1)$ is the desired wall temperature. If the heat conducting body is made up by composite material, the temperature at the interface can be handled by usual means, i.e. both the temperature and flux must be continuous. However, in this case, the spatial interval size, Δr , would vary from region to region such that particular node points coincide with the material interfaces and $T(M)$.

Apply Equation (3-2) to node points $n = 1, 2, \dots, N$ and, combining the boundary condition $T(0) = T(2)$ with the finite difference equation at $n = 1$ to eliminate $T(0)$, we have a set of N linear simultaneous equation with N unknown temperatures, $T(n)$; $n = 1, \dots, N+1$, $n \neq M$. The solution of this set of equations define the temperature field at a given time step, θ . The transient solution can thus be obtained by repeating the same procedure with successive increment of $\Delta\theta$.

The method outlined above is straightforward in practice and because of the implicit finite difference scheme, the stability of the computation is guaranteed. As long as reasonable increment sizes, Δr and $\Delta\theta$, are chosen, acceptable numerical accuracy can be expected.

It is noticed that if $M = N+1$, the inverse heat conduction problem is reduced to a more conventional type with a flux condition specified on one boundary (centerline) and a temperature condition specified on the other (wall). In this case, the coefficient matrix for the linear equations, as defined by Equation (3-2), is tri-diagonal. However, the presence of a known temperature, $T(M)$, $M \neq N+1$, in the linear set to replace the wall temperature, $T(N+1)$, destroys the tri-diagonality and consequently complicates the solution procedure since for linear equations with a tri-diagonal coefficient matrix, the solution can be obtained by a time saving matrix resolution technique which is not applicable to any other form of matrix.

Let us, for the time being, ignore the fact that $T(M)$ is known and assume that $T(N+1)$ is known instead. The linear equation, written in the usual manner is:

$$[J]\vec{T} = \vec{F} - C(N)T(N+1)\vec{G} \quad (3-7)$$

where $[J]$ is the tri-diagonal coefficient matrix defined by Equations (3-2) to (3-6).

\vec{T} is the solution vector with N components

\vec{F} is the "source" vector with the components defined by the quantities on the left-hand side of Equation (3-2).

\vec{G} is a vector with first $N-1$ components equal to zero and the N^{th} component equal to one, i.e. $\vec{G}(i) = 0, i \neq N, \vec{G}(i) = 1, i = N$.

If \vec{X} and \vec{Y} are, respectively, solutions of

$$[J]\vec{X} = \vec{F} \quad (3-8)$$

$$[J]\vec{Y} = -\vec{G} \quad (3-9)$$

The linearity of Equation (3-7) leads to

$$\vec{T} = \vec{X} + C(N)T(N+1)\vec{Y} \quad (3-10)$$

Equation (3-10), in scalar form for $n = M$, gives

$$T(M) = X(M) + C(N)T(N+1)Y(M) \quad (3-11)$$

or

$$T(N+1) = \frac{T(M) - X(M)}{C(N)Y(M)}, Y(M) \neq 0 \quad (3-12)$$

Since all the quantities on the right hand side of Equation (3-12) are known, the wall temperature $T(N+1)$, can be computed. The remaining temperature field can be obtained by repeated application of Equation (3-10).

If the transient temperature measurement $T(M)$ is both accurate and frequent enough, the method outlined above will produce acceptable results. In practice, however, such accuracy and frequency (as demanded by the numerical method) are almost impossible to achieve. Any error in $T(M)$, either due to instruments or due to interpretation, would be amplified in this numerical process and the calculations for wall temperature and wall flux would be erroneous. An error is usually propagative and oscillatory and results from a successive over and under correction of the heat balance as demanded by the governing heat conduction equation.

Therefore, it is desirable to devise a numerical method such that the input error of $T(M)$ could be damped during the subsequent computation steps. One such method is programmed in DATARH. It must be stressed that damping of input error can only improve the accuracy of the computed results by reducing the input error amplification. The inheritant error due to inaccurate input data still remains.

The basic principle of the method is to utilize the information of $T(M)$ available over an open time span when the computation is just entering this time span. Let the parenthesised superscript denote a relative time step, then the computation of $\vec{T}^{(1)}$ would not only involve an initial value $\vec{T}^{(0)}$, but also $\vec{T}^{(2)}(M), \vec{T}^{(3)}(M), \dots$. This calculation is followed by an optimization process to minimize the error amplification. This optimization can be accomplished in, although not restricted to, a least-squared sense.

Following Equation (3-2) and the subscript notation defined above, we have:

$$B(n)T^{(1)}(n-1) + A(n)T^{(1)}(n) + C(n)T^{(1)}(n+1) = -Q(n) - T^{(0)}(n) \quad (3-13)$$

$$B(N)T^{(1)}(N-1) + A(N)T^{(1)}(N) = -Q(N) - T^{(0)}(N) - C(N)T(N+1) \quad (3-14)$$

The solution using Equation (3-10) is;

$$\vec{T}^{(1)} = \vec{X}^{(1)} + C(N)T(N+1)\vec{Y}^{(1)} \quad (3-15)$$

In the above equation, all the components in $\vec{X}^{(1)}$ and $\vec{Y}^{(1)}$ are known. $\vec{T}^{(1)}$ is not known since the wall temperature $T(N+1)$ needs to be determined.

The computation can be carried out for one more time step as:

$$\begin{aligned} & B(n)T^{(2)}(n-1) + A(n)T^{(2)}(n) + C(n)T^{(2)}(n+1) \\ &= -Q(n) - T^{(1)}(n) \quad 1 \leq n \leq N-1 \quad (3-16) \\ &= -Q(n) - \vec{X}^{(1)}(n) - C(N)T^{(1)}(N+1)\vec{Y}^{(1)} \end{aligned}$$

$$\begin{aligned} & B(N)T^{(2)}(N-1) + A(N)T^{(2)}(N) \\ &= -Q(N) - T^{(1)}(N) - C(N)T^{(2)}(N+1) \quad (3-17) \\ &= -Q(N) - X^{(1)}(N) - C(N)T^{(1)}(N+1)Y^{(1)}(N) - C(N)T^{(2)}(N+1) \end{aligned}$$

The above equations form a linear system which is same as that defined in Equation (3-7) provided that the vectors \vec{F} and \vec{G} are suitably modified. The linear set has the solution of the form of Equation (3-10):

$$\vec{T}^{(2)} = \vec{X}^{(2)} + C(N)T(N+1)\vec{Y}^{(2)} \quad (3-18)$$

For the other time steps, similar equations can be written:

$$\vec{T}^{(3)} = \vec{X}^{(3)} + C(N)T(N+1)\vec{Y}^{(3)} \quad (3-19)$$

$$\vec{T}^{(j)} = \vec{X}^{(j)} + C(N)T(N+1)\vec{Y}^{(j)}; \quad j = 1, 2, \dots, J \quad (3-20)$$

In the above equation, the vectors $\vec{X}^{(j)}$ and $\vec{Y}^{(j)}$ are known for all j . The computation can terminate at any value of J . This set of equations are to be optimized to obtain the value of $T(N+1)$.

At a location where the measurements are recorded for $T^{(j)}(M)$, Equations (3-19) and (3-20) give

$$T^{(j)}(M) = X^{(j)}(M) + C(N)T(N+1)Y^{(j)}(M) \quad (3-21)$$

The measured temperatures $u^{(j)}$ are known for all values of j . The error between the computed and measured temperature is given as:

$$\begin{aligned}\theta(j) &= T^{(j)}(M) - u^{(j)} \\ &= X^{(j)}(M) + C(N)T(N+1)Y^{(j)}(M) - u^{(j)}; \quad j = 1, 2, \dots, J\end{aligned}\tag{3-22}$$

The problem is now reduced to finding a $T(N+1)$ such that θ is at a minimum. This can be accomplished by a least-squares method:

$$\theta^2 = \sum_{j=1}^J \left\{ \left[X^{(j)}(M) + C(N)T(N+1)Y^{(j)}(M) - u^{(j)} \right]^2 \right\}\tag{3-23}$$

$$\frac{d\theta^2}{dT(N+1)} = 0\tag{3-24}$$

$$\sum_{j=1}^J Y^{(j)}(M) \left[X^{(j)}(M) - u^{(j)} \right] + C(N)T(N+1) \sum_{j=1}^J \left[Y^{(j)}(M) \right]^2 = 0\tag{3-25}$$

$$\frac{1}{C(N)} \frac{\sum_{j=1}^J Y^{(j)}(M) \left[u^{(j)} - X^{(j)}(M) \right]}{\sum_{j=1}^J \left[Y^{(j)}(M) \right]^2} = T(N+1)\tag{3-26}$$

Therefore, the desired temperature field can be calculated by,

$$\vec{T}^{(1)} = \vec{X} + C(N)T(N+1)\vec{Y}^{(1)}\tag{3-27}$$

Equation (3-27) defines the initial values for the computations of the subsequent time step. The computation can be carried out repeatedly for each advance of time increment.

3.1.3 Structure of the source program DATARH.F

This section briefly describes the structure of the source program. Detailed comments may be found within the body of the source program as well. The reader is advised that it will be helpful if a listing of the program DATARH.F is referenced as the remainder of this section is being read, since this will enhance the reader's understanding of the description of the program structure that follows.

All real variables used in the program have been declared double precision numbers, as indicated by the use of the implicit double precision (a-h, o-z) statement. The program reads two character variables, title1 and rloc, that may each be up to 15 alphanumeric characters in length. These are intended to be identifiers of a test case. No intermediate spaces may be

present within each set of alphanumeric characters. However, each identifier may be of length less than 15 alphanumeric characters if desired.

The program utilizes a number of data arrays, which may be identified by examining the dimension statements within the main program and sub-programs. It is important to note that some of these arrays have been declared to be of length 10,000, while others have been declared to be of length 10 or 50. There are several arrays that have multiple dimensions; e.g., array t_i is seen to be of dimension 10 by 10. These numerical figures are indicative of limits built into the program.

The length 10,000 indicates that the current version of the program is capable of reading in up to a maximum of 10,000 sets of input data, each comprising time, clad temperature and power to the rod being analyzed. (See input file in1.dat described below.) It also indicates that the maximum number of points in time for which the program is capable of computing heat flux and heat transfer coefficient values is limited to 10,000.

The length 10 indicates that the region between two adjacent conduction nodes may be divided into a maximum of 10 sub-regions. As seen by the data ($r(i), i=1,5$) statement, the program is capable of handling five outer conduction nodes and one implied conduction node at the rod-center, and hence five regions. Thus, the length 50 arises from the fact that the total number of sub-regions that may be handled by this version of the program is 10 by 5.

The radial distance from the center of a heater rod to each outer conduction node is initialized by the data ($r(i), i=1,5$) statement. Currently, this statement contains radial data for RBHT heater rods, and values are in feet.

The program reads input data via two input files. The file names are expected to be in1.dat and in2.dat. These files must exist at the time the executable is run. The required contents of these files are described in a section that follows. The program will write output data to a file by the name of out1.dat. This file will be created by the executable during a run, and a file by this name must not be present in the working directory at run-time. (If the output file from a previous run exists, it must either be deleted, or be renamed.)

The program will terminate upon reaching the end of the input file in1.dat. As described in the section on input files that follows, the end of input data is signaled to the executable program by the use of characters END (case sensitive) in the input file in1.dat as input to character variable title1.

Initializing the number of sub-regions within the region between a given pair of conduction nodes is accomplished by the array $intv(i), i = 1$ through 5. As discussed above, the maximum number of sub-regions within any region is limited to 10. The heater-rod length is set to be 12 feet by means of variable tlength.

After all input data has been read, and once the initialization of the conduction region dimensions and heater rod length has been completed, the program will write a summary of the input data to the output file. It is after this that the computational procedures begin.

The first step is to convert the input time scale (array timer) so that the time of flood is treated as zero-time. This is accomplished by a do loop that causes the time of flood, tflood, to be subtracted from each time value (array timer) that was read by the program. Next, the number of data points that would be output by the program, jtime, is computed using the last

value of input time, timer(nscan), the first value of input time, timer(1), and the value of dt (which is the time interval between results computed by the program). Note that nscan is the number of sets of input data points; see description of input file in1.dat below. Now, an array of time values at which results will be computed, array time, is computed. This too is accomplished by a do loop, and is performed by first setting time(1) equal to timer(1), and then successively adding the value of dt to the current value of time to get the next value of time.

The next step is to compute an array of sink temperatures, Tsink. This array will have nscan number of values. It should be noted that the current version of the program treats the saturation temperature corresponding to the operating pressure as the sink temperature throughout the length of the heater rod. Thus, all values in array Tsink will numerically be the same.

The program will now access an interpolation subroutine (subroutine tbl) to compute the saturation temperature, rod power, and the clad temperature at each value in array time (the time values at which results are desired). The value of sink temperature computed, Tsink, will be written to the output file at this time as well.

Preparation of an array q that will contain volumetric heat generation rates at each value of array time is performed next. Each interpolated value of rod power (at a given value of time) is multiplied by the axial power factor, fax, and the radial power factor (if applicable), fp, and is divided by the total rod length. Then, each resulting value of q is converted to a volumetric heat generation rate by means of appropriate conversion factors and rod dimensions.

It should be noted that if the total power supplied to the rod that is being analyzed is input in file in2.dat (values of variable po11), then fp should be input as 1.0. (Zone power differences will be accounted for when total rod power is input.) It is important to note also that the value of fax is dependent on the axial height of the thermocouple from which clad temperatures have been obtained for input (values of variable tclad in file in2.dat). These have been calculated for each thermocouple location and for each rod in the RBHT rod bundle.

The program investigates the curvature of the future three data points next. The subroutine that performs the inverse conduction calculation is called after this computation. Once the inverse conduction calculation is completed for all time values desired, values of heat flux and heat transfer coefficient at the rod surface are computed. These values along with the computed rod surface temperature at each time value are then written to the output file. The program will then continue onto the next case (if input data are present), or will terminate if the end of input data has been reached.

It is important to note that the program limits the values of nscan and jtime to be 10,000 at most. See statements if (nscan .gt. 10,000) nscan=10,000 and if(jtime .gt. 10,000) jtime=10,000 that appear within the source program. This is in accordance with the limitation in the dimensioning of some arrays, as described previously. It should also be noted that the maximum time up to which the program will compute results is limited to 10,000 seconds after reflood. See statement tfinal=dmin1(2.0d+03, timer(nscan)) within the program.

3.1.4 RBHT Rod Geometry and Materials

The RBHT bundle and rod geometry is described in Section 2 of the report. Figure 2-36 shows the cross section of the RBHT bundle. The bundle has 45 heater rods and four unheated corner rods. The corner rods are used to support the bundle, grids and the thermocouple leads. The support rods are made from Inconel 600 tubing having a diameter of 9.525 mm (0.375 in.), a wall thickness of 2.108 mm (0.083 in.) and a form length of 3.96 m (156 in.). Figure 2-5 shows the cross section of an electrically heated rod. The heater rods are single ended and consist of a Monel 500 electrical resistance element filled and surrounded by hot pressed Boron Nitride (BN) insulation and enclosed in an Inconel cladding as shown in Figure 2-5. The heater rods are 3.657 m (12 ft) in heated length with a skewed axial power profile, as shown in Figure 2-6, with the peak power located at 2.74 m (9 ft) elevation. The bundle has a uniform radial power distribution. The maximum to average power ratio (P_{max}/P_{avg}) is 1.5, and the minimum to average power ratio (P_{min}/P_{avg}) is 0.5 at both ends of the heated length.

Figure 3-1 shows the description of the geometry for the RBHT heater rod geometry and dimensions.

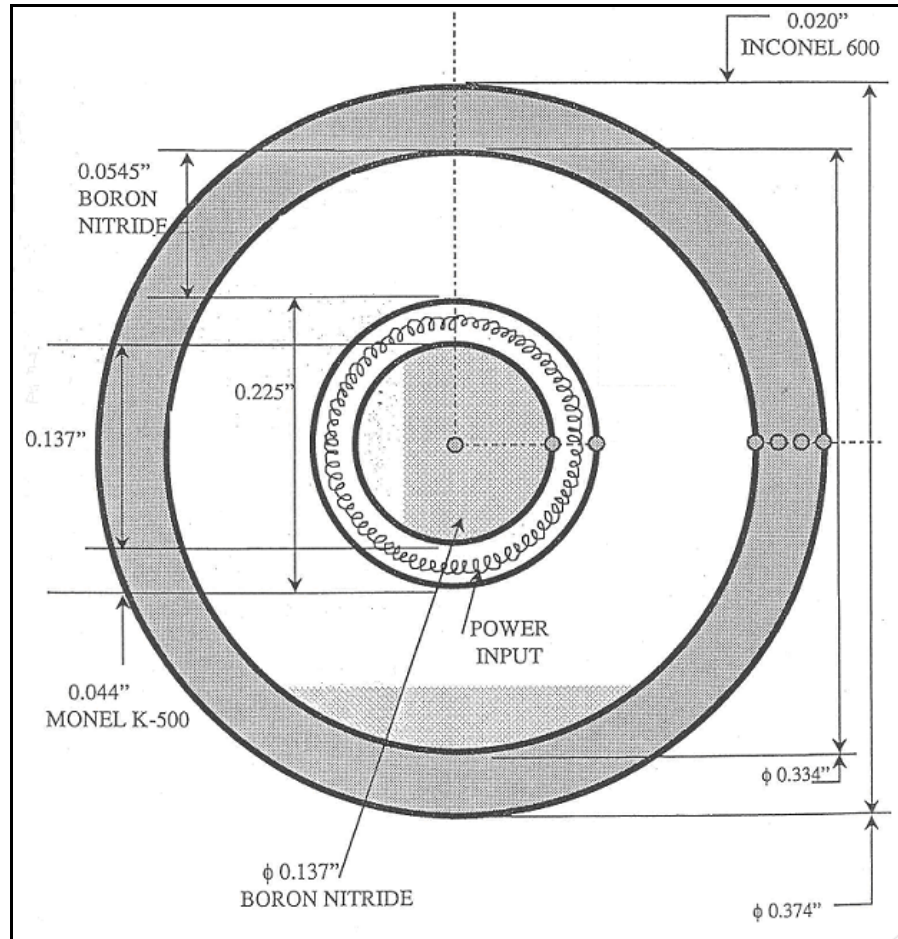

Figure 3-1: Geometry, Materials and Dimensions of RBHT Heater Rod

3.1.5 Input files required for executing the current version of the program

The program reads input data via two input files. The file names are expected to be in1.dat and in2.dat. These files must exist at the time the executable is run.

File in1.dat should contain sets of input data arranged in lines, one line being required per reflood experiment analyzed. Each line must have values for the following input variables in the specified format, separated by one or more spaces:

title1	Character, A15	Identifier for each experimental run.
Rloc	Character, A15	Rod location/elevation.
Nscan	Integer	Number of data points per channel.
Fax	Real	Axial power factor.
Fp	Real	Fraction of zone power to this rod.
Fka	Real	Volumetric fraction of KANTHAL.
Pres	Real	System pressure, psia.
Tflood	Real	Time of flood, s.
Dt	Real	Desired time interval between successive values of heat flux and heat transfer coefficient calculated by this program, s.

After the last set of values, a final additional line with 'END' (case sensitive) as the first two entries and zeros (in required format, real or integer) as remaining entries must be present. This signals end of input data to the executable program.

File in2.dat should contain nscan sets of time, rod power and clad temperature values per line of data in file in1.dat. (The value of nscan appears as an input in file in1.dat.) One set of values must appear on one line, each value separated by at least one space. A description of the data required follows:

Timer	Real	Array of time values, s.
po11	Real	Rod power from decay power table at each TIMER value, kW. Note that the power input into the individual rod under consideration, corrected for decay, must be input here.
Tclad	Real	Clad temperature, deg. F, at each timer value.
Nscan	Integer	Number of data points per channel. Value is given as an input in file in1.dat

The calculation of the axial power factors for the RBHT heater rods is given in Section 3.1.6. The sample input and output files from DATARH are given at the end of this section.

3.1.6 Calculation of the power factor at each thermocouple location

Stern Lab measured the resistance of each heater rod filament beginning from the bottom of the heated length to the end of the heated length. The measurements were made over increments of one tenth of the length of the rod and the cumulative resistances were reported. Table 3-1 shows a sample table of data from Stern Lab.

Table 3-1: Heater Number 1

Length (in)	Resistance (Ohm)
0	0.000
14.28	0.018
28.55	0.040
42.83	0.066
57.1	0.096
71.38	0.129
85.65	0.166
99.93	0.211
114.20	0.258
128.48	0.291
142.75	0.315

WINDOWS (EAST)

Rod A1 Support Rod	Rod B1 GR-7 PSP-15	Rod C1 GR-0 PSP-45	Rod D1 GR-7 PSP-16	Rod E1 GR-0 PSP-48	Rod F1 GR-0 PSP-42	Rod G1 Support Rod
Rod A2 GR-0 PSP-40	Rod B2 GR-1 PSP-36	Rod C2 GR-2 PSP-32	Rod D2 GR-6 PSP-12	Rod E2 GR-8 PSP-6	Rod F2 GR-1 PSP-37	Rod G2 GR-0 PSP-47
Rod A3 GR-0 PSP-49	Rod B3 GR-8 PSP-27	Rod C3 GR-5 PSP-4	Rod D3 GR-3 PSP-21	Rod E3 GR-4 PSP-7	Rod F3 GR-8 PSP-28	Rod G3 GR-0 PSP-43
Rod A4 GR-7 PSP-17	Rod B4 GR-3 PSP-22	Rod C4 GR-3 PSP-23	Rod D4 GR-3 PSP-25	Rod E4 GR-3 PSP-24	Rod F4 GR-5 PSP-2	Rod G4 GR-0 PSP-44
Rod A5 GR-0 PSP-41	Rod B5 GR-2 PSP-33	Rod C5 GR-4 PSP-8	Rod D5 GR-8 PSP-29	Rod E5 GR-4 PSP-9	Rod F5 GR-2 PSP-34	Rod G5 GR-0 PSP-50
Rod A6 GR-7 PSP-18	Rod B6 GR-1 PSP-38	Rod C6 GR-2 PSP-35	Rod D6 GR-6 PSP-13	Rod E6 GR-8 PSP-30	Rod F6 GR-1 PSP-39	Rod G6 GR-0 PSP-3
Rod A7 Support Rod	Rod B7 GR-0 PSP-1	Rod C7 GR-6 PSP-11	Rod D7 GR-7 PSP-19	Rod E7 GR-0 PSP-46	Rod F7 GR-7 PSP-20	Rod G7 Support Rod

WINDOWS (WEST)

Figure 3-2: RBHT- Test Facility, Heater Rod Locations (Looking down from Top)

Figure 3-2 shows the schematic of the RBHT test facility heater rod layout. The 7 x 7 bundle consists of 8 groups of rods as indicated by GR - # (group number), these are instrumented rods while GR-0 rods are un-instrumented. The PSP - # is the serial number of the rods as given by Stern Labs.

The heater rod is composed of a series of resistances along the length. The power shape that is required is obtained by appropriately changing the pitch of the heater element.

Using the data, the resistance for every incremental length (one tenth of the total length) is calculated by subtracting the value of resistance over the total length (0 to that axial location) from the previous value (0 to the previous axial location). This would give the resistance of the filament portion for that region (one-tenth of the total length). The incremental length over which the measurements are made is also calculated. This is a constant 36.25 mm or 36.27 mm (14.27 in. or 14.28 in.).

The axial power factor is defined as the ratio of the incremental resistance for that incremental length over the incremental length to the total resistance of the rod over the total heated length. Using this definition, the axial power factor over each incremental length is calculated.

This is plotted as a function of length to get the power shape for each rod. Since the measurements provided by Stern labs was over every tenth of the heated length, these points were plotted at an average axial position (for example – for the length between 36.27 cm (14.28 in.) and 72.52 cm (28.55 in.), the incremental resistance and hence the power factor over this span was plotted at a location of 54.39 cm (21.415 in.)). Such a plot is shown in Figure 3-3, for Rod F4 (Stern lab heater number 2)

Measurements from Stern labs were such that they bypassed the peak power location, meaning – the measurement was taken at 253.82 cm (99.93 in.) and 290.07 cm (114.20 in.) elevations. The peak power location was 274.32 cm (108 in.). In order to calculate the power factor at the peak power location and for any arbitrary location along the length of the heater rod, a straight line is fit for the power factor calculated using the data points between 0 and 274.32 cm (0 and 108 in.). The equation for the power factor is a function of length along the heater rod. Using this equation, the peak power factor is calculated for each rod (i.e. the value of power factor is calculated at 274.32 cm (108 in.) location). This is then used along with the remaining calculated values of power factors (for length beyond 274.32 cm (108 in.)) and another such plot is made. An equation relating the power ratio and the heated length is obtained for the region beyond 274.32 cm (108 in.). Thus, for each heater rod, two plots are made, one for the length of the heater rod below the peak power location and the other beyond the peak power location to the end of the heated length. Using the equations for the power ratio as a function of axial position, the power factor at any location along the heater rod is obtained.

This procedure is followed for each rod with thermocouples and the power factor for every thermocouple location is obtained.

Table 3-2 shows a typical calculation for one rod (The resistances are values before swaging).

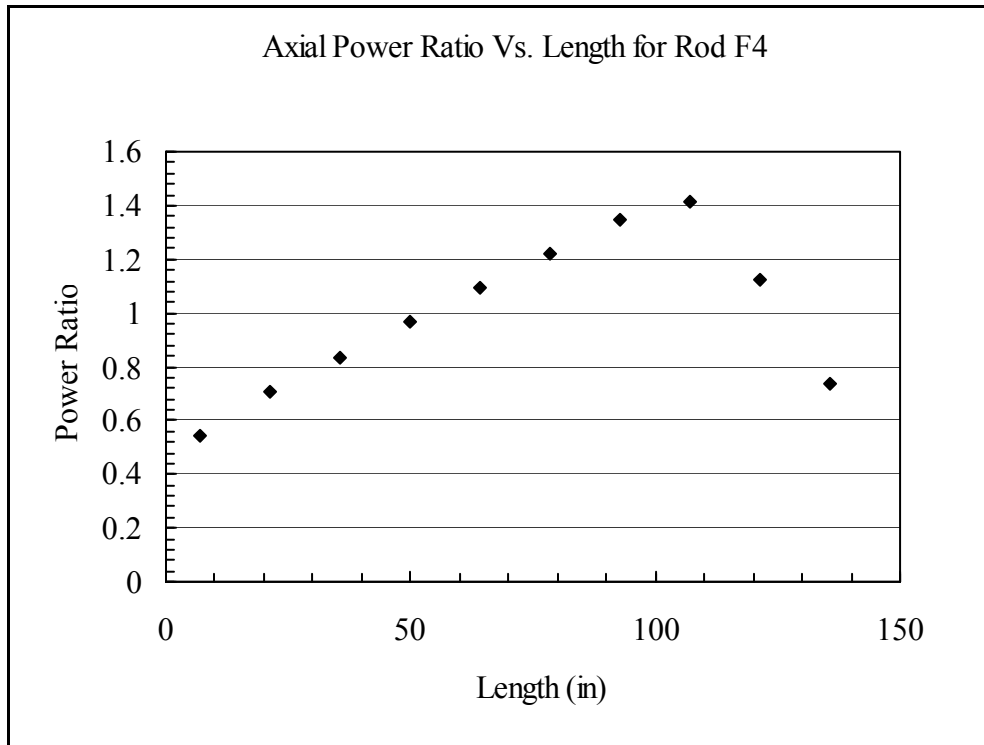

Figure 3-3: Axial Power Ratio for Rod F4, (Stern Heater number 2)

Table 3-2: Sample Power Factor Calculation for One Heater Rod

Stern Lab Heater Number 2: RBHT ROD F4								
Length	Increment	Averaged	Heater # 2	Difference	Power	Channel #	Instrument	Power
(in)	(in)	Length	Resistance		Ratio		Location	ratio
		(in)	Ohm	Ohm		THERMOCOUPLE INFORMATION		
0	14.28	7.14	0	0.017	0.55	98	85.6	1.29
14.28	14.27	21.415	0.017	0.022	0.71	99	88.4	1.31
28.55	14.28	35.69	0.039	0.026	0.84	100	92.4	1.35
42.83	14.27	49.965	0.065	0.03	0.96	101	94.3	1.37
57.1	14.28	64.24	0.095	0.034	1.09	102	97.2	1.39
71.38	14.27	78.515	0.129	0.038	1.22		108	1.49
85.65	14.28	92.79	0.167	0.042	1.35	103	108.8	1.47
99.93	14.27	107.065	0.209	0.044	1.42	104	111	1.41
		108			1.49			
114.2	14.28	121.34	0.253	0.035	1.13			
128.48	14.27	135.615	0.288	0.023	0.74			
142.75			0.311					

Figure 3-4 and Figure 3-5 show the plots of the power ratio as the function of length along the heater rod. Figure 3-4 is the plot from the beginning of the heated length to the peak power location (108 in.), while Figure 3-5 is the plot from the peak power location (274.32 cm (108 in.)) to the end of heated length.

The values of the axial power factor for all the thermocouples used in the RBHT facility is shown in Table 3-3. The values of the axial power factors range from 0 to 1.5, which is the value at peak power location of 274.32 cm (108 in.). For example: RodB1_47.9 refers to the thermocouple at 47.9 in. (121.67 cm) elevation for rod B1. These values are directly used in DATARH for the local rod heat flux and heat transfer coefficient calculations.

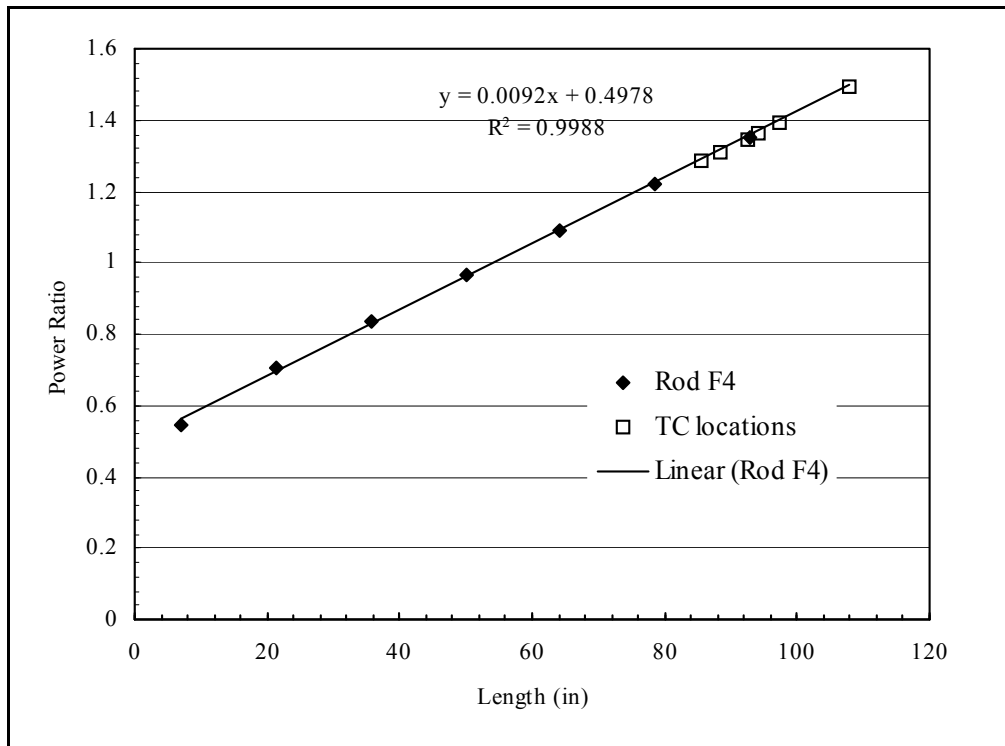

Figure 3-4: Power Factor as a function of length (beginning of heated length to PCT location)

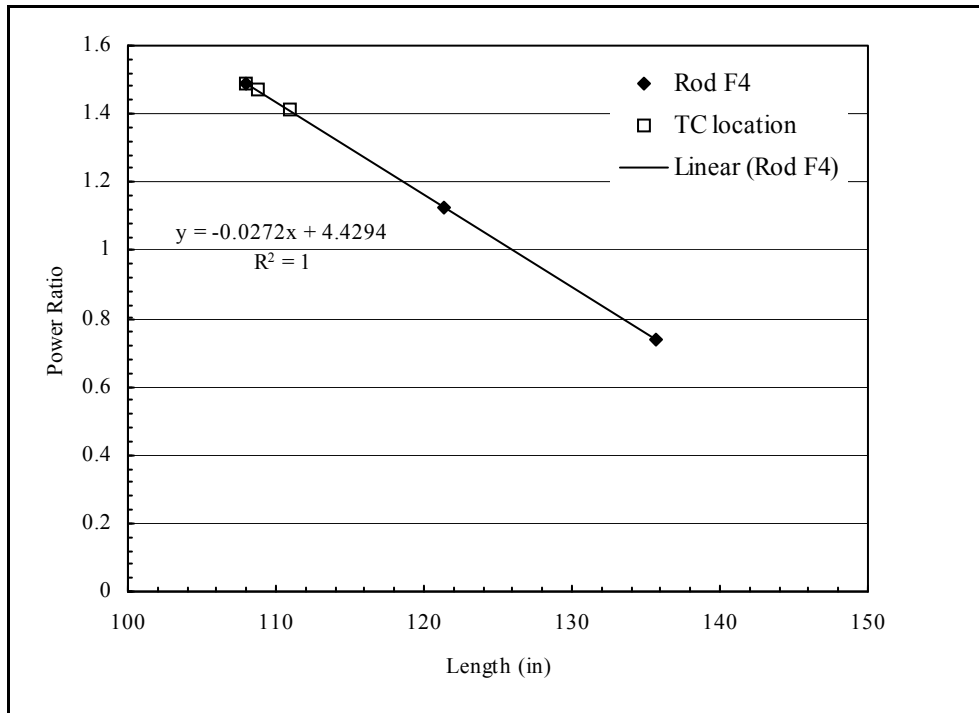

Figure 3-5: Power Factor as a function of length (from PCT location to the end of heater length)

Table 3-3: Axial Power Factors for the RBHT Heater Rods

Rod ID Elevation (inches)	Power Factor	Rod ID Elevation (inches)	Power Factor	Rod ID Elevation (inches)	Power Factor
RodB1_47.9	0.936	RodE2_66	1.111	RodF3_54	0.993
RodB1_63.6	1.082	RodE2_69.8	1.147	RodF3_57	1.022
RodB1_68.6	1.128	RodE2_72.9	1.176	RodF3_60	1.05
RodB1_79.7	1.231	RodE2_74.9	1.195	RodF3_66.1	1.108
RodB1_97.1	1.393	RodF2_4.1	0.519	RodF3_69.9	1.145
RodB1_114.8	1.314	RodF2_11.2	0.586	RodF3_73	1.174
RodB1_126.7	0.99	RodF2_16.2	0.634	RodF3_75	1.193
RodB1_139.4	0.644	RodF2_23.3	0.701	RodA4_48	0.94
RodD1_47.9	0.941	RodF2_29.2	0.757	RodA4_63.8	1.084
RodD1_63.8	1.093	RodF2_33.3	0.796	RodA4_68.8	1.13
RodD1_68.8	1.141	RodF2_35.3	0.815	RodA4_79.9	1.231
RodD1_79.9	1.248	RodF2_38.3	0.843	RodA4_97.1	1.387
RodD1_97.3	1.415	RodB3_50.2	0.956	RodA4_115	1.291
RodD1_115	1.317	RodB3_54.1	0.992	RodA4_126.8	0.977
RodD1_126.6	0.99	RodB3_56.9	1.018	RodA4_139.4	0.642
RodD1_139.4	0.629	RodB3_60.1	1.048	RodB4_88.4	1.303
RodB2_4.1	0.521	RodB3_66.1	1.104	RodB4_91.3	1.329
RodB2_11.2	0.589	RodB3_69.9	1.139	RodB4_93.3	1.347
RodB2_16.2	0.636	RodB3_73	1.168	RodB4_95.1	1.363
RodB2_23.3	0.704	RodB3_75	1.187	RodB4_100	1.407
RodB2_29.3	0.761	RodC3_79.8	1.228	RodB4_106	1.461
RodB2_33.3	0.799	RodC3_85.6	1.281	RodB4_109.9	1.414
RodB2_35.3	0.818	RodC3_88.5	1.308	RodB4_142.3	0.549
RodB2_38.4	0.847	RodC3_92.4	1.344	RodC4_88.4	1.328
RodC2_41	0.87	RodC3_94.4	1.362	RodC4_91.1	1.354
RodC2_53.1	0.983	RodC3_97.2	1.388	RodC4_93.4	1.376
RodC2_55	1	RodC3_108.8	1.463	RodC4_95.3	1.394
RodC2_57.8	1.026	RodD3_88.3	1.313	RodC4_100.1	1.439
RodC2_63.9	1.083	RodD3_91.3	1.341	RodC4_106.1	1.496
RodC2_73.8	1.175	RodD3_93.1	1.358	RodC4_110	1.448
RodC2_75.8	1.194	RodD3_95.3	1.378	RodC4_142.2	0.553
RodC2_76.8	1.203	RodD3_100.1	1.423	RodD4_88.3	1.323
RodD2_103.2	1.455	RodD3_106.1	1.479	RodD4_91.3	1.351
RodD2_106	1.481	RodD3_110	1.46	RodD4_93.2	1.369
RodD2_112.6	1.358	RodD3_142.1	0.51	RodD4_95.2	1.388
RodD2_114.9	1.295	RodE3_63.4	1.079	RodD4_100.1	1.434
RodD2_117.4	1.227	RodE3_113.6	1.331	RodD4_106.1	1.491
RodD2_120.8	1.134	RodE3_115.5	1.281	RodD4_110	1.44
RodD2_124.8	1.024	RodE3_118.5	1.203	RodD4_142.1	0.534
RodD2_128.6	0.92	RodE3_122.7	1.094	RodE4_88.4	1.303
RodE2_50.1	0.962	RodE3_126.5	0.995	RodE4_91.2	1.329
RodE2_54	0.998	RodE3_131.7	0.86	RodE4_93.2	1.347
RodE2_56.9	1.025	RodE3_135.6	0.759	RodE4_95.3	1.365
RodE2_59.9	1.054	RodF3_50.1	0.956	RodE4_100.9	1.416

Table 3-3: Axial Power Factors for the RBHT Heater Rods, Continued

Rod ID Elevation (inches)	Power Factor	Rod ID Elevation (inches)	Power Factor	Rod ID Elevation (inches)	Power Factor
RodE4_106.1	1.463	RodF5_57.8	1.022	RodE6_75	1.184
RodE4_110	1.428	RodF5_64	1.08	RodF6_4.1	0.528
RodE4_142.3	0.54	RodF5_73.8	1.171	RodF6_11.2	0.593
RodF4_85.6	1.285	RodF5_75.8	1.19	RodF6_16.3	0.639
RodF4_88.4	1.311	RodF5_76.8	1.199	RodF6_23.3	0.703
RodF4_92.4	1.348	RodA6_47.7	0.942	RodF6_29.3	0.757
RodF4_94.3	1.365	RodA6_63.6	1.085	RodF6_33.3	0.794
RodF4_97.2	1.392	RodA6_68.5	1.129	RodF6_35.3	0.812
RodF4_108.8	1.47	RodA6_79.8	1.231	RodF6_38.3	0.839
RodF4_111	1.41	RodA6_97.4	1.389	RodC7_112.6	1.323
RodB5_41	0.872	RodA6_115.1	1.29	RodC7_116.6	1.224
RodB5_52.9	0.982	RodA6_126.6	0.986	RodC7_124.4	1.03
RodB5_55	1.002	RodA6_139.9	0.633	RodC7_128.4	0.931
RodB5_57.8	1.028	RodB6_4.1	0.526	RodD7_47.9	0.948
RodB5_64	1.085	RodB6_11.2	0.592	RodD7_63.6	1.091
RodB5_73.9	1.177	RodB6_16.2	0.638	RodD7_68.8	1.138
RodB5_75.9	1.196	RodB6_23.3	0.703	RodD7_79.8	1.238
RodB5_76.9	1.205	RodB6_29.3	0.758	RodD7_97.1	1.396
RodC5_63.7	1.059	RodB6_33.3	0.795	RodD7_114.9	1.293
RodC5_113.6	1.298	RodB6_35.3	0.813	RodD7_126.7	0.958
RodC5_115.7	1.246	RodB6_38.4	0.842	RodD7_139.4	0.598
RodC5_122.7	1.073	RodC6_40.9	0.866	RodF7_47.9	0.946
RodC5_126.7	0.974	RodC6_52.8	0.981	RodF7_63.8	1.101
RodC5_131.6	0.853	RodC6_54.8	1.001	RodF7_68.9	1.15
RodC5_135.7	0.752	RodC6_57.8	1.03	RodF7_79.9	1.257
RodD5_50	0.959	RodC6_63.8	1.088	RodF7_97.2	1.425
RodD5_54.1	0.996	RodC6_73.7	1.184	RodF7_114.9	1.333
RodD5_56.9	1.022	RodC6_75.8	1.204	RodF7_126.8	0.953
RodD5_60	1.051	RodC6_76.8	1.214	RodF7_139.4	0.551
RodD5_66.1	1.107	RodD6_103.1	1.457		
RodD5_69.9	1.142	RodD6_106	1.484		
RodD5_72.9	1.169	RodD6_112.9	1.354		
RodD5_74.9	1.188	RodD6_114.9	1.298		
RodE5_63.6	1.085	RodD6_116.8	1.246		
RodE5_113.6	1.339	RodD6_120.9	1.132		
RodE5_115.4	1.292	RodD6_124.8	1.024		
RodE5_118.7	1.208	RodD6_128.7	0.916		
RodE5_122.6	1.108	RodE6_50.2	0.956		
RodE5_126.6	1.006	RodE6_54.1	0.992		
RodE5_131.6	0.878	RodE6_57	1.018		
RodE5_135.6	0.775	RodE6_60.2	1.048		
RodF5_41	0.866	RodE6_66.1	1.102		
RodF5_53.1	0.978	RodE6_70	1.138		
RodF5_55	0.996	RodE6_73.1	1.166		

Sample input file: in1.dat

```
RodD4_110 RodD4_110 8656 1.4396 1 0.863844 40 0 0.5
END END 0 0.00 0.0 0.00 0.0 0.0 0.0
```

This input file should contain values of the following variables, each value separated by one or more spaces:

TITLE1, RLOC, NSCAN, FAX, FP, FKA, PRES, TFLOOD, DT

TITLE1	Character, A15	Identifier for each experimental run.
RLOC	Character, A15	Rod location/elevation.
NSCAN	Integer	Number of data points per channel.
FAX	Real	Axial power factor.
FP	Real	Fraction of zone power to this rod.
FKA	Real	Volumetric fraction of KANTHAL.
PRES	Real	System pressure, psia.
TFLOOD	Real	Time of flood, s.
DT	Real	Desired time interval between successive values of heat flux and heat transfer coefficient calculated by this program, s.

One line of values per test case should be present.

After the last set of values, a final additional line with 'END' as the first two entries and zeros (in required format, real or integer) as remaining entries must be present.

Sample input file: in2.dat

0	3.194	1290.706
0.1	3.196	1290.153
0.2	3.196	1291.238
0.3	3.194	1292.015
0.4	3.193	1292.547
0.5	3.196	1293.427
0.6	3.197	1294.061
0.7	3.196	1294.470
0.8	3.199	1295.165
0.9	3.198	1296.147
1	3.197	1296.454
1.1	3.197	1297.313
1.2	3.197	1297.538
1.3	3.198	1298.623
1.4	3.199	1298.909
1.5	3.198	1299.647
1.6	3.195	1300.490
1.7	3.195	1300.901
1.8	3.200	1301.291
1.9	3.200	1302.195
2	3.200	1303.079

Note: This input file is truncated and continued below in view of print out. The file continues in steps of 0.1 seconds. Obviously, this text portion will not appear in the actual input file. This file usually is created in EXCEL and saved as in2.dat

871.8	3.201	274.289
871.9	3.202	275.174
872	3.201	274.204
872.1	3.203	274.057
872.2	3.202	274.162
872.3	3.202	274.014
872.4	3.202	273.951
872.5	3.201	273.382
872.6	3.200	273.361
872.7	3.201	273.930
872.8	3.202	273.234
872.9	3.202	273.234
873	3.202	274.162
873.1	3.202	274.310
873.2	2.543	274.774
873.3	0.021	273.445

SAMPLE OUTPUT FILE

***** RBHT EXPERIMENTS *****

***** Test ID : RodD4_110

***** Rod : RodD4_110

Initial Run Conditions :

No. of data points per Channel: 8656
Axial Power Factor: 1.43960
Fraction of Zone Power to rod: 1.00000
Volumetric fraction of KANTHAL: 0.86384
System pressure: 40.00000 psi
Time of Flood: 0.00000 sec
Desired time interval between
successive values of results: 0.50000 sec

Saturation Temperature is: 264.51414 deg. F

** Summary of Results **

** Test ID : RodD4_110 **

Time (s)	Data Temp (F)	Calculated Surface Temp (F)	Heat Flux (Btu/hr.ft ²)	Heat Transfer Coefficient (Btu/hr.ft ² .F)
0.00	1290.71	1290.18	0.5879E+04	0.5731E+01
0.50	1293.43	1292.26	0.3568E+04	0.3472E+01
1.00	1296.45	1295.18	0.1908E+04	0.1851E+01
1.50	1299.65	1298.13	0.1502E+04	0.1453E+01
2.00	1303.08	1301.33	0.7332E+03	0.7072E+00
2.50	1305.71	1304.41	0.7259E+03	0.6980E+00
3.00	1309.39	1307.64	0.2868E+03	0.2749E+00
3.50	1312.12	1310.69	0.5431E+03	0.5191E+00
4.00	1315.61	1313.85	0.2996E+03	0.2855E+00
4.50	1318.33	1316.86	0.5821E+03	0.5531E+00
5.00	1321.74	1319.73	0.9626E+03	0.9123E+00

Note: The results are truncated in view of saving paper for print-out. Time results continue in steps of 0.5 sec until here. Obviously this text line will not appear in the actual output file. This file can be opened in EXCEL or a program like notepad.

868.50	273.23	268.20	0.1270E+05	0.3448E+04
869.00	273.99	269.13	0.1178E+05	0.2549E+04
869.50	274.82	269.64	0.1211E+05	0.2364E+04
870.00	276.38	269.50	0.1314E+05	0.2636E+04
870.50	275.79	269.18	0.1375E+05	0.2949E+04
871.00	274.79	268.79	0.1408E+05	0.3289E+04

This is the end of RodD4_110

The format of input for file in1.dat has already described in the write-up for DATARH.F. What follows now is all the information pertaining to RBHT heater rods that need to be input into the file in1.dat, used for running DATARH.F.

For each experiment, the value of NSCAN (set as 8656), PRES (set as 40), TFLOOD (set as 0) and DT (set as 0.5) in the sample listing below, need to be changed prior to running the code to reflect the number of values of NSCAN, the experimental pressure and time of flood.

TITLE1, RLOC, FAX, FP and FKA are fixed values for the RBHT heater rods.

Note that file in1.dat contains ONLY one line as input. Please refer to the sample file in1.dat that has been provided.

RodB1_47.9	RodB1_47.9	8656	0.936	1	0.859	40	0	0.5
RodB1_63.6	RodB1_63.6	8656	1.082	1	0.866	40	0	0.5
RodB1_68.6	RodB1_68.6	8656	1.128	1	0.867	40	0	0.5
RodB1_79.7	RodB1_79.7	8656	1.231	1	0.869	40	0	0.5
RodB1_97.1	RodB1_97.1	8656	1.393	1	0.867	40	0	0.5
RodB1_114.8	RodB1_114.8	8656	1.314	1	0.867	40	0	0.5
RodB1_126.7	RodB1_126.7	8656	0.990	1	0.860	40	0	0.5
RodB1_139.4	RodB1_139.4	8656	0.644	1	0.816	40	0	0.5
RodD1_47.9	RodD1_47.9	8656	0.941	1	0.859	40	0	0.5
RodD1_63.8	RodD1_63.8	8656	1.093	1	0.866	40	0	0.5
RodD1_68.8	RodD1_68.8	8656	1.141	1	0.867	40	0	0.5
RodD1_79.9	RodD1_79.9	8656	1.248	1	0.869	40	0	0.5
RodD1_97.3	RodD1_97.3	8656	1.415	1	0.867	40	0	0.5
RodD1_115	RodD1_115	8656	1.317	1	0.867	40	0	0.5
RodD1_126.6	RodD1_126.6	8656	0.990	1	0.860	40	0	0.5
RodD1_139.4	RodD1_139.4	8656	0.629	1	0.816	40	0	0.5
RodB2_4.1	RodB2_4.1	8656	0.521	1	0.792	40	0	0.5
RodB2_11.2	RodB2_11.2	8656	0.589	1	0.811	40	0	0.5
RodB2_16.2	RodB2_16.2	8656	0.636	1	0.822	40	0	0.5
RodB2_23.3	RodB2_23.3	8656	0.704	1	0.835	40	0	0.5
RodB2_29.3	RodB2_29.3	8656	0.761	1	0.843	40	0	0.5
RodB2_33.3	RodB2_33.3	8656	0.799	1	0.847	40	0	0.5
RodB2_35.3	RodB2_35.3	8656	0.818	1	0.849	40	0	0.5
RodB2_38.4	RodB2_38.4	8656	0.847	1	0.852	40	0	0.5
RodC2_41	RodC2_41	8656	0.870	1	0.854	40	0	0.5
RodC2_53.1	RodC2_53.1	8656	0.983	1	0.862	40	0	0.5
RodC2_55	RodC2_55	8656	1.000	1	0.863	40	0	0.5
RodC2_57.8	RodC2_57.8	8656	1.026	1	0.864	40	0	0.5
RodC2_63.9	RodC2_63.9	8656	1.083	1	0.866	40	0	0.5
RodC2_73.8	RodC2_73.8	8656	1.175	1	0.868	40	0	0.5

4. CONCLUSIONS

4.1 Conclusions

A series of steam cooling experiments with droplet injection have been completed in the Rod Bundle Heat Transfer Facility at The Pennsylvania State University under the sponsorship of the Office of Research of the Nuclear Regulatory Commission. These experiments provide unique data in which a droplet flow of known drop diameters and flow rates were injected into superheated steam in a rod bundle. The experiments were steady-state non-equilibrium two-phase dispersed flow film boiling. Measurements were made of the entrained droplet diameters at different elevations in the bundle and at different sub-channels within the bundle. Measurements were also made of the superheated steam temperature, heater rod temperatures, housing and insulation temperatures as well as the flows and pressures of each phase.

The steam cooling with droplet injection experiments can be used to develop and assess dispersed flow film boiling models used in the NRC's safety analysis computer codes.

4.2 Recommendations for Future Work

There are areas of additional analysis of the current experimental data that could be completed. Such areas include the additional droplet injection testing with the point of injection located higher in the bundle such that it is closer to the peak power location. The current test series was limited as temperatures neared the scram temperature for several experiments. These areas of analysis, and others, would be useful in further validating the effectiveness of current correlations and models in modeling the newer advanced reactor designs and the possible transient scenarios that may occur in each.

5. REFERENCES

- 1 Rosal, E. R., Lin, T. F., McClellan, I. S., Hochreiter, L. E., Cheung, F.B. "The Pennsylvania State University and U.S. Nuclear Regulatory Commission Rod Bundle Heat Transfer Facility," *Proceedings 6th ASME-JSME Joint Thermal Engineering Conference, Paper No. TED-AJ03-625*, March 2003.
- 2 Wallis, Graham B. "One-Dimensional Two-Phase Flow," *McGraw-Hill Book Company, Inc.*, 1969.
- 3 Oxford Lasers. "HSI1000 Fast Illumination System," Operation Manual, Issue 2, Rev. 1 (1997), Oxford Lasers, Ltd.
- 4 Todd, Donald R., "Characterization of the VisiSizer Particle/Drop Sizing System," MS Thesis, Pennsylvania State University, 1999.
- 5 Lee, N., Wong, S., Yeh, H.C., and Hochreiter, L.E., "PWR FLECHT-SEASET Unblocked Bundle, Forced and Gravity Reflood Task Data Evaluation and Analysis Report," NUREG/CR-2256, February 1982.
- 6 Reinhardt, H.J., "Analysis of the Discrete Beck Method of Solving Ill-posed Parabolic Equations," *Inverse Problems*, 10 (1994), pp. 1345-1360.
- 7 Lee, N., Wong, S., Yeh, H.C., and Hochreiter, L.E., 'PWR FLECHT-SEASET Unblocked Bundle, Forced and Gravity Reflood Task Data Report Volume 1,' WCAP-9891, February 1982.
- 8 Young, Hugh D. "Statistical Treatment of Experimental Data," *McGraw-Hill Book Company, Inc.*, 1962.

APPENDIX A. DATA PLOTS FOR INDIVIDUAL EXPERIMENTS

The following data represents the validated results of the Steam Cooling with Droplet Injection Test Series. This data is presented for steady-state windows during the respective experiments. For each steady-state window, the following plots and tables are provided:

- **Summary and comment sheet** – lists the as-run conditions, notes droplet camera adjustments and movements, and notes any traversing operations made by the subchannel steam probe rakes.
- **Critical instrument plots** – verifies steady state was reached and maintained for boundary conditions and selected heater rod and steam temperature measurements. The following experimental data is plotted over the steady state time window:
 1. inlet and exhaust steam flow rates
 2. inlet steam temperature
 3. bundle power
 4. upper plenum pressure
 5. selected steam probe rake temperatures
 6. selected heat rod temperatures
- **Data table** – tabulations of the reduced data from DATARH.

Reduced heat transfer data is presented at all heater rod thermocouple locations within the inner 5 x 5 bundle, excluding the corner rods. That is, 21 rods totaling 130 thermocouple locations. The results are organized by heat rod location and most heater rods have 8 thermocouples instrumented at various axial locations. Figure A-1 below provides the heat rod and subchannel identification diagram which indicates the location of heater rods within the bundle.

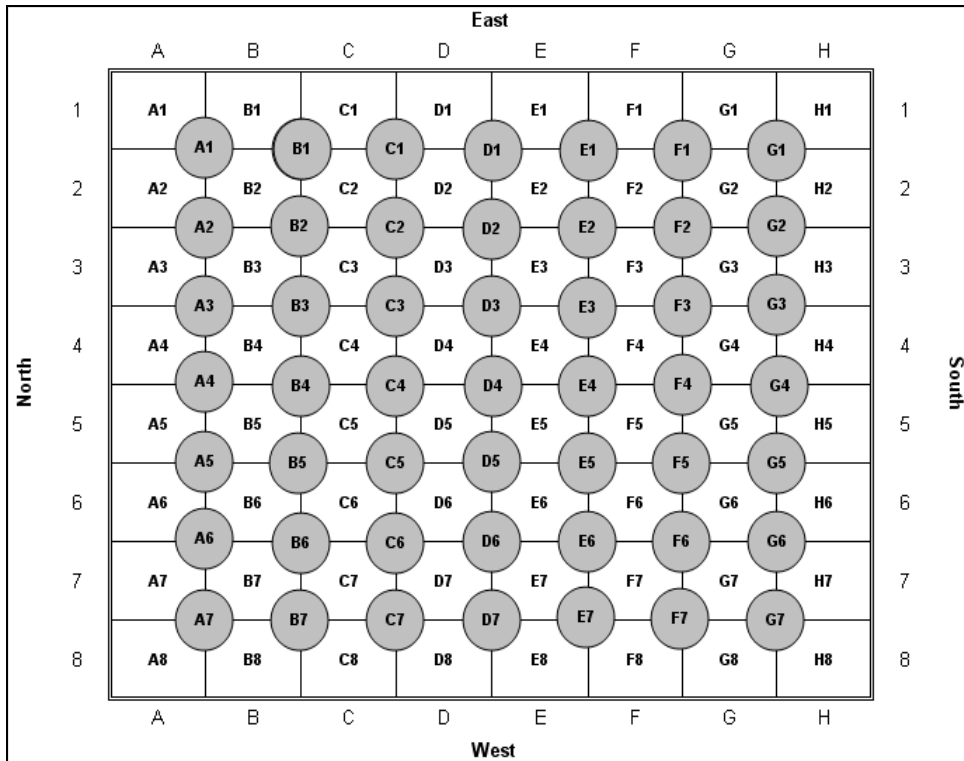

Figure A-1: Heater Rod and Subchannel Identification Diagram

RBHT Steam Cooling with Droplet Injection Test SCD-4001

Matrix Test # Shakedown

Test Conditions

Test Date – 9/8/2005

Steady State Time Window: 3600 - 4800

Upper Plenum Pressure: 2.76 bar (40 psia)

Bundle Power: 80.7 kW

Bundle Inlet Reynolds Number: 10000

Bundle Inlet Steam Flow: 199.9 kg/hr (438 lbm/hr)

Droplet Injection Flow: 0.0076 kg/s (0.0167 lbm/s)

Droplet Injection Hole Diameter: 0.381 mm (.015 in)

Droplet Injection Elevation: 1.295 m (51 in)

Bundle Flow Area: $4.656 \times 10^{-3} \text{ m}^2$ ($5.012 \times 10^{-2} \text{ ft}^2$)

Test Notes

- steam leak at 4800 seconds; test ended

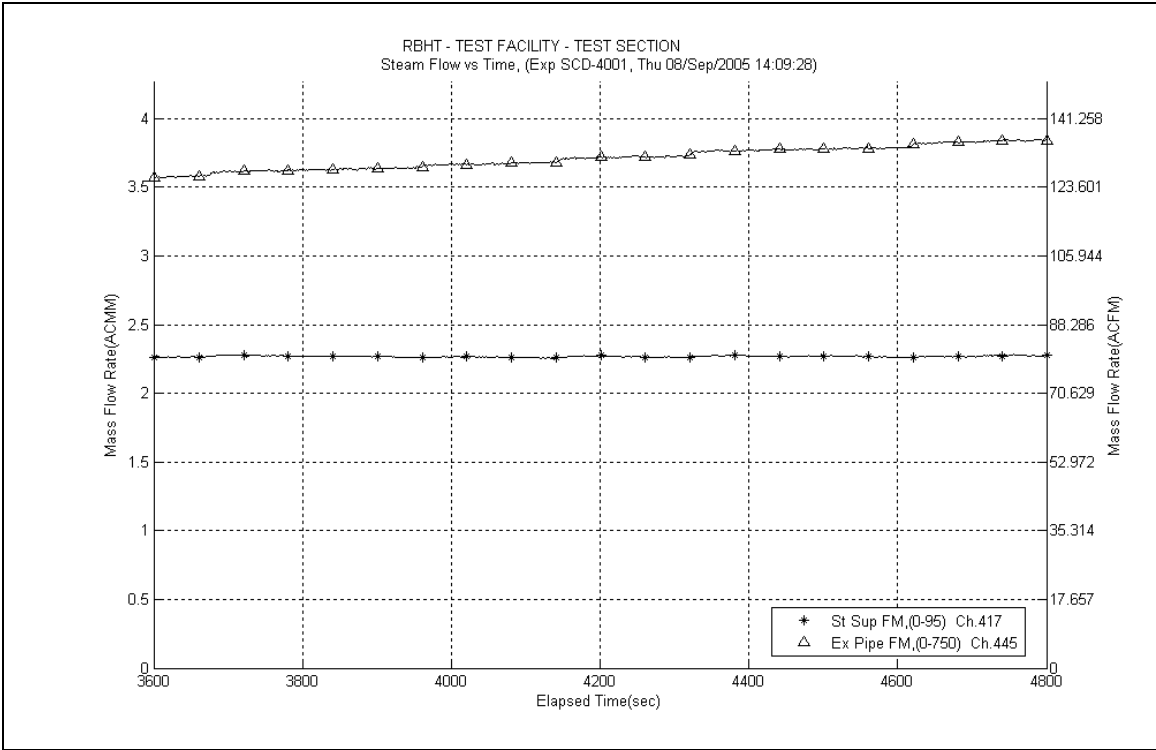

Figure A-2: Inlet and Exhaust Steam Flow Rates for Experiment 4001

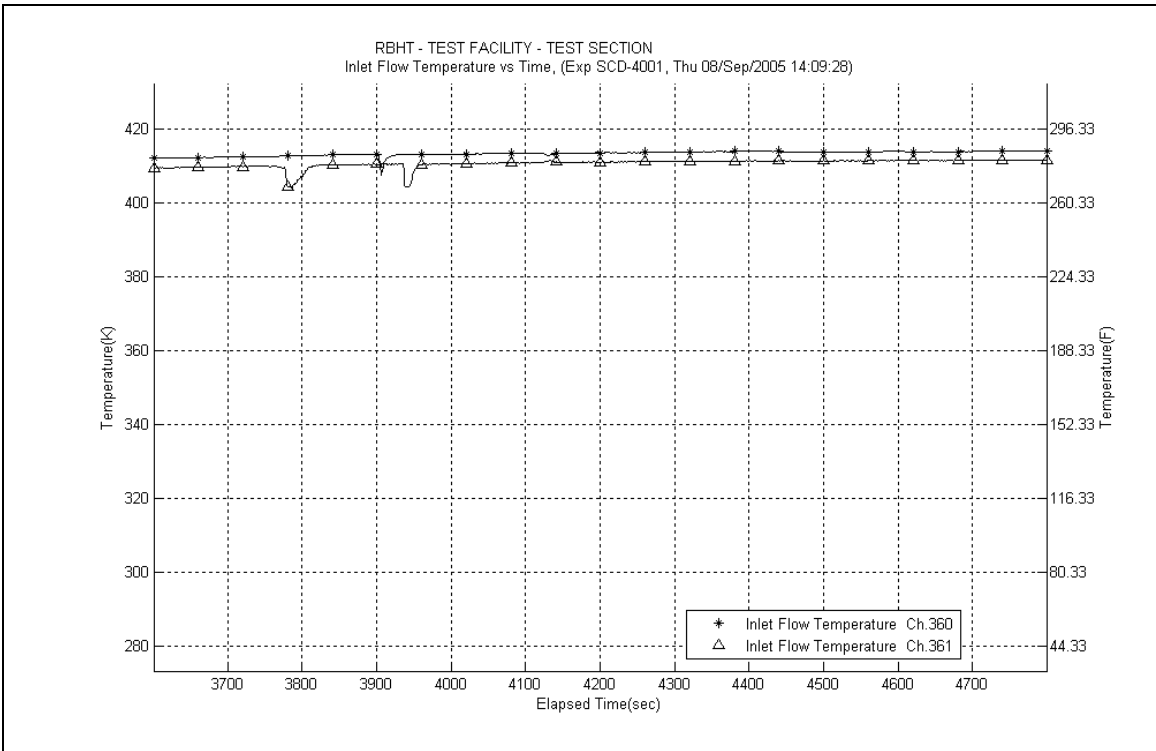

Figure A-3: Inlet Steam Temperature for Experiment 4001

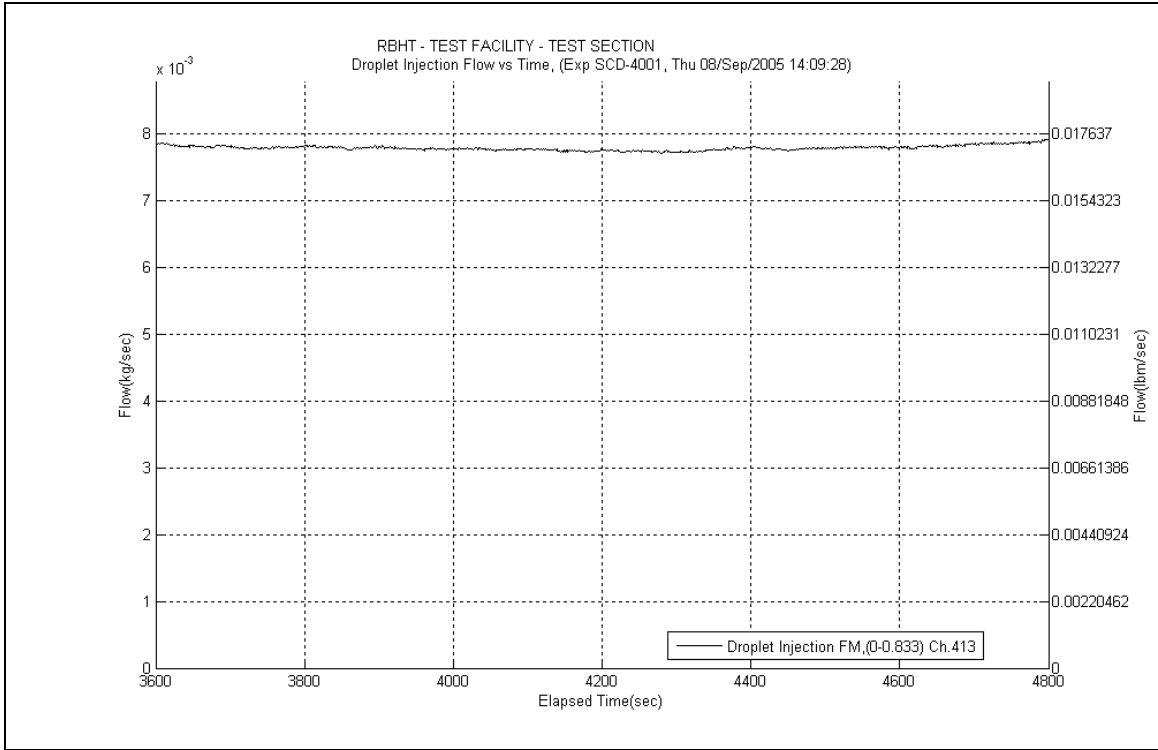

Figure A-4: Droplet Injection Flow Rate for Experiment 4001

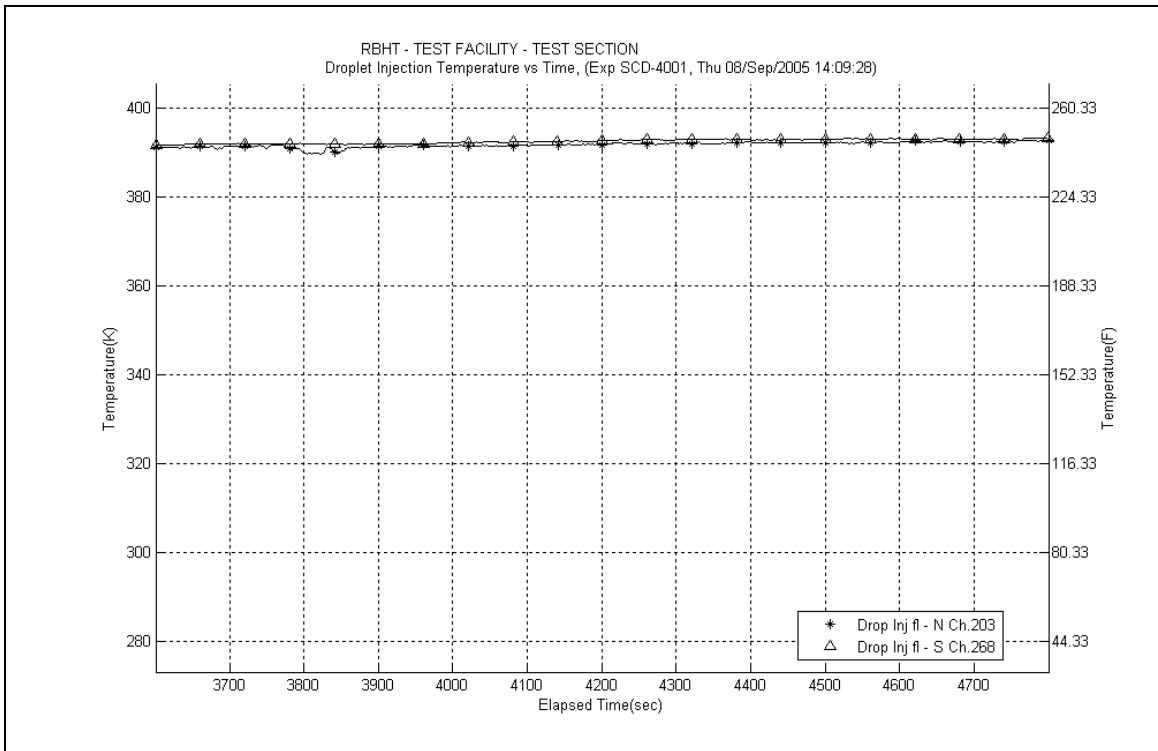

Figure A-5: Droplet Injection Temperature for Experiment 4001

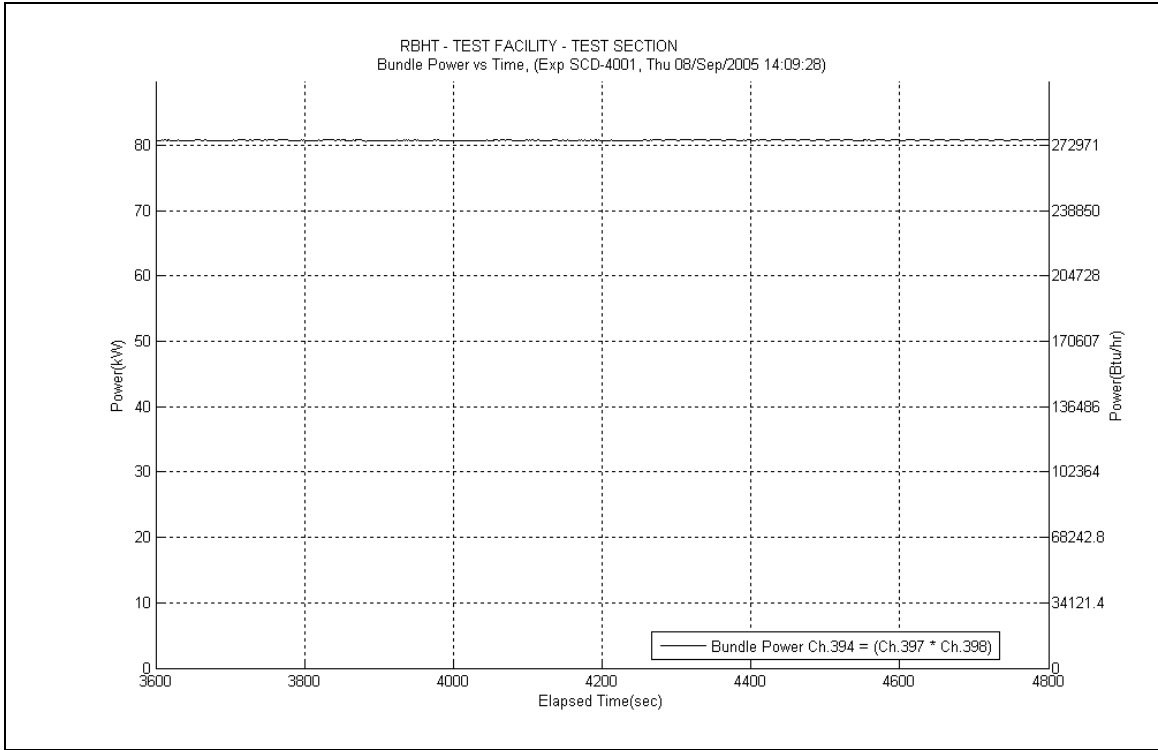

Figure A-6: Bundle Power for Experiment 4001

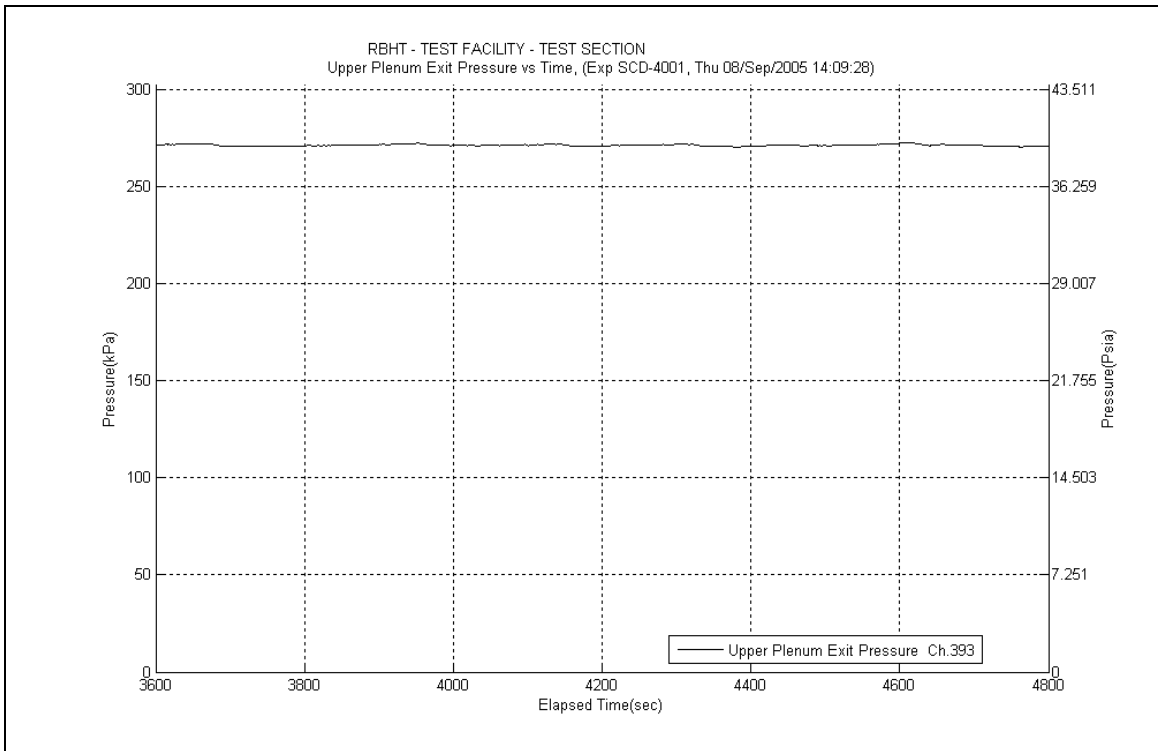

Figure A-7: Upper Plenum Pressure for Experiment 4001

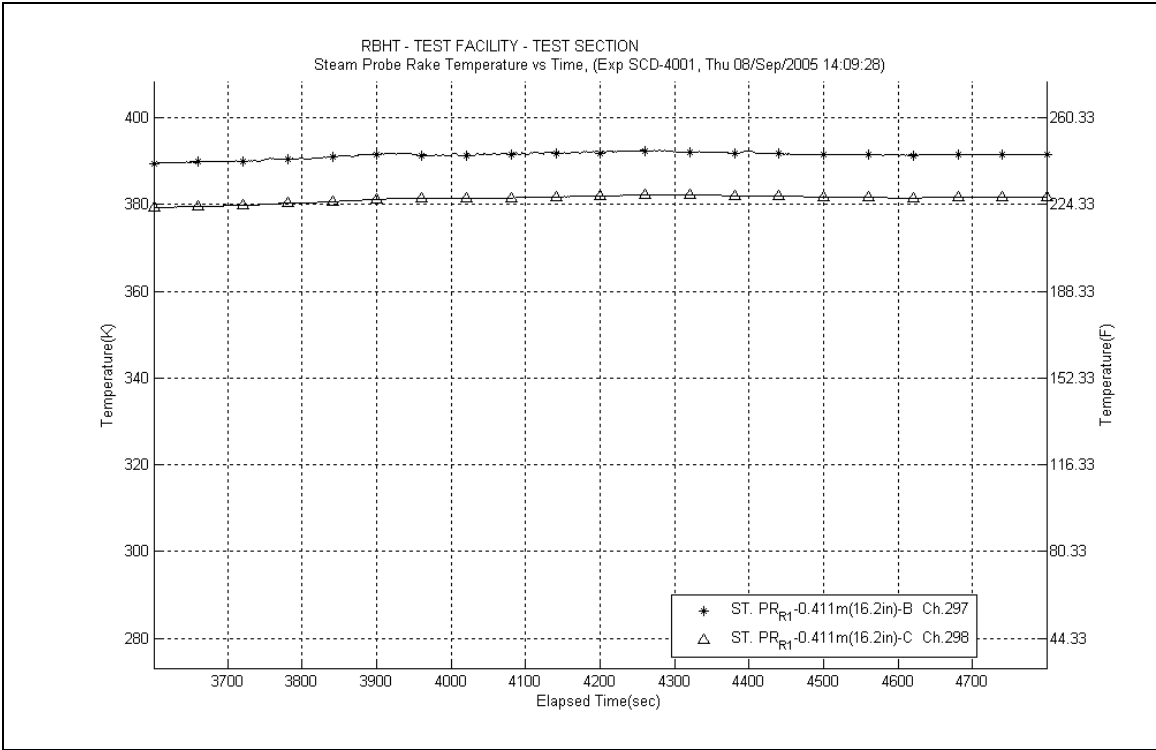

Figure A-8: Steam Probe Rake #1 Temperatures for Experiment 4001

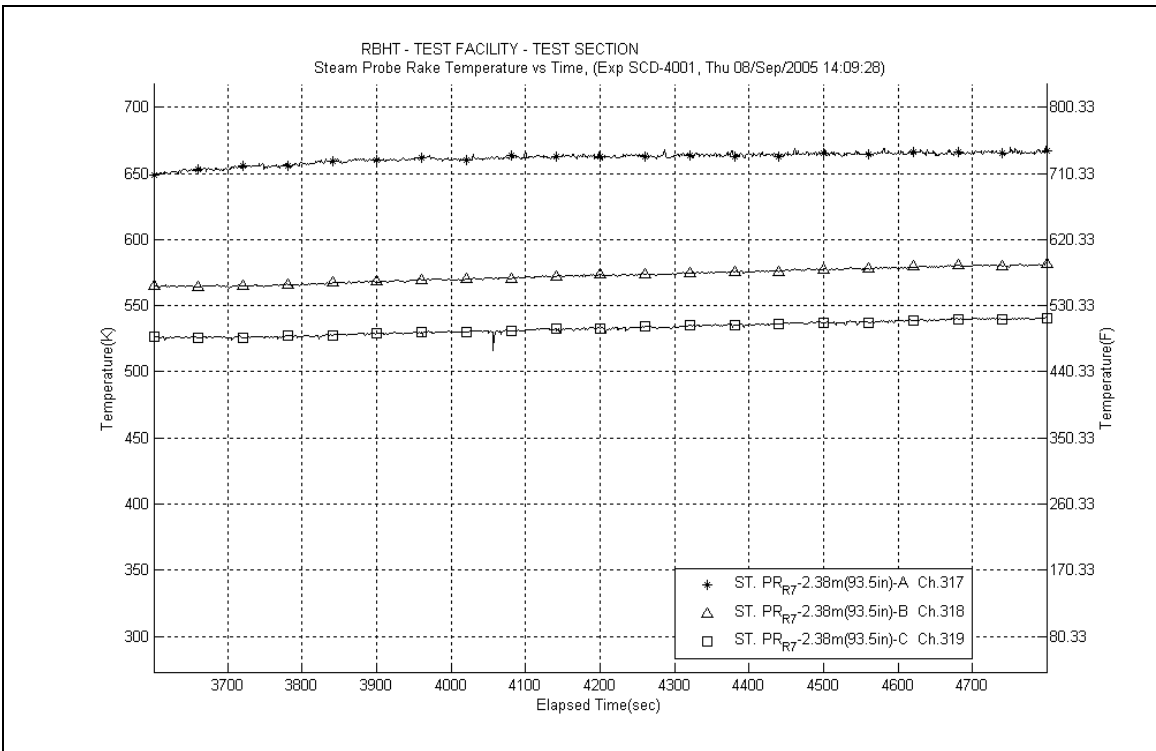

Figure A-9: Steam Probe Rake #7 Temperatures for Experiment 4001

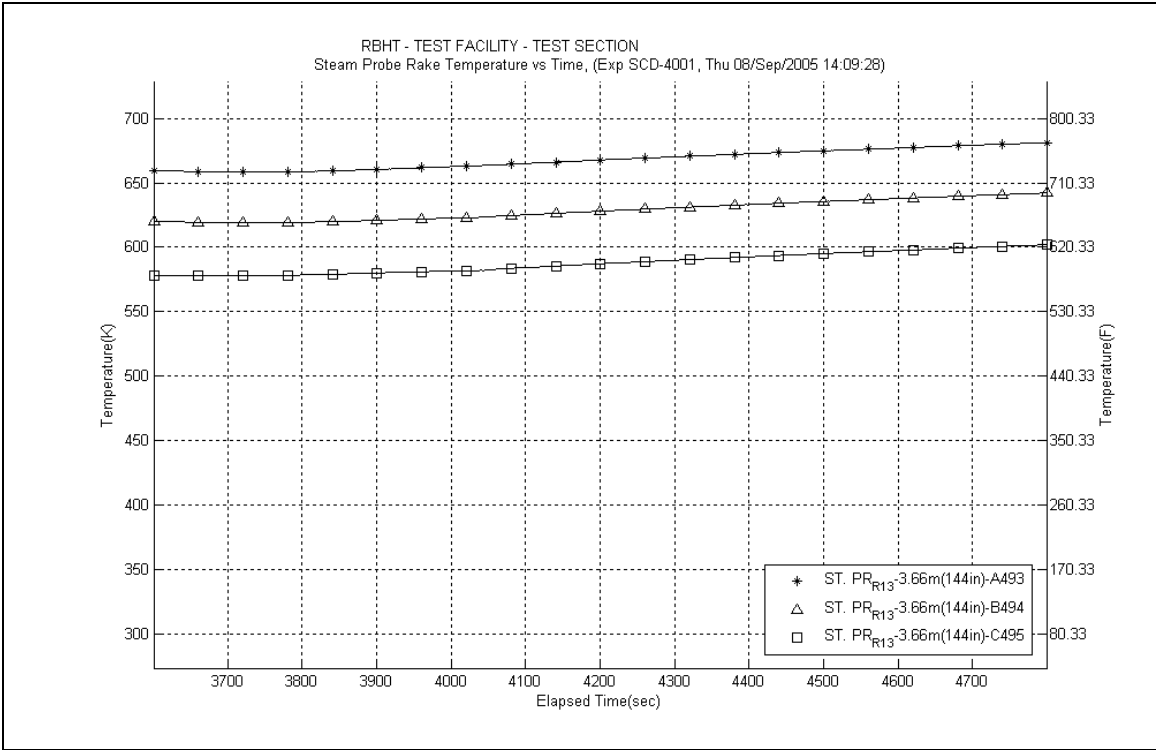

Figure A-10: Steam Probe Rake #13 Temperatures for Experiment 4001

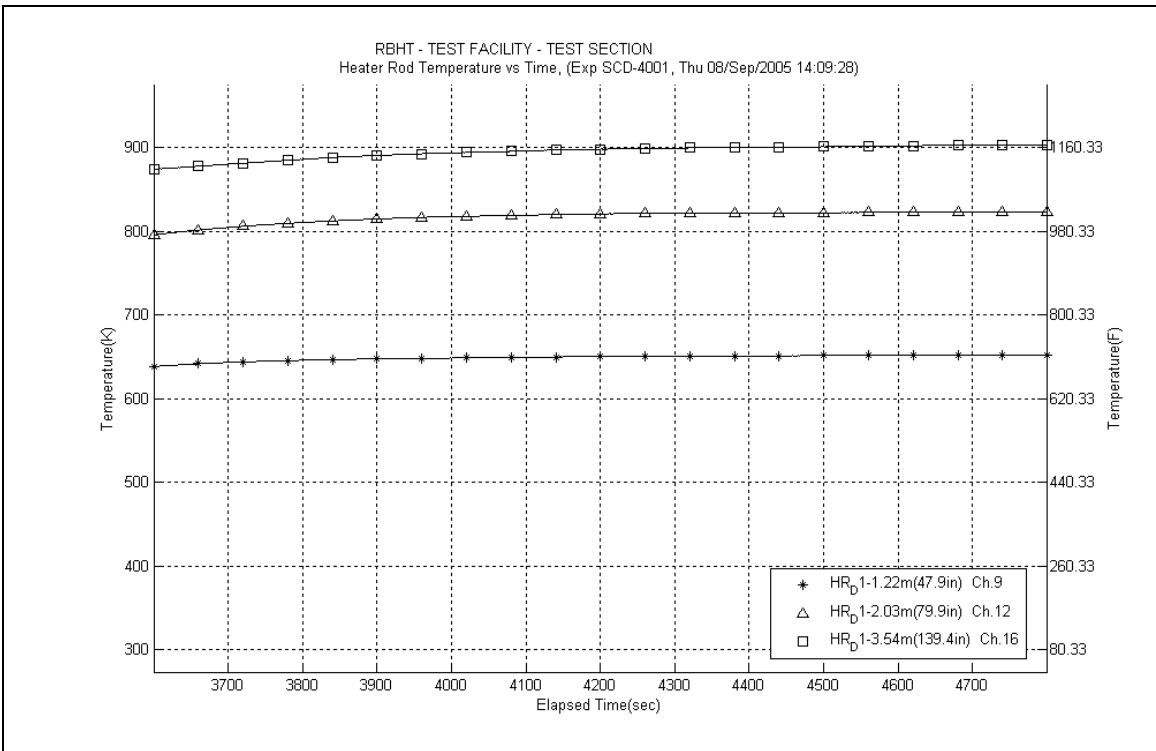

Figure A-11: Heater Rod D1 Temperatures for Experiment 4001

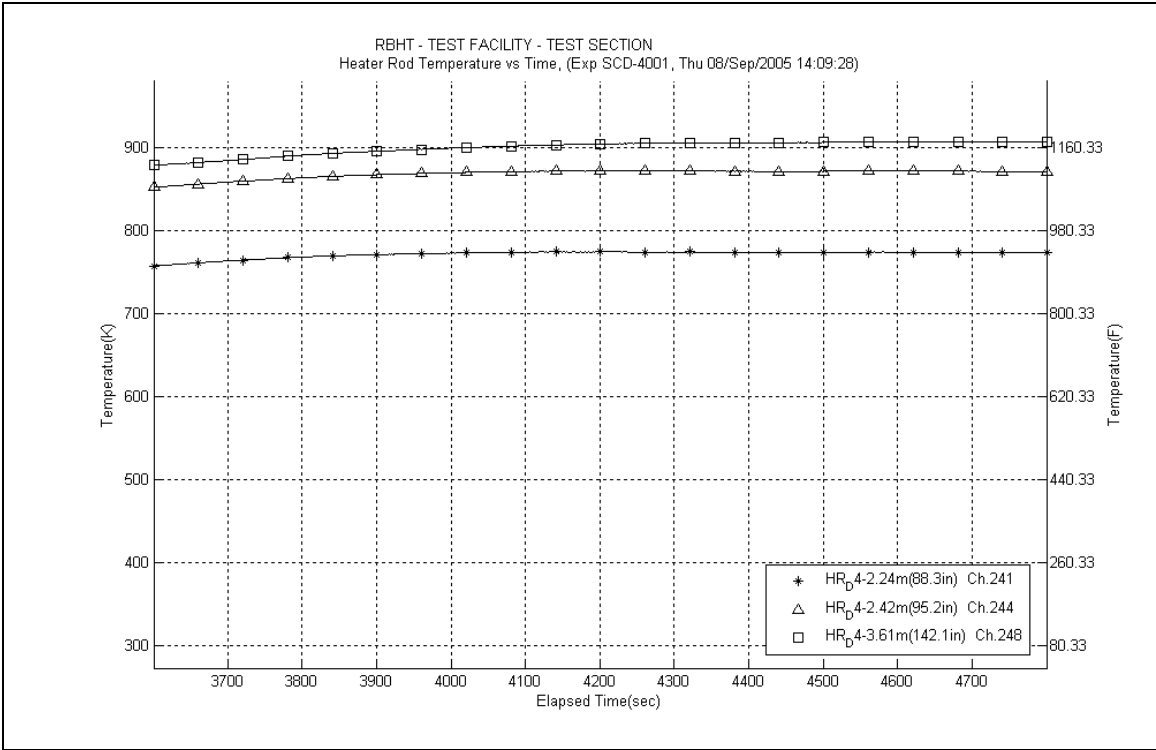

Figure A-12: Heater Rod D4 Temperatures for Experiment 4001

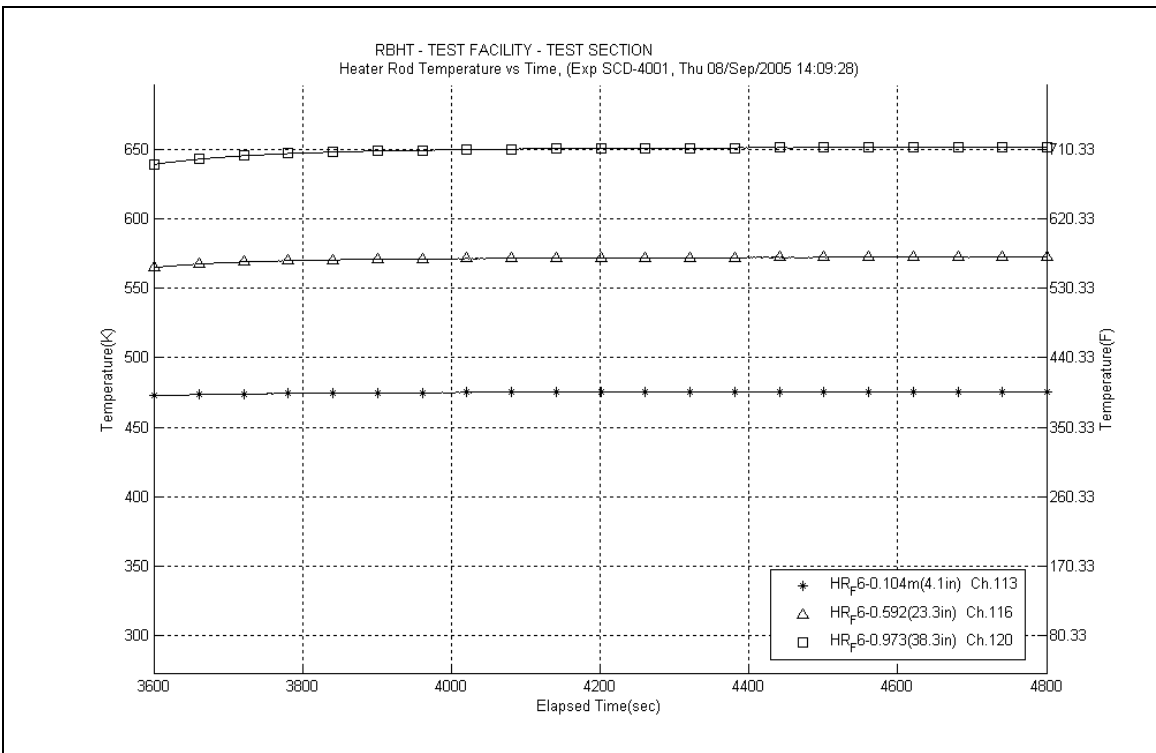

Figure A-13: Heater Rod F6 Temperatures for Experiment 4001

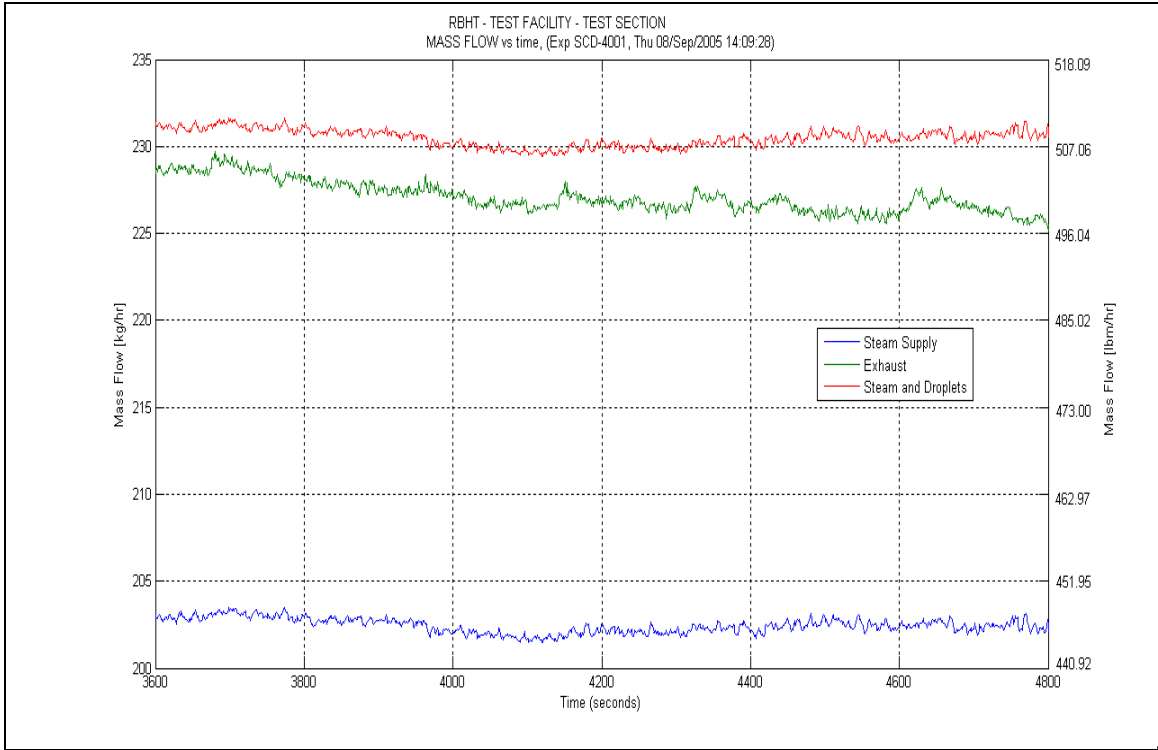

Figure A-14: Mass Flow for Experiment 4001

Table A-1: Summary of Steam Cooling Heat Transfer Reduced Data for Experiment 4001

SCD-4001-A		Inlet Reynolds: 10000										
Matrix test: shakedown		UP Pressure: 40 psia		275360 Btu/hr		80.70 kW		438.0 lbm/hr		0.0171 lbm/s		
Time Window: 3600-4800		Bundle Power:		H.R. Tw (°F)		H.R. Tw (K)		H.R. q" (Btu/hr-ft2)		H.R. q" (W/m2)		
Inner 3x3		Steam flow: 0.0652 kg/s		H.R. Tw (°F)		H.R. Tw (K)		H.R. q" (Btu/hr-ft2)		H.R. q" (W/m2)		
		Droplet flow: 0.0078 kg/s		Zgrid (m)		Zgrid (in)		Elevation (m)		Elevation (in)		
H.R. ID	H.R. Location	Channel Number	Elevation (in)	Zgrid (in)	Zgrid (m)	H.R. Tw (°F)	H.R. Tw (K)	H.R. q" (Btu/hr-ft2)	H.R. q" (W/m2)	h _{sat} (z) (Btu/hr-ft2-F)	h _{sat} (z) (W/m2-K)	
Gr-3	RodD3_88.3	185	88.3	-0.2	-0.005	1060.58	844.6	6955.28	21940.4	8.775	49.8	
	RodD3_91.3	186	91.3	2.8	0.071	1092.28	862.2	7050.49	22240.8	8.553	48.6	
	RodD3_93.1	187	93.1	4.6	0.117	935.23	774.9	6801.07	21454.0	10.193	57.9	
	RodD3_95.3	188	95.3	6.8	0.173	1034.35	830.0	6945.92	21910.9	9.064	51.5	
	RodD3_100.1	189	100.1	11.6	0.295	1128.55	882.3	7184.36	22663.1	8.349	47.4	
	RodD3_106.1	190	106.1	17.6	0.447	1204.90	924.8	7568.92	23876.1	8.079	45.9	
	RodD3_110	191	110	21.5	0.546	1150.88	894.7	7367.30	23240.1	8.345	47.4	
	RodD3_142.1	192	142.1	3.609	8.6	957.45	787.3	6774.10	21368.9	9.825	55.8	
Gr-3	RodC4_88.4	233	88.4	-0.1	-0.003	1176.44	909.0	6675.50	21057.9	7.348	41.7	
	RodC4_91.1	234	91.1	2.6	0.066	1195.67	919.6	6229.86	19652.1	6.716	38.1	
	RodC4_93.4	235	93.4	4.9	0.124	1208.49	926.8	5705.59	17998.3	6.067	34.5	
	RodC4_95.3	236	95.3	6.8	0.173	1209.37	927.2	5168.79	16304.9	5.491	31.2	
	RodC4_100.1	237	100.1	11.6	0.295	1106.00	869.8	7309.28	23057.1	8.722	49.5	
	RodC4_106.1	238	106.1	17.6	0.447	1188.77	915.8	7522.60	23730.0	8.170	46.4	
	RodC4_110	239	110	21.5	0.546	1202.64	923.5	7662.94	24172.8	8.199	46.6	
	RodC4_142.2	240	142.2	3.612	8.7	941.56	778.5	5612.09	17703.3	8.332	47.3	
Gr-3	RodD4_88.3	241	88.3	-0.2	-0.005	900.05	755.4	6049.37	19082.7	9.571	54.4	
	RodD4_91.3	242	91.3	2.8	0.071	943.88	779.8	6141.84	19374.4	9.087	51.6	
	RodD4_93.2	243	93.2	4.7	0.119	943.39	779.5	5466.75	17244.9	8.094	46.0	
	RodD4_95.2	244	95.2	6.7	0.170	1181.55	911.8	6428.99	20280.2	7.037	40.0	
	RodD4_100.1	245	100.1	11.6	0.295	1216.76	931.3	7652.83	24140.9	8.066	45.8	
	RodD4_106.1	246	106.1	17.6	0.447	1149.20	893.8	7560.52	23849.7	8.580	48.7	
	RodD4_142.1	248	142.1	3.609	8.6	820.58	711.3	5910.30	18644.1	10.696	60.7	
Gr-3	RodE4_88.4	201	88.4	-0.1	-0.003	1020.19	822.1	6889.74	21733.7	9.160	52.0	
	RodE4_91.2	202	91.2	2.7	0.069	1097.36	865.0	7078.88	22330.3	8.535	48.5	
	RodE4_95.3	204	95.3	6.8	0.173	1166.09	903.2	2736.19	8631.3	3.047	17.3	
	RodE4_100.9	205	100.9	12.4	0.315	1138.85	888.1	7448.12	23495.1	8.553	48.6	
	RodE4_142.3	208	142.3	3.614	8.8	916.92	764.8	6764.01	21337.1	10.423	59.2	

Table A-1: Summary of Steam Cooling Heat Transfer Reduced Data for Experiment 4001, continued

Gr-4	H.R. Location	Channel Number	Elevation (in)	Elevation (m)	Zgrid (in)	Zgrid (m)	H.R. Tw (°F)	H.R. Tw (K)	H.R. q" (Btu/hr-ft ²)	H.R. q" (W/m ²)	h _{sat} (z) (Btu/hr-ft ² -F)	h _{sat} (z) (W/m ² -K)
	RodE3_63.4	193	63.4	1.610	16.4	0.417	1172.47	906.7	3876.97	12229.9	4.286	24.3
	RodE3_113.6	194	113.6	2.885	0.85	0.022	1142.58	890.1	6703.67	21146.7	7.665	43.5
	RodE3_115.5	195	115.5	2.934	2.75	0.070	962.16	789.9	5572.02	17577.0	8.027	45.6
	RodE3_118.5	196	118.5	3.010	5.75	0.146	1198.26	921.1	6620.28	20883.7	7.117	40.4
	RodE3_122.7	197	122.7	3.117	9.95	0.253	1226.15	936.6	6208.04	19583.3	6.479	36.8
	RodE3_126.5	198	126.5	3.213	13.75	0.349	1236.52	942.3	5633.91	17772.2	5.817	33.0
	RodE3_131.7	199	131.7	3.345	-1.8	-0.046	1234.00	940.9	5115.73	16137.6	5.296	30.1
	RodE3_135.6	200	135.6	3.444	2.1	0.053	1145.80	891.9	4387.91	13841.7	4.999	28.4
Gr-4	RodC5_63.7	225	63.7	1.618	16.7	0.424	918.44	765.6	5417.09	17088.2	8.328	47.3
	RodC5_113.6	226	113.6	2.885	0.85	0.022	1126.64	881.3	6991.02	22053.2	8.142	46.2
	RodC5_115.7	227	115.7	2.939	2.95	0.075	1128.99	882.6	4503.81	14207.3	5.231	29.7
	RodC5_122.7	229	122.7	3.117	9.95	0.253	1151.95	895.3	3963.98	12504.4	4.484	25.5
	RodC5_126.7	230	126.7	3.218	13.95	0.354	800.63	700.2	4958.66	15642.1	9.310	52.9
	RodC5_131.6	231	131.6	3.343	-1.9	-0.048	822.47	712.3	5151.01	16248.8	9.290	52.8
	RodC5_135.7	232	135.7	3.447	2.2	0.056	882.09	745.4	5275.50	16641.6	8.591	48.8
Gr-4	RodE5_63.6	209	63.6	1.615	16.6	0.422	1159.70	899.7	2707.50	8540.8	3.036	17.2
	RodE5_113.6	210	113.6	2.885	0.85	0.022	1209.64	927.4	7740.14	24416.3	8.220	46.7
	RodE5_115.4	211	115.4	2.931	2.65	0.067	1111.18	872.7	7212.88	22753.0	8.554	48.6
	RodE5_118.7	212	118.7	3.015	5.95	0.151	1158.15	898.8	2806.81	8854.1	3.153	17.9
	RodE5_122.6	213	122.6	3.114	9.85	0.250	927.09	770.4	6861.13	21643.4	10.410	59.1
	RodE5_126.6	214	126.6	3.216	13.85	0.352	1029.90	827.5	7002.40	22089.1	9.191	52.2
	RodE5_131.6	215	131.6	3.343	-1.9	-0.048	1070.54	850.1	7092.49	22373.3	8.838	50.2
	RodE5_135.6	216	135.6	3.444	2.1	0.053	1101.38	867.3	7188.15	22675.0	8.625	49.0
Gr-5	RodC3_79.8	177	79.8	2.027	8.92	0.227	1071.46	850.6	6970.30	21987.8	8.675	49.3
	RodC3_85.6	178	85.6	2.174	14.72	0.374	1097.37	865.0	7053.77	22251.1	8.505	48.3
	RodC3_88.5	179	88.5	2.248	0	0.000	1137.29	887.2	2794.55	8815.4	3.215	18.3
	RodC3_92.4	180	92.4	2.347	3.9	0.099	748.55	671.2	4953.01	15624.3	10.307	58.5
	RodC3_94.4	181	94.4	2.398	5.9	0.150	782.44	690.1	5139.64	16213.0	9.991	56.7
	RodC3_97.2	182	97.2	2.469	8.7	0.221	1192.60	917.9	7616.34	24025.7	8.237	46.8
	RodC3_108.8	183	108.8	2.764	20.3	0.516	1122.76	879.1	7213.08	22753.7	8.439	47.9
Gr-8	RodD5_50	217	50	1.270	3	0.076	1158.51	899.0	4771.93	15053.0	5.359	30.4
	RodD5_54.1	218	54.1	1.374	7.1	0.180	1215.86	930.9	5518.43	17407.9	5.822	33.1
	RodD5_56.9	219	56.9	1.445	9.9	0.251	1212.65	929.1	5001.92	15778.6	5.295	30.1
	RodD5_60	220	60	1.524	13	0.330	1124.24	879.9	4371.22	13789.0	5.105	29.0
	RodD5_66.1	221	66.1	1.679	19.1	0.485	1147.53	892.9	3840.09	12113.6	4.366	24.8
	RodD5_69.9	222	69.9	1.775	-0.98	-0.025	965.64	791.8	6879.79	21702.3	9.862	56.0
	RodD5_72.9	223	72.9	1.852	2.02	0.051	1043.10	834.9	7008.48	22108.2	9.042	51.3
	RodD5_74.9	224	74.9	1.902	4.02	0.102	1080.88	855.9	7120.37	22461.2	8.759	49.7

Inner 3x3

Error! Reference source not found., continued

H.R. ID	H.R. Location	Channel Number	Elevation (in)	Elevation (m)	Zgrid (in)	Zgrid (m)	H.R. Tw (°F)	H.R. Tw (K)	H.R. q" (Btu/hr-ft2)	H.R. q" (W/m2)	h _{sat} (z) (Btu/hr-ft2-F)	h _{sat} (z) (W/m2-K)	
Gr-2	RodB5_41	153	41	1.041	13.5	0.343	529.23	549.4	3311.00	10444.5	12.675	72.0	
	RodB5_52.9	154	52.9	1.344	5.9	0.150	574.75	574.7	3648.58	11509.5	11.894	67.5	
	RodB5_55	155	55	1.397	8	0.203	605.38	591.7	3936.10	12416.4	11.667	66.3	
	RodB5_57.8	156	57.8	1.468	10.8	0.274	672.22	628.8	4121.58	13001.5	10.196	57.9	
	RodB5_64	157	64	1.626	17	0.432	698.51	643.4	4214.18	13293.6	9.789	55.6	
	RodB5_73.9	158	73.9	1.877	30.2	0.077	730.61	661.3	4359.72	13752.7	9.424	53.5	
	RodB5_75.9	159	75.9	1.928	5.02	0.128	748.71	671.3	4510.20	14227.4	9.382	53.3	
	RodB5_76.9	160	76.9	1.953	6.02	0.153	770.75	683.6	5088.83	16052.7	10.122	57.5	
	Gr-2	RodF5_41	105	41	1.041	13.5	0.343	520.53	544.6	3320.27	10473.8	13.148	74.7
		RodF5_53.1	106	53.1	1.349	6.1	0.155	567.11	570.4	3648.88	11510.4	12.199	69.3
		RodF5_55	107	55	1.397	8	0.203	591.49	584.0	3932.86	12406.2	12.158	69.0
		RodF5_57.8	108	57.8	1.468	10.8	0.274	659.02	621.5	4116.25	12984.7	10.527	59.8
		RodF5_64	109	64	1.626	17	0.432	680.02	633.2	4208.86	13276.8	10.215	58.0
		RodF5_73.8	110	73.8	1.875	2.92	0.074	707.80	648.6	4347.86	13715.3	9.886	56.1
		RodF5_75.8	111	75.8	1.925	4.92	0.125	779.40	688.4	4946.86	15604.9	9.673	54.9
		RodF5_76.8	112	76.8	1.951	5.92	0.150	819.50	710.6	5131.54	16187.4	9.305	52.8
Gr-2		RodC2_41	57	41	1.041	13.5	0.343	1101.84	867.5	3030.46	9559.6	3.634	20.6
		RodC2_53.1	58	53.1	1.349	6.1	0.155	695.20	641.6	4886.61	15414.8	11.439	65.0
		RodC2_55	59	55	1.397	8	0.203	963.24	790.5	6368.52	20089.5	9.160	52.0
		RodC2_57.8	60	57.8	1.468	10.8	0.274	1078.56	854.6	7188.39	22675.8	8.868	50.4
	RodC2_63.9	61	63.9	1.623	16.9	0.429	1120.39	877.8	6671.83	21046.3	7.827	44.4	
	RodC2_73.8	62	73.8	1.875	2.92	0.074	1143.91	890.9	5079.26	16022.5	5.799	32.9	
	RodC2_75.8	63	75.8	1.925	4.92	0.125	936.44	775.6	6175.32	19480.1	9.238	52.5	
	RodC2_76.8	64	76.8	1.951	5.92	0.150	950.10	783.2	6221.97	19627.2	9.122	51.8	
Gr-2	RodC6_40.9	137	40.9	1.039	13.4	0.340	842.70	723.5	5268.68	16620.1	9.168	52.1	
	RodC6_52.8	138	52.8	1.341	5.8	0.147	872.61	740.2	5420.12	17097.8	8.965	50.9	
	RodC6_54.8	139	54.8	1.392	7.8	0.198	939.48	777.3	5705.18	17997.0	8.496	48.3	
	RodC6_57.8	140	57.8	1.468	10.8	0.274	785.68	691.9	5901.69	18616.9	11.400	64.7	
	RodC6_63.8	141	63.8	1.621	16.8	0.427	879.18	743.8	6048.21	19079.1	9.896	56.2	
	RodC6_73.7	142	73.7	1.872	2.82	0.072	923.14	768.2	6141.66	19373.9	9.375	53.2	
	RodC6_75.8	143	75.8	1.925	4.92	0.125	999.47	810.6	6353.26	20041.4	8.686	49.3	
	RodC6_76.8	144	76.8	1.951	5.92	0.150	955.81	786.4	6635.99	20933.2	9.648	54.8	

Error! Reference source not found., continued

5x5 periphery		H.R. Location	Channel Number	Elevation (in)	Elevation (m)	Zgrid (in)	Zgrid (m)	H.R. Tw (°F)	H.R. Tw (K)	H.R. q" (Btu/hr-ft2)	H.R. q" (W/m2)	h _{sat} (z) (Btu/hr-ft2-F)	h _{sat} (z) (W/m2-K)
Gr-3	RodB4_88.4	161	88.4	2.245	-0.1	-0.003	786.9	6226.08	19640.2	9.040	51.3		
	RodB4_91.3	162	91.3	2.319	2.8	0.071	797.0	6274.29	19792.2	8.876	50.4		
	RodB4_93.3	163	93.3	2.370	4.8	0.122	794.55	6273.02	19792.2	8.876	50.4		
	RodB4_95.1	164	95.1	2.416	6.6	0.168	794.55	6273.02	19792.2	8.876	50.4		
	RodB4_100	165	100	2.540	11.5	0.292	794.55	6273.02	19792.2	8.876	50.4		
	RodB4_106	166	106	2.692	17.5	0.445	794.55	6273.02	19792.2	8.876	50.4		
	RodB4_109.9	167	109.9	2.791	21.4	0.544	794.55	6273.02	19792.2	8.876	50.4		
	RodB4_142.3	168	142.3	3.614	8.8	0.224	768.4	6123.70	19317.2	9.343	53.1		
Gr-5	RodF4_85.6	98	85.6	2.174	14.72	0.374	781.0	6157.88	19425.0	9.081	51.6		
	RodF4_88.4	99	88.4	2.245	-0.1	-0.003	789.1	6204.59	19572.4	8.956	50.9		
	RodF4_92.4	100	92.4	2.347	3.9	0.099	789.1	6204.59	19572.4	8.956	50.9		
	RodF4_94.3	101	94.3	2.395	5.8	0.147	789.1	6204.59	19572.4	8.956	50.9		
	RodF4_97.2	102	97.2	2.469	8.7	0.221	789.1	6204.59	19572.4	8.956	50.9		
	RodF4_108.8	103	108.8	2.764	20.3	0.516	789.1	6204.59	19572.4	8.956	50.9		
	RodF4_111	104	111	2.819	-1.75	-0.044	789.1	6204.59	19572.4	8.956	50.9		
	RodD2_103.2	65	103.2	2.621	14.7	0.373	877.9	7284.38	22978.6	8.545	48.5		
	RodD2_106	66	106	2.692	17.5	0.445	877.9	7284.38	22978.6	8.545	48.5		
	RodD2_112.6	67	112.6	2.860	-0.15	-0.004	877.9	7284.38	22978.6	8.545	48.5		
Gr-6	RodD6_103.1	129	103.1	2.619	14.6	0.371	904.4	6882.09	21709.6	7.645	43.4		
	RodD6_106	130	106	2.692	17.5	0.445	904.4	6882.09	21709.6	7.645	43.4		
	RodD6_112.9	131	112.9	2.868	0.15	0.004	904.4	6882.09	21709.6	7.645	43.4		
	RodD6_114.9	132	114.9	2.918	2.15	0.055	904.4	6882.09	21709.6	7.645	43.4		
	RodD6_116.8	133	116.8	2.967	4.05	0.103	904.4	6882.09	21709.6	7.645	43.4		
	RodD6_120.9	134	120.9	3.071	8.15	0.207	904.4	6882.09	21709.6	7.645	43.4		
	RodD6_124.8	135	124.8	3.170	12.05	0.306	904.4	6882.09	21709.6	7.645	43.4		
	RodD6_128.7	136	128.7	3.269	15.95	0.405	904.4	6882.09	21709.6	7.645	43.4		
	RodD2_114.9	68	114.9	2.918	2.15	0.055	908.4	6687.13	21094.5	7.369	41.9		
	RodD2_117.4	69	117.4	2.982	4.65	0.118	908.4	6687.13	21094.5	7.369	41.9		
RodD2_120.8	70	120.8	3.068	8.05	0.204	908.4	6687.13	21094.5	7.369	41.9			
RodD2_124.8	71	124.8	3.170	12.05	0.306	908.4	6687.13	21094.5	7.369	41.9			
RodD2_128.6	72	128.6	3.266	15.85	0.403	908.4	6687.13	21094.5	7.369	41.9			

Error! Reference source not found., continued

5x5 periphery		H.R.	Channel	Elevation	Elevation	Zgrid	Zgrid	H.R. Tw	H.R. Tw	H.R. Tw	H.R. q"	H.R. q"	h _{sat} (z)	h _{sat} (z)
Gr-8	Location	Number	(in)	(m)	(m)	(in)	(m)	(°F)	(K)	(Btu/hr-ft ²)	(W/m ²)	(Btu/hr-ft ² -F)	(W/m ² -K)	
	RodE2_50.1	73	50.1	1.273	3.1	0.079	865.44	736.2	5298.81	16715.1	8.869	50.4		
	RodE2_54	74	54	1.372	7	0.178	899.00	754.8	5442.14	17167.2	8.625	49.0		
	RodE2_56.9	75	56.9	1.445	9.9	0.251	944.26	780.0	5737.73	18099.7	8.484	48.2		
	RodE2_59.9	76	59.9	1.521	12.9	0.328	814.64	707.9	5935.70	18724.2	10.859	61.7		
	RodE2_66	77	66	1.676	19	0.483	900.19	755.5	6083.36	19190.0	9.623	54.6		
	RodE2_69.8	78	69.8	1.773	-1.08	-0.027	938.68	776.9	6177.81	19487.9	9.211	52.3		
	RodE2_72.9	79	72.9	1.852	2.02	0.051	404.79	480.3	2696.56	8506.3	19.713	111.9		
	RodE2_74.9	80	74.9	1.902	4.02	0.102	481.67	523.0	3043.63	9601.1	14.245	80.9		
Gr-8	RodB3_50.2	169	50.2	1.275	3.2	0.081	1201.37	922.8	5822.20	18366.1	6.238	35.4		
	RodB3_54.1	170	54.1	1.374	7.1	0.180	1202.36	923.4	5255.67	16579.0	5.625	31.9		
	RodB3_56.9	171	56.9	1.445	9.9	0.251	1195.24	919.4	4692.76	14803.3	5.061	28.7		
	RodB3_60.1	172	60.1	1.527	13.1	0.333	750.40	672.3	4483.21	14142.3	9.294	52.8		
	RodB3_66.1	173	66.1	1.679	19.1	0.485	812.33	706.7	5082.10	16031.5	9.336	53.0		
	RodB3_69.9	174	69.9	1.775	-0.98	-0.025	840.37	722.2	5180.16	16340.8	9.050	51.4		
	RodB3_73	175	73	1.854	2.12	0.054	875.12	741.6	5326.82	16803.5	8.774	49.8		
	RodB3_75	176	75	1.905	4.12	0.105	925.66	769.6	5622.80	17737.1	8.550	48.6		
Gr-8	RodF3_50.1	89	50.1	1.273	3.1	0.079	1053.33	840.6	6985.96	22037.2	8.896	50.5		
	RodF3_54	90	54	1.372	7	0.178	1084.82	858.0	7075.81	22320.6	8.663	49.2		
	RodF3_57	91	57	1.448	10	0.254	744.20	668.8	4479.29	14129.9	9.406	53.4		
	RodF3_60	92	60	1.524	13	0.330	778.03	687.6	5062.89	15970.9	9.927	56.4		
	RodF3_66.1	93	66.1	1.679	19.1	0.485	824.40	713.4	5155.45	16262.9	9.266	52.6		
	RodF3_70	94	70	1.778	-0.88	-0.022	876.96	742.6	5289.03	16684.2	8.685	49.3		
	RodF3_73	95	73	1.854	2.12	0.054	934.28	774.4	5582.55	17610.2	8.379	47.6		
	RodF3_75	96	75	1.905	4.12	0.105	907.11	759.3	6064.63	19130.9	9.489	53.9		
Gr-8	RodE6_50.2	121	50.2	1.275	3.2	0.081	532.67	551.3	3287.00	10368.8	12.419	70.5		
	RodE6_54.1	122	54.1	1.374	7.1	0.180	576.93	575.9	3635.03	11466.7	11.767	66.8		
	RodE6_57	123	57	1.448	10	0.254	600.19	588.8	3927.90	12390.5	11.824	67.1		
	RodE6_60.2	124	60.2	1.529	13.2	0.335	673.53	629.6	4124.31	13010.1	10.170	57.8		
	RodE6_66.1	125	66.1	1.679	19.1	0.485	697.23	642.7	4221.10	13315.5	9.834	55.8		
	RodE6_70	126	70	1.778	-0.88	-0.022	728.16	659.9	4365.95	13772.4	9.488	53.9		
	RodE6_73.1	127	73.1	1.857	2.22	0.056	772.31	684.4	4947.28	15606.2	9.810	55.7		
	RodE6_75	128	75	1.905	4.12	0.105	805.21	702.7	5143.04	16223.7	9.574	54.4		

RBHT Steam Cooling with Droplet Injection Test SCD-4029-A

Matrix Test # Shakedown

Test Conditions

Test Date – 9/22/2005

Steady State Time Window: 9000 - 9900

Upper Plenum Pressure: 2.76 bar (40 psia)

Bundle Power: 80.0 kW

Bundle Inlet Reynolds Number: 10000

Bundle Inlet Steam Flow: 199.9 kg/hr (438 lbm/hr)

Droplet Injection Flow: 0.0076 kg/s (0.0167 lbm/s)

Droplet Injection Hole Diameter: 0.381 mm (.015 in)

Droplet Injection Elevation: 1.295 m (51 in)

Bundle Flow Area: $4.656 \times 10^{-3} \text{ m}^2$ ($5.012 \times 10^{-2} \text{ ft}^2$)

Test Notes

- No steam probes were traversed in this steady state window.

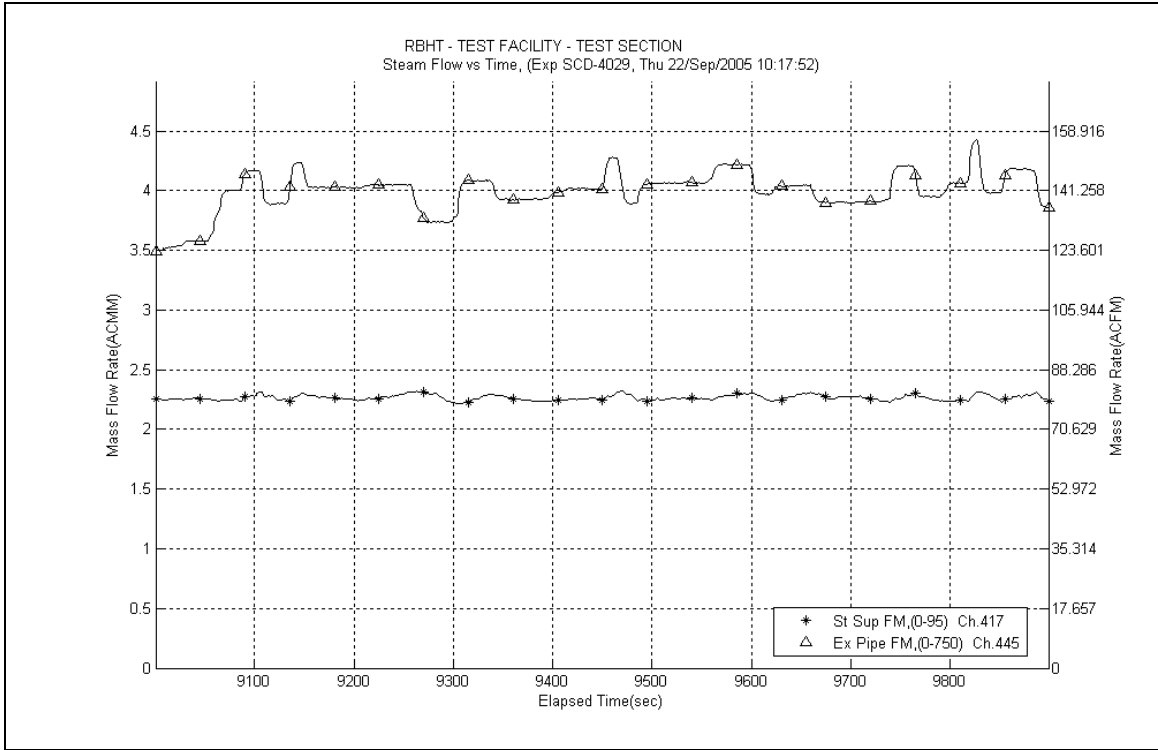

Figure A-15: Inlet and Exhaust Steam Flow Rates for Experiment 4029A

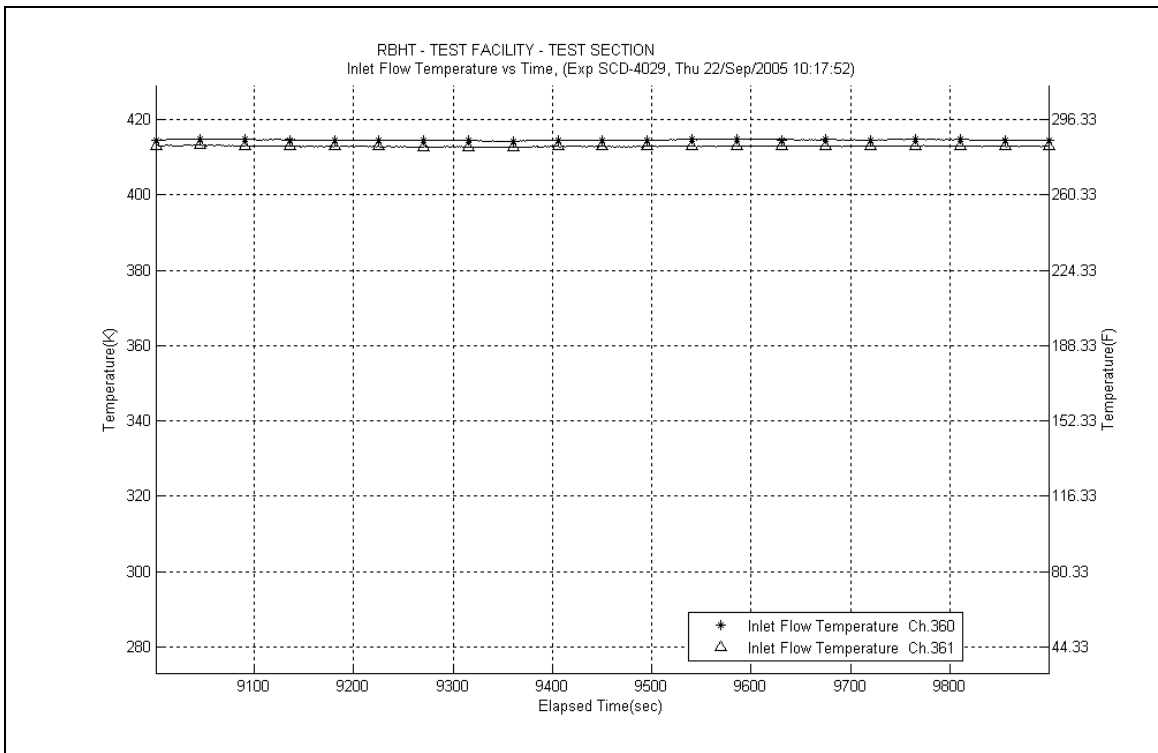

Figure A-16: Inlet Steam Temperature for Experiment 4029A

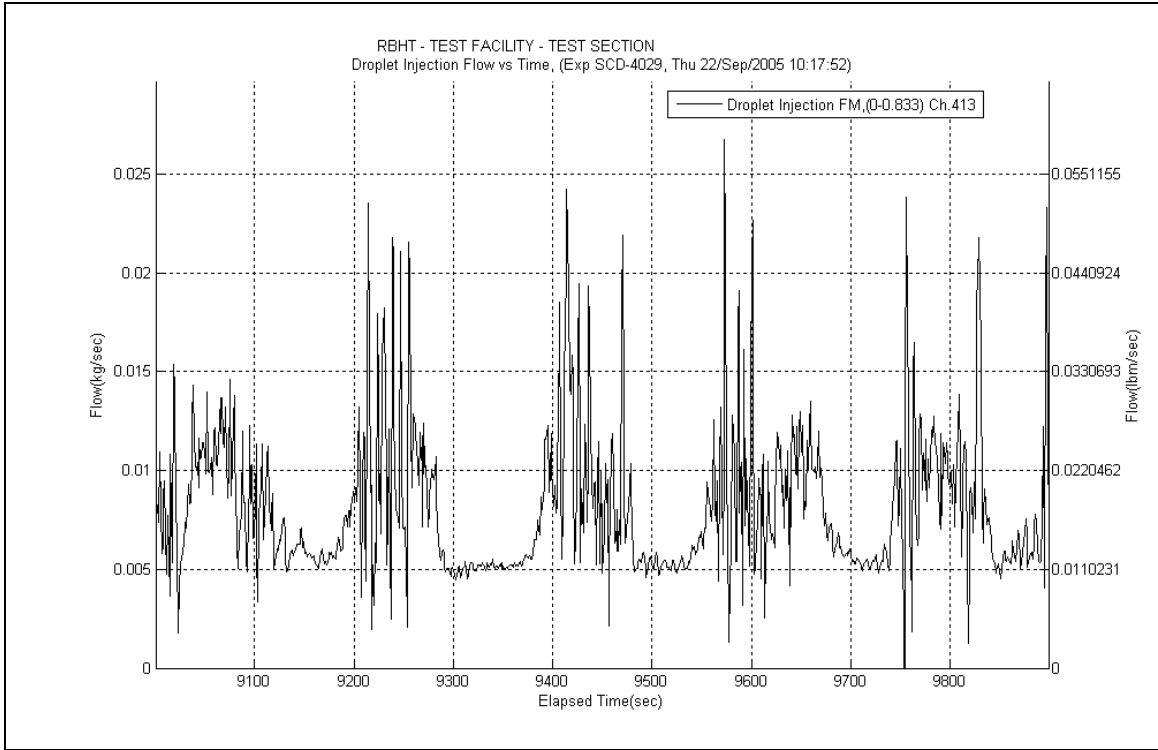

Figure A-17: Droplet Injection Flow Rate for Experiment 4029A

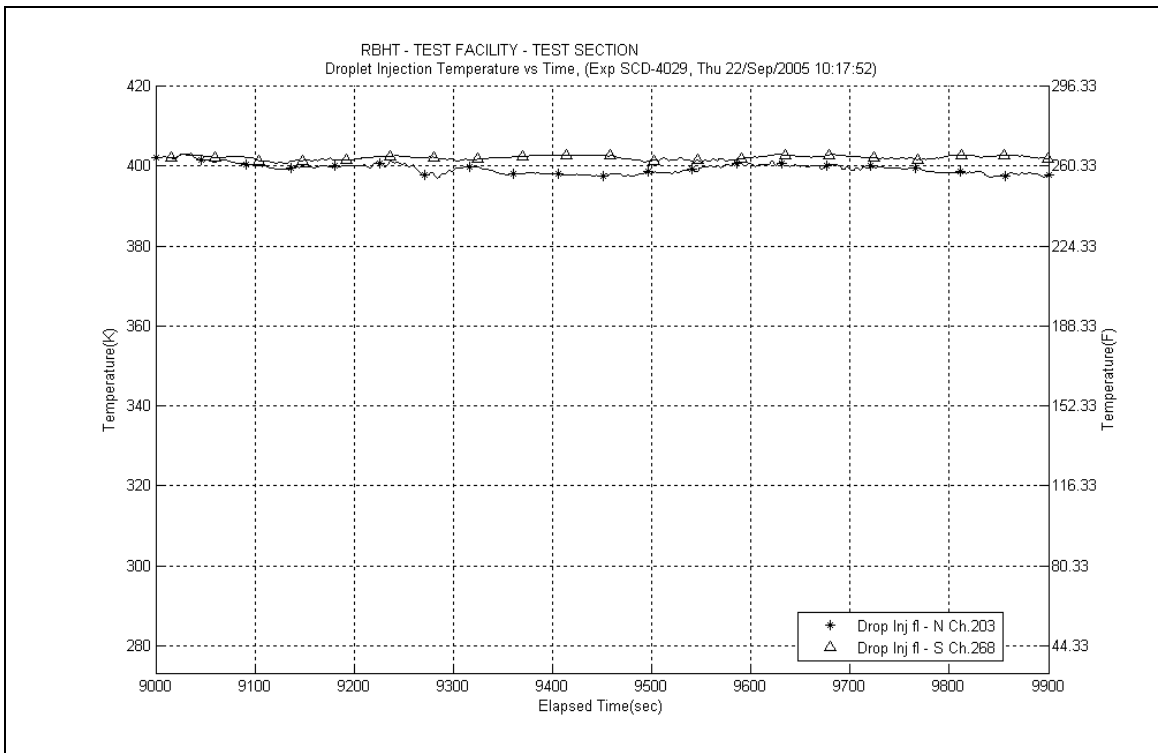

Figure A-18: Droplet Injection Temperature for Experiment 4029A

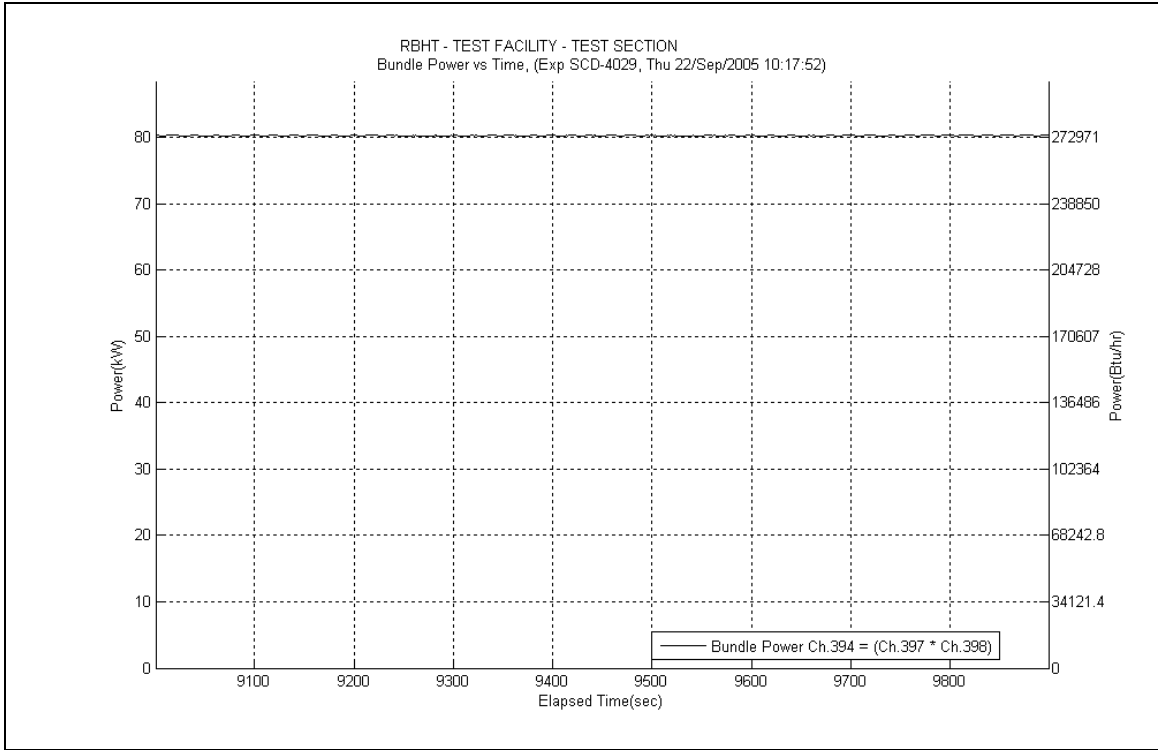

Figure A-19: Bundle Power for Experiment 4029A

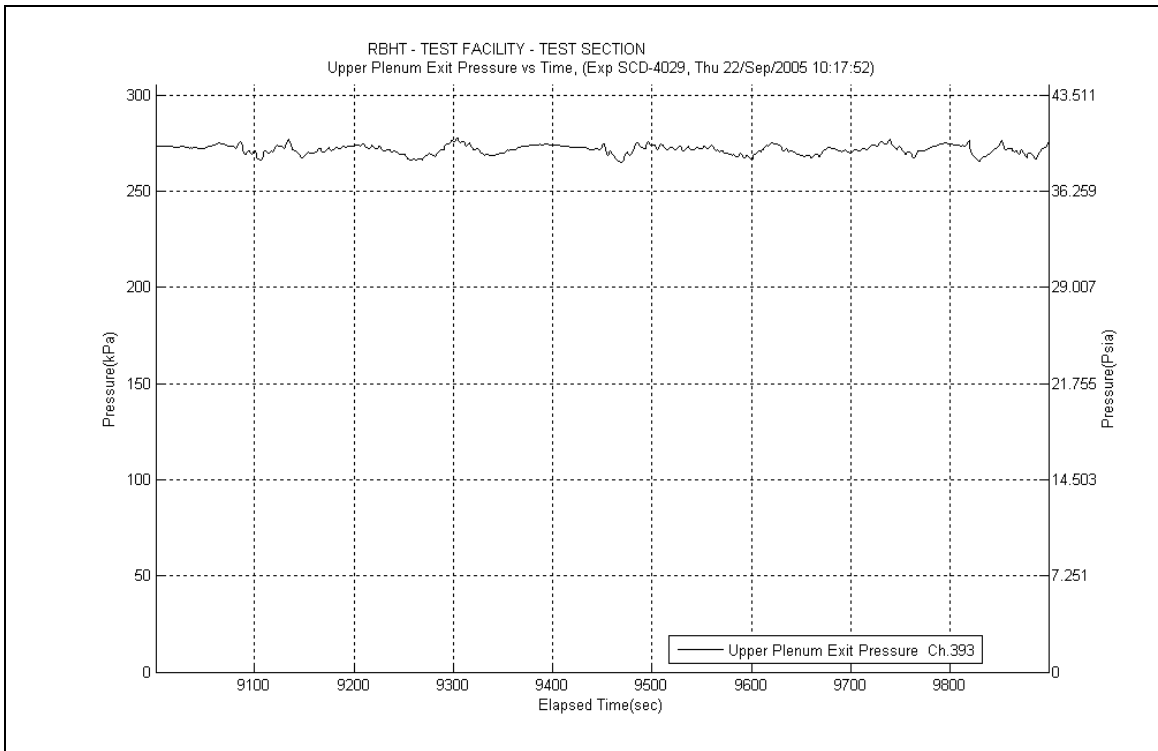

Figure A-20: Upper Plenum Pressure for Experiment 4029A

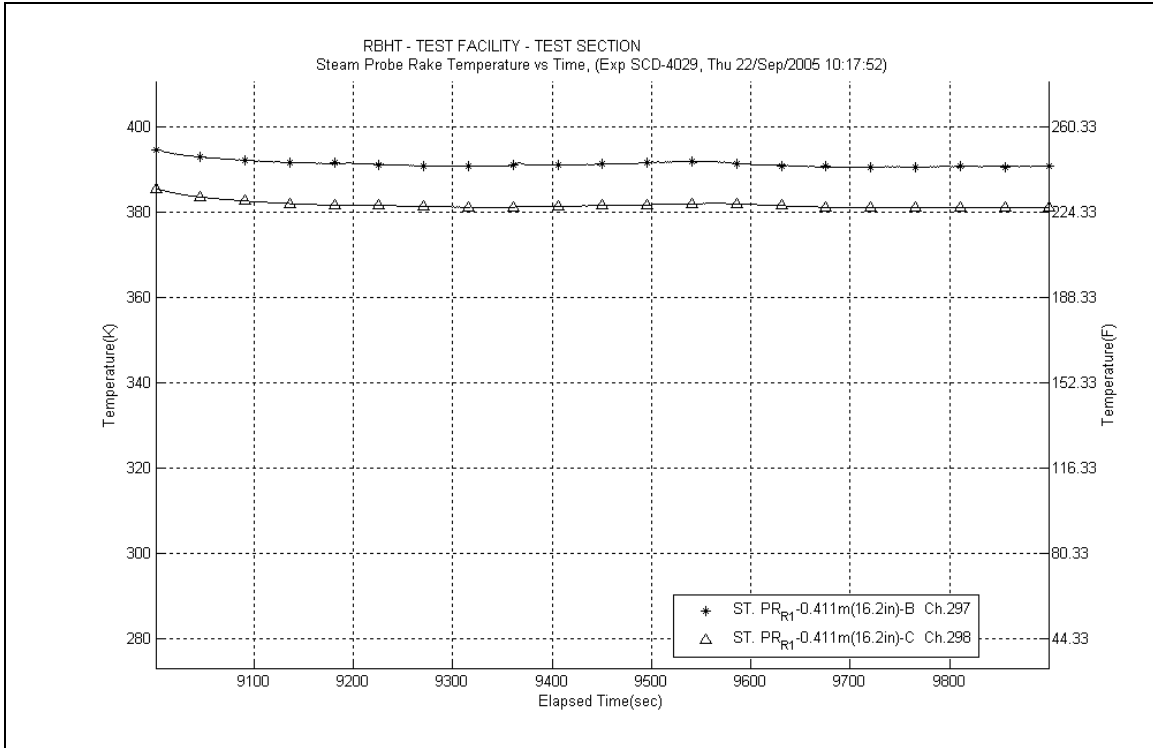

Figure A-21: Steam Probe Rake #1 Temperatures for Experiment 4029A

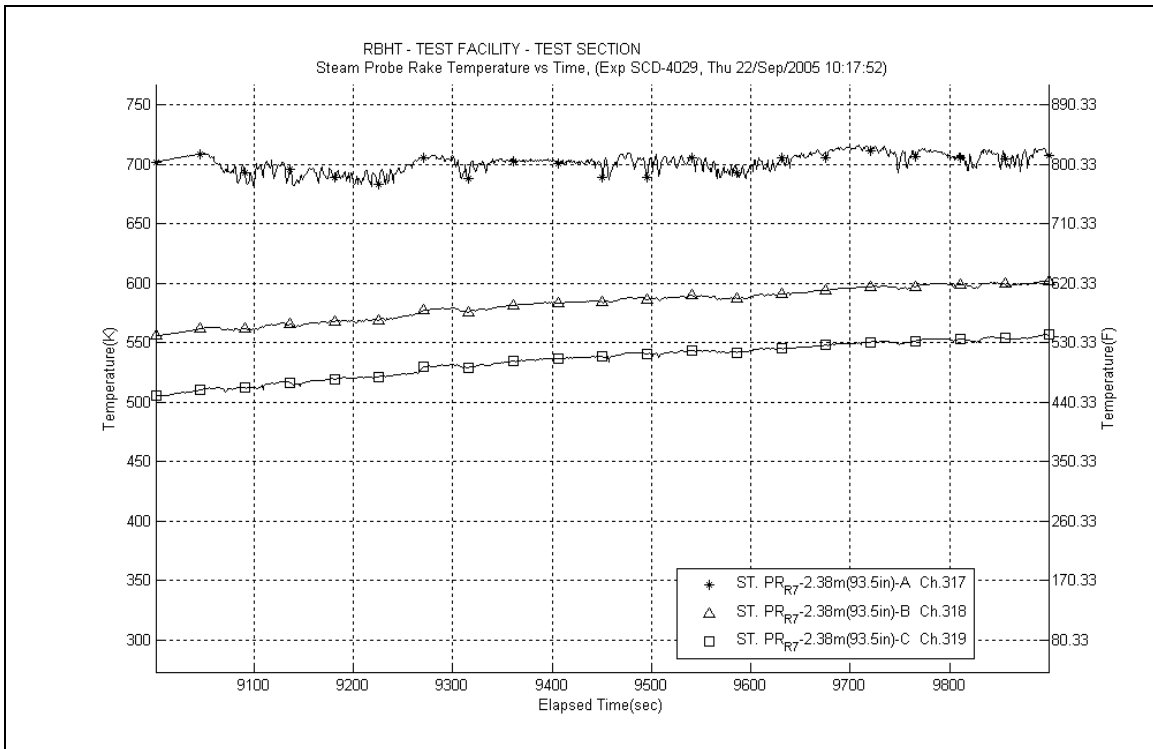

Figure A-22: Steam Probe Rake #7 Temperatures for Experiment 4029A

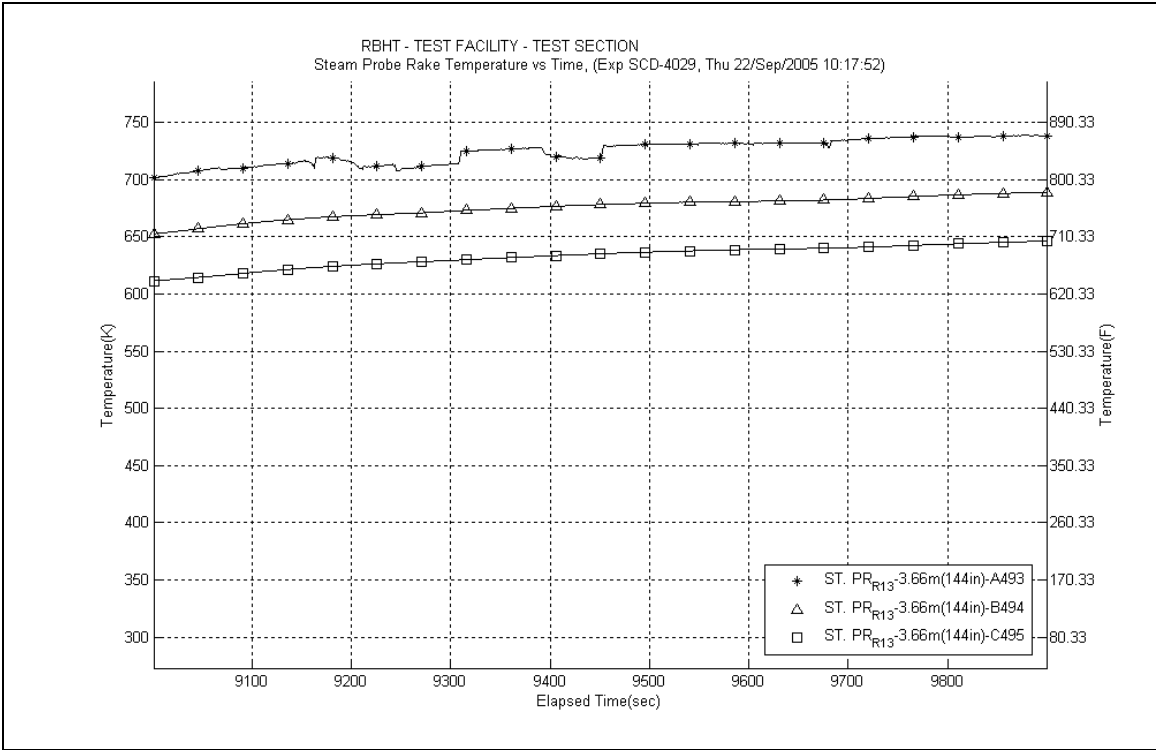

Figure A-23: Steam Probe Rake #13 Temperatures for Experiment 4029A

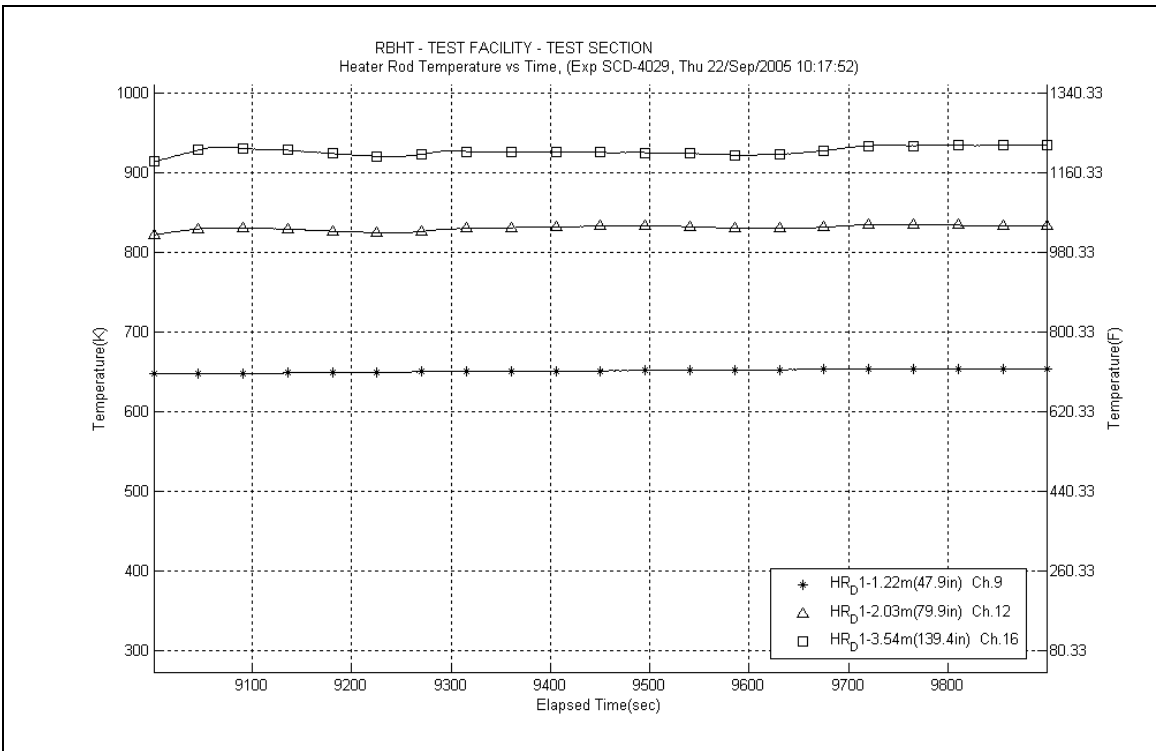

Figure A-24: Heater Rod D1 Temperatures for Experiment 4029A

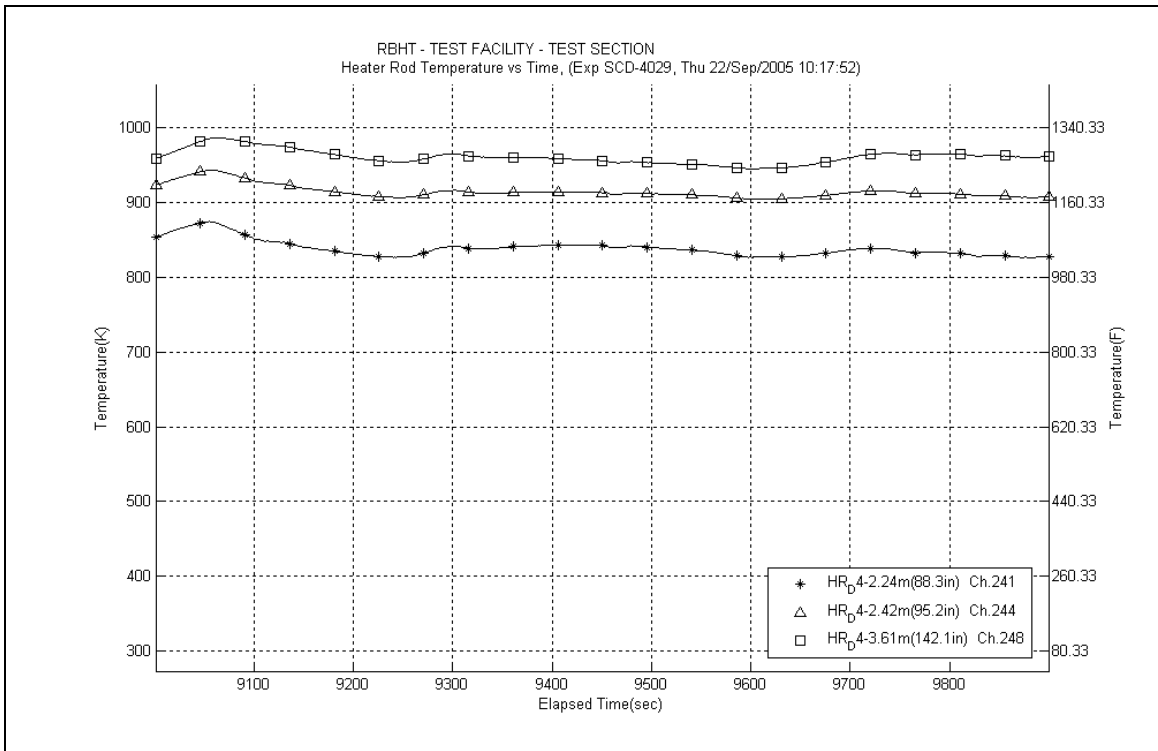

Figure A-25: Heater Rod D4 Temperatures for Experiment 4029A

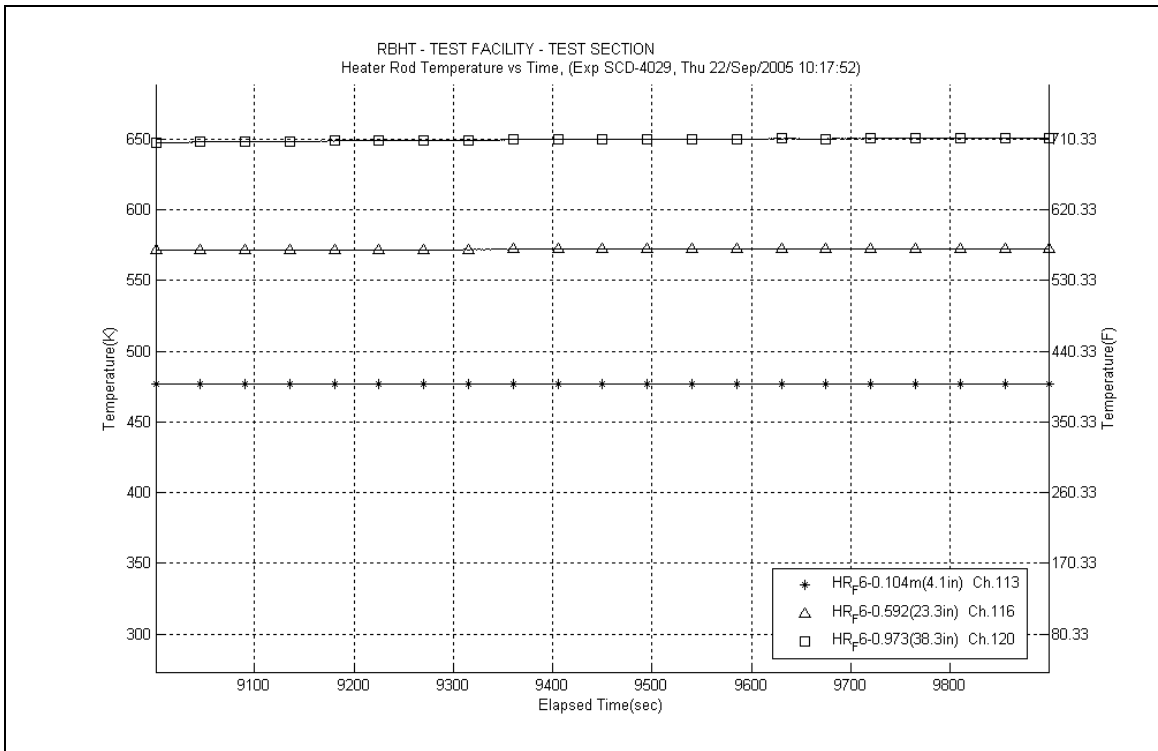

Figure A-26: Heater Rod F6 Temperatures for Experiment 4029A

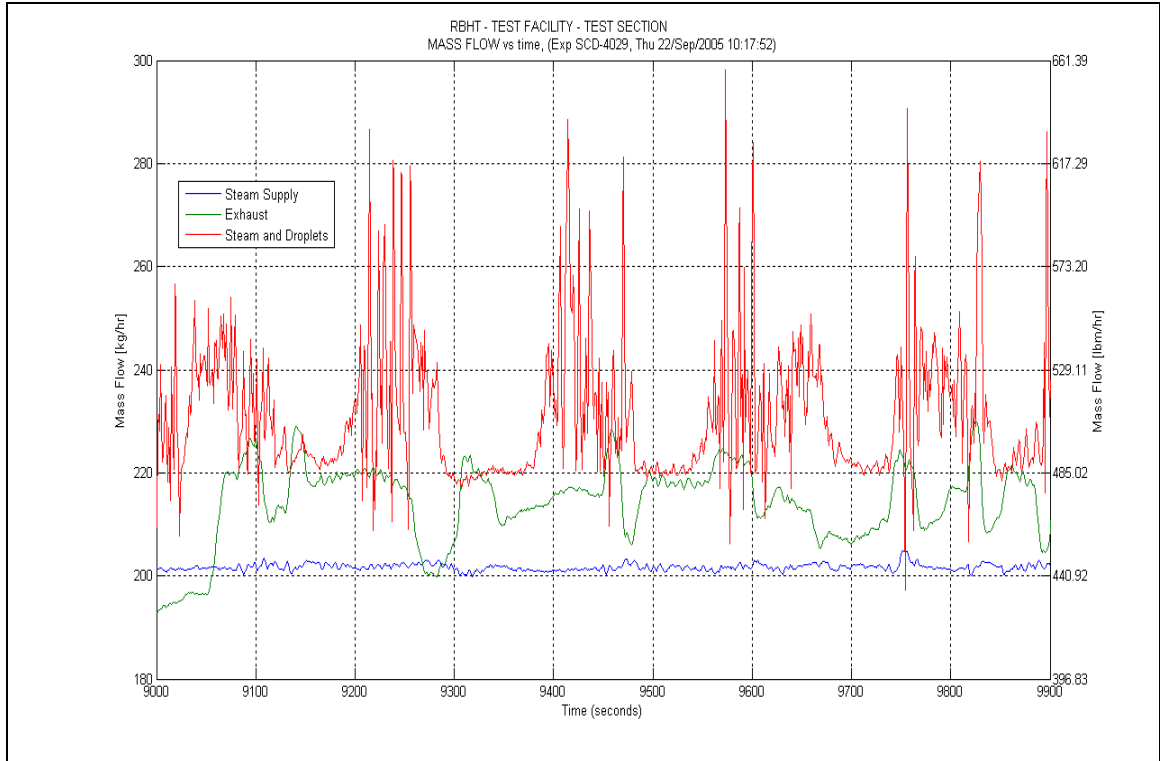

Figure A-27: Mass Flow for Experiment 4029A

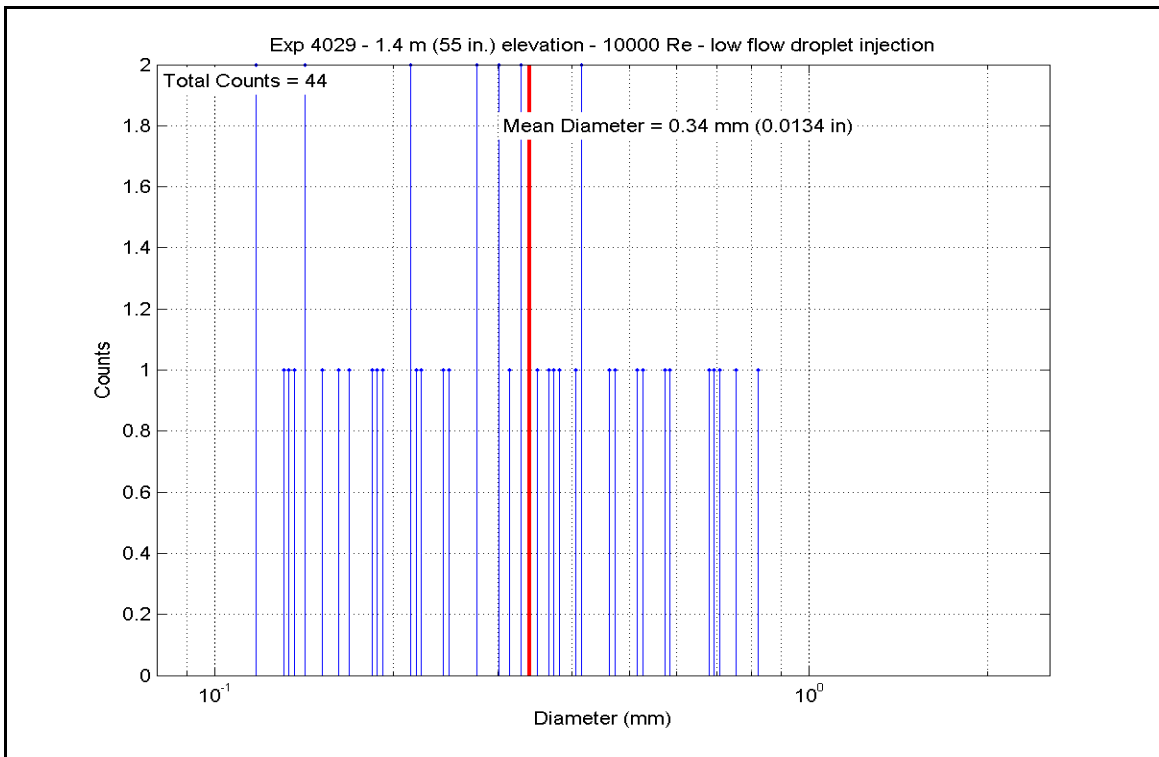

Figure A-28: Droplet Measurements at 1.397 m (55 in.) Elevation for Experiment 4029A

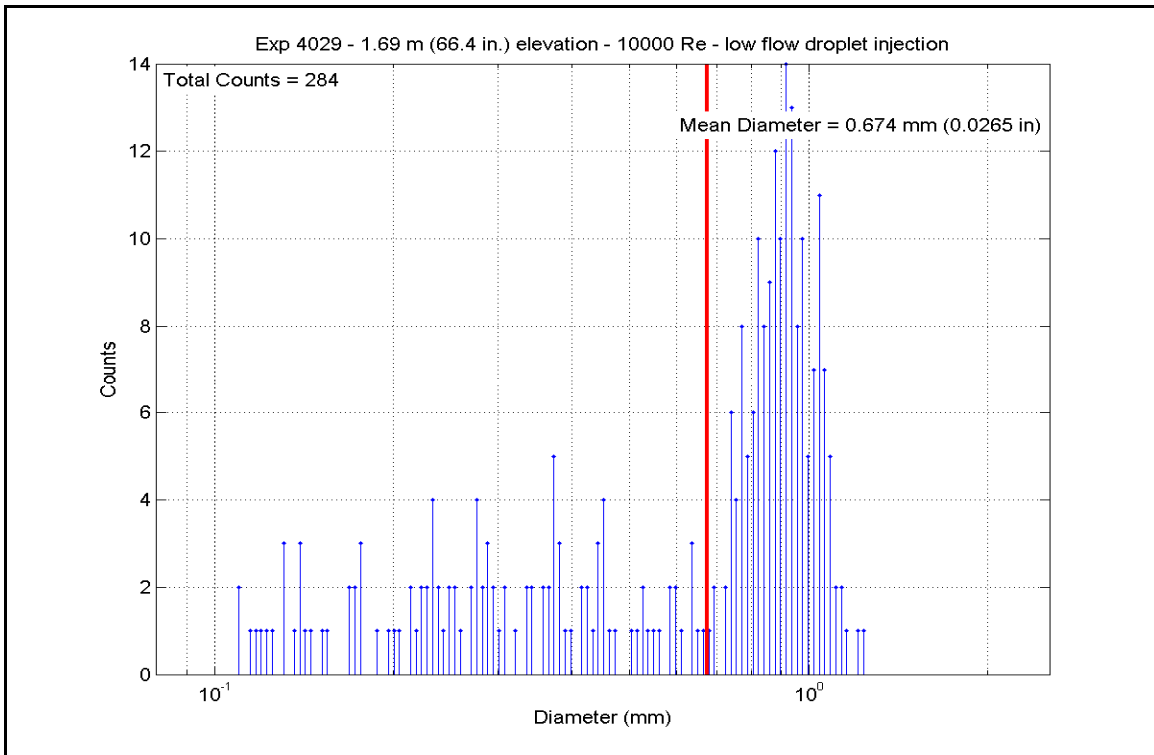

Figure A-29: Droplet Measurements at 1.687 m (66.4 in.) Elevation for Experiment 4029A

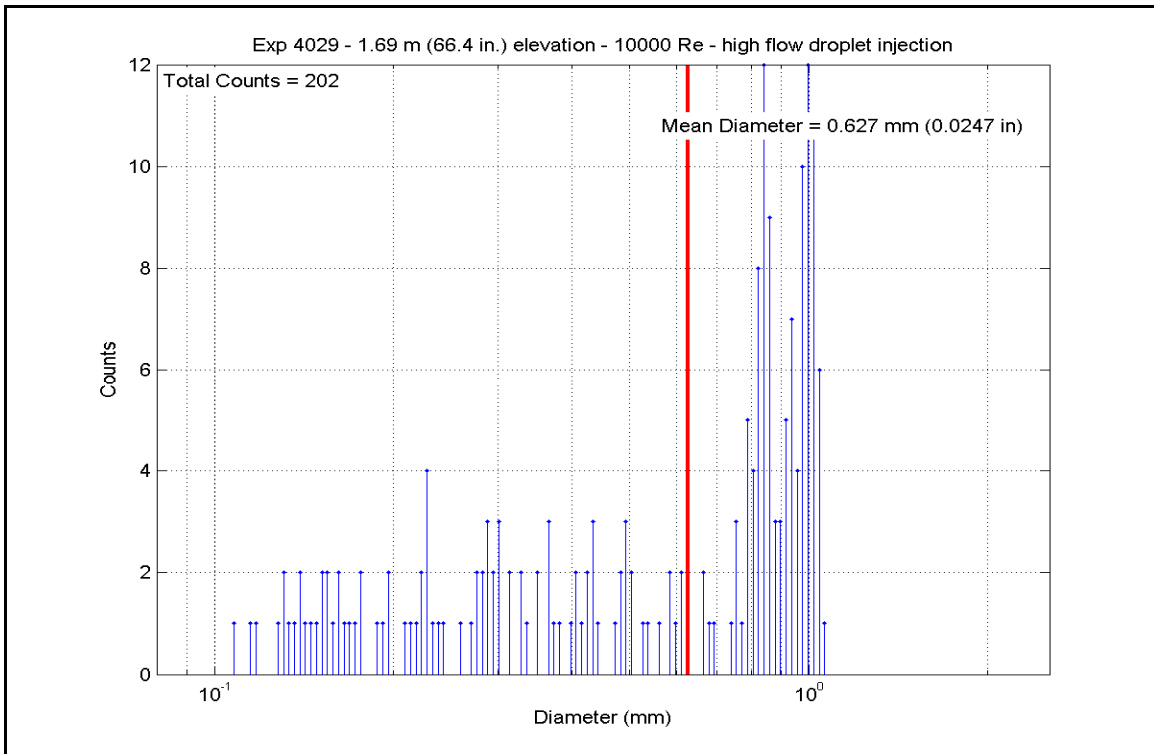

Figure A-30: Droplet Measurements at 1.687 m (66.4 in.) Elevation for Experiment 4029A

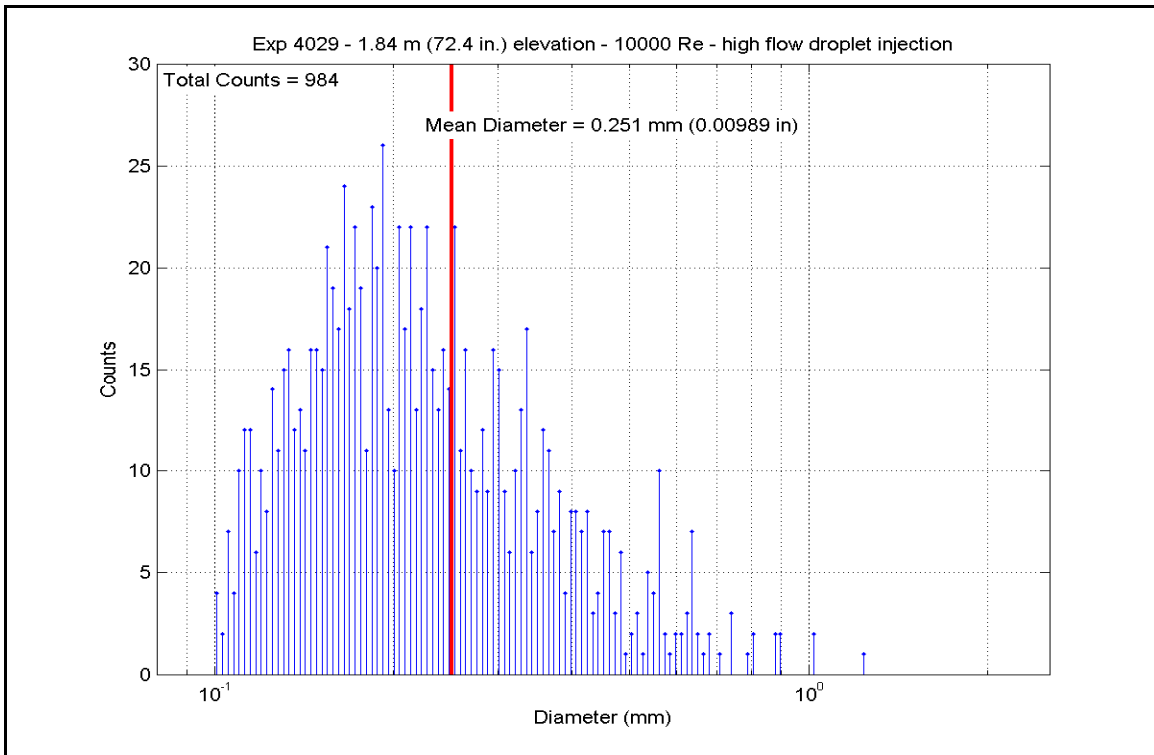

Figure A-31: Droplet Measurements at 1.839 m (72.4 in.) Elevation for Experiment 4029A

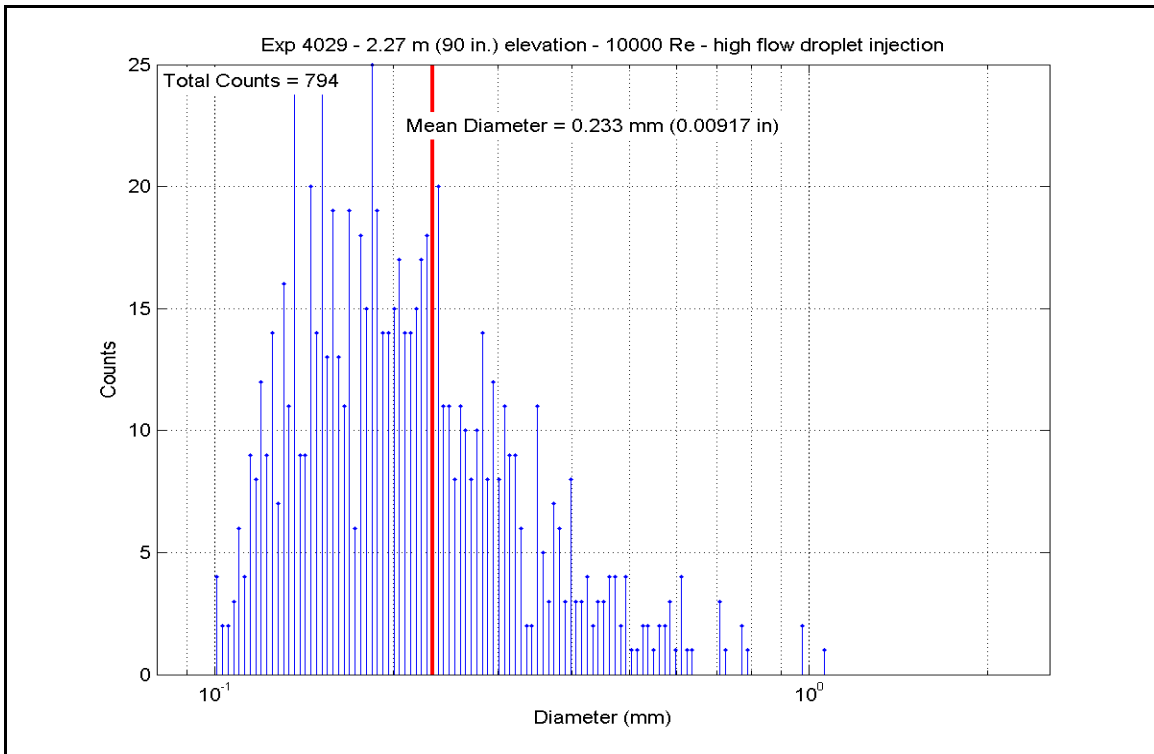

Figure A-32: Droplet Measurements at 2.286 m (90 in.) Elevation for Experiment 4029A

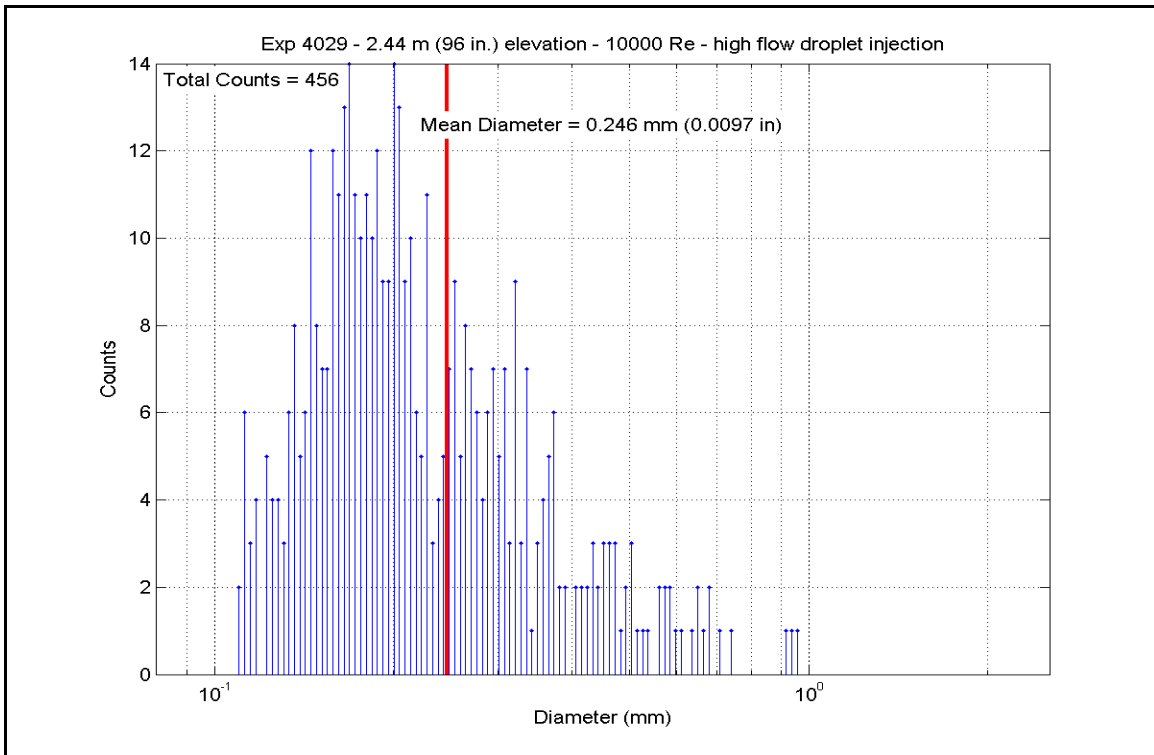

Figure A-33: Droplet Measurements at 2.438 m (96 in.) Elevation for Experiment 4029A

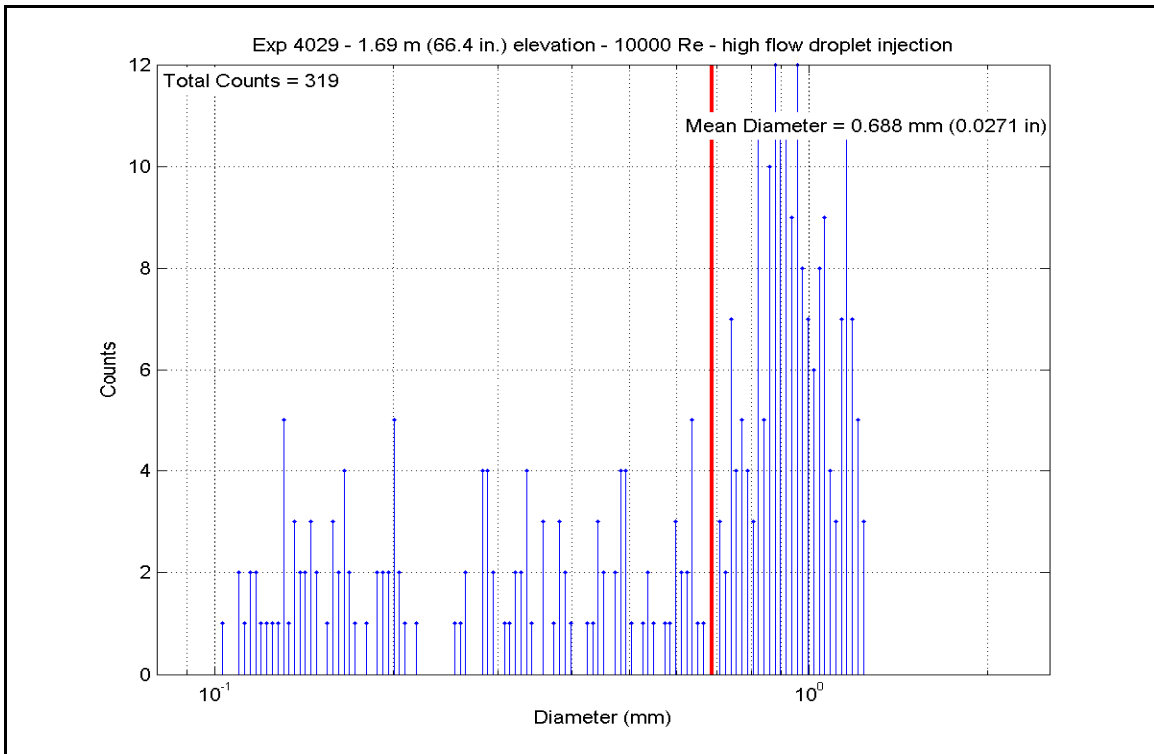

Figure A-34: Droplet Measurements at 1.687 m (66.4 in.) Elevation for Experiment 4029A

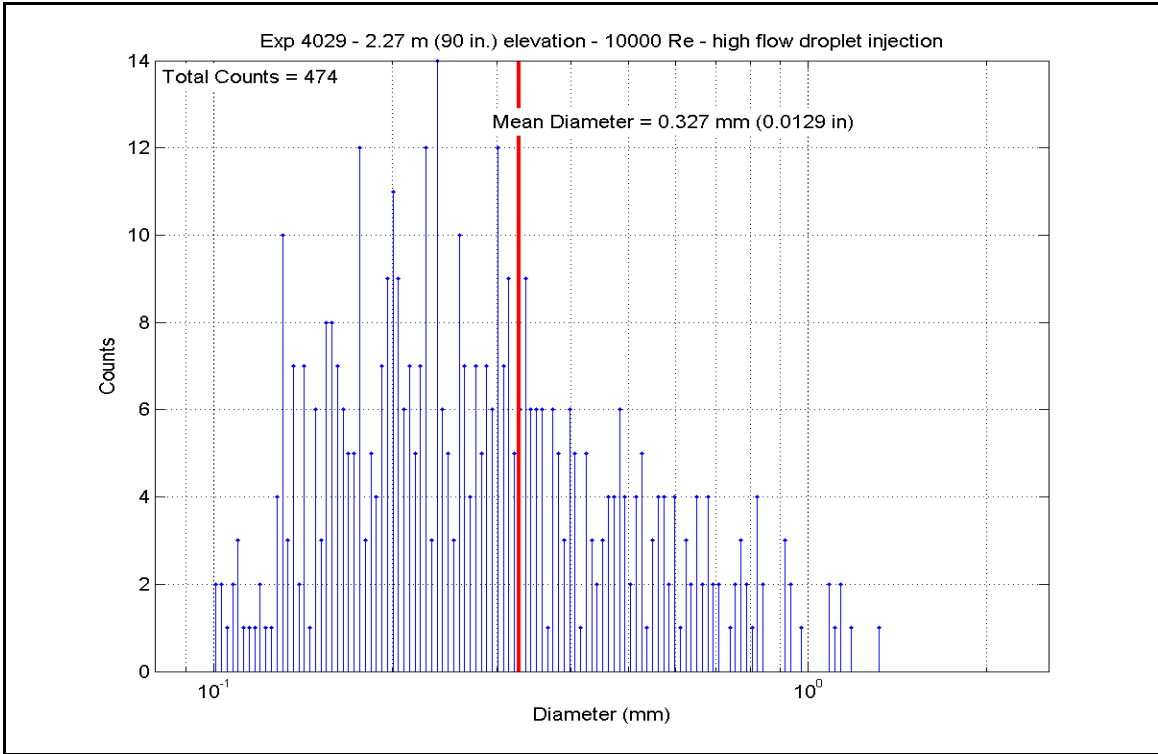

Figure A-35: Droplet Measurements at 2.286 m (90 in.) Elevation for Experiment 4029A

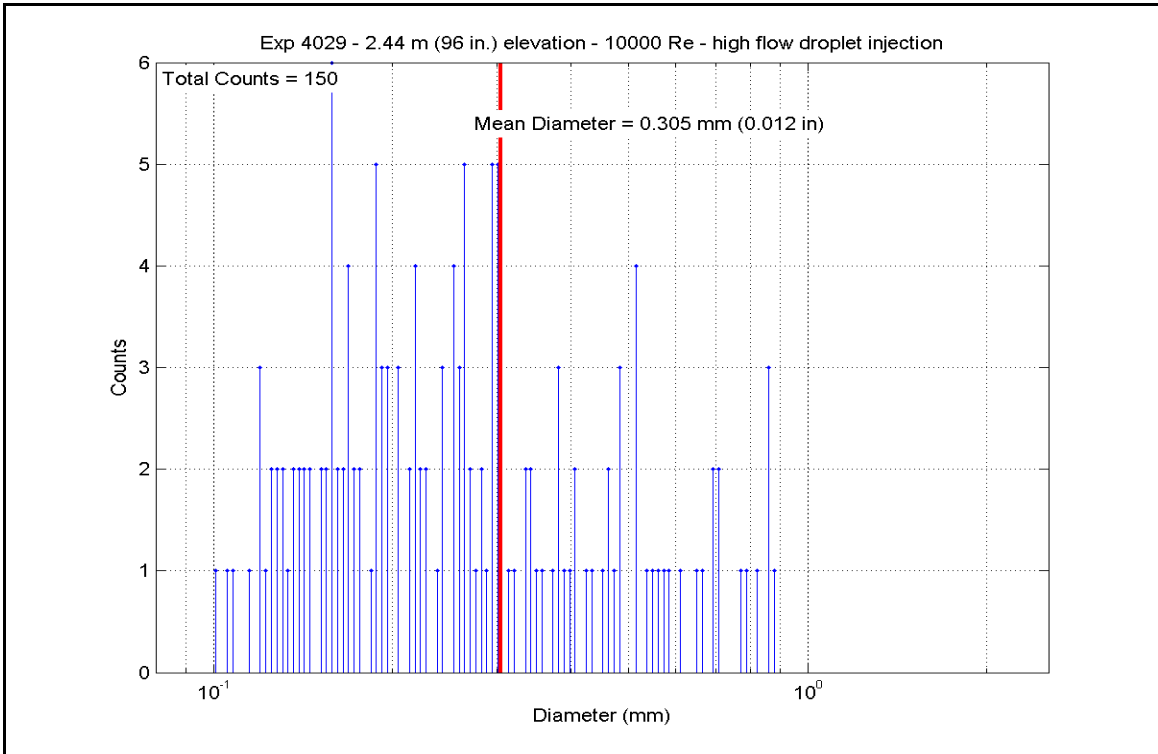

Figure A-36: Droplet Measurements at 2.438 m (96 in.) Elevation for Experiment 4029A

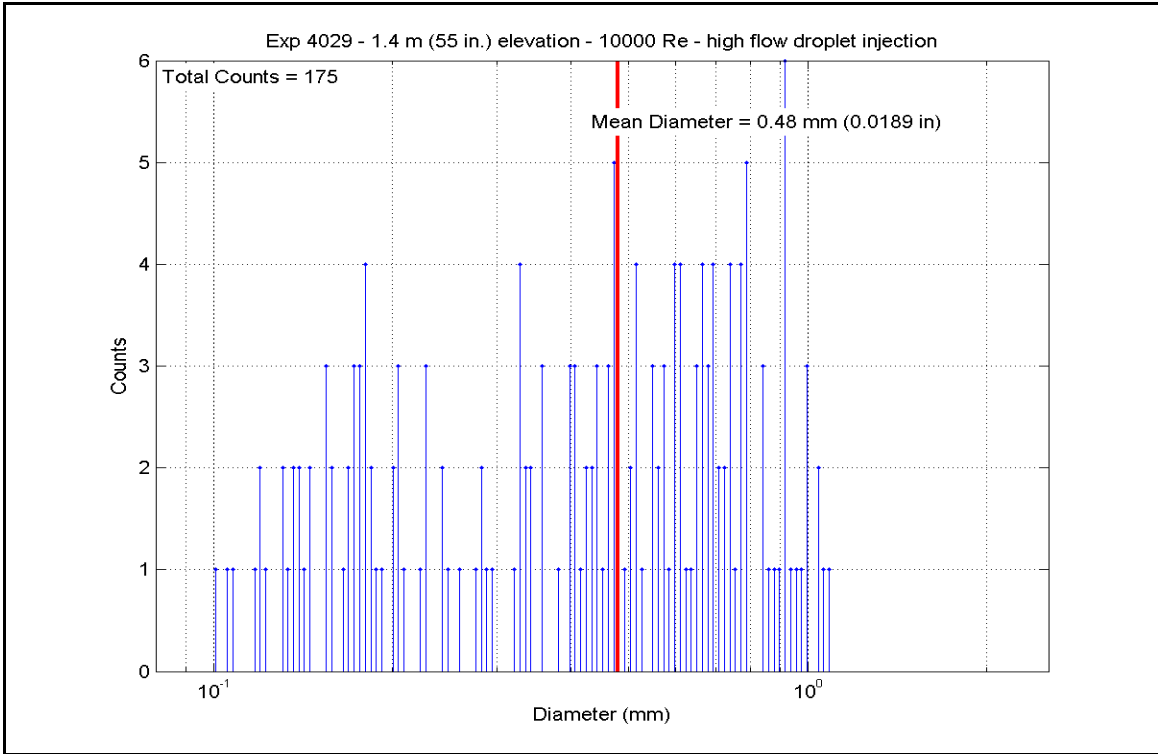

Figure A-37: Droplet Measurements at 1.397 m (55 in.) Elevation for Experiment 4029A

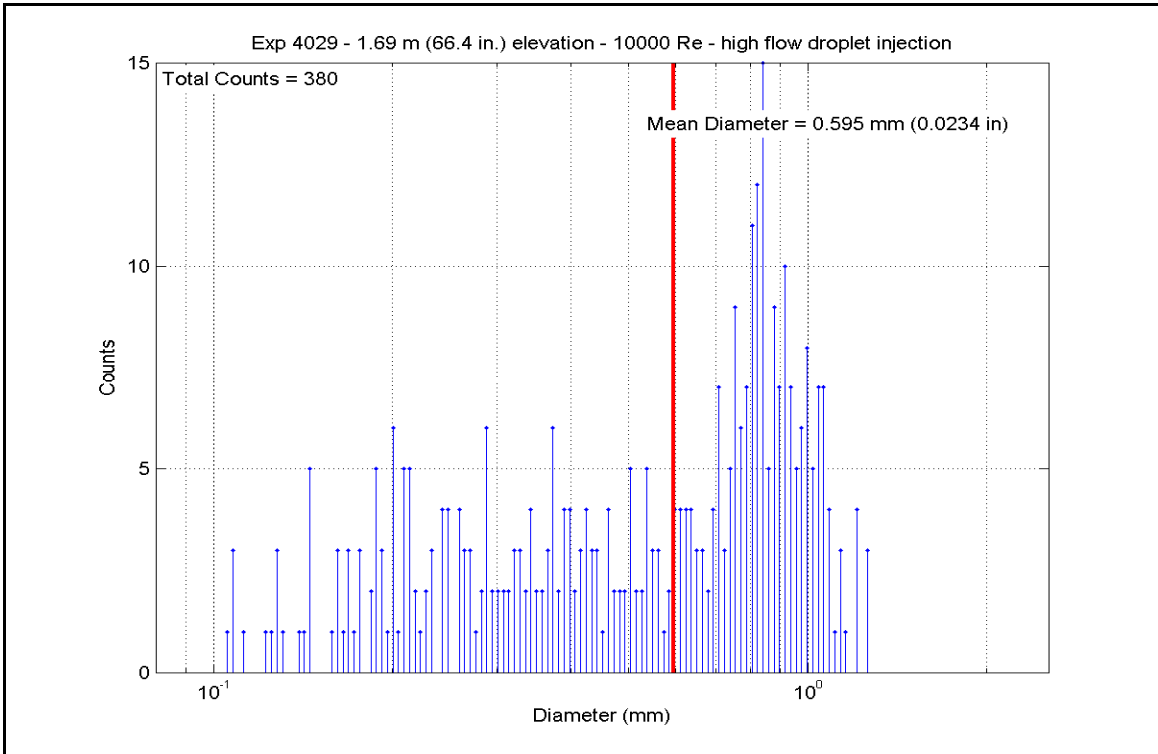

Figure A-38: Droplet Measurements at 1.687 m (66.4 in.) Elevation for Experiment 4029A

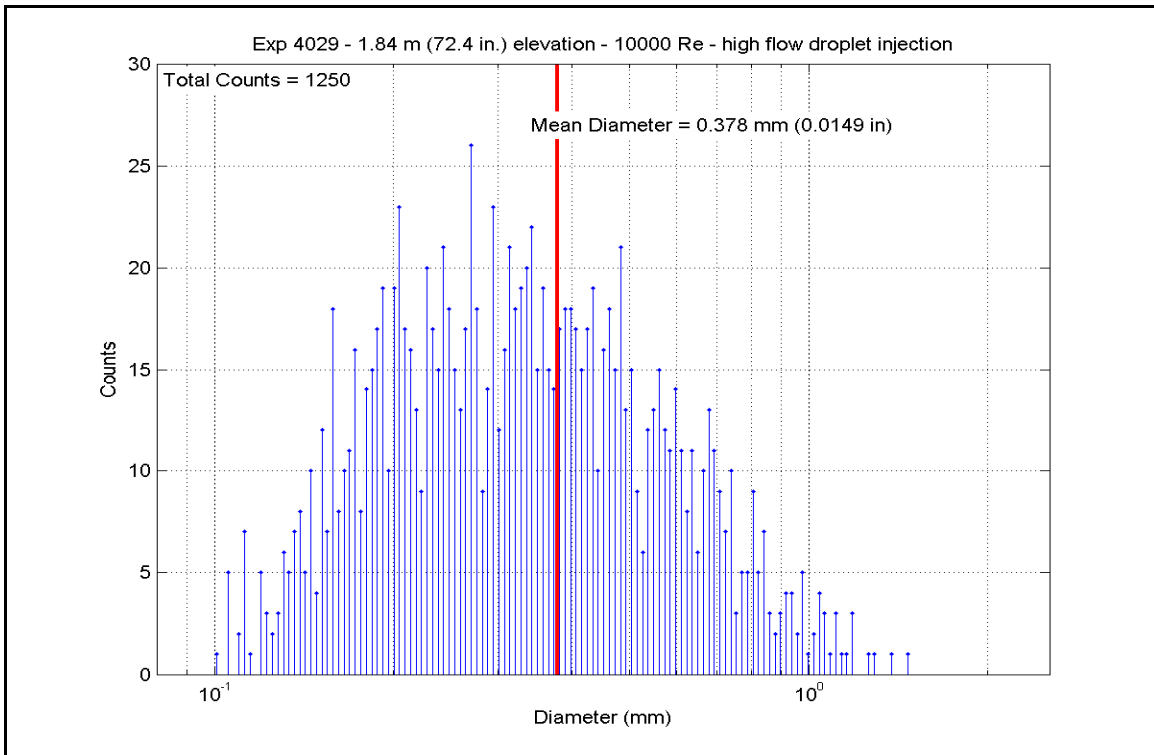

Figure A-39: Droplet Measurements at 1.839 m (72.4 in.) Elevation for Experiment 4029A

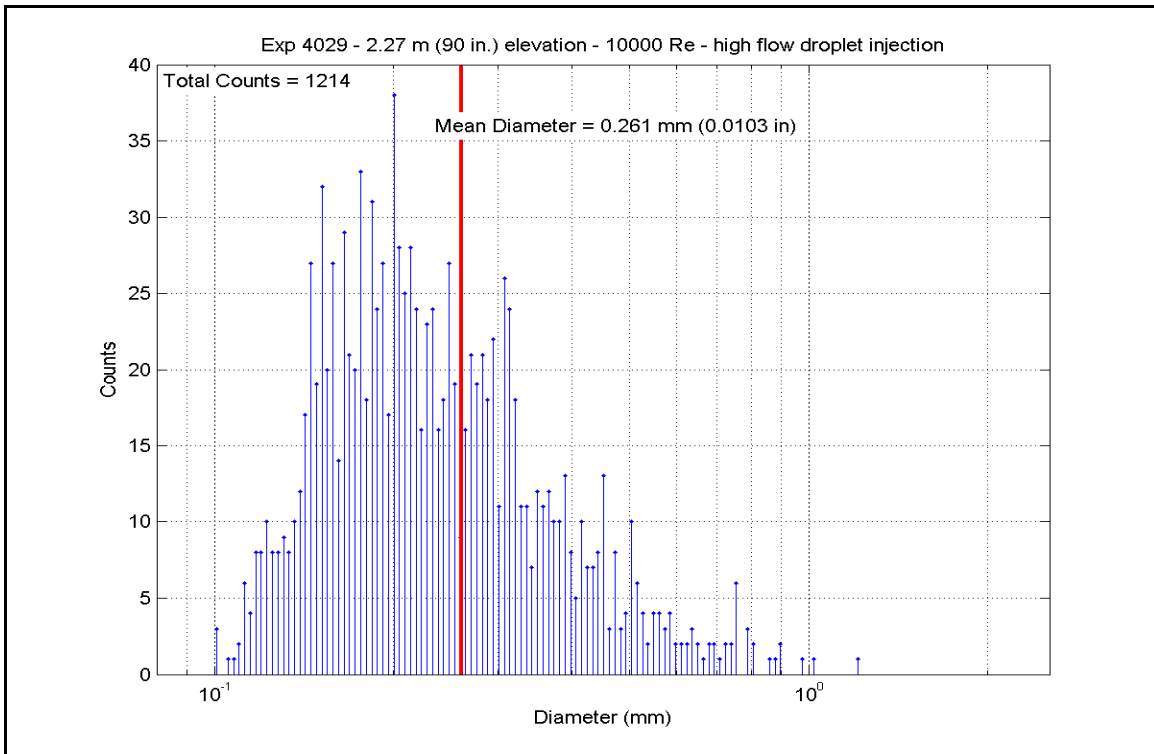

Figure A-40: Droplet Measurements at 2.286 m (90 in.) Elevation for Experiment 4029A

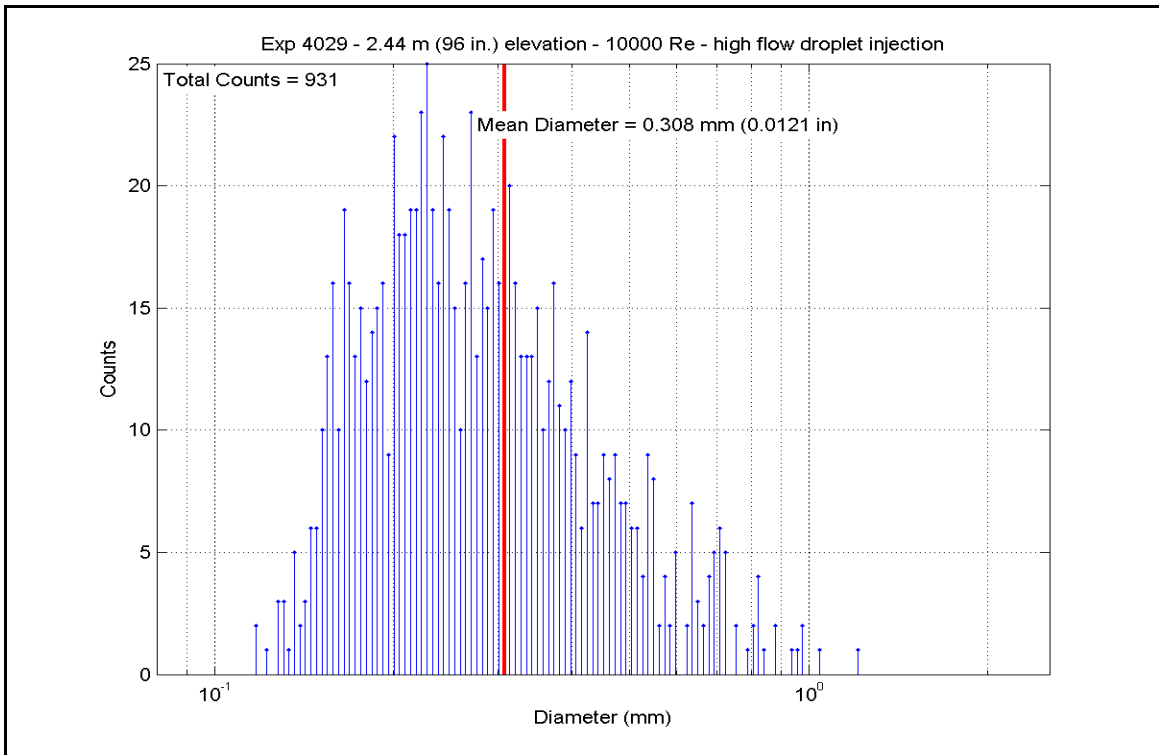

Figure A-41: Droplet Measurements at 2.438 m (96 in.) Elevation for Experiment 4029A

Error! Reference source not found.A

SCD-4029-A		Inlet Reynolds:		10000		40 psia						
Matrix test: shakedown		UP Pressure:		275.8 kPa		272971 Btu/hr						
Time Window: 9000-9900		Bundle Power:		80.00 kW		438.0 lbm/hr						
		Steam flow:		0.0652 kg/s		0.0167 lbm/s						
Inner 3x3		Droplet flow:		0.0076 kg/s								
H.R. ID	H.R. Location	Channel Number	Elevation (m)	Zgrid (in)	Zgrid (m)	H.R. Tw (°F)	H.R. Tw (K)	H.R. q" (Btu/hr-ft2)	H.R. q" (W/m2)	h _{sat} (z) (Btu/hr-ft2-F)	h _{sat} (z) (W/m2-K)	
Gr-3	RodD3_88.3	185	2.243	-0.2	-0.005	1129.02	882.6	6992.07	22056.5	8.121	46.1	
	RodD3_91.3	186	2.319	2.8	0.071	1157.25	898.3	7079.68	22332.8	7.961	45.2	
	RodD3_93.1	187	2.365	4.6	0.117	1034.79	830.3	6873.59	21682.7	8.964	50.9	
	RodD3_95.3	188	2.421	6.8	0.173	1118.26	876.6	7003.68	22093.1	8.237	46.8	
	RodD3_100.1	189	2.543	11.6	0.295	1192.13	917.7	7207.99	22737.6	7.800	44.3	
	RodD3_106.1	190	2.695	17.6	0.447	1278.00	965.4	7603.91	23986.5	7.529	42.8	
	RodD3_110	191	2.794	21.5	0.546	1231.31	939.4	7431.88	23443.9	7.715	43.8	
	RodD3_142.1	192	3.609	8.6	0.218	1031.96	828.7	6832.75	21553.9	8.944	50.8	
Gr-3	RodC4_88.4	233	2.245	-0.1	-0.003	1251.87	950.9	6828.54	21540.6	6.940	39.4	
	RodC4_91.1	234	2.314	2.6	0.066	1269.75	960.8	6363.94	20075.1	6.353	36.1	
	RodC4_93.4	235	2.372	4.9	0.124	1286.88	970.3	5834.25	18404.1	5.726	32.5	
	RodC4_95.3	236	2.421	6.8	0.173	1288.28	971.1	5295.21	16703.7	5.190	29.5	
	RodC4_100.1	237	2.543	11.6	0.295	1190.90	917.0	7385.50	23297.6	8.002	45.4	
	RodC4_106.1	238	2.695	17.6	0.447	1231.39	939.5	7573.78	23891.5	7.862	44.6	
	RodC4_110	239	2.794	21.5	0.546	1250.13	949.9	7711.94	24327.3	7.852	44.6	
	RodC4_142.2	240	3.612	8.7	0.221	958.54	787.9	5650.46	17824.4	8.183	46.5	
Gr-3	RodD4_88.3	241	2.243	-0.2	-0.005	959.32	788.3	6161.76	19437.3	8.913	50.6	
	RodD4_91.3	242	2.319	2.8	0.071	1003.50	812.9	6244.69	19698.9	8.490	48.2	
	RodD4_93.2	243	2.367	4.7	0.119	968.79	793.6	5514.96	17396.9	7.870	44.7	
	RodD4_95.2	244	2.418	6.7	0.170	1277.56	965.1	6604.36	20833.5	6.542	37.2	
	RodD4_100.1	245	2.543	11.6	0.295	1300.44	977.8	7698.33	24284.4	7.456	42.3	
	RodD4_106.1	246	2.695	17.6	0.447	1240.27	944.4	7649.31	24129.8	7.868	44.7	
	RodD4_142.1	248	3.609	8.6	0.218	878.03	743.2	6061.02	19119.5	9.936	56.4	
Gr-3	RodE4_88.4	201	2.245	-0.1	-0.003	1119.75	877.5	6938.48	21887.4	8.146	46.3	
	RodE4_91.2	202	2.316	2.7	0.069	1186.10	914.3	7126.46	22480.4	7.762	44.1	
	RodE4_95.3	204	2.421	6.8	0.173	1261.84	956.4	2778.86	8765.9	2.796	15.9	
	RodE4_100.9	205	2.563	12.4	0.315	1218.43	932.3	7513.14	23700.2	7.905	44.9	
	RodE4_142.3	208	3.614	8.8	0.224	1046.60	836.8	6827.69	21538.0	8.769	49.8	

Error! Reference source not found.A,continued

Gr-4	H.R. Location	Channel Number	Elevation (in)	Elevation (m)	Zgrid (in)	Zgrid (m)	H.R. Tw (°F)	H.R. Tw (K)	H.R. q" (Btu/hr-ft2)	H.R. q" (W/m2)	h _{sat} (z) (Btu/hr-ft2-F)	h _{sat} (z) (W/m2-K)
	RodE3_63.4	193	63.4	1.610	16.4	0.417	1267.59	959.6	3938.99	12425.6	3.941	22.4
	RodE3_113.6	194	113.6	2.885	0.85	0.022	1239.37	943.9	6801.46	21455.2	7.002	39.8
	RodE3_115.5	195	115.5	2.934	2.75	0.070	978.83	799.2	5602.13	17671.9	7.881	44.8
	RodE3_118.5	196	118.5	3.010	5.75	0.146	1283.74	968.6	6684.82	21087.3	6.581	37.4
	RodE3_122.7	197	122.7	3.117	9.95	0.253	1309.38	982.8	6266.01	19766.1	6.017	34.2
	RodE3_126.5	198	126.5	3.213	13.75	0.349	1324.89	991.4	5685.44	17934.7	5.379	30.5
	RodE3_131.7	199	131.7	3.345	-1.8	-0.046	1322.85	990.3	5164.50	16291.4	4.896	27.8
	RodE3_135.6	200	135.6	3.444	2.1	0.053	1247.66	948.5	4522.05	14264.8	4.616	26.2
Gr-4	RodC5_63.7	225	63.7	1.618	16.7	0.424	936.05	775.4	5486.34	17306.7	8.212	46.6
	RodC5_113.6	226	113.6	2.885	0.85	0.022	1199.00	921.5	7081.16	22337.5	7.606	43.2
	RodC5_115.7	227	115.7	2.939	2.95	0.075	1212.40	928.9	4723.04	14898.8	5.001	28.4
	RodC5_122.7	229	122.7	3.117	9.95	0.253	1236.63	942.4	4109.26	12962.7	4.242	24.1
	RodC5_126.7	230	126.7	3.218	13.95	0.354	799.53	699.6	4974.20	15691.1	9.358	53.1
	RodC5_131.6	231	131.6	3.343	-1.9	-0.048	822.40	712.3	5187.51	16364.0	9.357	53.1
	RodC5_135.7	232	135.7	3.447	2.2	0.056	891.16	750.5	5329.26	16811.2	8.552	48.6
Gr-4	RodE5_63.6	209	63.6	1.615	16.6	0.422	1269.52	960.7	2831.64	8932.4	2.827	16.1
	RodE5_113.6	210	113.6	2.885	0.85	0.022	1286.84	970.3	7796.22	24593.2	7.652	43.5
	RodE5_115.4	211	115.4	2.931	2.65	0.067	1182.19	912.1	7324.82	23106.1	8.012	45.5
	RodE5_118.7	212	118.7	3.015	5.95	0.151	1275.92	964.2	2909.60	9178.3	2.887	16.4
	RodE5_122.6	213	122.6	3.114	9.85	0.250	1046.73	836.9	7022.74	22153.2	9.018	51.2
	RodE5_126.6	214	126.6	3.216	13.85	0.352	1122.98	879.2	7135.45	22508.8	8.346	47.4
	RodE5_131.6	215	131.6	3.343	-1.9	-0.048	1156.54	897.9	7221.01	22778.7	8.127	46.2
	RodE5_135.6	216	135.6	3.444	2.1	0.053	1183.66	913.0	7314.20	23072.6	7.988	45.4
Gr-5	RodC3_79.8	177	79.8	2.027	8.92	0.227	1152.63	895.7	7007.48	22105.1	7.921	45.0
	RodC3_85.6	178	85.6	2.174	14.72	0.374	1177.25	909.4	7087.99	22359.1	7.795	44.3
	RodC3_88.5	179	88.5	2.248	0	0.000	1261.81	956.4	2805.93	8851.3	2.823	16.0
	RodC3_92.4	180	92.4	2.347	3.9	0.099	758.59	676.8	4966.77	15667.7	10.124	57.5
	RodC3_94.4	181	94.4	2.398	5.9	0.150	795.45	697.3	5145.20	16230.5	9.755	55.4
	RodC3_97.2	182	97.2	2.469	8.7	0.221	1265.34	958.3	7648.24	24126.4	7.669	43.5
	RodC3_108.8	183	108.8	2.764	20.3	0.516	1201.53	922.9	7238.43	22833.6	7.754	44.0
Gr-8	RodD5_50	217	50	1.270	3	0.076	1210.68	928.0	4840.87	15270.5	5.135	29.2
	RodD5_54.1	218	54.1	1.374	7.1	0.180	1319.54	988.5	5681.26	17921.5	5.403	30.7
	RodD5_56.9	219	56.9	1.445	9.9	0.251	1315.84	986.4	5158.12	16271.3	4.923	28.0
	RodD5_60	220	60	1.524	13	0.330	1239.01	943.7	4644.28	14650.4	4.783	27.2
	RodD5_66.1	221	66.1	1.679	19.1	0.485	1261.08	956.0	4017.83	12674.2	4.046	23.0
	RodD5_69.9	222	69.9	1.775	-0.98	-0.025	1046.59	836.8	7022.36	22152.0	9.019	51.2
	RodD5_72.9	223	72.9	1.852	2.02	0.051	1118.64	876.8	7129.89	22491.2	8.382	47.6
	RodD5_74.9	224	74.9	1.902	4.02	0.102	1154.14	896.6	7236.72	22828.2	8.167	46.4

Error! Reference source not found.A, continued

H.R. ID	H.R. Location	Channel Number	Elevation (in)	Elevation (m)	Zgrid (in)	Zgrid (m)	H.R. Tw (°F)	H.R. Tw (K)	H.R. q" (Btu/hr-ft2)	H.R. q" (W/m2)	h _{sat} (z) (Btu/hr-ft2-F)	h _{sat} (z) (W/m2-K)	
Gr-2	RodB5_41	153	41	1.041	13.5	0.343	527.64	548.5	3302.05	10416.3	12.718	72.2	
	RodB5_52.9	154	52.9	1.344	5.9	0.150	572.62	573.5	3639.76	11481.6	11.949	67.9	
	RodB5_55	155	55	1.397	8	0.203	603.46	590.6	3925.29	12382.3	11.701	66.5	
	RodB5_57.8	156	57.8	1.468	10.8	0.274	668.89	627.0	4116.20	12984.5	10.268	58.3	
	RodB5_64	157	64	1.626	17	0.432	695.10	641.5	4211.24	13284.4	9.860	56.0	
	RodB5_73.9	158	73.9	1.877	3.02	0.077	728.15	659.9	4359.50	13752.0	9.474	53.8	
	RodB5_75.9	159	75.9	1.928	5.02	0.128	747.56	670.7	4508.82	14223.1	9.402	53.4	
	RodB5_76.9	160	76.9	1.953	6.02	0.153	776.79	686.9	5099.74	16087.1	10.023	56.9	
	Gr-2	RodF5_41	105	41	1.041	13.5	0.343	523.96	546.5	3309.41	10439.5	12.929	73.4
		RodF5_53.1	106	53.1	1.349	6.1	0.155	568.74	571.3	3638.92	11479.0	12.100	68.7
	RodF5_55	107	55	1.397	8	0.203	590.18	583.3	3920.61	12367.6	12.169	69.1	
	RodF5_57.8	108	57.8	1.468	10.8	0.274	658.67	621.3	4107.25	12956.3	10.513	59.7	
	RodF5_64	109	64	1.626	17	0.432	679.79	633.0	4200.43	13250.2	10.200	57.9	
	RodF5_73.8	110	73.8	1.875	2.92	0.074	708.06	648.7	4340.29	13691.4	9.863	56.0	
	RodF5_75.8	111	75.8	1.925	4.92	0.125	776.45	686.7	4955.10	15630.9	9.745	55.3	
	RodF5_76.8	112	76.8	1.951	5.92	0.150	818.71	710.2	5147.13	16236.6	9.346	53.1	
Gr-2	RodC2_41	57	41	1.041	13.5	0.343	1165.69	903.0	3050.63	9623.2	3.398	19.3	
	RodC2_53.1	58	53.1	1.349	6.1	0.155	704.86	647.0	4877.86	15387.2	11.166	63.4	
	RodC2_55	59	55	1.397	8	0.203	1005.71	814.1	6343.54	20010.7	8.599	48.8	
	RodC2_57.8	60	57.8	1.468	10.8	0.274	1127.85	882.0	7175.74	22635.9	8.345	47.4	
	RodC2_63.9	61	63.9	1.623	16.9	0.429	1202.89	923.6	6661.04	21012.3	7.125	40.5	
	RodC2_73.8	62	73.8	1.875	2.92	0.074	1235.61	941.8	5047.77	15923.2	5.217	29.6	
	RodC2_75.8	63	75.8	1.925	4.92	0.125	994.03	807.6	6190.96	19529.4	8.527	48.4	
	RodC2_76.8	64	76.8	1.951	5.92	0.150	1006.27	814.4	6236.58	19673.3	8.448	48.0	
	Gr-2	RodC6_40.9	137	40.9	1.039	13.4	0.340	863.20	734.9	5274.21	16637.5	8.861	50.3
		RodC6_52.8	138	52.8	1.341	5.8	0.147	895.35	752.8	5426.09	17116.6	8.649	49.1
	RodC6_54.8	139	54.8	1.392	7.8	0.198	961.07	789.3	5712.53	18020.2	8.242	46.8	
	RodC6_57.8	140	57.8	1.468	10.8	0.274	879.36	743.9	5929.10	18703.3	9.698	55.1	
	RodC6_63.8	141	63.8	1.621	16.8	0.427	960.93	789.2	6067.24	19139.1	8.756	49.7	
	RodC6_73.7	142	73.7	1.872	2.82	0.072	1000.03	810.9	6159.93	19431.5	8.415	47.8	
	RodC6_75.8	143	75.8	1.925	4.92	0.125	1064.51	846.8	6389.13	20154.5	8.021	45.6	
	RodC6_76.8	144	76.8	1.951	5.92	0.150	1033.20	829.4	6698.54	21130.5	8.754	49.7	

Error! Reference source not found.A, continued

5x5 periphery		H.R. Location	Channel Number	Elevation (in)	Elevation (m)	Zgrid (in)	Zgrid (m)	H.R. Tw (°F)	H.R. Tw (K)	H.R. q" (Btu/hr-ft2)	H.R. q" (W/m2)	h _{sat} (z) (Btu/hr-ft2-F)	h _{sat} (z) (W/m2-K)
Gr-3	RodB4_88.4	88.4	2.245	-0.1	-0.003	815.1	6232.11	19659.2	8.427	47.9			
	RodB4_91.3	91.3	2.319	2.8	0.071	824.9	6283.99	19822.8	8.299	47.1			
	RodB4_93.3	93.3	2.370	4.8	0.122	400.13	2727.67	8604.4	20.643	117.2			
	RodB4_95.1	95.1	2.416	6.6	0.168	475.94	3065.01	9668.6	14.740	83.7			
	RodB4_100	100	2.540	11.5	0.292	1241.05	7543.33	23795.4	7.752	44.0			
	RodB4_106	106	2.692	17.5	0.445	1263.07	7675.37	24212.0	7.713	43.8			
	RodB4_109.9	109.9	2.791	21.4	0.544	1206.05	7076.85	22323.9	7.544	42.8			
	RodB4_142.3	142.3	3.614	8.8	0.224	982.16	6121.24	19309.4	8.571	48.7			
Gr-5	RodF4_85.6	85.6	2.174	14.72	0.374	813.3	6164.57	19446.1	8.373	47.5			
	RodF4_88.4	88.4	2.245	-0.1	-0.003	820.6	6211.27	19593.5	8.288	47.1			
	RodF4_92.4	92.4	2.347	3.9	0.099	476.1	2737.09	8634.1	21.176	120.3			
	RodF4_94.3	94.3	2.395	5.8	0.147	478.97	3070.16	9684.8	14.553	82.6			
	RodF4_97.2	97.2	2.469	8.7	0.221	1288.96	7783.23	24552.2	7.623	43.3			
	RodF4_108.8	108.8	2.764	20.3	0.516	1224.73	7591.43	23947.2	7.935	45.1			
	RodF4_111	111	2.819	-1.75	-0.044	1229.00	7495.84	23645.6	7.800	44.3			
	RodD2_103.2	103.2	2.621	14.7	0.373	1205.24	7321.31	23095.1	7.812	44.4			
	RodD2_106	106	2.692	17.5	0.445	1267.01	7584.43	23925.1	7.592	43.1			
	RodD2_112.6	112.6	2.860	-0.15	-0.004	1205.11	7380.27	23281.1	7.876	44.7			
Gr-6	RodD2_114.9	114.9	2.918	2.15	0.055	1251.81	6729.86	21229.3	6.841	38.8			
	RodD2_117.4	117.4	2.982	4.65	0.118	1271.55	6364.96	20078.3	6.342	36.0			
	RodD2_120.8	120.8	3.068	8.05	0.204	1296.09	5867.70	18509.6	5.707	32.4			
	RodD2_124.8	124.8	3.170	12.05	0.306	1302.57	5290.45	16688.7	5.114	29.0			
	RodD2_128.6	128.6	3.266	15.85	0.403	1296.13	4750.63	14985.9	4.621	26.2			
	RodD6_103.1	103.1	2.619	14.6	0.371	1253.37	6954.27	21937.3	7.058	40.1			
	RodD6_106	106	2.692	17.5	0.445	1242.46	7385.10	23296.3	7.579	43.0			
	RodD6_112.9	112.9	2.868	0.15	0.004	1227.17	7000.84	22084.1	7.299	41.4			
	RodD6_114.9	114.9	2.918	2.15	0.055	799.01	4976.49	15698.3	9.372	53.2			
	RodD6_116.8	116.8	2.967	4.05	0.103	821.94	5175.68	16326.7	9.343	53.1			
RodD6_120.9	120.9	3.071	8.15	0.207	1153.88	7085.79	22352.1	7.999	45.4				
RodD6_124.8	124.8	3.170	12.05	0.306	1186.59	7193.15	22690.8	7.831	44.5				
RodD6_128.7	128.7	3.269	15.95	0.405	1271.40	2614.25	8246.7	2.605	14.8				

Error! Reference source not found.A, continued

5x5 periphery		H.R.	Channel	Elevation	Elevation	Zgrid	Zgrid	H.R. Tw	H.R. Tw	H.R. q"	H.R. q"	h _{sat} (z)	h _{sat} (z)
Gr-8	Location	Number	(in)	(m)	(m)	(in)	(m)	(°F)	(K)	(W/m ²)	(Btu/hr-ft ²)	(W/m ² -K)	(Btu/hr-ft ² -F)
	RodE2_50.1	73	50.1	1.273	3.1	0.079	870.90	739.2	5319.03	16778.9	8.822	50.1	8.822
	RodE2_54	74	54	1.372	7	0.178	905.38	758.4	5465.31	17240.3	8.575	48.7	8.575
	RodE2_56.9	75	56.9	1.445	9.9	0.251	955.47	786.2	5754.20	18151.6	8.370	47.5	8.370
	RodE2_59.9	76	59.9	1.521	12.9	0.328	881.50	745.1	5961.17	18804.5	9.717	55.2	9.717
	RodE2_66	77	66	1.676	19	0.483	959.25	788.3	6096.21	19230.5	8.819	50.1	8.819
	RodE2_69.8	78	69.8	1.773	-1.08	-0.027	990.84	805.8	6194.18	19539.5	8.569	48.7	8.569
	RodE2_72.9	79	72.9	1.852	2.02	0.051	405.97	480.9	2687.85	8478.8	19.482	110.6	19.482
	RodE2_74.9	80	74.9	1.902	4.02	0.102	483.56	524.0	3036.42	9578.4	14.086	80.0	14.086
Gr-8	RodB3_50.2	169	50.2	1.275	3.2	0.081	1273.91	963.1	5888.35	18574.8	5.854	33.2	5.854
	RodB3_54.1	170	54.1	1.374	7.1	0.180	1277.73	965.2	5325.50	16799.3	5.274	30.0	5.274
	RodB3_56.9	171	56.9	1.445	9.9	0.251	1271.77	961.9	4761.87	15021.3	4.744	26.9	4.744
	RodB3_60.1	172	60.1	1.527	13.1	0.333	749.55	671.8	4485.08	14148.2	9.314	52.9	9.314
	RodB3_66.1	173	66.1	1.679	19.1	0.485	811.67	706.3	5102.70	16096.5	9.386	53.3	9.386
	RodB3_69.9	174	69.9	1.775	-0.98	-0.025	843.35	723.9	5199.04	16400.4	9.036	51.3	9.036
	RodB3_73	175	73	1.854	2.12	0.054	882.54	745.7	5347.78	16869.6	8.702	49.4	8.702
	RodB3_75	176	75	1.905	4.12	0.105	939.07	777.1	5636.65	17780.8	8.399	47.7	8.399
Gr-8	RodF3_50.1	89	50.1	1.273	3.1	0.079	1136.52	886.8	7017.51	22136.7	8.080	45.9	8.080
	RodF3_54	90	54	1.372	7	0.178	1165.27	902.7	7104.86	22412.3	7.918	45.0	7.918
	RodF3_57	91	57	1.448	10	0.254	744.22	668.8	4479.04	14129.1	9.405	53.4	9.405
	RodF3_60	92	60	1.524	13	0.330	776.29	686.6	5071.73	15998.8	9.978	56.7	9.978
	RodF3_66.1	93	66.1	1.679	19.1	0.485	826.62	714.6	5161.57	16282.2	9.240	52.5	9.240
	RodF3_70	94	70	1.778	-0.88	-0.022	884.28	746.6	5299.31	16716.7	8.599	48.8	8.599
	RodF3_73	95	73	1.854	2.12	0.054	943.65	779.6	5594.01	17646.3	8.279	47.0	8.279
	RodF3_75	96	75	1.905	4.12	0.105	971.88	795.3	6071.35	19152.1	8.626	49.0	8.626
Gr-8	RodE6_50.2	121	50.2	1.275	3.2	0.081	532.94	551.4	3281.91	10352.8	12.387	70.3	12.387
	RodE6_54.1	122	54.1	1.374	7.1	0.180	577.07	576.0	3632.23	11457.9	11.752	66.7	11.752
	RodE6_57	123	57	1.448	10	0.254	601.09	589.3	3919.65	12364.5	11.768	66.8	11.768
	RodE6_60.2	124	60.2	1.529	13.2	0.335	673.76	629.7	4119.39	12994.6	10.152	57.7	10.152
	RodE6_66.1	125	66.1	1.679	19.1	0.485	697.90	643.1	4217.46	13304.0	9.810	55.7	9.810
	RodE6_70	126	70	1.778	-0.88	-0.022	729.44	660.6	4364.49	13767.8	9.458	53.7	9.458
	RodE6_73.1	127	73.1	1.857	2.22	0.056	777.53	687.3	4960.61	15648.3	9.736	55.3	9.736
	RodE6_75	128	75	1.905	4.12	0.105	813.66	707.4	5146.78	16235.5	9.432	53.6	9.432

RBHT Steam Cooling with Droplet Injection Test SCD-4029-B

Matrix Test # Shakedown

Test Conditions

Test Date – 9/22/2005

Steady State Time Window: 9900 - 10680

Upper Plenum Pressure: 2.76 bar (40 psia)

Bundle Power: 80.0 kW

Bundle Inlet Reynolds Number: 10000

Bundle Inlet Steam Flow: 199.9 kg/hr (438 lbm/hr)

Droplet Injection Flow: 0.0151 kg/s (0.0333 lbm/s)

Droplet Injection Hole Diameter: 0.381 mm (.015 in)

Droplet Injection Elevation: 1.295 m (51 in)

Bundle Flow Area: $4.656 \times 10^{-3} \text{ m}^2$ ($5.012 \times 10^{-2} \text{ ft}^2$)

Test Notes

- No steam probes were traversed in this steady state window.

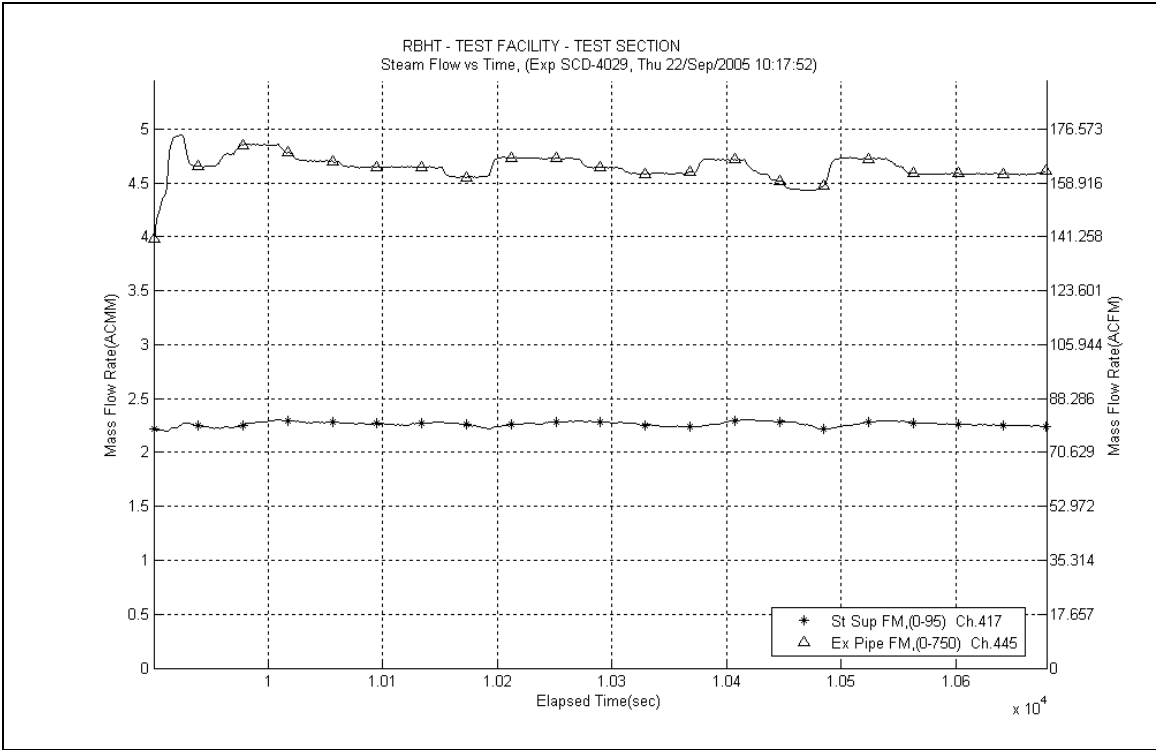

Figure A-42: Inlet and Exhaust Steam Flow Rates for Experiment 4029B

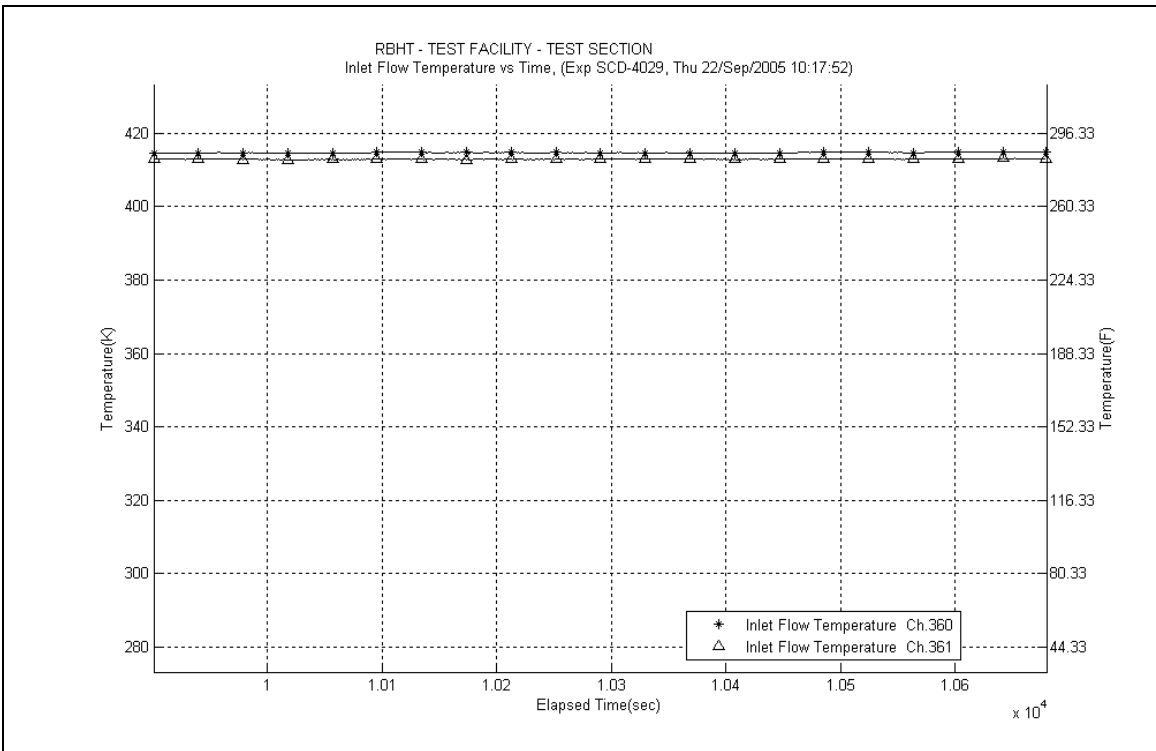

Figure A-43: Inlet Steam Temperature for Experiment 4029B

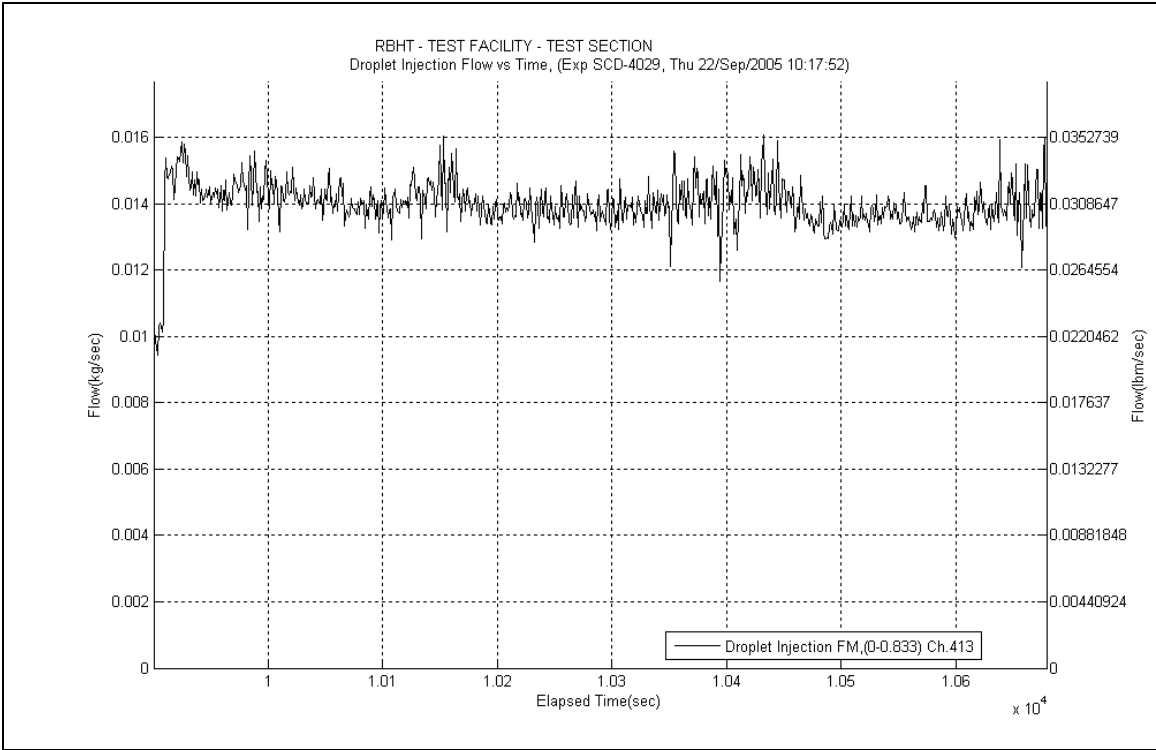

Figure A-44: Droplet Injection Flow Rate for Experiment 4029B

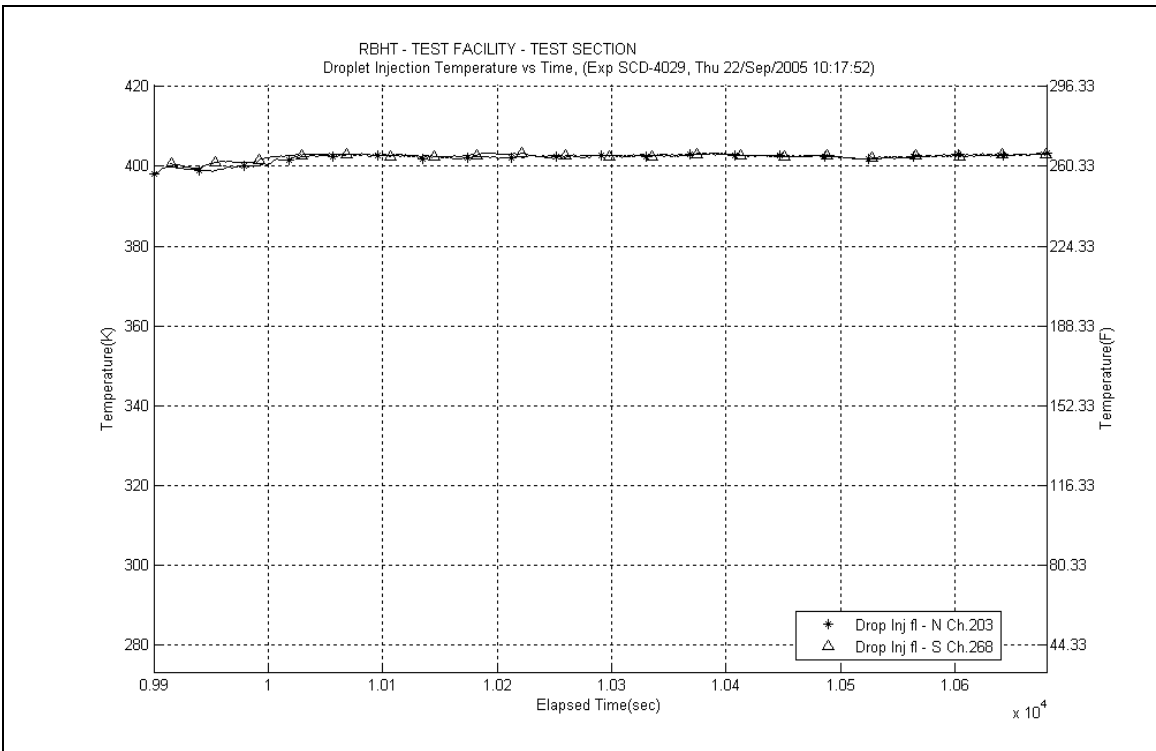

Figure A-45: Droplet Injection Temperature for Experiment 4029B

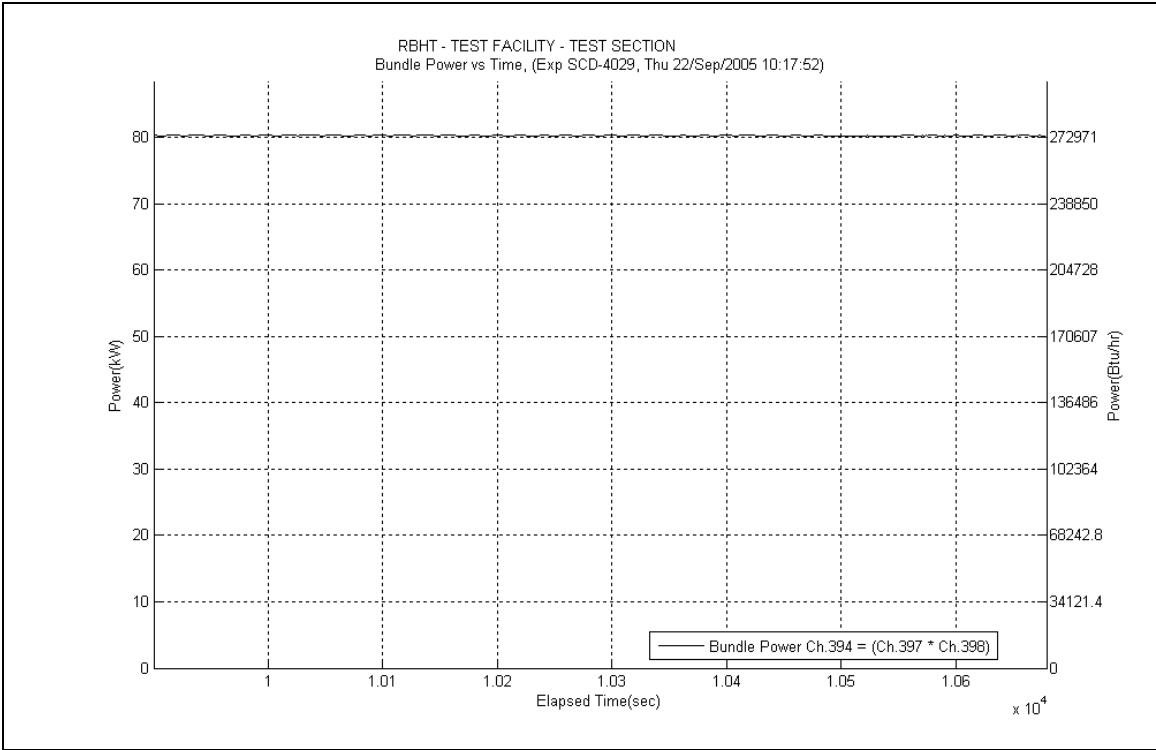

Figure A-46: Bundle Power for Experiment 4029B

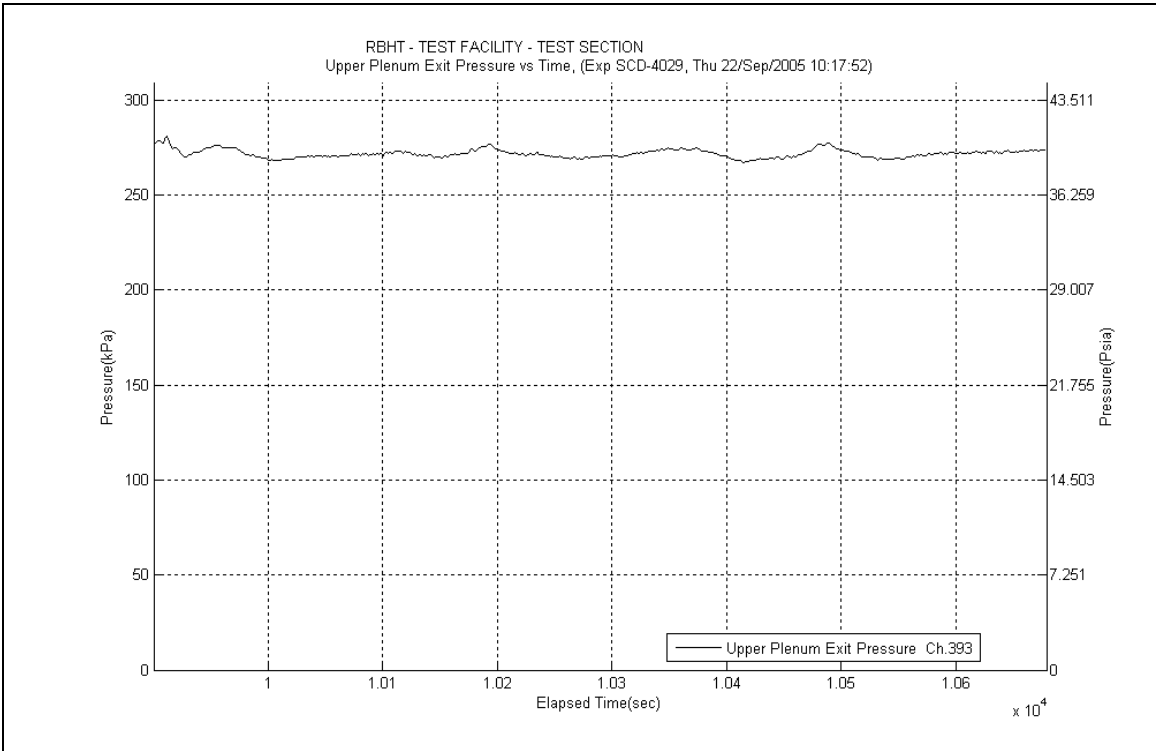

Figure A-47: Upper Plenum Pressure for Experiment 4029B

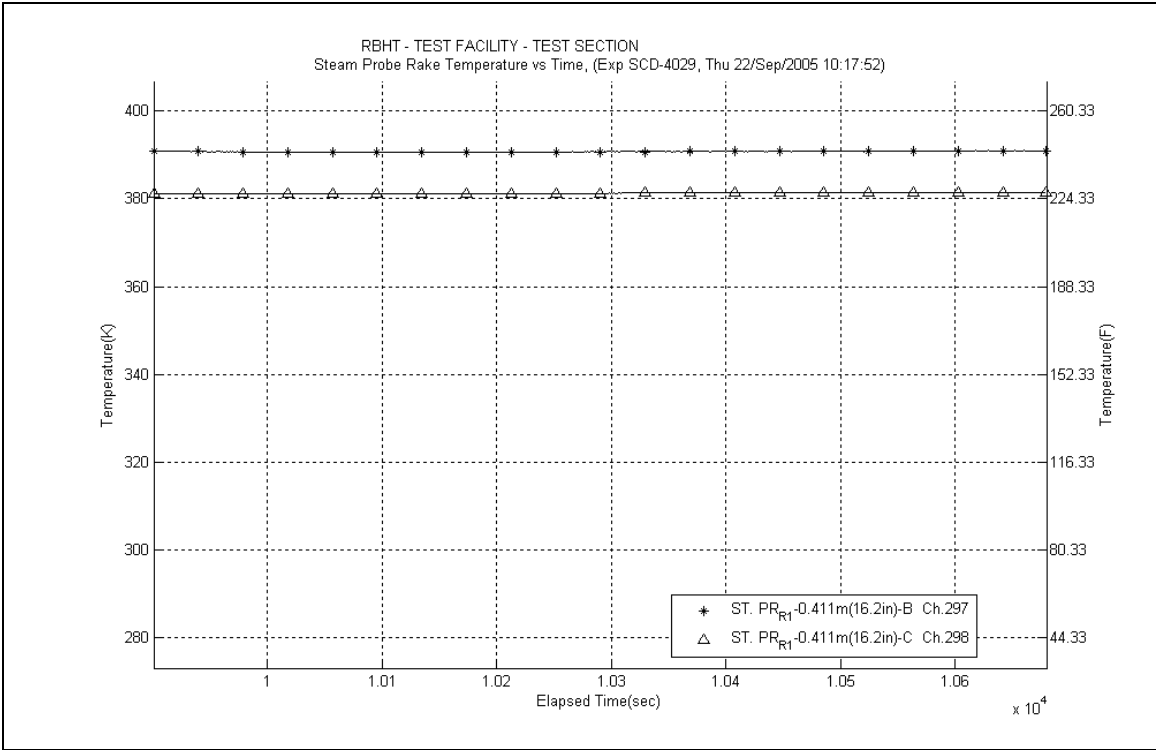

Figure A-48: Steam Probe Rake #1 Temperatures for Experiment 4029B

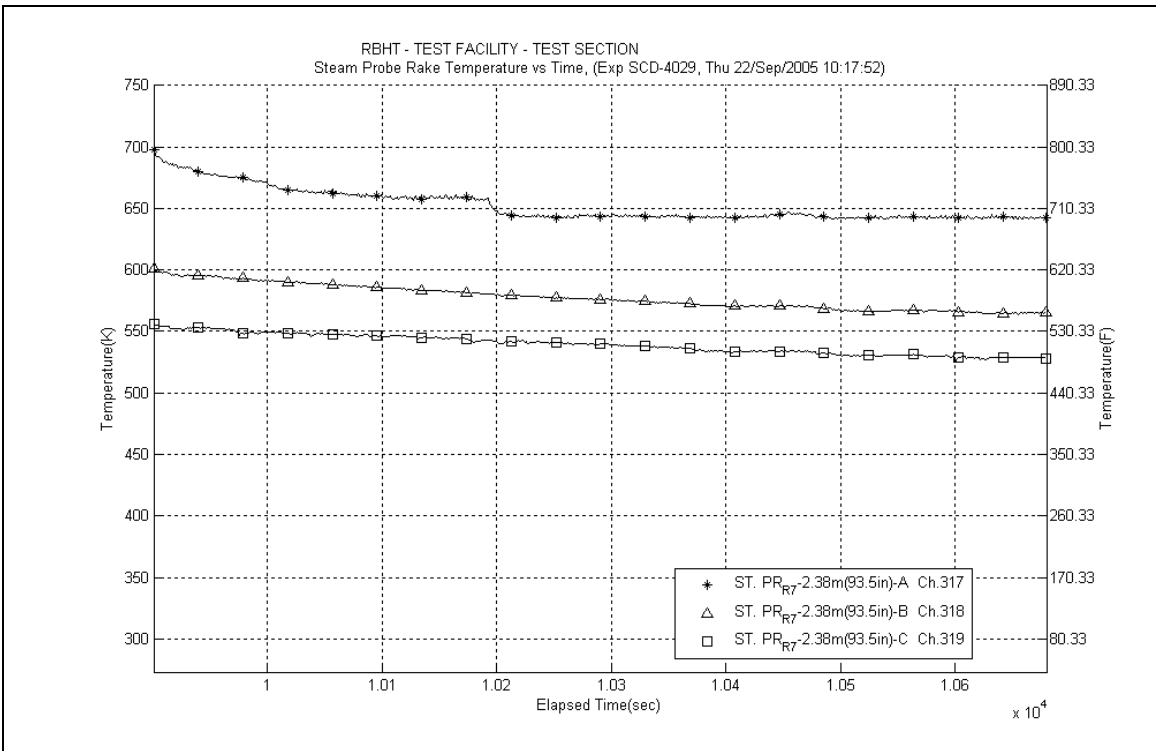

Figure A-49: Steam Probe Rake #7 Temperatures for Experiment 4029B

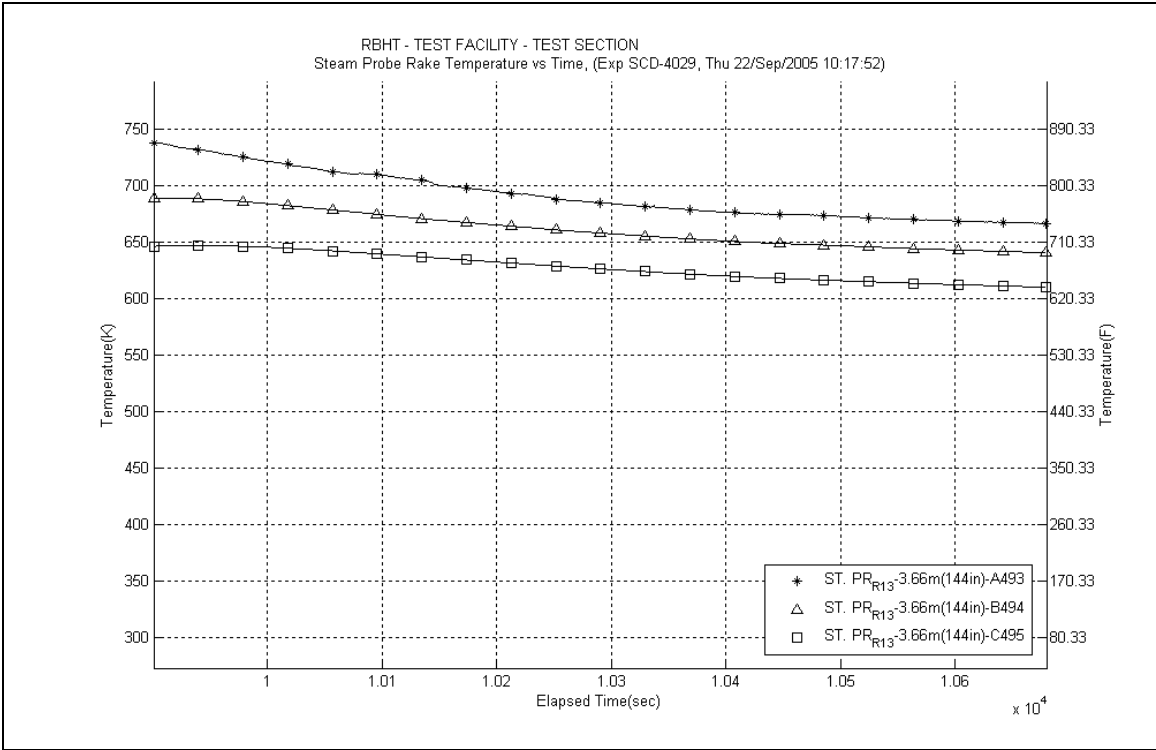

Figure A-50: Steam Probe Rake #13 Temperatures for Experiment 4029B

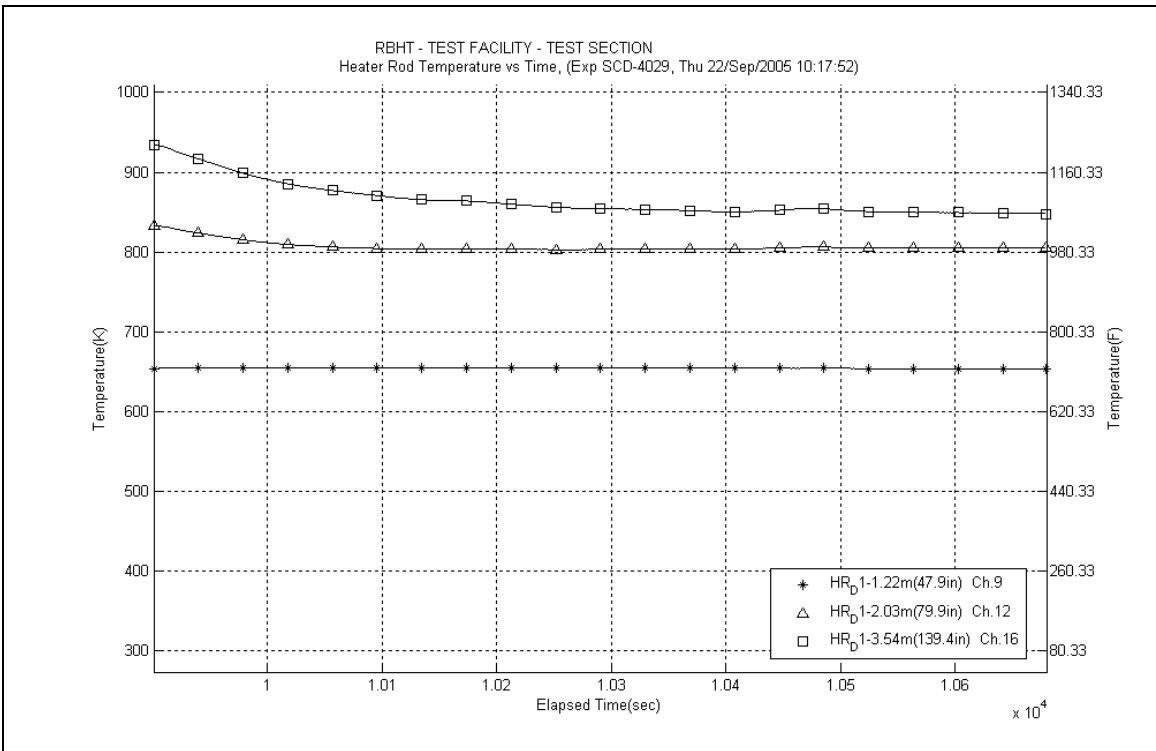

Figure A-51: Heater Rod D1 Temperatures for Experiment 4029B

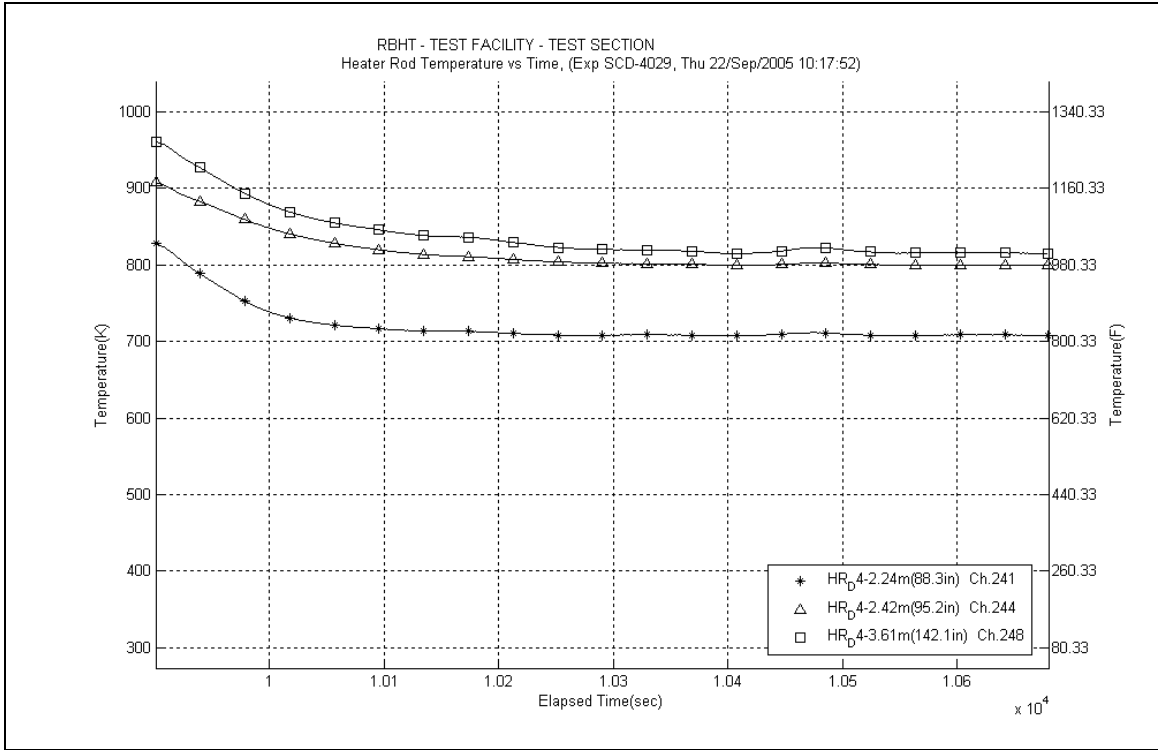

Figure A-52: Heater Rod D4 Temperatures for Experiment 4029B

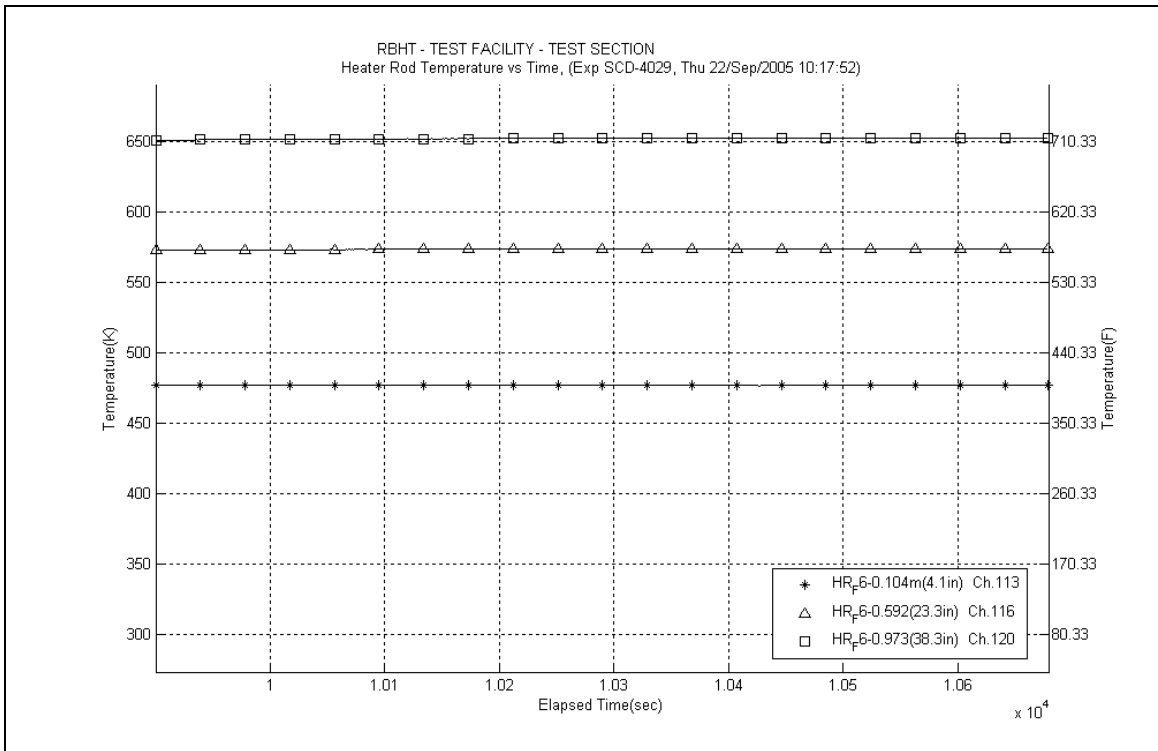

Figure A-53: Heater Rod F6 Temperatures for Experiment 4029B

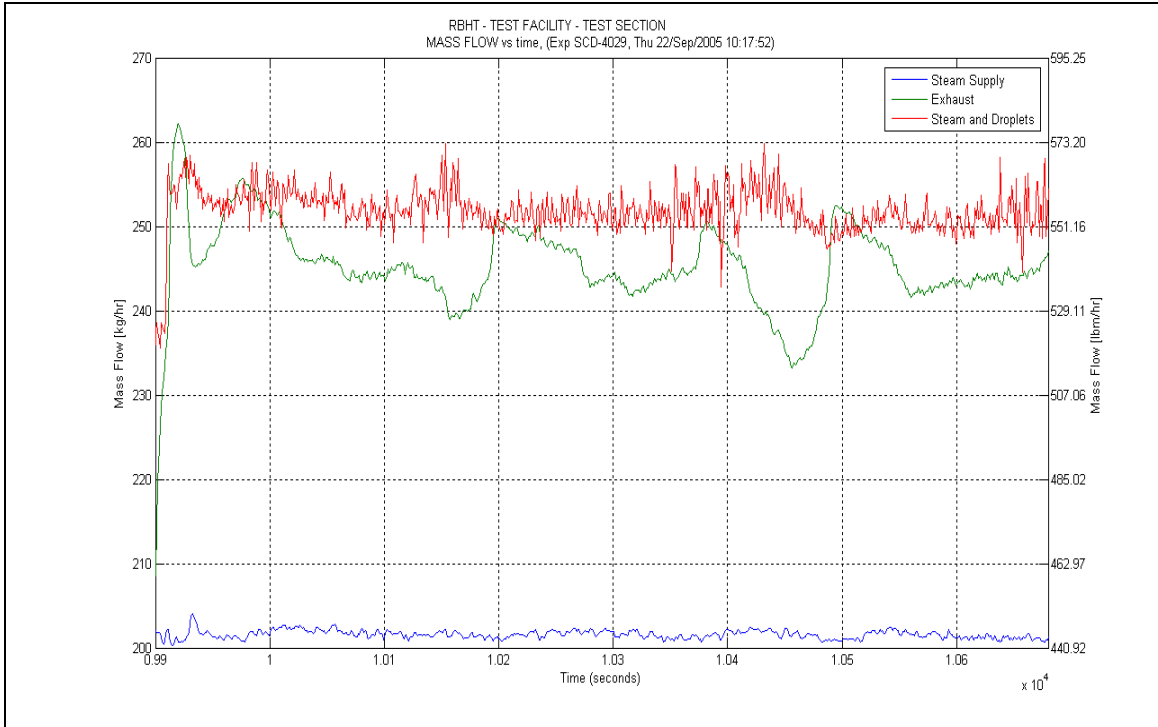

Figure A-54: Mass Flow for Experiment 4029B

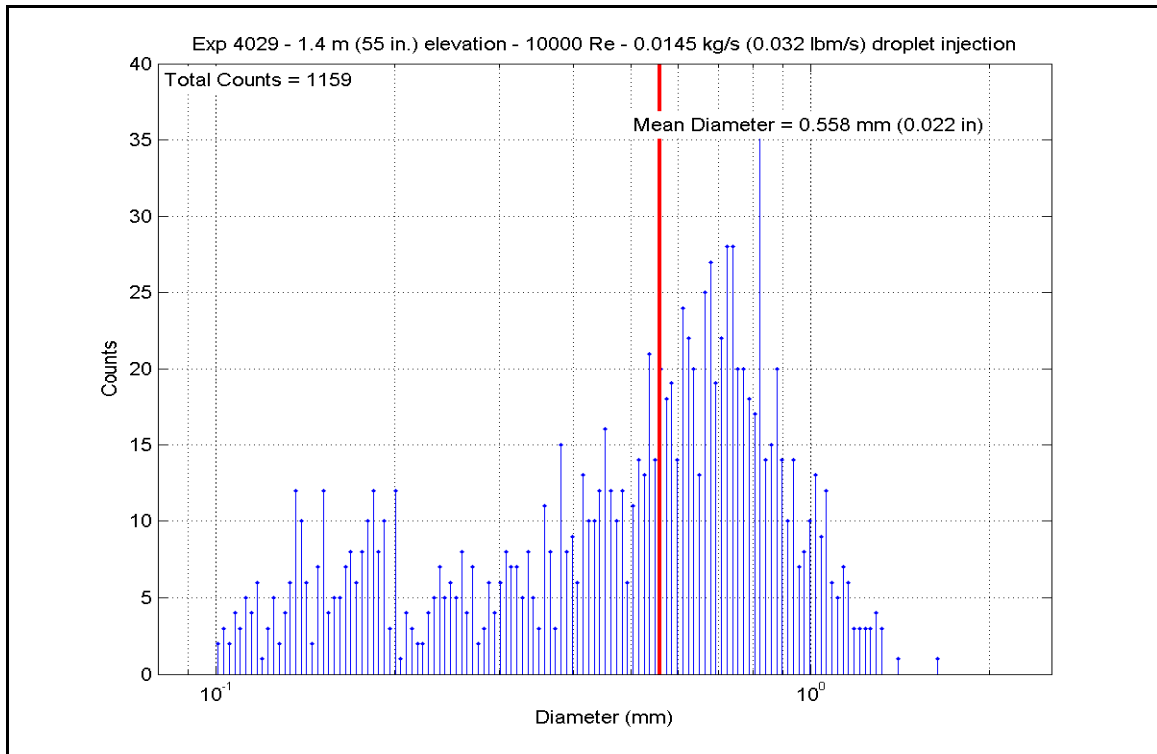

Figure A-55: Droplet Measurements at 1.397 m (55 in.) Elevation for Experiment 4029B

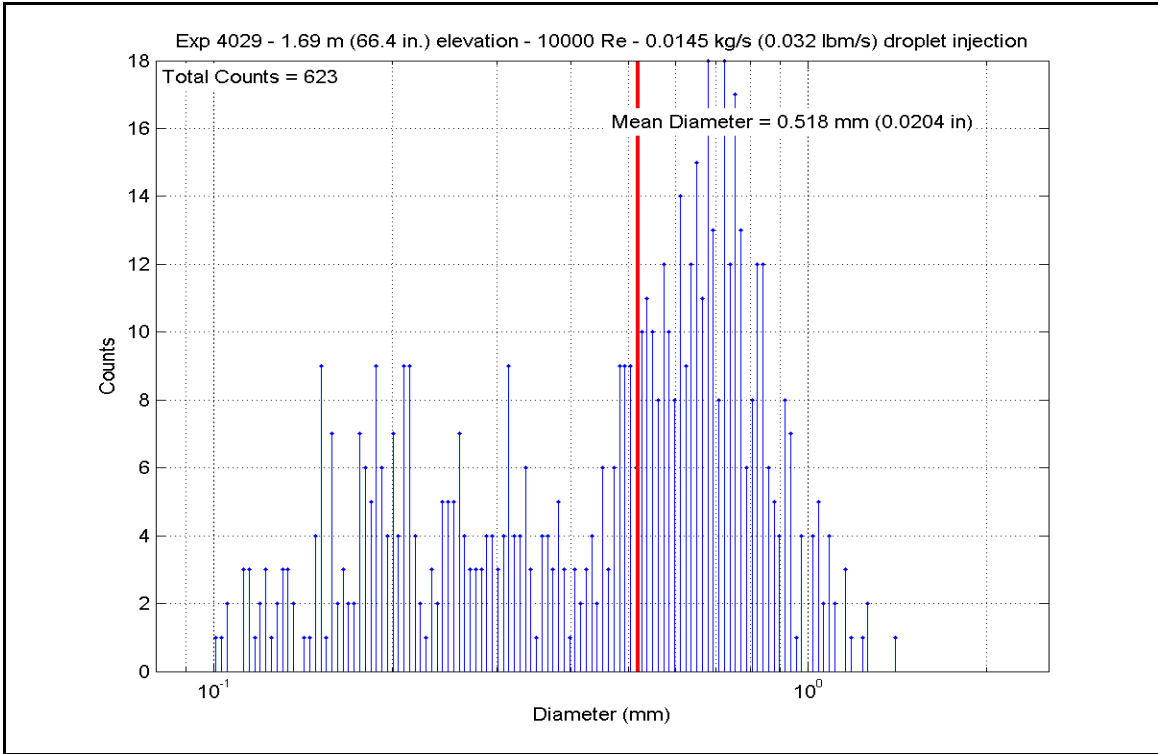

Figure A-56: Droplet Measurements at 1.687 m (66.4 in.) Elevation for Experiment 4029B

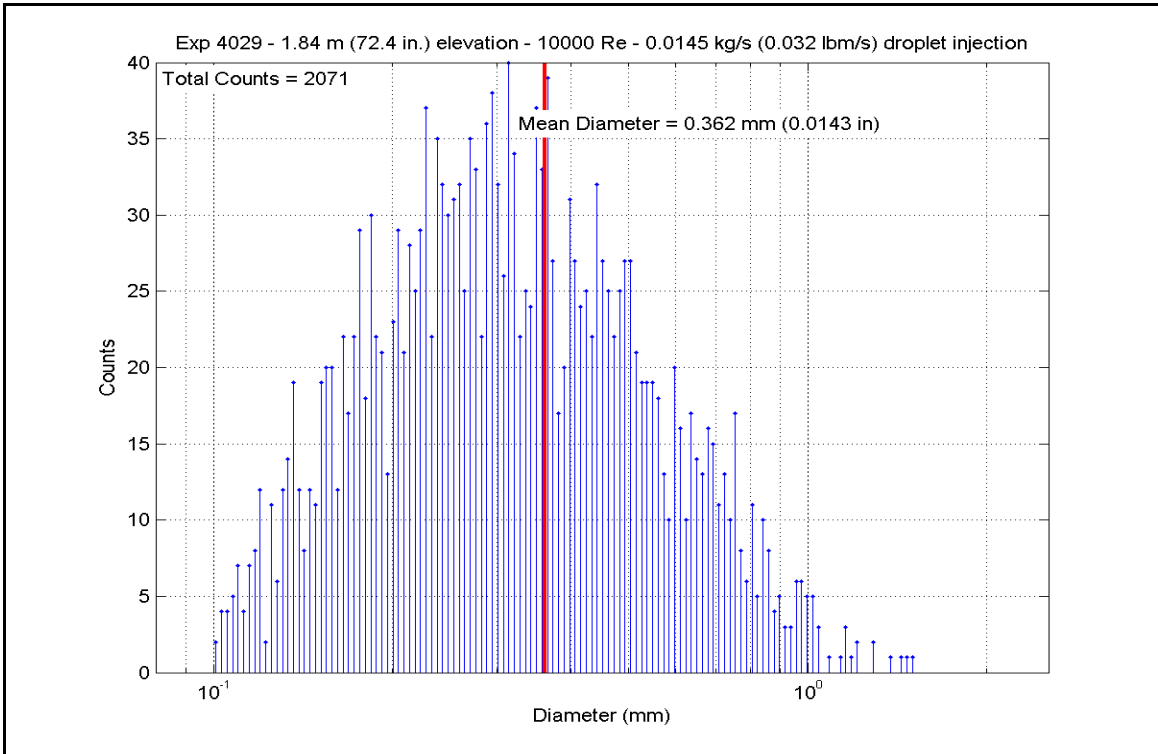

Figure A-57: Droplet Measurements at 1.839 m (72.4 in.) Elevation for Experiment 4029B

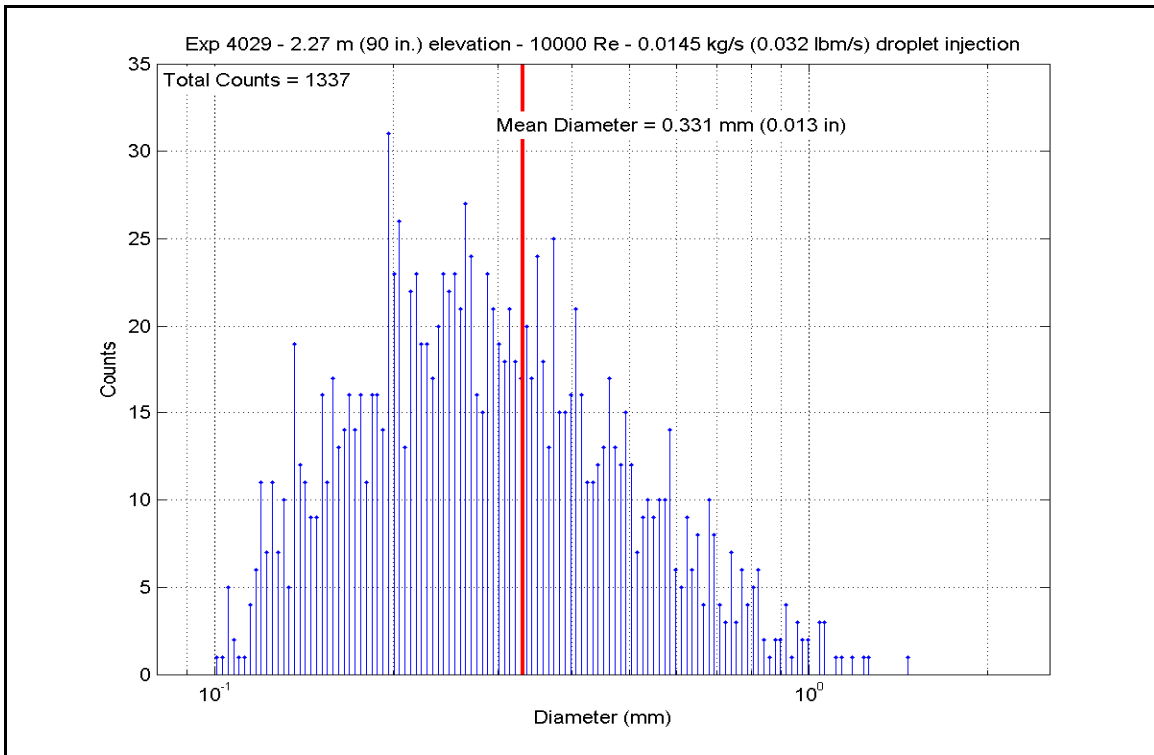

Figure A-58: Droplet Measurements at 2.286 m (90 in.) Elevation for Experiment 4029B

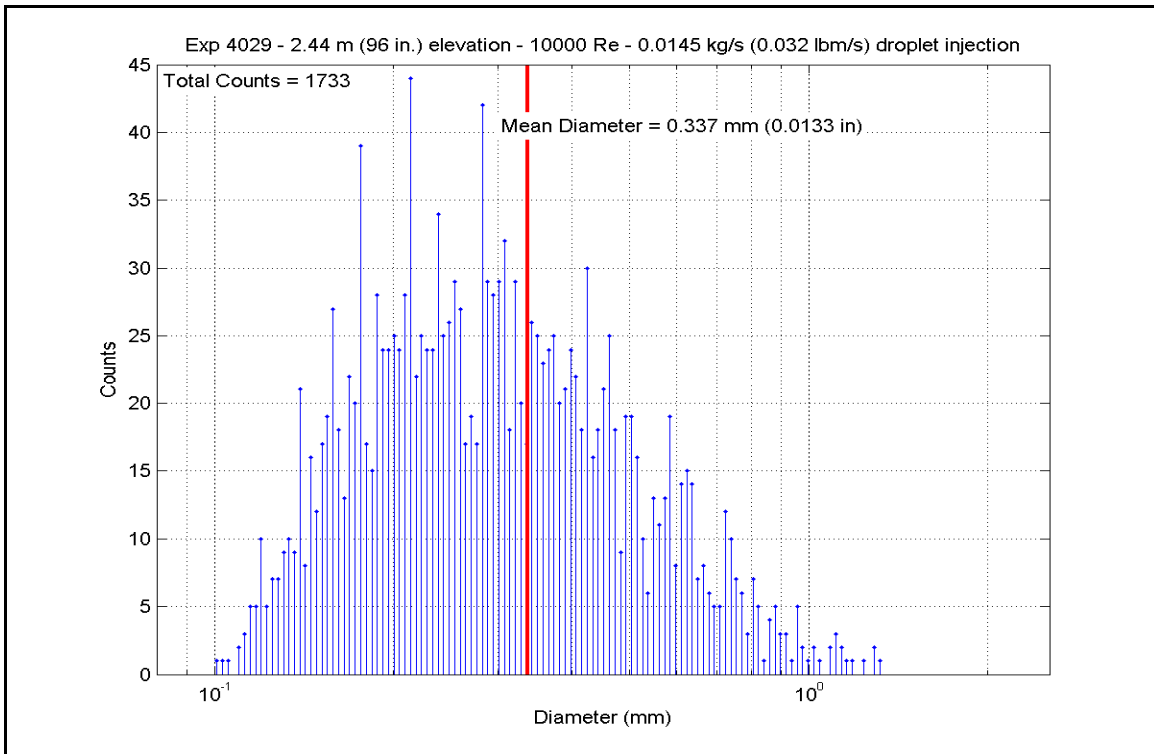

Figure A-59: Droplet Measurements at 2.438 m (96 in.) Elevation for Experiment 4029B

Error! Reference source not found.B

SCD-4029-B		Inlet Reynolds:		10000		40 psia							
Matrix test: shakedown		UP Pressure:		275.8 kPa		272971 Btu/hr							
Time Window: 9900-10680		Bundle Power:		80.00 kW		438.0 lbm/hr							
Inner 3x3		Stream flow:		0.0552 kg/s		0.0333 lbm/s							
		Droplet flow:		0.0151 kg/s									
H.R. ID	H.R. Location	Channel Number	Elevation (in)	Elevation (m)	Zgrid (in)	Zgrid (m)	H.R. Tw (°F)	H.R. Tw (K)	H.R. q" (Btu/hr-ft2)	H.R. q" (W/m2)	h _{sat} (z) (Btu/hr-ft2-F)	h _{sat} (z) (W/m2-K)	
Gr-3	RodD3_88.3	185	88.3	2.243	-0.2	-0.005	975.65	797.4	7374.31	23262.3	10.421	59.2	
	RodD3_91.3	186	91.3	2.319	2.8	0.071	1014.00	818.7	7453.58	23512.3	9.991	56.7	
	RodD3_93.1	187	93.1	2.365	4.6	0.117	844.17	724.4	7259.88	22901.3	12.600	71.6	
	RodD3_95.3	188	95.3	2.421	6.8	0.173	949.29	782.8	7378.41	23275.2	10.830	61.5	
	RodD3_100.1	189	100.1	2.543	11.6	0.295	1061.11	844.9	7564.41	23861.9	9.538	54.2	
	RodD3_106.1	190	106.1	2.695	17.6	0.447	1143.59	890.7	7976.39	25161.5	9.110	51.7	
	RodD3_110	191	110	2.794	21.5	0.546	1064.88	847.0	7827.20	24690.9	9.822	55.8	
	RodD3_142.1	192	142.1	3.609	3.609	8.6	850.61	727.9	7221.41	22780.0	12.395	70.4	
Gr-3	RodC4_88.4	233	88.4	2.245	-0.1	-0.003	1082.66	856.8	7121.34	22464.3	8.742	49.6	
	RodC4_91.1	234	91.1	2.314	2.6	0.066	1108.23	871.1	6680.71	21074.3	7.951	45.2	
	RodC4_93.4	235	93.4	2.372	4.9	0.124	1119.96	877.6	6187.52	19518.5	7.263	41.2	
	RodC4_95.3	236	95.3	2.421	6.8	0.173	1116.98	875.9	5671.37	17890.3	6.680	37.9	
	RodC4_100.1	237	100.1	2.543	11.6	0.295	1037.29	831.6	7716.19	24340.7	10.030	57.0	
	RodC4_106.1	238	106.1	2.695	17.6	0.447	1110.34	872.2	7899.69	24919.6	9.378	53.3	
	RodC4_110	239	110	2.794	21.5	0.546	1129.67	883.0	8038.83	25358.5	9.329	53.0	
	RodC4_142.2	240	142.2	3.612	3.612	8.7	929.41	771.7	5688.20	17943.4	8.600	48.8	
Gr-3	RodD4_88.3	241	88.3	2.243	-0.2	-0.005	845.73	725.2	6276.38	19798.8	10.864	61.7	
	RodD4_91.3	242	91.3	2.319	2.8	0.071	896.17	753.2	6371.78	20099.8	10.143	57.6	
	RodD4_93.2	243	93.2	2.367	4.7	0.119	928.61	771.3	5590.53	17635.3	8.463	48.1	
	RodD4_95.2	244	95.2	2.418	6.7	0.170	1080.43	855.6	6950.26	21924.6	8.555	48.6	
	RodD4_100.1	245	100.1	2.543	11.6	0.295	1149.60	894.0	8101.51	25556.2	9.190	52.2	
	RodD4_106.1	246	106.1	2.695	17.6	0.447	1066.92	848.1	8038.85	25358.6	10.062	57.1	
	RodD4_142.1	248	142.1	3.609	3.609	8.6	748.38	671.1	6131.57	19342.0	12.764	72.5	
	Gr-3	RodE4_88.4	201	88.4	2.245	-0.1	-0.003	945.42	780.6	7331.38	23126.8	10.823	61.5
RodE4_91.2		202	91.2	2.316	2.7	0.069	1026.04	825.4	7503.92	23671.1	9.899	56.2	
RodE4_95.3		204	95.3	2.421	6.8	0.173	1063.14	846.0	3378.32	10656.9	4.249	24.1	
RodE4_100.9		205	100.9	2.563	12.4	0.315	1046.20	836.6	7921.26	24987.6	10.179	57.8	
RodE4_142.3		208	142.3	3.614	8.8	0.224	847.48	726.2	7231.63	22812.2	12.480	70.9	

Error! Reference source not found.**B, continued**

Inner 3x3

	H.R. Location	Channel Number	Elevation (in)	Elevation (m)	Zgrid (in)	Zgrid (m)	H.R. Tw (°F)	H.R. Tw (K)	H.R. q" (Btu/hr-ft2)	H.R. q" (W/m2)	h _{sat} (z) (Btu/hr-ft2-F)	h _{sat} (z) (W/m2-K)
Gr-4	RodE3_63.4	193	63.4	1.610	16.4	0.417	1077.57	854.0	4472.21	14107.6	5.524	31.4
	RodE3_113.6	194	113.6	2.885	0.85	0.022	1045.28	836.1	7240.26	22839.4	9.315	52.9
	RodE3_115.5	195	115.5	2.934	2.75	0.070	957.40	787.3	5651.75	17828.4	8.198	46.6
	RodE3_118.5	196	118.5	3.010	5.75	0.146	1122.86	879.2	7091.62	22370.5	8.296	47.1
	RodE3_122.7	197	122.7	3.117	9.95	0.253	1148.33	893.3	6702.29	21142.4	7.613	43.2
	RodE3_126.5	198	126.5	3.213	13.75	0.349	1156.46	897.9	6169.40	19461.4	6.944	39.4
	RodE3_131.7	199	131.7	3.345	-1.8	-0.046	1151.12	894.9	5669.87	17885.6	6.420	36.5
	RodE3_135.6	200	135.6	3.444	2.1	0.053	1045.27	836.1	5006.48	15792.9	6.441	36.6
	RodC5_63.7	225	63.7	1.618	16.7	0.424	905.93	758.7	5514.76	17396.3	8.645	49.1
	RodC5_113.6	226	113.6	2.885	2.885	0.022	1038.19	832.1	7442.07	23476.0	9.663	54.9
Gr-4	RodC5_115.7	227	115.7	2.939	2.95	0.075	1012.34	817.8	5007.13	15795.0	6.727	38.2
	RodC5_122.7	229	122.7	3.117	9.95	0.253	1039.23	832.7	4521.17	14262.0	5.862	33.3
	RodC5_126.7	230	126.7	3.218	13.95	0.354	801.25	700.5	4981.53	15714.2	9.342	53.1
	RodC5_131.6	231	131.6	3.343	-1.9	-0.048	813.62	707.4	5198.33	16398.1	9.527	54.1
	RodC5_135.7	232	135.7	3.447	2.2	0.056	867.07	737.1	5354.14	16889.6	8.937	50.8
	RodE5_63.6	209	63.6	1.615	16.6	0.422	1044.64	835.7	3364.92	10614.6	4.333	24.6
	RodE5_113.6	210	113.6	2.885	0.85	0.022	1125.55	880.7	8211.61	25903.5	9.576	54.4
	RodE5_115.4	211	115.4	2.931	2.65	0.067	1016.93	820.3	7642.46	24108.1	10.205	58.0
	RodE5_118.7	212	118.7	3.015	5.95	0.151	1047.96	837.6	3481.91	10983.7	4.464	25.4
	RodE5_122.6	213	122.6	3.114	9.85	0.250	830.43	716.7	7318.31	23085.6	13.012	73.9
RodE5_126.6	214	126.6	3.216	13.85	0.352	929.99	772.0	7458.90	23529.1	11.267	64.0	
Gr-5	RodE5_131.6	215	131.6	3.343	-1.9	-0.048	970.85	794.7	7549.15	23813.8	10.741	61.0
	RodE5_135.6	216	135.6	3.444	2.1	0.053	1003.40	812.8	7643.21	24110.5	10.393	59.0
	RodC3_79.8	177	79.8	2.027	8.92	0.227	1000.49	811.2	7390.18	23312.3	10.089	57.3
	RodC3_85.6	178	85.6	2.174	14.72	0.374	1029.51	827.3	7470.69	23566.3	9.810	55.7
	RodC3_88.5	179	88.5	2.248	0	0.000	1047.84	837.5	3483.99	10990.3	4.468	25.4
	RodC3_92.4	180	92.4	2.347	3.9	0.099	757.80	676.4	4959.33	15644.2	10.125	57.5
	RodC3_94.4	181	94.4	2.398	5.9	0.150	792.98	695.9	5154.43	16259.7	9.818	55.8
	RodC3_97.2	182	97.2	2.469	8.7	0.221	1133.21	884.9	7997.07	25226.8	9.243	52.5
	RodC3_108.8	183	108.8	2.764	20.3	0.516	1069.49	849.5	7585.15	23927.4	9.464	53.7
	Gr-8	RodD5_50	217	50	1.270	3	0.076	1077.58	854.0	5211.44	16439.5	6.437
RodD5_54.1		218	54.1	1.374	7.1	0.180	1107.07	870.4	6117.09	19296.4	7.290	41.4
RodD5_56.9		219	56.9	1.445	9.9	0.251	1101.03	867.1	5615.82	17715.1	6.741	38.3
RodD5_60		220	60	1.524	13	0.330	987.42	803.9	4986.95	15731.3	6.932	39.4
RodD5_66.1		221	66.1	1.679	19.1	0.485	1016.80	820.3	4505.59	14212.9	6.017	34.2
RodD5_69.9		222	69.9	1.775	-0.98	-0.025	839.88	722.0	7338.98	23150.8	12.833	72.9
RodD5_72.9		223	72.9	1.852	2.02	0.051	935.81	775.3	7455.05	23517.0	11.163	63.4
RodD5_74.9		224	74.9	1.902	4.02	0.102	962.18	801.0	7555.09	23832.5	10.579	60.1

Error! Reference source not found.**B, continued**

H.R. ID	H.R. Location	Channel Number	Elevation (in)	Elevation (m)	Zgrid (in)	Zgrid (m)	H.R. Tw (°F)	H.R. Tw (K)	H.R. q" (Btu/hr-ft2)	H.R. q" (W/m2)	h _{sat} (z) (Btu/hr-ft2-F)	h _{sat} (z) (W/m2-K)	
Gr-2	RodB5_41	153	41	1.041	13.5	0.343	528.28	548.9	3308.99	10438.2	12.713	72.2	
	RodB5_52.9	154	52.9	1.344	5.9	0.150	573.15	573.8	3648.54	11509.3	11.957	67.9	
	RodB5_55	155	55	1.397	8	0.203	605.31	591.7	3931.94	12403.3	11.657	66.2	
	RodB5_57.8	156	57.8	1.468	10.8	0.274	670.80	628.0	4121.98	13002.8	10.233	58.1	
	RodB5_64	157	64	1.626	17	0.432	696.30	642.2	4219.32	13309.8	9.851	55.9	
	RodB5_73.9	158	73.9	1.877	30.2	0.077	728.70	660.2	4368.43	13780.2	9.482	53.8	
	RodB5_75.9	159	75.9	1.928	5.02	0.128	753.35	673.9	4506.60	14216.1	9.285	52.7	
	RodB5_76.9	160	76.9	1.953	6.02	0.153	766.91	681.4	5114.09	16132.4	10.251	58.2	
	Gr-2	RodF5_41	105	41	1.041	13.5	0.343	525.75	547.5	3312.26	10448.5	12.851	73.0
		RodF5_53.1	106	53.1	1.349	6.1	0.155	571.12	572.7	3641.79	11488.0	12.014	68.2
		RodF5_55	107	55	1.397	8	0.203	596.20	586.6	3917.58	12358.0	11.936	67.8
		RodF5_57.8	108	57.8	1.468	10.8	0.274	663.84	624.2	4108.18	12959.3	10.378	58.9
		RodF5_64	109	64	1.626	17	0.432	684.24	635.5	4204.86	13264.2	10.102	57.4
		RodF5_73.8	110	73.8	1.875	2.92	0.074	712.45	651.2	4347.27	13713.5	9.781	55.5
		RodF5_75.8	111	75.8	1.925	4.92	0.125	785.33	691.7	4932.20	15558.6	9.534	54.1
		RodF5_76.8	112	76.8	1.951	5.92	0.150	833.85	718.6	5101.12	16091.5	9.015	51.2
Gr-2		RodC2_41	57	41	1.041	13.5	0.343	1018.54	821.2	3540.74	11169.3	4.718	26.8
		RodC2_53.1	58	53.1	1.349	6.1	0.155	701.14	644.9	4896.21	15445.1	11.304	64.2
		RodC2_55	59	55	1.397	8	0.203	959.26	788.3	6519.82	20566.8	9.432	53.6
		RodC2_57.8	60	57.8	1.468	10.8	0.274	1037.39	831.7	7468.71	23560.0	9.707	55.1
	RodC2_63.9	61	63.9	1.623	16.9	0.429	1068.69	849.1	7090.40	22366.7	8.855	50.3	
	RodC2_73.8	62	73.8	1.875	2.92	0.074	1090.57	861.2	5572.77	17579.3	6.775	38.5	
	RodC2_75.8	63	75.8	1.925	4.92	0.125	915.17	763.8	6373.48	20105.2	9.848	55.9	
	RodC2_76.8	64	76.8	1.951	5.92	0.150	929.61	771.8	6418.76	20248.0	9.702	55.1	
Gr-2	RodC6_40.9	137	40.9	1.039	13.4	0.340	840.24	722.2	5337.48	16837.1	9.327	53.0	
	RodC6_52.8	138	52.8	1.341	5.8	0.147	845.50	725.1	5554.33	17521.1	9.618	54.6	
	RodC6_54.8	139	54.8	1.392	7.8	0.198	917.20	764.9	5839.02	18419.2	8.994	51.1	
	RodC6_57.8	140	57.8	1.468	10.8	0.274	754.46	674.5	6175.66	19481.1	12.695	72.1	
	RodC6_63.8	141	63.8	1.621	16.8	0.427	857.72	731.9	6291.37	19846.1	10.668	60.6	
	RodC6_73.7	142	73.7	1.872	2.82	0.072	902.81	756.9	6382.51	20133.6	10.054	57.1	
	RodC6_75.8	143	75.8	1.925	4.92	0.125	965.31	791.7	6596.21	20807.7	9.460	53.7	
	RodC6_76.8	144	76.8	1.951	5.92	0.150	853.76	729.7	7066.17	22290.2	12.063	68.5	

5x5 periphery

Error! Reference source not found.**B, continued**

5x5 periphery

	H.R. Location	Channel Number	Elevation (in)	Elevation (m)	Zgrid (in)	Zgrid (m)	H.R. Tw (°F)	H.R. Tw (K)	H.R. q" (Btu/hr-ft2)	H.R. q" (W/m2)	h _{sat} (z) (Btu/hr-ft2-F)	h _{sat} (z) (W/m2-K)
Gr-3	RodB4_88.4	161	88.4	2.245	-0.1	-0.003	922.87	768.1	6450.70	20348.7	9.850	55.9
	RodB4_91.3	162	91.3	2.319	2.8	0.071	941.00	778.1	6501.75	20509.8	9.661	54.9
	RodB4_93.3	163	93.3	2.370	4.8	0.122	938.41	476.7	2733.52	8622.9	20.961	119.0
	RodB4_95.1	164	95.1	2.416	6.6	0.168	477.33	520.6	3068.08	9678.3	14.657	83.2
	RodB4_100	165	100	2.540	11.5	0.292	1130.57	883.5	7863.64	24805.8	9.116	51.8
	RodB4_106	166	106	2.692	17.5	0.445	1153.83	896.4	8003.28	25246.3	9.035	51.3
	RodB4_109.9	167	109.9	2.791	21.4	0.544	1070.74	850.2	7411.49	23379.5	9.233	52.4
	RodB4_142.3	168	142.3	3.614	8.8	0.224	891.20	750.5	6357.75	20055.5	10.202	57.9
Gr-5	RodF4_85.6	98	85.6	2.174	14.72	0.374	913.66	763.0	6395.38	20174.2	9.905	56.3
	RodF4_88.4	99	88.4	2.245	-0.1	-0.003	930.13	772.1	6437.97	20308.6	9.723	55.2
	RodF4_92.4	100	92.4	2.347	3.9	0.099	397.24	476.1	2737.82	8636.4	21.184	120.3
	RodF4_94.3	101	94.3	2.395	5.8	0.147	481.09	522.6	3070.18	9684.9	14.408	81.8
	RodF4_97.2	102	97.2	2.469	8.7	0.221	1123.16	879.4	8190.03	25835.5	9.577	54.4
	RodF4_108.8	103	108.8	2.764	20.3	0.516	1040.32	833.3	7992.13	25211.2	10.348	58.8
	RodF4_111	104	111	2.819	-1.75	-0.044	1054.63	841.3	7901.06	24923.9	10.044	57.0
	RodD2_103.2	65	103.2	2.621	2.621	14.7	0.373	1049.31	838.3	7727.02	24374.9	9.890
Gr-6	RodD2_106	66	106	2.692	17.5	0.445	1126.49	881.2	7987.06	25195.2	9.304	52.8
	RodD2_112.6	67	112.6	2.860	-0.15	-0.004	1040.42	833.4	7780.66	24544.1	10.073	57.2
	RodD2_114.9	68	114.9	2.918	2.15	0.055	1116.79	875.8	7099.66	22395.9	8.364	47.5
	RodD2_117.4	69	117.4	2.982	4.65	0.118	1137.67	887.4	6750.22	21293.6	7.762	44.1
	RodD2_120.8	70	120.8	3.068	8.05	0.204	1160.16	899.9	6286.07	19829.4	7.046	40.0
	RodD2_124.8	71	124.8	3.170	12.05	0.306	1163.36	901.7	5734.19	18088.5	6.404	36.4
	RodD2_128.6	72	128.6	3.266	15.85	0.403	1151.14	894.9	5209.24	16432.6	5.899	33.5
	RodD6_103.1	129	103.1	2.619	2.619	14.6	0.371	1091.83	861.9	7337.90	23147.4	8.907
Gr-6	RodD6_106	130	106	2.692	17.5	0.445	1087.77	859.7	7765.96	24497.7	9.473	53.8
	RodD6_112.9	131	112.9	2.868	0.15	0.004	1054.41	841.2	7395.73	23329.8	9.404	53.4
	RodD6_114.9	132	114.9	2.918	2.15	0.055	805.91	703.1	4974.96	15693.5	9.249	52.5
	RodD6_116.8	133	116.8	2.967	4.05	0.103	828.64	715.7	5164.93	16292.8	9.213	52.3
	RodD6_120.9	134	120.9	3.071	8.15	0.207	993.14	807.1	7456.47	23521.4	10.283	58.4
	RodD6_124.8	135	124.8	3.170	12.05	0.306	1029.35	827.2	7561.15	23851.7	9.931	56.4
RodD6_128.7	136	128.7	3.269	15.95	0.405	1074.83	852.5	3221.71	10162.9	3.993	22.7	

Error! Reference source not found.**B, continued**

5x5 periphery		H.R.	Channel	Elevation	Elevation	Zgrid	Zgrid	H.R. Tw	H.R. Tw	H.R. Tw	H.R. q"	H.R. q"	h _{sat} (z)	h _{sat} (z)
Gr-8	Location	Number	(in)	(m)	(m)	(m)	(m)	(°F)	(K)	(Btu/hr-ft ²)	(W/m ²)	(Btu/hr-ft ² -F)	(W/m ² -K)	
	RodE2_50.1	73	50.1	1.273	3.1	0.079	869.96	738.7	5320.40	16783.2	8.839	50.2		
	RodE2_54	74	54	1.372	7	0.178	896.56	753.5	5485.81	17305.0	8.728	49.6		
	RodE2_56.9	75	56.9	1.445	9.9	0.251	931.78	773.0	5824.13	18372.2	8.774	49.8		
	RodE2_59.9	76	59.9	1.521	12.9	0.328	778.85	688.1	6170.29	19464.2	12.079	68.6		
	RodE2_66	77	66	1.676	19	0.483	875.28	741.6	6296.56	19862.5	10.368	58.9		
	RodE2_69.8	78	69.8	1.773	-1.08	-0.027	915.10	763.8	6377.63	20118.2	9.856	56.0		
	RodE2_72.9	79	72.9	1.852	2.02	0.051	406.42	481.2	2688.72	8481.6	19.425	110.3		
	RodE2_74.9	80	74.9	1.902	4.02	0.102	483.15	523.8	3040.93	9592.6	14.134	80.3		
Gr-8	RodB3_50.2	169	50.2	1.275	3.2	0.081	1110.65	872.4	6333.85	19980.1	7.517	42.7		
	RodB3_54.1	170	54.1	1.374	7.1	0.180	1109.30	871.7	5790.03	18264.6	6.882	39.1		
	RodB3_56.9	171	56.9	1.445	9.9	0.251	1099.77	866.4	5238.81	16525.8	6.298	35.8		
	RodB3_60.1	172	60.1	1.527	13.1	0.333	749.21	671.6	4495.04	14179.6	9.341	53.0		
	RodB3_66.1	173	66.1	1.679	19.1	0.485	824.79	713.6	5055.05	15946.1	9.079	51.6		
	RodB3_69.9	174	69.9	1.775	-0.98	-0.025	847.29	726.1	5176.51	16329.3	8.936	50.7		
	RodB3_73	175	73	1.854	2.12	0.054	875.90	742.0	5354.18	16889.8	8.808	50.0		
	RodB3_75	176	75	1.905	4.12	0.105	921.32	767.2	5686.60	17938.4	8.704	49.4		
Gr-8	RodF3_50.1	89	50.1	1.273	3.1	0.079	1000.68	811.3	7350.89	23188.4	10.033	57.0		
	RodF3_54	90	54	1.372	7	0.178	1031.75	828.6	7441.73	23474.9	9.744	55.3		
	RodF3_57	91	57	1.448	10	0.254	749.50	671.8	4482.51	14140.1	9.309	52.9		
	RodF3_60	92	60	1.524	13	0.330	778.46	687.9	5070.52	15994.9	9.933	56.4		
	RodF3_66.1	93	66.1	1.679	19.1	0.485	821.50	711.8	5177.95	16333.9	9.355	53.1		
	RodF3_70	94	70	1.778	-0.88	-0.022	870.49	739.0	5331.54	16818.3	8.849	50.3		
	RodF3_73	95	73	1.854	2.12	0.054	927.20	770.5	5638.08	17785.3	8.553	48.6		
	RodF3_75	96	75	1.905	4.12	0.105	873.05	740.4	6313.27	19915.2	10.434	59.3		
Gr-8	RodE6_50.2	121	50.2	1.275	3.2	0.081	532.32	551.1	3289.20	10375.8	12.444	70.7		
	RodE6_54.1	122	54.1	1.374	7.1	0.180	576.55	575.7	3639.26	11480.1	11.795	67.0		
	RodE6_57	123	57	1.448	10	0.254	599.96	588.7	3933.64	12408.7	11.850	67.3		
	RodE6_60.2	124	60.2	1.529	13.2	0.335	672.37	628.9	4137.99	13053.3	10.233	58.1		
	RodE6_66.1	125	66.1	1.679	19.1	0.485	696.66	642.4	4236.65	13364.5	9.883	56.1		
	RodE6_70	126	70	1.778	-0.88	-0.022	728.35	660.0	4385.13	13832.9	9.526	54.1		
	RodE6_73.1	127	73.1	1.857	2.22	0.056	784.02	690.9	4944.80	15598.4	9.583	54.4		
	RodE6_75	128	75	1.905	4.12	0.105	821.49	711.8	5137.05	16204.8	9.281	52.7		

RBHT Steam Cooling with Droplet Injection Test SCD-4029-C

Matrix Test # Shakedown

Test Conditions

Test Date – 9/22/2005

Steady State Time Window: 10800 - 11700

Upper Plenum Pressure: 2.76 bar (40 psia)

Bundle Power: 75.0 kW

Bundle Inlet Reynolds Number: 8000

Bundle Inlet Steam Flow: 159.4 kg/hr (351 lbm/hr)

Droplet Injection Flow: 0.0076 kg/s (0.0167 lbm/s)

Droplet Injection Hole Diameter: 0.381 mm (.015 in)

Droplet Injection Elevation: 1.295 m (51 in)

Bundle Flow Area: $4.656 \times 10^{-3} \text{ m}^2$ ($5.012 \times 10^{-2} \text{ ft}^2$)

Test Notes

- No steam probes were traversed in this steady state window.

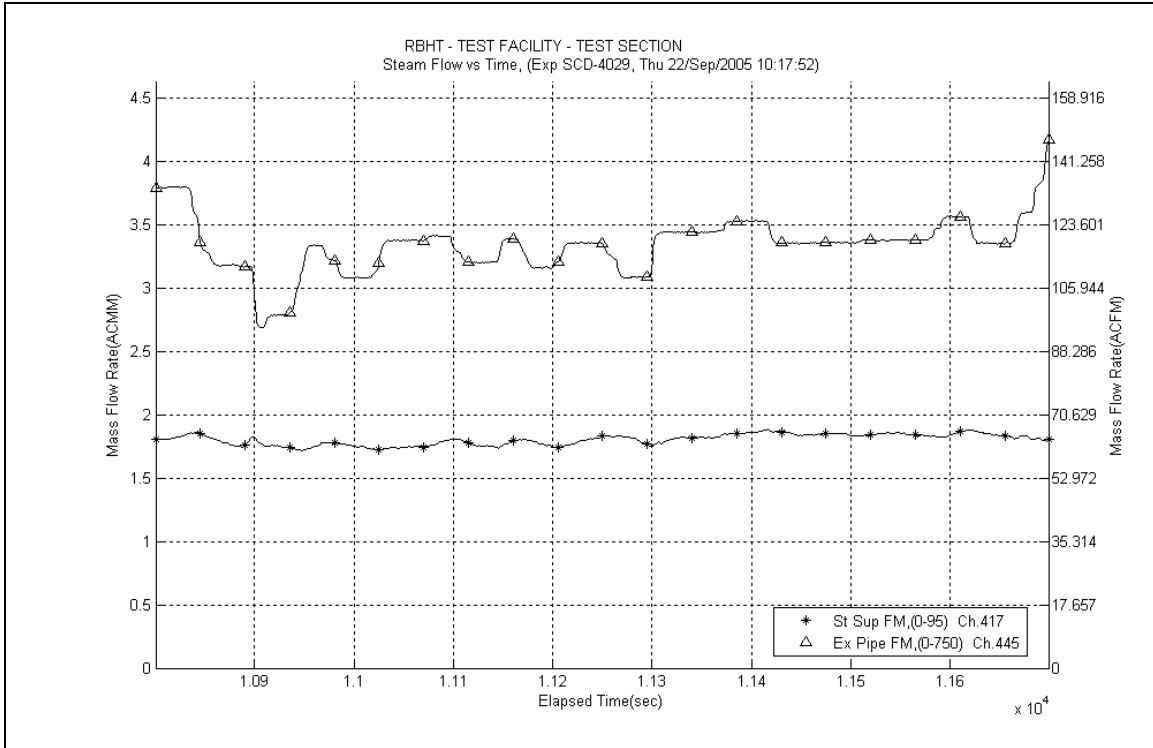

Figure A-60: Inlet and Exhaust Steam Flow Rates for Experiment 4029C

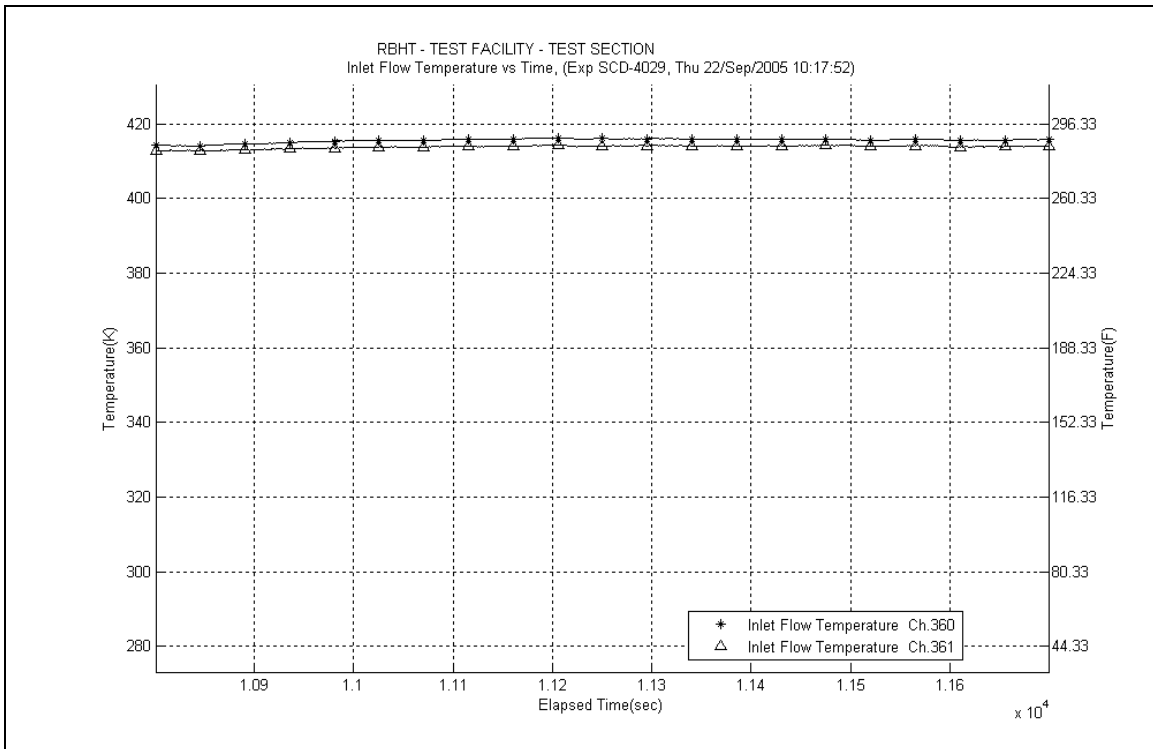

Figure A-61: Inlet Steam Temperature for Experiment 4029C

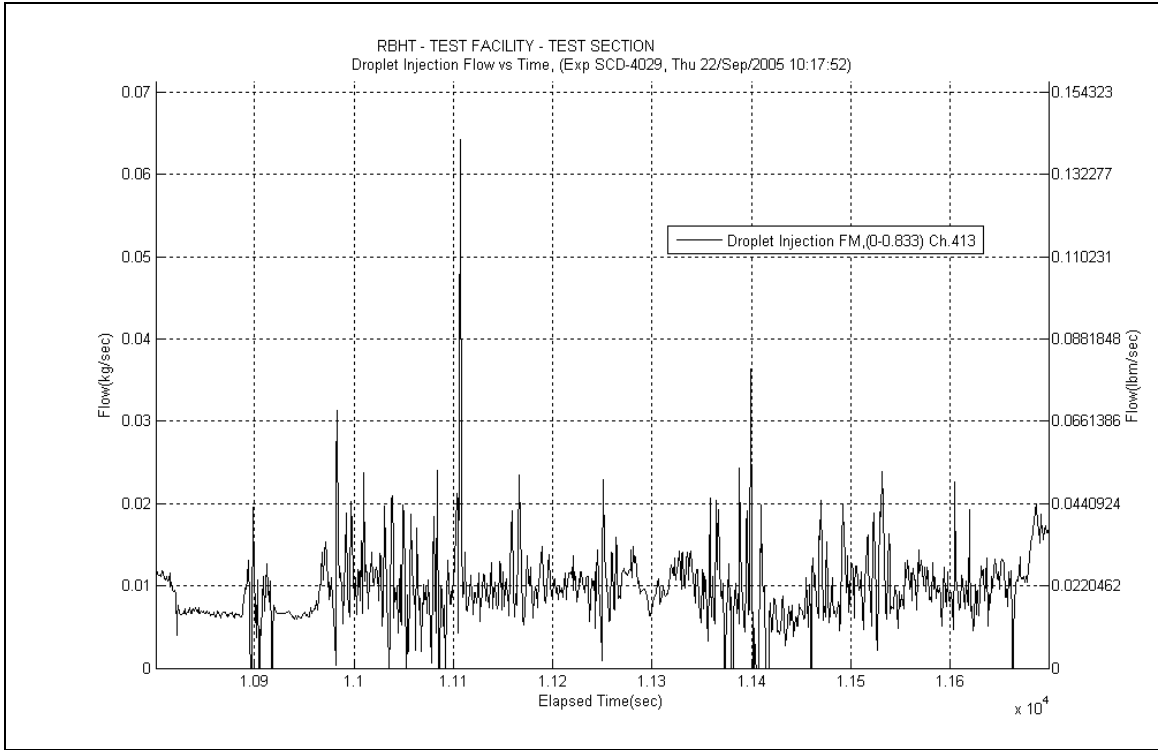

Figure A-62: Droplet Injection Flow Rate for Experiment 4029C

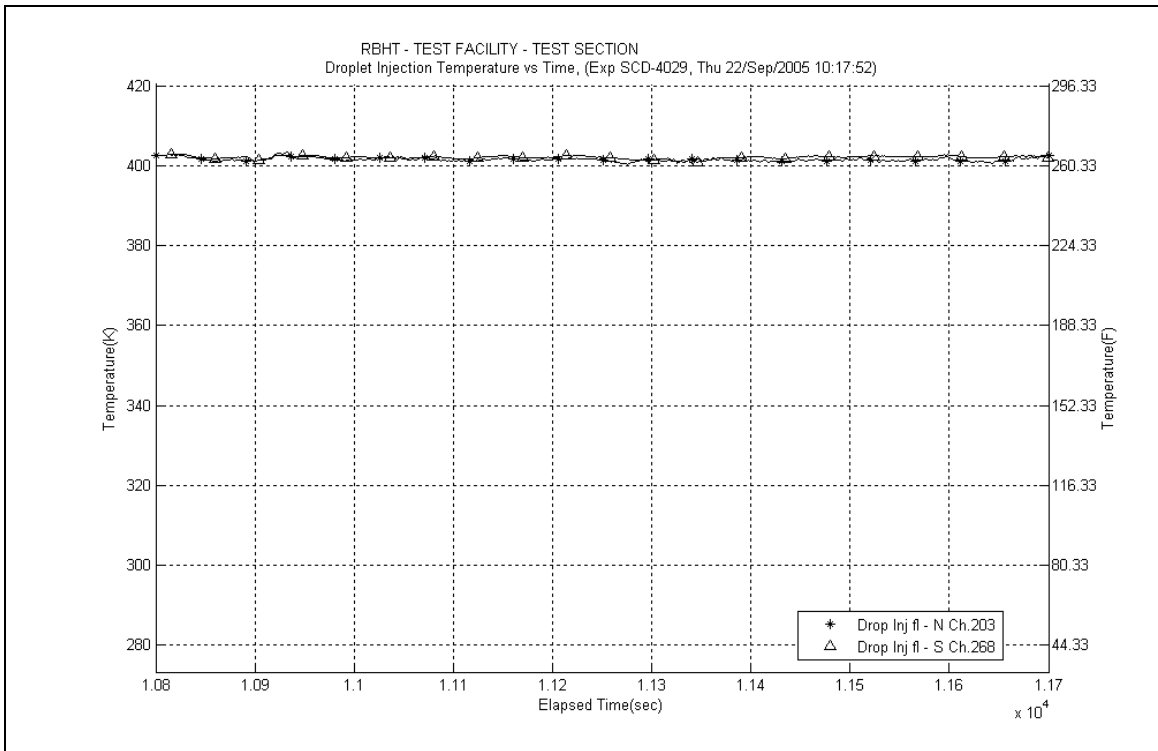

Figure A-63: Droplet Injection Temperature for Experiment 4029C

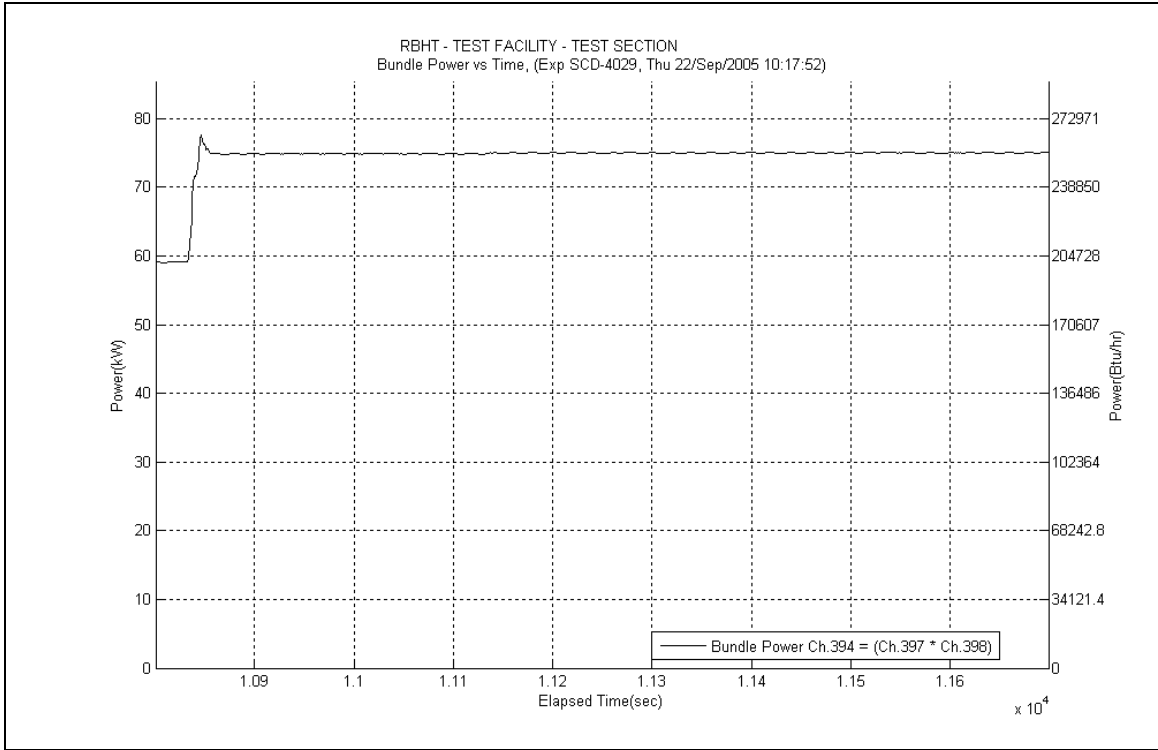

Figure A-64: Bundle Power for Experiment 4029C

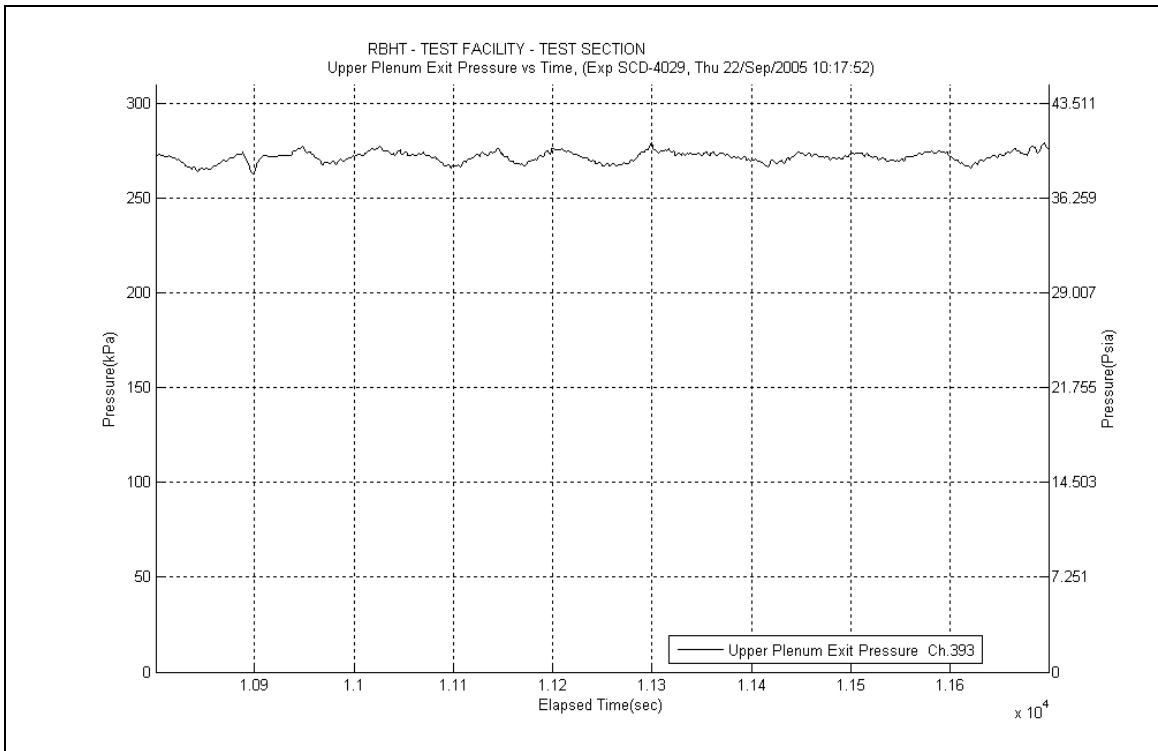

Figure A-65: Upper Plenum Pressure for Experiment 4029C

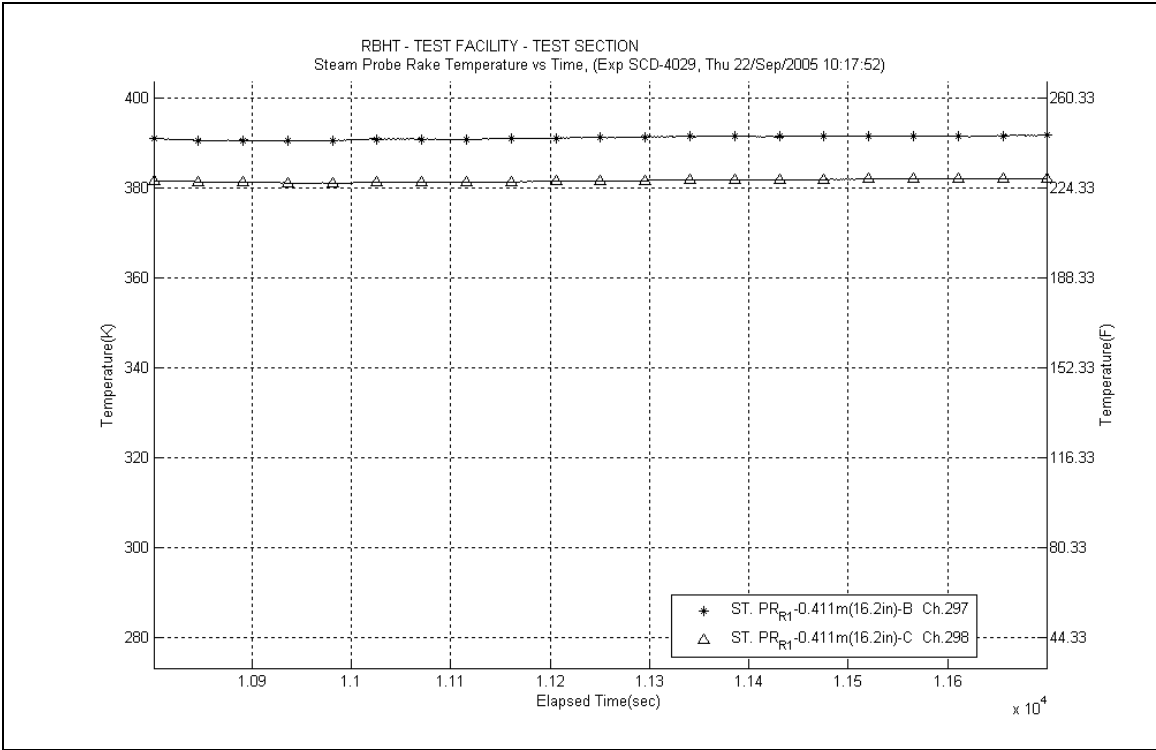

Figure A-66: Steam Probe Rake #1 Temperatures for Experiment 4029C

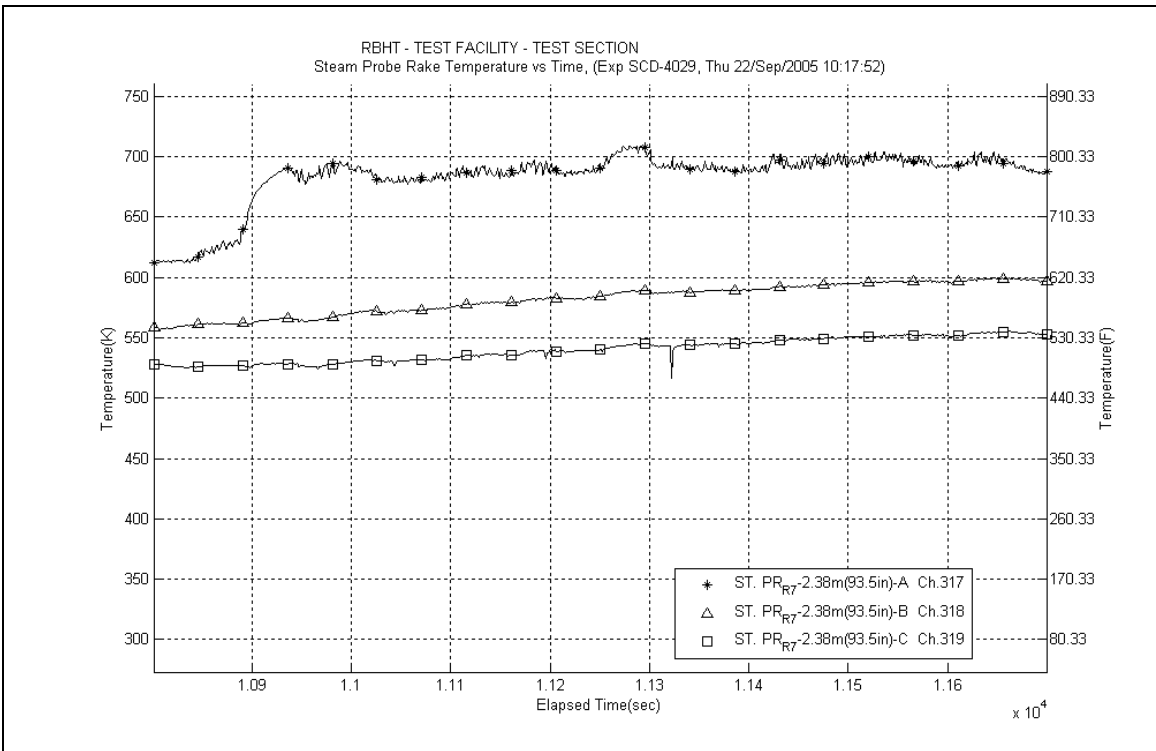

Figure A-67: Steam Probe Rake #7 Temperatures for Experiment 4029C

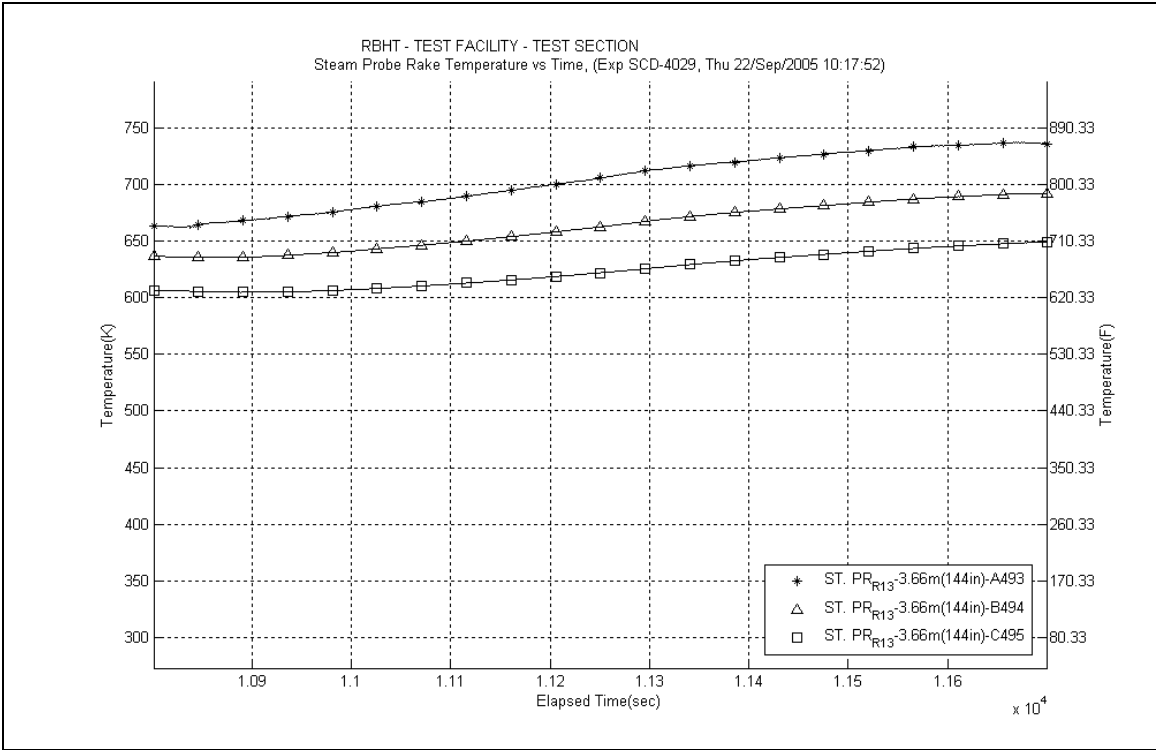

Figure A-68: Steam Probe Rake #13 Temperatures for Experiment 4029C

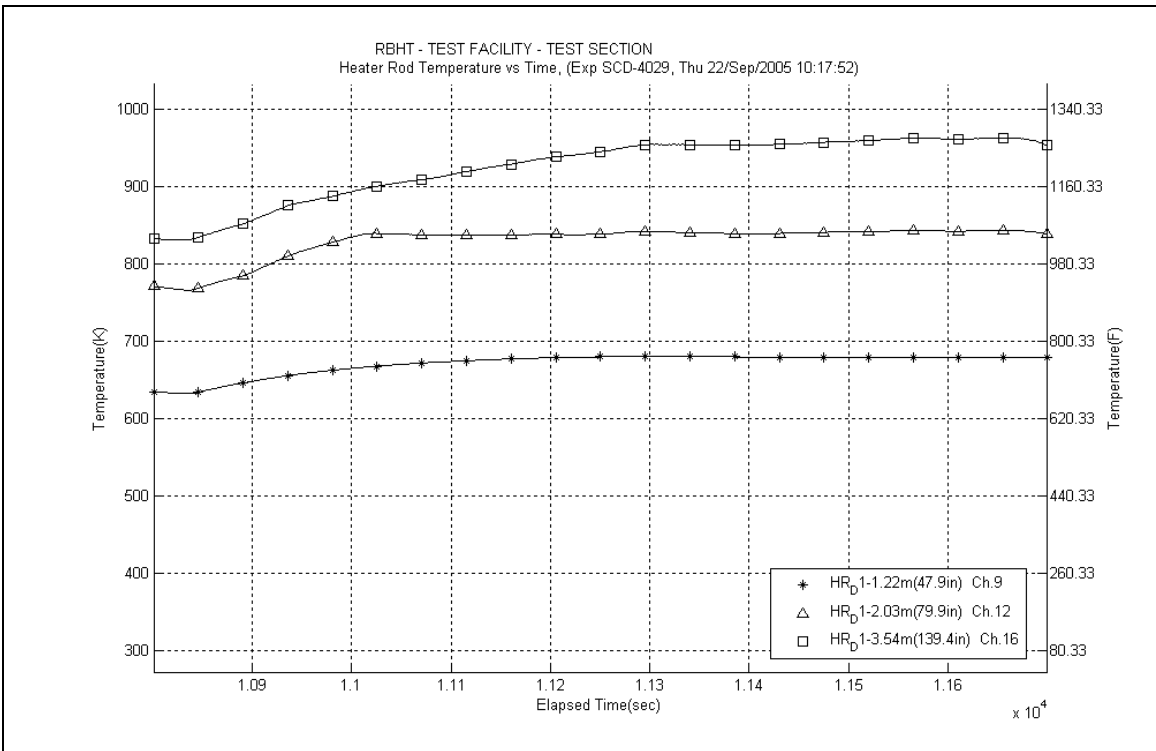

Figure A-69: Heater Rod D1 Temperatures for Experiment 4029C

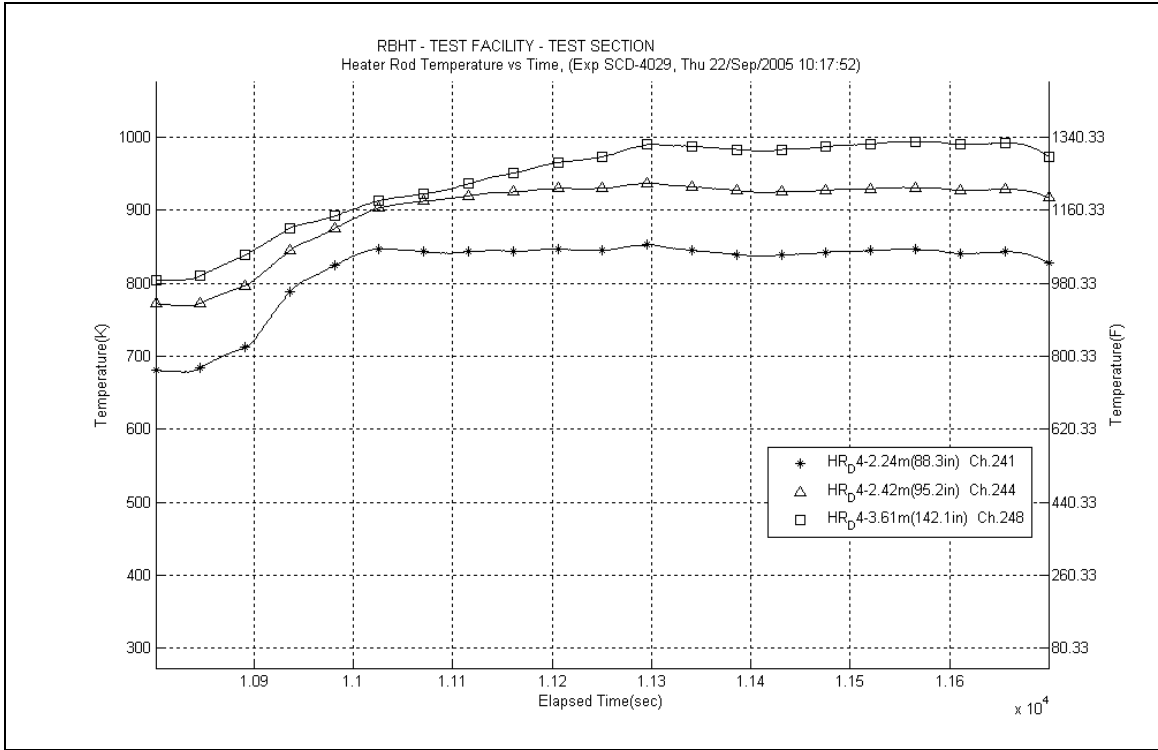

Figure A-70: Heater Rod D4 Temperatures for Experiment 4029C

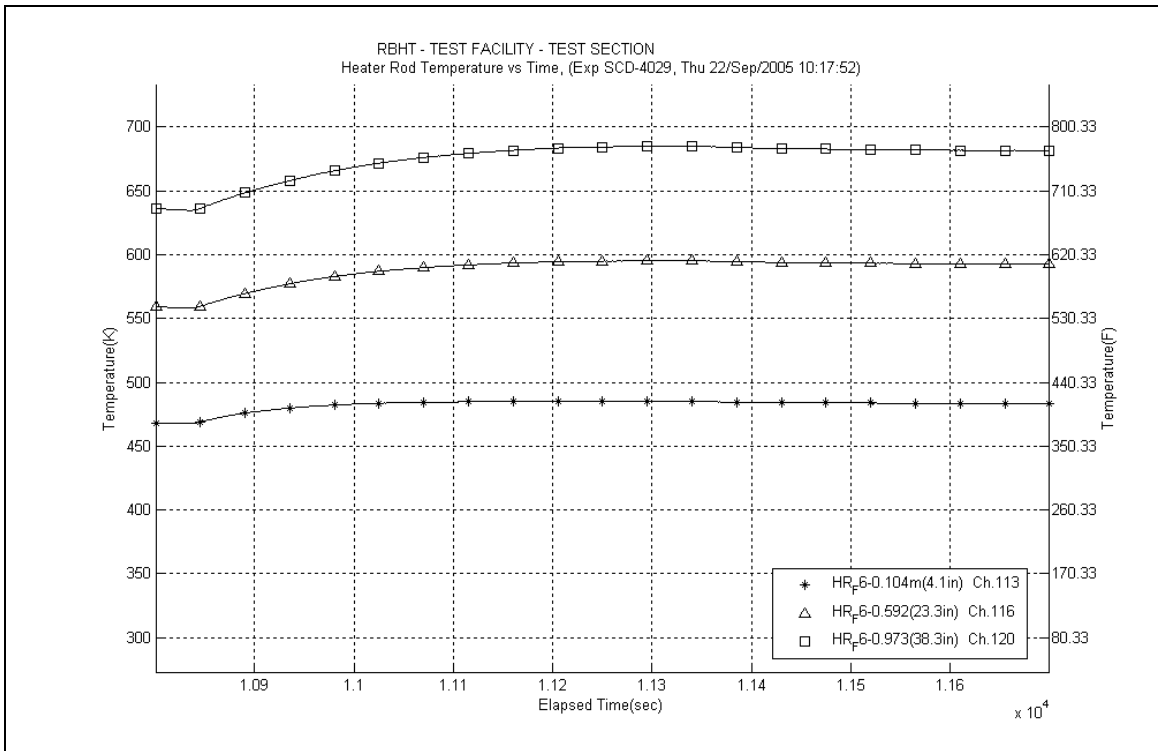

Figure A-71: Heater Rod F6 Temperatures for Experiment 4029C

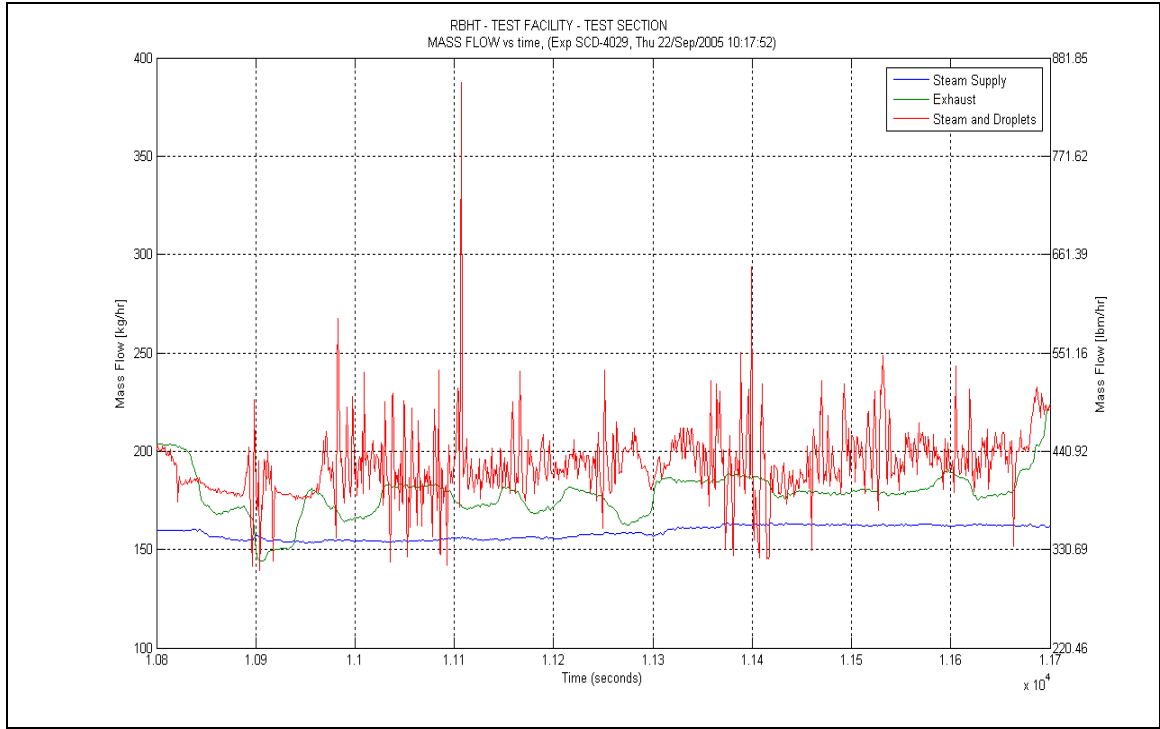

Figure A-72: Mass Flow for Experiment 4029C

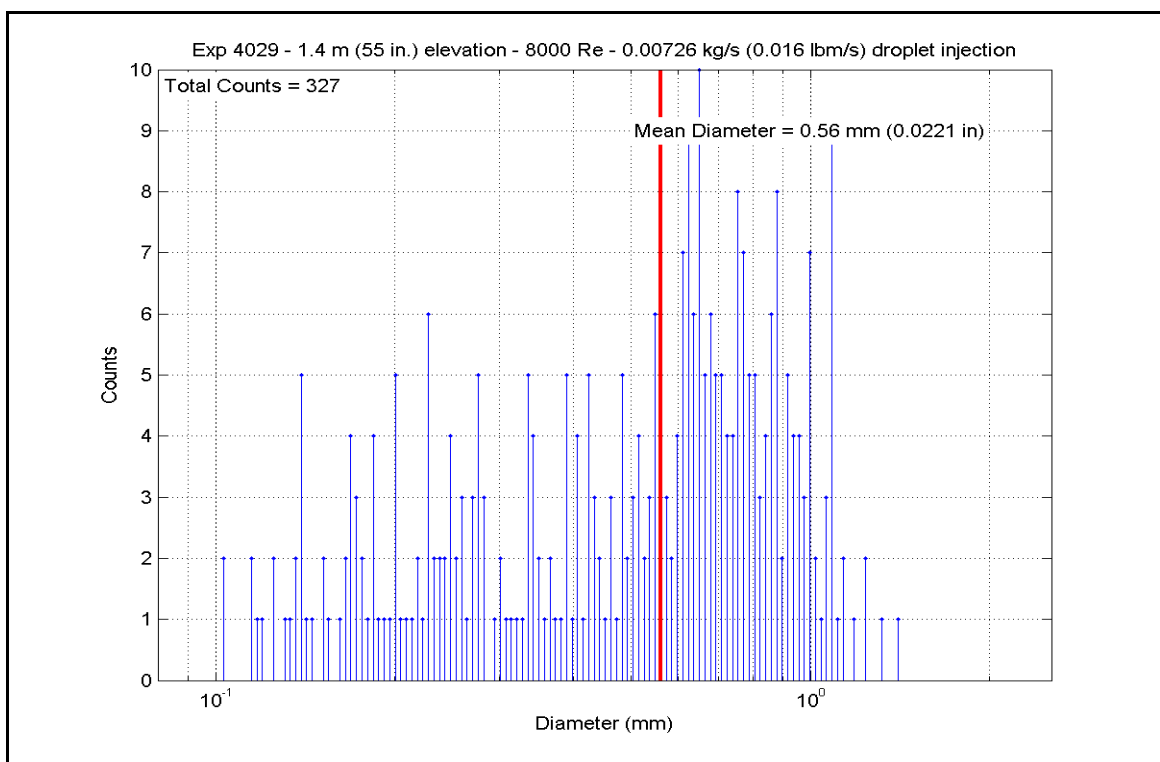

Figure A-73: Droplet Measurements at 1.397 m (55 in.) Elevation for Experiment 4029C

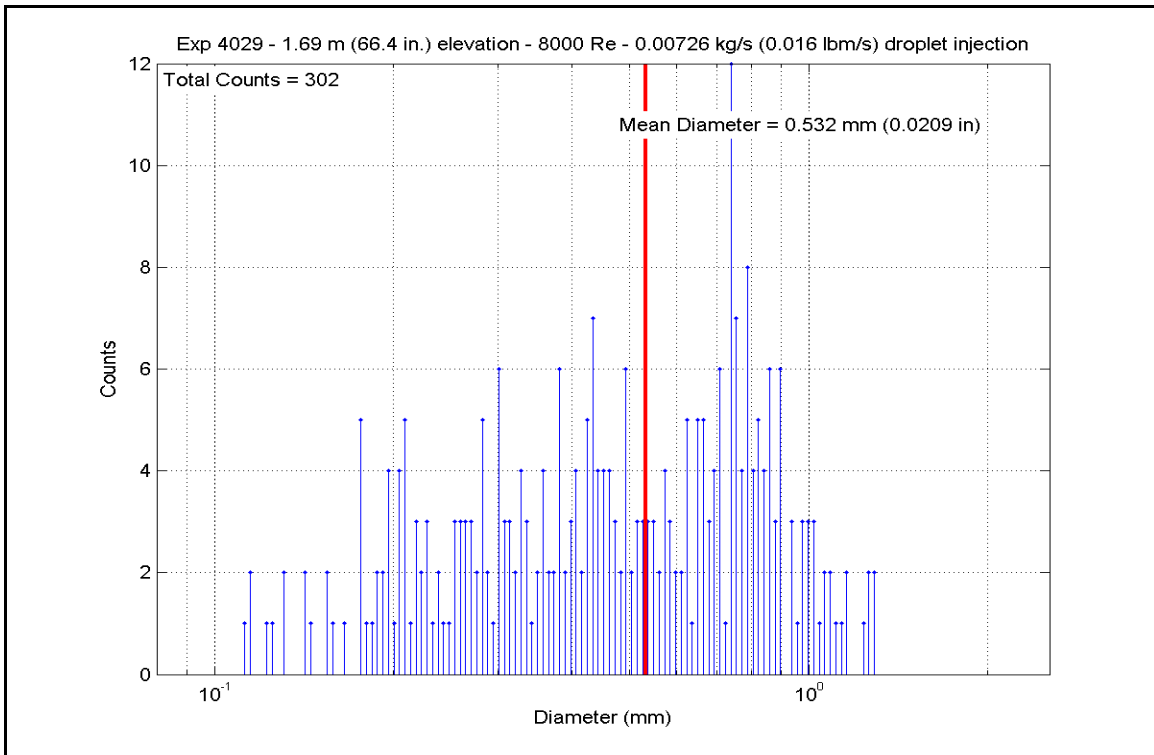

Figure A-74: Droplet Measurements at 1.687 m (66.4 in.) Elevation for Experiment 4029C

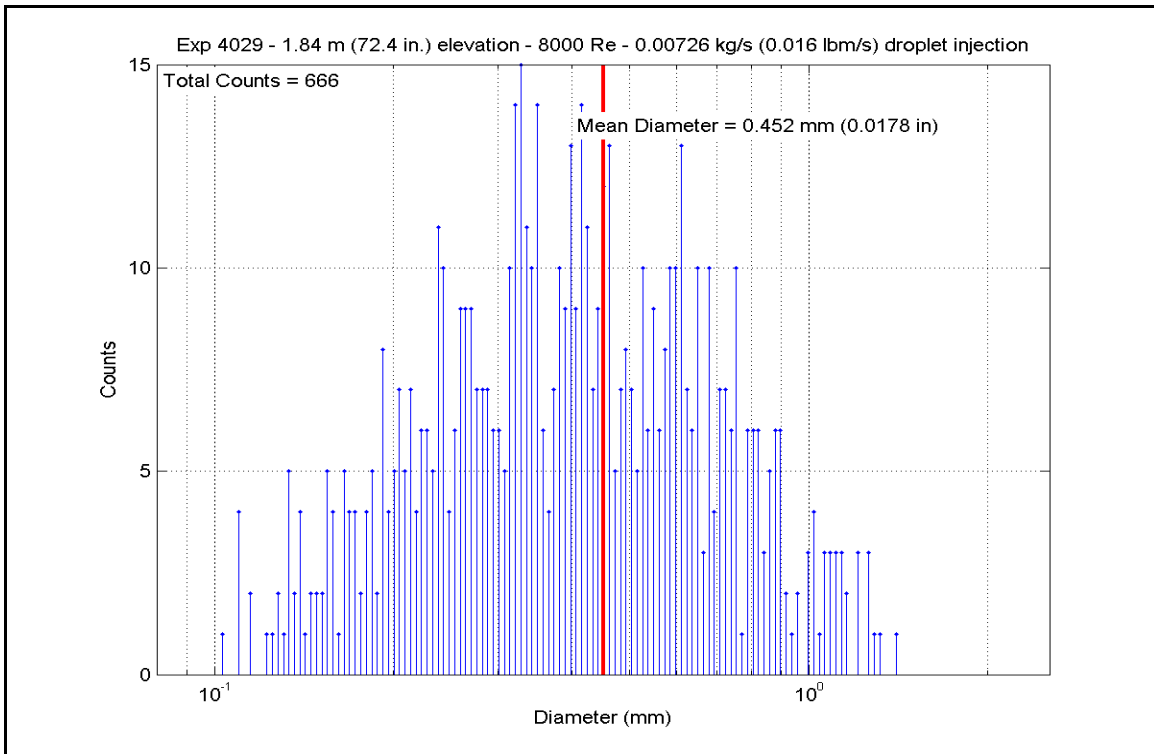

Figure A-75: Droplet Measurements at 1.839 m (72.4 in.) Elevation for Experiment 4029C

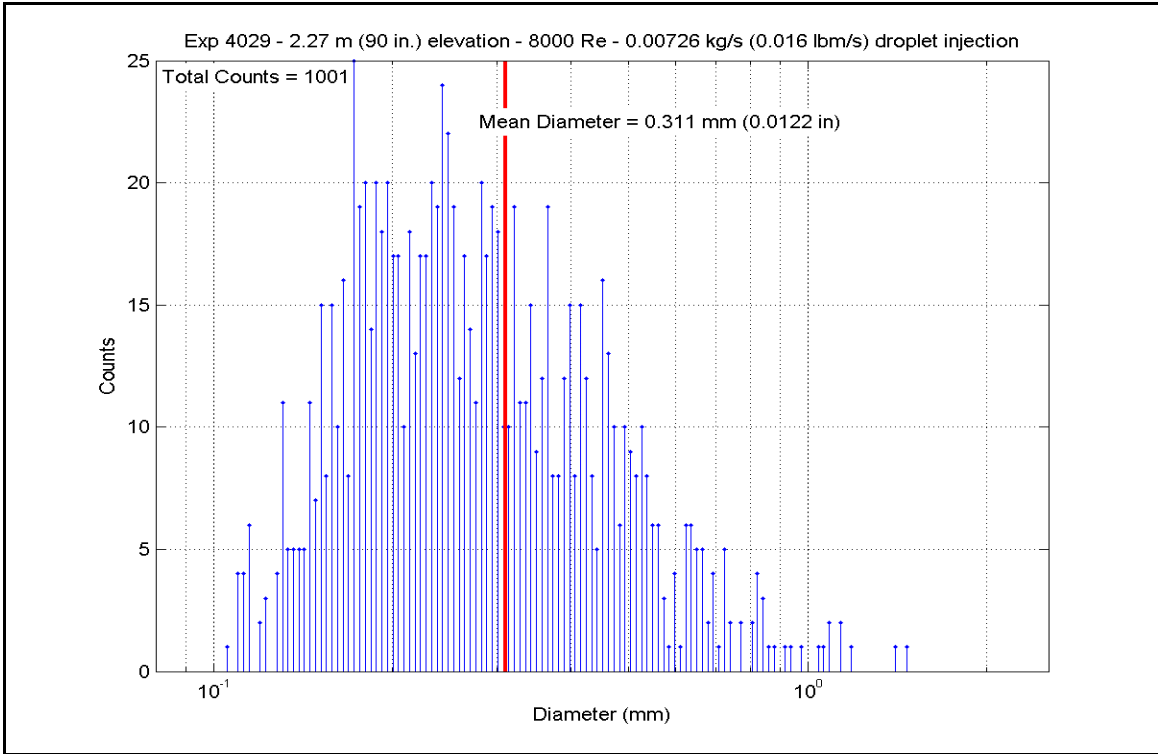

Figure A-76: Droplet Measurements at 2.286 m (90 in.) Elevation for Experiment 4029C

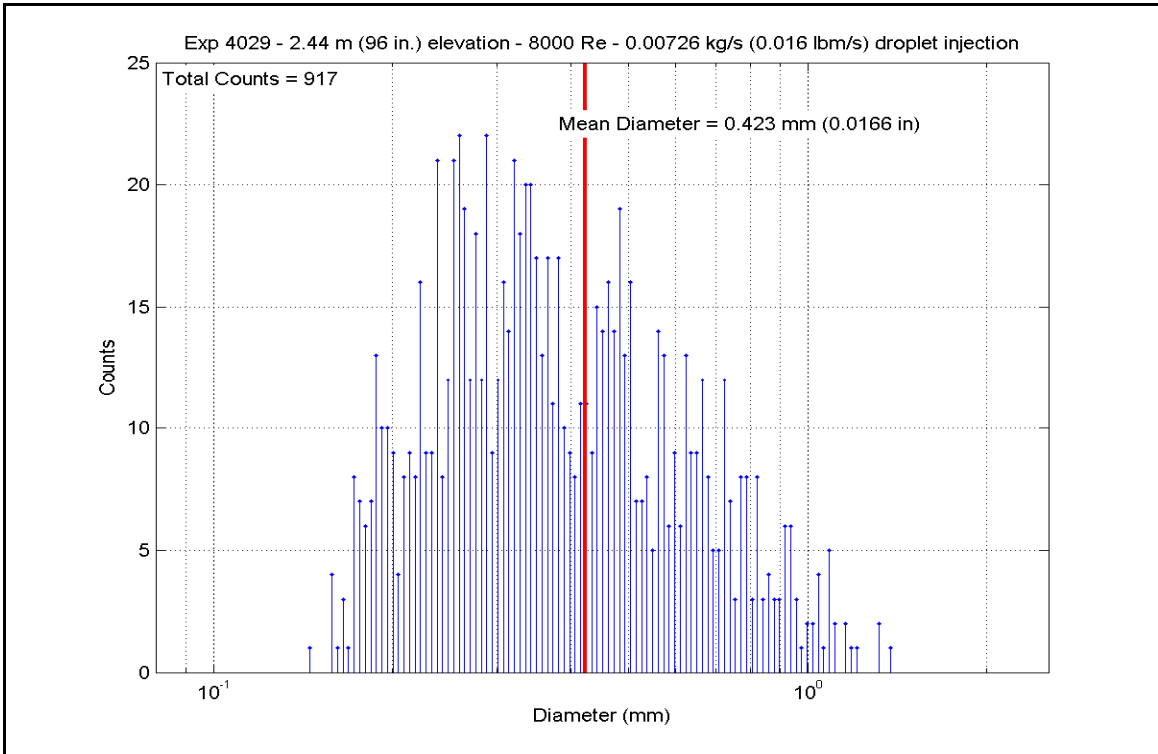

Figure A-77: Droplet Measurements at 2.438 m (96 in.) Elevation for Experiment 4029C

Error! Reference source not found.C

SCD-4029-C		Inlet Reynolds:		8000		40 psia							
Matrix test: shakedown		UP Pressure:		275.8 kPa		255911 Btu/hr							
Time Window: 10800-11700		Bundle Power:		75.00 kW		351.0 lbm/hr							
		Stream flow:		0.0442 kg/s		0.0167 lbm/s							
Inner 3x3		Droplet flow:		0.0076 kg/s		0.0167 lbm/s							
H.R. ID	H.R. Location	Channel Number	Elevation (in)	Elevation (m)	Zgrid (in)	Zgrid (m)	H.R. Tw (°F)	H.R. Tw (K)	H.R. q" (Btu/hr-ft2)	H.R. q" (W/m2)	h _{sat} (z) (Btu/hr-ft2-F)	h _{sat} (z) (W/m2-K)	
Gr-3	RodD3_88.3	185	88.3	2.243	-0.2	-0.005	1105.71	869.7	5984.23	18877.3	7.144	40.6	
	RodD3_91.3	186	91.3	2.319	2.8	0.071	1137.11	887.1	6077.55	19171.6	6.993	39.7	
	RodD3_93.1	187	93.1	2.365	4.6	0.117	1011.86	817.5	5828.87	18387.2	7.836	44.5	
	RodD3_95.3	188	95.3	2.421	6.8	0.173	1095.24	863.8	5954.27	18782.8	7.198	40.9	
	RodD3_100.1	189	100.1	2.543	11.6	0.295	1176.70	909.1	6206.42	19578.2	6.830	38.8	
	RodD3_106.1	190	106.1	2.695	17.6	0.447	1274.28	963.3	6521.39	20571.7	6.481	36.8	
	RodD3_110	191	110	2.794	21.5	0.546	1221.57	934.0	6319.76	19935.7	6.627	37.6	
	RodD3_142.1	192	142.1	3.609	3.609	8.6	1006.08	814.3	5818.82	18355.5	7.884	44.8	
	Gr-3	RodC4_88.4	233	88.4	2.245	-0.1	-0.003	1257.83	954.2	5703.66	17992.2	5.762	32.7
		RodC4_91.1	234	91.1	2.314	2.6	0.066	1275.96	964.2	5298.48	16714.1	5.257	29.9
RodC4_93.4		235	93.4	2.372	4.9	0.124	1290.71	972.4	4804.60	15156.1	4.698	26.7	
RodC4_95.3		236	95.3	2.421	6.8	0.173	1291.26	972.7	4302.83	13573.3	4.205	23.9	
RodC4_100.1		237	100.1	2.543	11.6	0.295	1202.27	923.3	6319.43	19934.7	6.764	38.4	
RodC4_106.1		238	106.1	2.695	17.6	0.447	1229.32	938.3	6511.12	20539.3	6.773	38.5	
RodC4_110		239	110	2.794	21.5	0.546	1249.91	949.8	6632.57	20922.4	6.755	38.4	
RodC4_142.2		240	142.2	3.612	3.612	8.7	999.68	810.8	4970.87	15680.6	6.794	38.6	
Gr-3		RodD4_88.3	241	88.3	2.243	-0.2	-0.005	916.79	764.7	5406.46	17054.7	8.333	47.3
		RodD4_91.3	242	91.3	2.319	2.8	0.071	964.79	791.4	5477.97	17280.3	7.862	44.6
	RodD4_93.2	243	93.2	2.367	4.7	0.119	1002.55	812.3	4833.43	15247.1	6.580	37.4	
	RodD4_95.2	244	95.2	2.418	6.7	0.170	1261.10	956.0	5455.27	17208.7	5.493	31.2	
	RodD4_100.1	245	100.1	2.543	11.6	0.295	1293.25	973.8	6560.37	20694.7	6.399	36.3	
	RodD4_106.1	246	106.1	2.695	17.6	0.447	1237.75	943.0	6474.60	20424.1	6.677	37.9	
	RodD4_142.1	248	142.1	3.609	3.609	8.6	831.25	717.2	5317.63	16774.5	9.441	53.6	
	Gr-3	RodE4_88.4	201	88.4	2.245	-0.1	-0.003	1095.88	864.2	5887.16	18571.0	7.111	40.4
		RodE4_91.2	202	91.2	2.316	2.7	0.069	1169.35	905.0	6055.47	19102.0	6.718	38.2
		RodE4_95.3	204	95.3	2.421	6.8	0.173	1239.24	943.8	1998.39	6303.9	2.058	11.7
RodE4_100.9		205	100.9	2.563	12.4	0.315	1203.98	924.3	6390.80	20159.8	6.828	38.8	
RodE4_142.3		208	142.3	3.614	3.614	8.8	1018.67	821.3	5776.86	18223.1	7.696	43.7	

Error! Reference source not found.C, continued

Gr-4	H.R. Location	Channel Number	Elevation (in)	Elevation (m)	Zgrid (in)	Zgrid (m)	H.R. Tw (°F)	H.R. Tw (K)	H.R. q" (Btu/hr-ft2)	H.R. q" (W/m2)	h _{sat} (z) (Btu/hr-ft2-F)	h _{sat} (z) (W/m2-K)
	RodE3_63.4	193	63.4	1.610	16.4	0.417	1257.30	953.9	3087.59	9739.8	3.121	17.7
	RodE3_113.6	194	113.6	2.885	0.85	0.022	1220.56	933.5	5684.85	17932.9	5.968	33.9
	RodE3_115.5	195	115.5	2.934	2.75	0.070	1016.09	819.9	4948.07	15608.7	6.614	37.6
	RodE3_118.5	196	118.5	3.010	5.75	0.146	1285.07	969.3	5619.90	17728.0	5.526	31.4
	RodE3_122.7	197	122.7	3.117	9.95	0.253	1309.03	982.6	5230.02	16498.1	5.024	28.5
	RodE3_126.5	198	126.5	3.213	13.75	0.349	1323.13	990.4	4684.60	14777.6	4.440	25.2
	RodE3_131.7	199	131.7	3.345	-1.8	-0.046	1320.70	989.1	4201.84	13254.7	3.991	22.7
	RodE3_135.6	200	135.6	3.444	2.1	0.053	1250.30	950.0	3618.36	11414.1	3.684	20.9
Gr-4	RodC5_63.7	225	63.7	1.618	16.7	0.424	964.87	791.4	4833.73	15248.0	6.936	39.4
	RodC5_113.6	226	113.6	2.885	0.85	0.022	1194.09	918.8	6000.47	18928.5	6.479	36.8
	RodC5_115.7	227	115.7	2.939	2.95	0.075	1220.20	933.3	3787.07	11946.3	3.977	22.6
	RodC5_122.7	229	122.7	3.117	9.95	0.253	1229.86	938.6	3227.73	10181.9	3.356	19.1
	RodC5_126.7	230	126.7	3.218	13.95	0.354	843.32	723.9	4426.41	13963.1	7.694	43.7
	RodC5_131.6	231	131.6	3.343	-1.9	-0.048	861.14	733.8	4613.58	14553.5	7.778	44.2
	RodC5_135.7	232	135.7	3.447	2.2	0.056	920.97	767.0	4716.80	14879.2	7.224	41.0
Gr-4	RodE5_63.6	209	63.6	1.615	16.6	0.422	1242.38	945.6	2001.57	6314.0	2.054	11.7
	RodE5_113.6	210	113.6	2.885	0.85	0.022	1274.99	963.7	6640.71	20948.1	6.595	37.5
	RodE5_115.4	211	115.4	2.931	2.65	0.067	1160.20	899.9	6227.63	19645.0	6.980	39.6
	RodE5_118.7	212	118.7	3.015	5.95	0.151	1239.38	943.9	2081.28	6565.4	2.143	12.2
	RodE5_122.6	213	122.6	3.114	9.85	0.250	1020.90	822.5	5909.55	18641.7	7.849	44.6
	RodE5_126.6	214	126.6	3.216	13.85	0.352	1097.48	865.1	6008.02	18952.3	7.243	41.1
	RodE5_131.6	215	131.6	3.343	-1.9	-0.048	1133.90	885.3	6084.43	19193.3	7.027	39.9
	RodE5_135.6	216	135.6	3.444	2.1	0.053	1164.32	902.2	6170.40	19464.5	6.884	39.1
Gr-5	RodC3_79.8	177	79.8	2.027	8.92	0.227	1114.46	874.5	6019.64	18988.9	7.112	40.4
	RodC3_85.6	178	85.6	2.174	14.72	0.374	1141.89	889.8	6093.97	19223.4	6.973	39.6
	RodC3_88.5	179	88.5	2.248	0	0.000	1213.06	929.3	2040.73	6437.5	2.159	12.3
	RodC3_92.4	180	92.4	2.347	3.9	0.099	797.14	698.2	4426.72	13964.1	8.366	47.5
	RodC3_94.4	181	94.4	2.398	5.9	0.150	835.46	719.5	4598.93	14507.3	8.104	46.0
	RodC3_97.2	182	97.2	2.469	8.7	0.221	1265.50	958.4	6564.18	20706.7	6.581	37.4
	RodC3_108.8	183	108.8	2.764	20.3	0.516	1191.05	917.1	6216.96	19611.4	6.735	38.2
Gr-8	RodD5_50	217	50	1.270	3	0.076	1203.09	923.8	4027.22	12703.9	4.307	24.5
	RodD5_54.1	218	54.1	1.374	7.1	0.180	1299.87	977.5	4583.60	14459.0	4.442	25.2
	RodD5_56.9	219	56.9	1.445	9.9	0.251	1296.48	975.6	4099.93	12933.2	3.986	22.6
	RodD5_60	220	60	1.524	13	0.330	1222.41	934.5	3627.18	11441.9	3.800	21.6
	RodD5_66.1	221	66.1	1.679	19.1	0.485	1232.15	939.9	3088.14	9678.4	3.182	18.1
	RodD5_69.9	222	69.9	1.775	-0.98	-0.025	1015.20	5936.10	18725.4	7.945	45.1	
	RodD5_72.9	223	72.9	1.852	2.02	0.051	1089.52	860.7	6043.68	19064.8	7.357	41.8
	RodD5_74.9	224	74.9	1.902	4.02	0.102	1128.91	882.5	6146.87	19390.3	7.140	40.5

Error! Reference source not found.C, continued

H.R. ID	H.R. Location	Channel Number	Elevation (in)	Elevation (m)	Zgrid (in)	Zgrid (m)	H.R. Tw (°F)	H.R. Tw (K)	H.R. q" (Btu/hr-ft2)	H.R. q" (W/m2)	h _{sat} (z) (Btu/hr-ft2-F)	h _{sat} (z) (W/m2-K)	
Gr-2	RodB5_41	153	41	1.041	13.5	0.343	552.24	562.2	2974.47	9382.9	10.465	59.4	
	RodB5_52.9	154	52.9	1.344	5.9	0.150	599.87	588.6	3269.84	10314.7	9.853	56.0	
	RodB5_55	155	55	1.397	8	0.203	629.78	605.3	3534.53	11149.7	9.770	55.5	
	RodB5_57.8	156	57.8	1.468	10.8	0.274	698.58	643.5	3691.37	11644.4	8.573	48.7	
	RodB5_64	157	64	1.626	17	0.432	726.11	658.8	3770.88	11895.2	8.231	46.7	
	RodB5_73.9	158	73.9	1.877	30.2	0.077	764.10	679.9	3893.22	12281.2	7.848	44.6	
	RodB5_75.9	159	75.9	1.928	5.02	0.128	794.59	696.8	4033.91	12725.0	7.660	43.5	
	RodB5_76.9	160	76.9	1.953	6.02	0.153	812.86	707.0	4569.09	14413.2	8.386	47.6	
	Gr-2	RodF5_41	105	41	1.041	13.5	0.343	551.56	561.8	2985.20	9416.8	10.527	59.8
		RodF5_53.1	106	53.1	1.349	6.1	0.155	597.60	587.4	3275.67	10333.1	9.938	56.4
		RodF5_55	107	55	1.397	8	0.203	617.52	598.4	3542.98	11176.3	10.137	57.6
		RodF5_57.8	108	57.8	1.468	10.8	0.274	693.17	640.5	3694.07	11652.9	8.688	49.3
		RodF5_64	109	64	1.626	17	0.432	717.77	654.1	3771.40	11896.9	8.385	47.6
		RodF5_73.8	110	73.8	1.875	2.92	0.074	753.06	673.7	3885.90	12258.1	8.011	45.5
		RodF5_75.8	111	75.8	1.925	4.92	0.125	819.26	710.5	4433.11	13984.2	8.042	45.7
		RodF5_76.8	112	76.8	1.951	5.92	0.150	861.38	733.9	4613.00	14551.7	7.774	44.1
Gr-2		RodC2_41	57	41	1.041	13.5	0.343	1142.90	890.3	2389.46	7537.5	2.731	15.5
		RodC2_53.1	58	53.1	1.349	6.1	0.155	735.85	664.2	4373.83	13797.2	9.349	53.1
		RodC2_55	59	55	1.397	8	0.203	990.28	805.5	5694.38	17962.9	7.884	44.8
		RodC2_57.8	60	57.8	1.468	10.8	0.274	1098.66	865.7	6319.83	19935.9	7.608	43.2
	RodC2_63.9	61	63.9	1.623	16.9	0.429	1170.26	905.5	5766.58	18190.7	6.391	36.3	
	RodC2_73.8	62	73.8	1.875	2.92	0.074	1194.08	918.8	4261.39	13442.5	4.602	26.1	
	RodC2_75.8	63	75.8	1.925	4.92	0.125	964.12	791.0	5501.09	17353.2	7.903	44.9	
	RodC2_76.8	64	76.8	1.951	5.92	0.150	978.57	799.0	5544.37	17489.7	7.803	44.3	
Gr-2	RodC6_40.9	137	40.9	1.039	13.4	0.340	898.96	754.8	4686.83	14784.6	7.428	42.2	
	RodC6_52.8	138	52.8	1.341	5.8	0.147	929.94	772.0	4772.31	15054.3	7.210	40.9	
	RodC6_54.8	139	54.8	1.392	7.8	0.198	990.91	805.9	5027.49	15859.2	6.955	39.5	
	RodC6_57.8	140	57.8	1.468	10.8	0.274	819.19	710.5	5287.19	16678.4	9.592	54.5	
	RodC6_63.8	141	63.8	1.621	16.8	0.427	913.96	763.1	5385.05	16987.1	8.337	47.3	
	RodC6_73.7	142	73.7	1.872	2.82	0.072	959.98	788.7	5459.34	17221.5	7.889	44.8	
	RodC6_75.8	143	75.8	1.925	4.92	0.125	1038.29	832.2	5617.24	17719.6	7.292	41.4	
	RodC6_76.8	144	76.8	1.951	5.92	0.150	1007.56	815.1	5753.69	18150.0	7.780	44.2	

Error! Reference source not found.C, continued

5x5 periphery		H.R.	Channel	Elevation	Elevation	Zgrid	Zgrid	H.R. Tw	H.R. Tw	H.R. Tw	H.R. q"	H.R. q"	H.R. q"	h _{sat} (z)	h _{sat} (z)
Gr-3	Location	Number	(in)	(m)	(in)	(m)	(°F)	(K)	(Btu/hr-ft ²)	(W/m ²)	(Btu/hr-ft ²)	(W/m ²)	(W/m ² -K)	(W/m ² -K)	
	RodB4_88.4	161	88.4	2.245	-0.1	-0.003	965.06	791.5	5567.29	17562.0	7.987	7.987	45.4	45.4	
	RodB4_91.3	162	91.3	2.319	2.8	0.071	984.85	802.5	5607.96	17690.3	7.823	7.823	44.4	44.4	
	RodB4_93.3	163	93.3	2.370	4.8	0.122	409.13	482.7	2483.36	7833.8	17.597	17.597	99.9	99.9	
	RodB4_95.1	164	95.1	2.416	6.6	0.168	492.75	529.1	2776.20	8757.5	12.353	12.353	70.1	70.1	
	RodB4_100	165	100	2.540	11.5	0.292	1244.02	946.5	6520.21	20568.0	6.680	6.680	37.9	37.9	
	RodB4_106	166	106	2.692	17.5	0.445	1267.95	959.8	6640.27	20946.7	6.641	6.641	37.7	37.7	
	RodB4_109.9	167	109.9	2.791	21.4	0.544	1212.99	929.3	6077.79	19172.4	6.432	6.432	36.5	36.5	
	RodB4_142.3	168	142.3	3.614	8.8	0.224	930.94	772.6	5478.31	17281.3	8.264	8.264	46.9	46.9	
Gr-5	RodF4_85.6	98	85.6	2.174	14.72	0.374	976.12	797.7	5459.81	17223.0	7.710	7.710	43.8	43.8	
	RodF4_88.4	99	88.4	2.245	-0.1	-0.003	992.58	806.8	5500.57	17351.6	7.591	7.591	43.1	43.1	
	RodF4_92.4	100	92.4	2.347	3.9	0.099	407.69	481.9	2494.94	7870.3	17.861	17.861	101.4	101.4	
	RodF4_94.3	101	94.3	2.395	5.8	0.147	497.74	531.9	2781.75	8775.0	12.108	12.108	68.8	68.8	
	RodF4_97.2	102	97.2	2.469	8.7	0.221	1279.05	966.0	6595.66	20806.0	6.524	6.524	37.0	37.0	
	RodF4_108.8	103	108.8	2.764	20.3	0.516	1214.39	930.0	6437.94	20308.5	6.803	6.803	38.6	38.6	
	RodF4_111	104	111	2.819	-1.75	-0.044	1214.90	930.3	6356.89	20052.8	6.713	6.713	38.1	38.1	
Gr-6	RodD2_103.2	65	103.2	2.621	14.7	0.373	1179.08	910.4	6279.74	19809.4	6.893	6.893	39.1	39.1	
	RodD2_106	66	106	2.692	17.5	0.445	1246.80	948.0	6535.72	20616.9	6.677	6.677	37.9	37.9	
	RodD2_112.6	67	112.6	2.860	-0.15	-0.004	1188.24	915.5	6347.75	20024.0	6.898	6.898	39.2	39.2	
	RodD2_114.9	68	114.9	2.918	2.15	0.055	1255.99	953.1	5744.80	18122.0	5.815	5.815	33.0	33.0	
	RodD2_117.4	69	117.4	2.982	4.65	0.118	1275.17	963.8	5404.90	17049.8	5.366	5.366	30.5	30.5	
	RodD2_120.8	70	120.8	3.068	8.05	0.204	1298.78	976.9	4937.72	15576.0	4.790	4.790	27.2	27.2	
	RodD2_124.8	71	124.8	3.170	12.05	0.306	1306.61	981.3	4395.66	13866.1	4.232	4.232	24.0	24.0	
	RodD2_128.6	72	128.6	3.266	15.85	0.403	1299.22	977.2	3886.38	12259.6	3.769	3.769	21.4	21.4	
Gr-6	RodD6_103.1	129	103.1	2.619	14.6	0.371	1256.78	953.6	5872.41	18524.5	5.939	5.939	33.7	33.7	
	RodD6_106	130	106	2.692	17.5	0.445	1232.47	940.1	6285.15	19826.5	6.517	6.517	37.0	37.0	
	RodD6_112.9	131	112.9	2.868	0.15	0.004	1229.36	938.4	5875.96	18535.7	6.112	6.112	34.7	34.7	
	RodD6_114.9	132	114.9	2.918	2.15	0.055	840.55	722.3	4456.82	14059.0	7.784	7.784	44.2	44.2	
	RodD6_116.8	133	116.8	2.967	4.05	0.103	864.44	735.6	4631.72	14610.8	7.766	7.766	44.1	44.1	
	RodD6_120.9	134	120.9	3.071	8.15	0.207	1132.21	884.4	6032.99	19031.1	6.981	6.981	39.6	39.6	
	RodD6_124.8	135	124.8	3.170	12.05	0.306	1167.04	903.7	6125.79	19323.8	6.814	6.814	38.7	38.7	
	RodD6_128.7	136	128.7	3.269	15.95	0.405	1246.71	948.0	1857.07	5858.1	1.897	1.897	10.8	10.8	

Error! Reference source not found.C, continued

5x5 periphery		H.R.	Channel	Elevation	Elevation	Zgrid	Zgrid	H.R. Tw	H.R. Tw	H.R. q"	H.R. q"	H.R. q"	h _{sat} (z)	h _{sat} (z)
Gr-8	Location	Number	(in)	(m)	(m)	(m)	(m)	(°F)	(K)	(W/m ²)	(Btu/hr-ft ²)	(W/m ²)	(W/m ² -K)	(Btu/hr-ft ² -F)
	RodE2_50.1	73	50.1	1.273	3.1	0.079	913.93	763.1	4741.92	14958.4	7.341	41.7	41.7	
	RodE2_54	74	54	1.372	7	0.178	951.06	783.7	4855.13	15315.5	7.108	40.4	40.4	
	RodE2_56.9	75	56.9	1.445	9.9	0.251	993.41	807.3	5097.76	16080.9	7.027	39.9	39.9	
	RodE2_59.9	76	59.9	1.521	12.9	0.328	836.26	720.0	5323.38	16792.6	9.368	53.2	53.2	
	RodE2_66	77	66	1.676	19	0.483	924.76	769.1	5432.08	17135.5	8.271	47.0	47.0	
	RodE2_69.8	78	69.8	1.773	-1.08	-0.027	963.95	790.9	5511.58	17386.3	7.920	45.0	45.0	
	RodE2_72.9	79	72.9	1.852	2.02	0.051	415.18	486.0	2448.16	7722.7	16.634	94.5	94.5	
	RodE2_74.9	80	74.9	1.902	4.02	0.102	500.14	533.2	2747.34	8666.5	11.835	67.2	67.2	
Gr-8	RodB3_50.2	169	50.2	1.275	3.2	0.081	1263.93	957.6	4900.75	15459.4	4.921	27.9	27.9	
	RodB3_54.1	170	54.1	1.374	7.1	0.180	1268.57	960.1	4367.02	13775.7	4.365	24.8	24.8	
	RodB3_56.9	171	56.9	1.445	9.9	0.251	1261.18	956.0	3840.23	12114.0	3.867	22.0	22.0	
	RodB3_60.1	172	60.1	1.527	13.1	0.333	801.73	700.8	3980.28	12555.8	7.457	42.4	42.4	
	RodB3_66.1	173	66.1	1.679	19.1	0.485	853.74	729.7	4556.87	14374.6	7.780	44.2	44.2	
	RodB3_69.9	174	69.9	1.775	-0.98	-0.025	882.91	745.9	4636.51	14625.9	7.540	42.8	42.8	
	RodB3_73	175	73	1.854	2.12	0.054	921.03	767.1	4755.21	15000.3	7.282	41.4	41.4	
	RodB3_75	176	75	1.905	4.12	0.105	980.82	800.3	4993.27	15751.3	7.005	39.8	39.8	
Gr-8	RodF3_50.1	89	50.1	1.273	3.1	0.079	1119.29	877.2	6024.30	19003.6	7.077	40.2	40.2	
	RodF3_54	90	54	1.372	7	0.178	1151.16	894.9	6101.09	19245.9	6.908	39.2	39.2	
	RodF3_57	91	57	1.448	10	0.254	795.12	697.1	3996.58	12607.2	7.582	43.1	43.1	
	RodF3_60	92	60	1.524	13	0.330	809.94	705.3	4547.81	14346.1	8.392	47.7	47.7	
	RodF3_66.1	93	66.1	1.679	19.1	0.485	860.56	733.5	4614.00	14554.9	7.787	44.2	44.2	
	RodF3_70	94	70	1.778	-0.88	-0.022	918.17	765.5	4712.79	14866.5	7.249	41.2	41.2	
	RodF3_73	95	73	1.854	2.12	0.054	988.59	804.6	4954.77	15629.8	6.876	39.0	39.0	
	RodF3_75	96	75	1.905	4.12	0.105	936.45	775.6	5381.50	16976.0	8.051	45.7	45.7	
Gr-8	RodE6_50.2	121	50.2	1.275	3.2	0.081	558.68	565.8	2952.91	9315.0	10.158	57.7	57.7	
	RodE6_54.1	122	54.1	1.374	7.1	0.180	604.56	591.2	3260.32	10284.7	9.687	55.0	55.0	
	RodE6_57	123	57	1.448	10	0.254	624.05	602.1	3527.46	11127.4	9.907	56.3	56.3	
	RodE6_60.2	124	60.2	1.529	13.2	0.335	698.58	643.5	3692.79	11648.9	8.576	48.7	48.7	
	RodE6_66.1	125	66.1	1.679	19.1	0.485	724.56	657.9	3776.94	11914.3	8.273	47.0	47.0	
	RodE6_70	126	70	1.778	-0.88	-0.022	760.79	678.0	3901.71	12307.9	7.918	45.0	45.0	
	RodE6_73.1	127	73.1	1.857	2.22	0.056	815.76	708.6	4434.44	13988.4	8.096	46.0	46.0	
	RodE6_75	128	75	1.905	4.12	0.105	851.72	728.6	4614.40	14556.1	7.905	44.9	44.9	

RBHT Steam Cooling with Droplet Injection Test SCD-4029-D

Matrix Test # Shakedown

Test Conditions

Test Date – 9/22/2005

Steady State Time Window: 11760 - 12600

Upper Plenum Pressure: 2.76 bar (40 psia)

Bundle Power: 75.0 kW

Bundle Inlet Reynolds Number: 8000

Bundle Inlet Steam Flow: 159.4 kg/hr (351 lbm/hr)

Droplet Injection Flow: 0.0151 kg/s (0.0333 lbm/s)

Droplet Injection Hole Diameter: 0.381 mm (.015 in)

Droplet Injection Elevation: 1.295 m (51 in)

Bundle Flow Area: $4.656 \times 10^{-3} \text{ m}^2$ ($5.012 \times 10^{-2} \text{ ft}^2$)

Test Notes

- No steam probes were traversed in this steady state window.

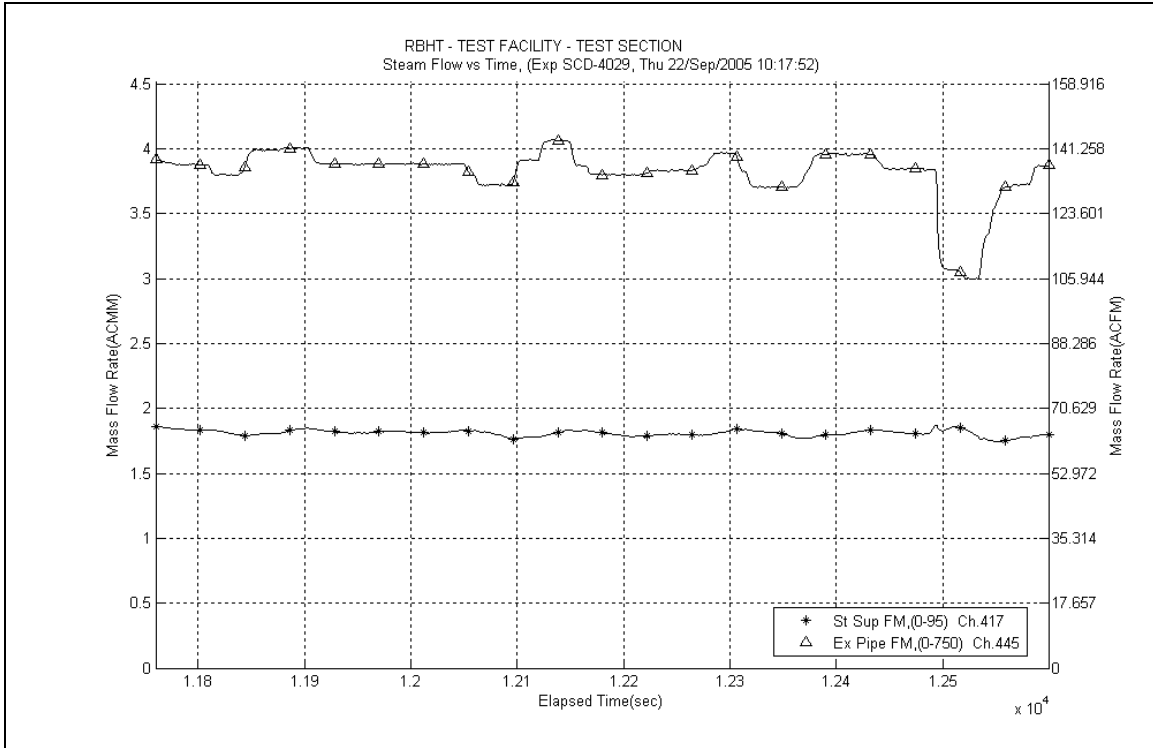

Figure A-78: Inlet and Exhaust Steam Flow Rates for Experiment 4029D

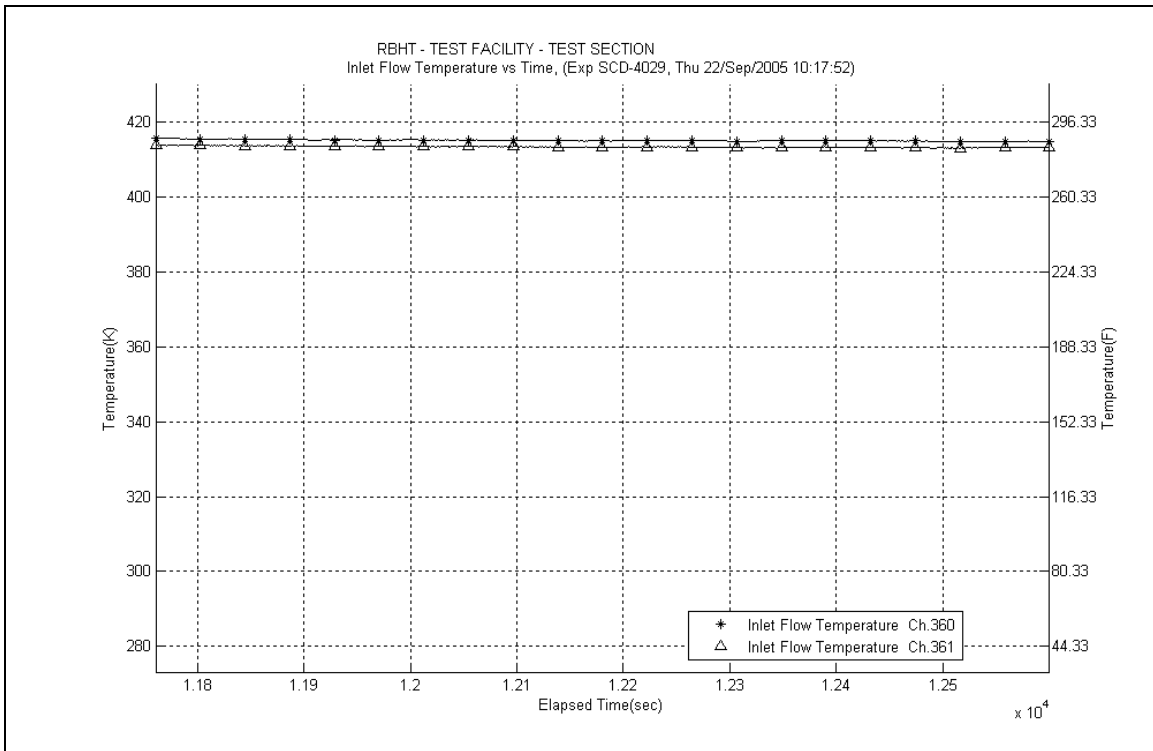

Figure A-79: Inlet Steam Temperature for Experiment 4029D

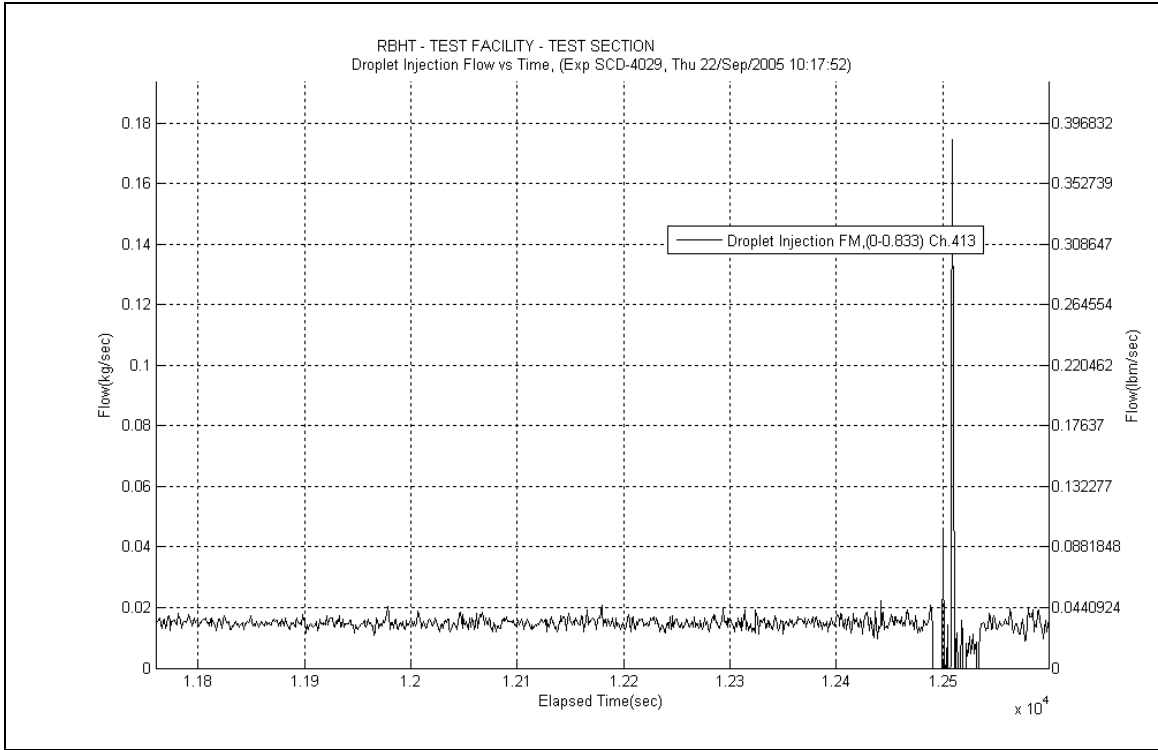

Figure A-80: Droplet Injection Flow Rate for Experiment 4029D

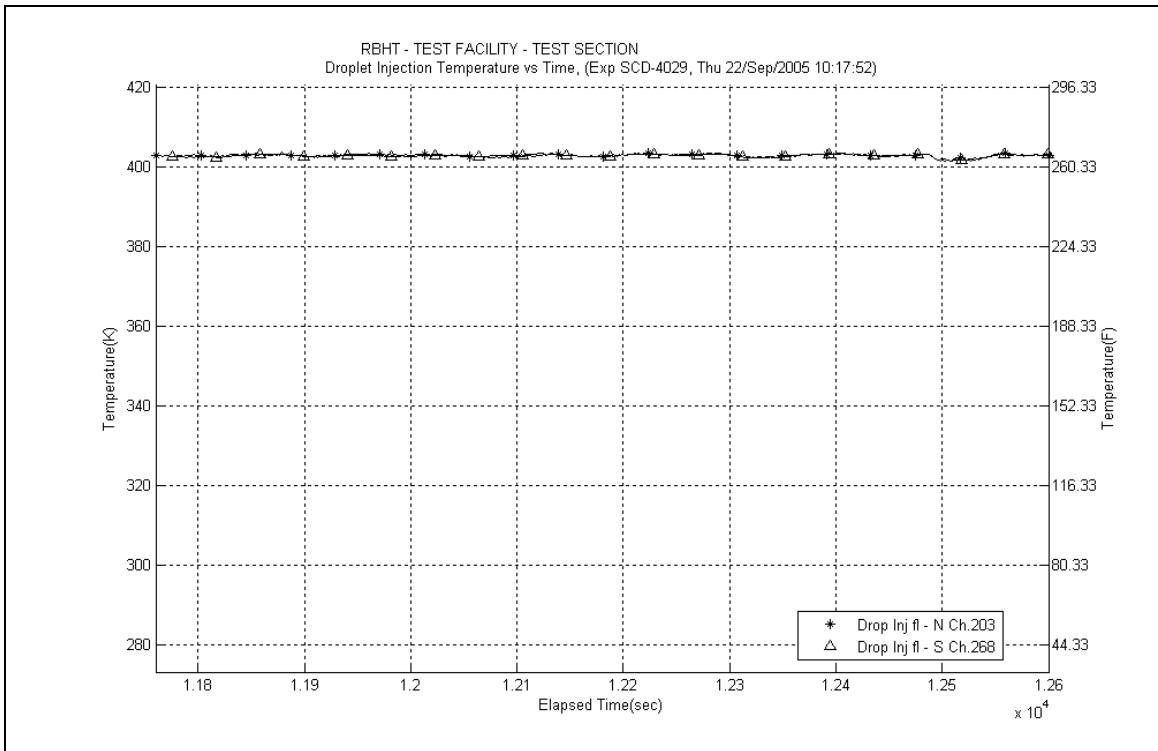

Figure A-81: Droplet Injection Temperature for Experiment 4029D

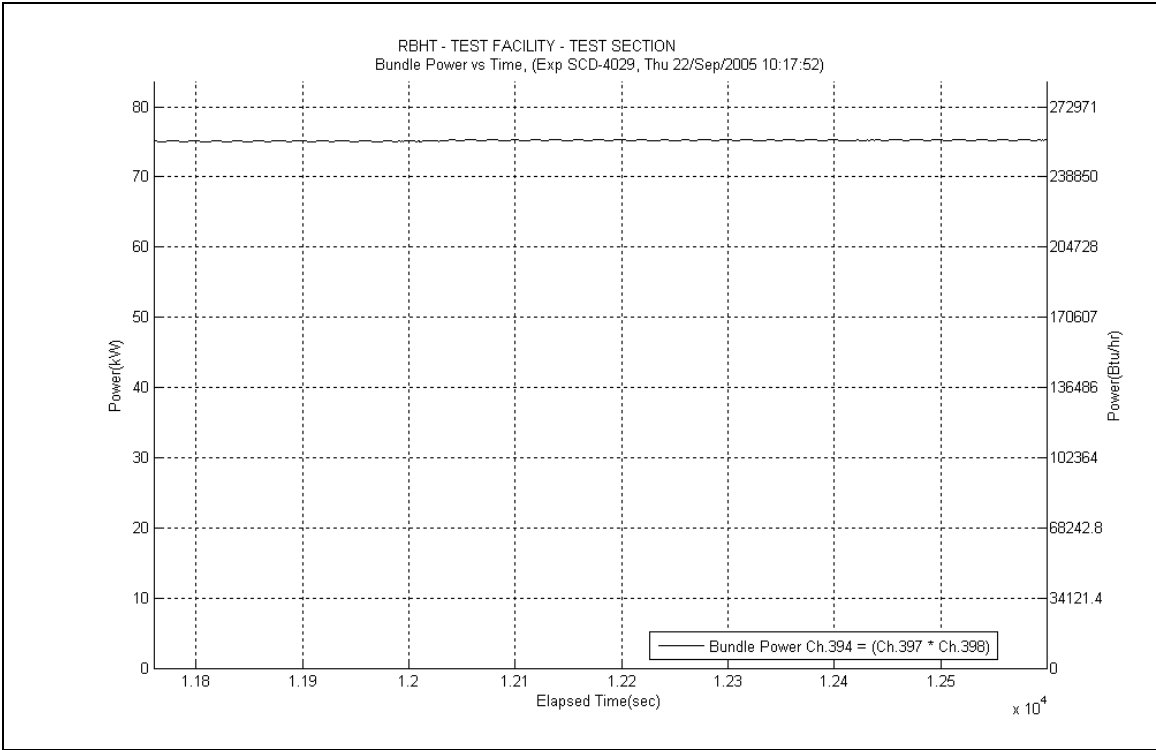

Figure A-82: Bundle Power for Experiment 4029D

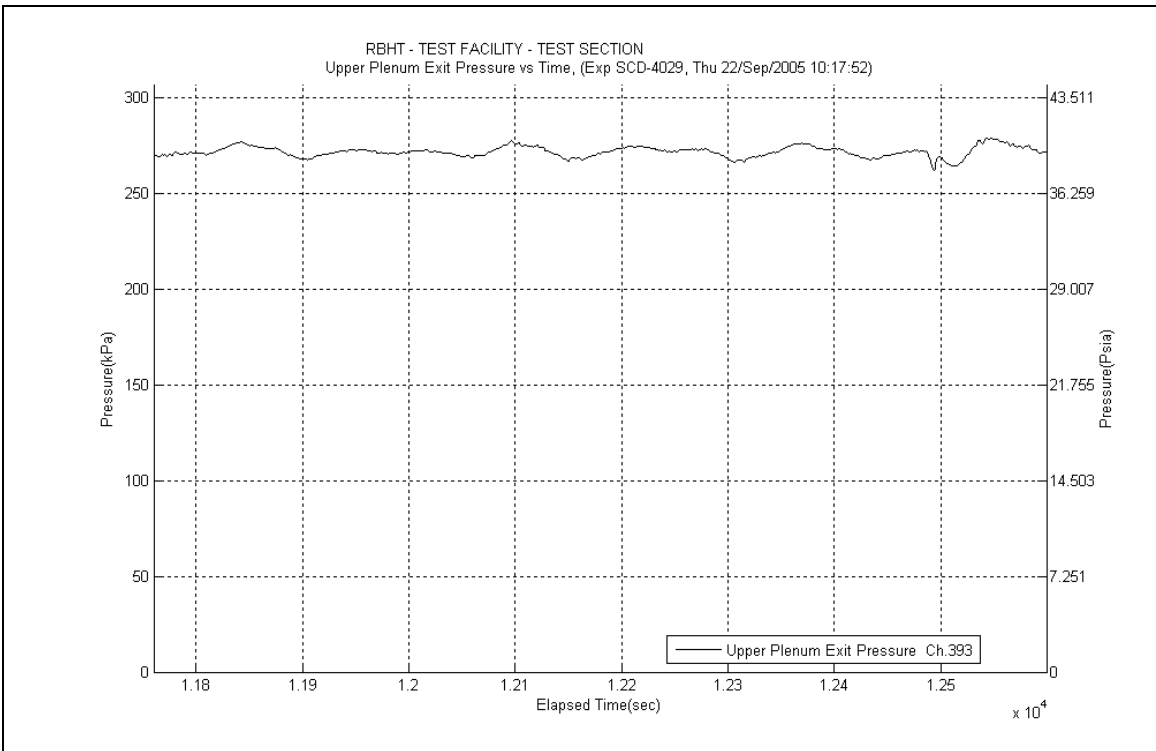

Figure A-83: Upper Plenum Pressure for Experiment 4029D

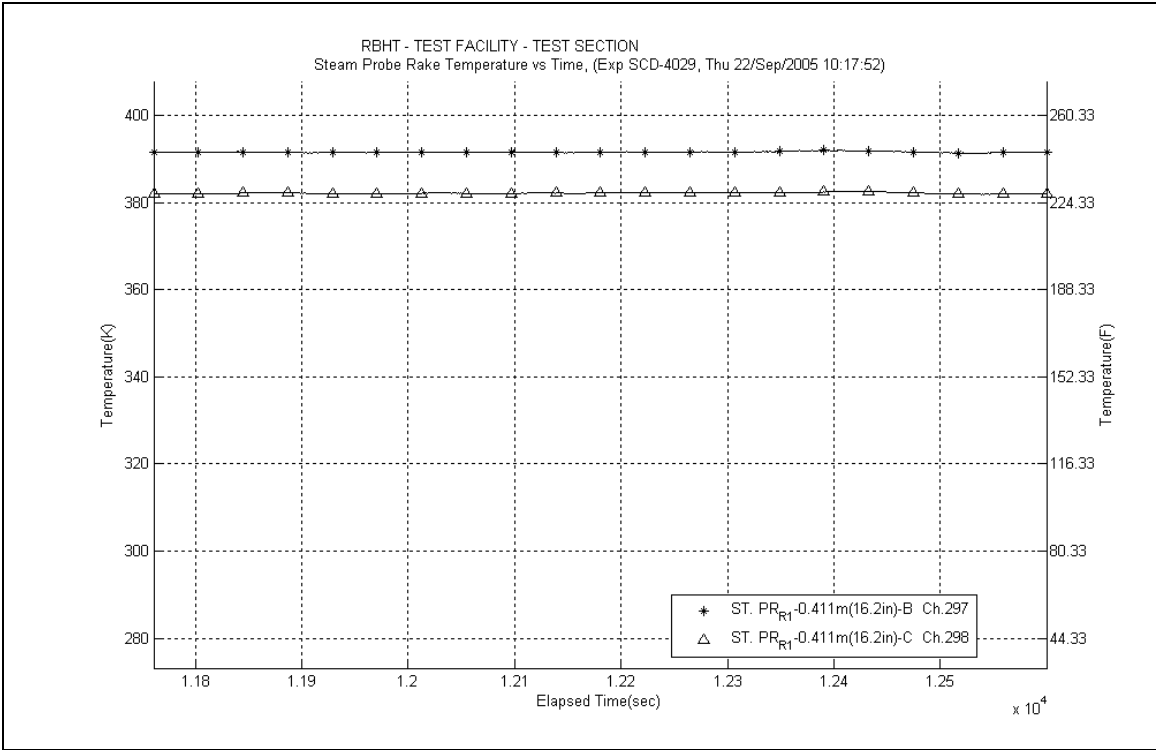

Figure A-84: Steam Probe Rake #1 Temperatures for Experiment 4029D

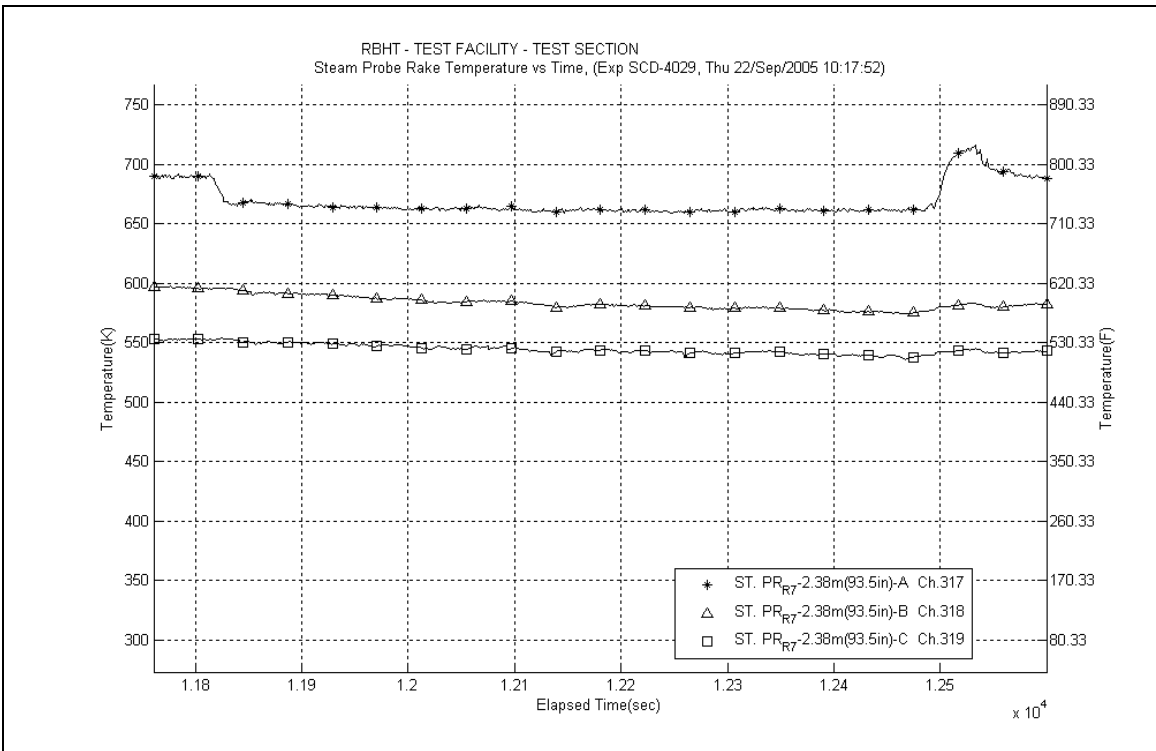

Figure A-85: Steam Probe Rake #7 Temperatures for Experiment 4029D

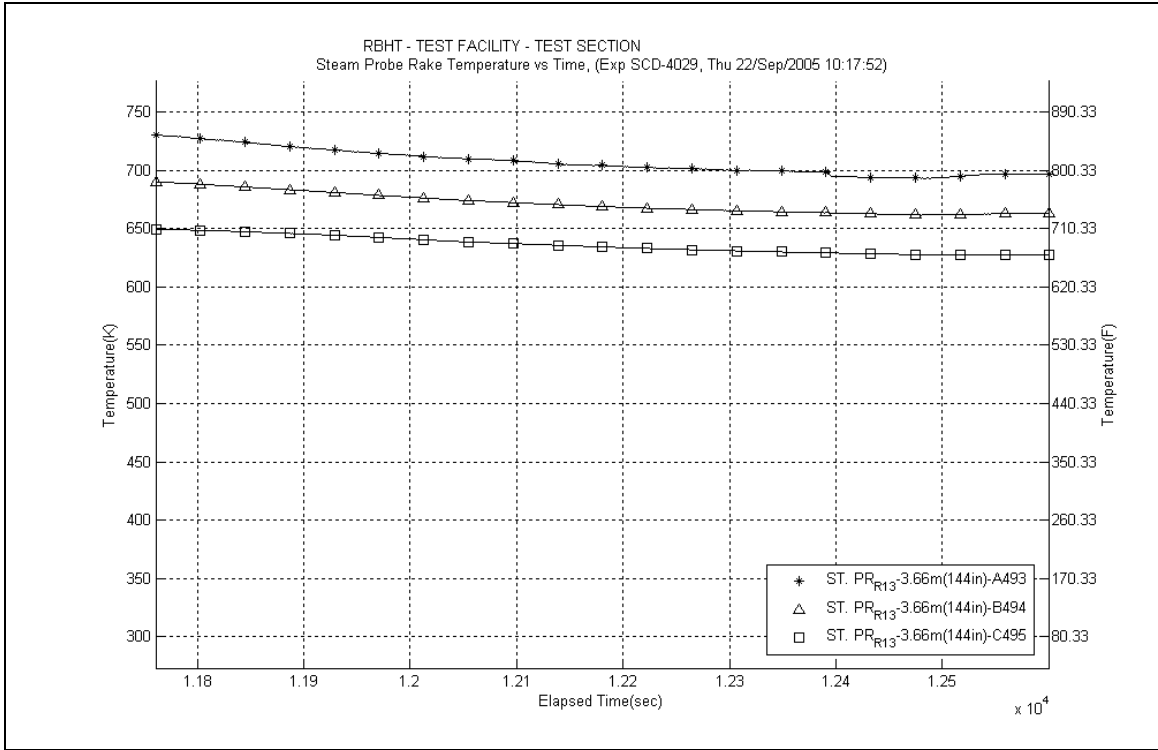

Figure A-86: Steam Probe Rake #13 Temperatures for Experiment 4029D

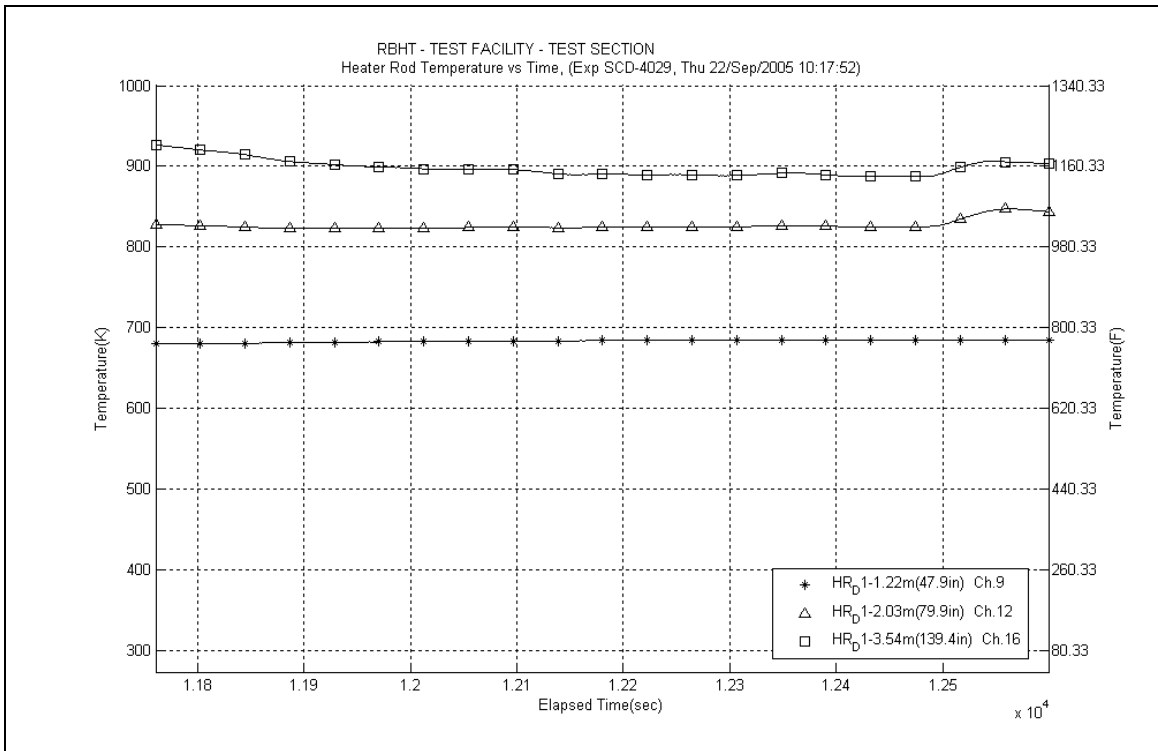

Figure A-87: Heater Rod D1 Temperatures for Experiment 4029D

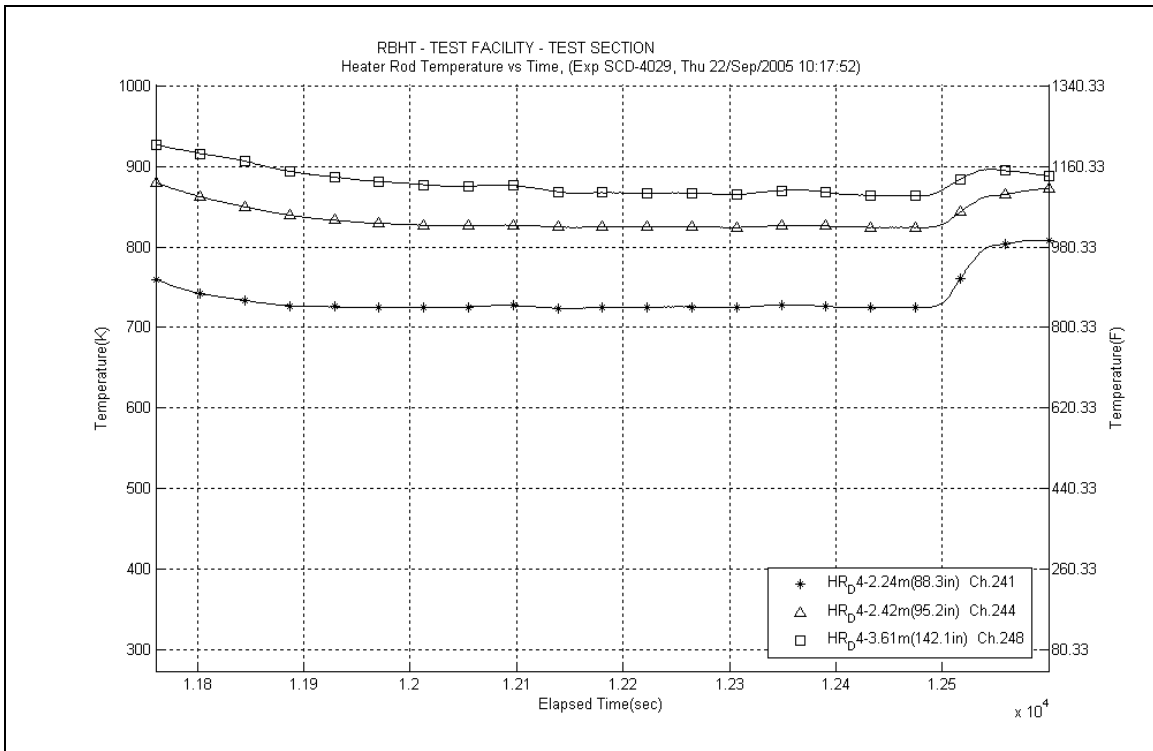

Figure A-88: Heater Rod D4 Temperatures for Experiment 4029D

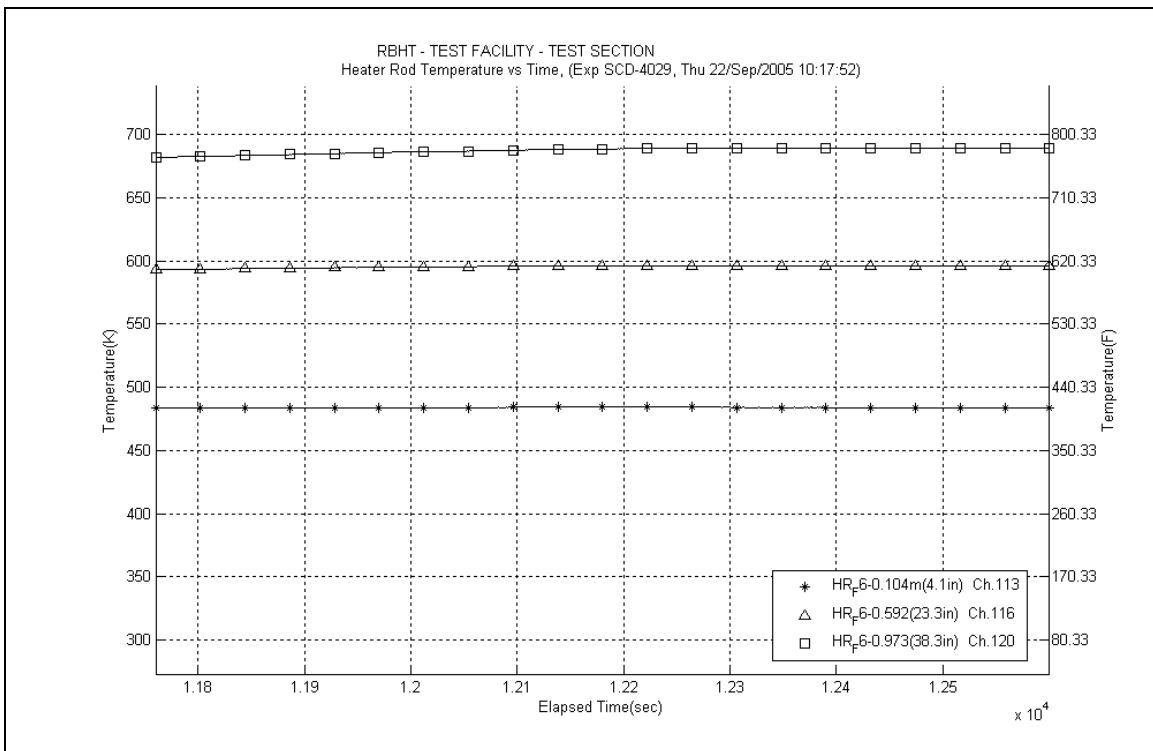

Figure A-89: Heater Rod F6 Temperatures for Experiment 4029D

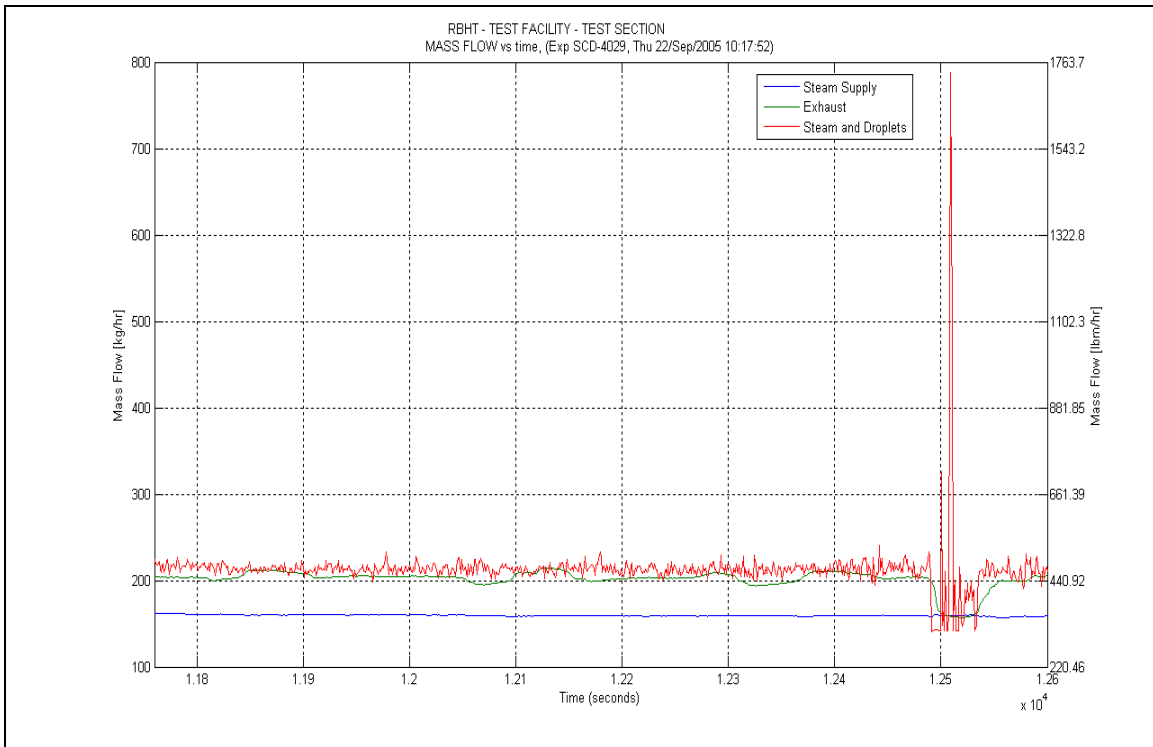

Figure A-90: Mass Flow for Experiment 4029D

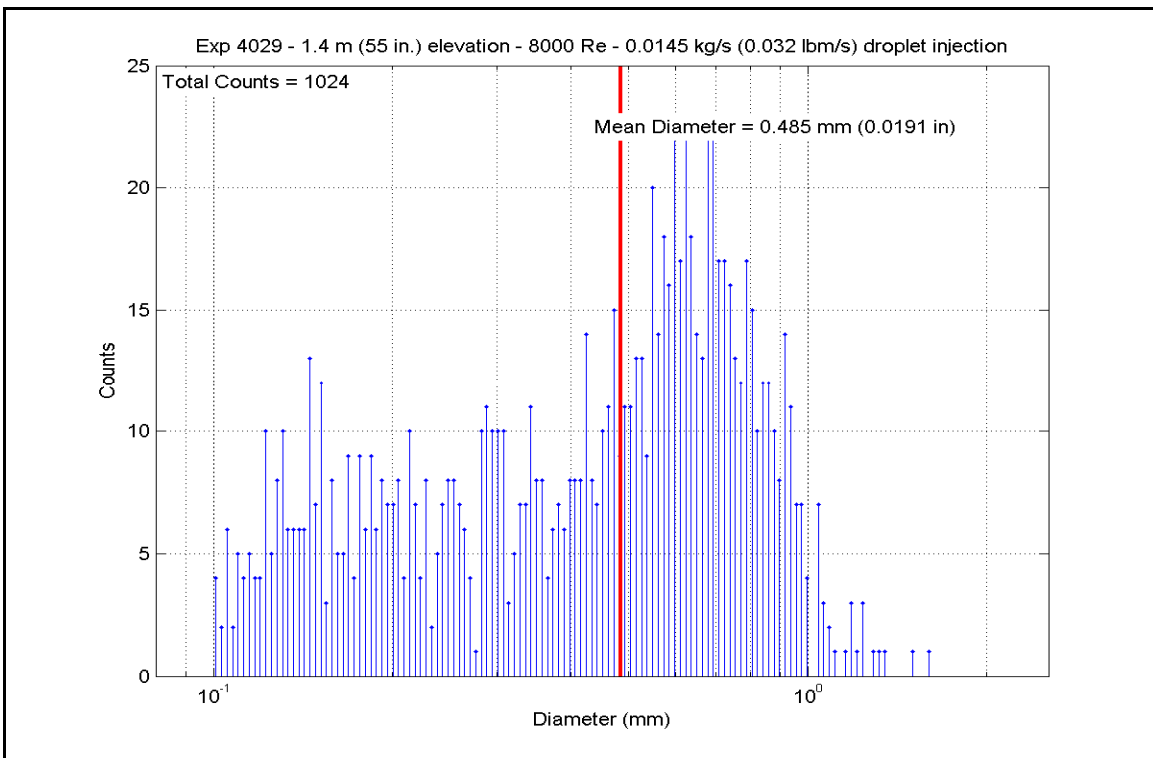

Figure A-91: Droplet Measurements at 1.397 m (55 in.) Elevation for Experiment 4029D

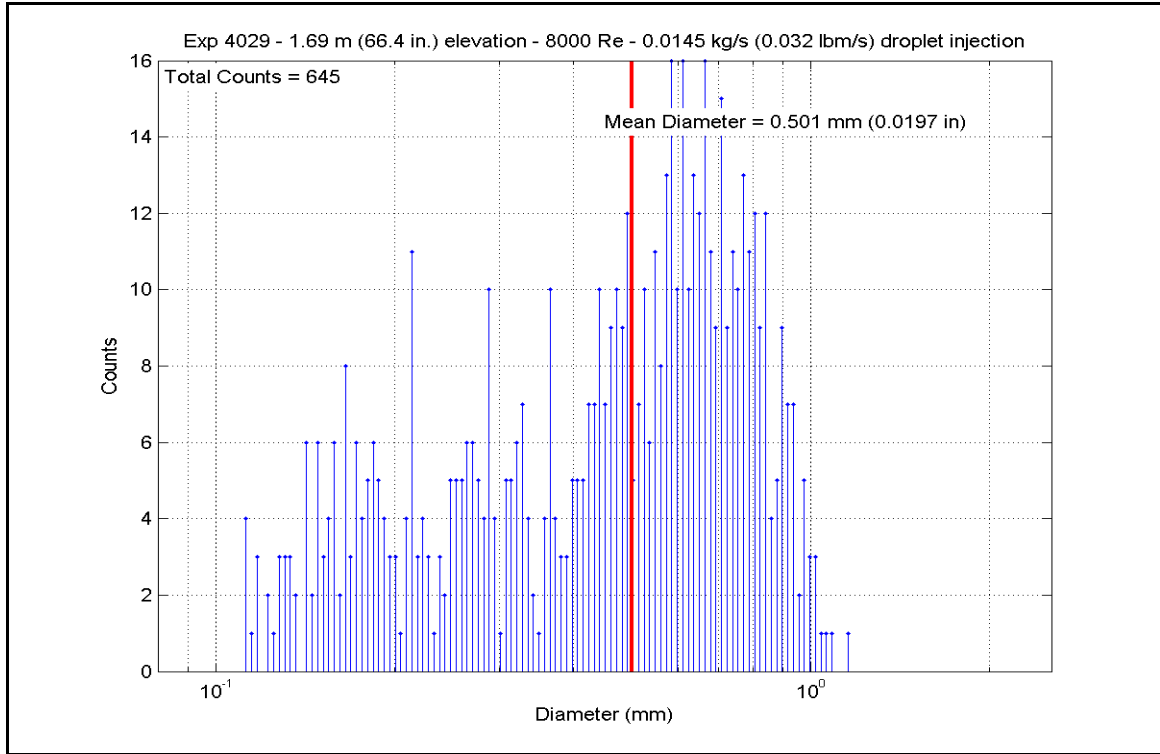

Figure A-92: Droplet Measurements at 1.687 m (66.4 in.) Elevation for Experiment 4029D

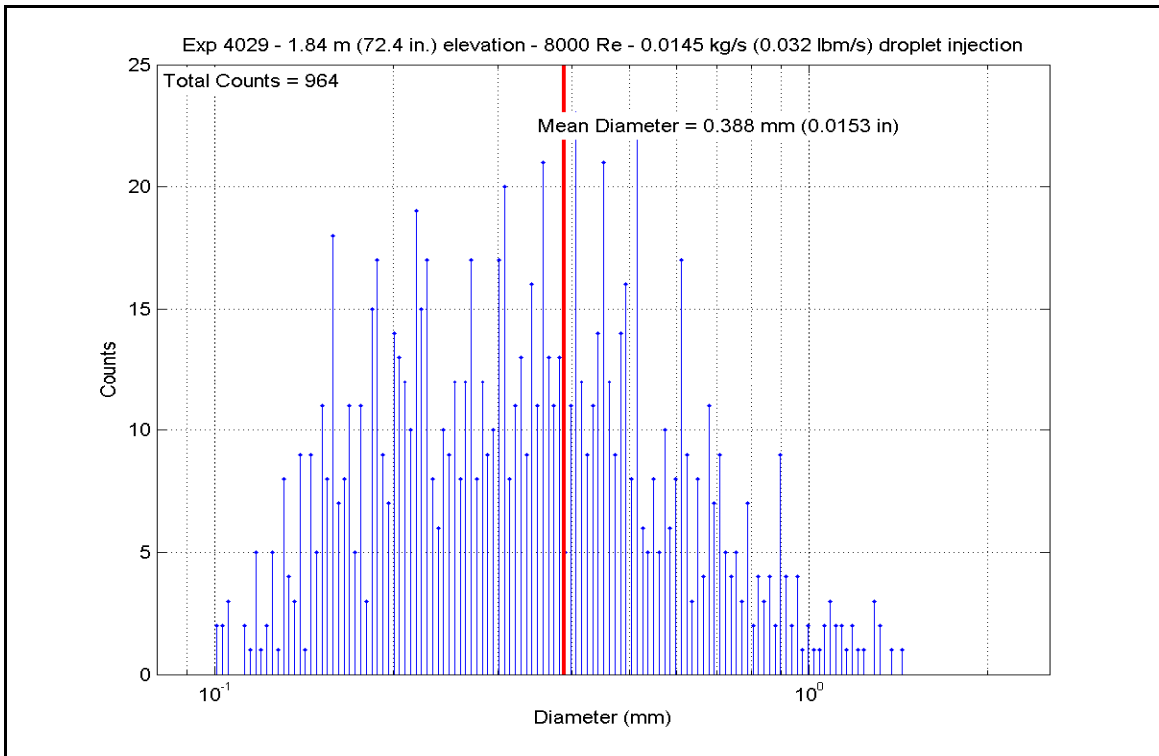

Figure A-93: Droplet Measurements at 1.839 m (72.4 in.) Elevation for Experiment 4029D

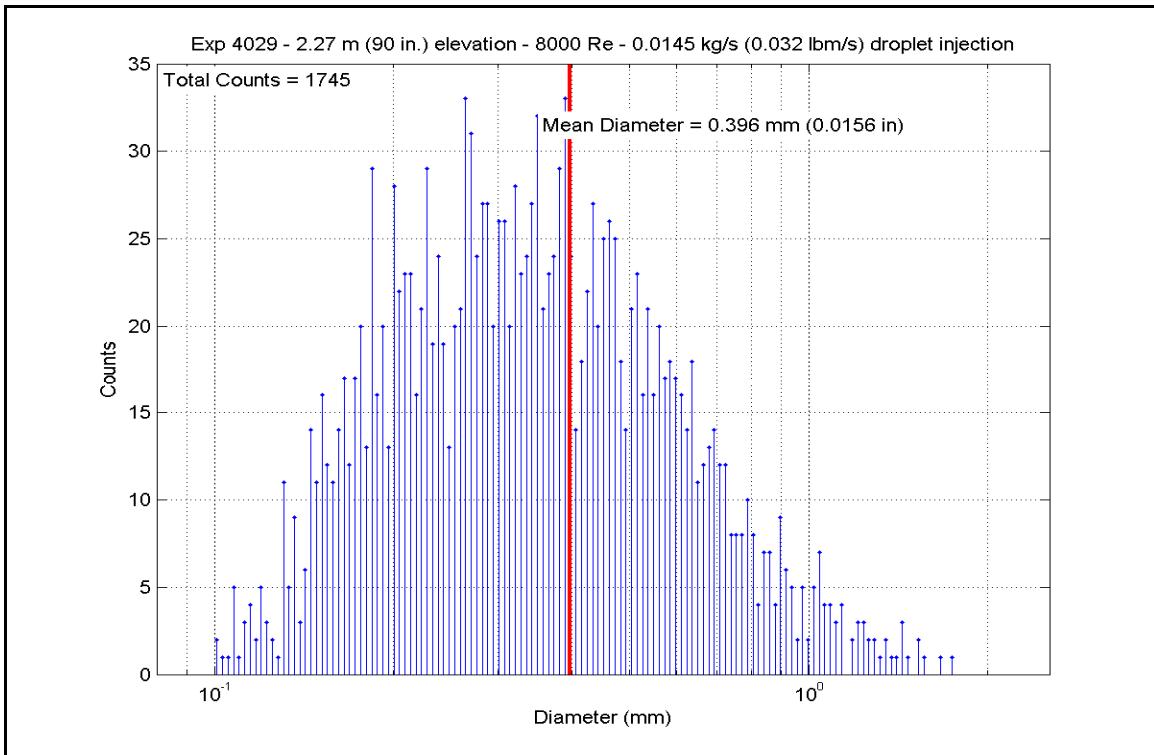

Figure A-94: Droplet Measurements at 2.286 m (90 in.) Elevation for Experiment 4029D

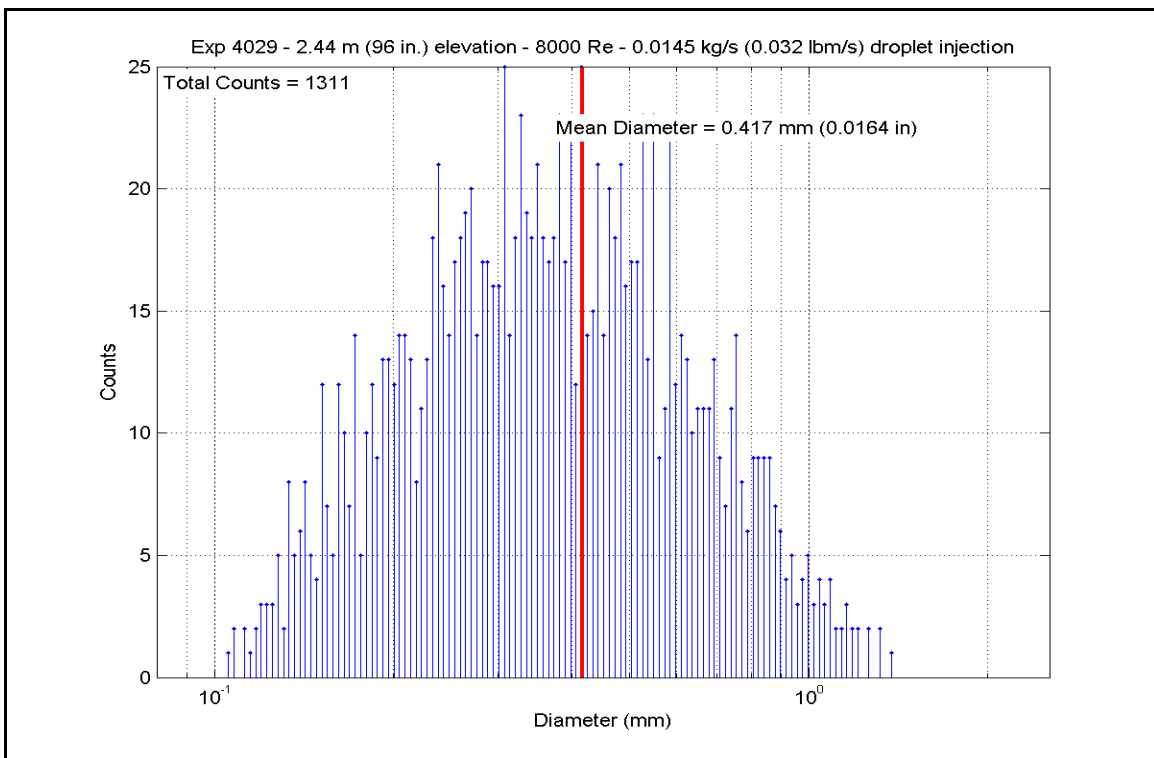

Figure A-95: Droplet Measurements at 2.438 m (96 in.) Elevation for Experiment 4029D

Error! Reference source not found.D

SCD-4029-D		Inlet Reynolds: 8000		40 psia		255911 Btu/hr		351.0 lbm/hr		0.0333 lbm/s	
Matrix test: shakedown		UP Pressure: 275.8 kPa		255911 Btu/hr		351.0 lbm/hr		0.0333 lbm/s			
Time Window: 11760-12600		Bundle Power: 75.00 kW		0.0442 kg/s		0.0151 kg/s					
Inner 3x3		Steam flow: 0.0442 kg/s		0.0151 kg/s							
Droplet flow: 0.0151 kg/s											
H.R. ID	H.R. Location	Channel Number	Elevation (m)	Zgrid (in)	Zgrid (m)	H.R. Tw (°F)	H.R. Tw (K)	H.R. q" (Btu/hr-ft2)	H.R. q" (W/m2)	h _{sat} (z) (Btu/hr-ft2-F)	h _{sat} (z) (W/m2-K)
Gr-3	RodD3_88.3	185	88.3	2.243	-0.2	1000.63	811.3	6504.21	20517.5	8.878	50.4
	RodD3_91.3	186	91.3	2.319	2.8	1043.46	835.1	6624.11	20895.8	8.542	48.5
	RodD3_93.1	187	93.1	2.365	4.6	870.67	739.1	6204.02	19570.6	10.294	58.5
	RodD3_95.3	188	95.3	2.421	6.8	976.58	797.9	6468.68	20405.4	9.129	51.8
	RodD3_100.1	189	100.1	2.543	11.6	1096.65	864.6	6779.91	21387.2	8.182	46.5
	RodD3_106.1	190	106.1	2.695	17.6	1199.48	921.7	7191.24	22684.8	7.720	43.8
	RodD3_110	191	110	2.794	21.5	1112.77	873.6	6973.56	21998.1	8.255	46.9
	RodD3_142.1	192	142.1	3.609	8.6	874.55	741.2	6204.51	19572.1	10.229	58.1
Gr-3	RodC4_88.4	233	88.4	2.245	-0.1	1132.91	884.8	6359.92	20062.4	7.353	41.8
	RodC4_91.1	234	91.1	2.314	2.6	1165.29	902.8	5970.20	18933.0	6.654	37.8
	RodC4_93.4	235	93.4	2.372	4.9	1187.76	915.2	5505.41	17366.8	5.986	34.0
	RodC4_95.3	236	95.3	2.421	6.8	1190.51	916.8	5019.24	15833.2	5.441	30.9
	RodC4_100.1	237	100.1	2.543	11.6	1102.83	868.1	6886.80	21724.4	8.249	46.8
	RodC4_106.1	238	106.1	2.695	17.6	1133.37	885.0	7151.45	22559.2	8.264	46.9
	RodC4_110	239	110	2.794	21.5	1157.50	898.4	7291.44	23000.9	8.197	46.6
	RodC4_142.2	240	142.2	3.612	8.7	995.39	808.4	5233.72	16509.8	7.195	40.9
Gr-3	RodD4_88.3	241	88.3	2.243	-0.2	867.87	737.5	5591.14	17637.3	9.321	52.9
	RodD4_91.3	242	91.3	2.319	2.8	918.13	765.4	5688.25	17943.6	8.749	49.7
	RodD4_93.2	243	93.2	2.367	4.7	989.94	805.3	5111.91	16125.5	7.081	40.2
	RodD4_95.2	244	95.2	2.418	6.7	1127.61	881.8	6119.60	19304.3	7.119	40.4
	RodD4_100.1	245	100.1	2.543	11.6	1206.94	925.9	7274.13	22946.2	7.747	44.0
	RodD4_106.1	246	106.1	2.695	17.6	1129.27	882.7	7162.25	22593.3	8.316	47.2
	RodD4_142.1	248	142.1	3.609	8.6	776.65	686.8	5494.37	17332.0	10.802	61.3
Gr-3	RodE4_88.4	201	88.4	2.245	-0.1	967.81	793.0	6409.63	20219.2	9.159	52.0
	RodE4_91.2	202	91.2	2.316	2.7	1056.82	842.5	6653.00	20986.9	8.434	47.9
	RodE4_95.3	204	95.3	2.421	6.8	1138.45	887.8	2777.49	8761.6	3.191	18.1
	RodE4_100.9	205	100.9	2.563	12.4	1095.77	864.1	7050.97	22242.3	8.518	48.4
	RodE4_142.3	208	142.3	3.614	8.8	869.63	738.5	6166.39	19451.9	10.249	58.2

Error! Reference source not found.D, continued

Gr-4	H.R. Location	Channel Number	Elevation (in)	Elevation (m)	Zgrid (in)	Zgrid (m)	H.R. Tw (°F)	H.R. Tw (K)	H.R. q" (Btu/hr-ft2)	H.R. q" (W/m2)	h _{sat} (z) (Btu/hr-ft2-F)	h _{sat} (z) (W/m2-K)
	RodE3_63.4	193	63.4	1.610	16.4	0.417	1159.25	899.4	3782.99	11933.4	4.245	24.1
	RodE3_113.6	194	113.6	2.885	0.85	0.022	1086.64	859.1	6351.59	20036.1	7.759	44.1
	RodE3_115.5	195	115.5	2.934	2.75	0.070	1022.43	823.4	5198.47	16398.6	6.891	39.1
	RodE3_118.5	196	118.5	3.010	5.75	0.146	1192.11	917.7	6300.61	19875.3	6.818	38.7
	RodE3_122.7	197	122.7	3.117	9.95	0.253	1222.03	934.3	5941.07	18741.1	6.227	35.4
	RodE3_126.5	198	126.5	3.213	13.75	0.349	1240.74	944.7	5428.94	17125.6	5.581	31.7
	RodE3_131.7	199	131.7	3.345	-1.8	-0.046	1239.96	944.2	4958.68	15642.2	5.102	29.0
	RodE3_135.6	200	135.6	3.444	2.1	0.053	1141.32	889.4	4256.04	13425.7	4.873	27.7
Gr-4	RodC5_63.7	225	63.7	1.618	16.7	0.424	957.24	787.2	5065.27	15978.4	7.349	41.7
	RodC5_113.6	226	113.6	2.885	0.85	0.022	1060.90	844.8	6619.85	20882.3	8.349	47.4
	RodC5_115.7	227	115.7	2.939	2.95	0.075	1087.59	859.6	4367.42	13777.0	5.329	30.3
	RodC5_122.7	229	122.7	3.117	9.95	0.253	1107.83	870.8	3876.37	12228.0	4.616	26.2
	RodC5_126.7	230	126.7	3.218	13.95	0.354	860.68	733.5	4635.38	14622.3	7.821	44.4
	RodC5_131.6	231	131.6	3.343	-1.9	-0.048	864.98	735.9	4805.26	15158.2	8.049	45.7
	RodC5_135.7	232	135.7	3.447	2.2	0.056	915.42	763.9	4926.91	15541.9	7.610	43.2
Gr-4	RodE5_63.6	209	63.6	1.615	16.6	0.422	1122.44	878.9	2751.50	8679.6	3.220	18.3
	RodE5_113.6	210	113.6	2.885	0.85	0.022	1180.74	911.3	7352.14	23192.3	8.055	45.7
	RodE5_115.4	211	115.4	2.931	2.65	0.067	1050.70	839.1	6769.99	21355.9	8.650	49.1
	RodE5_118.7	212	118.7	3.015	5.95	0.151	1119.09	877.1	2837.73	8951.6	3.334	18.9
	RodE5_122.6	213	122.6	3.114	9.85	0.250	863.07	734.9	6235.39	19669.5	10.478	59.5
	RodE5_126.6	214	126.6	3.216	13.85	0.352	958.67	788.0	6493.62	20484.1	9.402	53.4
	RodE5_131.6	215	131.6	3.343	-1.9	-0.048	1002.59	812.4	6619.97	20882.7	9.012	51.2
	RodE5_135.6	216	135.6	3.444	2.1	0.053	1041.22	833.8	6743.93	21273.7	8.722	49.5
Gr-5	RodC3_79.8	177	79.8	2.027	8.92	0.227	1024.49	824.5	6541.96	20636.6	8.648	49.1
	RodC3_85.6	178	85.6	2.174	14.72	0.374	1057.79	843.0	6637.62	20938.4	8.404	47.7
	RodC3_88.5	179	88.5	2.248	0	0.000	1113.11	873.8	2818.77	8891.8	3.335	18.9
	RodC3_92.4	180	92.4	2.347	3.9	0.099	815.70	708.5	4631.66	14610.6	8.457	48.0
	RodC3_94.4	181	94.4	2.398	5.9	0.150	852.18	728.8	4804.67	15156.3	8.225	46.7
	RodC3_97.2	182	97.2	2.469	8.7	0.221	1183.84	913.1	7203.79	22724.4	7.866	44.7
	RodC3_108.8	183	108.8	2.764	20.3	0.516	1097.66	865.2	6795.80	21437.3	8.191	46.5
Gr-8	RodD5_50	217	50	1.270	3	0.076	1120.64	877.9	4615.41	14559.3	5.413	30.7
	RodD5_54.1	218	54.1	1.374	7.1	0.180	1172.88	907.0	5325.10	16798.0	5.885	33.4
	RodD5_56.9	219	56.9	1.445	9.9	0.251	1169.26	905.0	4860.46	15332.3	5.393	30.6
	RodD5_60	220	60	1.524	13	0.330	1056.73	842.4	4233.11	13353.3	5.367	30.5
	RodD5_66.1	221	66.1	1.679	19.1	0.485	1082.34	856.7	3754.95	11845.0	4.611	26.2
	RodD5_69.9	222	69.9	1.775	-0.98	-0.025	870.26	738.9	6276.44	19799.0	10.421	59.2
	RodD5_72.9	223	72.9	1.852	2.02	0.051	963.32	790.6	6505.92	20522.9	9.357	53.1
	RodD5_74.9	224	74.9	1.902	4.02	0.102	1012.30	817.8	6655.73	20995.5	8.942	50.8

Error! Reference source not found.D, continued

H.R. ID	H.R. Location	Channel Number	Elevation (in)	Elevation (m)	Zgrid (in)	Zgrid (m)	H.R. Tw (°F)	H.R. Tw (K)	H.R. q" (Btu/hr-ft2)	H.R. q" (W/m2)	h _{sat} (z) (Btu/hr-ft2-F)	h _{sat} (z) (W/m2-K)	
Gr-2	RodB5_41	153	41	1.041	13.5	0.343	561.28	567.2	3095.40	9764.4	10.554	59.9	
	RodB5_52.9	154	52.9	1.344	5.9	0.150	611.18	594.9	3413.66	10768.4	9.947	56.5	
	RodB5_55	155	55	1.397	8	0.203	643.24	612.7	3675.66	11594.9	9.795	55.6	
	RodB5_57.8	156	57.8	1.468	10.8	0.274	714.87	652.5	3851.58	12149.8	8.619	48.9	
	RodB5_64	157	64	1.626	17	0.432	743.31	668.3	3940.35	12429.8	8.290	47.1	
	RodB5_73.9	158	73.9	1.877	3.02	0.077	782.42	690.1	4078.26	12864.9	7.928	45.0	
	RodB5_75.9	159	75.9	1.928	5.02	0.128	816.63	709.1	4207.66	13273.1	7.669	43.6	
	RodB5_76.9	160	76.9	1.953	6.02	0.153	826.42	714.5	4736.25	14940.5	8.481	48.2	
	Gr-2	RodF5_41	105	41	1.041	13.5	0.343	562.76	568.0	3094.85	9762.7	10.499	59.6
		RodF5_53.1	106	53.1	1.349	6.1	0.155	610.70	594.6	3404.22	10738.6	9.934	56.4
		RodF5_55	107	55	1.397	8	0.203	631.76	606.4	3665.81	11563.8	10.077	57.2
		RodF5_57.8	108	57.8	1.468	10.8	0.274	711.57	650.7	3836.36	12101.8	8.649	49.1
		RodF5_64	109	64	1.626	17	0.432	737.66	665.2	3922.09	12372.2	8.351	47.4
		RodF5_73.8	110	73.8	1.875	2.92	0.074	775.85	686.4	4051.05	12779.0	7.977	45.3
		RodF5_75.8	111	75.8	1.925	4.92	0.125	845.76	725.2	4621.86	14579.7	8.000	45.4
		RodF5_76.8	112	76.8	1.951	5.92	0.150	897.29	753.9	4791.80	15115.7	7.615	43.2
Gr-2		RodC2_41	57	41	1.041	13.5	0.343	1049.28	838.3	3013.27	9505.4	3.857	21.9
		RodC2_53.1	58	53.1	1.349	6.1	0.155	755.21	674.9	4566.43	14404.8	9.373	53.2
		RodC2_55	59	55	1.397	8	0.203	994.30	807.8	5924.35	18688.4	8.157	46.3
		RodC2_57.8	60	57.8	1.468	10.8	0.274	1058.19	843.3	6782.72	21396.1	8.584	48.7
	RodC2_63.9	61	63.9	1.623	16.9	0.429	1117.71	876.3	6320.25	19937.2	7.438	42.2	
	RodC2_73.8	62	73.8	1.875	2.92	0.074	1146.76	892.5	4886.22	15413.6	5.560	31.6	
	RodC2_75.8	63	75.8	1.925	4.92	0.125	952.15	784.3	5723.79	18055.7	8.366	47.5	
	RodC2_76.8	64	76.8	1.951	5.92	0.150	968.67	793.5	5772.05	18207.9	8.238	46.8	
Gr-2	RodC6_40.9	137	40.9	1.039	13.4	0.340	902.51	756.8	4927.74	15544.5	7.766	44.1	
	RodC6_52.8	138	52.8	1.341	5.8	0.147	909.09	760.4	5060.96	15964.8	7.894	44.8	
	RodC6_54.8	139	54.8	1.392	7.8	0.198	976.48	797.9	5345.58	16862.6	7.545	42.8	
	RodC6_57.8	140	57.8	1.468	10.8	0.274	788.34	693.3	5454.80	17207.2	10.483	59.5	
	RodC6_63.8	141	63.8	1.621	16.8	0.427	887.29	748.3	5584.92	17617.6	9.018	51.2	
	RodC6_73.7	142	73.7	1.872	2.82	0.072	935.95	775.3	5689.09	17946.2	8.517	48.4	
	RodC6_75.8	143	75.8	1.925	4.92	0.125	1006.30	814.4	5898.89	18608.1	7.990	45.4	
	RodC6_76.8	144	76.8	1.951	5.92	0.150	888.28	748.9	6033.07	19031.3	9.726	55.2	

Error! Reference source not found.D,continued

5x5 periphery		H.R.	Channel	Elevation	Elevation	Zgrid	Zgrid	H.R. Tw	H.R. Tw	H.R. q"	H.R. q"	H.R. q"	h _{sat} (z)	h _{sat} (z)
Gr-3	Location	Number	(in)	(m)	(m)	(in)	(m)	(°F)	(K)	(W/m ²)	(Btu/hr-ft ²)	(W/m ²)	(W/m ² -K)	(Btu/hr-ft ² -F)
	RodB4_88.4	161	88.4	2.245	-0.1	-0.003	938.22	776.6	5766.99	18192.0	5766.99	18192.0	8.605	8.605
	RodB4_91.3	162	91.3	2.319	2.8	0.071	957.62	787.4	5816.97	18349.6	5816.97	18349.6	8.435	8.435
	RodB4_93.3	163	93.3	2.370	4.8	0.122	411.26	483.9	2556.39	8064.1	2556.39	8064.1	17.844	17.844
	RodB4_95.1	164	95.1	2.416	6.6	0.168	499.79	533.0	2871.20	9057.2	2871.20	9057.2	12.387	12.387
	RodB4_100	165	100	2.540	11.5	0.292	1178.97	910.4	7101.27	22401.0	7101.27	22401.0	7.795	7.795
	RodB4_106	166	106	2.692	17.5	0.445	1208.45	926.7	7237.32	22830.1	7237.32	22830.1	7.696	7.696
	RodB4_109.9	167	109.9	2.791	21.4	0.544	1128.42	882.3	6618.17	20877.0	6618.17	20877.0	7.692	7.692
	RodB4_142.3	168	142.3	3.614	8.8	0.224	903.24	757.2	5658.68	17850.3	5658.68	17850.3	8.908	8.908
Gr-5	RodF4_85.6	98	85.6	2.174	14.72	0.374	947.01	781.5	5708.02	18005.9	5708.02	18005.9	8.406	8.406
	RodF4_88.4	99	88.4	2.245	-0.1	-0.003	964.07	791.0	5757.58	18162.3	5757.58	18162.3	8.272	8.272
	RodF4_92.4	100	92.4	2.347	3.9	0.099	410.36	483.3	2562.40	8083.1	2562.40	8083.1	18.000	18.000
	RodF4_94.3	101	94.3	2.395	5.8	0.147	505.80	536.4	2871.90	9059.4	2871.90	9059.4	12.077	12.077
	RodF4_97.2	102	97.2	2.469	8.7	0.221	1177.65	909.6	7340.49	23155.6	7340.49	23155.6	8.070	8.070
	RodF4_108.8	103	108.8	2.764	20.3	0.516	1100.68	866.9	7090.61	22367.3	7090.61	22367.3	8.515	8.515
	RodF4_111	104	111	2.819	-1.75	-0.044	1105.75	869.7	7046.09	22226.9	7046.09	22226.9	8.411	8.411
Gr-6	RodD2_103.2	65	103.2	2.621	14.7	0.373	1091.70	861.9	6865.53	21657.3	6865.53	21657.3	8.335	8.335
	RodD2_106	66	106	2.692	17.5	0.445	1180.33	911.1	7165.66	22604.1	7165.66	22604.1	7.854	7.854
	RodD2_112.6	67	112.6	2.860	-0.15	-0.004	1103.97	868.7	6912.55	21805.7	6912.55	21805.7	8.269	8.269
	RodD2_114.9	68	114.9	2.918	2.15	0.055	1177.20	909.4	6341.39	20003.9	6341.39	20003.9	6.975	6.975
	RodD2_117.4	69	117.4	2.982	4.65	0.118	1199.88	922.0	6023.70	19001.8	6023.70	19001.8	6.464	6.464
	RodD2_120.8	70	120.8	3.068	8.05	0.204	1228.81	938.0	5595.74	17651.7	5595.74	17651.7	5.824	5.824
	RodD2_124.8	71	124.8	3.170	12.05	0.306	1239.18	943.8	5077.47	16016.9	5077.47	16016.9	5.228	5.228
	RodD2_128.6	72	128.6	3.266	15.85	0.403	1229.62	938.5	4577.50	14439.7	4577.50	14439.7	4.760	4.760
Gr-6	RodD6_103.1	129	103.1	2.619	14.6	0.371	1159.35	899.5	6522.23	20574.4	6522.23	20574.4	7.317	7.317
	RodD6_106	130	106	2.692	17.5	0.445	1133.11	884.9	6939.83	21891.7	6939.83	21891.7	8.022	8.022
	RodD6_112.9	131	112.9	2.868	0.15	0.004	1098.03	865.4	6571.31	20729.2	6571.31	20729.2	7.917	7.917
	RodD6_114.9	132	114.9	2.918	2.15	0.055	864.85	735.8	4652.08	14675.0	4652.08	14675.0	7.794	7.794
	RodD6_116.8	133	116.8	2.967	4.05	0.103	887.88	748.6	4820.51	15206.3	4820.51	15206.3	7.777	7.777
	RodD6_120.9	134	120.9	3.071	8.15	0.207	1022.98	823.7	6589.08	20785.3	6589.08	20785.3	8.727	8.727
	RodD6_124.8	135	124.8	3.170	12.05	0.306	1063.58	846.3	6715.79	21185.0	6715.79	21185.0	8.441	8.441
	RodD6_128.7	136	128.7	3.269	15.95	0.405	1150.20	894.4	2622.10	8271.4	2622.10	8271.4	2.972	2.972

Error! Reference source not found.D, continued

5x5 periphery		H.R. Location	Channel Number	Elevation (in)	Elevation (m)	Zgrid (in)	Zgrid (m)	H.R. Tw (°F)	H.R. Tw (K)	H.R. q" (Btu/hr-ft2)	H.R. q" (W/m2)	h _{sat} (z) (Btu/hr-ft2-F)	h _{sat} (z) (W/m2-K)
Gr-8	RodE2_50.1	73	50.1	1.273	3.1	0.079	932.64	773.5	4944.49	15597.4	7.439	42.2	
	RodE2_54	74	54	1.372	7	0.178	965.69	791.9	5075.86	16011.8	7.275	41.3	
	RodE2_56.9	75	56.9	1.445	9.9	0.251	994.91	808.1	5355.35	16893.5	7.367	41.8	
	RodE2_59.9	76	59.9	1.521	12.9	0.328	807.24	703.8	5482.17	17293.5	10.166	57.7	
	RodE2_66	77	66	1.676	19	0.483	901.54	756.2	5610.63	17698.7	8.856	50.3	
	RodE2_69.8	78	69.8	1.773	-1.08	-0.027	943.86	779.7	5714.72	18027.1	8.456	48.0	
	RodE2_72.9	79	72.9	1.852	2.02	0.051	417.61	487.4	2517.21	7940.5	16.825	95.5	
	RodE2_74.9	80	74.9	1.902	4.02	0.102	505.88	536.4	2843.02	8968.3	11.951	67.9	
Gr-8	RodB3_50.2	169	50.2	1.275	3.2	0.081	1156.25	897.7	5607.30	17688.2	6.313	35.8	
	RodB3_54.1	170	54.1	1.374	7.1	0.180	1162.80	901.4	5095.06	16072.4	5.694	32.3	
	RodB3_56.9	171	56.9	1.445	9.9	0.251	1152.12	895.4	4574.46	14430.1	5.174	29.4	
	RodB3_60.1	172	60.1	1.527	13.1	0.333	822.86	712.5	4187.68	13210.0	7.547	42.9	
	RodB3_66.1	173	66.1	1.679	19.1	0.485	888.98	749.3	4744.84	14967.6	7.641	43.4	
	RodB3_69.9	174	69.9	1.775	-0.98	-0.025	912.07	762.1	4837.36	15259.5	7.511	42.7	
	RodB3_73	175	73	1.854	2.12	0.054	939.38	777.3	4963.87	15658.5	7.394	42.0	
	RodB3_75	176	75	1.905	4.12	0.105	987.22	803.8	5243.12	16539.4	7.290	41.4	
Gr-8	RodF3_50.1	89	50.1	1.273	3.1	0.079	1014.81	819.2	6533.90	20611.2	8.749	49.7	
	RodF3_54	90	54	1.372	7	0.178	1051.67	839.6	6640.49	20947.4	8.474	48.1	
	RodF3_57	91	57	1.448	10	0.254	818.51	710.1	4184.11	13198.8	7.600	43.2	
	RodF3_60	92	60	1.524	13	0.330	832.20	717.7	4737.30	14943.8	8.397	47.7	
	RodF3_66.1	93	66.1	1.679	19.1	0.485	873.84	740.8	4806.95	15163.5	7.934	45.1	
	RodF3_70	94	70	1.778	-0.88	-0.022	930.19	772.1	4928.49	15546.9	7.443	42.3	
	RodF3_73	95	73	1.854	2.12	0.054	998.84	810.3	5202.71	16412.0	7.119	40.4	
	RodF3_75	96	75	1.905	4.12	0.105	905.56	758.5	5604.27	17678.7	8.790	49.9	
Gr-8	RodE6_50.2	121	50.2	1.275	3.2	0.081	567.23	570.5	3071.62	9689.4	10.265	58.3	
	RodE6_54.1	122	54.1	1.374	7.1	0.180	615.22	597.2	3398.46	10720.4	9.788	55.6	
	RodE6_57	123	57	1.448	10	0.254	634.81	608.0	3671.49	11581.7	10.009	56.8	
	RodE6_60.2	124	60.2	1.529	13.2	0.335	712.27	651.1	3859.69	12175.4	8.688	49.3	
	RodE6_66.1	125	66.1	1.679	19.1	0.485	739.54	666.2	3951.13	12463.8	8.379	47.6	
	RodE6_70	126	70	1.778	-0.88	-0.022	777.68	687.4	4087.60	12894.3	8.020	45.5	
	RodE6_73.1	127	73.1	1.857	2.22	0.056	844.47	724.5	4623.56	14585.0	8.020	45.5	
	RodE6_75	128	75	1.905	4.12	0.105	880.87	744.7	4801.05	15144.9	7.834	44.5	

RBHT Steam Cooling with Droplet Injection Test SCD-4029-F

Matrix Test # Shakedown

Test Conditions

Test Date – 9/22/2005

Steady State Time Window: 13500 - 13980

Upper Plenum Pressure: 2.76 bar (40 psia)

Bundle Power: 60.0 kW

Bundle Inlet Reynolds Number: 6000

Bundle Inlet Steam Flow: 118.1 kg/hr (260 lbm/hr)

Droplet Injection Flow: 0.0151 kg/s (0.0333 lbm/s)

Droplet Injection Hole Diameter: 0.381 mm (.015 in)

Droplet Injection Elevation: 1.295 m (51 in)

Bundle Flow Area: $4.656 \times 10^{-3} \text{ m}^2$ ($5.012 \times 10^{-2} \text{ ft}^2$)

Test Notes

- No steam probes were traversed in this steady state window.

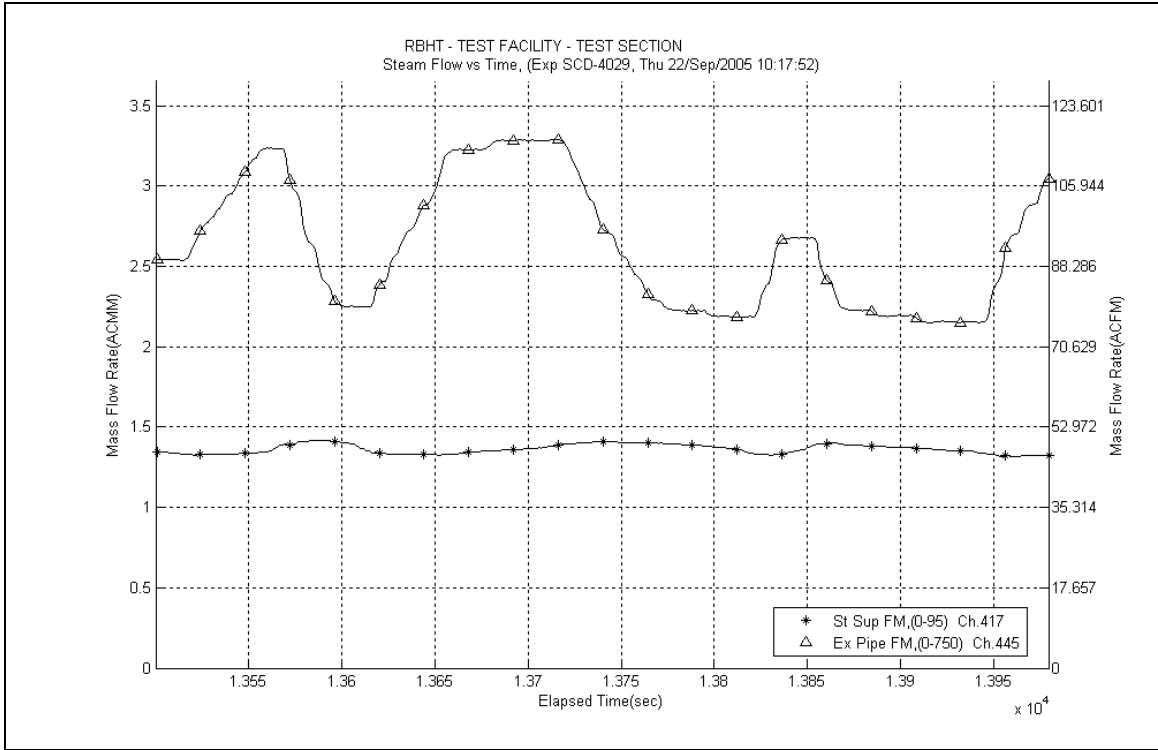

Figure A-96: Inlet and Exhaust Steam Flow Rates for Experiment 4029F

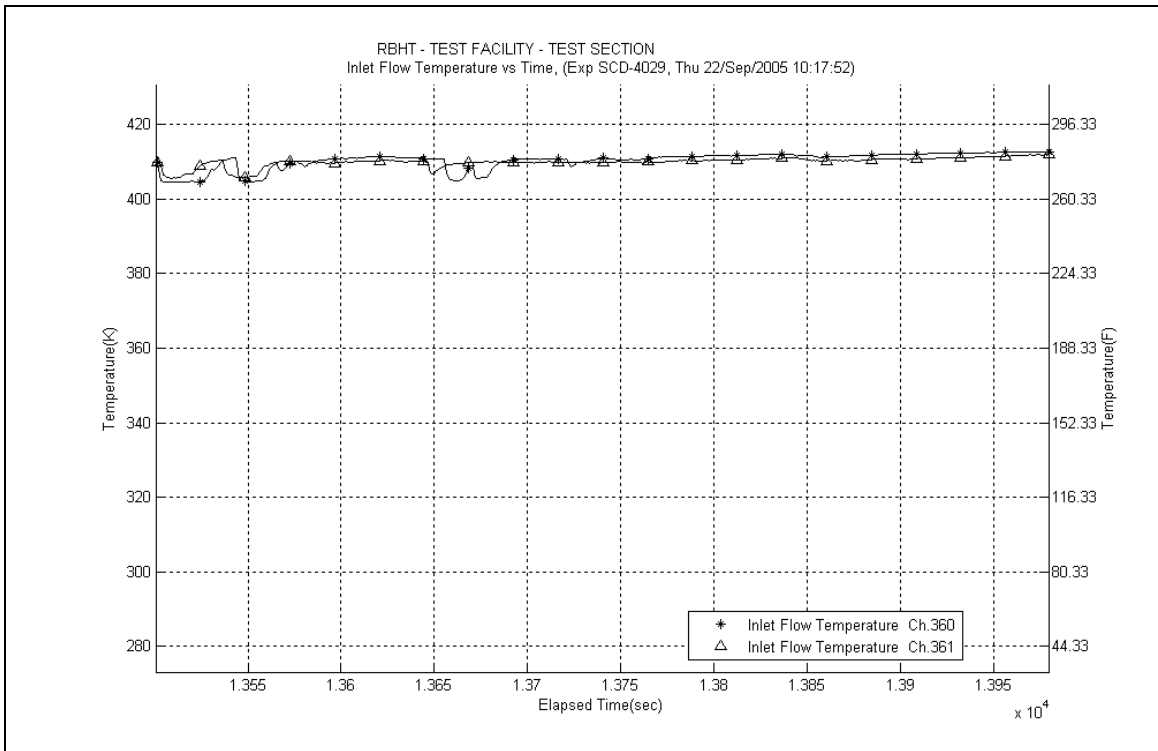

Figure A-97: Inlet Steam Temperature for Experiment 4029F

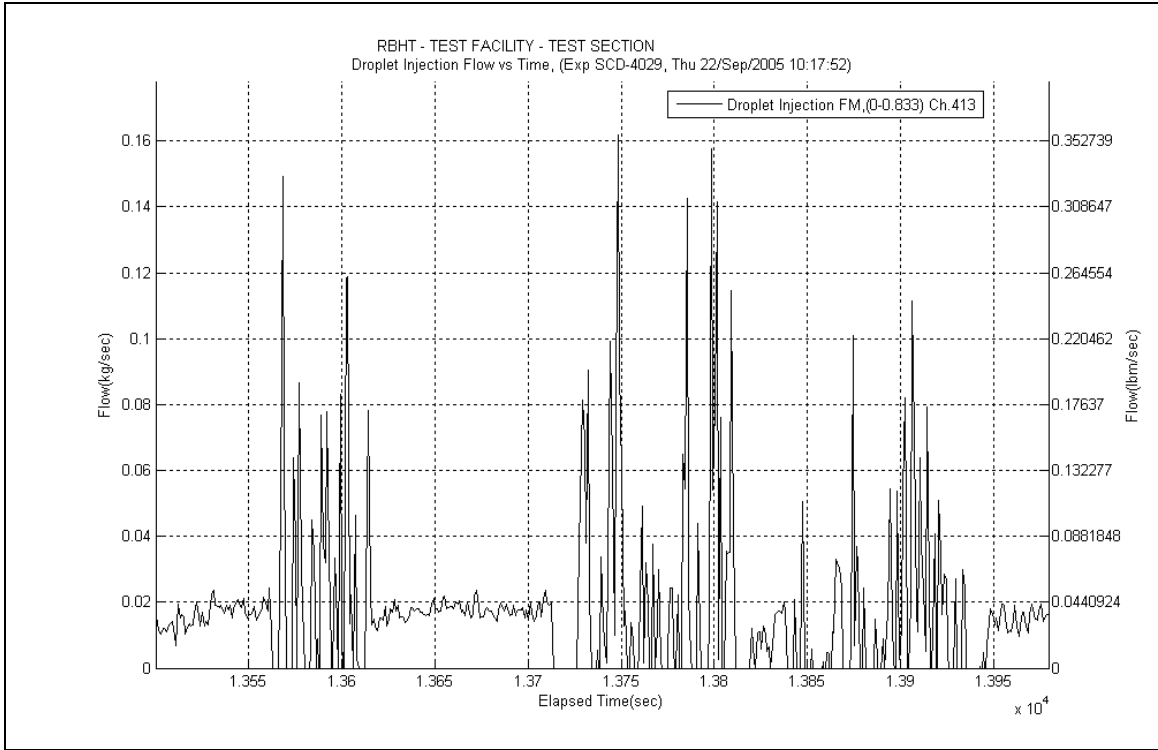

Figure A-98: Droplet Injection Flow Rate for Experiment 4029F

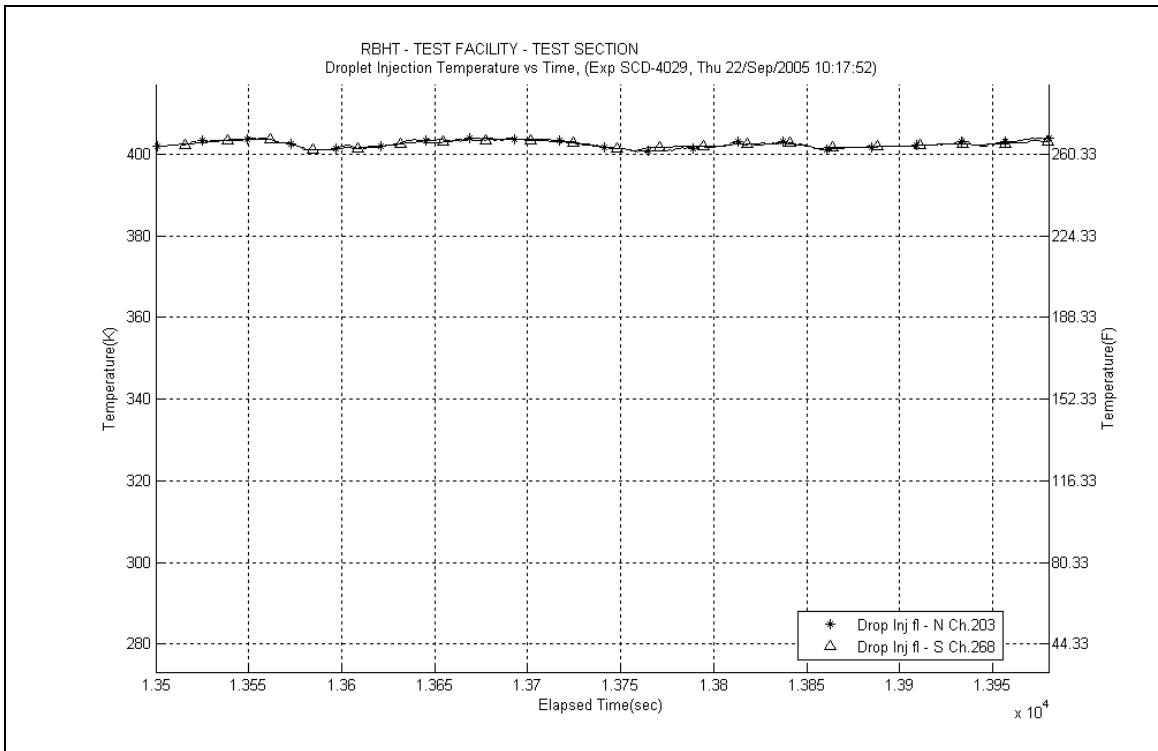

Figure A-99: Droplet Injection Temperature for Experiment 4029F

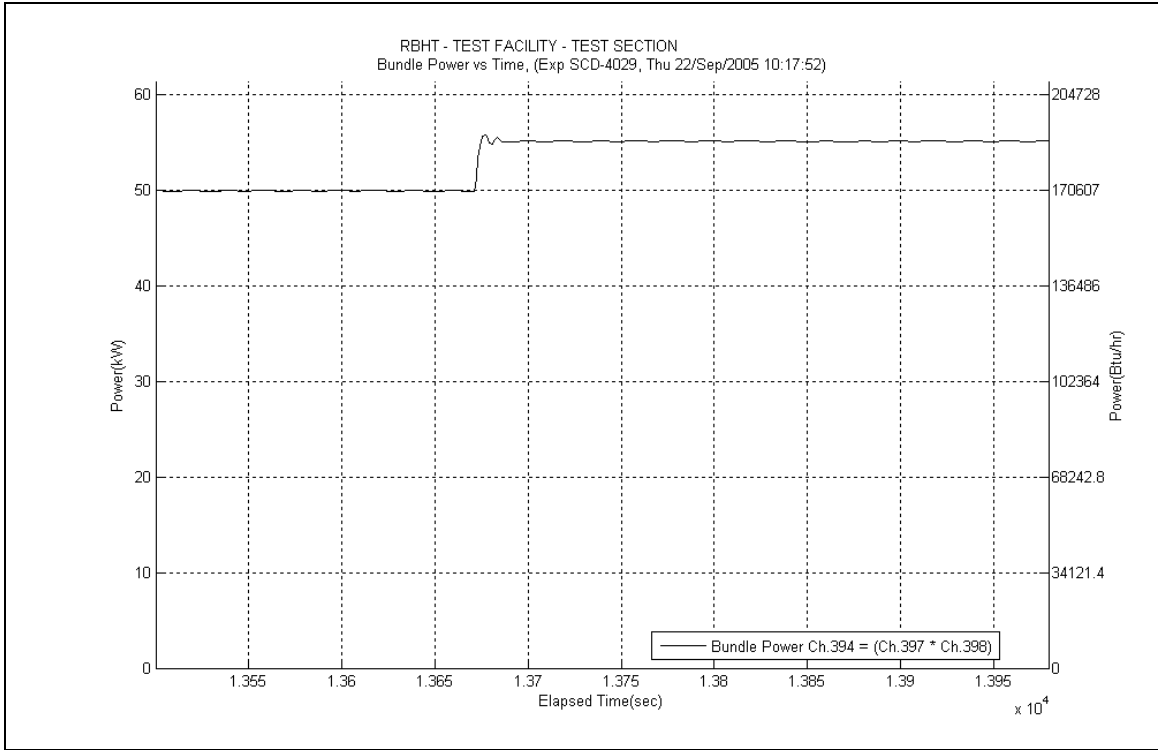

Figure A-100: Bundle Power for Experiment 4029F

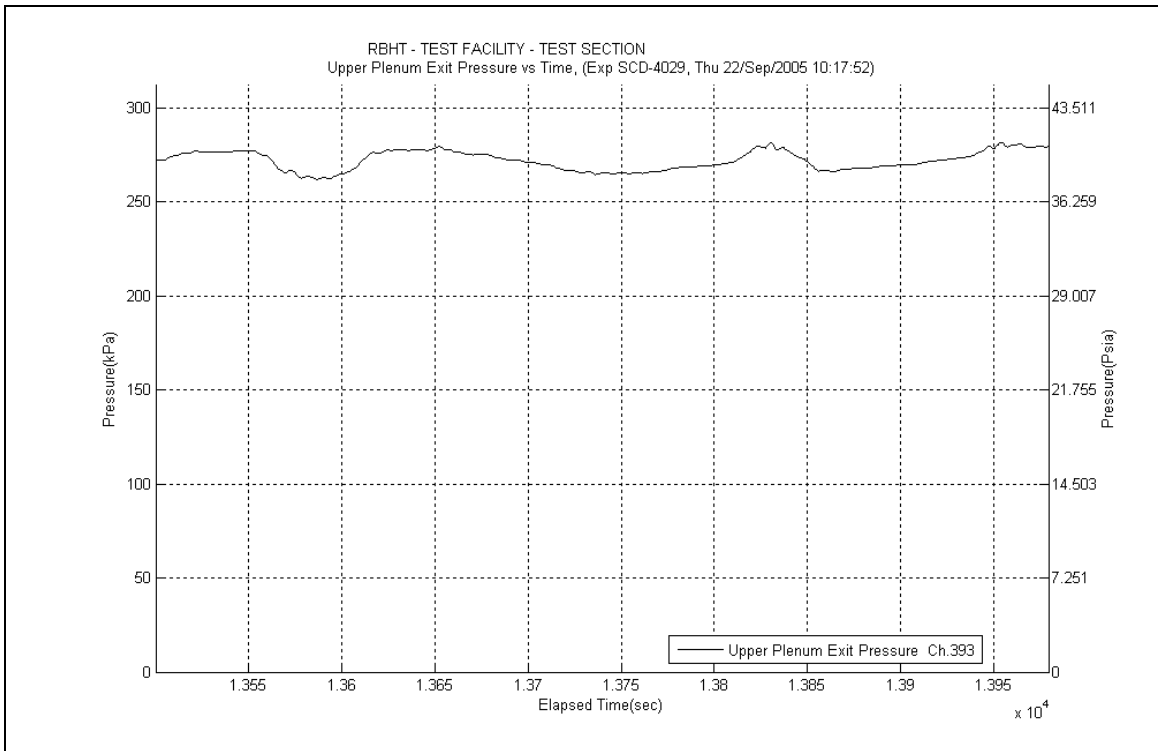

Figure A-101: Upper Plenum Pressure for Experiment 4029F

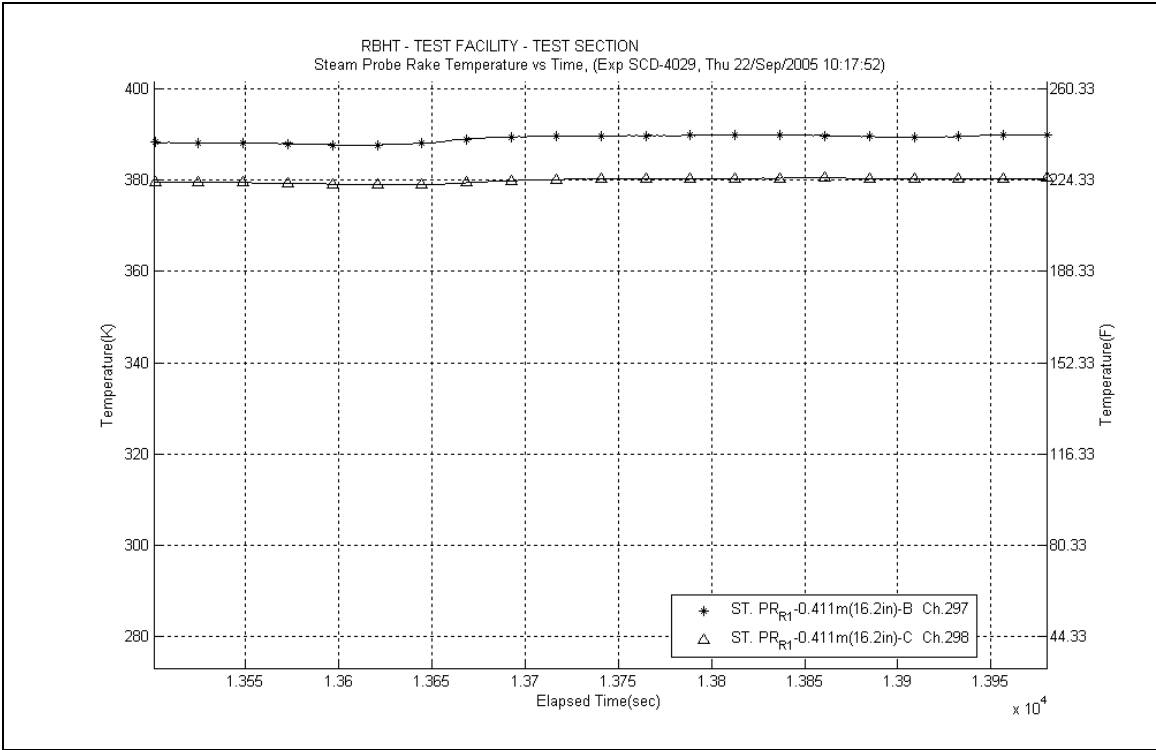

Figure A-102: Steam Probe Rake #1 Temperatures for Experiment 4029F

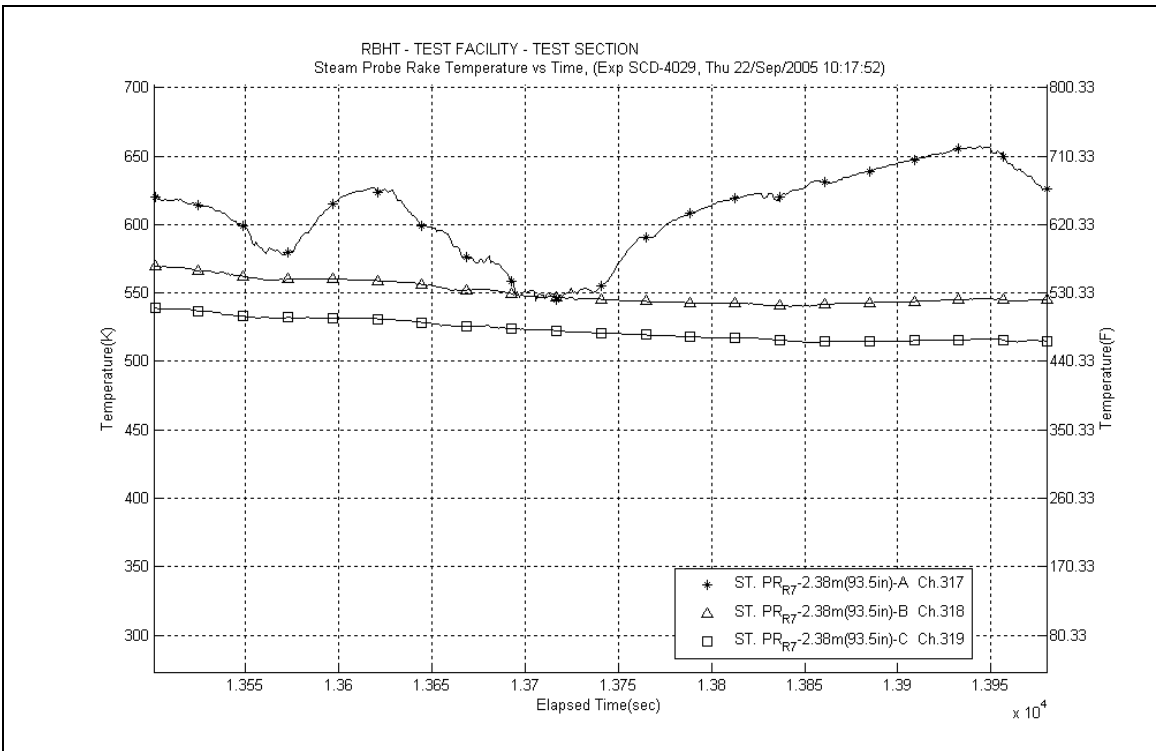

Figure A-103: Steam Probe Rake #7 Temperatures for Experiment 4029F

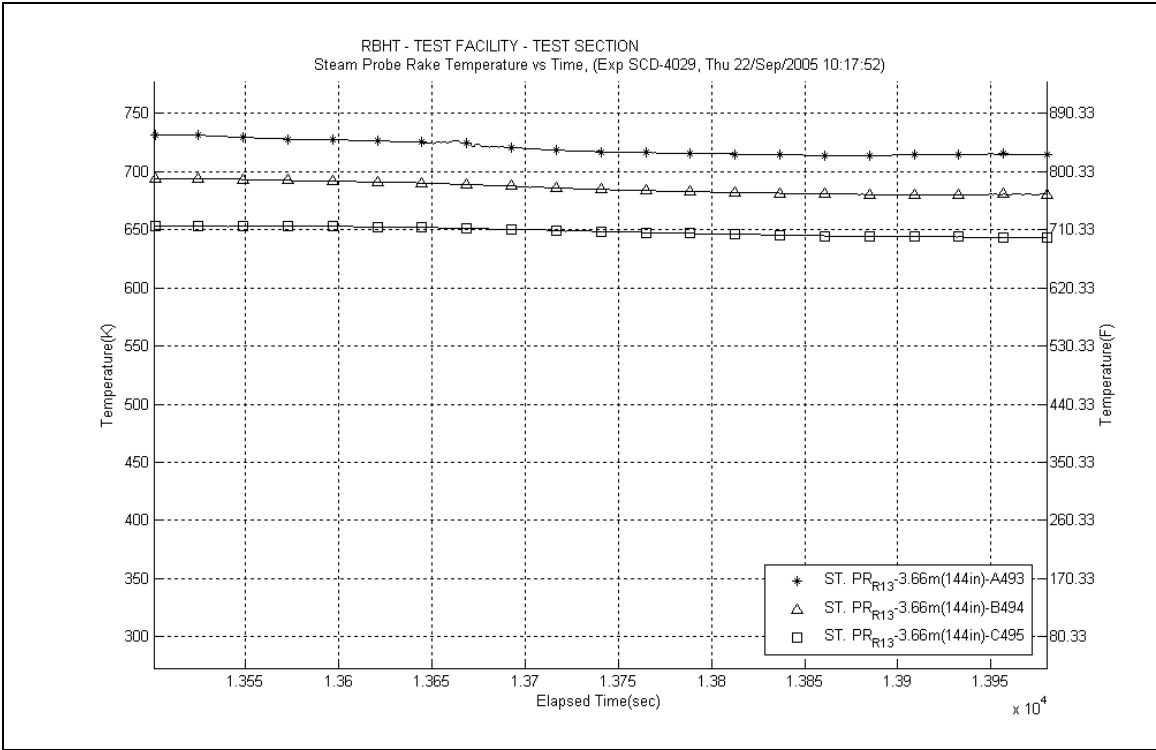

Figure A-104: Steam Probe Rake #13 Temperatures for Experiment 4029F

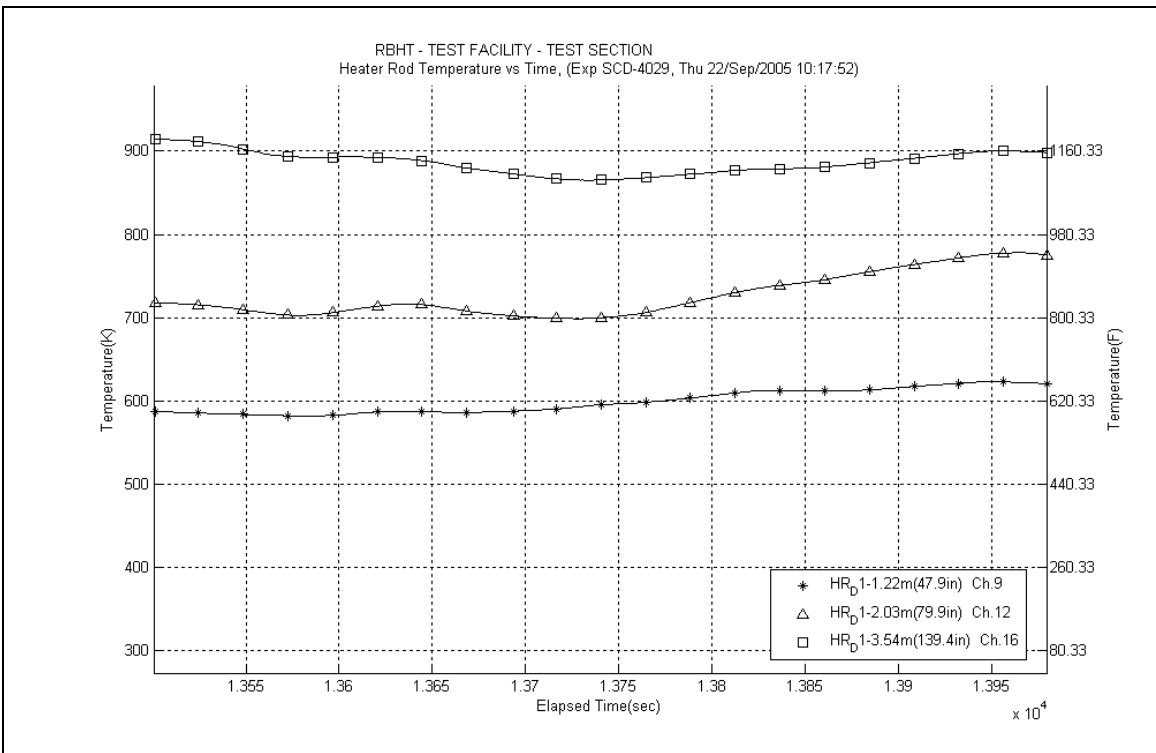

Figure A-105: Heater Rod D1 Temperatures for Experiment 4029F

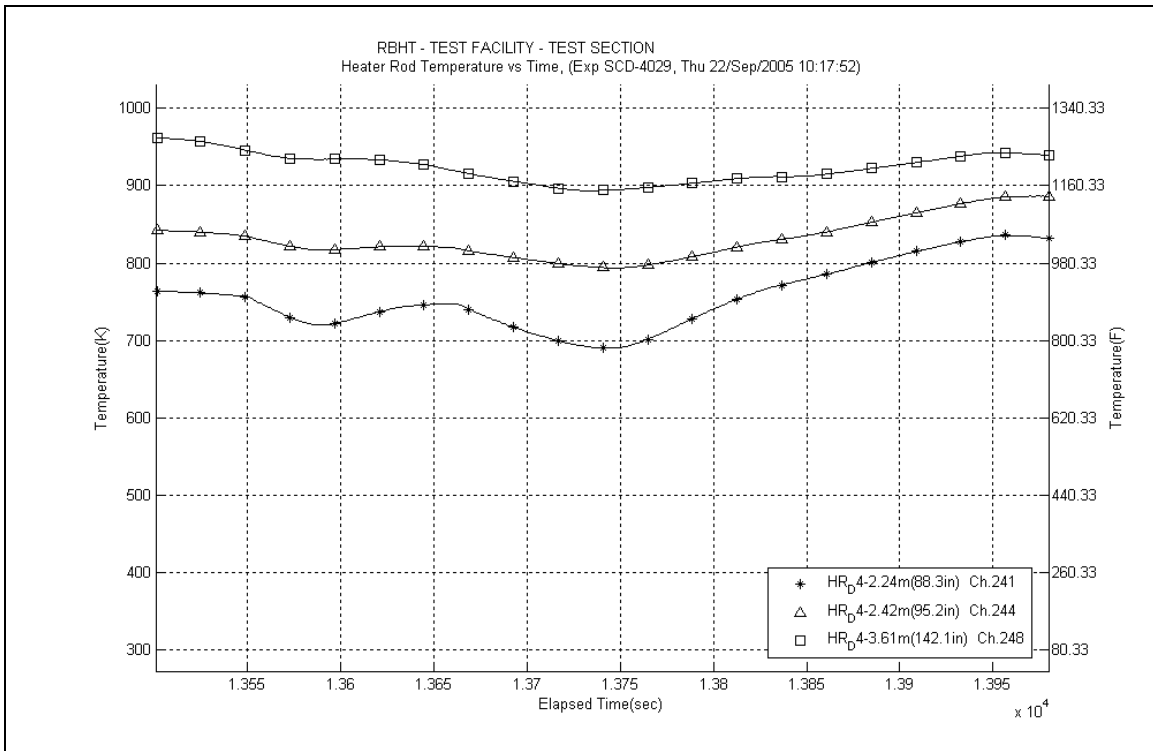

Figure A-106 Heater Rod D4 Temperatures for Experiment 4029F

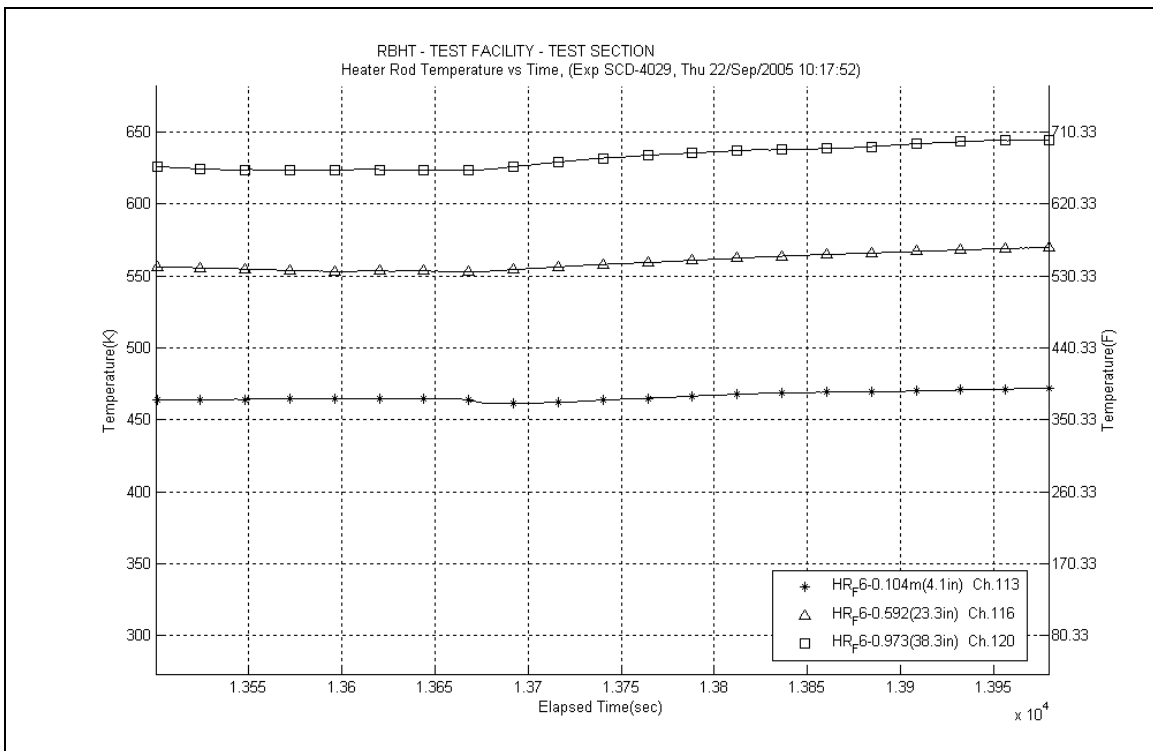

Figure A-107: Heater Rod F6 Temperatures for Experiment 4029F

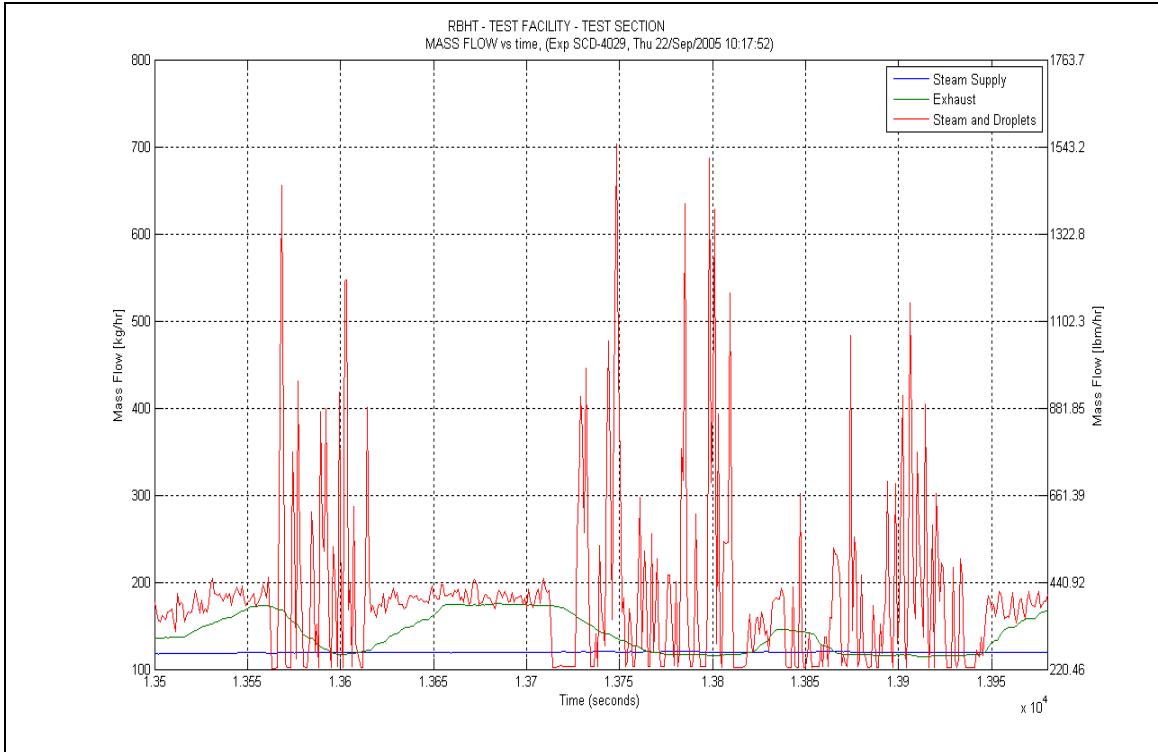

Figure A-108: Mass Flow for Experiment 4029F

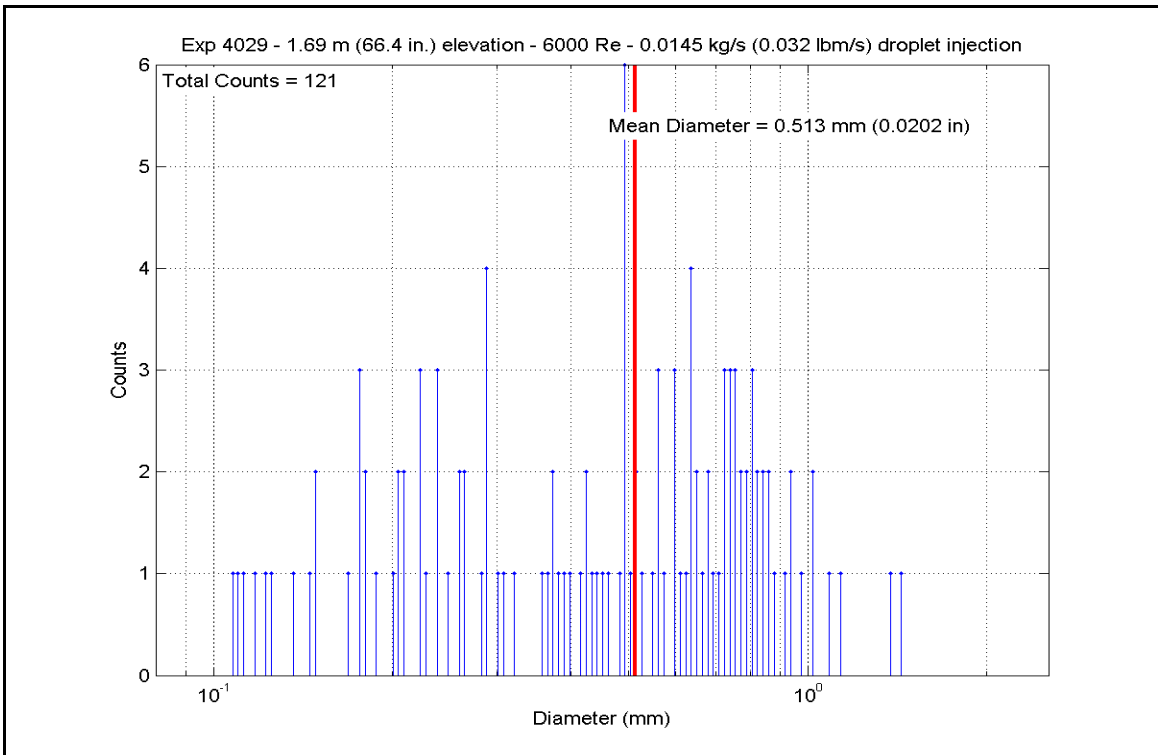

Figure A-109: Droplet Measurements at 1.687 m (66.4 in.) Elevation for Experiment 4029F

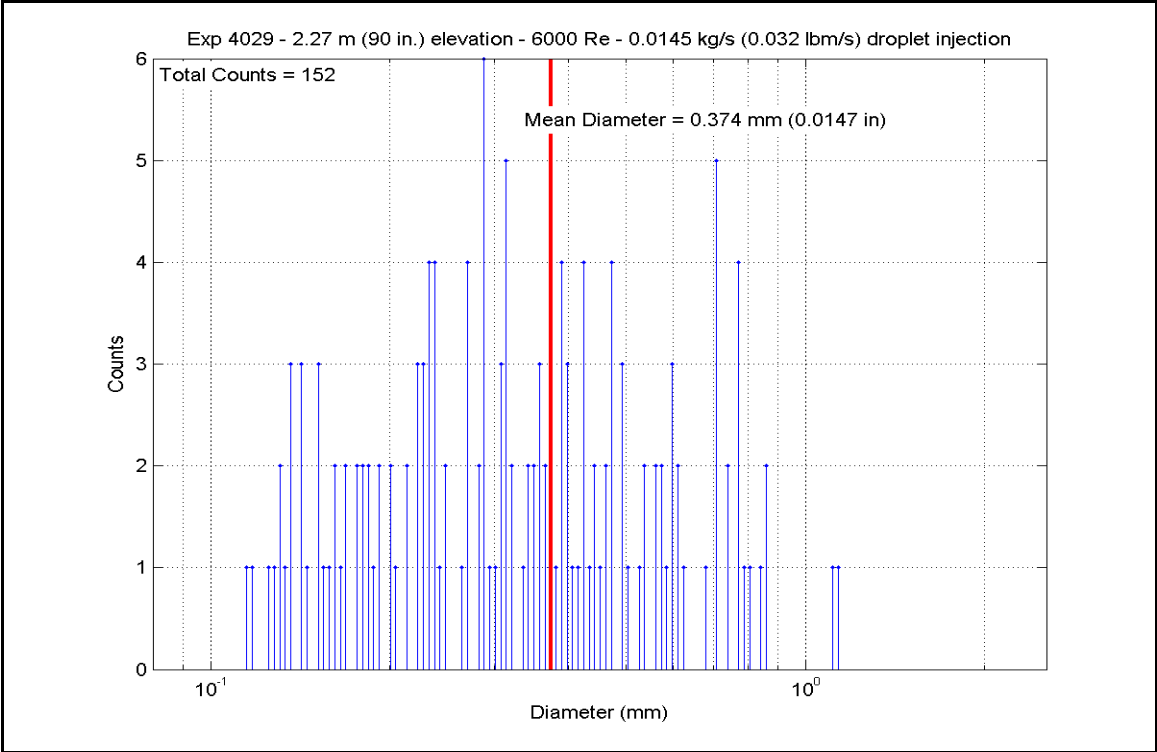

Figure A-110: Droplet Measurements at 2.286 m (90 in.) Elevation for Experiment 4029F

Error! Reference source not found.F

SCD-4029-F		Inlet Reynolds:		6000		40 psia							
Matrix test: shakedown		UP Pressure:		275.8 kPa		204728 Btu/hr							
Time Window: 13500-13980		Bundle Power:		60.00 kW		260.0 lbm/hr							
Inner 3x3		Steam flow:		0.0328 kg/s		0.0333 lbm/s							
		Droplet flow:		0.0151 kg/s									
H.R. ID	H.R. Location	Channel Number	Elevation (in)	Elevation (m)	Zgrid (in)	Zgrid (m)	H.R. Tw (°F)	H.R. Tw (K)	H.R. q" (Btu/hr-ft2)	H.R. q" (W/m2)	h _{sat} (z) (Btu/hr-ft2-F)	h _{sat} (z) (W/m2-K)	
Gr-3	RodD3_88.3	185	88.3	2.243	-0.2	-0.005	964.37	791.1	4305.33	13581.1	6.183	35.1	
	RodD3_91.3	186	91.3	2.319	2.8	0.071	995.59	808.5	4394.91	13863.7	6.040	34.3	
	RodD3_93.1	187	93.1	2.365	4.6	0.117	886.94	748.1	4089.79	12901.2	6.608	37.5	
	RodD3_95.3	188	95.3	2.421	6.8	0.173	962.26	790.0	4251.39	13411.0	6.124	34.8	
	RodD3_100.1	189	100.1	2.543	11.6	0.295	1034.73	830.2	4507.14	14217.8	5.878	33.4	
	RodD3_106.1	190	106.1	2.695	17.6	0.447	1138.27	887.7	4829.87	15235.8	5.550	31.5	
	RodD3_110	191	110	2.794	21.5	0.546	1096.26	864.4	4644.11	14649.8	5.607	31.8	
	RodD3_142.1	192	142.1	3.609	3.609	8.6	877.14	742.7	4098.00	12927.1	6.728	38.2	
	Gr-3	RodC4_88.4	233	88.4	2.245	-0.1	-0.003	1129.17	882.7	4396.95	13870.2	5.106	29.0
		RodC4_91.1	234	91.1	2.314	2.6	0.066	1151.67	895.2	4139.24	13057.2	4.684	26.6
RodC4_93.4		235	93.4	2.372	4.9	0.124	1173.24	907.2	3837.57	12105.6	4.239	24.1	
RodC4_95.3		236	95.3	2.421	6.8	0.173	1181.21	911.6	3512.04	11078.7	3.846	21.8	
RodC4_100.1		237	100.1	2.543	11.6	0.295	1080.07	855.4	4660.46	14701.4	5.739	32.6	
RodC4_106.1		238	106.1	2.695	17.6	0.447	1063.11	846.0	4814.29	15186.7	6.055	34.4	
RodC4_110		239	110	2.794	21.5	0.546	1088.20	859.9	4914.19	15501.8	5.991	34.0	
RodC4_142.2		240	142.2	3.612	3.612	8.7	822.04	712.1	3530.37	11136.6	6.372	36.2	
Gr-3		RodD4_88.3	241	88.3	2.243	-0.2	-0.005	798.15	698.8	3664.72	11560.4	6.913	39.3
		RodD4_91.3	242	91.3	2.319	2.8	0.071	839.81	721.9	3735.96	11785.1	6.534	37.1
	RodD4_93.2	243	93.2	2.367	4.7	0.119	826.26	714.4	3434.66	10834.6	6.152	34.9	
	RodD4_95.2	244	95.2	2.418	6.7	0.170	1155.69	897.4	4228.04	13337.4	4.763	27.0	
	RodD4_100.1	245	100.1	2.543	11.6	0.295	1158.67	899.1	4873.45	15373.3	5.472	31.1	
	RodD4_106.1	246	106.1	2.695	17.6	0.447	1131.74	884.1	4835.54	15253.7	5.598	31.8	
	RodD4_142.1	248	142.1	3.609	3.609	8.6	721.76	656.4	3709.93	11703.0	8.176	46.4	
	Gr-3	RodE4_88.4	201	88.4	2.245	-0.1	-0.003	960.73	789.1	4208.22	13274.8	6.075	34.5
		RodE4_91.2	202	91.2	2.316	2.7	0.069	1030.71	828.0	4400.24	13880.6	5.769	32.8
		RodE4_95.3	204	95.3	2.421	6.8	0.173	1189.50	916.2	2030.46	6405.1	2.203	12.5
RodE4_100.9		205	100.9	2.563	12.4	0.315	1079.13	854.9	4679.92	14762.8	5.770	32.8	
RodE4_142.3		208	142.3	3.614	3.614	8.8	893.37	751.7	4061.18	12811.0	6.494	36.9	

Error! Reference source not found.F, continued

H.R.		Channel	Elevation	Elevation	Zgrid	Zgrid	H.R. Tw	H.R. Tw	H.R. Tw	H.R. q"	H.R. q"	H.R. q"	h _{sat} (z)	h _{sat} (z)
Gr-4	Location	Number	(in)	(m)	(in)	(m)	(°F)	(K)	(Btu/hr-ft2)	(W/m2)	(Btu/hr-ft2-F)	(W/m2-K)	(W/m2-K)	(W/m2-K)
	RodE3_63.4	193	63.4	1.610	16.4	0.417	1185.89	914.2	2695.66	8503.5	2.937	16.7		
	RodE3_113.6	194	113.6	2.885	0.85	0.022	1118.09	876.5	4289.77	13532.1	5.046	28.7		
	RodE3_115.5	195	115.5	2.934	2.75	0.070	842.59	723.5	3504.65	11055.4	6.099	34.6		
	RodE3_118.5	196	118.5	3.010	5.75	0.146	1168.50	904.5	4277.05	13492.0	4.750	27.0		
	RodE3_122.7	197	122.7	3.117	9.95	0.253	1196.73	920.2	4048.54	12771.1	4.359	24.8		
	RodE3_126.5	198	126.5	3.213	13.75	0.349	1218.59	932.4	3718.82	11731.0	3.912	22.2		
	RodE3_131.7	199	131.7	3.345	-1.8	-0.046	1224.12	935.4	3411.07	10760.2	3.568	20.3		
	RodE3_135.6	200	135.6	3.444	2.1	0.053	1175.86	908.6	3002.96	9472.8	3.308	18.8		
Gr-4	RodC5_63.7	225	63.7	1.618	16.7	0.424	786.98	692.6	3382.14	10668.9	6.517	37.0		
	RodC5_113.6	226	113.6	2.885	0.85	0.022	1067.06	848.2	4489.12	14160.9	5.618	31.9		
	RodC5_115.7	227	115.7	2.939	2.95	0.075	1133.98	885.4	3193.48	10073.8	3.688	20.9		
	RodC5_122.7	229	122.7	3.117	9.95	0.253	1151.74	895.2	2844.81	8973.9	3.219	18.3		
	RodC5_126.7	230	126.7	3.218	13.95	0.354	690.84	639.2	2994.96	9447.6	7.083	40.2		
	RodC5_131.6	231	131.6	3.343	-1.9	-0.048	706.92	648.1	3153.01	9946.2	7.184	40.8		
	RodC5_135.7	232	135.7	3.447	2.2	0.056	750.54	672.3	3240.11	10220.9	6.715	38.1		
Gr-4	RodE5_63.6	209	63.6	1.615	16.6	0.422	1199.87	922.0	2073.19	6539.9	2.225	12.6		
	RodE5_113.6	210	113.6	2.885	0.85	0.022	1145.44	891.7	4918.06	15514.0	5.605	31.8		
	RodE5_115.4	211	115.4	2.931	2.65	0.067	1026.47	825.6	4568.53	14379.9	6.010	34.1		
	RodE5_118.7	212	118.7	3.015	5.95	0.151	1201.69	923.0	2131.18	6722.8	2.283	13.0		
	RodE5_122.6	213	122.6	3.114	9.85	0.250	902.92	757.0	4199.15	13246.2	6.614	37.6		
	RodE5_126.6	214	126.6	3.216	13.85	0.352	970.91	794.8	4359.91	13753.3	6.203	35.2		
	RodE5_131.6	215	131.6	3.343	-1.9	-0.048	1005.54	814.0	4453.49	14048.5	6.038	34.3		
	RodE5_135.6	216	135.6	3.444	2.1	0.053	1036.25	831.1	4542.96	14330.8	5.913	33.6		
Gr-5	RodC3_79.8	177	79.8	2.027	8.92	0.227	976.74	798.0	4333.18	13669.0	6.114	34.7		
	RodC3_85.6	178	85.6	2.174	14.72	0.374	1003.66	813.0	4414.54	13925.7	6.001	34.1		
	RodC3_88.5	179	88.5	2.248	0	0.000	1188.07	915.4	2061.15	6501.9	2.240	12.7		
	RodC3_92.4	180	92.4	2.347	3.9	0.099	653.20	618.3	3000.93	9466.4	7.790	44.2		
	RodC3_94.4	181	94.4	2.398	5.9	0.150	691.29	639.4	3171.87	10005.7	7.493	42.6		
	RodC3_97.2	182	97.2	2.469	8.7	0.221	1119.12	877.1	4836.47	15256.7	5.683	32.3		
	RodC3_108.8	183	108.8	2.764	20.3	0.516	1037.52	831.8	4512.13	14233.5	5.864	33.3		
Gr-8	RodD5_50	217	50	1.270	3	0.076	1096.88	864.7	3254.71	10267.0	3.927	22.3		
	RodD5_54.1	218	54.1	1.374	7.1	0.180	1205.20	924.9	3706.15	11691.1	3.954	22.5		
	RodD5_56.9	219	56.9	1.445	9.9	0.251	1211.42	928.4	3396.06	10712.9	3.600	20.4		
	RodD5_60	220	60	1.524	13	0.330	1165.52	902.9	3095.65	9765.2	3.449	19.6		
	RodD5_66.1	221	66.1	1.679	19.1	0.485	1178.47	910.1	2758.36	8701.3	3.030	17.2		
	RodD5_69.9	222	69.9	1.775	-0.98	-0.025	893.07	751.5	4254.87	13422.0	6.807	38.7		
	RodD5_72.9	223	72.9	1.852	2.02	0.051	958.43	787.8	4374.73	13800.1	6.336	36.0		
	RodD5_74.9	224	74.9	1.902	4.02	0.102	996.28	808.9	4476.52	14121.2	6.147	34.9		

Error! Reference source not found.F, continued

H.R. ID	H.R. Location	Channel Number	Elevation (in)	Elevation (m)	Zgrid (in)	Zgrid (m)	H.R. Tw (°F)	H.R. Tw (K)	H.R. q" (Btu/hr-ft2)	H.R. q" (W/m2)	h _{sat} (z) (Btu/hr-ft2-F)	h _{sat} (z) (W/m2-K)	
Gr-2	RodB5_41	153	41	1.041	13.5	0.343	505.33	536.1	2139.28	6748.4	9.014	51.2	
	RodB5_52.9	154	52.9	1.344	5.9	0.150	546.80	559.2	2357.08	7435.4	8.454	48.0	
	RodB5_55	155	55	1.397	8	0.203	569.23	571.6	2529.29	7978.6	8.396	47.7	
	RodB5_57.8	156	57.8	1.468	10.8	0.274	630.20	605.5	2643.76	8339.7	7.299	41.5	
	RodB5_64	157	64	1.626	17	0.432	654.74	619.1	2702.29	8524.4	6.987	39.7	
	RodB5_73.9	158	73.9	1.877	3.02	0.077	689.64	638.5	2794.43	8815.0	6.628	37.6	
	RodB5_75.9	159	75.9	1.928	5.02	0.128	721.49	656.2	2897.84	9141.2	6.390	36.3	
	RodB5_76.9	160	76.9	1.953	6.02	0.153	677.09	631.5	3110.99	9813.6	7.605	43.2	
	Gr-2	RodF5_41	105	41	1.041	13.5	0.343	509.30	538.3	2134.98	6734.8	8.848	50.2
		RodF5_53.1	106	53.1	1.349	6.1	0.155	546.64	559.1	2343.45	7392.4	8.410	47.8
		RodF5_55	107	55	1.397	8	0.203	555.86	564.2	2520.46	7950.8	8.756	49.7
		RodF5_57.8	108	57.8	1.468	10.8	0.274	619.33	599.4	2624.41	8278.7	7.470	42.4
		RodF5_64	109	64	1.626	17	0.432	643.60	612.9	2686.55	8474.7	7.153	40.6
		RodF5_73.8	110	73.8	1.875	2.92	0.074	677.15	631.6	2777.64	8762.1	6.789	38.6
		RodF5_75.8	111	75.8	1.925	4.92	0.125	684.28	635.5	2971.05	9372.2	7.137	40.5
		RodF5_76.8	112	76.8	1.951	5.92	0.150	718.53	654.6	3046.24	9609.4	6.762	38.4
Gr-2		RodC2_41	57	41	1.041	13.5	0.343	1079.86	855.3	2187.85	6901.6	2.695	15.3
		RodC2_53.1	58	53.1	1.349	6.1	0.155	603.21	590.5	3017.83	9519.8	9.003	51.1
		RodC2_55	59	55	1.397	8	0.203	785.38	691.7	3920.64	12367.7	7.578	43.0
		RodC2_57.8	60	57.8	1.468	10.8	0.274	913.27	762.7	4614.65	14556.9	7.151	40.6
	RodC2_63.9	61	63.9	1.623	16.9	0.429	1043.38	835.0	4382.62	13825.0	5.652	32.1	
	RodC2_73.8	62	73.8	1.875	2.92	0.074	1105.50	869.5	3438.57	10847.0	4.106	23.3	
	RodC2_75.8	63	75.8	1.925	4.92	0.125	817.95	709.8	3708.81	11699.4	6.744	38.3	
	RodC2_76.8	64	76.8	1.951	5.92	0.150	830.04	716.5	3754.25	11842.8	6.680	37.9	
	Gr-2	RodC6_40.9	137	40.9	1.039	13.4	0.340	742.38	667.8	3260.66	10285.8	6.873	39.0
		RodC6_52.8	138	52.8	1.341	5.8	0.147	755.47	675.1	3325.07	10488.9	6.821	38.7
		RodC6_54.8	139	54.8	1.392	7.8	0.198	826.92	714.8	3543.52	11178.0	6.340	36.0
		RodC6_57.8	140	57.8	1.468	10.8	0.274	725.63	658.5	3466.88	10936.3	7.576	43.0
RodC6_63.8		141	63.8	1.621	16.8	0.427	790.98	694.8	3595.82	11343.0	6.876	39.0	
RodC6_73.7		142	73.7	1.872	2.82	0.072	826.46	714.5	3685.79	11626.8	6.600	37.5	
RodC6_75.8		143	75.8	1.925	4.92	0.125	902.40	756.7	3809.20	12016.1	6.004	34.1	
RodC6_76.8		144	76.8	1.951	5.92	0.150	883.32	746.1	4000.53	12619.7	6.502	36.9	

Error! Reference source not found.F, continued

5x5 periphery		H.R. Location	Channel Number	Elevation (in)	Elevation (m)	Zgrid (in)	Zgrid (m)	H.R. Tw (°F)	H.R. Tw (K)	H.R. q" (Btu/hr-ft2)	H.R. q" (W/m2)	h _{sat} (z) (Btu/hr-ft2-F)	h _{sat} (z) (W/m2-K)
Gr-3	RodB4_88.4	161	88.4	2.245	-0.1	-0.003	815.89	708.6	3726.60	11755.6	6.802	38.6	
	RodB4_91.3	162	91.3	2.319	2.8	0.071	832.74	718.0	3768.23	11886.9	6.673	37.9	
	RodB4_93.3	163	93.3	2.370	4.8	0.122	377.66	465.2	1776.93	5605.3	16.203	92.0	
	RodB4_95.1	164	95.1	2.416	6.6	0.168	453.02	507.0	1991.74	6282.9	10.765	61.1	
	RodB4_100	165	100	2.540	11.5	0.292	1081.79	856.4	4798.96	15138.3	5.897	33.5	
	RodB4_106	166	106	2.692	17.5	0.445	1107.36	870.6	4900.10	15457.4	5.838	33.2	
	RodB4_109.9	167	109.9	2.791	21.4	0.544	1077.90	854.2	4498.85	14191.6	5.555	31.5	
	RodB4_142.3	168	142.3	3.614	8.8	0.224	785.96	692.0	3636.22	11470.4	7.020	39.9	
Gr-5	RodF4_85.6	98	85.6	2.174	14.72	0.374	821.66	711.8	3670.56	11578.8	6.630	37.6	
	RodF4_88.4	99	88.4	2.245	-0.1	-0.003	834.44	719.0	3716.73	11724.4	6.562	37.3	
	RodF4_92.4	100	92.4	2.347	3.9	0.099	378.68	465.8	1778.71	5610.9	16.070	91.3	
	RodF4_94.3	101	94.3	2.395	5.8	0.147	455.66	508.5	1985.03	6261.8	10.578	60.1	
	RodF4_97.2	102	97.2	2.469	8.7	0.221	1153.48	896.2	4901.97	15463.3	5.536	31.4	
	RodF4_108.8	103	108.8	2.764	20.3	0.516	1114.50	874.5	4767.52	15039.1	5.632	32.0	
	RodF4_111	104	111	2.819	-1.75	-0.044	1094.52	863.4	4673.08	14741.2	5.654	32.1	
	RodD2_103.2	65	103.2	2.621	14.7	0.373	1045.34	836.1	4611.31	14546.4	5.932	33.7	
	RodD2_106	66	106	2.692	17.5	0.445	1112.63	873.5	4829.16	15233.6	5.718	32.5	
	RodD2_112.6	67	112.6	2.860	-0.15	-0.004	1081.49	856.2	4679.38	14761.1	5.752	32.7	
Gr-6	RodD2_114.9	68	114.9	2.918	2.15	0.055	1123.42	879.5	4322.29	13634.7	5.053	28.7	
	RodD2_117.4	69	117.4	2.982	4.65	0.118	1145.50	891.8	4115.16	12981.3	4.690	26.6	
	RodD2_120.8	70	120.8	3.068	8.05	0.204	1177.19	909.4	3844.82	12128.5	4.229	24.0	
	RodD2_124.8	71	124.8	3.170	12.05	0.306	1193.06	918.2	3502.68	11049.2	3.786	21.5	
	RodD2_128.6	72	128.6	3.266	15.85	0.403	1195.28	919.4	3167.12	9990.7	3.416	19.4	
	RodD6_103.1	129	103.1	2.619	14.6	0.371	1139.08	888.2	4413.68	13923.0	5.067	28.8	
	RodD6_106	130	106	2.692	17.5	0.445	1093.79	863.0	4613.17	14552.3	5.586	31.7	
	RodD6_112.9	131	112.9	2.868	0.15	0.004	1104.22	868.8	4452.12	14044.2	5.324	30.2	
	RodD6_114.9	132	114.9	2.918	2.15	0.055	689.07	638.2	2994.40	9445.8	7.111	40.4	
	RodD6_116.8	133	116.8	2.967	4.05	0.103	708.31	648.9	3127.32	9865.1	7.103	40.3	
RodD6_120.9	134	120.9	3.071	8.15	0.207	998.85	810.3	4342.10	13697.2	5.941	33.7		
RodD6_124.8	135	124.8	3.170	12.05	0.306	1033.69	829.6	4440.39	14007.2	5.799	32.9		
RodD6_128.7	136	128.7	3.269	15.95	0.405	1198.00	920.9	1917.36	6048.3	2.062	11.7		

Error! Reference source not found.F, continued

5x5 periphery		H.R.	Channel Number	Elevation (in)	Elevation (m)	Zgrid (in)	Zgrid (m)	H.R. Tw (°F)	H.R. Tw (K)	H.R. q" (Btu/hr-ft2)	H.R. q" (W/m2)	h _{sat} (z) (Btu/hr-ft2-F)	h _{sat} (z) (W/m2-K)
Gr-8	RodE2_50.1	73	50.1	1.273	3.1	0.079	748.46	671.2	3239.66	10219.5	6.743	38.3	
	RodE2_54	74	54	1.372	7	0.178	784.62	691.3	3353.75	10579.4	6.492	36.9	
	RodE2_56.9	75	56.9	1.445	9.9	0.251	827.01	714.8	3568.40	11256.5	6.383	36.3	
	RodE2_59.9	76	59.9	1.521	12.9	0.328	726.01	658.7	3427.92	10813.4	7.484	42.5	
	RodE2_66	77	66	1.676	19	0.483	787.49	692.9	3550.17	11199.0	6.834	38.8	
	RodE2_69.8	78	69.8	1.773	-1.08	-0.027	818.45	710.1	3647.08	11504.7	6.626	37.6	
	RodE2_72.9	79	72.9	1.852	2.02	0.051	386.75	470.2	1753.64	5531.8	14.767	83.9	
	RodE2_74.9	80	74.9	1.902	4.02	0.102	458.09	509.9	1960.37	6184.0	10.313	58.6	
Gr-8	RodB3_50.2	169	50.2	1.275	3.2	0.081	1148.72	893.6	3840.57	12115.1	4.361	24.8	
	RodB3_54.1	170	54.1	1.374	7.1	0.180	1160.62	900.2	3502.34	11048.1	3.924	22.3	
	RodB3_56.9	171	56.9	1.445	9.9	0.251	1163.39	901.7	3155.24	9953.2	3.524	20.0	
	RodB3_60.1	172	60.1	1.527	13.1	0.333	726.42	658.9	2864.64	9036.5	6.249	35.5	
	RodB3_66.1	173	66.1	1.679	19.1	0.485	708.21	648.8	2991.04	9435.2	6.795	38.6	
	RodB3_69.9	174	69.9	1.775	-0.98	-0.025	729.64	660.7	3071.29	9688.4	6.653	37.8	
	RodB3_73	175	73	1.854	2.12	0.054	749.09	671.5	3179.36	10029.3	6.609	37.5	
	RodB3_75	176	75	1.905	4.12	0.105	799.52	699.6	3431.41	10824.4	6.456	36.7	
Gr-8	RodF3_50.1	89	50.1	1.273	3.1	0.079	966.70	792.4	4298.71	13560.3	6.152	34.9	
	RodF3_54	90	54	1.372	7	0.178	997.44	809.5	4388.64	13844.0	6.016	34.2	
	RodF3_57	91	57	1.448	10	0.254	720.92	655.9	2863.67	9033.4	6.323	35.9	
	RodF3_60	92	60	1.524	13	0.330	676.65	631.3	3085.39	9732.9	7.550	42.9	
	RodF3_66.1	93	66.1	1.679	19.1	0.485	715.82	653.1	3137.83	9898.3	7.007	39.8	
	RodF3_70	94	70	1.778	-0.88	-0.022	760.48	677.9	3216.63	10146.9	6.531	37.1	
	RodF3_73	95	73	1.854	2.12	0.054	822.23	712.2	3451.48	10887.7	6.227	35.4	
	RodF3_75	96	75	1.905	4.12	0.105	791.78	695.2	3579.01	11290.0	6.833	38.8	
Gr-8	RodE6_50.2	121	50.2	1.275	3.2	0.081	514.64	541.3	2112.71	6664.5	8.566	48.6	
	RodE6_54.1	122	54.1	1.374	7.1	0.180	554.70	563.5	2338.69	7377.4	8.157	46.3	
	RodE6_57	123	57	1.448	10	0.254	559.92	566.4	2503.04	7895.8	8.575	48.7	
	RodE6_60.2	124	60.2	1.529	13.2	0.335	623.97	602.0	2636.16	8315.8	7.406	42.1	
	RodE6_66.1	125	66.1	1.679	19.1	0.485	648.06	615.4	2703.08	8526.9	7.112	40.4	
	RodE6_70	126	70	1.778	-0.88	-0.022	681.44	633.9	2800.76	8835.0	6.774	38.5	
	RodE6_73.1	127	73.1	1.857	2.22	0.056	674.93	630.3	2971.46	9373.5	7.302	41.5	
	RodE6_75	128	75	1.905	4.12	0.105	705.61	647.4	3145.60	9922.8	7.188	40.8	

RBHT Steam Cooling with Droplet Injection Test SCD-4032-A

Matrix Test # Shakedown

Test Conditions

Test Date – 9/28/2005

Steady State Time Window: 10620 - 11400

Upper Plenum Pressure: 2.76 bar (40 psia)

Bundle Power: 80.0 kW

Bundle Inlet Reynolds Number: 10000

Bundle Inlet Steam Flow: 198.9 kg/hr (438 lbm/hr)

Droplet Injection Flow: 0.0076 kg/s (0.0167 lbm/s)

Droplet Injection Hole Diameter: 0.381 mm (.015 in)

Droplet Injection Elevation: 1.295 m (51 in)

Bundle Flow Area: $4.656 \times 10^{-3} \text{ m}^2$ ($5.012 \times 10^{-2} \text{ ft}^2$)

Test Notes

- No steam probes were traversed in this steady state window.

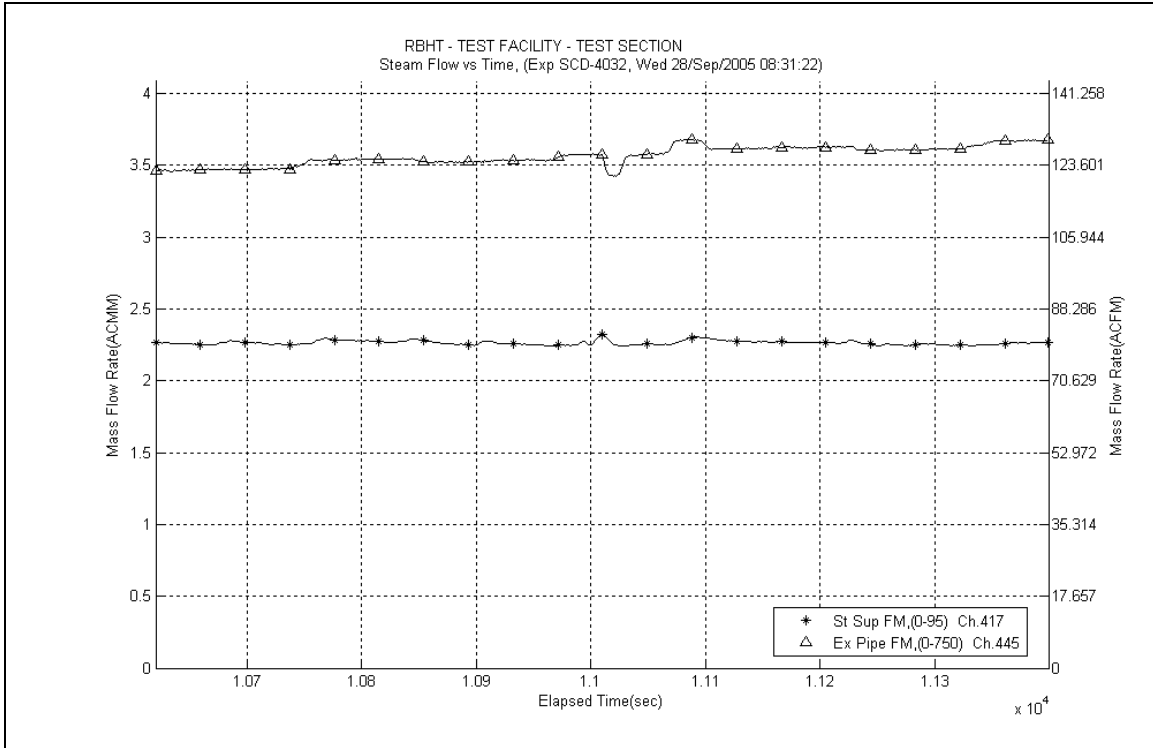

Figure A-111: Inlet and Exhaust Steam Flow Rates for Experiment 4032A

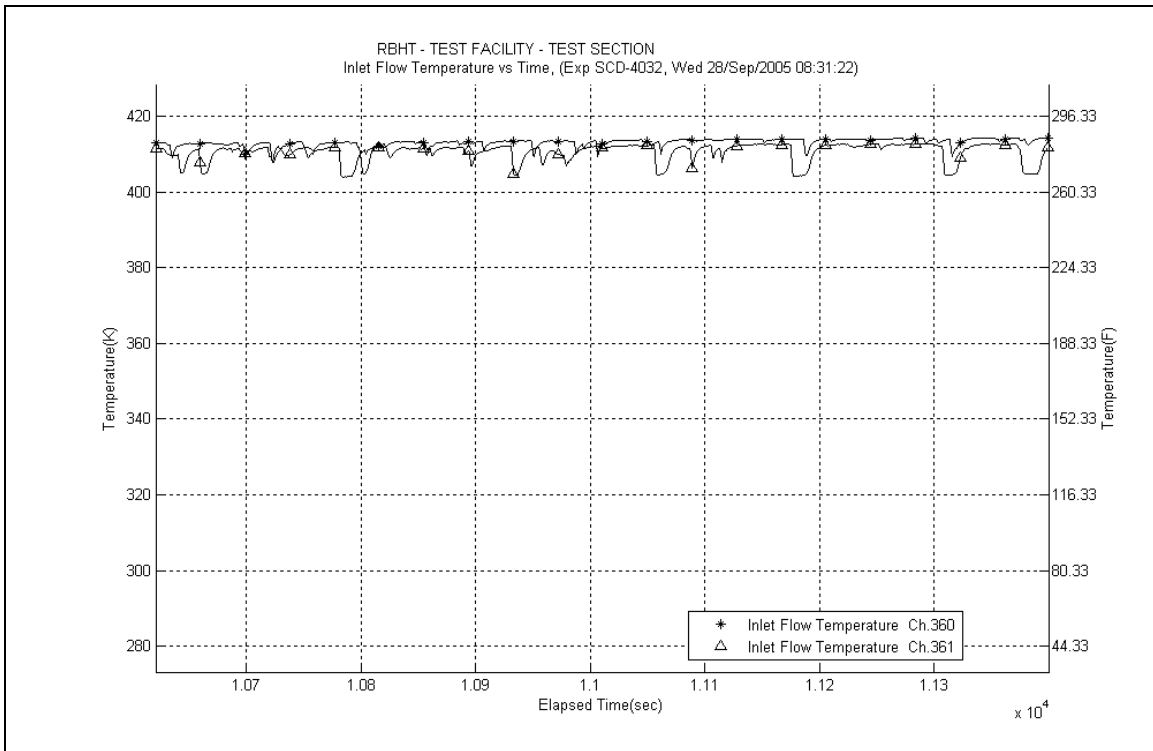

Figure A-112: Inlet Steam Temperature for Experiment 4032A

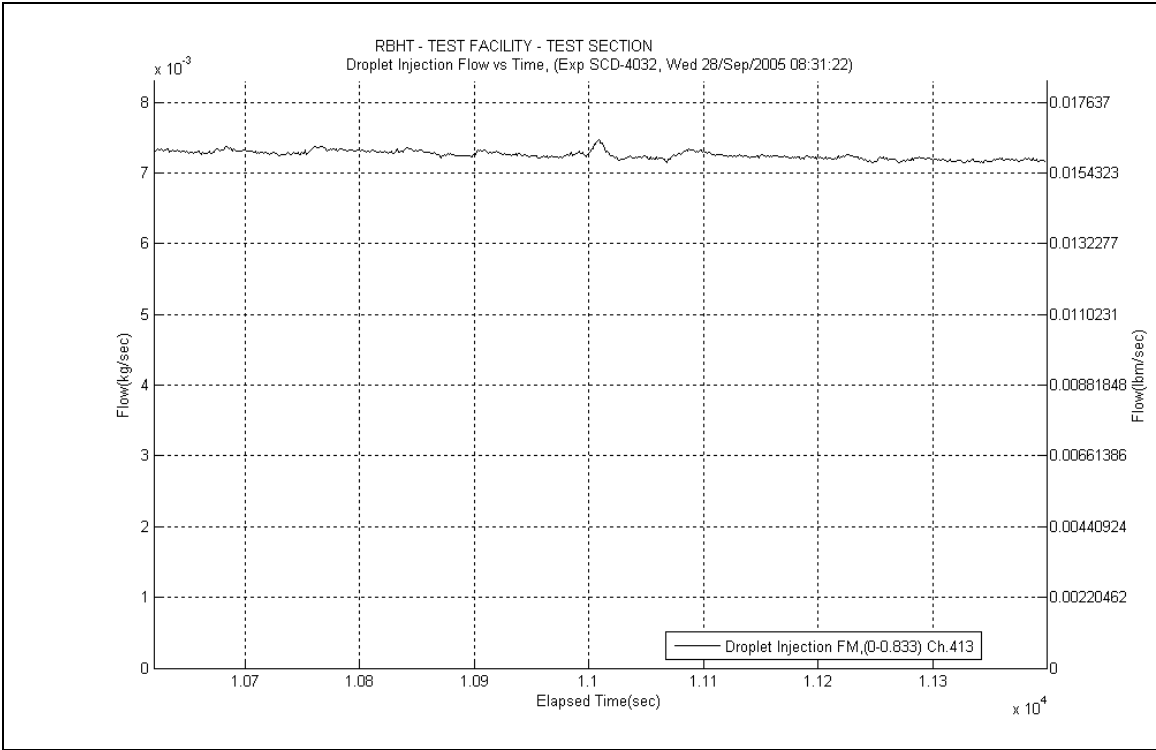

Figure A-113: Droplet Injection Flow Rate for Experiment 4032A

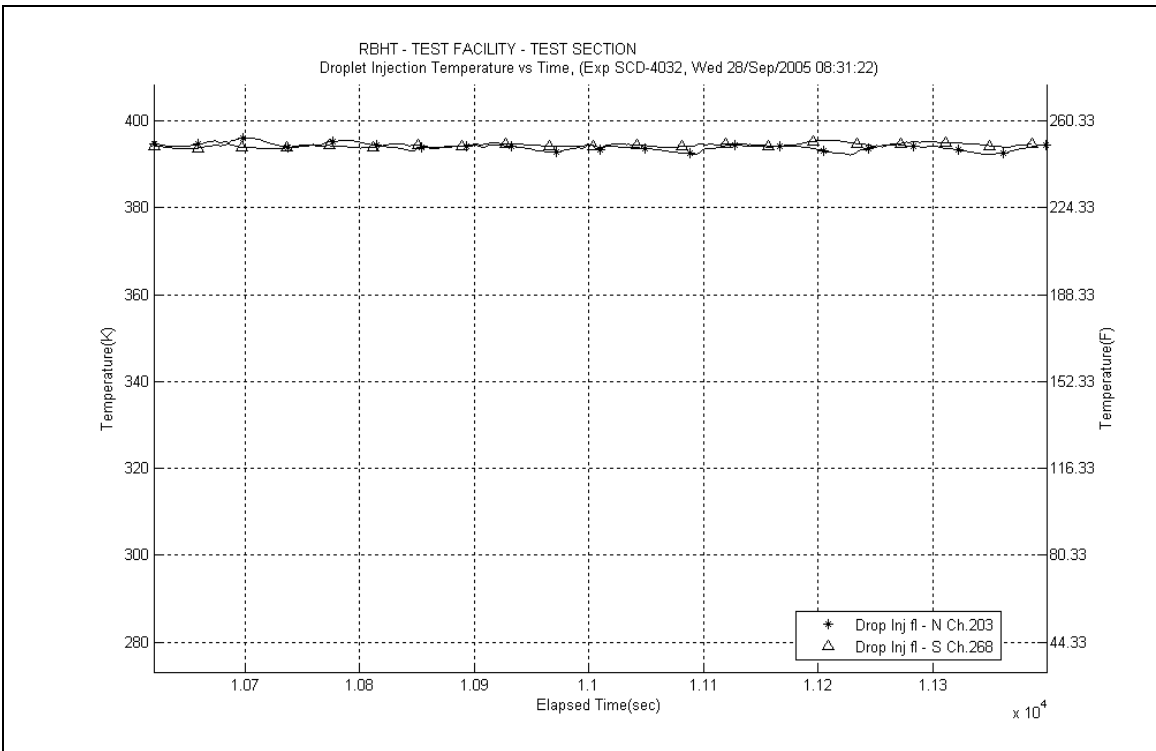

Figure A-114: Droplet Injection Temperature for Experiment 4032A

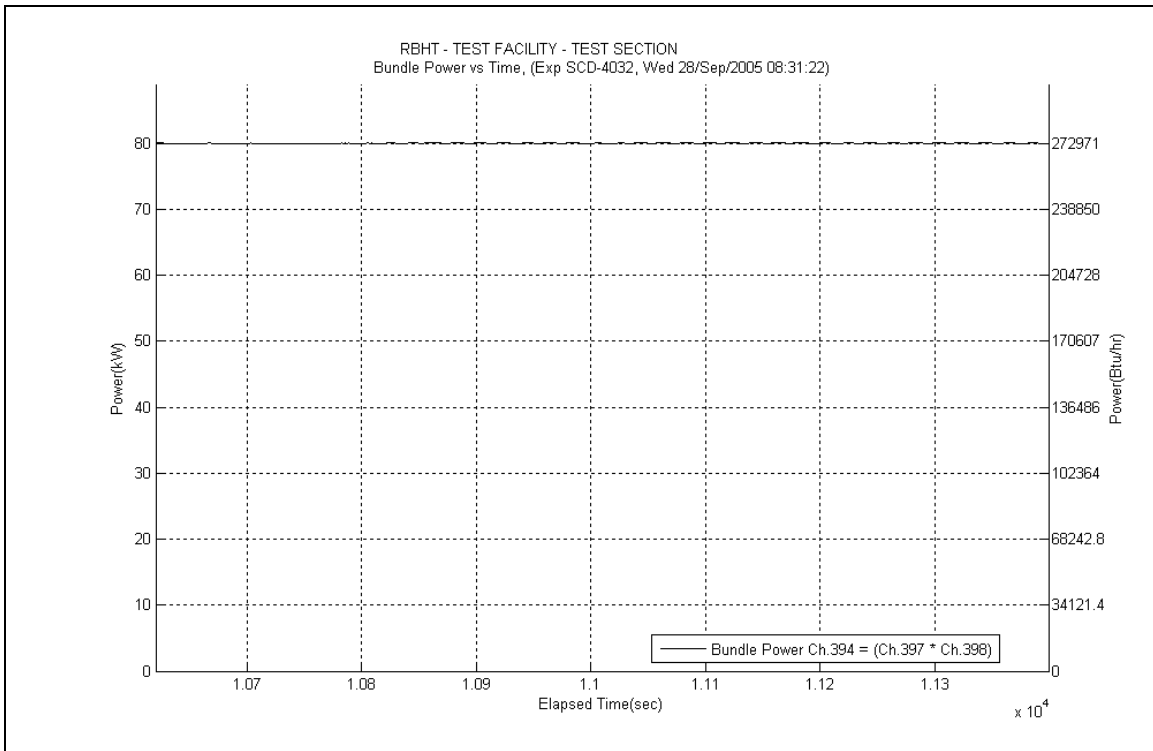

Figure A-115: Bundle Power for Experiment 4032A

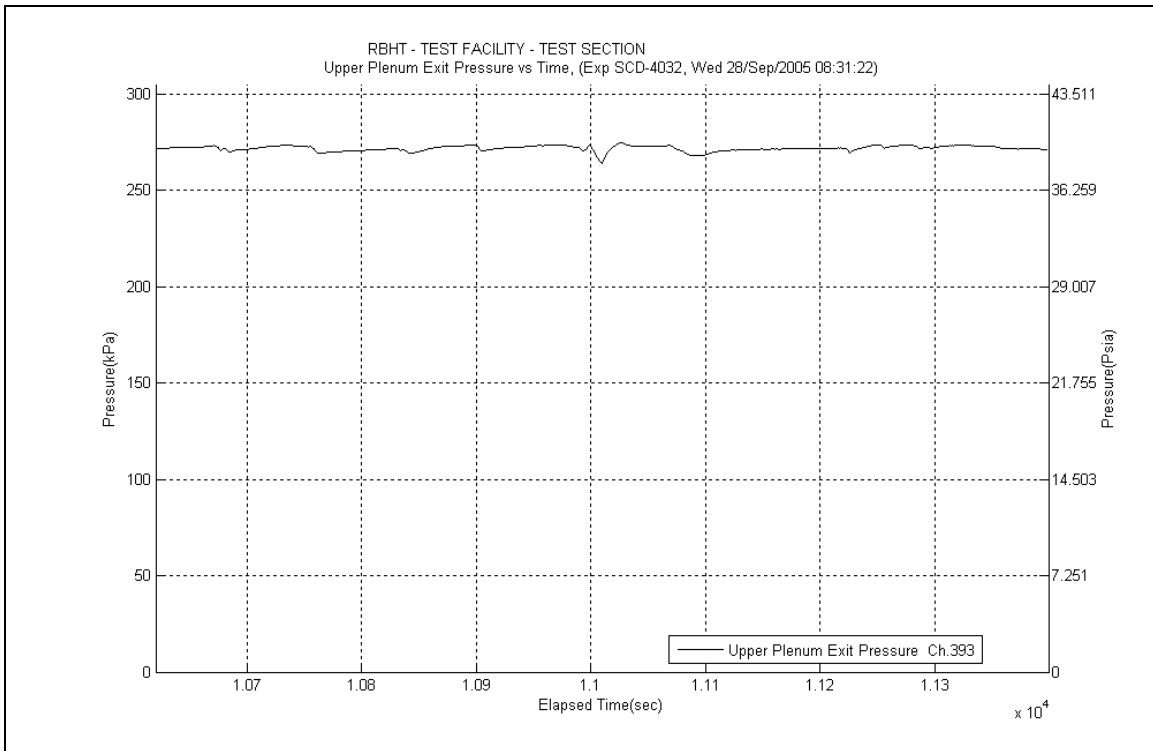

Figure A-116: Upper Plenum Pressure for Experiment 4032A

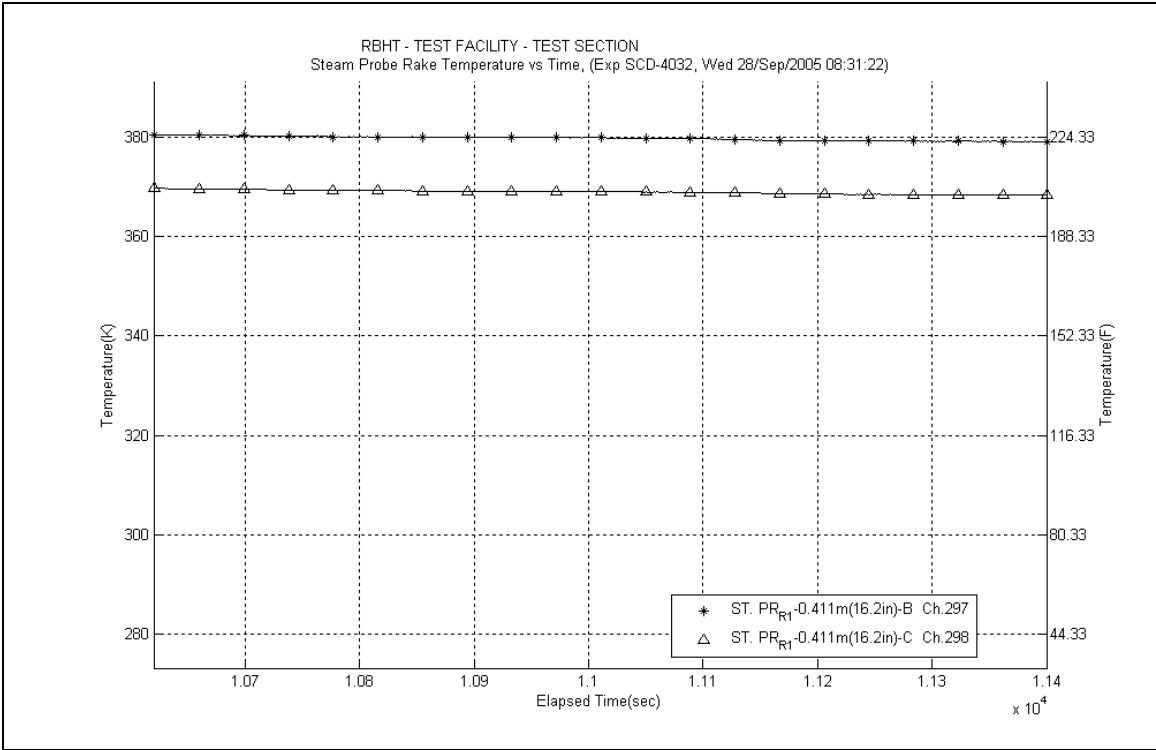

Figure A-117: Steam Probe Rake #1 Temperatures for Experiment 4032A

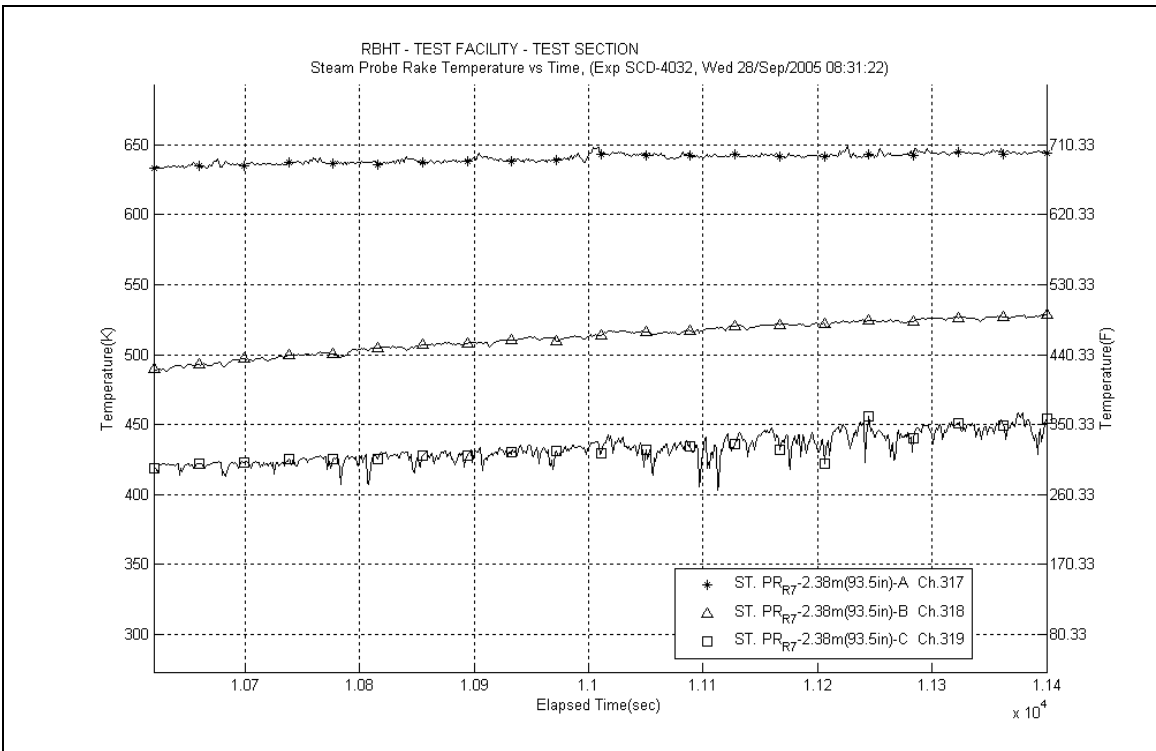

Figure A-118: Steam Probe Rake #7 Temperatures for Experiment 4032A

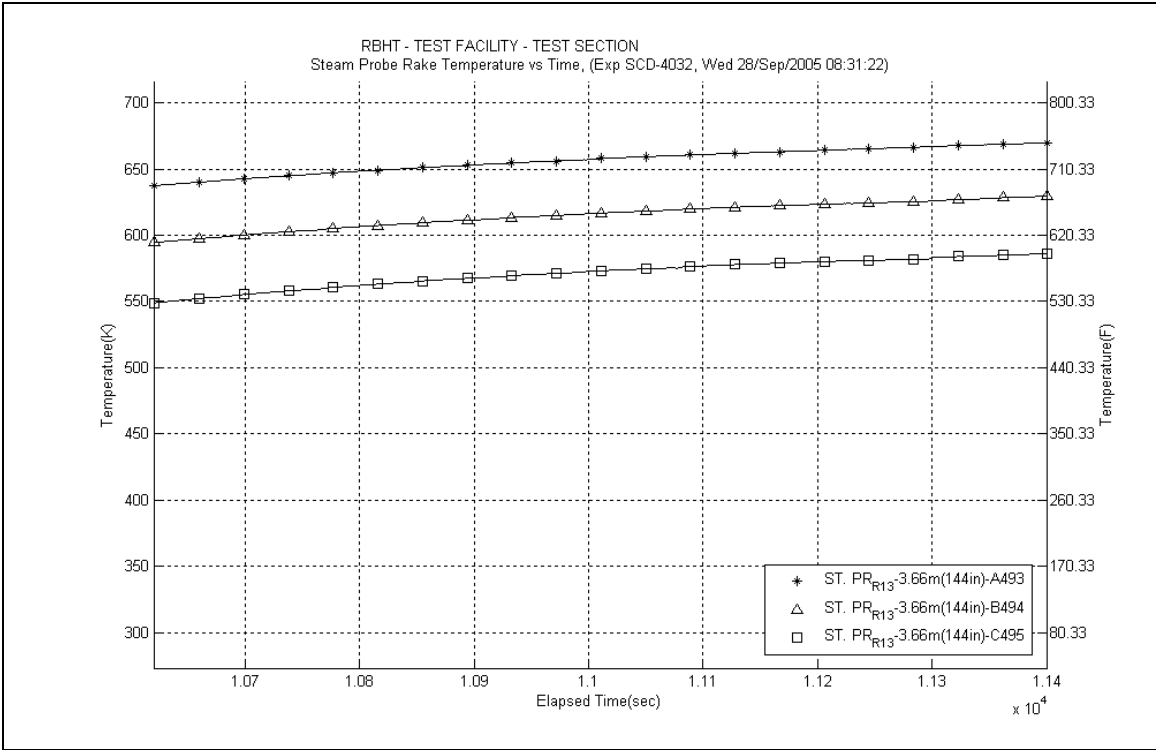

Figure A-119: Steam Probe Rake #13 Temperatures for Experiment 4032A

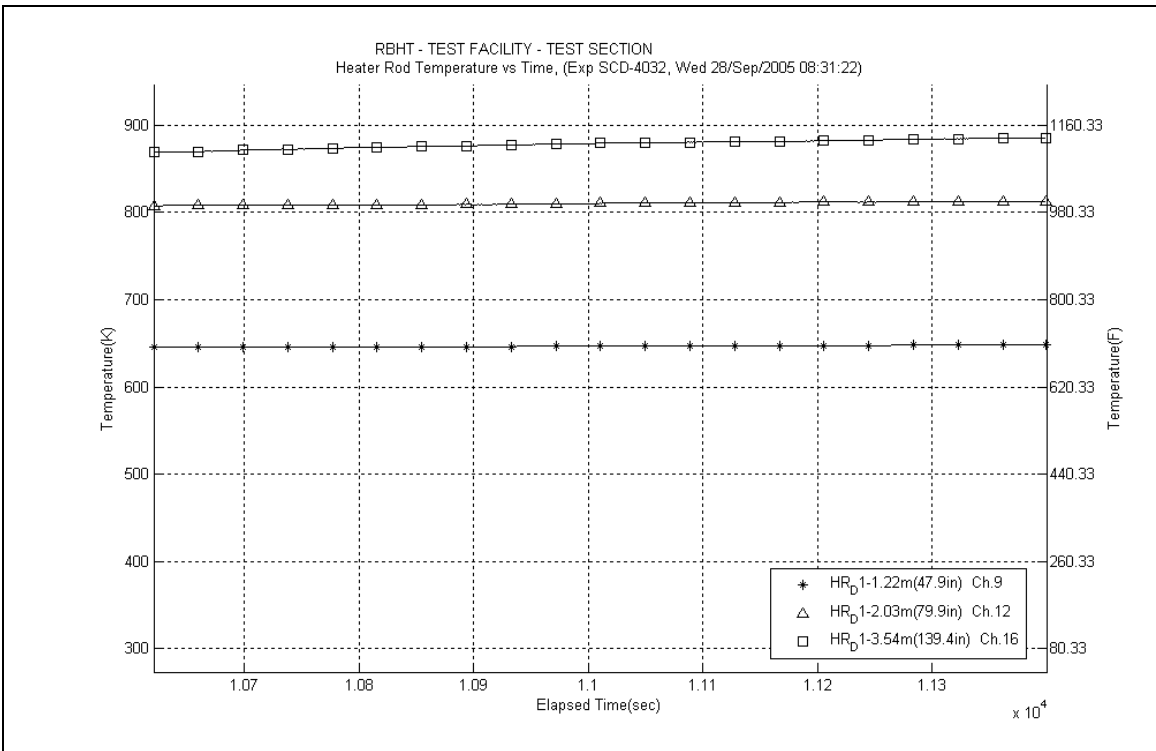

Figure A-120: Heater Rod D1 Temperatures for Experiment 4032A

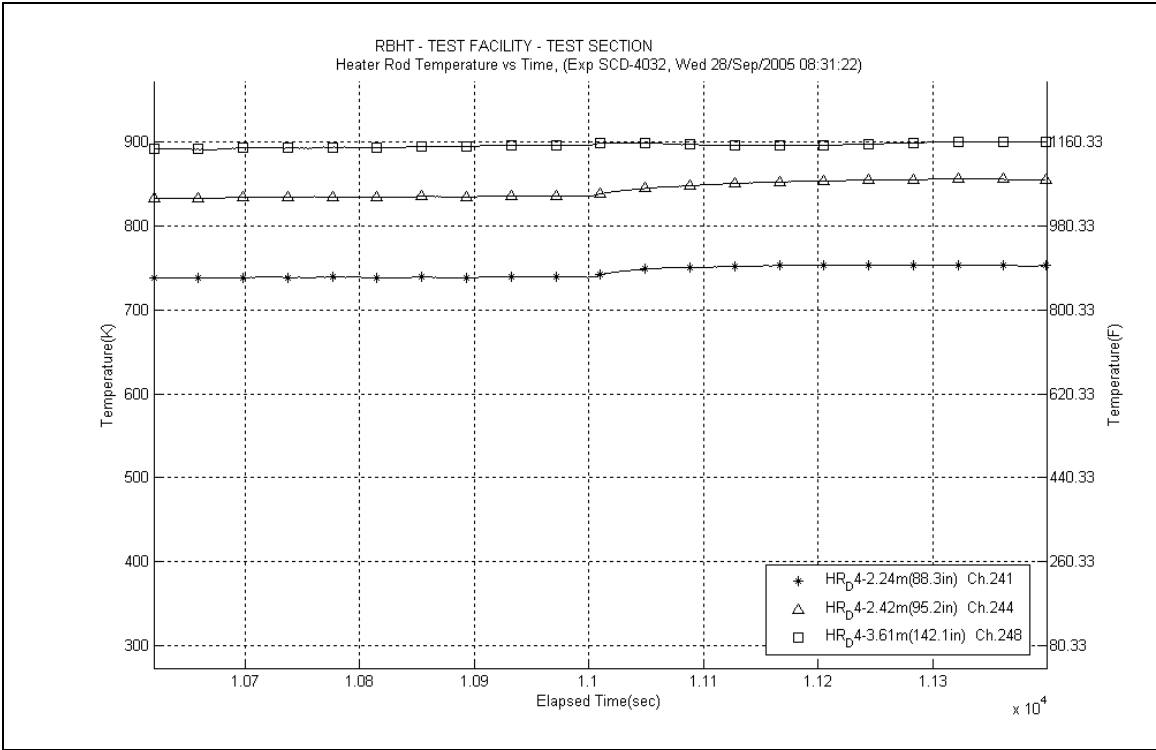

Figure A-121: Heater Rod D4 Temperatures for Experiment 4032A

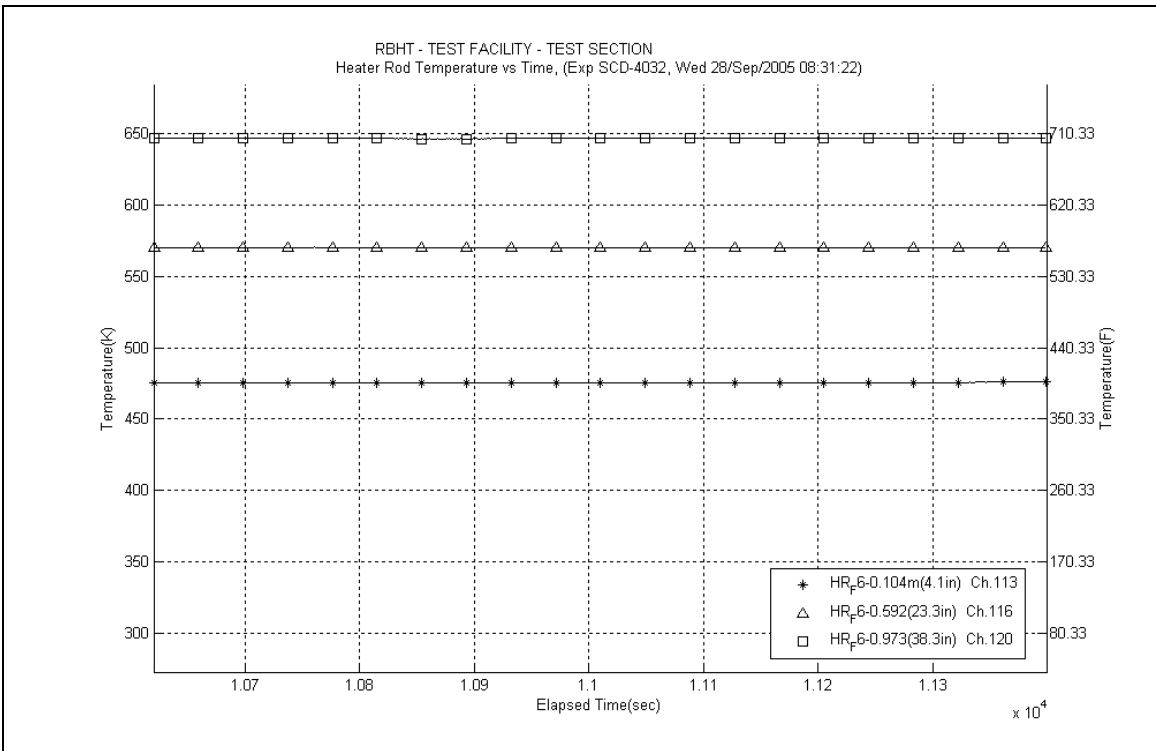

Figure A-122: Heater Rod F6 Temperatures for Experiment 4032A

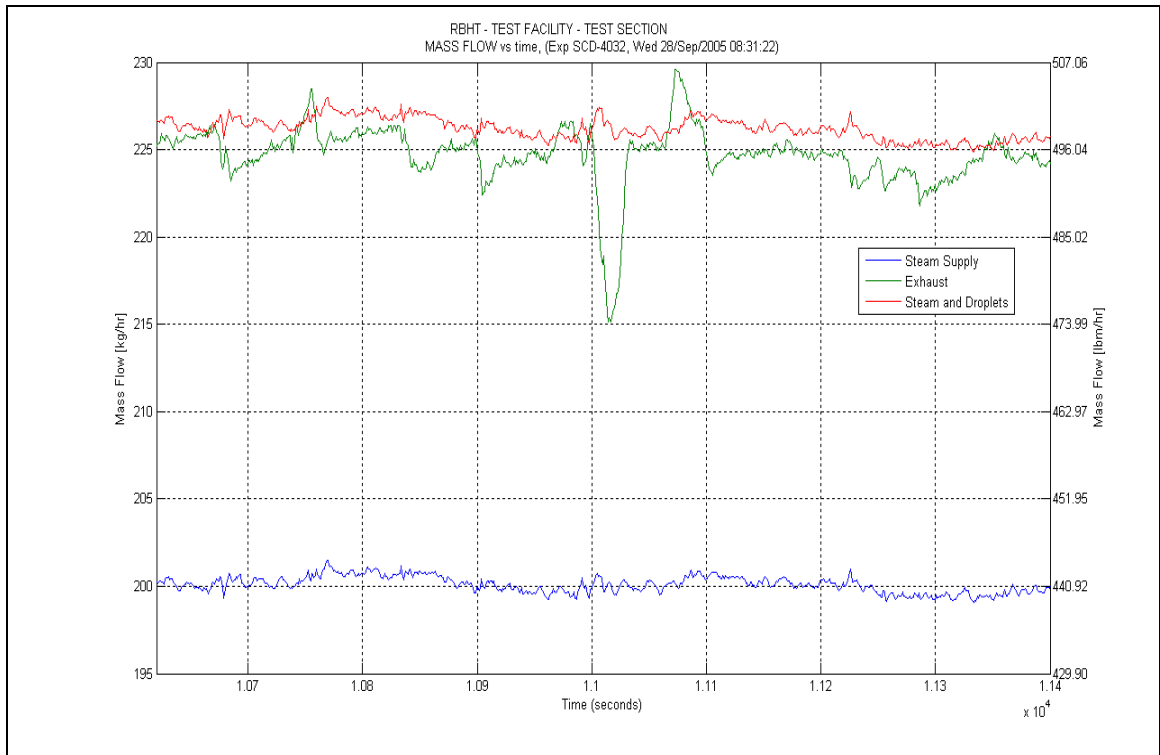

Figure A-123: Mass Flow for Experiment 4032A

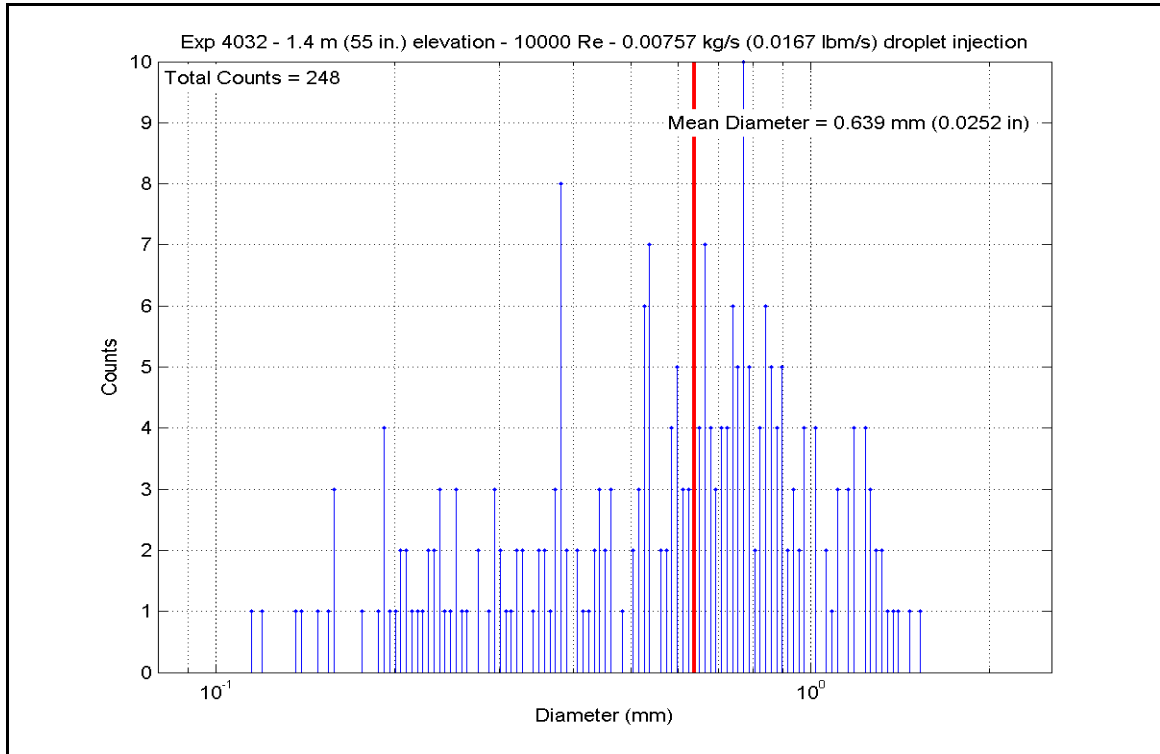

Figure A-124: Droplet Measurements at 1.397 m (55 in.) Elevation for Experiment 4032A

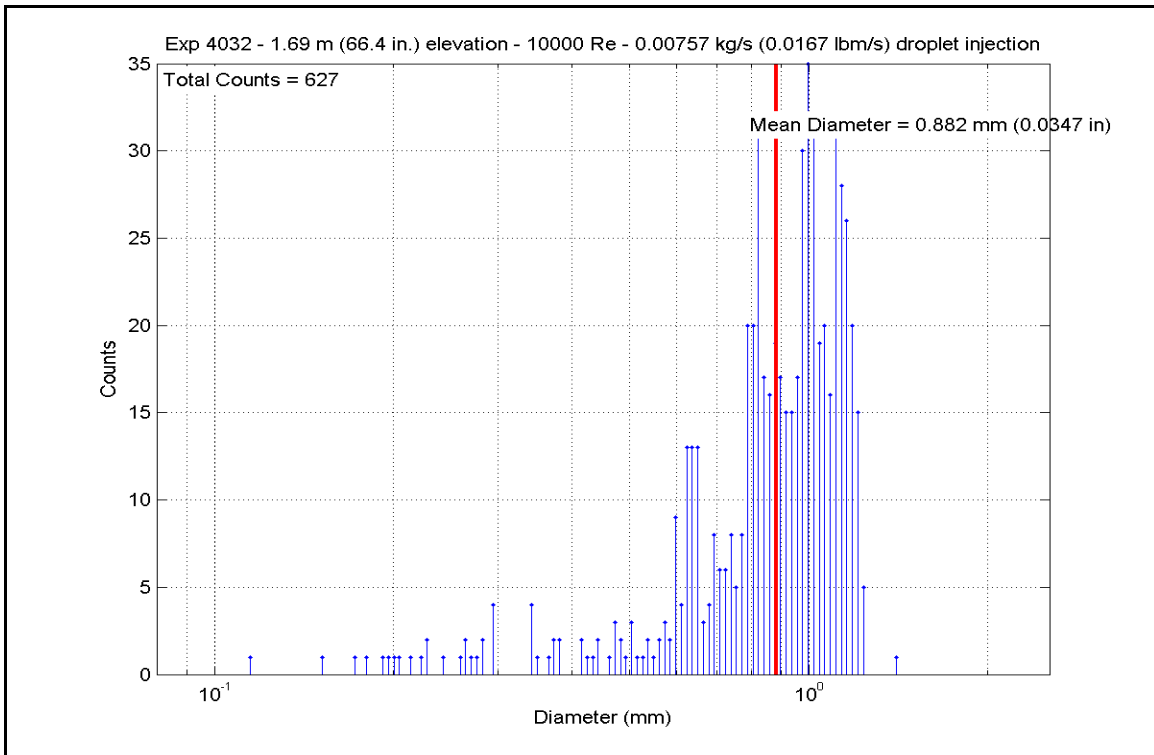

Figure A-125: Droplet Measurements at 1.687 m (66.4 in.) Elevation for Experiment 4032A

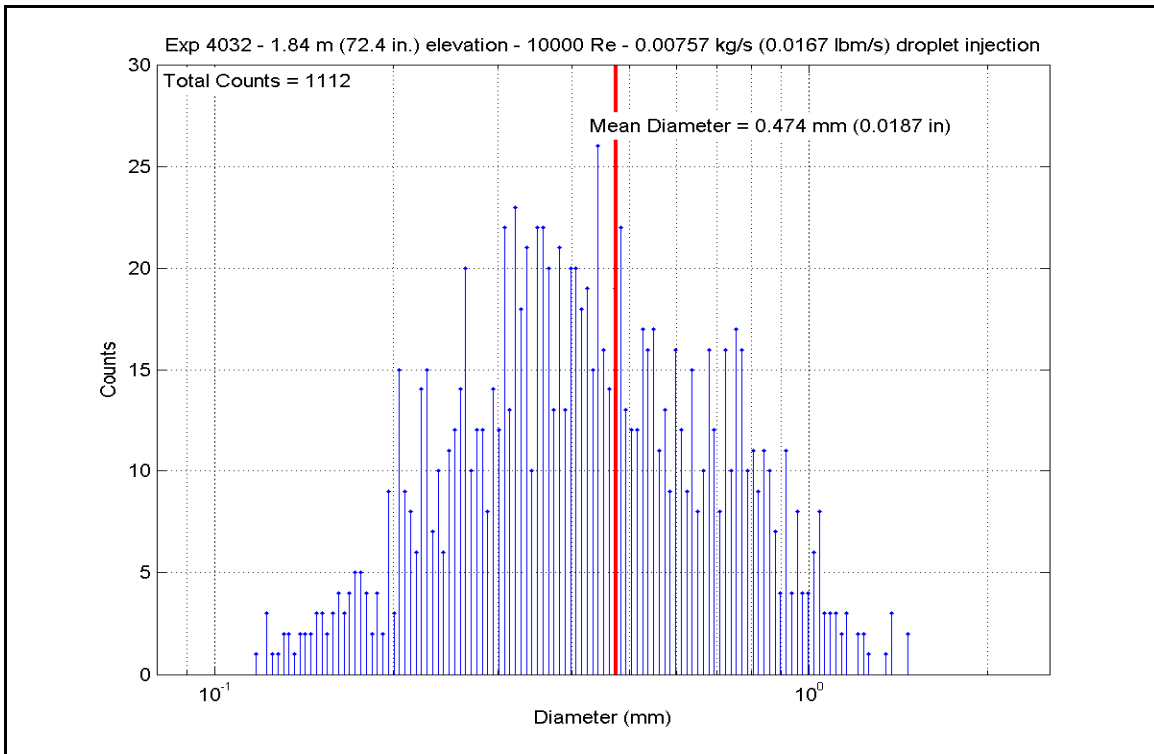

Figure A-126: Droplet Measurements at 1.839 m (72.4 in.) Elevation for Experiment 4032A

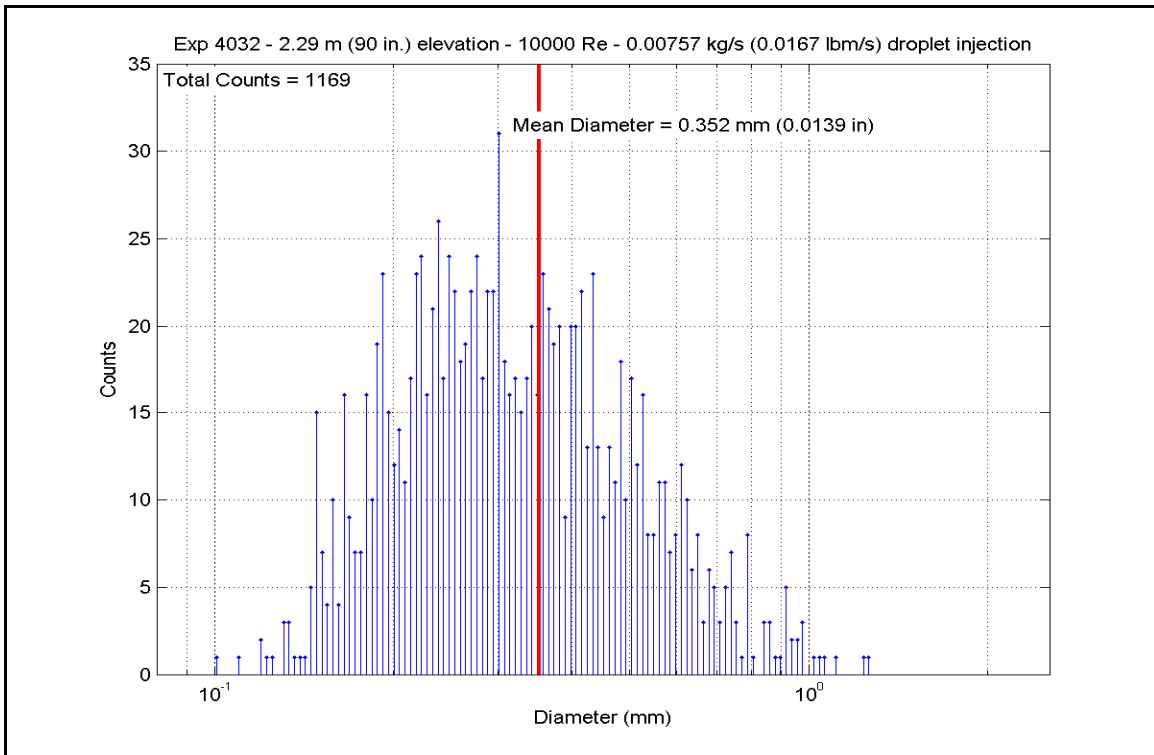

Figure A-127: Droplet Measurements at 2.286 m (90 in.) Elevation for Experiment 4032A

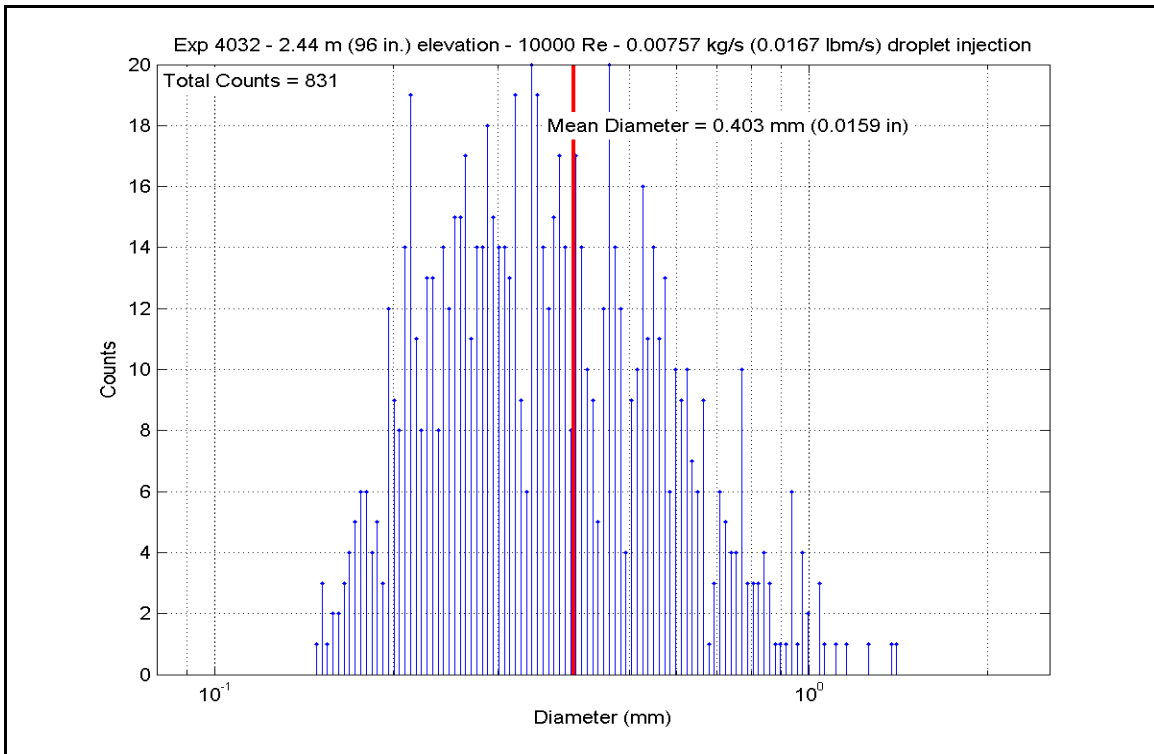

Figure A-128: Droplet Measurements at 2.438 m (96 in.) Elevation for Experiment 4032A

Error! Reference source not found.A

SCD-4032-A		Inlet Reynolds:		10000		40 psia		272971 Btu/hr		438.0 lbm/hr		0.0161 lbm/s	
Matrix test: shakedown		UP Pressure:		275.8 kPa		80.00 kW		0.0552 kg/s		0.0073 kg/s			
Time Window: 10620-11400		Bundle Power:											
Inner 3x3		Stream flow:											
Droplet flow:													
H.R. ID	H.R. Location	Channel Number	Elevation (in)	Elevation (m)	Zgrid (in)	Zgrid (m)	H.R. Tw (°F)	H.R. Tw (K)	H.R. q" (Btu/hr-ft2)	H.R. q" (W/m2)	h _{sat} (z) (Btu/hr-ft2-F)	h _{sat} (z) (W/m2-K)	
Gr-3	RodD3_88.3	185	88.3	2.243	-0.2	-0.005	1008.86	815.8	6900.83	21768.7	9.315	52.9	
	RodD3_91.3	186	91.3	2.319	2.8	0.071	1045.45	836.2	6994.99	22065.7	8.997	51.1	
	RodD3_93.1	187	93.1	2.365	4.6	0.117	902.31	756.7	6760.52	21326.0	10.658	60.5	
	RodD3_95.3	188	95.3	2.421	6.8	0.173	994.42	807.8	6892.22	21741.5	9.488	53.9	
	RodD3_100.1	189	100.1	2.543	11.6	0.295	1091.43	861.7	7128.03	22485.4	8.657	49.2	
	RodD3_106.1	190	106.1	2.695	17.6	0.447	1178.51	910.1	7517.67	23714.5	8.257	46.9	
	RodD3_110	191	110	2.794	2.695	21.5	1109.73	871.9	7308.88	23055.9	8.683	49.3	
	RodD3_142.1	192	142.1	3.609	3.609	8.6	892.06	751.0	6721.94	21204.4	10.771	61.2	
	Gr-3	RodC4_88.4	233	88.4	2.245	-0.1	-0.003	1168.99	904.8	6628.61	20910.0	7.357	41.8
		RodC4_91.1	234	91.1	2.314	2.6	0.066	1186.03	914.3	6194.97	19542.0	6.748	38.3
		RodC4_93.4	235	93.4	2.372	4.9	0.124	1200.65	922.4	5680.41	17918.8	6.091	34.6
		RodC4_95.3	236	95.3	2.421	6.8	0.173	1199.06	921.5	5148.03	16239.5	5.529	31.4
RodC4_100.1		237	100.1	2.543	11.6	0.295	1095.03	863.7	7232.96	22816.4	8.746	49.7	
RodC4_106.1		238	106.1	2.695	17.6	0.447	1158.10	898.8	7452.15	23507.8	8.372	47.5	
RodC4_110		239	110	2.794	2.794	21.5	1177.24	909.4	7592.32	23950.0	8.350	47.4	
RodC4_142.2		240	142.2	3.612	3.612	8.7	945.90	780.9	5602.31	17672.5	8.264	46.9	
Gr-3		RodD4_88.3	241	88.3	2.243	-0.2	-0.005	885.98	747.6	6032.86	19030.7	9.762	55.4
		RodD4_91.3	242	91.3	2.319	2.8	0.071	934.51	774.5	6125.97	19324.4	9.191	52.2
		RodD4_93.2	243	93.2	2.367	4.7	0.119	950.78	783.6	5463.40	17234.3	8.002	45.4
		RodD4_95.2	244	95.2	2.418	6.7	0.170	1170.12	905.4	6381.16	20129.4	7.074	40.2
	RodD4_100.1	245	100.1	2.543	11.6	0.295	1192.92	918.1	7596.44	23963.0	8.213	46.6	
	RodD4_106.1	246	106.1	2.695	17.6	0.447	1128.95	882.6	7510.11	23690.7	8.723	49.5	
	RodD4_142.1	248	142.1	3.609	3.609	8.6	792.64	695.7	5890.20	18580.6	11.227	63.8	
	Gr-3	RodE4_88.4	201	88.4	2.245	-0.1	-0.003	1006.44	814.5	6772.88	21365.0	9.172	52.1
		RodE4_91.2	202	91.2	2.316	2.7	0.069	1080.78	855.8	6977.88	22011.7	8.585	48.8
		RodE4_95.3	204	95.3	2.421	6.8	0.173	1156.02	897.6	2745.19	8659.7	3.091	17.6
		RodE4_100.9	205	100.9	2.563	12.4	0.315	1103.36	868.3	7355.98	23204.4	8.806	50.0
		RodE4_142.3	208	142.3	3.614	3.614	8.8	910.43	761.2	6633.58	20925.6	10.326	58.6

Error! Reference source not found.A, continued

Gr-4	H.R. Location	Channel Number	Elevation (in)	Elevation (m)	Zgrid (in)	Zgrid (m)	H.R. Tw (°F)	H.R. Tw (K)	H.R. q" (Btu/hr-ft2)	H.R. q" (W/m2)	h _{sat} (z) (Btu/hr-ft2-F)	h _{sat} (z) (W/m2-K)
	RodE3_63.4	193	63.4	1.610	16.4	0.417	1164.57	902.4	3877.78	12232.4	4.325	24.6
	RodE3_113.6	194	113.6	2.885	0.85	0.022	1128.68	882.4	6645.48	20963.2	7.721	43.8
	RodE3_115.5	195	115.5	2.934	2.75	0.070	959.46	788.4	5568.41	17565.5	8.053	45.7
	RodE3_118.5	196	118.5	3.010	5.75	0.146	1188.11	915.4	6580.67	20758.7	7.152	40.6
	RodE3_122.7	197	122.7	3.117	9.95	0.253	1213.47	929.5	6176.98	19485.3	6.533	37.1
	RodE3_126.5	198	126.5	3.213	13.75	0.349	1226.31	936.7	5610.08	17697.0	5.854	33.2
	RodE3_131.7	199	131.7	3.345	-1.8	-0.046	1222.21	934.4	5096.83	16077.9	5.341	30.3
	RodE3_135.6	200	135.6	3.444	2.1	0.053	1141.83	889.7	4404.08	13892.7	5.040	28.6
Gr-4	RodC5_63.7	225	63.7	1.618	16.7	0.424	919.16	766.0	5429.20	17126.4	8.338	47.3
	RodC5_113.6	226	113.6	2.885	0.85	0.022	1113.88	874.2	6938.16	21886.4	8.202	46.6
	RodC5_115.7	227	115.7	2.939	2.95	0.075	1116.67	875.7	4494.10	14176.6	5.295	30.1
	RodC5_122.7	229	122.7	3.117	9.95	0.253	1141.03	889.3	3964.65	12506.5	4.541	25.8
	RodC5_126.7	230	126.7	3.218	13.95	0.354	799.42	699.5	4957.45	15638.3	9.329	53.0
	RodC5_131.6	231	131.6	3.343	-1.9	-0.048	809.32	705.0	5150.16	16246.2	9.514	54.0
	RodC5_135.7	232	135.7	3.447	2.2	0.056	875.22	741.6	5282.37	16663.2	8.699	49.4
Gr-4	RodE5_63.6	209	63.6	1.615	16.6	0.422	1152.80	895.8	2723.16	8590.2	3.078	17.5
	RodE5_113.6	210	113.6	2.885	0.85	0.022	1176.94	909.2	7660.65	24165.5	8.428	47.9
	RodE5_115.4	211	115.4	2.931	2.65	0.067	1067.84	848.6	7111.91	22434.5	8.892	50.5
	RodE5_118.7	212	118.7	3.015	5.95	0.151	1154.87	897.0	2814.76	8879.2	3.174	18.0
	RodE5_122.6	213	122.6	3.114	9.85	0.250	879.35	743.9	6782.84	21396.5	11.095	63.0
	RodE5_126.6	214	126.6	3.216	13.85	0.352	981.79	800.8	6902.61	21774.3	9.670	54.9
	RodE5_131.6	215	131.6	3.343	-1.9	-0.048	1023.02	823.7	6985.79	22036.7	9.252	52.5
	RodE5_135.6	216	135.6	3.444	2.1	0.053	1055.77	841.9	7081.07	22337.2	8.989	51.0
Gr-5	RodC3_79.8	177	79.8	2.027	8.92	0.227	1030.48	827.9	6889.87	21734.1	9.036	51.3
	RodC3_85.6	178	85.6	2.174	14.72	0.374	1058.86	843.6	6977.07	22009.2	8.822	50.1
	RodC3_88.5	179	88.5	2.248	0	0.000	1137.18	887.1	2788.74	8797.1	3.208	18.2
	RodC3_92.4	180	92.4	2.347	3.9	0.099	756.92	675.9	4940.81	15585.8	10.106	57.4
	RodC3_94.4	181	94.4	2.398	5.9	0.150	778.74	688.0	5120.61	16153.0	10.026	56.9
	RodC3_97.2	182	97.2	2.469	8.7	0.221	1173.54	907.3	7538.45	23780.0	8.325	47.3
	RodC3_108.8	183	108.8	2.764	20.3	0.516	1106.72	870.2	7126.75	22481.3	8.497	48.3
Gr-8	RodD5_50	217	50	1.270	3	0.076	1128.20	882.2	4742.78	14961.1	5.514	31.3
	RodD5_54.1	218	54.1	1.374	7.1	0.180	1209.26	927.2	5489.63	17317.0	5.832	33.1
	RodD5_56.9	219	56.9	1.445	9.9	0.251	1203.94	924.2	4979.58	15708.1	5.320	30.2
	RodD5_60	220	60	1.524	13	0.330	1118.29	876.6	4370.56	13786.9	5.140	29.2
	RodD5_66.1	221	66.1	1.679	19.1	0.485	1141.47	889.5	3845.15	12129.5	4.402	25.0
	RodD5_69.9	222	69.9	1.775	-0.98	-0.025	891.98	750.9	6755.39	21309.9	10.826	61.5
	RodD5_72.9	223	72.9	1.852	2.02	0.051	986.79	803.6	6887.20	21725.7	9.582	54.4
	RodD5_74.9	224	74.9	1.902	4.02	0.102	1032.88	829.2	7009.57	22111.7	9.164	52.0

Error! Reference source not found.A, continued

H.R. ID	H.R. Location	Channel Number	Elevation (in)	Elevation (m)	Zgrid (in)	Zgrid (m)	H.R. Tw (°F)	H.R. Tw (K)	H.R. q" (Btu/hr-ft2)	H.R. q" (W/m2)	h _{sat} (z) (Btu/hr-ft2-F)	h _{sat} (z) (W/m2-K)	
Gr-2	RodB5_41	153	41	1.041	13.5	0.343	519.39	543.9	3290.82	10380.9	13.091	74.3	
	RodB5_52.9	154	52.9	1.344	5.9	0.150	564.46	569.0	3627.57	11443.2	12.236	69.5	
	RodB5_55	155	55	1.397	8	0.203	599.04	588.2	3912.98	12343.5	11.820	67.1	
	RodB5_57.8	156	57.8	1.468	10.8	0.274	663.99	624.3	4102.96	12942.8	10.361	58.8	
	RodB5_64	157	64	1.626	17	0.432	689.73	638.6	4198.37	13243.8	9.955	56.5	
	RodB5_73.9	158	73.9	1.877	3.02	0.077	722.38	656.7	4345.82	13708.9	9.564	54.3	
	RodB5_75.9	159	75.9	1.928	5.02	0.128	740.46	666.7	4499.62	14194.0	9.524	54.1	
	RodB5_76.9	160	76.9	1.953	6.02	0.153	769.57	682.9	5071.68	15998.6	10.112	57.4	
	Gr-2	RodF5_41	105	41	1.041	13.5	0.343	520.72	544.7	3301.25	10413.8	13.063	74.2
		RodF5_53.1	106	53.1	1.349	6.1	0.155	564.85	569.2	3630.95	11453.8	12.231	69.5
		RodF5_55	107	55	1.397	8	0.203	586.62	581.3	3912.16	12340.9	12.278	69.7
		RodF5_57.8	108	57.8	1.468	10.8	0.274	653.84	618.6	4101.09	12936.9	10.629	60.4
		RodF5_64	109	64	1.626	17	0.432	674.50	630.1	4195.30	13234.1	10.321	58.6
		RodF5_73.8	110	73.8	1.875	2.92	0.074	702.24	645.5	4336.55	13679.6	9.987	56.7
		RodF5_75.8	111	75.8	1.925	4.92	0.125	776.77	686.9	4938.20	15577.6	9.706	55.1
		RodF5_76.8	112	76.8	1.951	5.92	0.150	810.54	705.7	5122.65	16159.4	9.442	53.6
Gr-2		RodC2_41	57	41	1.041	13.5	0.343	1076.67	853.5	3014.85	9510.4	3.728	21.2
		RodC2_53.1	58	53.1	1.349	6.1	0.155	700.91	644.8	4861.50	15335.6	11.230	63.8
		RodC2_55	59	55	1.397	8	0.203	954.90	785.9	6347.93	20024.5	9.241	52.5
		RodC2_57.8	60	57.8	1.468	10.8	0.274	1054.76	841.3	7129.35	22489.5	9.062	51.5
	RodC2_63.9	61	63.9	1.623	16.9	0.429	1115.88	875.3	6604.61	20834.2	7.790	44.2	
	RodC2_73.8	62	73.8	1.875	2.92	0.074	1137.31	887.2	5024.37	15849.4	5.780	32.8	
	RodC2_75.8	63	75.8	1.925	4.92	0.125	923.52	768.4	6158.34	19426.5	9.395	53.4	
	RodC2_76.8	64	76.8	1.951	5.92	0.150	935.49	775.1	6206.22	19577.5	9.298	52.8	
	Gr-2	RodC6_40.9	137	40.9	1.039	13.4	0.340	839.67	721.9	5253.00	16570.6	9.189	52.2
		RodC6_52.8	138	52.8	1.341	5.8	0.147	857.97	732.0	5406.74	17055.6	9.164	52.0
		RodC6_54.8	139	54.8	1.392	7.8	0.198	930.11	772.1	5694.88	17964.8	8.601	48.8
		RodC6_57.8	140	57.8	1.468	10.8	0.274	771.97	684.2	5886.91	18569.9	11.681	66.3
RodC6_63.8		141	63.8	1.621	16.8	0.427	871.31	739.4	6024.43	19004.1	9.986	56.7	
RodC6_73.7		142	73.7	1.872	2.82	0.072	914.90	763.6	6118.69	19301.4	9.458	53.7	
RodC6_75.8		143	75.8	1.925	4.92	0.125	993.38	807.3	6335.04	19983.9	8.733	49.6	
RodC6_76.8		144	76.8	1.951	5.92	0.150	884.94	747.0	6606.98	20841.7	10.709	60.8	

Error! Reference source not found.A,continued

5x5 periphery		H.R.	Channel	Elevation	Elevation	Zgrid	Zgrid	H.R. Tw	H.R. Tw	H.R. q"	H.R. q"	h _{sat} (z)	h _{sat} (z)
Gr-3	Location	Number	(in)	(m)	(in)	(m)	(°F)	(K)	(W/m ²)	(Btu/hr-ft ²)	(W/m ²)	(Btu/hr-ft ²)	(W/m ² -K)
	RodB4_88.4	161	88.4	2.245	-0.1	-0.003	946.53	781.2	19578.8	6206.64	19578.8	9.147	51.9
	RodB4_91.3	162	91.3	2.319	2.8	0.071	964.39	791.1	19736.0	6256.45	19736.0	8.984	51.0
	RodB4_93.3	163	93.3	2.370	4.8	0.122	395.93	475.3	8567.9	2716.10	8567.9	21.231	120.6
	RodB4_95.1	164	95.1	2.416	6.6	0.168	470.87	517.0	9633.2	3053.81	9633.2	15.053	85.5
	RodB4_100	165	100	2.540	11.5	0.292	1166.30	903.3	23582.1	7475.69	23582.1	8.322	47.3
	RodB4_106	166	106	2.692	17.5	0.445	1189.18	916.0	24003.8	7609.39	24003.8	8.260	46.9
	RodB4_109.9	167	109.9	2.791	21.4	0.544	1119.68	877.4	22029.2	6983.43	22029.2	8.200	46.6
	RodB4_142.3	168	142.3	3.614	8.8	0.224	915.50	764.0	19252.0	6103.02	19252.0	9.426	53.5
Gr-5	RodF4_85.6	98	85.6	2.174	14.72	0.374	933.93	774.2	19268.8	6108.35	19268.8	9.173	52.1
	RodF4_88.4	99	88.4	2.245	-0.1	-0.003	949.60	782.9	19423.4	6157.35	19423.4	9.034	51.3
	RodF4_92.4	100	92.4	2.347	3.9	0.099	395.27	475.0	8600.8	2726.51	8600.8	21.424	121.7
	RodF4_94.3	101	94.3	2.395	5.8	0.147	474.82	519.2	9654.8	3060.66	9654.8	14.798	84.0
	RodF4_97.2	102	97.2	2.469	8.7	0.221	1177.35	909.5	24077.8	7632.83	24077.8	8.394	47.7
	RodF4_108.8	103	108.8	2.764	20.3	0.516	1111.09	872.6	23412.4	7421.91	23412.4	8.803	50.0
	RodF4_111	104	111	2.819	-1.75	-0.044	1108.27	871.1	23137.5	7334.77	23137.5	8.729	49.6
Gr-6	RodD2_103.2	65	103.2	2.621	14.7	0.373	1088.01	859.8	22703.6	7197.21	22703.6	8.777	49.8
	RodD2_106	66	106	2.692	17.5	0.445	1158.70	899.1	23621.6	7488.24	23621.6	8.407	47.7
	RodD2_112.6	67	112.6	2.860	-0.15	-0.004	1092.02	862.0	22889.4	7256.11	22889.4	8.806	50.0
	RodD2_114.9	68	114.9	2.918	2.15	0.055	1165.14	902.7	20989.7	6653.89	20989.7	7.417	42.1
	RodD2_117.4	69	117.4	2.982	4.65	0.118	1185.13	913.8	19872.2	6299.65	19872.2	6.869	39.0
	RodD2_120.8	70	120.8	3.068	8.05	0.204	1207.46	926.2	18349.2	5816.84	18349.2	6.192	35.2
	RodD2_124.8	71	124.8	3.170	12.05	0.306	1212.32	928.9	16551.2	5246.86	16551.2	5.556	31.6
	RodD2_128.6	72	128.6	3.266	15.85	0.403	1203.13	923.8	14849.0	4707.25	14849.0	5.034	28.6
Gr-6	RodD6_103.1	129	103.1	2.619	14.6	0.371	1157.28	898.3	21560.4	6834.81	21560.4	7.686	43.6
	RodD6_106	130	106	2.692	17.5	0.445	1139.10	888.2	22866.3	7248.79	22866.3	8.321	47.3
	RodD6_112.9	131	112.9	2.868	0.15	0.004	1143.45	890.6	21649.3	6862.99	21649.3	7.839	44.5
	RodD6_114.9	132	114.9	2.918	2.15	0.055	790.08	694.3	15655.3	4962.84	15655.3	9.506	54.0
	RodD6_116.8	133	116.8	2.967	4.05	0.103	807.03	703.7	16254.0	5152.64	16254.0	9.559	54.3
	RodD6_120.9	134	120.9	3.071	8.15	0.207	1035.64	830.7	21996.9	6973.17	21996.9	9.084	51.6
	RodD6_124.8	135	124.8	3.170	12.05	0.306	1071.09	850.4	22322.9	7076.52	22322.9	8.812	50.0
	RodD6_128.7	136	128.7	3.269	15.95	0.405	1161.36	900.6	8179.1	2592.83	8179.1	2.902	16.5

Error! Reference source not found.A, continued

5x5 periphery		H.R.	Channel Number	Elevation (in)	Elevation (m)	Zgrid (in)	Zgrid (m)	H.R. Tw (°F)	H.R. Tw (K)	H.R. q" (Btu/hr-ft2)	H.R. q" (W/m2)	h _{sat} (z) (Btu/hr-ft2-F)	h _{sat} (z) (W/m2-K)
Gr-8	RodE2_50.1	73	50.1	1.273	3.1	0.079	852.50	729.0	5290.93	16690.2	9.052	51.4	
	RodE2_54	74	54	1.372	7	0.178	884.51	746.8	5434.84	17144.2	8.815	50.1	
	RodE2_56.9	75	56.9	1.445	9.9	0.251	930.39	772.3	5728.63	18071.0	8.648	49.1	
	RodE2_59.9	76	59.9	1.521	12.9	0.328	799.95	699.8	5917.38	18666.4	11.124	63.2	
	RodE2_66	77	66	1.676	19	0.483	887.15	748.2	6066.01	19135.2	9.797	55.6	
	RodE2_69.8	78	69.8	1.773	-1.08	-0.027	924.01	768.7	6163.37	19442.4	9.395	53.4	
	RodE2_72.9	79	72.9	1.852	2.02	0.051	401.10	478.2	2678.34	8448.8	20.123	114.3	
	RodE2_74.9	80	74.9	1.902	4.02	0.102	480.49	522.3	3027.72	9550.9	14.249	80.9	
Gr-8	RodB3_50.2	169	50.2	1.275	3.2	0.081	1183.81	913.0	5794.91	18280.0	6.328	35.9	
	RodB3_54.1	170	54.1	1.374	7.1	0.180	1185.05	913.7	5233.70	16509.7	5.707	32.4	
	RodB3_56.9	171	56.9	1.445	9.9	0.251	1177.71	909.7	4677.54	14755.3	5.142	29.2	
	RodB3_60.1	172	60.1	1.527	13.1	0.333	742.68	668.0	4468.48	14095.8	9.414	53.5	
	RodB3_66.1	173	66.1	1.679	19.1	0.485	801.00	700.4	5066.60	15982.6	9.506	54.0	
	RodB3_69.9	174	69.9	1.775	-0.98	-0.025	831.26	717.2	5165.91	16295.8	9.171	52.1	
	RodB3_73	175	73	1.854	2.12	0.054	868.28	737.7	5314.20	16763.6	8.853	50.3	
	RodB3_75	176	75	1.905	4.12	0.105	924.37	768.9	5611.59	17701.8	8.549	48.6	
Gr-8	RodF3_50.1	89	50.1	1.273	3.1	0.079	1039.95	833.1	6889.27	21732.2	8.925	50.7	
	RodF3_54	90	54	1.372	7	0.178	1069.64	849.6	6981.83	22024.2	8.709	49.5	
	RodF3_57	91	57	1.448	10	0.254	737.53	665.1	4469.70	14099.7	9.519	54.1	
	RodF3_60	92	60	1.524	13	0.330	765.82	680.8	5053.78	15942.1	10.152	57.7	
	RodF3_66.1	93	66.1	1.679	19.1	0.485	814.93	708.1	5141.27	16218.1	9.400	53.4	
	RodF3_70	94	70	1.778	-0.88	-0.022	869.56	738.5	5275.23	16640.7	8.769	49.8	
	RodF3_73	95	73	1.854	2.12	0.054	932.52	773.4	5571.51	17575.3	8.384	47.6	
	RodF3_75	96	75	1.905	4.12	0.105	895.06	752.6	6009.62	18957.3	9.584	54.4	
Gr-8	RodE6_50.2	121	50.2	1.275	3.2	0.081	530.97	550.4	3273.80	10327.2	12.449	70.7	
	RodE6_54.1	122	54.1	1.374	7.1	0.180	573.81	574.2	3623.01	11428.8	11.847	67.3	
	RodE6_57	123	57	1.448	10	0.254	597.72	587.4	3910.68	12336.2	11.861	67.4	
	RodE6_60.2	124	60.2	1.529	13.2	0.335	668.73	626.9	4112.92	12974.2	10.263	58.3	
	RodE6_66.1	125	66.1	1.679	19.1	0.485	692.18	639.9	4211.67	13285.7	9.929	56.4	
	RodE6_70	126	70	1.778	-0.88	-0.022	723.00	657.0	4359.22	13751.2	9.581	54.4	
	RodE6_73.1	127	73.1	1.857	2.22	0.056	767.80	681.9	4940.18	15583.8	9.884	56.1	
	RodE6_75	128	75	1.905	4.12	0.105	797.90	698.6	5128.33	16177.3	9.678	55.0	

RBHT Steam Cooling with Droplet Injection Test SCD-4032-B

Matrix Test # Shakedown

Test Conditions

Test Date – 9/28/2005

Steady State Time Window: 11640 - 12540

Upper Plenum Pressure: 2.76 bar (40 psia)

Bundle Power: 80.0 kW

Bundle Inlet Reynolds Number: 10000

Bundle Inlet Steam Flow: 198.9 kg/hr (438 lbm/hr)

Droplet Injection Flow: 0.0151 kg/s (0.0333 lbm/s)

Droplet Injection Hole Diameter: 0.381 mm (.015 in)

Droplet Injection Elevation: 1.295 m (51 in)

Bundle Flow Area: $4.656 \times 10^{-3} \text{ m}^2$ ($5.012 \times 10^{-2} \text{ ft}^2$)

Test Notes

- No steam probes were traversed in this steady state window.

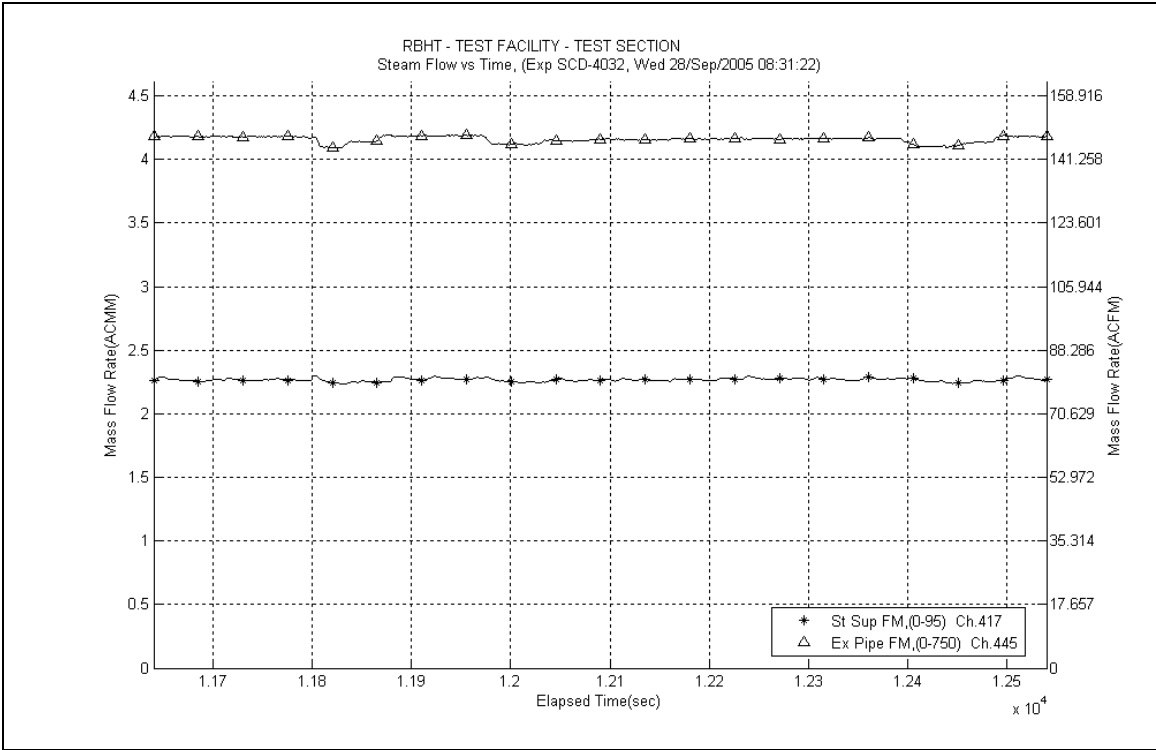

Figure A-129: Inlet and Exhaust Steam Flow Rates for Experiment 4032B

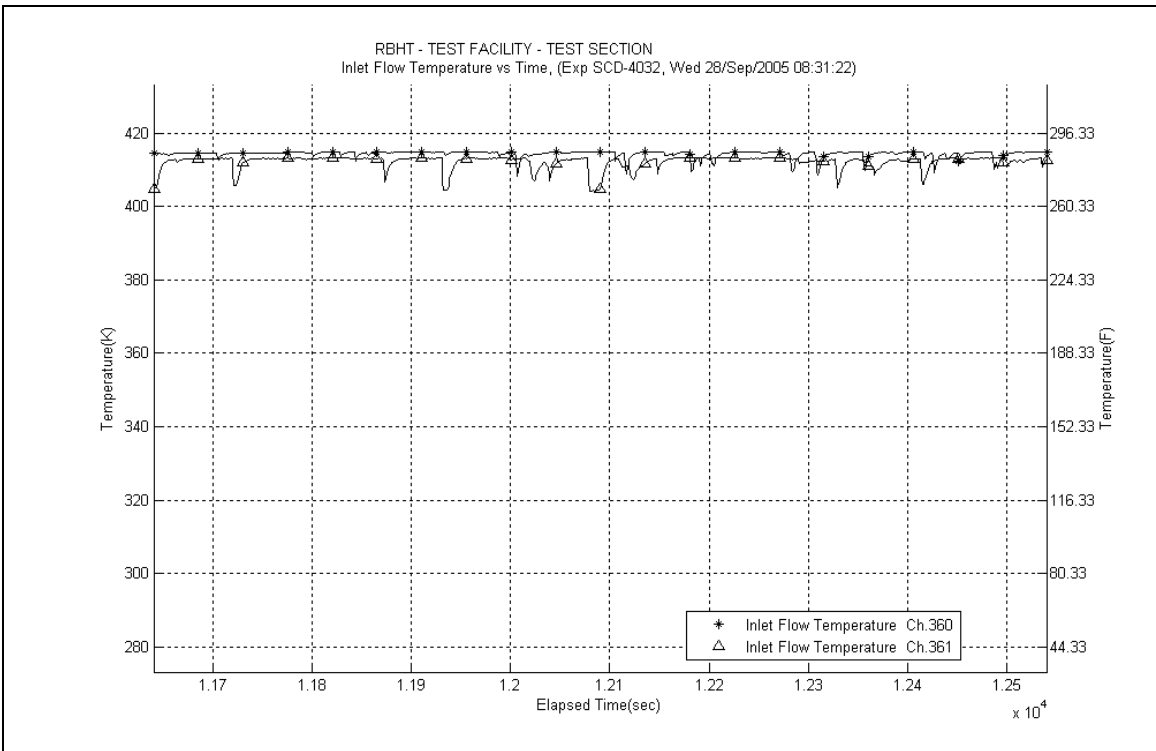

Figure A-130: Inlet Steam Temperature for Experiment 4032B

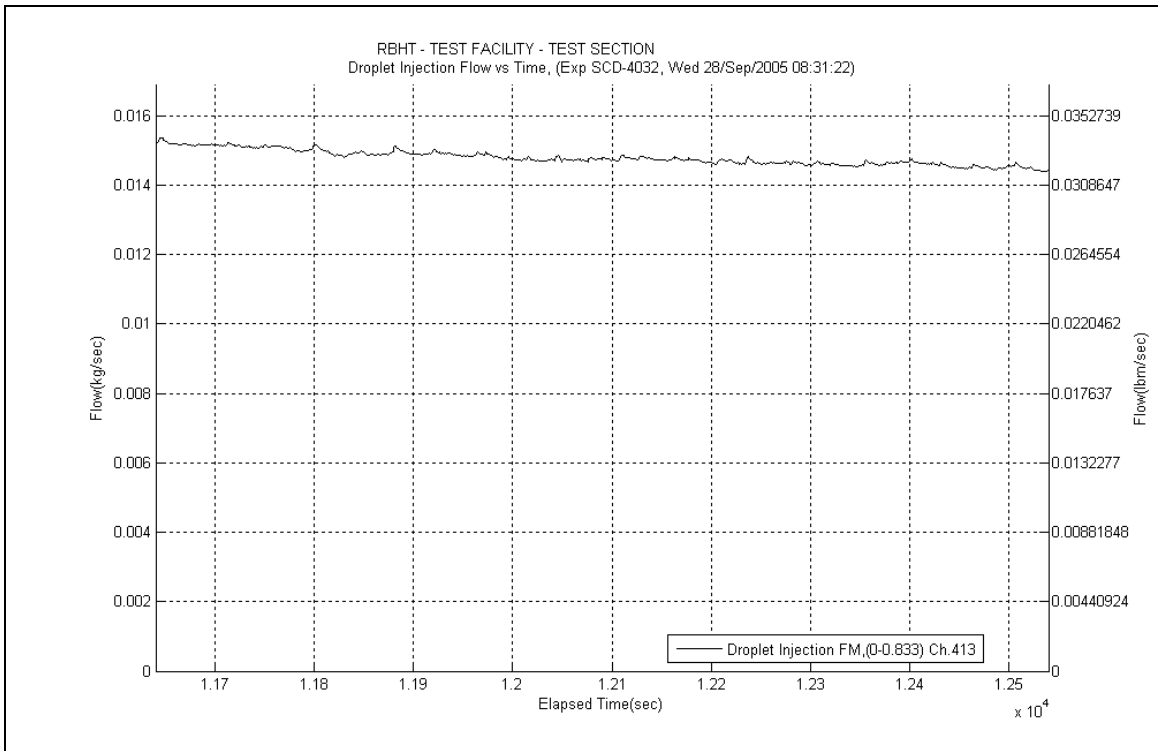

Figure A-131: Droplet Injection Flow Rate for Experiment 4032B

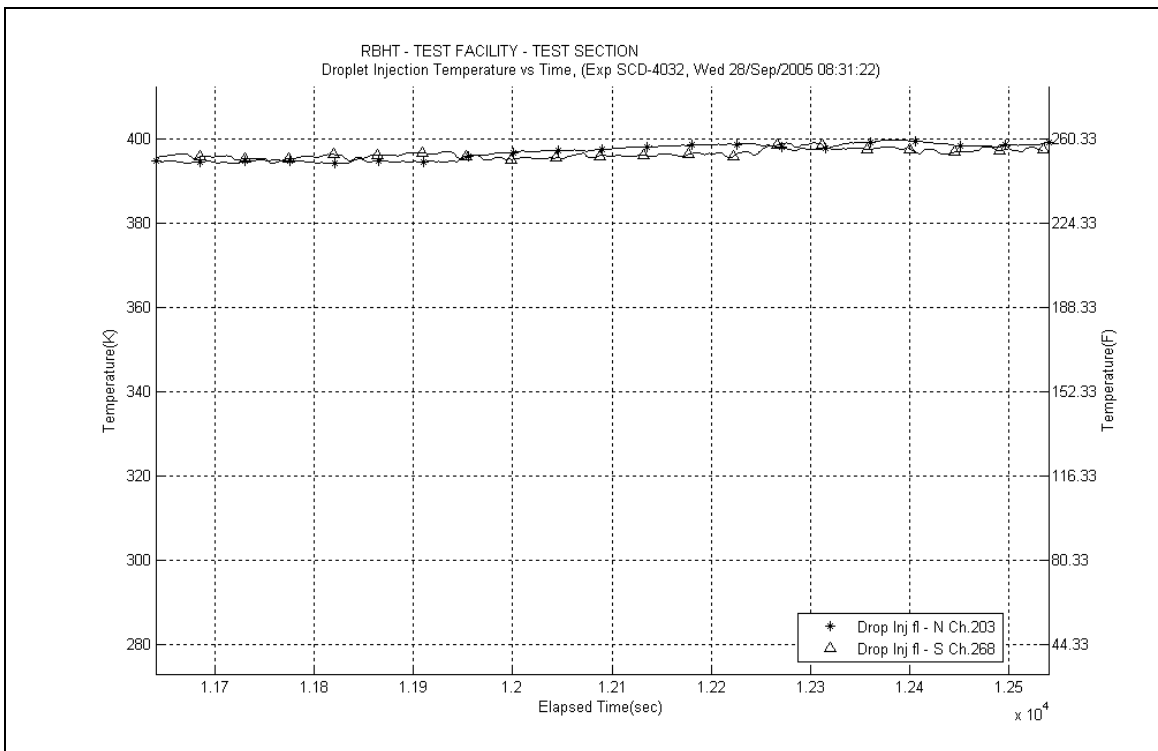

Figure A-132: Droplet Injection Temperature for Experiment 4032B

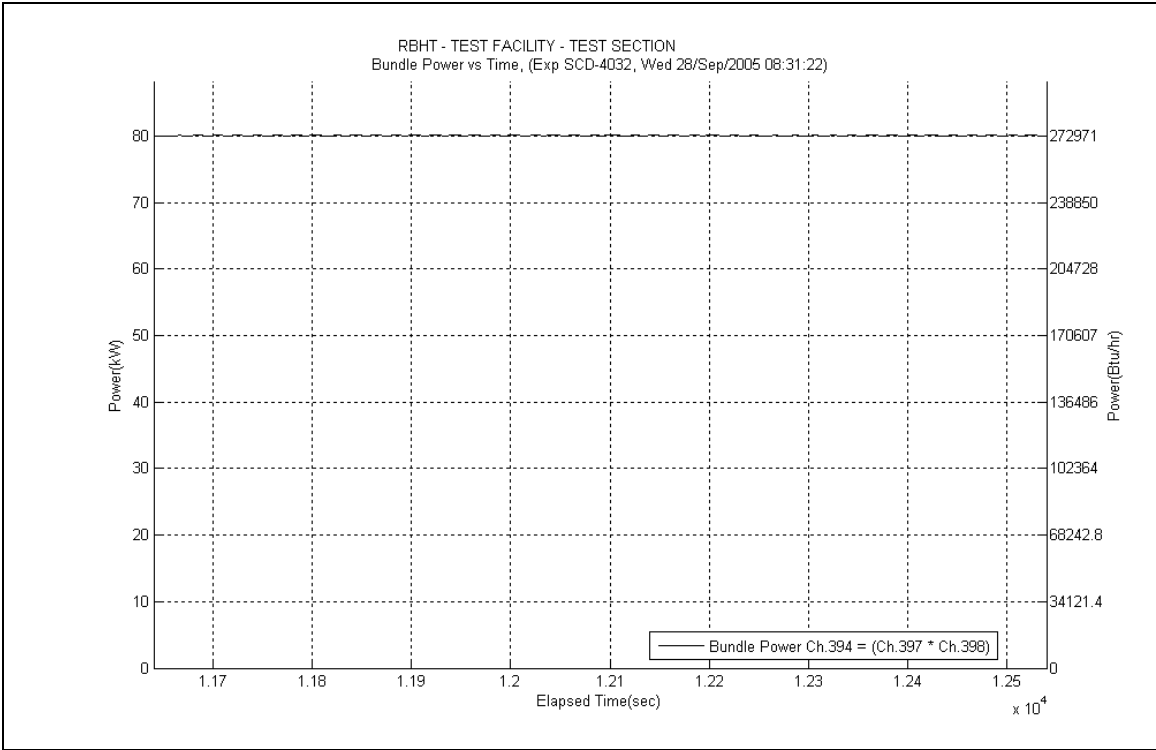

Figure A-133: Bundle Power for Experiment 4032B

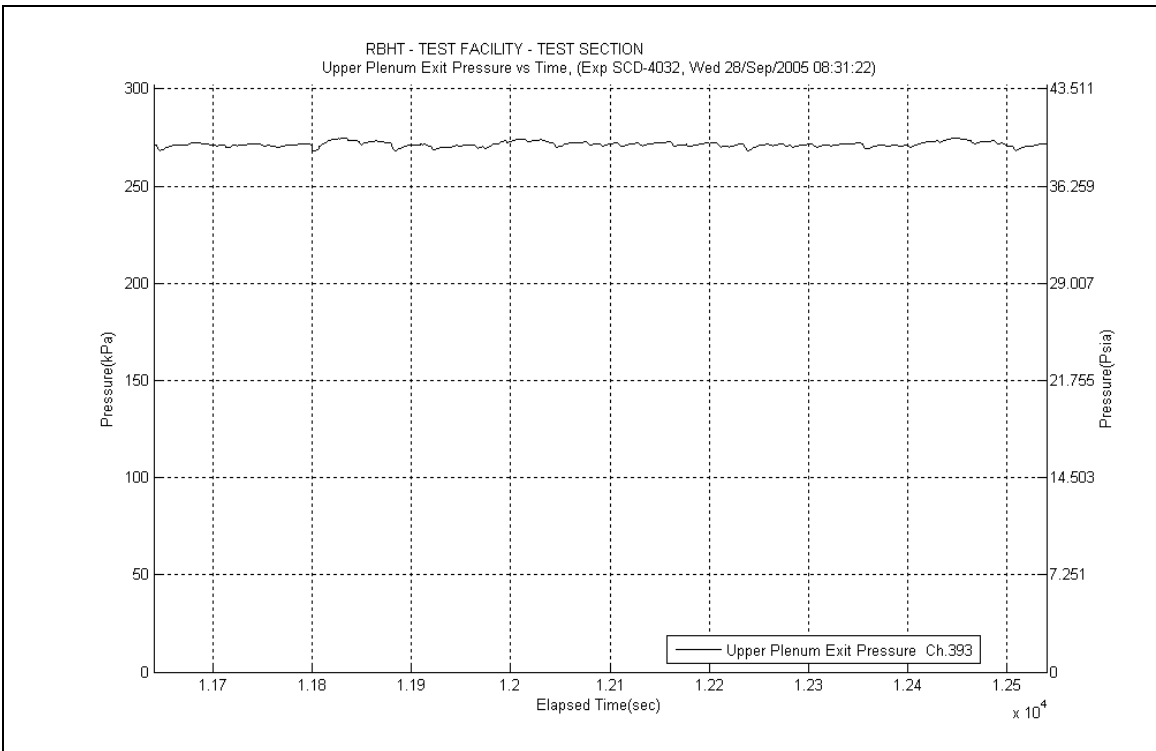

Figure A-134: Upper Plenum Pressure for Experiment 4032B

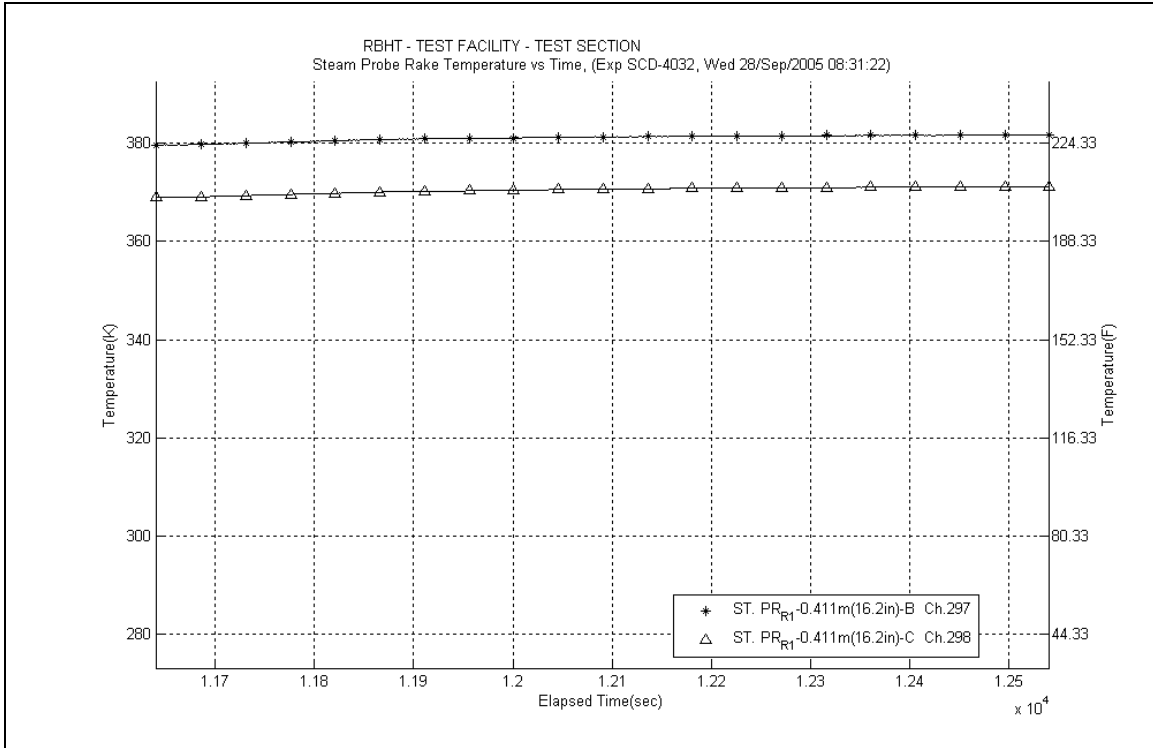

Figure A-135: Steam Probe Rake #1 Temperatures for Experiment 4032B

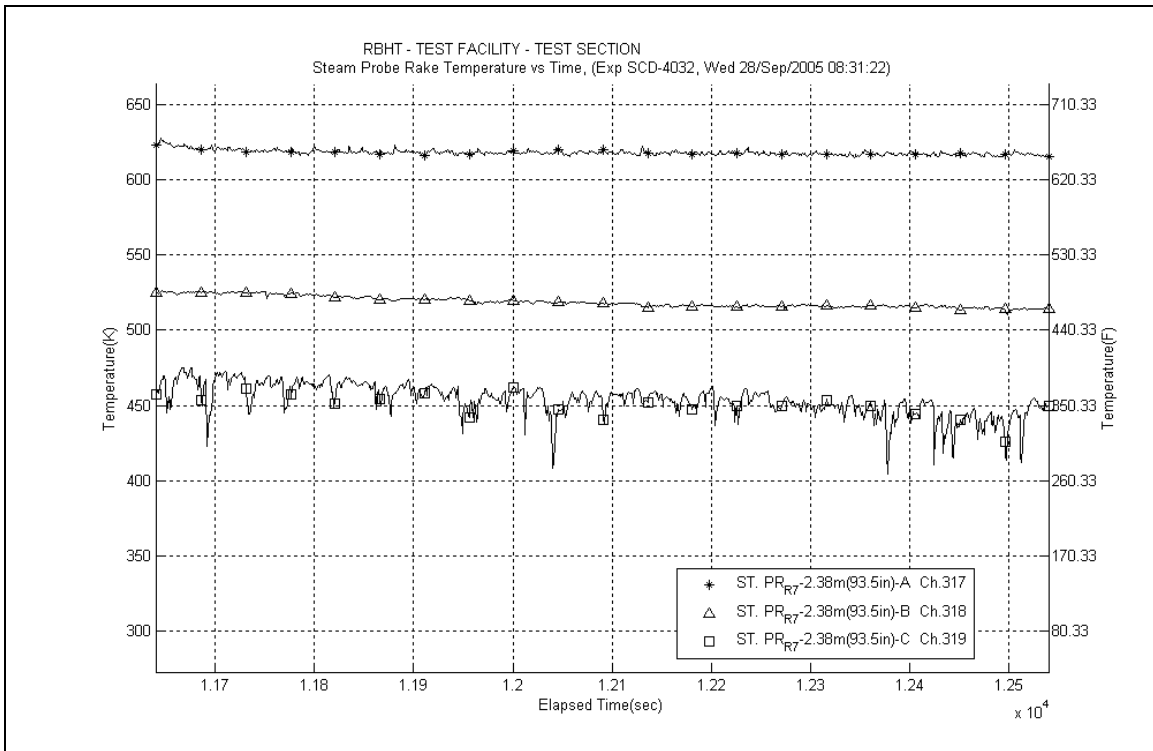

Figure A-136: Steam Probe Rake #7 Temperatures for Experiment 4032B

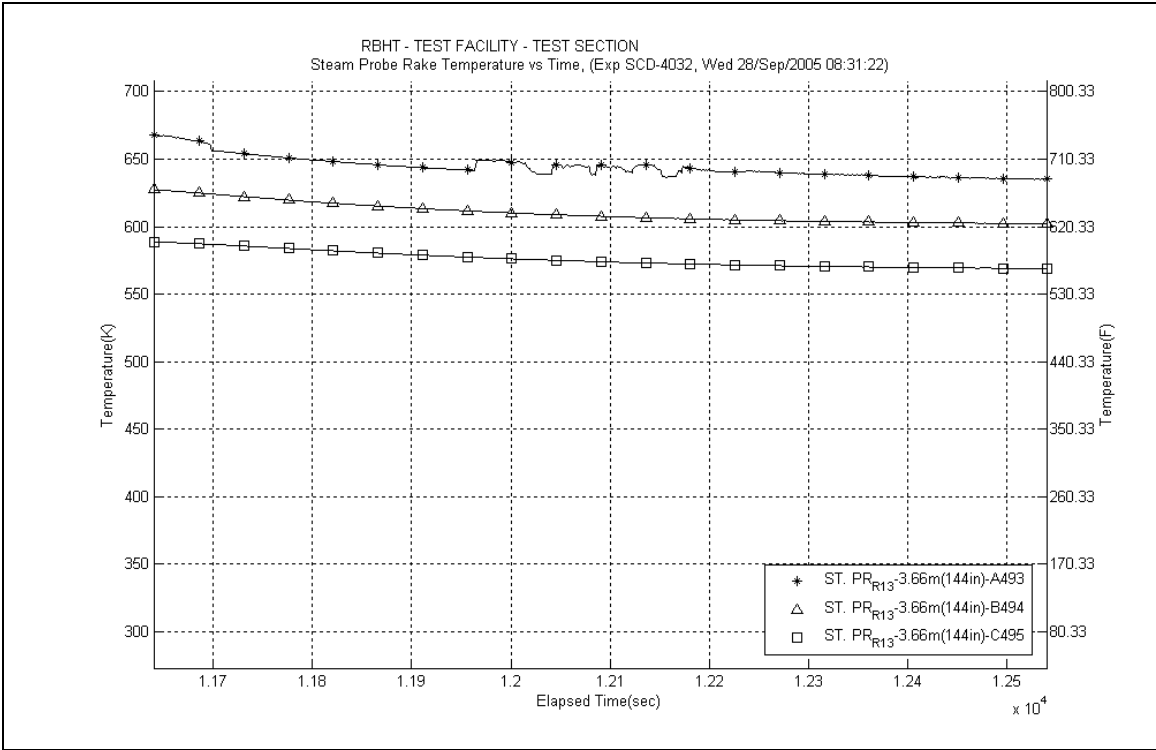

Figure A-137: Steam Probe Rake #13 Temperatures for Experiment 4032B

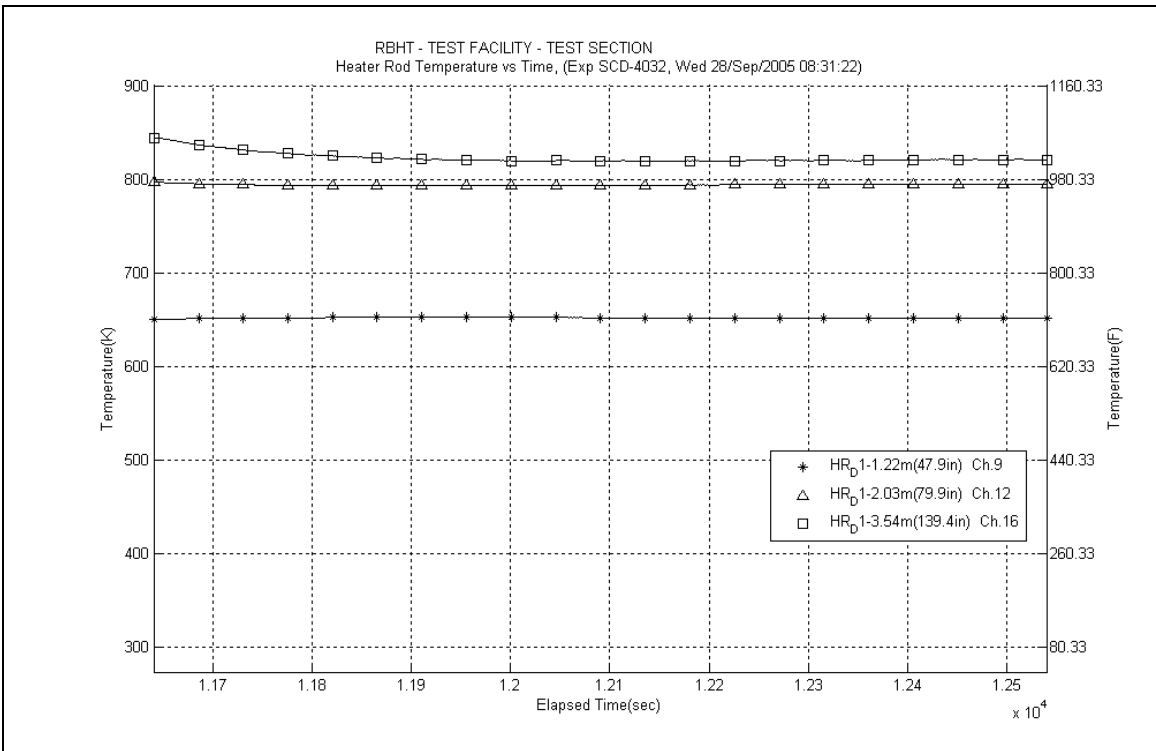

Figure A-138: Heater Rod D1 Temperatures for Experiment 4032B

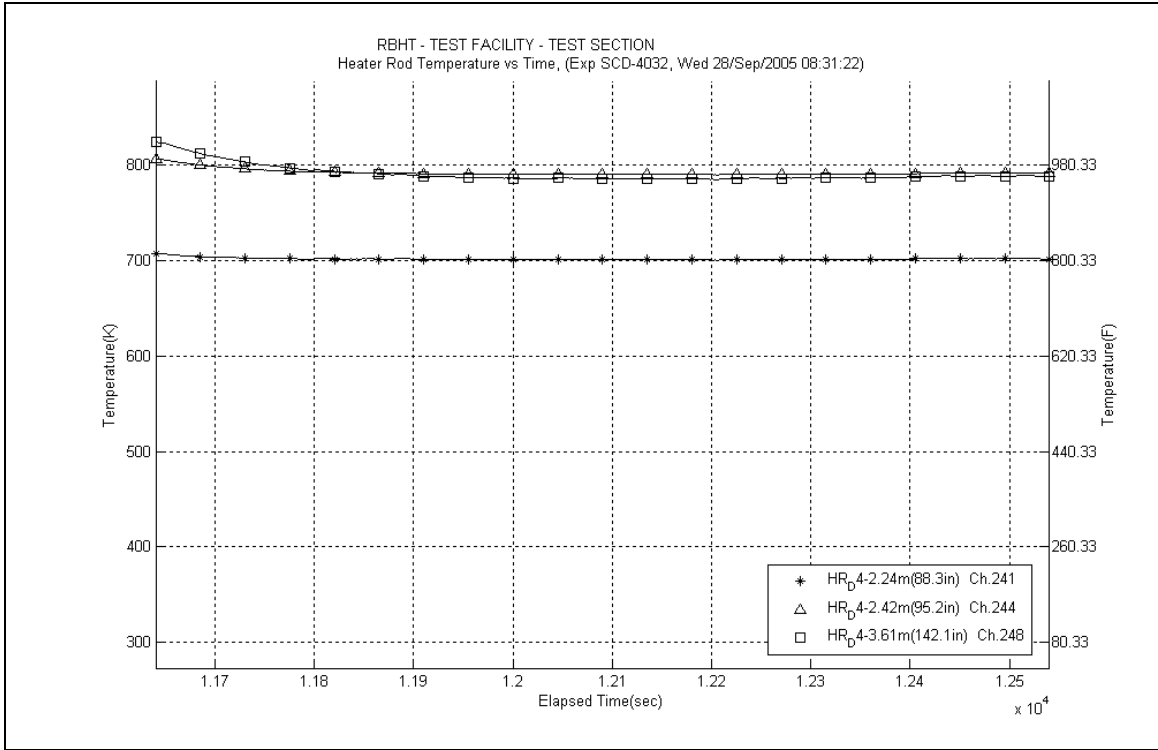

Figure A-139: Heater Rod D4 Temperatures for Experiment 4032B

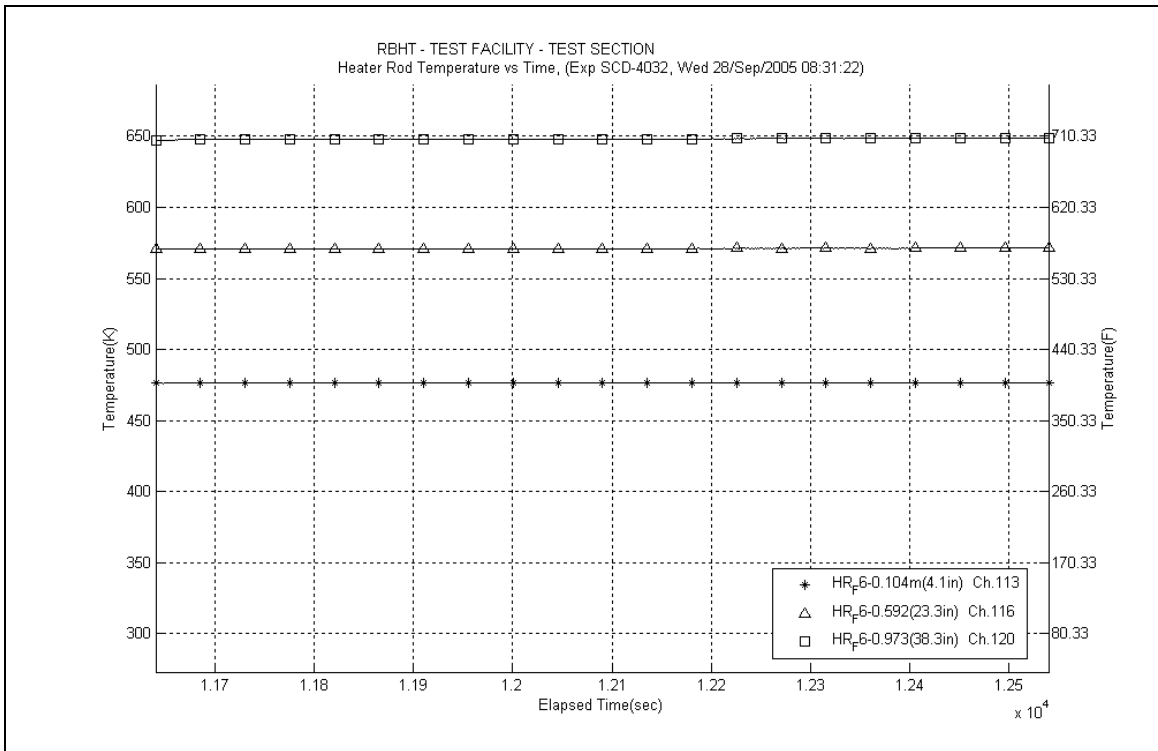

Figure A-140: Heater Rod F6 Temperatures for Experiment 4032B

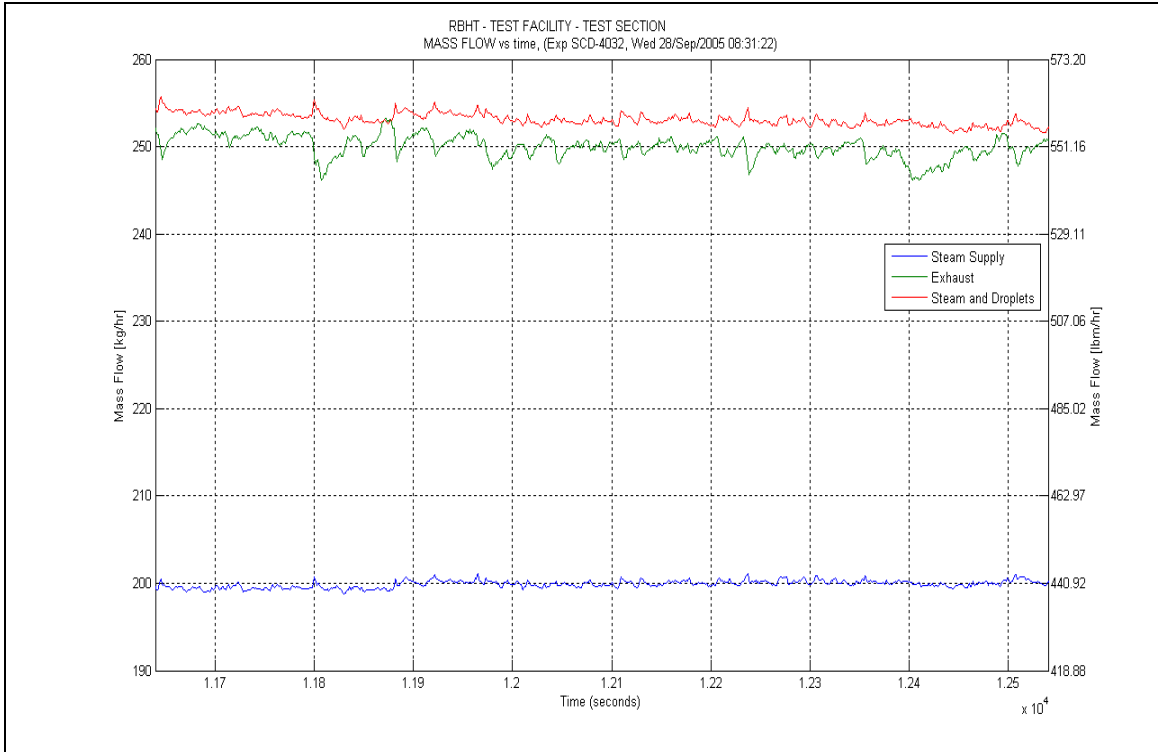

Figure A-141: Mass Flow for Experiment 4032B

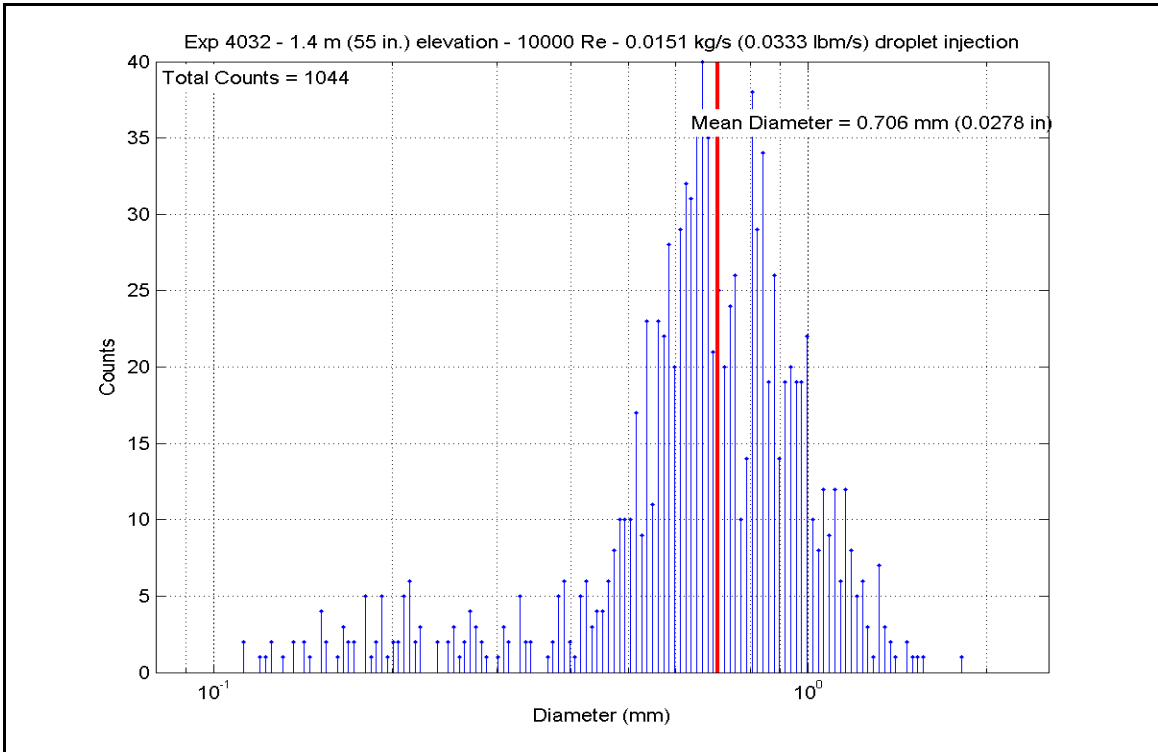

Figure A-142: Droplet Measurements at 1.397 m (55 in.) Elevation for Experiment 4032B

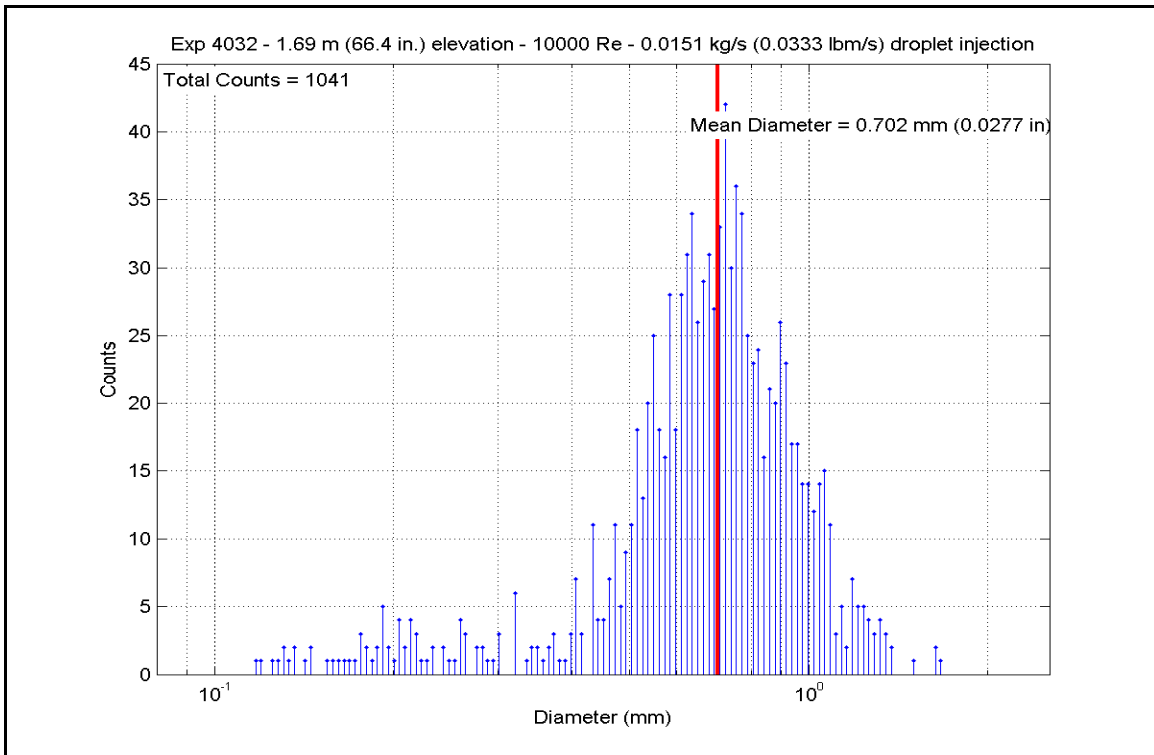

Figure A-143: Droplet Measurements at 1.687 m (66.4 in.) Elevation for Experiment 4032B

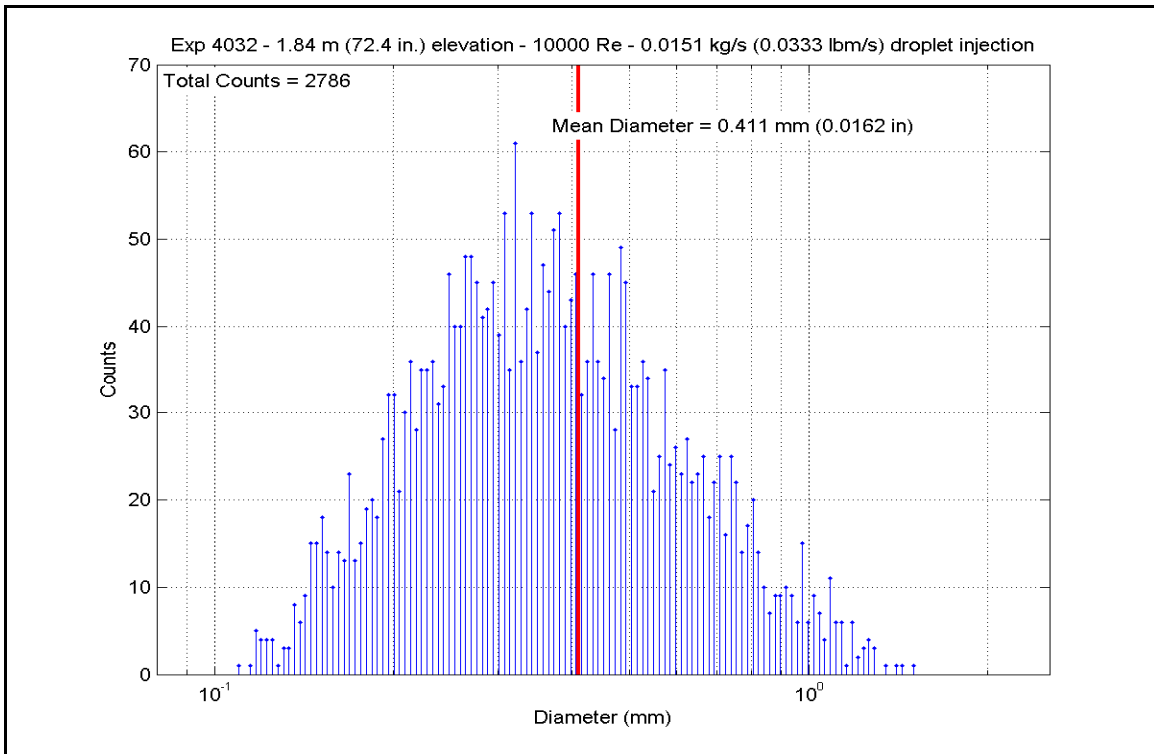

Figure A-144: Droplet Measurements at 1.839 m (72.4 in.) Elevation for Experiment 4032B

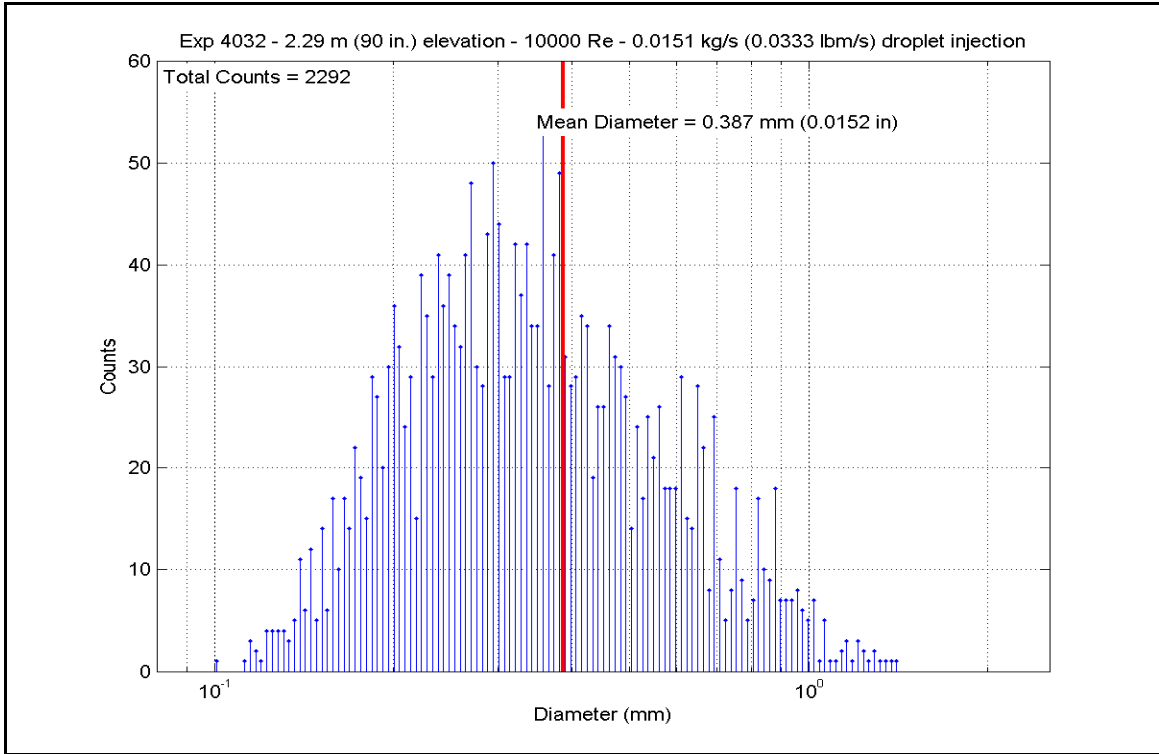

Figure A-145: Droplet Measurements at 2.286 m (90 in.) Elevation for Experiment 4032B

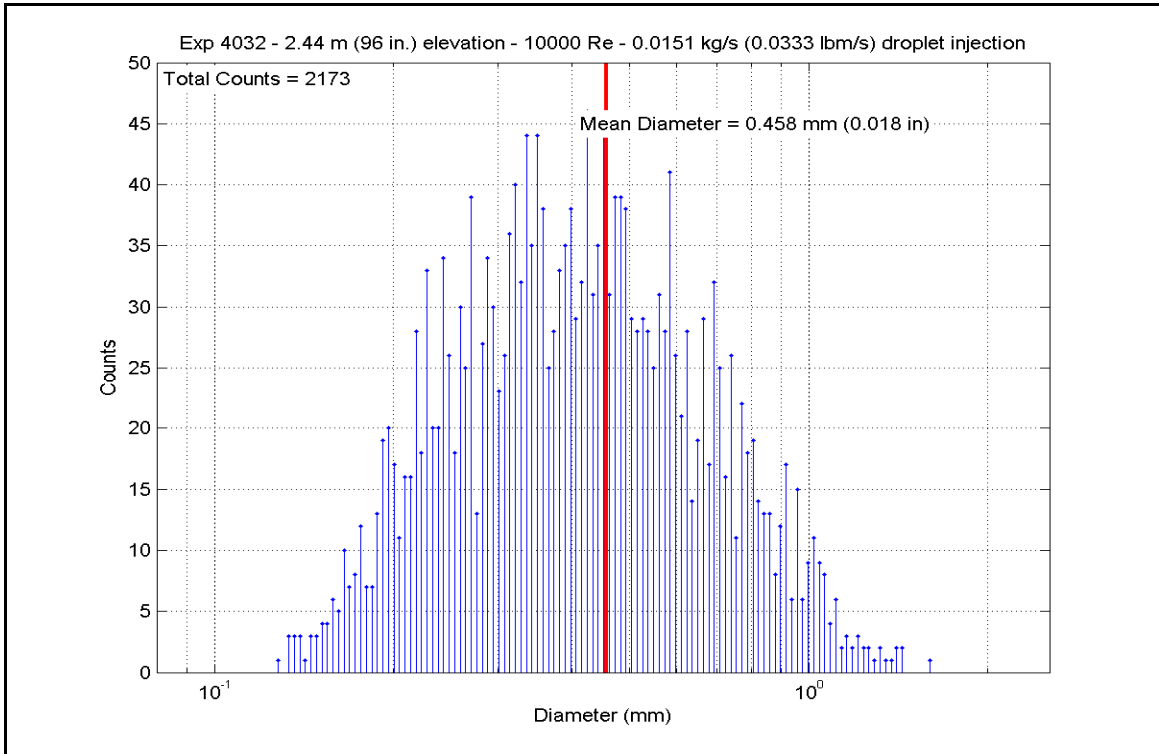

Figure A-146: Droplet Measurements at 2.438 m (96 in.) Elevation for Experiment 4032B

Error! Reference source not found.B

Test 4032-B		Inlet Reynolds:		10000		40 psia		272971 Btu/hr		438.0 lbm/hr		0.0333 lbm/s	
Matrix test shutdown		UP Pressure:		80.00 kW		80.00 kW		80.00 kW		0.0552 kg/s		0.0151 kg/s	
Time Window: 11640-12540		Bundle Power:		0.0552 kg/s		0.0552 kg/s		0.0552 kg/s		0.0552 kg/s		0.0552 kg/s	
Inner 3x3		Droplet flow:		0.0151 kg/s		0.0151 kg/s		0.0151 kg/s		0.0151 kg/s		0.0151 kg/s	
H.R. ID	H.R. Location	Channel Number	Elevation (in)	Elevation (m)	Zgrid (in)	Zgrid (m)	H.R. Tw (°F)	H.R. Tw (K)	H.R. q" (Btu/hr-ft2)	H.R. q" (W/m2)	h _{sat} (z) (Btu/hr-ft2-F)	h _{sat} (z) (W/m2-K)	
Gr-3	RodD3_88.3	185	88.3	2.243	-0.2	-0.005	929.40	771.7	6987.12	22040.9	10.564	60.0	
	RodD3_91.3	186	91.3	2.319	2.8	0.071	967.89	793.1	7089.57	22364.0	10.130	57.5	
	RodD3_93.1	187	93.1	2.365	4.6	0.117	805.47	702.9	6809.02	21479.1	12.669	71.9	
	RodD3_95.3	188	95.3	2.421	6.8	0.173	906.69	759.1	6970.82	21989.5	10.914	62.0	
	RodD3_100.1	189	100.1	2.543	11.6	0.295	1015.84	819.7	7228.88	22803.5	9.666	54.9	
	RodD3_106.1	190	106.1	2.695	17.6	0.447	1099.36	866.1	7628.92	24065.4	9.176	52.1	
	RodD3_110	191	110	2.794	2.695	21.5	1019.09	821.5	7417.69	23399.1	9.876	56.1	
	RodD3_142.1	192	142.1	3.609	3.609	8.6	808.89	704.8	6782.16	21394.3	12.539	71.2	
	Gr-3	RodC4_88.4	233	88.4	2.245	-0.1	-0.003	1040.03	833.2	6773.68	21367.6	8.774	49.8
		RodC4_91.1	234	91.1	2.314	2.6	0.066	1063.93	846.4	6339.92	19999.3	7.965	45.2
		RodC4_93.4	235	93.4	2.372	4.9	0.124	1072.02	850.9	5834.52	18405.0	7.257	41.2
		RodC4_95.3	236	95.3	2.421	6.8	0.173	1068.37	848.9	5308.73	16746.4	6.633	37.7
RodC4_100.1		237	100.1	2.543	11.6	0.295	1004.11	813.2	7332.21	23129.5	9.961	56.6	
RodC4_106.1		238	106.1	2.695	17.6	0.447	1073.68	851.9	7610.16	24006.3	9.446	53.6	
RodC4_110		239	110	2.794	2.794	21.5	1093.30	862.8	7748.66	24443.1	9.389	53.3	
RodC4_142.2		240	142.2	3.612	3.612	8.7	922.34	767.8	5602.16	17672.0	8.562	48.6	
Gr-3		RodD4_88.3	241	88.3	2.243	-0.2	-0.005	830.18	716.6	6049.31	19082.6	10.760	61.1
		RodD4_91.3	242	91.3	2.319	2.8	0.071	879.24	743.8	6150.24	19400.9	10.062	57.1
		RodD4_93.2	243	93.2	2.367	4.7	0.119	907.12	759.3	5483.03	17296.2	8.579	48.7
		RodD4_95.2	244	95.2	2.418	6.7	0.170	1021.57	822.9	6558.13	20687.6	8.703	49.4
	RodD4_100.1	245	100.1	2.543	11.6	0.295	1106.04	869.8	7715.20	24337.6	9.206	52.3	
	RodD4_106.1	246	106.1	2.695	17.6	0.447	1020.71	822.4	7611.96	24011.9	10.113	57.4	
	RodD4_142.1	248	142.1	3.609	3.609	8.6	734.06	663.2	5900.58	18613.4	12.661	71.9	
	Gr-3	RodE4_88.4	201	88.4	2.245	-0.1	-0.003	904.71	758.0	6914.71	21812.4	10.860	61.7
		RodE4_91.2	202	91.2	2.316	2.7	0.069	984.96	802.6	7118.68	22455.9	9.929	56.4
		RodE4_95.3	204	95.3	2.421	6.8	0.173	982.58	801.3	2918.24	9205.6	4.084	23.2
		RodE4_100.9	205	100.9	2.563	12.4	0.315	1003.28	812.7	7505.92	23677.4	10.208	58.0
		RodE4_142.3	208	142.3	3.614	3.614	8.8	808.66	704.6	6768.46	21351.1	12.519	71.1

Error! Reference source not found.**B, continued**

Inner 3x3

	H.R. Location	Channel Number	Elevation (in)	Elevation (m)	Zgrid (in)	Zgrid (m)	H.R. Tw (°F)	H.R. Tw (K)	H.R. q" (Btu/hr-ft2)	H.R. q" (W/m2)	h _{sat} (z) (Btu/hr-ft2-F)	h _{sat} (z) (W/m2-K)
Gr-4	RodE3_63.4	193	63.4	1.610	16.4	0.417	1009.34	816.1	4016.27	12669.3	5.418	30.8
	RodE3_113.6	194	113.6	2.885	0.85	0.022	981.98	800.9	6807.99	21475.8	9.535	54.1
	RodE3_115.5	195	115.5	2.934	2.75	0.070	958.40	787.8	5585.30	17618.8	8.090	45.9
	RodE3_118.5	196	118.5	3.010	5.75	0.146	1075.28	852.8	6689.77	21102.9	8.287	47.1
	RodE3_122.7	197	122.7	3.117	9.95	0.253	1096.12	864.3	6297.07	19864.1	7.604	43.2
	RodE3_126.5	198	126.5	3.213	13.75	0.349	1098.67	865.7	5745.79	18125.1	6.917	39.3
	RodE3_131.7	199	131.7	3.345	-1.8	-0.046	1091.06	861.5	5240.98	16532.7	6.368	36.2
	RodE3_135.6	200	135.6	3.444	2.1	0.053	984.26	802.2	4521.69	14263.7	6.313	35.9
	RodC5_63.7	225	63.7	1.618	16.7	0.424	882.77	745.8	5419.20	17094.9	8.815	50.1
	RodC5_113.6	226	113.6	2.885	0.85	0.022	986.11	803.2	7076.98	22324.3	9.855	56.0
Gr-4	RodC5_115.7	227	115.7	2.939	2.95	0.075	957.95	787.6	4622.28	14581.0	6.699	38.0
	RodC5_122.7	229	122.7	3.117	9.95	0.253	976.28	797.7	4115.10	12981.1	5.810	33.0
	RodC5_126.7	230	126.7	3.218	13.95	0.354	801.55	700.7	4948.52	15610.1	9.275	52.7
	RodC5_131.6	231	131.6	3.343	-1.9	-0.048	807.44	703.9	5130.27	16183.4	9.510	54.0
	RodC5_135.7	232	135.7	3.447	2.2	0.056	850.92	728.1	5273.07	16633.9	9.046	51.4
	RodE5_63.6	209	63.6	1.615	16.6	0.422	963.96	790.9	2908.17	9173.8	4.179	23.7
	RodE5_113.6	210	113.6	2.885	0.85	0.022	1082.72	856.9	7807.37	24628.4	9.583	54.4
	RodE5_115.4	211	115.4	2.931	2.65	0.067	976.83	798.1	7269.98	22933.1	10.256	58.2
	RodE5_118.7	212	118.7	3.015	5.95	0.151	965.33	791.7	3009.72	9494.2	4.316	24.5
	RodE5_122.6	213	122.6	3.114	9.85	0.250	801.06	700.4	6869.49	21669.8	12.887	73.2
RodE5_126.6	214	126.6	3.216	13.85	0.352	892.55	751.2	7037.31	22199.2	11.268	64.0	
RodE5_131.6	215	131.6	3.343	-1.9	-0.048	931.42	772.8	7140.52	22524.8	10.763	61.1	
RodE5_135.6	216	135.6	3.444	2.1	0.053	963.83	790.8	7246.81	22860.1	10.415	59.1	
Gr-5	RodC3_79.8	177	79.8	2.027	8.92	0.227	956.96	787.0	7013.11	22122.9	10.179	57.8
	RodC3_85.6	178	85.6	2.174	14.72	0.374	985.37	802.8	7101.94	22403.1	9.900	56.2
	RodC3_88.5	179	88.5	2.248	0	0.000	962.64	790.2	2973.80	9380.8	4.281	24.3
	RodC3_92.4	180	92.4	2.347	3.9	0.099	760.01	677.6	4949.31	15612.6	10.059	57.1
	RodC3_94.4	181	94.4	2.398	5.9	0.150	791.61	695.2	5131.67	16187.8	9.801	55.7
	RodC3_97.2	182	97.2	2.469	8.7	0.221	1097.76	865.2	7650.19	24132.5	9.220	52.4
	RodC3_108.8	183	108.8	2.764	20.3	0.516	1035.28	830.5	7240.61	22840.5	9.437	53.6
	RodD5_50	217	50	1.270	16.7	0.424	1025.01	824.8	4919.31	15518.0	6.498	36.9
	RodD5_54.1	218	54.1	1.374	7.1	0.180	1042.55	834.6	5685.21	17934.0	7.340	41.7
	RodD5_56.9	219	56.9	1.445	9.9	0.251	1035.93	830.9	5179.54	16338.9	6.745	38.3
RodD5_60	220	60	1.524	13	0.330	916.74	764.7	4517.01	14248.9	6.963	39.5	
RodD5_66.1	221	66.1	1.679	19.1	0.485	939.42	777.3	4015.24	12666.1	5.980	34.0	
RodD5_69.9	222	69.9	1.775	-0.98	-0.025	808.13	704.3	6893.16	21744.5	12.762	72.5	
RodD5_72.9	223	72.9	1.852	2.02	0.051	897.87	754.2	7046.10	22226.9	11.187	63.5	
RodD5_74.9	224	74.9	1.902	4.02	0.102	942.71	779.1	7169.30	22615.6	10.626	60.3	

Error! Reference source not found. **B, continued**

H.R. ID	H.R. Location	Channel Number	Elevation (in)	Elevation (m)	Zgrid (in)	Zgrid (m)	H.R. Tw (°F)	H.R. Tw (K)	H.R. q" (Btu/hr-ft2)	H.R. q" (W/m2)	h _{sat} (z) (Btu/hr-ft2-F)	h _{sat} (z) (W/m2-K)	
Gr-2	RodB5_41	153	41	1.041	13.5	0.343	524.43	546.7	3294.47	10392.4	12.847	73.0	
	RodB5_52.9	154	52.9	1.344	5.9	0.150	568.56	571.2	3634.57	11465.3	12.093	68.7	
	RodB5_55	155	55	1.397	8	0.203	603.84	590.8	3919.07	12362.7	11.670	66.3	
	RodB5_57.8	156	57.8	1.468	10.8	0.274	668.63	626.8	4108.91	12961.5	10.256	58.2	
	RodB5_64	157	64	1.626	17	0.432	694.20	641.0	4204.28	13262.4	9.865	56.0	
	RodB5_73.9	158	73.9	1.877	3.02	0.077	727.16	659.3	4351.32	13726.2	9.477	53.8	
	RodB5_75.9	159	75.9	1.928	5.02	0.128	747.94	670.9	4501.31	14199.4	9.379	53.3	
	RodB5_76.9	160	76.9	1.953	6.02	0.153	771.20	683.8	5078.58	16020.4	10.093	57.3	
	Gr-2	RodF5_41	105	41	1.041	13.5	0.343	522.36	545.6	3303.67	10421.4	12.988	73.8
		RodF5_53.1	106	53.1	1.349	6.1	0.155	566.64	570.2	3632.41	11458.4	12.163	69.1
		RodF5_55	107	55	1.397	8	0.203	591.55	584.0	3910.83	12336.7	12.087	68.6
		RodF5_57.8	108	57.8	1.468	10.8	0.274	658.02	620.9	4099.28	12931.2	10.510	59.7
		RodF5_64	109	64	1.626	17	0.432	678.20	632.1	4194.21	13230.6	10.225	58.1
		RodF5_73.8	110	73.8	1.875	2.92	0.074	705.38	647.3	4336.68	13680.1	9.915	56.3
		RodF5_75.8	111	75.8	1.925	4.92	0.125	784.55	691.2	4938.10	15577.2	9.560	54.3
		RodF5_76.8	112	76.8	1.951	5.92	0.150	834.44	719.0	5120.00	16151.1	9.039	51.3
Gr-2		RodC2_41	57	41	1.041	13.5	0.343	941.32	778.3	3209.33	10123.8	4.766	27.1
		RodC2_53.1	58	53.1	1.349	6.1	0.155	701.68	645.2	4873.88	15374.7	11.238	63.8
		RodC2_55	59	55	1.397	8	0.203	934.26	774.4	6378.21	20120.1	9.573	54.4
		RodC2_57.8	60	57.8	1.468	10.8	0.274	1007.18	814.9	7235.06	22823.0	9.788	55.6
	RodC2_63.9	61	63.9	1.623	16.9	0.429	1031.12	828.2	6746.26	21281.1	8.840	50.2	
	RodC2_73.8	62	73.8	1.875	2.92	0.074	1038.69	832.4	5198.14	16397.5	6.745	38.3	
	RodC2_75.8	63	75.8	1.925	4.92	0.125	882.53	745.7	6185.86	19513.3	10.066	57.2	
	RodC2_76.8	64	76.8	1.951	5.92	0.150	895.81	753.0	6234.34	19666.2	9.930	56.4	
Gr-2	RodC6_40.9	137	40.9	1.039	13.4	0.340	845.40	725.0	5268.10	16618.2	9.124	51.8	
	RodC6_52.8	138	52.8	1.341	5.8	0.147	849.47	727.3	5422.39	17104.9	9.325	53.0	
	RodC6_54.8	139	54.8	1.392	7.8	0.198	915.92	764.2	5720.53	18045.4	8.829	50.1	
	RodC6_57.8	140	57.8	1.468	10.8	0.274	746.27	670.0	5898.29	18606.1	12.333	70.0	
	RodC6_63.8	141	63.8	1.621	16.8	0.427	840.79	722.5	6051.81	19090.4	10.565	60.0	
	RodC6_73.7	142	73.7	1.872	2.82	0.072	883.66	746.3	6149.35	19398.1	9.988	56.7	
	RodC6_75.8	143	75.8	1.925	4.92	0.125	940.18	777.7	6372.08	20100.7	9.480	53.8	
	RodC6_76.8	144	76.8	1.951	5.92	0.150	819.46	710.6	6643.85	20958.0	12.048	68.4	

Error! Reference source not found.**B, continued**

5x5 periphery		H.R. Location	Channel Number	Elevation (in)	Elevation (m)	Zgrid (in)	Zgrid (m)	H.R. Tw (°F)	H.R. Tw (K)	H.R. q" (Btu/hr-ft ²)	H.R. q" (W/m ²)	h _{sat} (z) (Btu/hr-ft ² -F)	h _{sat} (z) (W/m ² -K)
Gr-3	RodB4_88.4	161	88.4	2.245	-0.1	-0.003	757.2	6233.07	19662.2	9.812	55.7		
	RodB4_91.3	162	91.3	2.319	2.8	0.071	766.9	6284.55	19824.6	9.629	54.7		
	RodB4_93.3	163	93.3	2.370	4.8	0.122	397.76	2721.64	8585.4	20.974	119.1		
	RodB4_95.1	164	95.1	2.416	6.6	0.168	473.58	3058.69	9648.6	14.878	84.5		
	RodB4_100	165	100	2.540	11.5	0.292	1083.80	7569.30	23877.3	9.278	52.7		
	RodB4_106	166	106	2.692	17.5	0.445	1107.38	7706.32	24309.6	9.181	52.1		
	RodB4_109.9	167	109.9	2.791	21.4	0.544	1022.79	7066.27	22290.5	9.362	53.2		
	RodB4_142.3	168	142.3	3.614	8.8	0.224	872.74	6125.90	19324.2	10.130	57.5		
Gr-5	RodF4_85.6	98	85.6	2.174	14.72	0.374	893.54	6166.20	19451.3	9.857	56.0		
	RodF4_88.4	99	88.4	2.245	-0.1	-0.003	909.18	6215.26	19606.0	9.693	55.0		
	RodF4_92.4	100	92.4	2.347	3.9	0.099	396.85	2730.35	8612.9	21.190	120.3		
	RodF4_94.3	101	94.3	2.395	5.8	0.147	477.59	3062.18	9659.6	14.610	83.0		
	RodF4_97.2	102	97.2	2.469	8.7	0.221	1080.60	7784.54	24556.3	9.580	54.4		
	RodF4_108.8	103	108.8	2.764	20.3	0.516	986.85	7566.97	23870.0	10.527	59.8		
	RodF4_111	104	111	2.819	-1.75	-0.044	1013.04	7485.22	23612.1	10.047	57.1		
	RodD2_103.2	65	103.2	2.621	14.7	0.373	1002.87	7334.27	23135.9	9.980	56.7		
	RodD2_106	66	106	2.692	17.5	0.445	1084.81	7621.20	24041.1	9.330	53.0		
	RodD2_112.6	67	112.6	2.860	-0.15	-0.004	998.08	7375.82	23267.0	10.103	57.4		
RodD2_114.9	68	114.9	2.918	2.15	0.055	1066.83	6756.43	21313.2	8.458	48.0			
RodD2_117.4	69	117.4	2.982	4.65	0.118	1086.09	6407.70	20213.1	7.833	44.5			
RodD2_120.8	70	120.8	3.068	8.05	0.204	1104.26	5935.92	18724.8	7.098	40.3			
RodD2_124.8	71	124.8	3.170	12.05	0.306	1104.61	5377.04	16961.9	6.427	36.5			
RodD2_128.6	72	128.6	3.266	15.85	0.403	1089.70	4843.10	15277.6	5.894	33.5			
Gr-6	RodD6_103.1	129	103.1	2.619	14.6	0.371	1047.14	6937.42	21884.1	8.904	50.6		
	RodD6_106	130	106	2.692	17.5	0.445	1047.67	7386.62	23301.1	9.474	53.8		
	RodD6_112.9	131	112.9	2.868	0.15	0.004	1009.41	6999.30	22079.3	9.441	53.6		
	RodD6_114.9	132	114.9	2.918	2.15	0.055	799.83	4963.70	15658.0	9.333	53.0		
	RodD6_116.8	133	116.8	2.967	4.05	0.103	820.14	5149.82	16245.1	9.327	53.0		
	RodD6_120.9	134	120.9	3.071	8.15	0.207	949.29	7066.14	22290.1	10.372	58.9		
	RodD6_124.8	135	124.8	3.170	12.05	0.306	984.79	7179.12	22646.5	10.016	56.9		
RodD6_128.7	136	128.7	3.269	15.95	0.405	992.29	2754.71	8689.7	3.803	21.6			

Error! Reference source not found.**B, continued**

5x5 periphery		H.R.	Channel Number	Elevation (in)	Elevation (m)	Zgrid (in)	Zgrid (m)	H.R. Tw (°F)	H.R. Tw (K)	H.R. q" (Btu/hr-ft2)	H.R. q" (W/m2)	h _{sat} (z) (Btu/hr-ft2-F)	h _{sat} (z) (W/m2-K)
Gr-8	RodE2_50.1	73	50.1	1.273	3.1	0.079	862.94	734.8	5291.24	16691.2	8.894	50.5	
	RodE2_54	74	54	1.372	7	0.178	889.73	749.7	5437.94	17154.0	8.747	49.7	
	RodE2_56.9	75	56.9	1.445	9.9	0.251	920.82	766.9	5734.20	18088.5	8.784	49.9	
	RodE2_59.9	76	59.9	1.521	12.9	0.328	764.75	680.2	5922.14	18681.4	11.922	67.7	
	RodE2_66	77	66	1.676	19	0.483	858.79	732.5	6073.69	19159.5	10.281	58.4	
	RodE2_69.8	78	69.8	1.773	-1.08	-0.027	897.07	753.7	6173.64	19474.7	9.814	55.7	
	RodE2_72.9	79	72.9	1.852	2.02	0.051	403.19	479.4	2681.93	8460.2	19.839	112.7	
	RodE2_74.9	80	74.9	1.902	4.02	0.102	481.12	522.7	3031.03	9561.4	14.222	80.8	
Gr-8	RodB3_50.2	169	50.2	1.275	3.2	0.081	1054.35	841.1	5950.04	18769.4	7.567	43.0	
	RodB3_54.1	170	54.1	1.374	7.1	0.180	1051.38	839.5	5397.50	17026.4	6.890	39.1	
	RodB3_56.9	171	56.9	1.445	9.9	0.251	1040.57	833.5	4840.16	15268.3	6.265	35.6	
	RodB3_60.1	172	60.1	1.527	13.1	0.333	747.37	670.6	4478.47	14127.3	9.342	53.1	
	RodB3_66.1	173	66.1	1.679	19.1	0.485	828.42	715.6	5071.85	15999.2	9.050	51.4	
	RodB3_69.9	174	69.9	1.775	-0.98	-0.025	853.86	729.7	5173.31	16319.2	8.830	50.1	
	RodB3_73	175	73	1.854	2.12	0.054	875.96	742.0	5328.83	16809.8	8.765	49.8	
	RodB3_75	176	75	1.905	4.12	0.105	914.10	763.2	5627.40	17751.6	8.710	49.5	
Gr-8	RodF3_50.1	89	50.1	1.273	3.1	0.079	967.83	793.1	7005.15	22097.7	10.010	56.8	
	RodF3_54	90	54	1.372	7	0.178	998.36	810.0	7100.91	22399.8	9.722	55.2	
	RodF3_57	91	57	1.448	10	0.254	743.62	668.5	4474.49	14114.8	9.408	53.4	
	RodF3_60	92	60	1.524	13	0.330	773.94	685.3	5050.75	15932.6	9.983	56.7	
	RodF3_66.1	93	66.1	1.679	19.1	0.485	815.74	708.6	5141.96	16220.3	9.388	53.3	
	RodF3_70	94	70	1.778	-0.88	-0.022	863.67	735.2	5277.97	16649.3	8.861	50.3	
	RodF3_73	95	73	1.854	2.12	0.054	918.28	765.5	5581.10	17605.6	8.583	48.7	
	RodF3_75	96	75	1.905	4.12	0.105	853.86	729.7	6066.44	19136.6	10.355	58.8	
Gr-8	RodE6_50.2	121	50.2	1.275	3.2	0.081	530.63	550.2	3278.04	10340.6	12.482	70.9	
	RodE6_54.1	122	54.1	1.374	7.1	0.180	573.97	574.2	3627.31	11442.3	11.855	67.3	
	RodE6_57	123	57	1.448	10	0.254	598.15	587.7	3918.17	12359.9	11.868	67.4	
	RodE6_60.2	124	60.2	1.529	13.2	0.335	669.00	627.0	4120.80	12999.1	10.276	58.4	
	RodE6_66.1	125	66.1	1.679	19.1	0.485	692.44	640.1	4218.91	13308.5	9.940	56.4	
	RodE6_70	126	70	1.778	-0.88	-0.022	723.11	657.1	4366.07	13772.8	9.594	54.5	
	RodE6_73.1	127	73.1	1.857	2.22	0.056	778.99	688.1	4942.30	15590.5	9.672	54.9	
	RodE6_75	128	75	1.905	4.12	0.105	817.08	709.3	5132.82	16191.5	9.348	53.1	

RBHT Steam Cooling with Droplet Injection Test SCD-4032-C

Matrix Test # Shakedown

Test Conditions

Test Date – 9/28/2005

Steady State Time Window: 12900 - 13920

Upper Plenum Pressure: 2.76 bar (40 psia)

Bundle Power: 72.0 kW

Bundle Inlet Reynolds Number: 8000

Bundle Inlet Steam Flow: 155.7 kg/hr (343 lbm/hr)

Droplet Injection Flow: 0.0076 kg/s (0.0167 lbm/s)

Droplet Injection Hole Diameter: 0.381 mm (.015 in)

Droplet Injection Elevation: 1.295 m (51 in)

Bundle Flow Area: $4.656 \times 10^{-3} \text{ m}^2$ ($5.012 \times 10^{-2} \text{ ft}^2$)

Test Notes

- No steam probes were traversed in this steady state window.

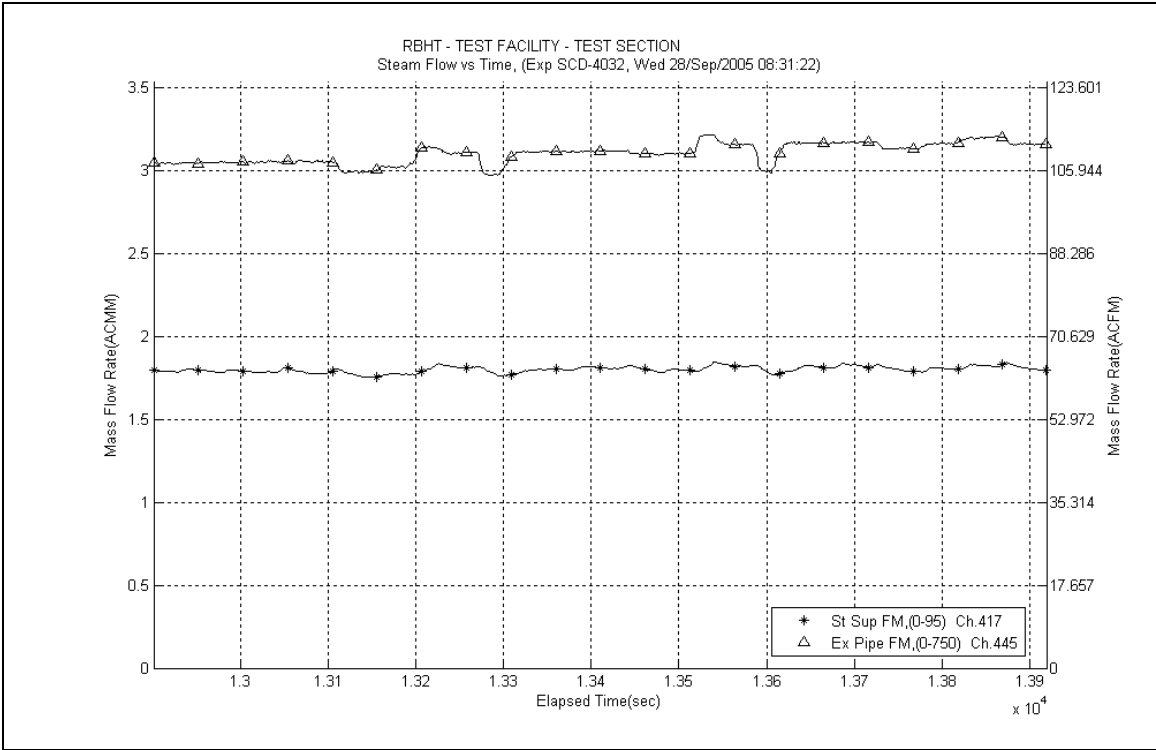

Figure A-147: Inlet and Exhaust Steam Flow Rates for Experiment 4032C

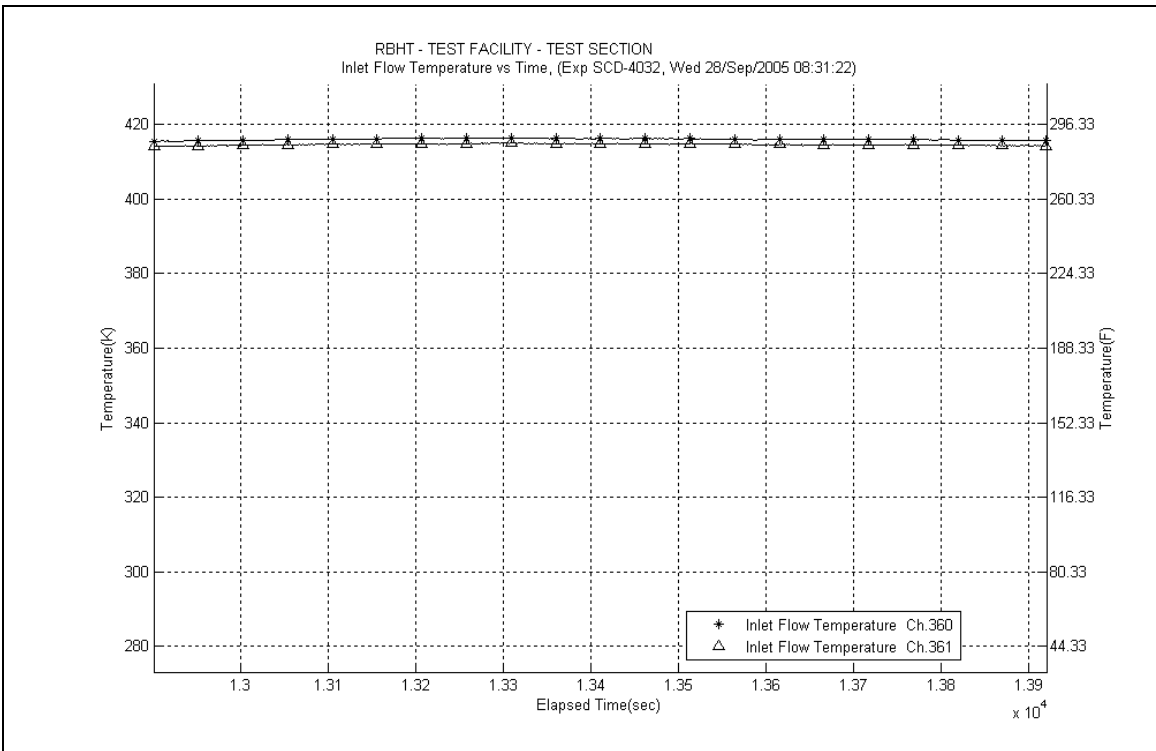

Figure A-148: Inlet Steam Temperature for Experiment 4032C

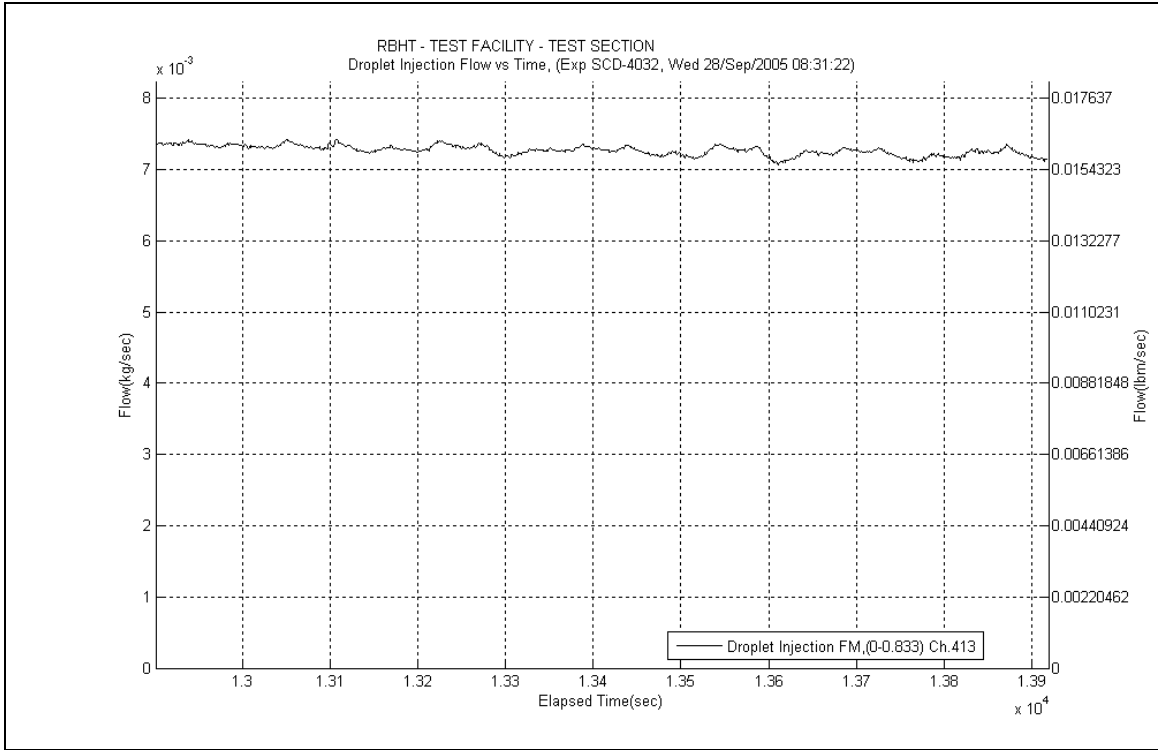

Figure A-149: Droplet Injection Flow Rate for Experiment 4032C

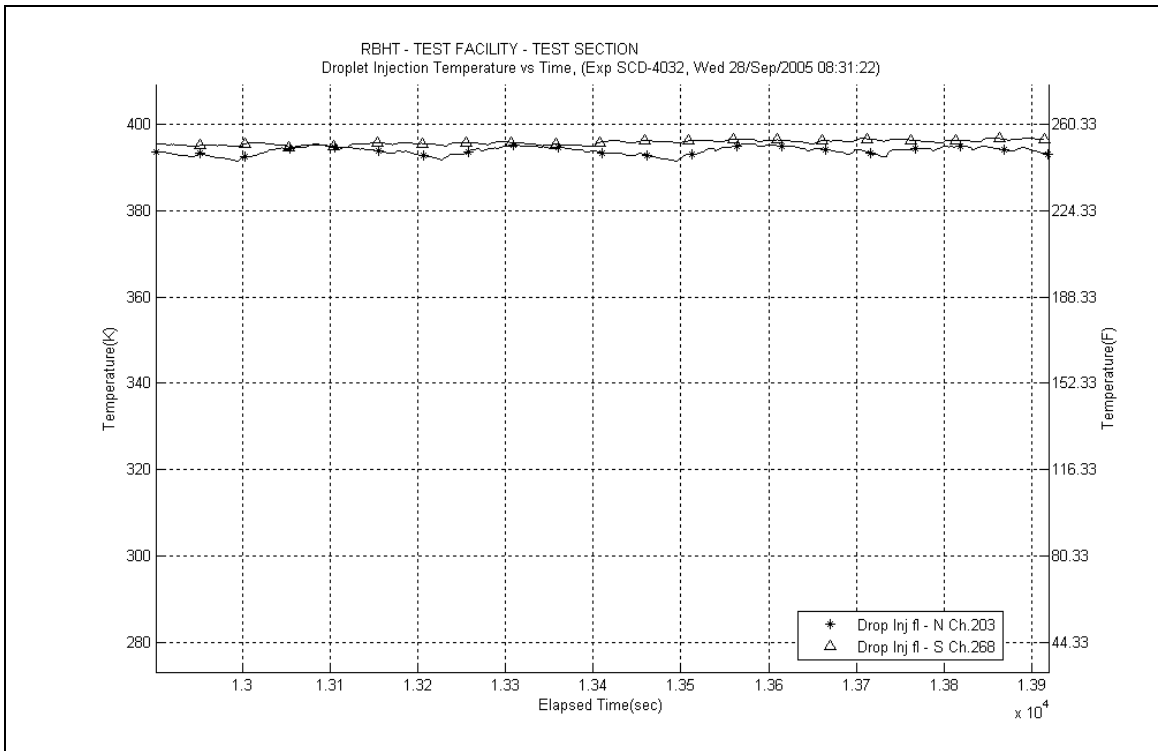

Figure A-150: Droplet Injection Temperature for Experiment 4032C

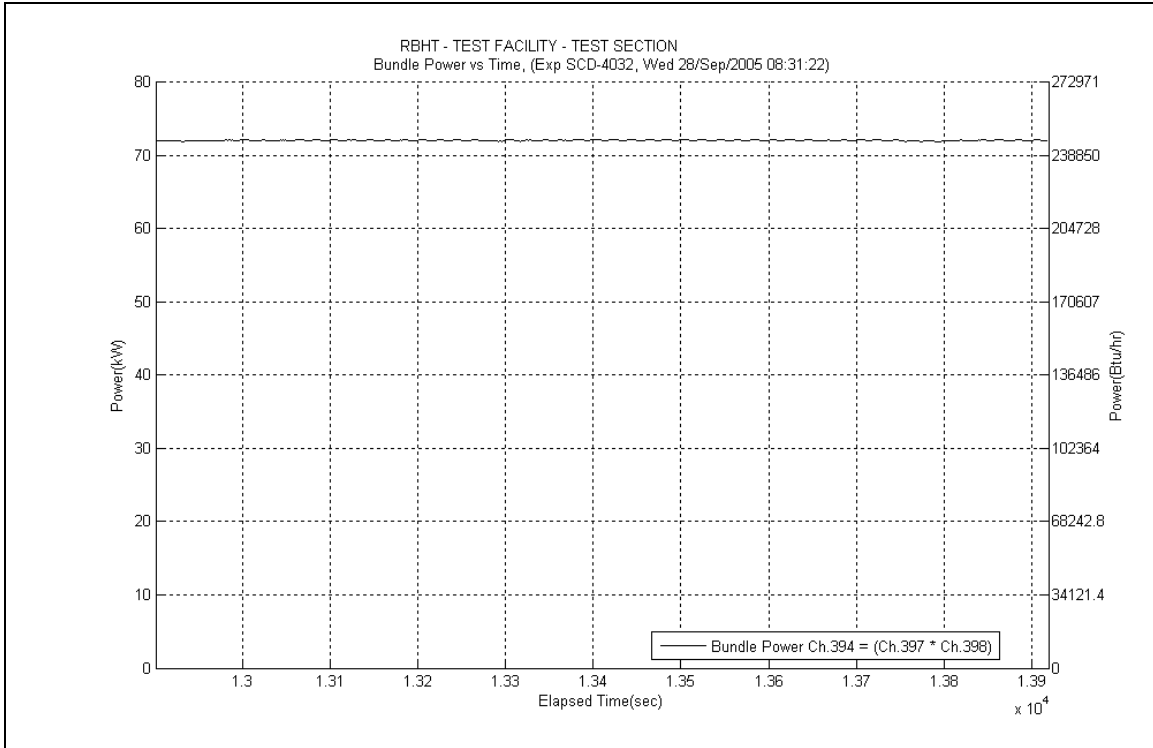

Figure A-151: Bundle Power for Experiment 4032C

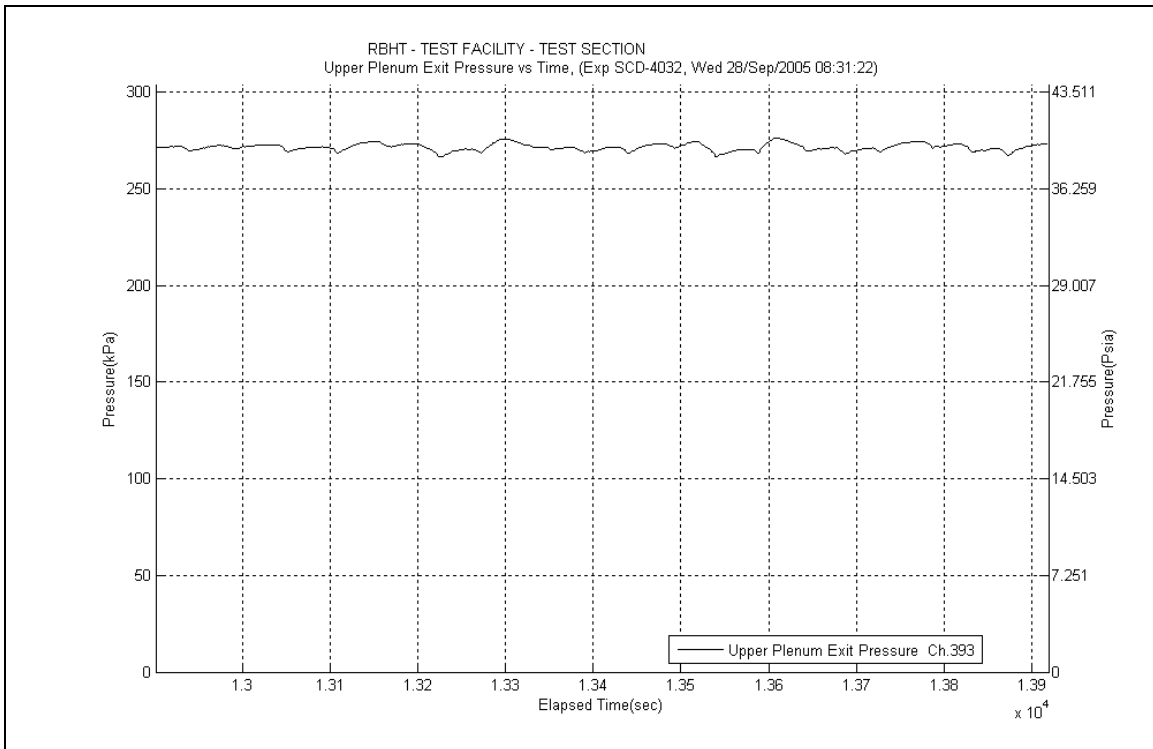

Figure A-152: Upper Plenum Pressure for Experiment 4032C

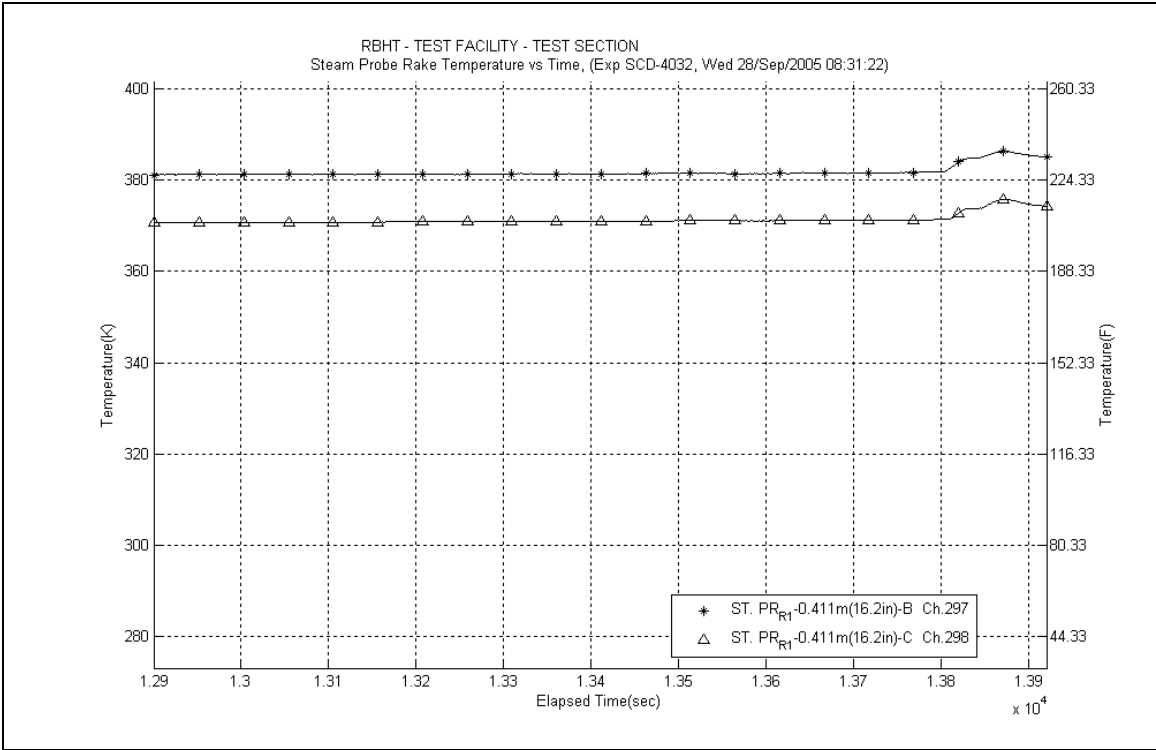

Figure A-153: Steam Probe Rake #1 Temperatures for Experiment 4032C

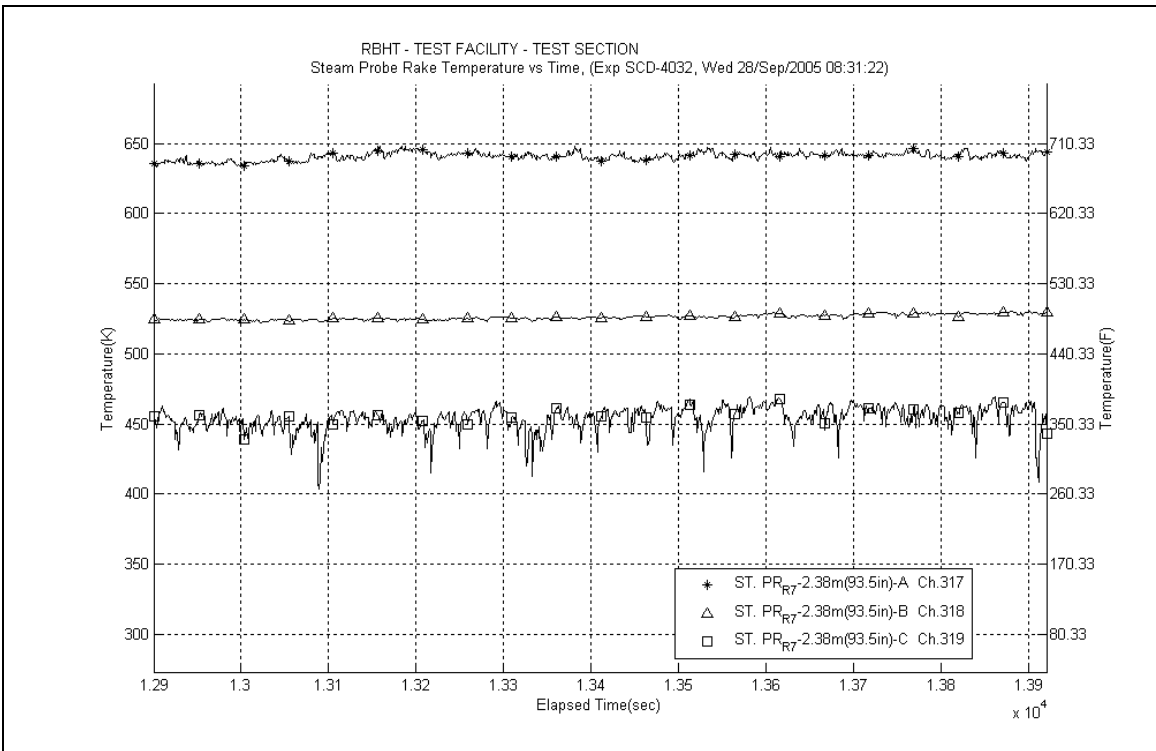

Figure A-154: Steam Probe Rake #7 Temperatures for Experiment 4032C

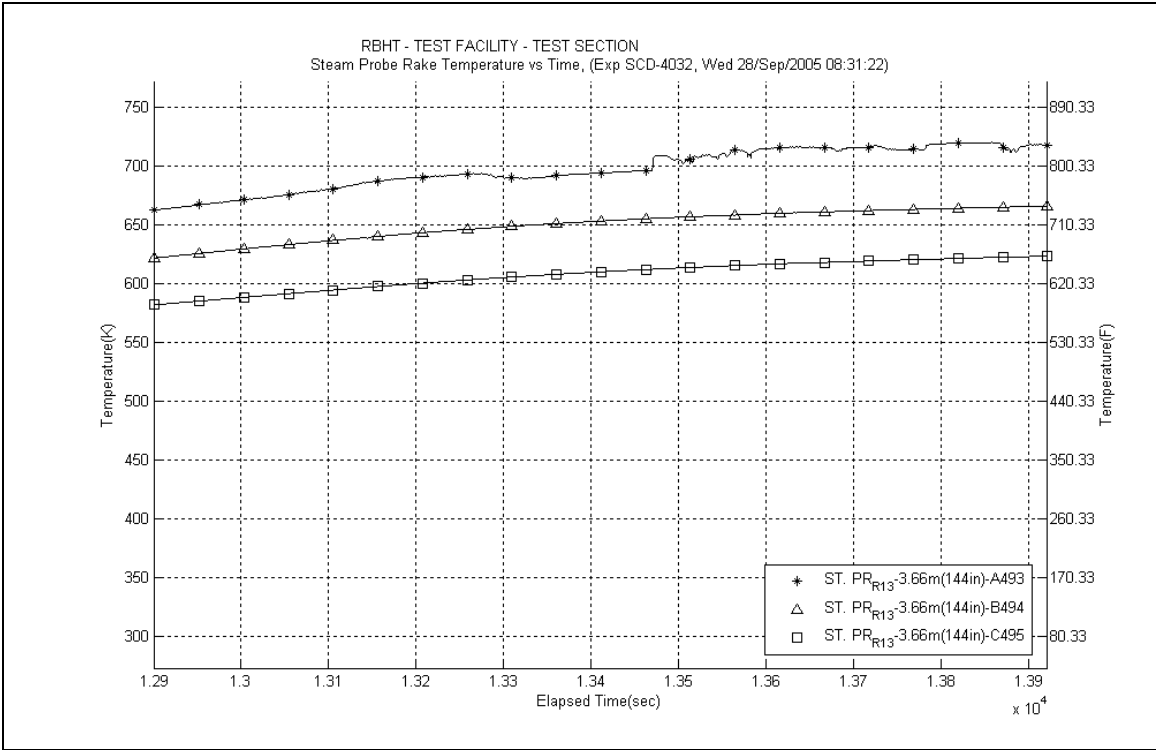

Figure A-155: Steam Probe Rake #13 Temperatures for Experiment 4032C

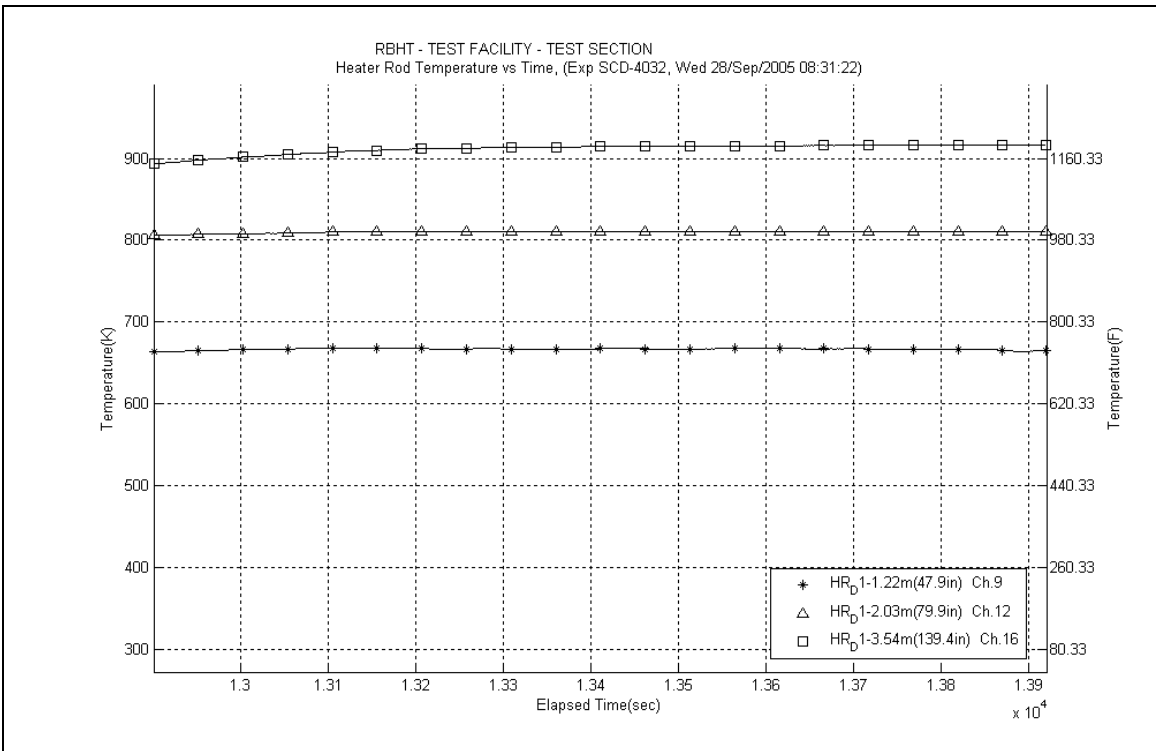

Figure A-156: Heater Rod D1 Temperatures for Experiment 4032C

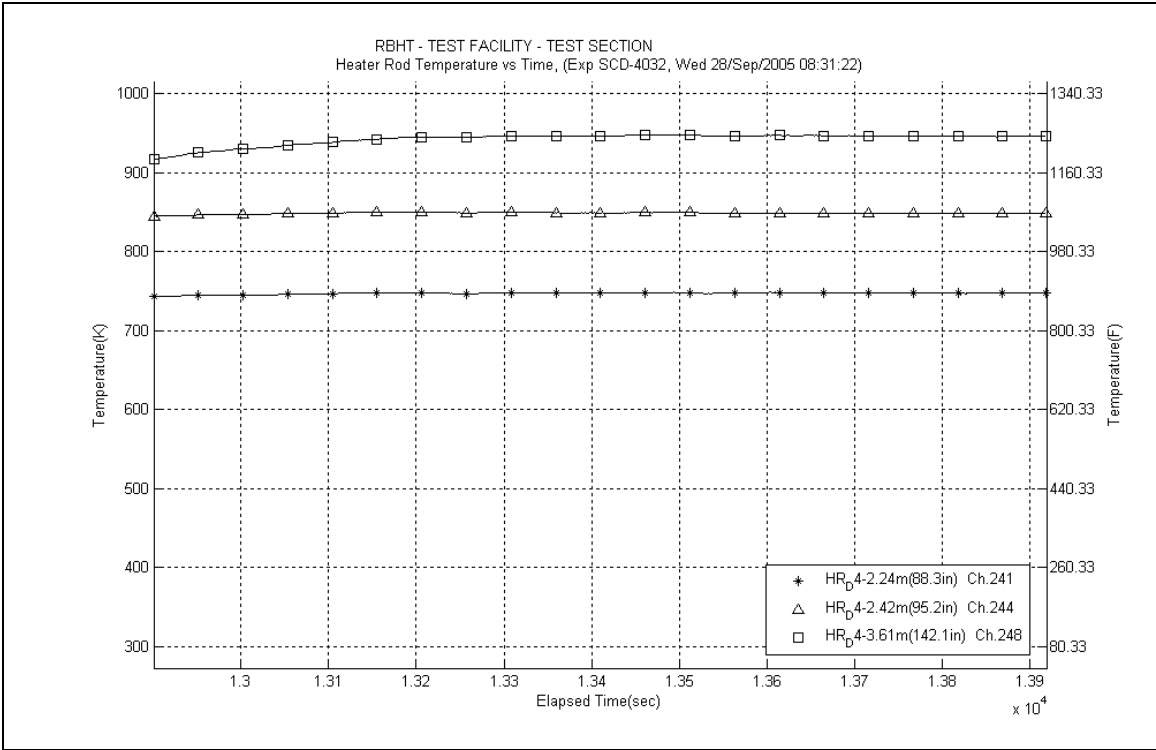

Figure A-157: Heater Rod D4 Temperatures for Experiment 4032C

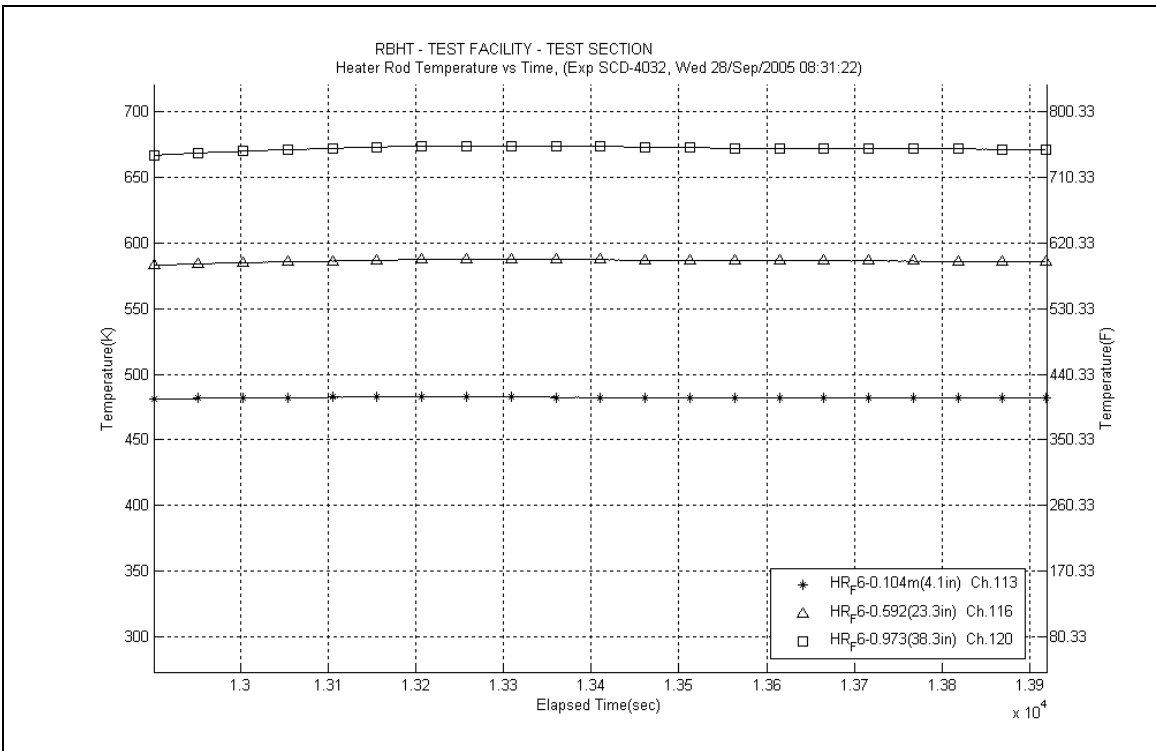

Figure A-158: Heater Rod F6 Temperatures for Experiment 4032C

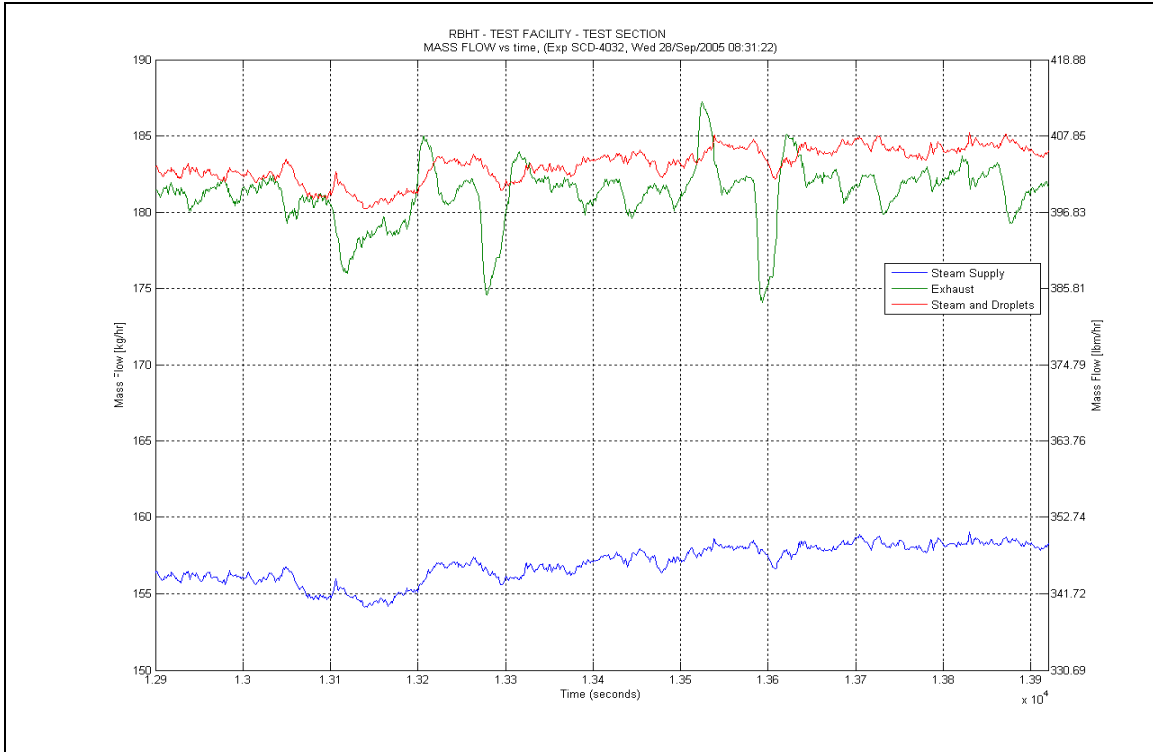

Figure A-159: Mass Flow for Experiment 4032C

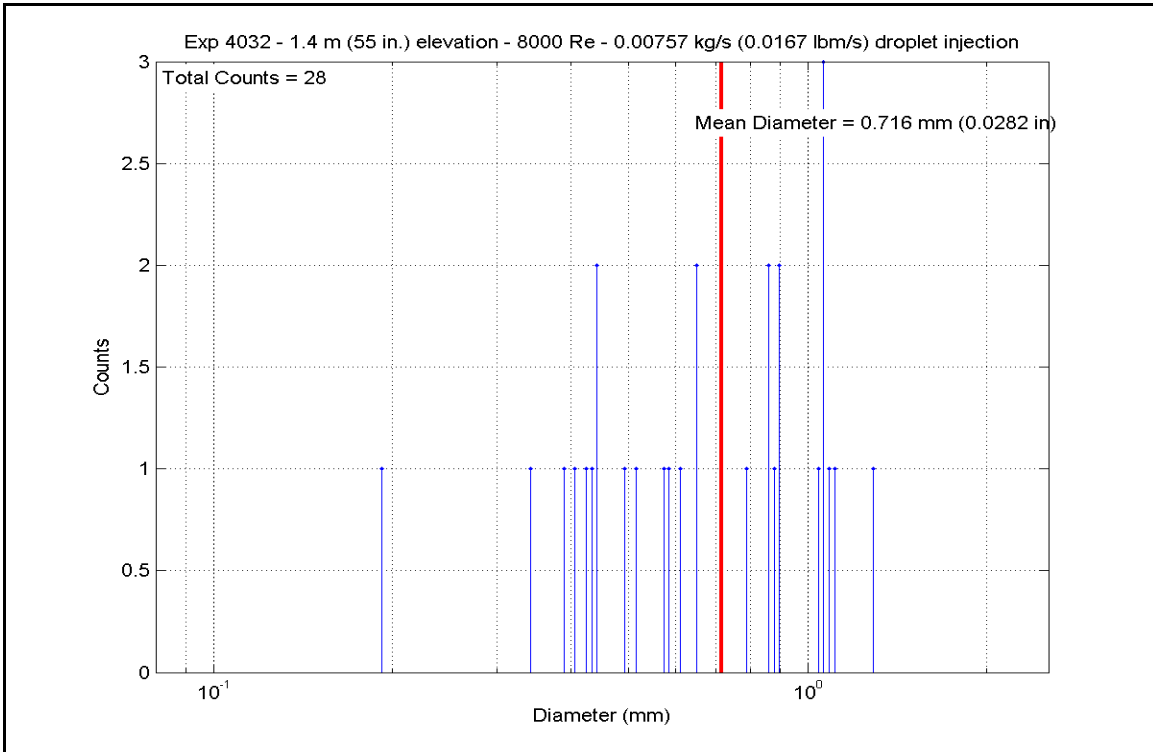

Figure A-160: Droplet Measurements at 1.397 m (55 in.) Elevation for Experiment 4032C

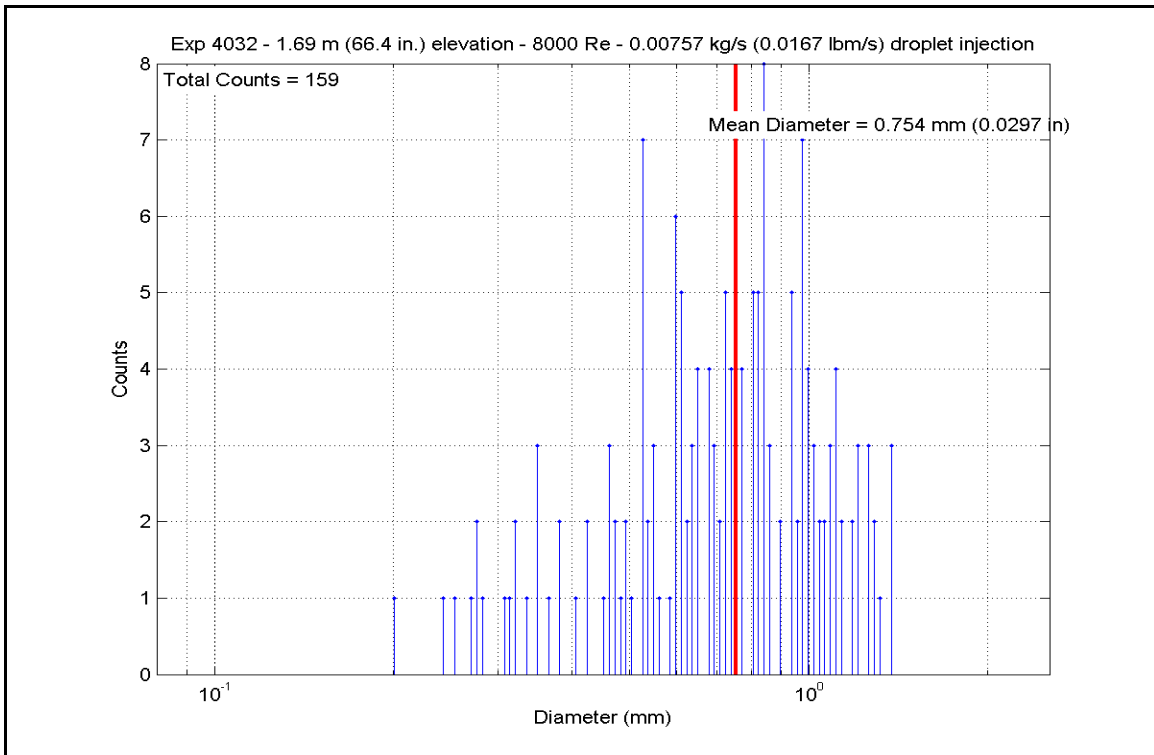

Figure A-161: Droplet Measurements at 1.687 m (66.4 in.) Elevation for Experiment 4032C

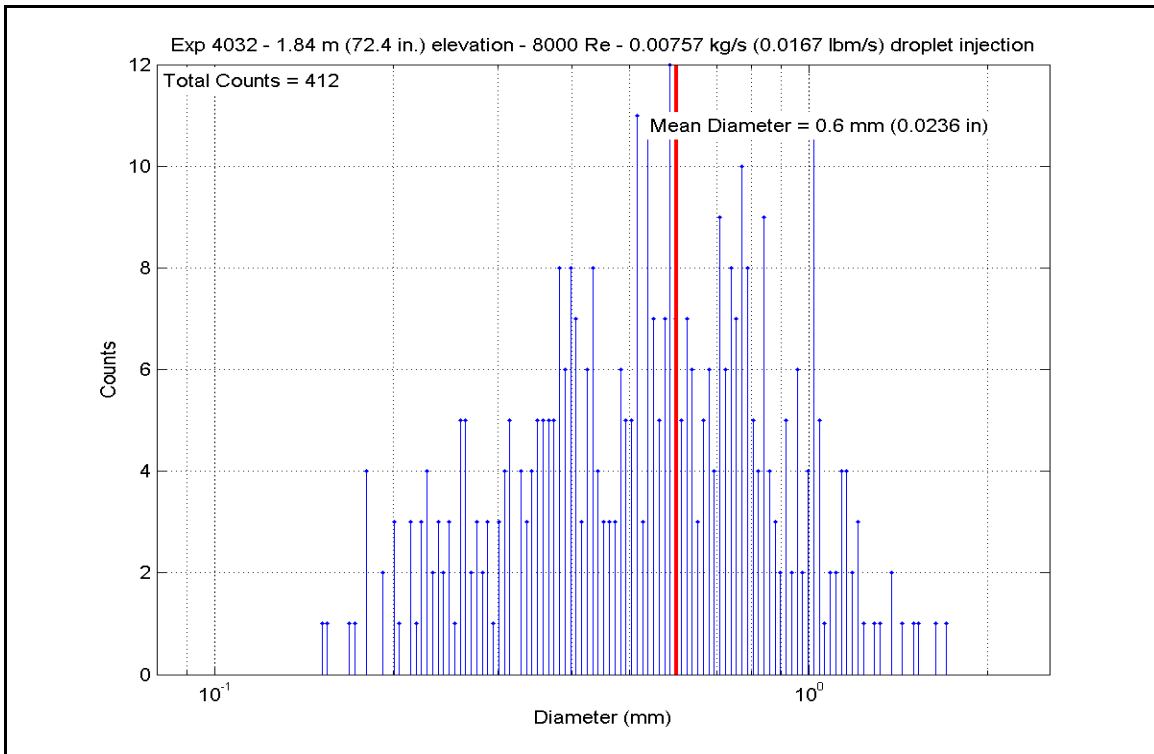

Figure A-162: Droplet Measurements at 1.839 m (72.4 in.) Elevation for Experiment 4032C

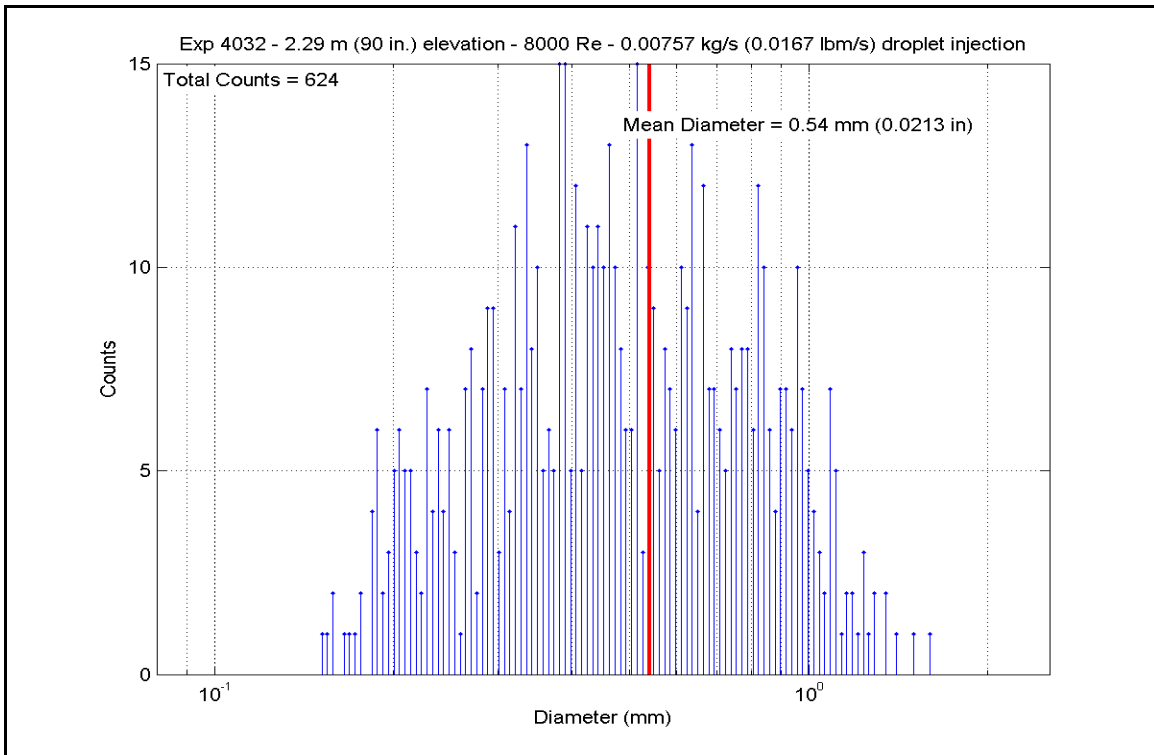

Figure A-163: Droplet Measurements at 2.286 m (90 in.) Elevation for Experiment 4032C

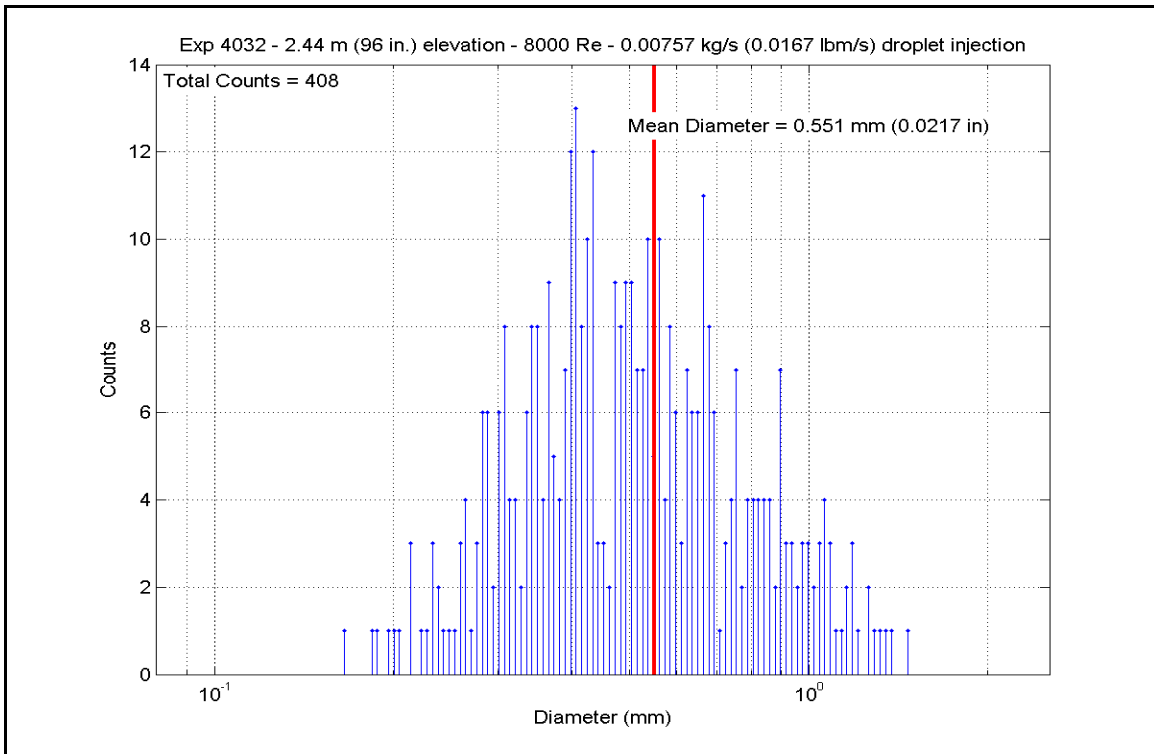

Figure A-164: Droplet Measurements at 2.438 m (96 in.) Elevation for Experiment 4032C

Error! Reference source not found.C

Test 4032-C		Inlet Reynolds:		8000		40 psia		245674 Btu/hr		40.5			
Matrix test shutdown		UP Pressure:		275.8 kPa		245674 Btu/hr		343.0 lbm/hr		40.5			
Time Window: 12900-13920		Bundle Power:		72.00 kW		343.0 lbm/hr		0.0162 lbm/s		40.5			
Inner 3x3		Stream flow:		0.0432 kg/s		0.0162 lbm/s				40.5			
Droplet flow:		0.0073 kg/s								40.5			
H.R. ID	H.R. Location	Channel Number	Elevation (in)	Elevation (m)	Zgrid (in)	Zgrid (m)	H.R. Tw (°F)	H.R. Tw (K)	H.R. q" (Btu/hr-ft2)	H.R. q" (W/m2)	h _{sat} (z) (Btu/hr-ft2-F)	h _{sat} (z) (W/m2-K)	
Gr-3	RodD3_88.3	185	88.3	2.243	-0.2	-0.005	1011.89	817.5	6251.52	19720.4	8.404	47.7	
	RodD3_91.3	186	91.3	2.319	2.8	0.071	1054.88	841.4	6334.71	19982.8	8.050	45.7	
	RodD3_93.1	187	93.1	2.365	4.6	0.117	894.98	752.6	6152.68	19408.6	9.813	55.7	
	RodD3_95.3	188	95.3	2.421	6.8	0.173	998.42	810.1	6256.42	19735.9	8.566	48.6	
	RodD3_100.1	189	100.1	2.543	11.6	0.295	1107.18	870.5	6451.24	20350.4	7.688	43.7	
	RodD3_106.1	190	106.1	2.695	17.6	0.447	1220.62	933.5	6794.84	21434.3	7.133	40.5	
	RodD3_110	191	110	2.794	21.5	0.546	1153.33	896.1	6619.80	20882.1	7.477	42.5	
	RodD3_142.1	192	142.1	3.609	3.609	8.6	884.62	746.8	6089.84	19210.4	9.876	56.1	
	Gr-3	RodC4_88.4	233	88.4	2.245	-0.1	-0.003	1223.98	935.4	5995.19	18911.8	6.271	35.6
		RodC4_91.1	234	91.1	2.314	2.6	0.066	1246.71	948.0	5593.14	17643.5	5.715	32.5
RodC4_93.4		235	93.4	2.372	4.9	0.124	1266.24	958.8	5114.92	16135.0	5.124	29.1	
RodC4_95.3		236	95.3	2.421	6.8	0.173	1270.22	961.1	4627.61	14597.8	4.617	26.2	
RodC4_100.1		237	100.1	2.543	11.6	0.295	1148.81	893.6	6558.77	20689.6	7.446	42.3	
RodC4_106.1		238	106.1	2.695	17.6	0.447	1174.28	907.7	6767.21	21347.2	7.467	42.4	
RodC4_110		239	110	2.794	21.5	0.546	1193.83	918.6	6892.65	21742.9	7.445	42.3	
RodC4_142.2		240	142.2	3.612	3.612	8.7	995.87	808.6	5022.03	15842.0	6.900	39.2	
Gr-3		RodD4_88.3	241	88.3	2.243	-0.2	-0.005	901.78	756.4	5423.49	17108.4	8.557	48.6
		RodD4_91.3	242	91.3	2.319	2.8	0.071	950.26	783.3	5509.04	17378.3	8.075	45.9
	RodD4_93.2	243	93.2	2.367	4.7	0.119	991.42	806.2	4900.41	15458.3	6.774	38.5	
	RodD4_95.2	244	95.2	2.418	6.7	0.170	1215.81	930.8	5774.78	18216.5	6.093	34.6	
	RodD4_100.1	245	100.1	2.543	11.6	0.295	1232.09	939.9	6877.79	21696.0	7.134	40.5	
	RodD4_106.1	246	106.1	2.695	17.6	0.447	1180.20	911.0	6790.48	21420.6	7.444	42.3	
	RodD4_142.1	248	142.1	3.609	3.609	8.6	814.42	707.8	5294.44	16701.3	9.689	55.0	
	Gr-3	RodE4_88.4	201	88.4	2.245	-0.1	-0.003	994.77	808.0	6188.50	19521.6	8.515	48.4
		RodE4_91.2	202	91.2	2.316	2.7	0.069	1085.03	858.2	6359.48	20061.0	7.784	44.2
		RodE4_95.3	204	95.3	2.421	6.8	0.173	1237.88	943.1	2412.73	7611.0	2.488	14.1
RodE4_100.9		205	100.9	2.563	12.4	0.315	1136.35	886.7	6688.98	21100.4	7.703	43.7	
RodE4_142.3		208	142.3	3.614	8.8	0.224	890.50	750.1	6063.35	19126.8	9.740	55.3	

Error! Reference source not found.C, continued

Gr-4	H.R. Location	Channel Number	Elevation (in)	Elevation (m)	Zgrid (in)	Zgrid (m)	H.R. Tw (°F)	H.R. Tw (K)	H.R. q" (Btu/hr-ft2)	H.R. q" (W/m2)	h _{sat} (z) (Btu/hr-ft2-F)	h _{sat} (z) (W/m2-K)
	RodE3_63.4	193	63.4	1.610	16.4	0.417	1242.38	945.6	3462.35	10922.0	3.553	20.2
	RodE3_113.6	194	113.6	2.885	0.85	0.022	1171.32	906.1	6022.72	18998.7	6.667	37.9
	RodE3_115.5	195	115.5	2.934	2.75	0.070	1004.50	813.4	5001.32	15776.7	6.791	38.6
	RodE3_118.5	196	118.5	3.010	5.75	0.146	1247.44	948.4	5948.36	18764.1	6.073	34.5
	RodE3_122.7	197	122.7	3.117	9.95	0.253	1277.04	964.8	5573.87	17582.8	5.524	31.4
	RodE3_126.5	198	126.5	3.213	13.75	0.349	1297.56	976.2	5050.83	15932.9	4.906	27.9
	RodE3_131.7	199	131.7	3.345	-1.8	-0.046	1298.94	977.0	4580.64	14449.6	4.443	25.2
	RodE3_135.6	200	135.6	3.444	2.1	0.053	1228.61	937.9	3953.82	12472.3	4.116	23.4
Gr-4	RodC5_63.7	225	63.7	1.618	16.7	0.424	950.26	783.3	4859.87	15330.5	7.123	40.5
	RodC5_113.6	226	113.6	2.885	0.85	0.022	1149.47	894.0	6284.52	19824.5	7.130	40.5
	RodC5_115.7	227	115.7	2.939	2.95	0.075	1199.35	921.7	4035.75	12730.8	4.333	24.6
	RodC5_122.7	229	122.7	3.117	9.95	0.253	1216.72	931.3	3539.62	11165.7	3.731	21.2
	RodC5_126.7	230	126.7	3.218	13.95	0.354	839.17	721.6	4443.08	14015.7	7.779	44.2
	RodC5_131.6	231	131.6	3.343	-1.9	-0.048	844.59	724.6	4611.30	14546.3	7.997	45.4
	RodC5_135.7	232	135.7	3.447	2.2	0.056	905.92	758.7	4728.27	14915.3	7.412	42.1
Gr-4	RodE5_63.6	209	63.6	1.615	16.6	0.422	1235.19	941.6	2384.07	7520.6	2.465	14.0
	RodE5_113.6	210	113.6	2.885	0.85	0.022	1210.06	927.6	6951.21	21927.6	7.379	41.9
	RodE5_115.4	211	115.4	2.931	2.65	0.067	1071.62	850.7	6476.20	20429.2	8.059	45.8
	RodE5_118.7	212	118.7	3.015	5.95	0.151	1231.43	939.5	2469.82	7791.0	2.564	14.6
	RodE5_122.6	213	122.6	3.114	9.85	0.250	882.74	745.8	6147.36	19391.8	10.000	56.8
	RodE5_126.6	214	126.6	3.216	13.85	0.352	982.92	801.4	6281.13	19813.8	8.786	49.9
	RodE5_131.6	215	131.6	3.343	-1.9	-0.048	1026.50	825.6	6363.97	20075.2	8.390	47.6
	RodE5_135.6	216	135.6	3.444	2.1	0.053	1065.14	847.1	6450.85	20349.2	8.093	46.0
Gr-5	RodC3_79.8	177	79.8	2.027	8.92	0.227	1030.67	828.0	6254.41	19729.5	8.201	46.6
	RodC3_85.6	178	85.6	2.174	14.72	0.374	1061.75	845.2	6329.38	19966.0	7.974	45.3
	RodC3_88.5	179	88.5	2.248	0	0.000	1208.50	926.8	2458.41	7755.1	2.614	14.8
	RodC3_92.4	180	92.4	2.347	3.9	0.099	791.72	695.2	4430.05	13974.6	8.459	48.0
	RodC3_94.4	181	94.4	2.398	5.9	0.150	813.87	707.5	4605.23	14527.2	8.437	47.9
	RodC3_97.2	182	97.2	2.469	8.7	0.221	1210.90	928.1	6834.95	21560.8	7.249	41.2
	RodC3_108.8	183	108.8	2.764	20.3	0.516	1126.71	881.3	6476.58	20430.4	7.542	42.8
Gr-8	RodD5_50	217	50	1.270	3	0.076	1173.14	907.1	4283.63	13512.7	4.733	26.9
	RodD5_54.1	218	54.1	1.374	7.1	0.180	1269.02	960.4	4948.87	15611.2	4.944	28.1
	RodD5_56.9	219	56.9	1.445	9.9	0.251	1270.64	961.3	4478.54	14127.6	4.467	25.4
	RodD5_60	220	60	1.524	13	0.330	1197.16	920.5	3919.40	12363.8	4.218	24.0
	RodD5_66.1	221	66.1	1.679	19.1	0.485	1214.89	930.3	3428.15	10814.1	3.620	20.6
	RodD5_69.9	222	69.9	1.775	-0.98	-0.025	888.10	748.8	6169.38	19461.3	9.949	56.5
	RodD5_72.9	223	72.9	1.852	2.02	0.051	982.40	801.1	6289.25	19839.4	8.804	50.0
	RodD5_74.9	224	74.9	1.902	4.02	0.102	1033.39	829.5	6391.90	20163.3	8.351	47.4

Error! Reference source not found.C, continued

H.R. ID	H.R. Location	Channel Number	Elevation (in)	Elevation (m)	Zgrid (in)	Zgrid (m)	H.R. Tw (°F)	H.R. Tw (K)	H.R. q" (Btu/hr-ft2)	H.R. q" (W/m2)	h _{sat} (z) (Btu/hr-ft2-F)	h _{sat} (z) (W/m2-K)	
Gr-2	RodB5_41	153	41	1.041	13.5	0.343	545.98	558.7	2961.73	9342.8	10.654	60.5	
	RodB5_52.9	154	52.9	1.344	5.9	0.150	592.86	584.7	3267.00	10305.7	10.057	57.1	
	RodB5_55	155	55	1.397	8	0.203	625.71	603.0	3523.71	11115.5	9.851	55.9	
	RodB5_57.8	156	57.8	1.468	10.8	0.274	695.03	641.5	3693.03	11649.7	8.648	49.1	
	RodB5_64	157	64	1.626	17	0.432	722.56	656.8	3777.95	11917.5	8.311	47.2	
	RodB5_73.9	158	73.9	1.877	30.2	0.077	760.88	678.1	3909.64	12333.0	7.932	45.0	
	RodB5_75.9	159	75.9	1.928	5.02	0.128	792.31	695.5	4043.75	12756.0	7.712	43.8	
	RodB5_76.9	160	76.9	1.953	6.02	0.153	800.51	700.1	4556.21	14372.6	8.556	48.6	
	Gr-2	RodF5_41	105	41	1.041	13.5	0.343	547.85	559.7	2965.91	9356.0	10.598	60.2
		RodF5_53.1	106	53.1	1.349	6.1	0.155	594.52	585.7	3262.62	10291.9	9.992	56.7
		RodF5_55	107	55	1.397	8	0.203	614.91	597.0	3518.70	11099.7	10.143	57.6
		RodF5_57.8	108	57.8	1.468	10.8	0.274	689.54	638.5	3685.30	11625.3	8.742	49.6
		RodF5_64	109	64	1.626	17	0.432	713.66	651.8	3767.96	11886.0	8.455	48.0
		RodF5_73.8	110	73.8	1.875	2.92	0.074	748.74	671.3	3891.73	12276.5	8.095	46.0
		RodF5_75.8	111	75.8	1.925	4.92	0.125	812.48	706.8	4431.18	13978.2	8.138	46.2
		RodF5_76.8	112	76.8	1.951	5.92	0.150	846.95	725.9	4594.34	14492.8	7.936	45.1
Gr-2		RodC2_41	57	41	1.041	13.5	0.343	1129.58	882.9	2702.88	8526.2	3.137	17.8
		RodC2_53.1	58	53.1	1.349	6.1	0.155	721.50	656.2	4389.53	13846.8	9.679	55.0
		RodC2_55	59	55	1.397	8	0.203	915.97	764.2	5688.67	17944.9	8.779	49.9
		RodC2_57.8	60	57.8	1.468	10.8	0.274	1042.65	834.6	6446.99	20337.0	8.322	47.3
	RodC2_63.9	61	63.9	1.623	16.9	0.429	1136.08	886.5	5979.61	18862.7	6.888	39.1	
	RodC2_73.8	62	73.8	1.875	2.92	0.074	1170.70	905.8	4533.59	14301.2	5.022	28.5	
	RodC2_75.8	63	75.8	1.925	4.92	0.125	932.17	773.2	5536.36	17464.4	8.336	47.3	
	RodC2_76.8	64	76.8	1.951	5.92	0.150	947.20	781.6	5579.65	17601.0	8.215	46.7	
Gr-2	RodC6_40.9	137	40.9	1.039	13.4	0.340	878.95	743.7	4723.25	14899.5	7.731	43.9	
	RodC6_52.8	138	52.8	1.341	5.8	0.147	903.86	757.5	4858.81	15327.1	7.641	43.4	
	RodC6_54.8	139	54.8	1.392	7.8	0.198	975.07	797.1	5111.61	16124.6	7.229	41.1	
	RodC6_57.8	140	57.8	1.468	10.8	0.274	788.98	693.7	5284.73	16670.7	10.144	57.6	
	RodC6_63.8	141	63.8	1.621	16.8	0.427	882.09	745.4	5418.35	17092.2	8.823	50.1	
	RodC6_73.7	142	73.7	1.872	2.82	0.072	928.17	771.0	5505.34	17366.6	8.339	47.4	
	RodC6_75.8	143	75.8	1.925	4.92	0.125	1017.11	820.4	5692.08	17955.7	7.598	43.2	
	RodC6_76.8	144	76.8	1.951	5.92	0.150	900.11	755.4	5964.36	18814.6	9.436	53.6	

Error! Reference source not found.C, continued

5x5 periphery		H.R.	Channel	Elevation	Elevation	Zgrid	Zgrid	H.R. Tw	H.R. Tw	H.R. q"	H.R. q"	h _{sat} (z)	h _{sat} (z)
Gr-3	Location	Number	(in)	(m)	(m)	(in)	(m)	(°F)	(K)	(W/m ²)	(Btu/hr-ft ²)	(W/m ² -K)	(Btu/hr-ft ² -F)
	RodB4_88.4	161	88.4	2.245	-0.1	-0.003	944.97	780.4	5596.12	17653.0	8.266	46.9	8.266
	RodB4_91.3	162	91.3	2.319	2.8	0.071	964.98	791.5	5640.94	17794.4	8.093	46.0	8.093
	RodB4_93.3	163	93.3	2.370	4.8	0.122	406.70	481.3	2448.40	7723.5	17.652	100.2	17.652
	RodB4_95.1	164	95.1	2.416	6.6	0.168	487.76	526.3	2753.14	8684.8	12.528	71.1	12.528
	RodB4_100	165	100	2.540	11.5	0.292	1185.91	914.2	6777.78	21380.5	7.384	41.9	7.384
	RodB4_106	166	106	2.692	17.5	0.445	1212.35	928.9	6895.08	21750.5	7.301	41.5	7.301
	RodB4_109.9	167	109.9	2.791	21.4	0.544	1155.04	897.1	6321.47	19941.1	7.126	40.5	7.126
	RodB4_142.3	168	142.3	3.614	8.8	0.224	911.30	761.6	5500.32	17350.8	8.550	48.6	8.550
Gr-5	RodF4_85.6	98	85.6	2.174	14.72	0.374	955.40	786.1	5537.36	17467.6	8.056	45.7	8.056
	RodF4_88.4	99	88.4	2.245	-0.1	-0.003	971.83	795.3	5580.24	17602.9	7.928	45.0	7.928
	RodF4_92.4	100	92.4	2.347	3.9	0.099	407.28	481.6	2455.31	7745.3	17.628	100.1	17.628
	RodF4_94.3	101	94.3	2.395	5.8	0.147	493.96	529.8	2754.27	8688.4	12.189	69.2	12.189
	RodF4_97.2	102	97.2	2.469	8.7	0.221	1209.00	927.0	6928.57	21856.2	7.363	41.8	7.363
	RodF4_108.8	103	108.8	2.764	20.3	0.516	1154.89	897.0	6726.73	21219.5	7.585	43.1	7.585
	RodF4_111	104	111	2.819	-1.75	-0.044	1144.84	891.4	6663.59	21020.3	7.600	43.2	7.600
Gr-6	RodD2_103.2	65	103.2	2.621	14.7	0.373	1102.20	867.7	6533.60	20610.3	7.832	44.5	7.832
	RodD2_106	66	106	2.692	17.5	0.445	1192.99	918.1	6783.23	21397.7	7.333	41.6	7.333
	RodD2_112.6	67	112.6	2.860	-0.15	-0.004	1135.63	886.3	6567.26	20716.4	7.569	43.0	7.569
	RodD2_114.9	68	114.9	2.918	2.15	0.055	1205.61	925.2	6015.79	18976.8	6.416	36.4	6.416
	RodD2_117.4	69	117.4	2.982	4.65	0.118	1228.87	938.1	5690.13	17949.5	5.922	33.6	5.922
	RodD2_120.8	70	120.8	3.068	8.05	0.204	1258.94	954.8	5241.99	16535.8	5.290	30.0	5.290
	RodD2_124.8	71	124.8	3.170	12.05	0.306	1271.23	961.6	4721.26	14893.2	4.706	26.7	4.706
	RodD2_128.6	72	128.6	3.266	15.85	0.403	1267.88	959.8	4228.86	13340.0	4.229	24.0	4.229
Gr-6	RodD6_103.1	129	103.1	2.619	14.6	0.371	1214.44	930.1	6185.87	19513.3	6.536	37.1	6.536
	RodD6_106	130	106	2.692	17.5	0.445	1162.14	901.0	6589.14	20785.4	7.369	41.8	7.369
	RodD6_112.9	131	112.9	2.868	0.15	0.004	1195.05	919.3	6214.95	19605.1	6.704	38.1	6.704
	RodD6_114.9	132	114.9	2.918	2.15	0.055	839.71	721.9	4457.79	14062.1	7.797	44.3	7.797
	RodD6_116.8	133	116.8	2.967	4.05	0.103	848.22	726.6	4626.58	14594.6	7.974	45.3	7.974
	RodD6_120.9	134	120.9	3.071	8.15	0.207	1043.28	835.0	6326.44	19956.8	8.160	46.3	8.160
	RodD6_124.8	135	124.8	3.170	12.05	0.306	1082.83	856.9	6417.71	20244.7	7.876	44.7	7.876
	RodD6_128.7	136	128.7	3.269	15.95	0.405	1237.83	943.1	2276.43	7181.0	2.347	13.3	2.347

Error! Reference source not found.C, continued

5x5 periphery		H.R.	Channel Number	Elevation (in)	Elevation (m)	Zgrid (in)	Zgrid (m)	H.R. Tw (°F)	H.R. Tw (K)	H.R. Tw (Btu/hr-ft2)	H.R. q" (W/m2)	h _{sat} (z) (Btu/hr-ft2-F)	h _{sat} (z) (W/m2-K)
Gr-8	RodE2_50.1	73	50.1	1.273	3.1	0.079	896.23	753.3	4751.86	14989.7	7.564	43.0	
	RodE2_54	74	54	1.372	7	0.178	935.56	775.1	4882.51	15401.9	7.314	41.5	
	RodE2_56.9	75	56.9	1.445	9.9	0.251	986.06	803.2	5149.13	16242.9	7.171	40.7	
	RodE2_59.9	76	59.9	1.521	12.9	0.328	804.45	702.3	5313.63	16761.9	9.905	56.3	
	RodE2_66	77	66	1.676	19	0.483	898.34	754.4	5456.11	17211.3	8.656	49.2	
	RodE2_69.8	78	69.8	1.773	-1.08	-0.027	938.46	776.7	5544.11	17488.9	8.269	47.0	
	RodE2_72.9	79	72.9	1.852	2.02	0.051	416.46	486.7	2412.22	7609.3	16.248	92.3	
	RodE2_74.9	80	74.9	1.902	4.02	0.102	499.59	532.9	2724.47	8594.3	11.764	66.8	
Gr-8	RodB3_50.2	169	50.2	1.275	3.2	0.081	1234.29	941.1	5235.20	16514.4	5.418	30.8	
	RodB3_54.1	170	54.1	1.374	7.1	0.180	1243.84	946.4	4722.57	14897.3	4.839	27.5	
	RodB3_56.9	171	56.9	1.445	9.9	0.251	1239.68	944.1	4212.97	13289.8	4.336	24.6	
	RodB3_60.1	172	60.1	1.527	13.1	0.333	801.25	700.5	4012.77	12658.3	7.525	42.7	
	RodB3_66.1	173	66.1	1.679	19.1	0.485	839.56	721.8	4551.55	14357.9	7.963	45.2	
	RodB3_69.9	174	69.9	1.775	-0.98	-0.025	869.82	738.6	4640.27	14637.7	7.710	43.8	
	RodB3_73	175	73	1.854	2.12	0.054	908.57	760.1	4776.21	15066.6	7.456	42.3	
	RodB3_75	176	75	1.905	4.12	0.105	970.47	794.5	5044.67	15913.4	7.181	40.8	
Gr-8	RodF3_50.1	89	50.1	1.273	3.1	0.079	1047.33	837.2	6269.72	19777.8	8.045	45.7	
	RodF3_54	90	54	1.372	7	0.178	1082.02	856.5	6351.52	20035.9	7.803	44.3	
	RodF3_57	91	57	1.448	10	0.254	795.58	697.4	4010.64	12651.6	7.602	43.2	
	RodF3_60	92	60	1.524	13	0.330	798.99	699.3	4543.54	14332.6	8.557	48.6	
	RodF3_66.1	93	66.1	1.679	19.1	0.485	851.85	728.6	4624.62	14588.4	7.921	45.0	
	RodF3_70	94	70	1.778	-0.88	-0.022	909.27	760.5	4743.23	14962.5	7.397	42.0	
	RodF3_73	95	73	1.854	2.12	0.054	983.62	801.8	5005.94	15791.2	6.995	39.7	
	RodF3_75	96	75	1.905	4.12	0.105	916.14	764.3	5451.33	17196.2	8.411	47.8	
Gr-8	RodE6_50.2	121	50.2	1.275	3.2	0.081	560.06	566.5	2940.84	9276.9	10.069	57.2	
	RodE6_54.1	122	54.1	1.374	7.1	0.180	606.81	592.5	3255.35	10269.0	9.608	54.6	
	RodE6_57	123	57	1.448	10	0.254	625.88	603.1	3515.53	11089.7	9.823	55.8	
	RodE6_60.2	124	60.2	1.529	13.2	0.335	700.54	644.6	3690.81	11642.6	8.533	48.5	
	RodE6_66.1	125	66.1	1.679	19.1	0.485	726.71	659.1	3777.14	11915.0	8.234	46.8	
	RodE6_70	126	70	1.778	-0.88	-0.022	763.44	679.5	3906.89	12324.3	7.886	44.8	
	RodE6_73.1	127	73.1	1.857	2.22	0.056	811.22	706.0	4437.61	13998.4	8.169	46.4	
	RodE6_75	128	75	1.905	4.12	0.105	832.42	717.8	4612.34	14549.6	8.172	46.4	

RBHT Steam Cooling with Droplet Injection Test SCD-4032-D

Matrix Test # Shakedown

Test Conditions

Test Date – 9/28/2005

Steady State Time Window: 14040 - 14940

Upper Plenum Pressure: 2.76 bar (40 psia)

Bundle Power: 72.0 kW

Bundle Inlet Reynolds Number: 8000

Bundle Inlet Steam Flow: 159.4 kg/hr (351 lbm/hr)

Droplet Injection Flow: 0.0151 kg/s (0.0333 lbm/s)

Droplet Injection Hole Diameter: 0.381 mm (.015 in)

Droplet Injection Elevation: 1.295 m (51 in)

Bundle Flow Area: $4.656 \times 10^{-3} \text{ m}^2$ ($5.012 \times 10^{-2} \text{ ft}^2$)

Test Notes

- No steam probes were traversed in this steady state window.

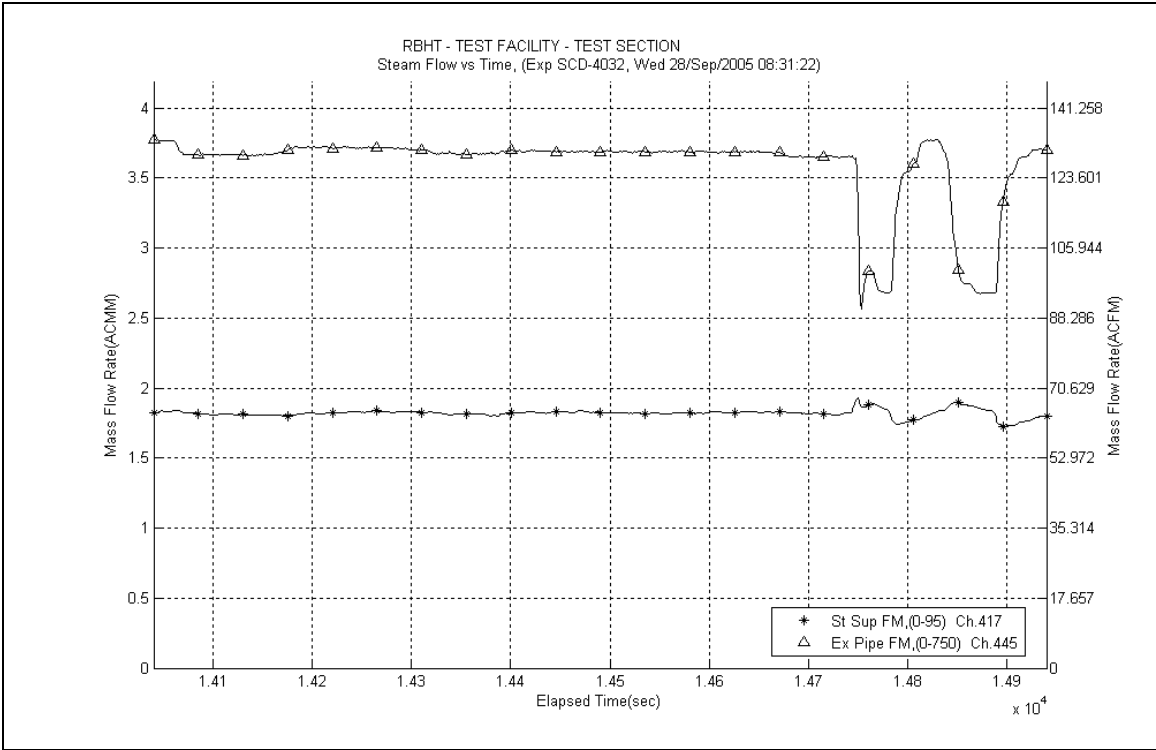

Figure A-165: Inlet and Exhaust Steam Flow Rates for Experiment 4032D

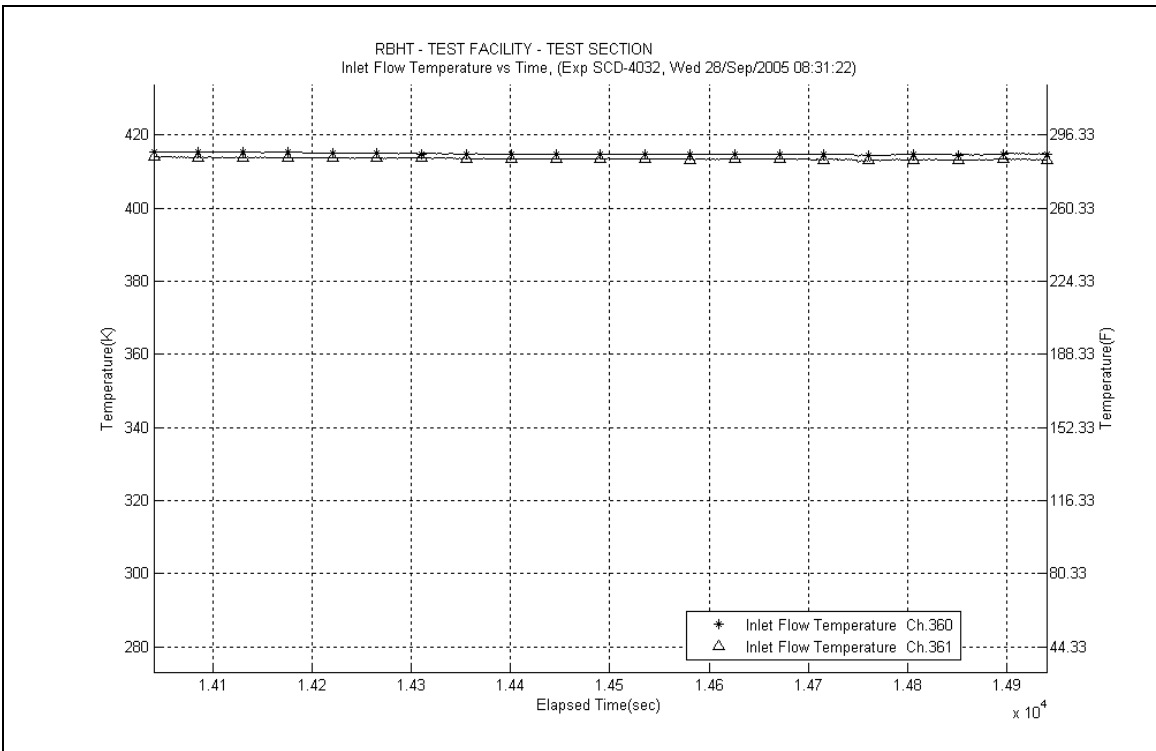

Figure A-166: Inlet Steam Temperature for Experiment 4032D

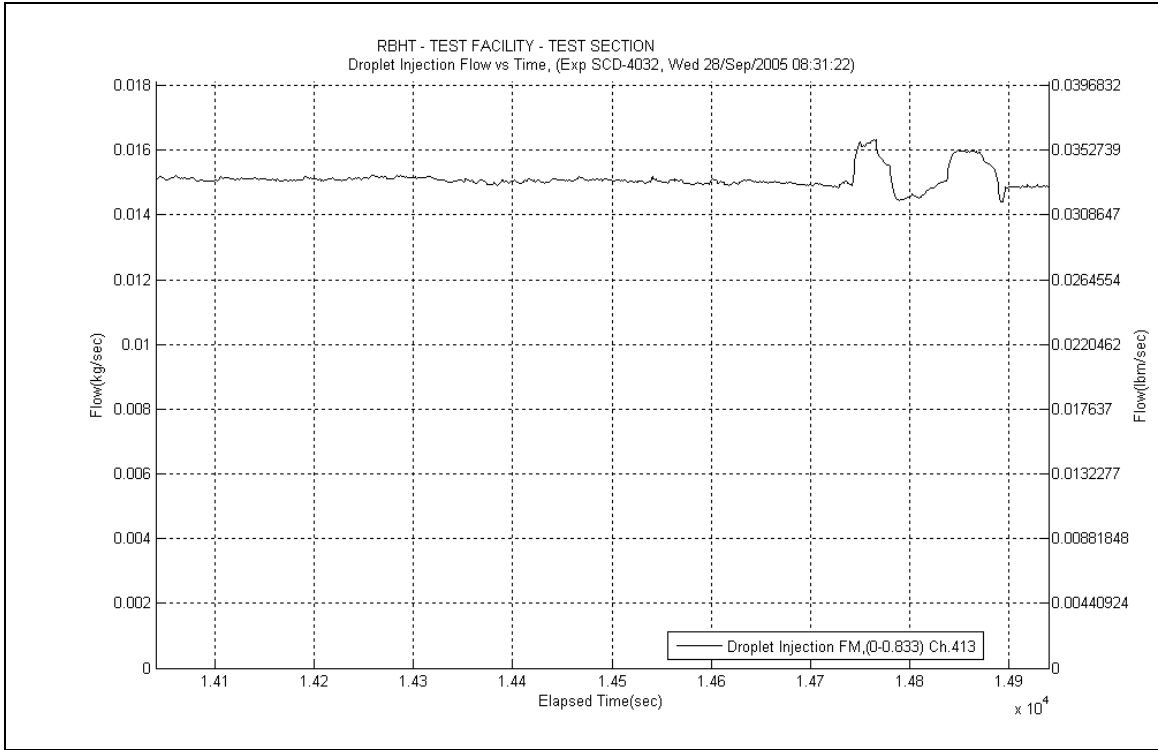

Figure A-167: Droplet Injection Flow Rate for Experiment 4032D

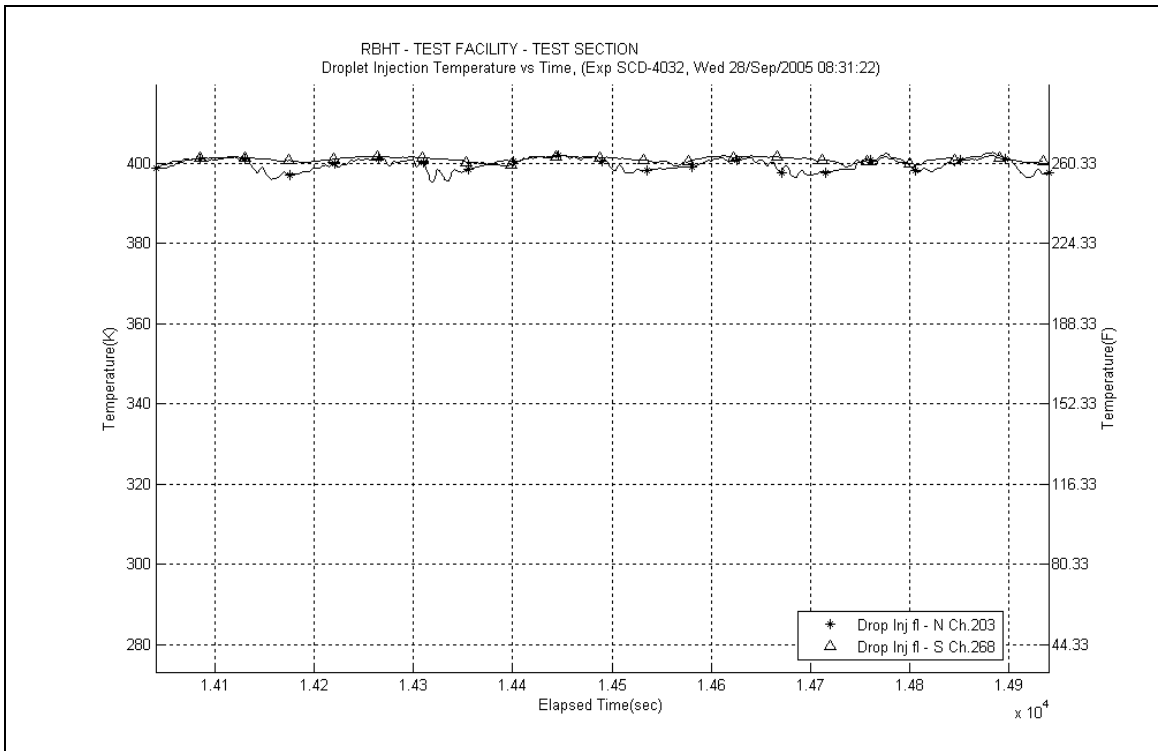

Figure A-168: Droplet Injection Temperature for Experiment 4032D

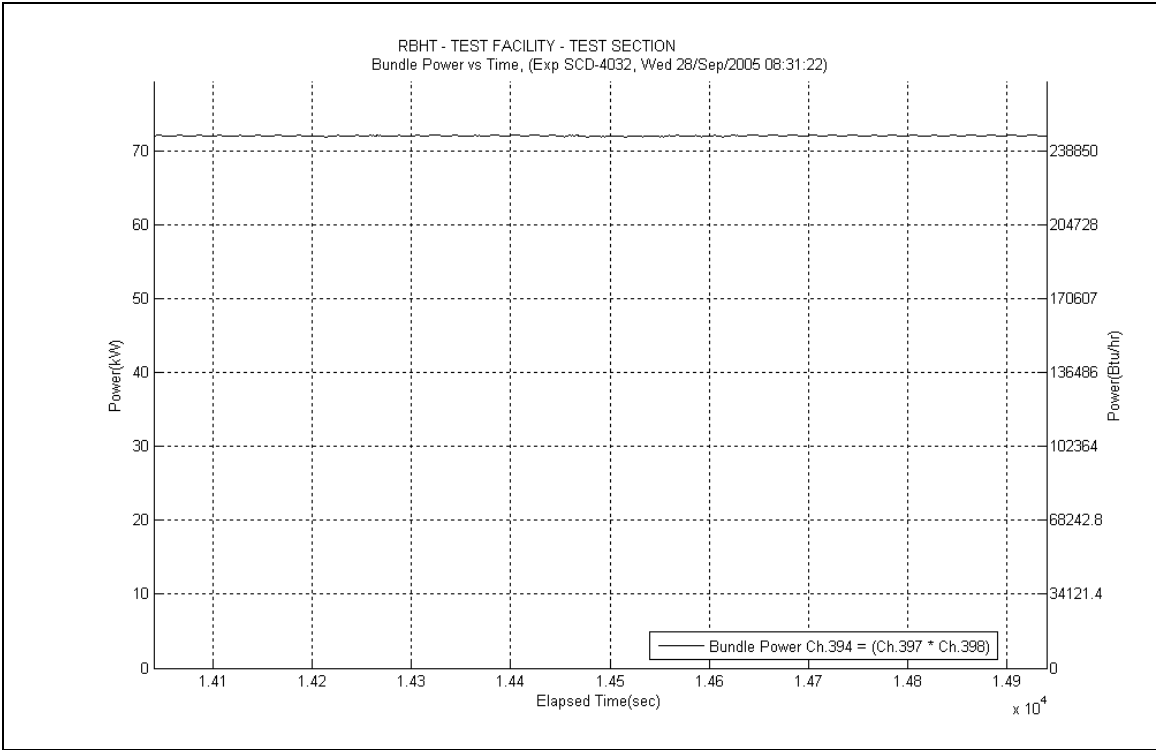

Figure A-169: Bundle Power for Experiment 4032D

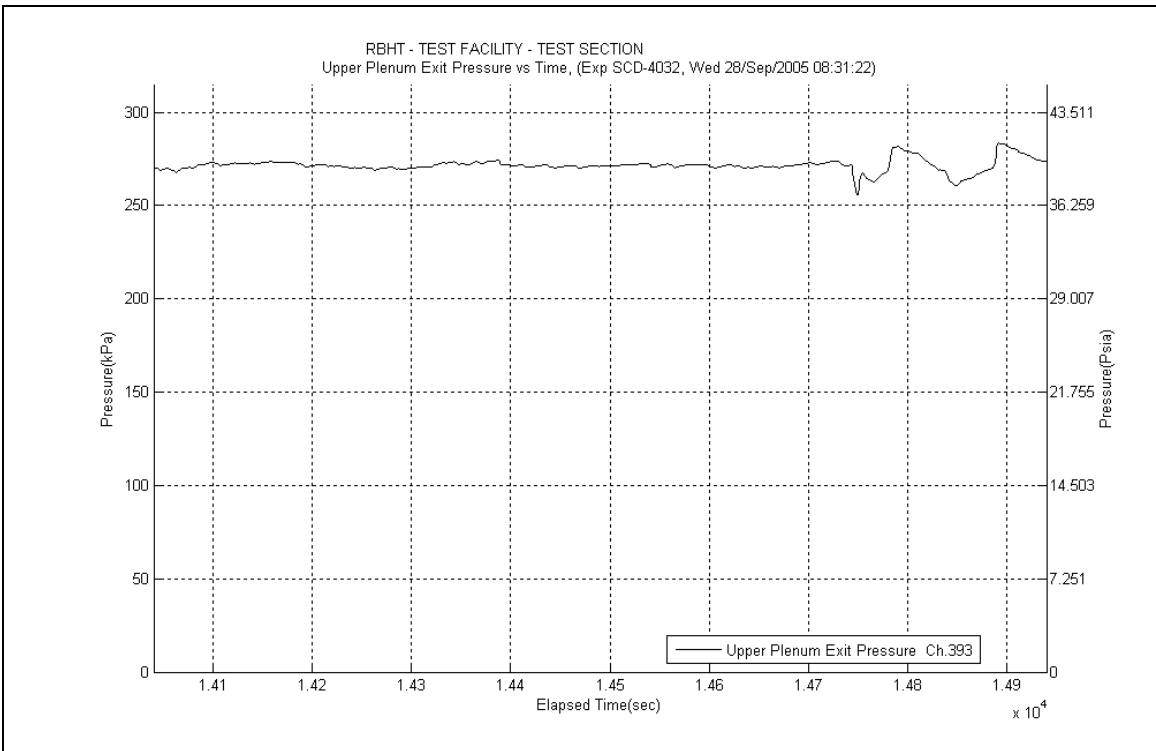

Figure A-170: Upper Plenum Pressure for Experiment 4032D

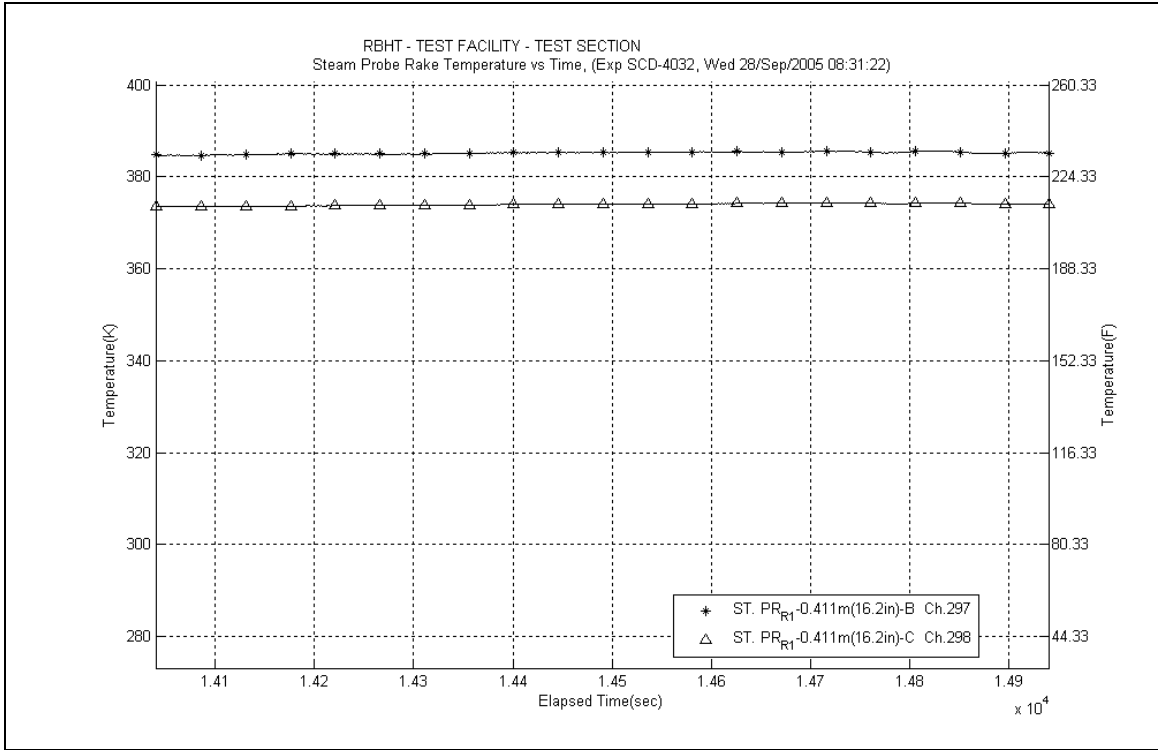

Figure A-171: Steam Probe Rake #1 Temperatures for Experiment 4032D

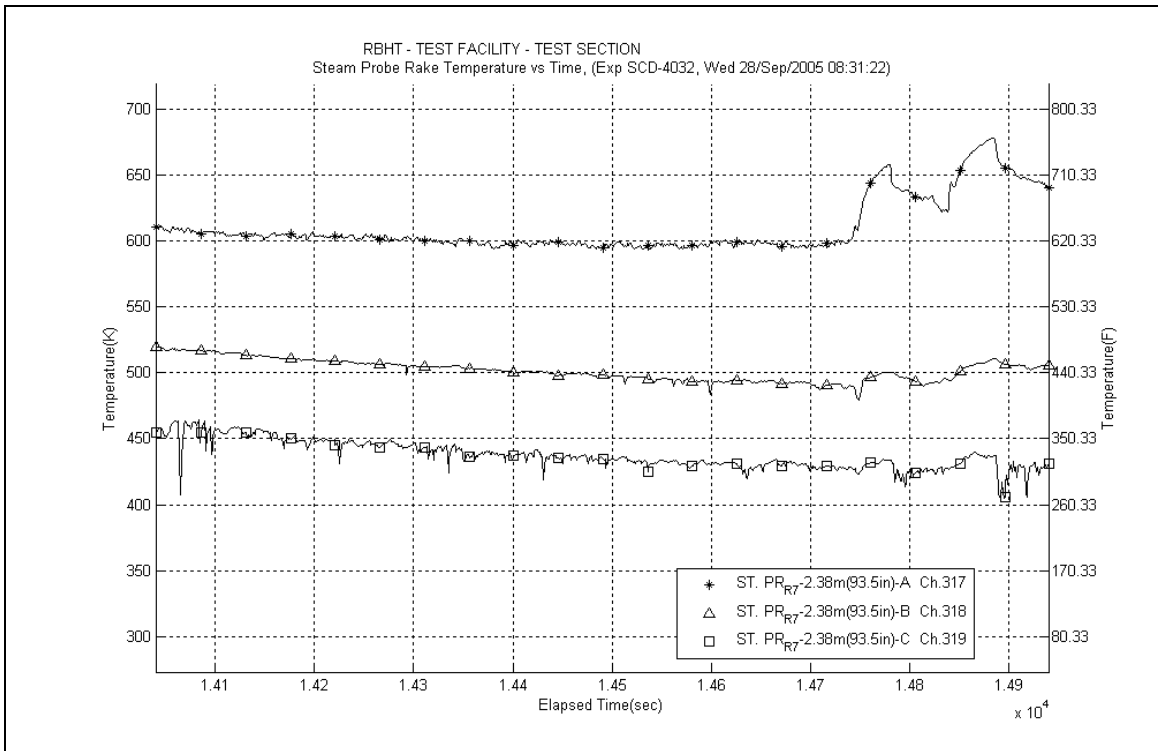

Figure A-172: Steam Probe Rake #7 Temperatures for Experiment 4032D

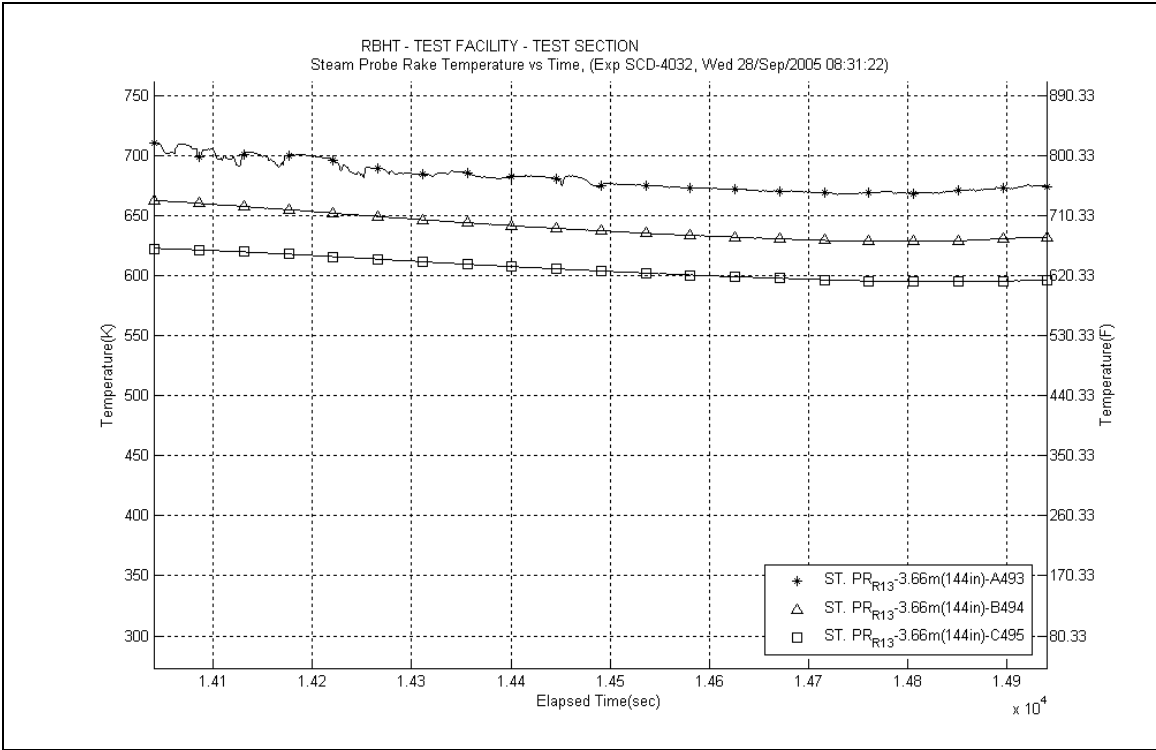

Figure A-173: Steam Probe Rake #13 Temperatures for Experiment 4032D

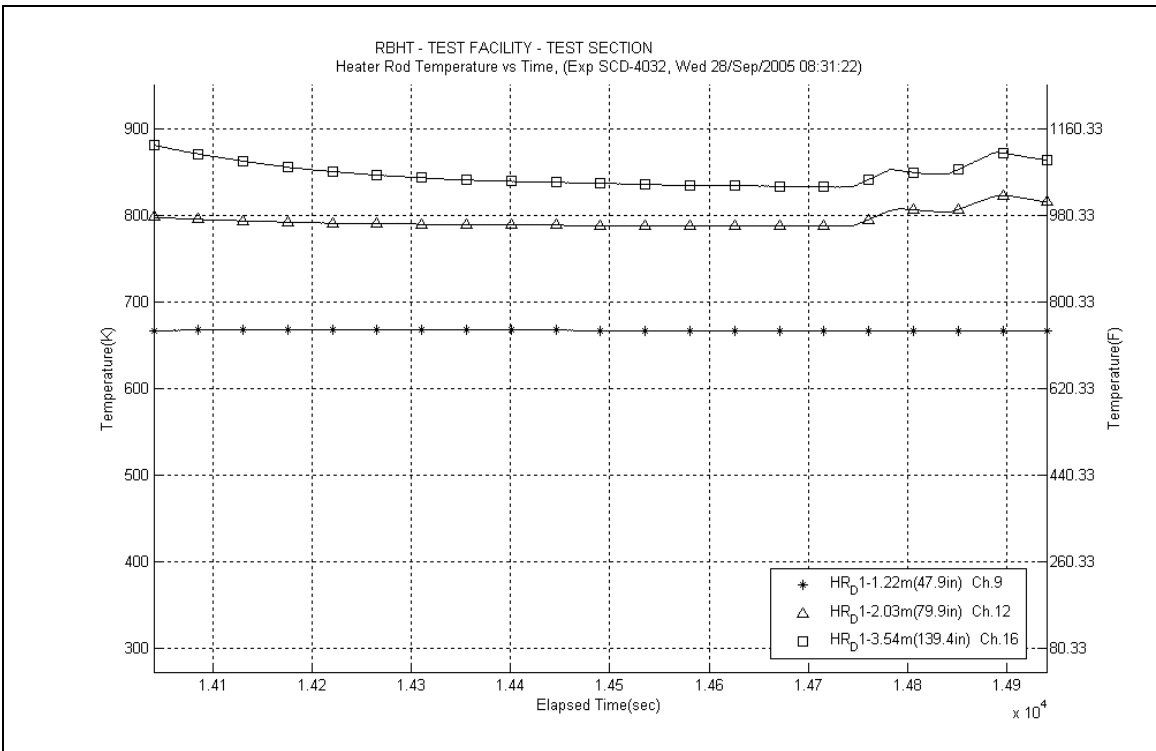

Figure A-174: Heater Rod D1 Temperatures for Experiment 4032D

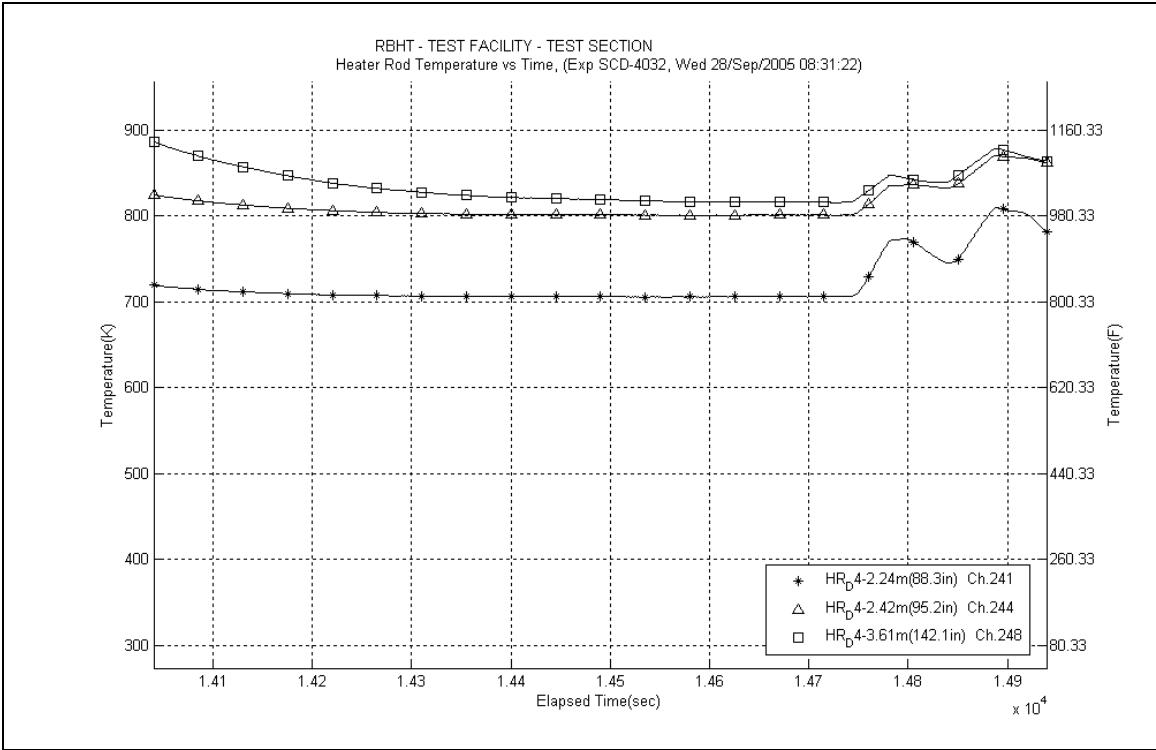

Figure A-175: Heater Rod D4 Temperatures for Experiment 4032D

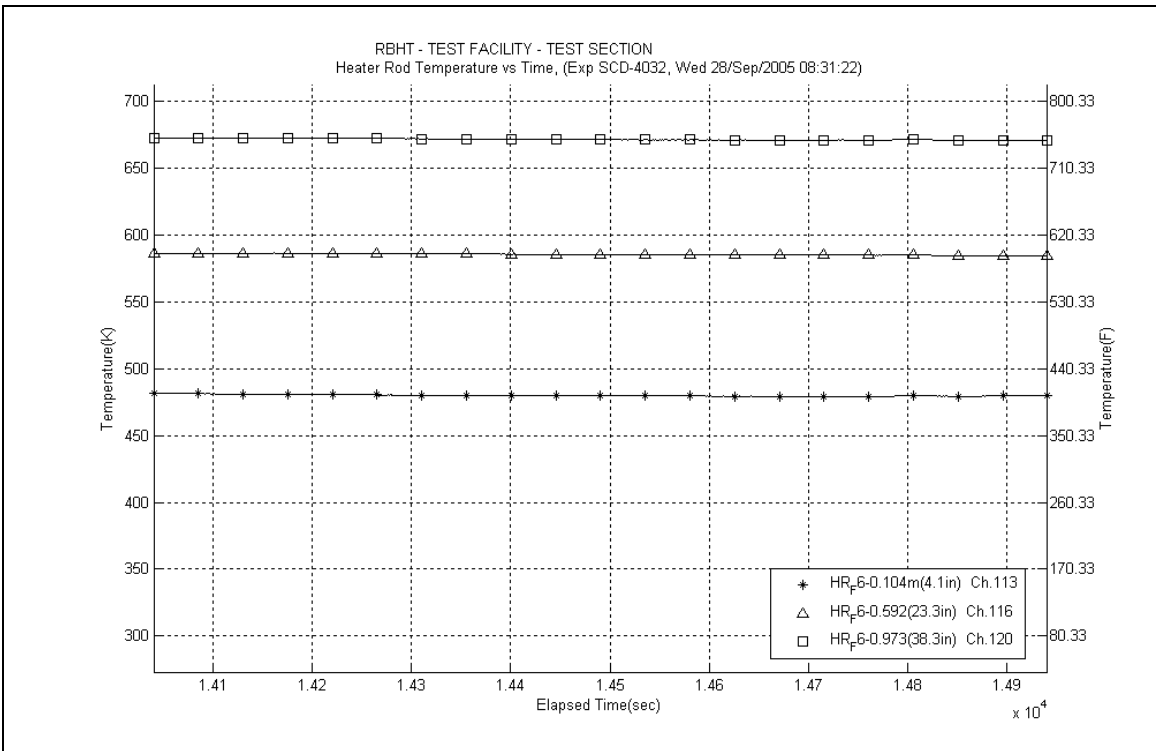

Figure A-176: Heater Rod F6 Temperatures for Experiment 4032D

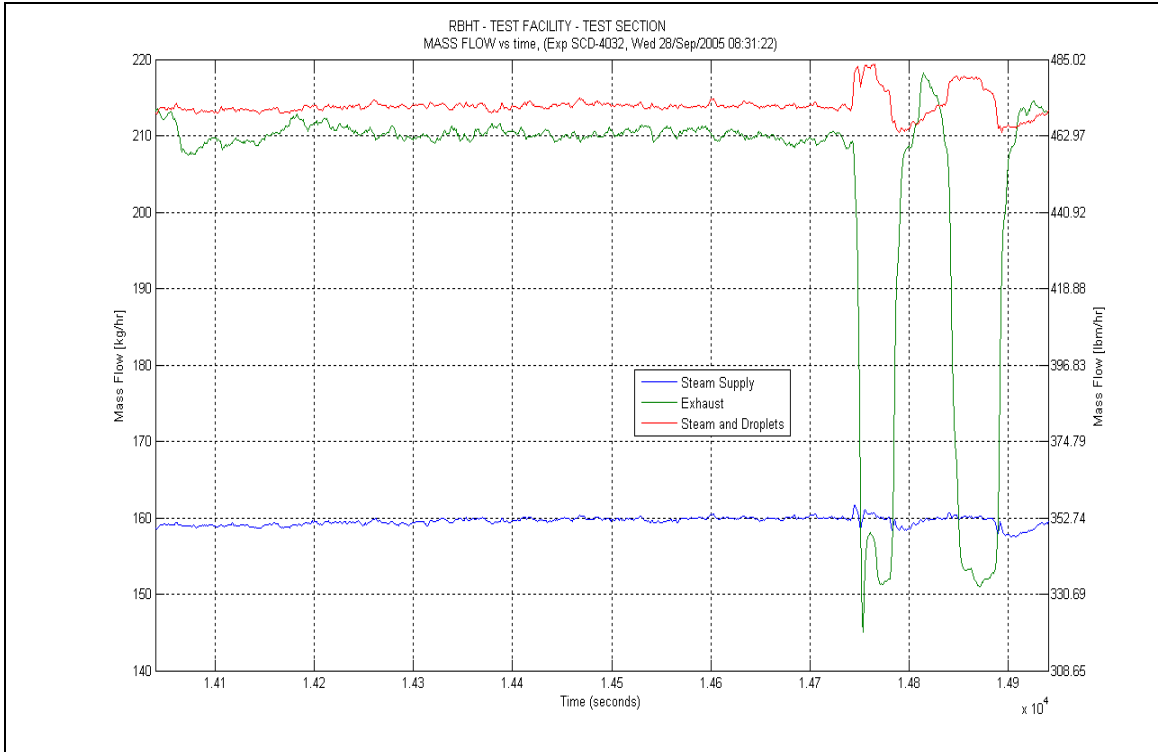

Figure A-177: Mass Flow for Experiment 4032D

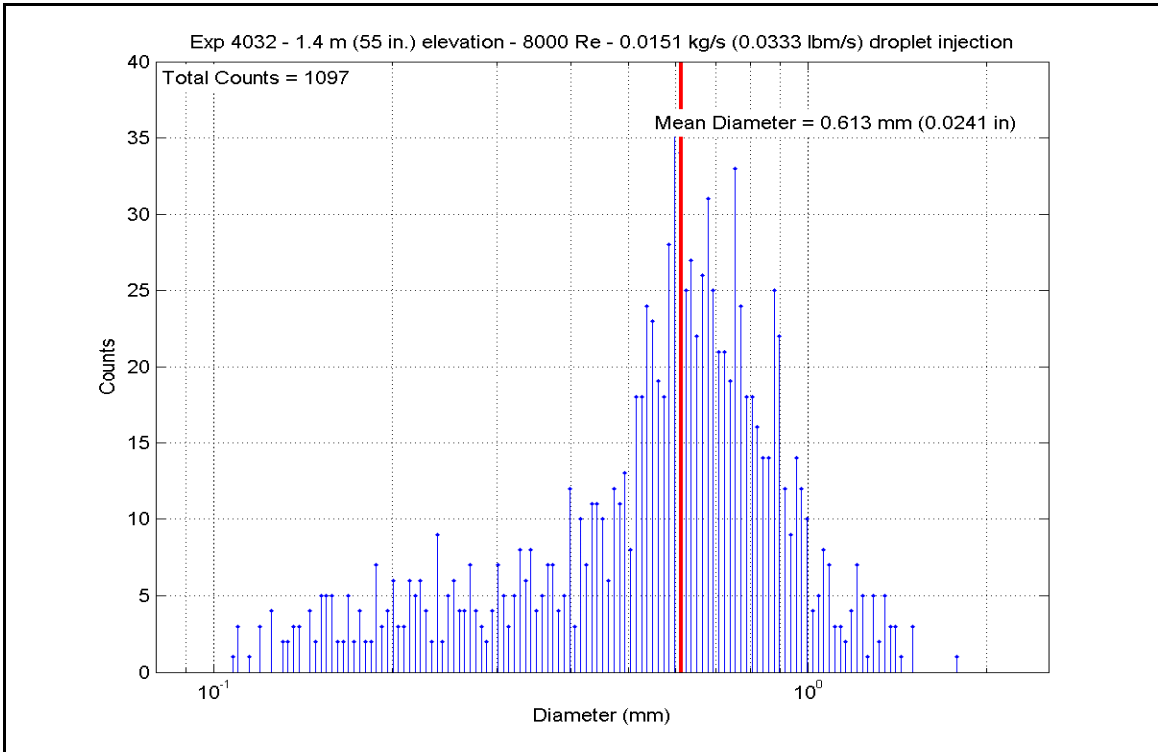

Figure A-178: Droplet Measurements at 1.397 m (55 in.) Elevation for Experiment 4032D

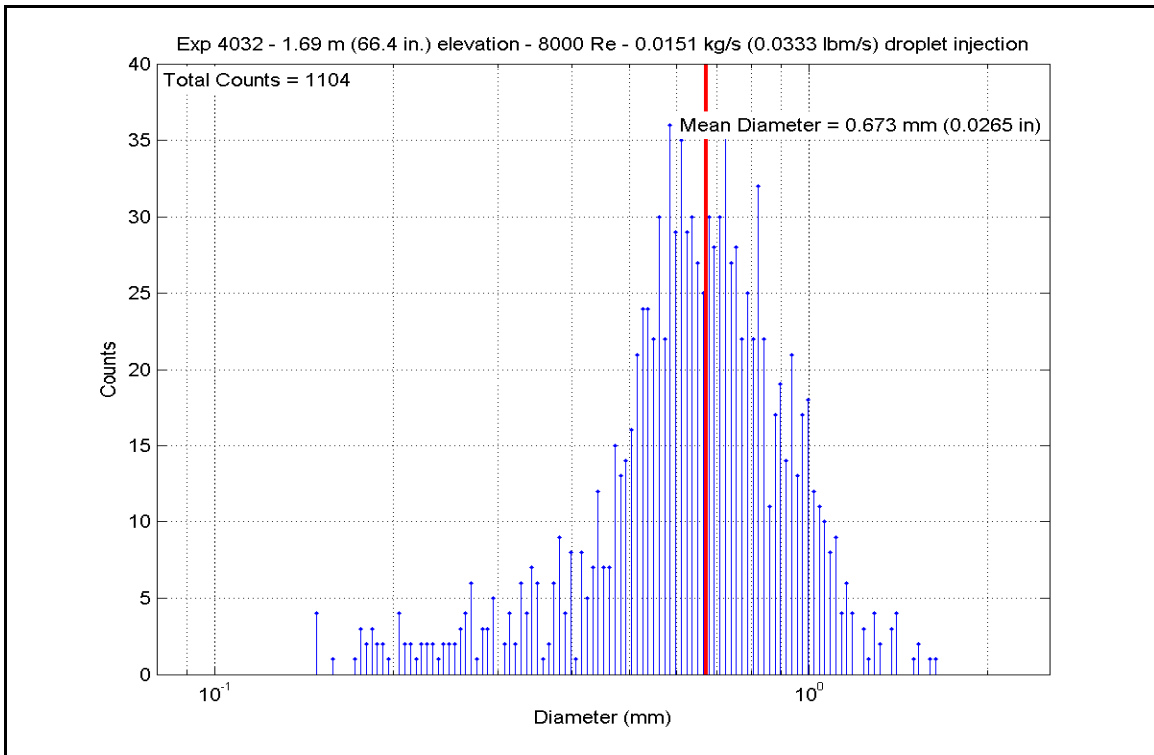

Figure A-179: Droplet Measurements at 1.687 m (66.4 in.) Elevation for Experiment 4032D

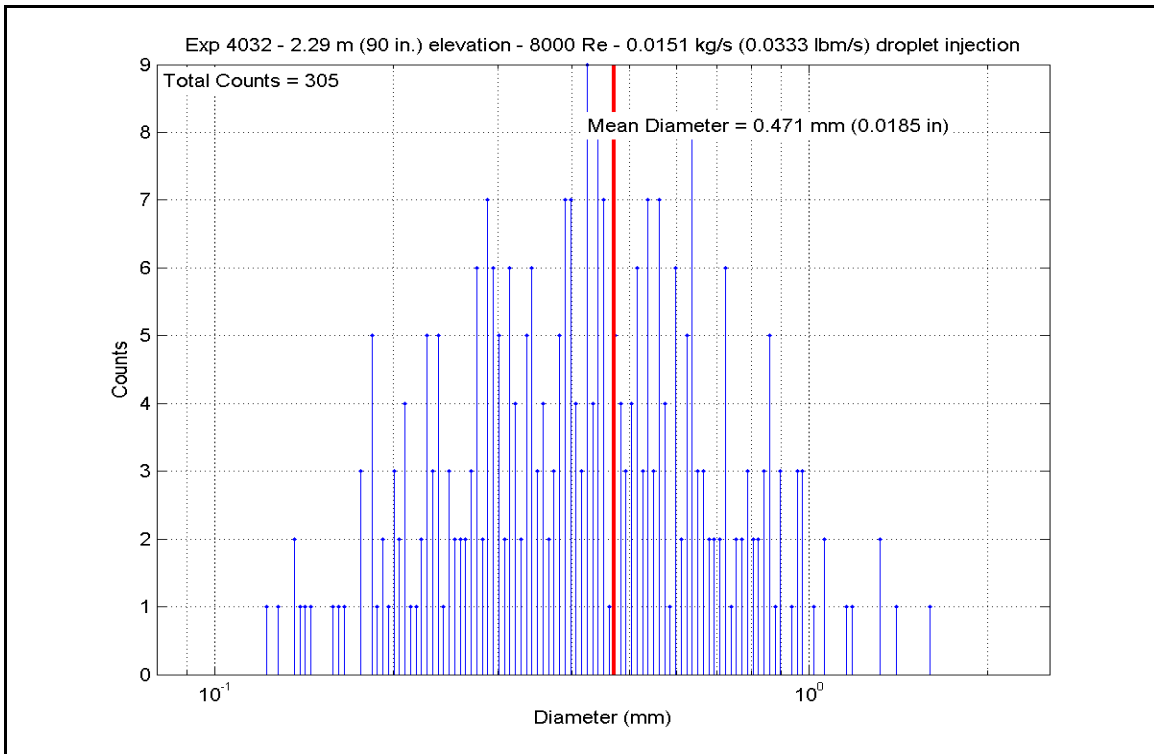

Figure A-180: Droplet Measurements at 2.286 m (90 in.) Elevation for Experiment 4032D

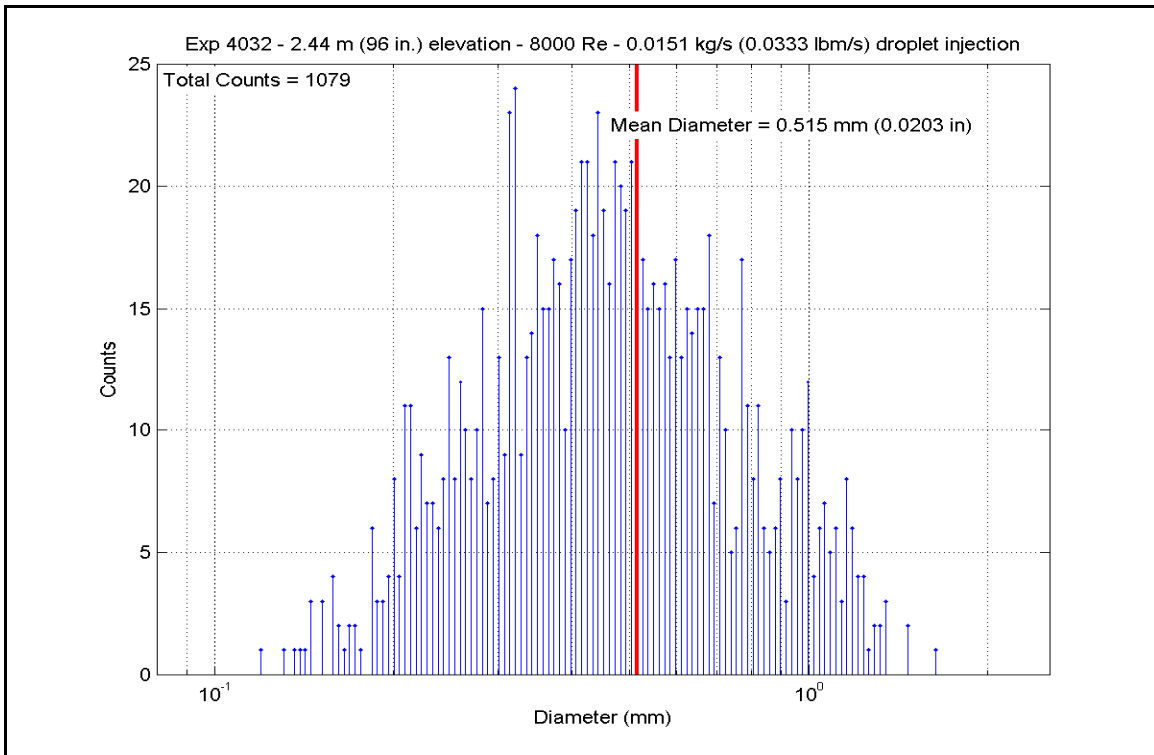

Figure A-181: Droplet Measurements at 2.438 m (96 in.) Elevation for Experiment 4032D

Error! Reference source not found.D

Test 4032-D		Inlet Reynolds:		8000		40 psia						
Matrix test shakedown		UP Pressure:		275.8 kPa		245674 Btu/hr						
Time Window: 14040-14940		Bundle Power:		7200 kW		351.0 lbm/hr						
Inner 3x3		Steam flow:		0.0442 kg/s		0.0332 lbm/s						
		Dropletflow:		0.0151 kg/s								
H.R. ID	H.R. Location	Channel Number	Elevation (in)	Elevation (m)	Zgrid (in)	Zgrid (m)	H.R. Tw (°F)	H.R. Tw (K)	H.R. q" (Btu/hr-ft2)	H.R. q" (W/m2)	h _{sat} (z) (Btu/hr-ft2-F)	h _{sat} (z) (W/m2-K)
Gr-3	RodD3_88.3	185	88.3	2.243	-0.2	-0.005	956.05	786.5	6088.827318	19207.2	8.849	50.3
	RodD3_91.3	186	91.3	2.319	2.8	0.071	995.03	808.2	6203.372571	19568.5	8.532	48.5
	RodD3_93.1	187	93.1	2.365	4.6	0.117	837.77	720.8	5860.996582	18488.5	10.287	58.4
	RodD3_95.3	188	95.3	2.421	6.8	0.173	934.91	774.8	6064.423654	19130.2	9.093	51.6
	RodD3_100.1	189	100.1	2.543	11.6	0.295	1045.12	836.0	6352.923931	20040.3	8.175	46.4
	RodD3_106.1	190	106.1	2.695	17.6	0.447	1141.89	889.8	6763.487507	21335.4	7.740	44.0
	RodD3_110	191	110	2.794	21.5	0.546	1076.05	853.2	6569.631316	20723.9	8.130	46.2
	RodD3_142.1	192	142.1	3.609	8.6	0.218	842.29	723.3	5840.869295	18425.0	10.171	57.8
Gr-3	RodC4_88.4	233	88.4	2.245	-0.1	-0.003	1074.80	852.5	6010.377568	18959.7	7.450	42.3
	RodC4_91.1	234	91.1	2.314	2.6	0.066	1103.42	868.4	5644.521377	17805.6	6.757	38.4
	RodC4_93.4	235	93.4	2.372	4.9	0.124	1121.83	878.6	5203.580788	16414.7	6.094	34.6
	RodC4_95.3	236	95.3	2.421	6.8	0.173	1122.26	878.8	4742.984453	14961.7	5.552	31.5
	RodC4_100.1	237	100.1	2.543	11.6	0.295	1049.33	838.3	6494.707385	20487.6	8.312	47.2
	RodC4_106.1	238	106.1	2.695	17.6	0.447	1084.11	857.7	6723.896169	21210.5	8.239	46.8
	RodC4_110	239	110	2.794	21.5	0.546	1107.67	870.7	6855.96724	21627.1	8.165	46.4
	RodC4_142.2	240	142.2	3.612	8.7	0.221	975.75	797.5	5013.798445	15816.0	7.084	40.2
Gr-3	RodD4_88.3	241	88.3	2.243	-0.2	-0.005	844.28	724.4	5318.05608	16775.8	9.228	52.4
	RodD4_91.3	242	91.3	2.319	2.8	0.071	891.85	750.8	5417.298168	17088.9	8.684	49.3
	RodD4_93.2	243	93.2	2.367	4.7	0.119	959.07	788.2	4888.699056	15421.4	7.074	40.2
	RodD4_95.2	244	95.2	2.418	6.7	0.170	1074.75	852.5	5761.7407	18175.4	7.142	40.6
	RodD4_100.1	245	100.1	2.543	11.6	0.295	1154.43	896.7	6834.159911	21558.4	7.710	43.8
	RodD4_106.1	246	106.1	2.695	17.6	0.447	1061.19	844.9	6752.237646	21299.9	8.513	48.3
	RodD4_142.1	248	142.1	3.609	8.6	0.218	753.71	674.1	5206.241716	16423.1	10.719	60.9
Gr-3	RodE4_88.4	201	88.4	2.245	-0.1	-0.003	932.46	773.4	5996.199334	18915.0	9.024	51.2
	RodE4_91.2	202	91.2	2.316	2.7	0.069	1014.47	819.0	6219.566907	19619.6	8.332	47.3
	RodE4_95.3	204	95.3	2.421	6.8	0.173	1055.35	841.7	2616.975515	8255.2	3.324	18.9
	RodE4_100.9	205	100.9	2.563	12.4	0.315	1062.56	845.7	6627.169906	20905.4	8.341	47.4
	RodE4_142.3	208	142.3	3.614	8.8	0.224	842.53	723.4	5820.350984	18360.3	10.131	57.5

Error! Reference source not found.D, continued

Gr-4	H.R. Location	Channel Number	Elevation (in)	Elevation (m)	Zgrid (in)	Zgrid (m)	H.R. Tw (°F)	H.R. Tw (K)	H.R. q" (Btu/hr-ft2)	H.R. q" (W/m2)	h _{sat} (Z) (Btu/hr-ft2-F)	h _{sat} (Z) (W/m2-K)
	RodE3_63.4	193	63.4	1.610	16.4	0.417	1076.91	853.7	3581.52	11297.9	4.428	25.1
	RodE3_113.6	194	113.6	2.885	0.85	0.022	1037.11	831.5	5966.85	18822.4	7.758	44.1
	RodE3_115.5	195	115.5	2.934	2.75	0.070	994.88	808.1	4987.51	15733.1	6.862	39.0
	RodE3_118.5	196	118.5	3.010	5.75	0.146	1115.27	875.0	5958.69	18796.7	7.033	39.9
	RodE3_122.7	197	122.7	3.117	9.95	0.253	1144.88	891.4	5619.89	17727.9	6.409	36.4
	RodE3_126.5	198	126.5	3.213	13.75	0.349	1161.68	900.8	5136.63	16203.5	5.748	32.6
	RodE3_131.7	199	131.7	3.345	-1.8	-0.046	1160.80	900.3	4692.11	14801.3	5.256	29.8
	RodE3_135.6	200	135.6	3.444	2.1	0.053	1060.35	844.5	4035.62	12730.4	5.093	28.9
Gr-4	RodC5_63.7	225	63.7	1.618	16.7	0.424	929.57	771.8	4841.90	15273.8	7.319	41.6
	RodC5_113.6	226	113.6	2.885	0.85	0.022	1006.71	814.7	6253.70	19727.3	8.466	48.1
	RodC5_115.7	227	115.7	2.939	2.95	0.075	1016.87	820.3	4103.59	12944.8	5.480	31.1
	RodC5_122.7	229	122.7	3.117	9.95	0.253	1037.14	831.6	3654.67	11528.6	4.752	27.0
	RodC5_126.7	230	126.7	3.218	13.95	0.354	839.51	721.8	4459.68	14068.1	7.803	44.3
	RodC5_131.6	231	131.6	3.343	-1.9	-0.048	840.44	722.3	4604.45	14524.7	8.044	45.7
	RodC5_135.7	232	135.7	3.447	2.2	0.056	889.23	749.4	4713.93	14870.1	7.588	43.1
Gr-4	RodE5_63.6	209	63.6	1.615	16.6	0.422	1044.78	835.8	2588.39	8165.1	3.332	18.9
	RodE5_113.6	210	113.6	2.885	0.85	0.022	1136.72	886.9	6894.64	21749.1	7.937	45.1
	RodE5_115.4	211	115.4	2.931	2.65	0.067	1009.74	816.3	6355.61	20048.8	8.569	48.7
	RodE5_118.7	212	118.7	3.015	5.95	0.151	1048.28	837.8	2668.09	8416.5	3.419	19.4
	RodE5_122.6	213	122.6	3.114	9.85	0.250	834.21	718.8	5893.15	18589.9	10.408	59.1
	RodE5_126.6	214	126.6	3.216	13.85	0.352	924.14	768.8	6101.34	19246.7	9.299	52.8
	RodE5_131.6	215	131.6	3.343	-1.9	-0.048	964.99	791.5	6212.16	19596.3	8.913	50.6
	RodE5_135.6	216	135.6	3.444	2.1	0.053	1001.02	811.5	6325.28	19953.1	8.629	49.0
Gr-5	RodC3_79.8	177	79.8	2.027	8.92	0.227	975.19	797.1	6113.77	19285.9	8.645	49.1
	RodC3_85.6	178	85.6	2.174	14.72	0.374	1005.52	814.0	6206.10	19577.1	8.415	47.8
	RodC3_88.5	179	88.5	2.248	0	0.000	1046.51	836.8	2638.85	8324.3	3.390	19.2
	RodC3_92.4	180	92.4	2.347	3.9	0.099	802.16	701.0	4451.53	14042.4	8.334	47.3
	RodC3_94.4	181	94.4	2.398	5.9	0.150	831.10	717.1	4604.34	14524.4	8.177	46.4
	RodC3_97.2	182	97.2	2.469	8.7	0.221	1132.00	884.3	6766.83	21346.0	7.832	44.5
	RodC3_108.8	183	108.8	2.764	20.3	0.516	1053.98	840.9	6354.36	20044.8	8.085	45.9
Gr-8	RodD5_50	217	50	1.270	3	0.076	1056.18	842.1	4372.73	13793.8	5.548	31.5
	RodD5_54.1	218	54.1	1.374	7.1	0.180	1114.63	874.6	5017.52	15827.8	5.926	33.7
	RodD5_56.9	219	56.9	1.445	9.9	0.251	1111.10	872.7	4578.78	14443.8	5.431	30.8
	RodD5_60	220	60	1.524	13	0.330	1003.07	812.6	3959.05	12488.8	5.386	30.6
	RodD5_66.1	221	66.1	1.679	19.1	0.485	1021.16	822.7	3524.08	11116.7	4.679	26.6
	RodD5_69.9	222	69.9	1.775	-0.98	-0.025	844.20	724.4	5936.56	18726.9	10.303	58.5
	RodD5_72.9	223	72.9	1.852	2.02	0.051	928.52	771.2	6116.12	19293.3	9.259	52.6
	RodD5_74.9	224	74.9	1.902	4.02	0.102	974.06	796.5	6249.29	19713.4	8.851	50.3

Error! Reference source not found.D, continued

H.R. ID	H.R. Location	Channel Number	Elevation (in)	Elevation (m)	Zgrid (in)	Zgrid (m)	H.R. Tw (°F)	H.R. Tw (K)	H.R. q" (Btu/hr-ft2)	H.R. q" (W/m2)	h _{sat} (z) (Btu/hr-ft2-F)	h _{sat} (z) (W/m2-K)	
Gr-2	RodB5_41	153	41	1.041	13.5	0.343	547.69	559.6	2975.42	9386.0	10.638	60.4	
	RodB5_52.9	154	52.9	1.344	5.9	0.150	593.36	585.0	3276.79	10336.6	10.071	57.2	
	RodB5_55	155	55	1.397	8	0.203	624.05	602.1	3534.70	11150.2	9.927	56.4	
	RodB5_57.8	156	57.8	1.468	10.8	0.274	692.25	640.0	3706.95	11693.6	8.738	49.6	
	RodB5_64	157	64	1.626	17	0.432	719.90	655.3	3792.40	11963.1	8.392	47.7	
	RodB5_73.9	158	73.9	1.877	3.02	0.077	758.28	676.6	3925.17	12381.9	8.006	45.5	
	RodB5_75.9	159	75.9	1.928	5.02	0.128	790.75	694.7	4062.69	12815.8	7.772	44.1	
	RodB5_76.9	160	76.9	1.953	6.02	0.153	807.33	703.9	4554.06	14365.8	8.444	48.0	
	Gr-2	RodF5_41	105	41	1.041	13.5	0.343	548.35	560.0	2981.33	9404.6	10.634	60.4
		RodF5_53.1	106	53.1	1.349	6.1	0.155	592.83	584.7	3278.24	10341.2	10.092	57.3
		RodF5_55	107	55	1.397	8	0.203	612.84	595.8	3531.75	11140.9	10.242	58.2
		RodF5_57.8	108	57.8	1.468	10.8	0.274	687.74	637.4	3700.75	11674.0	8.817	50.1
		RodF5_64	109	64	1.626	17	0.432	712.08	651.0	3785.36	11940.9	8.524	48.4
		RodF5_73.8	110	73.8	1.875	2.92	0.074	747.42	670.6	3912.60	12342.3	8.161	46.3
		RodF5_75.8	111	75.8	1.925	4.92	0.125	823.44	712.8	4446.62	14026.9	8.006	45.5
		RodF5_76.8	112	76.8	1.951	5.92	0.150	874.38	741.1	4599.41	14508.8	7.585	43.1
Gr-2		RodC2_41	57	41	1.041	13.5	0.343	982.52	801.2	2836.71	8948.4	3.970	22.5
		RodC2_53.1	58	53.1	1.349	6.1	0.155	730.99	661.5	4373.66	13796.7	9.447	53.6
		RodC2_55	59	55	1.397	8	0.203	915.77	764.1	5630.24	17760.6	8.692	49.4
		RodC2_57.8	60	57.8	1.468	10.8	0.274	971.79	795.3	6402.34	20196.2	9.097	51.7
	RodC2_63.9	61	63.9	1.623	16.9	0.429	1052.26	840.0	5992.46	18903.2	7.641	43.4	
	RodC2_73.8	62	73.8	1.875	2.92	0.074	1080.11	855.4	4621.21	14577.6	5.690	32.3	
	RodC2_75.8	63	75.8	1.925	4.92	0.125	902.62	756.8	5468.49	17250.4	8.617	48.9	
	RodC2_76.8	64	76.8	1.951	5.92	0.150	917.64	765.2	5516.05	17400.4	8.491	48.2	
Gr-2	RodC6_40.9	137	40.9	1.039	13.4	0.340	876.36	742.2	4708.92	14854.3	7.740	44.0	
	RodC6_52.8	138	52.8	1.341	5.8	0.147	882.54	745.7	4808.80	15169.4	7.825	44.4	
	RodC6_54.8	139	54.8	1.392	7.8	0.198	949.28	782.8	5097.80	16081.0	7.483	42.5	
	RodC6_57.8	140	57.8	1.468	10.8	0.274	771.00	683.7	5188.41	16366.8	10.315	58.6	
	RodC6_63.8	141	63.8	1.621	16.8	0.427	860.06	733.2	5321.82	16787.7	8.989	51.0	
	RodC6_73.7	142	73.7	1.872	2.82	0.072	903.32	757.2	5420.95	17100.4	8.533	48.5	
	RodC6_75.8	143	75.8	1.925	4.92	0.125	967.66	793.0	5639.63	17790.2	8.060	45.8	
	RodC6_76.8	144	76.8	1.951	5.92	0.150	871.09	739.3	5765.97	18188.8	9.561	54.3	

Error! Reference source not found.D, continued

5x5 periphery		H.R.	Channel	Elevation	Elevation	Zgrid	Zgrid	H.R. Tw	H.R. Tw	H.R. q"	H.R. q"	h _{sat} (z)	h _{sat} (z)
Gr-3	Location	Number	(in)	(m)	(m)	(in)	(m)	(°F)	(K)	(W/m ²)	(Btu/hr-ft ² -F)	(W/m ² -K)	(W/m ² -K)
	RodB4_88.4	161	88.4	2.245	-0.1	-0.003	905.34	758.3	5511.33	17385.5	8.647	49.1	49.1
	RodB4_91.3	162	91.3	2.319	2.8	0.071	923.50	768.4	5560.30	17540.0	8.483	48.2	48.2
	RodB4_93.3	163	93.3	2.370	4.8	0.122	402.45	479.0	2454.05	7741.3	18.252	103.7	103.7
	RodB4_95.1	164	95.1	2.416	6.6	0.168	485.96	525.3	2761.37	8710.7	12.669	71.9	71.9
	RodB4_100	165	100	2.540	11.5	0.292	1105.01	869.3	6680.94	21075.0	7.982	45.3	45.3
	RodB4_106	166	106	2.692	17.5	0.445	1132.86	884.7	6819.14	21511.0	7.885	44.8	44.8
	RodB4_109.9	167	109.9	2.791	21.4	0.544	1057.89	843.1	6261.95	19753.3	7.928	45.0	45.0
	RodB4_142.3	168	142.3	3.614	8.8	0.224	872.58	740.1	5407.30	17057.3	8.944	50.8	50.8
Gr-5	RodF4_85.6	98	85.6	2.174	14.72	0.374	917.53	765.1	5431.23	17132.8	8.362	47.5	47.5
	RodF4_88.4	99	88.4	2.245	-0.1	-0.003	933.08	773.7	5479.16	17284.0	8.238	46.8	46.8
	RodF4_92.4	100	92.4	2.347	3.9	0.099	403.23	479.4	2463.89	7772.3	18.220	103.5	103.5
	RodF4_94.3	101	94.3	2.395	5.8	0.147	492.39	528.9	2765.75	8724.6	12.325	70.0	70.0
	RodF4_97.2	102	97.2	2.469	8.7	0.221	1130.95	883.7	6869.72	21670.5	7.961	45.2	45.2
	RodF4_108.8	103	108.8	2.764	20.3	0.516	1060.40	844.5	6669.69	21039.5	8.417	47.8	47.8
	RodF4_111	104	111	2.819	-1.75	-0.044	1067.76	848.6	6606.60	20840.5	8.261	46.9	46.9
Gr-6	RodD2_103.2	65	103.2	2.621	14.7	0.373	1041.32	833.9	6447.24	20337.8	8.337	47.3	47.3
	RodD2_106	66	106	2.692	17.5	0.445	1123.58	879.6	6727.54	21222.0	7.863	44.7	44.7
	RodD2_112.6	67	112.6	2.860	-0.15	-0.004	1054.48	841.2	6505.73	20522.3	8.272	47.0	47.0
	RodD2_114.9	68	114.9	2.918	2.15	0.055	1102.42	867.8	5997.19	18918.1	7.187	40.8	40.8
	RodD2_117.4	69	117.4	2.982	4.65	0.118	1123.24	879.4	5696.10	17968.4	6.660	37.8	37.8
	RodD2_120.8	70	120.8	3.068	8.05	0.204	1148.29	893.3	5292.09	16693.9	6.012	34.1	34.1
	RodD2_124.8	71	124.8	3.170	12.05	0.306	1156.08	897.6	4800.58	15143.4	5.406	30.7	30.7
	RodD2_128.6	72	128.6	3.266	15.85	0.403	1145.26	891.6	4325.92	13646.1	4.931	28.0	28.0
Gr-6	RodD6_103.1	129	103.1	2.619	14.6	0.371	1081.98	856.5	6162.66	19440.1	7.571	43.0	43.0
	RodD6_106	130	106	2.692	17.5	0.445	1087.03	859.3	6498.78	20500.4	7.935	45.1	45.1
	RodD6_112.9	131	112.9	2.868	0.15	0.004	1043.11	834.9	6195.82	19544.7	7.993	45.4	45.4
	RodD6_114.9	132	114.9	2.918	2.15	0.055	842.06	723.2	4482.07	14138.7	7.808	44.3	44.3
	RodD6_116.8	133	116.8	2.967	4.05	0.103	865.17	736.0	4631.57	14610.3	7.756	44.0	44.0
	RodD6_120.9	134	120.9	3.071	8.15	0.207	978.79	799.1	6172.16	19470.1	8.683	49.3	49.3
	RodD6_124.8	135	124.8	3.170	12.05	0.306	1017.64	820.7	6290.34	19842.9	8.391	47.7	47.7
	RodD6_128.7	136	128.7	3.269	15.95	0.405	1063.80	846.4	2469.54	7790.2	3.103	17.6	17.6

Error! Reference source not found.D, continued

5x5 periphery		H.R.	Channel Number	Elevation (in)	Elevation (m)	Zgrid (in)	Zgrid (m)	H.R. Tw (°F)	H.R. Tw (K)	H.R. q" (Btu/hr-ft2)	H.R. q" (W/m2)	h _{sat} (z) (Btu/hr-ft2-F)	h _{sat} (z) (W/m2-K)
Gr-8	RodE2_50.1	73	50.1	1.273	3.1	0.079	908.58	760.1	4747.16	14974.9	7.411	42.1	
	RodE2_54	74	54	1.372	7	0.178	937.67	776.3	4867.60	15354.9	7.269	41.3	
	RodE2_56.9	75	56.9	1.445	9.9	0.251	959.55	788.5	5134.75	16197.6	7.425	42.2	
	RodE2_59.9	76	59.9	1.521	12.9	0.328	774.54	685.7	5224.47	16480.6	10.314	58.6	
	RodE2_66	77	66	1.676	19	0.483	867.22	737.2	5359.32	16906.0	8.944	50.8	
	RodE2_69.8	78	69.8	1.773	-1.08	-0.027	906.81	759.2	5458.83	17219.9	8.545	48.5	
	RodE2_72.9	79	72.9	1.852	2.02	0.051	412.46	484.5	2421.61	7639.0	16.764	95.2	
	RodE2_74.9	80	74.9	1.902	4.02	0.102	494.45	530.1	2742.17	8650.2	12.109	68.8	
Gr-8	RodB3_50.2	169	50.2	1.275	3.2	0.081	1094.32	863.3	5294.18	16700.5	6.407	36.4	
	RodB3_54.1	170	54.1	1.374	7.1	0.180	1099.06	866.0	4809.39	15171.2	5.787	32.9	
	RodB3_56.9	171	56.9	1.445	9.9	0.251	1088.76	860.2	4314.70	13610.7	5.257	29.9	
	RodB3_60.1	172	60.1	1.527	13.1	0.333	798.04	698.7	4038.80	12740.4	7.620	43.3	
	RodB3_66.1	173	66.1	1.679	19.1	0.485	867.40	737.3	4556.48	14373.4	7.602	43.2	
	RodB3_69.9	174	69.9	1.775	-0.98	-0.025	891.30	750.5	4646.06	14656.0	7.454	42.3	
	RodB3_73	175	73	1.854	2.12	0.054	915.92	764.2	4773.46	15057.9	7.367	41.8	
	RodB3_75	176	75	1.905	4.12	0.105	956.02	786.5	5031.66	15872.4	7.313	41.5	
Gr-8	RodF3_50.1	89	50.1	1.273	3.1	0.079	975.03	797.1	6103.31	19252.9	8.632	49.0	
	RodF3_54	90	54	1.372	7	0.178	1009.45	816.2	6205.42	19575.0	8.369	47.5	
	RodF3_57	91	57	1.448	10	0.254	793.29	696.1	4039.25	12741.8	7.690	43.7	
	RodF3_60	92	60	1.524	13	0.330	805.44	702.8	4532.46	14297.6	8.434	47.9	
	RodF3_66.1	93	66.1	1.679	19.1	0.485	843.22	723.8	4608.38	14537.1	8.011	45.5	
	RodF3_70	94	70	1.778	-0.88	-0.022	897.60	754.0	4724.23	14902.6	7.503	42.6	
	RodF3_73	95	73	1.854	2.12	0.054	961.57	789.6	4998.45	15767.6	7.207	40.9	
	RodF3_75	96	75	1.905	4.12	0.105	879.33	743.9	5333.23	16823.7	8.724	49.5	
Gr-8	RodE6_50.2	121	50.2	1.275	3.2	0.081	554.54	563.5	2962.33	9344.7	10.338	58.7	
	RodE6_54.1	122	54.1	1.374	7.1	0.180	599.50	588.4	3274.56	10329.6	9.878	56.1	
	RodE6_57	123	57	1.448	10	0.254	620.65	600.2	3534.71	11150.2	10.023	56.9	
	RodE6_60.2	124	60.2	1.529	13.2	0.335	695.88	642.0	3715.69	11721.2	8.684	49.3	
	RodE6_66.1	125	66.1	1.679	19.1	0.485	721.97	656.5	3804.44	12001.1	8.380	47.6	
	RodE6_70	126	70	1.778	-0.88	-0.022	758.12	676.5	3938.74	12424.8	8.036	45.6	
	RodE6_73.1	127	73.1	1.857	2.22	0.056	823.95	713.1	4445.96	14024.8	7.997	45.4	
	RodE6_75	128	75	1.905	4.12	0.105	861.85	734.2	4600.05	14510.9	7.746	44.0	

RBHT Steam Cooling with Droplet Injection Test SCD-4032-F

Matrix Test # Shakedown

Test Conditions

Test Date – 9/28/2005

Steady State Time Window: 15360 - 16380

Upper Plenum Pressure: 2.76 bar (40 psia)

Bundle Power: 65.0 kW

Bundle Inlet Reynolds Number: 6000

Bundle Inlet Steam Flow: 118.04 kg/hr (260 lbm/hr)

Droplet Injection Flow: 0.0151 kg/s (0.0333 lbm/s)

Droplet Injection Hole Diameter: 0.381 mm (.015 in)

Droplet Injection Elevation: 1.295 m (51 in)

Bundle Flow Area: $4.656 \times 10^{-3} \text{ m}^2$ ($5.012 \times 10^{-2} \text{ ft}^2$)

Test Notes

- No steam probes were traversed in this steady state window.

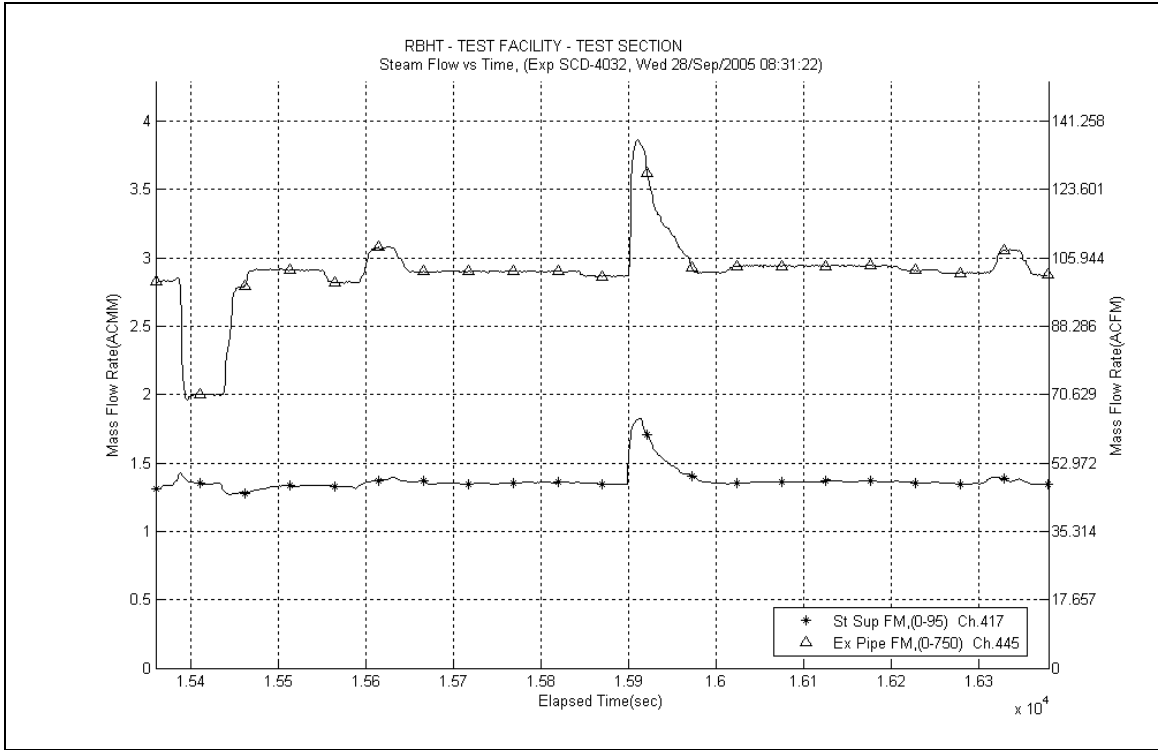

Figure A-182: Inlet and Exhaust Steam Flow Rates for Experiment 4032F

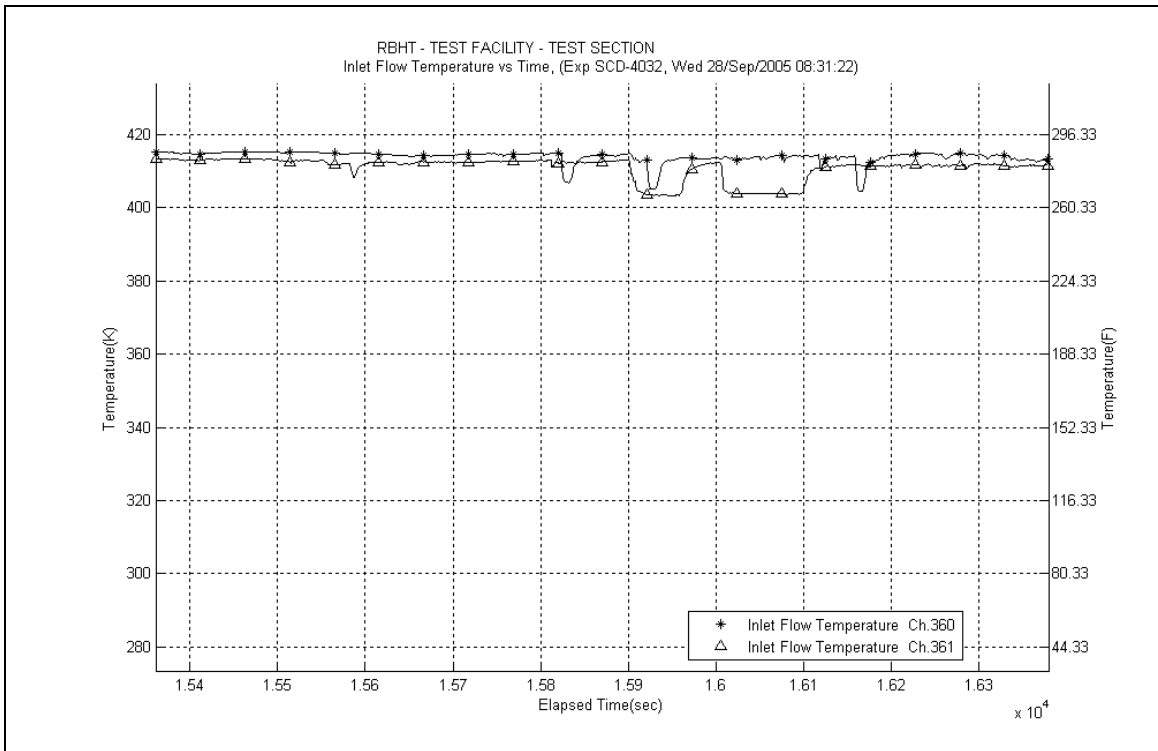

Figure A-183: Inlet Steam Temperature for Experiment 4032F

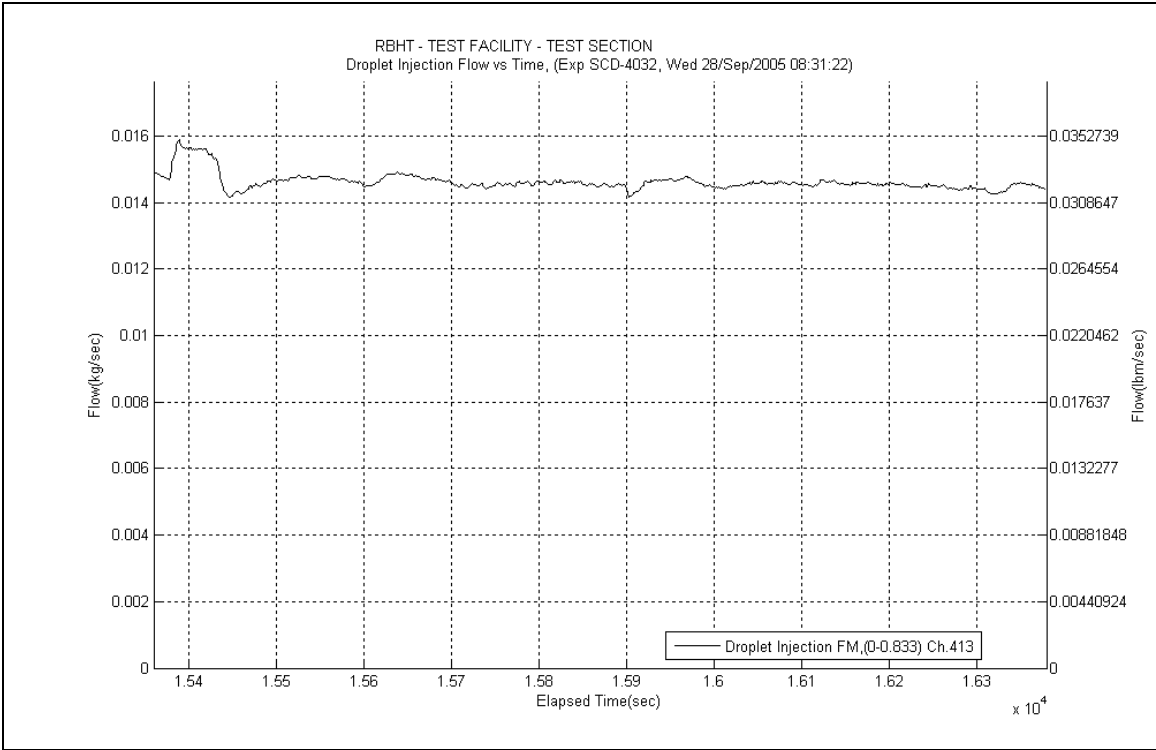

Figure A-184: Droplet Injection Flow Rate for Experiment 4032F

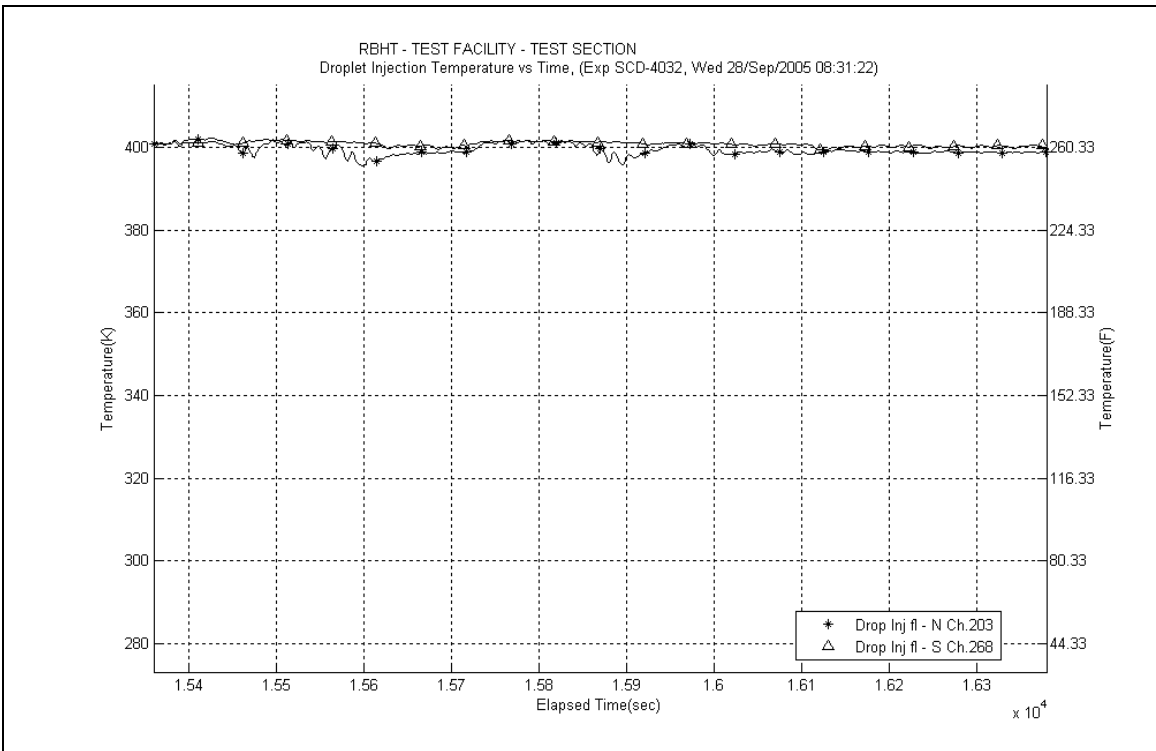

Figure A-185: Droplet Injection Temperature for Experiment 4032F

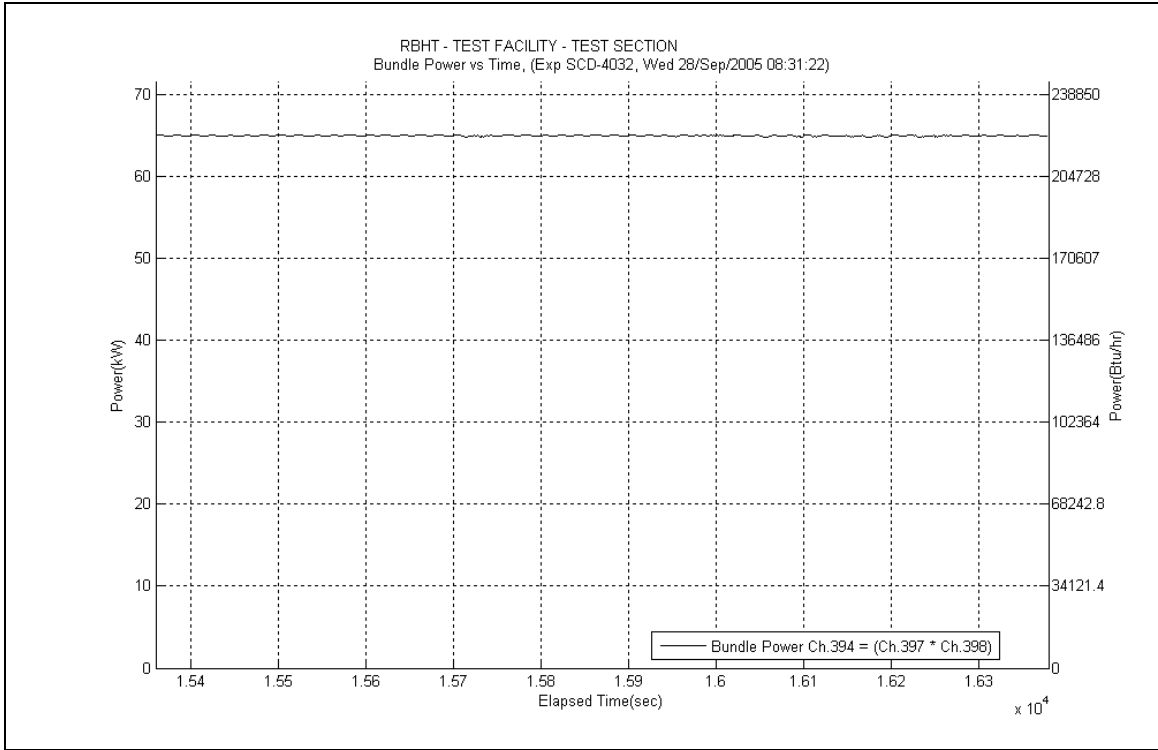

Figure A-186: Bundle Power for Experiment 4032F

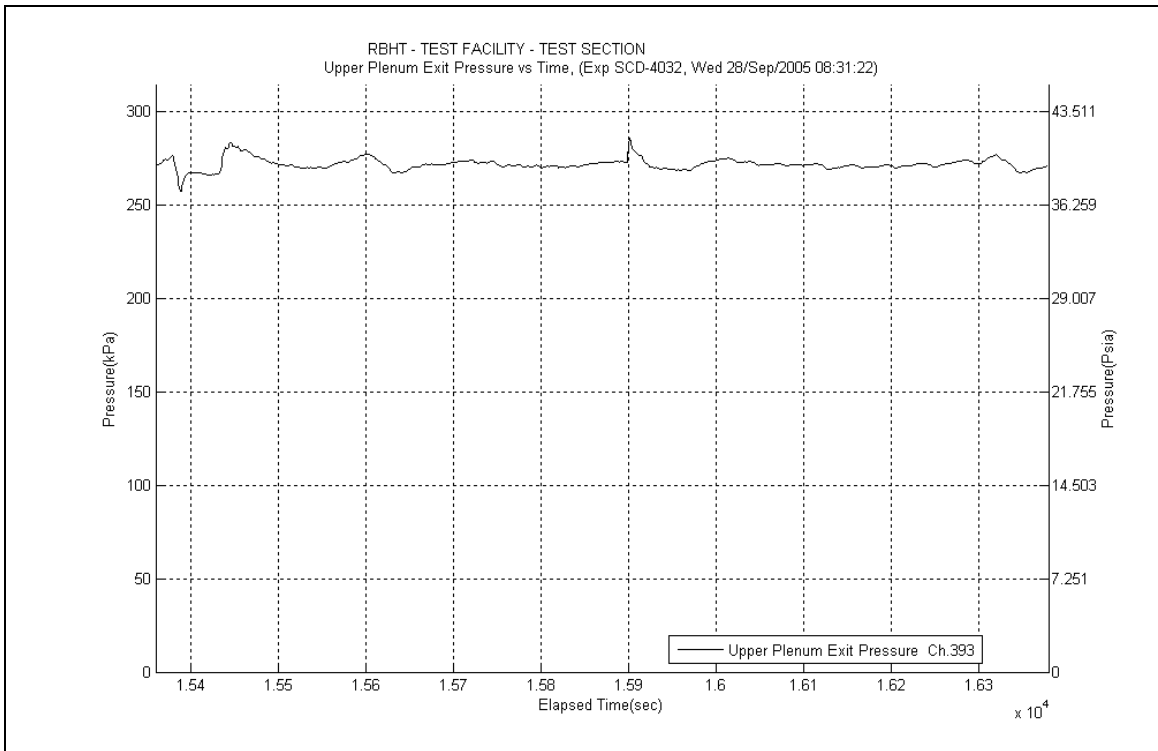

Figure A-187: Upper Plenum Pressure for Experiment 4032F

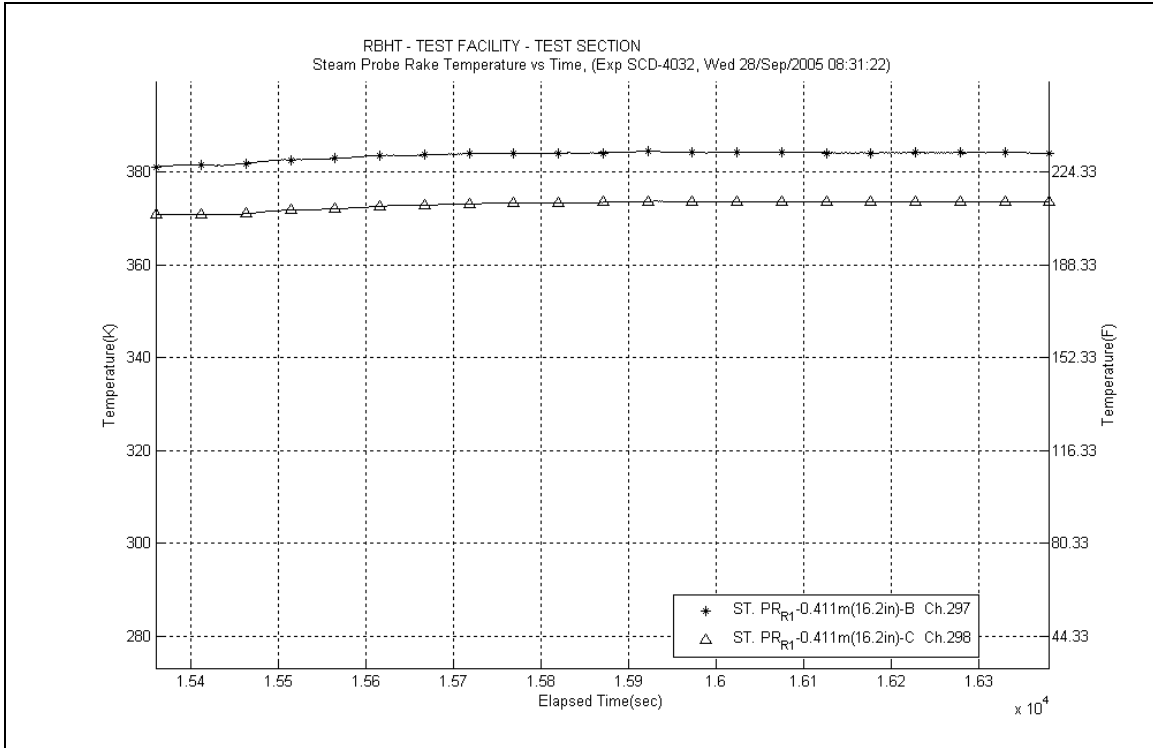

Figure A-188: Steam Probe Rake #1 Temperatures for Experiment 4032F

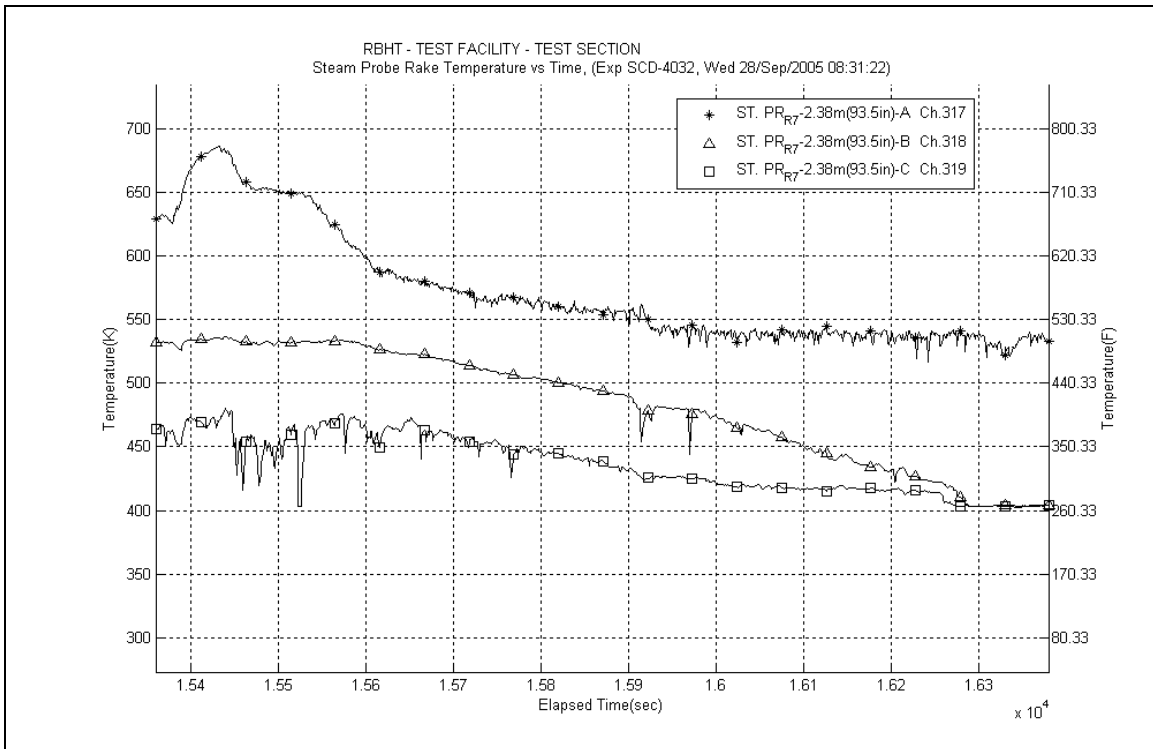

Figure A-189: Steam Probe Rake #7 Temperatures for Experiment 4032F

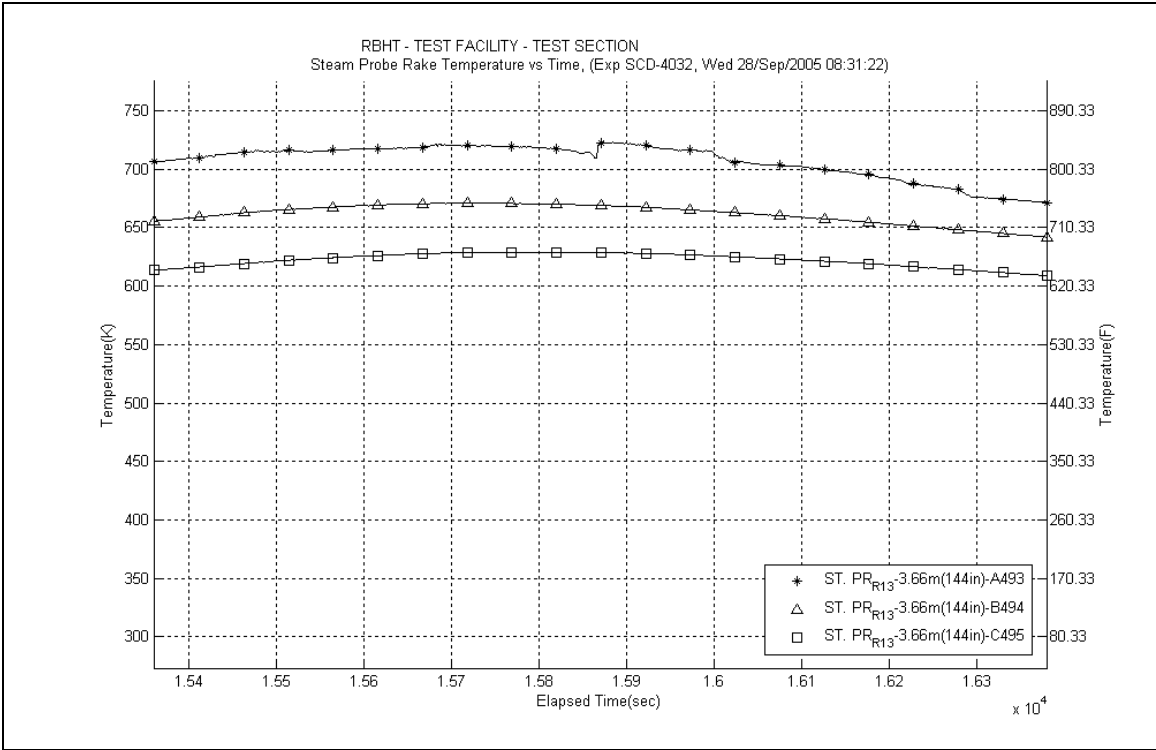

Figure A-190: Steam Probe Rake #13 Temperatures for Experiment 4032F

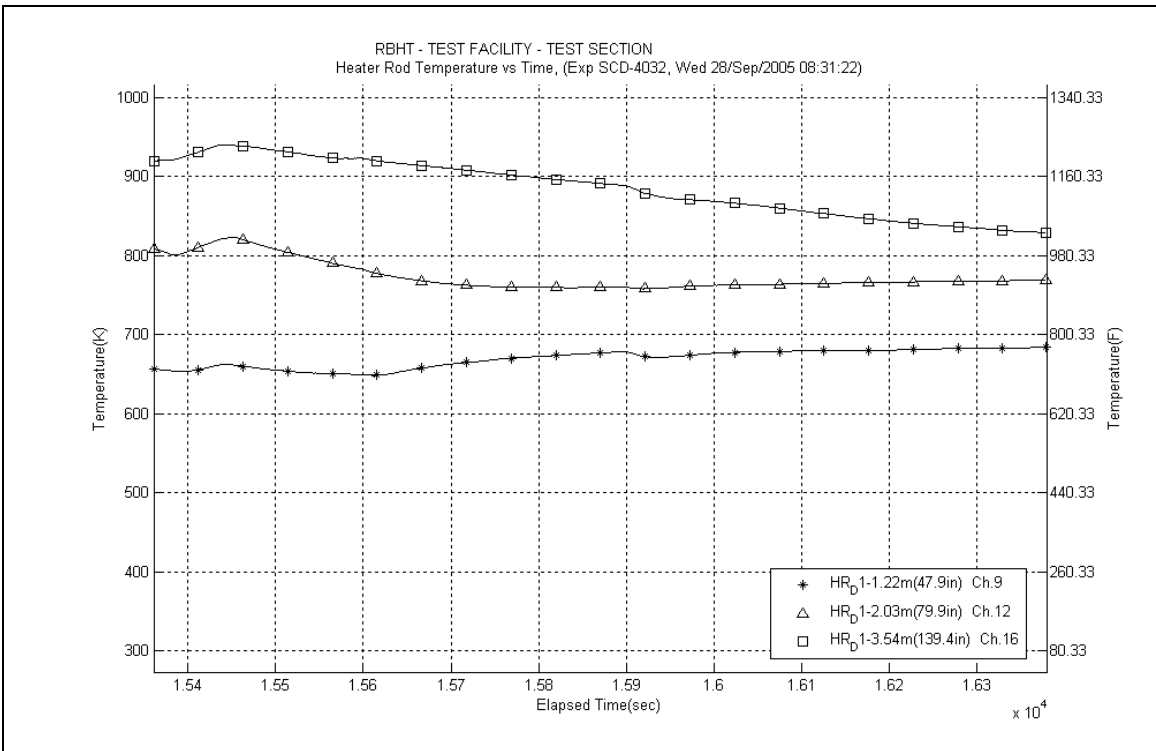

Figure A-191: Heater Rod D1 Temperatures for Experiment 4032F

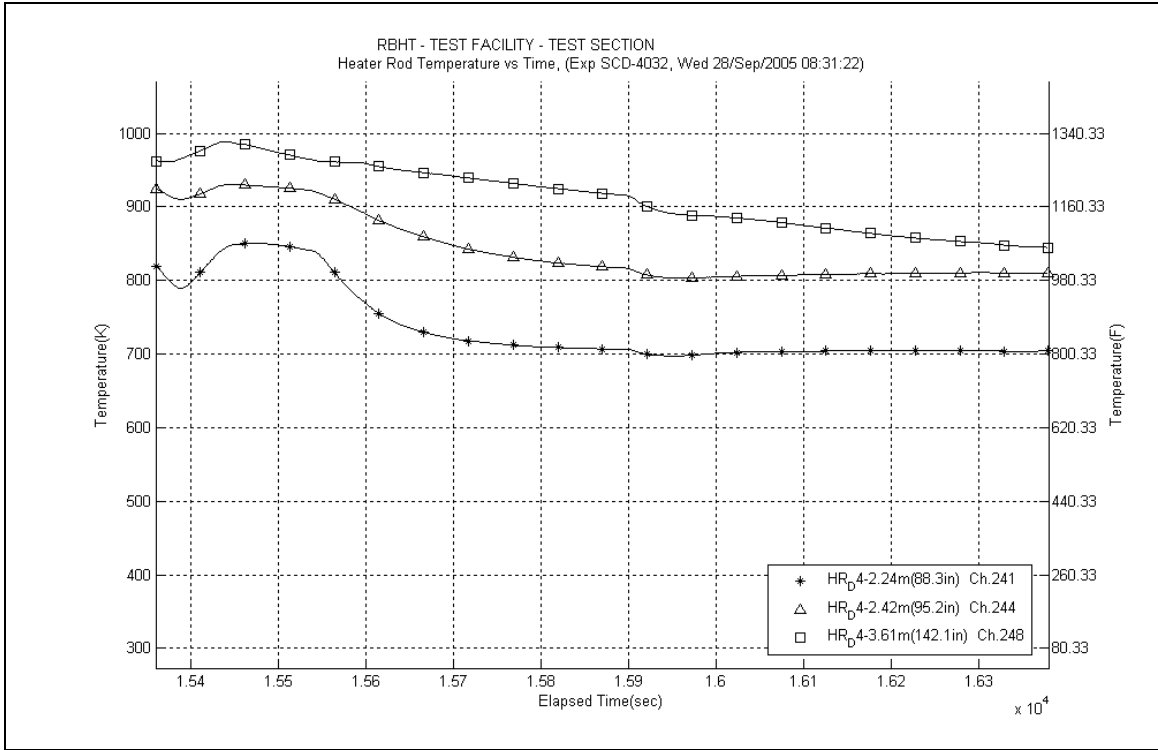

Figure A-192: Heater Rod D4 Temperatures for Experiment 4032F

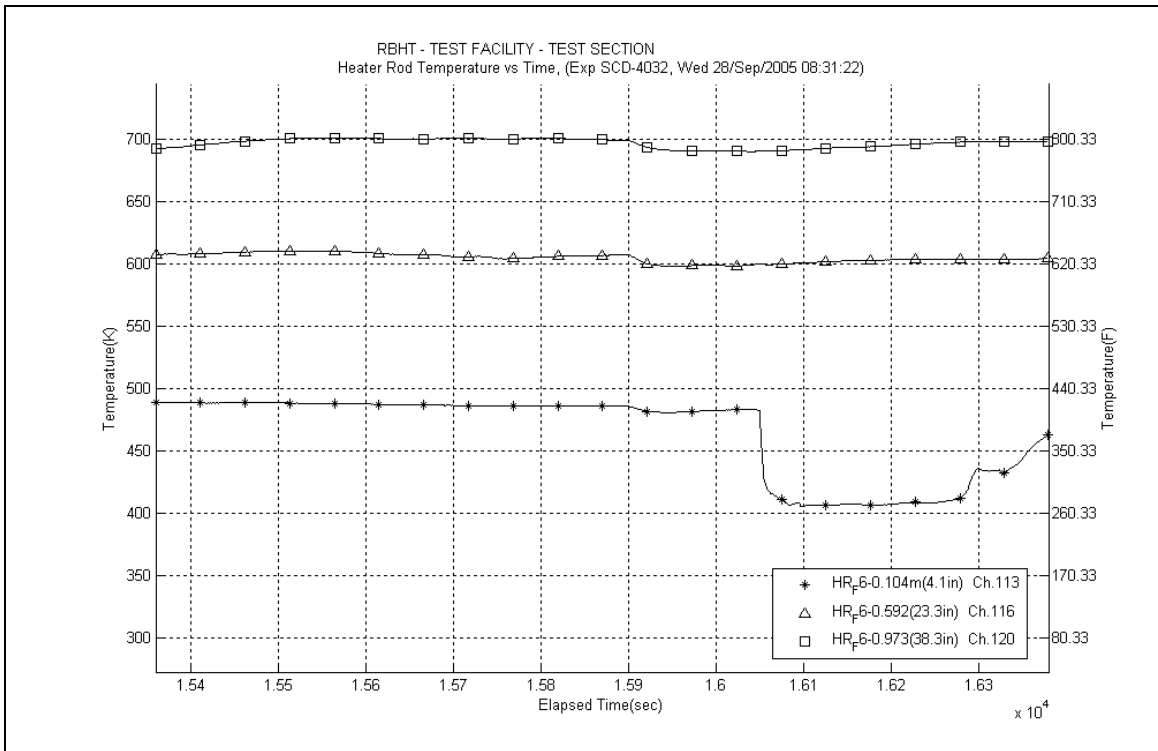

Figure A-193: Heater Rod F6 Temperatures for Experiment 4032F

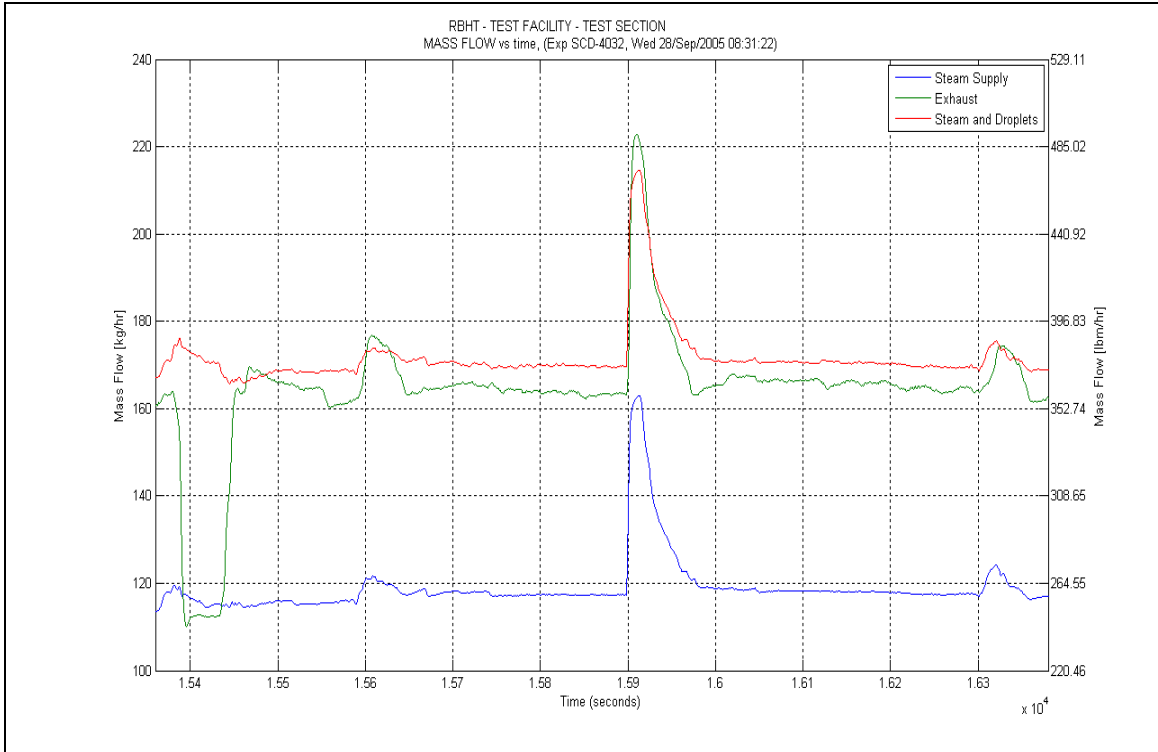

Figure A-194: Mass Flow for Experiment 4032F

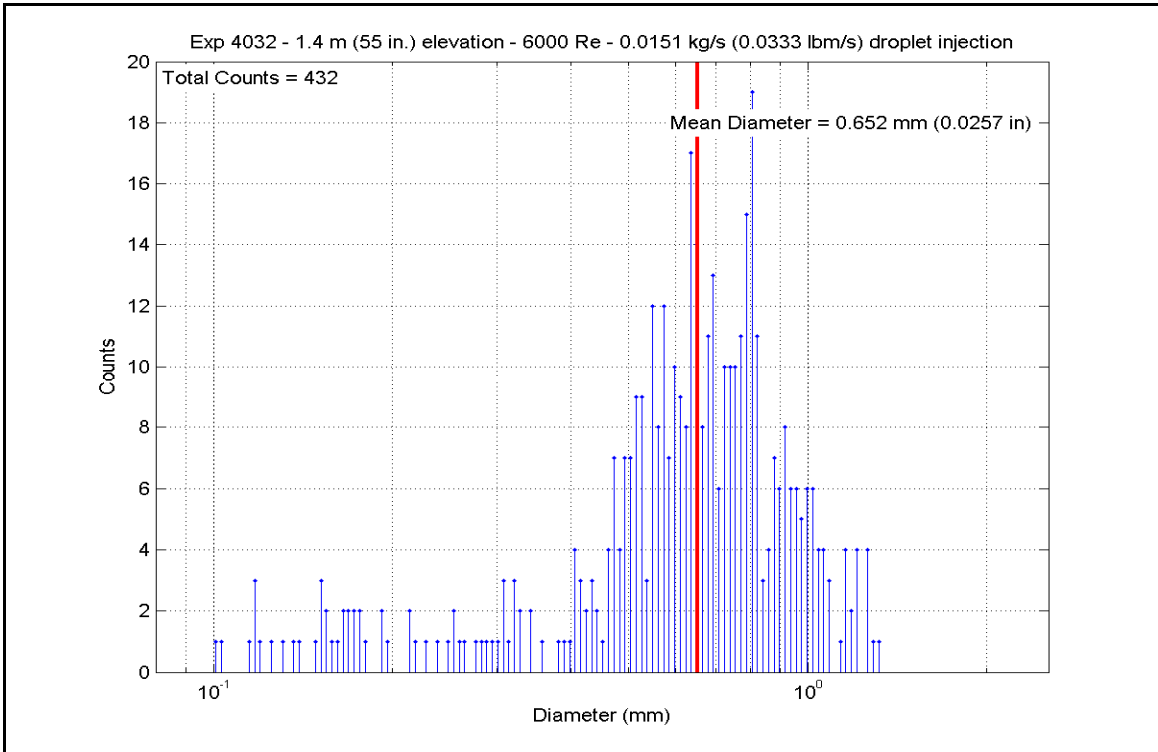

Figure A-195: Droplet Measurements at 1.397 m (55 in.) Elevation for Experiment 4032F

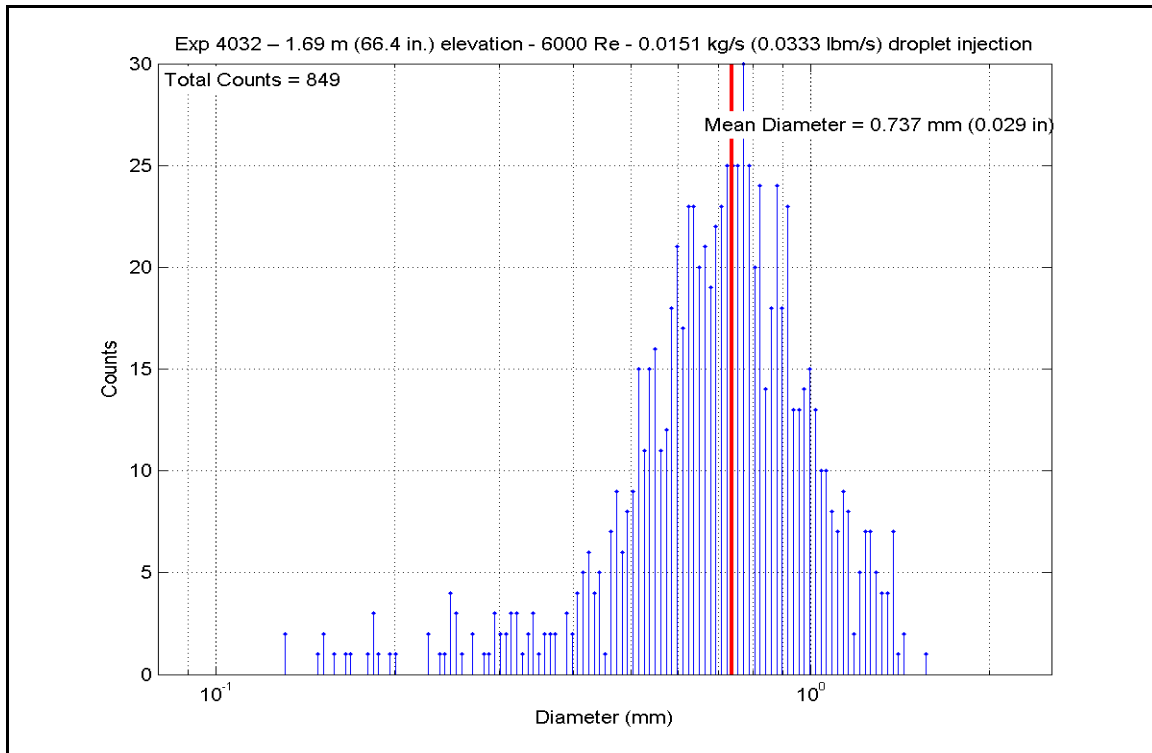

Figure A-196: Droplet Measurements at 1.687 m (66.4 in.) Elevation for Experiment 4032F

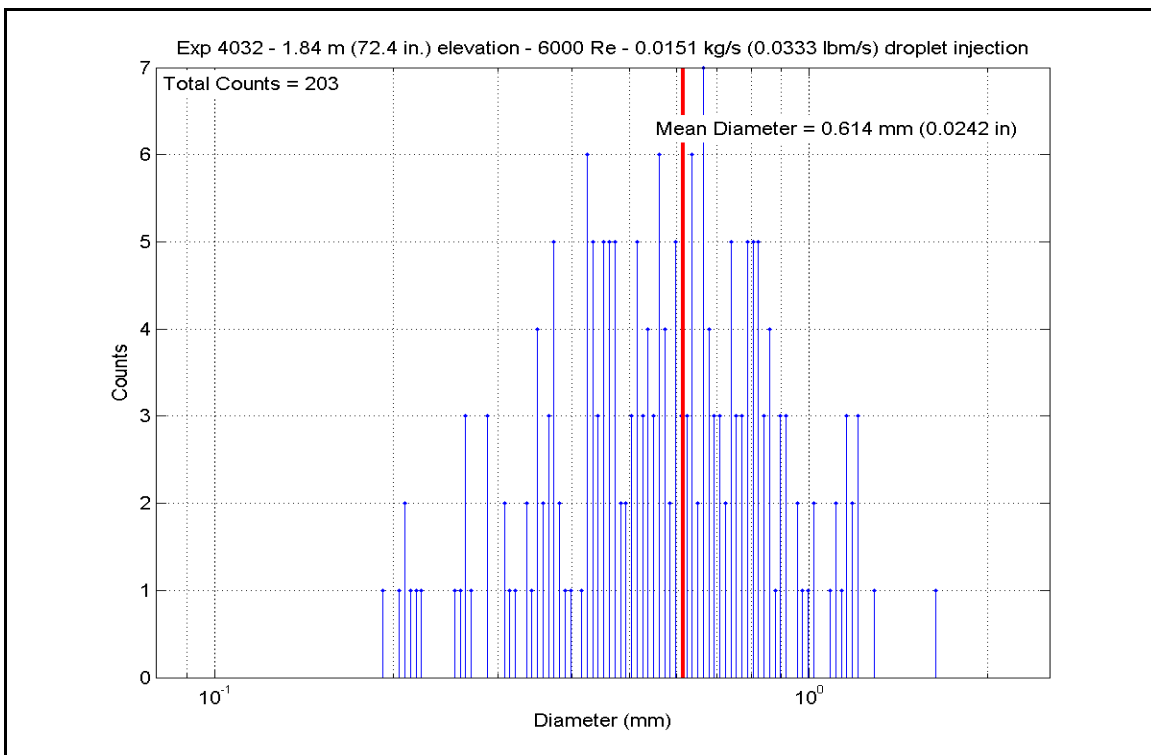

Figure A-197: Droplet Measurements at 1.839 m (72.4 in.) Elevation for Experiment 4032F

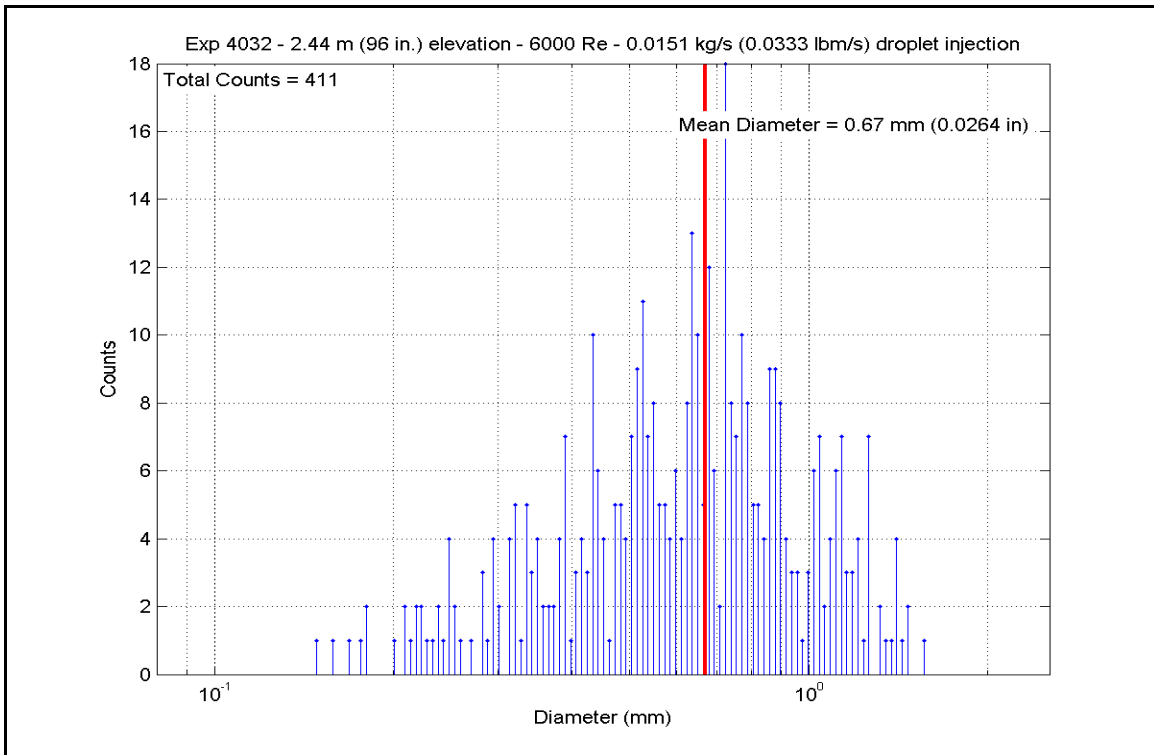

Figure A-198: Droplet Measurements at 2.438 m (96 in.) Elevation for Experiment 4032F

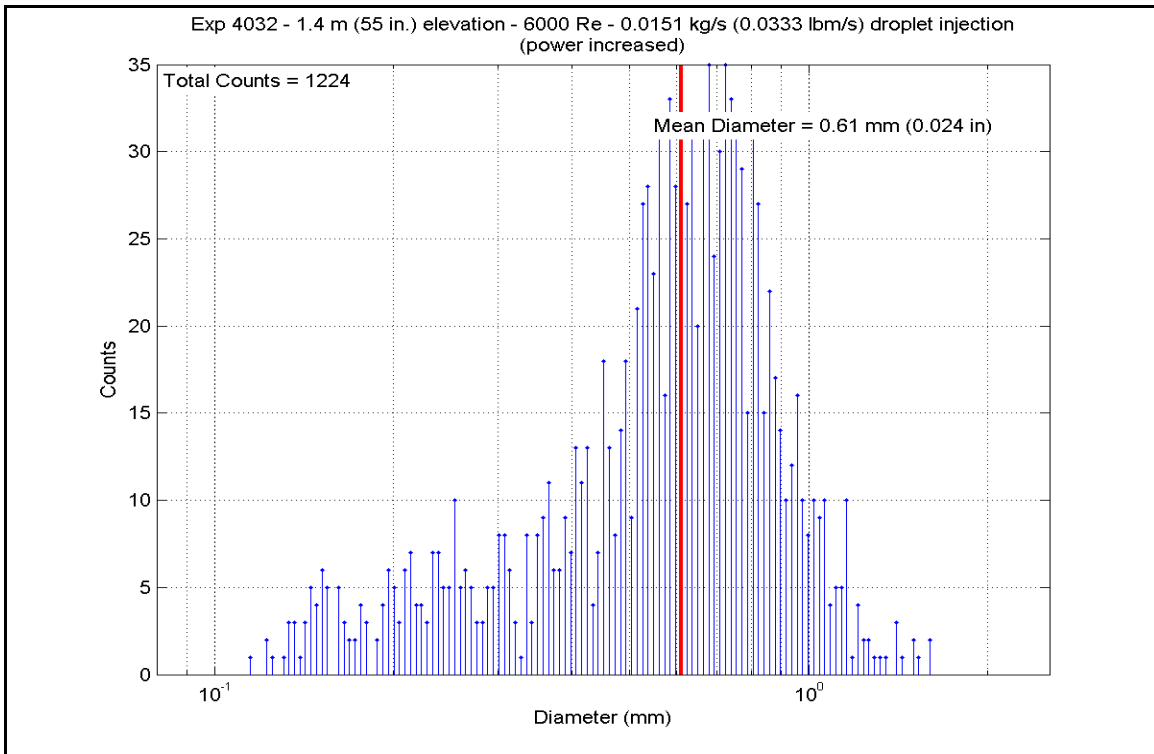

Figure A-199: Droplet Measurements at 1.397 m (55 in.) Elevation for Experiment 4032F

Error! Reference source not found.F

Test 4032-F		Inlet Reynolds:		6000		40 psia						
Matrix test shutdown		UP Pressure:		275.8 kPa		221789 Btu/hr						
Time Window: 15360-16380		Bundle Power:		65.00 kW		260.0 lbm/hr						
Inner 3x3		Stream flow:		0.0328 kg/s		0.032 lbm/s						
		Droplet flow:		0.0145 kg/s								
H.R. ID	H.R. Location	Channel Number	Elevation (in)	Elevation (m)	Zgrid (in)	Zgrid (m)	H.R. Tw (°F)	H.R. Tw (K)	H.R. q" (W/m ²)	h _{sat} (z) (Btu/hr-ft ² -F)	h _{sat} (z) (W/m ² -K)	
Gr-3	RodD3_88.3	185	88.3	2.243	-0.2	-0.005	994.09	807.6	19062.6	8.323	47.3	
	RodD3_91.3	186	91.3	2.319	2.8	0.071	1036.48	831.2	19267.3	7.948	45.1	
	RodD3_93.1	187	93.1	2.365	4.6	0.117	870.07	738.7	18742.2	9.868	56.0	
	RodD3_95.3	188	95.3	2.421	6.8	0.173	977.35	798.3	19070.9	8.523	48.4	
	RodD3_100.1	189	100.1	2.543	11.6	0.295	1087.06	859.3	19495.3	7.545	42.8	
	RodD3_106.1	190	106.1	2.695	17.6	0.447	1198.25	921.1	20612.4	7.024	39.9	
	RodD3_110	191	110	2.794	21.5	0.546	1142.88	890.3	19984.6	7.241	41.1	
	RodD3_142.1	192	142.1	3.609	3.609	8.6	870.09	738.8	18635.5	9.812	55.7	
	Gr-3	RodC4_88.4	233	88.4	2.245	-0.1	-0.003	1139.13	888.2	18957.9	6.899	39.2
		RodC4_91.1	234	91.1	2.314	2.6	0.066	1171.91	906.4	17708.3	6.210	35.3
RodC4_93.4		235	93.4	2.372	4.9	0.124	1196.87	920.3	16306.4	5.565	31.6	
RodC4_95.3		236	95.3	2.421	6.8	0.173	1206.84	925.8	14849.3	5.014	28.5	
RodC4_100.1		237	100.1	2.543	11.6	0.295	1060.08	844.3	20632.8	8.258	46.9	
RodC4_106.1		238	106.1	2.695	17.6	0.447	1118.75	876.9	20235.9	7.540	42.8	
RodC4_110		239	110	2.794	21.5	0.546	1148.08	893.2	20589.2	7.416	42.1	
RodC4_142.2		240	142.2	3.612	3.612	8.7	987.07	803.7	14397.4	6.347	36.0	
Gr-3		RodD4_88.3	241	88.3	2.243	-0.2	-0.005	823.77	713.0	16106.4	9.187	52.2
		RodD4_91.3	242	91.3	2.319	2.8	0.071	876.89	742.5	16428.5	8.553	48.6
	RodD4_93.2	243	93.2	2.367	4.7	0.119	956.67	786.9	14059.0	6.472	36.8	
	RodD4_95.2	244	95.2	2.418	6.7	0.170	1154.74	896.9	18400.7	6.578	37.4	
	RodD4_100.1	245	100.1	2.543	11.6	0.295	1221.16	933.8	20687.7	6.880	39.1	
	RodD4_106.1	246	106.1	2.695	17.6	0.447	1127.98	882.0	21085.5	7.773	44.1	
	RodD4_142.1	248	142.1	3.609	3.609	8.6	727.44	659.5	15338.2	10.583	60.1	
	Gr-3	RodE4_88.4	201	88.4	2.245	-0.1	-0.003	974.03	796.5	18912.4	8.492	48.2
		RodE4_91.2	202	91.2	2.316	2.7	0.069	1063.14	846.0	19345.2	7.713	43.8
		RodE4_95.3	204	95.3	2.421	6.8	0.173	1177.71	909.7	8317.5	2.898	16.5
RodE4_100.9		205	100.9	2.563	12.4	0.315	1132.79	884.7	20180.8	7.398	42.0	
RodE4_142.3		208	142.3	3.614	3.614	8.8	874.59	741.3	18580.5	9.710	55.1	

Error! Reference source not found.F, continued

Gr-4	H.R. Location	Channel Number	Elevation (in)	Elevation (m)	Zgrid (in)	Zgrid (m)	H.R. Tw (°F)	H.R. Tw (K)	H.R. q" (Btu/hr-ft2)	H.R. q" (W/m2)	h _{sat} (z) (Btu/hr-ft2-F)	h _{sat} (z) (W/m2-K)
	RodE3_63.4	193	63.4	1.610	16.4	0.417	1183.41	912.8	3592.94	11333.9	3.925	22.3
	RodE3_113.6	194	113.6	2.885	0.85	0.022	1100.30	866.7	6059.00	19113.1	7.280	41.3
	RodE3_115.5	195	115.5	2.934	2.75	0.070	997.55	809.6	4482.75	14140.8	6.145	34.9
	RodE3_118.5	196	118.5	3.010	5.75	0.146	1178.64	910.2	5967.42	18824.2	6.553	37.2
	RodE3_122.7	197	122.7	3.117	9.95	0.253	1214.96	930.4	5618.04	17722.1	5.933	33.7
	RodE3_126.5	198	126.5	3.213	13.75	0.349	1240.74	944.7	5134.25	16196.0	5.278	30.0
	RodE3_131.7	199	131.7	3.345	-1.8	-0.046	1247.76	948.6	4693.24	14804.8	4.790	27.2
	RodE3_135.6	200	135.6	3.444	2.1	0.053	1167.92	904.2	4049.45	12774.0	4.500	25.6
Gr-4	RodC5_63.7	225	63.7	1.618	16.7	0.424	929.29	771.6	4398.28	13874.4	6.651	37.8
	RodC5_113.6	226	113.6	2.885	0.85	0.022	1047.97	837.6	6246.95	19706.0	8.009	45.5
	RodC5_115.7	227	115.7	2.939	2.95	0.075	1123.06	879.3	4103.94	12945.9	4.800	27.3
	RodC5_122.7	229	122.7	3.117	9.95	0.253	1145.87	892.0	3653.99	11526.5	4.162	23.6
	RodC5_126.7	230	126.7	3.218	13.95	0.354	875.34	741.7	3921.67	12370.9	6.457	36.7
	RodC5_131.6	231	131.6	3.343	-1.9	-0.048	859.08	732.6	4106.15	12952.8	6.947	39.5
	RodC5_135.7	232	135.7	3.447	2.2	0.056	897.33	753.9	4255.46	13423.8	6.762	38.4
Gr-4	RodE5_63.6	209	63.6	1.615	16.6	0.422	1187.02	914.8	2635.77	8314.5	2.868	16.3
	RodE5_113.6	210	113.6	2.885	0.85	0.022	1209.38	927.2	6634.83	20929.6	7.048	40.0
	RodE5_115.4	211	115.4	2.931	2.65	0.067	1064.04	846.5	6244.52	19698.3	7.844	44.5
	RodE5_118.7	212	118.7	3.015	5.95	0.151	1192.38	917.8	2715.65	8566.5	2.938	16.7
	RodE5_122.6	213	122.6	3.114	9.85	0.250	868.73	738.0	6020.61	18992.0	10.022	56.9
	RodE5_126.6	214	126.6	3.216	13.85	0.352	973.99	796.5	6115.76	19292.2	8.663	49.2
	RodE5_131.6	215	131.6	3.343	-1.9	-0.048	1020.42	822.3	6177.59	19487.2	8.210	46.6
	RodE5_135.6	216	135.6	3.444	2.1	0.053	1061.25	845.0	6244.50	19698.3	7.872	44.7
Gr-5	RodC3_79.8	177	79.8	2.027	8.92	0.227	1010.45	816.7	6037.55	19045.4	8.132	46.2
	RodC3_85.6	178	85.6	2.174	14.72	0.374	1043.38	835.0	6097.99	19236.1	7.865	44.7
	RodC3_88.5	179	88.5	2.248	0	0.000	1179.55	910.7	2665.10	8407.1	2.924	16.6
	RodC3_92.4	180	92.4	2.347	3.9	0.099	808.76	704.7	3915.85	12352.6	7.241	41.1
	RodC3_94.4	181	94.4	2.398	5.9	0.150	833.20	718.3	4072.63	12847.1	7.206	40.9
	RodC3_97.2	182	97.2	2.469	8.7	0.221	1172.21	906.6	6561.34	20697.8	7.256	41.2
	RodC3_108.8	183	108.8	2.764	20.3	0.516	1083.28	857.2	6199.40	19556.0	7.604	43.2
Gr-8	RodD5_50	217	50	1.270	3	0.076	1108.08	871.0	4328.32	13653.7	5.152	29.3
	RodD5_54.1	218	54.1	1.374	7.1	0.180	1217.18	931.6	5048.84	15926.6	5.319	30.2
	RodD5_56.9	219	56.9	1.445	9.9	0.251	1226.09	936.5	4604.28	14524.2	4.806	27.3
	RodD5_60	220	60	1.524	13	0.330	1148.32	893.3	4041.13	12747.7	4.591	26.1
	RodD5_66.1	221	66.1	1.679	19.1	0.485	1164.28	902.2	3579.20	11290.6	3.993	22.7
	RodD5_69.9	222	69.9	1.775	-0.98	-0.025	877.90	743.1	5998.36	18921.8	9.835	55.9
	RodD5_72.9	223	72.9	1.852	2.02	0.051	973.50	796.2	6102.09	19249.0	8.649	49.1
	RodD5_74.9	224	74.9	1.902	4.02	0.102	1024.43	824.5	6179.40	19492.9	8.169	46.4

Error! Reference source not found.F, continued

H.R. ID	H.R. Location	Channel Number	Elevation (in)	Elevation (m)	Zgrid (in)	Zgrid (m)	H.R. Tw (°F)	H.R. Tw (K)	H.R. q" (Btu/hr-ft2)	H.R. q" (W/m2)	h _{sat} (z) (Btu/hr-ft2-F)	h _{sat} (z) (W/m2-K)	
Gr-2	RodB5_41	153	41	1.041	13.5	0.343	575.17	574.9	2673.21	8432.6	8.703	49.4	
	RodB5_52.9	154	52.9	1.344	5.9	0.150	633.11	607.1	2943.93	9286.6	8.063	45.8	
	RodB5_55	155	55	1.397	8	0.203	656.35	620.0	3187.65	10055.4	8.208	46.6	
	RodB5_57.8	156	57.8	1.468	10.8	0.274	731.24	661.6	3337.73	10528.9	7.205	40.9	
	RodB5_64	157	64	1.626	17	0.432	761.38	678.4	3413.64	10768.3	6.919	39.3	
	RodB5_73.9	158	73.9	1.877	30.2	0.077	804.82	702.5	3528.76	11131.5	6.573	37.3	
	RodB5_75.9	159	75.9	1.928	5.02	0.128	845.21	724.9	3642.53	11490.4	6.311	35.8	
	RodB5_76.9	160	76.9	1.953	6.02	0.153	822.07	712.1	4032.99	12722.1	7.279	41.3	
	Gr-2	RodF5_41	105	41	1.041	13.5	0.343	577.54	576.2	2695.57	8503.2	8.708	49.5
		RodF5_53.1	106	53.1	1.349	6.1	0.155	627.51	604.0	2959.01	9334.2	8.231	46.7
		RodF5_55	107	55	1.397	8	0.203	640.49	611.2	3179.67	10030.3	8.536	48.5
		RodF5_57.8	108	57.8	1.468	10.8	0.274	720.89	655.9	3324.76	10487.9	7.341	41.7
		RodF5_64	109	64	1.626	17	0.432	750.83	672.5	3397.73	10718.1	7.037	40.0
		RodF5_73.8	110	73.8	1.875	2.92	0.074	792.50	695.7	3503.97	11053.3	6.681	37.9
		RodF5_75.8	111	75.8	1.925	4.92	0.125	857.63	731.8	3965.66	12509.7	6.726	38.2
		RodF5_76.8	112	76.8	1.951	5.92	0.150	905.68	758.5	4100.43	12934.8	6.430	36.5
Gr-2		RodC2_41	57	41	1.041	13.5	0.343	1065.32	847.2	2815.59	8881.8	3.531	20.1
		RodC2_53.1	58	53.1	1.349	6.1	0.155	709.73	649.7	4011.56	12654.5	9.082	51.6
		RodC2_55	59	55	1.397	8	0.203	871.27	739.4	5338.52	16840.4	8.849	50.3
		RodC2_57.8	60	57.8	1.468	10.8	0.274	943.14	779.3	6181.68	19500.1	9.156	52.0
	RodC2_63.9	61	63.9	1.623	16.9	0.429	1054.98	841.5	5921.30	18678.7	7.524	42.7	
	RodC2_73.8	62	73.8	1.875	2.92	0.074	1124.26	880.0	4538.47	14316.6	5.300	30.1	
	RodC2_75.8	63	75.8	1.925	4.92	0.125	889.47	749.5	5188.80	16368.1	8.349	47.4	
	RodC2_76.8	64	76.8	1.951	5.92	0.150	906.23	758.8	5232.67	16506.5	8.199	46.6	
Gr-2	RodC6_40.9	137	40.9	1.039	13.4	0.340	879.24	743.8	4209.72	13279.6	6.887	39.1	
	RodC6_52.8	138	52.8	1.341	5.8	0.147	865.54	736.2	4373.55	13796.4	7.319	41.6	
	RodC6_54.8	139	54.8	1.392	7.8	0.198	944.87	780.3	4680.95	14766.0	6.916	39.3	
	RodC6_57.8	140	57.8	1.468	10.8	0.274	748.50	671.2	4864.27	15344.3	10.123	57.5	
	RodC6_63.8	141	63.8	1.621	16.8	0.427	846.98	725.9	5080.47	16026.3	8.775	49.8	
	RodC6_73.7	142	73.7	1.872	2.82	0.072	894.09	752.1	5173.74	16320.6	8.264	46.9	
	RodC6_75.8	143	75.8	1.925	4.92	0.125	971.90	795.3	5411.26	17069.8	7.688	43.7	
	RodC6_76.8	144	76.8	1.951	5.92	0.150	895.18	752.7	5691.57	17954.1	9.075	51.5	

Error! Reference source not found.F, continued

5x5 periphery		H.R. Location	Channel Number	Elevation (in)	Elevation (m)	Zgrid (in)	Zgrid (m)	H.R. Tw (°F)	H.R. Tw (K)	H.R. q" (Btu/hr-ft2)	H.R. q" (W/m2)	h _{sat} (z) (Btu/hr-ft2-F)	h _{sat} (z) (W/m2-K)
Gr-3	RodB4_88.4	161	88.4	2.245	-0.1	-0.003	748.9	5207.60	16427.4	8.394	47.7		
	RodB4_91.3	162	91.3	2.319	2.8	0.071	760.0	5256.11	16580.4	8.210	46.6		
	RodB4_93.3	163	93.3	2.370	4.8	0.122	414.06	2219.62	7001.8	15.196	86.3		
	RodB4_95.1	164	95.1	2.416	6.6	0.168	505.08	2485.54	7840.6	10.484	59.5		
	RodB4_100	165	100	2.540	11.5	0.292	1141.15	6434.37	20297.2	7.369	41.8		
	RodB4_106	166	106	2.692	17.5	0.445	1172.84	6534.97	20614.6	7.222	41.0		
	RodB4_109.9	167	109.9	2.791	21.4	0.544	1067.42	6274.48	19792.8	7.849	44.6		
	RodB4_142.3	168	142.3	3.614	8.8	0.224	851.90	5109.47	16117.8	8.751	49.7		
Gr-5	RodF4_85.6	98	85.6	2.174	14.72	0.374	760.1	5142.96	16223.5	8.029	45.6		
	RodF4_88.4	99	88.4	2.245	-0.1	-0.003	768.7	5186.78	16361.7	7.906	44.9		
	RodF4_92.4	100	92.4	2.347	3.9	0.099	464.2	2294.80	7239.0	21.266	120.8		
	RodF4_94.3	101	94.3	2.395	5.8	0.147	536.9	2505.14	7902.5	10.491	59.6		
	RodF4_97.2	102	97.2	2.469	8.7	0.221	1205.47	6620.26	20883.6	7.062	40.1		
	RodF4_108.8	103	108.8	2.764	20.3	0.516	1115.27	6638.68	20941.7	7.835	44.5		
	RodF4_111	104	111	2.819	-1.75	-0.044	886.9	6387.56	20149.6	7.352	41.8		
	RodD2_103.2	65	103.2	2.621	14.7	0.373	859.4	6251.07	19719.0	7.631	43.3		
	RodD2_106	66	106	2.692	17.5	0.445	908.7	6461.92	20384.1	7.117	40.4		
	RodD2_112.6	67	112.6	2.860	-0.15	-0.004	857.8	6480.77	20443.6	7.939	45.1		
Gr-6	RodD2_114.9	68	114.9	2.918	2.15	0.055	883.8	6008.01	18952.3	6.960	39.5		
	RodD2_117.4	69	117.4	2.982	4.65	0.118	899.3	5711.42	18016.7	6.410	36.4		
	RodD2_120.8	70	120.8	3.068	8.05	0.204	920.8	5295.11	16703.4	5.695	32.3		
	RodD2_124.8	71	124.8	3.170	12.05	0.306	931.4	4812.50	15181.0	5.072	28.8		
	RodD2_128.6	72	128.6	3.266	15.85	0.403	931.8	4358.06	13747.5	4.589	26.1		
	RodD6_103.1	129	103.1	2.619	14.6	0.371	886.1	6183.46	19505.7	7.130	40.5		
	RodD6_106	130	106	2.692	17.5	0.445	888.4	6308.62	19900.6	7.239	41.1		
	RodD6_112.9	131	112.9	2.868	0.15	0.004	865.8	6218.32	19615.7	7.485	42.5		
RodD6_114.9	132	114.9	2.918	2.15	0.055	739.4	3946.54	12449.4	6.542	37.2			
RodD6_116.8	133	116.8	2.967	4.05	0.103	750.5	4084.34	12884.1	6.554	37.2			
RodD6_120.9	134	120.9	3.071	8.15	0.207	825.9	6102.28	19249.7	8.041	45.7			
RodD6_124.8	135	124.8	3.170	12.05	0.306	850.5	6177.24	19486.1	7.690	43.7			
RodD6_128.7	136	128.7	3.269	15.95	0.405	916.3	2523.47	7960.3	2.738	15.5			

Error! Reference source not found.F, continued

5x5 periphery		H.R. Location	Channel Number	Elevation (in)	Elevation (m)	Zgrid (in)	Zgrid (m)	H.R. Tw (°F)	H.R. Tw (K)	H.R. q" (Btu/hr-ft2)	H.R. q" (W/m2)	h _{sat} (z) (Btu/hr-ft2-F)	h _{sat} (z) (W/m2-K)
Gr-8	RodE2_50.1	73	50.1	1.273	3.1	0.079	929.76	771.9	4215.38	13297.4	6.370	36.2	
	RodE2_54	74	54	1.372	7	0.178	954.18	785.5	4357.41	13745.5	6.350	36.1	
	RodE2_56.9	75	56.9	1.445	9.9	0.251	973.89	796.4	4633.70	14617.0	6.564	37.3	
	RodE2_59.9	76	59.9	1.521	12.9	0.328	757.81	676.4	4854.24	15312.7	9.910	56.3	
	RodE2_66	77	66	1.676	19	0.483	853.87	729.7	5066.26	15981.5	8.647	49.1	
	RodE2_69.8	78	69.8	1.773	-1.08	-0.027	895.25	752.7	5161.84	16283.0	8.229	46.7	
	RodE2_72.9	79	72.9	1.852	2.02	0.051	423.14	490.5	2182.45	6884.5	14.067	79.9	
	RodE2_74.9	80	74.9	1.902	4.02	0.102	509.81	538.6	2472.42	7799.2	10.225	58.1	
Gr-8	RodB3_50.2	169	50.2	1.275	3.2	0.081	1156.86	898.1	5258.34	16587.4	5.916	33.6	
	RodB3_54.1	170	54.1	1.374	7.1	0.180	1172.11	906.5	4778.99	15075.3	5.286	30.0	
	RodB3_56.9	171	56.9	1.445	9.9	0.251	1173.79	907.5	4309.04	13592.9	4.757	27.0	
	RodB3_60.1	172	60.1	1.527	13.1	0.333	850.99	728.1	3626.43	11439.6	6.220	35.3	
	RodB3_66.1	173	66.1	1.679	19.1	0.485	894.25	752.2	4031.16	12716.3	6.437	36.6	
	RodB3_69.9	174	69.9	1.775	-0.98	-0.025	918.16	765.5	4121.73	13002.0	6.340	36.0	
	RodB3_73	175	73	1.854	2.12	0.054	927.54	770.7	4260.14	13438.6	6.459	36.7	
	RodB3_75	176	75	1.905	4.12	0.105	960.55	789.0	4547.12	14343.9	6.566	37.3	
Gr-8	RodF3_50.1	89	50.1	1.273	3.1	0.079	998.08	809.9	6059.26	19113.9	8.299	47.1	
	RodF3_54	90	54	1.372	7	0.178	1036.35	831.1	6124.90	19321.0	7.971	45.3	
	RodF3_57	91	57	1.448	10	0.254	844.75	724.7	3605.12	11372.4	6.251	35.5	
	RodF3_60	92	60	1.524	13	0.330	832.54	717.9	4060.82	12809.8	7.193	40.8	
	RodF3_66.1	93	66.1	1.679	19.1	0.485	870.85	739.2	4146.23	13079.3	6.878	39.1	
	RodF3_70	94	70	1.778	-0.88	-0.022	928.36	771.1	4266.65	13459.2	6.461	36.7	
	RodF3_73	95	73	1.854	2.12	0.054	994.73	808.0	4518.76	14254.4	6.218	35.3	
	RodF3_75	96	75	1.905	4.12	0.105	871.53	739.6	5051.55	15935.1	8.370	47.5	
Gr-8	RodE6_50.2	121	50.2	1.275	3.2	0.081	581.27	578.3	2672.36	8429.9	8.530	48.4	
	RodE6_54.1	122	54.1	1.374	7.1	0.180	635.54	608.5	2955.10	9321.9	8.040	45.7	
	RodE6_57	123	57	1.448	10	0.254	646.92	614.8	3190.92	10065.8	8.421	47.8	
	RodE6_60.2	124	60.2	1.529	13.2	0.335	726.25	658.8	3348.67	10563.4	7.308	41.5	
	RodE6_66.1	125	66.1	1.679	19.1	0.485	755.62	675.2	3425.13	10804.6	7.024	39.9	
	RodE6_70	126	70	1.778	-0.88	-0.022	797.10	698.2	3539.34	11164.9	6.689	38.0	
	RodE6_73.1	127	73.1	1.857	2.22	0.056	862.74	734.7	3953.65	12471.8	6.648	37.8	
	RodE6_75	128	75	1.905	4.12	0.105	892.70	751.3	4093.05	12911.5	6.552	37.2	

RBHT Steam Cooling with Droplet Injection Test SCD-4035-A

Matrix Test # Shakedown

Test Conditions

Test Date – 10/4/2005

Steady State Time Window: 14100 - 15900

Upper Plenum Pressure: 2.76 bar (40 psia)

Bundle Power: 80.0 kW

Bundle Inlet Reynolds Number: 10000

Bundle Inlet Steam Flow: 202.03 kg/hr (445 lbm/hr)

Droplet Injection Flow: 0.0076 kg/s (0.0167 lbm/s)

Droplet Injection Hole Diameter: 0.381 mm (.015 in)

Droplet Injection Elevation: 1.295 m (51 in)

Bundle Flow Area: $4.656 \times 10^{-3} \text{ m}^2$ ($5.012 \times 10^{-2} \text{ ft}^2$)

Test Notes

- No steam probes were traversed in this steady state window.

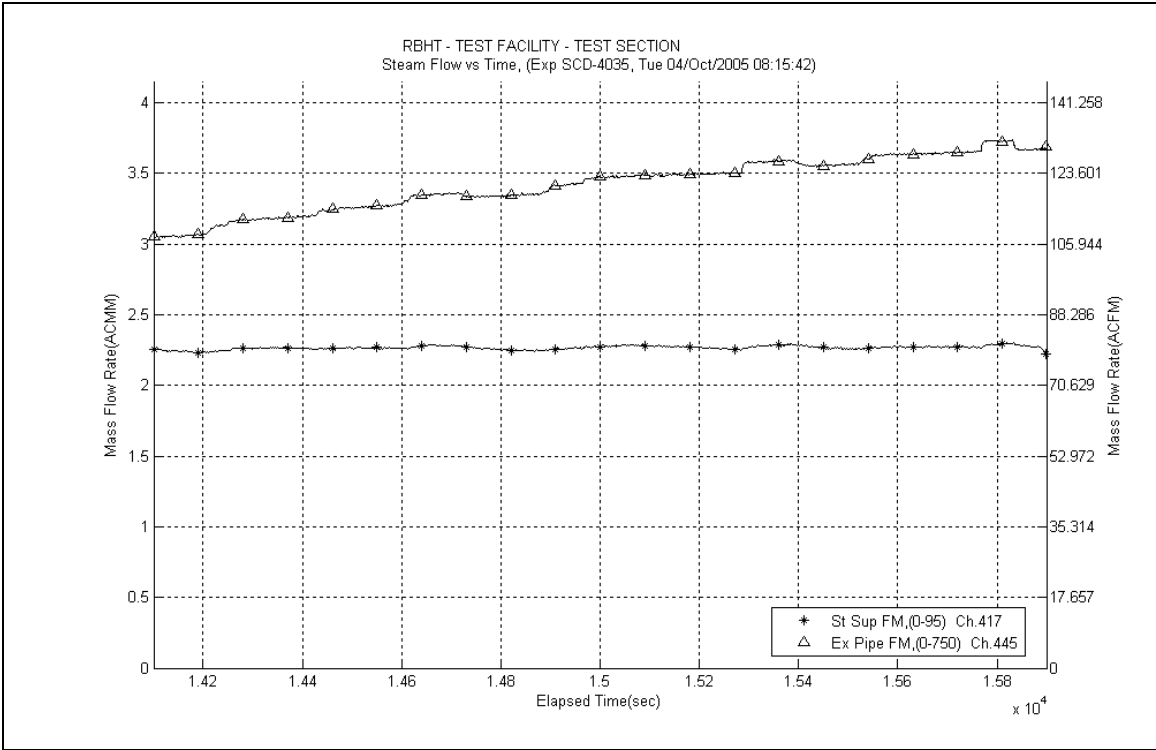

Figure A-200: Inlet and Exhaust Steam Flow Rates for Experiment 4035A

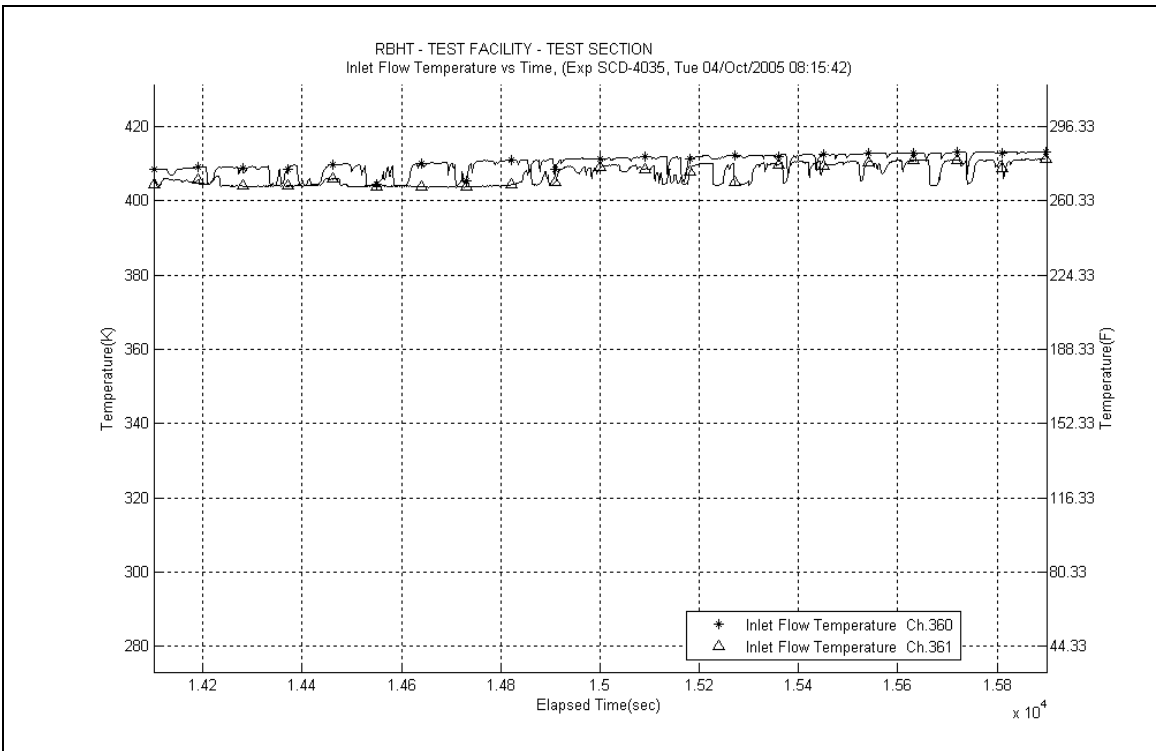

Figure A-201: Inlet Steam Temperature for Experiment 4035A

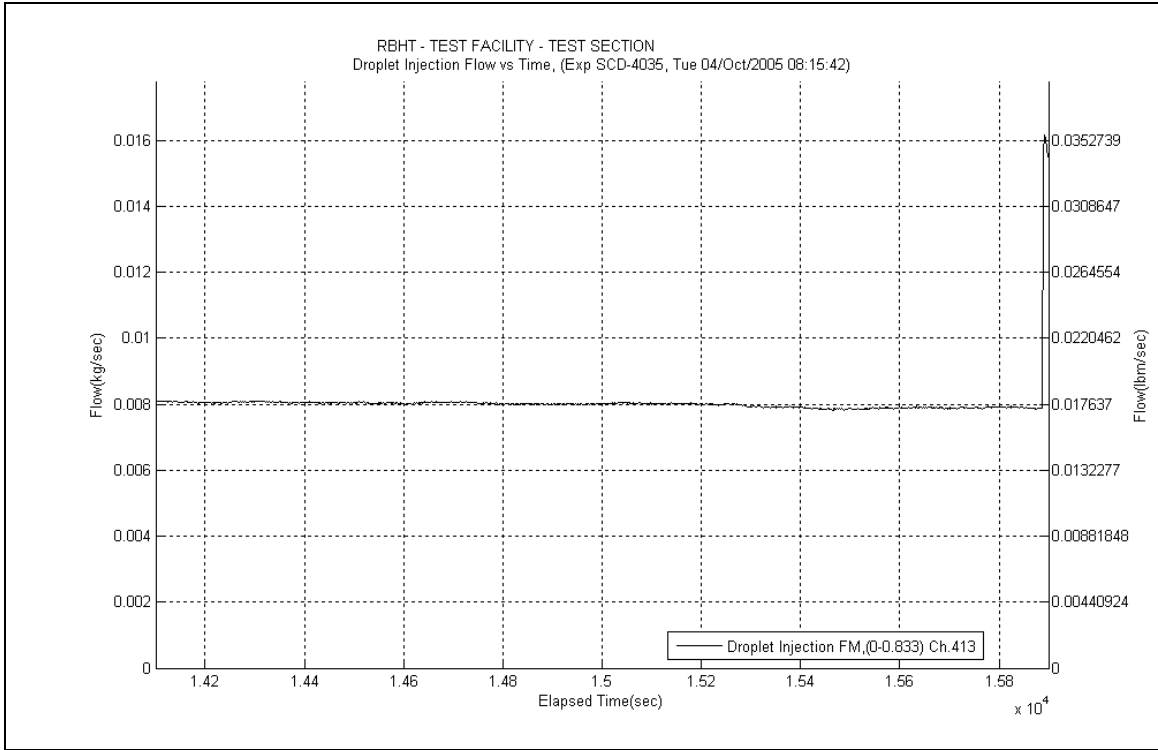

Figure A-202: Droplet Injection Flow Rate for Experiment 4035A

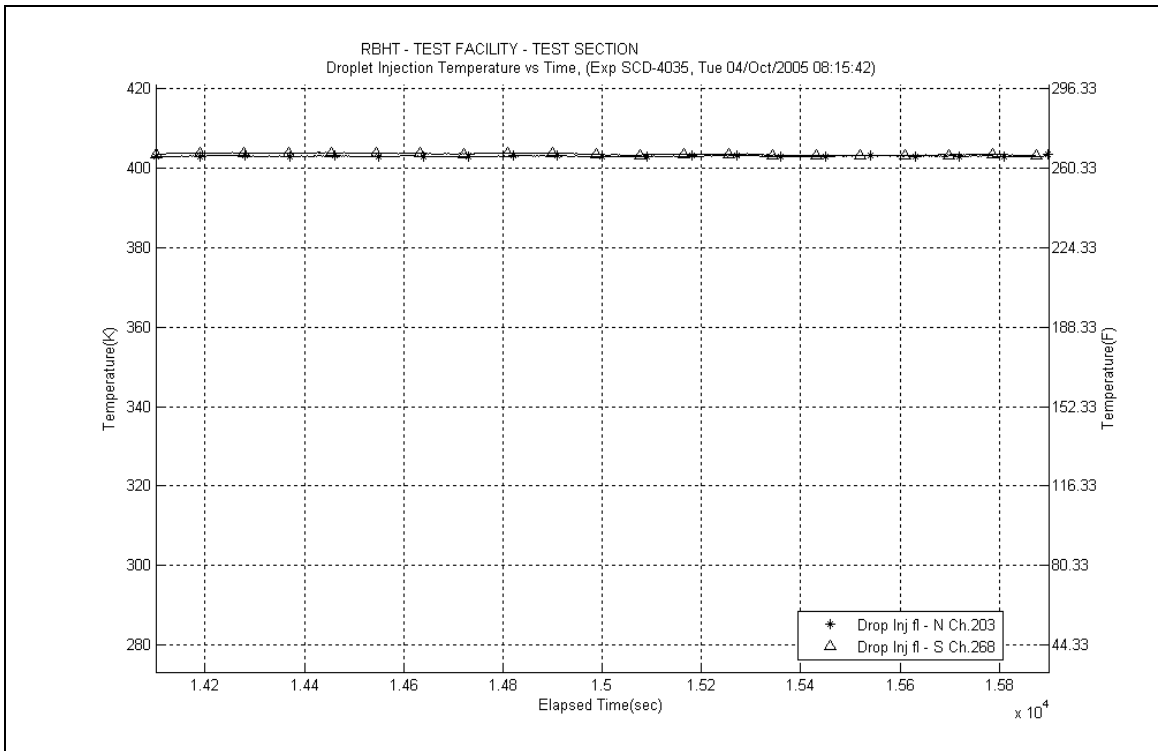

Figure A-203: Droplet Injection Temperature for Experiment 4035A

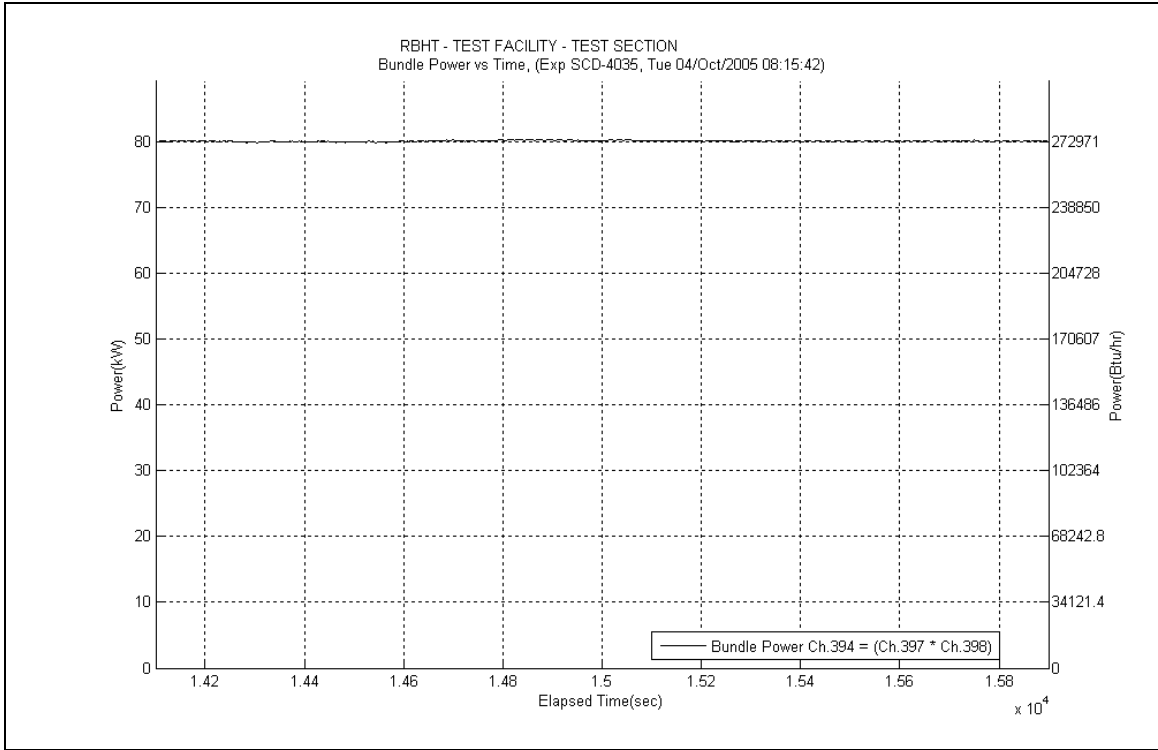

Figure A-204: Bundle Power for Experiment 4035A

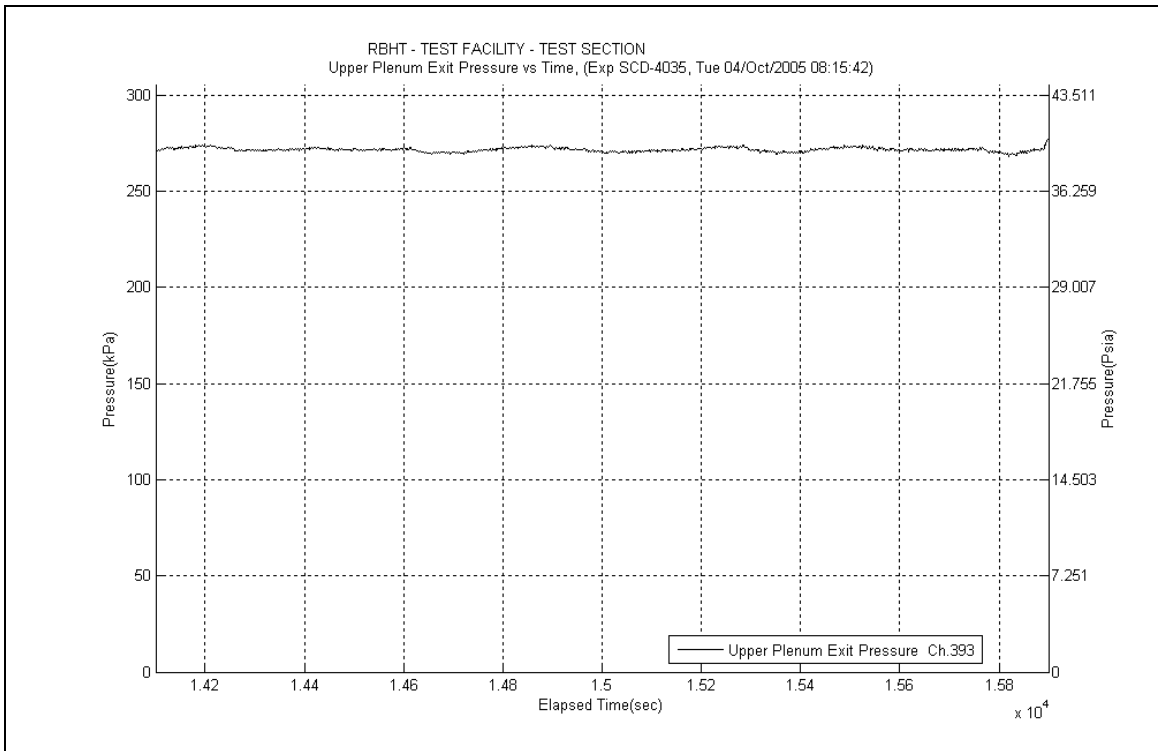

Figure A-205: Upper Plenum Pressure for Experiment 4035A

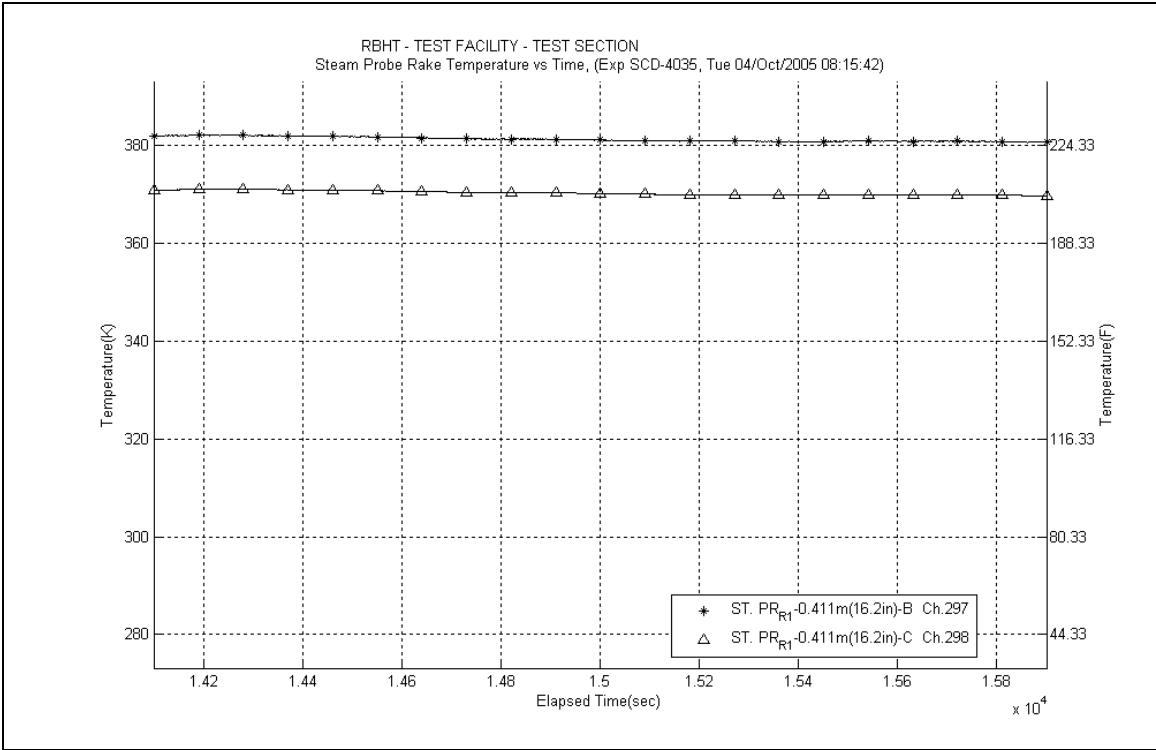

Figure A-206: Steam Probe Rake #1 Temperatures for Experiment 4035A

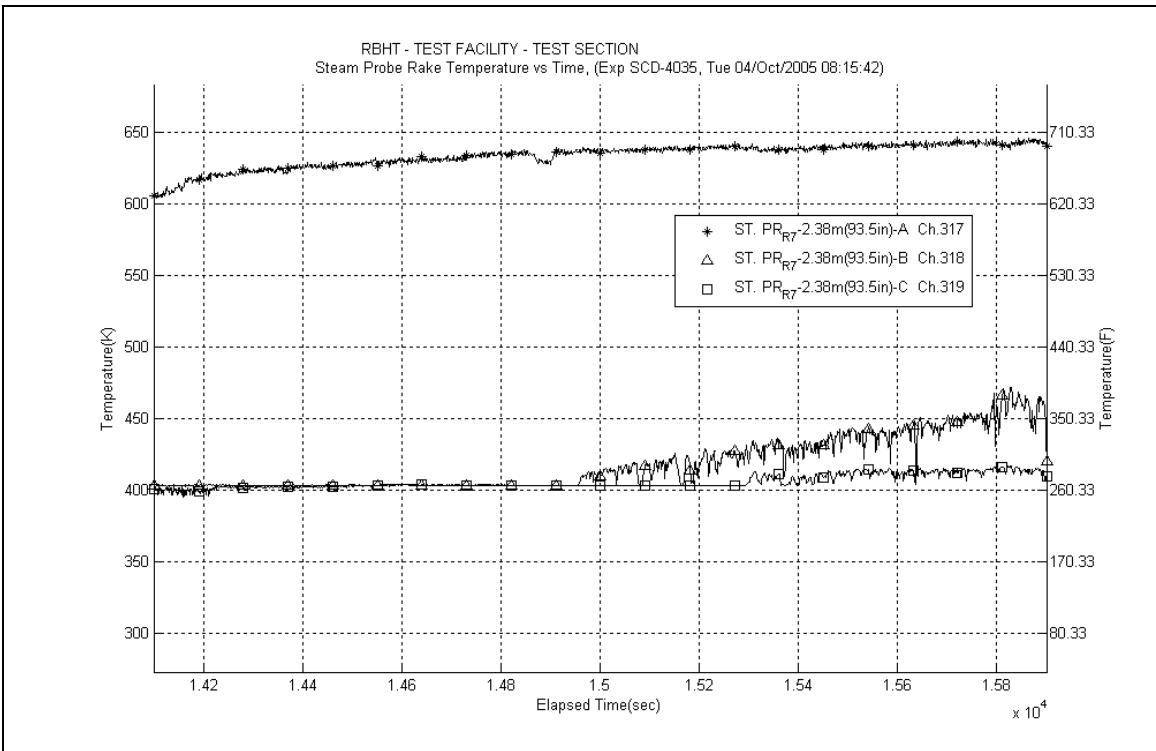

Figure A-207: Steam Probe Rake #7 Temperatures for Experiment 4035A

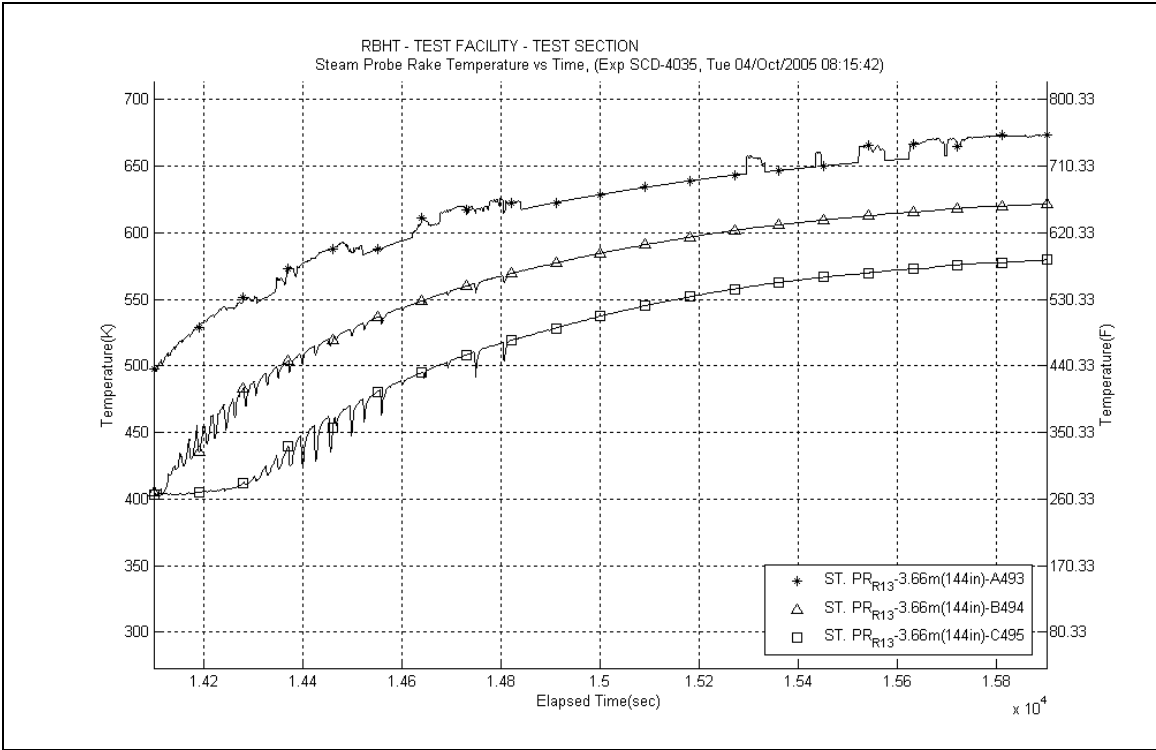

Figure A-208: Steam Probe Rake #13 Temperatures for Experiment 4035A

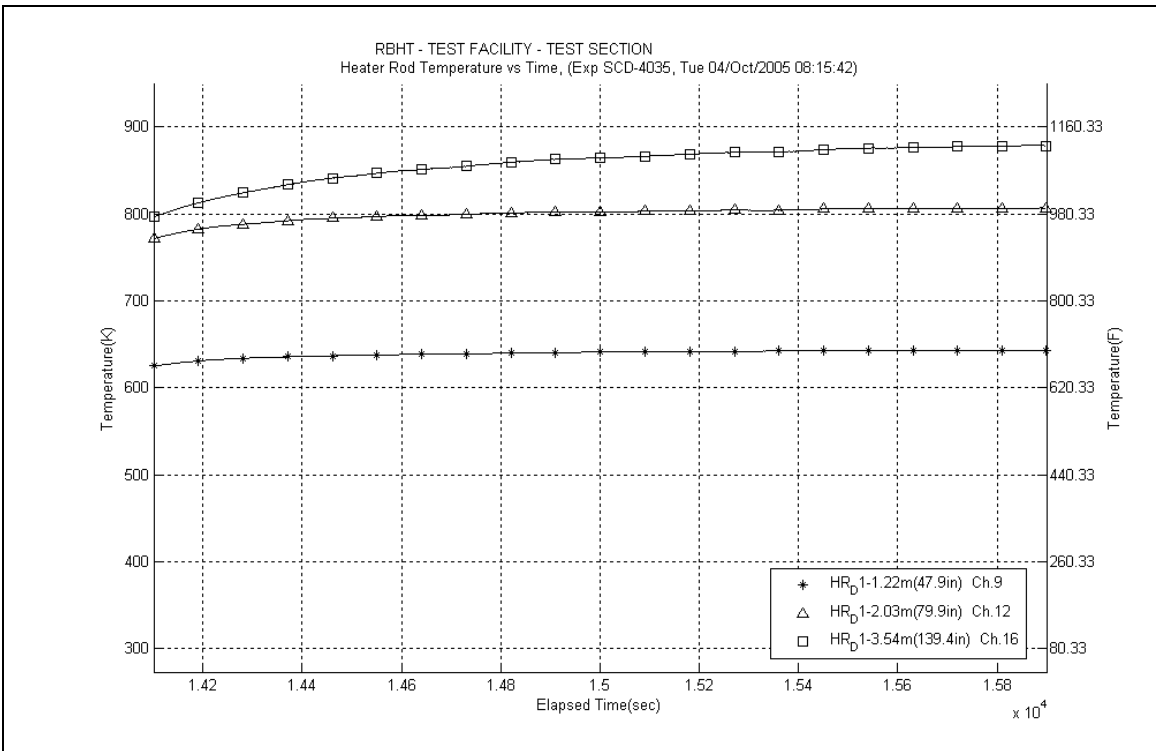

Figure A-209: Heater Rod D1 Temperatures for Experiment 4035A

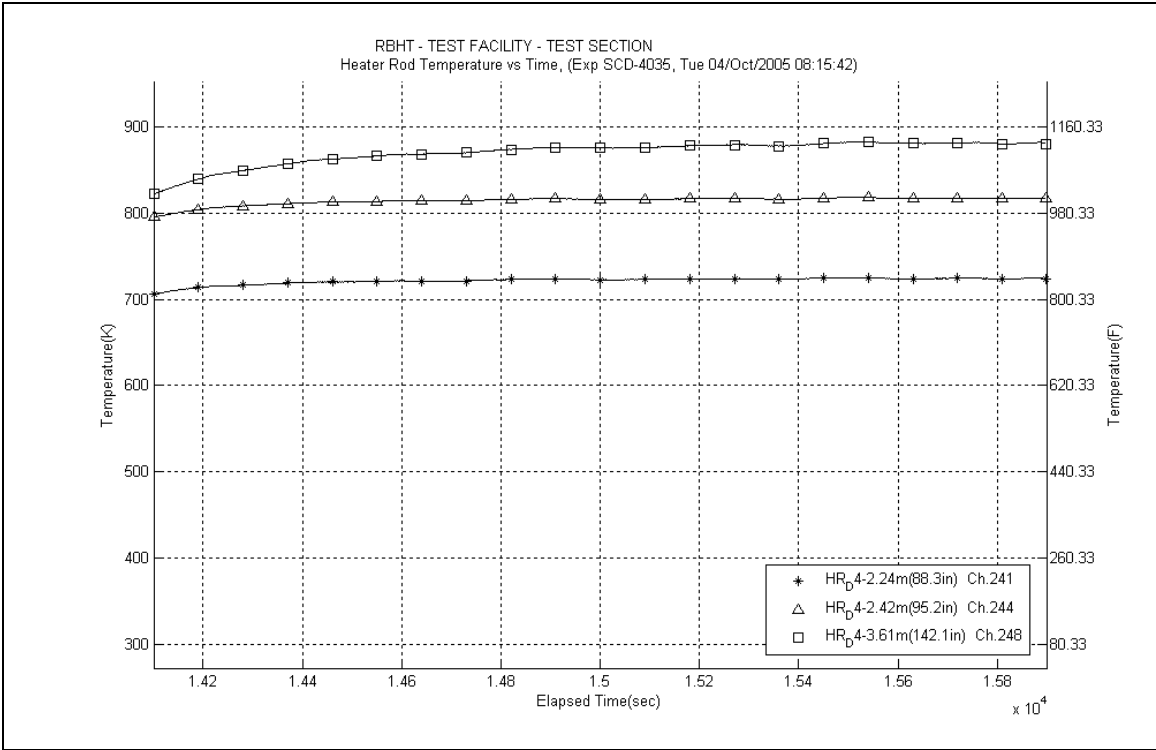

Figure A-210: Heater Rod D4 Temperatures for Experiment 4035A

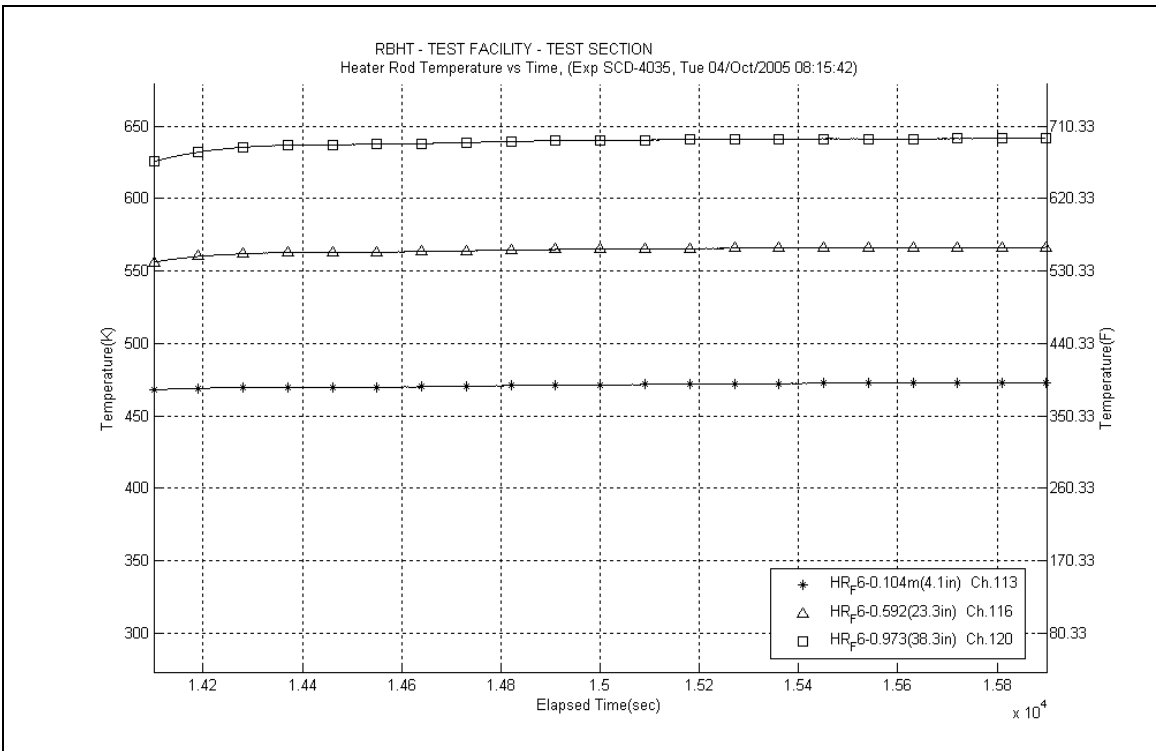

Figure A-211: Heater Rod F6 Temperatures for Experiment 4035A

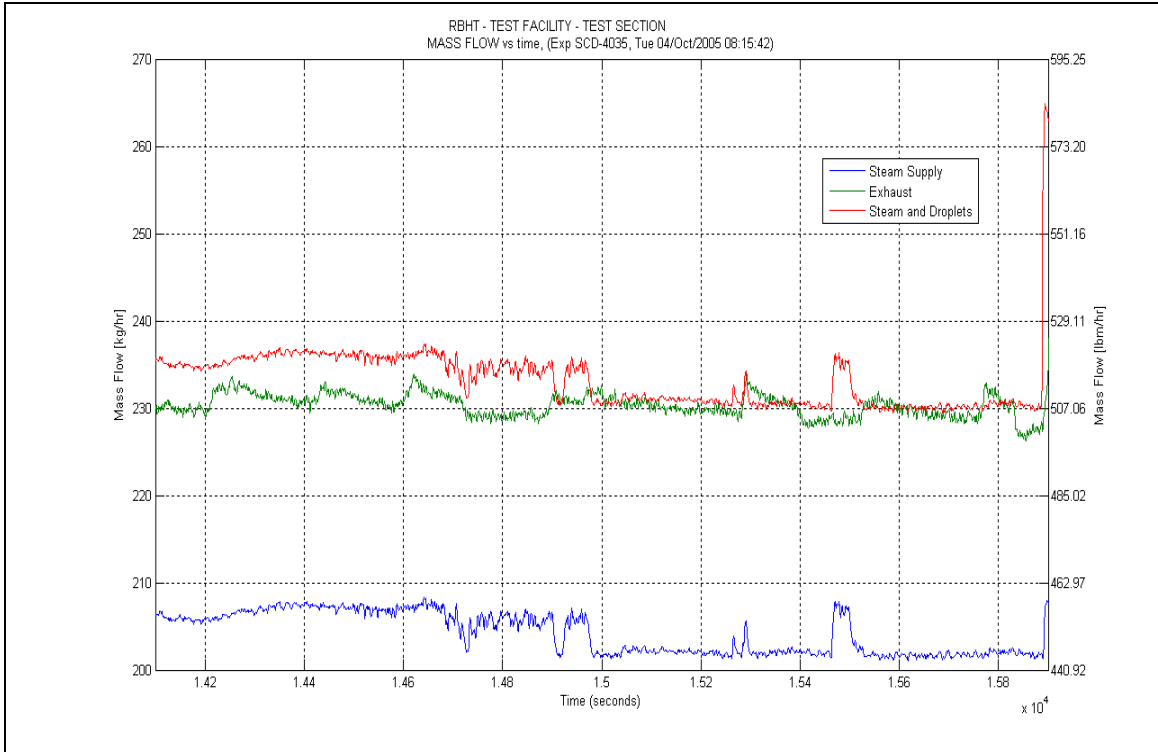

Figure A-212: Mass Flow for Experiment 4035A

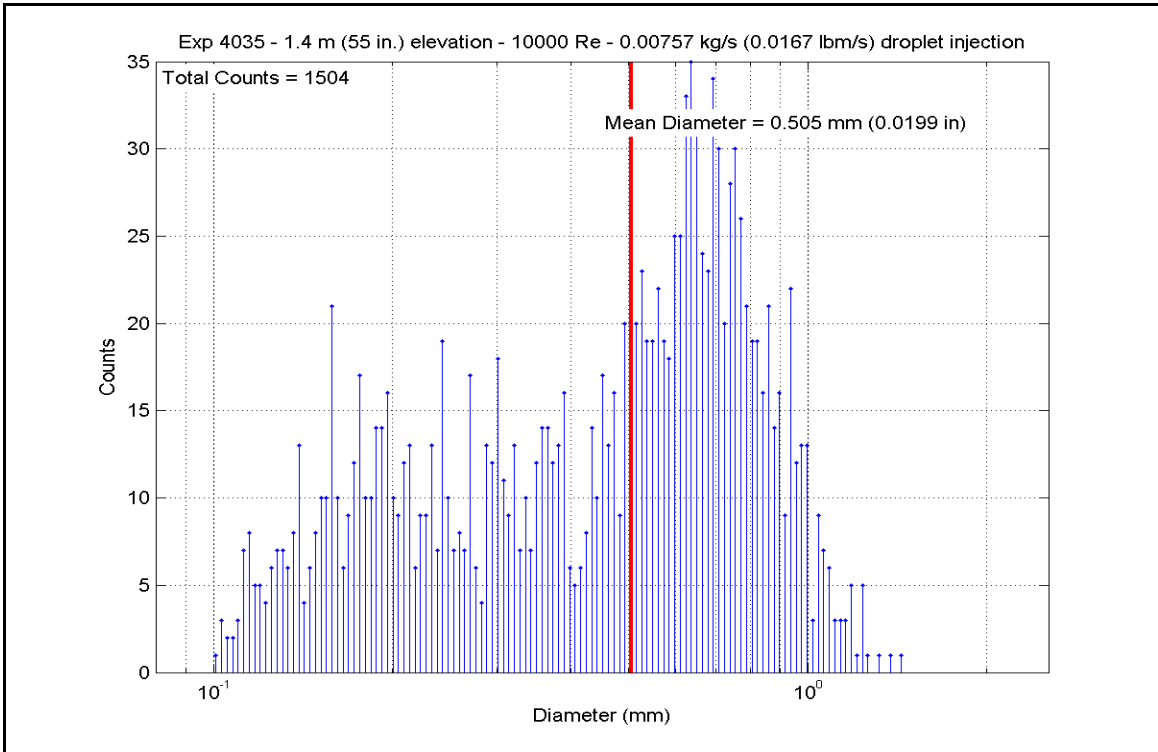

Figure A-213: Droplet Measurements at 1.397 m (55 in.) Elevation for Experiment 4035A

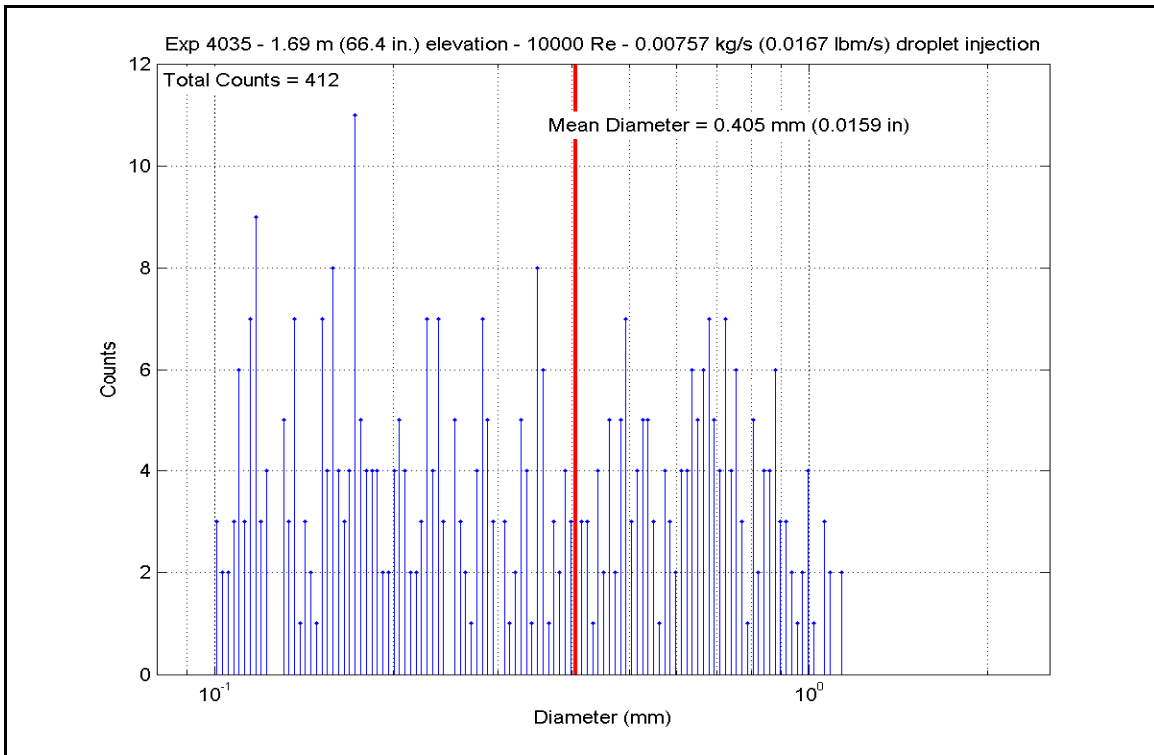

Figure A-214: Droplet Measurements at 1.687 m (66.4 in.) Elevation for Experiment 4035A

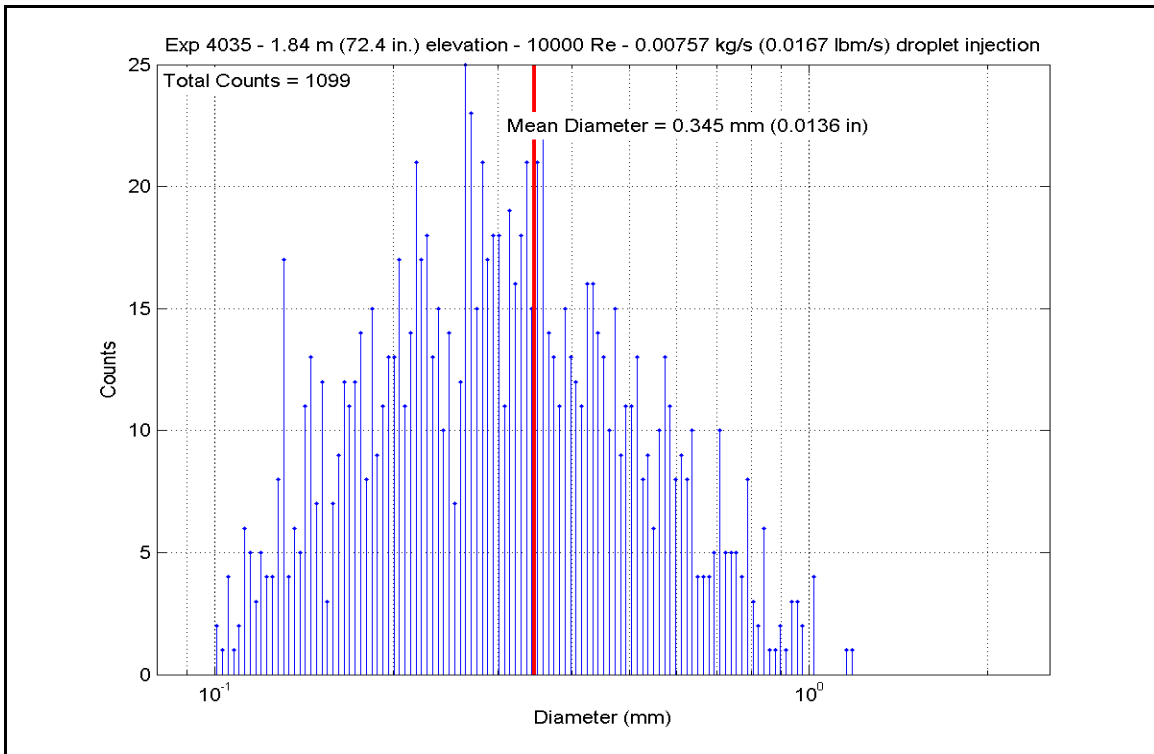

Figure A-215: Droplet Measurements at 1.839 m (72.4 in.) Elevation for Experiment 4035A

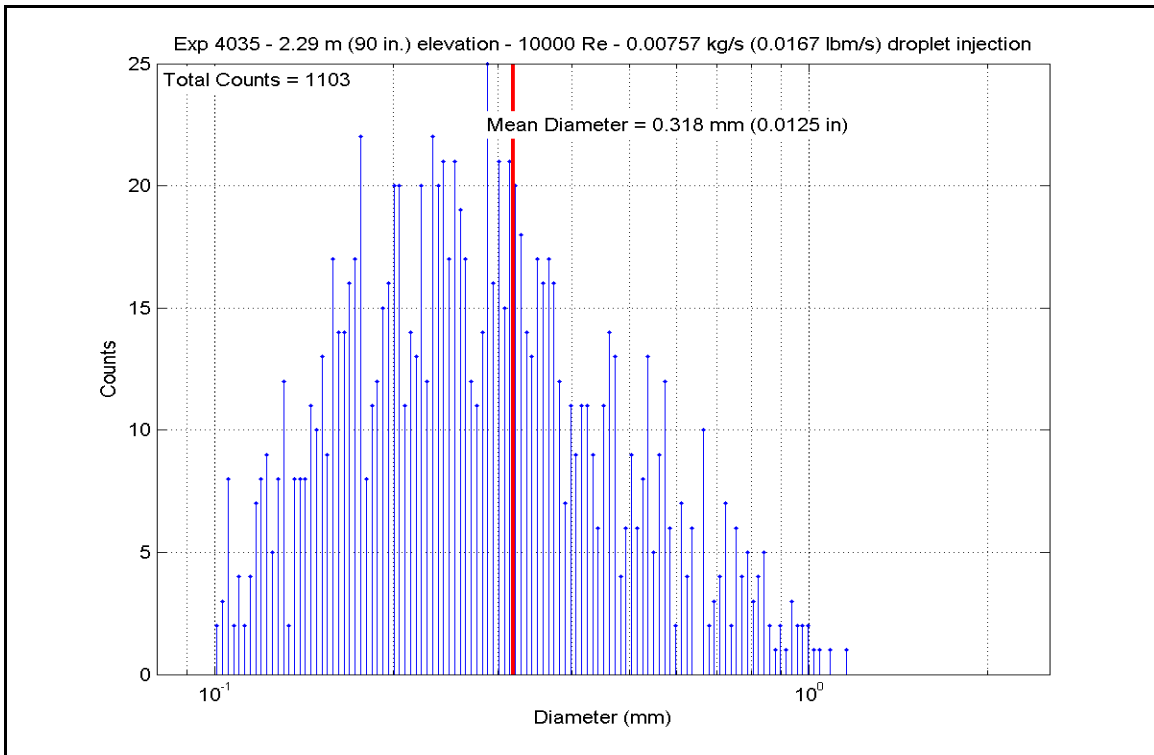

Figure A-216: Droplet Measurements at 2.286 m (90 in.) Elevation for Experiment 4035A

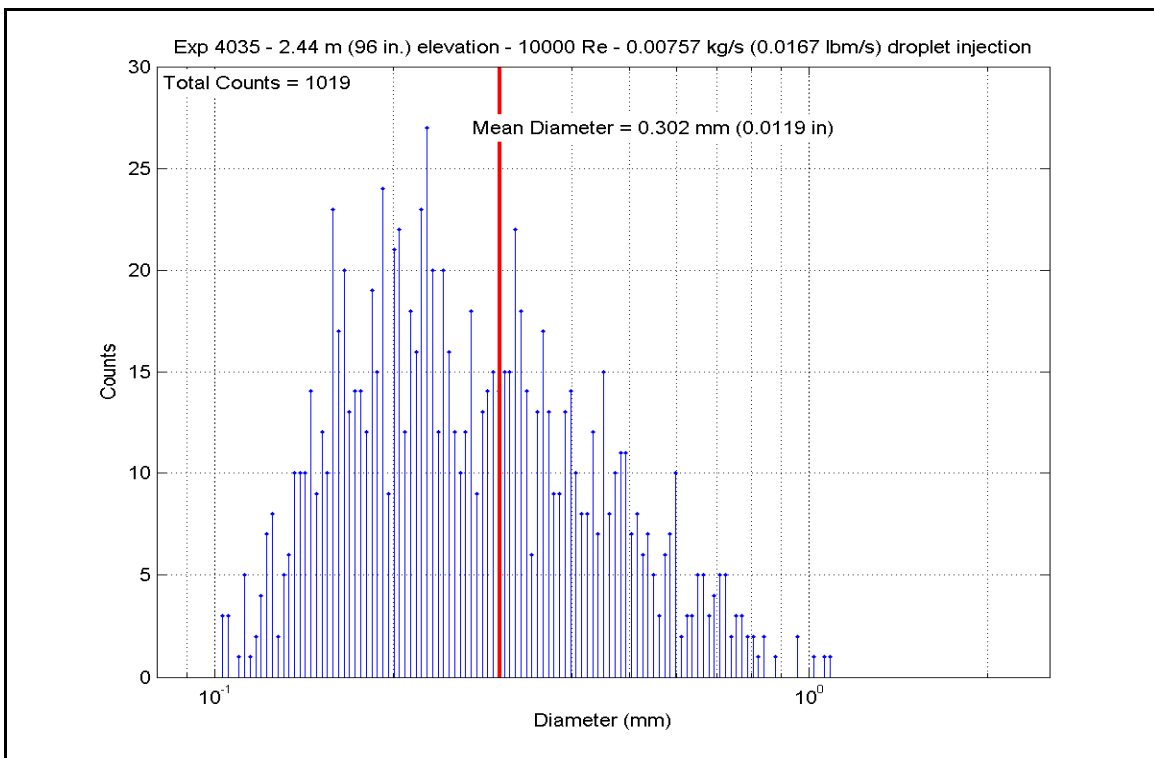

Figure A-217: Droplet Measurements at 2.438 m (96 in.) Elevation for Experiment 4035A

Table A-12: Summary of Steam Cooling Heat Transfer Reduced Data for Experiment 4035A

SCD-4035-A		Inlet Reynolds: 10000										
Matrix Test shakedown		UP Pressure: 40 psia		Bundle Power: 272971 Btu/hr		Steam flow: 445.0 lbm/hr		Dropletflow: 0.017 lbm/s				
Time Window: 14100-15900		275.8 kPa		80.00 kW		0.0561 kg/s		0.0077 kg/s				
Inner 3x3												
H.R. ID	H.R. Location	Channel Number	Elevation (in)	Elevation (m)	Zgrid (in)	Zgrid (m)	H.R. Tw (°F)	H.R. Tw (K)	H.R. q" (Btu/hr-ft ²)	H.R. q" (W/m ²)	h _{sat} (z) (Btu/hr-ft ² -F)	h _{sat} (z) (W/m ² -K)
Gr-3	RodD3_88.3	185	88.3	2.243	-0.2	-0.005	844.95	724.8	6769.67	21354.9	11.713	66.5
	RodD3_91.3	186	91.3	2.319	2.8	0.071	948.01	782.0	6906.73	21787.3	10.142	57.6
	RodD3_93.1	187	93.1	2.365	4.6	0.117	990.50	805.6	6990.44	22051.3	9.662	54.9
	RodD3_95.3	188	95.3	2.421	6.8	0.173	1026.61	825.7	7094.00	22378.0	9.339	53.0
	RodD3_100.1	189	100.1	2.543	11.6	0.295	1061.18	844.9	7312.09	23066.0	9.207	52.3
	RodD3_106.1	190	106.1	2.695	17.6	0.447	1149.73	894.1	7591.70	23948.0	8.600	48.8
	RodD3_110	191	110	2.794	21.5	0.546	1087.04	859.3	7504.19	23672.0	9.151	52.0
	RodD3_142.1	192	142.1	3.609	8.6	0.218	1117.64	876.3	2540.78	8014.9	2.987	17.0
Gr-3	RodC4_88.4	233	88.4	2.245	-0.1	-0.003	838.59	721.3	6840.64	21578.8	11.968	68.0
	RodC4_91.1	234	91.1	2.314	2.6	0.066	930.13	772.1	6968.81	21983.1	10.509	59.7
	RodC4_93.4	235	93.4	2.372	4.9	0.124	975.95	797.6	7078.12	22327.9	9.984	56.7
	RodC4_95.3	236	95.3	2.421	6.8	0.173	1011.10	817.1	7167.64	22610.3	9.633	54.7
	RodC4_100.1	237	100.1	2.543	11.6	0.295	1043.74	835.2	7406.04	23362.4	9.535	54.1
	RodC4_106.1	238	106.1	2.695	17.6	0.447	1122.23	878.8	7687.27	24249.5	8.989	51.0
	RodC4_110	239	110	2.794	21.5	0.546	1054.26	841.1	7448.97	23497.8	9.462	53.7
	RodC4_142.2	240	142.2	3.612	8.7	0.221	1098.60	865.7	2748.68	8670.7	3.305	18.8
Gr-3	RodD4_88.3	241	88.3	2.243	-0.2	-0.005	836.25	720.0	6814.49	21496.3	11.971	68.0
	RodD4_91.3	242	91.3	2.319	2.8	0.071	932.10	773.2	6955.64	21941.6	10.458	59.4
	RodD4_93.2	243	93.2	2.367	4.7	0.119	971.03	794.8	7045.13	22223.9	10.007	56.8
	RodD4_95.2	244	95.2	2.418	6.7	0.170	1002.66	812.4	7140.31	22524.1	9.706	55.1
	RodD4_100.1	245	100.1	2.543	11.6	0.295	1054.77	841.4	7381.81	23285.9	9.371	53.2
	RodD4_106.1	246	106.1	2.695	17.6	0.447	1125.53	880.7	7660.42	24164.8	8.923	50.7
	RodD4_142.1	248	142.1	3.609	8.6	0.218	1104.70	869.1	2650.25	8360.2	3.164	18.0
Gr-3	RodE4_88.4	201	88.4	2.245	-0.1	-0.003	840.61	722.4	6720.61	21200.2	11.716	66.5
	RodE4_91.2	202	91.2	2.316	2.7	0.069	943.52	779.5	6843.35	21587.4	10.116	57.4
	RodE4_95.3	204	95.3	2.421	6.8	0.173	1026.68	825.8	7027.36	22167.8	9.250	52.5
	RodE4_100.9	205	100.9	2.563	12.4	0.315	1090.61	861.3	7274.59	22947.7	8.833	50.2
	RodE4_142.3	208	142.3	3.614	8.8	0.224	1117.79	876.4	2694.83	8500.8	3.167	18.0

ble A-12: Summary of Steam Cooling Heat Transfer Reduced Data for Experiment 4035A, continued

Gr-4	Gr-4	Gr-4	Gr-5	Gr-8							
H.R. Location	Channel Number	Elevation (in)	Elevation (m)	Zgrid (in)	Zgrid (m)	H.R. Tw (°F)	H.R. Tw (K)	H.R. q" (Btu/hr-ft ²)	H.R. q" (W/m ²)	h _{sat} (z) (Btu/hr-ft ² -F)	h _{sat} (z) (W/m ² -K)
RodE3_63.4	193	63.4	1.610	16.4	0.417	948.11	782.1	5547.80	17500.5	8.145	46.3
RodE3_113.6	194	113.6	2.885	0.85	0.022	1129.04	882.6	6817.78	21506.7	7.909	44.9
RodE3_115.5	195	115.5	2.934	2.75	0.070	1158.66	899.1	6569.62	20723.9	7.368	41.8
RodE3_118.5	196	118.5	3.010	5.75	0.146	1183.62	919.0	6158.94	19428.4	6.719	38.2
RodE3_122.7	197	122.7	3.117	9.95	0.253	1194.56	919.0	5584.52	17616.4	6.021	34.2
RodE3_126.5	198	126.5	3.213	13.75	0.349	1189.67	916.3	5067.42	15985.2	5.492	31.2
RodE3_131.7	199	131.7	3.345	-1.8	-0.046	1112.11	873.2	4386.92	13838.5	5.191	29.5
RodE3_135.6	200	135.6	3.444	2.1	0.053	1133.89	885.3	3838.43	12108.3	4.428	25.1
RodC5_63.7	225	63.7	1.618	16.7	0.424	940.09	777.6	5428.44	17124.0	8.065	45.8
RodC5_113.6	226	113.6	2.885	0.85	0.022	1070.84	850.3	6684.20	21022.2	8.290	47.1
RodC5_115.7	227	115.7	2.939	2.95	0.075	1112.08	873.2	6380.19	20126.3	7.550	42.9
RodC5_122.7	229	122.7	3.117	9.95	0.253	1148.30	893.3	5470.11	17255.5	6.207	35.2
RodC5_126.7	230	126.7	3.218	13.95	0.354	1144.07	891.0	4954.43	15628.8	5.649	32.1
RodC5_131.6	231	131.6	3.343	-1.9	-0.048	1057.41	842.8	4335.63	13676.7	5.485	31.2
RodC5_135.7	232	135.7	3.447	2.2	0.056	1083.04	857.1	3797.77	11980.1	4.654	26.4
RodE5_63.6	209	63.6	1.615	16.6	0.422	934.52	774.6	5561.65	17544.2	8.332	47.3
RodE5_113.6	210	113.6	2.885	0.85	0.022	1094.86	863.6	6862.94	21649.2	8.290	47.1
RodE5_115.4	211	115.4	2.931	2.65	0.067	1124.44	880.1	6609.75	20850.5	7.709	43.8
RodE5_118.7	212	118.7	3.015	5.95	0.151	1147.27	892.7	6184.00	19444.4	7.002	39.8
RodE5_122.6	213	122.6	3.114	9.85	0.250	1161.40	900.6	5639.97	17791.3	6.306	35.8
RodE5_126.6	214	126.6	3.216	13.85	0.352	1158.73	899.1	5104.28	16101.4	5.724	32.5
RodE5_131.6	215	131.6	3.343	-1.9	-0.048	1075.24	852.7	4447.31	14029.0	5.502	31.2
RodE5_135.6	216	135.6	3.444	2.1	0.053	1099.17	866.0	3906.44	12322.9	4.694	26.7
RodC3_79.8	177	79.8	2.027	8.92	0.274	964.20	791.0	6316.49	19925.4	9.060	51.4
RodC3_85.6	178	85.6	2.174	14.72	0.374	847.89	726.4	6605.12	20835.9	11.371	64.6
RodC3_88.5	179	88.5	2.248	0	0.000	841.64	722.9	6742.53	21269.3	11.734	66.6
RodC3_92.4	180	92.4	2.347	3.9	0.099	959.75	788.6	6917.19	21820.3	9.985	56.7
RodC3_94.4	181	94.4	2.398	5.9	0.150	998.11	809.9	7008.66	22108.8	9.586	54.4
RodC3_97.2	182	97.2	2.469	8.7	0.221	1046.87	837.0	7129.81	22491.0	9.142	51.9
RodC3_108.8	183	108.8	2.764	20.3	0.516	1134.65	885.7	7506.60	23679.6	8.652	49.1
RodD5_50	217	50	1.270	3	0.076	788.62	693.5	4928.90	15548.2	9.449	53.7
RodD5_54.1	218	54.1	1.374	7.1	0.180	805.68	703.0	5117.69	16143.8	9.500	54.0
RodD5_56.9	219	56.9	1.445	9.9	0.251	868.13	737.7	5245.46	16546.8	8.726	49.6
RodD5_60	220	60	1.524	13	0.330	911.11	761.5	5388.83	16999.1	8.366	47.5
RodD5_66.1	221	66.1	1.679	19.1	0.485	952.48	784.5	5675.89	17904.6	8.280	47.0
RodD5_69.9	222	69.9	1.775	-0.98	-0.025	767.92	682.0	5877.41	18540.3	11.733	66.6
RodD5_72.9	223	72.9	1.852	2.02	0.051	858.15	732.1	6013.91	18970.9	10.173	57.8
RodD5_74.9	224	74.9	1.902	4.02	0.102	906.75	759.1	6105.28	19259.1	9.543	54.2

Inner 3x3

ble A-12: Summary of Steam Cooling Heat Transfer Reduced Data for Experiment 4035A, continued

H.R. ID	H.R. Location	Channel Number	Elevation (in)	Elevation (m)	Zgrid (in)	Zgrid (m)	H.R. Tw (°F)	H.R. Tw (K)	H.R. q" (Btu/hr-ft ²)	H.R. q" (W/m ²)	h _{sat} (z) (Btu/hr-ft ² -F)	h _{sat} (z) (W/m ² -K)	
5x5 periphery Gr-2	RodB5_41	153	41	1.041	13.5	0.343	730.34	661.1	4483.91	14144.5	9.677	55.0	
	RodB5_52.9	154	52.9	1.344	5.9	0.150	758.11	676.5	5056.81	15951.7	10.297	58.5	
	RodB5_55	155	55	1.397	8	0.203	813.72	707.4	5153.16	16255.7	9.426	53.5	
	RodB5_57.8	156	57.8	1.468	10.8	0.274	875.67	741.9	5284.25	16669.2	8.682	49.3	
	RodB5_64	157	64	1.626	17	0.432	939.88	777.5	5576.63	17591.5	8.288	47.1	
	RodB5_73.9	158	73.9	1.877	3.02	0.077	887.75	748.6	6062.76	19125.0	9.767	55.5	
	RodB5_75.9	159	75.9	1.928	5.02	0.128	924.49	769.0	6155.60	19417.8	9.362	53.2	
	RodB5_76.9	160	76.9	1.953	6.02	0.153	939.57	777.4	6202.38	19565.4	9.222	52.4	
	Gr-2	RodF5_41	105	41	1.041	13.5	0.343	726.95	659.2	4449.16	14034.9	9.673	54.9
		RodF5_53.1	106	53.1	1.349	6.1	0.155	758.88	677.0	5030.38	15868.3	10.227	58.1
	RodF5_55	107	55	1.397	8	0.203	802.21	701.0	5117.47	16143.1	9.562	54.3	
	RodF5_57.8	108	57.8	1.468	10.8	0.274	854.16	729.9	5247.23	16552.4	8.937	50.8	
	RodF5_64	109	64	1.626	17	0.432	910.37	761.1	5540.35	17477.0	8.611	48.9	
	RodF5_73.8	110	73.8	1.875	2.92	0.074	865.20	736.0	6018.62	18985.7	10.061	57.1	
	RodF5_75.8	111	75.8	1.925	4.92	0.125	905.73	758.6	6111.50	19278.7	9.568	54.3	
	RodF5_76.8	112	76.8	1.951	5.92	0.150	921.61	767.4	6158.08	19425.7	9.407	53.4	
Gr-2	RodC2_41	57	41	1.041	13.5	0.343	728.70	660.2	4474.06	14113.4	9.690	55.0	
	RodC2_53.1	58	53.1	1.349	6.1	0.155	790.69	694.6	5054.39	15944.1	9.652	54.8	
	RodC2_55	59	55	1.397	8	0.203	822.77	712.5	5142.26	16221.3	9.253	52.5	
	RodC2_57.8	60	57.8	1.468	10.8	0.274	857.68	731.9	5271.85	16630.0	8.925	50.7	
	RodC2_63.9	61	63.9	1.623	16.9	0.429	901.55	756.2	5558.88	17535.5	8.760	49.7	
	RodC2_73.8	62	73.8	1.875	2.92	0.074	872.86	740.3	6033.82	19033.7	9.959	56.6	
	RodC2_75.8	63	75.8	1.925	4.92	0.125	904.53	757.9	6129.64	19336.0	9.615	54.6	
	RodC2_76.8	64	76.8	1.951	5.92	0.150	917.48	765.1	6175.60	19480.9	9.494	53.9	
Gr-2	RodC6_40.9	137	40.9	1.039	13.4	0.340	730.35	661.1	4452.91	14046.7	9.610	54.6	
	RodC6_52.8	138	52.8	1.341	5.8	0.147	810.08	705.4	5048.25	15924.7	9.296	52.8	
	RodC6_54.8	139	54.8	1.392	7.8	0.198	839.14	721.6	5145.87	16232.6	8.994	51.1	
	RodC6_57.8	140	57.8	1.468	10.8	0.274	874.92	741.4	5295.46	16704.5	8.711	49.5	
	RodC6_63.8	141	63.8	1.621	16.8	0.427	923.63	768.5	5591.48	17638.3	8.515	48.4	
	RodC6_73.7	142	73.7	1.872	2.82	0.072	897.91	754.2	6097.53	19234.7	9.665	54.9	
	RodC6_75.8	143	75.8	1.925	4.92	0.125	928.18	771.0	6199.23	19555.5	9.376	53.2	
	RodC6_76.8	144	76.8	1.951	5.92	0.150	945.44	780.6	6247.46	19707.6	9.209	52.3	

Table A-12: Summary of Steam Cooling Heat Transfer Reduced Data for Experiment 4035A, continued

5x5 periphery		H.R. Location	Channel Number	Elevation (in)	Elevation (m)	Zgrid (in)	Zgrid (m)	H.R. Tw (°F)	H.R. Tw (K)	H.R. q" (Btu/hr-ft ²)	H.R. q" (W/m ²)	h _{sat} (z) (Btu/hr-ft ² -F)	h _{sat} (z) (W/m ² -K)
Gr-3	RodB4_88.4	161	88.4	2.245	-0.1	-0.003	831.31	717.2	6712.09	21173.3	21173.3	11.894	67.5
	RodB4_91.3	162	91.3	2.319	2.8	0.071	928.50	771.2	6839.74	21576.0	21576.0	10.340	58.7
	RodB4_93.3	163	93.3	2.370	4.8	0.122	971.05	794.8	6928.29	21855.3	21855.3	9.841	55.9
	RodB4_95.1	164	95.1	2.416	6.6	0.168	1002.46	812.3	7008.46	22108.2	22108.2	9.529	54.1
	RodB4_100	165	100	2.540	11.5	0.292	1030.58	827.9	7226.38	22795.6	22795.6	9.464	53.7
	RodB4_106	166	106	2.692	17.5	0.445	1103.95	868.7	7495.23	23643.7	23643.7	8.955	50.9
	RodB4_109.9	167	109.9	2.791	21.4	0.544	1035.02	830.4	7264.67	22916.4	22916.4	9.459	53.7
	RodB4_142.3	168	142.3	3.614	8.8	0.224	1078.65	854.6	2751.63	8680.0	8680.0	3.390	19.3
Gr-5	RodF4_85.6	98	85.6	2.174	14.72	0.374	915.26	763.9	6604.88	20835.1	20835.1	10.189	57.9
	RodF4_88.4	99	88.4	2.245	-0.1	-0.003	895.68	753.0	6737.65	21253.9	21253.9	10.717	60.9
	RodF4_92.4	100	92.4	2.347	3.9	0.099	996.68	809.1	6919.44	21827.4	21827.4	9.483	53.9
	RodF4_94.3	101	94.3	2.395	5.8	0.147	1028.79	826.9	7005.92	22100.2	22100.2	9.197	52.2
	RodF4_97.2	102	97.2	2.469	8.7	0.221	1069.15	849.3	7138.71	22519.1	22519.1	8.899	50.5
	RodF4_108.8	103	108.8	2.764	20.3	0.516	1138.81	888.0	7532.89	23762.5	23762.5	8.641	49.1
	RodF4_111	104	111	2.819	-1.75	-0.044	1061.97	845.4	7232.30	22814.3	22814.3	9.098	51.7
	RodD2_103.2	65	103.2	2.621	14.7	0.373	1128.95	882.6	6620.54	20884.5	20884.5	7.681	43.6
RodD2_106	66	106	2.692	17.5	0.445	1149.46	894.0	6260.60	19749.1	19749.1	7.094	40.3	
RodD2_112.6	67	112.6	2.860	-0.15	-0.004	1171.04	906.0	5770.14	18201.9	18201.9	6.383	36.2	
RodD2_114.9	68	114.9	2.918	2.15	0.055	1173.71	907.4	5194.95	16387.5	16387.5	5.729	32.5	
RodD2_117.4	69	117.4	2.982	4.65	0.118	1163.40	901.7	4653.01	14677.9	14677.9	5.191	29.5	
RodD2_120.8	70	120.8	3.068	8.05	0.204	1127.40	881.7	7448.34	23495.8	23495.8	8.657	49.2	
RodD2_124.8	71	124.8	3.170	12.05	0.306	1147.34	892.8	7581.17	23914.8	23914.8	8.612	48.9	
RodD2_128.6	72	128.6	3.266	15.85	0.403	1084.77	858.0	6956.40	21944.0	21944.0	8.507	48.3	
Gr-6	RodD6_103.1	129	103.1	2.619	14.6	0.371	1110.00	872.0	7466.77	23553.9	23553.9	8.857	50.3
	RodD6_106	130	106	2.692	17.5	0.445	1128.32	882.2	7604.40	23988.1	23988.1	8.829	50.1
	RodD6_112.9	131	112.9	2.868	0.15	0.004	1062.76	845.8	6945.16	21908.5	21908.5	8.728	49.6
	RodD6_114.9	132	114.9	2.918	2.15	0.055	1101.15	867.1	6649.45	20975.7	20975.7	7.972	45.3
	RodD6_116.8	133	116.8	2.967	4.05	0.103	1122.28	878.9	6370.43	20095.5	20095.5	7.448	42.3
	RodD6_120.9	134	120.9	3.071	8.15	0.207	1135.52	886.2	5790.77	18267.0	18267.0	6.667	37.9
	RodD6_124.8	135	124.8	3.170	12.05	0.306	1135.63	886.3	5225.08	16482.5	16482.5	6.015	34.2
	RodD6_128.7	136	128.7	3.269	15.95	0.405	1128.06	882.1	4662.98	14709.4	14709.4	5.415	30.8

ble A-12: Summary of Steam Cooling Heat Transfer Reduced Data for Experiment 4035A, continued

5x5 periphery		H.R. Location	Channel Number	Elevation (in)	Elevation (m)	Zgrid (in)	Zgrid (m)	H.R. Tw (°F)	H.R. Tw (K)	H.R. q" (Btu/hr-ft ²)	H.R. q" (W/m ²)	h _{sat} (z) (Btu/hr-ft ² -F)	h _{sat} (z) (W/m ² -K)
Gr-8	RodE2_50.1	73	50.1	1.273	3.1	0.079	783.75	690.8	4944.32	15596.9	9.568	54.3	
	RodE2_54	74	54	1.372	7	0.178	804.15	702.1	5131.48	16187.3	9.553	54.3	
	RodE2_56.9	75	56.9	1.445	9.9	0.251	853.05	729.3	5267.48	16616.3	8.988	51.0	
	RodE2_59.9	76	59.9	1.521	12.9	0.328	885.78	747.5	5410.20	17066.5	8.743	49.7	
	RodE2_66	77	66	1.676	19	0.483	921.34	767.2	5702.93	17989.9	8.716	49.5	
	RodE2_69.8	78	69.8	1.773	-1.08	-0.027	786.68	692.4	5899.61	18578.8	11.333	64.4	
	RodE2_72.9	79	72.9	1.852	2.02	0.051	874.91	741.4	6037.00	19043.7	9.931	56.4	
	RodE2_74.9	80	74.9	1.902	4.02	0.102	911.07	761.5	6132.77	19345.8	9.522	54.1	
Gr-8	RodB3_50.2	169	50.2	1.275	3.2	0.081	749.74	671.9	4924.99	15535.9	10.202	57.9	
	RodB3_54.1	170	54.1	1.374	7.1	0.180	774.55	685.7	5104.42	16101.9	10.057	57.1	
	RodB3_56.9	171	56.9	1.445	9.9	0.251	831.50	717.3	5229.16	16495.4	9.263	52.6	
	RodB3_60.1	172	60.1	1.527	13.1	0.333	842.28	723.3	5384.53	16985.5	9.360	53.2	
	RodB3_66.1	173	66.1	1.679	19.1	0.485	907.95	759.8	5672.08	17892.6	8.849	50.3	
	RodB3_69.9	174	69.9	1.775	-0.98	-0.025	748.72	671.3	5873.15	18526.9	12.192	69.2	
	RodB3_73	175	73	1.854	2.12	0.054	849.24	727.2	6013.54	18969.7	10.328	58.7	
	RodB3_75	176	75	1.905	4.12	0.105	893.15	751.6	6105.70	19260.4	9.751	55.4	
Gr-8	RodF3_50.1	89	50.1	1.273	3.1	0.079	766.87	681.4	4918.00	15513.8	9.838	55.9	
	RodF3_54	90	54	1.372	7	0.178	798.02	698.7	5105.93	16106.7	9.615	54.6	
	RodF3_57	91	57	1.448	10	0.254	860.19	733.3	5248.28	16555.7	8.848	50.2	
	RodF3_60	92	60	1.524	13	0.330	903.76	757.5	5391.19	17006.5	8.467	48.1	
	RodF3_66.1	93	66.1	1.679	19.1	0.485	926.59	770.1	5686.75	17938.8	8.622	49.0	
	RodF3_70	94	70	1.778	-0.88	-0.022	778.41	687.8	5883.68	18560.1	11.505	65.3	
	RodF3_73	95	73	1.854	2.12	0.054	880.61	744.6	6023.17	19000.1	9.816	55.7	
	RodF3_75	96	75	1.905	4.12	0.105	926.92	770.3	6117.59	19297.9	9.270	52.6	
Gr-8	RodE6_50.2	121	50.2	1.275	3.2	0.081	770.78	683.6	4917.27	15511.5	9.761	55.4	
	RodE6_54.1	122	54.1	1.374	7.1	0.180	813.90	707.5	5097.48	16080.0	9.321	52.9	
	RodE6_57	123	57	1.448	10	0.254	846.45	725.6	5233.28	16508.4	9.031	51.3	
	RodE6_60.2	124	60.2	1.529	13.2	0.335	870.18	738.8	5382.20	16978.2	8.923	50.7	
	RodE6_66.1	125	66.1	1.679	19.1	0.485	917.91	765.3	5659.44	17852.7	8.695	49.4	
	RodE6_70	126	70	1.778	-0.88	-0.022	785.50	691.8	5858.61	18481.0	11.299	64.2	
	RodE6_73.1	127	73.1	1.857	2.22	0.056	866.87	737.0	5998.80	18923.2	10.000	56.8	
	RodE6_75	128	75	1.905	4.12	0.105	902.74	756.9	6084.65	19194.0	9.571	54.4	

RBHT Steam Cooling with Droplet Injection Test SCD-4035-B

Matrix Test # Shakedown

Test Conditions

Test Date – 10/4/2005

Steady State Time Window: 16200 - 18300

Upper Plenum Pressure: 2.76 bar (40 psia)

Bundle Power: 80.0 kW

Bundle Inlet Reynolds Number: 10000

Bundle Inlet Steam Flow: 200.7 kg/hr (442 lbm/hr)

Droplet Injection Flow: 0.0151 kg/s (0.0333 lbm/s)

Droplet Injection Hole Diameter: 0.381 mm (.015 in)

Droplet Injection Elevation: 1.295 m (51 in)

Bundle Flow Area: $4.656 \times 10^{-3} \text{ m}^2$ ($5.012 \times 10^{-2} \text{ ft}^2$)

Test Notes

- No steam probes were traversed in this steady state window.

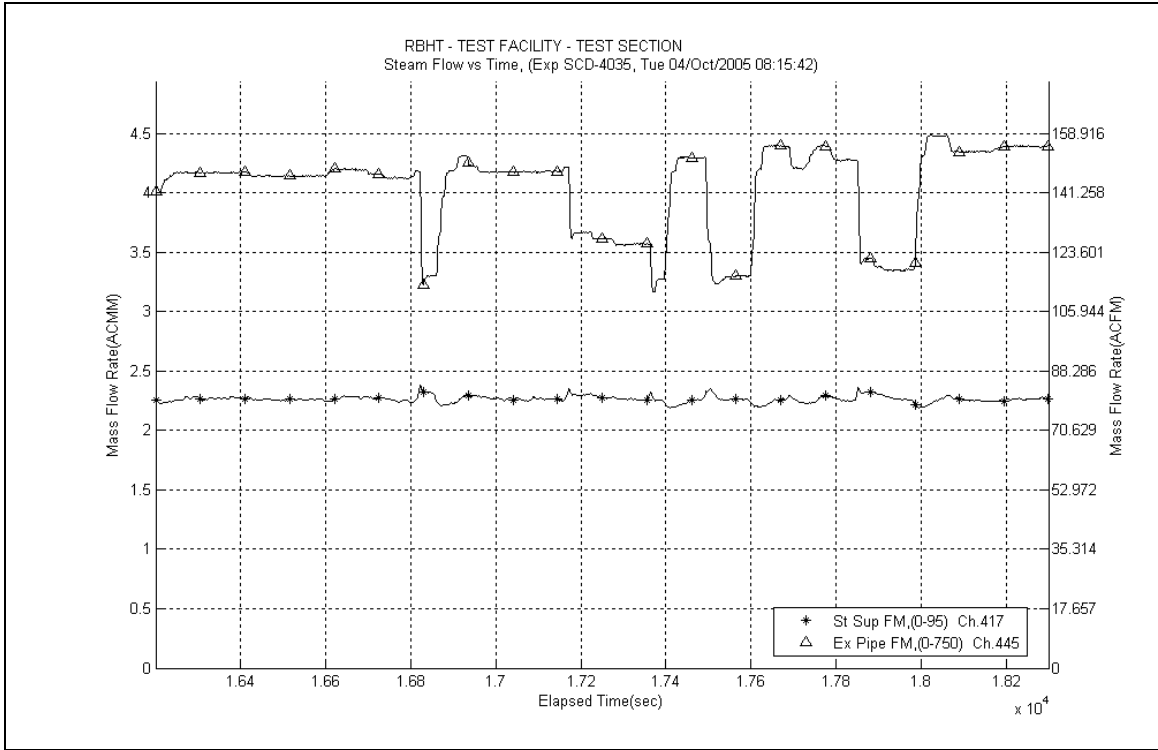

Figure A-218: Inlet and Exhaust Steam Flow Rates for Experiment 4035B

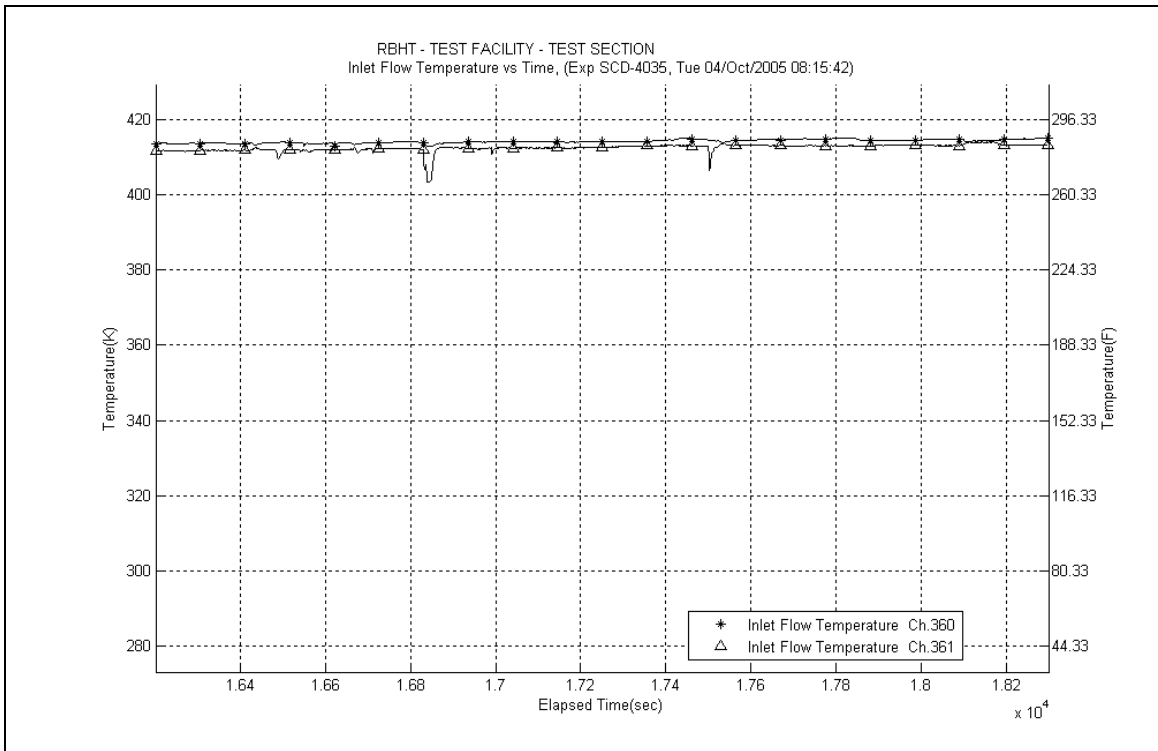

Figure A-219: Inlet Steam Temperature for Experiment 4035B

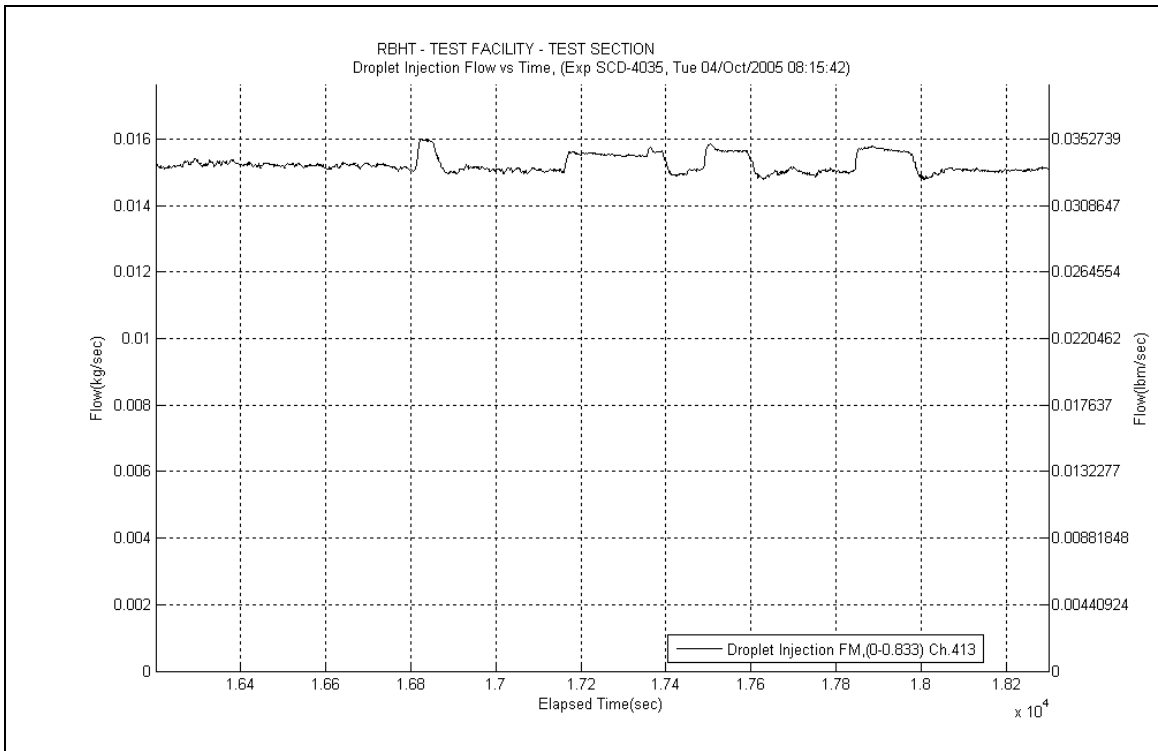

Figure A-220: Droplet Injection Flow Rate for Experiment 4035B

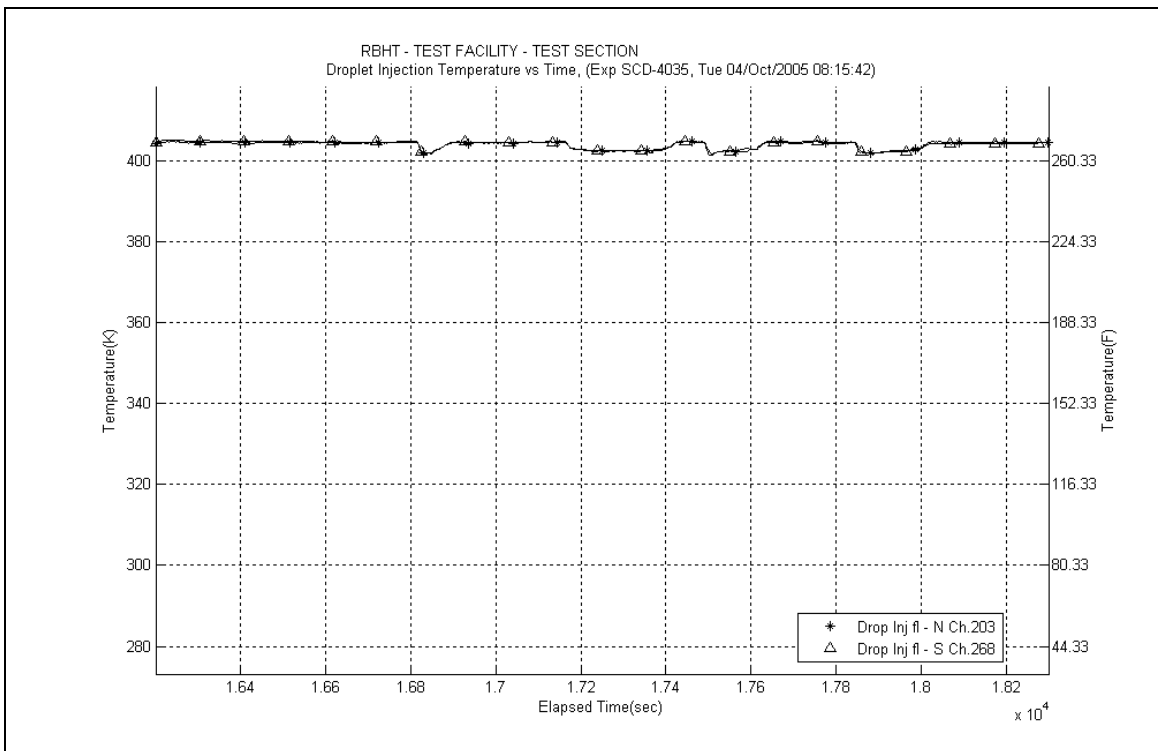

Figure A-221: Droplet Injection Temperature for Experiment 4035B

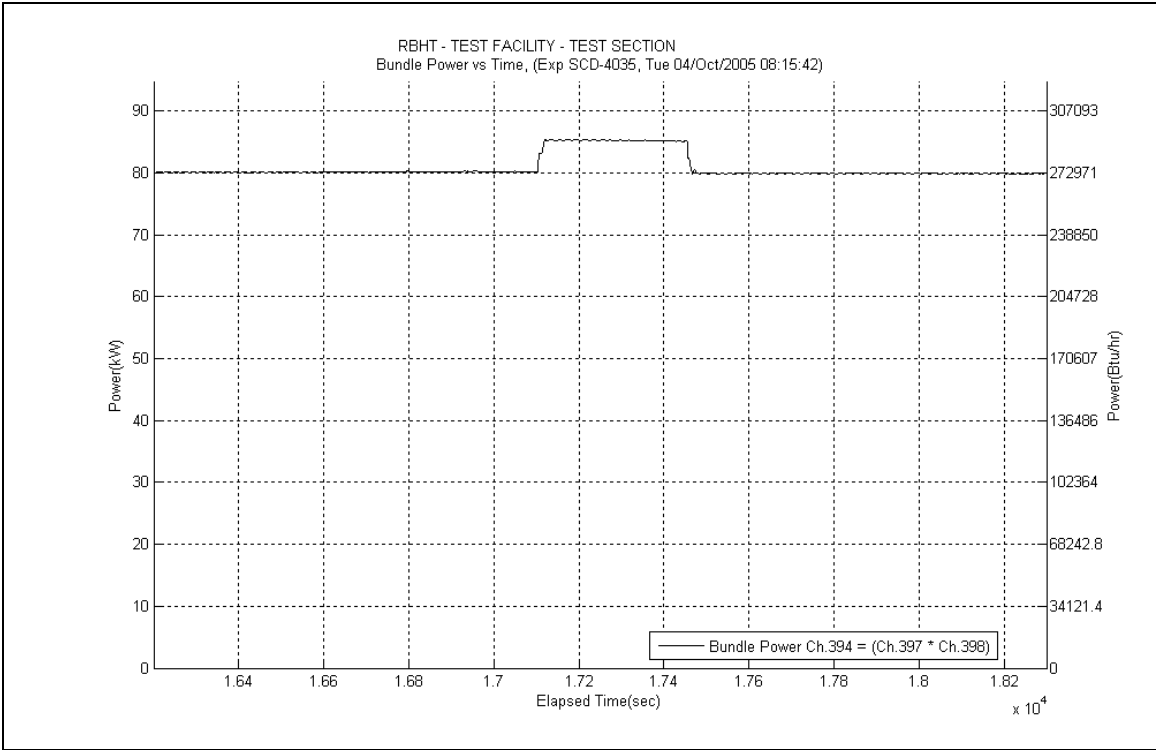

Figure A-222: Bundle Power for Experiment 4035B

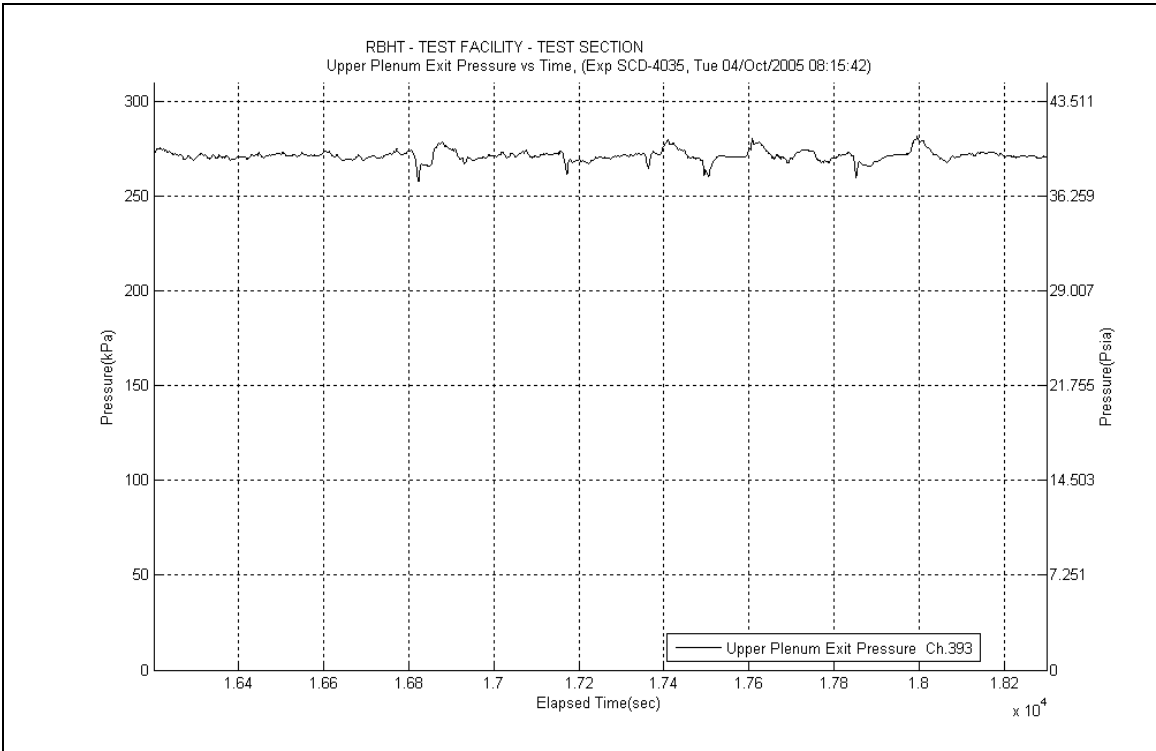

Figure A-223: Upper Plenum Pressure for Experiment 4035B

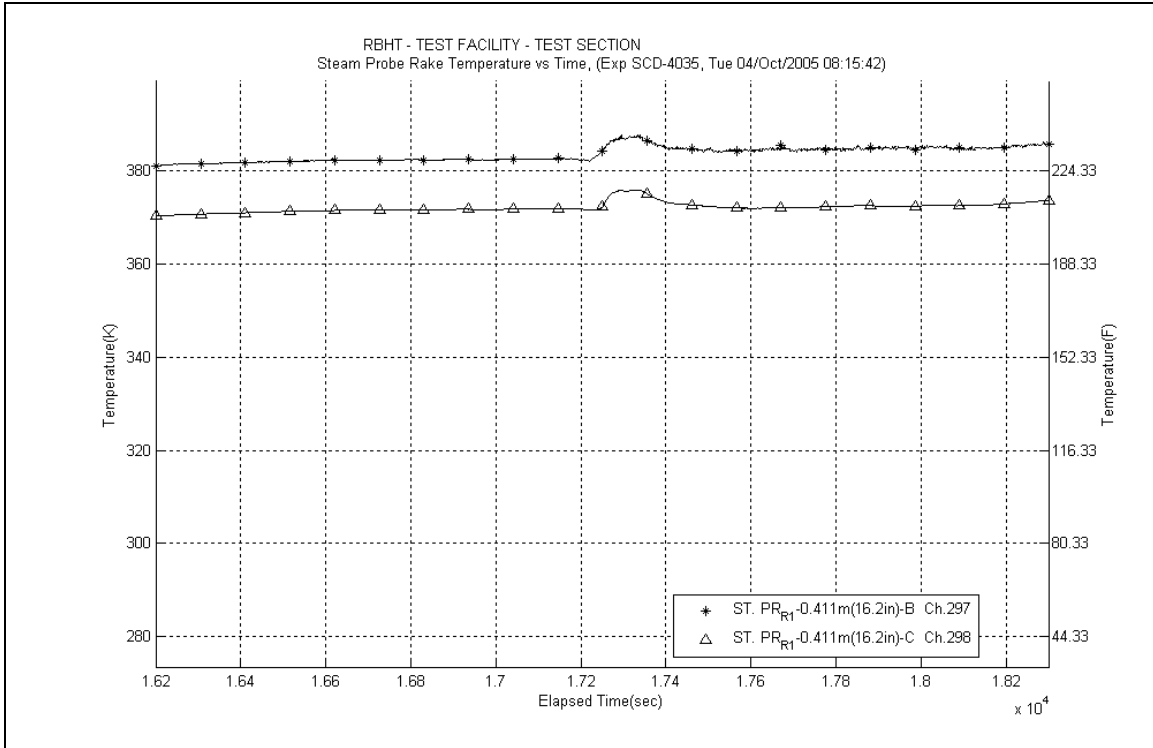

Figure A-224: Steam Probe Rake #1 Temperatures for Experiment 4035B

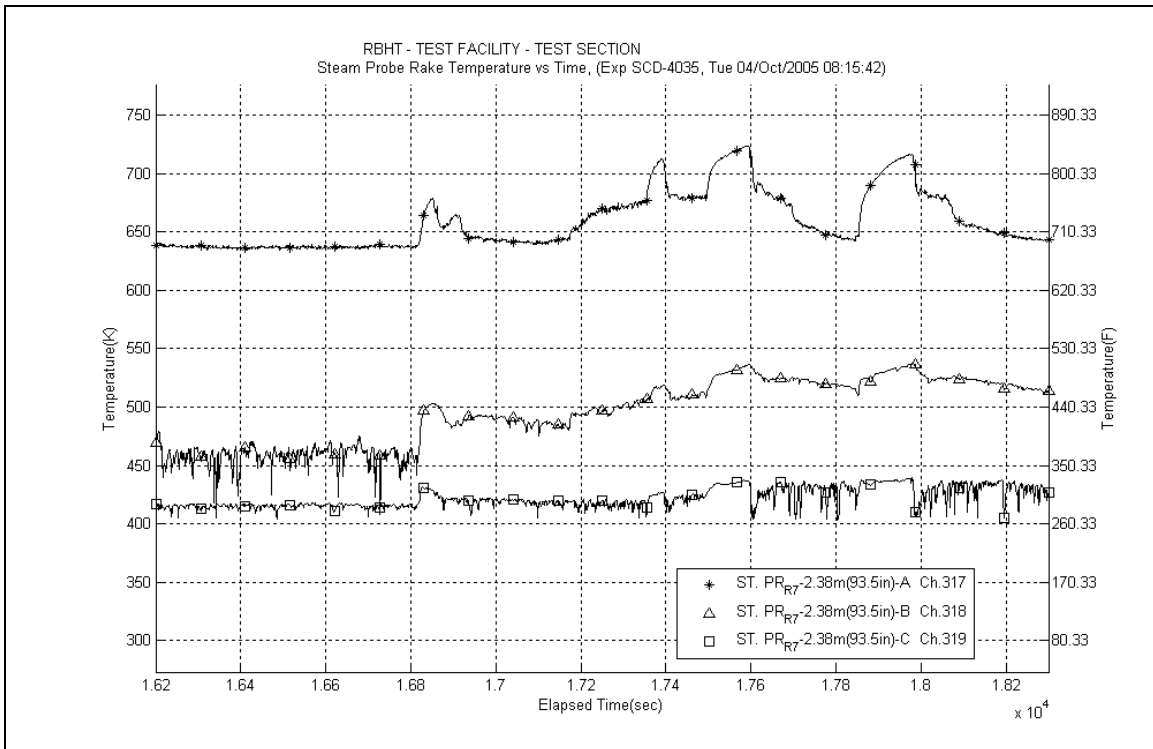

Figure A-225: Steam Probe Rake #7 Temperatures for Experiment 4035B

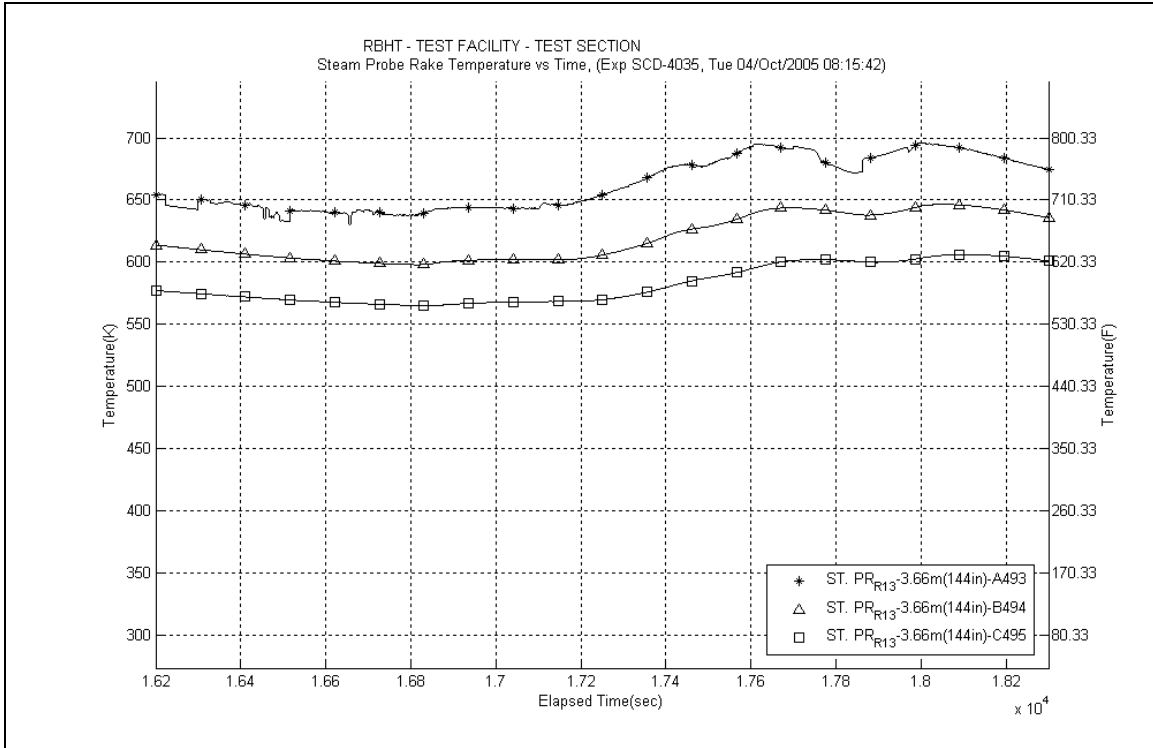

Figure A-226: Steam Probe Rake #13 Temperatures for Experiment 4035B

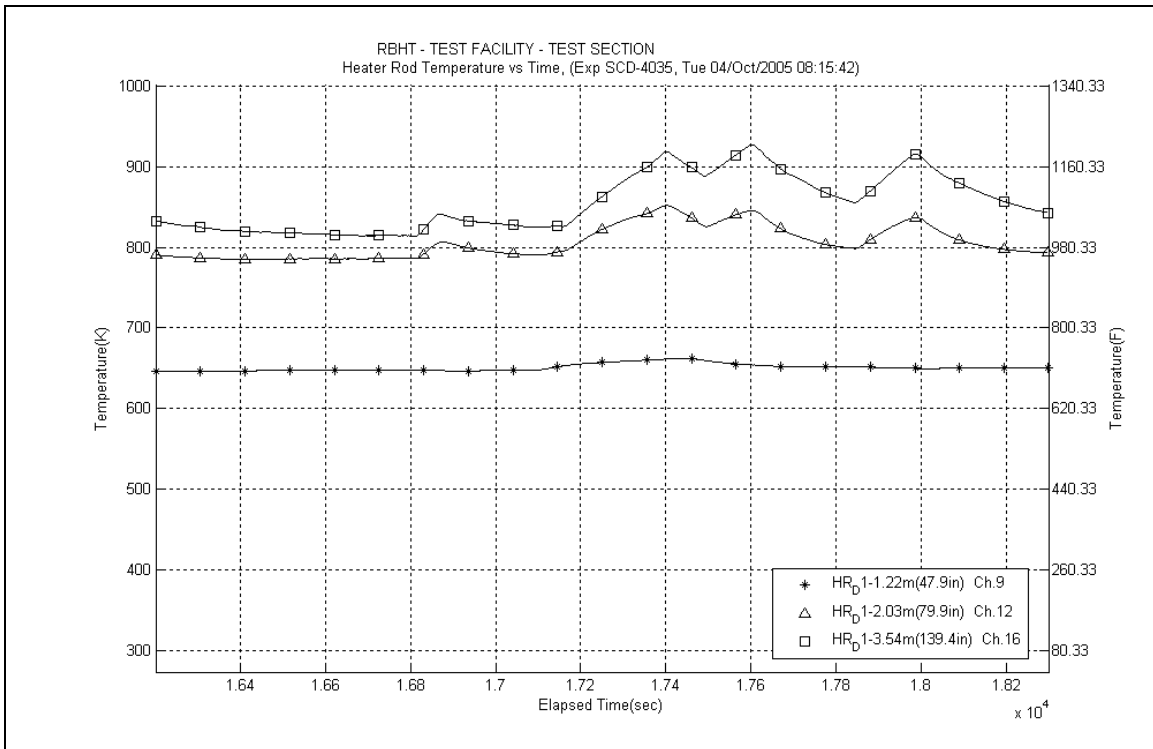

Figure A-227: Heater Rod D1 Temperatures for Experiment 4035B

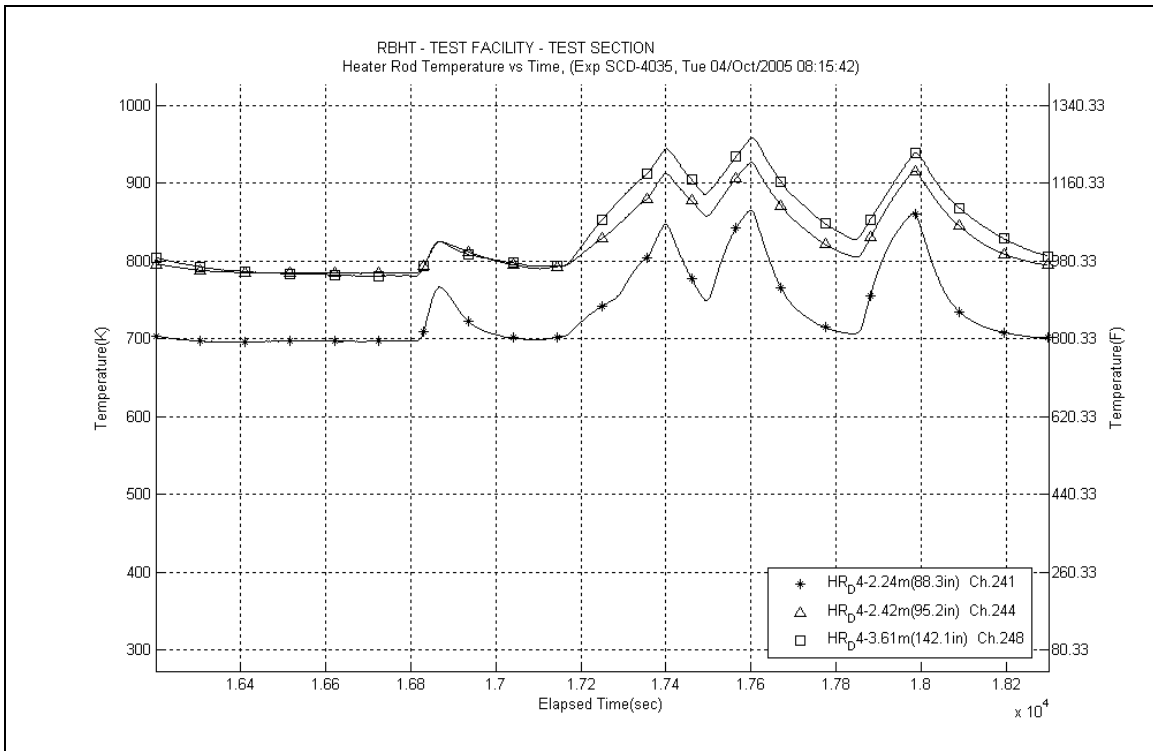

Figure A-228: Heater Rod D4 Temperatures for Experiment 4035B

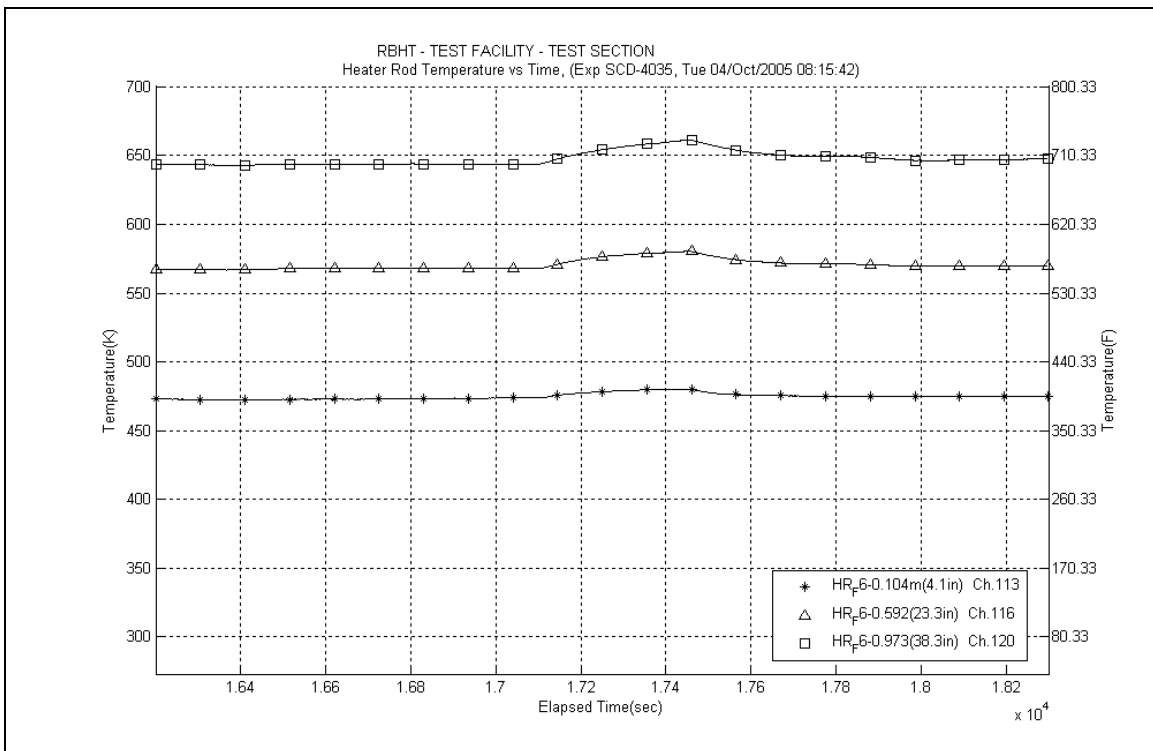

Figure A-229: Heater Rod F6 Temperatures for Experiment 4035B

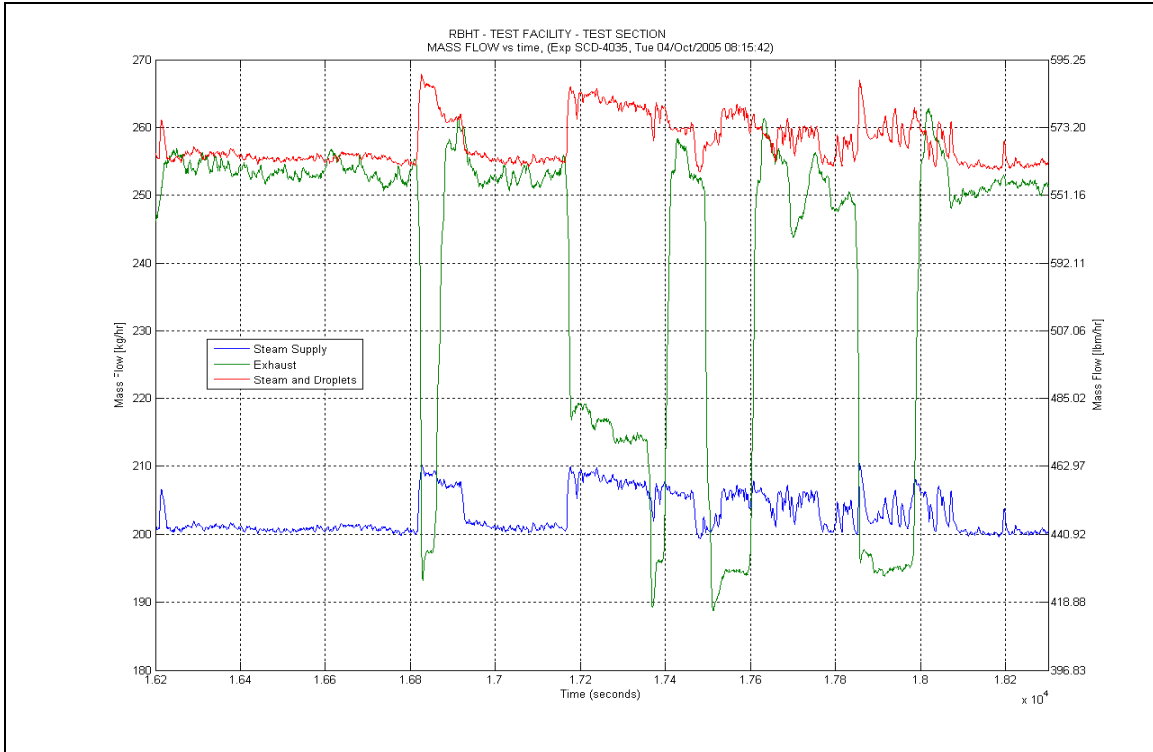

Figure A-230: Mass Flow for Experiment 4035B

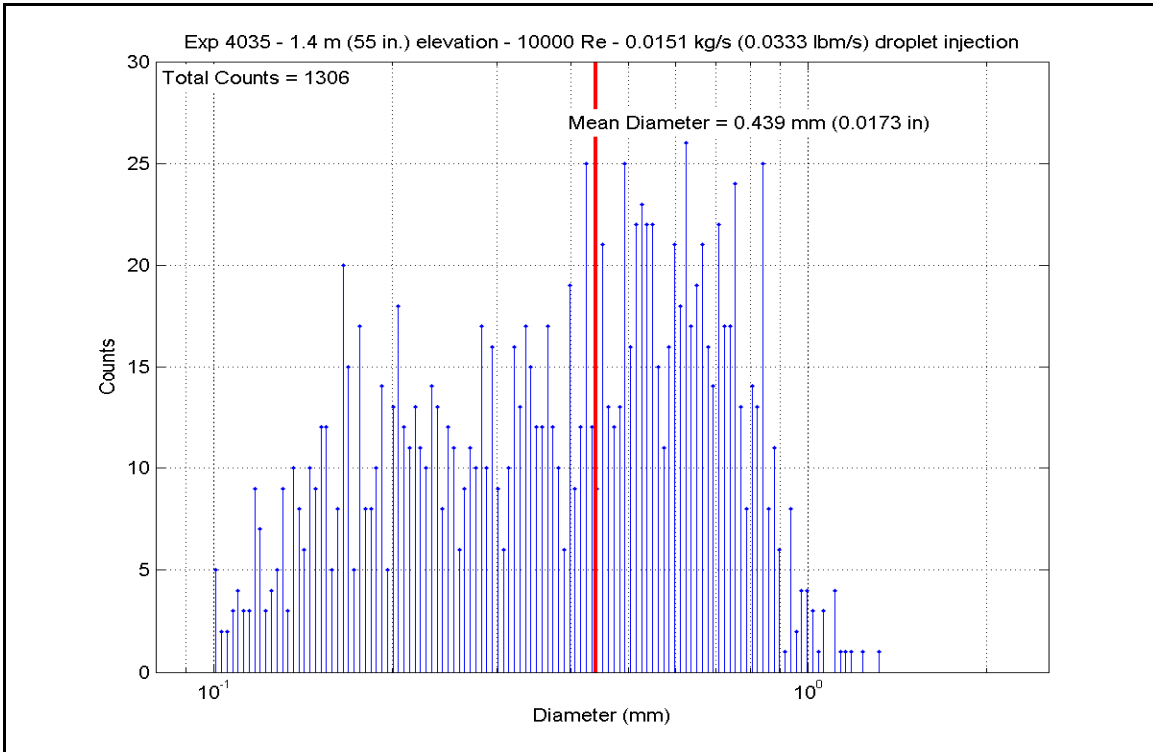

Figure A-231: Droplet Measurements at 1.397 m (55 in.) Elevation for Experiment 4035B

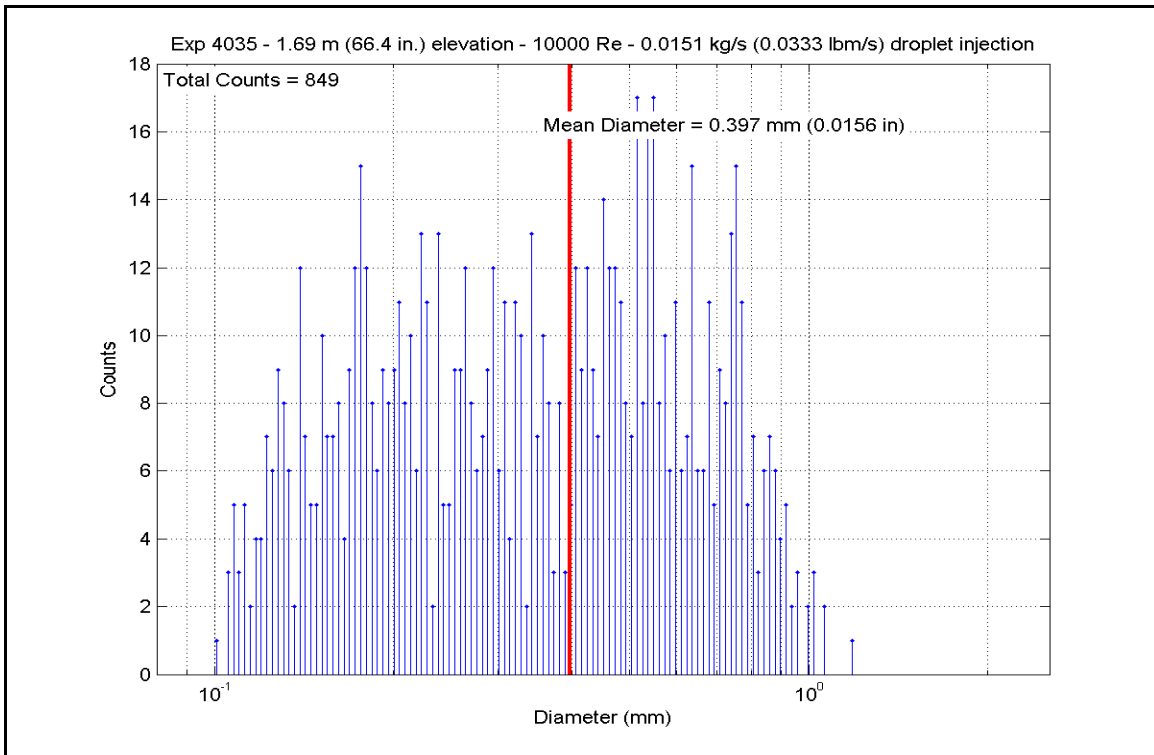

Figure A-232: Droplet Measurements at 1.687 m (66.4 in.) Elevation for Experiment 4035B

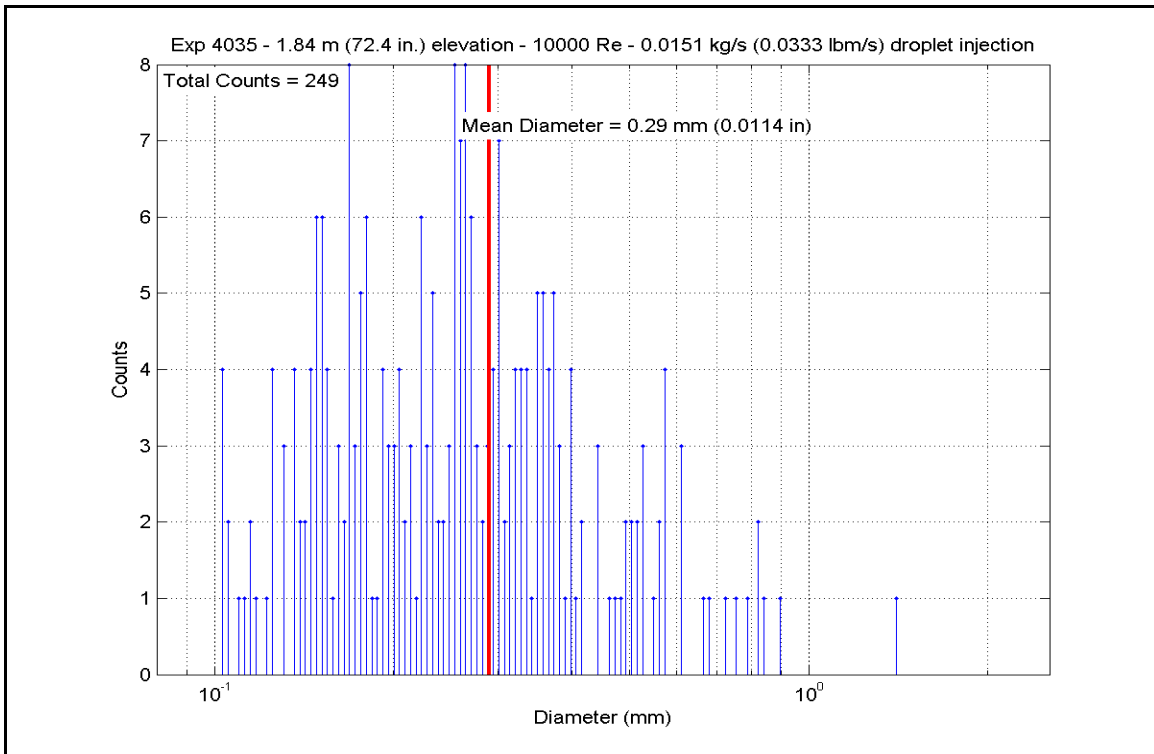

Figure A-233: Droplet Measurements at 1.839 m (72.4 in.) Elevation for Experiment 4035B

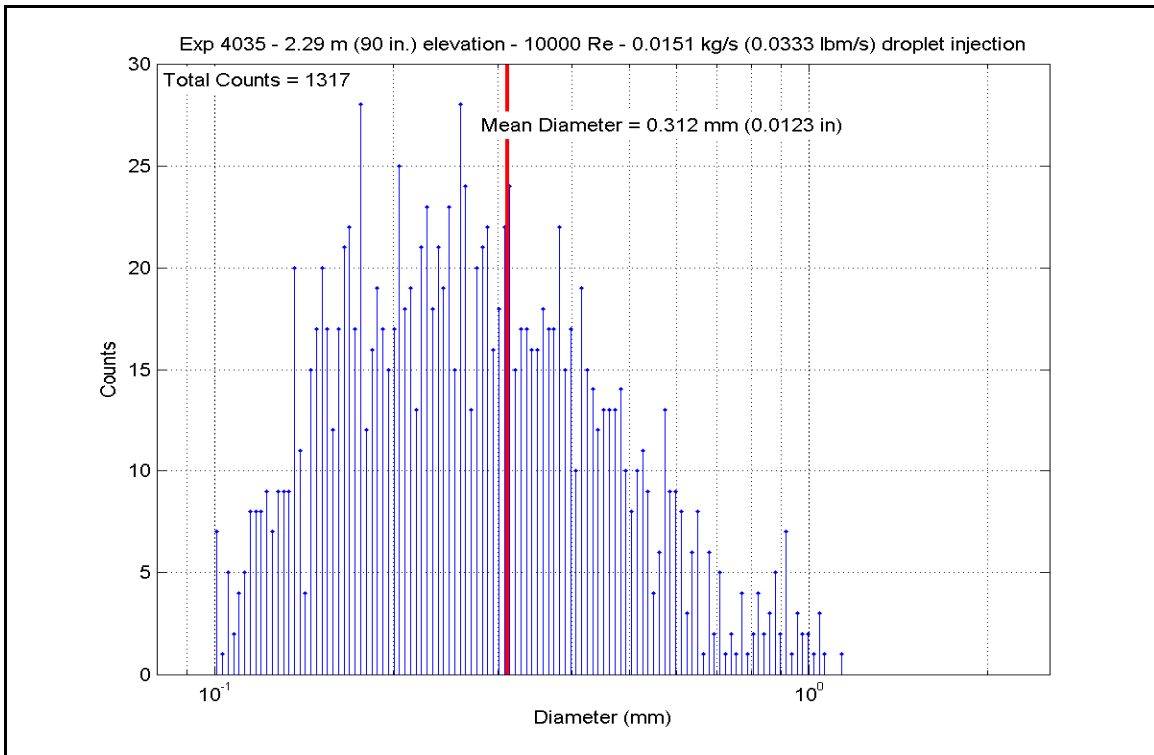

Figure A-234: Droplet Measurements at 2.286 m (90 in.) Elevation for Experiment 4035B

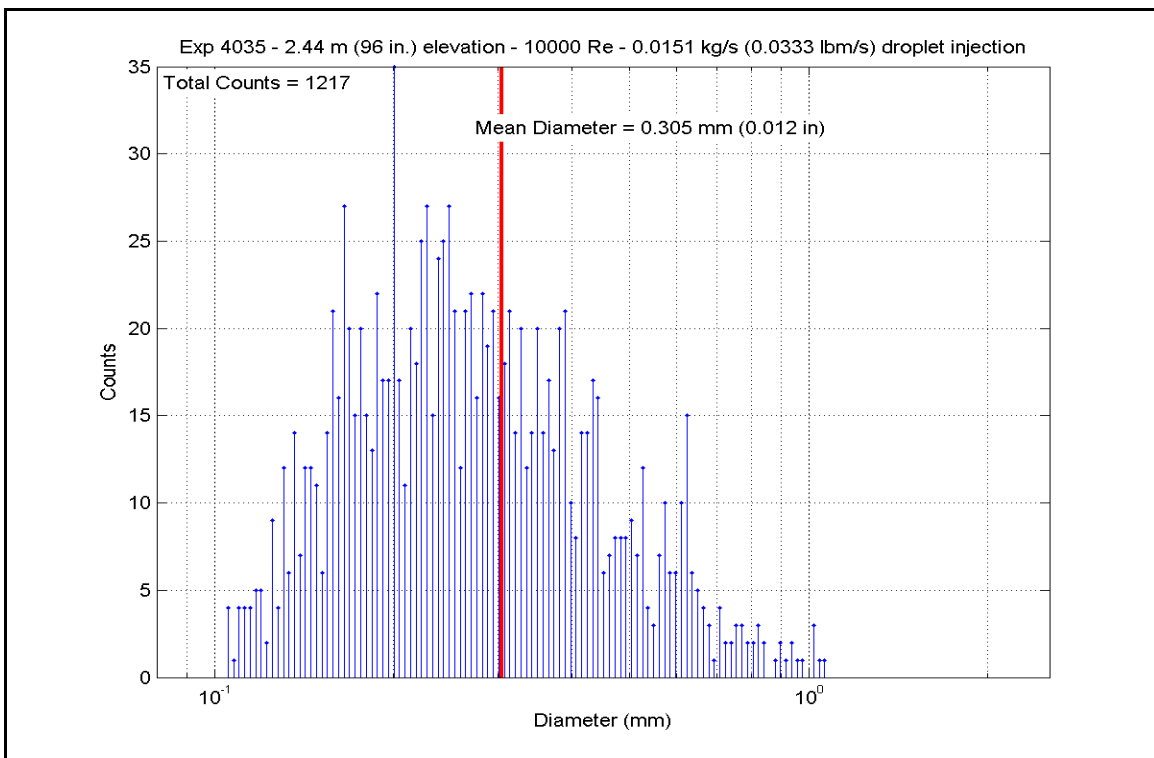

Figure A-235: Droplet Measurements at 2.438 m (96 in.) Elevation for Experiment 4035B

Table A-13: Summary of Steam Cooling Heat Transfer Reduced Data for Experiment 4035B

SCD-4035-B		Inlet Reynolds:		10000		40 psia							
Matrix Test shakedown		UP Pressure:		275.8 kPa		272971 Btu/hr							
Time Window 16200-18300		Bundle Power:		80.00 kW		442.0 lbm/hr							
Inner 3x3		Steam flow:		0.0557 kg/s		0.033 lbm/s							
		Droplet flow:		0.0150 kg/s									
H.R. ID	H.R. Location	Channel Number	Elevation (in)	Elevation (m)	Zgrid (in)	Zgrid (m)	H.R. Tw (°F)	H.R. Tw (K)	H.R. q" (Btu/hr-ft ²)	H.R. q' (W/m ²)	h _{sat} (z) (Btu/hr-ft ² -F)	h _{sat} (z) (W/m ² -K)	
Gr-3	RodD3_88.3	185	88.3	2.243	-0.2	-0.005	863.63	735.2	6868.23	21665.8	11.512	65.4	
	RodD3_91.3	186	91.3	2.319	2.8	0.071	961.80	789.7	7015.55	22130.6	10.097	57.3	
	RodD3_93.1	187	93.1	2.365	4.6	0.117	1002.08	812.1	7102.35	22404.4	9.662	54.9	
	RodD3_95.3	188	95.3	2.421	6.8	0.173	1036.51	831.2	7208.34	22738.7	9.367	53.2	
	RodD3_100.1	189	100.1	2.543	11.6	0.295	1073.45	851.7	7438.29	23464.1	9.223	52.4	
	RodD3_106.1	190	106.1	2.695	17.6	0.447	1154.63	896.8	7730.19	24384.9	8.709	49.5	
	RodD3_110	191	110	2.794	21.5	0.546	1078.94	854.8	7634.78	24083.9	9.403	53.4	
	RodD3_142.1	192	142.1	3.609	3.609	8.6	1070.53	850.1	2658.22	8385.4	3.308	18.8	
	Gr-3	RodC4_88.4	233	88.4	2.245	-0.1	-0.003	869.70	738.5	6953.02	21933.3	11.536	65.5
		RodC4_91.1	234	91.1	2.314	2.6	0.066	956.90	787.0	7087.63	22357.9	10.273	58.3
RodC4_93.4		235	93.4	2.372	4.9	0.124	998.11	809.9	7199.07	22709.5	9.847	55.9	
RodC4_95.3		236	95.3	2.421	6.8	0.173	1030.01	827.6	7291.03	22999.5	9.556	54.3	
RodC4_100.1		237	100.1	2.543	11.6	0.295	1057.97	843.1	7526.49	23742.3	9.515	54.0	
RodC4_106.1		238	106.1	2.695	17.6	0.447	1133.25	885.0	7824.45	24682.2	9.033	51.3	
RodC4_110		239	110	2.794	21.5	0.546	1054.42	841.2	7574.28	23893.1	9.619	54.6	
RodC4_142.2		240	142.2	3.612	3.612	8.7	1046.96	837.0	2888.14	9110.6	3.703	21.0	
Gr-3		RodD4_88.3	241	88.3	2.243	-0.2	-0.005	864.19	735.5	6921.92	21835.2	11.591	65.8
		RodD4_91.3	242	91.3	2.319	2.8	0.071	955.02	785.9	7070.09	22302.6	10.276	58.4
	RodD4_93.2	243	93.2	2.367	4.7	0.119	992.53	806.8	7161.58	22591.2	9.871	56.1	
	RodD4_95.2	244	95.2	2.418	6.7	0.170	1022.93	823.7	7257.81	22894.8	9.601	54.5	
	RodD4_100.1	245	100.1	2.543	11.6	0.295	1068.91	849.2	7495.95	23646.0	9.348	53.1	
	RodD4_106.1	246	106.1	2.695	17.6	0.447	1138.64	888.0	7790.62	24575.5	8.938	50.8	
	RodD4_142.1	248	142.1	3.609	3.609	8.6	1048.51	837.9	2787.55	8793.3	3.567	20.3	
	Gr-3	RodE4_88.4	201	88.4	2.245	-0.1	-0.003	873.98	740.9	6815.19	21498.5	11.228	63.8
		RodE4_91.2	202	91.2	2.316	2.7	0.069	965.78	791.9	6948.46	21918.9	9.944	56.5
		RodE4_95.3	204	95.3	2.421	6.8	0.173	1041.35	833.9	7138.55	22518.6	9.219	52.4
RodE4_100.9		205	100.9	2.563	12.4	0.315	1101.77	867.5	7398.96	23340.0	8.864	50.3	
RodE4_142.3		208	142.3	3.614	3.614	8.8	1063.47	846.2	2815.00	8879.9	3.534	20.1	

Table A-13: Summary of Steam Cooling Heat Transfer Reduced Data for Experiment 4035B, continued

Inner 3x3	H.R. Location	Channel Number	Elevation (in)	Elevation (m)	Zgrid (in)	Zgrid (m)	H.R. Tw (°F)	H.R. Tw (K)	H.R. q" (Btu/hr-ft ²)	H.R. q" (W/m ²)	h _{sat} (z) (Btu/hr-ft ² -F)	h _{sat} (z) (W/m ² -K)
Gr-4	RodE3_63.4	193	63.4	1.610	16.4	0.417	952.92	784.8	5633.02	17769.3	8.212	46.6
	RodE3_113.6	194	113.6	2.885	0.85	0.022	1113.86	874.2	6950.14	21924.2	8.207	46.6
	RodE3_115.5	195	115.5	2.934	2.75	0.070	1140.78	889.1	6690.99	21106.7	7.657	43.5
	RodE3_118.5	196	118.5	3.010	5.75	0.146	1162.84	901.4	6281.36	19814.5	7.012	39.8
	RodE3_122.7	197	122.7	3.117	9.95	0.253	1168.65	904.6	5708.83	18008.5	6.332	36.0
	RodE3_126.5	198	126.5	3.213	13.75	0.349	1162.18	901.0	5191.99	16378.1	5.800	32.9
	RodE3_131.7	199	131.7	3.345	-1.8	-0.046	1068.15	848.8	4488.72	14159.7	5.603	31.8
	RodE3_135.6	200	135.6	3.444	2.1	0.053	1091.76	861.9	3955.90	12478.9	4.796	27.2
Gr-4	RodC5_63.7	225	63.7	1.618	16.7	0.424	944.42	780.1	5543.45	17486.8	8.183	46.5
	RodC5_113.6	226	113.6	2.885	0.85	0.022	1053.03	840.4	6791.97	21425.3	8.641	49.1
	RodC5_115.7	227	115.7	2.939	2.95	0.075	1088.41	860.0	6520.74	20569.7	7.938	45.1
	RodC5_122.7	229	122.7	3.117	9.95	0.253	1109.05	871.5	5615.96	17715.6	6.669	37.9
	RodC5_126.7	230	126.7	3.218	13.95	0.354	1103.21	868.3	5099.29	16085.7	6.098	34.6
	RodC5_131.6	231	131.6	3.343	-1.9	-0.048	1000.53	811.2	4467.66	14093.2	6.091	34.6
	RodC5_135.7	232	135.7	3.447	2.2	0.056	1023.26	823.8	3938.26	12423.2	5.208	29.6
Gr-4	RodE5_63.6	209	63.6	1.615	16.6	0.422	937.28	776.1	5661.34	17858.7	8.446	48.0
	RodE5_113.6	210	113.6	2.885	0.85	0.022	1067.06	848.2	6998.45	22076.6	8.747	49.7
	RodE5_115.4	211	115.4	2.931	2.65	0.067	1093.91	863.1	6755.71	21310.9	8.170	46.4
	RodE5_118.7	212	118.7	3.015	5.95	0.151	1115.07	874.9	6311.73	19910.4	7.442	42.3
	RodE5_122.6	213	122.6	3.114	9.85	0.250	1123.35	879.5	5788.19	18258.8	6.759	38.4
	RodE5_126.6	214	126.6	3.216	13.85	0.352	1119.34	877.2	5252.96	16570.5	6.163	35.0
	RodE5_131.6	215	131.6	3.343	-1.9	-0.048	1023.00	823.7	4582.37	14455.1	6.061	34.4
	RodE5_135.6	216	135.6	3.444	2.1	0.053	1045.06	836.0	4049.58	12774.4	5.205	29.6
Gr-5	RodC3_79.8	177	79.8	2.027	8.92	0.227	972.17	795.5	6417.40	20243.7	9.101	51.7
	RodC3_85.6	178	85.6	2.174	14.72	0.374	872.60	740.2	6698.25	21129.6	11.060	62.8
	RodC3_88.5	179	88.5	2.248	0	0.000	869.16	738.2	6841.27	21580.8	11.361	64.5
	RodC3_92.4	180	92.4	2.347	3.9	0.099	979.99	799.8	7029.16	22173.5	9.859	56.0
	RodC3_94.4	181	94.4	2.398	5.9	0.150	1015.21	819.4	7124.07	22472.9	9.521	54.1
	RodC3_97.2	182	97.2	2.469	8.7	0.221	1060.81	844.7	7256.50	22890.6	9.141	51.9
	RodC3_108.8	183	108.8	2.764	20.3	0.516	1144.29	891.1	7647.42	24123.8	8.717	49.5
Gr-8	RodD5_50	217	50	1.270	3	0.076	800.61	700.2	5005.10	15788.6	9.380	53.3
	RodD5_54.1	218	54.1	1.374	7.1	0.180	803.06	701.5	5213.72	16446.7	9.726	55.2
	RodD5_56.9	219	56.9	1.445	9.9	0.251	866.86	737.0	5351.94	16882.7	8.922	50.7
	RodD5_60	220	60	1.524	13	0.330	912.67	762.4	5502.86	17358.8	8.523	48.4
	RodD5_66.1	221	66.1	1.679	19.1	0.485	949.38	782.8	5796.40	18284.7	8.494	48.2
	RodD5_69.9	222	69.9	1.775	-0.98	-0.025	771.33	683.9	5978.30	18858.5	11.854	67.3
	RodD5_72.9	223	72.9	1.852	2.02	0.051	860.32	733.3	6118.83	19301.9	10.313	58.6
	RodD5_74.9	224	74.9	1.902	4.02	0.102	906.36	758.9	6214.17	19602.6	9.719	55.2

Table A-13: Summary of Steam Cooling Heat Transfer Reduced Data for Experiment 4035B, continued

H.R. ID	H.R. Location	Channel Number	Elevation (in)	Elevation (m)	Zgrid (in)	Zgrid (m)	H.R. Tw (°F)	H.R. Tw (K)	H.R. Tw (Btu/hr-ft ²)	H.R. q" (W/m ²)	h _{sat} (z) (Btu/hr-ft ² -F)	h _{sat} (z) (W/m ² -K)
Gr-2	RodB5_41	153	41	1.041	13.5	0.343	747.52	670.7	4549.79	14352.3	9.468	53.8
	RodB5_52.9	154	52.9	1.344	5.9	0.150	773.56	685.1	5128.35	16177.4	10.124	57.5
	RodB5_55	155	55	1.397	8	0.203	824.64	713.5	5229.68	16497.0	9.378	53.3
	RodB5_57.8	156	57.8	1.468	10.8	0.274	885.51	747.3	5364.31	16921.7	8.673	49.3
	RodB5_64	157	64	1.626	17	0.432	949.29	782.8	5667.78	17879.0	8.307	47.2
	RodB5_73.9	158	73.9	1.877	3.02	0.077	908.49	760.1	6157.78	19424.7	9.599	54.5
Gr-2	RodB5_75.9	159	75.9	1.928	5.02	0.128	943.68	779.6	6255.17	19731.9	9.244	52.5
	RodB5_76.9	160	76.9	1.953	6.02	0.153	957.39	787.3	6304.02	19886.0	9.131	51.9
	RodF5_41	105	41	1.041	13.5	0.343	742.89	668.1	4521.01	14261.5	9.500	54.0
	RodF5_53.1	106	53.1	1.349	6.1	0.155	775.20	686.0	5110.71	16121.7	10.056	57.1
	RodF5_55	107	55	1.397	8	0.203	815.09	708.2	5202.23	16410.4	9.492	53.9
	RodF5_57.8	108	57.8	1.468	10.8	0.274	869.74	738.6	5334.05	16826.2	8.850	50.3
Gr-2	RodF5_64	109	64	1.626	17	0.432	926.59	770.1	5634.30	17773.4	8.542	48.5
	RodF5_73.8	110	73.8	1.875	2.92	0.074	882.98	745.9	6108.00	19267.7	9.916	56.3
	RodF5_75.8	111	75.8	1.925	4.92	0.125	920.44	766.7	6206.35	19577.9	9.498	53.9
	RodF5_76.8	112	76.8	1.951	5.92	0.150	935.15	774.9	6255.16	19731.9	9.362	53.2
	RodC2_41	57	41	1.041	13.5	0.343	742.00	667.6	4540.89	14324.2	9.560	54.3
	RodC2_53.1	58	53.1	1.349	6.1	0.155	809.71	705.2	5127.98	16176.2	9.449	53.7
Gr-2	RodC2_55	59	55	1.397	8	0.203	835.70	719.6	5221.49	16471.2	9.181	52.1
	RodC2_57.8	60	57.8	1.468	10.8	0.274	865.29	736.1	5358.91	16904.7	8.957	50.9
	RodC2_63.9	61	63.9	1.623	16.9	0.429	912.47	762.3	5658.60	17850.1	8.767	49.8
	RodC2_73.8	62	73.8	1.875	2.92	0.074	887.35	748.3	6141.79	19374.3	9.900	56.2
	RodC2_75.8	63	75.8	1.925	4.92	0.125	921.84	767.5	6238.04	19677.9	9.526	54.1
	RodC2_76.8	64	76.8	1.951	5.92	0.150	935.79	775.3	6286.09	19829.5	9.399	53.4
Gr-2	RodC6_40.9	137	40.9	1.039	13.4	0.340	748.72	671.3	4521.40	14262.7	9.386	53.3
	RodC6_52.8	138	52.8	1.341	5.8	0.147	827.32	715.0	5132.73	16191.2	9.160	52.0
	RodC6_54.8	139	54.8	1.392	7.8	0.198	856.27	731.1	5234.52	16512.3	8.883	50.4
	RodC6_57.8	140	57.8	1.468	10.8	0.274	882.64	745.7	5384.68	16986.0	8.746	49.7
	RodC6_63.8	141	63.8	1.621	16.8	0.427	925.28	769.4	5690.70	17951.3	8.645	49.1
	RodC6_73.7	142	73.7	1.872	2.82	0.072	880.28	744.4	6199.71	19557.0	10.109	57.4
Gr-2	RodC6_75.8	143	75.8	1.925	4.92	0.125	909.19	760.5	6306.01	19892.3	9.820	55.8
	RodC6_76.8	144	76.8	1.951	5.92	0.150	926.01	769.8	6356.84	20052.7	9.646	54.8

Table A-13: Summary of Steam Cooling Heat Transfer Reduced Data for Experiment 4035B, continued

5x5 periphery		H.R. Location	Channel Number	Elevation (in)	Elevation (m)	Zgrid (in)	Zgrid (m)	H.R. Tw (°F)	H.R. Tw (K)	H.R. q" (Btu/hr-ft ²)	H.R. q" (W/m ²)	h _{sat} (z) (Btu/hr-ft ² -F)	h _{sat} (z) (W/m ² -K)
Gr-3	RodB4_88.4	161	88.4	2.245	-0.1	-0.003	875.08	741.5	6813.24	21492.4	11.204	63.6	
	RodB4_91.3	162	91.3	2.319	2.8	0.071	965.12	791.6	6951.11	21927.3	9.957	56.5	
	RodB4_93.3	163	93.3	2.370	4.8	0.122	1004.07	813.2	7043.94	22220.1	9.557	54.3	
	RodB4_95.1	164	95.1	2.416	6.6	0.168	1032.63	829.1	7127.01	22482.1	9.309	52.9	
	RodB4_100	165	100	2.540	11.5	0.292	1059.28	843.9	7354.77	23200.6	9.283	52.7	
	RodB4_106	166	106	2.692	17.5	0.445	1132.31	884.4	7636.13	24088.2	8.825	50.1	
	RodB4_109.9	167	109.9	2.791	21.4	0.544	1053.48	840.6	7393.43	23322.6	9.401	53.4	
	RodB4_142.3	168	142.3	3.614	8.8	0.224	1038.77	832.5	2868.77	9049.5	3.717	21.1	
Gr-5	RodF4_85.6	98	85.6	2.174	14.72	0.374	951.97	784.2	6711.55	21171.6	9.798	55.6	
	RodF4_88.4	99	88.4	2.245	-0.1	-0.003	931.60	772.9	6852.95	21617.6	10.311	58.6	
	RodF4_92.4	100	92.4	2.347	3.9	0.099	1021.00	822.6	7045.52	22225.1	9.344	53.1	
	RodF4_94.3	101	94.3	2.395	5.8	0.147	1050.89	839.2	7135.14	22507.8	9.102	51.7	
	RodF4_97.2	102	97.2	2.469	8.7	0.221	1088.69	860.2	7272.29	22940.4	8.850	50.3	
	RodF4_108.8	103	108.8	2.764	20.3	0.516	1153.97	896.5	7677.12	24217.5	8.655	49.2	
	RodF4_111	104	111	2.819	-1.75	-0.044	1066.18	847.7	7363.40	23227.8	9.214	52.3	
	RodD2_103.2	65	103.2	2.621	14.7	0.373	1118.82	876.9	6766.42	21344.7	7.943	45.1	
Gr-6	RodD2_106	66	106	2.692	17.5	0.445	1138.36	887.8	6406.84	20210.4	7.353	41.8	
	RodD2_112.6	67	112.6	2.860	-0.15	-0.004	1157.31	898.3	5916.40	18663.3	6.645	37.7	
	RodD2_114.9	68	114.9	2.918	2.15	0.055	1158.65	899.1	5341.84	16850.8	5.991	34.0	
	RodD2_117.4	69	117.4	2.982	4.65	0.118	1146.11	892.1	4797.65	15134.2	5.457	31.0	
	RodD2_120.8	70	120.8	3.068	8.05	0.204	1129.42	882.8	7599.79	23973.6	8.812	50.0	
	RodD2_124.8	71	124.8	3.170	12.05	0.306	1151.78	895.3	7735.61	24402.0	8.743	49.7	
	RodD2_128.6	72	128.6	3.266	15.85	0.403	1076.13	853.2	7096.63	22386.3	8.771	49.8	
	RodD6_103.1	129	103.1	2.619	14.6	0.371	1085.10	858.2	7626.55	24058.0	9.322	52.9	
Gr-6	RodD6_106	130	106	2.692	17.5	0.445	1106.26	870.0	7765.01	24494.7	9.252	52.5	
	RodD6_112.9	131	112.9	2.868	0.15	0.004	1023.43	823.9	7086.76	22355.2	9.369	53.2	
	RodD6_114.9	132	114.9	2.918	2.15	0.055	1062.40	845.6	6796.03	21438.1	8.544	48.5	
	RodD6_116.8	133	116.8	2.967	4.05	0.103	1082.87	857.0	6520.64	20569.4	7.992	45.4	
	RodD6_120.9	134	120.9	3.071	8.15	0.207	1089.86	860.8	5927.28	18697.6	7.203	40.9	
	RodD6_124.8	135	124.8	3.170	12.05	0.306	1087.93	859.8	5362.44	16915.8	6.532	37.1	
	RodD6_128.7	136	128.7	3.269	15.95	0.405	1079.98	855.4	4797.56	15133.9	5.901	33.5	

Table A-13: Summary of Steam Cooling Heat Transfer Reduced Data for Experiment 4035B, continued

5x5 periphery		H.R.	Channel	Elevation	Elevation	Zgrid	Zgrid	H.R. Tw	H.R. Tw	H.R. Tw	H.R. q"	H.R. q"	H.R. q"	h _{sat} (z)	h _{sat} (z)
Gr-8	Location	Number	(in)	(m)	(in)	(m)	(in)	(°F)	(K)	(Btu/hr-ft ²)	(W/m ²)	(Btu/hr-ft ² -F)	(W/m ² -K)	(W/m ² -K)	
	RodE2_50.1	73	50.1	1.273	3.1	0.079	3.1	802.39	701.1	5018.03	15829.4	9.373	53.2		
	RodE2_54	74	54	1.372	7	0.178	7	819.14	710.5	5207.62	16427.5	9.432	53.6		
	RodE2_56.9	75	56.9	1.445	9.9	0.251	9.9	868.73	738.0	5349.87	16876.2	8.891	50.5		
	RodE2_59.9	76	59.9	1.521	12.9	0.328	12.9	902.30	756.6	5495.22	17334.7	8.650	49.1		
	RodE2_66	77	66	1.676	19	0.483	19	938.19	776.6	5795.21	18281.0	8.634	49.0		
	RodE2_69.8	78	69.8	1.773	-1.08	-0.027	-1.08	799.18	699.4	5986.68	18885.0	11.249	63.9		
	RodE2_72.9	79	72.9	1.852	2.02	0.051	2.02	891.02	750.4	6141.69	19374.0	9.842	55.9		
	RodE2_74.9	80	74.9	1.902	4.02	0.102	4.02	929.59	771.8	6239.74	19683.2	9.417	53.5		
Gr-8	RodB3_50.2	169	50.2	1.275	3.2	0.081	3.2	760.25	677.7	4993.00	15750.4	10.123	57.5		
	RodB3_54.1	170	54.1	1.374	7.1	0.180	7.1	793.10	696.0	5179.04	16337.3	9.844	55.9		
	RodB3_56.9	171	56.9	1.445	9.9	0.251	9.9	856.39	731.1	5315.44	16767.5	9.019	51.2		
	RodB3_60.1	172	60.1	1.527	13.1	0.333	13.1	873.48	740.6	5476.48	17275.6	9.030	51.3		
	RodB3_66.1	173	66.1	1.679	19.1	0.485	19.1	933.18	773.8	5770.09	18201.8	8.661	49.2		
	RodB3_69.9	174	69.9	1.775	-0.98	-0.025	-0.98	781.37	689.5	5958.96	18797.5	11.585	65.8		
	RodB3_73	175	73	1.854	2.12	0.054	2.12	876.03	742.1	6107.31	19265.5	10.028	56.9		
	RodB3_75	176	75	1.905	4.12	0.105	4.12	918.48	765.6	6203.27	19568.2	9.522	54.1		
Gr-8	RodF3_50.1	89	50.1	1.273	3.1	0.079	3.1	784.04	691.0	4993.09	15750.7	9.657	54.8		
	RodF3_54	90	54	1.372	7	0.178	7	817.36	709.5	5186.49	16360.8	9.424	53.5		
	RodF3_57	91	57	1.448	10	0.254	10	880.90	744.8	5335.24	16830.0	8.691	49.4		
	RodF3_60	92	60	1.524	13	0.330	13	925.13	769.3	5483.94	17299.1	8.333	47.3		
	RodF3_66.1	93	66.1	1.679	19.1	0.485	19.1	947.62	781.8	5787.39	18256.3	8.503	48.3		
	RodF3_70	94	70	1.778	-0.88	-0.022	-0.88	815.88	708.6	5989.61	18894.2	10.912	62.0		
	RodF3_73	95	73	1.854	2.12	0.054	2.12	910.65	761.3	6137.31	19360.1	9.535	54.1		
	RodF3_75	96	75	1.905	4.12	0.105	4.12	953.60	785.2	6234.68	19667.3	9.080	51.6		
Gr-8	RodE6_50.2	121	50.2	1.275	3.2	0.081	3.2	782.25	690.0	4992.22	15748.0	9.689	55.0		
	RodE6_54.1	122	54.1	1.374	7.1	0.180	7.1	832.97	718.1	5179.46	16338.6	9.151	52.0		
	RodE6_57	123	57	1.448	10	0.254	10	862.59	734.6	5319.07	16779.0	8.931	50.7		
	RodE6_60.2	124	60.2	1.529	13.2	0.335	13.2	879.00	743.7	5470.30	17256.1	8.938	50.8		
	RodE6_66.1	125	66.1	1.679	19.1	0.485	19.1	921.77	767.5	5757.01	18160.5	8.792	49.9		
	RodE6_70	126	70	1.778	-0.88	-0.022	-0.88	774.59	685.7	5944.38	18751.5	11.711	66.5		
	RodE6_73.1	127	73.1	1.857	2.22	0.056	2.22	858.61	732.4	6095.74	19229.0	10.304	58.5		
	RodE6_75	128	75	1.905	4.12	0.105	4.12	895.26	752.7	6187.71	19519.1	9.849	55.9		

RBHT Steam Cooling with Droplet Injection Test SCD-4035-C

Matrix Test # Shakedown

Test Conditions

Test Date – 10/4/2005

Steady State Time Window: 18540 - 19800

Upper Plenum Pressure: 2.76 bar (40 psia)

Bundle Power: 72.0 kW

Bundle Inlet Reynolds Number: 8000

Bundle Inlet Steam Flow: 156.6 kg/hr (345 lbm/hr)

Droplet Injection Flow: 0.0076 kg/s (0.0167 lbm/s)

Droplet Injection Hole Diameter: 0.381 mm (.015 in)

Droplet Injection Elevation: 1.295 m (51 in)

Bundle Flow Area: $4.656 \times 10^{-3} \text{ m}^2$ ($5.012 \times 10^{-2} \text{ ft}^2$)

Test Notes

- No steam probes were traversed in this steady state window.

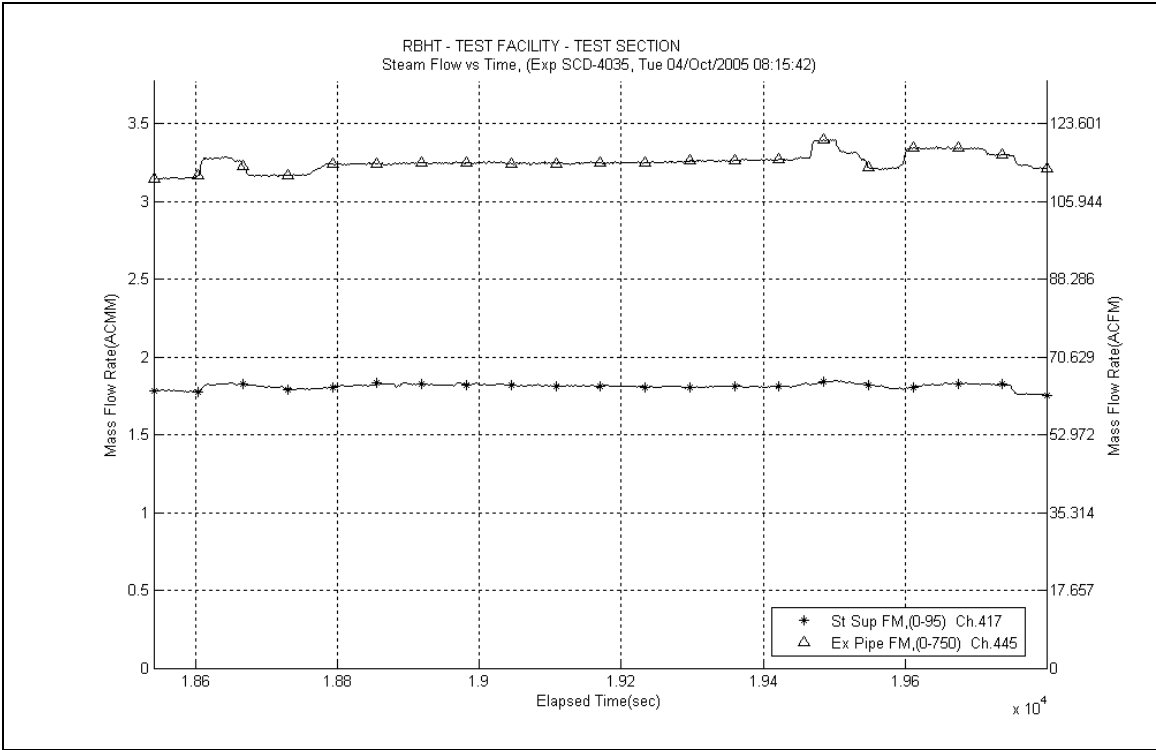

Figure A-236: Inlet and Exhaust Steam Flow Rates for Experiment 4035C

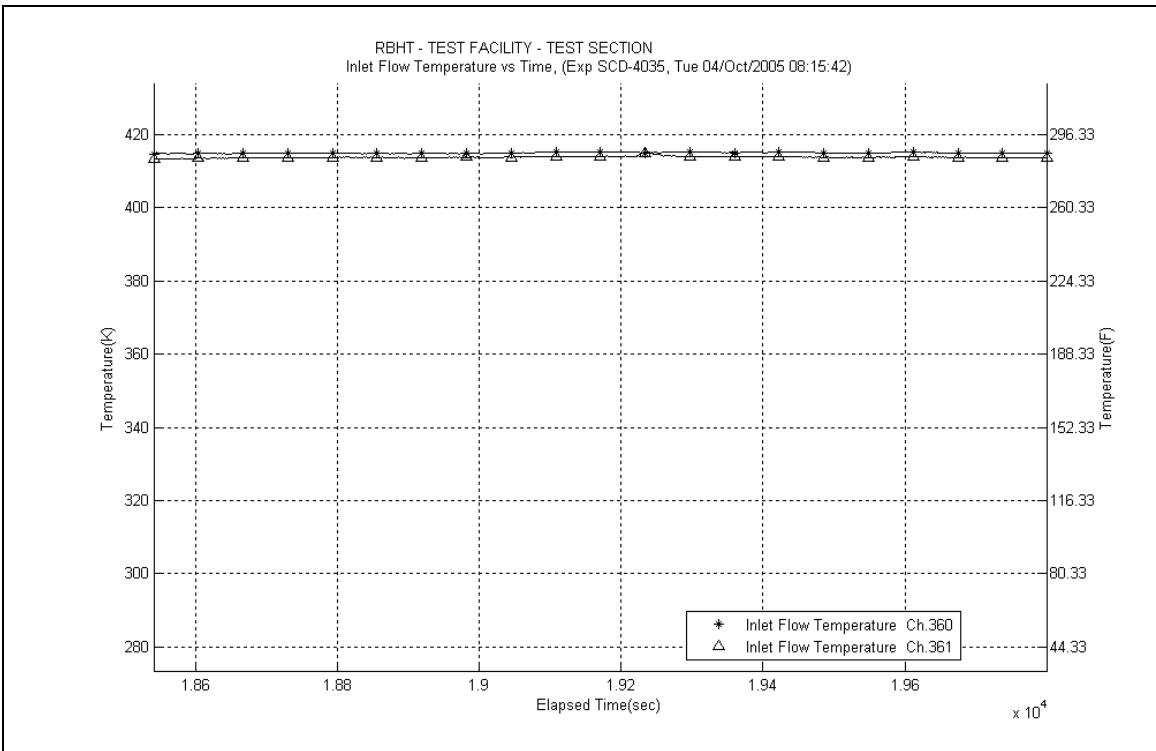

Figure A-237: Inlet Steam Temperature for Experiment 4035C

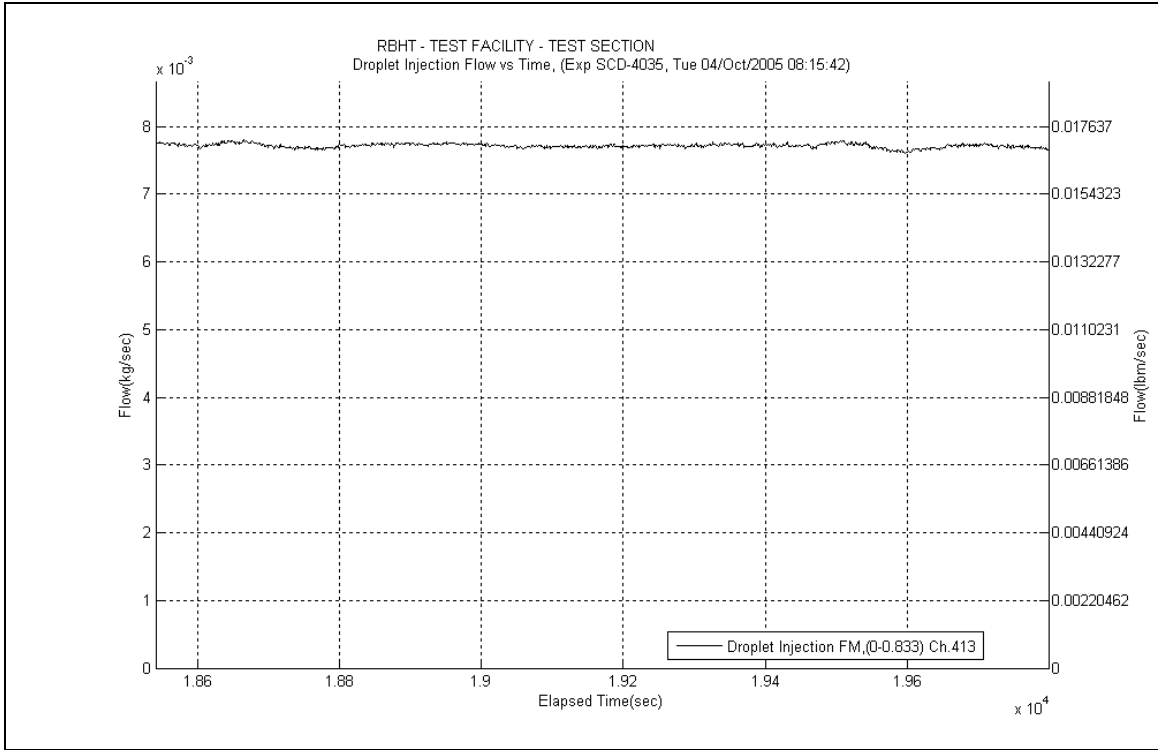

Figure A-238: Droplet Injection Flow Rate for Experiment 4035C

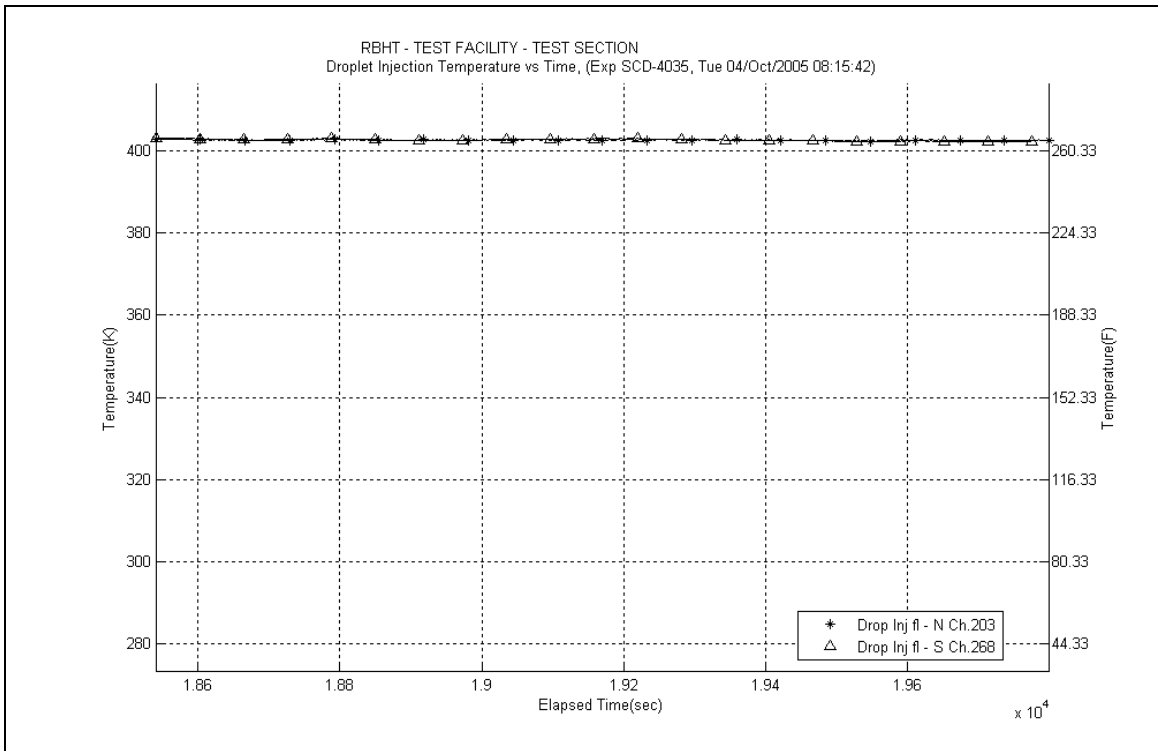

Figure A-239: Droplet Injection Temperature for Experiment 4035C

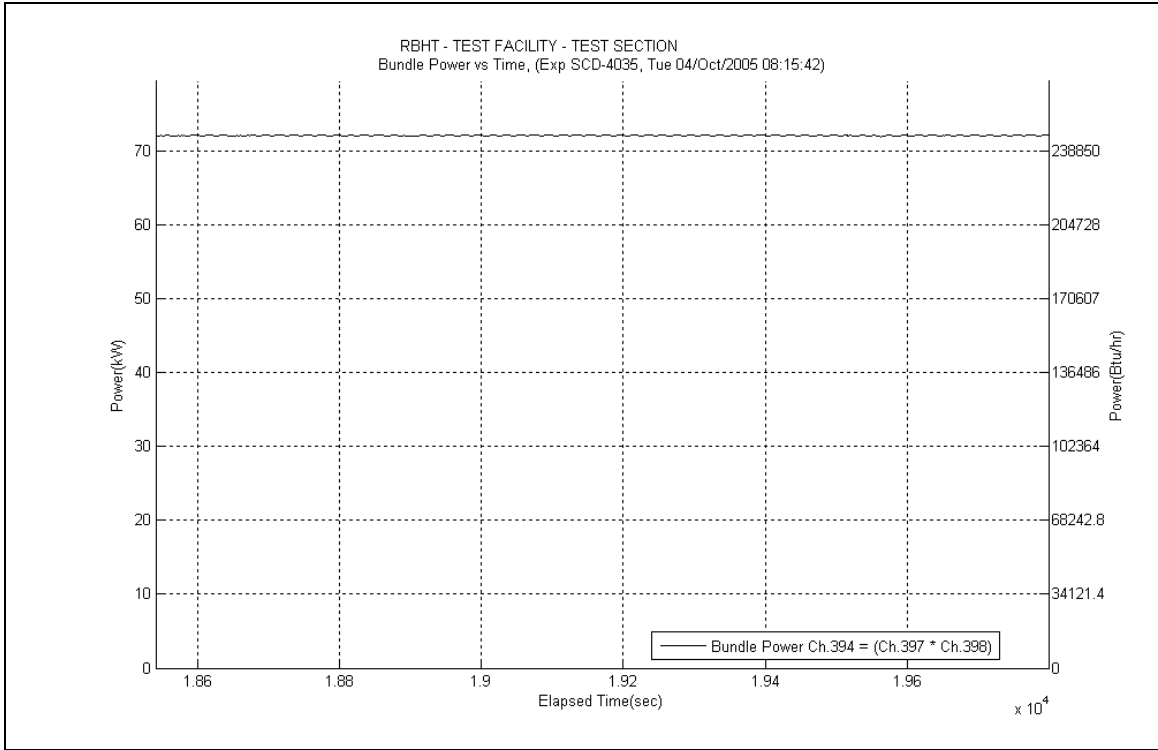

Figure A-240: Bundle Power for Experiment 4035C

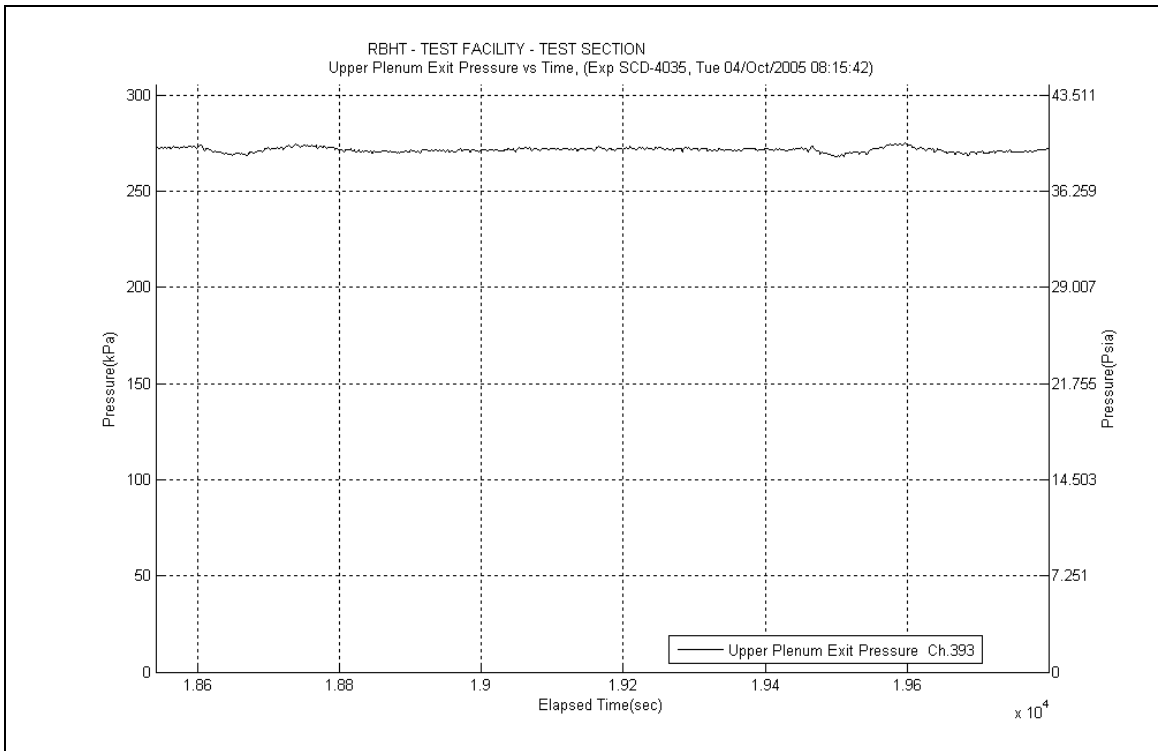

Figure A-241: Upper Plenum Pressure for Experiment 4035C

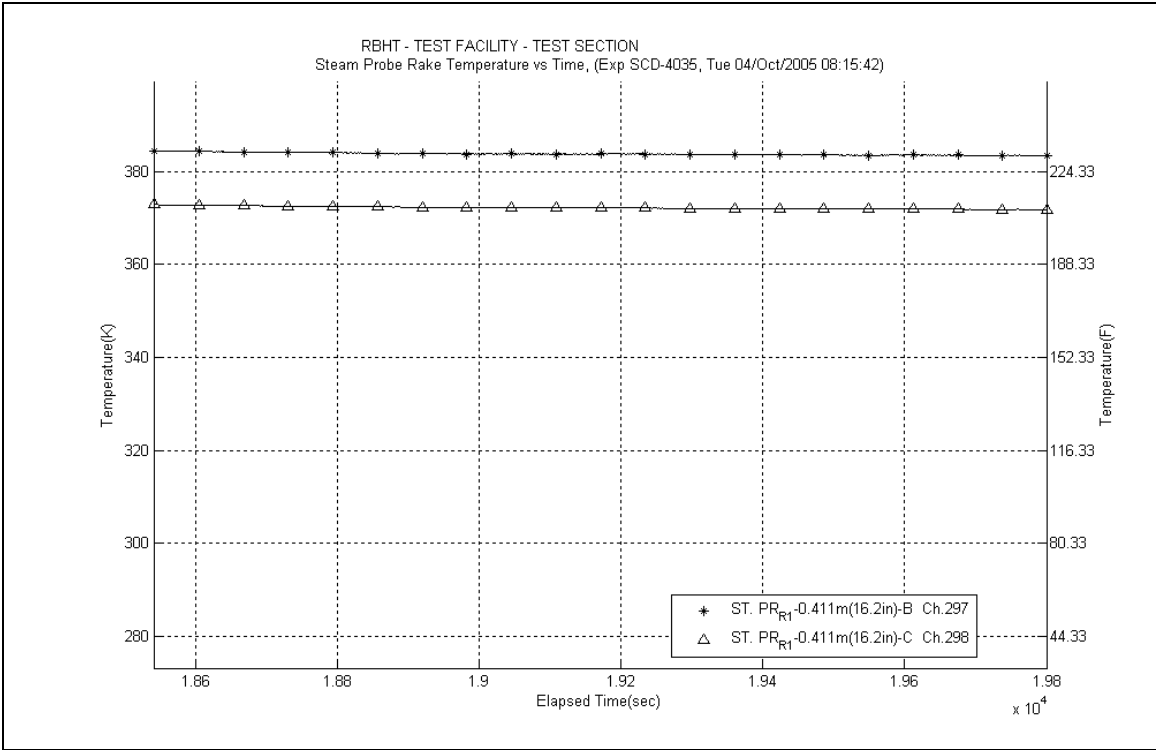

Figure A-242: Steam Probe Rake #1 Temperatures for Experiment 4035C

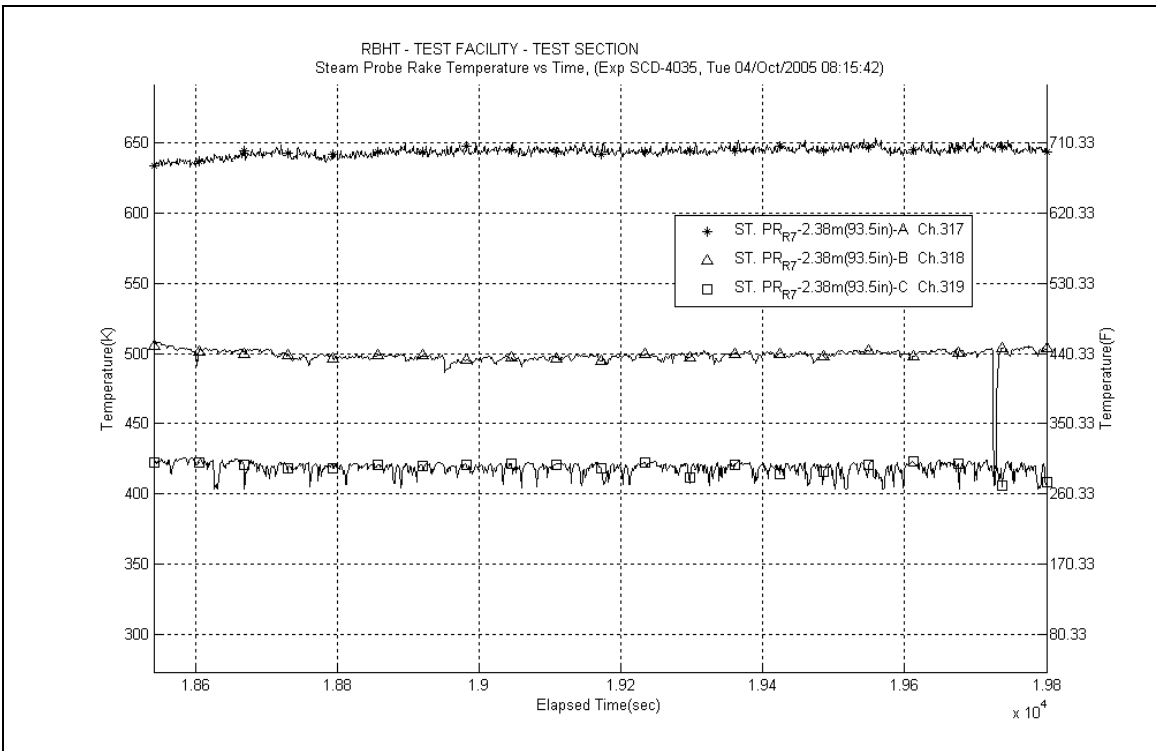

Figure A-243: Steam Probe Rake #7 Temperatures for Experiment 4035C

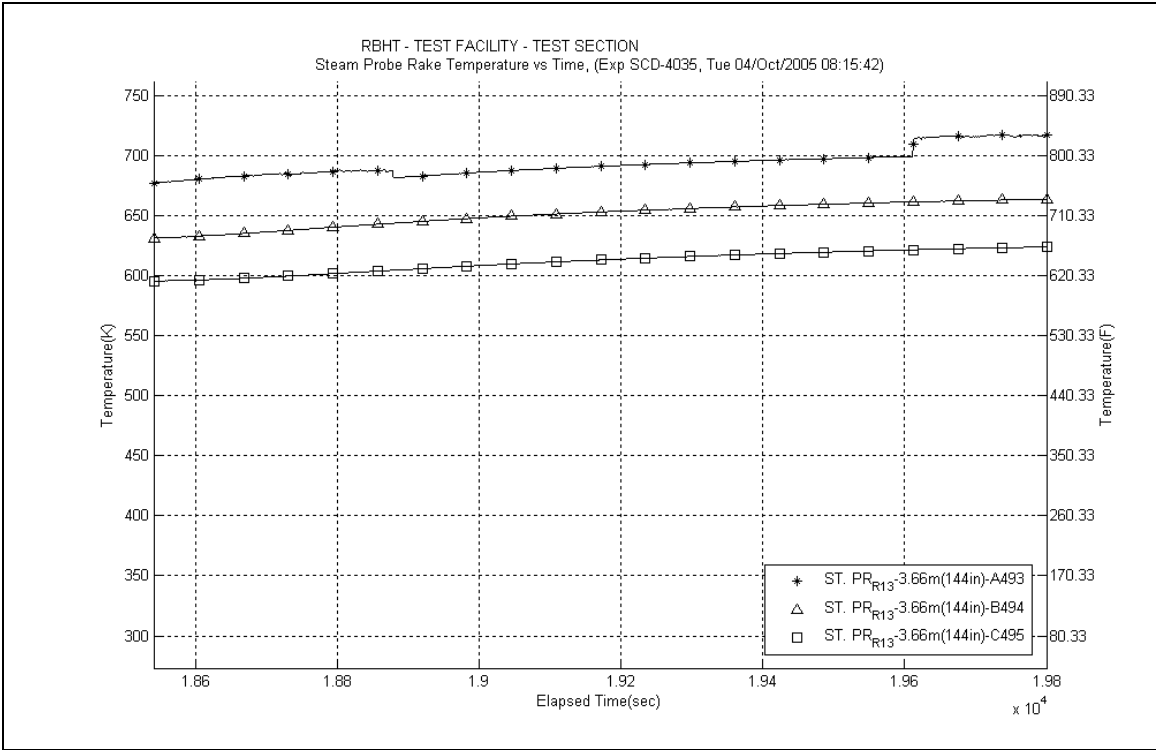

Figure A-244: Steam Probe Rake #13 Temperatures for Experiment 4035C

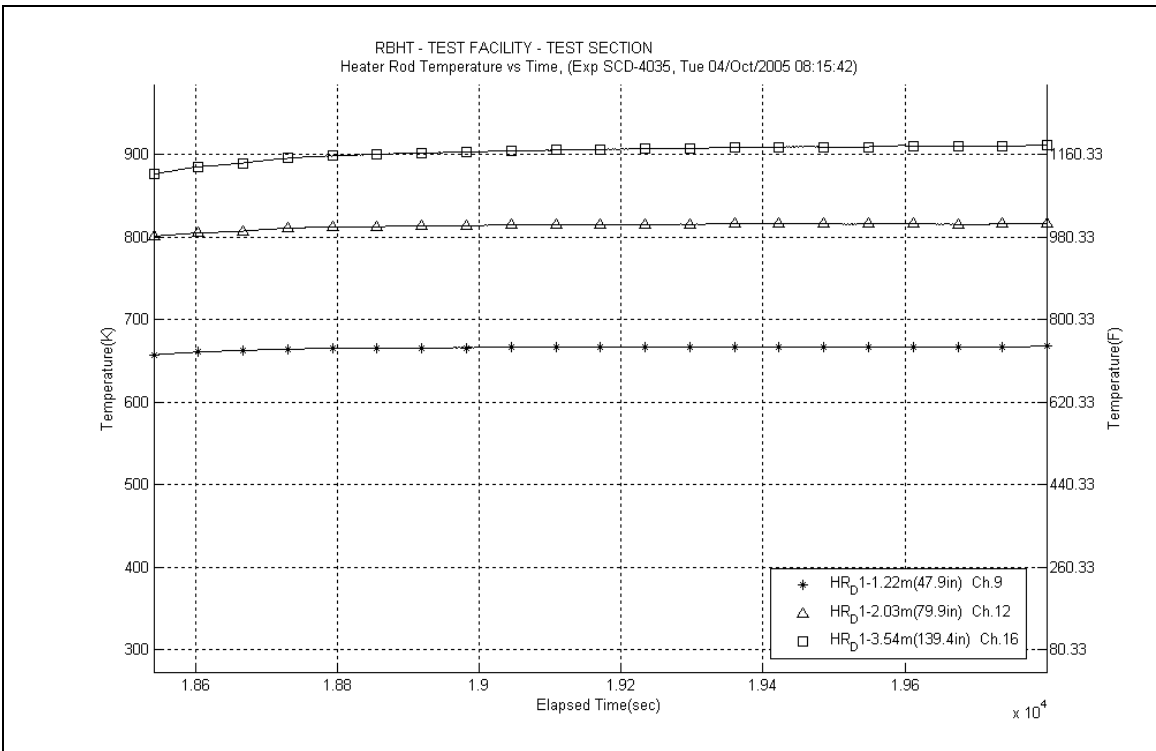

Figure A-245: Heater Rod D1 Temperatures for Experiment 4035C

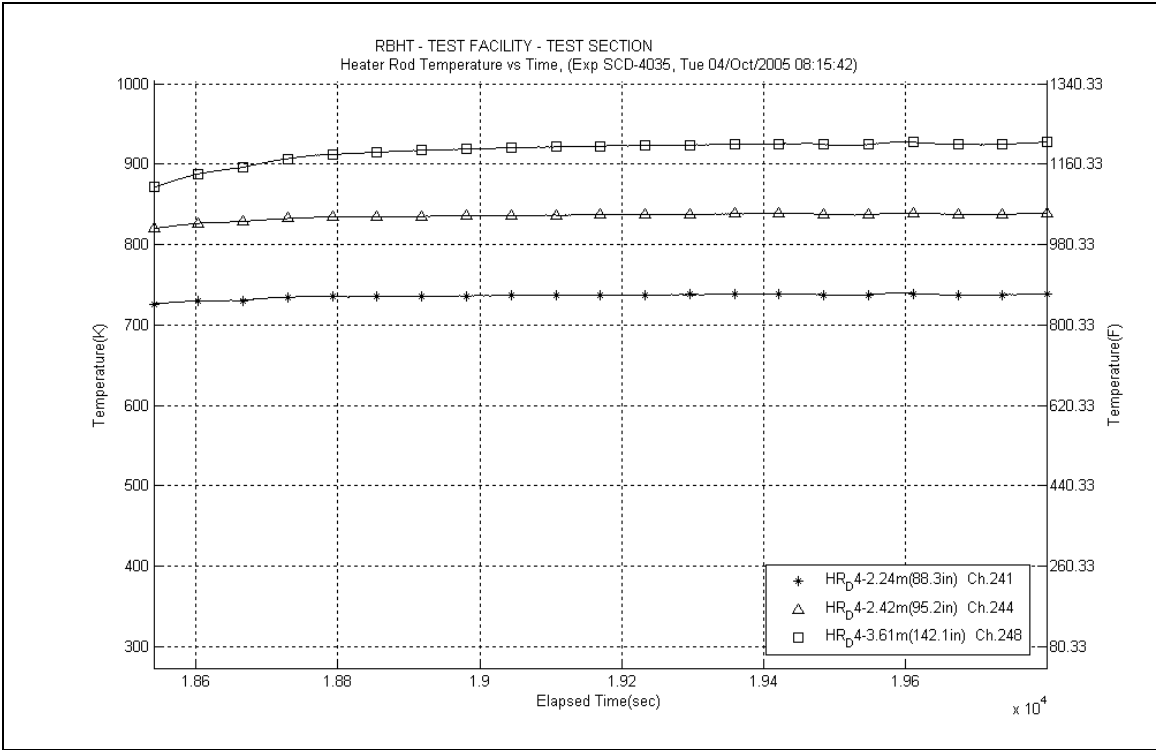

Figure A-246: Heater Rod D4 Temperatures for Experiment 4035C

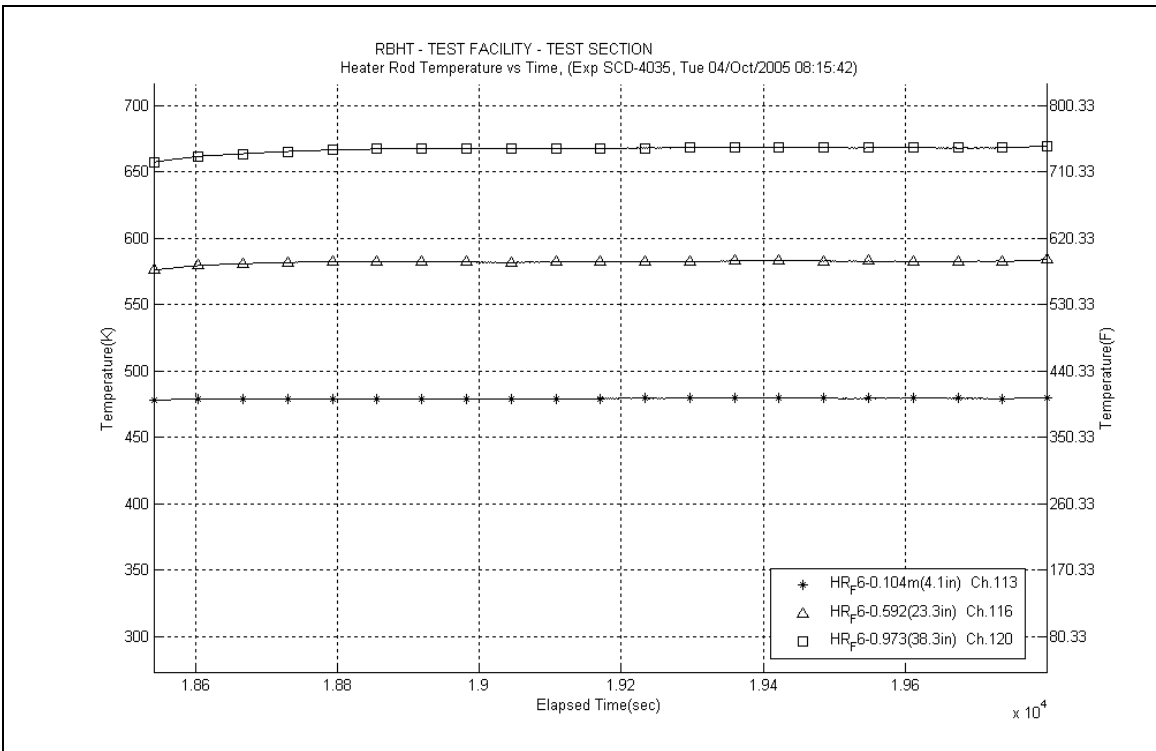

Figure A-247: Heater Rod F6 Temperatures for Experiment 4035C

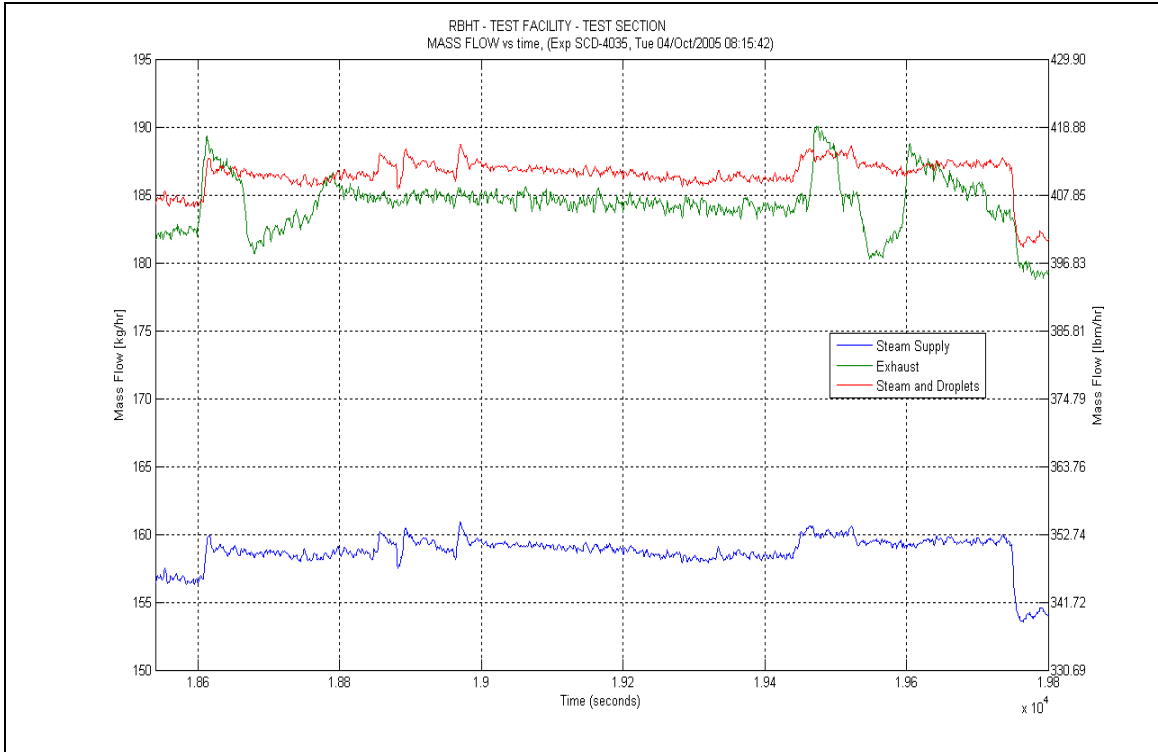

Figure A-248: Mass Flow for Experiment 4035C

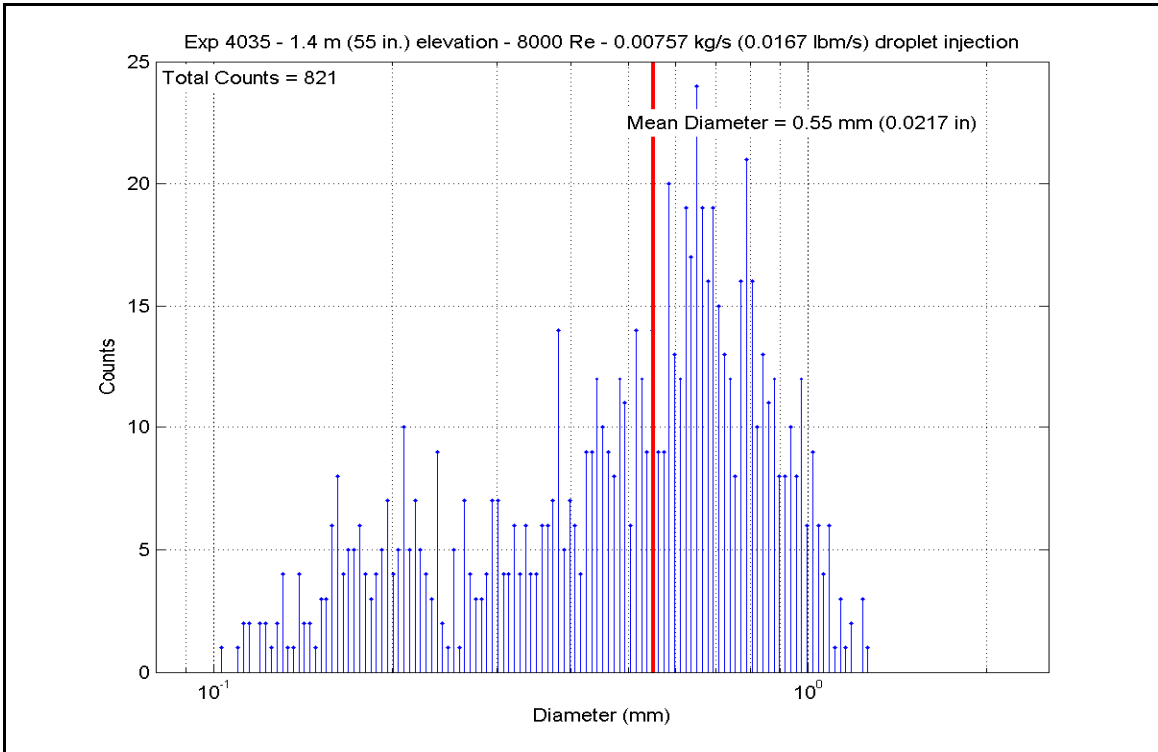

Figure A-249: Droplet Measurements at 1.397 m (55 in.) Elevation for Experiment 4035C

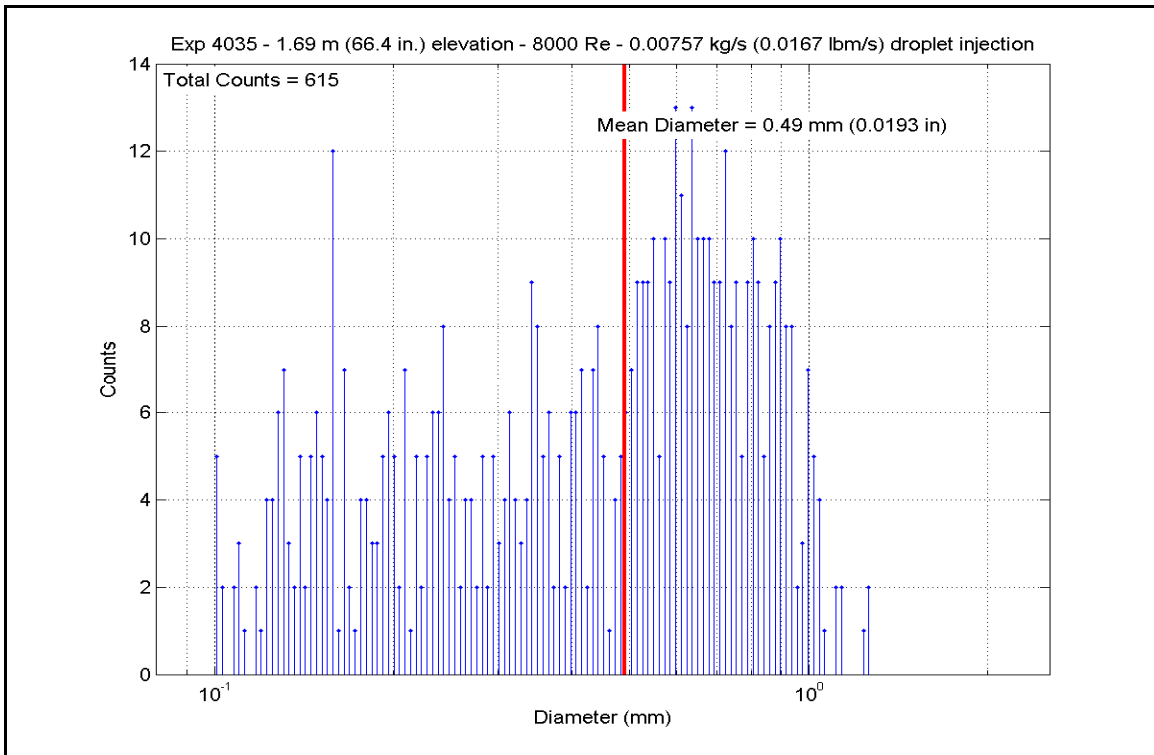

Figure A-250: Droplet Measurements at 1.687 m (66.4 in.) Elevation for Experiment 4035C

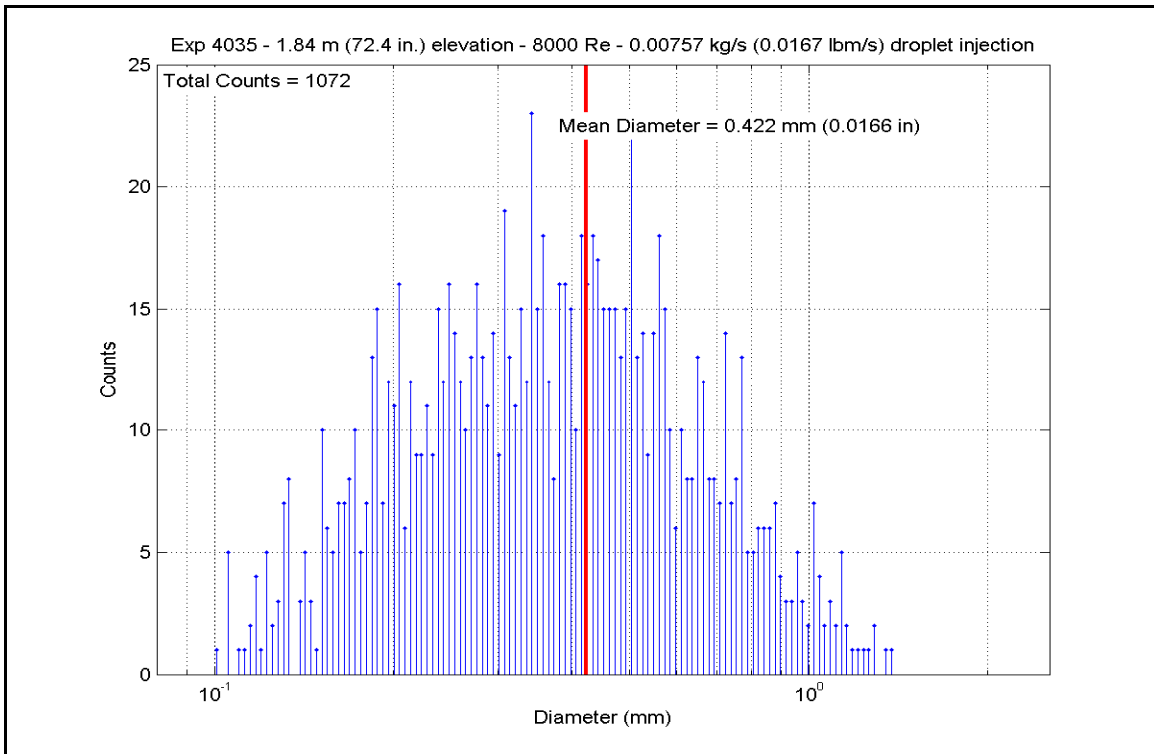

Figure A-251: Droplet Measurements at 1.839 m (72.4 in.) Elevation for Experiment 4035C

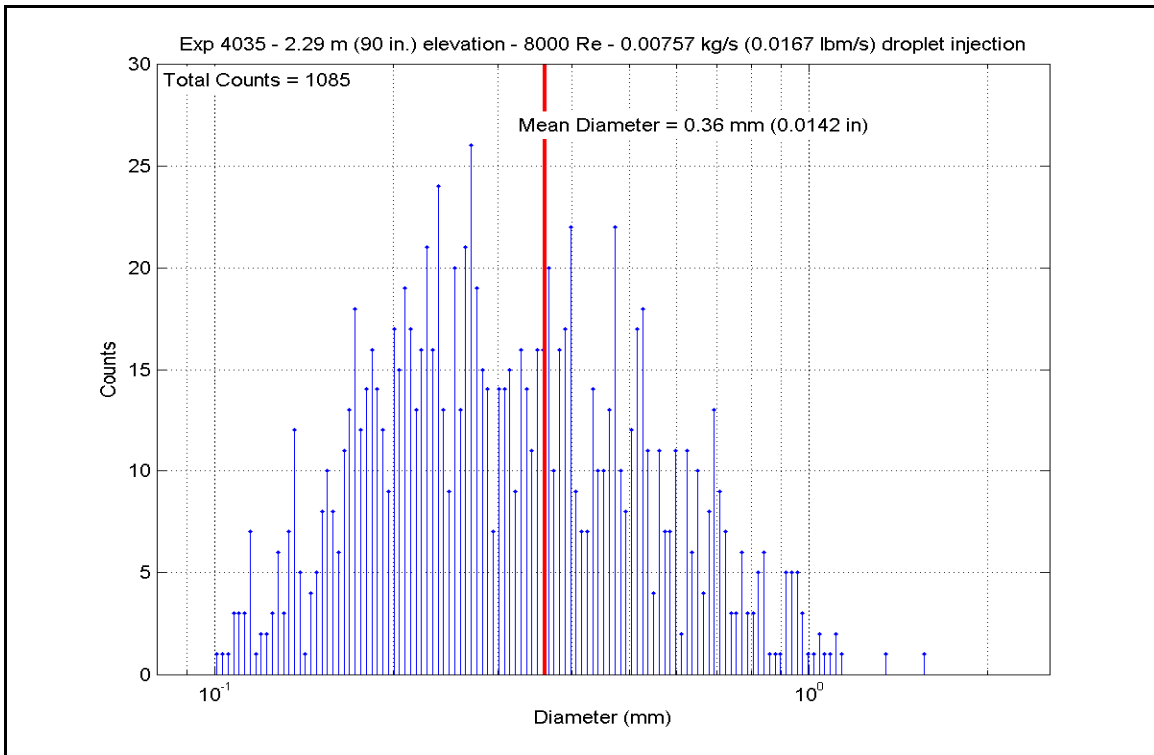

Figure A-252: Droplet Measurements at 2.286 m (90 in.) Elevation for Experiment 4035C

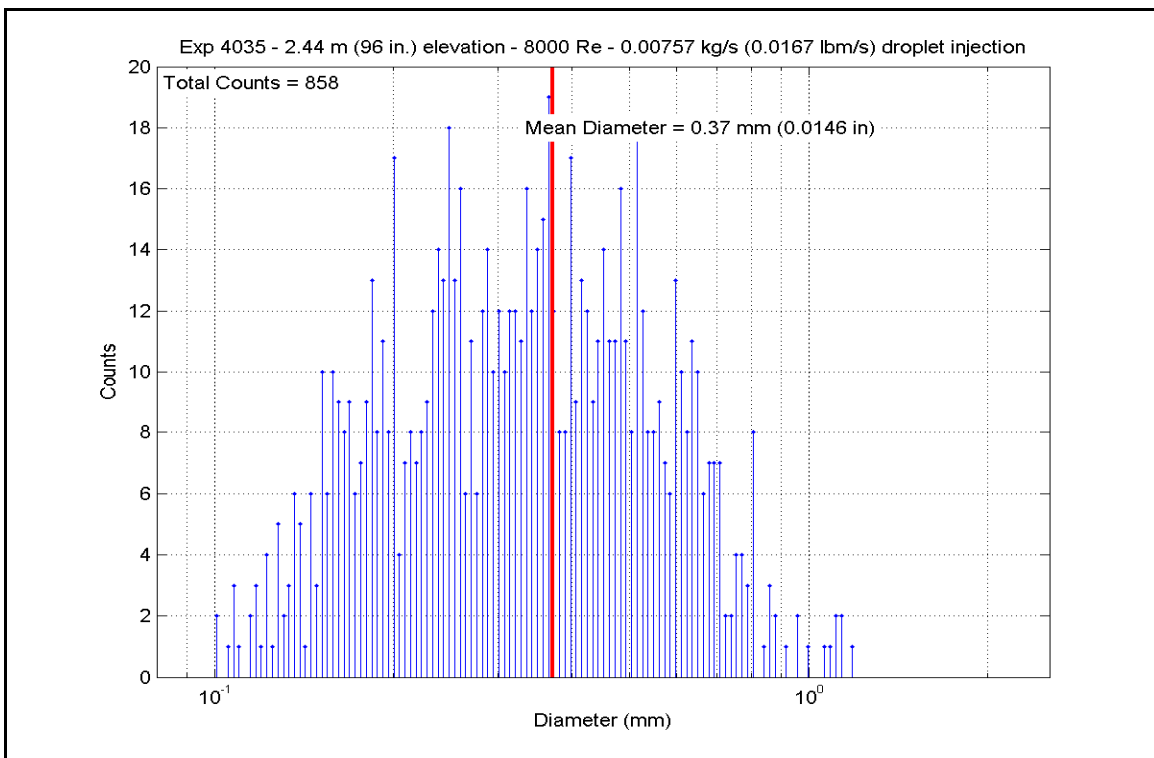

Figure A-253: Droplet Measurements at 2.438 m (96 in.) Elevation for Experiment 4035C

Table A-14: Summary of Steam Cooling Heat Transfer Reduced Data for Experiment 4035C

SCD-4035-C		Inlet Reynolds:		8000		UP Pressure:		40 psia				
Matrix Test		shakedown		275.8 kPa		Bundle Power:		245674 Btu/hr				
Time Window: 18540-19800		72.00 kW		0.0435 kg/s		Steam flow:		345.0 lbm/hr				
Inner 3x3		0.0077 kg/s		0.017 lbm/s		Dropletflow:						
H.R. ID	H.R. Location	Channel Number	Elevation (in)	Elevation (m)	Zgrid (in)	Zgrid (m)	H.R. Tw (°F)	H.R. Tw (K)	H.R. q" (Btu/hr-ft2)	H.R. q" (W/m2)	h _{sat} (z) (Btu/hr-ft2-F)	h _{sat} (z) (W/m2-K)
Gr-3	RodD3_88.3	185	88.3	2.243	-0.2	-0.005	866.94	737.0	6074.09	19160.7	10.124	57.5
	RodD3_91.3	186	91.3	2.319	2.8	0.071	973.49	796.2	6194.29	19539.9	8.768	49.8
	RodD3_93.1	187	93.1	2.365	4.6	0.117	1018.20	821.0	6267.13	19769.7	8.343	47.4
	RodD3_95.3	188	95.3	2.421	6.8	0.173	1057.74	843.0	6357.11	20053.5	8.039	45.7
	RodD3_100.1	189	100.1	2.543	11.6	0.295	1107.68	870.8	6555.28	20678.6	7.798	44.3
	RodD3_106.1	190	106.1	2.695	17.6	0.447	1198.95	921.5	6804.05	21463.4	7.301	41.5
	RodD3_110	191	110	2.794	21.5	0.546	1144.30	891.1	6722.14	21205.0	7.662	43.5
	RodD3_142.1	192	142.1	3.609	8.6	0.218	1201.51	922.9	2236.81	7056.0	2.394	13.6
Gr-3	RodC4_88.4	233	88.4	2.245	-0.1	-0.003	862.97	734.8	6152.83	19409.1	10.324	58.6
	RodC4_91.1	234	91.1	2.314	2.6	0.066	957.88	787.5	6262.97	19756.5	9.065	51.5
	RodC4_93.4	235	93.4	2.372	4.9	0.124	1006.51	814.5	6358.84	20059.0	8.599	48.8
	RodC4_95.3	236	95.3	2.421	6.8	0.173	1043.78	835.3	6437.93	20308.5	8.288	47.1
	RodC4_100.1	237	100.1	2.543	11.6	0.295	1090.77	861.4	6643.45	20956.8	8.065	45.8
	RodC4_106.1	238	106.1	2.695	17.6	0.447	1171.65	906.3	6898.70	21761.9	7.626	43.3
	RodC4_110	239	110	2.794	21.5	0.546	1111.53	872.9	6678.47	21067.2	7.908	44.9
	RodC4_142.2	240	142.2	3.612	8.7	0.221	1179.65	910.7	2412.92	7611.5	2.644	15.0
Gr-3	RodD4_88.3	241	88.3	2.243	-0.2	-0.005	862.60	734.6	6127.48	19329.1	10.288	58.4
	RodD4_91.3	242	91.3	2.319	2.8	0.071	960.49	789.0	6248.52	19710.9	9.010	51.2
	RodD4_93.2	243	93.2	2.367	4.7	0.119	1003.81	813.0	6325.94	19955.2	8.586	48.8
	RodD4_95.2	244	95.2	2.418	6.7	0.170	1041.21	833.8	6407.83	20213.5	8.277	47.0
	RodD4_100.1	245	100.1	2.543	11.6	0.295	1107.60	870.7	6614.63	20865.8	7.869	44.7
	RodD4_106.1	246	106.1	2.695	17.6	0.447	1176.05	908.7	6870.86	21674.1	7.558	42.9
	RodD4_142.1	248	142.1	3.609	8.6	0.218	1188.96	915.9	2325.65	7336.3	2.522	14.3
Gr-3	RodE4_88.4	201	88.4	2.245	-0.1	-0.003	866.29	736.6	6038.87	19049.6	10.077	57.2
	RodE4_91.2	202	91.2	2.316	2.7	0.069	968.32	793.3	6148.35	19395.0	8.767	49.8
	RodE4_95.3	204	95.3	2.421	6.8	0.173	1057.85	843.1	6311.57	19909.8	7.981	45.3
	RodE4_100.9	205	100.9	2.563	12.4	0.315	1134.57	885.7	6532.81	20607.7	7.530	42.8
	RodE4_142.3	208	142.3	3.614	8.8	0.224	1200.81	922.5	2374.51	7490.4	2.543	14.4

Table A-14: Summary of Steam Cooling Heat Transfer Reduced Data for Experiment 4035C, continued

Inner 3x3	H.I.R. Location	Channel Number	Elevation (in)	Elevation (m)	Zgrid (in)	Zgrid (m)	H.R. Tw (°F)	H.R. Tw (K)	H.R. q" (Btu/hr-ft ²)	H.R. q" (W/m ²)	h _{sat} (z) (Btu/hr-ft ² -F)	h _{sat} (z) (W/m ² -K)
Gr-4	RodE3_63.4	193	63.4	1.610	16.4	0.417	1002.00	812.0	4973.76	15689.7	6.767	38.4
	RodE3_113.6	194	113.6	2.885	0.85	0.022	1185.36	913.9	6126.84	19327.1	6.672	37.9
	RodE3_115.5	195	115.5	2.934	2.75	0.070	1217.79	931.9	5891.75	18585.5	6.197	35.2
	RodE3_118.5	196	118.5	3.010	5.75	0.146	1247.69	948.5	5518.16	17407.0	5.627	32.0
	RodE3_122.7	197	122.7	3.117	9.95	0.253	1266.63	959.1	4997.33	15764.1	4.999	28.4
	RodE3_126.5	198	126.5	3.213	13.75	0.349	1266.35	968.9	4529.41	14288.0	4.532	25.7
	RodE3_131.7	199	131.7	3.345	-1.8	-0.046	1195.06	919.3	3909.47	12332.4	4.213	23.9
	RodE3_135.6	200	135.6	3.444	2.1	0.053	1211.31	928.3	3424.48	10802.5	3.626	20.6
Gr-4	RodC5_63.7	225	63.7	1.618	16.7	0.424	984.54	802.3	4869.85	15361.9	6.787	38.5
	RodC5_113.6	226	113.6	2.885	2.885	0.022	1123.64	879.6	5967.46	18824.3	6.966	39.6
	RodC5_115.7	227	115.7	2.939	2.95	0.075	1165.57	902.9	5706.03	17999.7	6.350	36.1
	RodC5_122.7	229	122.7	3.117	9.95	0.253	1214.34	930.0	4869.11	15359.6	5.140	29.2
	RodC5_126.7	230	126.7	3.218	13.95	0.354	1213.87	929.7	4397.31	13871.3	4.644	26.4
	RodC5_131.6	231	131.6	3.343	-1.9	-0.048	1135.59	886.3	3847.66	12137.5	4.430	25.2
	RodC5_135.7	232	135.7	3.447	2.2	0.056	1158.32	898.9	3357.51	10591.3	3.767	21.4
	RodE5_63.6	209	63.6	1.615	16.6	0.422	981.37	800.6	4996.01	15759.9	6.994	39.7
Gr-4	RodE5_113.6	210	113.6	2.885	0.85	0.022	1148.34	893.3	6152.33	19407.5	6.981	39.6
	RodE5_115.4	211	115.4	2.931	2.65	0.067	1177.58	909.6	5924.63	18689.3	6.506	36.9
	RodE5_118.7	212	118.7	3.015	5.95	0.151	1202.91	923.7	5521.77	17418.4	5.900	33.5
	RodE5_122.6	213	122.6	3.114	9.85	0.250	1221.72	934.1	5045.28	15915.3	5.285	30.0
	RodE5_126.6	214	126.6	3.216	13.85	0.352	1225.29	936.1	4557.76	14377.5	4.756	27.0
	RodE5_131.6	215	131.6	3.343	-1.9	-0.048	1152.91	895.9	3973.56	12534.6	4.485	25.5
	RodE5_135.6	216	135.6	3.444	2.1	0.053	1172.90	907.0	3479.24	10975.3	3.841	21.8
	RodC3_79.8	177	79.8	2.027	2.027	8.92	1001.97	812.0	5671.20	17889.8	7.716	43.8
Gr-5	RodC3_85.6	178	85.6	2.174	14.72	0.374	882.38	745.6	5940.27	18738.6	9.653	54.8
	RodC3_88.5	179	88.5	2.248	0	0.000	865.36	736.1	6059.46	19114.6	10.127	57.5
	RodC3_92.4	180	92.4	2.347	3.9	0.099	986.02	803.2	6215.28	19606.1	8.644	49.1
	RodC3_94.4	181	94.4	2.398	5.9	0.150	1027.65	826.3	6296.45	19862.2	8.278	47.0
	RodC3_97.2	182	97.2	2.469	8.7	0.221	1080.40	855.6	6409.13	20217.6	7.879	44.7
	RodC3_108.8	183	108.8	2.764	20.3	0.516	1184.58	913.5	6743.44	21272.2	7.349	41.7
	RodD5_50	217	50	1.270	1.270	3	840.12	722.1	4418.14	13937.0	7.709	43.8
	RodD5_54.1	218	54.1	1.374	1.374	7.1	850.71	728.0	4594.45	14493.2	7.871	44.7
Gr-8	RodD5_56.9	219	56.9	1.445	9.9	0.251	906.39	758.9	4707.94	14851.2	7.363	41.8
	RodD5_60	220	60	1.524	13	0.330	946.82	781.4	4834.86	15251.6	7.112	40.4
	RodD5_66.1	221	66.1	1.679	19.1	0.485	993.18	807.1	5087.64	16049.0	7.006	39.8
	RodD5_69.9	222	69.9	1.775	-0.98	-0.025	789.12	693.8	5278.18	16650.0	10.109	57.4
	RodD5_72.9	223	72.9	1.852	2.02	0.051	879.42	743.9	5401.79	17039.9	8.820	50.1
	RodD5_74.9	224	74.9	1.902	4.02	0.102	929.17	771.6	5481.83	17292.4	8.279	47.0

Table A-14: Summary of Steam Cooling Heat Transfer Reduced Data for Experiment 4035C, continued

H.R. ID	H.R. Location	Channel Number	Elevation (in)	Elevation (m)	Zgrid (in)	Zgrid (m)	H.R. Tw (°F)	H.R. Tw (K)	H.R. Tw (Btu/hr-ft ²)	H.R. q" (W/m ²)	h _{sat} (z) (Btu/hr-ft ² -F)	h _{sat} (z) (W/m ² -K)
Gr-2	RodB5_41	153	41	1.041	13.5	0.343	783.18	690.5	4029.08	12709.7	7.805	44.3
	RodB5_52.9	154	52.9	1.344	5.9	0.150	808.16	704.3	4540.17	14322.0	8.390	47.6
	RodB5_55	155	55	1.397	8	0.203	860.70	733.5	4629.64	14604.2	7.798	44.3
	RodB5_57.8	156	57.8	1.468	10.8	0.274	922.85	768.1	4746.92	14974.2	7.238	41.1
	RodB5_64	157	64	1.626	17	0.432	993.41	807.3	5006.55	15793.2	6.892	39.1
	RodB5_73.9	158	73.9	1.877	3.02	0.077	913.67	763.0	5448.77	17188.1	8.426	47.8
Gr-2	RodB5_75.9	159	75.9	1.928	5.02	0.128	952.35	784.5	5532.70	17452.9	8.073	45.8
	RodB5_76.9	160	76.9	1.953	6.02	0.153	968.51	793.4	5574.59	17585.1	7.947	45.1
	RodF5_41	105	41	1.041	13.5	0.343	786.30	692.2	3993.46	12597.4	7.690	43.7
	RodF5_53.1	106	53.1	1.349	6.1	0.155	801.41	700.6	4523.16	14268.3	8.464	48.1
	RodF5_55	107	55	1.397	8	0.203	850.27	727.7	4603.52	14521.8	7.893	44.8
	RodF5_57.8	108	57.8	1.468	10.8	0.274	909.51	760.7	4718.74	14885.3	7.344	41.7
Gr-2	RodF5_64	109	64	1.626	17	0.432	979.47	799.5	4976.30	15697.7	6.985	39.7
	RodF5_73.8	110	73.8	1.875	2.92	0.074	892.33	751.1	5413.25	17076.1	8.657	49.2
	RodF5_75.8	111	75.8	1.925	4.92	0.125	933.81	774.2	5496.61	17339.1	8.243	46.8
	RodF5_76.8	112	76.8	1.951	5.92	0.150	950.70	783.5	5538.72	17471.9	8.101	46.0
	RodC2_41	57	41	1.041	13.5	0.343	782.55	690.1	4013.38	12660.2	7.785	44.2
	RodC2_53.1	58	53.1	1.349	6.1	0.155	841.13	722.7	4535.24	14306.4	7.899	44.9
Gr-2	RodC2_55	59	55	1.397	8	0.203	872.43	740.1	4614.19	14555.5	7.621	43.3
	RodC2_57.8	60	57.8	1.468	10.8	0.274	912.92	762.6	4730.19	14921.4	7.323	41.6
	RodC2_63.9	61	63.9	1.623	16.9	0.429	955.99	786.5	4990.41	15742.2	7.243	41.1
	RodC2_73.8	62	73.8	1.875	2.92	0.074	893.62	751.8	5438.06	17154.4	8.678	49.3
	RodC2_75.8	63	75.8	1.925	4.92	0.125	930.84	772.5	5525.06	17428.8	8.323	47.3
	RodC2_76.8	64	76.8	1.951	5.92	0.150	946.56	781.2	5567.38	17562.3	8.193	46.5
Gr-2	RodC6_40.9	137	40.9	1.039	13.4	0.340	791.62	695.2	3996.43	12606.7	7.618	43.3
	RodC6_52.8	138	52.8	1.341	5.8	0.147	858.70	732.4	4530.09	14290.2	7.656	43.5
	RodC6_54.8	139	54.8	1.392	7.8	0.198	885.89	747.5	4616.41	14562.5	7.459	42.4
	RodC6_57.8	140	57.8	1.468	10.8	0.274	920.60	766.8	4747.13	14974.8	7.263	41.2
	RodC6_63.8	141	63.8	1.621	16.8	0.427	973.87	796.4	5010.27	15804.9	7.088	40.3
	RodC6_73.7	142	73.7	1.872	2.82	0.072	905.62	758.5	5471.11	17258.6	8.567	48.7
Gr-2	RodC6_75.8	143	75.8	1.925	4.92	0.125	939.40	777.3	5561.58	17544.0	8.271	47.0
	RodC6_76.8	144	76.8	1.951	5.92	0.150	958.56	787.9	5604.43	17679.2	8.104	46.0

Table A-14: Summary of Steam Cooling Heat Transfer Reduced Data for Experiment 4035C, continued

5x5 periphery		H.R. Location	Channel Number	Elevation (in)	Elevation (m)	Zgrid (in)	Zgrid (m)	H.R. Tw (°F)	H.R. Tw (K)	H.R. q" (Btu/hr-ft ²)	H.R. q" (W/m ²)	h _{sat} (z) (Btu/hr-ft ² -F)	h _{sat} (z) (W/m ² -K)
Gr-3	RodB4_88.4	161	88.4	2.245	-0.1	-0.003	854.16	729.9	6041.94	19059.3	10.290	58.4	
	RodB4_91.3	162	91.3	2.319	2.8	0.071	955.04	785.9	6156.48	19420.6	8.948	50.8	
	RodB4_93.3	163	93.3	2.370	4.8	0.122	999.18	810.5	6236.01	19671.5	8.517	48.4	
	RodB4_95.1	164	95.1	2.416	6.6	0.168	1032.36	828.9	6308.33	19899.6	8.242	46.8	
	RodB4_100	165	100	2.540	11.5	0.292	1066.16	847.7	6506.07	20523.4	8.141	46.2	
	RodB4_106	166	106	2.692	17.5	0.445	1151.28	895.0	6749.78	21292.2	7.633	43.3	
	RodB4_109.9	167	109.9	2.791	21.4	0.544	1086.64	859.1	6537.24	20621.7	7.976	45.3	
	RodB4_142.3	168	142.3	3.614	8.8	0.224	1158.49	899.0	2423.07	7643.6	2.718	15.4	
Gr-5	RodF4_85.6	98	85.6	2.174	14.72	0.374	933.90	774.2	5959.18	18798.2	8.936	50.7	
	RodF4_88.4	99	88.4	2.245	-0.1	-0.003	889.52	749.6	6088.81	19207.2	9.781	55.5	
	RodF4_92.4	100	92.4	2.347	3.9	0.099	1012.44	817.8	6249.07	19712.7	8.383	47.6	
	RodF4_94.3	101	94.3	2.395	5.8	0.147	1049.48	838.4	6325.78	19954.7	8.084	45.9	
	RodF4_97.2	102	97.2	2.469	8.7	0.221	1095.95	864.2	6444.31	20328.6	7.774	44.1	
	RodF4_108.8	103	108.8	2.764	20.3	0.516	1182.00	912.0	6797.55	21442.9	7.429	42.2	
	RodF4_111	104	111	2.819	-1.75	-0.044	1120.69	878.0	6521.55	20572.2	7.639	43.4	
	RodD2_103.2	65	103.2	2.621	14.7	0.373	1182.32	912.2	5962.07	18807.3	6.514	37.0	
Gr-6	RodD2_106	66	106	2.692	17.5	0.445	1205.55	925.1	5637.85	17784.6	6.007	34.1	
	RodD2_112.6	67	112.6	2.860	-0.15	-0.004	1235.30	941.7	5192.43	16379.5	5.362	30.5	
	RodD2_114.9	68	114.9	2.918	2.15	0.055	1246.79	948.0	4671.78	14737.1	4.768	27.1	
	RodD2_117.4	69	117.4	2.982	4.65	0.118	1241.37	945.0	4180.44	13187.2	4.290	24.4	
	RodD2_120.8	70	120.8	3.068	8.05	0.204	1167.68	904.1	6708.44	21161.8	7.448	42.3	
	RodD2_124.8	71	124.8	3.170	12.05	0.306	1195.26	919.4	6826.83	21535.2	7.354	41.8	
	RodD2_128.6	72	128.6	3.266	15.85	0.403	1134.55	885.7	6262.86	19756.2	7.219	41.0	
	RodD6_103.1	129	103.1	2.619	14.6	0.371	1125.97	880.9	6708.48	21161.9	7.810	44.4	
Gr-6	RodD6_106	130	106	2.692	17.5	0.445	1149.73	894.1	6829.34	21543.1	7.737	43.9	
	RodD6_112.9	131	112.9	2.868	0.15	0.004	1106.29	870.0	6218.58	19616.5	7.409	42.1	
	RodD6_114.9	132	114.9	2.918	2.15	0.055	1145.83	891.9	5953.42	18780.1	6.774	38.5	
	RodD6_116.8	133	116.8	2.967	4.05	0.103	1168.88	904.8	5701.08	17984.1	6.321	35.9	
	RodD6_120.9	134	120.9	3.071	8.15	0.207	1188.62	915.7	5166.12	16296.5	5.605	31.8	
	RodD6_124.8	135	124.8	3.170	12.05	0.306	1195.91	919.8	4652.14	14675.2	5.008	28.4	
	RodD6_128.7	136	128.7	3.269	15.95	0.405	1190.74	916.9	4143.16	13069.6	4.485	25.5	

Table A-14: Summary of Steam Cooling Heat Transfer Reduced Data for Experiment 4035C, continued

5x5 periphery		H.R.	Channel	Elevation	Elevation	Zgrid	Zgrid	H.R. Tw	H.R. Tw	H.R. q"	H.R. q"	H.R. q"	h _{sat} (z)	h _{sat} (z)
Gr-8	Location	Number	(in)	(m)	(m)	(in)	(m)	(°F)	(K)	(W/m ²)	(Btu/hr-ft ²)	(W/m ²)	(W/m ² -K)	(Btu/hr-ft ² -F)
	RodE2_50.1	73	50.1	1.273	3.1	0.079	834.98	719.2	4439.14	14003.3	4439.14	14003.3	7.816	44.4
	RodE2_54	74	54	1.372	7	0.178	857.86	732.0	4609.34	14540.2	4609.34	14540.2	7.801	44.3
	RodE2_56.9	75	56.9	1.445	9.9	0.251	908.22	759.9	4732.71	14929.3	4732.71	14929.3	7.381	41.9
	RodE2_59.9	76	59.9	1.521	12.9	0.328	945.57	780.7	4860.55	15332.6	4860.55	15332.6	7.163	40.7
	RodE2_66	77	66	1.676	19	0.483	980.04	799.8	5124.45	16165.1	5124.45	16165.1	7.187	40.8
	RodE2_69.8	78	69.8	1.773	-1.08	-0.027	802.23	701.1	5311.72	16755.8	5311.72	16755.8	9.924	56.4
	RodE2_72.9	79	72.9	1.852	2.02	0.051	894.15	752.1	5442.61	17168.7	5442.61	17168.7	8.678	49.3
	RodE2_74.9	80	74.9	1.902	4.02	0.102	935.17	774.9	5527.44	17436.3	5527.44	17436.3	8.272	47.0
Gr-8	RodB3_50.2	169	50.2	1.275	3.2	0.081	797.68	698.5	4416.37	13931.4	4416.37	13931.4	8.322	47.3
	RodB3_54.1	170	54.1	1.374	7.1	0.180	824.94	713.7	4588.21	14473.5	4588.21	14473.5	8.223	46.7
	RodB3_56.9	171	56.9	1.445	9.9	0.251	878.96	743.7	4703.84	14838.3	4703.84	14838.3	7.686	43.7
	RodB3_60.1	172	60.1	1.527	13.1	0.333	891.74	750.8	4840.96	15270.8	4840.96	15270.8	7.749	44.0
	RodB3_66.1	173	66.1	1.679	19.1	0.485	959.46	788.4	5095.14	16072.6	5095.14	16072.6	7.358	41.8
	RodB3_69.9	174	69.9	1.775	-0.98	-0.025	775.03	685.9	5279.89	16655.4	5279.89	16655.4	10.393	59.0
	RodB3_73	175	73	1.854	2.12	0.054	875.49	741.8	5408.45	17061.0	5408.45	17061.0	8.888	50.5
	RodB3_75	176	75	1.905	4.12	0.105	922.26	767.7	5491.97	17324.4	5491.97	17324.4	8.381	47.6
Gr-8	RodF3_50.1	89	50.1	1.273	3.1	0.079	815.03	708.2	4413.97	13923.9	4413.97	13923.9	8.054	45.7
	RodF3_54	90	54	1.372	7	0.178	845.95	725.3	4586.59	14468.4	4586.59	14468.4	7.922	45.0
	RodF3_57	91	57	1.448	10	0.254	908.23	759.9	4714.62	14872.3	4714.62	14872.3	7.352	41.8
	RodF3_60	92	60	1.524	13	0.330	955.26	786.1	4842.49	15275.6	4842.49	15275.6	7.036	40.0
	RodF3_66.1	93	66.1	1.679	19.1	0.485	988.27	804.4	5106.83	16109.5	5106.83	16109.5	7.080	40.2
	RodF3_70	94	70	1.778	-0.88	-0.022	804.83	702.5	5301.21	16722.7	5301.21	16722.7	9.857	56.0
	RodF3_73	95	73	1.854	2.12	0.054	901.01	755.9	5431.09	17132.4	5431.09	17132.4	8.566	48.6
	RodF3_75	96	75	1.905	4.12	0.105	946.93	781.4	5516.34	17401.3	5516.34	17401.3	8.113	46.1
Gr-8	RodE6_50.2	121	50.2	1.275	3.2	0.081	815.78	708.6	4411.71	13916.7	4411.71	13916.7	8.039	45.7
	RodE6_54.1	122	54.1	1.374	7.1	0.180	856.77	731.4	4577.47	14439.6	4577.47	14439.6	7.761	44.1
	RodE6_57	123	57	1.448	10	0.254	892.46	751.2	4699.26	14823.8	4699.26	14823.8	7.513	42.7
	RodE6_60.2	124	60.2	1.529	13.2	0.335	923.88	768.6	4831.86	15242.1	4831.86	15242.1	7.356	41.8
	RodE6_66.1	125	66.1	1.679	19.1	0.485	968.86	793.6	5077.66	16017.5	5077.66	16017.5	7.235	41.1
	RodE6_70	126	70	1.778	-0.88	-0.022	790.91	694.8	5266.23	16612.3	5266.23	16612.3	10.052	57.1
	RodE6_73.1	127	73.1	1.857	2.22	0.056	877.14	742.7	5390.66	17004.8	5390.66	17004.8	8.835	50.2
	RodE6_75	128	75	1.905	4.12	0.105	917.13	764.9	5468.07	17249.0	5468.07	17249.0	8.411	47.8

RBHT Steam Cooling with Droplet Injection Test SCD-4035-D

Matrix Test # Shakedown

Test Conditions

Test Date – 10/4/2005

Steady State Time Window: 20040 - 21540

Upper Plenum Pressure: 2.76 bar (40 psia)

Bundle Power: 72.0 kW

Bundle Inlet Reynolds Number: 8000

Bundle Inlet Steam Flow: 157.1 kg/hr (346 lbm/hr)

Droplet Injection Flow: 0.0151 kg/s (0.0333 lbm/s)

Droplet Injection Hole Diameter: 0.381 mm (.015 in)

Droplet Injection Elevation: 1.295 m (51 in)

Bundle Flow Area: $4.656 \times 10^{-3} \text{ m}^2$ ($5.012 \times 10^{-2} \text{ ft}^2$)

Test Notes

- No steam probes were traversed in this steady state window.

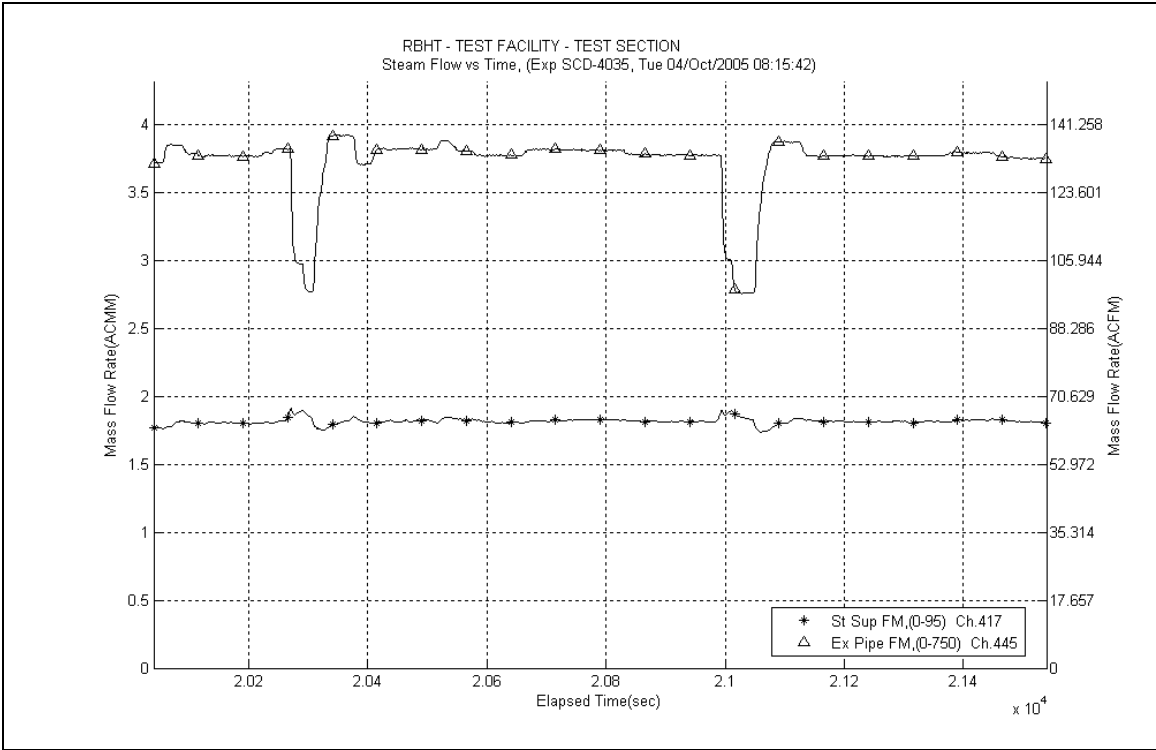

Figure A-254: Inlet and Exhaust Steam Flow Rates for Experiment 4035D

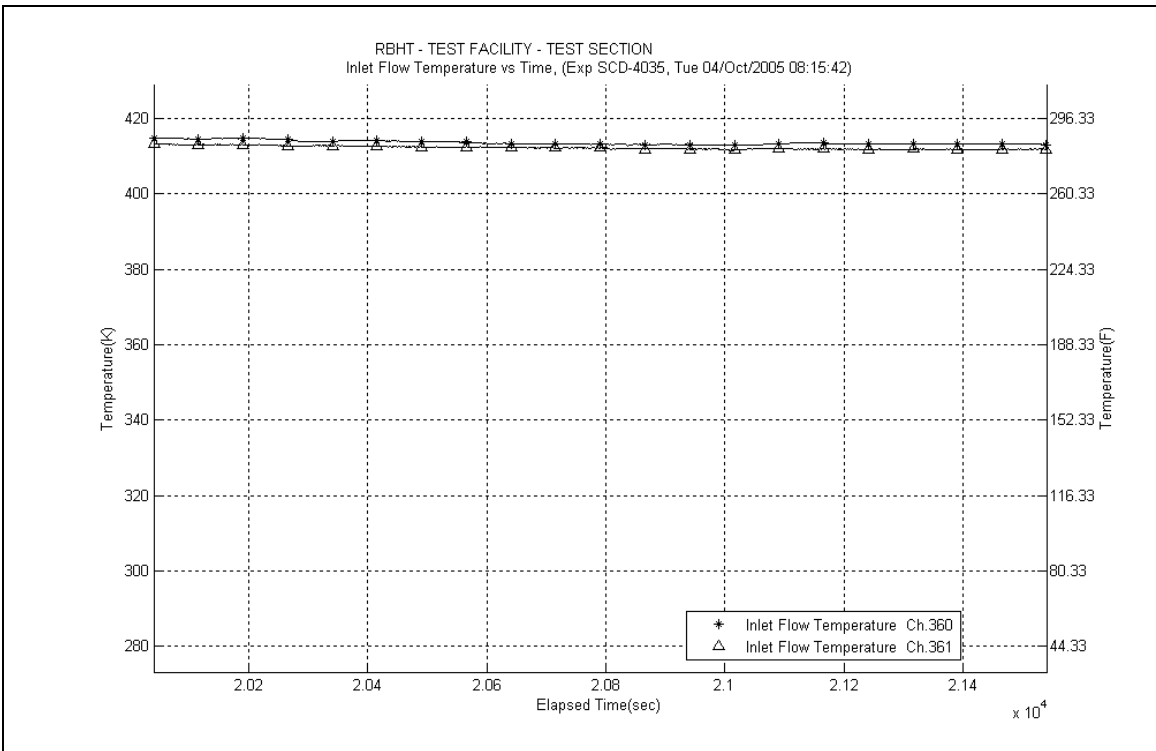

Figure A-255: Inlet Steam Temperature for Experiment 4035D

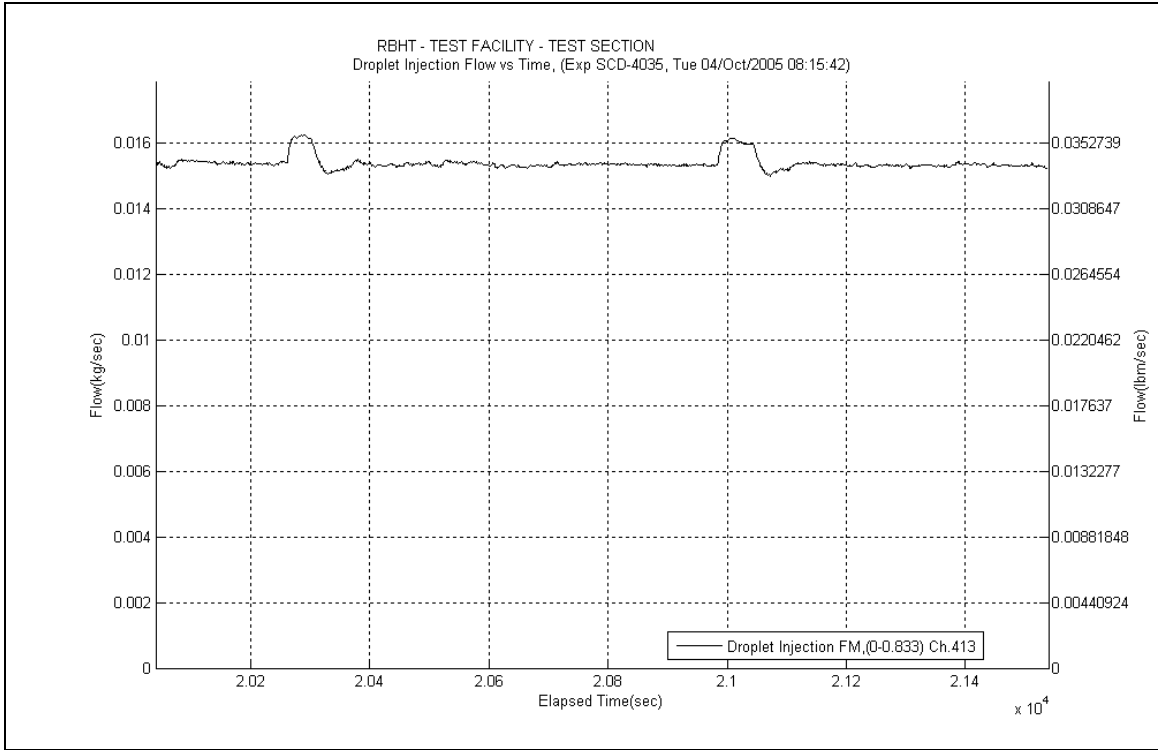

Figure A-256: Droplet Injection Flow Rate for Experiment 4035D

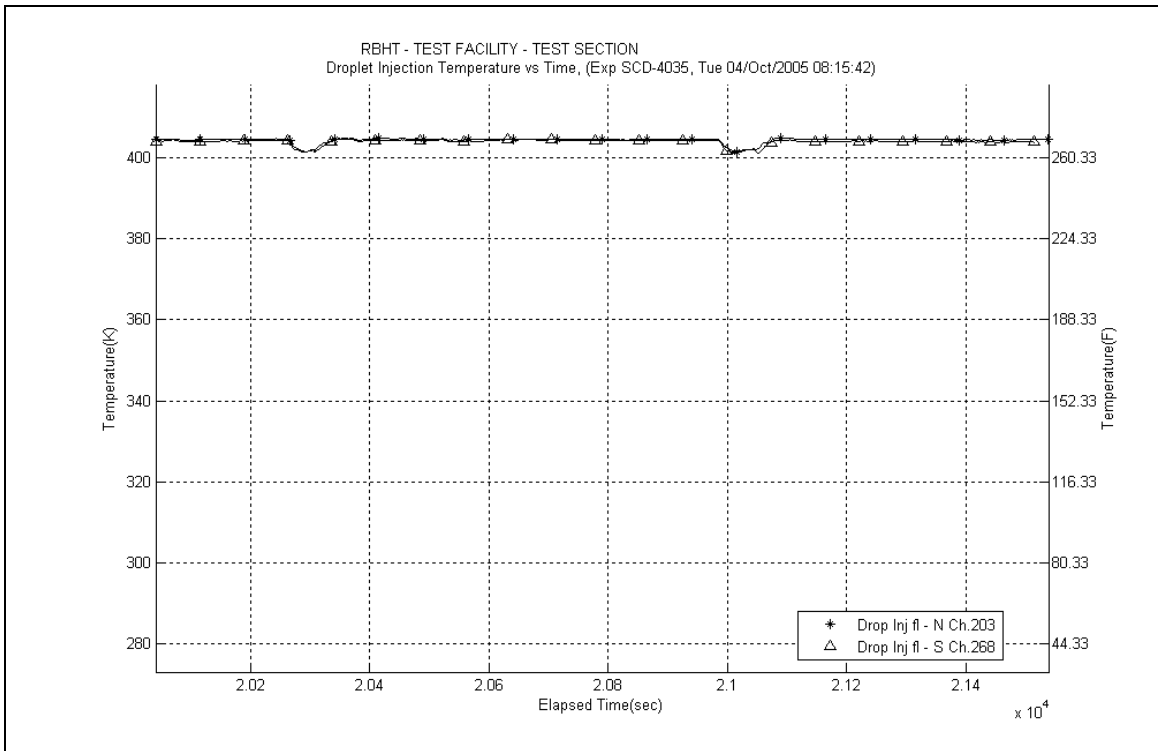

Figure A-257: Droplet Injection Temperature for Experiment 4035D

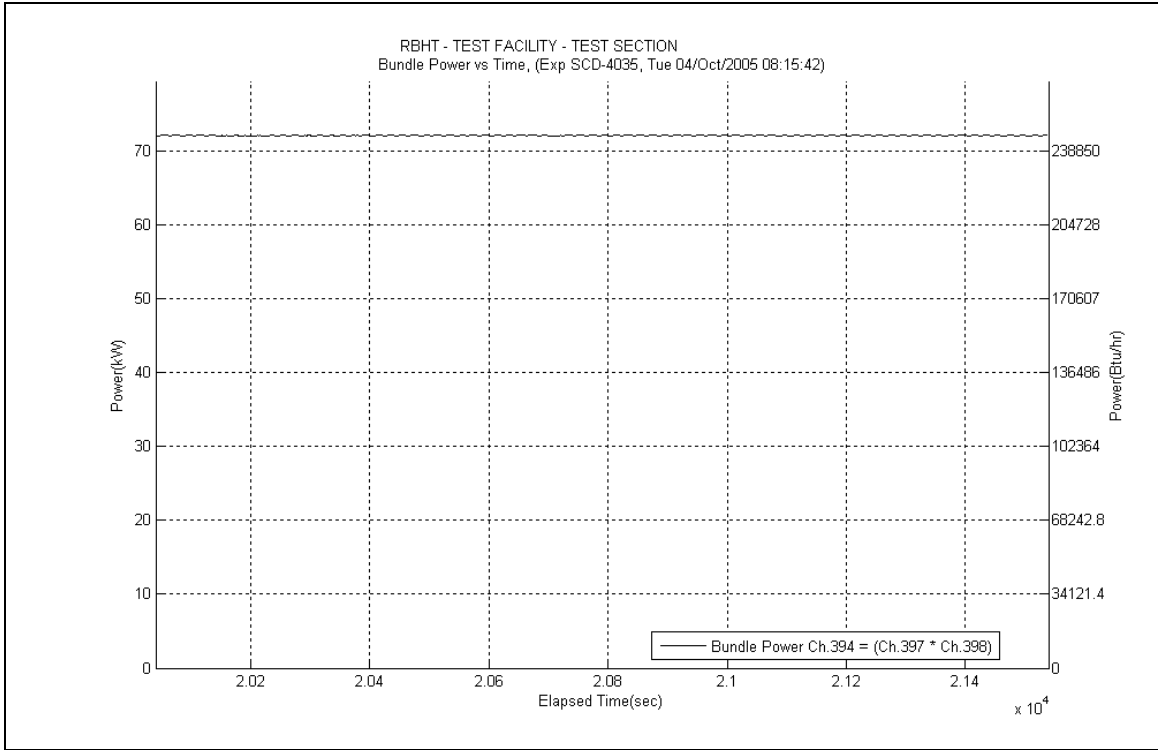

Figure A-258: Bundle Power for Experiment 4035D

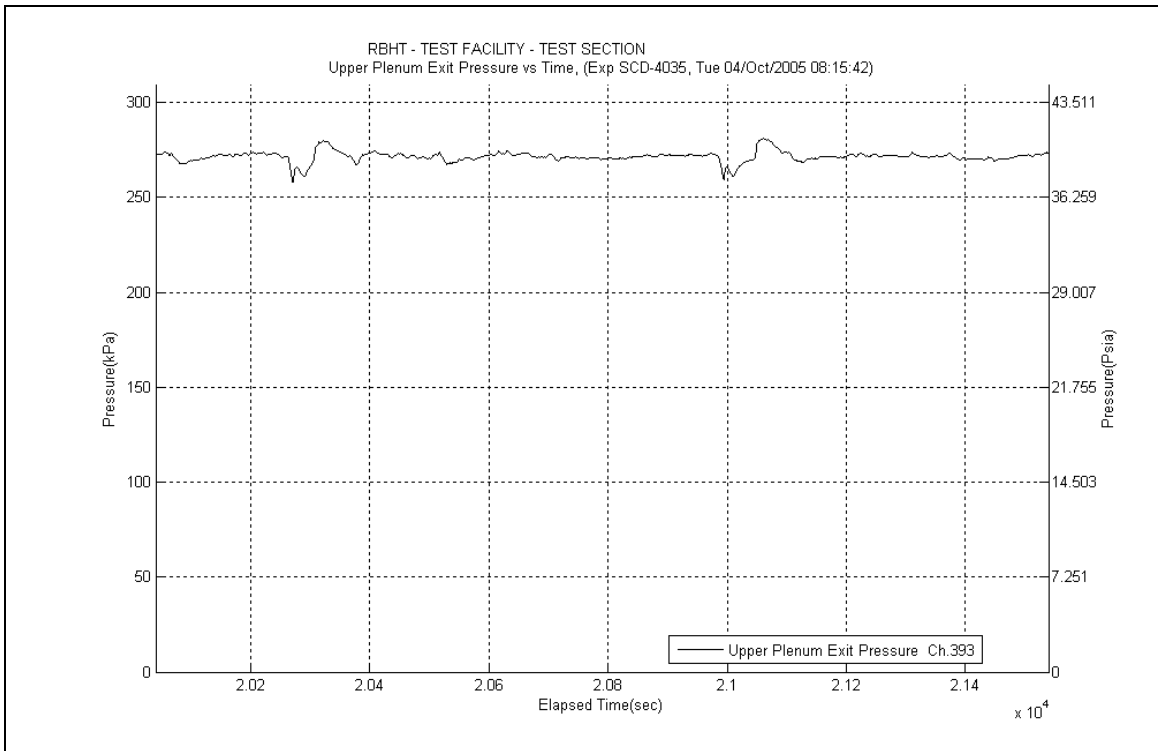

Figure A-259: Upper Plenum Pressure for Experiment 4035D

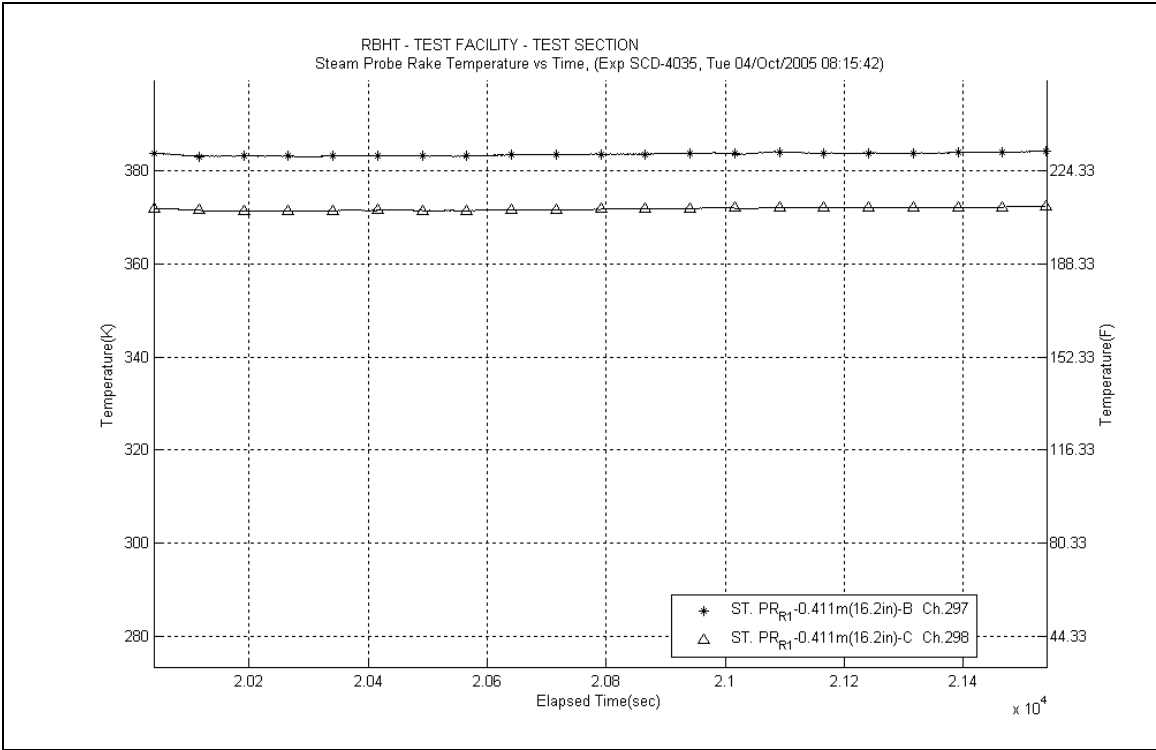

Figure A-260: Steam Probe Rake #1 Temperatures for Experiment 4035D

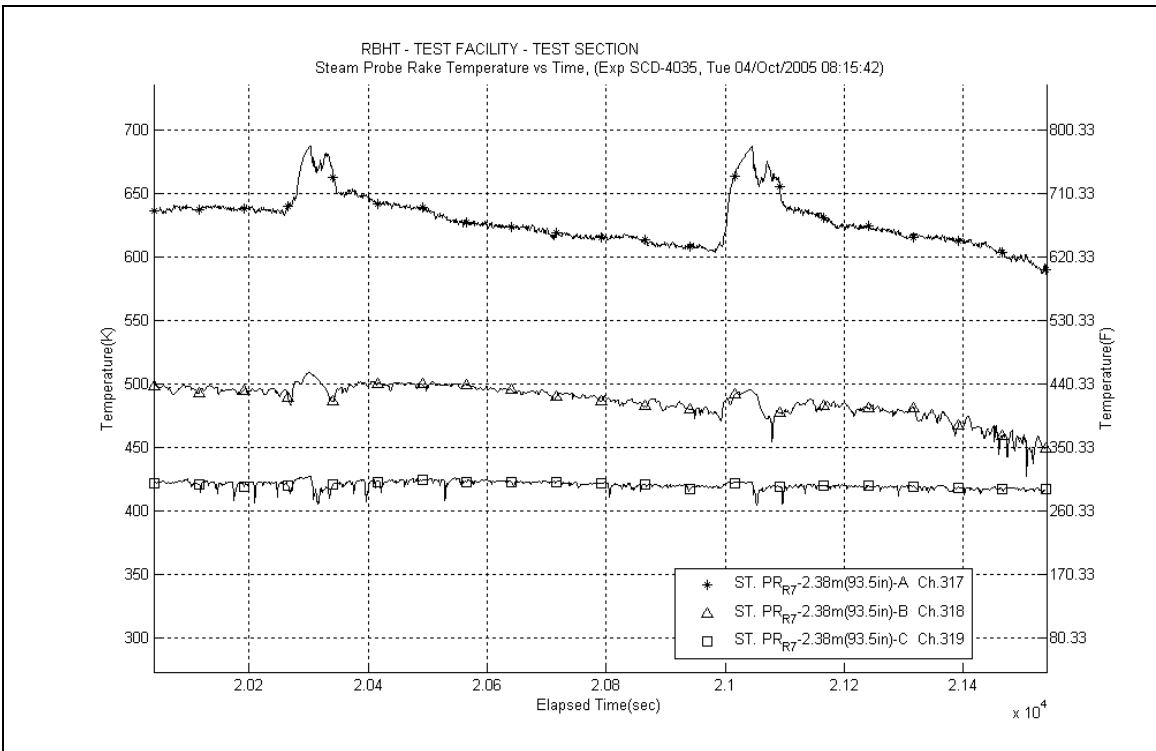

Figure A-261: Steam Probe Rake #7 Temperatures for Experiment 4035D

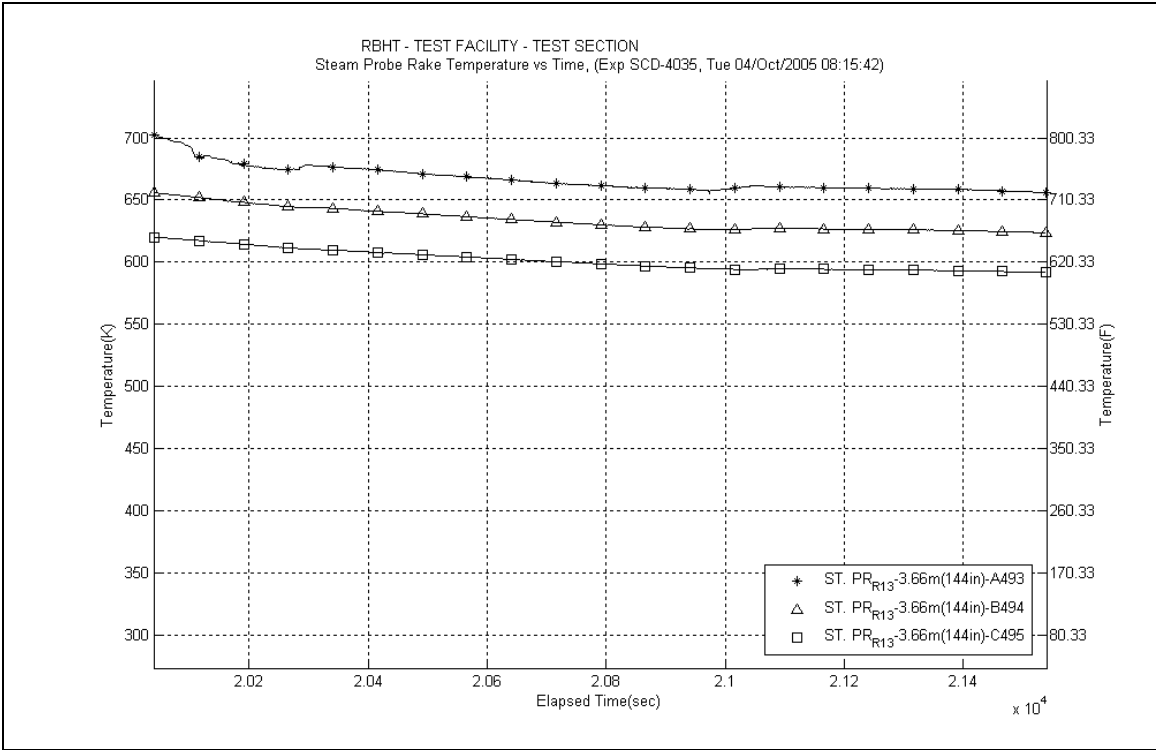

Figure A-262: Steam Probe Rake #13 Temperatures for Experiment 4035D

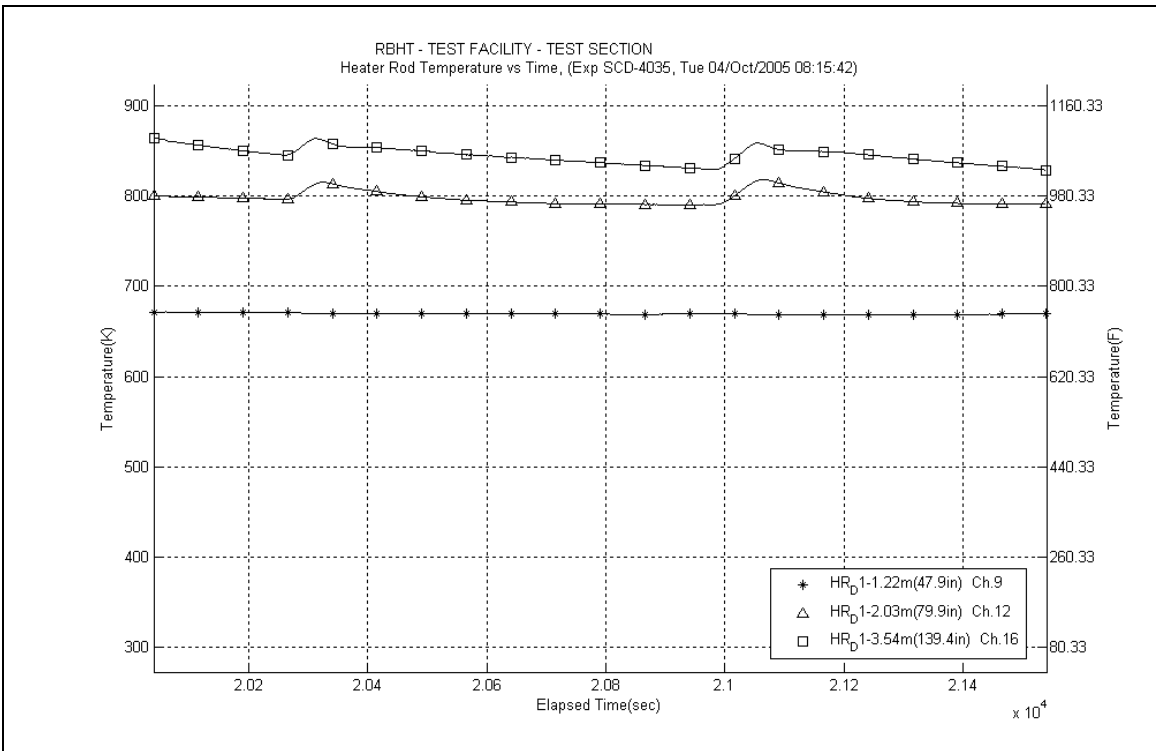

Figure A-263: Heater Rod D1 Temperatures for Experiment 4035D

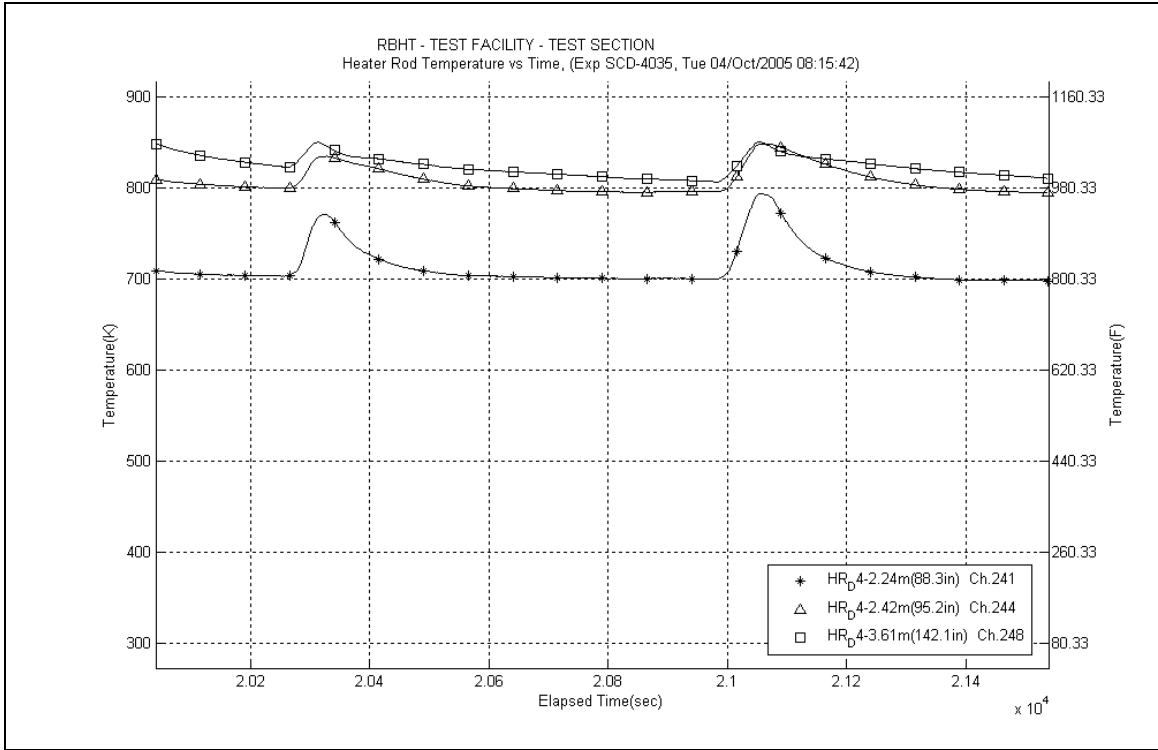

Figure A-264: Heater Rod D4 Temperatures for Experiment 4035D

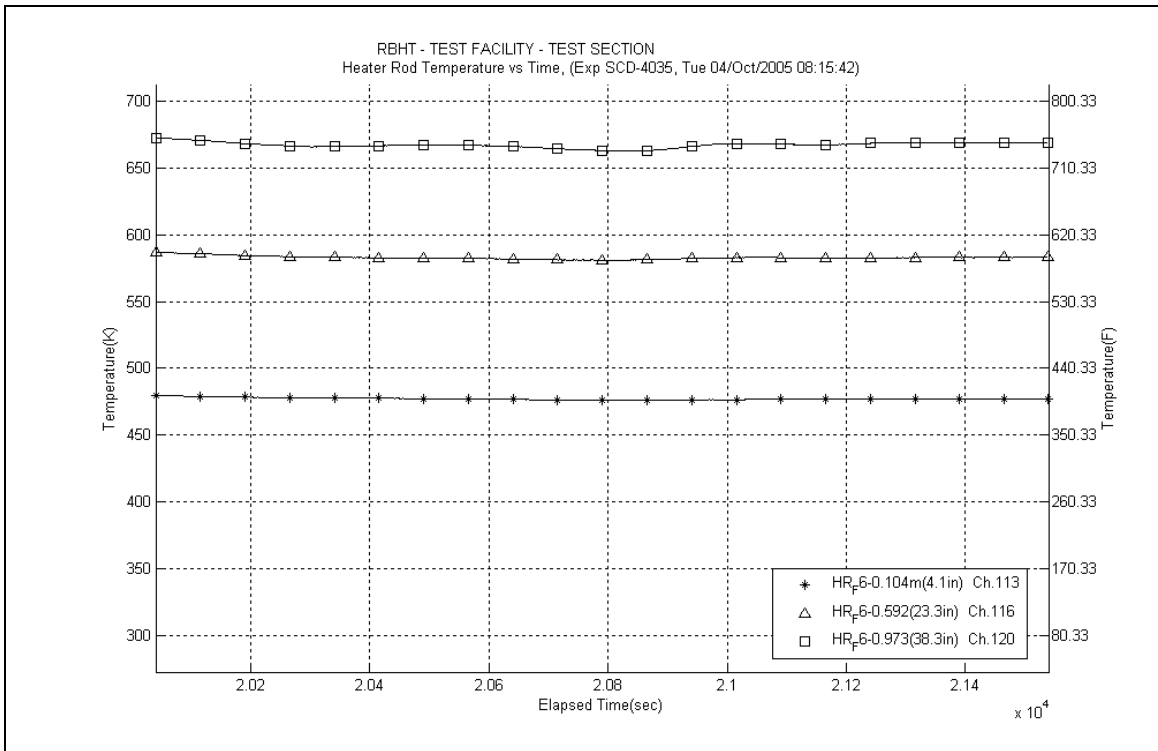

Figure A-265: Heater Rod F6 Temperatures for Experiment 4035D

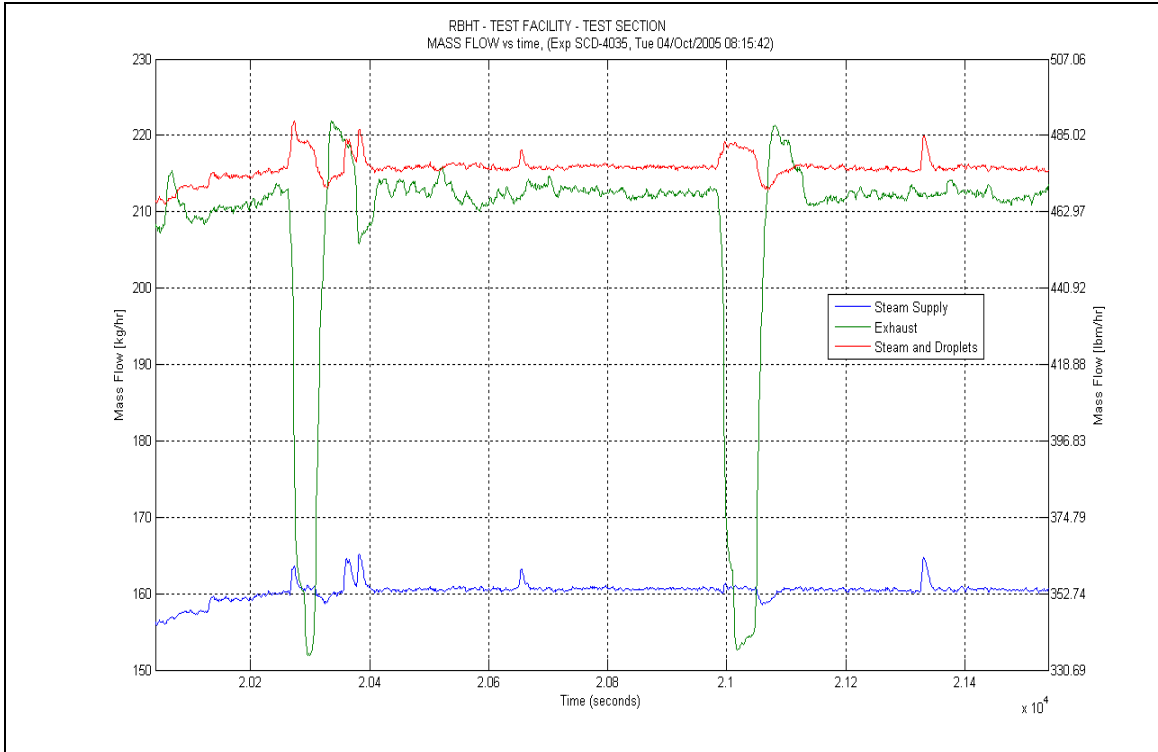

Figure A-266: Mass Flow for Experiment 4035D

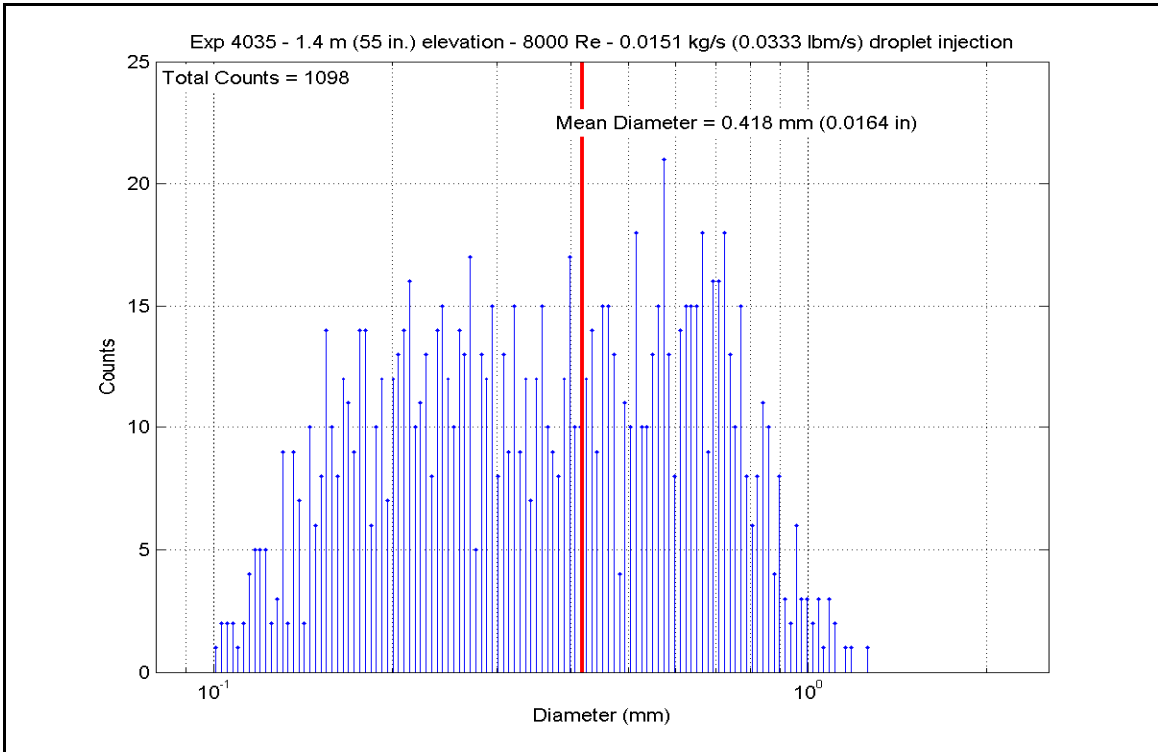

Figure A-267: Droplet Measurements at 1.397 m (55 in.) Elevation for Experiment 4035D

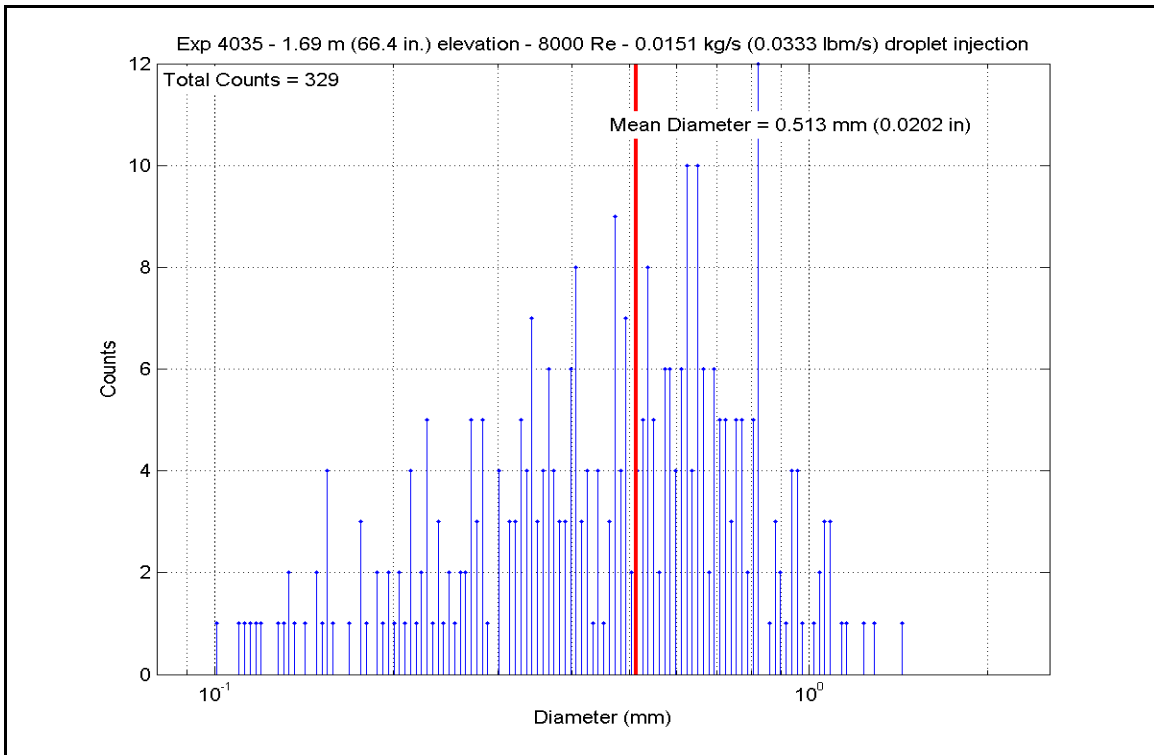

Figure A-268: Droplet Measurements at 1.687 m (66.4 in.) Elevation for Experiment 4035D

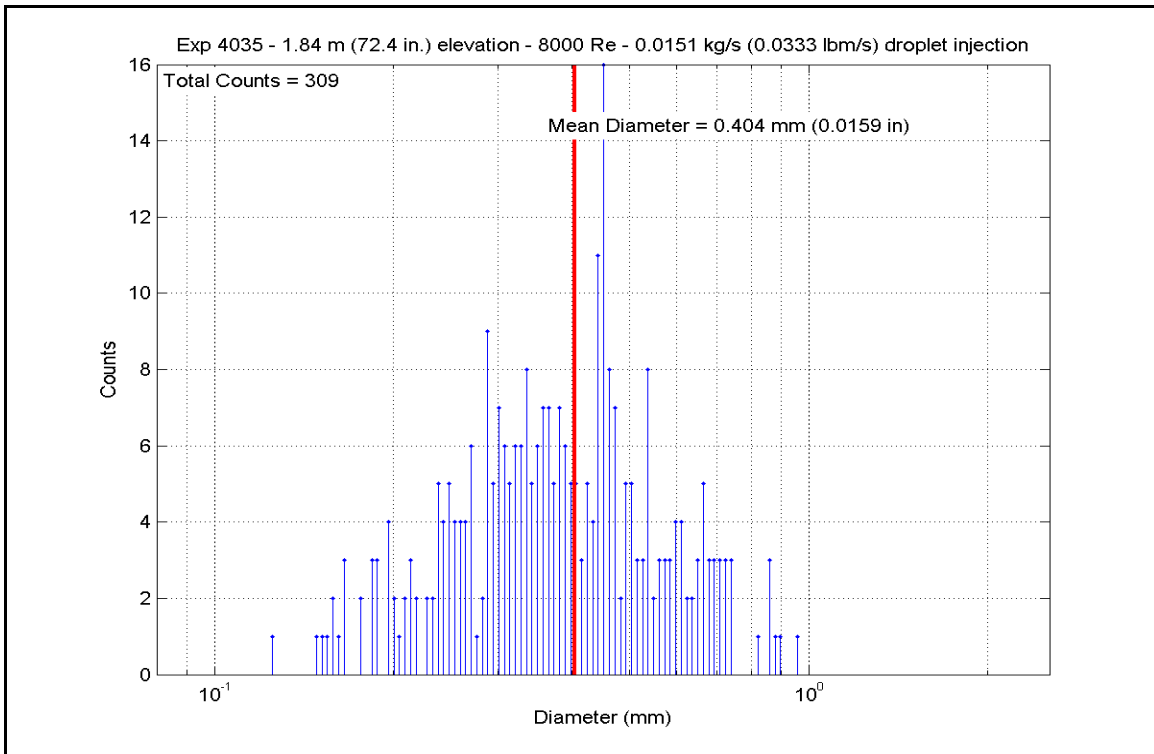

Figure A-269: Droplet Measurements at 1.839 m (72.4 in.) Elevation for Experiment 4035D

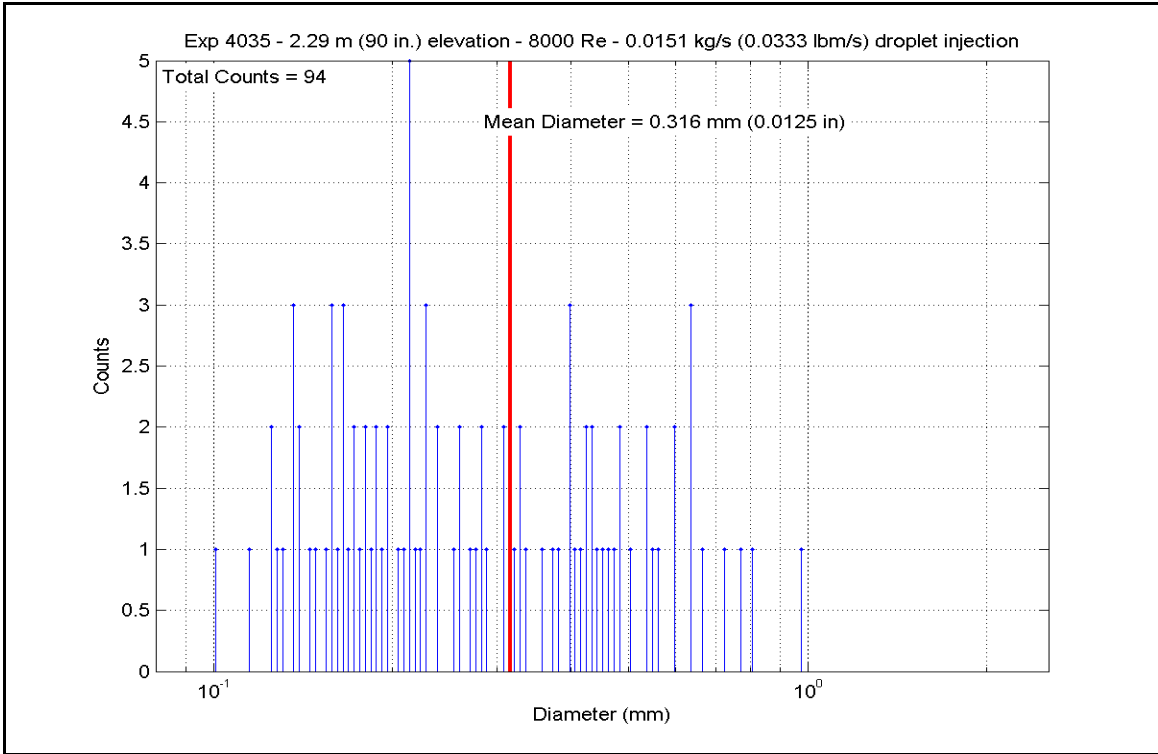

Figure A-270: Droplet Measurements at 2.286 m (90 in.) Elevation for Experiment 4035D

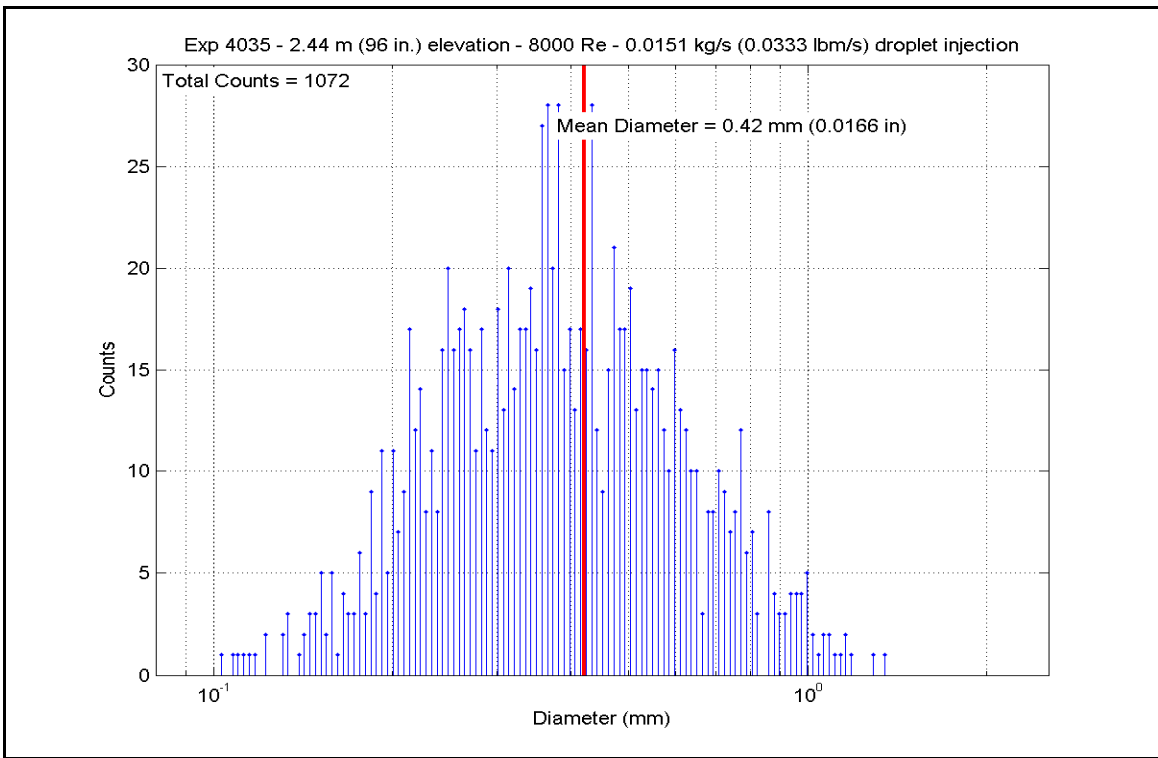

Figure A-271: Droplet Measurements at 2.438 m (96 in.) Elevation for Experiment 4035D

Table A-15: Summary of Steam Cooling Heat Transfer Reduced Data for Experiment 4035D

SCD-4035-D		Inlet Reynolds:		8000		UP Pressure:		40 psia					
Matrix Test shakedown		UP Pressure:		275.8 kPa		Bundle Power:		245674 Btu/hr					
Time Window: 20040-21540		Stream flow:		0.0436 kg/s		Dropletflow:		0.033 lbm/s					
Inner 3x3		Zgrid (in)		Zgrid (m)		H.R. Tw (°F)		H.R. Tw (K)					
H.R. ID	H.R. Location	Channel Number	Elevation (in)	Elevation (m)	Zgrid (in)	Zgrid (m)	H.R. Tw (°F)	H.R. Tw (K)	H.R. q" (Btu/hr-ft2)	H.R. q" (W/m2)	h _{sat} (z) (Btu/hr-ft2-F)	h _{sat} (z) (W/m2-K)	
Gr-3	RodD3_88.3	185	88.3	2.243	-0.2	-0.005	806.23	703.3	6792.46	21426.8	11.751	66.7	
	RodD3_91.3	186	91.3	2.319	2.8	0.071	905.53	758.4	6931.56	21865.6	11.678	66.3	
	RodD3_93.1	187	93.1	2.365	4.6	0.117	945.98	780.9	7016.04	22132.1	13.338	75.7	
	RodD3_95.3	188	95.3	2.421	6.8	0.173	980.01	799.8	7121.67	22465.3	11.995	68.1	
	RodD3_100.1	189	100.1	2.543	11.6	0.295	1013.87	818.6	7359.57	23215.8	11.198	63.6	
	RodD3_106.1	190	106.1	2.695	17.6	0.447	1096.74	864.7	7643.01	24109.9	10.650	60.5	
	RodD3_110	191	110	2.794	21.5	0.546	1015.90	819.8	7551.11	23820.0	11.266	64.0	
	RodD3_142.1	192	142.1	3.609	3.609	8.6	990.59	805.7	2619.00	8261.6	13.275	75.4	
	Gr-3	RodC4_88.4	233	88.4	2.245	-0.1	-0.003	814.91	708.1	6868.51	21666.7	10.180	57.8
		RodC4_91.1	234	91.1	2.314	2.6	0.066	901.99	756.5	6995.49	22067.3	9.039	51.3
		RodC4_93.4	235	93.4	2.372	4.9	0.124	943.06	779.3	7107.28	22419.9	8.047	45.7
		RodC4_95.3	236	95.3	2.421	6.8	0.173	974.65	796.8	7199.00	22709.2	7.324	41.6
RodC4_100.1		237	100.1	2.543	11.6	0.295	999.40	810.6	7433.42	23448.7	11.486	65.2	
RodC4_106.1		238	106.1	2.695	17.6	0.447	1076.80	853.6	7727.44	24376.2	10.977	62.3	
RodC4_110		239	110	2.794	21.5	0.546	992.65	806.8	7477.76	23588.6	10.942	62.1	
RodC4_142.2		240	142.2	3.612	3.612	8.7	962.85	790.3	2840.76	8961.2	12.240	69.5	
Gr-3	RodD4_88.3	241	88.3	2.243	-0.2	-0.005	807.42	703.9	6842.97	21586.2	12.218	69.4	
	RodD4_91.3	242	91.3	2.319	2.8	0.071	896.49	753.4	6981.70	22023.8	11.711	66.5	
	RodD4_93.2	243	93.2	2.367	4.7	0.119	933.37	773.9	7072.11	22309.0	10.798	61.3	
	RodD4_95.2	244	95.2	2.418	6.7	0.170	963.52	790.7	7167.89	22611.1	8.930	50.7	
	RodD4_100.1	245	100.1	2.543	11.6	0.295	1008.90	815.9	7408.25	23369.3	10.697	60.7	
	RodD4_106.1	246	106.1	2.695	17.6	0.447	1080.25	855.5	7697.42	24281.5	11.394	64.7	
	RodD4_142.1	248	142.1	3.609	3.609	8.6	963.33	790.6	2748.95	8671.6	13.598	77.2	
	Gr-3	RodE4_88.4	201	88.4	2.245	-0.1	-0.003	815.27	708.3	6747.49	21285.0	11.841	67.2
RodE4_91.2		202	91.2	2.316	2.7	0.069	907.92	759.8	6870.62	21673.4	11.234	63.8	
RodE4_95.3		204	95.3	2.421	6.8	0.173	984.00	802.0	7059.20	22268.3	3.759	21.3	
RodE4_100.9		205	100.9	2.563	12.4	0.315	1043.69	835.2	7322.36	23098.4	11.275	64.0	
RodE4_142.3	208	142.3	3.614	3.614	8.8	981.79	800.8	2787.68	8793.7	13.223	75.1		

Table A-15: Summary of Steam Cooling Heat Transfer Reduced Data for Experiment 4035D, continued

Inner 3x3	H.I.R. Location	Channel Number	Elevation (in)	Elevation (m)	Zgrid (in)	Zgrid (m)	H.R. Tw (°F)	H.R. Tw (K)	H.R. q" (Btu/hr-ft ²)	H.R. q" (W/m ²)	h _{sat} (z) (Btu/hr-ft ² -F)	h _{sat} (z) (W/m ² -K)
Gr-4	RodE3_63.4	193	63.4	1.610	16.4	0.417	930.24	772.2	5601.80	17670.9	5.338	30.3
	RodE3_113.6	194	113.6	2.885	0.85	0.022	1052.02	839.8	6876.19	21691.0	9.812	55.7
	RodE3_115.5	195	115.5	2.934	2.75	0.070	1077.85	854.2	6613.78	20863.2	10.880	61.8
	RodE3_118.5	196	118.5	3.010	5.75	0.146	1097.74	865.2	6210.10	19589.7	9.047	51.4
	RodE3_122.7	197	122.7	3.117	9.95	0.253	1099.92	866.4	5644.29	17804.9	8.247	46.8
	RodE3_126.5	198	126.5	3.213	13.75	0.349	1092.43	862.3	5133.25	16192.8	7.480	42.5
	RodE3_131.7	199	131.7	3.345	-1.8	-0.046	992.04	806.5	4431.80	13980.1	6.810	38.7
	RodE3_135.6	200	135.6	3.444	2.1	0.053	1016.18	819.9	3909.99	12334.1	6.330	35.9
Gr-4	RodC5_63.7	225	63.7	1.618	16.7	0.424	928.22	771.1	5482.62	17294.9	11.275	64.0
	RodC5_113.6	226	113.6	2.885	0.85	0.022	987.11	803.8	6701.52	21139.9	10.452	59.4
	RodC5_115.7	227	115.7	2.939	2.95	0.075	1021.05	822.6	6428.64	20279.2	5.949	33.8
	RodC5_122.7	229	122.7	3.117	9.95	0.253	1034.79	830.3	5534.22	17457.7	5.490	31.2
	RodC5_126.7	230	126.7	3.216	13.95	0.354	1028.56	826.8	5022.56	15843.7	11.985	68.1
	RodC5_131.6	231	131.6	3.343	-1.9	-0.048	919.03	765.9	4392.18	13855.1	11.914	67.7
	RodC5_135.7	232	135.7	3.447	2.2	0.056	939.86	777.5	3869.60	12206.6	11.401	64.7
	RodE5_63.6	209	63.6	1.615	16.6	0.422	913.19	762.7	5612.03	17703.2	3.723	21.1
Gr-4	RodE5_113.6	210	113.6	2.885	0.85	0.022	998.53	810.1	6934.36	21874.4	10.963	62.3
	RodE5_115.4	211	115.4	2.931	2.65	0.067	1025.95	825.3	6693.21	21113.7	11.469	65.1
	RodE5_118.7	212	118.7	3.015	5.95	0.151	1048.06	837.6	6256.79	19737.0	3.830	21.7
	RodE5_122.6	213	122.6	3.114	9.85	0.250	1053.91	840.9	5739.30	18104.6	13.646	77.5
	RodE5_126.6	214	126.6	3.216	13.85	0.352	1048.79	838.0	5209.09	16432.1	12.296	69.8
	RodE5_131.6	215	131.6	3.343	-1.9	-0.048	946.53	781.2	4541.85	14327.3	12.072	68.6
	RodE5_135.6	216	135.6	3.444	2.1	0.053	967.03	792.6	4011.97	12655.8	11.747	66.7
	RodC3_79.8	177	79.8	2.027	8.92	0.227	935.33	775.0	6340.49	20001.1	11.715	66.5
Gr-5	RodC3_85.6	178	85.6	2.174	14.72	0.374	820.81	711.4	6624.66	20897.5	11.420	64.9
	RodC3_88.5	179	88.5	2.248	0	0.000	815.00	708.1	6763.17	21334.4	3.838	21.8
	RodC3_92.4	180	92.4	2.347	3.9	0.099	927.41	770.6	6943.06	21901.9	13.235	75.2
	RodC3_94.4	181	94.4	2.398	5.9	0.150	963.32	790.6	7036.67	22197.2	12.323	70.0
	RodC3_97.2	182	97.2	2.469	8.7	0.221	1009.45	816.2	7169.96	22617.6	10.840	61.6
	RodC3_108.8	183	108.8	2.764	20.3	0.516	1091.39	861.7	7558.53	23843.4	11.113	63.1
	RodD5_50	217	50	1.270	3	0.076	790.46	694.5	4957.04	15637.0	6.919	39.3
	RodD5_54.1	218	54.1	1.374	7.1	0.180	788.54	693.5	5153.74	16257.5	7.417	42.1
Gr-8	RodD5_56.9	219	56.9	1.445	9.9	0.251	848.50	726.8	5285.18	16672.1	6.748	38.3
	RodD5_60	220	60	1.524	13	0.330	892.64	751.3	5434.47	17143.0	6.369	36.2
	RodD5_66.1	221	66.1	1.679	19.1	0.485	925.43	769.5	5725.14	18060.0	5.346	30.4
	RodD5_69.9	222	69.9	1.775	-0.98	-0.025	737.34	665.0	5908.33	18637.8	13.355	75.8
	RodD5_72.9	223	72.9	1.852	2.02	0.051	823.28	712.7	6043.93	19065.6	12.040	68.4
	RodD5_74.9	224	74.9	1.902	4.02	0.102	868.25	737.7	6136.60	19357.9	11.911	67.6

Table A-15: Summary of Steam Cooling Heat Transfer Reduced Data for Experiment 4035D, continued

H.R. ID	H.R. Location	Channel Number	Elevation (in)	Elevation (m)	Zgrid (in)	Zgrid (m)	H.R. Tw (°F)	H.R. Tw (K)	H.R. q" (Btu/hr-ft ²)	H.R. q" (W/m ²)	h _{sat} (z) (Btu/hr-ft ² -F)	h _{sat} (z) (W/m ² -K)
Gr-2	RodB5_41	153	41	1.041	13.5	0.343	741.58	667.4	4511.17	14230.5	9.506	54.0
	RodB5_52.9	154	52.9	1.344	5.9	0.150	761.29	678.3	5090.06	16056.6	10.298	58.5
	RodB5_55	155	55	1.397	8	0.203	811.22	706.1	5178.28	16334.9	9.515	54.0
	RodB5_57.8	156	57.8	1.468	10.8	0.274	869.58	738.5	5309.01	16747.3	8.810	50.0
	RodB5_64	157	64	1.626	17	0.432	932.09	773.2	5605.84	17683.6	8.429	47.9
	RodB5_73.9	158	73.9	1.877	3.02	0.077	878.83	743.6	6083.19	19189.4	9.943	56.5
Gr-2	RodB5_75.9	159	75.9	1.928	5.02	0.128	913.04	762.6	6177.33	19486.4	9.562	54.3
	RodB5_76.9	160	76.9	1.953	6.02	0.153	926.37	770.0	6225.24	19637.5	9.441	53.6
	RodF5_41	105	41	1.041	13.5	0.343	735.68	664.1	4486.01	14151.1	9.572	54.4
	RodF5_53.1	106	53.1	1.349	6.1	0.155	765.71	680.8	5075.66	16011.2	10.178	57.8
	RodF5_55	107	55	1.397	8	0.203	802.45	701.2	5153.46	16256.6	9.625	54.7
	RodF5_57.8	108	57.8	1.468	10.8	0.274	853.70	729.7	5280.76	16658.1	9.001	51.1
Gr-2	RodF5_64	109	64	1.626	17	0.432	909.04	760.4	5588.73	17629.6	8.705	49.4
	RodF5_73.8	110	73.8	1.875	2.92	0.074	848.96	727.0	6054.46	19098.8	10.404	59.1
	RodF5_75.8	111	75.8	1.925	4.92	0.125	886.57	747.9	6150.03	19400.3	9.926	56.4
	RodF5_76.8	112	76.8	1.951	5.92	0.150	901.29	756.1	6197.58	19550.3	9.771	55.5
	RodC2_41	57	41	1.041	13.5	0.343	733.66	663.0	4501.07	14198.6	9.645	54.8
	RodC2_53.1	58	53.1	1.349	6.1	0.155	800.40	700.0	5076.73	16014.5	9.518	54.1
Gr-2	RodC2_55	59	55	1.397	8	0.203	822.75	712.5	5167.03	16299.4	9.297	52.8
	RodC2_57.8	60	57.8	1.468	10.8	0.274	848.93	727.0	5304.79	16734.0	9.116	51.8
	RodC2_63.9	61	63.9	1.623	16.9	0.429	894.89	752.5	5595.28	17650.3	8.911	50.6
	RodC2_73.8	62	73.8	1.875	2.92	0.074	855.95	730.9	6065.41	19133.3	10.299	58.5
	RodC2_75.8	63	75.8	1.925	4.92	0.125	890.50	750.1	6163.06	19441.4	9.885	56.1
	RodC2_76.8	64	76.8	1.951	5.92	0.150	904.52	757.9	6211.79	19595.1	9.744	55.3
Gr-2	RodC6_40.9	137	40.9	1.039	13.4	0.340	742.41	667.8	4475.98	14119.5	9.415	53.5
	RodC6_52.8	138	52.8	1.341	5.8	0.147	822.23	712.2	5077.43	16016.7	9.145	51.9
	RodC6_54.8	139	54.8	1.392	7.8	0.198	850.24	727.7	5176.80	16330.2	8.876	50.4
	RodC6_57.8	140	57.8	1.468	10.8	0.274	871.71	739.7	5328.31	16808.2	8.811	50.0
	RodC6_63.8	141	63.8	1.621	16.8	0.427	911.85	762.0	5634.81	17775.0	8.738	49.6
	RodC6_73.7	142	73.7	1.872	2.82	0.072	847.45	726.2	6123.04	19315.1	10.549	59.9
Gr-2	RodC6_75.8	143	75.8	1.925	4.92	0.125	875.73	741.9	6228.47	19647.7	10.232	58.1
	RodC6_76.8	144	76.8	1.951	5.92	0.150	891.98	750.9	6278.53	19805.6	10.046	57.0

Table A-15: Summary of Steam Cooling Heat Transfer Reduced Data for Experiment 4035D, continued

5x5 periphery		H.R. Location	Channel Number	Elevation (in)	Elevation (m)	Zgrid (in)	Zgrid (m)	H.R. Tw (°F)	H.R. Tw (K)	H.R. q" (Btu/hr-ft ²)	H.R. q" (W/m ²)	h _{sat} (z) (Btu/hr-ft ² -F)	h _{sat} (z) (W/m ² -K)
Gr-3	RodB4_88.4	161	88.4	2.245	-0.1	-0.003	825.90	714.2	6733.58	21241.1	12.048	68.4	
	RodB4_91.3	162	91.3	2.319	2.8	0.071	915.86	764.2	6865.42	21657.0	10.581	60.1	
	RodB4_93.3	163	93.3	2.370	4.8	0.122	954.65	785.7	6957.14	21946.3	10.117	57.5	
	RodB4_95.1	164	95.1	2.416	6.6	0.168	983.02	801.5	7040.33	22208.7	9.833	55.8	
	RodB4_100	165	100	2.540	11.5	0.292	1006.71	814.7	7265.56	22919.2	9.822	55.8	
	RodB4_106	166	106	2.692	17.5	0.445	1082.56	856.8	7542.70	23793.5	9.249	52.5	
	RodB4_109.9	167	109.9	2.791	21.4	0.544	1000.05	811.0	7307.45	23051.3	9.969	56.6	
	RodB4_142.3	168	142.3	3.614	8.8	0.224	960.62	789.1	2819.73	8894.8	4.065	23.1	
Gr-5	RodF4_85.6	98	85.6	2.174	14.72	0.374	911.04	761.5	6647.23	20968.7	10.321	58.6	
	RodF4_88.4	99	88.4	2.245	-0.1	-0.003	882.56	745.7	6784.62	21402.1	11.022	62.6	
	RodF4_92.4	100	92.4	2.347	3.9	0.099	971.09	794.9	6971.77	21992.4	9.902	56.2	
	RodF4_94.3	101	94.3	2.395	5.8	0.147	1000.58	811.2	7061.04	22274.1	9.625	54.7	
	RodF4_97.2	102	97.2	2.469	8.7	0.221	1037.57	831.8	7198.04	22706.2	9.341	53.0	
	RodF4_108.8	103	108.8	2.764	20.3	0.516	1102.56	867.9	7597.62	23966.7	9.093	51.6	
	RodF4_111	104	111	2.819	-1.75	-0.044	1009.18	816.0	7297.00	23018.4	9.832	55.8	
	RodD2_103.2	65	103.2	2.621	14.7	0.373	1061.34	845.0	6687.93	21097.1	8.419	47.8	
RodD2_106	66	106	2.692	17.5	0.445	1080.30	855.5	6334.26	19981.4	7.788	44.2		
RodD2_112.6	67	112.6	2.860	-0.15	-0.004	1096.67	864.6	5852.55	18461.9	7.054	40.1		
RodD2_114.9	68	114.9	2.918	2.15	0.055	1096.06	864.3	5285.49	16673.1	6.375	36.2		
RodD2_117.4	69	117.4	2.982	4.65	0.118	1081.72	856.3	4745.69	14970.3	5.825	33.1		
RodD2_120.8	70	120.8	3.068	8.05	0.204	1076.74	853.6	7511.44	23694.8	9.276	52.7		
RodD2_124.8	71	124.8	3.170	12.05	0.306	1100.02	866.5	7645.55	24117.9	9.178	52.1		
RodD2_128.6	72	128.6	3.266	15.85	0.403	1019.42	821.7	7014.89	22128.5	9.323	52.9		
Gr-6	RodD6_103.1	129	103.1	2.619	14.6	0.371	1025.07	824.9	7549.83	23815.9	9.959	56.6	
	RodD6_106	130	106	2.692	17.5	0.445	1047.43	837.3	7685.09	24242.6	9.847	55.9	
	RodD6_112.9	131	112.9	2.868	0.15	0.004	957.52	787.3	7008.56	22108.5	10.150	57.6	
	RodD6_114.9	132	114.9	2.918	2.15	0.055	997.62	809.6	6721.19	21202.0	9.199	52.2	
	RodD6_116.8	133	116.8	2.967	4.05	0.103	1018.89	821.4	6447.68	20339.2	8.575	48.7	
	RodD6_120.9	134	120.9	3.071	8.15	0.207	1023.31	823.9	5855.47	18471.1	7.742	44.0	
	RodD6_124.8	135	124.8	3.170	12.05	0.306	1019.77	821.9	5296.97	16709.3	7.037	40.0	
	RodD6_128.7	136	128.7	3.269	15.95	0.405	1010.93	817.0	4737.53	14944.5	6.368	36.2	

Table A-15: Summary of Steam Cooling Heat Transfer Reduced Data for Experiment 4035D, continued

5x5 periphery		H.R.	Channel	Elevation	Elevation	Zgrid	Zgrid	H.R. Tw	H.R. Tw	H.R. q"	H.R. q"	H.R. q"	h _{sat} (z)	h _{sat} (z)
Gr-8	Location	Number	(in)	(m)	(m)	(in)	(m)	(°F)	(K)	(W/m ²)	(Btu/hr-ft ²)	(W/m ²)	(Btu/hr-ft ² -F)	(W/m ² -K)
	RodE2_50.1	73	50.1	1.273	3.1	0.079	793.97	696.5	4974.91	15693.4	4974.91	15693.4	9.441	53.6
	RodE2_54	74	54	1.372	7	0.178	806.13	703.2	5161.04	16280.5	5161.04	16280.5	9.573	54.4
	RodE2_56.9	75	56.9	1.445	9.9	0.251	853.91	729.8	5302.33	16726.2	5302.33	16726.2	9.034	51.3
	RodE2_59.9	76	59.9	1.521	12.9	0.328	885.04	747.1	5443.88	17172.7	5443.88	17172.7	8.808	50.0
	RodE2_66	77	66	1.676	19	0.483	917.96	765.4	5738.87	18103.3	5738.87	18103.3	8.816	50.1
	RodE2_69.8	78	69.8	1.773	-1.08	-0.027	764.52	680.1	5926.21	18694.2	5926.21	18694.2	11.911	67.6
	RodE2_72.9	79	72.9	1.852	2.02	0.051	859.20	732.7	6073.81	19159.8	6073.81	19159.8	10.256	58.2
	RodE2_74.9	80	74.9	1.902	4.02	0.102	898.46	754.5	6169.85	19462.8	6169.85	19462.8	9.771	55.5
Gr-8	RodB3_50.2	169	50.2	1.275	3.2	0.081	750.33	672.2	4944.52	15597.5	4944.52	15597.5	10.230	58.1
	RodB3_54.1	170	54.1	1.374	7.1	0.180	782.33	690.0	5135.51	16200.0	5135.51	16200.0	9.966	56.6
	RodB3_56.9	171	56.9	1.445	9.9	0.251	844.31	724.4	5271.77	16629.8	5271.77	16629.8	9.132	51.9
	RodB3_60.1	172	60.1	1.527	13.1	0.333	858.84	732.5	5404.69	17049.1	5404.69	17049.1	9.132	51.9
	RodB3_66.1	173	66.1	1.679	19.1	0.485	916.90	764.8	5706.49	18001.1	5706.49	18001.1	8.781	49.9
	RodB3_69.9	174	69.9	1.775	-0.98	-0.025	755.83	675.3	5901.21	18615.4	5901.21	18615.4	12.072	68.6
	RodB3_73	175	73	1.854	2.12	0.054	849.01	727.0	6043.74	19065.0	6043.74	19065.0	10.384	59.0
	RodB3_75	176	75	1.905	4.12	0.105	890.55	750.1	6135.47	19354.3	6135.47	19354.3	9.840	55.9
Gr-8	RodF3_50.1	89	50.1	1.273	3.1	0.079	774.93	685.9	4946.26	15603.0	4946.26	15603.0	9.738	55.3
	RodF3_54	90	54	1.372	7	0.178	807.10	703.8	5134.29	16196.1	5134.29	16196.1	9.506	54.0
	RodF3_57	91	57	1.448	10	0.254	867.59	737.4	5277.53	16648.0	5277.53	16648.0	8.787	49.9
	RodF3_60	92	60	1.524	13	0.330	909.57	760.7	5423.20	17107.5	5423.20	17107.5	8.440	47.9
	RodF3_66.1	93	66.1	1.679	19.1	0.485	928.96	771.5	5725.98	18062.6	5725.98	18062.6	8.650	49.1
	RodF3_70	94	70	1.778	-0.88	-0.022	783.78	690.8	5909.53	18641.6	5909.53	18641.6	11.435	64.9
	RodF3_73	95	73	1.854	2.12	0.054	879.55	744.0	6056.27	19104.5	6056.27	19104.5	9.887	56.1
	RodF3_75	96	75	1.905	4.12	0.105	922.67	768.0	6155.48	19417.5	6155.48	19417.5	9.388	53.3
Gr-8	RodE6_50.2	121	50.2	1.275	3.2	0.081	773.64	685.2	4951.36	15619.1	4951.36	15619.1	9.773	55.5
	RodE6_54.1	122	54.1	1.374	7.1	0.180	824.72	713.5	5138.78	16210.3	5138.78	16210.3	9.214	52.3
	RodE6_57	123	57	1.448	10	0.254	852.34	728.9	5280.21	16656.4	5280.21	16656.4	9.021	51.2
	RodE6_60.2	124	60.2	1.529	13.2	0.335	864.05	735.4	5427.49	17121.0	5427.49	17121.0	9.091	51.6
	RodE6_66.1	125	66.1	1.679	19.1	0.485	904.28	757.7	5707.93	18005.7	5707.93	18005.7	8.957	50.9
	RodE6_70	126	70	1.778	-0.88	-0.022	739.61	666.3	5891.81	18585.7	5891.81	18585.7	12.467	70.8
	RodE6_73.1	127	73.1	1.857	2.22	0.056	823.00	712.6	6037.73	19046.0	6037.73	19046.0	10.859	61.7
	RodE6_75	128	75	1.905	4.12	0.105	859.30	732.8	6125.34	19322.4	6125.34	19322.4	10.342	58.7

RBHT Steam Cooling with Droplet Injection Test SCD-4035-E

Matrix Test # Shakedown

Test Conditions

Test Date – 10/4/2005

Steady State Time Window: 21600 - 23100

Upper Plenum Pressure: 2.76 bar (40 psia)

Bundle Power: 70.0 kW

Bundle Inlet Reynolds Number: 6000

Bundle Inlet Steam Flow: 117.6 kg/hr (259 lbm/hr)

Droplet Injection Flow: 0.0076 kg/s (0.0167 lbm/s)

Droplet Injection Hole Diameter: 0.381 mm (.015 in)

Droplet Injection Elevation: 1.295 m (51 in)

Bundle Flow Area: $4.656 \times 10^{-3} \text{ m}^2$ ($5.012 \times 10^{-2} \text{ ft}^2$)

Test Notes

- No steam probes were traversed in this steady state window.

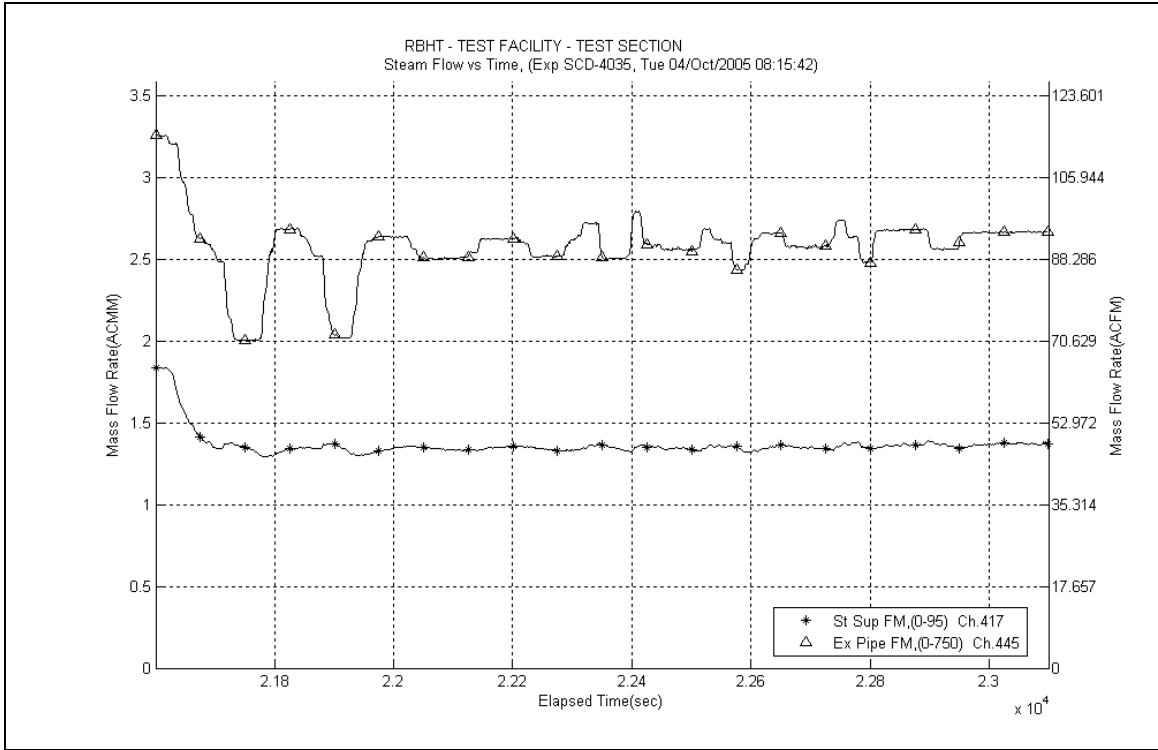

Figure A-272: Inlet and Exhaust Steam Flow Rates for Experiment 4035E

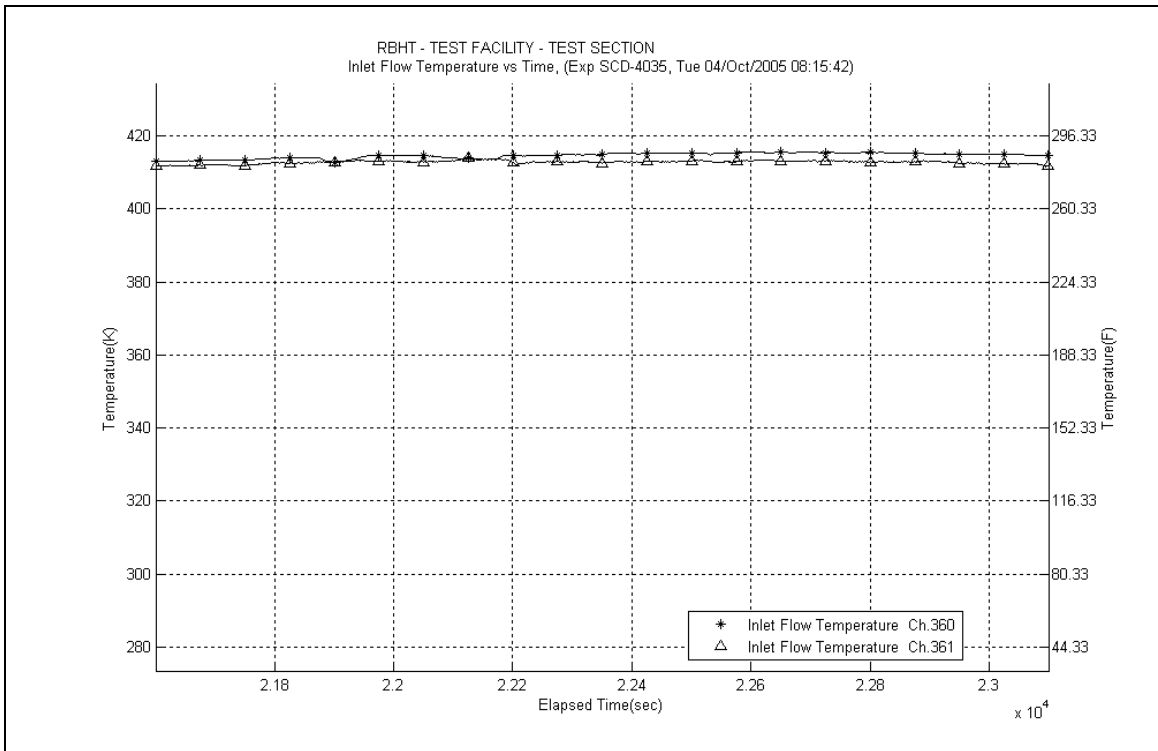

Figure A-273: Inlet Steam Temperature for Experiment 4035E

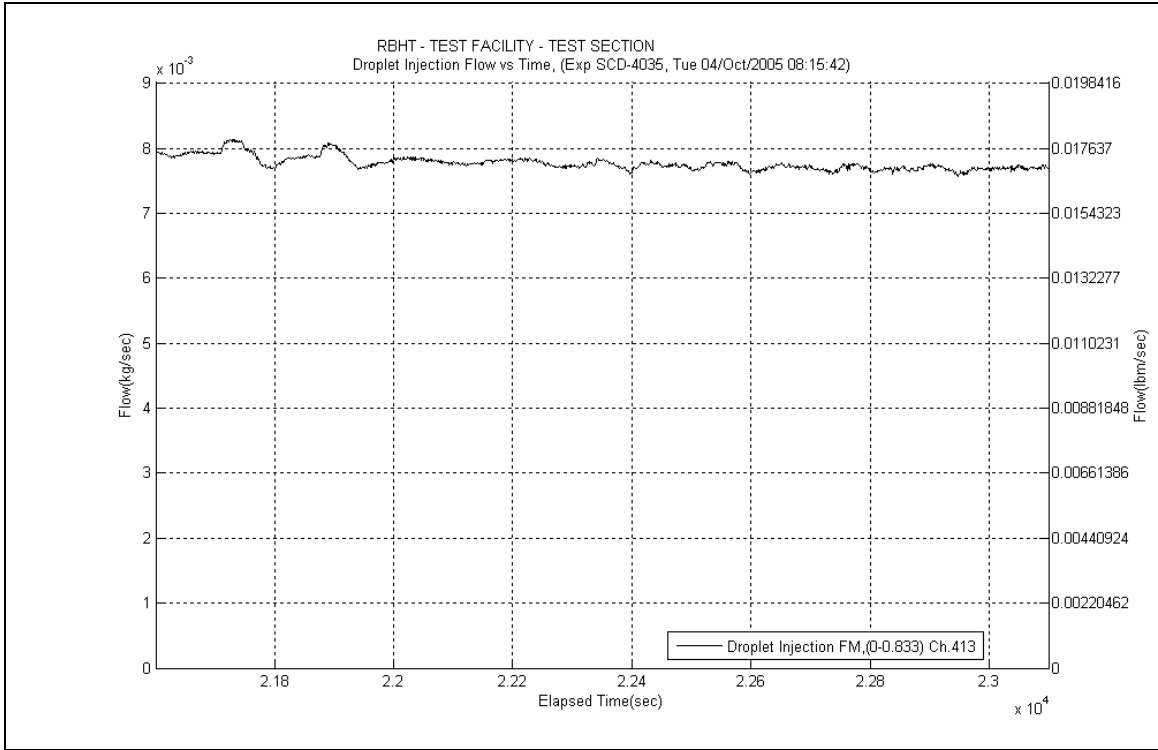

Figure A-274: Droplet Injection Flow Rate for Experiment 4035E

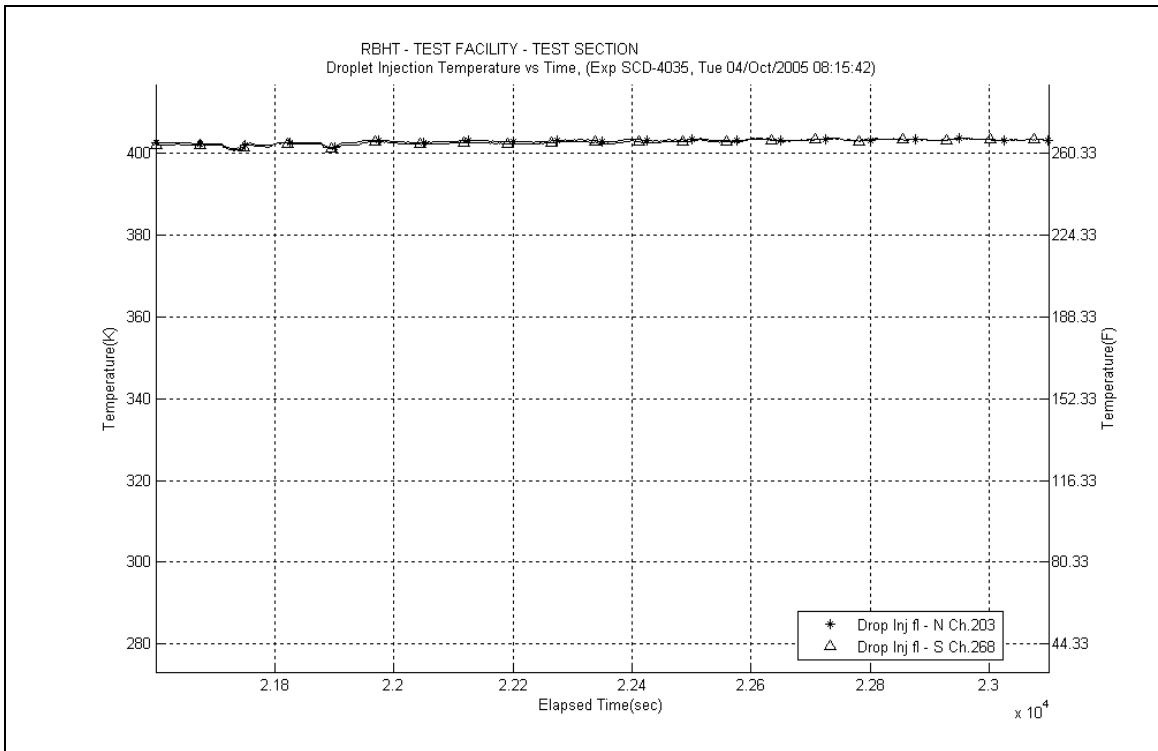

Figure A-275: Droplet Injection Temperature for Experiment 4035E

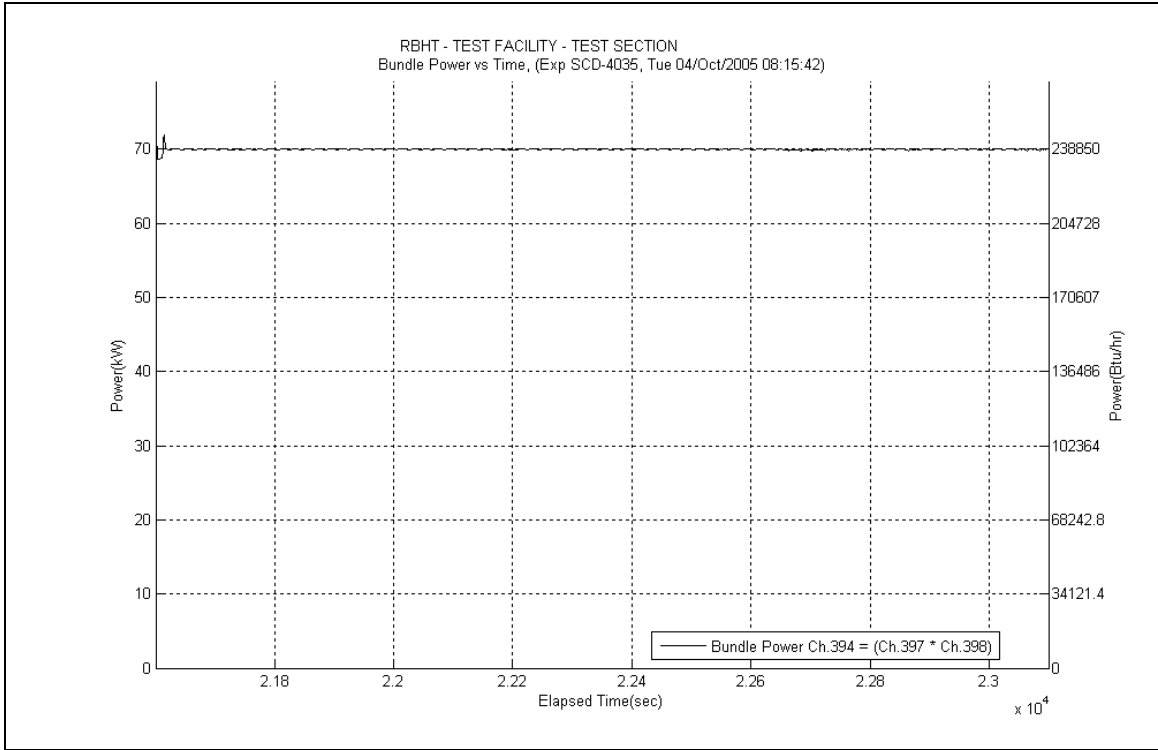

Figure A-276: Bundle Power for Experiment 4035E

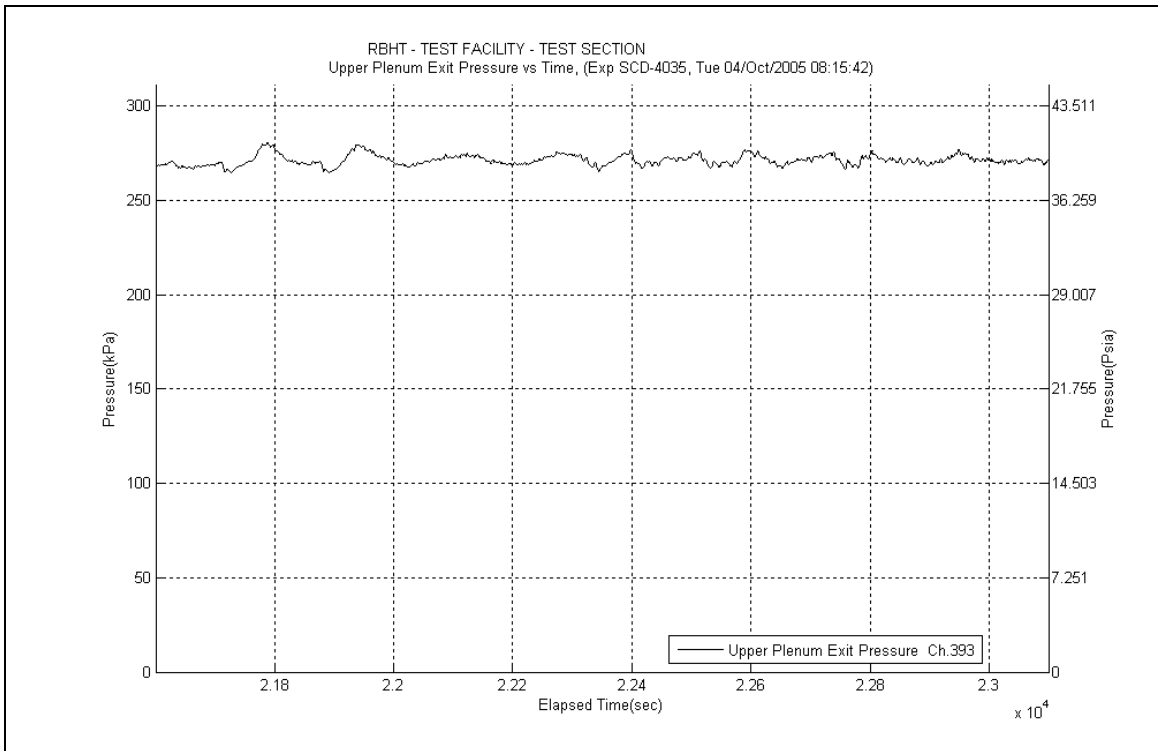

Figure A-277: Upper Plenum Pressure for Experiment 4035E

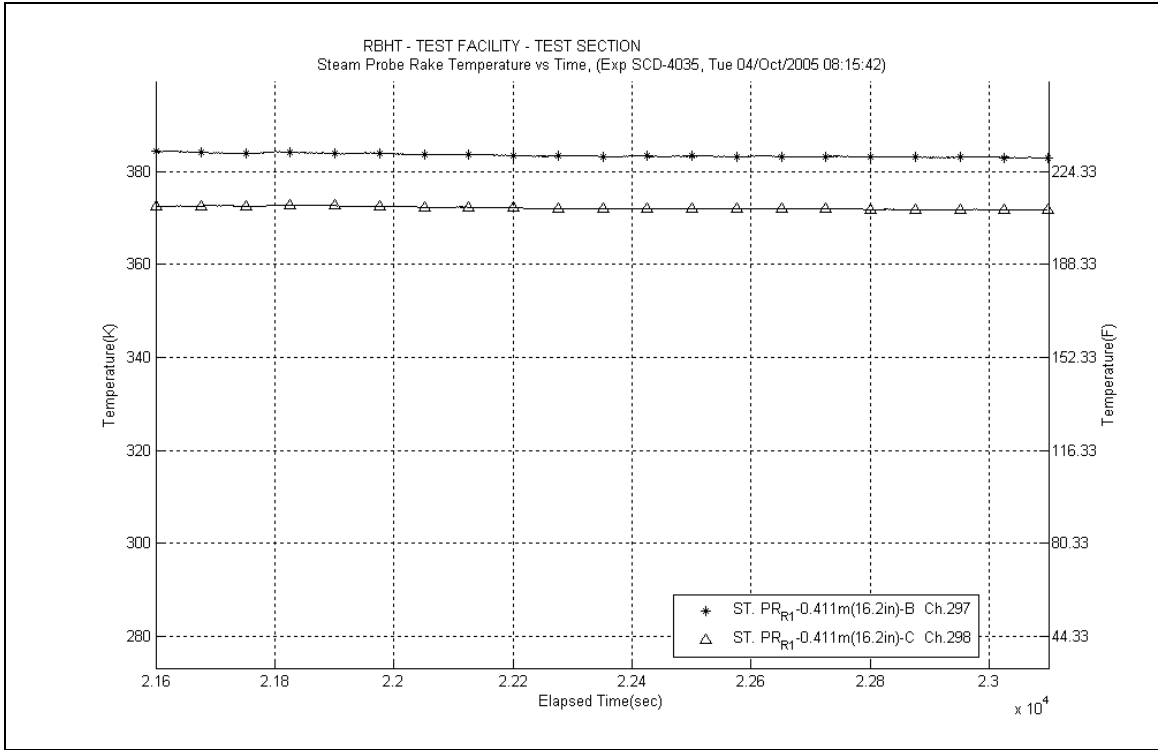

Figure A-278: Steam Probe Rake #1 Temperatures for Experiment 4035E

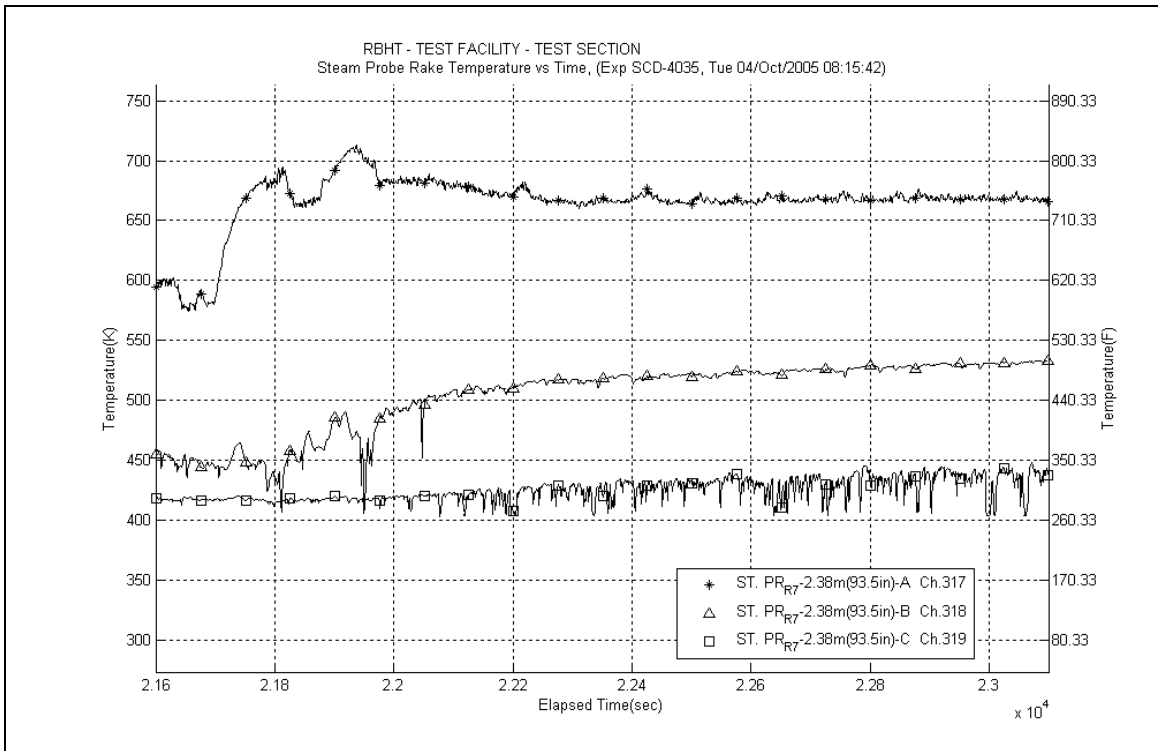

Figure A-279: Steam Probe Rake #7 Temperatures for Experiment 4035E

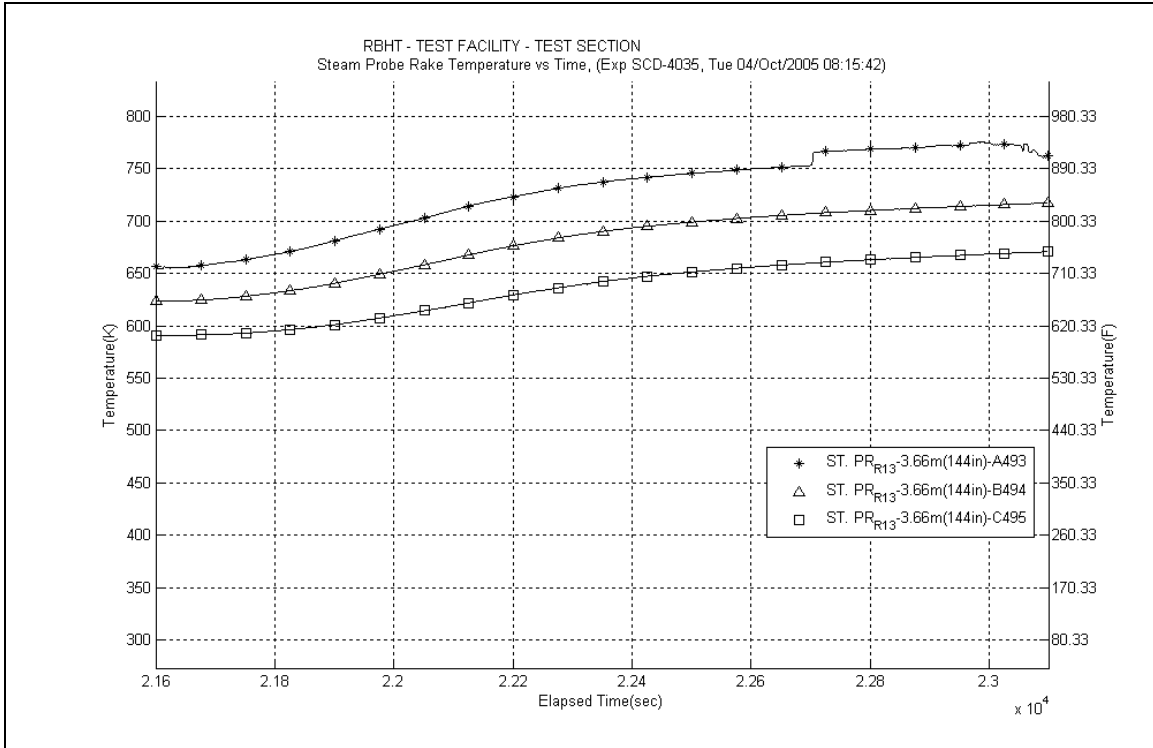

Figure A-280: Steam Probe Rake #13 Temperatures for Experiment 4035E

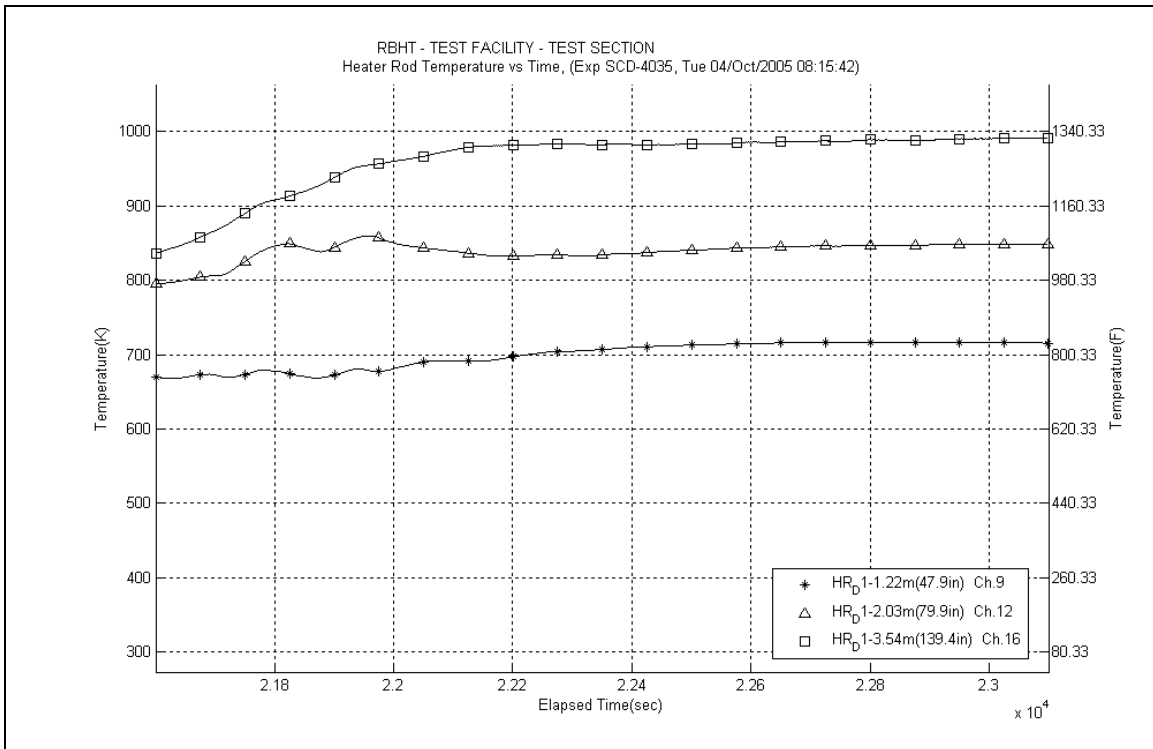

Figure A-281: Heater Rod D1 Temperatures for Experiment 4035E

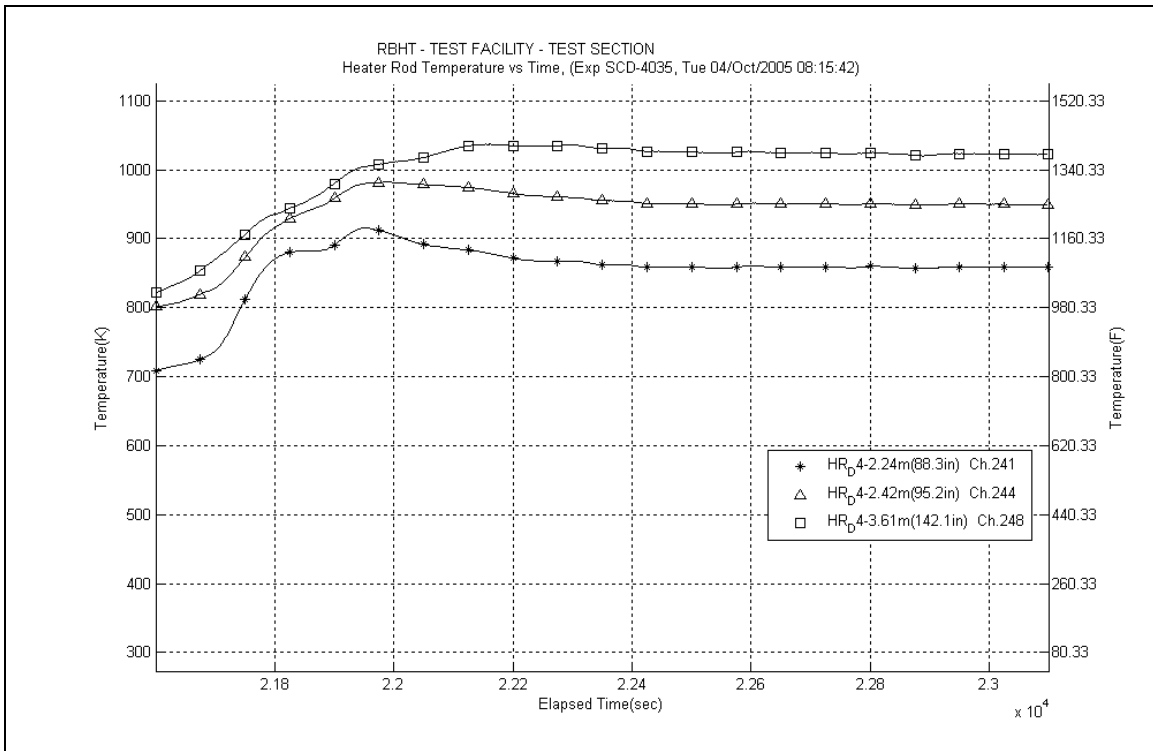

Figure A-282: Heater Rod D4 Temperatures for Experiment 4035E

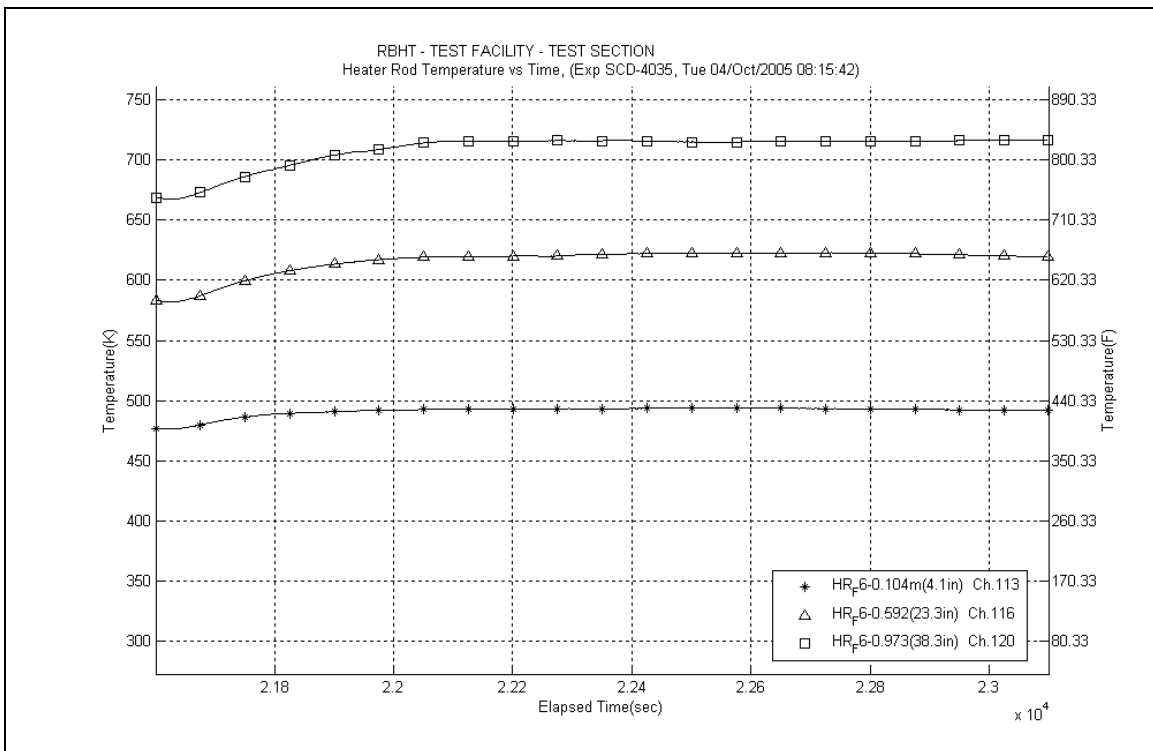

Figure A-283: Heater Rod F6 Temperatures for Experiment 4035E

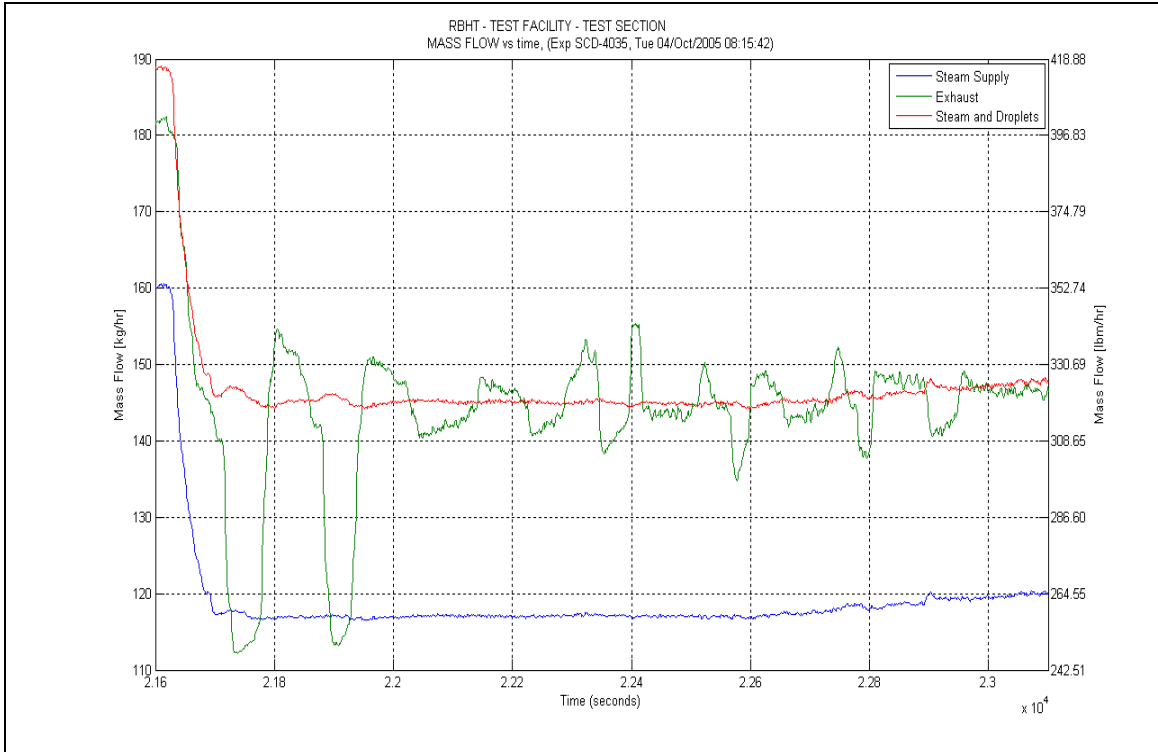

Figure A-284: Mass Flow for Experiment 4035E

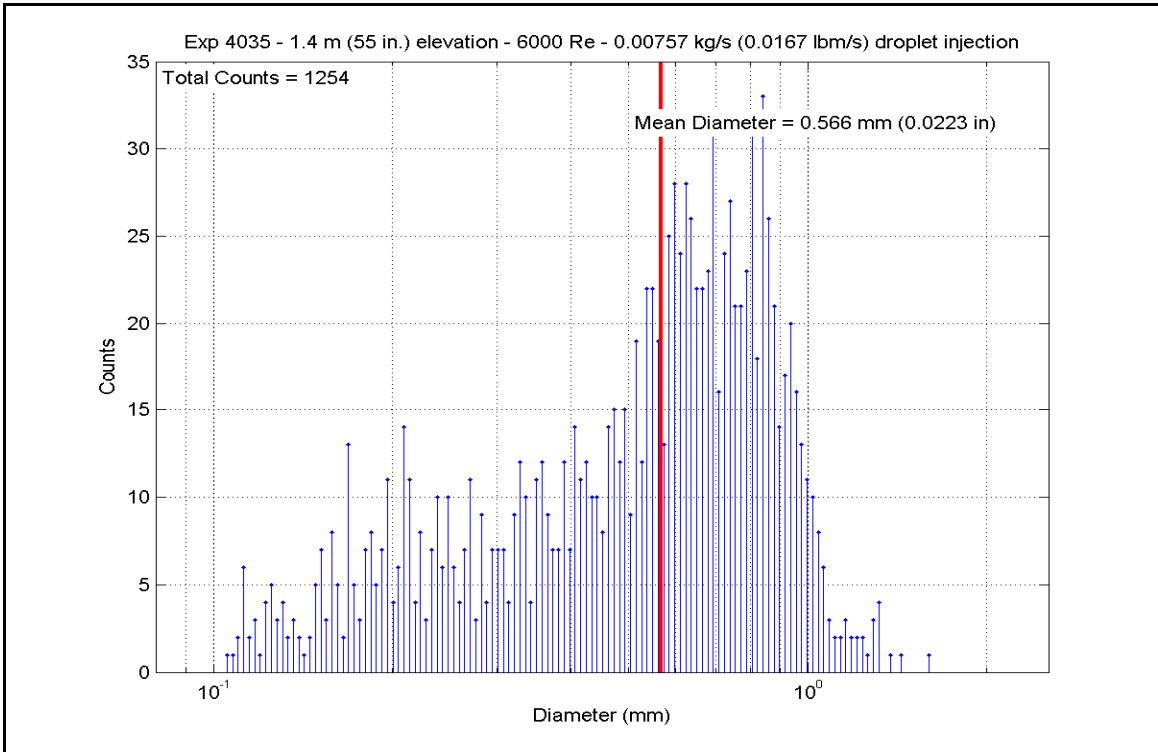

Figure A-285: Droplet Measurements at 1.397 m (55 in.) Elevation for Experiment 4035E

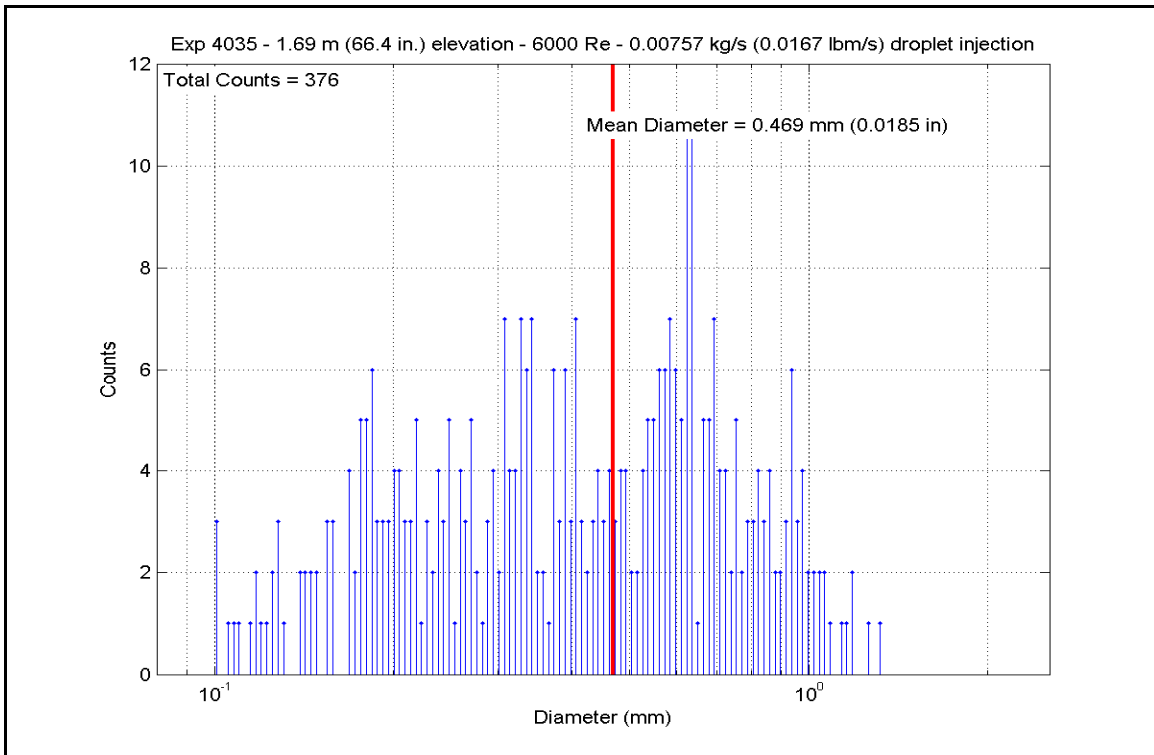

Figure A-286: Droplet Measurements at 1.687 m (66.4 in.) Elevation for Experiment 4035E

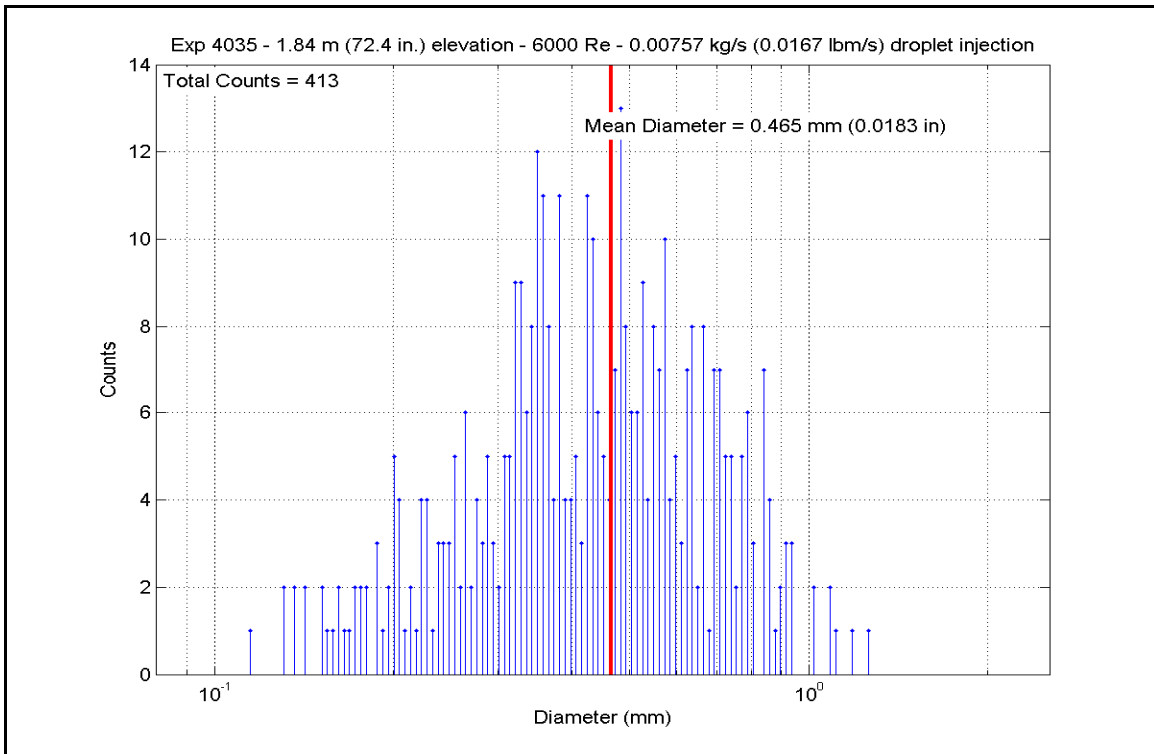

Figure A-287: Droplet Measurements at 1.839 m (72.4 in.) Elevation for Experiment 4035E

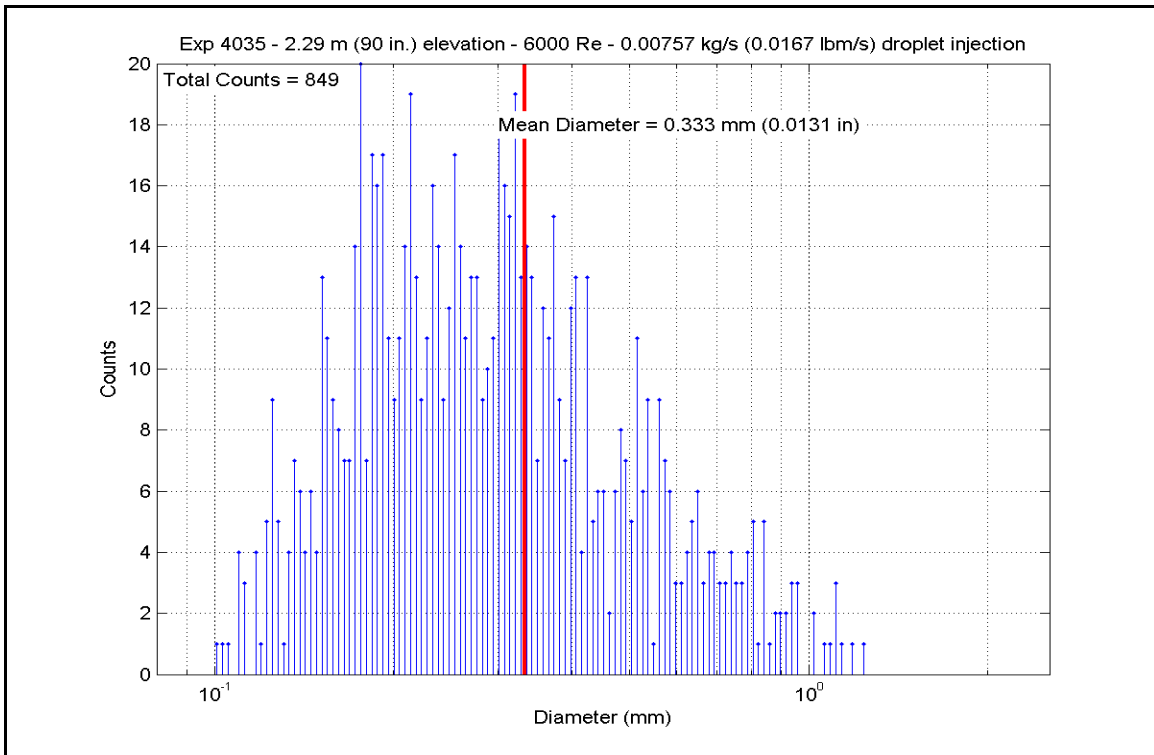

Figure A-288: Droplet Measurements at 2.286 m (90 in.) Elevation for Experiment 4035E

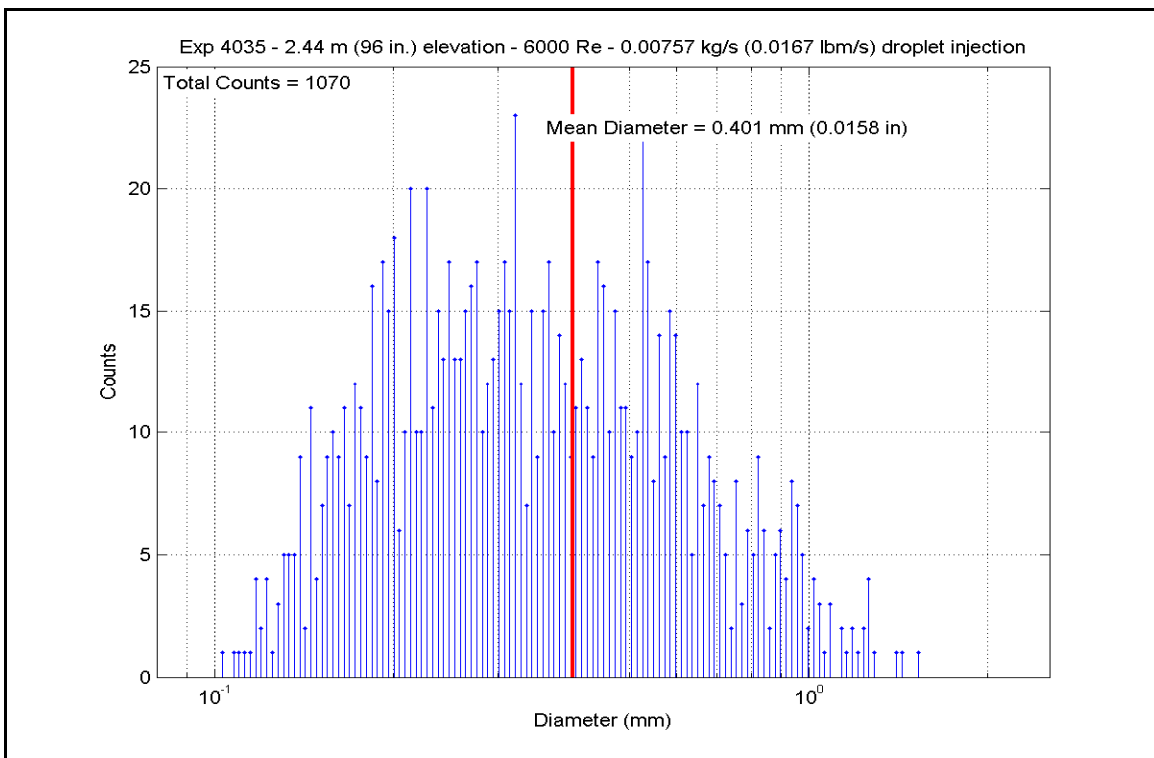

Figure A-289: Droplet Measurements at 2.438 m (96 in.) Elevation for Experiment 4035E

Table A-16: Summary of Steam Cooling Heat Transfer Reduced Data for Experiment 4035E

SCD-4035-E		Inlet Reynolds:		6000		UP Pressure:		40 psia					
Matrix Test		shakedown		275.8 kPa		Bundle Power:		238850 Btu/hr					
Time Window: 21600-23100				70.00 kW		Steam flow:		259.0 lbm/hr					
Inner 3x3				0.0326 kg/s		Dropletflow:		0.017 lbm/s					
H.R. ID	H.R. Location	Channel Number	Elevation (in)	Elevation (m)	Zgrid (in)	Zgrid (m)	H.R. Tw (°F)	H.R. Tw (K)	H.R. q" (Btu/hr-ft2)	H.R. q" (W/m2)	h _{sat} (z) (Btu/hr-ft2-F)	h _{sat} (z) (W/m2-K)	
Gr-3	RodD3_88.3	185	88.3	2.243	-0.2	-0.005	918.12	765.4	6853.55	21619.5	10.526	59.8	
	RodD3_91.3	186	91.3	2.319	2.8	0.071	1014.24	818.8	7027.85	22169.3	9.405	53.4	
	RodD3_93.1	187	93.1	2.365	4.6	0.117	1053.99	840.9	7116.93	22450.3	9.043	51.4	
	RodD3_95.3	188	95.3	2.421	6.8	0.173	1088.42	860.1	7222.61	22783.7	8.793	49.9	
	RodD3_100.1	189	100.1	2.543	11.6	0.295	1126.62	881.3	7474.93	23579.7	8.696	49.4	
	RodD3_106.1	190	106.1	2.695	17.6	0.447	1207.10	926.0	7775.23	24527.0	8.271	47.0	
	RodD3_110	191	110	2.794	27.94	0.546	1135.91	886.4	7655.27	24148.5	8.810	50.0	
	RodD3_142.1	192	142.1	3.609	3.609	8.6	1140.03	888.7	2508.51	7913.1	2.873	16.3	
	Gr-3	RodC4_88.4	233	88.4	2.245	-0.1	-0.003	918.76	765.8	7054.58	22253.7	10.824	61.5
	RodC4_91.1	234	91.1	2.314	2.6	0.066	1006.21	814.4	7177.74	22642.2	9.710	55.1	
	RodC4_93.4	235	93.4	2.372	4.9	0.124	1047.35	837.2	7283.36	22975.4	9.333	53.0	
	RodC4_95.3	236	95.3	2.421	6.8	0.173	1079.42	855.1	7372.01	23255.0	9.074	51.5	
	RodC4_100.1	237	100.1	2.543	11.6	0.295	1110.58	872.4	7586.74	23932.4	8.994	51.1	
	RodC4_106.1	238	106.1	2.695	17.6	0.447	1184.71	913.5	7892.61	24897.2	8.600	48.8	
	RodC4_110	239	110	2.794	21.5	0.546	1110.56	872.4	7613.46	24016.7	9.025	51.3	
	RodC4_142.2	240	142.2	3.612	8.7	0.221	1118.90	877.0	2817.04	8886.4	3.307	18.8	
Gr-3	RodD4_88.3	241	88.3	2.243	-0.2	-0.005	913.94	763.1	7015.83	22131.4	10.845	61.6	
	RodD4_91.3	242	91.3	2.319	2.8	0.071	1006.64	814.6	7149.20	22552.2	9.666	54.9	
	RodD4_93.2	243	93.2	2.367	4.7	0.119	1044.52	835.7	7235.16	22823.3	9.305	52.8	
	RodD4_95.2	244	95.2	2.418	6.7	0.170	1074.82	852.5	7327.66	23115.1	9.071	51.5	
	RodD4_100.1	245	100.1	2.543	11.6	0.295	1121.68	878.5	7545.07	23800.9	8.828	50.1	
	RodD4_106.1	246	106.1	2.695	17.6	0.447	1191.21	917.2	7842.45	24739.0	8.486	48.2	
	RodD4_142.1	248	142.1	3.609	3.609	8.6	1121.03	878.2	2703.39	8527.8	3.165	18.0	
	Gr-3	RodE4_88.4	201	88.4	2.245	-0.1	-0.003	928.27	771.1	6790.50	21420.6	10.269	58.3
		RodE4_91.2	202	91.2	2.316	2.7	0.069	1019.67	821.9	6949.89	21923.4	9.234	52.4
	RodE4_95.3	204	95.3	2.421	6.8	0.173	1093.77	863.0	7144.40	22537.0	8.641	49.1	
	RodE4_100.9	205	100.9	2.563	12.4	0.315	1153.69	896.3	7436.07	23457.1	8.386	47.6	
	RodE4_142.3	208	142.3	3.614	8.8	0.224	1133.65	885.2	2649.99	8359.4	3.058	17.4	

Table A-16: Summary of Steam Cooling Heat Transfer Reduced Data for Experiment 4035E, continued

Inner 3x3	H.I.R. Location	Channel Number	Elevation (in)	Elevation (m)	Zgrid (in)	Zgrid (m)	H.R. Tw (°F)	H.R. Tw (K)	H.R. q" (Btu/hr-ft ²)	H.R. q" (W/m ²)	h _{sat} (z) (Btu/hr-ft ² -F)	h _{sat} (z) (W/m ² -K)
Gr-4	RodE3_63.4	193	63.4	1.610	16.4	0.417	977.22	798.3	5672.57	17894.1	7.987	45.4
	RodE3_113.6	194	113.6	2.885	0.85	0.022	1170.35	905.6	6958.97	21952.1	7.704	43.7
	RodE3_115.5	195	115.5	2.934	2.75	0.070	1198.63	921.3	6655.87	20995.9	7.144	40.6
	RodE3_118.5	196	118.5	3.010	5.75	0.146	1221.91	934.2	6233.82	19664.6	6.528	37.1
	RodE3_122.7	197	122.7	3.117	9.95	0.253	1230.34	938.9	5635.12	17776.0	5.850	33.2
	RodE3_126.5	198	126.5	3.213	13.75	0.349	1224.39	935.6	5105.85	16106.4	5.333	30.3
	RodE3_131.7	199	131.7	3.345	-1.8	-0.046	1137.64	887.4	4324.80	13642.6	4.967	28.2
RodE3_135.6	200	135.6	3.444	2.1	0.053	1158.80	899.2	3831.01	12084.9	4.296	24.4	
Gr-4	RodC5_63.7	225	63.7	1.618	16.7	0.424	965.89	792.0	5649.75	17822.1	8.084	45.9
	RodC5_113.6	226	113.6	2.885	0.85	0.022	1113.22	873.8	6805.55	21468.1	8.042	45.7
	RodC5_115.7	227	115.7	2.939	2.95	0.075	1149.15	893.8	6573.73	20736.8	7.452	42.3
	RodC5_122.7	229	122.7	3.117	9.95	0.253	1175.13	908.2	5631.33	17764.0	6.201	35.2
	RodC5_126.7	230	126.7	3.218	13.95	0.354	1169.33	905.0	5101.64	16093.1	5.654	32.1
	RodC5_131.6	231	131.6	3.343	-1.9	-0.048	1074.95	852.6	4476.36	14120.7	5.540	31.5
	RodC5_135.7	232	135.7	3.447	2.2	0.056	1098.14	865.4	3916.22	12353.7	4.712	26.8
Gr-4	RodE5_63.6	209	63.6	1.615	16.6	0.422	960.82	789.2	5732.38	18082.8	8.262	46.9
	RodE5_113.6	210	113.6	2.885	0.85	0.022	1128.30	882.2	6980.89	22021.2	8.105	46.0
	RodE5_115.4	211	115.4	2.931	2.65	0.067	1153.33	896.1	6772.14	21362.7	7.641	43.4
	RodE5_118.7	212	118.7	3.015	5.95	0.151	1172.90	907.0	6315.19	19921.3	6.971	39.6
	RodE5_122.6	213	122.6	3.114	9.85	0.250	1182.79	912.5	5771.70	18206.8	6.302	35.8
	RodE5_126.6	214	126.6	3.216	13.85	0.352	1179.31	910.5	5222.48	16474.3	5.724	32.5
	RodE5_131.6	215	131.6	3.343	-1.9	-0.048	1089.86	860.9	4557.40	14376.3	5.538	31.5
RodE5_135.6	216	135.6	3.444	2.1	0.053	1112.15	873.2	3998.94	12614.7	4.732	26.9	
Gr-5	RodC3_79.8	177	79.8	2.027	8.92	0.227	1007.34	815.0	6465.37	20395.0	8.733	49.6
	RodC3_85.6	178	85.6	2.174	14.72	0.374	920.88	767.0	6650.51	20979.0	10.171	57.8
	RodC3_88.5	179	88.5	2.248	0	0.000	920.27	766.6	6837.60	21569.2	10.467	59.4
	RodC3_92.4	180	92.4	2.347	3.9	0.099	1029.65	827.4	7051.16	22242.9	9.246	52.5
	RodC3_94.4	181	94.4	2.398	5.9	0.150	1064.13	846.6	7150.92	22557.6	8.971	50.9
	RodC3_97.2	182	97.2	2.469	8.7	0.221	1108.35	871.1	7314.84	23074.7	8.694	49.4
	RodC3_108.8	183	108.8	2.764	20.3	0.516	1192.73	918.0	7707.82	24314.3	8.326	47.3
Gr-8	RodD5_50	217	50	1.270	3	0.076	813.16	707.1	5088.00	16050.1	9.316	52.9
	RodD5_54.1	218	54.1	1.374	7.1	0.180	820.93	711.4	5300.04	16719.0	9.568	54.3
	RodD5_56.9	219	56.9	1.445	9.9	0.251	888.82	749.2	5434.94	17144.5	8.740	49.6
	RodD5_60	220	60	1.524	13	0.330	936.26	775.5	5587.13	17624.6	8.348	47.4
	RodD5_66.1	221	66.1	1.679	19.1	0.485	976.67	798.0	5876.33	18536.9	8.280	47.0
	RodD5_69.9	222	69.9	1.775	-0.98	-0.025	803.18	701.6	6068.71	19143.8	11.318	64.3
	RodD5_72.9	223	72.9	1.852	2.02	0.051	894.26	752.2	6210.14	19589.9	9.900	56.2
RodD5_74.9	224	74.9	1.902	4.02	0.102	941.06	778.2	6303.54	19884.5	9.352	53.1	

Table A-16: Summary of Steam Cooling Heat Transfer Reduced Data for Experiment 4035E, continued

H.R. ID	H.R. Location	Channel Number	Elevation (in)	Elevation (m)	Zgrid (in)	Zgrid (m)	H.R. Tw (°F)	H.R. Tw (K)	H.R. q" (Btu/hr-ft ²)	H.R. q" (W/m ²)	h _{sat} (z) (Btu/hr-ft ² -F)	h _{sat} (z) (W/m ² -K)	
5x5 periphery Gr-2	RodB5_41	153	41	1.041	13.5	0.343	757.06	676.0	4630.80	14607.9	9.449	53.7	
	RodB5_52.9	154	52.9	1.344	5.9	0.150	787.81	693.0	5190.62	16373.8	9.966	56.6	
	RodB5_55	155	55	1.397	8	0.203	840.63	722.4	5305.33	16735.7	9.249	52.5	
	RodB5_57.8	156	57.8	1.468	10.8	0.274	903.76	757.5	5446.93	17182.3	8.554	48.6	
	RodB5_64	157	64	1.626	17	0.432	969.84	794.2	5761.90	18175.9	8.198	46.6	
	RodB5_73.9	158	73.9	1.877	3.02	0.077	937.61	776.3	6227.03	19643.2	9.286	52.7	
	RodB5_75.9	159	75.9	1.928	5.02	0.128	974.09	796.5	6325.92	19955.1	8.946	50.8	
	RodB5_76.9	160	76.9	1.953	6.02	0.153	988.30	804.4	6373.50	20105.2	8.836	50.2	
	Gr-2	RodF5_41	105	41	1.041	13.5	0.343	752.59	673.5	4590.41	14480.4	9.453	53.7
	RodF5_53.1	106	53.1	1.349	1.349	6.1	0.155	786.74	692.5	5180.18	16340.9	9.967	56.6
RodF5_55	107	55	1.397	1.397	8	0.203	829.77	716.4	5276.49	16644.7	9.376	53.2	
RodF5_57.8	108	57.8	1.468	1.468	10.8	0.274	886.68	748.0	5414.05	17078.6	8.737	49.6	
RodF5_64	109	64	1.626	1.626	17	0.432	944.46	780.1	5713.02	18021.7	8.433	47.9	
RodF5_73.8	110	73.8	1.875	1.875	2.92	0.074	911.89	762.0	6186.00	19513.7	9.592	54.5	
RodF5_75.8	111	75.8	1.925	1.925	4.92	0.125	949.93	783.1	6282.81	19819.1	9.200	52.2	
RodF5_76.8	112	76.8	1.951	1.951	5.92	0.150	964.92	791.4	6330.75	19970.4	9.071	51.5	
Gr-2	RodC2_41	57	41	1.041	13.5	0.343	753.08	673.8	4615.82	14560.6	9.496	53.9	
RodC2_53.1	58	53.1	1.349	1.349	6.1	0.155	821.83	711.9	5218.77	16462.6	9.406	53.4	
RodC2_55	59	55	1.397	1.397	8	0.203	851.47	728.4	5308.19	16744.7	9.082	51.6	
RodC2_57.8	60	57.8	1.468	1.468	10.8	0.274	884.61	746.8	5443.29	17170.9	8.814	50.1	
RodC2_63.9	61	63.9	1.623	1.623	16.9	0.429	934.79	774.7	5755.16	18154.6	8.618	48.9	
RodC2_73.8	62	73.8	1.875	1.875	2.92	0.074	918.98	765.9	6243.75	19695.9	9.577	54.4	
RodC2_75.8	63	75.8	1.925	1.925	4.92	0.125	953.46	785.1	6322.36	19943.9	9.210	52.3	
RodC2_76.8	64	76.8	1.951	1.951	5.92	0.150	967.33	792.8	6369.49	20092.5	9.095	51.6	
Gr-2	RodC6_40.9	137	40.9	1.039	13.4	0.340	759.38	677.3	4607.63	14534.8	9.358	53.1	
RodC6_52.8	138	52.8	1.341	1.341	5.8	0.147	838.21	721.0	5215.92	16453.6	9.131	51.9	
RodC6_54.8	139	54.8	1.392	1.392	7.8	0.198	868.40	737.8	5320.45	16783.4	8.847	50.2	
RodC6_57.8	140	57.8	1.468	1.468	10.8	0.274	899.07	754.9	5452.99	17201.5	8.627	49.0	
RodC6_63.8	141	63.8	1.621	1.621	16.8	0.427	944.38	780.0	5764.98	18185.6	8.511	48.3	
RodC6_73.7	142	73.7	1.872	1.872	2.82	0.072	914.81	763.6	6238.90	19680.6	9.631	54.7	
RodC6_75.8	143	75.8	1.925	1.925	4.92	0.125	944.08	779.9	6346.51	20020.1	9.373	53.2	
RodC6_76.8	144	76.8	1.951	1.951	5.92	0.150	961.39	789.5	6397.65	20181.4	9.213	52.3	

Table A-16: Summary of Steam Cooling Heat Transfer Reduced Data for Experiment 4035E, continued

5x5 periphery		H.R. Location	Channel Number	Elevation (in)	Elevation (m)	Zgrid (in)	Zgrid (m)	H.R. Tw (°F)	H.R. Tw (K)	H.R. q" (Btu/hr-ft ²)	H.R. q" (W/m ²)	h _{sat} (Z) (Btu/hr-ft ² -F)	h _{sat} (Z) (W/m ² -K)
Gr-3	RodB4_88.4	161	88.4	2.245	-0.1	-0.003	921.18	767.1	6828.05	21539.1	10.438	59.3	
	RodB4_91.3	162	91.3	2.319	2.8	0.071	1011.02	817.0	6984.04	22031.2	9.387	53.3	
	RodB4_93.3	163	93.3	2.370	4.8	0.122	1050.01	838.7	7080.12	22334.2	9.042	51.3	
	RodB4_95.1	164	95.1	2.416	6.6	0.168	1078.55	854.6	7163.52	22597.3	8.827	50.1	
	RodB4_100	165	100	2.540	11.5	0.292	1107.37	870.6	7413.65	23386.4	8.822	50.1	
	RodB4_106	166	106	2.692	17.5	0.445	1177.97	909.8	7712.11	24327.8	8.466	48.1	
	RodB4_109.9	167	109.9	2.791	21.4	0.544	1101.94	867.6	7447.17	23492.1	8.919	50.7	
	RodB4_142.3	168	142.3	3.614	8.8	0.224	1106.94	870.3	2741.07	8646.7	3.263	18.5	
Gr-5	RodF4_85.6	98	85.6	2.174	14.72	0.374	989.31	805.0	6781.22	21391.4	9.388	53.3	
	RodF4_88.4	99	88.4	2.245	-0.1	-0.003	976.87	798.1	6916.10	21816.9	9.743	55.3	
	RodF4_92.4	100	92.4	2.347	3.9	0.099	1067.10	848.2	7103.08	22406.7	8.878	50.4	
	RodF4_94.3	101	94.3	2.395	5.8	0.147	1097.10	864.9	7192.63	22689.1	8.665	49.2	
	RodF4_97.2	102	97.2	2.469	8.7	0.221	1135.37	886.1	7321.18	23094.7	8.431	47.9	
	RodF4_108.8	103	108.8	2.764	20.3	0.516	1201.16	922.7	7732.23	24391.3	8.277	47.0	
	RodF4_111	104	111	2.819	-1.75	-0.044	1117.75	876.3	7378.17	23274.5	8.673	49.3	
	RodD2_103.2	65	103.2	2.621	14.7	0.373	1171.62	906.3	6802.34	21458.0	7.520	42.7	
Gr-6	RodD2_106	66	106	2.692	17.5	0.445	1191.17	917.1	6431.57	20288.4	6.959	39.5	
	RodD2_112.6	67	112.6	2.860	-0.15	-0.004	1211.17	928.2	5920.28	18675.5	6.270	35.6	
	RodD2_114.9	68	114.9	2.918	2.15	0.055	1213.46	929.5	5325.11	16798.1	5.626	32.0	
	RodD2_117.4	69	117.4	2.982	4.65	0.118	1202.29	923.3	4767.15	15038.0	5.097	28.9	
	RodD2_120.8	70	120.8	3.068	8.05	0.204	1179.40	910.6	7657.09	24154.3	8.392	47.7	
	RodD2_124.8	71	124.8	3.170	12.05	0.306	1201.04	922.6	7799.10	24602.3	8.350	47.4	
	RodD2_128.6	72	128.6	3.266	15.85	0.403	1128.69	882.4	7132.18	22498.5	8.277	47.0	
	RodD6_103.1	129	103.1	2.619	14.6	0.371	1138.46	887.8	7642.73	24109.0	8.770	49.8	
Gr-6	RodD6_106	130	106	2.692	17.5	0.445	1158.73	899.1	7788.44	24568.6	8.734	49.6	
	RodD6_112.9	131	112.9	2.868	0.15	0.004	1083.85	857.5	7074.26	22315.7	8.660	49.2	
	RodD6_114.9	132	114.9	2.918	2.15	0.055	1120.79	878.0	6797.23	21441.9	7.961	45.2	
	RodD6_116.8	133	116.8	2.967	4.05	0.103	1140.32	888.9	6519.41	20565.5	7.465	42.4	
	RodD6_120.9	134	120.9	3.071	8.15	0.207	1150.44	894.5	5863.86	18497.6	6.638	37.7	
	RodD6_124.8	135	124.8	3.170	12.05	0.306	1149.56	894.0	5285.31	16672.5	5.989	34.0	
	RodD6_128.7	136	128.7	3.269	15.95	0.405	1142.16	889.9	4711.67	14863.0	5.384	30.6	

Table A-16: Summary of Steam Cooling Heat Transfer Reduced Data for Experiment 4035E, continued

5x5 Periphery		H.R.	Channel	Elevation	Elevation	Zgrid	Zgrid	H.R. Tw	H.R. Tw	H.R. q"	H.R. q"	H.R. q"	h _{sat} (z)	h _{sat} (z)
Gr-8	Location	Number	(in)	(m)	(m)	(in)	(m)	(°F)	(K)	(W/m ²)	(Btu/hr-ft ²)	(W/m ²)	(Btu/hr-ft ² -F)	(W/m ² -K)
	RodE2_50.1	73	50.1	1.273	3.1	0.079	813.69	707.4	5101.42	16092.4	9.331	53.0		
	RodE2_54	74	54	1.372	7	0.178	833.82	718.6	5288.74	16683.3	9.330	53.0		
	RodE2_56.9	75	56.9	1.445	9.9	0.251	885.56	747.4	5426.98	17119.4	8.774	49.8		
	RodE2_59.9	76	59.9	1.521	12.9	0.328	921.27	767.2	5571.34	17574.8	8.515	48.4		
	RodE2_66	77	66	1.676	19	0.483	960.34	788.9	5873.56	18528.2	8.471	48.1		
	RodE2_69.8	78	69.8	1.773	-1.08	-0.027	834.24	718.8	6039.06	19050.2	10.646	60.5		
	RodE2_72.9	79	72.9	1.852	2.02	0.051	922.96	768.1	6209.01	19586.3	9.466	53.8		
	RodE2_74.9	80	74.9	1.902	4.02	0.102	960.69	789.1	6311.72	19910.3	9.099	51.7		
Gr-8	RodB3_50.2	169	50.2	1.275	3.2	0.081	772.98	684.8	5079.23	16022.4	10.038	57.0		
	RodB3_54.1	170	54.1	1.374	7.1	0.180	804.77	702.5	5261.40	16597.1	9.784	55.6		
	RodB3_56.9	171	56.9	1.445	9.9	0.251	869.79	738.6	5398.03	17028.1	8.955	50.9		
	RodB3_60.1	172	60.1	1.527	13.1	0.333	892.55	751.2	5574.72	17585.4	8.912	50.6		
	RodB3_66.1	173	66.1	1.679	19.1	0.485	953.85	785.3	5866.04	18504.4	8.540	48.5		
	RodB3_69.9	174	69.9	1.775	-0.98	-0.025	806.02	703.2	5984.06	18876.7	11.102	63.0		
	RodB3_73	175	73	1.854	2.12	0.054	902.50	756.8	6167.65	19455.8	9.705	55.1		
	RodB3_75	176	75	1.905	4.12	0.105	946.17	781.0	6265.79	19765.4	9.226	52.4		
Gr-8	RodF3_50.1	89	50.1	1.273	3.1	0.079	797.23	698.3	5074.82	16008.5	9.571	54.4		
	RodF3_54	90	54	1.372	7	0.178	830.24	716.6	5272.96	16633.5	9.362	53.2		
	RodF3_57	91	57	1.448	10	0.254	897.28	753.9	5420.24	17098.1	8.600	48.8		
	RodF3_60	92	60	1.524	13	0.330	943.86	779.7	5567.22	17561.8	8.225	46.7		
	RodF3_66.1	93	66.1	1.679	19.1	0.485	969.33	793.9	5869.74	18516.1	8.358	47.5		
	RodF3_70	94	70	1.778	-0.88	-0.022	847.94	726.5	6074.41	19161.7	10.456	59.4		
	RodF3_73	95	73	1.854	2.12	0.054	942.03	778.7	6222.62	19629.3	9.218	52.3		
	RodF3_75	96	75	1.905	4.12	0.105	984.79	802.5	6317.26	19927.8	8.801	50.0		
Gr-8	RodE6_50.2	121	50.2	1.275	3.2	0.081	793.60	696.3	5069.17	15990.7	9.626	54.7		
	RodE6_54.1	122	54.1	1.374	7.1	0.180	843.64	724.1	5258.85	16589.0	9.120	51.8		
	RodE6_57	123	57	1.448	10	0.254	875.38	741.7	5392.32	17010.1	8.863	50.3		
	RodE6_60.2	124	60.2	1.529	13.2	0.335	895.83	753.1	5537.21	17467.1	8.806	50.0		
	RodE6_66.1	125	66.1	1.679	19.1	0.485	941.61	778.5	5827.52	18382.9	8.638	49.1		
	RodE6_70	126	70	1.778	-0.88	-0.022	807.39	703.9	6004.17	18940.1	11.111	63.1		
	RodE6_73.1	127	73.1	1.857	2.22	0.056	891.25	750.5	6164.11	19444.7	9.874	56.1		
	RodE6_75	128	75	1.905	4.12	0.105	928.29	771.1	6257.34	19738.8	9.462	53.7		

RBHT Steam Cooling with Droplet Injection Test SCD-4035-F

Matrix Test # Shakedown

Test Conditions

Test Date – 10/4/2005

Steady State Time Window: 23340 - 25200

Upper Plenum Pressure: 2.76 bar (40 psia)

Bundle Power: 70.0 kW

Bundle Inlet Reynolds Number: 6000

Bundle Inlet Steam Flow: 118.04 kg/hr (260 lbm/hr)

Droplet Injection Flow: 0.0151 kg/s (0.0333 lbm/s)

Droplet Injection Hole Diameter: 0.381 mm (.015 in)

Droplet Injection Elevation: 1.295 m (51 in)

Bundle Flow Area: $4.656 \times 10^{-3} \text{ m}^2$ ($5.012 \times 10^{-2} \text{ ft}^2$)

Test Notes

- No steam probes were traversed in this steady state window.

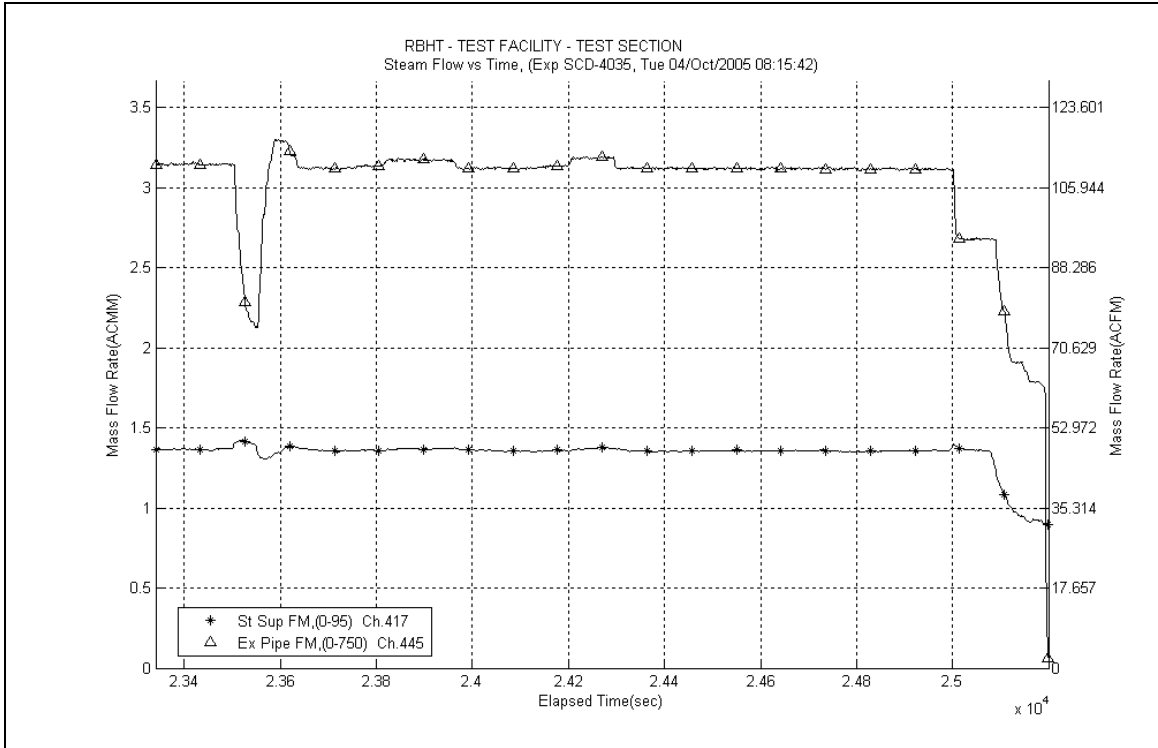

Figure A-290: Inlet and Exhaust Steam Flow Rates for Experiment 4035F

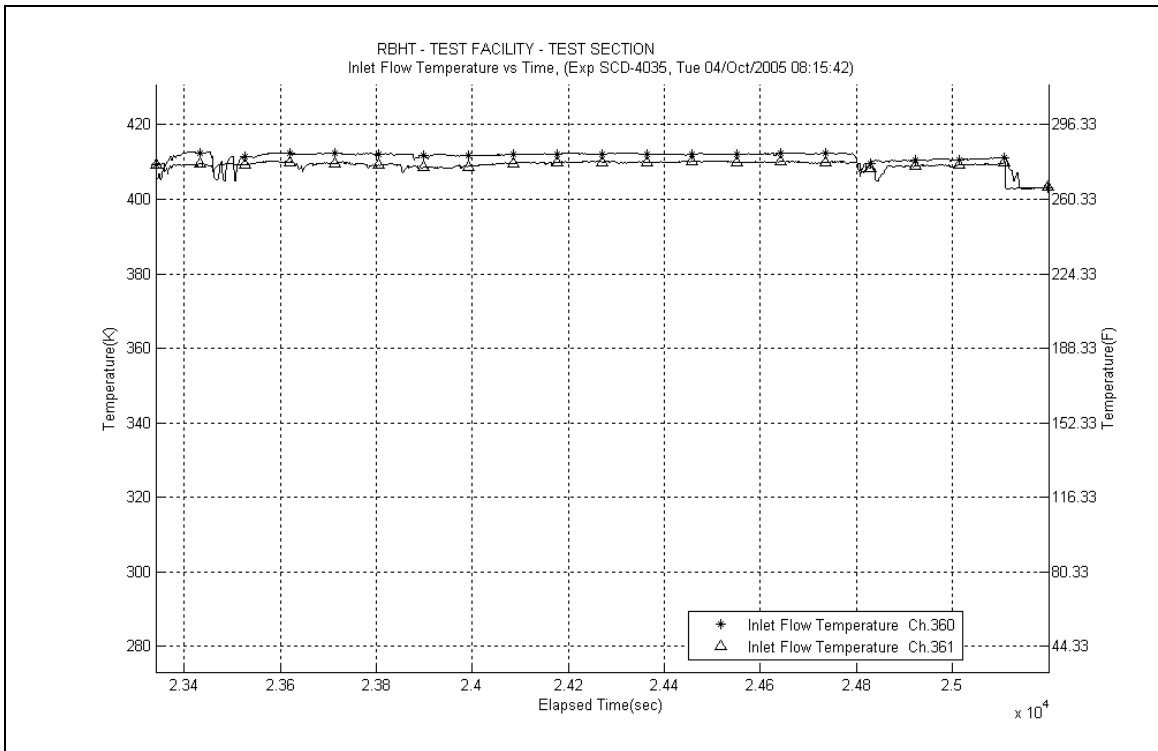

Figure A-291: Inlet Steam Temperature for Experiment 4035F

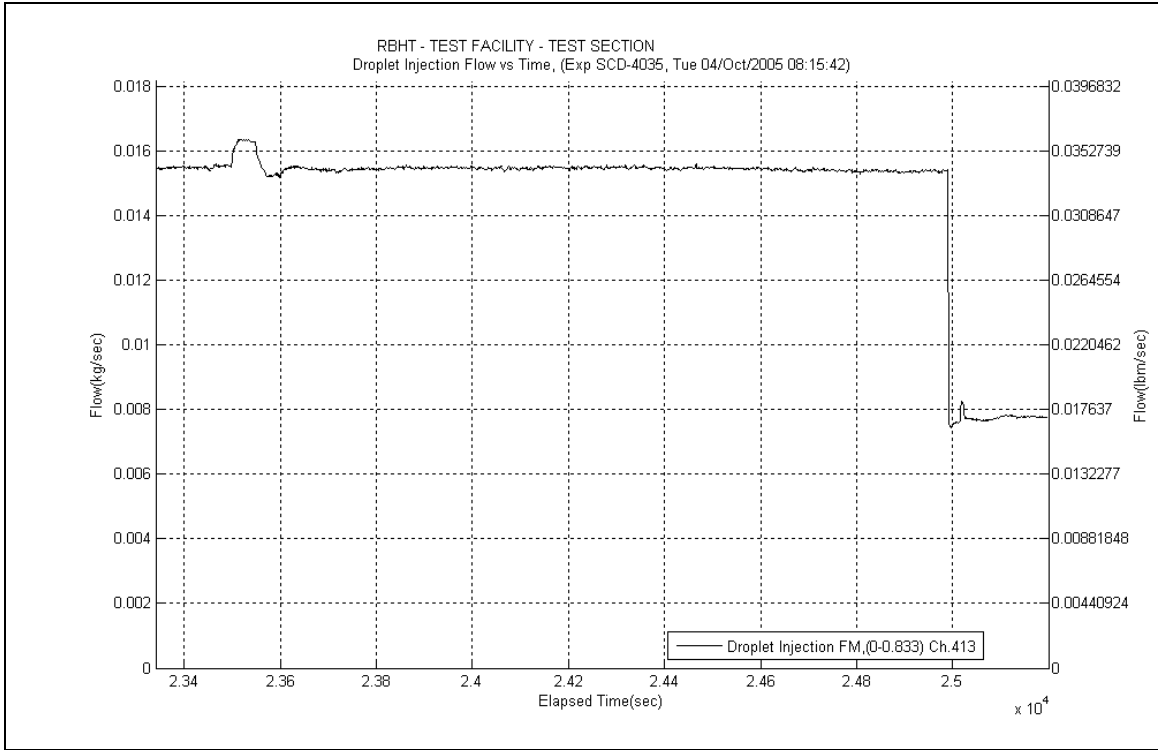

Figure A-292: Droplet Injection Flow Rate for Experiment 4035F

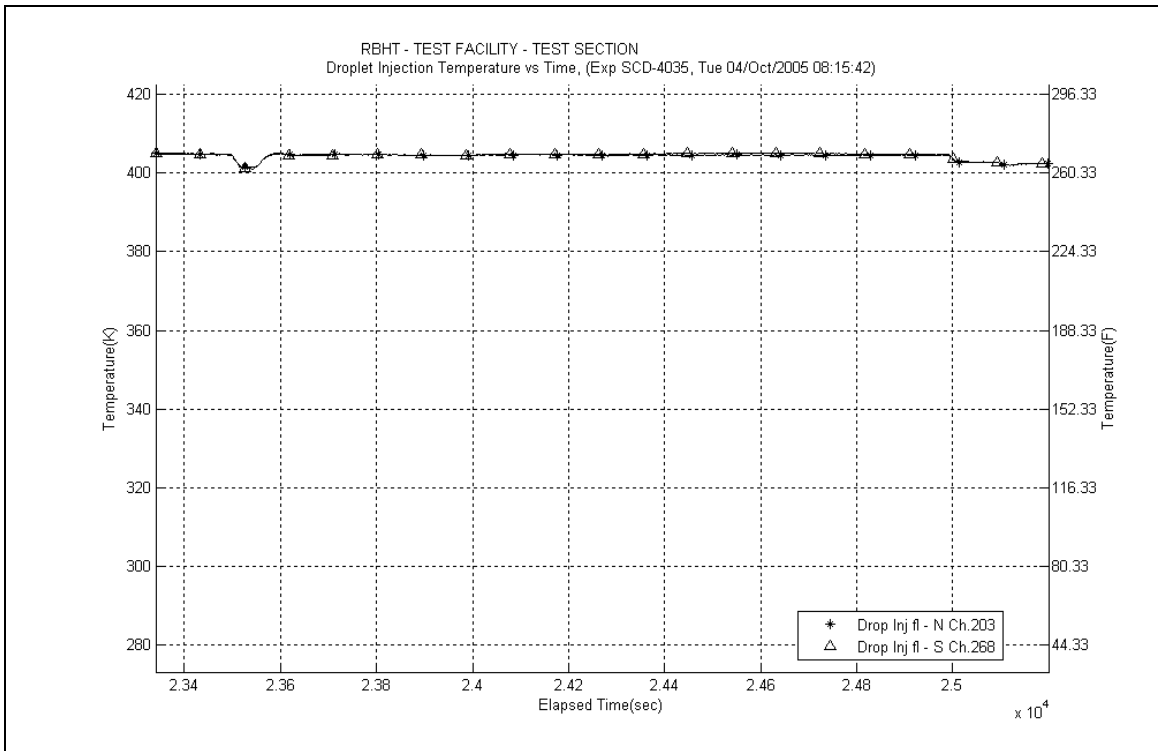

Figure A-293: Droplet Injection Temperature for Experiment 4035F

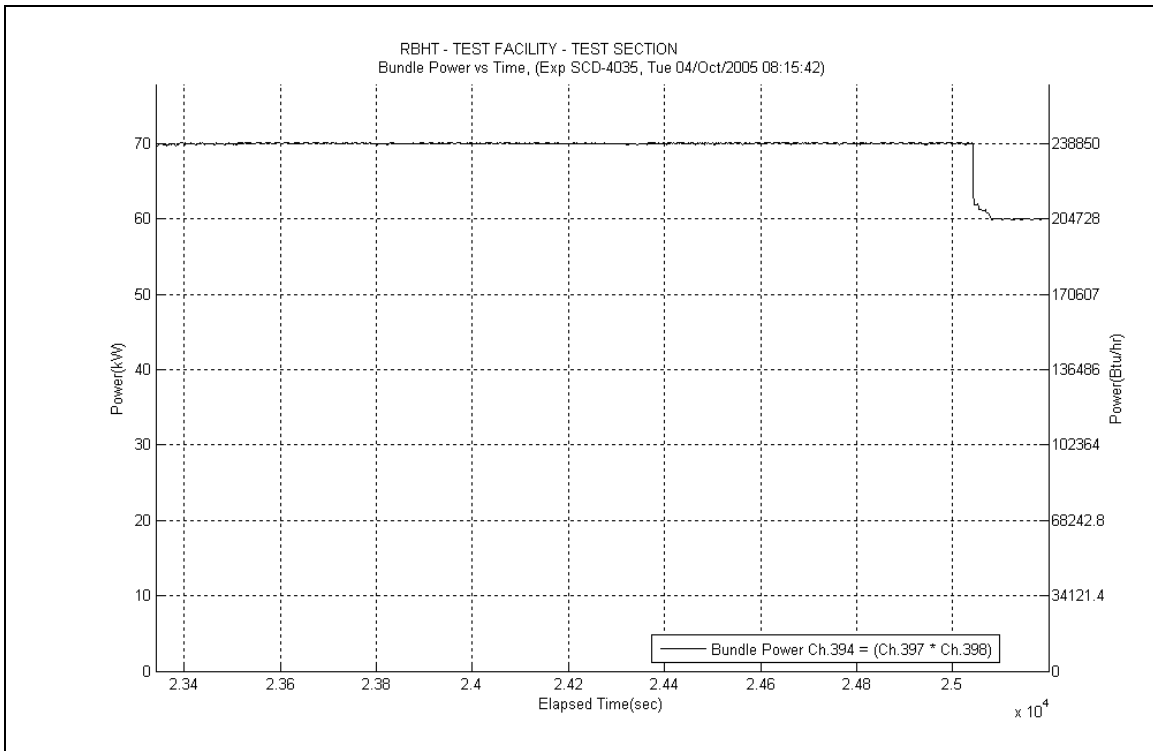

Figure A-294: Bundle Power for Experiment 4035F

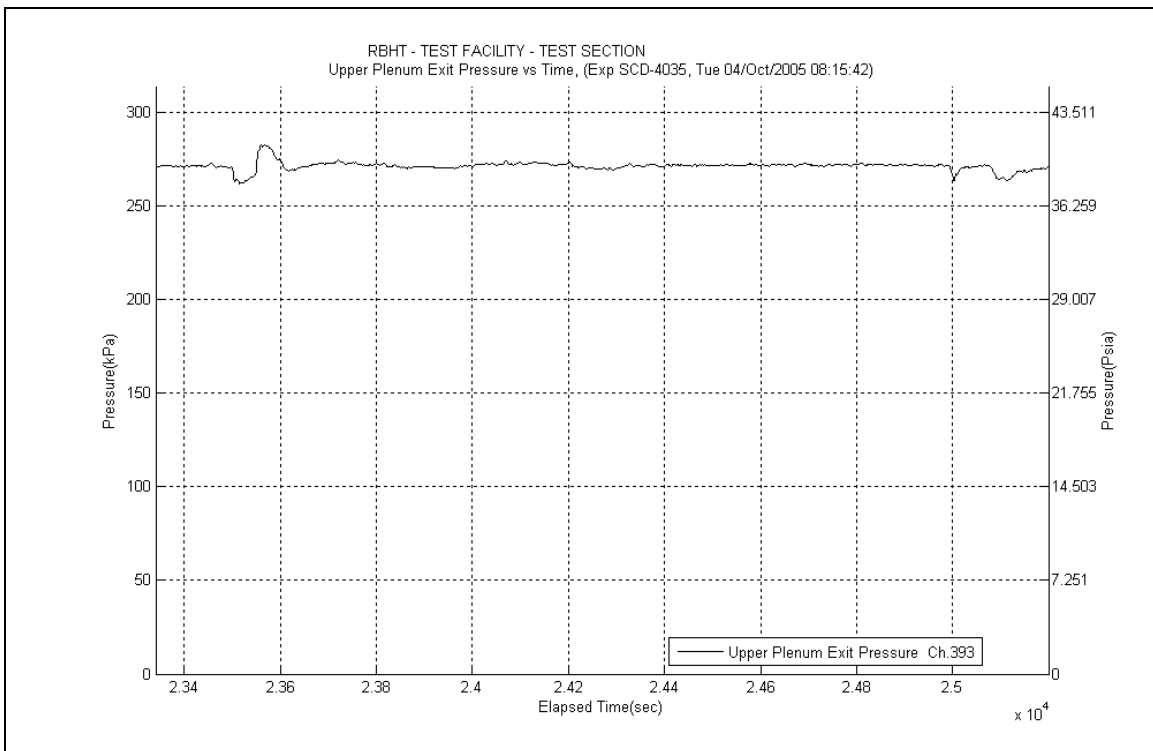

Figure A-295: Upper Plenum Pressure for Experiment 4035F

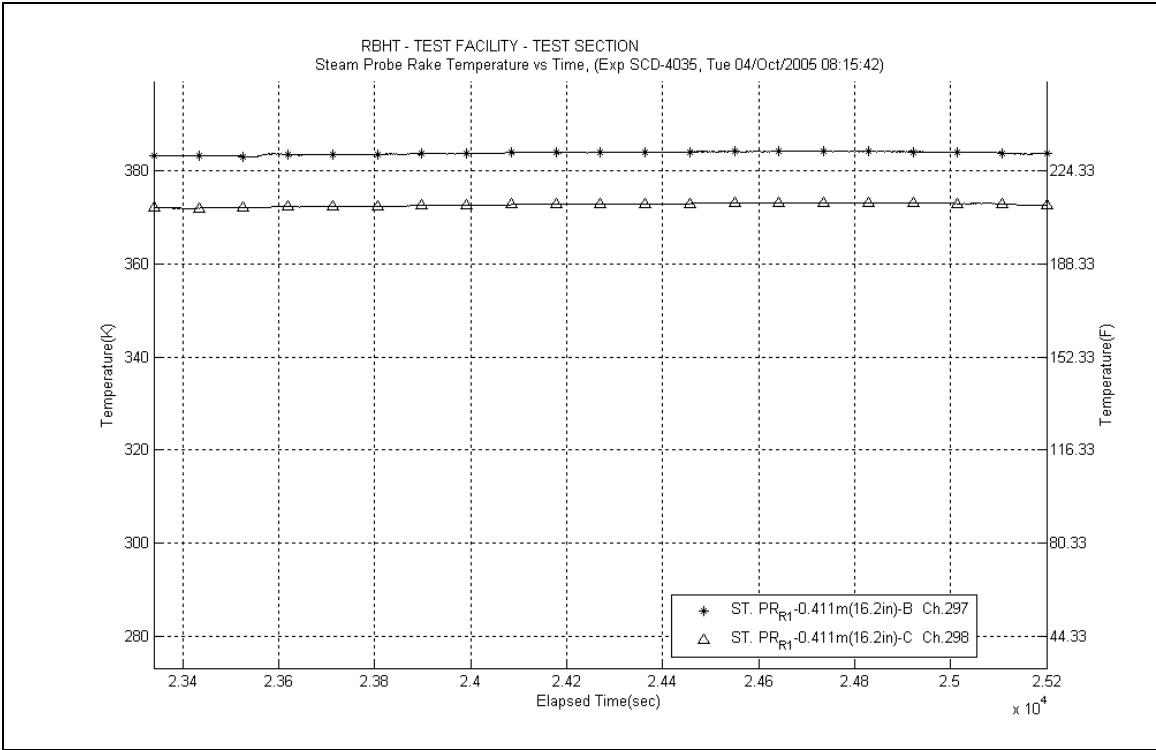

Figure A-296: Steam Probe Rake #1 Temperatures for Experiment 4035F

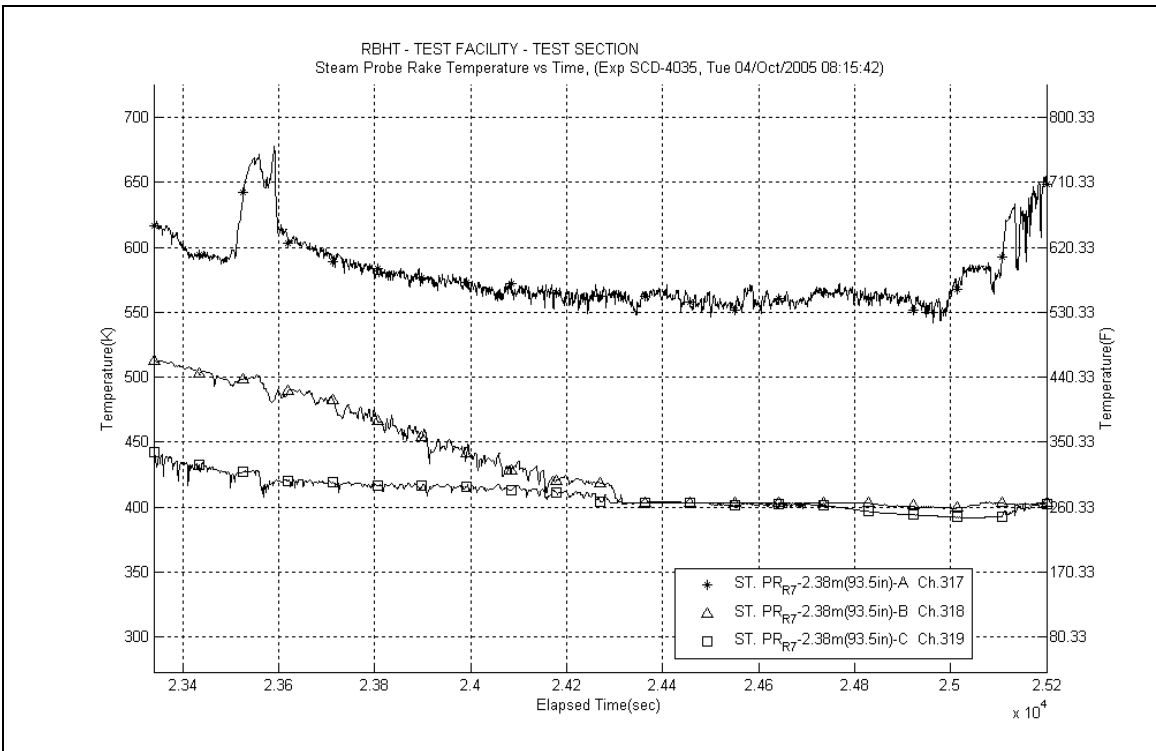

Figure A-297: Steam Probe Rake #7 Temperatures for Experiment 4035F

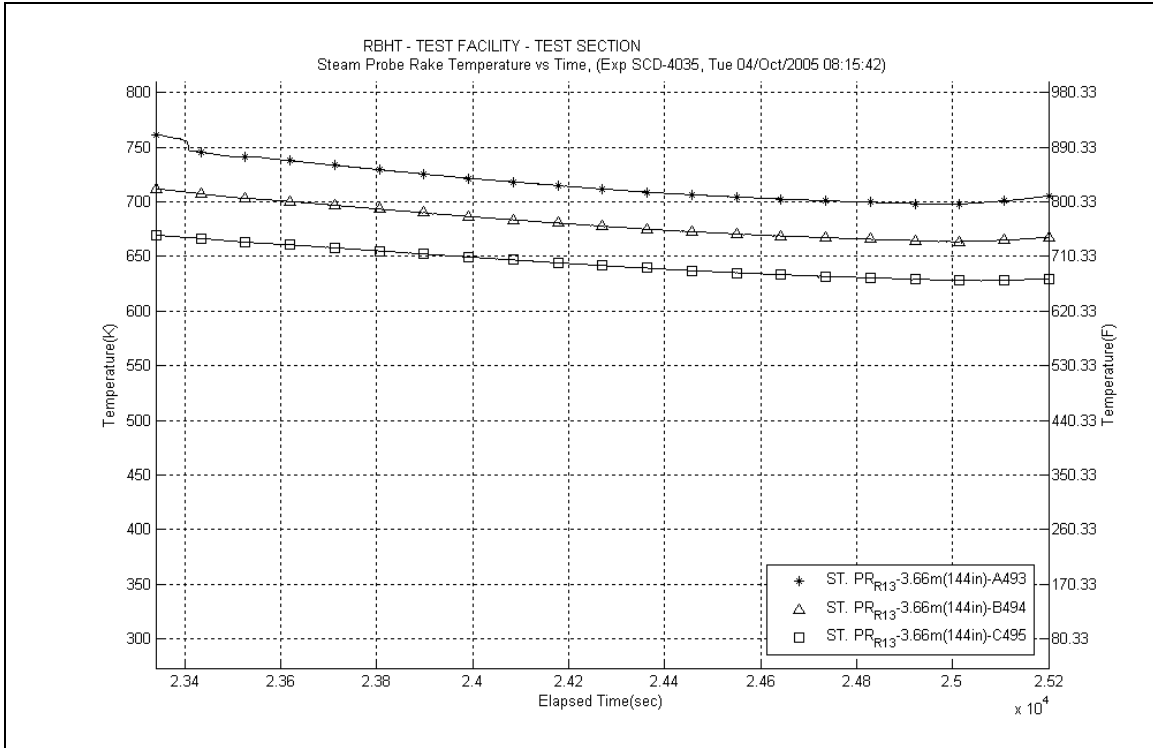

Figure A-298: Steam Probe Rake #13 Temperatures for Experiment 4035F

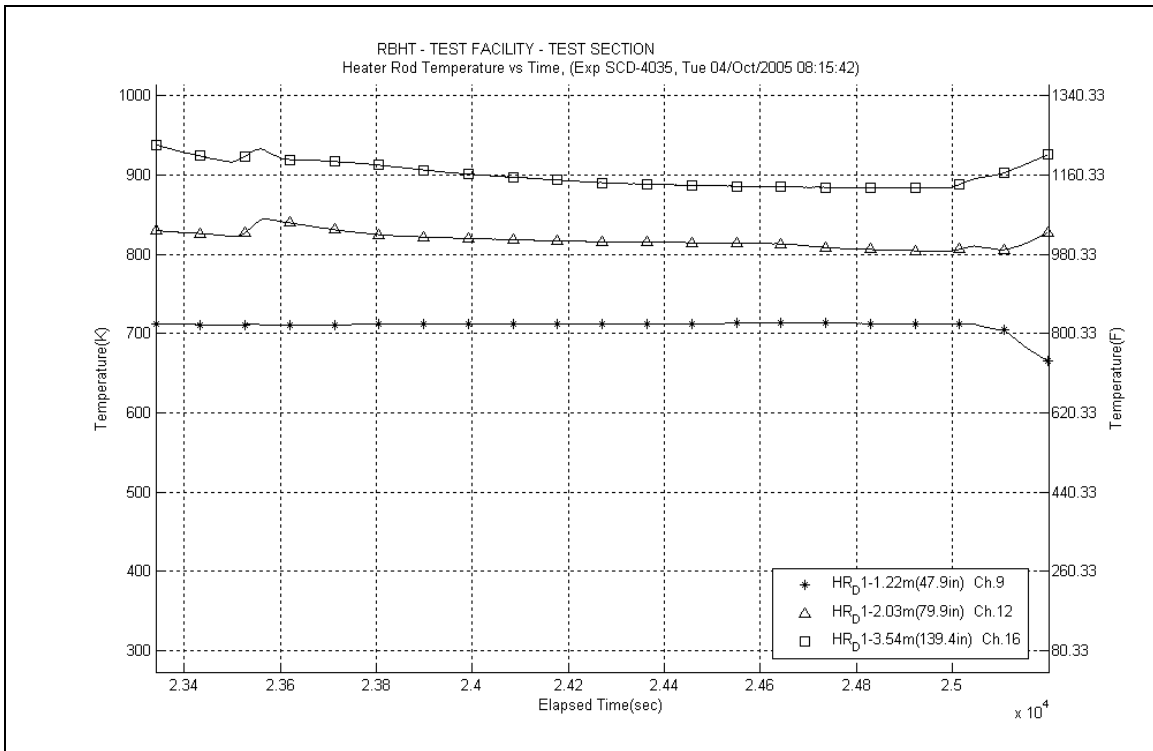

Figure A-299: Heater Rod D1 Temperatures for Experiment 4035F

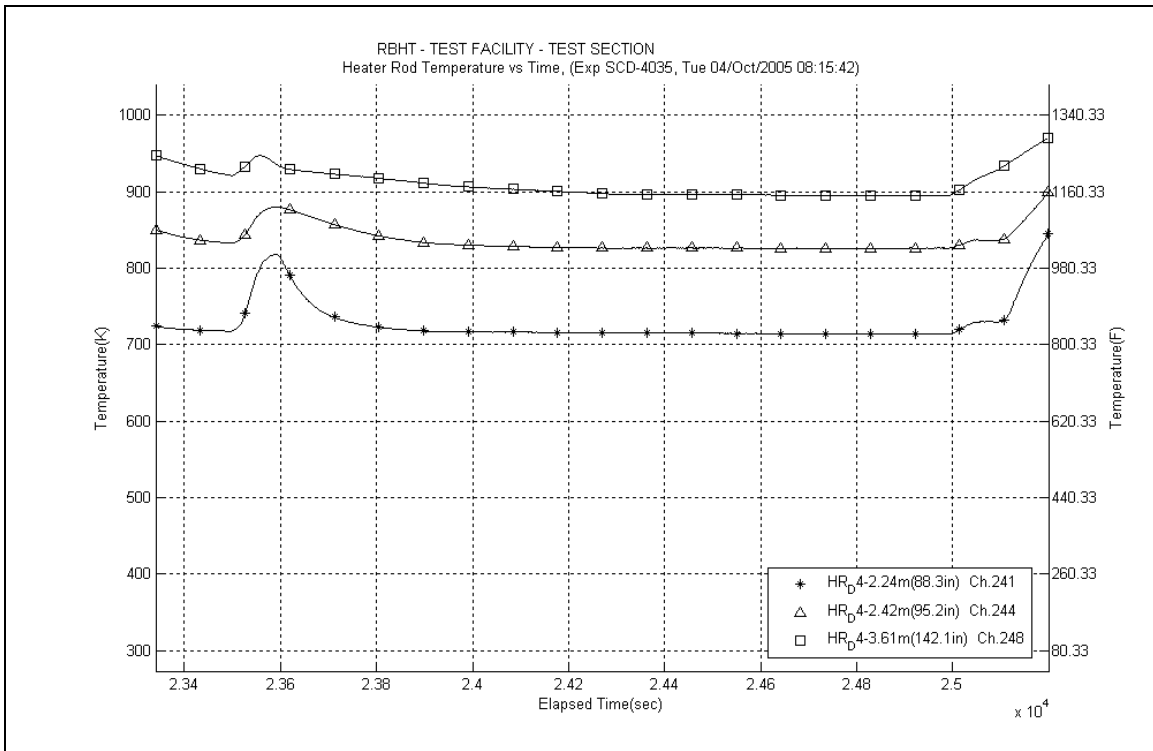

Figure A-300: Heater Rod D4 Temperatures for Experiment 4035F

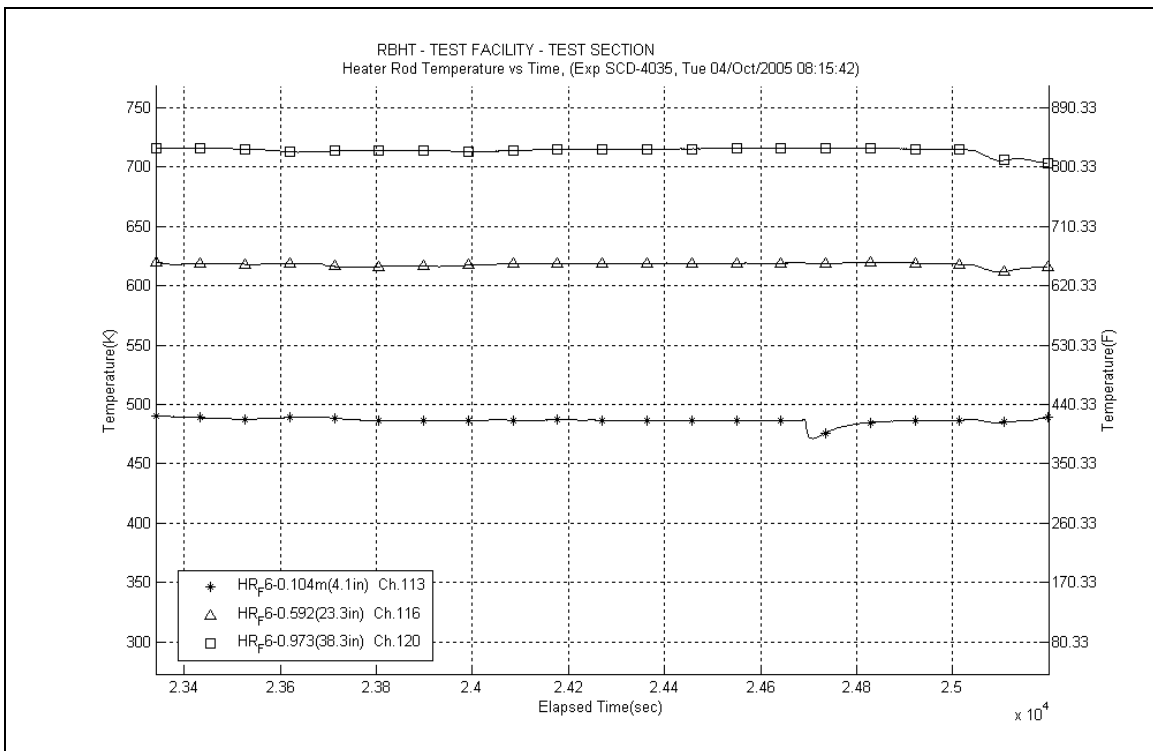

Figure A-301: Heater Rod F6 Temperatures for Experiment 4035F

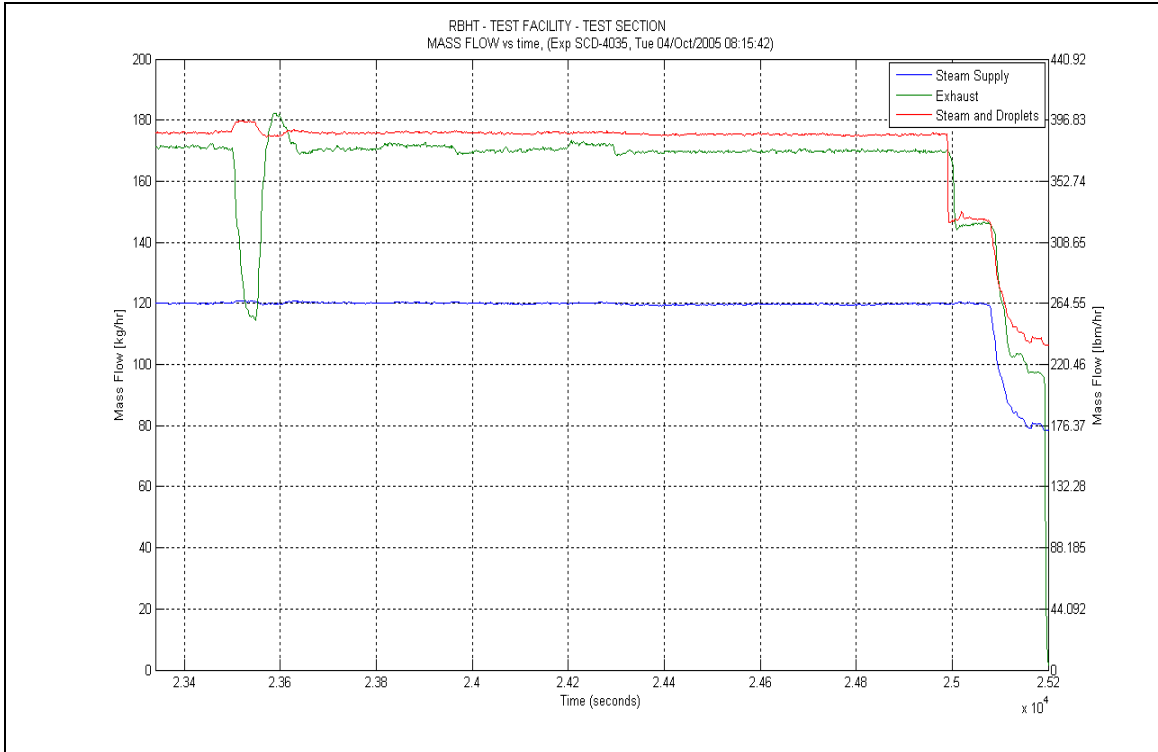

Figure A-302: Mass Flow for Experiment 4035F

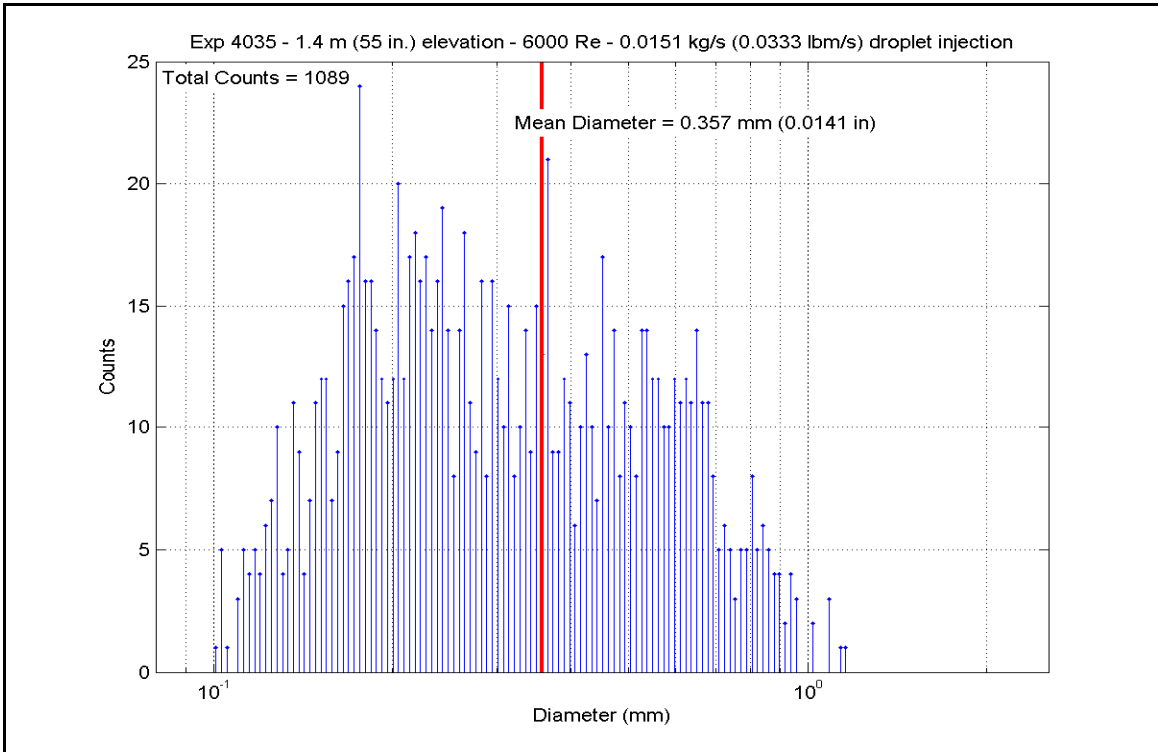

Figure A-303: Droplet Measurements at 1.397 m (55 in.) Elevation for Experiment 4035F

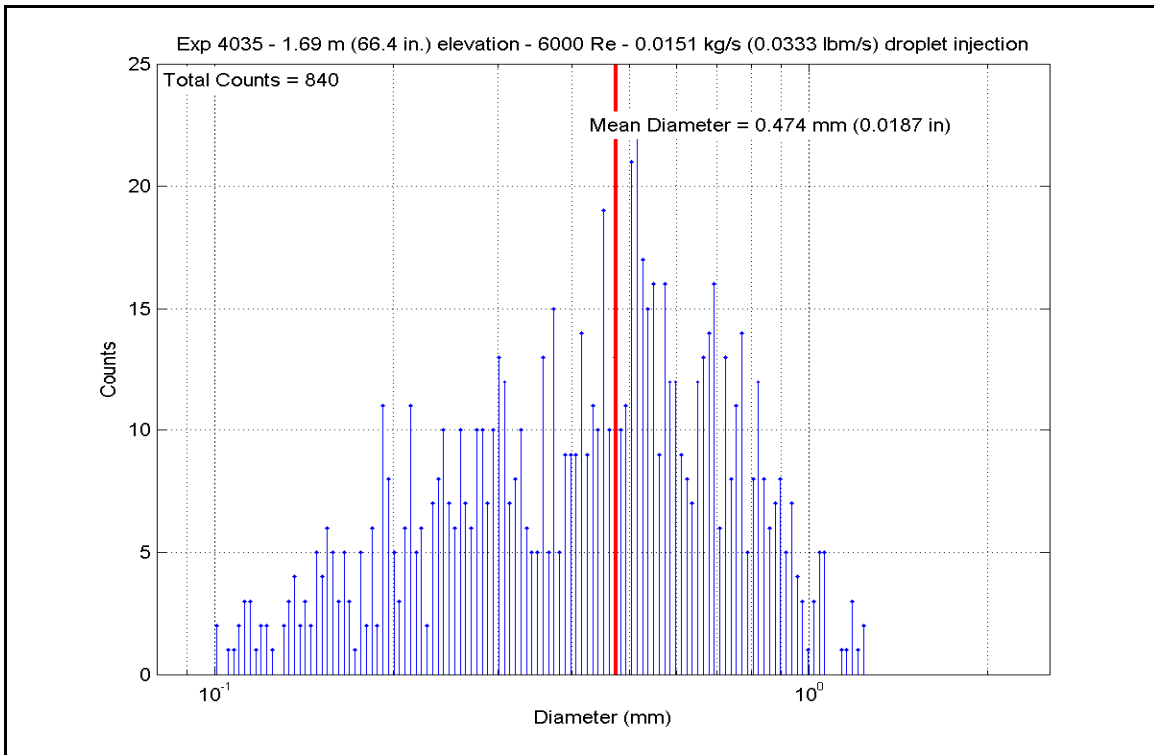

Figure A-304: Droplet Measurements at 1.687 m (66.4 in.) Elevation for Experiment 4035F

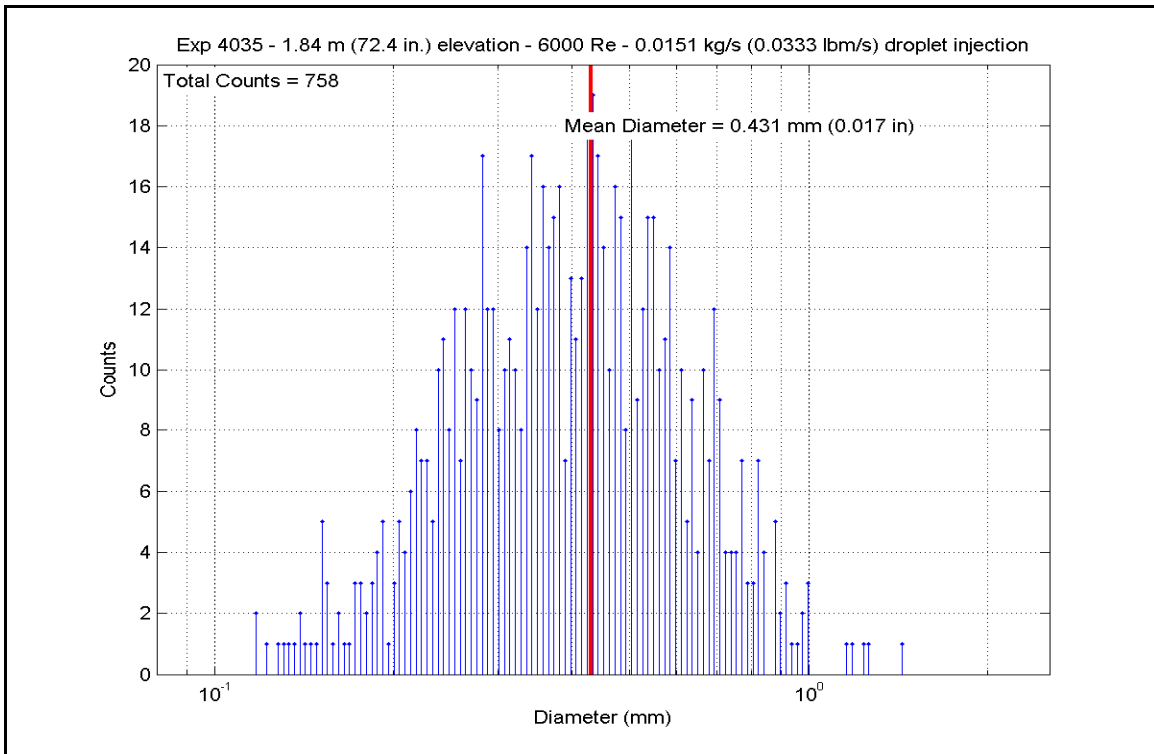

Figure A-305: Droplet Measurements at 1.839 m (72.4 in.) Elevation for Experiment 4035F

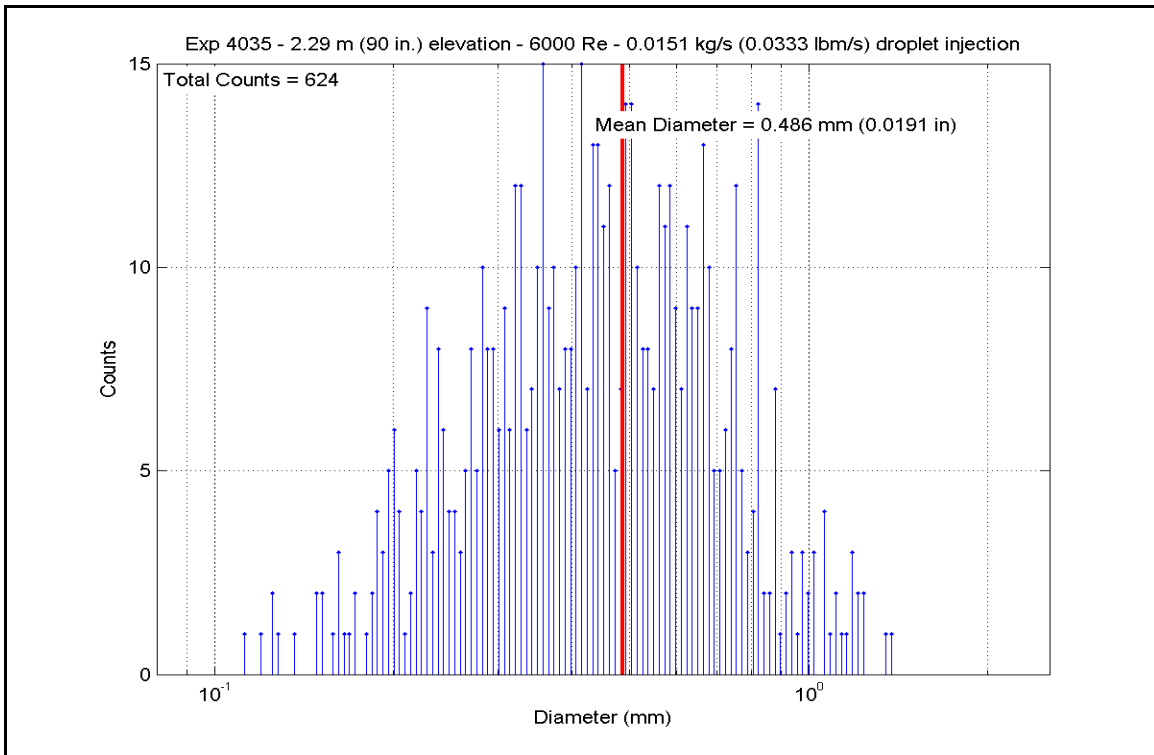

Figure A-306: Droplet Measurements at 2.286 m (90 in.) Elevation for Experiment 4035F

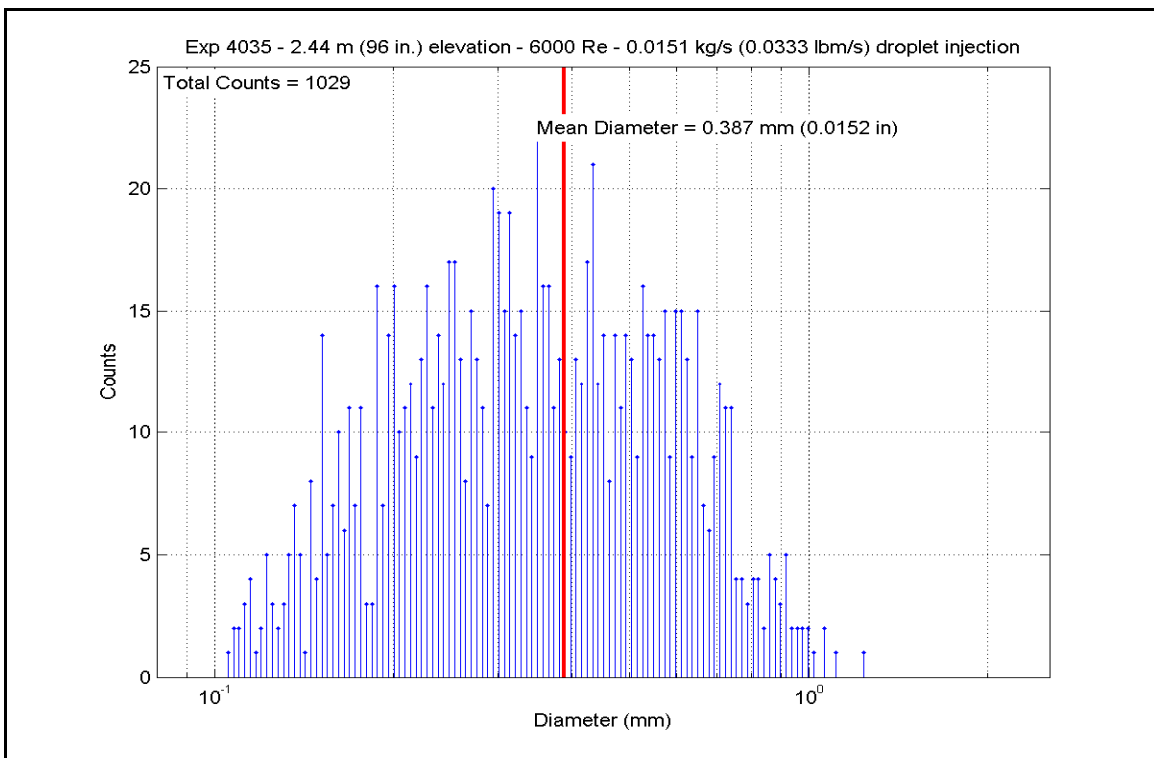

Figure A-307: Droplet Measurements at 2.438 m (96 in.) Elevation for Experiment 4035F

Table A-17: Summary of Steam Cooling Heat Transfer Reduced Data for Experiment 4035F

SCD-4035-F		Inlet Reynolds:		6000		40 psia							
Matrix Test		shakedown		UP Pressure:		238850 Btu/hr							
Time Window: 23340-25200		70.00 kW		260.0 lbm/hr									
Inner 3x3		0.0328 kg/s		0.033 lbm/s									
		0.0150 kg/s											
H.R. ID	H.R. Location	Channel Number	Elevation (in)	Elevation (m)	Zgrid (in)	Zgrid (m)	H.R. Tw (°F)	H.R. Tw (K)	H.R. q" (Btu/hr-ft2)	H.R. q" (W/m2)	h _{sat} (z) (Btu/hr-ft2-F)	h _{sat} (z) (W/m2-K)	
Gr-3	RodD3_88.3	185	88.3	2.243	-0.2	-0.005	1060.38	844.5	9065.00	28595.5	11.426	64.9	
	RodD3_91.3	186	91.3	2.319	2.8	0.071	1126.73	881.3	8410.00	26529.3	9.782	55.6	
	RodD3_93.1	187	93.1	2.365	4.6	0.117	1154.02	896.5	8362.00	26377.9	9.427	53.5	
	RodD3_95.3	188	95.3	2.421	6.8	0.173	1180.45	911.2	8345.00	26324.3	9.136	51.9	
	RodD3_100.1	189	100.1	2.543	11.6	0.295	1231.64	939.6	5825.00	18375.0	6.039	34.3	
	RodD3_106.1	190	106.1	2.695	17.6	0.447	1288.44	971.2	5801.00	18299.3	5.679	32.3	
	RodD3_110	191	110	2.794	21.5	0.546	1256.38	953.4	5886.00	18567.4	5.949	33.8	
	RodD3_142.1	192	142.1	3.609	8.6	0.218	1232.95	940.3	2839.00	8955.6	2.939	16.7	
Gr-3	RodC4_88.4	233	88.4	2.245	-0.1	-0.003	1062.29	845.5	4902.00	15463.4	6.164	35.0	
	RodC4_91.1	234	91.1	2.314	2.6	0.066	1112.20	873.3	4776.00	15065.9	5.651	32.1	
	RodC4_93.4	235	93.4	2.372	4.9	0.124	1138.90	888.1	4948.00	15608.5	5.675	32.2	
	RodC4_95.3	236	95.3	2.421	6.8	0.173	1162.33	901.1	5047.00	15920.8	5.637	32.0	
	RodC4_100.1	237	100.1	2.543	11.6	0.295	1215.87	930.9	5764.00	18182.5	6.075	34.5	
	RodC4_106.1	238	106.1	2.695	17.6	0.447	1272.41	962.3	5850.00	18453.8	5.819	33.0	
	RodC4_110	239	110	2.794	21.5	0.546	1239.75	944.1	6017.00	18980.6	6.186	35.1	
	RodC4_142.2	240	142.2	3.612	8.7	0.221	1197.38	920.6	211.60	667.5	0.227	1.3	
Gr-3	RodD4_88.3	241	88.3	2.243	-0.2	-0.005	1074.35	852.2	4841.00	15270.9	5.996	34.1	
	RodD4_91.3	242	91.3	2.319	2.8	0.071	1121.42	878.4	4626.00	14592.7	5.414	30.7	
	RodD4_93.2	243	93.2	2.367	4.7	0.119	1146.37	892.2	4631.00	14608.5	5.266	29.9	
	RodD4_95.2	244	95.2	2.418	6.7	0.170	1167.85	904.2	4789.00	15106.9	5.316	30.2	
	RodD4_100.1	245	100.1	2.543	11.6	0.295	1227.12	937.1	5588.00	17627.3	5.820	33.1	
	RodD4_106.1	246	106.1	2.695	17.6	0.447	1281.81	967.5	5971.00	18835.5	5.884	33.4	
	RodD4_142.1	248	142.1	3.609	8.6	0.218	1205.27	925.0	80.43	253.7	0.086	0.5	
Gr-3	RodE4_88.4	201	88.4	2.245	-0.1	-0.003	1071.66	850.7	9487.00	29926.7	11.790	67.0	
	RodE4_91.2	202	91.2	2.316	2.7	0.069	1130.39	883.4	8443.00	26633.4	9.779	55.5	
	RodE4_95.3	204	95.3	2.421	6.8	0.173	1188.20	915.5	8354.00	26352.7	9.069	51.5	
	RodE4_100.9	205	100.9	2.563	12.4	0.315	1242.12	945.4	5514.00	17393.9	5.655	32.1	
	RodE4_142.3	208	142.3	3.614	8.8	0.224	1231.11	939.3	2913.00	9189.1	3.021	17.2	

Table A-17: Summary of Steam Cooling Heat Transfer Reduced Data for Experiment 4035F, continued

Inner 3x3	H.I.R. Location	Channel Number	Elevation (in)	Elevation (m)	Zgrid (in)	Zgrid (m)	H.R. Tw (°F)	H.R. Tw (K)	H.R. q" (Btu/hr-ft ²)	H.R. q" (W/m ²)	h _{sat} (z) (Btu/hr-ft ² -F)	h _{sat} (z) (W/m ² -K)
Gr-4	RodE3_63.4	193	63.4	1.610	16.4	0.417	994.31	807.8	6101.00	19245.6	8.388	47.6
	RodE3_113.6	194	113.6	2.885	0.85	0.022	1279.24	966.1	4976.00	15696.8	4.916	27.9
	RodE3_115.5	195	115.5	2.934	2.75	0.070	1296.19	975.5	8679.00	27377.9	8.433	47.9
	RodE3_118.5	196	118.5	3.010	5.75	0.146	1313.46	985.1	8006.00	25254.9	7.651	43.4
	RodE3_122.7	197	122.7	3.117	9.95	0.253	1319.88	988.6	6984.00	22031.0	6.633	37.7
	RodE3_126.5	198	126.5	3.213	13.75	0.349	1312.71	984.7	6352.00	20037.4	6.074	34.5
	RodE3_131.7	199	131.7	3.345	-1.8	-0.046	1265.57	958.5	8278.00	26113.0	8.290	47.1
RodE3_135.6	200	135.6	3.444	2.1	0.053	1265.11	958.2	4975.00	15693.6	4.984	28.3	
Gr-4	RodC5_63.7	225	63.7	1.618	16.7	0.424	980.48	800.1	4947.00	15605.3	6.934	39.4
	RodC5_113.6	226	113.6	2.885	0.85	0.022	1249.02	949.3	4620.00	14573.8	4.705	26.7
	RodC5_115.7	227	115.7	2.939	2.95	0.075	1254.19	952.1	3739.00	11794.7	3.788	21.5
	RodC5_122.7	229	122.7	3.117	9.95	0.253	1270.32	961.1	2696.00	8504.5	2.687	15.3
	RodC5_126.7	230	126.7	3.216	13.95	0.354	1260.42	955.6	2168.00	6839.0	2.182	12.4
	RodC5_131.6	231	131.6	3.343	-1.9	-0.048	1224.58	935.7	1520.00	4794.8	1.587	9.0
	RodC5_135.7	232	135.7	3.447	2.2	0.056	1210.80	928.0	776.40	2449.2	0.823	4.7
Gr-4	RodE5_63.6	209	63.6	1.615	16.6	0.422	979.43	799.5	5139.00	16211.0	7.213	41.0
	RodE5_113.6	210	113.6	2.885	0.85	0.022	1250.19	949.9	5015.00	15819.8	5.101	29.0
	RodE5_115.4	211	115.4	2.931	2.65	0.067	1248.22	948.8	4230.00	13343.5	4.311	24.5
	RodE5_118.7	212	118.7	3.015	5.95	0.151	1254.88	952.5	3774.00	11905.1	3.820	21.7
	RodE5_122.6	213	122.6	3.114	9.85	0.250	1260.97	955.9	3287.00	10368.8	3.307	18.8
	RodE5_126.6	214	126.6	3.216	13.85	0.352	1255.62	952.9	2810.00	8864.1	2.842	16.1
	RodE5_131.6	215	131.6	3.343	-1.9	-0.048	1216.21	931.0	2000.00	6309.0	2.107	12.0
RodE5_135.6	216	135.6	3.444	2.1	0.053	1210.65	928.0	1354.00	4271.2	1.435	8.1	
Gr-5	RodC3_79.8	177	79.8	2.027	8.92	0.227	1066.55	847.9	6975.00	22002.6	8.724	49.5
	RodC3_85.6	178	85.6	2.174	14.72	0.374	1038.92	832.6	9570.00	30188.6	12.398	70.4
	RodC3_88.5	179	88.5	2.248	0	0.000	1049.60	838.5	9058.00	28573.5	11.574	65.7
	RodC3_92.4	180	92.4	2.347	3.9	0.099	1122.63	879.1	8057.00	25415.8	9.416	53.5
	RodC3_94.4	181	94.4	2.398	5.9	0.150	1145.42	891.7	7968.00	25135.1	9.071	51.5
	RodC3_97.2	182	97.2	2.469	8.7	0.221	1177.84	909.7	5857.00	18475.9	6.430	36.5
	RodC3_108.8	183	108.8	2.764	20.3	0.516	1265.81	958.6	6007.00	18949.1	6.014	34.2
Gr-8	RodD5_50	217	50	1.270	3	0.076	808.58	704.6	4874.00	15375.0	9.000	51.1
	RodD5_54.1	218	54.1	1.374	7.1	0.180	841.52	722.9	4970.00	15677.9	8.651	49.1
	RodD5_56.9	219	56.9	1.445	9.9	0.251	910.10	761.0	4848.00	15293.0	7.538	42.8
	RodD5_60	220	60	1.524	13	0.330	957.96	787.6	4950.00	15614.8	7.164	40.7
	RodD5_66.1	221	66.1	1.679	19.1	0.485	994.65	808.0	5143.00	16223.6	7.068	40.1
	RodD5_69.9	222	69.9	1.775	-0.98	-0.025	919.93	766.4	5226.00	16485.4	8.004	45.5
	RodD5_72.9	223	72.9	1.852	2.02	0.051	984.85	802.5	4744.00	14964.9	6.609	37.5
RodD5_74.9	224	74.9	1.902	4.02	0.102	1017.94	820.9	4711.00	14860.8	6.273	35.6	

Table A-17: Summary of Steam Cooling Heat Transfer Reduced Data for Experiment 4035F, continued

H.R. ID	H.R. Location	Channel Number	Elevation (in)	Elevation (m)	Zgrid (in)	Zgrid (m)	H.R. Tw (°F)	H.R. Tw (K)	H.R. q" (Btu/hr-ft ²)	H.R. q" (W/m ²)	h _{sat} (z) (Btu/hr-ft ² -F)	h _{sat} (z) (W/m ² -K)	
Gr-2	RodB5_41	153	41	1.041	13.5	0.343	743.30	668.3	4471.00	14103.8	9.387	53.3	
	RodB5_52.9	154	52.9	1.344	5.9	0.150	790.11	694.3	6010.00	18958.5	11.489	65.2	
	RodB5_55	155	55	1.397	8	0.203	845.71	725.2	5828.00	18384.4	10.071	57.2	
	RodB5_57.8	156	57.8	1.468	10.8	0.274	910.75	761.3	5779.00	18229.9	8.977	51.0	
	RodB5_64	157	64	1.626	17	0.432	974.15	796.6	5815.00	18343.4	8.223	46.7	
	RodB5_73.9	158	73.9	1.877	3.02	0.077	1001.94	812.0	6532.00	20605.2	8.888	50.5	
	RodB5_75.9	159	75.9	1.928	5.02	0.128	1032.94	829.2	6535.00	20614.7	8.532	48.5	
	RodB5_76.9	160	76.9	1.953	6.02	0.153	1045.59	836.3	6723.00	21207.7	8.635	49.0	
	Gr-2	RodF5_41	105	41	1.041	13.5	0.343	740.42	666.7	4482.00	14138.5	9.467	53.8
		RodF5_53.1	106	53.1	1.349	6.1	0.155	788.82	693.6	5141.00	16217.3	9.852	55.9
		RodF5_55	107	55	1.397	8	0.203	837.73	720.8	5144.00	16226.7	9.013	51.2
		RodF5_57.8	108	57.8	1.468	10.8	0.274	897.84	754.2	5195.00	16387.6	8.235	46.8
		RodF5_64	109	64	1.626	17	0.432	953.53	785.1	5474.00	17267.7	7.973	45.3
		RodF5_73.8	110	73.8	1.875	2.92	0.074	974.27	796.6	5328.00	16807.2	7.533	42.8
		RodF5_75.8	111	75.8	1.925	4.92	0.125	1003.42	812.8	5414.00	17078.5	7.352	41.7
		RodF5_76.8	112	76.8	1.951	5.92	0.150	1014.80	819.2	5361.00	16911.3	7.169	40.7
Gr-2		RodC2_41	57	41	1.041	13.5	0.343	740.08	666.5	4579.00	14444.5	9.679	55.0
		RodC2_53.1	58	53.1	1.349	6.1	0.155	818.69	710.2	4987.00	15731.5	9.039	51.3
		RodC2_55	59	55	1.397	8	0.203	852.28	728.9	5015.00	15819.8	8.569	48.7
		RodC2_57.8	60	57.8	1.468	10.8	0.274	889.34	749.5	5138.00	16207.8	8.256	46.9
	RodC2_63.9	61	63.9	1.623	16.9	0.429	935.38	775.0	5415.00	17081.6	8.102	46.0	
	RodC2_73.8	62	73.8	1.875	2.92	0.074	967.02	792.6	5273.00	16633.7	7.533	42.8	
	RodC2_75.8	63	75.8	1.925	4.92	0.125	1001.59	811.8	5478.00	17280.4	7.457	42.3	
	RodC2_76.8	64	76.8	1.951	5.92	0.150	1012.89	818.1	5583.00	17611.6	7.485	42.5	
Gr-2	RodC6_40.9	137	40.9	1.039	13.4	0.340	744.04	668.7	4459.00	14065.9	9.347	53.1	
	RodC6_52.8	138	52.8	1.341	5.8	0.147	829.53	716.2	5649.00	17819.8	10.042	57.0	
	RodC6_54.8	139	54.8	1.392	7.8	0.198	859.56	732.9	5636.00	17778.8	9.511	54.0	
	RodC6_57.8	140	57.8	1.468	10.8	0.274	898.88	754.8	5946.00	18756.7	9.410	53.4	
	RodC6_63.8	141	63.8	1.621	16.8	0.427	944.69	780.2	5761.00	18173.1	8.501	48.3	
	RodC6_73.7	142	73.7	1.872	2.82	0.072	984.13	802.1	6365.00	20078.4	8.876	50.4	
	RodC6_75.8	143	75.8	1.925	4.92	0.125	1005.33	813.9	6557.00	20684.1	8.881	50.4	
	RodC6_76.8	144	76.8	1.951	5.92	0.150	1020.08	822.1	6575.00	20740.8	8.731	49.6	

Table A-17: Summary of Steam Cooling Heat Transfer Reduced Data for Experiment 4035F, continued

5x5 periphery		H.R. Location	Channel Number	Elevation (in)	Elevation (m)	Zgrid (in)	Zgrid (m)	H.R. Tw (°F)	H.R. Tw (K)	H.R. q" (Btu/hr-ft ²)	H.R. q" (W/m ²)	h _{sat} (z) (Btu/hr-ft ² -F)	h _{sat} (z) (W/m ² -K)
Gr-3	RodB4_88.4	161	88.4	2.245	-0.003	1049.23	838.3	9307.00	29358.9	11.898	67.6		
	RodB4_91.3	162	91.3	2.319	0.071	1112.94	873.7	8316.00	26232.8	9.830	55.8		
	RodB4_93.3	163	93.3	2.370	0.122	1140.13	888.8	8313.00	26223.4	9.521	54.1		
	RodB4_95.1	164	95.1	2.416	0.168	1162.13	901.0	8204.00	25879.5	9.165	52.0		
	RodB4_100	165	100	2.540	0.292	1196.96	920.4	5677.00	17908.1	6.105	34.7		
	RodB4_106	166	106	2.692	0.445	1249.93	949.8	6003.00	18936.5	6.107	34.7		
	RodB4_109.9	167	109.9	2.791	0.544	1213.29	929.4	5861.00	18488.5	6.194	35.2		
	RodB4_142.3	168	142.3	3.614	0.224	1198.78	921.4	2918.00	9204.8	3.132	17.8		
Gr-5	RodF4_85.6	98	85.6	2.174	0.374	1068.77	849.1	5781.00	18236.2	7.210	40.9		
	RodF4_88.4	99	88.4	2.245	-0.003	1076.84	853.6	5823.00	18368.7	7.190	40.8		
	RodF4_92.4	100	92.4	2.347	0.099	1148.79	893.6	5526.00	17431.8	6.267	35.6		
	RodF4_94.3	101	94.3	2.395	0.147	1173.77	907.5	5560.00	17539.0	6.132	34.8		
	RodF4_97.2	102	97.2	2.469	0.221	1208.28	926.6	5811.00	18330.8	6.174	35.1		
	RodF4_108.8	103	108.8	2.764	0.516	1274.21	963.3	6013.00	18968.0	5.970	33.9		
	RodF4_111	104	111	2.819	-0.044	1231.98	939.8	6098.00	19236.1	6.319	35.9		
	RodD2_103.2	65	103.2	2.621	0.373	1255.64	953.0	5032.00	15873.4	5.090	28.9		
Gr-6	RodD2_106	66	106	2.692	0.445	1270.07	961.0	4608.00	14535.9	4.594	26.1		
	RodD2_112.6	67	112.6	2.860	-0.15	1284.81	969.2	4034.00	12725.3	3.963	22.5		
	RodD2_114.9	68	114.9	2.918	0.055	1285.38	969.5	3574.00	11274.2	3.509	19.9		
	RodD2_117.4	69	117.4	2.982	0.118	1277.49	965.1	2783.00	8779.0	2.754	15.6		
	RodD2_120.8	70	120.8	3.068	0.204	1235.89	942.0	6110.00	19274.0	6.306	35.8		
	RodD2_124.8	71	124.8	3.170	0.306	1255.78	953.0	6467.00	20400.2	6.540	37.1		
	RodD2_128.6	72	128.6	3.266	0.403	1224.53	935.7	5671.00	17889.2	5.923	33.6		
	RodD6_103.1	129	103.1	2.619	0.371	1209.69	927.4	6075.00	19163.6	6.444	36.6		
RodD6_106	130	106	2.692	0.445	1227.33	937.2	6069.00	19144.7	6.320	35.9			
RodD6_112.9	131	112.9	2.868	0.004	1206.47	925.6	5767.00	18192.0	6.139	34.9			
RodD6_114.9	132	114.9	2.918	0.055	1228.86	938.1	4469.00	14097.5	4.646	26.4			
RodD6_116.8	133	116.8	2.967	0.103	1237.42	942.8	4237.00	13365.6	4.366	24.8			
RodD6_120.9	134	120.9	3.071	0.207	1246.74	948.0	6661.00	21012.1	6.799	38.6			
RodD6_124.8	135	124.8	3.170	0.306	1245.88	947.5	6125.00	19321.3	6.257	35.5			
RodD6_128.7	136	128.7	3.269	0.405	1238.31	943.3	5413.00	17075.3	5.573	31.6			

Table A-17: Summary of Steam Cooling Heat Transfer Reduced Data for Experiment 4035F, continued

5x5 periphery		H.R. Location	Channel Number	Elevation (in)	Elevation (m)	Zgrid (in)	Zgrid (m)	H.R. Tw (°F)	H.R. Tw (K)	H.R. q" (Btu/hr-ft ²)	H.R. q" (W/m ²)	h _{sat} (z) (Btu/hr-ft ² -F)	h _{sat} (z) (W/m ² -K)
Gr-8	RodE2_50.1	73	50.1	1.273	3.1	0.079	801.09	700.4	4990.00	15741.0	9.343	53.1	
	RodE2_54	74	54	1.372	7	0.178	834.84	719.2	5097.00	16078.5	8.976	51.0	
	RodE2_56.9	75	56.9	1.445	9.9	0.251	888.23	748.8	5176.00	16327.7	8.332	47.3	
	RodE2_59.9	76	59.9	1.521	12.9	0.328	926.32	770.0	5267.00	16614.8	7.989	45.4	
	RodE2_66	77	66	1.676	19	0.483	967.83	793.1	5412.00	17072.2	7.722	43.9	
	RodE2_69.8	78	69.8	1.773	-1.08	-0.027	899.94	755.3	5601.00	17668.4	8.849	50.3	
	RodE2_72.9	79	72.9	1.852	2.02	0.051	972.04	795.4	5440.00	17160.5	7.716	43.8	
	RodE2_74.9	80	74.9	1.902	4.02	0.102	1002.22	812.2	5564.00	17551.6	7.568	43.0	
Gr-8	RodB3_50.2	169	50.2	1.275	3.2	0.081	763.89	679.8	5055.00	15946.0	10.173	57.8	
	RodB3_54.1	170	54.1	1.374	7.1	0.180	802.70	701.3	5612.00	17703.1	10.476	59.5	
	RodB3_56.9	171	56.9	1.445	9.9	0.251	866.91	737.0	6129.00	19333.9	10.217	58.0	
	RodB3_60.1	172	60.1	1.527	13.1	0.333	897.65	754.1	6270.00	19778.7	9.942	56.5	
	RodB3_66.1	173	66.1	1.679	19.1	0.485	958.41	787.8	6071.00	19151.0	8.781	49.9	
	RodB3_69.9	174	69.9	1.775	-0.98	-0.025	888.78	749.1	6991.00	22053.1	11.244	63.9	
	RodB3_73	175	73	1.854	2.12	0.054	962.36	790.0	6534.00	20611.5	9.397	53.4	
	RodB3_75	176	75	1.905	4.12	0.105	997.35	809.5	6539.00	20627.3	8.953	50.8	
Gr-8	RodF3_50.1	89	50.1	1.273	3.1	0.079	786.83	692.5	4876.00	15381.3	9.380	53.3	
	RodF3_54	90	54	1.372	7	0.178	827.56	715.1	5003.00	15782.0	8.925	50.7	
	RodF3_57	91	57	1.448	10	0.254	895.77	753.0	5233.00	16507.5	8.323	47.3	
	RodF3_60	92	60	1.524	13	0.330	944.10	779.9	5273.00	16633.7	7.788	44.2	
	RodF3_66.1	93	66.1	1.679	19.1	0.485	973.05	796.0	5422.00	17103.7	7.679	43.6	
	RodF3_70	94	70	1.778	-0.88	-0.022	914.83	763.6	5572.00	17576.9	8.601	48.8	
	RodF3_73	95	73	1.854	2.12	0.054	984.94	802.6	5478.00	17280.4	7.630	43.3	
	RodF3_75	96	75	1.905	4.12	0.105	1020.83	822.5	5477.00	17277.2	7.266	41.3	
Gr-8	RodE6_50.2	121	50.2	1.275	3.2	0.081	784.20	691.0	4902.00	15463.4	9.478	53.8	
	RodE6_54.1	122	54.1	1.374	7.1	0.180	838.83	721.4	5176.00	16327.7	9.052	51.4	
	RodE6_57	123	57	1.448	10	0.254	875.19	741.6	5228.00	16491.7	8.596	48.8	
	RodE6_60.2	124	60.2	1.529	13.2	0.335	899.05	754.8	5268.00	16617.9	8.335	47.3	
	RodE6_66.1	125	66.1	1.679	19.1	0.485	944.02	779.8	5425.00	17113.2	8.013	45.5	
	RodE6_70	126	70	1.778	-0.88	-0.022	880.39	744.5	5576.00	17589.5	9.090	51.6	
	RodE6_73.1	127	73.1	1.857	2.22	0.056	950.85	783.6	5340.00	16845.0	7.809	44.3	
	RodE6_75	128	75	1.905	4.12	0.105	982.73	801.3	5231.00	16501.2	7.309	41.5	

RBHT Steam Cooling with Droplet Injection Test SCD-4037-A

Matrix Test # 17a

Test Conditions

Test Date – 10/11/2005

Steady State Time Window: 16440 - 17400

Upper Plenum Pressure: 2.76 bar (40 psia)

Bundle Power: 80.0 kW

Bundle Inlet Reynolds Number: 10000

Bundle Inlet Steam Flow: 199.76 kg/hr (440 lbm/hr)

Droplet Injection Flow: 0.0036 kg/s (0.008 lbm/s)

Droplet Injection Hole Diameter: 0.381 mm (.015 in)

Droplet Injection Elevation: 1.295 m (51 in)

Bundle Flow Area: $4.656 \times 10^{-3} \text{ m}^2$ ($5.012 \times 10^{-2} \text{ ft}^2$)

Test Notes

- No steam probes were traversed in this steady state window.

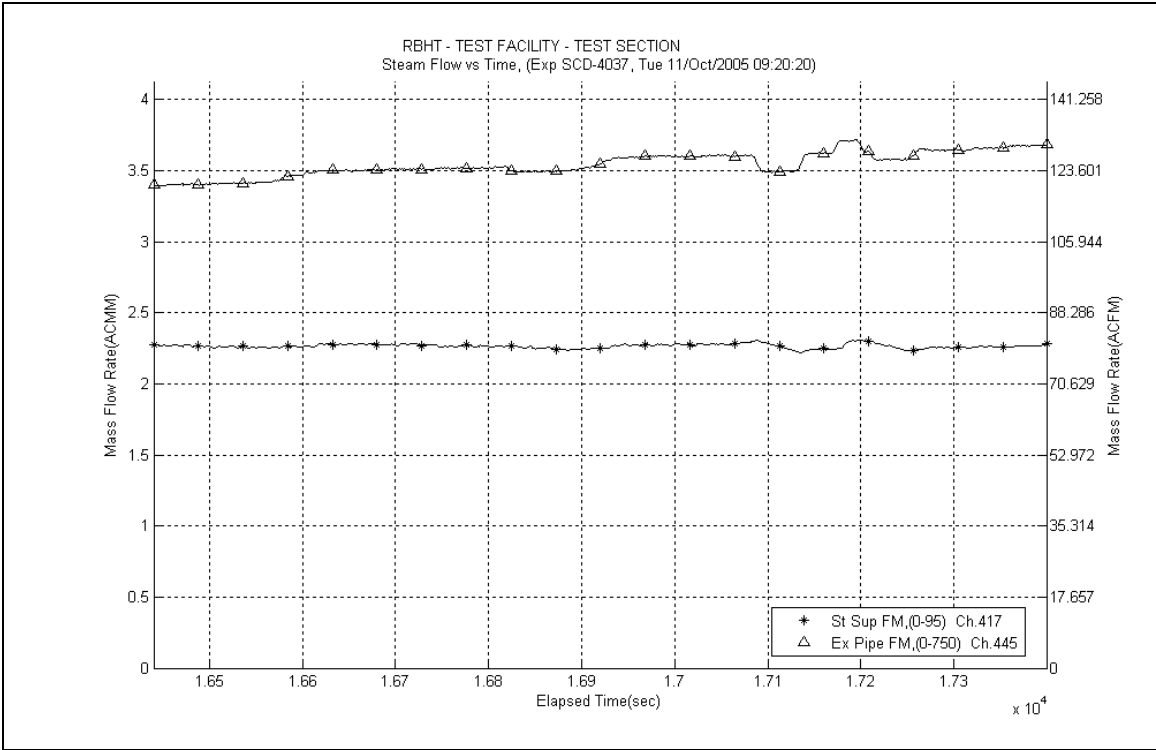

Figure A-308: Inlet and Exhaust Steam Flow Rates for Experiment 4037A

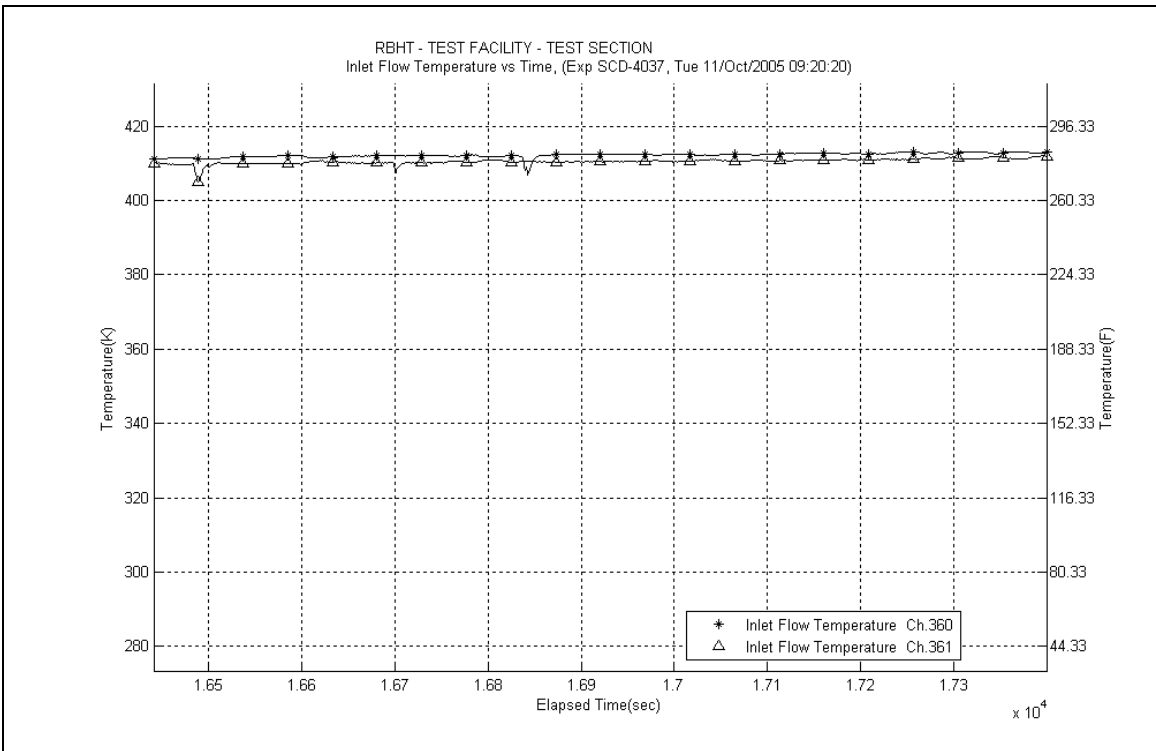

Figure A-309: Inlet Steam Temperature for Experiment 4037A

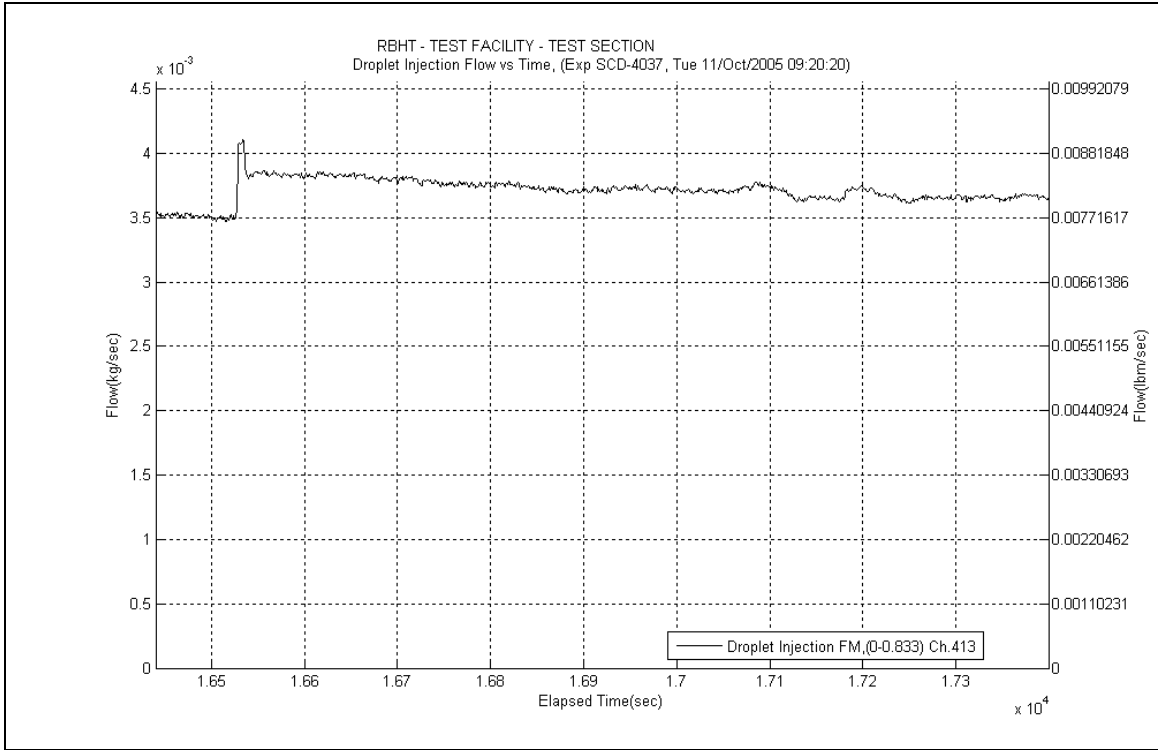

Figure A-310: Droplet Injection Flow Rate for Experiment 4037A

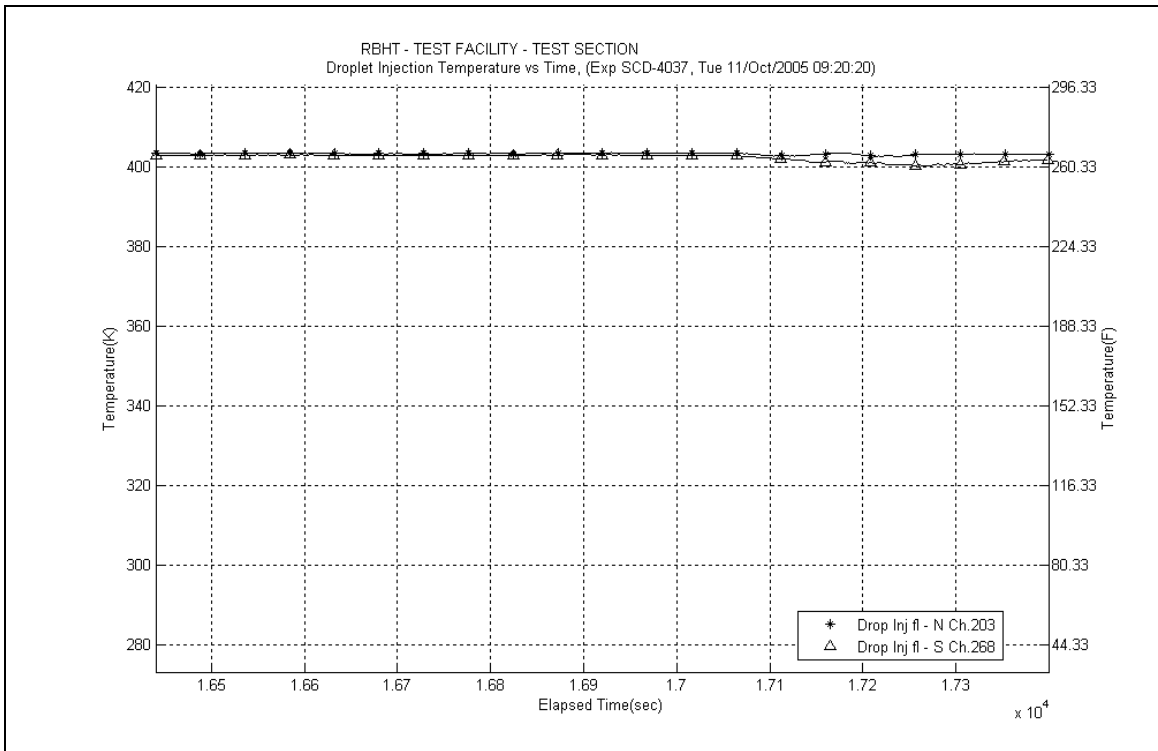

Figure A-311: Droplet Injection Temperature for Experiment 4037A

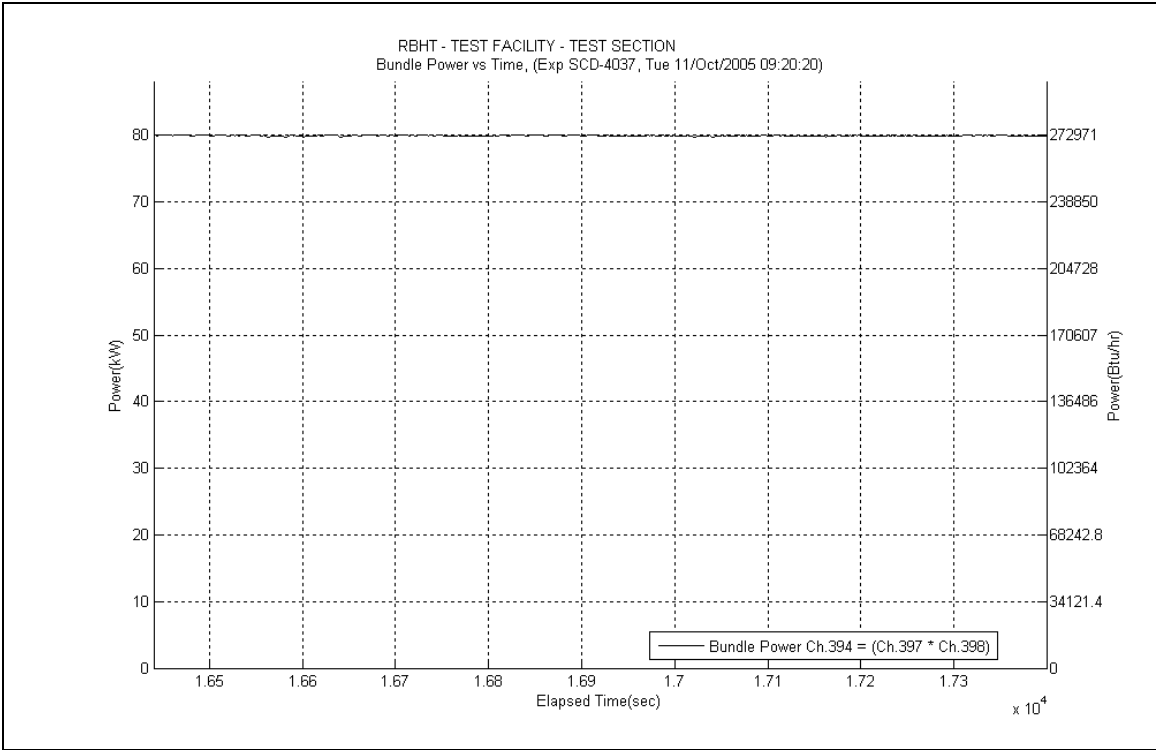

Figure A-312: Bundle Power for Experiment 4037A

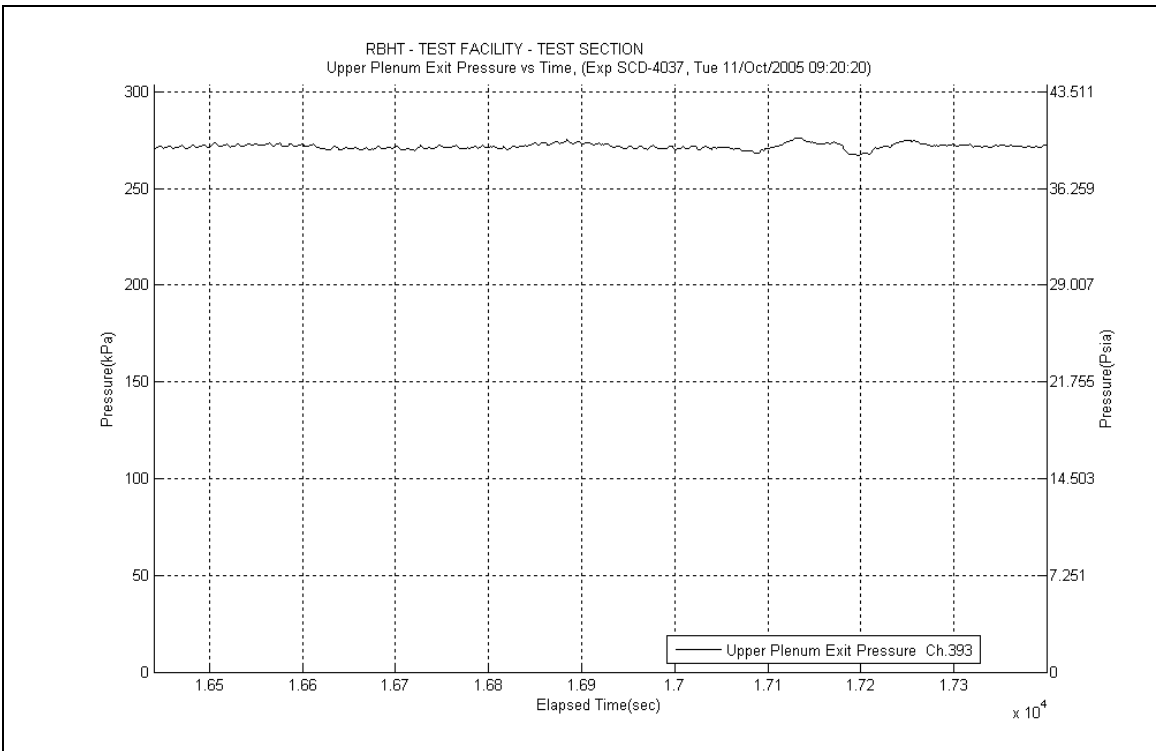

Figure A-313: Upper Plenum Pressure for Experiment 4037A

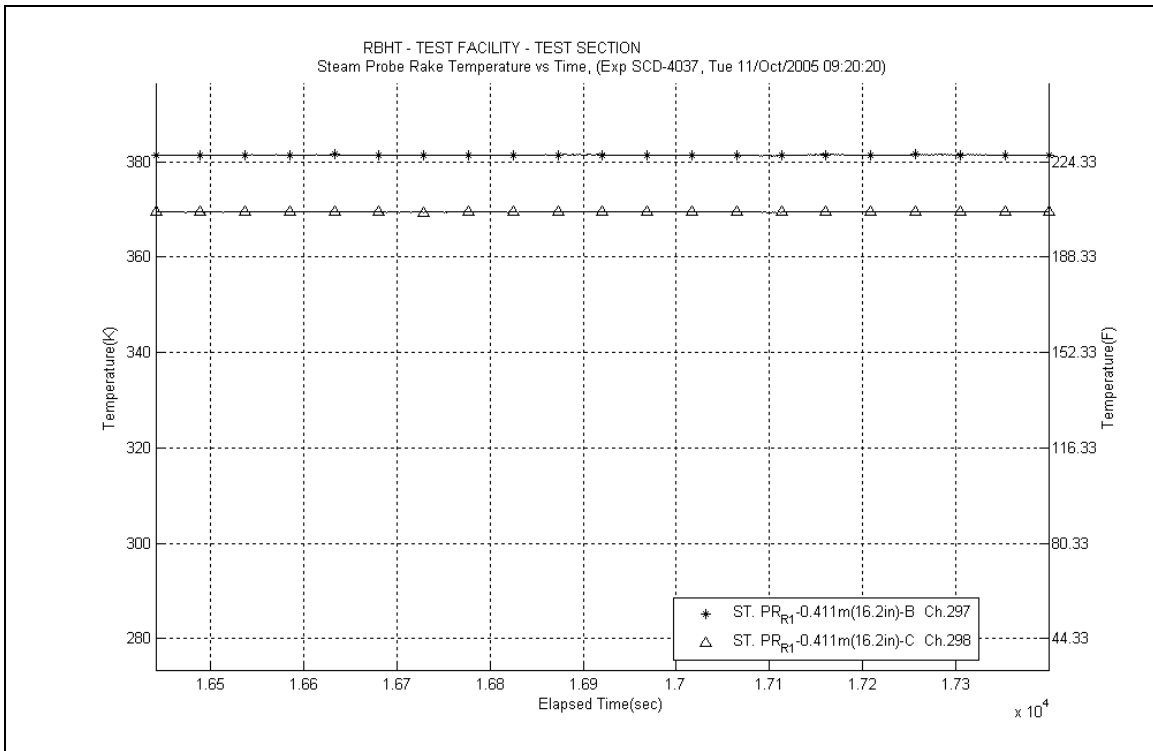

Figure A-314: Steam Probe Rake #1 Temperatures for Experiment 4037A

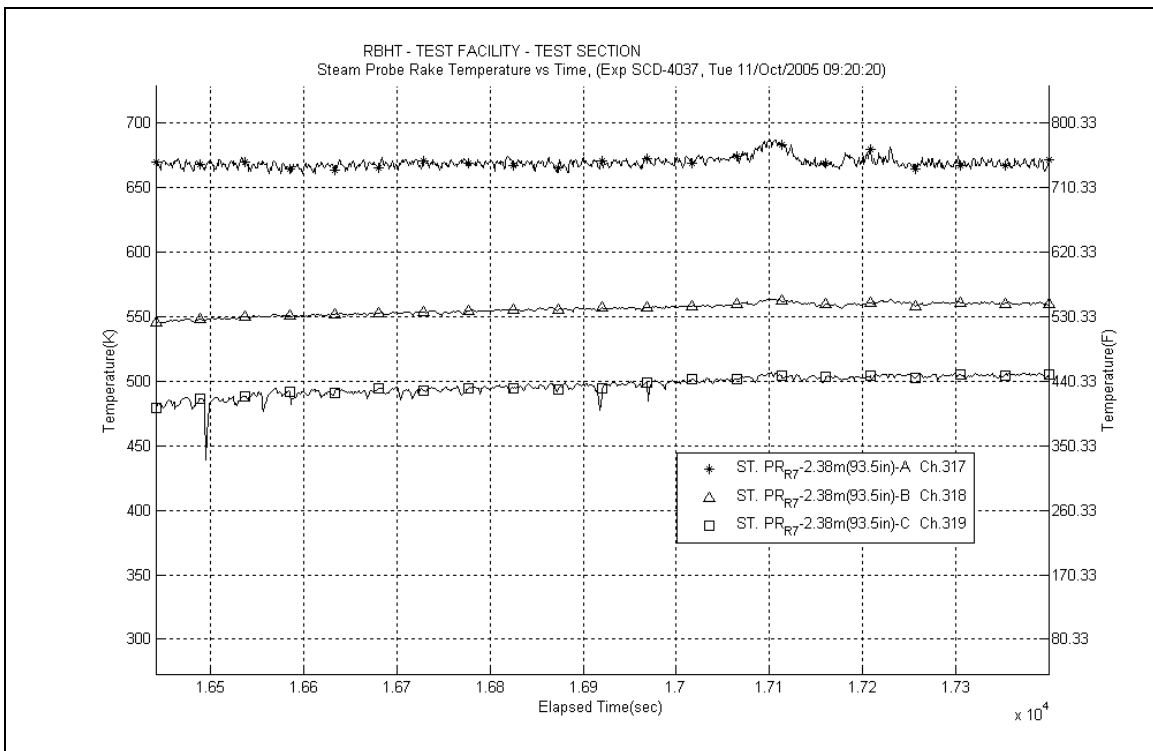

Figure A-315: Steam Probe Rake #7 Temperatures for Experiment 4037A

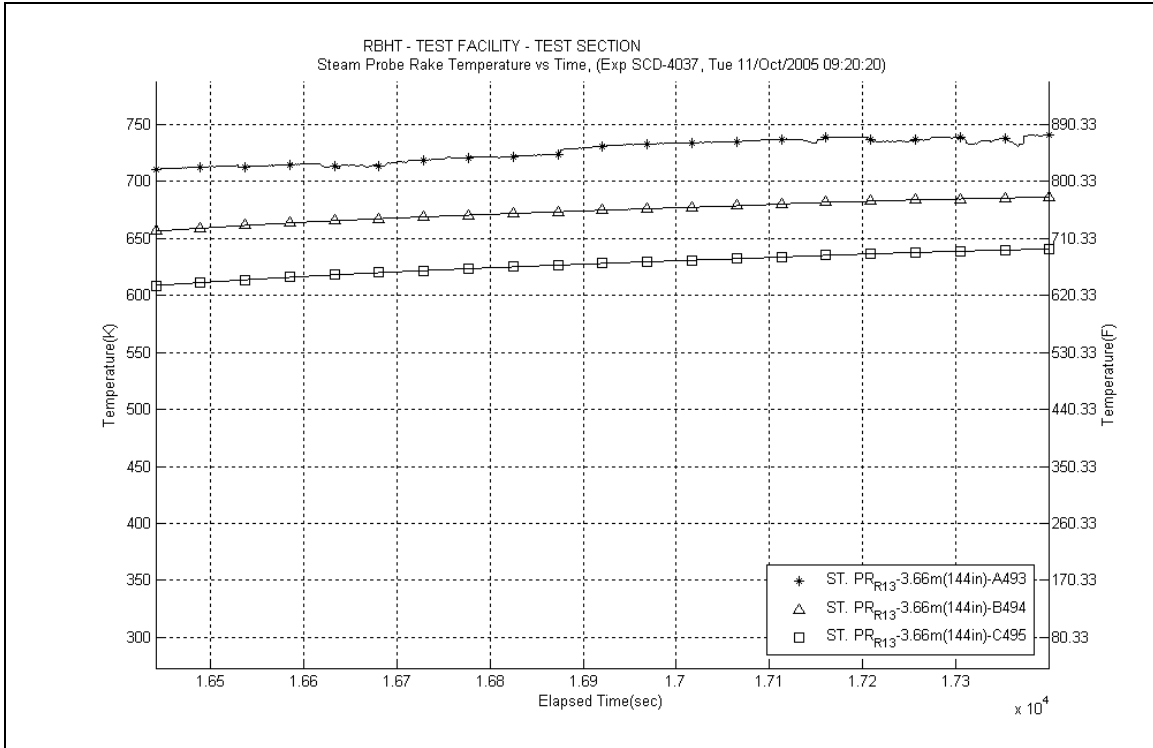

Figure A-316: Steam Probe Rake #13 Temperatures for Experiment 4037A

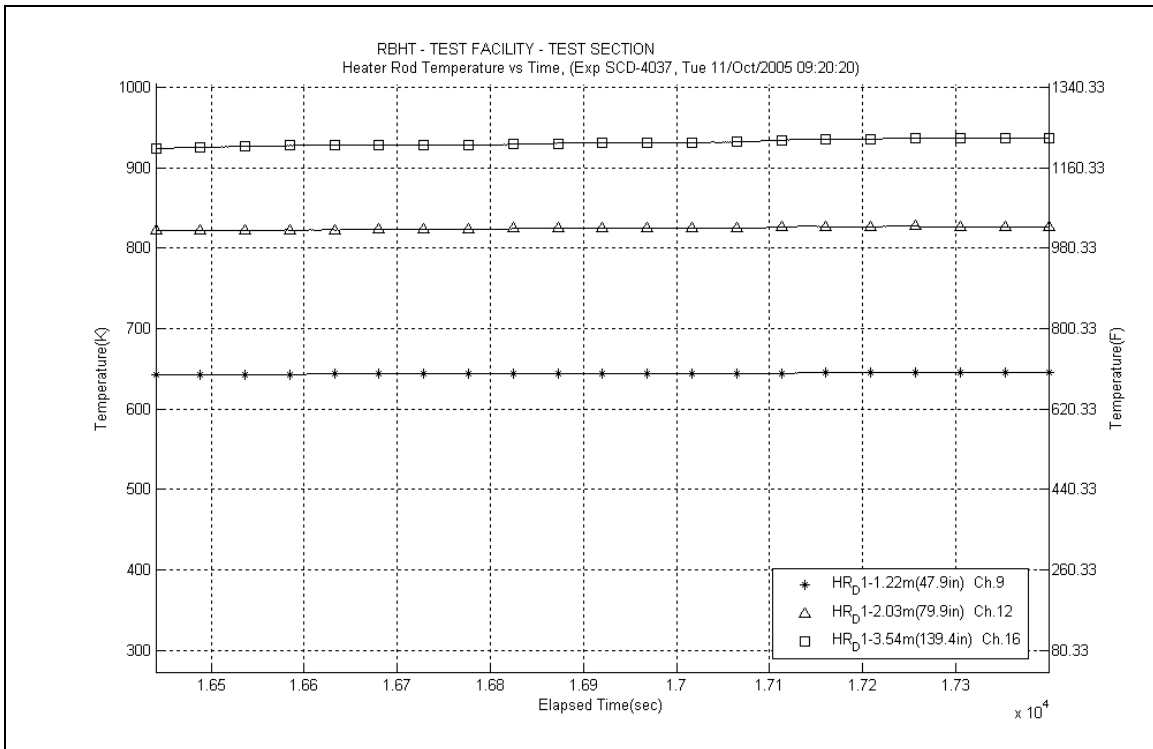

Figure A-317: Heater Rod D1 Temperatures for Experiment 4037A

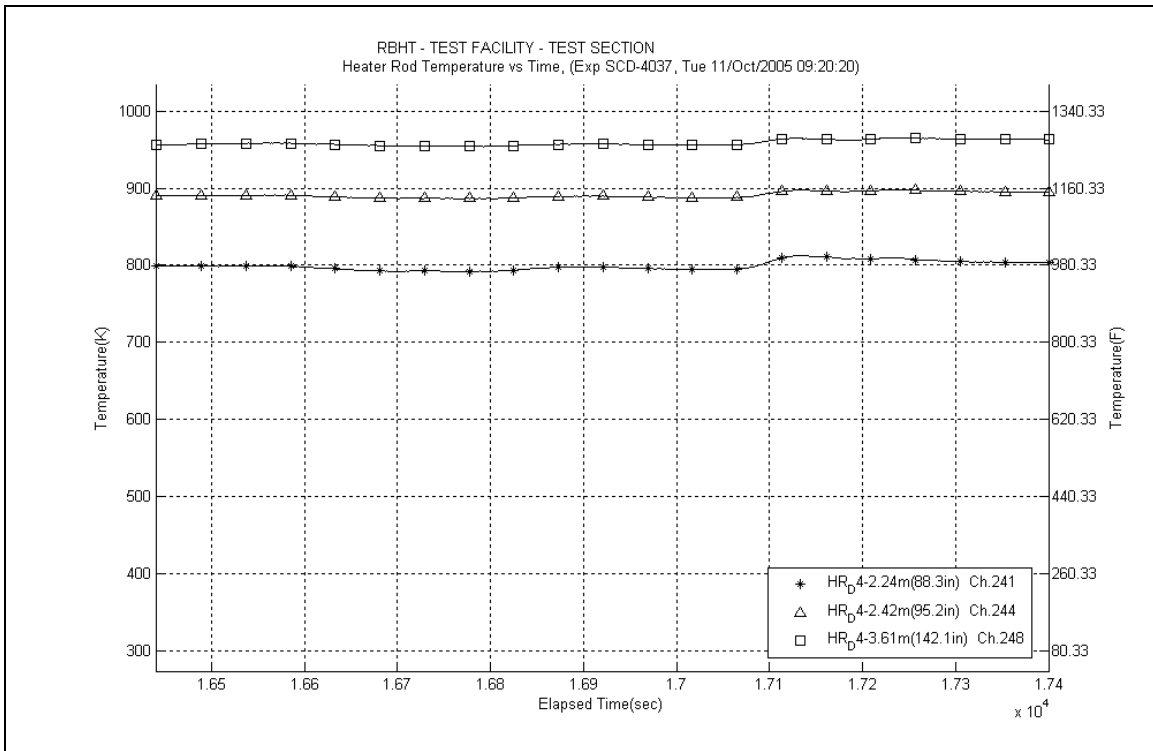

Figure A-318: Heater Rod D4 Temperatures for Experiment 4037A

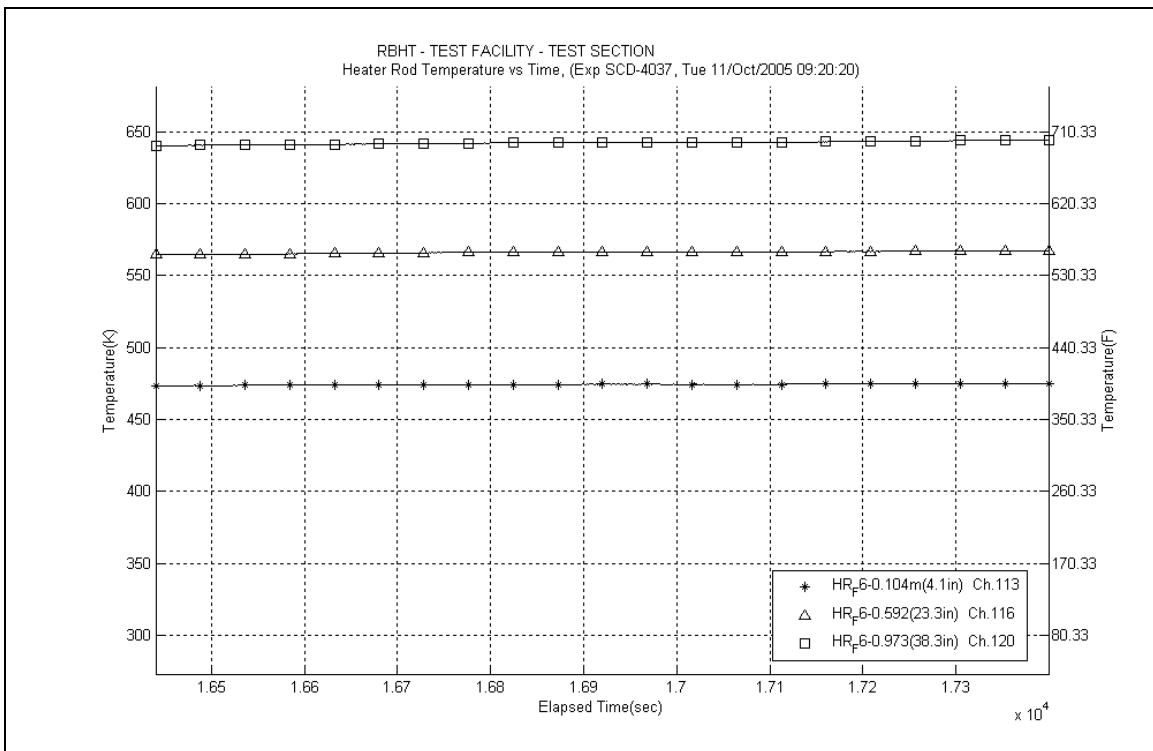

Figure A-319: Heater Rod F6 Temperatures for Experiment 4037A

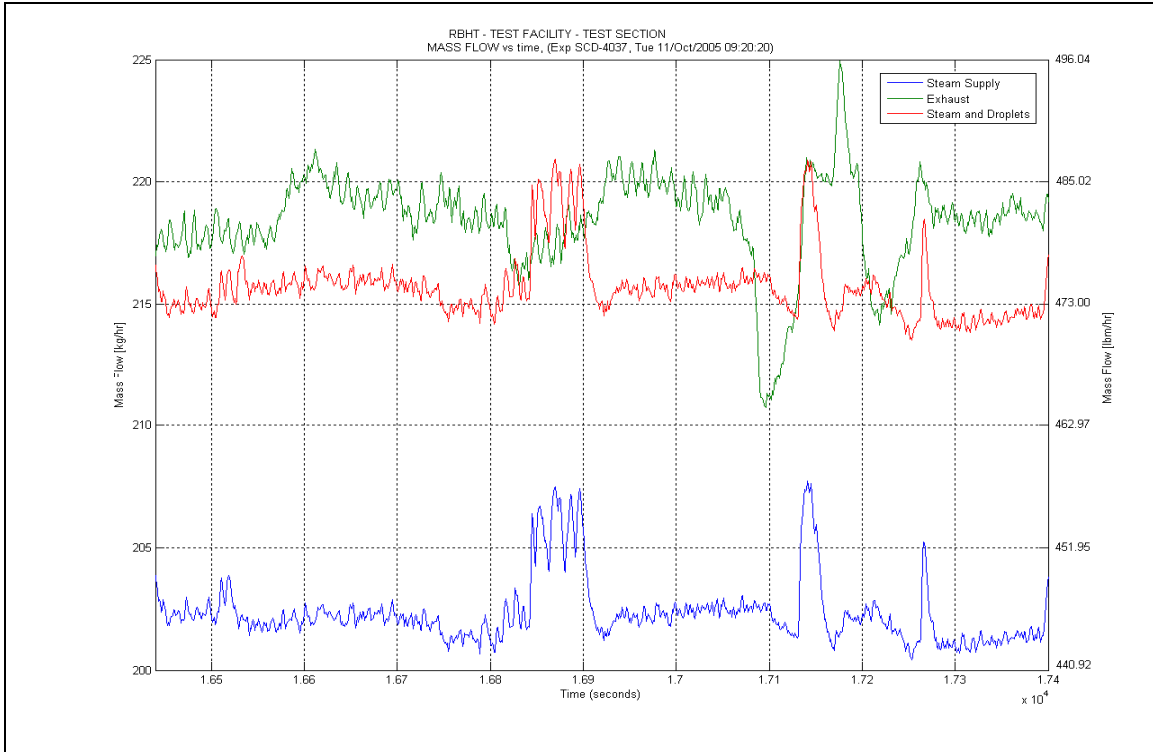

Figure A-320: Mass Flow for Experiment 4037A

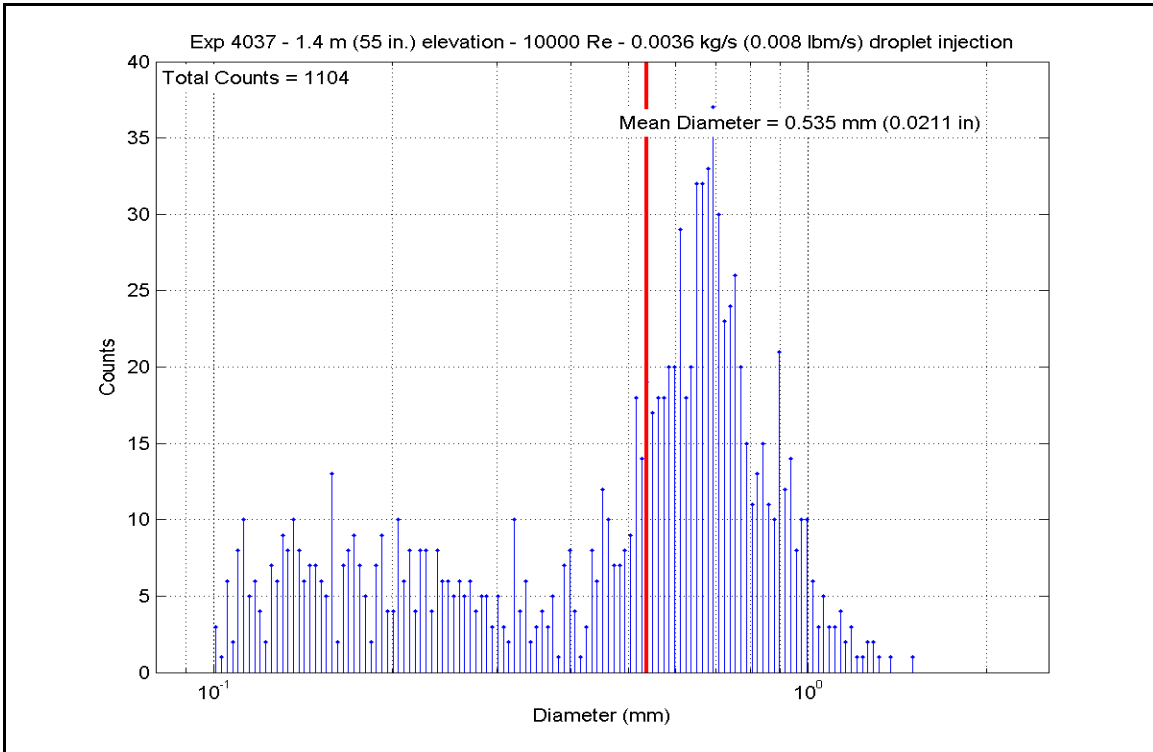

Figure A-321: Droplet Measurements at 1.397 m (55 in.) Elevation for Experiment 4037A

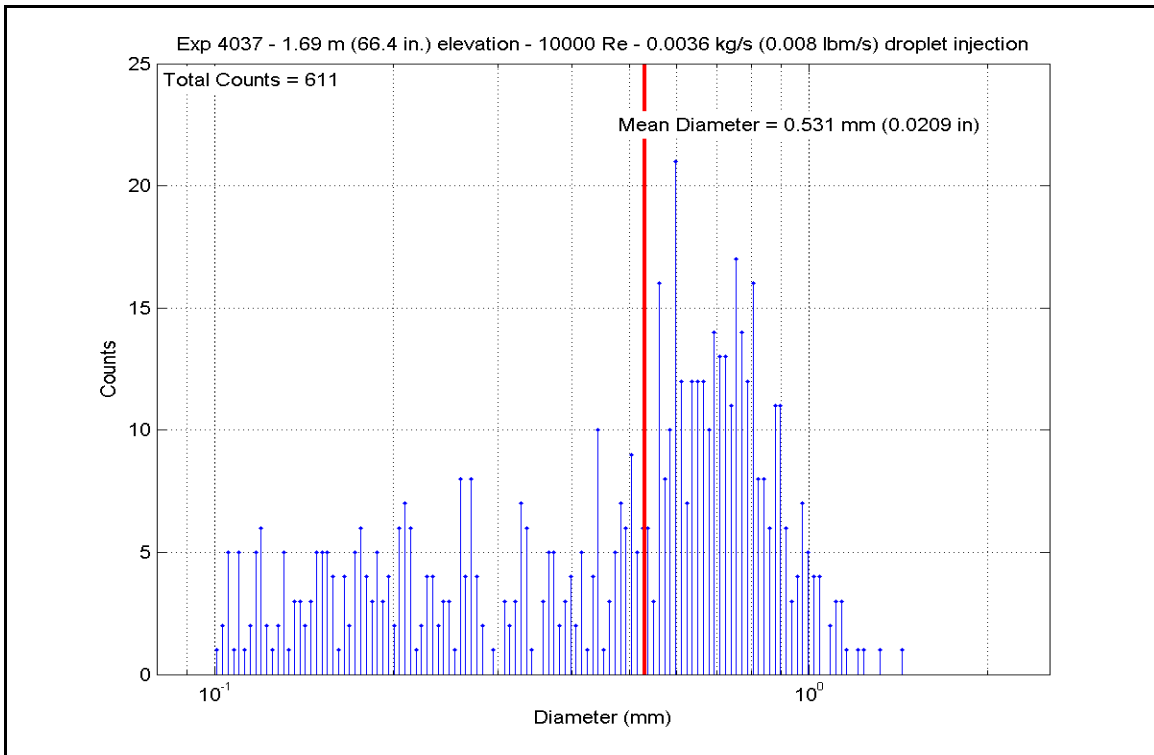

Figure A-322: Droplet Measurements at 1.687 m (66.4 in.) Elevation for Experiment 4037A

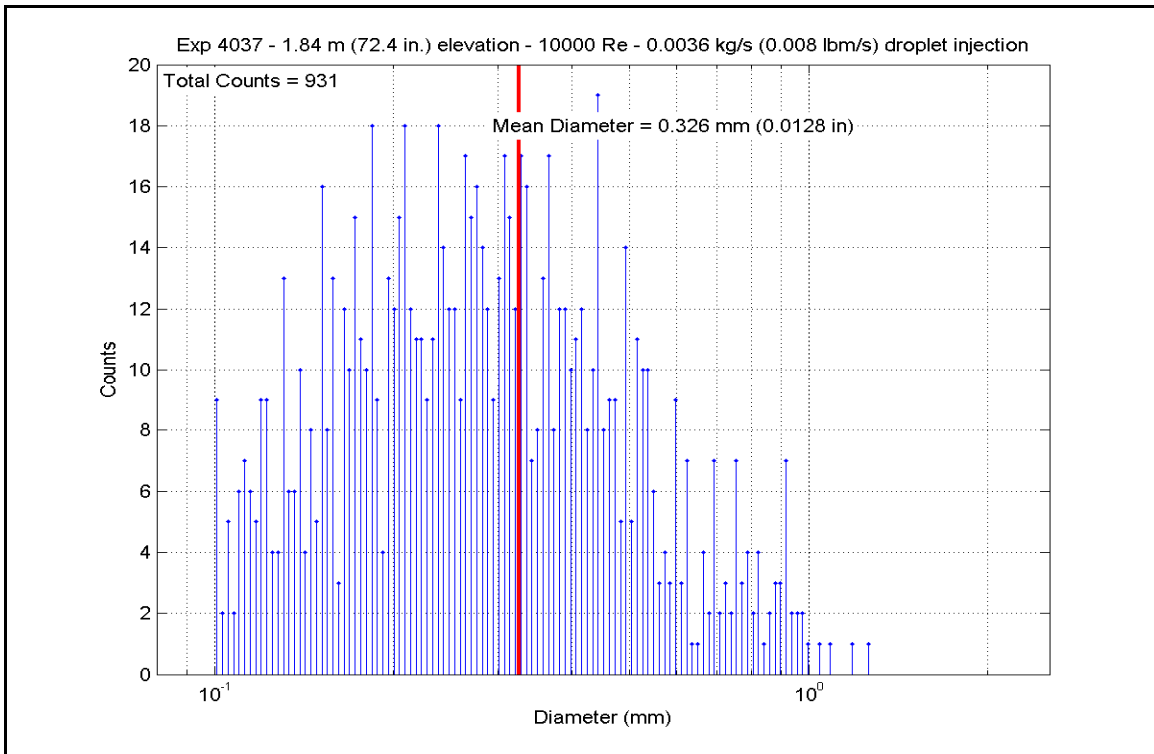

Figure A-323: Droplet Measurements at 1.839 m (72.4 in.) Elevation for Experiment 4037A

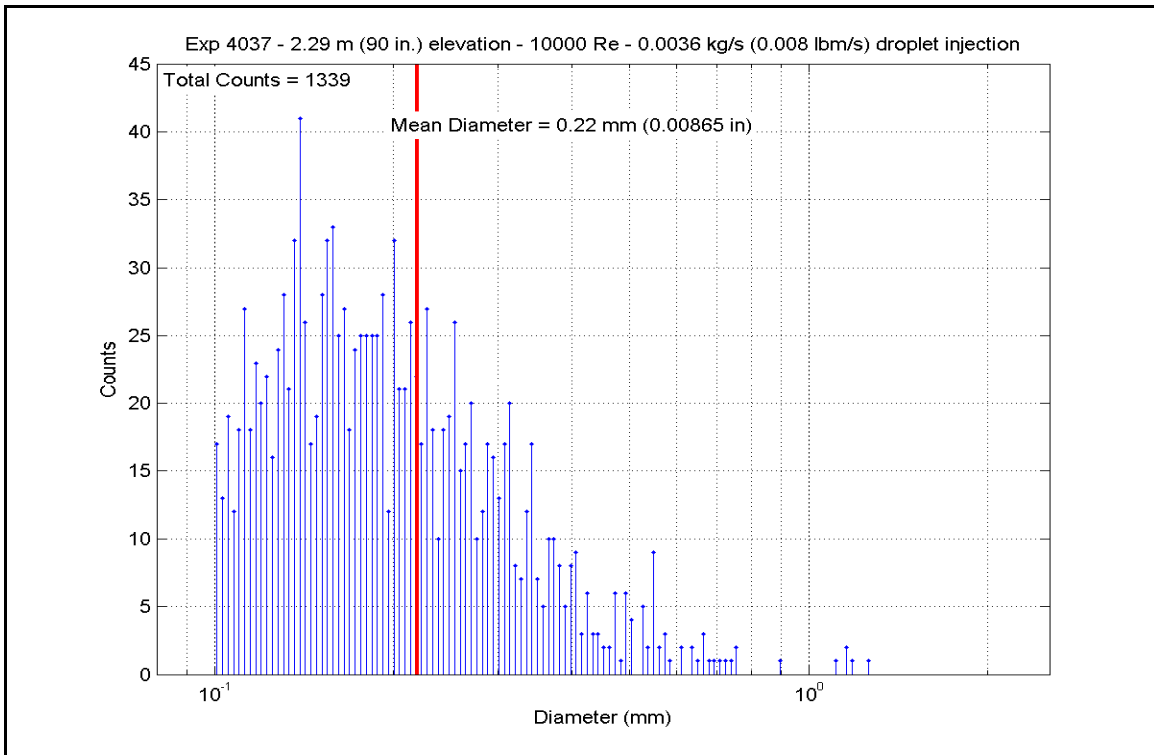

Figure A-324: Droplet Measurements at 2.286 m (90 in.) Elevation for Experiment 4037A

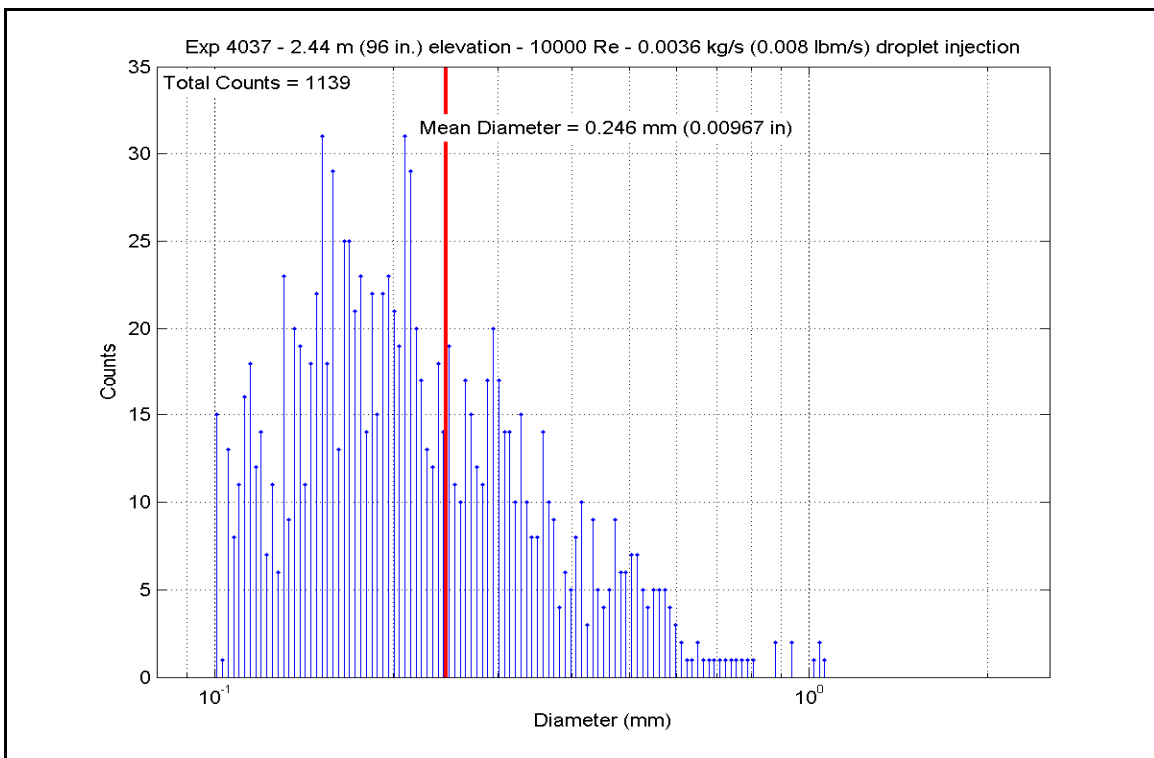

Figure A-325: Droplet Measurements at 2.438 m (96 in.) Elevation for Experiment 4037A

Table A-18: Summary of Steam Cooling t Transfer Reduced Data for Experiment 4037A

SCD-4037-A		Inlet Reynolds: 10000											
Matrix Test # 17a		UP Pressure: 275.8 kPa		40 psia		272971 Btu/hr		80.00 kW		21795.6			
Time Window: 16440-17400		Bundle Power: 0.0554 kg/s		440.0 lbm/hr		8.303		22065.9		8.080			
Inner 3x3		Droplet flow: 0.0036 kg/s		0.008 lbm/s		7.908		23143.0		44.9			
H.R. ID	H.R. Location	Channel Number	Elevation (in)	Elevation (m)	Zgrid (in)	Zgrid (m)	H.R. Tw (°F)	H.R. Tw (K)	H.R. q" (Btu/hr-ft2)	H.R. q" (W/m2)	h _{sat} (z) (Btu/hr-ft2-F)	h _{sat} (z) (W/m2-K)	
Gr-3	RodD3_88.3	185	88.3	2.243	-0.2	-0.005	981.41	800.6	6764.71	21339.3	9.469	53.8	
	RodD3_91.3	186	91.3	2.319	2.8	0.071	1070.04	849.8	6909.37	21795.6	8.604	48.9	
	RodD3_93.1	187	93.1	2.365	4.6	0.117	1109.51	871.8	6995.06	22065.9	8.303	47.1	
	RodD3_95.3	188	95.3	2.421	6.8	0.173	1145.96	892.0	7102.17	22403.8	8.080	45.9	
	RodD3_100.1	189	100.1	2.543	11.6	0.295	1194.76	919.1	7336.52	23143.0	7.908	44.9	
	RodD3_106.1	190	106.1	2.695	17.6	0.447	1265.95	958.7	7619.03	24034.2	7.627	43.3	
	RodD3_110	191	110	2.794	21.5	0.546	1207.50	926.2	7527.58	23745.8	8.004	45.5	
	RodD3_142.1	192	142.1	3.609	8.6	0.218	1263.64	957.4	2600.60	8203.6	2.609	14.8	
	Gr-3	RodC4_88.4	233	88.4	2.245	-0.1	-0.003	989.57	805.1	6846.28	21596.6	9.475	53.8
		RodC4_91.1	234	91.1	2.314	2.6	0.066	1073.50	851.8	6978.91	22015.0	8.653	49.1
		RodC4_93.4	235	93.4	2.372	4.9	0.124	1114.46	874.5	7093.01	22374.9	8.370	47.5
		RodC4_95.3	236	95.3	2.421	6.8	0.173	1144.83	891.4	7184.48	22663.4	8.184	46.5
RodC4_100.1		237	100.1	2.543	11.6	0.295	1180.02	910.9	7416.72	23396.0	8.123	46.1	
RodC4_106.1		238	106.1	2.695	17.6	0.447	1246.51	947.9	7708.41	24316.2	7.870	44.7	
RodC4_110		239	110	2.794	21.5	0.546	1182.33	912.2	7464.06	23545.4	8.155	46.3	
RodC4_142.2		240	142.2	3.612	8.7	0.221	1258.06	954.3	2829.90	8926.9	2.855	16.2	
Gr-3		RodD4_88.3	241	88.3	2.243	-0.2	-0.005	976.70	798.0	6820.31	21514.7	9.610	54.6
		RodD4_91.3	242	91.3	2.319	2.8	0.071	1069.62	849.6	6965.29	21972.0	8.678	49.3
		RodD4_93.2	243	93.2	2.367	4.7	0.119	1109.91	872.0	7057.25	22262.1	8.373	47.5
		RodD4_95.2	244	95.2	2.418	6.7	0.170	1141.61	889.6	7154.52	22568.9	8.180	46.5
	RodD4_100.1	245	100.1	2.543	11.6	0.295	1192.98	918.1	7395.18	23328.1	7.986	45.4	
	RodD4_106.1	246	106.1	2.695	17.6	0.447	1255.54	952.9	7683.05	24236.2	7.772	44.1	
	RodD4_142.1	248	142.1	3.609	8.6	0.218	1265.05	958.2	2732.78	8620.6	2.738	15.5	
	Gr-3	RodE4_88.4	201	88.4	2.245	-0.1	-0.003	984.50	802.3	6716.10	21185.9	9.360	53.2
RodE4_91.2		202	91.2	2.316	2.7	0.069	1074.67	852.4	6845.36	21593.7	8.475	48.1	
RodE4_95.3		204	95.3	2.421	6.8	0.173	1147.41	892.8	7035.31	22192.9	7.991	45.4	
RodE4_100.9		205	100.9	2.563	12.4	0.315	1206.81	925.8	7298.77	23024.0	7.766	44.1	
RodE4_142.3		208	142.3	3.614	8.8	0.224	1271.49	961.8	2758.20	8700.7	2.746	15.6	

Table A-18: Summary of Steam Cooling t Transfer Reduced Data for Experiment 4037A, continued

	H.R. Location	Channel Number	Elevation (in)	Elevation (m)	Zgrid (in)	Zgrid (m)	H.R. Tw (°F)	H.R. Tw (K)	H.R. q" (Btu/hr-ft ²)	H.R. q" (W/m ²)	h _{sat} (z) (Btu/hr-ft ² -F)	h _{sat} (z) (W/m ² -K)
Gr-4	RodE3_63.4	193	63.4	1.610	16.4	0.417	959.26	788.3	5571.24	17574.5	8.048	45.7
	RodE3_113.6	194	113.6	2.885	0.85	0.022	1237.87	943.1	6853.90	21620.6	7.060	40.1
	RodE3_115.5	195	115.5	2.934	2.75	0.070	1270.79	961.4	6596.82	20809.7	6.572	37.3
	RodE3_118.5	196	118.5	3.010	5.75	0.146	1299.61	977.4	6191.75	19531.9	5.996	34.1
	RodE3_122.7	197	122.7	3.117	9.95	0.253	1318.28	987.8	5625.21	17744.7	5.351	30.4
	RodE3_126.5	198	126.5	3.213	13.75	0.349	1317.66	987.4	5112.57	16127.6	4.866	27.6
	RodE3_131.7	199	131.7	3.345	-1.8	-0.046	1241.87	945.3	4421.06	13946.2	4.535	25.8
	RodE3_135.6	200	135.6	3.444	2.1	0.053	1266.25	958.8	3890.59	12272.9	3.894	22.1
	RodC5_63.7	225	63.7	1.618	16.7	0.424	955.79	786.4	5462.04	17230.0	7.930	45.0
	RodC5_113.6	226	113.6	2.885	2.885	0.022	1218.21	932.2	6696.01	21122.6	7.039	40.0
Gr-4	RodE5_115.7	227	115.7	2.939	2.95	0.075	1260.51	955.7	6427.38	20275.2	6.469	36.7
	RodC5_122.7	229	122.7	3.117	9.95	0.253	1309.94	983.1	5530.77	17446.8	5.303	30.1
	RodC5_126.7	230	126.7	3.218	13.95	0.354	1309.21	982.7	5018.57	15831.1	4.815	27.3
	RodC5_131.6	231	131.6	3.343	-1.9	-0.048	1234.48	941.2	4400.27	13880.6	4.548	25.8
	RodC5_135.7	232	135.7	3.447	2.2	0.056	1258.00	954.3	3869.44	12206.1	3.905	22.2
	RodE5_63.6	209	63.6	1.615	16.6	0.422	943.88	779.8	5594.99	17649.4	8.266	46.9
	RodE5_113.6	210	113.6	2.885	0.85	0.022	1225.46	936.2	6898.62	21761.7	7.198	40.9
	RodE5_115.4	211	115.4	2.931	2.65	0.067	1252.91	951.4	6657.79	21002.0	6.753	38.3
	RodE5_118.7	212	118.7	3.015	5.95	0.151	1277.61	965.2	6217.34	19612.6	6.152	34.9
	RodE5_122.6	213	122.6	3.114	9.85	0.250	1301.29	978.3	5699.85	17980.2	5.511	31.3
RodE5_126.6	214	126.6	3.216	13.85	0.352	1303.85	979.7	5168.90	16305.3	4.985	28.3	
RodE5_131.6	215	131.6	3.343	-1.9	-0.048	1234.24	941.1	4514.27	14240.3	4.667	26.5	
RodE5_135.6	216	135.6	3.444	2.1	0.053	1257.26	953.8	3979.63	12553.7	4.019	22.8	
Gr-5	RodC3_79.8	177	79.8	2.027	8.92	0.227	1011.75	817.5	6324.31	19950.0	8.492	48.2
	RodC3_85.6	178	85.6	2.174	14.72	0.374	978.22	798.8	6599.55	20818.3	9.279	52.7
	RodC3_88.5	179	88.5	2.248	0	0.000	977.12	798.2	6737.27	21252.7	9.488	53.9
	RodC3_92.4	180	92.4	2.347	3.9	0.099	1084.10	857.6	6921.21	21832.9	8.470	48.1
	RodC3_94.4	181	94.4	2.398	5.9	0.150	1116.32	875.5	7014.93	22128.6	8.259	46.9
	RodC3_97.2	182	97.2	2.469	8.7	0.221	1155.68	897.4	7147.45	22546.6	8.043	45.7
	RodC3_108.8	183	108.8	2.764	20.3	0.516	1239.08	943.8	7535.46	23770.6	7.752	44.0
	RodD5_50	217	50	1.270	1.270	0.076	812.55	706.8	4943.21	15593.3	9.061	51.5
	RodD5_54.1	218	54.1	1.374	840.95	0.180	840.95	722.6	5142.03	16220.5	8.959	50.9
	RodD5_56.9	219	56.9	1.445	892.88	0.251	892.88	751.4	5276.53	16644.8	8.431	47.9
RodD5_60	220	60	1.524	927.17	0.330	927.17	770.5	5424.75	17112.4	8.217	46.7	
RodD5_66.1	221	66.1	1.679	968.84	0.485	968.84	793.6	5707.96	18005.8	8.133	46.2	
RodD5_69.9	222	69.9	1.775	1011.75	-0.025	848.97	727.0	5892.73	18588.6	10.126	57.5	
RodD5_72.9	223	72.9	1.852	1011.75	0.051	921.76	767.5	6032.56	19029.7	9.213	52.3	
RodD5_74.9	224	74.9	1.902	966.76	0.102	966.76	792.5	6126.14	19324.9	8.755	49.7	

Inner 3x3

Table A-18: Summary of Steam Cooling t Transfer Reduced Data for Experiment 4037A, continued

H.R. ID	H.R. Location	Channel Number	Elevation (in)	Elevation (m)	Zgrid (in)	Zgrid (m)	H.R. Tw (°F)	H.R. Tw (K)	H.R. q" (Btu/hr-ft ²)	H.R. q" (W/m ²)	h _{sat} (z) (Btu/hr-ft ² -F)	h _{sat} (z) (W/m ² -K)	
Gr-2	RodB5_41	153	41	1.041	13.5	0.343	737.34	665.0	4496.48	14184.1	9.560	54.3	
	RodB5_52.9	154	52.9	1.344	5.9	0.150	793.28	696.1	5073.74	16005.1	9.641	54.7	
	RodB5_55	155	55	1.397	8	0.203	838.52	721.2	5178.29	16334.9	9.061	51.5	
	RodB5_57.8	156	57.8	1.468	10.8	0.274	887.87	748.6	5316.03	16769.4	8.562	48.6	
	RodB5_64	157	64	1.626	17	0.432	945.49	780.6	5609.63	17695.6	8.268	47.0	
	RodB5_73.9	158	73.9	1.877	3.02	0.077	943.12	779.3	6082.07	19185.9	8.996	51.1	
	RodB5_75.9	159	75.9	1.928	5.02	0.128	980.54	800.1	6175.88	19481.8	8.655	49.2	
	RodB5_76.9	160	76.9	1.953	6.02	0.153	996.26	808.9	6223.02	19630.5	8.533	48.5	
	Gr-2	RodF5_41	105	41	1.041	13.5	0.343	730.62	661.3	4460.59	14070.9	9.621	54.6
		RodF5_53.1	106	53.1	1.349	6.1	0.155	797.51	698.4	5045.37	15915.6	9.510	54.0
		RodF5_55	107	55	1.397	8	0.203	833.18	718.2	5134.15	16195.7	9.068	51.5
		RodF5_57.8	108	57.8	1.468	10.8	0.274	876.73	742.4	5270.17	16624.8	8.644	48.1
		RodF5_64	109	64	1.626	17	0.432	923.81	768.6	5566.83	17560.6	8.476	48.1
		RodF5_73.8	110	73.8	1.875	2.92	0.074	915.85	764.2	6038.35	19048.0	9.306	52.8
		RodF5_75.8	111	75.8	1.925	4.92	0.125	954.72	785.8	6132.35	19344.5	8.917	50.6
		RodF5_76.8	112	76.8	1.951	5.92	0.150	970.77	794.7	6179.79	19494.1	8.781	49.9
Gr-2		RodC2_41	57	41	1.041	13.5	0.343	732.00	662.0	4483.22	14142.3	9.641	54.8
		RodC2_53.1	58	53.1	1.349	6.1	0.155	851.70	728.5	5065.41	15978.8	8.663	49.2
		RodC2_55	59	55	1.397	8	0.203	869.27	738.3	5156.48	16266.1	8.562	48.6
		RodC2_57.8	60	57.8	1.468	10.8	0.274	897.60	754.0	5290.75	16689.7	8.390	47.6
	RodC2_63.9	61	63.9	1.623	16.9	0.429	926.61	770.2	5582.02	17608.5	8.463	48.1	
	RodC2_73.8	62	73.8	1.875	2.92	0.074	926.83	770.3	6051.94	19090.9	9.172	52.1	
	RodC2_75.8	63	75.8	1.925	4.92	0.125	955.78	786.4	6146.93	19390.5	8.924	50.7	
	RodC2_76.8	64	76.8	1.951	5.92	0.150	967.40	792.8	6194.62	19540.9	8.844	50.2	
Gr-2	RodC6_40.9	137	40.9	1.039	13.4	0.340	733.85	663.1	4468.39	14095.5	9.571	54.4	
	RodC6_52.8	138	52.8	1.341	5.8	0.147	852.79	729.1	5065.71	15979.8	8.648	49.1	
	RodC6_54.8	139	54.8	1.392	7.8	0.198	874.43	741.2	5164.70	16292.0	8.503	48.3	
	RodC6_57.8	140	57.8	1.468	10.8	0.274	907.49	759.5	5315.62	16768.1	8.299	47.1	
	RodC6_63.8	141	63.8	1.621	16.8	0.427	943.18	779.4	5615.39	17713.8	8.305	47.2	
	RodC6_73.7	142	73.7	1.872	2.82	0.072	979.41	799.5	6109.78	19273.3	8.576	48.7	
	RodC6_75.8	143	75.8	1.925	4.92	0.125	1005.40	813.9	6214.53	19603.7	8.416	47.8	
	RodC6_76.8	144	76.8	1.951	5.92	0.150	1022.47	823.4	6265.15	19763.4	8.293	47.1	

5x5 periphery

Table A-18: Summary of Steam Cooling t Transfer Reduced Data for Experiment 4037A, continued

5x5 periphery		H.I.R. Location	Channel Number	Elevation (in)	Elevation (m)	Zgrid (in)	Zgrid (m)	H.R. Tw (°F)	H.R. Tw (K)	H.R. q" (Btu/hr-ft ²)	H.R. q" (W/m ²)	h _{sat} (Z) (Btu/hr-ft ² -F)	h _{sat} (Z) (W/m ² -K)
Gr-3	RodB4_88.4	161	88.4	2.245	-0.1	-0.003	792.1	843.5	6718.73	21194.2	9.610	54.6	
	RodB4_91.3	162	91.3	2.319	2.8	0.071	1058.66	8653.45	21619.2	8.657	8.657	49.2	
	RodB4_93.3	163	93.3	2.370	4.8	0.122	1096.99	8648.49	21909.5	8.368	8.368	47.5	
	RodB4_95.1	164	95.1	2.416	6.6	0.168	1124.34	880.0	7027.45	22168.1	8.197	46.5	
	RodB4_100	165	100	2.540	11.5	0.292	1152.99	895.9	7252.47	22877.9	8.186	46.5	
	RodB4_106	166	106	2.692	17.5	0.445	1218.31	932.2	7531.27	23757.4	7.917	45.0	
	RodB4_109.9	167	109.9	2.791	21.4	0.544	1151.98	895.4	7294.42	23010.2	8.242	46.8	
	RodB4_142.3	168	142.3	3.614	8.8	0.224	1233.35	940.6	2812.53	8872.1	2.910	16.5	
Gr-5	RodF4_85.6	98	85.6	2.174	14.72	0.374	994.58	807.9	6625.87	20901.3	9.107	51.7	
	RodF4_88.4	99	88.4	2.245	-0.1	-0.003	995.11	808.2	6750.63	21294.9	9.271	52.7	
	RodF4_92.4	100	92.4	2.347	3.9	0.099	1096.09	864.3	6940.18	21892.8	8.371	47.5	
	RodF4_94.3	101	94.3	2.395	5.8	0.147	1128.79	882.5	7030.35	22177.2	8.158	46.3	
	RodF4_97.2	102	97.2	2.469	8.7	0.221	1169.02	904.8	7168.54	22613.2	7.947	45.1	
	RodF4_108.8	103	108.8	2.764	20.3	0.516	1241.66	945.2	7569.37	23877.6	7.766	44.1	
	RodF4_111	104	111	2.819	-1.75	-0.044	1169.56	905.1	7265.15	22917.9	8.049	45.7	
	RodD2_103.2	65	103.2	2.621	14.7	0.373	1237.28	942.7	6668.74	21036.5	6.873	39.0	
Gr-6	RodD2_106	66	106	2.692	17.5	0.445	1258.60	954.6	6313.38	19915.6	6.367	36.2	
	RodD2_112.6	67	112.6	2.860	-0.15	-0.004	1284.74	969.1	5829.01	18387.6	5.727	32.5	
	RodD2_114.9	68	114.9	2.918	2.15	0.055	1293.36	973.9	5259.58	16591.4	5.124	29.1	
	RodD2_117.4	69	117.4	2.982	4.65	0.118	1286.94	970.3	4720.82	14891.8	4.629	26.3	
	RodD2_120.8	70	120.8	3.068	8.05	0.204	1224.20	935.5	7489.69	23626.2	7.825	44.4	
	RodD2_124.8	71	124.8	3.170	12.05	0.306	1244.85	947.0	7623.42	24048.1	7.796	44.3	
	RodD2_128.6	72	128.6	3.266	15.85	0.403	1189.67	916.3	6995.23	22066.5	7.582	43.1	
	RodD6_103.1	129	103.1	2.619	14.6	0.371	1242.60	945.7	7511.94	23696.4	7.700	43.7	
Gr-6	RodD6_106	130	106	2.692	17.5	0.445	1259.82	955.3	7649.74	24131.1	7.705	43.8	
	RodD6_112.9	131	112.9	2.868	0.15	0.004	1213.36	929.5	6984.38	22032.2	7.380	41.9	
	RodD6_114.9	132	114.9	2.918	2.15	0.055	1253.59	951.8	6695.05	21119.5	6.786	38.5	
	RodD6_116.8	133	116.8	2.967	4.05	0.103	1273.42	962.8	6420.67	20254.0	6.380	36.2	
	RodD6_120.9	134	120.9	3.071	8.15	0.207	1290.60	972.4	5831.65	18396.0	5.697	32.4	
	RodD6_124.8	135	124.8	3.170	12.05	0.306	1297.43	976.2	5271.44	16628.8	5.116	29.1	
	RodD6_128.7	136	128.7	3.269	15.95	0.405	1292.34	973.3	4712.26	14864.8	4.596	26.1	

Table A-18: Summary of Steam Cooling t Transfer Reduced Data for Experiment 4037A, continued

5x5 periphery		H.R. Location	Channel Number	Elevation (in)	Elevation (m)	Zgrid (in)	Zgrid (m)	H.R. Tw (°F)	H.R. Tw (K)	H.R. q" (Btu/hr-ft ²)	H.R. q" (W/m ²)	h _{sat} (z) (Btu/hr-ft ² -F)	h _{sat} (z) (W/m ² -K)
Gr-8	RodE2_50.1	73	50.1	1.273	3.1	0.079	796.46	697.8	4956.05	15633.9	9.361	53.2	
	RodE2_54	74	54	1.372	7	0.178	862.56	734.6	5144.50	16228.3	8.638	49.1	
	RodE2_56.9	75	56.9	1.445	9.9	0.251	895.13	752.7	5285.27	16672.4	8.414	47.8	
	RodE2_59.9	76	59.9	1.521	12.9	0.328	925.71	769.7	5431.67	17134.2	8.246	46.8	
	RodE2_66	77	66	1.676	19	0.483	951.35	783.9	5725.80	18062.0	8.367	47.5	
	RodE2_69.8	78	69.8	1.773	-1.08	-0.027	854.07	729.9	5917.38	18666.4	10.080	57.2	
	RodE2_72.9	79	72.9	1.852	2.02	0.051	923.39	768.4	6062.05	19122.7	9.235	52.4	
	RodE2_74.9	80	74.9	1.902	4.02	0.102	956.46	786.7	6156.93	19422.0	8.930	50.7	
Gr-8	RodB3_50.2	169	50.2	1.275	3.2	0.081	757.28	676.1	4934.28	15565.2	10.064	57.2	
	RodB3_54.1	170	54.1	1.374	7.1	0.180	803.30	701.6	5121.74	16156.5	9.550	54.2	
	RodB3_56.9	171	56.9	1.445	9.9	0.251	839.39	721.7	5253.71	16572.8	9.179	52.1	
	RodB3_60.1	172	60.1	1.527	13.1	0.333	841.78	723.0	5403.36	17044.9	9.401	53.4	
	RodB3_66.1	173	66.1	1.679	19.1	0.485	908.15	759.9	5689.07	17946.2	8.873	50.4	
	RodB3_69.9	174	69.9	1.775	-0.98	-0.025	777.74	687.5	5870.55	18518.7	11.494	65.3	
	RodB3_73	175	73	1.854	2.12	0.054	878.74	743.6	6019.60	18988.8	9.840	55.9	
	RodB3_75	176	75	1.905	4.12	0.105	923.28	768.3	6115.48	19291.3	9.318	52.9	
Gr-8	RodF3_50.1	89	50.1	1.273	3.1	0.079	777.90	687.5	4932.93	15560.9	9.655	54.8	
	RodF3_54	90	54	1.372	7	0.178	838.47	721.2	5125.91	16169.7	8.970	50.9	
	RodF3_57	91	57	1.448	10	0.254	881.43	745.1	5273.74	16636.0	8.583	48.7	
	RodF3_60	92	60	1.524	13	0.330	913.24	762.7	5420.11	17097.7	8.387	47.6	
	RodF3_66.1	93	66.1	1.679	19.1	0.485	940.54	777.9	5714.13	18025.2	8.484	48.2	
	RodF3_70	94	70	1.778	-0.88	-0.022	826.15	714.3	5910.01	18643.1	10.570	60.0	
	RodF3_73	95	73	1.854	2.12	0.054	922.16	767.7	6052.02	19091.1	9.238	52.5	
	RodF3_75	96	75	1.905	4.12	0.105	967.22	792.7	6148.27	19394.7	8.780	49.9	
Gr-8	RodE6_50.2	121	50.2	1.275	3.2	0.081	789.40	693.9	4927.27	15543.1	9.432	53.6	
	RodE6_54.1	122	54.1	1.374	7.1	0.180	850.36	727.8	5111.59	16124.5	8.762	49.8	
	RodE6_57	123	57	1.448	10	0.254	880.87	744.7	5249.59	16559.8	8.552	48.6	
	RodE6_60.2	124	60.2	1.529	13.2	0.335	908.05	759.8	5401.96	17040.5	8.427	47.9	
	RodE6_66.1	125	66.1	1.679	19.1	0.485	936.24	775.5	5681.66	17922.8	8.490	48.2	
	RodE6_70	126	70	1.778	-0.88	-0.022	868.29	737.8	5867.78	18509.9	9.759	55.4	
	RodE6_73.1	127	73.1	1.857	2.22	0.056	941.27	778.3	6012.98	18967.9	8.918	50.6	
	RodE6_75	128	75	1.905	4.12	0.105	976.42	797.8	6101.82	19248.2	8.601	48.8	

RBHT Steam Cooling with Droplet Injection Test SCD-4037-B

Matrix Test # 17b

Test Conditions

Test Date – 10/11/2005

Steady State Time Window: 17880 - 18540

Upper Plenum Pressure: 2.76 bar (40 psia)

Bundle Power: 80.0 kW

Bundle Inlet Reynolds Number: 10000

Bundle Inlet Steam Flow: 199.76 kg/hr (440 lbm/hr)

Droplet Injection Flow: 0.0073 kg/s (0.016 lbm/s)

Droplet Injection Hole Diameter: 0.381 mm (.015 in)

Droplet Injection Elevation: 1.295 m (51 in)

Bundle Flow Area: $4.656 \times 10^{-3} \text{ m}^2$ ($5.012 \times 10^{-2} \text{ ft}^2$)

Test Notes

- No steam probes were traversed in this steady state window.

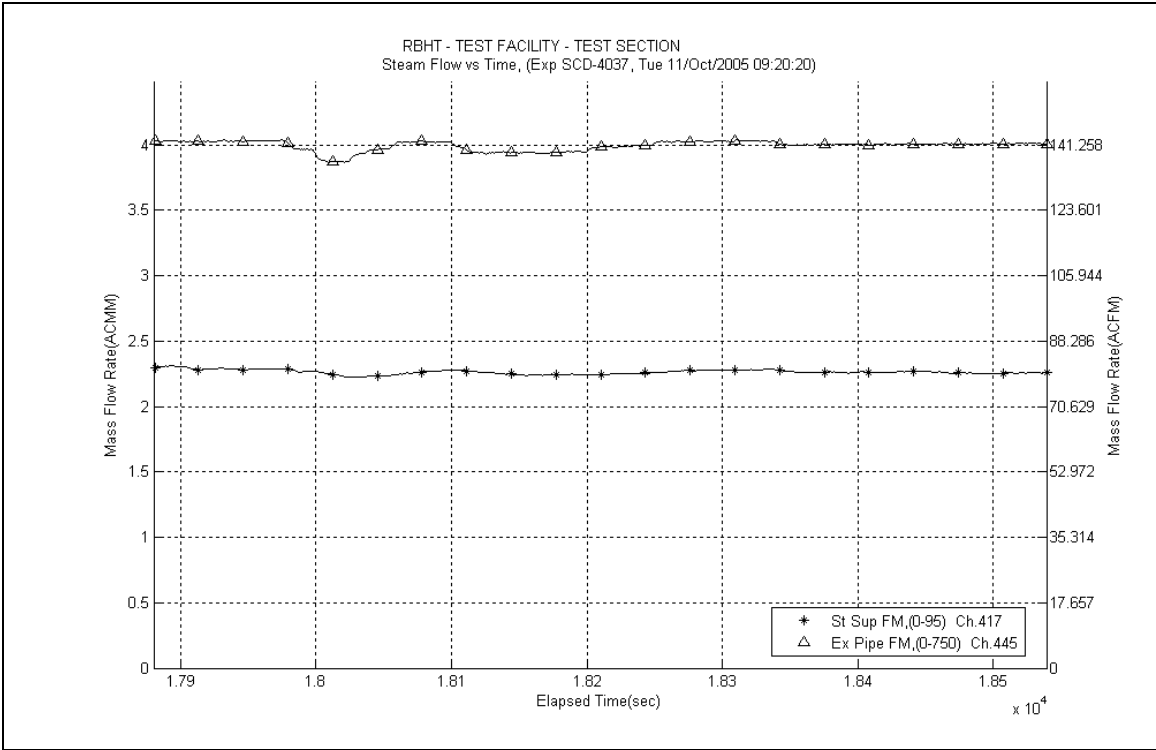

Figure A-326: Inlet and Exhaust Steam Flow Rates for Experiment 4037B

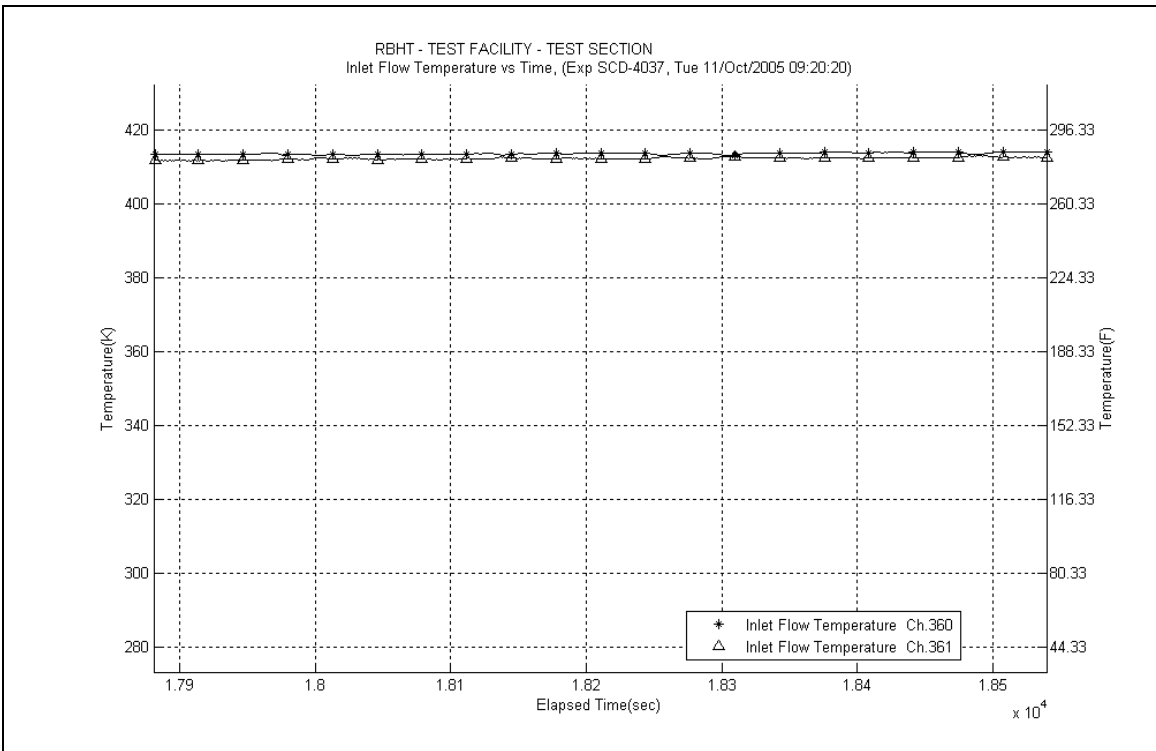

Figure A-327: Inlet Steam Temperature for Experiment 4037B

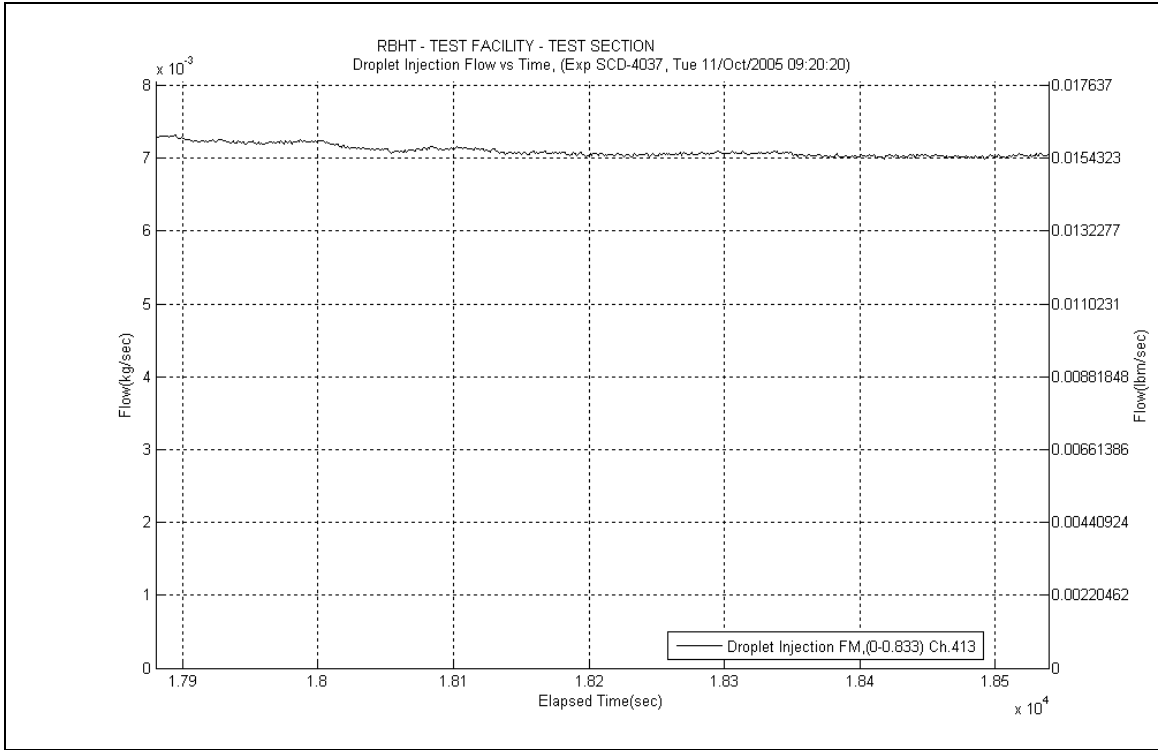

Figure A-328: Droplet Injection Flow Rate for Experiment 4037B

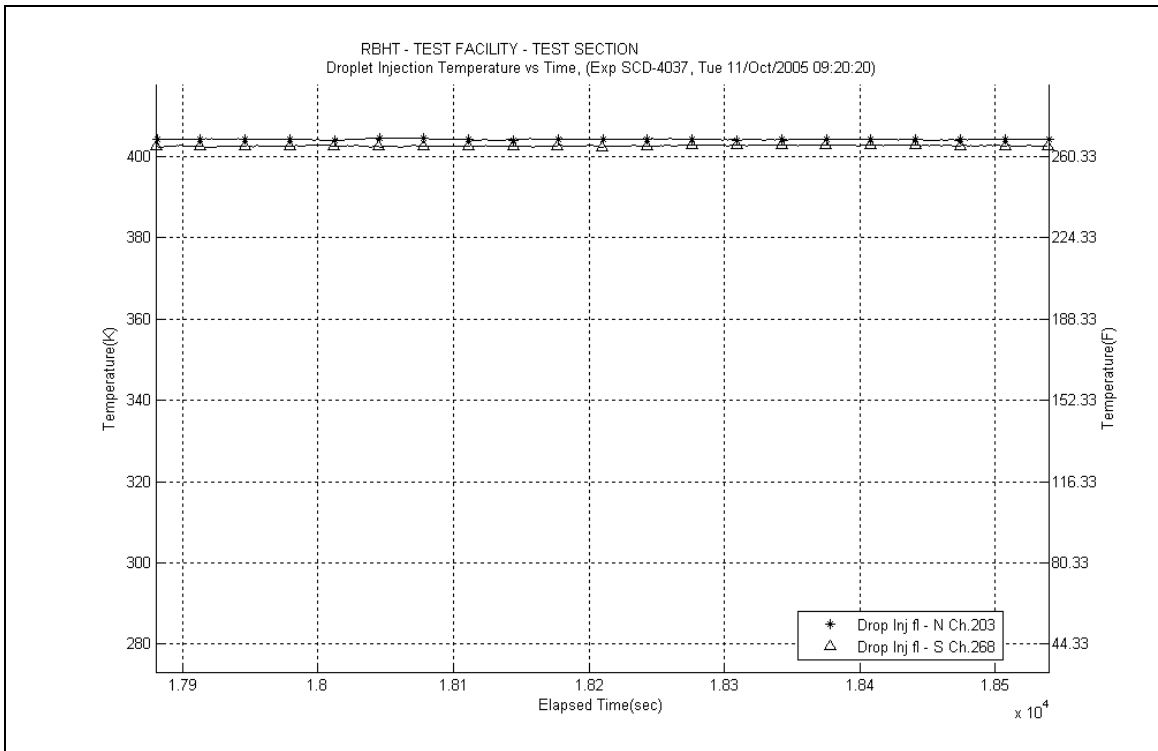

Figure A-329: Droplet Injection Temperature for Experiment 4037B

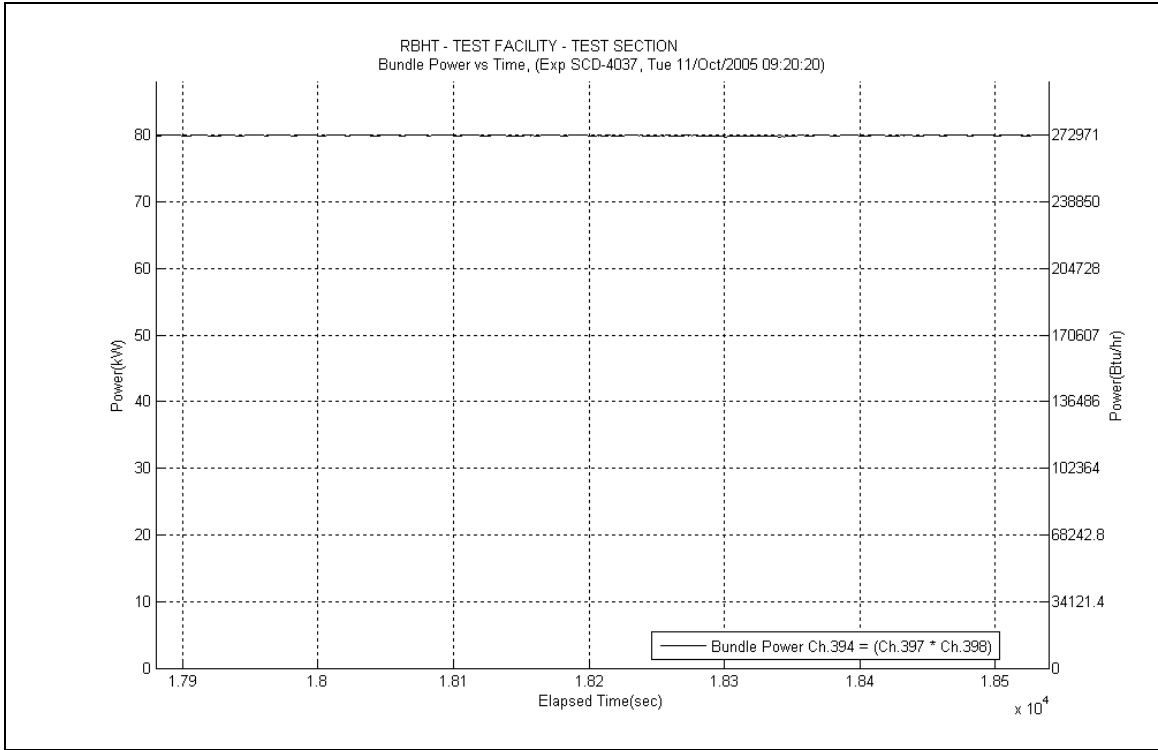

Figure A-330: Bundle Power for Experiment 4037B

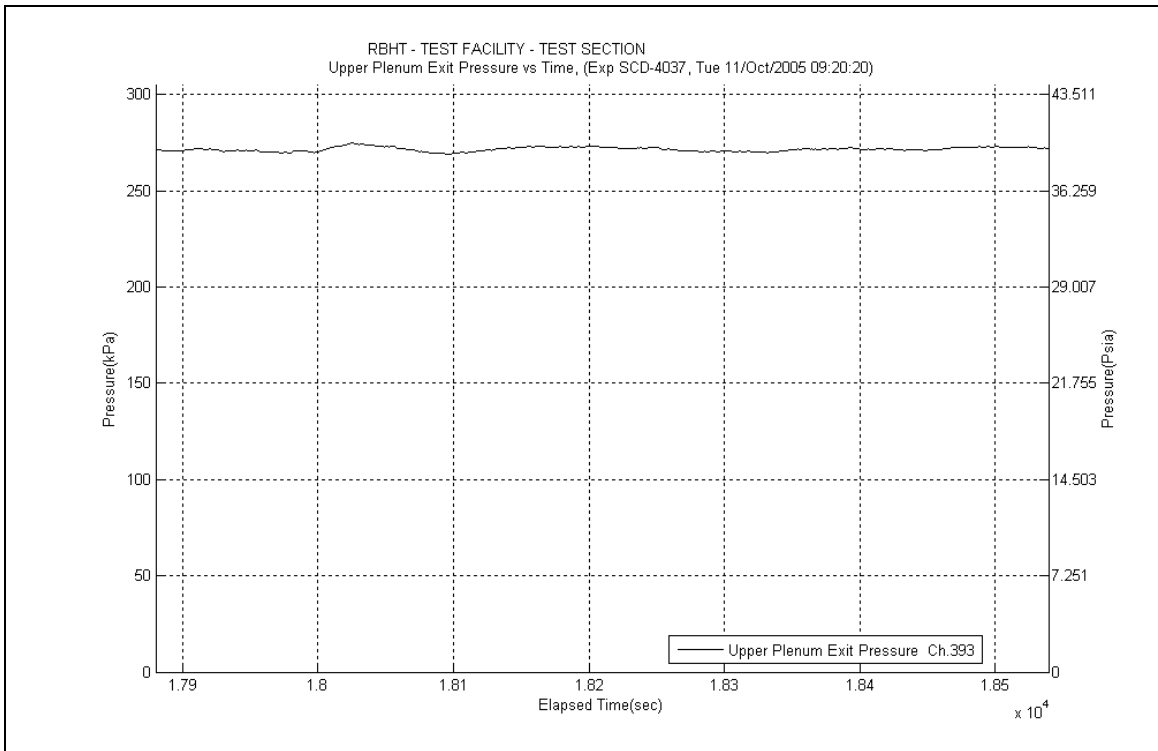

Figure A-331: Upper Plenum Pressure for Experiment 4037B

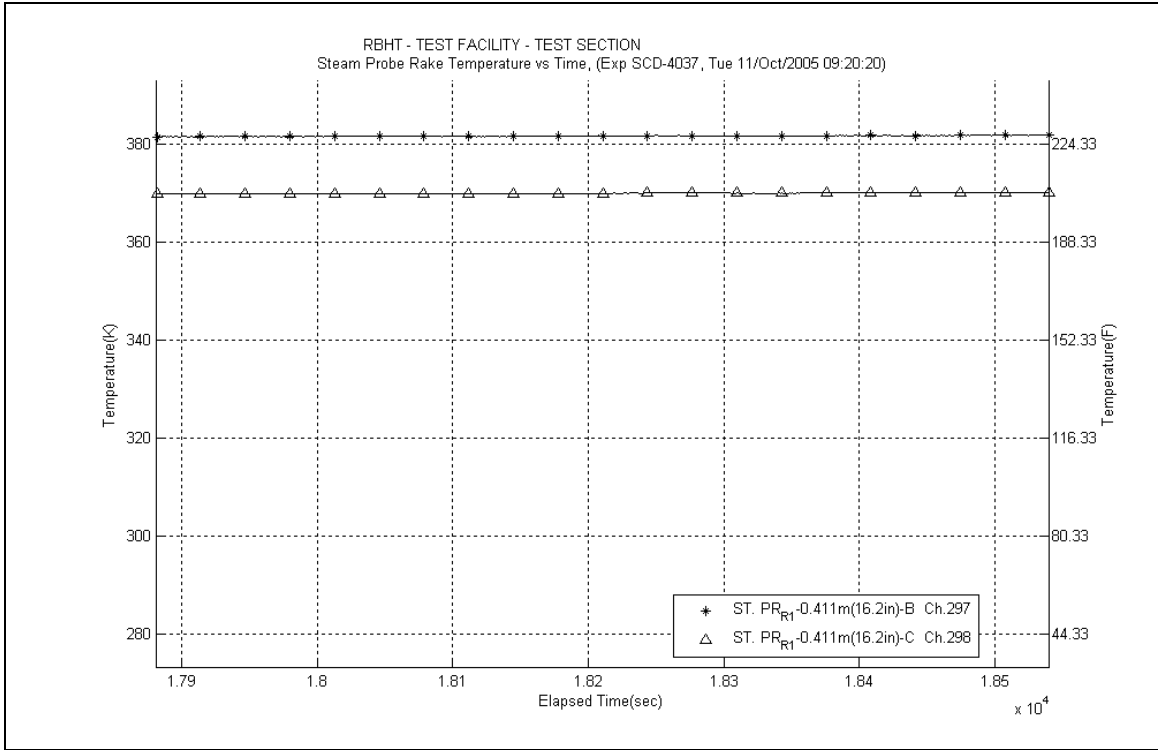

Figure A-332: Steam Probe Rake #1 Temperatures for Experiment 4037B

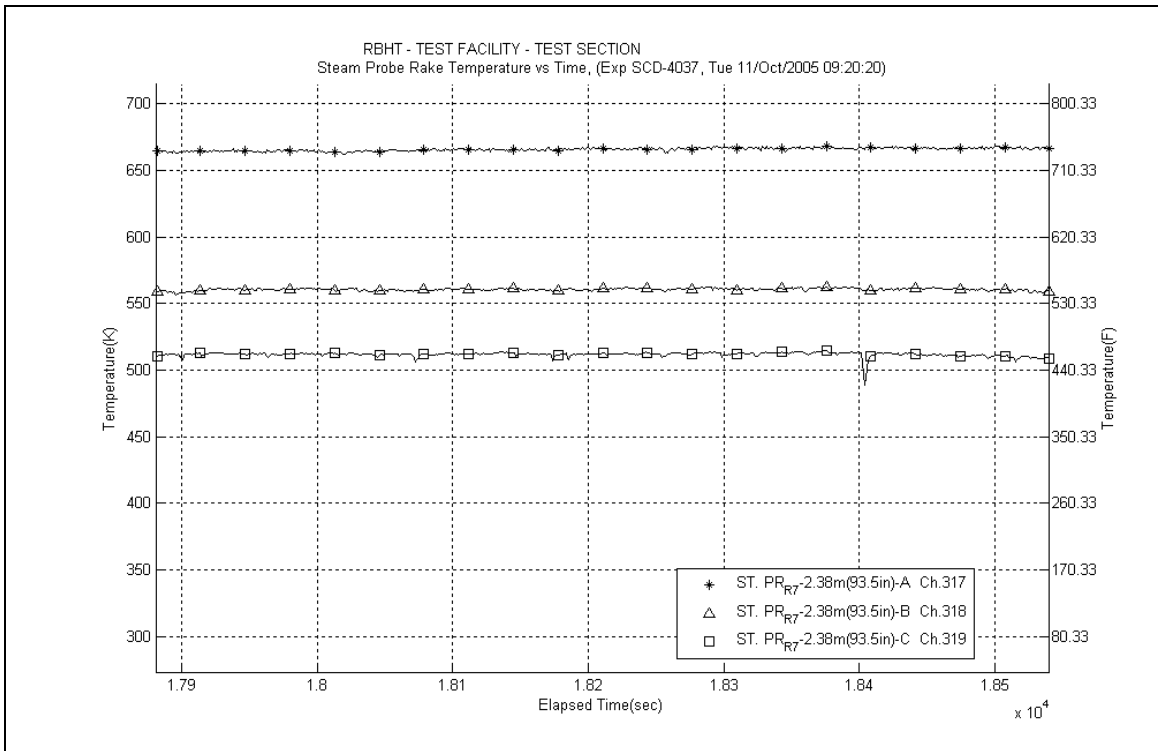

Figure A-333: Steam Probe Rake #7 Temperatures for Experiment 4037B

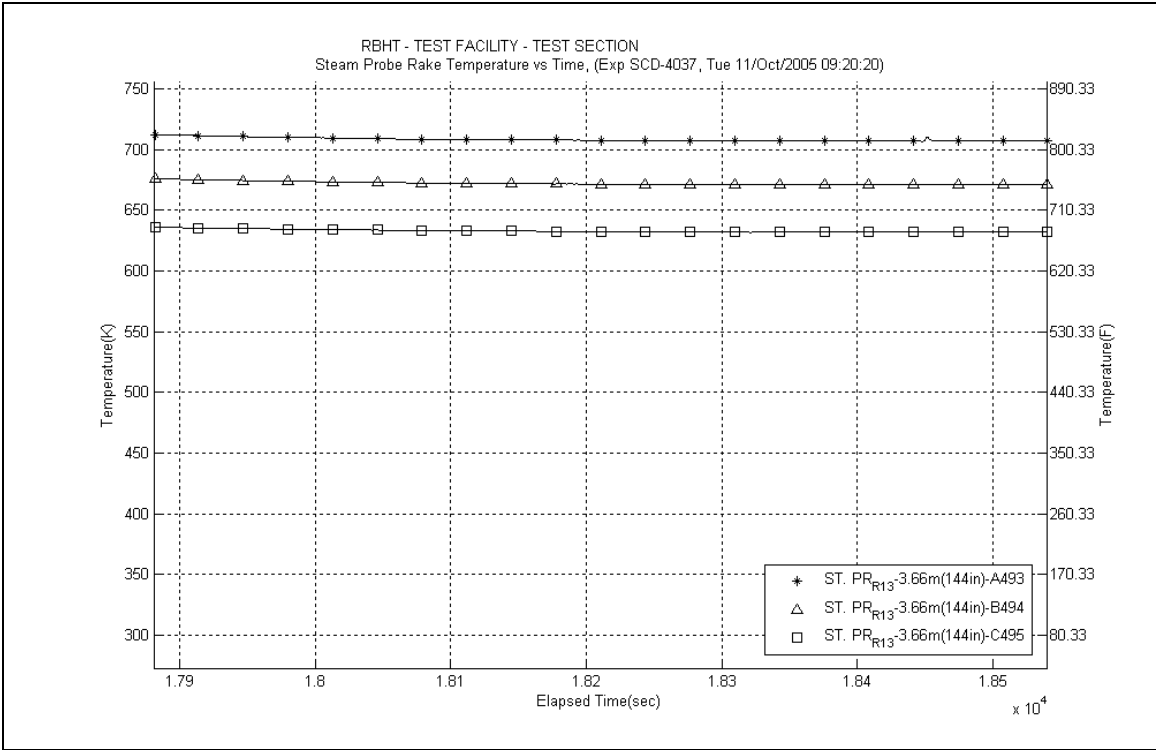

Figure A-334: Steam Probe Rake #13 Temperatures for Experiment 4037B

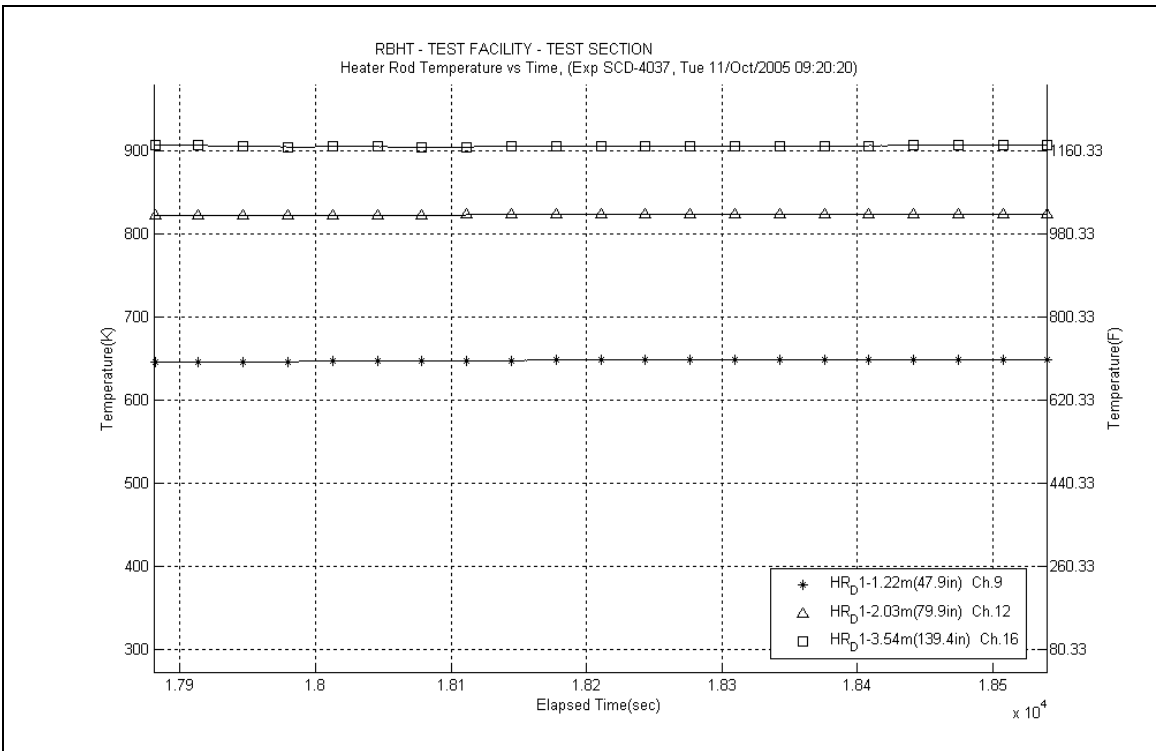

Figure A-335: Heater Rod D1 Temperatures for Experiment 4037B

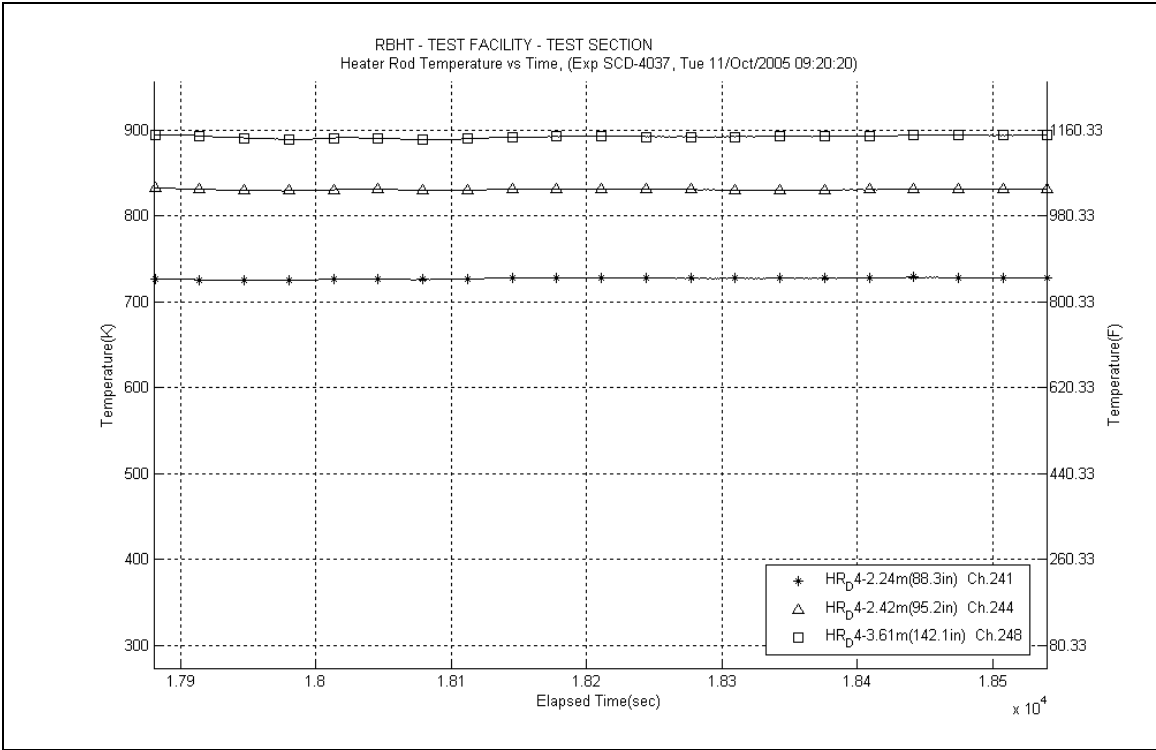

Figure A-336: Heater Rod D4 Temperatures for Experiment 4037B

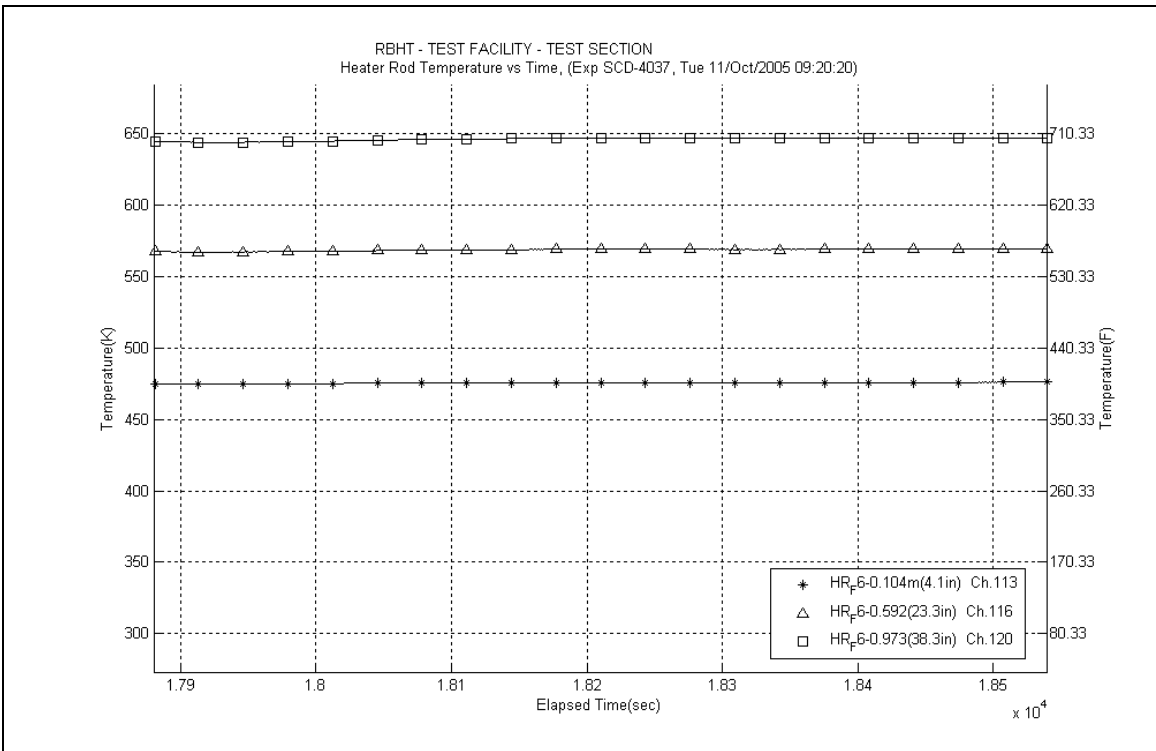

Figure A-337: Heater Rod F6 Temperatures for Experiment 4037B

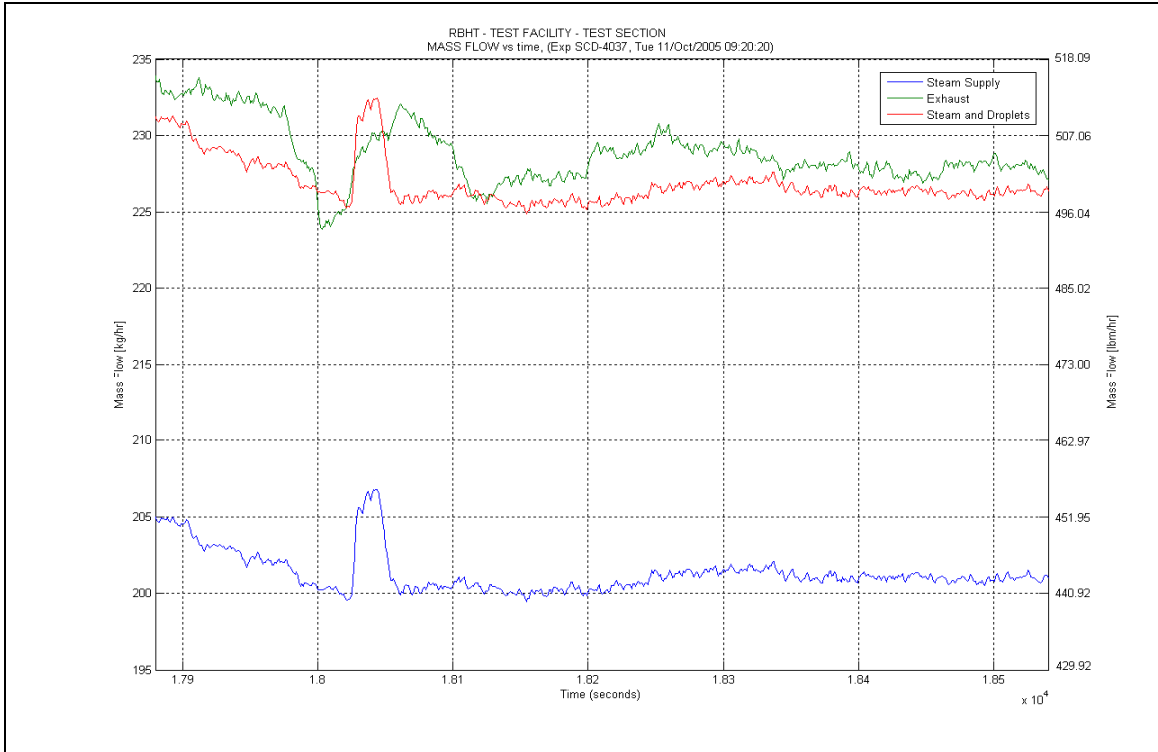

Figure A-338: Mass Flow for Experiment 4037B

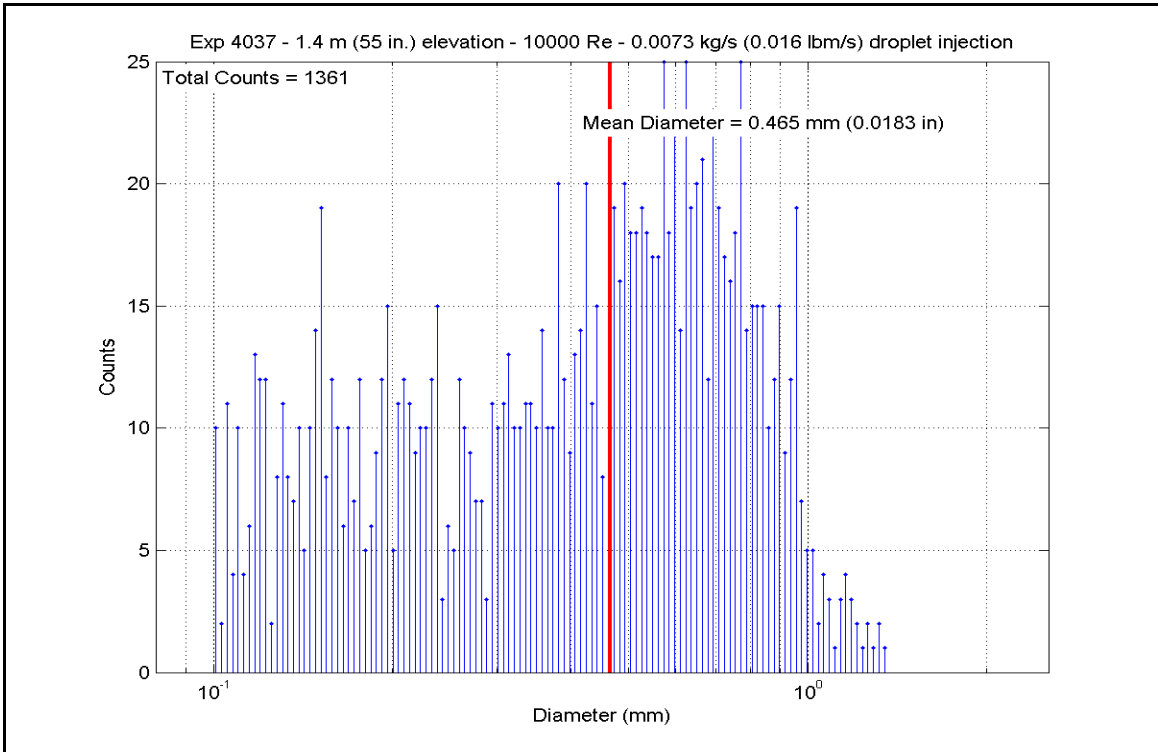

Figure A-339: Droplet Measurements at 1.397 m (55 in.) Elevation for Experiment 4037B

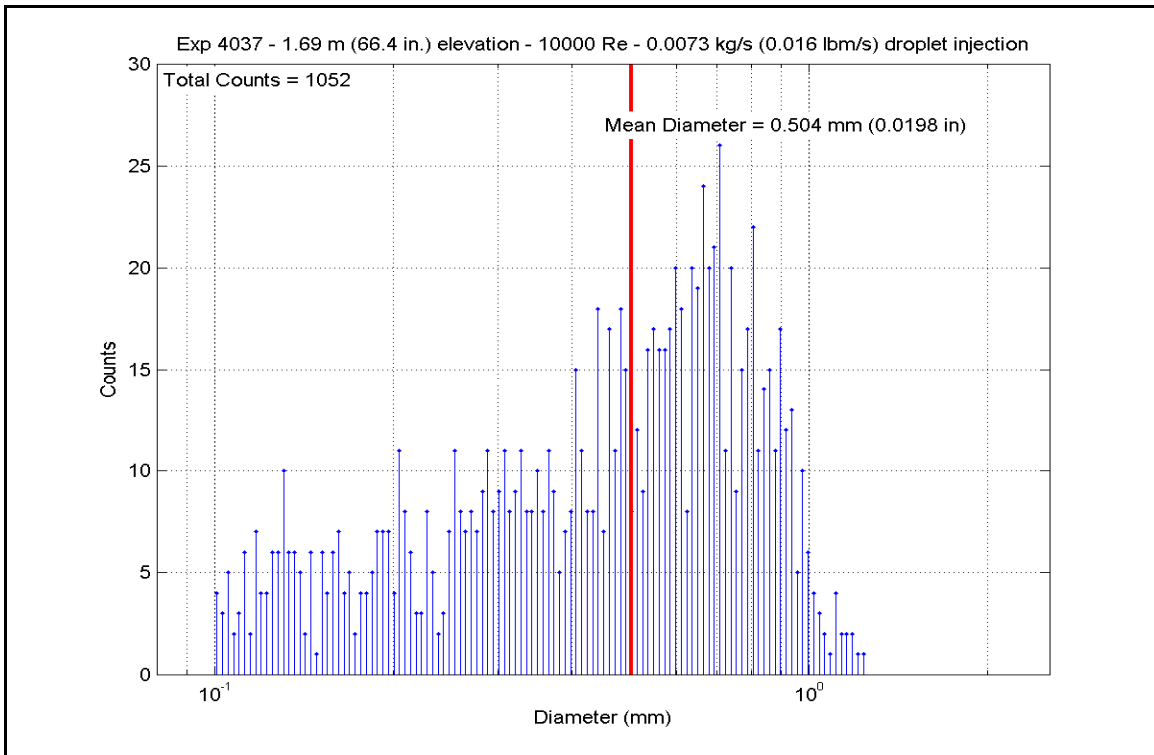

Figure A-340: Droplet Measurements at 1.687 m (66.4 in.) Elevation for Experiment 4037B

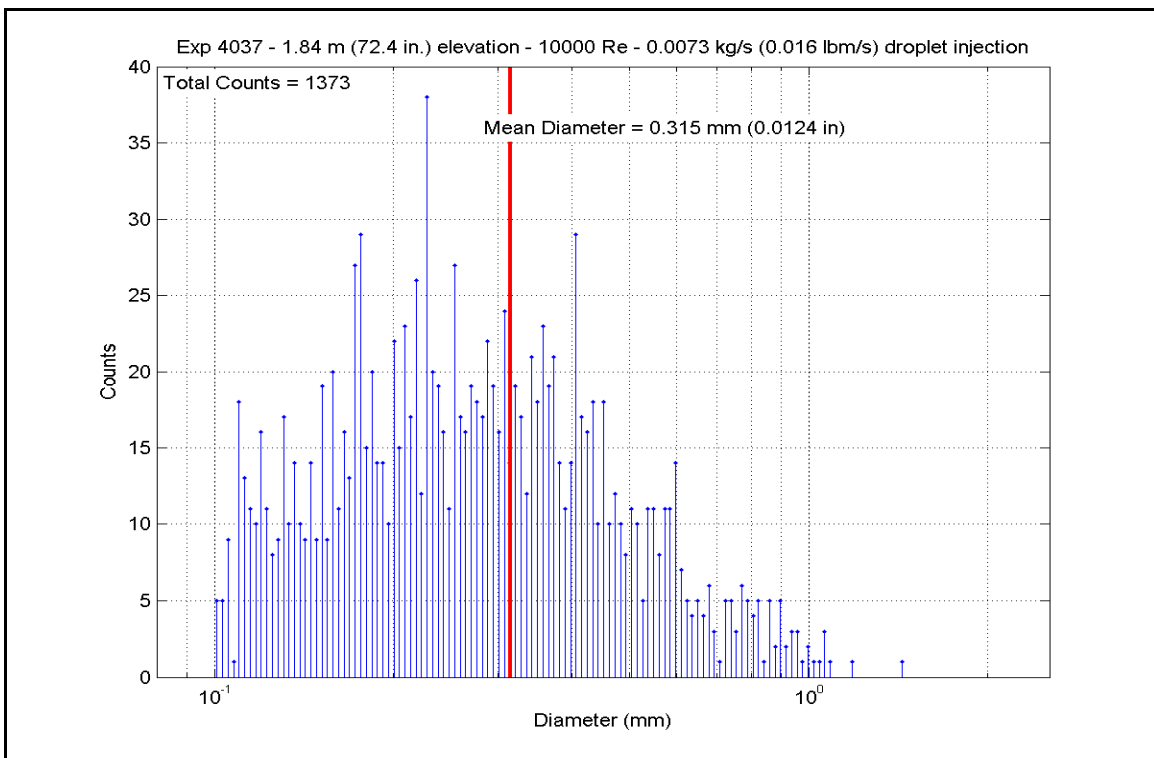

Figure A-341: Droplet Measurements at 1.839 m (72.4 in.) Elevation for Experiment 4037B

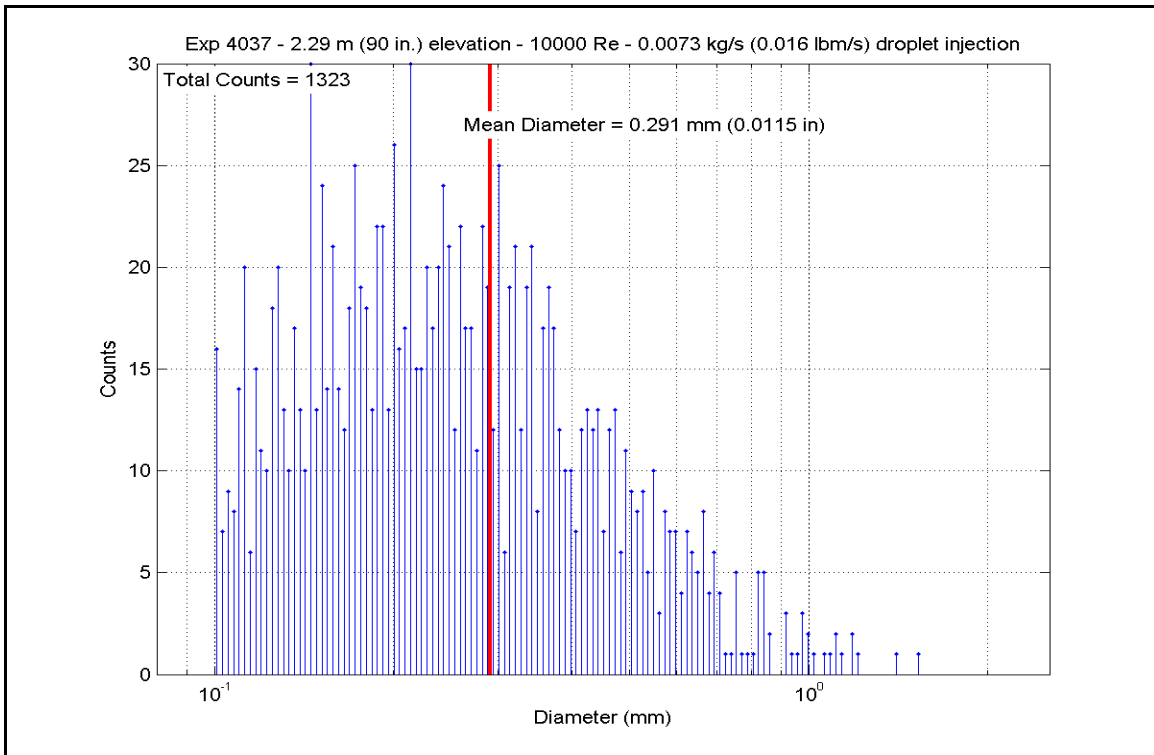

Figure A-342: Droplet Measurements at 2.286 m (90 in.) Elevation for Experiment 4037B

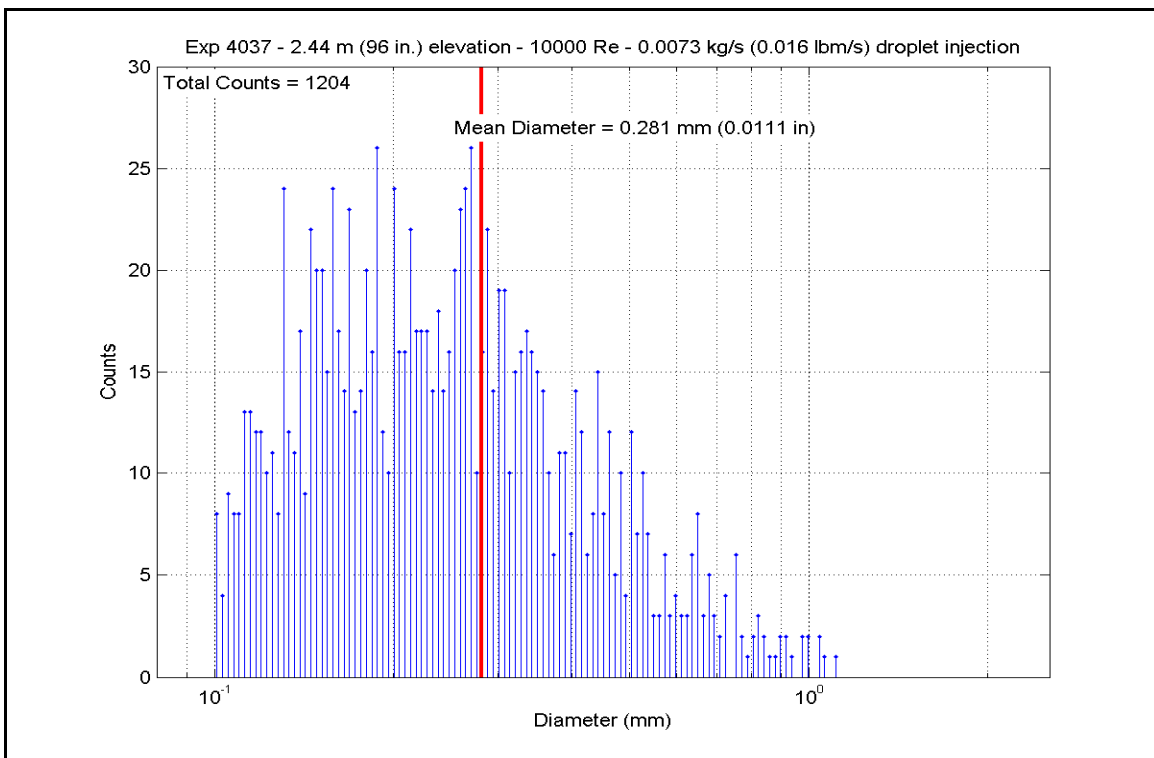

Figure A-343: Droplet Measurements at 2.438 m (96 in.) Elevation for Experiment 4037B

Table A-19: Summary of Steam Cooling Heat Transfer Reduced Data for Experiment 4037B

SCD-4037-B		Inlet Reynolds:		10000		UP Pressure:		40 psia					
Matrix Test # 17b		275.8 kPa		80.00 kW		272971 Btu/hr		440.0 lbm/hr					
Time Window: 17880-18540		0.0554 kg/s		0.0073 kg/s		0.016 lbm/s							
Inner 3x3													
H.R. ID	H.R. Location	Channel Number	Elevation (in)	Elevation (m)	Zgrid (in)	Zgrid (m)	H.R. Tw (°F)	H.R. Tw (K)	H.R. q" (Btu/hr-ft2)	H.R. q" (W/m2)	h _{sat} (z) (Btu/hr-ft2-F)	h _{sat} (z) (W/m2-K)	
Gr-3	RodD3_88.3	185	88.3	2.243	-0.2	-0.005	902.41	756.7	6777.11	21378.4	10.666	60.6	
	RodD3_91.3	186	91.3	2.319	2.8	0.071	986.04	803.2	6924.13	21842.2	9.630	54.7	
	RodD3_93.1	187	93.1	2.365	4.6	0.117	1026.18	825.5	7013.37	22123.7	9.238	52.5	
	RodD3_95.3	188	95.3	2.421	6.8	0.173	1062.59	845.7	7121.05	22463.4	8.951	50.8	
	RodD3_100.1	189	100.1	2.543	11.6	0.295	1107.84	870.8	7350.77	23188.0	8.742	49.6	
	RodD3_106.1	190	106.1	2.695	17.6	0.447	1192.35	917.8	7636.02	24087.8	8.252	46.9	
	RodD3_110	191	110	2.794	21.5	0.546	1125.39	880.6	7533.86	23765.6	8.777	49.8	
	RodD3_142.1	192	142.1	3.609	3.609	8.6	1165.60	902.9	2638.63	8323.6	2.936	16.7	
Gr-3	RodC4_88.4	233	88.4	2.245	-0.1	-0.003	855.49	730.6	6858.88	21636.3	11.655	66.2	
	RodC4_91.1	234	91.1	2.314	2.6	0.066	958.92	788.1	7006.60	22102.3	10.126	57.5	
	RodC4_93.4	235	93.4	2.372	4.9	0.124	1009.58	816.2	7123.37	22470.7	9.593	54.5	
	RodC4_95.3	236	95.3	2.421	6.8	0.173	1047.15	837.1	7215.90	22762.6	9.249	52.5	
	RodC4_100.1	237	100.1	2.543	11.6	0.295	1079.18	854.9	7441.11	23473.0	9.162	52.0	
	RodC4_106.1	238	106.1	2.695	17.6	0.447	1160.01	899.8	7734.60	24398.8	8.661	49.2	
	RodC4_110	239	110	2.794	21.5	0.546	1085.00	858.2	7476.84	23585.7	9.140	51.9	
	RodC4_142.2	240	142.2	3.612	3.612	8.7	1136.98	887.0	2861.28	9025.9	3.289	18.7	
Gr-3	RodD4_88.3	241	88.3	2.243	-0.2	-0.005	846.17	725.5	6832.19	21552.2	11.797	67.0	
	RodD4_91.3	242	91.3	2.319	2.8	0.071	953.63	785.2	6986.75	22039.7	10.175	57.8	
	RodD4_93.2	243	93.2	2.367	4.7	0.119	997.52	809.5	7083.33	22344.4	9.696	55.1	
	RodD4_95.2	244	95.2	2.418	6.7	0.170	1032.94	829.2	7182.64	22657.6	9.378	53.3	
	RodD4_100.1	245	100.1	2.543	11.6	0.295	1082.49	856.8	7415.47	23392.1	9.093	51.6	
	RodD4_106.1	246	106.1	2.695	17.6	0.447	1161.71	900.8	7703.53	24300.8	8.610	48.9	
	RodD4_142.1	248	142.1	3.609	3.609	8.6	1145.06	891.5	2767.38	9025.9	3.152	17.9	
Gr-3	RodE4_88.4	201	88.4	2.245	-0.1	-0.003	863.08	734.9	6731.69	21235.1	11.293	64.1	
	RodE4_91.2	202	91.2	2.316	2.7	0.069	979.93	799.8	6866.56	21660.6	9.631	54.7	
	RodE4_95.3	204	95.3	2.421	6.8	0.173	1065.60	847.4	7059.60	22269.5	8.840	50.2	
	RodE4_100.9	205	100.9	2.563	12.4	0.315	1130.71	883.5	7316.30	23079.3	8.471	48.1	
	RodE4_142.3	208	142.3	3.614	8.8	0.224	1165.46	902.8	2798.11	8826.6	3.114	17.7	

Table A-19: Summary of Steam Cooling Heat Transfer Reduced Data for Experiment 4037B, continued

Inner 3x3	H.R. Location	Channel Number	Elevation (in)	Elevation (m)	Zgrid (in)	Zgrid (m)	H.R. Tw (°F)	H.R. Tw (K)	H.R. q" (Btu/hr-ft ²)	H.R. q" (W/m ²)	h _{sat} (z) (Btu/hr-ft ² -F)	h _{sat} (z) (W/m ² -K)
Gr-4	RodE3_63.4	193	63.4	1.610	16.4	0.417	963.35	790.6	5665.67	17556.9	7.993	45.4
	RodE3_113.6	194	113.6	2.885	0.85	0.022	1164.47	902.3	6866.41	21660.1	7.651	43.4
	RodE3_115.5	195	115.5	2.934	2.75	0.070	1196.49	920.1	6617.74	20875.7	7.120	40.4
	RodE3_118.5	196	118.5	3.010	5.75	0.146	1223.38	935.0	6217.01	19611.5	6.501	36.9
	RodE3_122.7	197	122.7	3.117	9.95	0.253	1237.51	942.9	5653.57	17834.2	5.825	33.1
	RodE3_126.5	198	126.5	3.213	13.75	0.349	1233.73	940.8	5143.66	16225.7	5.321	30.2
	RodE3_131.7	199	131.7	3.345	-1.8	-0.046	1144.97	891.5	4441.14	14009.6	5.058	28.7
RodE3_135.6	200	135.6	3.444	2.1	0.053	1173.25	907.2	3923.47	12376.6	4.329	24.6	
Gr-4	RodC5_63.7	225	63.7	1.618	16.7	0.424	935.73	775.2	5455.80	17210.3	8.158	46.3
	RodC5_113.6	226	113.6	2.885	0.85	0.022	1108.16	871.0	6702.19	21142.1	7.968	45.2
	RodC5_115.7	227	115.7	2.939	2.95	0.075	1149.34	893.9	6442.77	20323.7	7.302	41.5
	RodC5_122.7	229	122.7	3.117	9.95	0.253	1188.68	915.8	5548.95	17504.2	6.020	34.2
	RodC5_126.7	230	126.7	3.216	13.95	0.354	1184.76	913.6	5040.04	15898.8	5.492	31.2
	RodC5_131.6	231	131.6	3.343	-1.9	-0.048	1087.58	859.6	4406.21	13899.4	5.370	30.5
	RodC5_135.7	232	135.7	3.447	2.2	0.056	1119.11	877.1	3887.89	12264.4	4.563	25.9
Gr-4	RodE5_63.6	209	63.6	1.615	16.6	0.422	935.30	775.0	5596.50	17654.2	8.374	47.6
	RodE5_113.6	210	113.6	2.885	0.85	0.022	1136.16	886.6	6912.82	21806.5	7.953	45.2
	RodE5_115.4	211	115.4	2.931	2.65	0.067	1166.93	903.7	6682.23	21079.1	7.425	42.2
	RodE5_118.7	212	118.7	3.015	5.95	0.151	1194.49	919.0	6247.25	19707.0	6.736	38.3
	RodE5_122.6	213	122.6	3.114	9.85	0.250	1213.92	929.8	5731.53	18080.1	6.053	34.4
	RodE5_126.6	214	126.6	3.216	13.85	0.352	1214.18	929.9	5202.38	16410.9	5.493	31.2
	RodE5_131.6	215	131.6	3.343	-1.9	-0.048	1128.02	882.1	4536.85	14311.5	5.269	29.9
	RodE5_135.6	216	135.6	3.444	2.1	0.053	1152.31	895.5	4012.58	12657.7	4.532	25.7
	RodC3_79.8	177	79.8	2.027	2.027	8.92	990.82	805.8	6334.33	19981.6	8.751	49.7
	RodC3_85.6	178	85.6	2.174	2.174	14.72	878.82	743.6	6613.71	20863.0	10.810	61.4
Gr-5	RodC3_88.5	179	88.5	2.248	0	0.000	880.04	744.3	6752.48	21300.7	11.015	62.6
	RodC3_92.4	180	92.4	2.347	3.9	0.099	1005.64	814.1	6941.77	21897.8	9.398	53.4
	RodC3_94.4	181	94.4	2.398	5.9	0.150	1044.50	835.7	7038.13	22201.8	9.052	51.4
	RodC3_97.2	182	97.2	2.469	8.7	0.221	1093.24	862.7	7169.07	22614.8	8.677	49.3
	RodC3_108.8	183	108.8	2.764	20.3	0.516	1179.43	910.6	7556.47	23836.9	8.282	47.0
	RodD5_50	217	50	1.270	1.270	3	820.51	711.2	4943.71	15594.9	8.932	50.7
	RodD5_54.1	218	54.1	1.374	1.374	7.1	841.24	722.7	5137.08	16204.9	8.946	50.8
	RodD5_56.9	219	56.9	1.445	1.445	9.9	890.31	750.0	5268.73	16620.2	8.453	48.0
	RodD5_60	220	60	1.524	1.524	13	919.12	766.0	5414.83	17081.1	8.303	47.2
	RodD5_66.1	221	66.1	1.679	1.679	19.1	954.44	785.6	5705.79	17998.9	8.300	47.1
RodD5_69.9	222	69.9	1.775	1.775	-0.98	808.44	704.5	5897.88	18604.9	10.893	61.9	
RodD5_72.9	223	72.9	1.852	1.852	2.02	884.06	746.5	6031.65	19026.8	9.775	55.5	
RodD5_74.9	224	74.9	1.902	1.902	4.02	929.90	772.0	6125.20	19321.9	9.240	52.5	

Table A-19: Summary of Steam Cooling Heat Transfer Reduced Data for Experiment 4037B, continued

H.R. ID	H.R. Location	Channel Number	Elevation (in)	Elevation (m)	Zgrid (in)	Zgrid (m)	H.R. Tw (°F)	H.R. Tw (K)	H.R. q" (Btu/hr-ft ²)	H.R. q" (W/m ²)	h _{sat} (z) (Btu/hr-ft ² -F)	h _{sat} (z) (W/m ² -K)	
Gr-2	RodB5_41	153	41	1.041	13.5	0.343	743.34	668.3	4490.49	14165.2	9.427	53.5	
	RodB5_52.9	154	52.9	1.344	5.9	0.150	793.76	696.4	5064.51	15976.0	9.614	54.6	
	RodB5_55	155	55	1.397	8	0.203	833.60	718.5	5162.10	16283.9	9.111	51.7	
	RodB5_57.8	156	57.8	1.468	10.8	0.274	884.07	746.5	5295.39	16704.3	8.581	48.7	
	RodB5_64	157	64	1.626	17	0.432	934.82	774.7	5593.12	17643.5	8.375	47.6	
	RodB5_73.9	158	73.9	1.877	3.02	0.077	903.24	757.2	6070.71	19150.1	9.542	54.2	
	RodB5_75.9	159	75.9	1.928	5.02	0.128	940.23	777.7	6165.77	19449.9	9.159	52.0	
	RodB5_76.9	160	76.9	1.953	6.02	0.153	955.83	786.4	6213.16	19599.4	9.020	51.2	
	Gr-2	RodF5_41	105	41	1.041	13.5	0.343	739.92	666.4	4463.24	14079.3	9.438	53.6
		RodF5_53.1	106	53.1	1.349	6.1	0.155	805.82	703.0	5046.07	15917.8	9.365	53.2
RodF5_55		107	55	1.397	8	0.203	840.35	722.2	5138.72	16210.1	8.963	50.9	
RodF5_57.8		108	57.8	1.468	10.8	0.274	884.34	746.7	5273.98	16636.8	8.543	48.5	
RodF5_64		109	64	1.626	17	0.432	930.04	772.1	5571.76	17576.1	8.403	47.7	
RodF5_73.8		110	73.8	1.875	2.92	0.074	895.38	752.8	6042.32	19060.5	9.616	54.6	
RodF5_75.8		111	75.8	1.925	4.92	0.125	935.23	774.9	6137.46	19360.6	9.185	52.2	
RodF5_76.8		112	76.8	1.951	5.92	0.150	952.03	784.3	6184.89	19510.2	9.029	51.3	
Gr-2		RodC2_41	57	41	1.041	13.5	0.343	739.62	666.3	4488.29	14158.3	9.497	53.9
		RodC2_53.1	58	53.1	1.349	6.1	0.155	859.12	732.7	5067.16	15984.3	8.558	48.6
	RodC2_55	59	55	1.397	8	0.203	878.00	743.2	5157.28	16268.6	8.441	47.9	
	RodC2_57.8	60	57.8	1.468	10.8	0.274	908.44	760.1	5291.25	16691.3	8.249	46.8	
	RodC2_63.9	61	63.9	1.623	16.9	0.429	935.89	775.3	5583.62	17613.5	8.348	47.4	
	RodC2_73.8	62	73.8	1.875	2.92	0.074	916.31	764.4	6065.02	19132.1	9.341	53.0	
	RodC2_75.8	63	75.8	1.925	4.92	0.125	948.80	782.5	6159.22	19429.3	9.034	51.3	
	RodC2_76.8	64	76.8	1.951	5.92	0.150	961.94	789.8	6206.58	19578.7	8.931	50.7	
	Gr-2	RodC6_40.9	137	40.9	1.039	13.4	0.340	739.45	666.2	4462.57	14077.2	9.446	53.6
		RodC6_52.8	138	52.8	1.341	5.8	0.147	858.79	732.5	5058.45	15956.9	8.548	48.5
RodC6_54.8		139	54.8	1.392	7.8	0.198	880.41	744.5	5157.90	16270.6	8.409	47.8	
RodC6_57.8		140	57.8	1.468	10.8	0.274	914.54	763.5	5308.13	16744.5	8.197	46.6	
RodC6_63.8		141	63.8	1.621	16.8	0.427	948.01	782.0	5606.92	17687.0	8.233	46.8	
RodC6_73.7		142	73.7	1.872	2.82	0.072	940.70	778.0	6110.14	19274.4	9.070	51.5	
RodC6_75.8		143	75.8	1.925	4.92	0.125	971.48	795.1	6213.51	19600.5	8.820	50.1	
RodC6_76.8		144	76.8	1.951	5.92	0.150	989.33	805.0	6263.22	19757.3	8.671	49.2	

Table A-19: Summary of Steam Cooling Heat Transfer Reduced Data for Experiment 4037B, continued

5x5 periphery		H.R. Location	Channel Number	Elevation (in)	Elevation (m)	Zgrid (in)	Zgrid (m)	H.R. Tw (°F)	H.R. Tw (K)	H.R. q" (Btu/hr-ft ²)	H.R. q" (W/m ²)	h _{sat} (z) (Btu/hr-ft ² -F)	h _{sat} (z) (W/m ² -K)
Gr-3	RodB4_88.4	161	88.4	2.245	-0.1	-0.003	869.03	738.2	6727.22	21221.0	11.174	63.5	
	RodB4_91.3	162	91.3	2.319	2.8	0.071	971.39	795.0	6867.02	21662.0	9.749	55.4	
	RodB4_93.3	163	93.3	2.370	4.8	0.122	1015.88	819.7	6962.90	21964.5	9.298	52.8	
	RodB4_95.1	164	95.1	2.416	6.6	0.168	1047.58	837.4	7046.99	22229.7	9.028	51.3	
	RodB4_100	165	100	2.540	11.5	0.292	1072.68	851.3	7269.03	22930.2	9.022	51.2	
	RodB4_106	166	106	2.692	17.5	0.445	1148.37	893.4	7551.13	23820.0	8.568	48.7	
	RodB4_109.9	167	109.9	2.791	21.4	0.544	1071.95	850.9	7300.21	23028.5	9.069	51.5	
	RodB4_142.3	168	142.3	3.614	8.8	0.224	1118.83	876.9	2842.39	8966.3	3.337	18.9	
Gr-5	RodF4_85.6	98	85.6	2.174	14.72	0.374	937.91	776.4	6629.69	20913.4	9.882	56.1	
	RodF4_88.4	99	88.4	2.245	-0.1	-0.003	914.66	763.5	6767.19	21347.1	10.449	59.3	
	RodF4_92.4	100	92.4	2.347	3.9	0.099	1022.39	823.4	6961.26	21959.3	9.215	52.3	
	RodF4_94.3	101	94.3	2.395	5.8	0.147	1057.23	842.7	7052.47	22247.0	8.925	50.7	
	RodF4_97.2	102	97.2	2.469	8.7	0.221	1100.81	866.9	7189.91	22680.6	8.623	49.0	
	RodF4_108.8	103	108.8	2.764	20.3	0.516	1175.97	908.7	7592.17	23949.5	8.352	47.4	
	RodF4_111	104	111	2.819	-1.75	-0.044	1092.46	862.3	7276.87	22954.9	8.815	50.1	
	RodD2_103.2	65	103.2	2.621	14.7	0.373	1182.63	912.4	6685.04	21088.0	7.301	41.5	
Gr-6	RodD2_106	66	106	2.692	17.5	0.445	1203.34	923.9	6331.74	19973.5	6.762	38.4	
	RodD2_112.6	67	112.6	2.860	-0.15	-0.004	1226.72	936.9	5851.62	18458.9	6.097	34.6	
	RodD2_114.9	68	114.9	2.918	2.15	0.055	1233.43	940.6	5285.39	16672.8	5.469	31.1	
	RodD2_117.4	69	117.4	2.982	4.65	0.118	1222.65	934.6	4747.99	14977.5	4.968	28.2	
	RodD2_120.8	70	120.8	3.068	8.05	0.204	1187.39	915.0	7506.57	23679.5	8.156	46.3	
	RodD2_124.8	71	124.8	3.170	12.05	0.306	1208.88	927.0	7640.25	24101.2	8.112	46.1	
	RodD2_128.6	72	128.6	3.266	15.85	0.403	1138.61	887.9	7007.32	22104.6	8.040	45.7	
	RodD6_103.1	129	103.1	2.619	14.6	0.371	1180.67	911.3	7536.16	23772.8	8.248	46.8	
RodD6_106	130	106	2.692	17.5	0.445	1196.94	920.3	7676.36	24215.1	8.255	46.9		
RodD6_112.9	131	112.9	2.868	0.15	0.004	1129.26	882.7	6998.03	22075.3	8.116	46.1		
RodD6_114.9	132	114.9	2.918	2.15	0.055	1168.53	904.6	6712.58	21174.8	7.446	42.3		
RodD6_116.8	133	116.8	2.967	4.05	0.103	1189.25	916.1	6440.69	20317.1	6.984	39.7		
RodD6_120.9	134	120.9	3.071	8.15	0.207	1202.40	923.4	5858.88	18481.8	6.263	35.6		
RodD6_124.8	135	124.8	3.170	12.05	0.306	1203.97	924.2	5301.79	16724.5	5.658	32.1		
RodD6_128.7	136	128.7	3.269	15.95	0.405	1195.19	919.4	4744.40	14966.2	5.111	29.0		

Table A-19: Summary of Steam Cooling Heat Transfer Reduced Data for Experiment 4037B, continued

5x5 periphery		H.R.	Channel	Elevation	Elevation	Zgrid	Zgrid	H.R. Tw	H.R. Tw	H.R. q"	H.R. q"	H.R. q"	h _{sat} (z)	h _{sat} (z)
Gr-8	RodE2_50.1	73	50.1	1.273	3.1	0.079	805.03	702.6	4959.96	15646.2	9.219	52.4	52.4	
	RodE2_54	74	54	1.372	7	0.178	871.57	739.6	5148.98	16242.5	8.517	48.4	48.4	
	RodE2_56.9	75	56.9	1.445	9.9	0.251	905.71	758.5	5288.35	16682.1	8.280	47.0	47.0	
	RodE2_59.9	76	59.9	1.521	12.9	0.328	937.08	776.0	5431.57	17133.9	8.106	46.0	46.0	
	RodE2_66	77	66	1.676	19	0.483	959.53	788.4	5729.26	18072.9	8.273	47.0	47.0	
	RodE2_69.8	78	69.8	1.773	-1.08	-0.027	853.67	729.6	5925.27	18691.3	10.100	57.4	57.4	
	RodE2_72.9	79	72.9	1.852	2.02	0.051	920.46	766.7	6071.46	19152.4	9.291	52.8	52.8	
	RodE2_74.9	80	74.9	1.902	4.02	0.102	952.94	784.8	6166.48	19452.1	8.990	51.1	51.1	
Gr-8	RodB3_50.2	169	50.2	1.275	3.2	0.081	757.09	676.0	4931.39	15556.1	10.062	57.1	57.1	
	RodB3_54.1	170	54.1	1.374	7.1	0.180	819.77	710.8	5117.88	16144.3	9.259	52.6	52.6	
	RodB3_56.9	171	56.9	1.445	9.9	0.251	859.49	732.9	5251.89	16567.1	8.864	50.3	50.3	
	RodB3_60.1	172	60.1	1.527	13.1	0.333	854.07	729.9	5406.73	17055.5	9.210	52.3	52.3	
	RodB3_66.1	173	66.1	1.679	19.1	0.485	911.78	761.9	5695.04	17965.0	8.833	50.2	50.2	
	RodB3_69.9	174	69.9	1.775	-0.98	-0.025	777.18	687.1	5881.20	18552.3	11.528	65.5	65.5	
	RodB3_73	175	73	1.854	2.12	0.054	868.37	737.8	6027.68	19014.3	10.023	56.9	56.9	
	RodB3_75	176	75	1.905	4.12	0.105	910.63	761.3	6123.38	19316.2	9.514	54.0	54.0	
Gr-8	RodF3_50.1	89	50.1	1.273	3.1	0.079	783.85	690.8	4930.91	15554.5	9.540	54.2	54.2	
	RodF3_54	90	54	1.372	7	0.178	850.30	727.8	5122.19	16158.0	8.781	49.9	49.9	
	RodF3_57	91	57	1.448	10	0.254	895.02	752.6	5269.68	16623.2	8.391	47.7	47.7	
	RodF3_60	92	60	1.524	13	0.330	926.23	769.9	5417.66	17090.0	8.218	46.7	46.7	
	RodF3_66.1	93	66.1	1.679	19.1	0.485	944.22	779.9	5717.28	18035.2	8.442	47.9	47.9	
	RodF3_70	94	70	1.778	-0.88	-0.022	816.86	709.2	5915.00	18658.9	10.757	61.1	61.1	
	RodF3_73	95	73	1.854	2.12	0.054	912.32	762.2	6060.89	19119.1	9.392	53.3	53.3	
	RodF3_75	96	75	1.905	4.12	0.105	956.25	786.6	6157.81	19424.8	8.934	50.7	50.7	
Gr-8	RodE6_50.2	121	50.2	1.275	3.2	0.081	793.11	696.0	4931.02	15554.9	9.373	53.2	53.2	
	RodE6_54.1	122	54.1	1.374	7.1	0.180	852.91	729.2	5115.64	16137.3	8.731	49.6	49.6	
	RodE6_57	123	57	1.448	10	0.254	884.44	746.7	5253.78	16573.0	8.509	48.3	48.3	
	RodE6_60.2	124	60.2	1.529	13.2	0.335	911.42	761.7	5404.17	17047.5	8.386	47.6	47.6	
	RodE6_66.1	125	66.1	1.679	19.1	0.485	938.17	776.6	5685.44	17934.7	8.471	48.1	48.1	
	RodE6_70	126	70	1.778	-0.88	-0.022	862.00	734.3	5870.56	18518.7	9.866	56.0	56.0	
	RodE6_73.1	127	73.1	1.857	2.22	0.056	928.84	771.4	6018.03	18983.9	9.093	51.6	51.6	
	RodE6_75	128	75	1.905	4.12	0.105	962.26	790.0	6108.25	19268.5	8.786	49.9	49.9	

RBHT Steam Cooling with Droplet Injection Test SCD-4037-C

Matrix Test # 17c

Test Conditions

Test Date – 10/11/2005

Steady State Time Window: 18660 - 19380

Upper Plenum Pressure: 2.76 bar (40 psia)

Bundle Power: 80.0 kW

Bundle Inlet Reynolds Number: 10000

Bundle Inlet Steam Flow: 199.76 kg/hr (440 lbm/hr)

Droplet Injection Flow: 0.0146 kg/s (0.032 lbm/s)

Droplet Injection Hole Diameter: 0.381 mm (.015 in)

Droplet Injection Elevation: 1.295 m (51 in)

Bundle Flow Area: $4.656 \times 10^{-3} \text{ m}^2$ ($5.012 \times 10^{-2} \text{ ft}^2$)

Test Notes

- No steam probes were traversed in this steady state window.

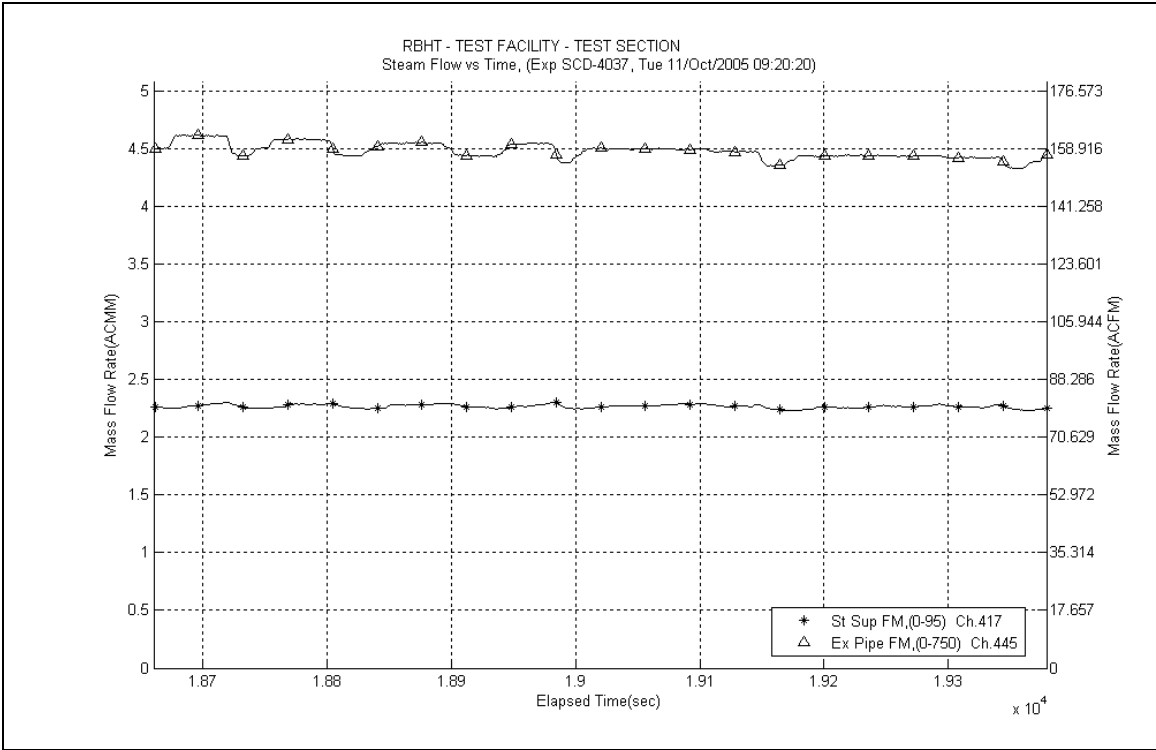

Figure A-344: Inlet and Exhaust Steam Flow Rates for Experiment 4037C

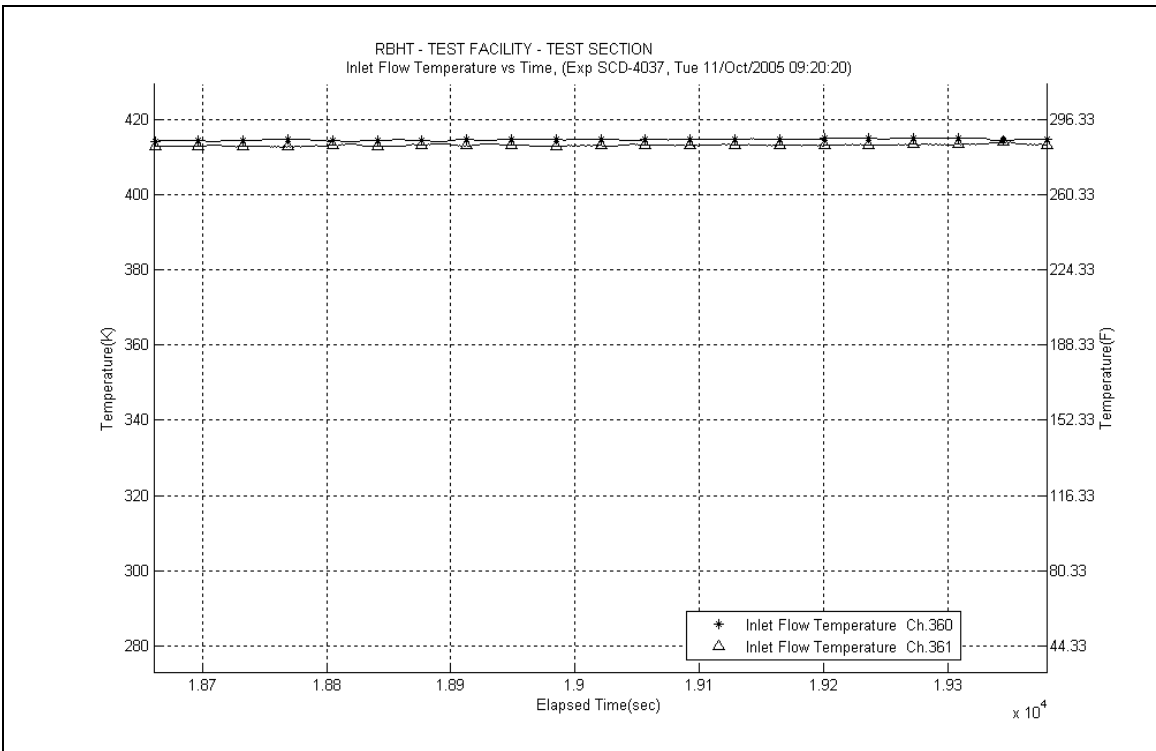

Figure A-345: Inlet Steam Temperature for Experiment 4037C

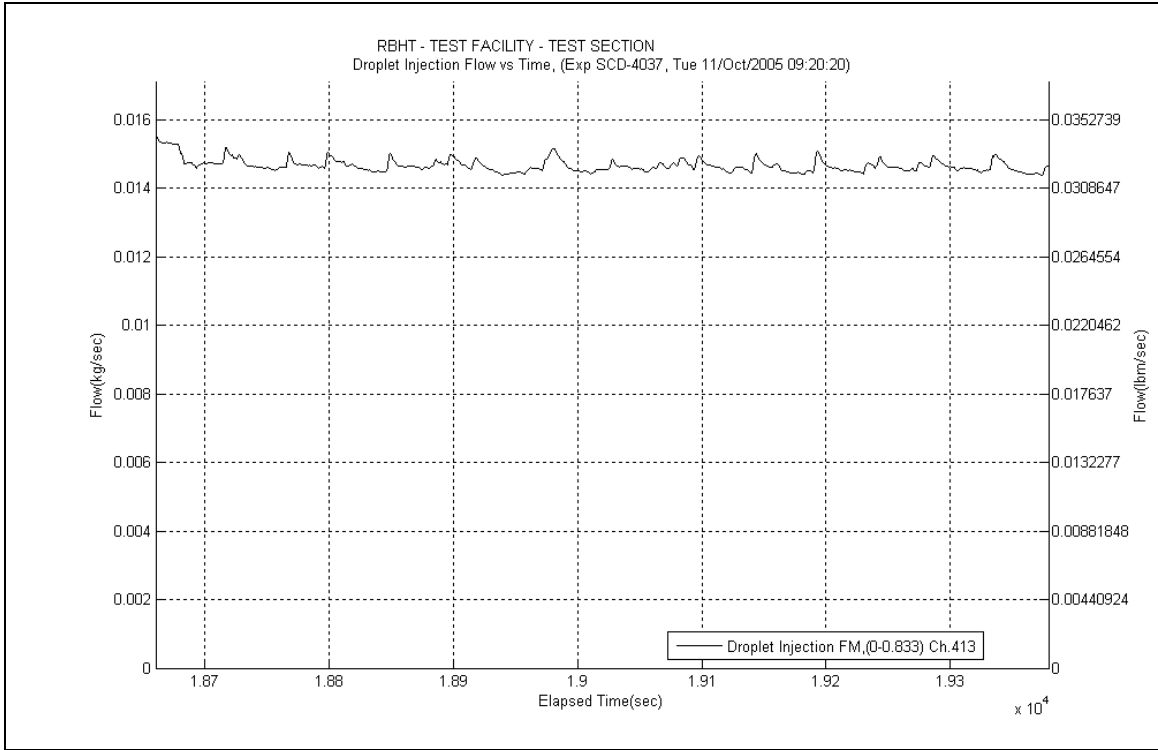

Figure A-346: Droplet Injection Flow Rate for Experiment 4037C

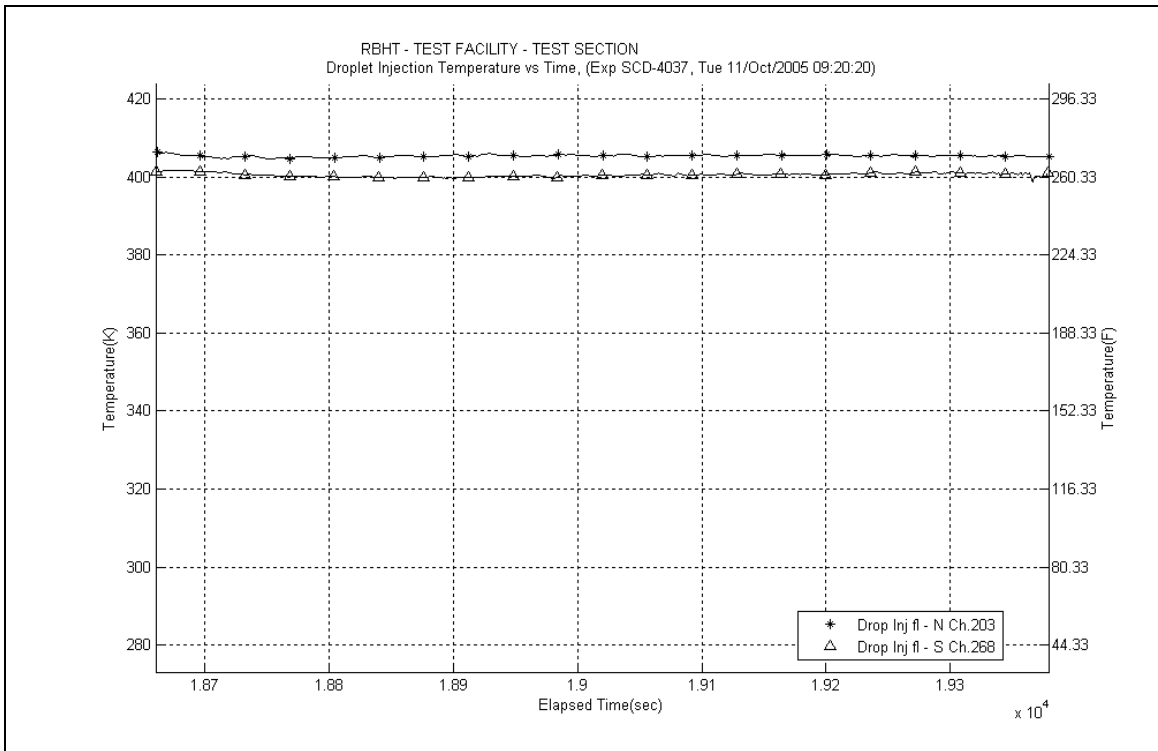

Figure A-347: Droplet Injection Temperature for Experiment 4037C

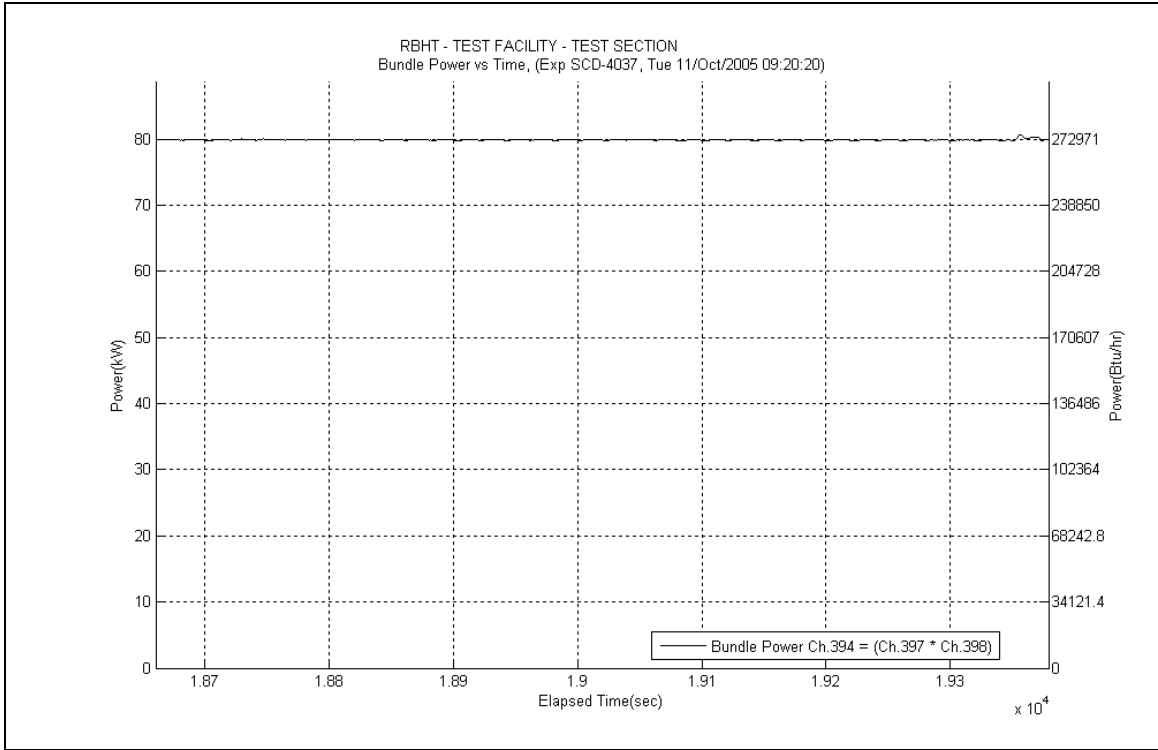

Figure A-348: Bundle Power for Experiment 4037C

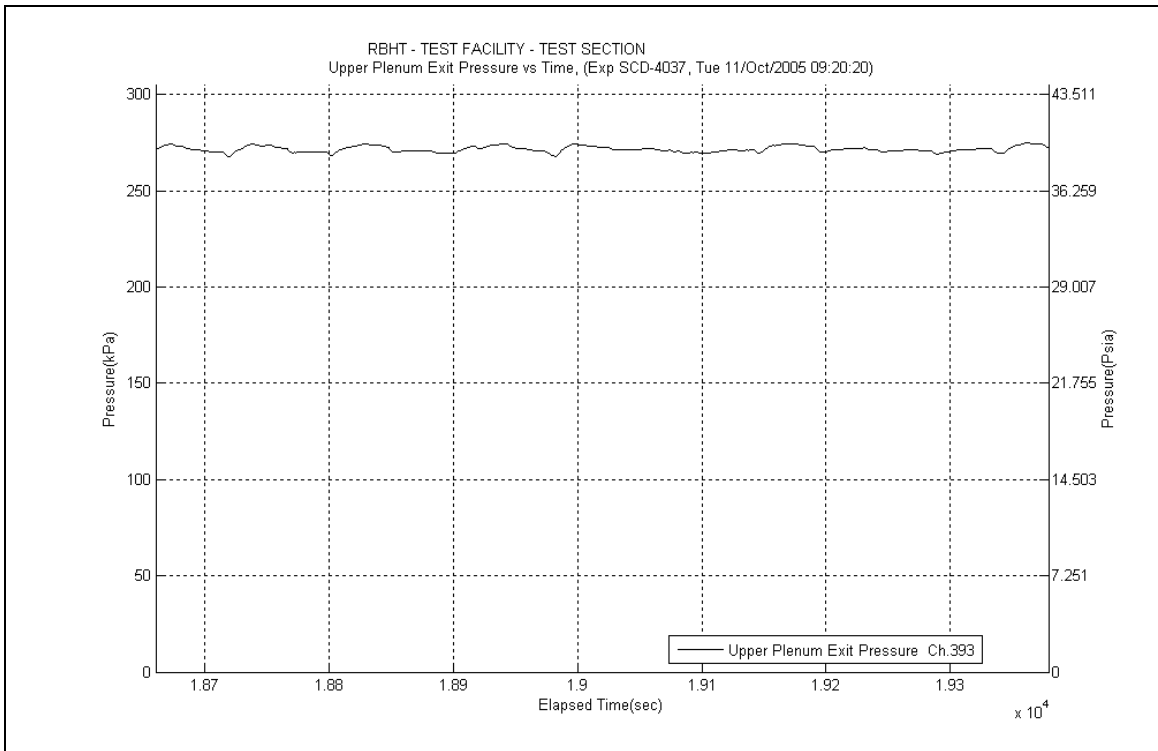

Figure A-349: Upper Plenum Pressure for Experiment 4037C

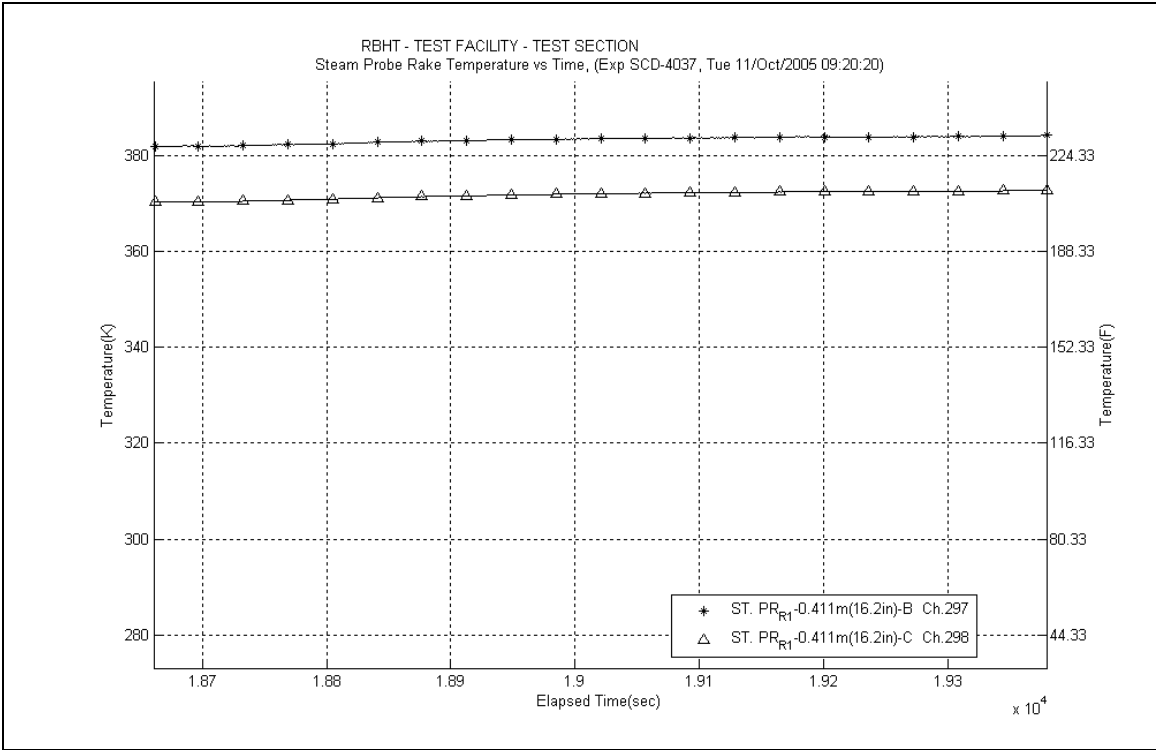

Figure A-350: Steam Probe Rake #1 Temperatures for Experiment 4037C

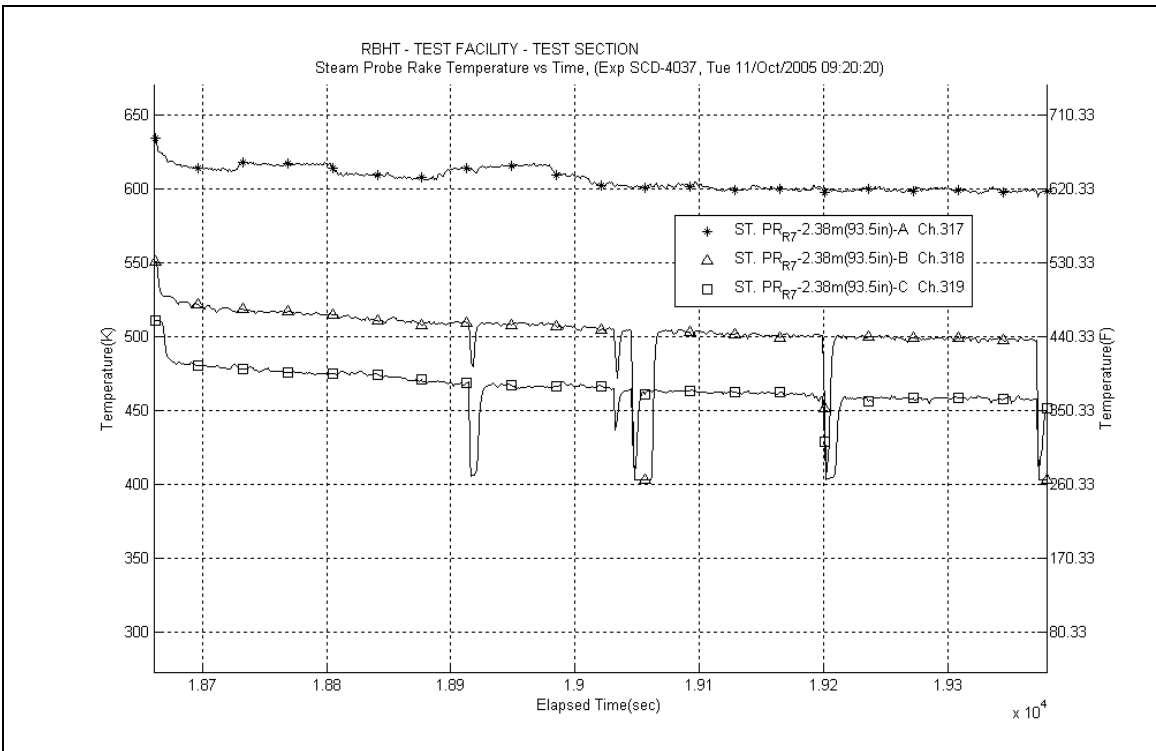

Figure A-351: Steam Probe Rake #7 Temperatures for Experiment 4037C

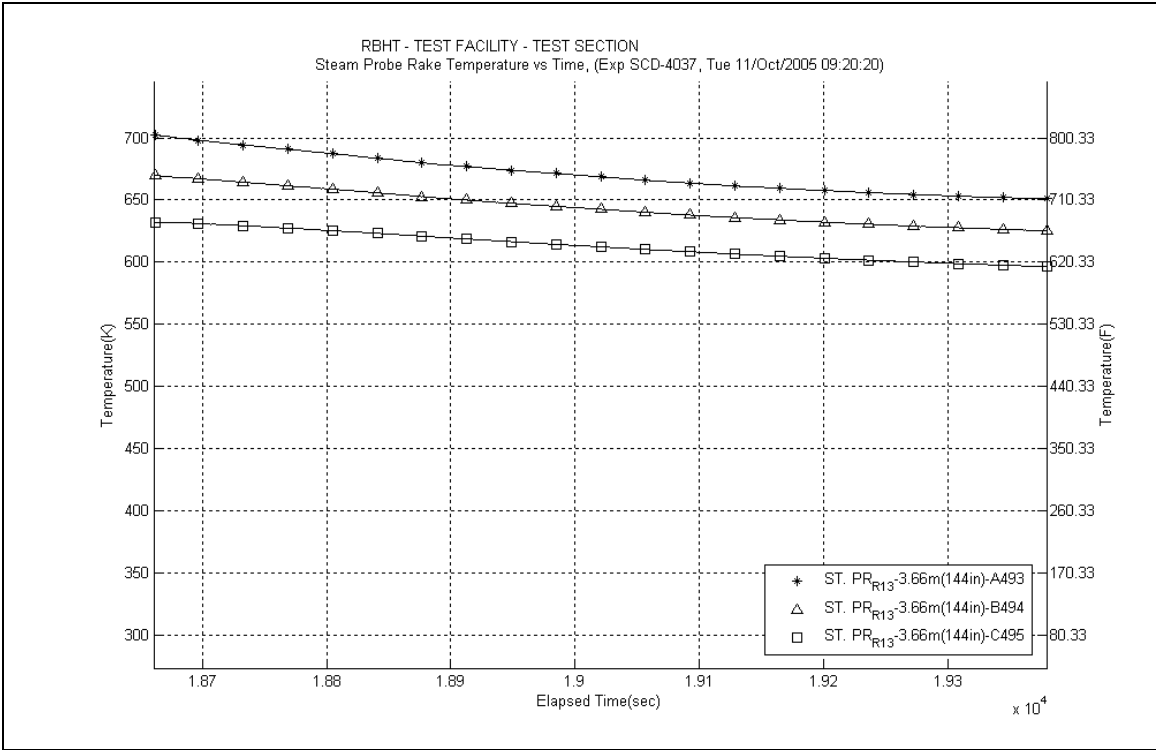

Figure A-352: Steam Probe Rake #13 Temperatures for Experiment 4037C

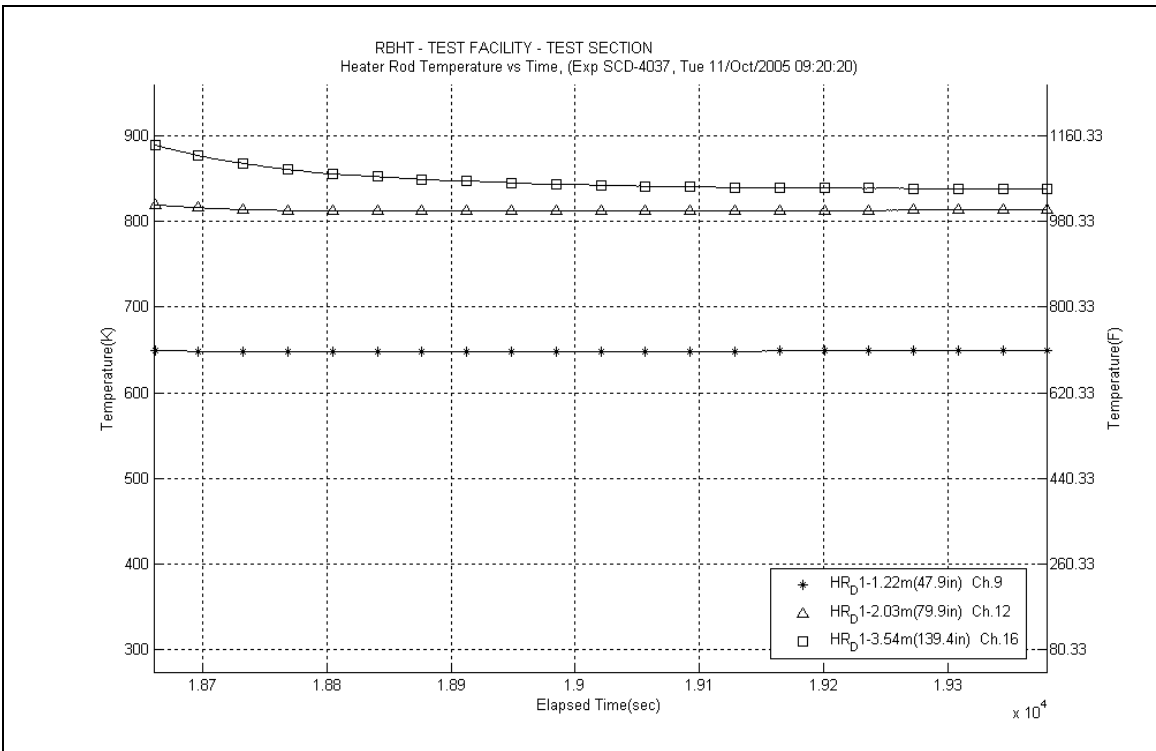

Figure A-353: Heater Rod D1 Temperatures for Experiment 4037C

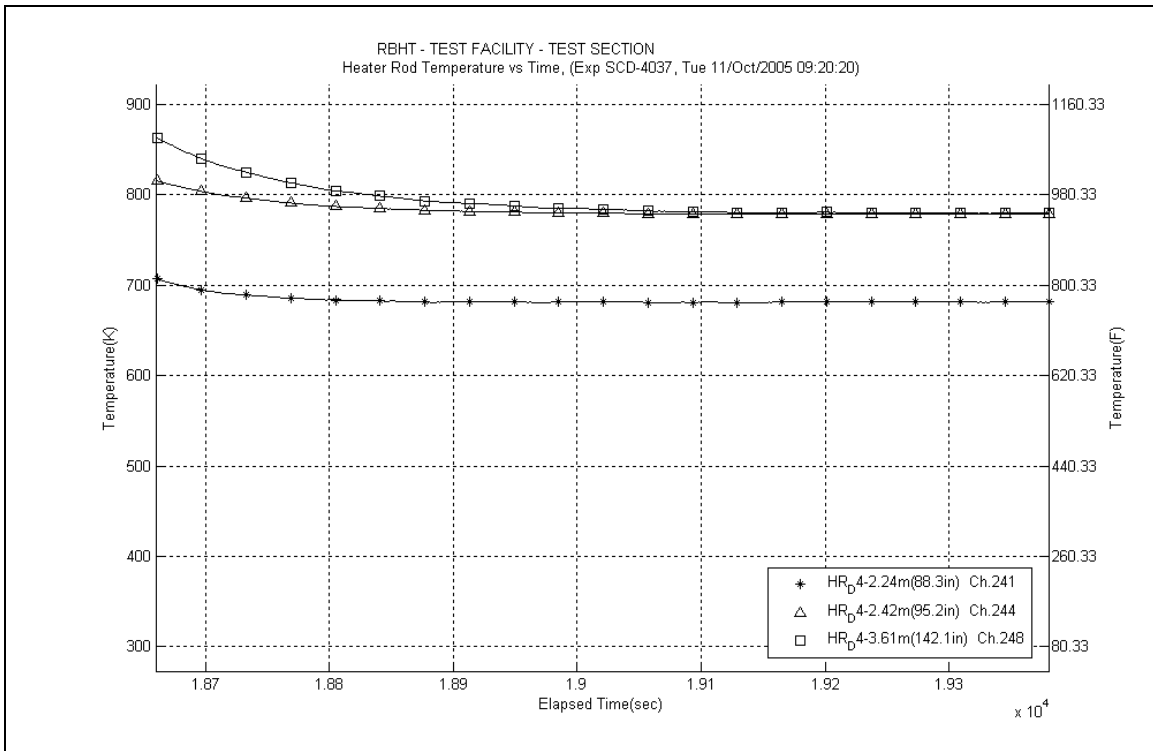

Figure A-354: Heater Rod D4 Temperatures for Experiment 4037C

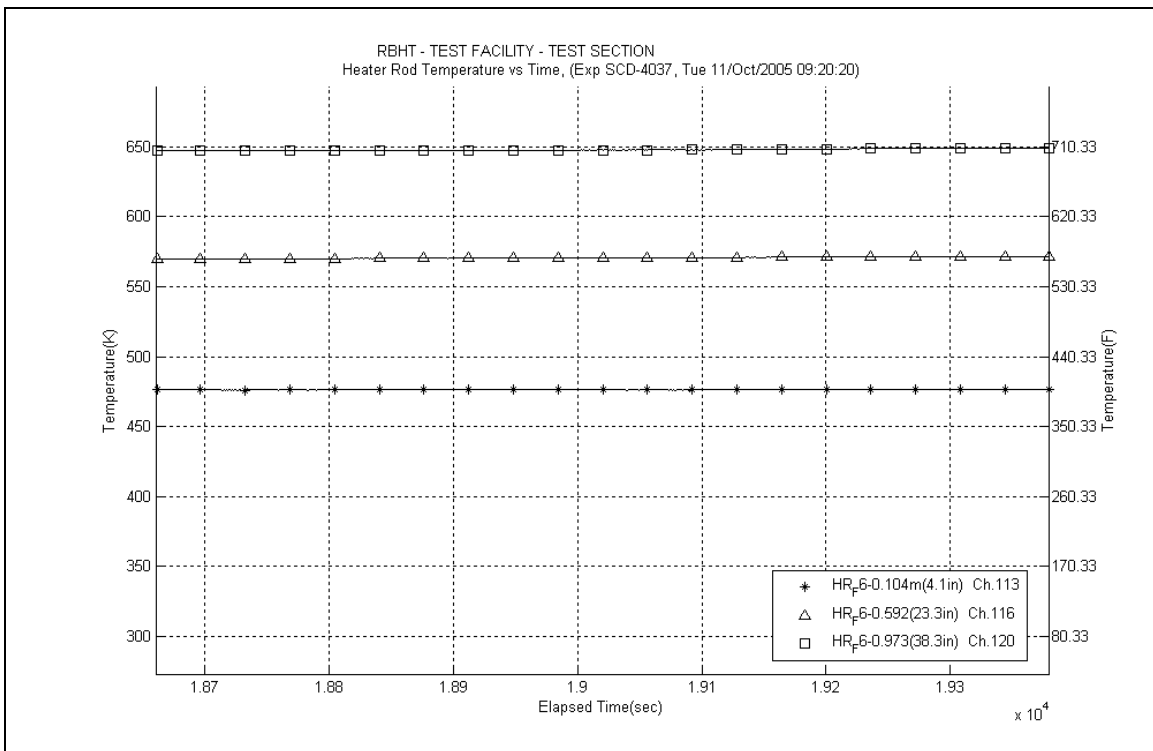

Figure A-355: Heater Rod F6 Temperatures for Experiment 4037C

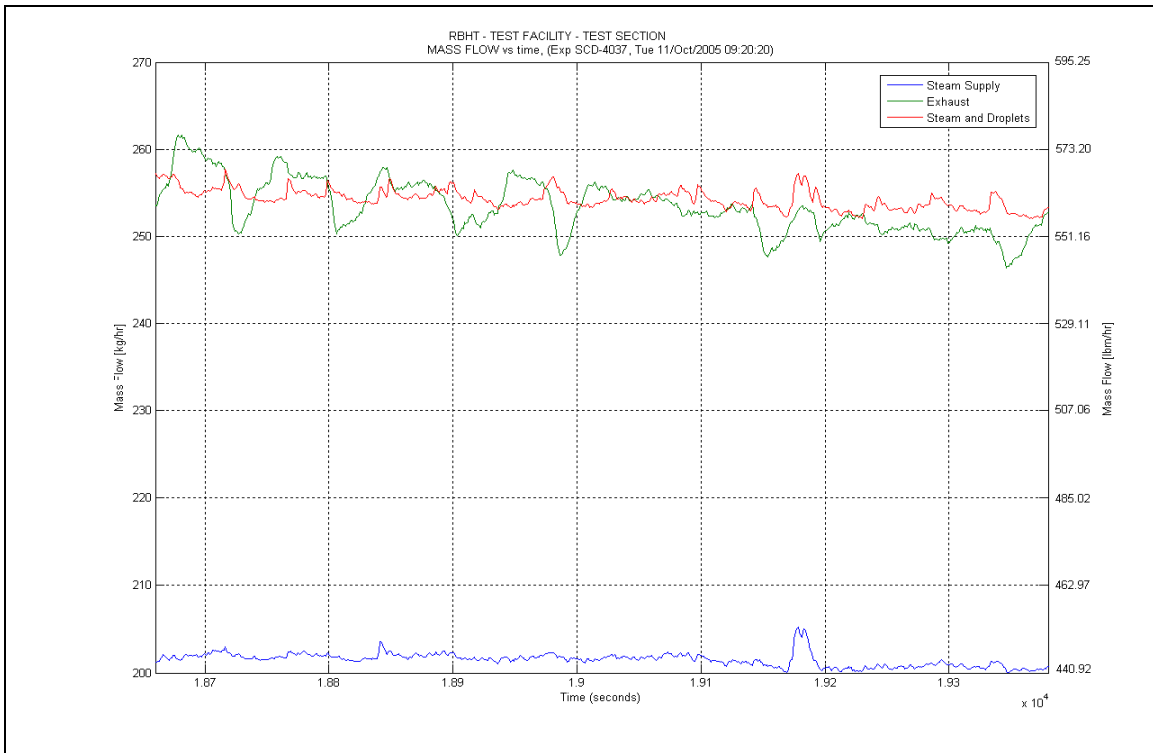

Figure A-356: Mass Flow for Experiment 4037C

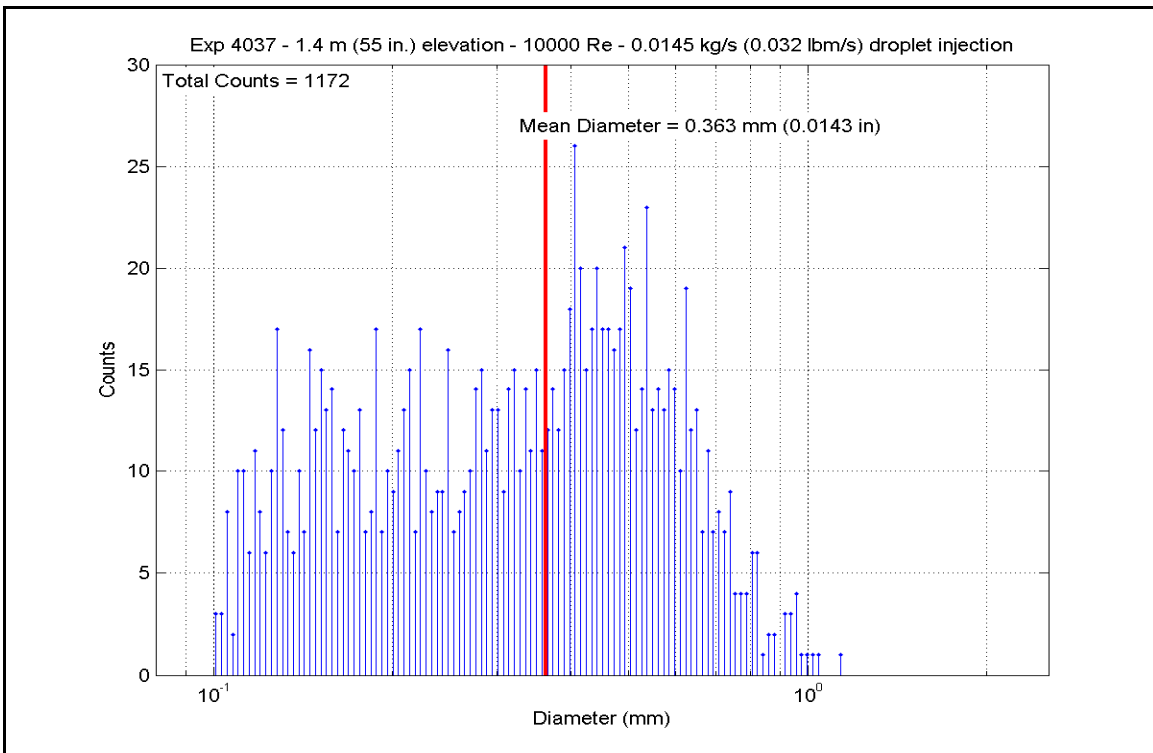

Figure A-357: Droplet Measurements at 1.397 m (55 in.) Elevation for Experiment 4037C

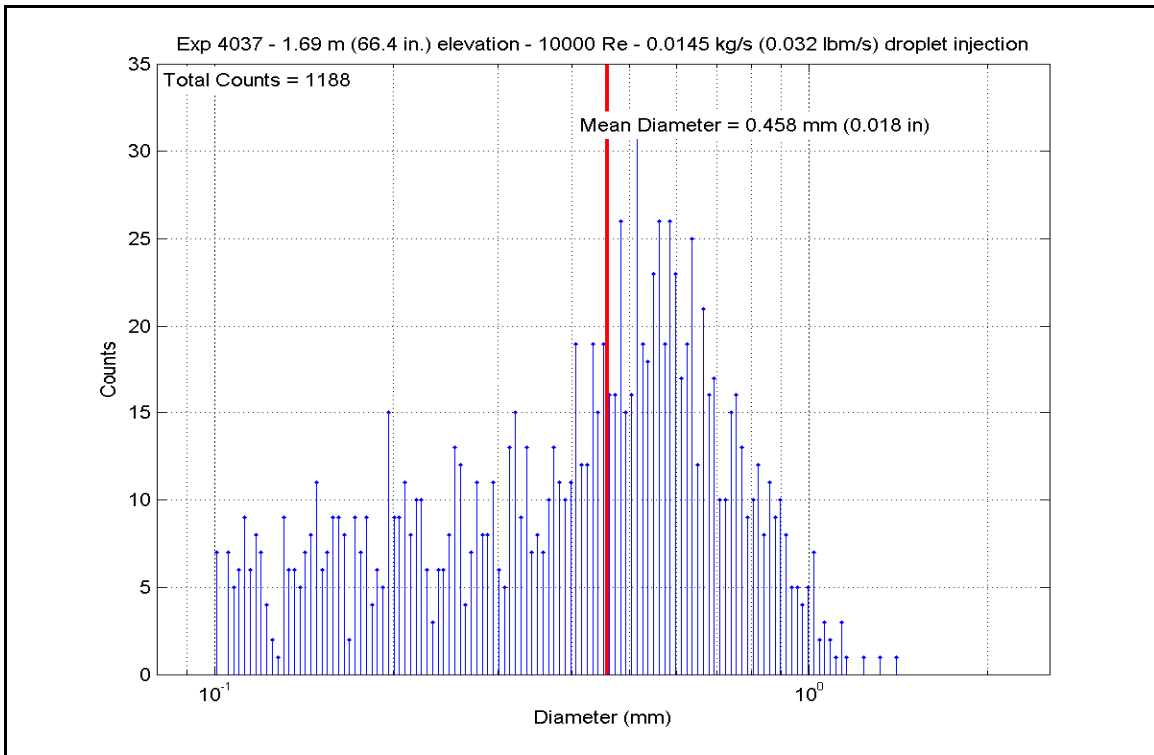

Figure A-358: Droplet Measurements at 1.687 m (66.4 in.) Elevation for Experiment 4037C

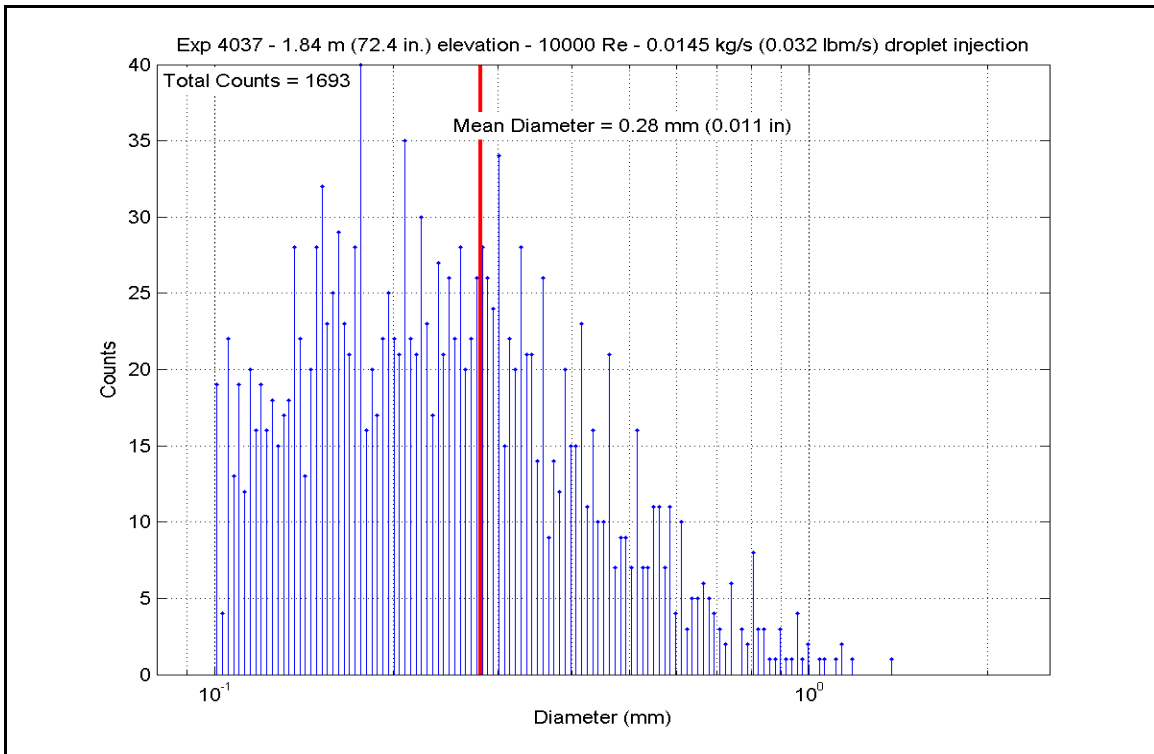

Figure A-359: Droplet Measurements at 1.839 m (72.4 in.) Elevation for Experiment 4037C

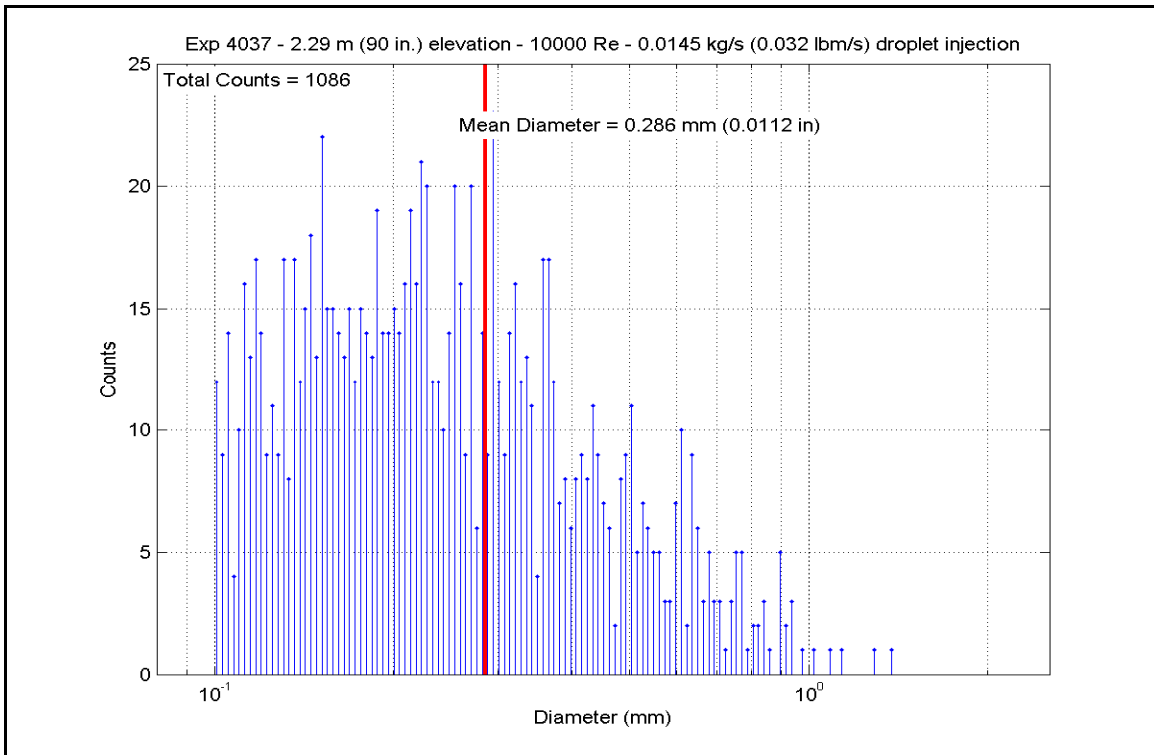

Figure A-360: Droplet Measurements at 2.286 m (90 in.) Elevation for Experiment 4037C

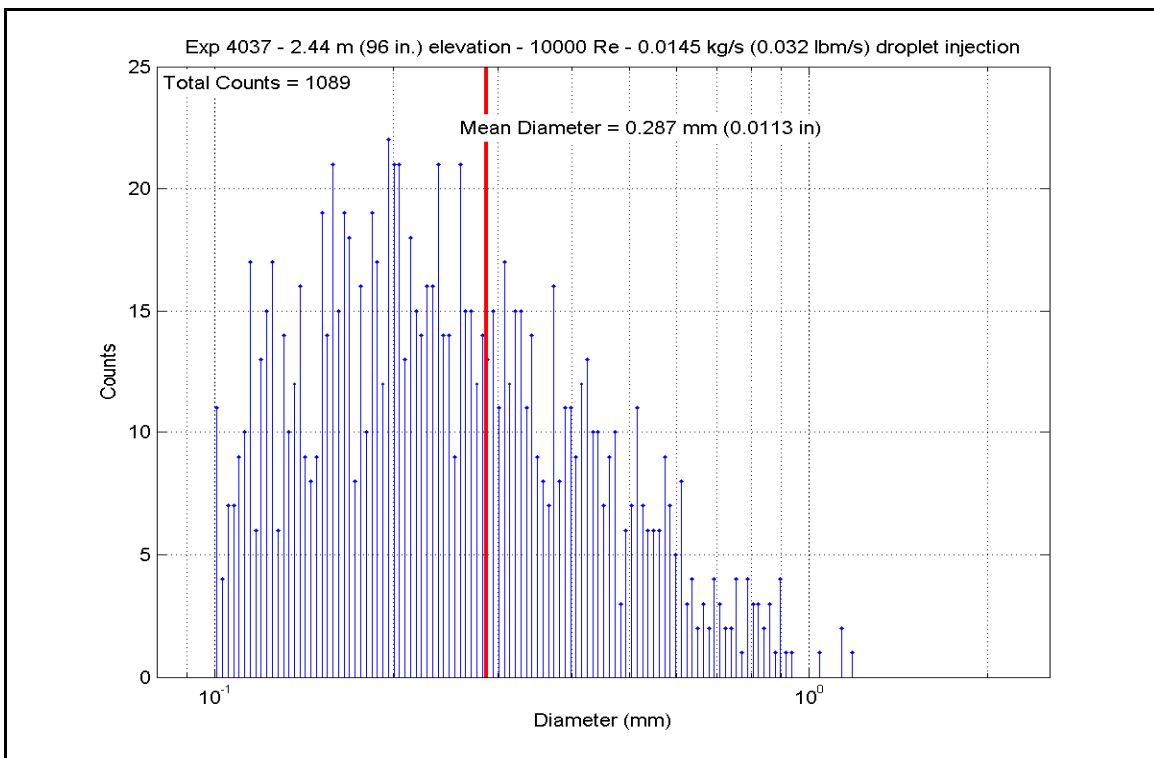

Figure A-361: Droplet Measurements at 2.438 m (96 in.) Elevation for Experiment 4037C

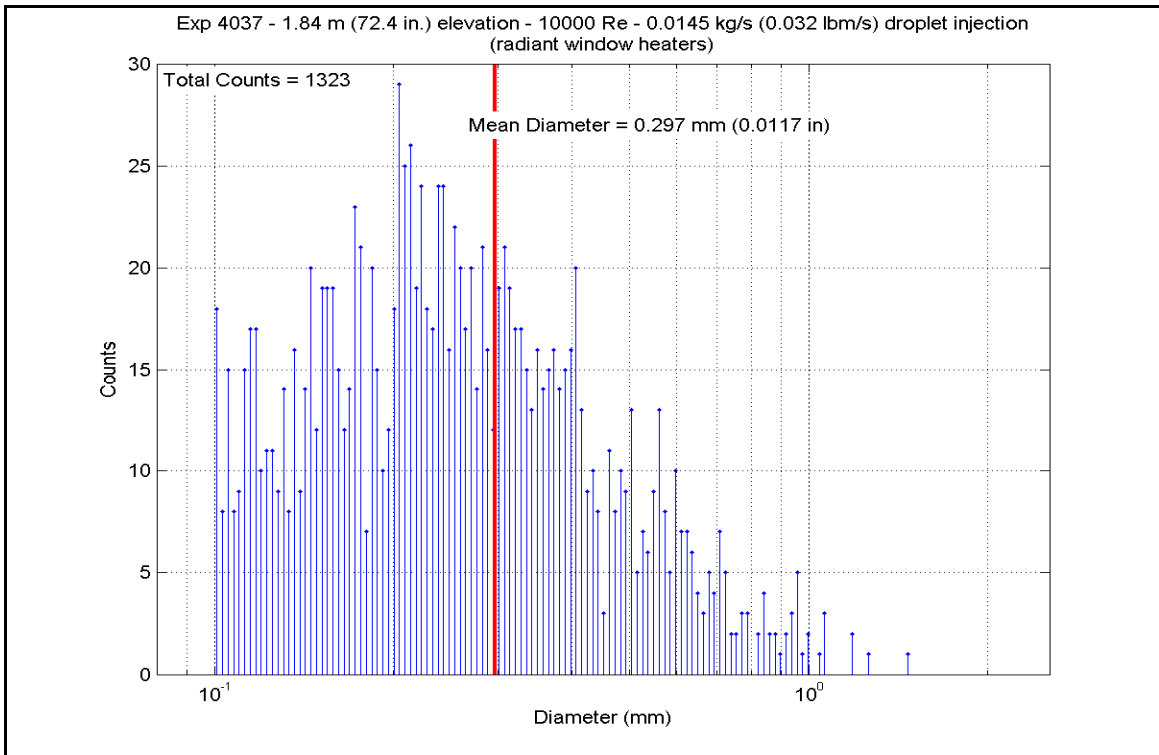

Figure A-362: Droplet Measurements at 1.839 m (72.4 in.) Elevation for Experiment 4037C

Table A-20: Summary of Steam Cooling Heat Transfer Reduced Data for Experiment 4037C

SCD-4037-C		Inlet Reynolds: 10000		UP Pressure: 40 psia		Bundle Power: 272971 Btu/hr		Steam flow: 440.0 lbm/hr		Dropletflow: 0.032 lbm/s		
H.R. ID	H.R. Location	Channel Number	Elevation (in)	Elevation (m)	Zgrid (in)	Zgrid (m)	H.R. Tw (°F)	H.R. Tw (K)	H.R. q" (Btu/hr-ft2)	H.R. q" (W/m2)	h _{sat} (z) (Btu/hr-ft2-F)	h _{sat} (z) (W/m2-K)
Gr-3	RodD3_88.3	185	88.3	2.243	-0.2	-0.005	807.09	703.8	6920.53	21830.8	12.814	72.8
	RodD3_91.3	186	91.3	2.319	2.8	0.071	902.79	756.9	7082.24	22340.9	11.139	63.3
	RodD3_93.1	187	93.1	2.365	4.6	0.117	943.75	779.7	7176.56	22638.5	10.605	60.2
	RodD3_95.3	188	95.3	2.421	6.8	0.173	980.04	799.8	7289.19	22993.7	10.223	58.1
	RodD3_100.1	189	100.1	2.543	11.6	0.295	1019.49	821.8	7511.59	23695.3	9.982	56.7
	RodD3_106.1	190	106.1	2.695	17.6	0.447	1107.55	870.7	7815.58	24654.2	9.298	52.8
	RodD3_110	191	110	2.794	21.5	0.546	984.63	802.4	7809.96	24636.5	10.883	61.8
	RodD3_142.1	192	142.1	3.609	8.6	0.218	1002.59	812.4	3006.53	9484.1	4.087	23.2
Gr-3	RodC4_88.4	233	88.4	2.245	-0.1	-0.003	780.71	689.1	6980.06	22018.6	13.588	77.2
	RodC4_91.1	234	91.1	2.314	2.6	0.066	878.28	743.3	7144.75	22538.1	11.688	66.4
	RodC4_93.4	235	93.4	2.372	4.9	0.124	926.84	770.3	7270.78	22935.7	11.019	62.6
	RodC4_95.3	236	95.3	2.421	6.8	0.173	963.62	790.7	7373.28	23259.0	10.584	60.1
	RodC4_100.1	237	100.1	2.543	11.6	0.295	991.71	806.3	7599.81	23973.6	10.487	59.6
	RodC4_106.1	238	106.1	2.695	17.6	0.447	1069.74	849.7	7913.81	24964.1	9.859	56.0
	RodC4_110	239	110	2.794	21.5	0.546	910.62	761.3	7821.55	24673.1	12.153	69.0
	RodC4_142.2	240	142.2	3.612	8.7	0.221	956.30	786.6	3272.16	10322.0	4.747	27.0
Gr-3	RodD4_88.3	241	88.3	2.243	-0.2	-0.005	768.62	682.4	6957.51	21947.5	13.870	78.8
	RodD4_91.3	242	91.3	2.319	2.8	0.071	869.91	738.7	7140.42	22524.4	11.843	67.3
	RodD4_93.2	243	93.2	2.367	4.7	0.119	912.67	762.4	7244.47	22852.7	11.220	63.7
	RodD4_95.2	244	95.2	2.418	6.7	0.170	949.16	782.7	7349.10	23182.7	10.773	61.2
	RodD4_100.1	245	100.1	2.543	11.6	0.295	995.94	808.7	7577.28	23902.5	10.395	59.0
	RodD4_106.1	246	106.1	2.695	17.6	0.447	1073.16	851.6	7886.94	24879.3	9.783	55.6
	RodD4_142.1	248	142.1	3.609	8.6	0.218	969.65	794.1	3161.03	9971.5	4.499	25.5
Gr-3	RodE4_88.4	201	88.4	2.245	-0.1	-0.003	802.47	701.2	6832.51	21553.2	12.760	72.5
	RodE4_91.2	202	91.2	2.316	2.7	0.069	904.13	757.7	7008.77	22109.2	11.001	62.5
	RodE4_95.3	204	95.3	2.421	6.8	0.173	986.81	803.6	7224.00	22788.1	10.036	57.0
	RodE4_100.9	205	100.9	2.563	12.4	0.315	1048.83	838.1	7483.04	23605.3	9.571	54.4
	RodE4_142.3	208	142.3	3.614	8.8	0.224	1012.31	817.8	3154.71	9951.5	4.233	24.0

Table A-20: Summary of Steam Cooling Heat Transfer Reduced Data for Experiment 4037C, continued

	H.R. Location	Channel Number	Elevation (in)	Elevation (m)	Zgrid (in)	Zgrid (m)	H.R. Tw (°F)	H.R. Tw (K)	H.R. q" (Btu/hr-ft ²)	H.R. q" (W/m ²)	h _{sat} (z) (Btu/hr-ft ² -F)	h _{sat} (z) (W/m ² -K)
Gr-4	RodE3_63.4	193	63.4	1.610	16.4	0.417	956.99	787.0	5599.63	17664.0	8.115	46.1
	RodE3_113.6	194	113.6	2.885	0.85	0.022	1040.11	833.2	7123.69	22471.7	9.214	52.3
	RodE3_115.5	195	115.5	2.934	2.75	0.070	1073.13	851.6	6902.62	21774.3	8.563	48.6
	RodE3_118.5	196	118.5	3.010	5.75	0.146	1098.21	865.5	6512.75	20544.5	7.835	44.5
	RodE3_122.7	197	122.7	3.117	9.95	0.253	1105.08	869.3	5967.93	18825.9	7.121	40.4
	RodE3_126.5	198	126.5	3.213	13.75	0.349	1101.42	867.3	5459.68	17222.6	6.543	37.2
	RodE3_131.7	199	131.7	3.345	-1.8	-0.046	990.59	805.7	4729.34	14918.7	6.536	37.1
	RodE3_135.6	200	135.6	3.444	2.1	0.053	1026.84	825.8	4243.26	13385.3	5.584	31.7
	RodC5_63.7	225	63.7	1.618	16.7	0.424	928.96	771.5	5479.53	17285.2	8.278	47.0
	RodC5_113.6	226	113.6	2.885	0.85	0.022	943.42	779.5	7017.39	22136.3	10.374	58.9
Gr-4	RodC5_115.7	227	115.7	2.939	2.95	0.075	993.73	807.4	6780.82	21390.1	9.331	53.0
	RodC5_122.7	229	122.7	3.117	9.95	0.253	1033.56	829.6	5897.55	18603.8	7.694	43.7
	RodC5_126.7	230	126.7	3.218	13.95	0.354	1033.06	829.3	5386.03	16990.2	7.031	39.9
	RodC5_131.6	231	131.6	3.343	-1.9	-0.048	909.99	760.9	4709.35	14855.7	7.324	41.6
	RodC5_135.7	232	135.7	3.447	2.2	0.056	939.40	777.3	4258.43	13433.2	6.333	36.0
	RodE5_63.6	209	63.6	1.615	16.6	0.422	913.53	762.9	5639.68	17790.4	8.723	49.5
	RodE5_113.6	210	113.6	2.885	0.85	0.022	1019.86	822.0	7160.17	22586.7	9.511	54.0
	RodE5_115.4	211	115.4	2.931	2.65	0.067	1055.44	841.7	6942.93	21901.5	8.806	50.0
	RodE5_118.7	212	118.7	3.015	5.95	0.151	1087.21	859.4	6504.54	20518.6	7.930	45.0
	RodE5_122.6	213	122.6	3.114	9.85	0.250	1101.45	867.3	6005.12	18943.1	7.197	40.9
RodE5_126.6	214	126.6	3.216	13.85	0.352	1100.54	866.8	5483.02	17296.2	6.578	37.4	
Gr-5	RodE5_131.6	215	131.6	3.343	-1.9	-0.048	993.06	807.1	4805.15	15157.9	6.618	37.6
	RodE5_135.6	216	135.6	3.444	2.1	0.053	1013.25	818.3	4322.89	13636.6	5.793	32.9
	RodC3_79.8	177	79.8	2.027	8.92	0.227	930.86	772.5	6454.32	20360.2	9.722	55.2
	RodC3_85.6	178	85.6	2.174	14.72	0.374	818.55	710.1	6720.71	21200.5	12.185	69.2
	RodC3_88.5	179	88.5	2.248	0	0.000	803.95	702.0	6869.84	21670.9	12.794	72.7
	RodC3_92.4	180	92.4	2.347	3.9	0.099	926.97	770.4	7088.23	22359.8	10.740	61.0
	RodC3_94.4	181	94.4	2.398	5.9	0.150	966.58	792.4	7189.90	22680.6	10.278	58.4
	RodC3_97.2	182	97.2	2.469	8.7	0.221	1015.40	819.5	7314.08	23072.3	9.773	55.5
	RodC3_108.8	183	108.8	2.764	20.3	0.516	1092.32	862.2	7743.11	24425.7	9.382	53.3
	RodD5_50	217	50	1.270	3	0.076	823.60	712.9	4943.37	15593.9	8.881	50.4
Gr-8	RodD5_54.1	218	54.1	1.374	7.1	0.180	798.47	699.0	5171.68	16314.1	9.731	55.3
	RodD5_56.9	219	56.9	1.445	9.9	0.251	866.24	736.6	5312.00	16756.7	8.865	50.3
	RodD5_60	220	60	1.524	13	0.330	895.88	753.1	5459.59	17222.3	8.681	49.3
	RodD5_66.1	221	66.1	1.679	19.1	0.485	928.97	771.5	5772.21	18208.4	8.720	49.5
	RodD5_69.9	222	69.9	1.775	-0.98	-0.025	742.80	668.0	6009.70	18957.6	12.631	71.7
	RodD5_72.9	223	72.9	1.852	2.02	0.051	817.69	709.6	6162.07	19438.3	11.190	63.5
	RodD5_74.9	224	74.9	1.902	4.02	0.102	862.56	734.6	6268.54	19774.1	10.526	59.8

Inner 3x3

Table A-20: Summary of Steam Cooling Heat Transfer Reduced Data for Experiment 4037C, continued

H.R. ID	H.R. Location	Channel Number	Elevation (in)	Elevation (m)	Zgrid (in)	Zgrid (m)	H.R. Tw (°F)	H.R. Tw (K)	H.R. q" (Btu/hr-ft ²)	H.R. q" (W/m ²)	h _{sat} (z) (Btu/hr-ft ² -F)	h _{sat} (z) (W/m ² -K)	
Gr-2	RodB5_41	153	41	1.041	13.5	0.343	749.75	671.9	4486.31	14152.1	9.293	52.8	
	RodB5_52.9	154	52.9	1.344	5.9	0.150	810.64	705.7	5050.81	15932.8	9.291	52.8	
	RodB5_55	155	55	1.397	8	0.203	849.25	727.2	5146.84	16235.7	8.840	50.2	
	RodB5_57.8	156	57.8	1.468	10.8	0.274	885.56	747.3	5299.06	16715.9	8.567	48.6	
	RodB5_64	157	64	1.626	17	0.432	936.47	775.6	5608.91	17693.3	8.378	47.6	
	RodB5_73.9	158	73.9	1.877	3.02	0.077	863.73	735.2	6158.37	19426.6	10.320	58.6	
	RodB5_75.9	159	75.9	1.928	5.02	0.128	897.99	754.3	6266.03	19766.2	9.931	56.4	
	RodB5_76.9	160	76.9	1.953	6.02	0.153	911.60	761.8	6319.25	19934.1	9.803	55.7	
	Gr-2	RodF5_41	105	41	1.041	13.5	0.343	743.20	668.3	4464.98	14084.8	9.376	53.2
		RodF5_53.1	106	53.1	1.349	6.1	0.155	809.73	705.2	5047.00	15920.8	9.299	52.8
		RodF5_55	107	55	1.397	8	0.203	846.86	725.8	5131.22	16186.4	8.849	50.3
		RodF5_57.8	108	57.8	1.468	10.8	0.274	880.00	744.3	5291.43	16691.8	8.632	49.0
		RodF5_64	109	64	1.626	17	0.432	926.66	770.2	5586.52	17622.7	8.469	48.1
		RodF5_73.8	110	73.8	1.875	2.92	0.074	875.39	741.7	6099.81	19241.9	10.026	56.9
		RodF5_75.8	111	75.8	1.925	4.92	0.125	912.18	762.1	6202.89	19567.0	9.614	54.6
		RodF5_76.8	112	76.8	1.951	5.92	0.150	927.56	770.7	6254.12	19728.6	9.468	53.8
Gr-2		RodC2_41	57	41	1.041	13.5	0.343	743.14	668.2	4483.14	14142.1	9.416	53.5
		RodC2_53.1	58	53.1	1.349	6.1	0.155	858.73	732.4	5074.35	16007.0	8.575	48.7
		RodC2_55	59	55	1.397	8	0.203	877.53	742.9	5165.76	16295.4	8.461	48.0
		RodC2_57.8	60	57.8	1.468	10.8	0.274	909.97	760.9	5296.47	16707.7	8.238	46.8
	RodC2_63.9	61	63.9	1.623	16.9	0.429	935.98	775.4	5592.81	17642.5	8.360	47.5	
	RodC2_73.8	62	73.8	1.875	2.92	0.074	885.04	747.1	6112.73	19282.6	9.890	56.2	
	RodC2_75.8	63	75.8	1.925	4.92	0.125	915.81	764.2	6211.49	19594.1	9.574	54.4	
	RodC2_76.8	64	76.8	1.951	5.92	0.150	929.01	771.5	6261.19	19750.9	9.458	53.7	
Gr-2	RodC6_40.9	137	40.9	1.039	13.4	0.340	738.60	665.7	4473.72	14112.4	9.486	53.9	
	RodC6_52.8	138	52.8	1.341	5.8	0.147	859.47	732.9	5067.29	15984.8	8.553	48.6	
	RodC6_54.8	139	54.8	1.392	7.8	0.198	879.83	744.2	5169.84	16308.3	8.436	47.9	
	RodC6_57.8	140	57.8	1.468	10.8	0.274	913.73	763.0	5322.20	16788.9	8.229	46.7	
	RodC6_63.8	141	63.8	1.621	16.8	0.427	932.94	773.7	5644.98	17807.1	8.477	48.1	
	RodC6_73.7	142	73.7	1.872	2.82	0.072	888.33	748.9	6223.67	19632.6	10.017	56.9	
	RodC6_75.8	143	75.8	1.925	4.92	0.125	918.36	765.6	6337.30	19991.0	9.729	55.3	
	RodC6_76.8	144	76.8	1.951	5.92	0.150	934.44	774.5	6392.94	20166.5	9.578	54.4	

5x5 periphery

Table A-20: Summary of Steam Cooling Heat Transfer Reduced Data for Experiment 4037C, continued

5x5 periphery		H.R. Location	Channel Number	Elevation (in)	Elevation (m)	Zgrid (in)	Zgrid (m)	H.R. Tw (°F)	H.R. Tw (K)	H.R. q" (Btu/hr-ft ²)	H.R. q" (W/m ²)	h _{sat} (z) (Btu/hr-ft ² -F)	h _{sat} (z) (W/m ² -K)
Gr-3	RodB4_88.4	161	88.4	2.245	-0.1	-0.003	795.30	697.2	6862.41	21647.5	12.990	63.7	73.8
	RodB4_91.3	162	91.3	2.319	2.8	0.071	892.96	751.5	7024.65	22159.3	11.222	60.5	60.5
	RodB4_93.3	163	93.3	2.370	4.8	0.122	936.21	775.5	7128.74	22487.6	10.653	58.5	58.5
	RodB4_95.1	164	95.1	2.416	6.6	0.168	967.52	792.9	7218.88	22771.9	10.305	58.6	58.6
	RodB4_100	165	100	2.540	11.5	0.292	988.28	804.4	7437.31	23461.0	10.311	54.8	54.8
	RodB4_106	166	106	2.692	17.5	0.445	1067.00	848.2	7726.21	24372.3	9.658	65.6	65.6
	RodB4_109.9	167	109.9	2.791	21.4	0.544	924.01	768.7	7585.99	23930.0	11.546	27.1	27.1
	RodB4_142.3	168	142.3	3.614	8.8	0.224	945.82	780.8	3239.53	10219.1	4.772		
Gr-5	RodF4_85.6	98	85.6	2.174	14.72	0.374	900.15	755.5	6732.50	21237.7	10.633	60.4	60.4
	RodF4_88.4	99	88.4	2.245	-0.1	-0.003	852.18	728.8	6903.58	21777.3	11.797	67.0	67.0
	RodF4_92.4	100	92.4	2.347	3.9	0.099	957.74	787.5	7104.57	22411.4	10.285	58.4	58.4
	RodF4_94.3	101	94.3	2.395	5.8	0.147	991.91	806.4	7200.31	22713.4	9.933	56.4	56.4
	RodF4_97.2	102	97.2	2.469	8.7	0.221	1033.94	829.8	7341.22	23157.9	9.572	54.4	54.4
	RodF4_108.8	103	108.8	2.764	20.3	0.516	1105.51	869.5	7760.25	24479.7	9.255	52.6	52.6
	RodF4_111	104	111	2.819	-1.75	-0.044	1008.77	815.8	7445.89	23488.1	10.038	57.0	57.0
	RodD2_103.2	65	103.2	2.621	14.7	0.373	1073.20	851.6	6913.74	21809.4	8.576	48.7	48.7
RodD2_106	66	106	2.692	17.5	0.445	1095.11	863.8	6563.08	20703.2	7.925	45.0	45.0	
RodD2_112.6	67	112.6	2.860	-0.15	-0.004	1115.45	875.1	6096.56	19231.6	7.186	40.8	40.8	
RodD2_114.9	68	114.9	2.918	2.15	0.055	1116.89	875.9	5546.30	17495.8	6.526	37.1	37.1	
RodD2_117.4	69	117.4	2.982	4.65	0.118	1099.23	866.1	5022.27	15842.7	6.035	34.3	34.3	
RodD2_120.8	70	120.8	3.068	8.05	0.204	1111.66	873.0	7666.41	24183.7	9.076	51.5	51.5	
RodD2_124.8	71	124.8	3.170	12.05	0.306	1133.84	885.3	7803.86	24617.3	9.003	51.1	51.1	
RodD2_128.6	72	128.6	3.266	15.85	0.403	1026.08	825.4	7225.25	22792.0	9.518	54.1	54.1	
Gr-6	RodD6_103.1	129	103.1	2.619	14.6	0.371	1090.79	861.4	7735.13	24400.5	9.390	53.3	53.3
	RodD6_106	130	106	2.692	17.5	0.445	1108.82	871.4	7873.02	24835.4	9.352	53.1	53.1
	RodD6_112.9	131	112.9	2.868	0.15	0.004	1011.74	817.5	7217.16	22766.5	9.691	55.0	55.0
	RodD6_114.9	132	114.9	2.918	2.15	0.055	1049.43	838.4	6964.26	21968.8	8.901	50.5	50.5
	RodD6_116.8	133	116.8	2.967	4.05	0.103	1068.27	848.9	6706.94	21157.1	8.370	47.5	47.5
	RodD6_120.9	134	120.9	3.071	8.15	0.207	1074.90	852.5	6160.38	19432.9	7.625	43.3	43.3
	RodD6_124.8	135	124.8	3.170	12.05	0.306	1073.02	851.5	5615.03	17712.6	6.966	39.6	39.6
	RodD6_128.7	136	128.7	3.269	15.95	0.405	1063.27	846.1	5062.09	15968.4	6.357	36.1	36.1

Table A-20: Summary of Steam Cooling Heat Transfer Reduced Data for Experiment 4037C, continued

5x5 periphery		H.R. Location	Channel Number	Elevation (in)	Elevation (m)	Zgrid (in)	Zgrid (m)	H.R. Tw (°F)	H.R. Tw (K)	H.R. q" (Btu/hr-ft ²)	H.R. q" (W/m ²)	h _{sat} (z) (Btu/hr-ft ² -F)	h _{sat} (z) (W/m ² -K)
Gr-8	RodE2_50.1	73	50.1	1.273	3.1	0.079	704.8	4958.24	15640.8	9.150	52.0		
	RodE2_54	74	54	1.372	7	0.178	741.1	5149.25	16243.3	8.479	48.1		
	RodE2_56.9	75	56.9	1.445	9.9	0.251	760.1	5291.24	16691.2	8.247	46.8		
	RodE2_59.9	76	59.9	1.521	12.9	0.328	777.4	5438.71	17156.4	8.087	45.9		
	RodE2_66	77	66	1.676	19	0.483	790.4	5733.32	18005.8	8.238	46.8		
	RodE2_69.8	78	69.8	1.773	-1.08	-0.027	728.4	5928.24	18700.6	10.143	57.6		
	RodE2_72.9	79	72.9	1.852	2.02	0.051	768.9	6070.30	19148.8	9.235	52.4		
	RodE2_74.9	80	74.9	1.902	4.02	0.102	785.3	6169.74	19462.4	8.983	51.0		
Gr-8	RodB3_50.2	169	50.2	1.275	3.2	0.081	673.0	4947.87	15608.1	10.206	58.0		
	RodB3_54.1	170	54.1	1.374	7.1	0.180	712.8	5119.94	16150.8	9.203	52.3		
	RodB3_56.9	171	56.9	1.445	9.9	0.251	737.1	5251.93	16567.2	8.752	49.7		
	RodB3_60.1	172	60.1	1.527	13.1	0.333	733.2	5411.90	17071.8	9.124	51.8		
	RodB3_66.1	173	66.1	1.679	19.1	0.485	750.8	5747.37	18130.1	9.198	52.2		
	RodB3_69.9	174	69.9	1.775	-0.98	-0.025	668.5	5941.60	18742.8	12.468	70.8		
	RodB3_73	175	73	1.854	2.12	0.054	719.3	6099.49	19240.9	10.736	61.0		
	RodB3_75	176	75	1.905	4.12	0.105	742.4	6198.36	19552.7	10.166	57.7		
Gr-8	RodF3_50.1	89	50.1	1.273	3.1	0.079	690.0	4940.06	15583.4	9.587	54.4		
	RodF3_54	90	54	1.372	7	0.178	727.7	5130.45	16184.0	8.799	50.0		
	RodF3_57	91	57	1.448	10	0.254	753.4	5276.60	16645.0	8.382	47.6		
	RodF3_60	92	60	1.524	13	0.330	772.9	5420.55	17099.1	8.157	46.3		
	RodF3_66.1	93	66.1	1.679	19.1	0.485	784.5	5717.16	18034.8	8.341	47.4		
	RodF3_70	94	70	1.778	-0.88	-0.022	718.2	5916.08	18662.3	10.450	59.3		
	RodF3_73	95	73	1.854	2.12	0.054	763.6	6065.34	19133.1	9.362	53.2		
	RodF3_75	96	75	1.905	4.12	0.105	784.9	6169.78	19462.6	8.991	51.1		
Gr-8	RodE6_50.2	121	50.2	1.275	3.2	0.081	697.3	4928.99	15548.5	9.327	53.0		
	RodE6_54.1	122	54.1	1.374	7.1	0.180	729.7	5116.72	16140.7	8.719	49.5		
	RodE6_57	123	57	1.448	10	0.254	746.8	5256.53	16581.7	8.511	48.3		
	RodE6_60.2	124	60.2	1.529	13.2	0.335	760.8	5419.44	17095.6	8.432	47.9		
	RodE6_66.1	125	66.1	1.679	19.1	0.485	773.3	5709.72	18011.3	8.582	48.7		
	RodE6_70	126	70	1.778	-0.88	-0.022	709.5	6004.24	18940.4	10.909	62.0		
	RodE6_73.1	127	73.1	1.857	2.22	0.056	748.7	6137.73	19361.5	9.884	56.1		
	RodE6_75	128	75	1.905	4.12	0.105	766.9	6227.48	19644.6	9.526	54.1		

RBHT Steam Cooling with Droplet Injection Test SCD-4037-D

Matrix Test # 16a

Test Conditions

Test Date – 10/11/2005

Steady State Time Window: 21900 - 22980

Upper Plenum Pressure: 2.76 bar (40 psia)

Bundle Power: 72.0 kW

Bundle Inlet Reynolds Number: 8000

Bundle Inlet Steam Flow: 158.9 kg/hr (350 lbm/hr)

Droplet Injection Flow: 0.0036 kg/s (0.008 lbm/s)

Droplet Injection Hole Diameter: 0.381 mm (.015 in)

Droplet Injection Elevation: 1.295 m (51 in)

Bundle Flow Area: $4.656 \times 10^{-3} \text{ m}^2$ ($5.012 \times 10^{-2} \text{ ft}^2$)

Test Notes

- No steam probes were traversed in this steady state window.

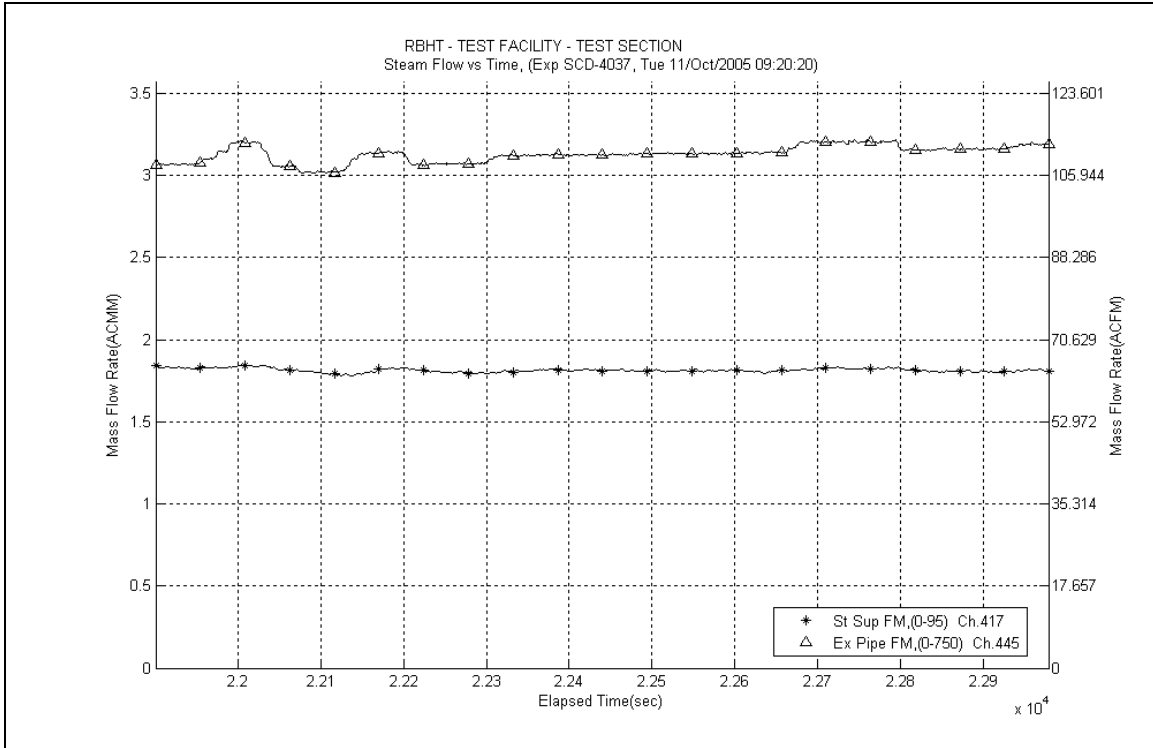

Figure A-363: Inlet and Exhaust Steam Flow Rates for Experiment 4037D

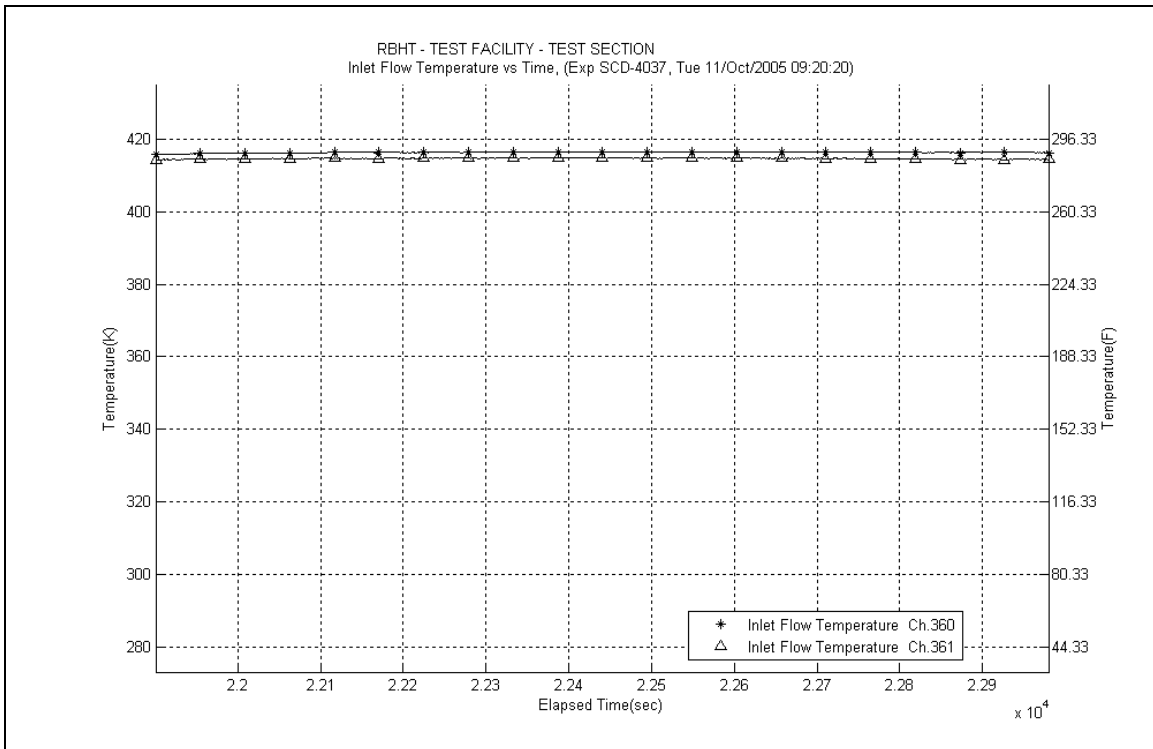

Figure A-364: Inlet Steam Temperature for Experiment 4037D

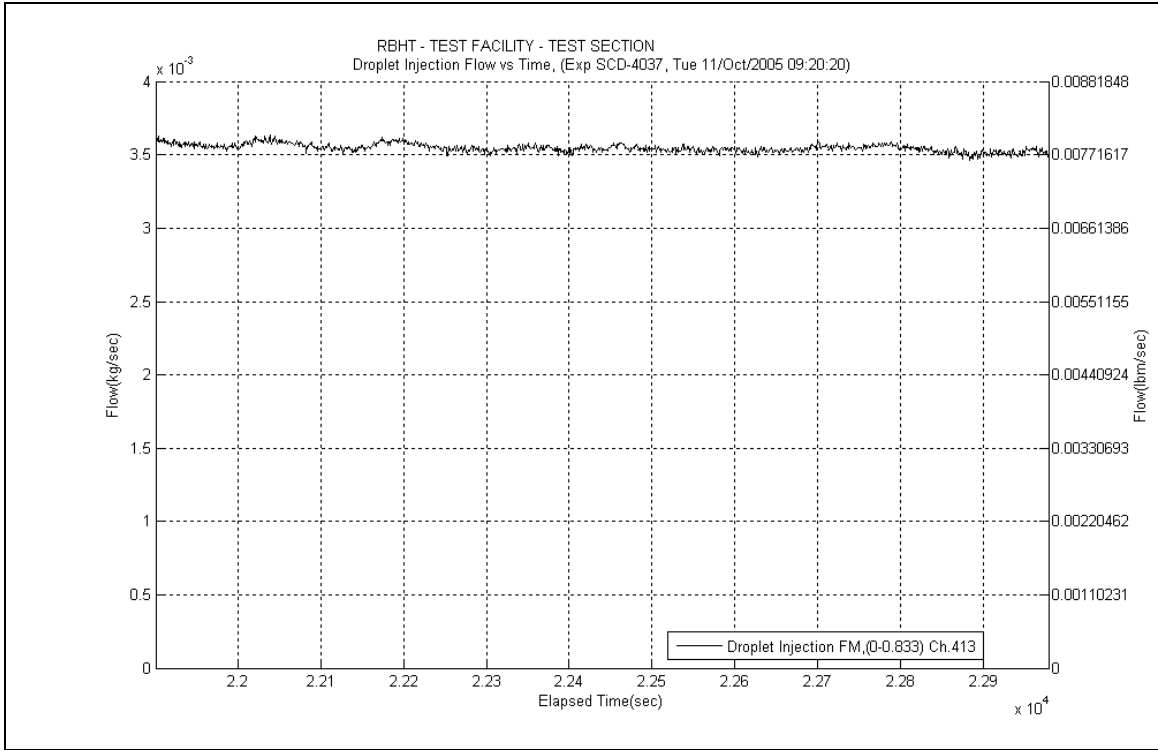

Figure A-365: Droplet Injection Flow Rate for Experiment 4037D

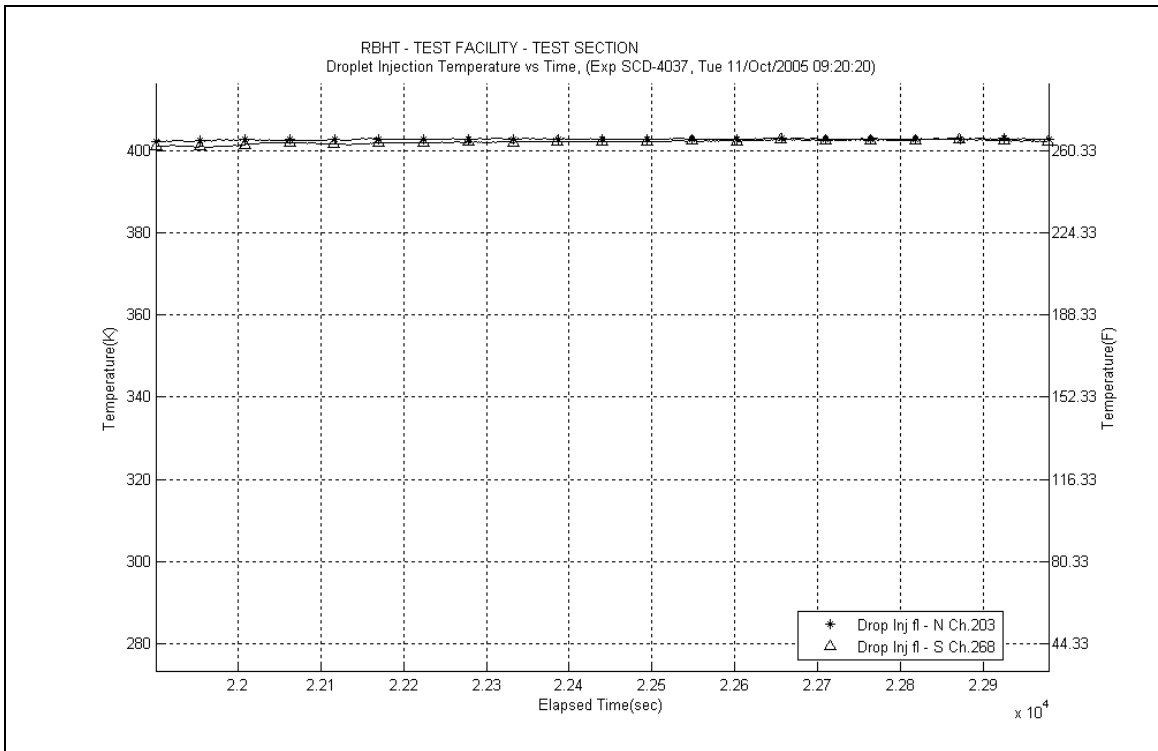

Figure A-366: Droplet Injection Temperature for Experiment 4037D

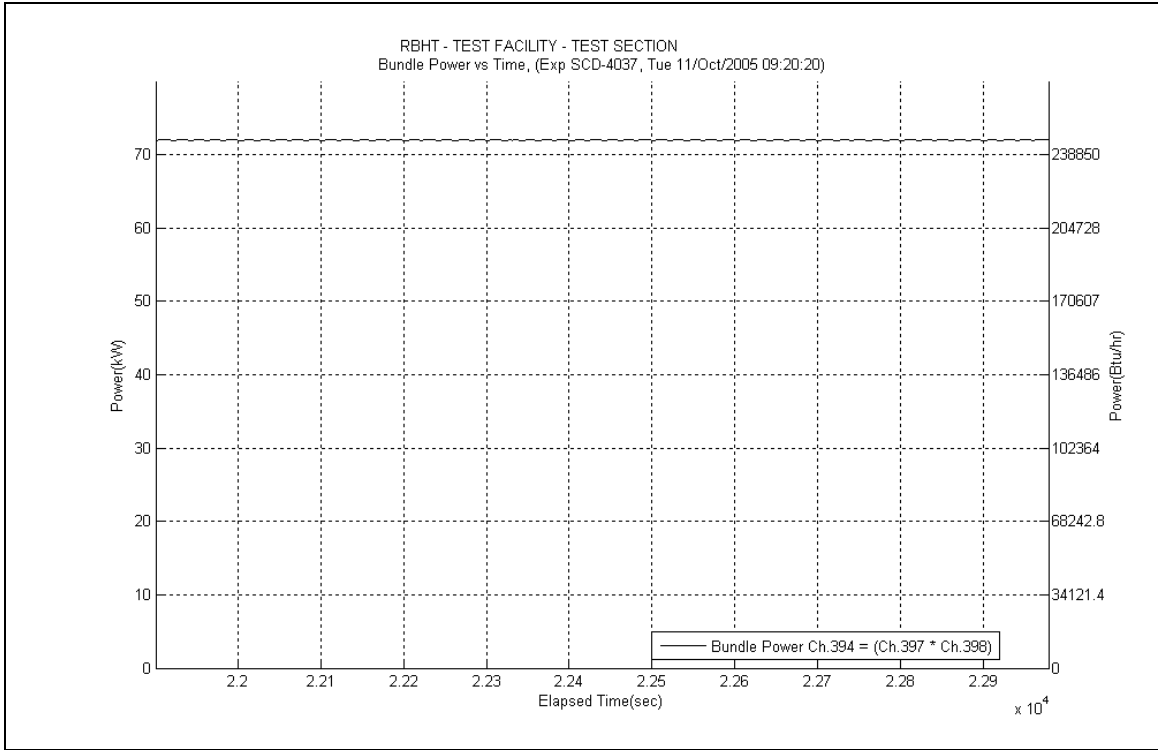

Figure A-367: Bundle Power for Experiment 4037D

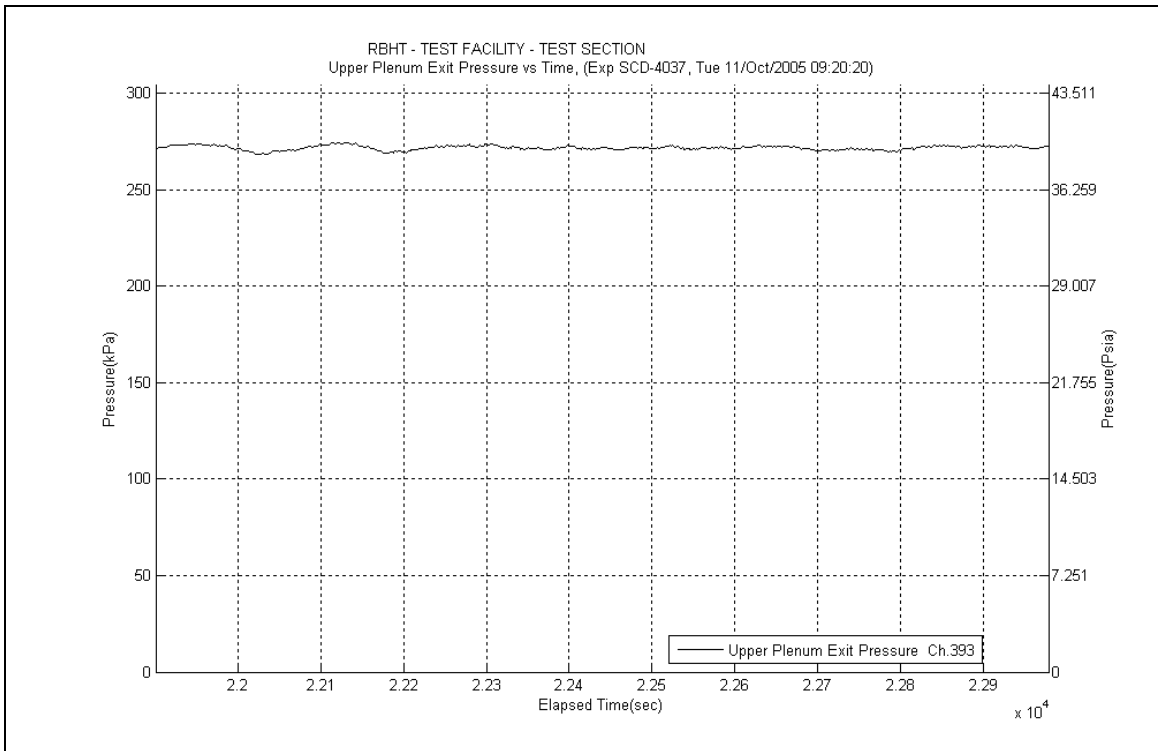

Figure A-368: Upper Plenum Pressure for Experiment 4037D

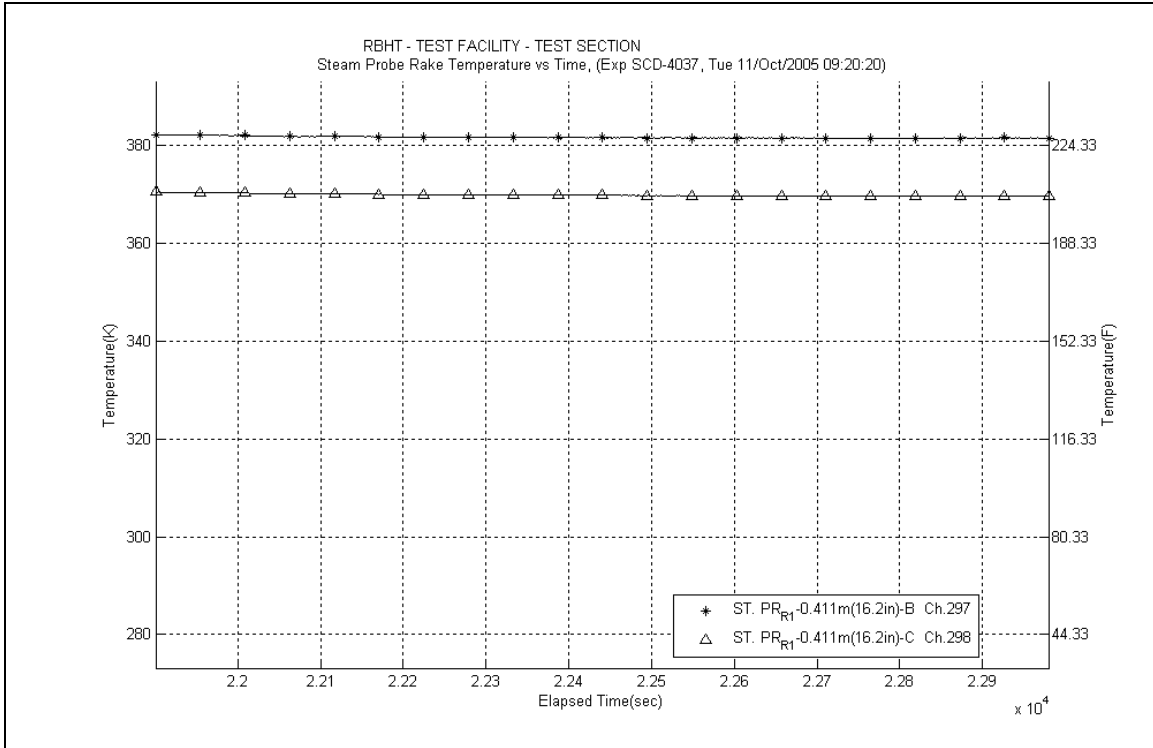

Figure A-369: Steam Probe Rake #1 Temperatures for Experiment 4037D

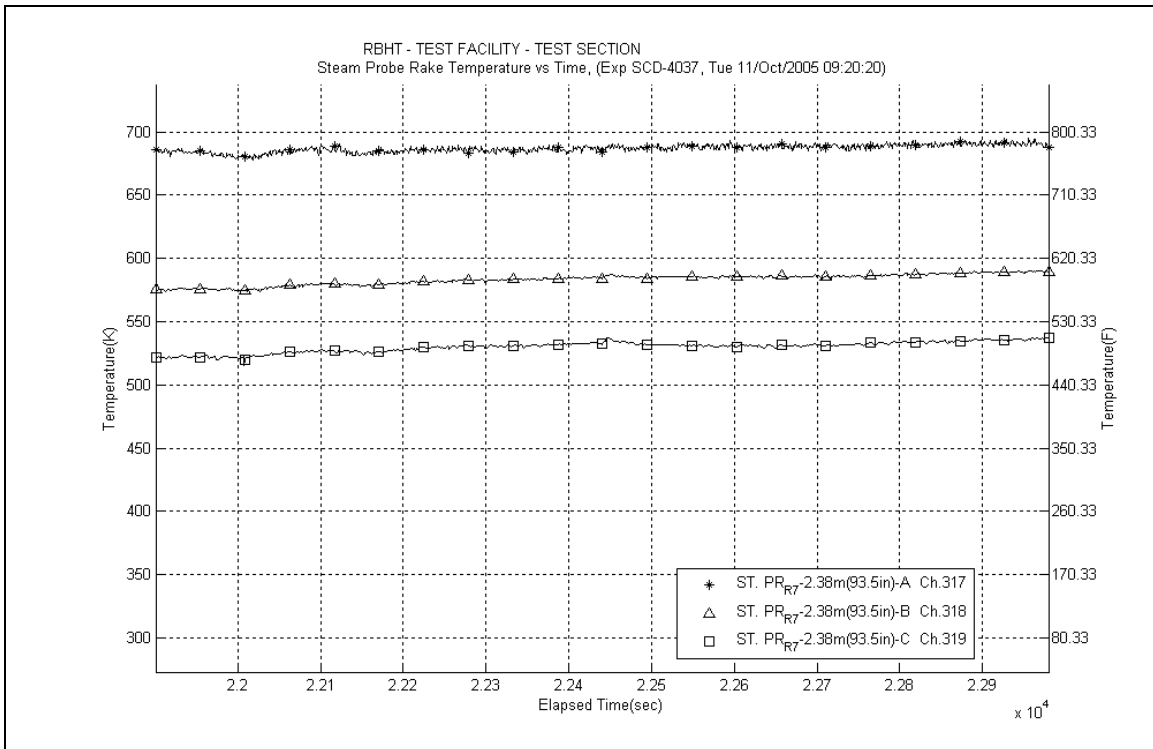

Figure A-370: Steam Probe Rake #7 Temperatures for Experiment 4037D

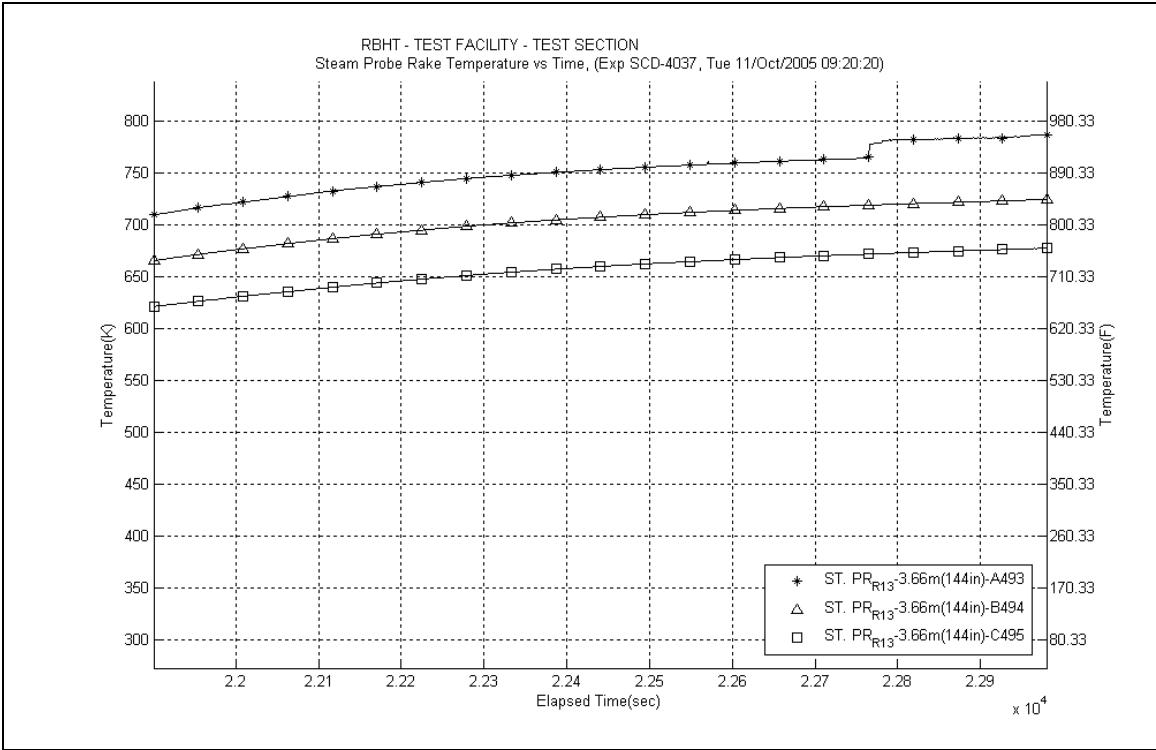

Figure A-371: Steam Probe Rake #13 Temperatures for Experiment 4037D

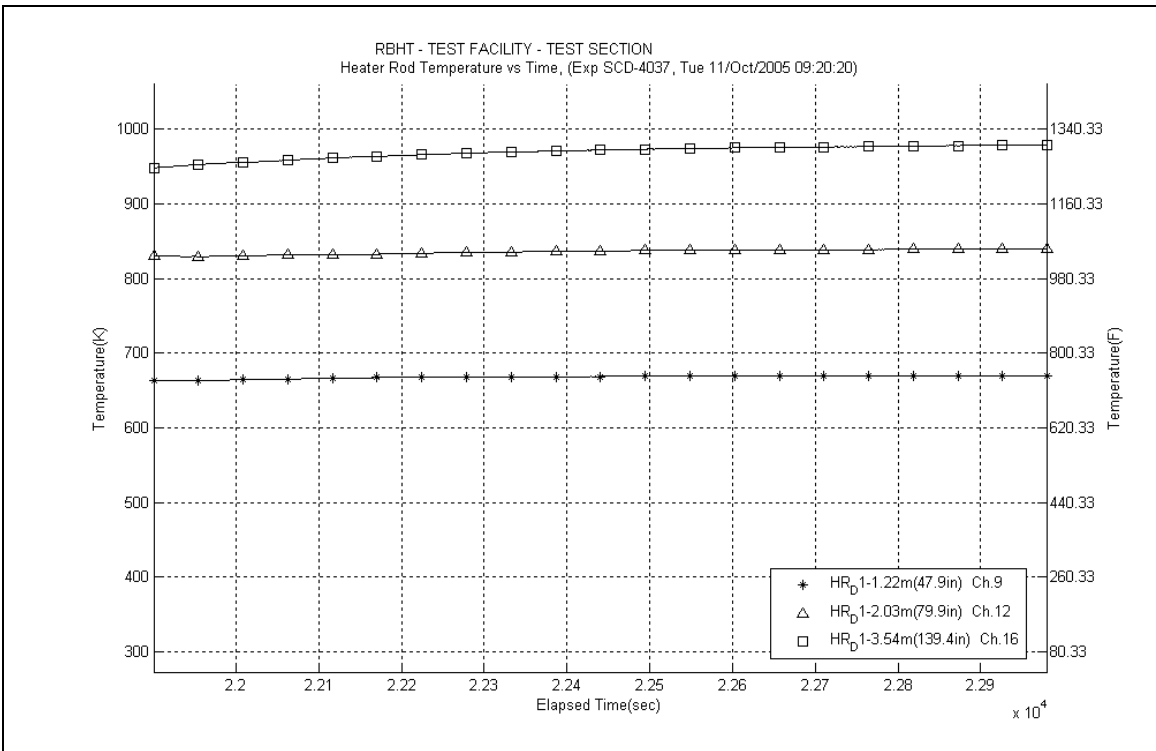

Figure A-372: Heater Rod D1 Temperatures for Experiment 4037D

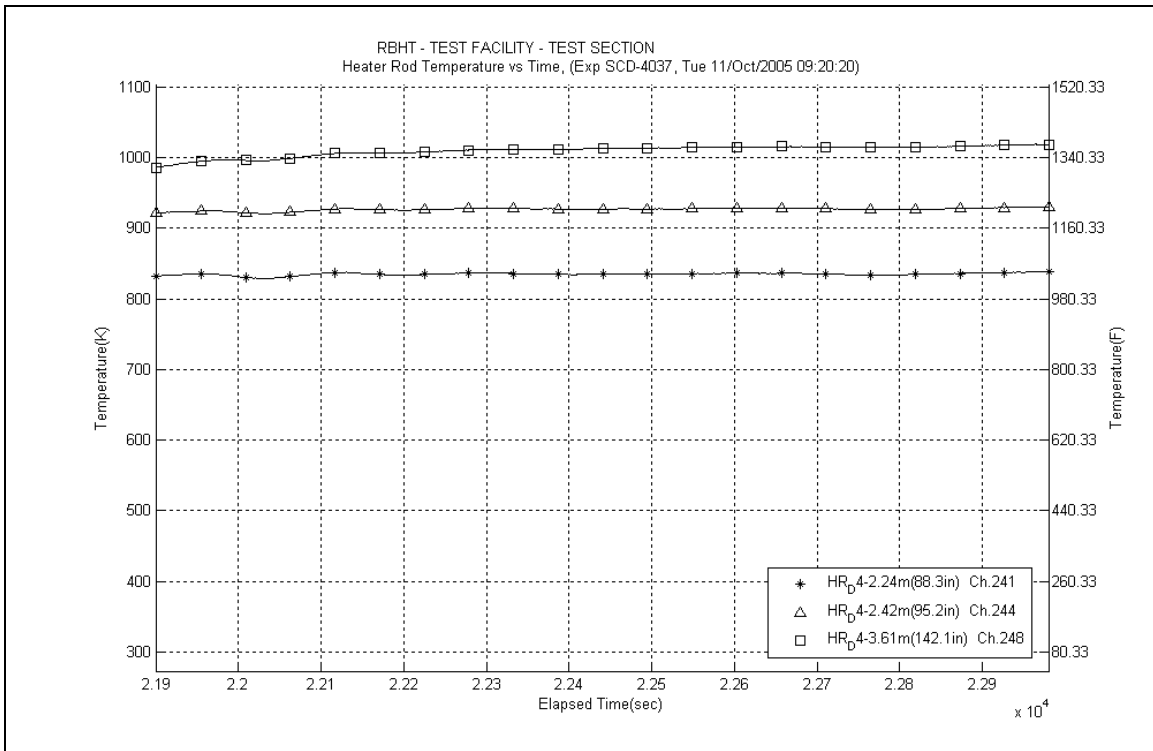

Figure A-373: Heater Rod D4 Temperatures for Experiment 4037D

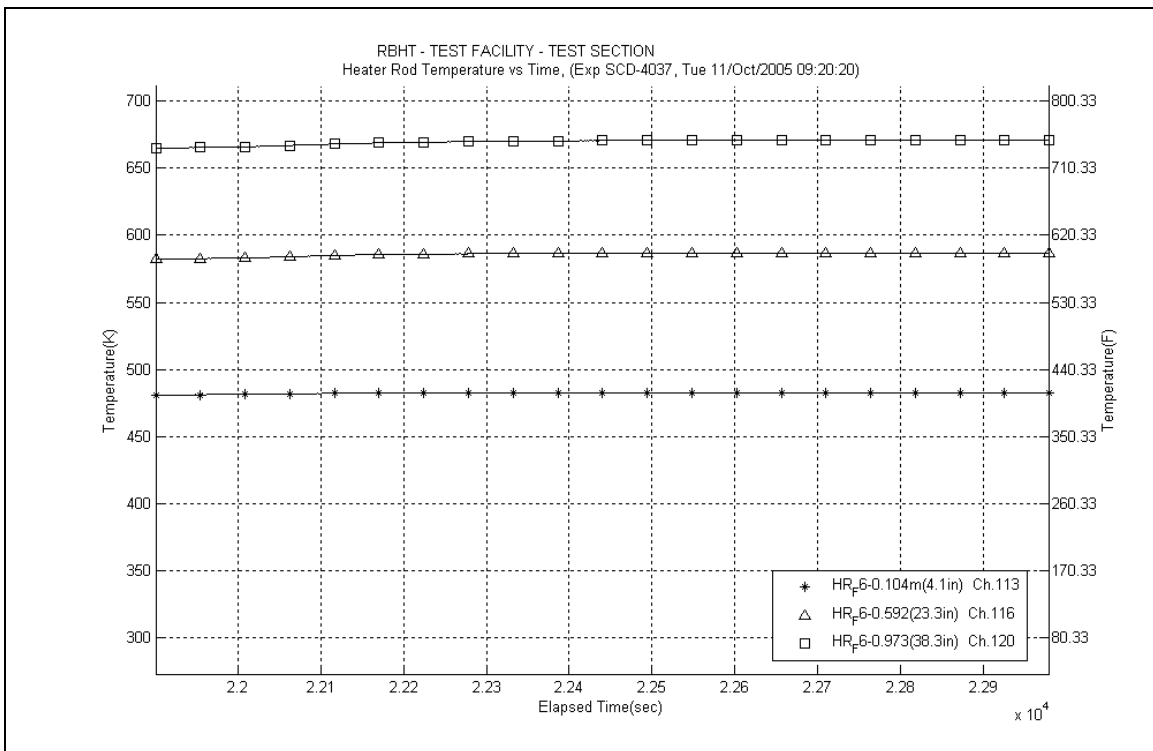

Figure A-374: Heater Rod F6 Temperatures for Experiment 4037D

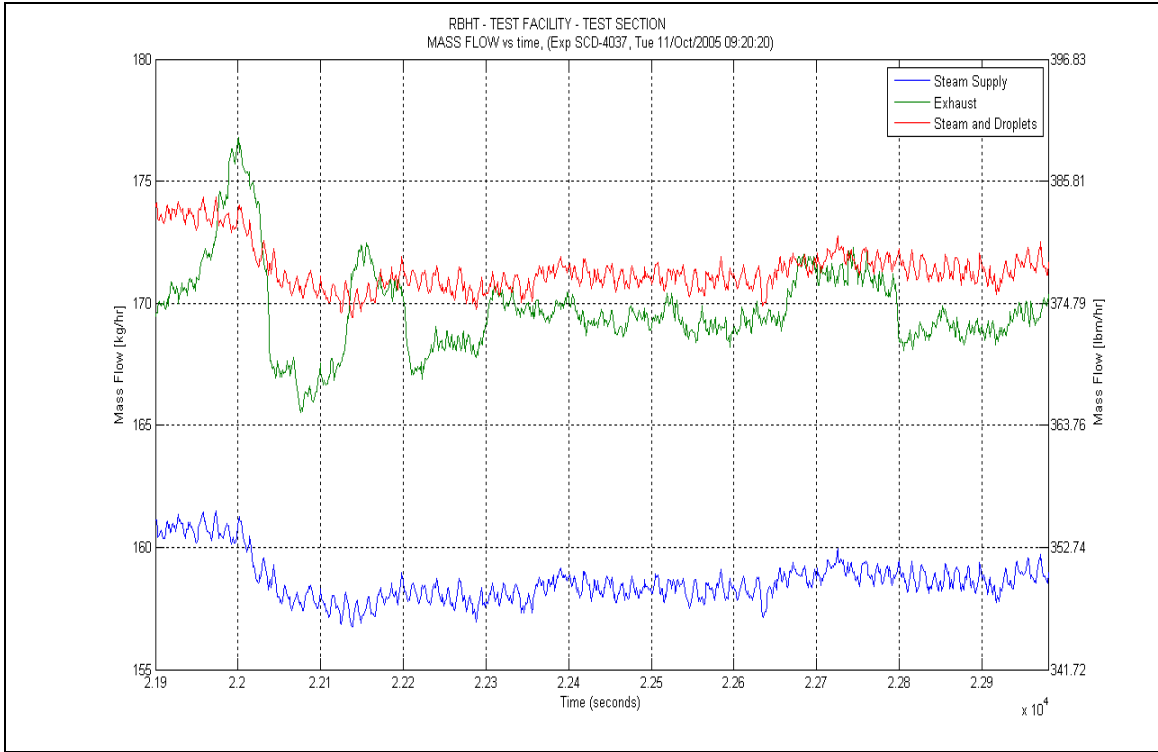

Figure A-375: Mass Flow for Experiment 4037D

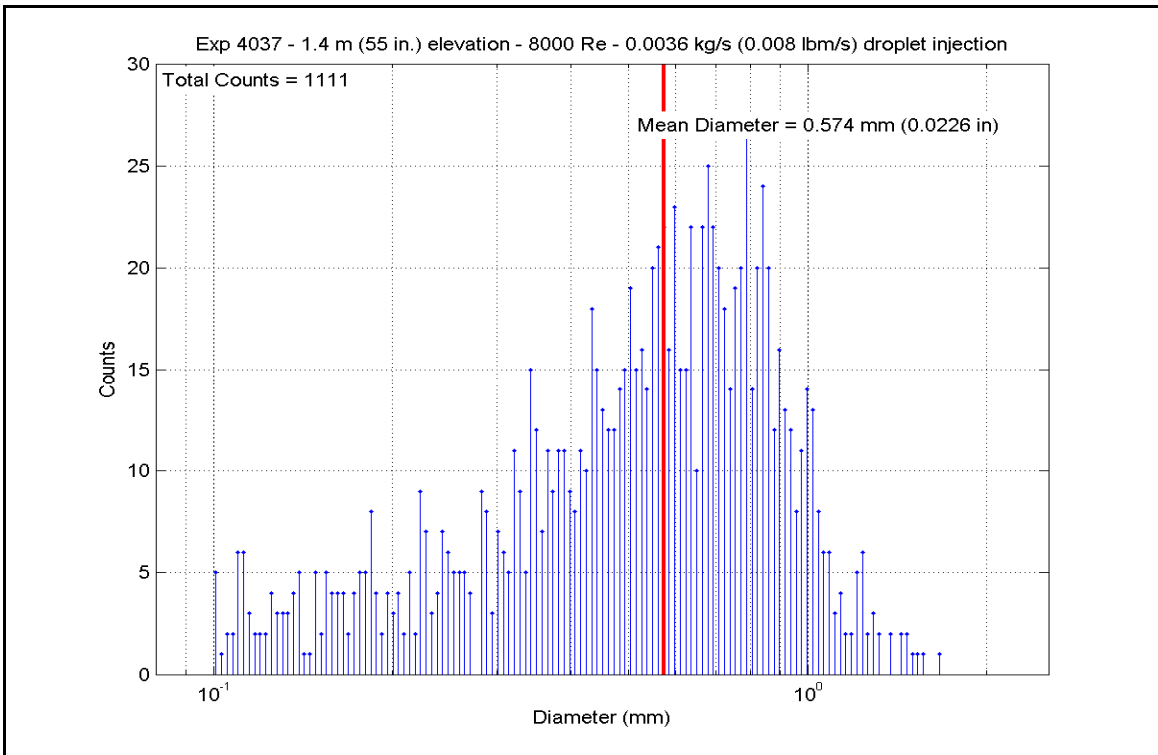

Figure A-376: Droplet Measurements at 1.397 m (55 in.) Elevation for Experiment 4037D

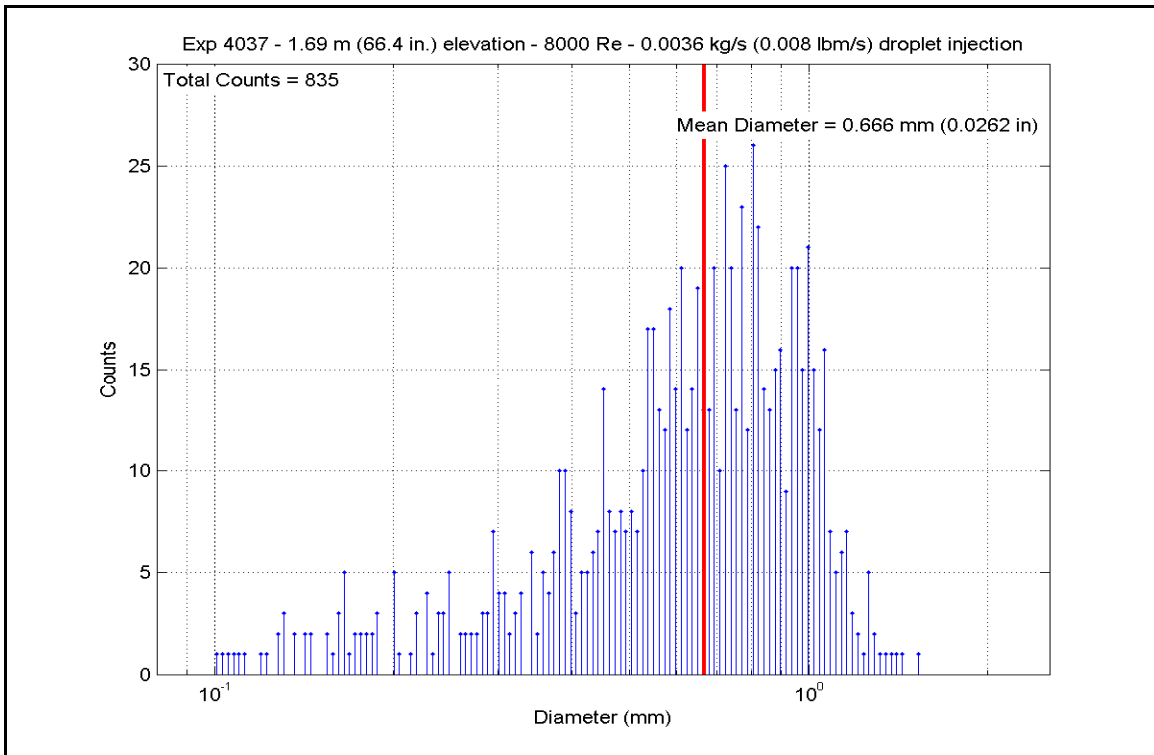

Figure A-377: Droplet Measurements at 1.687 m (66.4 in.) Elevation for Experiment 4037D

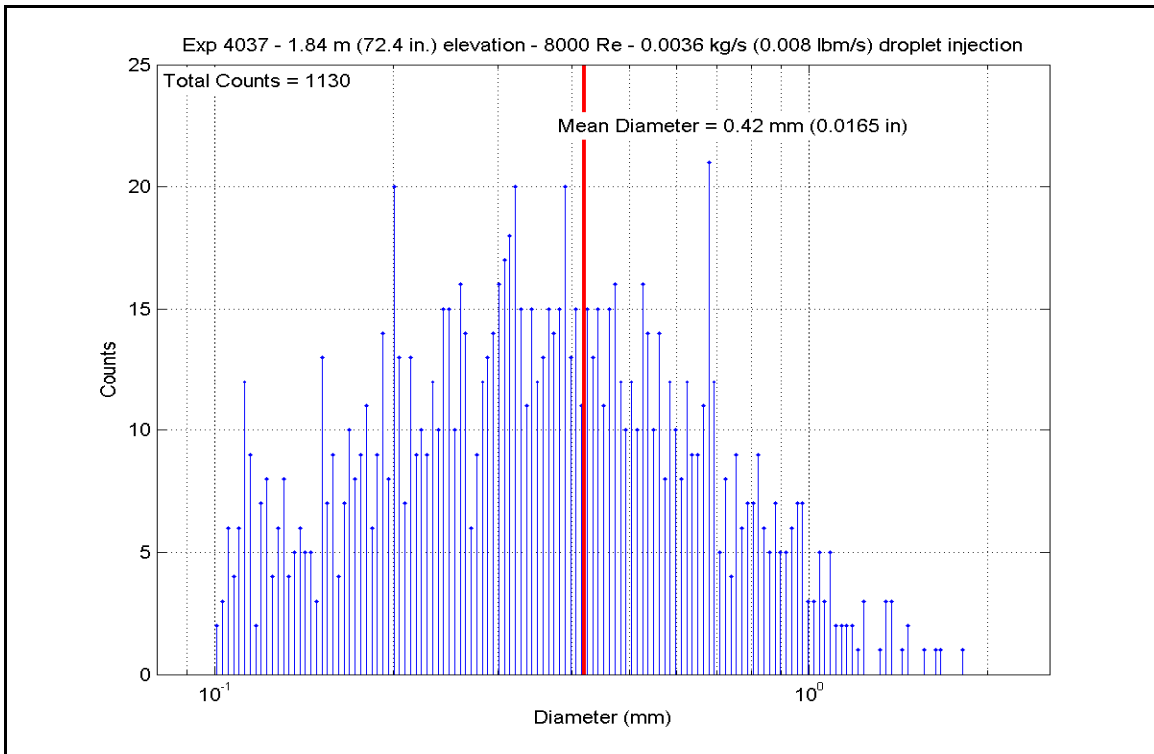

Figure A-378: Droplet Measurements at 1.839 m (72.4 in.) Elevation for Experiment 4037D

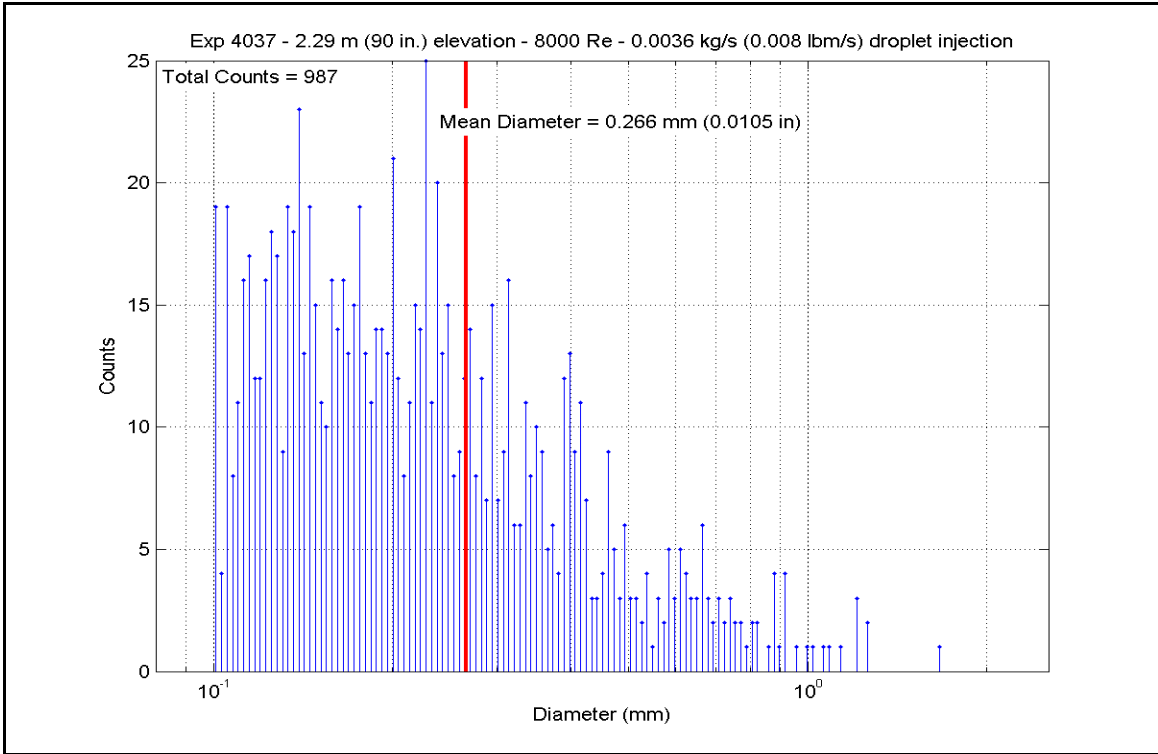

Figure A-379: Droplet Measurements at 2.286 m (90 in.) Elevation for Experiment 4037D

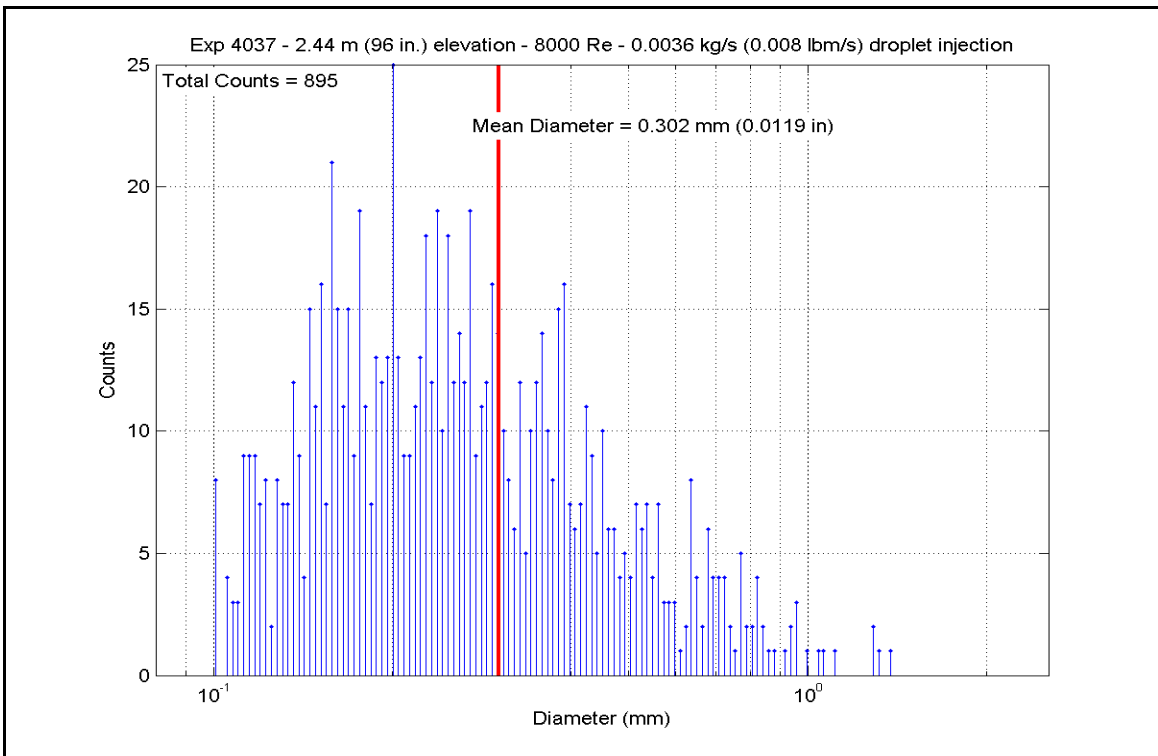

Figure A-380: Droplet Measurements at 2.438 m (96 in.) Elevation for Experiment 4037D

Table A-21: Summary of Steam Cooling Heat Transfer Reduced Data for Experiment 4037D

SCD-4037-D		Inlet Reynolds:		8000		UP Pressure:		40 psia				
Matrix Test # 16a		Bundle Power:		72.00 kW		245674 Btu/hr		350.0 lbm/hr				
Time Window: 21900-22980		Dropletflow:		0.0441 kg/s		0.008 lbm/s						
Inner 3x3		Zgrid (in)		Zgrid (m)		H.R. Tw (°F)		H.R. Tw (K)				
H.R. ID	H.R. Location	Channel Number	Elevation (in)	Elevation (m)	Zgrid (in)	Zgrid (m)	H.R. Tw (°F)	H.R. Tw (K)	H.R. q" (Btu/hr-ft2)	H.R. q" (W/m2)	h _{sat} (z) (Btu/hr-ft2-F)	h _{sat} (z) (W/m2-K)
Gr-3	RodD3_88.3	185	88.3	2.243	-0.2	-0.005	1041.26	833.8	6078.76	19175.5	7.851	44.6
	RodD3_91.3	186	91.3	2.319	2.8	0.071	1129.22	882.7	6207.88	19582.8	7.200	40.9
	RodD3_93.1	187	93.1	2.365	4.6	0.117	1168.49	904.5	6284.72	19825.2	6.971	39.6
	RodD3_95.3	188	95.3	2.421	6.8	0.173	1206.61	925.7	6379.57	20124.4	6.790	38.6
	RodD3_100.1	189	100.1	2.543	11.6	0.295	1268.33	960.0	6580.83	20759.2	6.572	37.3
	RodD3_106.1	190	106.1	2.695	17.6	0.447	1340.85	1000.3	6832.82	21554.1	6.363	36.1
	RodD3_110	191	110	2.794	21.5	0.546	1294.36	974.5	6748.57	21288.4	6.569	37.3
	RodD3_142.1	192	142.1	3.609	8.6	0.218	1352.56	1006.8	2251.98	7103.9	2.074	11.8
Gr-3	RodC4_88.4	233	88.4	2.245	-0.1	-0.003	1038.38	832.3	6145.57	19386.2	7.967	45.2
	RodC4_91.1	234	91.1	2.314	2.6	0.066	1120.21	877.7	6264.04	19759.9	7.342	41.7
	RodC4_93.4	235	93.4	2.372	4.9	0.124	1163.59	901.8	6363.21	20072.7	7.097	40.3
	RodC4_95.3	236	95.3	2.421	6.8	0.173	1197.58	920.7	6445.50	20332.3	6.926	39.3
	RodC4_100.1	237	100.1	2.543	11.6	0.295	1251.16	950.5	6656.27	20997.2	6.763	38.4
	RodC4_106.1	238	106.1	2.695	17.6	0.447	1322.06	989.8	6913.73	21809.4	6.553	37.2
	RodC4_110	239	110	2.794	21.5	0.546	1269.72	960.8	6696.48	21124.0	6.678	37.9
	RodC4_142.2	240	142.2	3.612	8.7	0.221	1348.06	1004.3	2436.85	7687.0	2.254	12.8
Gr-3	RodD4_88.3	241	88.3	2.243	-0.2	-0.005	1041.21	833.8	6129.96	19337.0	7.918	45.0
	RodD4_91.3	242	91.3	2.319	2.8	0.071	1129.20	882.7	6257.58	19739.5	7.258	41.2
	RodD4_93.2	243	93.2	2.367	4.7	0.119	1170.68	905.8	6337.83	19992.7	7.013	39.8
	RodD4_95.2	244	95.2	2.418	6.7	0.170	1206.10	925.4	6422.45	20259.6	6.839	38.8
	RodD4_100.1	245	100.1	2.543	11.6	0.295	1266.06	958.7	6633.50	20925.4	6.640	37.7
	RodD4_106.1	246	106.1	2.695	17.6	0.447	1332.11	995.4	6890.55	21736.3	6.469	36.7
	RodD4_142.1	248	142.1	3.609	8.6	0.218	1356.64	1009.1	2358.00	7438.3	2.164	12.3
Gr-3	RodE4_88.4	201	88.4	2.245	-0.1	-0.003	1049.75	838.6	6038.81	19049.4	7.715	43.8
	RodE4_91.2	202	91.2	2.316	2.7	0.069	1135.49	886.2	6153.53	19411.3	7.085	40.2
	RodE4_95.3	204	95.3	2.421	6.8	0.173	1214.44	930.1	6322.70	19944.9	6.673	37.9
	RodE4_100.9	205	100.9	2.563	12.4	0.315	1280.51	966.8	6555.88	20680.5	6.468	36.7
	RodE4_142.3	208	142.3	3.614	8.8	0.224	1358.02	1009.8	2391.10	7542.7	2.192	12.4

Table A-21: Summary of Steam Cooling Heat Transfer Reduced Data for Experiment 4037D, continued

Inner 3x3	H.R. Location	Channel Number	Elevation (in)	Elevation (m)	Zgrid (in)	Zgrid (m)	H.R. Tw (°F)	H.R. Tw (K)	H.R. q" (Btu/hr-ft ²)	H.R. q" (W/m ²)	h _{sat} (z) (Btu/hr-ft ² -F)	h _{sat} (z) (W/m ² -K)
Gr-4	RodE3_63.4	193	63.4	1.610	16.4	0.417	1008.54	815.7	4991.19	15744.7	6.731	38.2
	RodE3_113.6	194	113.6	2.885	0.85	0.022	1320.38	988.9	6139.73	19367.8	5.829	33.1
	RodE3_115.5	195	115.5	2.934	2.75	0.070	1352.43	1006.7	5899.31	18609.4	5.435	30.9
	RodE3_118.5	196	118.5	3.010	5.75	0.146	1381.48	1022.9	5528.65	17440.1	4.961	28.2
	RodE3_122.7	197	122.7	3.117	9.95	0.253	1401.96	1034.2	5010.23	15804.8	4.414	25.1
	RodE3_126.5	198	126.5	3.213	13.75	0.349	1404.54	1035.7	4542.73	14330.0	3.993	22.7
	RodE3_131.7	199	131.7	3.345	-1.8	-0.046	1341.75	1000.8	3917.47	12357.7	3.645	20.7
	RodE3_135.6	200	135.6	3.444	2.1	0.053	1354.86	1008.1	3434.17	10833.1	3.157	17.9
	RodC5_63.7	225	63.7	1.618	16.7	0.424	1009.63	816.3	4887.09	15416.3	6.581	37.4
	RodC5_113.6	226	113.6	2.885	0.85	0.022	1294.91	974.8	5984.29	18877.4	5.822	33.1
Gr-4	RodC5_115.7	227	115.7	2.939	2.95	0.075	1335.72	997.4	5725.73	18061.8	5.358	30.4
	RodC5_122.7	229	122.7	3.117	9.95	0.253	1387.65	1026.3	4899.19	15454.5	4.372	24.8
	RodC5_126.7	230	126.7	3.214	13.95	0.354	1391.45	1028.4	4428.77	13970.6	3.939	22.4
	RodC5_131.6	231	131.6	3.343	-1.9	-0.048	1327.31	992.8	3870.91	12210.8	3.651	20.7
	RodC5_135.7	232	135.7	3.447	2.2	0.056	1342.14	1001.0	3383.33	10672.7	3.147	17.9
	RodE5_63.6	209	63.6	1.615	16.6	0.422	999.31	810.5	5015.20	15820.5	6.848	38.9
	RodE5_113.6	210	113.6	2.885	0.85	0.022	1306.24	981.1	6180.04	19494.9	5.947	33.8
	RodE5_115.4	211	115.4	2.931	2.65	0.067	1332.47	995.6	5954.04	18782.0	5.588	31.7
	RodE5_118.7	212	118.7	3.015	5.95	0.151	1356.25	1008.8	5551.09	17510.9	5.096	28.9
	RodE5_122.6	213	122.6	3.114	9.85	0.250	1378.88	1021.4	5073.00	16002.8	4.563	25.9
RodE5_126.6	214	126.6	3.216	13.85	0.352	1383.37	1023.9	4587.93	14472.6	4.110	23.3	
Gr-5	RodE5_131.6	215	131.6	3.343	-1.9	-0.048	1325.47	991.7	3996.62	12607.3	3.776	21.4
	RodE5_135.6	216	135.6	3.444	2.1	0.053	1340.42	1000.0	3508.22	11066.7	3.268	18.6
	RodC3_79.8	177	79.8	2.027	8.92	0.227	1046.86	837.0	5682.44	17925.3	7.287	41.4
	RodC3_85.6	178	85.6	2.174	14.72	0.374	1025.11	824.9	5929.16	18703.5	7.821	44.4
	RodC3_88.5	179	88.5	2.248	0	0.000	1028.20	826.6	6049.61	19083.5	7.947	45.1
	RodC3_92.4	180	92.4	2.347	3.9	0.099	1135.24	886.1	6212.59	19597.6	7.155	40.6
	RodC3_94.4	181	94.4	2.398	5.9	0.150	1169.42	905.1	6296.10	19861.0	6.977	39.6
	RodC3_97.2	182	97.2	2.469	8.7	0.221	1212.98	929.2	6415.07	20236.3	6.781	38.5
	RodC3_108.8	183	108.8	2.764	20.3	0.516	1315.40	986.2	6757.32	21316.0	6.445	36.6
	Gr-8	RodD5_50	217	50	1.270	3	0.076	858.23	732.2	4436.40	13994.6	7.504
RodD5_54.1		218	54.1	1.374	7.1	0.180	882.23	745.5	4604.94	14526.3	7.485	42.5
RodD5_56.9		219	56.9	1.445	9.9	0.251	936.29	775.5	4722.71	14897.8	7.056	40.1
RodD5_60		220	60	1.524	13	0.330	976.73	798.0	4853.48	15310.3	6.839	38.8
RodD5_66.1		221	66.1	1.679	19.1	0.485	1022.23	823.3	5116.57	16140.2	6.775	38.5
RodD5_69.9		222	69.9	1.775	-0.98	-0.025	841.78	723.0	5289.73	16686.5	9.203	52.3
RodD5_72.9		223	72.9	1.852	2.02	0.051	929.46	771.7	5414.59	17080.3	8.173	46.4
RodD5_74.9		224	74.9	1.902	4.02	0.102	979.58	799.6	5500.20	17350.4	7.719	43.8

Table A-21: Summary of Steam Cooling Heat Transfer Reduced Data for Experiment 4037D, continued

5x5 periphery												
H.R. ID	H.R. Location	Channel Number	Elevation (in)	Elevation (m)	Zgrid (in)	Zgrid (m)	H.R. Tw (°F)	H.R. Tw (K)	H.R. q" (Btu/hr-ft ²)	H.R. q" (W/m ²)	h _{sat} (z) (Btu/hr-ft ² -F)	h _{sat} (z) (W/m ² -K)
Gr-2	RodB5_41	153	41	1.041	13.5	0.343	789.33	693.9	4034.60	12727.1	7.724	43.9
	RodB5_52.9	154	52.9	1.344	5.9	0.150	836.38	720.0	4547.36	14344.7	7.987	45.4
	RodB5_55	155	55	1.397	8	0.203	884.76	746.9	4632.26	14612.5	7.498	42.6
	RodB5_57.8	156	57.8	1.468	10.8	0.274	937.04	776.0	4749.50	14982.3	7.088	40.3
	RodB5_64	157	64	1.626	17	0.432	1002.95	812.6	5014.13	15817.1	6.813	38.7
	RodB5_73.9	158	73.9	1.877	3.02	0.077	951.25	783.8	5454.41	17205.9	7.971	45.3
Gr-2	RodB5_75.9	159	75.9	1.928	5.02	0.128	991.77	806.4	5540.78	17478.4	7.645	43.4
	RodB5_76.9	160	76.9	1.953	6.02	0.153	1009.24	816.1	5584.13	17615.1	7.523	42.7
	RodF5_41	105	41	1.041	13.5	0.343	791.12	694.9	4006.39	12638.2	7.644	43.4
	RodF5_53.1	106	53.1	1.349	6.1	0.155	836.87	720.3	4526.78	14279.7	7.943	45.1
	RodF5_55	107	55	1.397	8	0.203	874.72	741.3	4607.36	14533.9	7.581	43.1
	RodF5_57.8	108	57.8	1.468	10.8	0.274	918.91	765.9	4726.69	14910.3	7.251	41.2
Gr-2	RodF5_64	109	64	1.626	17	0.432	976.30	797.8	4993.78	15752.9	7.040	40.0
	RodF5_73.8	110	73.8	1.875	2.92	0.074	937.68	776.3	5424.92	17112.9	8.089	45.9
	RodF5_75.8	111	75.8	1.925	4.92	0.125	979.45	799.5	5510.94	17384.3	7.735	43.9
	RodF5_76.8	112	76.8	1.951	5.92	0.150	997.23	809.4	5553.73	17519.3	7.606	43.2
	RodC2_41	57	41	1.041	13.5	0.343	784.16	691.0	4029.91	12712.3	7.792	44.3
	RodC2_53.1	58	53.1	1.349	6.1	0.155	891.70	750.8	4541.41	14325.9	7.270	41.3
Gr-2	RodC2_55	59	55	1.397	8	0.203	911.58	761.8	4620.57	14575.6	7.168	40.7
	RodC2_57.8	60	57.8	1.468	10.8	0.274	944.99	780.4	4740.51	14953.9	6.992	39.7
	RodC2_63.9	61	63.9	1.623	16.9	0.429	989.37	805.0	5002.19	15779.4	6.925	39.3
	RodC2_73.8	62	73.8	1.875	2.92	0.074	927.59	770.7	5433.86	17141.1	8.226	46.7
	RodC2_75.8	63	75.8	1.925	4.92	0.125	959.17	788.2	5521.18	17416.6	7.977	45.3
	RodC2_76.8	64	76.8	1.951	5.92	0.150	973.03	795.9	5564.84	17554.3	7.882	44.8
Gr-2	RodC6_40.9	137	40.9	1.039	13.4	0.340	794.34	696.7	4008.33	12644.3	7.601	43.2
	RodC6_52.8	138	52.8	1.341	5.8	0.147	898.23	754.4	4539.04	14318.4	7.191	40.8
	RodC6_54.8	139	54.8	1.392	7.8	0.198	923.68	768.5	4625.82	14592.1	7.044	40.0
	RodC6_57.8	140	57.8	1.468	10.8	0.274	956.89	787.0	4758.03	15009.2	6.897	39.2
	RodC6_63.8	141	63.8	1.621	16.8	0.427	1004.84	813.6	5026.03	15854.6	6.812	38.7
	RodC6_73.7	142	73.7	1.872	2.82	0.072	974.11	796.5	5477.17	17277.7	7.746	44.0
Gr-2	RodC6_75.8	143	75.8	1.925	4.92	0.125	1006.28	814.4	5571.37	17574.9	7.536	42.8
	RodC6_76.8	144	76.8	1.951	5.92	0.150	1024.89	824.8	5616.22	17716.4	7.410	42.1

Table A-21: Summary of Steam Cooling Heat Transfer Reduced Data for Experiment 4037D, continued

5x5 periphery		H.R. Location	Channel Number	Elevation (in)	Elevation (m)	Zgrid (in)	Zgrid (m)	H.R. Tw (°F)	H.R. Tw (K)	H.R. q" (Btu/hr-ft ²)	H.R. q" (W/m ²)	h _{sat} (z) (Btu/hr-ft ² -F)	h _{sat} (z) (W/m ² -K)
Gr-3	RodB4_88.4	161	88.4	2.245	-0.1	-0.003	1022.67	823.5	6026.57	19010.8	7.975	45.3	
	RodB4_91.3	162	91.3	2.319	2.8	0.071	1110.86	872.5	6144.47	19382.7	7.281	41.4	
	RodB4_93.3	163	93.3	2.370	4.8	0.122	1150.37	894.5	6227.04	19643.2	7.049	40.0	
	RodB4_95.1	164	95.1	2.416	6.6	0.168	1180.23	911.1	6301.30	19877.4	6.900	39.2	
	RodB4_100	165	100	2.540	11.5	0.292	1221.10	933.8	6507.70	20528.5	6.821	38.7	
	RodB4_106	166	106	2.692	17.5	0.445	1288.77	971.4	6752.13	21299.6	6.608	37.5	
RodB4_109.9	167	109.9	2.791	21.4	0.544	1234.87	941.4	6537.19	20621.6	6.754	38.4		
RodB4_142.3	168	142.3	3.614	8.8	0.224	1317.37	987.2	2414.74	7617.3	2.299	13.1		
Gr-5	RodF4_85.6	98	85.6	2.174	14.72	0.374	1038.11	832.1	5961.81	18806.5	7.731	43.9	
	RodF4_88.4	99	88.4	2.245	-0.1	-0.003	1047.88	837.5	6078.53	19174.7	7.784	44.2	
	RodF4_92.4	100	92.4	2.347	3.9	0.099	1153.19	896.0	6248.45	19710.8	7.051	40.0	
	RodF4_94.3	101	94.3	2.395	5.8	0.147	1188.21	915.5	6328.47	19963.2	6.870	39.0	
	RodF4_97.2	102	97.2	2.469	8.7	0.221	1232.76	940.2	6449.85	20346.1	6.679	37.9	
	RodF4_108.8	103	108.8	2.764	20.3	0.516	1316.07	986.5	6804.00	21463.2	6.486	36.8	
RodF4_111	104	111	2.819	28.19	-1.75	1258.56	954.6	6531.58	20603.9	6.587	37.4		
Gr-6	RodD2_103.2	65	103.2	2.621	14.7	0.373	1308.29	982.2	5965.12	18817.0	5.729	32.5	
	RodD2_106	66	106	2.692	17.5	0.445	1330.59	994.6	5643.11	17801.2	5.306	30.1	
	RodD2_112.6	67	112.6	2.860	-0.15	-0.004	1359.63	1010.7	5200.85	16406.1	4.760	27.0	
	RodD2_114.9	68	114.9	2.918	2.15	0.055	1373.44	1018.4	4682.20	14770.0	4.232	24.0	
	RodD2_117.4	69	117.4	2.982	4.65	0.118	1372.53	1017.9	4191.93	13223.4	3.792	21.5	
	RodD2_120.8	70	120.8	3.068	8.05	0.204	1278.09	965.4	6716.85	21188.3	6.643	37.7	
RodD2_124.8	71	124.8	3.170	12.05	0.306	1303.36	979.5	6835.51	21562.6	6.596	37.5		
RodD2_128.6	72	128.6	3.266	15.85	0.403	1260.00	955.4	6265.86	19765.7	6.310	35.8		
Gr-6	RodD6_103.1	129	103.1	2.619	14.6	0.371	1291.43	972.8	6727.14	21220.8	6.567	37.3	
	RodD6_106	130	106	2.692	17.5	0.445	1313.27	985.0	6845.95	21595.6	6.543	37.2	
	RodD6_112.9	131	112.9	2.868	0.15	0.004	1278.17	965.5	6240.64	19686.1	6.172	35.0	
	RodD6_114.9	132	114.9	2.918	2.15	0.055	1315.84	986.4	5972.89	18841.5	5.695	32.3	
	RodD6_116.8	133	116.8	2.967	4.05	0.103	1335.13	997.1	5721.77	18049.3	5.357	30.4	
	RodD6_120.9	134	120.9	3.071	8.15	0.207	1354.15	1007.7	5178.74	16336.3	4.764	27.1	
RodD6_124.8	135	124.8	3.170	12.05	0.306	1363.82	1013.0	4688.42	14726.5	4.256	24.2		
RodD6_128.7	136	128.7	3.269	15.95	0.405	1362.30	1012.2	4159.05	13119.7	3.797	21.6		

Table A-21: Summary of Steam Cooling Heat Transfer Reduced Data for Experiment 4037D, continued

5x5 periphery		H.R. Location	Channel Number	Elevation (in)	Elevation (m)	Zgrid (in)	Zgrid (m)	H.R. Tw (°F)	H.R. Tw (K)	H.R. q" (Btu/hr-ft ²)	H.R. q" (W/m ²)	h _{sat} (z) (Btu/hr-ft ² -F)	h _{sat} (z) (W/m ² -K)
Gr-8	RodE2_50.1	73	50.1	1.273	3.1	0.079	843.76	724.1	4448.96	14034.2	7.714	43.8	
	RodE2_54	74	54	1.372	7	0.178	909.12	760.4	4611.14	14545.9	7.181	40.8	
	RodE2_56.9	75	56.9	1.445	9.9	0.251	944.37	780.0	4733.89	14933.0	6.989	39.7	
	RodE2_59.9	76	59.9	1.521	12.9	0.328	979.72	799.7	4862.29	15338.1	6.822	38.7	
	RodE2_66	77	66	1.676	19	0.483	1008.27	815.5	5133.87	16194.8	6.926	39.3	
	RodE2_69.8	78	69.8	1.773	-1.08	-0.027	867.12	737.1	5312.60	16758.6	8.853	50.3	
	RodE2_72.9	79	72.9	1.852	2.02	0.051	944.85	780.3	5443.82	17172.5	8.031	45.6	
	RodE2_74.9	80	74.9	1.902	4.02	0.102	980.33	800.0	5531.23	17448.3	7.754	44.0	
Gr-8	RodB3_50.2	169	50.2	1.275	3.2	0.081	793.34	696.1	4429.14	13971.7	8.415	47.8	
	RodB3_54.1	170	54.1	1.374	7.1	0.180	851.64	728.5	4589.32	14477.0	7.850	44.6	
	RodB3_56.9	171	56.9	1.445	9.9	0.251	901.07	756.0	4708.02	14851.5	7.425	42.2	
	RodB3_60.1	172	60.1	1.527	13.1	0.333	914.37	763.4	4846.38	15287.9	7.486	42.5	
	RodB3_66.1	173	66.1	1.679	19.1	0.485	976.24	797.7	5100.24	16088.7	7.191	40.8	
	RodB3_69.9	174	69.9	1.775	-0.98	-0.025	809.70	705.2	5274.75	16639.2	9.719	55.2	
	RodB3_73	175	73	1.854	2.12	0.054	911.68	761.9	5406.55	17055.0	8.386	47.6	
	RodB3_75	176	75	1.905	4.12	0.105	959.12	788.2	5492.52	17326.2	7.936	45.1	
Gr-8	RodF3_50.1	89	50.1	1.273	3.1	0.079	820.23	711.1	4428.22	13968.8	8.004	45.5	
	RodF3_54	90	54	1.372	7	0.178	878.35	743.3	4591.46	14483.8	7.510	42.7	
	RodF3_57	91	57	1.448	10	0.254	923.90	768.7	4723.47	14900.2	7.191	40.8	
	RodF3_60	92	60	1.524	13	0.330	959.59	788.5	4856.22	15318.9	7.012	39.8	
	RodF3_66.1	93	66.1	1.679	19.1	0.485	995.78	808.6	5125.23	16167.5	7.033	39.9	
	RodF3_70	94	70	1.778	-0.88	-0.022	841.72	723.0	5307.45	16742.4	9.235	52.4	
	RodF3_73	95	73	1.854	2.12	0.054	939.36	777.2	5439.72	17159.6	8.090	45.9	
	RodF3_75	96	75	1.905	4.12	0.105	985.84	803.1	5528.14	17438.5	7.690	43.7	
Gr-8	RodE6_50.2	121	50.2	1.275	3.2	0.081	834.75	719.1	4423.41	13953.6	7.791	44.2	
	RodE6_54.1	122	54.1	1.374	7.1	0.180	898.70	754.6	4583.12	14457.5	7.255	41.2	
	RodE6_57	123	57	1.448	10	0.254	930.14	772.1	4703.30	14836.6	7.092	40.3	
	RodE6_60.2	124	60.2	1.529	13.2	0.335	966.07	792.1	4837.85	15261.0	6.920	39.3	
	RodE6_66.1	125	66.1	1.679	19.1	0.485	991.71	806.3	5093.04	16066.0	7.028	39.9	
	RodE6_70	126	70	1.778	-0.88	-0.022	879.20	743.8	5264.04	16605.4	8.599	48.8	
	RodE6_73.1	127	73.1	1.857	2.22	0.056	950.55	783.5	5397.74	17027.2	7.897	44.8	
	RodE6_75	128	75	1.905	4.12	0.105	988.76	804.7	5476.99	17277.2	7.588	43.1	

RBHT Steam Cooling with Droplet Injection Test SCD-4037-E

Matrix Test # 16b

Test Conditions

Test Date – 10/11/2005

Steady State Time Window: 23400 - 24480

Upper Plenum Pressure: 2.76 bar (40 psia)

Bundle Power: 72.0 kW

Bundle Inlet Reynolds Number: 8000

Bundle Inlet Steam Flow: 158.9 kg/hr (350 lbm/hr)

Droplet Injection Flow: 0.0073 kg/s (0.016 lbm/s)

Droplet Injection Hole Diameter: 0.381 mm (.015 in)

Droplet Injection Elevation: 1.295 m (51 in)

Bundle Flow Area: $4.656 \times 10^{-3} \text{ m}^2$ ($5.012 \times 10^{-2} \text{ ft}^2$)

Test Notes

- No steam probes were traversed in this steady state window.

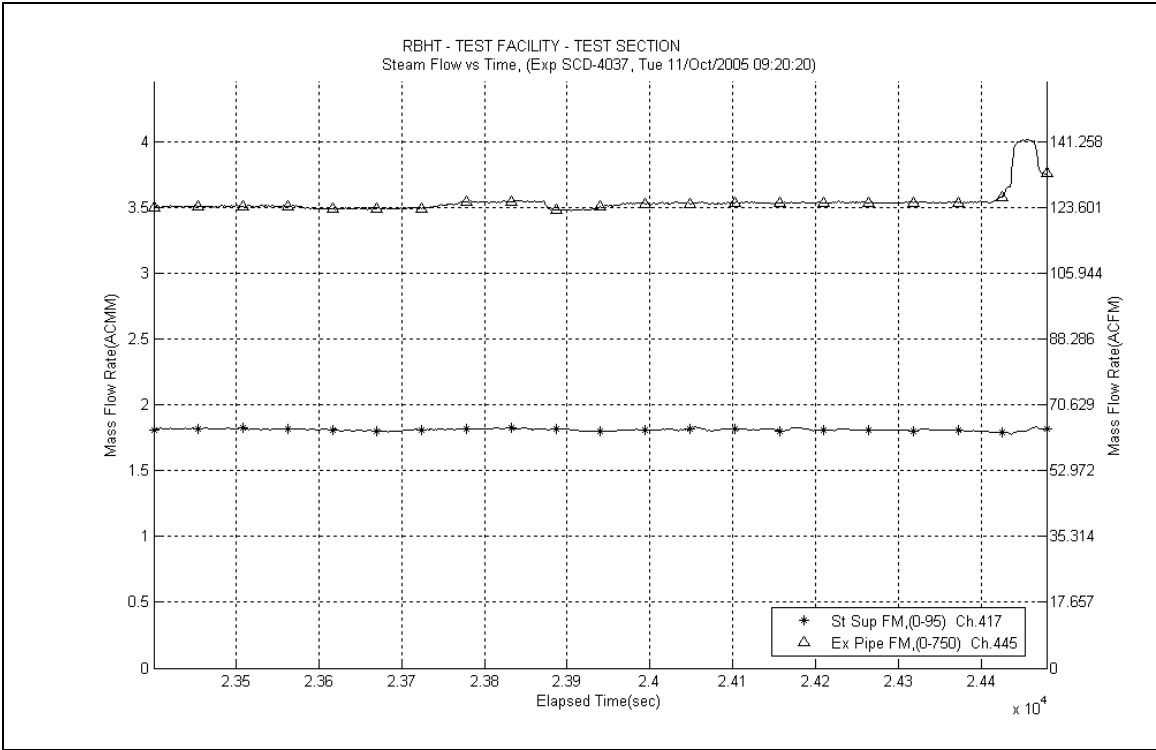

Figure A-381: Inlet and Exhaust Steam Flow Rates for Experiment 4037E

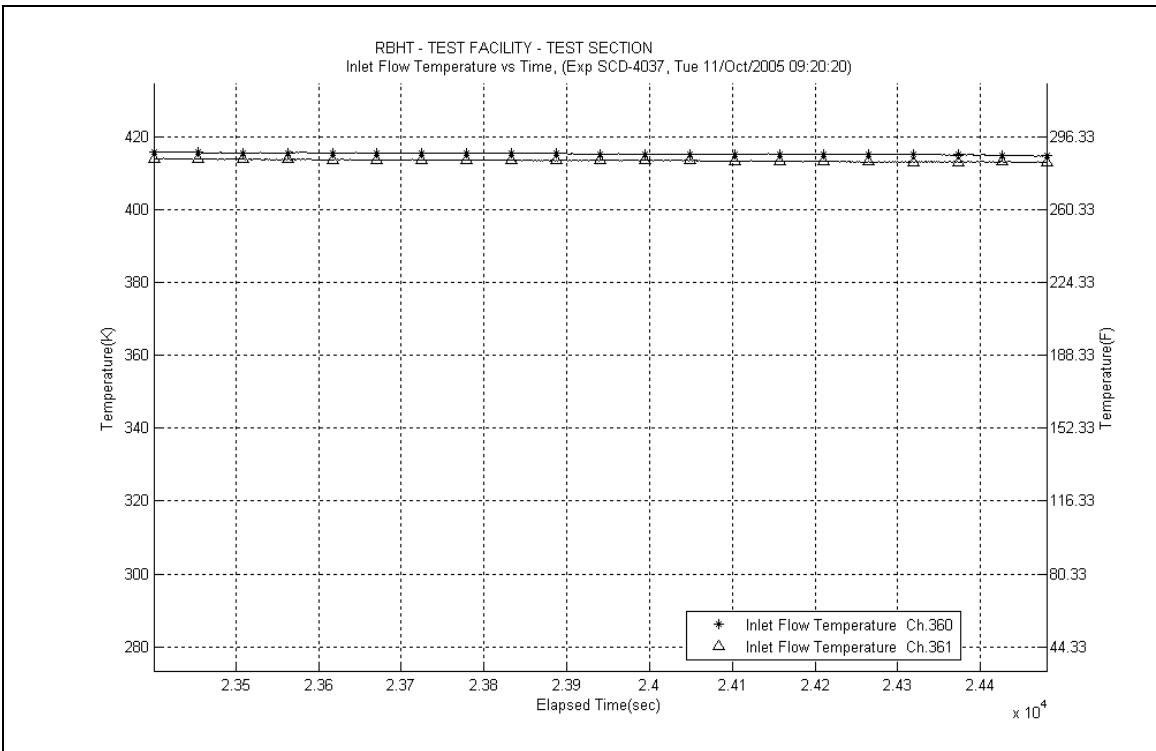

Figure A-382: Inlet Steam Temperature for Experiment 4037E

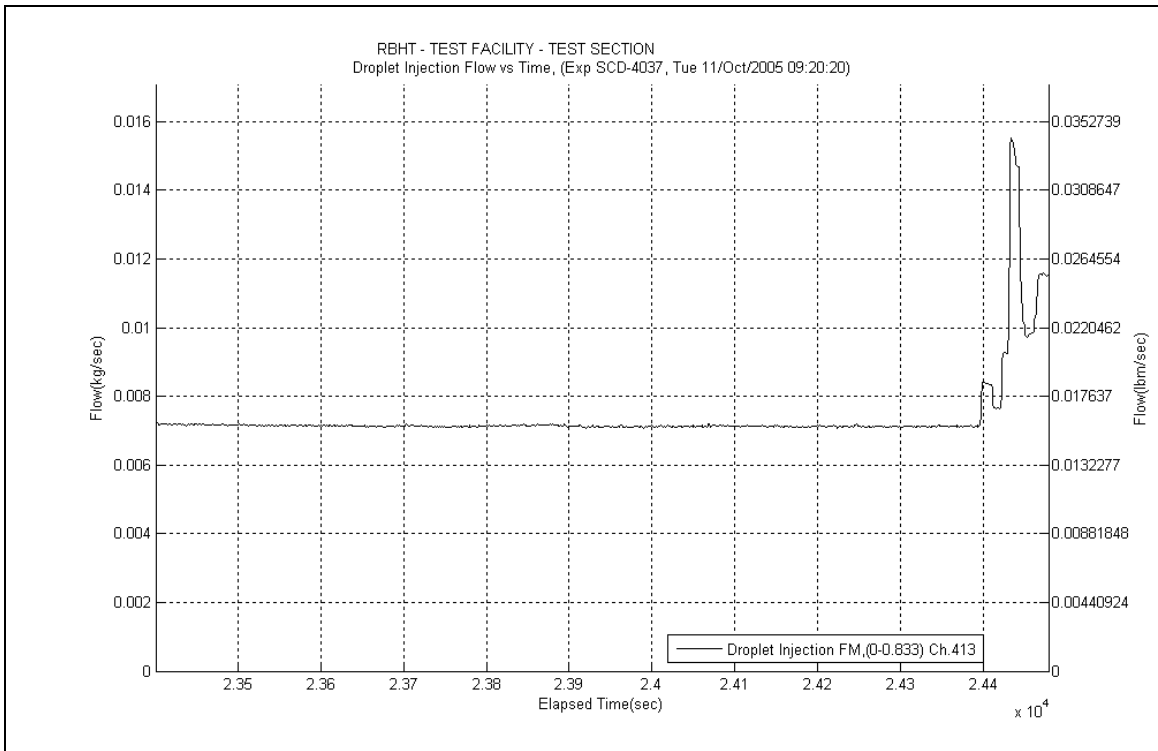

Figure A-383: Droplet Injection Flow Rate for Experiment 4037E

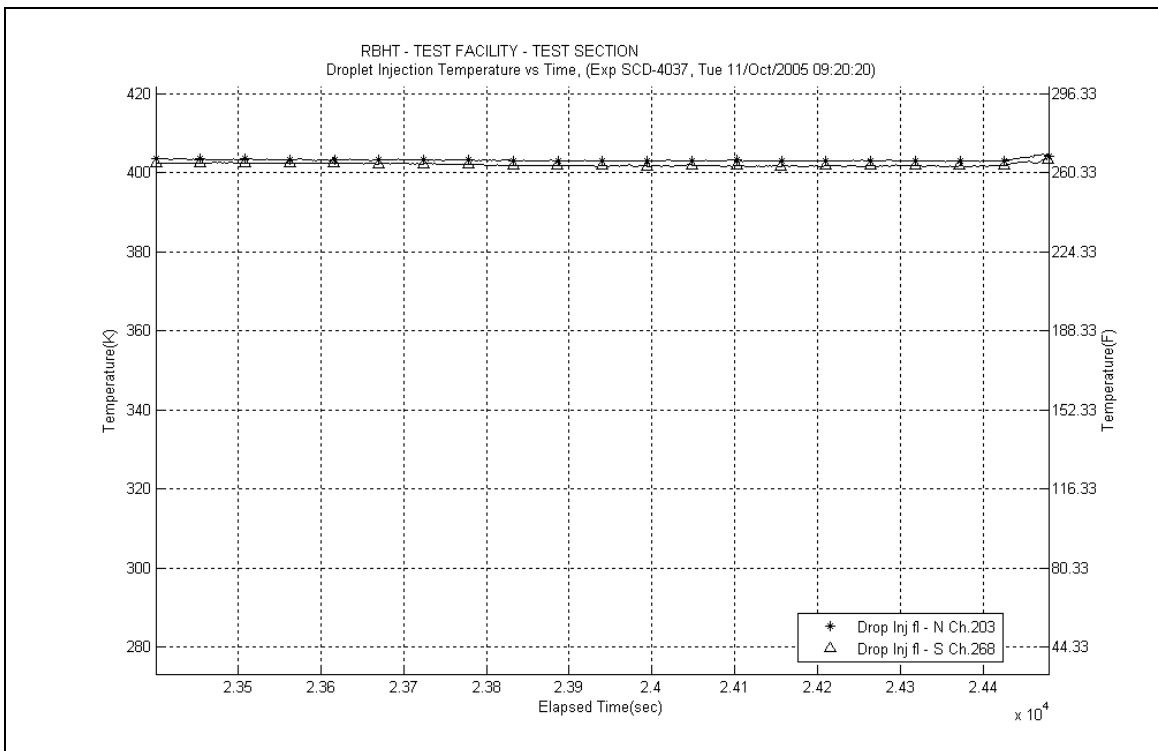

Figure A-384: Droplet Injection Temperature for Experiment 4037E

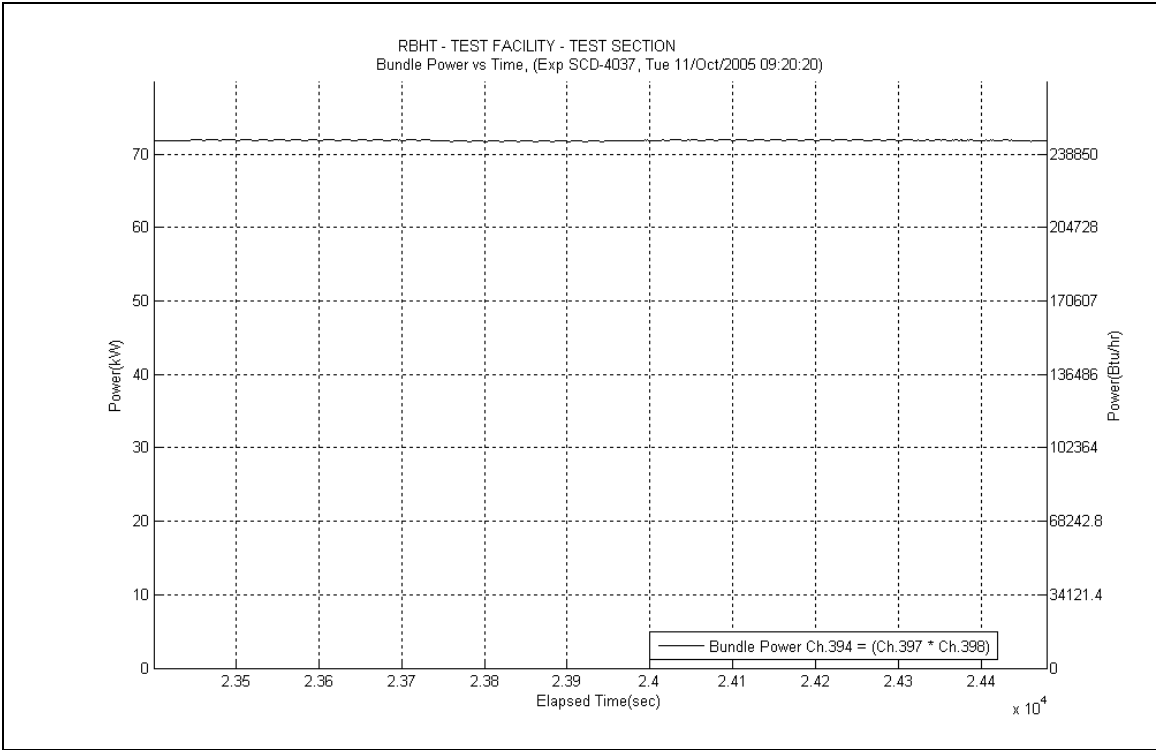

Figure A-385: Bundle Power for Experiment 4037E

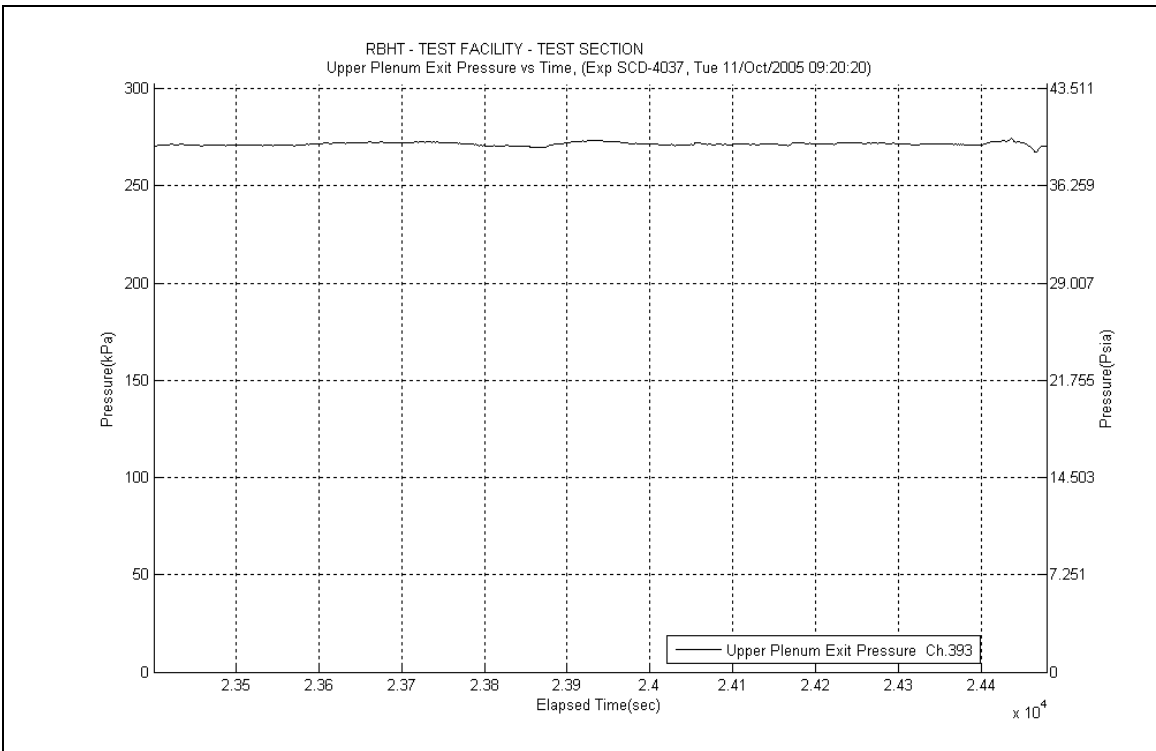

Figure A-386: Upper Plenum Pressure for Experiment 4037E

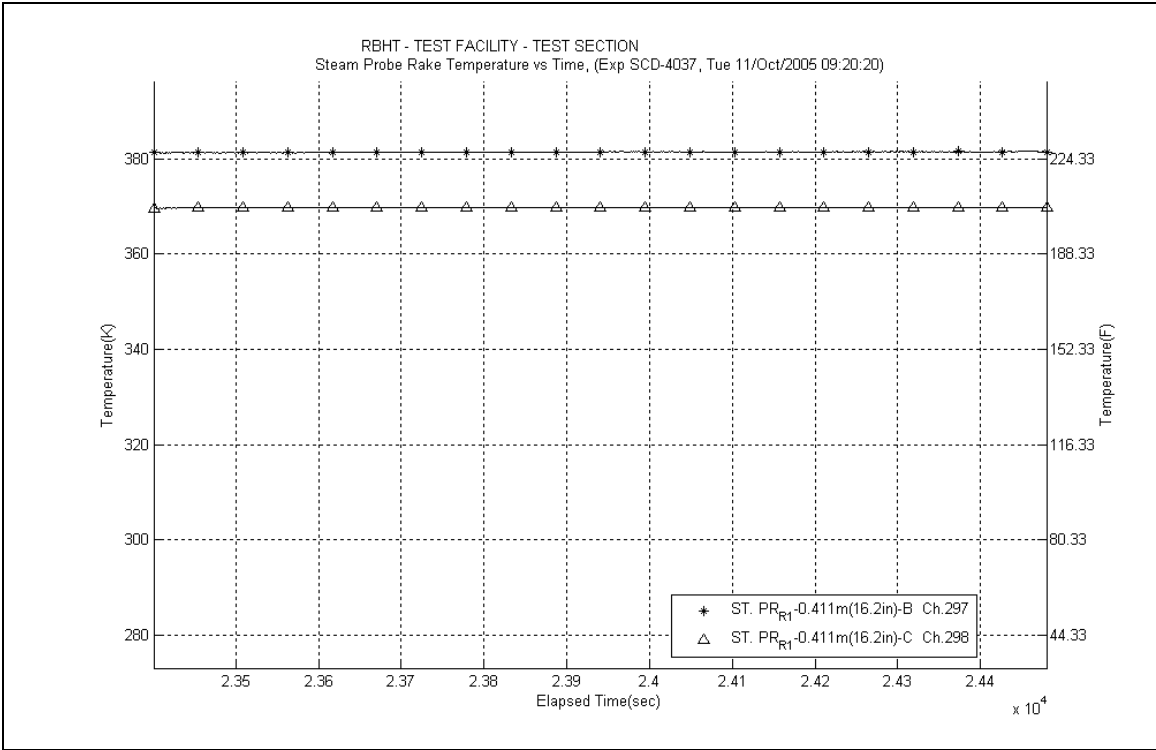

Figure A-387: Steam Probe Rake #1 Temperatures for Experiment 4037E

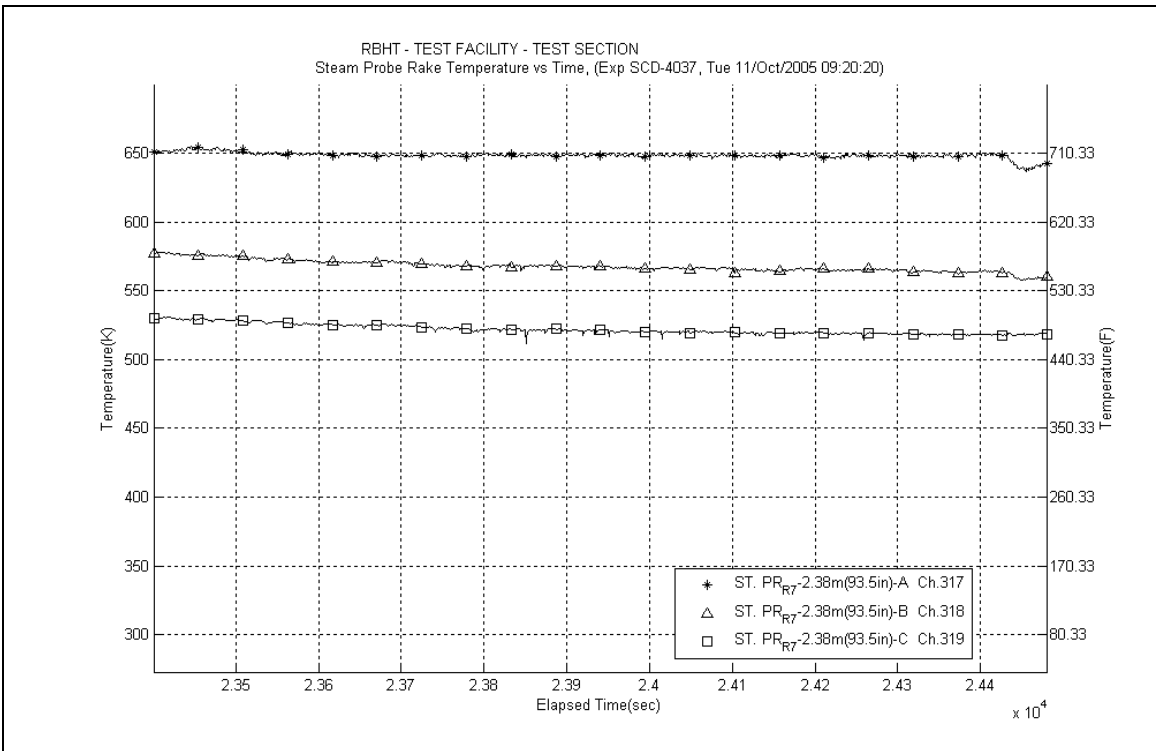

Figure A-388: Steam Probe Rake #7 Temperatures for Experiment 4037E

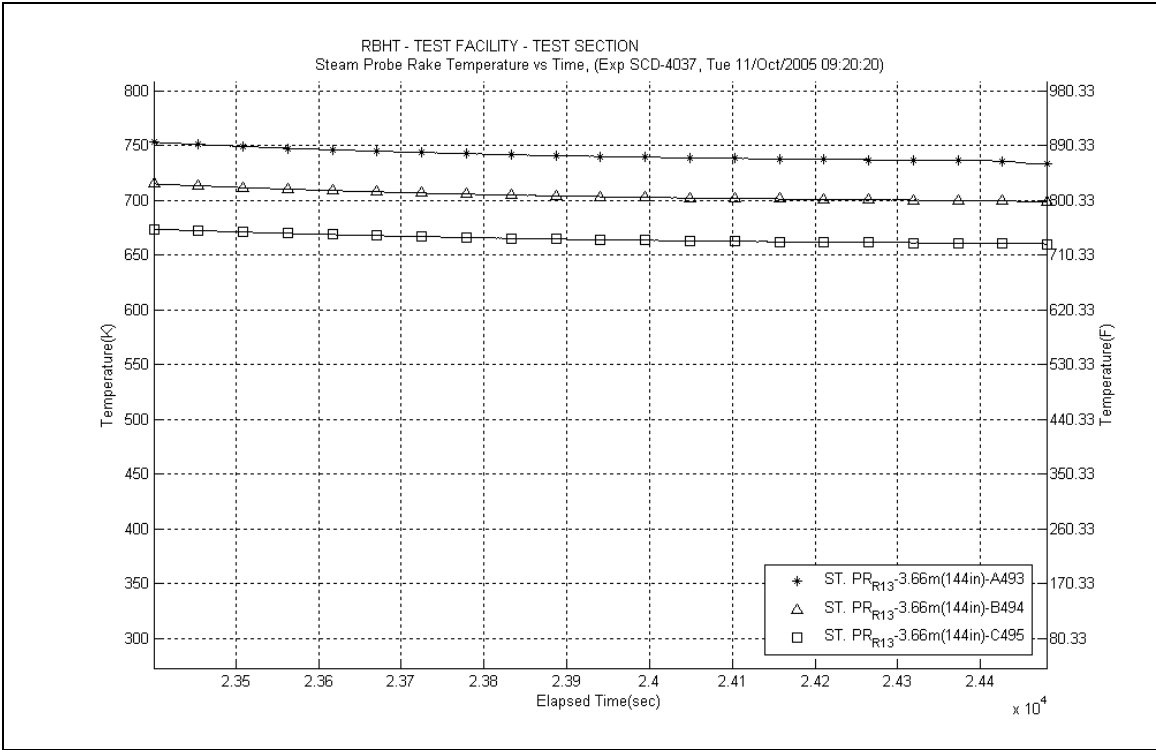

Figure A-389: Steam Probe Rake #13 Temperatures for Experiment 4037E

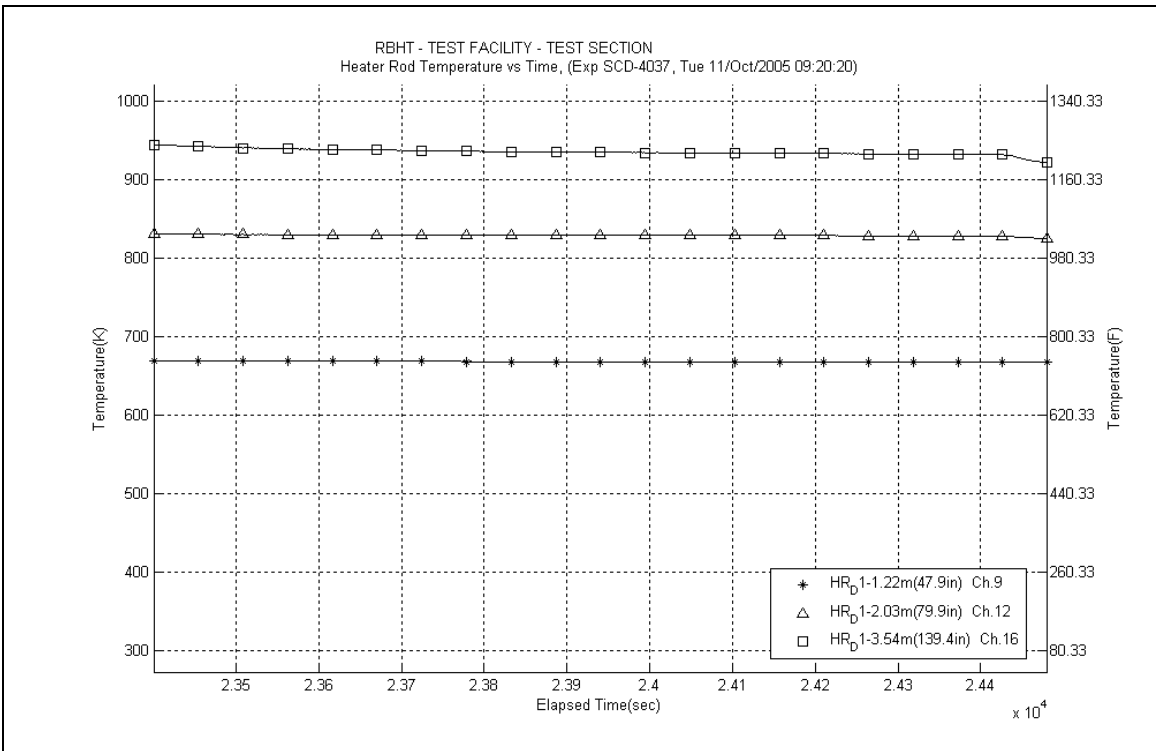

Figure A-390: Heater Rod D1 Temperatures for Experiment 4037E

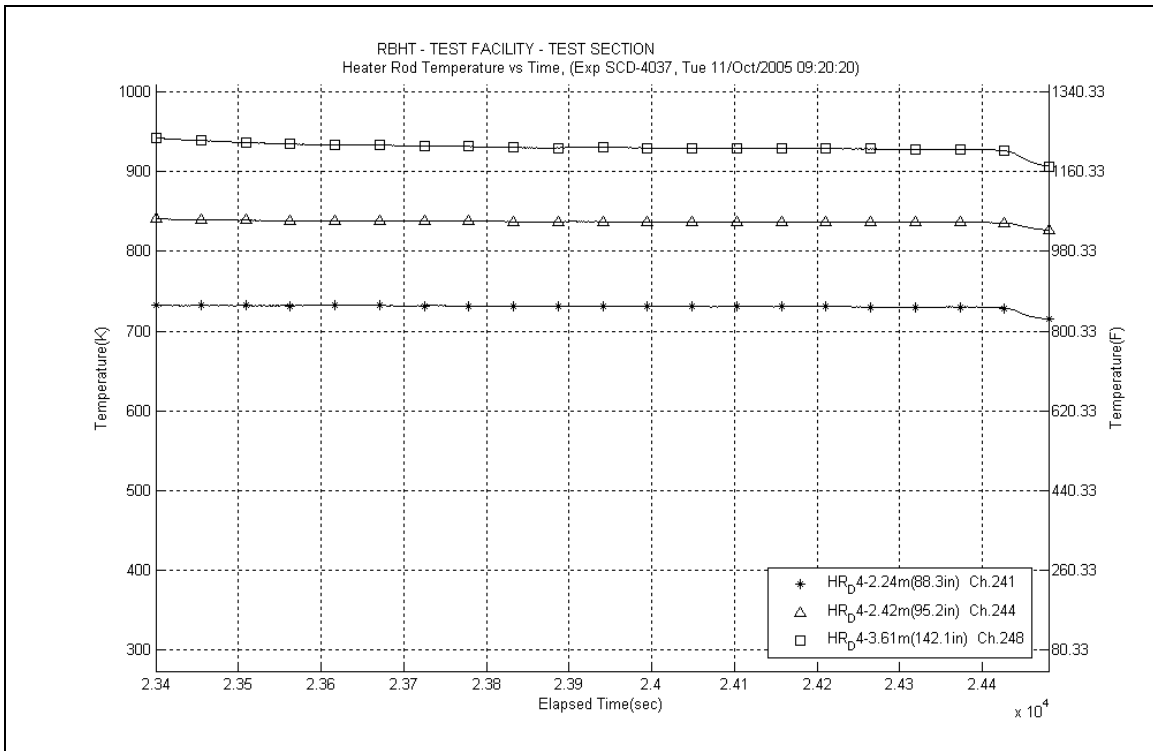

Figure A-391: Heater Rod D4 Temperatures for Experiment 4037E

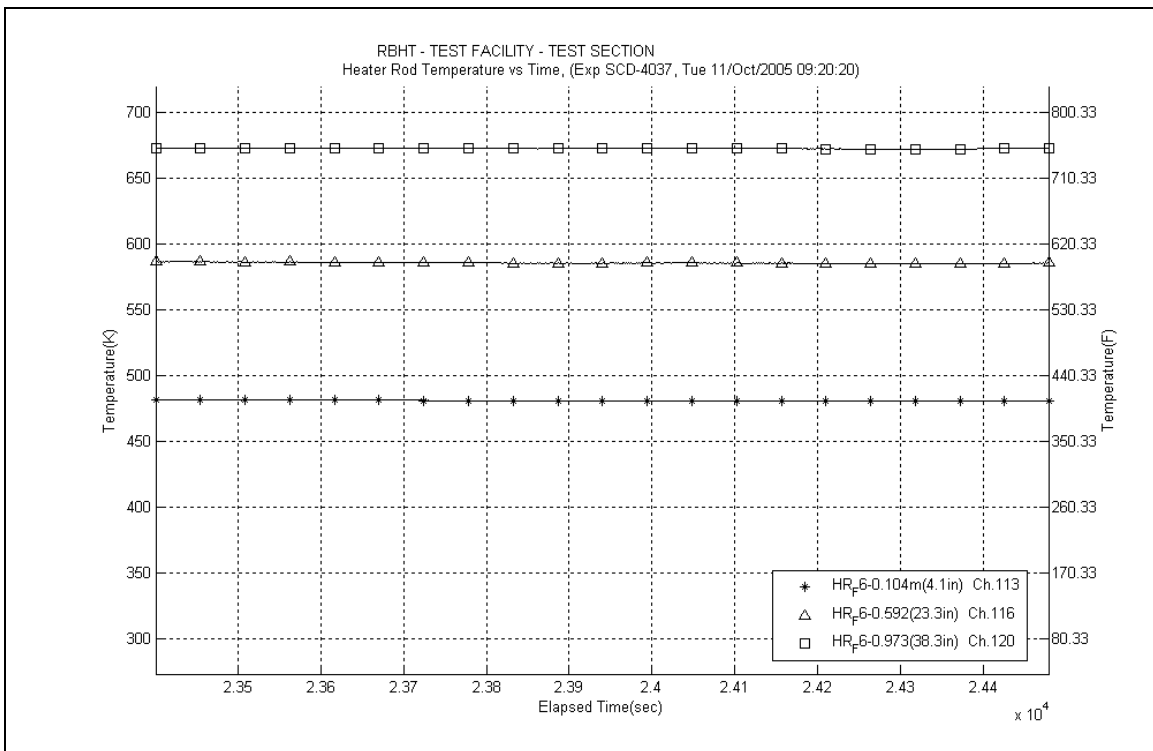

Figure A-392: Heater Rod F6 Temperatures for Experiment 4037E

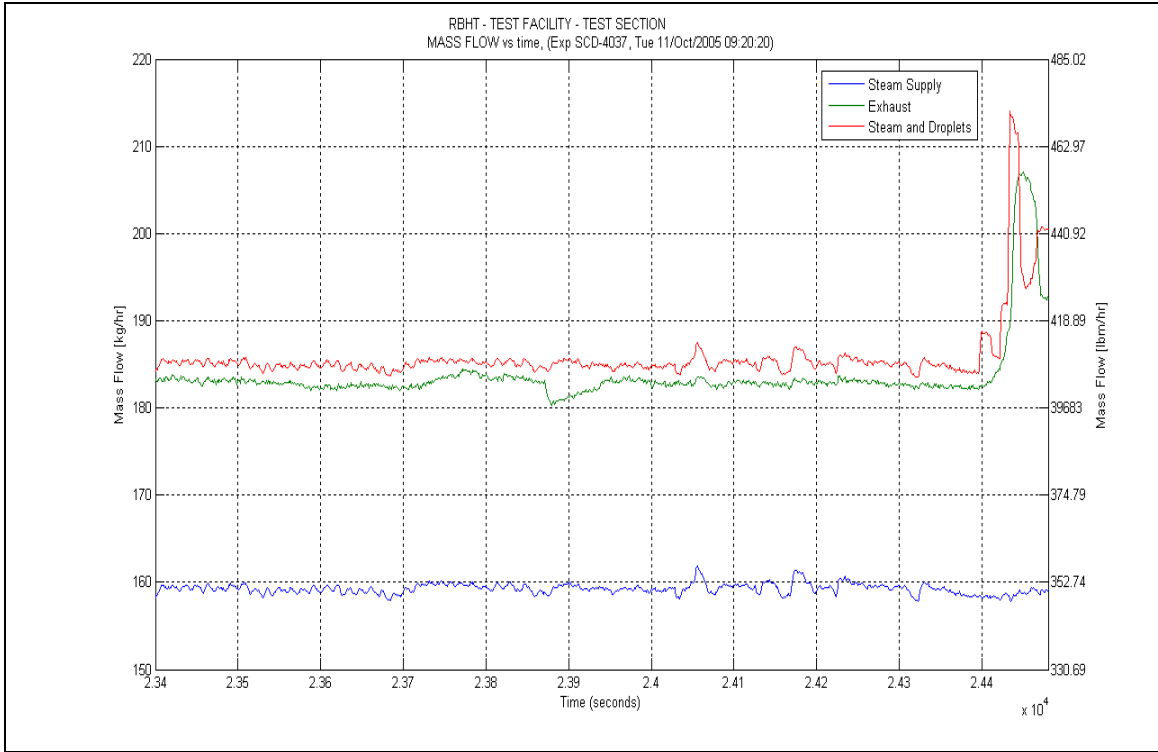

Figure A-393: Mass Flow for Experiment 4037E

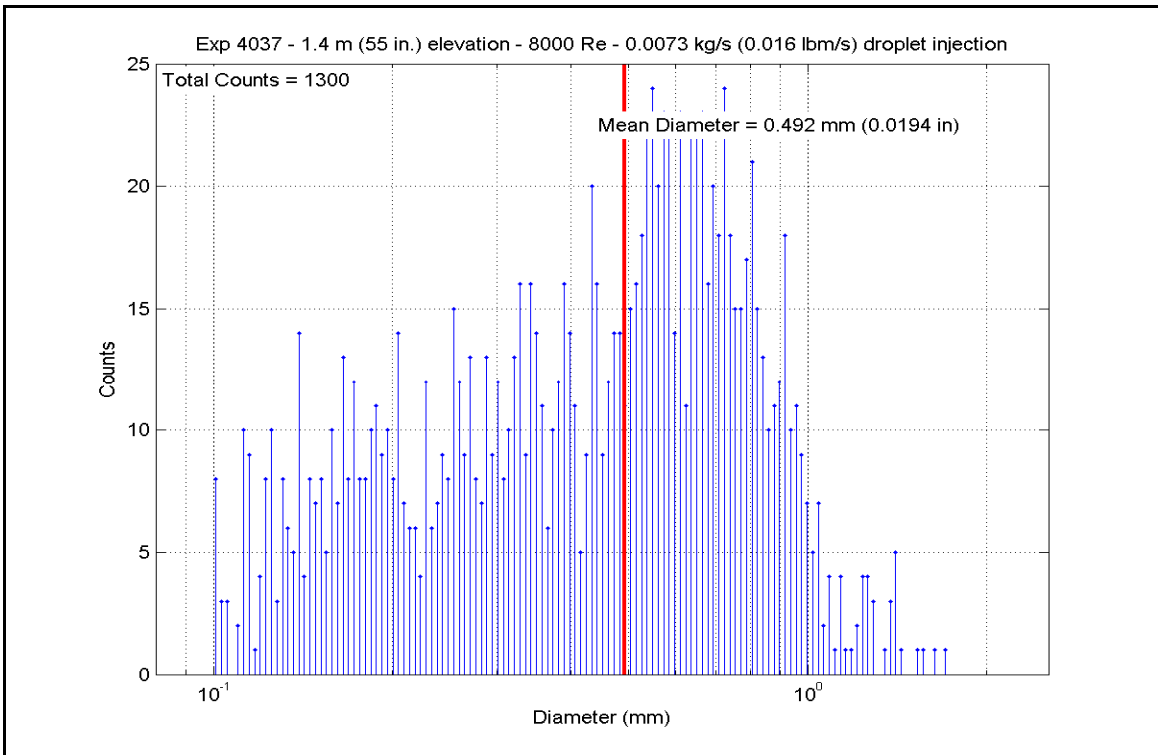

Figure A-394: Droplet Measurements at 1.397 m (55 in.) Elevation for Experiment 4037E

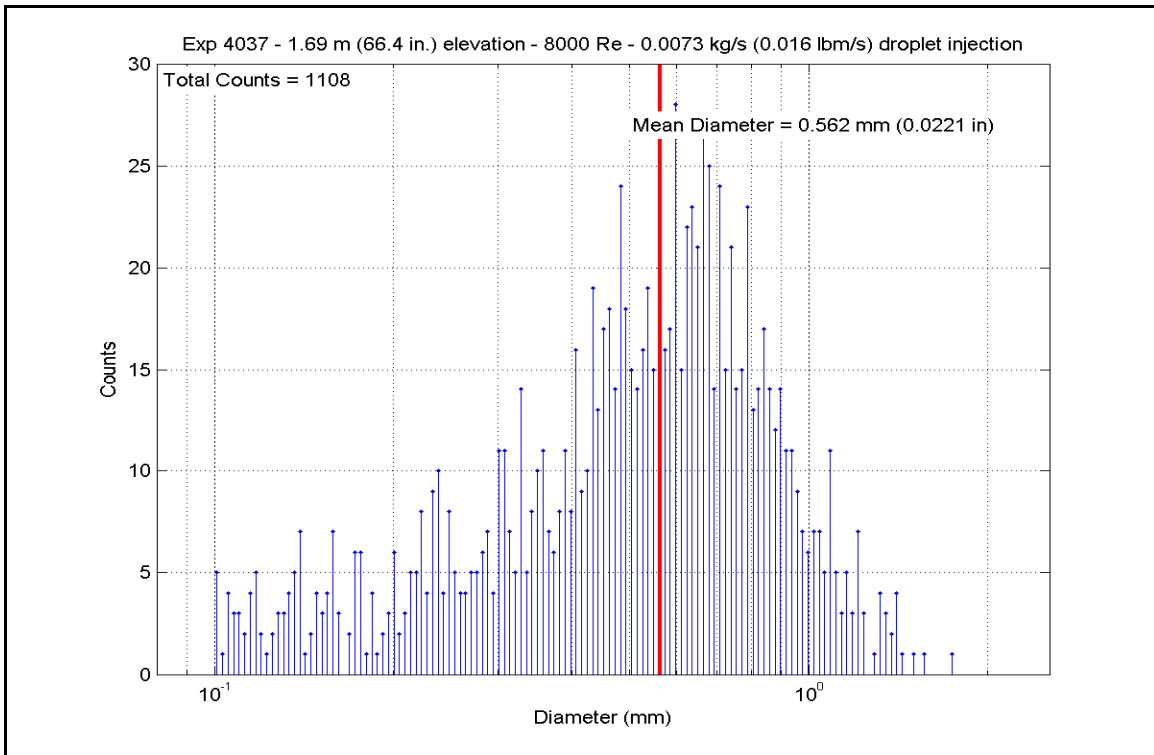

Figure A-395: Droplet Measurements at 1.687 m (66.4 in.) Elevation for Experiment 4037E

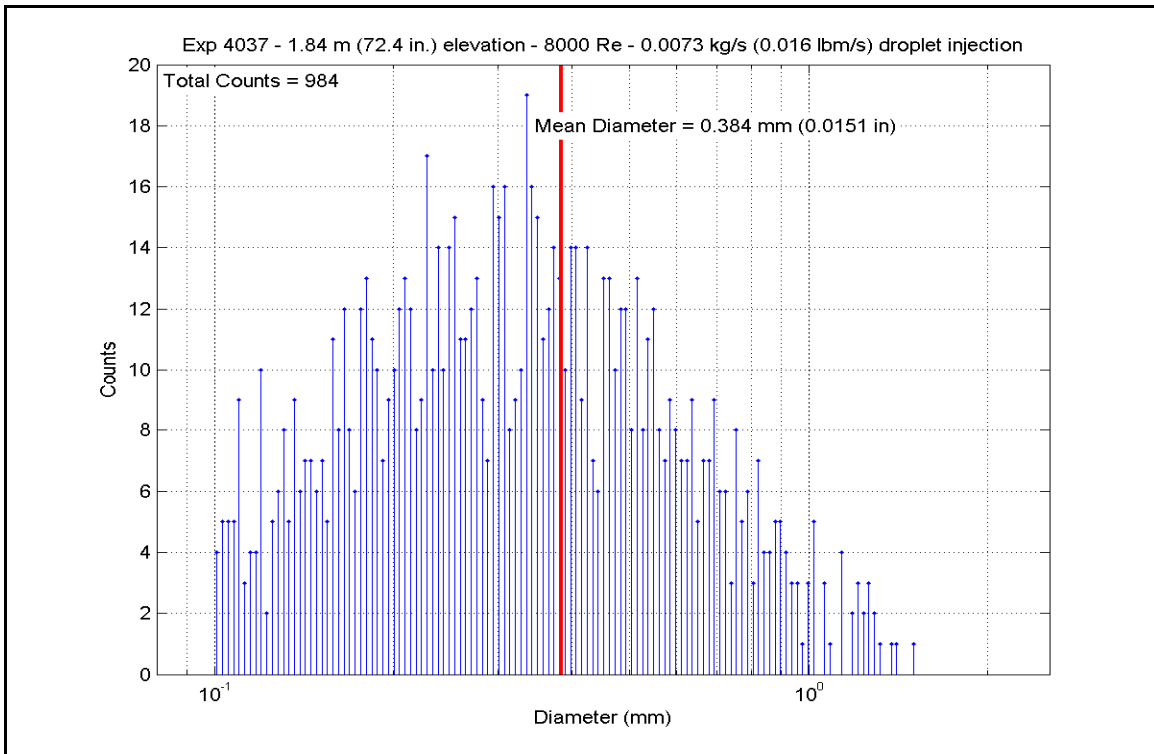

Figure A-396: Droplet Measurements at 1.839 m (72.4 in.) Elevation for Experiment 4037E

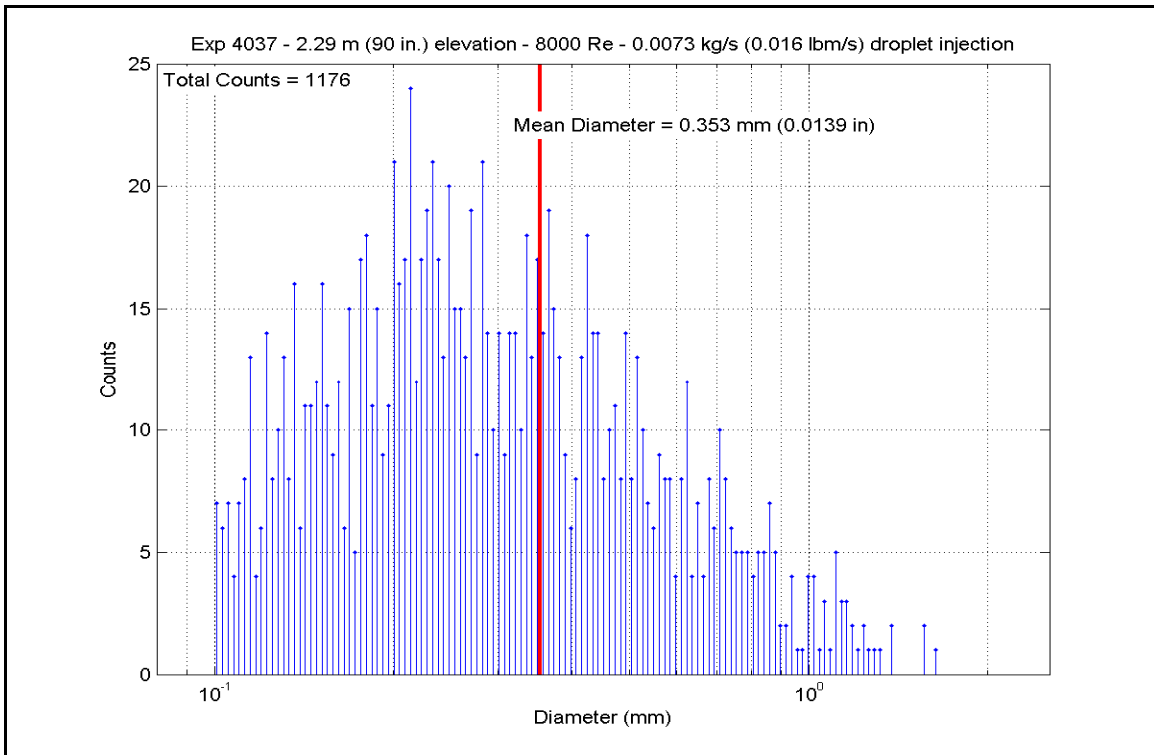

Figure A-397: Droplet Measurements at 2.286 m (90 in.) Elevation for Experiment 4037E

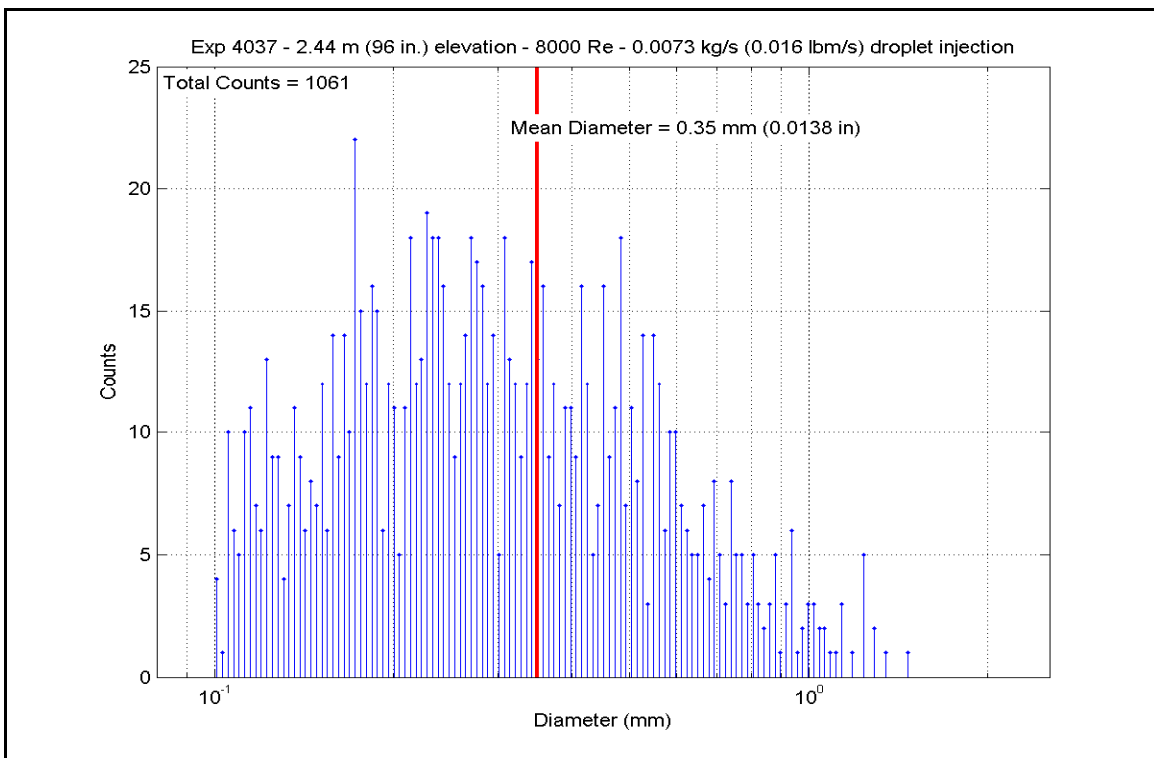

Figure A-398: Droplet Measurements at 2.438 m (96 in.) Elevation for Experiment 4037E

Tale A-22: Summary of Steam Cooling Heat Transfer Reduced Data for Experiment 4037E

SCD-4037-E		Inlet Reynolds:		8000		40 psia						
Matrix Test # 16b		UP Pressure:		275.8 kPa		245674 Btu/hr						
Time Window 23400-24480		Bundle Power:		72.00 kW		350.0 lbm/hr						
		Steam flow:		0.0441 kg/s		0.016 lbm/s						
Inner 3x3		Droplet flow:		0.0073 kg/s								
H.R. ID	H.R. Location	Channel Number	Elevation (in)	Elevation (m)	Zgrid (in)	Zgrid (m)	H.R. Tw (°F)	H.R. Tw (K)	H.R. q" (Btu/hr-ft ²)	H.R. q' (W/m ²)	h _{sat} (z) (Btu/hr-ft ² -F)	h _{sat} (z) (W/m ² -K)
Gr-3	RodD3_88.3	185	88.3	2.243	-0.2	-0.005	901.19	756.0	6162.95	19441.0	9.718	55.2
	RodD3_91.3	186	91.3	2.319	2.8	0.071	995.06	808.2	6275.30	19795.4	8.619	48.9
	RodD3_93.1	187	93.1	2.365	4.6	0.117	1037.53	831.8	6350.48	20032.6	8.242	46.8
	RodD3_95.3	188	95.3	2.421	6.8	0.173	1077.25	853.8	6443.89	20327.3	7.953	45.2
	RodD3_100.1	189	100.1	2.543	11.6	0.295	1146.56	892.4	6663.61	21020.4	7.576	43.0
	RodD3_106.1	190	106.1	2.695	17.6	0.447	1230.30	938.9	6920.01	21829.2	7.184	40.8
	RodD3_110	191	110	2.794	21.5	0.546	1172.84	906.9	6850.41	21609.6	7.563	42.9
	RodD3_142.1	192	142.1	3.609	8.6	0.218	1235.31	941.7	2469.29	7789.4	2.550	14.5
Gr-3	RodC4_88.4	233	88.4	2.245	-0.1	-0.003	865.45	736.2	6207.59	19581.8	10.373	58.9
	RodC4_91.1	234	91.1	2.314	2.6	0.066	964.92	791.4	6328.35	19962.8	9.067	51.5
	RodC4_93.4	235	93.4	2.372	4.9	0.124	1017.28	820.5	6432.33	20290.8	8.573	48.7
	RodC4_95.3	236	95.3	2.421	6.8	0.173	1057.63	842.9	6517.22	20558.6	8.243	46.8
	RodC4_100.1	237	100.1	2.543	11.6	0.295	1124.61	880.2	6739.32	21259.2	7.858	44.6
	RodC4_106.1	238	106.1	2.695	17.6	0.447	1197.22	920.5	7001.90	22087.5	7.527	42.7
	RodC4_110	239	110	2.794	21.5	0.546	1131.10	883.8	6792.58	21427.2	7.861	44.6
	RodC4_142.2	240	142.2	3.612	8.7	0.221	1208.11	926.5	2674.34	8436.2	2.842	16.1
Gr-3	RodD4_88.3	241	88.3	2.243	-0.2	-0.005	853.55	729.6	6190.33	19527.4	10.554	59.9
	RodD4_91.3	242	91.3	2.319	2.8	0.071	958.40	787.8	6317.28	19927.9	9.137	51.9
	RodD4_93.2	243	93.2	2.367	4.7	0.119	1004.55	813.5	6400.50	20190.4	8.678	49.3
	RodD4_95.2	244	95.2	2.418	6.7	0.170	1045.39	836.1	6487.24	20464.0	8.334	47.3
	RodD4_100.1	245	100.1	2.543	11.6	0.295	1125.03	880.4	6711.03	21169.9	7.821	44.4
	RodD4_106.1	246	106.1	2.695	17.6	0.447	1193.60	918.5	6972.68	21995.3	7.525	42.7
	RodD4_142.1	248	142.1	3.609	8.6	0.218	1215.58	930.7	2589.22	8167.7	2.730	15.5
Gr-3	RodE4_88.4	201	88.4	2.245	-0.1	-0.003	864.09	735.4	6087.30	19202.4	10.195	57.9
	RodE4_91.2	202	91.2	2.316	2.7	0.069	972.38	795.6	6207.68	19582.1	8.800	50.0
	RodE4_95.3	204	95.3	2.421	6.8	0.173	1066.48	847.9	6383.14	20135.6	7.984	45.3
	RodE4_100.9	205	100.9	2.563	12.4	0.315	1147.10	892.7	6623.42	20893.6	7.526	42.7
	RodE4_142.3	208	142.3	3.614	8.8	0.224	1230.64	939.1	2605.31	8218.5	2.704	15.4

Tale A-22: Summary of Steam Cooling Heat Transfer Reduced Data for Experiment 4037E, continued

	H.I.R. Location	Channel Number	Elevation (in)	Elevation (m)	Zgrid (in)	Zgrid (m)	H.R. Tw (°F)	H.R. Tw (K)	H.R. q" (Btu/hr-ft ²)	H.R. q" (W/m ²)	h _{sat} (z) (Btu/hr-ft ² -F)	h _{sat} (z) (W/m ² -K)
Gr-4	RodE3_63.4	193	63.4	1.610	16.4	0.417	1013.71	818.5	5026.70	15856.7	6.732	38.2
	RodE3_113.6	194	113.6	2.885	0.85	0.022	1207.11	926.0	6244.10	19697.0	6.642	37.7
	RodE3_115.5	195	115.5	2.934	2.75	0.070	1242.60	945.7	6013.18	18968.6	6.164	35.0
	RodE3_118.5	196	118.5	3.010	5.75	0.146	1274.29	963.3	5654.86	17838.3	5.614	31.9
	RodE3_122.7	197	122.7	3.117	9.95	0.253	1296.93	975.9	5153.96	16258.2	5.004	28.4
	RodE3_126.5	198	126.5	3.213	13.75	0.349	1300.12	977.7	4699.54	14824.7	4.549	25.8
	RodE3_131.7	199	131.7	3.345	-1.8	-0.046	1218.17	932.1	4100.39	12934.7	4.311	24.5
	RodE3_135.6	200	135.6	3.444	2.1	0.053	1238.65	943.5	3615.87	11406.3	3.721	21.1
	RodC5_63.7	225	63.7	1.618	16.7	0.424	988.81	804.7	4934.89	15567.1	6.837	38.8
	RodC5_113.6	226	113.6	2.885	0.85	0.022	1145.28	891.6	6099.83	19241.9	6.945	39.4
Gr-4	RodC5_115.7	227	115.7	2.939	2.95	0.075	1191.99	917.6	5857.00	18475.9	6.332	36.0
	RodC5_122.7	229	122.7	3.117	9.95	0.253	1248.77	949.1	5065.17	15978.1	5.159	29.3
	RodC5_126.7	230	126.7	3.218	13.95	0.354	1250.96	950.3	4611.01	14545.4	4.686	26.6
	RodC5_131.6	231	131.6	3.343	-1.9	-0.048	1155.35	897.2	4085.71	12888.4	4.599	26.1
	RodC5_135.7	232	135.7	3.447	2.2	0.056	1182.43	912.3	3601.40	11360.6	3.934	22.3
	RodE5_63.6	209	63.6	1.615	16.6	0.422	972.34	795.6	5037.68	15891.4	7.142	40.6
	RodE5_113.6	210	113.6	2.885	0.85	0.022	1175.60	908.5	6283.88	19822.5	6.916	39.3
	RodE5_115.4	211	115.4	2.931	2.65	0.067	1208.36	926.7	6063.38	19126.9	6.441	36.6
	RodE5_118.7	212	118.7	3.015	5.95	0.151	1238.09	943.2	5672.59	17894.2	5.841	33.2
	RodE5_122.6	213	122.6	3.114	9.85	0.250	1262.04	956.5	5214.42	16448.9	5.240	29.8
RodE5_126.6	214	126.6	3.216	13.85	0.352	1266.46	959.0	4742.26	14959.5	4.745	26.9	
Gr-5	RodE5_131.6	215	131.6	3.343	-1.9	-0.048	1184.37	913.4	4176.32	13174.2	4.552	25.9
	RodE5_135.6	216	135.6	3.444	2.1	0.053	1204.90	924.8	3691.45	11644.7	3.936	22.4
	RodC3_79.8	177	79.8	2.027	8.92	0.227	1012.63	817.9	5737.41	18098.7	7.695	43.7
	RodC3_85.6	178	85.6	2.174	14.72	0.374	898.42	754.5	5975.15	18848.6	9.463	53.7
	RodC3_88.5	179	88.5	2.248	0	0.000	890.59	750.1	6123.25	19315.8	9.819	55.8
	RodC3_92.4	180	92.4	2.347	3.9	0.099	1017.54	820.7	6286.85	19831.9	8.376	47.6
	RodC3_94.4	181	94.4	2.398	5.9	0.150	1058.72	843.6	6372.26	20101.3	8.049	45.7
	RodC3_97.2	182	97.2	2.469	8.7	0.221	1110.67	872.4	6494.11	20485.7	7.697	43.7
	RodC3_108.8	183	108.8	2.764	20.3	0.516	1222.00	934.3	6848.06	21602.2	7.171	40.7
	RodD5_50	217	50	1.270	3	0.076	863.73	735.2	4453.87	14049.7	7.464	42.4
Gr-8	RodD5_54.1	218	54.1	1.374	7.1	0.180	885.02	747.1	4669.74	14730.7	7.556	42.9
	RodD5_56.9	219	56.9	1.445	9.9	0.251	931.11	772.7	4766.21	15035.0	7.177	40.8
	RodD5_60	220	60	1.524	13	0.330	962.59	790.1	4899.84	15456.5	7.044	40.0
	RodD5_66.1	221	66.1	1.679	19.1	0.485	992.68	806.9	5155.40	16262.7	7.104	40.3
	RodD5_69.9	222	69.9	1.775	-0.98	-0.025	787.93	693.1	5330.26	16814.3	10.232	58.1
	RodD5_72.9	223	72.9	1.852	2.02	0.051	881.18	744.9	5461.52	17228.4	8.892	50.5
	RodD5_74.9	224	74.9	1.902	4.02	0.102	931.80	773.0	5546.49	17496.4	8.343	47.4

Inner 3x3

Tale A-22: Summary of Steam Cooling Heat Transfer Reduced Data for Experiment 4037E, continued

5x5 periphery													
H.R. ID	H.R. Location	Channel Number	Elevation (in)	Elevation (m)	Zgrid (in)	Zgrid (m)	H.R. Tw (°F)	H.R. Tw (K)	H.R. q" (Btu/hr-ft ²)	H.R. q" (W/m ²)	h _{sat} (z) (Btu/hr-ft ² -F)	h _{sat} (z) (W/m ² -K)	
Gr-2	RodB5_41	153	41	1.041	13.5	0.343	790.68	694.6	4046.77	12765.5	7.728	43.9	
	RodB5_52.9	154	52.9	1.344	5.9	0.150	835.53	719.6	4551.69	14358.3	8.006	45.5	
	RodB5_55	155	55	1.397	8	0.203	878.66	743.5	4651.88	14674.4	7.605	43.2	
	RodB5_57.8	156	57.8	1.468	10.8	0.274	933.32	773.9	4777.41	15070.3	7.170	40.7	
	RodB5_64	157	64	1.626	17	0.432	989.00	804.8	5043.69	15910.3	6.986	39.7	
	RodB5_73.9	158	73.9	1.877	3.02	0.077	914.30	763.3	5488.29	17312.8	8.479	48.2	
Gr-2	RodB5_75.9	159	75.9	1.928	5.02	0.128	952.88	784.8	5575.26	17587.1	8.129	46.2	
	RodB5_76.9	160	76.9	1.953	6.02	0.153	969.86	794.2	5619.26	17726.0	7.995	45.4	
	RodF5_41	105	41	1.041	13.5	0.343	793.50	696.2	4023.36	12691.7	7.642	43.4	
	RodF5_53.1	106	53.1	1.349	6.1	0.155	842.84	723.6	4536.90	14311.7	7.879	44.7	
	RodF5_55	107	55	1.397	8	0.203	875.26	741.6	4617.40	14565.6	7.591	43.1	
	RodF5_57.8	108	57.8	1.468	10.8	0.274	924.33	768.9	4748.22	14978.3	7.224	41.0	
Gr-2	RodF5_64	109	64	1.626	17	0.432	978.52	799.0	5015.09	15820.1	7.048	40.0	
	RodF5_73.8	110	73.8	1.875	2.92	0.074	907.92	759.8	5448.11	17186.1	8.501	48.3	
	RodF5_75.8	111	75.8	1.925	4.92	0.125	950.07	783.2	5534.83	17459.6	8.103	46.0	
	RodF5_76.8	112	76.8	1.951	5.92	0.150	968.25	793.3	5578.29	17596.7	7.955	45.2	
	RodC2_41	57	41	1.041	13.5	0.343	783.82	690.8	4041.11	12747.7	7.819	44.4	
	RodC2_53.1	58	53.1	1.349	6.1	0.155	902.40	756.7	4567.42	14407.9	7.188	40.8	
Gr-2	RodC2_55	59	55	1.397	8	0.203	925.26	769.4	4650.20	14669.0	7.064	40.1	
	RodC2_57.8	60	57.8	1.468	10.8	0.274	960.78	789.1	4771.07	15050.3	6.877	39.1	
	RodC2_63.9	61	63.9	1.623	16.9	0.429	1002.02	812.1	5034.65	15881.8	6.850	38.9	
	RodC2_73.8	62	73.8	1.875	2.92	0.074	919.89	766.4	5475.41	17272.2	8.386	47.6	
	RodC2_75.8	63	75.8	1.925	4.92	0.125	953.62	785.2	5559.69	17538.0	8.097	46.0	
	RodC2_76.8	64	76.8	1.951	5.92	0.150	967.93	793.1	5602.71	17673.8	7.993	45.4	
Gr-2	RodC6_40.9	137	40.9	1.039	13.4	0.340	790.69	694.6	4024.87	12696.4	7.686	43.6	
	RodC6_52.8	138	52.8	1.341	5.8	0.147	900.93	755.9	4559.93	14384.3	7.193	40.8	
	RodC6_54.8	139	54.8	1.392	7.8	0.198	927.39	770.6	4650.81	14671.0	7.043	40.0	
	RodC6_57.8	140	57.8	1.468	10.8	0.274	963.49	790.6	4787.73	15102.9	6.874	39.0	
	RodC6_63.8	141	63.8	1.621	16.8	0.427	1009.24	816.1	5073.18	16003.4	6.835	38.8	
	RodC6_73.7	142	73.7	1.872	2.82	0.072	943.58	779.6	5533.13	17454.3	8.178	46.4	
Gr-2	RodC6_75.8	143	75.8	1.925	4.92	0.125	974.91	797.0	5626.08	17747.5	7.947	45.1	
	RodC6_76.8	144	76.8	1.951	5.92	0.150	993.29	807.2	5670.04	17886.1	7.807	44.3	

Tale A-22: Summary of Steam Cooling Heat Transfer Reduced Data for Experiment 4037E, continued

5x5 periphery		H.R. Location	Channel Number	Elevation (in)	Elevation (m)	Zgrid (in)	Zgrid (m)	H.R. Tw (°F)	H.R. Tw (K)	H.R. q" (Btu/hr-ft ²)	H.R. q" (W/m ²)	h _{sat} (z) (Btu/hr-ft ² -F)	h _{sat} (z) (W/m ² -K)
Gr-3	RodB4_88.4	161	88.4	2.245	-0.1	-0.003	864.73	735.8	6079.48	19177.7	10.171	57.8	
	RodB4_91.3	162	91.3	2.319	2.8	0.071	970.61	794.6	6208.11	19583.5	8.823	50.1	
	RodB4_93.3	163	93.3	2.370	4.8	0.122	1017.88	820.9	6294.41	19855.7	8.383	47.6	
	RodB4_95.1	164	95.1	2.416	6.6	0.168	1052.89	840.3	6372.04	20100.6	8.108	46.0	
	RodB4_100	165	100	2.540	11.5	0.292	1099.75	866.3	6583.48	20767.6	7.906	44.9	
	RodB4_106	166	106	2.692	17.5	0.445	1181.00	911.5	6835.05	21561.2	7.478	42.5	
	RodB4_109.9	167	109.9	2.791	21.4	0.544	1113.44	874.0	6627.89	20907.7	7.830	44.5	
	RodB4_142.3	168	142.3	3.614	8.8	0.224	1189.52	916.2	2649.90	8359.1	2.872	16.3	
Gr-5	RodF4_85.6	98	85.6	2.174	14.72	0.374	937.84	776.4	6003.67	18938.6	8.949	50.8	
	RodF4_88.4	99	88.4	2.245	-0.1	-0.003	894.40	752.3	6137.41	19360.4	9.782	55.6	
	RodF4_92.4	100	92.4	2.347	3.9	0.099	1019.90	822.0	6306.44	19893.7	8.376	47.6	
	RodF4_94.3	101	94.3	2.395	5.8	0.147	1059.22	843.8	6387.57	20149.6	8.063	45.8	
	RodF4_97.2	102	97.2	2.469	8.7	0.221	1109.01	871.5	6512.29	20543.0	7.734	43.9	
	RodF4_108.8	103	108.8	2.764	20.3	0.516	1203.26	923.9	6881.04	21706.3	7.349	41.7	
	RodF4_111	104	111	2.819	-1.75	-0.044	1134.63	885.7	6614.67	20866.0	7.624	43.3	
	RodD2_103.2	65	103.2	2.621	14.7	0.373	1224.42	935.6	6076.09	19167.0	6.346	36.0	
RodD2_106	66	106	2.692	17.5	0.445	1247.57	948.5	5759.30	18167.7	5.873	33.4		
RodD2_112.6	67	112.6	2.860	-0.15	-0.004	1277.07	964.9	5330.87	16816.2	5.278	30.0		
RodD2_114.9	68	114.9	2.918	2.15	0.055	1291.33	972.8	4825.10	15220.8	4.710	26.8		
RodD2_117.4	69	117.4	2.982	4.65	0.118	1286.86	970.3	4346.55	13711.2	4.262	24.2		
RodD2_120.8	70	120.8	3.068	8.05	0.204	1208.41	926.7	6804.19	21463.8	7.228	41.0		
RodD2_124.8	71	124.8	3.170	12.05	0.306	1234.98	941.5	6925.47	21846.4	7.155	40.6		
RodD2_128.6	72	128.6	3.266	15.85	0.403	1175.79	908.6	6367.92	20087.6	7.007	39.8		
Gr-6	RodD6_103.1	129	103.1	2.619	14.6	0.371	1188.03	915.4	6818.97	21510.4	7.404	42.0	
	RodD6_106	130	106	2.692	17.5	0.445	1205.59	925.1	6940.36	21893.4	7.394	42.0	
	RodD6_112.9	131	112.9	2.868	0.15	0.004	1152.85	895.8	6356.34	20051.1	7.175	40.7	
	RodD6_114.9	132	114.9	2.918	2.15	0.055	1194.56	919.0	6097.51	19234.6	6.574	37.3	
	RodD6_116.8	133	116.8	2.967	4.05	0.103	1217.79	931.9	5854.64	18468.5	6.158	35.0	
	RodD6_120.9	134	120.9	3.071	8.15	0.207	1237.40	942.8	5328.48	16808.7	5.491	31.2	
	RodD6_124.8	135	124.8	3.170	12.05	0.306	1244.98	947.0	4831.11	15239.7	4.940	28.1	
	RodD6_128.7	136	128.7	3.269	15.95	0.405	1239.17	943.8	4332.93	13668.2	4.457	25.3	

Tale A-22: Summary of Steam Cooling Heat Transfer Reduced Data for Experiment 4037E, continued

5x5 periphery		H.R.	Channel	Elevation	Elevation	Zgrid	Zgrid	H.R. Tw	H.R.Tw	H.R. q"	H.R. q"	H.R. q"	h _{sat} (z)	h _{sat} (z)	h _{sat} (z)
Gr-8	Location	Number	(in)	(m)	(m)	(in)	(m)	(°F)	(K)	(W/m ²)	(Btu/hr-ft ²)	(W/m ²)	(W/m ² -K)	(Btu/hr-ft ² -F)	(W/m ² -K)
	RodE2_50.1	73	50.1	1.273	3.1	0.079	847.39	726.1	4468.34	14095.4	7.699	43.7			
	RodE2_54	74	54	1.372	7	0.178	916.11	764.3	4638.71	14632.8	7.146	40.6			
	RodE2_56.9	75	56.9	1.445	9.9	0.251	954.72	785.8	4765.72	15033.5	6.930	39.4			
	RodE2_59.9	76	59.9	1.521	12.9	0.328	992.77	806.9	4897.94	15450.5	6.749	38.3			
	RodE2_66	77	66	1.676	19	0.483	1018.23	821.1	5162.99	16286.6	6.873	39.0			
	RodE2_69.8	78	69.8	1.773	-1.08	-0.027	852.20	728.8	5331.56	16818.4	9.111	51.7			
	RodE2_72.9	79	72.9	1.852	2.02	0.051	926.77	770.2	5470.35	17256.2	8.291	47.1			
	RodE2_74.9	80	74.9	1.902	4.02	0.102	962.76	790.2	5557.30	17530.5	7.987	45.4			
Gr-8	RodB3_50.2	169	50.2	1.275	3.2	0.081	799.18	699.4	4449.66	14036.4	8.361	47.5			
	RodB3_54.1	170	54.1	1.374	7.1	0.180	860.64	733.5	4609.11	14539.4	7.764	44.1			
	RodB3_56.9	171	56.9	1.445	9.9	0.251	903.26	757.2	4725.38	14906.2	7.427	42.2			
	RodB3_60.1	172	60.1	1.527	13.1	0.333	905.45	758.4	4872.34	15369.8	7.632	43.3			
	RodB3_66.1	173	66.1	1.679	19.1	0.485	956.33	786.7	5125.47	16168.3	7.435	42.2			
	RodB3_69.9	174	69.9	1.775	-0.98	-0.025	783.31	690.5	5296.49	16707.8	10.258	58.3			
	RodB3_73	175	73	1.854	2.12	0.054	879.60	744.0	5435.08	17145.0	8.872	50.4			
	RodB3_75	176	75	1.905	4.12	0.105	926.02	769.8	5522.74	17421.5	8.380	47.6			
Gr-8	RodF3_50.1	89	50.1	1.273	3.1	0.079	826.19	714.4	4443.42	14016.8	7.946	45.1			
	RodF3_54	90	54	1.372	7	0.178	895.91	753.1	4613.91	14554.6	7.336	41.7			
	RodF3_57	91	57	1.448	10	0.254	942.57	779.0	4743.68	14963.9	7.022	39.9			
	RodF3_60	92	60	1.524	13	0.330	976.69	798.0	4871.65	15367.6	6.864	39.0			
	RodF3_66.1	93	66.1	1.679	19.1	0.485	994.49	807.9	5135.81	16200.9	7.060	40.1			
	RodF3_70	94	70	1.778	-0.88	-0.022	824.62	713.5	5314.07	16763.2	9.530	54.1			
	RodF3_73	95	73	1.854	2.12	0.054	916.84	764.7	5453.78	17204.0	8.392	47.7			
	RodF3_75	96	75	1.905	4.12	0.105	960.08	788.7	5543.41	17486.7	7.998	45.4			
Gr-8	RodE6_50.2	121	50.2	1.275	3.2	0.081	837.04	720.4	4439.44	14004.2	7.788	44.2			
	RodE6_54.1	122	54.1	1.374	7.1	0.180	902.03	756.5	4605.75	14528.8	7.253	41.2			
	RodE6_57	123	57	1.448	10	0.254	936.49	775.6	4730.15	14921.3	7.065	40.1			
	RodE6_60.2	124	60.2	1.529	13.2	0.335	971.33	795.0	4867.43	15354.3	6.911	39.2			
	RodE6_66.1	125	66.1	1.679	19.1	0.485	989.31	805.0	5119.27	16148.7	7.087	40.2			
	RodE6_70	126	70	1.778	-0.88	-0.022	850.25	727.7	5318.58	16777.5	9.119	51.8			
	RodE6_73.1	127	73.1	1.857	2.22	0.056	922.10	767.7	5431.69	17134.3	8.291	47.1			
	RodE6_75	128	75	1.905	4.12	0.105	959.00	788.1	5511.15	17384.9	7.964	45.2			

RBHT Steam Cooling with Droplet Injection Test SCD-4037-F

Matrix Test # 16c

Test Conditions

Test Date – 10/11/2005

Steady State Time Window: 24720 - 25320

Upper Plenum Pressure: 2.76 bar (40 psia)

Bundle Power: 72.0 kW

Bundle Inlet Reynolds Number: 8000

Bundle Inlet Steam Flow: 158.9 kg/hr (350 lbm/hr)

Droplet Injection Flow: 0.011 kg/s (0.024 lbm/s)

Droplet Injection Hole Diameter: 0.381 mm (.015 in)

Droplet Injection Elevation: 1.295 m (51 in)

Bundle Flow Area: $4.656 \times 10^{-3} \text{ m}^2$ ($5.012 \times 10^{-2} \text{ ft}^2$)

Test Notes

- No steam probes were traversed in this steady state window.

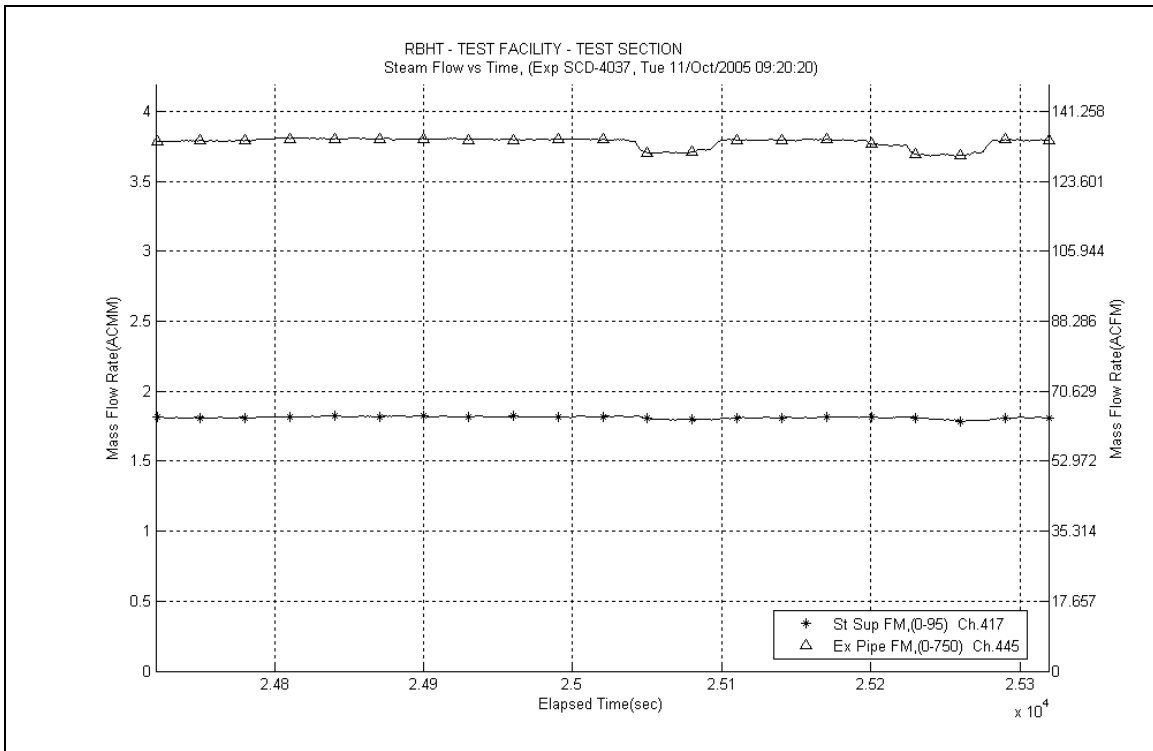

Figure A-399: Inlet and Exhaust Steam Flow Rates for Experiment 4037F

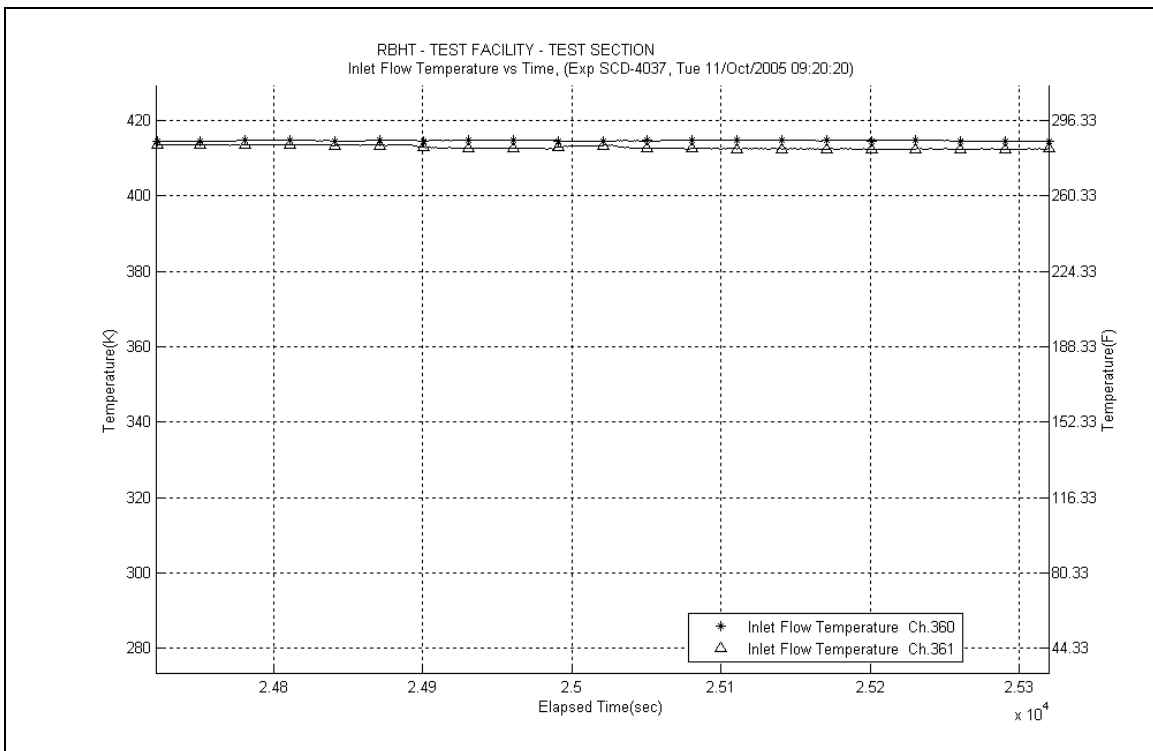

Figure A-400: Inlet Steam Temperature for Experiment 4037F

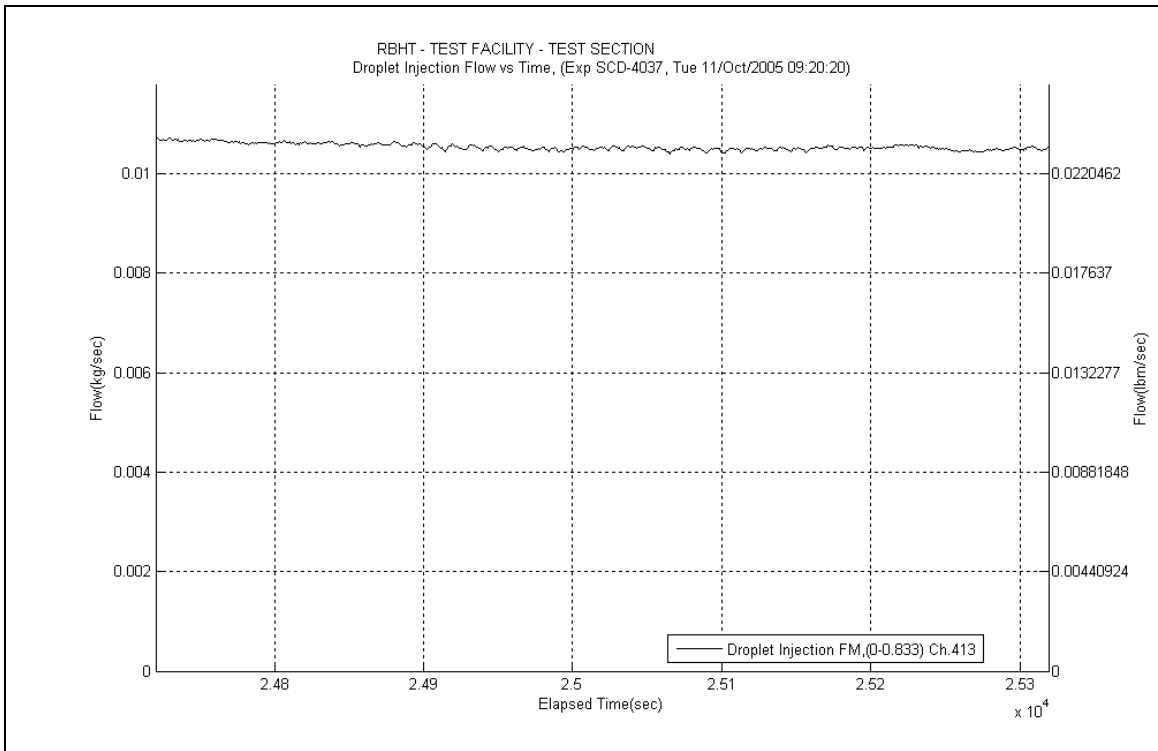

Figure A-401: Droplet Injection Flow Rate for Experiment 4037F

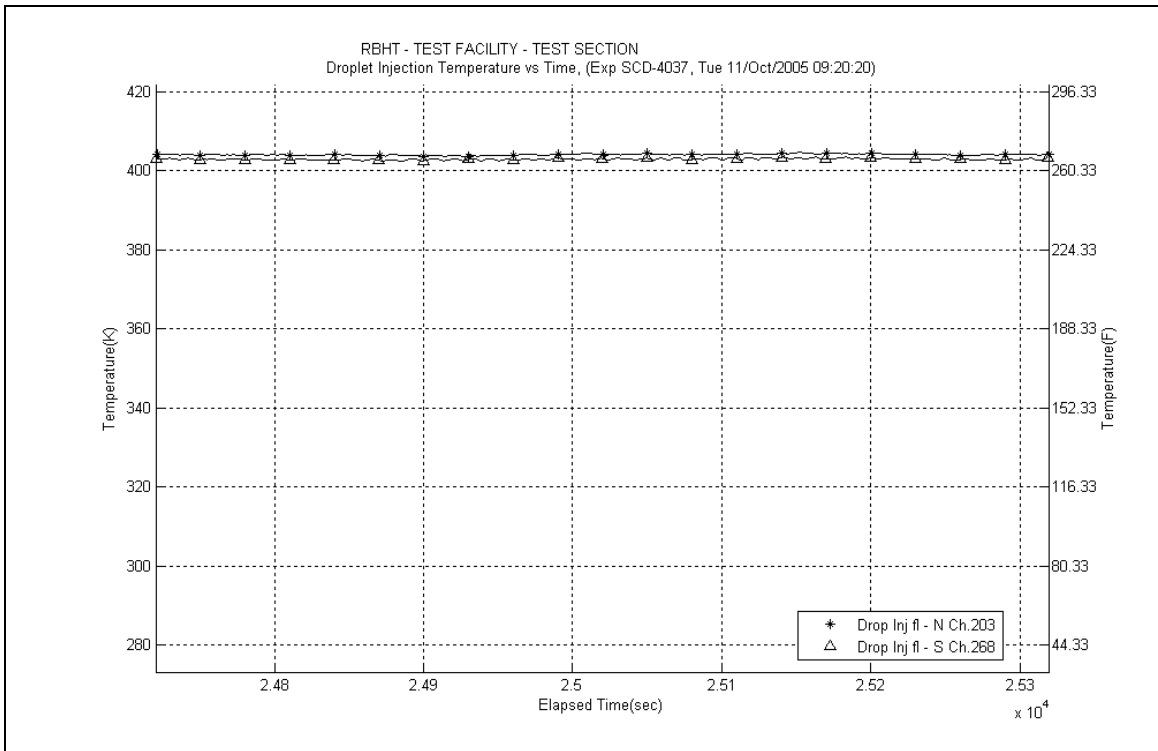

Figure A-402: Droplet Injection Temperature for Experiment 4037F

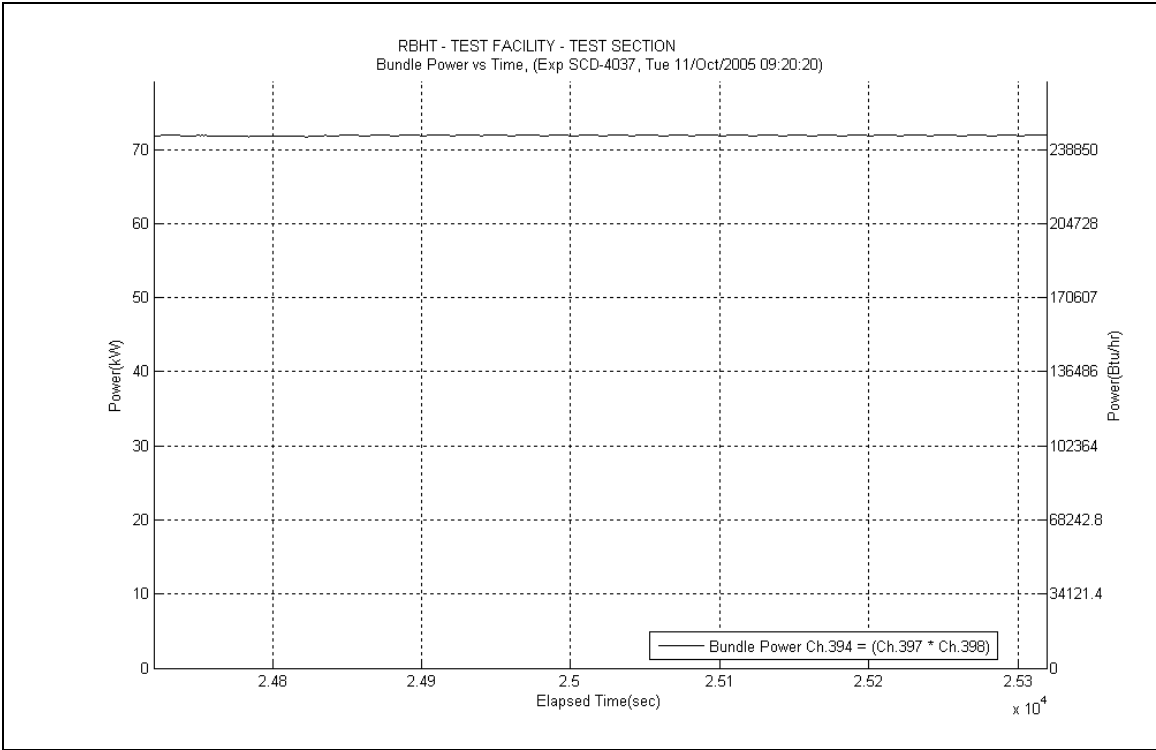

Figure A-403: Bundle Power for Experiment 4037F

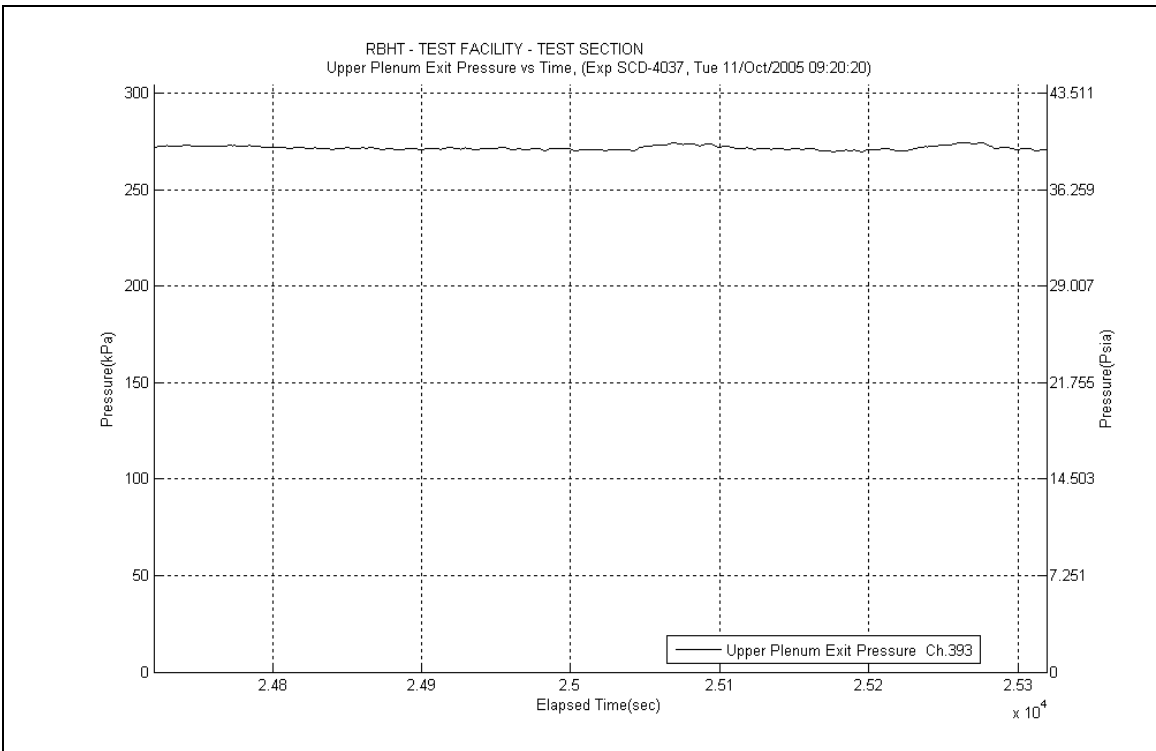

Figure A-404: Upper Plenum Pressure for Experiment 4037F

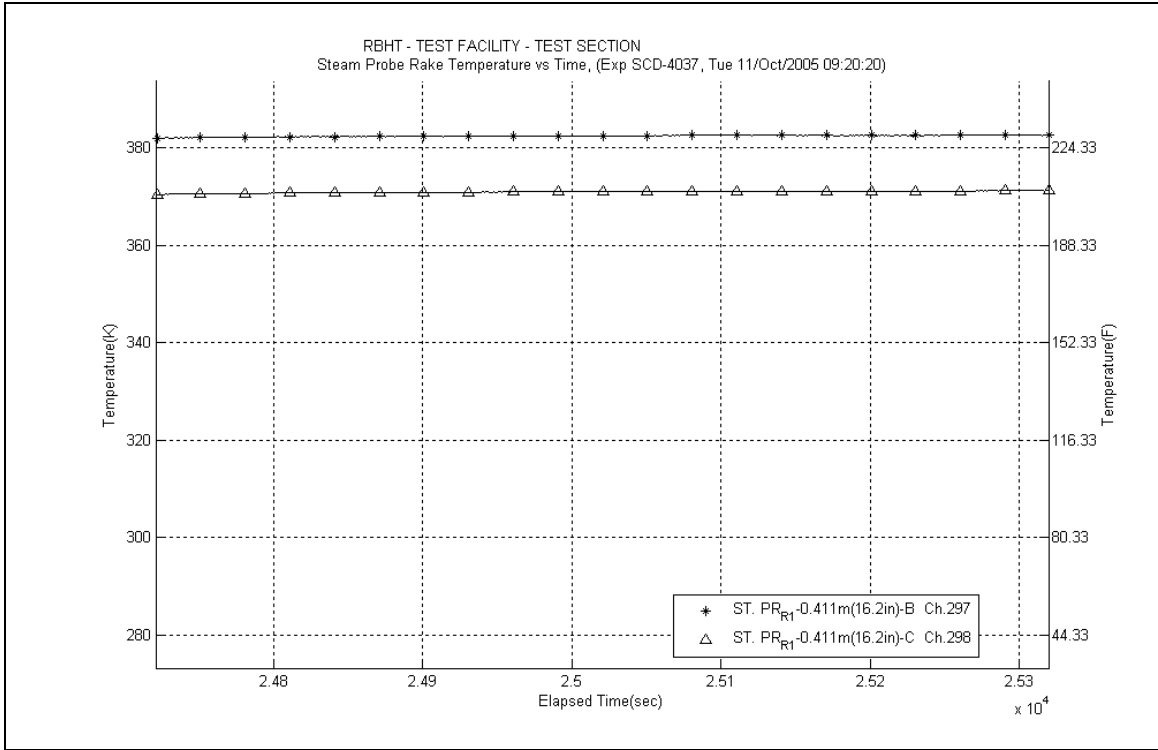

Figure A-405: Steam Probe Rake #1 Temperatures for Experiment 4037F

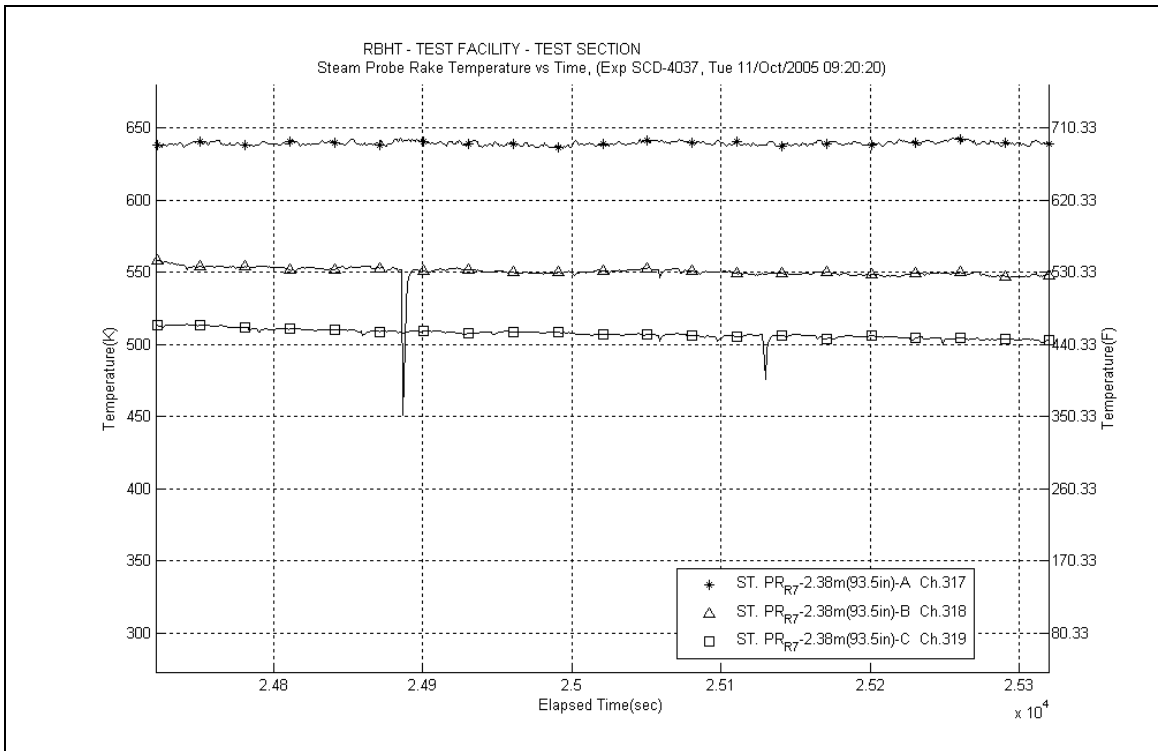

Figure A-406: Steam Probe Rake #7 Temperatures for Experiment 4037F

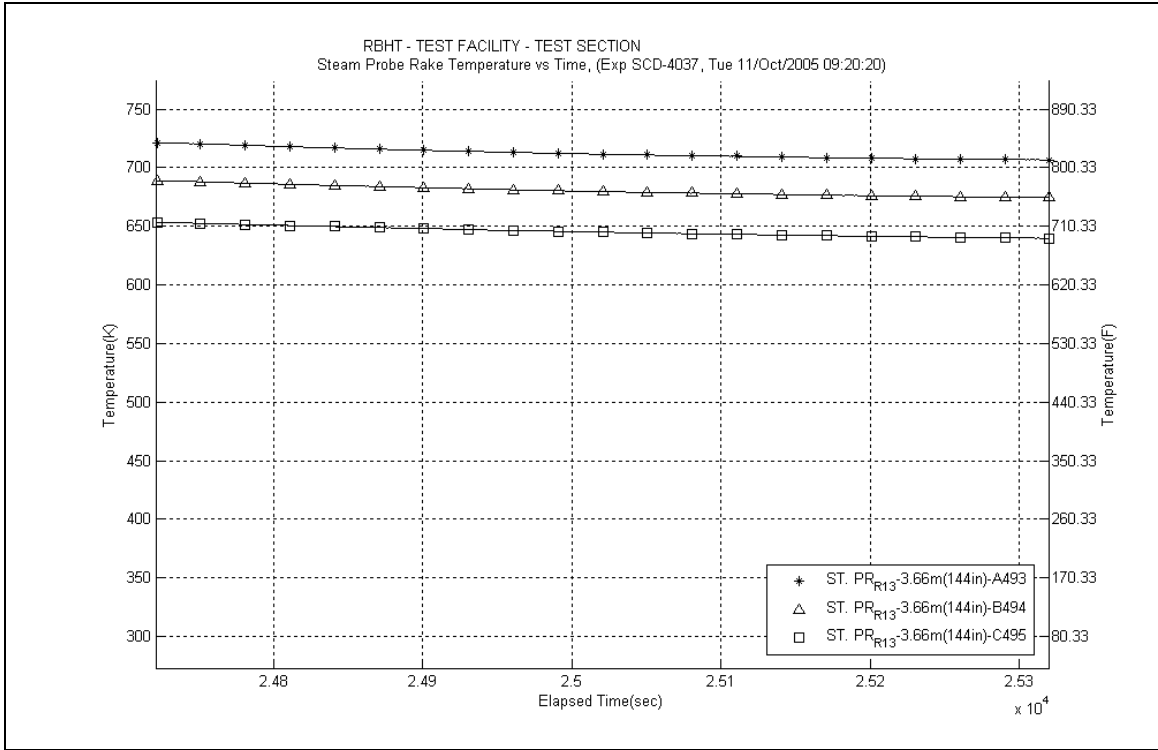

Figure A-407: Steam Probe Rake #13 Temperatures for Experiment 4037F

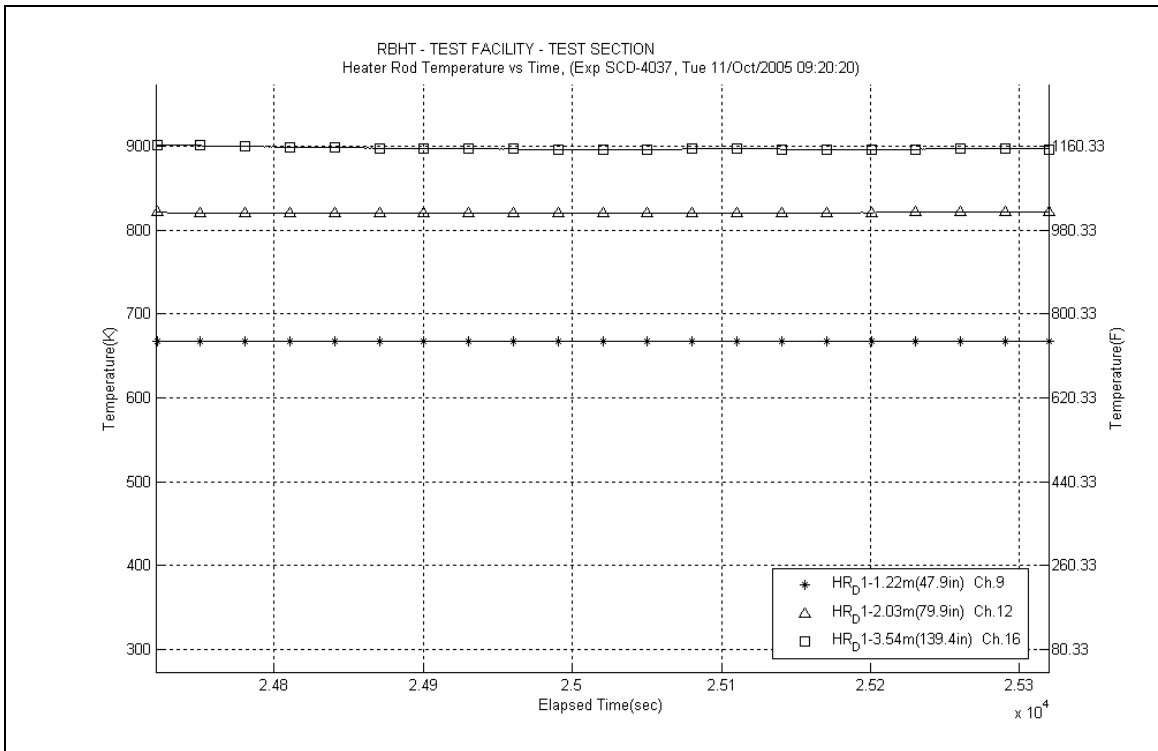

Figure A-408: Heater Rod D1 Temperatures for Experiment 4037F

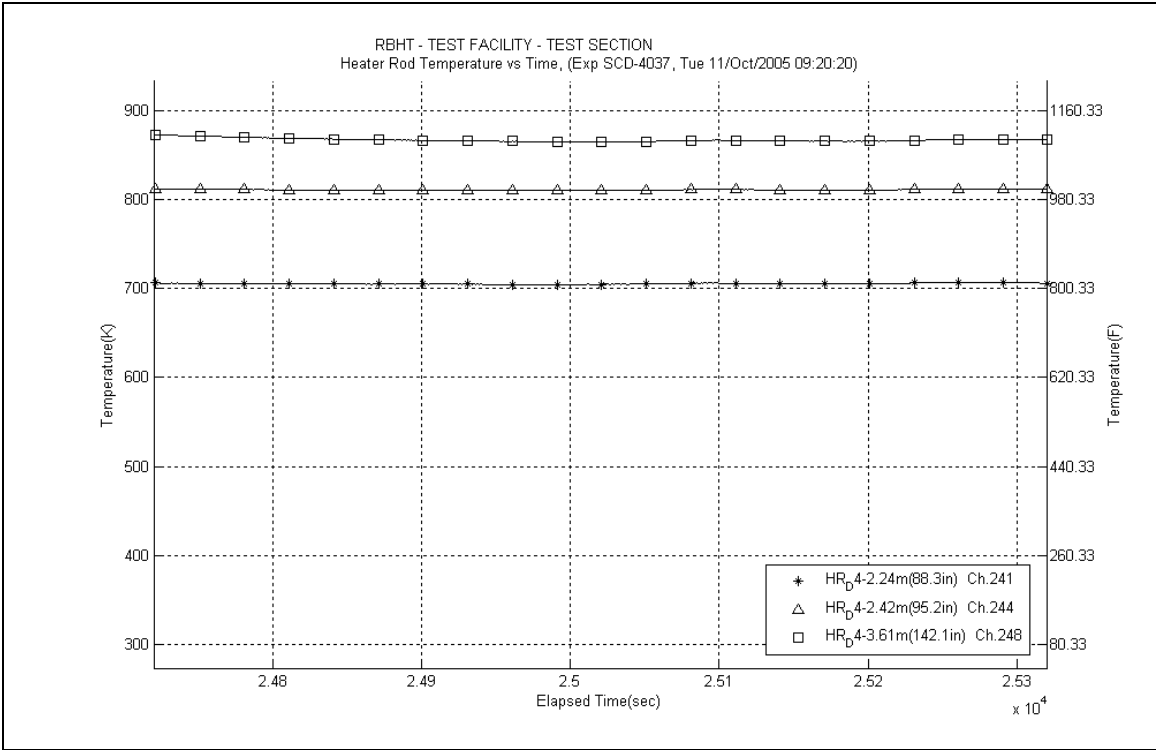

Figure A-409: Heater Rod D4 Temperatures for Experiment 4037F

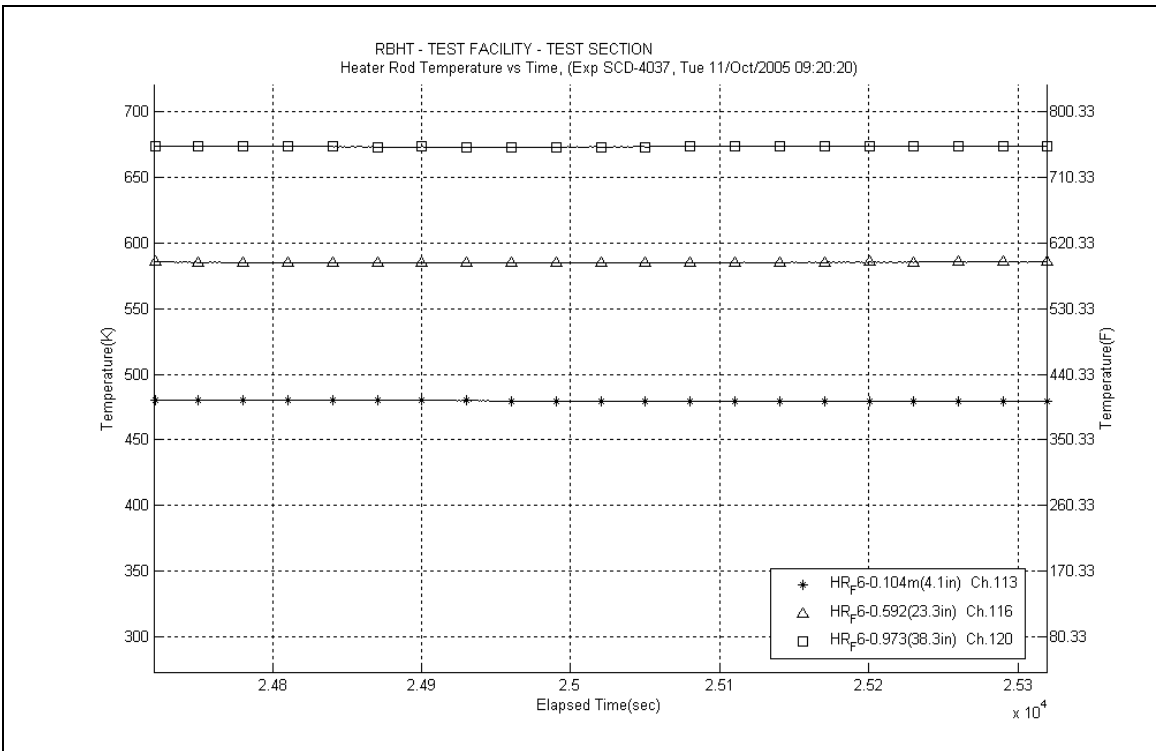

Figure A-410: Heater Rod F6 Temperatures for Experiment 4037F

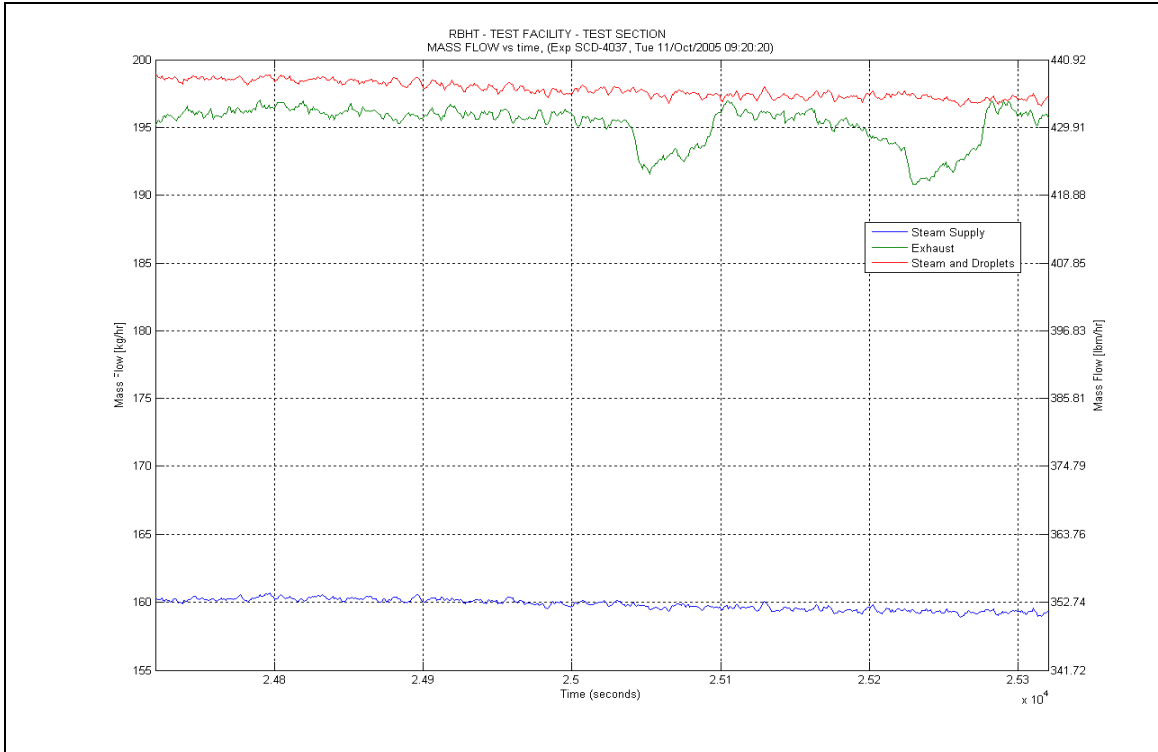

Figure A-411: Mass Flow for Experiment 4037F

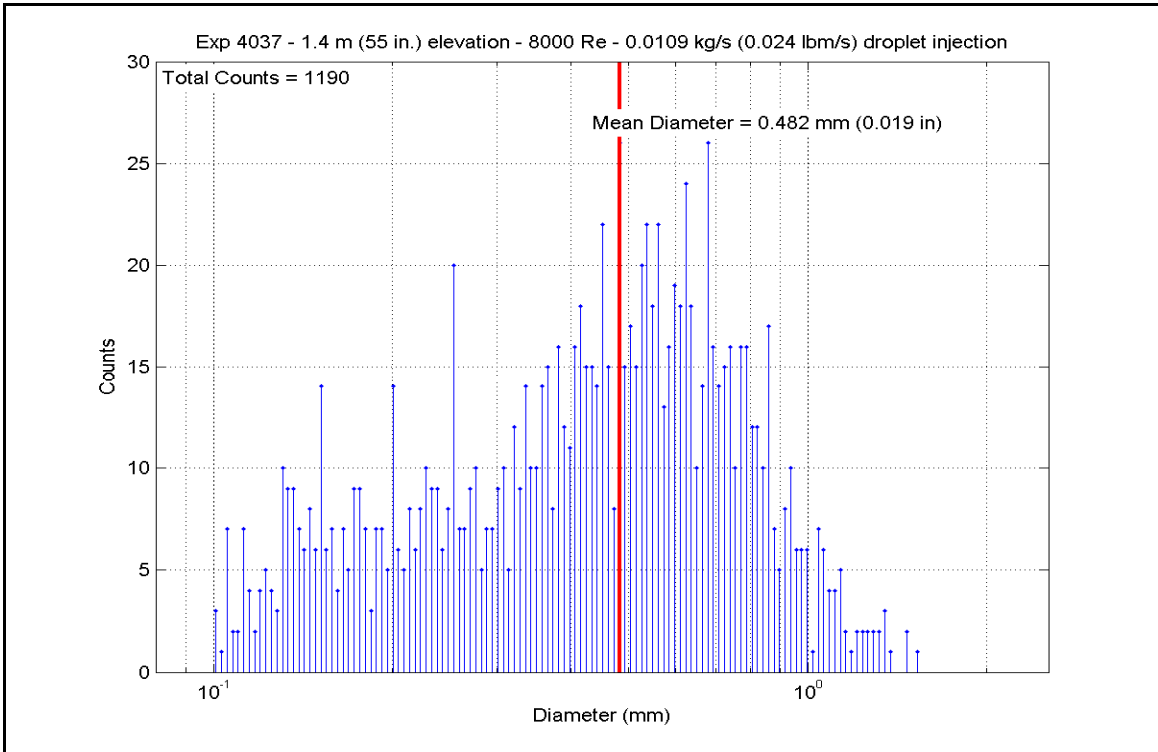

Figure A-412: Droplet Measurements at 1.397 m (55 in.) Elevation for Experiment 4037F

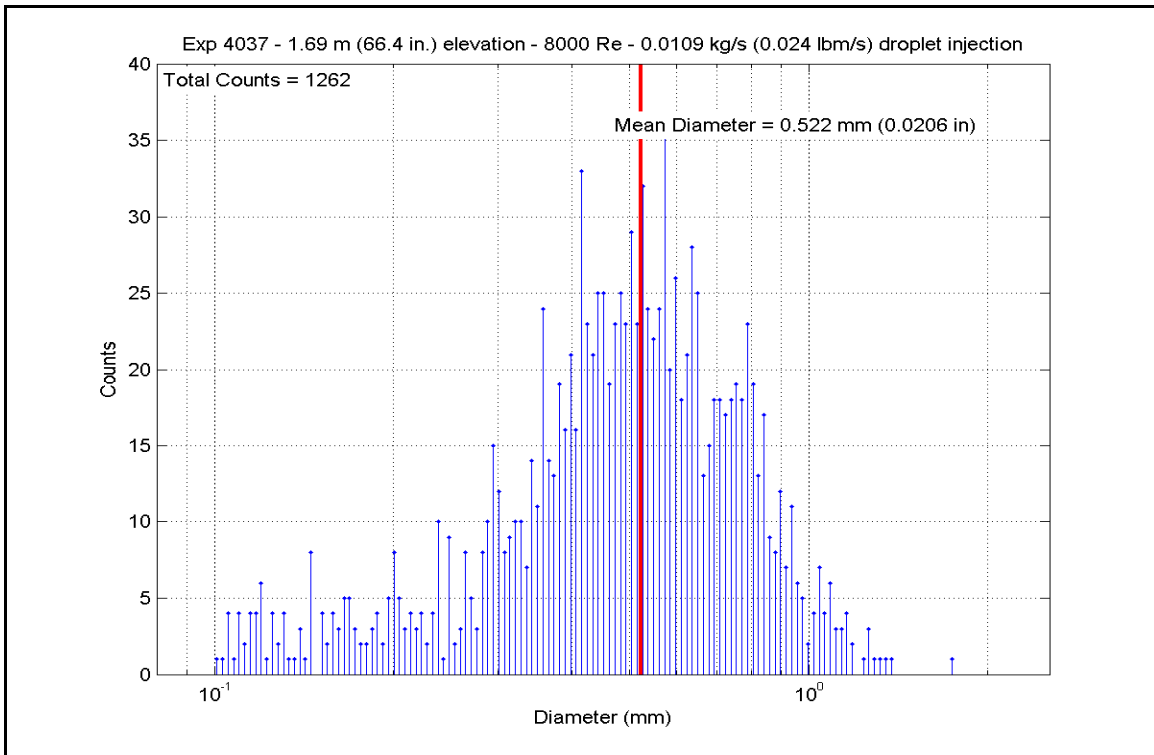

Figure A-413: Droplet Measurements at 1.687 m (66.4 in.) Elevation for Experiment 4037F

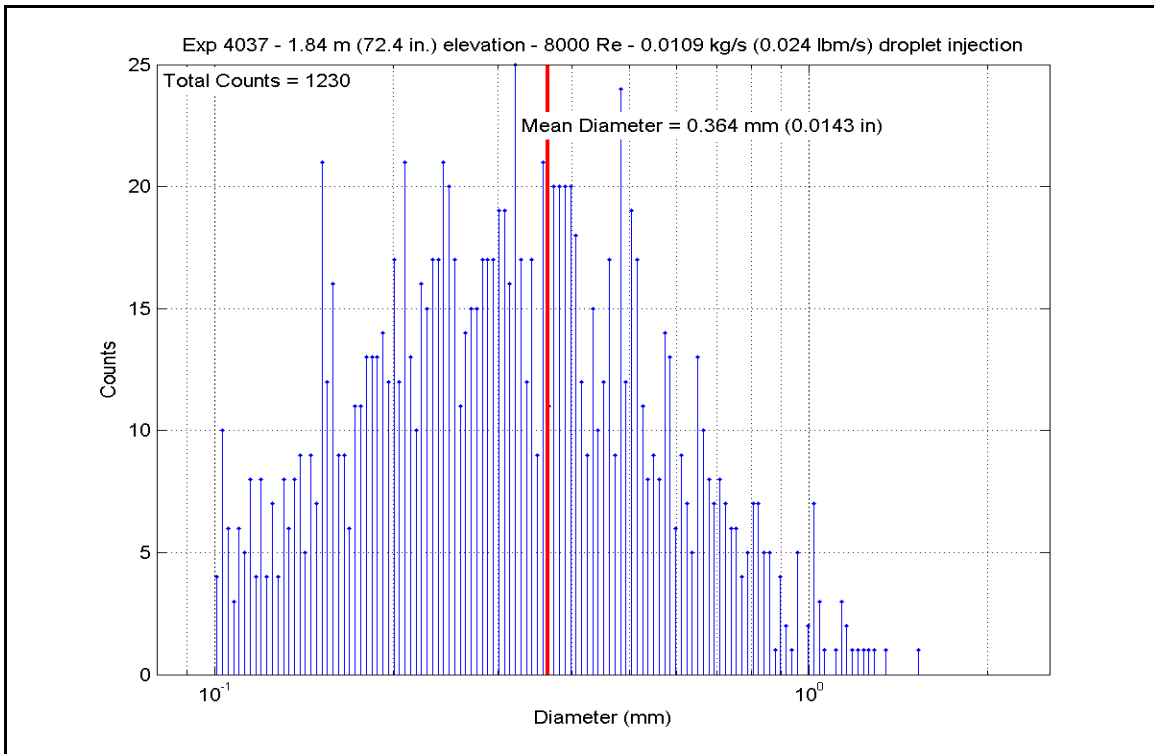

Figure A-414: Droplet Measurements at 1.839 m (72.4 in.) Elevation for Experiment 4037F

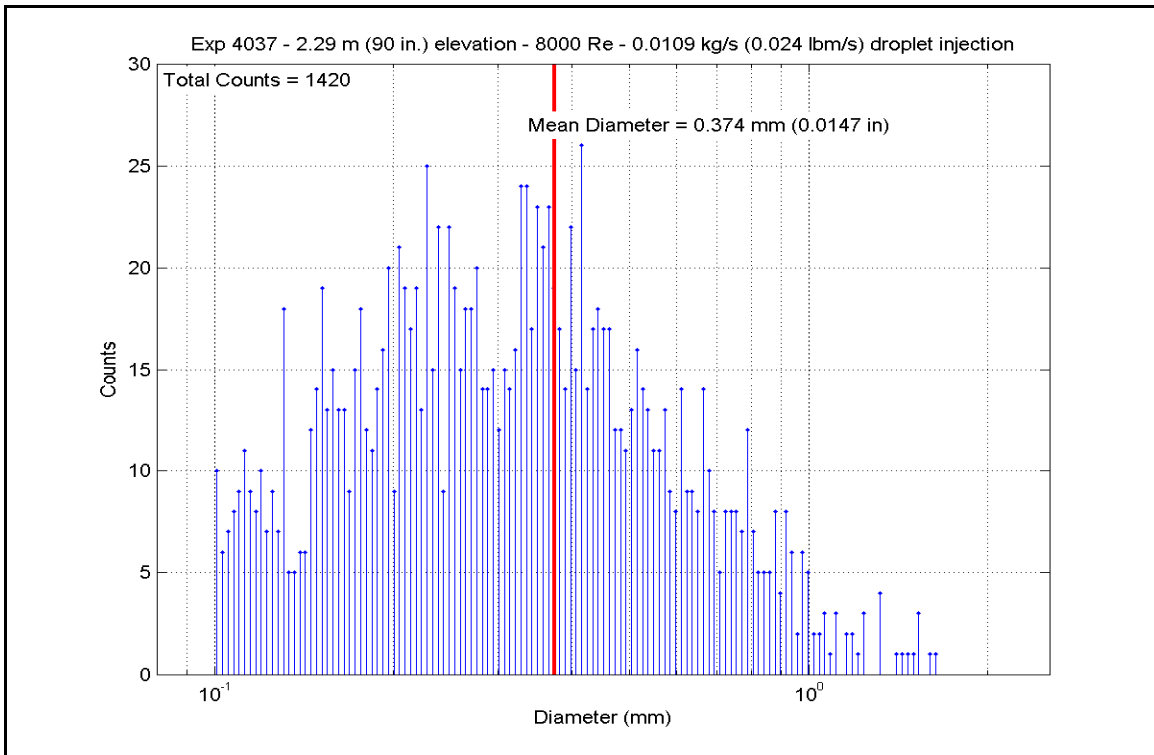

Figure A-415: Droplet Measurements at 2.286 m (90 in.) Elevation for Experiment 4037F

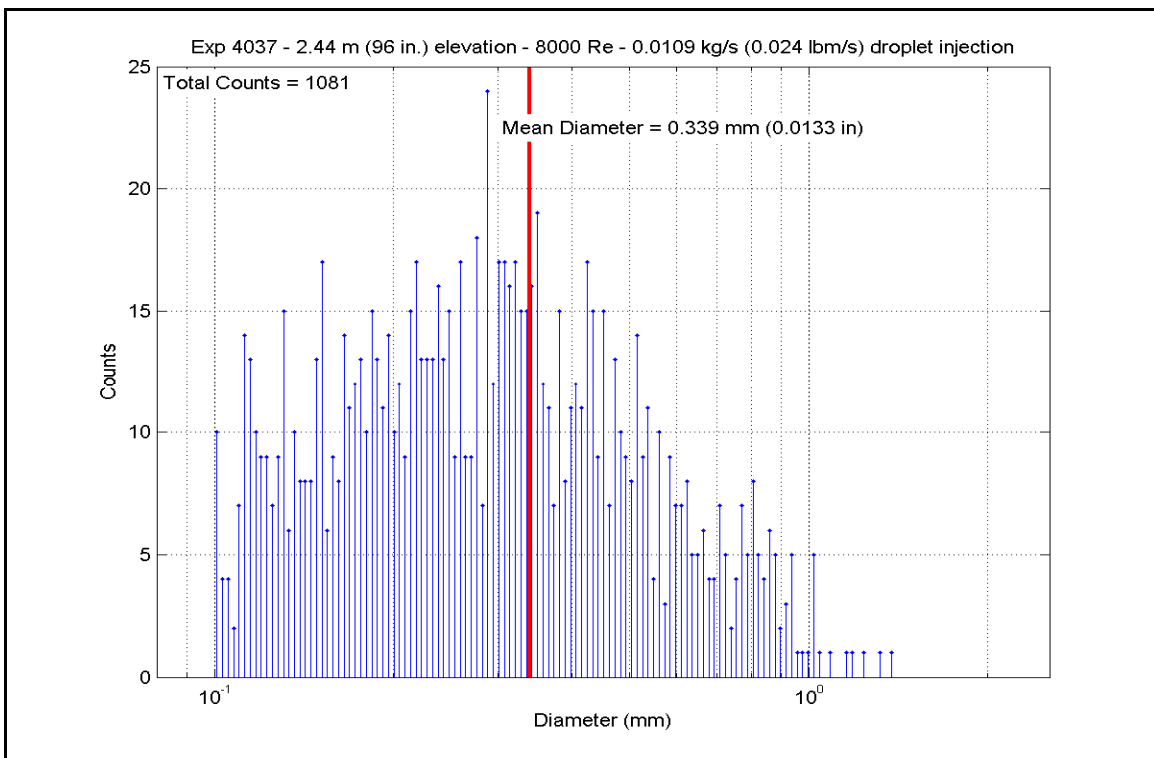

Figure A-416: Droplet Measurements at 2.438 m (96 in.) Elevation for Experiment 4037F

Table A-23: Summary of Steam Cooling Heat Transfer Reduced Data for Experiment 4037F

SCD-4037-F		Inlet Reynolds: 8000										
Matrix Test #16c		UP Pressure: 275.8 kPa		40 psia		H.R. q'		H.R. q''		h _{sat} (z)		
Time Window 24720-25320		Bundle Power: 72.00 kW		245674 Btu/hr		(W/m ²)		(Btu/hr-ft ²)		(W/m ² -K)		
Inner 3x3		Steam flow: 0.0441 kg/s		350.0 lbm/hr		H.R. Tw		H.R. Tw		h _{sat} (z)		
		Droplet flow: 0.0109 kg/s		0.024 lbm/s		(°F)		(K)		(Btu/hr-ft ²)		
H.R. ID	H.R. Location	Channel Number	Elevation (in)	Elevation (m)	Zgrid (in)	Zgrid (m)	H.R. Tw (°F)	H.R. Tw (K)	H.R. q' (W/m ²)	H.R. q'' (Btu/hr-ft ²)	h _{sat} (z) (Btu/hr-ft ²)	h _{sat} (z) (W/m ² -K)
Gr-3	RodD3_88.3	185	88.3	2.243	-0.2	-0.005	837.24	720.5	19238.2	6098.64	10.695	60.7
	RodD3_91.3	186	91.3	2.319	2.8	0.071	939.95	777.6	19644.7	6227.53	9.254	52.6
	RodD3_93.1	187	93.1	2.365	4.6	0.117	984.36	802.2	19894.4	6306.69	8.792	49.9
	RodD3_95.3	188	95.3	2.421	6.8	0.173	1024.91	824.8	20200.1	6403.59	8.449	48.0
	RodD3_100.1	189	100.1	2.543	11.6	0.295	1088.94	860.3	20853.2	6610.63	8.043	45.7
	RodD3_106.1	190	106.1	2.695	17.6	0.447	1177.92	909.8	21677.8	6872.01	7.544	42.8
	RodD3_110	191	110	2.794	21.5	0.546	1079.65	855.2	21436.3	6795.47	8.362	47.5
	RodD3_142.1	192	142.1	3.609	8.6	0.218	1131.72	884.1	7561.3	2396.98	2.772	15.7
Gr-3	RodC4_88.4	233	88.4	2.245	-0.1	-0.003	827.60	715.1	19463.4	6170.04	11.006	62.5
	RodC4_91.1	234	91.1	2.314	2.6	0.066	922.47	767.9	19835.7	6288.07	9.593	54.5
	RodC4_93.4	235	93.4	2.372	4.9	0.124	972.52	795.7	20155.2	6389.34	9.056	51.4
	RodC4_95.3	236	95.3	2.421	6.8	0.173	1011.42	817.3	20424.0	6474.56	8.697	49.4
	RodC4_100.1	237	100.1	2.543	11.6	0.295	1071.61	850.7	21099.6	6688.74	8.313	47.2
	RodC4_106.1	238	106.1	2.695	17.6	0.447	1147.64	892.9	21940.8	6955.39	7.898	44.9
	RodC4_110	239	110	2.794	21.5	0.546	1065.95	847.6	21247.5	6735.60	8.431	47.9
	RodC4_142.2	240	142.2	3.612	8.7	0.221	1095.18	863.8	8209.4	2602.44	3.142	17.8
Gr-3	RodD4_88.3	241	88.3	2.243	-0.2	-0.005	807.95	704.2	19388.3	6146.23	11.362	64.5
	RodD4_91.3	242	91.3	2.319	2.8	0.071	911.55	761.8	19806.6	6278.84	9.741	55.3
	RodD4_93.2	243	93.2	2.367	4.7	0.119	957.24	787.2	20071.9	6362.95	9.218	52.4
	RodD4_95.2	244	95.2	2.418	6.7	0.170	997.71	809.7	20348.3	6450.55	8.828	50.1
	RodD4_100.1	245	100.1	2.543	11.6	0.295	1070.98	850.4	21028.3	6666.11	8.291	47.1
	RodD4_106.1	246	106.1	2.695	17.6	0.447	1145.15	891.6	21866.3	6931.77	7.894	44.8
	RodD4_142.1	248	142.1	3.609	8.6	0.218	1100.54	866.8	7936.0	2515.76	3.018	17.1
Gr-3	RodE4_88.4	201	88.4	2.245	-0.1	-0.003	829.58	716.2	19099.1	6054.56	10.762	61.1
	RodE4_91.2	202	91.2	2.316	2.7	0.069	931.03	772.6	19466.2	6170.93	9.293	52.8
	RodE4_95.3	204	95.3	2.421	6.8	0.173	1021.67	823.0	6346.77	20020.9	8.410	47.8
	RodE4_100.9	205	100.9	2.563	12.4	0.315	1099.76	866.4	6582.87	20765.7	7.905	44.9
	RodE4_142.3	208	142.3	3.614	8.8	0.224	1125.09	880.4	2542.12	8019.1	2.963	16.8

Table A-23: Summary of Steam Cooling Heat Transfer Reduced Data for Experiment 4037F, continued

Inner 3x3	H.I.R. Location	Channel Number	Elevation (in)	Elevation (m)	Zgrid (in)	Zgrid (m)	H.R. Tw (°F)	H.R. Tw (K)	H.R. q" (Btu/hr-ft ²)	H.R. q" (W/m ²)	h _{sat} (z) (Btu/hr-ft ² -F)	h _{sat} (z) (W/m ² -K)
Gr-4	RodE3_63.4	193	63.4	1.610	16.4	0.417	992.18	806.6	5008.34	15798.8	6.906	39.2
	RodE3_113.6	194	113.6	2.885	0.85	0.022	1115.61	875.2	6184.20	19508.1	7.287	41.4
	RodE3_115.5	195	115.5	2.934	2.75	0.070	1153.64	896.3	5957.79	18793.8	6.720	38.2
	RodE3_118.5	196	118.5	3.010	5.75	0.146	1187.34	915.0	5600.09	17665.5	6.085	34.6
	RodE3_122.7	197	122.7	3.117	9.95	0.253	1209.30	927.2	5097.17	16079.0	5.409	30.7
	RodE3_126.5	198	126.5	3.213	13.75	0.349	1212.96	929.2	4641.56	14641.8	4.907	27.9
	RodE3_131.7	199	131.7	3.345	-1.8	-0.046	1118.73	876.9	4002.96	12627.3	4.700	26.7
RodE3_135.6	200	135.6	3.444	2.1	0.053	1142.96	890.4	3539.35	11164.9	4.041	22.9	
Gr-4	RodC5_63.7	225	63.7	1.618	16.7	0.424	964.20	791.0	4921.72	15525.6	7.059	40.1
	RodC5_113.6	226	113.6	2.885	0.85	0.022	1062.51	845.7	6034.45	19036.7	7.586	43.1
	RodC5_115.7	227	115.7	2.939	2.95	0.075	1103.80	868.6	5797.47	18288.1	6.928	39.3
	RodC5_122.7	229	122.7	3.117	9.95	0.253	1148.93	893.7	5007.76	15797.0	5.678	32.2
	RodC5_126.7	230	126.7	3.218	13.95	0.354	1146.36	892.2	4555.13	14369.2	5.180	29.4
	RodC5_131.6	231	131.6	3.343	-1.9	-0.048	1037.29	831.6	3982.75	12563.6	5.170	29.4
	RodC5_135.7	232	135.7	3.447	2.2	0.056	1064.20	846.5	3515.78	11090.5	4.411	25.0
Gr-4	RodE5_63.6	209	63.6	1.615	16.6	0.422	979.89	799.8	5037.63	15891.2	7.067	40.1
	RodE5_113.6	210	113.6	2.885	0.85	0.022	1080.16	855.5	6228.25	19647.0	7.659	43.5
	RodE5_115.4	211	115.4	2.931	2.65	0.067	1116.68	875.7	6018.29	18984.7	7.083	40.2
	RodE5_118.7	212	118.7	3.015	5.95	0.151	1150.66	894.6	5633.29	17770.2	6.375	36.2
	RodE5_122.6	213	122.6	3.114	9.85	0.250	1172.91	907.0	5177.51	16332.5	5.715	32.5
	RodE5_126.6	214	126.6	3.216	13.85	0.352	1175.54	908.4	4706.58	14846.9	5.180	29.4
	RodE5_131.6	215	131.6	3.343	-1.9	-0.048	1078.47	854.5	4104.55	12947.8	5.058	28.7
RodE5_135.6	216	135.6	3.444	2.1	0.053	1103.46	868.4	3630.14	11451.3	4.340	24.6	
Gr-5	RodC3_79.8	177	79.8	2.027	8.92	0.227	978.63	799.1	5701.11	17984.2	8.011	45.5
	RodC3_85.6	178	85.6	2.174	14.72	0.374	874.30	741.1	5949.26	18767.0	9.796	55.6
	RodC3_88.5	179	88.5	2.248	0	0.000	846.34	725.6	6074.08	19160.7	10.484	59.5
	RodC3_92.4	180	92.4	2.347	3.9	0.099	969.46	794.0	6238.59	19679.6	8.881	50.4
	RodC3_94.4	181	94.4	2.398	5.9	0.150	1010.71	816.9	6324.26	19949.9	8.504	48.3
	RodC3_97.2	182	97.2	2.469	8.7	0.221	1063.51	846.2	6445.79	20333.2	8.093	46.0
	RodC3_108.8	183	108.8	2.764	20.3	0.516	1174.24	907.7	6796.91	21440.9	7.492	42.5
Gr-8	RodD5_50	217	50	1.270	3	0.076	857.82	731.9	4463.45	14079.9	7.555	42.9
	RodD5_54.1	218	54.1	1.374	7.1	0.180	851.77	728.6	4635.95	14624.1	7.928	45.0
	RodD5_56.9	219	56.9	1.445	9.9	0.251	900.62	755.7	4759.00	15012.3	7.511	42.7
	RodD5_60	220	60	1.524	13	0.330	934.83	774.7	4895.89	15444.1	7.331	41.6
	RodD5_66.1	221	66.1	1.679	19.1	0.485	969.19	793.8	5157.27	16268.6	7.345	41.7
	RodD5_69.9	222	69.9	1.775	-0.98	-0.025	755.97	675.4	5314.11	16763.4	10.868	61.7
	RodD5_72.9	223	72.9	1.852	2.02	0.051	838.04	720.9	5442.88	17169.6	9.532	54.1
RodD5_74.9	224	74.9	1.902	4.02	0.102	884.42	746.7	5529.39	17442.5	8.956	50.9	

Table A-23: Summary of Steam Cooling Heat Transfer Reduced Data for Experiment 4037F, continued

H.R. ID	H.R. Location	Channel Number	Elevation (in)	Elevation (m)	Zgrid (in)	Zgrid (m)	H.R. Tw (°F)	H.R. Tw (K)	H.R. q" (Btu/hr-ft ²)	H.R. q" (W/m ²)	h _{sat} (z) (Btu/hr-ft ² -F)	h _{sat} (z) (W/m ² -K)	
Gr-2	RodB5_41	153	41	1.041	13.5	0.343	794.03	696.5	4044.27	12757.7	7.674	43.6	
	RodB5_52.9	154	52.9	1.344	5.9	0.150	846.60	725.7	4558.99	14381.3	7.866	44.7	
	RodB5_55	155	55	1.397	8	0.203	880.38	744.5	4653.68	14680.0	7.587	43.1	
	RodB5_57.8	156	57.8	1.468	10.8	0.274	928.63	771.3	4775.24	15063.5	7.217	41.0	
	RodB5_64	157	64	1.626	17	0.432	985.95	803.1	5040.00	15898.7	7.010	39.8	
	RodB5_73.9	158	73.9	1.877	3.02	0.077	889.28	749.4	5469.02	17252.0	8.789	49.9	
	RodB5_75.9	159	75.9	1.928	5.02	0.128	925.33	769.4	5556.20	17527.0	8.440	47.9	
	RodB5_76.9	160	76.9	1.953	6.02	0.153	940.69	778.0	5600.31	17666.2	8.313	47.2	
	Gr-2	RodF5_41	105	41	1.041	13.5	0.343	790.68	694.6	4024.15	12694.2	7.684	43.6
		RodF5_53.1	106	53.1	1.349	6.1	0.155	848.50	726.8	4547.74	14345.9	7.821	44.4
RodF5_55		107	55	1.397	8	0.203	885.41	747.3	4628.83	14601.6	7.485	42.5	
RodF5_57.8		108	57.8	1.468	10.8	0.274	928.09	771.0	4748.34	14978.6	7.183	40.8	
RodF5_64		109	64	1.626	17	0.432	980.27	800.0	5015.42	15821.1	7.032	39.9	
RodF5_73.8		110	73.8	1.875	2.92	0.074	898.50	754.5	5440.46	17161.9	8.615	48.9	
RodF5_75.8		111	75.8	1.925	4.92	0.125	938.23	776.6	5526.56	17433.5	8.233	46.8	
RodF5_76.8		112	76.8	1.951	5.92	0.150	955.10	786.0	5569.61	17569.3	8.094	46.0	
Gr-2		RodC2_41	57	41	1.041	13.5	0.343	784.96	691.5	4043.76	12756.0	7.807	44.3
		RodC2_53.1	58	53.1	1.349	6.1	0.155	899.79	755.3	4565.18	14400.9	7.214	41.0
	RodC2_55	59	55	1.397	8	0.203	921.98	767.6	4646.12	14656.2	7.094	40.3	
	RodC2_57.8	60	57.8	1.468	10.8	0.274	957.81	787.5	4765.15	15031.7	6.898	39.2	
	RodC2_63.9	61	63.9	1.623	16.9	0.429	1000.70	811.3	5028.39	15862.1	6.854	38.9	
	RodC2_73.8	62	73.8	1.875	2.92	0.074	910.05	761.0	5456.82	17213.5	8.486	48.2	
	RodC2_75.8	63	75.8	1.925	4.92	0.125	944.86	780.3	5542.63	17484.2	8.177	46.4	
	RodC2_76.8	64	76.8	1.951	5.92	0.150	959.35	788.3	5584.51	17616.3	8.066	45.8	
	Gr-2	RodC6_40.9	137	40.9	1.039	13.4	0.340	788.05	693.2	4019.97	12681.0	7.715	43.8
		RodC6_52.8	138	52.8	1.341	5.8	0.147	898.41	754.5	4556.75	14374.3	7.217	41.0
RodC6_54.8		139	54.8	1.392	7.8	0.198	923.59	768.5	4646.41	14657.1	7.077	40.2	
RodC6_57.8		140	57.8	1.468	10.8	0.274	958.00	787.6	4782.19	15085.4	6.921	39.3	
RodC6_63.8		141	63.8	1.621	16.8	0.427	988.38	804.5	5048.16	15924.4	6.998	39.7	
RodC6_73.7		142	73.7	1.872	2.82	0.072	893.20	751.6	5501.02	17353.0	8.785	49.9	
RodC6_75.8		143	75.8	1.925	4.92	0.125	925.20	769.4	5595.16	17649.9	8.501	48.3	
RodC6_76.8		144	76.8	1.951	5.92	0.150	943.66	779.6	5640.05	17791.5	8.335	47.3	

Table A-23: Summary of Steam Cooling Heat Transfer Reduced Data for Experiment 4037F, continued

5x5 periphery		H.R. Location	Channel Number	Elevation (in)	Elevation (m)	Zgrid (in)	Zgrid (m)	H.R. Tw (°F)	H.R. Tw (K)	H.R. q" (Btu/hr-ft ²)	H.R. q" (W/m ²)	h _{sat} (z) (Btu/hr-ft ² -F)	h _{sat} (z) (W/m ² -K)
Gr-3	RodB4_88.4	161	88.4	2.245	-0.1	-0.003	842.11	723.2	6046.40	19073.4	10.514	59.7	
	RodB4_91.3	162	91.3	2.319	2.8	0.071	940.92	778.1	6166.50	19452.2	9.150	52.0	
	RodB4_93.3	163	93.3	2.370	4.8	0.122	985.61	802.9	6251.31	19719.8	8.699	49.4	
	RodB4_95.1	164	95.1	2.416	6.6	0.168	1018.94	821.4	6327.55	19960.3	8.415	47.8	
	RodB4_100	165	100	2.540	11.5	0.292	1065.08	847.1	6535.20	20615.3	8.189	46.5	
	RodB4_106	166	106	2.692	17.5	0.445	1146.78	892.5	6785.72	21405.6	7.713	43.8	
	RodB4_109.9	167	109.9	2.791	21.4	0.544	1072.55	851.2	6570.22	20725.8	8.156	46.3	
	RodB4_142.3	168	142.3	3.614	8.8	0.224	1088.28	860.0	2584.77	8153.6	3.147	17.9	
Gr-5	RodF4_85.6	98	85.6	2.174	14.72	0.374	920.22	766.6	5970.06	18832.6	9.139	51.9	
	RodF4_88.4	99	88.4	2.245	-0.1	-0.003	864.16	735.5	6089.75	19210.1	10.198	57.9	
	RodF4_92.4	100	92.4	2.347	3.9	0.099	981.81	800.8	6261.31	19751.3	8.759	49.7	
	RodF4_94.3	101	94.3	2.395	5.8	0.147	1019.55	821.8	6343.79	20011.5	8.430	47.9	
	RodF4_97.2	102	97.2	2.469	8.7	0.221	1067.84	848.6	6469.53	20408.1	8.078	45.9	
	RodF4_108.8	103	108.8	2.764	20.3	0.516	1157.37	898.4	6834.34	21558.9	7.676	43.6	
	RodF4_111	104	111	2.819	-1.75	-0.044	1072.62	851.3	6553.93	20674.4	8.135	46.2	
	RodD2_103.2	65	103.2	2.621	14.7	0.373	1159.32	899.4	6030.24	19022.4	6.758	38.4	
RodD2_106	66	106	2.692	17.5	0.445	1181.93	912.0	5712.96	18021.5	6.244	35.5		
RodD2_112.6	67	112.6	2.860	-0.15	-0.004	1210.02	927.6	5282.97	16665.1	5.602	31.8		
RodD2_114.9	68	114.9	2.918	2.15	0.055	1222.11	934.3	4776.33	15066.9	5.001	28.4		
RodD2_117.4	69	117.4	2.982	4.65	0.118	1213.39	929.5	4295.07	13548.8	4.538	25.8		
RodD2_120.8	70	120.8	3.068	8.05	0.204	1156.74	898.0	6757.25	21315.8	7.595	43.1		
RodD2_124.8	71	124.8	3.170	12.05	0.306	1184.43	913.4	6880.07	21703.2	7.499	42.6		
RodD2_128.6	72	128.6	3.266	15.85	0.403	1114.52	874.6	6316.42	19925.1	7.453	42.3		
Gr-6	RodD6_103.1	129	103.1	2.619	14.6	0.371	1113.18	873.8	6786.95	21409.4	8.021	45.5	
	RodD6_106	130	106	2.692	17.5	0.445	1135.86	886.4	6912.48	21805.4	7.956	45.2	
	RodD6_112.9	131	112.9	2.868	0.15	0.004	1065.39	847.3	6305.73	19891.4	7.898	44.9	
	RodD6_114.9	132	114.9	2.918	2.15	0.055	1105.66	869.6	6051.09	19088.2	7.215	41.0	
	RodD6_116.8	133	116.8	2.967	4.05	0.103	1129.16	882.7	5810.59	18329.5	6.740	38.3	
	RodD6_120.9	134	120.9	3.071	8.15	0.207	1145.93	892.0	5289.66	16686.2	6.018	34.2	
	RodD6_124.8	135	124.8	3.170	12.05	0.306	1150.58	894.6	4792.68	15118.5	5.424	30.8	
	RodD6_128.7	136	128.7	3.269	15.95	0.405	1140.98	889.3	4293.46	13543.7	4.913	27.9	

Table A-23: Summary of Steam Cooling Heat Transfer Reduced Data for Experiment 4037F, continued

5x5 periphery		H.R.	Channel	Elevation	Elevation	Zgrid	Zgrid	H.R. Tw	H.R.Tw	H.R. q"	H.R. q"	H.R. q"	h _{sat} (z)	h _{sat} (z)
Gr-8	Location	Number	(in)	(m)	(m)	(in)	(m)	(°F)	(K)	(W/m ²)	(Btu/hr-ft ²)	(W/m ²)	(W/m ² -K)	(Btu/hr-ft ² -F)
	RodE2_50.1	73	50.1	1.273	3.1	0.079	843.83	724.2	4470.29	14101.5	4470.29	14101.5	7.750	44.0
	RodE2_54	74	54	1.372	7	0.178	912.05	762.1	4641.28	14640.9	4641.28	14640.9	7.195	40.9
	RodE2_56.9	75	56.9	1.445	9.9	0.251	949.69	783.0	4767.13	15037.9	4767.13	15037.9	6.983	39.7
	RodE2_59.9	76	59.9	1.521	12.9	0.328	986.84	803.6	4897.41	15448.9	4897.41	15448.9	6.803	38.6
	RodE2_66	77	66	1.676	19	0.483	1012.53	817.9	5161.58	16282.2	5161.58	16282.2	6.923	39.3
	RodE2_69.8	78	69.8	1.773	-1.08	-0.027	843.57	724.0	5322.04	16788.4	5322.04	16788.4	9.230	52.4
	RodE2_72.9	79	72.9	1.852	2.02	0.051	916.62	764.6	5458.16	17217.8	5458.16	17217.8	8.402	47.7
	RodE2_74.9	80	74.9	1.902	4.02	0.102	952.33	784.4	5545.72	17494.0	5545.72	17494.0	8.092	46.0
Gr-8	RodB3_50.2	169	50.2	1.275	3.2	0.081	792.65	695.7	4432.25	13981.5	4432.25	13981.5	8.432	47.9
	RodB3_54.1	170	54.1	1.374	7.1	0.180	861.46	734.0	4606.31	14530.6	4606.31	14530.6	7.749	44.0
	RodB3_56.9	171	56.9	1.445	9.9	0.251	908.01	759.8	4723.46	14900.1	4723.46	14900.1	7.369	41.8
	RodB3_60.1	172	60.1	1.527	13.1	0.333	904.80	758.0	4851.54	15304.2	4851.54	15304.2	7.607	43.2
	RodB3_66.1	173	66.1	1.679	19.1	0.485	959.03	788.2	5125.19	16167.4	5125.19	16167.4	7.406	42.1
	RodB3_69.9	174	69.9	1.775	-0.98	-0.025	781.50	689.5	5288.78	16683.5	5288.78	16683.5	10.279	58.4
	RodB3_73	175	73	1.854	2.12	0.054	874.26	741.1	5422.67	17105.8	5422.67	17105.8	8.930	50.7
	RodB3_75	176	75	1.905	4.12	0.105	919.37	766.1	5508.34	17376.1	5508.34	17376.1	8.444	48.0
Gr-8	RodF3_50.1	89	50.1	1.273	3.1	0.079	821.41	711.7	4442.61	14014.2	4442.61	14014.2	8.013	45.5
	RodF3_54	90	54	1.372	7	0.178	891.89	750.9	4617.76	14566.7	4617.76	14566.7	7.390	42.0
	RodF3_57	91	57	1.448	10	0.254	940.30	777.8	4749.01	14980.7	4749.01	14980.7	7.053	40.1
	RodF3_60	92	60	1.524	13	0.330	978.39	798.9	4880.62	15395.9	4880.62	15395.9	6.861	39.0
	RodF3_66.1	93	66.1	1.679	19.1	0.485	1003.10	812.6	5147.30	16237.1	5147.30	16237.1	6.993	39.7
	RodF3_70	94	70	1.778	-0.88	-0.022	832.46	717.8	5317.76	16774.9	5317.76	16774.9	9.404	53.4
	RodF3_73	95	73	1.854	2.12	0.054	914.24	763.3	5446.79	17181.9	5446.79	17181.9	8.415	47.8
	RodF3_75	96	75	1.905	4.12	0.105	955.27	786.1	5533.77	17456.3	5533.77	17456.3	8.040	45.7
Gr-8	RodE6_50.2	121	50.2	1.275	3.2	0.081	835.98	719.8	4441.37	14010.3	4441.37	14010.3	7.806	44.3
	RodE6_54.1	122	54.1	1.374	7.1	0.180	900.49	755.6	4609.03	14539.2	4609.03	14539.2	7.276	41.3
	RodE6_57	123	57	1.448	10	0.254	934.64	774.6	4731.99	14927.1	4731.99	14927.1	7.088	40.2
	RodE6_60.2	124	60.2	1.529	13.2	0.335	967.59	792.9	4867.78	15355.4	4867.78	15355.4	6.948	39.5
	RodE6_66.1	125	66.1	1.679	19.1	0.485	983.06	801.5	5120.13	16151.5	5120.13	16151.5	7.150	40.6
	RodE6_70	126	70	1.778	-0.88	-0.022	802.31	701.1	5287.65	16679.9	5287.65	16679.9	9.878	56.1
	RodE6_73.1	127	73.1	1.857	2.22	0.056	885.32	747.2	5420.99	17100.5	5420.99	17100.5	8.767	49.8
	RodE6_75	128	75	1.905	4.12	0.105	924.39	768.9	5503.54	17360.9	5503.54	17360.9	8.372	47.5

RBHT Steam Cooling with Droplet Injection Test SCD-4037-H

Matrix Test # 15b

Test Conditions

Test Date – 10/11/2005

Steady State Time Window: 26340 - 27120

Upper Plenum Pressure: 2.76 bar (40 psia)

Bundle Power: 64.0 kW

Bundle Inlet Reynolds Number: 6000

Bundle Inlet Steam Flow: 118.04 kg/hr (260 lbm/hr)

Droplet Injection Flow: 0.0073 kg/s (0.016 lbm/s)

Droplet Injection Hole Diameter: 0.381 mm (.015 in)

Droplet Injection Elevation: 1.295 m (51 in)

Bundle Flow Area: $4.656 \times 10^{-3} \text{ m}^2$ ($5.012 \times 10^{-2} \text{ ft}^2$)

Test Notes

- No steam probes were traversed in this steady state window.

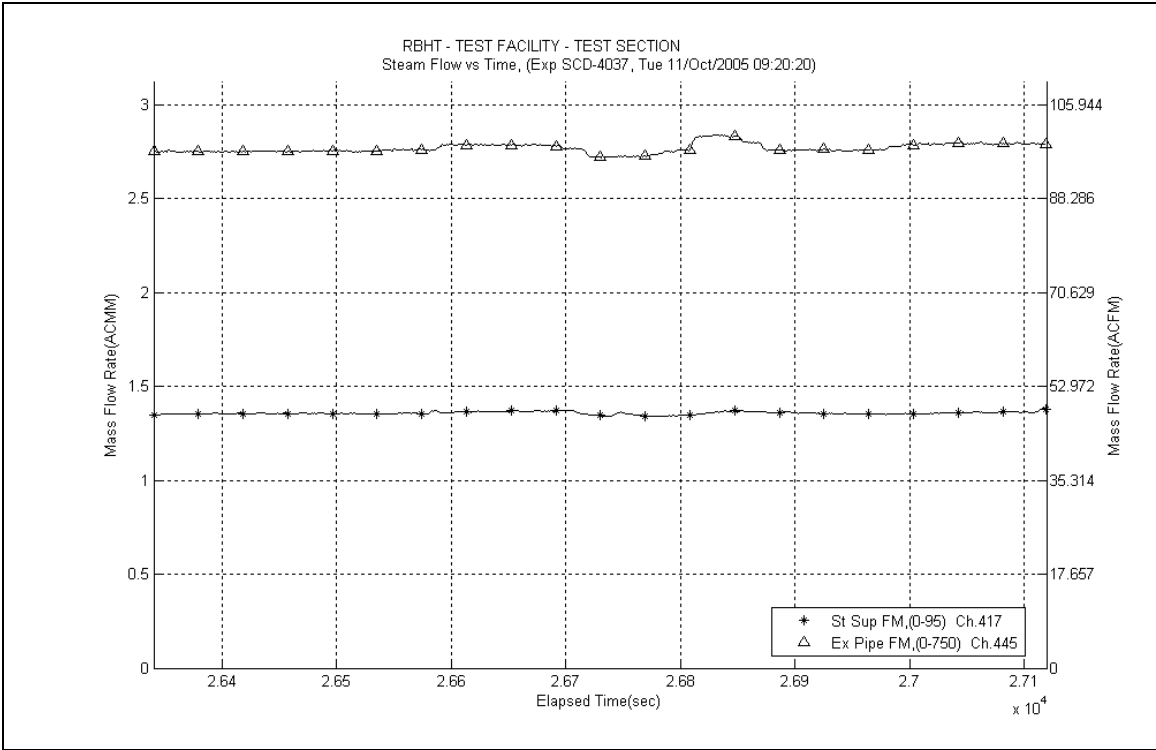

Figure A-417: Inlet and Exhaust Steam Flow Rates for Experiment 4037H

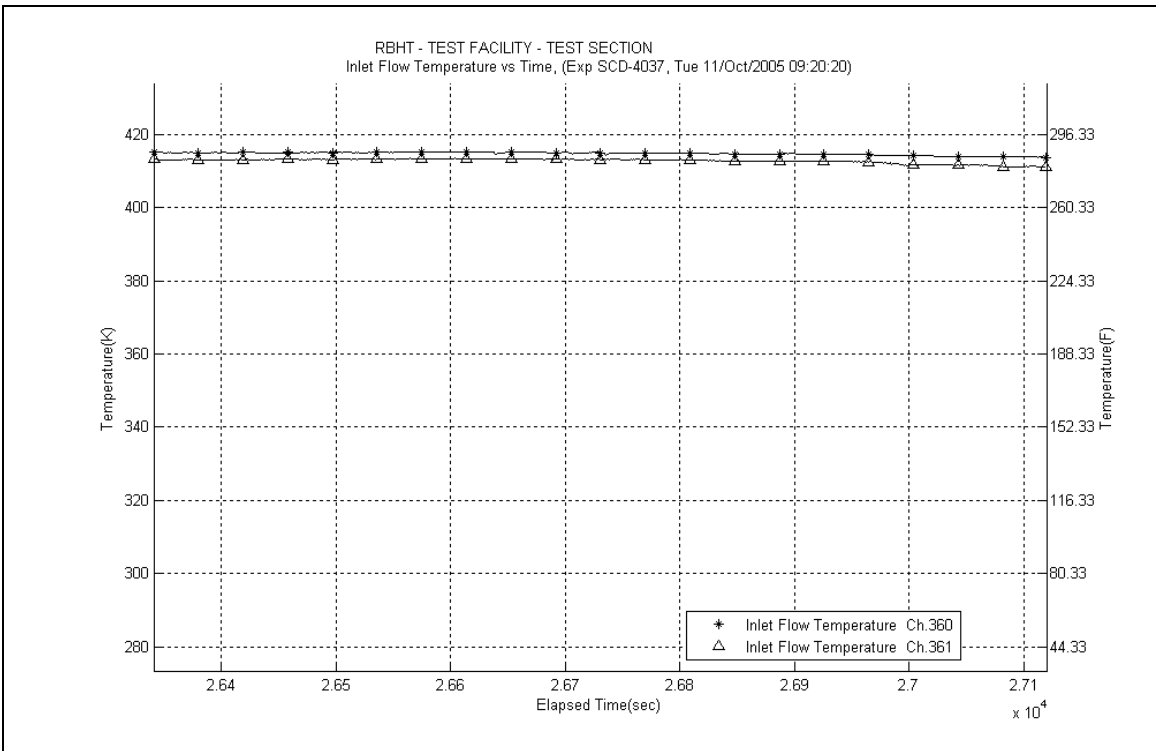

Figure A-418: Inlet Steam Temperature for Experiment 4037H

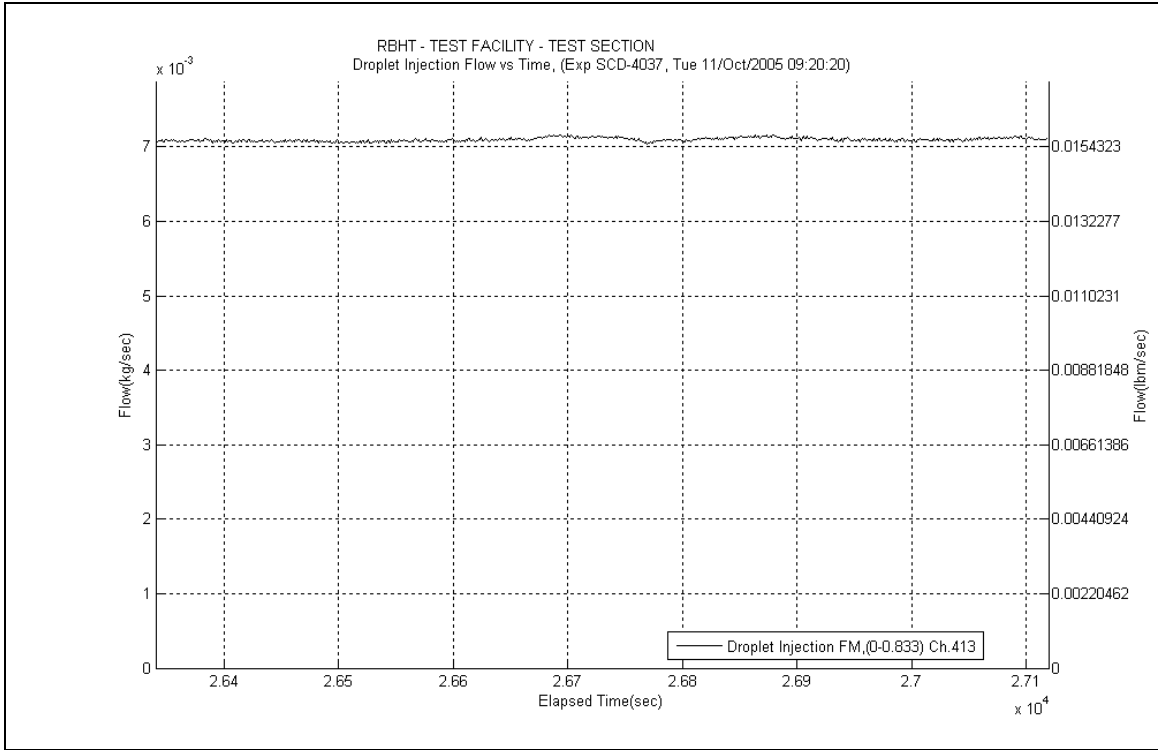

Figure A-419: Droplet Injection Flow Rate for Experiment 4037H

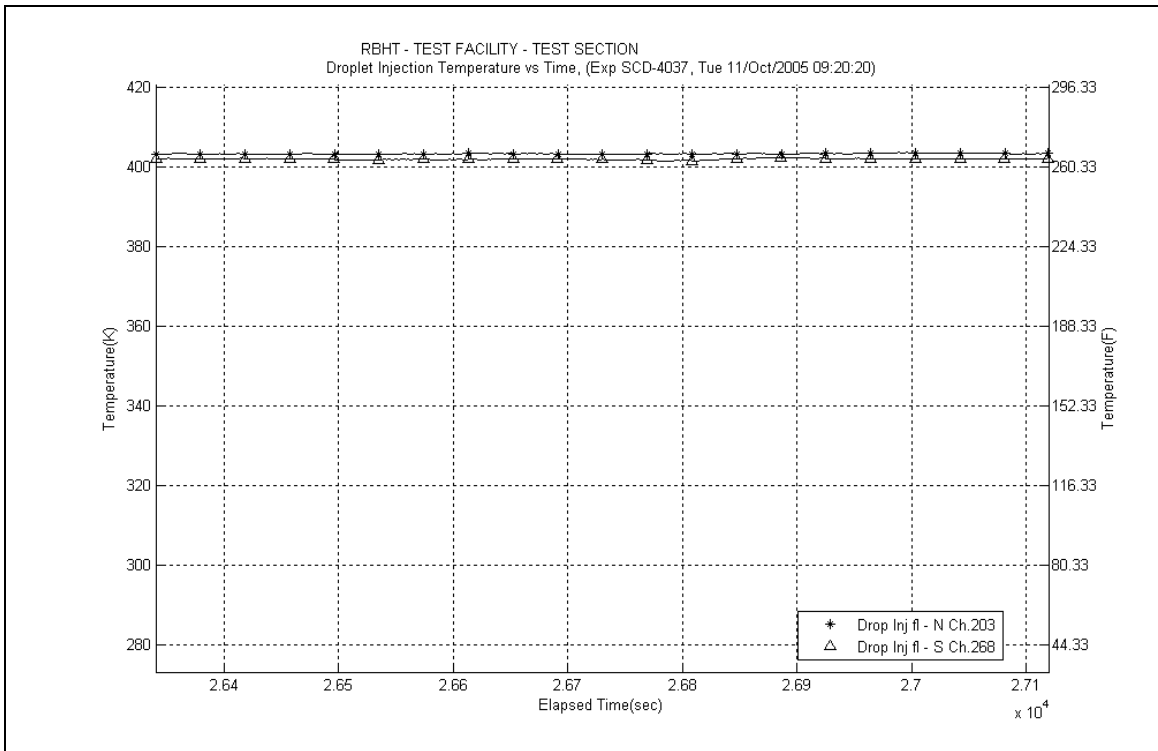

Figure A-420: Droplet Injection Temperature for Experiment 4037H

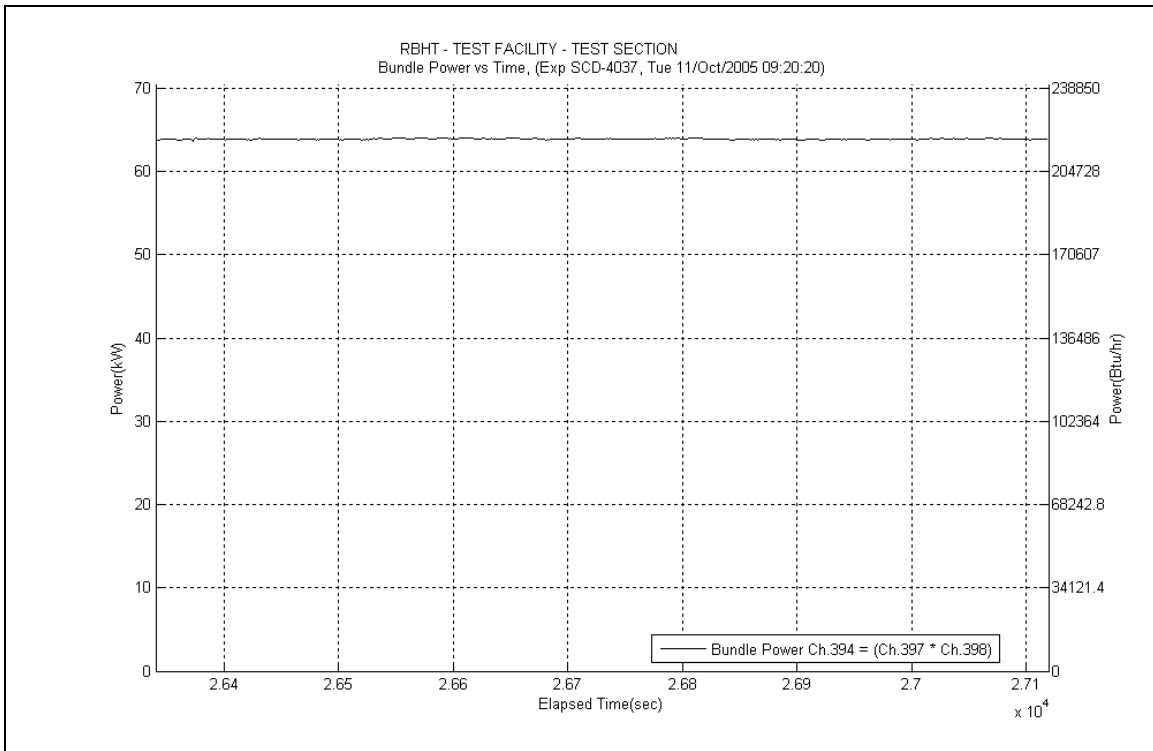

Figure A-421: Bundle Power for Experiment 4037H

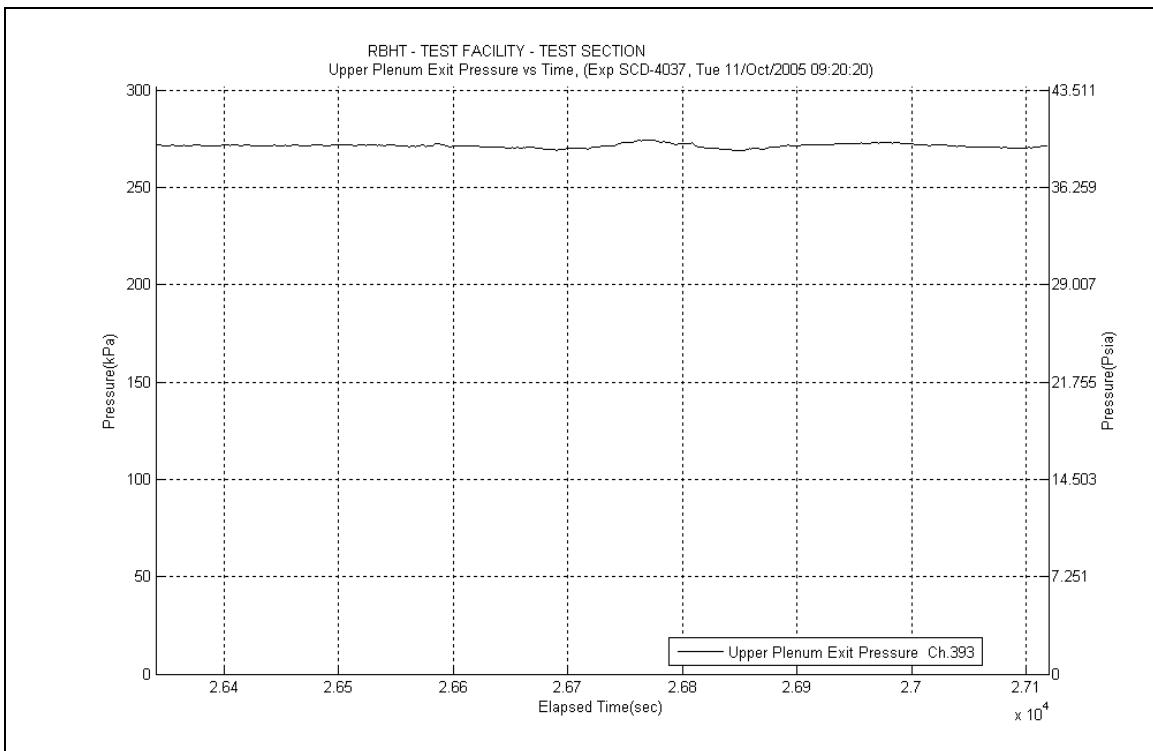

Figure A-422: Upper Plenum Pressure for Experiment 4037H

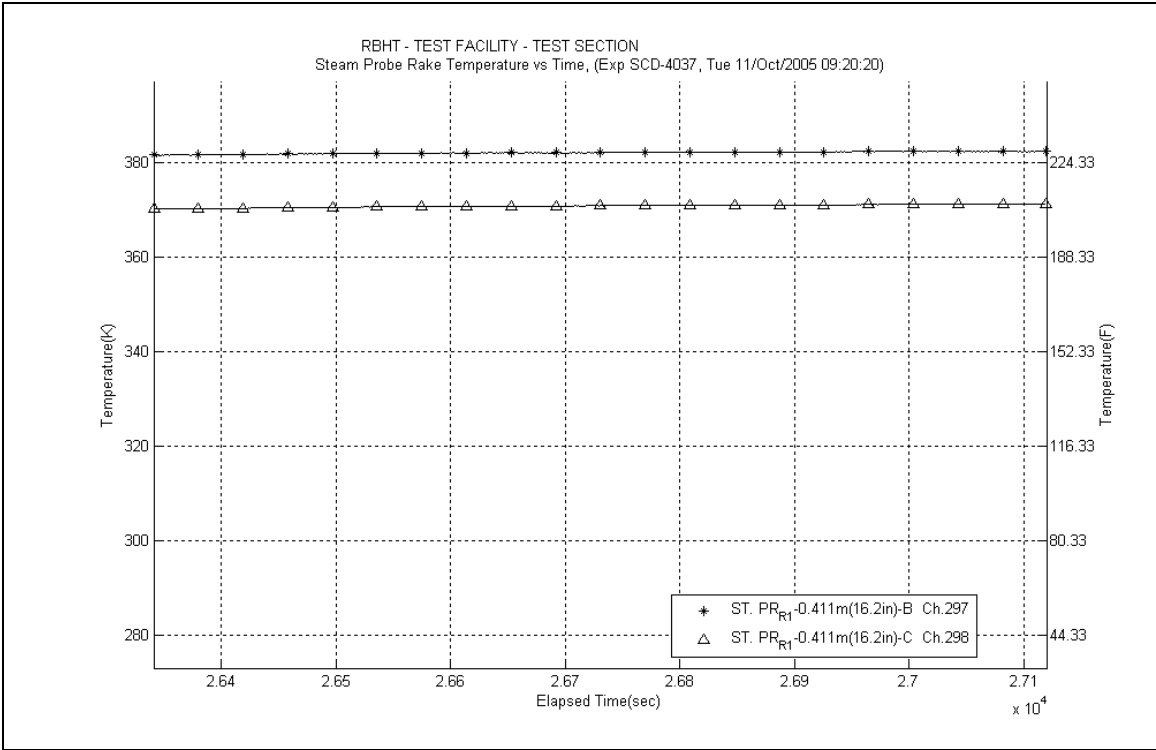

Figure A-423: Steam Probe Rake #1 Temperatures for Experiment 4037H

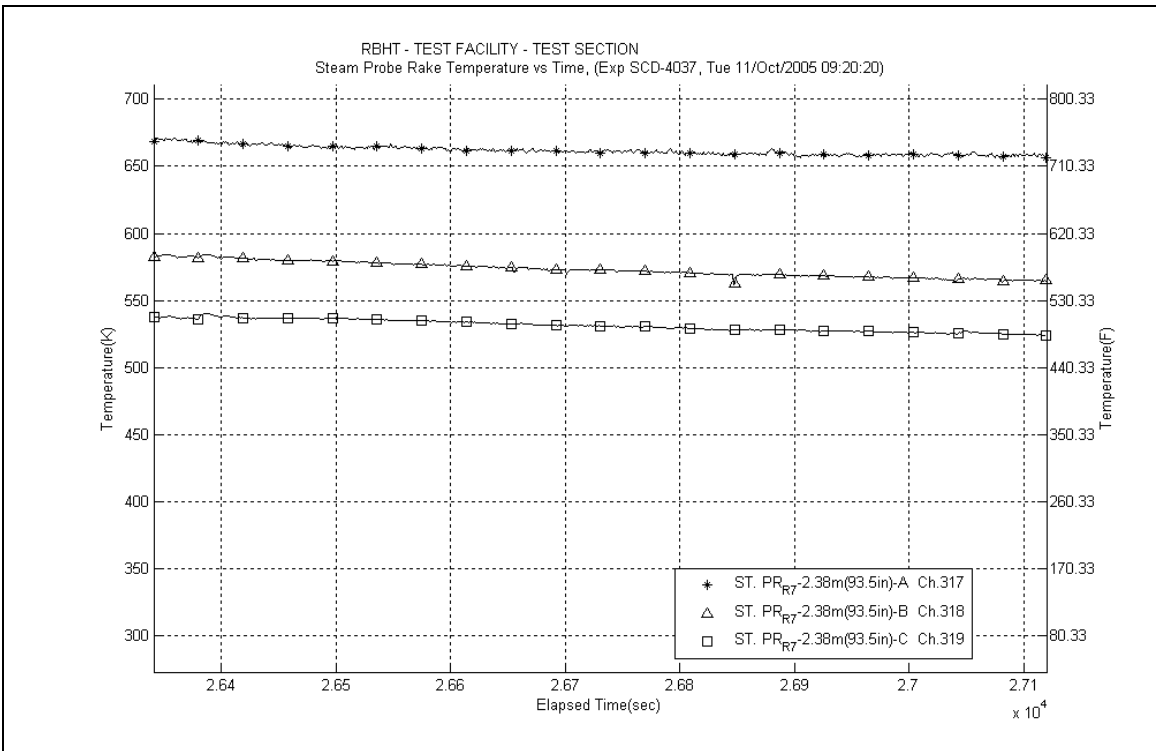

Figure A-424: Steam Probe Rake #7 Temperatures for Experiment 4037H

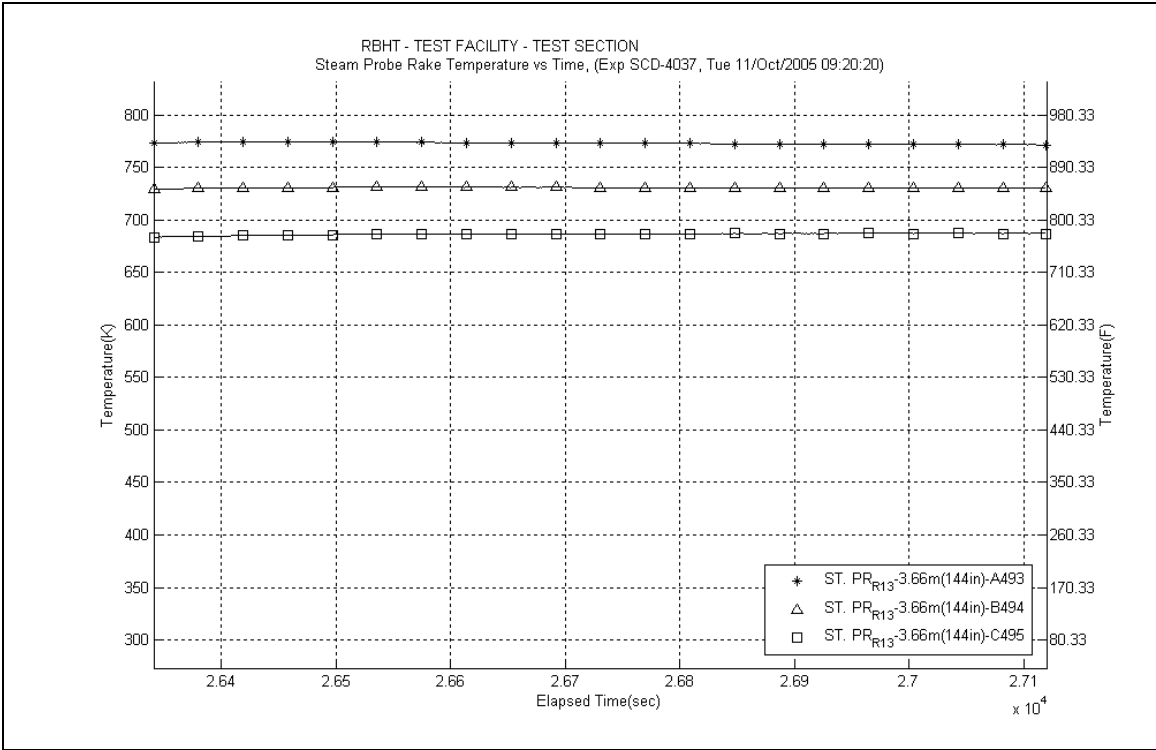

Figure A-425: Steam Probe Rake #13 Temperatures for Experiment 4037H

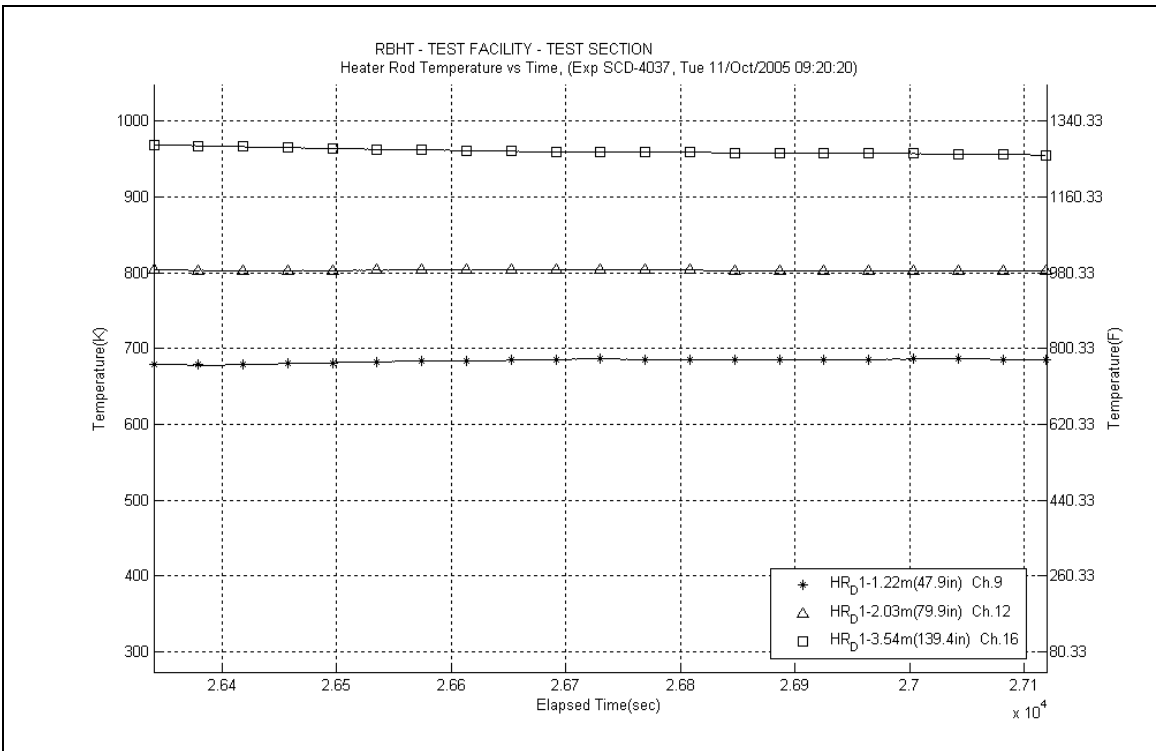

Figure A-426: Heater Rod D1 Temperatures for Experiment 4037H

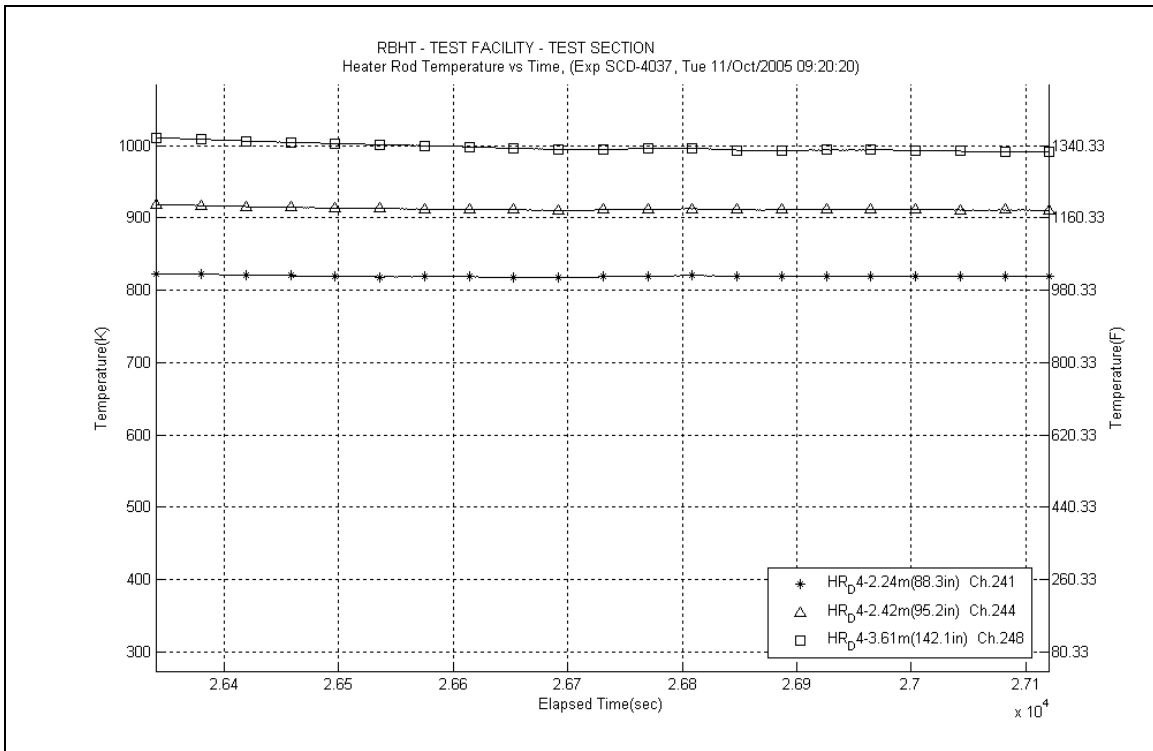

Figure A-427: Heater Rod D4 Temperatures for Experiment 4037H

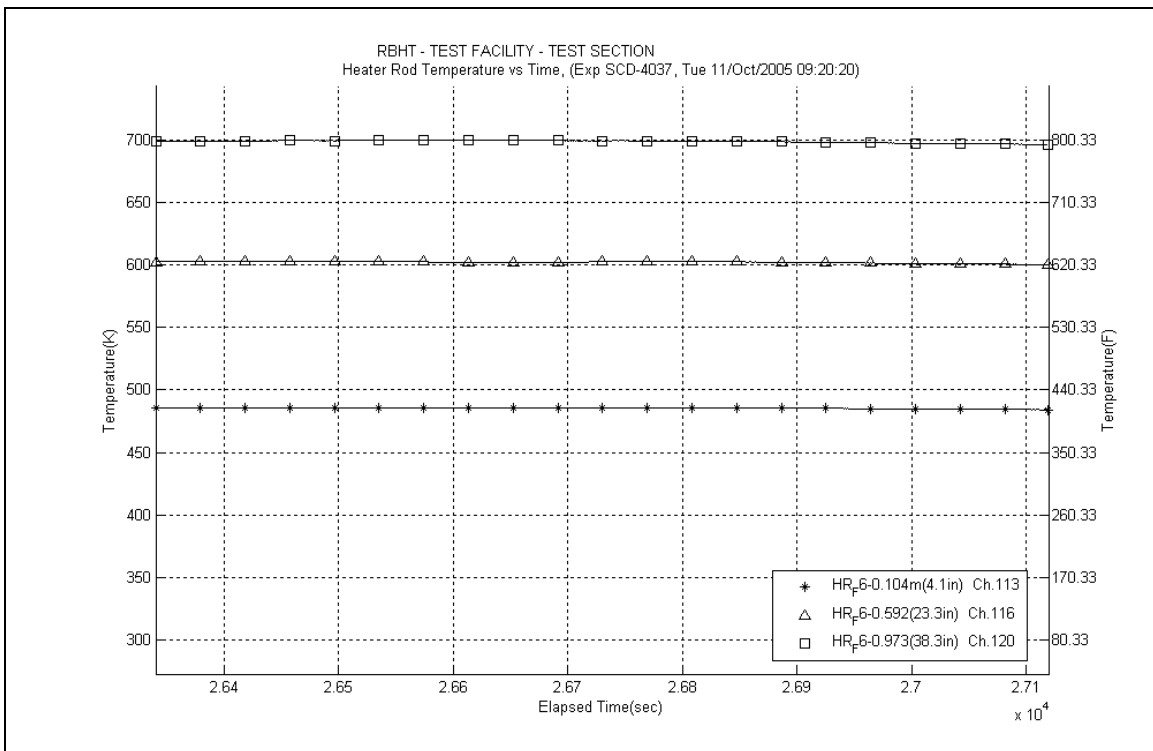

Figure A-428: Heater Rod F6 Temperatures for Experiment 4037H

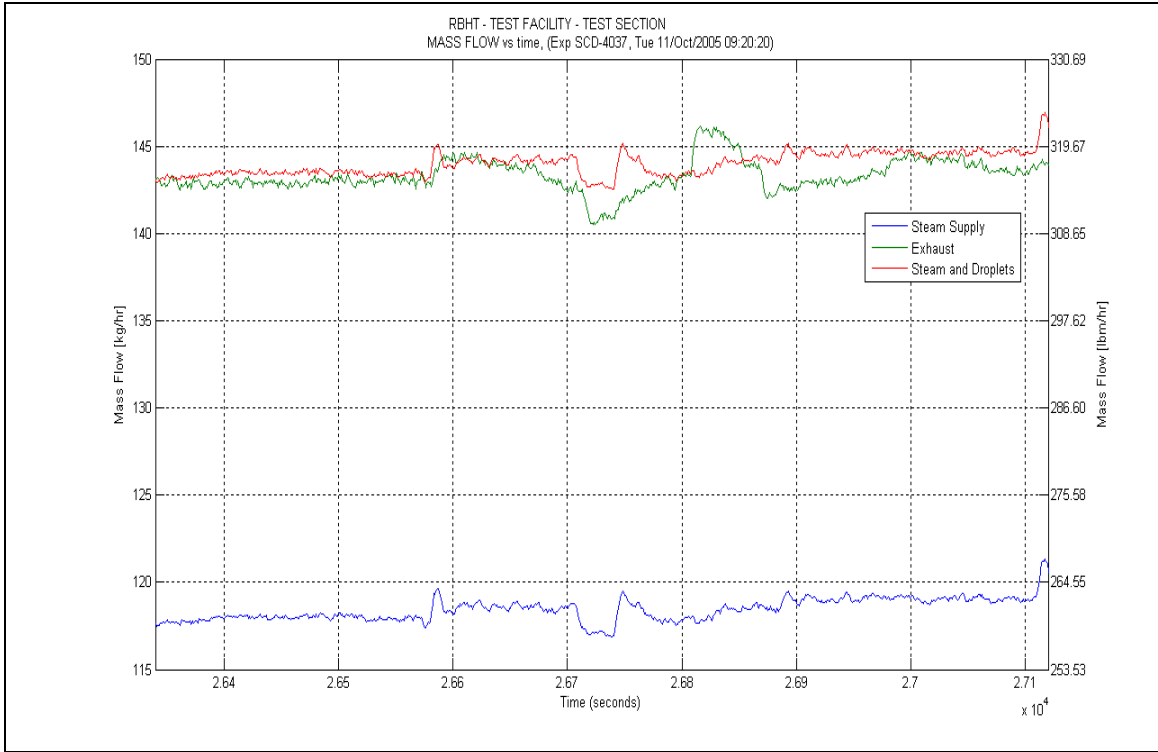

Figure A-429: Mass Flow for Experiment 4037H

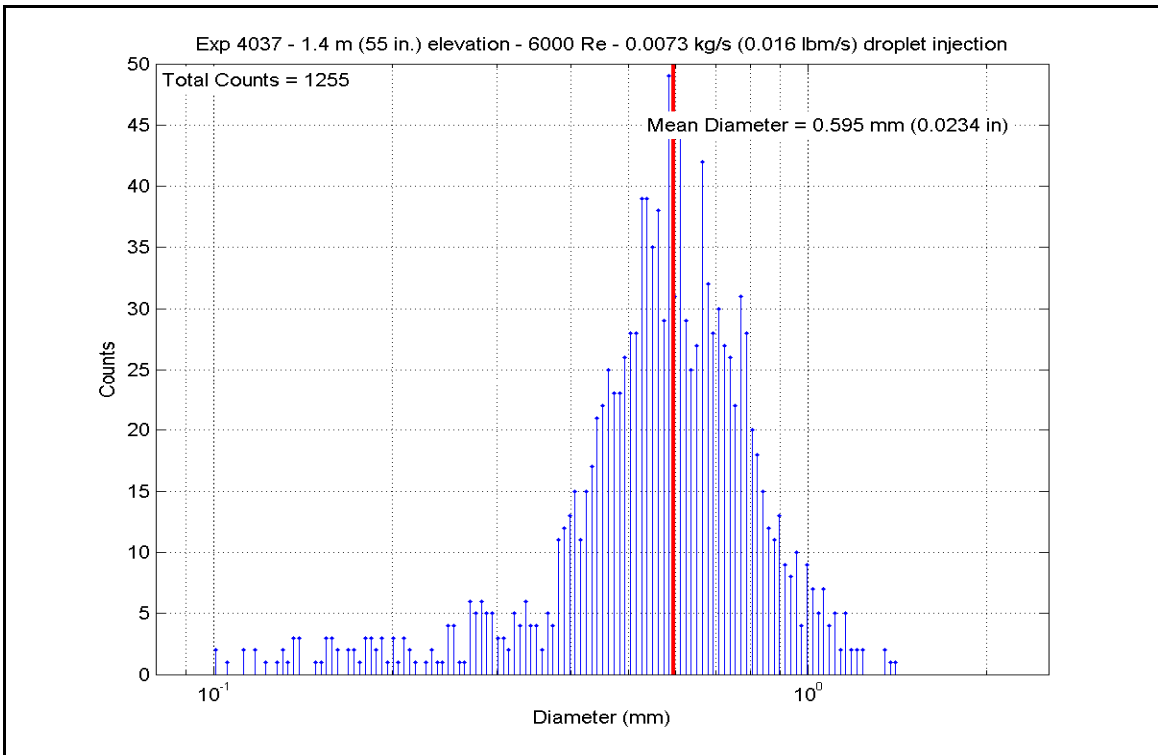

Figure A-430: Droplet Measurements at 1.397 m (55 in.) Elevation for Experiment 4037H

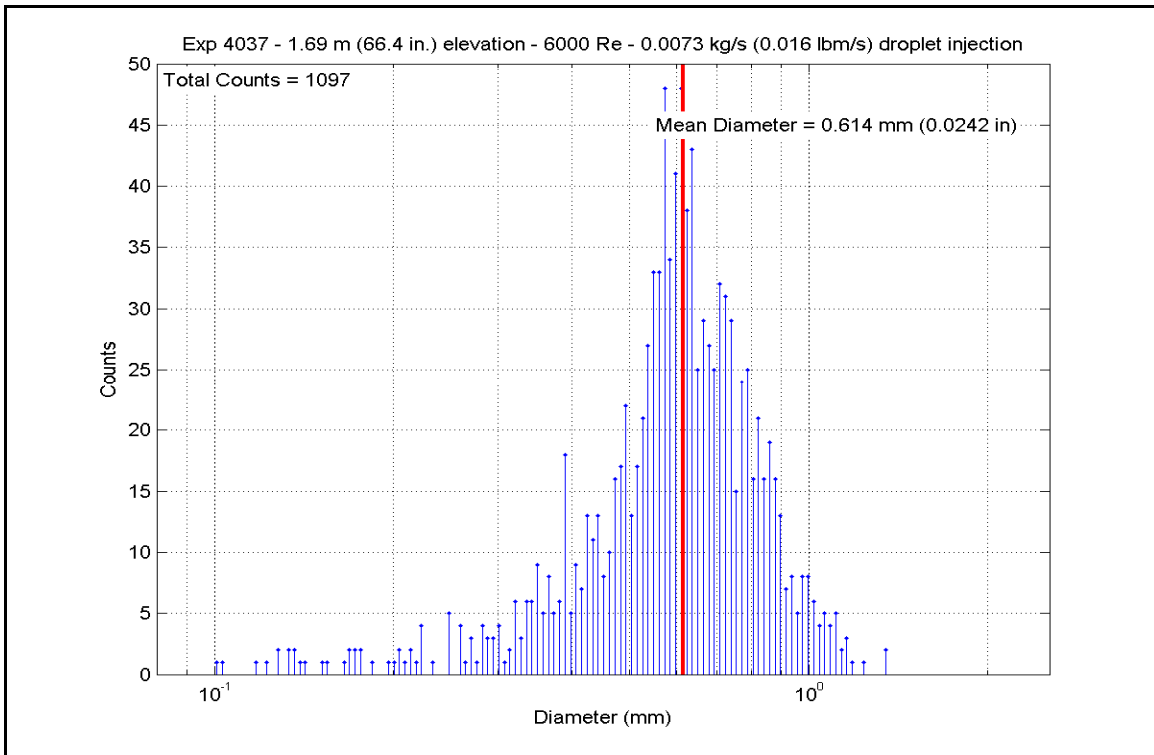

Figure A-431: Droplet Measurements at 1.687 m (66.4 in.) Elevation for Experiment 4037H

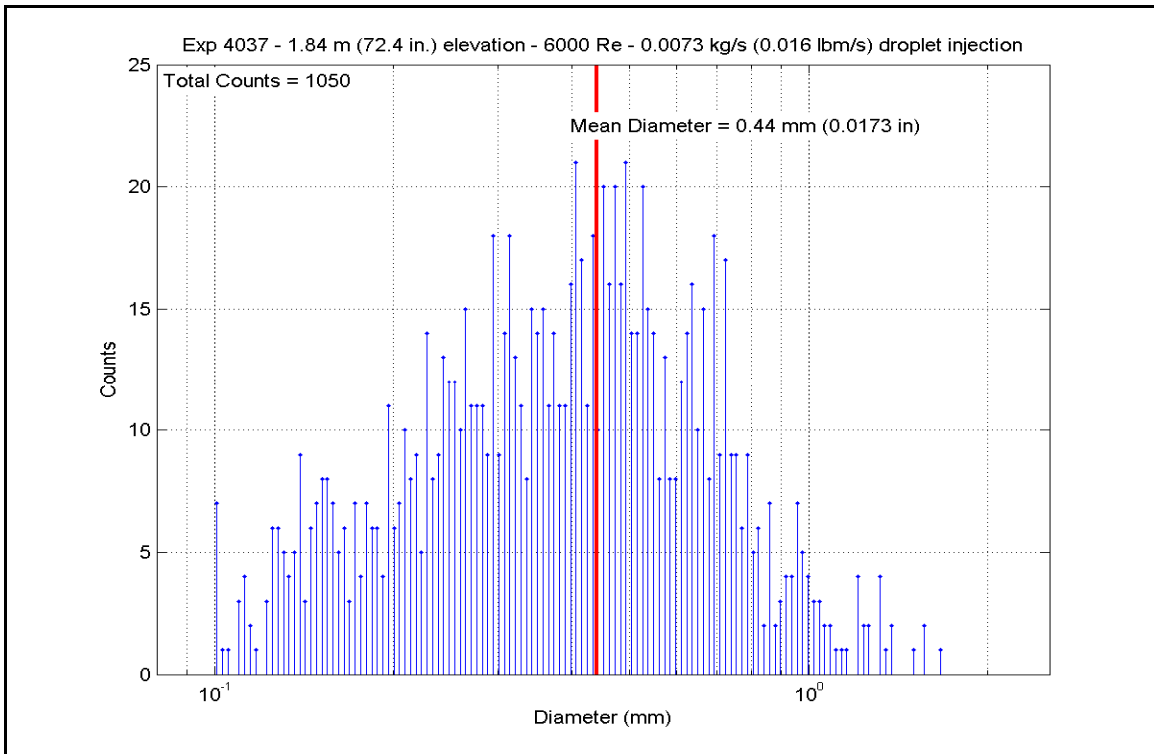

Figure A-432: Droplet Measurements at 1.839 m (72.4 in.) Elevation for Experiment 4037H

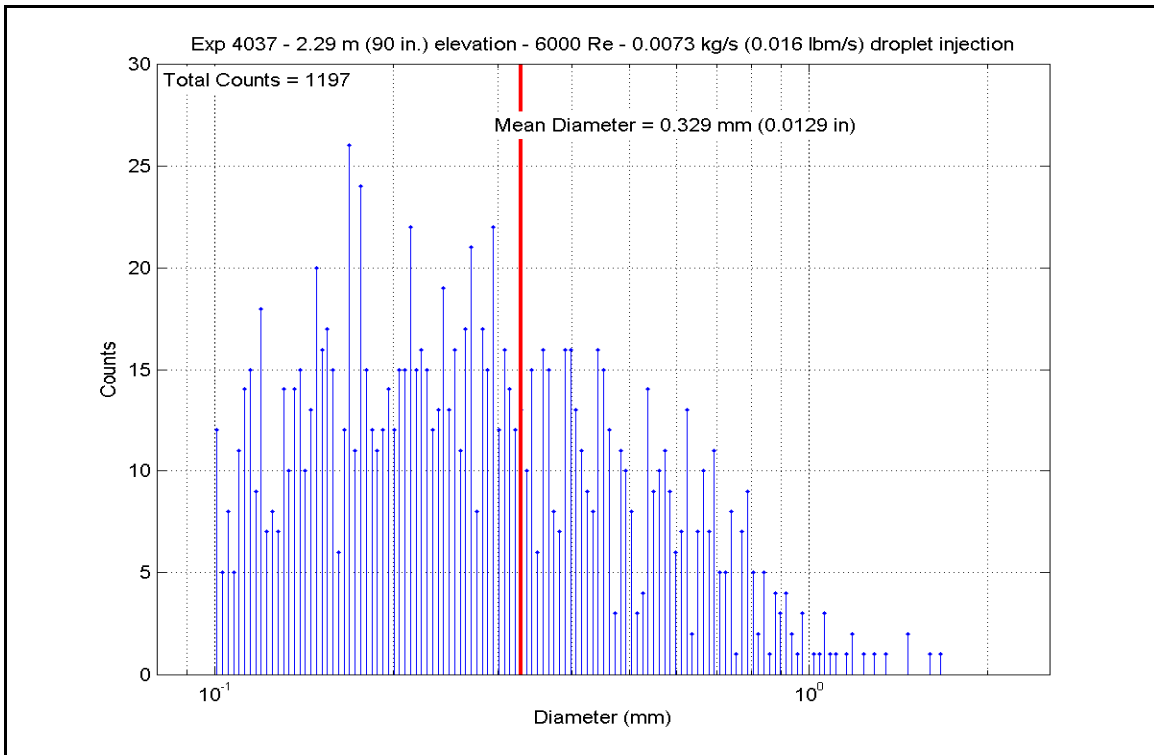

Figure A-433: Droplet Measurements at 2.286 m (90 in.) Elevation for Experiment 4037H

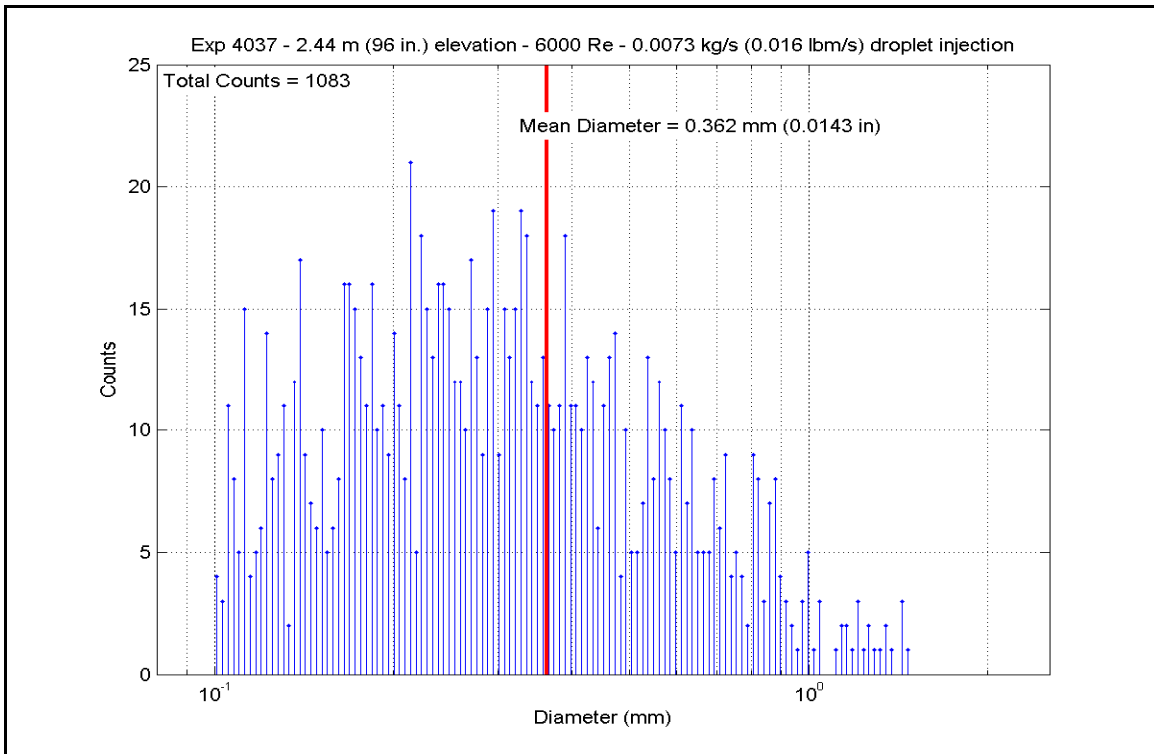

Figure A-434: Droplet Measurements at 2.438 m (96 in.) Elevation for Experiment 4037H

Table A-24: Summary of Steam Cooling Heat Transfer Reduced Data for Experiment 4037H

SCD-4037-H		Inlet Reynolds: 6000									
Matrix Test #15b		UP Pressure: 275.8 kPa		40 psia		218377 Btu/hr		H.R. Tw		H.R. Tw	
Time Window: 26340-27120		Bundle Power: 64.00 kW		260.0 lbm/hr		0.0328 kg/s		H.R. Tw		H.R. Tw	
Inner 3x3		Steam flow: 0.0073 kg/s		0.016 lbm/s		0.0073 kg/s		H.R. Tw		H.R. Tw	
Droplet flow: 0.0073 kg/s		Zgrid		Zgrid		Elevation		Elevation		Elevation	
H.R. ID	Channel Number	H.R. Location	Elevation (in)	Zgrid (in)	Zgrid (m)	H.R. Tw (°F)	H.R. Tw (K)	H.R. q" (Btu/hr-ft ²)	H.R. q" (W/m ²)	h _{sat} (z) (Btu/hr-ft ² -F)	h _{sat} (z) (W/m ² -K)
Gr-3	185	RodD3_88.3	88.3	-0.2	-0.005	1013.48	818.4	5436.33	17148.9	7.283	41.4
	186	RodD3_91.3	91.3	2.8	0.071	1103.89	868.6	5557.90	17532.4	6.641	37.7
	187	RodD3_93.1	93.1	4.6	0.117	1146.35	892.2	5632.99	17769.3	6.406	36.4
	188	RodD3_95.3	95.3	6.8	0.173	1185.86	914.2	5723.33	18054.2	6.229	35.4
	189	RodD3_100.1	100.1	11.6	0.295	1255.72	953.0	5920.20	18675.3	5.988	34.0
	190	RodD3_106.1	106.1	17.6	0.447	1326.19	992.1	6159.52	19430.2	5.815	33.0
	191	RodD3_110	110	21.5	0.546	1287.58	970.7	6083.93	19191.8	5.961	33.9
	192	RodD3_142.1	142.1	8.6	0.218	1333.71	996.3	2205.96	6958.7	2.068	11.7
	233	RodC4_88.4	88.4	-0.1	-0.003	1012.23	817.7	5513.10	17391.1	7.398	42.0
Gr-3	234	RodC4_91.1	91.1	2.6	0.066	1091.34	861.7	5624.56	17742.7	6.823	38.7
	235	RodC4_93.4	93.4	4.9	0.124	1136.19	886.6	5719.10	18040.9	6.580	37.4
	236	RodC4_95.3	95.3	6.8	0.173	1173.14	907.1	5796.37	18284.6	6.397	36.3
	237	RodC4_100.1	100.1	11.6	0.295	1238.61	943.5	5990.63	18897.4	6.166	35.0
	238	RodC4_106.1	106.1	17.6	0.447	1314.74	985.8	6231.66	19657.8	5.948	33.8
	239	RodC4_110	110	21.5	0.546	1273.51	962.9	6033.47	19032.6	5.994	34.0
	240	RodC4_142.2	142.2	8.7	0.221	1338.97	999.2	2387.86	7532.5	2.228	12.7
	241	RodD4_88.3	88.3	-0.2	-0.005	1013.75	818.6	5480.83	17289.3	7.340	41.7
	242	RodD4_91.3	91.3	2.8	0.071	1101.08	867.1	5605.64	17683.0	6.721	38.2
Gr-3	243	RodD4_93.2	93.2	4.7	0.119	1144.74	891.3	5684.85	17932.9	6.477	36.8
	244	RodD4_95.2	95.2	6.7	0.170	1181.30	911.6	5769.12	18198.7	6.310	35.8
	245	RodD4_100.1	100.1	11.6	0.295	1247.66	948.5	5966.80	18822.3	6.084	34.6
	246	RodD4_106.1	106.1	17.6	0.447	1315.29	986.1	6204.81	19573.1	5.919	33.6
	248	RodD4_142.1	142.1	8.6	0.218	1336.27	997.7	2307.66	7279.5	2.158	12.3
	201	RodE4_88.4	88.4	-0.1	-0.003	1012.17	817.7	5388.33	16997.5	7.231	41.1
	202	RodE4_91.2	91.2	2.7	0.069	1096.34	864.4	5502.40	17357.3	6.635	37.7
	204	RodE4_95.3	95.3	6.8	0.173	1178.42	910.0	5664.10	17867.4	6.215	35.3
	205	RodE4_100.9	100.9	12.4	0.315	1248.89	949.2	5880.81	18551.0	5.989	34.0
208	RodE4_142.3	142.3	8.8	0.224	1324.92	991.4	2318.84	7314.8	2.192	12.4	

Table A-24: Summary of Steam Cooling Heat Transfer Reduced Data for Experiment 4037H, continued

Inner 3x3	H.R. Location	Channel Number	Elevation (in)	Elevation (m)	Zgrid (in)	Zgrid (m)	H.R. Tw (°F)	H.R. Tw (K)	H.R. q" (Btu/hr-ft ²)	H.R. q" (W/m ²)	h _{sat} (z) (Btu/hr-ft ² -F)	h _{sat} (z) (W/m ² -K)
Gr-4	RodE3_63.4	193	63.4	1.610	16.4	0.417	1014.69	819.1	4424.47	13957.0	5.918	33.6
	RodE3_113.6	194	113.6	2.885	0.85	0.022	1300.86	978.1	5543.02	17485.5	5.361	30.4
	RodE3_115.5	195	115.5	2.934	2.75	0.070	1332.84	995.8	5346.89	16866.8	5.017	28.5
	RodE3_118.5	196	118.5	3.010	5.75	0.146	1361.72	1011.9	5032.19	15874.0	4.597	26.1
	RodE3_122.7	197	122.7	3.117	9.95	0.253	1381.90	1023.1	4588.86	14475.5	4.116	23.4
	RodE3_126.5	198	126.5	3.213	13.75	0.349	1384.59	1024.6	4185.29	13202.5	3.745	21.3
	RodE3_131.7	199	131.7	3.345	-1.8	-0.046	1317.99	987.6	3626.10	11438.5	3.450	19.6
	RodE3_135.6	200	135.6	3.444	2.1	0.053	1326.23	992.2	3214.36	10139.7	3.035	17.2
	RodC5_63.7	225	63.7	1.618	16.7	0.424	983.66	801.8	4357.24	13744.9	6.080	34.5
	RodC5_113.6	226	113.6	2.885	0.85	0.022	1277.20	964.9	5422.05	17103.9	5.367	30.5
Gr-4	RodC5_115.7	227	115.7	2.939	2.95	0.075	1316.86	987.0	5217.28	16457.9	4.970	28.2
	RodC5_122.7	229	122.7	3.117	9.95	0.253	1368.60	1015.7	4517.41	14250.2	4.101	23.3
	RodC5_126.7	230	126.7	3.214	13.95	0.354	1373.62	1018.5	4114.49	12979.2	3.718	21.1
	RodC5_131.6	231	131.6	3.343	-1.9	-0.048	1311.46	984.0	3611.14	11391.4	3.457	19.6
	RodC5_135.7	232	135.7	3.447	2.2	0.056	1322.81	990.3	3197.49	10086.5	3.028	17.2
	RodE5_63.6	209	63.6	1.615	16.6	0.422	997.01	809.3	4428.62	13970.1	6.066	34.5
	RodE5_113.6	210	113.6	2.885	0.85	0.022	1270.87	961.4	5566.84	17560.6	5.545	31.5
	RodE5_115.4	211	115.4	2.931	2.65	0.067	1299.79	977.5	5383.19	16981.3	5.212	29.6
	RodE5_118.7	212	118.7	3.015	5.95	0.151	1327.32	992.8	5039.93	15898.4	4.753	27.0
	RodE5_122.6	213	122.6	3.114	9.85	0.250	1349.74	1005.2	4637.48	14628.9	4.283	24.3
RodE5_126.6	214	126.6	3.216	13.85	0.352	1353.02	1007.1	4221.12	13315.5	3.887	22.1	
Gr-5	RodE5_131.6	215	131.6	3.343	-1.9	-0.048	1287.50	970.7	3688.16	11634.3	3.614	20.5
	RodE5_135.6	216	135.6	3.444	2.1	0.053	1301.74	978.6	3272.06	10321.7	3.162	18.0
	RodC3_79.8	177	79.8	2.027	8.92	0.227	1003.47	812.9	5088.43	16051.5	6.909	39.2
	RodC3_85.6	178	85.6	2.174	14.72	0.374	1001.14	811.6	5313.20	16760.5	7.237	41.1
	RodC3_88.5	179	88.5	2.248	0	0.000	1009.52	816.2	5422.24	17104.4	7.302	41.5
	RodC3_92.4	180	92.4	2.347	3.9	0.099	1113.65	874.1	5580.51	17603.7	6.591	37.4
	RodC3_94.4	181	94.4	2.398	5.9	0.150	1150.94	894.8	5661.20	17858.3	6.405	36.4
	RodC3_97.2	182	97.2	2.469	8.7	0.221	1195.22	919.4	5771.85	18207.3	6.218	35.3
	RodC3_108.8	183	108.8	2.764	20.3	0.516	1304.31	980.0	6101.62	19247.6	5.882	33.4
	Gr-8	RodD5_50	217	50	1.270	3	0.076	898.22	754.4	3941.77	12434.3	6.245
RodD5_54.1		218	54.1	1.374	7.1	0.180	916.56	764.6	4090.55	12903.6	6.297	35.8
RodD5_56.9		219	56.9	1.445	9.9	0.251	949.49	782.9	4195.67	13235.2	6.148	34.9
RodD5_60		220	60	1.524	13	0.330	968.71	793.5	4309.65	13594.8	6.142	34.9
RodD5_66.1		221	66.1	1.679	19.1	0.485	989.57	805.1	4548.75	14349.0	6.295	35.8
RodD5_69.9		222	69.9	1.775	-0.98	-0.025	763.31	679.4	4715.34	14874.6	9.501	54.0
RodD5_72.9		223	72.9	1.852	2.02	0.051	859.72	733.0	4829.31	15234.1	8.148	46.3
RodD5_74.9		224	74.9	1.902	4.02	0.102	912.47	762.3	4910.76	15491.0	7.608	43.2

Table A-24: Summary of Steam Cooling Heat Transfer Reduced Data for Experiment 4037H, continued

H.R. ID	H.R. Location	Channel Number	Elevation (in)	Elevation (m)	Zgrid (in)	Zgrid (m)	H.R. Tw (°F)	H.R. Tw (K)	H.R. q" (Btu/hr-ft ²)	H.R. q" (W/m ²)	h _{sat} (z) (Btu/hr-ft ² -F)	h _{sat} (z) (W/m ² -K)
Gr-2	RodB5_41	153	41	1.041	13.5	0.343	841.87	723.1	3604.53	11370.5	6.270	35.6
	RodB5_52.9	154	52.9	1.344	5.9	0.150	851.30	728.3	4054.59	12790.2	6.939	39.4
	RodB5_55	155	55	1.397	8	0.203	893.44	751.7	4139.00	13056.5	6.607	37.5
	RodB5_57.8	156	57.8	1.468	10.8	0.274	941.69	778.5	4250.37	13407.8	6.300	35.8
	RodB5_64	157	64	1.626	17	0.432	985.78	803.0	4482.76	14140.9	6.237	35.4
	RodB5_73.9	158	73.9	1.877	3.02	0.077	902.40	756.7	4875.48	15379.7	7.673	43.6
	RodB5_75.9	159	75.9	1.928	5.02	0.128	943.88	779.7	4956.02	15633.8	7.322	41.6
	RodB5_76.9	160	76.9	1.953	6.02	0.153	961.59	789.6	4996.75	15762.2	7.194	40.9
	RodF5_41	105	41	1.041	13.5	0.343	842.79	723.6	3575.52	11279.0	6.210	35.3
	RodF5_53.1	106	53.1	1.349	6.1	0.155	892.56	751.2	4023.18	12691.1	6.431	36.5
Gr-2	RodF5_55	107	55	1.397	8	0.203	918.82	765.8	4097.26	12924.8	6.286	35.7
	RodF5_57.8	108	57.8	1.468	10.8	0.274	963.05	790.4	4191.01	13220.5	6.021	34.2
	RodF5_64	109	64	1.626	17	0.432	1013.87	818.6	4422.78	13951.6	5.922	33.6
	RodF5_73.8	110	73.8	1.875	2.92	0.074	881.72	745.2	4826.60	15225.5	7.852	44.6
	RodF5_75.8	111	75.8	1.925	4.92	0.125	921.97	767.6	4906.93	15478.9	7.492	42.5
	RodF5_76.8	112	76.8	1.951	5.92	0.150	939.84	777.5	4946.72	15604.4	7.352	41.8
	RodC2_41	57	41	1.041	13.5	0.343	838.06	721.0	3576.89	11283.3	6.264	35.6
	RodC2_53.1	58	53.1	1.349	6.1	0.155	907.57	759.6	4031.90	12718.6	6.294	35.7
	RodC2_55	59	55	1.397	8	0.203	929.01	771.5	4105.39	12950.4	6.201	35.2
	RodC2_57.8	60	57.8	1.468	10.8	0.274	958.28	787.8	4214.42	13294.4	6.097	34.6
RodC2_63.9	61	63.9	1.623	16.9	0.429	990.50	805.7	4452.99	14047.0	6.155	35.0	
RodC2_73.8	62	73.8	1.875	2.92	0.074	880.31	744.4	4856.48	15319.8	7.918	45.0	
RodC2_75.8	63	75.8	1.925	4.92	0.125	920.88	767.0	4934.65	15566.3	7.547	42.9	
RodC2_76.8	64	76.8	1.951	5.92	0.150	938.81	776.9	4973.96	15690.4	7.404	42.0	
Gr-2	RodC6_40.9	137	40.9	1.039	13.4	0.340	842.33	723.3	3582.25	11300.2	6.226	35.4
	RodC6_52.8	138	52.8	1.341	5.8	0.147	930.75	772.5	4047.11	12766.6	6.097	34.6
	RodC6_54.8	139	54.8	1.392	7.8	0.198	956.70	786.9	4129.09	13025.2	5.987	34.0
	RodC6_57.8	140	57.8	1.468	10.8	0.274	990.47	805.6	4252.93	13415.9	5.878	33.4
	RodC6_63.8	141	63.8	1.621	16.8	0.427	1035.40	830.6	4495.24	14180.2	5.850	33.2
	RodC6_73.7	142	73.7	1.872	2.82	0.072	905.89	758.6	4896.73	15446.7	7.664	43.5
	RodC6_75.8	143	75.8	1.925	4.92	0.125	939.90	777.5	4980.83	15712.0	7.402	42.0
	RodC6_76.8	144	76.8	1.951	5.92	0.150	959.49	788.4	5022.04	15842.0	7.252	41.2

Table A-24: Summary of Steam Cooling Heat Transfer Reduced Data for Experiment 4037H, continued

5x5 periphery		H.R. Location	Channel Number	Elevation (in)	Elevation (m)	Zgrid (in)	Zgrid (m)	H.R. Tw (°F)	H.R. Tw (K)	H.R. q" (Btu/hr-ft ²)	H.R. q" (W/m ²)	h _{sat} (z) (Btu/hr-ft ² -F)	h _{sat} (z) (W/m ² -K)
Gr-3	RodB4_88.4	161	88.4	2.245	-0.1	-0.003	1000.93	811.4	5410.90	17068.7	17068.7	7.373	41.9
	RodB4_91.3	162	91.3	2.319	2.8	0.071	1087.02	859.3	5530.56	17446.1	17446.1	6.744	38.3
	RodB4_93.3	163	93.3	2.370	4.8	0.122	1127.81	881.9	5607.54	17689.0	17689.0	6.514	37.0
	RodB4_95.1	164	95.1	2.416	6.6	0.168	1158.72	899.1	5675.75	17904.2	17904.2	6.365	36.1
	RodB4_100	165	100	2.540	11.5	0.292	1206.85	925.8	5857.52	18477.6	18477.6	6.232	35.4
	RodB4_106	166	106	2.692	17.5	0.445	1279.42	966.2	6091.92	19216.9	19216.9	6.017	34.2
	RodB4_109.9	167	109.9	2.791	21.4	0.544	1240.22	944.4	5898.36	18606.4	18606.4	6.061	34.4
	RodB4_142.3	168	142.3	3.614	8.8	0.224	1321.76	989.7	2362.91	7453.8	7453.8	2.240	12.7
Gr-5	RodF4_85.6	98	85.6	2.174	14.72	0.374	997.71	809.7	5314.28	16763.9	16763.9	7.273	41.3
	RodF4_88.4	99	88.4	2.245	-0.1	-0.003	1008.05	815.4	5420.82	17100.0	17100.0	7.315	41.5
	RodF4_92.4	100	92.4	2.347	3.9	0.099	1115.50	875.1	5580.92	17605.0	17605.0	6.577	37.4
	RodF4_94.3	101	94.3	2.395	5.8	0.147	1151.91	895.3	5656.78	17844.3	17844.3	6.393	36.3
	RodF4_97.2	102	97.2	2.469	8.7	0.221	1198.48	921.2	5772.61	18209.7	18209.7	6.197	35.2
	RodF4_108.8	103	108.8	2.764	20.3	0.516	1286.22	969.9	6104.79	19257.6	19257.6	5.990	34.0
	RodF4_111	104	111	2.819	-1.75	-0.044	1233.46	940.6	5854.59	18468.3	18468.3	6.058	34.4
	RodD2_103.2	65	103.2	2.621	14.7	0.373	1286.60	970.2	5407.30	17057.3	17057.3	5.303	30.1
RodD2_106	66	106	2.692	17.5	0.445	1310.21	983.3	5128.34	16177.4	16177.4	4.916	27.9	
RodD2_112.6	67	112.6	2.860	-0.15	-0.004	1342.52	1001.2	4752.05	14990.3	14990.3	4.418	25.1	
RodD2_114.9	68	114.9	2.918	2.15	0.055	1358.54	1010.1	4306.07	13583.5	13583.5	3.945	22.4	
RodD2_117.4	69	117.4	2.982	4.65	0.118	1358.44	1010.1	3881.04	12242.7	12242.7	3.556	20.2	
RodD2_120.8	70	120.8	3.068	8.05	0.204	1251.06	950.4	6050.95	19087.7	19087.7	6.149	34.9	
RodD2_124.8	71	124.8	3.170	12.05	0.306	1279.25	966.1	6160.82	19434.3	19434.3	6.086	34.6	
RodD2_128.6	72	128.6	3.266	15.85	0.403	1240.04	944.3	5659.05	17851.5	17851.5	5.816	33.0	
Gr-6	RodD6_103.1	129	103.1	2.619	14.6	0.371	1243.50	946.2	6053.86	19096.9	19096.9	6.200	35.2
	RodD6_106	130	106	2.692	17.5	0.445	1269.25	960.5	6168.06	19457.1	19457.1	6.154	34.9
	RodD6_112.9	131	112.9	2.868	0.15	0.004	1232.79	940.3	5640.79	17793.9	17793.9	5.841	33.2
	RodD6_114.9	132	114.9	2.918	2.15	0.055	1274.83	963.6	5418.96	17094.1	17094.1	5.377	30.5
	RodD6_116.8	133	116.8	2.967	4.05	0.103	1297.05	976.0	5206.22	16423.0	16423.0	5.054	28.7
	RodD6_120.9	134	120.9	3.071	8.15	0.207	1318.41	987.8	4746.08	14971.5	14971.5	4.514	25.6
	RodD6_124.8	135	124.8	3.170	12.05	0.306	1326.55	992.3	4305.85	13582.8	13582.8	4.064	23.1
	RodD6_128.7	136	128.7	3.269	15.95	0.405	1328.61	993.5	3862.48	12184.2	12184.2	3.638	20.7

Table A-24: Summary of Steam Cooling Heat Transfer Reduced Data for Experiment 4037H, continued

5x5 periphery		H.R. Location	Channel Number	Elevation (in)	Elevation (m)	Zgrid (in)	Zgrid (m)	H.R. Tw (°F)	H.R. Tw (K)	H.R. q" (Btu/hr-ft ²)	H.R. q" (W/m ²)	h _{sat} (z) (Btu/hr-ft ² -F)	h _{sat} (z) (W/m ² -K)
Gr-8	RodE2_50.1	73	50.1	1.273	3.1	0.079	753.3	3939.64	12427.6	6.261	35.6		
	RodE2_54	74	54	1.372	7	0.178	788.0	4082.29	12877.6	5.901	33.5		
	RodE2_56.9	75	56.9	1.445	9.9	0.251	807.4	4187.88	13210.7	5.763	32.7		
	RodE2_59.9	76	59.9	1.521	12.9	0.328	823.8	4302.95	13573.6	5.691	32.3		
	RodE2_66	77	66	1.676	19	0.483	838.4	4549.11	14350.2	5.814	33.0		
	RodE2_69.8	78	69.8	1.773	-1.08	-0.027	706.6	4724.26	14902.7	8.666	49.2		
	RodE2_72.9	79	72.9	1.852	2.02	0.051	751.7	4842.52	15275.7	7.732	43.9		
	RodE2_74.9	80	74.9	1.902	4.02	0.102	774.2	4921.30	15524.2	7.380	41.9		
Gr-8	RodB3_50.2	169	50.2	1.275	3.2	0.081	693.4	3957.52	12484.0	7.589	43.1		
	RodB3_54.1	170	54.1	1.374	7.1	0.180	724.0	4098.78	12929.6	7.110	40.4		
	RodB3_56.9	171	56.9	1.445	9.9	0.251	740.1	4212.65	13288.8	6.958	39.5		
	RodB3_60.1	172	60.1	1.527	13.1	0.333	721.2	4342.32	13697.8	7.598	43.1		
	RodB3_66.1	173	66.1	1.679	19.1	0.485	780.4	4566.16	14403.9	6.733	38.2		
	RodB3_69.9	174	69.9	1.775	-0.98	-0.025	675.6	4719.85	14888.8	9.644	54.8		
	RodB3_73	175	73	1.854	2.12	0.054	733.5	4836.19	15255.8	8.148	46.3		
	RodB3_75	176	75	1.905	4.12	0.105	761.2	4914.79	15503.7	7.637	43.4		
Gr-8	RodF3_50.1	89	50.1	1.273	3.1	0.079	745.5	3916.50	12354.6	6.365	36.1		
	RodF3_54	90	54	1.372	7	0.178	777.8	4060.57	12809.1	6.030	34.2		
	RodF3_57	91	57	1.448	10	0.254	801.3	4175.83	13172.7	5.834	33.1		
	RodF3_60	92	60	1.524	13	0.330	815.6	4295.24	13549.3	5.793	32.9		
	RodF3_66.1	93	66.1	1.679	19.1	0.485	822.3	4550.09	14353.3	6.039	34.3		
	RodF3_70	94	70	1.778	-0.88	-0.022	698.8	4720.86	14891.9	8.888	50.5		
	RodF3_73	95	73	1.854	2.12	0.054	751.6	4839.28	15265.5	7.728	43.9		
	RodF3_75	96	75	1.905	4.12	0.105	775.5	4919.63	15519.0	7.352	41.8		
Gr-8	RodE6_50.2	121	50.2	1.275	3.2	0.081	745.6	3937.74	12421.6	6.399	36.3		
	RodE6_54.1	122	54.1	1.374	7.1	0.180	781.1	4079.73	12869.5	6.006	34.1		
	RodE6_57	123	57	1.448	10	0.254	798.4	4193.96	13229.8	5.903	33.5		
	RodE6_60.2	124	60.2	1.529	13.2	0.335	818.3	4310.63	13597.9	5.777	32.8		
	RodE6_66.1	125	66.1	1.679	19.1	0.485	824.7	4529.18	14287.3	5.977	33.9		
	RodE6_70	126	70	1.778	-0.88	-0.022	702.4	4688.59	14790.1	8.720	49.5		
	RodE6_73.1	127	73.1	1.857	2.22	0.056	744.0	4809.07	15170.2	7.851	44.6		
	RodE6_75	128	75	1.905	4.12	0.105	765.5	4884.37	15407.7	7.501	42.6		

RBHT Steam Cooling with Droplet Injection Test SCD-4041-A

Matrix Test # 9a

Test Conditions

Test Date – 10/26/2005

Steady State Time Window: 13320 – 14400

Upper Plenum Pressure: 2.76 bar (40 psia)

Bundle Power: 80.0 kW

Bundle Inlet Reynolds Number: 10000

Bundle Inlet Steam Flow: 199.6 kg/hr (440 lbm/hr)

Droplet Injection Flow: 0.0036 kg/s (0.008 lbm/s)

Droplet Injection Hole Diameter: 0.381 mm (.015 in)

Droplet Injection Elevation: 1.295 m (51 in)

Bundle Flow Area: $4.656 \times 10^{-3} \text{ m}^2$ ($5.012 \times 10^{-2} \text{ ft}^2$)

Test Notes

- No steam probes were traversed in this steady state window.

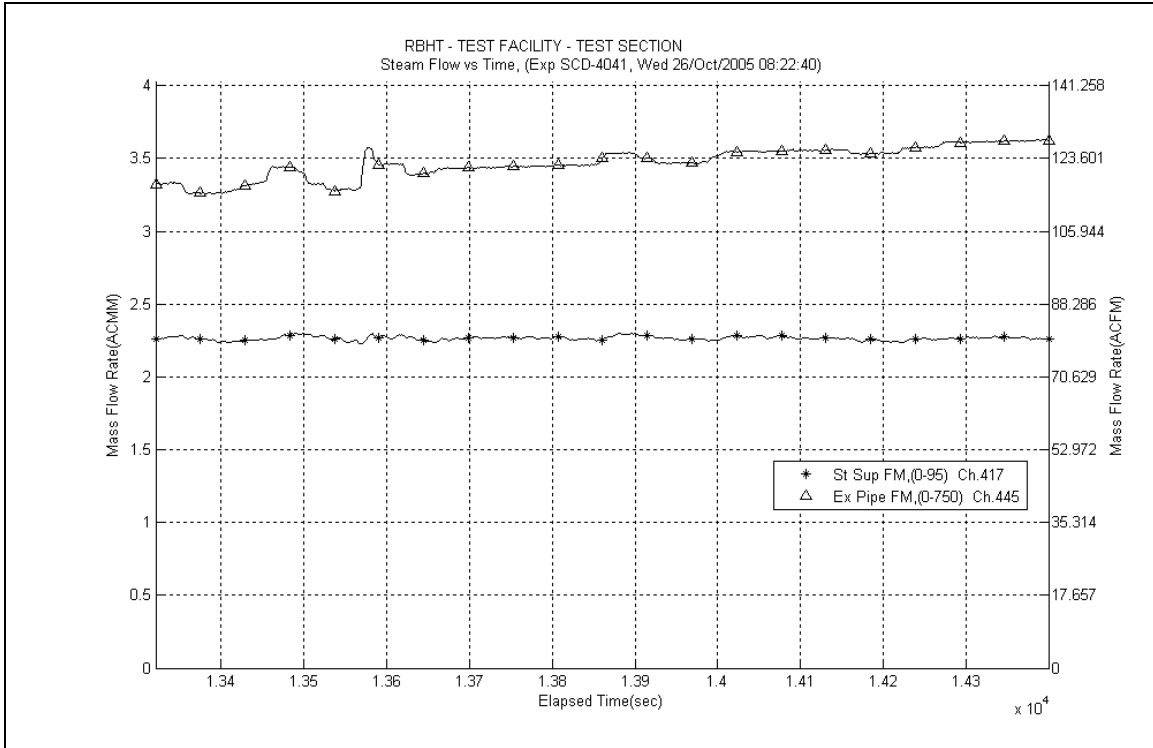

Figure A-435: Inlet and Exhaust Steam Flow Rates for Experiment 4041A

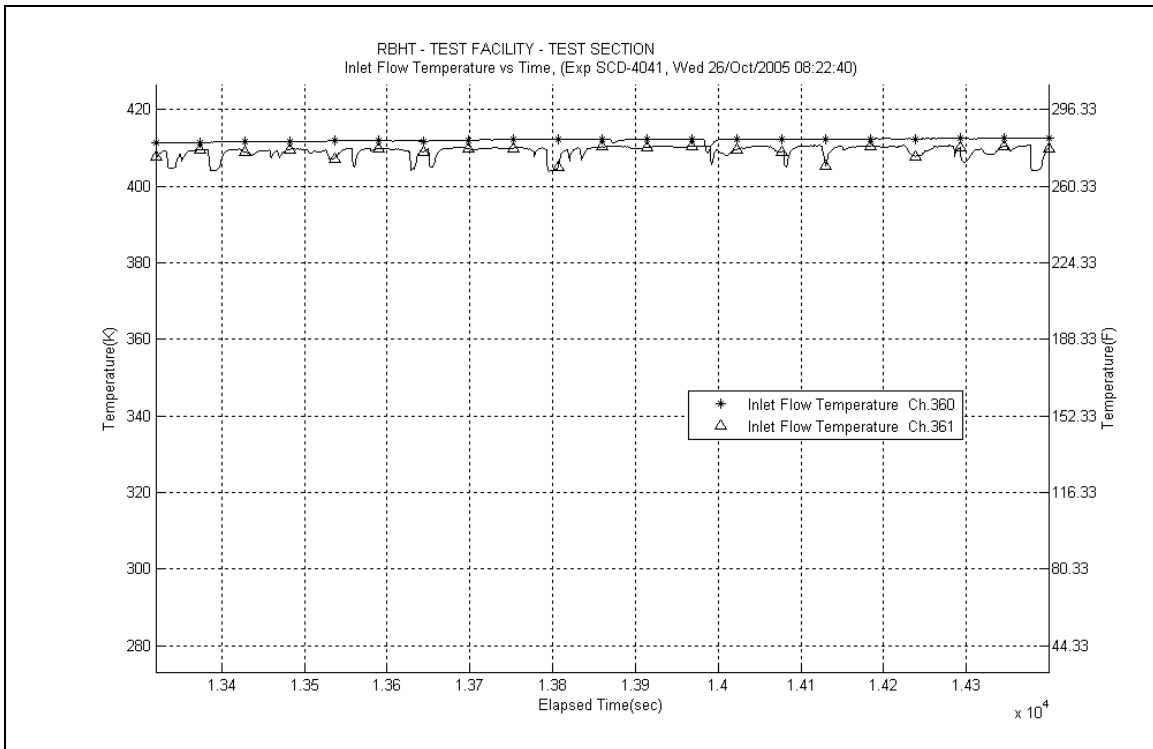

Figure A-436: Inlet Steam Temperature for Experiment 4041A

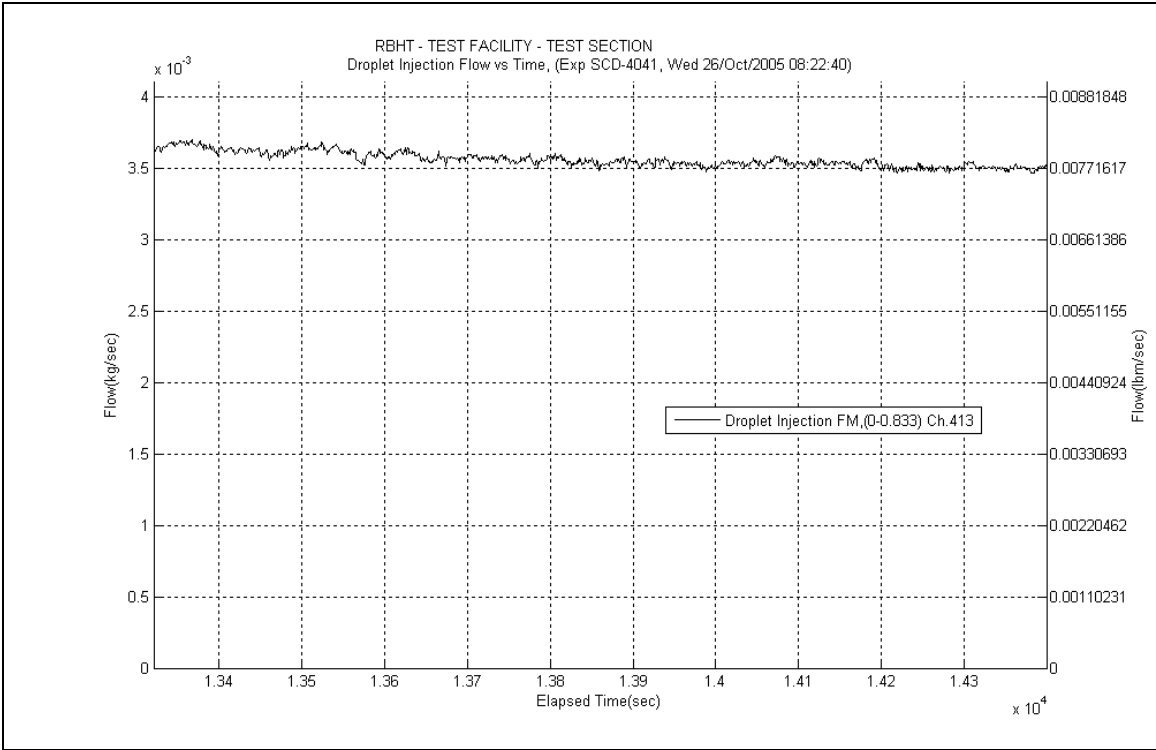

Figure A-437: Droplet Injection Flow Rate for Experiment 4041A

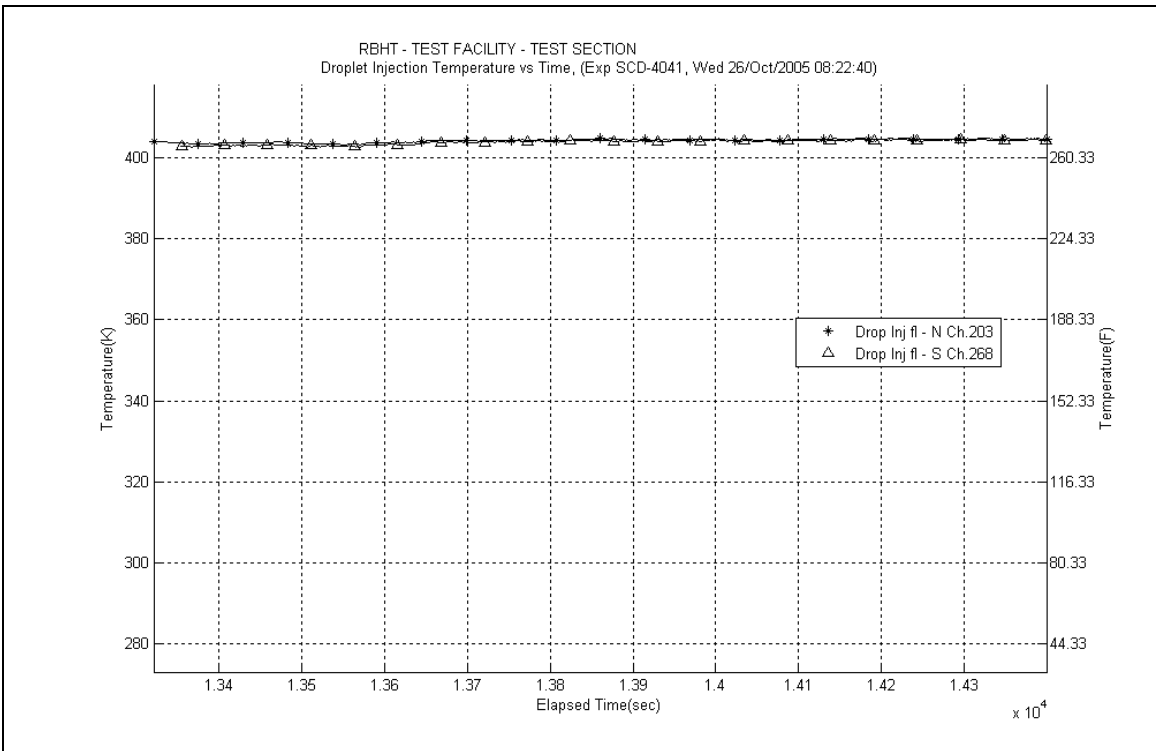

Figure A-438: Droplet Injection Temperature for Experiment 4041A

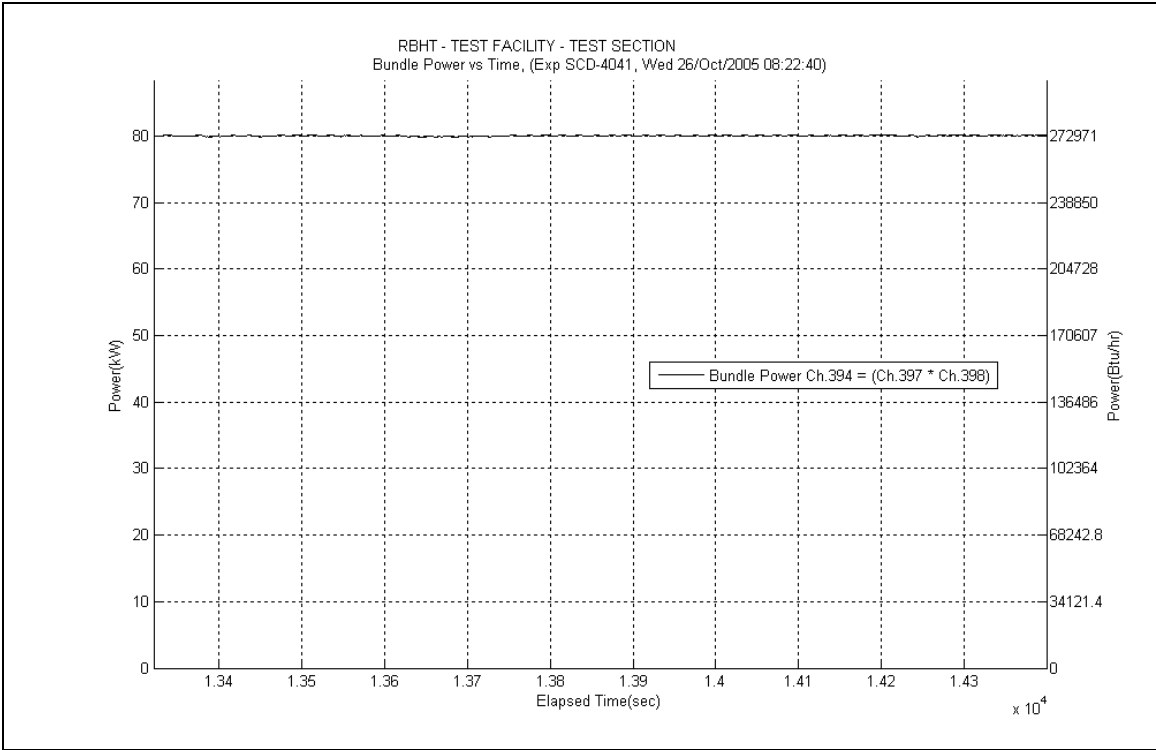

Figure A-439: Bundle Power for Experiment 4041A

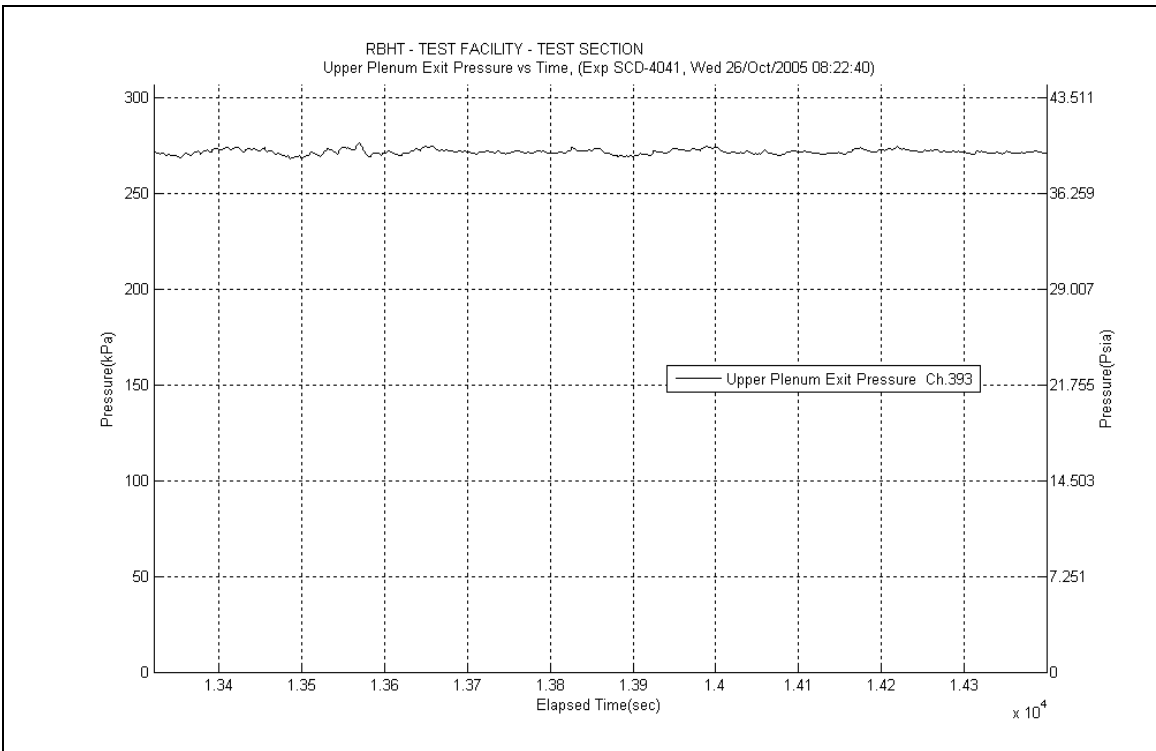

Figure A-440: Upper Plenum Pressure for Experiment 4041A

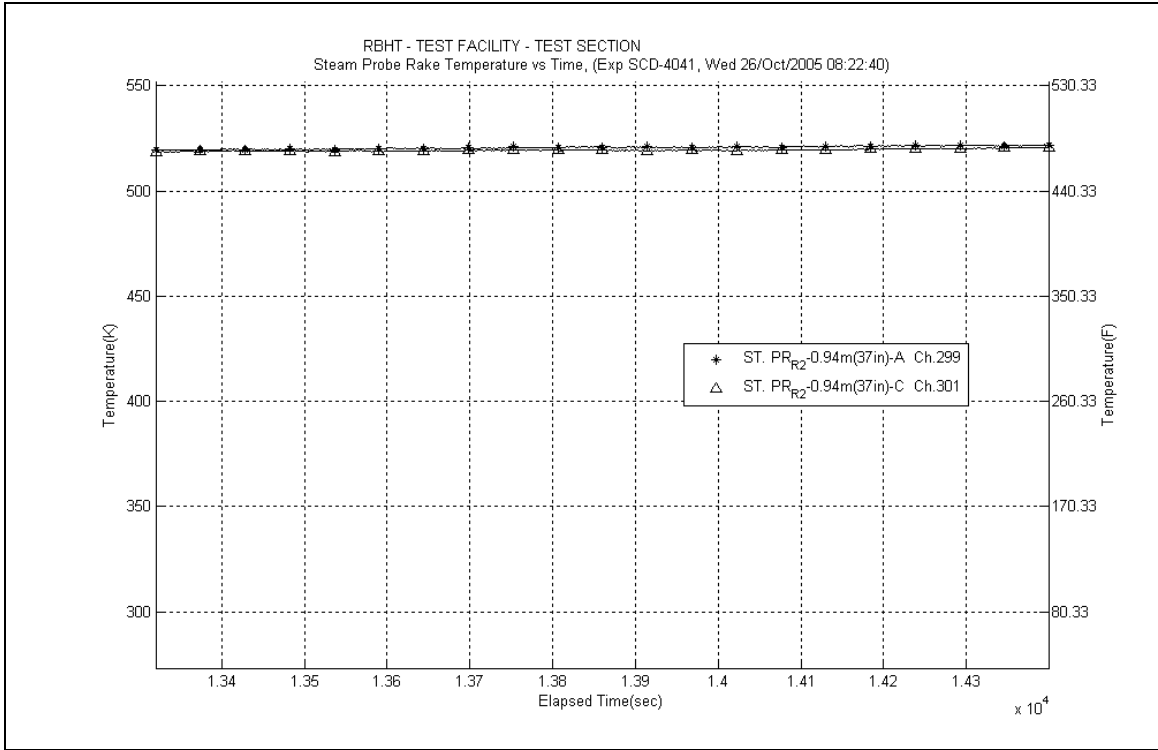

Figure A-441: Steam Probe Rake #2 Temperatures for Experiment 4041A

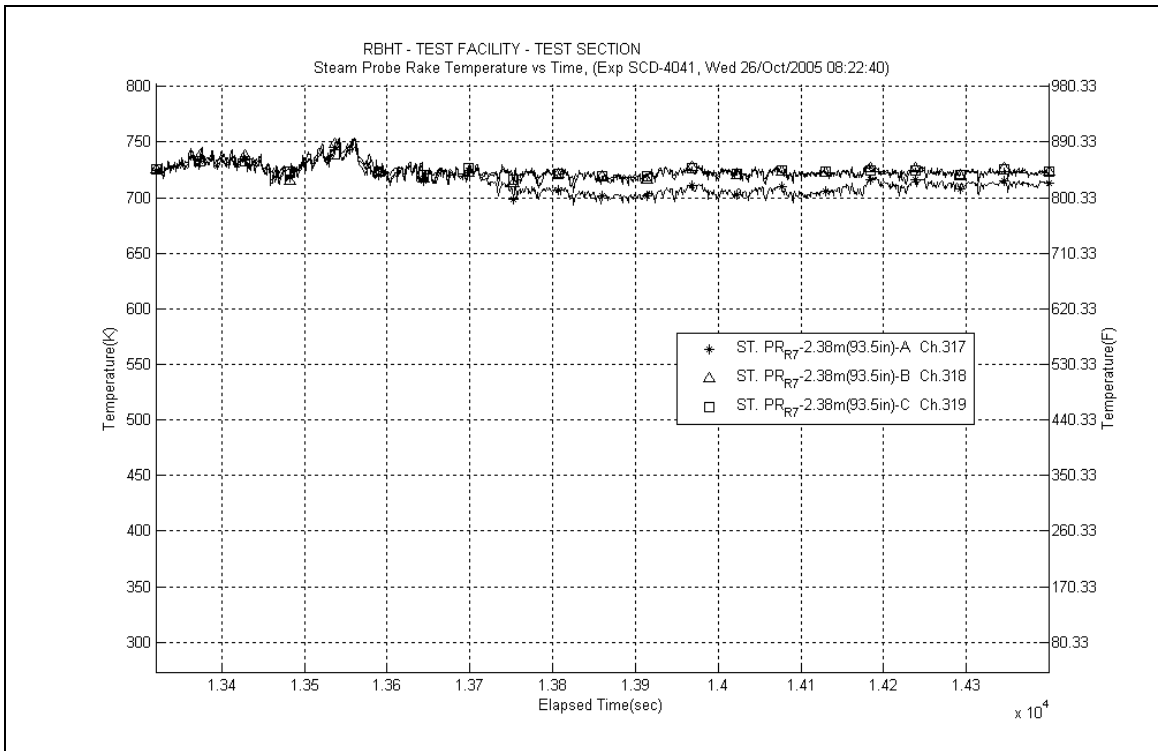

Figure A-442: Steam Probe Rake #7 Temperatures for Experiment 4041A

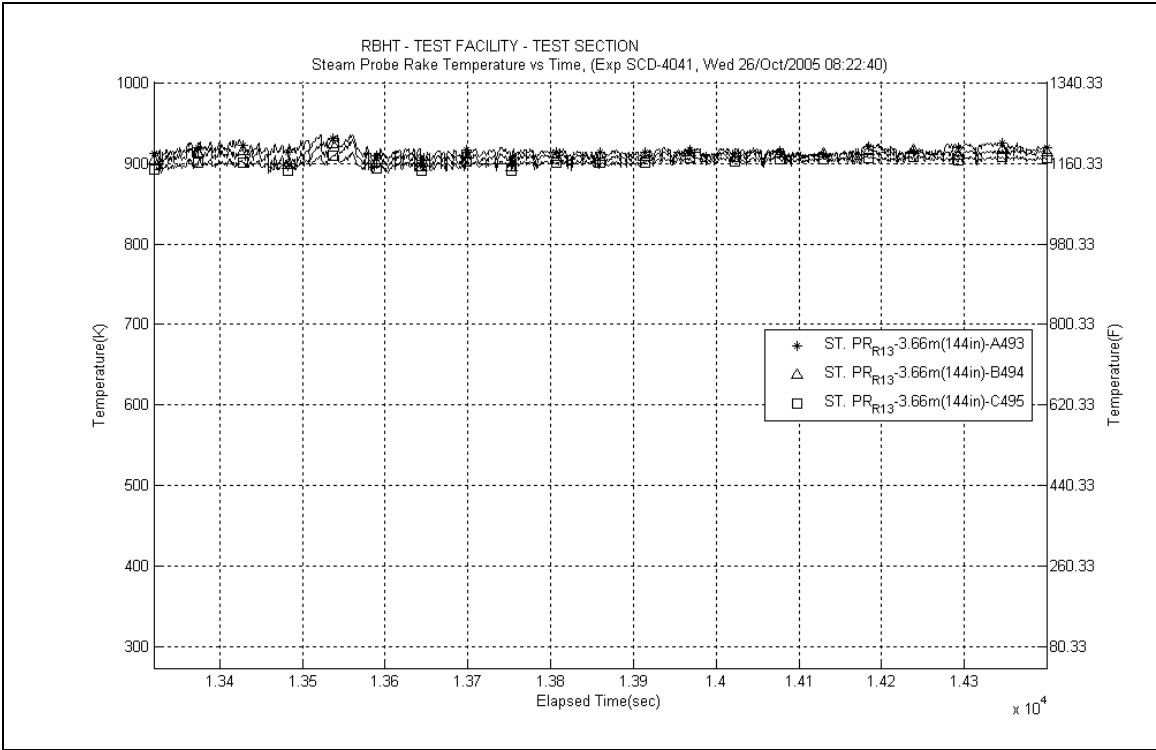

Figure A-443: Steam Probe Rake #13 Temperatures for Experiment 4041A

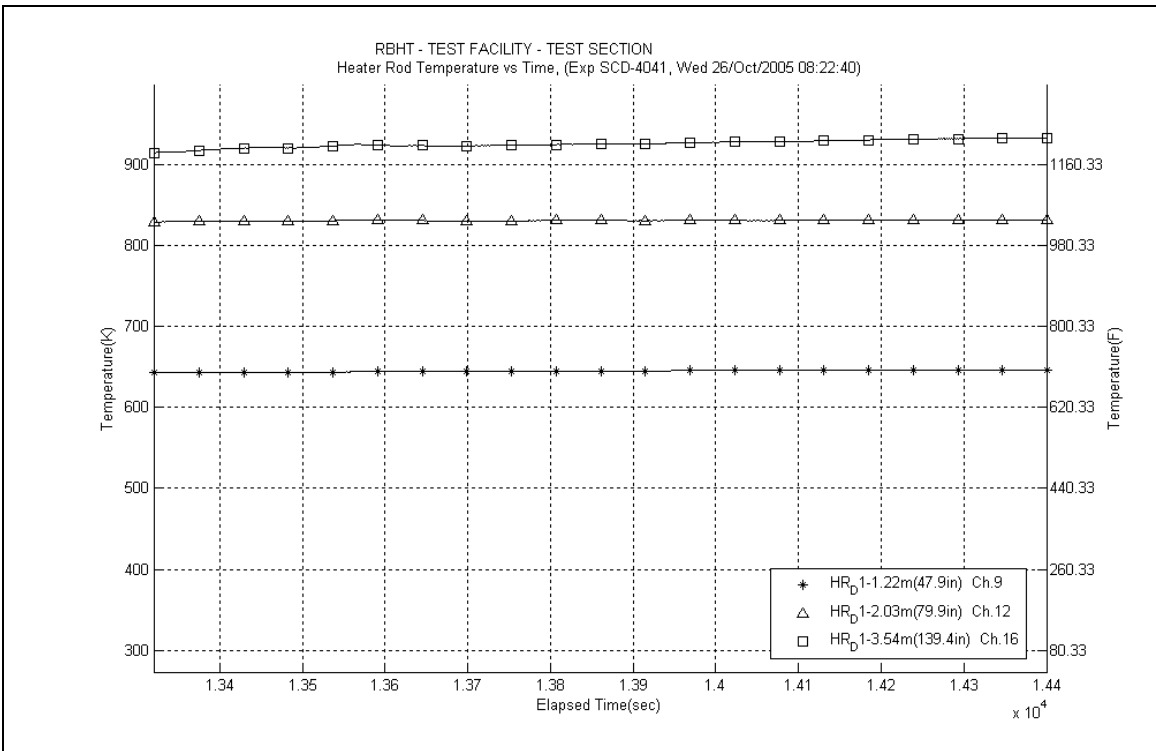

Figure A-444: Heater Rod D1 Temperatures for Experiment 4041A

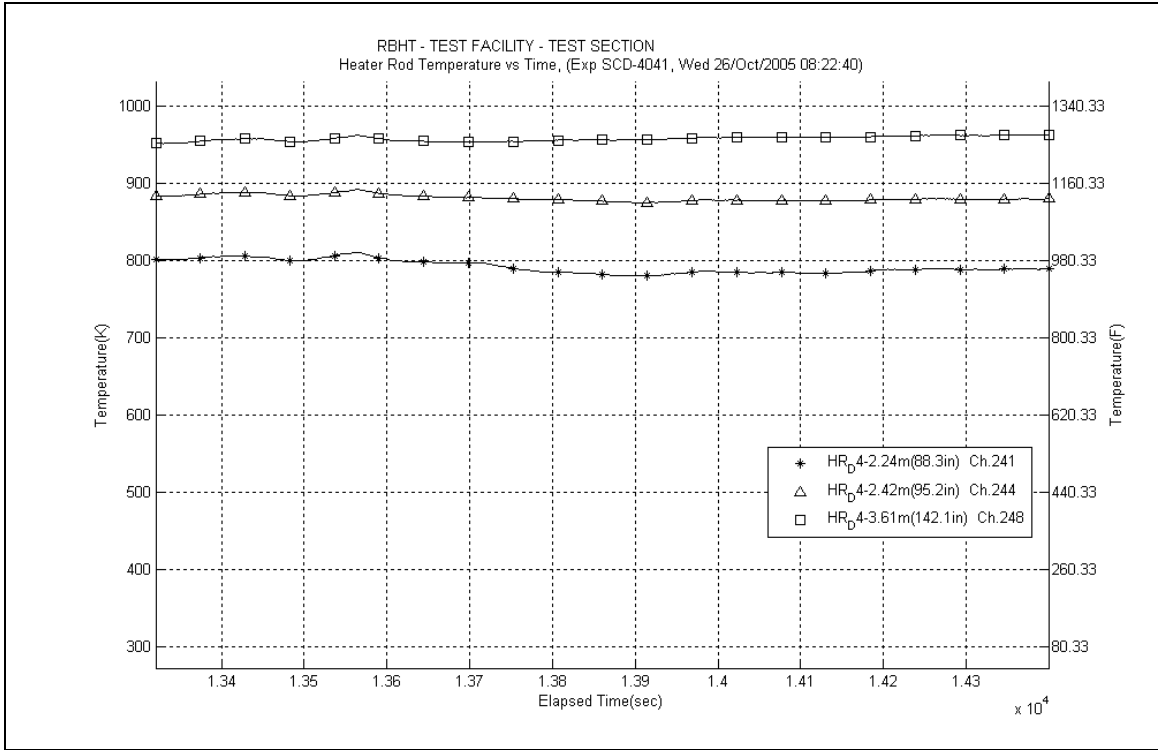

Figure A-445: Heater Rod D4 Temperatures for Experiment 401A

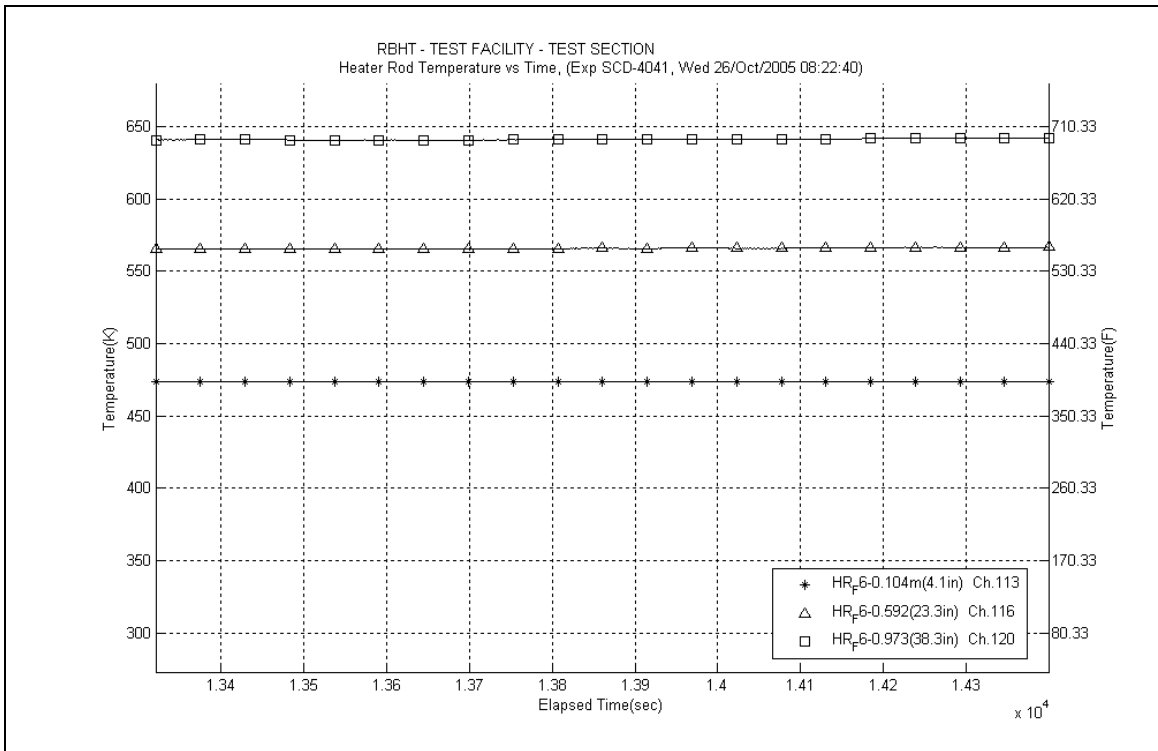

Figure A-446: Heater Rod F6 Temperatures for Experiment 401A

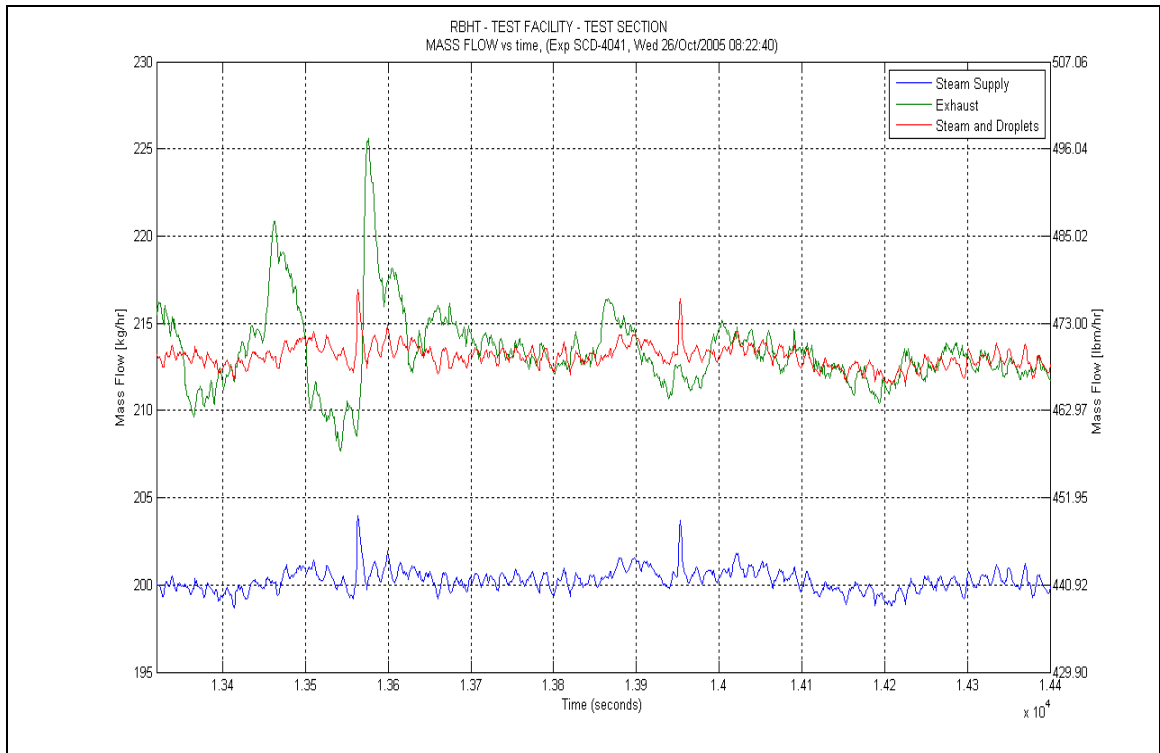

Figure A-447: Mass Flow for Experiment 4041A

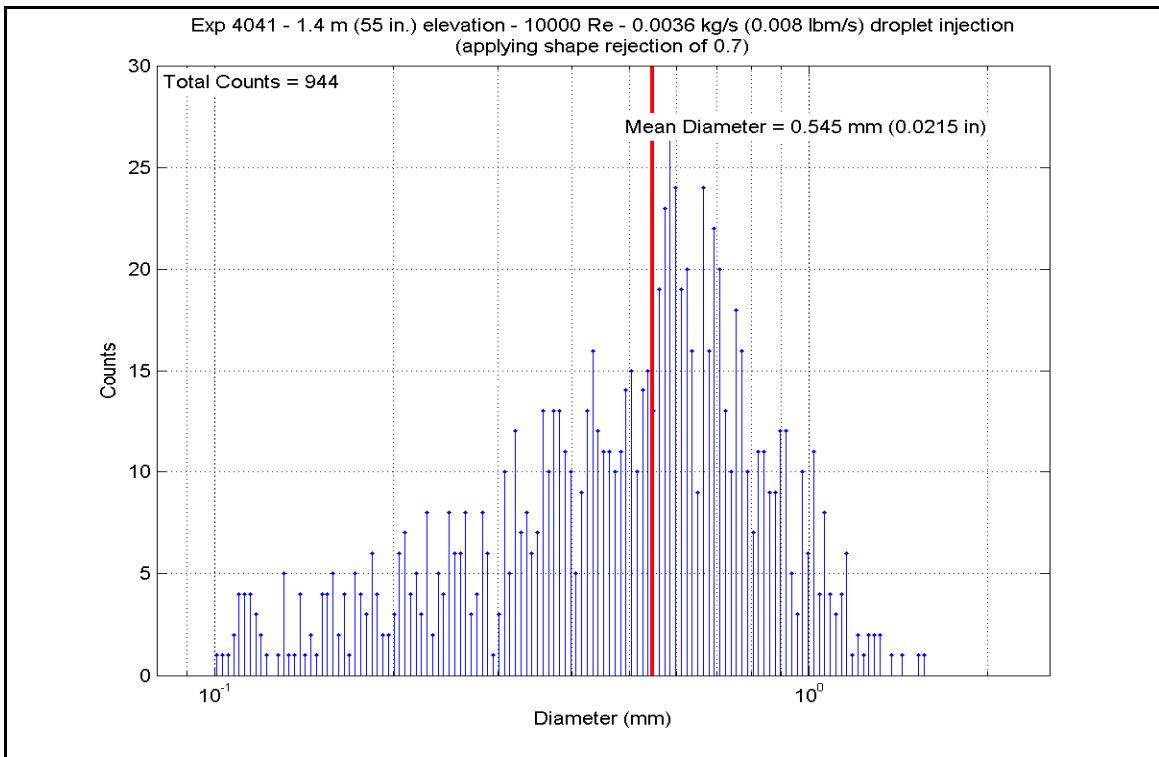

Figure A-448: Droplet Measurements at 1.397 m (55 in.) Elevation for Experiment 4041A

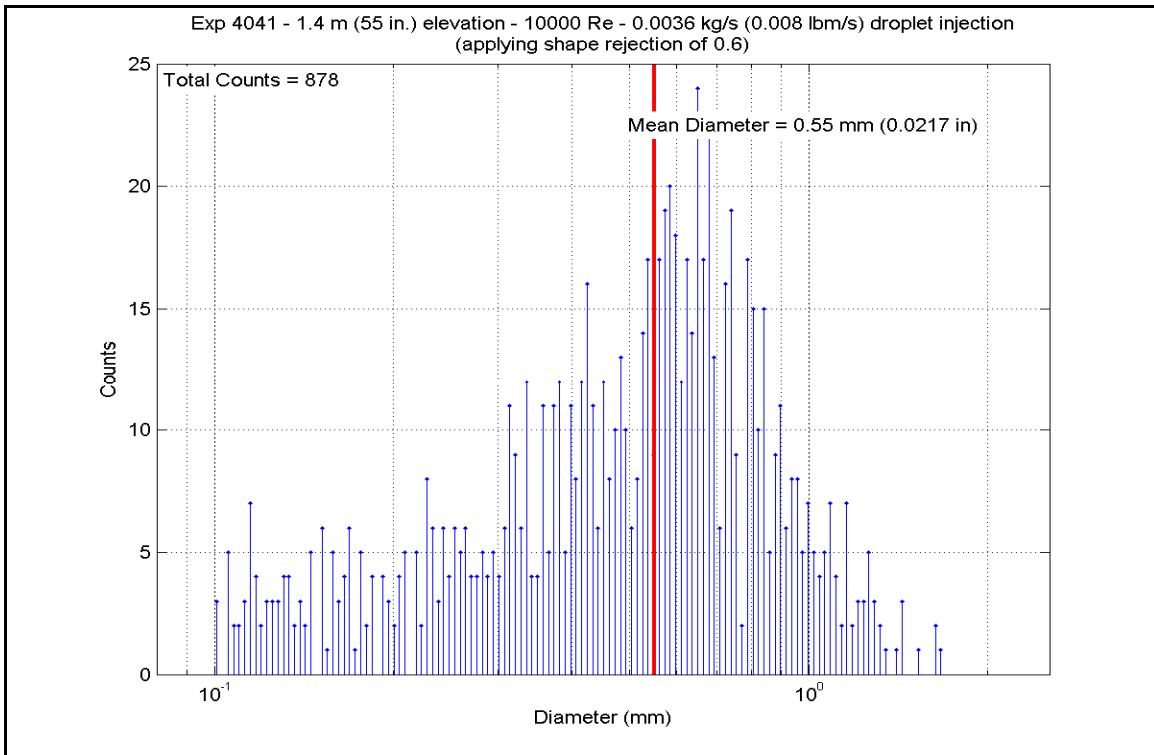

Figure A-449: Droplet Measurements at 1.397 m (55 in.) Elevation for Experiment 4041A

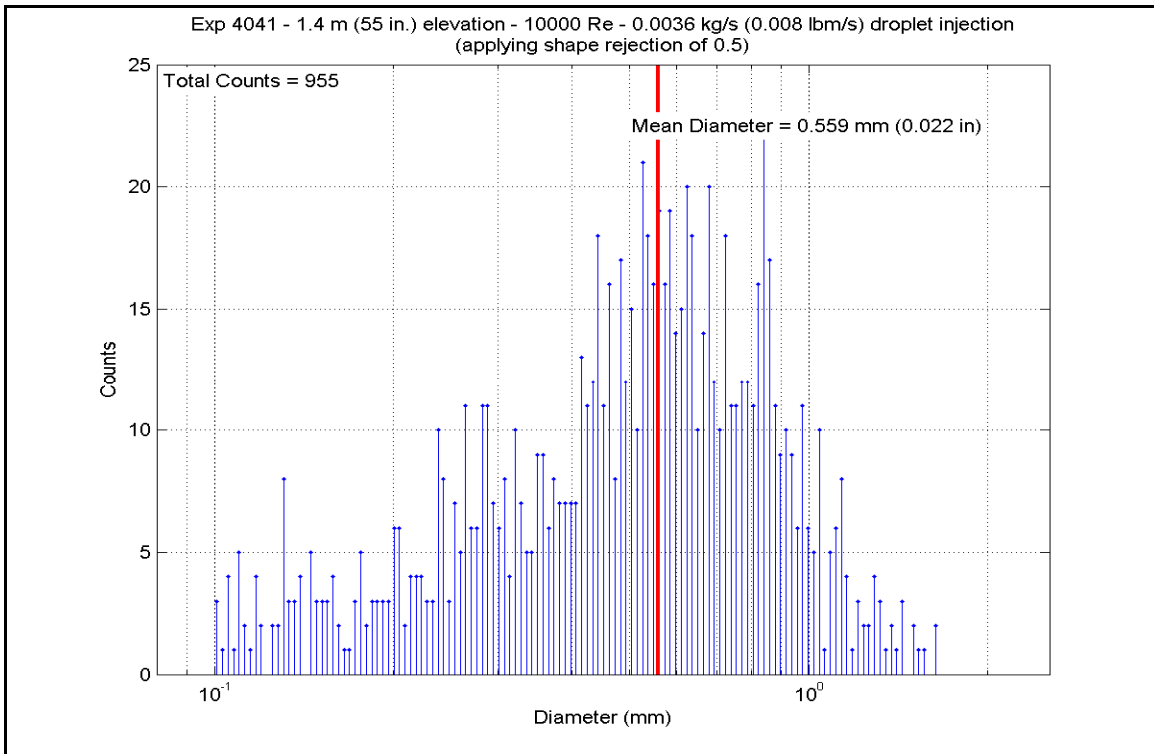

Figure A-450: Droplet Measurements at 1.397 m (55 in.) Elevation for Experiment 4041A

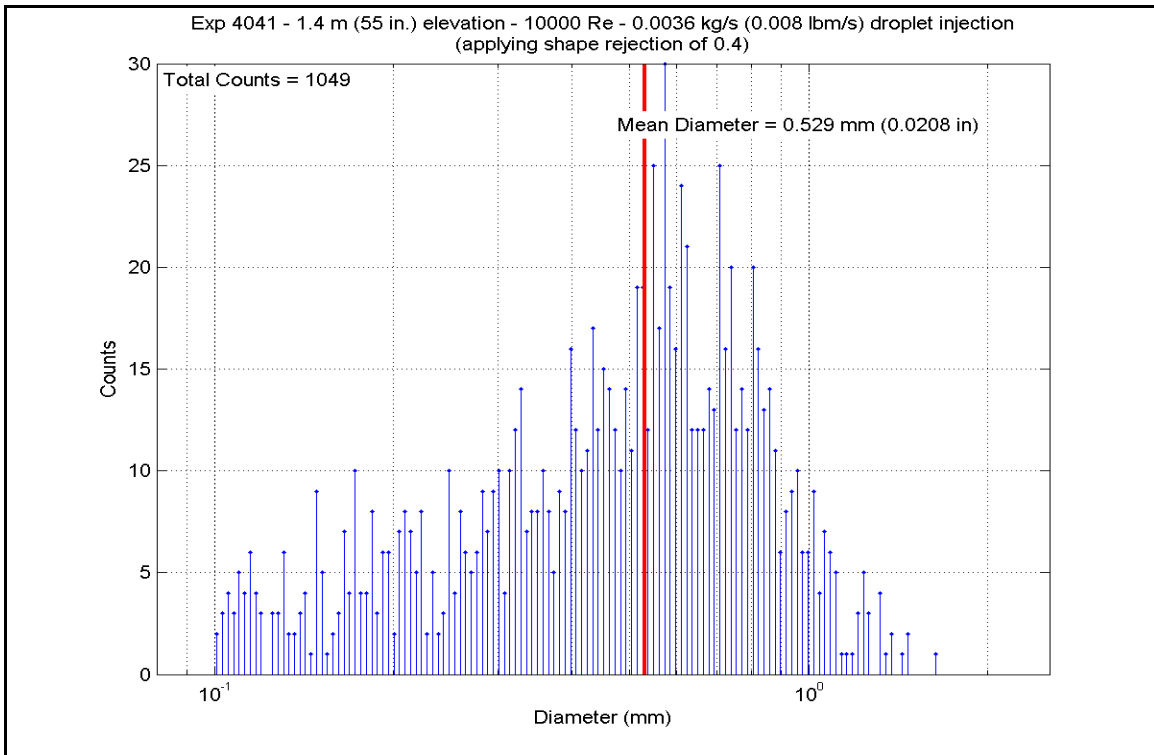

Figure A-451: Droplet Measurements at 1.397 m (55 in.) Elevation for Experiment 4041A

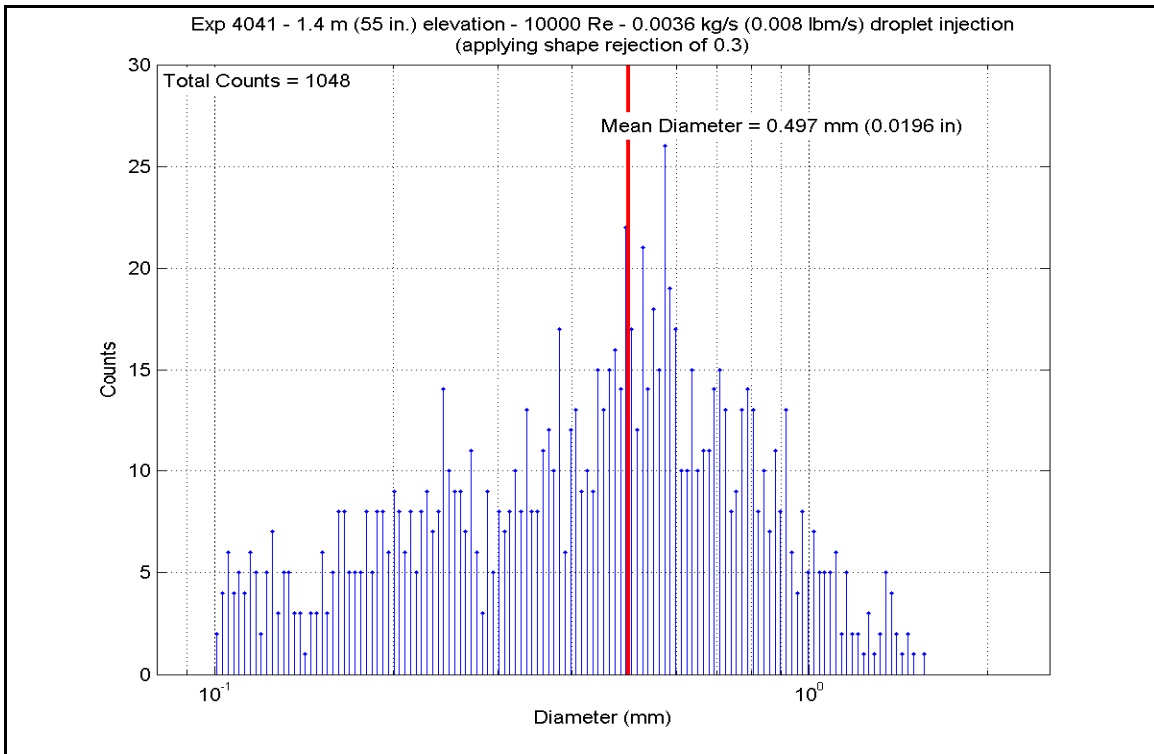

Figure A-452: Droplet Measurements at 1.397 m (55 in.) Elevation for Experiment 4041A

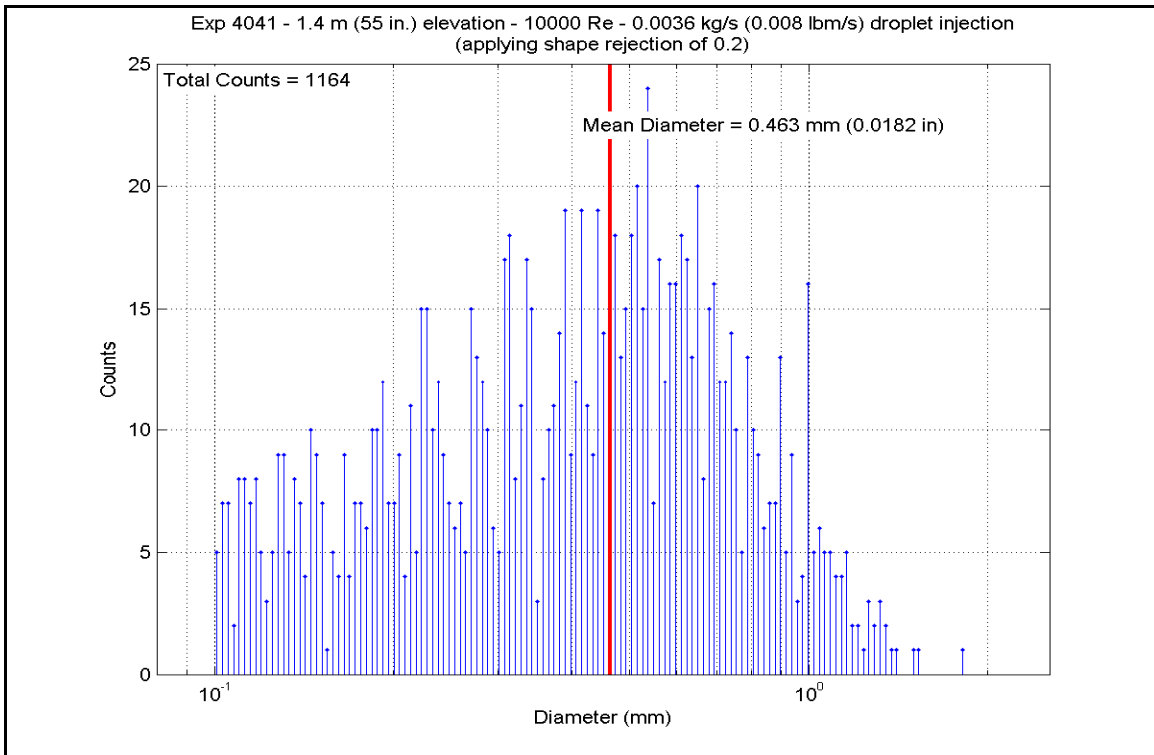

Figure A-453: Droplet Measurements at 1.397 m (55 in.) Elevation for Experiment 4041A

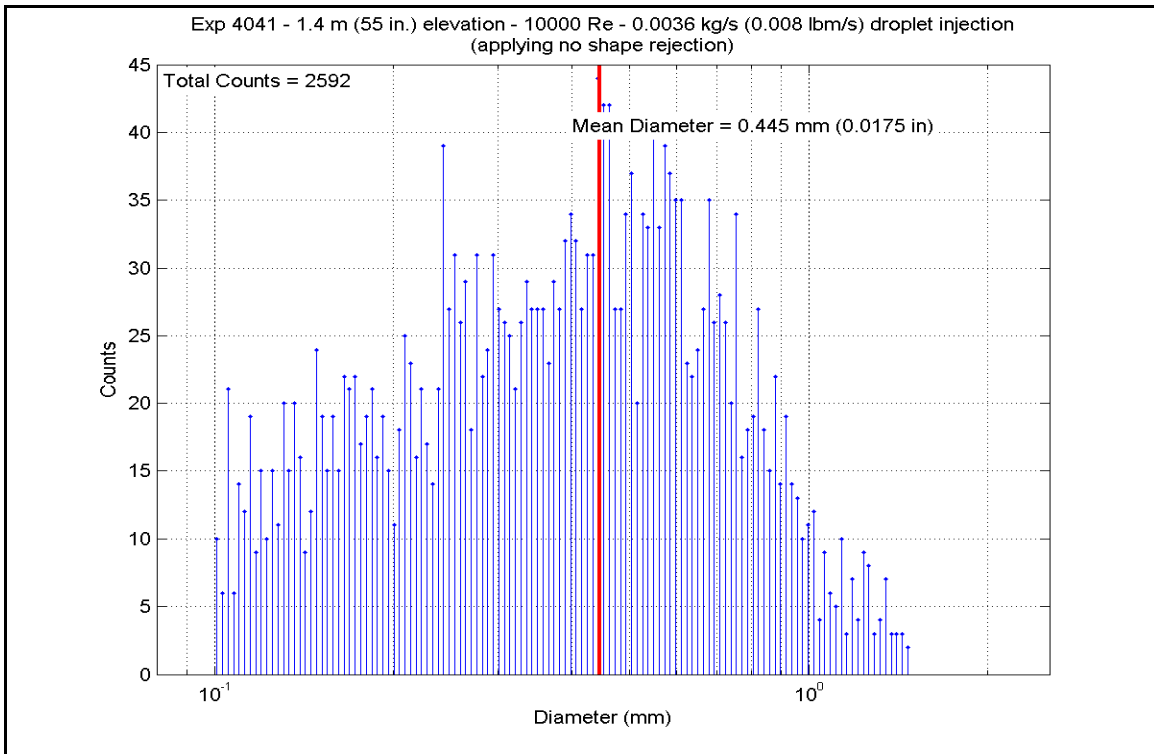

Figure A-454: Droplet Measurements at 1.397 m (55 in.) Elevation for Experiment 4041A

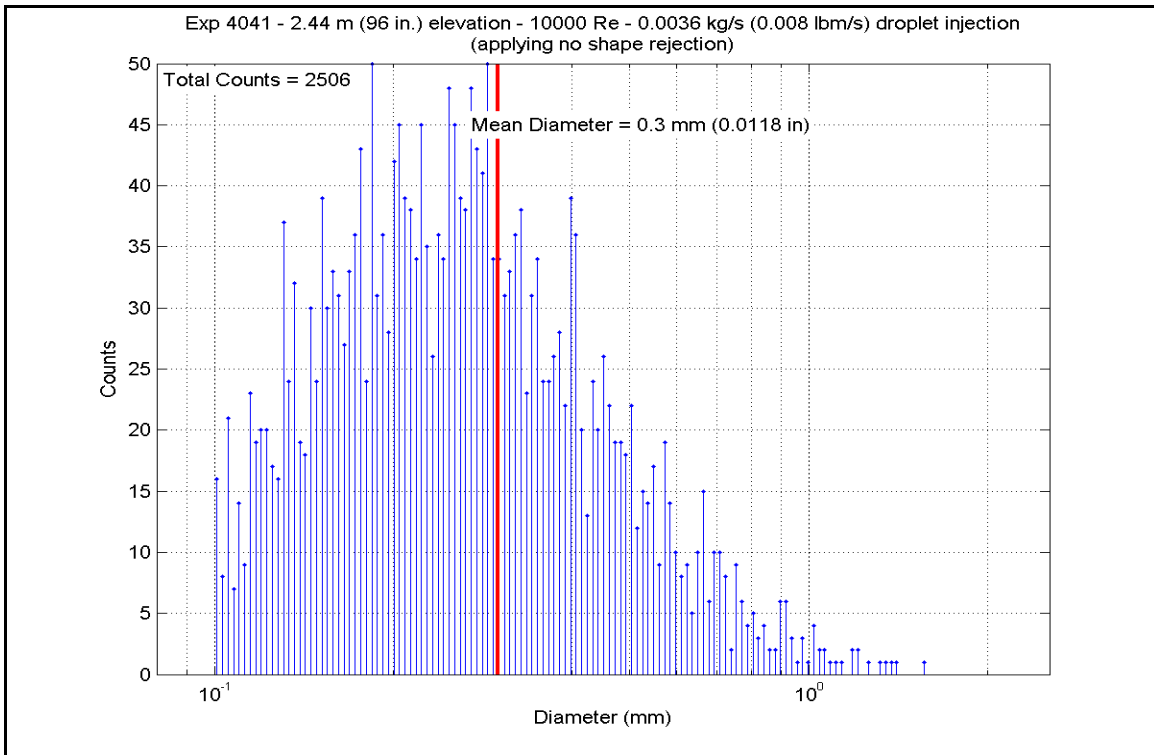

Figure A-455: Droplet Measurements at 2.438 m (96 in.) Elevation for Experiment 4041A

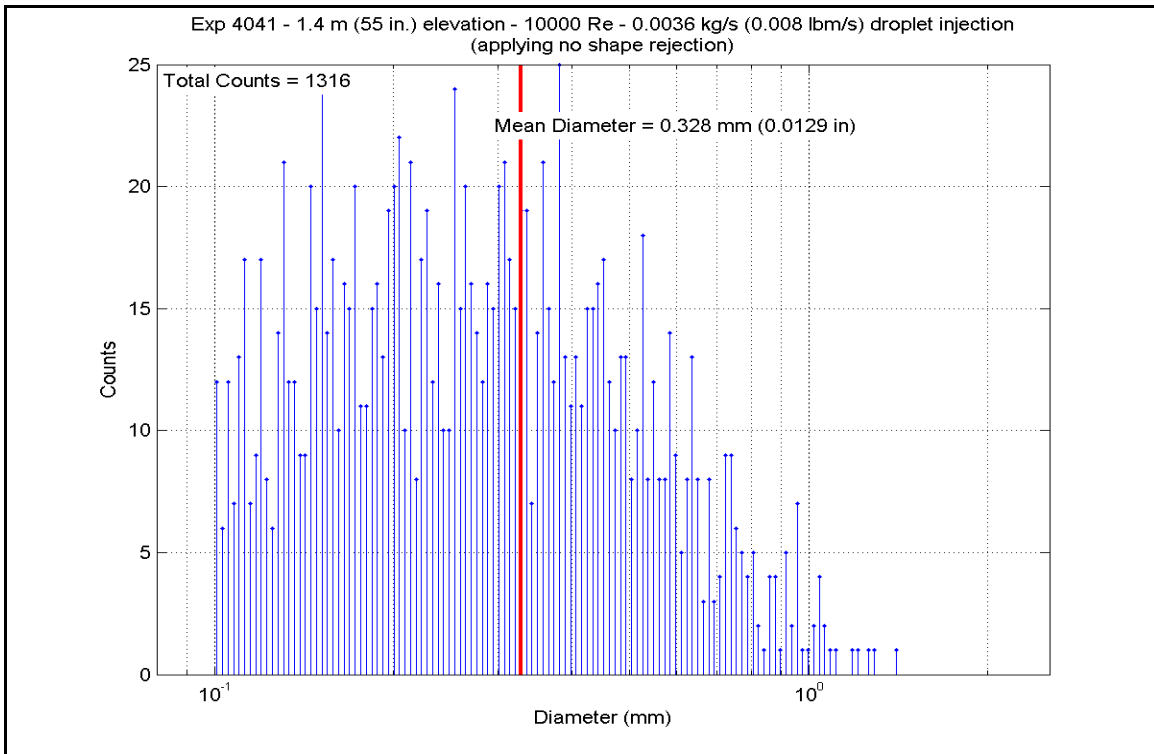
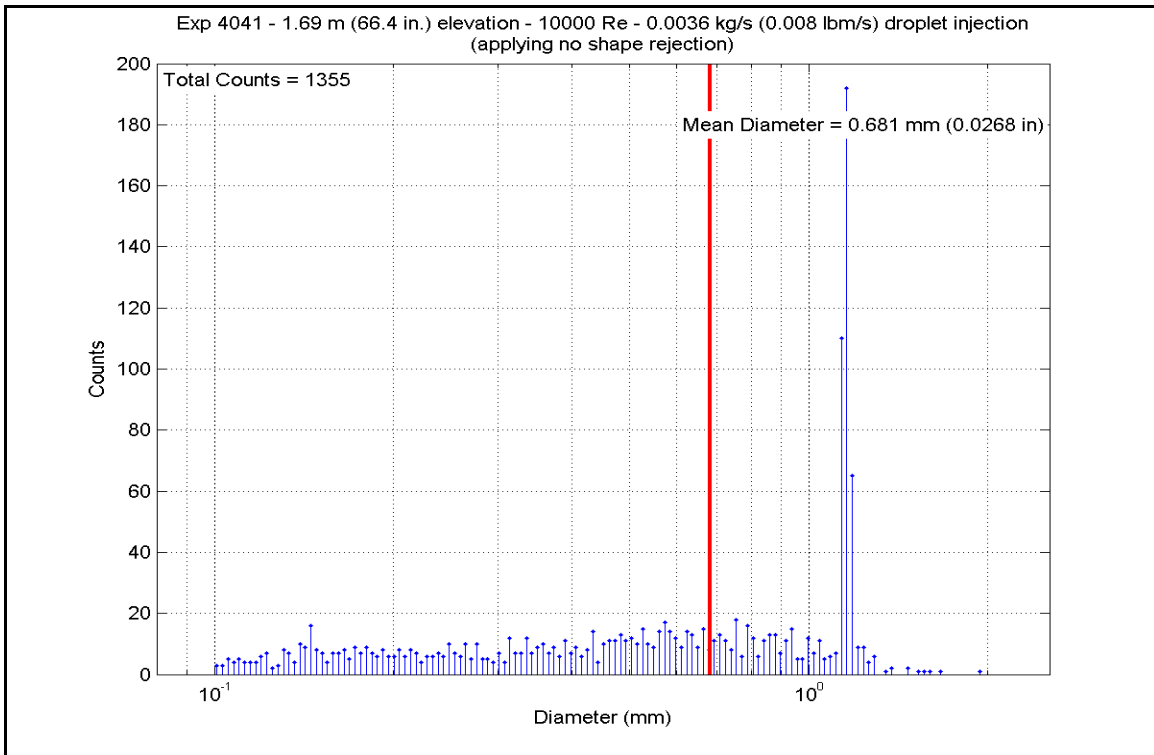

Figure A-456: Droplet Measurements at 1.397 m (55 in.) Elevation for Experiment 4041A



FFigure A-457: Droplet Measurements at 1.687 m (66.4 in.) Elevation for Experiment 4041A

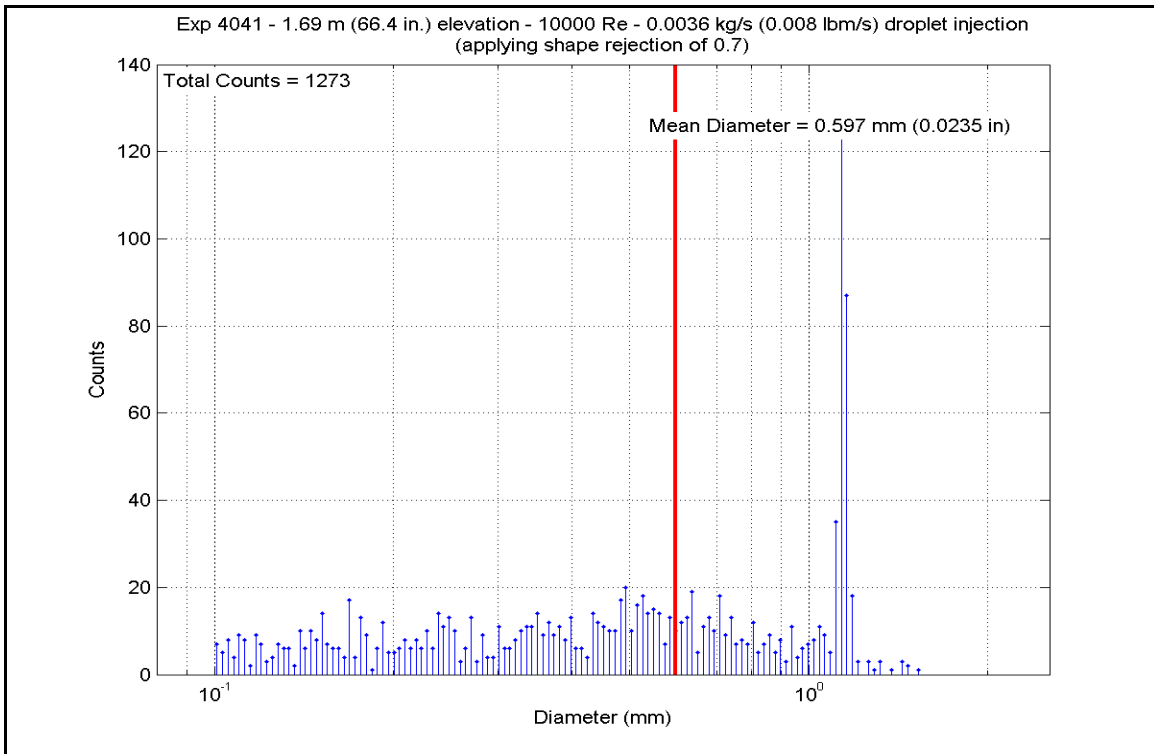

Figure A-458: Droplet Measurements at 1.687 m (66.4 in.) Elevation for Experiment 4041A

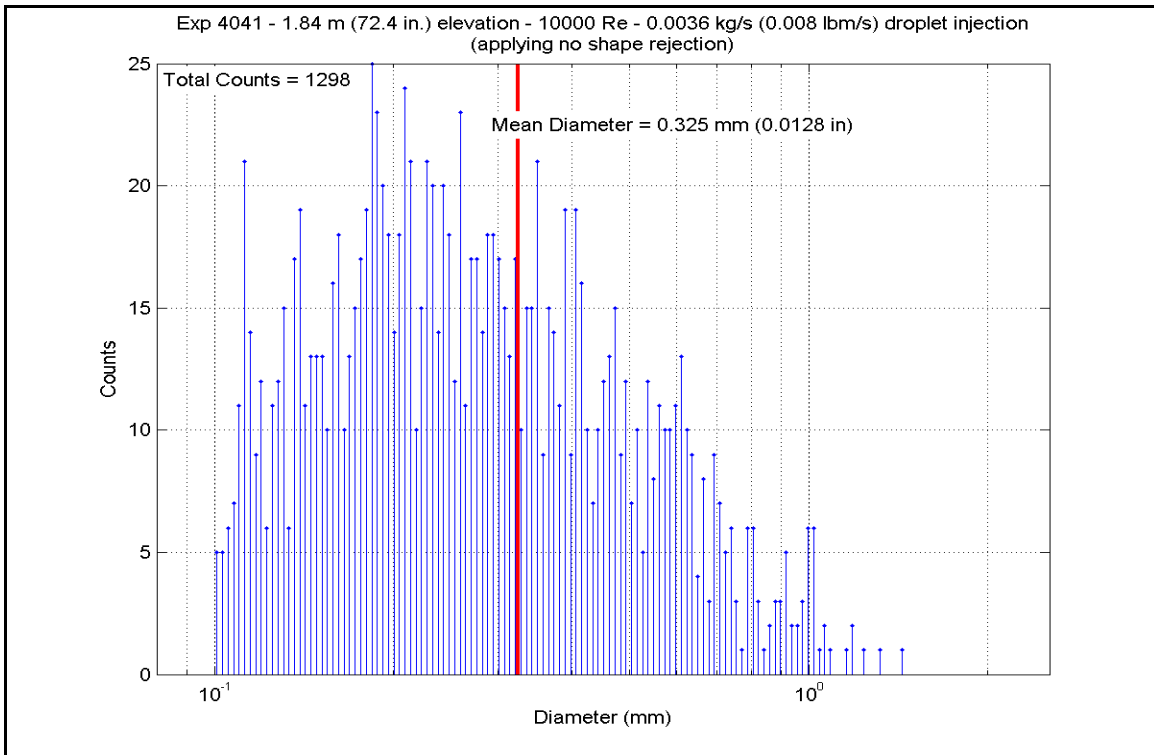

Figure A-459: Droplet Measurements at 1.839 m (72.4 in.) Elevation for Experiment 4041A

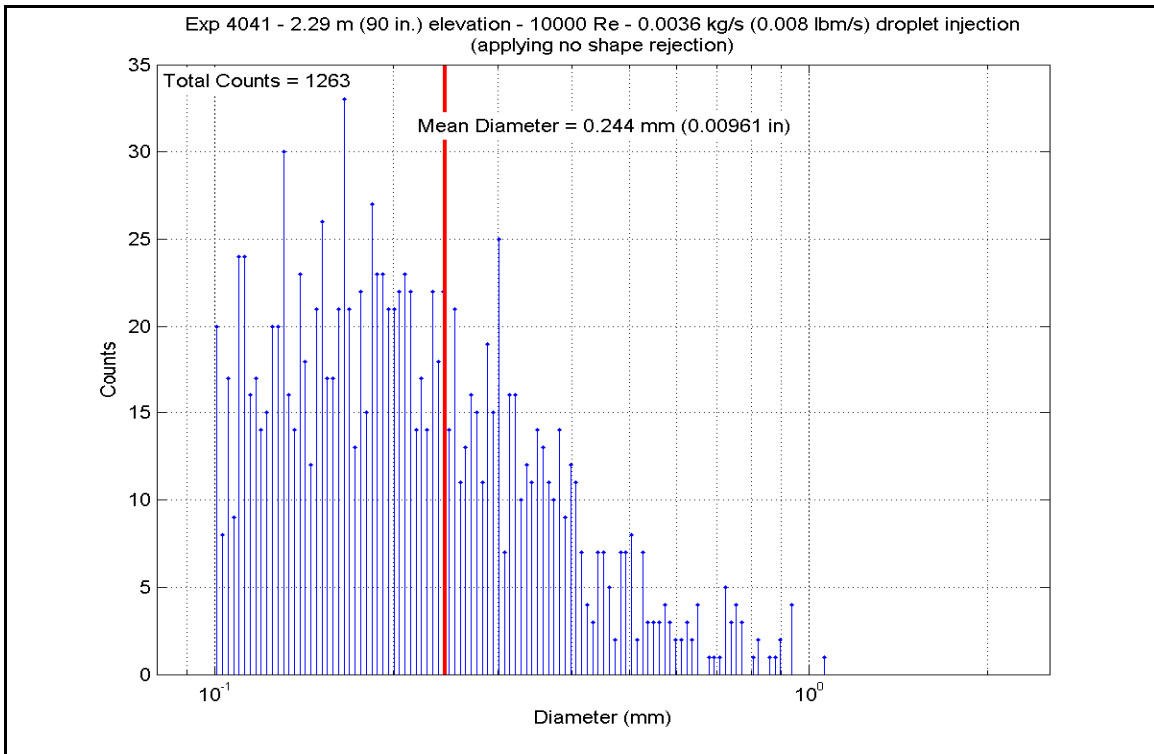

Figure A-460: Droplet Measurements at 2.286 m (90 in.) Elevation for Experiment 4041A

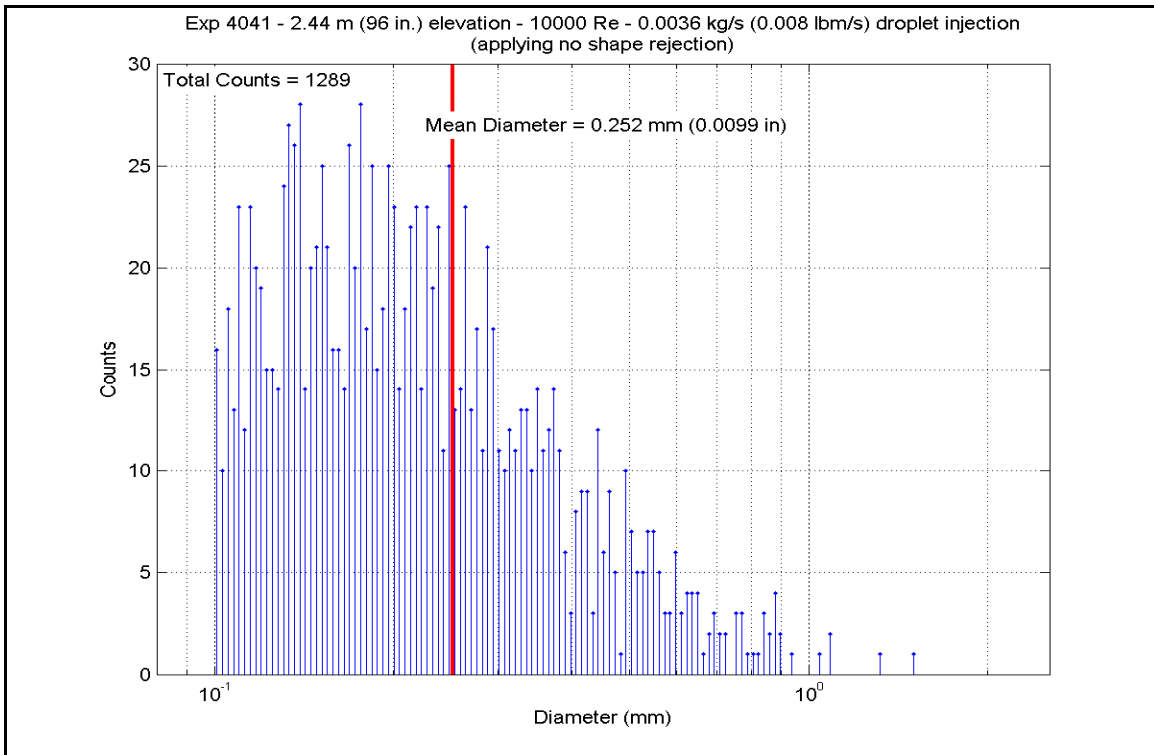

Figure A-461: Droplet Measurements at 2.438 m (96 in.) Elevation for Experiment 4041A

Table A-25: Summary of Steam Cooling Heat Transfer Reduced Data for Experiment 4041A

SCD-4041-A		Inlet Reynolds:		10000		40 psia							
Matrix Test # 9a		UP Pressure:		275.8 kPa		272971 Btu/hr							
Time Window 13320-14400		Bundle Power:		80.00 kW		440.0 lbm/hr							
Inner 3x3		Steam flow:		0.0554 kg/s		0.008 lbm/s							
		Droplet flow:		0.0036 kg/s									
H.R. ID	H.R. Location	Channel Number	Elevation (in)	Elevation (m)	Zgrid (in)	Zgrid (m)	H.R. Tw (°F)	H.R. Tw (K)	H.R. Tw (K)	H.R. q" (Btu/hr-ft ²)	H.R. q" (W/m ²)	h _{sat} (z) (Btu/hr-ft ² -F)	h _{sat} (z) (W/m ² -K)
Gr-3	RodD3_88.3	185	88.3	2.243	-0.2	-0.005	979.54	799.6	799.6	6824.43	21527.7	9.578	54.4
	RodD3_91.3	186	91.3	2.319	2.8	0.071	1064.26	846.6	846.6	6961.07	21958.7	8.731	49.6
	RodD3_93.1	187	93.1	2.365	4.6	0.117	1067.02	848.2	848.2	7044.57	22222.1	8.805	50.0
	RodD3_95.3	188	95.3	2.421	6.8	0.173	1111.68	873.0	873.0	7146.03	22542.1	8.460	48.0
	RodD3_100.1	189	100.1	2.543	11.6	0.295	1192.57	917.9	917.9	7371.96	23254.8	7.965	45.2
	RodD3_106.1	190	106.1	2.695	17.6	0.447	1250.82	950.3	950.3	7656.56	24152.6	7.783	44.2
	RodD3_110	191	110	2.794	21.5	0.546	1186.21	914.4	914.4	7564.13	23861.0	8.229	46.7
	RodD3_142.1	192	142.1	3.609	8.6	0.218	1259.30	955.0	955.0	2597.31	8193.2	2.617	14.9
Gr-3	RodC4_88.4	233	88.4	2.245	-0.1	-0.003	993.40	807.3	807.3	6883.71	21714.7	9.477	53.8
	RodC4_91.1	234	91.1	2.314	2.6	0.066	1073.33	851.7	851.7	7014.21	22126.3	8.699	49.4
	RodC4_93.4	235	93.4	2.372	4.9	0.124	1092.37	862.2	862.2	7126.18	22479.5	8.634	49.0
	RodC4_95.3	236	95.3	2.421	6.8	0.173	1135.88	886.4	886.4	7217.21	22766.7	8.306	47.2
	RodC4_100.1	237	100.1	2.543	11.6	0.295	1186.84	914.7	914.7	7448.25	23495.5	8.097	46.0
	RodC4_106.1	238	106.1	2.695	17.6	0.447	1242.06	945.4	945.4	7745.44	24433.0	7.944	45.1
	RodC4_110	239	110	2.794	21.5	0.546	1183.68	913.0	913.0	7497.44	23650.7	8.179	46.4
	RodC4_142.2	240	142.2	3.612	8.7	0.221	1267.87	959.7	959.7	2820.06	8895.9	2.818	16.0
Gr-3	RodD4_88.3	241	88.3	2.243	-0.2	-0.005	963.48	790.6	790.6	6882.60	21711.1	9.882	56.1
	RodD4_91.3	242	91.3	2.319	2.8	0.071	1059.92	844.2	844.2	7013.06	22122.7	8.845	50.2
	RodD4_93.2	243	93.2	2.367	4.7	0.119	1086.57	859.0	859.0	7102.21	22403.9	8.666	49.2
	RodD4_95.2	244	95.2	2.418	6.7	0.170	1123.56	879.6	879.6	7193.90	22693.2	8.399	47.7
	RodD4_100.1	245	100.1	2.543	11.6	0.295	1199.07	921.5	921.5	7424.45	23420.4	7.966	45.2
	RodD4_106.1	246	106.1	2.695	17.6	0.447	1236.26	942.2	942.2	7712.48	24329.0	7.957	45.2
	RodD4_142.1	248	142.1	3.609	8.6	0.218	1262.95	957.0	957.0	2726.36	8600.3	2.737	15.5
Gr-3	RodE4_88.4	201	88.4	2.245	-0.1	-0.003	974.12	796.5	796.5	6759.15	21321.8	9.559	54.3
	RodE4_91.2	202	91.2	2.316	2.7	0.069	1063.22	846.0	846.0	6882.59	21711.1	8.644	49.1
	RodE4_95.3	204	95.3	2.421	6.8	0.173	1130.89	883.6	883.6	7069.21	22299.8	8.183	46.5
	RodE4_100.9	205	100.9	2.563	12.4	0.315	1190.99	917.0	917.0	7323.88	23103.2	7.926	45.0
	RodE4_142.3	208	142.3	3.614	8.8	0.224	1259.21	954.9	954.9	2749.75	8674.1	2.771	15.7

Table A-25: Summary of Steam Cooling Heat Transfer Reduced Data for Experiment 4041A, continued

Inner 3x3	H.R. Location	Channel Number	Elevation (in)	Elevation (m)	Zgrid (in)	Zgrid (m)	H.R. Tw (°F)	H.R. Tw (K)	H.R. q" (Btu/hr-ft ²)	H.R. q" (W/m ²)	h _{sat} (z) (Btu/hr-ft ² -F)	h _{sat} (z) (W/m ² -K)
Gr-4	RodE3_63.4	193	63.4	1.610	16.4	0.417	957.27	787.2	5566.45	17559.4	8.064	45.8
	RodE3_113.6	194	113.6	2.885	0.85	0.022	1222.46	934.5	6872.28	21678.6	7.193	40.8
	RodE3_115.5	195	115.5	2.934	2.75	0.070	1255.45	952.8	6613.26	20861.5	6.691	38.0
	RodE3_118.5	196	118.5	3.010	5.75	0.146	1283.03	968.2	6205.71	19575.9	6.108	34.7
	RodE3_122.7	197	122.7	3.117	9.95	0.253	1295.96	975.3	5633.42	17770.6	5.475	31.1
	RodE3_126.5	198	126.5	3.213	13.75	0.349	1297.57	976.2	5118.12	16145.1	4.966	28.2
	RodE3_131.7	199	131.7	3.345	-1.8	-0.046	1222.97	934.8	4421.54	13947.8	4.625	26.3
	RodE3_135.6	200	135.6	3.444	2.1	0.053	1251.99	950.9	3889.20	12268.5	3.948	22.4
Gr-4	RodC5_63.7	225	63.7	1.618	16.7	0.424	952.55	784.6	5478.49	17281.9	7.991	45.4
	RodC5_113.6	226	113.6	2.885	0.85	0.022	1215.73	930.8	6704.45	21149.2	7.067	40.1
	RodC5_115.7	227	115.7	2.939	2.95	0.075	1256.69	953.5	6432.86	20292.5	6.500	36.9
	RodC5_122.7	229	122.7	3.117	9.95	0.253	1305.23	980.5	5527.86	17437.6	5.324	30.2
	RodC5_126.7	230	126.7	3.218	13.95	0.354	1304.45	980.1	5014.26	15817.5	4.833	27.4
	RodC5_131.6	231	131.6	3.343	-1.9	-0.048	1227.55	937.3	4388.31	13842.9	4.569	25.9
	RodC5_135.7	232	135.7	3.447	2.2	0.056	1253.62	951.8	3856.25	12164.5	3.909	22.2
	RodE5_63.6	209	63.6	1.615	16.6	0.422	860.98	733.7	5606.39	17685.4	9.439	53.6
Gr-5	RodE5_113.6	210	113.6	2.885	0.85	0.022	1149.38	893.9	6900.50	21767.6	7.820	44.4
	RodE5_115.4	211	115.4	2.931	2.65	0.067	1204.59	924.6	6662.84	21017.9	7.106	40.4
	RodE5_118.7	212	118.7	3.015	5.95	0.151	1250.71	950.2	6221.70	19626.4	6.325	35.9
	RodE5_122.6	213	122.6	3.114	9.85	0.250	1283.43	968.4	5700.14	17981.1	5.608	31.8
	RodE5_126.6	214	126.6	3.216	13.85	0.352	1299.49	977.3	5168.52	16304.1	5.006	28.4
	RodE5_131.6	215	131.6	3.343	-1.9	-0.048	1282.83	968.1	4504.34	14208.9	4.434	25.2
	RodE5_135.6	216	135.6	3.444	2.1	0.053	1250.20	949.9	3976.20	12542.9	4.044	23.0
	RodC3_79.8	177	79.8	2.027	8.92	0.227	998.77	810.2	6370.42	20095.5	8.706	49.4
Gr-8	RodC3_85.6	178	85.6	2.174	14.72	0.374	975.28	797.2	6647.63	20970.0	9.386	53.3
	RodC3_88.5	179	88.5	2.248	0	0.000	984.27	802.2	6786.02	21406.5	9.461	53.7
	RodC3_92.4	180	92.4	2.347	3.9	0.099	1081.47	856.2	6966.78	21976.7	8.554	48.6
	RodC3_94.4	181	94.4	2.398	5.9	0.150	1091.34	861.7	7055.83	22257.6	8.559	48.6
	RodC3_97.2	182	97.2	2.469	8.7	0.221	1141.38	889.5	7187.59	22673.3	8.220	46.7
	RodC3_108.8	183	108.8	2.764	20.3	0.516	1241.60	945.2	7575.00	23895.3	7.772	44.1
	RodD5_50	217	50	1.270	3	0.076	804.52	702.3	4955.73	15632.9	9.220	52.4
	RodD5_54.1	218	54.1	1.374	7.1	0.180	832.57	717.9	5149.72	16244.8	9.105	51.7
Gr-8	RodD5_56.9	219	56.9	1.445	9.9	0.251	882.73	745.8	5280.00	16655.7	8.575	48.7
	RodD5_60	220	60	1.524	13	0.330	918.94	765.9	5420.16	17097.9	8.314	47.2
	RodD5_66.1	221	66.1	1.679	19.1	0.485	957.46	787.3	5718.88	18040.2	8.283	47.0
	RodD5_69.9	222	69.9	1.775	-0.98	-0.025	838.35	721.1	5896.30	18599.9	10.320	58.6
	RodD5_72.9	223	72.9	1.852	2.02	0.051	910.91	761.4	6039.94	19053.0	9.380	53.3
	RodD5_74.9	224	74.9	1.902	4.02	0.102	955.29	786.1	6136.19	19356.6	8.915	50.6

Table A-25: Summary of Steam Cooling Heat Transfer Reduced Data for Experiment 4041A, continued

H.R. ID	H.R. Location	Channel Number	Elevation (in)	Elevation (m)	Zgrid (in)	Zgrid (m)	H.R. Tw (°F)	H.R. Tw (K)	H.R. q" (Btu/hr-ft ²)	H.R. q" (W/m ²)	h _{sat} (z) (Btu/hr-ft ² -F)	h _{sat} (z) (W/m ² -K)	
Gr-2	RodB5_41	153	41	1.041	13.5	0.343	741.35	667.2	4498.70	14191.1	9.484	53.9	
	RodB5_52.9	154	52.9	1.344	5.9	0.150	807.46	704.0	5072.86	16002.3	9.386	53.3	
	RodB5_55	155	55	1.397	8	0.203	847.02	725.9	5174.25	16322.2	8.921	50.7	
	RodB5_57.8	156	57.8	1.468	10.8	0.274	897.80	754.2	5307.32	16741.9	8.414	47.8	
	RodB5_64	157	64	1.626	17	0.432	954.47	785.6	5605.24	17681.7	8.153	46.3	
	RodB5_73.9	158	73.9	1.877	3.02	0.077	957.66	787.4	6123.72	19317.3	8.867	50.4	
	RodB5_75.9	159	75.9	1.928	5.02	0.128	990.27	805.5	6213.65	19601.0	8.591	48.8	
	RodB5_76.9	160	76.9	1.953	6.02	0.153	1002.87	812.5	6258.94	19743.8	8.506	48.3	
	Gr-2	RodF5_41	105	41	1.041	13.5	0.343	730.77	661.4	4476.63	14121.5	9.653	54.8
	RodF5_53.1	106	53.1	1.349	1.349	6.1	0.155	791.21	694.9	5058.91	15958.3	9.651	54.8
RodF5_55	107	55	1.397	1.397	8	0.203	829.00	715.9	5148.00	16239.4	9.160	52.0	
RodF5_57.8	108	57.8	1.468	1.468	10.8	0.274	874.91	741.4	5279.13	16653.0	8.684	49.3	
RodF5_64	109	64	1.626	1.626	17	0.432	920.47	766.7	5574.33	17584.2	8.530	48.4	
RodF5_73.8	110	73.8	1.875	1.875	2.92	0.074	905.27	758.3	6053.94	19097.2	9.485	53.9	
RodF5_75.8	111	75.8	1.925	1.925	4.92	0.125	944.90	780.3	6149.76	19399.4	9.072	51.5	
RodF5_76.8	112	76.8	1.951	1.951	5.92	0.150	960.78	789.1	6198.00	19551.6	8.934	50.7	
Gr-2	RodC2_41	57	41	1.041	13.5	0.343	734.28	663.3	4495.31	14180.5	9.620	54.6	
	RodC2_53.1	58	53.1	1.349	6.1	0.155	857.65	731.8	5077.54	16017.1	8.597	48.8	
	RodC2_55	59	55	1.397	8	0.203	876.31	742.2	5168.32	16303.5	8.482	48.2	
	RodC2_57.8	60	57.8	1.468	10.8	0.274	906.28	758.9	5300.72	16721.1	8.292	47.1	
	RodC2_63.9	61	63.9	1.623	16.9	0.429	937.22	776.1	5593.78	17645.6	8.346	47.4	
	RodC2_73.8	62	73.8	1.875	2.92	0.074	944.10	779.9	6088.37	19205.7	8.992	51.1	
	RodC2_75.8	63	75.8	1.925	4.92	0.125	971.66	795.2	6183.80	19506.8	8.776	49.8	
	RodC2_76.8	64	76.8	1.951	1.951	5.92	982.12	801.0	6231.14	19656.1	8.713	49.5	
	Gr-2	RodC6_40.9	137	40.9	1.039	13.4	0.340	738.42	665.6	4475.74	14118.7	9.494	53.9
	RodC6_52.8	138	52.8	1.341	1.341	5.8	0.147	854.43	730.1	5071.71	15998.7	8.634	49.0
RodC6_54.8	139	54.8	1.392	1.392	7.8	0.198	875.07	741.5	5173.15	16318.7	8.507	48.3	
RodC6_57.8	140	57.8	1.468	1.468	10.8	0.274	909.07	760.4	5322.53	16789.9	8.290	47.1	
RodC6_63.8	141	63.8	1.621	1.621	16.8	0.427	946.12	781.0	5621.76	17733.8	8.278	47.0	
RodC6_73.7	142	73.7	1.872	1.872	2.82	0.072	979.59	799.6	6131.08	19340.5	8.604	48.9	
RodC6_75.8	143	75.8	1.925	1.925	4.92	0.125	1003.18	812.7	6233.78	19664.5	8.468	48.1	
RodC6_76.8	144	76.8	1.951	1.951	5.92	0.150	1019.73	821.9	6282.23	19817.3	8.346	47.4	

Table A-25: Summary of Steam Cooling Heat Transfer Reduced Data for Experiment 4041A, continued

5x5 periphery		H.R. Location	Channel Number	Elevation (in)	Elevation (m)	Zgrid (in)	Zgrid (m)	H.R. Tw (°F)	H.R. Tw (K)	H.R. q" (Btu/hr-ft ²)	H.R. q" (W/m ²)	h _{sat} (z) (Btu/hr-ft ² -F)	h _{sat} (z) (W/m ² -K)
Gr-3	RodB4_88.4	161	88.4	2.245	-0.1	-0.003	806.7	992.34	6754.24	21306.3	9.312	52.9	
	RodB4_91.3	162	91.3	2.319	2.8	0.071	853.5	1076.56	6883.44	21713.8	8.503	48.3	
	RodB4_93.3	163	93.3	2.370	4.8	0.122	859.5	1087.48	6971.19	21990.6	8.497	48.3	
	RodB4_95.1	164	95.1	2.416	6.6	0.168	875.3	1115.84	7051.27	22243.2	8.307	47.2	
	RodB4_100	165	100	2.540	11.5	0.292	896.7	1154.47	7276.64	22954.2	8.199	46.6	
	RodB4_106	166	106	2.692	17.5	0.445	940.5	1233.17	7553.43	23827.3	7.818	44.4	
	RodB4_109.9	167	109.9	2.791	21.4	0.544	907.8	1174.42	7314.50	23073.6	8.061	45.8	
	RodB4_142.3	168	142.3	3.614	8.8	0.224	953.2	1256.01	2790.43	8802.4	2.821	16.0	
Gr-5	RodF4_85.6	98	85.6	2.174	14.72	0.374	800.3	980.95	6635.46	20931.6	9.294	52.8	
	RodF4_88.4	99	88.4	2.245	-0.1	-0.003	804.9	989.20	6763.89	21336.7	9.366	53.2	
	RodF4_92.4	100	92.4	2.347	3.9	0.099	859.2	1086.93	6961.77	21960.9	8.491	48.2	
	RodF4_94.3	101	94.3	2.395	5.8	0.147	877.0	1118.86	7051.89	22245.2	8.278	47.0	
	RodF4_97.2	102	97.2	2.469	8.7	0.221	898.6	1157.80	7189.28	22678.6	8.071	45.8	
	RodF4_108.8	103	108.8	2.764	20.3	0.516	935.7	1224.63	7583.39	23921.8	7.919	45.0	
	RodF4_111	104	111	2.819	-1.75	-0.044	896.2	1153.46	7271.59	22938.2	8.203	46.6	
	RodD2_103.2	65	103.2	2.621	14.7	0.373	938.8	1230.11	6695.77	21121.8	6.952	39.5	
RodD2_106	66	106	2.692	17.5	0.445	950.7	1251.57	6338.80	19995.8	6.438	36.6		
RodD2_112.6	67	112.6	2.860	-0.15	-0.004	963.2	1274.17	5851.22	18457.7	5.810	33.0		
RodD2_114.9	68	114.9	2.918	2.15	0.055	969.2	1284.86	5279.46	16654.1	5.187	29.5		
RodD2_117.4	69	117.4	2.982	4.65	0.118	966.3	1279.59	4738.03	14946.1	4.679	26.6		
RodD2_120.8	70	120.8	3.068	8.05	0.204	931.7	1217.45	7520.17	23722.4	7.912	44.9		
RodD2_124.8	71	124.8	3.170	12.05	0.306	944.1	1239.80	7654.14	24145.0	7.868	44.7		
RodD2_128.6	72	128.6	3.266	15.85	0.403	913.3	1184.32	7025.66	22162.5	7.659	43.5		
Gr-6	RodD6_103.1	129	103.1	2.619	14.6	0.371	935.9	1225.03	7525.16	23738.1	7.855	44.6	
	RodD6_106	130	106	2.692	17.5	0.445	945.1	1241.58	7662.79	24172.3	7.863	44.7	
	RodD6_112.9	131	112.9	2.868	0.15	0.004	919.5	1195.41	6985.41	22035.5	7.524	42.7	
	RodD6_114.9	132	114.9	2.918	2.15	0.055	942.1	1236.02	6693.21	21113.7	6.907	39.2	
	RodD6_116.8	133	116.8	2.967	4.05	0.103	954.6	1258.66	6419.99	20251.9	6.474	36.8	
	RodD6_120.9	134	120.9	3.071	8.15	0.207	964.2	1275.90	5828.82	18387.0	5.777	32.8	
	RodD6_124.8	135	124.8	3.170	12.05	0.306	968.2	1283.14	5268.36	16619.0	5.185	29.4	
	RodD6_128.7	136	128.7	3.269	15.95	0.405	965.5	1278.18	4706.51	14846.7	4.654	26.4	

Table A-25: Summary of Steam Cooling Heat Transfer Reduced Data for Experiment 4041A, continued

5x5 periphery		H.R. Location	Channel Number	Elevation (in)	Elevation (m)	Zgrid (in)	Zgrid (m)	H.R. Tw (°F)	H.R. Tw (K)	H.R. q" (Btu/hr-ft ²)	H.R. q" (W/m ²)	h _{sat} (z) (Btu/hr-ft ² -F)	h _{sat} (z) (W/m ² -K)
Gr-8	RodE2_50.1	73	50.1	1.273	3.1	0.079	795.04	697.1	4973.95	15690.3	9.420	53.5	
	RodE2_54	74	54	1.372	7	0.178	861.67	734.1	5164.39	16291.1	8.684	49.3	
	RodE2_56.9	75	56.9	1.445	9.9	0.251	894.40	752.3	5303.11	16728.7	8.453	48.0	
	RodE2_59.9	76	59.9	1.521	12.9	0.328	925.90	769.8	5448.24	17186.5	8.269	47.0	
	RodE2_66	77	66	1.676	19	0.483	952.11	784.3	5743.90	18119.1	8.384	47.6	
	RodE2_69.8	78	69.8	1.773	-1.08	-0.027	855.90	730.9	5929.74	18705.4	10.069	57.2	
	RodE2_72.9	79	72.9	1.852	2.02	0.051	924.08	768.8	6078.69	19175.2	9.251	52.5	
	RodE2_74.9	80	74.9	1.902	4.02	0.102	955.94	786.5	6175.06	19479.2	8.963	50.9	
Gr-8	RodB3_50.2	169	50.2	1.275	3.2	0.081	763.60	679.6	4942.42	15590.9	9.952	56.5	
	RodB3_54.1	170	54.1	1.374	7.1	0.180	823.88	713.1	5121.07	16154.4	9.196	52.2	
	RodB3_56.9	171	56.9	1.445	9.9	0.251	864.47	735.6	5255.61	16578.8	8.796	50.0	
	RodB3_60.1	172	60.1	1.527	13.1	0.333	880.95	744.8	5410.05	17066.0	8.812	50.0	
	RodB3_66.1	173	66.1	1.679	19.1	0.485	932.37	773.4	5702.44	17988.3	8.570	48.7	
	RodB3_69.9	174	69.9	1.775	-0.98	-0.025	814.75	708.0	5916.46	18663.5	10.801	61.3	
	RodB3_73	175	73	1.854	2.12	0.054	901.40	756.2	6066.25	19136.0	9.562	54.3	
	RodB3_75	176	75	1.905	4.12	0.105	941.16	778.2	6159.64	19430.6	9.137	51.9	
Gr-8	RodF3_50.1	89	50.1	1.273	3.1	0.079	776.87	687.0	4944.71	15598.1	9.698	55.1	
	RodF3_54	90	54	1.372	7	0.178	841.72	723.0	5133.45	16193.5	8.932	50.7	
	RodF3_57	91	57	1.448	10	0.254	882.42	745.6	5275.98	16643.1	8.573	48.7	
	RodF3_60	92	60	1.524	13	0.330	914.33	763.3	5418.18	17091.7	8.370	47.5	
	RodF3_66.1	93	66.1	1.679	19.1	0.485	940.32	777.8	5716.59	18033.0	8.490	48.2	
	RodF3_70	94	70	1.778	-0.88	-0.022	821.12	711.6	5889.73	18579.2	10.629	60.4	
	RodF3_73	95	73	1.854	2.12	0.054	919.53	766.2	6043.11	19063.0	9.261	52.6	
	RodF3_75	96	75	1.905	4.12	0.105	963.85	790.8	6143.71	19380.3	8.816	50.1	
Gr-8	RodE6_50.2	121	50.2	1.275	3.2	0.081	779.56	688.5	4940.85	15585.9	9.640	54.7	
	RodE6_54.1	122	54.1	1.374	7.1	0.180	839.88	722.0	5125.26	16167.6	8.946	50.8	
	RodE6_57	123	57	1.448	10	0.254	871.92	739.8	5261.33	16596.9	8.698	49.4	
	RodE6_60.2	124	60.2	1.529	13.2	0.335	899.20	754.9	5413.23	17076.0	8.563	48.6	
	RodE6_66.1	125	66.1	1.679	19.1	0.485	926.23	769.9	5696.57	17969.8	8.641	49.1	
	RodE6_70	126	70	1.778	-0.88	-0.022	856.59	731.3	5879.54	18547.0	9.972	56.6	
	RodE6_73.1	127	73.1	1.857	2.22	0.056	927.20	770.5	6022.88	18999.2	9.123	51.8	
	RodE6_75	128	75	1.905	4.12	0.105	959.75	788.6	6112.26	19281.1	8.823	50.1	

RBHT Steam Cooling with Droplet Injection Test SCD-4041-B

Matrix Test # 9b

Test Conditions

Test Date – 10/26/2005

Steady State Time Window: 17400 – 17940

Upper Plenum Pressure: 2.76 bar (40 psia)

Bundle Power: 80.0 kW

Bundle Inlet Reynolds Number: 10000

Bundle Inlet Steam Flow: 199.6 kg/hr (440 lbm/hr)

Droplet Injection Flow: 0.0073 kg/s (0.016 lbm/s)

Droplet Injection Hole Diameter: 0.381 mm (.015 in)

Droplet Injection Elevation: 1.295 m (51 in)

Bundle Flow Area: $4.656 \times 10^{-3} \text{ m}^2$ ($5.012 \times 10^{-2} \text{ ft}^2$)

Test Notes

- No steam probes were traversed in this steady state window.

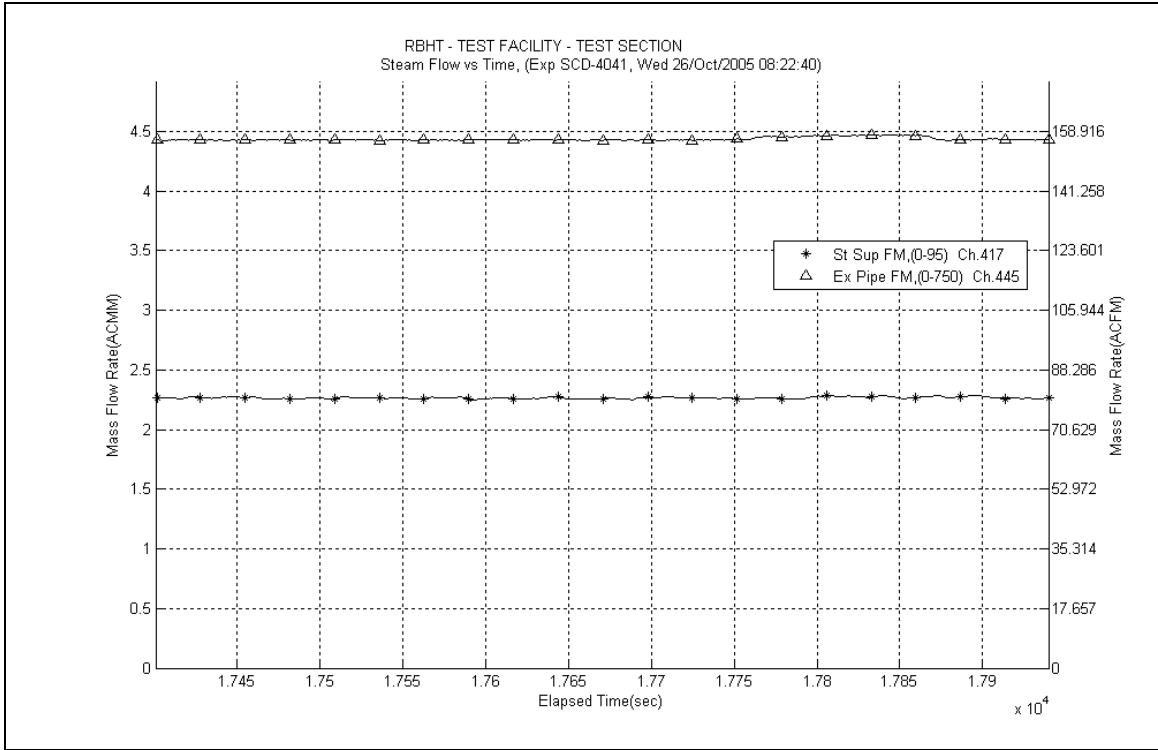

Figure A-462: Inlet and Exhaust Steam Flow Rates for Experiment 4041B

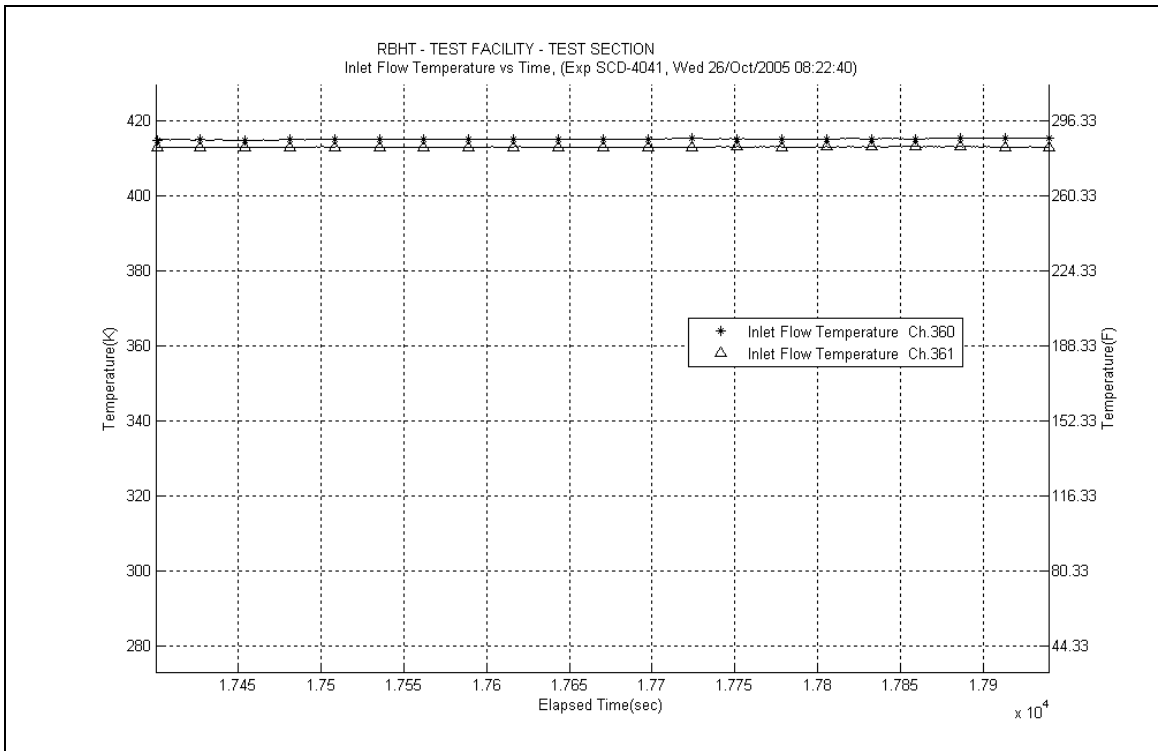

Figure A-463: Inlet Steam Temperature for Experiment 4041B

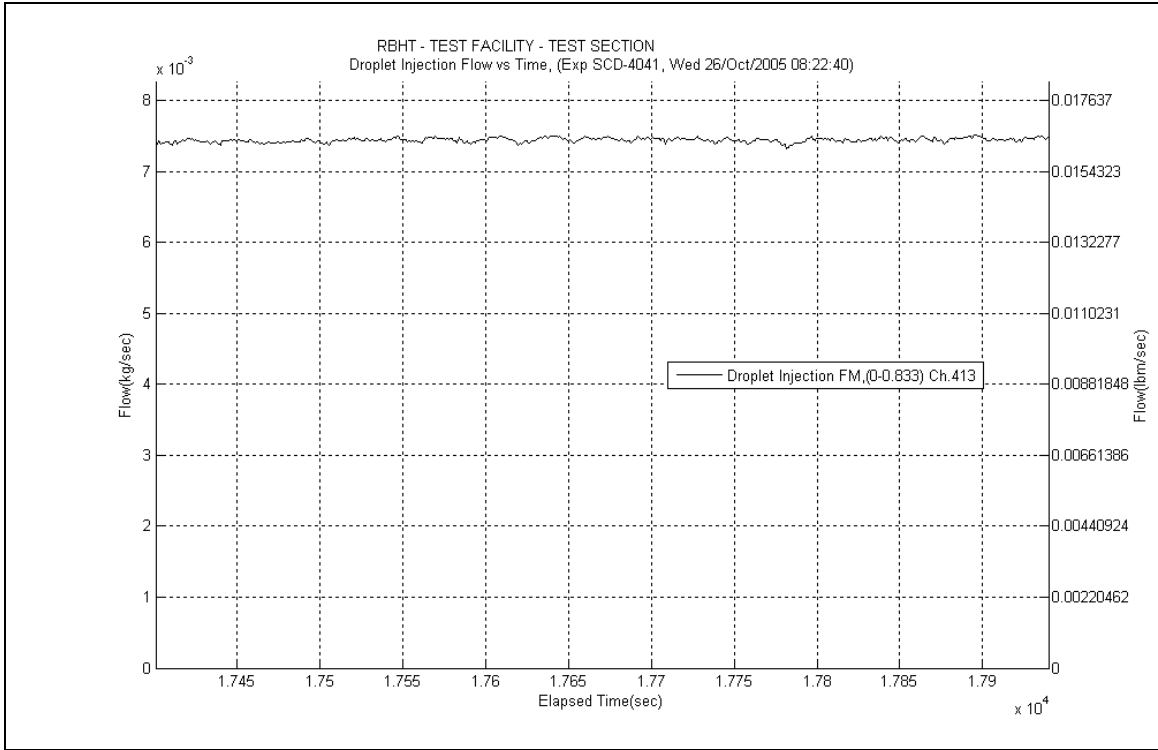

Figure A-464: Droplet Injection Flow Rate for Experiment 4041B

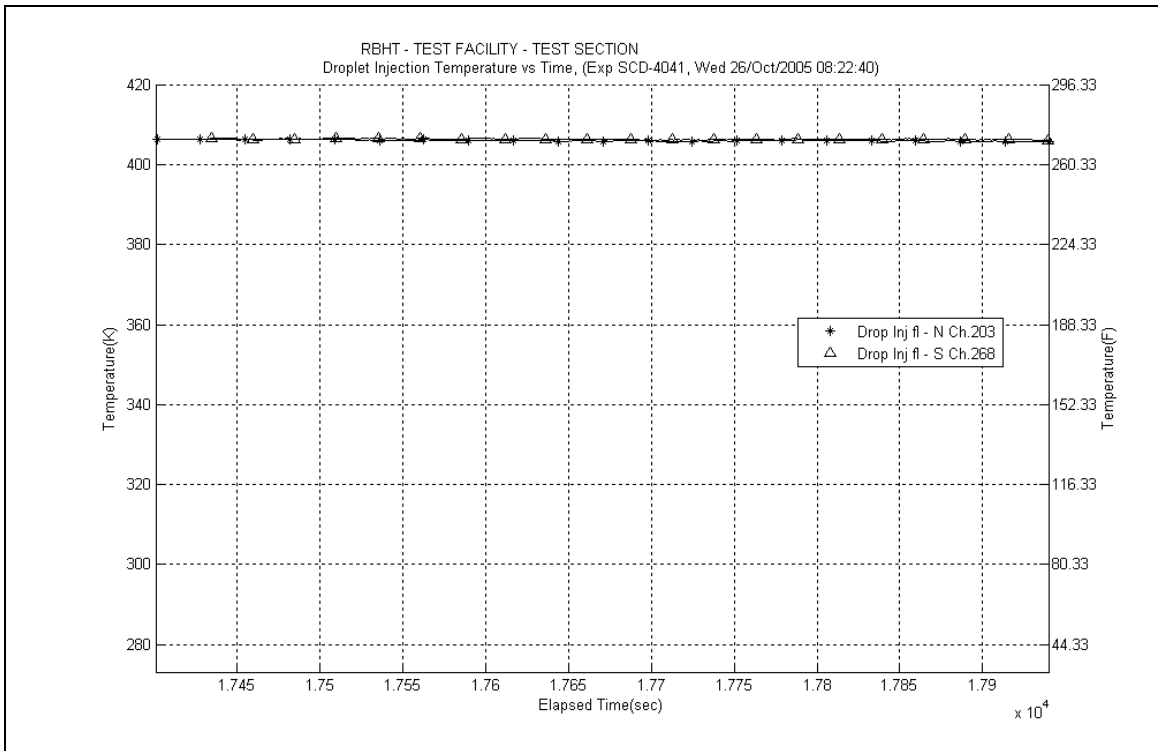

Figure A-465: Droplet Injection Temperature for Experiment 4041B

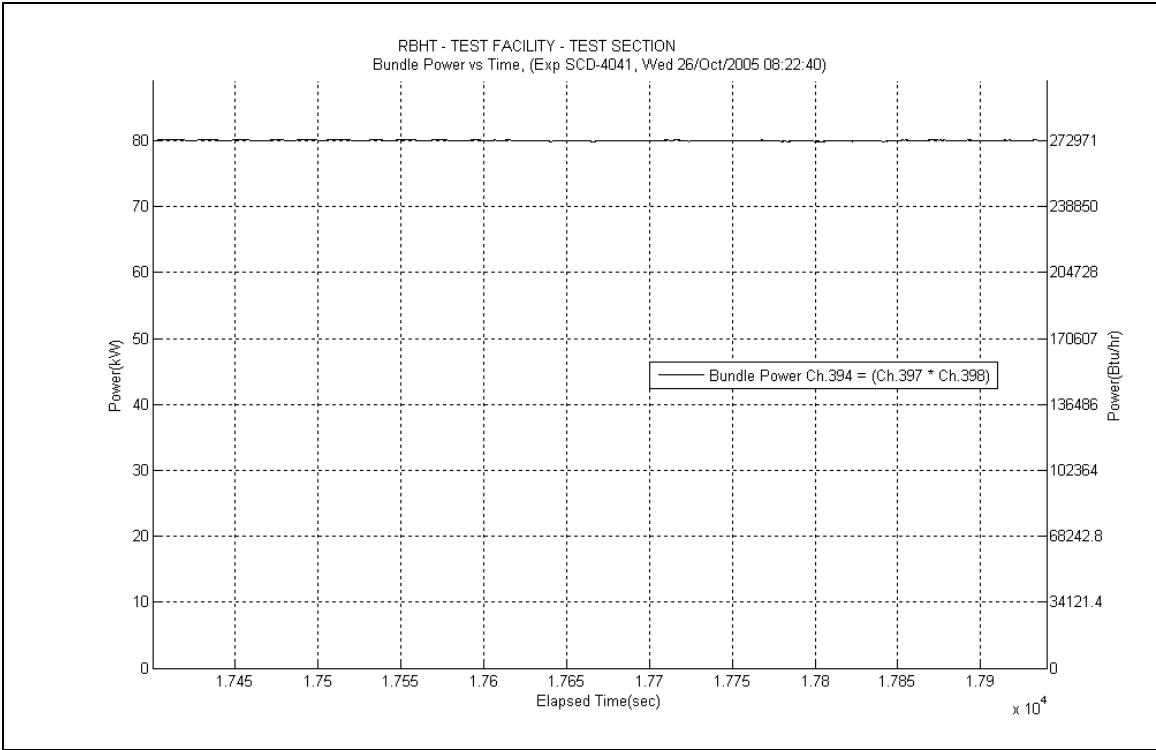

Figure A-466: Bundle Power for Experiment 4041B

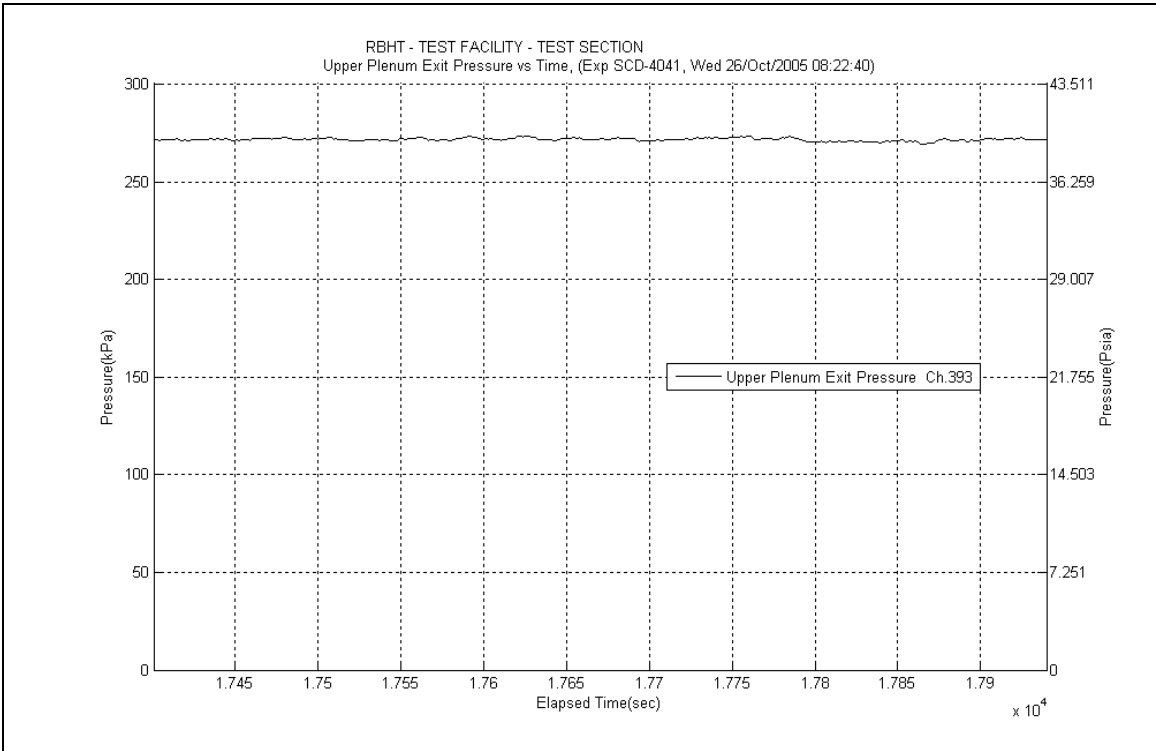

Figure A-467: Upper Plenum Pressure for Experiment 4041B

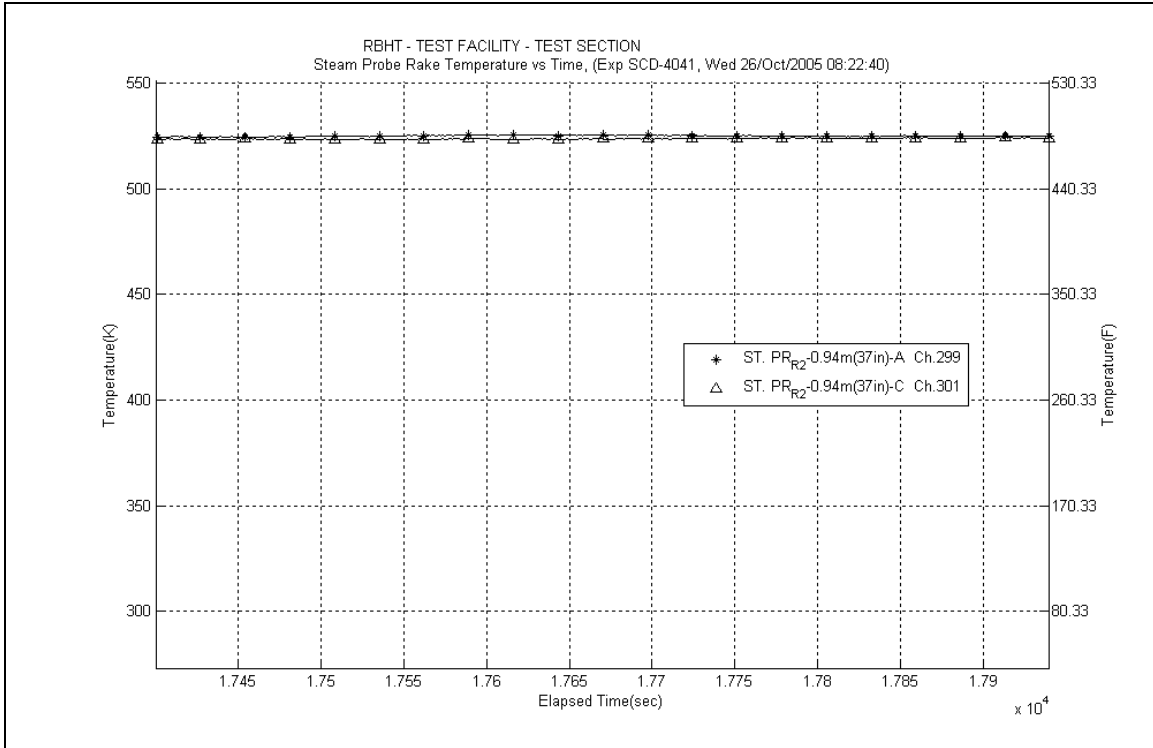

Figure A-468: Steam Probe Rake #2 Temperatures for Experiment 4041B

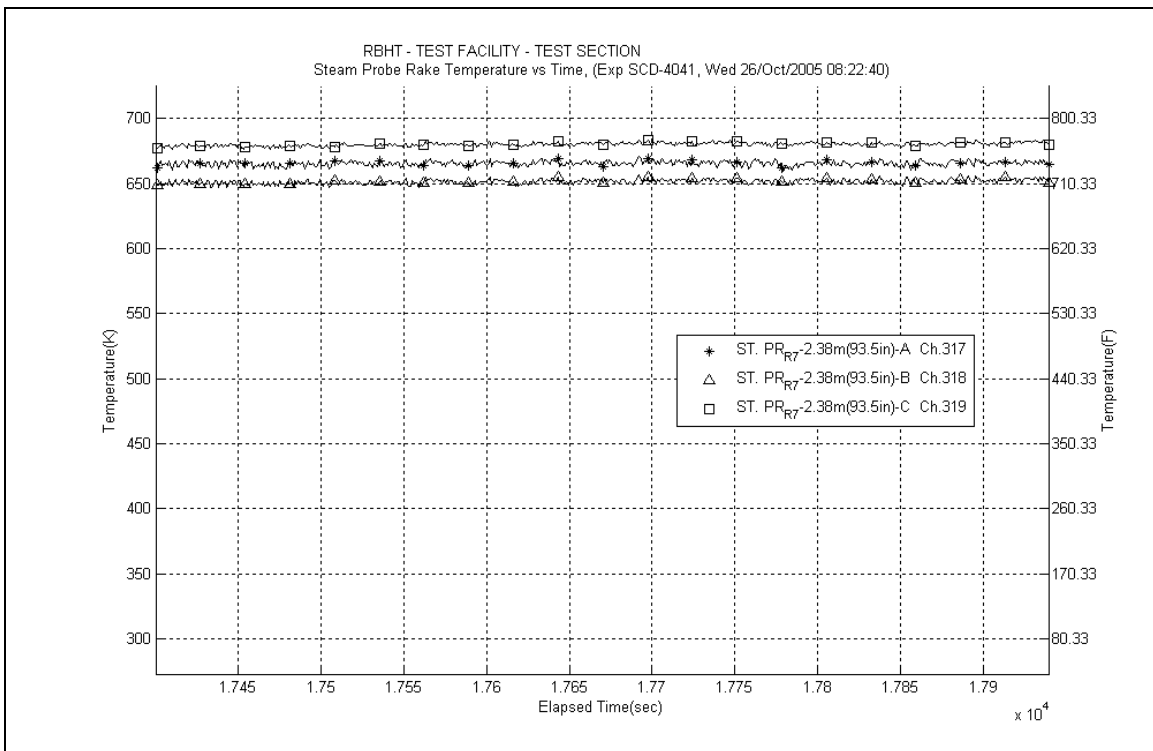

Figure A-469: Steam Probe Rake #7 Temperatures for Experiment 4041B

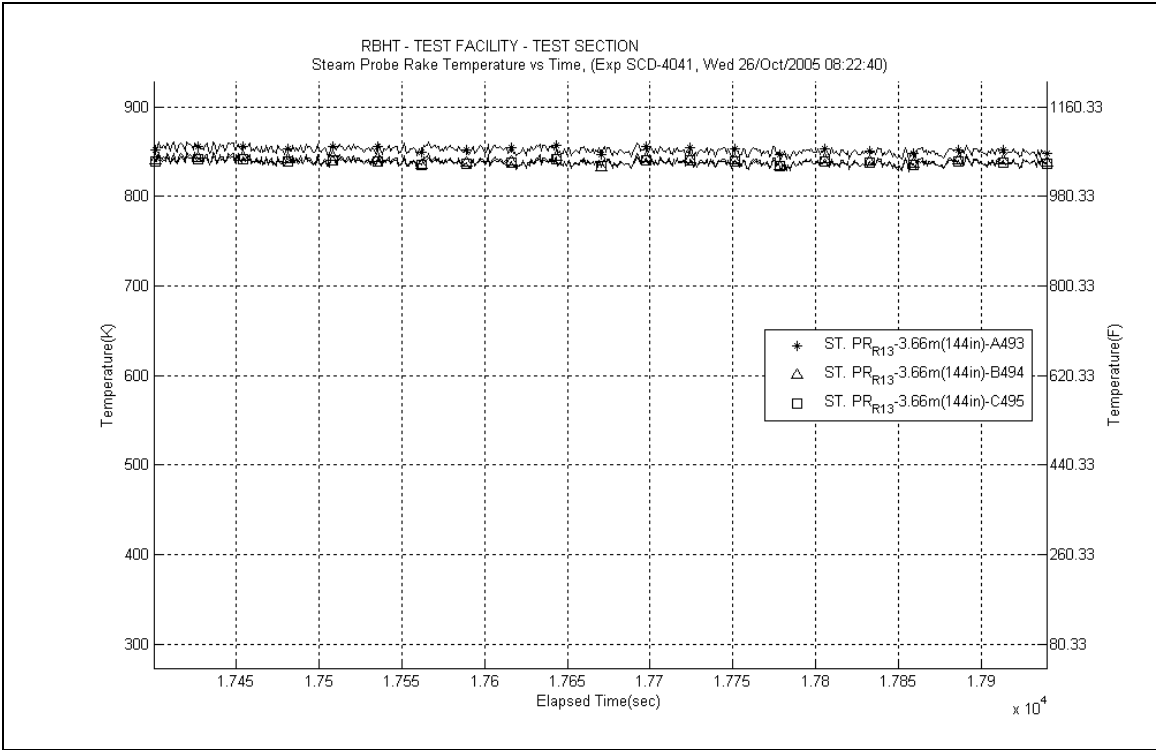

Figure A-470: Steam Probe Rake #13 Temperatures for Experiment 4041B

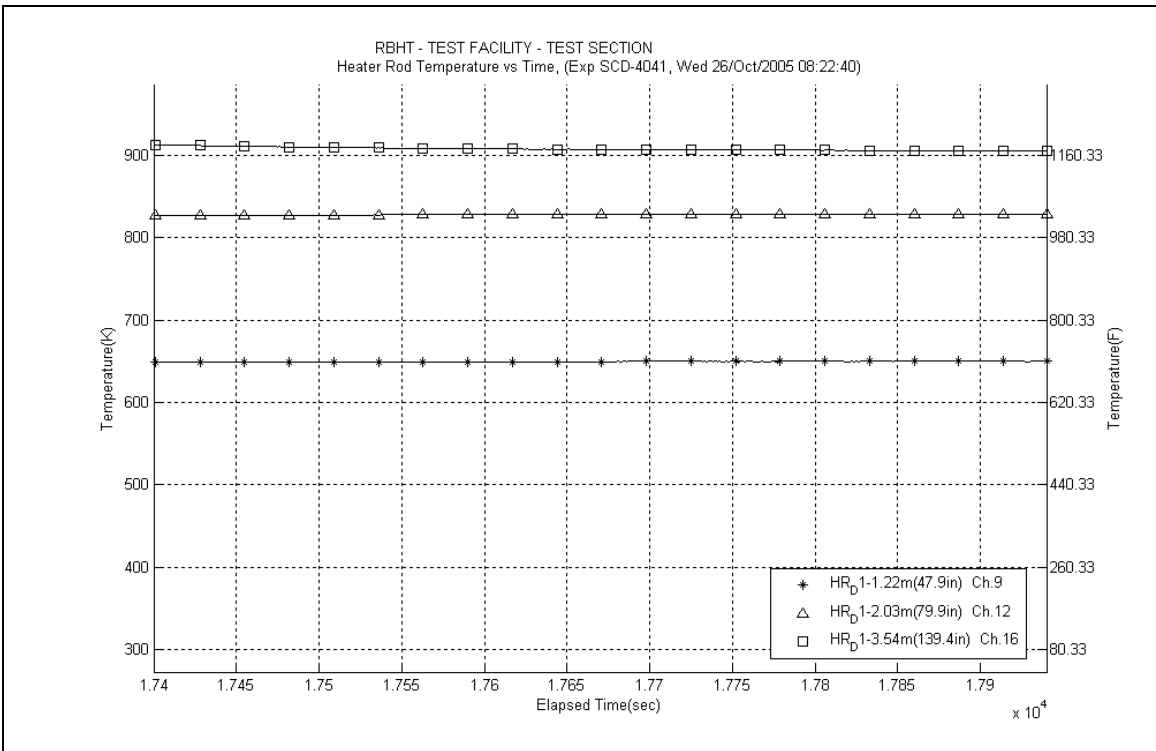

Figure A-471: Heater Rod D1 Temperatures for Experiment 4041B

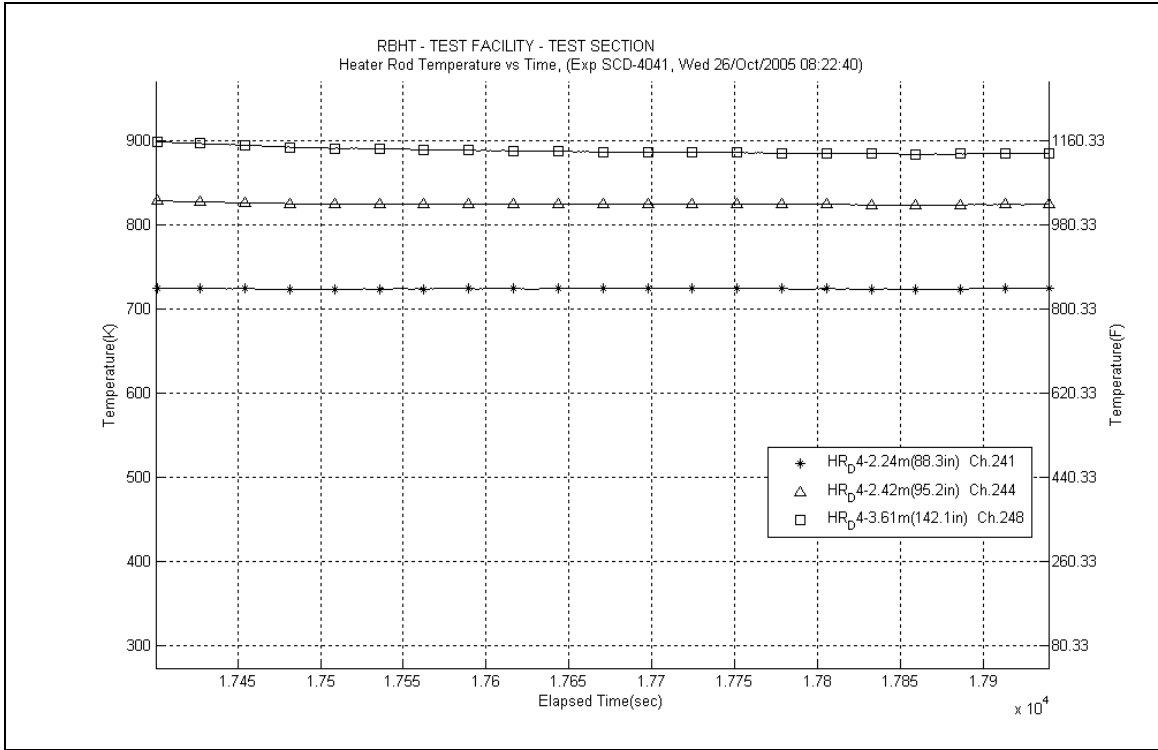

Figure A-472: Heater Rod D4 Temperatures for Experiment 4041B

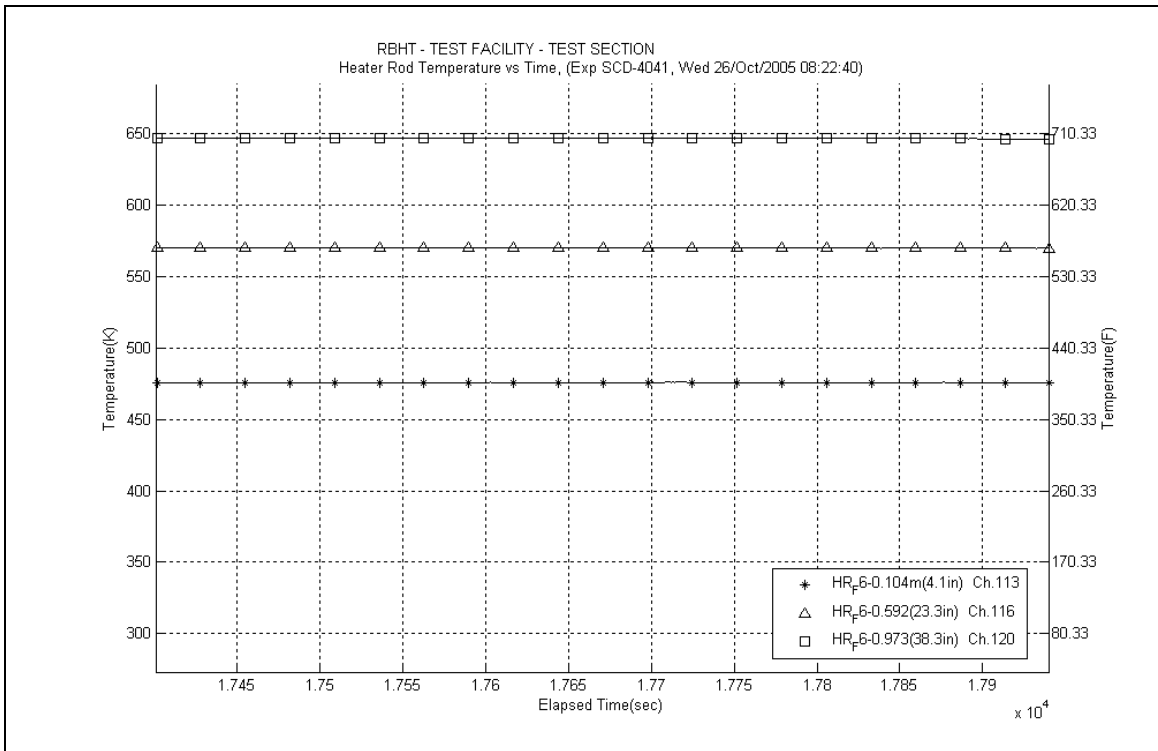

Figure A-473: Heater Rod F6 Temperatures for Experiment 4041B

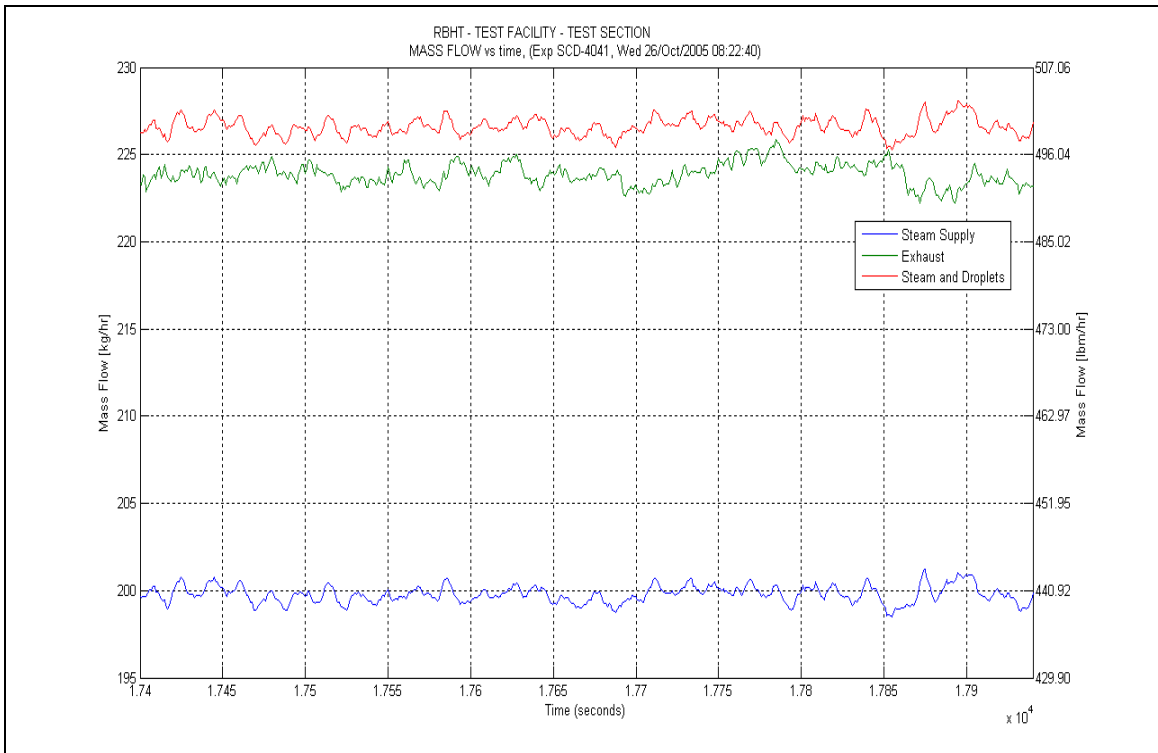

Figure A-474: Mass Flow for Experiment 4041B

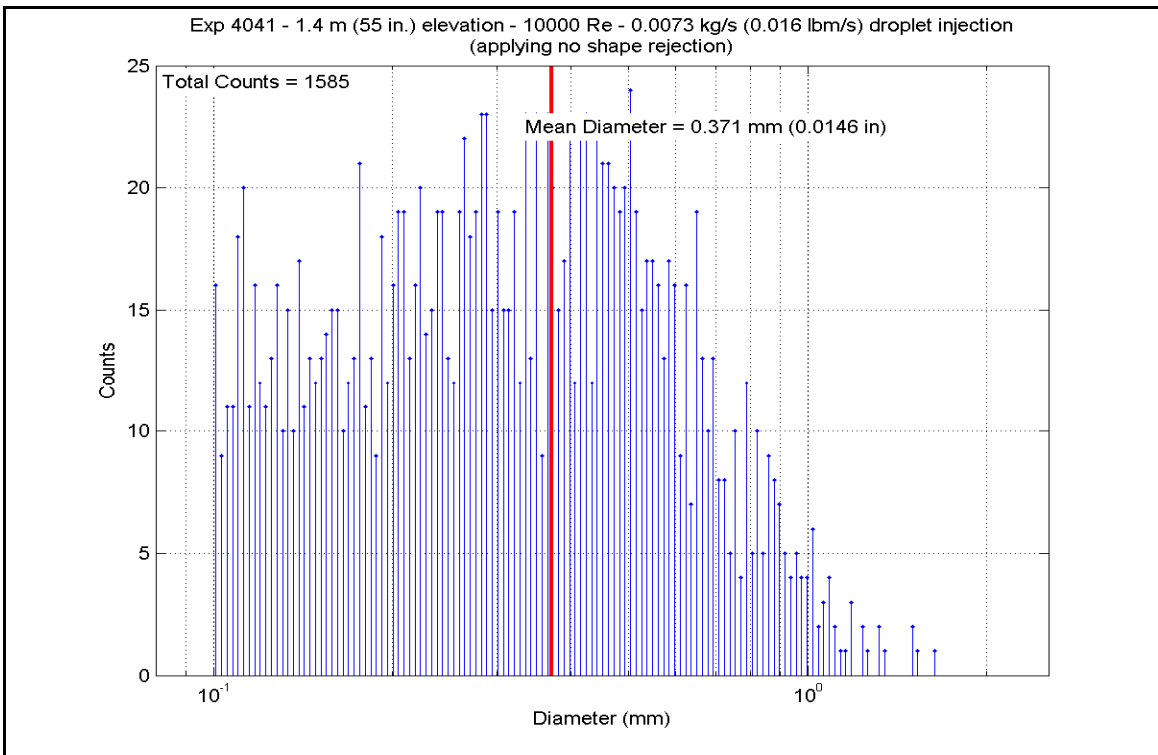

Figure A-475: Droplet Measurements at 1.397 m (55 in.) Elevation for Experiment 4041B

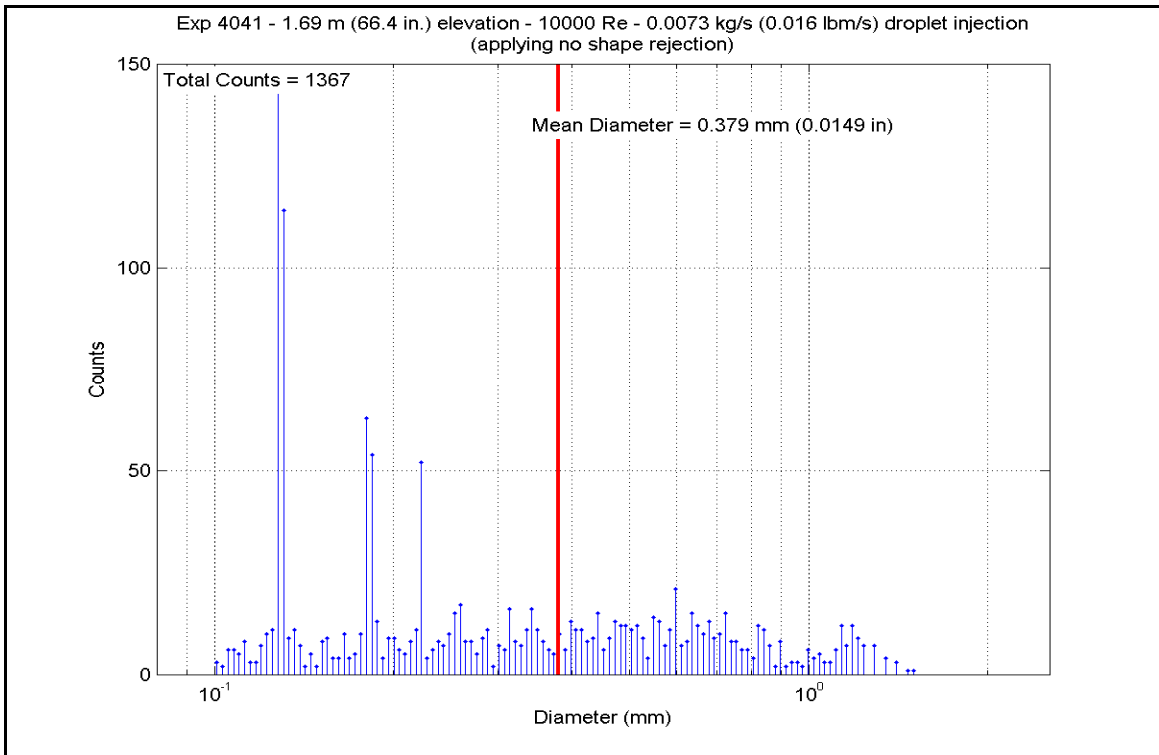

Figure A-476: Droplet Measurements at 1.687 m (66.4 in.) Elevation for Experiment 4041B

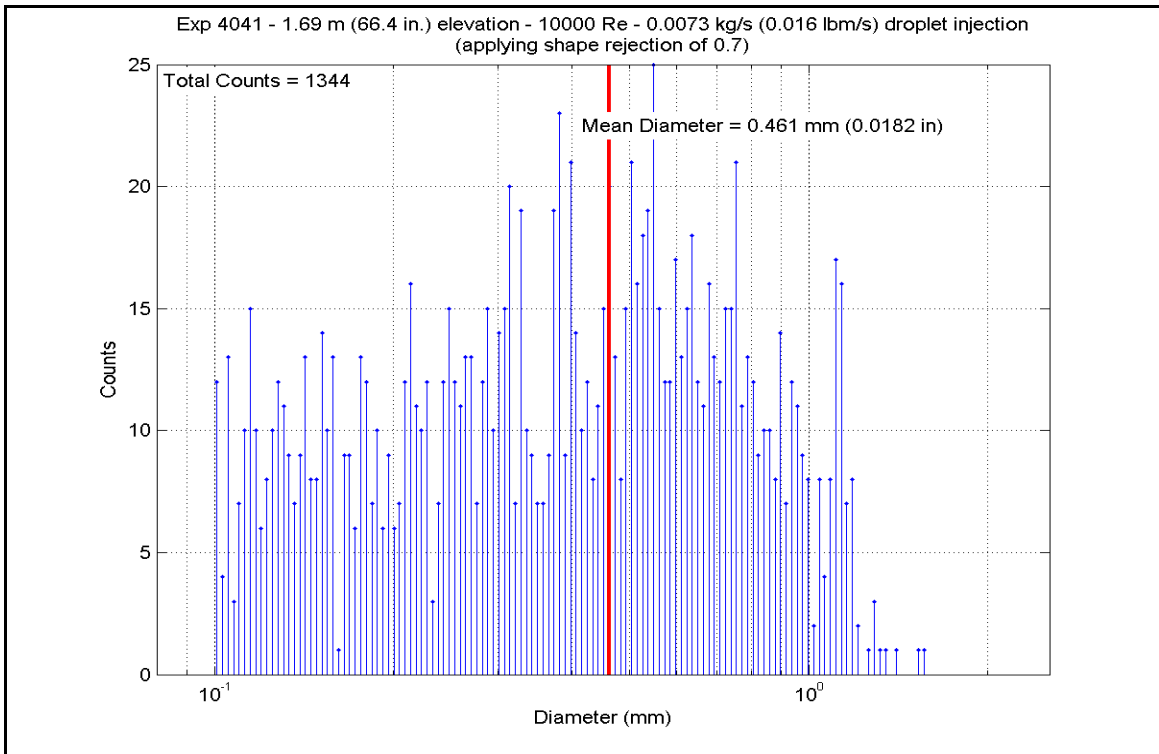

Figure A-477: Droplet Measurements at 1.687 m (66.4 in.) Elevation for Experiment 4041B

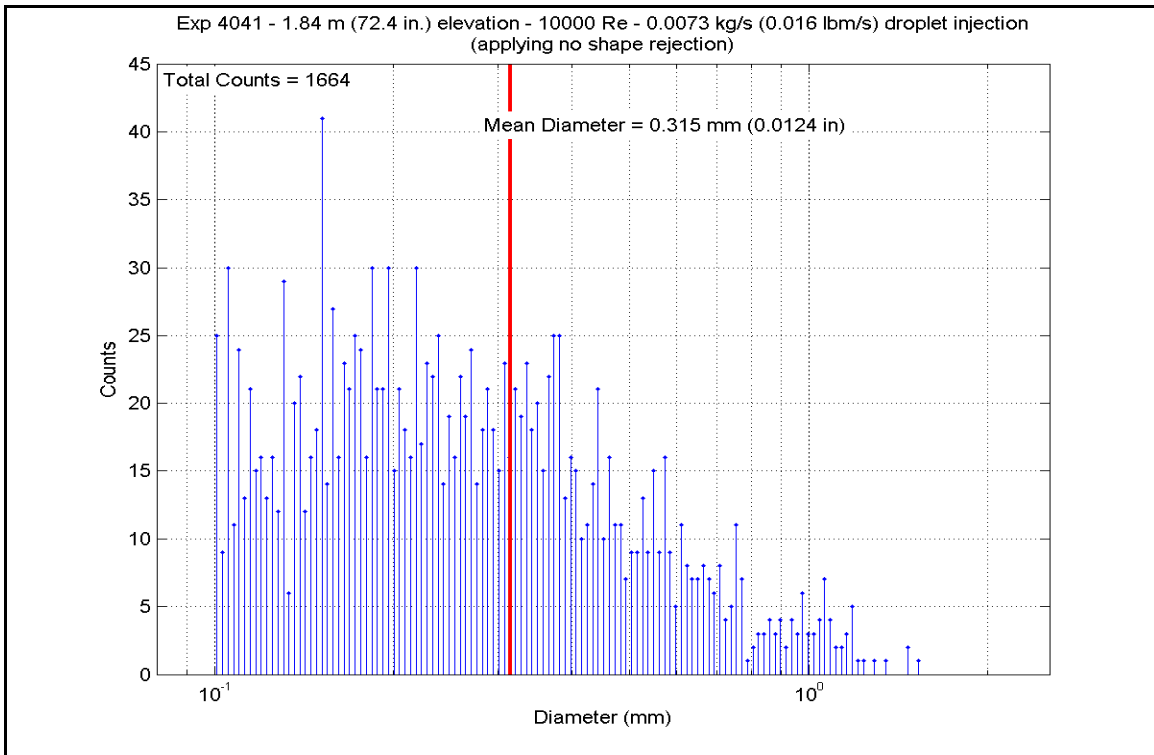

Figure A-478: Droplet Measurements at 1.839 m (72.4 in.) Elevation for Experiment 4041B

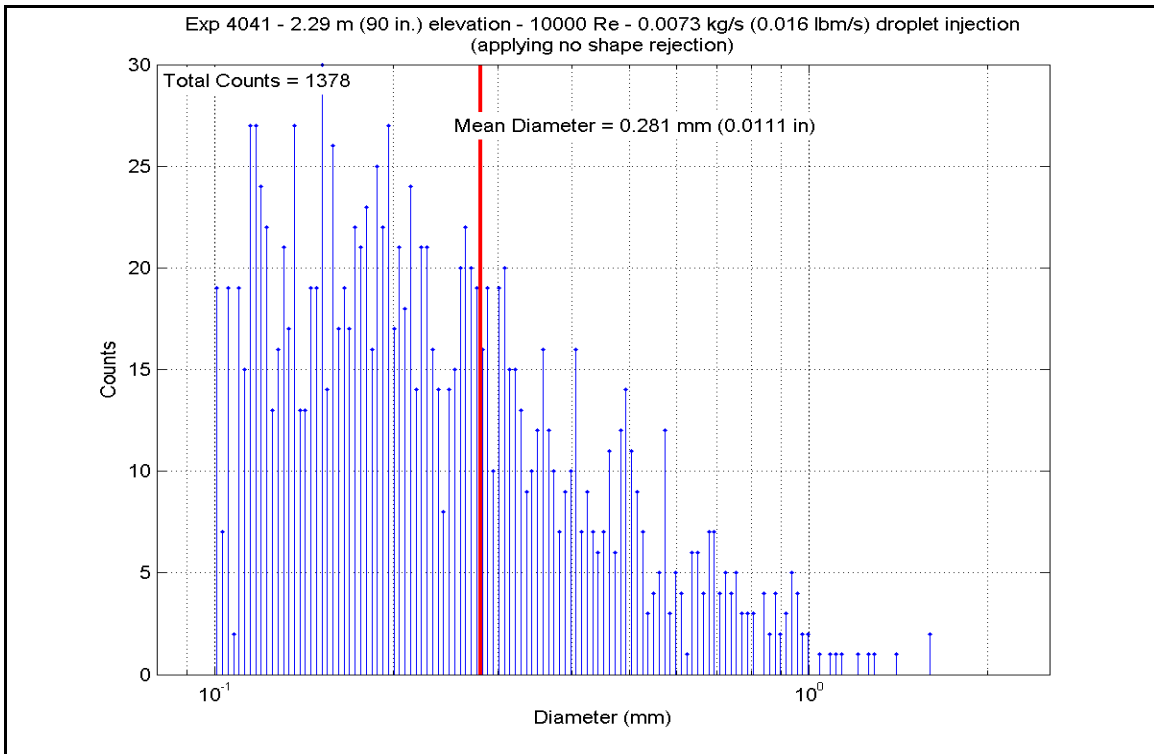

Figure A-479: Droplet Measurements at 2.286 m (90 in.) Elevation for Experiment 4041B

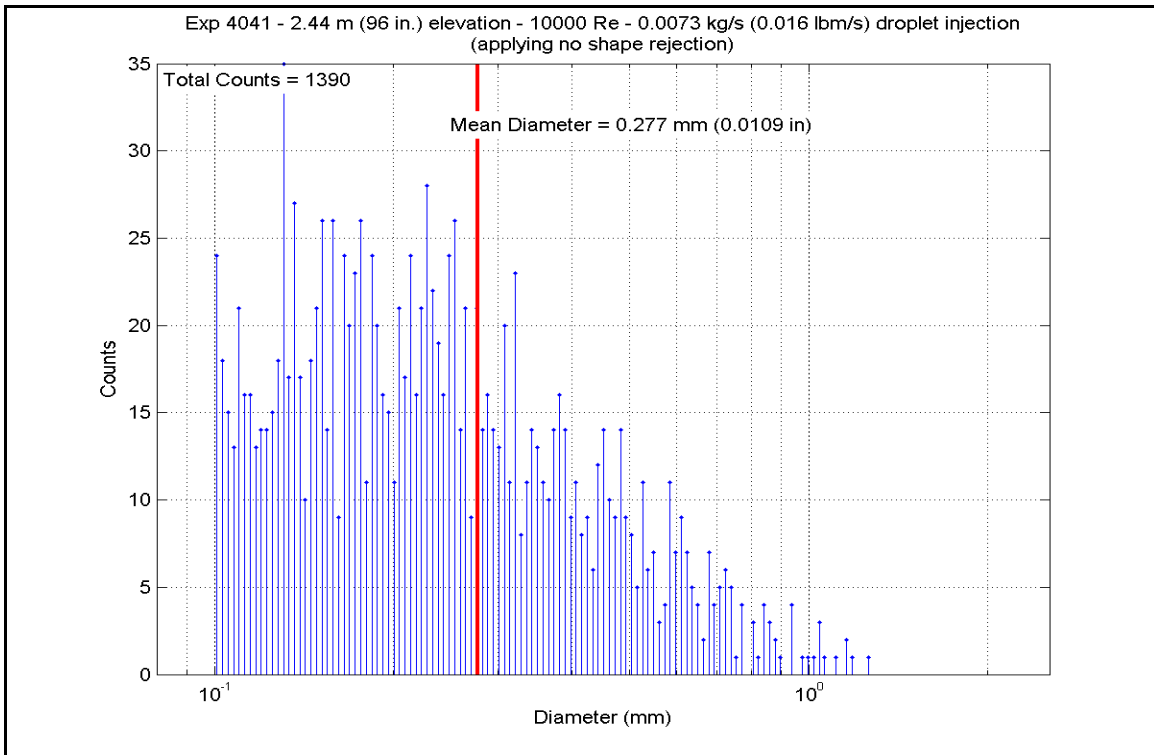

Figure A-480: Droplet Measurements at 2.438 m (96 in.) Elevation for Experiment 4041B

Table A-26: Summary of Steam Cooling Heat Transfer Reduced Data for Experiment 4041B

SCD-4041-B		Inlet Reynolds:		10000		40 psia						
Matrix Test # 9b		UP Pressure:		275.8 kPa		272971 Btu/hr						
Time Window 17400-17940		Bundle Power:		80.00 kW		440.0 lbm/hr						
		Steam flow:		0.0554 kg/s		0.016 lbm/s						
Inner 3x3		Droplet flow:		0.0073 kg/s								
H.R. ID	H.R. Location	Channel Number	Elevation (in)	Elevation (m)	Zgrid (in)	Zgrid (m)	H.R. Tw (°F)	H.R. Tw (K)	H.R. q" (Btu/hr-ft ²)	H.R. q' (W/m ²)	h _{sat} (z) (Btu/hr-ft ² -F)	h _{sat} (z) (W/m ² -K)
Gr-3	RodD3_88.3	185	88.3	2.243	-0.2	-0.005	905.07	758.2	6793.93	21431.5	10.648	60.5
	RodD3_91.3	186	91.3	2.319	2.8	0.071	985.25	802.7	6956.41	21944.0	9.685	55.0
	RodD3_93.1	187	93.1	2.365	4.6	0.117	984.88	802.5	7046.77	22229.0	9.816	55.7
	RodD3_95.3	188	95.3	2.421	6.8	0.173	1035.23	830.5	7155.79	22573.0	9.315	52.9
	RodD3_100.1	189	100.1	2.543	11.6	0.295	1118.57	876.8	7374.41	23262.6	8.660	49.2
	RodD3_106.1	190	106.1	2.695	17.6	0.447	1180.43	911.2	7665.69	24181.4	8.392	47.7
	RodD3_110	191	110	2.794	21.5	0.546	1104.54	869.0	7563.22	23858.2	9.030	51.3
	RodD3_142.1	192	142.1	3.609	8.6	0.218	1165.64	903.0	2723.23	8590.4	3.030	17.2
Gr-3	RodC4_88.4	233	88.4	2.245	-0.1	-0.003	854.19	729.9	6876.51	21691.9	11.711	66.5
	RodC4_91.1	234	91.1	2.314	2.6	0.066	958.97	788.1	7021.43	22149.1	10.147	57.6
	RodC4_93.4	235	93.4	2.372	4.9	0.124	987.62	804.1	7134.44	22505.6	9.900	56.2
	RodC4_95.3	236	95.3	2.421	6.8	0.173	1036.64	831.3	7231.73	22812.5	9.396	53.4
	RodC4_100.1	237	100.1	2.543	11.6	0.295	1078.81	854.7	7463.19	23542.6	9.193	52.2
	RodC4_106.1	238	106.1	2.695	17.6	0.447	1145.17	891.6	7763.53	24490.1	8.841	50.2
	RodC4_110	239	110	2.794	21.5	0.546	1069.20	849.4	7510.63	23692.3	9.363	53.2
	RodC4_142.2	240	142.2	3.612	8.7	0.221	1130.62	883.5	2941.04	9277.5	3.405	19.3
Gr-3	RodD4_88.3	241	88.3	2.243	-0.2	-0.005	841.00	722.6	6848.72	21604.3	11.932	67.8
	RodD4_91.3	242	91.3	2.319	2.8	0.071	946.33	781.1	7007.60	22105.5	10.316	58.6
	RodD4_93.2	243	93.2	2.367	4.7	0.119	976.23	797.7	7105.30	22413.7	10.018	56.9
	RodD4_95.2	244	95.2	2.418	6.7	0.170	1022.12	823.2	7206.36	22732.5	9.543	54.2
	RodD4_100.1	245	100.1	2.543	11.6	0.295	1105.42	869.5	7445.84	23487.9	8.881	50.4
	RodD4_106.1	246	106.1	2.695	17.6	0.447	1144.41	891.2	7739.30	24413.6	8.821	50.1
	RodD4_142.1	248	142.1	3.609	8.6	0.218	1137.97	887.6	2850.42	8991.7	3.273	18.6
Gr-3	RodE4_88.4	201	88.4	2.245	-0.1	-0.003	876.91	742.5	6753.48	21303.9	11.073	62.9
	RodE4_91.2	202	91.2	2.316	2.7	0.069	981.73	800.8	6892.46	21742.3	9.643	54.8
	RodE4_95.3	204	95.3	2.421	6.8	0.173	1058.52	843.4	7089.80	22364.8	8.957	50.9
	RodE4_100.9	205	100.9	2.563	12.4	0.315	1123.46	879.5	7346.51	23174.6	8.578	48.7
	RodE4_142.3	208	142.3	3.614	8.8	0.224	1159.17	899.4	2903.60	9159.4	3.255	18.5

Table A-26: Summary of Steam Cooling Heat Transfer Reduced Data for Experiment 4041B, continued

Inner 3x3	H.R. Location	Channel Number	Elevation (in)	Elevation (m)	Zgrid (in)	Zgrid (m)	H.R. Tw (°F)	H.R. Tw (K)	H.R. q" (Btu/hr-ft ²)	H.R. q" (W/m ²)	h _{sat} (z) (Btu/hr-ft ² -F)	h _{sat} (z) (W/m ² -K)
Gr-4	RodE3_63.4	193	63.4	1.610	16.4	0.417	949.01	782.6	5579.13	17599.4	8.180	46.5
	RodE3_113.6	194	113.6	2.885	0.85	0.022	1146.85	892.5	6907.77	21790.6	7.851	44.6
	RodE3_115.5	195	115.5	2.934	2.75	0.070	1181.41	911.7	6668.06	21034.4	7.292	41.4
	RodE3_118.5	196	118.5	3.010	5.75	0.146	1209.21	927.2	6271.48	19783.4	6.656	37.8
	RodE3_122.7	197	122.7	3.117	9.95	0.253	1217.21	931.6	5716.54	18032.8	6.016	34.2
	RodE3_126.5	198	126.5	3.213	13.75	0.349	1217.82	931.9	5211.47	16439.6	5.481	31.1
	RodE3_131.7	199	131.7	3.345	-1.8	-0.046	1136.01	886.5	4499.04	14192.2	5.177	29.4
	RodE3_135.6	200	135.6	3.444	2.1	0.053	1169.61	905.2	3993.30	12596.9	4.424	25.1
	RodC5_63.7	225	63.7	1.618	16.7	0.424	925.75	769.7	5464.89	17239.0	8.296	47.1
	RodC5_113.6	226	113.6	2.885	0.85	0.022	1080.13	855.4	6738.89	21257.8	8.288	47.1
Gr-4	RodC5_115.7	227	115.7	2.939	2.95	0.075	1118.42	876.7	6478.95	20437.8	7.610	43.2
	RodC5_122.7	229	122.7	3.117	9.95	0.253	1153.76	896.3	5605.19	17681.6	6.321	35.9
	RodC5_126.7	230	126.7	3.218	13.95	0.354	1149.46	894.0	5099.86	16087.5	5.779	32.8
	RodC5_131.6	231	131.6	3.343	-1.9	-0.048	1054.11	841.0	4461.29	14073.1	5.668	32.2
	RodC5_135.7	232	135.7	3.447	2.2	0.056	1092.52	862.3	3953.18	12470.3	4.789	27.2
	RodE5_63.6	209	63.6	1.615	16.6	0.422	844.41	724.5	5617.09	17719.1	9.728	55.2
	RodE5_113.6	210	113.6	2.885	0.85	0.022	993.13	807.1	6964.74	21970.3	9.592	54.5
	RodE5_115.4	211	115.4	2.931	2.65	0.067	1070.41	850.0	6731.08	21233.2	8.378	47.6
	RodE5_118.7	212	118.7	3.015	5.95	0.151	1133.98	885.4	6299.91	19873.1	7.266	41.3
	RodE5_122.6	213	122.6	3.114	9.85	0.250	1171.94	906.5	5789.80	18263.9	6.398	36.3
RodE5_126.6	214	126.6	3.216	13.85	0.352	1182.44	912.3	5267.47	16616.2	5.754	32.7	
Gr-5	RodE5_131.6	215	131.6	3.343	-1.9	-0.048	1166.82	903.6	4612.06	14548.7	5.126	29.1
	RodE5_135.6	216	135.6	3.444	2.1	0.053	1134.01	885.4	4080.22	12871.1	4.706	26.7
	RodC3_79.8	177	79.8	2.027	8.92	0.227	959.14	788.2	6337.89	19992.9	9.157	52.0
	RodC3_85.6	178	85.6	2.174	14.72	0.374	874.91	741.4	6626.45	20903.1	10.900	61.9
	RodC3_88.5	179	88.5	2.248	0	0.000	887.54	748.5	6778.44	21382.6	10.923	62.0
	RodC3_92.4	180	92.4	2.347	3.9	0.099	1000.82	811.4	6972.22	21993.9	9.501	54.0
	RodC3_94.4	181	94.4	2.398	5.9	0.150	1016.71	820.2	7065.27	22287.4	9.424	53.5
	RodC3_97.2	182	97.2	2.469	8.7	0.221	1070.46	850.1	7187.34	22672.5	8.945	50.8
	RodC3_108.8	183	108.8	2.764	20.3	0.516	1164.73	902.4	7579.54	23909.7	8.443	47.9
	RodD5_50	217	50	1.270	1.270	0.076	814.78	708.0	4954.82	15630.0	9.045	51.4
Gr-8	RodD5_54.1	218	54.1	1.374	7.1	0.180	816.03	708.7	5149.57	16244.3	9.379	53.3
	RodD5_56.9	219	56.9	1.445	9.9	0.251	859.21	732.7	5282.05	16662.2	8.919	50.7
	RodD5_60	220	60	1.524	13	0.330	889.79	749.7	5428.04	17122.8	8.716	49.5
	RodD5_66.1	221	66.1	1.679	19.1	0.485	928.98	771.5	5718.75	18039.8	8.639	49.1
	RodD5_69.9	222	69.9	1.775	-0.98	-0.025	788.05	693.2	5896.99	18602.1	11.317	64.3
	RodD5_72.9	223	72.9	1.852	2.02	0.051	860.17	733.2	6040.89	19056.0	10.184	57.8
	RodD5_74.9	224	74.9	1.902	4.02	0.102	905.22	758.3	6137.77	19361.6	9.617	54.6

Table A-26: Summary of Steam Cooling Heat Transfer Reduced Data for Experiment 4041B, continued

H.R. ID	H.R. Location	Channel Number	Elevation (in)	Elevation (m)	Zgrid (in)	Zgrid (m)	H.R. Tw (°F)	H.R. Tw (K)	H.R. q" (Btu/hr-ft ²)	H.R. q" (W/m ²)	h _{sat} (z) (Btu/hr-ft ² -F)	h _{sat} (z) (W/m ² -K)	
Gr-2	RodB5_41	153	41	1.041	13.5	0.343	752.18	673.3	4500.25	14196.0	9.275	52.7	
	RodB5_52.9	154	52.9	1.344	5.9	0.150	813.31	707.2	5067.14	15984.3	9.275	52.7	
	RodB5_55	155	55	1.397	8	0.203	848.58	726.8	5169.42	16306.9	8.889	50.5	
	RodB5_57.8	156	57.8	1.468	10.8	0.274	889.22	749.4	5303.95	16731.3	8.524	48.4	
	RodB5_64	157	64	1.626	17	0.432	938.06	776.5	5602.94	17674.5	8.349	47.4	
	RodB5_73.9	158	73.9	1.877	3.02	0.077	897.41	753.9	6084.48	19193.5	9.652	54.8	
	RodB5_75.9	159	75.9	1.928	5.02	0.128	933.32	773.9	6181.38	19499.2	9.277	52.7	
	RodB5_76.9	160	76.9	1.953	6.02	0.153	947.39	781.7	6229.62	19651.3	9.156	52.0	
	Gr-2	RodF5_41	105	41	1.041	13.5	0.343	741.38	667.3	4477.07	14122.9	9.438	53.6
		RodF5_53.1	106	53.1	1.349	6.1	0.155	796.51	697.9	5050.25	15931.0	9.538	54.2
RodF5_55		107	55	1.397	8	0.203	833.34	718.3	5140.48	16215.7	9.077	51.5	
RodF5_57.8		108	57.8	1.468	10.8	0.274	878.02	743.2	5276.26	16644.0	8.635	49.0	
RodF5_64		109	64	1.626	17	0.432	922.35	767.8	5578.30	17596.8	8.512	48.3	
RodF5_73.8		110	73.8	1.875	2.92	0.074	888.88	749.2	6062.05	19122.7	9.748	55.4	
RodF5_75.8		111	75.8	1.925	4.92	0.125	928.24	771.1	6159.24	19429.3	9.315	52.9	
RodF5_76.8		112	76.8	1.951	5.92	0.150	944.33	780.0	6207.91	19582.9	9.165	52.0	
Gr-2		RodC2_41	57	41	1.041	13.5	0.343	734.29	663.3	4488.60	14190.8	9.627	54.7
		RodC2_53.1	58	53.1	1.349	6.1	0.155	856.61	731.3	5079.18	16022.3	8.614	48.9
	RodC2_55	59	55	1.397	8	0.203	875.04	741.5	5170.14	16309.2	8.503	48.3	
	RodC2_57.8	60	57.8	1.468	10.8	0.274	906.20	758.8	5306.02	16737.8	8.301	47.1	
	RodC2_63.9	61	63.9	1.623	16.9	0.429	935.79	775.3	5600.83	17667.8	8.375	47.6	
	RodC2_73.8	62	73.8	1.875	2.92	0.074	921.90	767.5	6065.00	19132.1	9.261	52.6	
	RodC2_75.8	63	75.8	1.925	4.92	0.125	949.24	782.7	6159.83	19431.2	9.029	51.3	
	RodC2_76.8	64	76.8	1.951	5.92	0.150	960.01	788.7	6207.96	19583.0	8.958	50.9	
	Gr-2	RodC6_40.9	137	40.9	1.039	13.4	0.340	748.73	671.3	4474.77	14115.7	9.289	52.8
		RodC6_52.8	138	52.8	1.341	5.8	0.147	866.18	736.6	5069.24	15990.9	8.460	48.0
RodC6_54.8		139	54.8	1.392	7.8	0.198	887.39	748.4	5170.28	16309.7	8.334	47.3	
RodC6_57.8		140	57.8	1.468	10.8	0.274	921.86	767.5	5321.90	16787.9	8.127	46.2	
RodC6_63.8		141	63.8	1.621	16.8	0.427	955.00	785.9	5622.69	17736.8	8.172	46.4	
RodC6_73.7		142	73.7	1.872	2.82	0.072	939.06	777.1	6119.26	19303.2	9.105	51.7	
RodC6_75.8		143	75.8	1.925	4.92	0.125	968.05	793.2	6225.69	19639.0	8.880	50.4	
RodC6_76.8		144	76.8	1.951	5.92	0.150	985.10	802.6	6276.81	19800.2	8.741	49.6	

Table A-26: Summary of Steam Cooling Heat Transfer Reduced Data for Experiment 4041B, continued

5x5 periphery		H.R. Location	Channel Number	Elevation (in)	Elevation (m)	Zgrid (in)	Zgrid (m)	H.R. Tw (°F)	H.R. Tw (K)	H.R. q" (Btu/hr-ft ²)	H.R. q" (W/m ²)	h _{sat} (z) (Btu/hr-ft ² -F)	h _{sat} (z) (W/m ² -K)
Gr-3	RodB4_88.4	161	88.4	2.245	-0.1	-0.003	889.00	749.3	6757.29	21315.9	10.864	61.7	
	RodB4_91.3	162	91.3	2.319	2.8	0.071	978.50	799.0	6903.75	21777.9	9.703	55.1	
	RodB4_93.3	163	93.3	2.370	4.8	0.122	992.05	806.5	6993.39	22060.6	9.645	54.8	
	RodB4_95.1	164	95.1	2.416	6.6	0.168	1024.88	824.7	7080.32	22334.9	9.342	53.1	
	RodB4_100	165	100	2.540	11.5	0.292	1057.07	842.6	7285.93	22983.5	9.222	52.4	
	RodB4_106	166	106	2.692	17.5	0.445	1142.56	890.1	7571.41	23884.0	8.648	49.1	
	RodB4_109.9	167	109.9	2.791	21.4	0.544	1064.83	846.9	7320.57	23092.7	9.176	52.1	
	RodB4_142.3	168	142.3	3.614	8.8	0.224	1126.85	881.4	2950.50	9307.4	3.431	19.5	
Gr-5	RodF4_85.6	98	85.6	2.174	14.72	0.374	937.46	776.2	6657.83	21002.1	9.930	56.4	
	RodF4_88.4	99	88.4	2.245	-0.1	-0.003	926.89	770.3	6787.62	21411.6	10.286	58.4	
	RodF4_92.4	100	92.4	2.347	3.9	0.099	1026.64	825.7	6982.64	22026.7	9.192	52.2	
	RodF4_94.3	101	94.3	2.395	5.8	0.147	1059.14	843.8	7076.81	22323.8	8.934	50.7	
	RodF4_97.2	102	97.2	2.469	8.7	0.221	1099.90	866.4	7220.87	22778.2	8.670	49.2	
	RodF4_108.8	103	108.8	2.764	20.3	0.516	1163.34	901.7	7636.24	24088.5	8.519	48.4	
	RodF4_111	104	111	2.819	-1.75	-0.044	1076.93	853.7	7329.18	23119.9	9.049	51.4	
Gr-6	RodD2_103.2	65	103.2	2.621	14.7	0.373	1175.06	908.2	6706.99	21157.2	7.386	41.9	
	RodD2_106	66	106	2.692	17.5	0.445	1196.75	920.2	6355.75	20049.2	6.836	38.8	
	RodD2_112.6	67	112.6	2.860	-0.15	-0.004	1219.16	932.7	5879.28	18546.2	6.175	35.1	
	RodD2_114.9	68	114.9	2.918	2.15	0.055	1227.29	937.2	5317.22	16773.2	5.537	31.4	
	RodD2_117.4	69	117.4	2.982	4.65	0.118	1216.94	931.4	4781.90	15084.5	5.034	28.6	
	RodD2_120.8	70	120.8	3.068	8.05	0.204	1175.96	908.7	7531.63	23758.5	8.286	47.1	
	RodD2_124.8	71	124.8	3.170	12.05	0.306	1198.97	921.5	7667.46	24187.0	8.227	46.7	
	RodD2_128.6	72	128.6	3.266	15.85	0.403	1131.63	884.1	7029.95	22176.0	8.131	46.2	
Gr-6	RodD6_103.1	129	103.1	2.619	14.6	0.371	1157.93	898.7	7556.37	23836.6	8.481	48.2	
	RodD6_106	130	106	2.692	17.5	0.445	1171.61	906.3	7698.04	24283.5	8.510	48.3	
	RodD6_112.9	131	112.9	2.868	0.15	0.004	1090.86	861.4	7027.14	22167.1	8.530	48.4	
	RodD6_114.9	132	114.9	2.918	2.15	0.055	1128.62	882.4	6746.69	21282.4	7.830	44.5	
	RodD6_116.8	133	116.8	2.967	4.05	0.103	1151.13	894.9	6480.04	20441.3	7.329	41.6	
	RodD6_120.9	134	120.9	3.071	8.15	0.207	1165.00	902.6	5917.74	18667.5	6.590	37.4	
	RodD6_124.8	135	124.8	3.170	12.05	0.306	1167.06	903.7	5368.27	16934.2	5.964	33.9	
	RodD6_128.7	136	128.7	3.269	15.95	0.405	1157.89	898.6	4814.39	15187.0	5.404	30.7	

Table A-26: Summary of Steam Cooling Heat Transfer Reduced Data for Experiment 4041B, continued

5x5 periphery		H.R.	Channel	Elevation	Elevation	Zgrid	Zgrid	H.R. Tw	H.R.Tw	H.R. q"	H.R. q"	h _{sat} (z)	h _{sat} (z)
Gr-8	Location	Number	(in)	(m)	(m)	(in)	(m)	(°F)	(K)	(W/m ²)	(Btu/hr-ft ²)	(W/m ² -K)	(Btu/hr-ft ² -F)
	RodE2_50.1	73	50.1	1.273	3.1	0.079	805.25	702.7	4972.32	15685.2	4972.32	9.238	52.5
	RodE2_54	74	54	1.372	7	0.178	871.16	739.4	5160.56	16279.0	5160.56	8.542	48.5
	RodE2_56.9	75	56.9	1.445	9.9	0.251	903.98	757.6	5301.19	16722.6	5301.19	8.322	47.3
	RodE2_59.9	76	59.9	1.521	12.9	0.328	934.21	774.4	5446.42	17180.7	5446.42	8.163	46.4
	RodE2_66	77	66	1.676	19	0.483	957.69	787.4	5744.90	18122.3	5744.90	8.318	47.2
	RodE2_69.8	78	69.8	1.773	-1.08	-0.027	844.28	724.4	5939.43	18735.9	5939.43	10.289	58.4
	RodE2_72.9	79	72.9	1.852	2.02	0.051	913.31	762.8	6090.30	19211.9	6090.30	9.423	53.5
	RodE2_74.9	80	74.9	1.902	4.02	0.102	947.70	781.9	6186.87	19516.5	6186.87	9.089	51.6
Gr-8	RodB3_50.2	169	50.2	1.275	3.2	0.081	764.35	680.0	4940.24	15584.0	4940.24	9.933	56.4
	RodB3_54.1	170	54.1	1.374	7.1	0.180	830.47	716.7	5128.74	16178.6	5128.74	9.102	51.7
	RodB3_56.9	171	56.9	1.445	9.9	0.251	872.76	740.2	5264.24	16606.0	5264.24	8.690	49.4
	RodB3_60.1	172	60.1	1.527	13.1	0.333	867.30	737.2	5411.14	17069.5	5411.14	9.014	51.2
	RodB3_66.1	173	66.1	1.679	19.1	0.485	916.74	764.7	5695.03	17965.0	5695.03	8.765	49.8
	RodB3_69.9	174	69.9	1.775	-0.98	-0.025	786.64	692.4	5873.39	18527.6	5873.39	11.303	64.2
	RodB3_73	175	73	1.854	2.12	0.054	868.64	737.9	6026.66	19011.1	6026.66	10.017	56.9
	RodB3_75	176	75	1.905	4.12	0.105	907.45	759.5	6123.46	19316.5	6123.46	9.561	54.3
Gr-8	RodF3_50.1	89	50.1	1.273	3.1	0.079	782.16	689.9	4941.15	15586.9	4941.15	9.591	54.5
	RodF3_54	90	54	1.372	7	0.178	848.44	726.7	5131.92	16188.6	5131.92	8.826	50.1
	RodF3_57	91	57	1.448	10	0.254	892.05	751.0	5285.35	16672.6	5285.35	8.456	48.0
	RodF3_60	92	60	1.524	13	0.330	920.11	766.5	5439.57	17159.1	5439.57	8.329	47.3
	RodF3_66.1	93	66.1	1.679	19.1	0.485	937.63	776.3	5732.66	18083.7	5732.66	8.548	48.5
	RodF3_70	94	70	1.778	-0.88	-0.022	805.55	702.9	5952.91	18778.4	5952.91	11.054	62.8
	RodF3_73	95	73	1.854	2.12	0.054	908.77	760.2	6088.27	19205.5	6088.27	9.487	53.9
	RodF3_75	96	75	1.905	4.12	0.105	952.70	784.7	6182.36	19502.2	6182.36	9.016	51.2
Gr-8	RodE6_50.2	121	50.2	1.275	3.2	0.081	789.03	693.7	4945.66	15601.1	4945.66	9.474	53.8
	RodE6_54.1	122	54.1	1.374	7.1	0.180	848.59	726.8	5130.79	16185.1	5130.79	8.822	50.1
	RodE6_57	123	57	1.448	10	0.254	879.86	744.2	5268.88	16620.7	5268.88	8.597	48.8
	RodE6_60.2	124	60.2	1.529	13.2	0.335	906.50	759.0	5421.23	17101.3	5421.23	8.477	48.1
	RodE6_66.1	125	66.1	1.679	19.1	0.485	930.30	772.2	5700.51	17982.2	5700.51	8.594	48.8
	RodE6_70	126	70	1.778	-0.88	-0.022	846.45	725.6	5823.00	18554.8	5823.00	10.151	57.6
	RodE6_73.1	127	73.1	1.857	2.22	0.056	911.03	761.5	6033.72	19033.4	6033.72	9.369	53.2
	RodE6_75	128	75	1.905	4.12	0.105	942.90	779.2	6125.54	19323.0	6125.54	9.063	51.5

RBHT Steam Cooling with Droplet Injection Test SCD-4041-C

Matrix Test # 9c

Test Conditions

Test Date – 10/26/2005

Steady State Time Window: 18060 – 18780

Upper Plenum Pressure: 2.76 bar (40 psia)

Bundle Power: 80.0 kW

Bundle Inlet Reynolds Number: 10000

Bundle Inlet Steam Flow: 199.6 kg/hr (440 lbm/hr)

Droplet Injection Flow: 0.011 kg/s (0.024 lbm/s)

Droplet Injection Hole Diameter: 0.381 mm (.015 in)

Droplet Injection Elevation: 1.295 m (51 in)

Bundle Flow Area: $4.656 \times 10^{-3} \text{ m}^2$ ($5.012 \times 10^{-2} \text{ ft}^2$)

Test Notes

- No steam probes were traversed in this steady state window.

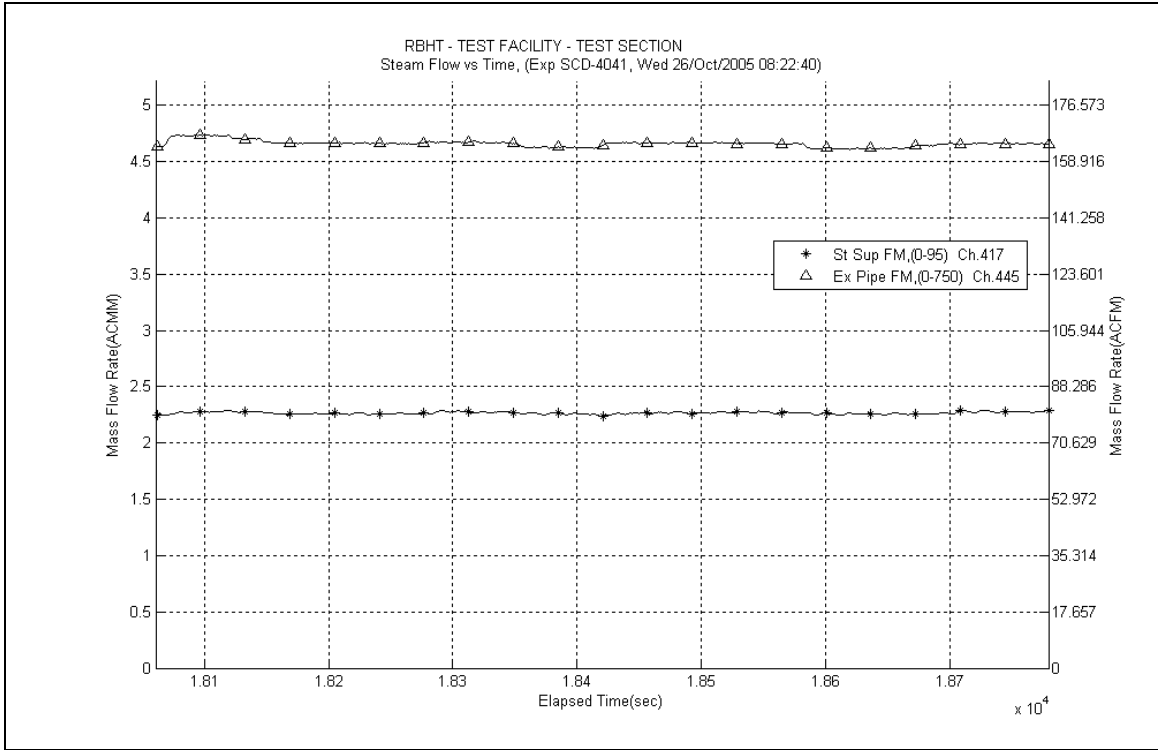

Figure A-481: Inlet and Exhaust Steam Flow Rates for Experiment 4041C

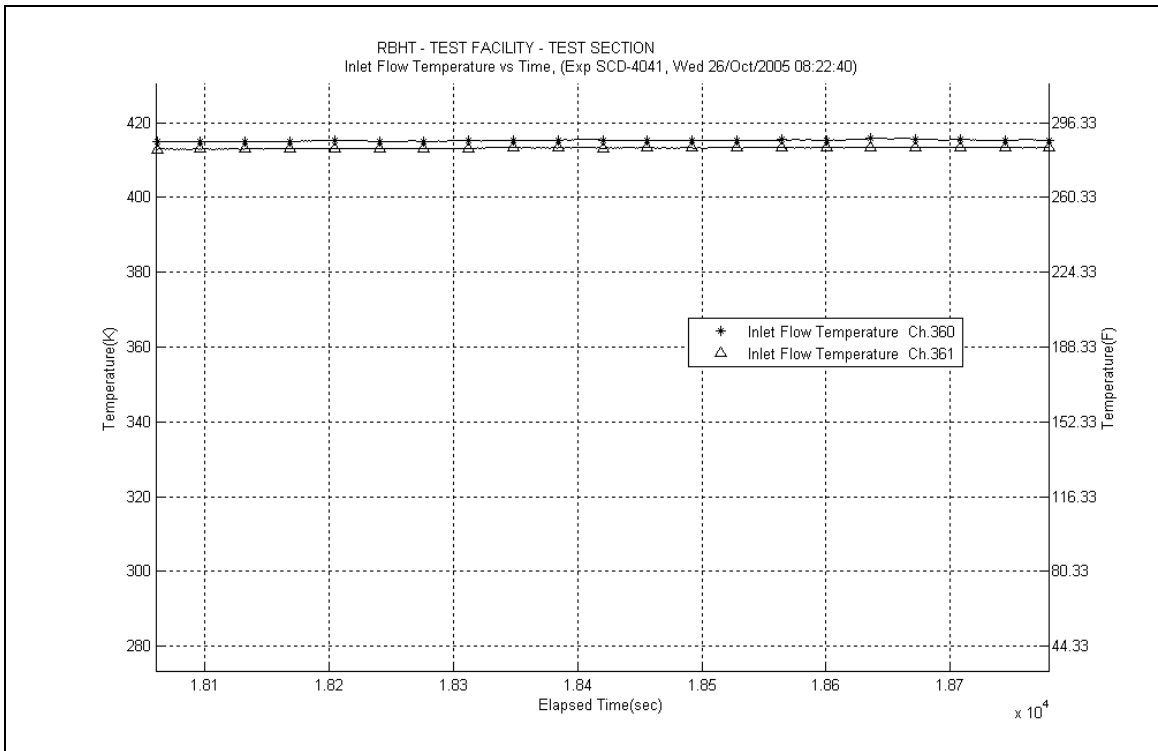

Figure A-482: Inlet Steam Temperature for Experiment 4041C

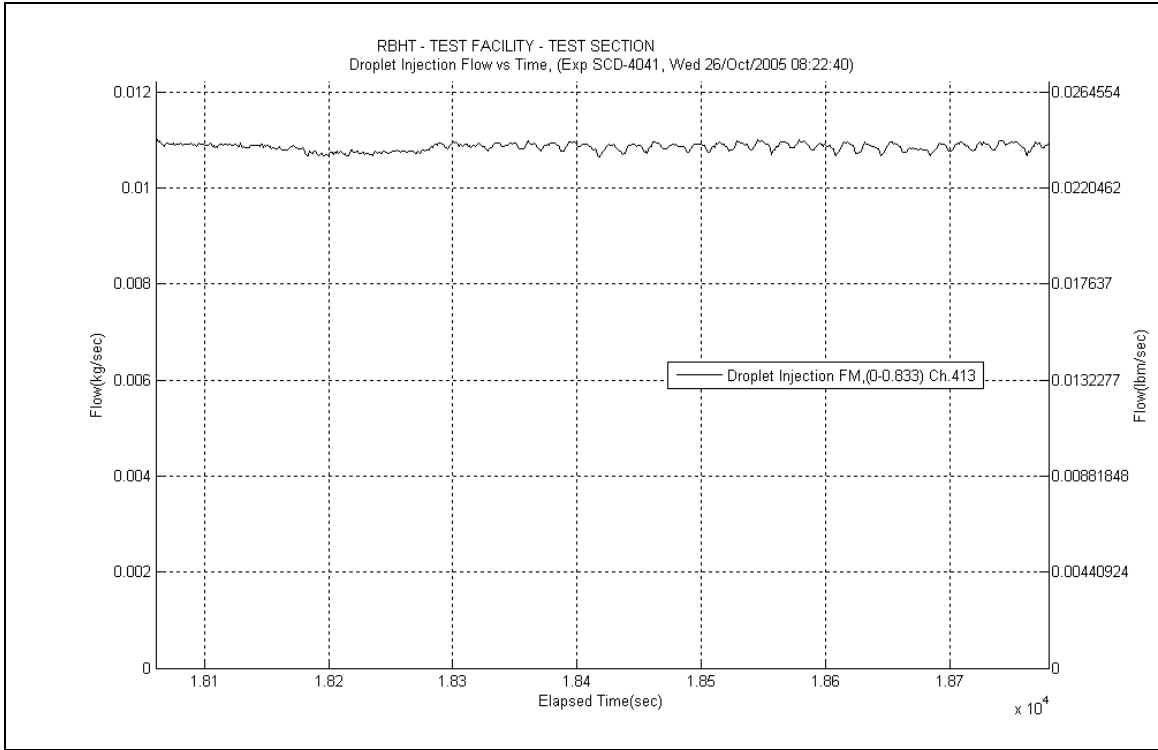

Figure A-483: Droplet Injection Flow Rate for Experiment 4041C

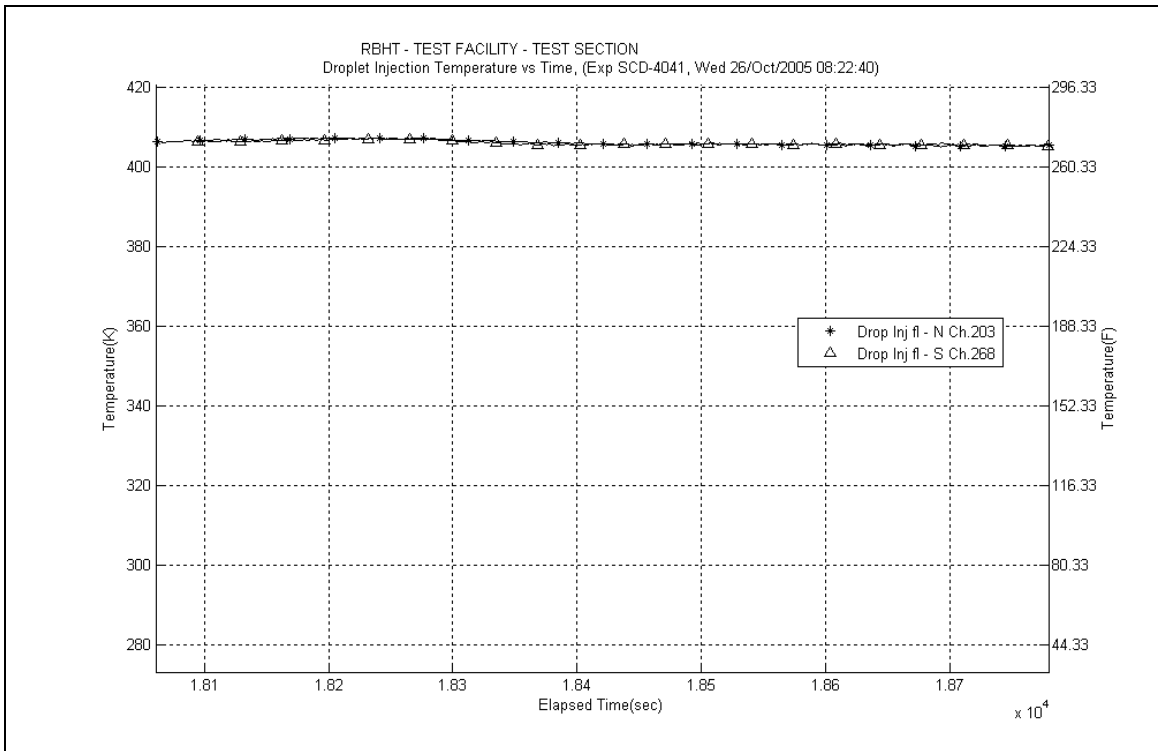

Figure A-484: Droplet Injection Temperature for Experiment 4041C

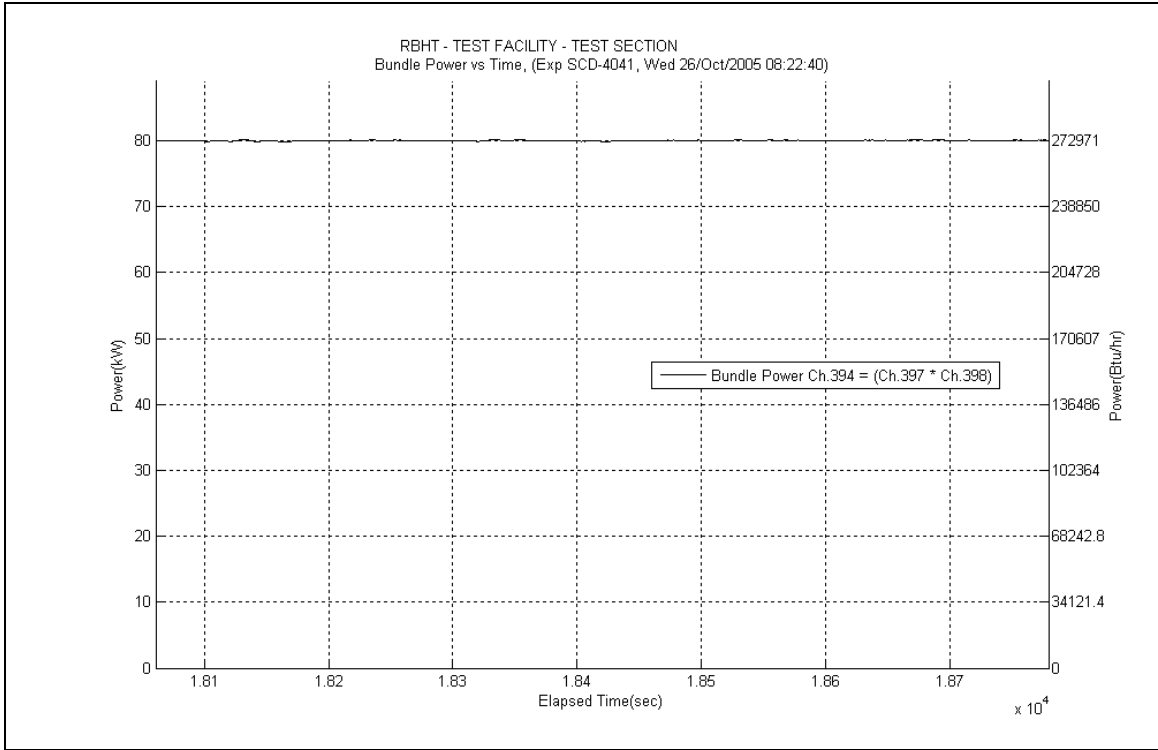

Figure A-485: Bundle Power for Experiment 4041C

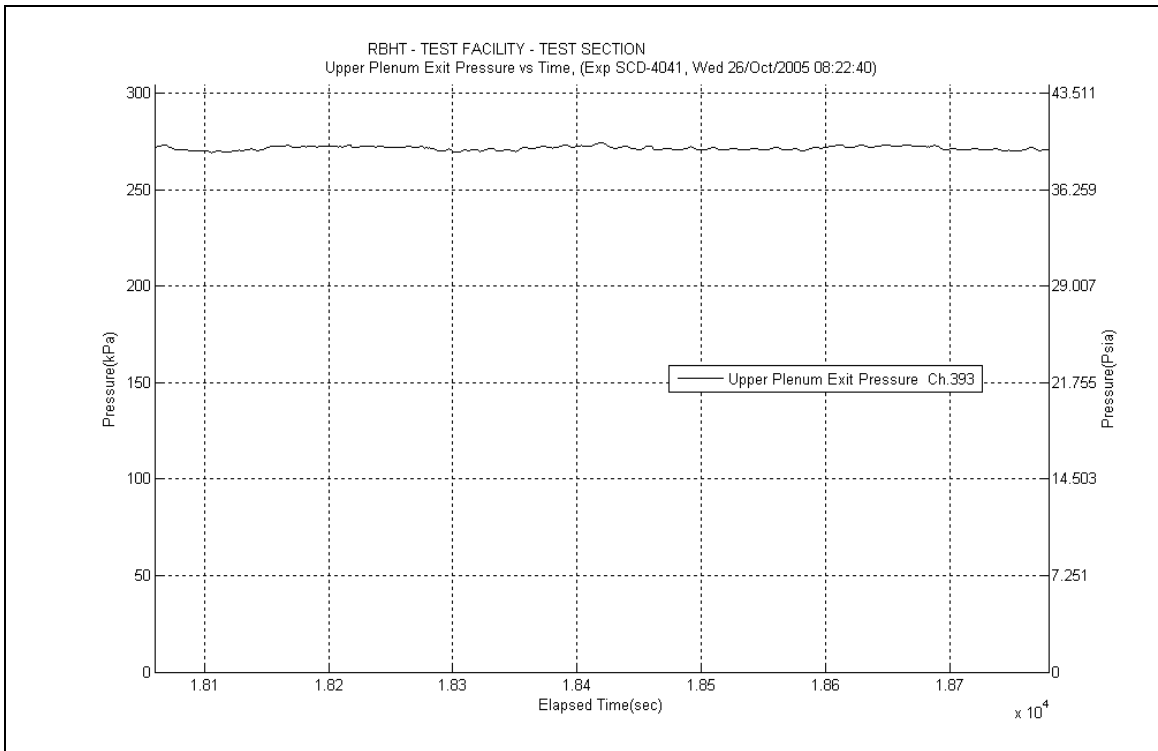

Figure A-486: Upper Plenum Pressure for Experiment 4041C

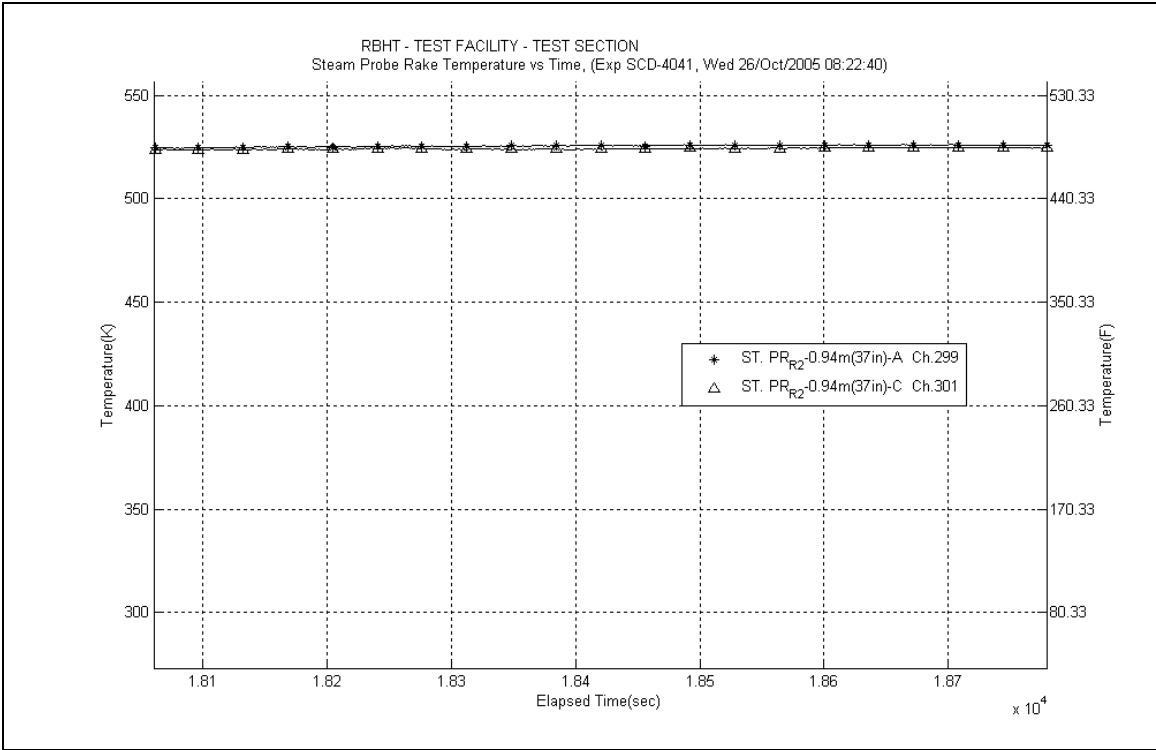

Figure A-487: Steam Probe Rake #2 Temperatures for Experiment 4041C

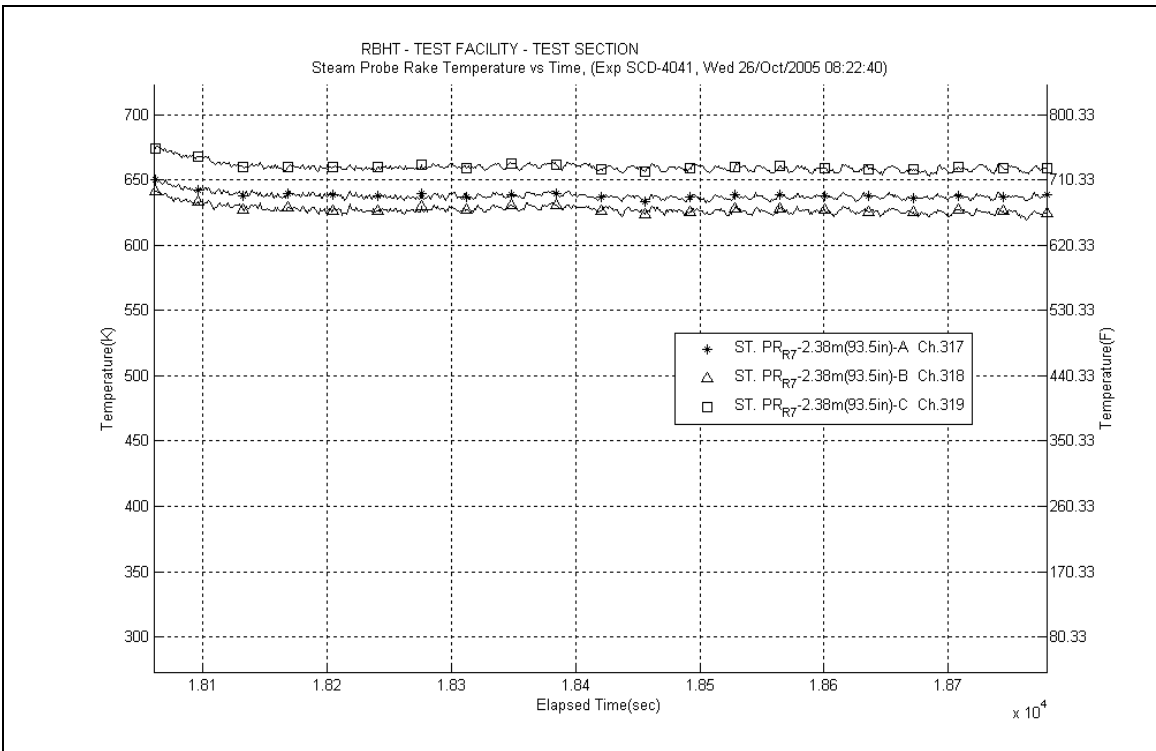

Figure A-488: Steam Probe Rake #7 Temperatures for Experiment 4041C

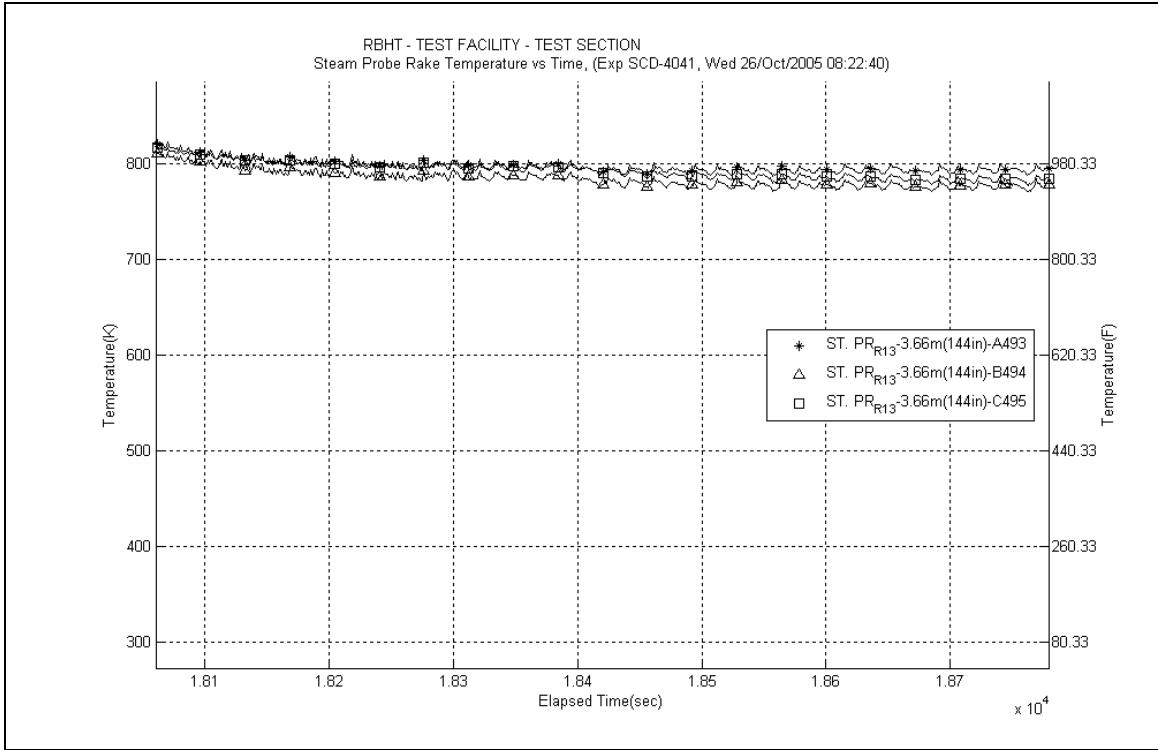

Figure A-489: Steam Probe Rake #13 Temperatures for Experiment 4041C

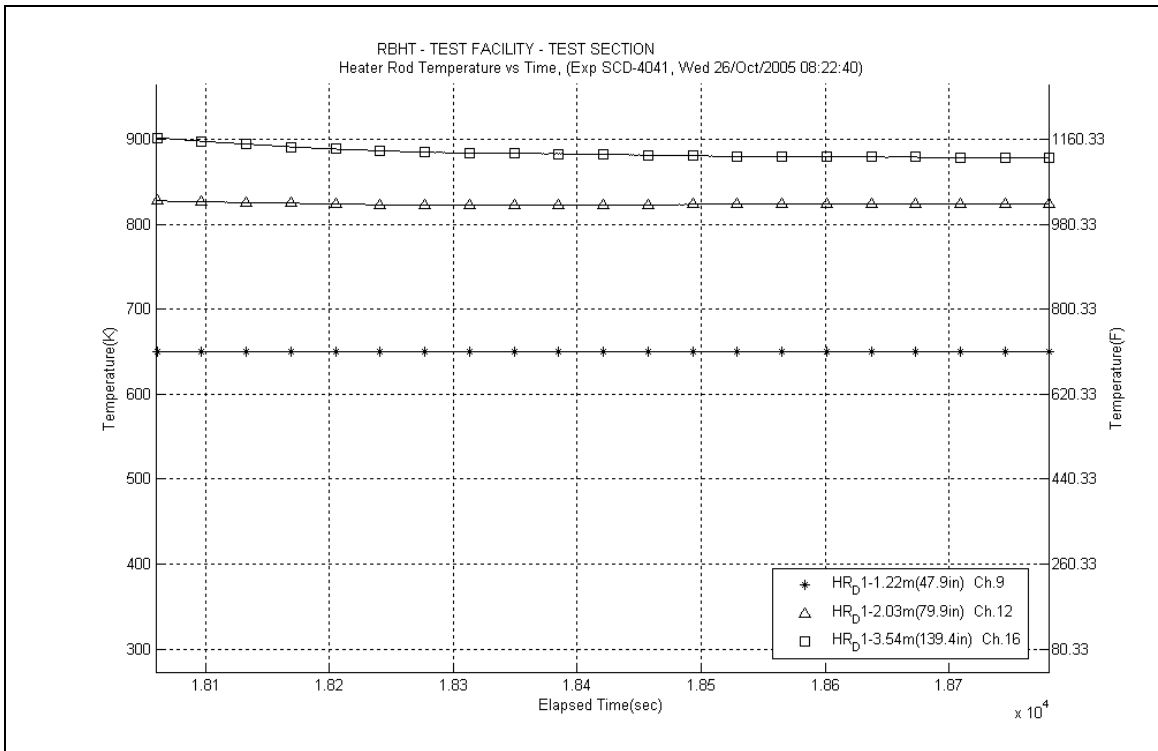

Figure A-490: Heater Rod D1 Temperatures for Experiment 4041C

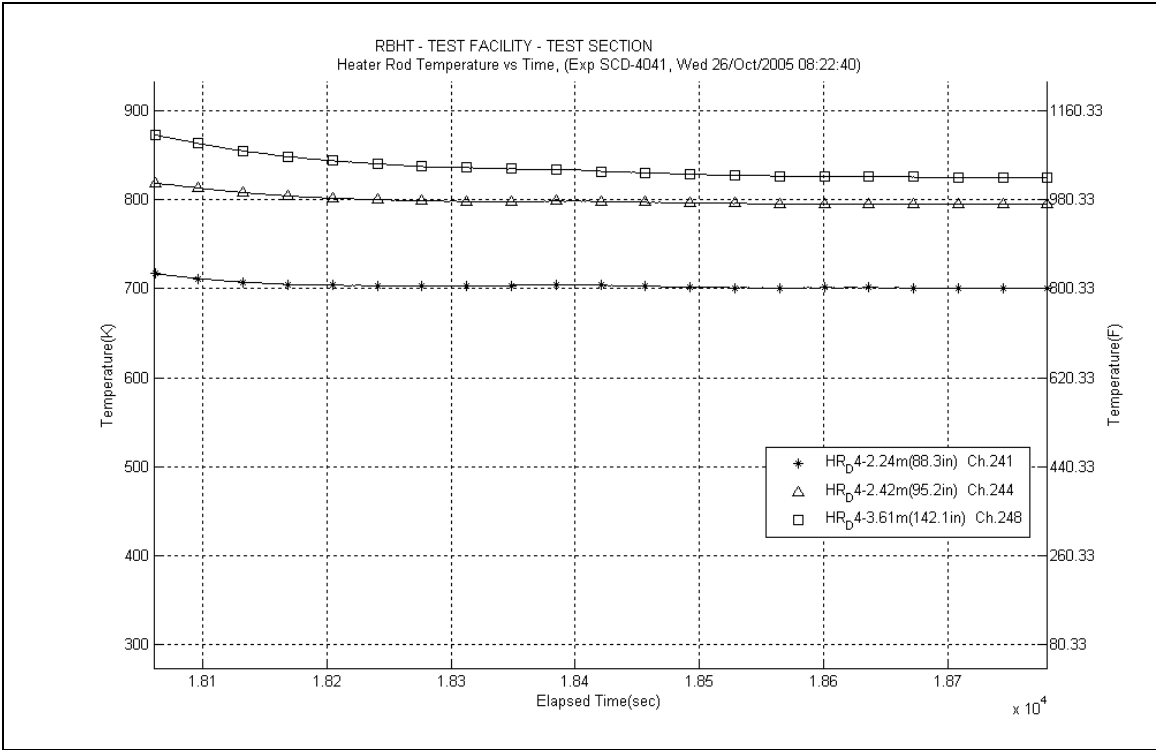

Figure A-491: Heater Rod D4 Temperatures for Experiment 401C

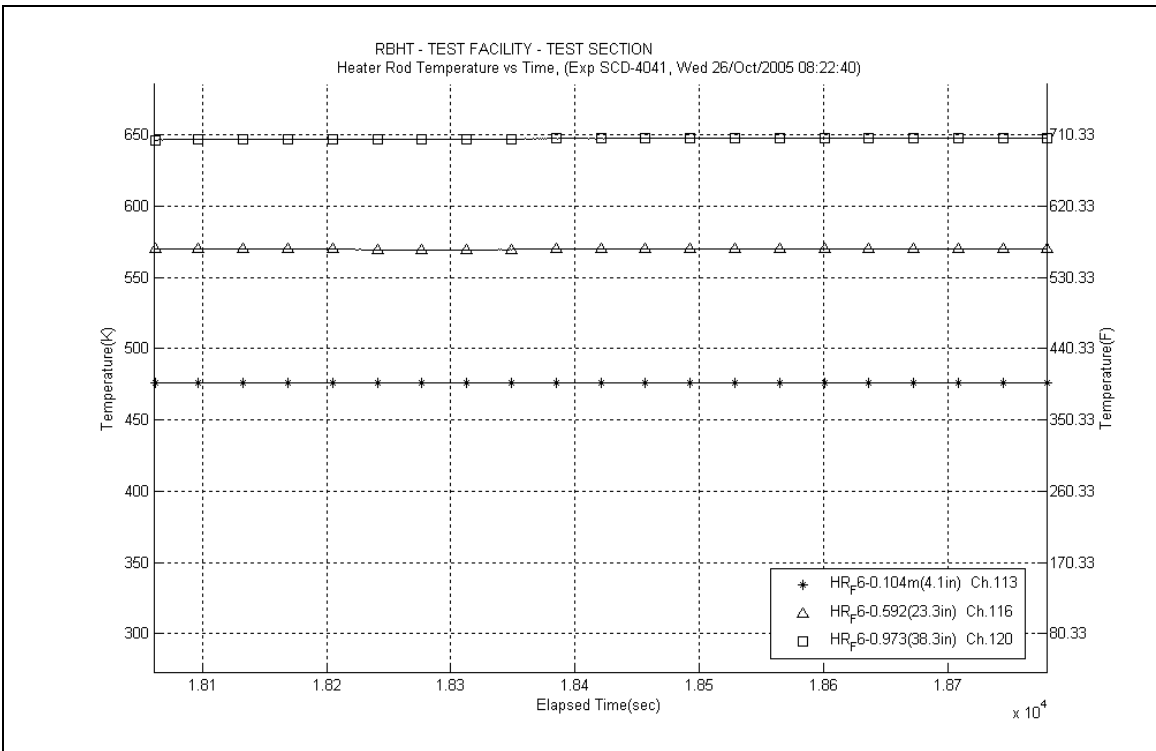

Figure A-492: Heater Rod F6 Temperatures for Experiment 401C

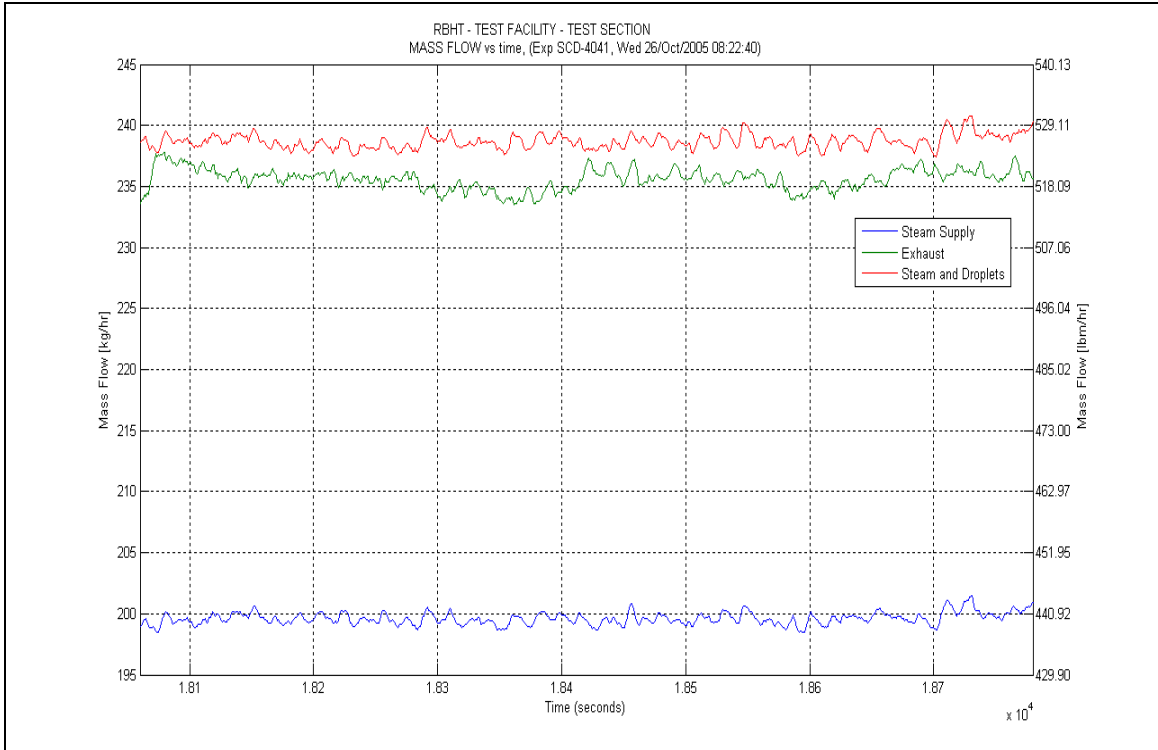

Figure A-493: Mass Flow for Experiment 4041C

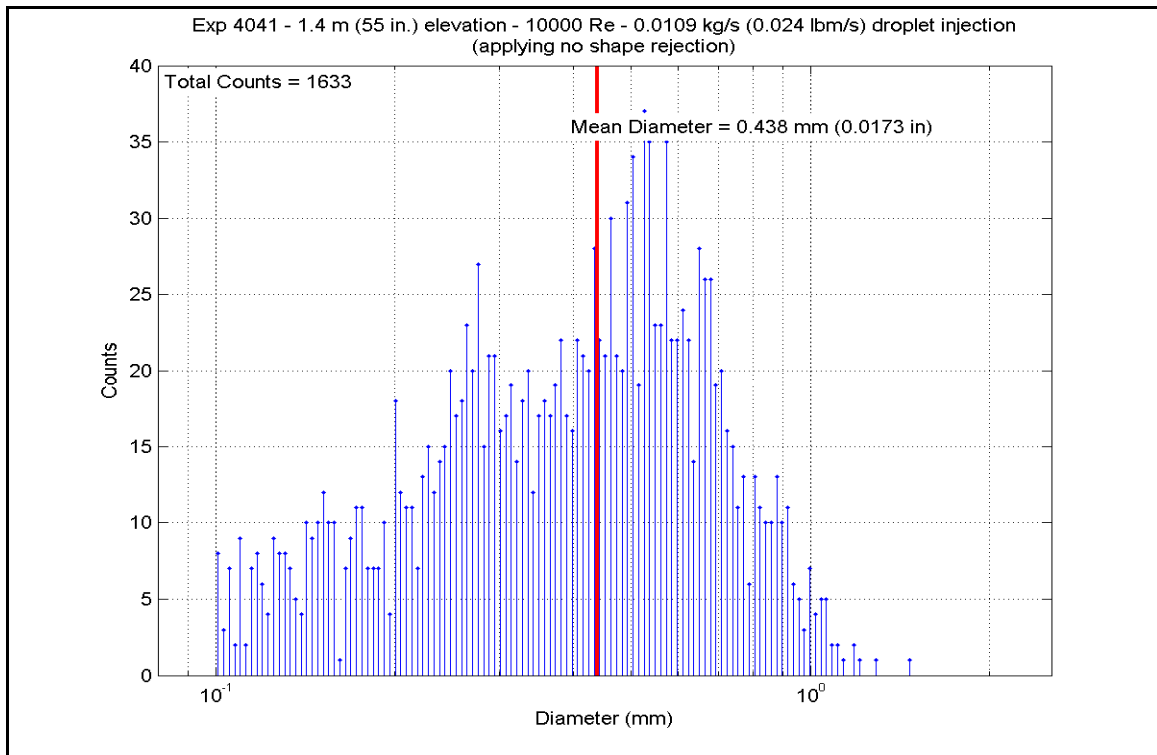

Figure A-494: Droplet Measurements at 1.397 m (55 in.) Elevation for Experiment 4041C

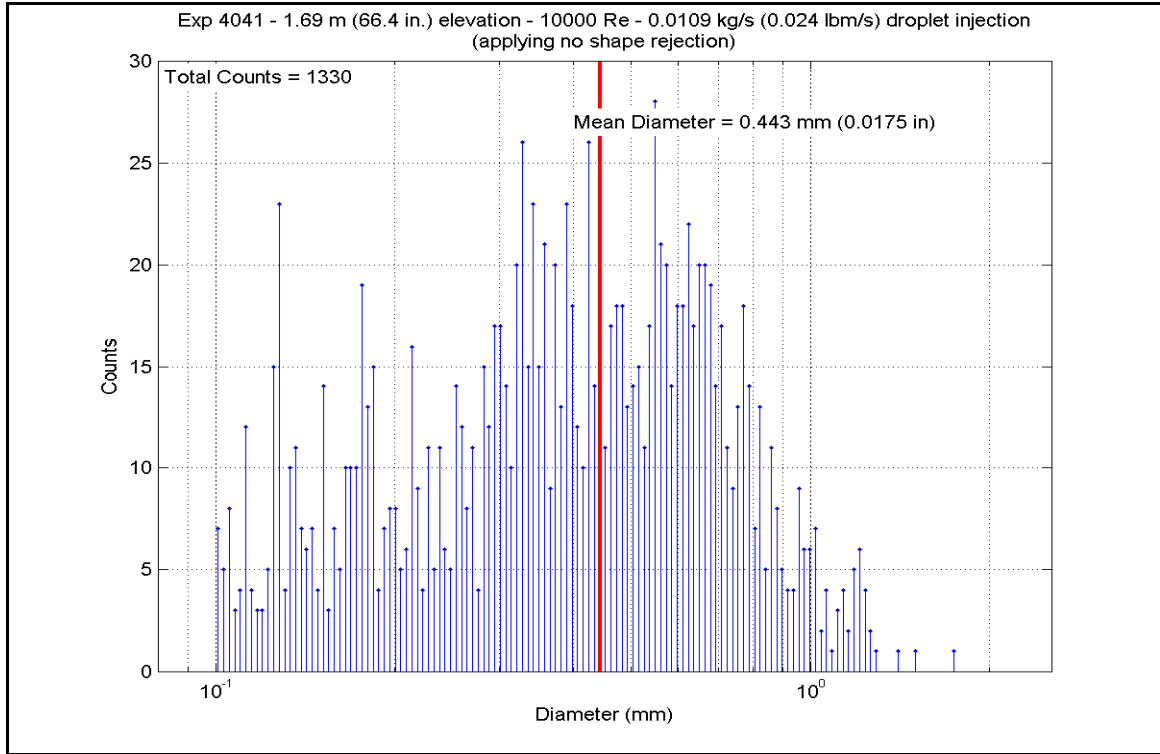

Figure A-495: Droplet Measurements at 1.687 m (66.4 in.) Elevation for Experiment 4041C

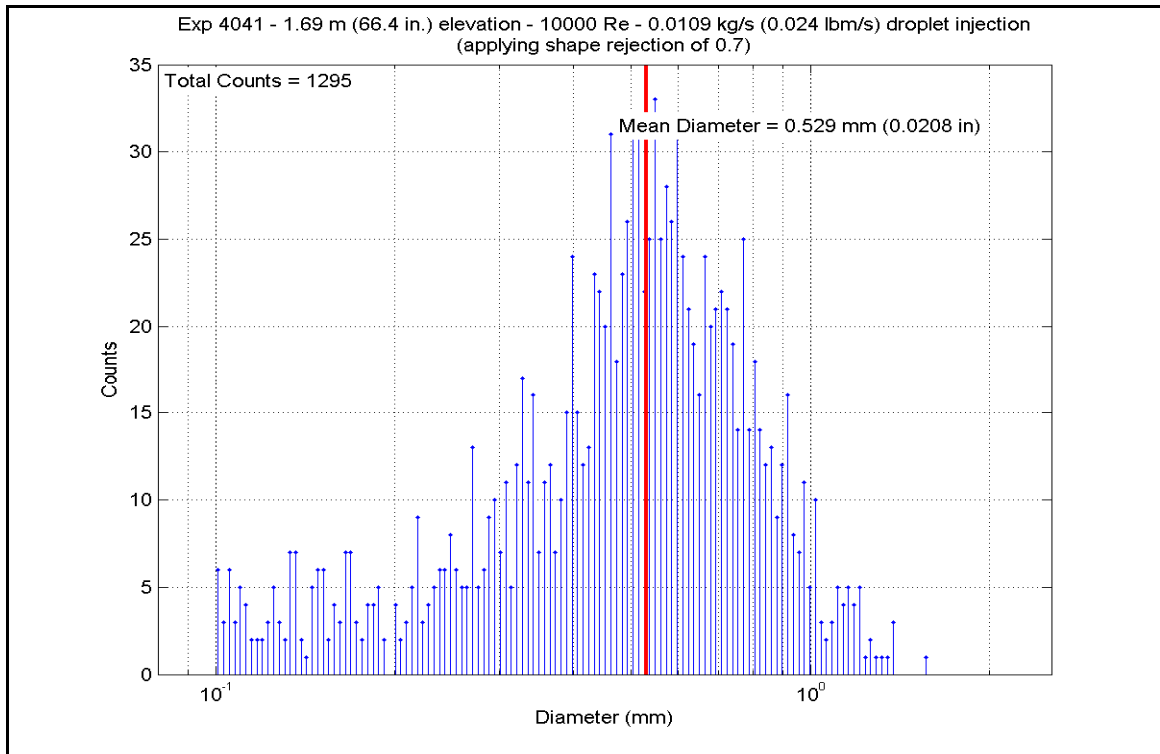

Figure A-496: Droplet Measurements at 1.687 m (66.4 in.) Elevation for Experiment 4041C

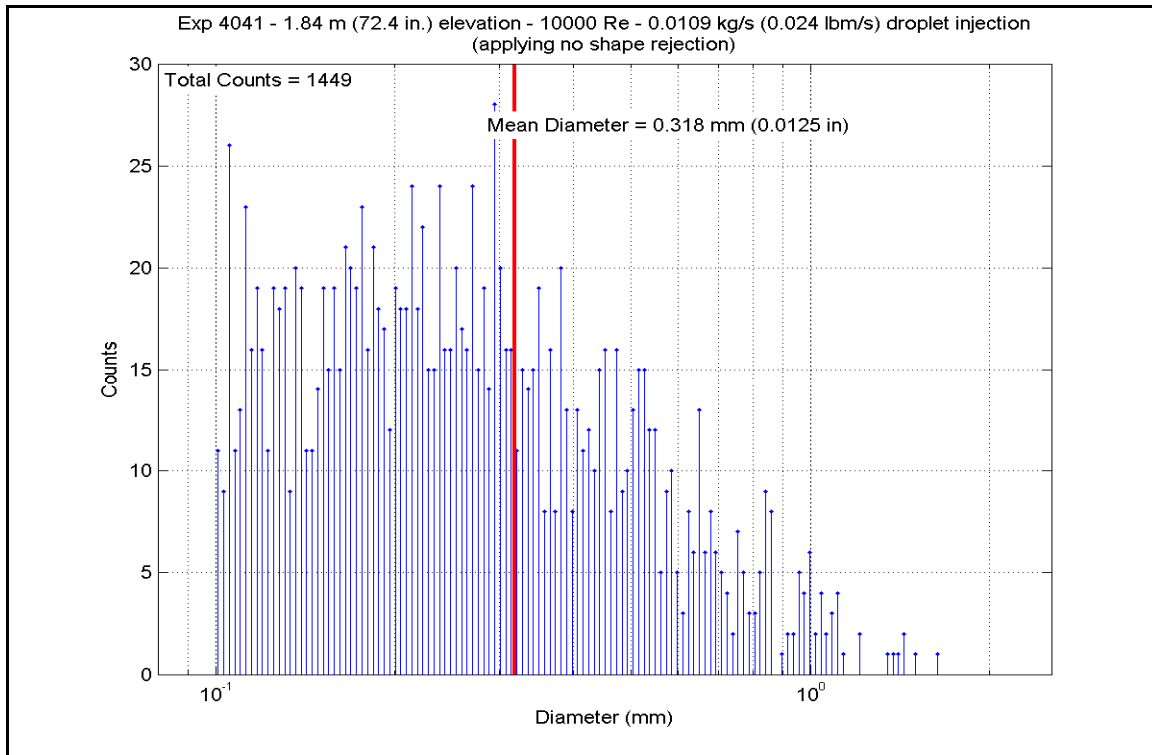

Figure A-497: Droplet Measurements at 1.839 m (72.4 in.) Elevation for Experiment 4041C

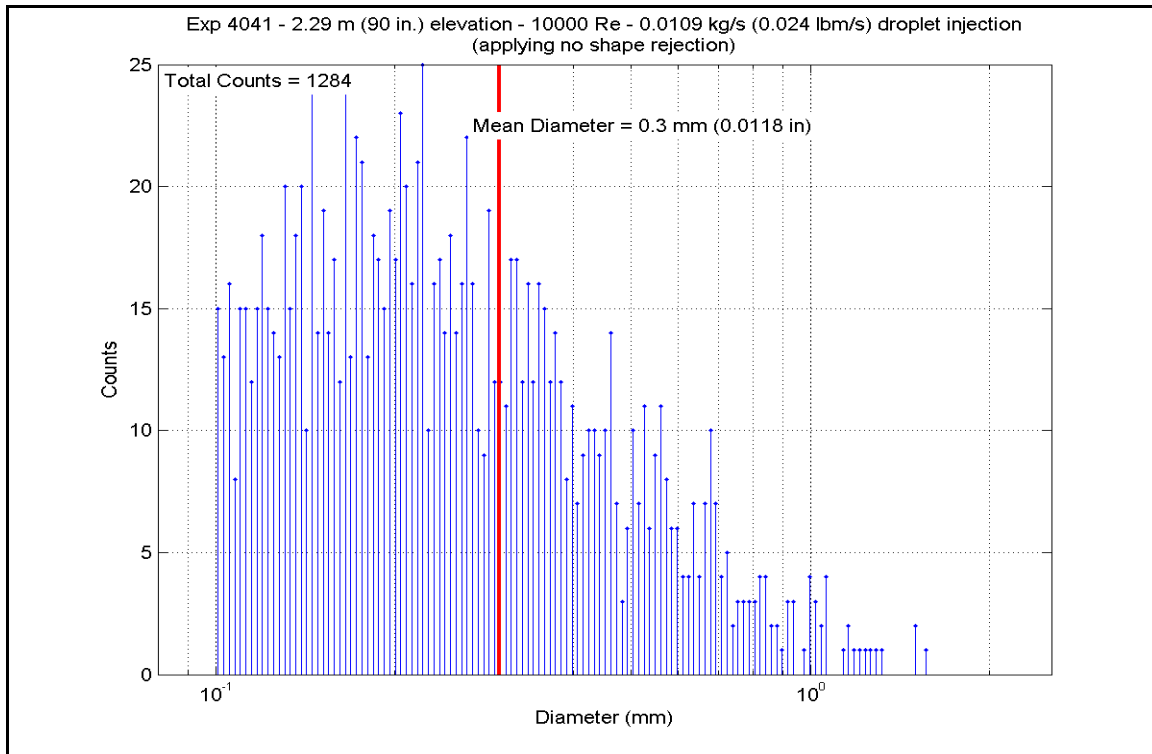

Figure A-498: Droplet Measurements at 2.286 m (90 in.) Elevation for Experiment 4041C

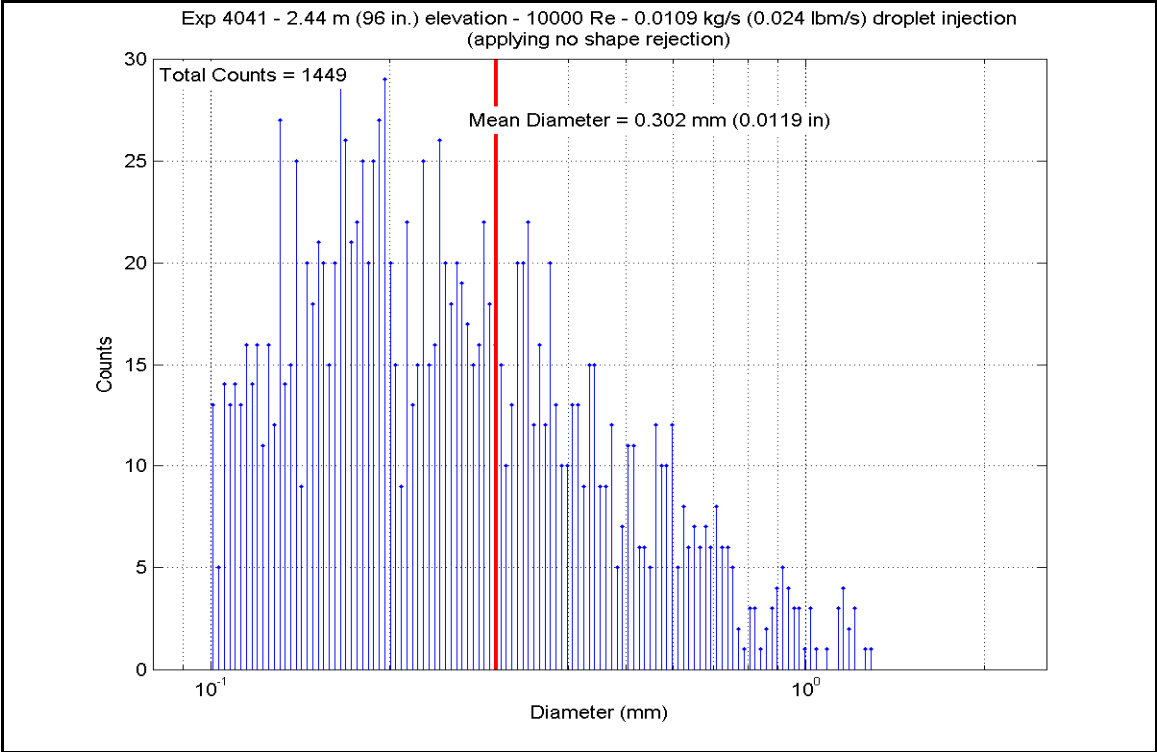

Figure A-499: Droplet Measurements at 2.438 m (96 in.) Elevation for Experiment 4041C

Table A-27: Summary of Steam Cooling Heat Transfer Reduced Data for Experiment 4041C

SCD-4041-C		Inlet Reynolds:		10000		40 psia						
Matrix Test # 9c		UP Pressure:		275.8 kPa		272971 Btu/hr						
Time Window 18060-18780		Bundle Power:		80.00 kW		440.0 lbm/hr						
		Steam flow:		0.0554 kg/s		0.024 lbm/s						
Inner 3x3		Droplet flow:		0.0109 kg/s								
H.R. ID	H.R. Location	Channel Number	Elevation (in)	Elevation (m)	Zgrid (in)	Zgrid (m)	H.R. Tw (°F)	H.R. Tw (K)	H.R. q" (Btu/hr-ft ²)	H.R. q" (W/m ²)	h _{sat} (z) (Btu/hr-ft ² -F)	h _{sat} (z) (W/m ² -K)
Gr-3	RodD3_88.3	185	88.3	2.243	-0.2	-0.005	869.59	738.5	6884.79	21718.1	11.425	64.9
	RodD3_91.3	186	91.3	2.319	2.8	0.071	951.19	783.8	7080.19	22176.7	10.275	58.4
	RodD3_93.1	187	93.1	2.365	4.6	0.117	949.83	783.1	7119.47	22458.4	10.426	59.2
	RodD3_95.3	188	95.3	2.421	6.8	0.173	999.02	810.4	7232.30	22814.3	9.880	56.1
	RodD3_100.1	189	100.1	2.543	11.6	0.295	1083.63	857.4	7445.96	23488.3	9.118	51.8
	RodD3_106.1	190	106.1	2.695	17.6	0.447	1146.69	892.4	7731.21	24388.1	8.789	49.9
	RodD3_110	191	110	2.794	21.5	0.546	1054.68	841.3	7651.51	24136.7	9.714	55.2
	RodD3_142.1	192	142.1	3.609	8.6	0.218	1090.96	861.5	2853.27	9000.6	3.463	19.7
Gr-3	RodC4_88.4	233	88.4	2.245	-0.1	-0.003	815.25	708.3	6951.00	21926.9	12.678	72.0
	RodC4_91.1	234	91.1	2.314	2.6	0.066	913.41	762.8	7105.25	22413.5	10.992	62.4
	RodC4_93.4	235	93.4	2.372	4.9	0.124	942.23	778.8	7219.07	22772.5	10.691	60.7
	RodC4_95.3	236	95.3	2.421	6.8	0.173	991.02	805.9	7317.78	23083.9	10.107	57.4
	RodC4_100.1	237	100.1	2.543	11.6	0.295	1037.96	832.0	7545.58	23802.5	9.787	55.6
	RodC4_106.1	238	106.1	2.695	17.6	0.447	1101.78	867.5	7851.44	24767.4	9.405	53.4
	RodC4_110	239	110	2.794	21.5	0.546	1005.28	813.9	7639.24	24098.0	10.347	56.8
	RodC4_142.2	240	142.2	3.612	8.7	0.221	1037.12	831.5	3092.94	9756.7	4.016	22.8
Gr-3	RodD4_88.3	241	88.3	2.243	-0.2	-0.005	804.06	702.1	6911.98	21803.8	12.870	73.1
	RodD4_91.3	242	91.3	2.319	2.8	0.071	903.48	757.3	7081.26	22337.8	11.126	63.2
	RodD4_93.2	243	93.2	2.367	4.7	0.119	931.17	772.7	7180.37	22650.5	10.811	61.4
	RodD4_95.2	244	95.2	2.418	6.7	0.170	976.96	798.1	7283.00	22974.2	10.258	58.3
	RodD4_100.1	245	100.1	2.543	11.6	0.295	1061.53	845.1	7525.69	23739.8	9.472	53.8
	RodD4_106.1	246	106.1	2.695	17.6	0.447	1097.40	865.0	7819.11	24665.4	9.416	53.5
	RodD4_142.1	248	142.1	3.609	8.6	0.218	1044.05	835.4	2982.06	9406.9	3.838	21.8
Gr-3	RodE4_88.4	201	88.4	2.245	-0.1	-0.003	830.17	716.6	6845.32	21593.6	12.155	69.0
	RodE4_91.2	202	91.2	2.316	2.7	0.069	932.90	773.7	6992.08	22056.5	10.500	59.6
	RodE4_95.3	204	95.3	2.421	6.8	0.173	1011.63	817.4	7182.90	22658.5	9.646	54.8
	RodE4_100.9	205	100.9	2.563	12.4	0.315	1077.59	854.0	7421.90	23412.4	9.156	52.0
	RodE4_142.3	208	142.3	3.614	8.8	0.224	1073.57	851.8	3019.04	9523.6	3.743	21.3

Table A-27: Summary of Steam Cooling Heat Transfer Reduced Data for Experiment 4041C, continued

Inner 3x3	H.R. Location	Channel Number	Elevation (in)	Elevation (m)	Zgrid (in)	Zgrid (m)	H.R. Tw (°F)	H.R. Tw (K)	H.R. q" (Btu/hr-ft ²)	H.R. q" (W/m ²)	h _{sat} (z) (Btu/hr-ft ² -F)	h _{sat} (z) (W/m ² -K)
Gr-4	RodE3_63.4	193	63.4	1.610	16.4	0.417	945.52	780.7	5588.55	17629.1	8.236	46.8
	RodE3_113.6	194	113.6	2.885	0.85	0.022	1084.70	858.0	7008.45	22108.2	8.571	48.7
	RodE3_115.5	195	115.5	2.934	2.75	0.070	1122.85	879.2	6787.44	21411.0	7.931	45.0
	RodE3_118.5	196	118.5	3.010	5.75	0.146	1149.34	893.9	6390.16	20157.7	7.242	41.1
	RodE3_122.7	197	122.7	3.117	9.95	0.253	1152.33	895.6	5839.26	18420.0	6.596	37.5
	RodE3_126.5	198	126.5	3.213	13.75	0.349	1152.26	895.5	5330.48	16815.0	6.021	34.2
	RodE3_131.7	199	131.7	3.345	-1.8	-0.046	1062.86	845.8	4633.37	14616.0	5.822	33.1
	RodE3_135.6	200	135.6	3.444	2.1	0.053	1098.00	865.4	4115.36	12981.9	4.952	28.1
	RodC5_63.7	225	63.7	1.618	16.7	0.424	916.74	764.7	5483.26	17296.9	8.439	47.9
	RodC5_113.6	226	113.6	2.885	0.85	0.022	1007.31	815.0	6872.29	21678.6	9.283	52.7
Gr-4	RodC5_115.7	227	115.7	2.939	2.95	0.075	1046.98	837.0	6607.82	20844.4	8.472	48.1
	RodC5_122.7	229	122.7	3.117	9.95	0.253	1076.00	853.2	5733.23	18085.5	7.087	40.2
	RodC5_126.7	230	126.7	3.218	13.95	0.354	1071.88	850.9	5224.68	16481.2	6.491	36.9
	RodC5_131.6	231	131.6	3.343	-1.9	-0.048	960.47	789.0	4596.26	14498.9	6.628	37.6
	RodC5_135.7	232	135.7	3.447	2.2	0.056	996.55	809.0	4104.44	12947.5	5.626	31.9
	RodE5_63.6	209	63.6	1.615	16.6	0.422	842.17	723.2	5567.15	17561.6	9.679	55.0
	RodE5_113.6	210	113.6	2.885	0.85	0.022	905.70	758.5	7120.87	22462.8	11.149	63.3
	RodE5_115.4	211	115.4	2.931	2.65	0.067	980.22	799.9	6915.50	21814.9	9.696	55.1
	RodE5_118.7	212	118.7	3.015	5.95	0.151	1043.54	835.1	6498.07	20498.2	8.368	47.5
	RodE5_122.6	213	122.6	3.114	9.85	0.250	1078.06	854.3	6000.54	18928.7	7.398	42.0
RodE5_126.6	214	126.6	3.216	13.85	0.352	1083.08	857.1	5489.14	17315.5	6.726	38.2	
Gr-5	RodE5_131.6	215	131.6	3.343	-1.9	-0.048	1060.84	844.7	4806.69	15162.7	6.055	34.4
	RodE5_135.6	216	135.6	3.444	2.1	0.053	1059.03	843.7	4124.56	13010.9	5.208	29.6
	RodC3_79.8	177	79.8	2.027	8.92	0.227	943.86	779.7	6397.93	20182.3	9.452	53.7
	RodC3_85.6	178	85.6	2.174	14.72	0.374	859.78	733.0	6672.91	21049.7	11.257	63.9
	RodC3_88.5	179	88.5	2.248	0	0.000	857.59	731.8	6847.77	21601.3	11.595	65.8
	RodC3_92.4	180	92.4	2.347	3.9	0.099	971.00	794.8	7035.88	22194.7	9.994	56.8
	RodC3_94.4	181	94.4	2.398	5.9	0.150	988.57	804.6	7126.61	22480.9	9.877	56.1
	RodC3_97.2	182	97.2	2.469	8.7	0.221	1042.08	834.3	7249.93	22869.9	9.354	53.1
	RodC3_108.8	183	108.8	2.764	20.3	0.516	1134.56	885.7	7647.35	24123.6	8.815	50.1
	RodD5_50	217	50	1.270	3	0.076	816.02	708.7	4948.65	15610.5	9.014	51.2
Gr-8	RodD5_54.1	218	54.1	1.374	7.1	0.180	791.45	695.1	5186.65	16361.3	9.890	56.2
	RodD5_56.9	219	56.9	1.445	9.9	0.251	840.34	722.2	5311.32	16754.6	9.264	52.6
	RodD5_60	220	60	1.524	13	0.330	877.23	742.7	5452.30	17199.3	8.935	50.7
	RodD5_66.1	221	66.1	1.679	19.1	0.485	914.00	763.1	5755.30	18155.1	8.895	50.5
	RodD5_69.9	222	69.9	1.775	-0.98	-0.025	732.24	662.2	5973.70	18844.0	12.840	72.9
	RodD5_72.9	223	72.9	1.852	2.02	0.051	816.89	709.2	6126.07	19324.7	11.141	63.3
	RodD5_74.9	224	74.9	1.902	4.02	0.102	862.75	734.7	6223.96	19633.5	10.447	59.3

Table A-27: Summary of Steam Cooling Heat Transfer Reduced Data for Experiment 4041C, continued

5x5 periphery												
H.R. ID	H.R. Location	Channel Number	Elevation (in)	Elevation (m)	Zgrid (in)	Zgrid (m)	H.R. Tw (°F)	H.R. Tw (K)	H.R. q" (Btu/hr-ft ²)	H.R. q" (W/m ²)	h _{sat} (z) (Btu/hr-ft ² -F)	h _{sat} (z) (W/m ² -K)
Gr-2	RodB5_41	153	41	1.041	13.5	0.343	752.94	673.7	4505.29	14211.9	9.271	52.7
	RodB5_52.9	154	52.9	1.344	5.9	0.150	819.59	710.7	5066.11	15981.1	9.168	52.1
	RodB5_55	155	55	1.397	8	0.203	856.40	731.2	5159.32	16275.1	8.753	49.7
	RodB5_57.8	156	57.8	1.468	10.8	0.274	885.65	747.4	5320.90	16784.8	8.601	48.8
	RodB5_64	157	64	1.626	17	0.432	930.97	772.6	5631.15	17763.5	8.481	48.2
	RodB5_73.9	158	73.9	1.877	3.02	0.077	880.06	744.3	6141.42	19373.1	10.018	56.9
Gr-2	RodB5_75.9	159	75.9	1.928	5.02	0.128	914.42	763.4	6243.46	19695.0	9.644	54.8
	RodB5_76.9	160	76.9	1.953	6.02	0.153	927.98	770.9	6293.41	19852.6	9.521	54.1
	RodF5_41	105	41	1.041	13.5	0.343	742.60	667.9	4470.30	14101.6	9.399	53.4
	RodF5_53.1	106	53.1	1.349	6.1	0.155	802.32	701.1	5046.18	15918.2	9.426	53.5
	RodF5_55	107	55	1.397	8	0.203	840.15	722.1	5131.22	16186.4	8.953	50.8
	RodF5_57.8	108	57.8	1.468	10.8	0.274	883.12	746.0	5263.17	16602.7	8.543	48.5
Gr-2	RodF5_64	109	64	1.626	17	0.432	921.50	767.3	5566.55	17559.7	8.505	48.3
	RodF5_73.8	110	73.8	1.875	2.92	0.074	869.95	738.7	6063.23	19126.5	10.056	57.1
	RodF5_75.8	111	75.8	1.925	4.92	0.125	908.59	760.1	6163.05	19441.3	9.606	54.6
	RodF5_76.8	112	76.8	1.951	5.92	0.150	924.38	768.9	6212.61	19597.7	9.450	53.7
	RodC2_41	57	41	1.041	13.5	0.343	737.60	665.1	4478.95	14128.8	9.518	54.0
	RodC2_53.1	58	53.1	1.349	6.1	0.155	859.06	732.6	5065.91	15980.4	8.556	48.6
Gr-2	RodC2_55	59	55	1.397	8	0.203	877.47	742.9	5156.63	16266.6	8.447	48.0
	RodC2_57.8	60	57.8	1.468	10.8	0.274	908.96	760.3	5289.10	16684.5	8.239	46.8
	RodC2_63.9	61	63.9	1.623	16.9	0.429	938.50	776.8	5583.22	17612.3	8.315	47.2
	RodC2_73.8	62	73.8	1.875	2.92	0.074	917.47	765.1	6074.90	19163.3	9.339	53.0
	RodC2_75.8	63	75.8	1.925	4.92	0.125	943.59	779.6	6172.09	19469.9	9.122	51.8
	RodC2_76.8	64	76.8	1.951	5.92	0.150	954.12	785.4	6221.06	19624.3	9.054	51.4
Gr-2	RodC6_40.9	137	40.9	1.039	13.4	0.340	748.54	671.2	4477.63	14124.7	9.299	52.8
	RodC6_52.8	138	52.8	1.341	5.8	0.147	866.99	737.0	5071.04	15996.6	8.452	48.0
	RodC6_54.8	139	54.8	1.392	7.8	0.198	888.13	748.8	5171.76	16314.3	8.326	47.3
	RodC6_57.8	140	57.8	1.468	10.8	0.274	922.71	768.0	5321.01	16785.1	8.115	46.1
	RodC6_63.8	141	63.8	1.621	16.8	0.427	955.32	786.1	5622.00	17734.6	8.168	46.4
	RodC6_73.7	142	73.7	1.872	2.82	0.072	913.21	762.7	6183.26	19505.1	9.568	54.3
Gr-2	RodC6_75.8	143	75.8	1.925	4.92	0.125	940.84	778.1	6294.63	19856.4	9.341	53.0
	RodC6_76.8	144	76.8	1.951	5.92	0.150	957.14	787.1	6347.53	20023.3	9.197	52.2

Table A-27: Summary of Steam Cooling Heat Transfer Reduced Data for Experiment 4041C, continued

5x5 periphery		H.R. Location	Channel Number	Elevation (in)	Elevation (m)	Zgrid (in)	Zgrid (m)	H.R. Tw (°F)	H.R. Tw (K)	H.R. q" (Btu/hr-ft ²)	H.R. q" (W/m ²)	h _{sat} (z) (Btu/hr-ft ² -F)	h _{sat} (z) (W/m ² -K)
Gr-3	RodB4_88.4	161	88.4	2.245	-0.1	-0.003	848.24	726.6	6868.09	21665.4	11.816	67.1	
	RodB4_91.3	162	91.3	2.319	2.8	0.071	942.17	778.8	6986.27	22038.2	10.347	58.8	
	RodB4_93.3	163	93.3	2.370	4.8	0.122	956.22	786.6	7074.93	22317.9	10.265	58.3	
	RodB4_95.1	164	95.1	2.416	6.6	0.168	990.16	805.5	7156.91	22576.5	9.897	56.2	
	RodB4_100	165	100	2.540	11.5	0.292	1019.23	821.6	7372.87	23257.7	9.801	55.7	
	RodB4_106	166	106	2.692	17.5	0.445	1106.41	870.0	7654.21	24145.2	9.119	51.8	
	RodB4_109.9	167	109.9	2.791	21.4	0.544	1017.21	820.5	7427.00	23428.5	9.900	56.2	
	RodB4_142.3	168	142.3	3.614	8.8	0.224	1042.63	834.6	3098.71	9774.9	3.995	22.7	
Gr-5	RodF4_85.6	98	85.6	2.174	14.72	0.374	896.25	753.3	6697.78	21128.1	10.644	60.4	
	RodF4_88.4	99	88.4	2.245	-0.1	-0.003	864.03	735.4	6879.89	21702.6	11.524	65.4	
	RodF4_92.4	100	92.4	2.347	3.9	0.099	969.76	794.1	7073.20	22312.4	10.065	57.2	
	RodF4_94.3	101	94.3	2.395	5.8	0.147	1004.30	813.3	7163.52	22597.3	9.716	55.2	
	RodF4_97.2	102	97.2	2.469	8.7	0.221	1047.10	837.1	7305.03	23043.7	9.364	53.2	
	RodF4_108.8	103	108.8	2.764	20.3	0.516	1110.02	872.0	7704.11	24302.6	9.139	51.9	
	RodF4_111	104	111	2.819	-1.75	-0.044	996.36	808.9	7429.75	23437.1	10.187	57.8	
Gr-6	RodD2_103.2	65	103.2	2.621	14.7	0.373	1138.93	888.1	6783.38	21398.2	7.780	44.2	
	RodD2_106	66	106	2.692	17.5	0.445	1159.76	899.7	6432.89	20292.5	7.206	40.9	
	RodD2_112.6	67	112.6	2.860	-0.15	-0.004	1179.96	910.9	5958.38	18795.7	6.526	37.1	
	RodD2_114.9	68	114.9	2.918	2.15	0.055	1185.16	913.8	5399.17	17031.7	5.880	33.4	
	RodD2_117.4	69	117.4	2.982	4.65	0.118	1172.07	906.5	4868.42	15357.4	5.379	30.5	
	RodD2_120.8	70	120.8	3.068	8.05	0.204	1151.20	894.9	7582.12	23917.8	8.575	48.7	
	RodD2_124.8	71	124.8	3.170	12.05	0.306	1173.77	907.5	7718.96	24349.4	8.513	48.3	
	RodD2_128.6	72	128.6	3.266	15.85	0.403	1098.98	865.9	7097.77	22389.9	8.531	48.4	
Gr-6	RodD6_103.1	129	103.1	2.619	14.6	0.371	1106.77	870.2	7652.47	24139.7	9.113	51.7	
	RodD6_106	130	106	2.692	17.5	0.445	1121.79	878.6	7787.46	24565.6	9.110	51.7	
	RodD6_112.9	131	112.9	2.868	0.15	0.004	1028.73	826.9	7118.67	22455.9	9.345	53.1	
	RodD6_114.9	132	114.9	2.918	2.15	0.055	1067.14	848.2	6838.06	21570.7	8.546	48.5	
	RodD6_116.8	133	116.8	2.967	4.05	0.103	1089.01	860.4	6574.05	20737.9	7.998	45.4	
	RodD6_120.9	134	120.9	3.071	8.15	0.207	1100.43	866.7	6035.21	19038.1	7.241	41.1	
	RodD6_124.8	135	124.8	3.170	12.05	0.306	1099.15	866.0	5487.04	17308.9	6.594	37.4	
	RodD6_128.7	136	128.7	3.269	15.95	0.405	1087.01	859.3	4936.97	15573.7	6.021	34.2	

Table A-27: Summary of Steam Cooling Heat Transfer Reduced Data for Experiment 4041C, continued

5x5 periphery		H.R. Location	Channel Number	Elevation (in)	Elevation (m)	Zgrid (in)	Zgrid (m)	H.R. Tw (°F)	H.R. Tw (K)	H.R. q" (Btu/hr-ft ²)	H.R. q" (W/m ²)	h _{sat} (z) (Btu/hr-ft ² -F)	h _{sat} (z) (W/m ² -K)
Gr-8	RodE2_50.1	73	50.1	1.273	3.1	0.079	806.09	703.2	4968.91	15674.4	9.217	52.3	
	RodE2_54	74	54	1.372	7	0.178	872.09	739.9	5158.71	16273.1	8.525	48.4	
	RodE2_56.9	75	56.9	1.445	9.9	0.251	905.20	758.3	5298.60	16714.4	8.302	47.1	
	RodE2_59.9	76	59.9	1.521	12.9	0.328	935.48	775.1	5444.57	17174.9	8.145	46.3	
	RodE2_66	77	66	1.676	19	0.483	958.02	787.6	5742.49	18114.7	8.310	47.2	
	RodE2_69.8	78	69.8	1.773	-1.08	-0.027	838.22	721.0	5932.57	18714.3	10.386	59.0	
	RodE2_72.9	79	72.9	1.852	2.02	0.051	905.92	758.7	6083.82	19191.4	9.522	54.1	
	RodE2_74.9	80	74.9	1.902	4.02	0.102	939.41	777.3	6183.32	19505.3	9.196	52.2	
Gr-8	RodB3_50.2	169	50.2	1.275	3.2	0.081	765.09	680.4	4941.65	15588.4	9.921	56.3	
	RodB3_54.1	170	54.1	1.374	7.1	0.180	832.65	718.0	5125.13	16167.2	9.061	51.5	
	RodB3_56.9	171	56.9	1.445	9.9	0.251	874.71	741.3	5259.80	16592.1	8.655	49.2	
	RodB3_60.1	172	60.1	1.527	13.1	0.333	864.61	735.7	5429.14	17126.2	9.085	51.6	
	RodB3_66.1	173	66.1	1.679	19.1	0.485	909.36	760.6	5732.76	18084.0	8.925	50.7	
	RodB3_69.9	174	69.9	1.775	-0.98	-0.025	772.51	684.5	5928.30	18700.8	11.727	66.6	
	RodB3_73	175	73	1.854	2.12	0.054	855.87	730.9	6080.79	19181.8	10.326	58.6	
	RodB3_75	176	75	1.905	4.12	0.105	894.67	752.4	6177.56	19487.1	9.842	55.9	
Gr-8	RodF3_50.1	89	50.1	1.273	3.1	0.079	781.65	689.6	4945.11	15599.4	9.609	54.6	
	RodF3_54	90	54	1.372	7	0.178	850.21	727.7	5131.61	16187.7	8.799	50.0	
	RodF3_57	91	57	1.448	10	0.254	893.45	751.7	5280.14	16656.2	8.429	47.9	
	RodF3_60	92	60	1.524	13	0.330	919.01	765.9	5433.34	17139.5	8.333	47.3	
	RodF3_66.1	93	66.1	1.679	19.1	0.485	930.49	772.3	5739.11	18104.0	8.650	49.1	
	RodF3_70	94	70	1.778	-0.88	-0.022	792.51	695.7	5935.05	18722.1	11.294	64.1	
	RodF3_73	95	73	1.854	2.12	0.054	893.37	751.7	6078.67	19175.2	9.705	55.1	
	RodF3_75	96	75	1.905	4.12	0.105	936.88	775.9	6179.61	19493.6	9.225	52.4	
Gr-8	RodE6_50.2	121	50.2	1.275	3.2	0.081	791.72	695.2	4926.23	15539.8	9.388	53.3	
	RodE6_54.1	122	54.1	1.374	7.1	0.180	850.95	728.1	5112.08	16126.1	8.754	49.7	
	RodE6_57	123	57	1.448	10	0.254	881.62	745.2	5250.10	16561.4	8.542	48.5	
	RodE6_60.2	124	60.2	1.529	13.2	0.335	906.70	759.1	5404.10	17047.2	8.448	48.0	
	RodE6_66.1	125	66.1	1.679	19.1	0.485	926.22	769.9	5694.21	17962.4	8.638	49.1	
	RodE6_70	126	70	1.778	-0.88	-0.022	795.85	697.5	5941.98	18744.0	11.236	63.8	
	RodE6_73.1	127	73.1	1.857	2.22	0.056	872.54	740.1	6087.96	19204.5	10.054	57.1	
	RodE6_75	128	75	1.905	4.12	0.105	906.37	758.9	6177.53	19487.0	9.662	54.9	

RBHT Steam Cooling with Droplet Injection Test SCD-4041-D

Matrix Test # 9d

Test Conditions

Test Date – 10/26/2005

Steady State Time Window: 19260 – 20100

Upper Plenum Pressure: 2.76 bar (40 psia)

Bundle Power: 80.0 kW

Bundle Inlet Reynolds Number: 10000

Bundle Inlet Steam Flow: 199.6 kg/hr (440 lbm/hr)

Droplet Injection Flow: 0.015 kg/s (0.032 lbm/s)

Droplet Injection Hole Diameter: 0.381 mm (.015 in)

Droplet Injection Elevation: 1.295 m (51 in)

Bundle Flow Area: $4.656 \times 10^{-3} \text{ m}^2$ ($5.012 \times 10^{-2} \text{ ft}^2$)

Test Notes

- No steam probes were traversed in this steady state window.

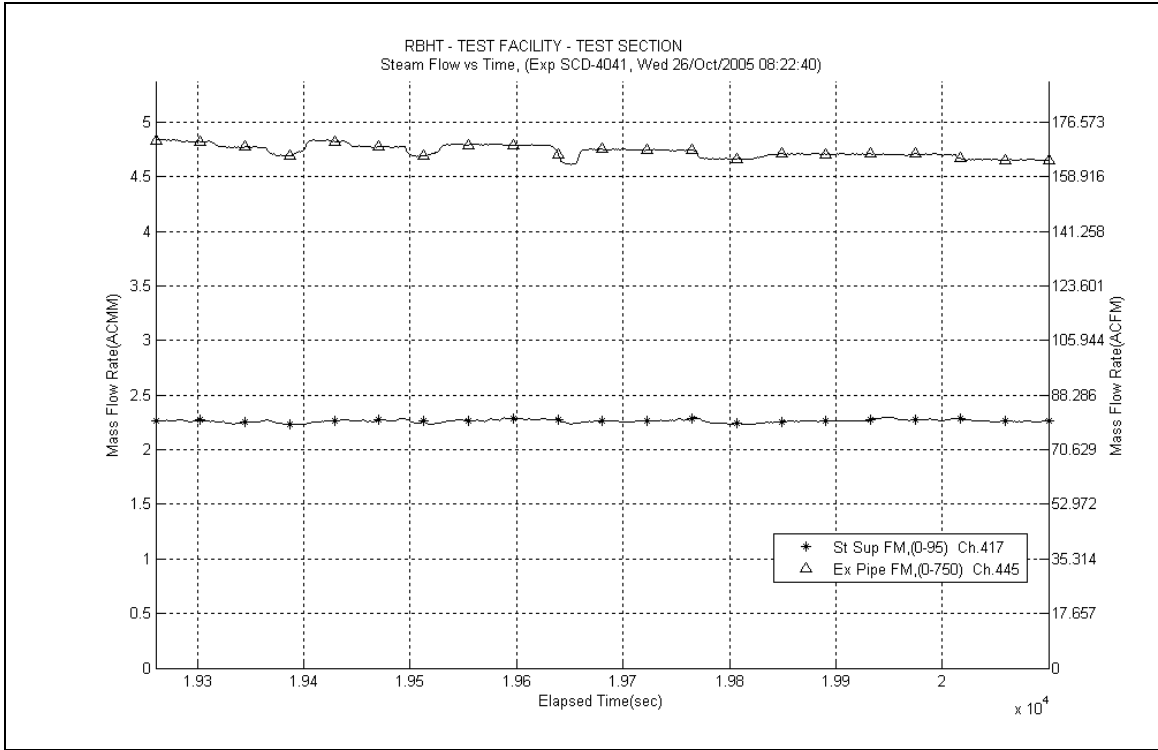

Figure A-500: Inlet and Exhaust Steam Flow Rates for Experiment 4041D

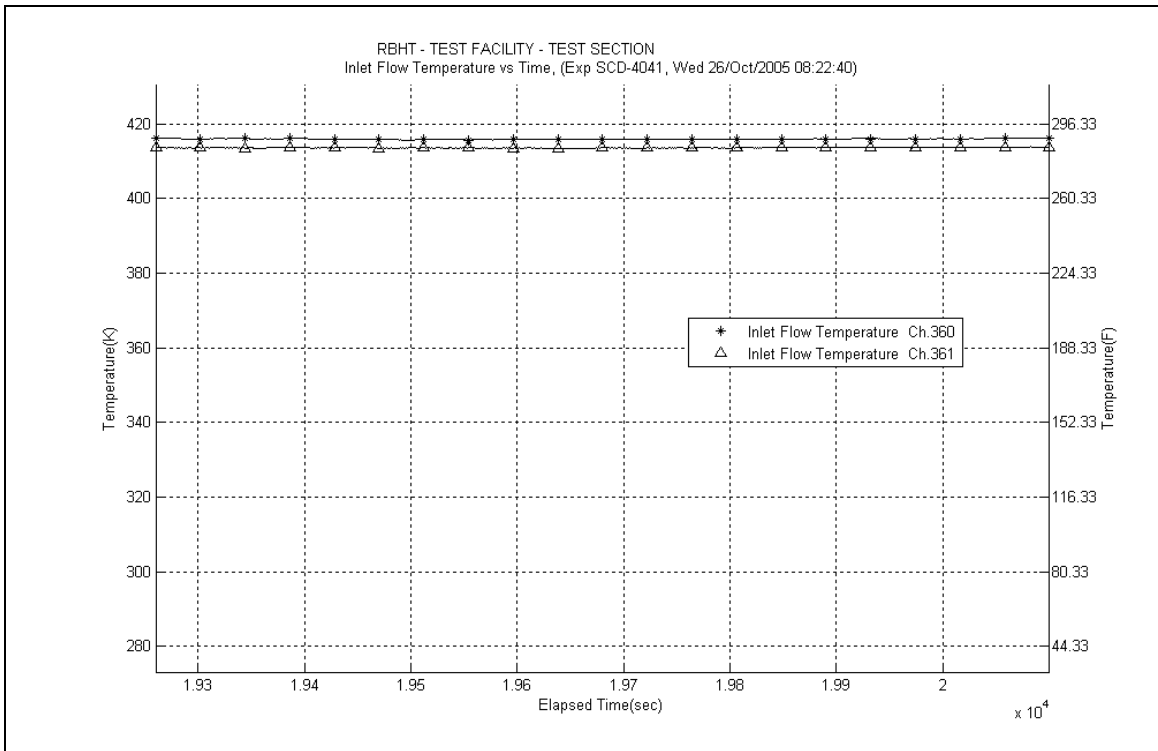

Figure A-501: Inlet Steam Temperature for Experiment 4041D

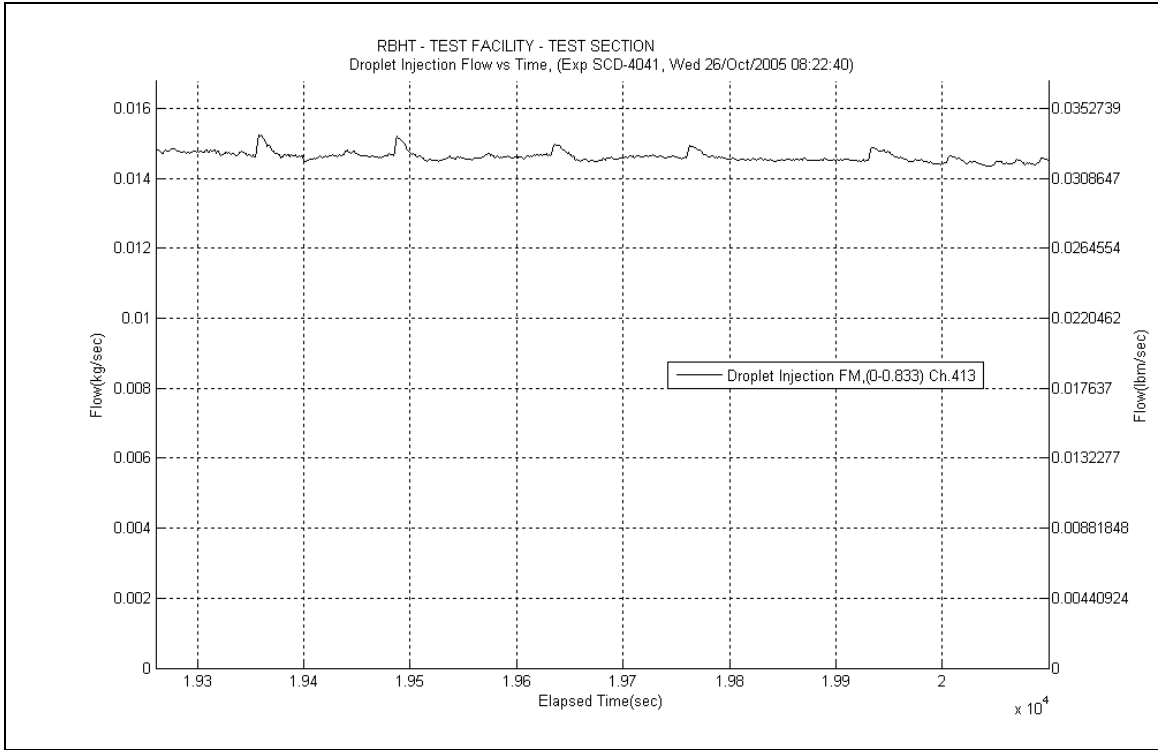

Figure A-502: Droplet Injection Flow Rate for Experiment 4041D

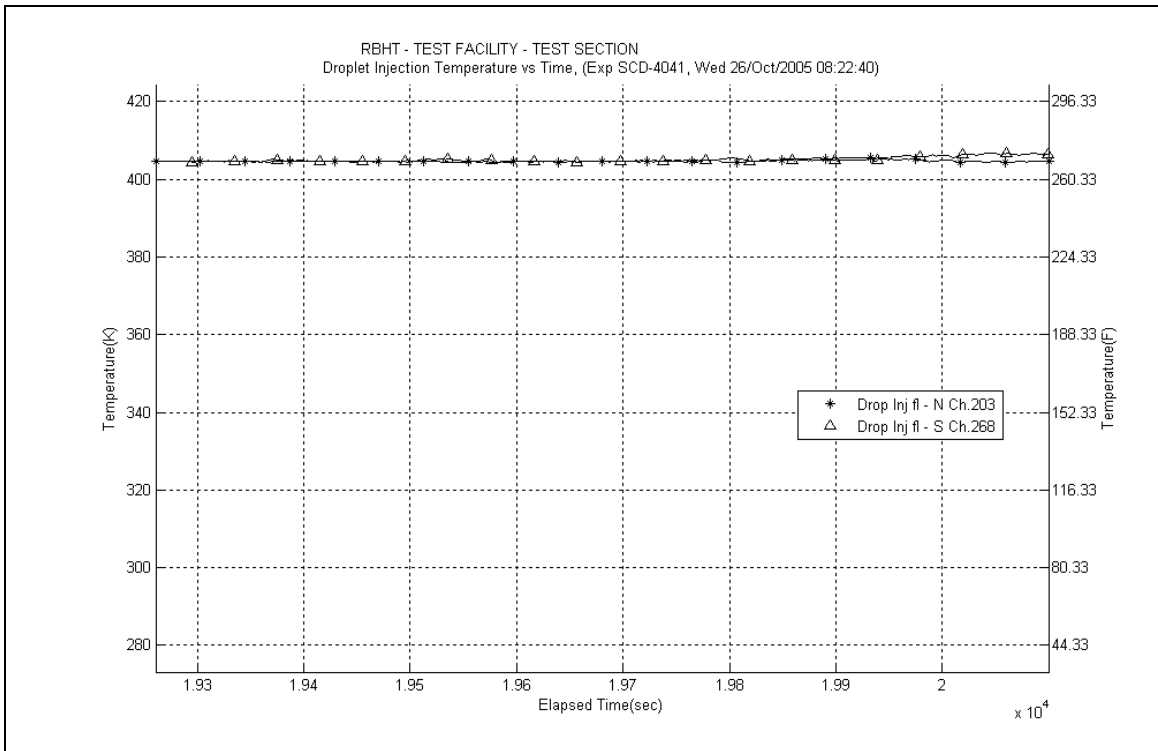

Figure A-503: Droplet Injection Temperature for Experiment 4041D

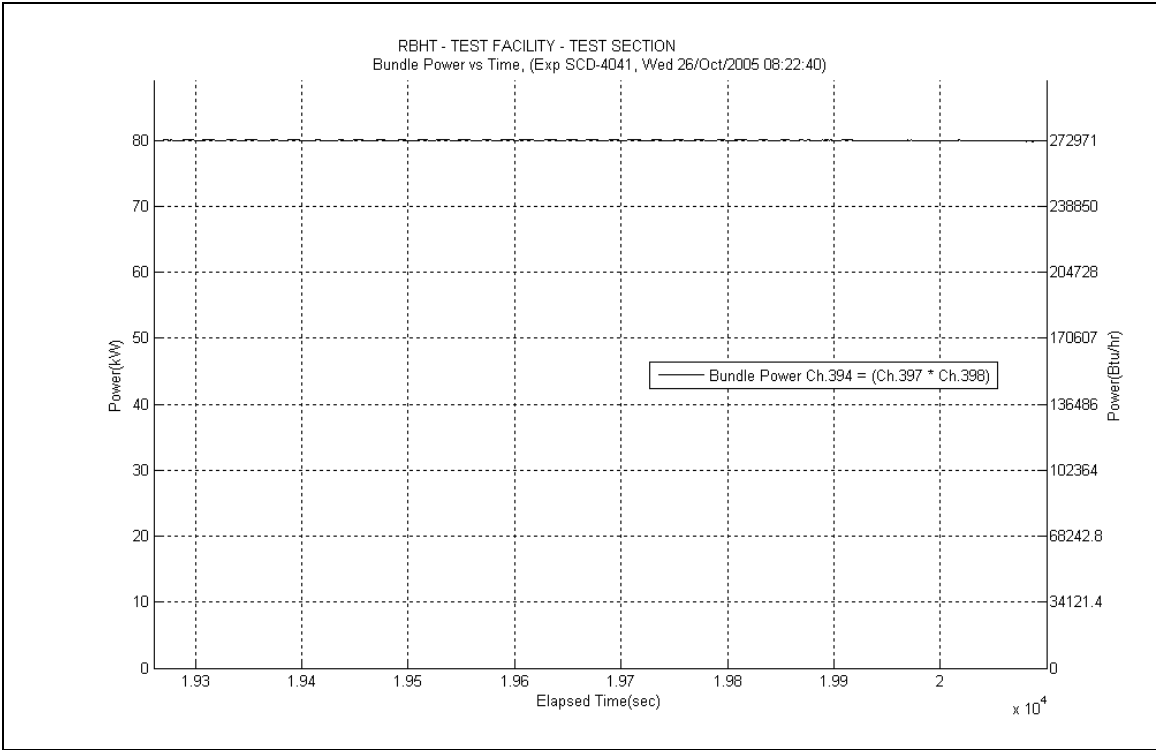

Figure A-504: Bundle Power for Experiment 4041D

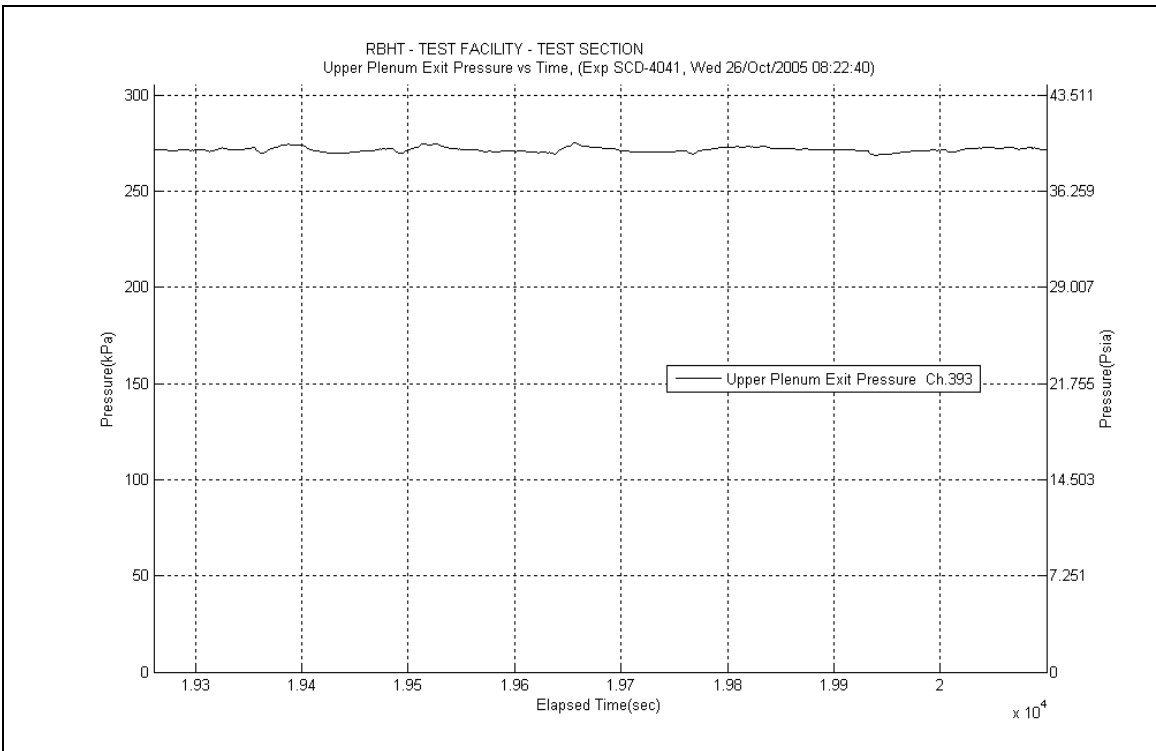

Figure A-505: Upper Plenum Pressure for Experiment 4041D

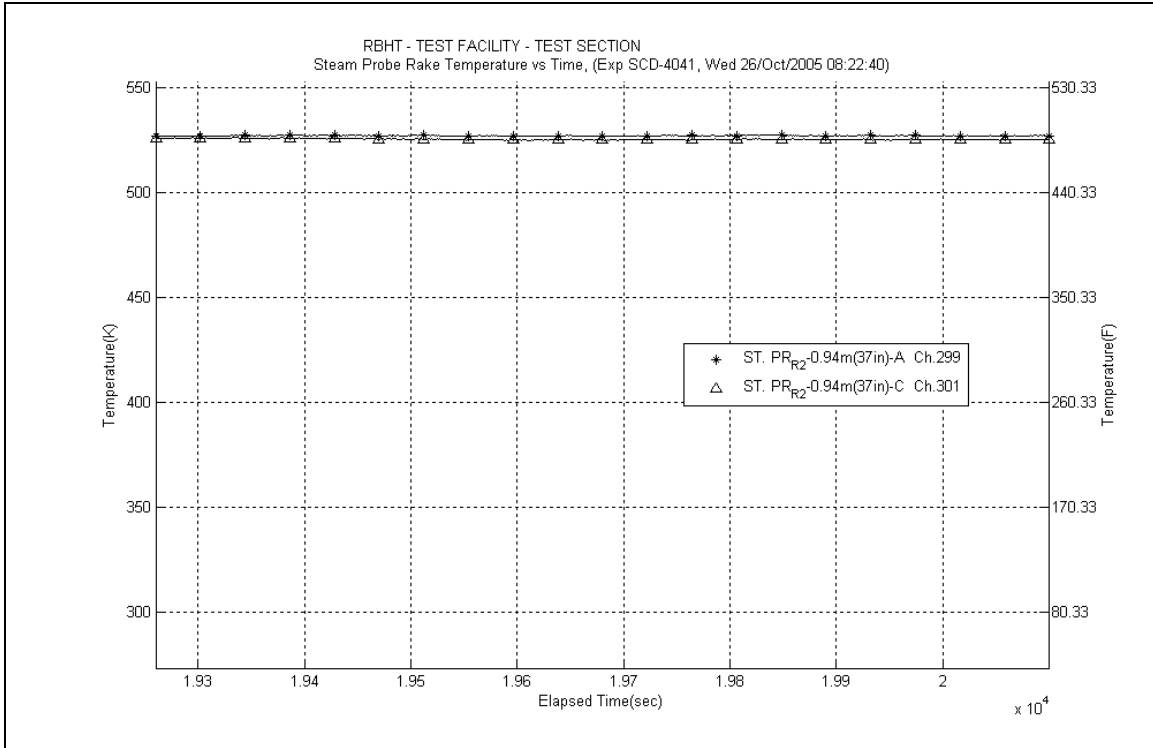

Figure A-506: Steam Probe Rake #2 Temperatures for Experiment 4041D

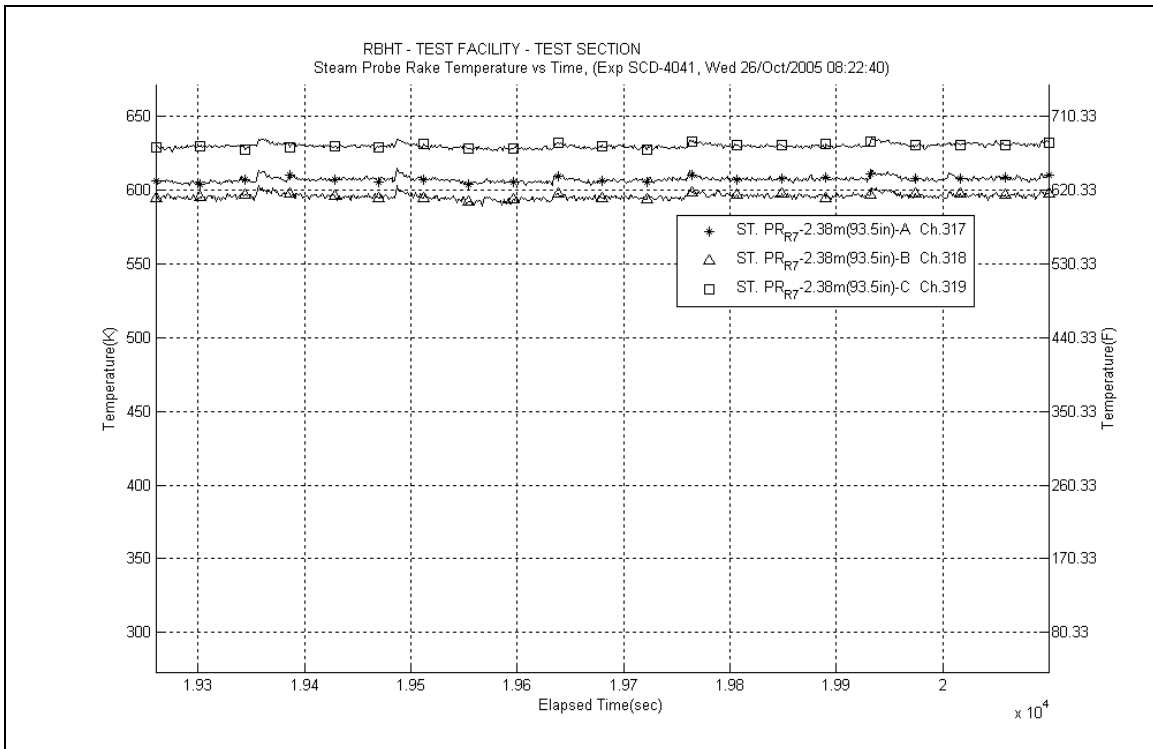

Figure A-507: Steam Probe Rake #7 Temperatures for Experiment 4041D

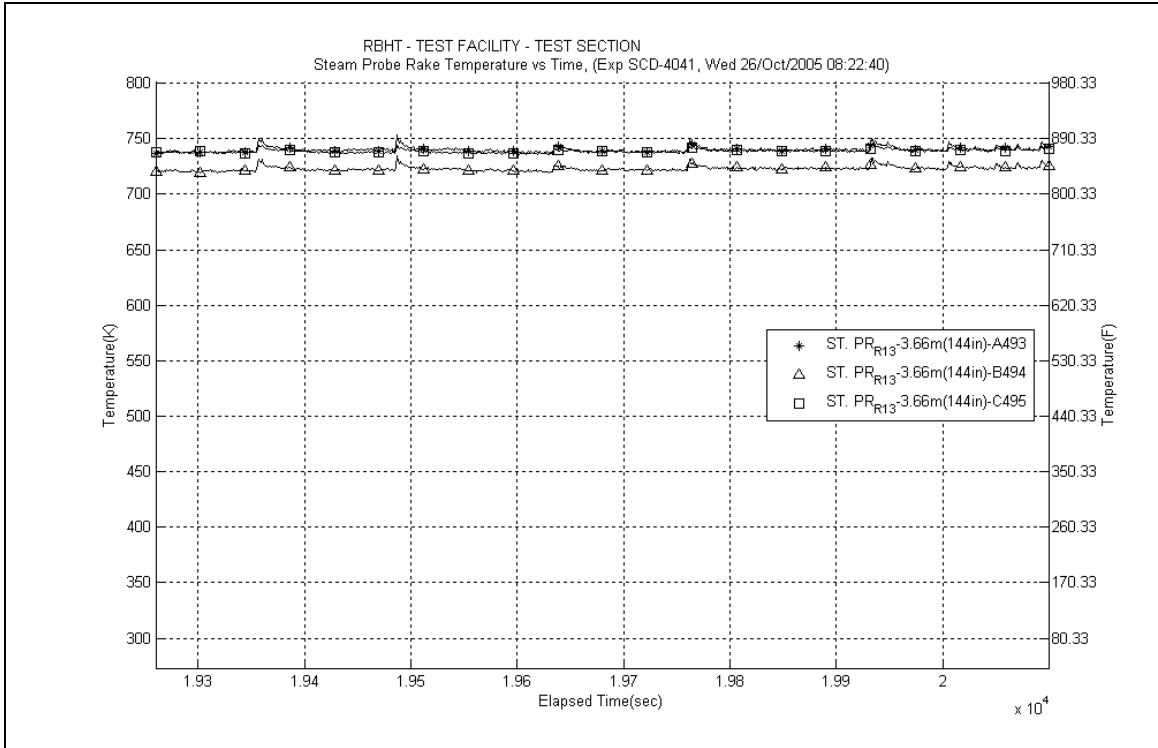

Figure A-508: Steam Probe Rake #13 Temperatures for Experiment 4041D

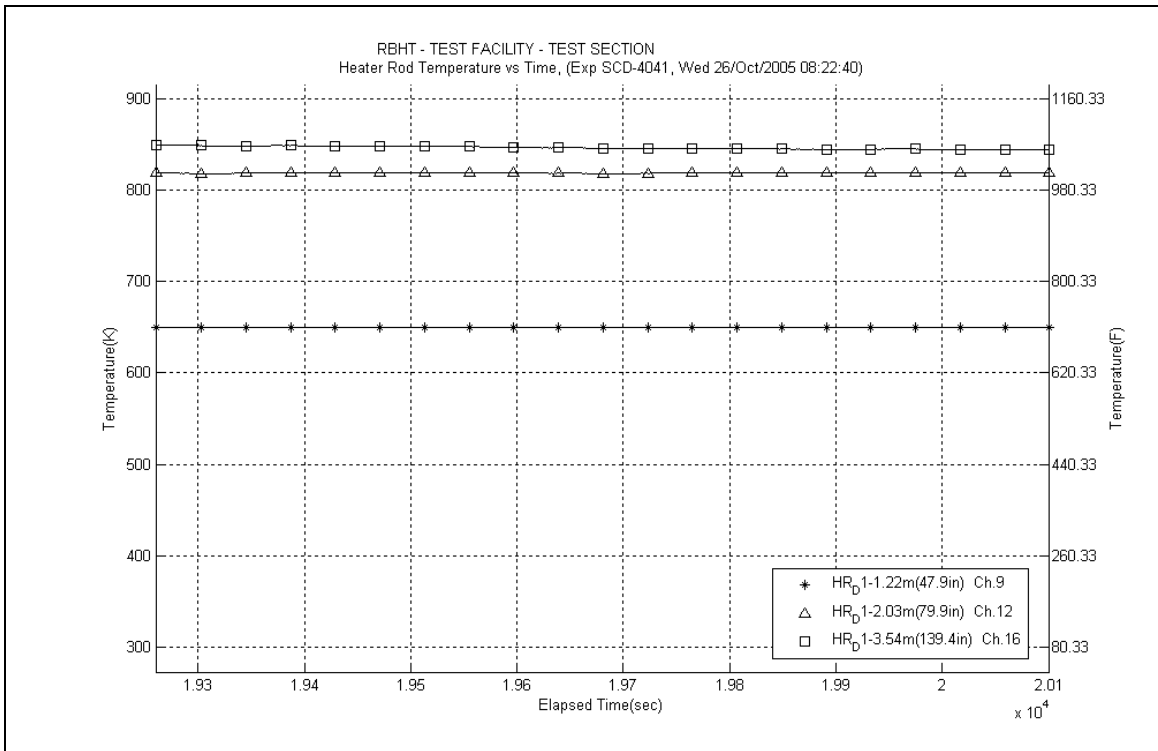

Figure A-509: Heater Rod D1 Temperatures for Experiment 4041D

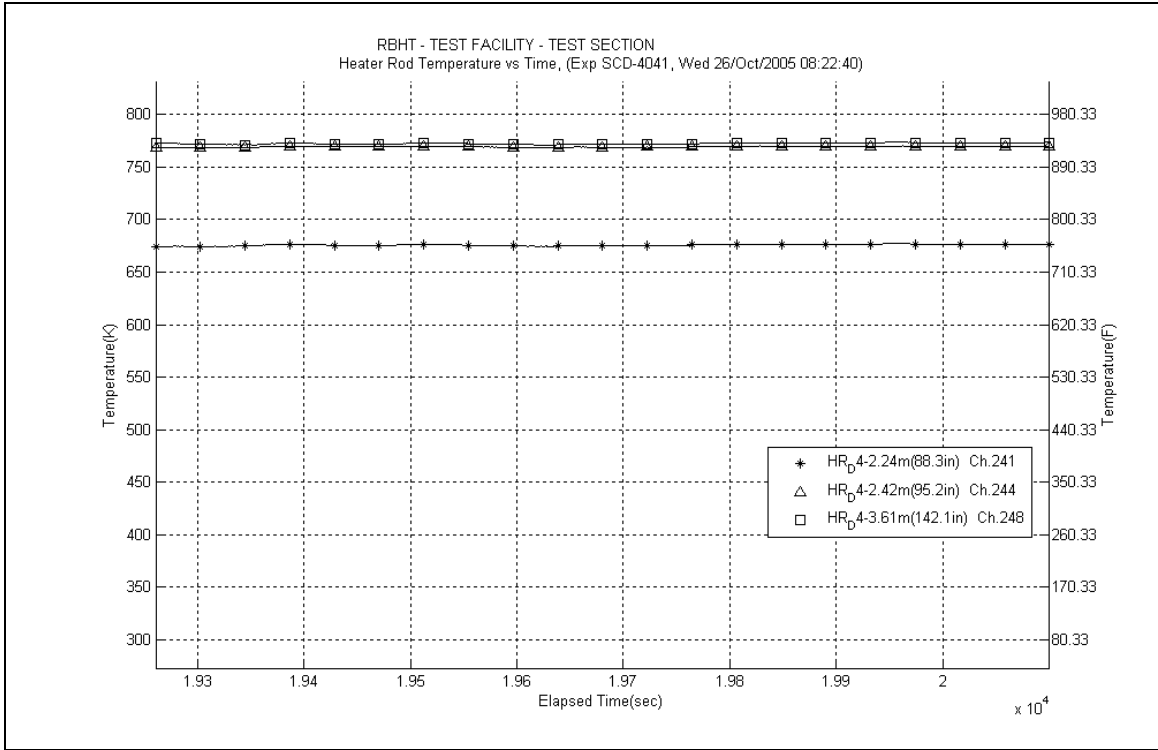

Figure A-510: Heater Rod D4 Temperatures for Experiment 4041D

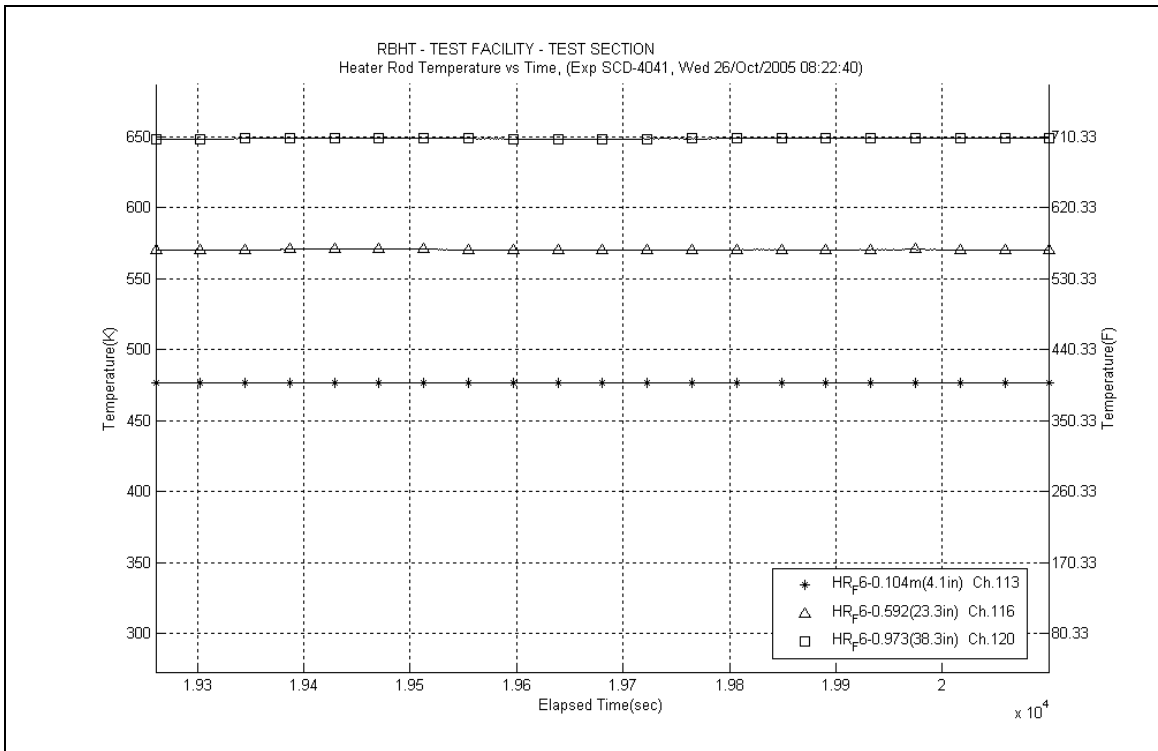

Figure A-511: Heater Rod F6 Temperatures for Experiment 4041D

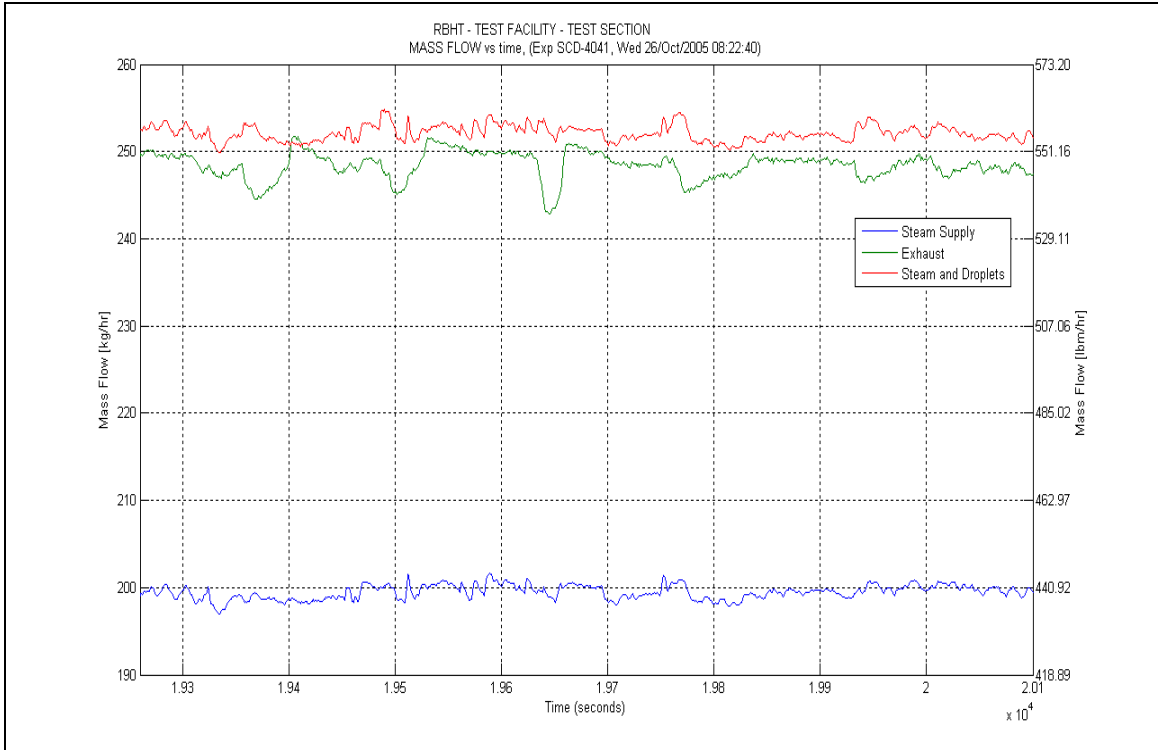

Figure A-512: Mass Flow for Experiment 4041D

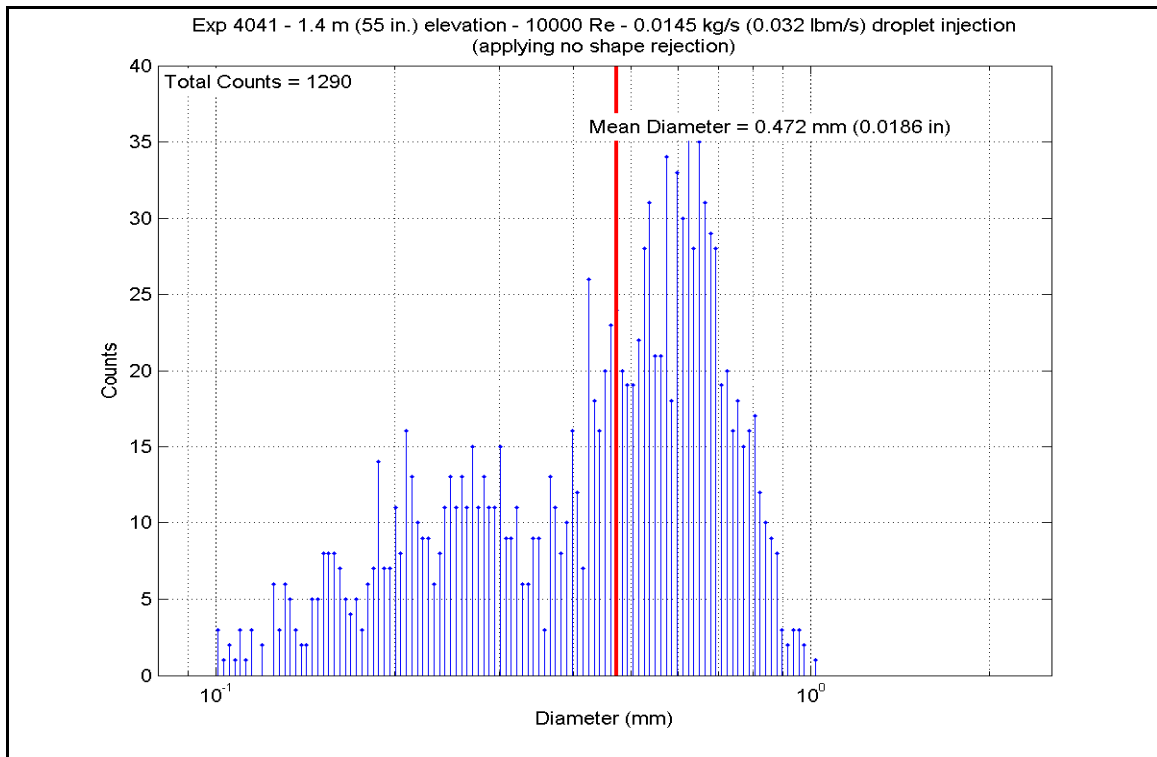

Figure A-513: Droplet Measurements at 1.397 m (55 in.) Elevation for Experiment 4041D

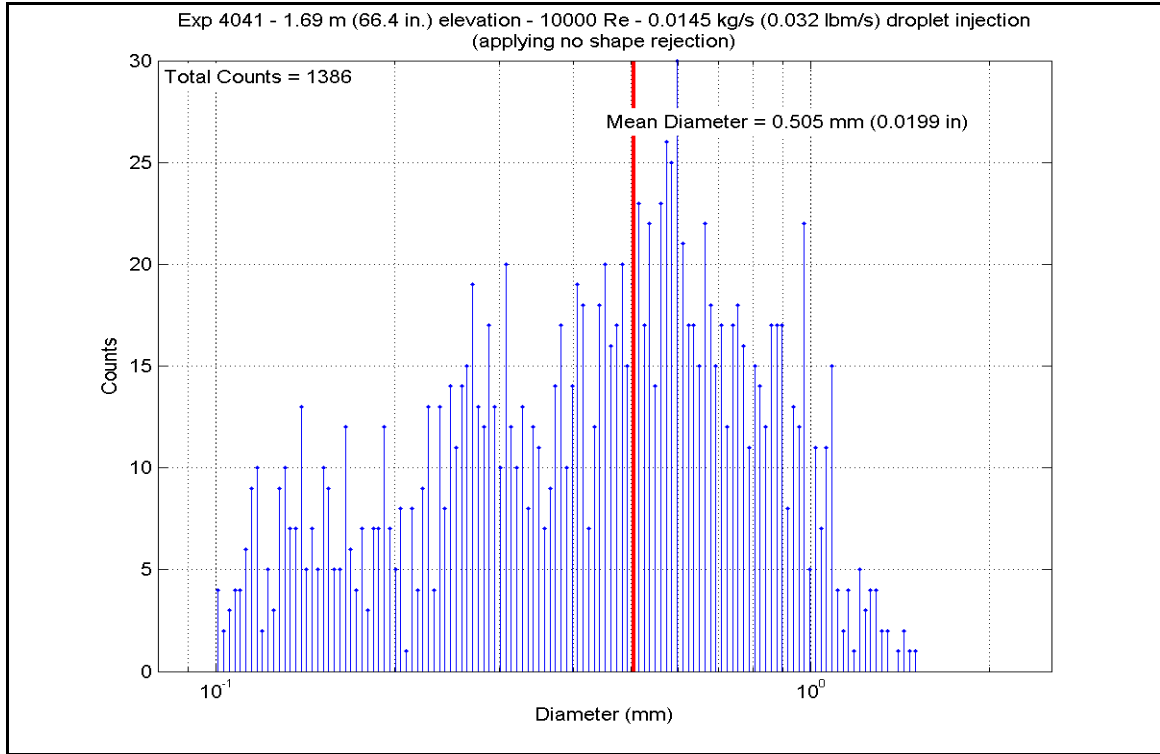

Figure A-514: Droplet Measurements at 1.687 m (66.4 in.) Elevation for Experiment 4041D

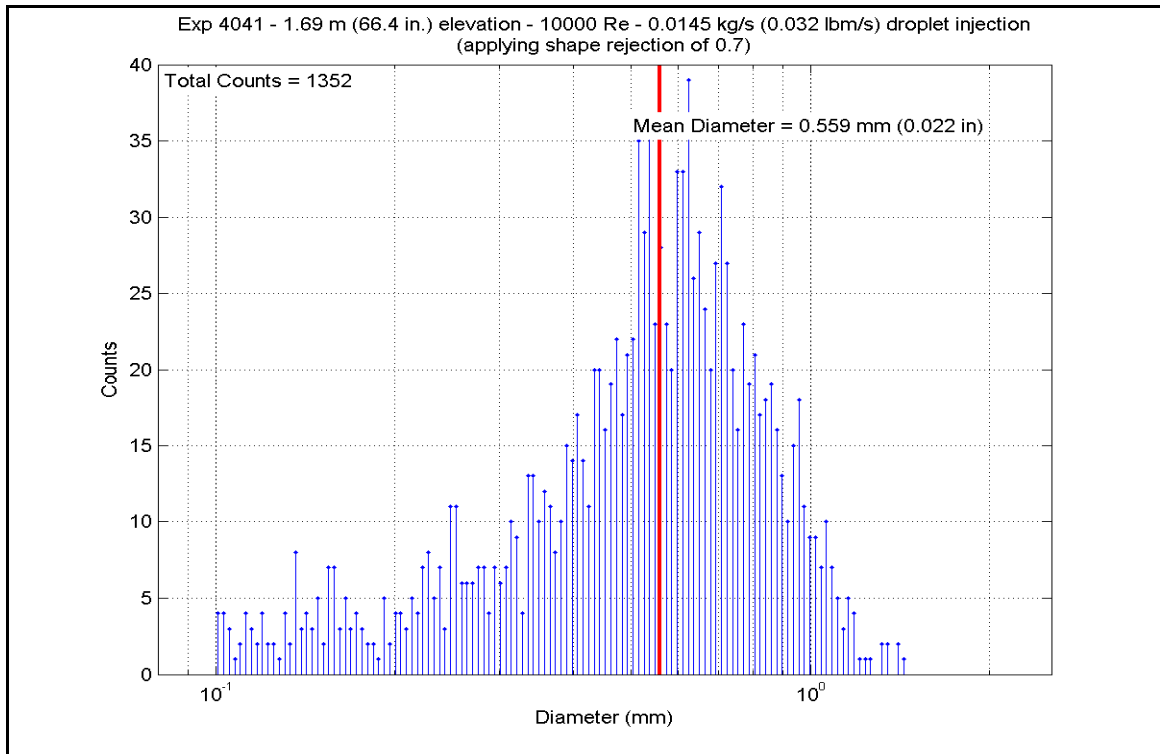

Figure A-515: Droplet Measurements at 1.687 m (66.4 in.) Elevation for Experiment 4041D

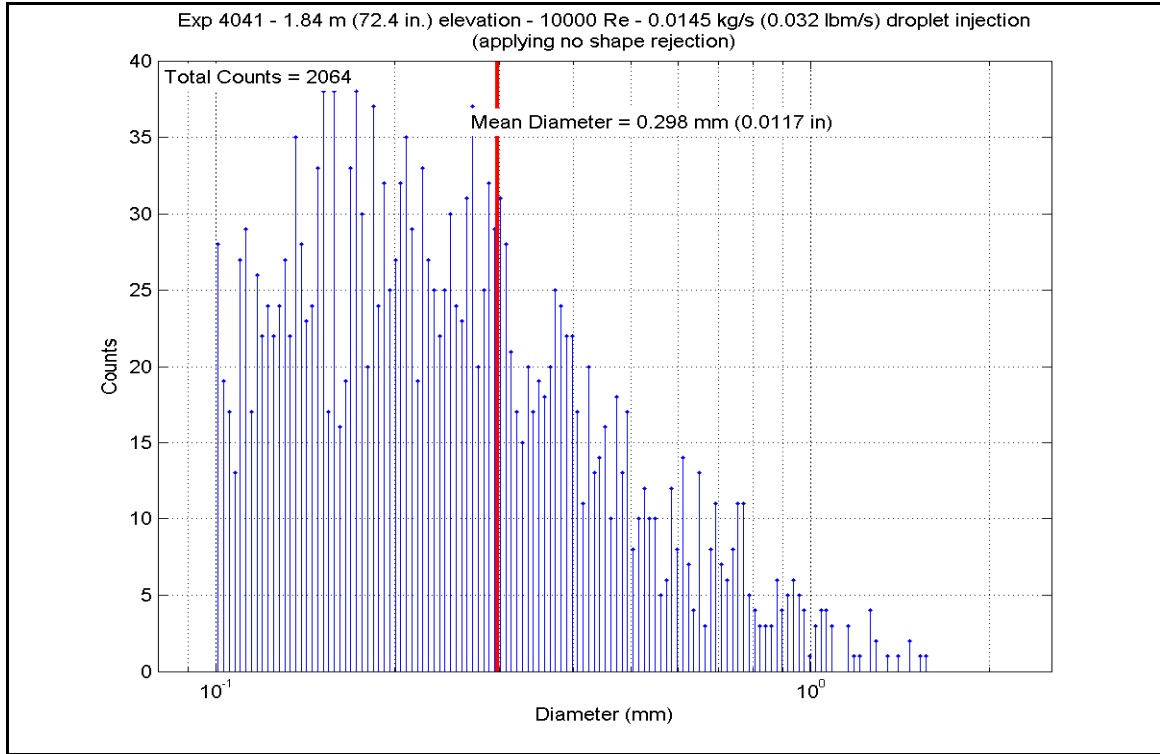

Figure A-516: Droplet Measurements at 1.839 m (72.4 in.) Elevation for Experiment 4041D

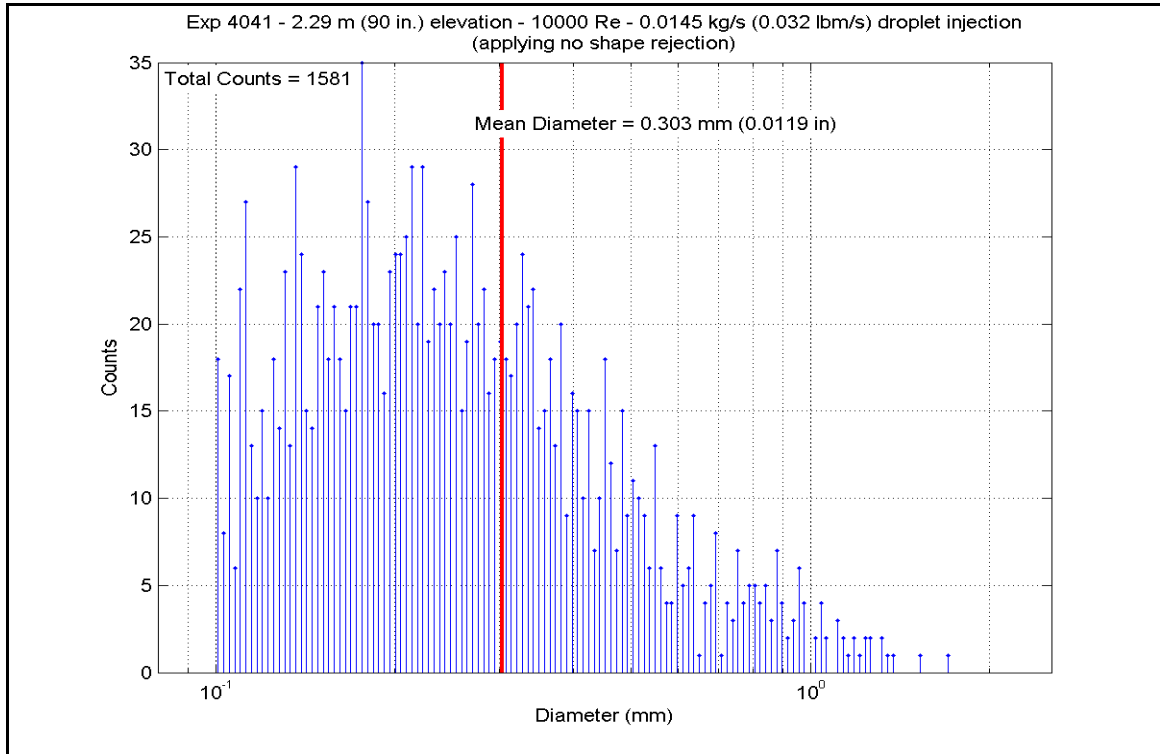

Figure A-517: Droplet Measurements at 2.286 m (90 in.) Elevation for Experiment 4041D

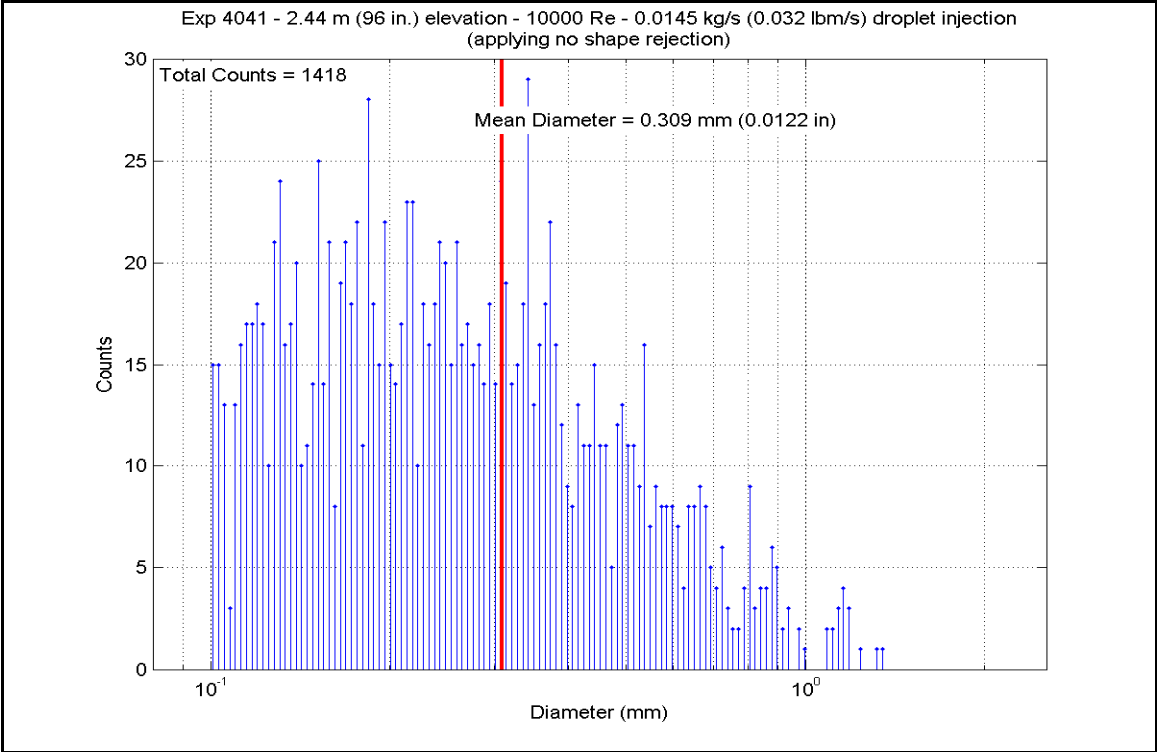

Figure A-518: Droplet Measurements at 2.438 m (96 in.) Elevation for Experiment 4041D

Table A-28: Summary of Steam Cooling Heat Transfer Reduced Data for Experiment 4041D

SCD-4041-D		Inlet Reynolds:		10000		40 psia							
Matrix Test # 9d		UP Pressure:		275.8 kPa		272971 Btu/hr							
Time Window 19260-20100		Bundle Power:		80.00 kW		440.0 lbm/hr							
Inner 3x3		Steam flow:		0.0554 kg/s		0.032 lbm/s							
		Droplet flow:		0.0145 kg/s									
H.R. ID	H.R. Location	Channel Number	Elevation (in)	Elevation (m)	Zgrid (in)	Zgrid (m)	H.R. Tw (°F)	H.R. Tw (K)	H.R. q" (Btu/hr-ft ²)	H.R. q' (W/m ²)	h _{sat} (z) (Btu/hr-ft ² -F)	h _{sat} (z) (W/m ² -K)	
Gr-3	RodD3_88.3	185	88.3	2.243	-0.2	-0.005	812.43	706.7	6781.07	21390.9	12.433	70.6	
	RodD3_91.3	186	91.3	2.319	2.8	0.071	896.65	753.5	6926.27	21848.9	11.000	62.5	
	RodD3_93.1	187	93.1	2.365	4.6	0.117	896.64	753.5	7011.62	22118.2	11.136	63.2	
	RodD3_95.3	188	95.3	2.421	6.8	0.173	944.26	780.0	7119.34	22458.0	10.512	59.7	
	RodD3_100.1	189	100.1	2.543	11.6	0.295	1032.39	828.9	7352.18	23192.5	9.606	54.6	
	RodD3_106.1	190	106.1	2.695	17.6	0.447	1094.25	863.3	7643.76	24112.2	9.240	52.5	
	RodD3_110	191	110	2.794	21.5	0.546	967.78	793.0	7606.46	23994.6	10.854	61.6	
	RodD3_142.1	192	142.1	3.609	8.6	0.218	985.53	802.9	2640.60	8329.8	3.675	20.9	
Gr-3	RodC4_88.4	233	88.4	2.245	-0.1	-0.003	773.56	685.1	6860.15	21640.3	13.543	76.9	
	RodC4_91.1	234	91.1	2.314	2.6	0.066	867.31	737.2	6993.19	22060.0	11.649	66.2	
	RodC4_93.4	235	93.4	2.372	4.9	0.124	893.58	751.8	7106.87	22418.6	11.342	64.4	
	RodC4_95.3	236	95.3	2.421	6.8	0.173	939.52	777.3	7200.83	22715.0	10.707	60.8	
	RodC4_100.1	237	100.1	2.543	11.6	0.295	988.86	804.7	7435.53	23455.4	10.300	58.5	
	RodC4_106.1	238	106.1	2.695	17.6	0.447	1047.64	837.4	7728.23	24378.7	9.900	56.2	
	RodC4_110	239	110	2.794	21.5	0.546	876.93	742.6	7496.66	23648.2	12.291	69.8	
	RodC4_142.2	240	142.2	3.612	8.7	0.221	925.32	769.4	2851.14	8993.9	4.331	24.6	
Gr-3	RodD4_88.3	241	88.3	2.243	-0.2	-0.005	753.80	674.1	6836.12	21564.6	14.043	79.7	
	RodD4_91.3	242	91.3	2.319	2.8	0.071	850.48	727.9	6981.70	22023.8	11.966	68.0	
	RodD4_93.2	243	93.2	2.367	4.7	0.119	877.59	742.9	7074.21	22315.6	11.586	65.8	
	RodD4_95.2	244	95.2	2.418	6.7	0.170	922.22	767.7	7173.09	22627.5	10.948	62.2	
	RodD4_100.1	245	100.1	2.543	11.6	0.295	1007.10	814.9	7411.56	23379.8	10.014	56.9	
	RodD4_106.1	246	106.1	2.695	17.6	0.447	1037.71	831.9	7704.33	24303.3	9.996	56.8	
	RodD4_142.1	248	142.1	3.609	8.6	0.218	929.04	771.5	2762.43	8714.1	4.173	23.7	
Gr-3	RodE4_88.4	201	88.4	2.245	-0.1	-0.003	780.44	689.0	6733.24	21240.0	13.114	74.5	
	RodE4_91.2	202	91.2	2.316	2.7	0.069	878.92	743.7	6865.07	21655.9	11.219	63.7	
	RodE4_95.3	204	95.3	2.421	6.8	0.173	955.39	786.1	7056.65	22260.2	10.251	58.2	
	RodE4_100.9	205	100.9	2.563	12.4	0.315	1022.99	823.7	7317.84	23084.1	9.680	55.0	
	RodE4_142.3	208	142.3	3.614	8.8	0.224	958.96	788.1	2805.80	8850.9	4.055	23.0	

Table A-28: Summary of Steam Cooling Heat Transfer Reduced Data for Experiment 4041, continued

Inner 3x3	H.R. Location	Channel Number	Elevation (in)	Elevation (m)	Zgrid (in)	Zgrid (m)	H.R. Tw (°F)	H.R. Tw (K)	H.R. q" (Btu/hr-ft ²)	H.R. q" (W/m ²)	h _{sat} (z) (Btu/hr-ft ² -F)	h _{sat} (z) (W/m ² -K)
Gr-4	RodE3_63.4	193	63.4	1.610	16.4	0.417	939.25	777.2	5581.94	17608.2	8.303	47.2
	RodE3_113.6	194	113.6	2.885	0.85	0.022	1006.82	814.7	6917.74	21822.0	9.351	53.1
	RodE3_115.5	195	115.5	2.934	2.75	0.070	1041.13	833.8	6651.66	20982.7	8.592	48.8
	RodE3_118.5	196	118.5	3.010	5.75	0.146	1062.80	845.8	6242.41	19691.7	7.844	44.5
	RodE3_122.7	197	122.7	3.117	9.95	0.253	1061.12	844.9	5675.12	17902.2	7.146	40.6
	RodE3_126.5	198	126.5	3.213	13.75	0.349	1060.33	844.4	5164.98	16292.9	6.511	37.0
	RodE3_131.7	199	131.7	3.345	-1.8	-0.046	963.79	790.8	4451.38	14041.9	6.388	36.3
	RodE3_135.6	200	135.6	3.444	2.1	0.053	998.40	810.0	3933.42	12408.0	5.378	30.5
	RodC5_63.7	225	63.7	1.618	16.7	0.424	939.41	777.3	5470.91	17258.0	8.136	46.2
	RodC5_113.6	226	113.6	2.885	0.85	0.022	916.82	764.7	6704.20	21148.4	10.317	58.6
Gr-4	RodC5_115.7	227	115.7	2.939	2.95	0.075	960.00	788.7	6435.49	20300.8	9.286	52.7
	RodC5_122.7	229	122.7	3.117	9.95	0.253	990.03	805.4	5538.00	17469.6	7.659	43.5
	RodC5_126.7	230	126.7	3.218	13.95	0.354	988.73	804.7	5026.72	15856.8	6.965	39.6
	RodC5_131.6	231	131.6	3.343	-1.9	-0.048	873.84	740.8	4399.61	13878.6	6.129	41.2
	RodC5_135.7	232	135.7	3.447	2.2	0.056	899.84	755.3	3878.46	12234.6	6.129	34.8
	RodE5_63.6	209	63.6	1.615	16.6	0.422	829.32	716.1	5606.44	17685.5	9.970	56.6
	RodE5_113.6	210	113.6	2.885	0.85	0.022	829.18	716.0	6921.15	21832.8	12.311	69.9
	RodE5_115.4	211	115.4	2.931	2.65	0.067	906.78	759.1	6688.73	21099.6	10.455	59.4
	RodE5_118.7	212	118.7	3.015	5.95	0.151	969.63	794.1	6258.18	19741.4	8.907	50.6
	RodE5_122.6	213	122.6	3.114	9.85	0.250	997.65	809.6	5745.75	18125.0	7.864	44.7
RodE5_126.6	214	126.6	3.216	13.85	0.352	998.20	809.9	5217.37	16458.2	7.135	40.5	
Gr-5	RodE5_131.6	215	131.6	3.343	-1.9	-0.048	975.57	797.4	4552.07	14359.5	6.424	36.5
	RodE5_135.6	216	135.6	3.444	2.1	0.053	964.24	791.1	4016.75	12670.8	5.761	32.7
	RodC3_79.8	177	79.8	2.027	8.92	0.227	901.37	756.1	6337.37	19991.2	9.990	56.7
	RodC3_85.6	178	85.6	2.174	14.72	0.374	811.49	706.2	6610.28	20852.1	12.140	68.9
	RodC3_88.5	179	88.5	2.248	0	0.000	805.76	703.0	6753.33	21303.4	12.535	71.2
	RodC3_92.4	180	92.4	2.347	3.9	0.099	914.77	763.6	6943.41	21903.0	10.719	60.9
	RodC3_94.4	181	94.4	2.398	5.9	0.150	932.86	773.6	7039.24	22205.3	10.572	60.0
	RodC3_97.2	182	97.2	2.469	8.7	0.221	988.70	804.6	7175.37	22634.7	9.942	56.5
	RodC3_108.8	183	108.8	2.764	20.3	0.516	1075.10	852.7	7570.33	23880.6	9.368	53.2
	RodD5_50	217	50	1.270	1.270	0.076	821.39	711.7	4949.17	15612.2	8.927	50.7
Gr-8	RodD5_54.1	218	54.1	1.374	7.1	0.180	748.05	671.0	5138.47	16209.3	10.682	60.7
	RodD5_56.9	219	56.9	1.445	9.9	0.251	833.90	718.6	5274.31	16637.8	9.304	52.8
	RodD5_60	220	60	1.524	13	0.330	879.10	743.8	5424.89	17112.8	8.863	50.3
	RodD5_66.1	221	66.1	1.679	19.1	0.485	903.44	757.3	5716.85	18033.8	8.983	51.0
	RodD5_69.9	222	69.9	1.775	-0.98	-0.025	711.63	650.7	5900.30	18612.5	13.270	75.4
	RodD5_72.9	223	72.9	1.852	2.02	0.051	787.89	693.1	6037.14	19044.1	11.590	65.8
	RodD5_74.9	224	74.9	1.902	4.02	0.102	828.82	715.8	6130.67	19339.2	10.912	62.0

Table A-28: Summary of Steam Cooling Heat Transfer Reduced Data for Experiment 4041, continued

H.R. ID	H.R. Location	Channel Number	Elevation (in)	Elevation (m)	Zgrid (in)	Zgrid (m)	H.R. Tw (°F)	H.R. Tw (K)	H.R. q" (Btu/hr-ft ²)	H.R. q" (W/m ²)	h _{sat} (z) (Btu/hr-ft ² -F)	h _{sat} (z) (W/m ² -K)
Gr-2	RodB5_41	153	41	1.041	13.5	0.343	754.52	674.5	4502.26	14202.4	9.235	52.4
	RodB5_52.9	154	52.9	1.344	5.9	0.150	826.65	714.6	5073.16	16003.3	9.065	51.5
	RodB5_55	155	55	1.397	8	0.203	864.47	735.6	5175.42	16325.9	8.662	49.2
	RodB5_57.8	156	57.8	1.468	10.8	0.274	905.76	758.6	5310.24	16751.2	8.313	47.2
	RodB5_64	157	64	1.626	17	0.432	942.84	779.2	5605.05	17681.1	8.293	47.1
	RodB5_73.9	158	73.9	1.877	3.02	0.077	866.61	736.8	6081.04	19182.7	10.142	57.6
	RodB5_75.9	159	75.9	1.928	5.02	0.128	896.47	753.4	6175.51	19480.7	9.811	55.7
	RodB5_76.9	160	76.9	1.953	6.02	0.153	908.53	760.1	6222.88	19630.1	9.700	55.1
	RodF5_41	105	41	1.041	13.5	0.343	745.44	669.5	4474.45	14114.7	9.352	53.1
	RodF5_53.1	106	53.1	1.349	6.1	0.155	807.97	704.2	5056.26	15950.0	9.347	53.1
Gr-2	RodF5_55	107	55	1.397	8	0.203	846.84	725.8	5146.72	16235.3	8.876	50.4
	RodF5_57.8	108	57.8	1.468	10.8	0.274	887.35	748.3	5281.56	16660.7	8.514	48.3
	RodF5_64	109	64	1.626	17	0.432	900.63	755.7	5583.31	17612.6	8.812	50.0
	RodF5_73.8	110	73.8	1.875	2.92	0.074	849.25	727.2	6049.06	19081.8	10.389	59.0
	RodF5_75.8	111	75.8	1.925	4.92	0.125	886.05	747.6	6146.14	19388.0	9.928	56.4
	RodF5_76.8	112	76.8	1.951	5.92	0.150	901.23	756.1	6194.54	19540.7	9.767	55.5
	RodC2_41	57	41	1.041	13.5	0.343	742.21	667.7	4499.86	14194.8	9.469	53.8
	RodC2_53.1	58	53.1	1.349	6.1	0.155	866.01	736.5	5077.68	16017.5	8.477	48.1
	RodC2_55	59	55	1.397	8	0.203	884.38	746.7	5169.17	16306.2	8.373	47.5
	RodC2_57.8	60	57.8	1.468	10.8	0.274	914.53	763.4	5306.89	16740.6	8.196	46.5
RodC2_63.9	61	63.9	1.623	16.9	0.429	935.53	775.1	5602.41	17672.8	8.380	47.6	
RodC2_73.8	62	73.8	1.875	2.92	0.074	894.18	752.1	6075.27	19164.5	9.687	55.0	
RodC2_75.8	63	75.8	1.925	4.92	0.125	921.84	767.5	6169.52	19461.7	9.421	53.5	
RodC2_76.8	64	76.8	1.951	5.92	0.150	933.00	773.7	6217.48	19613.0	9.336	53.0	
Gr-2	RodC6_40.9	137	40.9	1.039	13.4	0.340	751.21	672.7	4471.51	14105.4	9.235	52.4
	RodC6_52.8	138	52.8	1.341	5.8	0.147	870.10	738.8	5067.11	15984.2	8.402	47.7
	RodC6_54.8	139	54.8	1.392	7.8	0.198	890.69	750.2	5167.47	16300.8	8.285	47.1
	RodC6_57.8	140	57.8	1.468	10.8	0.274	925.85	769.7	5318.40	16776.9	8.072	45.8
	RodC6_63.8	141	63.8	1.621	16.8	0.427	962.60	790.2	5618.98	17725.1	8.078	45.9
	RodC6_73.7	142	73.7	1.872	2.82	0.072	916.95	764.8	6117.08	19296.3	9.412	53.4
	RodC6_75.8	143	75.8	1.925	4.92	0.125	940.16	777.7	6222.09	19627.6	9.243	52.5
	RodC6_76.8	144	76.8	1.951	5.92	0.150	954.53	785.7	6271.84	19784.5	9.122	51.8

Table A-28: Summary of Steam Cooling Heat Transfer Reduced Data for Experiment 4041, continued

5x5 periphery		H.R. Location	Channel Number	Elevation (in)	Elevation (m)	Zgrid (in)	Zgrid (m)	H.R. Tw (°F)	H.R. Tw (K)	H.R. q" (Btu/hr-ft ²)	H.R. q" (W/m ²)	h _{sat} (z) (Btu/hr-ft ² -F)	h _{sat} (z) (W/m ² -K)
Gr-3	RodB4_88.4	161	88.4	2.245	-0.1	-0.003	691.7	6727.55	21222.0	12.976	73.7		
	RodB4_91.3	162	91.3	2.319	2.8	0.071	745.3	6863.62	21651.3	11.163	63.4		
	RodB4_93.3	163	93.3	2.370	4.8	0.122	753.5	6955.93	21942.5	11.048	62.7		
	RodB4_95.1	164	95.1	2.416	6.6	0.168	772.3	7040.88	22210.4	10.612	60.3		
	RodB4_100	165	100	2.540	11.5	0.292	790.0	7268.33	22928.0	10.453	59.4		
	RodB4_106	166	106	2.692	17.5	0.445	838.2	7549.84	23816.0	9.653	54.8		
	RodB4_109.9	167	109.9	2.791	21.4	0.544	753.1	7340.37	23155.2	11.671	66.3		
	RodB4_142.3	168	142.3	3.614	8.8	0.224	774.7	2836.38	8947.4	4.247	24.1		
Gr-5	RodF4_85.6	98	85.6	2.174	14.72	0.374	731.7	6641.83	20951.6	11.249	63.9		
	RodF4_88.4	99	88.4	2.245	-0.1	-0.003	712.7	6772.54	21364.0	12.176	69.1		
	RodF4_92.4	100	92.4	2.347	3.9	0.099	771.1	6964.09	21968.2	10.532	59.8		
	RodF4_94.3	101	94.3	2.395	5.8	0.147	789.4	7054.72	22254.1	10.162	57.7		
	RodF4_97.2	102	97.2	2.469	8.7	0.221	811.7	7193.83	22629.9	9.797	55.6		
	RodF4_108.8	103	108.8	2.764	20.3	0.516	840.7	7599.72	23973.3	9.662	54.9		
	RodF4_111	104	111	2.819	-1.75	-0.044	748.5	7292.21	23003.3	11.750	66.7		
	RodD2_103.2	65	103.2	2.621	14.7	0.373	851.5	6726.40	21218.4	8.345	47.4		
Gr-6	RodD2_106	66	106	2.692	17.5	0.445	862.7	6367.52	20086.4	7.706	43.8		
	RodD2_112.6	67	112.6	2.860	-0.15	-0.004	873.5	5882.05	18554.9	6.956	39.5		
	RodD2_114.9	68	114.9	2.918	2.15	0.055	874.9	5314.90	16765.9	6.266	35.6		
	RodD2_117.4	69	117.4	2.982	4.65	0.118	866.2	4774.51	15061.2	5.735	32.6		
	RodD2_120.8	70	120.8	3.068	8.05	0.204	873.0	7526.68	23742.9	8.910	50.6		
	RodD2_124.8	71	124.8	3.170	12.05	0.306	885.2	7662.92	24172.7	8.842	50.2		
	RodD2_128.6	72	128.6	3.266	15.85	0.403	832.0	7060.19	22271.4	9.157	52.0		
	RodD6_103.1	129	103.1	2.619	14.6	0.371	839.3	7537.09	23775.8	9.612	54.6		
RodD6_106	130	106	2.692	17.5	0.445	848.4	7674.01	24207.7	9.587	54.4			
RodD6_112.9	131	112.9	2.868	0.15	0.004	786.0	6988.06	22075.4	10.168	57.7			
RodD6_114.9	132	114.9	2.918	2.15	0.055	807.3	6711.34	21170.9	9.238	52.5			
RodD6_116.8	133	116.8	2.967	4.05	0.103	819.4	6439.80	20314.3	8.607	48.9			
RodD6_120.9	134	120.9	3.071	8.15	0.207	821.3	5852.89	18462.9	7.787	44.2			
RodD6_124.8	135	124.8	3.170	12.05	0.306	820.9	5296.36	16707.4	7.052	40.0			
RodD6_128.7	136	128.7	3.269	15.95	0.405	814.0	4740.13	14952.7	6.418	36.4			

Table A-28: Summary of Steam Cooling Heat Transfer Reduced Data for Experiment 4041, continued

5x5 periphery		H.R. Location	Channel Number	Elevation (in)	Elevation (m)	Zgrid (in)	Zgrid (m)	H.R. Tw (°F)	H.R. Tw (K)	H.R. q" (Btu/hr-ft ²)	H.R. q" (W/m ²)	h _{sat} (z) (Btu/hr-ft ² -F)	h _{sat} (z) (W/m ² -K)
Gr-8	RodE2_50.1	73	50.1	1.273	3.1	0.079	807.64	704.1	4972.21	15684.8	9.197	52.2	
	RodE2_54	74	54	1.372	7	0.178	872.47	740.1	5162.29	16284.4	8.526	48.4	
	RodE2_56.9	75	56.9	1.445	9.9	0.251	907.01	759.3	5301.83	16724.6	8.284	47.0	
	RodE2_59.9	76	59.9	1.521	12.9	0.328	939.51	777.3	5444.31	17174.1	8.095	46.0	
	RodE2_66	77	66	1.676	19	0.483	960.64	789.1	5742.80	18115.7	8.279	47.0	
	RodE2_69.8	78	69.8	1.773	-1.08	-0.027	842.53	723.4	5942.20	18744.7	10.325	58.6	
	RodE2_72.9	79	72.9	1.852	2.02	0.051	903.86	757.5	6086.80	19200.8	9.558	54.3	
	RodE2_74.9	80	74.9	1.902	4.02	0.102	934.80	774.7	6181.77	19500.4	9.257	52.6	
Gr-8	RodB3_50.2	169	50.2	1.275	3.2	0.081	766.96	681.5	4939.37	15581.2	9.879	56.1	
	RodB3_54.1	170	54.1	1.374	7.1	0.180	834.28	718.9	5130.19	16183.2	9.044	51.4	
	RodB3_56.9	171	56.9	1.445	9.9	0.251	875.17	741.6	5264.72	16607.6	8.657	49.2	
	RodB3_60.1	172	60.1	1.527	13.1	0.333	857.13	731.6	5411.11	17069.3	9.169	52.1	
	RodB3_66.1	173	66.1	1.679	19.1	0.485	889.43	749.5	5702.78	17989.4	9.162	52.0	
	RodB3_69.9	174	69.9	1.775	-0.98	-0.025	746.91	670.3	5873.30	18527.3	12.238	69.5	
	RodB3_73	175	73	1.854	2.12	0.054	821.18	711.6	6035.88	19040.2	10.892	61.9	
	RodB3_75	176	75	1.905	4.12	0.105	857.66	731.8	6135.73	19355.1	10.388	59.0	
Gr-8	RodF3_50.1	89	50.1	1.273	3.1	0.079	785.56	691.8	4937.88	15576.5	9.522	54.1	
	RodF3_54	90	54	1.372	7	0.178	853.38	729.5	5130.67	16184.7	8.750	49.7	
	RodF3_57	91	57	1.448	10	0.254	898.36	754.5	5277.08	16646.6	8.358	47.5	
	RodF3_60	92	60	1.524	13	0.330	926.23	769.9	5424.50	17111.6	8.229	46.7	
	RodF3_66.1	93	66.1	1.679	19.1	0.485	933.49	774.0	5735.51	18092.7	8.606	48.9	
	RodF3_70	94	70	1.778	-0.88	-0.022	796.43	697.8	5927.39	18698.0	11.196	63.6	
	RodF3_73	95	73	1.854	2.12	0.054	891.47	750.6	6068.22	19142.2	9.717	55.2	
	RodF3_75	96	75	1.905	4.12	0.105	930.77	772.5	6166.34	19451.7	9.290	52.8	
Gr-8	RodE6_50.2	121	50.2	1.275	3.2	0.081	795.00	697.0	4937.87	15576.5	9.352	53.1	
	RodE6_54.1	122	54.1	1.374	7.1	0.180	853.53	729.6	5122.95	16160.3	8.734	49.6	
	RodE6_57	123	57	1.448	10	0.254	883.28	746.1	5259.68	16591.7	8.534	48.5	
	RodE6_60.2	124	60.2	1.529	13.2	0.335	906.73	759.1	5410.82	17068.4	8.458	48.0	
	RodE6_66.1	125	66.1	1.679	19.1	0.485	923.93	768.7	5687.16	17940.1	8.657	49.2	
	RodE6_70	126	70	1.778	-0.88	-0.022	787.04	692.6	5874.02	18529.6	11.295	64.1	
	RodE6_73.1	127	73.1	1.857	2.22	0.056	850.79	728.0	6024.56	19004.5	10.320	58.6	
	RodE6_75	128	75	1.905	4.12	0.105	881.77	745.2	6115.76	19292.2	9.948	56.5	

RBHT Steam Cooling with Droplet Injection Test SCD-4041-E

Matrix Test # 8a

Test Conditions

Test Date – 10/26/2005

Steady State Time Window: 22500 – 23280

Upper Plenum Pressure: 2.76 bar (40 psia)

Bundle Power: 72.0 kW

Bundle Inlet Reynolds Number: 8000

Bundle Inlet Steam Flow: 158.8 kg/hr (350 lbm/hr)

Droplet Injection Flow: 0.0036 kg/s (0.008 lbm/s)

Droplet Injection Hole Diameter: 0.381 mm (.015 in)

Droplet Injection Elevation: 1.295 m (51 in)

Bundle Flow Area: $4.656 \times 10^{-3} \text{ m}^2$ ($5.012 \times 10^{-2} \text{ ft}^2$)

Test Notes

- No steam probes were traversed in this steady state window.

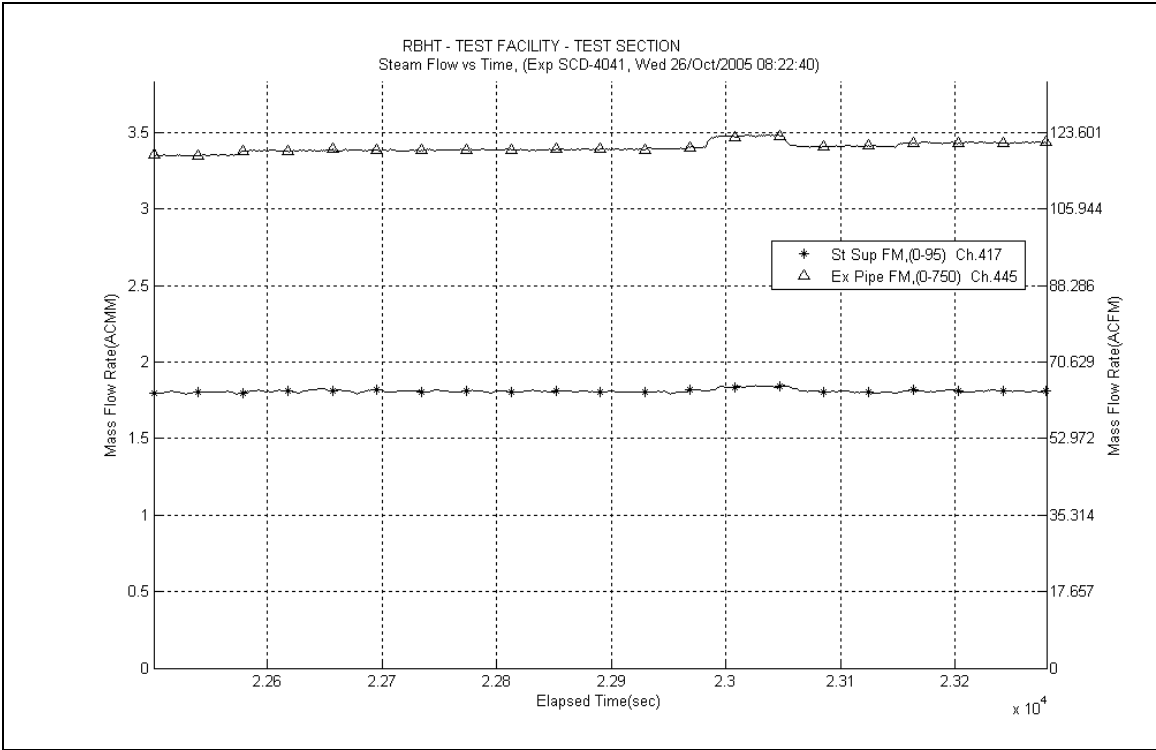

Figure A-519: Inlet and Exhaust Steam Flow Rates for Experiment 4041E

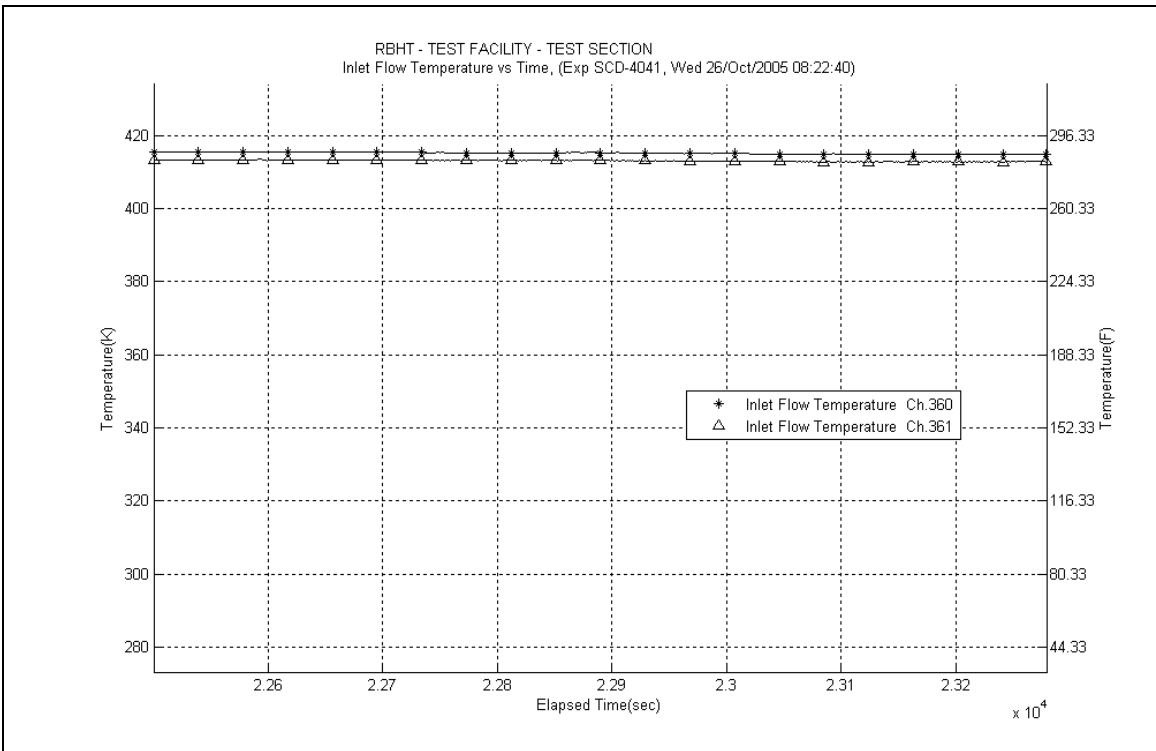

Figure A-520: Inlet Steam Temperature for Experiment 4041E

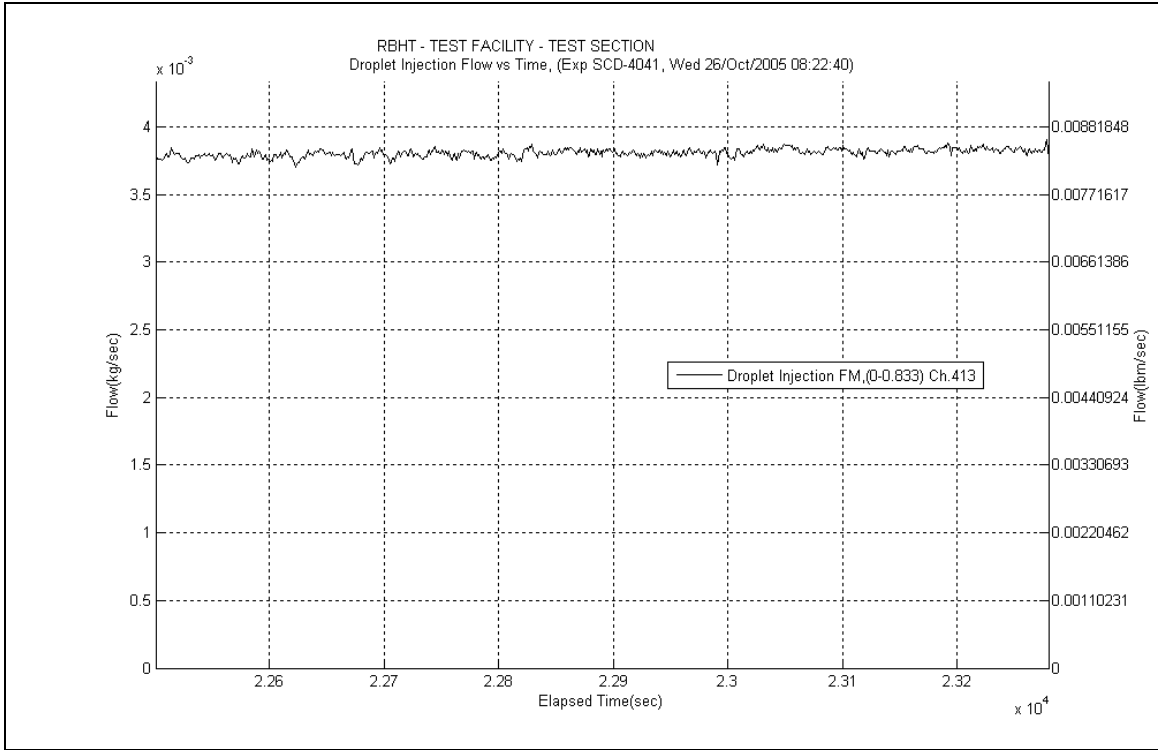

Figure A-521: Droplet Injection Flow Rate for Experiment 4041E

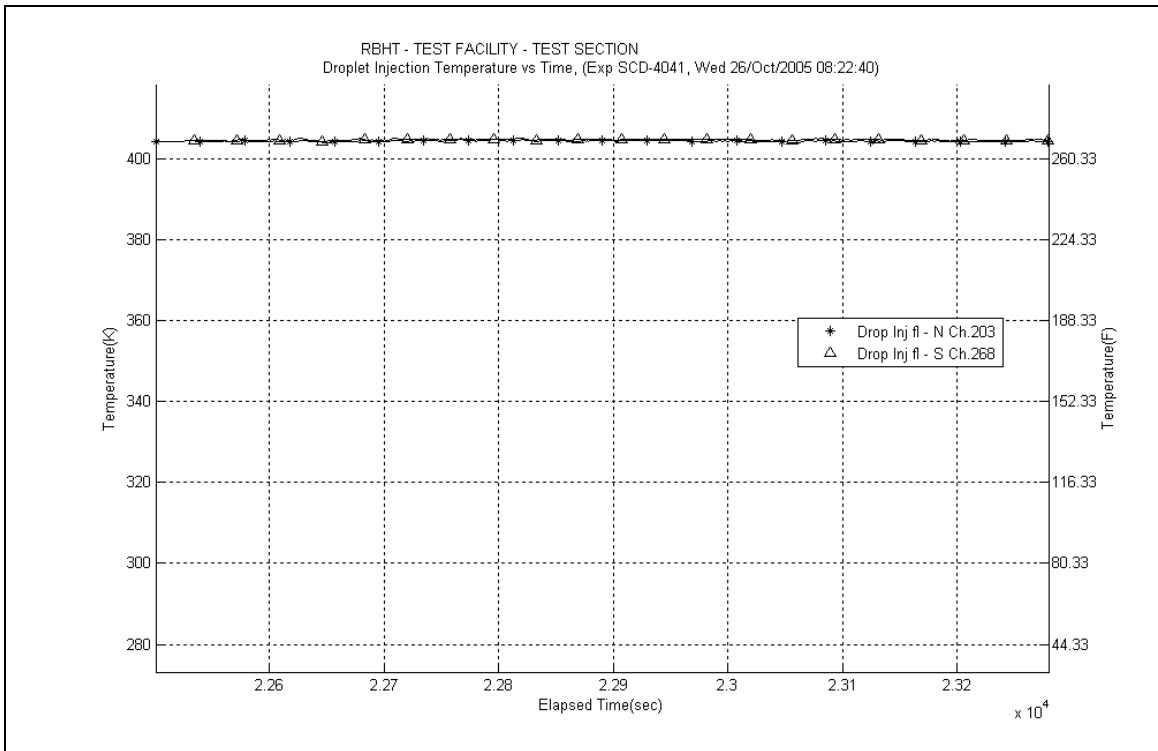

Figure A-522: Droplet Injection Temperature for Experiment 4041E

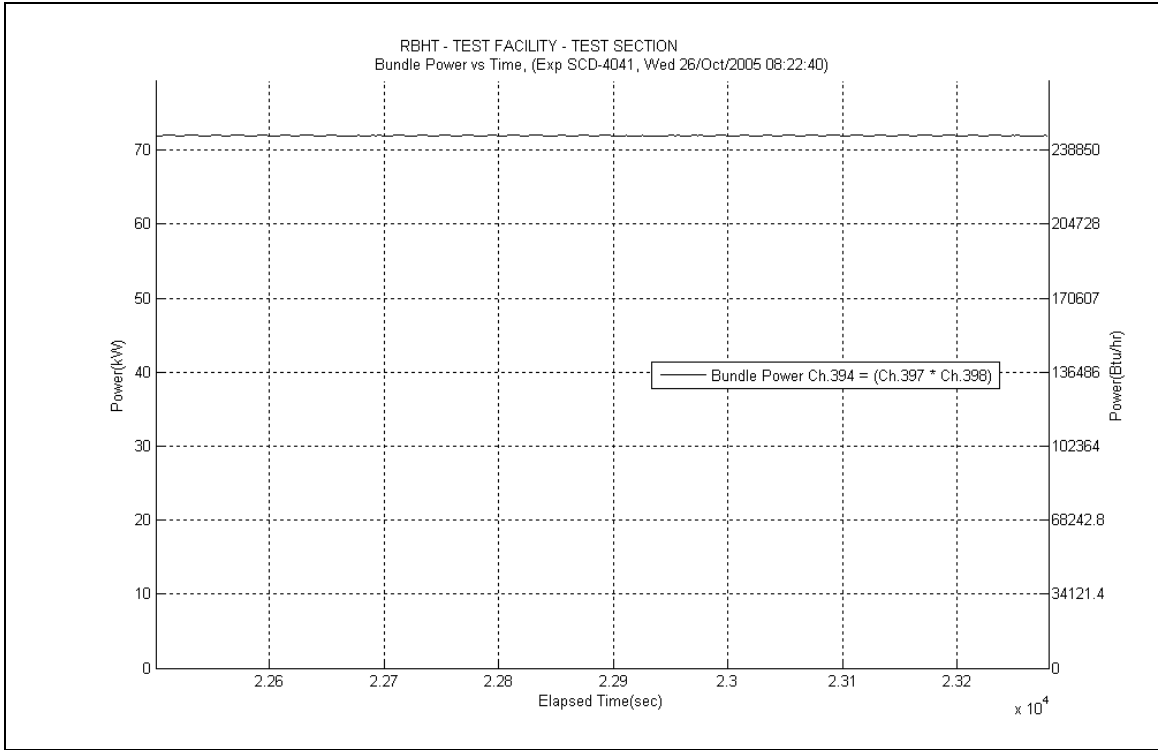

Figure A-523: Bundle Power for Experiment 4041E

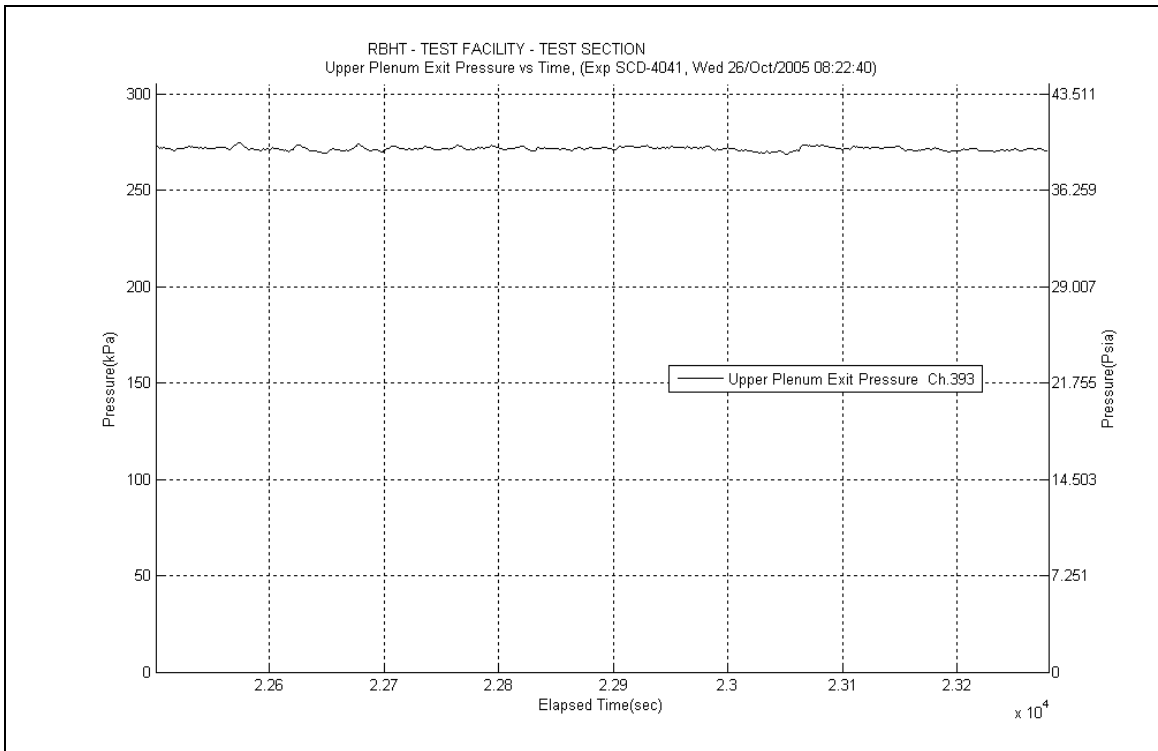

Figure A-524: Upper Plenum Pressure for Experiment 4041E

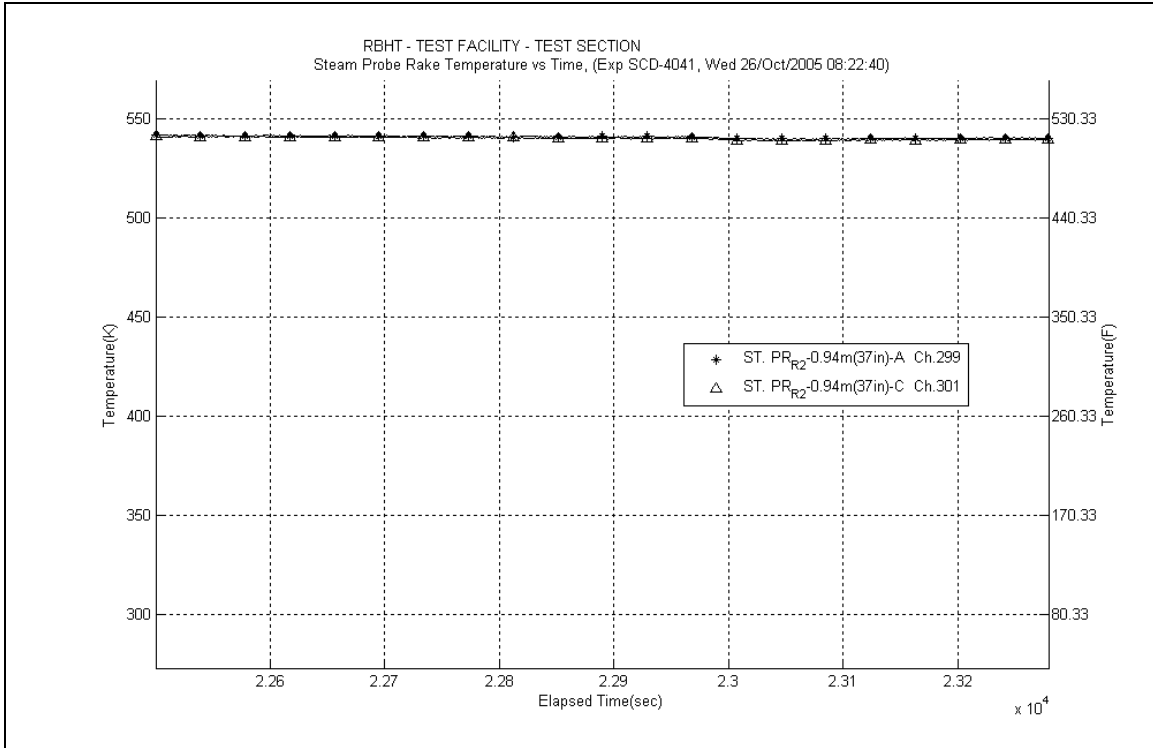

Figure A-525: Steam Probe Rake #2 Temperatures for Experiment 4041E

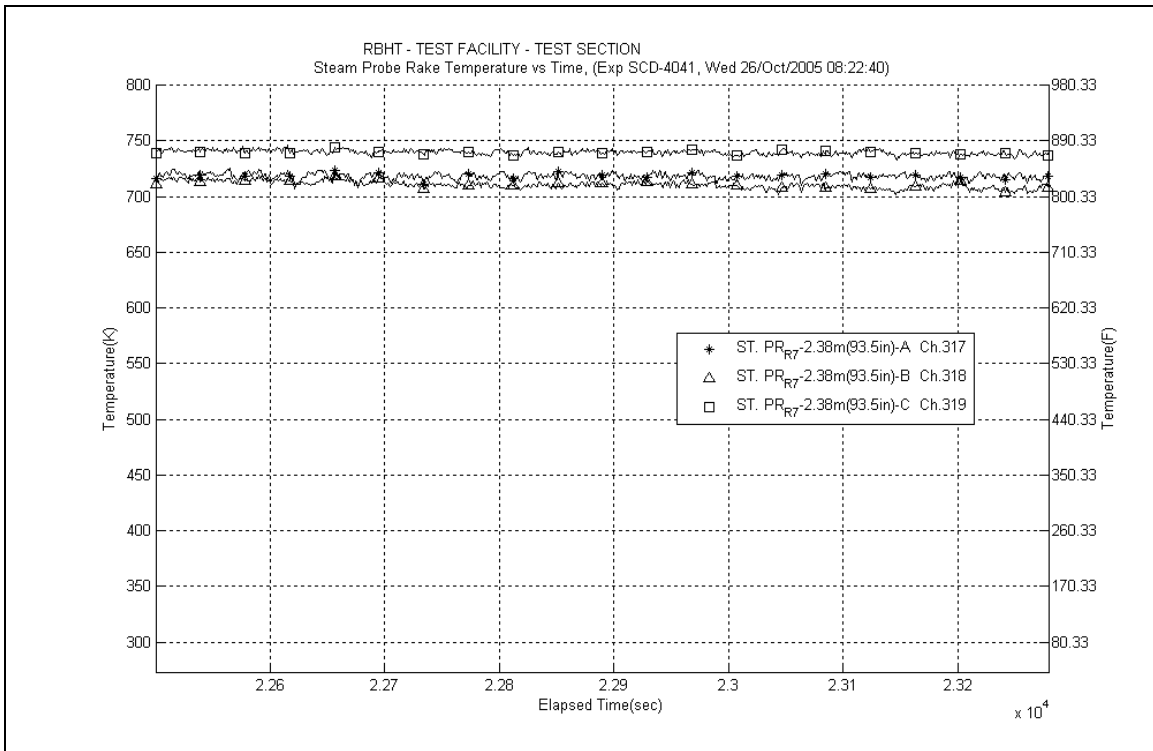

Figure A-526: Steam Probe Rake #7 Temperatures for Experiment 4041E

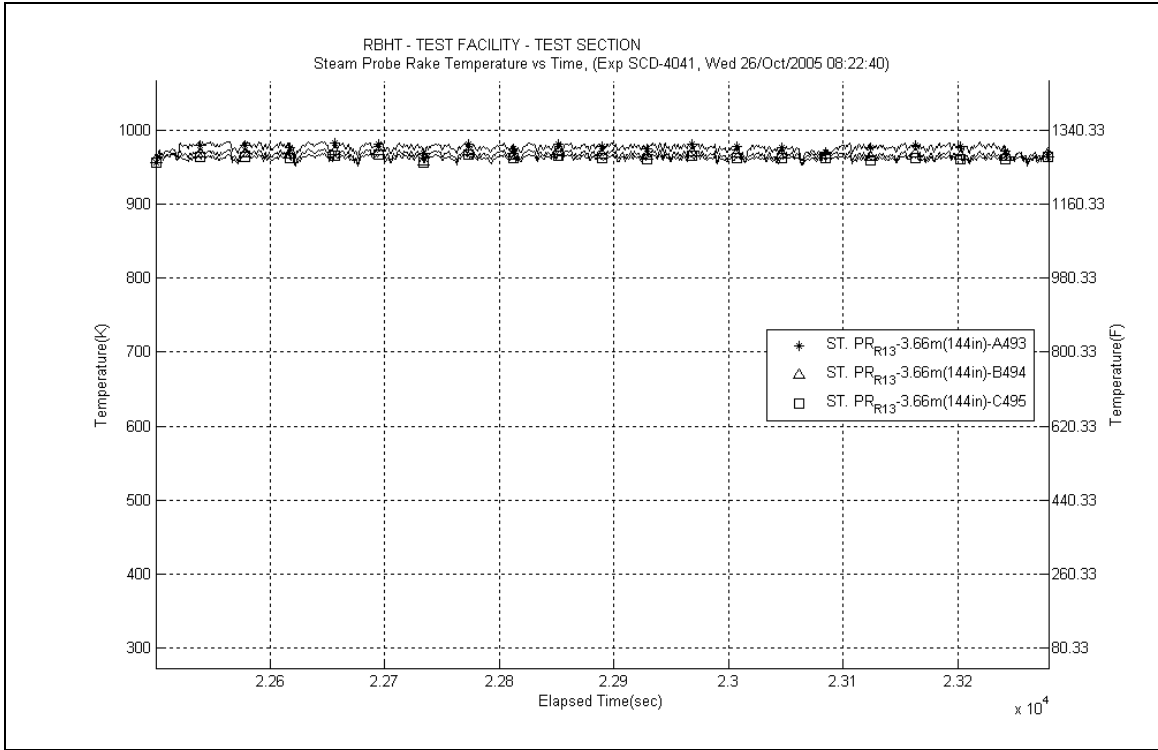

Figure A-527: Steam Probe Rake #13 Temperatures for Experiment 4041E

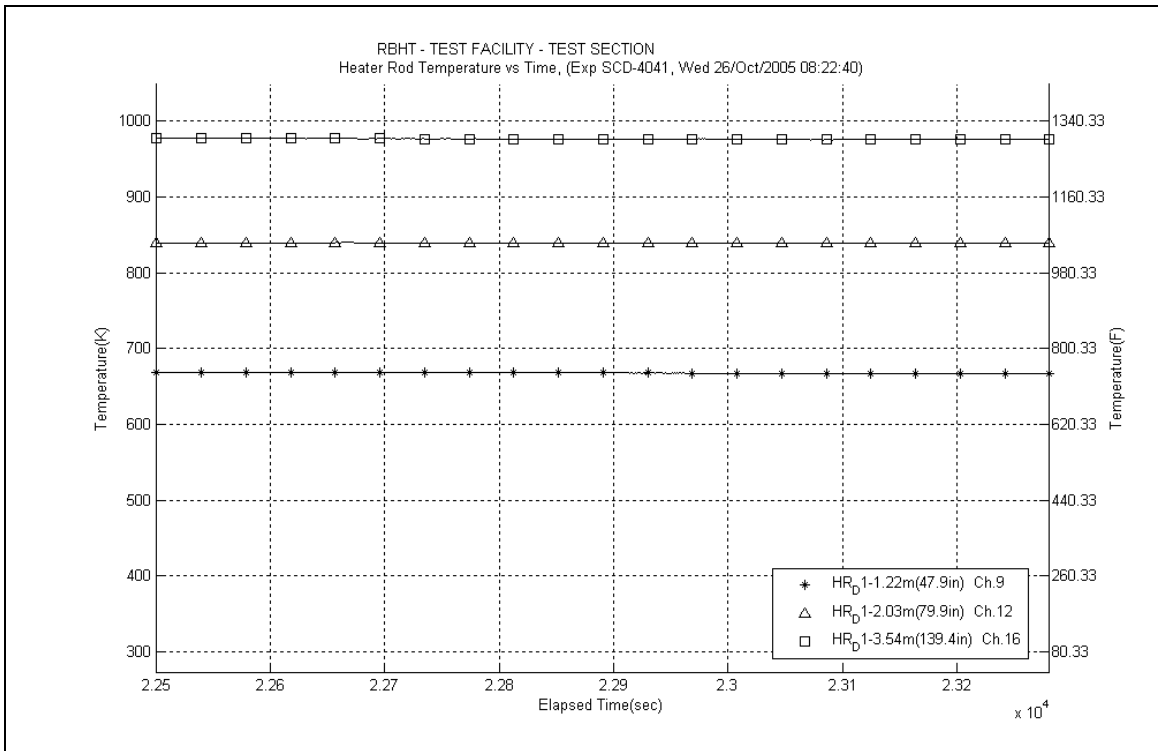

Figure A-528: Heater Rod D1 Temperatures for Experiment 4041E

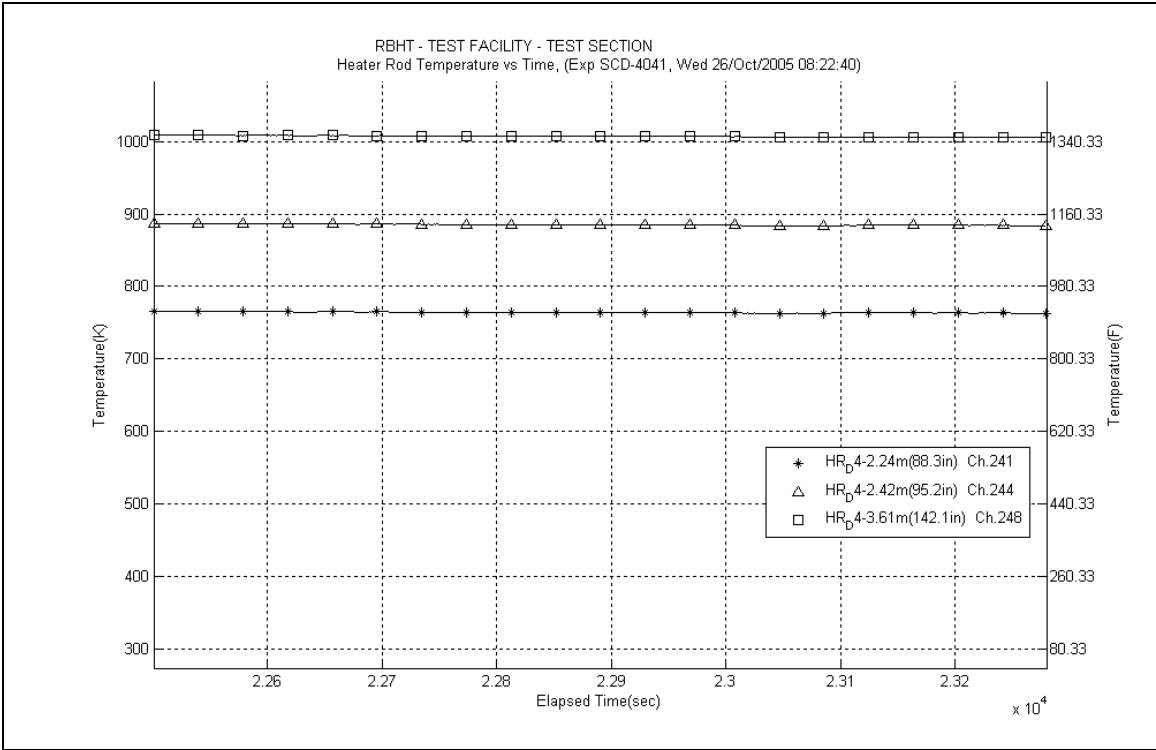

Figure A-529: Heater Rod D4 Temperatures for Experiment 4041E

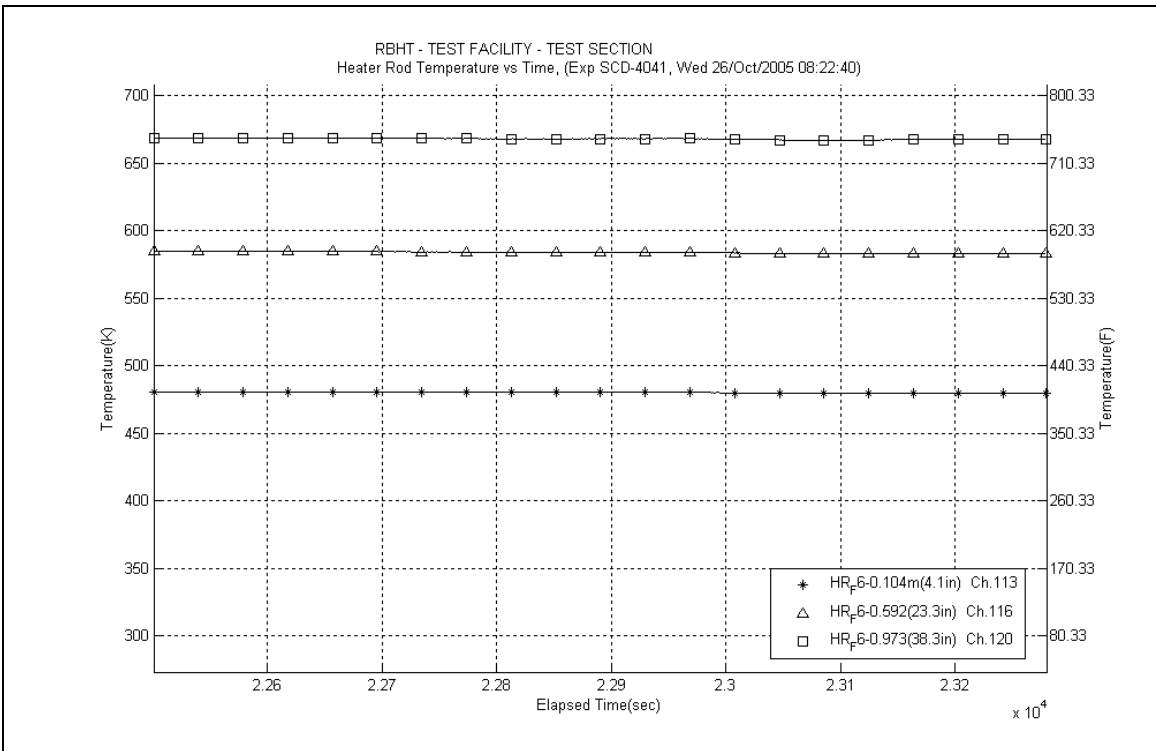

Figure A-530: Heater Rod F6 Temperatures for Experiment 4041E

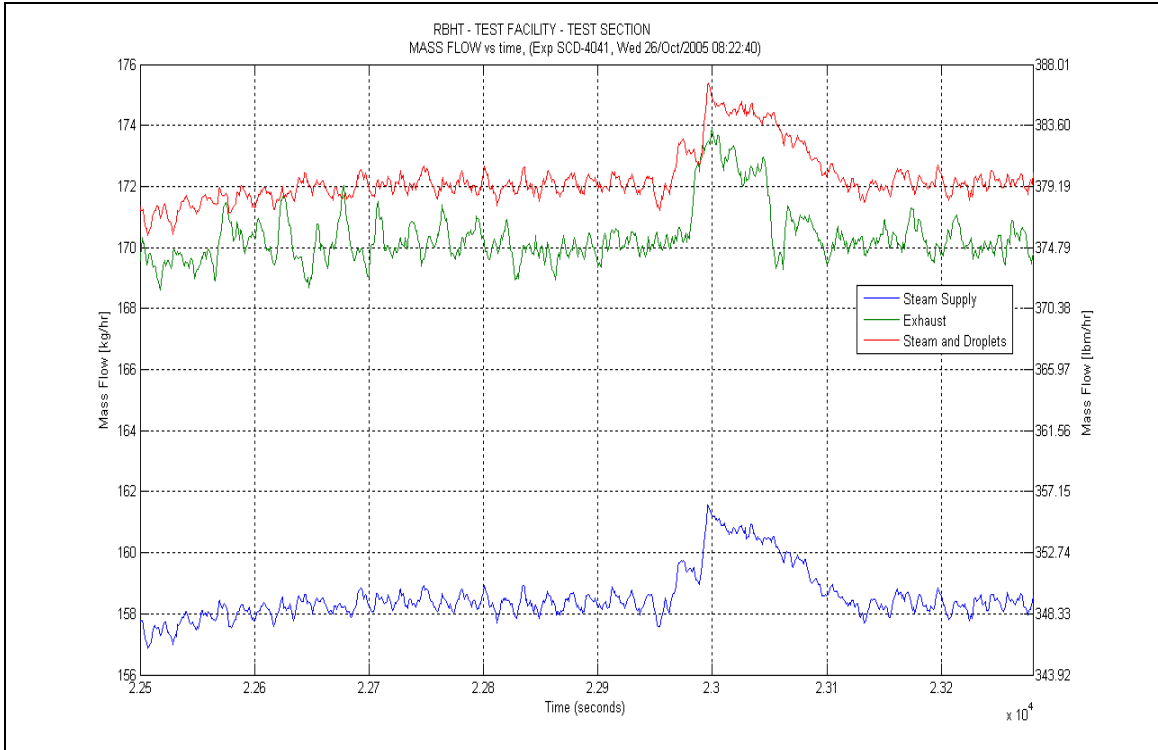

Figure A-531: Mass Flow for Experiment 4041E

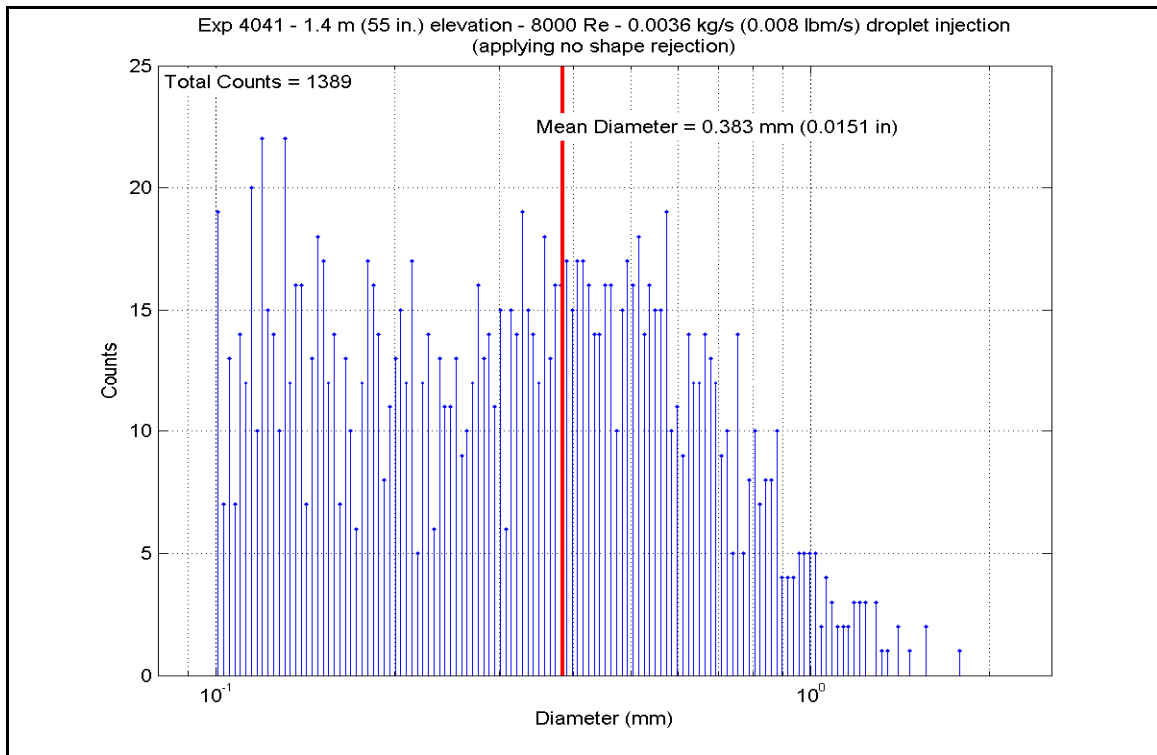

Figure A-532: Droplet Measurements at 1.397 m (55 in.) Elevation for Experiment 4041E

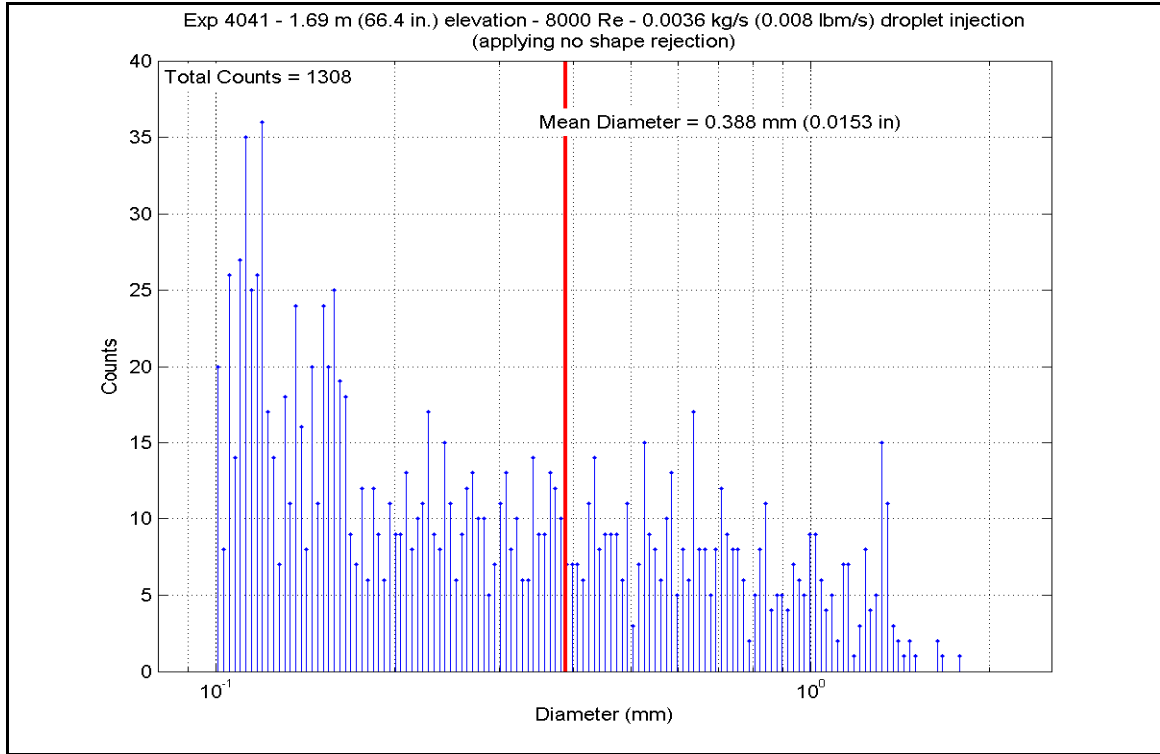

Figure A-533: Droplet Measurements at 1.687 m (66.4 in.) Elevation for Experiment 4041E

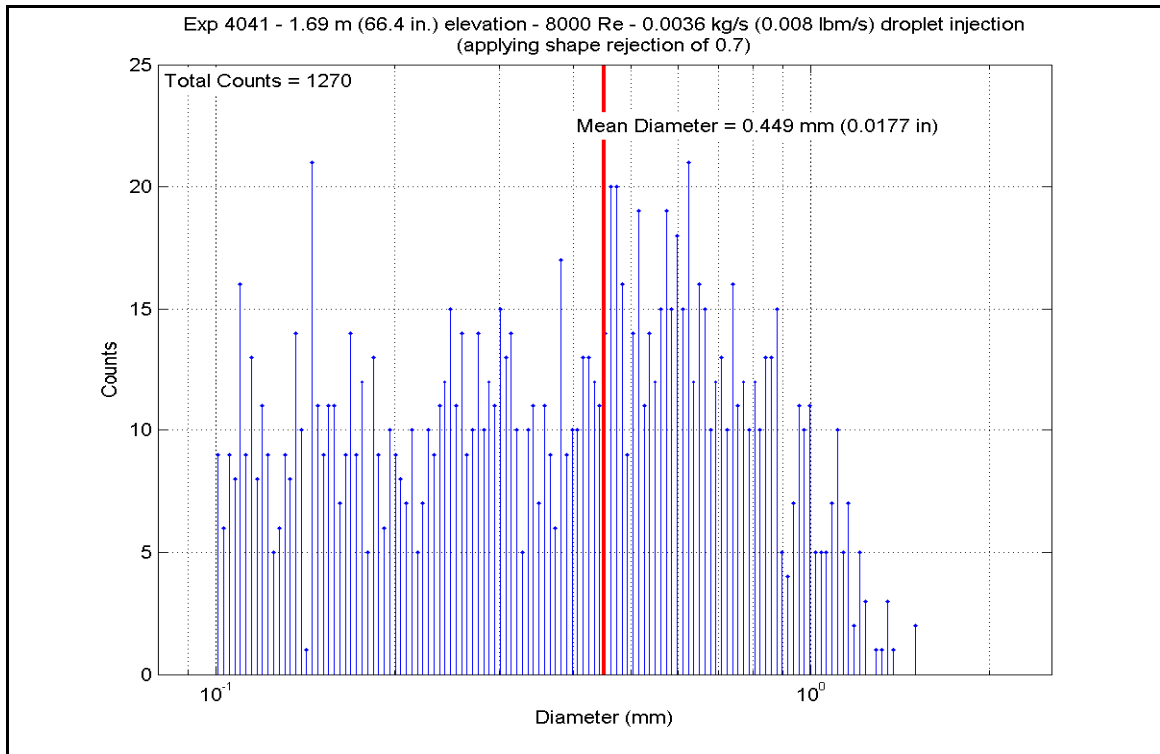

Figure A-534: Droplet Measurements at 1.687 m (66.4 in.) Elevation for Experiment 4041E

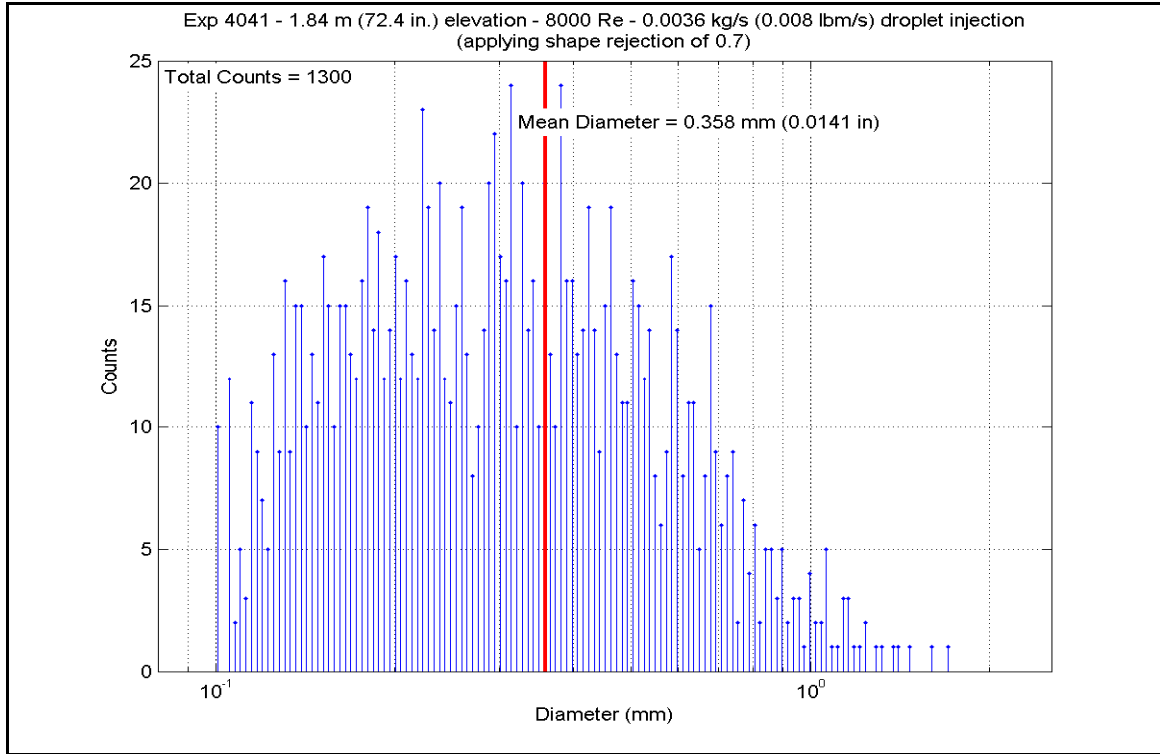

Figure A-535: Droplet Measurements at 1.839 m (72.4 in.) Elevation for Experiment 4041E

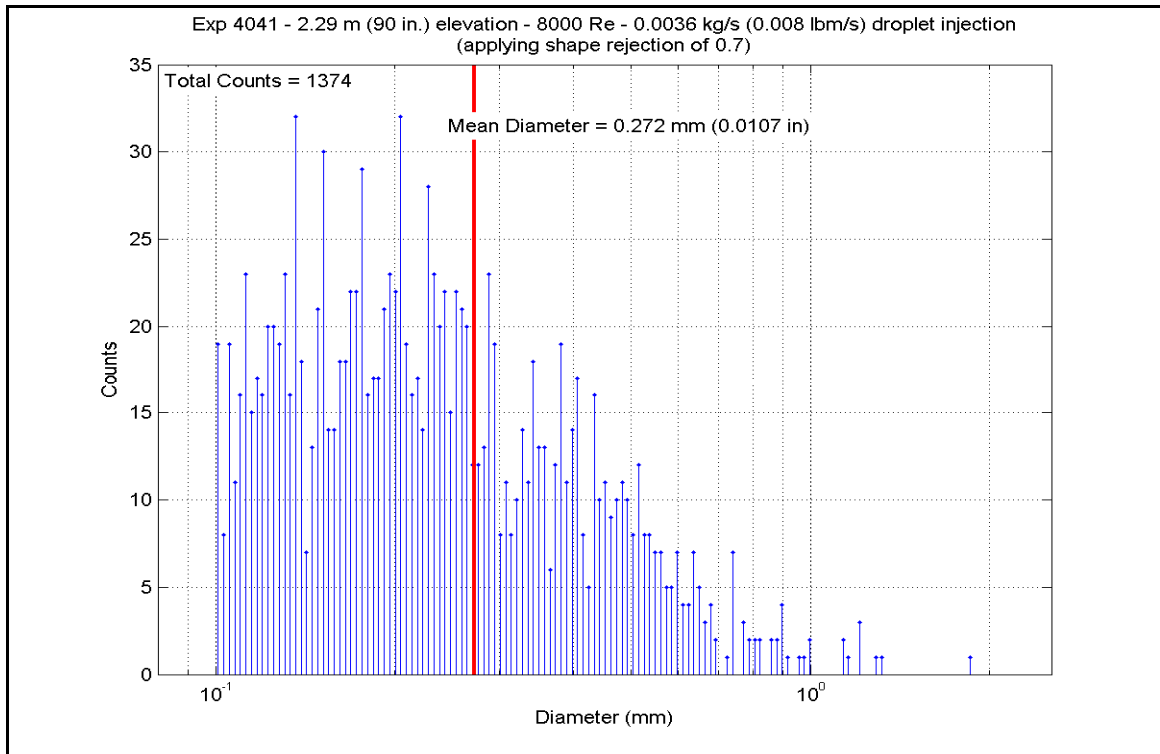

Figure A-536: Droplet Measurements at 2.286 m (90 in.) Elevation for Experiment 4041E

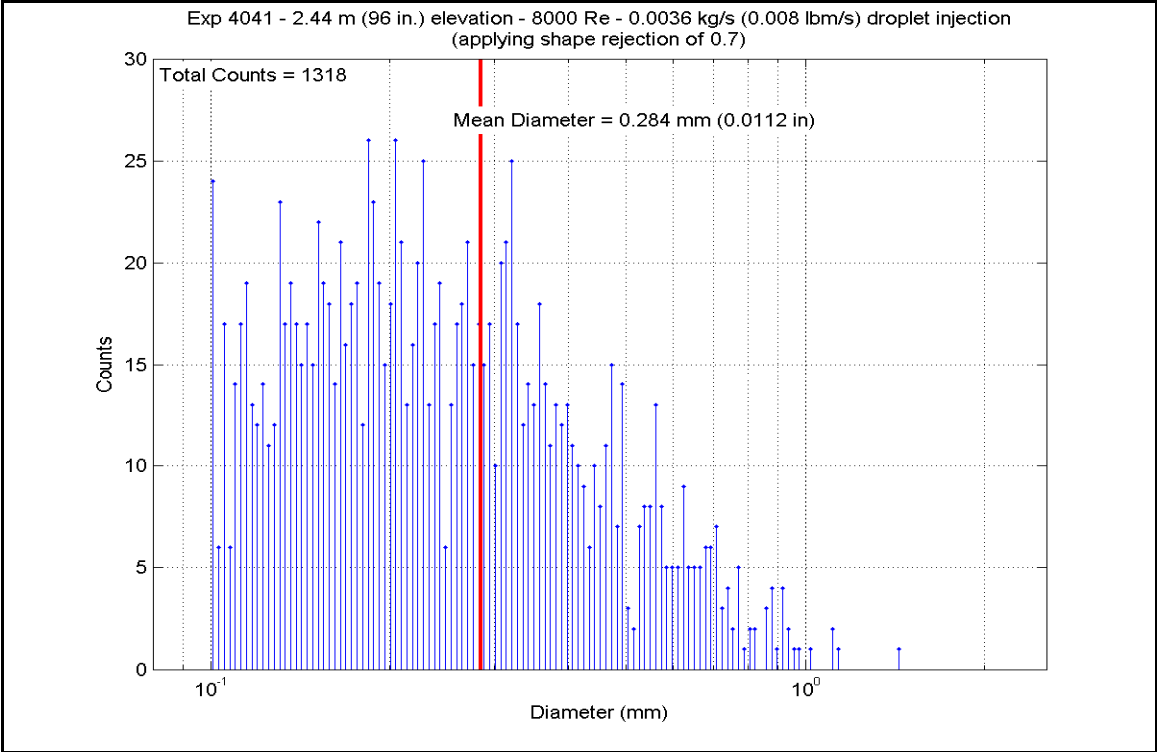

Figure A-537: Droplet Measurements at 2.438 m (96 in.) Elevation for Experiment 4041E

Table A-29: Summary of Steam Cooling Heat Transfer Reduced Data for Experiment 4041E

SCD-4041-E		Inlet Reynolds:		8000		40 psia						
Matrix Test # 8a		UP Pressure:		275.8 kPa		245674 Btu/hr						
Time Window: 22500-23280		Bundle Power:		7200 kW		350.0 lbm/hr						
Inner 3x3		Steam flow:		0.0441 kg/s		0.008 lbm/s						
		Dropletflow:		0.0036 kg/s								
H.R. ID	H.R. Location	Channel Number	Elevation (in)	Elevation (m)	Zgrid (in)	Zgrid (m)	H.R. Tw (°F)	H.R. Tw (K)	H.R. q" (Btu/hr-ft ²)	H.R. q" (W/m ²)	h _{sat} (z) (Btu/hr-ft ² -F)	h _{sat} (z) (W/m ² -K)
Gr-3	RodD3_88.3	185	88.3	2.243	-0.2	-0.005	980.17	799.9	6770.98	21359.1	9.494	53.9
	RodD3_91.3	186	91.3	2.319	2.8	0.071	1064.63	846.8	6916.64	21818.5	8.672	49.2
	RodD3_93.1	187	93.1	2.365	4.6	0.117	1065.38	847.3	7005.27	22098.1	8.774	49.8
	RodD3_95.3	188	95.3	2.421	6.8	0.173	1111.59	872.9	7110.58	22430.3	8.419	47.8
	RodD3_100.1	189	100.1	2.543	11.6	0.295	1191.90	917.5	7342.68	23162.5	7.939	45.1
	RodD3_106.1	190	106.1	2.695	17.6	0.447	1252.23	951.1	7628.54	24064.2	7.743	44.0
	RodD3_110	191	110	2.794	21.5	0.546	1189.63	916.3	7526.33	23741.8	8.157	46.3
	RodD3_142.1	192	142.1	3.609	8.6	0.218	1279.41	966.2	2625.19	8281.2	2.593	14.7
Gr-3	RodC4_88.4	233	88.4	2.245	-0.1	-0.003	987.73	804.1	6862.70	21648.4	9.522	54.1
	RodC4_91.1	234	91.1	2.314	2.6	0.066	1069.98	849.8	6994.00	22062.6	8.710	49.5
	RodC4_93.4	235	93.4	2.372	4.9	0.124	1090.33	861.1	7109.43	22426.7	8.635	49.0
	RodC4_95.3	236	95.3	2.421	6.8	0.173	1135.90	886.4	7199.62	22711.2	8.286	47.1
	RodC4_100.1	237	100.1	2.543	11.6	0.295	1187.77	915.2	7435.08	23453.9	8.075	45.9
	RodC4_106.1	238	106.1	2.695	17.6	0.447	1240.66	944.6	7734.04	24397.0	7.943	45.1
	RodC4_110	239	110	2.794	21.5	0.546	1182.86	912.5	7491.51	23632.0	8.180	46.5
	RodC4_142.2	240	142.2	3.612	8.7	0.221	1284.56	969.0	2862.38	9029.4	2.813	16.0
Gr-3	RodD4_88.3	241	88.3	2.243	-0.2	-0.005	967.87	793.1	6806.68	21471.7	9.712	55.2
	RodD4_91.3	242	91.3	2.319	2.8	0.071	1063.34	846.1	6963.91	21967.7	8.745	49.7
	RodD4_93.2	243	93.2	2.367	4.7	0.119	1090.77	861.4	7058.60	22266.4	8.569	48.7
	RodD4_95.2	244	95.2	2.418	6.7	0.170	1128.71	882.4	7157.29	22577.7	8.306	47.2
	RodD4_100.1	245	100.1	2.543	11.6	0.295	1203.41	923.9	7399.02	23340.2	7.901	44.9
	RodD4_106.1	246	106.1	2.695	17.6	0.447	1244.04	946.5	7684.30	24240.1	7.865	44.7
	RodD4_142.1	248	142.1	3.609	8.6	0.218	1284.16	968.8	2743.60	8654.7	2.697	15.3
Gr-3	RodE4_88.4	201	88.4	2.245	-0.1	-0.003	986.88	803.6	6704.81	21150.3	9.314	52.9
	RodE4_91.2	202	91.2	2.316	2.7	0.069	1074.19	852.1	6840.06	21577.0	8.474	48.1
	RodE4_95.3	204	95.3	2.421	6.8	0.173	1142.72	890.2	7032.04	22182.6	8.030	45.6
	RodE4_100.9	205	100.9	2.563	12.4	0.315	1201.44	922.8	7284.31	22978.4	7.795	44.3
	RodE4_142.3	208	142.3	3.614	8.8	0.224	1284.13	968.8	2764.81	8721.6	2.718	15.4

Table A-29: Summary of Steam Cooling Heat Transfer Reduced Data for Experiment 4041E, continued

Inner 3x3	H.R. Location	Channel Number	Elevation (in)	Elevation (m)	Zgrid (in)	Zgrid (m)	H.R. Tw (°F)	H.R. Tw (K)	H.R. q" (Btu/hr-ft ²)	H.R. q" (W/m ²)	h _{sat} (z) (Btu/hr-ft ² -F)	h _{sat} (z) (W/m ² -K)
Gr-4	RodE3_63.4	193	63.4	1.610	16.4	0.417	953.57	785.1	5560.88	17541.8	8.100	46.0
	RodE3_113.6	194	113.6	2.885	0.85	0.022	1228.93	938.1	6835.15	21561.5	7.106	40.4
	RodE3_115.5	195	115.5	2.934	2.75	0.070	1262.61	956.8	6593.34	20798.7	6.622	37.6
	RodE3_118.5	196	118.5	3.010	5.75	0.146	1291.22	972.7	6192.14	19533.1	6.046	34.3
	RodE3_122.7	197	122.7	3.117	9.95	0.253	1305.42	980.6	5628.15	17754.0	5.420	30.8
	RodE3_126.5	198	126.5	3.213	13.75	0.349	1307.96	982.0	5116.67	16140.6	4.915	27.9
	RodE3_131.7	199	131.7	3.345	-1.8	-0.046	1234.72	941.3	4403.78	13891.7	4.551	25.8
RodE3_135.6	200	135.6	3.444	2.1	0.053	1268.99	960.4	3894.74	12286.0	3.887	22.1	
Gr-4	RodC5_63.7	225	63.7	1.618	16.7	0.424	949.29	782.8	5469.20	17252.6	8.016	45.5
	RodC5_113.6	226	113.6	2.885	0.85	0.022	1216.24	931.1	6722.17	21205.1	7.082	40.2
	RodC5_115.7	227	115.7	2.939	2.95	0.075	1258.24	954.4	6450.47	20348.0	6.507	37.0
	RodC5_122.7	229	122.7	3.117	9.95	0.253	1309.16	982.7	5556.92	17529.3	5.332	30.3
	RodC5_126.7	230	126.7	3.218	13.95	0.354	1308.52	982.3	5044.82	15913.9	4.844	27.5
	RodC5_131.6	231	131.6	3.343	-1.9	-0.048	1233.14	940.5	4426.00	13961.8	4.581	26.0
	RodC5_135.7	232	135.7	3.447	2.2	0.056	1264.30	957.8	3893.54	12282.2	3.904	22.2
Gr-4	RodE5_63.6	209	63.6	1.615	16.6	0.422	892.56	751.2	5604.66	17679.9	8.959	50.9
	RodE5_113.6	210	113.6	2.885	0.85	0.022	1135.61	886.3	6884.87	21718.3	7.926	45.0
	RodE5_115.4	211	115.4	2.931	2.65	0.067	1190.52	916.8	6642.24	20952.9	7.192	40.8
	RodE5_118.7	212	118.7	3.015	5.95	0.151	1232.39	940.0	6205.74	19576.0	6.428	36.5
	RodE5_122.6	213	122.6	3.114	9.85	0.250	1260.95	955.9	5689.92	17948.9	5.725	32.5
	RodE5_126.6	214	126.6	3.216	13.85	0.352	1273.38	962.8	5161.23	16281.1	5.129	29.1
	RodE5_131.6	215	131.6	3.343	-1.9	-0.048	1288.34	971.1	4475.57	14118.2	4.382	24.9
RodE5_135.6	216	135.6	3.444	2.1	0.053	1286.74	970.2	3965.17	12508.1	3.888	22.1	
Gr-5	RodC3_79.8	177	79.8	2.027	8.92	0.227	989.62	805.2	6348.88	20027.5	8.786	49.9
	RodC3_85.6	178	85.6	2.174	14.72	0.374	969.65	794.1	6625.15	20899.0	9.429	53.5
	RodC3_88.5	179	88.5	2.248	0	0.000	980.86	800.3	6759.69	21323.4	9.469	53.8
	RodC3_92.4	180	92.4	2.347	3.9	0.099	1076.55	853.5	6945.36	21909.1	8.579	48.7
	RodC3_94.4	181	94.4	2.398	5.9	0.150	1087.77	859.7	7043.29	22218.1	8.581	48.7
	RodC3_97.2	182	97.2	2.469	8.7	0.221	1139.01	888.2	7174.85	22633.1	8.228	46.7
	RodC3_108.8	183	108.8	2.764	20.3	0.516	1239.40	943.9	7566.57	23868.8	7.781	44.2
Gr-8	RodD5_50	217	50	1.270	3	0.076	812.98	707.0	4948.91	15611.3	9.064	51.5
	RodD5_54.1	218	54.1	1.374	7.1	0.180	835.64	719.6	5144.75	16229.1	9.047	51.4
	RodD5_56.9	219	56.9	1.445	9.9	0.251	884.91	747.0	5275.90	16642.8	8.538	48.5
	RodD5_60	220	60	1.524	13	0.330	922.90	768.1	5421.03	17100.6	8.265	46.9
	RodD5_66.1	221	66.1	1.679	19.1	0.485	960.39	788.9	5709.77	18011.5	8.235	46.8
	RodD5_69.9	222	69.9	1.775	-0.98	-0.025	839.97	722.0	5881.48	18553.1	10.265	58.3
	RodD5_72.9	223	72.9	1.852	2.02	0.051	913.55	762.9	6026.21	19009.7	9.321	52.9
RodD5_74.9	224	74.9	1.902	4.02	0.102	959.01	788.2	6124.03	19318.2	8.850	50.3	

Table A-29: Summary of Steam Cooling Heat Transfer Reduced Data for Experiment 4041, continued

H.R. ID	H.R. Location	Channel Number	Elevation (in)	Elevation (m)	Zgrid (in)	Zgrid (m)	H.R. Tw (°F)	H.R. Tw (K)	H.R. q" (Btu/hr-ft ²)	H.R. q" (W/m ²)	h _{sat} (z) (Btu/hr-ft ² -F)	h _{sat} (z) (W/m ² -K)	
Gr-2	RodB5_41	153	41	1.041	13.5	0.343	748.00	670.9	4498.02	14189.0	9.351	53.1	
	RodB5_52.9	154	52.9	1.344	5.9	0.150	812.54	706.8	5074.86	16008.6	9.302	52.8	
	RodB5_55	155	55	1.397	8	0.203	849.73	727.4	5173.83	16320.9	8.879	50.4	
	RodB5_57.8	156	57.8	1.468	10.8	0.274	899.18	754.9	5309.08	16747.5	8.398	47.7	
	RodB5_64	157	64	1.626	17	0.432	953.39	785.0	5607.29	17688.2	8.169	46.4	
	RodB5_73.9	158	73.9	1.877	3.02	0.077	936.49	775.6	6095.59	19228.5	9.105	51.7	
	RodB5_75.9	159	75.9	1.928	5.02	0.128	972.20	795.5	6188.30	19521.0	8.775	49.8	
	RodB5_76.9	160	76.9	1.953	6.02	0.153	986.28	803.3	6234.53	19666.8	8.668	49.2	
	Gr-2	RodF5_41	105	41	1.041	13.5	0.343	738.18	665.5	4466.16	14088.5	9.479	53.8
		RodF5_53.1	106	53.1	1.349	6.1	0.155	795.40	697.3	5050.10	15930.5	9.557	54.3
RodF5_55		107	55	1.397	8	0.203	833.63	718.5	5140.55	16215.9	9.072	51.5	
RodF5_57.8		108	57.8	1.468	10.8	0.274	882.01	745.4	5273.07	16633.9	8.574	48.7	
RodF5_64		109	64	1.626	17	0.432	933.37	773.9	5569.32	17568.4	8.358	47.5	
RodF5_73.8		110	73.8	1.875	2.92	0.074	932.16	773.2	6024.58	19004.5	9.057	51.4	
RodF5_75.8		111	75.8	1.925	4.92	0.125	969.12	793.8	6123.64	19317.0	8.722	49.5	
RodF5_76.8		112	76.8	1.951	5.92	0.150	984.23	802.2	6173.69	19474.9	8.608	48.9	
Gr-2		RodC2_41	57	41	1.041	13.5	0.343	733.65	663.0	4490.65	14165.8	9.623	54.6
		RodC2_53.1	58	53.1	1.349	6.1	0.155	856.35	731.1	5074.15	16006.4	8.610	48.9
	RodC2_55	59	55	1.397	8	0.203	874.89	741.4	5165.92	16295.9	8.498	48.3	
	RodC2_57.8	60	57.8	1.468	10.8	0.274	905.75	758.6	5298.64	16714.5	8.295	47.1	
	RodC2_63.9	61	63.9	1.623	16.9	0.429	936.50	775.6	5591.71	17639.0	8.352	47.4	
	RodC2_73.8	62	73.8	1.875	2.92	0.074	934.07	774.3	6078.82	19175.6	9.113	51.8	
	RodC2_75.8	63	75.8	1.925	4.92	0.125	961.62	789.6	6173.01	19472.7	8.887	50.5	
	RodC2_76.8	64	76.8	1.951	5.92	0.150	972.17	795.5	6219.15	19618.3	8.819	50.1	
	Gr-2	RodC6_40.9	137	40.9	1.039	13.4	0.340	745.30	669.4	4469.23	14098.2	9.344	53.1
		RodC6_52.8	138	52.8	1.341	5.8	0.147	862.97	734.8	5064.90	15977.2	8.499	48.3
RodC6_54.8		139	54.8	1.392	7.8	0.198	883.36	746.1	5165.05	16293.2	8.380	47.6	
RodC6_57.8		140	57.8	1.468	10.8	0.274	918.27	765.5	5314.94	16766.0	8.161	46.3	
RodC6_63.8		141	63.8	1.621	16.8	0.427	956.16	786.6	5614.94	17712.3	8.147	46.3	
RodC6_73.7		142	73.7	1.872	2.82	0.072	979.44	799.5	6116.57	19294.7	8.585	48.8	
RodC6_75.8		143	75.8	1.925	4.92	0.125	1004.87	813.6	6221.30	19625.1	8.431	47.9	
RodC6_76.8		144	76.8	1.951	5.92	0.150	1022.20	823.3	6272.52	19786.7	8.306	47.2	

Table A-29: Summary of Steam Cooling Heat Transfer Reduced Data for Experiment 4041, continued

5x5 periphery		H.R. Location	Channel Number	Elevation (in)	Elevation (m)	Zgrid (in)	Zgrid (m)	H.R. Tw (°F)	H.R. Tw (K)	H.R. q" (Btu/hr-ft ²)	H.R. q" (W/m ²)	h _{sat} (z) (Btu/hr-ft ² -F)	h _{sat} (z) (W/m ² -K)
Gr-3	RodB4_88.4	161	88.4	2.245	-0.1	-0.003	798.9	6747.81	21286.0	9.486	53.9		
	RodB4_91.3	162	91.3	2.319	2.8	0.071	847.4	6881.42	21707.5	8.616	48.9		
	RodB4_93.3	163	93.3	2.370	4.8	0.122	854.9	6975.48	22004.2	8.588	48.8		
	RodB4_95.1	164	95.1	2.416	6.6	0.168	872.2	7058.35	22265.6	8.371	47.5		
	RodB4_100	165	100	2.540	11.5	0.292	894.4	7289.90	22996.0	8.254	46.9		
	RodB4_106	166	106	2.692	17.5	0.445	938.4	7567.09	23870.4	7.862	44.6		
	RodB4_109.9	167	109.9	2.791	21.4	0.544	903.9	7343.89	23166.3	8.157	46.3		
	RodB4_142.3	168	142.3	3.614	8.8	0.224	962.0	2855.08	9006.3	2.841	16.1		
Gr-5	RodF4_85.6	98	85.6	2.174	14.72	0.374	813.9	6602.34	20827.1	8.941	50.8		
	RodF4_88.4	99	88.4	2.245	-0.1	-0.003	815.4	6739.01	21258.2	9.094	51.6		
	RodF4_92.4	100	92.4	2.347	3.9	0.099	868.0	6927.30	21852.2	8.289	47.1		
	RodF4_94.3	101	94.3	2.395	5.8	0.147	885.5	7018.03	22138.4	8.092	46.0		
	RodF4_97.2	102	97.2	2.469	8.7	0.221	906.9	7157.69	22578.9	7.902	44.9		
	RodF4_108.8	103	108.8	2.764	20.3	0.516	945.8	7552.15	23823.3	7.739	43.9		
	RodF4_111	104	111	2.819	-1.75	-0.044	907.2	7231.13	22810.6	7.979	45.3		
	RodD2_103.2	65	103.2	2.621	14.7	0.373	941.6	6683.60	21083.4	6.904	39.2		
RodD2_106	66	106	2.692	17.5	0.445	954.1	6331.26	19972.0	6.391	36.3			
RodD2_112.6	67	112.6	2.860	-0.15	-0.004	967.9	5850.05	18454.0	5.761	32.7			
RodD2_114.9	68	114.9	2.918	2.15	0.055	974.7	5283.54	16666.9	5.141	29.2			
RodD2_117.4	69	117.4	2.982	4.65	0.118	972.3	4744.68	14967.1	4.636	26.3			
RodD2_120.8	70	120.8	3.068	8.05	0.204	932.7	7508.81	23686.6	7.886	44.8			
RodD2_124.8	71	124.8	3.170	12.05	0.306	945.4	7641.25	24104.3	7.837	44.5			
RodD2_128.6	72	128.6	3.266	15.85	0.403	915.5	7008.69	22108.9	7.608	43.2			
Gr-6	RodD6_103.1	129	103.1	2.619	14.6	0.371	940.8	7522.05	23728.3	7.780	44.2		
	RodD6_106	130	106	2.692	17.5	0.445	950.4	7659.86	24163.0	7.784	44.2		
	RodD6_112.9	131	112.9	2.868	0.15	0.004	924.7	6991.54	22054.8	7.456	42.3		
	RodD6_114.9	132	114.9	2.918	2.15	0.055	947.2	6703.01	21144.6	6.851	38.9		
	RodD6_116.8	133	116.8	2.967	4.05	0.103	959.3	6432.50	20291.3	6.432	36.5		
	RodD6_120.9	134	120.9	3.071	8.15	0.207	969.1	5844.22	18435.6	5.743	32.6		
	RodD6_124.8	135	124.8	3.170	12.05	0.306	972.9	5285.09	16671.8	5.159	29.3		
	RodD6_128.7	136	128.7	3.269	15.95	0.405	970.3	4726.65	14910.2	4.635	26.3		

Table A-29: Summary of Steam Cooling Heat Transfer Reduced Data for Experiment 4041, continued

5x5 periphery		H.R. Location	Channel Number	Elevation (in)	Elevation (m)	Zgrid (in)	Zgrid (m)	H.R. Tw (°F)	H.R.Tw (K)	H.R. q" (Btu/hr-ft ²)	H.R. q" (W/m ²)	h _{sat} (z) (Btu/hr-ft ² -F)	h _{sat} (z) (W/m ² -K)
Gr-8	RodE2_50.1	73	50.1	1.273	3.1	0.079	801.76	700.8	4961.65	15651.5	9.278	52.7	
	RodE2_54	74	54	1.372	7	0.178	868.07	737.6	5149.70	16244.7	8.568	48.7	
	RodE2_56.9	75	56.9	1.445	9.9	0.251	901.51	756.2	5290.80	16689.8	8.338	47.4	
	RodE2_59.9	76	59.9	1.521	12.9	0.328	933.01	773.7	5437.76	17153.4	8.165	46.4	
	RodE2_66	77	66	1.676	19	0.483	960.93	789.2	5733.77	18087.2	8.263	46.9	
	RodE2_69.8	78	69.8	1.773	-1.08	-0.027	853.59	729.6	5901.80	18617.2	10.061	57.1	
	RodE2_72.9	79	72.9	1.852	2.02	0.051	924.44	768.9	6054.41	19098.6	9.209	52.3	
	RodE2_74.9	80	74.9	1.902	4.02	0.102	959.51	788.4	6151.74	19405.7	8.883	50.4	
Gr-8	RodB3_50.2	169	50.2	1.275	3.2	0.081	766.26	681.1	4938.25	15577.7	9.891	56.2	
	RodB3_54.1	170	54.1	1.374	7.1	0.180	827.17	714.9	5112.46	16127.2	9.127	51.8	
	RodB3_56.9	171	56.9	1.445	9.9	0.251	869.84	738.6	5255.50	16578.5	8.718	49.5	
	RodB3_60.1	172	60.1	1.527	13.1	0.333	889.54	738.5	5407.36	17057.5	8.974	51.0	
	RodB3_66.1	173	66.1	1.679	19.1	0.485	926.91	770.3	5699.13	17977.9	8.636	49.0	
	RodB3_69.9	174	69.9	1.775	-0.98	-0.025	800.59	700.1	5899.77	18610.8	11.057	62.8	
	RodB3_73	175	73	1.854	2.12	0.054	889.01	749.3	6045.58	19070.8	9.719	55.2	
	RodB3_75	176	75	1.905	4.12	0.105	929.11	771.5	6142.78	19377.4	9.278	52.7	
Gr-8	RodF3_50.1	89	50.1	1.273	3.1	0.079	781.74	689.7	4930.23	15552.4	9.578	54.4	
	RodF3_54	90	54	1.372	7	0.178	847.12	726.0	5122.78	16159.8	8.831	50.1	
	RodF3_57	91	57	1.448	10	0.254	892.15	751.0	5269.97	16624.1	8.430	47.9	
	RodF3_60	92	60	1.524	13	0.330	922.83	768.1	5413.33	17076.3	8.254	46.9	
	RodF3_66.1	93	66.1	1.679	19.1	0.485	944.43	780.1	5706.25	18000.4	8.423	47.8	
	RodF3_70	94	70	1.778	-0.88	-0.022	833.10	718.2	5890.15	18580.5	10.405	59.1	
	RodF3_73	95	73	1.854	2.12	0.054	932.95	773.7	6036.27	19041.4	9.064	51.5	
	RodF3_75	96	75	1.905	4.12	0.105	975.69	797.4	6136.53	19357.7	8.659	49.2	
Gr-8	RodE6_50.2	121	50.2	1.275	3.2	0.081	788.48	693.4	4931.31	15555.8	9.456	53.7	
	RodE6_54.1	122	54.1	1.374	7.1	0.180	847.72	726.3	5116.42	16139.7	8.811	50.0	
	RodE6_57	123	57	1.448	10	0.254	880.23	744.4	5253.38	16571.8	8.567	48.6	
	RodE6_60.2	124	60.2	1.529	13.2	0.335	909.83	760.8	5403.55	17045.5	8.406	47.7	
	RodE6_66.1	125	66.1	1.679	19.1	0.485	934.90	774.8	5686.56	17938.3	8.514	48.4	
	RodE6_70	126	70	1.778	-0.88	-0.022	867.64	737.4	5870.84	18519.6	9.774	55.5	
	RodE6_73.1	127	73.1	1.857	2.22	0.056	939.89	777.5	6013.44	18969.4	8.937	50.8	
	RodE6_75	128	75	1.905	4.12	0.105	973.60	796.3	6099.57	19241.1	8.632	49.0	

RBHT Steam Cooling with Droplet Injection Test SCD-4041-F

Matrix Test # 8b

Test Conditions

Test Date – 10/26/2005

Steady State Time Window: 23880 – 24300

Upper Plenum Pressure: 2.76 bar (40 psia)

Bundle Power: 72.0 kW

Bundle Inlet Reynolds Number: 8000

Bundle Inlet Steam Flow: 158.8 kg/hr (350 lbm/hr)

Droplet Injection Flow: 0.0073 kg/s (0.016 lbm/s)

Droplet Injection Hole Diameter: 0.381 mm (.015 in)

Droplet Injection Elevation: 1.295 m (51 in)

Bundle Flow Area: $4.656 \times 10^{-3} \text{ m}^2$ ($5.012 \times 10^{-2} \text{ ft}^2$)

Test Notes

- No steam probes were traversed in this steady state window.

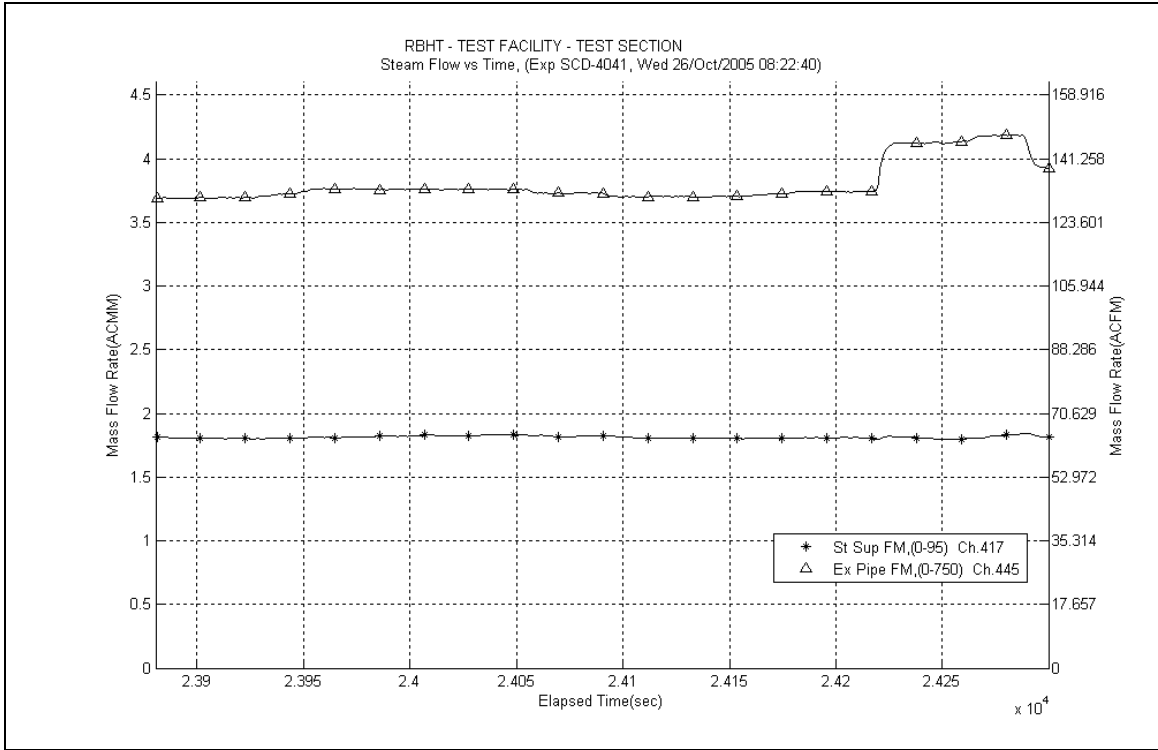

Figure A-538: Inlet and Exhaust Steam Flow Rates for Experiment 4041F

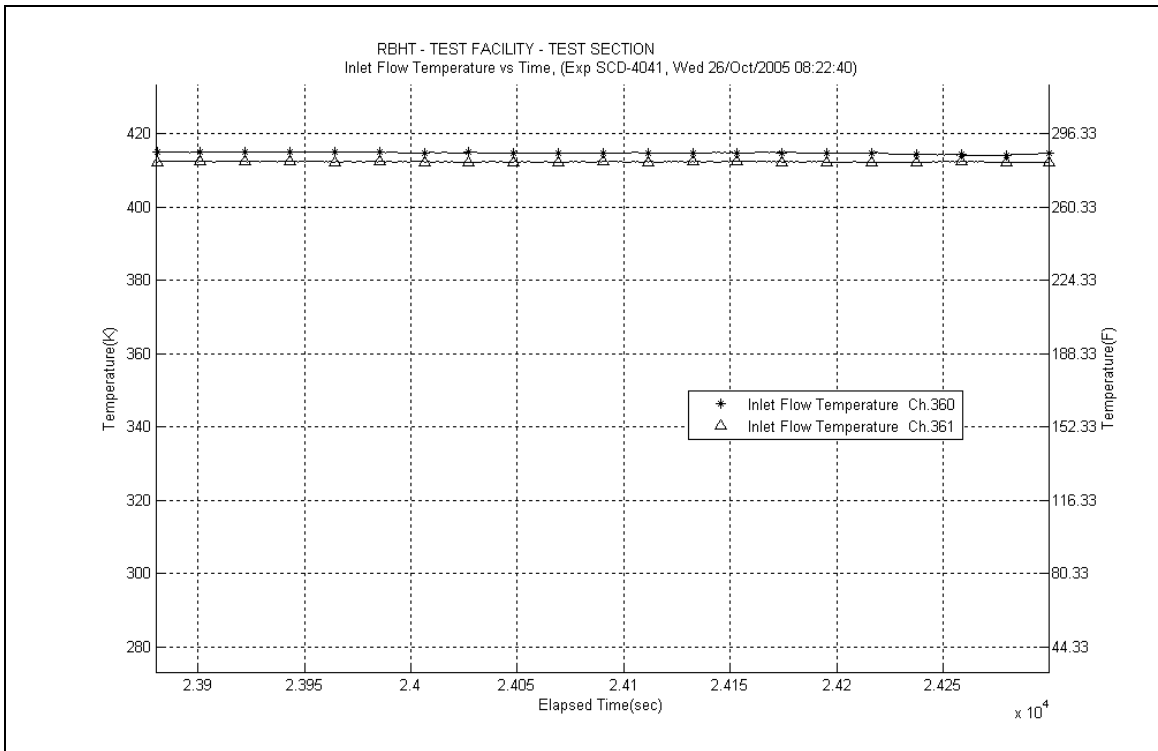

Figure A-539: Inlet Steam Temperature for Experiment 4041F

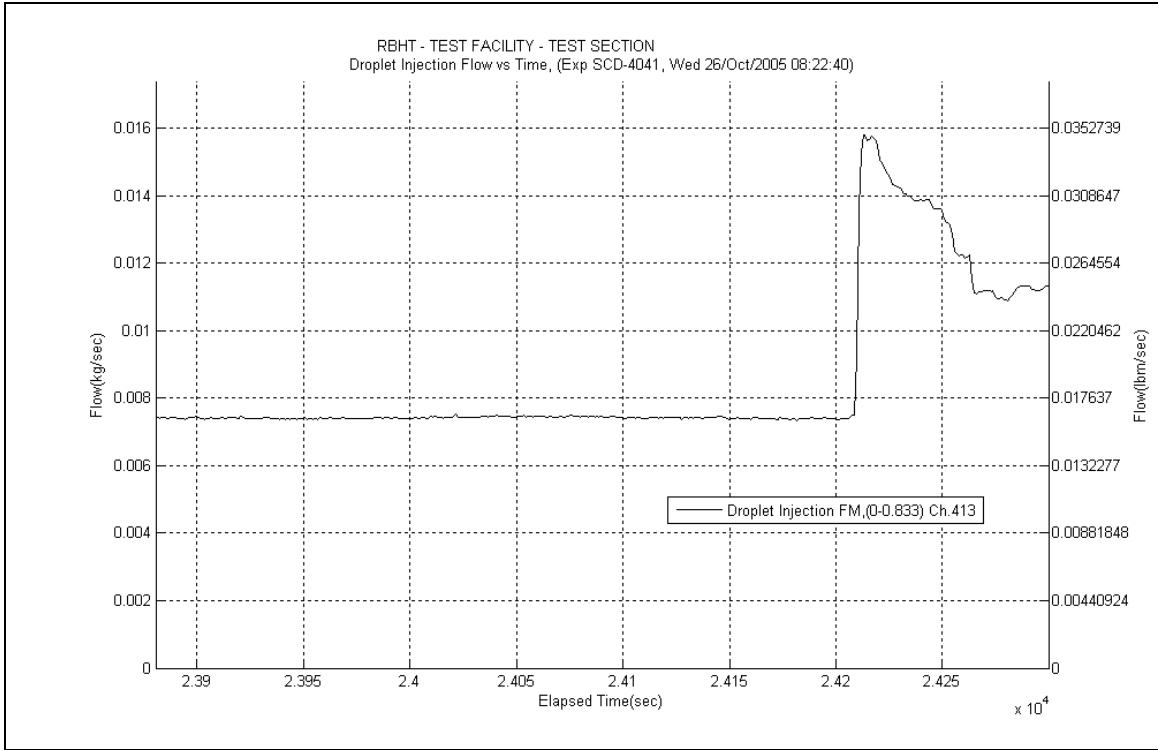

Figure A-540: Droplet Injection Flow Rate for Experiment 4041F

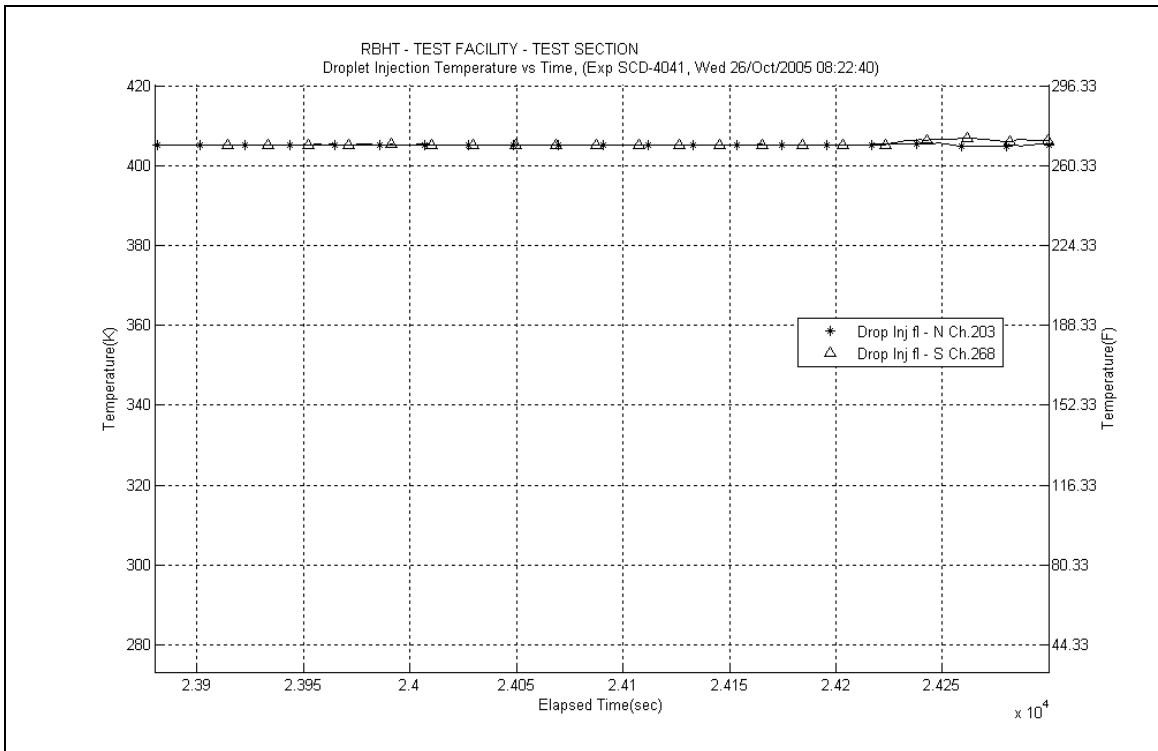

Figure A-541: Droplet Injection Temperature for Experiment 4041F

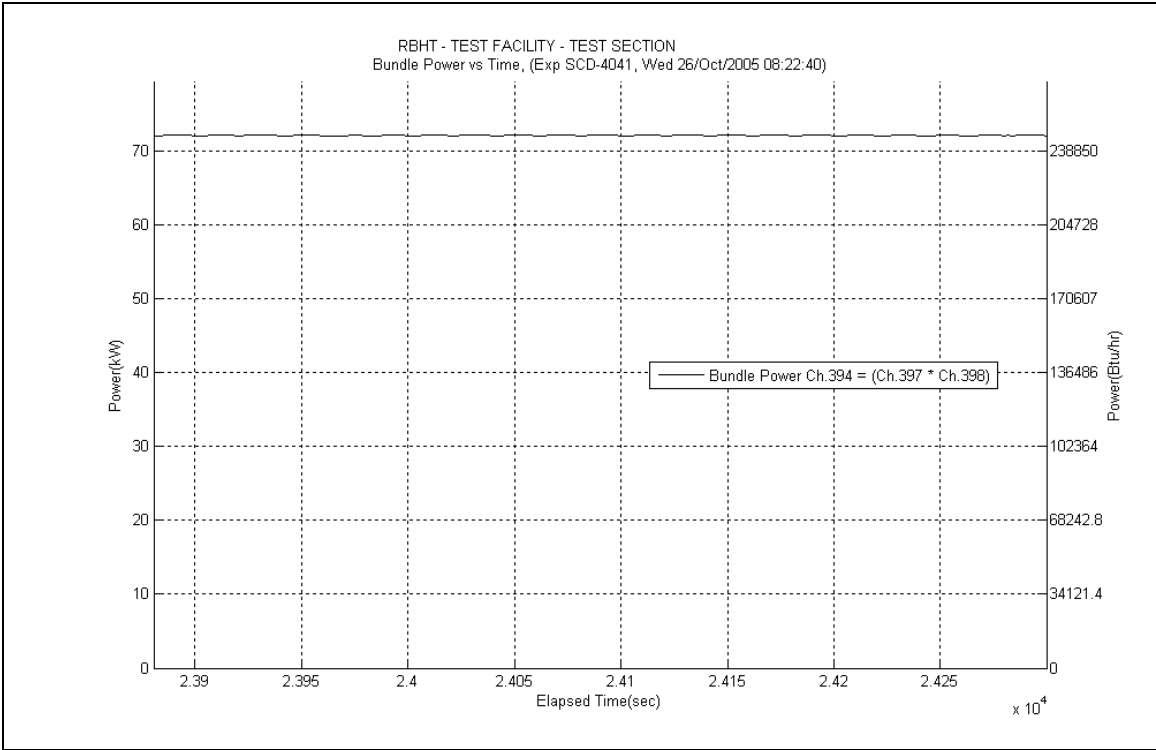

Figure A-542: Bundle Power for Experiment 4041F

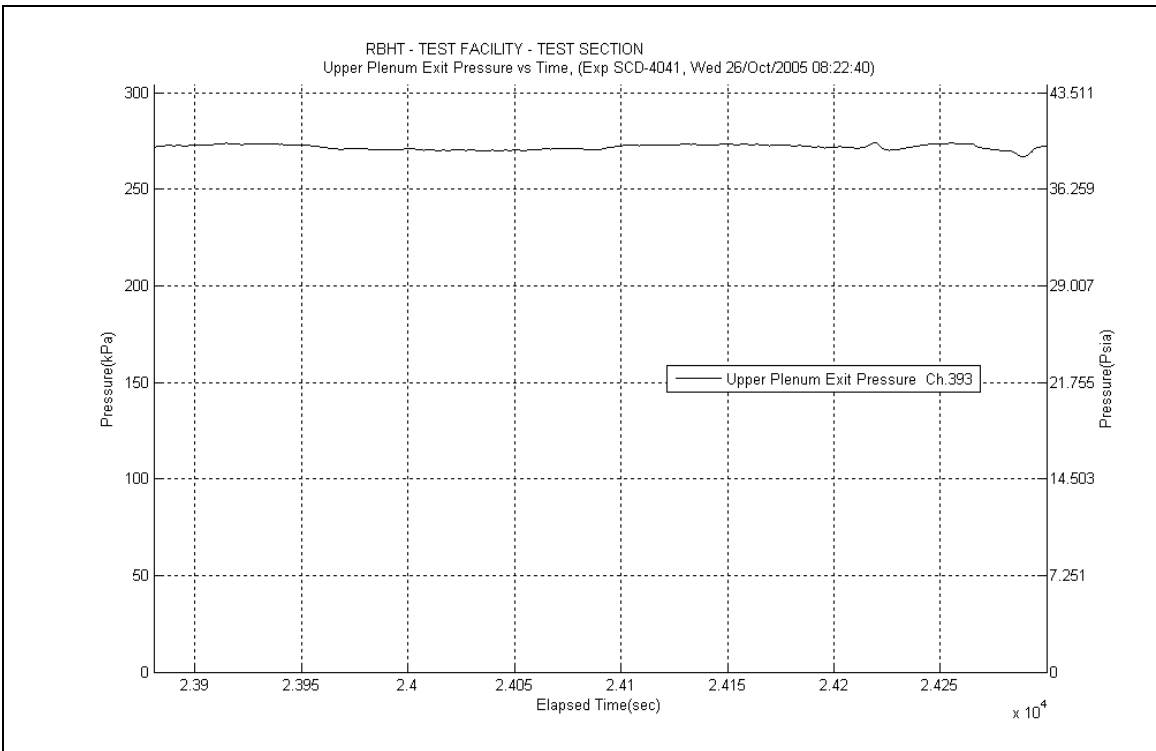

Figure A-543: Upper Plenum Pressure for Experiment 4041F

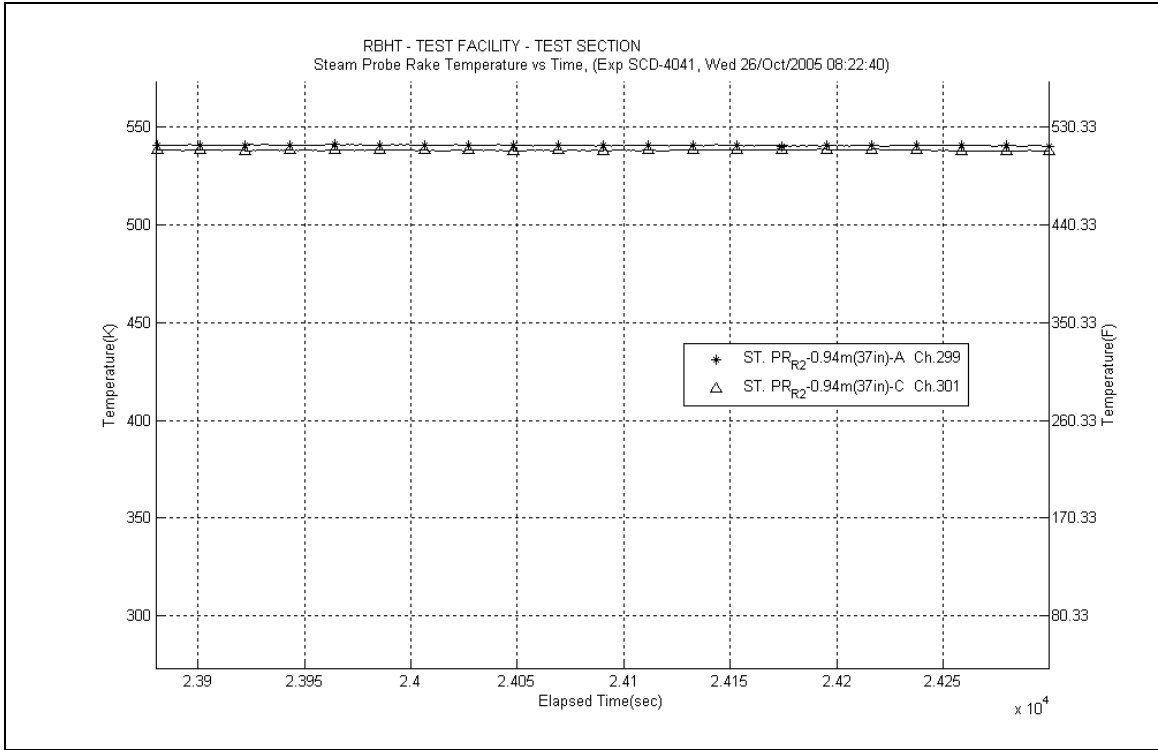

Figure A-544: Steam Probe Rake #2 Temperatures for Experiment 4041F

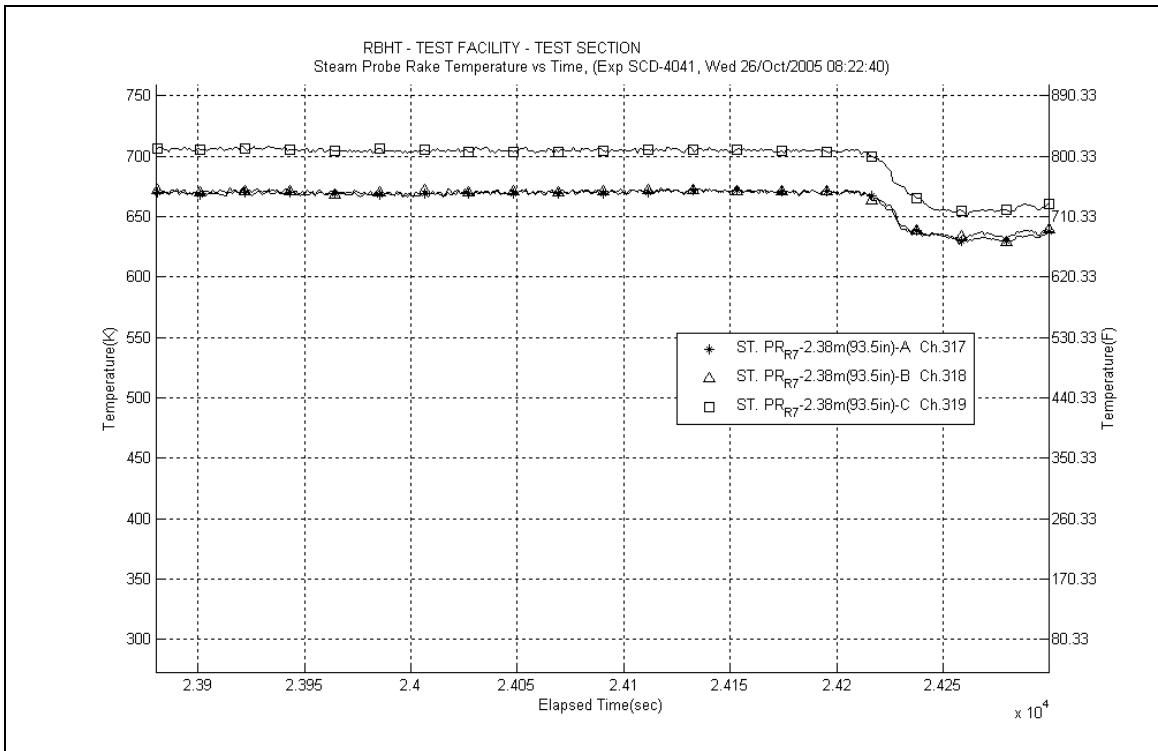

Figure A-545: Steam Probe Rake #7 Temperatures for Experiment 4041F

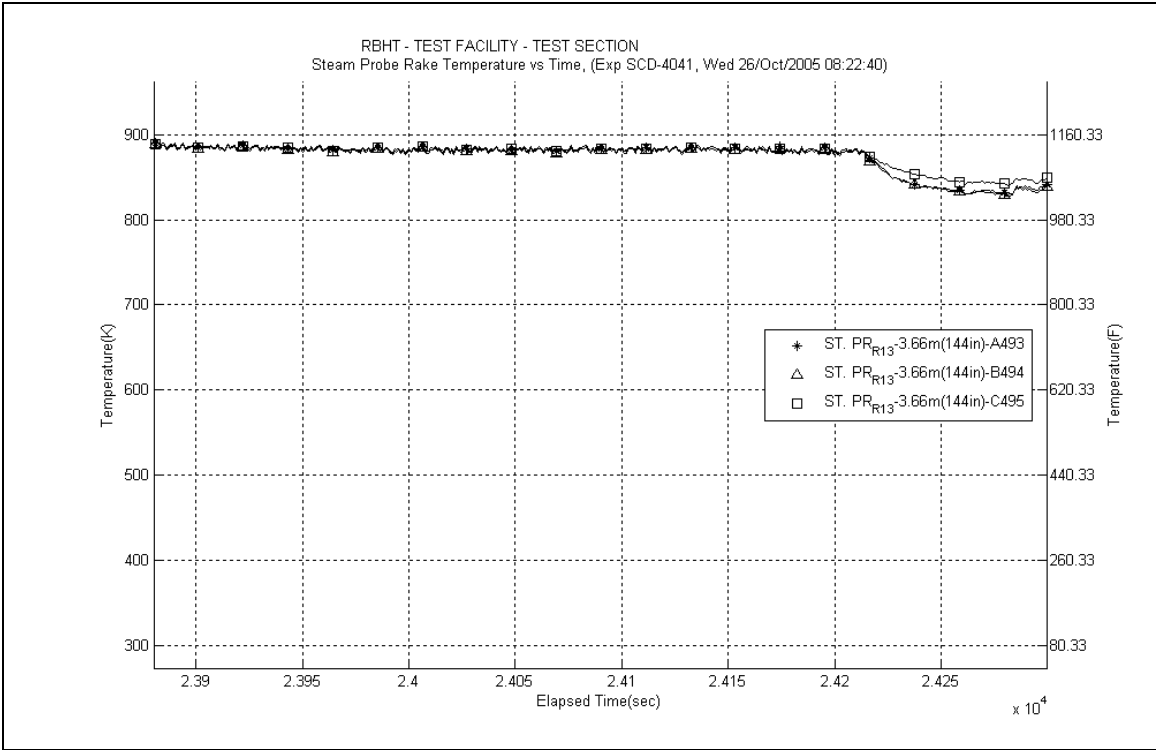

Figure A-546: Steam Probe Rake #13 Temperatures for Experiment 4041F

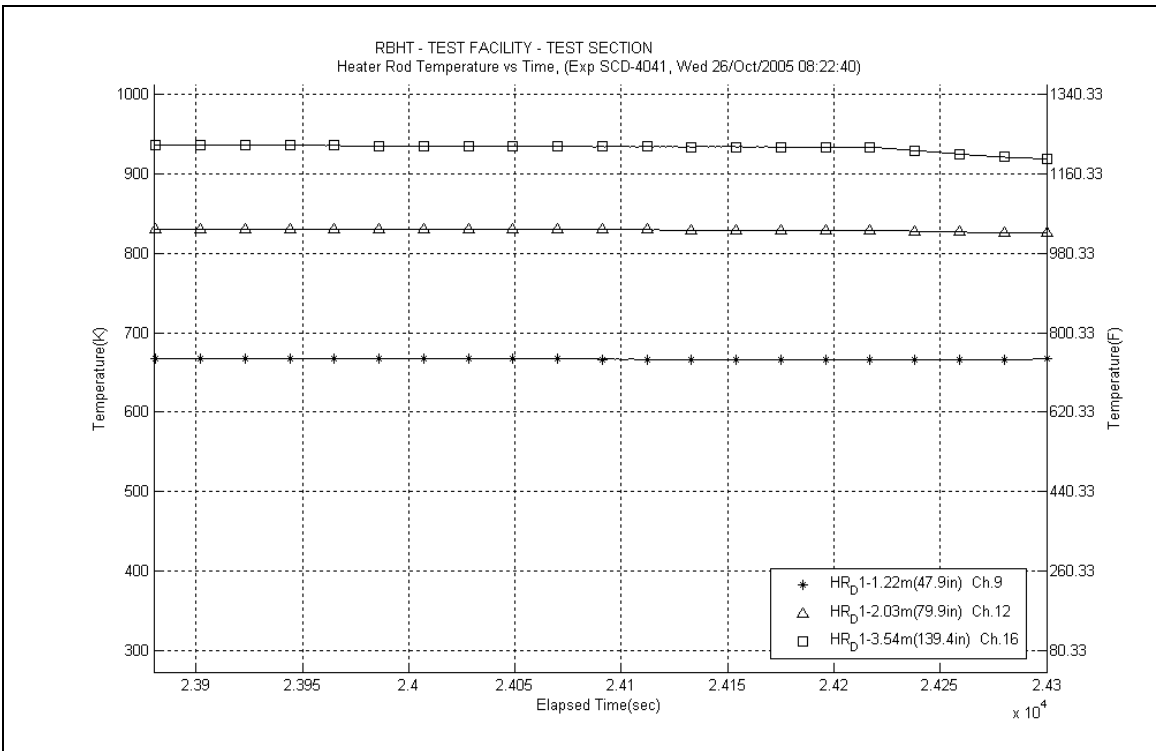

Figure A-547: Heater Rod D1 Temperatures for Experiment 4041F

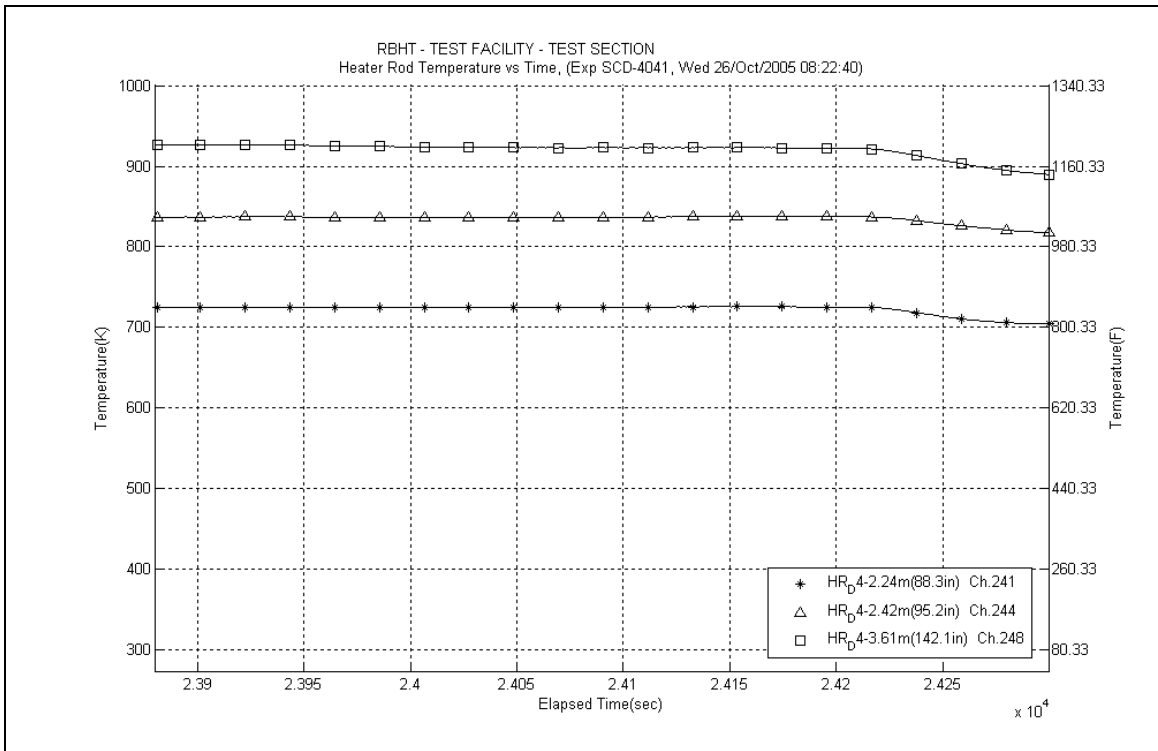

Figure A-548: Heater Rod D4 Temperatures for Experiment 4041F

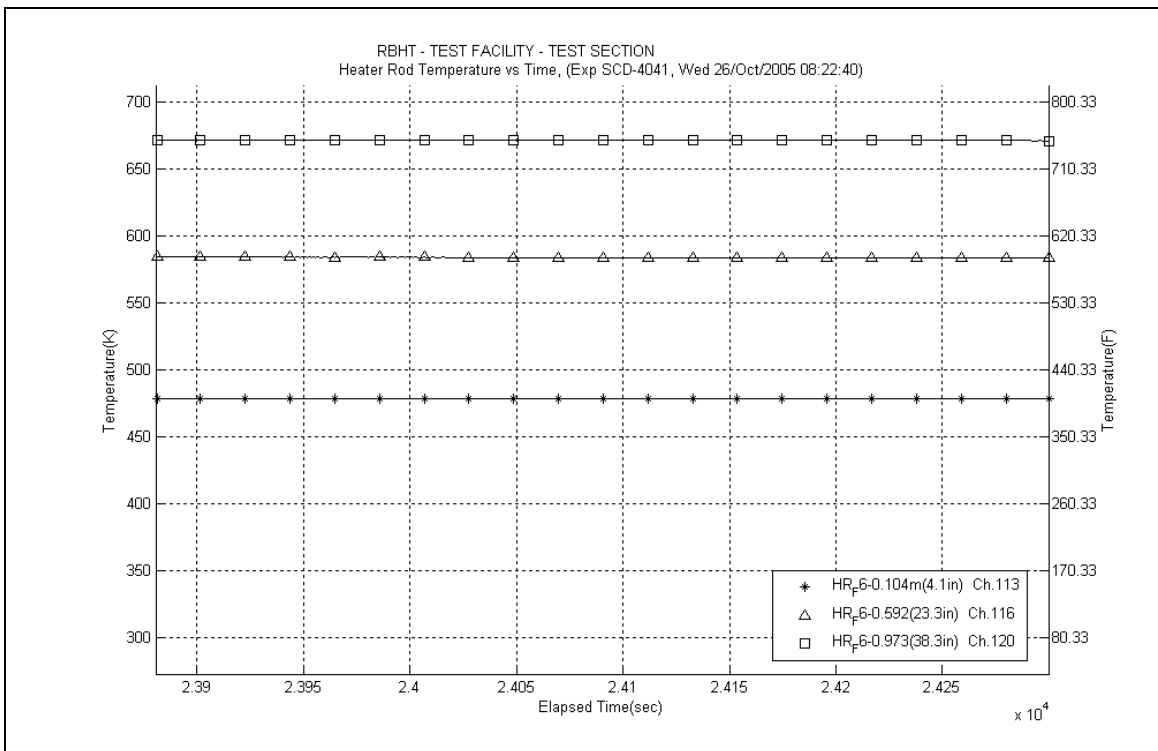

Figure A-549: Heater Rod F6 Temperatures for Experiment 4041F

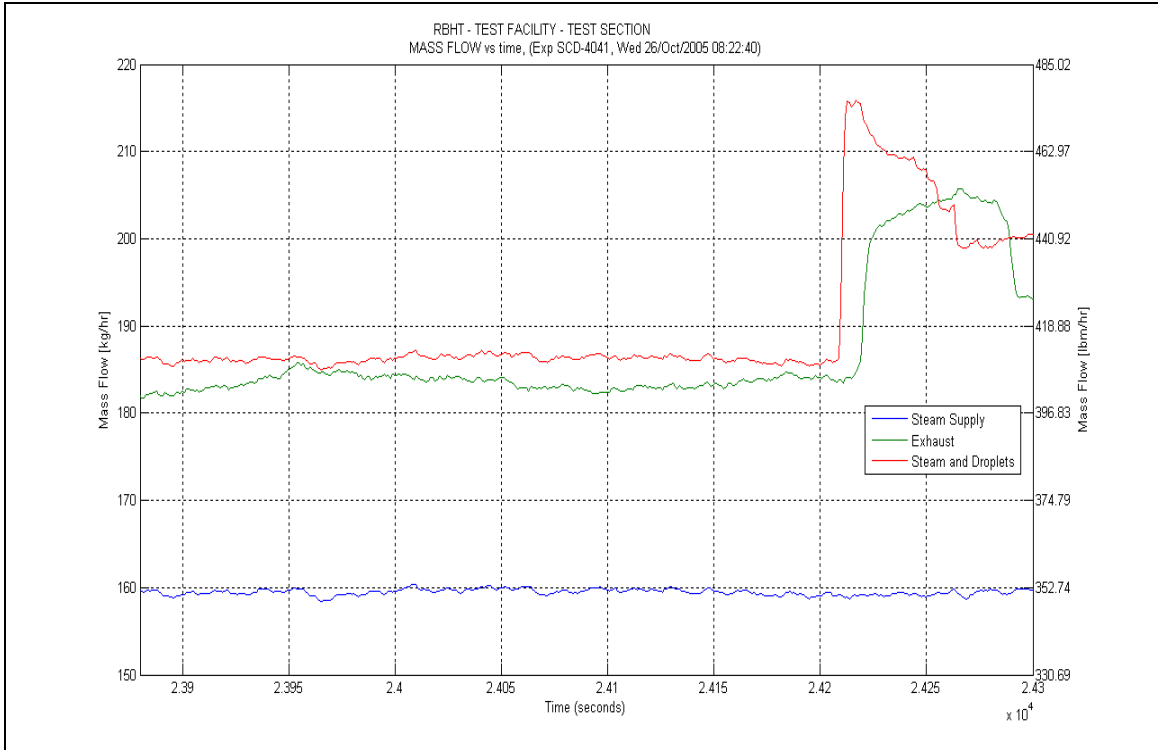

Figure A-550: Mass Flow for Experiment 4041F

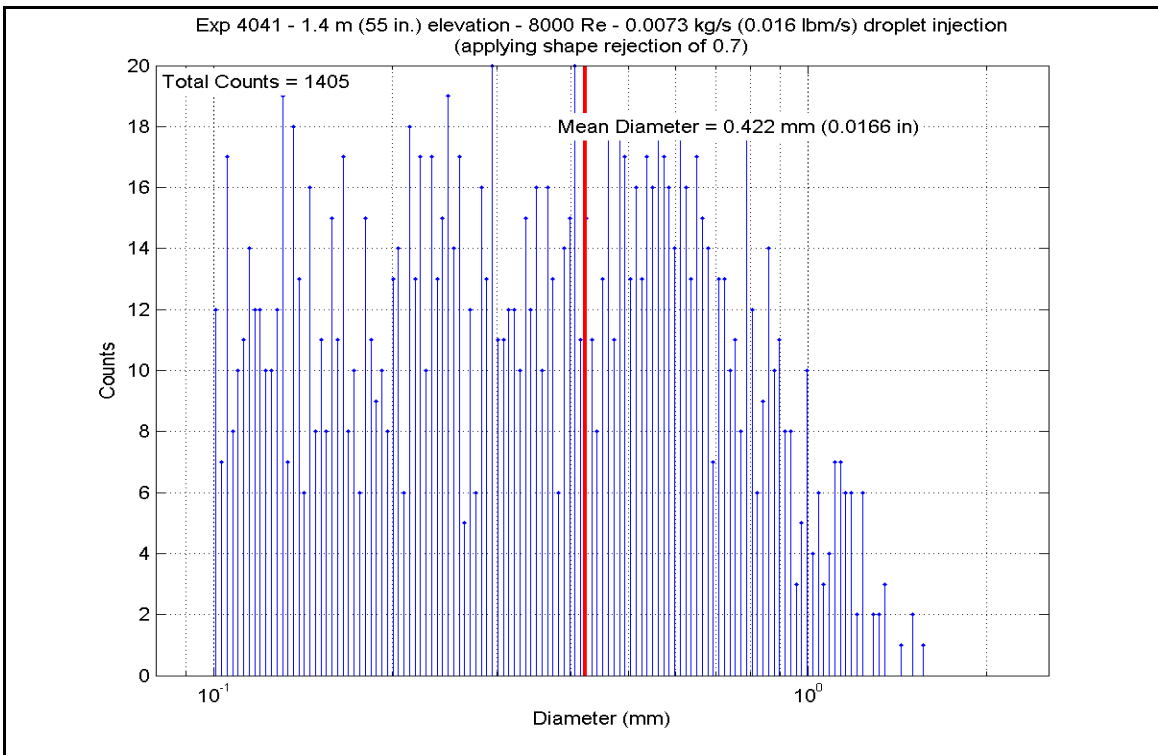

Figure A-551: Droplet Measurements at 1.397 m (55 in.) Elevation for Experiment 4041F

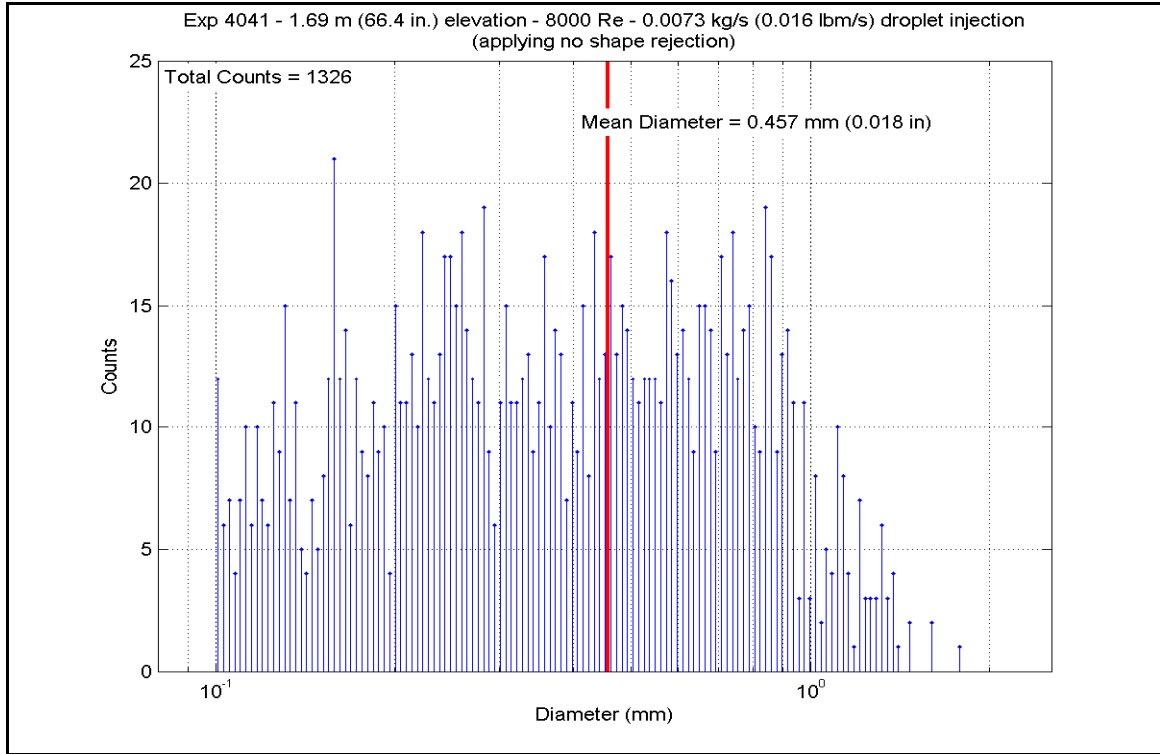

Figure A-552: Droplet Measurements at 1.687 m (66.4 in.) Elevation for Experiment 4041F

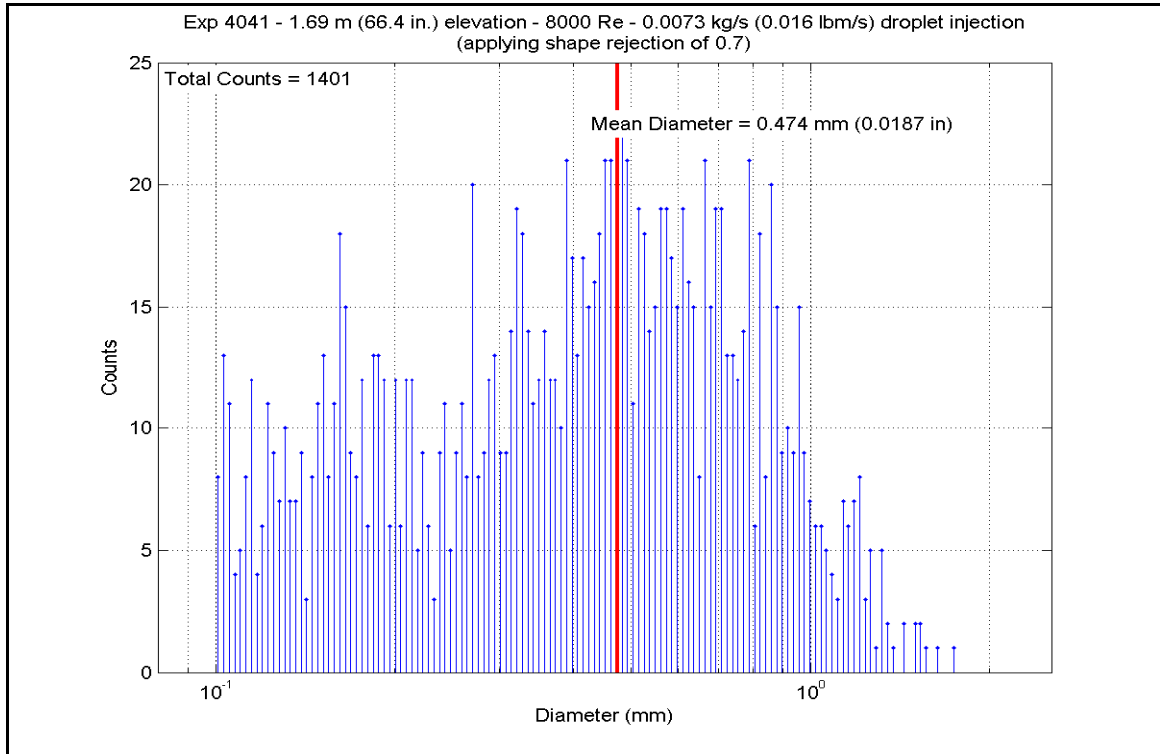

Figure A-553: Droplet Measurements at 1.687 m (66.4 in.) Elevation for Experiment 4041F

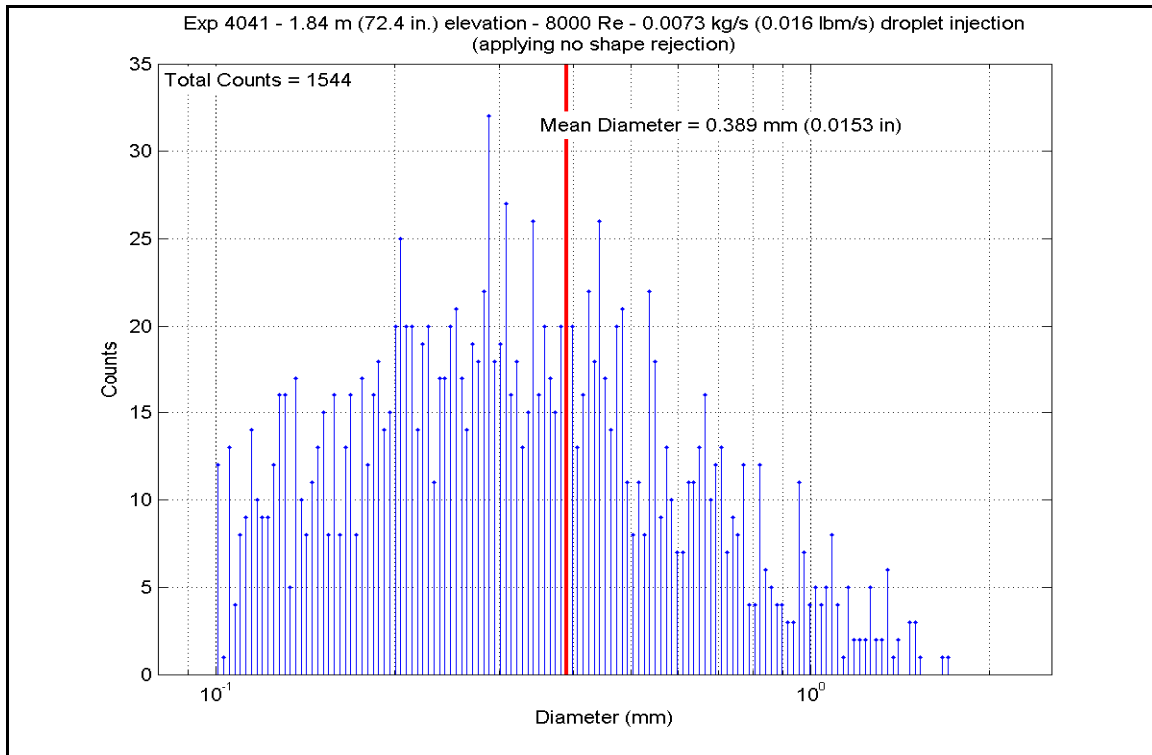

Figure A-554: Droplet Measurements at 1.839 m (72.4 in.) Elevation for Experiment 4041F

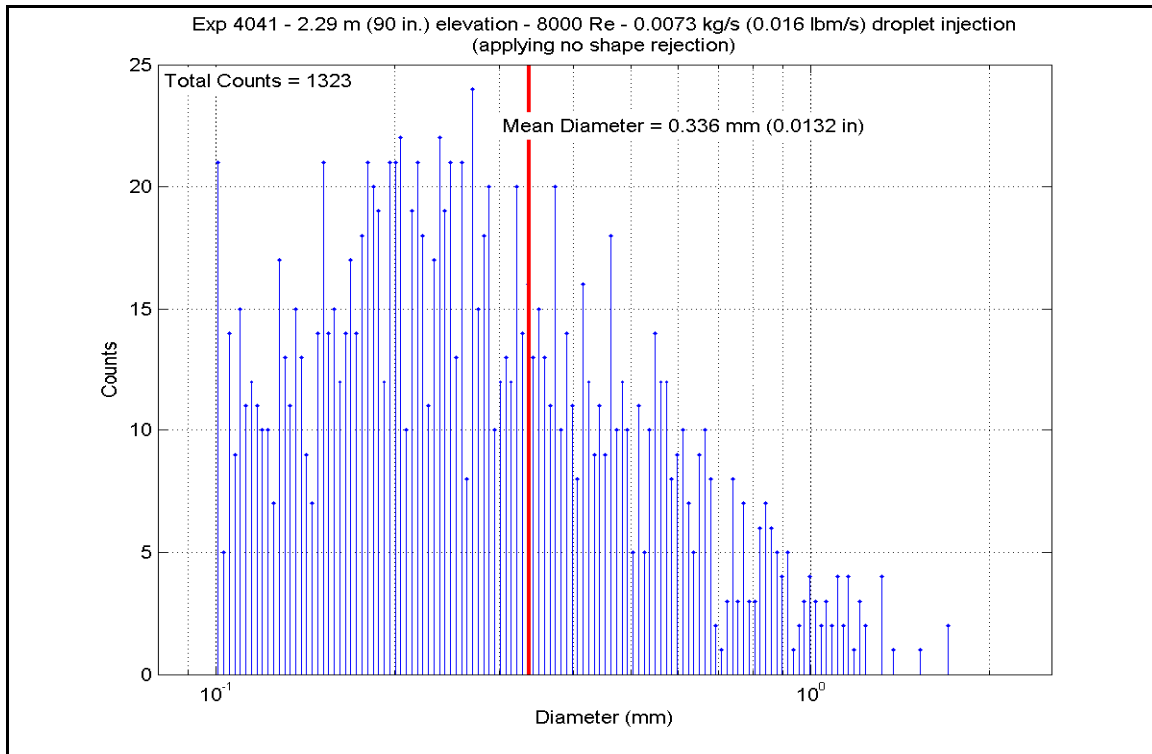

Figure A-555: Droplet Measurements at 2.286 m (90 in.) Elevation for Experiment 4041F

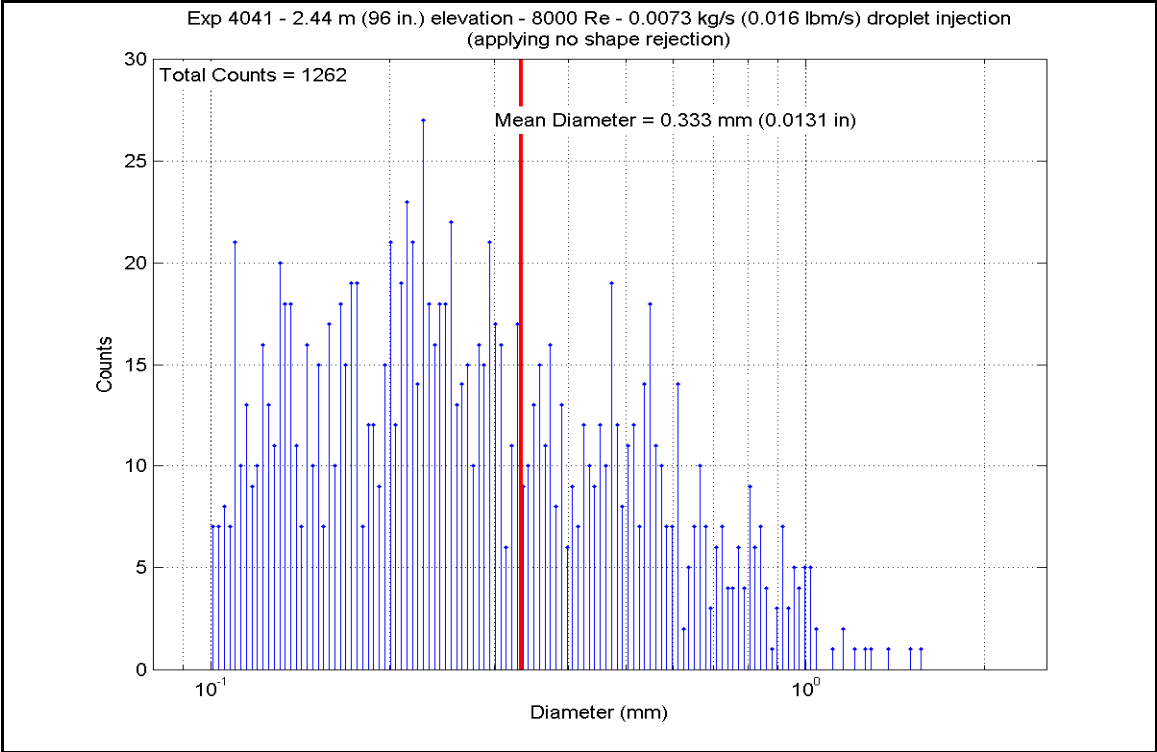

Figure A-556: Droplet Measurements at 2.438 m (96 in.) Elevation for Experiment 4041F

Table A-30: Summary of Steam Cooling Heat Transfer Reduced Data for Experiment 4041F

SCD-4041-F		Inlet Reynolds: 8000										
Matrix Test # 8b		UP Pressure: 275.8 kPa		40 psia		8000		8000		8000		
Time Window 23880-24300		Bundle Power: 72.00 kW		245674 Btu/hr		245674 Btu/hr		245674 Btu/hr		245674 Btu/hr		
Inner 3x3		Steam flow: 0.0441 kg/s		350.0 lbm/hr		350.0 lbm/hr		350.0 lbm/hr		350.0 lbm/hr		
		Droplet flow: 0.0073 kg/s		0.016 lbm/s		0.016 lbm/s		0.016 lbm/s		0.016 lbm/s		
H.R. ID	H.R. Location	Channel Number	Elevation (in)	Elevation (m)	Zgrid (in)	Zgrid (m)	H.R. Tw (°F)	H.R. Tw (K)	H.R. q" (Btu/hr-ft ²)	H.R. q' (W/m ²)	h _{sat} (z) (Btu/hr-ft ² -F)	h _{sat} (z) (W/m ² -K)
Gr-3	RodD3_88.3	185	88.3	2.243	-0.2	-0.005	908.34	760.0	6976.96	22008.8	10.879	61.8
	RodD3_91.3	186	91.3	2.319	2.8	0.071	992.13	806.6	7161.73	22591.7	9.877	56.1
	RodD3_93.1	187	93.1	2.365	4.6	0.117	992.47	806.7	7255.30	22886.8	10.001	56.8
	RodD3_95.3	188	95.3	2.421	6.8	0.173	1043.14	834.9	7346.37	23174.1	9.465	53.8
	RodD3_100.1	189	100.1	2.543	11.6	0.295	1123.60	879.6	7503.57	23670.0	8.760	49.7
	RodD3_106.1	190	106.1	2.695	17.6	0.447	1185.75	914.1	7788.48	24568.7	8.477	48.1
	RodD3_110	191	110	2.794	21.5	0.546	1108.83	871.4	7674.16	24208.1	9.116	51.8
	RodD3_142.1	192	142.1	3.609	8.6	0.218	1183.29	912.8	2956.93	9327.6	3.227	18.3
Gr-3	RodC4_88.4	233	88.4	2.245	-0.1	-0.003	860.41	733.4	7183.62	22660.7	12.106	68.7
	RodC4_91.1	234	91.1	2.314	2.6	0.066	966.35	792.2	7263.93	22914.1	10.387	59.0
	RodC4_93.4	235	93.4	2.372	4.9	0.124	994.20	807.7	7328.97	23119.2	10.078	57.2
	RodC4_95.3	236	95.3	2.421	6.8	0.173	1043.65	835.2	7414.91	23390.3	9.547	54.2
	RodC4_100.1	237	100.1	2.543	11.6	0.295	1084.70	858.0	7616.06	24024.9	9.314	52.9
	RodC4_106.1	238	106.1	2.695	17.6	0.447	1151.84	895.3	7911.57	24957.1	8.941	50.8
	RodC4_110	239	110	2.794	21.5	0.546	1075.97	853.1	7672.10	24201.7	9.484	53.9
	RodC4_142.2	240	142.2	3.612	8.7	0.221	1148.41	893.4	3187.92	10056.3	3.617	20.5
Gr-3	RodD4_88.3	241	88.3	2.243	-0.2	-0.005	843.83	724.2	6985.69	22036.4	12.110	68.8
	RodD4_91.3	242	91.3	2.319	2.8	0.071	952.41	784.5	7197.38	22704.1	10.501	59.6
	RodD4_93.2	243	93.2	2.367	4.7	0.119	983.12	801.5	7292.71	23004.8	10.184	57.8
	RodD4_95.2	244	95.2	2.418	6.7	0.170	1029.46	827.3	7383.67	23291.8	9.684	55.0
	RodD4_100.1	245	100.1	2.543	11.6	0.295	1112.46	873.4	7593.04	23952.2	8.981	51.0
	RodD4_106.1	246	106.1	2.695	17.6	0.447	1151.74	895.2	7882.38	24865.0	8.909	50.6
	RodD4_142.1	248	142.1	3.609	8.6	0.218	1155.97	897.6	3076.21	9703.9	3.460	19.7
Gr-3	RodE4_88.4	201	88.4	2.245	-0.1	-0.003	880.23	744.4	6819.04	21510.7	11.120	63.1
	RodE4_91.2	202	91.2	2.316	2.7	0.069	986.97	803.7	6996.17	22069.4	9.717	55.2
	RodE4_95.3	204	95.3	2.421	6.8	0.173	1064.88	847.0	7206.16	22731.8	9.032	51.3
	RodE4_100.9	205	100.9	2.563	12.4	0.315	1128.94	882.6	7443.65	23481.0	8.636	49.0
	RodE4_142.3	208	142.3	3.614	8.8	0.224	1181.03	911.5	3153.82	9948.7	3.450	19.6

Table A-30: Summary of Steam Cooling Heat Transfer Reduced Data for Experiment 4041, continued

Inner 3x3	H.R. Location	Channel Number	Elevation (in)	Elevation (m)	Zgrid (in)	Zgrid (m)	H.R. Tw (°F)	H.R. Tw (K)	H.R. q" (Btu/hr-ft ²)	H.R. q" (W/m ²)	h _{sat} (z) (Btu/hr-ft ² -F)	h _{sat} (z) (W/m ² -K)
Gr-4	RodE3_63.4	193	63.4	1.610	16.4	0.417	948.48	782.3	5576.83	17592.1	8.183	46.5
	RodE3_113.6	194	113.6	2.885	0.85	0.022	1153.37	896.1	7003.67	22093.1	7.902	44.9
	RodE3_115.5	195	115.5	2.934	2.75	0.070	1190.84	916.9	6796.80	21440.5	7.357	41.8
	RodE3_118.5	196	118.5	3.010	5.75	0.146	1219.88	933.1	6411.69	20225.7	6.729	38.2
	RodE3_122.7	197	122.7	3.117	9.95	0.253	1229.56	938.5	5867.40	18508.7	6.096	34.6
	RodE3_126.5	198	126.5	3.213	13.75	0.349	1231.24	939.4	5375.57	16957.2	5.575	31.7
	RodE3_131.7	199	131.7	3.345	-1.8	-0.046	1147.58	892.9	4635.61	14623.0	5.264	29.9
	RodE3_135.6	200	135.6	3.444	2.1	0.053	1184.11	913.2	4166.29	13142.6	4.543	25.8
Gr-4	RodC5_63.7	225	63.7	1.618	16.7	0.424	924.36	768.9	5474.72	17270.0	8.328	47.3
	RodC5_113.6	226	113.6	2.885	0.85	0.022	1088.03	859.8	6895.91	21753.2	8.399	47.7
	RodC5_115.7	227	115.7	2.939	2.95	0.075	1127.88	882.0	6662.20	21015.9	7.739	43.9
	RodC5_122.7	229	122.7	3.117	9.95	0.253	1167.19	903.8	5827.92	18384.2	6.474	36.8
	RodC5_126.7	230	126.7	3.218	13.95	0.354	1163.96	902.0	5327.95	16807.0	5.940	33.7
	RodC5_131.6	231	131.6	3.343	-1.9	-0.048	1066.12	847.7	4626.72	14595.0	5.790	32.9
	RodC5_135.7	232	135.7	3.447	2.2	0.056	1107.43	870.6	4155.08	13107.2	4.944	28.1
Gr-4	RodE5_63.6	209	63.6	1.615	16.6	0.422	841.10	722.7	5582.14	17608.9	9.723	55.2
	RodE5_113.6	210	113.6	2.885	0.85	0.022	1008.53	815.7	7318.55	23086.4	9.869	56.0
	RodE5_115.4	211	115.4	2.931	2.65	0.067	1088.54	860.1	7067.49	22294.4	8.603	48.9
	RodE5_118.7	212	118.7	3.015	5.95	0.151	1154.52	896.8	6643.45	20956.8	7.485	42.5
	RodE5_122.6	213	122.6	3.114	9.85	0.250	1194.51	919.0	6147.53	19392.4	6.628	37.6
	RodE5_126.6	214	126.6	3.216	13.85	0.352	1206.82	925.8	5640.37	17792.5	6.002	34.1
	RodE5_131.6	215	131.6	3.343	-1.9	-0.048	1185.38	913.9	4906.83	15478.6	5.343	30.3
	RodE5_135.6	216	135.6	3.444	2.1	0.053	1145.39	891.7	4123.56	13007.8	4.694	26.7
Gr-5	RodC3_79.8	177	79.8	2.027	8.92	0.227	958.28	787.8	6406.34	20208.8	9.267	52.6
	RodC3_85.6	178	85.6	2.174	14.72	0.374	881.61	745.2	7069.14	22299.6	11.502	65.3
	RodC3_88.5	179	88.5	2.248	0	0.000	896.54	753.5	7153.97	22567.2	11.364	64.5
	RodC3_92.4	180	92.4	2.347	3.9	0.099	1008.57	815.7	7193.46	22691.8	9.700	55.1
	RodC3_94.4	181	94.4	2.398	5.9	0.150	1023.34	823.9	7239.60	22837.3	9.572	54.4
	RodC3_97.2	182	97.2	2.469	8.7	0.221	1074.42	852.3	7314.10	23072.3	9.059	51.4
	RodC3_108.8	183	108.8	2.764	20.3	0.516	1168.90	904.8	7692.98	24267.5	8.530	48.4
Gr-8	RodD5_50	217	50	1.270	3	0.076	813.97	707.6	4957.32	15637.9	9.063	51.5
	RodD5_54.1	218	54.1	1.374	7.1	0.180	815.31	708.3	5150.78	16248.1	9.394	53.3
	RodD5_56.9	219	56.9	1.445	9.9	0.251	858.36	732.2	5289.23	16684.9	8.944	50.8
	RodD5_60	220	60	1.524	13	0.330	888.81	749.2	5443.29	17170.9	8.754	49.7
	RodD5_66.1	221	66.1	1.679	19.1	0.485	928.27	771.1	5747.64	18130.9	8.692	49.4
	RodD5_69.9	222	69.9	1.775	-0.98	-0.025	787.07	692.6	5912.41	18650.7	11.368	64.6
	RodD5_72.9	223	72.9	1.852	2.02	0.051	859.34	732.8	6063.89	19128.5	10.237	58.1
	RodD5_74.9	224	74.9	1.902	4.02	0.102	904.75	758.0	6168.78	19459.4	9.673	54.9

Table A-30: Summary of Steam Cooling Heat Transfer Reduced Data for Experiment 4041, continued

5x5 periphery														
H.R. ID	H.R. Location	Channel Number	Elevation (in)	Elevation (m)	Zgrid (in)	Zgrid (m)	H.R. Tw (°F)	H.R. Tw (K)	H.R. q" (Btu/hr-ft ²)	H.R. q" (W/m ²)	h _{sat} (z) (Btu/hr-ft ² -F)	h _{sat} (z) (W/m ² -K)	h _{sat} (z)	
Gr-2	RodB5_41	153	41	1.041	13.5	0.343	750.90	672.5	4490.84	14166.3	9.281	52.7	52.7	
	RodB5_52.9	154	52.9	1.344	5.9	0.150	811.18	706.0	5073.34	16003.8	9.323	52.9	52.9	
	RodB5_55	155	55	1.397	8	0.203	846.74	725.8	5178.08	16334.3	8.932	50.7	50.7	
	RodB5_57.8	156	57.8	1.468	10.8	0.274	887.64	748.5	5315.18	16766.7	8.564	48.6	48.6	
	RodB5_64	157	64	1.626	17	0.432	936.79	775.8	5623.06	17737.9	8.395	47.7	47.7	
	RodB5_73.9	158	73.9	1.877	3.02	0.077	897.39	753.9	6122.30	19312.8	9.712	55.2	55.2	
	RodB5_75.9	159	75.9	1.928	5.02	0.128	933.59	774.0	6226.09	19640.2	9.340	53.0	53.0	
	RodB5_76.9	160	76.9	1.953	6.02	0.153	947.80	781.9	6277.61	19802.7	9.221	52.4	52.4	
	Gr-2	RodF5_41	105	41	1.041	13.5	0.343	740.78	666.9	4474.01	14113.3	9.443	53.6	53.6
		RodF5_53.1	106	53.1	1.349	6.1	0.155	794.57	696.8	5045.41	15915.8	9.564	54.3	54.3
RodF5_55		107	55	1.397	8	0.203	831.11	717.1	5136.44	16202.9	9.105	51.7	51.7	
RodF5_57.8		108	57.8	1.468	10.8	0.274	876.02	742.0	5277.50	16647.9	8.666	49.2	49.2	
RodF5_64		109	64	1.626	17	0.432	921.02	767.0	5587.62	17626.2	8.544	48.5	48.5	
RodF5_73.8		110	73.8	1.875	2.92	0.074	889.96	749.8	6083.57	19190.6	9.766	55.5	55.5	
RodF5_75.8		111	75.8	1.925	4.92	0.125	929.60	771.8	6187.26	19517.7	9.338	53.0	53.0	
RodF5_76.8		112	76.8	1.951	5.92	0.150	945.78	780.8	6238.88	19680.6	9.191	52.2	52.2	
Gr-2		RodC2_41	57	41	1.041	13.5	0.343	734.73	663.6	4502.09	14201.8	9.625	54.7	54.7
		RodC2_53.1	58	53.1	1.349	6.1	0.155	856.95	731.5	5087.37	16048.1	8.623	49.0	49.0
	RodC2_55	59	55	1.397	8	0.203	875.32	741.7	5178.58	16335.8	8.513	48.3	48.3	
	RodC2_57.8	60	57.8	1.468	10.8	0.274	906.68	759.1	5314.54	16764.7	8.308	47.2	47.2	
	RodC2_63.9	61	63.9	1.623	16.9	0.429	936.50	775.7	5609.59	17695.4	8.379	47.6	47.6	
	RodC2_73.8	62	73.8	1.875	2.92	0.074	920.82	766.9	6085.01	19195.2	9.307	52.9	52.9	
	RodC2_75.8	63	75.8	1.925	4.92	0.125	947.96	782.0	6179.03	19491.7	9.074	51.5	51.5	
	RodC2_76.8	64	76.8	1.951	5.92	0.150	958.70	788.0	6226.59	19641.8	9.002	51.1	51.1	
	Gr-2	RodC6_40.9	137	40.9	1.039	13.4	0.340	748.05	671.0	4465.13	14085.3	9.282	52.7	52.7
		RodC6_52.8	138	52.8	1.341	5.8	0.147	865.34	736.1	5067.80	15986.4	8.470	48.1	48.1
RodC6_54.8		139	54.8	1.392	7.8	0.198	886.58	747.9	5168.94	16305.4	8.343	47.4	47.4	
RodC6_57.8		140	57.8	1.468	10.8	0.274	921.20	767.1	5319.45	16780.2	8.131	46.2	46.2	
RodC6_63.8		141	63.8	1.621	16.8	0.427	954.49	785.6	5625.91	17746.9	8.183	46.5	46.5	
RodC6_73.7		142	73.7	1.872	2.82	0.072	939.11	777.1	6153.06	19409.8	9.155	52.0	52.0	
RodC6_75.8		143	75.8	1.925	4.92	0.125	968.46	793.4	6267.65	19771.3	8.935	50.7	50.7	
RodC6_76.8		144	76.8	1.951	5.92	0.150	985.63	802.9	6320.26	19937.3	8.795	49.9	49.9	

Table A-30: Summary of Steam Cooling Heat Transfer Reduced Data for Experiment 4041, continued

5x5 periphery		H.R. Location	Channel Number	Elevation (in)	Elevation (m)	Zgrid (in)	Zgrid (m)	H.R. Tw (°F)	H.R. Tw (K)	H.R. q" (Btu/hr-ft ²)	H.R. q" (W/m ²)	h _{sat} (z) (Btu/hr-ft ² -F)	h _{sat} (z) (W/m ² -K)
Gr-3	RodB4_88.4	161	88.4	2.245	-0.1	-0.003	754.3	7068.69	22298.2	11.202	63.6		
	RodB4_91.3	162	91.3	2.319	2.8	0.071	804.3	7151.45	22559.2	9.918	56.3		
	RodB4_93.3	163	93.3	2.370	4.8	0.122	811.4	7223.43	22786.3	9.843	55.9		
	RodB4_95.1	164	95.1	2.416	6.6	0.168	829.9	7315.37	23076.3	9.536	54.2		
	RodB4_100	165	100	2.540	11.5	0.292	845.0	7432.38	23445.5	9.356	53.1		
	RodB4_106	166	106	2.692	17.5	0.445	893.1	7717.12	24343.7	8.761	49.8		
	RodB4_109.9	167	109.9	2.791	21.4	0.544	849.1	7457.55	23524.8	9.302	52.8		
	RodB4_142.3	168	142.3	3.614	8.8	0.224	894.3	3259.86	10283.2	3.691	21.0		
Gr-5	RodF4_85.6	98	85.6	2.174	14.72	0.374	777.9	6702.11	21141.8	9.952	56.5		
	RodF4_88.4	99	88.4	2.245	-0.1	-0.003	771.7	6832.53	21553.2	10.315	58.6		
	RodF4_92.4	100	92.4	2.347	3.9	0.099	827.7	7058.31	22265.4	9.248	52.5		
	RodF4_94.3	101	94.3	2.395	5.8	0.147	846.2	7159.65	22585.1	8.990	51.1		
	RodF4_97.2	102	97.2	2.469	8.7	0.221	869.4	7311.81	23065.1	8.723	49.5		
	RodF4_108.8	103	108.8	2.764	20.3	0.516	905.8	7746.63	24436.7	8.571	48.7		
	RodF4_111	104	111	2.819	-1.75	-0.044	858.2	7438.37	23464.3	9.092	51.6		
	RodD2_103.2	65	103.2	2.621	14.7	0.373	909.7	6778.21	21381.9	7.441	42.3		
RodD2_106	66	106	2.692	17.5	0.445	922.1	6428.08	20277.4	6.889	39.1			
RodD2_112.6	67	112.6	2.860	-0.15	-0.004	935.0	5955.47	18786.5	6.227	35.4			
RodD2_114.9	68	114.9	2.918	2.15	0.055	940.0	5406.47	17054.7	5.600	31.8			
RodD2_117.4	69	117.4	2.982	4.65	0.118	934.7	4882.87	15403.0	5.109	29.0			
RodD2_120.8	70	120.8	3.068	8.05	0.204	910.4	7607.59	23998.1	8.342	47.4			
RodD2_124.8	71	124.8	3.170	12.05	0.306	923.3	7746.38	24436.0	8.283	47.0			
RodD2_128.6	72	128.6	3.266	15.85	0.403	885.3	7098.90	22393.5	8.189	46.5			
Gr-6	RodD6_103.1	129	103.1	2.619	14.6	0.371	901.4	7650.64	24133.9	8.541	48.5		
	RodD6_106	130	106	2.692	17.5	0.445	909.3	7799.05	24602.1	8.570	48.7		
	RodD6_112.9	131	112.9	2.868	0.15	0.004	864.8	7129.52	22490.1	8.589	48.8		
	RodD6_114.9	132	114.9	2.918	2.15	0.055	886.6	6872.09	21678.0	7.907	44.9		
	RodD6_116.8	133	116.8	2.967	4.05	0.103	899.8	6617.22	20874.0	7.410	42.1		
	RodD6_120.9	134	120.9	3.071	8.15	0.207	910.4	6110.94	19277.0	6.700	38.1		
	RodD6_124.8	135	124.8	3.170	12.05	0.306	912.5	5570.43	17571.9	6.083	34.5		
	RodD6_128.7	136	128.7	3.269	15.95	0.405	907.9	5021.71	15841.0	5.533	31.4		

Table A-30: Summary of Steam Cooling Heat Transfer Reduced Data for Experiment 4041, continued

5x5 periphery		H.R. Location	Channel Number	Elevation (in)	Elevation (m)	Zgrid (in)	Zgrid (m)	H.R. Tw (°F)	H.R.Tw (K)	H.R. q" (Btu/hr-ft ²)	H.R. q" (W/m ²)	h _{sat} (z) (Btu/hr-ft ² -F)	h _{sat} (z) (W/m ² -K)
Gr-8	RodE2_50.1	73	50.1	1.273	3.1	0.079	805.11	702.7	4964.42	15660.3	9.226	52.4	
	RodE2_54	74	54	1.372	7	0.178	870.84	739.2	5154.48	16259.8	8.536	48.5	
	RodE2_56.9	75	56.9	1.445	9.9	0.251	903.63	757.4	5296.14	16706.7	8.319	47.2	
	RodE2_59.9	76	59.9	1.521	12.9	0.328	933.79	774.1	5441.52	17165.3	8.161	46.3	
	RodE2_66	77	66	1.676	19	0.483	957.80	787.5	5744.43	18120.8	8.316	47.2	
	RodE2_69.8	78	69.8	1.773	-1.08	-0.027	845.44	725.1	5942.67	18746.2	10.274	58.3	
	RodE2_72.9	79	72.9	1.852	2.02	0.051	915.37	763.9	6091.44	19215.4	9.395	53.4	
	RodE2_74.9	80	74.9	1.902	4.02	0.102	949.65	783.0	6187.57	19518.7	9.064	51.5	
Gr-8	RodB3_50.2	169	50.2	1.275	3.2	0.081	763.89	679.8	4942.49	15591.1	9.947	56.5	
	RodB3_54.1	170	54.1	1.374	7.1	0.180	830.16	716.6	5128.12	16176.6	9.106	51.7	
	RodB3_56.9	171	56.9	1.445	9.9	0.251	872.68	740.2	5265.92	16611.3	8.694	49.4	
	RodB3_60.1	172	60.1	1.527	13.1	0.333	866.06	736.5	5414.42	17079.8	9.038	51.3	
	RodB3_66.1	173	66.1	1.679	19.1	0.485	914.69	763.5	5709.51	18010.6	8.815	50.1	
	RodB3_69.9	174	69.9	1.775	-0.98	-0.025	783.43	690.6	5879.59	18547.2	11.385	64.7	
	RodB3_73	175	73	1.854	2.12	0.054	866.55	736.8	6049.34	19082.6	10.090	57.3	
	RodB3_75	176	75	1.905	4.12	0.105	905.59	758.5	6150.36	19401.3	9.631	54.7	
Gr-8	RodF3_50.1	89	50.1	1.273	3.1	0.079	781.46	689.5	4940.86	15586.0	9.604	54.5	
	RodF3_54	90	54	1.372	7	0.178	847.48	726.2	5127.14	16173.6	8.833	50.2	
	RodF3_57	91	57	1.448	10	0.254	892.57	751.2	5286.17	16675.2	8.450	48.0	
	RodF3_60	92	60	1.524	13	0.330	922.05	767.6	5442.50	17168.4	8.309	47.2	
	RodF3_66.1	93	66.1	1.679	19.1	0.485	938.35	776.7	5731.70	18080.6	8.538	48.5	
	RodF3_70	94	70	1.778	-0.88	-0.022	811.13	706.0	5966.33	18820.8	10.965	62.3	
	RodF3_73	95	73	1.854	2.12	0.054	911.84	762.0	6091.43	19215.4	9.446	53.6	
	RodF3_75	96	75	1.905	4.12	0.105	955.43	786.2	6191.67	19531.6	8.994	51.1	
Gr-8	RodE6_50.2	121	50.2	1.275	3.2	0.081	788.82	693.6	4944.35	15597.0	9.475	53.8	
	RodE6_54.1	122	54.1	1.374	7.1	0.180	848.39	726.7	5129.29	16180.4	8.822	50.1	
	RodE6_57	123	57	1.448	10	0.254	879.69	744.1	5268.32	16618.9	8.599	48.8	
	RodE6_60.2	124	60.2	1.529	13.2	0.335	906.37	758.9	5422.97	17106.8	8.482	48.2	
	RodE6_66.1	125	66.1	1.679	19.1	0.485	929.92	772.0	5705.93	17999.4	8.607	48.9	
	RodE6_70	126	70	1.778	-0.88	-0.022	845.38	725.0	5887.83	18573.2	10.180	57.8	
	RodE6_73.1	127	73.1	1.857	2.22	0.056	910.88	761.4	6048.36	19079.5	9.394	53.3	
	RodE6_75	128	75	1.905	4.12	0.105	943.09	779.3	6144.14	19381.7	9.088	51.6	

RBHT Steam Cooling with Droplet Injection Test SCD-4041-G

Matrix Test # 8c

Test Conditions

Test Date – 10/26/2005

Steady State Time Window: 24660 – 25080

Upper Plenum Pressure: 2.76 bar (40 psia)

Bundle Power: 72.0 kW

Bundle Inlet Reynolds Number: 8000

Bundle Inlet Steam Flow: 158.8 kg/hr (350 lbm/hr)

Droplet Injection Flow: 0.011 kg/s (0.024 lbm/s)

Droplet Injection Hole Diameter: 0.381 mm (.015 in)

Droplet Injection Elevation: 1.295 m (51 in)

Bundle Flow Area: $4.656 \times 10^{-3} \text{ m}^2$ ($5.012 \times 10^{-2} \text{ ft}^2$)

Test Notes

- No steam probes were traversed in this steady state window.

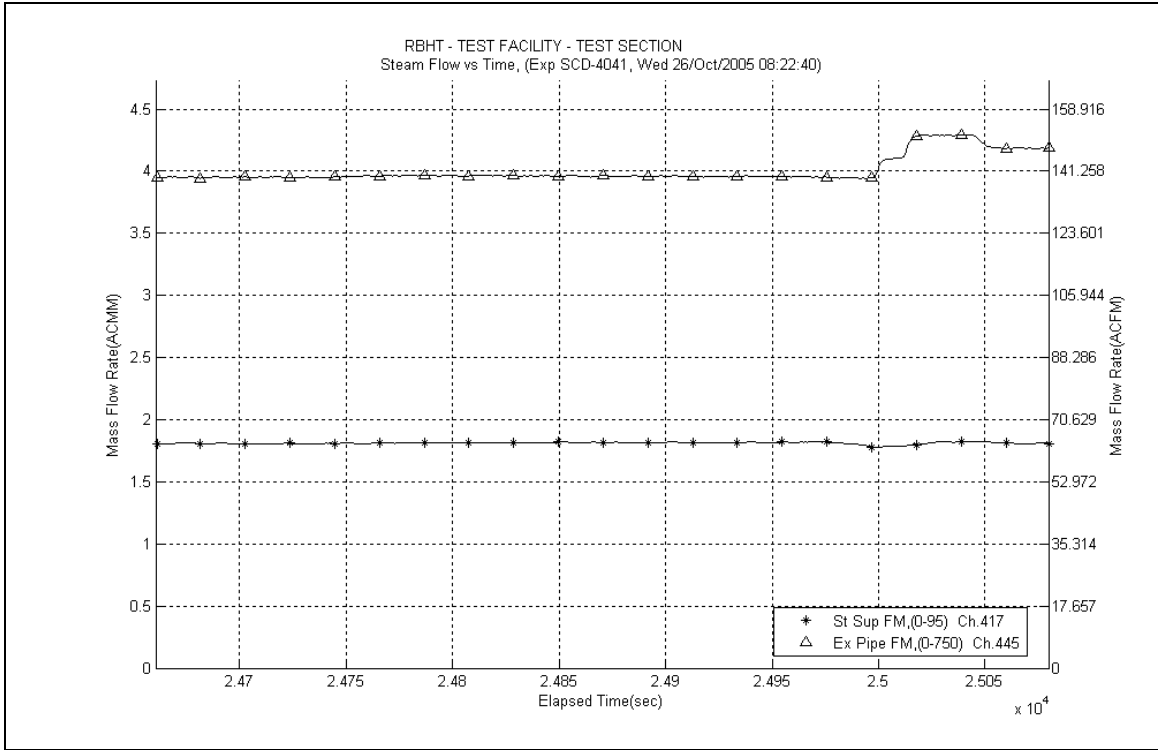

Figure A-557: Inlet and Exhaust Steam Flow Rates for Experiment 4041G

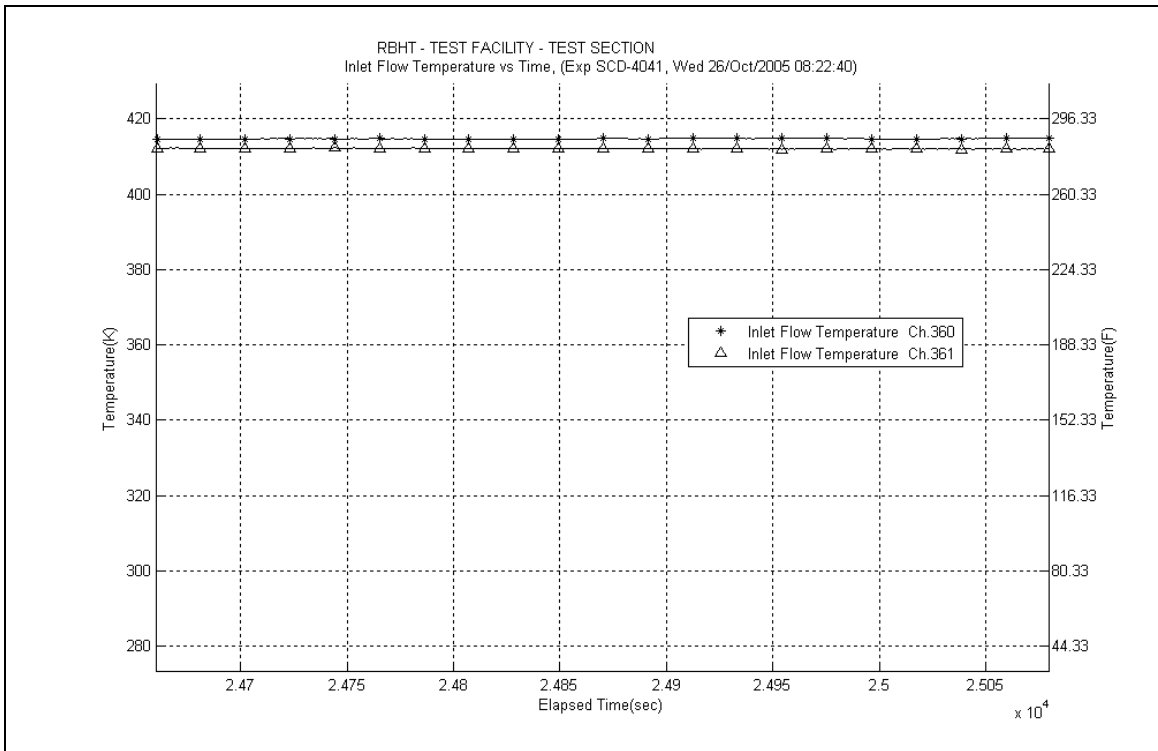

Figure A-558: Inlet Steam Temperature for Experiment 4041G

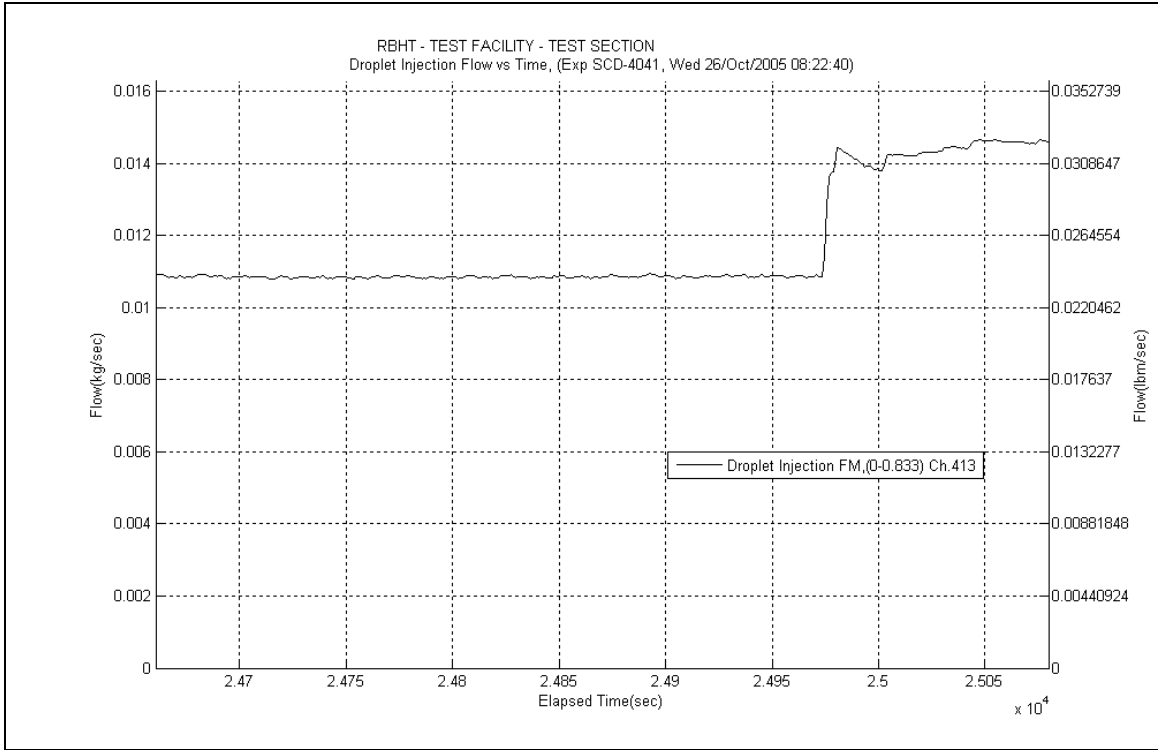

Figure A-559: Droplet Injection Flow Rate for Experiment 4041G

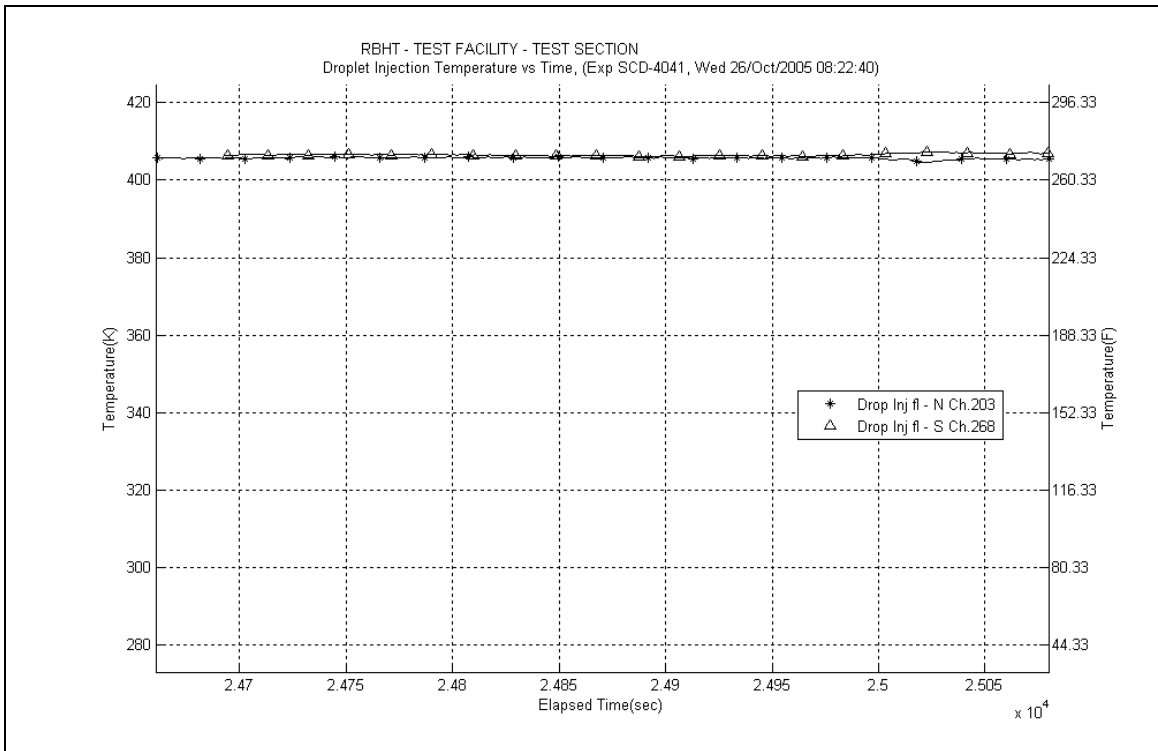

Figure A-560: Droplet Injection Temperature for Experiment 4041G

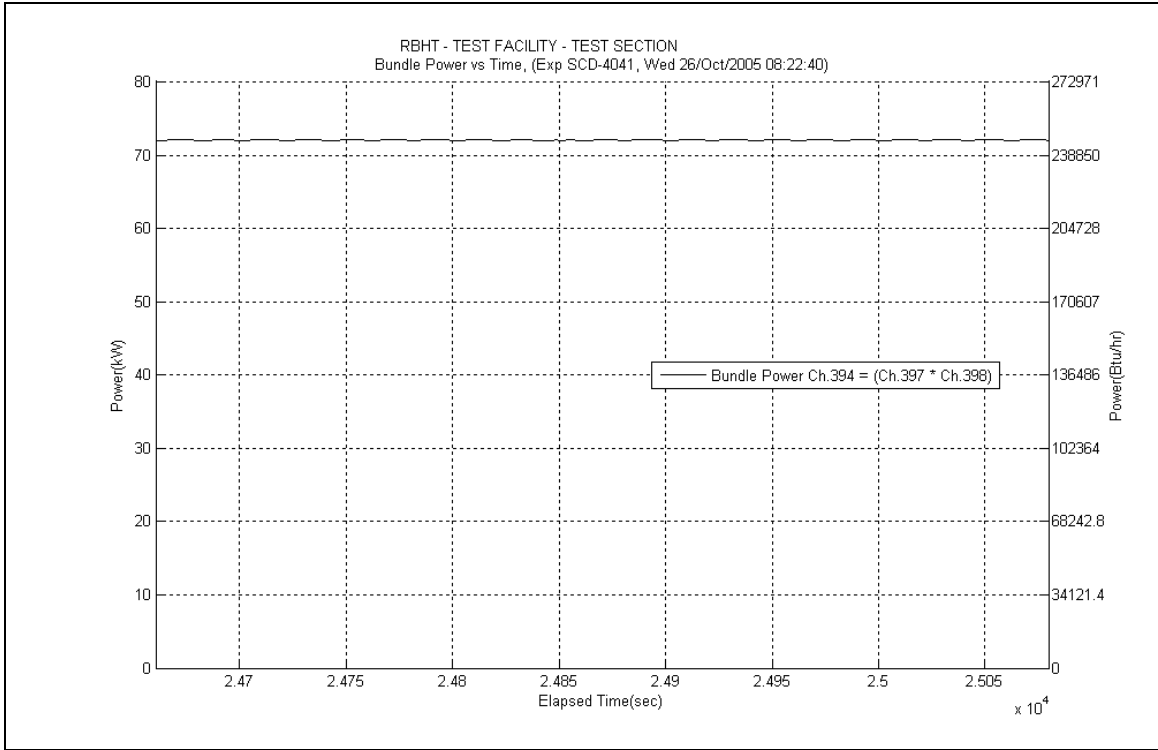

Figure A-561: Bundle Power for Experiment 4041G

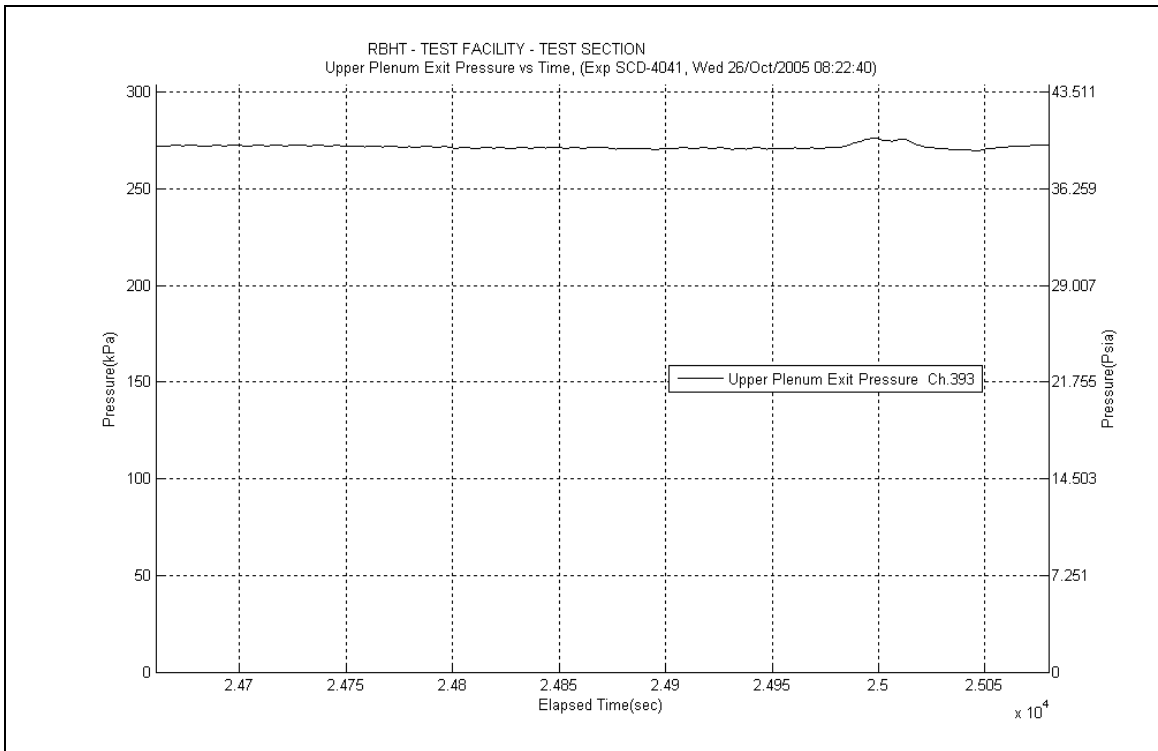

Figure A-562: Upper Plenum Pressure for Experiment 4041G

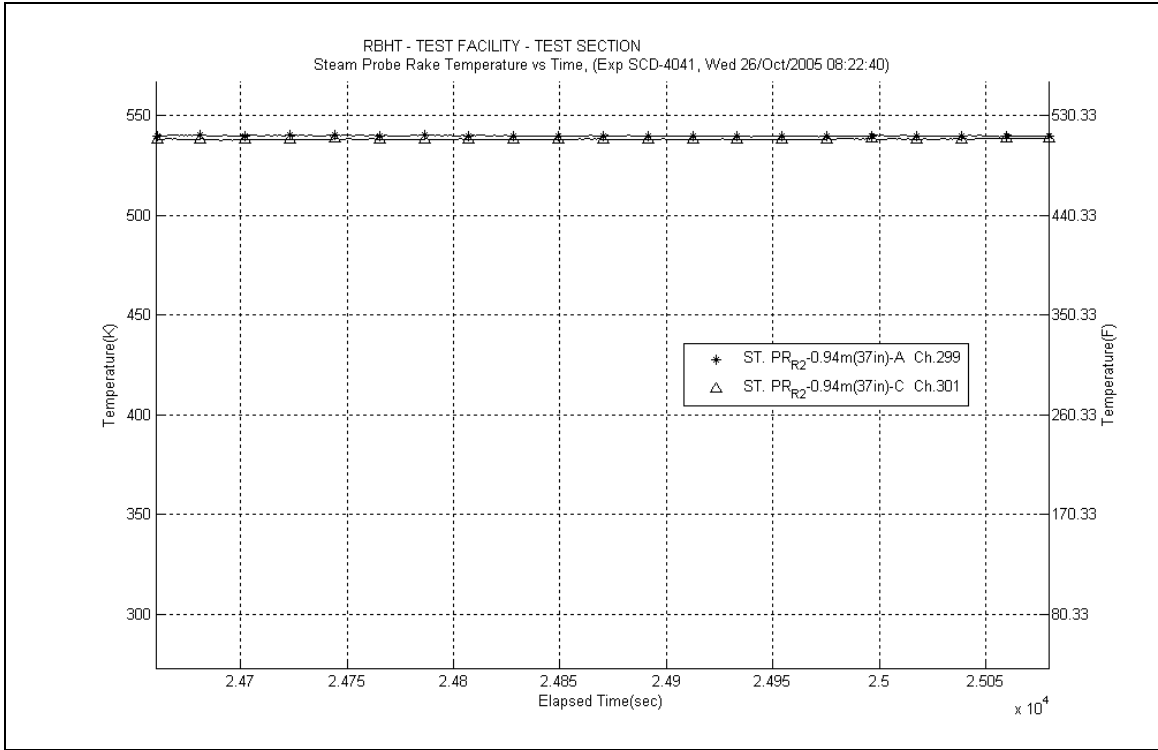

Figure A-563: Steam Probe Rake #2 Temperatures for Experiment 4041G

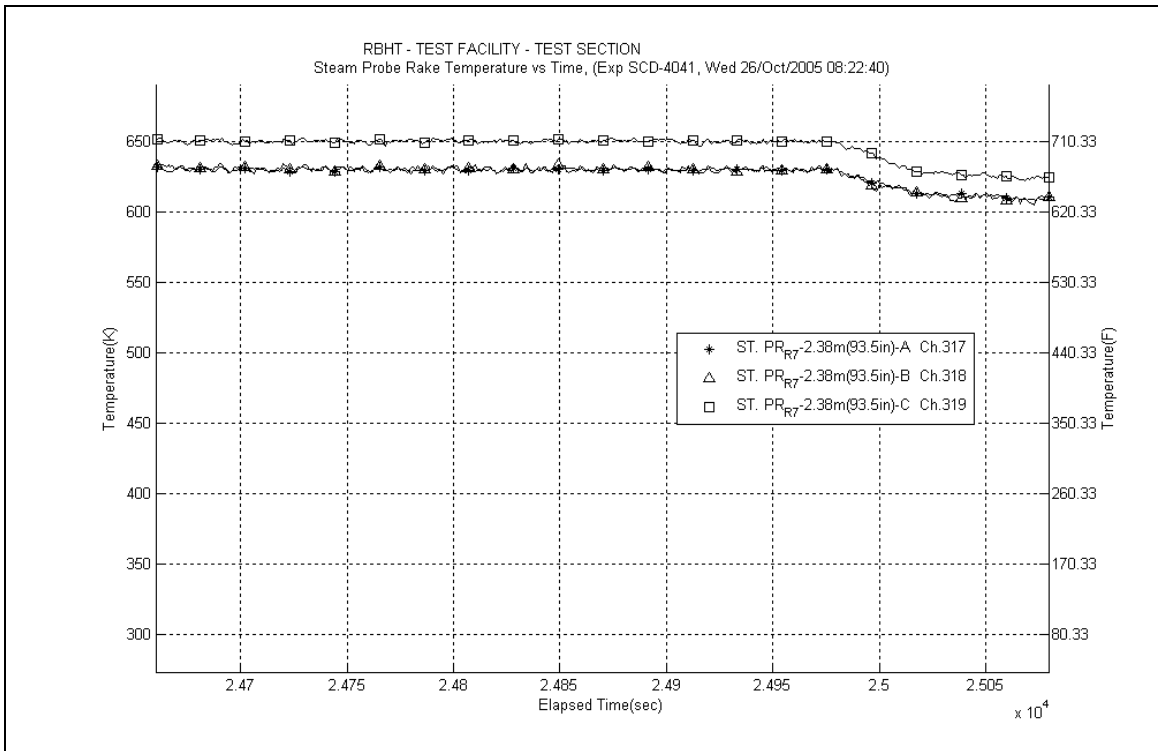

Figure A-564: Steam Probe Rake #7 Temperatures for Experiment 4041G

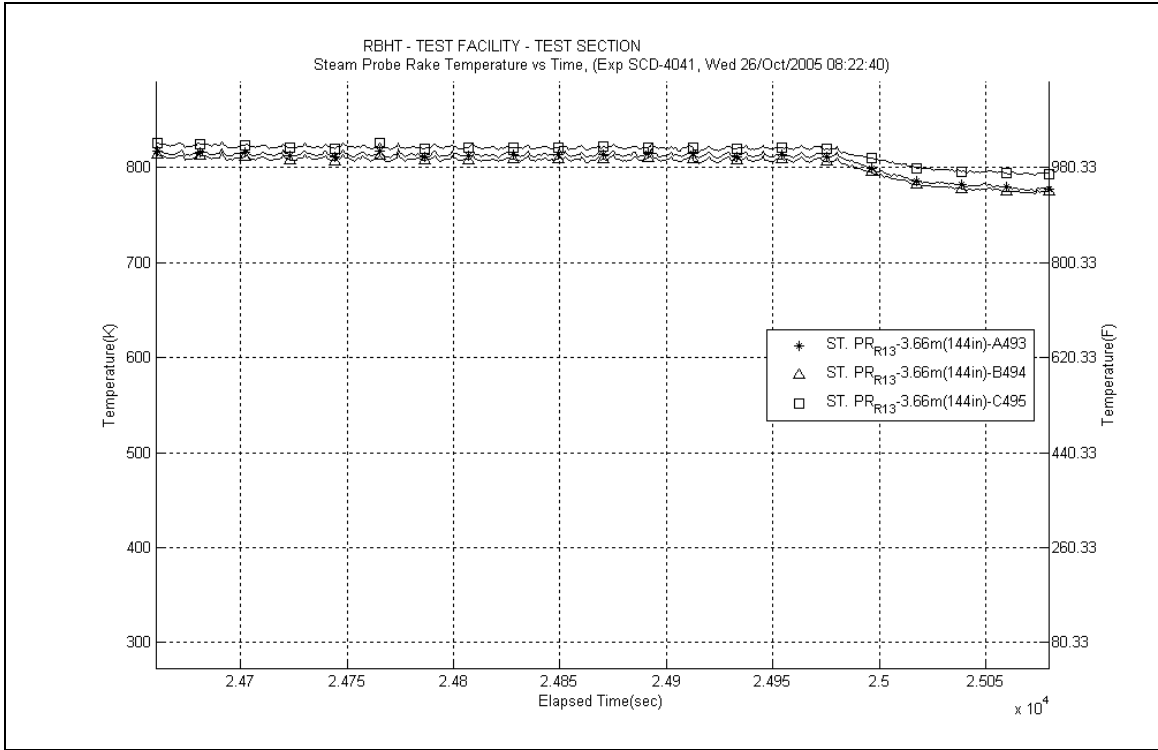

Figure A-565: Steam Probe Rake #13 Temperatures for Experiment 4041G

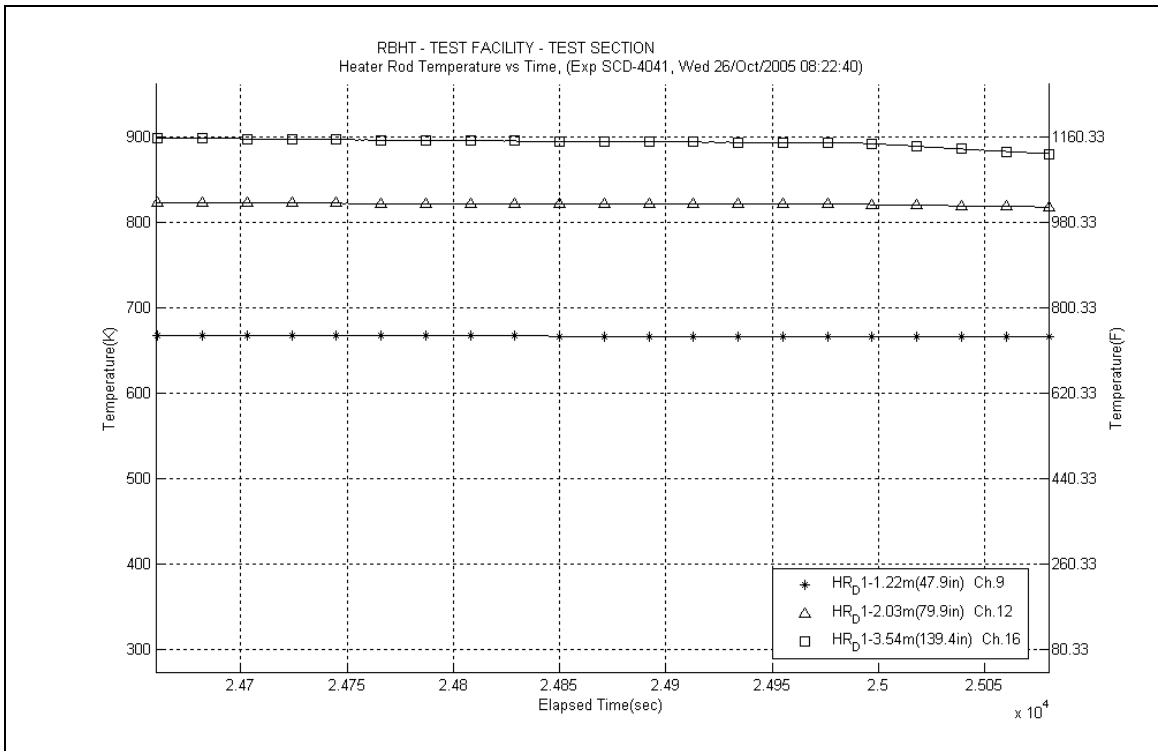

Figure A-566: Heater Rod D1 Temperatures for Experiment 4041G

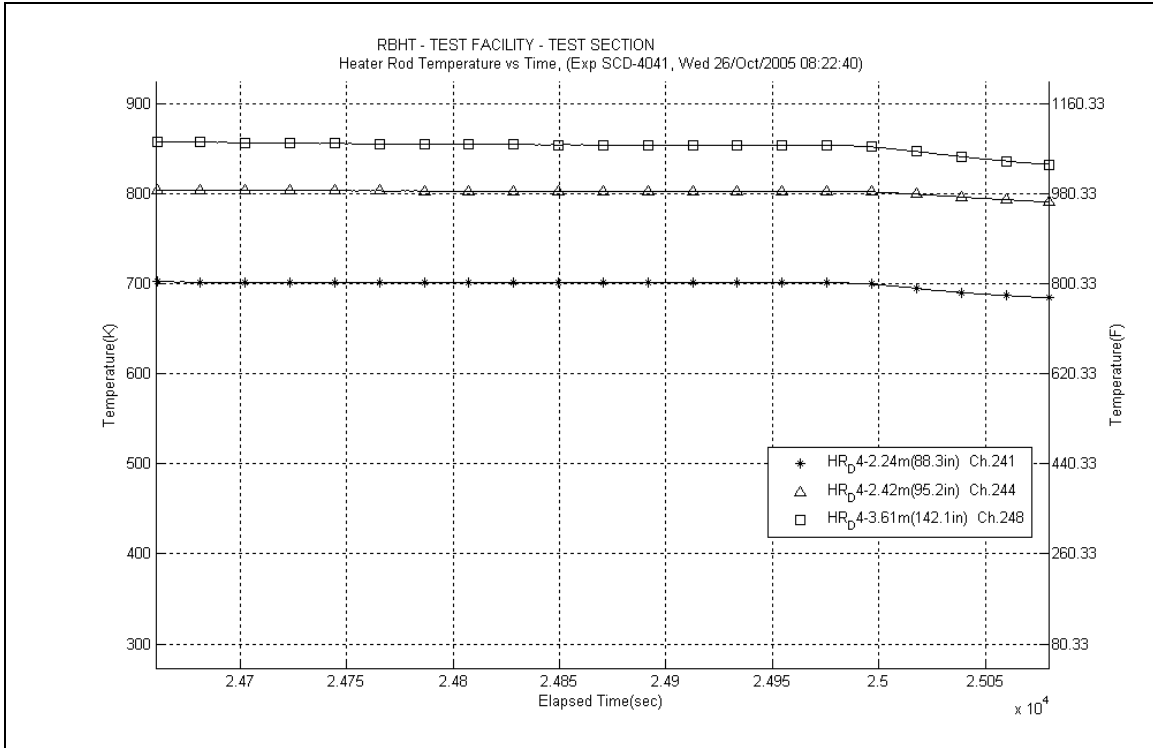

Figure A-567: Heater Rod D4 Temperatures for Experiment 4041G

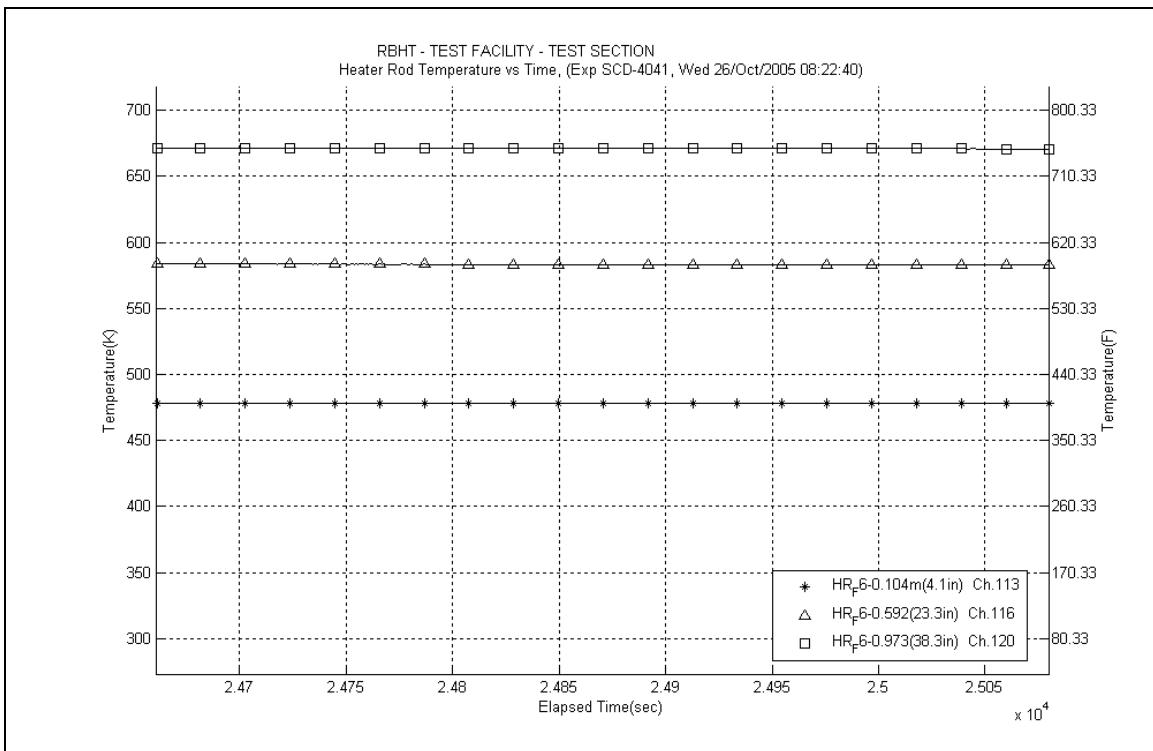

Figure A-568: Heater Rod F6 Temperatures for Experiment 4041G

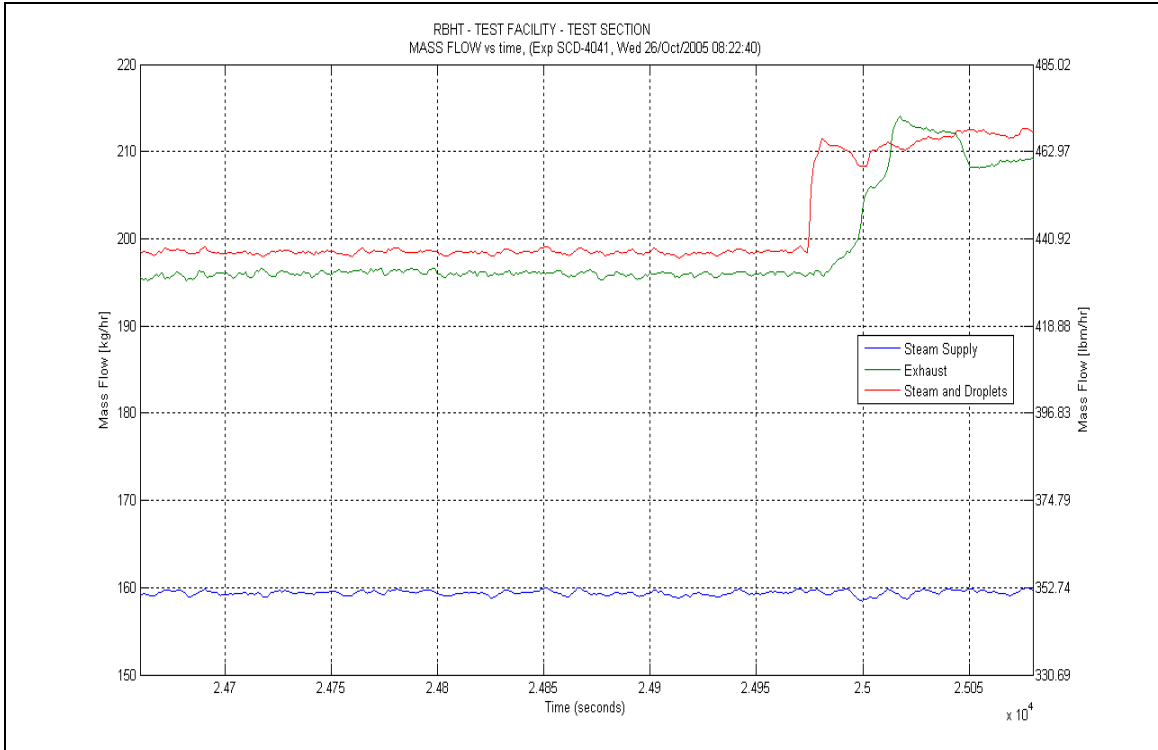

Figure A-569: Mass Flow for Experiment 4041G

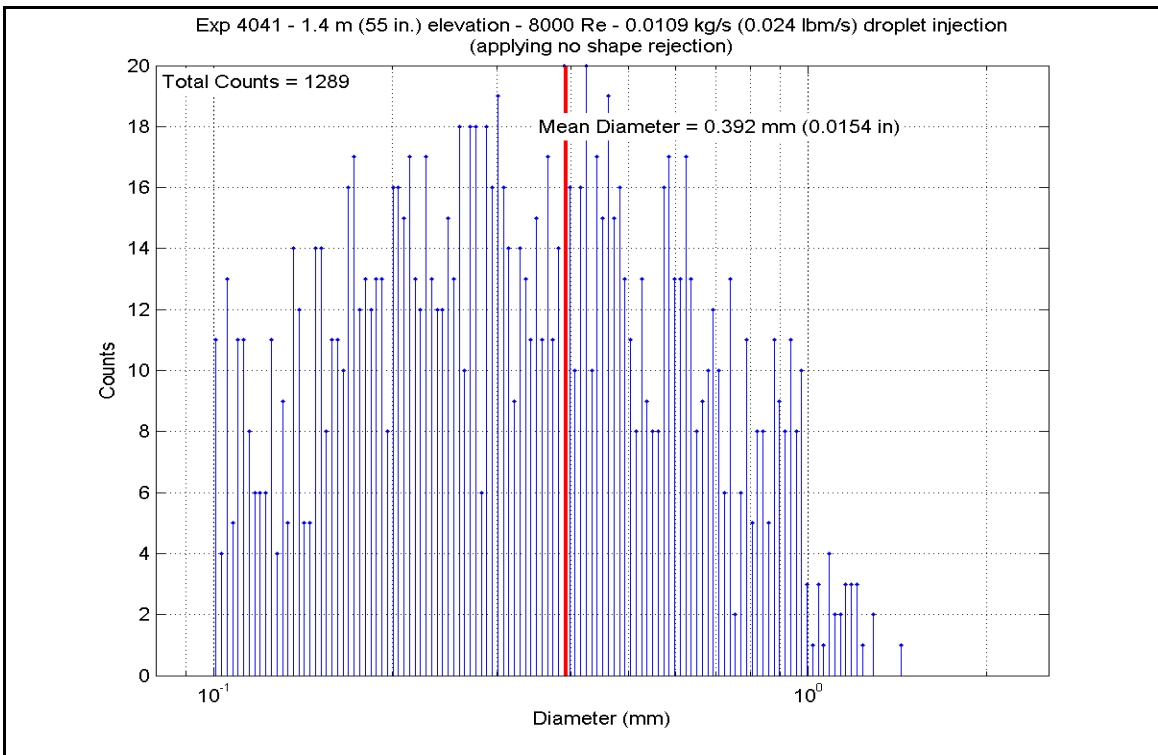

Figure A-570: Droplet Measurements at 1.397 m (55 in.) Elevation for Experiment 4041G

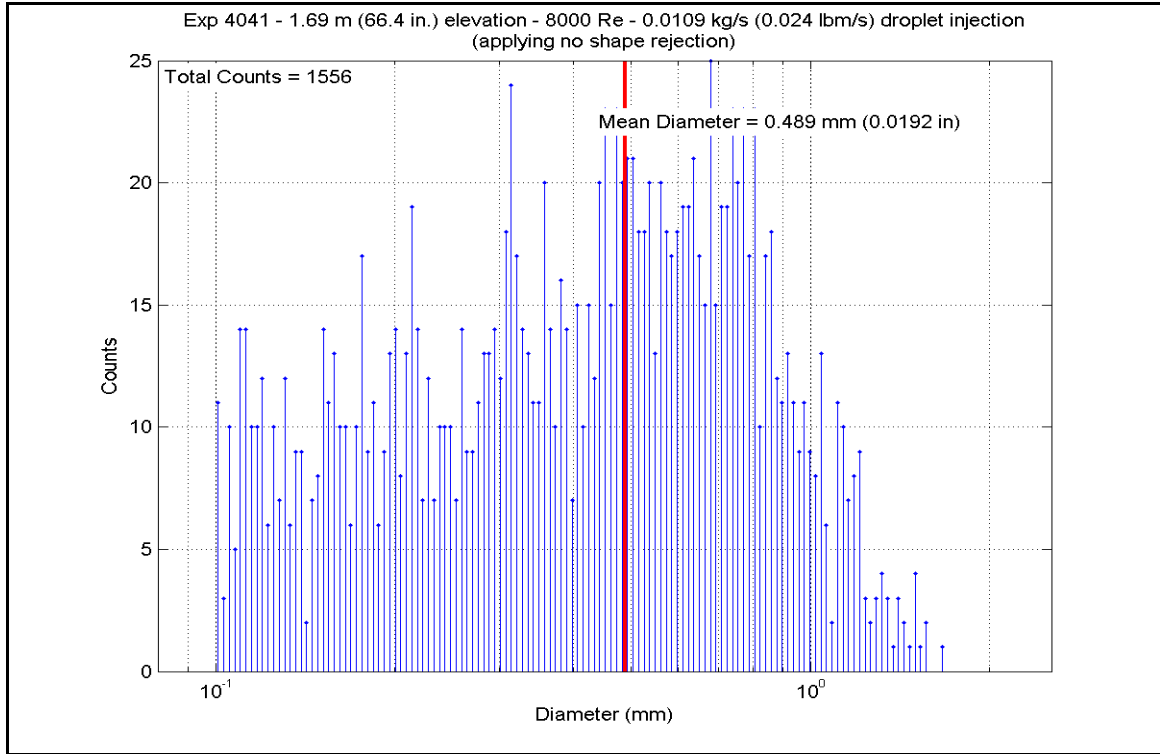

Figure A-571: Droplet Measurements at 1.687 m (66.4 in.) Elevation for Experiment 4041G

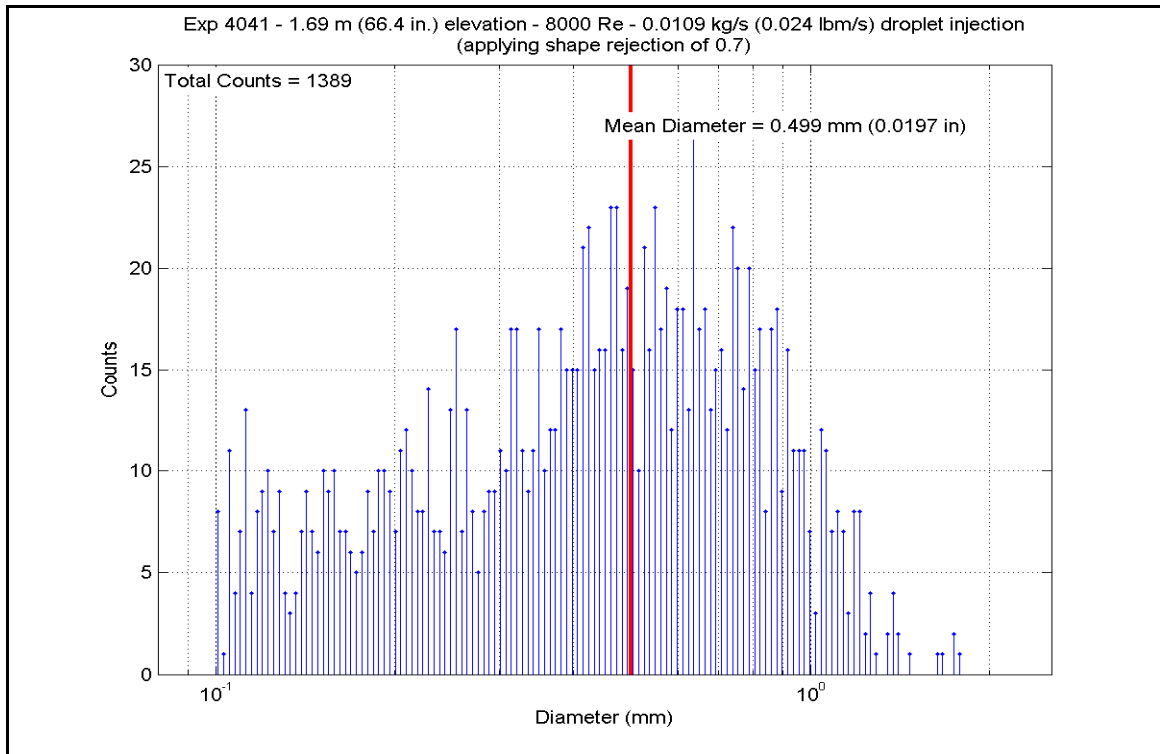

Figure A-572: Droplet Measurements at 1.687 m (66.4 in.) Elevation for Experiment 4041G

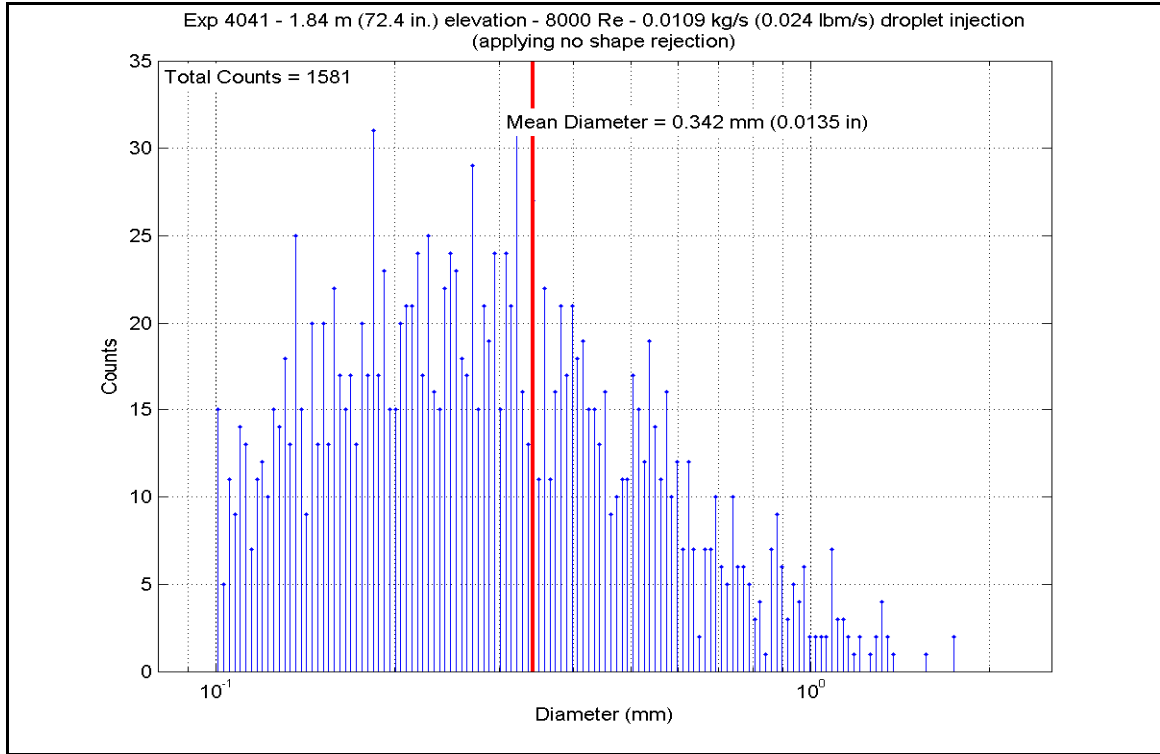

Figure A-573: Droplet Measurements at 1.839 m (72.4 in.) Elevation for Experiment 4041G

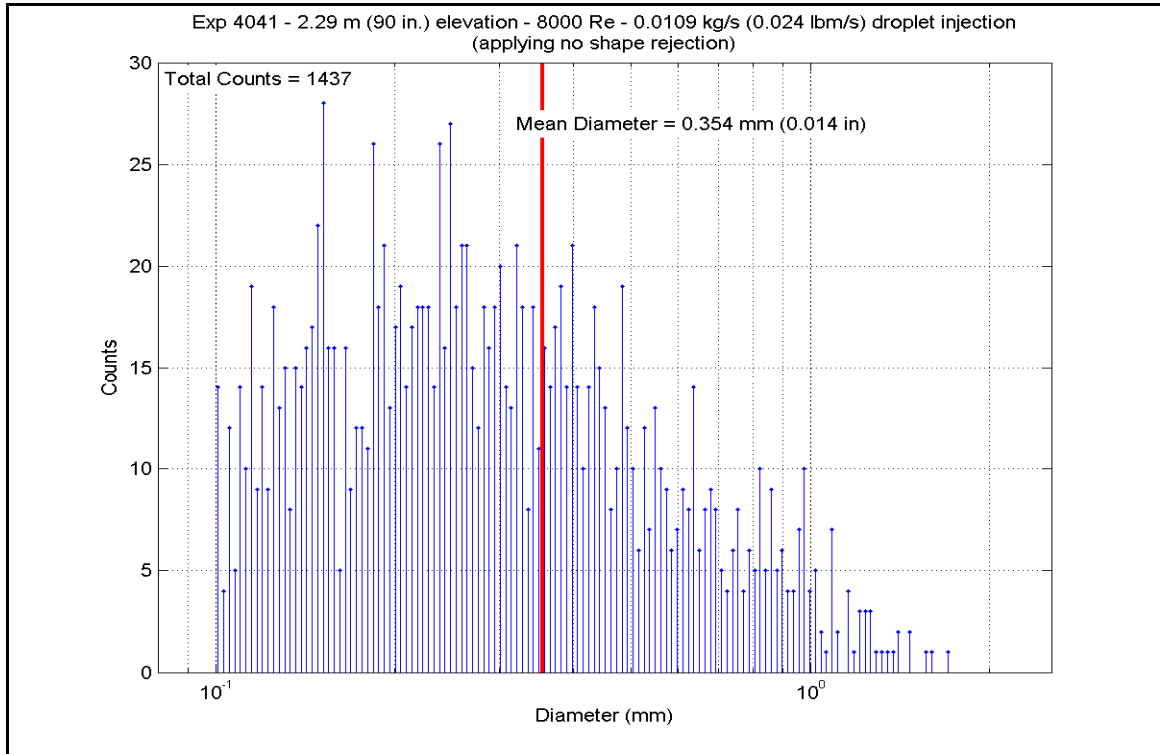

Figure A-574: Droplet Measurements at 2.286 m (90 in.) Elevation for Experiment 4041G

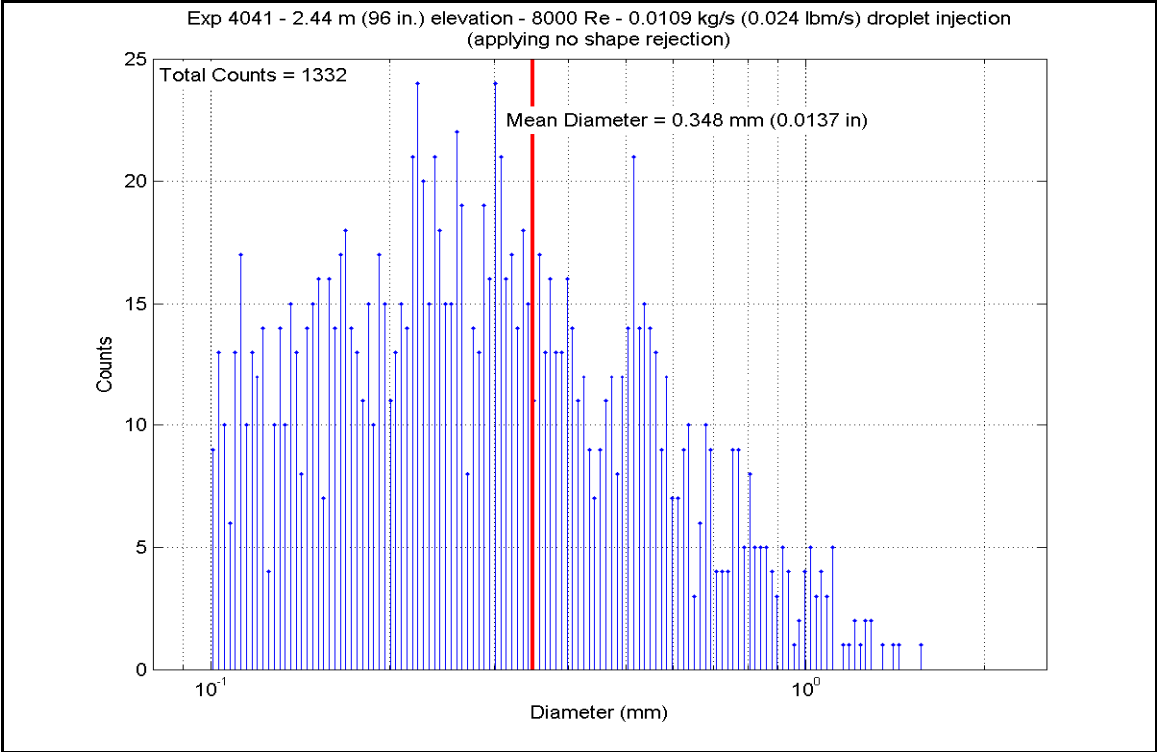

Figure A-575: Droplet Measurements at 2.438 m (96 in.) Elevation for Experiment 4041G

Table A-31: Summary of Steam Cooling Heat Transfer Reduced Data for Experiment 4041G

SCD-4041-G		Inlet Reynolds:		8000		40 psia						
Matrix Test # 8c		UP Pressure:		275.8 kPa		245674 Btu/hr						
Time Window 24660-25080		Bundle Power:		72.00 kW		350.0 lbm/hr						
Inner 3x3		Steam flow:		0.0441 kg/s		0.024 lbm/s						
		Droplet flow:		0.0109 kg/s								
H.R. ID	H.R. Location	Channel Number	Elevation (in)	Elevation (m)	Zgrid (in)	Zgrid (m)	H.R. Tw (°F)	H.R. Tw (K)	H.R. q" (Btu/hr-ft ²)	H.R. q' (W/m ²)	h _{sat} (z) (Btu/hr-ft ² -F)	h _{sat} (z) (W/m ² -K)
Gr-3	RodD3_88.3	185	88.3	2.243	-0.2	-0.005	905.70	758.5	6789.79	21418.4	10.631	60.4
	RodD3_91.3	186	91.3	2.319	2.8	0.071	985.15	802.7	6934.45	21874.7	9.656	54.8
	RodD3_93.1	187	93.1	2.365	4.6	0.117	984.33	802.2	7023.06	22154.3	9.791	55.6
	RodD3_95.3	188	95.3	2.421	6.8	0.173	1034.80	830.3	7126.74	22481.3	9.282	52.7
	RodD3_100.1	189	100.1	2.543	11.6	0.295	1118.23	876.6	7357.26	23208.5	8.643	49.1
	RodD3_106.1	190	106.1	2.695	17.6	0.447	1179.80	910.8	7646.87	24122.0	8.377	47.6
	RodD3_110	191	110	2.794	21.5	0.546	1104.24	868.8	7551.11	23820.0	9.019	51.2
	RodD3_142.1	192	142.1	3.609	8.6	0.218	1160.36	900.0	2666.47	8411.4	2.985	17.0
Gr-3	RodC4_88.4	233	88.4	2.245	-0.1	-0.003	854.60	730.2	6869.58	21670.1	11.691	66.4
	RodC4_91.1	234	91.1	2.314	2.6	0.066	958.78	788.0	7001.71	22086.9	10.121	57.5
	RodC4_93.4	235	93.4	2.372	4.9	0.124	987.31	803.9	7116.92	22450.3	9.880	56.1
	RodC4_95.3	236	95.3	2.421	6.8	0.173	1036.04	830.9	7211.90	22749.9	9.378	53.3
	RodC4_100.1	237	100.1	2.543	11.6	0.295	1078.32	854.4	7444.93	23485.0	9.176	52.1
	RodC4_106.1	238	106.1	2.695	17.6	0.447	1144.30	891.1	7741.44	24420.4	8.824	50.1
	RodC4_110	239	110	2.794	21.5	0.546	1068.29	848.9	7490.81	23629.8	9.348	53.1
	RodC4_142.2	240	142.2	3.612	8.7	0.221	1125.59	880.7	2875.10	9069.5	3.349	19.0
Gr-3	RodD4_88.3	241	88.3	2.243	-0.2	-0.005	840.98	722.6	6849.73	21607.5	11.934	67.8
	RodD4_91.3	242	91.3	2.319	2.8	0.071	945.89	780.9	6994.35	22063.7	10.303	58.5
	RodD4_93.2	243	93.2	2.367	4.7	0.119	975.47	797.3	7089.52	22363.9	10.007	56.8
	RodD4_95.2	244	95.2	2.418	6.7	0.170	1021.10	822.7	7187.63	22673.4	9.531	54.1
	RodD4_100.1	245	100.1	2.543	11.6	0.295	1104.21	868.8	7425.23	23422.9	8.869	50.4
	RodD4_106.1	246	106.1	2.695	17.6	0.447	1142.83	890.3	7721.11	24356.2	8.816	50.1
	RodD4_142.1	248	142.1	3.609	8.6	0.218	1132.26	884.4	2787.70	8793.8	3.222	18.3
Gr-3	RodE4_88.4	201	88.4	2.245	-0.1	-0.003	876.06	742.1	6752.53	21300.9	11.087	63.0
	RodE4_91.2	202	91.2	2.316	2.7	0.069	980.63	800.2	6881.67	21708.2	9.643	54.8
	RodE4_95.3	204	95.3	2.421	6.8	0.173	1057.12	842.7	7073.84	22314.4	8.953	50.8
	RodE4_100.9	205	100.9	2.563	12.4	0.315	1121.96	878.7	7335.17	23138.8	8.580	48.2
	RodE4_142.3	208	142.3	3.614	8.8	0.224	1151.76	895.2	2837.58	8951.1	3.207	18.2

Table A-31: Summary of Steam Cooling Heat Transfer Reduced Data for Experiment 4041, continued

Inner 3x3	H.R. Location	Channel Number	Elevation (in)	Elevation (m)	Zgrid (in)	Zgrid (m)	H.R. Tw (°F)	H.R. Tw (K)	H.R. q" (Btu/hr-ft ²)	H.R. q" (W/m ²)	h _{sat} (z) (Btu/hr-ft ² -F)	h _{sat} (z) (W/m ² -K)
Gr-4	RodE3_63.4	193	63.4	1.610	16.4	0.417	949.46	782.8	5579.29	17599.9	8.175	46.4
	RodE3_113.6	194	113.6	2.885	0.85	0.022	1145.28	891.6	6884.09	21715.9	7.838	44.5
	RodE3_115.5	195	115.5	2.934	2.75	0.070	1179.04	910.4	6631.67	20919.6	7.271	41.3
	RodE3_118.5	196	118.5	3.010	5.75	0.146	1206.30	925.5	6229.73	19651.7	6.632	37.7
	RodE3_122.7	197	122.7	3.117	9.95	0.253	1213.57	929.6	5665.45	17871.7	5.985	34.0
	RodE3_126.5	198	126.5	3.213	13.75	0.349	1213.82	929.7	5155.75	16263.8	5.445	30.9
	RodE3_131.7	199	131.7	3.345	-1.8	-0.046	1132.49	884.5	4460.62	14071.0	5.154	29.3
	RodE3_135.6	200	135.6	3.444	2.1	0.053	1165.06	902.6	3945.30	12445.5	4.393	24.9
	RodC5_63.7	225	63.7	1.618	16.7	0.424	926.58	770.1	5470.02	17255.2	8.293	47.1
	RodC5_113.6	226	113.6	2.885	0.85	0.022	1078.73	854.7	6711.65	21171.9	8.268	47.0
Gr-4	RodC5_115.7	227	115.7	2.939	2.95	0.075	1116.62	875.7	6445.26	20331.6	7.586	43.1
	RodC5_122.7	229	122.7	3.117	9.95	0.253	1150.65	894.6	5552.56	17515.6	6.284	35.7
	RodC5_126.7	230	126.7	3.218	13.95	0.354	1145.90	892.0	5042.11	15905.3	5.737	32.6
	RodC5_131.6	231	131.6	3.343	-1.9	-0.048	1050.76	839.1	4411.56	13916.3	5.629	32.0
	RodC5_135.7	232	135.7	3.447	2.2	0.056	1088.28	860.0	3893.12	12280.8	4.740	26.9
	RodE5_63.6	209	63.6	1.615	16.6	0.422	839.12	721.6	5692.38	17956.6	9.950	56.5
	RodE5_113.6	210	113.6	2.885	0.85	0.022	1000.50	811.2	6900.80	21768.6	9.408	53.4
	RodE5_115.4	211	115.4	2.931	2.65	0.067	1077.79	854.1	6598.40	20814.7	8.138	46.2
	RodE5_118.7	212	118.7	3.015	5.95	0.151	1141.59	889.6	6127.09	19327.9	7.006	39.8
	RodE5_122.6	213	122.6	3.114	9.85	0.250	1179.64	910.7	5589.69	17632.7	6.125	34.8
RodE5_126.6	214	126.6	3.216	13.85	0.352	1189.99	916.5	5050.96	15933.3	5.472	31.1	
Gr-5	RodE5_131.6	215	131.6	3.343	-1.9	-0.048	1166.58	903.5	4525.21	14274.8	5.030	28.6
	RodE5_135.6	216	135.6	3.444	2.1	0.053	1123.89	879.8	4060.43	12808.6	4.739	26.9
	RodC3_79.8	177	79.8	2.027	8.92	0.227	960.86	789.2	6339.65	19998.4	9.137	51.9
	RodC3_85.6	178	85.6	2.174	14.72	0.374	876.19	742.1	6606.60	20840.5	10.845	61.6
	RodC3_88.5	179	88.5	2.248	0	0.000	888.40	748.9	6755.69	21310.8	10.872	61.7
	RodC3_92.4	180	92.4	2.347	3.9	0.099	1000.94	811.5	6939.56	21890.8	9.455	53.7
	RodC3_94.4	181	94.4	2.398	5.9	0.150	1016.76	820.2	7036.52	22196.7	9.385	53.3
	RodC3_97.2	182	97.2	2.469	8.7	0.221	1070.68	850.2	7170.69	22619.9	8.922	50.7
	RodC3_108.8	183	108.8	2.764	20.3	0.516	1164.68	902.4	7562.30	23855.3	8.424	47.8
	RodD5_50	217	50	1.270	1.270	0.076	815.10	708.2	4965.29	15663.0	9.059	51.4
Gr-8	RodD5_54.1	218	54.1	1.374	7.1	0.180	816.04	708.7	5162.96	16286.5	9.404	53.4
	RodD5_56.9	219	56.9	1.445	9.9	0.251	859.32	732.8	5295.09	16703.4	8.940	50.8
	RodD5_60	220	60	1.524	13	0.330	890.08	749.9	5443.84	17172.6	8.737	49.6
	RodD5_66.1	221	66.1	1.679	19.1	0.485	929.40	771.7	5732.24	18082.4	8.654	49.1
	RodD5_69.9	222	69.9	1.775	-0.98	-0.025	788.20	693.3	5905.13	18627.7	11.330	64.3
	RodD5_72.9	223	72.9	1.852	2.02	0.051	860.45	733.4	6052.82	19093.6	10.199	57.9
	RodD5_74.9	224	74.9	1.902	4.02	0.102	905.48	758.4	6149.95	19400.0	9.632	54.7

Table A-31: Summary of Steam Cooling Heat Transfer Reduced Data for Experiment 4041, continued

H.R. ID	H.R. Location	Channel Number	Elevation (in)	Elevation (m)	Zgrid (in)	Zgrid (m)	H.R. Tw (°F)	H.R. Tw (K)	H.R. q" (Btu/hr-ft ²)	H.R. q" (W/m ²)	h _{sat} (z) (Btu/hr-ft ² -F)	h _{sat} (z) (W/m ² -K)	
Gr-2	RodB5_41	153	41	1.041	13.5	0.343	752.71	673.5	4502.04	14201.7	9.269	52.6	
	RodB5_52.9	154	52.9	1.344	5.9	0.150	814.64	707.9	5074.98	16009.0	9.267	52.6	
	RodB5_55	155	55	1.397	8	0.203	849.79	727.5	5175.16	16325.0	8.880	50.4	
	RodB5_57.8	156	57.8	1.468	10.8	0.274	890.32	750.0	5308.26	16744.9	8.516	48.4	
	RodB5_64	157	64	1.626	17	0.432	939.13	777.1	5604.62	17679.8	8.339	47.4	
	RodB5_73.9	158	73.9	1.877	3.02	0.077	898.15	754.3	6082.07	19185.9	9.637	54.7	
	RodB5_75.9	159	75.9	1.928	5.02	0.128	934.06	774.3	6176.88	19485.0	9.260	52.6	
	RodB5_76.9	160	76.9	1.953	6.02	0.153	948.13	782.1	6224.74	19635.9	9.139	51.9	
	Gr-2	RodF5_41	105	41	1.041	13.5	0.343	741.50	667.3	4485.69	14150.1	9.454	53.7
		RodF5_53.1	106	53.1	1.349	6.1	0.155	797.04	698.2	5064.05	15974.6	9.554	54.3
	RodF5_55	107	55	1.397	8	0.203	834.02	718.7	5155.68	16263.6	9.093	51.6	
	RodF5_57.8	108	57.8	1.468	10.8	0.274	878.74	743.6	5290.91	16690.2	8.649	49.1	
	RodF5_64	109	64	1.626	17	0.432	922.90	768.1	5591.86	17639.5	8.525	48.4	
	RodF5_73.8	110	73.8	1.875	2.92	0.074	888.38	748.9	6066.71	19137.4	9.763	55.4	
	RodF5_75.8	111	75.8	1.925	4.92	0.125	927.67	770.7	6163.34	19442.3	9.329	53.0	
	RodF5_76.8	112	76.8	1.951	5.92	0.150	943.76	779.7	6211.73	19594.9	9.179	52.1	
Gr-2	RodC2_41	57	41	1.041	13.5	0.343	734.14	663.2	4495.09	14179.8	9.623	54.6	
	RodC2_53.1	58	53.1	1.349	6.1	0.155	856.61	731.3	5074.74	16008.3	8.607	48.9	
	RodC2_55	59	55	1.397	8	0.203	875.04	741.5	5165.79	16295.5	8.496	48.2	
	RodC2_57.8	60	57.8	1.468	10.8	0.274	906.08	758.8	5301.56	16723.8	8.296	47.1	
	RodC2_63.9	61	63.9	1.623	16.9	0.429	935.50	775.1	5596.86	17655.3	8.372	47.5	
	RodC2_73.8	62	73.8	1.875	2.92	0.074	922.48	767.9	6070.62	19149.8	9.261	52.6	
	RodC2_75.8	63	75.8	1.925	4.92	0.125	949.89	783.1	6167.01	19453.8	9.031	51.3	
	RodC2_76.8	64	76.8	1.951	5.92	0.150	960.66	789.1	6214.75	19604.4	8.959	50.9	
	Gr-2	RodC6_40.9	137	40.9	1.039	13.4	0.340	748.91	671.4	4476.63	14121.5	9.289	52.8
		RodC6_52.8	138	52.8	1.341	5.8	0.147	866.69	736.9	5070.00	15993.3	8.454	48.0
	RodC6_54.8	139	54.8	1.392	7.8	0.198	887.91	748.7	5171.69	16314.1	8.329	47.3	
	RodC6_57.8	140	57.8	1.468	10.8	0.274	922.33	767.8	5322.80	16790.8	8.122	46.1	
	RodC6_63.8	141	63.8	1.621	16.8	0.427	955.44	786.2	5622.10	17734.9	8.166	46.4	
	RodC6_73.7	142	73.7	1.872	2.82	0.072	939.55	777.3	6119.38	19303.6	9.099	51.7	
	RodC6_75.8	143	75.8	1.925	4.92	0.125	968.48	793.4	6223.89	19633.3	8.873	50.4	
	RodC6_76.8	144	76.8	1.951	5.92	0.150	985.52	802.9	6273.71	19790.4	8.731	49.6	

Table A-31: Summary of Steam Cooling Heat Transfer Reduced Data for Experiment 4041, continued

5x5 periphery		H.R. Location	Channel Number	Elevation (in)	Elevation (m)	Zgrid (in)	Zgrid (m)	H.R. Tw (°F)	H.R. Tw (K)	H.R. q" (Btu/hr-ft ²)	H.R. q" (W/m ²)	h _{sat} (z) (Btu/hr-ft ² -F)	h _{sat} (z) (W/m ² -K)
Gr-3	RodB4_88.4	161	88.4	2.245	-0.1	0.003	889.62	749.6	6734.80	21244.9	10.817	61.4	
	RodB4_91.3	162	91.3	2.319	2.8	0.071	978.30	798.9	6868.49	21666.7	9.656	54.8	
	RodB4_93.3	163	93.3	2.370	4.8	0.122	991.85	806.4	6961.26	21959.3	9.604	54.5	
	RodB4_95.1	164	95.1	2.416	6.6	0.168	1024.45	824.5	7046.25	22227.4	9.303	52.8	
	RodB4_100	165	100	2.540	11.5	0.292	1057.06	842.6	7278.13	22958.8	9.212	52.3	
	RodB4_106	166	106	2.692	17.5	0.445	1142.27	890.0	7553.70	23828.1	8.630	49.0	
	RodB4_109.9	167	109.9	2.791	21.4	0.544	1065.00	847.0	7312.08	23065.9	9.163	52.0	
	RodB4_142.3	168	142.3	3.614	8.8	0.224	1120.41	877.8	2865.26	9038.5	3.357	19.1	
Gr-5	RodF4_85.6	98	85.6	2.174	14.72	0.374	936.69	775.8	6646.26	20965.6	9.924	56.4	
	RodF4_88.4	99	88.4	2.245	-0.1	-0.003	926.39	770.0	6776.94	21377.9	10.278	58.4	
	RodF4_92.4	100	92.4	2.347	3.9	0.099	1025.93	825.3	6970.83	21989.5	9.185	52.2	
	RodF4_94.3	101	94.3	2.395	5.8	0.147	1058.23	843.3	7062.02	22277.1	8.925	50.7	
	RodF4_97.2	102	97.2	2.469	8.7	0.221	1098.59	865.7	7202.98	22721.8	8.662	49.2	
	RodF4_108.8	103	108.8	2.764	20.3	0.516	1161.29	900.5	7611.01	24008.9	8.511	48.3	
	RodF4_111	104	111	2.819	-1.75	-0.044	1074.86	852.5	7296.91	23018.1	9.032	51.3	
Gr-6	RodD2_103.2	65	103.2	2.621	14.7	0.373	1174.79	908.0	6698.95	21131.8	7.379	41.9	
	RodD2_106	66	106	2.692	17.5	0.445	1196.26	920.0	6345.02	20015.4	6.828	38.8	
	RodD2_112.6	67	112.6	2.860	-0.15	-0.004	1218.32	932.2	5862.59	18493.6	6.163	35.0	
	RodD2_114.9	68	114.9	2.918	2.15	0.055	1226.13	936.6	5297.60	16711.3	5.523	31.4	
	RodD2_117.4	69	117.4	2.982	4.65	0.118	1215.60	930.7	4759.00	15012.3	5.017	28.5	
	RodD2_120.8	70	120.8	3.068	8.05	0.204	1175.70	908.5	7519.92	23721.6	8.275	47.0	
	RodD2_124.8	71	124.8	3.170	12.05	0.306	1198.63	921.3	7655.37	24148.9	8.217	46.7	
	RodD2_128.6	72	128.6	3.266	15.85	0.403	1131.50	884.0	7023.48	22155.6	8.124	46.1	
Gr-6	RodD6_103.1	129	103.1	2.619	14.6	0.371	1156.67	898.0	7546.47	23805.3	8.482	48.2	
	RodD6_106	130	106	2.692	17.5	0.445	1170.22	905.5	7686.33	24246.5	8.510	48.3	
	RodD6_112.9	131	112.9	2.868	0.15	0.004	1089.32	860.5	7010.50	22114.6	8.525	48.4	
	RodD6_114.9	132	114.9	2.918	2.15	0.055	1126.81	881.4	6721.47	21202.9	7.817	44.4	
	RodD6_116.8	133	116.8	2.967	4.05	0.103	1148.96	893.7	6445.57	20332.5	7.308	41.5	
	RodD6_120.9	134	120.9	3.071	8.15	0.207	1161.27	900.5	5857.37	18477.1	6.550	37.2	
	RodD6_124.8	135	124.8	3.170	12.05	0.306	1162.59	901.3	5299.15	16716.2	5.917	33.6	
	RodD6_128.7	136	128.7	3.269	15.95	0.405	1152.98	895.9	4740.24	14953.1	5.350	30.4	

Table A-31: Summary of Steam Cooling Heat Transfer Reduced Data for Experiment 4041, continued

5x5 periphery		H.R. Location	Channel Number	Elevation (in)	Elevation (m)	Zgrid (in)	Zgrid (m)	H.R. Tw (°F)	H.R. Tw (K)	H.R. q" (Btu/hr-ft ²)	H.R. q" (W/m ²)	h _{sat} (z) (Btu/hr-ft ² -F)	h _{sat} (z) (W/m ² -K)
Gr-8	RodE2_50.1	73	50.1	1.273	3.1	0.079	805.15	702.7	4972.90	15687.0	9.241	52.5	
	RodE2_54	74	54	1.372	7	0.178	871.21	739.4	5161.55	16282.1	8.543	48.5	
	RodE2_56.9	75	56.9	1.445	9.9	0.251	904.08	757.6	5302.04	16725.3	8.322	47.3	
	RodE2_59.9	76	59.9	1.521	12.9	0.328	934.39	774.5	5447.92	17185.5	8.163	46.4	
	RodE2_66	77	66	1.676	19	0.483	957.66	787.4	5742.83	18115.8	8.315	47.2	
	RodE2_69.8	78	69.8	1.773	-1.08	-0.027	843.80	724.2	5918.55	18670.1	10.261	58.3	
	RodE2_72.9	79	72.9	1.852	2.02	0.051	912.36	762.2	6076.99	19169.9	9.416	53.5	
	RodE2_74.9	80	74.9	1.902	4.02	0.102	946.75	781.3	6176.63	19484.2	9.087	51.6	
Gr-8	RodB3_50.2	169	50.2	1.275	3.2	0.081	764.96	680.3	4933.33	15562.2	9.907	56.3	
	RodB3_54.1	170	54.1	1.374	7.1	0.180	830.75	716.9	5121.97	16157.3	9.086	51.6	
	RodB3_56.9	171	56.9	1.445	9.9	0.251	872.94	740.3	5254.74	16576.1	8.672	49.2	
	RodB3_60.1	172	60.1	1.527	13.1	0.333	888.04	737.6	5408.79	17062.0	8.999	51.1	
	RodB3_66.1	173	66.1	1.679	19.1	0.485	918.07	765.4	5700.61	17982.6	8.756	49.7	
	RodB3_69.9	174	69.9	1.775	-0.98	-0.025	788.14	693.2	5890.80	18582.5	11.304	64.2	
	RodB3_73	175	73	1.854	2.12	0.054	870.21	738.8	6033.04	19031.2	10.002	56.8	
	RodB3_75	176	75	1.905	4.12	0.105	908.94	760.3	6129.31	19334.9	9.548	54.2	
Gr-8	RodF3_50.1	89	50.1	1.273	3.1	0.079	782.45	690.1	4945.60	15600.9	9.595	54.5	
	RodF3_54	90	54	1.372	7	0.178	848.86	727.0	5135.80	16200.9	8.827	50.1	
	RodF3_57	91	57	1.448	10	0.254	892.00	750.9	5281.08	16659.2	8.450	48.0	
	RodF3_60	92	60	1.524	13	0.330	919.50	766.2	5427.58	17121.3	8.318	47.2	
	RodF3_66.1	93	66.1	1.679	19.1	0.485	937.23	776.1	5729.21	18072.8	8.548	48.5	
	RodF3_70	94	70	1.778	-0.88	-0.022	803.68	701.9	5944.43	18751.7	11.076	62.9	
	RodF3_73	95	73	1.854	2.12	0.054	907.49	759.5	6083.17	19189.4	9.498	53.9	
	RodF3_75	96	75	1.905	4.12	0.105	951.61	784.0	6175.20	19479.7	9.020	51.2	
Gr-8	RodE6_50.2	121	50.2	1.275	3.2	0.081	788.77	693.6	4957.58	15638.7	9.501	54.0	
	RodE6_54.1	122	54.1	1.374	7.1	0.180	848.40	726.7	5143.20	16224.2	8.846	50.2	
	RodE6_57	123	57	1.448	10	0.254	879.67	744.1	5281.30	16659.9	8.620	49.0	
	RodE6_60.2	124	60.2	1.529	13.2	0.335	906.30	758.9	5434.77	17144.0	8.501	48.3	
	RodE6_66.1	125	66.1	1.679	19.1	0.485	930.17	772.1	5717.77	18036.7	8.622	49.0	
	RodE6_70	126	70	1.778	-0.88	-0.022	846.28	725.5	5902.35	18619.0	10.189	57.9	
	RodE6_73.1	127	73.1	1.857	2.22	0.056	910.80	761.4	6046.77	19074.5	9.392	53.3	
	RodE6_75	128	75	1.905	4.12	0.105	942.60	779.0	6136.95	19359.0	9.084	51.6	

RBHT Steam Cooling with Droplet Injection Test SCD-4041-H

Matrix Test # 8d

Test Conditions

Test Date – 10/26/2005

Steady State Time Window: 25440 – 25680

Upper Plenum Pressure: 2.76 bar (40 psia)

Bundle Power: 72.0 kW

Bundle Inlet Reynolds Number: 8000

Bundle Inlet Steam Flow: 158.8 kg/hr (350 lbm/hr)

Droplet Injection Flow: 0.015 kg/s (0.032 lbm/s)

Droplet Injection Hole Diameter: 0.381 mm (.015 in)

Droplet Injection Elevation: 1.295 m (51 in)

Bundle Flow Area: $4.656 \times 10^{-3} \text{ m}^2$ ($5.012 \times 10^{-2} \text{ ft}^2$)

Test Notes

- No steam probes were traversed in this steady state window.

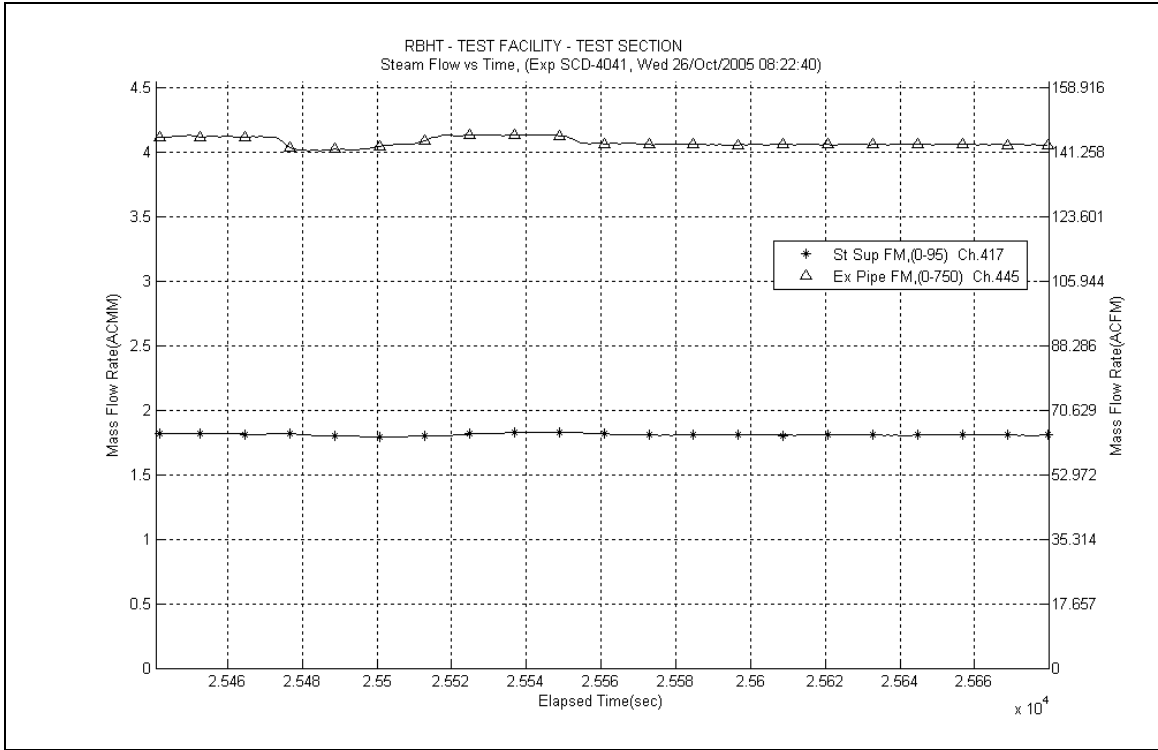

Figure A-576: Inlet and Exhaust Steam Flow Rates for Experiment 4041H

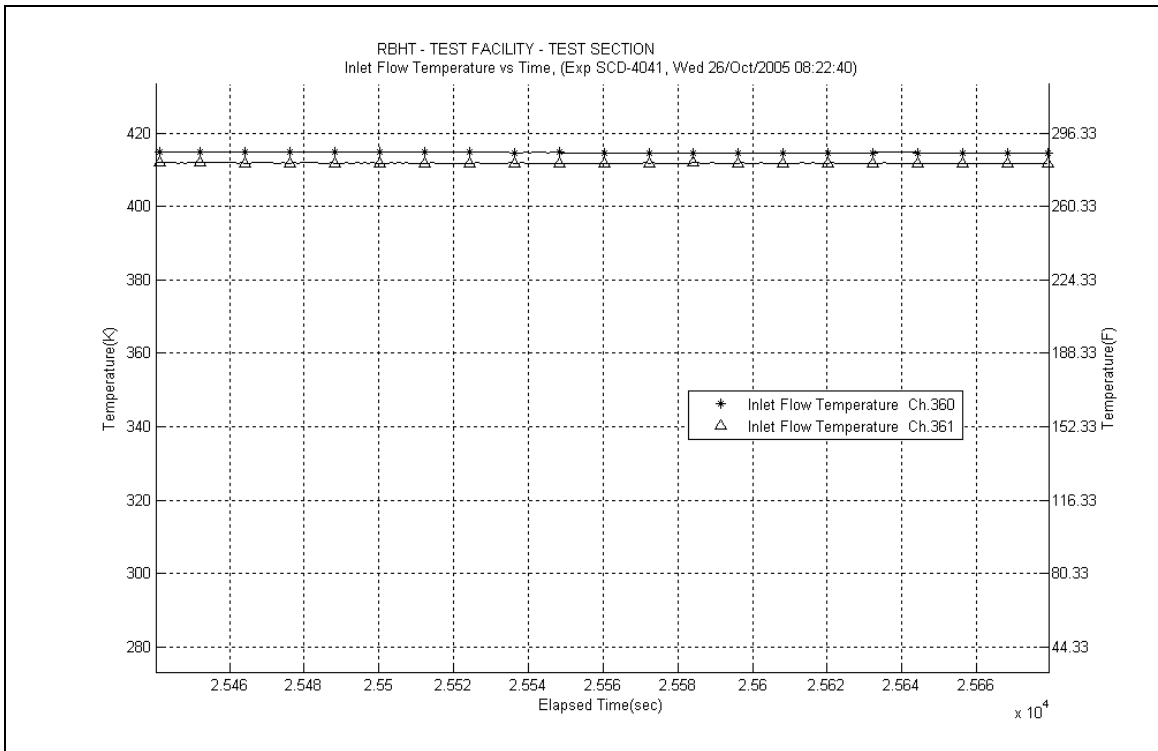

Figure A-577: Inlet Steam Temperature for Experiment 4041H

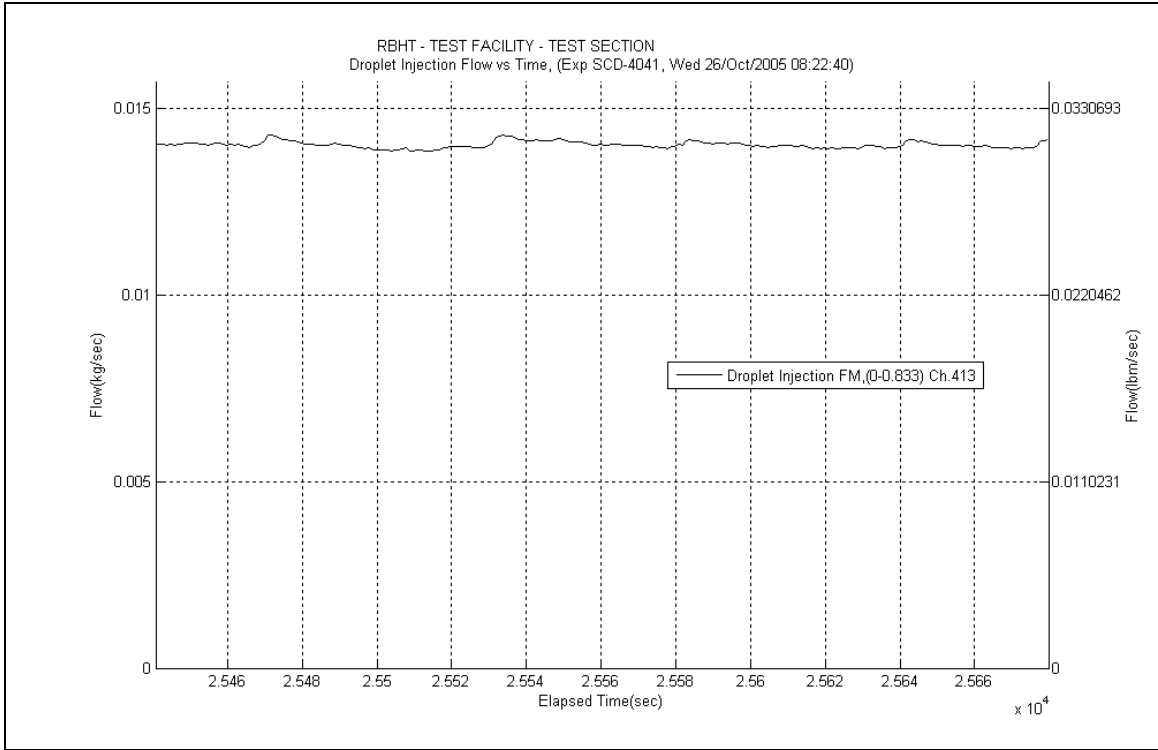

Figure A-578: Droplet Injection Flow Rate for Experiment 4041H

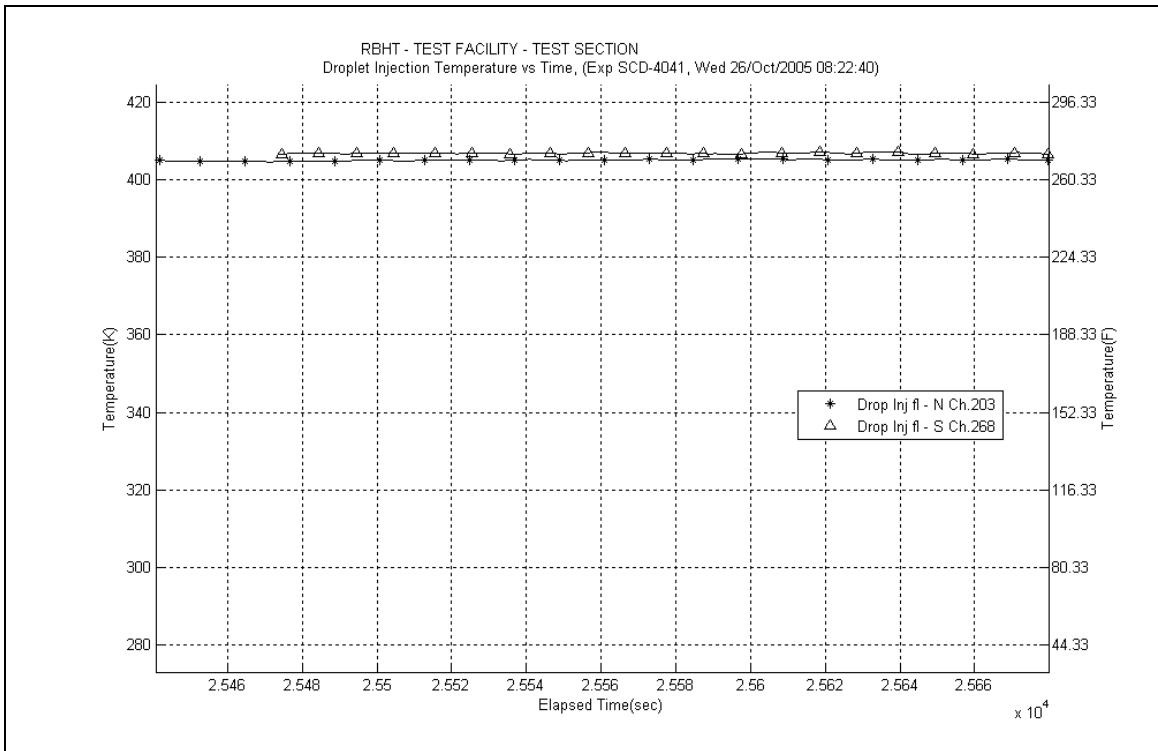

Figure A-579: Droplet Injection Temperature for Experiment 4041H

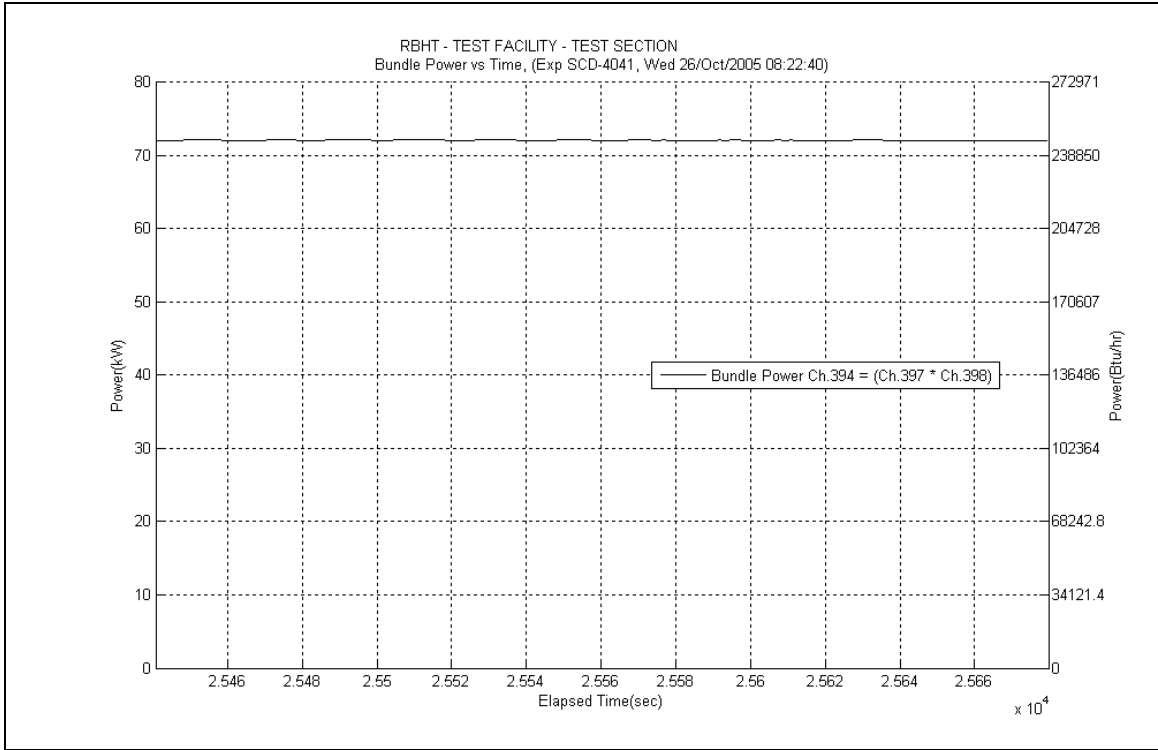

Figure A-580: Bundle Power for Experiment 4041H

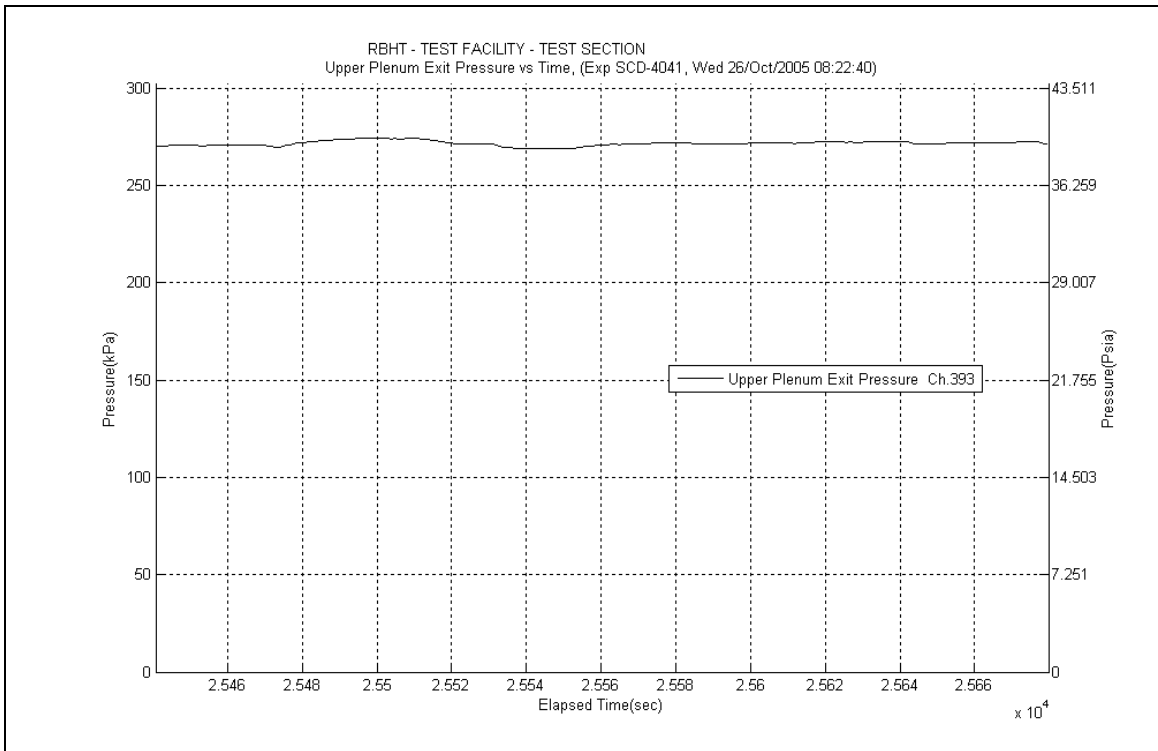

Figure A-581: Upper Plenum Pressure for Experiment 4041H

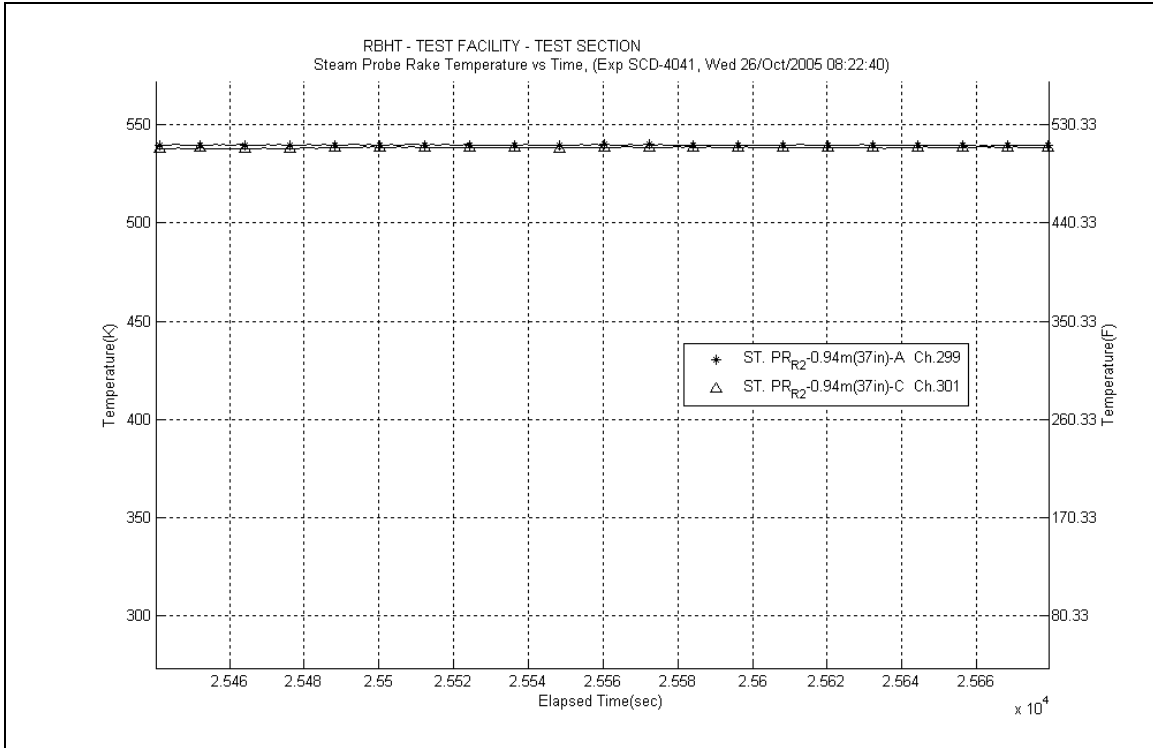

Figure A-582: Steam Probe Rake #2 Temperatures for Experiment 4041H

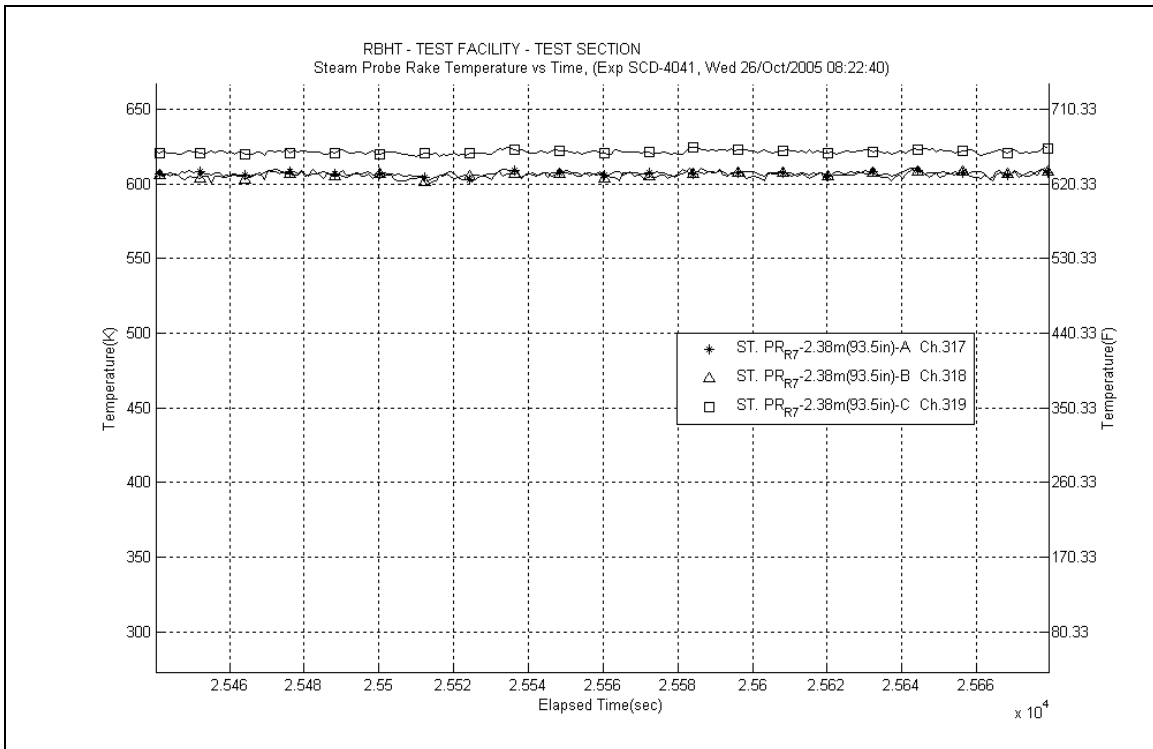

Figure A-583: Steam Probe Rake #7 Temperatures for Experiment 4041H

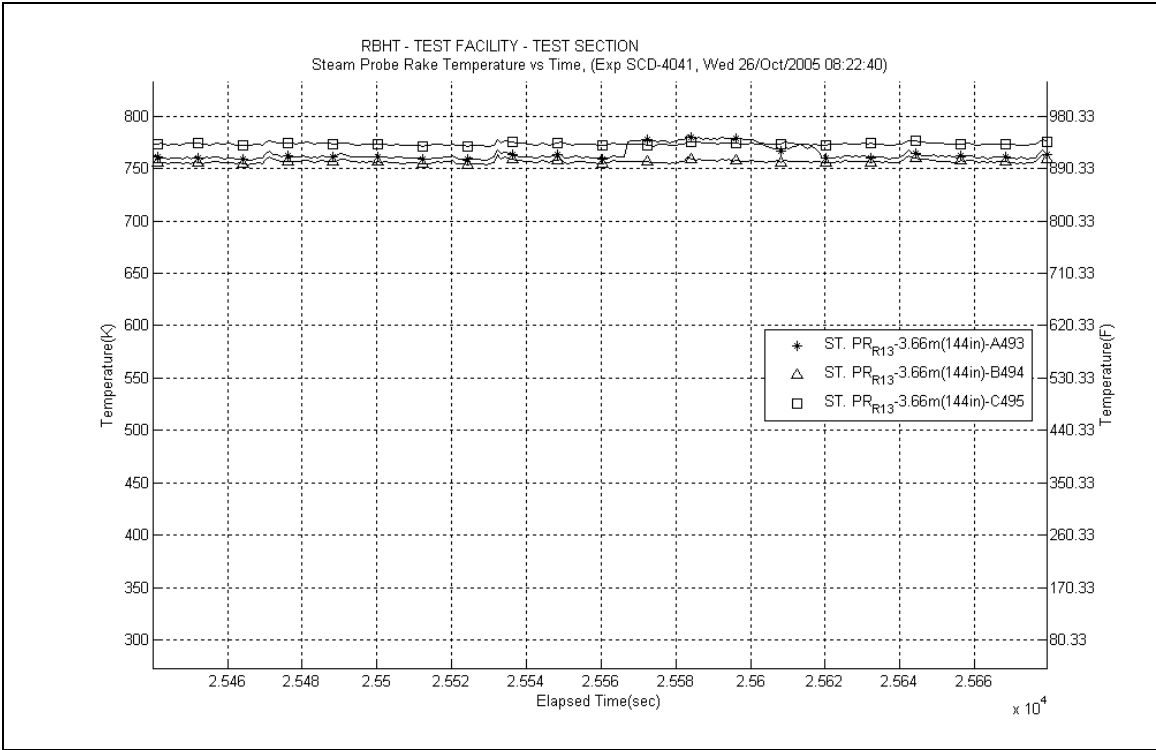

Figure A-584: Steam Probe Rake #13 Temperatures for Experiment 4041H

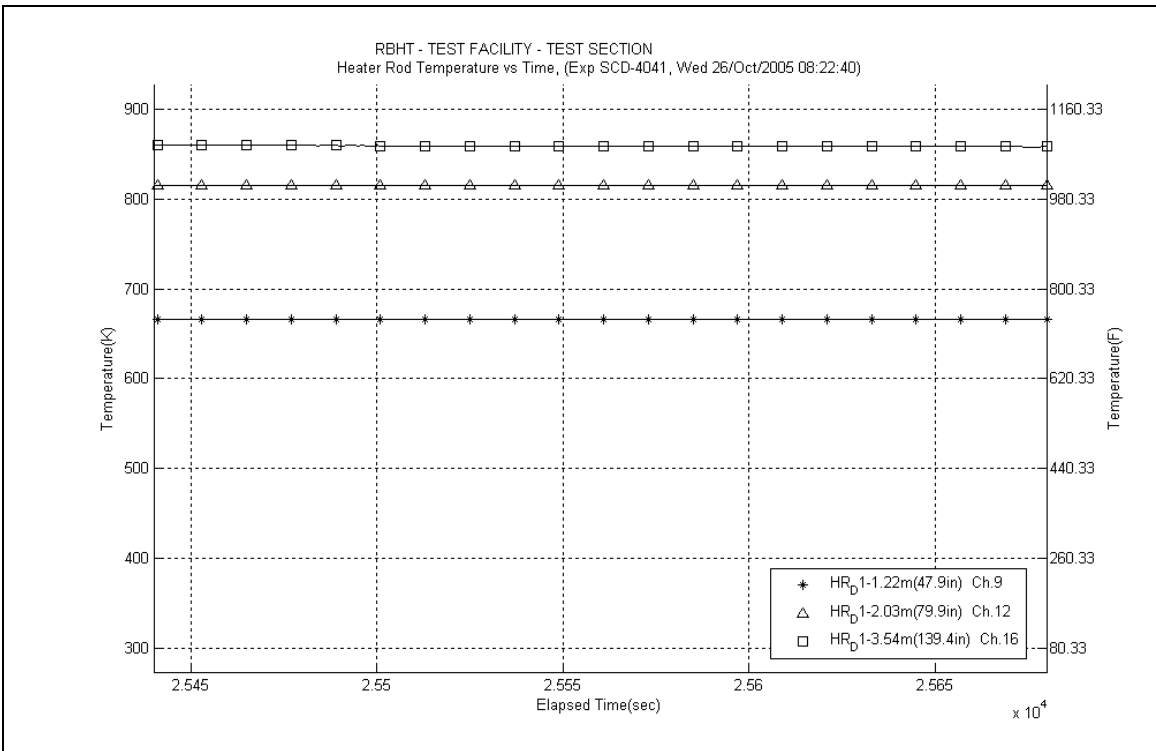

Figure A-585: Heater Rod D1 Temperatures for Experiment 4041H

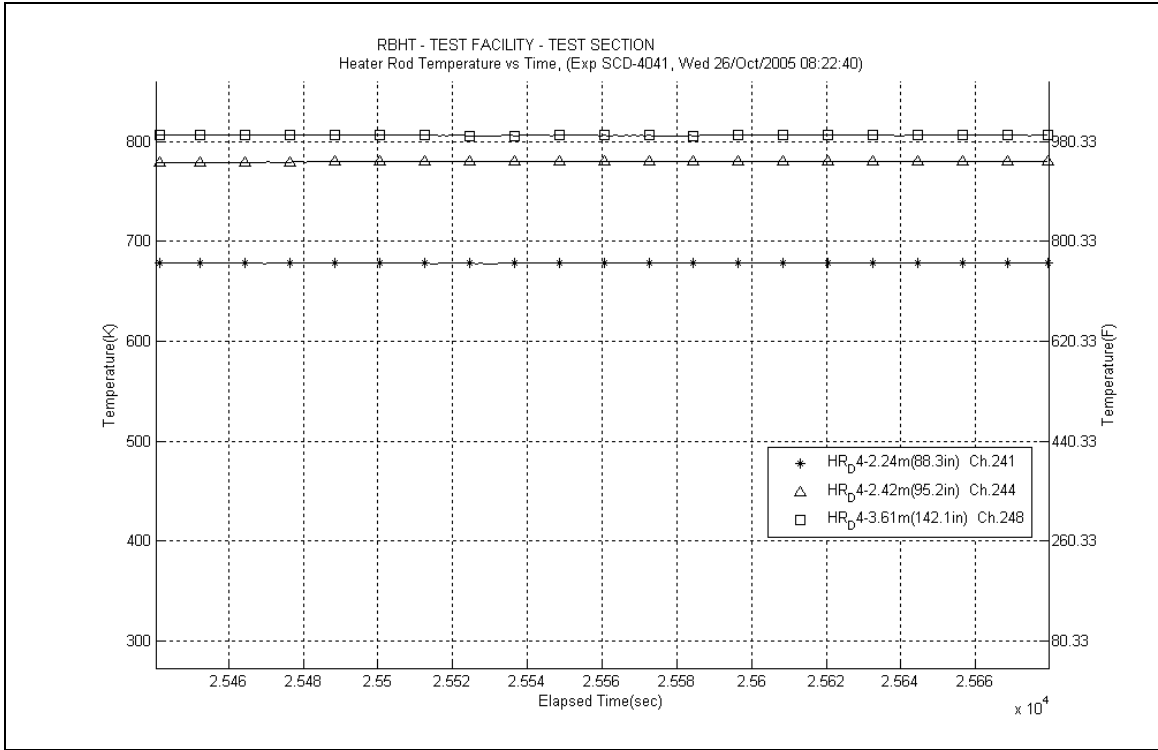

Figure A-586: Heater Rod D4 Temperatures for Experiment 4041H

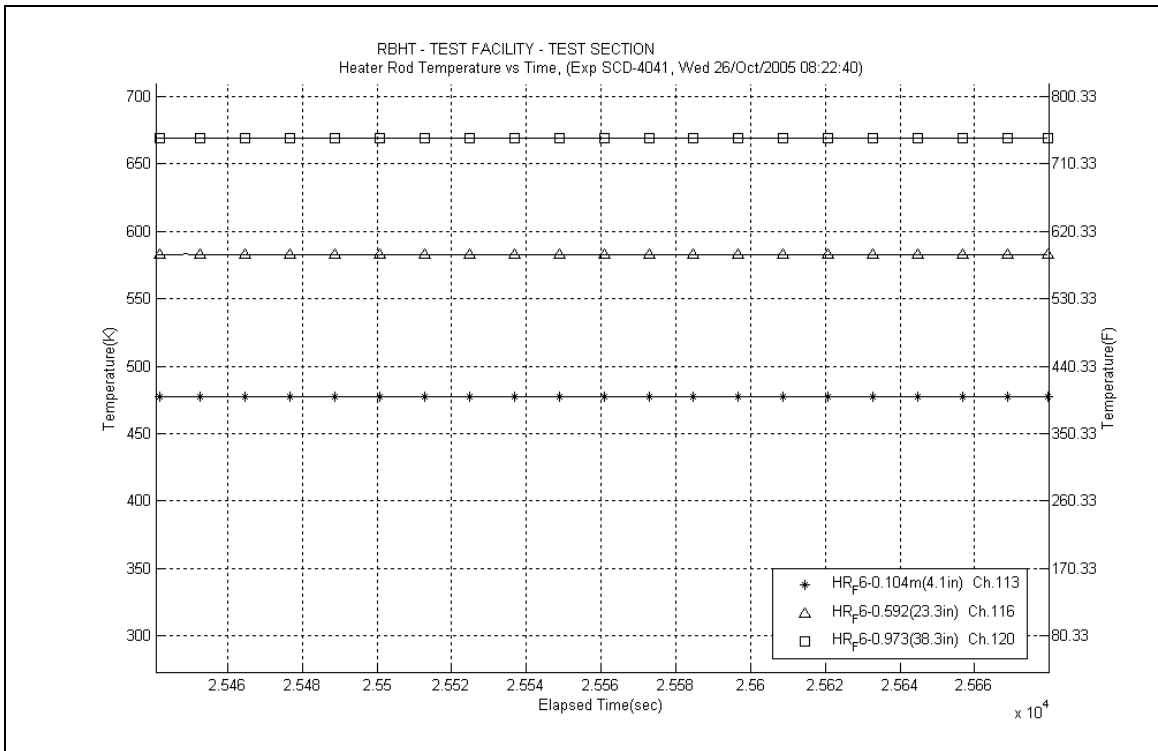

Figure A-587: Heater Rod F6 Temperatures for Experiment 4041H

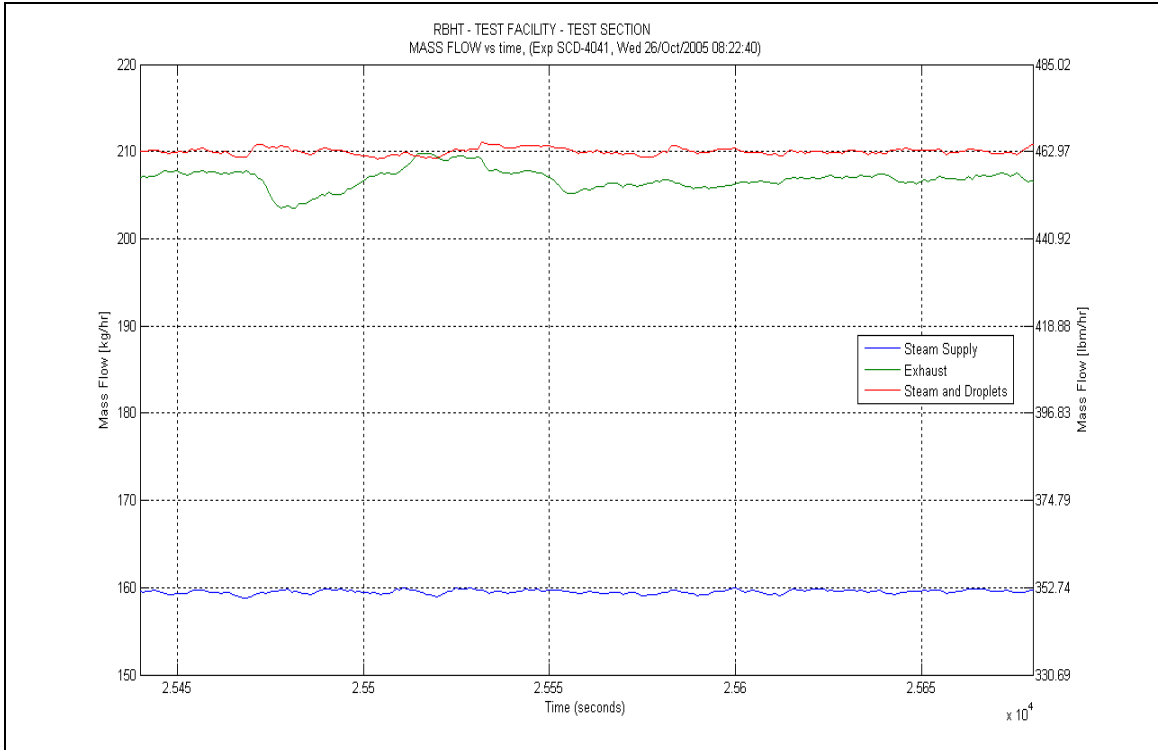

Figure A-588: Mass Flow for Experiment 4041H

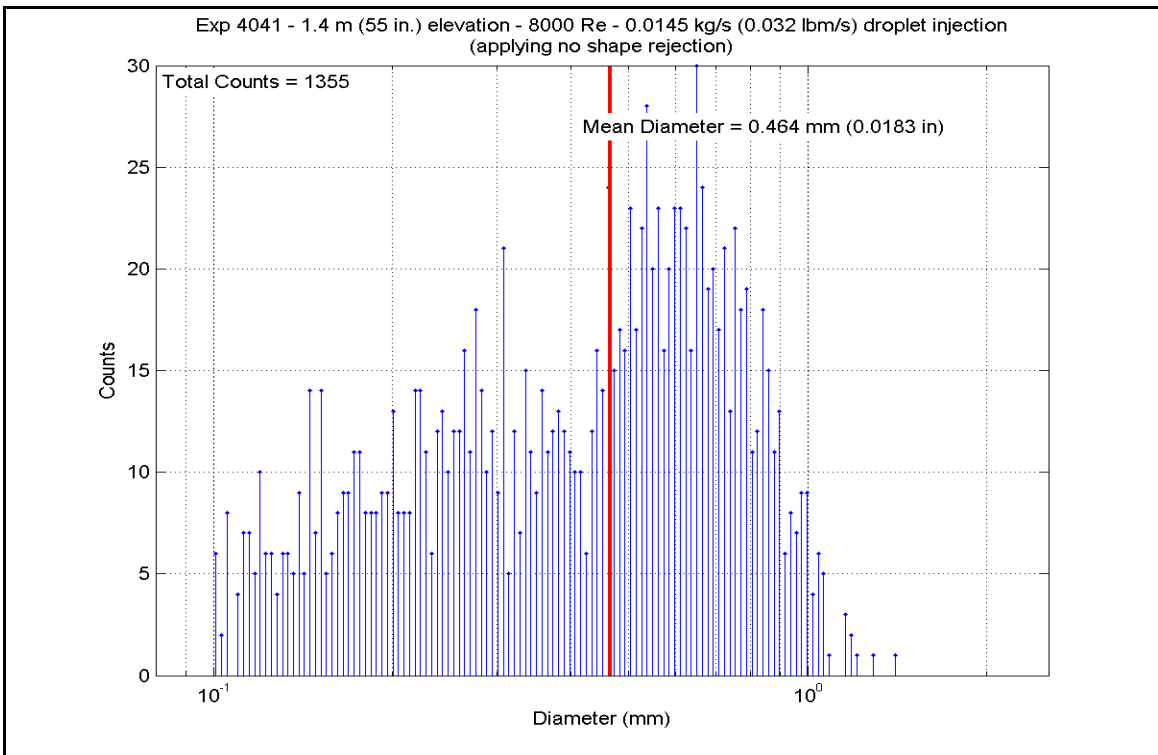

Figure A-589: Droplet Measurements at 1.397 m (55 in.) Elevation for Experiment 4041H

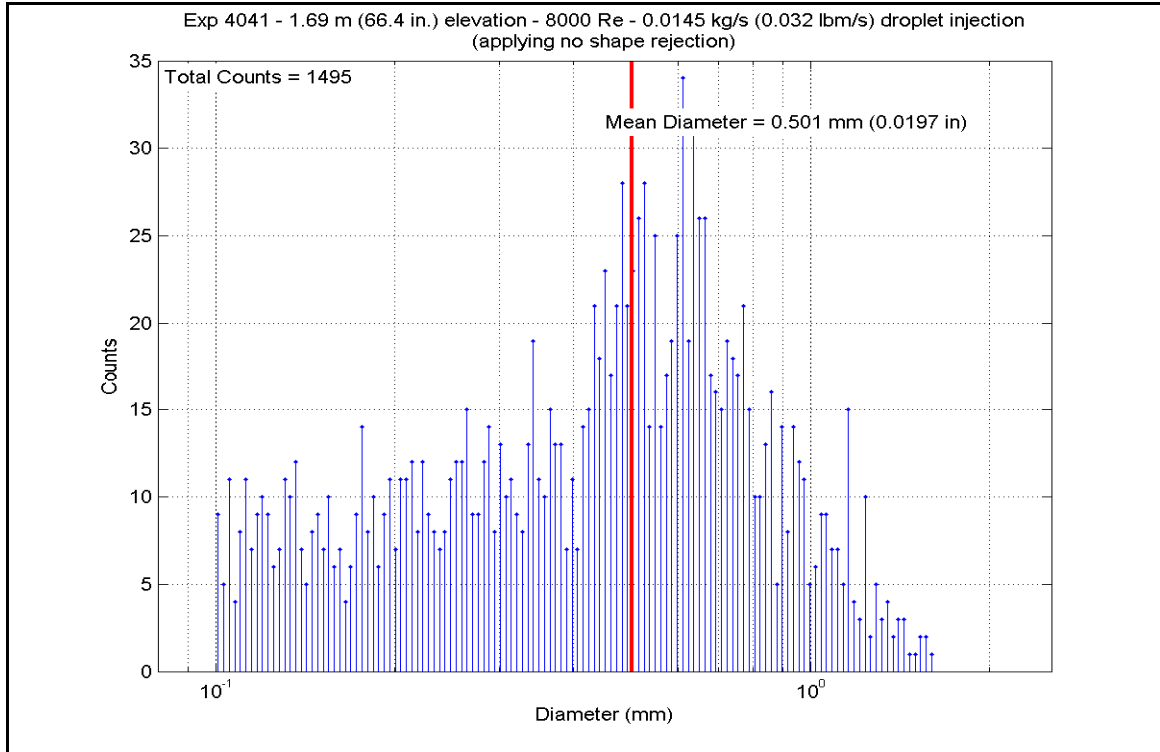

Figure A-590: Droplet Measurements at 1.687 m (66.4 in.) Elevation for Experiment 4041H

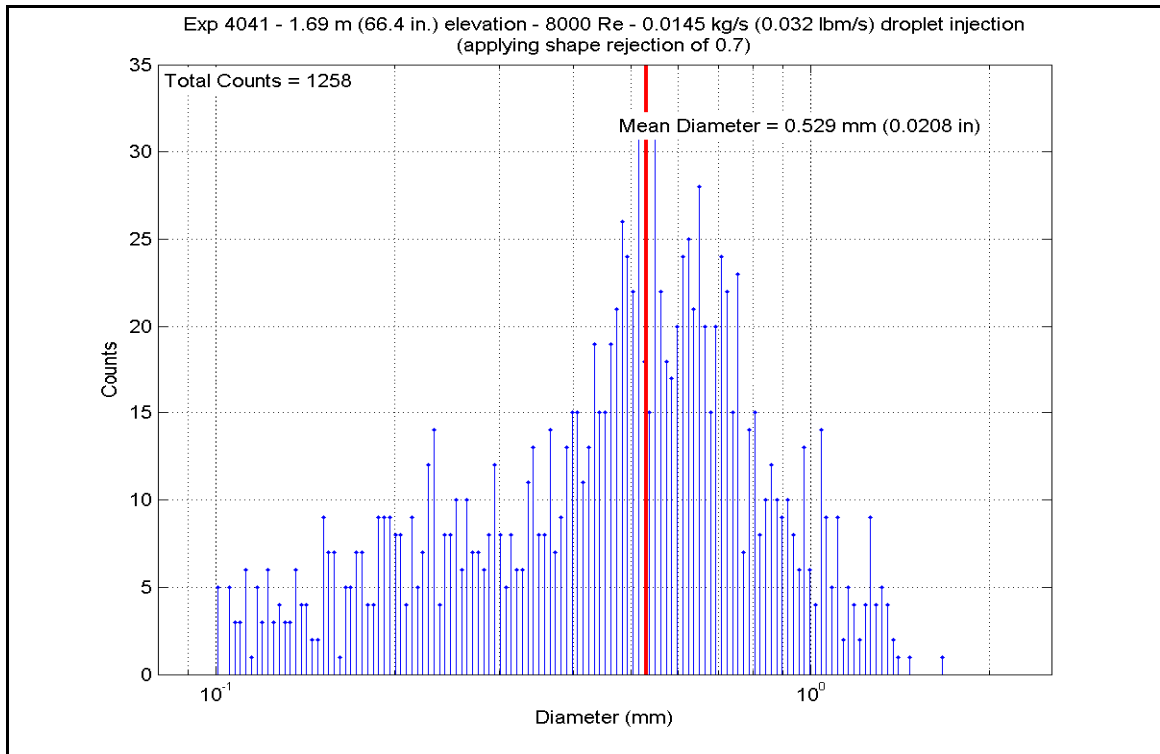

Figure A-591: Droplet Measurements at 1.687 m (66.4 in.) Elevation for Experiment 4041H

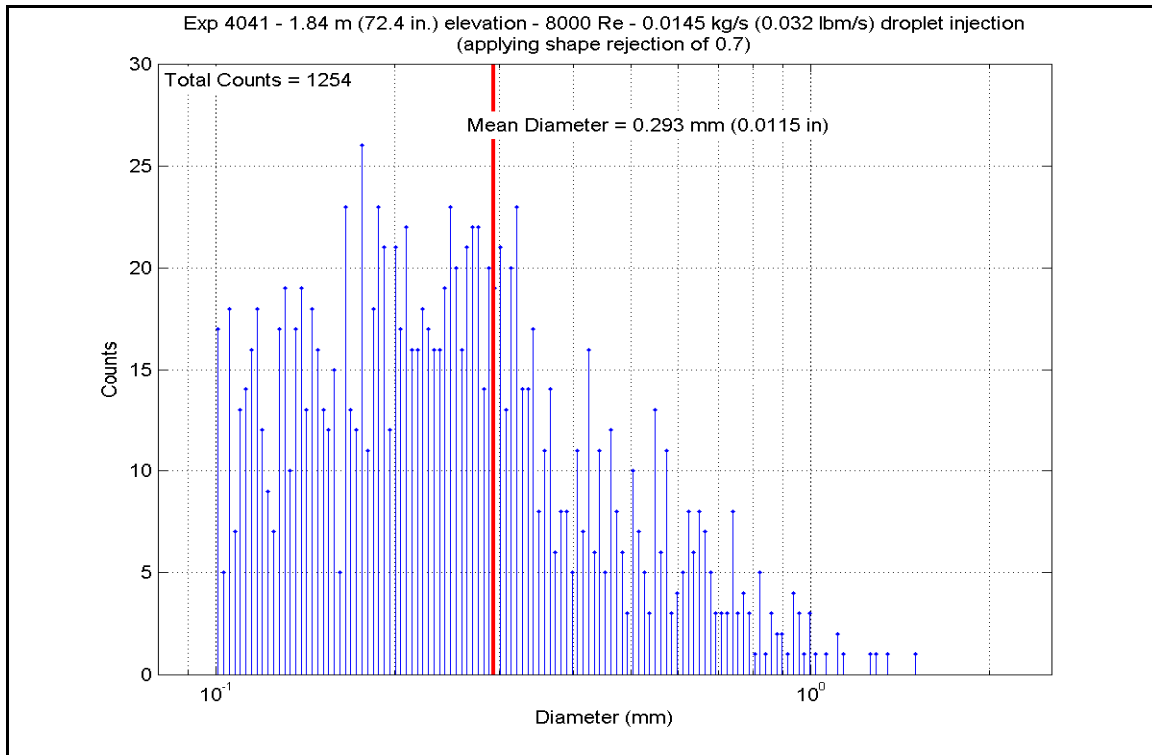

Figure A-592: Droplet Measurements at 1.839 m (72.4 in.) Elevation for Experiment 4041H

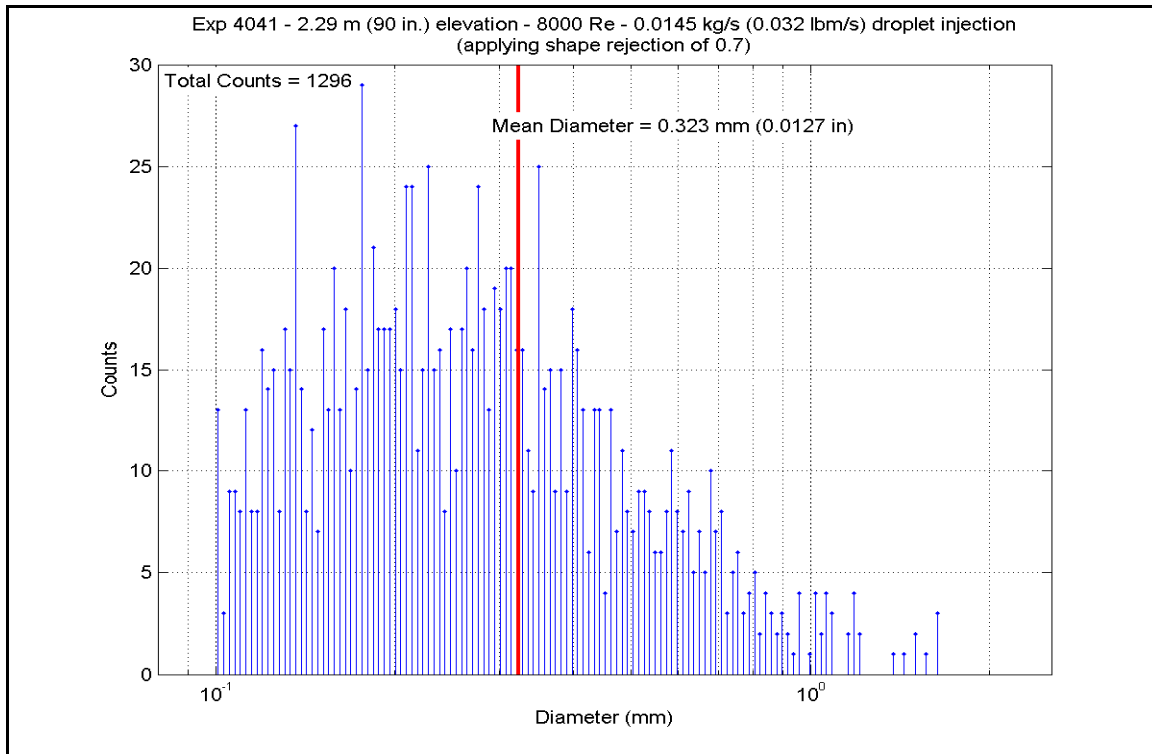

Figure A-593: Droplet Measurements at 2.286 m (90 in.) Elevation for Experiment 4041H

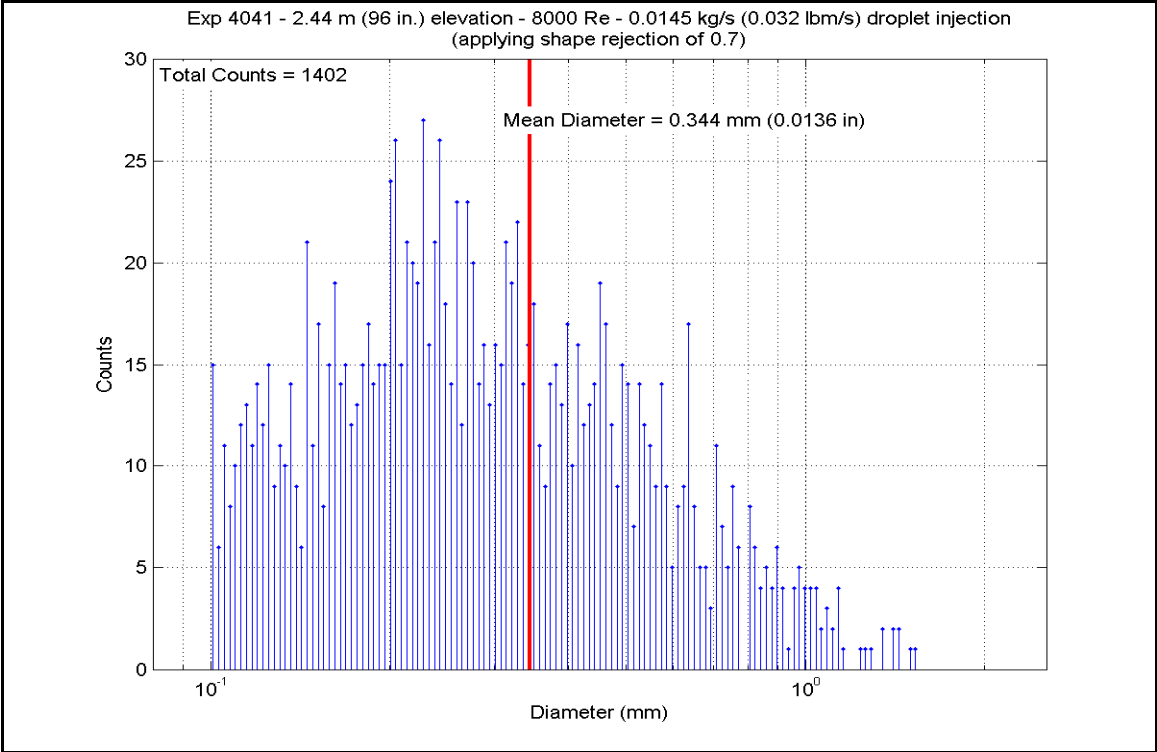

Figure A-594: Droplet Measurements at 2.438 m (96 in.) Elevation for Experiment 4041H

Table A-32: Summary of Steam Cooling Heat Transfer Reduced Data for Experiment 4041H

SCD-4041-H		Inlet Reynolds:		8000		40 psia							
Matrix Test # 8d		UP Pressure:		275.8 kPa		245674 Btu/hr							
Time Window: 25440-25680		Bundle Power:		7200 kW		350.0 lbm/hr							
Inner 3x3		Steam flow:		0.0441 kg/s		0.032 lbm/s							
		Dropletflow:		0.0145 kg/s									
H.R. ID	H.R. Location	Channel Number	Elevation (in)	Elevation (m)	Zgrid (in)	Zgrid (m)	H.R. Tw (°F)	H.R. Tw (K)	H.R. q" (Btu/hr-ft2)	H.R. q" (W/m2)	h _{sat} (z) (Btu/hr-ft2-F)	h _{sat} (z) (W/m2-K)	
Gr-3	RodD3_88.3	185	88.3	2.243	-0.2	-0.005	879.84	744.2	7169.44	22616.0	11.699	66.4	
	RodD3_91.3	186	91.3	2.319	2.8	0.071	964.49	791.2	7277.12	22955.7	10.433	59.2	
	RodD3_93.1	187	93.1	2.365	4.6	0.117	963.39	790.6	7362.98	23226.5	10.573	60.0	
	RodD3_95.3	188	95.3	2.421	6.8	0.173	1013.71	818.5	7495.61	23644.9	10.038	57.0	
	RodD3_100.1	189	100.1	2.543	11.6	0.295	1094.65	863.5	7651.39	24136.3	9.245	52.5	
	RodD3_106.1	190	106.1	2.695	17.6	0.447	1157.86	898.6	7928.39	25010.1	8.900	50.5	
	RodD3_110	191	110	2.794	21.5	0.546	1065.04	847.1	7857.91	24787.8	9.847	55.9	
	RodD3_142.1	192	142.1	3.609	3.609	8.6	1120.88	878.1	3243.78	10232.5	3.799	21.6	
	Gr-3	RodC4_88.4	233	88.4	2.245	-0.1	-0.003	821.86	712.0	7108.51	22423.8	12.811	72.8
	RodC4_91.1	234	91.1	2.314	2.6	0.066	923.72	768.6	7338.47	23149.2	11.174	63.5	
	RodC4_93.4	235	93.4	2.372	4.9	0.124	953.41	785.0	7454.87	23516.4	10.861	61.7	
	RodC4_95.3	236	95.3	2.421	6.8	0.173	1003.58	812.9	7555.41	23633.5	10.257	58.3	
	RodC4_100.1	237	100.1	2.543	11.6	0.295	1050.58	839.0	7766.40	24499.1	9.911	56.3	
	RodC4_106.1	238	106.1	2.695	17.6	0.447	1116.24	875.5	8066.64	25446.2	9.499	53.9	
	RodC4_110	239	110	2.794	21.5	0.546	1021.26	822.7	7980.10	25173.2	10.580	60.1	
	RodC4_142.2	240	142.2	3.612	8.7	0.221	1067.40	848.4	3432.69	10828.4	4.289	24.4	
Gr-3	RodD4_88.3	241	88.3	2.243	-0.2	-0.005	809.32	705.0	7038.31	22202.3	12.978	73.7	
	RodD4_91.3	242	91.3	2.319	2.8	0.071	912.78	762.5	7275.76	22951.4	11.267	64.0	
	RodD4_93.2	243	93.2	2.367	4.7	0.119	941.96	778.7	7388.95	23308.4	10.947	62.2	
	RodD4_95.2	244	95.2	2.418	6.7	0.170	989.07	804.9	7501.83	23664.5	10.389	59.0	
	RodD4_100.1	245	100.1	2.543	11.6	0.295	1075.41	852.8	7747.15	24438.4	9.583	54.4	
	RodD4_106.1	246	106.1	2.695	17.6	0.447	1111.56	872.9	8035.14	25346.8	9.514	54.0	
	RodD4_142.1	248	142.1	3.609	3.609	8.6	1072.37	851.1	3335.15	10520.7	4.141	23.5	
	Gr-3	RodE4_88.4	201	88.4	2.245	-0.1	-0.003	838.37	721.1	7100.65	22399.0	12.427	70.6
		RodE4_91.2	202	91.2	2.316	2.7	0.069	946.69	781.3	7334.71	23137.3	10.791	61.3
	RodE4_95.3	204	95.3	2.421	6.8	0.173	1027.32	826.1	7509.04	23687.3	9.876	56.1	
	RodE4_100.9	205	100.9	2.563	12.4	0.315	1088.98	860.4	7644.52	24114.6	9.300	52.8	
	RodE4_142.3	208	142.3	3.614	8.8	0.224	1105.01	869.3	3465.53	10932.0	4.135	23.5	

Table A-32: Summary of Steam Cooling Heat Transfer Reduced Data for Experiment 4041, continued

	H.R. Location	Channel Number	Elevation (in)	Elevation (m)	Zgrid (in)	Zgrid (m)	H.R. Tw (°F)	H.R. Tw (K)	H.R. q" (Btu/hr-ft ²)	H.R. q" (W/m ²)	h _{sat} (z) (Btu/hr-ft ² -F)	h _{sat} (z) (W/m ² -K)
Gr-4	RodE3_63.4	193	63.4	1.610	16.4	0.417	946.52	781.2	5654.78	17838.0	8.322	47.3
	RodE3_113.6	194	113.6	2.885	0.85	0.022	1096.73	864.7	7296.91	23018.1	8.794	49.9
	RodE3_115.5	195	115.5	2.934	2.75	0.070	1142.62	890.2	7195.01	22696.7	8.217	46.7
	RodE3_118.5	196	118.5	3.010	5.75	0.146	1170.87	905.9	6788.25	21413.5	7.510	42.6
	RodE3_122.7	197	122.7	3.117	9.95	0.253	1175.52	908.4	6252.36	19723.1	6.882	39.1
	RodE3_126.5	198	126.5	3.213	13.75	0.349	1176.49	909.0	5746.95	18128.8	6.319	35.9
	RodE3_131.7	199	131.7	3.345	-1.8	-0.046	1081.56	856.2	5060.88	15964.5	6.213	35.3
	RodE3_135.6	200	135.6	3.444	2.1	0.053	1122.45	879.0	4553.33	14363.5	5.323	30.2
	RodC5_63.7	225	63.7	1.618	16.7	0.424	916.63	764.6	5540.29	17476.8	8.528	48.4
	RodC5_113.6	226	113.6	2.885	0.85	0.022	1024.57	824.6	7196.75	22702.1	9.500	53.9
Gr-4	RodC5_115.7	227	115.7	2.939	2.95	0.075	1065.76	847.5	6929.61	21859.5	8.676	49.3
	RodC5_122.7	229	122.7	3.117	9.95	0.253	1099.05	866.0	6056.76	19106.0	7.279	41.3
	RodC5_126.7	230	126.7	3.218	13.95	0.354	1096.16	864.3	5544.12	17488.9	6.686	38.0
	RodC5_131.6	231	131.6	3.343	-1.9	-0.048	981.56	800.7	4868.93	15359.0	6.814	38.7
	RodC5_135.7	232	135.7	3.447	2.2	0.056	1022.68	823.5	4445.82	14024.3	5.883	33.4
	RodE5_63.6	209	63.6	1.615	16.6	0.422	831.95	717.6	5416.17	17085.3	9.587	54.4
	RodE5_113.6	210	113.6	2.885	0.85	0.022	924.85	769.2	7735.59	24401.9	11.759	66.8
	RodE5_115.4	211	115.4	2.931	2.65	0.067	1005.87	814.2	7633.39	24079.5	10.331	58.7
	RodE5_118.7	212	118.7	3.015	5.95	0.151	1073.57	851.8	7243.40	22849.3	8.981	51.0
	RodE5_122.6	213	122.6	3.114	9.85	0.250	1111.40	872.8	6781.77	21393.1	8.031	45.6
RodE5_126.6	214	126.6	3.216	13.85	0.352	1119.18	877.1	6304.83	19888.6	7.398	42.0	
Gr-5	RodE5_131.6	215	131.6	3.343	-1.9	-0.048	1093.39	862.8	5519.39	17410.9	6.679	37.9
	RodE5_135.6	216	135.6	3.444	2.1	0.053	1072.17	851.0	4218.16	13306.2	5.239	29.8
	RodC3_79.8	177	79.8	2.027	8.92	0.227	948.40	782.3	6534.95	20614.5	9.591	54.5
	RodC3_85.6	178	85.6	2.174	14.72	0.374	864.91	735.9	6829.24	21542.8	11.422	64.9
	RodC3_88.5	179	88.5	2.248	0	0.000	866.91	737.0	7109.09	22425.6	11.850	67.3
	RodC3_92.4	180	92.4	2.347	3.9	0.099	982.99	801.5	7284.10	22977.7	10.173	57.8
	RodC3_94.4	181	94.4	2.398	5.9	0.150	1000.35	811.1	7350.22	23186.3	10.023	56.9
	RodC3_97.2	182	97.2	2.469	8.7	0.221	1050.57	839.0	7439.19	23466.9	9.494	53.9
	RodC3_108.8	183	108.8	2.764	20.3	0.516	1144.41	891.2	7820.67	24670.3	8.913	50.6
	Gr-8	RodD5_50	217	50	1.270	3	0.076	814.58	707.9	4950.32	15615.8	9.040
RodD5_54.1		218	54.1	1.374	7.1	0.180	791.65	695.2	5153.02	16255.2	9.822	55.8
RodD5_56.9		219	56.9	1.445	9.9	0.251	841.88	723.1	5316.05	16769.5	9.247	52.5
RodD5_60		220	60	1.524	13	0.330	877.79	743.0	5498.09	17343.7	9.002	51.1
RodD5_66.1		221	66.1	1.679	19.1	0.485	915.25	763.8	5816.54	18348.3	8.973	51.0
RodD5_69.9		222	69.9	1.775	-0.98	-0.025	734.43	663.4	6048.54	19080.1	12.940	73.5
RodD5_72.9		223	72.9	1.852	2.02	0.051	822.64	712.4	6265.23	19763.7	11.276	64.0
RodD5_74.9		224	74.9	1.902	4.02	0.102	869.61	738.5	6376.30	20114.0	10.581	60.1

Inner 3x3

Table A-32: Summary of Steam Cooling Heat Transfer Reduced Data for Experiment 4041, continued

H.R. ID	H.R. Location	Channel Number	Elevation (in)	Elevation (m)	Zgrid (in)	Zgrid (m)	H.R. Tw (°F)	H.R. Tw (K)	H.R. q" (Btu/hr-ft ²)	H.R. q" (W/m ²)	h _{sat} (z) (Btu/hr-ft ² -F)	h _{sat} (z) (W/m ² -K)	
Gr-2	RodB5_41	153	41	1.041	13.5	0.343	753.17	673.8	4501.04	14198.5	9.258	52.6	
	RodB5_52.9	154	52.9	1.344	5.9	0.150	818.50	710.1	5068.15	15987.5	9.190	52.2	
	RodB5_55	155	55	1.397	8	0.203	855.12	730.4	5165.37	16294.1	8.783	49.9	
	RodB5_57.8	156	57.8	1.468	10.8	0.274	886.28	747.8	5340.54	16846.7	8.624	49.0	
	RodB5_64	157	64	1.626	17	0.432	933.10	773.8	5699.81	17980.1	8.557	48.6	
	RodB5_73.9	158	73.9	1.877	3.02	0.077	885.80	747.5	6262.75	19755.8	10.121	57.5	
	RodB5_75.9	159	75.9	1.928	5.02	0.128	921.27	767.2	6375.85	20112.6	9.745	55.3	
	RodB5_76.9	160	76.9	1.953	6.02	0.153	935.21	774.9	6429.72	20282.6	9.622	54.6	
	Gr-2	RodF5_41	105	41	1.041	13.5	0.343	741.39	667.3	4465.54	14086.5	9.413	53.5
		RodF5_53.1	106	53.1	1.349	6.1	0.155	799.47	699.5	5088.52	16051.7	9.556	54.3
		RodF5_55	107	55	1.397	8	0.203	836.56	720.1	5189.95	16371.7	9.112	51.7
		RodF5_57.8	108	57.8	1.468	10.8	0.274	879.45	744.0	5334.19	16826.7	8.710	49.5
		RodF5_64	109	64	1.626	17	0.432	918.08	765.4	5653.82	17835.0	8.684	49.3
		RodF5_73.8	110	73.8	1.875	2.92	0.074	868.48	737.9	6137.33	19360.2	10.204	57.9
		RodF5_75.8	111	75.8	1.925	4.92	0.125	907.89	759.8	6253.07	19725.3	9.757	55.4
		RodF5_76.8	112	76.8	1.951	5.92	0.150	924.00	768.7	6311.00	19908.0	9.606	54.5
Gr-2		RodC2_41	57	41	1.041	13.5	0.343	734.24	663.3	4508.11	14220.8	9.648	54.8
		RodC2_53.1	58	53.1	1.349	6.1	0.155	856.59	731.3	5096.85	16078.0	8.645	49.1
		RodC2_55	59	55	1.397	8	0.203	874.94	741.4	5190.23	16372.6	8.537	48.5
		RodC2_57.8	60	57.8	1.468	10.8	0.274	906.26	758.9	5322.38	16789.4	8.326	47.3
	RodC2_63.9	61	63.9	1.623	16.9	0.429	935.81	775.3	5610.30	17697.7	8.388	47.6	
	RodC2_73.8	62	73.8	1.875	2.92	0.074	915.69	764.1	6129.60	19335.8	9.449	53.7	
	RodC2_75.8	63	75.8	1.925	4.92	0.125	941.96	778.7	6232.16	19659.4	9.233	52.4	
	RodC2_76.8	64	76.8	1.951	5.92	0.150	952.60	784.6	6280.15	19810.7	9.160	52.0	
Gr-2	RodC6_40.9	137	40.9	1.039	13.4	0.340	748.88	671.4	4471.92	14106.7	9.280	52.7	
	RodC6_52.8	138	52.8	1.341	5.8	0.147	866.73	736.9	5069.82	15992.7	8.453	48.0	
	RodC6_54.8	139	54.8	1.392	7.8	0.198	887.99	748.7	5174.21	16322.0	8.332	47.3	
	RodC6_57.8	140	57.8	1.468	10.8	0.274	922.50	767.9	5321.24	16785.9	8.118	46.1	
	RodC6_63.8	141	63.8	1.621	16.8	0.427	955.20	786.0	5625.27	17744.9	8.174	46.4	
	RodC6_73.7	142	73.7	1.872	2.82	0.072	919.73	766.3	6380.70	20127.9	9.775	55.5	
	RodC6_75.8	143	75.8	1.925	4.92	0.125	948.68	782.4	6500.05	20504.4	9.535	54.1	
	RodC6_76.8	144	76.8	1.951	5.92	0.150	965.74	791.9	6559.20	20691.0	9.387	53.3	

5x5 periphery

Table A-32: Summary of Steam Cooling Heat Transfer Reduced Data for Experiment 4041, continued

5x5 periphery		H.R. Location	Channel Number	Elevation (in)	Elevation (m)	Zgrid (in)	Zgrid (m)	H.R. Tw (°F)	H.R. Tw (K)	H.R. q" (Btu/hr-ft ²)	H.R. q" (W/m ²)	h _{sat} (z) (Btu/hr-ft ² -F)	h _{sat} (z) (W/m ² -K)
Gr-3	RodB4_88.4	161	88.4	2.245	-0.1	-0.003	732.3	7158.03	22580.0	12.102	68.7	59.7	59.1
	RodB4_91.3	162	91.3	2.319	2.8	0.071	786.4	7245.41	22855.6	10.519	59.1	59.1	59.1
	RodB4_93.3	163	93.3	2.370	4.8	0.122	794.2	7317.79	23084.0	10.411	56.9	56.2	56.2
	RodB4_95.1	164	95.1	2.416	6.6	0.168	813.1	7386.84	23301.8	10.023	52.3	56.6	56.6
	RodB4_100	165	100	2.540	11.5	0.292	827.4	7548.10	23810.5	9.896	24.3	24.3	24.3
	RodB4_106	166	106	2.692	17.5	0.445	876.3	7829.10	24696.9	9.204	10.866	10.866	10.866
	RodB4_109.9	167	109.9	2.791	21.4	0.544	826.8	7591.71	23948.0	9.969	11.787	11.787	11.787
	RodB4_142.3	168	142.3	3.614	8.8	0.224	854.8	3469.83	10945.6	4.273	10.312	10.312	10.312
Gr-5	RodF4_85.6	98	85.6	2.174	14.72	0.374	900.68	6885.27	21719.6	10.866	61.7	66.9	66.9
	RodF4_88.4	99	88.4	2.245	-0.1	-0.003	873.83	7152.52	22562.6	11.787	58.6	56.5	56.5
	RodF4_92.4	100	92.4	2.347	3.9	0.099	800.0	7355.38	23202.5	9.943	54.4	53.0	53.0
	RodF4_94.3	101	94.3	2.395	5.8	0.147	819.4	7439.08	23466.6	9.574	59.9	59.9	59.9
	RodF4_97.2	102	97.2	2.469	8.7	0.221	843.8	7583.76	23923.0	9.330	10.549	10.549	10.549
	RodF4_108.8	103	108.8	2.764	20.3	0.516	878.4	7972.02	25147.8	8.682	49.3	48.9	48.9
	RodF4_111	104	111	2.819	-1.75	-0.044	816.8	7843.68	24742.9	10.549	49.2	49.2	49.2
	RodD2_103.2	65	103.2	2.621	14.7	0.373	893.3	6976.32	22006.8	7.917	45.0	41.7	41.7
Gr-6	RodD2_106	66	106	2.692	17.5	0.445	905.4	6624.84	20898.1	7.337	37.8	34.1	34.1
	RodD2_112.6	67	112.6	2.860	-0.15	-0.004	917.4	6149.41	19398.3	6.650	31.3	31.3	31.3
	RodD2_114.9	68	114.9	2.918	2.15	0.055	921.0	5955.42	17650.8	6.009	49.3	49.3	49.3
	RodD2_117.4	69	117.4	2.982	4.65	0.118	914.2	5071.68	15998.6	5.519	46.2	46.2	46.2
	RodD2_120.8	70	120.8	3.068	8.05	0.204	899.3	7744.83	24431.1	8.682	48.9	48.9	48.9
	RodD2_124.8	71	124.8	3.170	12.05	0.306	912.0	7880.80	24860.0	8.614	49.2	49.2	49.2
	RodD2_128.6	72	128.6	3.266	15.85	0.403	870.2	7279.45	22963.0	8.668	52.5	52.5	52.5
	RodD6_103.1	129	103.1	2.619	14.6	0.371	878.9	7910.58	24953.9	9.249	52.5	52.5	52.5
RodD6_106	130	106	2.692	17.5	0.445	887.0	8037.65	25354.8	9.240	54.0	54.0	54.0	
RodD6_112.9	131	112.9	2.868	0.15	0.004	833.9	7357.42	23209.0	9.502	49.3	49.3	49.3	
RodD6_114.9	132	114.9	2.918	2.15	0.055	856.3	7077.80	22326.9	8.687	46.2	46.2	46.2	
RodD6_116.8	133	116.8	2.967	4.05	0.103	869.5	6826.63	21534.6	8.142	42.2	42.2	42.2	
RodD6_120.9	134	120.9	3.071	8.15	0.207	880.8	6383.07	20135.4	7.433	38.6	38.6	38.6	
RodD6_124.8	135	124.8	3.170	12.05	0.306	881.3	5848.39	18448.7	6.803	35.6	35.6	35.6	
RodD6_128.7	136	128.7	3.269	15.95	0.405	875.5	5318.38	16776.8	6.262				

Table A-32: Summary of Steam Cooling Heat Transfer Reduced Data for Experiment 4041, continued

5x5 periphery		H.R. Location	Channel Number	Elevation (in)	Elevation (m)	Zgrid (in)	Zgrid (m)	H.R. Tw (°F)	H.R. Tw (K)	H.R. q" (Btu/hr-ft ²)	H.R. q" (W/m ²)	h _{sat} (z) (Btu/hr-ft ² -F)	h _{sat} (z) (W/m ² -K)
Gr-8	RodE2_50.1	73	50.1	1.273	3.1	0.079	806.17	703.2	4952.86	15655.4	9.205	52.3	
	RodE2_54	74	54	1.372	7	0.178	872.24	740.0	5154.87	16261.0	8.517	48.4	
	RodE2_56.9	75	56.9	1.445	9.9	0.251	905.12	758.2	5298.71	16714.8	8.304	47.2	
	RodE2_59.9	76	59.9	1.521	12.9	0.328	935.38	775.0	5449.77	17191.3	8.154	46.3	
	RodE2_66	77	66	1.676	19	0.483	958.61	787.9	5754.13	18151.4	8.320	47.2	
	RodE2_69.8	78	69.8	1.773	-1.08	-0.027	841.20	722.7	6111.27	19278.0	10.643	60.4	
	RodE2_72.9	79	72.9	1.852	2.02	0.051	908.84	760.3	6167.19	19454.4	9.609	54.6	
	RodE2_74.9	80	74.9	1.902	4.02	0.102	942.27	778.9	6259.89	19746.8	9.270	52.6	
Gr-8	RodB3_50.2	169	50.2	1.275	3.2	0.081	764.67	680.2	4953.93	15627.2	9.954	56.5	
	RodB3_54.1	170	54.1	1.374	7.1	0.180	832.01	717.6	5128.85	16179.0	9.077	51.5	
	RodB3_56.9	171	56.9	1.445	9.9	0.251	874.37	741.1	5266.15	16612.1	8.670	49.2	
	RodB3_60.1	172	60.1	1.527	13.1	0.333	865.00	735.9	5447.51	17184.2	9.110	51.7	
	RodB3_66.1	173	66.1	1.679	19.1	0.485	911.08	761.5	5799.31	18293.9	9.004	51.1	
	RodB3_69.9	174	69.9	1.775	-0.98	-0.025	773.88	685.3	6005.49	18944.3	11.848	67.3	
	RodB3_73	175	73	1.854	2.12	0.054	858.95	732.6	6187.55	19518.6	10.453	59.4	
	RodB3_75	176	75	1.905	4.12	0.105	898.20	754.4	6283.72	19822.0	9.955	56.5	
Gr-8	RodF3_50.1	89	50.1	1.273	3.1	0.079	781.92	689.8	4951.43	15619.3	9.616	54.6	
	RodF3_54	90	54	1.372	7	0.178	849.88	727.5	5126.64	16172.0	8.795	49.9	
	RodF3_57	91	57	1.448	10	0.254	893.69	751.9	5294.06	16700.1	8.448	48.0	
	RodF3_60	92	60	1.524	13	0.330	920.51	766.8	5497.00	17340.3	8.411	47.8	
	RodF3_66.1	93	66.1	1.679	19.1	0.485	933.74	774.1	5827.11	18381.6	8.740	49.6	
	RodF3_70	94	70	1.778	-0.88	-0.022	795.11	697.1	6060.80	19118.8	11.476	65.2	
	RodF3_73	95	73	1.854	2.12	0.054	895.30	752.8	6174.43	19477.2	9.827	55.8	
	RodF3_75	96	75	1.905	4.12	0.105	939.04	777.1	6277.94	19803.8	9.342	53.0	
Gr-8	RodE6_50.2	121	50.2	1.275	3.2	0.081	788.83	693.6	4903.98	15469.6	9.398	53.4	
	RodE6_54.1	122	54.1	1.374	7.1	0.180	848.13	726.6	5097.56	16080.3	8.772	49.8	
	RodE6_57	123	57	1.448	10	0.254	878.78	743.6	5237.06	16520.3	8.560	48.6	
	RodE6_60.2	124	60.2	1.529	13.2	0.335	903.78	757.5	5401.52	17039.1	8.483	48.2	
	RodE6_66.1	125	66.1	1.679	19.1	0.485	924.55	769.0	5725.08	18059.8	8.707	49.4	
	RodE6_70	126	70	1.778	-0.88	-0.022	795.73	697.4	6049.51	19083.2	11.442	65.0	
	RodE6_73.1	127	73.1	1.857	2.22	0.056	874.73	741.3	6241.99	19690.3	10.271	58.3	
	RodE6_75	128	75	1.905	4.12	0.105	909.29	760.5	6337.54	19991.8	9.867	56.0	

RBHT Steam Cooling with Droplet Injection Test SCD-4041-I

Matrix Test # 7a

Test Conditions

Test Date – 10/26/2005

Steady State Time Window: 26460 – 27000

Upper Plenum Pressure: 2.76 bar (40 psia)

Bundle Power: 64.0 kW

Bundle Inlet Reynolds Number: 6000

Bundle Inlet Steam Flow: 117.9 kg/hr (260 lbm/hr)

Droplet Injection Flow: 0.0036 kg/s (0.008 lbm/s)

Droplet Injection Hole Diameter: 0.381 mm (.015 in)

Droplet Injection Elevation: 1.295 m (51 in)

Bundle Flow Area: $4.656 \times 10^{-3} \text{ m}^2$ ($5.012 \times 10^{-2} \text{ ft}^2$)

Test Notes

- No steam probes were traversed in this steady state window.

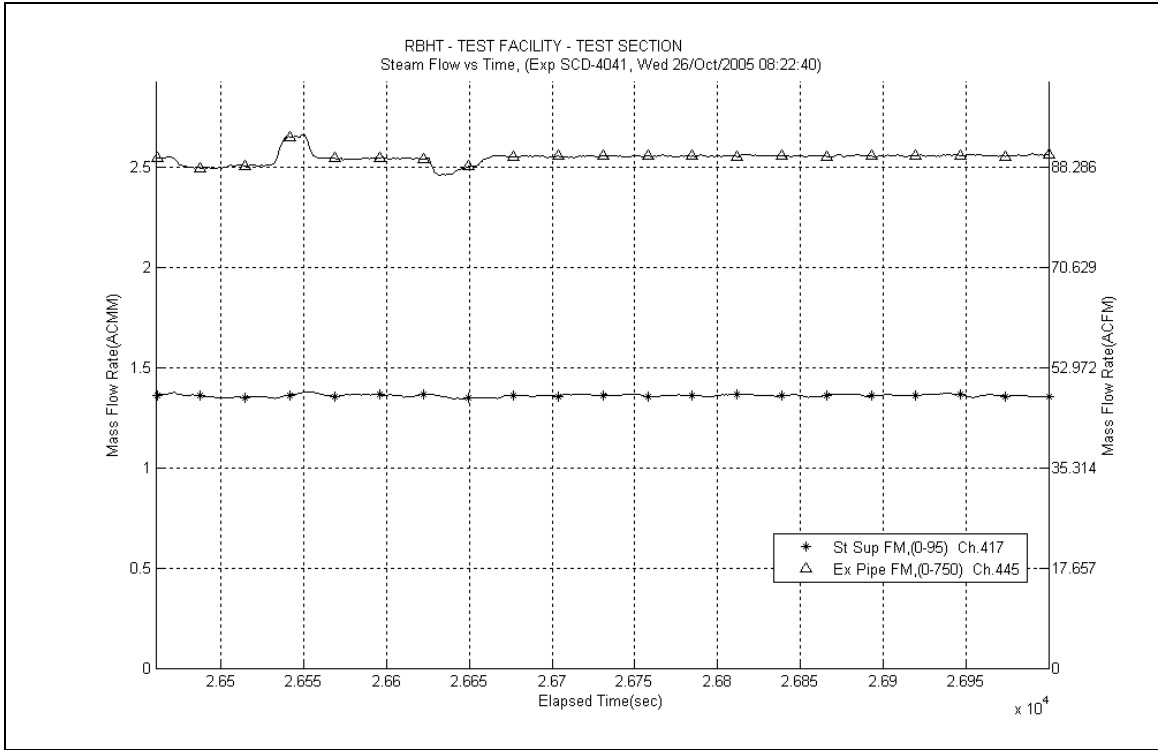

Figure A-595: Inlet and Exhaust Steam Flow Rates for Experiment 40411

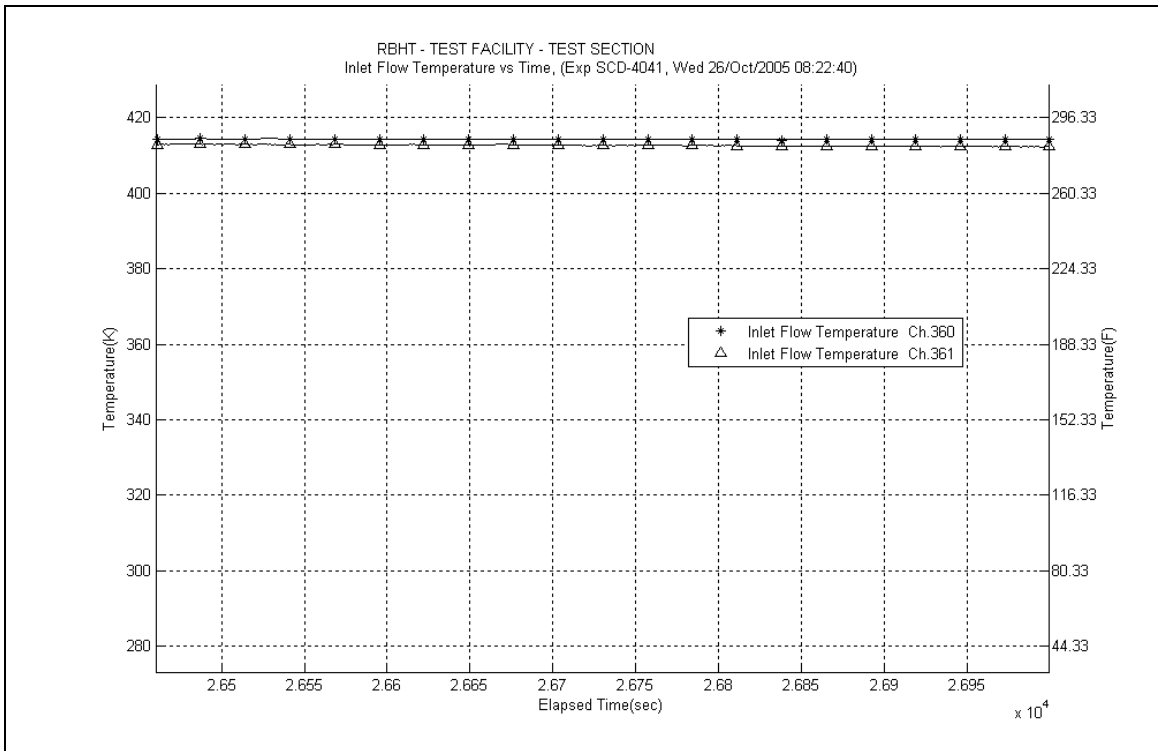

Figure A-596: Inlet Steam Temperature for Experiment 40411

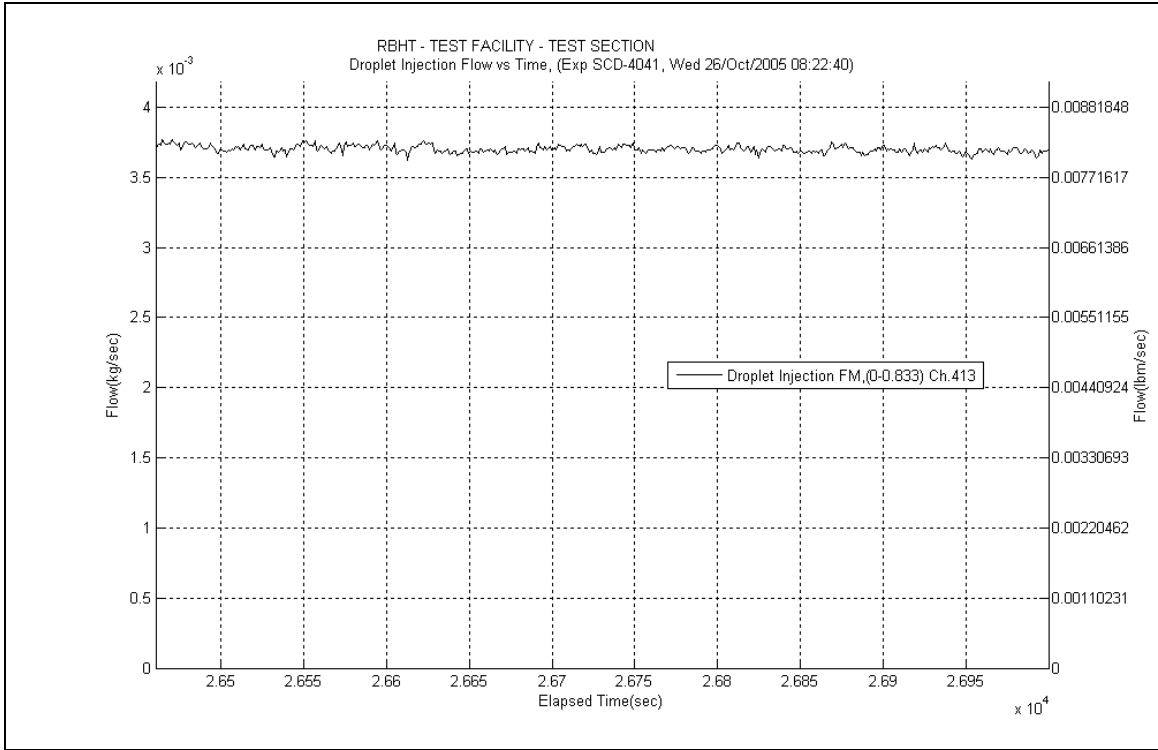

Figure A-597: Droplet Injection Flow Rate for Experiment 4041I

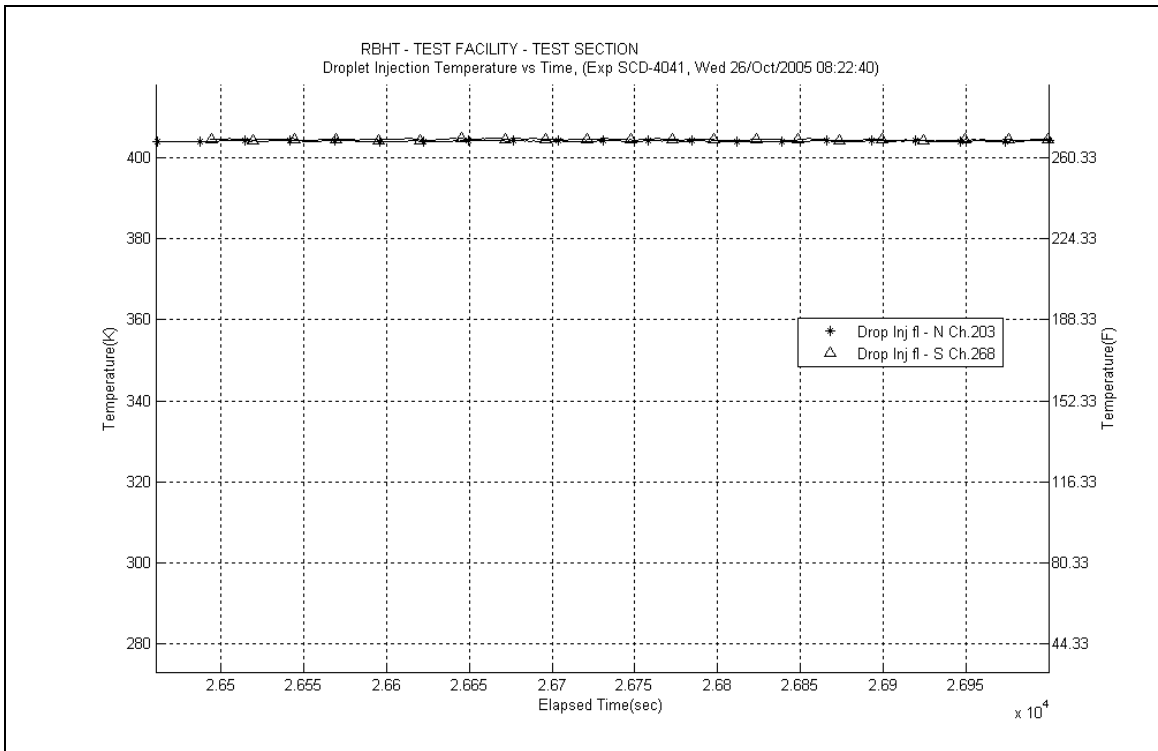

Figure A-598: Droplet Injection Temperature for Experiment 4041I

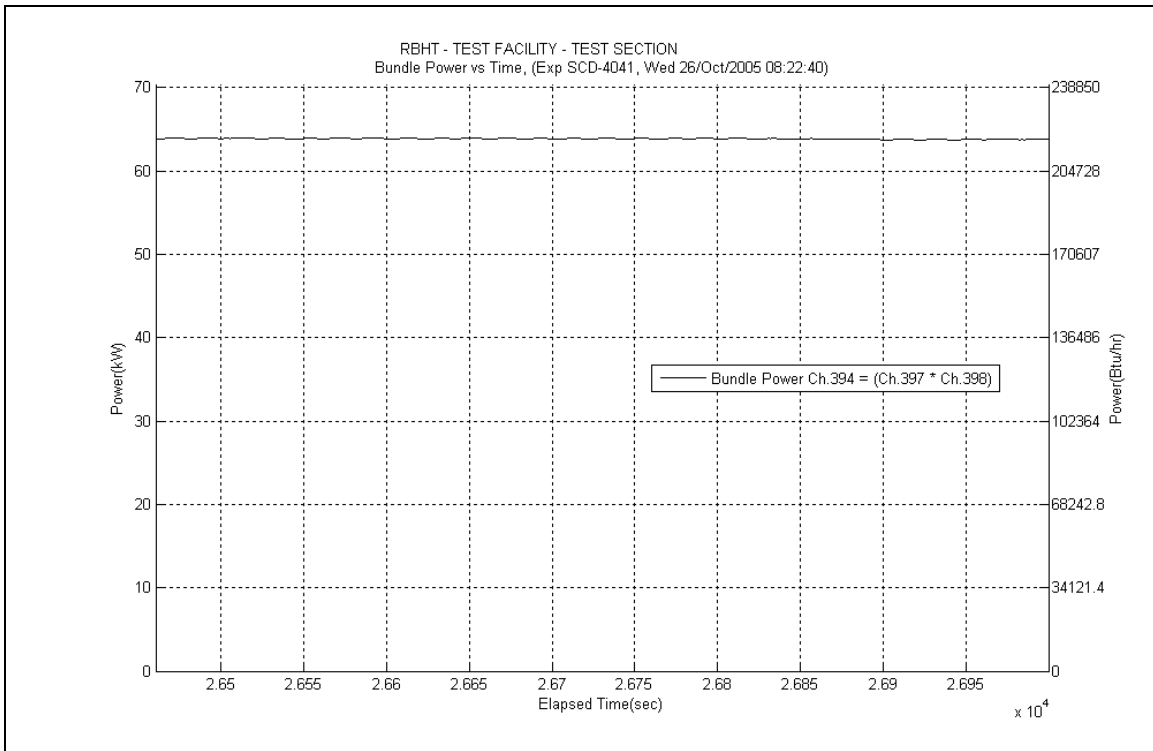

Figure A-599: Bundle Power for Experiment 4041I

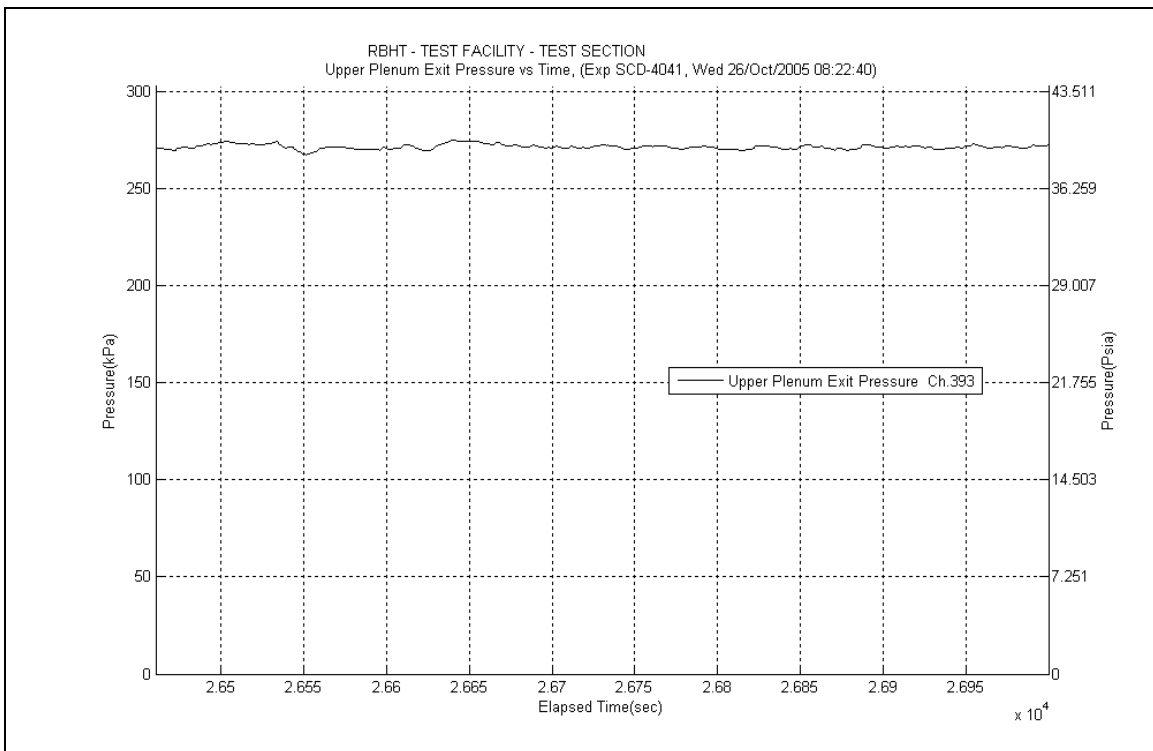

Figure A-600: Upper Plenum Pressure for Experiment 4041I

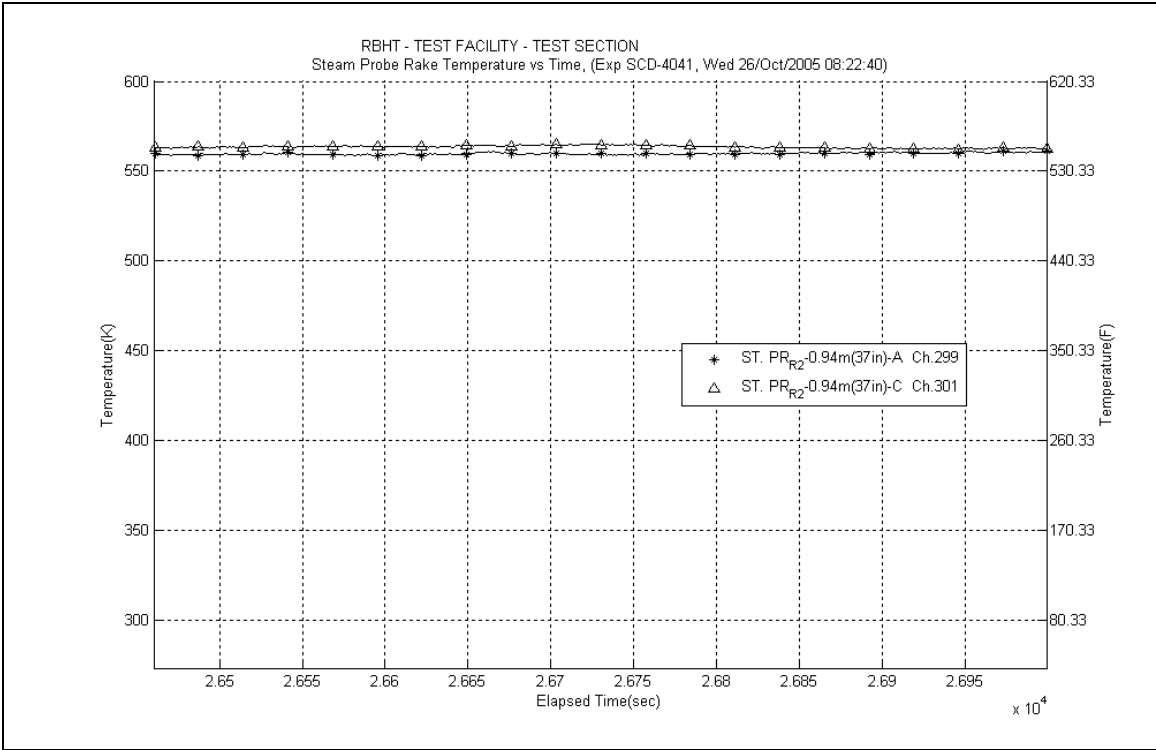

Figure A-601: Steam Probe Rake #2 Temperatures for Experiment 40411

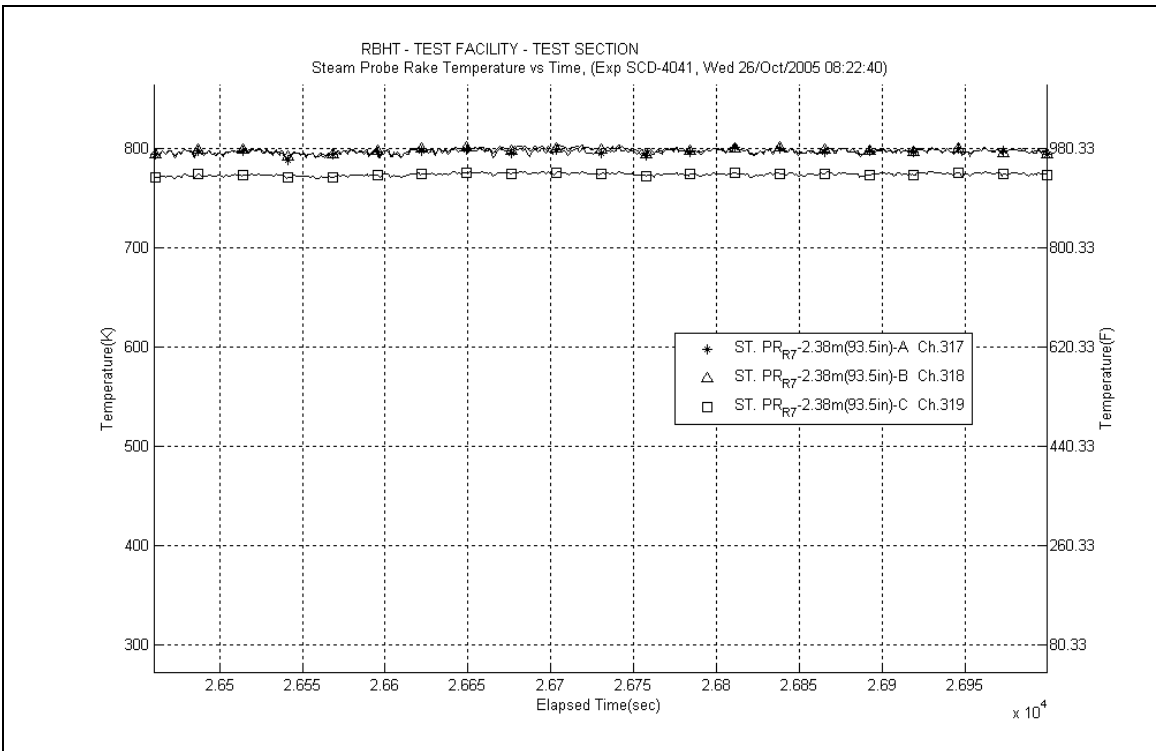

Figure A-602: Steam Probe Rake #7 Temperatures for Experiment 40411

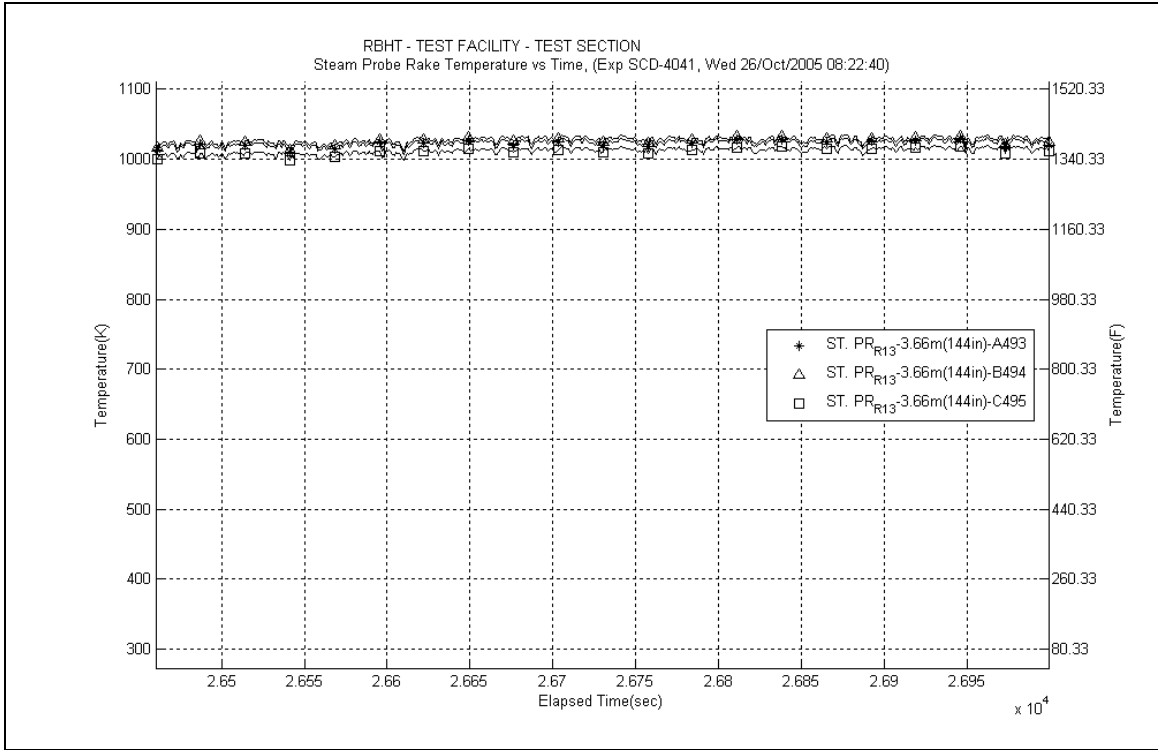

Figure A-603: Steam Probe Rake #13 Temperatures for Experiment 4041I

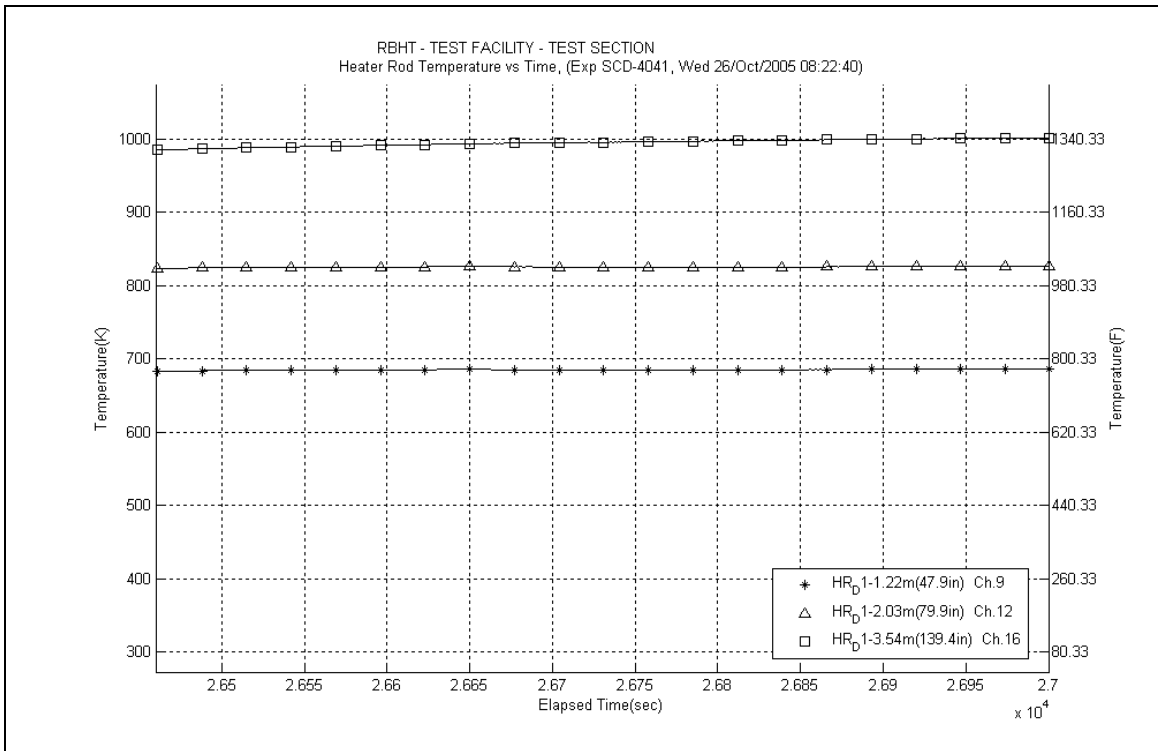

Figure A-604: Heater Rod D1 Temperatures for Experiment 4041I

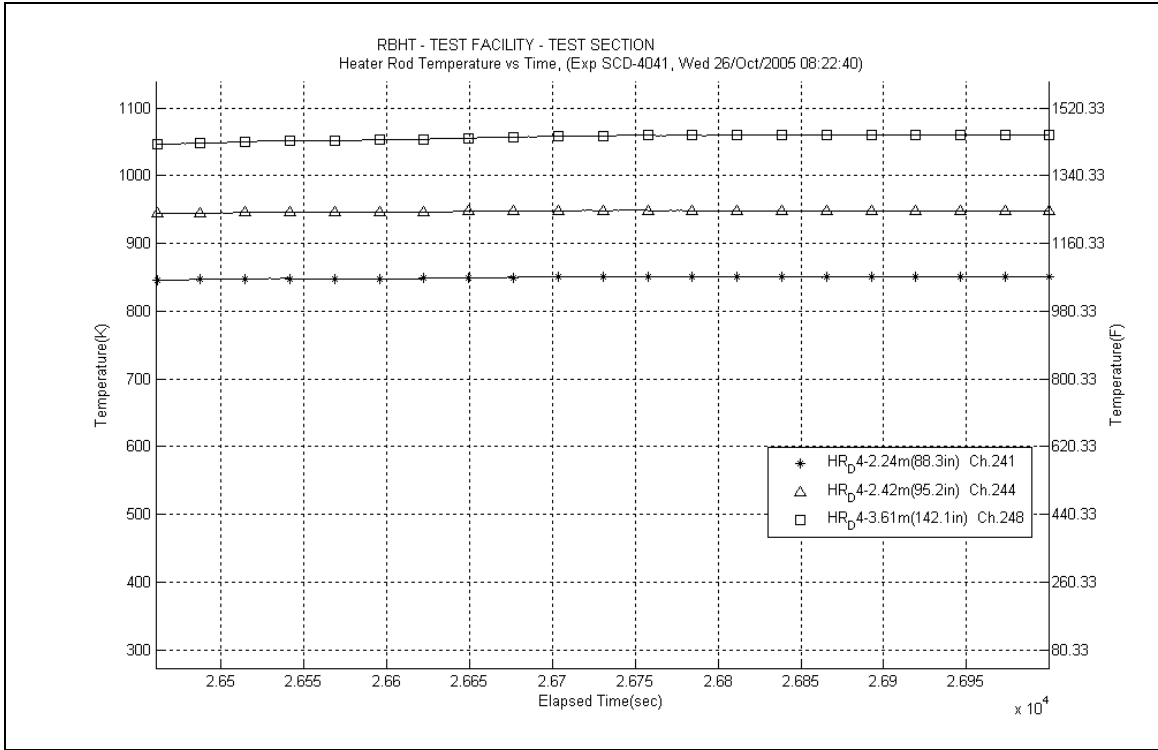

Figure A-605: Heater Rod D4 Temperatures for Experiment 40411

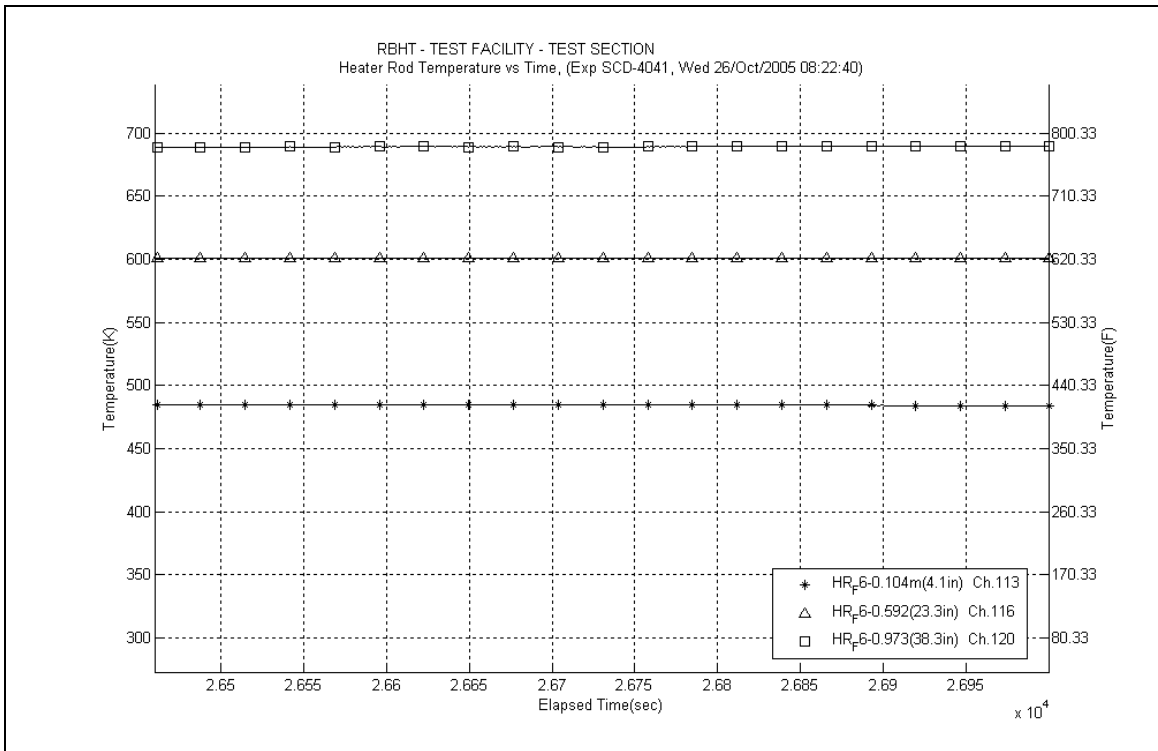

Figure A-606: Heater Rod F6 Temperatures for Experiment 40411

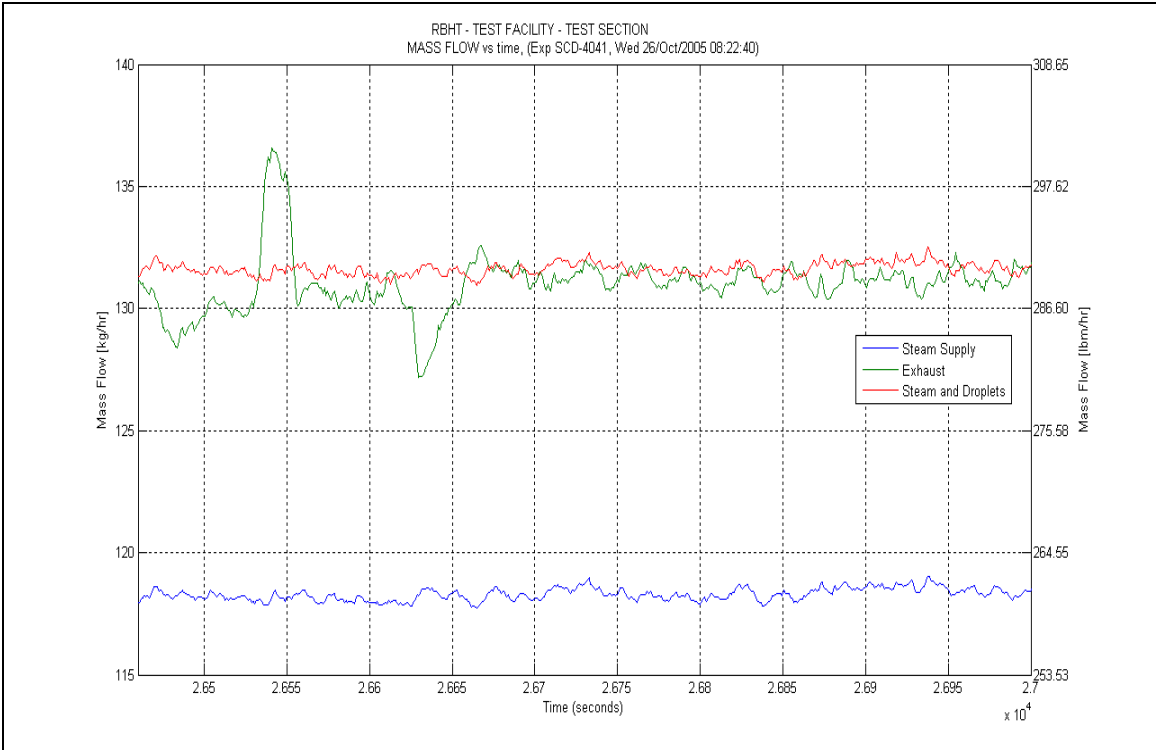

Figure A-607: Mass Flow for Experiment 4041

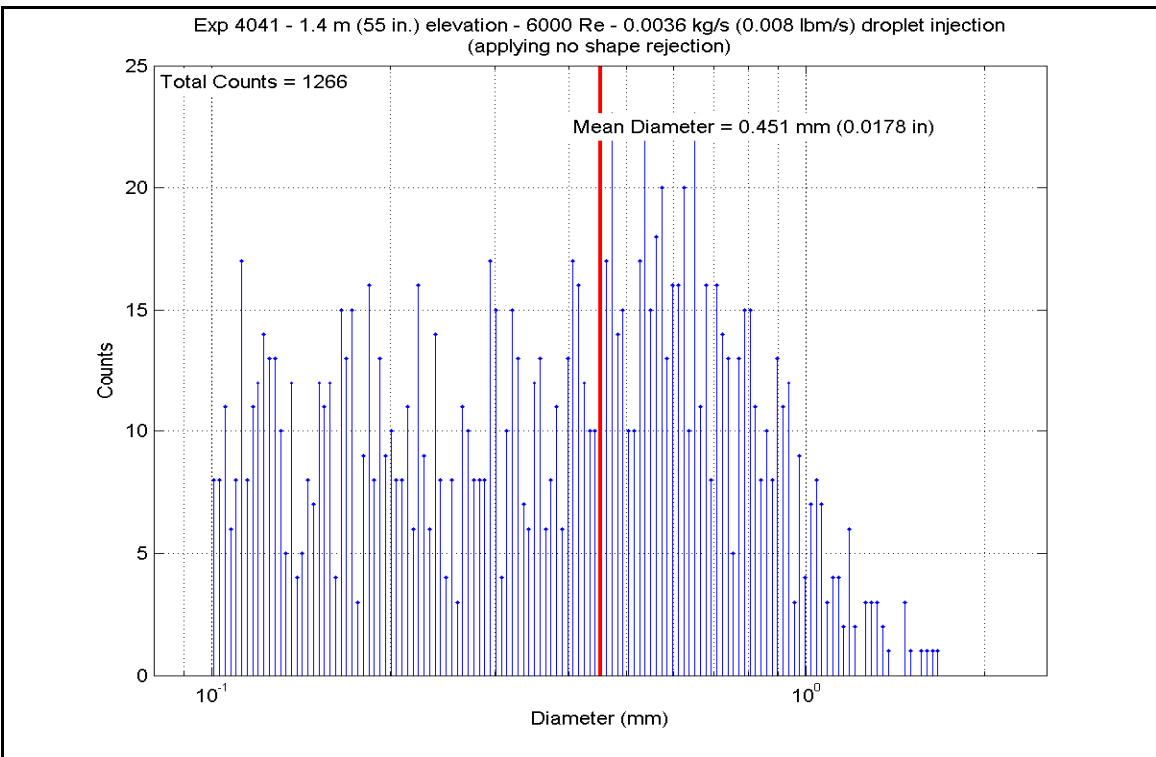

Figure A-608: Droplet Measurements at 1.397 m (55 in.) Elevation for Experiment 4041

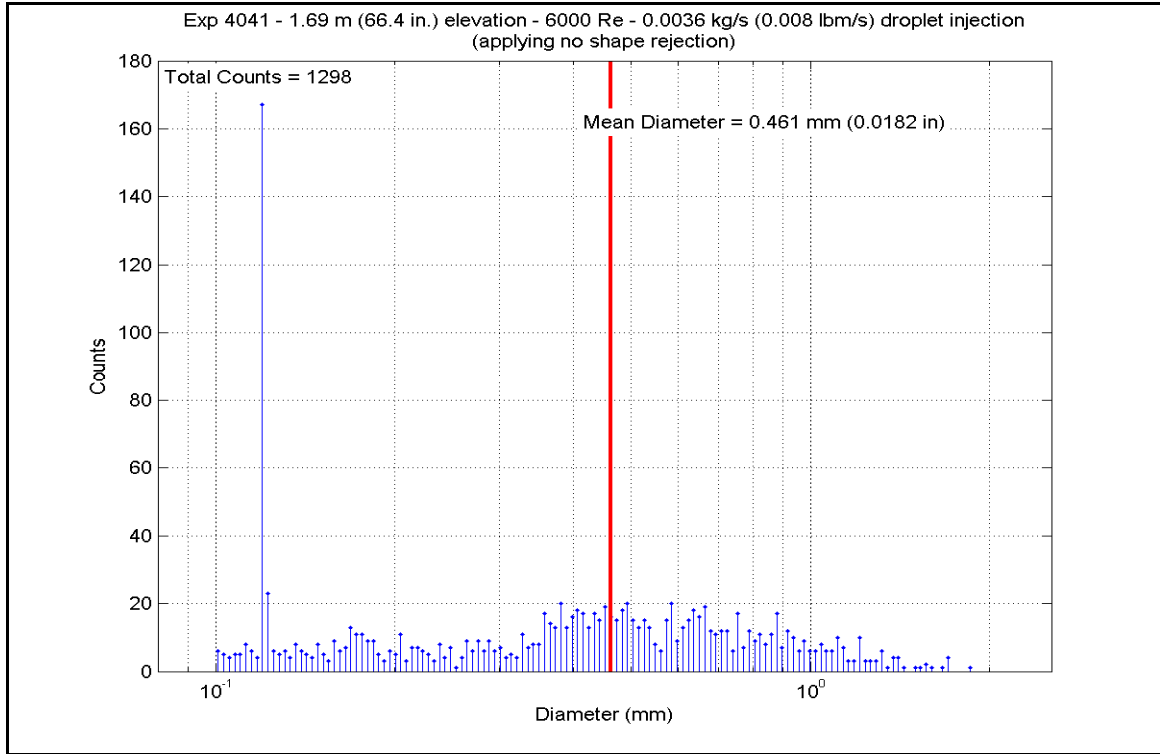

Figure A-609: Droplet Measurements at 1.687 m (66.4 in.) Elevation for Experiment 4041I

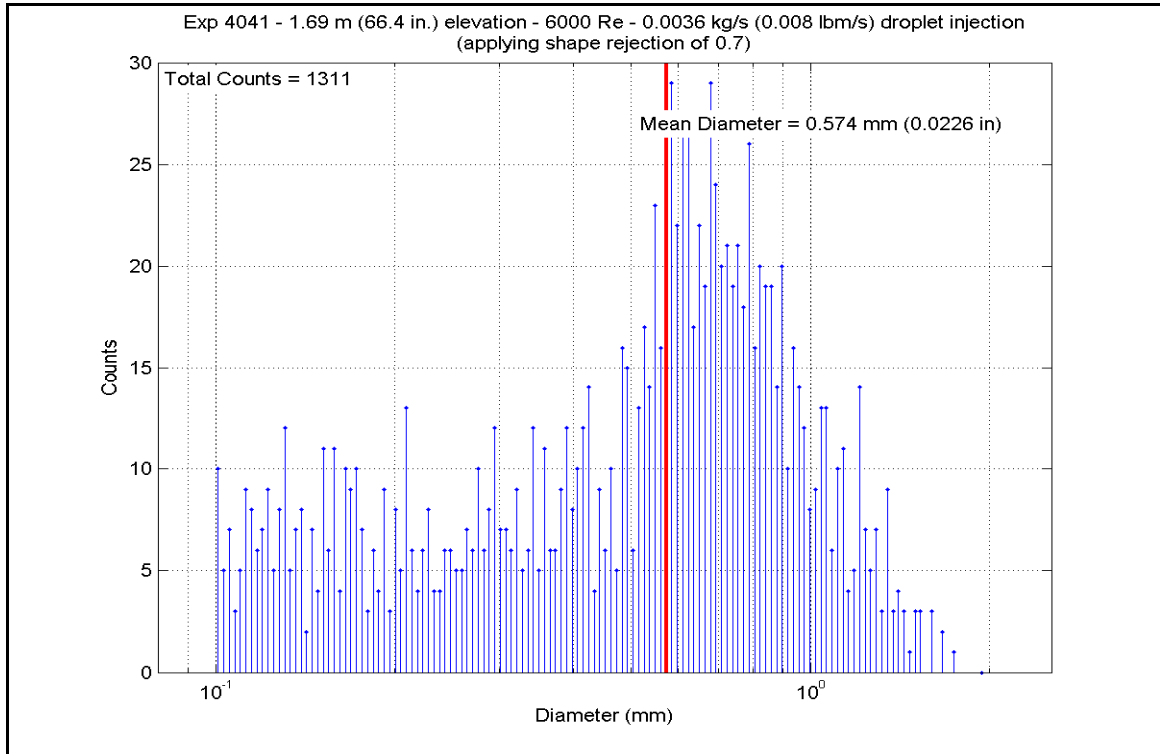

Figure A-610: Droplet Measurements at 1.687 m (66.4 in.) Elevation for Experiment 4041I

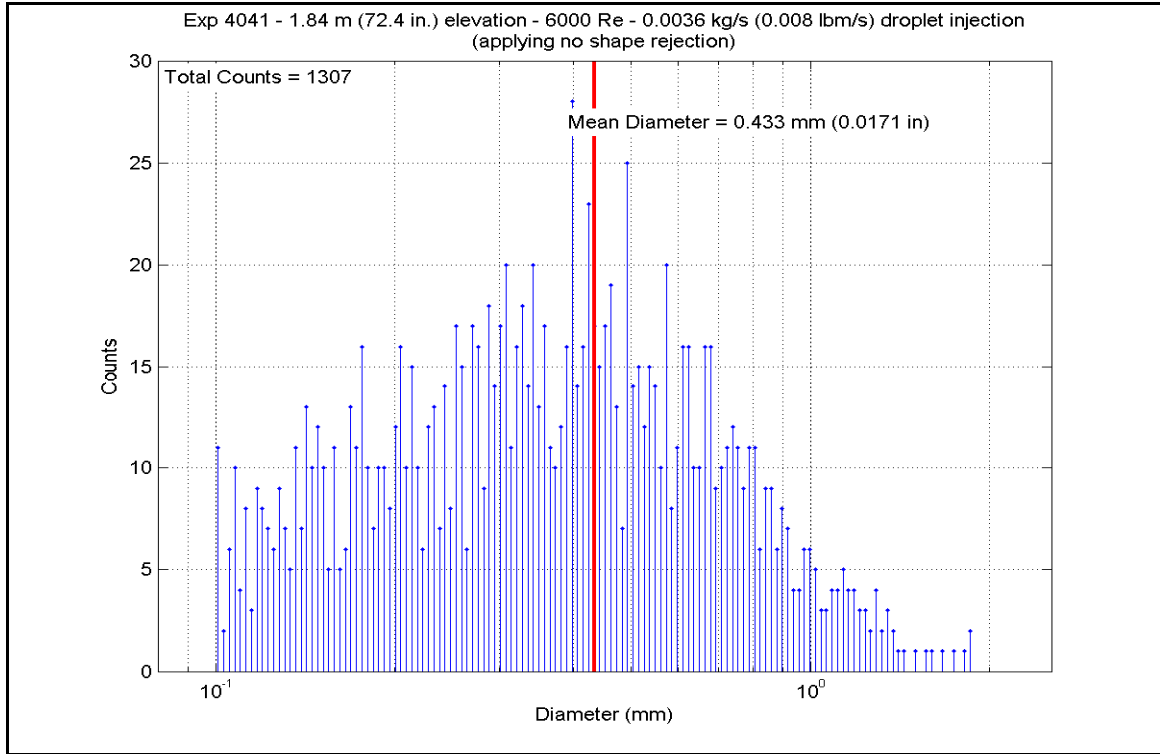

Figure A-611: Droplet Measurements at 1.839 m (72.4 in.) Elevation for Experiment 4041

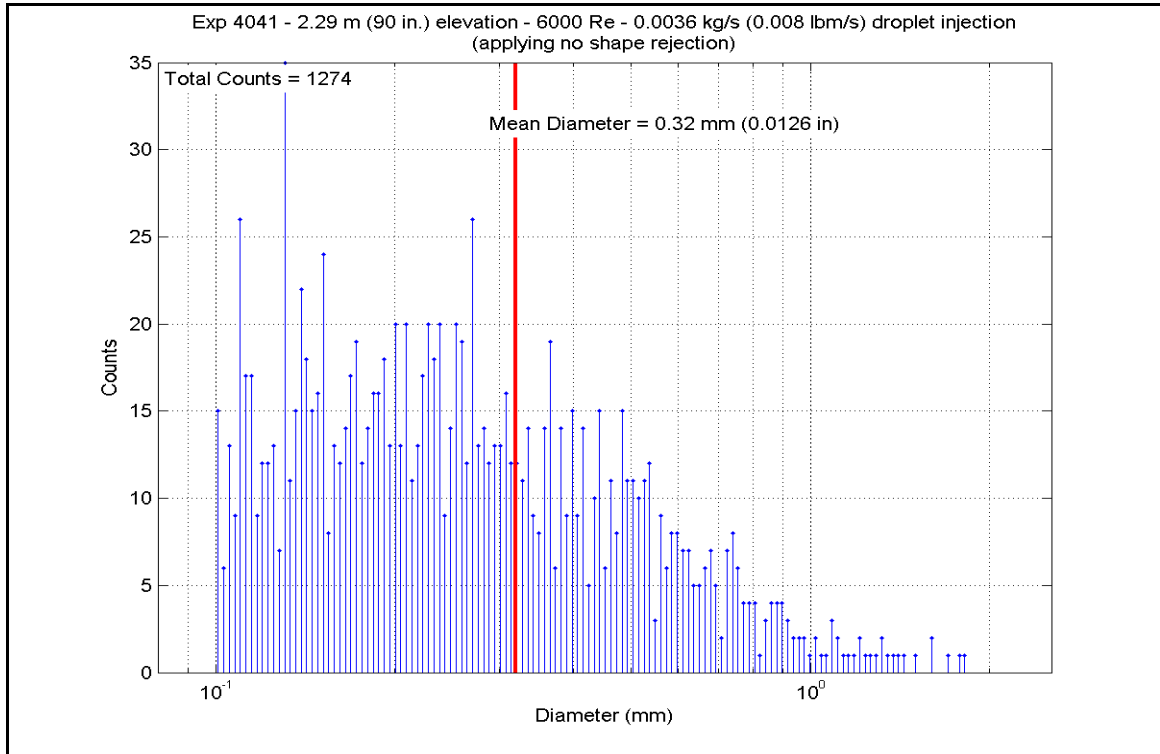

Figure A-612: Droplet Measurements at 2.286 m (90 in.) Elevation for Experiment 4041

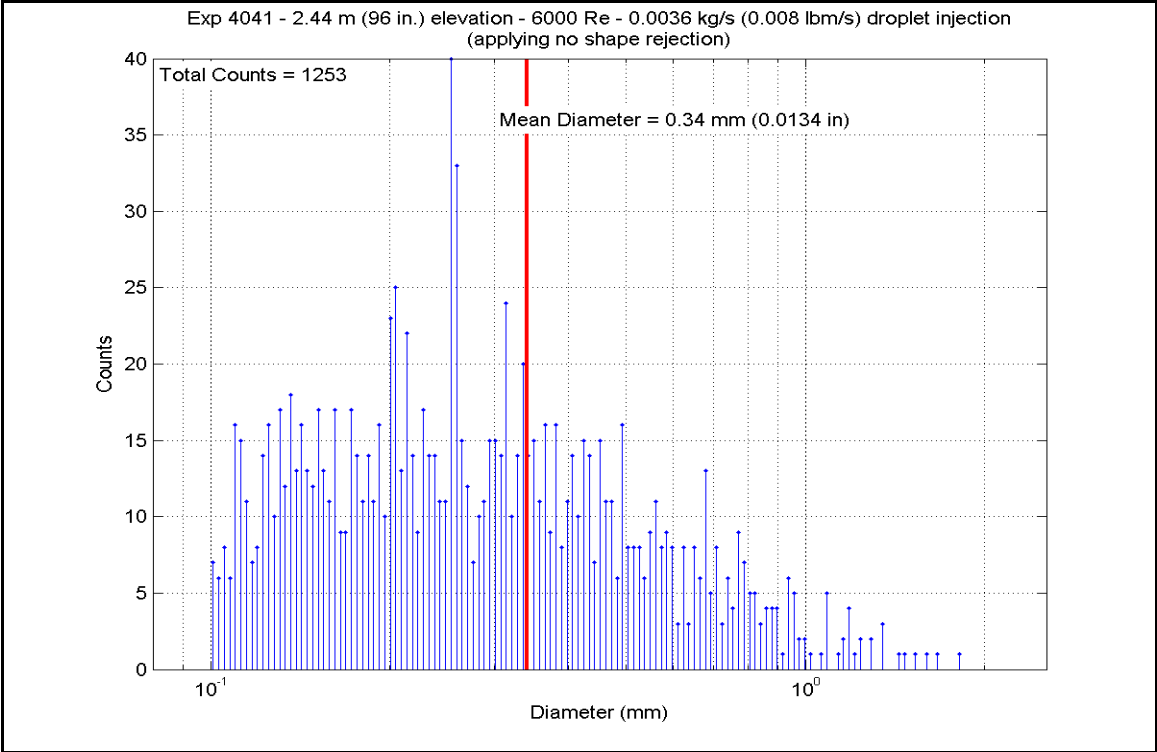

Figure A-613: Droplet Measurements at 2.438 m (96 in.) Elevation for Experiment 40411

Table A-33: Summary of Steam Cooling Heat Transfer Reduced Data for Experiment 40411

SCD-4041-I		Inlet Reynolds:		6000		UP Pressure:		40 psia				
Matrix Test #7a		UP Pressure:		275.8 kPa		Bundle Power:		218377 Btu/hr				
Time Window: 26460-27000		Bundle Power:		64.00 kW		Steam flow:		260.0 lbm/hr				
Inner 3x3		Dropletflow:		0.0036 kg/s		Dropletflow:		0.008 lbm/s				
H.R. ID	H.R. Location	Channel Number	Elevation (in)	Elevation (m)	Zgrid (in)	Zgrid (m)	H.R. Tw (°F)	H.R. Tw (K)	H.R. q" (Btu/hr-ft2)	H.R. q" (W/m2)	h _{sat} (z) (Btu/hr-ft2-F)	h _{sat} (z) (W/m2-K)
Gr-3	RodD3_88.3	185	88.3	2.243	-0.2	-0.005	864.75	735.8	6789.93	21418.8	11.359	64.5
	RodD3_91.3	186	91.3	2.319	2.8	0.071	944.72	780.2	6933.13	21870.6	10.230	58.1
	RodD3_93.1	187	93.1	2.365	4.6	0.117	942.88	779.2	7017.42	22136.4	10.383	59.0
	RodD3_95.3	188	95.3	2.421	6.8	0.173	991.52	806.2	7125.87	22478.6	9.835	55.9
	RodD3_100.1	189	100.1	2.543	11.6	0.295	1077.98	854.2	7364.14	23230.2	9.081	51.6
	RodD3_106.1	190	106.1	2.695	17.6	0.447	1141.26	889.4	7648.32	24126.6	8.748	49.7
	RodD3_110	191	110	2.794	21.5	0.546	1048.00	837.6	7614.70	24020.6	9.750	55.4
	RodD3_142.1	192	142.1	3.609	8.6	0.218	1072.07	851.0	2643.15	8337.8	3.283	18.6
Gr-3	RodC4_88.4	233	88.4	2.245	-0.1	-0.003	808.97	704.8	6894.70	21749.3	12.722	72.2
	RodC4_91.1	234	91.1	2.314	2.6	0.066	905.89	758.6	7025.64	22162.4	10.997	62.4
	RodC4_93.4	235	93.4	2.372	4.9	0.124	934.60	774.6	7138.26	22517.6	10.692	60.7
	RodC4_95.3	236	95.3	2.421	6.8	0.173	982.73	801.3	7232.45	22814.8	10.105	57.4
	RodC4_100.1	237	100.1	2.543	11.6	0.295	1030.03	827.6	7456.74	23522.3	9.773	55.5
	RodC4_106.1	238	106.1	2.695	17.6	0.447	1091.96	862.0	7763.06	24488.6	9.410	53.4
	RodC4_110	239	110	2.794	21.5	0.546	991.24	806.1	7650.82	24134.5	10.564	60.0
	RodC4_142.2	240	142.2	3.612	8.7	0.221	1013.87	818.6	2907.18	9170.7	3.892	22.1
Gr-3	RodD4_88.3	241	88.3	2.243	-0.2	-0.005	798.84	699.2	6870.15	21671.9	12.918	73.4
	RodD4_91.3	242	91.3	2.319	2.8	0.071	896.94	753.7	7007.51	22105.2	11.124	63.2
	RodD4_93.2	243	93.2	2.367	4.7	0.119	924.08	768.7	7096.29	22385.2	10.800	61.3
	RodD4_95.2	244	95.2	2.418	6.7	0.170	969.49	794.0	7192.36	22688.3	10.238	58.1
	RodD4_100.1	245	100.1	2.543	11.6	0.295	1053.50	840.6	7423.35	23417.0	9.439	53.6
	RodD4_106.1	246	106.1	2.695	17.6	0.447	1089.23	860.5	7710.24	24321.9	9.377	53.3
	RodD4_142.1	248	142.1	3.609	8.6	0.218	1025.04	824.8	2792.05	8807.5	3.683	20.9
Gr-3	RodE4_88.4	201	88.4	2.245	-0.1	-0.003	826.11	714.3	6733.94	21242.2	12.044	68.4
	RodE4_91.2	202	91.2	2.316	2.7	0.069	926.75	770.2	6860.78	21642.3	10.399	59.1
	RodE4_95.3	204	95.3	2.421	6.8	0.173	1004.42	813.4	7048.08	22233.2	9.558	54.3
	RodE4_100.9	205	100.9	2.563	12.4	0.315	1071.86	850.8	7320.20	23091.6	9.095	51.6
	RodE4_142.3	208	142.3	3.614	8.8	0.224	1056.61	842.4	2782.71	8778.1	3.524	20.0

Table A-33: Summary of Steam Cooling Heat Transfer Reduced Data for Experiment 4041, continued

	H.R. Location	Channel Number	Elevation (in)	Elevation (m)	Zgrid (in)	Zgrid (m)	H.R. Tw (°F)	H.R. Tw (K)	H.R. q" (Btu/hr-ft ²)	H.R. q" (W/m ²)	h _{sat} (z) (Btu/hr-ft ² -F)	h _{sat} (z) (W/m ² -K)
Gr-4	RodE3_63.4	193	63.4	1.610	16.4	0.417	946.30	781.1	5584.77	17617.1	8.221	46.7
	RodE3_113.6	194	113.6	2.885	0.85	0.022	1078.83	854.7	6887.27	21725.9	8.484	48.2
	RodE3_115.5	195	115.5	2.934	2.75	0.070	1113.51	874.0	6613.44	20862.1	7.813	44.4
	RodE3_118.5	196	118.5	3.010	5.75	0.146	1138.85	888.1	6211.63	19594.6	7.125	40.5
	RodE3_122.7	197	122.7	3.117	9.95	0.253	1140.69	889.1	5643.68	17803.0	36.7	36.7
	RodE3_126.5	198	126.5	3.213	13.75	0.349	1140.19	888.8	5133.04	16192.2	5.879	33.4
	RodE3_131.7	199	131.7	3.345	-1.8	-0.046	1053.79	840.8	4423.21	13953.0	5.622	31.9
	RodE3_135.6	200	135.6	3.444	2.1	0.053	1085.74	858.6	3909.74	12333.3	4.775	27.1
	RodC5_63.7	225	63.7	1.618	16.7	0.424	918.28	765.5	5439.86	17160.0	8.353	47.4
	RodC5_113.6	226	113.6	2.885	0.85	0.022	994.57	807.9	6751.63	21298.0	9.280	52.7
Gr-4	RodC5_115.7	227	115.7	2.939	2.95	0.075	1033.86	829.7	6476.17	20429.1	8.445	48.0
	RodC5_122.7	229	122.7	3.117	9.95	0.253	1060.30	844.4	5585.25	17618.7	7.041	40.0
	RodC5_126.7	230	126.7	3.218	13.95	0.354	1055.59	841.8	5072.88	16002.4	6.433	36.5
	RodC5_131.6	231	131.6	3.343	-1.9	-0.048	944.30	780.0	4458.84	14065.4	6.583	37.4
	RodC5_135.7	232	135.7	3.447	2.2	0.056	977.30	798.3	3926.12	12385.0	5.527	31.4
	RodE5_63.6	209	63.6	1.615	16.6	0.422	845.76	725.2	5641.21	17795.2	9.747	55.4
	RodE5_113.6	210	113.6	2.885	0.85	0.022	896.33	753.3	6937.65	21884.8	11.024	62.6
	RodE5_115.4	211	115.4	2.931	2.65	0.067	968.62	793.5	6689.28	21101.3	9.534	54.1
	RodE5_118.7	212	118.7	3.015	5.95	0.151	1029.84	827.5	6252.07	19722.1	8.196	46.5
	RodE5_122.6	213	122.6	3.114	9.85	0.250	1062.81	845.8	5735.33	18092.1	7.207	40.9
RodE5_126.6	214	126.6	3.216	13.85	0.352	1066.36	847.8	5206.67	16424.5	6.514	37.0	
RodE5_131.6	215	131.6	3.343	-1.9	-0.048	1045.36	836.1	4541.69	14326.8	5.835	33.1	
RodE5_135.6	216	135.6	3.444	2.1	0.053	1052.16	839.9	4024.01	12693.7	5.125	29.1	
Gr-5	RodC3_79.8	177	79.8	2.027	8.92	0.227	940.98	778.1	6351.66	20036.3	9.424	53.5
	RodC3_85.6	178	85.6	2.174	14.72	0.374	855.96	730.9	6647.54	20969.7	11.287	64.1
	RodC3_88.5	179	88.5	2.248	0	0.000	852.02	728.7	6776.11	21375.2	11.583	65.8
	RodC3_92.4	180	92.4	2.347	3.9	0.099	964.59	791.3	6965.92	21974.0	9.986	56.7
	RodC3_94.4	181	94.4	2.398	5.9	0.150	982.41	801.2	7056.95	22261.1	9.864	56.0
	RodC3_97.2	182	97.2	2.469	8.7	0.221	1036.83	831.4	7206.55	22733.1	9.361	53.2
	RodC3_108.8	183	108.8	2.764	20.3	0.516	1128.03	882.1	7597.74	23967.1	8.824	50.1
	RodD5_50	217	50	1.270	3	0.076	817.21	709.4	4954.09	15627.7	9.004	51.1
	RodD5_54.1	218	54.1	1.374	7.1	0.180	784.91	691.4	5197.36	16395.1	10.035	57.0
	RodD5_56.9	219	56.9	1.445	9.9	0.251	837.29	720.5	5299.39	16716.9	9.292	52.8
RodD5_60	220	60	1.524	13	0.330	875.83	741.9	5438.32	17155.2	8.932	50.7	
RodD5_66.1	221	66.1	1.679	19.1	0.485	910.75	761.3	5757.30	18161.4	8.943	50.8	
RodD5_69.9	222	69.9	1.775	-0.98	-0.025	727.93	659.8	5940.59	18739.6	12.888	73.2	
RodD5_72.9	223	72.9	1.852	2.02	0.051	811.57	706.2	6076.69	19168.9	11.159	63.4	
RodD5_74.9	224	74.9	1.902	4.02	0.102	857.27	731.6	6170.92	19466.2	10.454	59.4	

Inner 3x3

Table A-33: Summary of Steam Cooling Heat Transfer Reduced Data for Experiment 4041, continued

H.R. ID	H.R. Location	Channel Number	Elevation (in)	Elevation (m)	Zgrid (in)	Zgrid (m)	H.R. Tw (°F)	H.R. Tw (K)	H.R. q" (Btu/hr-ft ²)	H.R. q" (W/m ²)	h _{sat} (z) (Btu/hr-ft ² -F)	h _{sat} (z) (W/m ² -K)	
Gr-2	RodB5_41	153	41	1.041	13.5	0.343	752.59	673.5	4504.11	14208.2	9.275	52.7	
	RodB5_52.9	154	52.9	1.344	5.9	0.150	821.04	711.5	5074.56	16007.7	9.159	52.0	
	RodB5_55	155	55	1.397	8	0.203	859.07	732.6	5174.12	16321.8	8.739	49.6	
	RodB5_57.8	156	57.8	1.468	10.8	0.274	886.26	747.7	5316.15	16769.8	8.585	48.8	
	RodB5_64	157	64	1.626	17	0.432	930.65	772.4	5606.99	17687.2	8.449	48.0	
	RodB5_73.9	158	73.9	1.877	3.02	0.077	875.11	741.5	6092.13	19217.6	10.018	56.9	
	RodB5_75.9	159	75.9	1.928	5.02	0.128	908.91	760.3	6189.37	19524.4	9.642	54.8	
	RodB5_76.9	160	76.9	1.953	6.02	0.153	922.44	767.8	6237.48	19676.1	9.517	54.0	
	Gr-2	RodF5_41	105	41	1.041	13.5	0.343	743.67	668.5	4474.57	14115.0	9.387	53.3
		RodF5_53.1	106	53.1	1.349	6.1	0.155	805.05	702.6	5055.97	15949.1	9.397	53.4
		RodF5_55	107	55	1.397	8	0.203	844.66	724.6	5141.47	16218.8	8.901	50.5
		RodF5_57.8	108	57.8	1.468	10.8	0.274	889.14	749.3	5259.99	16592.6	8.455	48.0
		RodF5_64	109	64	1.626	17	0.432	927.98	770.9	5552.47	17515.3	8.400	47.7
		RodF5_73.8	110	73.8	1.875	2.92	0.074	874.33	741.1	6038.22	19047.6	9.942	56.5
		RodF5_75.8	111	75.8	1.925	4.92	0.125	912.72	762.4	6133.84	19349.2	9.499	53.9
		RodF5_76.8	112	76.8	1.951	5.92	0.150	928.43	771.2	6181.86	19500.7	9.346	53.1
Gr-2		RodC2_41	57	41	1.041	13.5	0.343	742.92	668.1	4490.43	14165.1	9.435	53.6
		RodC2_53.1	58	53.1	1.349	6.1	0.155	863.28	735.0	5076.50	16013.8	8.514	48.3
		RodC2_55	59	55	1.397	8	0.203	881.88	745.3	5166.78	16298.6	8.403	47.7
		RodC2_57.8	60	57.8	1.468	10.8	0.274	913.62	762.9	5300.27	16719.7	8.197	46.5
	RodC2_63.9	61	63.9	1.623	16.9	0.429	942.69	779.1	5597.45	17657.1	8.284	47.0	
	RodC2_73.8	62	73.8	1.875	2.92	0.074	920.22	766.6	6083.21	19189.5	9.313	52.9	
	RodC2_75.8	63	75.8	1.925	4.92	0.125	946.30	781.1	6183.08	19504.5	9.102	51.7	
	RodC2_76.8	64	76.8	1.951	5.92	0.150	956.82	786.9	6230.72	19654.8	9.032	51.3	
Gr-2	RodC6_40.9	137	40.9	1.039	13.4	0.340	747.86	670.8	4477.28	14123.6	9.311	52.9	
	RodC6_52.8	138	52.8	1.341	5.8	0.147	867.12	737.1	5072.59	16001.5	8.453	48.0	
	RodC6_54.8	139	54.8	1.392	7.8	0.198	888.28	748.9	5172.80	16317.6	8.326	47.3	
	RodC6_57.8	140	57.8	1.468	10.8	0.274	922.89	768.1	5323.45	16792.8	8.116	46.1	
	RodC6_63.8	141	63.8	1.621	16.8	0.427	955.88	786.4	5623.47	17739.2	8.163	46.4	
	RodC6_73.7	142	73.7	1.872	2.82	0.072	912.11	762.1	6114.49	19288.2	9.478	53.8	
	RodC6_75.8	143	75.8	1.925	4.92	0.125	939.04	777.1	6219.83	19620.5	9.255	52.6	
	RodC6_76.8	144	76.8	1.951	5.92	0.150	955.05	786.0	6269.70	19777.8	9.112	51.7	

5x5 periphery

Table A-33: Summary of Steam Cooling Heat Transfer Reduced Data for Experiment 4041, continued

H.R. Location		Channel Number	Elevation (in)	Elevation (m)	Zgrid (in)	Zgrid (m)	H.R. Tw (°F)	H.R. Tw (K)	H.R. q" (Btu/hr-ft ²)	H.R. q" (W/m ²)	h _{sat} (z) (Btu/hr-ft ² -F)	h _{sat} (z) (W/m ² -K)
Gr-3	RodB4_88.4	161	88.4	2.245	-0.1	-0.003	834.95	719.2	6858.11	21633.9	12.075	68.6
	RodB4_91.3	162	91.3	2.319	2.8	0.071	930.60	772.4	6957.15	21946.3	10.484	59.5
	RodB4_93.3	163	93.3	2.370	4.8	0.122	945.32	780.5	7032.44	22183.8	10.367	58.9
	RodB4_95.1	164	95.1	2.416	6.6	0.168	979.47	799.5	7111.02	22431.7	9.981	56.7
	RodB4_100	165	100	2.540	11.5	0.292	1009.36	816.1	7341.26	23158.0	9.889	56.2
	RodB4_106	166	106	2.692	17.5	0.445	1096.71	864.7	7619.87	24036.9	9.184	52.2
	RodB4_109.9	167	109.9	2.791	21.4	0.544	1004.95	813.7	7403.70	23355.0	10.033	57.0
	RodB4_142.3	168	142.3	3.614	8.8	0.224	1014.22	818.8	2883.47	9095.9	3.859	21.9
Gr-5	RodF4_85.6	98	85.6	2.174	14.72	0.374	899.73	755.2	6593.27	20798.5	10.420	59.2
	RodF4_88.4	99	88.4	2.245	-0.1	-0.003	861.07	733.7	6748.50	21288.1	11.360	64.5
	RodF4_92.4	100	92.4	2.347	3.9	0.099	966.48	792.3	6953.85	21935.9	9.941	56.5
	RodF4_94.3	101	94.3	2.395	5.8	0.147	1000.80	811.4	7042.94	22216.9	9.598	54.5
	RodF4_97.2	102	97.2	2.469	8.7	0.221	1042.99	834.8	7180.28	22650.2	9.253	52.5
	RodF4_108.8	103	108.8	2.764	20.3	0.516	1106.82	870.3	7582.22	23918.1	9.028	51.3
	RodF4_111	104	111	2.819	-1.75	-0.044	993.02	807.1	7293.49	23007.3	10.046	57.0
	RodD2_103.2	65	103.2	2.621	14.7	0.373	1133.31	885.0	6735.37	21246.7	7.775	44.2
Gr-6	RodD2_106	66	106	2.692	17.5	0.445	1153.49	896.2	6379.32	20123.6	7.196	40.9
	RodD2_112.6	67	112.6	2.860	-0.15	-0.004	1172.70	906.9	5891.72	18585.4	6.505	36.9
	RodD2_114.9	68	114.9	2.918	2.15	0.055	1177.13	909.3	5323.16	16791.9	5.849	33.2
	RodD2_117.4	69	117.4	2.982	4.65	0.118	1163.25	901.6	4782.60	15086.7	5.336	30.3
	RodD2_120.8	70	120.8	3.068	8.05	0.204	1148.27	893.3	7523.77	23733.7	8.537	48.5
	RodD2_124.8	71	124.8	3.170	12.05	0.306	1170.51	905.7	7659.25	24161.1	8.477	48.1
	RodD2_128.6	72	128.6	3.266	15.85	0.403	1094.82	863.6	7042.40	22215.2	8.507	48.3
	RodD6_103.1	129	103.1	2.619	14.6	0.371	1099.96	866.5	7546.40	23805.1	9.060	51.4
Gr-6	RodD6_106	130	106	2.692	17.5	0.445	1115.15	874.9	7683.04	24236.1	9.059	51.4
	RodD6_112.9	131	112.9	2.868	0.15	0.004	1022.38	823.4	7029.57	22174.8	9.306	52.8
	RodD6_114.9	132	114.9	2.918	2.15	0.055	1059.72	844.1	6748.51	21288.2	8.513	48.3
	RodD6_116.8	133	116.8	2.967	4.05	0.103	1080.49	855.6	6473.28	20420.0	7.957	45.2
	RodD6_120.9	134	120.9	3.071	8.15	0.207	1087.20	859.4	5860.77	18487.8	7.146	40.6
	RodD6_124.8	135	124.8	3.170	12.05	0.306	1084.55	857.9	5303.65	16730.3	6.487	36.8
RodD6_128.7	136	128.7	3.269	15.95	0.405	1071.49	850.6	4744.13	14965.3	5.897	33.5	

5x5 periphery

Table A-33: Summary of Steam Cooling Heat Transfer Reduced Data for Experiment 4041, continued

5x5 periphery		H.R. Location	Channel Number	Elevation (in)	Elevation (m)	Zgrid (in)	Zgrid (m)	H.R. Tw (°F)	H.R. Tw (K)	H.R. q" (Btu/hr-ft ²)	H.R. q" (W/m ²)	h _{sat} (z) (Btu/hr-ft ² -F)	h _{sat} (z) (W/m ² -K)
Gr-8	RodE2_50.1	73	50.1	1.273	3.1	0.079	806.32	703.3	4972.87	15686.9	9.221	52.4	
	RodE2_54	74	54	1.372	7	0.178	872.36	740.0	5162.52	16285.2	8.528	48.4	
	RodE2_56.9	75	56.9	1.445	9.9	0.251	905.69	758.5	5302.60	16727.1	8.302	47.1	
	RodE2_59.9	76	59.9	1.521	12.9	0.328	936.12	775.4	5447.15	17183.0	8.141	46.2	
	RodE2_66	77	66	1.676	19	0.483	958.82	788.1	5743.29	18117.2	8.302	47.1	
	RodE2_69.8	78	69.8	1.773	-1.08	-0.027	844.44	724.5	5916.05	18662.2	10.245	58.2	
	RodE2_72.9	79	72.9	1.852	2.02	0.051	909.22	760.5	6063.72	19128.0	9.442	53.6	
	RodE2_74.9	80	74.9	1.902	4.02	0.102	942.14	778.8	6163.34	19442.2	9.129	51.8	
Gr-8	RodB3_50.2	169	50.2	1.275	3.2	0.081	765.43	680.6	4944.41	15597.1	9.920	56.3	
	RodB3_54.1	170	54.1	1.374	7.1	0.180	833.56	718.5	5131.06	16185.9	9.057	51.4	
	RodB3_56.9	171	56.9	1.445	9.9	0.251	875.66	741.9	5264.92	16608.2	8.650	49.1	
	RodB3_60.1	172	60.1	1.527	13.1	0.333	864.45	735.6	5415.68	17083.8	9.065	51.5	
	RodB3_66.1	173	66.1	1.679	19.1	0.485	908.61	760.2	5701.11	17984.1	8.886	50.5	
	RodB3_69.9	174	69.9	1.775	-0.98	-0.025	771.53	684.0	5881.49	18553.1	11.657	66.2	
	RodB3_73	175	73	1.854	2.12	0.054	853.47	729.5	6040.10	19053.5	10.299	58.5	
	RodB3_75	176	75	1.905	4.12	0.105	892.08	751.0	6138.18	19362.9	9.820	55.8	
Gr-8	RodF3_50.1	89	50.1	1.273	3.1	0.079	781.44	689.5	4945.11	15599.3	9.613	54.6	
	RodF3_54	90	54	1.372	7	0.178	850.50	727.9	5138.19	16208.4	8.806	50.0	
	RodF3_57	91	57	1.448	10	0.254	894.07	752.1	5283.38	16666.4	8.426	47.8	
	RodF3_60	92	60	1.524	13	0.330	920.48	766.8	5430.84	17131.6	8.311	47.2	
	RodF3_66.1	93	66.1	1.679	19.1	0.485	932.37	773.4	5715.69	18030.2	8.590	48.8	
	RodF3_70	94	70	1.778	-0.88	-0.022	795.33	697.2	5915.11	18659.2	11.196	63.6	
	RodF3_73	95	73	1.854	2.12	0.054	896.94	753.7	6052.96	19094.1	9.609	54.6	
	RodF3_75	96	75	1.905	4.12	0.105	940.21	777.7	6149.62	19399.0	9.135	51.9	
Gr-8	RodE6_50.2	121	50.2	1.275	3.2	0.081	793.72	696.3	4938.22	15577.6	9.375	53.2	
	RodE6_54.1	122	54.1	1.374	7.1	0.180	853.07	729.3	5123.19	16161.1	8.742	49.6	
	RodE6_57	123	57	1.448	10	0.254	883.75	746.3	5262.08	16599.2	8.532	48.5	
	RodE6_60.2	124	60.2	1.529	13.2	0.335	909.19	760.5	5413.33	17076.4	8.430	47.9	
	RodE6_66.1	125	66.1	1.679	19.1	0.485	928.68	771.3	5696.97	17971.1	8.610	48.9	
	RodE6_70	126	70	1.778	-0.88	-0.022	798.51	699.0	5896.35	18600.0	11.094	63.0	
	RodE6_73.1	127	73.1	1.857	2.22	0.056	873.40	740.6	6043.33	19063.7	9.966	56.6	
	RodE6_75	128	75	1.905	4.12	0.105	906.75	759.1	6131.02	19340.3	9.584	54.4	

RBHT Steam Cooling with Droplet Injection Test SCD-4041-J

Matrix Test # 7b

Test Conditions

Test Date – 10/26/2005

Steady State Time Window: 27540 – 27840

Upper Plenum Pressure: 2.76 bar (40 psia)

Bundle Power: 64.0 kW

Bundle Inlet Reynolds Number: 6000

Bundle Inlet Steam Flow: 117.9 kg/hr (260 lbm/hr)

Droplet Injection Flow: 0.0073 kg/s (0.016 lbm/s)

Droplet Injection Hole Diameter: 0.381 mm (.015 in)

Droplet Injection Elevation: 1.295 m (51 in)

Bundle Flow Area: $4.656 \times 10^{-3} \text{ m}^2$ ($5.012 \times 10^{-2} \text{ ft}^2$)

Test Notes

- No steam probes were traversed in this steady state window.

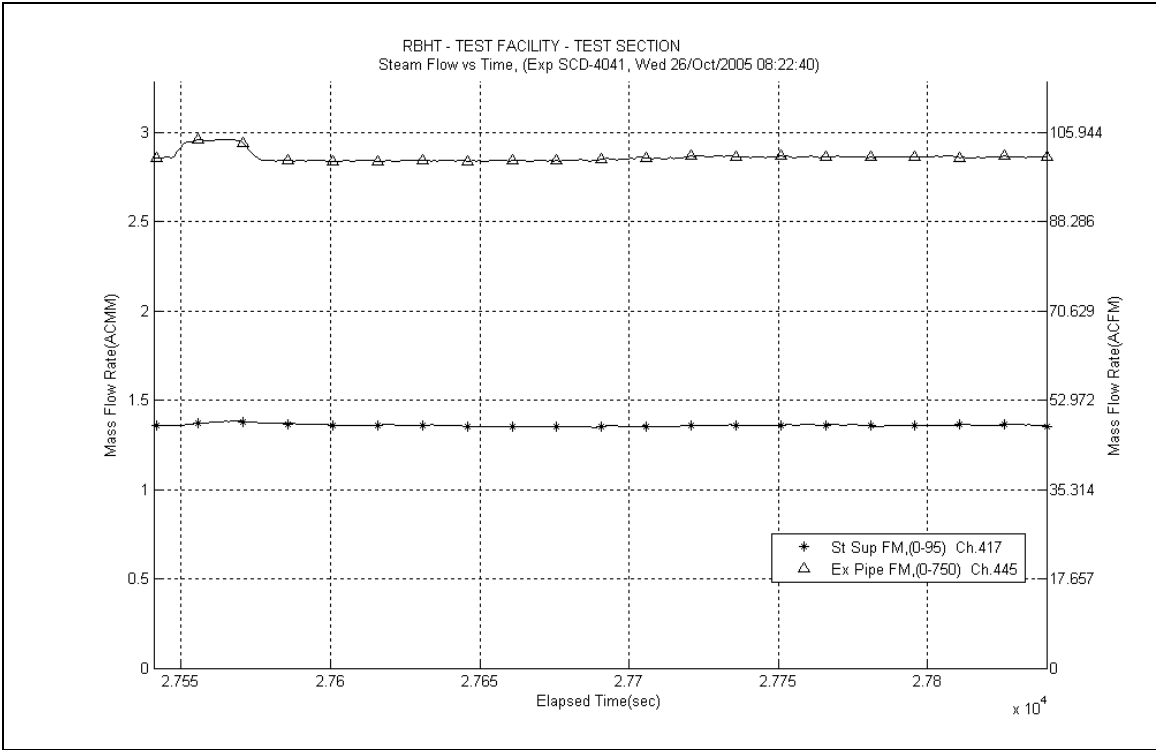

Figure A-614: Inlet and Exhaust Steam Flow Rates for Experiment 4041J

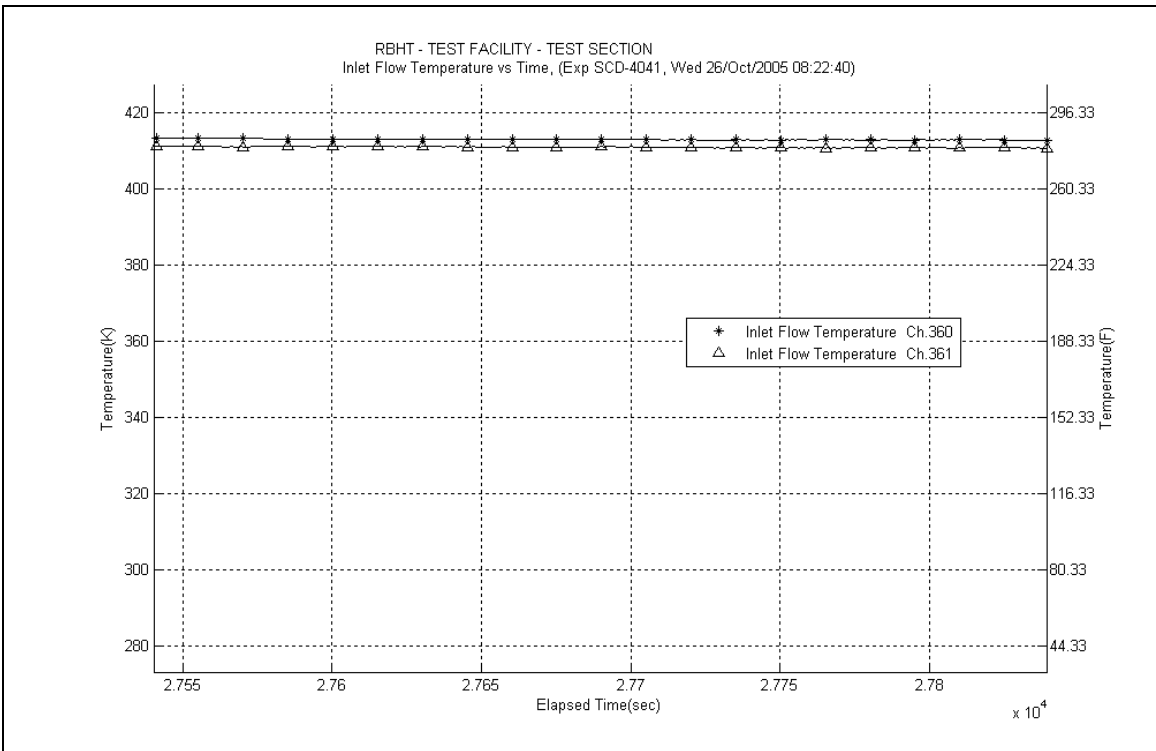

Figure A-615: Inlet Steam Temperature for Experiment 4041J

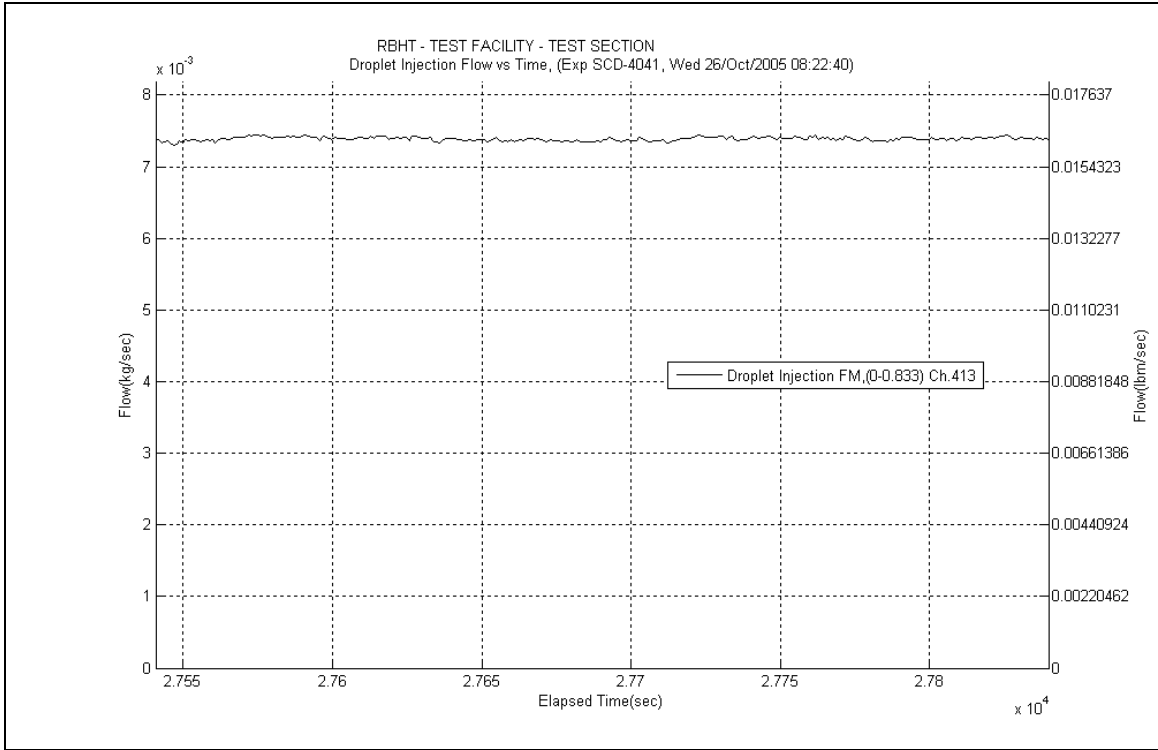

Figure A-616: Droplet Injection Flow Rate for Experiment 4041J

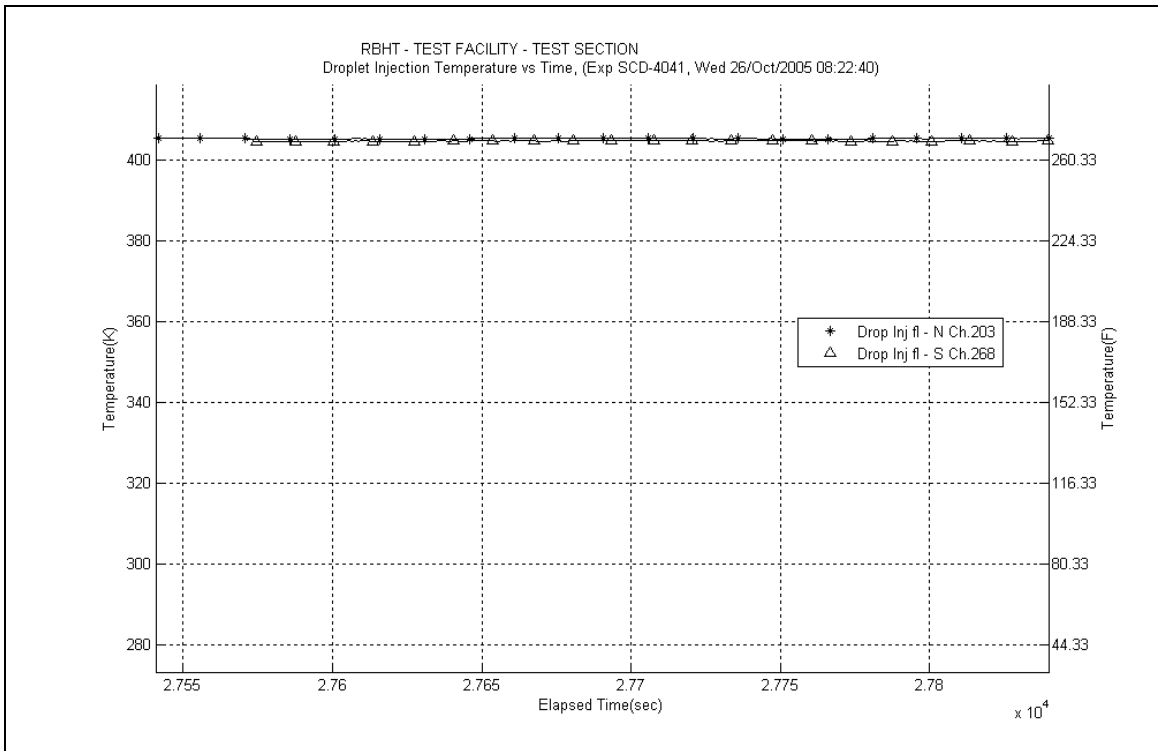

Figure A-617: Droplet Injection Temperature for Experiment 4041J

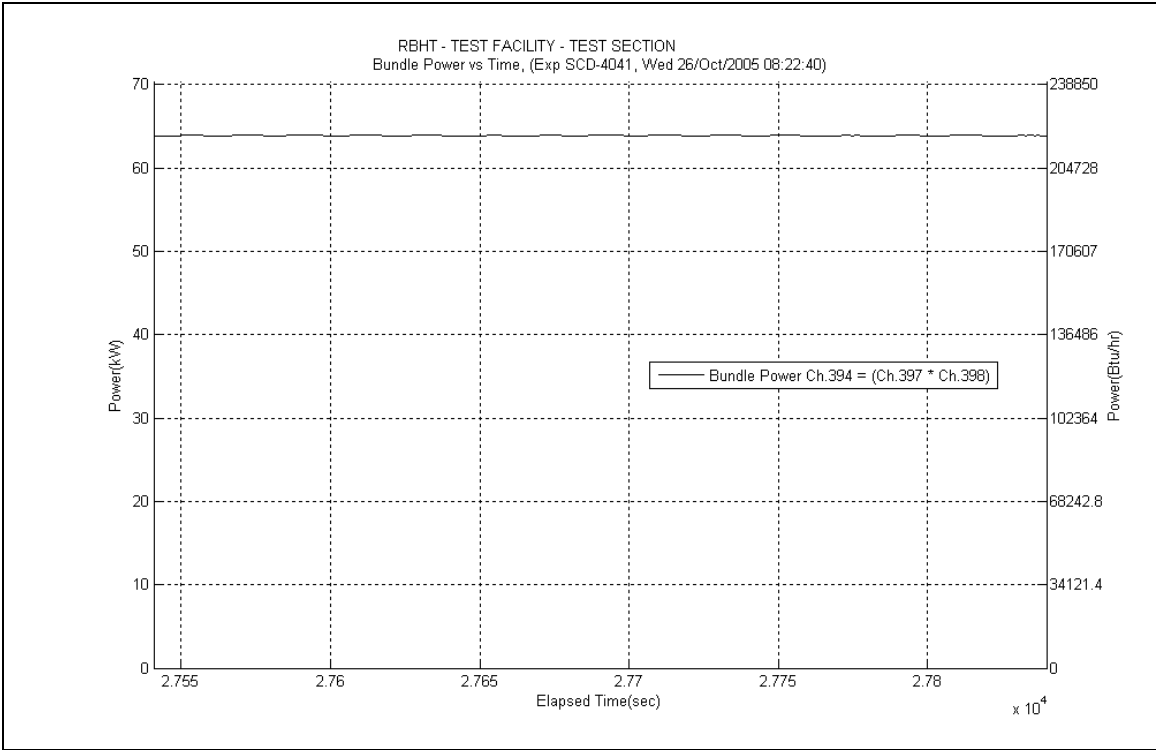

Figure A-618: Bundle Power for Experiment 4041J

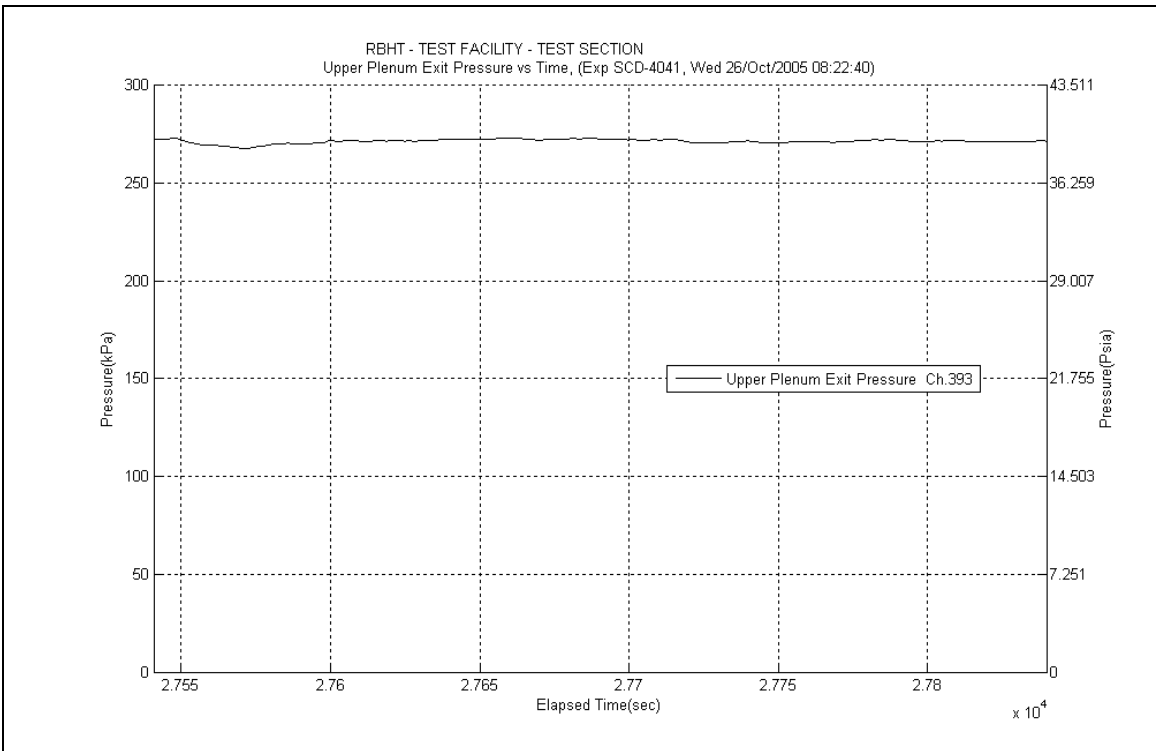

Figure A-619: Upper Plenum Pressure for Experiment 4041J

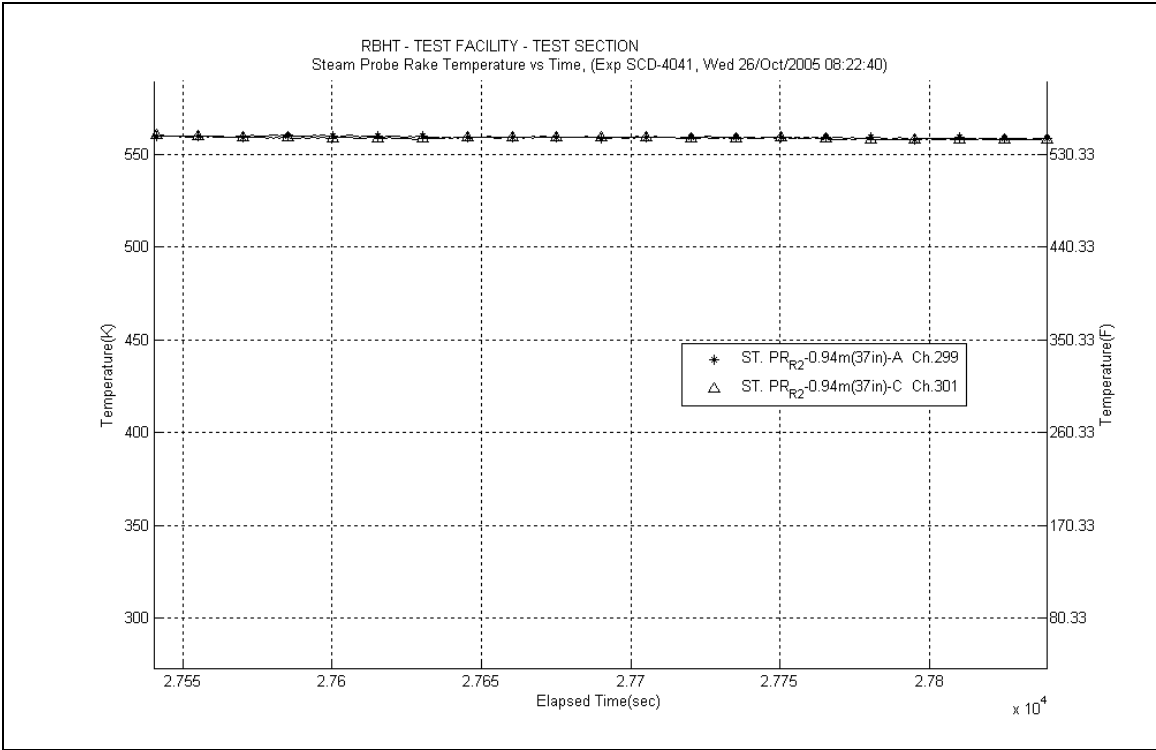

Figure A-620: Steam Probe Rake #2 Temperatures for Experiment 4041J

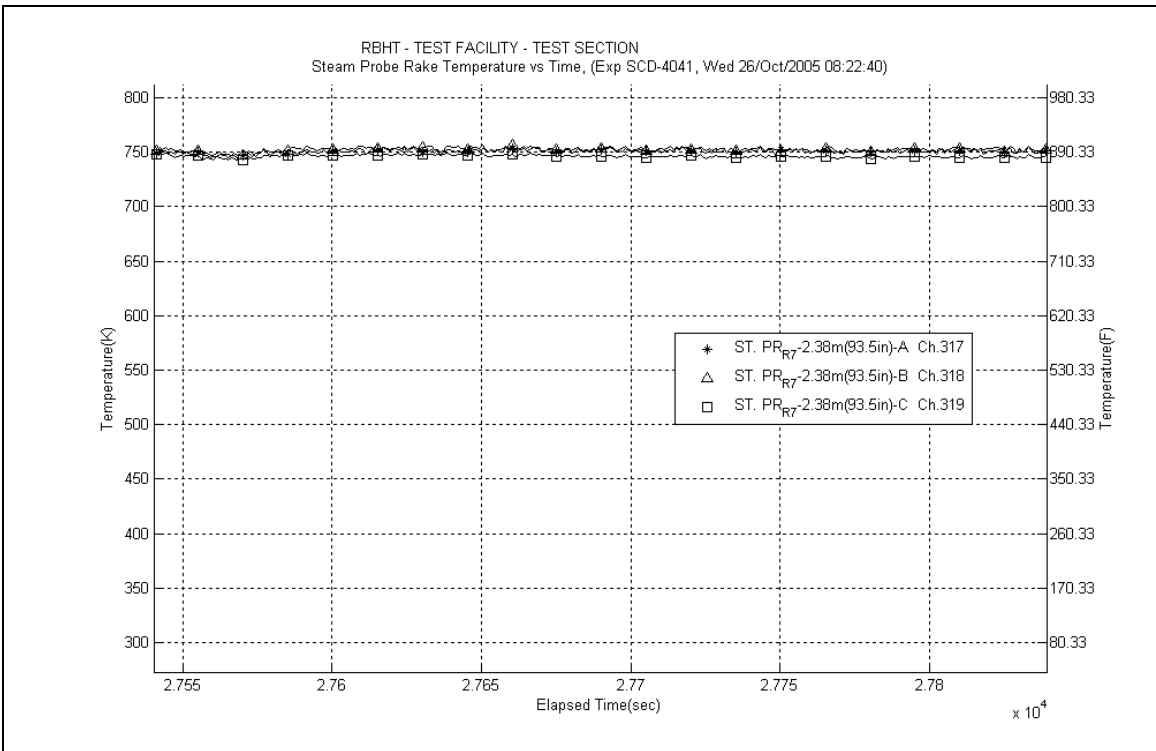

Figure A-621: Steam Probe Rake #7 Temperatures for Experiment 4041J

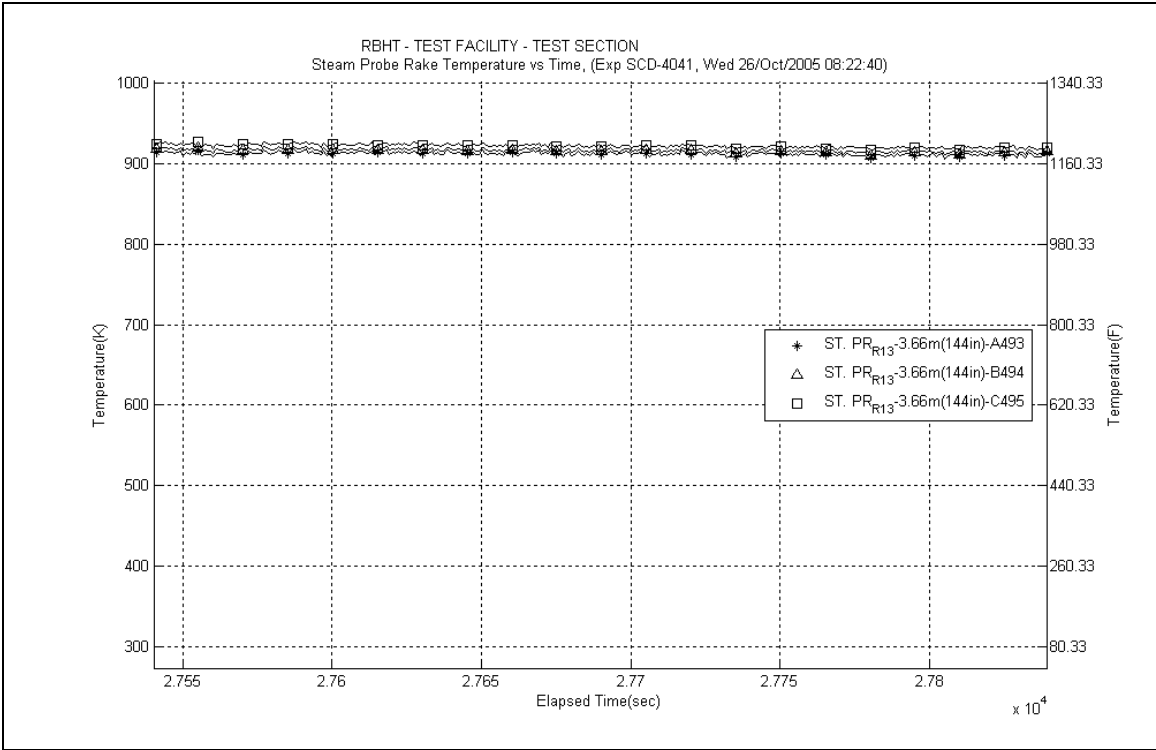

Figure A-622: Steam Probe Rake #13 Temperatures for Experiment 4041J

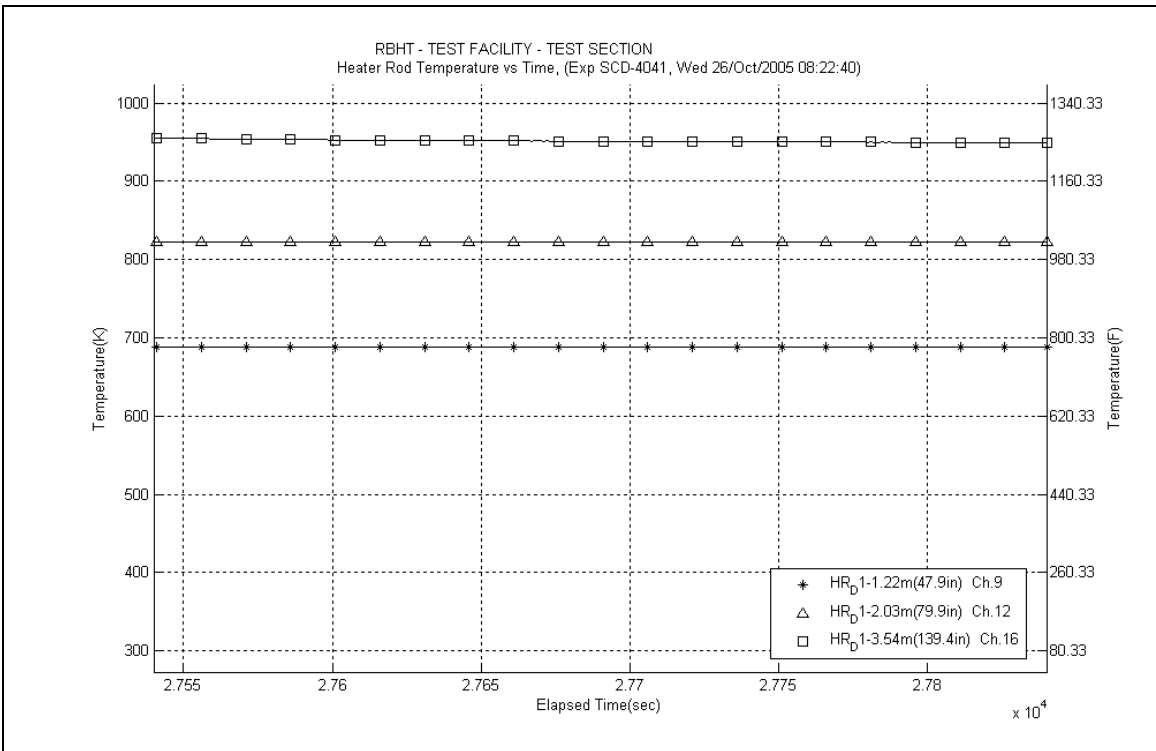

Figure A-623: Heater Rod D1 Temperatures for Experiment 4041J

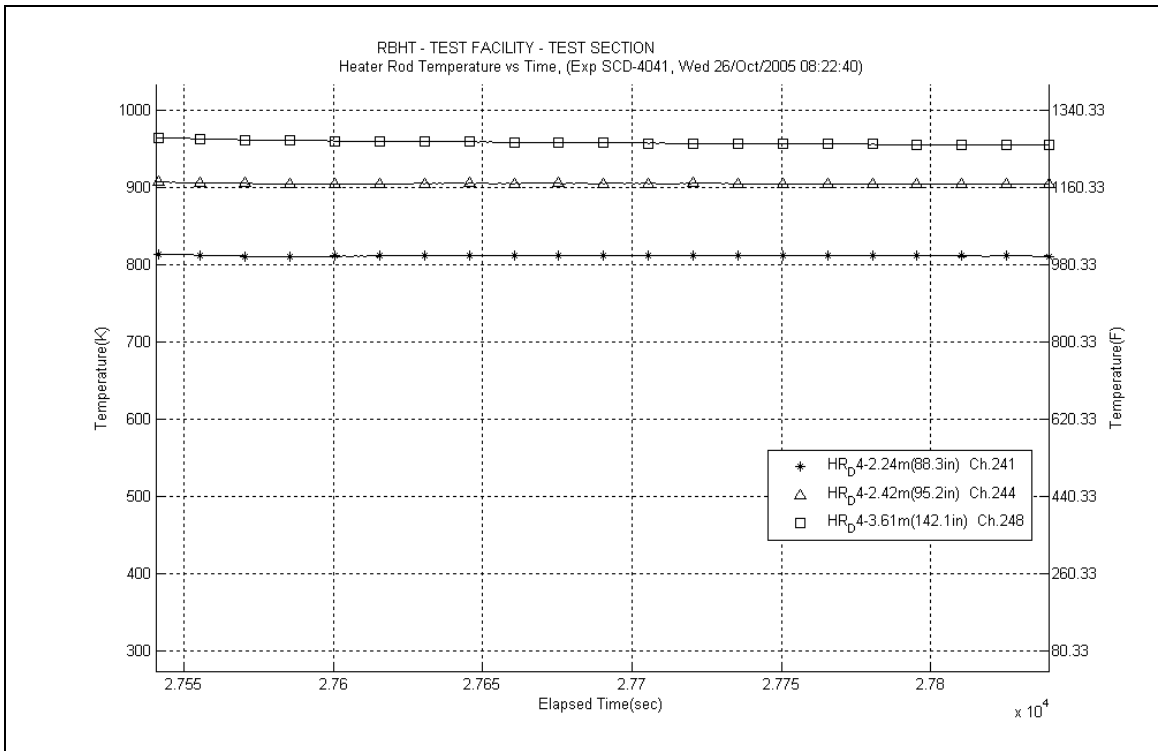

Figure A-624: Heater Rod D4 Temperatures for Experiment 4041J

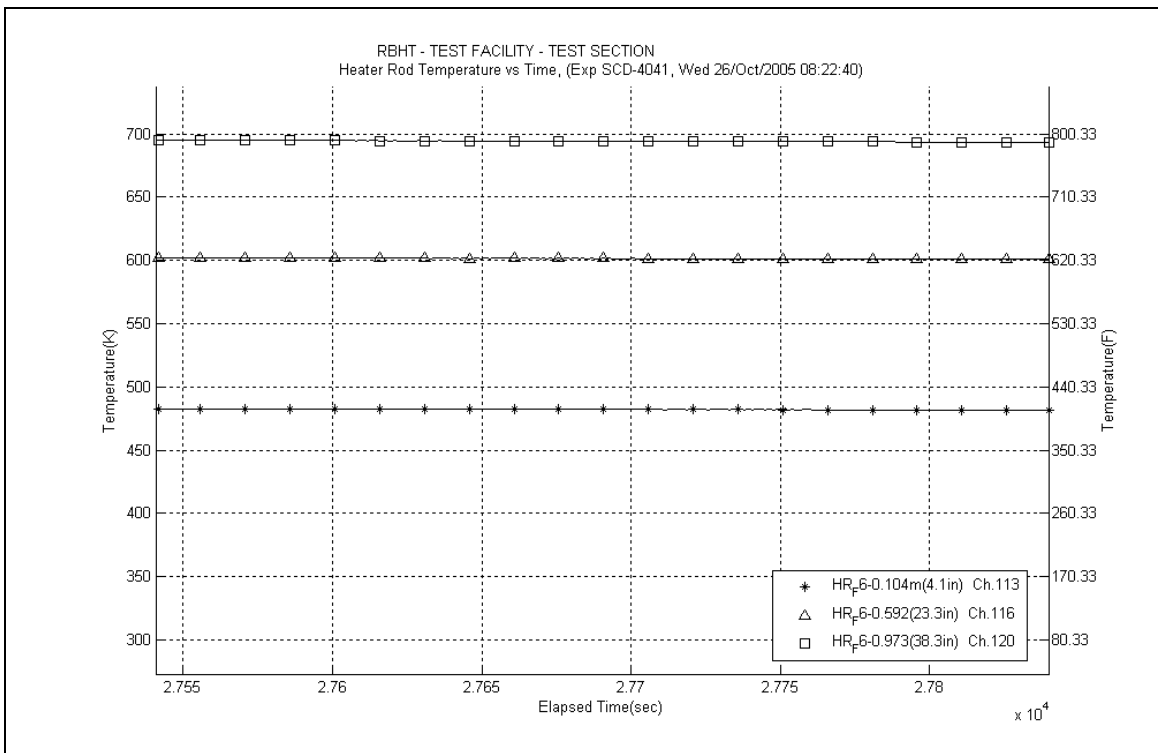

Figure A-625: Heater Rod F6 Temperatures for Experiment 4041J

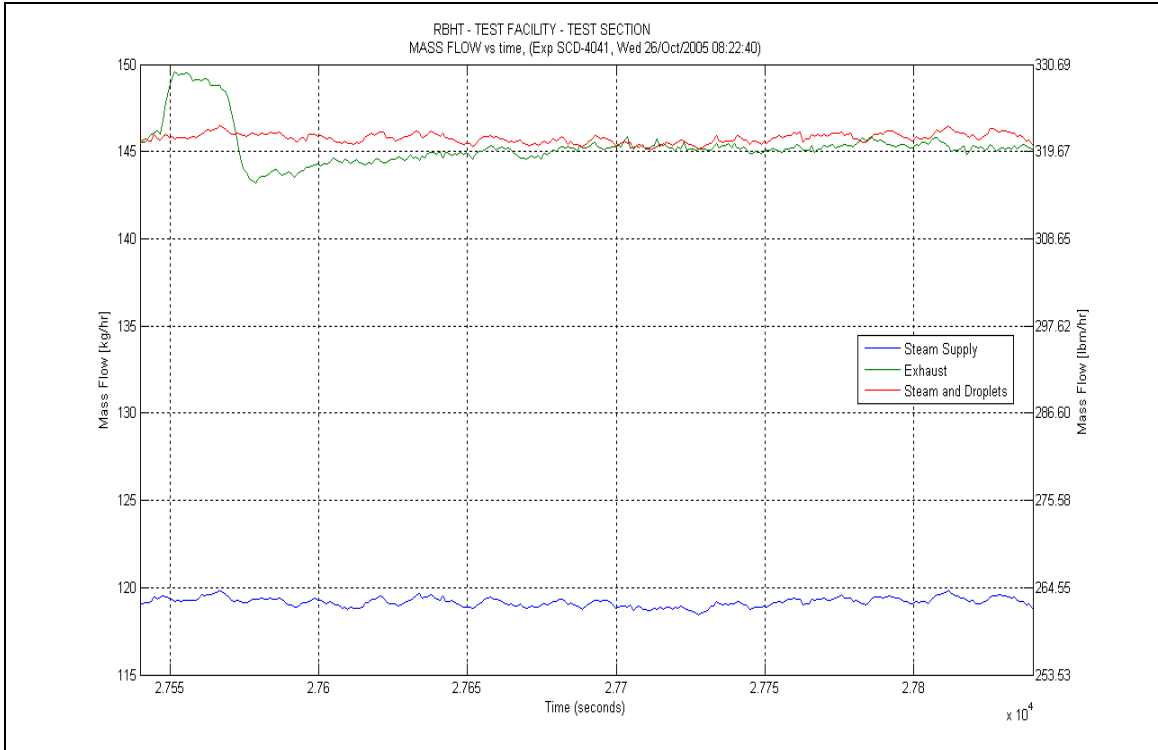

Figure A-626: Mass Flow for Experiment 4041J

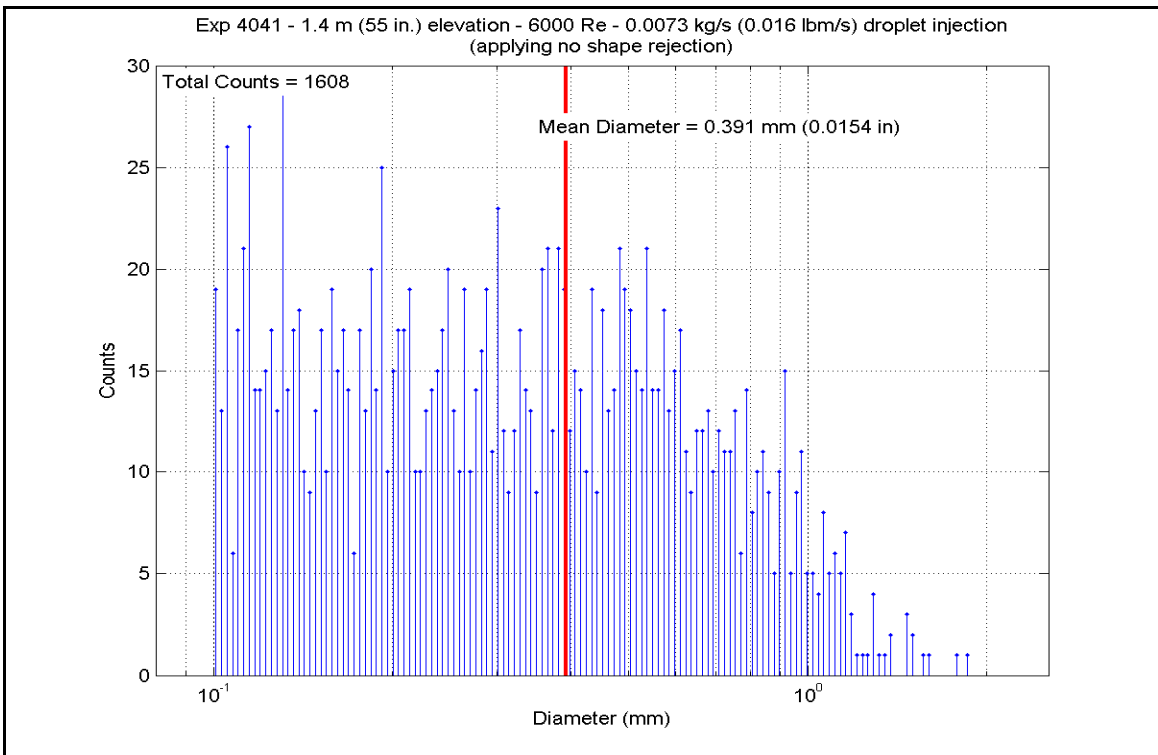

Figure A-627: Droplet Measurements at 1.397 m (55 in.) Elevation for Experiment 4041J

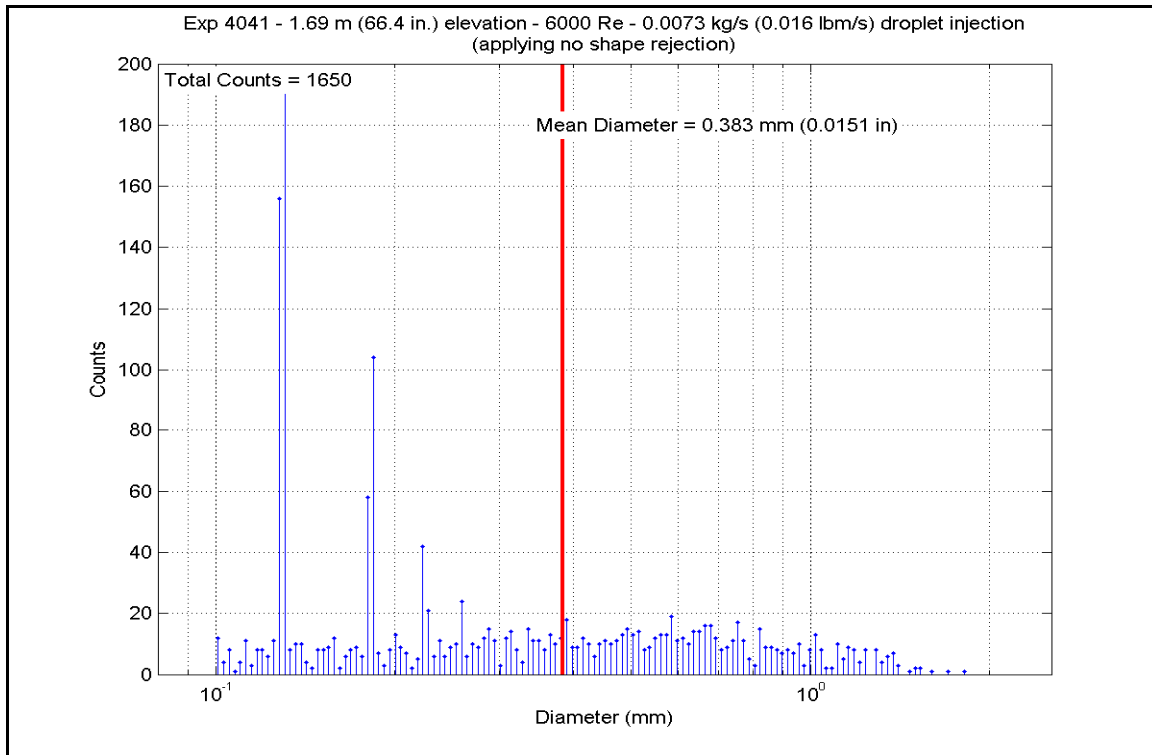

Figure A-628: Droplet Measurements at 1.687 m (66.4 in.) Elevation for Experiment 4041J

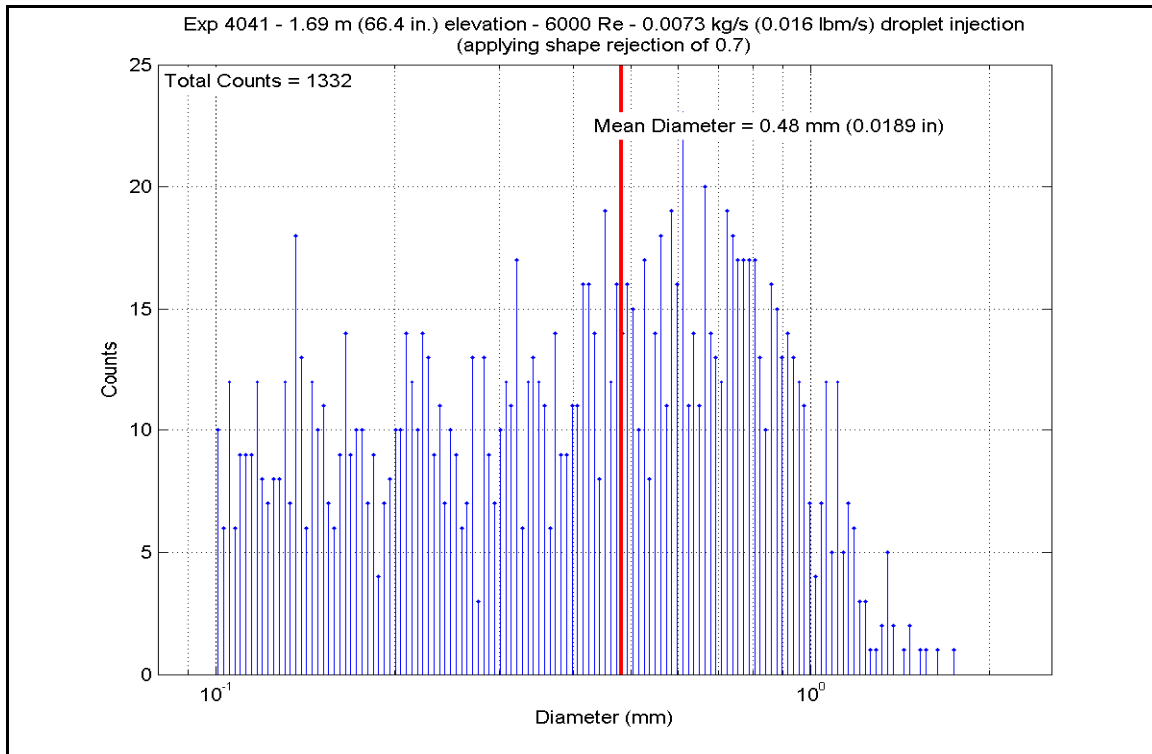

Figure A-629: Droplet Measurements at 1.687 m (66.4 in.) Elevation for Experiment 4041J

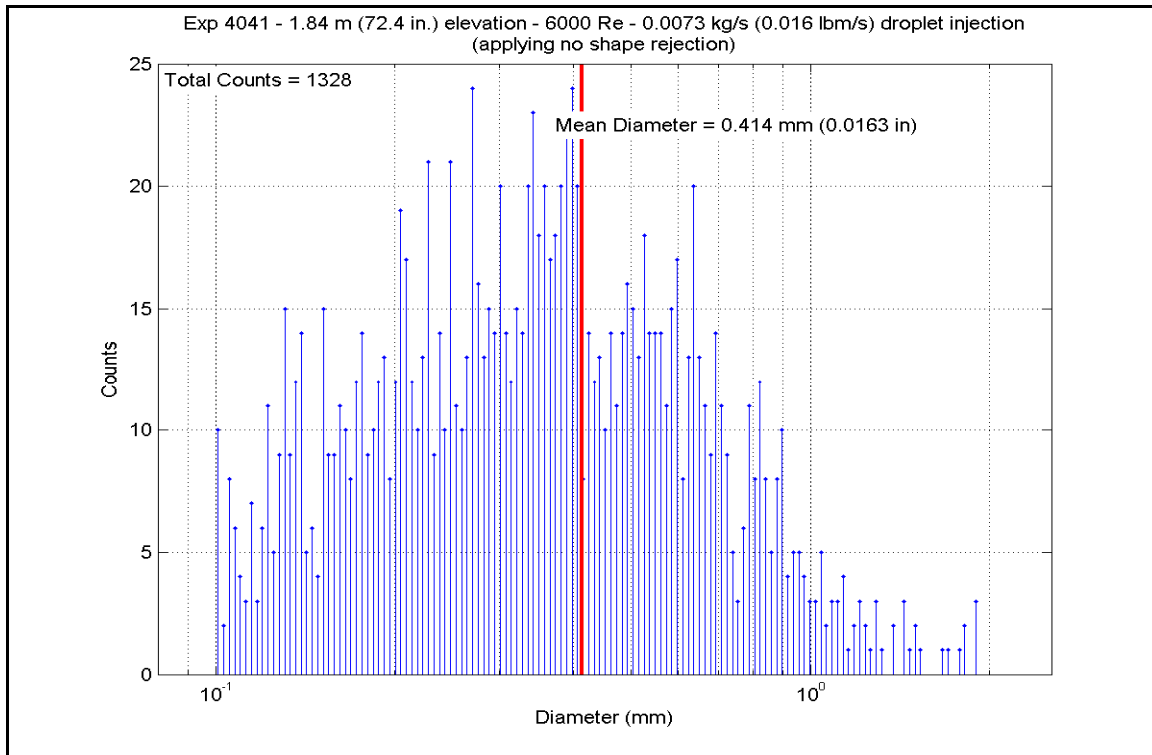

Figure A-630: Droplet Measurements at 1.839 m (72.4 in.) Elevation for Experiment 4041J

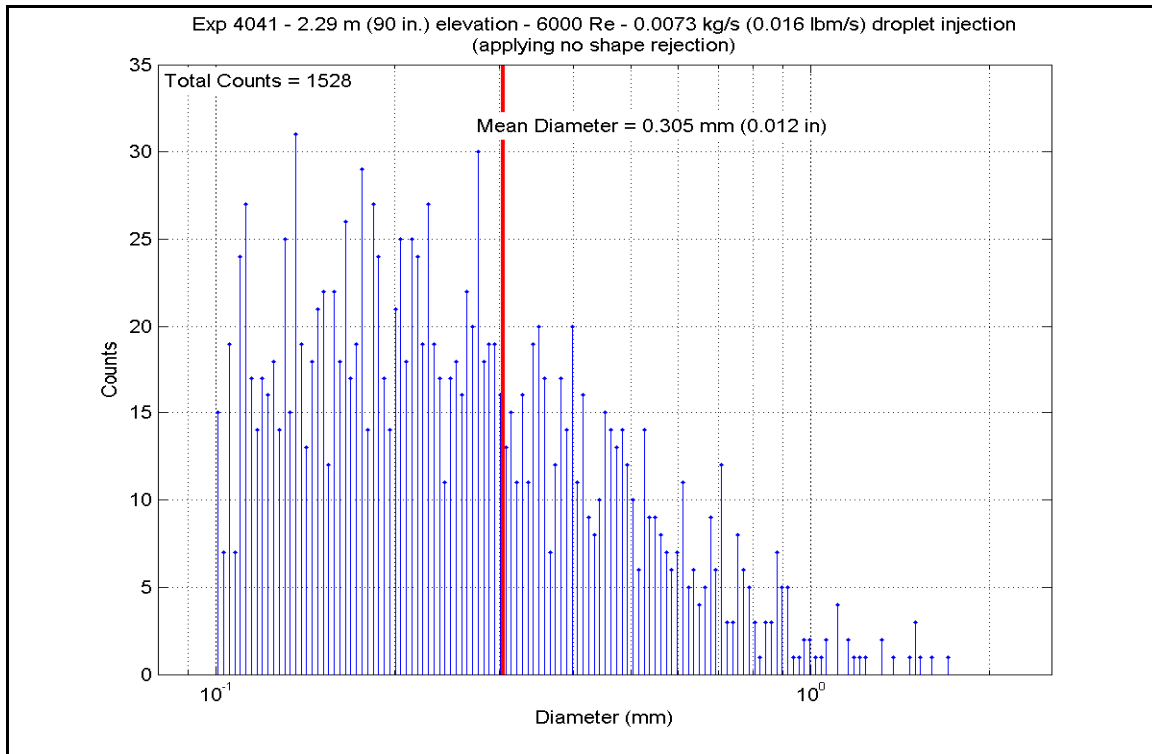

Figure A-631: Droplet Measurements at 2.286 m (90 in.) Elevation for Experiment 4041J

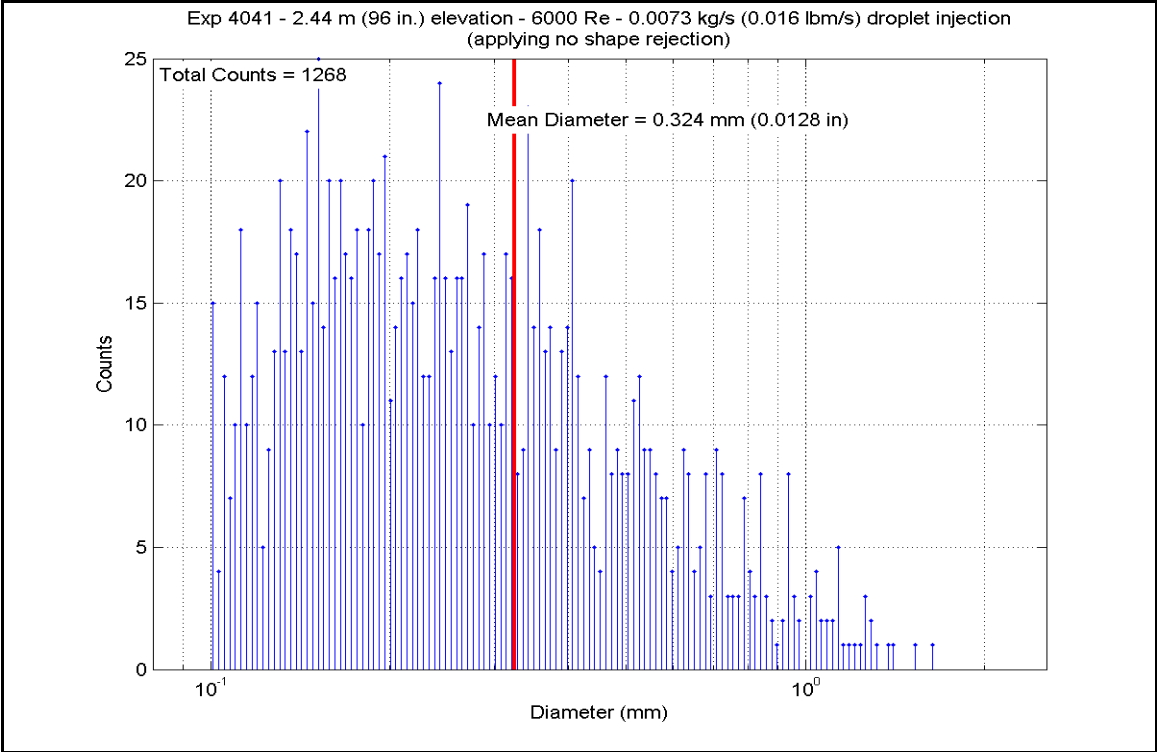

Figure A-632: Droplet Measurements at 2.438 m (96 in.) Elevation for Experiment 4041J

Table A-34: Summary of Steam Cooling Heat Transfer Reduced Data for Experiment 4041J

SCD-4041-J		Inlet Reynolds:		6000		40 psia							
Matrix Test #7b		UP Pressure:		275.8 kPa		218377 Btu/hr							
Time Window: 27540-27840		Bundle Power:		64.00 kW		260.0 lbm/hr							
Inner 3x3		Steam flow:		0.0328 kg/s		0.016 lbm/s							
		Dropletflow:		0.0073 kg/s									
H.R. ID	H.R. Location	Channel Number	Elevation (in)	Elevation (m)	Zgrid (in)	Zgrid (m)	H.R. Tw (°F)	H.R. Tw (K)	H.R. q" (Btu/hr-ft ²)	H.R. q" (W/m ²)	h _{sat} (z) (Btu/hr-ft ² -F)	h _{sat} (z) (W/m ² -K)	
Gr-3	RodD3_88.3	185	88.3	2.243	-0.2	-0.005	811.37	706.1	6798.39	21445.5	12.488	70.9	
	RodD3_91.3	186	91.3	2.319	2.8	0.071	896.21	753.3	6955.26	21940.4	11.054	62.8	
	RodD3_93.1	187	93.1	2.365	4.6	0.117	896.38	753.4	7046.77	22229.0	11.196	63.6	
	RodD3_95.3	188	95.3	2.421	6.8	0.173	944.40	780.0	7156.99	22576.7	10.565	60.0	
	RodD3_100.1	189	100.1	2.543	11.6	0.295	1032.17	828.8	7388.18	23306.0	9.656	54.8	
	RodD3_106.1	190	106.1	2.695	17.6	0.447	1094.52	863.4	7683.92	24238.9	9.285	52.7	
	RodD3_110	191	110	2.794	21.5	0.546	981.82	800.8	7568.51	23874.9	10.588	60.1	
	RodD3_142.1	192	142.1	3.609	3.609	8.6	992.29	806.6	2774.98	8753.7	3.826	21.7	
	Gr-3												
Gr-3	RodC4_88.4	233	88.4	2.245	-0.1	-0.003	771.20	683.8	6858.83	21636.2	13.603	77.3	
	RodC4_91.1	234	91.1	2.314	2.6	0.066	865.10	736.0	6993.13	22059.8	11.692	66.4	
	RodC4_93.4	235	93.4	2.372	4.9	0.124	891.56	750.7	7112.34	22435.9	11.388	64.7	
	RodC4_95.3	236	95.3	2.421	6.8	0.173	937.80	776.4	7212.35	22751.4	10.752	61.1	
	RodC4_100.1	237	100.1	2.543	11.6	0.295	987.38	803.9	7466.41	23552.8	10.364	58.9	
	RodC4_106.1	238	106.1	2.695	17.6	0.447	1045.78	836.4	7764.38	24492.7	9.970	56.6	
	RodC4_110	239	110	2.794	21.5	0.546	878.57	743.5	7511.89	23696.3	12.283	69.8	
	RodC4_142.2	240	142.2	3.612	3.612	8.7	927.36	770.6	2960.51	9338.9	4.483	25.5	
	Gr-3												
Gr-3	RodD4_88.3	241	88.3	2.243	-0.2	-0.005	752.36	673.3	6853.15	21618.3	14.120	80.2	
	RodD4_91.3	242	91.3	2.319	2.8	0.071	849.14	727.1	7002.32	22088.8	12.029	68.3	
	RodD4_93.2	243	93.2	2.367	4.7	0.119	876.36	742.2	7099.22	22394.5	11.650	66.2	
	RodD4_95.2	244	95.2	2.418	6.7	0.170	921.50	767.3	7203.25	22722.7	11.006	62.5	
	RodD4_100.1	245	100.1	2.543	11.6	0.295	1006.74	814.7	7457.34	23524.2	10.081	57.2	
	RodD4_106.1	246	106.1	2.695	17.6	0.447	1038.12	832.1	7770.33	24511.5	10.077	57.2	
	RodD4_142.1	248	142.1	3.609	3.609	8.6	933.59	774.0	2898.94	9144.7	4.349	24.7	
	Gr-3												
	Gr-3	RodE4_88.4	201	88.4	2.245	-0.1	-0.003	781.25	689.4	6805.88	21469.2	13.234	75.2
RodE4_91.2		202	91.2	2.316	2.7	0.069	880.07	744.3	6938.19	21886.5	11.317	64.3	
RodE4_95.3		204	95.3	2.421	6.8	0.173	956.91	787.0	7140.29	22524.0	10.350	58.8	
RodE4_100.9		205	100.9	2.563	12.4	0.315	1023.50	824.0	7388.22	23306.1	9.766	55.5	
RodE4_142.3		208	142.3	3.614	3.614	8.8	970.34	794.4	3011.04	9498.3	4.281	24.3	
Gr-3													

Table A-34: Summary of Steam Cooling Heat Transfer Reduced Data for Experiment 4041, continued

	H.R. Location	Channel Number	Elevation (in)	Elevation (m)	Zgrid (in)	Zgrid (m)	H.R. Tw (°F)	H.R. Tw (K)	H.R. q" (Btu/hr-ft ²)	H.R. q" (W/m ²)	h _{sat} (z) (Btu/hr-ft ² -F)	h _{sat} (z) (W/m ² -K)
Gr-4	RodE3_63.4	193	63.4	1.610	16.4	0.417	939.13	777.1	5578.45	17597.2	8.300	47.1
	RodE3_113.6	194	113.6	2.885	0.85	0.022	1016.63	820.2	6953.95	21936.0	9.276	52.7
	RodE3_115.5	195	115.5	2.934	2.75	0.070	1050.79	839.1	6748.76	21289.0	8.610	48.9
	RodE3_118.5	196	118.5	3.010	5.75	0.146	1072.23	851.1	6371.95	20100.3	7.913	44.9
	RodE3_122.7	197	122.7	3.117	9.95	0.253	1070.99	850.4	5829.51	18389.2	7.251	41.2
	RodE3_126.5	198	126.5	3.213	13.75	0.349	1071.00	850.4	5329.41	16811.6	6.629	37.6
	RodE3_131.7	199	131.7	3.345	-1.8	-0.046	971.55	795.1	4626.04	14592.8	6.566	37.3
	RodE3_135.6	200	135.6	3.444	2.1	0.053	1007.69	815.2	4100.78	12935.9	5.536	31.4
	RodC5_63.7	225	63.7	1.618	16.7	0.424	937.36	776.1	5457.56	17215.9	8.141	46.2
	RodC5_113.6	226	113.6	2.885	0.85	0.022	914.81	763.6	6738.74	21257.4	10.402	59.1
Gr-4	RodC5_115.7	227	115.7	2.939	2.95	0.075	958.52	787.9	6485.46	20458.4	9.379	53.3
	RodC5_122.7	229	122.7	3.117	9.95	0.253	988.76	804.7	5615.11	17712.9	7.780	44.2
	RodC5_126.7	230	126.7	3.218	13.95	0.354	987.84	804.2	5108.92	16116.1	7.087	40.2
	RodC5_131.6	231	131.6	3.343	-1.9	-0.048	871.29	739.4	4459.96	14068.9	7.380	41.9
	RodC5_135.7	232	135.7	3.447	2.2	0.056	899.31	755.0	3951.02	12463.5	6.249	35.5
	RodE5_63.6	209	63.6	1.615	16.6	0.422	826.58	714.6	5597.15	17656.2	10.002	56.8
	RodE5_113.6	210	113.6	2.885	0.85	0.022	829.70	716.3	7010.14	22113.5	12.458	70.7
	RodE5_115.4	211	115.4	2.931	2.65	0.067	909.91	760.9	6796.72	21440.2	10.572	60.0
	RodE5_118.7	212	118.7	3.015	5.95	0.151	975.20	797.2	6379.88	20125.3	9.009	51.2
	RodE5_122.6	213	122.6	3.114	9.85	0.250	1004.84	813.6	5883.56	18559.7	7.974	45.3
RodE5_126.6	214	126.6	3.216	13.85	0.352	1005.97	814.2	5362.61	16916.4	7.257	41.2	
RodE5_131.6	215	131.6	3.343	-1.9	-0.048	982.95	801.5	4699.16	14823.5	6.564	37.3	
RodE5_135.6	216	135.6	3.444	2.1	0.053	968.92	793.7	4124.27	13010.0	5.876	33.4	
Gr-5	RodC3_79.8	177	79.8	2.027	8.92	0.227	900.30	755.5	6364.45	20076.7	10.050	57.1
	RodC3_85.6	178	85.6	2.174	14.72	0.374	810.15	705.5	6620.91	20885.7	12.190	69.2
	RodC3_88.5	179	88.5	2.248	0	0.000	805.49	702.9	6779.49	21385.9	12.590	71.5
	RodC3_92.4	180	92.4	2.347	3.9	0.099	915.96	764.2	6975.47	22004.1	10.749	61.0
	RodC3_94.4	181	94.4	2.398	5.9	0.150	934.22	774.4	7074.96	22318.0	10.604	60.2
	RodC3_97.2	182	97.2	2.469	8.7	0.221	989.66	805.2	7204.32	22726.0	9.969	56.6
	RodC3_108.8	183	108.8	2.764	20.3	0.516	1077.43	853.9	7611.66	24011.0	9.392	53.3
	RodD5_50	217	50	1.270	16.7	0.424	818.66	710.2	4942.82	15592.1	8.960	50.9
	RodD5_54.1	218	54.1	1.374	7.1	0.180	742.39	667.8	5112.91	16128.7	10.755	61.1
	RodD5_56.9	219	56.9	1.445	9.9	0.251	829.48	716.2	5257.08	16583.4	9.346	53.1
Gr-8	RodD5_60	220	60	1.524	13	0.330	874.78	741.4	5390.35	17003.9	8.869	50.4
	RodD5_66.1	221	66.1	1.679	19.1	0.485	896.79	753.6	5626.62	17749.2	8.934	50.7
	RodD5_69.9	222	69.9	1.775	-0.98	-0.025	706.94	648.1	5844.61	18436.8	13.285	75.4
	RodD5_72.9	223	72.9	1.852	2.02	0.051	782.60	690.2	5993.71	18907.2	11.625	66.0
	RodD5_74.9	224	74.9	1.902	4.02	0.102	823.27	712.7	6095.93	19229.6	10.959	62.2

Inner 3x3

Table A-34: Summary of Steam Cooling Heat Transfer Reduced Data for Experiment 4041, continued

H.R. ID	H.R. Location	Channel Number	Elevation (in)	Elevation (m)	Zgrid (in)	Zgrid (m)	H.R. Tw (°F)	H.R. Tw (K)	H.R. q" (Btu/hr-ft ²)	H.R. q" (W/m ²)	h _{sat} (z) (Btu/hr-ft ² -F)	h _{sat} (z) (W/m ² -K)	
Gr-2	RodB5_41	153	41	1.041	13.5	0.343	753.54	674.0	4505.43	14212.4	9.260	52.6	
	RodB5_52.9	154	52.9	1.344	5.9	0.150	824.67	713.5	5066.34	15981.8	9.085	51.6	
	RodB5_55	155	55	1.397	8	0.203	863.09	734.9	5172.98	16318.2	8.678	49.3	
	RodB5_57.8	156	57.8	1.468	10.8	0.274	904.33	757.8	5311.92	16756.4	8.335	47.3	
	RodB5_64	157	64	1.626	17	0.432	940.19	777.7	5614.88	17712.2	8.341	47.4	
	RodB5_73.9	158	73.9	1.877	3.02	0.077	864.58	735.7	6077.92	19172.8	10.171	57.8	
	RodB5_75.9	159	75.9	1.928	5.02	0.128	894.05	752.1	6178.07	19488.7	9.853	56.0	
	RodB5_76.9	160	76.9	1.953	6.02	0.153	905.93	758.7	6226.61	19641.8	9.745	55.3	
	Gr-2	RodF5_41	105	41	1.041	13.5	0.343	744.49	669.0	4472.23	14107.6	9.366	53.2
		RodF5_53.1	106	53.1	1.349	6.1	0.155	806.87	703.6	5051.76	15935.8	9.357	53.1
		RodF5_55	107	55	1.397	8	0.203	845.70	725.2	5145.89	16327.7	8.892	50.5
		RodF5_57.8	108	57.8	1.468	10.8	0.274	886.20	747.7	5307.50	16742.5	8.571	48.7
		RodF5_64	109	64	1.626	17	0.432	904.50	757.9	5709.62	18011.0	8.956	50.9
		RodF5_73.8	110	73.8	1.875	2.92	0.074	849.45	727.3	6130.36	19338.2	10.525	59.8
		RodF5_75.8	111	75.8	1.925	4.92	0.125	886.54	747.9	6231.22	19656.4	10.058	57.1
		RodF5_76.8	112	76.8	1.951	5.92	0.150	901.81	756.4	6281.76	19815.8	9.895	56.2
Gr-2		RodC2_41	57	41	1.041	13.5	0.343	742.66	668.0	4496.24	14183.4	9.453	53.7
		RodC2_53.1	58	53.1	1.349	6.1	0.155	864.59	735.7	5061.57	15966.7	8.470	48.1
		RodC2_55	59	55	1.397	8	0.203	883.06	746.0	5154.56	16260.1	8.367	47.5
		RodC2_57.8	60	57.8	1.468	10.8	0.274	914.22	763.3	5294.59	16701.8	8.180	46.5
	RodC2_63.9	61	63.9	1.623	16.9	0.429	936.93	775.9	5599.84	17664.7	8.359	47.5	
	RodC2_73.8	62	73.8	1.875	2.92	0.074	895.27	752.7	6096.01	19229.9	9.703	55.1	
	RodC2_75.8	63	75.8	1.925	4.92	0.125	921.43	767.3	6182.90	19504.0	9.448	53.7	
	RodC2_76.8	64	76.8	1.951	5.92	0.150	932.01	773.2	6228.62	19648.2	9.366	53.2	
Gr-2	RodC6_40.9	137	40.9	1.039	13.4	0.340	749.39	671.7	4467.00	14091.2	9.260	52.6	
	RodC6_52.8	138	52.8	1.341	5.8	0.147	868.14	737.7	5088.75	15989.3	8.432	47.9	
	RodC6_54.8	139	54.8	1.392	7.8	0.198	888.74	749.1	5170.75	16311.1	8.317	47.2	
	RodC6_57.8	140	57.8	1.468	10.8	0.274	924.13	768.8	5321.62	16787.1	8.098	46.0	
	RodC6_63.8	141	63.8	1.621	16.8	0.427	960.44	789.0	5616.10	17716.0	8.099	46.0	
	RodC6_73.7	142	73.7	1.872	2.82	0.072	915.43	763.9	6123.45	19316.4	9.444	53.6	
	RodC6_75.8	143	75.8	1.925	4.92	0.125	938.70	776.9	6229.94	19652.3	9.275	52.7	
	RodC6_76.8	144	76.8	1.951	5.92	0.150	953.09	784.9	6281.41	19814.7	9.155	52.0	

5x5 periphery

Table A-34: Summary of Steam Cooling Heat Transfer Reduced Data for Experiment 4041, continued

5x5 periphery		H.R. Location	Channel Number	Elevation (in)	Elevation (m)	Zgrid (in)	Zgrid (m)	H.R. Tw (°F)	H.R. Tw (K)	H.R. q" (Btu/hr-ft ²)	H.R. q" (W/m ²)	h _{sat} (z) (Btu/hr-ft ² -F)	h _{sat} (z) (W/m ² -K)
Gr-3	RodB4_88.4	161	88.4	2.245	-0.1	-0.003	785.23	691.6	6752.99	21302.3	13.031	74.0	
	RodB4_91.3	162	91.3	2.319	2.8	0.071	881.38	745.0	6882.50	21710.8	11.202	63.6	
	RodB4_93.3	163	93.3	2.370	4.8	0.122	896.08	753.2	6985.17	22034.7	11.104	63.1	
	RodB4_95.1	164	95.1	2.416	6.6	0.168	930.30	772.2	7072.69	22310.8	10.663	60.6	
	RodB4_100	165	100	2.540	11.5	0.292	961.67	789.6	7304.99	23043.6	10.516	59.7	
	RodB4_106	166	106	2.692	17.5	0.445	1049.72	838.6	7595.04	23958.6	9.703	55.1	
	RodB4_109.9	167	109.9	2.791	21.4	0.544	902.63	756.8	7348.33	23180.3	11.561	65.7	
	RodB4_142.3	168	142.3	3.614	8.8	0.224	939.83	777.5	2948.65	9301.5	4.382	24.9	
Gr-5	RodF4_85.6	98	85.6	2.174	14.72	0.374	858.00	732.0	6726.82	21219.7	11.382	64.6	
	RodF4_88.4	99	88.4	2.245	-0.1	-0.003	822.67	712.4	6838.99	21573.6	12.308	69.9	
	RodF4_92.4	100	92.4	2.347	3.9	0.099	928.39	771.1	7045.24	22224.2	10.652	60.5	
	RodF4_94.3	101	94.3	2.395	5.8	0.147	961.54	789.6	7137.61	22515.6	10.277	58.4	
	RodF4_97.2	102	97.2	2.469	8.7	0.221	1002.09	812.1	7281.84	22970.6	9.906	56.3	
	RodF4_108.8	103	108.8	2.764	20.3	0.516	1056.67	842.4	7756.62	24468.3	9.823	55.8	
	RodF4_111	104	111	2.819	-1.75	-0.044	895.79	753.0	7784.95	24557.6	12.381	70.3	
	RodD2_103.2	65	103.2	2.621	14.7	0.373	1079.22	854.9	6735.74	21247.9	8.293	47.1	
	RodD2_106	66	106	2.692	17.5	0.445	1098.82	865.8	6392.10	20163.9	7.684	43.6	
	RodD2_112.6	67	112.6	2.860	-0.15	-0.004	1117.80	876.4	5924.60	18689.1	6.964	39.5	
Gr-6	RodD2_114.9	68	114.9	2.918	2.15	0.055	1120.67	878.0	5369.12	16936.9	6.289	35.7	
	RodD2_117.4	69	117.4	2.982	4.65	0.118	1104.90	869.2	4838.39	15262.7	5.774	32.8	
	RodD2_120.8	70	120.8	3.068	8.05	0.204	1112.14	873.2	7533.14	23763.3	8.914	50.6	
	RodD2_124.8	71	124.8	3.170	12.05	0.306	1134.55	885.7	7672.05	24201.5	8.843	50.2	
	RodD2_128.6	72	128.6	3.266	15.85	0.403	1045.81	836.4	7047.13	22230.2	9.049	51.4	
	RodD6_103.1	129	103.1	2.619	14.6	0.371	1052.48	840.1	7582.99	23920.6	9.654	54.8	
	RodD6_106	130	106	2.692	17.5	0.445	1068.61	849.0	7721.89	24358.7	9.633	54.7	
	RodD6_112.9	131	112.9	2.868	0.15	0.004	953.76	785.2	7038.21	22202.0	10.248	58.2	
Gr-6	RodD6_114.9	132	114.9	2.918	2.15	0.055	992.57	806.8	6759.74	21323.6	9.316	52.9	
	RodD6_116.8	133	116.8	2.967	4.05	0.103	1014.97	819.2	6494.83	20487.9	8.683	49.3	
	RodD6_120.9	134	120.9	3.071	8.15	0.207	1020.69	822.4	5947.86	18762.5	7.892	44.8	
	RodD6_124.8	135	124.8	3.170	12.05	0.306	1021.14	822.7	5399.82	17033.7	7.160	40.7	
	RodD6_128.7	136	128.7	3.269	15.95	0.405	1009.45	816.2	4845.41	15284.8	6.526	37.1	

Table A-34: Summary of Steam Cooling Heat Transfer Reduced Data for Experiment 4041, continued

5x5 periphery		H.R. Location	Channel Number	Elevation (in)	Elevation (m)	Zgrid (in)	Zgrid (m)	H.R. Tw (°F)	H.R. Tw (K)	H.R. q" (Btu/hr-ft2)	H.R. q" (W/m2)	h _{sat} (z) (Btu/hr-ft2-F)	h _{sat} (z) (W/m2-K)
Gr-8	RodE2_50.1	73	50.1	1.273	3.1	0.079	704.1	807.67	704.1	4971.41	15682.3	9.195	52.2
	RodE2_54	74	54	1.372	7	0.178	740.3	872.83	740.3	5165.11	16293.3	8.526	48.4
	RodE2_56.9	75	56.9	1.445	9.9	0.251	759.3	907.01	759.3	5304.91	16734.3	8.289	47.1
	RodE2_59.9	76	59.9	1.521	12.9	0.328	776.7	938.37	776.7	5443.04	17170.1	8.107	46.0
	RodE2_66	77	66	1.676	19	0.483	788.8	960.13	788.8	5744.89	18122.2	8.288	47.1
	RodE2_69.8	78	69.8	1.773	-1.08	-0.027	724.1	843.70	724.1	5907.62	18635.6	10.244	58.2
	RodE2_72.9	79	72.9	1.852	2.02	0.051	757.1	903.18	757.1	6056.31	19104.6	9.520	54.1
	RodE2_74.9	80	74.9	1.902	4.02	0.102	774.1	933.64	774.1	6155.98	19419.0	9.234	52.4
Gr-8	RodB3_50.2	169	50.2	1.275	3.2	0.081	680.5	765.23	680.5	4933.00	15561.2	9.901	56.2
	RodB3_54.1	170	54.1	1.374	7.1	0.180	718.9	834.38	718.9	5129.71	16181.7	9.041	51.3
	RodB3_56.9	171	56.9	1.445	9.9	0.251	741.9	875.74	741.9	5272.45	16631.9	8.661	49.2
	RodB3_60.1	172	60.1	1.527	13.1	0.333	732.0	858.00	732.0	5437.44	17152.4	9.200	52.2
	RodB3_66.1	173	66.1	1.679	19.1	0.485	750.4	891.12	750.4	5739.26	18104.5	9.196	52.2
	RodB3_69.9	174	69.9	1.775	-0.98	-0.025	670.4	747.13	670.4	5929.82	18705.6	12.350	70.1
	RodB3_73	175	73	1.854	2.12	0.054	712.8	823.36	712.8	6061.08	19119.7	10.894	61.9
	RodB3_75	176	75	1.905	4.12	0.105	733.6	860.88	733.6	6166.87	19453.4	10.384	59.0
Gr-8	RodF3_50.1	89	50.1	1.273	3.1	0.079	690.1	782.44	690.1	4926.01	15539.1	9.557	54.3
	RodF3_54	90	54	1.372	7	0.178	728.6	851.74	728.6	5128.74	16178.6	8.771	49.8
	RodF3_57	91	57	1.448	10	0.254	753.4	896.46	753.4	5275.18	16640.6	8.380	47.6
	RodF3_60	92	60	1.524	13	0.330	768.4	923.54	768.4	5410.26	17066.7	8.241	46.8
	RodF3_66.1	93	66.1	1.679	19.1	0.485	772.8	931.42	772.8	5679.72	17916.7	8.548	48.5
	RodF3_70	94	70	1.778	-0.88	-0.022	697.3	795.54	697.3	5896.49	18600.5	11.156	63.4
	RodF3_73	95	73	1.854	2.12	0.054	750.0	890.37	750.0	6075.00	19163.6	9.745	55.3
	RodF3_75	96	75	1.905	4.12	0.105	772.1	930.13	772.1	6185.59	19512.4	9.328	53.0
Gr-8	RodE6_50.2	121	50.2	1.275	3.2	0.081	696.4	793.77	696.4	4941.30	15587.3	9.380	53.3
	RodE6_54.1	122	54.1	1.374	7.1	0.180	728.8	852.25	728.8	5124.00	16163.7	8.755	49.7
	RodE6_57	123	57	1.448	10	0.254	745.2	881.69	745.2	5263.56	16603.9	8.563	48.6
	RodE6_60.2	124	60.2	1.529	13.2	0.335	757.9	904.49	757.9	5415.79	17084.1	8.496	48.2
	RodE6_66.1	125	66.1	1.679	19.1	0.485	767.0	920.95	767.0	5702.82	17989.5	8.721	49.5
	RodE6_70	126	70	1.778	-0.88	-0.022	690.1	782.59	690.1	5882.77	18557.2	11.410	64.8
	RodE6_73.1	127	73.1	1.857	2.22	0.056	726.4	847.90	726.4	6051.50	19089.5	10.417	59.2
	RodE6_75	128	75	1.905	4.12	0.105	744.0	879.47	744.0	6149.15	19397.5	10.040	57.0

RBHT Steam Cooling with Droplet Injection Test SCD-4041-K

Matrix Test # 7c

Test Conditions

Test Date – 10/26/2005

Steady State Time Window: 28620 – 28980

Upper Plenum Pressure: 2.76 bar (40 psia)

Bundle Power: 64.0 kW

Bundle Inlet Reynolds Number: 6000

Bundle Inlet Steam Flow: 117.9 kg/hr (260 lbm/hr)

Droplet Injection Flow: 0.011 kg/s (0.024 lbm/s)

Droplet Injection Hole Diameter: 0.381 mm (.015 in)

Droplet Injection Elevation: 1.295 m (51 in)

Bundle Flow Area: $4.656 \times 10^{-3} \text{ m}^2$ ($5.012 \times 10^{-2} \text{ ft}^2$)

Test Notes

- No steam probes were traversed in this steady state window.

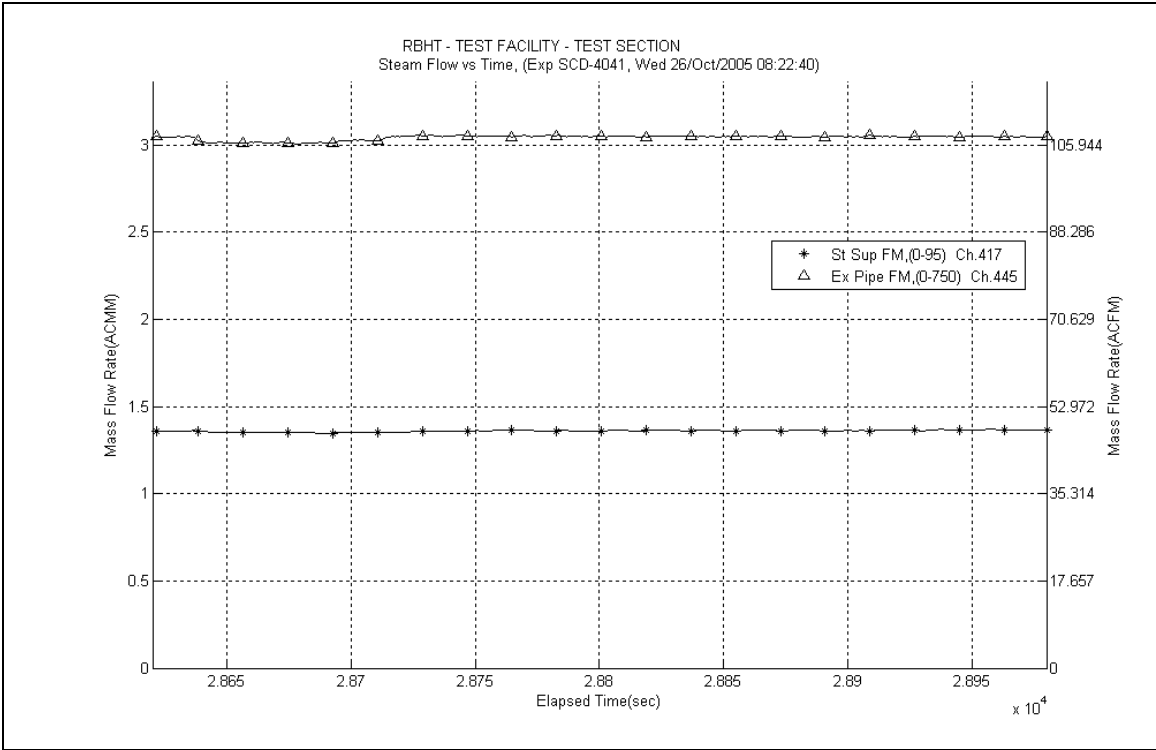

Figure A-633: Inlet and Exhaust Steam Flow Rates for Experiment 4041K

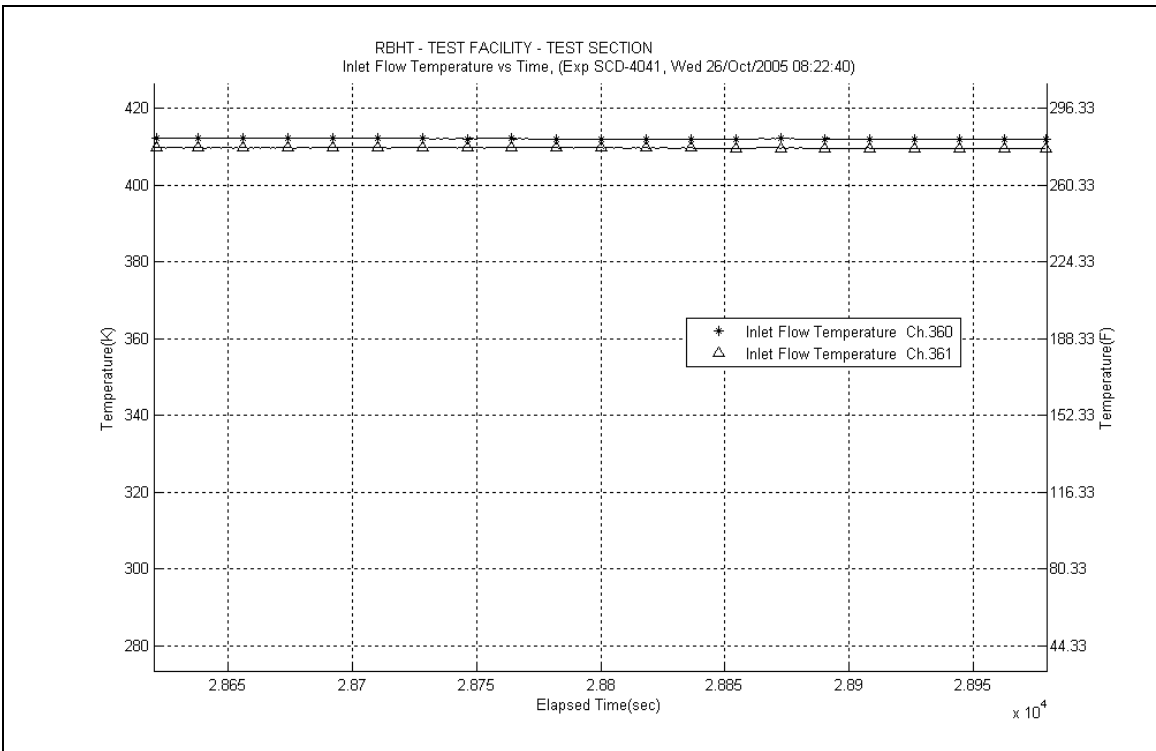

Figure A-634: Inlet Steam Temperature for Experiment 4041K

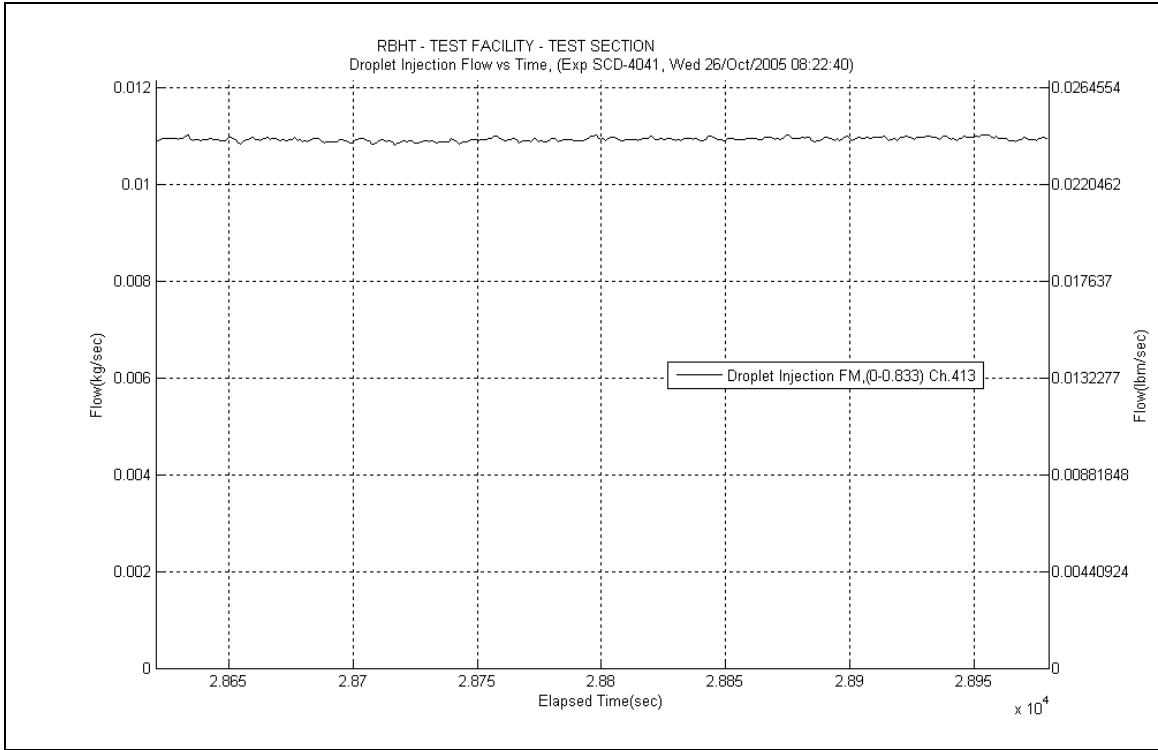

Figure A-635: Droplet Injection Flow Rate for Experiment 4041K

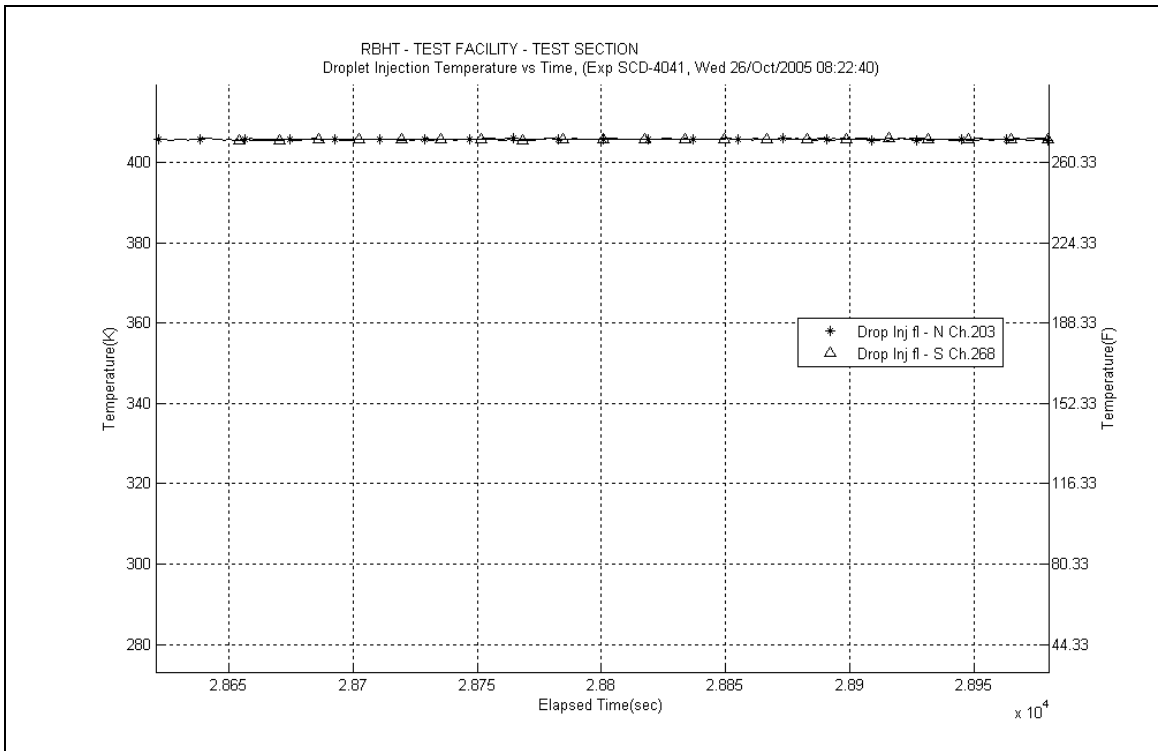

Figure A-636: Droplet Injection Temperature for Experiment 4041K

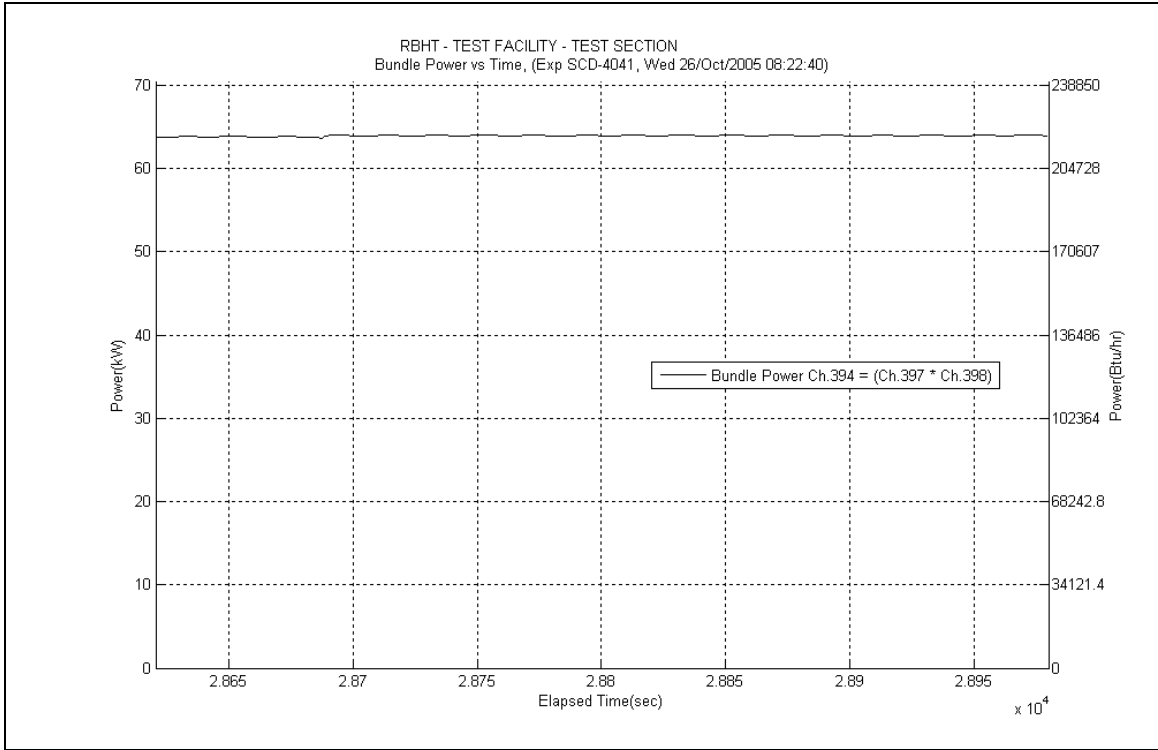

Figure A-637: Bundle Power for Experiment 4041K

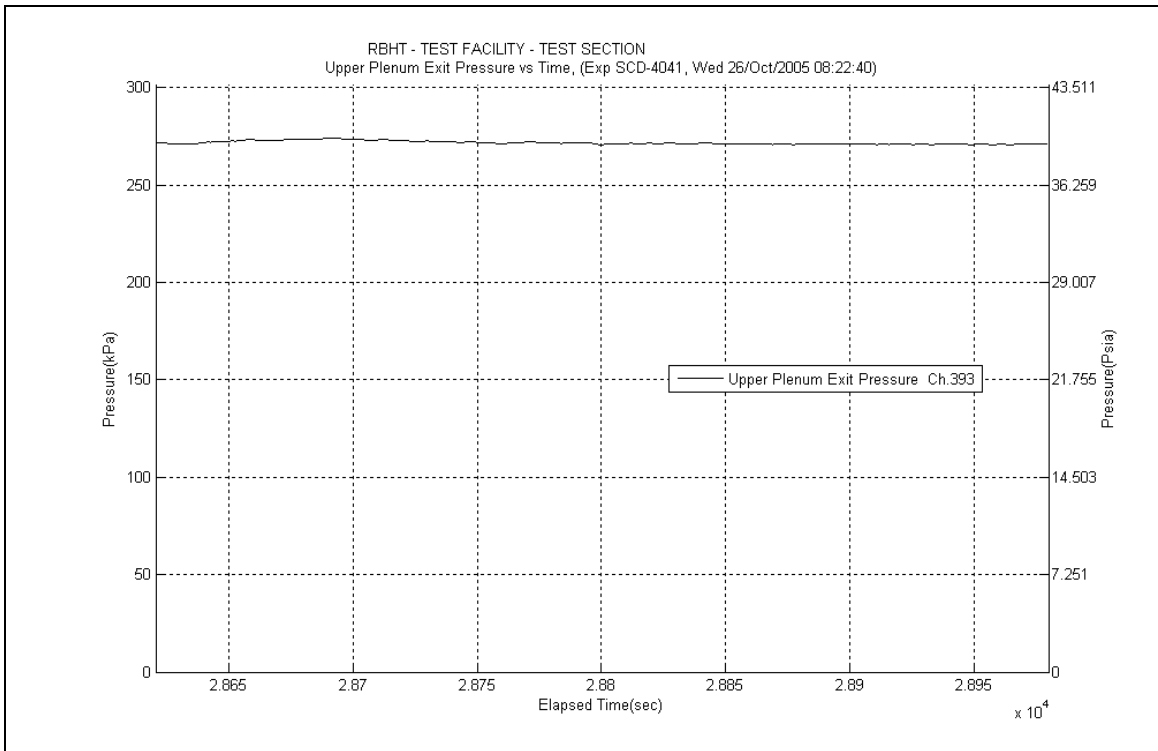

Figure A-638: Upper Plenum Pressure for Experiment 4041K

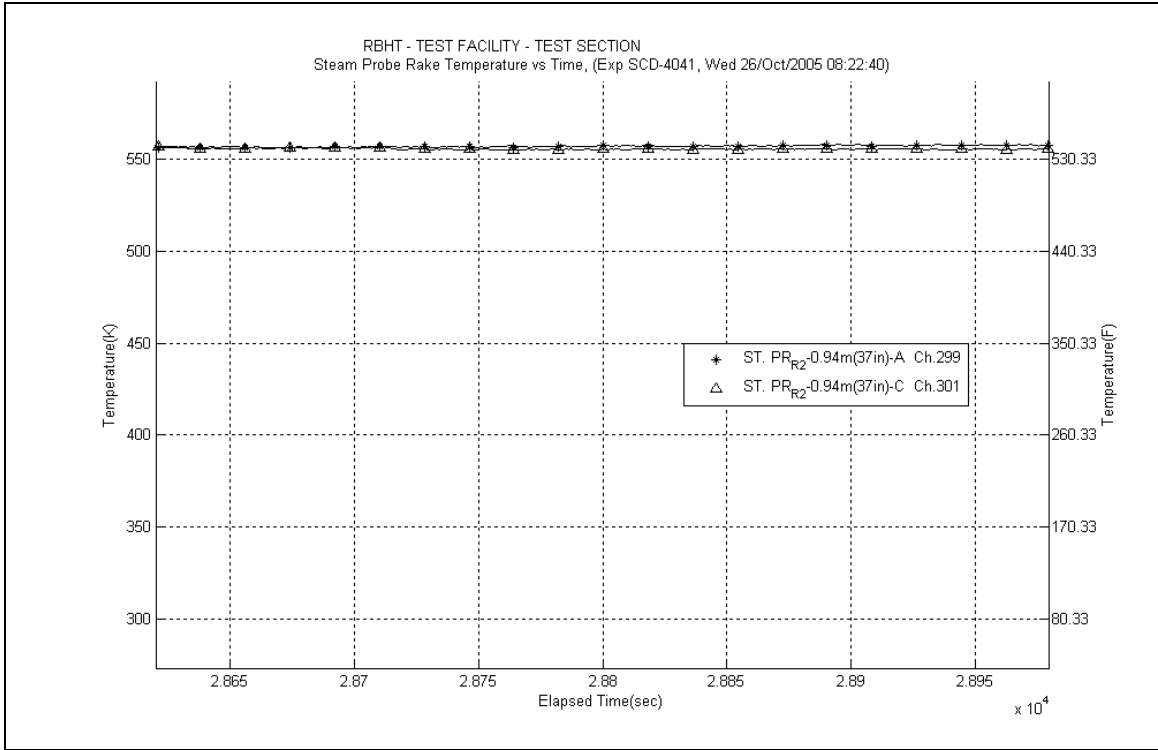

Figure A-639: Steam Probe Rake #2 Temperatures for Experiment 4041K

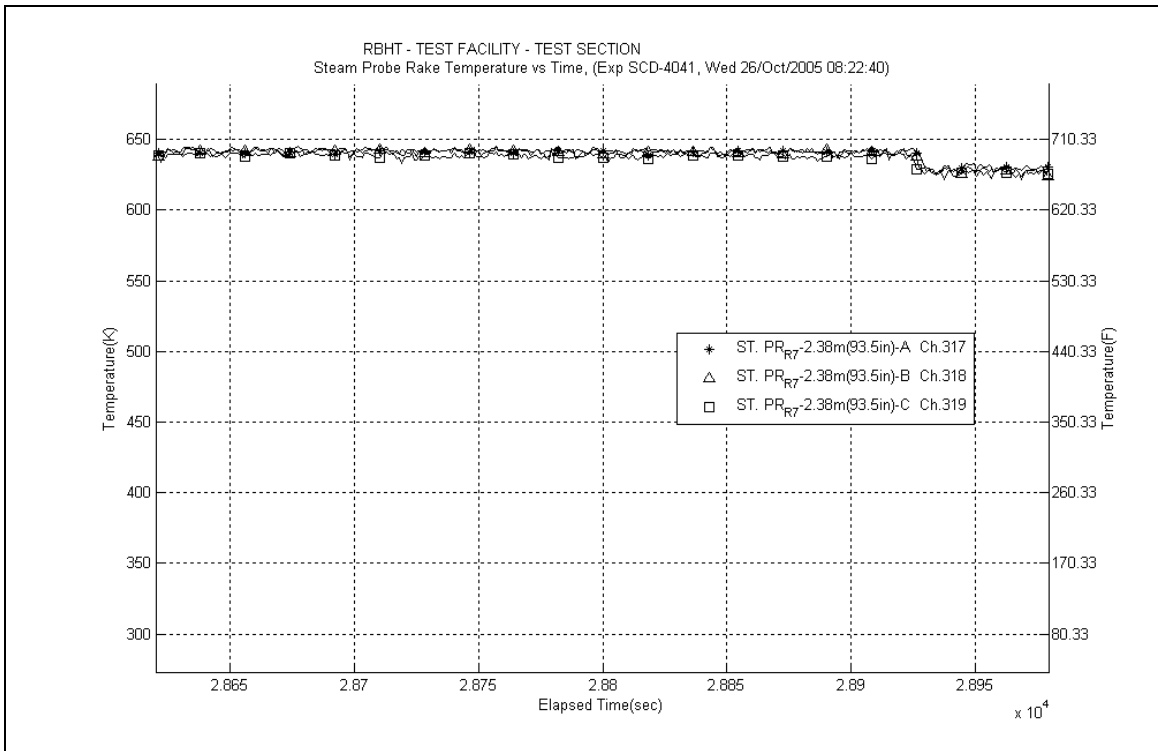

Figure A-640: Steam Probe Rake #7 Temperatures for Experiment 4041K

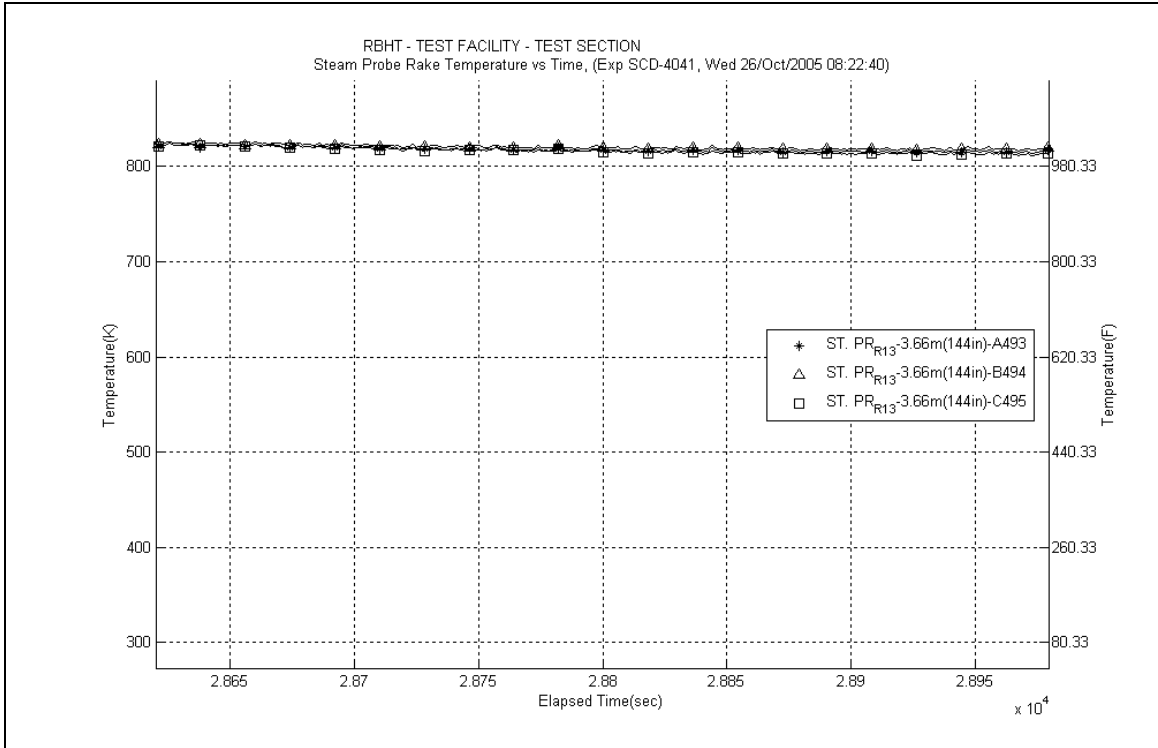

Figure A-641: Steam Probe Rake #13 Temperatures for Experiment 4041K

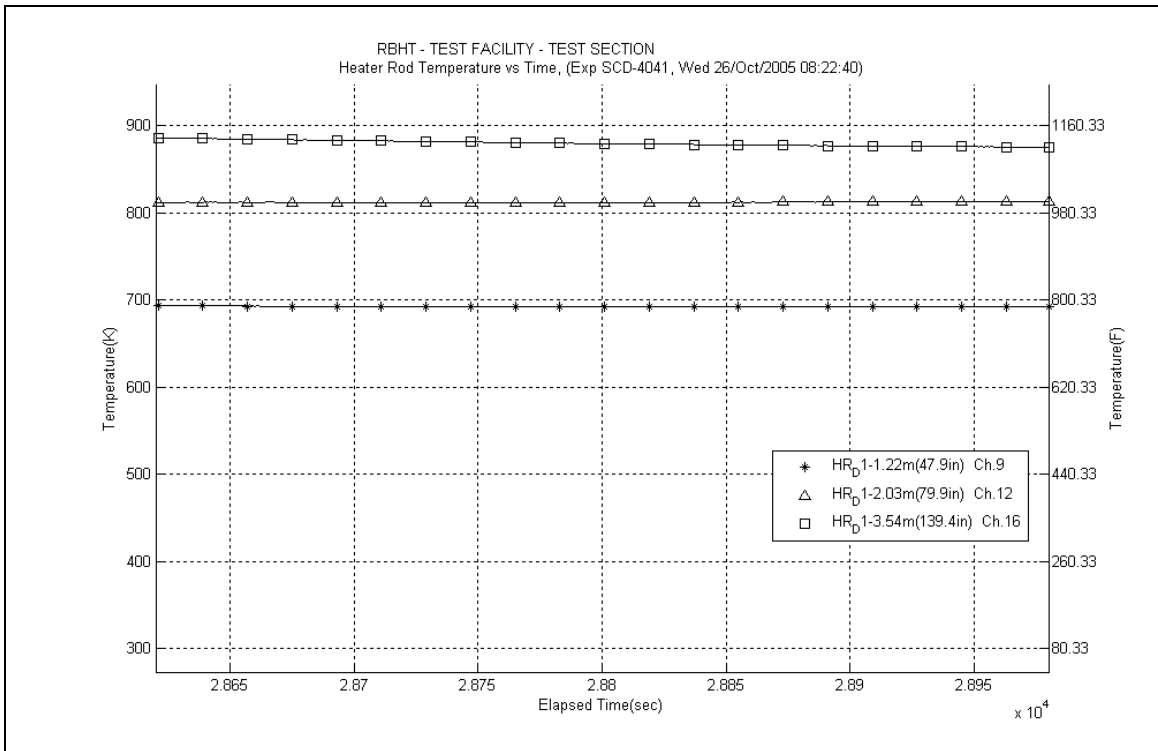

Figure A-642: Heater Rod D1 Temperatures for Experiment 4041K

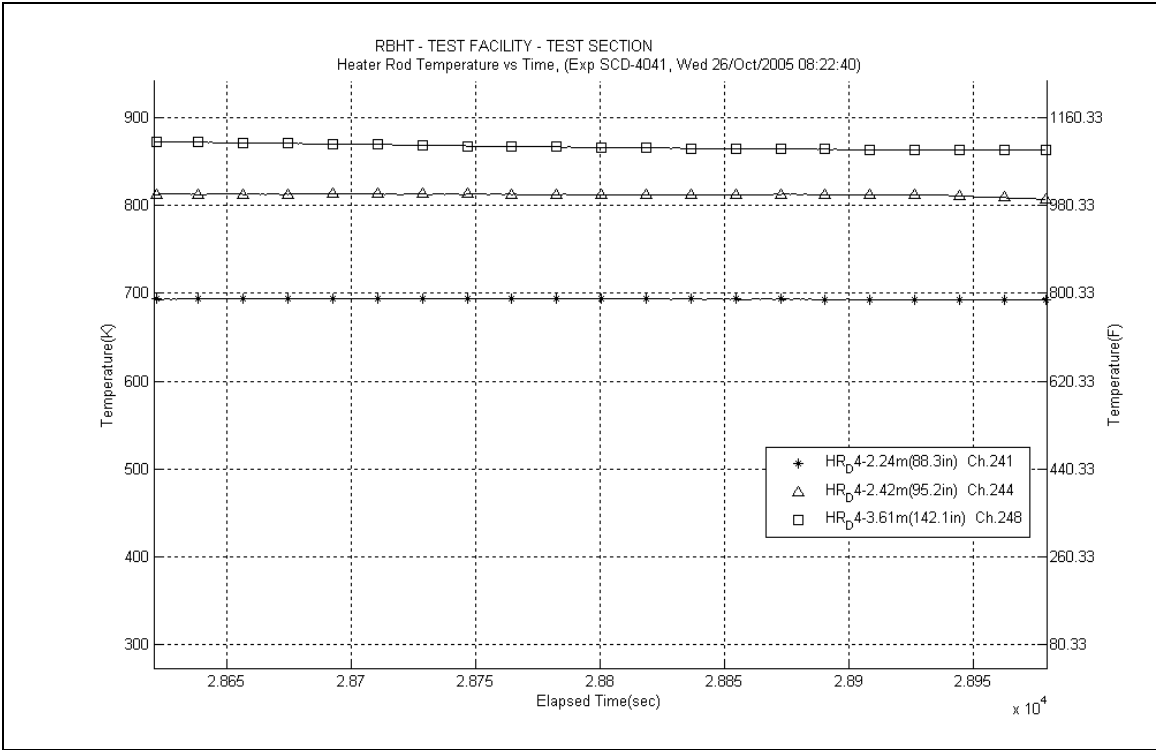

Figure A-643: Heater Rod D4 Temperatures for Experiment 4041K

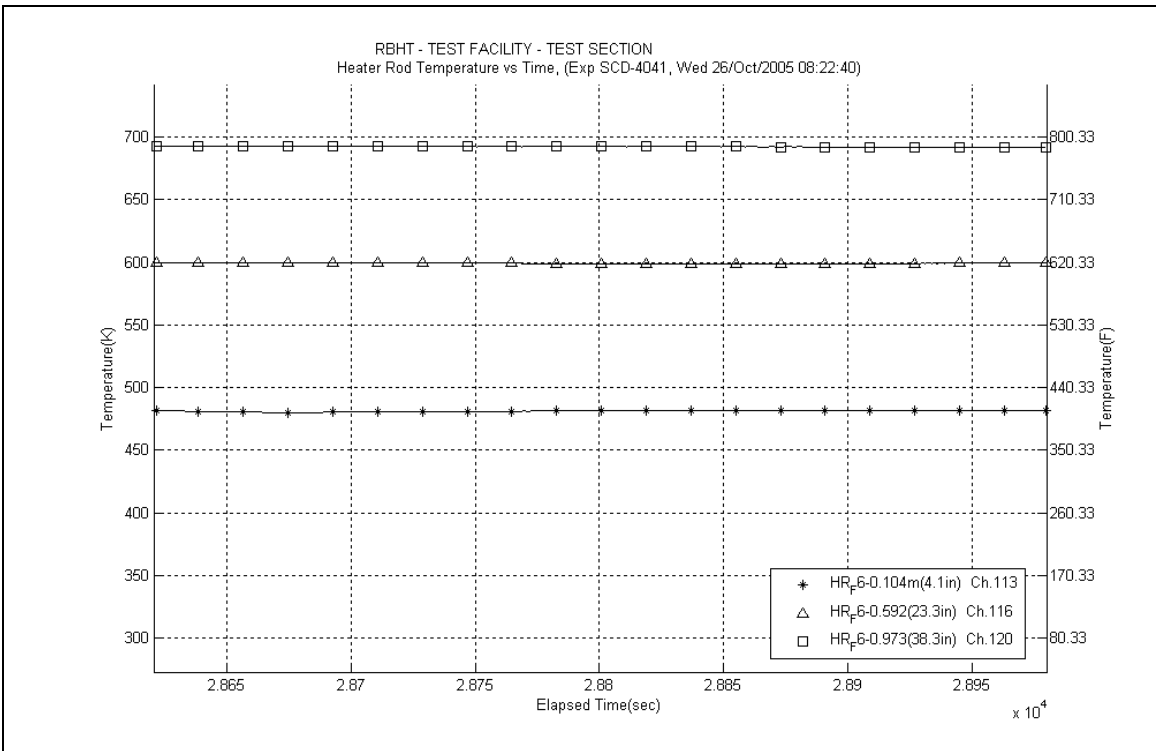

Figure A-644: Heater Rod F6 Temperatures for Experiment 4041K

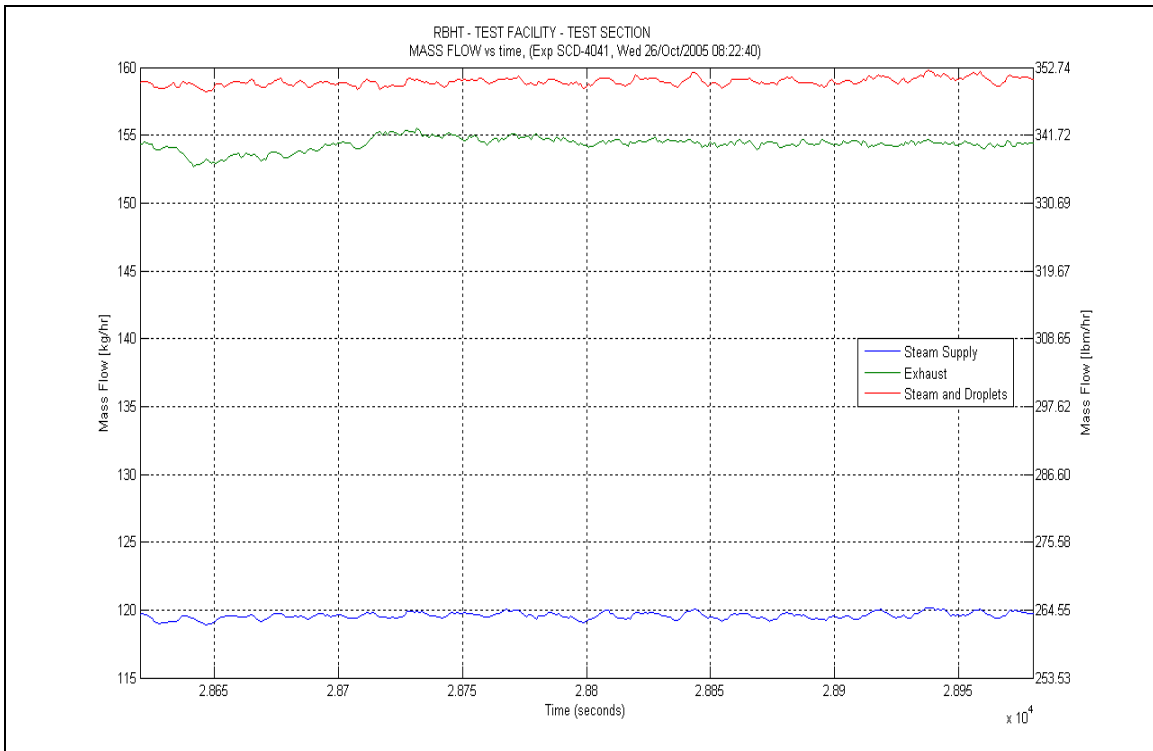

Figure A-645: Mass Flow for Experiment 4041K

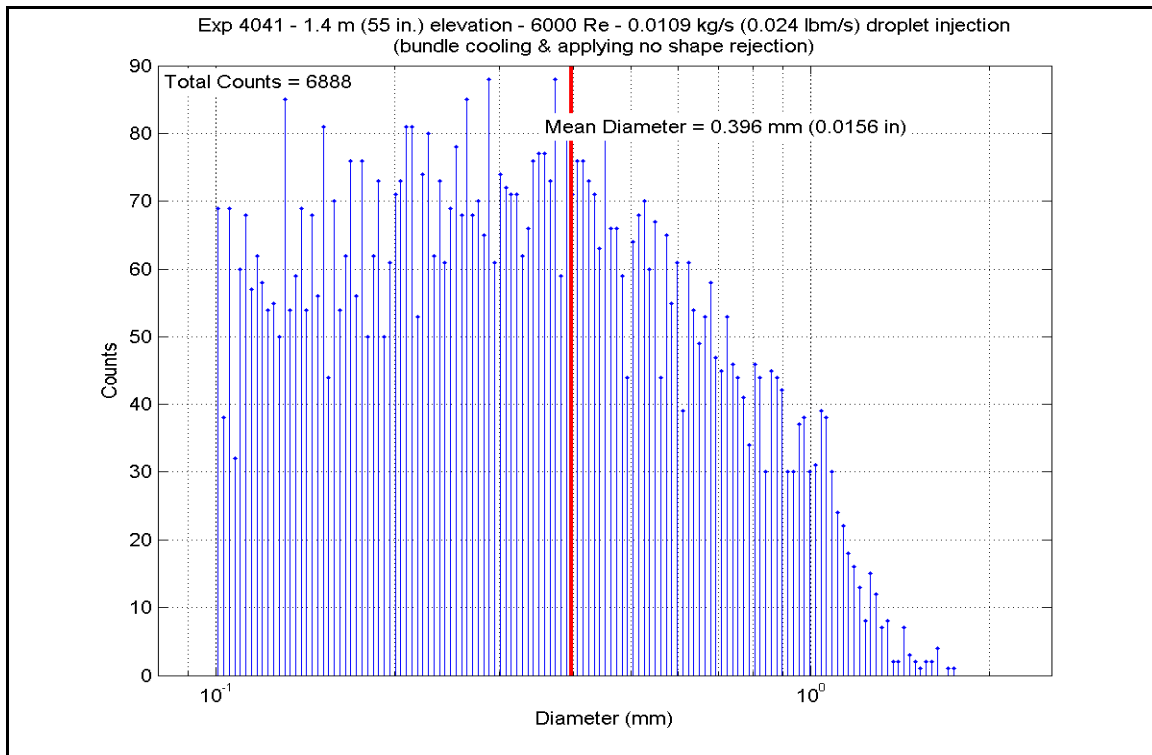

Figure A-646: Droplet Measurements at 1.397 m (55 in.) Elevation for Experiment 4041K

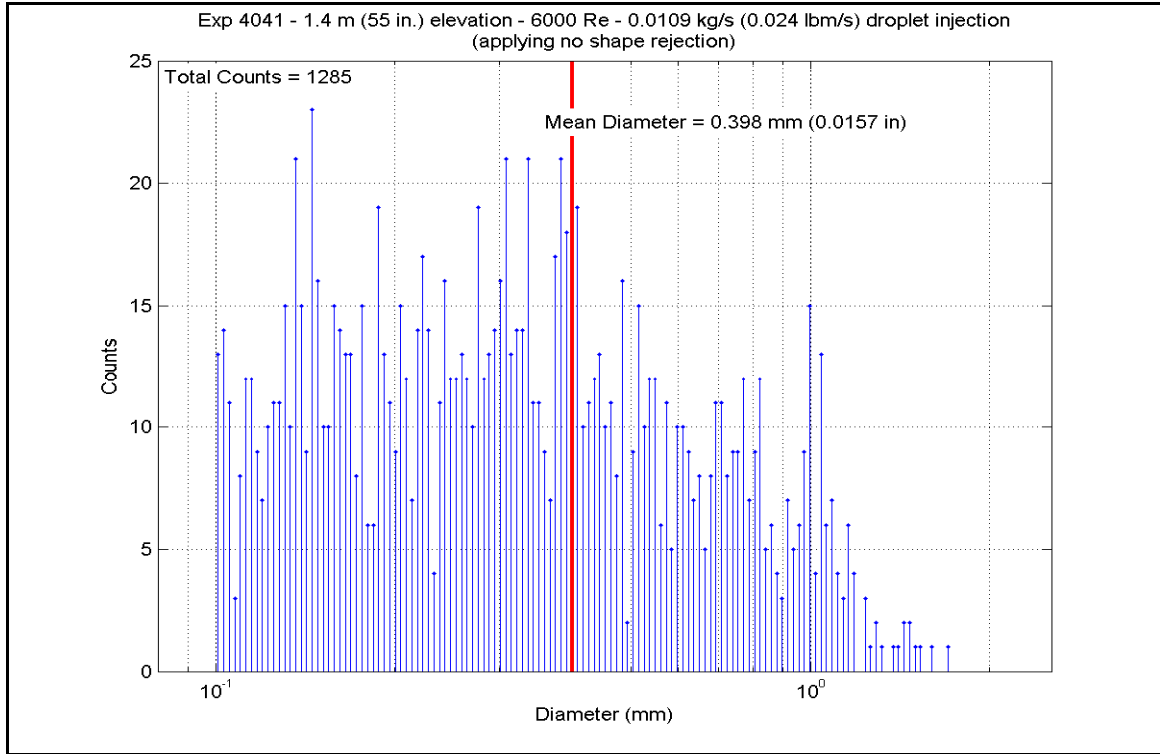

Figure A-647: Droplet Measurements at 1.397 m (55 in.) Elevation for Experiment 4041K

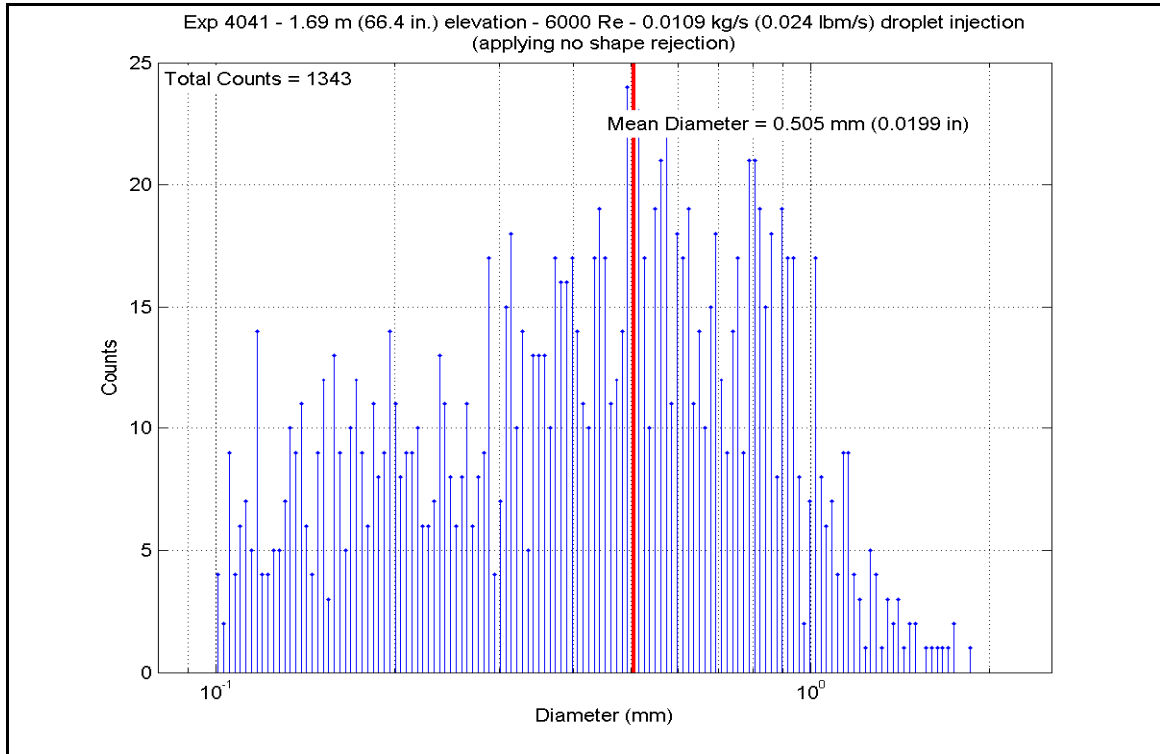

Figure A-648: Droplet Measurements at 1.687 m (66.4 in.) Elevation for Experiment 4041K

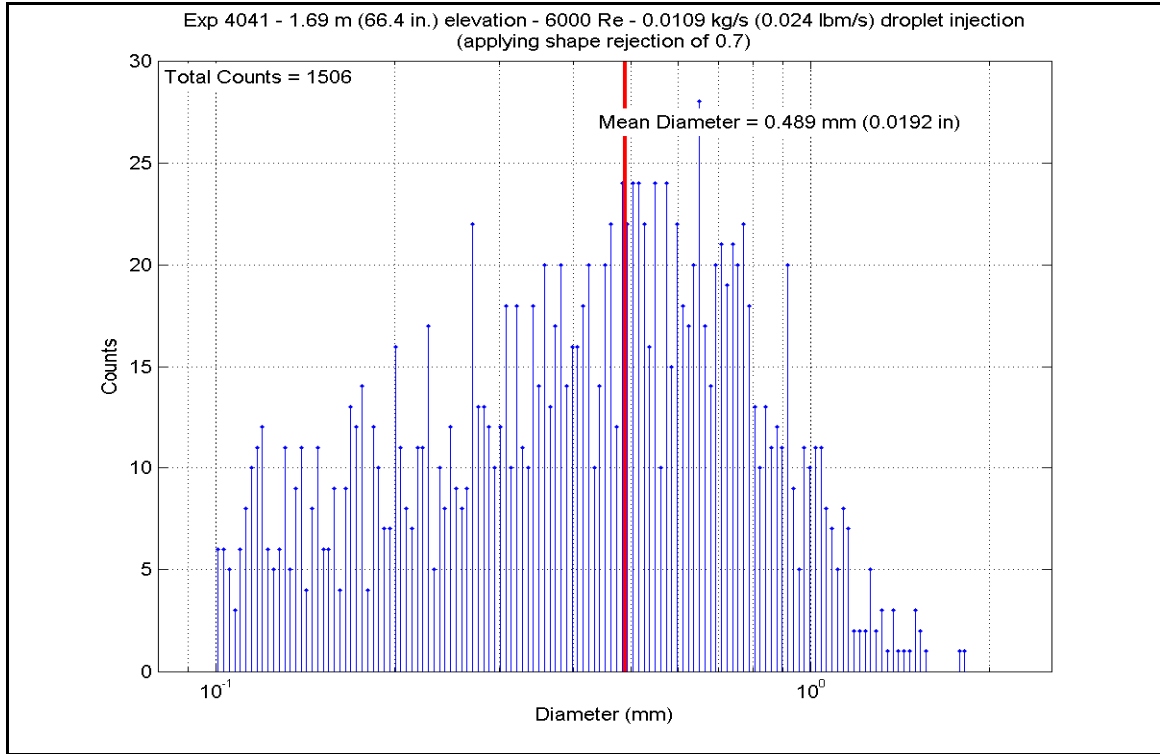

Figure A-649: Droplet Measurements at 1.687 m (66.4 in.) Elevation for Experiment 4041K

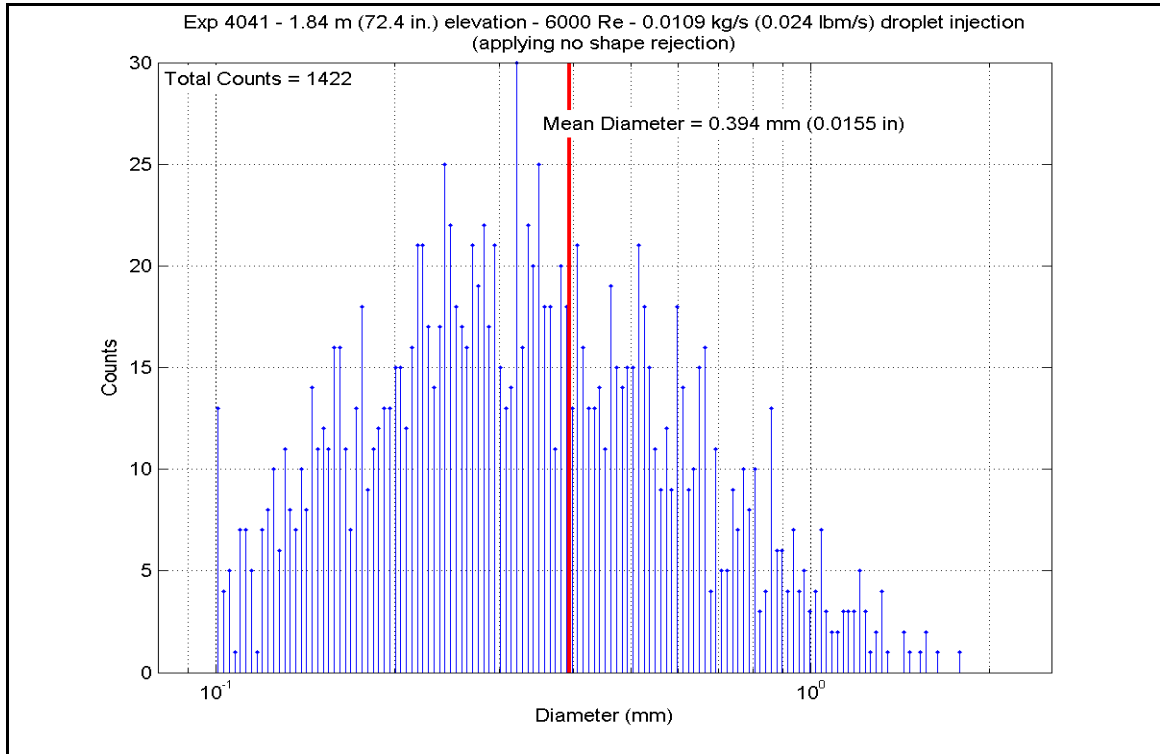

Figure A-650: Droplet Measurements at 1.839 m (72.4 in.) Elevation for Experiment 4041K

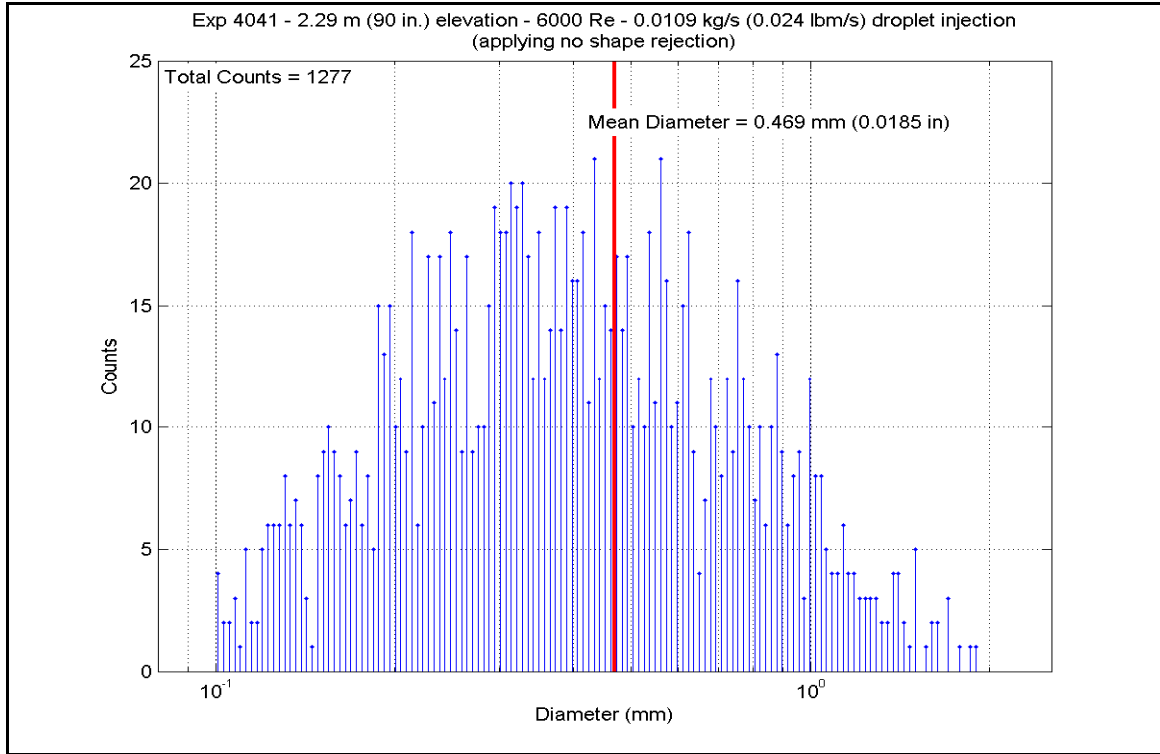

Figure A-651: Droplet Measurements at 2.286 m (90 in.) Elevation for Experiment 4041K

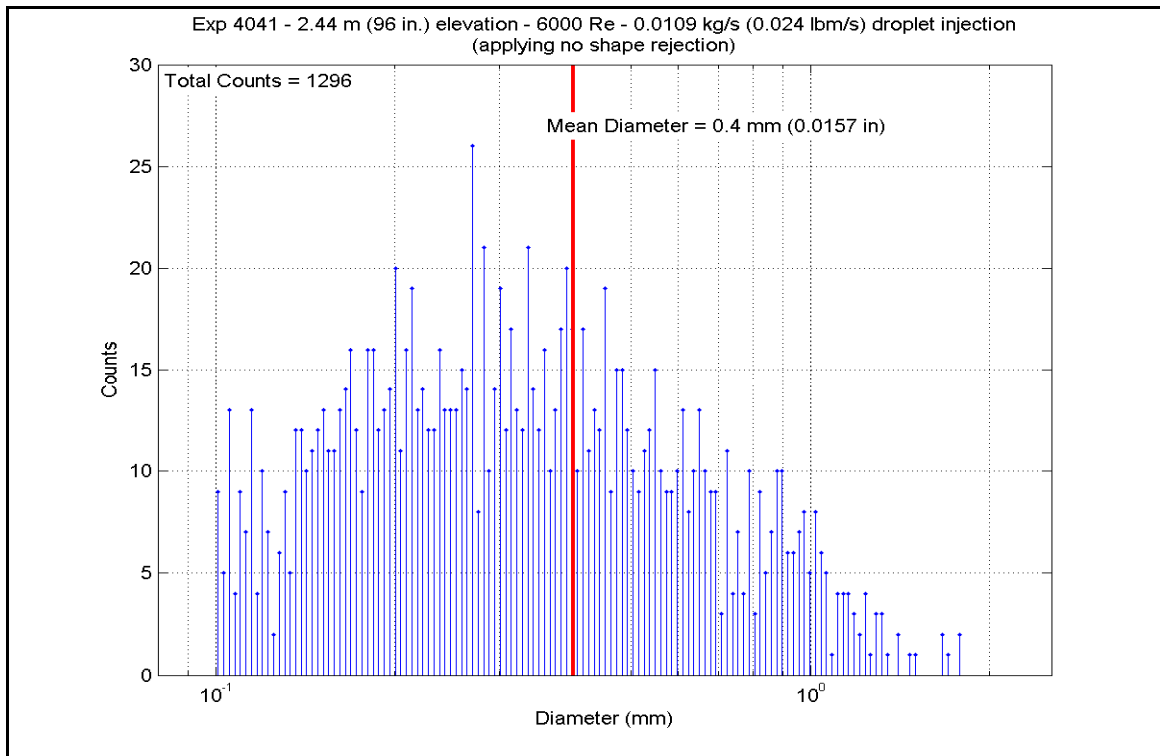

Figure A-652: Droplet Measurements at 2.438 m (96 in.) Elevation for Experiment 4041K

TableHeat Transfer Reduced Data for Experiment 4041K

SCD-4041-K		Inlet Reynolds:		6000		UP Pressure:		40 psia					
Matrix Test #7c		Bundle Power:		218377 Btu/hr		Steam flow:		260.0 lbm/hr					
Time Window: 28620-28980		Droplet flow:		0.0328 kg/s		0.024 lbm/s							
Inner 3x3													
H.R. ID	H.R. Location	Channel Number	Elevation (in)	Elevation (m)	Zgrid (in)	Zgrid (m)	H.R. Tw (°F)	H.R. Tw (K)	H.R. q" (Btu/hr-ft ²)	H.R. q" (W/m ²)	h _{sat} (z) (Btu/hr-ft ²)	h _{sat} (z) (W/m ² -K)	
Gr-3	RodD3_88.3	185	88.3	2.243	-0.2	-0.005	812.00	706.5	6776.41	21376.2	12.434	70.6	
	RodD3_91.3	186	91.3	2.319	2.8	0.071	896.08	753.2	6918.08	21823.1	10.997	62.5	
	RodD3_93.1	187	93.1	2.365	4.6	0.117	896.17	753.2	7003.71	22093.2	11.132	63.2	
	RodD3_95.3	188	95.3	2.421	6.8	0.173	943.71	779.7	7108.54	22423.9	10.505	59.7	
	RodD3_100.1	189	100.1	2.543	11.6	0.295	1032.16	828.8	7334.53	23136.8	9.586	54.4	
	RodD3_106.1	190	106.1	2.695	17.6	0.447	1093.70	863.0	7627.17	24059.9	9.226	52.4	
	RodD3_110	191	110	2.794	21.5	0.546	957.45	787.3	7536.40	23773.6	10.915	62.0	
	RodD3_142.1	192	142.1	3.609	3.609	8.6	984.45	802.3	2630.09	8296.6	3.666	20.8	
Gr-3	RodC4_88.4	233	88.4	2.245	-0.1	-0.003	773.98	685.4	6850.59	21610.2	13.513	76.7	
	RodC4_91.1	234	91.1	2.314	2.6	0.066	867.65	737.4	6983.43	22029.2	11.626	66.0	
	RodC4_93.4	235	93.4	2.372	4.9	0.124	893.94	752.0	7099.97	22396.8	11.325	64.3	
	RodC4_95.3	236	95.3	2.421	6.8	0.173	939.80	777.5	7192.02	22687.2	10.690	60.7	
	RodC4_100.1	237	100.1	2.543	11.6	0.295	989.24	804.9	7423.10	23416.2	10.278	58.4	
	RodC4_106.1	238	106.1	2.695	17.6	0.447	1048.16	837.7	7715.23	24337.7	9.877	56.1	
	RodC4_110	239	110	2.794	21.5	0.546	874.53	741.2	7482.73	23604.3	12.317	69.9	
	RodC4_142.2	240	142.2	3.612	3.612	8.7	926.13	769.9	2831.05	8930.5	4.295	24.4	
Gr-3	RodD4_88.3	241	88.3	2.243	-0.2	-0.005	754.20	674.4	6828.20	21539.6	14.015	79.6	
	RodD4_91.3	242	91.3	2.319	2.8	0.071	850.87	728.1	6970.67	21989.0	11.939	67.8	
	RodD4_93.2	243	93.2	2.367	4.7	0.119	877.94	743.1	7062.45	22278.5	11.560	65.6	
	RodD4_95.2	244	95.2	2.418	6.7	0.170	922.40	767.8	7162.16	22593.0	10.928	62.1	
	RodD4_100.1	245	100.1	2.543	11.6	0.295	1007.40	815.0	7399.77	23342.6	9.994	56.8	
	RodD4_106.1	246	106.1	2.695	17.6	0.447	1037.99	832.0	7693.37	24268.7	9.979	56.7	
	RodD4_142.1	248	142.1	3.609	3.609	8.6	929.17	771.6	2746.43	8663.6	4.148	23.6	
	Gr-3	RodE4_88.4	201	88.4	2.245	-0.1	-0.003	780.69	689.1	6747.28	21284.3	13.135	74.6
RodE4_91.2		202	91.2	2.316	2.7	0.069	879.15	743.8	6871.89	21677.4	11.226	63.7	
RodE4_95.3		204	95.3	2.421	6.8	0.173	955.52	786.2	7058.46	22265.9	10.252	58.2	
RodE4_100.9		205	100.9	2.563	12.4	0.315	1023.19	823.8	7313.98	23072.0	9.672	54.9	
RodE4_142.3		208	142.3	3.614	3.614	8.8	957.80	787.5	2797.52	8824.8	4.050	23.0	

TableHeat Transfer Reduced Data for Experiment 4041, continued

	H.R. Location	Channel Number	Elevation (in)	Elevation (m)	Zgrid (in)	Zgrid (m)	H.R. Tw (°F)	H.R. Tw (K)	H.R. q" (Btu/hr-ft ²)	H.R. q" (W/m ²)	h _{sat} (z) (Btu/hr-ft ² -F)	h _{sat} (z) (W/m ² -K)
Gr-4	RodE3_63.4	193	63.4	1.610	16.4	0.417	938.68	776.9	5580.40	17603.4	8.308	47.2
	RodE3_113.6	194	113.6	2.885	0.85	0.022	999.36	810.6	6887.70	21727.3	9.405	53.4
	RodE3_115.5	195	115.5	2.934	2.75	0.070	1035.57	830.7	6646.62	20966.8	8.648	49.1
	RodE3_118.5	196	118.5	3.010	5.75	0.146	1058.99	843.7	6242.42	19691.7	7.882	44.8
	RodE3_122.7	197	122.7	3.117	9.95	0.253	1058.07	843.2	5671.68	17891.3	7.170	40.7
	RodE3_126.5	198	126.5	3.213	13.75	0.349	1057.43	842.8	5159.06	16274.2	6.527	37.1
	RodE3_131.7	199	131.7	3.345	-1.8	-0.046	961.63	789.6	4461.65	14074.3	6.423	36.5
	RodE3_135.6	200	135.6	3.444	2.1	0.053	996.51	809.0	3936.03	12416.2	5.395	30.6
	RodC5_63.7	225	63.7	1.618	16.7	0.424	940.17	777.7	5471.66	17260.4	8.128	46.2
	RodC5_113.6	226	113.6	2.885	0.85	0.022	917.30	765.0	6707.69	21159.4	10.315	58.6
Gr-4	RodC5_115.7	227	115.7	2.939	2.95	0.075	960.55	789.0	6436.10	20302.7	9.280	52.7
	RodC5_122.7	229	122.7	3.117	9.95	0.253	991.50	806.2	5532.71	17452.9	7.637	43.4
	RodC5_126.7	230	126.7	3.218	13.95	0.354	990.27	805.5	5018.91	15832.2	6.939	39.4
	RodC5_131.6	231	131.6	3.343	-1.9	-0.048	876.00	742.0	4396.52	13868.8	7.219	41.0
	RodC5_135.7	232	135.7	3.447	2.2	0.056	901.27	756.1	3867.99	12201.6	6.098	34.6
	RodE5_63.6	209	63.6	1.615	16.6	0.422	829.38	716.1	5617.32	17719.8	9.989	56.7
	RodE5_113.6	210	113.6	2.885	0.85	0.022	829.46	716.2	6950.70	21926.0	12.358	70.2
	RodE5_115.4	211	115.4	2.931	2.65	0.067	906.44	759.0	6715.69	21184.6	10.502	59.6
	RodE5_118.7	212	118.7	3.015	5.95	0.151	968.66	793.5	6280.80	19812.8	8.951	50.8
	RodE5_122.6	213	122.6	3.114	9.85	0.250	996.43	808.9	5766.68	18191.0	7.906	44.9
RodE5_126.6	214	126.6	3.216	13.85	0.352	996.96	809.2	5237.20	16520.7	7.175	40.7	
Gr-5	RodE5_131.6	215	131.6	3.343	-1.9	-0.048	974.42	796.7	4564.25	14397.9	6.452	36.6
	RodE5_135.6	216	135.6	3.444	2.1	0.053	963.78	790.8	4010.65	12651.6	5.756	32.7
	RodC3_79.8	177	79.8	2.027	8.92	0.227	900.71	755.8	6335.31	19984.7	9.997	56.8
	RodC3_85.6	178	85.6	2.174	14.72	0.374	810.69	705.8	6608.54	20846.6	12.155	69.0
	RodC3_88.5	179	88.5	2.248	0	0.000	805.31	702.8	6742.65	21269.7	12.526	71.1
	RodC3_92.4	180	92.4	2.347	3.9	0.099	913.73	763.0	6930.25	21861.5	10.716	60.9
	RodC3_94.4	181	94.4	2.398	5.9	0.150	931.88	773.1	7028.58	22171.7	10.571	60.0
	RodC3_97.2	182	97.2	2.469	8.7	0.221	967.90	804.2	7157.99	22579.9	9.929	56.4
	RodC3_108.8	183	108.8	2.764	20.3	0.516	1073.79	851.9	7553.50	23827.5	9.362	53.2
	RodD5_50	217	50	1.270	16.7	0.424	821.83	711.9	4945.43	15600.4	8.913	50.6
Gr-8	RodD5_54.1	218	54.1	1.374	7.1	0.180	748.80	671.4	5147.32	16237.2	10.684	60.7
	RodD5_56.9	219	56.9	1.445	9.9	0.251	834.64	719.1	5273.55	16635.4	9.290	52.8
	RodD5_60	220	60	1.524	13	0.330	880.09	744.3	5426.29	17117.2	8.851	50.3
	RodD5_66.1	221	66.1	1.679	19.1	0.485	905.03	758.2	5723.78	18055.7	8.971	50.9
	RodD5_69.9	222	69.9	1.775	-0.98	-0.025	712.88	651.4	5908.21	18637.4	13.251	75.2
	RodD5_72.9	223	72.9	1.852	2.02	0.051	789.15	693.8	6041.36	19057.5	11.570	65.7
	RodD5_74.9	224	74.9	1.902	4.02	0.102	830.16	716.6	6136.37	19357.2	10.896	61.9

Inner 3x3

TableHeat Transfer Reduced Data for Experiment 4041, continued

H.R. ID	H.R. Location	Channel Number	Elevation (in)	Elevation (m)	Zgrid (in)	Zgrid (m)	H.R. Tw (°F)	H.R. Tw (K)	H.R. q" (Btu/hr-ft ²)	H.R. q" (W/m ²)	h _{sat} (z) (Btu/hr-ft ² -F)	h _{sat} (z) (W/m ² -K)	
Gr-2	RodB5_41	153	41	1.041	13.5	0.343	754.43	674.5	4498.84	14191.6	9.230	52.4	
	RodB5_52.9	154	52.9	1.344	5.9	0.150	826.88	714.8	5067.45	15985.3	8.051	51.4	
	RodB5_55	155	55	1.397	8	0.203	864.48	735.6	5168.71	16304.7	8.651	49.1	
	RodB5_57.8	156	57.8	1.468	10.8	0.274	905.64	758.5	5301.90	16724.8	8.302	47.1	
	RodB5_64	157	64	1.626	17	0.432	943.44	779.5	5601.58	17670.2	8.281	47.0	
	RodB5_73.9	158	73.9	1.877	3.02	0.077	867.14	737.1	6084.13	19192.4	10.138	57.6	
	RodB5_75.9	159	75.9	1.928	5.02	0.128	897.31	753.9	6175.46	19480.5	9.797	55.6	
	RodB5_76.9	160	76.9	1.953	6.02	0.153	909.47	760.6	6222.27	19628.2	9.685	55.0	
	Gr-2	RodF5_41	105	41	1.041	13.5	0.343	745.47	669.5	4468.12	14094.7	9.338	53.0
		RodF5_53.1	106	53.1	1.349	6.1	0.155	808.16	704.4	5052.86	15939.2	9.337	53.0
		RodF5_55	107	55	1.397	8	0.203	847.05	726.0	5144.11	16227.1	8.868	50.4
		RodF5_57.8	108	57.8	1.468	10.8	0.274	887.67	748.5	5284.73	16670.7	8.515	48.4
		RodF5_64	109	64	1.626	17	0.432	900.51	755.7	5578.43	17597.2	8.806	50.0
		RodF5_73.8	110	73.8	1.875	2.92	0.074	849.61	727.4	6058.88	19112.7	10.400	59.1
		RodF5_75.8	111	75.8	1.925	4.92	0.125	886.50	747.9	6156.81	19421.6	9.938	56.4
		RodF5_76.8	112	76.8	1.951	5.92	0.150	901.68	756.3	6205.49	19575.2	9.777	55.5
Gr-2		RodC2_41	57	41	1.041	13.5	0.343	741.48	667.3	4491.33	14167.9	9.466	53.8
		RodC2_53.1	58	53.1	1.349	6.1	0.155	865.29	736.1	5072.09	15999.9	8.478	48.1
		RodC2_55	59	55	1.397	8	0.203	883.63	746.3	5163.11	16287.0	8.373	47.6
		RodC2_57.8	60	57.8	1.468	10.8	0.274	913.56	762.9	5299.82	16718.3	8.197	46.5
	RodC2_63.9	61	63.9	1.623	16.9	0.429	933.88	774.2	5590.64	17635.7	8.383	47.6	
	RodC2_73.8	62	73.8	1.875	2.92	0.074	893.02	751.5	6065.07	19132.3	9.688	55.0	
	RodC2_75.8	63	75.8	1.925	4.92	0.125	921.23	767.2	6170.35	19464.4	9.431	53.6	
	RodC2_76.8	64	76.8	1.951	5.92	0.150	932.56	773.5	6221.97	19627.2	9.348	53.1	
Gr-2	RodC6_40.9	137	40.9	1.039	13.4	0.340	751.29	672.8	4469.43	14098.8	9.229	52.4	
	RodC6_52.8	138	52.8	1.341	5.8	0.147	870.40	738.9	5064.29	15975.3	8.393	47.7	
	RodC6_54.8	139	54.8	1.392	7.8	0.198	891.00	750.4	5164.79	16292.3	8.277	47.0	
	RodC6_57.8	140	57.8	1.468	10.8	0.274	926.10	769.9	5315.21	16766.8	8.064	45.8	
	RodC6_63.8	141	63.8	1.621	16.8	0.427	962.86	790.3	5615.18	17713.1	8.069	45.8	
	RodC6_73.7	142	73.7	1.872	2.82	0.072	917.40	765.0	6119.48	19303.9	9.409	53.4	
	RodC6_75.8	143	75.8	1.925	4.92	0.125	940.52	777.9	6220.49	19622.5	9.236	52.4	
	RodC6_76.8	144	76.8	1.951	5.92	0.150	954.90	785.9	6270.65	19780.8	9.116	51.8	

5x5 periphery

TableHeat Transfer Reduced Data for Experiment 4041, continued

5x5 periphery		H.R. Location	Channel Number	Elevation (in)	Elevation (m)	Zgrid (in)	Zgrid (m)	H.R. Tw (°F)	H.R. Tw (K)	H.R. q" (Btu/hr-ft ²)	H.R. q" (W/m ²)	h _{sat} (z) (Btu/hr-ft ² -F)	h _{sat} (z) (W/m ² -K)
Gr-3	RodB4_88.4	161	88.4	2.245	-0.003	785.43	691.7	6726.58	21219.0	12.975	73.7		
	RodB4_91.3	162	91.3	2.319	0.071	881.81	745.3	6856.97	21630.3	11.153	63.3		
	RodB4_93.3	163	93.3	2.370	0.122	896.75	753.6	6955.13	21940.0	11.044	62.7		
	RodB4_95.1	164	95.1	2.416	0.168	930.53	772.3	7033.27	22186.5	10.600	60.2		
	RodB4_100	165	100	2.540	0.292	962.76	790.2	7255.11	22886.2	10.428	59.2		
	RodB4_106	166	106	2.692	0.445	1049.07	838.2	7533.59	23764.7	9.633	54.7		
	RodB4_109.9	167	109.9	2.791	0.544	888.87	749.2	7330.59	23124.3	11.788	66.9		
	RodB4_142.3	168	142.3	3.614	0.224	934.79	774.7	2813.89	8876.4	4.214	23.9		
Gr-5	RodF4_85.6	98	85.6	2.174	0.374	857.17	731.6	6660.55	21010.7	11.286	64.1		
	RodF4_88.4	99	88.4	2.245	-0.003	823.21	712.7	6789.43	21417.3	12.207	69.3		
	RodF4_92.4	100	92.4	2.347	0.099	928.64	771.3	6970.65	21988.9	10.535	59.8		
	RodF4_94.3	101	94.3	2.395	0.147	961.59	789.6	7059.75	22270.0	10.164	57.7		
	RodF4_97.2	102	97.2	2.469	0.221	1001.65	811.8	7198.94	22709.1	9.799	55.6		
	RodF4_108.8	103	108.8	2.764	0.516	1053.69	840.8	7604.79	23989.3	9.667	54.9		
	RodF4_111	104	111	2.819	-0.044	887.34	748.3	7298.60	23023.4	11.766	66.8		
	RodD2_103.2	65	103.2	2.621	0.373	1067.64	848.5	6695.22	21120.1	8.362	47.5		
Gr-6	RodD2_106	66	106	2.692	0.445	1088.88	860.3	6344.90	20015.0	7.720	43.8		
	RodD2_112.6	67	112.6	2.860	-0.004	1109.32	871.7	5866.07	18504.5	6.964	39.5		
	RodD2_114.9	68	114.9	2.918	0.055	1112.16	873.2	5299.49	16717.3	6.270	35.6		
	RodD2_117.4	69	117.4	2.982	0.118	1096.74	864.7	4759.76	15014.7	5.736	32.6		
	RodD2_120.8	70	120.8	3.068	0.204	1110.68	872.4	7518.96	23718.6	8.912	50.6		
	RodD2_124.8	71	124.8	3.170	0.306	1132.55	884.6	7652.90	24141.1	8.842	50.2		
	RodD2_128.6	72	128.6	3.266	0.403	1031.12	828.2	7019.21	22142.1	9.186	52.2		
	RodD6_103.1	129	103.1	2.619	0.371	1050.96	839.2	7534.57	23767.8	9.611	54.6		
Gr-6	RodD6_106	130	106	2.692	0.445	1067.43	848.4	7673.05	24204.6	9.586	54.4		
	RodD6_112.9	131	112.9	2.868	0.004	956.10	786.5	7003.96	22094.0	10.164	57.7		
	RodD6_114.9	132	114.9	2.918	0.055	994.28	807.8	6716.09	21185.9	9.234	52.4		
	RodD6_116.8	133	116.8	2.967	0.103	1015.90	819.8	6440.52	20316.6	8.600	48.8		
	RodD6_120.9	134	120.9	3.071	0.207	1019.07	821.5	5842.32	18429.6	7.768	44.1		
	RodD6_124.8	135	124.8	3.170	0.306	1018.21	821.0	5284.40	16669.6	7.035	39.9		
RodD6_128.7	136	128.7	3.269	0.405	1005.61	814.0	4729.31	14918.6	6.403	36.4			

TableHeat Transfer Reduced Data for Experiment 4041, continued

5x5 periphery		H.R. Location	Channel Number	Elevation (in)	Elevation (m)	Zgrid (in)	Zgrid (m)	H.R. Tw (°F)	H.R. Tw (K)	H.R. q" (Btu/hr-ft ²)	H.R. q" (W/m ²)	h _{sat} (z) (Btu/hr-ft ² -F)	h _{sat} (z) (W/m ² -K)
Gr-8	RodE2_50.1	73	50.1	1.273	3.1	0.079	703.9	4966.87	15664.8	9.189	52.2		
	RodE2_54	74	54	1.372	7	0.178	739.8	5155.33	16262.5	8.521	48.4		
	RodE2_56.9	75	56.9	1.445	9.9	0.251	759.1	5293.72	16699.0	8.275	47.0		
	RodE2_59.9	76	59.9	1.521	12.9	0.328	777.3	5438.02	17154.2	8.087	45.9		
	RodE2_66	77	66	1.676	19	0.483	788.9	5734.64	18089.9	8.271	47.0		
	RodE2_69.8	78	69.8	1.773	-1.08	-0.027	722.8	5961.81	18806.5	10.379	58.9		
	RodE2_72.9	79	72.9	1.852	2.02	0.051	757.1	6103.81	19254.5	9.597	54.5		
	RodE2_74.9	80	74.9	1.902	4.02	0.102	774.4	6200.02	19558.0	9.292	52.8		
Gr-8	RodB3_50.2	169	50.2	1.275	3.2	0.081	681.3	4937.40	15575.0	9.882	56.1		
	RodB3_54.1	170	54.1	1.374	7.1	0.180	718.4	5122.86	16160.1	9.043	51.4		
	RodB3_56.9	171	56.9	1.445	9.9	0.251	741.1	5259.59	16591.4	8.661	49.2		
	RodB3_60.1	172	60.1	1.527	13.1	0.333	730.6	5420.18	17098.0	9.212	52.3		
	RodB3_66.1	173	66.1	1.679	19.1	0.485	748.9	5714.63	18026.8	9.197	52.2		
	RodB3_69.9	174	69.9	1.775	-0.98	-0.025	670.1	5911.77	18648.7	12.329	70.0		
	RodB3_73	175	73	1.854	2.12	0.054	710.9	6038.89	19049.7	10.921	62.0		
	RodB3_75	176	75	1.905	4.12	0.105	731.0	6134.37	19350.9	10.412	59.1		
Gr-8	RodF3_50.1	89	50.1	1.273	3.1	0.079	692.0	4935.39	15568.7	9.511	54.0		
	RodF3_54	90	54	1.372	7	0.178	729.6	5124.99	16166.8	8.736	49.6		
	RodF3_57	91	57	1.448	10	0.254	754.6	5277.98	16649.4	8.356	47.5		
	RodF3_60	92	60	1.524	13	0.330	769.6	5453.12	17201.9	8.280	47.0		
	RodF3_66.1	93	66.1	1.679	19.1	0.485	773.6	5757.20	18161.1	8.648	49.1		
	RodF3_70	94	70	1.778	-0.88	-0.022	696.7	5962.42	18808.4	11.305	64.2		
	RodF3_73	95	73	1.854	2.12	0.054	750.4	6097.45	19234.4	9.771	55.5		
	RodF3_75	96	75	1.905	4.12	0.105	772.3	6191.70	19531.7	9.332	53.0		
Gr-8	RodE6_50.2	121	50.2	1.275	3.2	0.081	697.1	4932.45	15559.4	9.340	53.0		
	RodE6_54.1	122	54.1	1.374	7.1	0.180	729.6	5117.58	16143.4	8.724	49.5		
	RodE6_57	123	57	1.448	10	0.254	746.2	5254.35	16574.8	8.523	48.4		
	RodE6_60.2	124	60.2	1.529	13.2	0.335	759.4	5406.27	17054.1	8.445	48.0		
	RodE6_66.1	125	66.1	1.679	19.1	0.485	769.2	5683.61	17928.9	8.639	49.1		
	RodE6_70	126	70	1.778	-0.88	-0.022	693.3	5884.40	18562.3	11.290	64.1		
	RodE6_73.1	127	73.1	1.857	2.22	0.056	728.6	6034.16	19034.7	10.319	58.6		
	RodE6_75	128	75	1.905	4.12	0.105	745.8	6121.90	19311.5	9.943	56.5		

RBHT Steam Cooling with Droplet Injection Test SCD-4042-A

Matrix Test # 3a

Test Conditions

Test Date – 11/1/2005

Steady State Time Window: 11940 – 13680

Upper Plenum Pressure: 1.38 bar (20 psia)

Bundle Power: 60.0 kW

Bundle Inlet Reynolds Number: 6000

Bundle Inlet Steam Flow: 121.7 kg/hr (268 lbm/hr)

Droplet Injection Flow: 0.0036 kg/s (0.008 lbm/s)

Droplet Injection Hole Diameter: 0.381 mm (.015 in)

Droplet Injection Elevation: 1.295 m (51 in)

Bundle Flow Area: $4.656 \times 10^{-3} \text{ m}^2$ ($5.012 \times 10^{-2} \text{ ft}^2$)

Test Notes

- No steam probes were traversed in this steady state window.

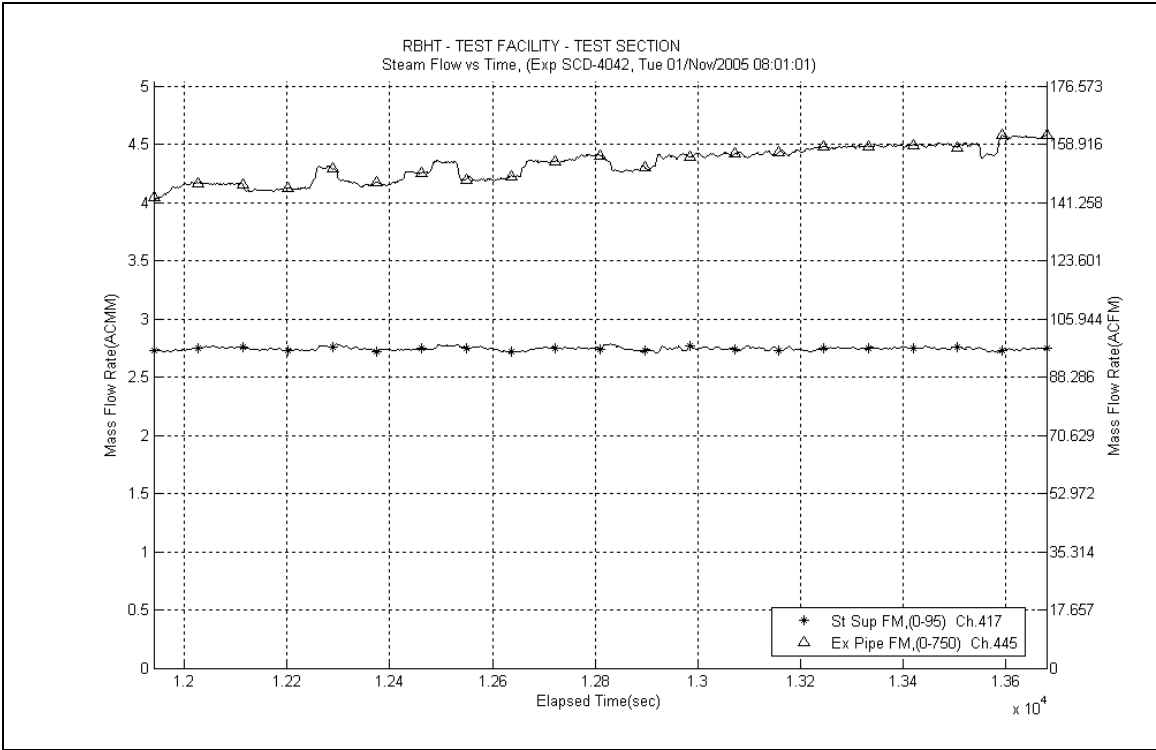

Figure A-653: Inlet and Exhaust Steam Flow Rates for Experiment 4042A

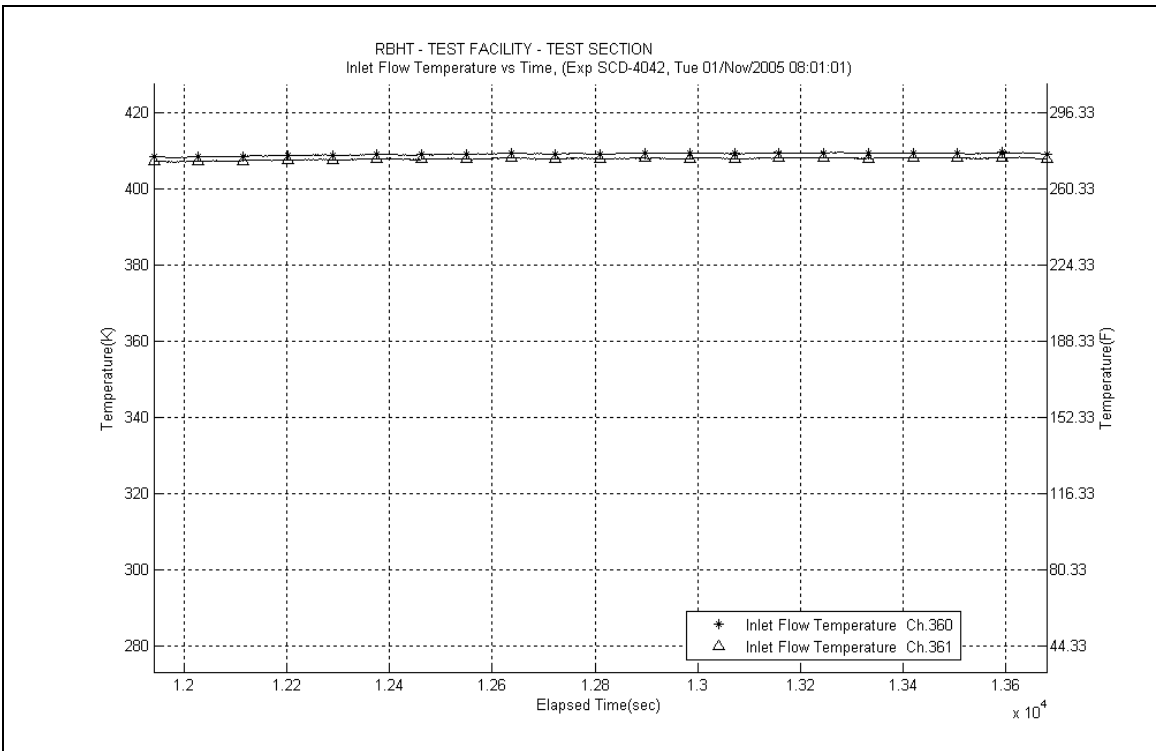

Figure A-654: Inlet Steam Temperature for Experiment 4042A

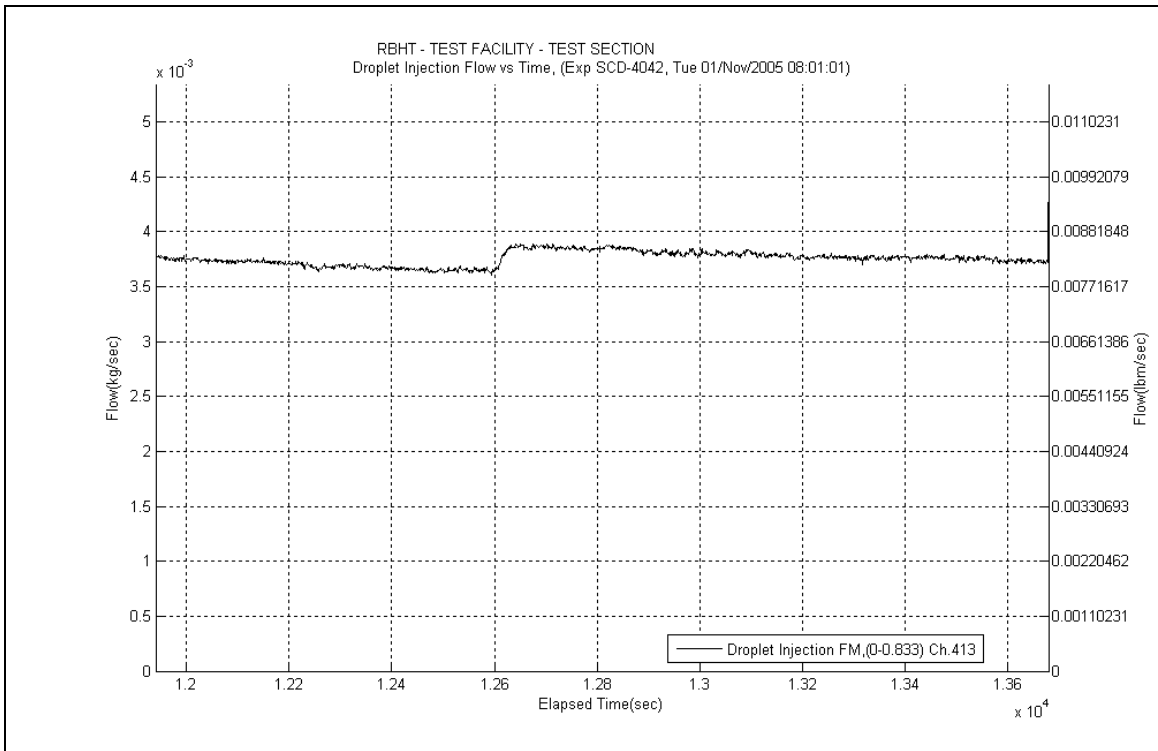

Figure A-655: Droplet Injection Flow Rate for Experiment 4042A

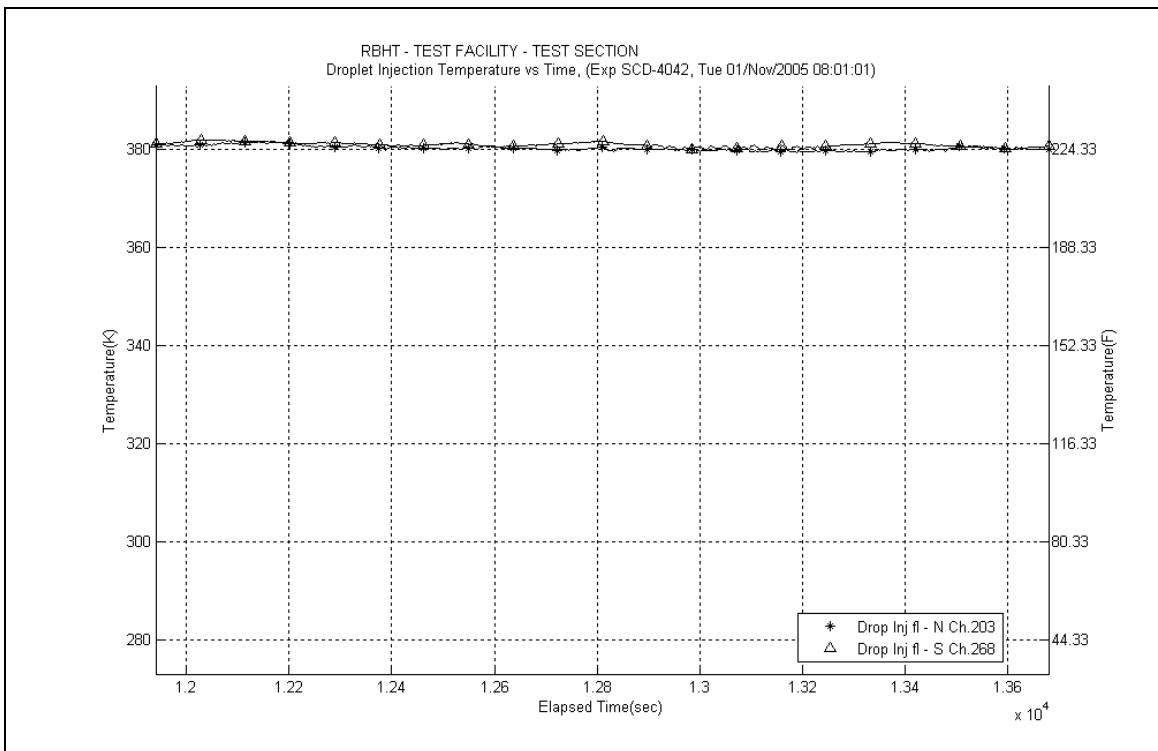

Figure A-656: Droplet Injection Temperature for Experiment 4042A

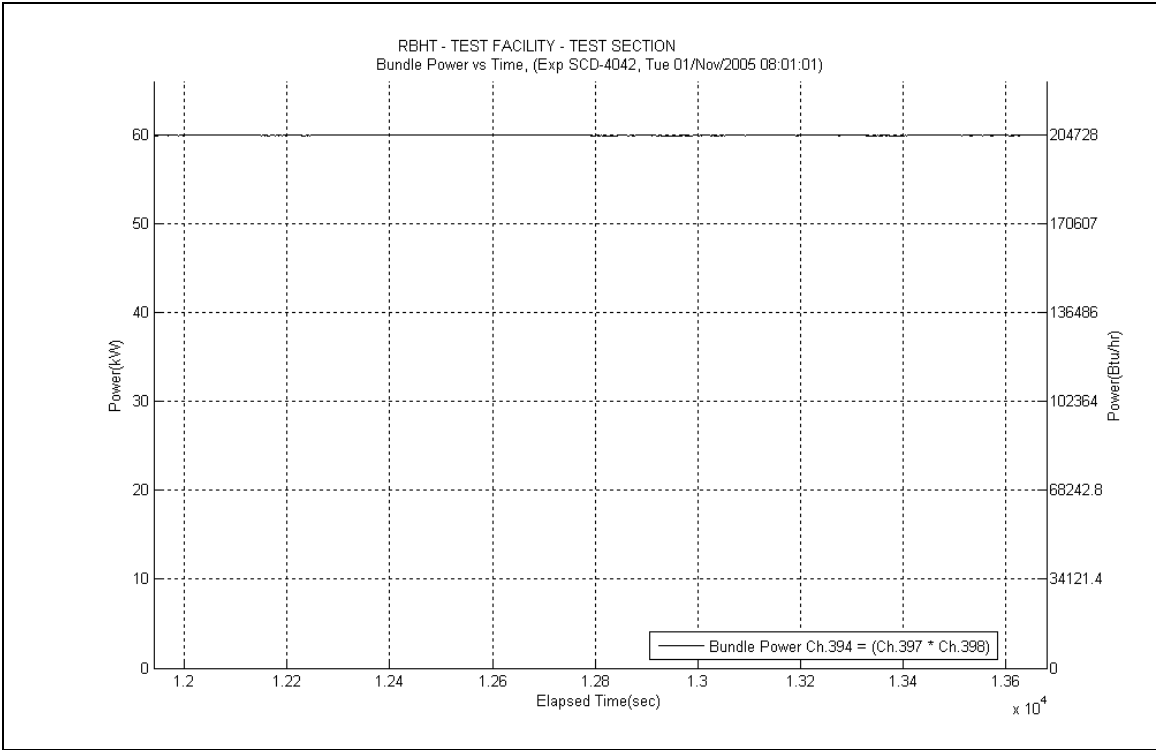

Figure A-657: Bundle Power for Experiment 4042A

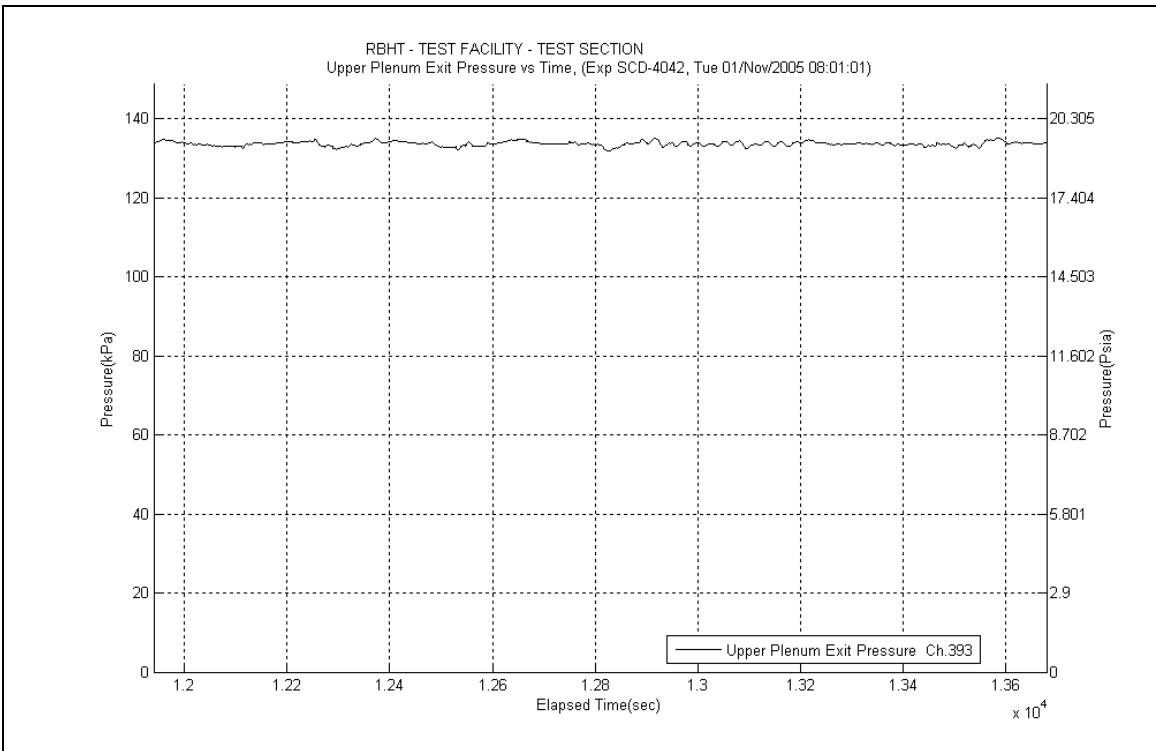

Figure A-658: Upper Plenum Pressure for Experiment 4042A

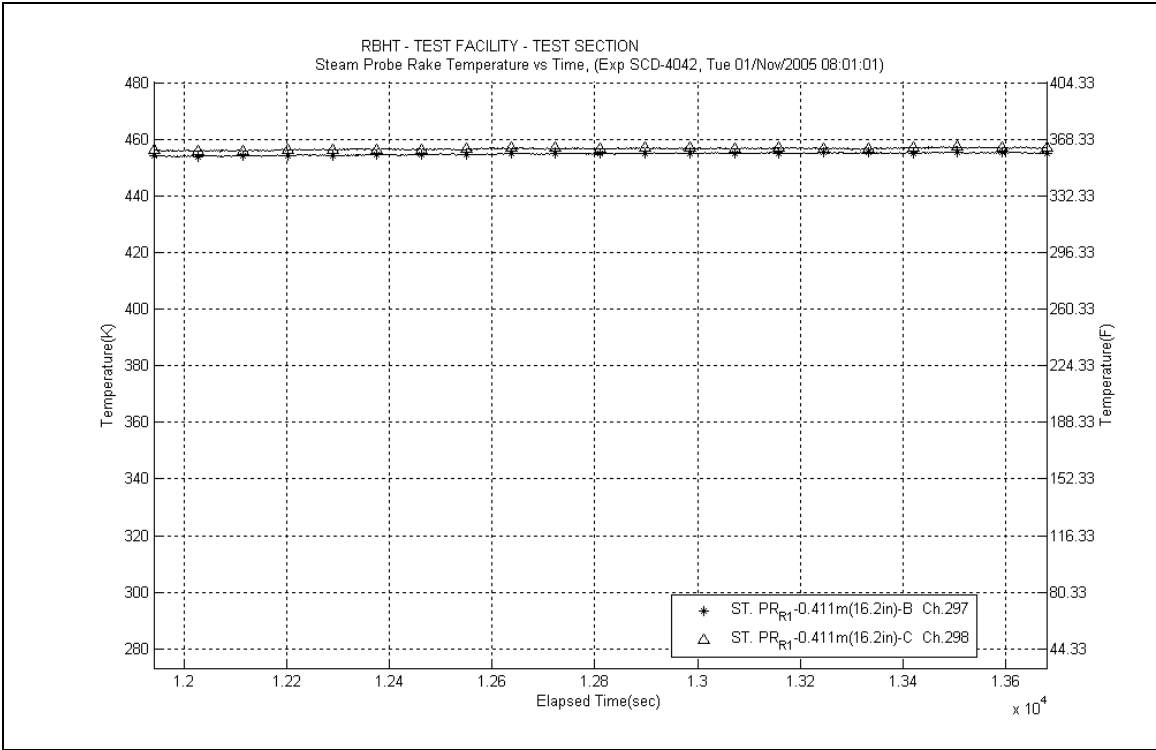

Figure A-659: Steam Probe Rake #1 Temperatures for Experiment 4042A

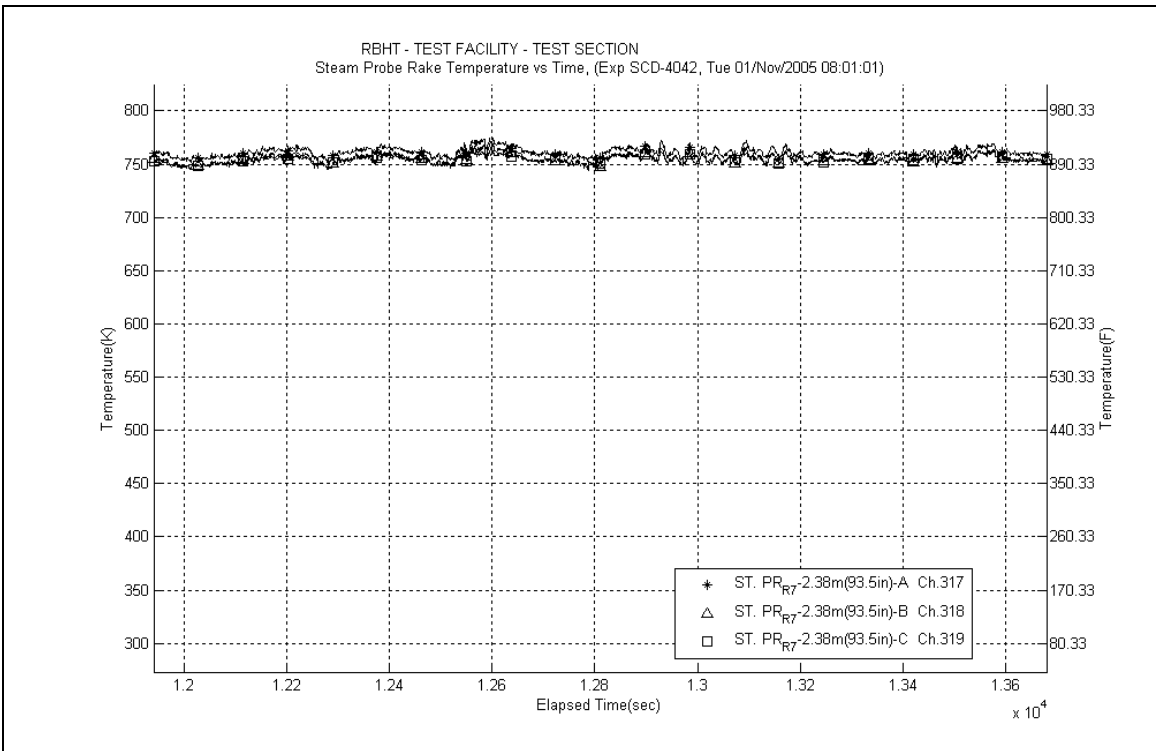

Figure A-660: Steam Probe Rake #7 Temperatures for Experiment 4042A

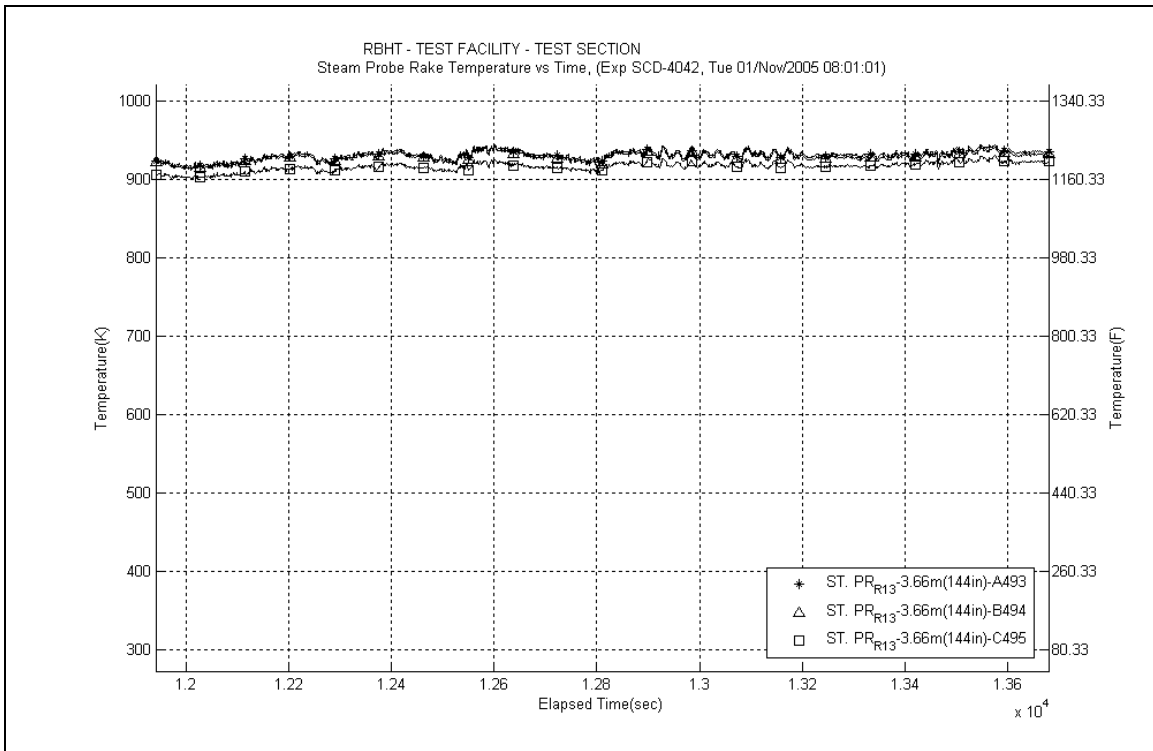

Figure A-661: Steam Probe Rake #13 Temperatures for Experiment 4042A

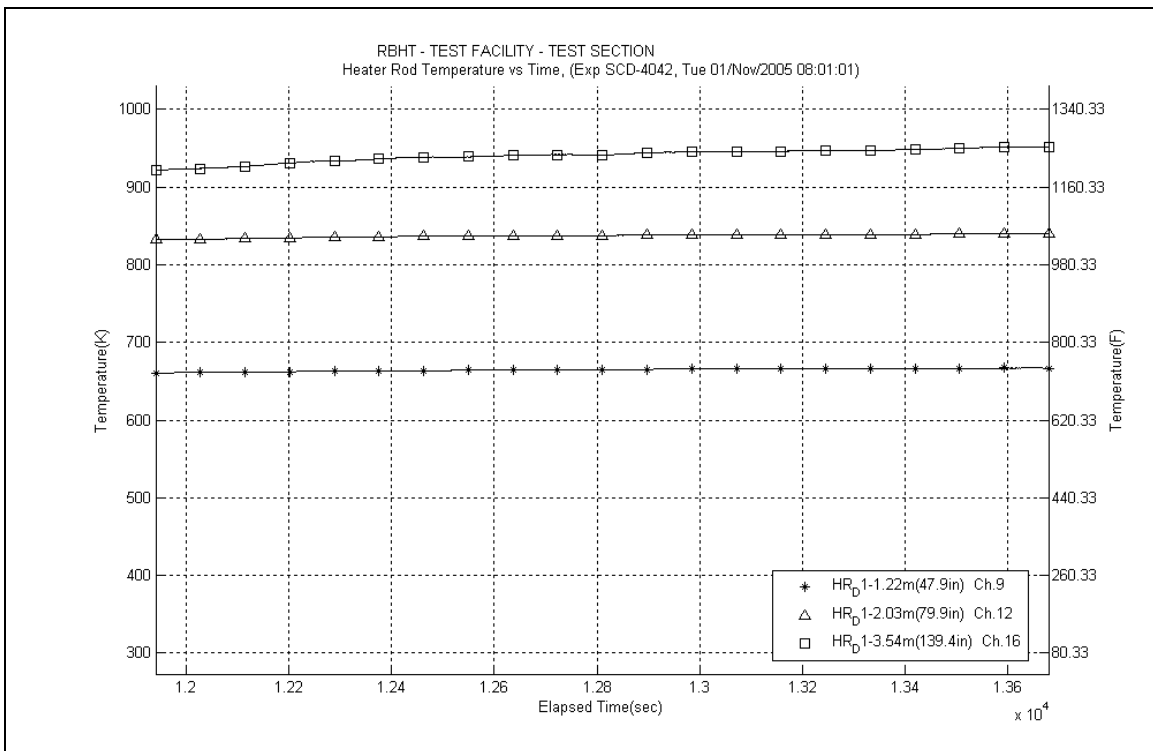

Figure A-662: Heater Rod D1 Temperatures for Experiment 4042A

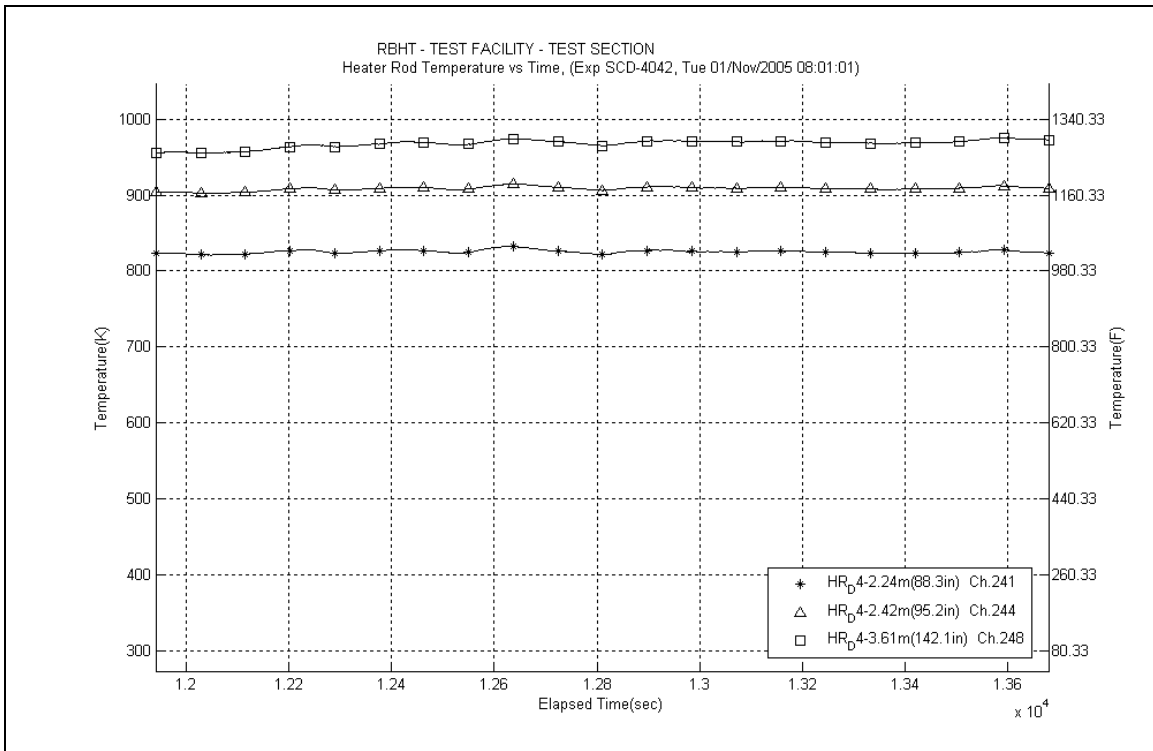

Figure A-663: Heater Rod D4 Temperatures for Experiment 4042A

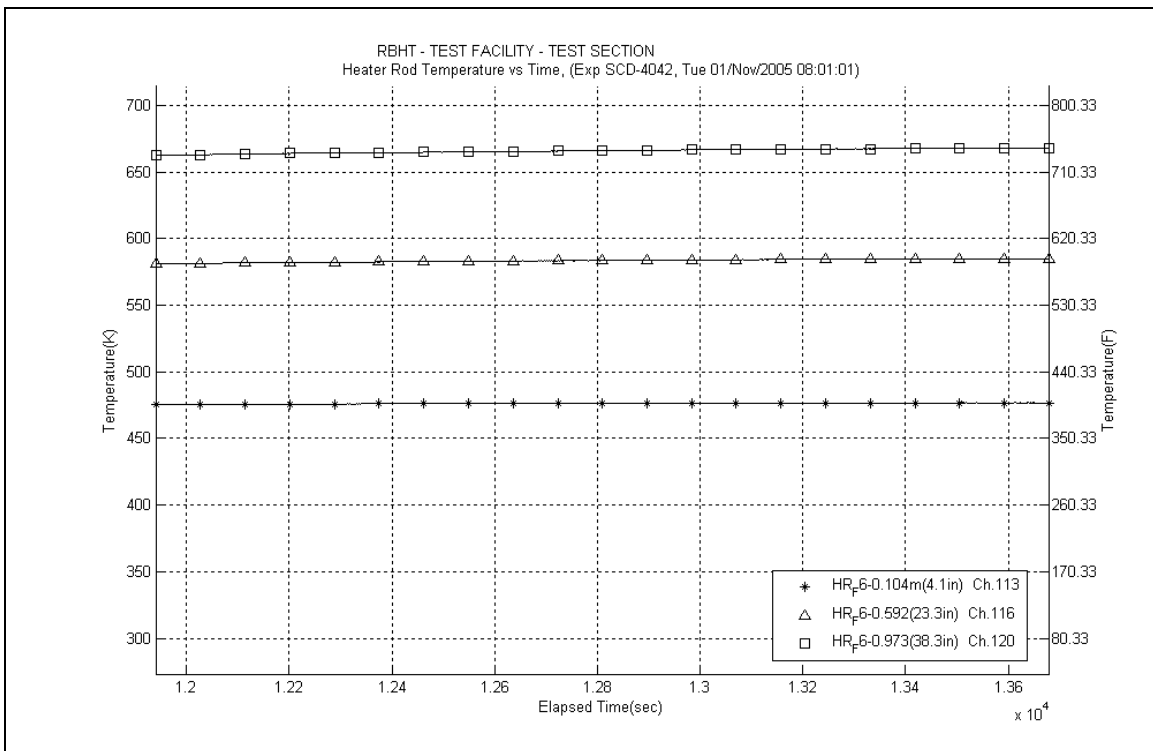

Figure A-664: Heater Rod F6 Temperatures for Experiment 4042A

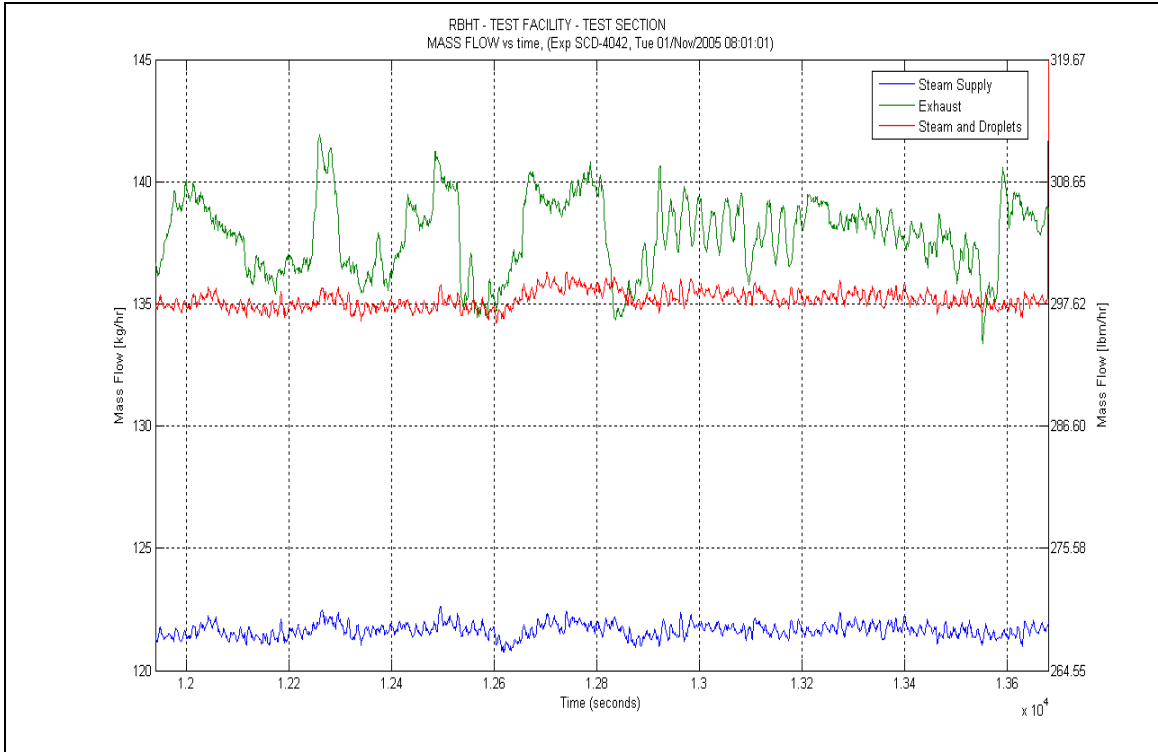

Figure A-665: Mass Flow for Experiment 4042A

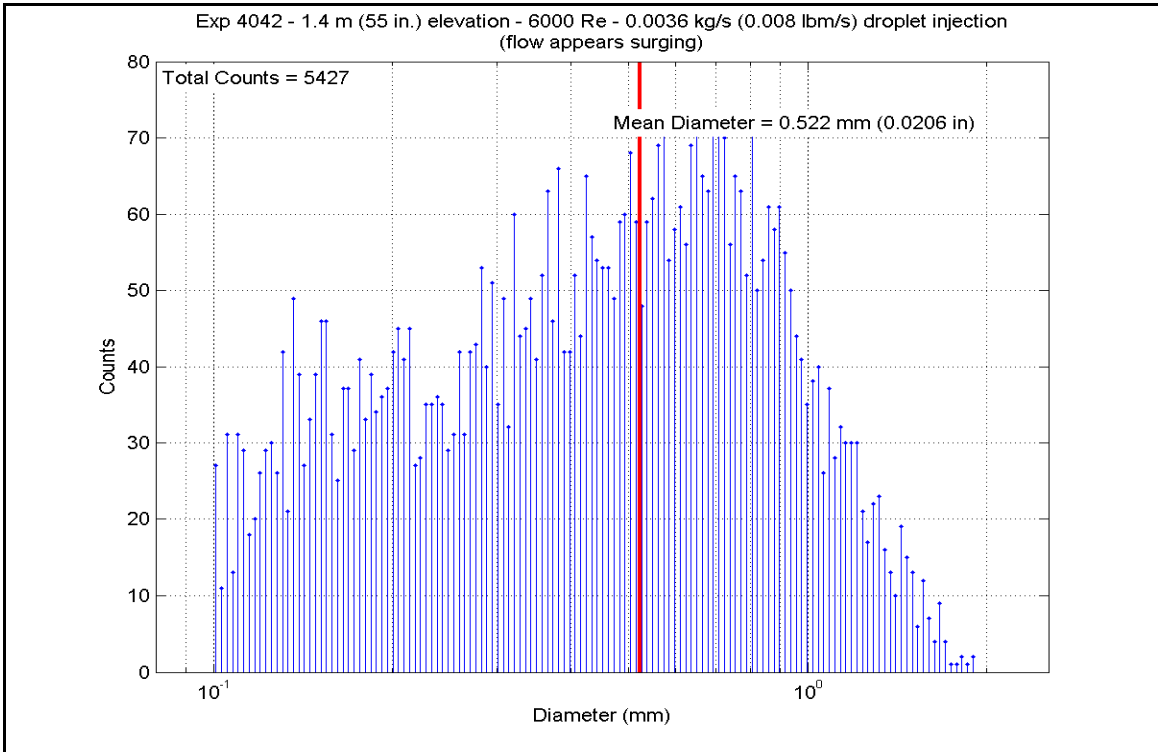

Figure A-666: Droplet Measurements at 1.397 m (55 in.) Elevation for Experiment 4042A

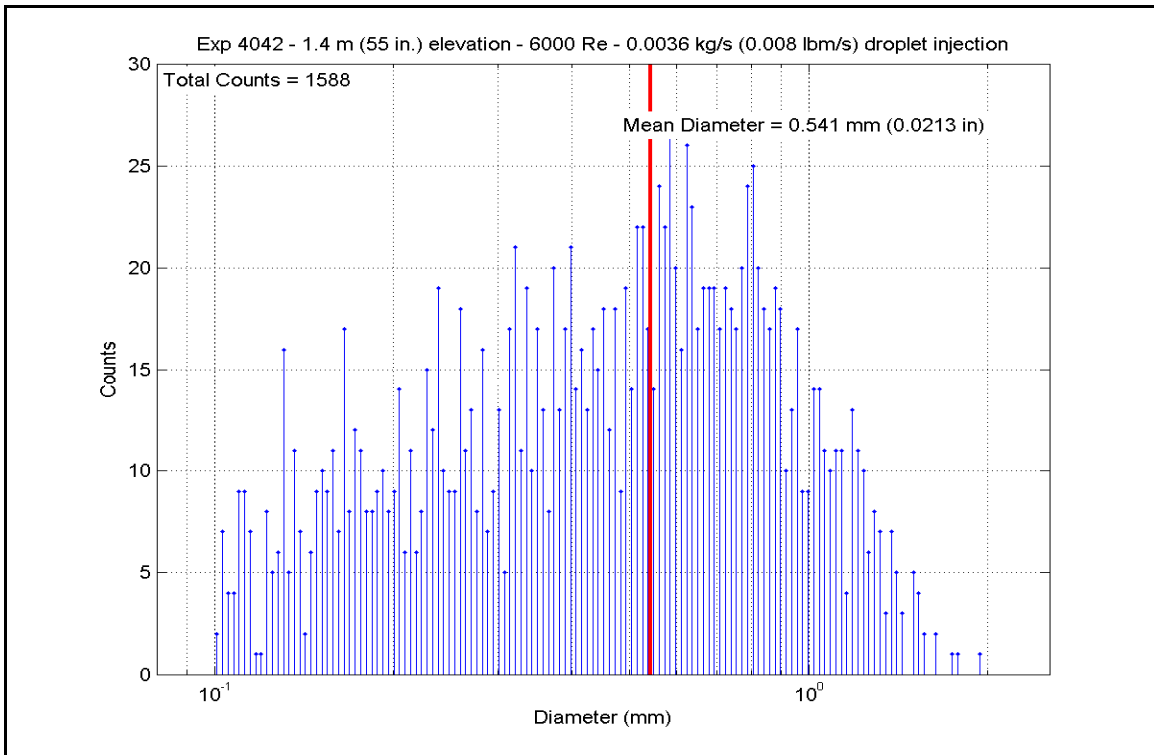

Figure A-667: Droplet Measurements at 1.397 m (55 in.) Elevation for Experiment 4042A

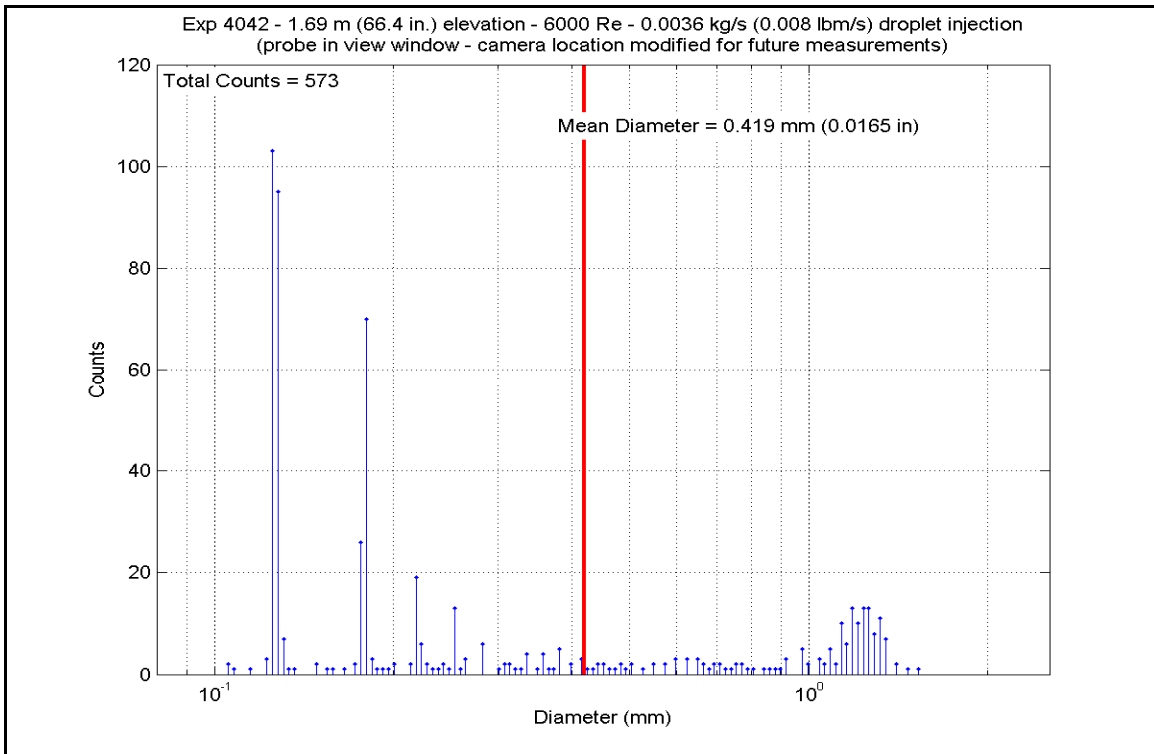

Figure A-668: Droplet Measurements at 1.687 m (66.4 in.) Elevation for Experiment 4042A

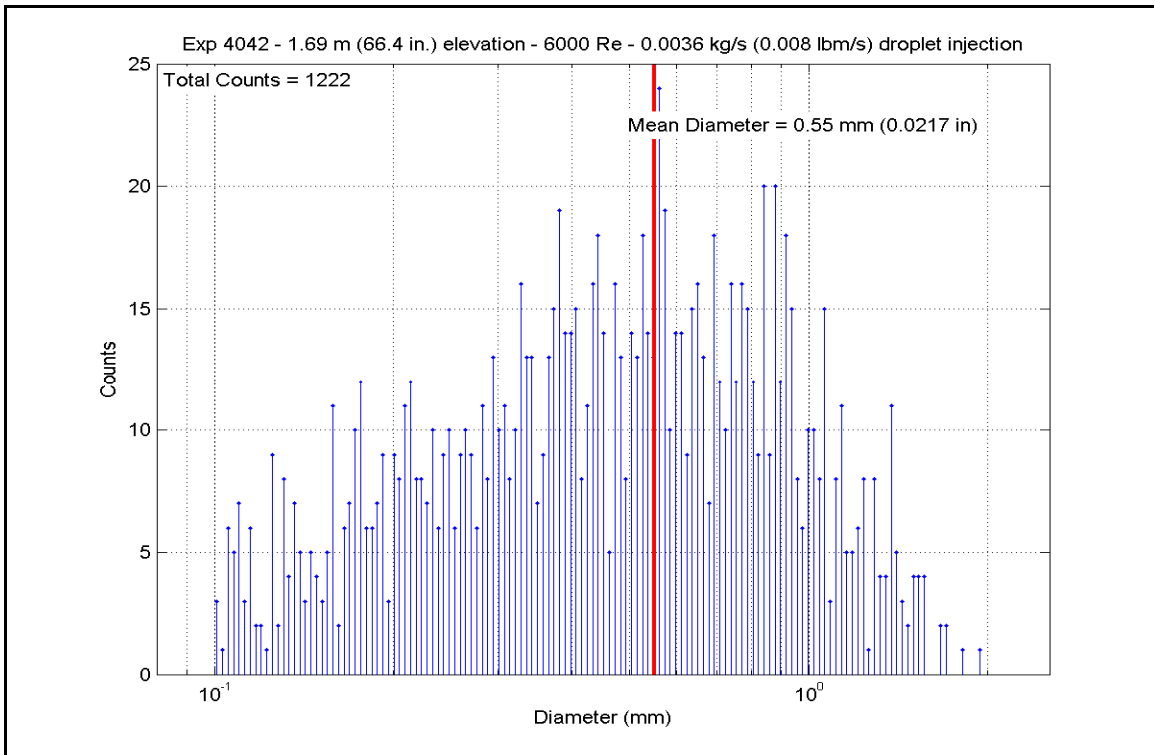

Figure A-669: Droplet Measurements at 1.687 m (66.4 in.) Elevation for Experiment 4042A

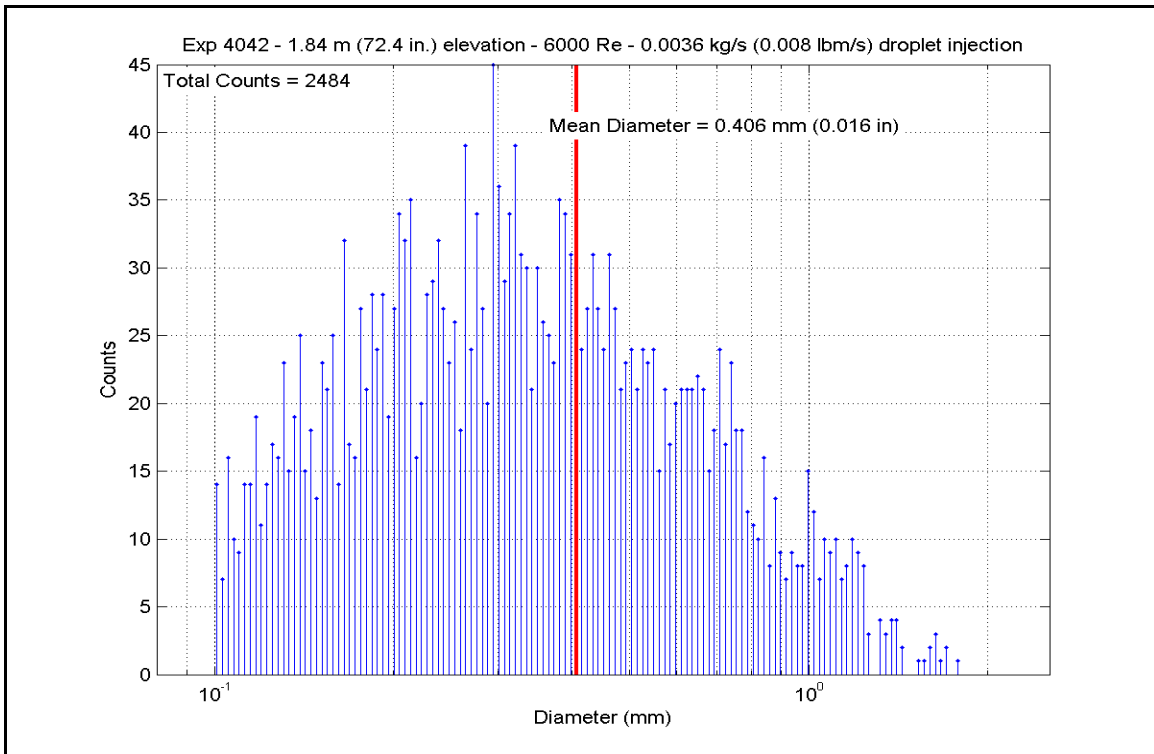

Figure A-670: Droplet Measurements at 1.839 m (72.4 in.) Elevation for Experiment 4042A

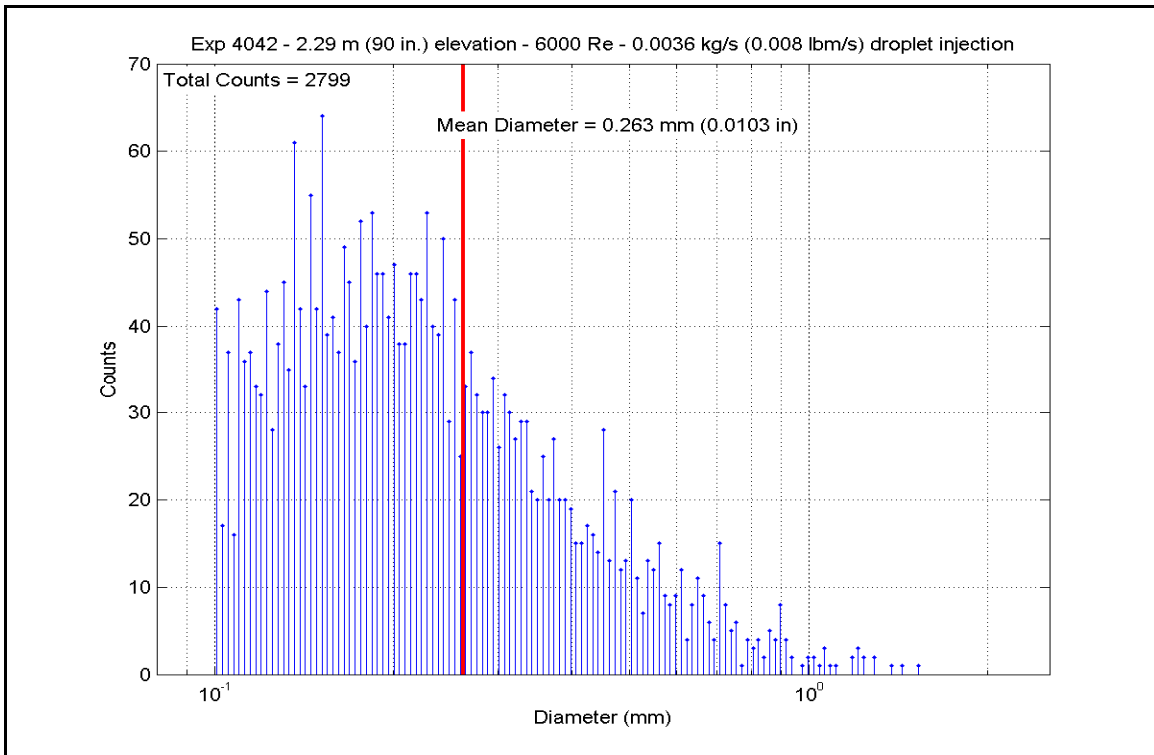

Figure A-671: Droplet Measurements at 2.286 m (90 in.) Elevation for Experiment 4042A

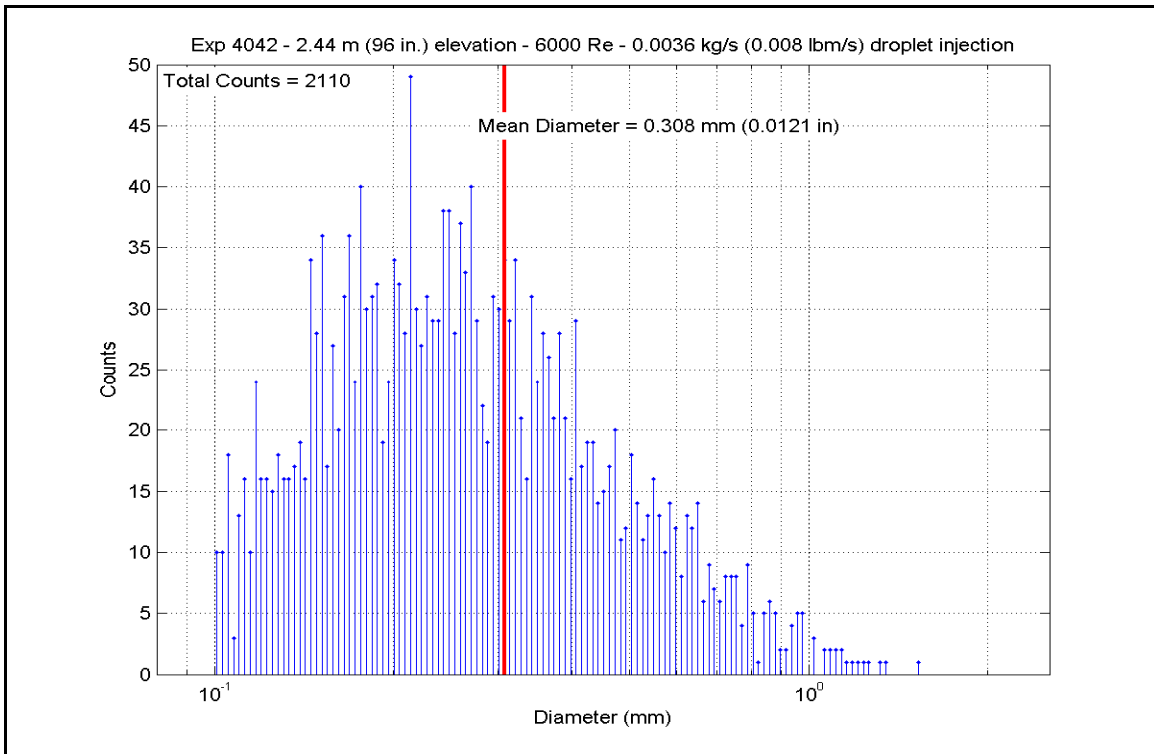

Figure A-672: Droplet Measurements at 2.438 m (96 in.) Elevation for Experiment 4042A

Table A-35: Summary of Steam Cooling Heat Transfer Reduced Data for Experiment 4042A

SCD-4042-A		Inlet Reynolds: 6000		UP Pressure: 20 psia		Bundle Power: 204728 Btu/hr		Steam flow: 268.0 lbm/hr		Droplet flow: 0.008 lbm/s		
Matrix Test # 3a	Time Window: 11940-13680	Channel Number	Elevation (in)	Elevation (m)	Zgrid (in)	Zgrid (m)	H.R. Tw (°F)	H.R. Tw (K)	H.R. q" (Btu/hr-ft ²)	H.R. q" (W/m ²)	h _{sat} (z) (Btu/hr-ft ² -F)	h _{sat} (z) (W/m ² -K)
Gr-3	Inner 3x3	RodD3_88.3	88.3	2.243	-0.2	-0.005	1026.33	825.6	5084.22	16038.2	6.369	36.2
		RodD3_91.3	91.3	2.319	2.8	0.071	1100.23	866.6	5190.17	16372.4	5.950	33.8
		RodD3_93.1	93.1	2.365	4.6	0.117	1115.02	874.8	5257.54	16584.9	5.927	33.7
		RodD3_95.3	95.3	2.421	6.8	0.173	1157.35	898.3	5334.09	16826.4	5.740	32.6
		RodD3_100.1	100.1	2.543	11.6	0.295	1233.51	940.7	5504.73	17364.7	5.475	31.1
		RodD3_106.1	106.1	2.695	17.6	0.447	1295.90	975.3	5717.74	18036.6	5.354	30.4
		RodD3_110	110	2.794	21.5	0.546	1240.53	944.6	5653.46	17833.8	5.583	31.7
		RodD3_142.1	142.1	3.609	8.6	0.218	1283.72	968.5	1934.33	6101.8	1.832	10.4
		RodC4_88.4	88.4	2.245	-0.1	-0.003	1028.96	827.0	5147.56	16238.0	6.427	36.5
		RodC4_91.1	91.1	2.314	2.6	0.066	1106.45	870.1	5243.29	16540.0	5.969	33.9
Gr-3	Inner 3x3	RodC4_93.4	93.4	2.372	4.9	0.124	1132.98	884.8	5326.02	16800.9	5.885	33.4
		RodC4_95.3	95.3	2.421	6.8	0.173	1175.69	908.5	5390.53	17004.4	5.688	32.3
		RodC4_100.1	100.1	2.543	11.6	0.295	1224.79	935.8	5563.46	17549.9	5.581	31.7
		RodC4_106.1	106.1	2.695	17.6	0.447	1282.37	967.8	5789.04	18261.5	5.491	31.2
		RodC4_110	110	2.794	21.5	0.546	1226.53	936.8	5611.17	17700.4	5.619	31.9
		RodC4_142.2	142.2	3.612	8.7	0.221	1276.18	964.4	2103.45	6635.3	2.007	11.4
		RodD4_88.3	88.3	2.243	-0.2	-0.005	1024.08	824.3	5127.99	16176.2	6.442	36.6
		RodD4_91.3	91.3	2.319	2.8	0.071	1104.59	869.0	5233.83	16510.1	5.971	33.9
		RodD4_93.2	93.2	2.367	4.7	0.119	1134.82	885.8	5302.32	16726.2	5.847	33.2
		RodD4_95.2	95.2	2.418	6.7	0.170	1173.82	907.5	5370.11	16940.0	5.678	32.2
RodD4_100.1	100.1	2.543	11.6	0.295	1245.82	947.5	5548.16	17501.7	5.451	31.0		
RodD4_106.1	106.1	2.695	17.6	0.447	1286.08	969.9	5766.66	18190.9	5.450	31.0		
RodD4_142.1	142.1	3.609	8.6	0.218	1281.44	967.3	2032.86	6412.7	1.930	11.0		
Gr-3	Inner 3x3	RodE4_88.4	88.4	2.245	-0.1	-0.003	1028.43	826.7	5045.20	15915.1	6.303	35.8
		RodE4_91.2	91.2	2.316	2.7	0.069	1105.84	869.7	5139.93	16213.9	5.855	33.3
		RodE4_95.3	95.3	2.421	6.8	0.173	1174.98	908.1	5281.10	16659.2	5.577	31.7
		RodE4_100.9	100.9	2.563	12.4	0.315	1241.31	945.0	5474.68	17289.9	5.403	30.7
		RodE4_142.3	142.3	3.614	8.8	0.224	1284.72	969.1	2048.89	6463.2	1.939	11.0

Table A-35: Summary of Steam Cooling Heat Transfer Reduced Data for Experiment 4042, continued

Inner 3x3	H.R. Location	Channel Number	Elevation (in)	Elevation (m)	Zgrid (in)	Zgrid (m)	H.R. Tw (°F)	H.R. Tw (K)	H.R. q" (Btu/hr-ft ²)	H.R. q" (W/m ²)	h _{sat} (z) (Btu/hr-ft ² -F)	h _{sat} (z) (W/m ² -K)
Gr-4	RodE3_63.4	193	63.4	1.610	16.4	0.417	1008.72	815.8	4180.35	13186.9	5.355	30.4
	RodE3_113.6	194	113.6	2.885	0.85	0.022	1266.23	958.8	5140.99	16217.3	4.952	28.1
	RodE3_115.5	195	115.5	2.934	2.75	0.070	1294.62	974.6	4945.64	15601.0	4.637	26.3
	RodE3_118.5	196	118.5	3.010	5.75	0.146	1319.73	988.6	4639.91	14636.6	4.250	24.1
	RodE3_122.7	197	122.7	3.117	9.95	0.253	1334.71	996.9	4213.21	13290.6	3.807	21.6
	RodE3_126.5	198	126.5	3.213	13.75	0.349	1338.84	999.2	3827.54	12074.0	3.446	19.6
	RodE3_131.7	199	131.7	3.345	-1.8	-0.046	1270.80	961.4	3307.45	10433.4	3.172	18.0
	RodE3_135.6	200	135.6	3.444	2.1	0.053	1283.24	968.3	2903.25	9158.3	2.751	15.6
	RodC5_63.7	225	63.7	1.618	16.7	0.424	1016.76	820.2	4102.76	12942.2	5.202	29.5
	RodC5_113.6	226	113.6	2.885	0.85	0.022	1236.77	942.5	5023.99	15848.2	4.980	28.3
Gr-4	RodC5_115.7	227	115.7	2.939	2.95	0.075	1272.80	962.5	4817.30	15196.2	4.611	26.2
	RodC5_122.7	229	122.7	3.117	9.95	0.253	1319.75	988.6	4139.35	13057.6	3.791	21.5
	RodC5_126.7	230	126.7	3.218	13.95	0.354	1324.09	991.0	3753.87	11841.6	3.425	19.4
	RodC5_131.6	231	131.6	3.343	-1.9	-0.048	1249.68	949.6	3292.66	10386.7	3.223	18.3
	RodC5_135.7	232	135.7	3.447	2.2	0.056	1262.31	956.7	2886.73	9106.2	2.791	15.8
	RodE5_63.6	209	63.6	1.615	16.6	0.422	944.42	780.1	4188.72	13213.3	5.847	33.2
	RodE5_113.6	210	113.6	2.885	0.85	0.022	1186.08	914.3	5167.39	16300.5	5.393	30.6
	RodE5_115.4	211	115.4	2.931	2.65	0.067	1226.28	936.6	4981.21	15713.2	4.990	28.3
	RodE5_118.7	212	118.7	3.015	5.95	0.151	1263.40	957.3	4648.42	14663.4	4.489	25.5
	RodE5_122.6	213	122.6	3.114	9.85	0.250	1289.48	971.8	4256.34	13426.6	4.010	22.8
RodE5_126.6	214	126.6	3.216	13.85	0.352	1302.84	979.2	3857.21	12167.6	3.589	20.4	
Gr-5	RodE5_131.6	215	131.6	3.343	-1.9	-0.048	1293.66	974.1	3375.47	10647.9	3.167	18.0
	RodE5_135.6	216	135.6	3.444	2.1	0.053	1286.47	970.1	2974.67	9383.6	2.810	16.0
	RodC3_79.8	177	79.8	2.027	8.92	0.227	1014.27	818.9	4753.96	14996.4	6.046	34.3
	RodC3_85.6	178	85.6	2.174	14.72	0.374	1012.48	817.9	4962.85	15655.3	6.326	35.9
	RodC3_88.5	179	88.5	2.248	0	0.000	1019.97	822.0	5062.87	15970.8	6.393	36.3
	RodC3_92.4	180	92.4	2.347	3.9	0.099	1109.20	871.6	5197.55	16395.7	5.898	33.5
	RodC3_94.4	181	94.4	2.398	5.9	0.150	1128.59	882.4	5267.80	16617.3	5.849	33.2
	RodC3_97.2	182	97.2	2.469	8.7	0.221	1180.48	911.2	5365.57	16925.7	5.633	32.0
	RodC3_108.8	183	108.8	2.764	20.3	0.516	1280.67	966.9	5657.94	17848.0	5.375	30.5
	RodD5_50	217	50	1.270	1.270	0.076	853.40	729.5	3709.98	11703.1	5.932	33.7
Gr-8	RodD5_54.1	218	54.1	1.374	7.1	0.180	884.49	746.8	3856.48	12165.3	5.874	33.4
	RodD5_56.9	219	56.9	1.445	9.9	0.251	936.52	775.7	3956.42	12480.5	5.584	31.7
	RodD5_60	220	60	1.524	13	0.330	978.62	799.1	4066.74	12828.5	5.418	30.8
	RodD5_66.1	221	66.1	1.679	19.1	0.485	1022.30	823.3	4284.81	13516.4	5.394	30.6
	RodD5_69.9	222	69.9	1.775	-0.98	-0.025	883.32	746.1	4429.33	13972.3	6.759	38.4
	RodD5_72.9	223	72.9	1.852	2.02	0.051	944.97	780.4	4530.67	14292.0	6.319	35.9
	RodD5_74.9	224	74.9	1.902	4.02	0.102	990.18	805.5	4600.46	14512.2	6.036	34.3

Table A-35: Summary of Steam Cooling Heat Transfer Reduced Data for Experiment 4042, continued

5x5 periphery												
H.R. ID	H.R. Location	Channel Number	Elevation (in)	Elevation (m)	Zgrid (in)	Zgrid (m)	H.R. Tw (°F)	H.R. Tw (K)	H.R. q" (Btu/hr-ft ²)	H.R. q" (W/m ²)	h _{sat} (z) (Btu/hr-ft ² -F)	h _{sat} (z) (W/m ² -K)
Gr-2	RodB5_41	153	41	1.041	13.5	0.343	790.53	694.6	3376.17	10650.1	6.002	34.1
	RodB5_52.9	154	52.9	1.344	5.9	0.150	850.78	728.0	3806.29	12006.9	6.112	34.7
	RodB5_55	155	55	1.397	8	0.203	892.90	751.4	3883.25	12249.7	5.840	33.2
	RodB5_57.8	156	57.8	1.468	10.8	0.274	946.12	781.0	3984.35	12568.6	5.548	31.5
	RodB5_64	157	64	1.626	17	0.432	1007.19	814.9	4206.98	13270.9	5.399	30.7
	RodB5_73.9	158	73.9	1.877	3.02	0.077	949.19	782.7	4568.75	14412.1	6.335	36.0
Gr-2	RodB5_75.9	159	75.9	1.928	5.02	0.128	989.34	805.0	4640.11	14637.2	6.095	34.6
	RodB5_76.9	160	76.9	1.953	6.02	0.153	1006.22	814.4	4675.75	14749.7	6.008	34.1
	RodF5_41	105	41	1.041	13.5	0.343	786.45	692.3	3350.43	10568.9	6.000	34.1
	RodF5_53.1	106	53.1	1.349	6.1	0.155	832.89	718.1	3784.61	11938.5	6.257	35.5
	RodF5_55	107	55	1.397	8	0.203	869.31	738.3	3852.64	12153.2	6.007	34.1
	RodF5_57.8	108	57.8	1.468	10.8	0.274	914.55	763.5	3951.12	12463.8	5.755	32.7
Gr-2	RodF5_64	109	64	1.626	17	0.432	970.19	794.4	4172.15	13161.0	5.621	31.9
	RodF5_73.8	110	73.8	1.875	2.92	0.074	934.13	774.3	4530.06	14290.1	6.415	36.4
	RodF5_75.8	111	75.8	1.925	4.92	0.125	974.99	797.0	4600.29	14511.6	6.158	35.0
	RodF5_76.8	112	76.8	1.951	5.92	0.150	992.74	806.9	4635.56	14622.9	6.062	34.4
	RodC2_41	57	41	1.041	13.5	0.343	791.55	695.1	3368.15	10624.8	5.977	33.9
	RodC2_53.1	58	53.1	1.349	6.1	0.155	901.68	756.3	3804.46	12001.2	5.647	32.1
Gr-2	RodC2_55	59	55	1.397	8	0.203	924.41	768.9	3873.14	12217.8	5.562	31.6
	RodC2_57.8	60	57.8	1.468	10.8	0.274	958.97	788.1	3972.30	12530.6	5.434	30.9
	RodC2_63.9	61	63.9	1.623	16.9	0.429	1008.45	815.6	4190.33	13218.4	5.369	30.5
	RodC2_73.8	62	73.8	1.875	2.92	0.074	944.02	779.8	4544.69	14336.2	6.347	36.0
	RodC2_75.8	63	75.8	1.925	4.92	0.125	973.42	796.2	4614.55	14556.6	6.191	35.2
	RodC2_76.8	64	76.8	1.951	5.92	0.150	985.65	803.0	4649.26	14666.1	6.136	34.8
Gr-2	RodC6_40.9	137	40.9	1.039	13.4	0.340	798.05	698.7	3354.66	10582.3	5.885	33.4
	RodC6_52.8	138	52.8	1.341	5.8	0.147	895.27	752.7	3799.65	11986.0	5.694	32.3
	RodC6_54.8	139	54.8	1.392	7.8	0.198	924.12	768.8	3875.21	12224.3	5.567	31.6
	RodC6_57.8	140	57.8	1.468	10.8	0.274	958.85	788.1	3987.24	12577.7	5.456	31.0
	RodC6_63.8	141	63.8	1.621	16.8	0.427	1014.44	819.0	4211.09	13283.9	5.355	30.4
	RodC6_73.7	142	73.7	1.872	2.82	0.072	1011.08	817.1	4589.44	14477.4	5.861	33.3
Gr-2	RodC6_75.8	143	75.8	1.925	4.92	0.125	1039.96	833.1	4667.00	14722.0	5.748	32.6
	RodC6_76.8	144	76.8	1.951	5.92	0.150	1057.28	842.7	4704.25	14839.5	5.673	32.2

Table A-35: Summary of Steam Cooling Heat Transfer Reduced Data for Experiment 4042, continued

5x5 periphery		H.R. Location	Channel Number	Elevation (in)	Elevation (m)	Zgrid (in)	Zgrid (m)	H.R. Tw (°F)	H.R. Tw (K)	H.R. q" (Btu/hr-ft ²)	H.R. q" (W/m ²)	h _{sat} (z) (Btu/hr-ft ² -F)	h _{sat} (z) (W/m ² -K)
Gr-3	RodB4_88.4	161	88.4	2.245	-0.1	-0.003	813.0	5043.61	15910.1	6.502	36.9		
	RodB4_91.3	162	91.3	2.319	2.8	0.071	858.3	5140.71	16216.4	5.997	34.1		
	RodB4_93.3	163	93.3	2.370	4.8	0.122	869.3	5209.29	16432.7	5.939	33.7		
	RodB4_95.1	164	95.1	2.416	6.6	0.168	883.2	5269.56	16622.8	5.841	33.2		
	RodB4_100	165	100	2.540	11.5	0.292	907.1	5439.08	17157.6	5.755	32.7		
	RodB4_106	166	106	2.692	17.5	0.445	948.8	5644.68	17806.1	5.533	31.4		
	RodB4_109.9	167	109.9	2.791	21.4	0.544	915.4	5471.87	17261.0	5.699	32.4		
	RodB4_142.3	168	142.3	3.614	8.8	0.224	950.3	2083.94	6573.8	2.037	11.6		
Gr-5	RodF4_85.6	98	85.6	2.174	14.72	0.374	822.8	4970.46	15679.3	6.264	35.6		
	RodF4_88.4	99	88.4	2.245	-0.1	-0.003	825.4	5067.43	15985.2	6.349	36.1		
	RodF4_92.4	100	92.4	2.347	3.9	0.099	878.7	5208.35	16429.7	5.826	33.1		
	RodF4_94.3	101	94.3	2.395	5.8	0.147	896.8	5275.28	16640.9	5.694	32.3		
	RodF4_97.2	102	97.2	2.469	8.7	0.221	920.4	5378.46	16966.3	5.551	31.5		
	RodF4_108.8	103	108.8	2.764	20.3	0.516	961.6	5677.34	17909.2	5.442	30.9		
	RodF4_111	104	111	2.819	-1.75	-0.044	928.0	5449.26	17189.7	5.545	31.5		
Gr-6	RodD2_103.2	65	103.2	2.621	14.7	0.373	959.9	5000.55	15774.2	4.807	27.3		
	RodD2_106	66	106	2.692	17.5	0.445	970.9	4732.31	14928.1	4.465	25.4		
	RodD2_112.6	67	112.6	2.860	-0.15	-0.004	983.6	4366.99	13775.7	4.033	22.9		
	RodD2_114.9	68	114.9	2.918	2.15	0.055	991.8	3937.94	12422.2	3.588	20.4		
	RodD2_117.4	69	117.4	2.982	4.65	0.118	990.6	3532.49	11143.2	3.225	18.3		
	RodD2_120.8	70	120.8	3.068	8.05	0.204	951.5	5624.45	17742.3	5.487	31.2		
	RodD2_124.8	71	124.8	3.170	12.05	0.306	965.1	5724.28	18057.2	5.454	31.0		
	RodD2_128.6	72	128.6	3.266	15.85	0.403	938.9	5250.52	16562.8	5.238	29.7		
Gr-6	RodD6_103.1	129	103.1	2.619	14.6	0.371	964.3	5633.24	17770.1	5.375	30.5		
	RodD6_106	130	106	2.692	17.5	0.445	974.0	5736.06	18094.4	5.383	30.6		
	RodD6_112.9	131	112.9	2.868	0.15	0.004	944.8	5236.19	16517.6	5.169	29.4		
	RodD6_114.9	132	114.9	2.918	2.15	0.055	961.9	5014.05	15816.8	4.804	27.3		
	RodD6_116.8	133	116.8	2.967	4.05	0.103	972.0	4806.47	15162.0	4.526	25.7		
	RodD6_120.9	134	120.9	3.071	8.15	0.207	981.6	4363.66	13765.2	4.044	23.0		
	RodD6_124.8	135	124.8	3.170	12.05	0.306	986.2	3943.44	12439.6	3.626	20.6		
	RodD6_128.7	136	128.7	3.269	15.95	0.405	984.3	3522.61	11112.1	3.249	18.5		

Table A-35: Summary of Steam Cooling Heat Transfer Reduced Data for Experiment 4042, continued

5x5 periphery		H.R. Location	Channel Number	Elevation (in)	Elevation (m)	Zgrid (in)	Zgrid (m)	H.R. Tw (°F)	H.R. Tw (K)	H.R. q" (Btu/hr-ft ²)	H.R. q" (W/m ²)	h _{sat} (z) (Btu/hr-ft ² -F)	h _{sat} (z) (W/m ² -K)
Gr-8	RodE2_50.1	73	50.1	1.273	3.1	0.079	845.86	725.3	3723.04	11744.3	6.026	34.2	
	RodE2_54	74	54	1.372	7	0.178	911.63	761.8	3865.78	12194.6	5.655	32.1	
	RodE2_56.9	75	56.9	1.445	9.9	0.251	948.45	782.3	3970.72	12525.6	5.511	31.3	
	RodE2_59.9	76	59.9	1.521	12.9	0.328	985.12	802.7	4079.21	12867.9	5.388	30.6	
	RodE2_66	77	66	1.676	19	0.483	1017.31	820.5	4302.05	13570.8	5.450	31.0	
	RodE2_69.8	78	69.8	1.773	-1.08	-0.027	881.09	744.9	4445.93	14024.7	6.808	38.7	
	RodE2_72.9	79	72.9	1.852	2.02	0.051	945.26	780.5	4551.97	14359.2	6.346	36.0	
	RodE2_74.9	80	74.9	1.902	4.02	0.102	978.83	799.2	4623.16	14583.8	6.157	35.0	
Gr-8	RodB3_50.2	169	50.2	1.275	3.2	0.081	808.51	704.5	3702.83	11680.6	6.379	36.2	
	RodB3_54.1	170	54.1	1.374	7.1	0.180	871.40	739.5	3841.61	12118.4	5.971	33.9	
	RodB3_56.9	171	56.9	1.445	9.9	0.251	914.95	763.7	3942.14	12435.5	5.739	32.6	
	RodB3_60.1	172	60.1	1.527	13.1	0.333	924.81	769.2	4057.61	12799.7	5.823	33.1	
	RodB3_66.1	173	66.1	1.679	19.1	0.485	972.80	795.8	4273.55	13480.9	5.738	32.6	
	RodB3_69.9	174	69.9	1.775	-0.98	-0.025	815.02	708.2	4416.09	13930.5	7.523	42.7	
	RodB3_73	175	73	1.854	2.12	0.054	896.95	753.7	4523.58	14269.6	6.762	38.4	
	RodB3_75	176	75	1.905	4.12	0.105	935.06	774.8	4592.95	14488.5	6.496	36.9	
Gr-8	RodF3_50.1	89	50.1	1.273	3.1	0.079	822.72	712.4	3702.35	11679.1	6.225	35.4	
	RodF3_54	90	54	1.372	7	0.178	881.26	745.0	3841.95	12119.4	5.881	33.4	
	RodF3_57	91	57	1.448	10	0.254	926.59	770.1	3950.83	12462.9	5.655	32.1	
	RodF3_60	92	60	1.524	13	0.330	963.19	790.5	4059.91	12807.0	5.522	31.4	
	RodF3_66.1	93	66.1	1.679	19.1	0.485	1002.34	812.2	4283.40	13512.0	5.532	31.4	
	RodF3_70	94	70	1.778	-0.88	-0.022	844.67	724.6	4431.75	13980.0	7.187	40.8	
	RodF3_73	95	73	1.854	2.12	0.054	933.57	774.0	4537.54	14313.7	6.431	36.5	
	RodF3_75	96	75	1.905	4.12	0.105	978.90	799.2	4609.77	14541.5	6.139	34.9	
Gr-8	RodE6_50.2	121	50.2	1.275	3.2	0.081	823.32	712.8	3696.02	11659.1	6.208	35.3	
	RodE6_54.1	122	54.1	1.374	7.1	0.180	886.68	748.0	3834.70	12096.6	5.822	33.1	
	RodE6_57	123	57	1.448	10	0.254	921.76	767.5	3937.30	12420.2	5.675	32.2	
	RodE6_60.2	124	60.2	1.529	13.2	0.335	962.03	789.8	4050.98	12778.8	5.519	31.3	
	RodE6_66.1	125	66.1	1.679	19.1	0.485	989.33	805.0	4259.86	13437.7	5.595	31.8	
	RodE6_70	126	70	1.778	-0.88	-0.022	919.25	766.1	4400.22	13880.5	6.366	36.1	
	RodE6_73.1	127	73.1	1.857	2.22	0.056	973.28	796.1	4510.44	14228.2	6.052	34.4	
	RodE6_75	128	75	1.905	4.12	0.105	1006.70	814.7	4577.79	14440.6	5.879	33.4	

RBHT Steam Cooling with Droplet Injection Test SCD-4042-B

Matrix Test # 3b

Test Conditions

Test Date – 11/1/2005

Steady State Time Window: 13920 – 14580

Upper Plenum Pressure: 1.38 bar (20 psia)

Bundle Power: 60.0 kW

Bundle Inlet Reynolds Number: 6000

Bundle Inlet Steam Flow: 122.6 kg/hr (270 lbm/hr)

Droplet Injection Flow: 0.0073 kg/s (0.016 lbm/s)

Droplet Injection Hole Diameter: 0.381 mm (.015 in)

Droplet Injection Elevation: 1.295 m (51 in)

Bundle Flow Area: $4.656 \times 10^{-3} \text{ m}^2$ ($5.012 \times 10^{-2} \text{ ft}^2$)

Test Notes

- No steam probes were traversed in this steady state window.

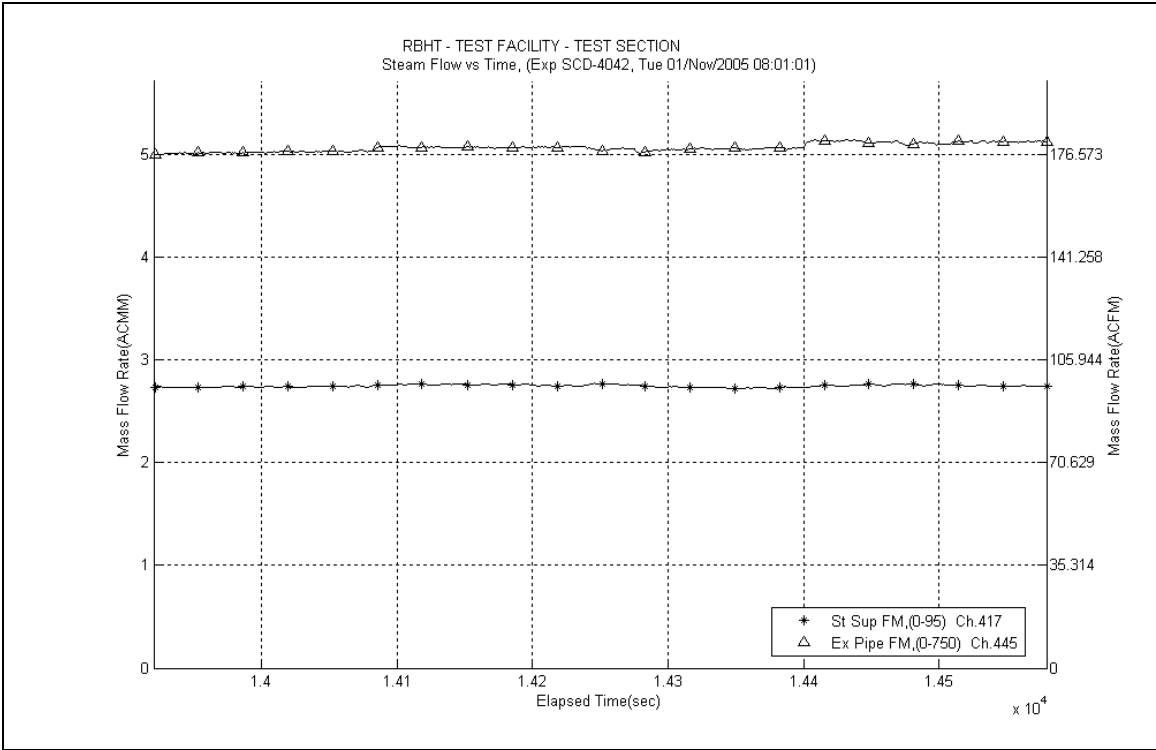

Figure A-673: Inlet and Exhaust Steam Flow Rates for Experiment 4042B

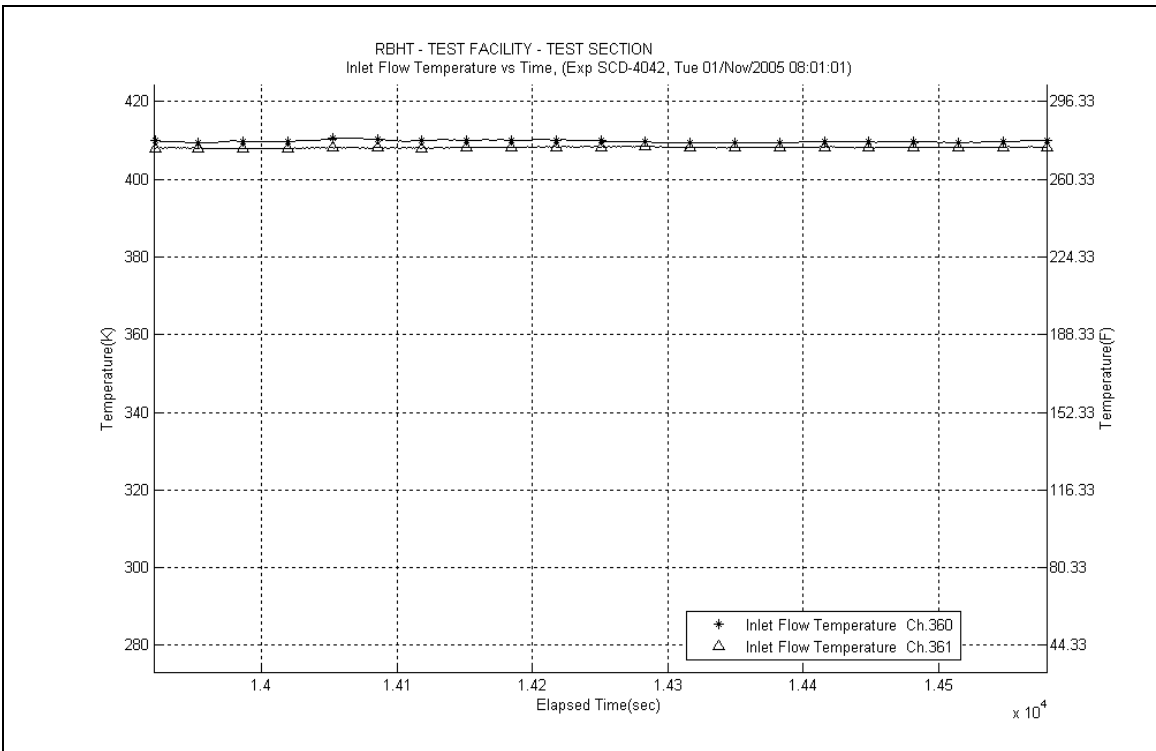

Figure A-674: Inlet Steam Temperature for Experiment 4042B

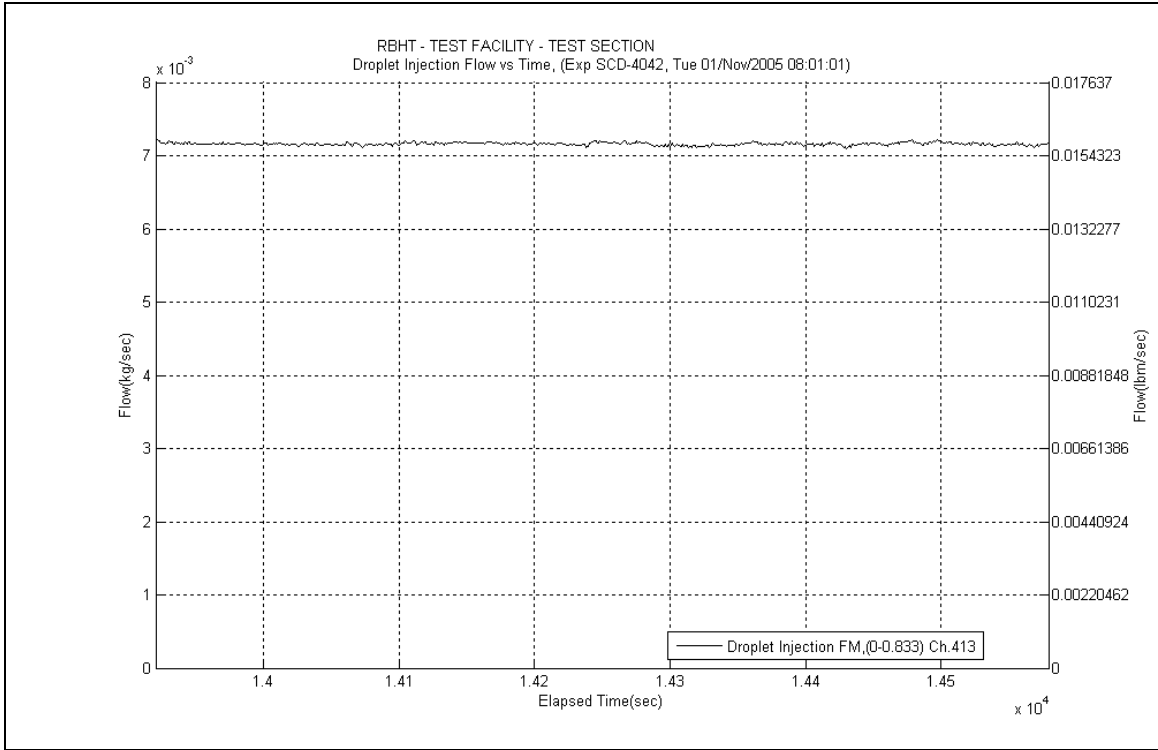

Figure A-675: Droplet Injection Flow Rate for Experiment 4042B

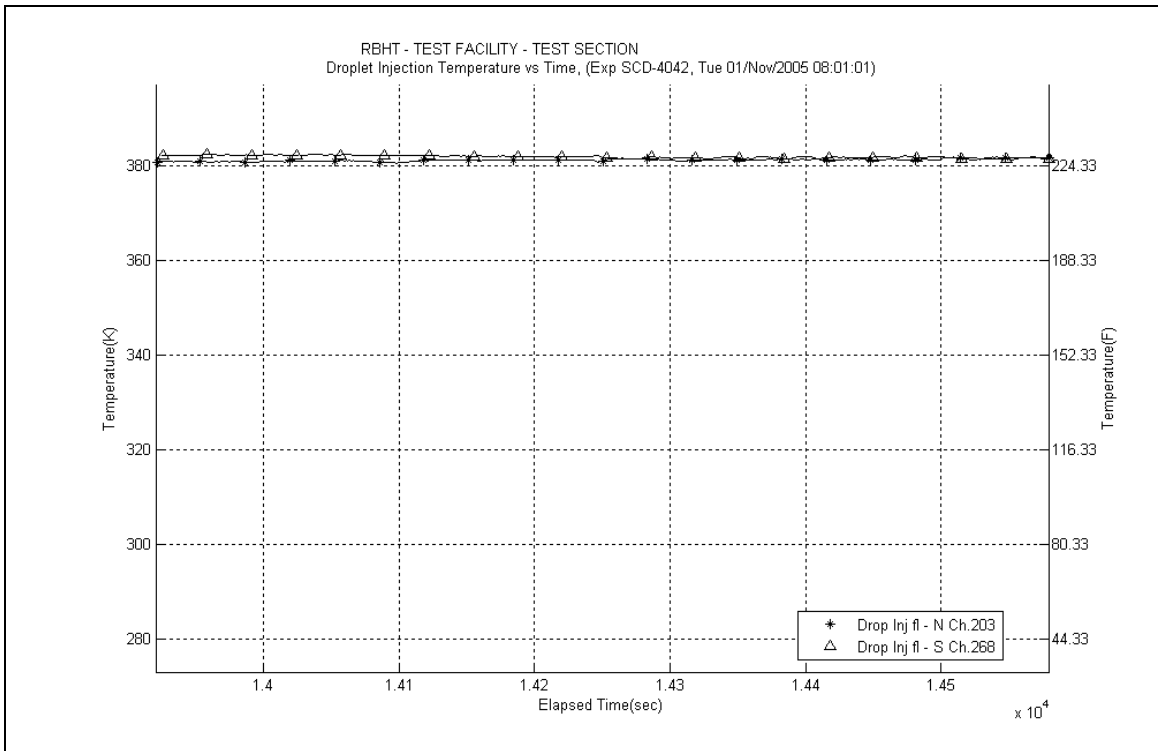

Figure A-676: Droplet Injection Temperature for Experiment 4042B

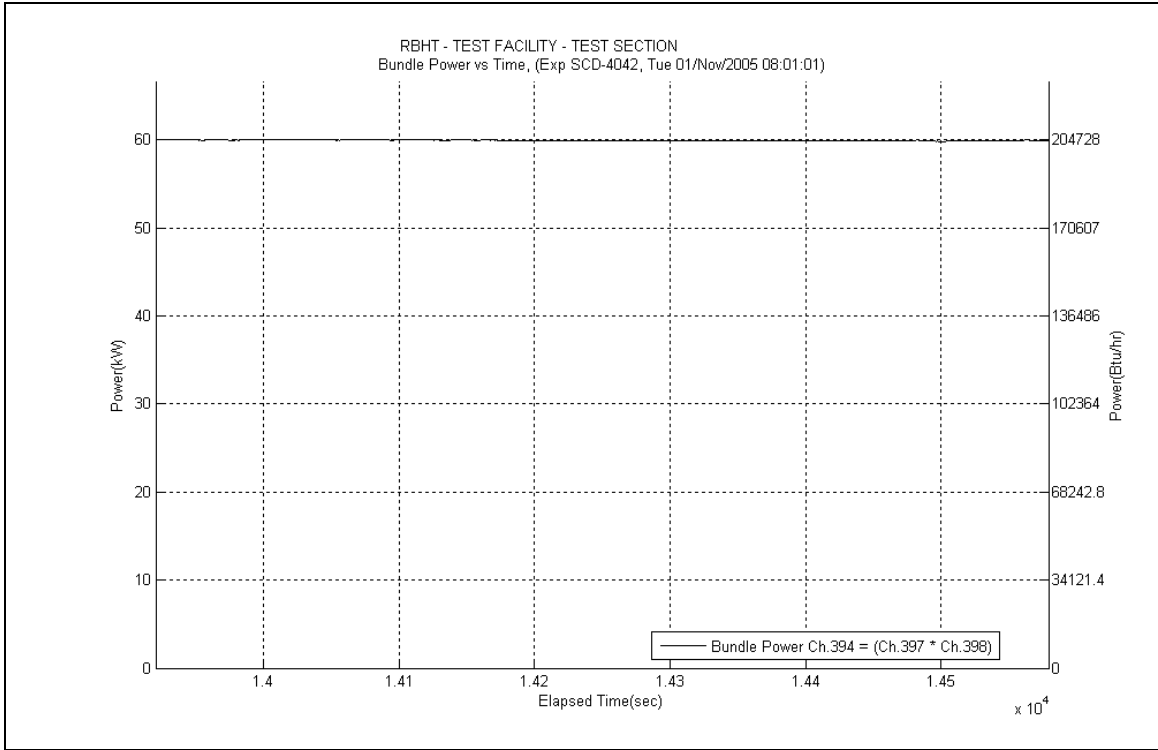

Figure A-677: Bundle Power for Experiment 4042B

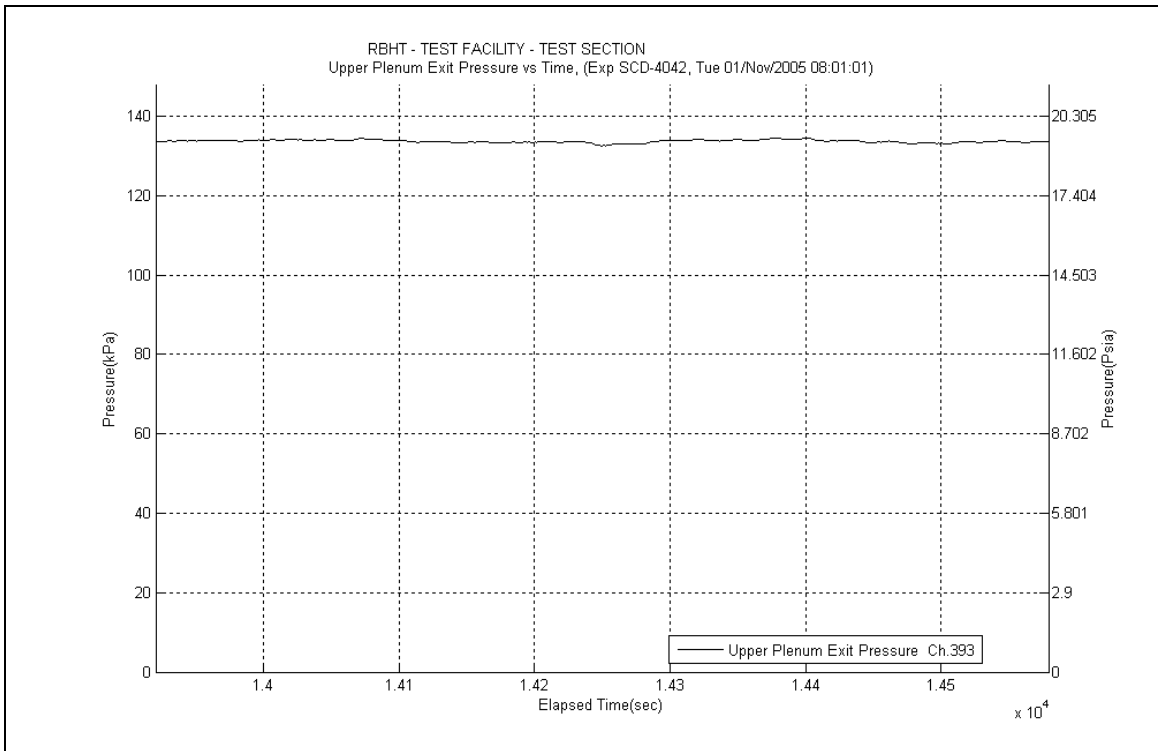

Figure A-678: Upper Plenum Pressure for Experiment 4042B

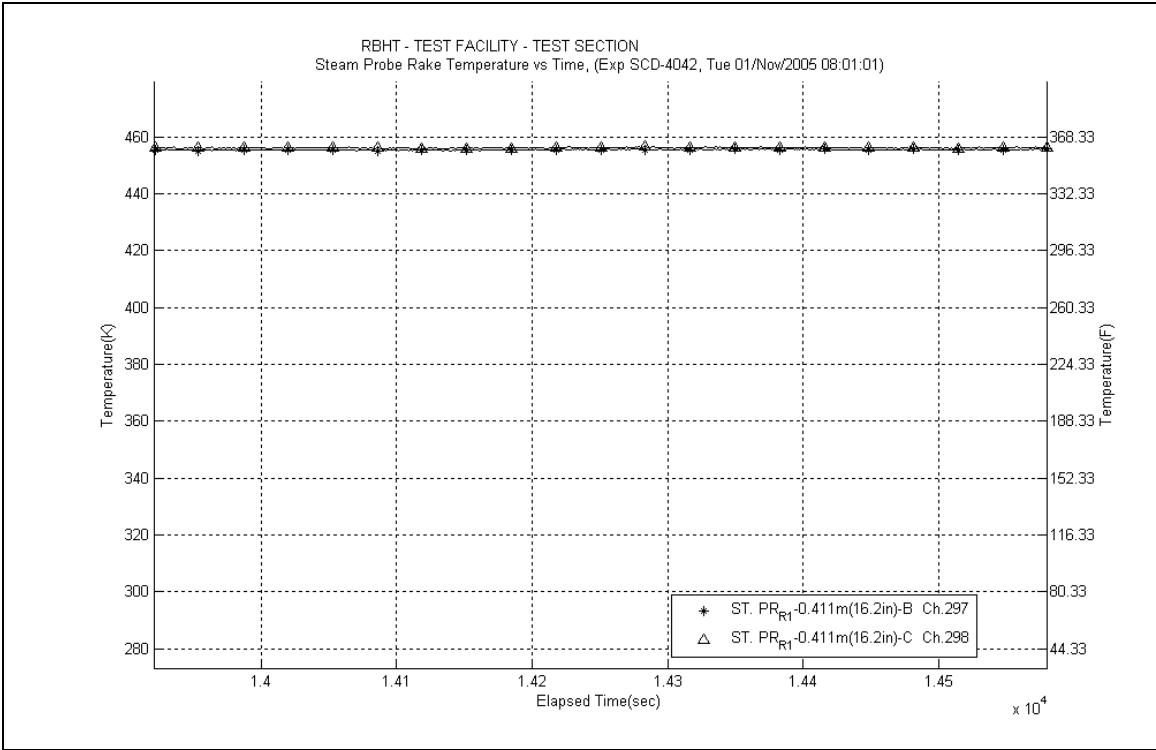

Figure A-679: Steam Probe Rake #1 Temperatures for Experiment 4042B

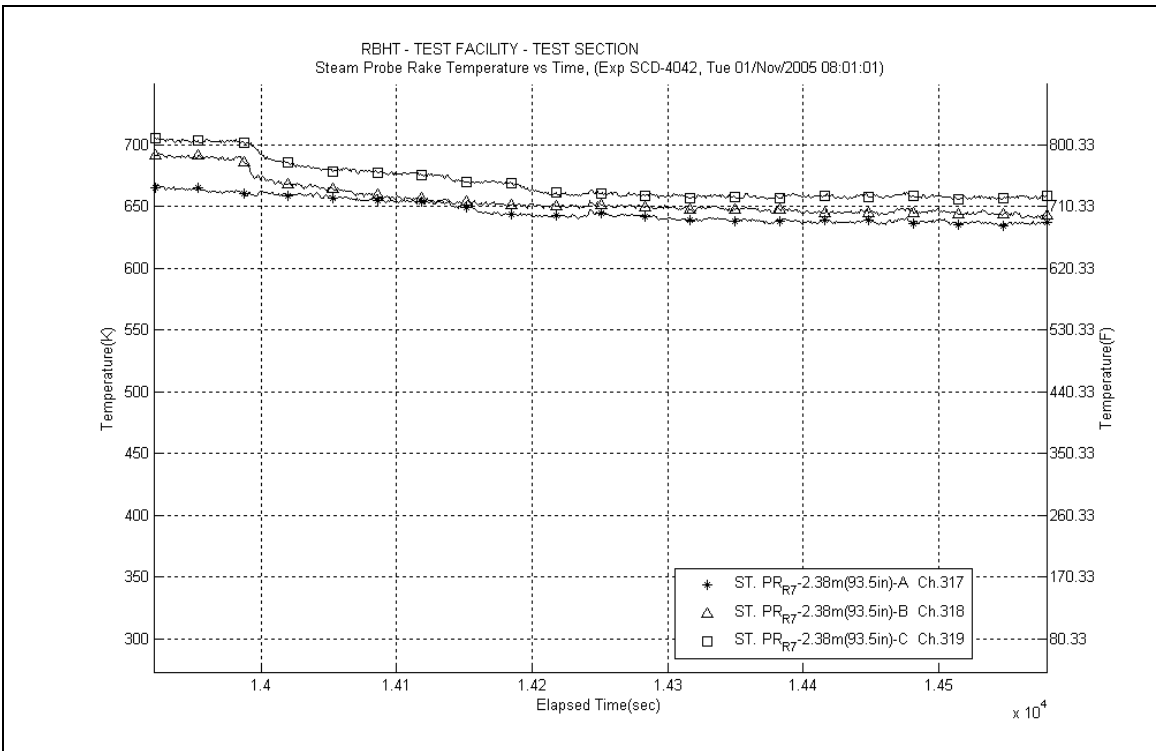

Figure A-680: Steam Probe Rake #7 Temperatures for Experiment 4042B

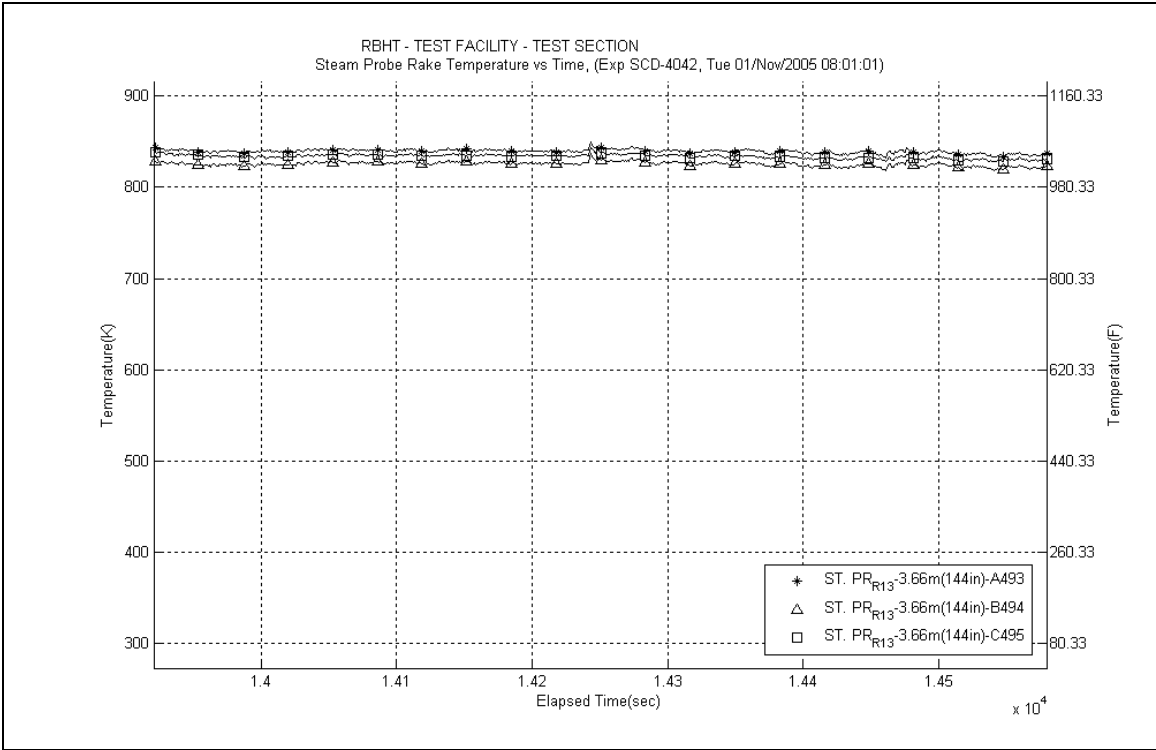

Figure A-681: Steam Probe Rake #13 Temperatures for Experiment 4042B

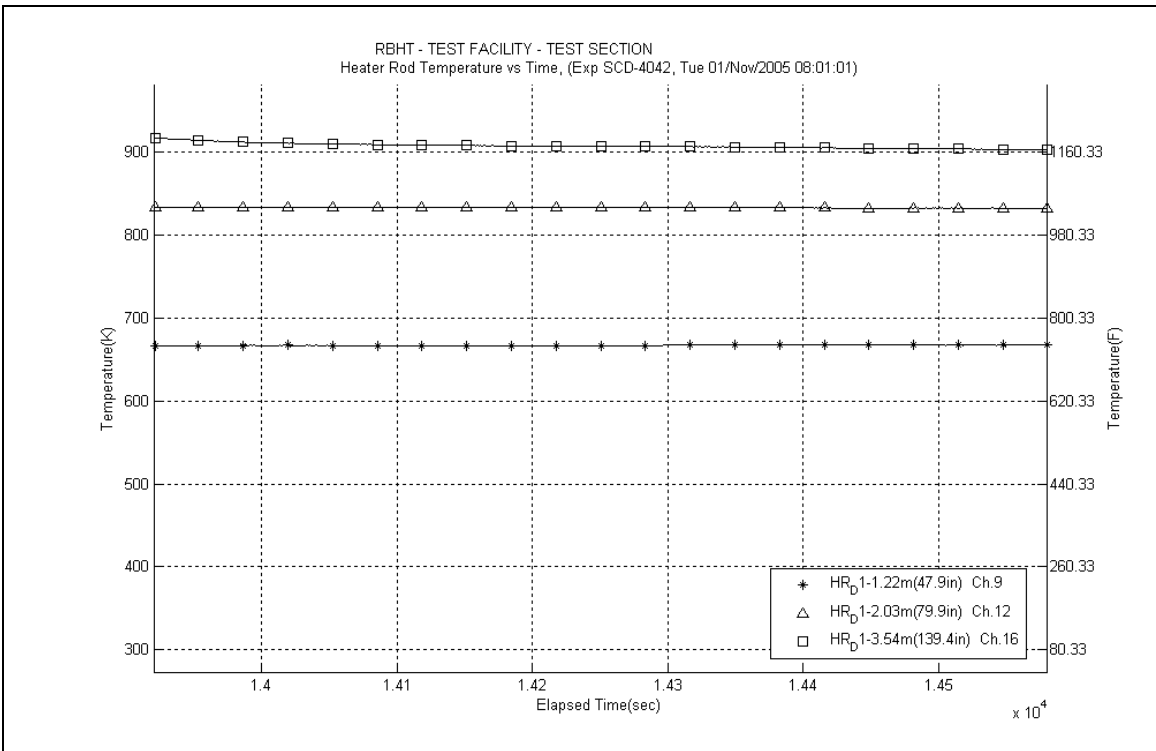

Figure A-682: Heater Rod D1 Temperatures for Experiment 4042B

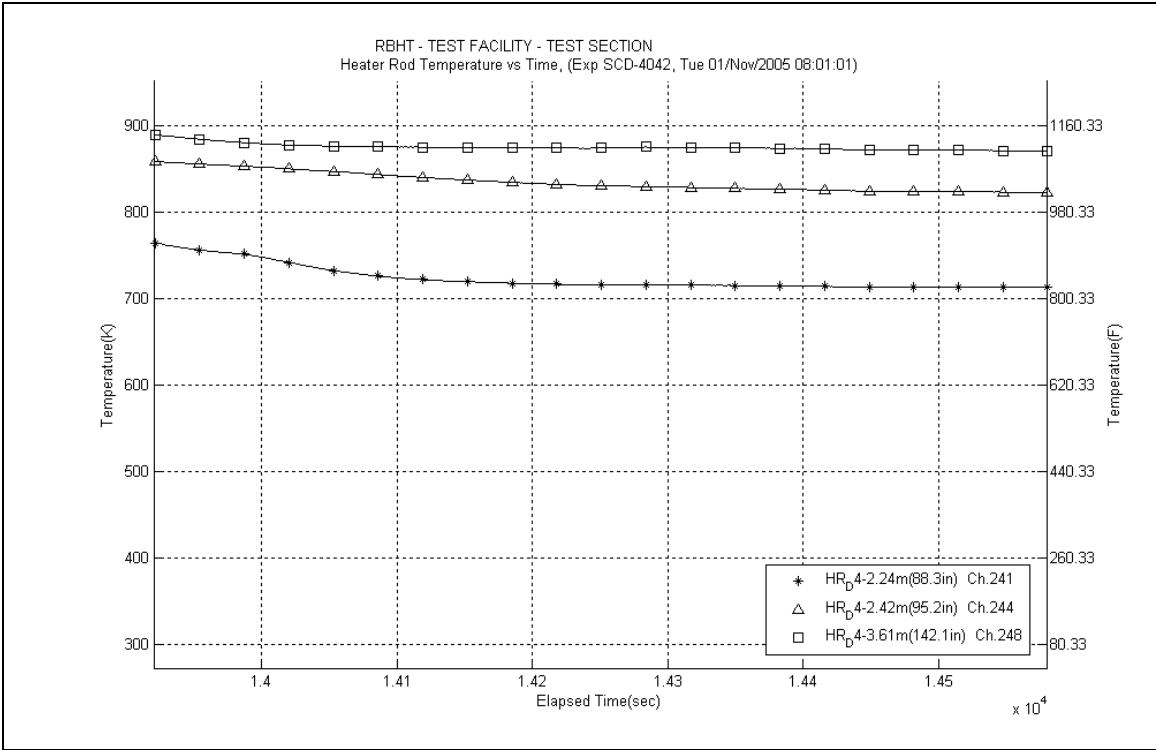

Figure A-683: Heater Rod D4 Temperatures for Experiment 4042B

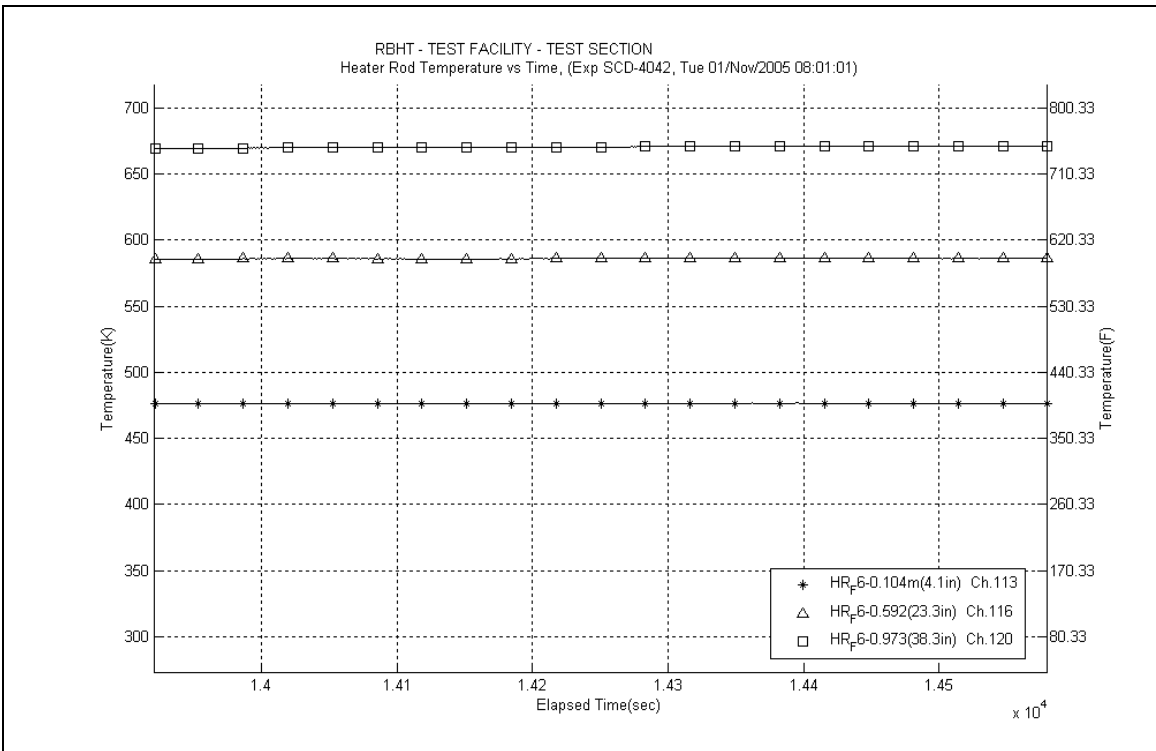

Figure A-684: Heater Rod F6 Temperatures for Experiment 4042B

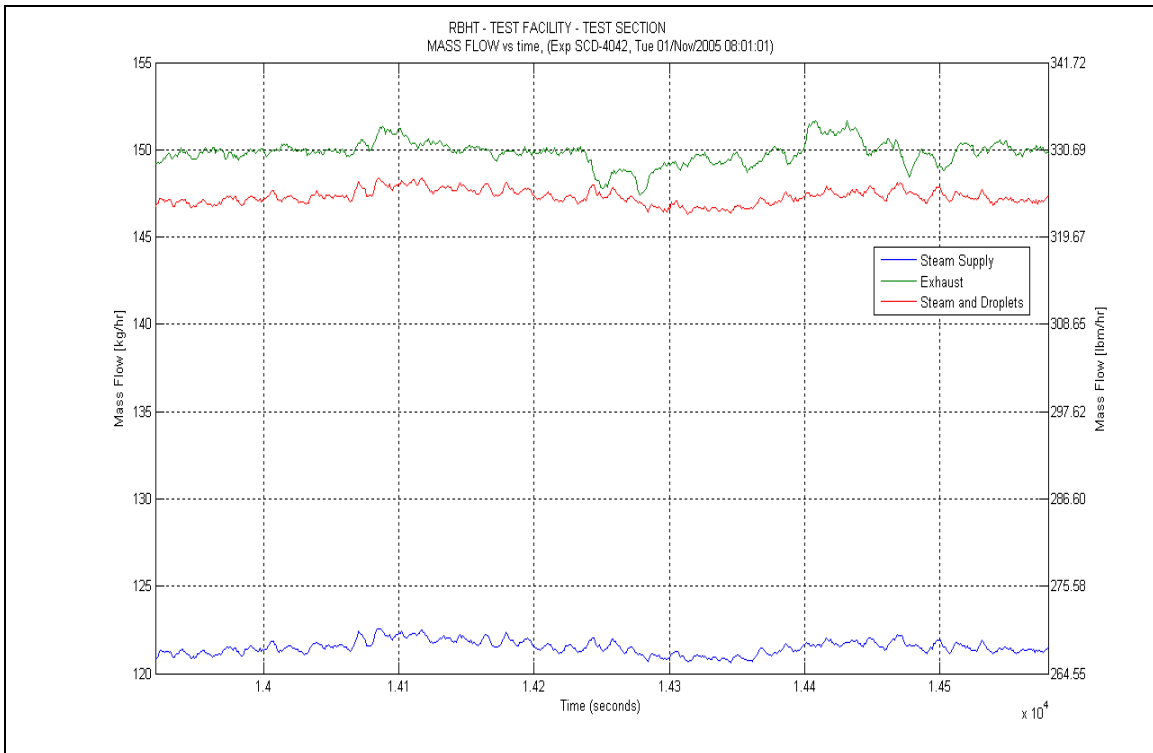

Figure A-685: Mass Flow for Experiment 4042B

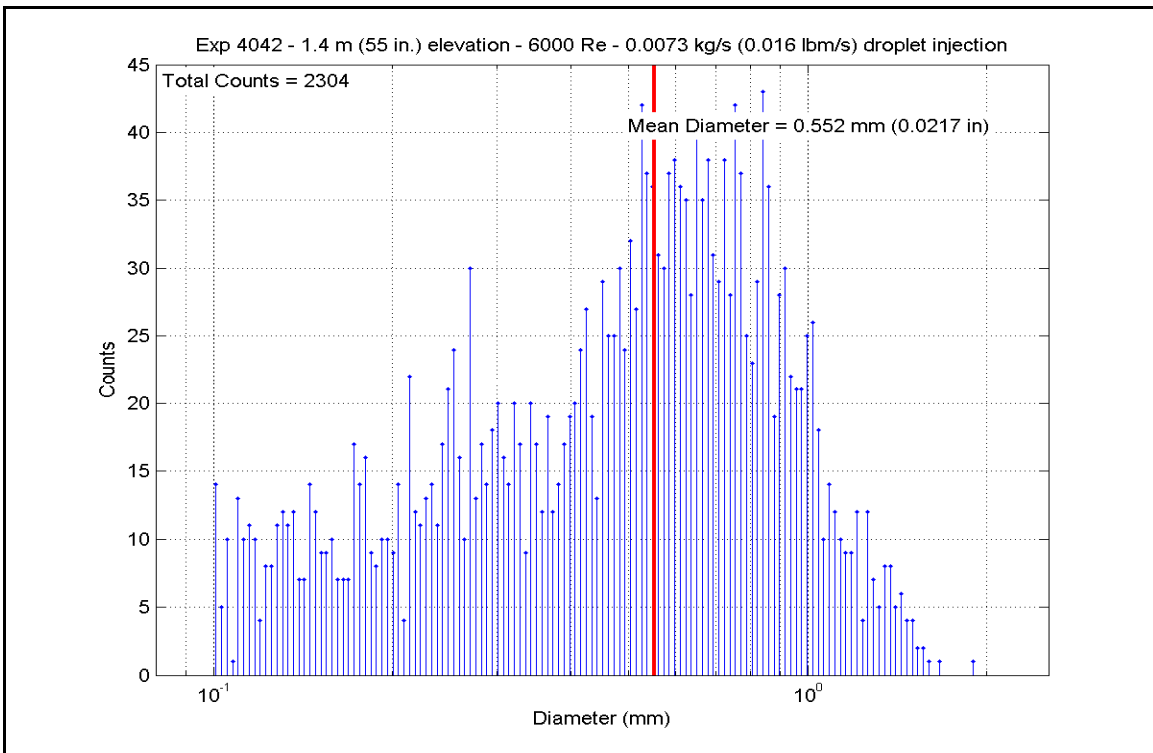

Figure A-686: Droplet Measurements at 1.397 m (55 in.) Elevation for Experiment 4042B

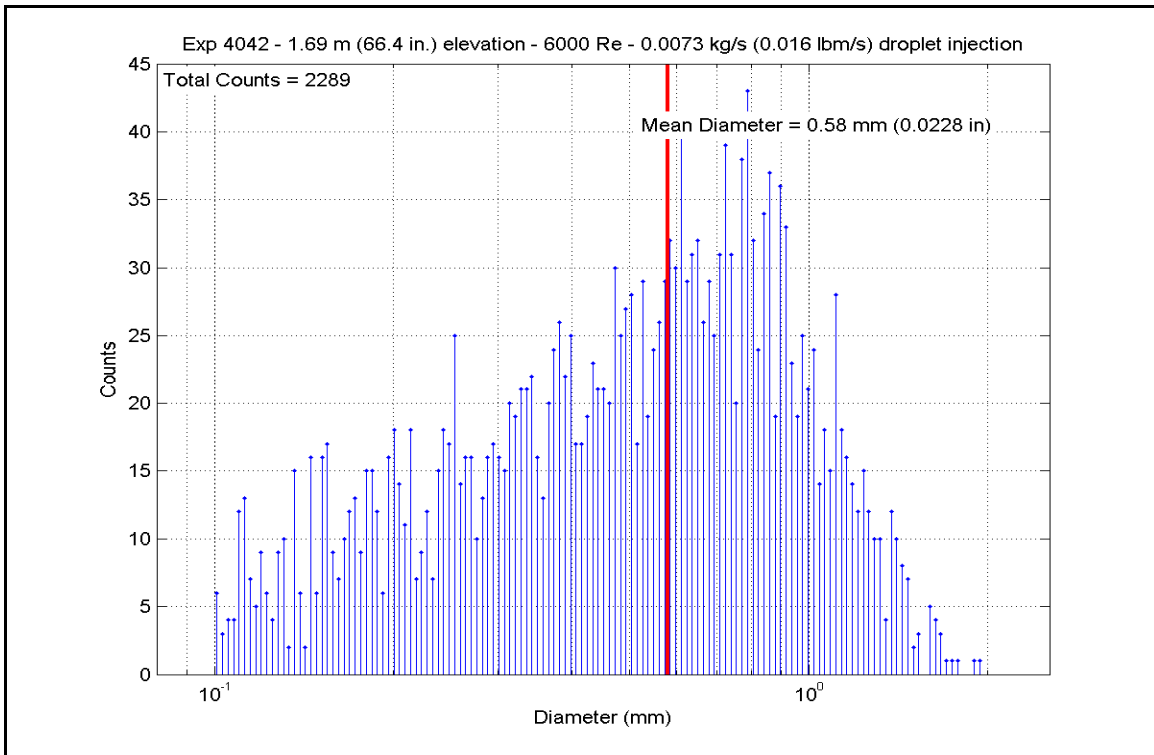

Figure A-687: Droplet Measurements at 1.687 m (66.4 in.) Elevation for Experiment 4042B

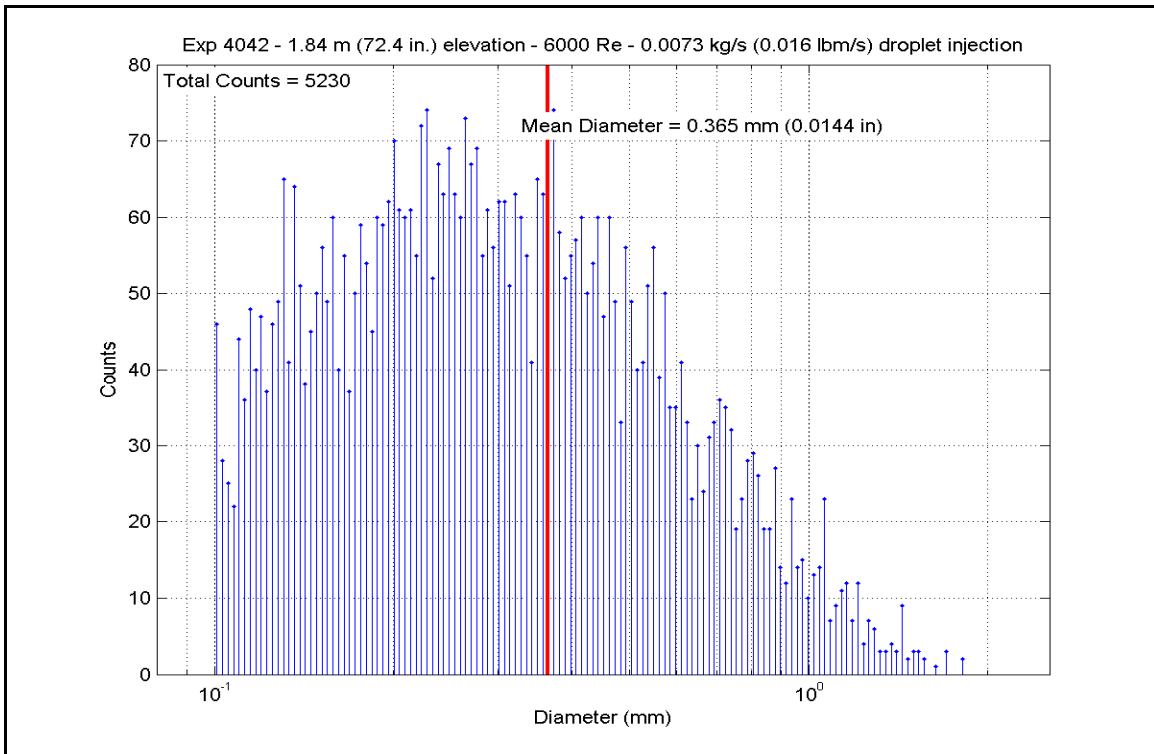

Figure A-688: Droplet Measurements at 1.839 m (72.4 in.) Elevation for Experiment 4042B

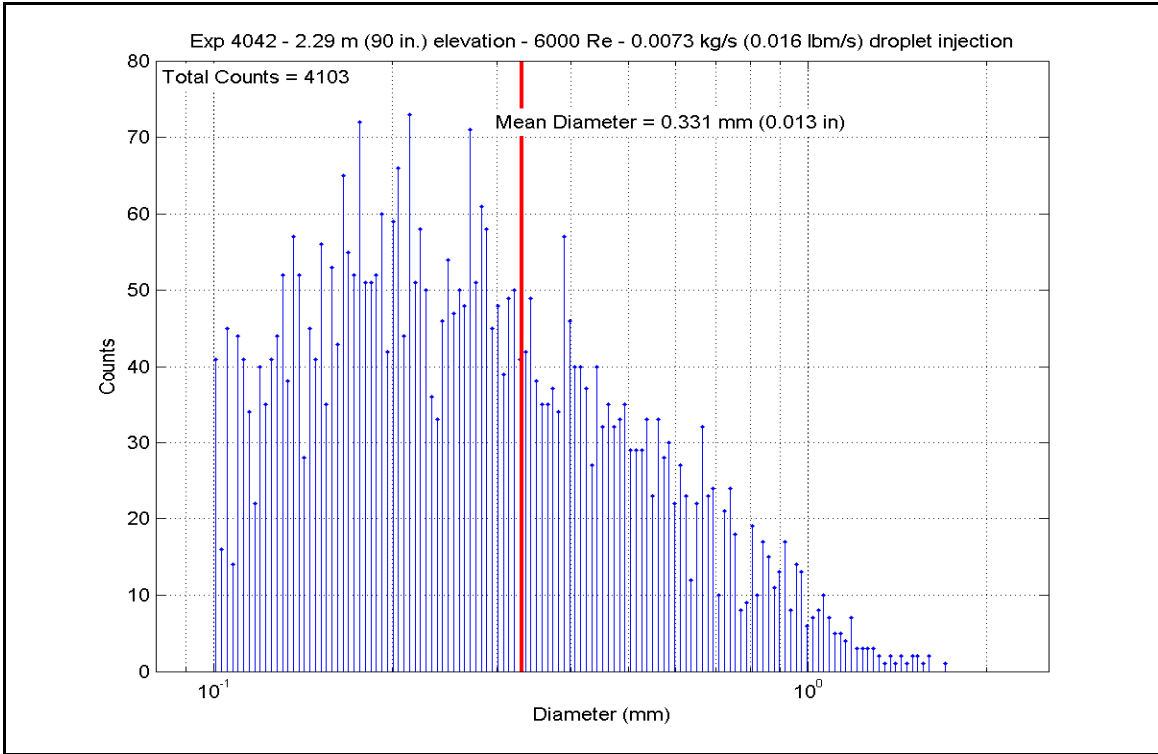

Figure A-689: Droplet Measurements at 2.286 m (90 in.) Elevation for Experiment 4042B

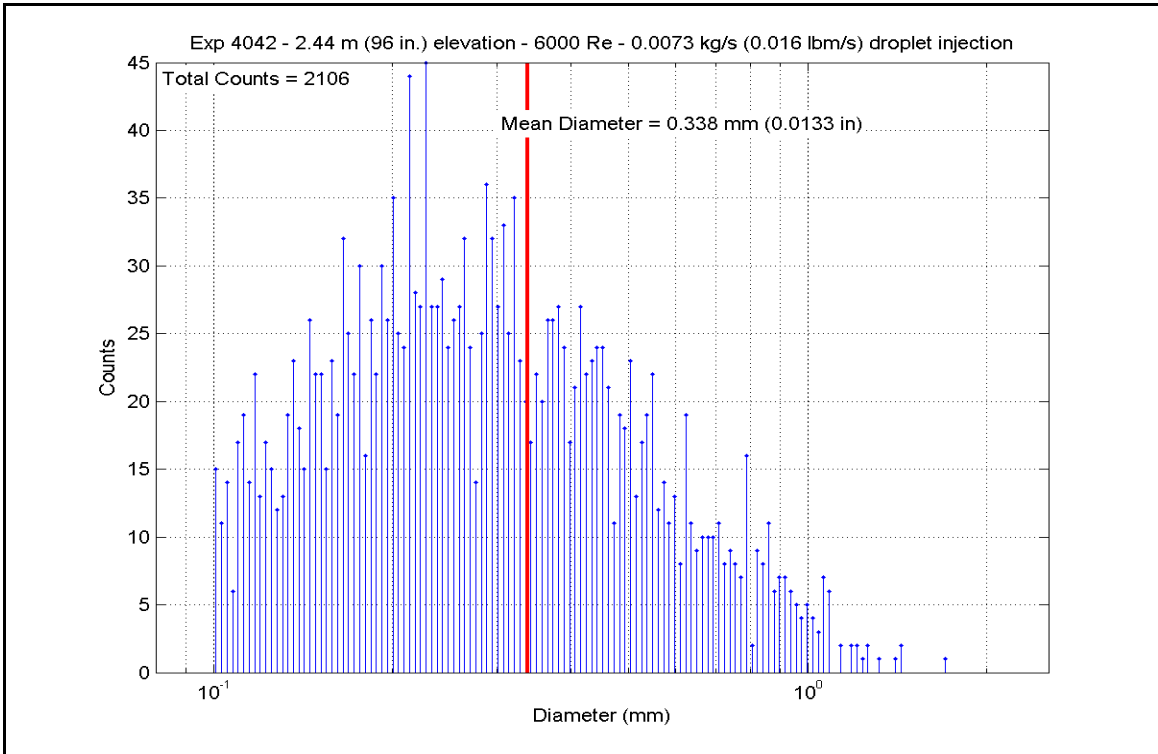

Figure A-690: Droplet Measurements at 2.438 m (96 in.) Elevation for Experiment 4042B

Table A-36: Summary of Steam Cooling Heat Transfer Reduced Data for Experiment 4042B

SCD-4042-B		Inlet Reynolds: 6000										
Matrix Test # 3b		UP Pressure: 137.9 kPa		20 psia		204728 Btu/hr		204728 Btu/hr				
Time Window: 13920-14580		Bundle Power: 60.00 kW		270.0 lbm/hr		270.0 lbm/hr		270.0 lbm/hr				
Inner 3x3		Steam flow: 0.0340 kg/s		0.016 lbm/s		0.016 lbm/s		0.016 lbm/s				
Droplet flow: 0.0073 kg/s		0.0073 kg/s		0.0073 kg/s		0.0073 kg/s		0.0073 kg/s				
H.R. ID	H.R. Location	Channel Number	Elevation (in)	Elevation (m)	Zgrid (in)	Zgrid (m)	H.R. Tw (°F)	H.R. Tw (K)	H.R. q" (Btu/hr-ft ²)	H.R. q" (W/m ²)	h _{sat} (z) (Btu/hr-ft ² -F)	h _{sat} (z) (W/m ² -K)
Gr-3	RodD3_88.3	185	88.3	2.243	-0.2	-0.005	888.34	748.9	5342.56	16853.1	8.091	45.9
	RodD3_91.3	186	91.3	2.319	2.8	0.071	976.44	797.8	5415.55	17083.4	7.236	41.1
	RodD3_93.1	187	93.1	2.365	4.6	0.117	979.63	799.6	5455.25	17208.6	7.258	41.2
	RodD3_95.3	188	95.3	2.421	6.8	0.173	1037.22	831.6	5517.09	17403.6	6.818	38.7
	RodD3_100.1	189	100.1	2.543	11.6	0.295	1129.86	883.1	5655.13	17839.1	6.271	35.6
	RodD3_106.1	190	106.1	2.695	17.6	0.447	1202.18	923.3	5856.47	18474.2	6.012	34.1
	RodD3_110	191	110	2.794	21.5	0.546	1125.18	880.5	5751.16	18142.0	6.410	36.4
	RodD3_142.1	192	142.1	3.609	8.6	0.218	1147.56	892.9	2067.90	6523.2	2.249	12.8
Gr-3	RodC4_88.4	233	88.4	2.245	-0.1	-0.003	865.10	736.0	5426.88	17119.1	8.518	48.4
	RodC4_91.1	234	91.1	2.314	2.6	0.066	968.86	793.6	5472.22	17262.1	7.386	41.9
	RodC4_93.4	235	93.4	2.372	4.9	0.124	1000.63	811.3	5519.59	17411.5	7.144	40.6
	RodC4_95.3	236	95.3	2.421	6.8	0.173	1053.37	840.6	5571.12	17574.1	6.750	38.3
	RodC4_100.1	237	100.1	2.543	11.6	0.295	1099.58	866.2	5733.01	18084.8	6.578	37.4
	RodC4_106.1	238	106.1	2.695	17.6	0.447	1171.29	906.1	5926.23	18694.3	6.282	35.7
	RodC4_110	239	110	2.794	21.5	0.546	1092.69	862.4	5693.72	17960.8	6.585	37.4
	RodC4_142.2	240	142.2	3.612	8.7	0.221	1110.10	872.1	2253.68	7109.2	2.555	14.5
Gr-3	RodD4_88.3	241	88.3	2.243	-0.2	-0.005	841.11	722.7	5368.90	16936.2	8.757	49.7
	RodD4_91.3	242	91.3	2.319	2.8	0.071	952.87	784.7	5462.40	17231.1	7.536	42.8
	RodD4_93.2	243	93.2	2.367	4.7	0.119	989.40	805.0	5504.94	17365.3	7.230	41.1
	RodD4_95.2	244	95.2	2.418	6.7	0.170	1041.83	834.2	5555.92	17526.2	6.827	38.8
	RodD4_100.1	245	100.1	2.543	11.6	0.295	1130.55	883.5	5705.49	17998.0	6.322	35.9
	RodD4_106.1	246	106.1	2.695	17.6	0.447	1174.25	907.7	5905.48	18628.8	6.241	35.4
	RodD4_142.1	248	142.1	3.609	8.6	0.218	1115.38	875.0	2166.76	6835.0	2.442	13.9
Gr-3	RodE4_88.4	201	88.4	2.245	-0.1	-0.003	859.61	732.9	5296.51	16707.9	8.386	47.6
	RodE4_91.2	202	91.2	2.316	2.7	0.069	969.63	794.1	5376.28	16959.5	7.249	41.2
	RodE4_95.3	204	95.3	2.421	6.8	0.173	1057.67	843.0	5480.17	17287.2	6.605	37.5
	RodE4_100.9	205	100.9	2.563	12.4	0.315	1138.31	887.8	5640.53	17793.0	6.196	35.2
	RodE4_142.3	208	142.3	3.614	8.8	0.224	1144.58	891.2	2182.41	6884.4	2.381	13.5

Table A-36: Summary of Steam Cooling Heat Transfer Reduced Data for Experiment 4042, continued

Inner 3x3	H.R. Location	Channel Number	Elevation (in)	Elevation (m)	Zgrid (in)	Zgrid (m)	H.R. Tw (°F)	H.R. Tw (K)	H.R. q" (Btu/hr-ft ²)	H.R. q" (W/m ²)	h _{sat} (z) (Btu/hr-ft ² -F)	h _{sat} (z) (W/m ² -K)
Gr-4	RodE3_63.4	193	63.4	1.610	16.4	0.417	1009.91	816.4	4174.59	13168.8	5.339	30.3
	RodE3_113.6	194	113.6	2.885	0.85	0.022	1161.11	900.4	5221.48	16471.1	5.596	31.8
	RodE3_115.5	195	115.5	2.934	2.75	0.070	1190.97	917.0	5024.10	15848.5	5.217	29.6
	RodE3_118.5	196	118.5	3.010	5.75	0.146	1216.21	931.0	4721.52	14894.0	4.778	27.1
	RodE3_122.7	197	122.7	3.117	9.95	0.253	1228.81	938.0	4303.35	13574.9	4.300	24.4
	RodE3_126.5	198	126.5	3.213	13.75	0.349	1233.66	940.7	3927.63	12389.7	3.906	22.2
	RodE3_131.7	199	131.7	3.345	-1.8	-0.046	1137.98	887.6	3368.31	10625.3	3.702	21.0
RodE3_135.6	200	135.6	3.444	2.1	0.053	1158.20	898.8	2993.55	9443.1	3.218	18.3	
Gr-4	RodC5_63.7	225	63.7	1.618	16.7	0.424	985.27	802.7	4106.33	12953.4	5.423	30.8
	RodC5_113.6	226	113.6	2.885	0.85	0.022	1096.05	864.3	5087.07	16047.2	5.860	33.3
	RodC5_115.7	227	115.7	2.939	2.95	0.075	1133.92	885.3	4885.10	15410.1	5.392	30.6
	RodC5_122.7	229	122.7	3.117	9.95	0.253	1182.94	912.6	4232.66	13351.9	4.432	25.2
	RodC5_126.7	230	126.7	3.218	13.95	0.354	1183.91	913.1	3862.13	12183.1	4.040	22.9
	RodC5_131.6	231	131.6	3.343	-1.9	-0.048	1057.08	842.6	3369.91	10630.4	4.065	23.1
	RodC5_135.7	232	135.7	3.447	2.2	0.056	1077.91	854.2	2991.26	9435.9	3.520	20.0
Gr-4	RodE5_63.6	209	63.6	1.615	16.6	0.422	941.03	778.2	4197.61	13241.4	5.887	33.4
	RodE5_113.6	210	113.6	2.885	0.85	0.022	1039.70	833.0	5285.20	16672.2	6.511	37.0
	RodE5_115.4	211	115.4	2.931	2.65	0.067	1094.52	863.4	5084.40	16038.7	5.868	33.3
	RodE5_118.7	212	118.7	3.015	5.95	0.151	1144.57	891.2	4744.58	14966.8	5.176	29.4
	RodE5_122.6	213	122.6	3.114	9.85	0.250	1177.64	909.6	4357.09	13744.4	4.588	26.1
	RodE5_126.6	214	126.6	3.216	13.85	0.352	1191.59	917.4	3966.48	12512.3	4.116	23.4
	RodE5_131.6	215	131.6	3.343	-1.9	-0.048	1201.34	922.8	3450.93	10886.0	3.545	20.1
RodE5_135.6	216	135.6	3.444	2.1	0.053	1140.57	889.0	3040.15	9590.1	3.331	18.9	
Gr-5	RodC3_79.8	177	79.8	2.027	8.92	0.227	978.70	799.1	4771.58	15052.0	6.356	36.1
	RodC3_85.6	178	85.6	2.174	14.72	0.374	893.78	751.9	5200.45	16404.8	7.811	44.4
	RodC3_88.5	179	88.5	2.248	0	0.000	885.25	747.2	5348.03	16870.4	8.137	46.2
	RodC3_92.4	180	92.4	2.347	3.9	0.099	1000.13	811.0	5414.54	17080.2	7.012	39.8
	RodC3_94.4	181	94.4	2.398	5.9	0.150	1024.55	824.6	5450.29	17192.9	6.842	38.9
	RodC3_97.2	182	97.2	2.469	8.7	0.221	1083.20	857.1	5529.83	17443.9	6.466	36.7
	RodC3_108.8	183	108.8	2.764	20.3	0.516	1188.29	915.5	5770.88	18204.3	6.010	34.1
Gr-8	RodD5_50	217	50	1.270	3	0.076	860.26	733.3	3705.38	11688.6	5.861	33.3
	RodD5_54.1	218	54.1	1.374	7.1	0.180	882.43	745.6	3852.78	12153.6	5.887	33.4
	RodD5_56.9	219	56.9	1.445	9.9	0.251	930.99	772.6	3952.62	12468.5	5.623	31.9
	RodD5_60	220	60	1.524	13	0.330	966.38	792.3	4066.78	12828.6	5.508	31.3
	RodD5_66.1	221	66.1	1.679	19.1	0.485	990.06	805.4	4292.27	13540.0	5.632	32.0
	RodD5_69.9	222	69.9	1.775	-0.98	-0.025	821.10	711.5	4430.87	13977.2	7.471	42.4
	RodD5_72.9	223	72.9	1.852	2.02	0.051	889.96	749.8	4540.99	14324.6	6.860	39.0
RodD5_74.9	224	74.9	1.902	4.02	0.102	937.30	776.1	4614.94	14557.8	6.506	36.9	

Table A-36: Summary of Steam Cooling Heat Transfer Reduced Data for Experiment 4042, continued

H.R. ID	H.R. Location	Channel Number	Elevation (in)	Elevation (m)	Zgrid (in)	Zgrid (m)	H.R. Tw (°F)	H.R. Tw (K)	H.R. q" (Btu/hr-ft ²)	H.R. q" (W/m ²)	h _{sat} (z) (Btu/hr-ft ² -F)	h _{sat} (z) (W/m ² -K)
Gr-2	RodB5_41	153	41	1.041	13.5	0.343	792.49	695.6	3373.95	10643.1	5.977	33.9
	RodB5_52.9	154	52.9	1.344	5.9	0.150	853.69	729.6	3802.92	11996.3	6.078	34.5
	RodB5_55	155	55	1.397	8	0.203	886.51	747.9	3882.96	12248.8	5.897	33.5
	RodB5_57.8	156	57.8	1.468	10.8	0.274	937.21	776.0	3984.61	12569.5	5.618	31.9
	RodB5_64	157	64	1.626	17	0.432	992.71	806.9	4211.87	13286.4	5.508	31.3
	RodB5_73.9	158	73.9	1.877	3.02	0.077	914.28	763.3	4575.44	14433.2	6.667	37.9
Gr-2	RodB5_75.9	159	75.9	1.928	5.02	0.128	952.44	784.5	4649.96	14668.3	6.419	36.5
	RodB5_76.9	160	76.9	1.953	6.02	0.153	968.48	793.4	4687.00	14785.2	6.330	35.9
	RodF5_41	105	41	1.041	13.5	0.343	792.22	695.5	3345.41	10553.1	5.929	33.7
	RodF5_53.1	106	53.1	1.349	6.1	0.155	835.70	719.6	3782.89	11933.1	6.225	35.4
	RodF5_55	107	55	1.397	8	0.203	869.03	738.2	3850.38	12146.0	6.007	34.1
	RodF5_57.8	108	57.8	1.468	10.8	0.274	917.54	765.1	3946.87	12450.4	5.724	32.5
Gr-2	RodF5_64	109	64	1.626	17	0.432	969.70	794.1	4176.07	13173.4	5.630	32.0
	RodF5_73.8	110	73.8	1.875	2.92	0.074	907.76	759.7	4540.30	14322.4	6.679	37.9
	RodF5_75.8	111	75.8	1.925	4.92	0.125	949.85	783.1	4614.92	14557.8	6.393	36.3
	RodF5_76.8	112	76.8	1.951	5.92	0.150	968.11	793.2	4652.23	14675.5	6.286	35.7
	RodC2_41	57	41	1.041	13.5	0.343	795.16	697.1	3365.77	10617.3	5.934	33.7
	RodC2_53.1	58	53.1	1.349	6.1	0.155	904.73	758.0	3803.76	11999.0	5.621	31.9
Gr-2	RodC2_55	59	55	1.397	8	0.203	927.30	770.5	3873.10	12217.7	5.539	31.5
	RodC2_57.8	60	57.8	1.468	10.8	0.274	963.55	790.7	3972.61	12531.6	5.401	30.7
	RodC2_63.9	61	63.9	1.623	16.9	0.429	1011.98	817.6	4193.58	13228.7	5.349	30.4
	RodC2_73.8	62	73.8	1.875	2.92	0.074	932.98	773.7	4555.97	14371.8	6.463	36.7
	RodC2_75.8	63	75.8	1.925	4.92	0.125	963.31	790.5	4625.04	14589.7	6.290	35.7
	RodC2_76.8	64	76.8	1.951	5.92	0.150	976.37	797.8	4661.17	14703.7	6.228	35.4
Gr-2	RodC6_40.9	137	40.9	1.039	13.4	0.340	800.69	700.2	3350.35	10568.7	5.850	33.2
	RodC6_52.8	138	52.8	1.341	5.8	0.147	900.36	755.6	3794.61	11970.1	5.644	32.0
	RodC6_54.8	139	54.8	1.392	7.8	0.198	928.37	771.1	3870.05	12208.1	5.526	31.4
	RodC6_57.8	140	57.8	1.468	10.8	0.274	963.69	790.8	3983.37	12565.5	5.414	30.7
	RodC6_63.8	141	63.8	1.621	16.8	0.427	1013.45	818.4	4212.45	13288.2	5.363	30.5
	RodC6_73.7	142	73.7	1.872	2.82	0.072	982.01	800.9	4600.43	14512.1	6.101	34.6
Gr-2	RodC6_75.8	143	75.8	1.925	4.92	0.125	1012.42	817.8	4681.00	14766.2	5.967	33.9
	RodC6_76.8	144	76.8	1.951	5.92	0.150	1029.81	827.5	4719.45	14887.5	5.886	33.4

Table A-36: Summary of Steam Cooling Heat Transfer Reduced Data for Experiment 4042, continued

5x5 periphery		H.R. Location	Channel Number	Elevation (in)	Elevation (m)	Zgrid (in)	Zgrid (m)	H.R. Tw (°F)	H.R. Tw (K)	H.R. q" (Btu/hr-ft ²)	H.R. q" (W/m ²)	h _{sat} (z) (Btu/hr-ft ² -F)	h _{sat} (z) (W/m ² -K)
Gr-3	RodB4_88.4	161	88.4	2.245	-0.1	-0.003	886.25	747.7	5278.02	16649.5	8.018	45.5	
	RodB4_91.3	162	91.3	2.319	2.8	0.071	982.23	801.1	5344.40	16858.9	7.086	40.2	
	RodB4_93.3	163	93.3	2.370	4.8	0.122	1000.32	811.1	5390.44	17004.2	6.980	39.6	
	RodB4_95.1	164	95.1	2.416	6.6	0.168	1034.70	830.2	5438.77	17156.6	6.742	38.3	
	RodB4_100	165	100	2.540	11.5	0.292	1076.06	853.2	5584.70	17616.9	6.585	37.4	
	RodB4_106	166	106	2.692	17.5	0.445	1162.93	901.4	5779.89	18232.7	6.182	35.1	
	RodB4_109.9	167	109.9	2.791	21.4	0.544	1083.83	857.5	5565.35	17555.9	6.503	36.9	
	RodB4_142.3	168	142.3	3.614	8.8	0.224	1106.56	870.1	2253.73	7109.4	2.565	14.6	
Gr-5	RodF4_85.6	98	85.6	2.174	14.72	0.374	945.49	780.6	5105.95	16106.7	7.116	40.4	
	RodF4_88.4	99	88.4	2.245	-0.1	-0.003	917.57	765.1	5280.28	16656.6	7.657	43.5	
	RodF4_92.4	100	92.4	2.347	3.9	0.099	1024.91	824.8	5391.29	17006.8	6.765	38.4	
	RodF4_94.3	101	94.3	2.395	5.8	0.147	1062.55	845.7	5451.25	17196.0	6.532	37.1	
	RodF4_97.2	102	97.2	2.469	8.7	0.221	1110.59	872.4	5543.38	17486.6	6.281	35.7	
	RodF4_108.8	103	108.8	2.764	20.3	0.516	1189.08	916.0	5795.95	18283.3	6.031	34.2	
	RodF4_111	104	111	2.819	-1.75	-0.044	1111.56	872.9	5525.70	17430.8	6.254	35.5	
	RodD2_103.2	65	103.2	2.621	14.7	0.373	1185.77	914.1	5076.38	16013.4	5.300	30.1	
RodD2_106	66	106	2.692	17.5	0.445	1205.08	924.9	4808.49	15168.4	4.921	27.9		
RodD2_112.6	67	112.6	2.860	-0.15	-0.004	1225.41	936.2	4447.50	14029.7	4.459	25.3		
RodD2_114.9	68	114.9	2.918	2.15	0.055	1239.81	944.2	4028.24	12707.1	3.981	22.6		
RodD2_117.4	69	117.4	2.982	4.65	0.118	1230.51	939.0	3625.07	11435.3	3.616	20.5		
RodD2_120.8	70	120.8	3.068	8.05	0.204	1198.16	921.0	5734.98	18091.0	5.911	33.6		
RodD2_124.8	71	124.8	3.170	12.05	0.306	1224.87	935.9	5834.52	18405.0	5.853	33.2		
RodD2_128.6	72	128.6	3.266	15.85	0.403	1149.79	894.1	5331.54	16818.3	5.784	32.8		
Gr-6	RodD6_103.1	129	103.1	2.619	14.6	0.371	1213.66	929.6	5725.92	18062.4	5.809	33.0	
	RodD6_106	130	106	2.692	17.5	0.445	1227.65	937.4	5827.64	18383.3	5.830	33.1	
	RodD6_112.9	131	112.9	2.868	0.15	0.004	1132.15	884.3	5296.40	16707.5	5.858	33.3	
	RodD6_114.9	132	114.9	2.918	2.15	0.055	1163.62	901.8	5077.66	16017.5	5.427	30.8	
	RodD6_116.8	133	116.8	2.967	4.05	0.103	1184.48	913.4	4879.17	15391.3	5.101	29.0	
	RodD6_120.9	134	120.9	3.071	8.15	0.207	1201.36	922.8	4449.43	14035.7	4.571	26.0	
	RodD6_124.8	135	124.8	3.170	12.05	0.306	1208.70	926.9	4045.00	12760.0	4.125	23.4	
	RodD6_128.7	136	128.7	3.269	15.95	0.405	1197.85	920.8	3635.48	11468.1	3.748	21.3	

Table A-36: Summary of Steam Cooling Heat Transfer Reduced Data for Experiment 4042, continued

5x5 periphery		H.R. Location	Channel Number	Elevation (in)	Elevation (m)	Zgrid (in)	Zgrid (m)	H.R. Tw (°F)	H.R. Tw (K)	H.R. q" (Btu/hr-ft ²)	H.R. q" (W/m ²)	h _{sat} (z) (Btu/hr-ft ² -F)	h _{sat} (z) (W/m ² -K)
Gr-8	RodE2_50.1	73	50.1	1.273	3.1	0.079	850.05	727.6	3722.02	11741.1	5.983	34.0	
	RodE2_54	74	54	1.372	7	0.178	916.45	764.5	3862.64	12184.7	5.611	31.9	
	RodE2_56.9	75	56.9	1.445	9.9	0.251	954.48	785.6	3967.56	12515.7	5.461	31.0	
	RodE2_59.9	76	59.9	1.521	12.9	0.328	991.83	806.4	4076.81	12860.3	5.337	30.3	
	RodE2_66	77	66	1.676	19	0.483	1019.83	821.9	4301.93	13570.4	5.433	30.9	
	RodE2_69.8	78	69.8	1.773	-1.08	-0.027	874.35	741.1	4441.28	14010.0	6.871	39.0	
	RodE2_72.9	79	72.9	1.852	2.02	0.051	936.23	775.5	4557.55	14376.8	6.435	36.5	
	RodE2_74.9	80	74.9	1.902	4.02	0.102	969.61	794.0	4632.33	14612.7	6.246	35.5	
Gr-8	RodB3_50.2	169	50.2	1.275	3.2	0.081	808.78	704.7	3704.75	11686.6	6.379	36.2	
	RodB3_54.1	170	54.1	1.374	7.1	0.180	877.04	742.6	3842.19	12120.2	5.920	33.6	
	RodB3_56.9	171	56.9	1.445	9.9	0.251	915.55	764.0	3942.21	12435.7	5.734	32.6	
	RodB3_60.1	172	60.1	1.527	13.1	0.333	913.47	762.9	4059.44	12805.5	5.922	33.6	
	RodB3_66.1	173	66.1	1.679	19.1	0.485	959.85	788.6	4279.88	13500.9	5.848	33.2	
	RodB3_69.9	174	69.9	1.775	-0.98	-0.025	795.32	697.2	4419.96	13942.8	7.791	44.2	
	RodB3_73	175	73	1.854	2.12	0.054	873.80	740.8	4536.02	14308.9	7.024	39.9	
	RodB3_75	176	75	1.905	4.12	0.105	913.34	762.8	4609.83	14541.7	6.726	38.2	
Gr-8	RodF3_50.1	89	50.1	1.273	3.1	0.079	830.17	716.6	3700.13	11672.1	6.145	34.9	
	RodF3_54	90	54	1.372	7	0.178	899.28	755.0	3841.78	12118.9	5.723	32.5	
	RodF3_57	91	57	1.448	10	0.254	944.22	779.9	3950.85	12463.0	5.516	31.3	
	RodF3_60	92	60	1.524	13	0.330	978.43	798.9	4060.37	12808.4	5.411	30.7	
	RodF3_66.1	93	66.1	1.679	19.1	0.485	1002.90	812.5	4290.02	13532.9	5.536	31.4	
	RodF3_70	94	70	1.778	-0.88	-0.022	825.72	714.1	4443.21	14016.1	7.434	42.2	
	RodF3_73	95	73	1.854	2.12	0.054	917.38	765.0	4550.35	14354.1	6.601	37.5	
	RodF3_75	96	75	1.905	4.12	0.105	961.05	789.3	4626.24	14593.5	6.311	35.8	
Gr-8	RodE6_50.2	121	50.2	1.275	3.2	0.081	832.44	717.8	3692.83	11649.0	6.109	34.7	
	RodE6_54.1	122	54.1	1.374	7.1	0.180	896.37	753.4	3830.03	12081.8	5.730	32.5	
	RodE6_57	123	57	1.448	10	0.254	931.44	772.8	3933.90	12409.5	5.592	31.8	
	RodE6_60.2	124	60.2	1.529	13.2	0.335	969.50	794.0	4050.02	12775.8	5.462	31.0	
	RodE6_66.1	125	66.1	1.679	19.1	0.485	992.10	806.5	4260.91	13441.1	5.576	31.7	
	RodE6_70	126	70	1.778	-0.88	-0.022	909.48	760.6	4408.20	13905.7	6.469	36.7	
	RodE6_73.1	127	73.1	1.857	2.22	0.056	958.21	787.7	4518.45	14253.4	6.188	35.1	
	RodE6_75	128	75	1.905	4.12	0.105	990.40	805.6	4586.24	14467.3	6.015	34.2	

RBHT Steam Cooling with Droplet Injection Test SCD-4042-C

Matrix Test # 3c

Test Conditions

Test Date – 11/1/2005

Steady State Time Window: 15060 – 15660

Upper Plenum Pressure: 1.38 bar (20 psia)

Bundle Power: 60.0 kW

Bundle Inlet Reynolds Number: 6000

Bundle Inlet Steam Flow: 122.6 kg/hr (270 lbm/hr)

Droplet Injection Flow: 0.011 kg/s (0.024 lbm/s)

Droplet Injection Hole Diameter: 0.381 mm (.015 in)

Droplet Injection Elevation: 1.295 m (51 in)

Bundle Flow Area: $4.656 \times 10^{-3} \text{ m}^2$ ($5.012 \times 10^{-2} \text{ ft}^2$)

Test Notes

- No steam probes were traversed in this steady state window.

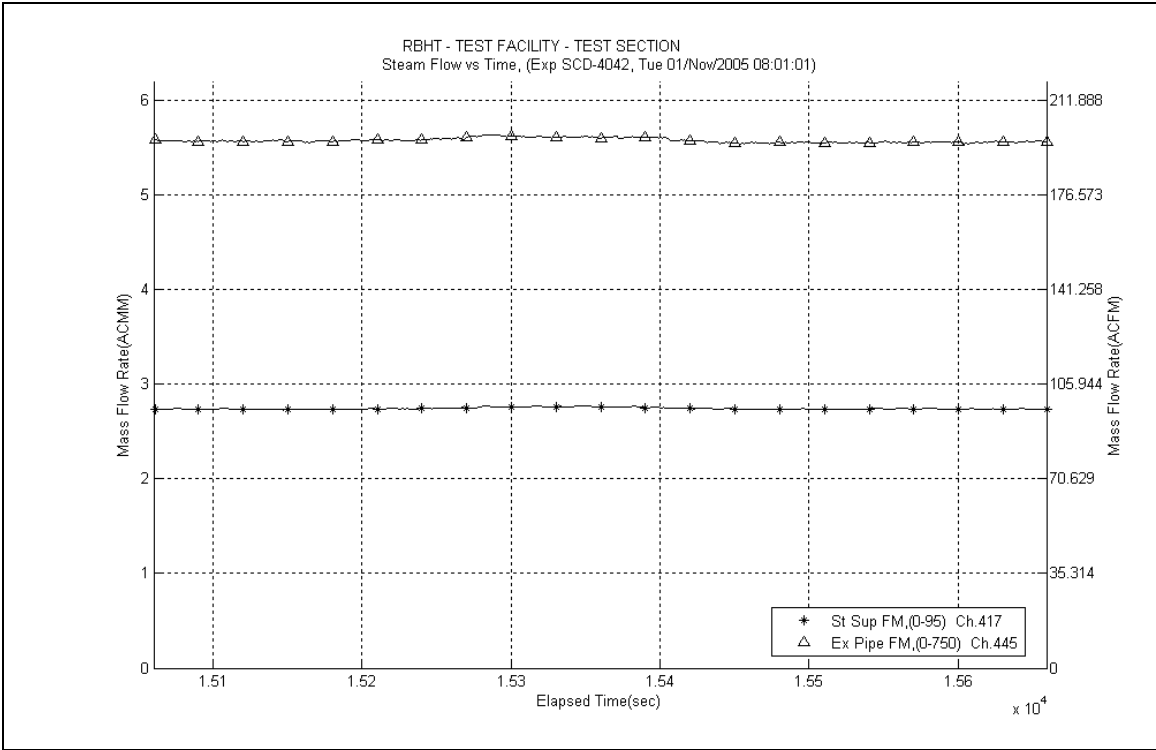

Figure A-691: Inlet and Exhaust Steam Flow Rates for Experiment 4042C

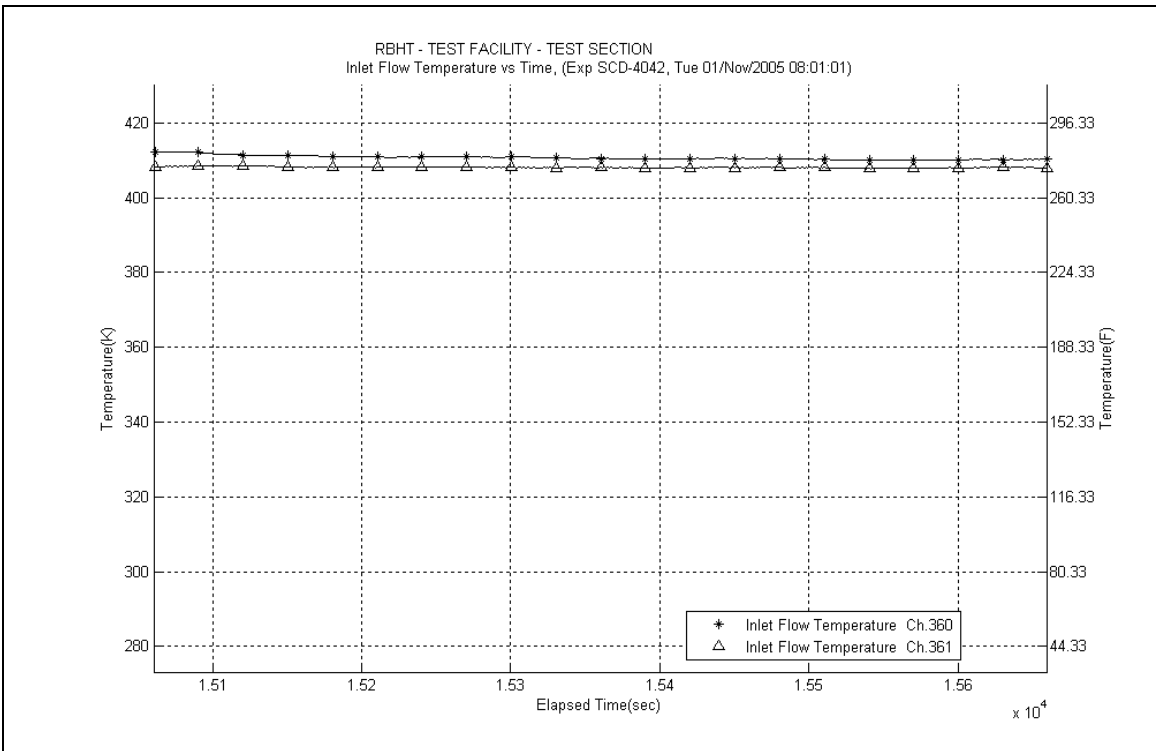

Figure A-692: Inlet Steam Temperature for Experiment 4042C

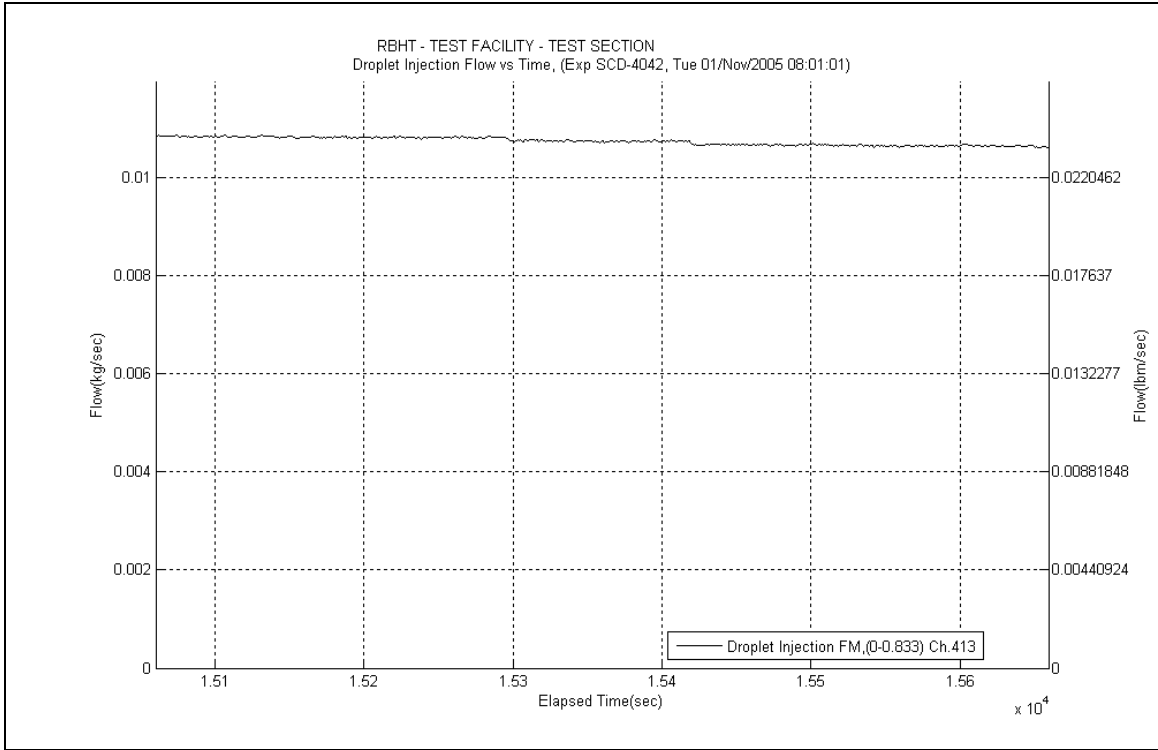

Figure A-693: Droplet Injection Flow Rate for Experiment 4042C

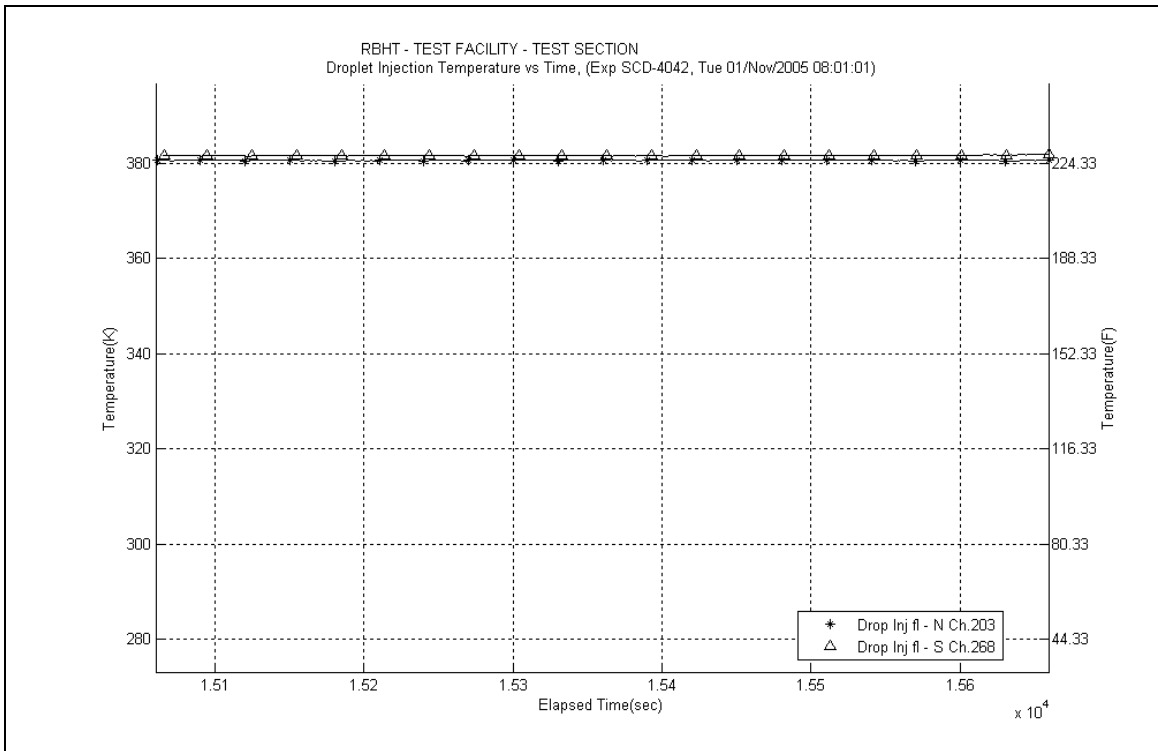

Figure A-694: Droplet Injection Temperature for Experiment 4042C

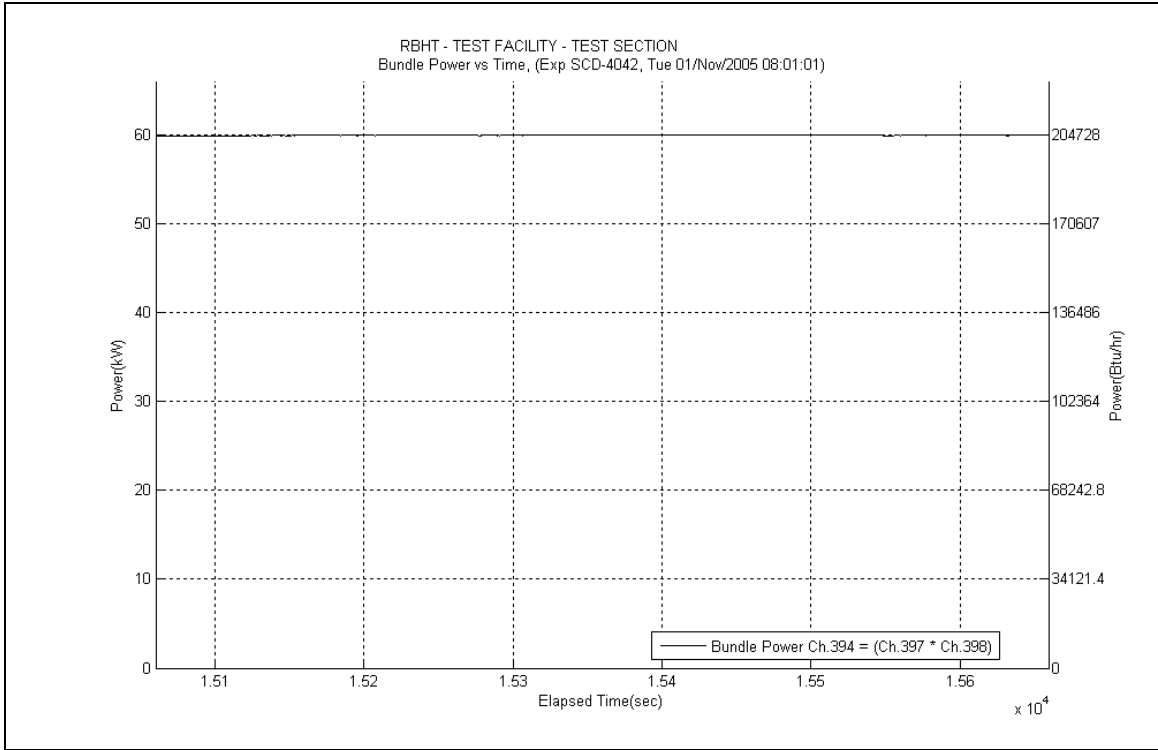

Figure A-695: Bundle Power for Experiment 4042C

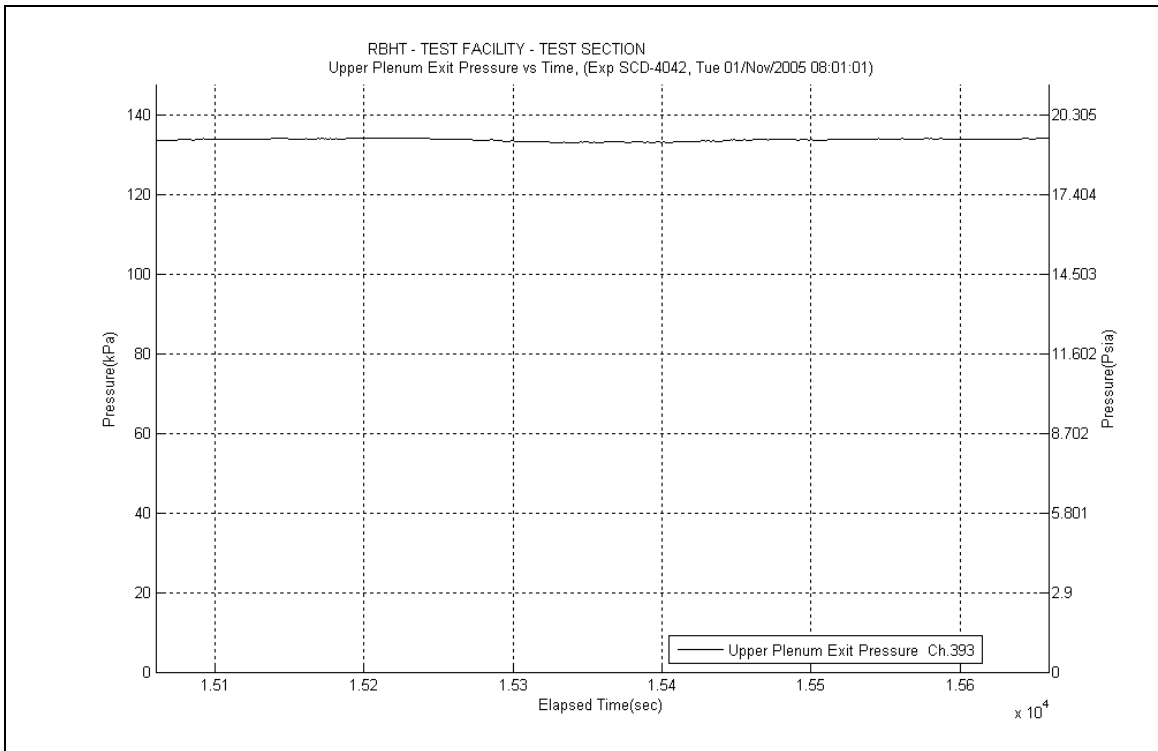

Figure A-696: Upper Plenum Pressure for Experiment 4042C

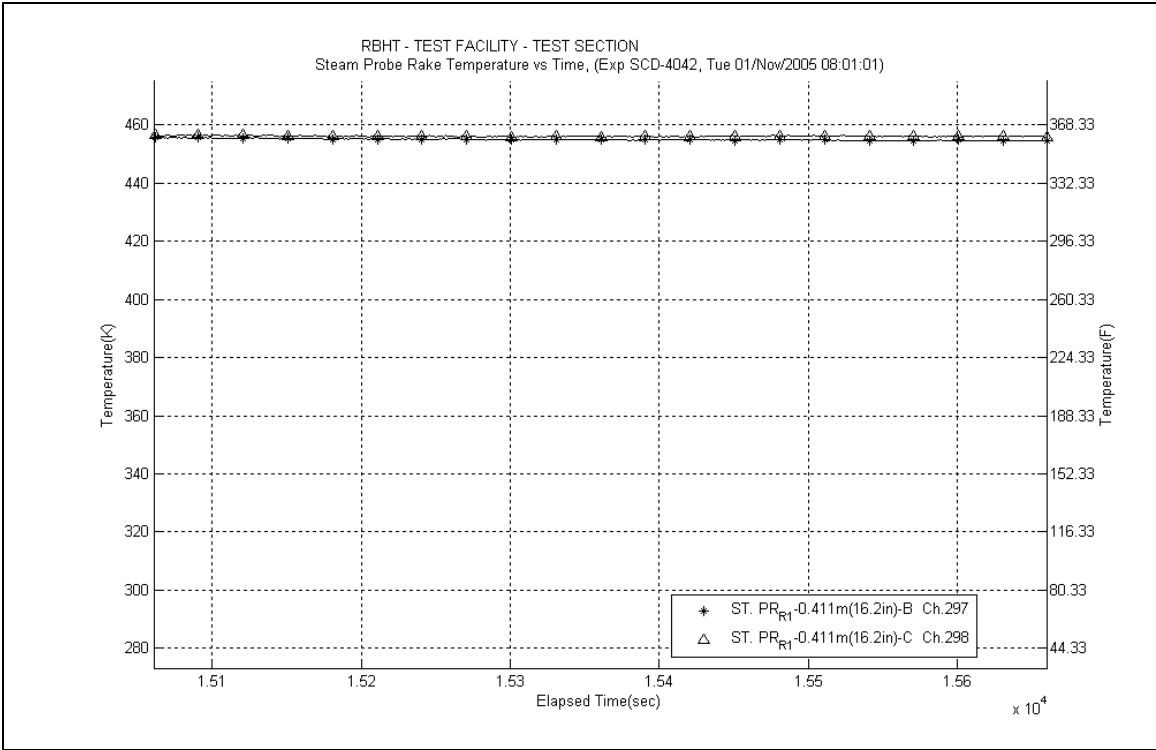

Figure A-697: Steam Probe Rake #1 Temperatures for Experiment 4042C

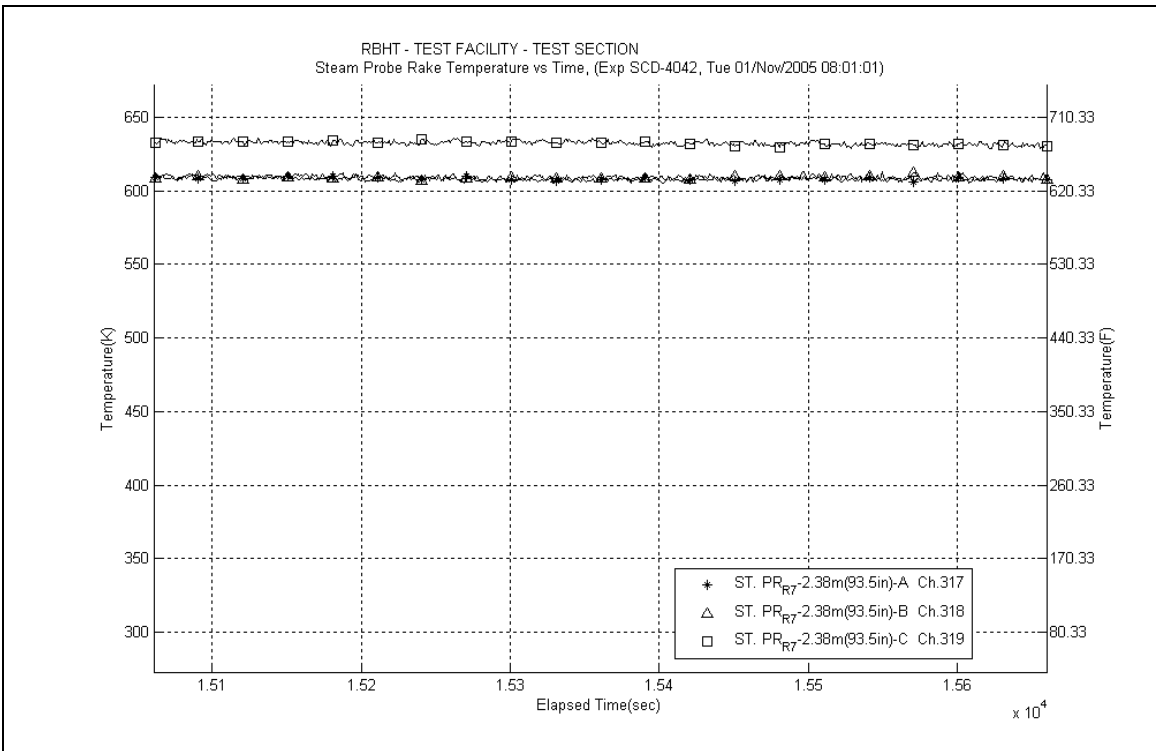

Figure A-698: Steam Probe Rake #7 Temperatures for Experiment 4042C

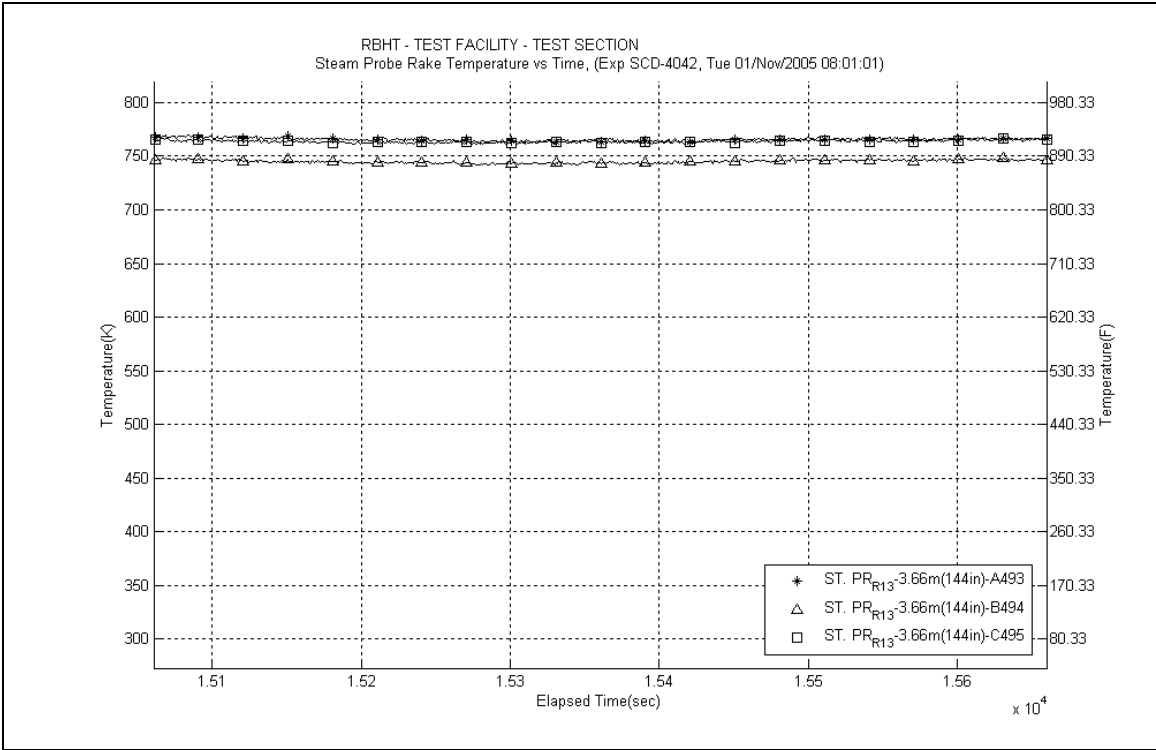

Figure A-699: Steam Probe Rake #13 Temperatures for Experiment 4042C

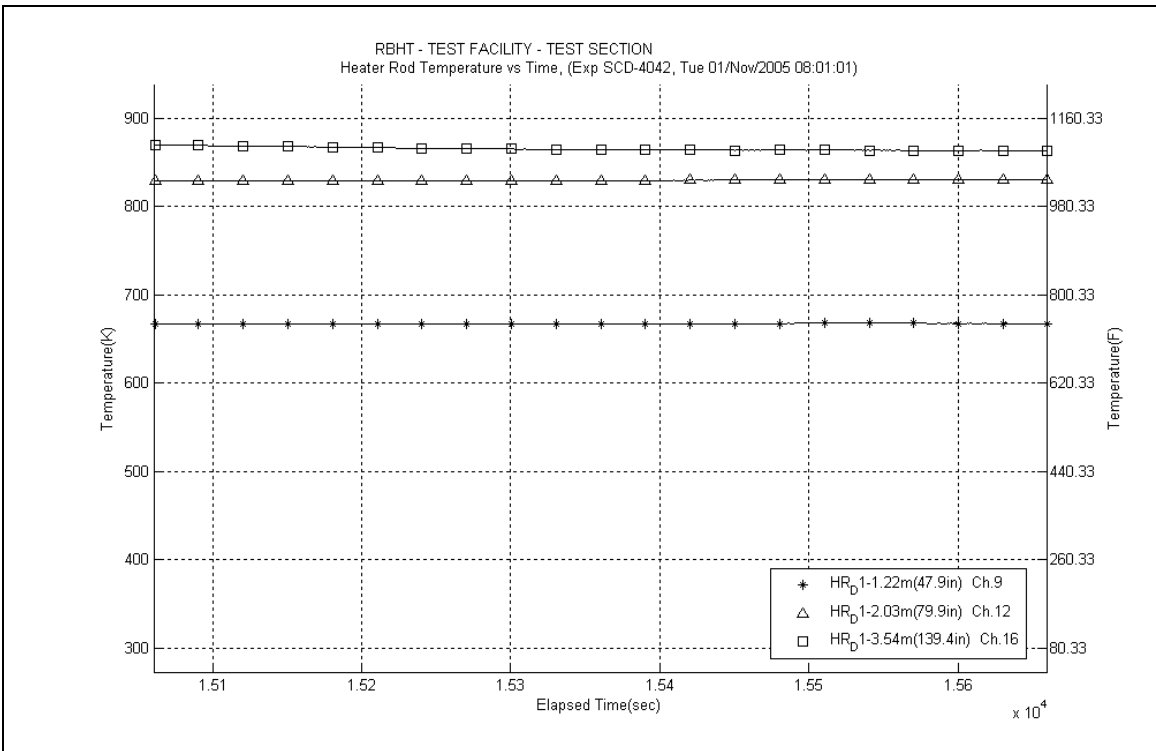

Figure A-700: Heater Rod D1 Temperatures for Experiment 4042C

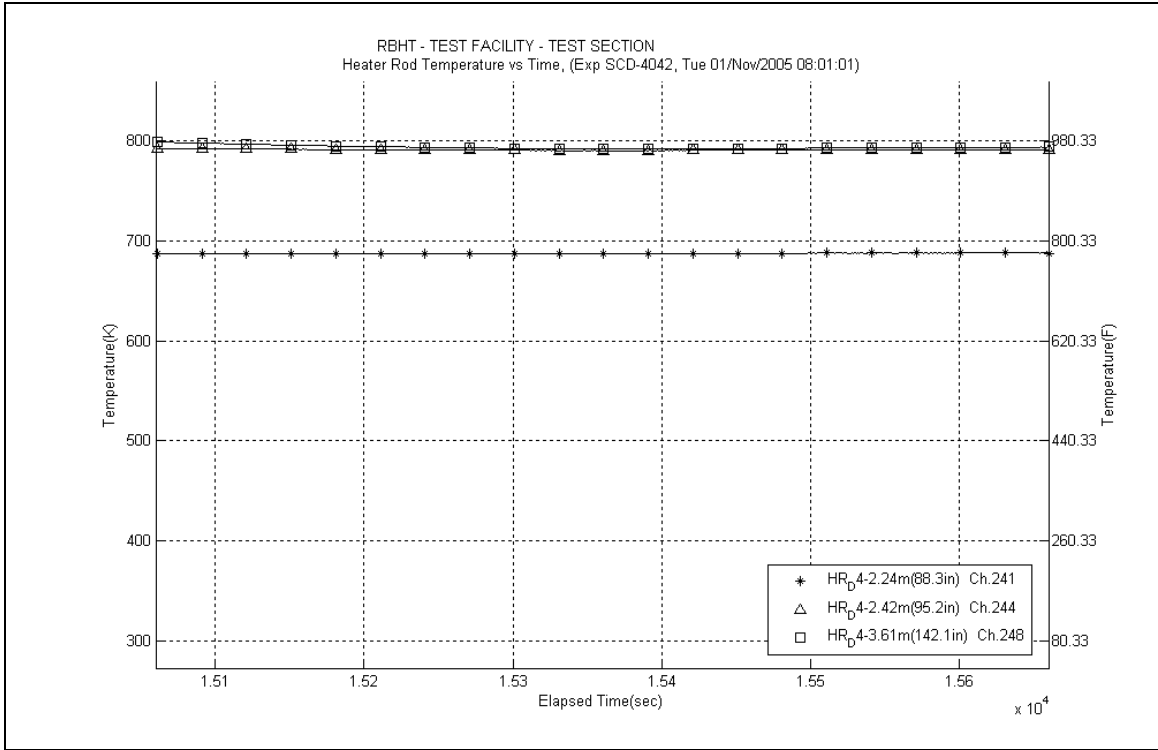

Figure A-701: Heater Rod D4 Temperatures for Experiment 4042C

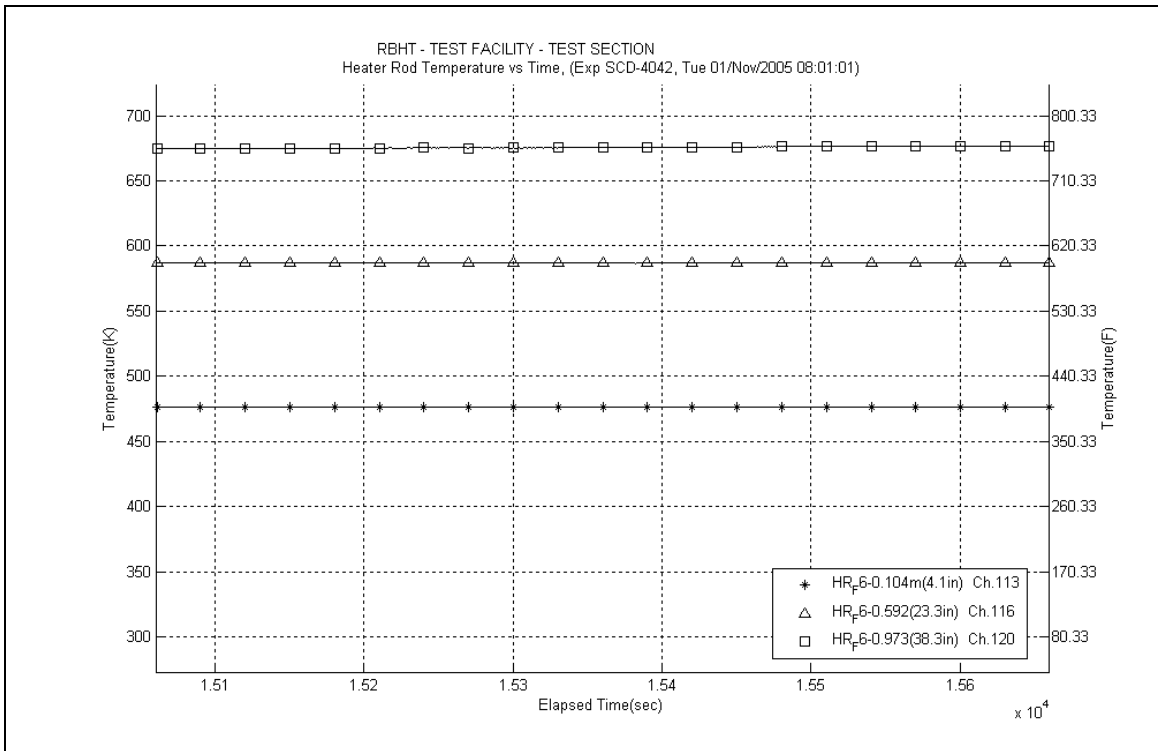

Figure A-702: Heater Rod F6 Temperatures for Experiment 4042C

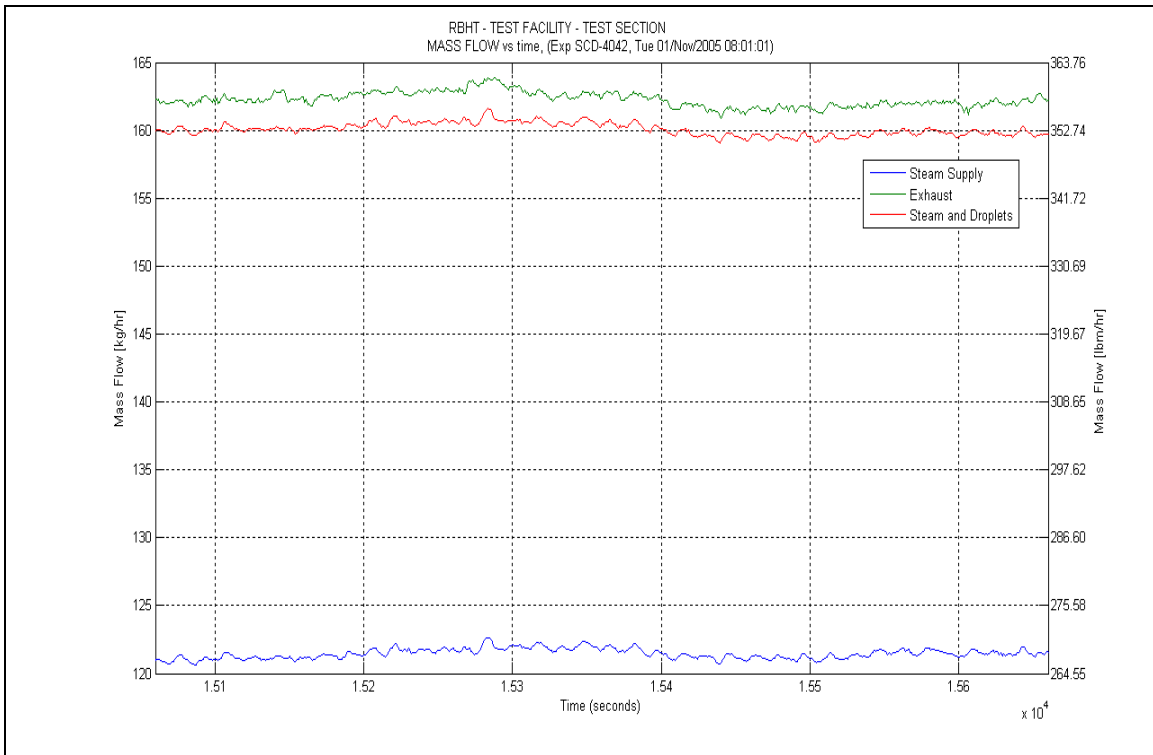

Figure A-703: Mass Flow for Experiment 4042C

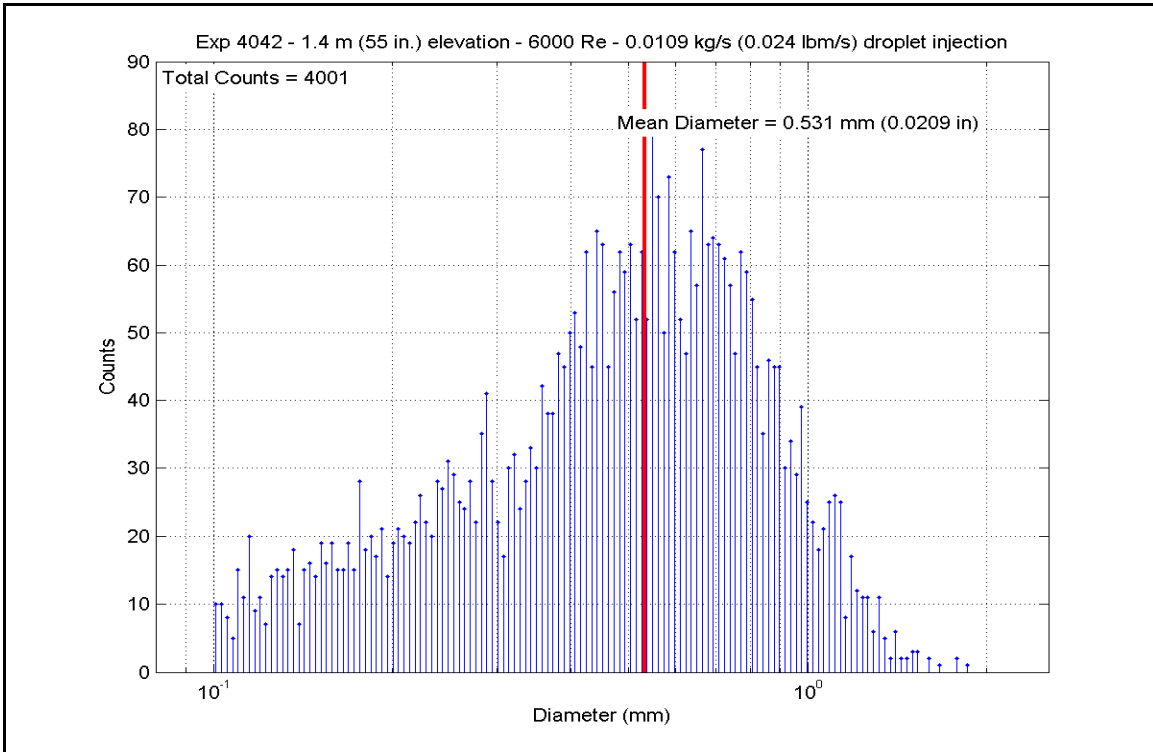

Figure A-704: Droplet Measurements at 1.397 m (55 in.) Elevation for Experiment 4042C

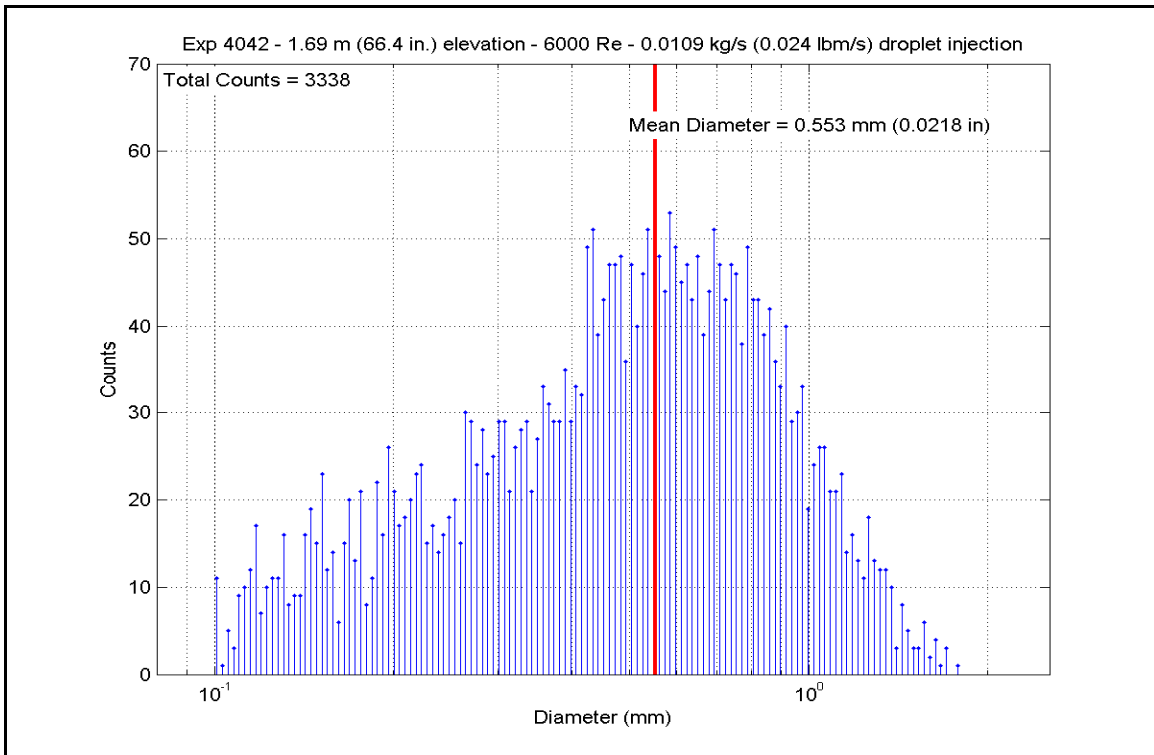

Figure A-705: Droplet Measurements at 1.687 m (66.4 in.) Elevation for Experiment 4042C

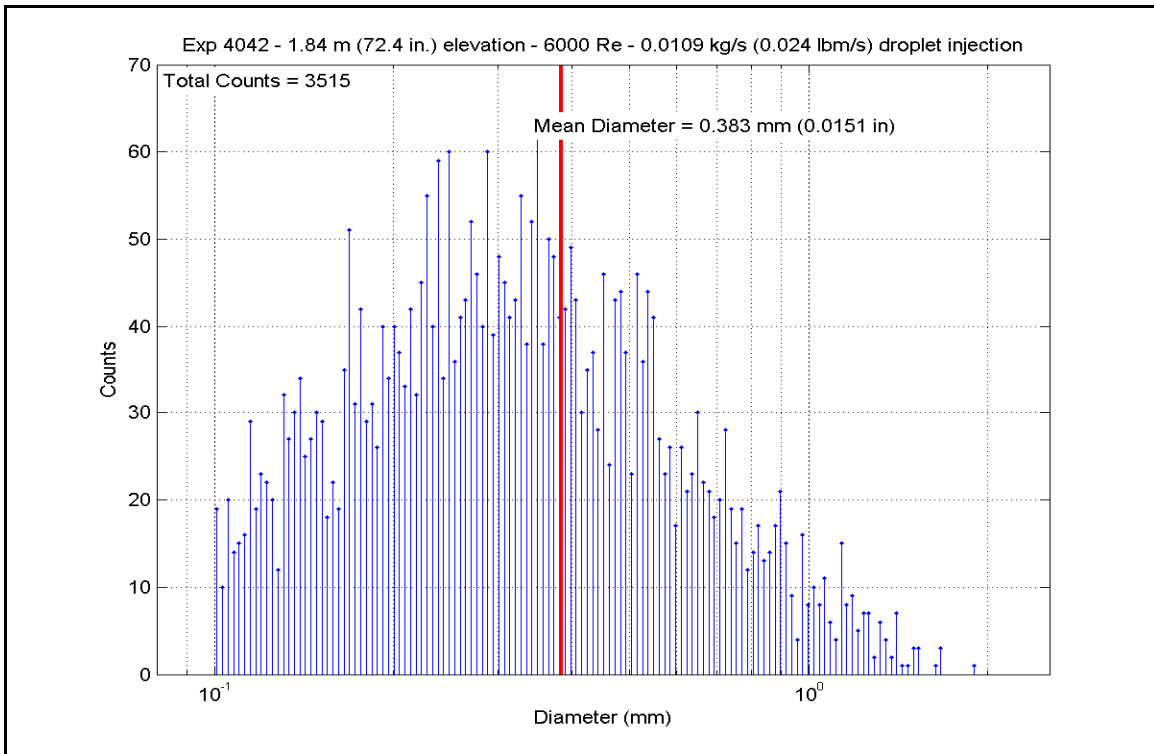

Figure A-706: Droplet Measurements at 1.839 m (72.4 in.) Elevation for Experiment 4042C

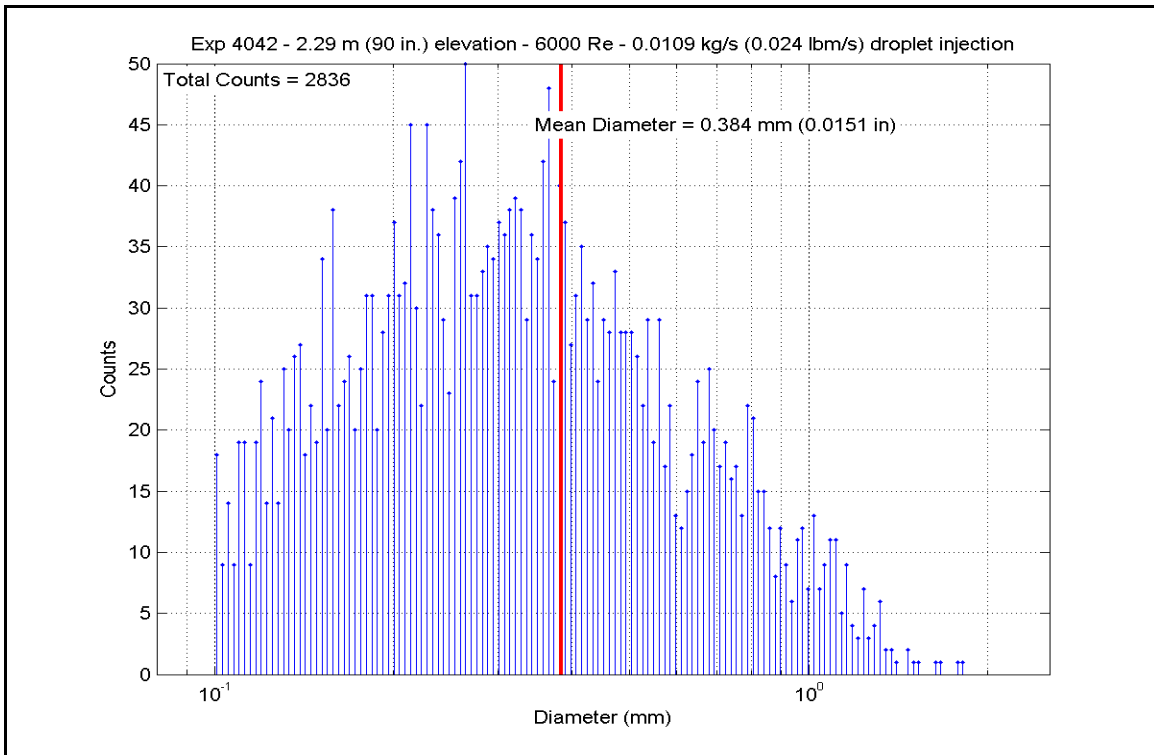

Figure A-707: Droplet Measurements at 2.286 m (90 in.) Elevation for Experiment 4042C

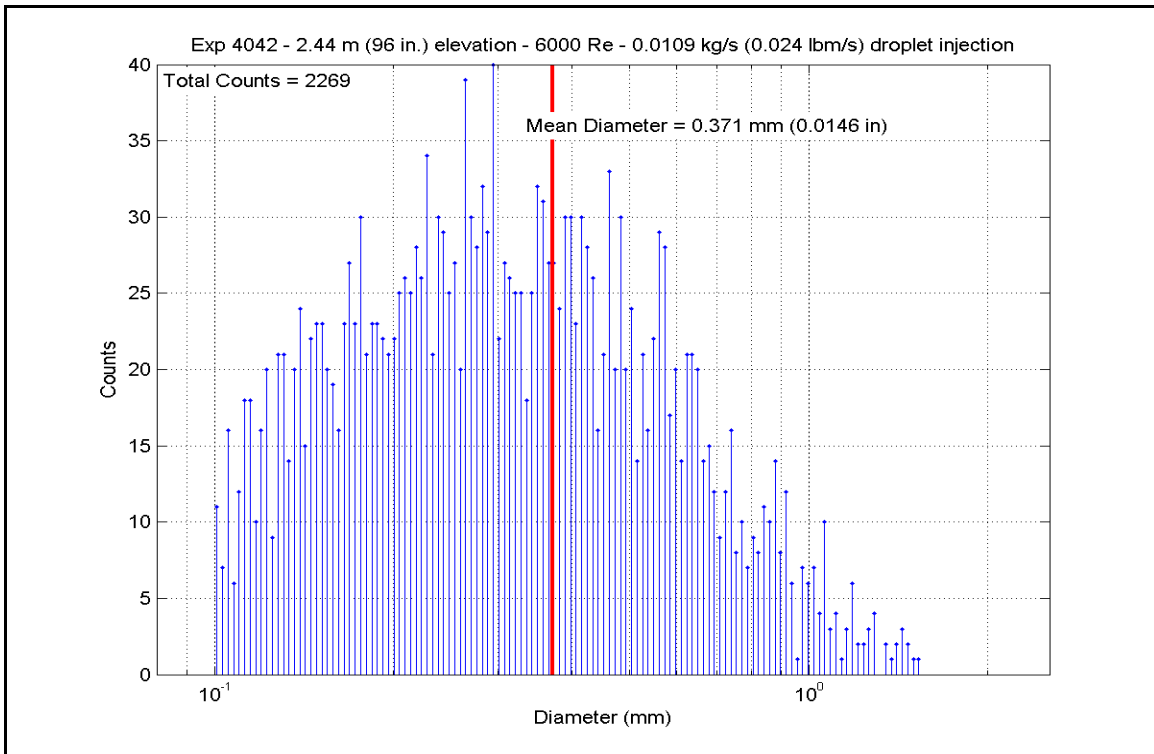

Figure A-708: Droplet Measurements at 2.438 m (96 in.) Elevation for Experiment 4042C

Table A-37: Summary of Steam Cooling Heat Transfer Reduced Data for Experiment 4042C

SCD-4042-C		Inlet Reynolds: 6000											
Matrix Test # 3c		UP Pressure: 137.9 kPa		20 psia		204728 Btu/hr		20 psia					
Time Window: 15060-15660		Bundle Power: 60.00 kW		270.0 lbm/hr		270.0 lbm/hr		0.024 lbm/s					
Inner 3x3		Steam flow: 0.0340 kg/s		0.0109 kg/s		0.024 lbm/s		0.024 lbm/s					
Droplet flow: 0.0109 kg/s													
H.R. ID	H.R. Location	Channel Number	Elevation (in)	Elevation (m)	Zgrid (in)	Zgrid (m)	H.R. Tw (°F)	H.R. Tw (K)	H.R. q" (Btu/hr-ft ²)	H.R. q" (W/m ²)	h _{sat} (z) (Btu/hr-ft ² -F)	h _{sat} (z) (W/m ² -K)	
Gr-3	RodD3_88.3	185	88.3	2.243	-0.2	-0.005	826.19	714.4	5090.74	16058.8	8.510	48.3	
	RodD3_91.3	186	91.3	2.319	2.8	0.071	913.45	762.8	5197.76	16396.3	7.583	43.1	
	RodD3_93.1	187	93.1	2.365	4.6	0.117	918.37	765.6	5256.17	16580.6	7.614	43.2	
	RodD3_95.3	188	95.3	2.421	6.8	0.173	972.65	795.7	5341.50	16849.7	7.173	40.7	
	RodD3_100.1	189	100.1	2.543	11.6	0.295	1064.80	846.9	5520.61	17414.8	6.597	37.5	
	RodD3_106.1	190	106.1	2.695	17.6	0.447	1138.78	888.0	5741.39	18111.2	6.304	35.8	
	RodD3_110	191	110	2.794	21.5	0.546	1005.35	813.9	5670.96	17889.0	7.295	41.4	
	RodD3_142.1	192	142.1	3.609	3.609	8.6	1024.62	824.6	2004.44	6323.0	2.516	14.3	
Gr-3	RodC4_88.4	233	88.4	2.245	-0.1	-0.003	792.10	695.4	5147.40	16237.5	9.125	51.8	
	RodC4_91.1	234	91.1	2.314	2.6	0.066	885.97	747.6	5248.58	16556.6	7.977	45.3	
	RodC4_93.4	235	93.4	2.372	4.9	0.124	919.21	766.0	5335.43	16830.6	7.719	43.8	
	RodC4_95.3	236	95.3	2.421	6.8	0.173	972.20	795.5	5407.36	17057.5	7.266	41.3	
	RodC4_100.1	237	100.1	2.543	11.6	0.295	1016.76	820.2	5607.26	17688.1	7.109	40.4	
	RodC4_106.1	238	106.1	2.695	17.6	0.447	1090.34	861.1	5813.94	18340.1	6.742	38.3	
	RodC4_110	239	110	2.794	21.5	0.546	932.06	773.2	5626.14	17747.7	7.991	45.4	
	RodC4_142.2	240	142.2	3.612	3.612	8.7	959.58	788.5	2172.32	6852.6	2.969	16.9	
Gr-3	RodD4_88.3	241	88.3	2.243	-0.2	-0.005	775.34	686.1	5127.99	16176.3	9.369	53.2	
	RodD4_91.3	242	91.3	2.319	2.8	0.071	874.34	741.1	5242.13	16536.3	8.110	46.1	
	RodD4_93.2	243	93.2	2.367	4.7	0.119	908.77	760.2	5312.69	16758.9	7.804	44.3	
	RodD4_95.2	244	95.2	2.418	6.7	0.170	961.59	789.6	5386.26	16990.9	7.342	41.7	
	RodD4_100.1	245	100.1	2.543	11.6	0.295	1049.31	838.3	5572.04	17577.0	6.784	38.5	
	RodD4_106.1	246	106.1	2.695	17.6	0.447	1093.08	862.6	5788.68	18260.4	6.692	38.0	
	RodD4_142.1	248	142.1	3.609	3.609	8.6	967.71	793.0	2101.22	6628.3	2.841	16.1	
Gr-3	RodE4_88.4	201	88.4	2.245	-0.1	-0.003	799.41	699.5	5047.58	15922.6	8.834	50.2	
	RodE4_91.2	202	91.2	2.316	2.7	0.069	896.27	753.3	5149.50	16244.1	7.706	43.8	
	RodE4_95.3	204	95.3	2.421	6.8	0.173	982.03	800.9	5296.08	16706.5	7.024	39.9	
	RodE4_100.9	205	100.9	2.563	12.4	0.315	1065.26	847.2	5495.12	17334.4	6.563	37.3	
	RodE4_142.3	208	142.3	3.614	8.8	0.224	1008.10	815.4	2128.66	6714.9	2.729	15.5	

Table A-37: Summary of Steam Cooling Heat Transfer Reduced Data for Experiment 4042, continued

Inner 3x3	H.R. Location	Channel Number	Elevation (in)	Elevation (m)	Zgrid (in)	Zgrid (m)	H.R. Tw (°F)	H.R. Tw (K)	H.R. q" (Btu/hr-ft ²)	H.R. q" (W/m ²)	h _{sat} (z) (Btu/hr-ft ² -F)	h _{sat} (z) (W/m ² -K)
Gr-4	RodE3_63.4	193	63.4	1.610	16.4	0.417	1017.45	820.6	4178.59	13181.3	5.293	30.1
	RodE3_113.6	194	113.6	2.885	0.85	0.022	1055.96	842.0	5162.76	16285.9	6.236	35.4
	RodE3_115.5	195	115.5	2.934	2.75	0.070	1088.38	860.0	4973.85	15690.0	5.781	32.8
	RodE3_118.5	196	118.5	3.010	5.75	0.146	1114.95	874.8	4674.52	14745.8	5.270	29.9
	RodE3_122.7	197	122.7	3.117	9.95	0.253	1126.93	881.4	4256.28	13426.5	4.735	26.9
	RodE3_126.5	198	126.5	3.213	13.75	0.349	1131.07	883.7	3877.29	12230.9	4.293	24.4
	RodE3_131.7	199	131.7	3.345	-1.8	-0.046	1019.88	822.0	3336.20	10524.0	4.213	23.9
RodE3_135.6	200	135.6	3.444	2.1	0.053	1042.74	834.7	2956.19	9325.3	3.628	20.6	
Gr-4	RodC5_63.7	225	63.7	1.618	16.7	0.424	965.96	792.0	4116.15	12984.4	5.578	31.7
	RodC5_113.6	226	113.6	2.885	0.85	0.022	961.34	789.4	5040.45	15900.1	6.873	39.0
	RodC5_115.7	227	115.7	2.939	2.95	0.075	1002.35	812.2	4844.42	15281.7	6.256	35.5
	RodC5_122.7	229	122.7	3.117	9.95	0.253	1052.51	840.1	4188.87	13213.8	5.080	28.9
	RodC5_126.7	230	126.7	3.218	13.95	0.354	1052.85	840.3	3812.04	12025.1	4.622	26.2
	RodC5_131.6	231	131.6	3.343	-1.9	-0.048	904.31	757.8	3321.80	10478.6	4.912	24.4
	RodC5_135.7	232	135.7	3.447	2.2	0.056	920.51	766.8	2934.64	9257.3	4.238	27.9
Gr-4	RodE5_63.6	209	63.6	1.615	16.6	0.422	914.74	763.6	4197.23	13240.1	6.112	34.7
	RodE5_113.6	210	113.6	2.885	0.85	0.022	924.61	769.0	5204.25	16416.8	7.471	42.4
	RodE5_115.4	211	115.4	2.931	2.65	0.067	983.31	801.7	5027.04	15857.8	6.656	37.8
	RodE5_118.7	212	118.7	3.015	5.95	0.151	1036.45	831.2	4706.03	14845.2	5.821	33.1
	RodE5_122.6	213	122.6	3.114	9.85	0.250	1069.15	849.3	4326.50	13647.9	5.144	29.2
	RodE5_126.6	214	126.6	3.216	13.85	0.352	1080.87	855.9	3937.02	12419.3	4.616	26.2
	RodE5_131.6	215	131.6	3.343	-1.9	-0.048	1083.19	857.1	3415.32	10773.6	3.994	22.7
RodE5_135.6	216	135.6	3.444	2.1	0.053	1009.58	816.3	3025.27	9543.2	3.871	22.0	
Gr-5	RodC3_79.8	177	79.8	2.027	8.92	0.227	952.87	784.7	4756.74	15005.1	6.562	37.3
	RodC3_85.6	178	85.6	2.174	14.72	0.374	840.60	722.4	4961.46	15650.9	8.099	46.0
	RodC3_88.5	179	88.5	2.248	0	0.000	825.53	714.0	5068.24	15987.8	8.482	48.2
	RodC3_92.4	180	92.4	2.347	3.9	0.099	939.81	777.5	5205.47	16420.7	7.313	41.5
	RodC3_94.4	181	94.4	2.398	5.9	0.150	965.01	791.5	5279.45	16654.0	7.163	40.7
	RodC3_97.2	182	97.2	2.469	8.7	0.221	1022.63	823.5	5384.49	16985.4	6.776	38.5
	RodC3_108.8	183	108.8	2.764	20.3	0.516	1120.32	877.8	5683.84	17929.7	6.370	36.2
Gr-8	RodD5_50	217	50	1.270	3	0.076	860.66	733.5	3718.53	11730.1	5.878	33.4
	RodD5_54.1	218	54.1	1.374	7.1	0.180	843.19	723.8	3852.68	12153.3	6.263	35.6
	RodD5_56.9	219	56.9	1.445	9.9	0.251	898.86	754.7	3953.94	12472.7	5.894	33.5
	RodD5_60	220	60	1.524	13	0.330	939.50	777.3	4071.35	12843.1	5.722	32.5
	RodD5_66.1	221	66.1	1.679	19.1	0.485	959.56	788.5	4292.07	13539.3	5.867	33.3
	RodD5_69.9	222	69.9	1.775	-0.98	-0.025	746.56	670.1	4428.67	13970.2	8.540	48.5
	RodD5_72.9	223	72.9	1.852	2.02	0.051	829.86	716.4	4532.89	14299.0	7.532	42.8
RodD5_74.9	224	74.9	1.902	4.02	0.102	875.72	741.9	4604.95	14526.3	7.109	40.4	

Table A-37: Summary of Steam Cooling Heat Transfer Reduced Data for Experiment 4042, continued

5x5 periphery													
H.R. ID	H.R. Location	Channel Number	Elevation (in)	Elevation (m)	Zgrid (in)	Zgrid (m)	H.R. Tw (°F)	H.R. Tw (K)	H.R. q" (Btu/hr-ft ²)	H.R. q" (W/m ²)	h _{sat} (z) (Btu/hr-ft ² -F)	h _{sat} (z) (W/m ² -K)	
Gr-2	RodB5_41	153	41	1.041	13.5	0.343	797.23	698.3	3367.74	10623.5	5.916	33.6	
	RodB5_52.9	154	52.9	1.344	5.9	0.150	866.12	736.5	3801.54	11991.9	5.957	33.8	
	RodB5_55	155	55	1.397	8	0.203	903.22	757.2	3883.37	12250.1	5.751	32.7	
	RodB5_57.8	156	57.8	1.468	10.8	0.274	937.02	775.9	3985.02	12570.7	5.620	31.9	
	RodB5_64	157	64	1.626	17	0.432	987.69	804.1	4210.41	13281.7	5.542	31.5	
	RodB5_73.9	158	73.9	1.877	3.02	0.077	882.74	745.8	4569.76	14415.3	6.979	39.6	
	RodB5_75.9	159	75.9	1.928	5.02	0.128	919.29	766.1	4644.02	14649.6	6.718	38.2	
	RodB5_76.9	160	76.9	1.953	6.02	0.153	934.77	774.7	4679.82	14762.5	6.621	37.6	
	Gr-2	RodF5_41	105	41	1.041	13.5	0.343	796.34	697.8	3349.57	10566.2	5.894	33.5
		RodF5_53.1	106	53.1	1.349	6.1	0.155	850.45	727.8	3787.90	11948.9	6.085	34.6
RodF5_55		107	55	1.397	8	0.203	885.36	747.2	3855.07	12160.8	5.864	33.3	
RodF5_57.8		108	57.8	1.468	10.8	0.274	932.54	773.5	3954.53	12474.6	5.613	31.9	
RodF5_64		109	64	1.626	17	0.432	974.36	796.7	4175.77	13172.5	5.595	31.8	
RodF5_73.8		110	73.8	1.875	2.92	0.074	883.98	746.5	4537.95	14315.0	6.918	39.3	
RodF5_75.8		111	75.8	1.925	4.92	0.125	925.54	769.6	4609.55	14540.8	6.608	37.5	
RodF5_76.8		112	76.8	1.951	5.92	0.150	943.25	779.4	4645.54	14654.4	6.495	36.9	
Gr-2		RodC2_41	57	41	1.041	13.5	0.343	797.29	698.3	3368.09	10624.6	5.916	33.6
		RodC2_53.1	58	53.1	1.349	6.1	0.155	905.68	758.5	3807.11	12009.5	5.618	31.9
	RodC2_55	59	55	1.397	8	0.203	928.03	770.9	3875.68	12225.8	5.536	31.4	
	RodC2_57.8	60	57.8	1.468	10.8	0.274	964.80	791.4	3975.89	12541.9	5.396	30.6	
	RodC2_63.9	61	63.9	1.623	16.9	0.429	1012.78	818.0	4194.66	13232.0	5.345	30.4	
	RodC2_73.8	62	73.8	1.875	2.92	0.074	926.27	770.0	4558.38	14379.4	6.528	37.1	
	RodC2_75.8	63	75.8	1.925	4.92	0.125	956.77	786.9	4627.01	14595.9	6.349	36.1	
	RodC2_76.8	64	76.8	1.951	5.92	0.150	970.18	794.4	4661.87	14705.9	6.281	35.7	
	Gr-2	RodC6_40.9	137	40.9	1.039	13.4	0.340	805.40	702.8	3354.02	10580.3	5.809	33.0
		RodC6_52.8	138	52.8	1.341	5.8	0.147	906.24	758.8	3800.84	11989.7	5.604	31.8
RodC6_54.8		139	54.8	1.392	7.8	0.198	932.63	773.5	3875.81	12226.2	5.500	31.2	
RodC6_57.8		140	57.8	1.468	10.8	0.274	966.84	792.5	3989.01	12583.3	5.399	30.7	
RodC6_63.8		141	63.8	1.621	16.8	0.427	1013.20	818.3	4221.89	13317.9	5.377	30.5	
RodC6_73.7		142	73.7	1.872	2.82	0.072	934.04	774.3	4603.63	14522.2	6.520	37.0	
RodC6_75.8		143	75.8	1.925	4.92	0.125	964.38	791.1	4683.16	14773.0	6.360	36.1	
RodC6_76.8		144	76.8	1.951	5.92	0.150	981.46	800.6	4721.28	14893.3	6.266	35.6	

Table A-37: Summary of Steam Cooling Heat Transfer Reduced Data for Experiment 4042, continued

5x5 periphery		H.R. Location	Channel Number	Elevation (in)	Elevation (m)	Zgrid (in)	Zgrid (m)	H.R. Tw (°F)	H.R. Tw (K)	H.R. q" (Btu/hr-ft ²)	H.R. q" (W/m ²)	h _{sat} (z) (Btu/hr-ft ² -F)	h _{sat} (z) (W/m ² -K)
Gr-3	RodB4_88.4	161	88.4	2.245	-0.1	0.003	806.99	703.7	5042.60	15906.9	8.709	49.5	
	RodB4_91.3	162	91.3	2.319	2.8	0.071	900.57	755.7	5153.22	16255.8	7.662	43.5	
	RodB4_93.3	163	93.3	2.370	4.8	0.122	921.19	767.1	5224.55	16480.8	7.537	42.8	
	RodB4_95.1	164	95.1	2.416	6.6	0.168	957.43	787.3	5287.95	16680.8	7.249	41.2	
	RodB4_100	165	100	2.540	11.5	0.292	999.46	810.6	5462.72	17232.2	7.081	40.2	
	RodB4_106	166	106	2.692	17.5	0.445	1089.36	860.6	5673.62	17897.4	6.587	37.4	
	RodB4_109.9	167	109.9	2.791	21.4	0.544	995.08	808.2	5480.40	17287.9	7.144	40.6	
	RodB4_142.3	168	142.3	3.614	8.8	0.224	961.16	789.4	2160.94	6816.7	2.947	16.7	
Gr-5	RodF4_85.6	98	85.6	2.174	14.72	0.374	893.34	751.7	4985.08	15725.4	7.493	42.5	
	RodF4_88.4	99	88.4	2.245	-0.1	-0.003	843.11	723.8	5087.72	16049.2	8.271	47.0	
	RodF4_92.4	100	92.4	2.347	3.9	0.099	952.68	784.6	5231.52	16502.8	7.219	41.0	
	RodF4_94.3	101	94.3	2.395	5.8	0.147	990.34	805.6	5300.73	16721.1	6.953	39.5	
	RodF4_97.2	102	97.2	2.469	8.7	0.221	1039.07	832.6	5407.40	17057.6	6.667	37.9	
	RodF4_108.8	103	108.8	2.764	20.3	0.516	1117.25	876.1	5710.32	18013.2	6.422	36.5	
	RodF4_111	104	111	2.819	-1.75	-0.044	1023.24	823.8	5473.96	17267.6	6.883	39.1	
	RodD2_103.2	65	103.2	2.621	14.7	0.373	1110.16	872.1	5030.02	15867.2	5.702	32.4	
RodD2_106	66	106	2.692	17.5	0.445	1129.36	882.8	4766.76	15036.7	5.288	30.0		
RodD2_112.6	67	112.6	2.860	-0.15	-0.004	1148.81	893.6	4410.40	13912.6	4.790	27.2		
RodD2_114.9	68	114.9	2.918	2.15	0.055	1161.85	900.8	3990.13	12586.9	4.273	24.3		
RodD2_117.4	69	117.4	2.982	4.65	0.118	1146.70	892.4	3587.76	11317.6	3.905	22.2		
RodD2_120.8	70	120.8	3.068	8.05	0.204	1149.56	894.0	5647.36	17814.6	6.128	34.8		
RodD2_124.8	71	124.8	3.170	12.05	0.306	1176.49	909.0	5750.51	18140.0	6.063	34.4		
RodD2_128.6	72	128.6	3.266	15.85	0.403	1081.54	856.2	5273.83	16636.3	6.179	35.1		
Gr-6	RodD6_103.1	129	103.1	2.619	14.6	0.371	1107.23	870.5	5690.76	17951.5	6.472	36.8	
	RodD6_106	130	106	2.692	17.5	0.445	1124.06	879.9	5792.60	18272.8	6.464	36.7	
	RodD6_112.9	131	112.9	2.868	0.15	0.004	1008.54	815.7	5276.41	16644.4	6.760	38.4	
	RodD6_114.9	132	114.9	2.918	2.15	0.055	1043.96	835.3	5064.64	15976.4	6.207	35.2	
	RodD6_116.8	133	116.8	2.967	4.05	0.103	1066.12	847.7	4866.96	15352.8	5.807	33.0	
	RodD6_120.9	134	120.9	3.071	8.15	0.207	1082.37	856.7	4434.14	13987.5	5.190	29.5	
	RodD6_124.8	135	124.8	3.170	12.05	0.306	1088.81	860.3	4023.17	12691.1	4.674	26.5	
	RodD6_128.7	136	128.7	3.269	15.95	0.405	1073.19	851.6	3607.62	11380.2	4.268	24.2	

Table A-37: Summary of Steam Cooling Heat Transfer Reduced Data for Experiment 4042, continued

5x5 periphery		H.R.	Channel	Elevation	Elevation	Zgrid	Zgrid	H.R. Tw	H.R. Tw	H.R. q"	H.R. q"	H.R. q"	h _{sat} (z)	h _{sat} (z)	h _{sat} (z)
Gr-8	Location	Number	(in)	(m)	(m)	(in)	(m)	(°F)	(K)	(W/m ²)	(Btu/hr-ft ²)	(W/m ²)	(W/m ² -K)	(Btu/hr-ft ² -F)	(W/m ² -K)
	RodE2_50.1	73	50.1	1.273	3.1	0.079	851.83	728.6	3731.17	11770.0	3731.17	11770.0	5.981	34.0	5.981
	RodE2_54	74	54	1.372	7	0.178	917.91	765.3	3873.05	12217.5	3873.05	12217.5	5.614	31.9	5.614
	RodE2_56.9	75	56.9	1.445	9.9	0.251	955.00	785.9	3979.02	12551.8	3979.02	12551.8	5.473	31.1	5.473
	RodE2_59.9	76	59.9	1.521	12.9	0.328	992.64	806.8	4087.62	12894.4	4087.62	12894.4	5.346	30.4	5.346
	RodE2_66	77	66	1.676	19	0.483	1021.27	822.7	4307.63	13588.4	4307.63	13588.4	5.430	30.8	5.430
	RodE2_69.8	78	69.8	1.773	-1.08	-0.027	872.78	740.2	4438.54	14001.4	4438.54	14001.4	6.884	39.1	6.884
	RodE2_72.9	79	72.9	1.852	2.02	0.051	933.20	773.8	4556.06	14372.1	4556.06	14372.1	6.461	36.7	6.461
	RodE2_74.9	80	74.9	1.902	4.02	0.102	965.47	791.7	4628.94	14602.0	4628.94	14602.0	6.277	35.6	6.277
Gr-8	RodB3_50.2	169	50.2	1.275	3.2	0.081	808.44	704.5	3704.52	11685.9	3704.52	11685.9	6.382	36.2	6.382
	RodB3_54.1	170	54.1	1.374	7.1	0.180	880.41	744.5	3843.69	12124.9	3843.69	12124.9	5.892	33.5	5.892
	RodB3_56.9	171	56.9	1.445	9.9	0.251	924.80	769.1	3944.42	12442.7	3944.42	12442.7	5.661	32.1	5.661
	RodB3_60.1	172	60.1	1.527	13.1	0.333	924.62	769.1	4059.01	12804.2	4059.01	12804.2	5.827	33.1	5.827
	RodB3_66.1	173	66.1	1.679	19.1	0.485	961.82	789.7	4274.74	13484.7	4274.74	13484.7	5.825	33.1	5.825
	RodB3_69.9	174	69.9	1.775	-0.98	-0.025	790.23	694.4	4413.72	13923.1	4413.72	13923.1	7.850	44.6	7.850
	RodB3_73	175	73	1.854	2.12	0.054	864.62	735.7	4520.97	14261.4	4520.97	14261.4	7.102	40.3	7.102
	RodB3_75	176	75	1.905	4.12	0.105	902.88	757.0	4591.64	14484.3	4591.64	14484.3	6.804	38.6	6.804
Gr-8	RodF3_50.1	89	50.1	1.273	3.1	0.079	830.82	716.9	3704.85	11686.9	3704.85	11686.9	6.146	34.9	6.146
	RodF3_54	90	54	1.372	7	0.178	900.49	755.6	3849.90	12144.5	3849.90	12144.5	5.725	32.5	5.725
	RodF3_57	91	57	1.448	10	0.254	946.83	781.4	3959.22	12489.4	3959.22	12489.4	5.508	31.3	5.508
	RodF3_60	92	60	1.524	13	0.330	983.24	801.6	4068.95	12835.5	4068.95	12835.5	5.388	30.6	5.388
	RodF3_66.1	93	66.1	1.679	19.1	0.485	1009.15	816.0	4293.16	13542.8	4293.16	13542.8	5.496	31.2	5.496
	RodF3_70	94	70	1.778	-0.88	-0.022	822.18	712.1	4444.98	14021.7	4444.98	14021.7	7.481	42.5	7.481
	RodF3_73	95	73	1.854	2.12	0.054	912.27	762.2	4549.16	14350.3	4549.16	14350.3	6.648	37.8	6.648
	RodF3_75	96	75	1.905	4.12	0.105	953.98	785.4	4619.88	14573.4	4619.88	14573.4	6.364	36.1	6.364
Gr-8	RodE6_50.2	121	50.2	1.275	3.2	0.081	836.49	720.1	3700.75	11674.0	3700.75	11674.0	6.082	34.5	6.082
	RodE6_54.1	122	54.1	1.374	7.1	0.180	899.88	755.3	3838.55	12108.7	3838.55	12108.7	5.713	32.4	5.713
	RodE6_57	123	57	1.448	10	0.254	935.02	774.8	3940.95	12431.7	3940.95	12431.7	5.574	31.7	5.574
	RodE6_60.2	124	60.2	1.529	13.2	0.335	971.39	795.0	4054.88	12791.1	4054.88	12791.1	5.455	31.0	5.455
	RodE6_66.1	125	66.1	1.679	19.1	0.485	986.61	803.5	4263.95	13450.6	4263.95	13450.6	5.621	31.9	5.621
	RodE6_70	126	70	1.778	-0.88	-0.022	845.15	724.9	4409.49	13909.8	4409.49	13909.8	7.145	40.6	7.145
	RodE6_73.1	127	73.1	1.857	2.22	0.056	901.98	756.5	4517.97	14251.9	4517.97	14251.9	6.703	38.1	6.703
	RodE6_75	128	75	1.905	4.12	0.105	936.61	775.7	4587.48	14471.2	4587.48	14471.2	6.474	36.8	6.474

RBHT Steam Cooling with Droplet Injection Test SCD-4042-D

Matrix Test # 3d

Test Conditions

Test Date – 11/1/2005

Steady State Time Window: 16200 – 16800

Upper Plenum Pressure: 1.38 bar (20 psia)

Bundle Power: 60.0 kW

Bundle Inlet Reynolds Number: 6000

Bundle Inlet Steam Flow: 122.6 kg/hr (270 lbm/hr)

Droplet Injection Flow: 0.0145 kg/s (0.032 lbm/s)

Droplet Injection Hole Diameter: 0.381 mm (.015 in)

Droplet Injection Elevation: 1.295 m (51 in)

Bundle Flow Area: $4.656 \times 10^{-3} \text{ m}^2$ ($5.012 \times 10^{-2} \text{ ft}^2$)

Test Notes

- No steam probes were traversed in this steady state window.

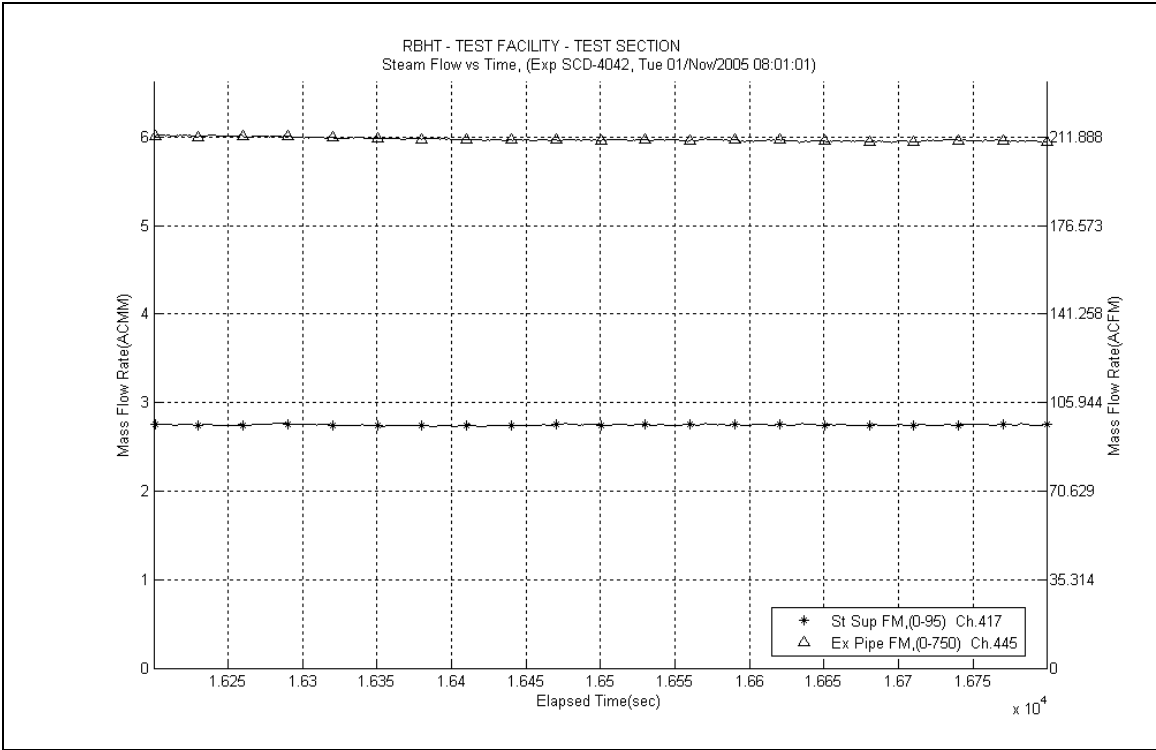

Figure A-709: Inlet and Exhaust Steam Flow Rates for Experiment 4042D

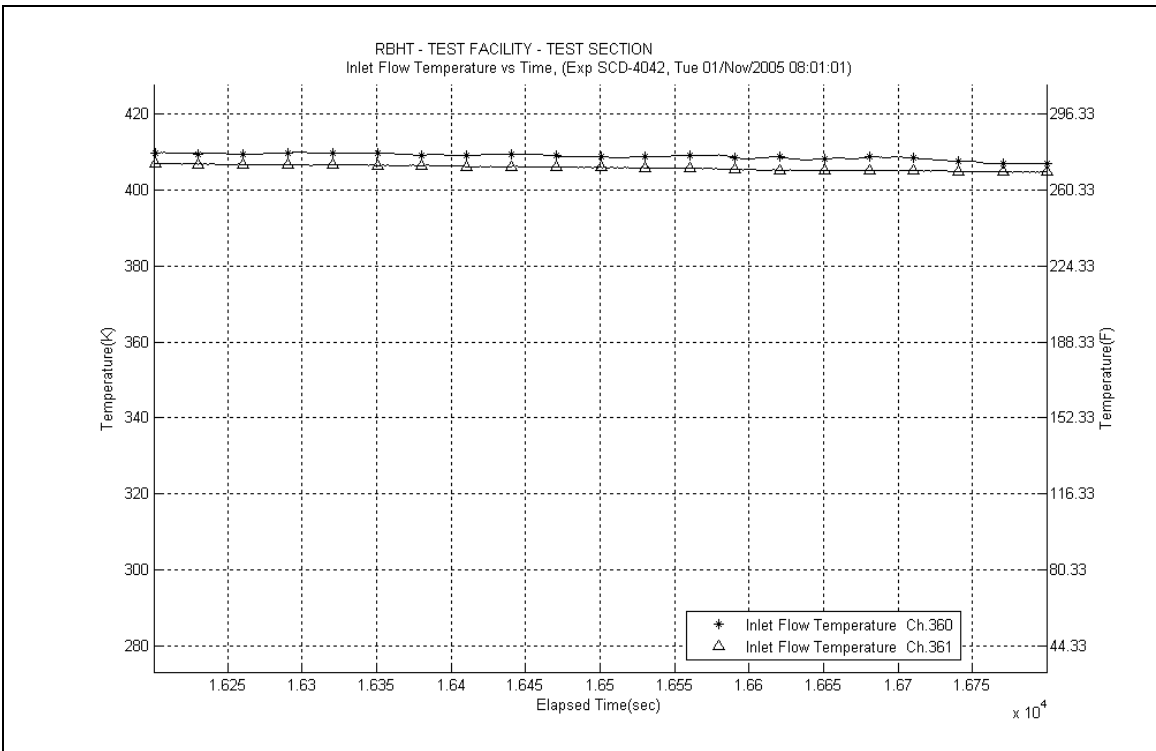

Figure A-710: Inlet Steam Temperature for Experiment 4042D

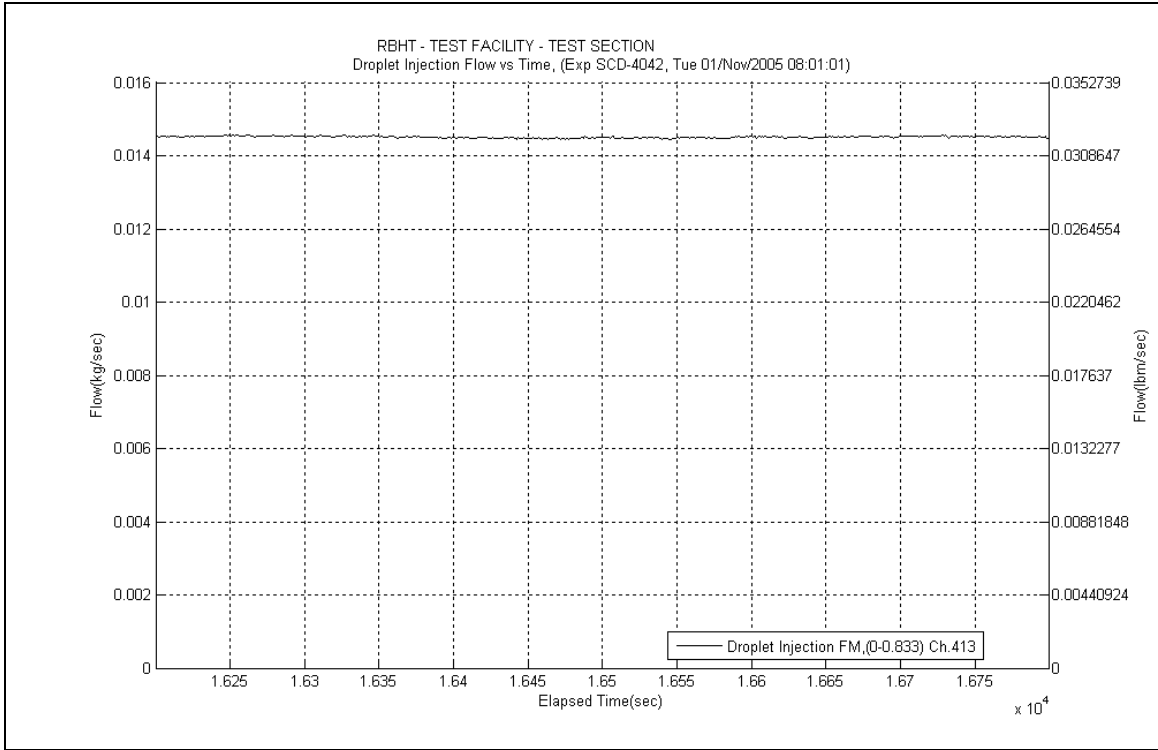

Figure A-711: Droplet Injection Flow Rate for Experiment 4042D

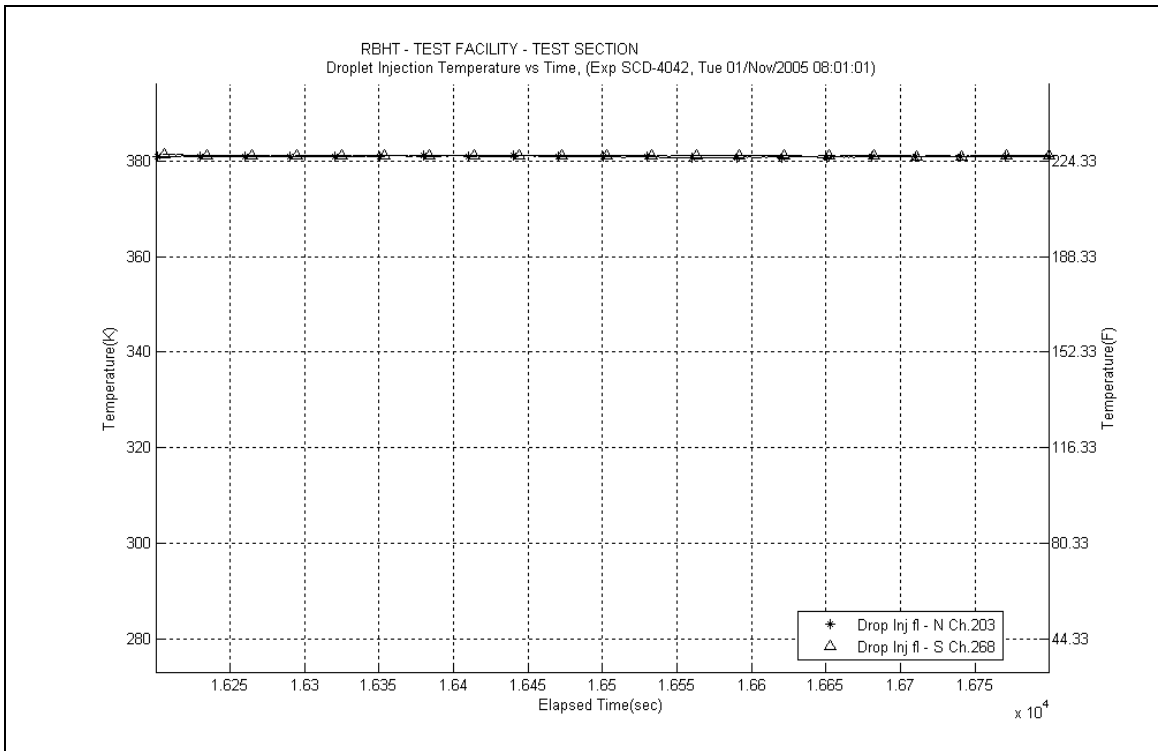

Figure A-712: Droplet Injection Temperature for Experiment 4042D

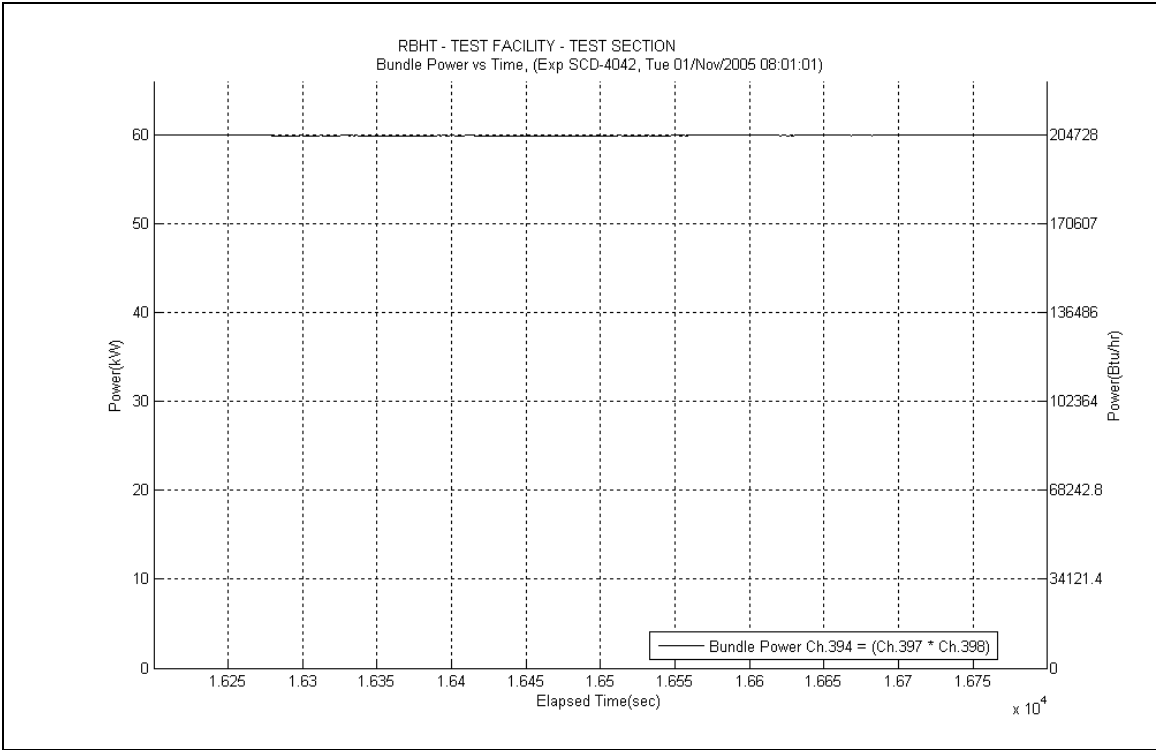

Figure A-713: Bundle Power for Experiment 4042D

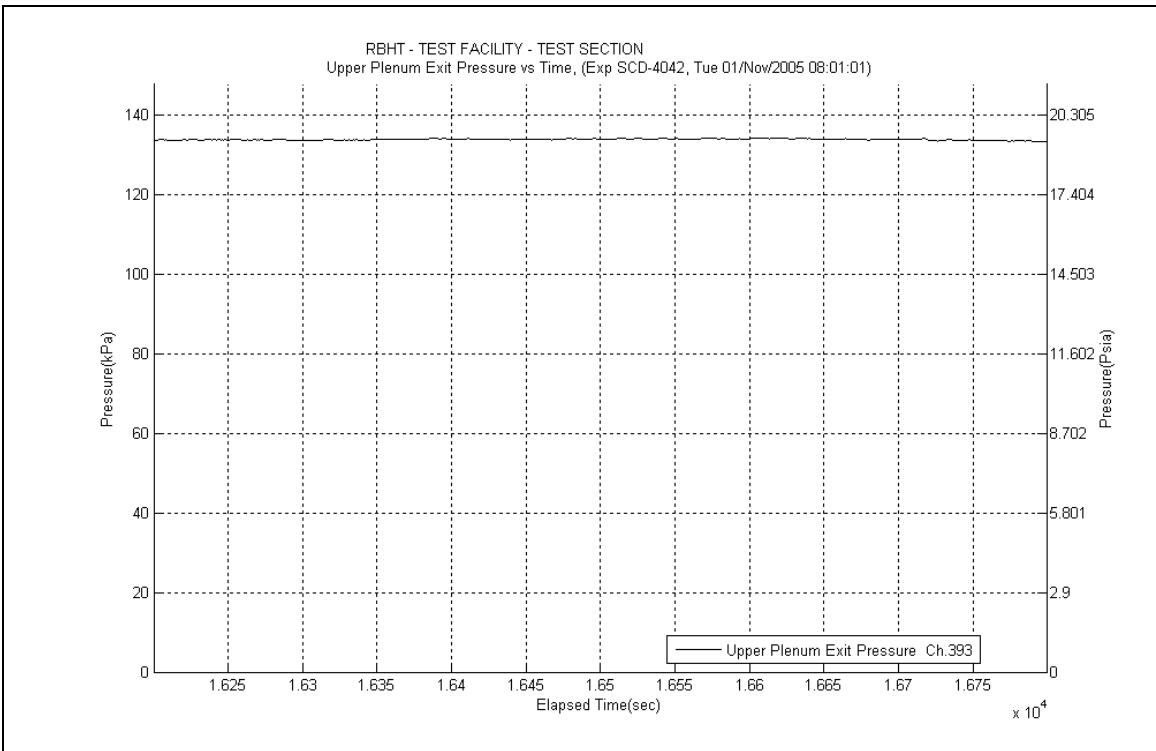

Figure A-714: Upper Plenum Pressure for Experiment 4042D

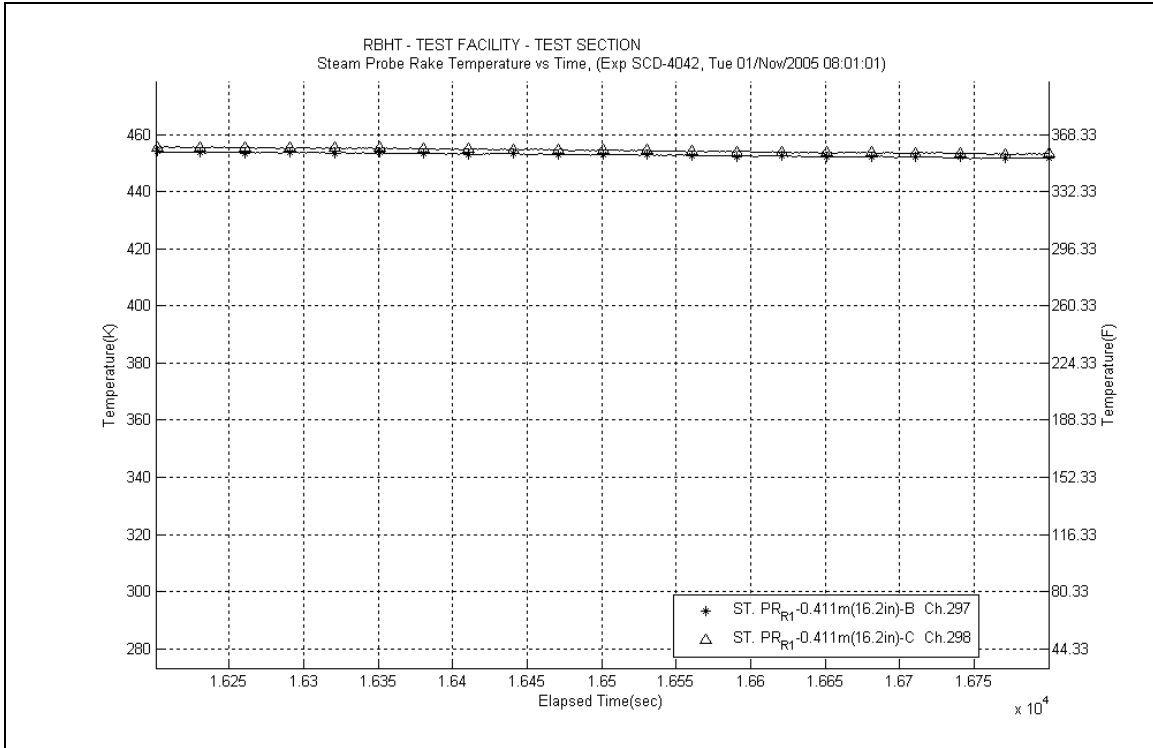

Figure A-715: Steam Probe Rake #1 Temperatures for Experiment 4042D

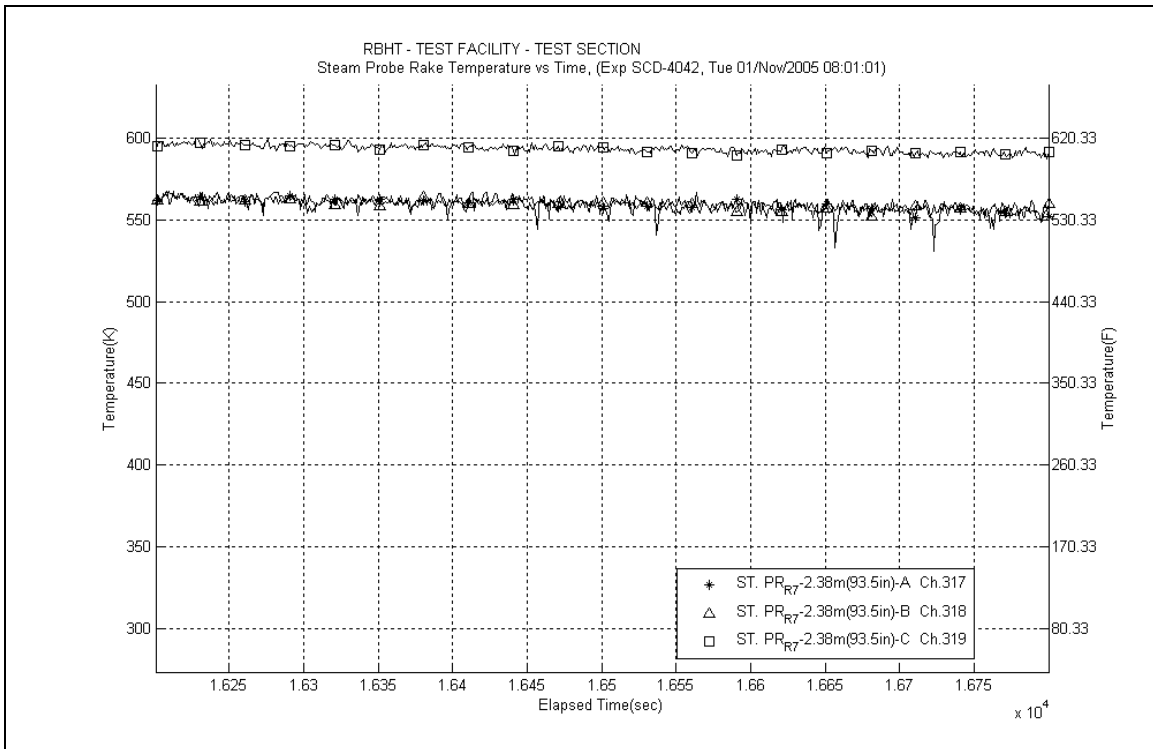

Figure A-716: Steam Probe Rake #7 Temperatures for Experiment 4042D

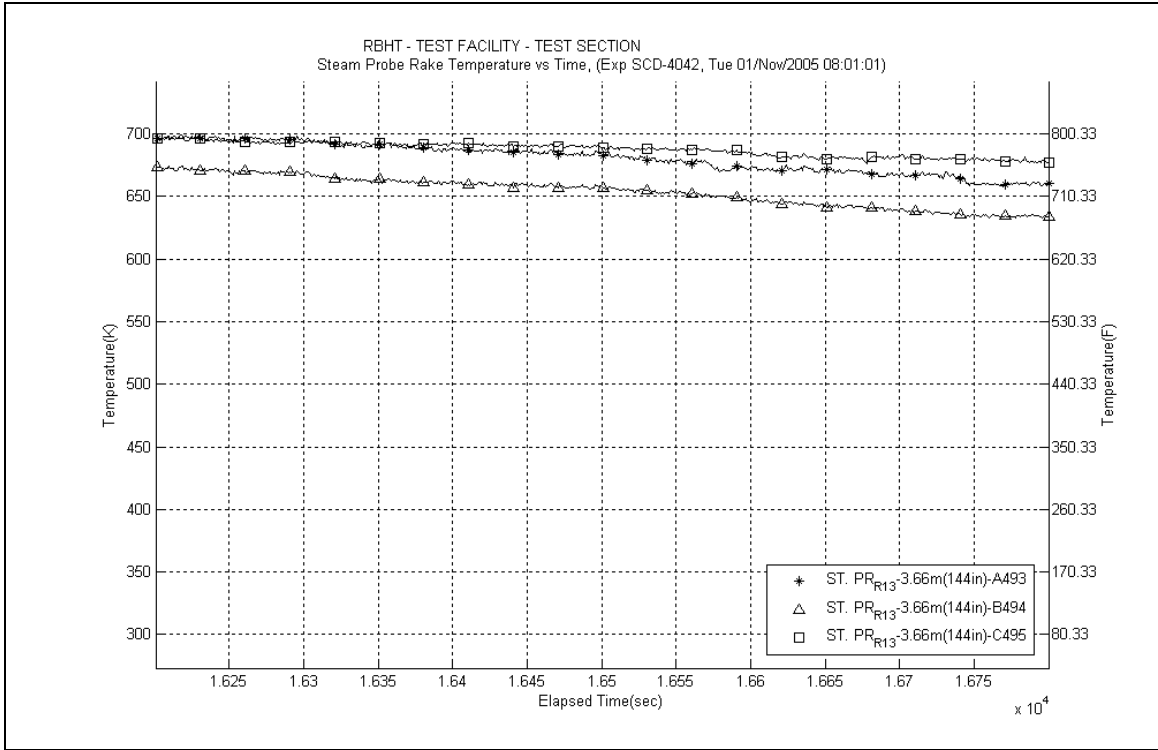

Figure A-717: Steam Probe Rake #13 Temperatures for Experiment 4042D

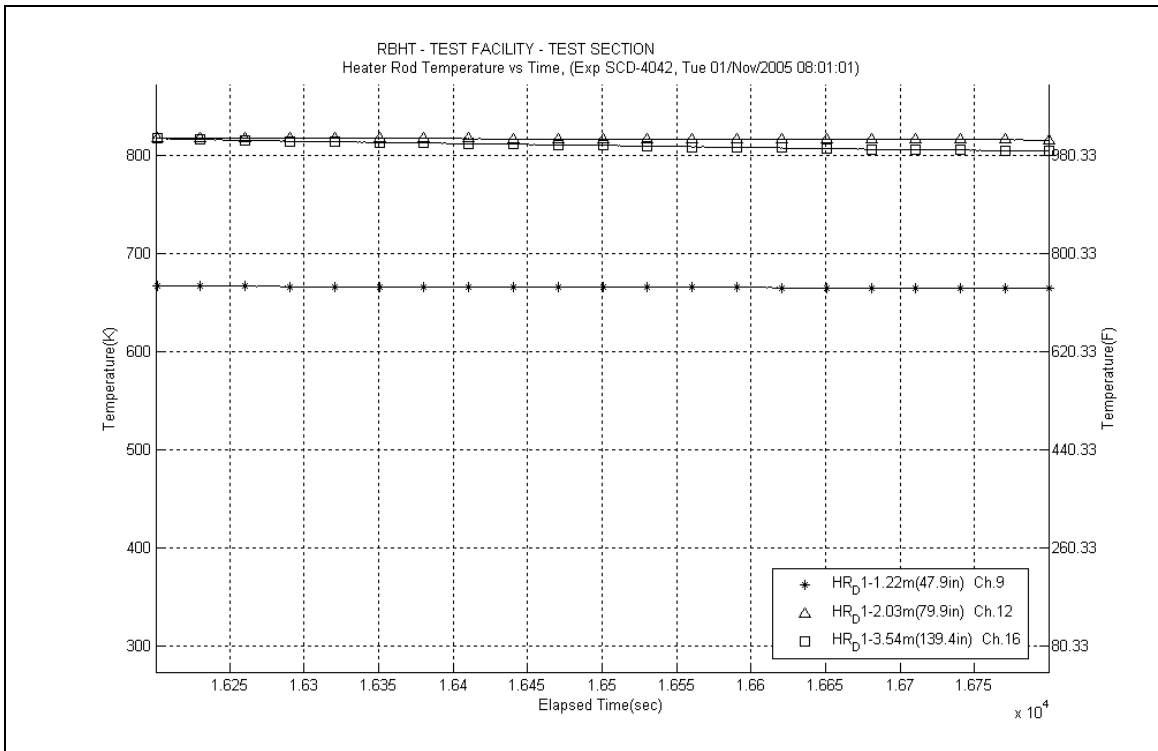

Figure A-718: Heater Rod D1 Temperatures for Experiment 4042D

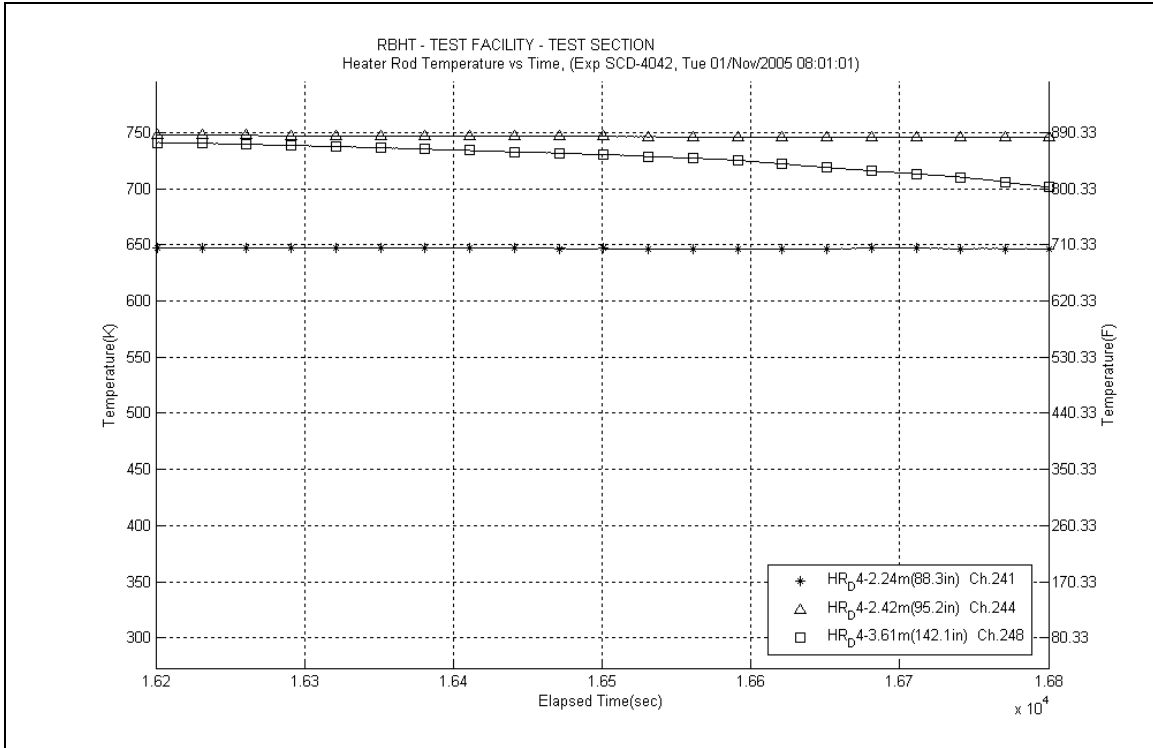

Figure A-719: Heater Rod D4 Temperatures for Experiment 4042D

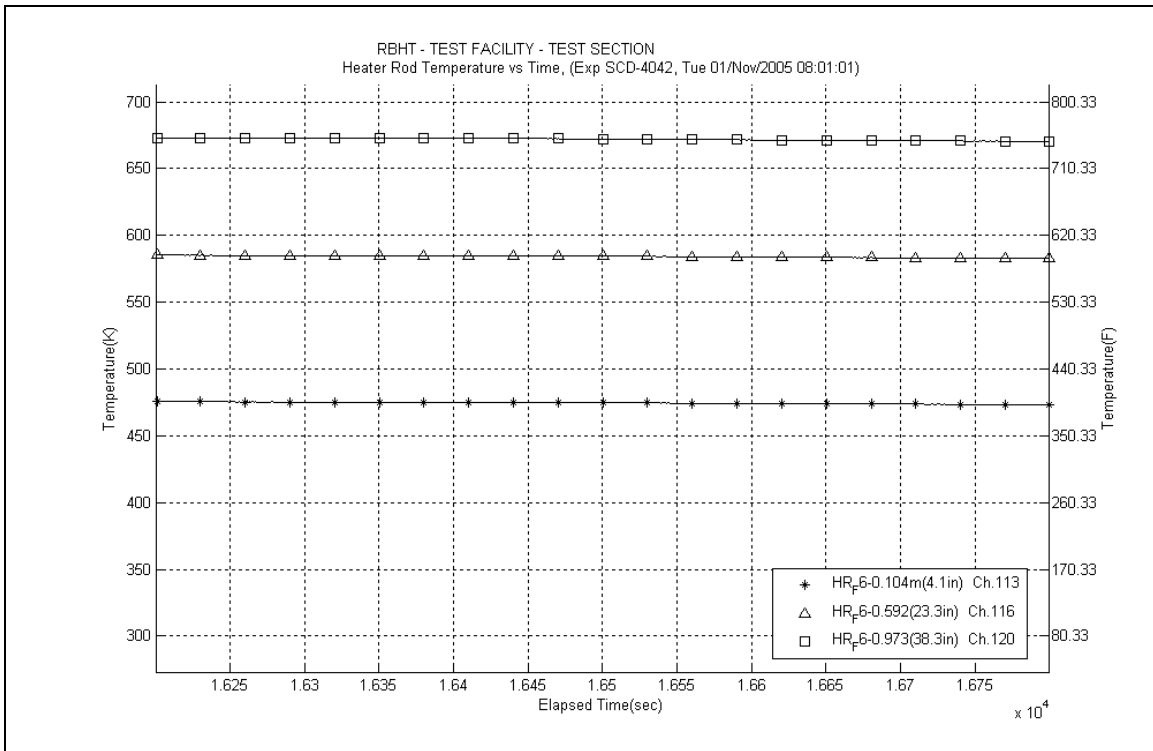

Figure A-720: Heater Rod F6 Temperatures for Experiment 4042D

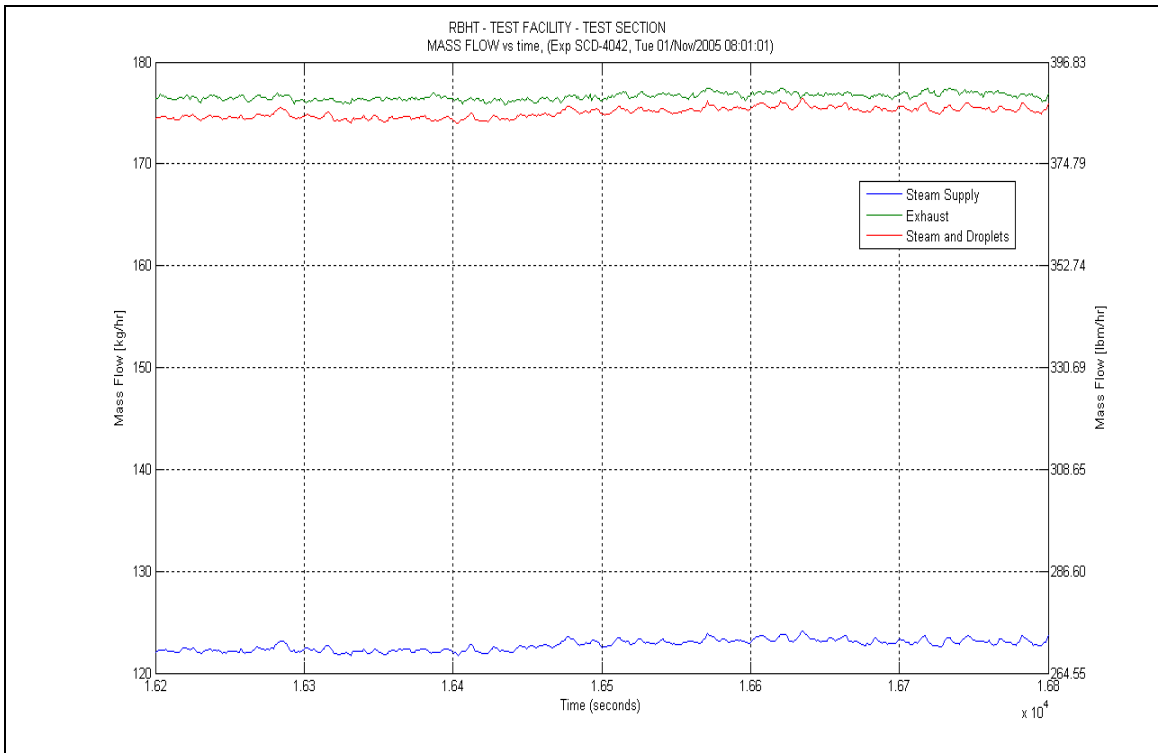

Figure A-721: Mass Flow for Experiment 4042D

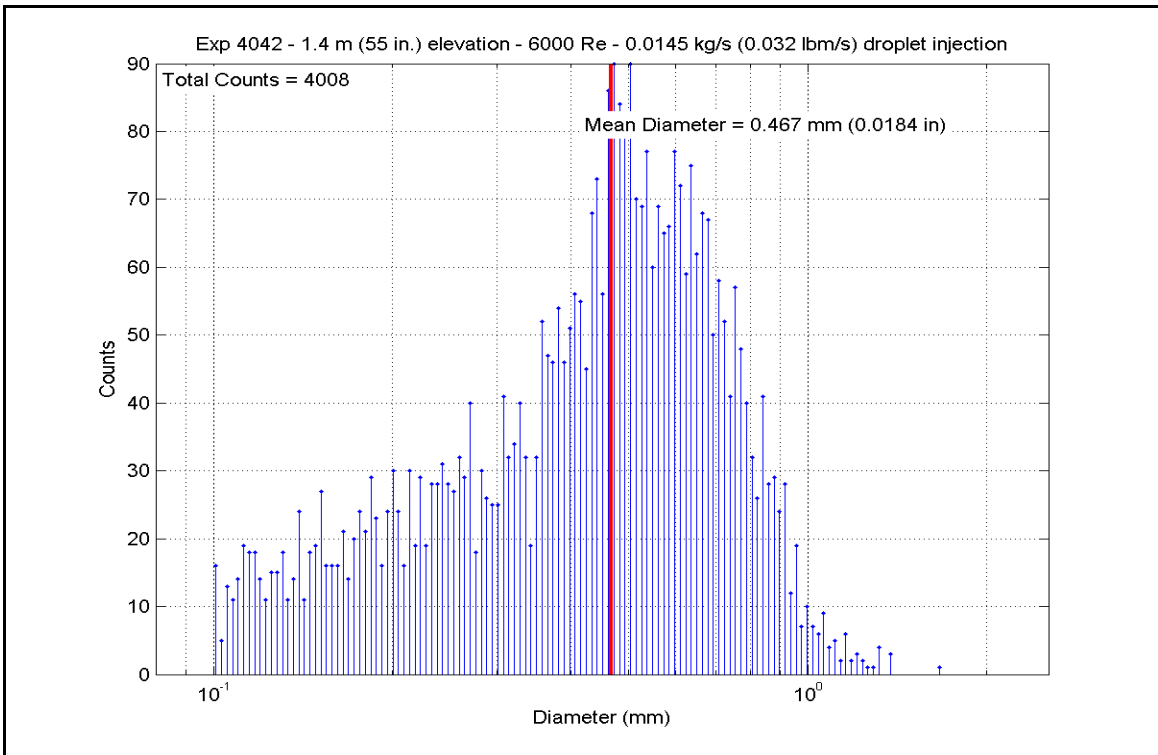

Figure A-722: Droplet Measurements at 1.397 m (55 in.) Elevation for Experiment 4042D

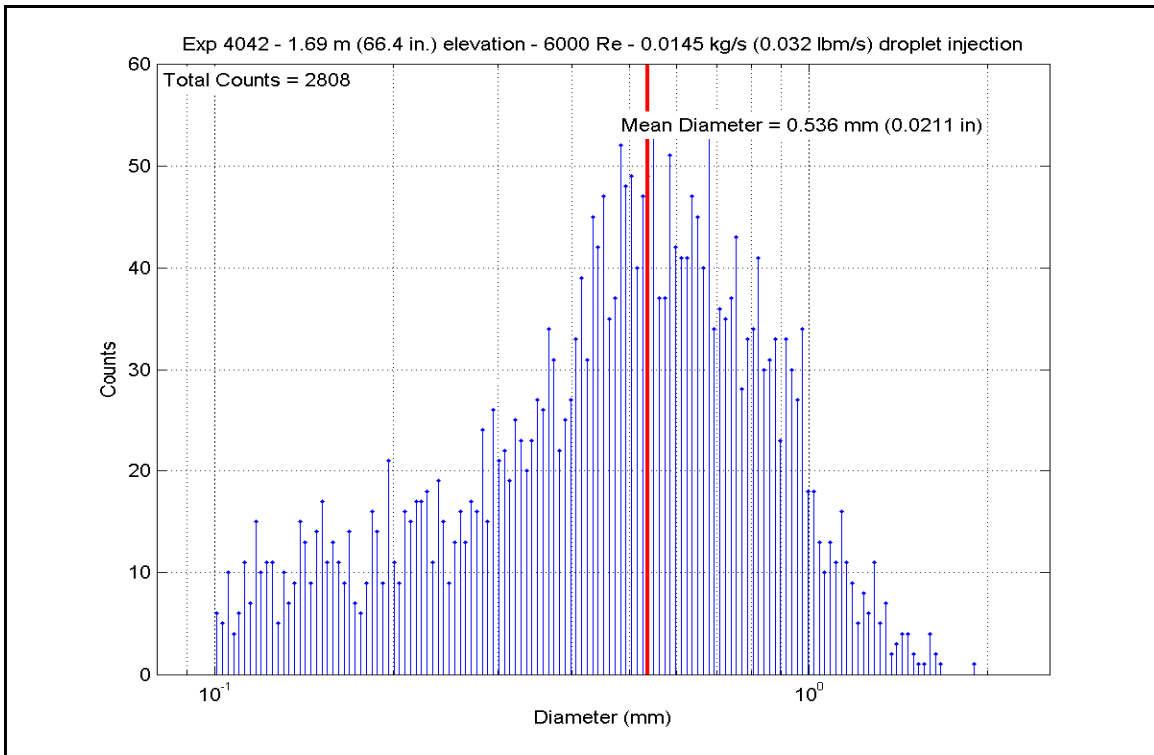

Figure A-723: Droplet Measurements at 1.687 m (66.4 in.) Elevation for Experiment 4042D

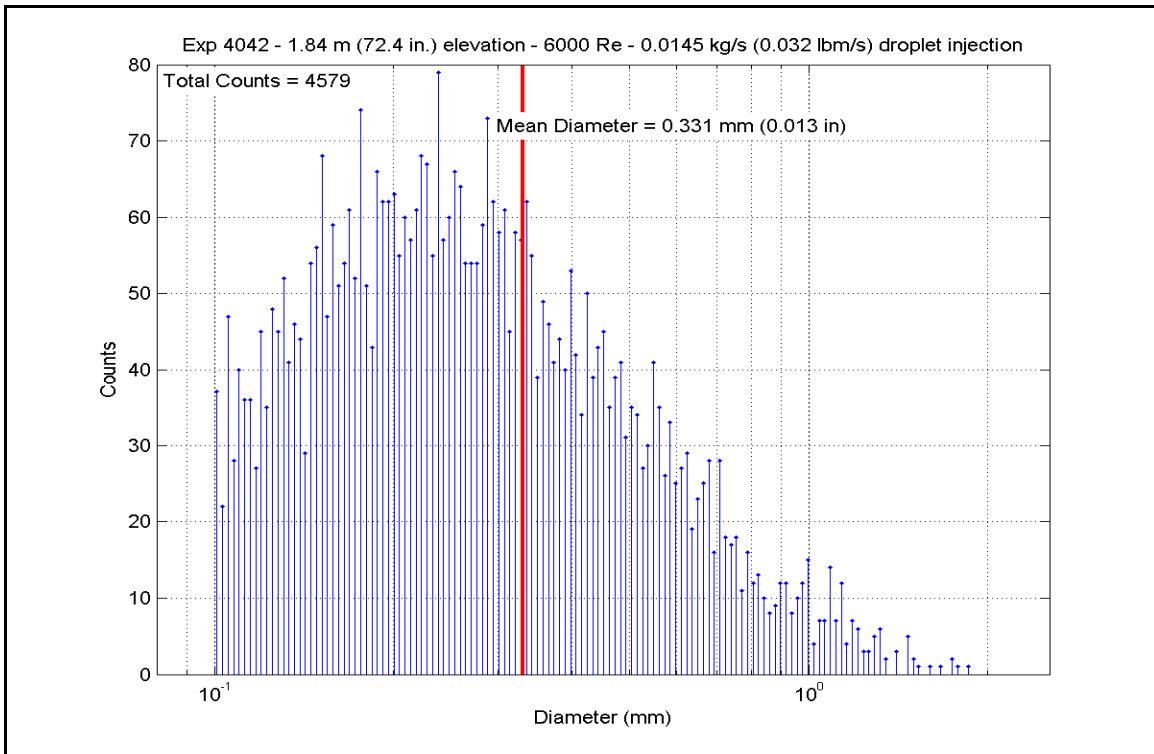

Figure A-724: Droplet Measurements at 1.839 m (72.4 in.) Elevation for Experiment 4042D

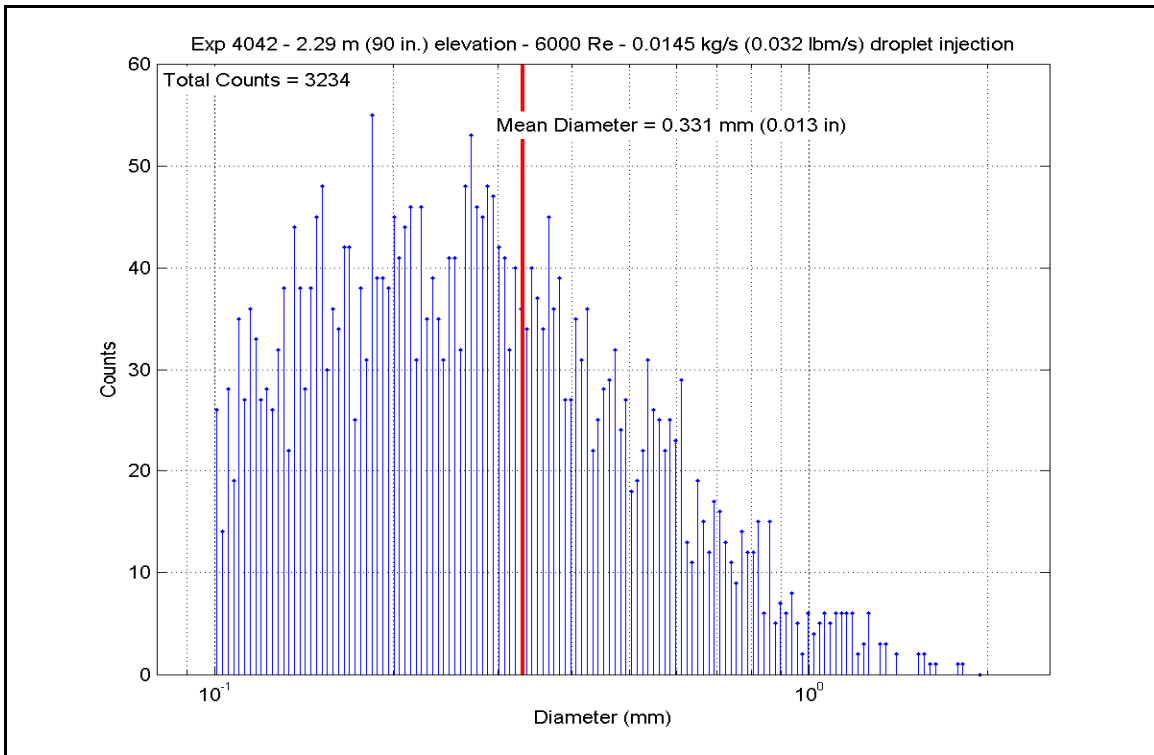

Figure A-725: Droplet Measurements at 2.286 m (90 in.) Elevation for Experiment 4042D

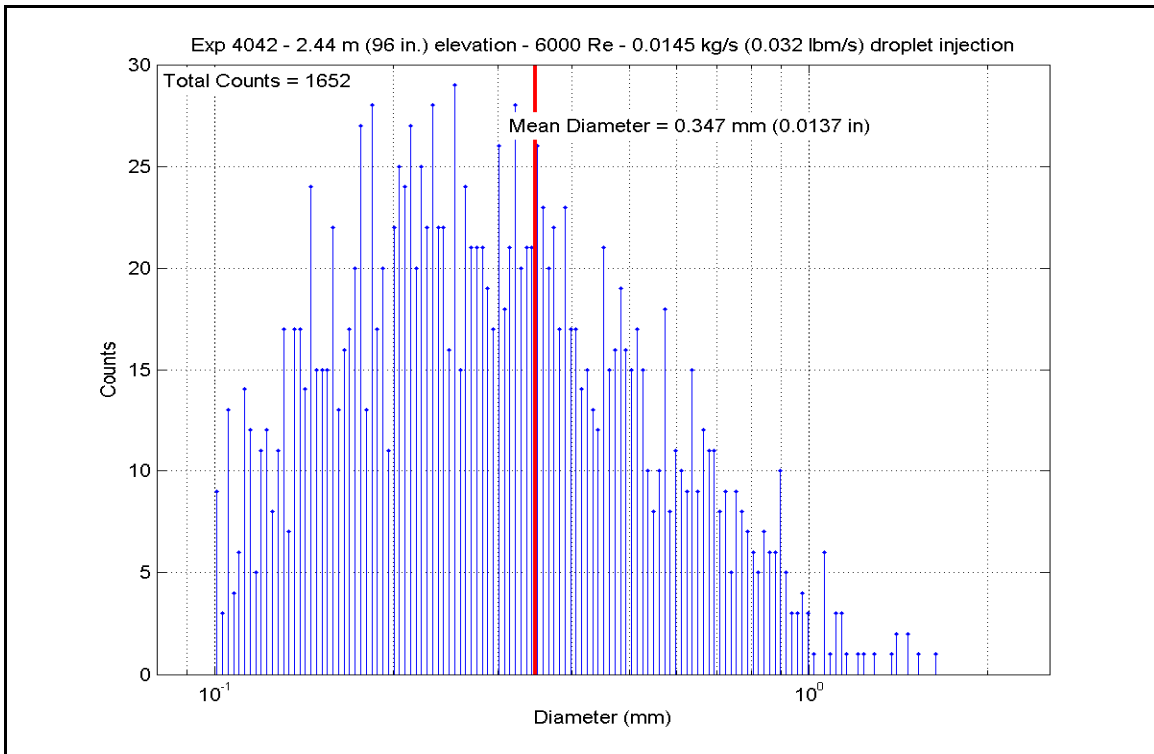

Figure A-726: Droplet Measurements at 2.438 m (96 in.) Elevation for Experiment 4042D

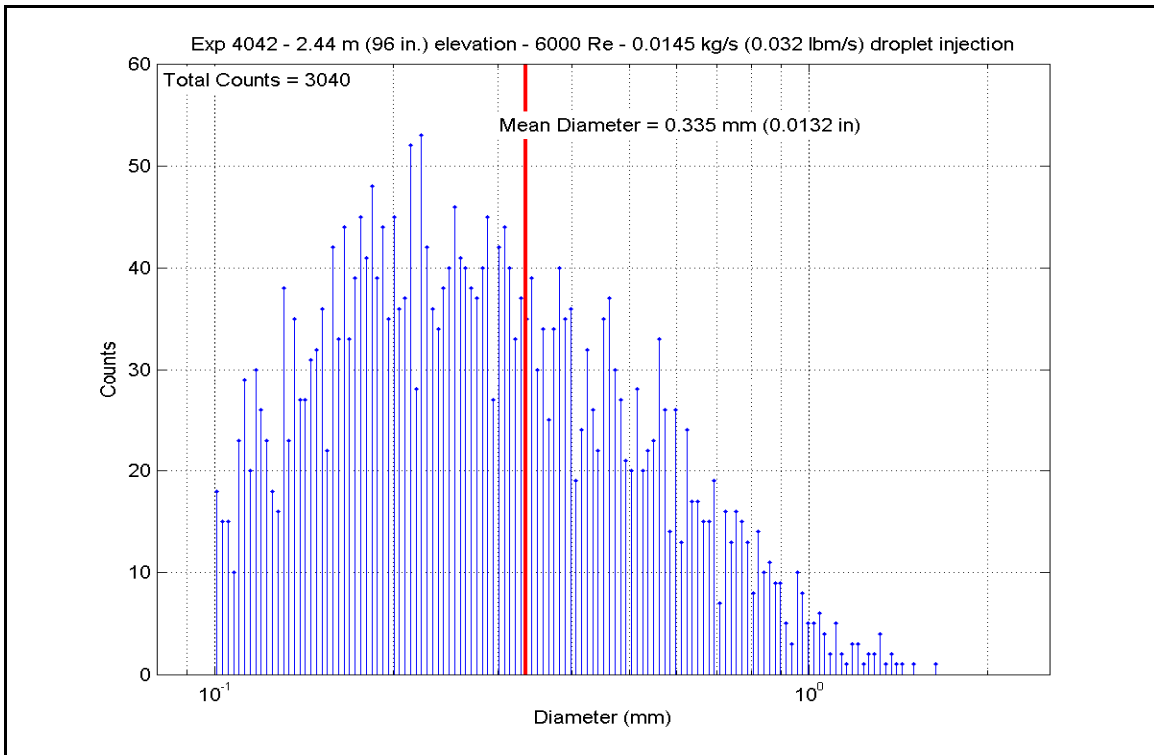

Figure A-727: Droplet Measurements at 2.438 m (96 in.) Elevation for Experiment 4042D

Table A-38: Summary of Steam Cooling Heat Transfer Reduced Data for Experiment 4042D

SCD-4042-D		Inlet Reynolds:		6000		20 psia		204728 Btu/hr		270.0 lbm/hr		0.032 lbm/s	
Matrix Test # 3d		UP Pressure:		137.9 kPa		204728 Btu/hr		270.0 lbm/hr		270.0 lbm/hr		0.032 lbm/s	
Time Window: 16200-16800		Bundle Power:		60.00 kW		270.0 lbm/hr		270.0 lbm/hr		270.0 lbm/hr		0.032 lbm/s	
Inner 3x3		Steam flow:		0.0340 kg/s		270.0 lbm/hr		270.0 lbm/hr		270.0 lbm/hr		0.032 lbm/s	
		Droplet flow:		0.0145 kg/s		270.0 lbm/hr		270.0 lbm/hr		270.0 lbm/hr		0.032 lbm/s	
H.R. ID	H.R. Location	Channel Number	Elevation (in)	Elevation (m)	Zgrid (in)	Zgrid (m)	H.R. Tw (°F)	H.R. Tw (K)	H.R. q" (Btu/hr-ft ²)	H.R. q" (W/m ²)	h _{sat} (z) (Btu/hr-ft ² -F)	h _{sat} (z) (W/m ² -K)	
Gr-3	RodD3_88.3	185	88.3	2.243	-0.2	-0.005	767.93	682.0	5094.83	16071.6	9.436	53.6	
	RodD3_91.3	186	91.3	2.319	2.8	0.071	848.89	727.0	5208.33	16429.7	8.389	47.6	
	RodD3_93.1	187	93.1	2.365	4.6	0.117	853.85	729.7	5280.51	16657.4	8.437	47.9	
	RodD3_95.3	188	95.3	2.421	6.8	0.173	902.95	757.0	5356.98	16998.6	7.937	45.1	
	RodD3_100.1	189	100.1	2.543	11.6	0.295	991.21	806.0	5538.18	17470.2	7.256	41.2	
	RodD3_106.1	190	106.1	2.695	17.6	0.447	1065.47	847.3	5766.36	18190.0	6.885	39.1	
	RodD3_110	191	110	2.794	21.5	0.546	876.93	742.6	5721.48	18048.4	8.817	50.1	
	RodD3_142.1	192	142.1	3.609	3.609	8.6	907.33	759.4	2101.15	6628.1	3.093	17.6	
	RodC4_88.4	233	88.4	2.245	2.245	-0.1	737.87	665.3	5153.41	16256.4	10.107	57.4	
Gr-3	RodC4_91.1	234	91.1	2.314	2.6	0.066	826.22	714.4	5255.23	16577.6	8.785	49.9	
	RodC4_93.4	235	93.4	2.372	4.9	0.124	855.79	730.8	5341.93	16851.1	8.509	48.3	
	RodC4_95.3	236	95.3	2.421	6.8	0.173	904.04	757.6	5413.10	17075.6	8.007	45.5	
	RodC4_100.1	237	100.1	2.543	11.6	0.295	946.50	781.2	5615.85	17715.2	7.816	44.4	
	RodC4_106.1	238	106.1	2.695	17.6	0.447	1018.16	821.0	5835.39	18407.7	7.385	41.9	
	RodC4_110	239	110	2.794	21.5	0.546	830.19	716.6	5641.63	17796.5	9.368	53.2	
	RodC4_142.2	240	142.2	3.612	3.612	8.7	850.64	728.0	2262.27	7136.3	3.633	20.6	
	RodD4_88.3	241	88.3	2.243	2.243	-0.2	702.75	645.8	5132.09	16189.2	10.810	61.4	
	RodD4_91.3	242	91.3	2.319	2.319	2.8	796.36	697.8	5246.00	16548.5	9.230	52.4	
Gr-3	RodD4_93.2	243	93.2	2.367	4.7	0.119	831.69	717.4	5316.83	16771.9	8.807	50.0	
	RodD4_95.2	244	95.2	2.418	6.7	0.170	882.02	745.4	5390.54	17004.5	8.242	46.8	
	RodD4_100.1	245	100.1	2.543	11.6	0.295	968.41	793.4	5685.63	17619.9	7.544	42.8	
	RodD4_106.1	246	106.1	2.695	17.6	0.447	1003.46	812.9	5847.54	18446.1	7.541	42.8	
	RodD4_142.1	248	142.1	3.609	3.609	8.6	850.25	727.7	2259.96	7129.0	3.632	20.6	
	RodE4_88.4	201	88.4	2.245	2.245	-0.1	701.05	644.8	5055.67	15948.1	10.687	60.7	
	RodE4_91.2	202	91.2	2.316	2.316	2.7	787.66	693.0	5159.96	16277.1	9.220	52.4	
	RodE4_95.3	204	95.3	2.421	2.421	6.8	877.31	742.8	5310.62	16752.3	8.179	46.4	
	RodE4_100.9	205	100.9	2.563	2.563	12.4	957.35	787.2	5517.55	17405.1	7.565	43.0	
RodE4_142.3	208	142.3	3.614	3.614	8.8	892.72	751.3	2252.10	7104.3	3.388	19.2		

Table A-38: Summary of Steam Cooling Heat Transfer Reduced Data for Experiment 4042, continued

Gr-4	Gr-4	Gr-4	Gr-4	Gr-5	Gr-8						
Inner 3x3	Inner 3x3	Inner 3x3	Inner 3x3	Inner 3x3	Inner 3x3						
H.R. Location	Channel Number	Elevation (in)	Elevation (m)	Zgrid (in)	Zgrid (m)	H.R. Tw (°F)	H.R. Tw (K)	H.R. q" (Btu/hr-ft ²)	H.R. q" (W/m ²)	h _{sat} (z) (Btu/hr-ft ² -F)	h _{sat} (z) (W/m ² -K)
RodE3_63.4	193	63.4	1.610	16.4	0.417	991.04	806.0	4188.09	13211.3	5.489	31.2
RodE3_113.6	194	113.6	2.885	0.85	0.022	917.72	765.2	5204.75	16418.4	7.546	42.9
RodE3_115.5	195	115.5	2.934	2.75	0.070	955.19	786.0	5024.79	15850.7	6.910	39.2
RodE3_118.5	196	118.5	3.010	5.75	0.146	986.32	803.3	4735.59	14938.4	6.245	35.5
RodE3_122.7	197	122.7	3.117	9.95	0.253	1000.32	811.1	4329.02	13655.9	5.605	31.8
RodE3_126.5	198	126.5	3.213	13.75	0.349	1005.51	814.0	3957.53	12484.0	5.090	28.9
RodE3_131.7	199	131.7	3.345	-1.8	-0.046	879.37	743.9	3436.76	10841.3	5.276	30.0
RodE3_135.6	200	135.6	3.444	2.1	0.053	913.01	762.6	3033.96	9570.6	4.429	25.2
RodC5_63.7	225	63.7	1.618	16.7	0.424	992.98	807.0	4108.02	12958.7	5.370	30.5
RodC5_113.6	226	113.6	2.885	0.85	0.022	836.12	719.9	5070.13	15993.7	8.337	47.3
RodC5_115.7	227	115.7	2.939	2.95	0.075	882.73	745.8	4891.06	15428.9	7.470	42.4
RodC5_122.7	229	122.7	3.117	9.95	0.253	942.27	778.9	4256.71	13427.8	5.960	33.8
RodC5_126.7	230	126.7	3.216	13.95	0.354	947.26	781.6	3883.16	12249.4	5.399	30.7
RodC5_131.6	231	131.6	3.343	-1.9	-0.048	813.06	707.1	3474.19	10959.3	5.938	33.7
RodC5_135.7	232	135.7	3.447	2.2	0.056	830.85	717.0	3048.17	9615.5	5.056	28.7
RodE5_63.6	209	63.6	1.615	16.6	0.422	898.35	754.5	4198.12	13243.0	6.263	35.6
RodE5_113.6	210	113.6	2.885	0.85	0.022	365.88	458.6	6482.57	20449.3	47.014	267.0
RodE5_115.4	211	115.4	2.931	2.65	0.067	427.40	492.8	6557.91	20686.9	32.888	186.8
RodE5_118.7	212	118.7	3.015	5.95	0.151	515.08	541.5	6443.66	20326.5	22.445	127.5
RodE5_122.6	213	122.6	3.114	9.85	0.250	619.19	599.4	6171.69	19468.6	15.777	89.6
RodE5_126.6	214	126.6	3.216	13.85	0.352	723.27	657.2	5808.53	18323.0	11.728	66.6
RodE5_131.6	215	131.6	3.343	-1.9	-0.048	872.14	739.9	5366.34	16928.1	8.331	47.3
RodE5_135.6	216	135.6	3.444	2.1	0.053	869.44	738.4	4773.61	15058.4	7.442	42.3
RodC3_79.8	177	79.8	2.027	8.92	0.227	905.22	758.3	4769.86	15046.5	7.043	40.0
RodC3_85.6	178	85.6	2.174	14.72	0.374	784.72	691.3	4986.06	15728.5	8.956	50.9
RodC3_88.5	179	88.5	2.248	0	0.000	772.93	684.8	5077.52	16017.0	9.318	52.9
RodC3_92.4	180	92.4	2.347	3.9	0.099	880.82	744.7	5219.93	16466.3	7.996	45.4
RodC3_94.4	181	94.4	2.398	5.9	0.150	904.50	757.9	5292.67	16695.7	7.824	44.4
RodC3_97.2	182	97.2	2.469	8.7	0.221	957.97	787.6	5396.03	17021.8	7.392	42.0
RodC3_108.8	183	108.8	2.764	20.3	0.516	1042.37	834.5	5711.98	18018.4	7.014	39.8
RodD5_50	217	50	1.270	3	0.076	854.49	730.1	3723.41	11745.5	5.943	33.8
RodD5_54.1	218	54.1	1.374	7.1	0.180	784.71	691.3	3869.44	12206.1	6.951	39.5
RodD5_56.9	219	56.9	1.445	9.9	0.251	871.78	739.7	3968.63	12519.0	6.165	35.0
RodD5_60	220	60	1.524	13	0.330	927.85	770.8	4076.34	12858.8	5.825	33.1
RodD5_66.1	221	66.1	1.679	19.1	0.485	943.98	779.8	4293.89	13545.1	5.997	34.1
RodD5_69.9	222	69.9	1.775	-0.98	-0.025	717.83	654.2	4426.98	13964.9	9.038	51.3
RodD5_72.9	223	72.9	1.852	2.02	0.051	789.13	693.8	4532.84	14298.8	8.078	45.9
RodD5_74.9	224	74.9	1.902	4.02	0.102	831.72	717.4	4604.06	14523.5	7.626	43.3

Table A-38: Summary of Steam Cooling Heat Transfer Reduced Data for Experiment 4042, continued

H.R. ID	H.R. Location	Channel Number	Elevation (in)	Elevation (m)	Zgrid (in)	Zgrid (m)	H.R. Tw (°F)	H.R. Tw (K)	H.R. q" (Btu/hr-ft ²)	H.R. q" (W/m ²)	h _{sat} (z) (Btu/hr-ft ² -F)	h _{sat} (z) (W/m ² -K)
Gr-2	RodB5_41	153	41	1.041	13.5	0.343	795.08	697.1	3386.77	10683.6	5.972	33.9
	RodB5_52.9	154	52.9	1.344	5.9	0.150	864.64	735.7	3813.04	12028.2	5.989	34.0
	RodB5_55	155	55	1.397	8	0.203	902.78	756.9	3888.98	12267.8	5.763	32.7
	RodB5_57.8	156	57.8	1.468	10.8	0.274	945.13	780.4	3992.87	12595.5	5.568	31.6
	RodB5_64	157	64	1.626	17	0.432	998.23	809.9	4210.70	13282.7	5.467	31.0
	RodB5_73.9	158	73.9	1.877	3.02	0.077	864.04	735.4	4565.45	14401.7	7.178	40.8
Gr-2	RodB5_75.9	159	75.9	1.928	5.02	0.128	898.77	754.7	4637.47	14628.9	6.914	39.3
	RodB5_76.9	160	76.9	1.953	6.02	0.153	913.32	762.8	4673.63	14743.0	6.820	38.7
	RodF5_41	105	41	1.041	13.5	0.343	790.81	694.7	3365.00	10614.9	5.979	34.0
	RodF5_53.1	106	53.1	1.349	6.1	0.155	847.50	726.2	3800.69	11989.3	6.135	34.8
	RodF5_55	107	55	1.397	8	0.203	883.20	746.0	3868.77	12204.0	5.905	33.5
	RodF5_57.8	108	57.8	1.468	10.8	0.274	929.33	771.7	3967.22	12514.6	5.657	32.1
Gr-2	RodF5_64	109	64	1.626	17	0.432	965.85	792.0	4189.66	13216.3	5.678	32.2
	RodF5_73.8	110	73.8	1.875	2.92	0.074	857.17	731.6	4526.99	14280.4	7.195	40.9
	RodF5_75.8	111	75.8	1.925	4.92	0.125	897.88	754.2	4601.48	14515.4	6.869	39.0
	RodF5_76.8	112	76.8	1.951	5.92	0.150	915.30	763.9	4638.48	14632.1	6.749	38.3
	RodC2_41	57	41	1.041	13.5	0.343	793.01	695.9	3381.20	10666.0	5.984	34.0
	RodC2_53.1	58	53.1	1.349	6.1	0.155	904.31	757.8	3814.61	12033.2	5.640	32.0
Gr-2	RodC2_55	59	55	1.397	8	0.203	925.76	769.7	3883.12	12249.3	5.565	31.6
	RodC2_57.8	60	57.8	1.468	10.8	0.274	961.49	789.5	3984.23	12568.2	5.432	30.8
	RodC2_63.9	61	63.9	1.623	16.9	0.429	1005.53	814.0	4204.68	13263.7	5.408	30.7
	RodC2_73.8	62	73.8	1.875	2.92	0.074	895.59	752.9	4564.20	14397.8	6.837	38.8
	RodC2_75.8	63	75.8	1.925	4.92	0.125	926.41	770.0	4637.90	14630.2	6.641	37.7
	RodC2_76.8	64	76.8	1.951	5.92	0.150	939.80	777.5	4674.30	14745.1	6.567	37.3
Gr-2	RodC6_40.9	137	40.9	1.039	13.4	0.340	802.18	701.0	3364.93	10614.7	5.860	33.3
	RodC6_52.8	138	52.8	1.341	5.8	0.147	903.72	757.4	3812.87	12027.7	5.643	32.0
	RodC6_54.8	139	54.8	1.392	7.8	0.198	929.96	772.0	3887.05	12261.7	5.537	31.4
	RodC6_57.8	140	57.8	1.468	10.8	0.274	964.67	791.3	3999.97	12617.9	5.430	30.8
	RodC6_63.8	141	63.8	1.621	16.8	0.427	1016.92	820.3	4225.08	13328.0	5.356	30.4
	RodC6_73.7	142	73.7	1.872	2.82	0.072	928.93	771.4	4587.59	14471.6	6.545	37.2
Gr-2	RodC6_75.8	143	75.8	1.925	4.92	0.125	956.13	786.6	4667.52	14723.7	6.410	36.4
	RodC6_76.8	144	76.8	1.951	5.92	0.150	971.62	795.2	4705.07	14842.1	6.327	35.9

Table A-38: Summary of Steam Cooling Heat Transfer Reduced Data for Experiment 4042, continued

5x5 periphery		H.R. Location	Channel Number	Elevation (in)	Elevation (m)	Zgrid (in)	Zgrid (m)	H.R. Tw (°F)	H.R. Tw (K)	H.R. q" (Btu/hr-ft ²)	H.R. q" (W/m ²)	h _{sat} (z) (Btu/hr-ft ² -F)	h _{sat} (z) (W/m ² -K)
Gr-3	RodB4_88.4	161	88.4	2.245	-0.1	-0.003	763.48	679.5	5056.20	15949.8	9.442	53.6	
	RodB4_91.3	162	91.3	2.319	2.8	0.071	855.27	730.5	5156.75	16267.0	8.221	46.7	
	RodB4_93.3	163	93.3	2.370	4.8	0.122	872.54	740.1	5227.81	16491.1	8.111	46.1	
	RodB4_95.1	164	95.1	2.416	6.6	0.168	906.84	759.2	5294.34	16701.0	7.799	44.3	
	RodB4_100	165	100	2.540	11.5	0.292	941.43	778.4	5469.47	17253.4	7.666	43.5	
	RodB4_106	166	106	2.692	17.5	0.445	1034.94	830.3	5684.04	17930.3	7.044	40.0	
	RodB4_109.9	167	109.9	2.791	21.4	0.544	852.27	728.9	5509.47	17379.6	8.825	50.1	
	RodB4_142.3	168	142.3	3.614	8.8	0.224	859.43	732.8	2202.63	6948.2	3.488	19.8	
Gr-5	RodF4_85.6	98	85.6	2.174	14.72	0.374	836.24	720.0	4999.73	15771.7	8.220	46.7	
	RodF4_88.4	99	88.4	2.245	-0.1	-0.003	771.79	684.1	5086.55	16045.5	9.354	53.1	
	RodF4_92.4	100	92.4	2.347	3.9	0.099	868.74	738.0	5237.69	16522.3	8.174	46.4	
	RodF4_94.3	101	94.3	2.395	5.8	0.147	904.57	757.9	5308.72	16746.4	7.847	44.6	
	RodF4_97.2	102	97.2	2.469	8.7	0.221	950.88	783.6	5416.92	17087.7	7.494	42.6	
	RodF4_108.8	103	108.8	2.764	20.3	0.516	991.73	806.3	5770.78	18203.9	7.556	42.9	
	RodF4_111	104	111	2.819	-1.75	-0.044	798.68	699.1	5523.16	17422.8	9.678	55.0	
	RodD2_103.2	65	103.2	2.621	14.7	0.373	1011.67	817.4	5062.40	15969.3	6.460	36.7	
RodD2_106	66	106	2.692	17.5	0.445	1034.96	830.3	4803.21	15151.7	5.952	33.8		
RodD2_112.6	67	112.6	2.860	-0.15	-0.004	1056.24	842.2	4454.64	14052.2	5.378	30.5		
RodD2_114.9	68	114.9	2.918	2.15	0.055	1066.13	847.7	4038.20	12738.5	4.818	27.4		
RodD2_117.4	69	117.4	2.982	4.65	0.118	1045.96	836.5	3636.48	11471.3	4.446	25.2		
RodD2_120.8	70	120.8	3.068	8.05	0.204	1091.50	861.8	5657.18	17845.6	6.551	37.2		
RodD2_124.8	71	124.8	3.170	12.05	0.306	1118.51	876.8	5760.13	18170.3	6.468	36.7		
RodD2_128.6	72	128.6	3.266	15.85	0.403	966.51	792.3	5296.87	16709.0	7.172	40.7		
Gr-6	RodD6_103.1	129	103.1	2.619	14.6	0.371	1025.27	825.0	5688.93	17945.7	7.136	40.5	
	RodD6_106	130	106	2.692	17.5	0.445	1041.83	834.2	5822.76	18367.9	7.155	40.6	
	RodD6_112.9	131	112.9	2.868	0.15	0.004	860.32	733.3	5371.23	16943.6	8.494	48.2	
	RodD6_114.9	132	114.9	2.918	2.15	0.055	912.81	762.5	5177.40	16332.1	7.560	42.9	
	RodD6_116.8	133	116.8	2.967	4.05	0.103	945.26	780.5	4980.12	15709.8	6.943	39.4	
	RodD6_120.9	134	120.9	3.071	8.15	0.207	967.68	793.0	4556.56	14373.7	6.160	35.0	
	RodD6_124.8	135	124.8	3.170	12.05	0.306	979.97	799.8	4148.20	13085.5	5.516	31.3	
	RodD6_128.7	136	128.7	3.269	15.95	0.405	969.64	794.1	3731.21	11770.1	5.031	28.6	

Table A-38: Summary of Steam Cooling Heat Transfer Reduced Data for Experiment 4042, continued

5x5 periphery		H.R. Location	Channel Number	Elevation (in)	Elevation (m)	Zgrid (in)	Zgrid (m)	H.R. Tw (°F)	H.R. Tw (K)	H.R. q" (Btu/hr-ft ²)	H.R. q" (W/m ²)	h _{sat} (z) (Btu/hr-ft ² -F)	h _{sat} (z) (W/m ² -K)
Gr-8	RodE2_50.1	73	50.1	1.273	3.1	0.079	846.74	725.8	3736.87	11787.9	6.039	34.3	
	RodE2_54	74	54	1.372	7	0.178	912.35	762.2	3879.01	12236.3	5.668	32.2	
	RodE2_56.9	75	56.9	1.445	9.9	0.251	949.06	782.6	3984.42	12568.9	5.526	31.4	
	RodE2_59.9	76	59.9	1.521	12.9	0.328	986.11	803.2	4093.20	12912.0	5.399	30.7	
	RodE2_66	77	66	1.676	19	0.483	1011.84	817.5	4313.86	13608.1	5.503	31.3	
	RodE2_69.8	78	69.8	1.773	-1.08	-0.027	841.32	722.8	4446.14	14025.3	7.249	41.2	
	RodE2_72.9	79	72.9	1.852	2.02	0.051	904.10	757.7	4560.61	14386.4	6.745	38.3	
	RodE2_74.9	80	74.9	1.902	4.02	0.102	936.66	775.7	4634.27	14618.8	6.539	37.1	
Gr-8	RodB3_50.2	169	50.2	1.275	3.2	0.081	804.91	702.5	3712.68	11711.6	6.435	36.5	
	RodB3_54.1	170	54.1	1.374	7.1	0.180	878.46	743.4	3852.51	12152.8	5.923	33.6	
	RodB3_56.9	171	56.9	1.445	9.9	0.251	921.48	767.3	3952.80	12469.1	5.700	32.4	
	RodB3_60.1	172	60.1	1.527	13.1	0.333	907.67	759.6	4066.23	12826.9	5.983	34.0	
	RodB3_66.1	173	66.1	1.679	19.1	0.485	935.52	775.1	4287.05	13523.5	6.059	34.4	
	RodB3_69.9	174	69.9	1.775	-0.98	-0.025	746.95	670.3	4421.95	13949.0	8.521	48.4	
	RodB3_73	175	73	1.854	2.12	0.054	823.88	713.1	4533.26	14300.2	7.608	43.2	
	RodB3_75	176	75	1.905	4.12	0.105	864.86	735.9	4606.94	14532.6	7.234	41.1	
Gr-8	RodF3_50.1	89	50.1	1.273	3.1	0.079	826.00	714.3	3716.83	11724.7	6.215	35.3	
	RodF3_54	90	54	1.372	7	0.178	891.55	750.7	3857.95	12169.9	5.814	33.0	
	RodF3_57	91	57	1.448	10	0.254	935.31	775.0	3968.64	12519.1	5.611	31.9	
	RodF3_60	92	60	1.524	13	0.330	970.78	794.7	4077.54	12862.6	5.490	31.2	
	RodF3_66.1	93	66.1	1.679	19.1	0.485	992.80	806.9	4301.10	13567.8	5.624	31.9	
	RodF3_70	94	70	1.778	-0.88	-0.022	800.41	700.0	4436.59	13995.2	7.751	44.0	
	RodF3_73	95	73	1.854	2.12	0.054	882.76	745.8	4549.57	14351.6	6.948	39.5	
	RodF3_75	96	75	1.905	4.12	0.105	921.91	767.5	4623.27	14584.1	6.663	37.8	
Gr-8	RodE6_50.2	121	50.2	1.275	3.2	0.081	832.91	718.1	3712.00	11709.5	6.136	34.8	
	RodE6_54.1	122	54.1	1.374	7.1	0.180	894.87	752.5	3851.13	12148.4	5.775	32.8	
	RodE6_57	123	57	1.448	10	0.254	929.72	771.9	3955.71	12478.3	5.637	32.0	
	RodE6_60.2	124	60.2	1.529	13.2	0.335	965.63	791.8	4069.97	12838.7	5.518	31.3	
	RodE6_66.1	125	66.1	1.679	19.1	0.485	978.44	799.0	4280.42	13502.6	5.704	32.4	
	RodE6_70	126	70	1.778	-0.88	-0.022	824.89	713.6	4410.19	13912.0	7.389	42.0	
	RodE6_73.1	127	73.1	1.857	2.22	0.056	876.42	742.3	4520.49	14259.9	6.972	39.6	
	RodE6_75	128	75	1.905	4.12	0.105	909.17	760.5	4587.56	14471.5	6.735	38.2	

RBHT Steam Cooling with Droplet Injection Test SCD-4042-F

Matrix Test # 2b

Test Conditions

Test Date – 11/1/2005

Steady State Time Window: 18300 – 19140

Upper Plenum Pressure: 1.38 bar (20 psia)

Bundle Power: 55.0 kW

Bundle Inlet Reynolds Number: 4000

Bundle Inlet Steam Flow: 83.5 kg/hr (184 lbm/hr)

Droplet Injection Flow: 0.0073 kg/s (0.016 lbm/s)

Droplet Injection Hole Diameter: 0.381 mm (.015 in)

Droplet Injection Elevation: 1.295 m (51 in)

Bundle Flow Area: $4.656 \times 10^{-3} \text{ m}^2$ ($5.012 \times 10^{-2} \text{ ft}^2$)

Test Notes

- No steam probes were traversed in this steady state window.

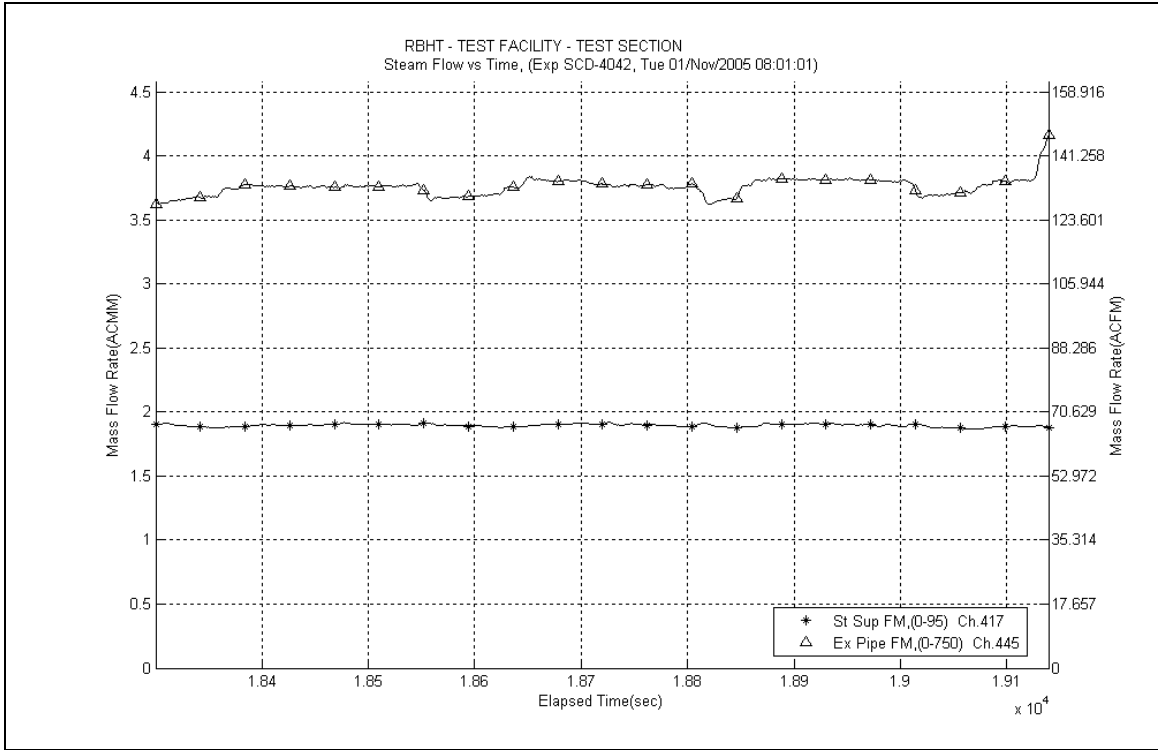

Figure A-728: Inlet and Exhaust Steam Flow Rates for Experiment 4042F

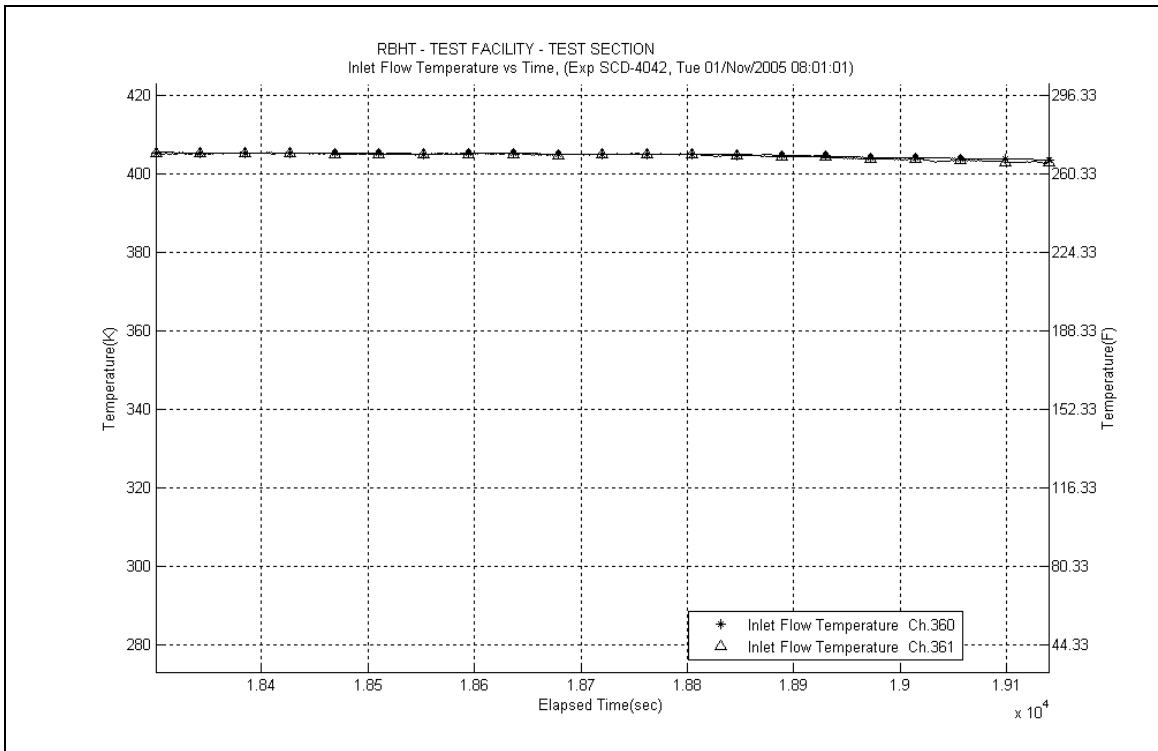

Figure A-729: Inlet Steam Temperature for Experiment 4042F

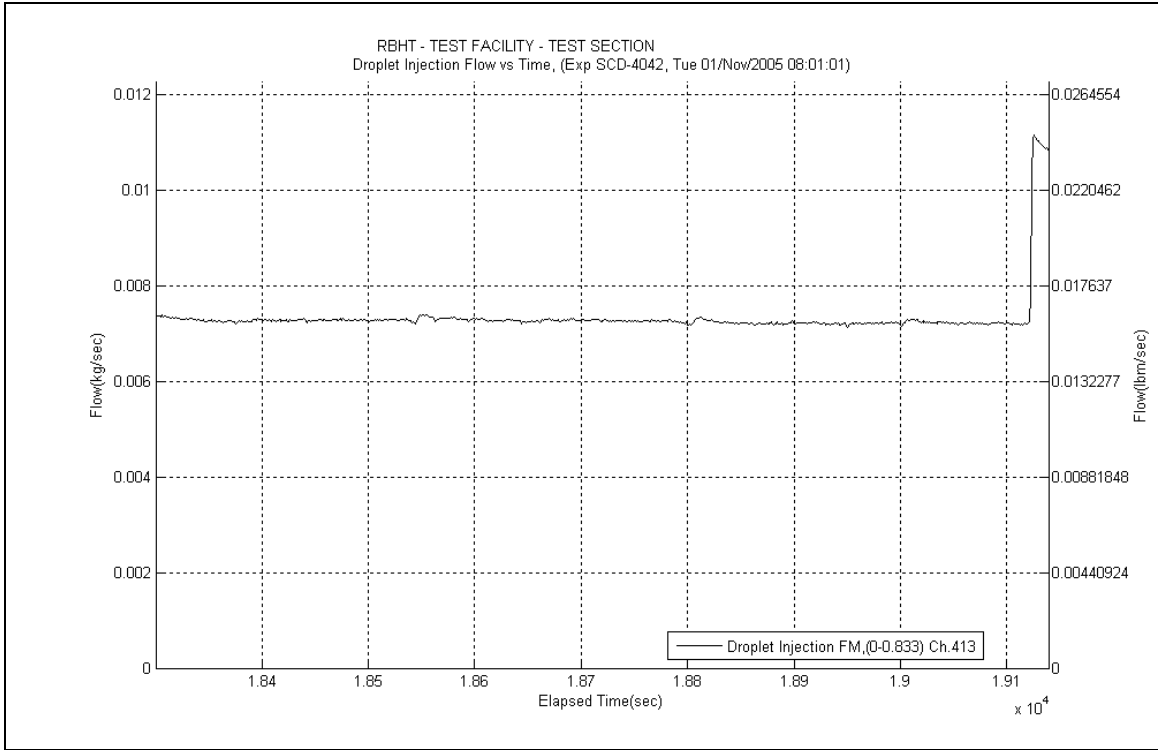

Figure A-730: Droplet Injection Flow Rate for Experiment 4042F

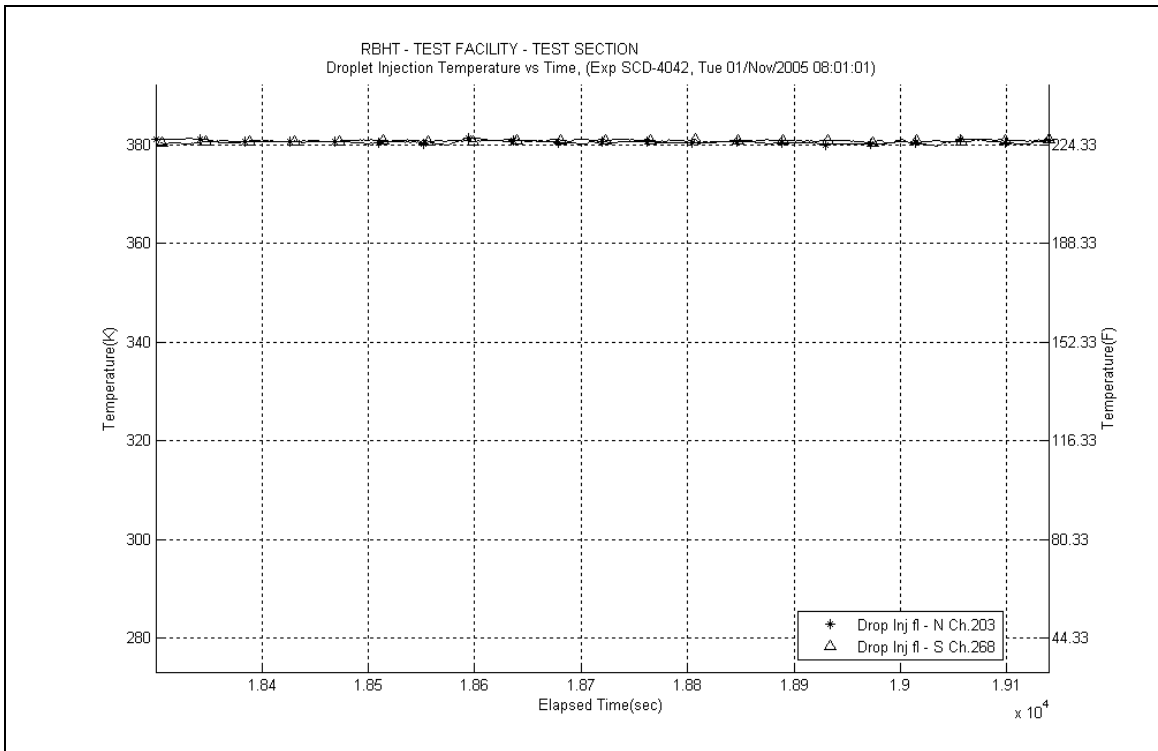

Figure A-731: Droplet Injection Temperature for Experiment 4042F

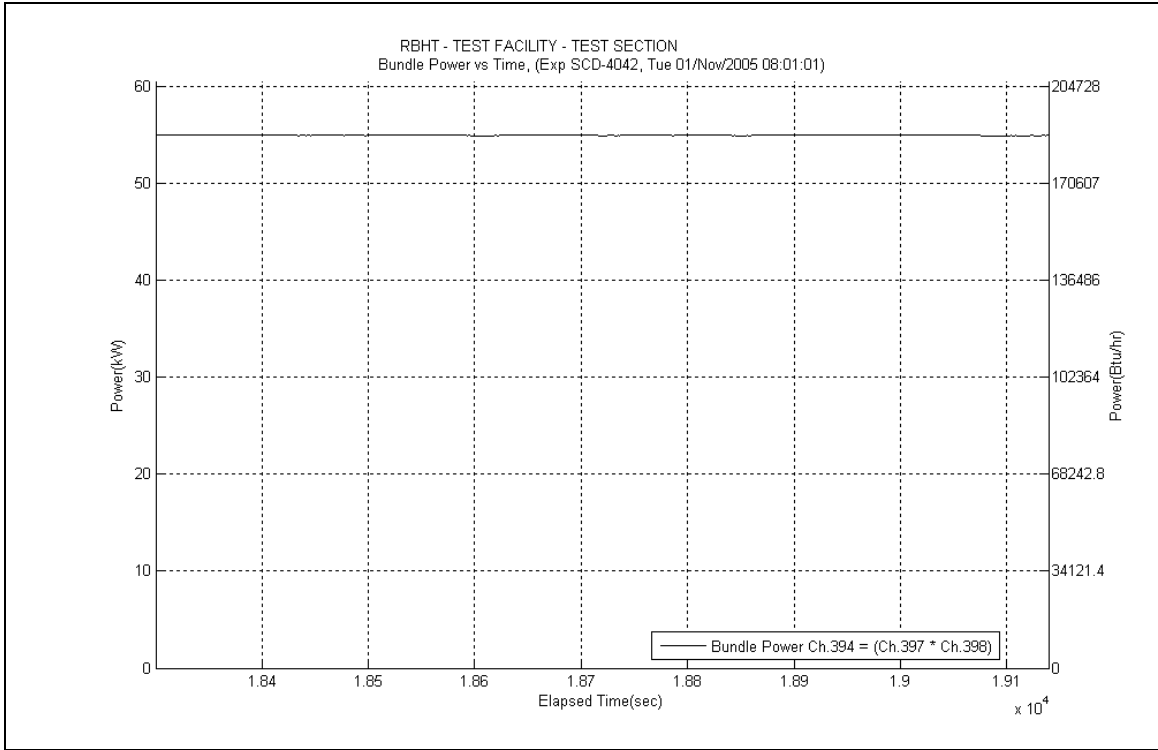

Figure A-732: Bundle Power for Experiment 4042F

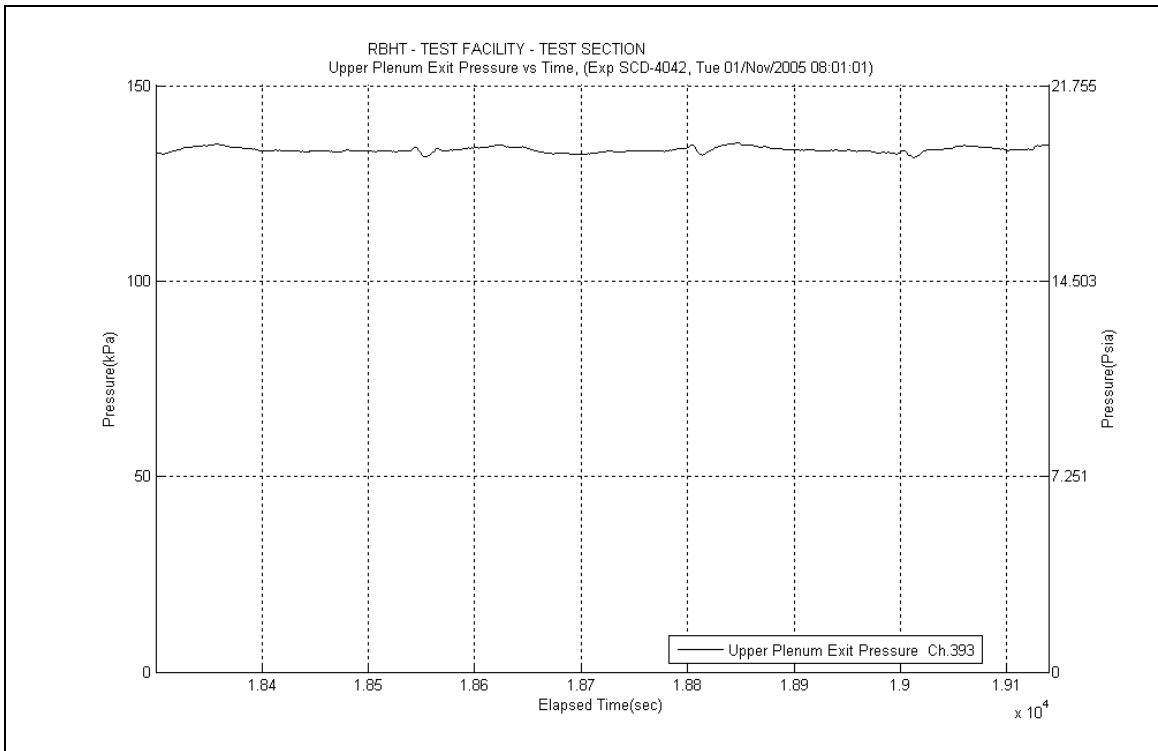

Figure A-733: Upper Plenum Pressure for Experiment 4042F

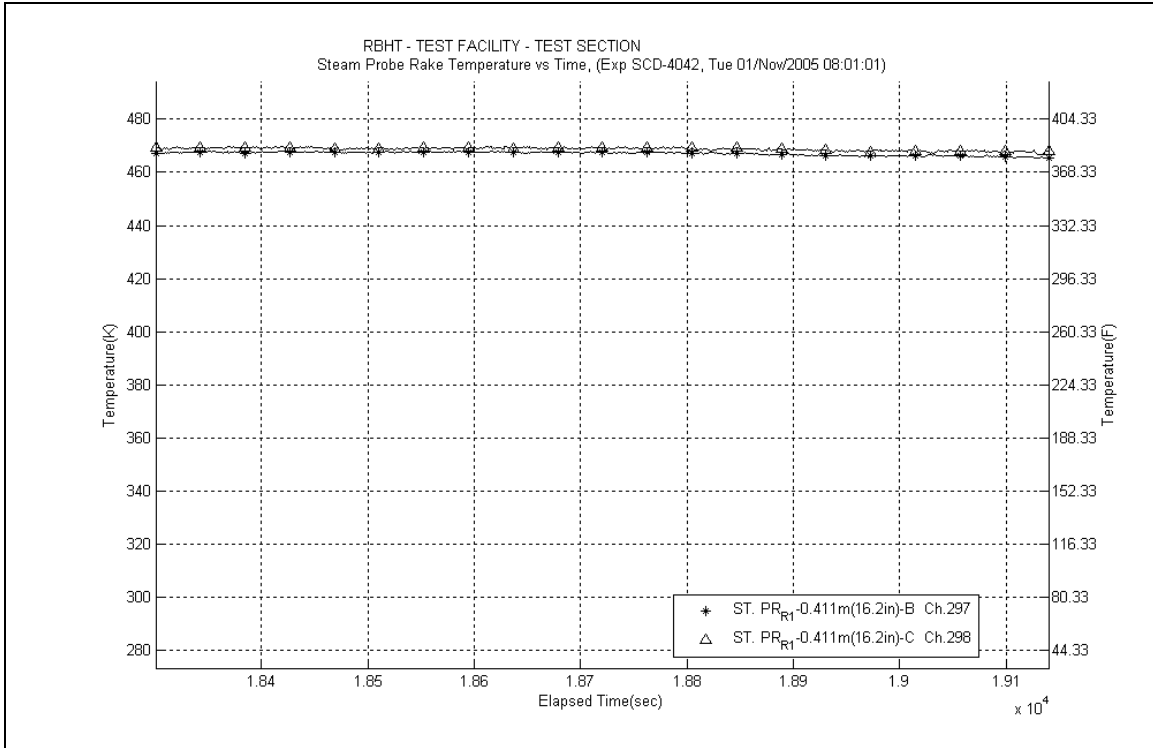

Figure A-734: Steam Probe Rake #1 Temperatures for Experiment 4042F

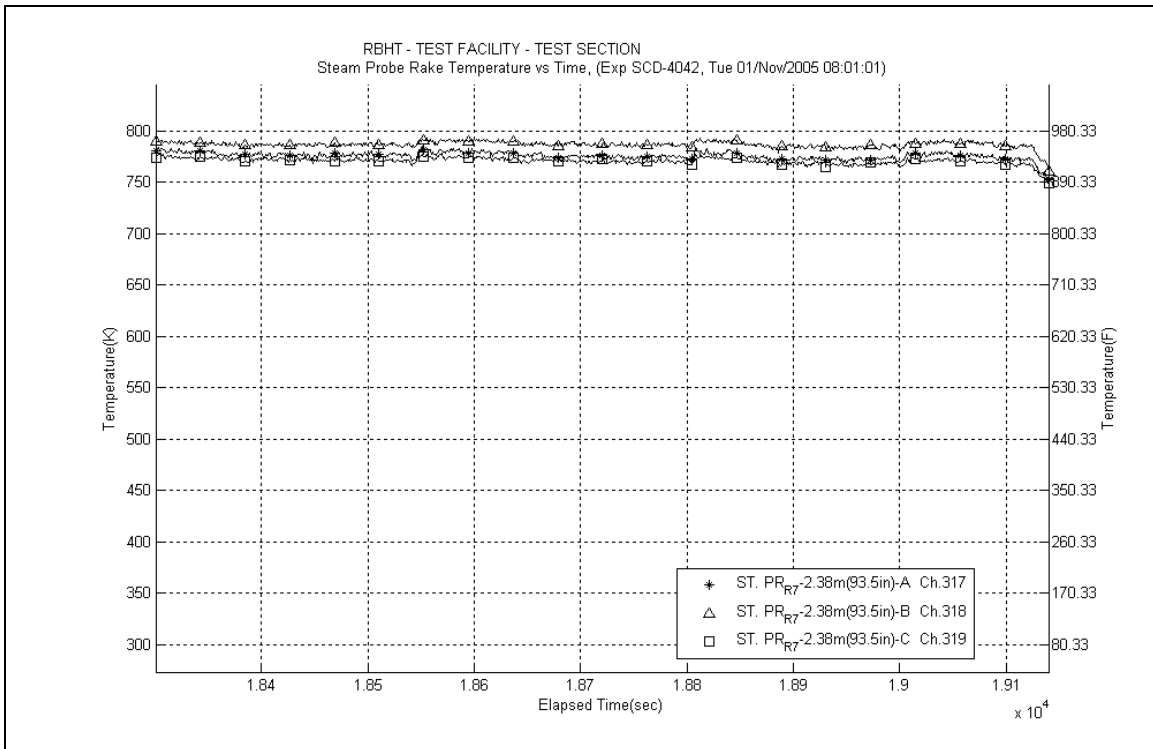

Figure A-735: Steam Probe Rake #7 Temperatures for Experiment 4042F

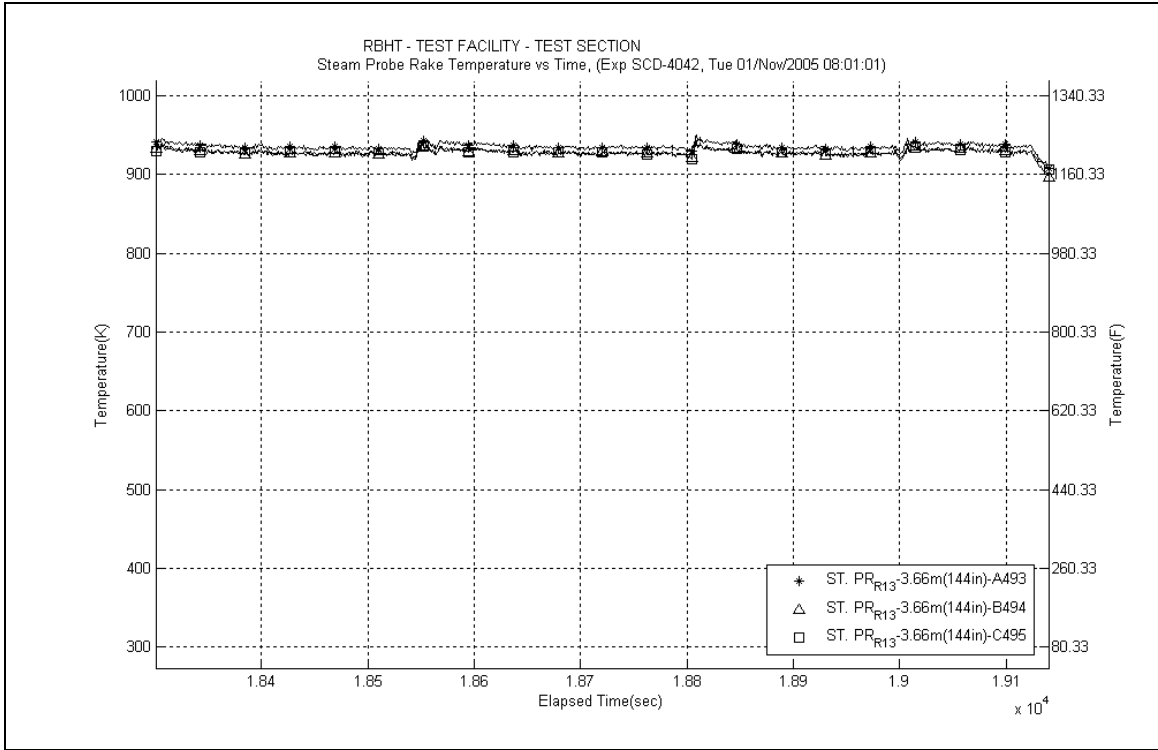

Figure A-736: Steam Probe Rake #13 Temperatures for Experiment 4042F

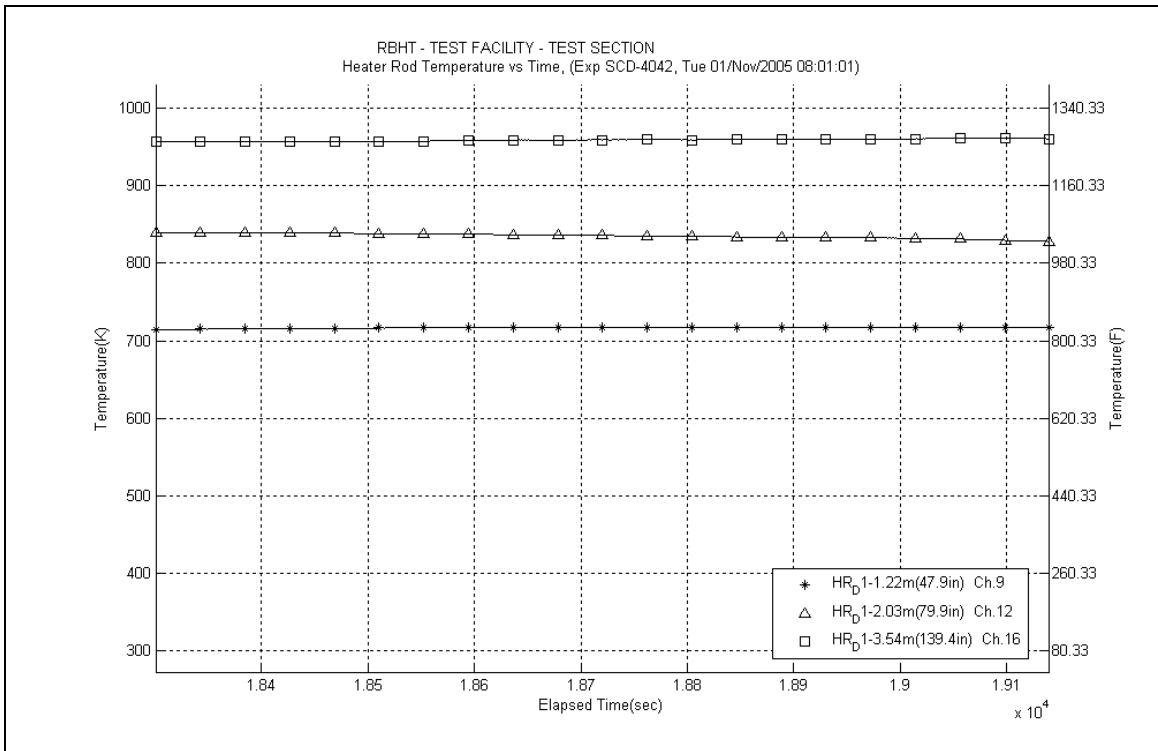

Figure A-737: Heater Rod D1 Temperatures for Experiment 4042F

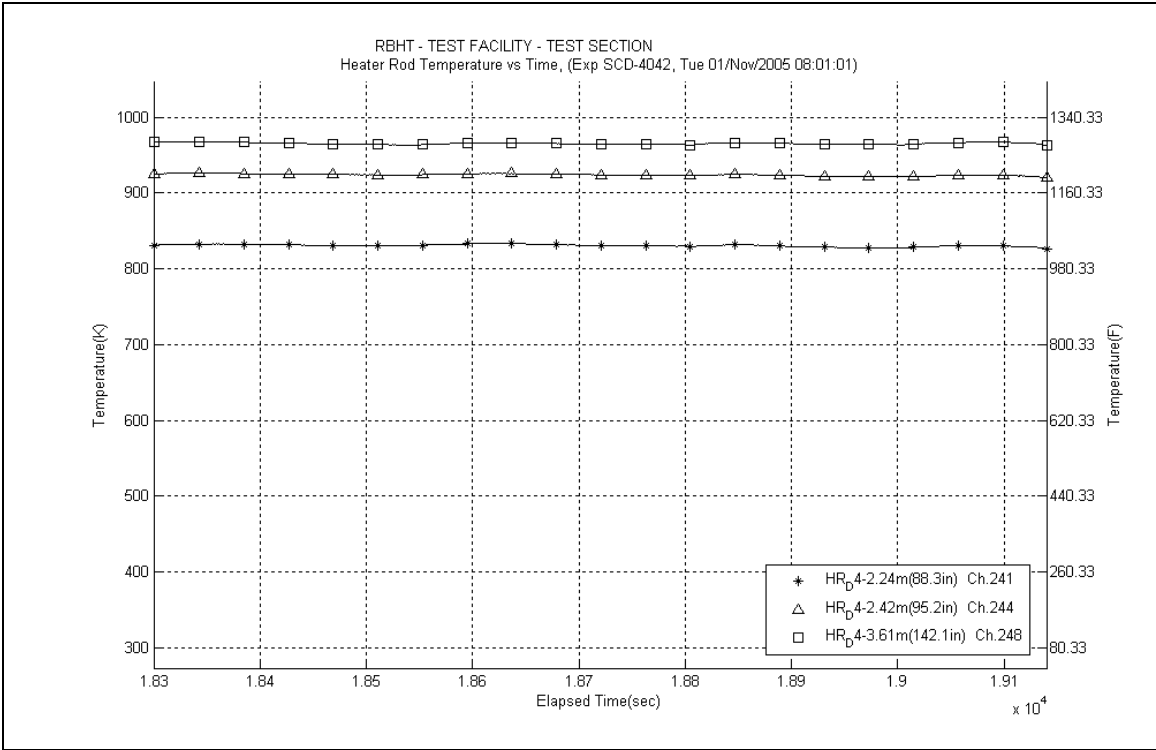

Figure A-738: Heater Rod D4 Temperatures for Experiment 4042F

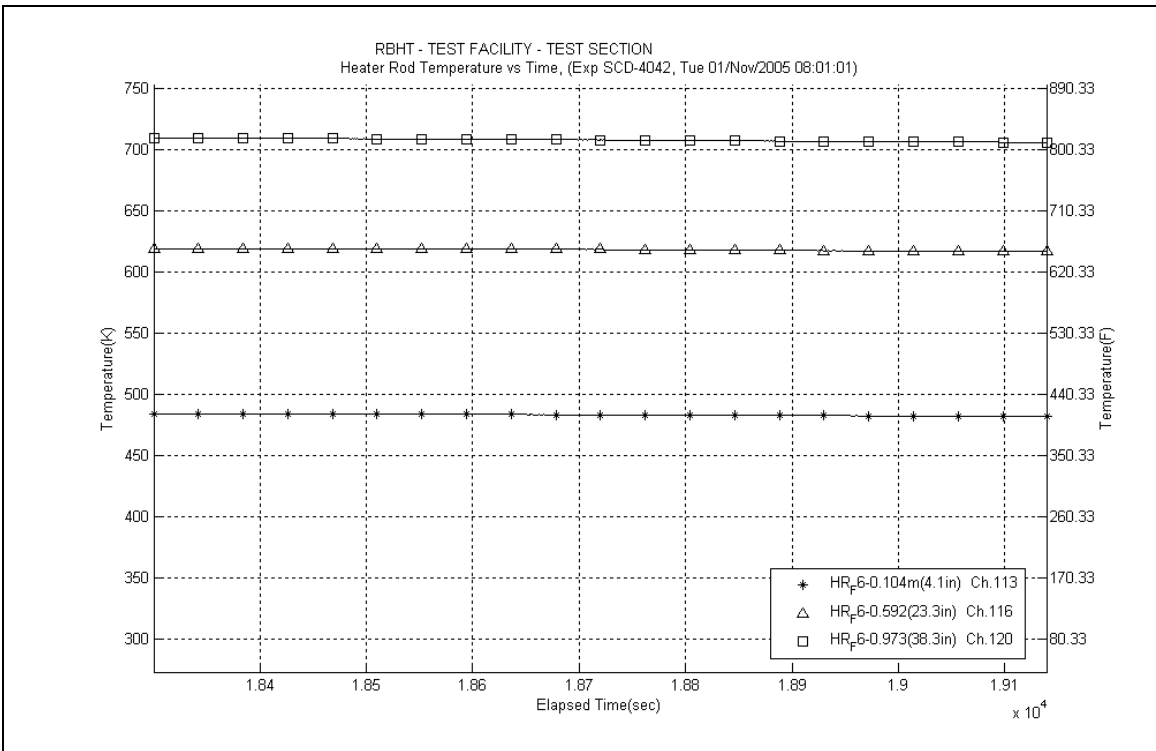

Figure A-739: Heater Rod F6 Temperatures for Experiment 4042F

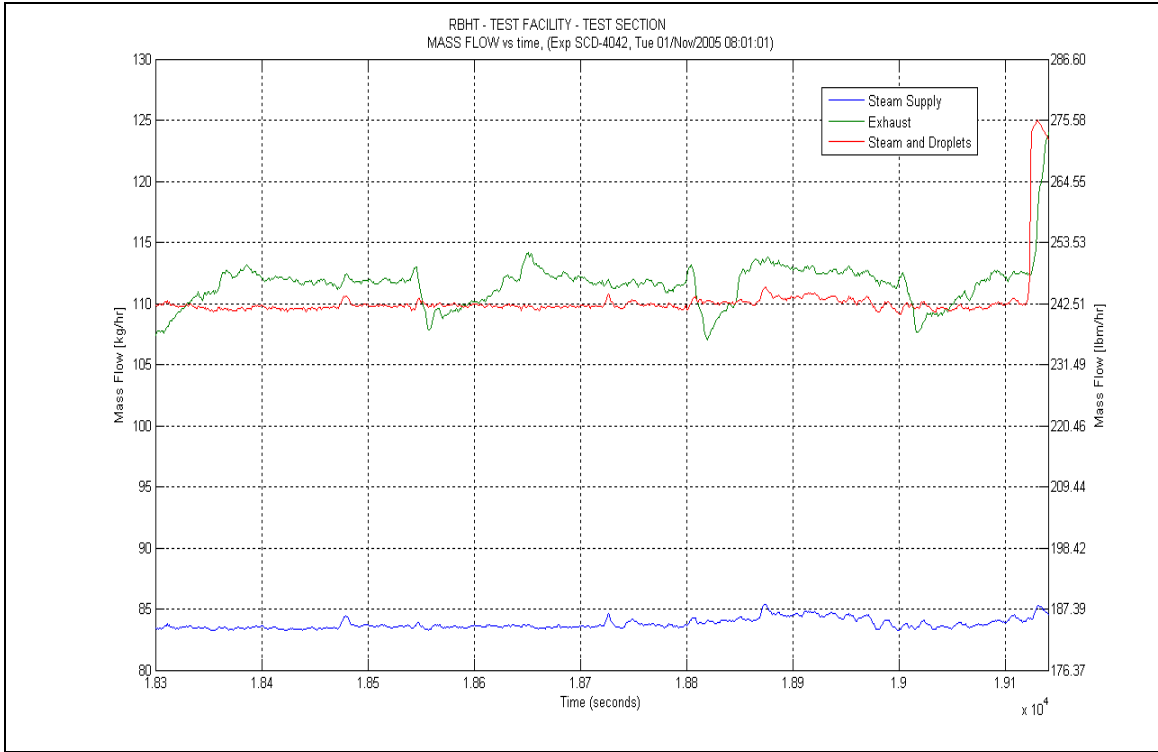

Figure A-740: Mass Flow for Experiment 4042F

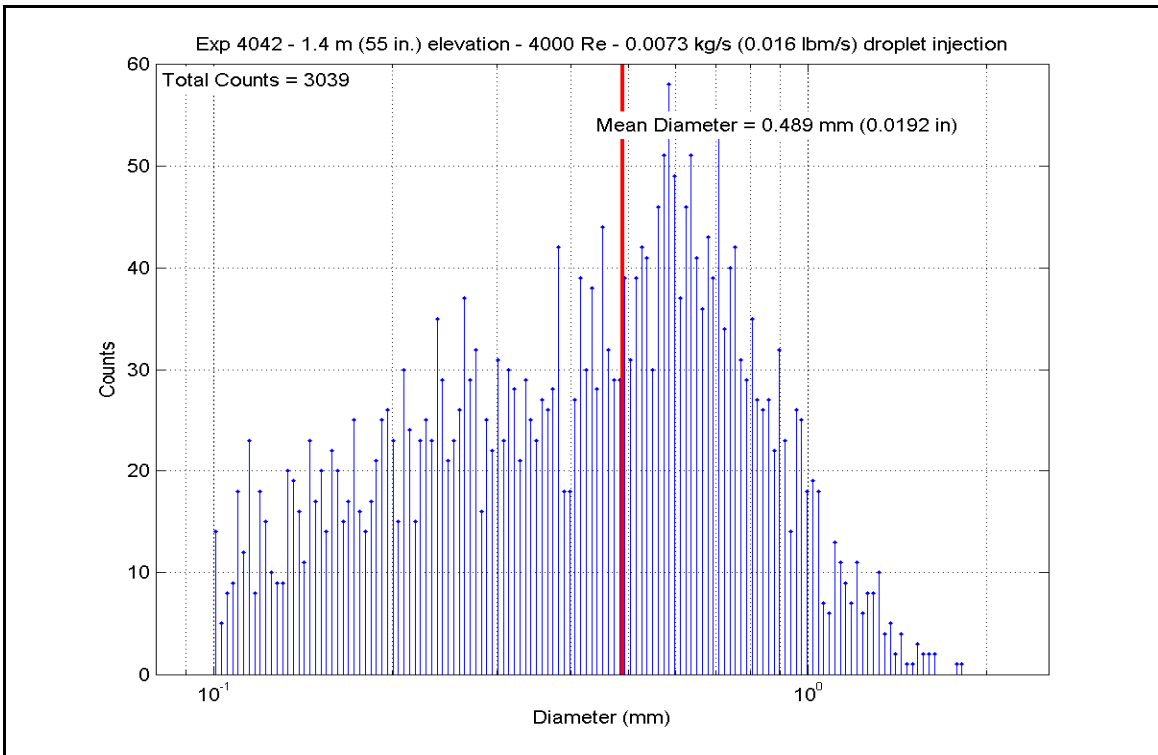

Figure A-741: Droplet Measurements at 1.397 m (55 in.) Elevation for Experiment 4042F

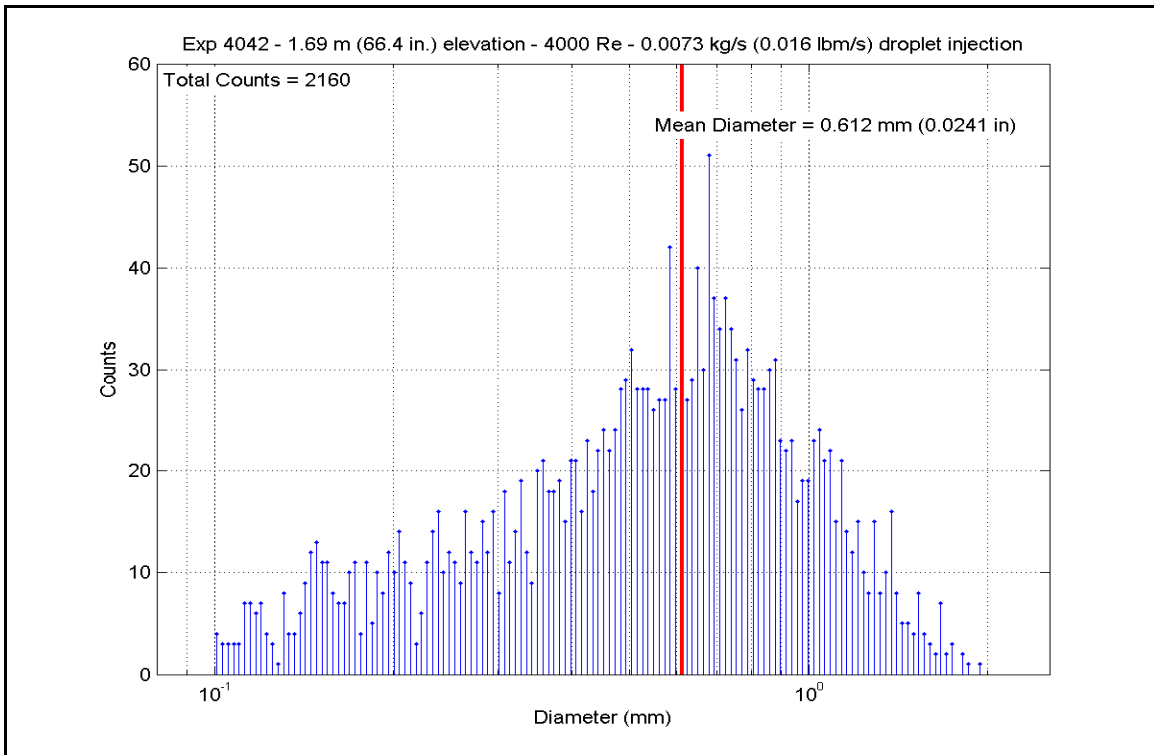

Figure A-742: Droplet Measurements at 1.687 m (66.4 in.) Elevation for Experiment 4042F

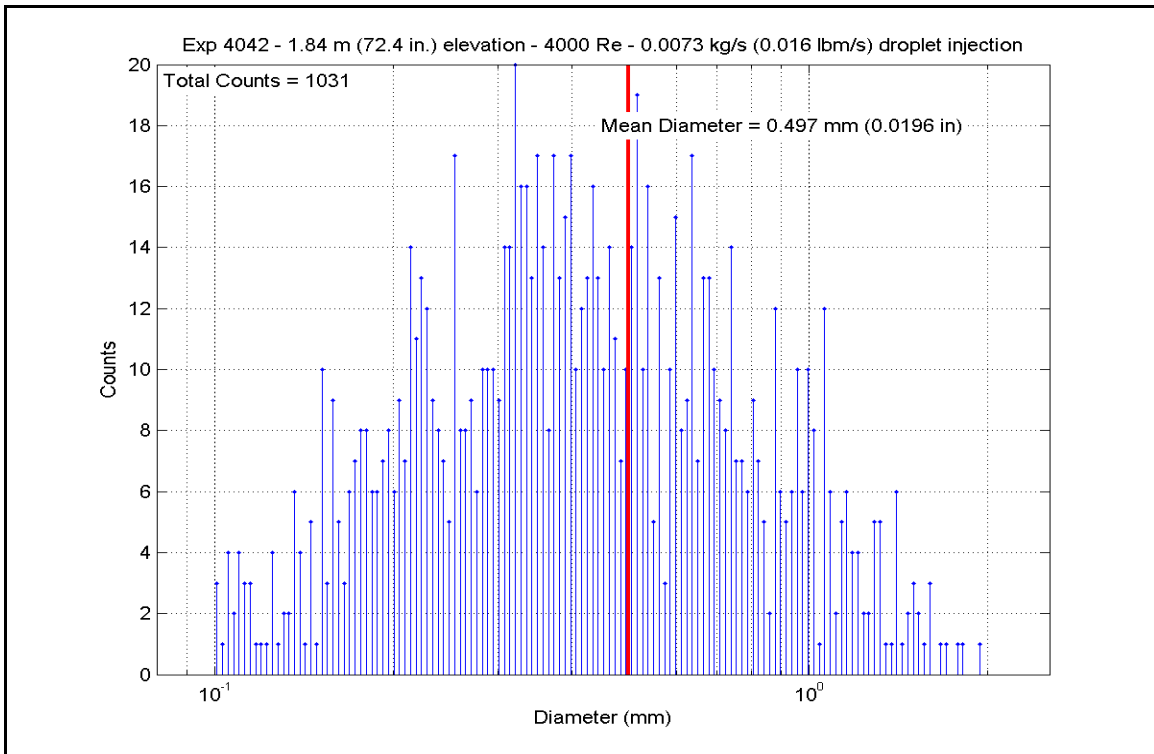

Figure A-743: Droplet Measurements at 1.839 m (72.4 in.) Elevation for Experiment 4042F

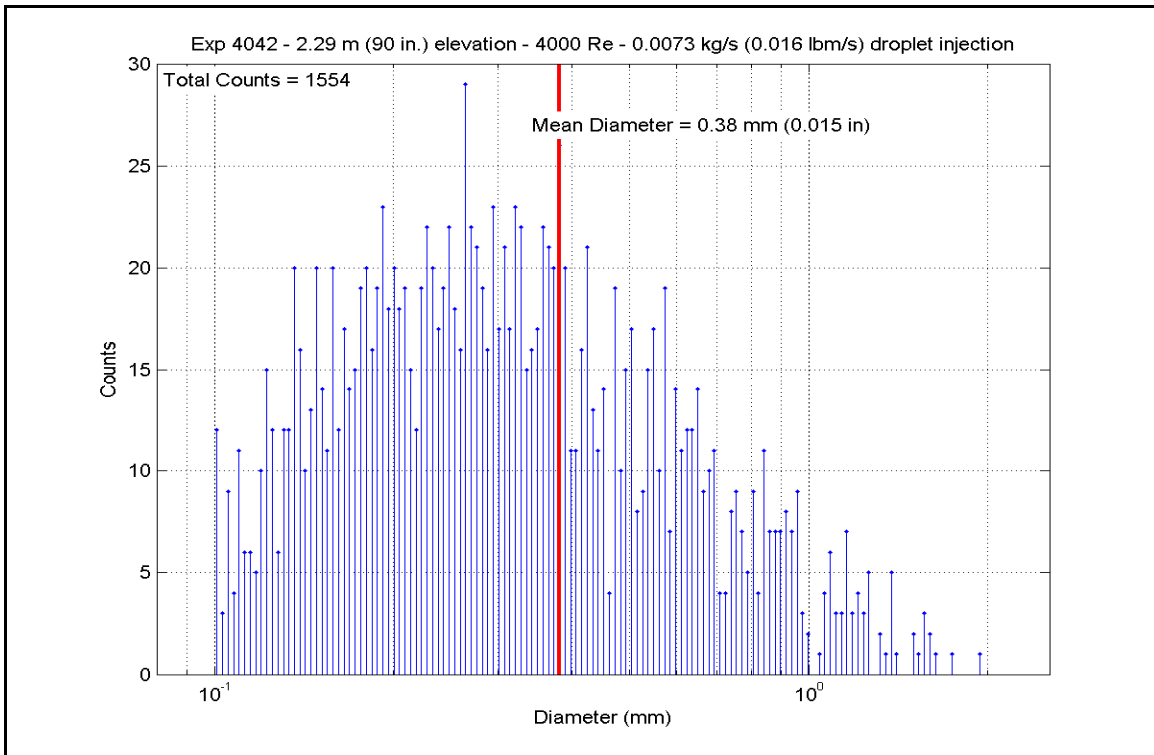

Figure A-744: Droplet Measurements at 2.286 m (90 in.) Elevation for Experiment 4042F

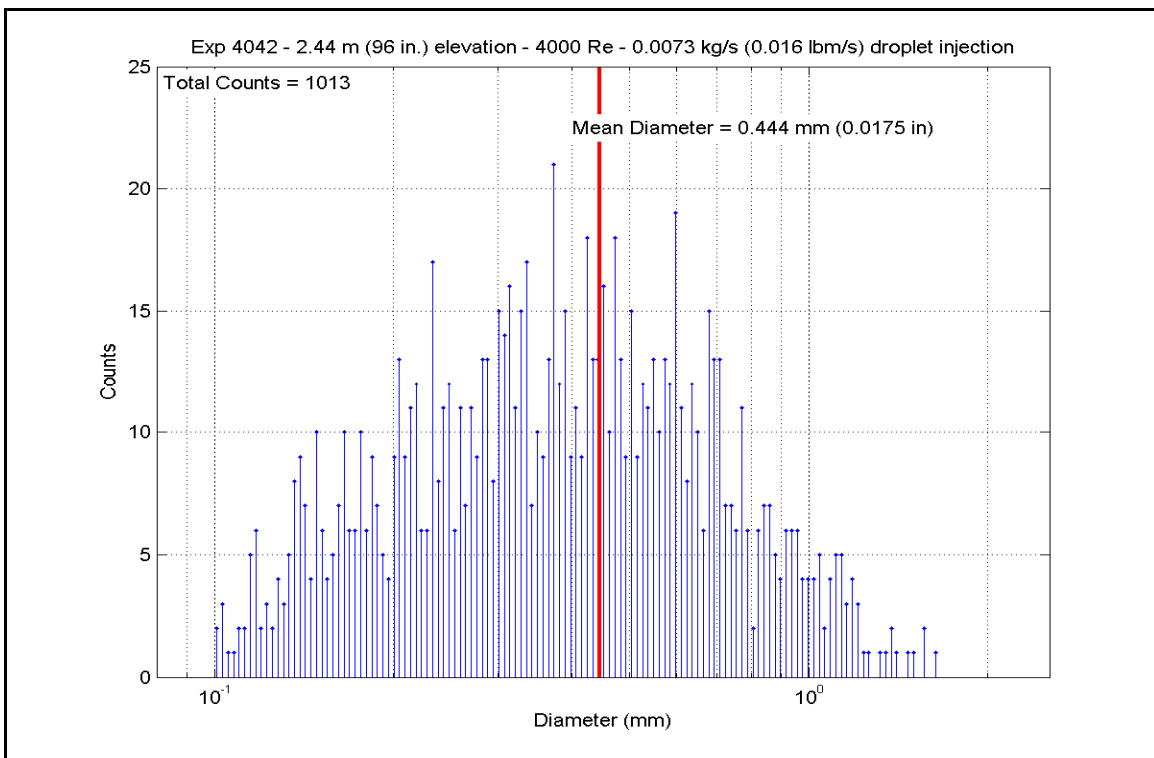

Figure A-745: Droplet Measurements at 2.438 m (96 in.) Elevation for Experiment 4042F

Table A-39: Summary of Steam Cooling Heat Transfer Reduced Data for Experiment 4042F

Test 4042-F		Inlet Reynolds:		4000		20 psia		187668 Btu/hr		184.0 lbm/hr		0.0232 kg/s		0.0073 kg/s	
Matrix test # 2b		UP Pressure:		137.9 kPa		55.00 kW		184.0 lbm/hr		0.0232 kg/s		0.0073 kg/s			
Time Window: 18300-19140		Bundle Power:		184.0 lbm/hr		0.0232 kg/s		0.0073 kg/s							
Inner 3x3		Droplet flow:		0.0073 kg/s											
H.R. ID	H.R. Location	Channel Number	Elevation (in)	Elevation (m)	Zgrid (in)	Zgrid (m)	H.R. Tw (°F)	H.R. Tw (K)	H.R. q" (Btu/hr-ft ²)	H.R. q" (W/m ²)	h _{sat} (z) (Btu/hr-ft ² -F)	h _{sat} (z) (W/m ² -K)			
Gr-3	RodD3_88.3	185	88.3	2.243	-0.2	-0.005	1140.17	888.8	4779.17	15075.9	5.239	29.8			
	RodD3_91.3	186	91.3	2.319	2.8	0.071	1170.28	905.5	4842.62	15276.1	5.139	29.2			
	RodD3_93.1	187	93.1	2.365	4.6	0.117	1047.56	837.4	4674.44	14745.5	5.704	32.4			
	RodD3_95.3	188	95.3	2.421	6.8	0.173	1126.17	881.0	4771.18	15050.7	5.312	30.2			
	RodD3_100.1	189	100.1	2.543	11.6	0.295	1225.72	936.3	4948.46	15609.9	4.960	28.2			
	RodD3_106.1	190	106.1	2.695	17.6	0.447	1331.30	995.0	5227.05	16488.7	4.738	26.9			
	RodD3_110	191	110	2.794	21.5	0.546	1276.14	964.3	5081.08	16028.3	4.848	27.5			
	RodD3_142.1	192	142.1	3.609	8.6	0.218	1050.79	839.1	4651.74	14673.9	5.654	32.1			
Gr-3	RodC4_88.4	233	88.4	2.245	-0.1	-0.003	1250.52	950.1	4615.41	14559.3	4.514	25.6			
	RodC4_91.1	234	91.1	2.314	2.6	0.066	1291.09	972.6	4316.68	13617.0	4.060	23.1			
	RodC4_93.4	235	93.4	2.372	4.9	0.124	1319.53	988.4	3962.83	12500.7	3.631	20.6			
	RodC4_95.3	236	95.3	2.421	6.8	0.173	1329.41	993.9	3599.55	11354.8	3.268	18.6			
	RodC4_100.1	237	100.1	2.543	11.6	0.295	1253.62	951.8	5057.75	15954.7	4.931	28.0			
	RodC4_106.1	238	106.1	2.695	17.6	0.447	1259.62	955.2	5223.85	16478.7	5.064	28.8			
	RodC4_110	239	110	2.794	21.5	0.546	1284.09	968.8	5319.05	16778.9	5.037	28.6			
	RodC4_142.2	240	142.2	3.612	8.7	0.221	1034.24	829.9	3838.14	12107.4	4.761	27.0			
Gr-3	RodD4_88.3	241	88.3	2.243	-0.2	-0.005	871.60	739.6	4174.13	13167.3	6.486	36.8			
	RodD4_91.3	242	91.3	2.319	2.8	0.071	920.83	766.9	4238.80	13371.3	6.118	34.7			
	RodD4_93.2	243	93.2	2.367	4.7	0.119	1074.46	852.3	3769.38	11890.5	4.453	25.3			
	RodD4_95.2	244	95.2	2.418	6.7	0.170	1291.15	972.7	4446.21	14025.6	4.182	23.7			
	RodD4_100.1	245	100.1	2.543	11.6	0.295	1344.64	1002.4	5284.03	16668.5	4.732	26.9			
	RodD4_106.1	246	106.1	2.695	17.6	0.447	1291.59	972.9	5228.00	16491.7	4.915	27.9			
	RodD4_142.1	248	142.1	3.609	8.6	0.218	779.39	688.4	4089.78	12901.2	7.417	42.1			
Gr-3	RodE4_88.4	201	88.4	2.245	-0.1	-0.003	1111.65	873.0	4732.80	14929.6	5.356	30.4			
	RodE4_91.2	202	91.2	2.316	2.7	0.069	1192.68	918.0	4864.17	15344.0	5.042	28.6			
	RodE4_95.3	204	95.3	2.421	6.8	0.173	1283.73	968.6	1911.96	6031.3	1.811	10.3			
	RodE4_100.9	205	100.9	2.563	12.4	0.315	1234.74	941.3	5150.56	16247.5	5.116	29.1			
	RodE4_142.3	208	142.3	3.614	8.8	0.224	1032.86	829.2	4640.75	14639.2	5.766	32.7			

Table A-39: Summary of Steam Cooling Heat Transfer Reduced Data for Experiment 4042, continued

Inner 3x3	H.R. Location	Channel Number	Elevation (in)	Elevation (m)	Zgrid (in)	Zgrid (m)	H.R. Tw (°F)	H.R. Tw (K)	H.R. q" (Btu/hr-ft ²)	H.R. q" (W/m ²)	h _{sat} (z) (Btu/hr-ft ² -F)	h _{sat} (z) (W/m ² -K)
Gr-4	RodE3_63.4	193	63.4	1.610	16.4	0.417	1301.99	978.7	2687.05	8476.3	2.502	14.2
	RodE3_113.6	194	113.6	2.885	0.85	0.022	1256.93	953.7	4659.96	14699.8	4.529	25.7
	RodE3_115.5	195	115.5	2.934	0.70	0.070	1115.20	874.9	3835.80	12100.0	4.324	24.6
	RodE3_118.5	196	118.5	3.010	0.146	0.146	1338.16	998.8	4562.25	14391.6	4.110	23.3
	RodE3_122.7	197	122.7	3.117	0.253	0.253	1362.32	1012.2	4285.42	13518.3	3.778	21.5
	RodE3_126.5	198	126.5	3.213	0.349	0.349	1377.09	1020.4	3896.98	12293.0	3.391	19.3
	RodE3_131.7	199	131.7	3.345	-1.8	-0.046	1379.12	1021.6	3545.31	11183.7	3.080	17.5
	RodE3_135.6	200	135.6	3.444	0.053	0.053	1301.94	978.7	3051.52	9626.0	2.841	16.1
	RodC5_63.7	225	63.7	1.618	1.618	16.7	1051.13	839.3	3731.77	11771.9	4.534	25.7
	RodC5_113.6	226	113.6	2.885	0.85	0.022	1236.80	942.5	4870.98	15365.5	4.828	27.4
Gr-4	RodC5_115.7	227	115.7	2.939	2.95	0.075	1336.91	998.1	3145.18	9921.5	2.836	16.1
	RodC5_122.7	229	122.7	3.117	9.95	0.253	1288.53	971.2	2753.61	8686.2	2.596	14.7
	RodC5_126.7	230	126.7	3.218	13.95	0.354	971.03	794.8	3411.34	10761.1	4.591	26.1
	RodC5_131.6	231	131.6	3.343	-1.9	-0.048	988.24	804.4	3540.44	11168.3	4.657	26.4
	RodC5_135.7	232	135.7	3.447	2.2	0.056	1028.51	826.8	3628.32	11445.5	4.532	25.7
	RodE5_63.6	209	63.6	1.615	1.615	16.6	1277.78	965.3	1895.70	5980.0	1.806	10.3
	RodE5_113.6	210	113.6	2.885	0.85	0.022	1323.44	990.6	5347.30	16868.1	4.881	27.7
	RodE5_115.4	211	115.4	2.931	2.931	2.65	1201.56	922.9	4958.22	15640.7	5.093	28.9
	RodE5_118.7	212	118.7	3.015	3.015	5.95	1276.45	964.5	1963.55	6194.0	1.873	10.6
	RodE5_122.6	213	122.6	3.114	3.114	9.85	1034.39	830.0	4705.67	14844.0	5.836	33.1
Gr-5	RodE5_126.6	214	126.6	3.216	13.85	0.352	1114.71	874.7	4808.64	15168.9	5.423	30.8
	RodE5_131.6	215	131.6	3.343	-1.9	-0.048	1155.31	897.2	4871.46	15367.0	5.253	29.8
	RodE5_135.6	216	135.6	3.444	2.1	0.053	1202.07	923.2	4939.44	15581.5	5.071	28.8
	RodC3_79.8	177	79.8	2.027	2.027	8.92	1137.09	887.1	4795.32	15126.8	5.275	30.0
	RodC3_85.6	178	85.6	2.174	2.174	14.72	1166.18	903.2	4853.36	15309.9	5.173	29.4
	RodC3_88.5	179	88.5	2.248	0	0.000	1260.82	955.8	1949.64	6150.1	1.888	10.7
	RodC3_92.4	180	92.4	2.347	0.099	0.099	921.61	767.4	3396.58	10714.5	4.897	27.8
	RodC3_94.4	181	94.4	2.398	5.9	0.150	984.01	802.0	3523.28	11114.2	4.660	26.5
	RodC3_97.2	182	97.2	2.469	2.469	8.7	1304.56	980.1	5261.15	16596.3	4.887	27.8
	RodC3_108.8	183	108.8	2.764	2.764	20.3	1213.85	929.7	4977.39	15701.2	5.049	28.7
Gr-8	RodD5_50	217	50	1.270	3	0.076	1263.06	957.1	3339.68	10535.0	3.227	18.3
	RodD5_54.1	218	54.1	1.374	7.1	0.180	1335.71	997.4	3834.51	12095.9	3.462	19.7
	RodD5_56.9	219	56.9	1.445	9.9	0.251	1337.29	998.3	3486.55	10998.3	3.143	17.8
	RodD5_60	220	60	1.524	13	0.330	1244.73	946.9	3045.05	9605.6	2.995	17.0
	RodD5_66.1	221	66.1	1.679	19.1	0.485	1254.30	952.2	2679.68	8453.1	2.611	14.8
	RodD5_69.9	222	69.9	1.775	-0.98	-0.025	1032.46	829.0	4722.62	14897.5	5.871	33.3
	RodD5_72.9	223	72.9	1.852	2.02	0.051	1111.21	872.7	4818.75	15200.7	5.456	31.0
	RodD5_74.9	224	74.9	1.902	1.902	4.02	1152.65	895.7	4894.11	15438.5	5.293	30.1

Table A-39: Summary of Steam Cooling Heat Transfer Reduced Data for Experiment 4042, continued

5x5 periphery												
H.R. ID	H.R. Location	Channel Number	Elevation (in)	Elevation (m)	Zgrid (in)	Zgrid (m)	H.R. Tw (°F)	H.R. Tw (K)	H.R. q" (Btu/hr-ft ²)	H.R. q" (W/m ²)	h _{sat} (z) (Btu/hr-ft ² -F)	h _{sat} (z) (W/m ² -K)
Gr-2	RodB5_41	153	41	1.041	13.5	0.343	585.96	580.9	2271.71	7166.1	6.346	36.0
	RodB5_52.9	154	52.9	1.344	5.9	0.150	657.08	620.4	2503.02	7895.8	5.833	33.1
	RodB5_55	155	55	1.397	8	0.203	680.19	633.3	2698.99	8514.0	5.969	33.9
	RodB5_57.8	156	57.8	1.468	10.8	0.274	761.13	678.2	2832.88	8936.3	5.314	30.2
	RodB5_64	157	64	1.626	17	0.432	794.81	696.9	2898.00	9141.8	5.113	29.0
	RodB5_73.9	158	73.9	1.877	3.02	0.077	841.76	723.0	2998.33	9458.2	4.885	27.7
Gr-2	RodB5_75.9	159	75.9	1.928	5.02	0.128	885.58	747.4	3102.25	9786.0	4.718	26.8
	RodB5_76.9	160	76.9	1.953	6.02	0.153	971.15	794.9	3495.30	11025.9	4.703	26.7
	RodF5_41	105	41	1.041	13.5	0.343	590.91	583.7	2274.29	7174.2	6.267	35.6
	RodF5_53.1	106	53.1	1.349	6.1	0.155	652.08	617.6	2502.03	7892.6	5.900	33.5
	RodF5_55	107	55	1.397	8	0.203	656.23	619.9	2699.62	8516.0	6.304	35.8
	RodF5_57.8	108	57.8	1.468	10.8	0.274	740.90	667.0	2832.79	8936.0	5.523	31.4
Gr-2	RodF5_64	109	64	1.626	17	0.432	771.98	684.2	2897.25	9139.4	5.326	30.2
	RodF5_73.8	110	73.8	1.875	2.92	0.074	813.34	707.2	2993.85	9444.1	5.115	29.0
	RodF5_75.8	111	75.8	1.925	4.92	0.125	930.13	772.1	3399.80	10724.7	4.842	27.5
	RodF5_76.8	112	76.8	1.951	5.92	0.150	995.73	808.6	3525.33	11120.7	4.592	26.1
	RodC2_41	57	41	1.041	13.5	0.343	1200.15	922.1	2124.72	6702.4	2.186	12.4
	RodC2_53.1	58	53.1	1.349	6.1	0.155	810.54	705.7	3336.15	10523.9	5.727	32.5
Gr-2	RodC2_55	59	55	1.397	8	0.203	926.89	770.3	4382.36	13824.2	6.270	35.6
	RodC2_57.8	60	57.8	1.468	10.8	0.274	1097.76	865.2	4957.67	15639.0	5.700	32.4
	RodC2_63.9	61	63.9	1.623	16.9	0.429	1206.22	925.5	4611.51	14547.0	4.714	26.8
	RodC2_73.8	62	73.8	1.875	2.92	0.074	1254.55	952.3	3522.86	11112.8	3.432	19.5
	RodC2_75.8	63	75.8	1.925	4.92	0.125	976.51	797.9	4268.35	13464.5	5.702	32.4
	RodC2_76.8	64	76.8	1.951	5.92	0.150	994.92	808.1	4300.28	13566.2	5.607	31.8
Gr-2	RodC6_40.9	137	40.9	1.039	13.4	0.340	1024.91	824.8	3618.22	11413.7	4.540	25.8
	RodC6_52.8	138	52.8	1.341	5.8	0.147	1016.66	820.2	3747.03	11820.0	4.751	27.0
	RodC6_54.8	139	54.8	1.392	7.8	0.198	1045.06	836.0	3938.05	12422.6	4.820	27.4
	RodC6_57.8	140	57.8	1.468	10.8	0.274	802.28	701.1	4075.35	12855.7	7.096	40.3
	RodC6_63.8	141	63.8	1.621	16.8	0.427	869.89	738.6	4169.02	13151.2	6.495	36.9
	RodC6_73.7	142	73.7	1.872	2.82	0.072	914.98	763.7	4226.52	13332.5	6.152	34.9
Gr-2	RodC6_75.8	143	75.8	1.925	4.92	0.125	1017.50	820.7	4367.10	13776.0	5.531	31.4
	RodC6_76.8	144	76.8	1.951	5.92	0.150	1031.73	828.6	4557.69	14377.2	5.671	32.2

Table A-39: Summary of Steam Cooling Heat Transfer Reduced Data for Experiment 4042, continued

H.R.		Channel Number	Elevation (in)	Elevation (m)	Zgrid (in)	Zgrid (m)	H.R. Tw (°F)	H.R. Tw (K)	H.R. q" (Btu/hr-ft ²)	H.R. q" (W/m ²)	h _{sat} (z) (Btu/hr-ft ² -F)	h _{sat} (z) (W/m ² -K)
Location	Number											
Gr-3	RodB4_88.4	161	88.4	2.245	-0.1	-0.003	968.72	788.0	4301.96	13570.5	5.887	33.4
	RodB4_91.3	162	91.3	2.319	2.8	0.071	977.89	798.6	4335.47	13676.3	5.781	32.8
	RodB4_93.3	163	93.3	2.370	4.8	0.122	411.08	483.8	1873.63	5910.4	10.234	58.1
	RodB4_95.1	164	95.1	2.416	6.6	0.168	505.79	536.4	2106.90	6646.2	7.584	43.1
	RodB4_100	165	100	2.540	11.5	0.292	1292.20	973.3	5194.94	16387.4	4.882	27.7
	RodB4_106	166	106	2.692	17.5	0.445	1320.95	989.2	5288.52	16682.6	4.839	27.5
	RodB4_109.9	167	109.9	2.791	21.4	0.544	1284.68	969.1	4853.60	15310.7	4.593	26.1
	RodB4_142.3	168	142.3	3.614	8.8	0.224	925.36	769.5	4232.44	13351.2	6.069	34.5
Gr-5	RodF4_85.6	98	85.6	2.174	14.72	0.374	948.83	782.5	4265.22	13454.6	5.917	33.6
	RodF4_88.4	99	88.4	2.245	-0.1	-0.003	967.25	792.7	4298.09	13598.3	5.814	33.0
	RodF4_92.4	100	92.4	2.347	3.9	0.099	409.39	482.8	1880.01	5930.5	10.364	58.9
	RodF4_94.3	101	94.3	2.395	5.8	0.147	507.86	537.5	2109.39	6654.1	7.537	42.8
	RodF4_97.2	102	97.2	2.469	8.7	0.221	1323.12	990.4	5332.55	16821.5	4.869	27.7
	RodF4_108.8	103	108.8	2.764	20.3	0.516	1267.46	959.5	5186.83	16361.9	4.990	28.3
	RodF4_111	104	111	2.819	-1.75	-0.044	1269.35	960.6	5126.49	16171.5	4.923	28.0
	RodD2_103.2	65	103.2	2.621	14.7	0.373	1199.53	921.8	5032.36	15874.6	5.180	29.4
Gr-6	RodD2_106	66	106	2.692	17.5	0.445	1291.17	972.7	5220.34	16467.6	4.910	27.9
	RodD2_112.6	67	112.6	2.860	-0.15	-0.004	1240.35	944.5	5064.99	15977.5	5.003	28.4
	RodD2_114.9	68	114.9	2.918	2.15	0.055	1318.81	988.0	4612.48	14550.1	4.228	24.0
	RodD2_117.4	69	117.4	2.982	4.65	0.118	1338.96	999.2	4368.28	13779.7	3.932	22.3
	RodD2_120.8	70	120.8	3.068	8.05	0.204	1362.04	1012.1	4035.27	12729.3	3.558	20.2
	RodD2_124.8	71	124.8	3.170	12.05	0.306	1375.39	1019.5	3644.07	11495.2	3.176	18.0
	RodD2_128.6	72	128.6	3.266	15.85	0.403	1369.76	1016.3	3272.04	10321.7	2.866	16.3
	RodD6_103.1	129	103.1	2.619	14.6	0.371	1311.48	984.0	4758.85	15011.8	4.392	24.9
RodD6_106	130	106	2.692	17.5	0.445	1266.17	958.8	5062.40	15969.3	4.876	27.7	
RodD6_112.9	131	112.9	2.868	0.15	0.004	1212.23	928.8	4824.09	15217.6	4.901	27.8	
RodD6_114.9	132	114.9	2.918	2.15	0.055	960.94	789.2	3407.55	10749.1	4.649	26.4	
RodD6_116.8	133	116.8	2.967	4.05	0.103	1029.34	827.2	3538.42	11162.0	4.416	25.1	
RodD6_120.9	134	120.9	3.071	8.15	0.207	1154.78	896.9	4828.78	15232.4	5.210	29.6	
RodD6_124.8	135	124.8	3.170	12.05	0.306	1203.93	924.2	4902.15	15463.8	5.023	28.5	
RodD6_128.7	136	128.7	3.269	15.95	0.405	1293.11	973.8	1802.79	5686.9	1.693	9.6	

Table A-39: Summary of Steam Cooling Heat Transfer Reduced Data for Experiment 4042, continued

5x5 periphery		H.R. Location	Channel Number	Elevation (in)	Elevation (m)	Zgrid (in)	Zgrid (m)	H.R. Tw (°F)	H.R. Tw (K)	H.R. q" (Btu/hr-ft2)	H.R. q" (W/m2)	h _{sat} (Z) (Btu/hr-ft2-F)	h _{sat} (Z) (W/m2-K)
Gr-8	RodE2_50.1	73	50.1	1.273	0.079	3.1	0.079	1068.62	849.0	3634.29	11464.4	4.323	24.6
	RodE2_54	74	54	1.372	0.178	7	0.178	1103.45	868.4	3735.12	11782.4	4.266	24.2
	RodE2_56.9	75	56.9	1.445	0.251	9.9	0.251	1112.12	873.2	3955.73	12478.4	4.474	25.4
	RodE2_59.9	76	59.9	1.521	0.328	12.9	0.328	821.13	711.6	4124.69	13011.3	6.954	39.5
	RodE2_66	77	66	1.676	0.483	19	0.483	918.84	765.8	4226.52	13332.5	6.118	34.7
	RodE2_69.8	78	69.8	1.773	-0.027	-1.08	-0.027	960.10	788.8	4295.54	13550.3	5.867	33.3
	RodE2_72.9	79	72.9	1.852	0.051	2.02	0.051	416.83	486.9	1848.75	5831.9	9.791	55.6
	RodE2_74.9	80	74.9	1.902	0.102	4.02	0.102	514.65	541.3	2085.87	6579.9	7.277	41.3
Gr-8	RodB3_50.2	169	50.2	1.275	0.081	3.2	0.081	1309.01	982.6	4048.36	12770.5	3.745	21.3
	RodB3_54.1	170	54.1	1.374	0.180	7.1	0.180	1315.02	985.9	3668.17	11571.2	3.375	19.2
	RodB3_56.9	171	56.9	1.445	0.251	9.9	0.251	1313.11	984.9	3283.01	10356.3	3.026	17.2
	RodB3_60.1	172	60.1	1.527	0.333	13.1	0.333	886.43	747.8	3075.34	9701.2	4.671	26.5
	RodB3_66.1	173	66.1	1.679	0.485	19.1	0.485	1011.98	817.6	3492.57	11017.3	4.455	25.3
	RodB3_69.9	174	69.9	1.775	-0.025	-0.98	-0.025	1037.99	832.0	3562.68	11238.5	4.398	25.0
	RodB3_73	175	73	1.854	0.054	2.12	0.054	1068.62	849.1	3667.90	11570.4	4.363	24.8
	RodB3_75	176	75	1.905	0.105	4.12	0.105	1110.91	872.5	3880.96	12242.5	4.396	25.0
Gr-8	RodF3_50.1	89	50.1	1.273	0.079	3.1	0.079	1129.58	882.9	4810.97	15176.2	5.336	30.3
	RodF3_54	90	54	1.372	0.178	7	0.178	1165.97	903.1	4872.82	15371.3	5.195	29.5
	RodF3_57	91	57	1.448	0.254	10	0.254	864.77	735.8	3085.82	9734.2	4.846	27.5
	RodF3_60	92	60	1.524	0.330	13	0.330	946.66	781.3	3478.89	10974.2	4.841	27.5
	RodF3_66.1	93	66.1	1.679	0.485	19.1	0.485	977.40	798.4	3541.15	11170.6	4.725	26.8
	RodF3_70	94	70	1.778	-0.022	-0.88	-0.022	1027.79	826.4	3632.47	11458.6	4.542	25.8
	RodF3_73	95	73	1.854	0.054	2.12	0.054	1077.13	853.8	3835.12	12097.9	4.517	25.6
	RodF3_75	96	75	1.905	0.105	4.12	0.105	905.61	758.5	4198.37	13243.8	6.196	35.2
Gr-8	RodE6_50.2	121	50.2	1.275	0.081	3.2	0.081	593.72	585.2	2255.16	7113.9	6.166	35.0
	RodE6_54.1	122	54.1	1.374	0.180	7.1	0.180	657.25	620.5	2496.48	7875.2	5.816	33.0
	RodE6_57	123	57	1.448	0.254	10	0.254	674.14	629.9	2690.23	8486.3	6.030	34.2
	RodE6_60.2	124	60.2	1.529	0.335	13.2	0.335	760.09	677.6	2826.93	8917.5	5.313	30.2
	RodE6_66.1	125	66.1	1.679	0.485	19.1	0.485	791.30	695.0	2893.07	9126.2	5.136	29.2
	RodE6_70	126	70	1.778	-0.022	-0.88	-0.022	834.24	718.8	2993.00	9441.4	4.937	28.0
	RodE6_73.1	127	73.1	1.857	0.056	2.22	0.056	958.24	787.7	3385.98	10681.1	4.637	26.3
	RodE6_75	128	75	1.905	0.105	4.12	0.105	1016.46	820.1	3516.62	11093.2	4.460	25.3

BIBLIOGRAPHIC DATA SHEET

(See instructions on the reverse)

2. TITLE AND SUBTITLE
Rod Bundle Heat Transfer Facility- Steam Cooling with Droplet Injection Experiments Data Report

3. DATE REPORT PUBLISHED

MONTH	YEAR
May	2015

4. FIN OR GRANT NUMBER
N6154

5. AUTHOR(S)
L.E. Hochreiter, F-B. Cheung, T. F. Lin, D.J. Miller, B.R. Lowery

6. TYPE OF REPORT
Technical

7. PERIOD COVERED (Inclusive Dates)
Mar. 2005 - Aug. 2008

8. PERFORMING ORGANIZATION - NAME AND ADDRESS (If NRC, provide Division, Office or Region, U. S. Nuclear Regulatory Commission, and mailing address; if contractor, provide name and mailing address.)
The Pennsylvania State University
University Park, PA 16802

9. SPONSORING ORGANIZATION - NAME AND ADDRESS (If NRC, type "Same as above", if contractor, provide NRC Division, Office or Region, U. S. Nuclear Regulatory Commission, and mailing address.)
Division of Systems Analysis
Office of Nuclear Regulatory Research
U.S. Nuclear Regulatory Commission
Washington, DC 20555-0001

10. SUPPLEMENTARY NOTES
K. Tien, NRC Project Manager

11. ABSTRACT (200 words or less)
As part of the Nuclear Regulatory Commission safety analysis computer code development efforts, the Rod Bundle Heat Transfer (RBHT) test facility has been designed and constructed at The Pennsylvania State University. The test series described in this report is the steam cooling tests with droplet injection. A total of 85 steady-state steam cooling experiments with prescribed droplet injection was performed in the RBHT. The purpose of the experiments was to examine steady-state dispersed flow film boiling in prototypical rod bundle geometry for computer code model development and validation. The Rod Bundle Heat Transfer facility is a full length, 3.66 m (12 ft.), 7 by 7 rod array with typical Pressurized Water Reactor rod diameters of 9.49 mm (0.374 in.) and a rod pitch of 12.59 mm (0.496 in.). The heater rods have a top skewed power shape with a peak to average power of 1.5 at the 2.74 m (9 ft.) elevation. The RBHT facility has been designed using prototypical mixing vane spacer grids. The bundle inlet steam Reynolds number ranged from 2000 to 15,000 with most of the experiments at the lower Reynolds number range. The droplets were injected upward in the center of the sub-channels at the 1.295 m (51 in.) elevation using two or four injection tubes. The injection tubes used a single row, linear hole pattern of four holes per sub-channel and four sub-channels per tube in the center of the bundle. One additional hole was located at the center of the rod gap location to minimize the chance of local

12. KEY WORDS/DESCRIPTORS (List words or phrases that will assist researchers in locating the report.)
heat transfer enhancement, mixing vane, super heated steam, reactor safety, reactor systems codes, reflood heat transfer, rod bundle, spacer grid, thermal hydraulics, droplet injection

13. AVAILABILITY STATEMENT
unlimited

14. SECURITY CLASSIFICATION
(This Page)
unclassified

(This Report)
unclassified

15. NUMBER OF PAGES

16. PRICE



Federal Recycling Program



**UNITED STATES
NUCLEAR REGULATORY COMMISSION**
WASHINGTON, DC 20555-0001

OFFICIAL BUSINESS



**NUREG/CR-7192
Volume 1**

**Rod Bundle Heat Transfer Facility Steam Cooling with Droplet Injection
Experiments Data Report**

May 2015