



**Pacific Gas and
Electric Company®**

James M. Welsch
Site Vice President

Diablo Canyon Power Plant
Mail Code 104/6
P. O. Box 56
Avila Beach, CA 93424

805.545.3242
Internal: 691.3242
Fax: 805.545.4884

April 29, 2015

PG&E Letter DCL-15-053

U.S. Nuclear Regulatory Commission
ATTN: Document Control Desk
Washington, DC 20555-0001

10 CFR 50.36a(a)(2)

Docket No. 50-275, OL-DPR-80
Docket No. 50-323, OL-DPR-82
Diablo Canyon Units 1 and 2
2014 Annual Radioactive Effluent Release Report

Dear Commissioners and Staff:

Pacific Gas and Electric Company (PG&E) is submitting the enclosed 2014 Annual Radioactive Effluent Release Report in accordance with 10 CFR 50.36a(a)(2) and Section 5.6.3 of the Diablo Canyon Power Plant (DCPP) Technical Specifications.

Enclosure 1 is the DCPP 2014 Annual Radioactive Effluent Release Report, which describes the quantities of radioactive gaseous and liquid effluents released from the plant, and the solid radioactive waste shipments made during the period of January 1, 2014, through December 31, 2014.

Enclosure 2 is a compact disk containing meteorological data as described in Enclosure 1, Section VIII, "Meteorological Data." If you have any questions, please contact John Knemeyer at (805) 545-4472.

PG&E makes no new or revised regulatory commitments in this letter (as defined by NEI 99-04).

Sincerely,

James M. Welsch

IE48
NRR



bnsn/4540/64105147

Enclosures

cc: Diablo Distribution

cc/encl: Penny Borenstein, San Luis Obispo County Health Officer (w/o CD)

Marc L. Dapas, NRC Region IV Administrator

Kenneth A. Harris Jr., Executive Officer, CCRWQCB (w/o CD)

Thomas R. Hipschman, NRC Senior Resident Inspector

Siva P. Lingam, NRR Project Manager

Bernice E. Minga, INPO (w/o CD)

Gonzalo Perez, Branch Chief, California Department of Public Health
(w/o CD)

Enclosure 1
Diablo Canyon Power Plant
2014 Annual Radioactive Effluent Release Report

**DIABLO CANYON POWER PLANT
2014 ANNUAL RADIOACTIVE EFFLUENT RELEASE REPORT**



January 1 - December 31, 2014



DIABLO CANYON POWER PLANT

Annual Radioactive Effluent Release Report
January 1, 2014 through December 31, 2014

Table of Contents

	Introduction	1
I.	Supplemental Information	2
II.	Changes to Radwaste Management	9
III.	Changes to the Offsite Dose Calculation Manual	10
IV.	Land Use Census	11
V.	Gaseous and Liquid Effluents	11
	Table 1 - Gaseous Effluents – Summation of All Releases	12
	Table 2 - Gaseous Effluents – Ground-Level Releases	15
	Table 3 - Gaseous Effluents – Lower Limits of Detection	19
	Table 4 – Liquid Effluents – Summation of All Releases	21
	Table 5 – Liquid Effluents – Nuclides Released	25
	Table 6 – Liquid Effluents – Lower Limit of Detection (LLD)	30
VI.	Solid Waste Shipments	33
VII.	Radiation Dose due to Gaseous and Liquid Effluents	35
	Table 7 – Radiation Dose Due to the Release of Radioactive Liquid Effluents	41
	Table 8 – Radiation Dose Due to the Release of Radioactive Gaseous Effluents	42
	Table 9 – Percent of Technical Specification Limits for Radioactive Liquid	45
	Table 10 – Percent of Technical Specification Limits for Radioactive Gaseous Effluents	46
	Table 11 – Onsite Dose to Members of the Public	48
VIII.	Meteorological Data	53

DIABLO CANYON POWER PLANT

**Annual Radioactive Effluent Release Report
January 1, 2014 through December 31, 2014**

Attachments

1. Diablo Canyon Power Plant Program Directive, CY2, "Radiological Monitoring and Controls Program," Revision 7
2. Diablo Canyon Power Plant Interdepartmental Administrative Procedure (IDAP), CY2.ID1, "Radioactive Effluent Controls Program," Revision 12
3. IDAP RP1.ID11, "Environmental Radiological Monitoring Procedure," Revision 12
4. IDAP RP1.ID11, "Environmental Radiological Monitoring Procedure," Revision 12A
5. Diablo Canyon Power Plant Chemical Analysis Procedure, CAP A-8, "Off-Site Dose Calculations," Revision 36
6. Diablo Canyon Power Plant Departmental Administrative Procedure, RP2.DC2, "Radwaste Solidification Process Control Program," Revision 15
7. Diablo Canyon Power Plant Departmental Administrative Procedure, RP2.DC3, "Radwaste Dewatering Process Control Program," Revision 9
8. 2014 DCPD Land Use Census

DIABLO CANYON POWER PLANT

2014 Annual Radioactive Effluent Release Report

Introduction

The 2014 Annual Radioactive Effluent Release Report (ARERR) summarizes gaseous and liquid radiological effluent releases from Diablo Canyon Power Plant's (DCPP) Units 1 and 2. The report includes the dose due to release of radioactive liquid and gaseous effluents and summarizes solid radwaste shipments. The report contains information required by Units 1 and 2 Technical Specification (TS) 5.6.3 and is presented in the general format of Regulatory Guide 1.21, "Measuring, Evaluating, and Reporting Radioactivity in Solid Wastes and Releases of Radioactive Materials in Liquid and Gaseous Effluents from Light-Water Nuclear Power Plants," Appendix B, "Effluent and Waste Disposal Report." Procedure revisions that implement the Off-Site Dose Calculation Manual and one compact disk containing meteorological data are attached.

In all cases, the doses associated with plant effluent releases during the report period were much less than the respective TS limits.

I. Supplemental Information

A. Regulatory Limits

1. Gaseous Effluents

a. Noble Gas Dose Rate Limit

The dose rate in areas at or beyond the site boundary due to radioactive noble gases released in gaseous effluents is limited to less than or equal to 500 millirem (mR) per year to the total body and less than or equal to 3000 mR per year to the skin. (Attachment 6 of CY2.ID1, "Radioactive Effluent Controls Program" [RECP])

b. Particulate and Iodine Dose Rate Limit

The dose rate in areas at or beyond the site boundary due to iodine-131, iodine-133, tritium, and all radionuclides in particulate form with half lives greater than 8 days in gaseous effluents, is limited to less than or equal to 1500 mR per year to any organ. (Attachment 6 of RECP)

c. Noble Gas Dose Limit

The air dose due to noble gases released in gaseous effluents from each reactor unit to areas at or beyond the site boundary is limited to the following:

Radiation Type	Calendar Quarter Limit Attachment 7 of RECP	Calendar Year Limit Attachment 7 of RECP
Gamma	5 millirad	10 millirad
Beta	10 millirad	20 millirad

d. Particulate and Iodine Dose Limit

The dose to an individual from iodine-131, iodine-133, tritium, and all radionuclides in particulate form with half lives greater than 8 days in gaseous effluents released from each reactor unit to areas at or beyond the site boundary is limited to less than or equal to 7.5 mR to any organ in any calendar quarter and less than or equal to 15 mR to any organ during a calendar year. (Attachment 8 of RECP)

2. Liquid Effluents

a. Concentration

With the exception of dissolved or entrained noble gases, the concentration of radioactive material released from the site in liquid form is limited to the concentrations specified in 10 CFR Part 20, Appendix B, Table 2, Column 2. For dissolved or entrained noble gases, the total specific activity is limited to 2×10^{-4} microcuries/milliliter ($\mu\text{Ci/ml}$). (Attachment 3 of RECP)

b. Dose

The dose or dose commitment to a member of the public from radioactive materials in liquid effluents released from each reactor unit to areas at or beyond the site boundary is limited to the following:

Dose Type	Calendar Quarter Limit Attachment 4 of RECP	Calendar Year Limit Attachment 4 of RECP
Total Body	1.5 millirem	3 millirem
Any Organ	5 millirem	10 millirem

B. Maximum Permissible Concentrations

1. Gaseous Effluents

Maximum permissible concentrations are not used for determining allowable release rates for gaseous effluents at DCPD.

2. Liquid Effluents

With the exception of dissolved or entrained noble gases, the concentrations listed in 10 CFR 20, Appendix B, Table 2, Column 2, for radionuclides are used for determining the allowable release concentration at the point of discharge from the site for liquid effluents. For dissolved or entrained noble gases, the allowable release concentration for liquid effluents at the point of discharge is limited to 2×10^{-4} $\mu\text{Ci/ml}$ total activity.

C. Measurements and Approximations of Total Radioactivity

1. Gaseous Effluents

a. Fission and Activation Gases

A pair of off-line monitors equipped with beta scintillator detectors measure the gaseous radioactivity released from the plant vent. The readings from these monitors are correlated to the isotopic concentrations determined in grab samples that are analyzed in the laboratory using a germanium detector.

For plant vent noble gas releases, grab sample results are used to quantify releases. The individual batch release data are used to quantify the radioactivity discharged from the gas decay tanks and containment.

A noble gas grab sample is obtained from the plant vent and analyzed at least weekly. The isotopic mixture is assumed to remain constant between grab sample analyses.

Containment purges, gas decay tank releases, and air ejector discharges are released via the plant vent.

The gaseous radioactivity released from the steam generator blowdown tank vent is measured by analyzing liquid or steam condensate grab samples with a germanium detector. The ratio of unit masses of water flashing to steam and water entering the tank is used to calculate the activity. The isotopic concentrations are assumed to remain constant between grab samples.

Other potential pathways for releasing gaseous radioactivity are periodically monitored by collecting grab samples and analyzing these samples with a germanium detector system.

b. Iodines

Radioiodines released from the plant vent are measured through continuous sample collection on silver zeolite cartridges. The cartridges are changed at least weekly and analyzed with a germanium detector. The radioiodine releases are averaged over the period of cartridge sample collection.

Other potential pathways for releasing radioiodines are periodically measured by collecting samples using charcoal or silver zeolite cartridges and analyzing with a germanium detector.

Radioactive materials in particulate form released from the plant vent are measured through continuous sample collection on particulate filters. The filters are changed at least weekly and analyzed with a germanium detector. The particulate radioactivity is averaged over the period of particulate filter sample collection. Each filter is analyzed for alpha emitters using an internal proportional counter. Plant vent particulate filters collected during a quarter are used for the composite analysis for strontium-89 and -90, which is counted on an internal proportional counter after chemical separation.

Other potential pathways for releasing radioactive particulate are periodically monitored by collecting samples using particulate filters and analyzing these filters with a germanium detector.

c. Tritium

Tritium released from the plant vent is monitored by passing a measured volume of plant vent sample through a water column and determining the tritium increase in the water. An aliquot of the water is counted in a liquid scintillation spectrometer. The minimum routine sample frequency for tritium in the plant vent is weekly. The tritium concentration is assumed to remain constant between samples.

d. Estimations of Overall Error

Sources of error considered for gaseous batch releases are: 1) calibration source; 2) calibration counting; 3) sampling; 4) sample counting; and 5) gas decay tank pressure gauge/containment exhaust fan flow rate.

Sources of error for continuous release are: 1) calibration source; 2) calibration counting; 3) sampling; 4) sample counting; 5) process monitor (RE-14) reading (fission gases only); and 6) plant vent exhaust fan flow rate.

$$\text{Total error} = (\sigma^2_1 + \sigma^2_2 + \sigma^2_3 + \dots + \sigma^2_i)^{1/2}$$

Where σ_i = error associated with each component.

2. Liquid Effluents

a. Batch Releases

Each tank of liquid radwaste is analyzed for principal gamma emitters using a germanium detector prior to release. A monthly prerelease analysis includes measurement of dissolved and entrained gases. Volume-proportional monthly and quarterly composites are prepared from aliquots of each tank volume discharged. The monthly composite is analyzed for tritium using a liquid scintillation spectrometer and gross alpha radioactivity using an internal proportional counter. The quarterly composite is analyzed for iron-55 using a liquid scintillation spectrometer and for strontium-89 and -90 using an internal proportional detector following chemical separations. The quarterly composite for discharges from the auxiliary building are also analyzed for nickel-63, uranium-233/234/235/236/238 and plutonium-238/239/240/241/242.

b. Continuous Releases

For the continuous liquid releases of the steam generator blowdown tank and turbine building sump oily water separator, daily grab samples are collected and aliquots are proportioned for weekly, monthly, and quarterly composites.

The oily water separator weekly composite is analyzed for principal gamma emitters using a germanium detector. The steam generator blowdown tank weekly composite is analyzed for principal gamma emitters and iodine-131.

The steam generator blowdown tank monthly composite is analyzed for tritium using a liquid scintillation spectrometer and for gross alpha using an internal proportional counter.

The steam generator blowdown tank quarterly composite is analyzed for iron-55 using a liquid scintillation spectrometer and for strontium-89 and strontium-90 using an internal proportional counter following chemical separation. The results for each of the composites are averaged over the period of the composite.

In addition, one grab sample of the steam generator blowdown tank is analyzed monthly for dissolved and entrained gases using a germanium detector. The results of this analysis are assumed to remain constant over the period of one month.

A grab sample of the steam generator blowdown is collected at least weekly and analyzed for gamma activity using a germanium detector. This analysis is used to monitor activity, however, is not used in effluent calculations unless a significant change is detected.

Note on dilution volume:

Tables 4A, 4B and 4C, "Liquid Effluents - Summation of All Releases," Item F., lists the, "Volume of circulating saltwater used during release periods," in liters. This value is calculated by multiplying the discharge duration by the circulating water flow rate. The values listed in the Tables are the summation of the circulating water discharge volume calculated for each individual batch and continuous discharge period. Therefore, in the case where two or more simultaneous discharges into the same circulating water are occurring, the calculated volume of circulating water is duplicated, and therefore the sum of the dilution volumes for the batch releases and continuous releases are greater than the actual dilution volume since each discharge incorporates the circulating discharge flow rate in its own dose calculation.

c. Estimation of Overall Error

Sources of error considered for liquid releases are: 1) calibration source error; 2) calibration counting error; 3) sampling error; 4) sample counting error; and 5) volume of waste release error.

These sources of error are independent of one another. Therefore the total error is calculated according to the following formula:

$$\text{Total error} = (\sigma_1^2 + \sigma_2^2 + \sigma_3^2 + \dots + \sigma_i^2)^{1/2}$$

Where σ_i = error associated with each component.

D. Batch Releases

1. Liquid

a. Number of batch releases.....	627
b. Total time period for batch releases.....	2766 hours
c. Maximum time period for a batch release.....	168 hours
d. Average time period for a batch release.....	4.41 hours
e. Minimum time period for a batch release.....	0.38 hours
f. Average saltwater flow during batch releases.....	1.06E+06 gallons per minute (gpm)

2. Gaseous

a. Number of batch releases.....	140
b. Total time period for batch releases.....	1430 hours
c. Maximum time period for a batch release.....	72.00 hours
d. Average time period for a batch release.....	10.21 hours
e. Minimum time period for a batch release.....	0.30 hours

E. Abnormal Release (Gaseous and Liquid)

No abnormal releases occurred during 2014.

F. Any liquid or gaseous effluent monitoring systems that became inoperable during the reporting period were corrected within the time limits specified in Attachments 1 and 2.

II. Changes to Radwaste Management

A. Major Changes to Liquid, Gaseous and Solid Radwaste Treatment System

No major changes were made to the treatment system during 2014.

As reported in 2012, an enhancement was made to the liquid radwaste treatment system in 2012. Modifications were made to provide mobile radwaste system connections downstream of in-plant vessels. This enables the use of a leased reverse osmosis unit (RO) in place of the vendor-supplied advance filtration unit that had been connected to the mobile radwaste system at the front of in-plant treatment systems.

During 2014, a leased RO unit remained in service.

B. Changes to the Radwaste Process Control Program (PCP)

There were no changes to the Radwaste PCP promulgated by Plant Administration Procedures. See Attachments 6 and 7:

- RP2.DC2, "Radwaste Solidification Process Control Program,"
- RP2.DC3, "Radwaste Dewatering Process Control Program"

III. Changes to the Offsite Dose Calculation Manual (ODCM)

The Diablo Canyon ODCM is made up of the following procedures:

- Nuclear Power Generation Program Directive Procedure, CY2, "Radiological Monitoring and Controls Program" (RMCP)
- Nuclear Power Generation Interdepartmental Administrative Procedure (IDAP), CY2.ID1, "Radioactive Effluent Controls Program" (RECP)
- IDAP RP1.ID11, "Environmental Radiological Monitoring Procedure (ERMP)
- Diablo Canyon Power Plant Chemical Analysis Procedure, CAP A-8, "Offsite Dose Calculation Procedure" (ODCP)

If no changes were made to an ODCM procedure during the reporting period, the most recent revision is included as an attachment in order to provide a complete, current copy of the ODCM used during the reporting period.

If changes were made to procedures during the reporting period, they are described below. A copy of each revision made during the reporting period is included as an attachment. Changes that were strictly editorial are not described below.

A. RMCP

1. No changes were made to the RMCP during 2014.
2. See Attachment 1.

B. RECP

1. Revision 12 of the RECP was implemented during 2014.
2. Revision 12 added new step that directs the user to ensure that changes to RP2.DC3 are described in the ARRER.
3. Revision 12 adds direction for sampling the condenser vacuum pump exhaust; specifically while the main steam isolation valves are open. This addition corrects an inconsistency between plant procedures and the UFSAR section 10.4.2.3. Frequency of sampling this exhaust is set at every 24 hours for consistency and conservatism. References have been added to ensure these commitments are not modified without due consideration.
4. This revision was implemented on 09/04/2014.
5. See Attachment 2.

C. ERMP

1. Revisions 12 and 12A of the ERMP were implemented during 2014.
2. Revision 12 included enhancement of Table 2 for Detection Capabilities/Lower Limits of Detection to NUREG-1301 values and to add soil matrix detection limits.
3. Revision 12 also added supplementary sampling for airborne carbon-14 and vegetation at location 7E1. A TLD was also added at location 2F2.
4. Revision 12 was issued on 2/10/2014. See Attachment 3.
5. Revision 12A was an editorial correction issued on 2/20/2014.
6. See Attachment 4.

D. ODCP

1. No changes to the ODCP were made during 2014.
2. See Attachment 5.

IV. Land Use Census

Changes to the Land Use Census Program are included as Attachment 7.

V. Gaseous and Liquid Effluent Release Report

Tables 1 through 3 describe 2014 releases of gaseous effluents.
Tables 4 through 6 describe 2014 releases of liquid effluents.

**DIABLO CANYON POWER PLANT
ANNUAL RADIOACTIVE EFFLUENT RELEASE REPORT 2014**

**TABLE 1A
GASEOUS EFFLUENTS - SUMMATION OF ALL RELEASES**

Units	First Quarter	Second Quarter	Est.Total Error %
-------	---------------	----------------	-------------------

A. Fission and activation gases

1. Total release	Ci	1.02E+0	5.89E+0	24%
2. Average release rate for period	μCi/sec	1.32E-1	7.49E-1	
3. Percent of technical specification limit ¹	%	1.23E-3	2.24E-3	

B. Iodines

1. Total iodine-131	Ci	MDA	MDA	24%
2. Average release rate for period	μCi/sec	MDA	MDA	
3. Percent of technical specification limit ¹	%	MDA	MDA	

C. Particulates

1. Particulates with half-lives >8 days	Ci	MDA	MDA	24%
2. Average release rate for period	μCi/sec	MDA	MDA	
3. Percent of technical specification limit ¹	%	MDA	MDA	
4. Gross alpha radioactivity	Ci	MDA	2.21E-7	

D. Tritium

1. Total release	Ci	4.37E+1	1.63E+1	13%
2. Average release rate for period	μCi/sec	5.62E+0	2.08E+0	
3. Percent of technical specification limit ¹	%	1.27E-5	4.70E-6	

MDA = Less than the "a posteriori" minimum detectable activity (microcuries per unit mass or volume). This note applies to all tables.

¹ RECP Attachment 6 Limit

**DIABLO CANYON POWER PLANT
 ANNUAL RADIOACTIVE EFFLUENT RELEASE REPORT 2014**

**TABLE 1B
 GASEOUS EFFLUENTS - SUMMATION OF ALL RELEASES**

Units	Third Quarter	Fourth Quarter	Est.Total Error %
-------	---------------	----------------	-------------------

A. Fission and activation gases

1. Total release	Ci	1.78E-2	1.20E+0	24%
2. Average release rate for period	μCi/sec	2.23E-3	1.51E-1	
3. Percent of technical specification limit ¹	%	2.09E-5	1.38E-3	

B. Iodines

1. Total iodine-131	Ci	MDA	MDA	24%
2. Average release rate for period	μCi/sec	MDA	MDA	
3. Percent of technical specification limit ¹	%	MDA	MDA	

C. Particulates

1. Particulates with half-lives >8 days	Ci	MDA	MDA	24%
2. Average release rate for period	μCi/sec	MDA	MDA	
3. Percent of technical specification limit ¹	%	MDA	MDA	
4. Gross alpha radioactivity	Ci	3.05E-8	2.90E-7	

D. Tritium

1. Total release	Ci	1.72E+1	3.60E+1	13%
2. Average release rate for period	μCi/sec	2.16E+0	4.53E+0	
3. Percent of technical specification limit ¹	%	4.89E-6	1.03E-5	

MDA = Less than the "a posteriori" minimum detectable activity (microcuries per unit mass or volume). This note applies to all tables.

¹ RECP Attachment 6 Limit

**DIABLO CANYON POWER PLANT
 ANNUAL RADIOACTIVE EFFLUENT RELEASE REPORT 2014
 TABLE 1C
 GASEOUS EFFLUENTS - SUMMATION OF ALL RELEASES**

Units	Annual Total
-------	--------------

A. Fission and activation gases

1. Total release	Ci	8.14E+0
2. Average release rate for period	μCi/sec	2.58E-1
3. Percent of technical specification limit ¹	%	1.21E-3

B. Iodines

1. Total iodine-131	Ci	MDA
2. Average release rate for period	μCi/sec	MDA
3. Percent of technical specification limit ¹	%	MDA

C. Particulates

1. Particulates with half-lives >8 days	Ci	MDA
2. Average release rate for period	μCi/sec	MDA
3. Percent of technical specification limit ¹	%	MDA
4. Gross alpha radioactivity	Ci	5.42E-7

D. Tritium

1. Total release	Ci	1.13E+2
2. Average release rate for period	μCi/sec	3.59E+0
3. Percent of technical specification limit ¹	%	8.12E-6

MDA = less than the "a posteriori" minimum detectable activity (microcuries per unit mass or volume). This note applies to all tables.

¹ RECP Attachment 6 Limit

**DIABLO CANYON POWER PLANT
 ANNUAL RADIOACTIVE EFFLUENT RELEASE REPORT 2014**

**TABLE 2A
 GASEOUS EFFLUENTS - GROUND LEVEL RELEASES**

Nuclides Released	Units	First Quarter		Second Quarter	
		Continuous Mode	Batch Mode	Continuous Mode	Batch Mode

1. Fission gases

argon-41	Ci	MDA	1.02E+0	MDA	1.36E+0
krypton-85	Ci	MDA	3.67E-3	MDA	MDA
krypton-85m	Ci	MDA	MDA	MDA	MDA
krypton-87	Ci	MDA	MDA	MDA	MDA
krypton-88	Ci	MDA	MDA	MDA	MDA
xenon-131m	Ci	MDA	MDA	MDA	MDA
xenon-133	Ci	MDA	1.49E-3	MDA	2.89E+0
xenon-133m	Ci	MDA	MDA	MDA	2.21E-2
xenon-135	Ci	MDA	MDA	MDA	1.47E+0
xenon-135m	Ci	MDA	MDA	MDA	4.01E-2
xenon-138	Ci	MDA	MDA	MDA	1.08E-1
TOTAL FOR PERIOD	Ci	MDA	1.02E+0	MDA	5.89E+0

2. Iodines

iodine-131	Ci	MDA	MDA
iodine-133	Ci	MDA	MDA
iodine-135	Ci	MDA	MDA
TOTAL FOR PERIOD	Ci	MDA	MDA

MDA = Less than the "a posteriori" minimum detectable activity (microcuries per unit mass or volume). This note applies to all tables.

**DIABLO CANYON POWER PLANT
 ANNUAL RADIOACTIVE EFFLUENT RELEASE REPORT 2014
 TABLE 2A (Continued)
 GASEOUS EFFLUENTS - GROUND LEVEL RELEASES**

Nuclides Released	Units	Continuous Mode	
		First Quarter	Second Quarter

3. Particulates

barium-140	Ci	MDA	MDA
cesium-134	Ci	MDA	MDA
cesium-137	Ci	MDA	MDA
cerium-141	Ci	MDA	MDA
cerium-144	Ci	MDA	MDA
chromium-51	Ci	MDA	MDA
cobalt-57	Ci	MDA	MDA
cobalt-58	Ci	MDA	MDA
cobalt-60	Ci	MDA	MDA
iron-59	Ci	MDA	MDA
lanthanum-140	Ci	MDA	MDA
manganese-54	Ci	MDA	MDA
molybdenum-99	Ci	MDA	MDA
ruthenium-103	Ci	MDA	MDA
strontium-89	Ci	MDA	MDA
strontium-90	Ci	MDA	MDA
zinc-65	Ci	MDA	MDA
zirconium-95	Ci	MDA	MDA
TOTAL FOR PERIOD	Ci	MDA	MDA

MDA = Less than the "a posteriori" minimum detectable activity (microcuries per unit mass or volume).
 This note applies to all tables.

**DIABLO CANYON POWER PLANT
 ANNUAL RADIOACTIVE EFFLUENT RELEASE REPORT 2014
 TABLE 2B
 GASEOUS EFFLUENTS - GROUND LEVEL RELEASES**

Nuclides Released	Units	Third Quarter		Fourth Quarter	
		Continuous Mode	Batch Mode	Continuous Mode	Batch Mode

1. Fission gases

argon-41	Ci	MDA	1.78E-2	MDA	1.17E+0
krypton-85	Ci	MDA	MDA	MDA	2.02E-3
krypton-85m	Ci	MDA	MDA	MDA	MDA
krypton-87	Ci	MDA	MDA	MDA	MDA
krypton-88	Ci	MDA	MDA	MDA	MDA
xenon-131m	Ci	MDA	MDA	MDA	MDA
xenon-133	Ci	MDA	MDA	MDA	2.86E-2
xenon-133m	Ci	MDA	MDA	MDA	3.61E-4
xenon-135	Ci	MDA	MDA	MDA	2.13E-4
xenon-135m	Ci	MDA	MDA	MDA	MDA
xenon-138	Ci	MDA	MDA	MDA	MDA
TOTAL FOR PERIOD	Ci	MDA	1.78E-2	MDA	1.20E+0

2. Iodines

iodine-131	Ci	MDA	MDA
iodine-133	Ci	MDA	MDA
iodine-135	Ci	MDA	MDA
TOTAL FOR PERIOD	Ci	MDA	MDA

MDA = Less than the "a posteriori" minimum detectable activity (microcuries per unit mass or volume). This note applies to all tables.

**DIABLO CANYON POWER PLANT
 ANNUAL RADIOACTIVE EFFLUENT RELEASE REPORT 2014
 TABLE 2B (Continued)
 GASEOUS EFFLUENTS - GROUND LEVEL RELEASES**

Nuclides Released	Units	Continuous Mode	
		Third Quarter	Fourth Quarter

3. Particulates

barium-140	Ci	MDA	MDA
cesium-134	Ci	MDA	MDA
cesium-137	Ci	MDA	MDA
cerium-141	Ci	MDA	MDA
cerium-144	Ci	MDA	MDA
chromium-51	Ci	MDA	MDA
cobalt-57	Ci	MDA	MDA
cobalt-58	Ci	MDA	MDA
cobalt-60	Ci	MDA	MDA
iron-59	Ci	MDA	MDA
lanthanum-140	Ci	MDA	MDA
manganese-54	Ci	MDA	MDA
molybdenum-99	Ci	MDA	MDA
ruthenium-103	Ci	MDA	MDA
strontium-89	Ci	MDA	MDA
strontium-90	Ci	MDA	MDA
zinc-65	Ci	MDA	MDA
zirconium-95	Ci	MDA	MDA
TOTAL FOR PERIOD	Ci	MDA	MDA

MDA = Less than the "a posteriori" minimum detectable activity (microcuries per unit mass or volume).
 This note applies to all tables.

**DIABLO CANYON POWER PLANT
 ANNUAL RADIOACTIVE EFFLUENT RELEASE REPORT 2014**

**TABLE 3
 GASEOUS EFFLUENTS - LOWER LIMITS OF DETECTION**

Nuclide	Units	Continuous Mode	Batch Mode	
			Containment Purge	Gas Decay Tank

1. Fission gases

argon-41	μCi/ml	3.17E-8	3.17E-8	3.17E-8
krypton-85	μCi/ml	2.20E-6	2.20E-6	2.20E-6
krypton-85m	μCi/ml	6.24E-9	6.24E-9	6.24E-9
krypton-87	μCi/ml	5.05E-8	5.05E-8	5.05E-8
krypton-88	μCi/ml	3.22E-8	3.22E-8	3.22E-8
xenon-131m	μCi/ml	1.87E-7	1.87E-7	1.87E-7
xenon-133	μCi/ml	1.70E-8	1.70E-8	1.70E-8
xenon-133m	μCi/ml	4.91E-8	4.91E-8	4.91E-8
xenon-135	μCi/ml	6.23E-9	6.23E-9	6.23E-9
xenon-135m	μCi/ml	3.28E-6	3.28E-6	3.28E-6
xenon-138	μCi/ml	9.07E-6	9.07E-6	9.07E-6

2. Tritium

hydrogen-3	μCi/ml	4.52E-9	4.52E-9	N/A
------------	--------	---------	---------	-----

3. Iodines

iodine-131	μCi/ml	4.89E-13	N/A
iodine-133	μCi/ml	1.54E-12	N/A
iodine-135	μCi/ml	9.98E-11	N/A

**DIABLO CANYON POWER PLANT
 ANNUAL RADIOACTIVE EFFLUENT RELEASE REPORT 2014
 TABLE 3 (Continued)
 GASEOUS EFFLUENTS - LOWER LIMITS OF DETECTION**

Nuclide	Units	Continuous Mode
---------	-------	-----------------

4. Particulates

barium-140	μCi/ml	1.99E-12
cesium-134	μCi/ml	5.08E-13
cesium-137	μCi/ml	4.17E-13
cerium-141	μCi/ml	3.98E-13
cerium-144	μCi/ml	1.49E-12
chromium-51	μCi/ml	2.99E-12
cobalt-57	μCi/ml	2.18E-13
cobalt-58	μCi/ml	7.10E-13
cobalt-60	μCi/ml	8.81E-13
iron-59	μCi/ml	5.73E-13
lanthanum-140	μCi/ml	1.13E-12
manganese-54	μCi/ml	5.55E-13
molybdenum-99	μCi/ml	3.97E-13
ruthenium-103	μCi/ml	3.48E-13
strontium-89	μCi/ml	2.14E-15
strontium-90	μCi/ml	4.14E-16
zinc-65	μCi/ml	9.54E-13
zirconium-95	μCi/ml	3.67E-13
gross alpha	μCi/ml	1.97E-15

DIABLO CANYON POWER PLANT
ANNUAL RADIOACTIVE EFFLUENT RELEASE REPORT 2014

TABLE 4A
LIQUID EFFLUENTS - SUMMATION OF ALL RELEASES

Units	First Quarter	Second Quarter	Est.Total Error %
-------	---------------	----------------	-------------------

A. Fission and activation products

1. Total release (not including tritium, gases, alpha)	Ci	1.05E-2	8.76E-3	24%
2. Average diluted concentration during period	μCi/ml	5.07E-12	3.27E-12	
3. Percent of applicable limit ¹	%	5.49E-5	1.16E-5	

B. Tritium

1. Total release	Ci	1.02E+3	2.44E+2	13%
2. Average diluted concentration during period	μCi/ml	4.94E-7	9.10E-8	
3. Percent of applicable limit ¹	%	4.94E-2	9.10E-3	

C. Dissolved and entrained gasses

1. Total release	Ci	1.02E-3	1.40E-4	24%
2. Average diluted concentration during period	μCi/ml	4.92E-13	5.23E-14	
3. Percent of applicable limit ¹	%	2.46E-7	2.61E-8	

D. Gross Alpha

1. Total release	Ci	MDA	MDA	61%
------------------	----	-----	-----	-----

E. Volume of waste release (prior to dilution)	liters	8.25E+7	8.14E+7	5%
--	--------	---------	---------	----

F. Volume of circulating saltwater used during release periods	liters	2.07E+12	2.68E+12	7%
--	--------	----------	----------	----

MDA = Less than the "a posteriori" minimum detectable activity (microcuries per unit mass or volume). This note applies to all tables.

¹ RECP 6.1.6.1 Limit

**DIABLO CANYON POWER PLANT
ANNUAL RADIOACTIVE EFFLUENT RELEASE REPORT 2014**

**TABLE 4B
LIQUID EFFLUENTS - SUMMATION OF ALL RELEASES**

Units	Third Quarter	Fourth Quarter	Est.Total Error %
-------	---------------	----------------	-------------------

A. Fission and activation products

1. Total release (not including tritium, gases, alpha)	Ci	3.08E-3	5.30E-3	24%
2. Average diluted concentration during period	μCi/ml	1.15E-12	2.39E-12	
3. Percent of applicable limit ¹	%	1.64E-5	1.80E-5	

B. Tritium

1. Total release	Ci	5.45E+2	4.27E+2	13%
2. Average diluted concentration during period	μCi/ml	2.04E-7	1.92E-7	
3. Percent of applicable limit ¹	%	2.04E-2	1.92E-2	

C. Dissolved and entrained gasses

1. Total release	Ci	7.09E-4	9.31E-4	24%
2. Average diluted concentration during period	μCi/ml	2.65E-13	4.19E-13	
3. Percent of applicable limit ¹	%	1.32E-7	2.10E-7	

D. Gross Alpha

1. Total release	Ci	MDA	MDA	61%
------------------	----	-----	-----	-----

E. Volume of waste release (prior to dilution)	liters	8.30E+7	7.99E+7	5%
--	--------	---------	---------	----

F. Volume of circulating saltwater used during release periods	liters	2.68E+12	2.22E+12	7%
--	--------	----------	----------	----

MDA = Less than the "a posteriori" minimum detectable activity (microcuries per unit mass or volume). This note applies to all tables.

¹RECP 6.1.6.1 Limit

**DIABLO CANYON POWER PLANT
 ANNUAL RADIOACTIVE EFFLUENT RELEASE REPORT 2014**

**TABLE 4C
 LIQUID EFFLUENTS - SUMMATION OF ALL RELEASES**

Units	Annual Total
-------	--------------

A. Fission and activation products

1. Total release (not including tritium, gases, alpha)	Ci	2.77E-2
2. Average diluted concentration during period	μCi/ml	2.87E-12
3. Percent of applicable limit ¹	%	2.37E-5

B. Tritium

1. Total release	Ci	2.24E+3
2. Average diluted concentration during period	μCi/ml	2.32E-7
3. Percent of applicable limit ¹	%	2.32E-2

C. Dissolved and entrained gasses

1. Total release	Ci	2.80E-3
2. Average diluted concentration during period	μCi/ml	2.90E-13
3. Percent of applicable limit ¹	%	1.45E-7

D. Gross Alpha

1. Total release	Ci	MDA
------------------	----	-----

E. Volume of waste release (prior to dilution)	liters	3.27E+8
--	--------	---------

F. Volume of circulating saltwater used during release periods	liters	9.65E+12
--	--------	----------

MDA = Less than the "a posteriori" minimum detectable activity (microcuries per unit mass or volume). This note applies to all tables.

¹ RECP 6.1.6.1 Limit

**DIABLO CANYON POWER PLANT
ANNUAL RADIOACTIVE EFFLUENT RELEASE REPORT 2014
TABLE 5A
LIQUID EFFLUENTS - NUCLIDES RELEASED**

Nuclides Released	Units	First Quarter		Second Quarter	
		Continuous Mode	Batch Mode	Continuous Mode	Batch Mode
antimony-122	Ci	MDA	MDA	MDA	MDA
antimony-124	Ci	MDA	MDA	MDA	MDA
antimony-125	Ci	MDA	9.14E-4	MDA	1.05E-4
barium-140	Ci	MDA	MDA	MDA	MDA
beryllium-7	Ci	MDA	MDA	MDA	MDA
bromine-82	Ci	MDA	MDA	MDA	MDA
cerium-141	Ci	MDA	MDA	MDA	MDA
cerium-143	Ci	MDA	MDA	MDA	MDA
cerium-144	Ci	MDA	MDA	MDA	MDA
cesium-134	Ci	MDA	MDA	MDA	MDA
cesium-136	Ci	MDA	MDA	MDA	MDA
cesium-137	Ci	MDA	5.10E-5	MDA	2.75E-6
chromium-51	Ci	MDA	4.69E-4	MDA	5.99E-5
cobalt-57	Ci	MDA	MDA	MDA	MDA
cobalt-58	Ci	MDA	4.04E-4	MDA	2.41E-4
cobalt-60	Ci	MDA	2.92E-3	MDA	6.40E-4
iron-55	Ci	MDA	2.52E-3	MDA	7.60E-3
iron-59	Ci	MDA	2.46E-5	MDA	MDA
lanthanum-140	Ci	MDA	MDA	MDA	MDA

MDA = Less than the "a posteriori" minimum detectable activity (microcuries per unit mass or volume). This note applies to all tables.

**DIABLO CANYON POWER PLANT
 ANNUAL RADIOACTIVE EFFLUENT RELEASE REPORT 2014
 TABLE 5A (CONTINUED)
 LIQUID EFFLUENTS - NUCLIDES RELEASED**

Nuclides Released	Units	First Quarter		Second Quarter	
		Continuous Mode	Batch Mode	Continuous Mode	Batch Mode
manganese-54	Ci	MDA	4.19E-5	MDA	1.52E-5
manganese-56	Ci	MDA	MDA	MDA	MDA
molybdenum-99	Ci	MDA	MDA	MDA	7.59E-7
nickel-63	Ci	MDA	3.10E-3	MDA	8.56E-5
niobium-95	Ci	MDA	5.35E-5	MDA	1.14E-5
neodymium-147	Ci	MDA	MDA	MDA	MDA
plutonium-238	Ci	MDA	MDA	MDA	MDA
plutonium-239/240	Ci	MDA	MDA	MDA	MDA
plutonium-241	Ci	MDA	MDA	MDA	MDA
plutonium-242	Ci	MDA	MDA	MDA	MDA
ruthenium-103	Ci	MDA	MDA	MDA	MDA
silver-110m	Ci	MDA	MDA	MDA	MDA
sodium-24	Ci	MDA	MDA	MDA	MDA
strontium-89	Ci	MDA	MDA	MDA	MDA
strontium-90	Ci	MDA	MDA	MDA	MDA
strontium-91	Ci	MDA	MDA	MDA	MDA
strontium-92	Ci	MDA	MDA	MDA	MDA
tellurium-129m	Ci	MDA	MDA	MDA	MDA

MDA = Less than the "a posteriori" minimum detectable activity (microcuries per unit mass or volume). This note applies to all tables.

**DIABLO CANYON POWER PLANT
 ANNUAL RADIOACTIVE EFFLUENT RELEASE REPORT 2014
 TABLE 5A (CONTINUED)
 LIQUID EFFLUENTS - NUCLIDES RELEASED**

Nuclides Released	Units	First Quarter		Second Quarter	
		Continuous Mode	Batch Mode	Continuous Mode	Batch Mode
tellurium-132	Ci	MDA	MDA	MDA	MDA
tin-113	Ci	MDA	MDA	MDA	MDA
tin-117m	Ci	MDA	MDA	MDA	MDA
tungsten-187	Ci	MDA	MDA	MDA	MDA
uranium-233/234	Ci	MDA	MDA	MDA	MDA
uranium-235/236	Ci	MDA	MDA	MDA	MDA
uranium-238	Ci	MDA	MDA	MDA	MDA
zinc-65	Ci	MDA	MDA	MDA	MDA
zirconium-95	Ci	MDA	1.28E-5	MDA	2.42E-6
iodine-131	Ci	MDA	MDA	MDA	MDA
iodine-132	Ci	MDA	MDA	MDA	MDA
iodine-133	Ci	MDA	MDA	MDA	MDA
iodine-135	Ci	MDA	MDA	MDA	MDA
TOTAL FOR PERIOD	Ci	MDA	1.05E-2	MDA	8.76E-3

DISSOLVED AND ENTRAINED GASES

xenon-133	Ci	MDA	1.01E-3	MDA	1.40E-4
xenon-133m	Ci	MDA	MDA	MDA	MDA
xenon-135	Ci	MDA	7.52E-6	MDA	MDA
krypton-85	Ci	MDA	MDA	MDA	MDA
krypton-88	Ci	MDA	MDA	MDA	MDA
TOTAL FOR PERIOD	Ci	MDA	1.02E-3	MDA	1.40E-4

MDA = Less than the "a posteriori" minimum detectable activity (microcuries per unit mass or volume). This note applies to all tables.

**DIABLO CANYON POWER PLANT
ANNUAL RADIOACTIVE EFFLUENT RELEASE REPORT 2014
TABLE 5B
LIQUID EFFLUENTS - NUCLIDES RELEASED**

Nuclides Released	Units	Third Quarter		Fourth Quarter	
		Continuous Mode	Batch Mode	Continuous Mode	Batch Mode
antimony-122	Ci	MDA	MDA	MDA	MDA
antimony-124	Ci	MDA	MDA	MDA	MDA
antimony-125	Ci	MDA	2.10E-4	MDA	4.09E-5
barium-140	Ci	MDA	MDA	MDA	MDA
beryllium-7	Ci	MDA	MDA	MDA	MDA
bromine-82	Ci	MDA	MDA	MDA	MDA
cerium-141	Ci	MDA	MDA	MDA	MDA
cerium-143	Ci	MDA	MDA	MDA	MDA
cerium-144	Ci	MDA	MDA	MDA	MDA
cesium-134	Ci	MDA	MDA	MDA	MDA
cesium-136	Ci	MDA	MDA	MDA	MDA
cesium-137	Ci	MDA	MDA	MDA	MDA
chromium-51	Ci	MDA	MDA	MDA	8.46E-4
cobalt-57	Ci	MDA	MDA	MDA	MDA
cobalt-58	Ci	MDA	1.32E-4	MDA	4.46E-4
cobalt-60	Ci	MDA	1.23E-3	MDA	9.95E-4
iron-55	Ci	MDA	1.07E-3	MDA	2.64E-3
iron-59	Ci	MDA	MDA	MDA	5.04E-7
lanthanum-140	Ci	MDA	MDA	MDA	MDA

MDA = Less than the "a posteriori" minimum detectable activity (microcuries per unit mass or volume). This note applies to all tables.

**DIABLO CANYON POWER PLANT
ANNUAL RADIOACTIVE EFFLUENT RELEASE REPORT 2014
TABLE 5B (CONTINUED)
LIQUID EFFLUENTS - NUCLIDES RELEASED**

Nuclides Released	Units	Third Quarter		Fourth Quarter	
		Continuous Mode	Batch Mode	Continuous Mode	Batch Mode
manganese-54	Ci	MDA	2.41E-5	MDA	3.61E-5
manganese-56	Ci	MDA	MDA	MDA	MDA
molybdenum-99	Ci	MDA	MDA	MDA	MDA
nickel-63	Ci	MDA	4.13E-4	MDA	1.85E-4
niobium-95	Ci	MDA	3.91E-6	MDA	4.91E-5
neodymium-147	Ci	MDA	MDA	MDA	MDA
plutonium-238	Ci	MDA	MDA	MDA	MDA
plutonium-239/240	Ci	MDA	MDA	MDA	MDA
plutonium-241	Ci	MDA	MDA	MDA	MDA
plutonium-242	Ci	MDA	MDA	MDA	MDA
ruthenium-103	Ci	MDA	MDA	MDA	MDA
silver-110m	Ci	MDA	MDA	MDA	MDA
sodium-24	Ci	MDA	MDA	MDA	MDA
strontium-89	Ci	MDA	MDA	MDA	MDA
strontium-90	Ci	MDA	MDA	MDA	MDA
strontium-91	Ci	MDA	MDA	MDA	MDA
strontium-92	Ci	MDA	MDA	MDA	MDA
tellurium-129m	Ci	MDA	MDA	MDA	MDA

MDA = Less than the "a posteriori" minimum detectable activity (microcuries per unit mass or volume). This note applies to all tables.

**DIABLO CANYON POWER PLANT
 ANNUAL RADIOACTIVE EFFLUENT RELEASE REPORT 2014
 TABLE 5B (CONTINUED)
 LIQUID EFFLUENTS - NUCLIDES RELEASED**

Nuclides Released	Units	Third Quarter		Fourth Quarter	
		Continuous Mode	Batch Mode	Continuous Mode	Batch Mode
tellurium-132	Ci	MDA	MDA	MDA	MDA
tin-113	Ci	MDA	MDA	MDA	MDA
tin-117m	Ci	MDA	MDA	MDA	MDA
tungsten-187	Ci	MDA	MDA	MDA	MDA
uranium-233/234	Ci	MDA	MDA	MDA	MDA
uranium-235/236	Ci	MDA	MDA	MDA	MDA
uranium-238	Ci	MDA	MDA	MDA	MDA
zinc-65	Ci	MDA	MDA	MDA	6.13E-5
zirconium-95	Ci	MDA	MDA	MDA	MDA
iodine-131	Ci	MDA	MDA	MDA	MDA
iodine-132	Ci	MDA	MDA	MDA	MDA
iodine-133	Ci	MDA	MDA	MDA	MDA
iodine-135	Ci	MDA	MDA	MDA	MDA
TOTAL FOR PERIOD	Ci	MDA	3.08E-3	MDA	5.30E-3

DISSOLVED AND ENTRAINED GASES

xenon-133	Ci	MDA	7.03E-4	MDA	9.03E-4
xenon-133m	Ci	MDA	MDA	MDA	MDA
xenon-135	Ci	MDA	5.95E-6	MDA	2.85E-5
krypton-85	Ci	MDA	MDA	MDA	MDA
krypton-88	Ci	MDA	MDA	MDA	MDA
TOTAL FOR PERIOD	Ci	MDA	7.09E-4	MDA	9.31E-4

MDA = Less than the "a posteriori" minimum detectable activity (microcuries per unit mass or volume). This note applies to all tables.

DIABLO CANYON POWER PLANT
 ANNUAL RADIOACTIVE EFFLUENT RELEASE REPORT 2014

TABLE 6
 LIQUID EFFLUENTS - LOWER LIMITS OF DETECTION

Nuclide	Units	LLD
antimony-122	μCi/ml	1.98E-7
antimony-124	μCi/ml	1.05E-7
antimony-125	μCi/ml	2.53E-7
barium-140	μCi/ml	5.40E-7
beryllium-7	μCi/ml	7.12E-7
bromine-82	μCi/ml	1.86E-7
cerium-141	μCi/ml	1.12E-7
cerium-143	μCi/ml	2.15E-7
cerium-144	μCi/ml	3.82E-7
cesium-134	μCi/ml	9.17E-8
cesium-136	μCi/ml	1.37E-7
cesium-137	μCi/ml	1.13E-7
chromium-51	μCi/ml	8.37E-7
cobalt-57	μCi/ml	6.18E-8
cobalt-58	μCi/ml	1.39E-7
cobalt-60	μCi/ml	3.60E-7
iron-55	μCi/ml	8.22E-7
iron-59	μCi/ml	1.67E-7
lanthanum-140	μCi/ml	2.03E-7
manganese-54	μCi/ml	1.47E-7
manganese-56	μCi/ml	7.28E-5
molybdenum-99	μCi/ml	6.78E-8
nickel-63	μCi/ml	3.73E-8
niobium-95	μCi/ml	8.99E-8

DIABLO CANYON POWER PLANT
 ANNUAL RADIOACTIVE EFFLUENT RELEASE REPORT 2014

TABLE 6 (CONTINUED)
 LIQUID EFFLUENTS - LOWER LIMITS OF DETECTION

Nuclide	Units	LLD
neodymium-147	μCi/ml	2.96E-7
plutonium-238	μCi/ml	4.09E-8
plutonium-239/240	μCi/ml	3.97E-8
plutonium-241	μCi/ml	4.42E-8
plutonium-242	μCi/ml	3.21E-8
ruthenium-103	μCi/ml	1.13E-7
silver-110m	μCi/ml	1.01E-7
sodium-24	μCi/ml	5.56E-7
strontium-89	μCi/ml	4.70E-8
strontium-90	μCi/ml	2.38E-8
strontium-91	μCi/ml	7.64E-7
strontium-92	μCi/ml	1.02E-4
tellurium-129m	μCi/ml	3.56E-6
tellurium-132	μCi/ml	1.05E-7
tin-113	μCi/ml	9.33E-8
tin-117m	μCi/ml	7.60E-8
tungsten-187	μCi/ml	4.97E-7
uranium-233/234	μCi/ml	2.50E-8
uranium-235/236	μCi/ml	3.80E-8
uranium-238	μCi/ml	3.07E-8
zinc-65	μCi/ml	3.06E-7
zirconium-95	μCi/ml	2.38E-7
gross alpha	μCi/ml	9.85E-8
hydrogen-3	μCi/ml	4.32E-6

DIABLO CANYON POWER PLANT
ANNUAL RADIOACTIVE EFFLUENT RELEASE REPORT 2014
TABLE 6 (CONTINUED)
LIQUID EFFLUENTS - LOWER LIMITS OF DETECTION

Nuclide	Units	LLD
iodine-131	$\mu\text{Ci/ml}$	7.62E-8
iodine-132	$\mu\text{Ci/ml}$	9.02E-5
iodine-133	$\mu\text{Ci/ml}$	2.40E-7
iodine-135	$\mu\text{Ci/ml}$	6.06E-6
xenon-133	$\mu\text{Ci/ml}$	2.23E-7
xenon-133m	$\mu\text{Ci/ml}$	8.73E-7
xenon-135	$\mu\text{Ci/ml}$	3.98E-7
krypton-85	$\mu\text{Ci/ml}$	2.09E-5
krypton-88	$\mu\text{Ci/ml}$	7.46E-5

VI. Solid Radwaste Shipments

Solid Waste and Irradiated Fuel Shipment

A. Solid Waste Shipped Off-site for Burial or Disposal (Not irradiated fuel)

1. Type of Waste	Unit	12 Month Period	Est. Total Error, %
a. Spent Resins, Filter Sludges, Evaporator Bottoms, etc.	m ³ Ci	7.93E+00 1.26E+02	9.00E+0
b. Dry Compressible Waste, Contaminated Equipment, etc.	m ³ Ci	1.50E+01 4.41E-01	9.00E+0
c. Irradiated Components, Control Rods, etc.	m ³ Ci	0.00E+0 0.00E+0	0.00E+0
d. Other	m ³ Ci	0.00E+0 0.00E+0	0.00E+0

2. Estimate of Major Nuclide Composition (by type of waste)

a.	Ni-63	%	4.31E+01
	Co-60	%	2.40E+01
	Fe-55	%	2.01E+01
	C-14	%	7.05E+00
	H-3	%	9.17E-01
b.	Fe-55	%	3.16E+01
	Co-60	%	2.39E+01
	Ni-63	%	1.51E+01
	Cr-51	%	5.08E+00
	Nb-95	%	2.95E+00
c.	Not Applicable	%	N/A
d.	Not Applicable	%	N/A

Solid Waste and Irradiated Fuel Shipment (Continued)

3. Solid Waste Disposition

Number of Shipments	Mode of Transportation	Destination
5	Truck	Clive, UT
2	Rail	Clive, UT
3	Truck	Andrew, TX

4. Supplemental Information Required by former TS 6.9.1.6

Solidification Agent	Type of Container	Number of Containers	10 CFR 61 Waste Class	Shipping Type
Cement	IP1	1	C	IP2 - LSAIL
Polymer	IP1	2	C	Type B

B. Irradiated Fuel Shipments (Disposition)

Number of Shipments	Mode of Transportation	Destination
None	N/A	N/A

VII. Radiation Dose Due to Gaseous and Liquid Effluents

A. Radiation Doses from Radioactive Liquid Effluents

The radiation dose contributions to the total body and each individual organ due to releases of radioactive liquid effluents for the maximum exposed adult member of the public have been calculated in accordance with the methodology stated in the ODCP. Dose contributions listed in Table 7 show conformance to Attachment 4 of the RECP.

B. Radiation Doses from Radioactive Gaseous Effluents

1. The radiation dose contributions due to radioactive gaseous effluents at the site boundary for each of the land sectors have been calculated in accordance with the calculation methodology stated in the ODCP. The dose contribution related to operation of each unit has been calculated separately. The latest five-year historical average meteorology conditions were used in these calculations. In addition to the site boundary doses, the dose to an individual (critical receptor) due to radioiodines, tritium, and particulates released in gaseous effluents with half-lives greater than eight days is determined in accordance with the methodology in the ODCP that is based on the methodology described in NUREG-0133. Dose contributions listed in Table 8, which represents the maximum dose for age groups, organs, and geographic locations for the report period, show conformance to Attachments 6, 7 and 8 of the RECP.
2. The radiation dose to a member of the public at the site boundary from two locations other than the plant vent have been calculated. The results are conservatively based upon laboratory determination of the isotopic source term and calculation of the discharge flow. The respective doses from these two sources are reported separately here:
 - a. Radiation Doses from Chemistry Laboratory Radioactive Gaseous Effluents - Closest Site Boundary (800m)
 - i. The dose due to the radioactive gaseous effluent from the primary chemistry laboratory during the report period is evaluated to be:
 1. Total gamma air dose = $4.25E-06$ mrad
 2. Total beta air dose = $1.51E-06$ mrad
 - b. Radiation Doses from Post Accident Sampling System Radioactive Gaseous Effluents - Closest Site Boundary (800m)
 - i. The dose due to radioactive gaseous effluents from the post accident sampling system during the report period is evaluated to be:
 1. Total gamma air dose = $3.67E-07$ mrad
 2. Total beta air dose = $1.30E-07$ mrad

3. Radiation Dose from Radioactive Gaseous Effluents to Individuals Due to Consumption of Grazing Animals on Property Surrounding the Site.

The Land Use Census identified that during 2014, ranchers in the area around the plant slaughtered cattle, goats, sheep, deer and wild pigs for personal consumption. As part of the DCCP Radiological Environmental Monitoring Program (REMP), samples of cow, goat and sheep meat were analyzed for radioactivity. Results of those analyses are available in the 2014 Annual Radiological Environmental Operating Report.

Based upon the isotopes (other than C-14) discharged in gaseous form during 2014, the maximum calculated dose due to these identified meat pathways is 4.92 E-03 mrem. The greatest contributor to this dose is H-3.

4. Atmospheric Release Of Carbon-14

- a. Historically, C-14 has not been considered a "principle radionuclide" in terms of its concentration in radioactive effluents and its dose consequence to offsite receptors. Naturally occurring C-14 is prevalent in the environment. In addition, nuclear weapons testing in the 1950s and 1960s significantly increased the amount of C-14 in the atmosphere. Therefore, power plants typically did not analyze for, nor report information for C-14 in annual reports.
- b. In June, 2009, the NRC revised its guidance in Regulatory Guide (RG) 1.21, "Measuring, Evaluating and Reporting Radioactivity In Solid Wastes And Releases Of Radioactive Materials In Liquid And Gaseous Effluents From Light-Water-Cooled Nuclear Power Plants", Revision 2. This document states that analytical methods for determining C-14 have improved. Coincidentally, the radioactive effluents from commercial power plants have decreased to the point that C-14 is likely to be a principle radionuclide in gaseous effluents. Also, because the dose contribution of C-14 from liquid radioactive waste is much less than that contributed by gaseous radioactive waste, evaluation of C-14 in liquid radioactive waste is not required.
- c. As a result, the NRC states that licensees should evaluate whether C-14 is a principal radionuclide for gaseous releases from their facility.
- d. RG 1.21 goes on to explain, in part:
 - i. The quantity of C-14 discharged can be estimated by sample measurements or by use of a normalized C-14 source term and scaling factors based on power generation, or estimated by use of the GALE code from NUREG-0017.
 - ii. If sampling is performed, the sampling frequency may be adjusted to that interval that allows adequate measurement and reporting of effluents.

- iii. If estimating C-14 based on scaling factors and fission rates, a precise and detailed evaluation of C-14 is not necessary. It is not necessary to calculate uncertainties for C-14 or to include C-14 uncertainty in any subsequent calculation of overall uncertainty.
- e. In order to aid the nuclear power industry in estimating C-14 production, the Electric Power Research Institute (EPRI) developed 2010 Technical Report 1021106, "Estimation of Carbon-14 in Nuclear Power Plant Gaseous Effluents," December 2010. This is the guidance Diablo Canyon uses to estimate the production and release quantities of C-14.
- f. Calculated carbon-14 production, discharge parameters and resulting dose to the nearest member of the public are reported here; separately from tables 1, 2, 8, 10 and 11

Calculated C-14 production, per Unit	U1=12.0 Ci/EFPY⁽¹⁾ U2=12.0 Ci/EFPY⁽¹⁾
2014 Unit capacity factors	U1 = 0.8691 U2 = 0.8665
Fraction release of produced C-14	0.98
Fraction of C-14 chemical form assumed	Organic = 0.70 Inorganic = 0.30
Curies C-14 released to atmosphere	U1 = 10.22 U2 = 10.19
Critical receptor dose ⁽²⁾ [Adult (bone)], mrem	3.43E-01

⁽¹⁾Effective Full Power Year

⁽²⁾Due to ingestion of meat (cattle) assumed to graze up to the site boundary in the NW sector

- g. Summary:
 - i. The quantity of C-14 released to the atmosphere for 2014 was
Unit 1 = 10.22 curies
Unit 2 = 10.19 curies
 - ii. The resulting critical receptor dose is:
Adult (bone), due to ingestion of meat = 3.43E-01 mrem.

C. Radiation Doses from Direct Radiation (Line-of-Sight Plus Sky-Shine) - Closest Site Boundary

1. For the report period, the greatest radiation dose to a member of the public at the site boundary from the following areas is evaluated to be 2.53E-01 mR:
 - Radioactive waste containers outside of plant buildings
 - Storage of contaminated tools and equipment inside plant buildings
 - Old Steam Generator Storage Facility, which contains:
 - Four Unit 2 old steam generators since 2008.
 - Four Unit 1 old steam generators since 2009.
 - One Unit 2 old reactor head since 2009.
 - One Unit 1 old reactor head since 2010.
 - Independent Spent Fuel Storage Installation (ISFSI).
 - The Diablo Canyon ISFSI received casks as follows:

Year	# Casks
2009	8
2010	8
2011	0
2012	7
2013	6
2014	0

The nearest full-time resident to the site is approximately 1.5 miles away, and is separated from direct line-of-site by mountainous terrain. However, doses from direct radiation are calculated at the site boundary. Sky-shine is included in the direct radiation calculation. The occupancy time at the site boundary is conservatively assumed to be 2,080 hours, based upon a 40-hour work week and 52 weeks per year.

D. 40 CFR 190 Considerations

The release of radioactivity in liquid and gaseous effluents resulted in doses that are small percentages of the TS limits as shown in Tables 9 and 10. In addition, the direct radiation from various sources, including the ISFSI, resulted in doses that are a small percentage of 40 CFR 190 limits. The total doses reported for 2014 from liquid and gaseous effluents and direct radiation shows that Diablo Canyon complied with all 40 CFR 190 limits.

E. Radiation Doses from Radioactive Liquid and Gaseous Effluents to Members of the Public Due To Their Activities Inside The Site Boundary

1. Liquid Effluents

The radiation dose to members of the public within the site boundary due to the release of radioactive liquid effluents is evaluated as negligible. The bases for this evaluation are discharge piping location and the source term that was present during the reporting period. Specifically; locations of the discharge piping for liquid radwaste are mostly embedded in concrete, located in remote or inaccessible areas, and/or underground. In addition, the quantity of radioactivity released through liquid radwaste piping was very small. (Refer to Tables 4A-4C.)

2. Gaseous Effluents

The radiation dose to members of the public within the site boundary due to the release of radioactive gaseous effluents is listed in Table 11.

G. Sub-surface water radioactive contamination

Recent events at other nuclear plant sites have involved identification of equipment leaks containing low levels of radioactivity. In some cases, these leaks have resulted in radioactive contamination of ground water and storm water that may leave the plant sites. Any plant equipment leaks that could result in such an event at Diablo Canyon are documented in the corrective action program (CAP). Analysis of samples of sub-surface water at Diablo Canyon has indicated the only radioactive isotope currently present is tritium. At this time, there is no evidence to point to plant system leakage as the source for this tritium.

Sampling and analysis of Auxiliary Building roof drains, Auxiliary Building drywell, and the containment structure observation wells have identified detectable tritium activity. This tritium has been evaluated as most likely coming from the rain wash-out of gaseous tritium exiting the plant vent system. This tritium is being accounted for in the plant vent release, and rain water tritium is being accounted for per plant approved procedures. These practices will continue until such time that new industry guidance is provided to account for this pathway in a different manner.

Refer to the 2014 Annual Radiological Environmental Operating Report for the data that has been evaluated to date for the sampling locations.

H. NEI 07-07 Voluntary Communication for sub-surface water

Section 2, "Communication," Objective 2.4, "Annual Reporting," of NEI 07-07 lists the acceptance criteria for annual reporting of "ground water" information, as follows:

1. Acceptance Criterion 2.4.b.i:
Reporting of on-site ground water sample results that are taken in support of the Groundwater Protection Initiative (GPI), but are not part of the REMP program are reported in the ARERR required by 10 CFR 50.36a(a)(2).
 - For 2014, there were no on-site ground water results for samples taken in support of the GPI that are not part of the REMP program.
2. Acceptance Criterion 2.4.b.ii:
Reporting of on-site ground water "sample results for those long-term monitoring sample points that are not included in REMP are reported in the ARERR."
 - For 2014, there were no on-site ground water sample results for long term monitoring sample points not included in the REMP.
3. Acceptance Criterion 2.4.c.i
Voluntary communications of the description of all spills or leaks, made per Objective 2.2 acceptance criterion, shall be included in the ARERR.
 - For 2014, no voluntary communications were made per Objective 2.2.
4. Acceptance Criterion 2.4.c.ii:
Voluntary communications of all on-site or off-site ground water sample results that exceeded the REMP reporting thresholds as described in the ODCM that were communicated per Objective 2.2 acceptance criterion b shall be included in the ARERR.
 - For 2014, no voluntary communications were made per Objective 2.2.

**DIABLO CANYON POWER PLANT
 ANNUAL RADIOACTIVE EFFLUENT RELEASE REPORT 2014**

**TABLE 7
 RADIATION DOSE DUE TO THE RELEASE OF RADIOACTIVE LIQUID EFFLUENTS**

	millirem				
	First Quarter	Second Quarter	Third Quarter	Fourth Quarter	Annual Total
Total Body	1.50E-04	5.34E-05	5.29E-05	8.49E-05	3.41E-04
Bone	2.05E-04	2.00E-04	3.91E-05	1.22E-04	5.66E-04
Liver	2.01E-04	1.58E-04	6.70E-05	1.55E-04	5.80E-04
Thyroid	1.20E-04	2.00E-05	4.54E-05	5.24E-05	2.38E-04
Kidney	1.21E-04	2.00E-05	4.54E-05	7.05E-05	2.57E-04
Lung	1.57E-04	9.64E-05	5.64E-05	9.32E-05	4.03E-04
G.I. LLI	3.04E-04	1.20E-04	8.12E-05	1.89E-04	6.93E-04

DIABLO CANYON POWER PLANT
 ANNUAL RADIOACTIVE EFFLUENT RELEASE REPORT 2014

TABLE 8A

RADIATION DOSE¹ DUE TO THE RELEASE OF RADIOACTIVE GASEOUS EFFLUENTS (UNIT 1)

		First Quarter Dose	Second Quarter Dose	Third Quarter Dose	Fourth Quarter Dose	Annual Total Dose
Site Boundary						
Noble Gas						
Gamma Air Dose	mrad	1.57E-3	1.51E-5	1.21E-5	1.36E-5	1.61E-3
Beta Air Dose	mrad	5.56E-4	5.31E-6	4.28E-6	4.81E-6	5.71E-4
		First Quarter Dose	Second Quarter Dose	Third Quarter Dose	Fourth Quarter Dose	Annual Total Dose
Nearest Residence-NNW						
I, P, T ^{2,3}						
Critical Receptor (Highest Organ)	mrem	5.95E-4	1.74E-4	1.66E-4	1.73E-4	1.11E-3
		First Quarter Dose	Second Quarter Dose	Third Quarter Dose	Fourth Quarter Dose	Annual Total Dose
Nearest Vegetable Garden - NNE						
I, P, T ^{2,4}						
Critical Receptor (Highest Organ)	mrem	4.17E-5	1.27E-5	1.21E-5	1.27E-5	7.92E-5

DIABLO CANYON POWER PLANT
 ANNUAL RADIOACTIVE EFFLUENT RELEASE REPORT 2014

TABLE 8B

RADIATION DOSE¹ DUE TO THE RELEASE OF RADIOACTIVE GASEOUS EFFLUENTS (UNIT 2)

		First Quarter Dose	Second Quarter Dose	Third Quarter Dose	Fourth Quarter Dose	Annual Total Dose
Site Boundary						
Noble Gas						
Gamma Air Dose	mrad	8.64E-6	2.95E-3	1.56E-5	1.82E-3	4.79E-3
Beta Air Dose	mrad	3.05E-6	1.96E-3	5.50E-6	6.46E-4	2.61E-3
		First Quarter Dose	Second Quarter Dose	Third Quarter Dose	Fourth Quarter Dose	Annual Total Dose
Nearest Residence-NNW						
I, P, T ^{2,3}						
Critical Receptor (Highest Organ)	mrem	1.14E-4	8.44E-4	9.12E-5	4.41E-4	1.49E-3
		First Quarter Dose	Second Quarter Dose	Third Quarter Dose	Fourth Quarter Dose	Annual Total Dose
Nearest Vegetable Garden - NNE						
I, P, T ^{2,4}						
Critical Receptor (Highest Organ)	mrem	8.35E-6	5.06E-5	6.67E-6	2.98E-5	9.54E-5

Notes for Tables 8A and 8B

1. The doses reported in these tables represent the maximum doses due to the stated source term for the most-affected age groups and organs at the respective geographic locations for the quarter and the year.
2. Radioiodines, radioactive material in particulate form, and radionuclides other than noble gases with half-lives greater than eight days.
3. The inhalation and ground plane pathways are included for this location.
4. The inhalation, ground plane and vegetable pathways are included for this location.

DIABLO CANYON POWER PLANT
 ANNUAL RADIOACTIVE EFFLUENT RELEASE REPORT 2014

TABLE 9

PERCENT OF TECHNICAL SPECIFICATION LIMITS¹ FOR RADIOACTIVE LIQUID EFFLUENTS

	Percent				
	First Quarter	Second Quarter	Third Quarter	Fourth Quarter	Annual Total
Total Body	9.97E-03	3.56E-03	3.52E-03	5.66E-03	1.14E-02
Bone	4.09E-03	4.01E-03	7.81E-04	2.43E-03	5.66E-03
Liver	4.02E-03	3.15E-03	1.34E-03	3.09E-03	5.80E-03
Thyroid	2.41E-03	4.00E-04	9.08E-04	1.05E-03	2.38E-03
Kidney	2.41E-03	4.01E-04	9.09E-04	1.41E-03	2.57E-03
Lung	3.15E-03	1.93E-03	1.13E-03	1.86E-03	4.03E-03
G.I. LLI	6.07E-03	2.40E-03	1.62E-03	3.78E-03	6.93E-03

NOTE:

¹RECP 6.1.4.1

DIABLO CANYON POWER PLANT
 ANNUAL RADIOACTIVE EFFLUENT RELEASE REPORT 2014

TABLE 10A

PERCENT OF TECHNICAL SPECIFICATION LIMITS¹ FOR RADIOACTIVE GASEOUS EFFLUENTS (UNIT 1)

		First Quarter % of TS Limit	Second Quarter % of TS Limit	Third Quarter % of TS Limit	Fourth Quarter % of TS Limit	Annual Total % of TS Limit
Site Boundary						
Noble Gas						
Gamma Air Dose	mrad	3.15E-2	3.01E-4	2.43E-4	2.73E-4	1.61E-2
Beta Air Dose	mrad	5.56E-3	5.31E-5	4.28E-5	4.81E-5	2.85E-3
Nearest Residence - NNW						
I, P, T						
Critical Receptor (Highest Organ)	mrem	7.94E-3	2.32E-3	2.21E-3	2.31E-3	7.39E-3
Nearest Vegetable Garden - ESE						
I, P, T						
Critical Receptor (Highest Organ)	mrem	5.56E-4	1.70E-4	1.62E-4	1.69E-4	5.28E-4

NOTE:

¹RECP Attachments 6, 7 and 8

DIABLO CANYON POWER PLANT
 ANNUAL RADIOACTIVE EFFLUENT RELEASE REPORT 2014

TABLE 10B

PERCENT OF TECHNICAL SPECIFICATION LIMITS¹ FOR RADIOACTIVE GASEOUS EFFLUENTS (UNIT 2)

		First Quarter % of TS Limit	Second Quarter % of TS Limit	Third Quarter % of TS Limit	Fourth Quarter % of TS Limit	Annual Total % of TS Limit
Site Boundary						
<u>Noble Gas</u>						
Gamma Air Dose	mrad	1.73E-4	5.89E-2	3.12E-4	3.64E-2	4.79E-2
Beta Air Dose	mrad	3.05E-5	1.96E-2	5.50E-5	6.46E-3	1.31E-2
Nearest Residence-NNW						
<u>I, P, T</u>						
Critical Receptor (Highest Organ)	mrem	1.52E-3	1.13E-2	1.22E-3	5.88E-3	9.94E-3
Nearest Vegetable Garden - NNE						
<u>I, P, T (ESE)</u>						
Critical Receptor (Highest Organ)	mrem	1.11E-4	6.75E-4	8.89E-5	3.97E-4	6.36E-4

NOTE:

¹RECP Attachments 6, 7 and 8

**DIABLO CANYON POWER PLANT
ANNUAL RADIOACTIVE EFFLUENT RELEASE REPORT 2014
TABLE 11A
RADIATION DOSE DUE TO RELEASE OF RADIOACTIVE GASEOUS EFFLUENTS
FIRST QUARTER, 2014
ON-SITE DOSE TO MEMBERS OF THE PUBLIC (SPECIAL INTEREST GROUPS)**

Specific Activity	Exposure Location (Sectors)	Exposure Closest Dist. (meters)	Exposure Time (Hours)	External Dose		Internal Dose	
				Noble Gas		Iodines, Particulates, and Tritium	
				Whole Body	Skin	Ground Plane	Inhalation
Police at Shooting Range	SE	700	52.0	5.77E-5	8.42E-5	0.00E+0	1.79E-4
Tour Participants							
(a) Simulator Bldg.	S	310	1.00	7.56E-7	1.10E-6	0.00E+0	2.35E-6
(b) Bio Lab	SSE	460	1.50	1.13E-6	1.66E-6	0.00E+0	3.52E-6
(c) Overlook	E	210	0.25	5.26E-7	7.69E-7	0.00E+0	1.63E-6
American Indians at Burial Grounds	NW	200	24.0	2.09E-4	3.05E-4	0.00E+0	6.48E-4
	NNW	200	24.0	1.46E-4	2.13E-4	0.00E+0	4.54E-4
Ranch Hands driving cattle around site	NW	250	0.25	1.46E-6	2.13E-6	0.00E+0	4.52E-6
	NNW	350	0.25	5.58E-7	8.15E-7	0.00E+0	1.73E-6
	N	320	0.25	3.71E-7	5.41E-7	0.00E+0	1.15E-6
	NNE	450	0.25	1.45E-7	2.12E-7	0.00E+0	4.50E-7
	NE	630	0.25	7.38E-8	1.08E-7	0.00E+0	2.29E-7

NOTE: All doses are in mrem.

**DIABLO CANYON POWER PLANT
ANNUAL RADIOACTIVE EFFLUENT RELEASE REPORT 2014
TABLE 11B
RADIATION DOSE DUE TO RELEASE OF RADIOACTIVE GASEOUS EFFLUENTS
SECOND QUARTER, 2014
ON-SITE DOSE TO MEMBERS OF THE PUBLIC (SPECIAL INTEREST GROUPS)**

Specific Activity	Exposure Location (Sectors)	Exposure Closest Dist. (meters)	Exposure Time (Hours)	External Dose		Internal Dose	
				Noble Gas		Iodines, Particulates, and Tritium	
				Whole Body	Skin	Ground Plane	Inhalation
Police at Shooting Range	SE	700	52.0	1.06E-4	1.74E-4	0.00E+0	6.69E-5
Tour Participants							
(a) Simulator Bldg.	S	310	1.00	1.40E-6	2.28E-6	0.00E+0	8.78E-7
(b) Bio Lab	SSE	460	1.50	2.09E-6	3.42E-6	0.00E+0	1.32E-6
(c) Overlook	E	210	0.25	9.71E-7	1.59E-6	0.00E+0	6.11E-7
American Indians at Burial Grounds	NW NNW	200 200	24.0 24.0	3.85E-4 2.70E-4	6.29E-4 4.40E-4	0.00E+0 0.00E+0	2.42E-4 1.70E-4
Ranch Hands driving cattle around site	NW NNW N NNE NE	250 350 320 450 630	0.25 0.25 0.25 0.25 0.25	2.69E-6 1.03E-6 6.84E-7 2.68E-7 1.36E-7	4.39E-6 1.68E-6 1.12E-6 4.37E-7 2.22E-7	0.00E+0 0.00E+0 0.00E+0 0.00E+0 0.00E+0	1.69E-6 6.48E-7 4.30E-7 1.68E-7 8.56E-8

NOTE: All doses are in mrem.

**DIABLO CANYON POWER PLANT
ANNUAL RADIOACTIVE EFFLUENT RELEASE REPORT 2014
TABLE 11C
RADIATION DOSE DUE TO RELEASE OF RADIOACTIVE GASEOUS EFFLUENTS
THIRD QUARTER, 2014
ON-SITE DOSE TO MEMBERS OF THE PUBLIC (SPECIAL INTEREST GROUPS)**

Specific Activity	Exposure Location (Sectors)	Exposure Closest Dist. (meters)	Exposure Time (Hours)	External Dose		Internal Dose	
				Noble Gas		Iodines, Particulates, and Tritium	
				Whole Body	Skin	Ground Plane	Inhalation
Police at Shooting Range	SE	700	52.0	1.01E-6	1.47E-6	0.00E+0	7.05E-5
Tour Participants							
(a) Simulator Bldg.	S	310	1.00	1.32E-8	1.92E-8	0.00E+0	9.24E-7
(b) Bio Lab	SSE	460	1.50	1.98E-8	2.89E-8	0.00E+0	1.39E-6
(c) Overlook	E	210	0.25	9.17E-9	1.34E-8	0.00E+0	6.43E-7
American Indians at Burial Grounds	NW NNW	200 200	24.0 24.0	3.64E-6 2.55E-6	5.31E-6 3.72E-6	0.00E+0 0.00E+0	2.55E-4 1.79E-4
Ranch Hands driving cattle around site	NW NNW N NNE NE	250 350 320 450 630	0.25 0.25 0.25 0.25 0.25	2.54E-8 9.73E-9 6.46E-9 2.53E-9 1.29E-9	3.71E-8 1.42E-8 9.43E-9 3.69E-9 1.88E-9	0.00E+0 0.00E+0 0.00E+0 0.00E+0 0.00E+0	1.78E-6 6.82E-7 4.53E-7 1.77E-7 9.02E-8

NOTE: All doses are in mrem.

**DIABLO CANYON POWER PLANT
 ANNUAL RADIOACTIVE EFFLUENT RELEASE REPORT 2014
 TABLE 11D
 RADIATION DOSE DUE TO RELEASE OF RADIOACTIVE GASEOUS EFFLUENTS
 FOURTH QUARTER, 2014
 ON-SITE DOSE TO MEMBERS OF THE PUBLIC (SPECIAL INTEREST GROUPS)**

Specific Activity	Exposure Location (Sectors)	Exposure Closest Dist. (meters)	Exposure Time (Hours)	External Dose		Internal Dose	
				Noble Gas		Iodines, Particulates, and Tritium	
				Whole Body	Skin	Ground Plane	Inhalation
Police at Shooting Range	SE	700	52.0	6.64E-5	9.69E-5	0.00E+0	1.48E-4
Tour Participants							
(a) Simulator Bldg.	S	310	1.00	8.70E-7	1.27E-6	0.00E+0	1.94E-6
(b) Bio Lab	SSE	460	1.50	1.31E-6	1.91E-6	0.00E+0	2.91E-6
(c) Overlook	E	210	0.25	6.06E-7	8.85E-7	0.00E+0	1.35E-6
American Indians at Burial Grounds	NW	200	24.0	2.40E-4	3.51E-4	0.00E+0	5.35E-4
	NNW	200	24.0	1.68E-4	2.46E-4	0.00E+0	3.74E-4
Ranch Hands driving cattle around site	NW	250	0.25	1.68E-6	2.45E-6	0.00E+0	3.73E-6
	NNW	350	0.25	6.42E-7	9.38E-7	0.00E+0	1.43E-6
	N	320	0.25	4.27E-7	6.23E-7	0.00E+0	9.50E-7
	NNE	450	0.25	1.67E-7	2.44E-7	0.00E+0	3.71E-7
	NE	630	0.25	8.49E-8	1.24E-7	0.00E+0	1.89E-7

NOTE: All doses are in mrem.

**DIABLO CANYON POWER PLANT
ANNUAL RADIOACTIVE EFFLUENT RELEASE REPORT 2014
TABLE 11E
RADIATION DOSE DUE TO RELEASE OF RADIOACTIVE GASEOUS EFFLUENTS
ANNUAL TOTAL, 2014
ON-SITE DOSE TO MEMBERS OF THE PUBLIC (SPECIAL INTEREST GROUPS)**

Specific Activity	Exposure Location (Sectors)	Exposure Closest Dist. (meters)	Exposure Time (Hours)	External Dose		Internal Dose	
				Noble Gas		Iodines, Particulates, and Tritium	
				Whole Body	Skin	Ground Plane	Inhalation
Police at Shooting Range	SE	700	208.0	2.31E-4	3.56E-4	0.00E+0	4.64E-4
Tour Participants							
(a) Simulator Bldg.	S	310	4.00	3.04E-6	4.67E-6	0.00E+0	6.09E-6
(b) Bio Lab	SSE	460	6.00	4.55E-6	7.01E-6	0.00E+0	9.13E-6
(c) Overlook	E	210	1.00	2.11E-6	3.25E-6	0.00E+0	4.24E-6
American Indians at Burial Grounds	NW	200	96.0	8.38E-4	1.29E-3	0.00E+0	1.68E-3
	NNW	200	96.0	5.86E-4	9.03E-4	0.00E+0	1.18E-3
Ranch Hands driving cattle around site	NW	250	1	5.85E-6	9.01E-6	0.00E+0	1.17E-5
	NNW	350	1	2.24E-6	3.45E-6	0.00E+0	4.49E-6
	N	320	1	1.49E-6	2.29E-6	0.00E+0	2.98E-6
	NNE	450	1	5.82E-7	8.96E-7	0.00E+0	1.17E-6
	NE	630	1	2.96E-7	4.56E-7	0.00E+0	5.94E-7

NOTE: All doses are in mrem.

VIII. Meteorological Data

Meteorological Data

The hour-by-hour listing of wind speed, wind direction, atmospheric stability and precipitation is contained on compact disc with this submittal.

Compact Diskette Information

Filename	Sensitivity	File Size	Description
NRC13	Non-SGI	1.3 Mb	Diablo Canyon Primary Meteorological Data

Special Instructions: The CD-R media are read-only, 700MB compact diskettes.

Attachment 1

**Diablo Canyon Power Plant Program Directive,
CY2, "Radiological Monitoring and Controls Program," Revision 7**

Radiological Monitoring and Controls Program

01/25/10
Effective Date

QUALITY RELATED

Table of Contents

1.	PROGRAM OVERVIEW	1
2.	APPLICABILITY	2
3.	DEFINITIONS	3
4.	PROGRAM OBJECTIVES AND REQUIREMENTS	3
5.	RESPONSIBILITIES	7
6.	KEY IMPLEMENTING DOCUMENTS	8
7.	CLOSELY RELATED PROGRAMS	8
8.	RECORDS	9
9.	REFERENCES	9
10.	GRADED QA REQUIREMENTS FOR RADIOLOGICAL MONITORING AND CONTROLS PROGRAM	11

1. PROGRAM OVERVIEW

- 1.1 It is the policy of nuclear generation that the release of radioactive materials to the environment be in compliance with Federal regulations and be "As Low As Reasonably Achievable" (ALARA). The overall objectives are to protect the health and safety of the public from undue radiation exposure and to minimize the amount of radioactive effluents resulting from the operation of the plant.
- 1.2 This PD defines the overall policies and general requirements related to the Radiological Monitoring and Controls Program (RMCP). This includes the Radiological Environmental Monitoring Program (REMP), and the Radioactive Effluent Controls Program (RECP).

-
- 1.3 The scope of this PD is focused on the control of releases of radioactive material to the environment, and minimizing radiological impact on the general public. Radiation protection of plant workers and visitors within the restricted area of the plant is within the scope of RP1, "Radiation Protection."
 - 1.4 Figure 1 illustrates the hierarchy of procedures associated with this PD.

Figure 1: CY2 Hierarchy of Procedures

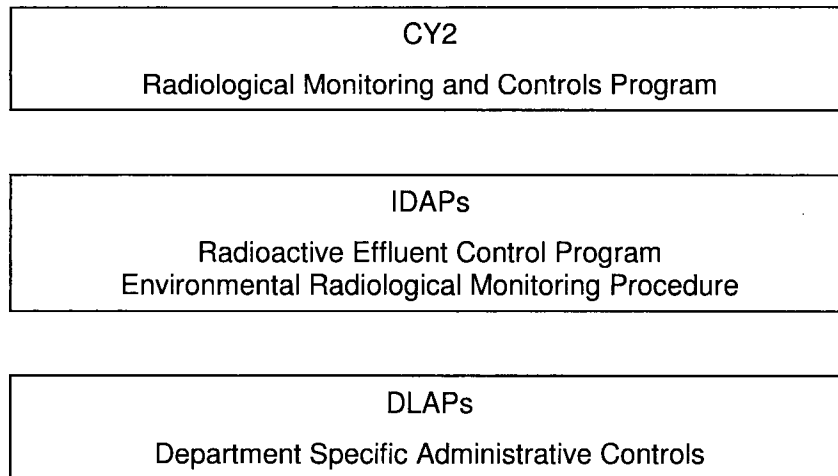

- 1.5 This document was converted; therefore, revision bars are not included.

2. APPLICABILITY

This PD is applicable to all persons involved in radioactive effluent control, monitoring, and management activities. This includes all nuclear generation personnel, personnel matrixed to nuclear generation from other company organizations, personnel in other company organizations that are engaged in activities in support of nuclear generation, and contractor personnel that are working under nuclear generation supervision.

3. DEFINITIONS

- 3.1 ALARA (acronym for "as low as reasonably achievable"): A term that means making every reasonable effort to maintain exposures to radiation as far below the dose limits of 10 CFR 20 as is practical consistent with the purpose for which the licensed activity is undertaken, taking into account the state of technology, the economics of improvements in relation to state of technology, the economics of improvements in relation to benefits to the public health and safety, and in relation to utilization of nuclear energy and licensed materials in the public interest. The specific objectives of achieving ALARA effluents are based on those described in 10 CFR 50, Appendix I.
- 3.2 Environmental Radiological Monitoring Procedure (ERMP): Contains a description of sample locations, types of sample locations, methods and frequency of analysis, and reporting requirements.
- 3.3 Offsite Dose Calculation Procedure (ODCP): Contains the methodology and parameters used in the calculation of offsite doses due to radioactive gaseous and liquid effluents and in the calculation of gaseous and liquid effluent monitoring Alarm/Trip Setpoints.
- 3.4 Radiological Monitoring and Controls Program (RMCP): Contains the Radioactive Effluent Controls and Radiological Environmental Monitoring Programs required by Technical Specifications 5.5.1 and 5.5.4 and descriptions of the information that should be included in the Annual Radiological Environmental Operating and Annual Radioactive Effluent Release Reports required by Technical Specifications 5.6.2 and 5.6.3.

4. PROGRAM OBJECTIVES AND REQUIREMENTS**4.1 Program Objectives:**

The nuclear generation radiological monitoring and controls program is established to meet the following objectives:

- 4.1.1 Ensure that systems, methods, and controls are established to meet applicable regulatory requirements and objectives for release of radioactive effluents.

Liquid and gaseous radioactive waste processing systems provide the means for controlling radioactive releases. It is also important to establish administrative controls with clear delineation of responsibilities to ensure that monitoring, measurement, and release activities are properly sequenced, authorized, and controlled.

4.2 Program Requirements

The basic requirement for the radiological monitoring and controls program shall be to maintain radioactive releases to the unrestricted areas surrounding the plant in conformance with applicable Federal regulations and ALARA. The following sections provide additional requirements for various elements of the program.

-
- 4.2.1 Changes to the RMCP (including ODCP, ERMP and RECP) shall be processed in accordance with the requirements of the plant Technical Specification Section 5.5.1.
- 4.2.2 Radiological Environmental Monitoring Program
- a. A Radiological Environmental Monitoring Program (REMP) shall be established and maintained to comply with the plant Technical Specification 5.5.1, Radiological Environmental Monitoring Program requirements. The program shall be provided to monitor the radiation and radionuclides in the environs of the plant, and shall address the following:
 1. Monitoring, sampling, analysis, and reporting of radiation and radionuclides in the environment in accordance with the methodology and parameters in the Environmental Radiological Monitoring Procedure (ERMP),
 2. A Land Use Census to ensure that changes in the use of areas at and beyond the site boundary are identified and that modifications to the monitoring program are made if required by the results of this census, and
 3. Participation in an Interlaboratory Comparison Program to ensure that independent checks on the precision and accuracy of the measurements of radioactive materials in the environmental sample matrices are performed as part of the quality assurance program for environmental monitoring.
- 4.2.3 Radioactive Effluent Control Program
- a. Monitoring requirements shall be established and maintained for all major and potentially significant paths for release of radioactive material during normal plant operation, including anticipated operational occurrences, to comply with Regulatory Guide 1.21, Revision 1, June 1974, requirements.
 - b. Procedures shall be established and maintained to define the methods and requirements for control of liquid and gaseous radioactive discharges within the limits of the plant Technical Specification Section 5.5.4. These procedures shall address the following:
 1. Limitations on the operability of radioactive liquid and gaseous monitoring instrumentation including surveillance requirements and setpoint determination in accordance with methodology in the Offsite Dose Calculation Procedure, (ODCP).
 2. Limitations on the concentrations of radioactive material released in liquid effluents to unrestricted areas conforming to 10 CFR Part 20, Appendix B, Table 2, Column 2.

-
3. Monitoring, sampling, and analysis of radioactive liquid and gaseous effluents in accordance with 10 CFR 20.1302 and with the methodology and parameters in the ODCP.
 4. Limitations on the annual and quarterly doses or dose commitment to a member of the public from radioactive materials in liquid effluents released from each unit to unrestricted areas conforming to Appendix I to 10 CFR Part 50.
 5. Determination of cumulative and projected dose contributions from radioactive effluents for the current calendar quarter and current calendar year in accordance with the methodology and parameters in the ODCP at least every 31 days.
 6. Limitations on the operability and use of the liquid and gaseous effluent treatment systems to ensure that the appropriate portions of these systems are used to reduce releases of radioactivity when the projected doses in a 31-day period would exceed 2 percent of the guidelines for the annual dose or dose commitment conforming to Appendix I to 10 CFR Part 50.
 7. Limitations on the dose rate resulting from radioactive material released in gaseous effluents from the site to areas at or beyond the site boundary shall be limited to the following:
 - a) For noble gases: Less than or equal to a dose rate of 500 mrem/yr to the whole body and less than or equal to a dose rate of 3000 mrem/yr to the skin.
 - b) For Iodine-131, for Iodine-133, for tritium, and for all radionuclides in particulate form with half-lives greater than 8 days: Less than or equal to a dose rate of 1500 mrem/yr to any organ.
 8. Limitations on the annual and quarterly air doses resulting from noble gases released in gaseous effluents from each unit to areas beyond the site boundary conforming to Appendix I to 10 CFR Part 50.
 9. Limitations on the annual and quarterly doses to members of the public from Iodine-131, Iodine-133, tritium, and all radionuclides in particulate form with half-lives greater than 8 days in gaseous effluents released from each unit to areas beyond the site boundary conforming to Appendix I to 10 CFR Part 50.
 10. Limitations on the annual dose or dose commitment to any member of the public due to releases of radioactivity and to radiation from uranium fuel cycle sources conforming to 40 CFR Part 190.
 11. The provisions of SR 3.0.2 and SR 3.0.3 are applicable to the Radioactive Effluent Controls Program Surveillance Frequency.

-
- c. Sampling and analysis methods associated with effluent monitoring activities shall be controlled in accordance with a department level administrative procedure that controls material and equipment used for analysis for the chemistry and radiochemistry programs.
 - d. Systems that are known pathways for radioactive releases shall be explicitly addressed. Periodic sampling of systems with the potential of becoming radioactively contaminated should also be addressed.
 - e. An onsite meteorological program shall be established and maintained in accordance with the requirements of Regulatory Guide 1.23, February 1972, to provide sufficient data for the performance of dose assessments.
 - f. The collection and processing of technical data required to support the Annual Radioactive Effluent Release Report and non-routine reports to the NRC to comply with the plant Technical Specification 5.6.3 shall be defined as part of this program. The processing of these reports shall be performed in accordance with XI1; "Regulatory Interface."

4.2.4 Offsite Dose Calculation Procedures

- a. Offsite Dose Calculation Procedures (ODCP) shall be established and maintained to define and control the methods for determining offsite doses. NRC Regulatory Guide 1.109, Revision 1, October 1977, as well as its interpretation through NUREG 0133, should be used as guidance for establishing acceptable methods. These procedures shall address the following:
 - 1. Methods for determining monitoring instrumentation alarm setpoints are addressed in accordance with a Department-Level Administrative Procedure (DLAP) under CY2.
 - 2. Methods for determining effluent concentrations.
 - 3. Methods for calculating doses to persons in unrestricted areas surrounding the plant from all exposure pathways.
- b. Changes to the ODCP shall be processed in accordance with the requirements of Technical Specification 5.5.1.

4.2.5 Environmental Radiological Monitoring Procedure

- a. An Environmental Radiological Monitoring Procedure (ERMP) shall be established and shall contain a description of sample locations, types of sample locations, methods and frequency of analysis, and reporting requirements.

4.2.6 Radwaste Treatment Systems

- a. Radwaste treatment systems shall be provided to control the processing and release of radioactive materials in gaseous and liquid effluent in compliance with Technical Specification requirements. The design of these systems shall be controlled in accordance with CF3, "Design Control," and the requirements of Regulatory Guide 1.143, October 1979.
- b. Approval of changes to the radwaste treatment systems shall be processed in accordance with the requirements of CF4, "Modification Control."

4.2.7 Quality Assurance Requirements

In addition to requirements specified in earlier sections and those requirements utilizing procedures in Section 6.2, the control program shall be subject to the quality assurance requirements specified in CY1, "Chemistry/Radiochemistry."

4.3 Support by the Company Departments

Departments outside of nuclear generation may be called upon to support nuclear generation activities associated with the Radioactive Monitoring Controls Program. The contract or agreement between nuclear generation and other departments shall ensure the support is performed in accordance with the requirements of this PD.

For example: Meteorological services may perform annual meteorological data reviews and calculate dispersion and deposition factors for use the radioactive effluents control program.

5. **RESPONSIBILITIES**

- 5.1 The Chief Nuclear Officer is responsible for establishing the policy and general requirements for the Radiological Monitoring and Controls Program, for providing management support and guidance for the program's implementation, and ensuring compliance with all regulatory requirements is maintained. The chief nuclear officer is also responsible for ensuring that support from reporting departments is provided for the Radiological Monitoring and Controls Program.
- 5.2 The Station Director is responsible for the overall development, implementation, and maintenance of the Radiological Monitoring and Controls Program in accordance with the requirements of this PD.
- 5.3 The senior director operations services is responsible for the direct implementation of the Radiological Monitoring and Controls Program with the exception of the design of radwaste treatment and effluent monitoring systems.
- 5.4 The senior director engineering services is responsible for maintaining the design bases for installed plant radwaste treatment and effluent monitoring systems, structures, and components and providing technical support to the plant for the operation and maintenance of these systems.

-
- 5.5 The quality verification director is responsible for auditing the Radiological Monitoring and Controls Program as outlined in Section 10.3.10.
- 5.6 The maintenance services director is responsible for maintaining the radiation monitoring systems and the hardware and software for the Rad Effluent program.

6. KEY IMPLEMENTING DOCUMENTS

6.1 Inter-Departmental Administrative Procedures (IDAPs)

Inter-Department Administrative Procedures shall be developed to address the following aspects of the Radiological Monitoring and Controls Program:

- 6.1.1 An IDAP shall be developed to define the requirements and responsibilities associated with the Radioactive Effluent Control Program.
- 6.1.2 An IDAP shall be developed to define the requirements and responsibilities associated with the Environmental Radiological Monitoring Procedure.

6.2 Department-Level Administrative Procedures (DLAPs)

Departments responsible for performing activities related to the Radioactive Effluent Control program shall develop DLAPs as appropriate to control program activities.

7. CLOSELY RELATED PROGRAMS

7.1 Interfaces

This section describes each of the principal interfaces and boundaries between this Program Directive and other management processes.

7.1.1 AD10, "Records"

"Records" provides for the retention of Radiological Monitoring and Controls Program records.

7.1.2 CF3, "Design Control"

"Design Control" addresses the implementation of design activities for installed radwaste treatment and effluent monitoring systems in accordance with the requirements of NRC Regulatory Guide 1.143.

7.1.3 CF4, "Modification Control"

"Modification Control" addresses the implementation of modification activities for installed effluent monitoring systems.

7.1.4 CY1, "Chemistry/Radiochemistry"

"Chemistry/Radiochemistry" addresses the methods for chemistry/radiochemistry sampling and analysis of liquid and gaseous radioactive effluents in support of this PD.

7.1.5 CY2.ID1, "Radioactive Effluent Controls Program"

"Radioactive Effluent Controls Program" contains the general program requirements to ensure the requirements of 10 CFR Part 20 and 10 CFR Part 50, Appendix I, are met.

7.1.6 OM7, "Problem Resolution"

"Problem Resolution" addresses deficiencies identified during the implementation of the radioactive effluent control program. OM7 also addresses evaluating nonconformances for reportability in accordance with Technical Specifications.

7.1.7 TQ1, "Personnel Training and Qualification"

"Personnel Training and Qualification" identifies training and qualification requirements for personnel.

7.1.8 XI1, "Regulatory Interface"

"Regulatory Interface" addresses the process for required reporting and communication with outside agencies.

8. RECORDS

None

9. REFERENCES

9.1 Diablo Canyon Nuclear Power Plant Facility Operating Licenses (Unit 1, Unit 2)

9.2 QA Commitments:

9.2.1 FSAR Chapter 17.2

9.2.2 Regulatory Guide 1.33

9.3 Regulatory Guides:

9.3.1 Guide 1.109, Revision 1, October 1977, "Calculation of Annual Doses to Man From Routine Releases of Reactor Effluents for the Purpose of Evaluating Compliance with 10 CFR Part 50 Appendix I"

9.3.2 Guide 1.143, October 1979, "Design Guidance for Radioactive Waste Management Systems, Structures, and Components Installed in Light-Water-Cooled Nuclear Power Plants"

9.3.3 Guide 1.21, Revision 1, June 1974, "Measuring, Evaluating, and Reporting Radioactivity in Solid Wastes and Releases of Radioactive Materials in Liquid and Gaseous Effluent from Light-Water-Cooled Nuclear Power Plants"

-
- 9.3.4 Guide 1.23, February 1972, "Onsite Meteorological Programs"
 - 9.3.5 Guide 4.1, Revision 1, April 1975, "Programs for Monitoring Radioactivity in the Environs of Nuclear Power Plants"
 - 9.3.6 Guide 4.15, Revision 1, February 1979, "Quality Assurance For Radiological Monitoring Programs (Normal Operations) - Effluent Streams and the Environment"
 - 9.4 Title 10, Code of Federal Regulations:
 - 9.4.1 Part 20, "Standards for Protection Against Radiation"
 - 9.4.2 Part 50, Appendix I
 - 9.4.3 Part 50, Appendix A, GDC 60, 64
 - 9.4.4 Part 50.36a, "Technical Specifications on Effluents from Nuclear Power Reactors"
 - 9.5 Title 40, Code of Federal Regulations, "Environmental Radiation Protection Standards for Nuclear Power Operations"

10. GRADED QA REQUIREMENTS FOR RADIOLOGICAL MONITORING AND CONTROLS PROGRAM

The basis for these Graded QA requirements is to comply with the regulations of 10 CFR 20, 10 CFR 50, 40 CFR 190, the Technical Specifications and Regulatory Guides 1.21, and 4.15.

10.1 Graded Items

Radioactive Effluent monitoring instruments are classified as Category 2 or Category 3 items per Regulatory Guide 1.97, "Instrumentation for Light-Water-Cooled Nuclear Power Plants to Assess Plant and Environs Conditions During and Following an Accident." These instruments are used for detection and assessment of releases and possibly detection of containment breach with accomplishment of mitigation of the breach. These items fall under Graded QA requirements.

10.2 Graded Activities

10.2.1 Installed radiation monitors required per Technical Specification 3.3.3 for monitoring radioactive effluents during plant operations or accidents shall be calibrated at prescribed intervals.

10.2.2 Sampling and analysis of liquid and gaseous effluents shall be performed in accordance with CY1, "Chemistry/Radiochemistry."

10.2.3 Calculations, computer programs, and procedures for evaluating the dose associated with radioactive effluents shall be performed in accordance with approved quality related procedures.

10.3 Graded Requirements

10.3.1 Effluent releases shall be maintained ALARA and shall be performed in accordance with the requirements of this Program Directive to limit the concentrations, doses and doserates as specified in DCPP Technical Specification 5.5.4, NRC regulations 10 CFR 20, 10 CFR 50 Appendix I, and EPA regulation 40 CFR 190.

10.3.2 The Annual Radiological Environmental Operating Report shall be developed in accordance with Technical Specification 5.6.2.

10.3.3 The Annual Radioactive Effluent Release Report shall be developed in accordance with Technical Specification 5.6.3.

10.3.4 Records that support and document the Radiological Monitoring and Controls Program shall be controlled in accordance with AD10, "Records."

-
- 10.3.5 Personnel involved in direct implementation of chemistry/radiochemistry, operations, or radiation protection activities in support of the Radiological Monitoring and Controls Program are qualified in accordance with the requirements of TQ1, "Personnel Training and Qualification." In addition, personnel involved in direct implementation of activities in support of the Radiological Environmental Monitoring Program are qualified in accordance with the requirements of an interdepartmental administrative procedure for Environmental Radiological Monitoring (ERMP).
- 10.3.6 Notifications and reports to and correspondence with regulatory agencies shall be done in accordance with XI1, "Regulatory Interface."
- 10.3.7 Written plans, procedures and instructions for implementing Radiological Monitoring and Controls Program shall be prepared, processed, and controlled in accordance with AD1, "Administrative Control Program."
- 10.3.8 Procurement of quality-related equipment or services shall be in accordance with written procedures. Applicable regulatory requirements, design bases, and any other requirements necessary to assure adequate quality shall be included in or invoked by reference in documents for procurement of items or services. Test or acceptance requirements and documentation to be submitted by the supplier shall be identified in the procurement documents. Receipt inspection requirements, if required, shall be identified in the procurement documents.
- 10.3.9 Deficiencies identified during implementation of this program shall be documented and controlled in accordance with OM7, "Problem Resolution."
- 10.3.10 FSAR Chapter 17.18, "Audits," prescribes the audit frequency for various portions of the RMCP:
- a. The performance of activities required by the quality assurance program for the Radioactive Effluents Control Program shall be audited at least once per 24 months unless specified otherwise.
 - b. The Radiological Environmental Monitoring Program, implementing procedures, and program results shall be audited at least once per 24 months.
 - c. The Offsite Dose Calculation Procedure and its implementing procedures shall be audited at least once per 24 months.

Attachment 2

**Diablo Canyon Power Plant Interdepartmental Administrative Procedure,
CY2.ID1, "Radioactive Effluent Controls Program," Revision 12**

Radioactive Effluent Controls Program

09/04/14
Effective Date

QUALITY RELATED

Table of Contents

1.	SCOPE	1
2.	DISCUSSION	2
3.	DEFINITIONS	2
4.	RESPONSIBILITIES	3
5.	INSTRUCTIONS	4
5.1	Administrative Requirements	4
5.2	Reporting Requirements	4
5.3	Revisions to the RECP	8
5.4	Major Changes to Liquid, Gaseous, and Solid Radwaste Treatment Systems.....	8
6.	RECORDS.....	8
7.	REFERENCES	8

ATTACHMENTS:

1.	Radioactive Liquid Effluent Monitoring Instrumentation Operational Requirements	10
2.	Radioactive Gaseous Effluent Monitoring Instrumentation Operational Requirements	14
3.	Liquid Effluents - CONCENTRATION Operational Requirements	18
4.	Liquid Effluents - Dose Operational Requirements.....	22
5.	Liquid Radwaste Treatment System Dose Operational Requirements	23
6.	Gaseous Effluents - Dose Rate Operational Requirements.....	24
7.	Dose - Noble Gases Operational Requirements	29
8.	Iodine 131, Iodine 133, Tritium, and Radioactive Material in Particulate Form	30
9.	Gaseous Radwaste Treatment System Operational Requirements.....	32
10.	Total Dose Operational Requirements	33
11.	Radiological Environmental Monitoring Operational Requirements	35
12.	Land Use Census Operational Requirements	36
13.	High Alarm Setpoints - FB & CR Ventilation Systems Actuation Instrumentation.....	37

1. SCOPE

1.1 This procedure contains the general program requirements of the Radioactive Effluent Controls Program. This program ensures that the requirements of 10 CFR Part 20 and 10 CFR Part 50 Appendix I are met.

2. DISCUSSION

- 2.1 This procedure provides the general requirements for Radioactive Effluent Controls Program in accordance with the Technical Specifications and the implementation Generic Letter 89-01, "Implementation of Programmatic Controls for Radiological Effluent Technical Specifications in the Administrative Controls Section of the Technical Specifications and the Relocation of Procedural Details of RETS to the Off-Site Dose Calculation Manual or to the Process Control Program."
- 2.2 The following Technical Specification definitions are applicable: T.S. Section 5.5.1
- 2.2.1 The Off-site Dose Calculation Manual (ODCM) shall contain the methodology and parameters used in the calculation of off-site doses resulting from radioactive gaseous and liquid effluents, in the calculation of gaseous and liquid effluent monitoring alarm and trip setpoints, and in the conduct of radiological environmental monitoring program; and
- 2.2.2 The ODCM shall contain the radioactive effluent controls and radiological environmental monitoring activities, and the description of the information that should be included in the Annual Radiological Environmental Operating, and the Radioactive Effluent Release Reports required by Technical Specification 5.6.2 and 5.6.3.
- 2.2.3 The Diablo Canyon ODCM is made up of the following procedures:
- CAP A-8, "Off-site Dose Calculation Procedure"
 - CY2.ID1, "Radioactive Effluent Controls Program"
 - RP1.ID11, "Environmental Radiological Monitoring Procedure"
 - CY2, "Radiological Monitoring and Controls Program"
- Changes to each of these procedures shall be processed in accordance with the requirements of Technical Specification Section 5.5.1.
- 2.3 The specific methodology and parameters used in the calculation of off-site doses resulting from radioactive gaseous and liquid effluents and in the calculation of gaseous and liquid effluent monitoring Alarm/Trip Setpoints, is contained in CAP A-8, "Off-Site Dose Calculations Procedure (ODCP)." As such, CAP A-8 is incorporated in this procedure by reference. Therefore, the requirements for revisions to this procedure also apply to CAP A-8.

3. DEFINITIONS

- 3.1 Shutdown: Taking the reactor sub-critical.
- 3.2 Startup: Taking the reactor critical.

4. RESPONSIBILITIES

4.1 The chemistry manager is responsible for:

- 4.1.1 Implementation of the Off-Site Dose Calculation Procedure in a manner that meets regulatory requirements and preparing the Annual Radiological Effluent Release Report.
- 4.1.2 Providing direction to the operations staff in the processing of radioactive waste streams.
- 4.1.3 Ensuring that a comparison of the Annual Radioactive Effluent Release Report and the Annual Radiological Environmental Operating Report is performed.
- 4.1.4 Ensuring that dose commitment increases due to the Land Use Census in accordance with Attachment 12 are determined and communicated promptly to radiation protection.

4.2 The radiation protection manager is responsible for:

- 4.2.1 Ensuring the performance of the annual land use census and that the results are provided to chemistry so that chemistry can establish the dose requirements of Attachment 12.
- 4.2.2 Ensuring that the results of the annual Land Use Census are included in the Annual Radiological Environmental Operating Report.
- 4.2.3 Ensuring that changes to the Environmental Radiological Monitoring Procedure are provided to chemistry for inclusion in the Annual Radiological Effluent Release Report.
- 4.2.4 Ensuring preparation, review and approval of the Nonroutine Radiological Environmental Operating Report when required by Attachment 11.

5. INSTRUCTIONS

5.1 Administrative Requirements

- 5.1.1 It is the intent of the Radioactive Effluent Control Program to monitor all significant release pathways from the power plant. A pathway is considered significant if a conservative evaluation yields an additional dose increment equal to or more than 10 percent of the total from all pathways considered in this program.
- 5.1.2 At times, minor release pathways occur from the power plant due to plant maintenance activities. For example, leaving Containment when the equipment hatch or door is open. These minor release pathways are usually negligible from a radioactive effluents control program release and dose perspective, and are well within the margin of error of the significant monitored pathway and dose models.
- 5.1.3 Attachments 1-12 of this procedure contains the operational requirements of the Radioactive Effluent Controls Program.
- 5.1.4 The operational requirements are implemented by Equipment Control Guidelines (reference OP1.DC16), CAP A-8, and XI1.ID2.
 - a. The Equipment Control Guidelines implement those requirements that are related to equipment and have specific allowed outage times or operator actions.
 - b. CAP A-8 includes the methodology and parameters used in the calculation of off-site doses resulting from radioactive gaseous and liquid effluents and in the calculation of gaseous and liquid effluent monitoring alarm/trip setpoints.
 - c. XI1.ID2 implements the reporting requirements.

5.2 Reporting Requirements

- 5.2.1 Annual Radioactive Effluent Release Report
 - a. Report Schedule
 - 1. Annual Radioactive Effluent Release Reports covering the operation of the unit during the previous calendar year shall be submitted before May 1 of each year, in accordance with 10 CFR 50.36a.

- b. The Annual Radioactive Effluent Release Reports shall include:
1. A summary of the quantities of radioactive liquid and gaseous effluents and solid waste released from the unit as outlined in Regulatory Guide 1.21, "Measuring, Evaluating, and Reporting Radioactivity in Solid Wastes and Releases of Radioactive Materials in Liquid and Gaseous Effluents from Light-Water-Cooled Nuclear Power Plants," Revision 1, June 1974, with data summarized on a quarterly basis following the format of Appendix B thereof. For solid wastes, the format for Table 3 in Appendix B shall be supplemented with three additional categories; class of solid wastes (as defined by 10 CFR Part 61), type of container (e.g., LSA, Type A, Type B, Large Quantity) and SOLIDIFICATION agent or absorbent (e.g., cement, urea formaldehyde).
 2. A list and description of unplanned releases as defined in ODCP from the site to UNRESTRICTED AREAS of radioactive materials in gaseous and liquid effluents made during the reporting period;
 3. Changes to the OCDM.
 - a) Pursuant to Technical Specification 5.5.1, changes to the following procedures made during the reporting period shall be included as described below:

NOTE: An FSAR update may be used in lieu of the ARERR for communicating changes to the NRC, regarding the PCP.

- 1) RP2.DC2, "Radwaste Solidification Process Control Program (PCP)"
 - 2) RP2.DC3, "Radwaste Dewatering Process Control Program"
 - 3) CY2.ID1, "Radioactive Effluent Controls Program (RECP)"
 - 4) CY2, "Radiological Monitoring and Controls Program (RMCP)"
 - 5) RP1.ID11, "Environmental Radiological Monitoring Program (ERMP)"
 - 6) CAP A-8, "Off-Site Dose Calculations"
- b) If a change is made to any of these procedures, include a legible copy of each procedure in the report. This provides a complete copy of the ODC in the report.
 - c) If multiple changes to any one procedure are made during the reporting period, include a copy of each revision.

-
- d) Each procedure change shall be identified by markings in the margin of the affected pages, clearly indicating the area of the page that was changed.
 - e) The date the change was implemented shall be indicated (e.g., the first page of the procedure should indicate the implementation date).
4. A listing of new locations for dose calculations and/or environmental monitoring identified by the Land Use Census pursuant to Attachment 12.
 5. An explanation as to why the inoperability of liquid or gaseous effluent monitoring instrumentation was not corrected within the time specified in attachments 1 and 2.
 6. Description of the events leading to liquid holdup tanks or gas storage tanks exceeding the limits of ECG 19.1 or ECG 24.3.
- c. A discussion of major changes to the Radwaste Treatment Systems (liquid, gaseous and solid). The discussion of each change shall contain:
1. A summary of the evaluation that led to the determination that the change could be made in accordance with 10 CFR 50.59.
 2. Sufficient detailed information to totally support the reason for the change without benefit of additional or supplemental information.
 3. A detailed description of the equipment, components and processes involved and the interfaces with other plant systems.
 4. An evaluation of the change which shows the predicted releases of radioactive materials in liquid and gaseous effluents and/or quantity of solid waste that differ from those previously predicted in the License application and amendments thereto.
 5. An evaluation of the change which shows the expected maximum exposures to a MEMBER OF THE PUBLIC in the UNRESTRICTED AREA and to the general population that differ from those previously estimated in the License application and amendments thereto.
 6. A comparison of the predicted releases of radioactive materials, in liquid and gaseous effluents and in solid waste, to the actual releases for the period prior to when the changes are to be made.
 7. An estimate of the exposure to plant operating personnel as a result of the change.
 8. Otherwise the above information may be submitted as part of the annual FSAR update.

-
- d. In addition, the Annual Radioactive Effluent Release Report shall also include:
1. An annual summary of hourly meteorological data collected over the previous year. This annual summary may be either:
 - a) In the form of an hour-by-hour listing on magnetic tape/hard disk or other media of wind speed, wind direction, atmospheric stability, and precipitation (if measured).
 - b) In the form of joint frequency distributions of wind speed, wind direction, and atmospheric stability.
 - c) The licensee has the option of retaining this summary of required meteorological data on site in a file that shall be provided to the NRC upon request.
 2. An assessment of the radiation doses due to the radioactive liquid and gaseous effluents released from the unit or station during the previous calendar year.
 3. An assessment of the radiation doses from radioactive liquid and gaseous effluents to MEMBERS OF THE PUBLIC due to their activities inside the SITE BOUNDARY (see FSAR Figure 2.1-2) during the report period.
 4. All assumptions used in making these assessments, i.e., specific activity, exposure time and location.
 - a) The meteorological conditions concurrent with the time of release of radioactive materials in gaseous effluents, as determined by sampling frequency and measurement, shall be used for determining the gaseous pathway doses.
 - b) The assessment of radiation doses shall be performed in accordance with the methodology and parameters in the OFF-SITE DOSE CALCULATIONS (ODC).
 5. An assessment of radiation doses to the likely most exposed MEMBER OF THE PUBLIC from reactor releases and other nearby uranium fuel cycle sources, including doses from primary effluent pathways and direct radiation, for the previous calendar year to show conformance with 40 CFR Part 190, "Environmental Radiation Protection Standards for Nuclear Power Operation." Acceptable methods for calculating the dose contribution from liquid and gaseous effluents are given in Regulatory Guide 1.109, Rev. 1, October 1977.

-
- e. A single submittal may be made for a multiple unit plant.
 - 1. The submittal should combine those sections that are common to all units at the plant.
 - 2. For units with separate radwaste system, the submittal shall specify the releases of radioactive material from each unit.

5.3 Revisions to the RECP

5.3.1 The requirements for revision to the RECP also apply to CAP A-8.

5.3.2 The requirements are provided in Technical Specification 5.5.1.

5.4 Major Changes to Liquid, Gaseous, and Solid Radwaste Treatment Systems

5.4.1 Major changes to the liquid, gaseous, and solid radwaste treatment systems shall become effective upon review and acceptance provided the change could be made in accordance with 10 CFR 50.59.

6. RECORDS

6.1 Data Sheets and records will be maintained in the Records Management System (RMS) in accordance with CY1.DC1, "Analytical Data Processing Responsibilities."

7. REFERENCES

- 7.1 CAP A-5, "Liquid Radwaste Discharge Management"
- 7.2 CAP A-6, "Gaseous Radwaste Sampling and Analysis for Release"
- 7.3 CAP A-8, "Off-site Dose Calculations"
- 7.4 CF4.ID1, "Modification Request and Authorization"
- 7.5 CF6.ID1, "Setpoint Control Program"
- 7.6 CY2, "Radiological Monitoring and Controls Program"
- 7.7 OP1.DC16, "Control of Plant Equipment Not Required by the Technical Specifications"
- 7.8 RP1.ID11, "Environmental Radiological Monitoring Procedure"
- 7.9 XI1.ID2, "Regulatory Reporting Requirements and Reporting Process"

-
- 7.10 Action Requests/Notifications
 - 7.10.1 A0581581, "Track LAR Revising Fuel Handling Requirements per TSTF-51"
 - 7.10.2 A0619600, "Rad Effluent Sampling of Ni-63"
 - 7.10.3 A0660441, "ODCM Change Identification Discrepancies"
 - 7.10.4 A0702694, "Evaluate Detection Limit Differences for ECG and Procedures"
 - 7.10.5 50453741, "Update CY2.ID1 for PCP"
 - 7.10.6 50596176, "CY2.ID1 Needs Revision"
 - 7.10.7 50624472, "DA-Vac Ops - Not Consistent w/FSAR"
 - 7.11 License Amendment 67/66, January 22, 1992
 - 7.12 License Amendment 184/186, January 3, 2006
 - 7.13 License Amendment Request 93-04
 - 7.14 10 CFR 20.1302
 - 7.15 10 CFR 50.36a
 - 7.16 10 CFR 50 Appendix I
 - 7.17 40 CFR 190
 - 7.18 Regulatory Guide 1.21, Revision 1, June 1974
 - 7.19 Regulatory Guide 1.109, Revision 1, October 1977
 - 7.20 QA Commitments:
 - 7.20.1 FSAR Chapter 17.2
 - 7.20.2 Reg Guide 4.15

1. Radioactive Liquid Effluent Monitoring Instrumentation (also covered by ECG 39.3)
 - a. Commitment for Operation
 - 1) The radioactive liquid effluent monitoring instrumentation channels shown in Table 1 shall be OPERABLE with their Alarm/Trip Setpoints set to ensure that the limits of Attachment 3 are not exceeded. The Alarm/Trip Setpoints of these channels shall be determined in accordance with the methodology and parameters in the OFF-SITE DOSE CALCULATIONS (ODC).
 - 2) Applicability: At all times.
 - 3) Action:
 - a) With a radioactive liquid effluent monitoring instrumentation channel Alarm/Trip Setpoint less conservative than required by Attachment 3, immediately suspend the release of radioactive liquid effluents monitored by the affected channel or declare the channel inoperable.
 - b) With less than the minimum number of radioactive liquid effluent monitoring instrumentation channels OPERABLE, take the ACTION shown in Table 1. Restore the inoperable instrumentation to OPERABLE status within the time specified in the ACTION, or explain in the next Annual Radioactive Effluent Release Report why this inoperability was not corrected within the time specified.
 - b. Surveillance Requirements
 - 1) Each radioactive liquid effluent monitoring instrumentation channel shall be demonstrated OPERABLE by performance of the CHANNEL CHECK, SOURCE CHECK, CHANNEL CALIBRATION and CHANNEL FUNCTIONAL TEST at the frequencies shown in Table 2.
 - 2) At least one saltwater pump shall be determined operating and providing dilution to the discharge structure at least once per 4 hours whenever dilution is required to meet the limits of Attachment 3.

**Radioactive Liquid Effluent Monitoring
Instrumentation Operational Requirements**

Table 1: Radioactive Liquid Effluent Monitoring Instrumentation

Instrument	Minimum Channels Operable	Action
1. Radioactivity Monitors Providing Alarm and Automatic Termination of Release		
a. Liquid Radwaste Effluent Line (RM-18)#	1	1
b. Steam Generator Blowdown Tank (RM-23)	1	2
2. Flow Rate Measurement Devices		
a. Liquid Radwaste Effluent Line (FIT-243)#	1	4
b. Steam Generator Blowdown Effluent Lines (FR-53)	1	4
c. Oily Water Separator Effluent Line (FR-251)#	1	4
3. Radioactivity Monitor Not Providing Automatic Termination of Release		
Oily Water Separator Effluent Line (RM-3)#	1	3

This Radioactive Liquid Effluent Monitoring Instrumentation is common to both units.

Action Statements

- ACTION 1** With the number of channels OPERABLE less than required by the Minimum Channels OPERABLE requirement, effluent releases via this pathway may continue for up to 14 days provided that prior to initiating a release:
- a. At least two independent samples are analyzed in accordance with Attachment 3.
 - b. At least two technically qualified members of the facility staff independently verify the release rate calculations and discharge line valvings.
- Otherwise, suspend release of radioactive effluents via this pathway.
- ACTION 2** With the number of channels OPERABLE less than required by the Minimum Channels OPERABLE requirement, effluent releases via this pathway may continue for up to 30 days provided grab samples are analyzed for radioactivity (beta or gamma) at a lower limit of detection of no more than 10^{-7} microcuries/ml.^{Ref 7.10.4}
- a. At least once per 12 hours when the specific activity of the secondary coolant is greater than 0.01 microcuries/gram DOSE EQUIVALENT I-131, or
 - b. At least once per 24 hours when the specific activity of the secondary coolant is less than or equal to 0.01 microcuries/gram DOSE EQUIVALENT I-131.
- ACTION 3** With the number of channels OPERABLE less than required by the Minimum Channels OPERABLE requirement, effluent releases via this pathway may continue for up to 30 days provided that, at least once per 12 hours, grab samples are collected and analyzed for radioactivity (beta or gamma) at a lower limit of detection of no more than 10^{-7} microcuries/ml or transfer the oily water separator effluent to the Liquid Radwaste Treatment System.^{Ref 7.10.4}
- ACTION 4** With the number of channels OPERABLE less than required by the Minimum Channels OPERABLE requirement, effluent releases via this pathway may continue for up to 30 days provided the flow rate is estimated at least once per 4 hours during actual releases. Pump performance curves may be used to estimate flow.

**Radioactive Liquid Effluent Monitoring
Instrumentation Operational Requirements**

Attachment 1: Page 3 of 4

Table 2: Radioactive Liquid Effluent Monitoring Instrumentation Surveillance Requirements

Instrument	Channel Check	Source Check	Channel Calibration	Channel Functional Test
1. Radioactivity Monitors Providing Alarm and Automatic Termination of Release				
a. Liquid Radwaste Effluent Line (RM-18)	D	P	R(3)	Q(1)
b. Steam Generator Blowdown Tank (RM-23)	D	M	R(3)	Q(1)
2. Flow Rate Measurement Devices				
a. Liquid Radwaste Effluent Line (FIT-243)	D(4)	N.A.	R	Q
b. Steam Generator Blowdown Effluent Line (FR-53)	D(4)	N.A.	R	Q
c. Oily Water Separator Effluent Line (FR-251)	Daily(4)	N.A.	R	Q
3. Radioactivity Monitor Not Providing Automatic Termination of Release				
a. Oily Water Separator Effluent Line (RM-3)	D	M	R(3)	Q(2)

- (1) The CHANNEL FUNCTIONAL TEST shall also demonstrate that automatic isolation of this pathway and Control Room alarm annunciation occurs if any of the following conditions exists:
 - a. Instrument indicates measured levels above the Alarm/Trip Setpoint (isolation and alarm), or
 - b. Relay control circuit failure (isolation only), or
 - c. Instrument indicates a downscale failure (alarm only), or
 - d. Instrument controls not set in operate mode (alarm only).
- (2) The CHANNEL FUNCTIONAL TEST shall also demonstrate that Control Room alarm annunciation occurs if any of the following conditions exist:
 - a. Instrument indicates measured levels above the Alarm Setpoint, or
 - b. Circuit failure, or
 - c. Instrument indicates a downscale failure, or
 - d. Instrument controls not set in operate mode.
- (3) The initial CHANNEL CALIBRATION shall be performed using one or more of the reference standards certified by the National Bureau of Standards (NBS) or using standards that have been obtained from suppliers that participate in measurement assurance activities with NBS. These standards shall permit calibrating the system over its intended range of energy and measurement range. For subsequent CHANNEL CALIBRATION, sources that have been related to the initial calibration shall be used.
- (4) CHANNEL CHECK shall consist of verifying indication of flow during periods of release. CHANNEL CHECK for FR-251 shall be made once per calendar day,* and for FIT-243 and FR-53 shall be made at least once per 24 hours on days on which continuous, periodic, or batch releases are made.
- (5) Frequency Notation

<u>Notation</u>	<u>Frequency</u>
D	At least once per 24 hours
Daily	At least once per calendar day*
M	At least once per 31 days
Q	At least once per 92 days
R	At least once per 18 months
P	Completed prior to each release
N.A.	Not Applicable

* The frequency "once per calendar day" could result in two successive channel checks nearly 48 hours apart over a two day period. This frequency is different from and should not be confused with the frequency notation "D" (at least once per 24 hours) defined in Technical Specifications.

Bases: Radioactive Liquid Effluent Monitoring Instrumentation

The radioactive liquid effluent instrumentation is provided to monitor and control, as applicable, the releases of radioactive materials in liquid effluents during actual or potential releases of liquid effluents. The Alarm/Trip Setpoints for these instruments shall be calculated and adjusted in accordance with the methodology and parameters in the ODCP to ensure that the alarm/trip will occur prior to exceeding the limits of 10 CFR Part 20. The OPERABILITY and use of this instrumentation is consistent with the requirements of General Design Criteria (GDC): GDC 17, 1967; GDC 18, 1967; and GDC 70, 1967.

1. Radioactive Gaseous Effluent Monitoring Instrumentation (also covered by ECG 39.4)
 - a. Commitment for Operation
 - 1) The radioactive gaseous effluent monitoring instrumentation channels shown in Table 3 shall be OPERABLE with their Alarm/Trip Setpoints set to ensure that the limits of Attachment 6 is not exceeded. The Alarm/Trip Setpoints of these channels meeting Attachment 6 shall be determined and adjusted in accordance with the methodology and parameters in the ODCP.
 - 2) Applicability: As shown in Table 3.
 - 3) Action:
 - a) With a radioactive gaseous effluent monitoring instrumentation channel Alarm/Trip Setpoint less conservative than required by the above Commitment, immediately suspend the release of radioactive gaseous effluents monitored by the affected channel, or declare the channel inoperable.
 - b) With the number of OPERABLE radioactive gaseous effluent monitoring instrumentation channels less than the Minimum Channels OPERABLE, take the ACTION shown in Table 3. Restore the inoperable instrumentation to OPERABLE status within the time specified in the ACTION or explain in the next Annual Radioactive Effluent Release Report why this inoperability was not corrected within the time specified.
 - b. Surveillance Requirements
 - 1) Each radioactive gaseous effluent monitoring instrumentation channel shall be demonstrated OPERABLE by performance of the CHANNEL CHECK, SOURCE CHECK, CHANNEL CALIBRATION and CHANNEL FUNCTIONAL TEST at the frequencies shown in Table 4.

**Radioactive Gaseous Effluent Monitoring
Instrumentation Operational Requirements**

Table 3: Radioactive Gaseous Effluent Monitoring Instrumentation

Instrument	Minimum Channel Operable	Applicability	Action
1. Gaseous Radwaste System Noble Gas Activity Monitor - Providing Alarm and Automatic Termination of Release (RM-22)	1	*	5
2. Plant Vent system			
a. Noble Gas Activity Monitor Providing Alarm (RM-14 or RM-14R)	1	*	7
b. Iodine Sampler	1	*	9
c. Particulate Sampler	1	*	9
d. Flow Rate Monitor (FR-12)	1	*	6
e. Iodine Sampler Flow Rate Monitor	1	*	6
3. Containment Purge System Noble Gas Activity Monitor - Providing Alarm and Automatic Termination of Release (RM-44A or 44B)	2 ⁽¹⁾	**	8

⁽¹⁾ 2 channels required in MODES 1, 2, 3 and 4. Only 1 channel required during movement of recently irradiated fuel assemblies within containment.

* At all times.

** MODES 1-4; also MODE 6 during CORE ALTERATIONS or movement of irradiated fuel within containment.

ACTION 5 With the number of channels OPERABLE less than required by the Minimum Channels OPERABLE requirement, the contents of the tank(s) may be released to the environment for up to 14 days provided that prior to initiating the release:

- a. At least two independent samples of the tank's contents are analyzed, and
- b. At least two technically qualified members of the facility staff independently verify the release rate calculations and discharge valve lineup.

Otherwise, suspend release of radioactive effluents via this pathway.

ACTION 6 With the number of channels OPERABLE less than required by the Minimum Channels OPERABLE requirement, effluent releases via this pathway may continue for up to 30 days provided the flow rate is estimated at least once per 4 hours.

ACTION 7 With the number of channels OPERABLE less than required by the Minimum Channels OPERABLE requirement, effluent releases via this pathway may continue for up to 30 days provided grab samples are taken at least once per 12 hours and these samples are analyzed for radioactivity within 24 hours.

ACTION 8 With the number of channels OPERABLE less than required by the Minimum Channels OPERABLE requirement, immediately suspend containment PURGING of radioactive effluents via this pathway.

ACTION 9 With the number of channels OPERABLE less than required by the Minimum Channels OPERABLE requirement, effluent releases via the affected pathway may continue for up to 30 days provided samples are continuously collected with auxiliary sampling equipment as required in Commitment Table 6.

NOTE FOR ACTION 9: To respond to the low flow alarm, determine that a simple fix cannot be made and that an auxiliary sampler is needed. Move the sampler in, hook up and verify operation, a maximum of two hours is considered a reasonable time. Over two hours should be considered as exceeding the time limitation of the commitment for operation (ECG 39.4).

**Radioactive Gaseous Effluent Monitoring
Instrumentation Operational Requirements**

Table 4: Radioactive Gaseous Effluent Monitoring Instrumentation Surveillance Requirements

Instrument	Channel Check	Source Check	Channel Calibration	Channel Functional Test	Modes for Which Surveillance Is Required
1. Gaseous Radwaste System Noble Gas Activity Monitor - Providing Alarm and Automatic Termination of Release (RM-22)	P	P	R(3)	Q(1)	*
2. Plant Vent System					
a. Noble Gas Activity Monitor Providing Alarm (RM-14 or RM-14R)	D	M	R(3)	Q(2)	*
b. Iodine Sampler	W(4)	N.A.	N.A.	N.A.	*
c. Particulate Sampler	W(4)	N.A.	N.A.	N.A.	*
d. Flow Rate Monitor (FR-12)	D	N.A.	R	Q	*
e. Iodine Sampler Flow Rate Monitor	D	N.A.	R	Q	*
3. Containment Purge System Noble Gas Activity Monitor - Providing Alarm and Automatic Termination of Release (RM-44A or 44B)	D	P	R(3)	Q(1)	**

* At all times.

** MODES 1-4; also MODE 6 during CORE ALTERATIONS or movement of irradiated fuel within containment.

- (1) The CHANNEL FUNCTIONAL TEST shall also demonstrate that automatic isolation of this pathway and control room alarm annunciation occurs if any of the following conditions exists:
 - a. Instrument indicates measured levels above the Alarm/Trip Setpoint (isolation and alarm), or
 - b. Instrument indicates a downscale failure (alarm only), or
 - c. Instrument controls not set in operate mode (alarm only).
- (2) The CHANNEL FUNCTIONAL TEST shall also demonstrate that control room alarm annunciation occurs if any of the following conditions exist:
 - a. Instrument indicates measured levels above the Alarm Setpoint, or
 - b. Circuit failure, or
 - c. Instrument indicates a downscale failure, or
 - d. Instrument controls not set in operate mode.
- (3) The initial CHANNEL CALIBRATION shall be performed using one or more of the reference standards certified by the National Bureau of Standards (NBS) or using standards that have been obtained from suppliers that participate in measurement assurance activities with NBS. These standards shall permit calibrating the system over its intended range of energy and measurement range. For subsequent CHANNEL CALIBRATION, sources that have been related to the initial calibration shall be used.
- (4) The CHANNEL CHECK shall consist of verifying that the iodine cartridge and particulate filter are installed in the sample holders.
- (5) Frequency Notation

<u>Notation</u>	<u>Frequency</u>
D	At least once per 24 hours
W	At least once per 7 days
M	At least once per 31 days
Q	At least once per 92 days
R	At least once per 18 months
P	Completed prior to each release
N.A.	Not Applicable

Bases: Radioactive Gaseous Effluent Monitoring Instrumentation

The radioactive gaseous effluent instrumentation is provided to monitor and control, as applicable, the releases of radioactive materials in gaseous effluents during actual or potential releases of gaseous effluents. The Alarm/Trip Setpoints for these instruments shall be calculated and adjusted in accordance with the methodology and parameters in the ODCP to ensure that the alarm/trip will occur prior to exceeding the limits of NUREG 0133. The OPERABILITY and use of this instrumentation is consistent with the requirements of General Design Criteria (GDC): GDC 17, 1967; GDC 18, 1967; and GDC 70, 1967. The sensitivity of any noble gas activity monitors used to show compliance with the gaseous effluent release requirements of Attachment 7 shall be such that concentrations as low as $1 \times 10^{-5} \mu\text{Ci/ml}$ are measurable.

1. Liquid Effluents - CONCENTRATION

a. Commitment for Operation

1) The concentration of radioactive material released in liquid effluents to UNRESTRICTED AREAS (see FSAR Figure 2.1-2) shall be limited to the concentrations specified in 10 CFR Part 20, Appendix B, Table 2, Column 2 for radionuclides other than dissolved or entrained noble gases. For dissolved or entrained noble gases, the concentration shall be limited to 2×10^{-4} microcurie/ml total activity.

2) Applicability: At all times.

3) Action:

With the concentration of radioactive material released in liquid effluents to UNRESTRICTED AREAS exceeding the above limits, immediately restore the concentration to within the above limits.

b. Surveillance Requirements

1) Radioactive liquid wastes shall be sampled and analyzed according to the sampling and analysis program of Table 5.

2) The results of the radioactivity analyses shall be used in accordance with the methodology and parameters in the ODCP to assure that the concentrations at the point of release are maintained within the limits of Attachment 3.

Liquid Effluents - CONCENTRATION Operational Requirements

Table 5: Radioactive Liquid Waste Sampling and Analysis Program

Liquid Release Type	Sampling Frequency	Minimum Analysis Frequency	Type Of Activity Analysis	Lower Limit of Detection (LLD) ($\mu\text{Ci/ml}$) ⁽¹⁾
1. Batch Waste Release Tanks ⁽⁴⁾	P Each Batch	P Each Batch	Principal Gamma Emitters ⁽⁶⁾	5×10^{-7}
			I-131	1×10^{-6}
	P One Batch/M	M	Dissolved and Entrained Gases (Gamma emitters)	1×10^{-5}
	P Each Batch	M Composite ⁽²⁾	H-3	1×10^{-5}
			Gross Alpha	1×10^{-7}
	P Each Batch	Q Composite ⁽²⁾	Sr-89, Sr-90	5×10^{-8}
			Fe-55	1×10^{-6}
			Pu-238, Pu-239, Pu-240, Pu-241, Pu-242	5×10^{-8}
			U-233, U-234, U-235, U-236, U-238	5×10^{-8}
	2. Continuous Releases ⁽⁵⁾ Steam Generator Blowdown Tank	D Grab Sample	W Composite ⁽³⁾	Principal Gamma Emitters ⁽⁶⁾
I-131				1×10^{-6}
M Grab Sample		M	Dissolved and Entrained Gases (Gamma emitters)	1×10^{-5}
D Grab Sample		M Composite ⁽³⁾	H-3	1×10^{-5}
			Gross Alpha	1×10^{-7}
D Grab Sample		Q Composite ⁽³⁾	Sr-89, Sr-90	5×10^{-8}
	Fe-55		1×10^{-6}	
3. Continuous Releases ⁽⁵⁾ Oily Water Separator Effluent	D Grab Sample	W Composite ⁽³⁾	Principal Gamma Emitters ⁽⁶⁾	5×10^{-7}

Table Notations - next page

Liquid Effluents - CONCENTRATION Operational Requirements

Table Notations

- (1) The LLD is defined, for the purposes of these specifications, as the smallest concentration of radioactive material in a sample that will yield a net count, above system background, that will be detected with 95% probability with only 5% probability of falsely concluding that a blank observation represents a "real" signal.

For a particular measurement system, which may include radiochemical separation:

$$LLD = \frac{4.66s_b}{E * V * 2.22 \times 10^6 * Y * \exp(-\lambda\Delta t)}$$

Where:

- LLD = the "a priori" lower limit of detection (microcuries per unit mass or volume),
- s_b = the standard deviation of the background counting rate or of the counting rate of a blank sample as appropriate (counts per minute),
- E = the counting efficiency (counts per disintegration),
- V = the sample size (units of mass or volume),
- 2.22×10^6 = the number of disintegrations per minute per microcurie,
- Y = the fractional radiochemical yield, when applicable,
- λ = the radioactive decay constant for the particular radionuclide (sec^{-1}), and
- Δt = the elapsed time between the midpoint of sample collection and the time of counting (sec).

Typical values of E, V, Y, and Δt should be used in the calculation.

It should be recognized that the LLD is defined as an a priori (before the fact) limit representing the capability of a measurement system and not as an a posteriori (after the fact) limit for a particular measurement.

- (2) A composite sample is one in which the quantity of liquid sampled is proportional to the quantity of liquid waste discharged and in which the method of sampling employed results in a specimen which is representative of the liquids released.
- (3) To be representative of the quantities and concentrations of radioactive materials in liquid effluents, samples shall be composited in proportion to the rate of flow of the effluent stream. Prior to analyses, all samples taken for the composite shall be thoroughly mixed in order for the composite sample to be representative of the effluent release.
- (4) A batch release is the discharge of liquid wastes of a discrete volume. Prior to sampling for analyses, each batch shall be isolated, and then thoroughly mixed, by a method described in the ODCP, to assure representative sampling.
- (5) A continuous release is the discharge of liquid wastes of a nondiscrete volume; e.g., from a volume of system that has an input flow during the continuous release.
- (6) The principal gamma emitters for which the LLD specification applies include the following radionuclides: Mn-54, Fe-59, Co-58, Co-60, Zn-65, Mo-99, Cs-134, Cs-137, and Ce-141. Ce-144 shall also be measured but with an LLD of 5×10^{-6} . This list does not mean that only these nuclides are to be considered. Other gamma peaks that are identifiable, together with those of the above nuclides, shall also be analyzed and reported in the Annual Radioactive Effluent Release Report.

If two or more redundant sample and analysis results of the same discharge pathway indicate slight differences in low level isotopic mixture, the analysis resulting in higher calculated dose should be used. The isotopes chosen to represent the discharge shall be reported.

- (7) Frequency Notation:

<u>Notation</u>	<u>Frequency</u>
D	At least once per 24 hours.
W	At least once per 7 days.
M	At least once per 31 days.
Q	At least once per 92 days.
P	Completed prior to each release.

**Liquid Effluents - CONCENTRATION Operational
Requirements**

Attachment 3: Page 4 of 4

Bases: Liquid Effluents - Concentration

This Regulatory Commitment is provided to ensure that the concentration of radioactive materials released in liquid waste effluents to UNRESTRICTED AREAS will be less than the concentration levels specified in 10 CFR Part 20, Appendix B, Table 2, Column 2. This limitation provides additional assurance that the levels of radioactive materials in bodies of water in UNRESTRICTED AREAS will result in exposures within: (1) the Section II.A design objectives of Appendix I, 10 CFR Part 50, to a MEMBER OF THE PUBLIC, and (2) the limits of 10 CFR 20.1301(e) to the population. The concentration limit for dissolved or entrained noble gases is based upon the assumption that Xe-135 is the controlling radioisotope and its Effluent Concentration Limit (ECL) in air (submersion) was converted to an equivalent concentration in water using the methods described in International Commission on Radiological Protection (ICRP) Publication 2.

This Regulatory Commitment applies to the release of radioactive materials in liquid effluents from all units at the site.

The required detection capabilities for radioactive materials in liquid waste samples are tabulated in terms of the Lower Limits Of Detection (LLDs). Detailed discussion of the LLD, and other detection limits can be found in Currie, L.A., "Lower Limit of Detection: Definition and Elaboration of a Proposed Position for Radiological Effluent and Environmental Measurements," NUREG/CR-4007 (September 1984), and in the HASL Procedures Manual, HASL-300 (revised annually).

1. Liquid Effluents - Dose

a. Commitment for Operation

- 1) The dose or dose commitment to a MEMBER OF THE PUBLIC from radioactive materials in liquid effluents released, from each unit, to UNRESTRICTED AREAS (see FSAR Figure 2.1-2) shall be limited to the following:
 - a) During any calendar quarter to less than or equal to 1.5 mrem to the whole body and to less than or equal to 5 mrem to any organ.
 - b) During any calendar year to less than or equal to 3 mrem to the whole body and to less than or equal to 10 mrem to any organ.
- 2) Applicability: At all times.
- 3) Action:
 - a) With the calculated dose from the release of radioactive materials in liquid effluents exceeding any of the above limits, prepare and submit to the Commission within 30 days, pursuant to 10 CFR 50.4, a Special Report that identifies the cause(s) for exceeding the limit(s) and defines the corrective actions that have been taken to reduce the releases and the proposed corrective actions to be taken to assure that subsequent releases will be in compliance with the above limits.

b. Surveillance Requirements

- 1) Cumulative dose contributions from liquid effluents for the current calendar quarter and the current calendar year shall be determined in accordance with the methodology and parameters in the ODCP at least once per 31 days.

Bases: Liquid Effluents - Dose

This Regulatory Commitment is provided to implement the requirements of Sections II.A, III.A and IV.A of Appendix I, 10 CFR Part 50. The Limiting Condition for Operation implements the guides set forth in Section II.A of Appendix I. The ACTION statements provide the required operating flexibility and at the same time implement the guides set forth in Section IV.A of Appendix I to assure that the releases of radioactive material in liquid effluents to UNRESTRICTED AREAS will be kept "as low as is reasonably achievable." The dose calculation methodology and parameters in the ODCP implement the requirements in Section III.A of Appendix I that conformance with the guides of Appendix I be shown by calculational procedures based on models and data, such that the actual exposure of a MEMBER OF THE PUBLIC through appropriate pathways is unlikely to be substantially underestimated. The equations specified in the ODCP for calculating the doses due to the actual release rates of radioactive materials in liquid effluents are consistent with the methodology provided in Regulatory Guide 1.109, "Calculation of Annual Doses to Man from Routine Releases of Reactor Effluents for the Purpose of Evaluating Compliance with 10 CFR Part 50, Appendix I," Revision 1, October 1977 and Regulatory Guide 1.113, "Estimating Aquatic Dispersion of Effluents from Accidental and Routine Reactor Releases for the Purpose of Implementing Appendix I," April 1977.

This Regulatory Commitment applies to the release of radioactive materials in liquid effluents from each unit at the site. For units with shared Radwaste Treatment Systems, the liquid effluents from the shared system are to be proportioned among the units sharing that system.

**Liquid Radwaste Treatment System Dose
Operational Requirements**

Attachment 5: Page 1 of 1

1. Liquid Radwaste Treatment System

a. Commitment for Operation

NOTE: The Liquid Radwaste Treatment System is common to both units.

- 1) The Liquid Radwaste Treatment System shall be OPERABLE and appropriate portions of the system shall be used to reduce the radioactive materials in liquid wastes prior to their discharge when the projected doses due to the liquid effluent, from each unit, to UNRESTRICTED AREAS (see FSAR Figure 2.1-2) would exceed 0.06 mrem to the whole body or 0.2 mrem to any organ in a 31-day period.
- 2) Applicability: At all times.
- 3) Action:
 - a) With any portion of the Liquid Radwaste Treatment System not in operation and with radioactive liquid waste being discharged without treatment and in excess of the above limits, prepare and submit to the Commission within 30 days, pursuant to 10 CFR 50.4, a Special Report which includes the following information:
 - (1) Explanation of why liquid radwaste was being discharged without treatment, identification of any inoperable equipment or subsystems, and the reason for the inoperability,
 - (2) Action(s) taken to restore the inoperable equipment to OPERABLE status, and
 - (3) Summary description of action(s) taken to prevent a recurrence.

b. Surveillance Requirements

- 1) Doses due to liquid releases from each unit to UNRESTRICTED AREAS shall be projected at least once per 31 days, in accordance with the methodology and parameters in the ODCP when Liquid Radwaste Treatment Systems are not being fully utilized.
- 2) The installed Liquid Radwaste Treatment System shall be considered OPERABLE by meeting attachments 3 and 4.

Bases: Liquid Radwaste Treatment System

The OPERABILITY of the Liquid Radwaste Treatment System ensures that this system will be available for use whenever liquid effluents require treatment prior to release to the environment. The requirement that the appropriate portions of this system be used when specified provides assurance that the releases of radioactive materials in liquid effluents will be kept "as low as is reasonably achievable." This specification implements the requirements of 10 CFR 50.36a, General Design Criterion 60 of Appendix A to 10 CFR Part 50 and the design objective given in Section II.D of Appendix I to 10 CFR Part 50. The specified limits governing the use of appropriate portions of the Liquid Radwaste Treatment System were specified as a suitable fraction of the dose design objectives set forth in Section II.A of Appendix I, 10 CFR Part 50, for liquid effluents.

This Regulatory Commitment applies to the release of radioactive materials in liquid effluents from each unit at the site. For units with shared Radwaste Treatment Systems, the liquid effluents from the shared system are to be proportioned among the units sharing that system.

**Gaseous Effluents - Dose Rate Operational
Requirements**

Attachment 6: Page 1 of 5

1. Gaseous Effluents - Dose Rate

a. Commitment for Operation

- 1) The dose rate due to radioactive materials released in gaseous effluents from the site to areas at or beyond the SITE BOUNDARY (see FSAR Figure 2.1-2) shall be limited to the following:
 - a) For noble gases: Less than or equal to 500 mrem/yr to the whole body and less than or equal to 3000 mrem/yr to the skin.
 - b) For Iodine-131, for Iodine-133, for tritium, and for all radionuclides in particulate form with half-lives greater than 8 days: Less than or equal to 1500 mrem/yr to any organ.
- 2) Applicability: At all times.
- 3) Action:
With the dose rate(s) exceeding the above limits, immediately decrease the release rate to within the above limit(s).

b. Surveillance Requirements

- 1) The dose rate due to noble gases in gaseous effluents shall be determined to be within the above limits in accordance with the methodology and procedures of the ODCP.
- 2) The dose rate due to Iodine-131, Iodine-133, tritium, and all radionuclides in particulate form with half-lives greater than 8 days in gaseous effluents shall be determined to be within the above limits in accordance with the methodology and procedures of the ODCP by obtaining representative samples and performing analyses in accordance with the sampling and analysis program specified in Table 6.

Gaseous Effluents - Dose Rate Operational Requirements

Table 6: Radioactive Gaseous Waste Sampling and Analysis Program

Gaseous Release Type	Sampling Frequency	Minimum Analysis Frequency	Type of Activity Analysis	Lower Limit of Detection (LLD) ($\mu\text{Ci/ml}$) ⁽¹⁾
1. Waste Gas Decay Tank	P Each Tank Grab Sample	P Each Tank	Principal Gamma Emitters ⁽⁷⁾ (noble gases)	1×10^{-4}
2. Containment Purge	P Each Purge ⁽²⁾ Grab Sample	P Each Purge ⁽²⁾	Principal Gamma Emitters ⁽⁷⁾ (noble gases)	1×10^{-4}
			I-131, I-133	1×10^{-9}
			Principal Gamma Emitters (particulates)	1×10^{-9}
			H-3	1×10^{-5}
3. Plant Vent	M ⁽²⁾ Grab Sample	M ⁽²⁾	Principal Gamma Emitters ⁽⁷⁾ (noble gases)	1×10^{-4}
	W ^{(3) (5)} Grab Sample	W	H-3	1×10^{-6}
4. All Release Types as listed in 1., 2., 3., above, at the plant vent	Continuous ⁽⁶⁾	W ⁽⁴⁾	I-131	1×10^{-12}
		Charcoal Sample	I-133	1×10^{-10}
	Continuous ⁽⁶⁾	W ⁽⁴⁾ Particulate Sample	Principal Gamma Emitters ⁽⁷⁾	1×10^{-11}
	Continuous ⁽⁶⁾	M Composite Particulate Sample	Gross Alpha	1×10^{-11}
	Continuous ⁽⁶⁾	Q Composite Particulate Sample	Sr-89, Sr-90	1×10^{-11}
5. Steam Generator Blowdown Tank Vent	M ⁽⁸⁾	M ⁽⁸⁾	Principal Gamma Emitters ⁽⁷⁾ (noble gases)	1×10^{-4}
6. Main Condenser Nash Vacuum Pump Exhaust	24H ⁽¹⁰⁾	24H ⁽¹⁰⁾	Principal Gamma Emitters ⁽⁷⁾ (noble gases)	1×10^{-4}

Table Notations - next page

Gaseous Effluents - Dose Rate Operational
Requirements

Attachment 6: Page 3 of 5

Table Notations

- (1) The LLD is defined, for purposes of these specifications, as the smallest concentration of radioactive material in a sample that will yield a net count, above system background, that will be detected with 95% probability with only 5% probability of falsely concluding that a blank observation represents a "real" signal.

For a particular measurement system, which may include radiochemical separation:

$$LLD = \frac{4.66s_b}{E * V * 2.22 \times 10^6 * Y * \exp(-\lambda\Delta t)}$$

Where:

LLD	=	the "a priori" lower limit of detection (microcuries per unit mass or volume),
s_b	=	the standard deviation of the background counting rate or of the counting rate of a blank sample as appropriate (counts per minute),
E	=	the counting efficiency (counts per disintegration),
V	=	the sample size (units of mass or volume),
2.22×10^6	=	the number of disintegrations per minute per microcurie,
Y	=	the fractional radiochemical yield, when applicable,
λ	=	the radioactive decay constant for the particular radionuclide (sec^{-1}), and
Δt	=	the elapsed time between the midpoint of sample collection and the time of counting (sec).

Typical values of E, V, Y, and Δt should be used in the calculation.

It should be recognized that the LLD is defined as an a priori (before the fact) limit representing the capability of a measurement system and not as an a posteriori (after the fact) limit for a particular measurement.

- (2) Sampling and analyses shall also be performed following shutdown, startup, or a THERMAL POWER change exceeding 15% of the RATED THERMAL POWER within a 1-hour period, when either:
- Analysis shows that the DOSE EQUIVALENT I-131 concentration in the reactor coolant has increased more than a factor of 3.
 - The noble gas monitor shows that effluent activity has increased more than a factor of 3.
- (3) Tritium grab samples shall be taken at least once per 24 hours when the refueling canal is flooded.
- (4) Samples shall be changed at least once per 7 days and analyses shall be completed within 48 hours after changing or after removal from sampler. Sampling shall also be performed at least once per 24 hours for at least 7 days following each shutdown, startup or THERMAL POWER change exceeding 15% of RATED THERMAL POWER within a 1-hour period and analyses shall be completed within 48 hours of changing. When samples collected for 24 hours are analyzed, the corresponding LLD's may be increased by a factor of 10.
- This requirement only applies when either:
- Analysis shows that the DOSE EQUIVALENT I-131 concentration in the reactor coolant has increased more than a factor of 3.
 - The noble gas monitor shows that effluent activity has increased more than a factor of 3.
- (5) Tritium grab samples shall be taken at least once per 7 days from the ventilation exhaust from the spent fuel pool area, whenever spent fuel is in the spent fuel pool.
- (6) The ratio of the sample flow rate to the sampled stream flow rate shall be known for the time period covered by each dose or dose rate calculation made in accordance with attachments 6, 7, and 8.
- (7) The principal gamma emitters for which the LLD specification applies include the following radionuclides: Kr-87, Kr-88, Xe-133, Xe-133m, Xe-135, and Xe-138 in noble gas releases and Mn-54, Fe-59, Co-58, Co-60, Zn-65, Mo-99, I-131, Cs-134, Cs-137, Ce-141, and Ce-144 in iodine and particulate releases. This list does not mean that only these nuclides are to be considered. Other gamma peaks that are identifiable, together with those of the above nuclides, shall also be analyzed and reported in the Annual Radioactive Effluent Release Report.
- If two or more redundant sample and analysis results of the same discharge pathway indicate slight differences in low level isotopic mixture, the analysis resulting in higher calculated dose should be used. The isotopes chosen to represent the discharge shall be reported
- (8) Grab samples shall be taken and analyzed at least once per 31 days whenever there is flow through the steam generator blowdown tank. Releases of radioiodines shall be estimated based on secondary coolant concentration and partitioning factors during releases or shall be measured.

-- Table Notations Continued On Next Page --

Table Notations
(continued)

(9) Frequency Notation

<u>Notation</u>	<u>Frequency</u>
W	At least once per 7 days
M	At least once per 31 days
Q	At least once per 92 days
P	Completed prior to each release
24H	At least once per 24 hours

(10) When the main condenser vacuum pump is operating and being used to evacuate the main condenser.

**Gaseous Effluents - Dose Rate Operational
Requirements**

Attachment 6: Page 5 of 5

Bases: Gaseous Effluents - Dose Rate

This Regulatory Commitment is provided to ensure that the dose at any time at and beyond the SITE BOUNDARY from gaseous effluents from all units on the site will be within the annual dose limits of NUREG 0133 to UNRESTRICTED AREAS. The annual dose limits are the doses to be associated with the concentrations of 10 CFR Part 20, Appendix B, Table 2, Column 1. These limits provide reasonable assurance that radioactive material discharged in gaseous effluents will not result in the exposure of a MEMBER OF THE PUBLIC in an UNRESTRICTED AREA, either within or outside the SITE BOUNDARY, to average concentrations exceeding the limits to be specified in Appendix B, Table 2 of 10 CFR Part 20 (10 CFR Part 20.1302(c)). For MEMBERS OF THE PUBLIC who may at times be within the SITE BOUNDARY, the occupancy of that MEMBER OF THE PUBLIC will usually be sufficiently low to compensate for any increase in the atmospheric diffusion factor above that for the SITE BOUNDARY. Examples of calculations for such MEMBERS OF THE PUBLIC, with the appropriate occupancy factors, shall be given in the ODCP. The specified release rate limits of NUREG 0133 restrict, presently, the corresponding gamma and beta dose rates above background to a MEMBER OF THE PUBLIC at or beyond the SITE BOUNDARY to less than or equal to 500 mrem/year to the whole body or to less than or equal to 3000 mrem/year to the skin. These release rate limits also restrict, at all times, the corresponding thyroid dose rate above background to a child via the inhalation pathway to less than or equal to 1500 mrem/year.

This Regulatory Commitment applies to the release of radioactive materials in gaseous effluents from all units at the site.

The required detection capabilities for radioactive material in gaseous waste samples are tabulated in terms of the lower limits of detection (LLDs). Detailed discussion of the LLD, and other detection limits can be found in Currie, L.A., "Lower Limit of Detection: Definition and Elaboration of a Proposed Position for Radiological Effluent and Environmental Measurements," NUREG/CR-4007 (September 1984), and in the HASL Procedures Manual, HASL-300 (revised annually).

Dose - Noble Gases Operational Requirements

Attachment 7: Page 1 of 1

1. Dose - Noble Gases

a. Commitment for Operation

- 1) The air dose due to noble gases released in gaseous effluents, from each unit, to areas at or beyond the SITE BOUNDARY (see FSAR Figure 2.1-2) shall be limited to the following:
 - a) During any calendar quarter: Less than or equal to 5 mrad for gamma radiation and less than or equal to 10 mrad for beta radiation, and
 - b) During any calendar year: Less than or equal to 10 mrad for gamma radiation and less than or equal to 20 mrad for beta radiation.
- 2) Applicability: At all times.
- 3) Action:
 - a) With the calculated air dose from radioactive noble gases in gaseous effluents exceeding any of the above limits, prepare and submit to the Commission within 30 days, pursuant to 10 CFR 50.4, a Special Report that identifies the cause(s) for exceeding the limit(s), defines the corrective actions that have been taken to reduce the releases and the proposed corrective actions to be taken to assure that subsequent releases will be in compliance with the above limits.

b. Surveillance Requirements

- 1) Cumulative dose contributions for the current calendar quarter and current calendar year for noble gases shall be determined in accordance with the methodology and parameters in the ODCP at least once per 31 days.

Bases: Dose - Noble Gases

This Regulatory Commitment is provided to implement the requirements of Sections II.B, III.A and IV.A of Appendix I, 10 CFR Part 50. The Limiting Condition for Operation implements the guides set forth in Section II.B of Appendix I. The ACTION statements provide the required operation flexibility and at the same time implement the guides set forth in Section IV.A of Appendix I to assure that the releases of radioactive material in gaseous effluents to UNRESTRICTED AREAS will be kept "as low as is reasonably achievable." The Surveillance Requirements implement the requirements in Section III.A of Appendix I that conformance with the guides of Appendix I be shown by calculational procedures based on models and data such that the actual exposure of a MEMBER OF THE PUBLIC through appropriate pathways is unlikely to be substantially underestimated. The dose calculation methodology and parameters established in the ODCP for calculating the doses due to the actual release rates of radioactive noble gases in gaseous effluents are consistent with the methodology provided in Regulatory Guide 1.109, "Calculation of Annual Doses to Man from Routine Releases of Reactor Effluents for the Purpose of Evaluating Compliance with 10 CFR Part 50, Appendix I," Revision 1, October 1977 and Regulatory Guide 1.111, "Methods for Estimating Atmospheric Transport and Dispersion of Gaseous Effluents in Routine Releases from Light-Water-Cooled Reactors," Revision 1, July 1977. The ODCP equations provided for determining the air doses at and beyond the SITE BOUNDARY are based upon the historical average atmospheric conditions.

This Regulatory Commitment applies to the release of radioactive materials in gaseous effluents from each unit at the site. For units with shared Radwaste Treatment Systems, the gaseous effluents from the shared system are proportioned among the units sharing the system.

**Iodine 131, Iodine 133, Tritium, and Radioactive
Material in Particulate Form**

Attachment 8: Page 1 of 2

1. Dose - Iodine-131, Iodine-133, Tritium, and Radioactive Material in Particulate Form
 - a. Commitment for Operation
 - 1) The dose to a MEMBER OF THE PUBLIC from Iodine-131, Iodine-133, tritium and all radionuclides in particulate form with half-lives greater than 8 days in gaseous effluents released, from each unit, to areas at and beyond the SITE BOUNDARY (see Figure 2.1-2) shall be limited to the following:
 - a) During any calendar quarter: Less than or equal to 7.5 mrem to any organ and,
 - b) During any calendar year: Less than or equal to 15 mrem to any organ.
 - 2) Applicability: At all times.
 - 3) Action:
 - a) With the calculated dose from the release of Iodine-131, Iodine-133, tritium, and radionuclides in particulate form with half-lives greater than 8 days, in gaseous effluents exceeding any of the above limits, prepare and submit to the Commission within 30 days, pursuant to 10 CFR 50.4, a Special Report that identifies the cause(s) for exceeding the limit(s), defines the corrective actions that have been taken to reduce the releases and the proposed actions to be taken to assure that subsequent releases will be in compliance with the above limits.
 - b. Surveillance Requirements
 - 1) Cumulative dose contributions for the current calendar quarter and current calendar year for Iodine-131, Iodine-133, tritium, and radionuclides in particulate form with half-lives greater than 8 days shall be determined in accordance with the methodology and parameters in the ODCP at least once per 31 days.

Bases: Dose - Iodine-131, Iodine-133, Tritium, and Radioactive Material in Particulate Form

This Regulatory Commitment is provided to implement the requirements of Sections II.C, III.A, and IV.A of Appendix I, 10 CFR Part 50. The Limiting Conditions for Operation are the guides set forth in Section II.C of Appendix I. The ACTION statements provide the required operating flexibility and at the same time implement the guides set forth in Section IV.A of Appendix I to assure that the releases of radioactive materials in gaseous effluents to UNRESTRICTED AREAS will be kept "as low as is reasonably achievable." The ODCP calculational methods specified in the Surveillance Requirements implement the requirements in Section III.A of Appendix I that conformance with the guides of Appendix I be shown by calculational procedures based on models and data, such that the actual exposure of a MEMBER OF THE PUBLIC through appropriate pathways is unlikely to be substantially underestimated. The ODCP calculational methodology and parameters for calculating the doses due to the actual release rates of the subject materials are consistent with the methodology provided in Regulatory Guide 1.109, "Calculation of Annual Doses to Man from Routine Releases of Reactor Effluents for the Purpose of Evaluating Compliance with 10 CFR Part 50, Appendix I," Revision 1, October 1977 and Regulatory Guide 1.111, "Methods for Estimating Atmospheric Transport and Dispersion of Gaseous Effluents in Routine Releases from Light-Water-Cooled Reactors,;" Revision 1, July 1977. These equations also provide for determining the actual doses based upon the historical average atmospheric conditions. The release rate specifications for Iodine-131, Iodine-133, tritium, and radionuclides in particulate form with half-lives greater than 8 days are dependent upon the existing radionuclide pathways to man in the areas at and beyond the SITE BOUNDARY. The pathways that were examined in the development of the calculations were: (1) individual inhalation of airborne radionuclides, (2) deposition of radionuclides onto green leafy vegetation with subsequent consumption by man, (3) deposition onto grassy areas where milk animals and meat-producing animals graze with consumption of the milk and meat by man, and (4) deposition on the ground with subsequent exposure of man.

This Regulatory Commitment applies to the release of radioactive materials in gaseous effluents from each unit at the site. For units with shared Radwaste Treatment Systems, the gaseous effluents from the shared system are proportioned among the units sharing that system.

Gaseous Radwaste Treatment System Operational Requirements

Attachment 9: Page 1 of 1

1. Gaseous Radwaste Treatment System

a. Commitment for Operation

- 1) The GASEOUS RADWASTE SYSTEM and the VENTILATION EXHAUST TREATMENT SYSTEM shall be OPERABLE. The appropriate portions of these systems shall be used to reduce releases of radioactivity when the projected doses in 31 days due to gaseous effluent releases, from each unit, to areas at and beyond the SITE BOUNDARY (see FSAR Figure 2.1-2), would exceed 0.2 mrad to air from gamma radiation or 0.4 mrad to air from beta radiation or 0.3 mrem to any organ of a MEMBER OF THE PUBLIC.
- 2) Applicability: At all times.
- 3) Action:
 - a) With radioactive gaseous waste being discharged without treatment and in excess of the above limits, prepare and submit to the Commission within 30 days, pursuant to 10 CFR 50.4, a Special Report that includes the following information:
 - (1) Identification of the inoperable equipment or subsystems and the reason for inoperability,
 - (2) Action(s) taken to restore the inoperable equipment to OPERABLE status, and
 - (3) Summary description of action(s) taken to prevent a recurrence.

b. Surveillance Requirements

- 1) Doses due to gaseous releases from each unit to areas at and beyond the SITE BOUNDARY shall be projected at least once per 31 days, in accordance with the methodology and parameters in the ODCP when Gaseous Radwaste Treatment Systems are not being fully utilized.
- 2) The installed VENTILATION EXHAUST TREATMENT SYSTEM and GASEOUS RADWASTE SYSTEM shall be considered OPERABLE by meeting attachments 6, 7, or 8.

Bases: Gaseous Radwaste Treatment System

The OPERABILITY of the GASEOUS RADWASTE SYSTEM and the VENTILATION EXHAUST TREATMENT SYSTEM ensures that the systems will be available for use whenever gaseous effluents require treatment prior to release to the environment. The requirement that the appropriate portions of these systems be used, when specified, provides reasonable assurance that the releases of radioactive materials in gaseous effluents will be kept "as low as is reasonably achievable." This specification implements the requirements of 10 CFR 50.36a, General Design Criterion 60 of Appendix A to 10 CFR Part 50 and the design objectives given in Section II.D of Appendix I to 10 CFR Part 50. The specified limits governing the use of appropriate portions of the systems were specified as a suitable fraction of the dose design objectives set forth in Sections II.B and II.C of Appendix I, 10 CFR Part 50, for gaseous effluents.

This Regulatory Commitment applies to the release of radioactive materials in gaseous effluents from each unit at the site. For units with shared Radwaste Treatment Systems, the gaseous effluents from the shared system are proportioned among the units sharing that system.

1. Total Dose

a. Commitment for Operation

- 1) The annual (calendar year) dose or dose commitment to any MEMBER OF THE PUBLIC due to releases of radioactivity and to radiation from uranium fuel cycle sources shall be limited to less than or equal to 25 mremS to the whole body or any organ, except the thyroid, which shall be limited to less than or equal to 75 mremS.
- 2) Applicability: At all times.
- 3) Action:
 - a) With the calculated doses from the release of radioactive materials in liquid or gaseous effluents exceeding twice the limits of attachments 4, 7, or 8, calculations shall be made including direct radiation contributions from the units and from outside storage tanks to determine whether the above limits of Attachment 10 have been exceeded. If such is the case, prepare and submit to the Commission within 30 days, pursuant to 10 CFR 50.4, a Special Report that defines the corrective action to be taken to reduce subsequent releases to prevent recurrence of exceeding the above limits and includes the schedule for achieving conformance with the above limits. This Special Report, as defined in 10 CFR 20.2203(a), shall include an analysis that estimates the radiation exposure (dose) to a MEMBER OF THE PUBLIC from uranium fuel cycle sources, including all effluent pathway and direct radiation, for the calendar year that includes the release(s) covered by this report. It shall also describe levels of radiation and concentrations of radioactive material involved, and the cause of the exposure levels or concentrations. If the estimated dose(s) exceeds the above limits, and if the release condition resulting in violation of 40 CFR Part 190 has not already been corrected, the Special Report shall include a request for a variance in accordance with the provisions of 40 CFR Part 190. Submittal of the report is considered a timely request, and a variance is granted until staff action on the request is complete.

b. Surveillance Requirements

- 1) Cumulative dose contributions from liquid and gaseous effluents shall be determined in accordance with attachments 4, 7, and 8, and in accordance with the methodology and parameters in the ODCP.
- 2) Cumulative dose contributions from direct radiation from the units and from outside storage tanks shall be determined in accordance with the methodology and parameters in the ODCP. This requirement is applicable only under conditions set forth in ACTION a) of Attachment 10.

Bases: Total Dose

This Regulatory Commitment is provided to meet the dose limitations of 40 CFR Part 190 that have been incorporated into 10 CFR Part 20 by 46 FR 18525. The specification requires the preparation and submittal of a Special Report whenever the calculated doses due to releases of radioactivity and to radiation from uranium fuel cycle sources exceed 25 mremS to the whole body or any organ, except the thyroid, which shall be limited to less than or equal to 75 mremS. For sites containing up to four reactors, it is highly unlikely that the resultant dose to a MEMBER OF THE PUBLIC will exceed the dose limits of 40 CFR Part 190 if the individual reactors remain within twice the dose design objectives of Appendix I, and if direct radiation doses from the units and from outside storage tanks are kept small. The Special Report will describe a course of action that should result in the limitation of the annual dose to a MEMBER OF THE PUBLIC to within the 40 CFR Part 190 limits. For the purposes of the Special Report, it may be assumed that the dose commitment to the MEMBER OF THE PUBLIC from other uranium fuel cycle sources is negligible, with the exception that dose contribution from other nuclear fuel cycle facilities at the same site or within a radius of 8 km must be considered. If the dose to any MEMBER OF THE PUBLIC is estimated to exceed the requirements of 40 CFR Part 190, the Special Report with a request for a variance (provided the release conditions resulting in violation of 40 CFR Part 190 have not already been corrected), in accordance with the provisions of 40 CFR 190.11 and 10 CFR 20.2203(a), is considered to be a timely request and fulfills the requirements of 40 CFR Part 190 until NRC staff action is completed. The variance only relates to the limits of 40 CFR Part 190, and does not apply in any way to the other requirements for dose limitation of 10 CFR Part 20, as addressed in attachments 3 and 6. An individual is not considered a MEMBER OF THE PUBLIC during any period in which he/she is engaged in carrying out any operation that is part of the nuclear fuel cycle.

**Radiological Environmental Monitoring
Operational Requirements**

Attachment 11: Page 1 of 1

1. Radiological Environmental Monitoring

a. Commitment for Operation

- 1) The Radiological Environmental Monitoring Program shall be conducted as specified in RP1.ID11, "Environmental Radiological Monitoring Procedure."
- 2) Applicability: At all times.
- 3) Action:
 - a) With the confirmed level of radioactivity as the result of plant effluents in an environmental sampling medium at a specified location exceeding the "Reporting Levels for Nonroutine Operating Reports" in RP1.ID11 when averaged over any calendar quarter, prepare and submit to the Commission within 30 days from the end of the quarter, pursuant to 10 CFR 50.4, a Nonroutine Radiological Environmental Operating Report that identifies the cause(s) for exceeding the limit(s) and defines the corrective actions to be taken to reduce radioactive effluents so that the potential annual dose to a MEMBER OF THE PUBLIC is less than the calendar year limits of attachments 4, 7, or 8,. A confirmatory reanalysis of the original, a duplicate, or a new sample may be desirable, as appropriate. The results of the confirmatory analysis shall be completed at the earliest time consistent with the analysis, but in any case within 30 days. When more than one of the radionuclides from "Reporting Levels for Nonroutine Operating Reports" in RP1.ID11 are detected in the sampling medium, this report shall be submitted if:

$$\frac{\text{concentration}(1)}{\text{reportinglevel}(1)} + \frac{\text{concentration}(2)}{\text{reportinglevel}(2)} + \dots \geq 1.0$$

When radionuclides other than those in the "Reporting Levels for Nonroutine Operating Reports" in RP1.ID11 are detected and are the result of plant effluents, a Nonroutine Radiological Environmental Operating Report shall be submitted if the potential annual dose to a MEMBER OF THE PUBLIC from all radionuclides is equal to or greater than the calendar year limits of attachments 4, 7, or 8,. This report shall include an evaluation of any release conditions, environmental factors, or other aspects necessary to explain the anomalous result.

1. LAND USE CENSUS

- a. A Land Use Census shall be conducted as specified in RP1.ID11, "Environmental Radiological Monitoring Procedure."
 - 1) Applicability: At all times.
 - 2) Action:
 - a) With a Land Use Census identifying a location(s) that yields a calculated dose or dose commitment greater than the values currently being calculated in Attachment 8, identify the new location(s) in the next Annual Radioactive Effluent Release Report.
 - b) With a Land Use Census identifying a location(s) that yields a calculated dose or dose commitment (via the same exposure pathway) 20% greater than at a location from which samples are currently being obtained in accordance with Attachment 11, add the new location(s) within 30 days to the Radiological Environmental Monitoring Program given in the ERMP. The sampling location(s), excluding the control station location, having the lowest calculated dose or dose commitment(s), via the same exposure pathway, may be deleted from this monitoring program after October 31 of the year in which this Land Use Census was conducted. Submit in the next Annual Radioactive Effluent Release Report documentation for a change in the ERMP including a revised figure(s) and table(s) for the ERMP reflecting the new location(s) with information supporting the change in sampling locations.

1. Fuel Building Ventilation System (FBVS) Instrumentation, RE-58 and RE-59

a. RE-58 Nominal Setpoint ≤ 75 mr/hr

1) Bases

a) Fuel Handling Accident in Fuel Handling Building

- (1) The basis for the RE-58 high alarm setpoint is to initiate actions to mitigate offsite dose consequences from air borne releases resulting from a fuel handling accident in the Spent Fuel Pool area. Routing ventilation exhaust from the Spent Fuel Pool area through the charcoal filter, thus stripping halogens (principally iodine isotopes) mitigates off-site dose consequences. The rerouting of the ventilation is accomplished automatically upon receipt of a RE-58 high alarm. Receipt of the high alarm also signals personnel to evacuate the area. PG&E performed a calculation (RA-90-1-0 "High and Alert Alarm Setpoint for RE-58") to base the high alarm setpoint of RE-58 on the airborne radioactivity concentration in the fuel Handling Building for the FSAR Update Expected Case accident release during a fuel handling accident. The Expected Case Accident consequence presented in the FSAR Update is a less severe, but more probable accident than the FSAR Update Design Basis Case fuel handling accident. This resulted in a more conservative (lower) setpoint than that for the Design Basis Accident Case. This calculation analyzed the detector sensitivity to the various release nuclides as presented in the FSAR Update.
- (2) The high alarm setpoint is set to a value more consistent with the Expected Case Accident dose rates which eliminates spurious ESF actuation while limiting the off-site consequences due to this accident. A ≤ 75 mr/hr setpoint equates to a site boundary whole body dose of 1.46mr for the duration of the accident, which has been evaluated as being acceptable.

b) Inadvertent Criticality in the Spent Fuel Pool

- (1) The high density Spent Fuel Pool racks were redesigned to assure that a K_{eff} equal to or less than 0.95 is maintained with the racks fully loaded with fuel of the highest anticipated reactivity in each of two regions, and flooded with unborated water at a temperature corresponding to the highest reactivity. PG&E submitted PG&E Letter No. DCL-85-30, "Re-racking of Spent Fuel Pools," on September 19, 1985. The results of the criticality analysis for normal and abnormal operations were evaluated in this report. LAR 85-13 (PG&E Letter No. DCL-85-333) was submitted on October 30, 1985, and summarized the results of the Spent Fuel Pool re-racking report. Postulated events that could potentially involve accidental criticality were examined and it was concluded that the limiting value for criticality (K_{eff} of 0.95) would not be exceeded. Therefore, an inadvertent criticality in the Spent Fuel Pool is not considered a credible accident and an evaluation of the effect of raising the actuation setpoint on RE-58 was not required.
- (2) Radiation monitor RE-59, which monitors the new fuel storage vault area, also provides indication of inadvertent criticality and changes in dose rate for radiation protection purposes.

**High Alarm Setpoints - FB & CR Ventilation
Systems Actuation Instrumentation**

Attachment 13: Page 2 of 2

- b. RE-59 Nominal Setpoint ≤ 15 mr/hr
 - 1) Bases
 - a) In DCPD FSAR update in Chapter 12, Table 12.1-1, "Plant Zone Classifications," the Fuel Handling Building areas in which RE-59 is located is classified as Zone III, "Controlled Assess Requiring Short-Term Occupancy" as indicated in Design Criteria Memorandum DCM-T20.
 - b) The Zone III design maximum dose rate is ≤ 15 mr/hr. If the radiation flux reaches this value, the high alarm will be actuated and the ventilation mode will change as indicated above with the RE-58 high alarm actuation.
2. Control Room Ventilation System (CRVS) Instrumentation, RS-25A and RS-26A
 - a. RS-25A/RS-26A Nominal Setpoint ≤ 2 mr/hr
 - 1) Bases
 - a) Per calculations DV-1-23 and DV-2-23 attachment 2:
 - (1) The applicable NRC requirement for the radiation exposure (dose) to personnel in the Main Control Room is 10 CFR 20.105 "Permissible Level of Radiation in Unrestricted Areas" (superseded). Section b (1) of 10 CFR 20.105 limits the radiation dose for unrestricted areas to 2mr/hr and Section b (2) limits the dose to 100mr in seven consecutive days. If an operator works in the control room for 48 hours per week (12 hours per day and 4 days per week, a normal operator work week) during a 2mr/hr dose rate, the operator will receive a 96mr dose. This is less than the 100mr/week dose limit of 10 CFR 20.105 (superseded). Thus, a setpoint of ≤ 2 mr/hr has been established for the Control Room Air Inlet Radiation Monitors. If the radiation flux reaches this value at any of the detectors, a change in the ventilation to Mode 4 will be initiated.
 - (2) 10 CFR 20.105 has been superseded and any changes to this setpoint will require a basis change to reflect the requirements of 10 CFR 50 Appendix A Criterion 19.
3. All of the setpoints are controlled by the setpoint control program CF6.ID1 and require a design change vehicle (request per CF4.ID1) to change. Actual field setpoints are set more conservative to account for instrument errors.

Attachment 3

**Diablo Canyon Power Plant Interdepartmental Administrative Procedure,
RP1.ID11, "Environmental Radiological Monitoring Procedure," Revision 12**

Environmental Radiological Monitoring Procedure

02/10/14
Effective Date

QUALITY RELATED

Table of Contents

1.	SCOPE.....	1
2.	DISCUSSION	2
3.	DEFINITIONS	2
4.	RESPONSIBILITIES	3
5.	INSTRUCTIONS	5
6.	RECORDS.....	10
7.	REFERENCES	10
8.	Radiological Environmental Monitoring Program.....	11
9.	Detection Capabilities/Lower Limits of Detection (LLD).....	17
10.	AREOR REMP Program Summary Matrix	19
11.	Reporting (Notification) Levels for REMP	20
12.	Distances and Directions to REMP Monitoring Stations	21
13.	Summary of Cross-Check Program with State of California	24

ATTACHMENTS:

1.	DCPP Onsite ERMP Stations	25
2.	DCPP Offsite ERMP Stations	26
3.	DCPP Onsite ERMP Stations Satelite Map.....	27

1. SCOPE

- 1.1 This procedure constitutes the Environmental Radiological Monitoring Procedure (ERMP) and implements the requirements of the Radiological Environmental Monitoring Program (REMP) for the plant per Technical Specification 5.5.1, 5.6.2, and the ISFSI Environmental Report, Section 6.2. This procedure is part of the Offsite Dose Calculation Manual (ODCM).
- 1.2 Administrative requirements for the DCPP Groundwater Protection Initiative (GPI) program are located in RP1.ID13.

2. DISCUSSION

- 2.1 The purpose of a Radiological Environmental Monitoring Program is to provide a basis for evaluating concentrations of radioactive materials and radiation levels in the environment from radiological releases once a reactor is operational.
- 2.2 This procedure describes the supplemental and minimum required program, describing sample locations, types of sample locations, methods and frequency of analysis, reporting requirements, performance of land use census, and participation in an interlaboratory comparison program.
- 2.3 This procedure also contains the state of California Department of Public Health (CDPH) cross-check program.
- 2.4 The program described by this procedure provides measurements of radiation and of radioactive materials in those exposure pathways and for those nuclides that lead to the highest potential radiation exposures of members of the public resulting from plant operation. This monitoring program implements section IV.B.2, IV.B.3, and IV.C of Appendix I to 10 CFR 50 and supplements the Radioactive Effluent Control Program. Guidance for this monitoring program is provided by the Radiological Assessment Branch Technical Position on Radiological Environmental Monitoring, revision 1, November, 1979. Due to DCPD site characteristics, some program requirements may vary from the Branch Technical Position on REMP (BTP 1979).
- 2.5 The Diablo Canyon ODCM is made up of the following procedures:
 - 2.5.1 CY2, "Radiological Monitoring and Controls Program"
 - 2.5.2 CY2.ID1, "Radioactive Effluent Controls Program"
 - 2.5.3 RP1.ID11, "Environmental Radiological Monitoring Procedure"
 - 2.5.4 CAP A-8, "Off-Site Dose Calculation Procedure"

3. DEFINITIONS

- 3.1 Broadleaf Vegetation: The leafy portion of plants such as lettuce, cabbage, spinach, or other similar leafy plants, typically used for human consumption.
- 3.2 Supplemental Sample: Samples that should be collected when available, but when they are not available, they are not subject to the substitution requirements of Table 1, Note 1. These types of samples are specifically designated as "supplemental" in Table 1.

4. RESPONSIBILITIES

- 4.1 Radiation protection manager is responsible for ensuring implementation of this procedure, including approving the Annual Radiological Environmental Operating Report (AREOR) prior to its submittal to the NRC. This should be a signature page at the front of the AREOR.
- 4.2 REMP engineer is responsible for:
- 4.2.1 Identifying and evaluating the significant pathways of radiological impact to man and biota (e.g., food vectors, recreational use, water use) and subsequent updating of the REMP.
 - 4.2.2 Ensuring the performance of the annual land use census and that the results are provided to chemistry so that chemistry can establish the dose requirements of CY2.ID1,"Radioactive Effluent Controls Program."
 - 4.2.3 Preparation of the Annual Radiological Environmental Operating Report (AREOR).
 - 4.2.4 Ensuring that changes to the ERMP are provided to chemistry for inclusion in the Annual Radiological Effluent Release Report.
 - 4.2.5 Ensuring the required REMP sampling and monitoring are performed.
 - 4.2.6 Ensuring that the environmental TLD program is maintained.
 - 4.2.7 Implementing and communicating contracts with the environmental vendor lab (REMP).
 - 4.2.8 Ensuring that the personnel responsible for the management and for the implementation of the REMP receive training on the changes to the REMP at least annually.
 - a. Such training consists of topics related to the changes in the plant's REMP procedures, industry events, any changes in technology that pertain to REMP sampling techniques or to the analysis of REMP samples and the nature and goals of the quality assurance program.
 - b. Proficiency of personnel who perform activities affecting the quality of the REMP can be maintained by retraining, reexamining, recertifying, or by periodic performance reviews as appropriate.
 - c. Initial training is provided on an as needed basis to new personnel responsible for quality related REMP activities.

- 4.3 REMP environmental lab vendor is responsible for:
- 4.3.1 Ensuring analysis is performed for the samples as required by the ERMP.
 - 4.3.2 Ensuring that participation is maintained in an interlaboratory comparison program sufficient to satisfy step 5.3.1.
 - 4.3.3 Ensuring that REMP sample results exceeding the criteria of RP1.ID11, "Environmental Radiological Monitoring Procedure," Table 4, are communicated promptly to DCPD as per the contract.
 - 4.3.4 Ensuring communication with DCPD per the contract. Examples include:
 - Sample results not meeting the contract "a-priori" LLDs
 - Exceeding contract notification levels
 - Problems with lab REMP sample analyses
 - Problems with sample shipments
 - Interlaboratory comparison program issues
 - 4.3.5 Ensuring that appropriate procedures are established and maintained for sample handling, sample analysis and all associated laboratory equipment.
 - 4.3.6 Ensuring qualifications and training of vendor lab personnel.
 - 4.3.7 Ensuring contract compliance.
- 4.4 DCPD regulatory services department is responsible for ensuring that reports required by the ERMP are submitted to the appropriate recipients per XI1.ID2, "Regulatory Reporting Requirements and Reporting Process."

5. INSTRUCTIONS

5.1 Sampling and Monitoring

<p>NOTE: Sampling procedures for the REMP pathways and OSGSF sump monitoring are controlled in the DCPD plant manual, Volume 7, "Radiation Protection-Radiation Control Procedures," "RCP EM" series of procedures.</p>
--

5.1.1 Environmental samples shall be collected and analyzed according to Table 1 at the locations shown in Table 5 and Figure 1, (Attachment 1) and Figure 2 (Attachment 2).

- a. Analytical techniques used shall be such that the detection capabilities in Table 2 are routinely achieved.
- b. The sampling frequencies specified in Table 1 are allowed an extension of 25 percent (NUREG 1301, Page 16, Section 4.0.2).

5.1.2 The Old Steam Generator Storage Facility (OSGSF) inspection sumps shall be monitored quarterly to ensure there is no standing water in the sumps. If water is found.^{Ref 7.2.3}

- a. Initiate the corrective action process.
- b. Perform isotopic analysis for plant related isotopes.
- c. Disposition the water per plant protocols.

5.2 Land Use Census (LUC)

5.2.1 The land use census satisfies the requirements of section IV.B.3 of Appendix I to 10 CFR 50.

- a. Restricting the census to gardens of greater than 500 square feet provides assurance that significant exposure pathways via broadleaf vegetation will be identified and monitored as necessary.
- b. The size of the garden is the minimum to produce the quantity of 26 kg/year of broadleaf assumed in Regulatory Guide 1.109 for consumption by a child.

-
- 5.2.2 A land use census shall be conducted at least once per year, during the growing season between February 15 and December 1. The LUC will determine the locations in each of the 16 meteorological sectors within a distance of 8 km (5 mi) for.^{Ref 7.2.1}
- a. The nearest milk animal.
 - b. The nearest residence.
 - c. The nearest garden of greater than 50 square meters (500 sq. ft.) producing broadleaf vegetation.

<p>NOTE: Broadleaf vegetation sampling may be performed at the site boundary in a sector with the highest D/Q in lieu of the garden census portion of the land use census.</p>

- 5.2.3 The land use census shall be conducted using that information which will provide the best results, which typically consists of discussions with landowners/tenants in conjunction with an aerial survey. Local agricultural authorities may also be consulted.
- 5.2.4 If the land use census identifies a location(s) that yields a calculated dose or dose commitment greater than the values currently being calculated per CY2.ID1, the new location(s) shall be identified in the next Annual Radioactive Effluent Release Report.
- 5.2.5 If the land use census identifies a location(s) that yields a calculated dose or dose commitment (via the same exposure pathway) 20 percent greater than at a location from which samples are currently being obtained per CY2.ID1, add the new location(s) within 30 days to the radiological environmental monitoring program given in this ERMP.
- a. The sampling location(s), excluding the control station location, having the lowest calculated dose or dose commitment(s), via the same exposure pathway, may be deleted from this monitoring program after October 31 of the year in which this land use census was conducted.
 - b. Documentation for a change in the ERMP shall be submitted in the next Annual Radioactive Effluent Release Report including a revised figure(s) and table(s) for the ERMP reflecting the new location(s) with information supporting the change in sampling locations.

5.3 Cross-Check Programs

- 5.3.1 Participation shall be maintained in an interlaboratory comparison program. This participation should include each of the determinations (sample medium-radionuclide combination) as described in Table 1 to ensure independent checks on the precision and accuracy of the measurements of radioactive materials in the ERMP samples.
- 5.3.2 Participation shall be maintained in a split-sampling program with the State of California Department of Public Health (CDPH) as required by CDPH.
- The program shall consist of radiological analyses of duplicate (split) samples or replicate analyses of the same sample by both the REMP environmental lab vendor and CDPH.
 - The sample results from the REMP environmental lab vendor are available to CDPH in the DCPD Annual Radiological Environmental Operating Report (AREOR) or as requested by CDPH.
 - The sample types, analyses performed, and frequencies of collection are given in Table 6.

5.4 Annual Radiological Environmental Operating Report (AREOR)

- 5.4.1 A report on the radiological environmental monitoring program shall be prepared annually and submitted to the NRC prior to May 1 of the following year per DCPD Tech Spec 5.6.2.
- 5.4.2 The Annual Radiological Environmental Operating Report shall include:
- Summaries, interpretations, and an analysis of trends of the results of the radiological environmental monitoring program activities for the report period.
 - A comparison with preoperational studies, operational controls (as appropriate), and previous environmental surveillance reports.
 - An assessment of the observed impacts of the plant operation on the environment.
 - The results of the land use census.
 - The results of analyses of all radiological environmental samples and of all environmental radiation measurements taken during the period pursuant to the locations specified in tables and figures in this ERMP as well as summarized and tabulated results of these analyses and measurements in the format of Table 3 or equivalent.
 - A summary description of the radiological environmental monitoring program.
 - Legible maps covering all sampling locations keyed to a table giving distances and directions from the centerline of Unit One Reactor.^{Ref 7.2.5}

- h. The results of licensee or REMP analysis lab vendor participation in the interlaboratory comparison program and the corrective action taken if the specified program is not being performed as required.
- i. The reason for not conducting the radiological environmental monitoring program as required, and discussion of all deviations from the sampling schedule of Table 1, including plans for preventing a recurrence.
- j. A discussion of environmental sample measurements that exceed the reporting levels of Table 4, but are not the result of plant effluents (i.e., demonstrated by comparison with a control station or with preoperational data).
- k. A discussion of all analyses in which the LLD required by Table 2 was not achievable.
- l. Signature approval of the AREOR by the DCPP RP manager.
- m. Results of the Old Steam Generator Storage Facility (OSGSF) quarterly sump monitoring for standing water in vault sumps. Report plant related isotopic activity detected and disposition of water.^{Ref 7.2.3}
- n. Combined percent availability of REMP airsamplers. This is done by reporting the percentage of actual runtime (as compared to available runtime) during the year for all REMP airsamplers as a combined percentage.^{T31239}
- o. Routine groundwater radiological monitoring as performed for the industry NEI Groundwater Protection Initiative 07-07 (GPI) shall be reported in the AREOR.

5.4.3 The Annual Radiological Environmental Operating Report (AREOR) shall be distributed to the following agencies.^{Ref 7.2.2}

NOTE: The May 1st deadline for submittal applies to the NRC only.

- Nuclear Regulatory Commission (NRC)
- Chief, Radiological Health Branch, CA Dept of Public Health (CDPH)
- Executive Officer, Regional Water Quality Control Board, Central Coast
- Executive Officer, San Luis Obispo County Air Pollution Control District
- San Luis Obispo County Health Officer (Environmental Health Dept)

5.5 Nonroutine Reports

5.5.1 Supplementary Report

- a. In the event that some results are not available for inclusion with the report, the report shall be submitted noting and explaining the reasons for the missing results.
 1. The missing data shall be submitted as soon as possible in a supplementary report.

5.5.2 Nonroutine Radiological Environmental Operating Report

- a. If a measured radionuclide concentration resulting from plant effluents in an environmental sampling medium, averaged over any calendar quarter sampling period, exceeds the reporting level given in Table 4, or when radionuclides other than those in Table 4 are detected and are the result of plant effluents where the potential annual dose to a member of the public from all radionuclides is equal to or greater than the calendar year limits of Appendix I of 10 CFR 50, a nonroutine radiological environmental operating report shall be prepared per CY2.ID1.
 1. This report is not required if the measured level of radioactivity was not the result of plant effluents, however, in such an event, the condition shall be reported and described in the annual radiological environmental operating report.

5.6 ERMP Changes

5.6.1 Changes to this procedure shall be processed per the requirements of the plant Technical Specification Section 5.5.1.

5.6.2 Notification of Sample Unavailability

<p>NOTE: The currently approved ERMP allows for substitution of milk and broadleaf vegetation sampling with additional air sampling in two sectors.</p>
--

- a. If milk or vegetation sampling is not being performed as required by Table 1, identify specific locations for obtaining replacement samples and add them within 30 days to the radiological environmental monitoring program given in the ERMP.
 1. The specific locations from which samples were unavailable may then be deleted from the monitoring program.
 2. Submit in the next Annual Radioactive Effluent Release Report documentation for a change in the ERMP including a revised figure(s) and table for the ERMP reflecting the new location(s) with supporting information identifying the cause of the unavailability of samples and justifying the selection of the new location(s) for obtaining samples.

6. RECORDS

- 6.1 Performance of the land use census shall be documented, including as a minimum the names of persons contacted and dates of contact. This documentation does not need to appear in the required reports, but should be entered into the records management system for the duration of the plant license following the guidance of AD10.ID1, "Storage and Control of Quality Assurance Records."
- 6.2 Changes to the ERMP shall be retained in the records management system for the duration of the plant operating license following the guidance of AD10.ID1, "Storage and Control of Quality Assurance Records."
- 6.3 REMP training shall be documented and recorded per plant protocols. Training records shall also be placed in the records management system (RMS) following the guidance of AD10.ID1, "Storage and Control of Quality Assurance Records."

7. REFERENCES

- 7.1 RMS RLOC 001157-1162 & 001157-1163, "State Acceptance Letter"
- 7.2 Corrective Actions:
 - 7.2.1 A0565194, "Request DCPD Biologist or Cal Poly AG Define Growing Season"
 - 7.2.2 A0619597, "Inconsistencies or Improvements to RP1.ID11"
 - 7.2.3 A0719469, "Establish Quarterly Monitoring of OSGSF"
 - 7.2.4 SAPN 50032742, "REMP Audit Dates and Numbers, Important Document Locations"
 - 7.2.5 SAPN 50356855, "Revise RP1.ID11"
- 7.3 DCPD ISFSI, License SNM-2511, Environmental Report, Docket 72-26
- 7.4 PCD T02694, T04341, T31239, T35263, T36656

8. **Radiological Environmental Monitoring Program**

Table 1: Radiological Environmental Monitoring Program Matrix

Exposure Pathway and/or Sample Type	Number of Representative Samples and Sample Locations ¹	Sampling Stations	Collection Frequency	Type of Analysis	Required or Supplemental
1. Direct Radiation ²	Thirty-two routine monitoring stations containing thermo luminescent dosimeters (TLDs) such that at least two (2) phosphors are present at each station, placed as follows:				
	An inner ring of stations, one in each terrestrial meteorological sector in the general area of the SITE BOUNDARY;	0S1, 0S2, WN1, 1S1, 2S1, 3S1, 4S1, 5S1, 5S3, 6S1, 7S1, 8S1, 8S2, 9S1, and MT1	Quarterly	Gamma Dose	Required
	An outer ring of stations, one in each terrestrial meteorological sector in the 2.5 to 14 km range from the site; and	0B1, 1A1, 1C1, 2D1, 3D1, 4C1, 5C1, 6D1, and 7C1	Quarterly	Gamma Dose	Required
	One or two areas to serve as control stations; and	2F2, 4D1, 5F1	Quarterly	Gamma Dose	Required
	The balance of the stations to be placed in special interest areas such as population centers, nearby residences, or schools.	5F3, 7D1, 7D2, 7F1, and 7G2	Quarterly	Gamma Dose	Required
	A minimum of four stations around the ISFSI	IS1, IS2, IS3, IS4, IS5, IS6, IS7, IS8	Quarterly	Gamma Dose	Required
2. Airborne Radioiodine	Samples from ≥ 4 stations: Three samples from close to the three SITE BOUNDARY locations (0S2, 8S1, & MT1) in different sectors. One sample from the vicinity of a community having the highest calculated annual average ground level D/Q (7D1).	0S2, 8S1, MT1, 7D1 5F1 (control)	Continuous sampler operation with sample collection weekly or more frequently if required by dust loading.	I-131 analysis	Required
	If food products are unavailable, additional air sampling will be done in the NNW (station 1S1) and SE (Station 8S2) sectors.	1S1 & 8S2	Continuous sampler operation with sample collection weekly or more frequently if required by dust loading.	I-131 analysis	Required

Table 1: Radiological Environmental Monitoring Program Matrix (continued)

Exposure Pathway and/or Sample Type	Number of Representative Samples and Sample Locations ¹	Sampling Stations	Collection Frequency	Type of Analysis	Required or Supplemental
3. Airborne Particulate	Samples from ≥ 4 stations: Three samples from close to the three SITE BOUNDARY locations (0S2, 8S1, & MT1) in different sectors. One sample from the vicinity of a community having the highest calculated annual average ground level D/Q (7D1).	0S2, 8S1, MT1, 7D1 5F1 (control)	Continuous sampler operation with sample collection weekly or more frequently if required by dust loading.	Weekly gross beta radioactivity analysis following filter change ³ . Quarterly gamma isotopic analysis ⁴ of composite consisting of approx 12 filters (by location).	Required
	If food products are unavailable, additional air sampling will be done in the NNW (station 1S1) and SE (Station 8S2) sectors.	1S1 & 8S2	Continuous sampler operation with sample collection weekly or more frequently if required by dust loading.	Weekly gross beta radioactivity analysis following filter change ³ . Quarterly gamma isotopic analysis ⁴ of composite consisting of approx 12 filters (by location).	Required
4. Airborne Carbon-14	Samples from 3 stations: One sample from each of the NW and SE sectors close to the site (0S2 and 8S1). One sample used as a control station (5F1).	0S2, 8S1 5F1 (control)	Continuous sampler operation with sample collection weekly or more frequently if required by dust loading.	C-14 analysis	Supplemental

Table 1: Radiological Environmental Monitoring Program Matrix (continued)

Exposure Pathway and/or Sample Type	Number of Representative Samples and Sample Locations ¹	Sampling Stations	Collection Frequency	Type of Analysis	Required or Supplemental
5. Waterborne					
a. Surface Ocean Water	One sample from the plant Outfall, Diablo Cove, and an area not influenced by plant discharge.	OUT, DCM, and 7C2	Monthly (grab sample)	Gamma isotopic ⁴ and tritium analysis.	Required
	One sample from the plant Outfall, Diablo Cove, and an area not influenced by plant discharge.	OUT, DCM, and 7C2	Quarterly (grab sample)	Gross Beta, Total Sr 89/90, Fe-55, and Ni-63	Supplemental
b. Drinking Water	One sample from the plant drinking water, one sample from Diablo Creek (upstream of plant), and one control sample.	DW1 and 5S2; OEL (control)	Monthly (grab sample)	Gamma isotopic ⁴ , I-131, and tritium analysis.	Required
	One sample from the plant drinking water, one sample from Diablo Creek (upstream of plant), and one control sample.	DW1 and 5S2; OEL (control)	Quarterly (grab sample)	Gross Beta, Total Sr 89/90, Fe-55, and Ni-63	Supplemental
	One sample from Diablo Creek (downstream of plant) and one sample from Blanchard Spring	WN2 and 1A2	Quarterly (grab sample)	Gamma isotopic ⁴ , tritium, I-131, gross beta, Total Sr 89/90, Fe-55, and Ni-63	Supplemental
c. Groundwater	One sample from wells located under or downgradient from the plant power block.	OW1, OW2, DY1, GW1, and GW2	Quarterly (grab sample, when available)	Gamma isotopic ⁴ , tritium, gross beta, Total Sr 89/90, Fe-55, and Ni-63	Supplemental
	One sample from a well located outside the plant power block (control sample).	WW2, 8S3	Quarterly (grab sample, when available)	Gamma isotopic ⁴ , tritium, gross beta, Total Sr 89/90, Fe-55, and Ni-63	Supplemental
d. Sediment	One sample of offshore ocean sediment from Diablo Cove and Rattlesnake Canyon.	DCM and 7C2	Annual (grab sample)	Gamma isotopic ⁴	Required
	One sample of offshore ocean sediment from Diablo Cove and Rattlesnake Canyon.	DCM and 7C2	Annual (grab sample)	Total Sr 89/90, Fe-55, and Ni-63	Supplemental
	One sample from each of five local recreational beaches.	AVA, MDO, PMO, CYA, and CBA	Semi- Annual (grab sample)	Gamma isotopic ⁴ , Total Sr 89/90, Fe-55, and Ni-63	Supplemental
e. Marine Flora	One sample of kelp	DCM, PON, POS, and 7C2	Quarterly (when available)	Gamma isotopic ⁴	Supplemental
	One sample of intertidal algae	DCM and 7C2	Quarterly (when available)	Gamma isotopic ⁴	Supplemental

Table 1: Radiological Environmental Monitoring Program Matrix (continued)

Exposure Pathway and/or Sample Type	Number of Representative Samples and Sample Locations ¹	Sampling Stations	Collection Frequency	Type of Analysis	Required or Supplemental
6. Ingestion					
a. Milk	Samples from milking animals in three locations within 5 km distance having the highest dose potential. If there are none, then one sample from milking animals in each of three areas between 5 to 8 km distance where doses are calculated to be greater than 1 mrem per year. One sample from milking animals at a control location 15 to 30 km distant and in the least prevalent wind direction. NOTE: The sample (5F2) should be taken monthly even if there are no indicator samples available.	5F2	Semimonthly when animals are on pasture; monthly at other times.	Gamma isotopic ⁴ and I-131 analysis.	Supplemental
b. Fish and Invertebrates	One sample of rock fish (family Sebastes) and one sample of perch (family Embiotocidae)	DCM and 7C2	Quarterly (grab sample)	Gamma isotopic ⁴ analysis on edible portions of each sample.	Required
	One sample of rock fish (family Sebastes) and one sample of perch (family Embiotocidae)	PON and POS	Quarterly (grab sample)	Gamma isotopic ⁴ analysis on edible portions of each sample.	Supplemental
	One sample of mussel (family Mytilus)	DCM and 7C2	Quarterly (grab sample)	Gamma isotopic ⁴ analysis on edible portions of each sample.	Required
	One sample of mussel (family Mytilus)	PON	Annual ^(A0584392) (grab sample)	Gamma isotopic ⁴ analysis on edible portions of each sample.	Supplemental
	One sample of mussel (family Mytilus)	POS	Quarterly (grab sample)	Gamma isotopic ⁴ analysis on edible portions of each sample.	Supplemental
	One sample of locally harvested market fish.	7D3 or 2F1 (should alternate between locations)	Quarterly (grab sample)	Gamma isotopic ⁴ analysis on edible portions of each sample.	Supplemental

Table 1: Radiological Environmental Monitoring Program Matrix (continued)

Exposure Pathway and/or Sample Type	Number of Representative Samples and Sample Locations ¹	Sampling Stations	Collection Frequency	Type of Analysis	Required or Supplemental
c. Broadleaf Vegetation ⁵	Three samples of broadleaf vegetation grown nearest off-site locations of highest calculated annual average ground level D/Q IF milk sampling is not performed.		Monthly (when available)	Gamma isotopic ⁴ analysis (that includes I-131) on edible portion.	Required (see notation #5)
	One sample of each of the similar broadleaf vegetation grown 15 to 30 km distant in the least prevalent wind direction IF milk sampling is not performed.		Monthly (when available)	Gamma isotopic ⁴ analysis (that includes I-131) on edible portion.	Required (see notation #5)
d. Vegetative Crops	One sample of broadleaf vegetation or vegetables or fruit	5F2, 7C1, and 7G1	Monthly (when available)	Gamma isotopic ⁴ analysis on edible portion.	Supplemental
	One sample of broadleaf vegetation or vegetables or fruit.	3C1, 6C1, and 7E1	Quarterly (as provided by land owner)	Gamma isotopic ⁴ analysis on edible portion.	Supplemental
e. Meat	One sample of each species (cow, goat, sheep, deer, or pig) of edible meat portion slaughtered for personal consumption (not mass market).	BCM, BGM, BSM, JDM, JPM, ACM, ADM, APM	Quarterly (when available and provided by land owners within 8 km of plant site)	Gamma isotopic ⁴ analysis, and Total Sr 89/90 on edible portion.	Supplemental

Table 1: Radiological Environmental Monitoring Program Matrix (continued)

Table 1 Notes:

- 1 Deviations are permitted from the required sampling schedule if specimens are unobtainable due to circumstances such as hazardous conditions, seasonal unavailability, malfunction of automatic sampling equipment and other legitimate reasons. If specimens are unobtainable due to sampling equipment malfunction, effort shall be made to complete corrective action prior to the end of the next sampling period. All deviations from the sampling schedule shall be documented in the Annual Radiological Environmental Operating Report. It is recognized that, at times, it may not be possible or practicable to continue to obtain samples of the media of choice at the most desired location or time. In these instances, suitable specific alternative media and locations may be chosen for the particular pathway in question and appropriate substitutions made within 30 days in the Radiological Environmental Monitoring Program, and submitted in the next Annual Radioactive Effluent Release Report, including a revised figure(s) and table for the ERMP reflecting the new location(s) with supporting information identifying the cause of the unavailability of samples for that pathway and justifying the selection of the new location(s) for obtaining samples.
- 2 For the purposes of this table, a thermoluminescent dosimeter (TLD) is considered to be one phosphor. There are normally three calcium sulfate phosphors in an environmental TLD BADGE. Film badges shall not be used as dosimeters for measuring direct radiation. The DCCP E-Plan is committed to placement of 3 TLD badges each quarter at each REMP TLD location to allow for monthly readout in case of an event.
- 3 Airborne particulate sample filters shall be analyzed for gross beta radioactivity 24 hours or more after sampling to allow for radon and thoron daughter decay. If gross beta activity in air particulate samples is greater than 10 times the yearly mean of control samples, gamma isotopic analysis shall be performed on the individual samples.
- 4 Gamma isotopic analysis means the identification and quantification of gamma-emitting radionuclides that may be attributable to the effluents from the facility.
- 5 If broadleaf vegetation food products are unavailable, additional air sampling as specified in Table 1, Parts 2 & 3 will be done in the NNW (Station 1S1) and SE (Station 8S2) sectors.
- 6 The Branch Technical Position (Nov 79) states, "Any location from which milk can no longer be obtained may be dropped from the surveillance program after notifying the NRC in writing that they are no longer obtainable at that location". Although the milk sampling performed at 5F2 is outside the 5-mile radius and is supplemental to the REMP, this notification should take place if 5F2 milk sampling ceases.

9. Detection Capabilities/Lower Limits of Detection (LLD)

Table 2: Environmental Detection Capabilities/Lower Limits of Detection (LLD) Matrix

Analysis	Water (pCi/L)	Airborne Particulate or Gases (pCi/m ³)	Fish (pCi/kg, wet)	Milk (pCi/L)	Food Products (pCi/kg, wet)	Soil/Sediment (pCi/kg, dry) ^f
Gross beta	4	0.01				
H-3	400 ^d					
Mn-54	15		130			150
Fe-59	30		260			300
Co-58	15		130			150
Co-60	15		130			150
Zn-65	30		260			300
Zr-95	30					300
Nb-95	15					150
I-131	1 ^e	0.07		1	60	150
Cs-134	15	0.05	130	15	60	150
Cs-137	18	0.06	150	18	80	180
Ba-140	60			60		600
La-140	15			15		150

^a The gamma emitters and corresponding LLD values listed are derived from standard ODCM guidance for environmental samples as found in Table 4.12-1 in NUREG-1301. This list does not mean that only these nuclides are to be considered. Other peaks that are identifiable, together with those of the above nuclides, shall also be analyzed and reported in the Annual Radiological Environmental Operating Report.

^b Required detection capabilities for thermoluminescent dosimeters used for environmental measurements shall be per the recommendations of Regulatory Guide 4.13, Revision 1, July 1977.

^c The LLD is defined, for purposes of these specifications, as the a-priori smallest concentration of radioactive material in a sample that will yield a net count, above system background, that will be detected with 95 percent probability with only 5 percent probability of falsely concluding that a blank observation represents a "real" signal.

^d If no drinking water pathway exists, a value of 3,000 pCi/L may be used for tritium. All groundwater wells should use the 400 pCi/L tritium value regardless of drinking water use.

^e The LLD value of 1 pCi/L for I-131 is applicable only to groundwater and sources used as drinking water. If no drinking water pathway exists, a value of 15 pCi/L may be used for I-131.

^f The gamma emitters LLD values listed are derived from the Cs-134/137 10:1 ratio established in the environmental LLDs in NUREG-1301, Table 4.12-1.

Table 2: Environmental Detection Capabilities/Lower Limits of Detection (LLD) Matrix (Continue)

Table 2 Notes:

For a particular measurement system, which may include radiochemical separation:

$$\text{LLD} = \frac{4.66S_b}{E \times V \times 2.22 \times Y \times \exp(-\lambda t)}$$

Where:

- LLD = the "a priori" the lower limit of detection as defined above (as pCi per unit mass or volume)
- S_b = the standard deviation of the background counting rate or of the counting rate of a blank sample as appropriate (as counts per minute)
- E = the counting efficiency (as counts per disintegration)
- V = the sample size (in units of mass or volume)
- 2.22 = the number of disintegrations per minute per picocurie
- Y = the fractional radiochemical yield (when applicable)
- λ = the radioactive decay constant for the particular radionuclide
- t = the elapsed time between sample collection (or end of the sample collection period) and time of counting

The value of S_b used in the calculation of the LLD for a detection system will be based on the actual observed variance of the background counting rate or of the counting rate of the blank samples (as appropriate) rather than on an unverified theoretically predicted variance. In calculating the LLD for a radionuclide determined by gamma-ray spectrometry, the background will include the typical contributions of other radionuclides normally present in the samples (e.g., potassium-40 in milk samples).

Analyses will be performed in such a manner that the stated LLDs will be achieved under routine conditions. Occasionally background fluctuations, unavoidably small sample sizes, the presence of interfering nuclides, or other uncontrollable circumstances may render these LLDs unachievable. In such cases, the contributing factors will be identified and described in the Annual Environmental Radiological Operating Report.

Typical values of E, V, Y and t should be used in the calculation. It should be recognized that the LLD is defined as a-priori (before the fact) limit representing the capability of a measurement system and not as a-posteriori (after the fact) limit for a particular measurement.

10. **AREOR REMP Program Summary Matrix**

Table 3: Environmental Radiological Monitoring Program Summary Matrix

Name of Facility _____ Docket No. _____
 Location of Facility _____ Reporting Period _____
 (County, State)

Medium or Pathway Sampled (Unit of Measurement)	Type and Total Number of Analyses Performed	Lower Limit of Detection (a) (LLD)	Location with Highest Annual Mean		All Indicator Locations Mean (b) Range (b)	Control Locations Mean (b) Range(b)	Number of Reportable Occurrences
			Name, Distance and Direction	Mean (b) Range (b)			

- (a) Unless indicated the LLDs specified in Table 2 were met.
- (b) Mean and the range based upon detectable measurements only. Fraction of detectable measurements at specified locations is indicated in parentheses; e.g., (10/12) means that 10 out of 12 samples contained detectable activity.

11. **Reporting (Notification) Levels for REMP**

Table 4: Reporting (Notification) Levels for Radioactivity Concentration in Env Samples Matrix

Analysis	Water (pCi/L)	Airborne Particulate or Gases (pCi/m ³)	Fish (pCi/kg, wet)	Milk (pCi/L)	Food Products (pCi/kg, wet)
H-3	¹ 20,000				
Mn-54	1,000		30,000		
Fe-59	400		10,000		
Co-58	1,000		30,000		
Co-60	300		10,000		
Zn-65	300		20,000		
Zr-Nb-95	400				
I-131	² 2	0.9		3	100
Cs-134	30	10	1,000	60	1,000
Cs-137	50	20	2,000	70	2,000
Ba-La-140	200			300	

¹ For drinking water samples. This is the 40 CFR 141 value. If no drinking water pathway exists, a value of 30,000 pCi/L may be used.

² If no drinking water pathway exists, a value of 20 pCi/L may be used.

Note: Table Reference in Commitment Database T35263

12. Distances and Directions to REMP Monitoring Stations

Table 5: Distances and Directions to REMP Monitoring Stations Matrix

Station Code*	Station Name	Radial Direction (True Heading) (Degrees)	Radial Distance from Plant	
			Km	(Miles)
0S1	Exclusion Fence-Northwest Corner	320	0.16	(0.1)
0S2	North Gate	320	0.8	(0.5)
1S1	Wastewater Pond	330	0.64	(0.4)
2S1	Back Road-300 m North of Plant	0	0.32	(0.2)
3S1	Road NW of 230 kV Switchyard	23	0.64	(0.4)
4S1	Back Road Between Switchyards	43	0.8	(0.5)
5S1	500 kV Switchyard	58	0.64	(0.4)
5S2	Diablo Creek Weir	65	0.96	(0.6)
5S3	Microwave Tower Road	70	1.02	(0.7)
6S1	Microwave Tower	94	0.8	(0.5)
7S1	Overlook Road	112	0.48	(0.3)
8S1	Target Range	125	0.8	(0.5)
8S2	Southwest Site Boundary	128	1.76	(1.1)
8S3	DCSF96-1 (monitor well)	145	0.52	(0.33)
9S1	South Cove	167	0.64	(0.4)
MT1	Meteorological Tower	185	0.32	(0.2)
DCM	Diablo Cove Marine	270	0.32	(0.2)
WN1	Northwest Guard Shack	290	0.32	(0.2)
WN2	Diablo Creek Outlet	283	0.25	(0.15)
1A1	Crowbar Canyon	327	2.56	(1.6)
1A2	Blanchard Spring	331	2.4	(1.5)
0B1	Point Buchon	325	5.76	(3.6)
1C1	Montana de Oro Campground	336	7.52	(4.7)
3C1	Ranch Vegetation	20	7.16	(4.5)
4C1	Clark Valley Gravel Pit	45	9.28	(5.8)
5C1	Junction Prefumo/See Canyon Roads	64	7.52	(4.7)
6C1	Household Garden	98	7.24	(4.5)
7C1	Pecho Creek Ruins (Mello Farm)	120	6.56	(4.1)
7C2	Rattlesnake Canyon	124	7.52	(4.7)

Table 5: Distances and Directions to REMP Monitoring Stations Matrix (Continue)

Station Code*	Station Name	Radial Direction (True Heading) (Degrees)	Radial Distance from Plant	
			Km	(Miles)
2D1	Sunnyside School	10	11.04	(6.9)
3D1	Clark Valley	24	9.92	(6.2)
4D1	Los Osos Valley Road	36	12.16	(7.6)
6D1	Junction See/Davis Canyon Roads	89	13.4	(8.3)
7D1	Avila Gate	118	10.56	(6.6)
7D2	Avila Beach	110	12.16	(7.6)
7D3	Avila Pier	120	11.0	(6.9)
7E1	Avila Valley Barn	103	13.94	(8.66)
2F1	Morro Bay (Commercial Landing)	0	17.44	(10.9)
2F2	Morro Bay Power Plant	358	17.9	(11.2)
5F1	SLO OEL	79	16.41	(10.2)
5F2	Cal Poly Farm	60	20.16	(12.6)
5F3	SLO County Health Department	70	20.32	(12.7)
7F1	Shell Beach	110	17.28	(10.8)
7G1	Arroyo Grande (Kawaoka Farm)	115	26.88	(16.8)
7G2	Oceano Substation	118	27.68	(17.3)
AVA	Avila Beach (near pier)	109	11.75	(7.3)
CBA	Cambria Moonstone Beach	330	45.86	(28.5)
CYA	Cayucos Beach (near pier)	350	26.87	(16.7)
DY1	Drywell 115'	77	0.041	(0.026)
DW1	Drinking Water, Plant Potable Water Sys	161	0.59	(0.37)
GW1	Groundwater Monitoring Well 1	271	0.15	(0.09)
GW2	Groundwater Monitoring Well 2	204	0.21	(0.13)
IS1 - IS8	ISFSI	65	0.48	(0.3)
MDO	Montana de Oro (Spooners Cove)	336	7.56	(4.7)
OW1	Observation Well 01	336	0.07	(0.046)
OW2	Observation Well 02	157	0.07	(0.045)
OEL	Offsite Emergency Lab	79	16.41	(10.2)
OUT	Plant Outfall	270	0.32	(0.2)
PMO	Pismo Beach (near pier)	113	20.76	(12.9)

Table 5: Distances and Directions to REMP Monitoring Stations Matrix (Continue)

PON	Pacific Ocean North of Diablo Cove	305	2.4	(1.5)
POS	Pacific Ocean South of Diablo Cove	180	0.64	(0.4)
WW2	Water Well 02	70	1.02	(0.63)

Table 5 Notes:

- * Station Code (XYZ):
 - X - First number (0-9) represents the radial sector in which the station is located:

0 - Northwest	5 - East-northeast
1 - North-northwest	6 - East
2 - North	7 - East-southeast
3 - North-northeast	8 - Southeast
4 - Northeast	9 - South-southeast
 - Y - Letter (S, A-H) represents the distance from the plant:
 - S - On-site
 - A - 0-2 miles from plant (but off-site)
 - B - 2-4 miles from plant
 - C - 4-6 miles from plant
 - D - 6-8 miles from plant
 - E - 8-10 miles from plant
 - F - 10-15 miles from plant
 - G - 15-20 miles from plant
 - H - Greater than 20 miles from plant
 - Z - Second number represents the station number within the zone.
- * Station Codes exceptions:

The following stations do not follow the coding system:

 - Diablo Cove Marine (DCM)
 - Meteorological Tower (MT1)
 - Northwest guard shack (WN1)
 - Diablo Creek outlet (WN2)
 - Pacific Ocean North (PON)
 - Pacific Ocean South (POS)
 - Offsite Emergency Lab (OEL)
 - Plant outfall (OUT)
 - Drinking water (DW1)
 - Water Well 02 (WW2)
 - Observation Well 01 (OW1)
 - Observation Well 02 (OW2)
 - Drywell 115 (DY1)
 - Avila Beach (AVA)
 - Montana de Oro - Spooners Cove (MDO)
 - Pismo Beach (PMO)
 - Cayucos Beach (CYA)
 - Cambria - Moonstone Beach (CBA)
 - Blanchard Cow Meat (BCM)
 - Blanchard Goat Meat (BGM)
 - Blanchard Sheep Meat (BSM)
 - Johe Deer Meat (JDM)
 - Johe Pig Meat (JPM)
 - Andre Cow Meat (ACM)
 - Andre Deer Meat (ADM)
 - Andre Pig Meat (APM)
 - ISFSI TLDs (IS1 - IS8)

13. Summary of Cross-Check Program with State of California

Table 6: Summary of Cross-Check Program with State of California Matrix

Sample Type	Station No.	Frequency ¹	Radioanalyses
Milk (supplemental)	5F2	Monthly	Gamma Isotopic (incl. I-131 and K-40)
Drinking Water	DW1	Monthly	Gamma Isotopic (incl. I-131), H-3
Outfall Water	OUT	Monthly	Gamma Isotopic, H-3
Diablo Creek	5S2	Monthly	Gamma Isotopic, H-3
Vegetative Crops (supplemental)	7G1	Quarterly	Gamma Isotopic
Fish or Invertebrate	DCM	Quarterly	Gamma Isotopic
Air Particulates and Radioiodine	² 5F1, 7D1	Weekly & Quarterly	Gross Beta, I-131, Qtrly Gamma Isotopic (composite airborne particulate samples)
Sediment	DCM	Annually	Gamma Isotopic
Direct Radiation (TLD)	MT1, 1A1, 1C1, 4D1, 5F3, 5S1, 7D1, 7C1, 7F1, 8S2	Quarterly	Gamma Exposure (mR)
Kelp (supplemental)	DCM	Quarterly	Gamma Isotopic

¹ When available² The California State CDPH air sampler used for correlation with DCPD 5F1 is located at the SLO County Health Dept on Johnson Avenue (near DCPD TLD station 5F3)

Figure 1

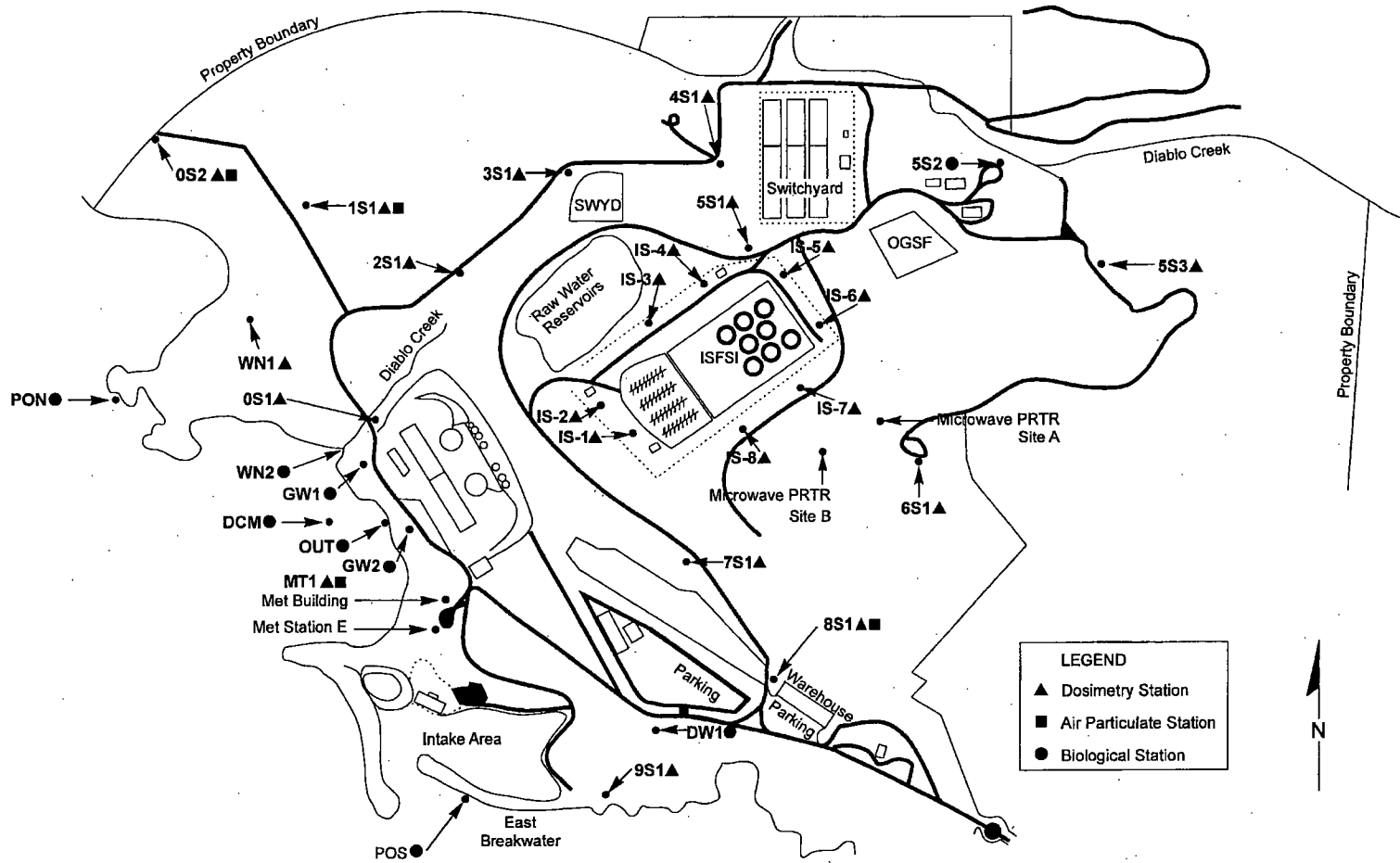

DCPD Onsite ERMP Stations

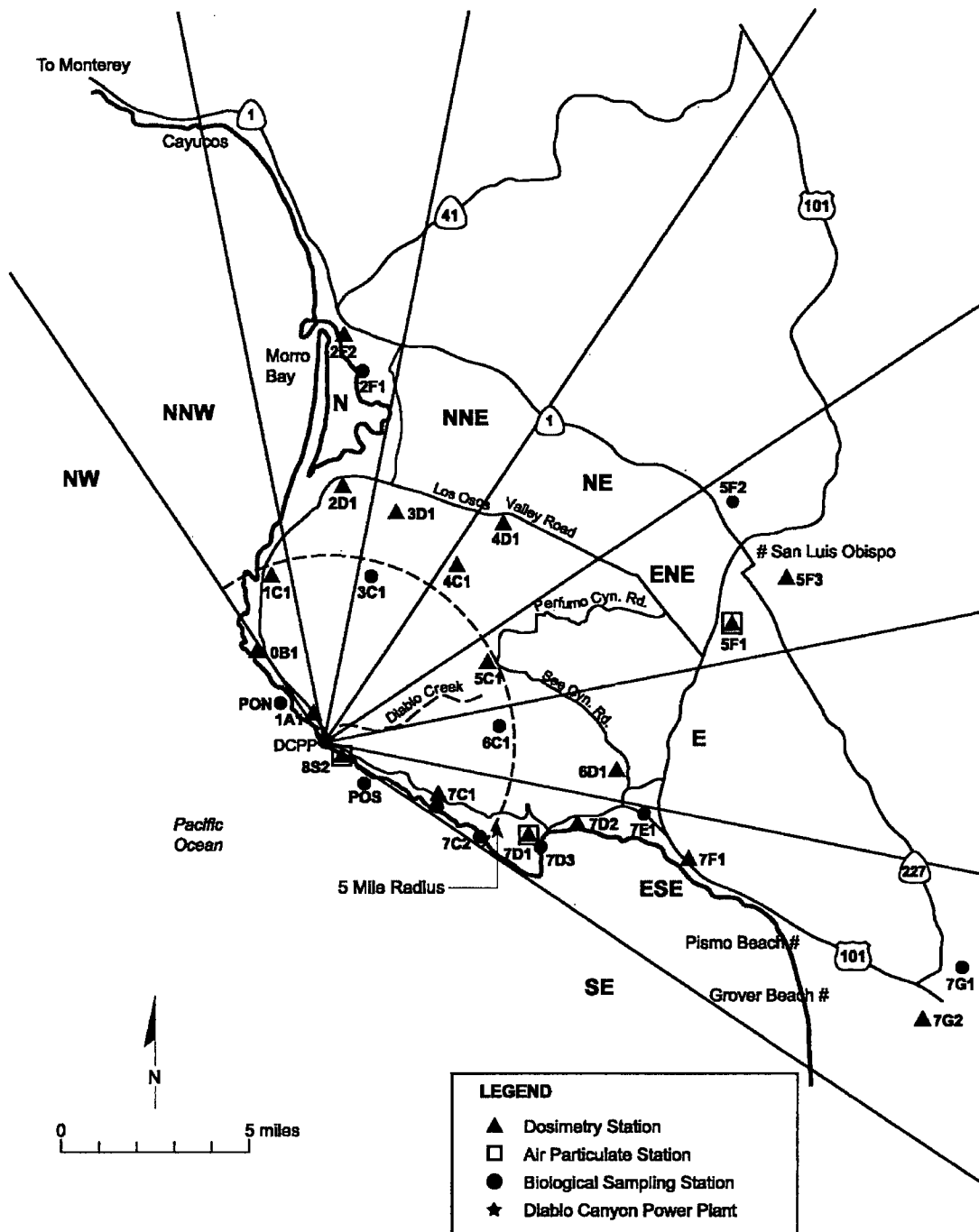

Units 1 and 2 Diablo Canyon off-site stations.

Figure 2



Figure 3

Attachment 4

**Diablo Canyon Power Plant Interdepartmental Administrative Procedure,
RP1.ID11, "Environmental Radiological Monitoring Procedure," Revision 12A**

Environmental Radiological Monitoring Procedure

02/20/14
Effective Date

QUALITY RELATED

Table of Contents

1.	SCOPE	1
2.	DISCUSSION	2
3.	DEFINITIONS	2
4.	RESPONSIBILITIES	3
5.	INSTRUCTIONS	5
6.	RECORDS.....	10
7.	REFERENCES	10
8.	Radiological Environmental Monitoring Program.....	11
9.	Detection Capabilities/Lower Limits of Detection (LLD).....	17
10.	AREOR REMP Program Summary Matrix	19
11.	Reporting (Notification) Levels for REMP	20
12.	Distances and Directions to REMP Monitoring Stations	21
13.	Summary of Cross-Check Program with State of California	24
ATTACHMENTS:		
1.	D CPP Onsite ERMP Stations	25
2.	D CPP Offsite ERMP Stations	26
3.	D CPP Onsite ERMP Stations Satellite Map.....	27

1. SCOPE

- 1.1 This procedure constitutes the Environmental Radiological Monitoring Procedure (ERMP) and implements the requirements of the Radiological Environmental Monitoring Program (REMP) for the plant per Technical Specification 5.5.1, 5.6.2, and the ISFSI Environmental Report, Section 6.2. This procedure is part of the Offsite Dose Calculation Manual (ODCM).
- 1.2 Administrative requirements for the D CPP Groundwater Protection Initiative (GPI) program are located in RP1.ID13.

2. DISCUSSION

- 2.1 The purpose of a Radiological Environmental Monitoring Program is to provide a basis for evaluating concentrations of radioactive materials and radiation levels in the environment from radiological releases once a reactor is operational.
- 2.2 This procedure describes the supplemental and minimum required program, describing sample locations, types of sample locations, methods and frequency of analysis, reporting requirements, performance of land use census, and participation in an interlaboratory comparison program.
- 2.3 This procedure also contains the state of California Department of Public Health (CDPH) cross-check program.
- 2.4 The program described by this procedure provides measurements of radiation and of radioactive materials in those exposure pathways and for those nuclides that lead to the highest potential radiation exposures of members of the public resulting from plant operation. This monitoring program implements section IV.B.2, IV.B.3, and IV.C of Appendix I to 10 CFR 50 and supplements the Radioactive Effluent Control Program. Guidance for this monitoring program is provided by the Radiological Assessment Branch Technical Position on Radiological Environmental Monitoring, revision 1, November, 1979. Due to DCPD site characteristics, some program requirements may vary from the Branch Technical Position on REMP (BTP 1979).
- 2.5 The Diablo Canyon ODCM is made up of the following procedures:
 - 2.5.1 CY2, "Radiological Monitoring and Controls Program"
 - 2.5.2 CY2.ID1, "Radioactive Effluent Controls Program"
 - 2.5.3 RP1.ID11, "Environmental Radiological Monitoring Procedure"
 - 2.5.4 CAP A-8, "Off-Site Dose Calculation Procedure"

3. DEFINITIONS

- 3.1 Broadleaf Vegetation: The leafy portion of plants such as lettuce, cabbage, spinach, or other similar leafy plants, typically used for human consumption.
- 3.2 Supplemental Sample: Samples that should be collected when available, but when they are not available, they are not subject to the substitution requirements of Table 1, Note 1. These types of samples are specifically designated as "supplemental" in Table 1.

4. RESPONSIBILITIES

- 4.1 Radiation protection manager is responsible for ensuring implementation of this procedure, including approving the Annual Radiological Environmental Operating Report (AREOR) prior to its submittal to the NRC. This should be a signature page at the front of the AREOR.
- 4.2 REMP engineer is responsible for:
- 4.2.1 Identifying and evaluating the significant pathways of radiological impact to man and biota (e.g., food vectors, recreational use, water use) and subsequent updating of the REMP.
 - 4.2.2 Ensuring the performance of the annual land use census and that the results are provided to chemistry so that chemistry can establish the dose requirements of CY2.ID1, "Radioactive Effluent Controls Program."
 - 4.2.3 Preparation of the Annual Radiological Environmental Operating Report (AREOR).
 - 4.2.4 Ensuring that changes to the ERMP are provided to chemistry for inclusion in the Annual Radiological Effluent Release Report.
 - 4.2.5 Ensuring the required REMP sampling and monitoring are performed.
 - 4.2.6 Ensuring that the environmental TLD program is maintained.
 - 4.2.7 Implementing and communicating contracts with the environmental vendor lab (REMP).
 - 4.2.8 Ensuring that the personnel responsible for the management and for the implementation of the REMP receive training on the changes to the REMP at least annually.
 - a. Such training consists of topics related to the changes in the plant's REMP procedures, industry events, any changes in technology that pertain to REMP sampling techniques or to the analysis of REMP samples and the nature and goals of the quality assurance program.
 - b. Proficiency of personnel who perform activities affecting the quality of the REMP can be maintained by retraining, reexamining, recertifying, or by periodic performance reviews as appropriate.
 - c. Initial training is provided on an as needed basis to new personnel responsible for quality related REMP activities.

-
- 4.3 REMP environmental lab vendor is responsible for:
- 4.3.1 Ensuring analysis is performed for the samples as required by the ERMP.
 - 4.3.2 Ensuring that participation is maintained in an interlaboratory comparison program sufficient to satisfy step 5.3.1.
 - 4.3.3 Ensuring that REMP sample results exceeding the criteria of RP1.ID11, "Environmental Radiological Monitoring Procedure," Table 4, are communicated promptly to DCPP as per the contract.
 - 4.3.4 Ensuring communication with DCPP per the contract. Examples include:
 - Sample results not meeting the contract "a-priori" LLDs
 - Exceeding contract notification levels
 - Problems with lab REMP sample analyses
 - Problems with sample shipments
 - Interlaboratory comparison program issues
 - 4.3.5 Ensuring that appropriate procedures are established and maintained for sample handling, sample analysis and all associated laboratory equipment.
 - 4.3.6 Ensuring qualifications and training of vendor lab personnel.
 - 4.3.7 Ensuring contract compliance.
- 4.4 DCPP regulatory services department is responsible for ensuring that reports required by the ERMP are submitted to the appropriate recipients per XI1.ID2, "Regulatory Reporting Requirements and Reporting Process."

5. INSTRUCTIONS

5.1 Sampling and Monitoring

<p>NOTE: Sampling procedures for the REMP pathways and OSGSF sump monitoring are controlled in the DCPD plant manual, Volume 7, "Radiation Protection-Radiation Control Procedures," "RCP EM" series of procedures.</p>
--

5.1.1 Environmental samples shall be collected and analyzed according to Table 1 at the locations shown in Table 5 and Figure 1, (Attachment 1) and Figure 2 (Attachment 2).

- a. Analytical techniques used shall be such that the detection capabilities in Table 2 are routinely achieved.
- b. The sampling frequencies specified in Table 1 are allowed an extension of 25 percent (NUREG 1301, Page 16, Section 4.0.2).

5.1.2 The Old Steam Generator Storage Facility (OSGSF) inspection sumps shall be monitored quarterly to ensure there is no standing water in the sumps. If water is found:^{Ref 7.2.3}

- a. Initiate the corrective action process.
- b. Perform isotopic analysis for plant related isotopes.
- c. Disposition the water per plant protocols.

5.2 Land Use Census (LUC)

5.2.1 The land use census satisfies the requirements of section IV.B.3 of Appendix I to 10 CFR 50.

- a. Restricting the census to gardens of greater than 500 square feet provides assurance that significant exposure pathways via broadleaf vegetation will be identified and monitored as necessary.
- b. The size of the garden is the minimum to produce the quantity of 26 kg/year of broadleaf assumed in Regulatory Guide 1.109 for consumption by a child.

-
- 5.2.2 A land use census shall be conducted at least once per year, during the growing season between February 15 and December 1. The LUC will determine the locations in each of the 16 meteorological sectors within a distance of 8 km (5 mi) for:^{Ref 7.2.1}
- a. The nearest milk animal.
 - b. The nearest residence.
 - c. The nearest garden of greater than 50 square meters (500 sq. ft.) producing broadleaf vegetation.

<p>NOTE: Broadleaf vegetation sampling may be performed at the site boundary in a sector with the highest D/Q in lieu of the garden census portion of the land use census.</p>

- 5.2.3 The land use census shall be conducted using that information which will provide the best results, which typically consists of discussions with landowners/tenants in conjunction with an aerial survey. Local agricultural authorities may also be consulted.
- 5.2.4 If the land use census identifies a location(s) that yields a calculated dose or dose commitment greater than the values currently being calculated per CY2.ID1, the new location(s) shall be identified in the next Annual Radioactive Effluent Release Report.
- 5.2.5 If the land use census identifies a location(s) that yields a calculated dose or dose commitment (via the same exposure pathway) 20 percent greater than at a location from which samples are currently being obtained per CY2.ID1, add the new location(s) within 30 days to the radiological environmental monitoring program given in this ERMP.
- a. The sampling location(s), excluding the control station location, having the lowest calculated dose or dose commitment(s), via the same exposure pathway, may be deleted from this monitoring program after October 31 of the year in which this land use census was conducted.
 - b. Documentation for a change in the ERMP shall be submitted in the next Annual Radioactive Effluent Release Report including a revised figure(s) and table(s) for the ERMP reflecting the new location(s) with information supporting the change in sampling locations.

5.3 Cross-Check Programs

- 5.3.1 Participation shall be maintained in an interlaboratory comparison program. This participation should include each of the determinations (sample medium-radionuclide combination) as described in Table 1 to ensure independent checks on the precision and accuracy of the measurements of radioactive materials in the ERMP samples.
- 5.3.2 Participation shall be maintained in a split-sampling program with the State of California Department of Public Health (CDPH) as required by CDPH.
- The program shall consist of radiological analyses of duplicate (split) samples or replicate analyses of the same sample by both the REMP environmental lab vendor and CDPH.
 - The sample results from the REMP environmental lab vendor are available to CDPH in the DCPD Annual Radiological Environmental Operating Report (AREOR) or as requested by CDPH.
 - The sample types, analyses performed, and frequencies of collection are given in Table 6.

5.4 Annual Radiological Environmental Operating Report (AREOR)

- 5.4.1 A report on the radiological environmental monitoring program shall be prepared annually and submitted to the NRC prior to May 1 of the following year per DCPD Tech Spec 5.6.2.
- 5.4.2 The Annual Radiological Environmental Operating Report shall include:
- Summaries, interpretations, and an analysis of trends of the results of the radiological environmental monitoring program activities for the report period.
 - A comparison with preoperational studies, operational controls (as appropriate), and previous environmental surveillance reports.
 - An assessment of the observed impacts of the plant operation on the environment.
 - The results of the land use census.
 - The results of analyses of all radiological environmental samples and of all environmental radiation measurements taken during the period pursuant to the locations specified in tables and figures in this ERMP as well as summarized and tabulated results of these analyses and measurements in the format of Table 3 or equivalent.
 - A summary description of the radiological environmental monitoring program.
 - Legible maps covering all sampling locations keyed to a table giving distances and directions from the centerline of Unit One Reactor.^{Ref 7.2.5}

-
- h. The results of licensee or REMP analysis lab vendor participation in the interlaboratory comparison program and the corrective action taken if the specified program is not being performed as required.
 - i. The reason for not conducting the radiological environmental monitoring program as required, and discussion of all deviations from the sampling schedule of Table 1, including plans for preventing a recurrence.
 - j. A discussion of environmental sample measurements that exceed the reporting levels of Table 4, but are not the result of plant effluents (i.e., demonstrated by comparison with a control station or with preoperational data).
 - k. A discussion of all analyses in which the LLD required by Table 2 was not achievable.
 - l. Signature approval of the AREOR by the DCPP RP manager.
 - m. Results of the Old Steam Generator Storage Facility (OSGSF) quarterly sump monitoring for standing water in vault sumps. Report plant related isotopic activity detected and disposition of water.^{Ref 7.2.3}
 - n. Combined percent availability of REMP airsamplers. This is done by reporting the percentage of actual runtime (as compared to available runtime) during the year for all REMP airsamplers as a combined percentage.^{T31239}
 - o. Routine groundwater radiological monitoring as performed for the industry NEI Groundwater Protection Initiative 07-07 (GPI) shall be reported in the AREOR.

5.4.3 The Annual Radiological Environmental Operating Report (AREOR) shall be distributed to the following agencies.^{Ref 7.2.2}

NOTE: The May 1 st deadline for submittal applies to the NRC only.
--

- Nuclear Regulatory Commission (NRC)
- Chief, Radiological Health Branch, CA Dept of Public Health (CDPH)
- Executive Officer, Regional Water Quality Control Board, Central Coast
- Executive Officer, San Luis Obispo County Air Pollution Control District
- San Luis Obispo County Health Officer (Environmental Health Dept)

5.5 Nonroutine Reports

5.5.1 Supplementary Report

- a. In the event that some results are not available for inclusion with the report, the report shall be submitted noting and explaining the reasons for the missing results.
 1. The missing data shall be submitted as soon as possible in a supplementary report.

5.5.2 Nonroutine Radiological Environmental Operating Report

- a. If a measured radionuclide concentration resulting from plant effluents in an environmental sampling medium, averaged over any calendar quarter sampling period, exceeds the reporting level given in Table 4, or when radionuclides other than those in Table 4 are detected and are the result of plant effluents where the potential annual dose to a member of the public from all radionuclides is equal to or greater than the calendar year limits of Appendix I of 10 CFR 50, a nonroutine radiological environmental operating report shall be prepared per CY2.ID1.
 1. This report is not required if the measured level of radioactivity was not the result of plant effluents, however, in such an event, the condition shall be reported and described in the annual radiological environmental operating report.

5.6 ERMP Changes

5.6.1 Changes to this procedure shall be processed per the requirements of the plant Technical Specification Section 5.5.1.

5.6.2 Notification of Sample Unavailability

<p>NOTE: The currently approved ERMP allows for substitution of milk and broadleaf vegetation sampling with additional air sampling in two sectors.</p>
--

- a. If milk or vegetation sampling is not being performed as required by Table 1, identify specific locations for obtaining replacement samples and add them within 30 days to the radiological environmental monitoring program given in the ERMP.
 1. The specific locations from which samples were unavailable may then be deleted from the monitoring program.
 2. Submit in the next Annual Radioactive Effluent Release Report documentation for a change in the ERMP including a revised figure(s) and table for the ERMP reflecting the new location(s) with supporting information identifying the cause of the unavailability of samples and justifying the selection of the new location(s) for obtaining samples.

6. RECORDS

- 6.1 Performance of the land use census shall be documented, including as a minimum the names of persons contacted and dates of contact. This documentation does not need to appear in the required reports, but should be entered into the records management system for the duration of the plant license following the guidance of AD10.ID1, "Storage and Control of Quality Assurance Records."
- 6.2 Changes to the ERMP shall be retained in the records management system for the duration of the plant operating license following the guidance of AD10.ID1, "Storage and Control of Quality Assurance Records."
- 6.3 REMP training shall be documented and recorded per plant protocols. Training records shall also be placed in the records management system (RMS) following the guidance of AD10.ID1, "Storage and Control of Quality Assurance Records."

7. REFERENCES

- 7.1 RMS RLOC 001157-1162 & 001157-1163, "State Acceptance Letter"
- 7.2 Corrective Actions:
 - 7.2.1 A0565194, "Request DCPD Biologist or Cal Poly AG Define Growing Season"
 - 7.2.2 A0619597, "Inconsistencies or Improvements to RP1.ID11"
 - 7.2.3 A0719469, "Establish Quarterly Monitoring of OSGSF"
 - 7.2.4 SAPN 50032742, "REMP Audit Dates and Numbers, Important Document Locations"
 - 7.2.5 SAPN 50356855, "Revise RP1.ID11"
- 7.3 DCPD ISFSI, License SNM-2511, Environmental Report, Docket 72-26
- 7.4 PCD T02694, T04341, T31239, T35263, T36656

8. Radiological Environmental Monitoring Program

Table 1: Radiological Environmental Monitoring Program Matrix

Exposure Pathway and/or Sample Type	Number of Representative Samples and Sample Locations ¹	Sampling Stations	Collection Frequency	Type of Analysis	Required or Supplemental
1. Direct Radiation ²	Thirty-two routine monitoring stations containing thermo luminescent dosimeters (TLDs) such that at least two (2) phosphors are present at each station, placed as follows:				
	An inner ring of stations, one in each terrestrial meteorological sector in the general area of the SITE BOUNDARY;	0S1, 0S2, WN1, 1S1, 2S1, 3S1, 4S1, 5S1, 5S3, 6S1, 7S1, 8S1, 8S2, 9S1, and MT1	Quarterly	Gamma Dose	Required
	An outer ring of stations, one in each terrestrial meteorological sector in the 2.5 to 14 km range from the site; and	0B1, 1A1, 1C1, 2D1, 3D1, 4C1, 5C1, 6D1, and 7C1	Quarterly	Gamma Dose	Required
	One or two areas to serve as control stations; and	2F2, 4D1, 5F1	Quarterly	Gamma Dose	Required
	The balance of the stations to be placed in special interest areas such as population centers, nearby residences, or schools.	5F3, 7D1, 7D2, 7F1, and 7G2	Quarterly	Gamma Dose	Required
	A minimum of four stations around the ISFSI	IS1, IS2, IS3, IS4, IS5, IS6, IS7, IS8	Quarterly	Gamma Dose	Required
2. Airborne Radioiodine	Samples from ≥ 4 stations: Three samples from close to the three SITE BOUNDARY locations (0S2, 8S1, & MT1) in different sectors. One sample from the vicinity of a community having the highest calculated annual average ground level D/Q (7D1).	0S2, 8S1, MT1, 7D1 5F1 (control)	Continuous sampler operation with sample collection weekly or more frequently if required by dust loading.	I-131 analysis	Required
	If food products are unavailable, additional air sampling will be done in the NNW (station 1S1) and SE (Station 8S2) sectors.	1S1 & 8S2	Continuous sampler operation with sample collection weekly or more frequently if required by dust loading.	I-131 analysis	Required

Table 1: Radiological Environmental Monitoring Program Matrix (continued)

Exposure Pathway and/or Sample Type	Number of Representative Samples and Sample Locations ¹	Sampling Stations	Collection Frequency	Type of Analysis	Required or Supplemental
3. Airborne Particulate	Samples from ≥ 4 stations: Three samples from close to the three SITE BOUNDARY locations (0S2, 8S1, & MT1) in different sectors. One sample from the vicinity of a community having the highest calculated annual average ground level D/Q (7D1).	0S2, 8S1, MT1, 7D1 5F1 (control)	Continuous sampler operation with sample collection weekly or more frequently if required by dust loading.	Weekly gross beta radioactivity analysis following filter change ³ . Quarterly gamma isotopic analysis ⁴ of composite consisting of approx 12 filters (by location).	Required
	If food products are unavailable, additional air sampling will be done in the NNW (station 1S1) and SE (Station 8S2) sectors.	1S1 & 8S2	Continuous sampler operation with sample collection weekly or more frequently if required by dust loading.	Weekly gross beta radioactivity analysis following filter change ³ . Quarterly gamma isotopic analysis ⁴ of composite consisting of approx 12 filters (by location).	Required
4. Airborne Carbon-14	Samples from 3 stations: One sample from each of the NW and SE sectors close to the site (0S2 and 8S1). One sample used as a control station (5F1).	0S2, 8S1 5F1 (control)	Continuous sampler operation with sample collection weekly or more frequently if required by dust loading.	C-14 analysis	Supplemental

Table 1: Radiological Environmental Monitoring Program Matrix (continued)

Exposure Pathway and/or Sample Type	Number of Representative Samples and Sample Locations ¹	Sampling Stations	Collection Frequency	Type of Analysis	Required or Supplemental
5. Waterborne					
a. Surface Ocean Water	One sample from the plant Outfall, Diablo Cove, and an area not influenced by plant discharge.	OUT, DCM, and 7C2	Monthly (grab sample)	Gamma isotopic ⁴ and tritium analysis.	Required
	One sample from the plant Outfall, Diablo Cove, and an area not influenced by plant discharge.	OUT, DCM, and 7C2	Quarterly (grab sample)	Gross Beta, Total Sr 89/90, Fe-55, and Ni-63	Supplemental
b. Drinking Water	One sample from the plant drinking water, one sample from Diablo Creek (upstream of plant), and one control sample.	DW1 and 5S2; OEL (control)	Monthly (grab sample)	Gamma isotopic ⁴ , I-131, and tritium analysis.	Required
	One sample from the plant drinking water, one sample from Diablo Creek (upstream of plant), and one control sample.	DW1 and 5S2; OEL (control)	Quarterly (grab sample)	Gross Beta, Total Sr 89/90, Fe-55, and Ni-63	Supplemental
	One sample from Diablo Creek (downstream of plant) and one sample from Blanchard Spring	WN2 and 1A2	Quarterly (grab sample)	Gamma isotopic ⁴ , tritium, I-131, gross beta, Total Sr 89/90, Fe-55, and Ni-63	Supplemental
c. Groundwater	One sample from wells located under or downgradient from the plant power block.	OW1, OW2, DY1, GW1, and GW2	Quarterly (grab sample, when available)	Gamma isotopic ⁴ , tritium, gross beta, Total Sr 89/90, Fe-55, and Ni-63	Supplemental
	One sample from a well located outside the plant power block (control sample).	WW2, 8S3	Quarterly (grab sample, when available)	Gamma isotopic ⁴ , tritium, gross beta, Total Sr 89/90, Fe-55, and Ni-63	Supplemental
d. Sediment	One sample of offshore ocean sediment from Diablo Cove and Rattlesnake Canyon.	DCM and 7C2	Annual (grab sample)	Gamma isotopic ⁴	Required
	One sample of offshore ocean sediment from Diablo Cove and Rattlesnake Canyon.	DCM and 7C2	Annual (grab sample)	Total Sr 89/90, Fe-55, and Ni-63	Supplemental
	One sample from each of five local recreational beaches.	AVA, MDO, PMO, CYA, and CBA	Semi- Annual (grab sample)	Gamma isotopic ⁴ , Total Sr 89/90, Fe-55, and Ni-63	Supplemental
e. Marine Flora	One sample of kelp	DCM, PON, POS, and 7C2	Quarterly (when available)	Gamma isotopic ⁴	Supplemental
	One sample of intertidal algae	DCM and 7C2	Quarterly (when available)	Gamma isotopic ⁴	Supplemental

Table 1: Radiological Environmental Monitoring Program Matrix (continued)

Exposure Pathway and/or Sample Type	Number of Representative Samples and Sample Locations ¹	Sampling Stations	Collection Frequency	Type of Analysis	Required or Supplemental
6. Ingestion					
a. Milk	Samples from milking animals in three locations within 5 km distance having the highest dose potential. If there are none, then one sample from milking animals in each of three areas between 5 to 8 km distance where doses are calculated to be greater than 1 mrem per year. One sample from milking animals at a control location 15 to 30 km distant and in the least prevalent wind direction. NOTE: The sample (5F2) should be taken monthly even if there are no indicator samples available.	5F2	Semimonthly when animals are on pasture; monthly at other times.	Gamma isotopic ⁴ and I-131 analysis.	Supplemental
b. Fish and Invertebrates	One sample of rock fish (family Sebastes) and one sample of perch (family Embiotocidae)	DCM and 7C2	Quarterly (grab sample)	Gamma isotopic ⁴ analysis on edible portions of each sample.	Required
	One sample of rock fish (family Sebastes) and one sample of perch (family Embiotocidae)	PON and POS	Quarterly (grab sample)	Gamma isotopic ⁴ analysis on edible portions of each sample.	Supplemental
	One sample of mussel (family Mytilus)	DCM and 7C2	Quarterly (grab sample)	Gamma isotopic ⁴ analysis on edible portions of each sample.	Required
	One sample of mussel (family Mytilus)	PON	Annual ^(A0584392) (grab sample)	Gamma isotopic ⁴ analysis on edible portions of each sample.	Supplemental
	One sample of mussel (family Mytilus)	POS	Quarterly (grab sample)	Gamma isotopic ⁴ analysis on edible portions of each sample.	Supplemental
	One sample of locally harvested market fish.	7D3 or 2F1 (should alternate between locations)	Quarterly (grab sample)	Gamma isotopic ⁴ analysis on edible portions of each sample.	Supplemental

Table 1: Radiological Environmental Monitoring Program Matrix (continued)

Exposure Pathway and/or Sample Type	Number of Representative Samples and Sample Locations ¹	Sampling Stations	Collection Frequency	Type of Analysis	Required or Supplemental
c. Broadleaf Vegetation ⁵	Three samples of broadleaf vegetation grown nearest off-site locations of highest calculated annual average ground level D/Q <u>IF</u> milk sampling is not performed.		Monthly (when available)	Gamma isotopic ⁴ analysis (that includes I-131) on edible portion.	Required (see notation #5)
	One sample of each of the similar broadleaf vegetation grown 15 to 30 km distant in the least prevalent wind direction <u>IF</u> milk sampling is not performed.		Monthly (when available)	Gamma isotopic ⁴ analysis (that includes I-131) on edible portion.	Required (see notation #5)
d. Vegetative Crops	One sample of broadleaf vegetation or vegetables or fruit	5F2, 7C1, and 7G1	Monthly (when available)	Gamma isotopic ⁴ analysis on edible portion.	Supplemental
	One sample of broadleaf vegetation or vegetables or fruit.	3C1, 6C1, and 7E1	Quarterly (as provided by land owner)	Gamma isotopic ⁴ analysis on edible portion.	Supplemental
e. Meat	One sample of each species (cow, goat, sheep, deer, or pig) of edible meat portion slaughtered for personal consumption (not mass market).	BCM, BGM, BSM, JDM, JPM, ACM, ADM, APM	Quarterly (when available and provided by land owners within 8 km of plant site)	Gamma isotopic ⁴ analysis, and Total Sr 89/90 on edible portion.	Supplemental

Table 1: Radiological Environmental Monitoring Program Matrix (continued)

Table 1 Notes:

- 1 Deviations are permitted from the required sampling schedule if specimens are unobtainable due to circumstances such as hazardous conditions, seasonal unavailability, malfunction of automatic sampling equipment and other legitimate reasons. If specimens are unobtainable due to sampling equipment malfunction, effort shall be made to complete corrective action prior to the end of the next sampling period. All deviations from the sampling schedule shall be documented in the Annual Radiological Environmental Operating Report. It is recognized that, at times, it may not be possible or practicable to continue to obtain samples of the media of choice at the most desired location or time. In these instances, suitable specific alternative media and locations may be chosen for the particular pathway in question and appropriate substitutions made within 30 days in the Radiological Environmental Monitoring Program, and submitted in the next Annual Radioactive Effluent Release Report, including a revised figure(s) and table for the ERMP reflecting the new location(s) with supporting information identifying the cause of the unavailability of samples for that pathway and justifying the section of the new location(s) for obtaining samples.
- 2 For the purposes of this table, a thermoluminescent dosimeter (TLD) is considered to be one phosphor. There are normally three calcium sulfate phosphors in an environmental TLD BADGE. Film badges shall not be used as dosimeters for measuring direct radiation. The DCP E-Plan is committed to placement of 3 TLD badges each quarter at each REMP TLD location to allow for monthly readout in case of an event.
- 3 Airborne particulate sample filters shall be analyzed for gross beta radioactivity 24 hours or more after sampling to allow for radon and thoron daughter decay. If gross beta activity in air particulate samples is greater than 10 times the yearly mean of control samples, gamma isotopic analysis shall be performed on the individual samples.
- 4 Gamma isotopic analysis means the identification and quantification of gamma-emitting radionuclides that may be attributable to the effluents from the facility.
- 5 If broadleaf vegetation food products are unavailable, additional air sampling as specified in Table 1, Parts 2 & 3 will be done in the NNW (Station 1S1) and SE (Station 8S2) sectors.
- 6 The Branch Technical Position (Nov 79) states, "Any location from which milk can no longer be obtained may be dropped from the surveillance program after notifying the NRC in writing that they are no longer obtainable at that location". Although the milk sampling performed at 5F2 is outside the 5-mile radius and is supplemental to the REMP, this notification should take place if 5F2 milk sampling ceases.

9. Detection Capabilities/Lower Limits of Detection (LLD)

Table 2: Environmental Detection Capabilities/Lower Limits of Detection (LLD) Matrix

Analysis	Water (pCi/L)	Airborne Particulate or Gases (pCi/m ³)	Fish (pCi/kg, wet)	Milk (pCi/L)	Food Products (pCi/kg, wet)	Soil/Sediment (pCi/kg, dry) ^f
Gross beta	4	0.01				
H-3	400 ^d					
Mn-54	15		130			150
Fe-59	30		260			300
Co-58	15		130			150
Co-60	15		130			150
Zn-65	30		260			300
Zr-95	30					300
Nb-95	15					150
I-131	1 ^e	0.07		1	60	
Cs-134	15	0.05	130	15	60	150
Cs-137	18	0.06	150	18	80	180
Ba-140	60			60		600
La-140	15			15		150

^a The gamma emitters and corresponding LLD values listed are derived from standard ODCM guidance for environmental samples as found in Table 4.12-1 in NUREG-1301. This list does not mean that only these nuclides are to be considered. Other peaks that are identifiable, together with those of the above nuclides, shall also be analyzed and reported in the Annual Radiological Environmental Operating Report.

^b Required detection capabilities for thermoluminescent dosimeters used for environmental measurements shall be per the recommendations of Regulatory Guide 4.13, Revision 1, July 1977.

^c The LLD is defined, for purposes of these specifications, as the a-priori smallest concentration of radioactive material in a sample that will yield a net count, above system background, that will be detected with 95 percent probability with only 5 percent probability of falsely concluding that a blank observation represents a "real" signal.

^d If no drinking water pathway exists, a value of 3,000 pCi/L may be used for tritium. All groundwater wells should use the 400 pCi/L tritium value regardless of drinking water use.

^e The LLD value of 1 pCi/L for I-131 is applicable only to sources used as drinking water. If no drinking water pathway exists, a value of 15 pCi/L may be used for I-131.

^f The gamma emitters LLD values listed are derived from the Cs-134/137 10:1 ratio established in the environmental LLDs in NUREG-1301, Table 4.12-1.

Table 2: Environmental Detection Capabilities/Lower Limits of Detection (LLD) Matrix (Continue)

Table 2 Notes:

For a particular measurement system, which may include radiochemical separation:

$$\text{LLD} = \frac{4.66S_b}{E \times V \times 2.22 \times Y \times \exp(-\lambda t)}$$

Where:

- LLD = the "a priori" the lower limit of detection as defined above (as pCi per unit mass or volume)
- S_b = the standard deviation of the background counting rate or of the counting rate of a blank sample as appropriate (as counts per minute)
- E = the counting efficiency (as counts per disintegration)
- V = the sample size (in units of mass or volume)
- 2.22 = the number of disintegrations per minute per picocurie
- Y = the fractional radiochemical yield (when applicable)
- λ = the radioactive decay constant for the particular radionuclide
- t = the elapsed time between sample collection (or end of the sample collection period) and time of counting

The value of S_b used in the calculation of the LLD for a detection system will be based on the actual observed variance of the background counting rate or of the counting rate of the blank samples (as appropriate) rather than on an unverified theoretically predicted variance. In calculating the LLD for a radionuclide determined by gamma-ray spectrometry, the background will include the typical contributions of other radionuclides normally present in the samples (e.g., potassium-40 in milk samples).

Analyses will be performed in such a manner that the stated LLDs will be achieved under routine conditions. Occasionally background fluctuations, unavoidably small sample sizes, the presence of interfering nuclides, or other uncontrollable circumstances may render these LLDs unachievable. In such cases, the contributing factors will be identified and described in the Annual Environmental Radiological Operating Report.

Typical values of E, V, Y and t should be used in the calculation. It should be recognized that the LLD is defined as a-priori (before the fact) limit representing the capability of a measurement system and not as a-posteriori (after the fact) limit for a particular measurement.

10. **AREOR REMP Program Summary Matrix**

Table 3: Environmental Radiological Monitoring Program Summary Matrix

Name of Facility _____ Docket No. _____

Location of Facility _____ Reporting Period _____
(County, State)

Medium or Pathway Sampled (Unit of Measurement)	Type and Total Number of Analyses Performed	Lower Limit of Detection (a) (LLD)	Location with Highest Annual Mean		All Indicator Locations Mean (b) Range (b)	Control Locations Mean (b) Range(b)	Number of Reportable Occurrences
			Name, Distance and Direction	Mean (b) Range (b)			

- (a) Unless indicated the LLDs specified in Table 2 were met.
- (b) Mean and the range based upon detectable measurements only. Fraction of detectable measurements at specified locations is indicated in parentheses; e.g., (10/12) means that 10 out of 12 samples contained detectable activity.

11. Reporting (Notification) Levels for REMP

Table 4: Reporting (Notification) Levels for Radioactivity Concentration in Env Samples Matrix

Analysis	Water (pCi/L)	Airborne Particulate or Gases (pCi/m ³)	Fish (pCi/kg, wet)	Milk (pCi/L)	Food Products (pCi/kg, wet)
H-3	¹ 20,000				
Mn-54	1,000		30,000		
Fe-59	400		10,000		
Co-58	1,000		30,000		
Co-60	300		10,000		
Zn-65	300		20,000		
Zr-Nb-95	400				
I-131	² 2	0.9		3	100
Cs-134	30	10	1,000	60	1,000
Cs-137	50	20	2,000	70	2,000
Ba-La-140	200			300	

¹ For drinking water samples. This is the 40 CFR 141 value. If no drinking water pathway exists, a value of 30,000 pCi/L may be used.

² If no drinking water pathway exists, a value of 20 pCi/L may be used.

Note: Table Reference in Commitment Database T35263

12. Distances and Directions to REMP Monitoring Stations

Table 5: Distances and Directions to REMP Monitoring Stations Matrix

Station Code*	Station Name	Radial Direction (True Heading) (Degrees)	Radial Distance from Plant	
			Km	(Miles)
0S1	Exclusion Fence-Northwest Corner	320	0.16	(0.1)
0S2	North Gate	320	0.8	(0.5)
1S1	Wastewater Pond	330	0.64	(0.4)
2S1	Back Road-300 m North of Plant	0	0.32	(0.2)
3S1	Road NW of 230 kV Switchyard	23	0.64	(0.4)
4S1	Back Road Between Switchyards	43	0.8	(0.5)
5S1	500 kV Switchyard	58	0.64	(0.4)
5S2	Diablo Creek Weir	65	0.96	(0.6)
5S3	Microwave Tower Road	70	1.02	(0.7)
6S1	Microwave Tower	94	0.8	(0.5)
7S1	Overlook Road	112	0.48	(0.3)
8S1	Target Range	125	0.8	(0.5)
8S2	Southwest Site Boundary	128	1.76	(1.1)
8S3	DCSF96-1 (monitor well)	145	0.52	(0.33)
9S1	South Cove	167	0.64	(0.4)
MT1	Meteorological Tower	185	0.32	(0.2)
DCM	Diablo Cove Marine	270	0.32	(0.2)
WN1	Northwest Guard Shack	290	0.32	(0.2)
WN2	Diablo Creek Outlet	283	0.25	(0.15)
1A1	Crowbar Canyon	327	2.56	(1.6)
1A2	Blanchard Spring	331	2.4	(1.5)
0B1	Point Buchon	325	5.76	(3.6)
1C1	Montana de Oro Campground	336	7.52	(4.7)
3C1	Ranch Vegetation	20	7.16	(4.5)
4C1	Clark Valley Gravel Pit	45	9.28	(5.8)
5C1	Junction Prefumo/See Canyon Roads	64	7.52	(4.7)
6C1	Household Garden	98	7.24	(4.5)
7C1	Pecho Creek Ruins (Mello Farm)	120	6.56	(4.1)
7C2	Rattlesnake Canyon	124	7.52	(4.7)

Table 5: Distances and Directions to REMP Monitoring Stations Matrix (Continue)

Station Code*	Station Name	Radial Direction (True Heading) (Degrees)	Radial Distance from Plant	
			Km	(Miles)
2D1	Sunnyside School	10	11.04	(6.9)
3D1	Clark Valley	24	9.92	(6.2)
4D1	Los Osos Valley Road	36	12.16	(7.6)
6D1	Junction See/Davis Canyon Roads	89	13.4	(8.3)
7D1	Avila Gate	118	10.56	(6.6)
7D2	Avila Beach	110	12.16	(7.6)
7D3	Avila Pier	120	11.0	(6.9)
7E1	Avila Valley Barn	103	13.94	(8.66)
2F1	Morro Bay (Commercial Landing)	0	17.44	(10.9)
2F2	Morro Bay Power Plant	358	17.9	(11.2)
5F1	SLO OEL	79	16.41	(10.2)
5F2	Cal Poly Farm	60	20.16	(12.6)
5F3	SLO County Health Department	70	20.32	(12.7)
7F1	Shell Beach	110	17.28	(10.8)
7G1	Arroyo Grande (Kawaoka Farm)	115	26.88	(16.8)
7G2	Oceano Substation	118	27.68	(17.3)
AVA	Avila Beach (near pier)	109	11.75	(7.3)
CBA	Cambria Moonstone Beach	330	45.86	(28.5)
CYA	Cayucos Beach (near pier)	350	26.87	(16.7)
DY1	Drywell 115'	77	0.041	(0.026)
DW1	Drinking Water, Plant Potable Water Sys	161	0.59	(0.37)
GW1	Groundwater Monitoring Well 1	271	0.15	(0.09)
GW2	Groundwater Monitoring Well 2	204	0.21	(0.13)
IS1 - IS8	ISFSI	65	0.48	(0.3)
MDO	Montana de Oro (Spooners Cove)	336	7.56	(4.7)
OW1	Observation Well 01	336	0.07	(0.046)
OW2	Observation Well 02	157	0.07	(0.045)
OEL	Offsite Emergency Lab	79	16.41	(10.2)
OUT	Plant Outfall	270	0.32	(0.2)
PMO	Pismo Beach (near pier)	113	20.76	(12.9)

Table 5: Distances and Directions to REMP Monitoring Stations Matrix (Continue)

PON	Pacific Ocean North of Diablo Cove	305	2.4	(1.5)
POS	Pacific Ocean South of Diablo Cove	180	0.64	(0.4)
WW2	Water Well 02	70	1.02	(0.63)

Table 5 Notes:

* Station Code (XYZ):

X - First number (0-9) represents the radial sector in which the station is located:

- | | |
|---------------------|---------------------|
| 0 - Northwest | 5 - East-northeast |
| 1 - North-northwest | 6 - East |
| 2 - North | 7 - East-southeast |
| 3 - North-northeast | 8 - Southeast |
| 4 - Northeast | 9 - South-southeast |

Y - Letter (S, A-H) represents the distance from the plant:

- S - On-site
- A - 0-2 miles from plant (but off-site)
- B - 2-4 miles from plant
- C - 4-6 miles from plant
- D - 6-8 miles from plant
- E - 8-10 miles from plant
- F - 10-15 miles from plant
- G - 15-20 miles from plant
- H - Greater than 20 miles from plant

Z - Second number represents the station number within the zone.

* Station Codes exceptions:

The following stations do not follow the coding system:

- Diablo Cove Marine (DCM)
- Meteorological Tower (MT1)
- Northwest guard shack (WN1)
- Diablo Creek outlet (WN2)
- Pacific Ocean North (PON)
- Pacific Ocean South (POS)
- Offsite Emergency Lab (OEL)
- Plant outfall (OUT)
- Drinking water (DW1)
- Water Well 02 (WW2)
- Observation Well 01 (OW1)
- Observation Well 02 (OW2)
- Drywell 115 (DY1)
- Avila Beach (AVA)
- Montana de Oro - Spooners Cove (MDO)
- Pismo Beach (PMO)
- Cayucos Beach (CYA)
- Cambria - Moonstone Beach (CBA)
- Blanchard Cow Meat (BCM)
- Blanchard Goat Meat (BGM)
- Blanchard Sheep Meat (BSM)
- Johe Deer Meat (JDM)
- Johe Pig Meat (JPM)
- Andre Cow Meat (ACM)
- Andre Deer Meat (ADM)
- Andre Pig Meat (APM)
- ISFSI TLDs (IS1 - IS8)

13. Summary of Cross-Check Program with State of California

Table 6: Summary of Cross-Check Program with State of California Matrix

Sample Type	Station No.	Frequency ¹	Radioanalyses
Milk (supplemental)	5F2	Monthly	Gamma Isotopic (incl. I-131 and K-40)
Drinking Water	DW1	Monthly	Gamma Isotopic (incl. I-131), H-3
Outfall Water	OUT	Monthly	Gamma Isotopic, H-3
Diablo Creek	5S2	Monthly	Gamma Isotopic, H-3
Vegetative Crops (supplemental)	7G1	Quarterly	Gamma Isotopic
Fish or Invertebrate	DCM	Quarterly	Gamma Isotopic
Air Particulates and Radioiodine	² 5F1, 7D1	Weekly & Quarterly	Gross Beta, I-131, Qtrly Gamma Isotopic (composite airborne particulate samples)
Sediment	DCM	Annually	Gamma Isotopic
Direct Radiation (TLD)	MT1, 1A1, 1C1, 4D1, 5F3, 5S1, 7D1, 7C1, 7F1, 8S2	Quarterly	Gamma Exposure (mR)
Kelp (supplemental)	DCM	Quarterly	Gamma Isotopic

¹ When available

² The California State CDPH air sampler used for correlation with DCPD 5F1 is located at the SLO County Health Dept on Johnson Avenue (near DCPD TLD station 5F3)

Figure 1

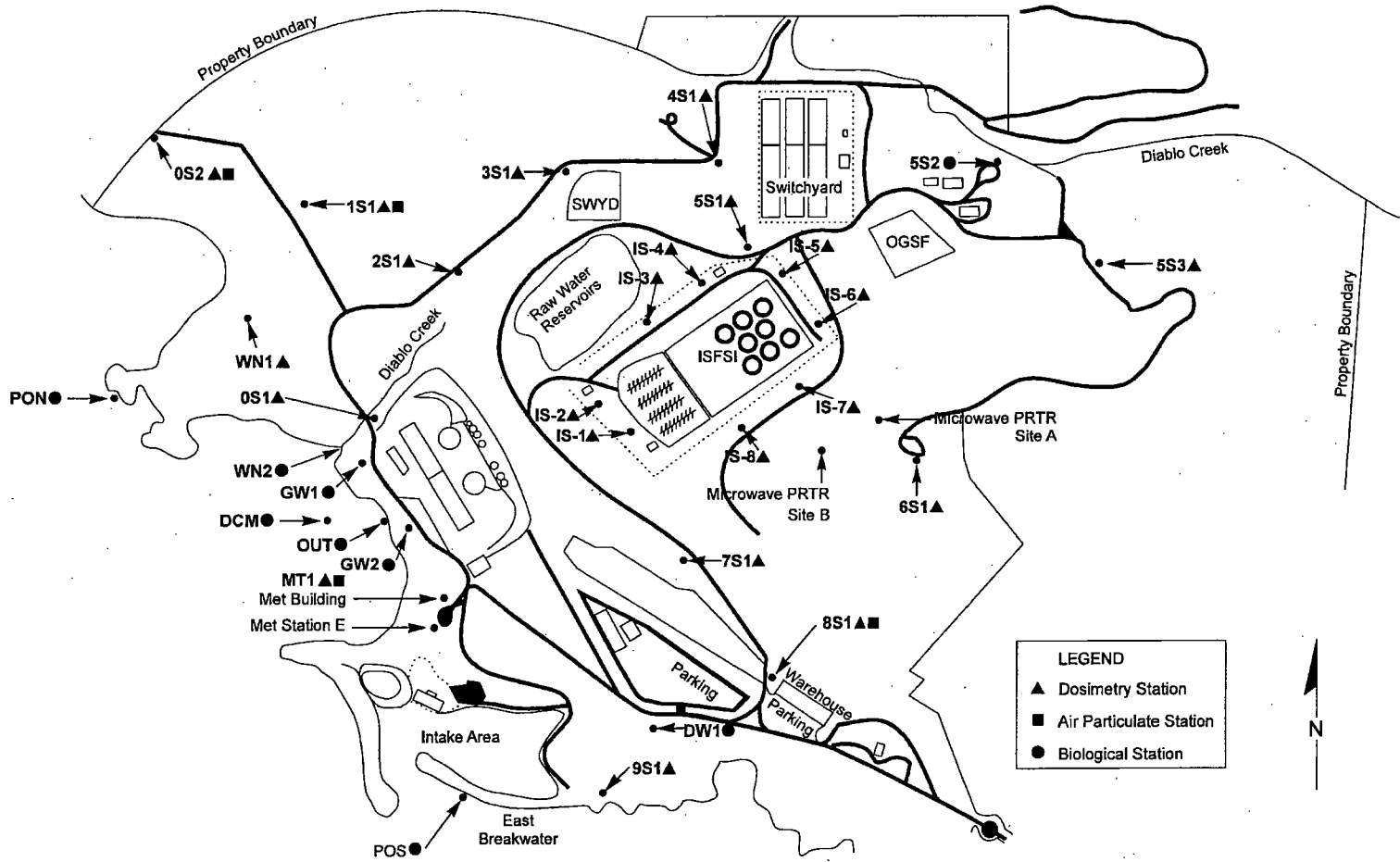

DCPD Onsite ERMP Stations

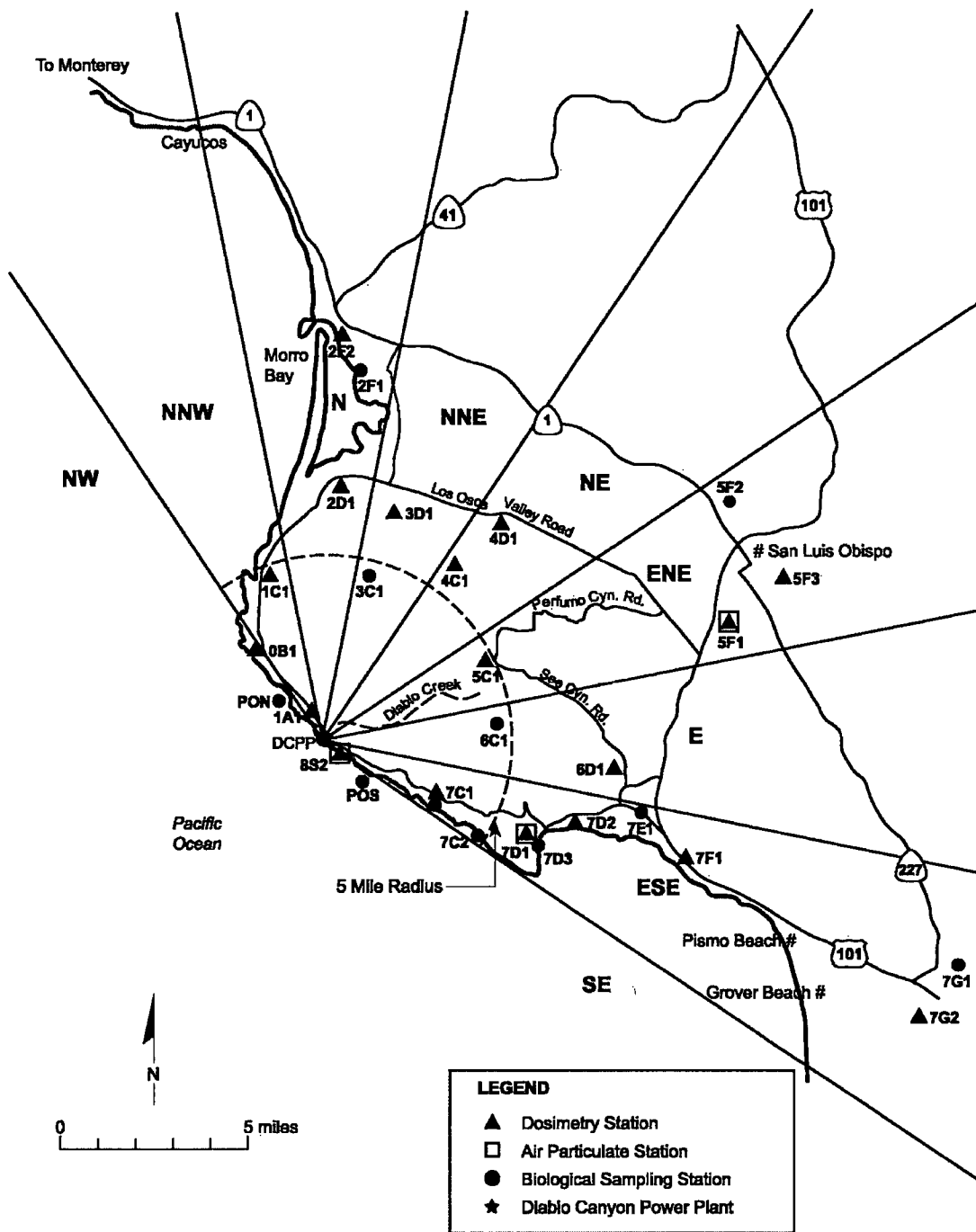

Units 1 and 2 Diablo Canyon off-site stations.

Figure 2

DCPP Onsite ERMP Stations Satellite Map

Attachment 3: Page 1 of 1



Figure 3

Attachment 5

**Diablo Canyon Power Plant Chemical Analysis Procedure,
CAP A-8, "Offsite Dose Calculations," Revision 36**

Off-Site Dose Calculations

07/31/12
Effective Date

QUALITY RELATED
REFERENCE USE

Table of Contents

1.	SCOPE	1
2.	DISCUSSION.....	2
3.	DEFINITIONS	2
4.	RESPONSIBILITIES	3
5.	INSTRUCTIONS	4
5.1	Liquid Effluents	4
5.2	Gaseous Effluents.....	18
5.3	40 CFR 190 Dose Calculations	45
5.4	On-Site Dose to Members of the Public	49
6.	RECORDS.....	52
7.	REFERENCES	52

ATTACHMENTS:

1.	LRW Composite Dose Factors.....	54
2.	Summary of Land Use Census Evaluation	57
3.	GRW Dose Parameters: Noble Gas Dose Factors.....	58
4.	GRW Dose Parameters: Child, Inhalation, Worst Case Organ	59
5.	GRW Dose Parameters: Ground Plane Dose Factors.....	60
6.	GRW Dose Parameters: Infant, Inhalation Pathway	61
7.	GRW Dose Parameters: Child, Inhalation Pathway.....	62
8.	GRW Dose Parameters: Teen, Inhalation Pathway.....	63
9.	GRW Dose Parameters: Adult, Inhalation Pathway.....	64
10.	GRW Dose Parameters: Child, Vegetation Pathway	65
11.	GRW Dose Parameters: Teen, Vegetation Pathway	66
12.	GRW Dose Parameters: Adult, Vegetation Pathway	67
13.	Liquid Discharges Monitored for Radioactivity.....	68
14.	Gaseous Releases Monitored for Radioactivity	69

1. SCOPE

- 1.1 This administrative procedure provides the calculational methodology for radiological liquid and gaseous effluents for Diablo Canyon.
- 1.2 Dose methodologies are based on models and data that make it unlikely to substantially underestimate the actual exposure of an individual through any of the appropriate pathways. Attachments containing the values for the various parameters used in these expressions are also included.

- 1.3 Implementation of the Environmental Radiological Monitoring Procedure (ERMP) is found in RP1.ID11.
- 1.4 Changes to CAP A-8 are processed per the requirements of DCPP Technical Specification (TS) Section 5.5.1.^{T02694}
- 1.5 This procedure has been rewritten; therefore, revision bars are not included.

2. **DISCUSSION**

- 2.1 This procedure is used in support of the Radiological Monitoring and Controls Program (RMCP), the Radioactive Effluent Controls Program (RECP), and with routine radioactive liquid and gaseous releases to the unrestricted area.
- 2.2 Program limits are based on the dose commitment to a member of the general public related to the release of radionuclides through either direct or indirect exposure (e.g., submersion in a cloud of radioactive noble gases, radionuclides deposited on the ground, direct radiation from radionuclides stored on-site, inhalation or ingestion of radionuclides via a food pathway such as milk, meat, vegetable, fish, etc.).

3. **DEFINITIONS**

- 3.1 Allocation Factor (AF): A factor used in the DCPP high alarm setpoint (HASP) methodology that limits:
 - Effluent concentrations from simultaneous liquid discharges.
 - Noble gas effluent dose rate from simultaneous atmospheric releases.
- 3.2 Critical Receptor: That individual who receives the largest dose based on the combination of dose pathways that have been shown to actually exist.
- 3.3 Effluent Concentration Limit (ECL): Liquid effluents entering the unrestricted area are limited to the concentrations listed in 10 CFR 20, Appendix B, Table 2, Column 2.
- 3.4 Expected Reading (ER): The anticipated monitor response based on the known release pathway concentration and the specific monitor response factors.
- 3.5 High Alarm Setpoint (HASP): An "administrative limit" set per CY2.DC1 to ensure radiation monitor release setpoints calculated do not exceed the liquid or gaseous effluent concentration limits of 10 CFR 20.
- 3.6 Safety Factor (SF): The SF is defined as 0.9 and provides for a HASP at 90% of the 10 CFR 20 concentration limits.
- 3.7 Unplanned (Liquid or Gaseous) Release: An unplanned release is an unexpected and potentially unmonitored release to the environment due to operational error or equipment malfunctions.

4. RESPONSIBILITIES

- 4.1 The chemistry and environmental operations manager is responsible for ensuring the off-site dose calculational procedure (ODCP) meets all RECP and TS requirements with regards to calculated doses delivered by the plant to the unrestricted area surrounding the site.
- 4.2 The chemistry engineer supervisor is responsible for ensuring this procedure's program is followed and implemented where appropriate, especially in regards to RECP or TS requirements.
- 4.3 The radiochemistry staff engineer is responsible for:
- Correct and timely implementation of all the procedure's calculational methodology, where appropriate, for each radioactive effluent released.
 - Reviewing the results; cross (spot) checking the calculations; and maintaining an updated archive of post release calculated doses for annual report purposes.
 - Providing oversight of the effluents program's ODCP to:
 - Confirm compliance with RECP or TS.
 - Provide technical support.
 - Recommend or design improvements to the dose calculational methodology and the effluent program control.
 - Investigate long-term planning toward effluent related activities and their associated dose calculations.
- 4.4 The digital systems group is responsible for:
- Ensuring any supporting computer software is maintained current and compatible with the procedure's calculational methodology.
 - Ensuring computer hardware is maintained operable at all times.

5. INSTRUCTIONS**5.1 Liquid Effluents****5.1.1 Dose Calculation**

- a. Units 1 and 2 share a common liquid radioactive waste (LRW) treatment system. Effluent doses due to releases discharged via the common LRW are apportioned between the units, with 50% credited to Unit 1 and 50% credited to Unit 2.
- b. The dose contributions to the total body and each individual organ (bone, liver, thyroid, kidney, lung, and GI-LLI) of the maximum exposed individual (adult) due to consumption of saltwater fish and saltwater invertebrates is calculated for all radionuclides identified in liquid effluents released to unrestricted areas per eq 1^{T30837}:

$$D_o = F_\ell \Delta t \sum_i A_{io} C_i e^{-\lambda_i t_m} \quad (\text{eq 1})$$

Where:

D_o = dose commitment to organ "o" (mrem)

F_ℓ = near field average dilution factor during release period defined as:

$$\frac{\text{Waste flow}}{\text{Dilution flow} \times Z} \quad (\text{eq 2})$$

Where: Z = site-specific factor for the mixing effect of discharge structure; specifically, it is the credit taken for dilution which occurs between the discharge structure and the body of water which contaminates fish or invertebrates in the liquid ingestion pathway. For DCPP, $Z = 5$.

Δt = time period for the release (hrs)

A_{io} = site-specific ingestion dose commitment factor to organ "o" due to radionuclide "i" (mrem/hr per $\mu\text{Ci/mL}$) defined in eq 3

C_i = concentration of radionuclide "i" in undiluted liquid effluent ($\mu\text{Ci/mL}$)

λ_i = decay constant of radionuclide "i"

t_m = time interval between end of sampling and midpoint of release

- c. The site-specific ingestion dose commitment factor, A_{io} , is defined as:^{T30837}

$$A_{io} = k_o (U_F BF_i + U_I BI_i) DF_i \quad (\text{eq 3})$$

Where:

- k_o = conversion factor of $1.14E+05$ (pCi/ μ Ci x mL/L x yr/hr)
- U_F = saltwater fish consumption rate (kg of fish/yr)
(For DCP, $U_F = 21$ kg/yr; value is from NUREG 0133, Section 4.3.1.)
- BF_i = saltwater bioaccumulation factor for radionuclide "i" in fish flesh (pCi/kg per pCi/L).
[Values for BF_i are from Table A-1 of Regulatory (Reg.) Guide 1.109, except uranium and plutonium, which are from NUREG/CR-4013.]
- U_I = saltwater invertebrate consumption rate (kg/yr)
(For DCP, $U_I = 5$ kg/yr; value is from NUREG 0133, Section 4.3.1).
- BI_i = saltwater bioaccumulation factor for radionuclide "i" in invertebrate flesh (pCi/Kg per pCi/L)
[Values for BI_i are from Table A-1 of Reg. Guide 1.109, except uranium and plutonium, which are from NUREG-4013.]
- DF_i = adult ingestion dose conversion factor for radionuclide "i" (mrem/pCi ingested).
[Values from Reg. Guide 1.109, Table E-11, with exceptions detailed in step 5.1.1c.1.]
1. The DF_i exceptions are:
 - a) H-3, Br-82, Sb-124, Sb-125, Pu-238, Pu-239, Pu-240, Pu-241 and Pu-242, ingestion dose conversion factors from EMP-155.
 - b) As-76, Sn-113, Sn-117m and Sb-122 ingestion dose conversion factors calculated by ORNL using ICRP-2 methodology.
 - c) U-233, U-234, U-235, U-236 and U-238 ingestion dose conversion factors from NUREG-0172.
 2. Site-specific values for A_{io} are listed in Attachment 1.
 - a) When necessary, these factors were corrected for ingrowth of daughter radionuclides following ingestion of the parent.
 - b) All radionuclides treated in this manner are followed by "+D."^{Ref 7.10, 7.12}

5.1.2 Effluent Concentration Limit (ECL) Calculation

- a. The ECL for the identified mixture of radionuclides in the "jth" batch of liquids is calculated as follows:

$$ECL_{-j} = \frac{\sum_{i=1}^n C_{ij}}{\sum_{i=1}^n \frac{C_{ij}}{ECL_{-ij}}} \quad (\text{eq 4})$$

Where:

ECL_{-j} = unrestricted area total undiluted ECL for the "jth" particular mixture of identified radionuclides ($\mu\text{Ci/mL}$)

C_{ij} = concentration of radionuclide "i" ($\mu\text{Ci/mL}$) for "jth" mixture

ECL_{-ij} = ECL in unrestricted area water for radionuclide "i" in general ($\mu\text{Ci/mL}$)
[Values from 10 CFR 20, Appendix B, Table 2, Column 2.]

- b. The overall ECL for simultaneous discharges is given by eq 5.

$$ECL_{\text{overall}} = \frac{\sum_{j=1}^n \Phi_j C_j}{\sum_{j=1}^n \frac{\Phi_j C_j}{ECL_{-j}}} \quad (\text{eq 5})$$

Where:

ECL_{overall} = unrestricted area ECL for current radionuclide mixture for concurrent "j" discharges ($\mu\text{Ci/mL}$)

C_j = total activity concentration for "jth" individual stream ($\mu\text{Ci/mL}$)

ECL_{-j} = total ECL for "jth" individual mixture (or stream) calculated per eq 4 ($\mu\text{Ci/mL}$)

Φ_j = ratio of an individual discharge "jth" pathway flowrate to sum total of all individual undiluted pathway flowrates defined as:

$$\frac{f_j}{\sum_j f_j} \quad (\text{eq 6})$$

Where: f_j = undiluted effluent flowrate for pathway, "j"

5.1.3 Liquid Effluent Radiation Monitor Setpoint Methodology

a. Introduction

1. The DCCP RECP requires liquid effluent monitors to be OPERABLE with their alarm/trip setpoints set to ensure that the effluent concentration limits of 10 CFR 20 are not exceeded.^{T34939}
2. The alarm/trip setpoints for the liquid effluent radiation monitors are derived from the concentration limits in Appendix B, Table 2, Column 2 of 10 CFR 20.1001-2404.
3. The alarm/trip setpoints are applied at the unrestricted area boundary and take into account appropriate factors for dilution, dispersion, or decay of radioactive materials that may occur between the point of discharge and the unrestricted area boundary.

b. Allocation and Safety Factors

1. The limits of RECP Attachment 3 are site limits which require the setpoint methodology ensures simultaneous releases do not exceed the liquid effluent concentration limits of 10 CFR 20 in the unrestricted area.^{T34939}
2. The DCCP high alarm setpoint (HASP) methodology uses an allocation factor (AF) which may be adjusted based on operational requirements with the restriction that the sum of liquid release AFs be less than or equal to 1.

Discharge Pathway	Radiation Monitor	Allocation Factor
Oily Water Separator	RE-3	0.01
Liquid Radwaste System	RE-18	0.90
Steam Generator Blowdown (Unit 1)	RE-23 (U1)	0.04
Steam Generator Blowdown (Unit 2)	RE-23 (U2)	0.04
Miscellaneous	N/A	0.01

3. An additional level of conservatism in the HASP methodology is implemented by the use of a safety factor (SF).

c. Tritium Correction Factor

NOTE 1: Due to an aggressive liquid radwaste treatment program, the liquid effluents at DCPD typically contain very low levels of gamma emitters.

NOTE 2: In the past, DCPD used to recycle waste water using evaporators to reduce the overall volume of liquid waste discharged, which resulted in higher tritium concentration in liquid effluents when compared with the low gamma emitter concentrations. As a result, standard HASP methodology resulted in very low setpoints, in some cases, barely above the monitor background.

1. The liquid HASP methodology used by DCPD uses a tritium correction factor (TCF) which assumes a constant, but conservative, tritium concentration in the liquid effluent and results in an operationally reasonable setpoint while ensuring that liquid effluent concentrations released to the unrestricted areas do not exceed 10 CFR 20 limits.
 - a) Although recycling waste water using evaporators has been discontinued, using the TCF is retained as a good practice.
2. The TCF is defined in eq 7:

$$TCF = \left[1 - \left(\frac{C_{H3}/ECL_{H3}}{F/f} \right) \right] \quad (\text{eq 7})$$

Where:

ECL_{H3} = effluent concentration limit of tritium

C_{H3} = tritium concentration in release mix, pre-dilution ($\mu\text{Ci/mL}$)
[Tritium concentration " C_{H3} " is conservatively estimated.]

F = conservative dilution flowrate (gpm)

f = conservative undiluted effluent flowrate (gpm)

d. Liquid Effluent Radiation Monitor Setpoint Calculations

1. The actual setpoint used by operations shall be equal to or less than the actual value calculated by the HASP methodology described in this section.
 - a) The HASP represents the maximum operational setpoint.
2. HASP Methodology for RE-3: Oily Water Separator (OWS)
 - a) Normal Conditions
 - 1) Under normal conditions, the OWS stream does not contain any radioactive material. Only when there is primary-to-secondary leakage does this become a potential liquid effluent discharge point.
 - 2) To insure that no unplanned or unmonitored releases take place via the OWS, RE-3 monitors the discharge even when no activity has been identified in the effluent.
 - 3) When no significant primary-to-secondary leakage is taking place, or when no activity has been identified in the OWS, the RE-3 HASP is calculated per eq 8:

$$\text{HASP}_{\text{RE-3}} = 3 \times \text{BKGD}_{\text{RE-3}} \text{ (eq 8)}$$

b) Primary-to-Secondary Leakage

- 1) When primary-to-secondary leakage results in activity being detected in the OWS, a HASP should be calculated per eq 9:

$$HASP_{RE-3} = BKGD_{RE-3} + (AF)(SF) \times \sum_{\gamma} k_{\gamma} C_{\gamma} \left[\frac{F/f}{\sum_{i \neq H3} C_i / ECL_i} \right] \times TCF \quad (\text{eq 9})$$

Where:

$HASP_{RE-3}$ = high alarm setpoint for RE-3 (cpm)

$BKGD_{RE-3}$ = background reading for RE-3 (cpm)

AF = OWS allocation factor from Table 1

SF = safety factor for RE-3 (0.9)

k_{γ} = monitor response factor (cpm/ μ Ci/mL)

C_{γ} = concentration of gamma emitting isotopes in release mix, pre-dilution (μ Ci/mL)

F = dilution flowrate (gpm)

f = undiluted effluent flowrate (gpm)

C_i = concentration of radionuclide "i" in release mix, pre-dilution (μ Ci/mL)

ECL_i = effluent concentration limit of radionuclide "i"

TCF = tritium correction factor defined in eq 7

- c) The greater HASP value calculated by eq 8 or eq 9 should be used.

3. HASP Methodology for RE-18: Liquid Radwaste System

a) The RE-18 HASP is calculated per eq 10:

$$\text{HASP}_{\text{RE-18}} = \text{BKGD}_{\text{RE-18}} + (\text{AF})(\text{SF}) \times \sum_{\gamma} k_{\gamma} C_{\gamma} \left[\frac{F/f}{\sum_{i \neq \text{H3}} C_i / \text{ECL}_i} \right] \times \text{TCF} \quad (\text{eq 10})$$

Where:

HASP_{RE-18} = high alarm setpoint for RE-18 (cpm)BKGD_{RE-18} = background reading for RE-18 (cpm)

AF = LRW source allocation factor from Table 1

SF = safety factor for RE-18 (0.9)

k_γ = monitor response factor (cpm/μCi/mL)C_γ = concentration of gamma emitting isotopes in release mix, pre-dilution (μCi/mL)

F = dilution flowrate (gpm)

f = undiluted effluent flowrate (gpm)

C_i = concentration of radionuclide "i" in release mix, pre-dilution (μCi/mL)ECL_i = effluent concentration limit of radionuclide "i"

TCF = tritium correction factor defined in eq 7

4. HASP Methodology for RE-23: Steam Generator Blowdown (SGBD) Tank

a) The RE-23 HASP is calculated per eq 11:

$$\text{HASP}_{\text{RE-23}} = \text{BKGD}_{\text{RE-23}} + (\text{AF})(\text{SF}) \times \sum_{\gamma} k_{\gamma} C_{\gamma} \left[\frac{F/f}{\sum_{i \neq \text{H3}} C_i / \text{ECL}_i} \right] \times \text{TCF} \quad (\text{eq 11})$$

Where:

- $\text{HASP}_{\text{RE-23}}$ = high alarm setpoint for RE-23 (cpm)
 $\text{BKGD}_{\text{RE-23}}$ = background reading for RE-23 (cpm)
 AF = SGBD effluent system allocation factor for each unit from Table 1
 SF = safety factor for RE-23 (0.9)
 k_{γ} = monitor response factor (cpm/ $\mu\text{Ci}/\text{mL}$)
 C_{γ} = concentration of gamma emitting isotopes in the release mix, pre-dilution ($\mu\text{Ci}/\text{mL}$)
 F = dilution flowrate (gpm)
 f = undiluted effluent flowrate (gpm)
 C_i = concentration of radionuclide "i" in the release mix, pre-dilution ($\mu\text{Ci}/\text{mL}$)
 ECL_i = effluent concentration limit of radionuclide "i"
 TCF = tritium correction factor defined in eq 7

5.1.4 Liquid Effluent Dose Projection

- a. The projected dose contributions from each reactor unit due to liquid effluents for the current calendar month, quarter, and current calendar year shall be calculated per the methodology and parameters in the ODCP at least once per 31 days.

1. The purpose of dose projections is to determine whether appropriate treatment of liquid radioactive materials in relation to maintaining releases "as low as reasonably achievable" is necessary.

- b. The projected dose from each reactor unit is given by eq 12:

$$D_P = D_{P,U} + \frac{1}{2} D_{P,Com} \quad (\text{eq 12})$$

Where:

D_P = projected dose

$D_{P,U}$ = projected dose attributed to reactor unit, U

$D_{P,Com}$ = projected dose common to both reactor units

- c. The 31-day projected dose is calculated per eq 13.

$$D_P^M = 31 \left(\frac{D_A^{PM} + d_A^{CM} + d_P^{CB}}{T + t} \right) \quad (\text{eq 13})$$

Where:

D_P^M = projected dose for the next 31-day period

D_A^{PM} = previous month's actual dose

d_A^{CM} = current month actual dose to date

d_P^{CB} = projected dose from current batch release

T = number of days in the previous month

t = number of days into the present month

d. The projected quarterly doses are calculated per eq 14:

$$D_P^{CQ} = d_A^{CQ} + (92 - t) \left(\frac{D_A^{PQ} + d_A^{CQ} + d_P^{CB}}{T + t} \right) \quad (\text{eq 14})$$

Where:

D_P^{CQ} = projected dose for the current calendar quarter

d_A^{CQ} = current quarter to date actual dose

D_A^{PQ} = previous quarter's actual dose

d_P^{CB} = projected dose from the current batch release

T = number of days in the previous quarter

t = number of days into the present quarter

e. Projected yearly doses are calculated per eq 15:

$$D_P^{CY} = d_A^{CY} + (366 - t) \left(\frac{D_A^{PY} + d_A^{CY} + d_P^{CB}}{T + t} \right) \quad (\text{eq 15})$$

Where:

D_P^{CY} = projected dose for the current calendar year

d_A^{CY} = current year to date actual dose

D_A^{PY} = previous year's actual dose

d_P^{CB} = projected dose from the current batch release

T = number of days in the previous year

t = number of days into the present year

5.1.5 Liquid Limiting Flowrate Methodology - ECL Based

- a. The maximum effluent flowrate through monitors RE-3, RE-18, and RE-23 as well as for releases from the Condensate Demineralizer Regeneration System waste tank or miscellaneous release points, is established to provide further control over effluent releases.
- b. The release rate limit is calculated from the effluent concentration and the 10 CFR 20 effluent concentration limits per eq 16:

$$f = \frac{F(AF)(SF)(TCF)}{\sum_{i \neq H-3} \frac{C_i}{ECL_i}} \quad (\text{eq 16})$$

Where:

f = maximum operational undiluted liquid radwaste effluent discharge flowrate (gpm)

F = expected dilution flowrate (gpm)

AF = LRW source allocation factor from Table 1

SF = safety factor (0.9)

TCF = tritium correction factor defined in eq 7

C_i = concentration of isotopes "i" in the release mix, pre-dilution ($\mu\text{Ci/mL}$)

ECL_i = effluent concentration limit of radionuclide "i" ($\mu\text{Ci/mL}$)

- c. When the term, $\sum_{i \neq H-3} \frac{C_i}{ECL_i}$ equals zero, calculate the limiting flowrate per eq 17:

$$f = F (AF) (SF) (TCF) \quad (\text{eq 17})$$

(Other terms are as previously defined.)

5.1.6 Liquid Limiting Flowrates - LLD Based

- a. When there is no primary-to-secondary leakage, the oily water separator and various miscellaneous release points are assumed to be uncontaminated.
- b. To establish practical operational flowrate limits for any sources when they are considered uncontaminated, use eq 18.
- c. While no activity may be present, eq 18 assumes a concentration equal to the lower limit of detection (LLD) for the nuclides listed in CY2.ID1, Attachment 3, Table 5.

$$f = \frac{F(AF)(SF)}{4.3} \quad (\text{eq 18})$$

Where:

f = maximum operational undiluted liquid radwaste effluent discharge flowrate (gpm)

F = expected dilution flowrate (gpm)

AF = LRW source allocation factor from Table 1

SF = safety factor (0.9)

4.3 = total ECL fraction as given by $\sum_i \frac{LLD_i}{ECL_i}$ (eq 19)

Where: LLD_i = lower limit of detection for radionuclide "i" ($\mu\text{Ci/mL}$) from CY2.ID1, Attachment 3, Table 5

ECL_i = effluent concentration limit of radionuclide "i" ($\mu\text{Ci/mL}$)

- 5.1.7 Unplanned Liquid Releases (Abnormal Releases)
- a. Unmonitored, Unplanned Release
 - 1. Write a report (normally performed by the radiochemistry effluents engineer) describing the event with a calculation, if possible, of the percent of release rate limit listed in CY2.ID1.
 - 2. Forward this report to PSRC for review.
 - 3. Describe the release in the Annual Radioactive Effluent Release Report.
 - b. Monitored, Unplanned Releases
 - 1. Releases Exceeding 1% of CY2.ID1 Release Rate Limit
 - a) Write a report (normally performed by the radiochemistry effluents engineer) describing the event.
 - b) Forward this report to PSRC for review.
 - c) Describe the release in the Annual Radioactive Effluent Release Report.

5.2 Gaseous Effluents

5.2.1 Effluent Pathway Overview

a. Significant Pathway

1. During normal operations, the only significant path for gaseous radioactive waste (GRW) release to the environment is via the plant vent.
2. This source is used to calculate dose rates and real-time doses to the unrestricted area due to noble gases, vaporous radioiodines, and airborne radio-particulates.
3. The plant vent also has redundant monitoring for these types of gaseous releases.

b. Miscellaneous Pathways

1. The following pathways are considered miscellaneous:
 - SGBD tank vent
 - Chemistry lab fume hood
 - Main condenser Nash vacuum pump discharge
2. These miscellaneous release sources are not continuously monitored but may have dose rates and dose calculated for their path to the unrestricted area.

5.2.2 Meteorological

a. Methodology

1. Equations for calculating gaseous effluent concentration limits, high alarm setpoints, dose rates, and critical receptor doses use historical average atmospheric conditions per methodologies of Reg. Guides 1.109 and 1.111, and NUREGs 0133 and 0472.
2. The historical average dispersion (χ/Q) and deposition (D/Q) values are derived from the methodology of Reg. Guide 1.111 as implemented by NUREG 2919 (computer code XOQDOQ).
3. DCPD dispersion and deposition values are based on the latest five years of meteorological data and are updated when the value of χ/Q or D/Q changes by more than ten percent.
4. Current values are listed in Attachment 2.

b. Long-term Releases

1. These releases are characterized as those that are generally continuous and stable in release rate, such as normal ventilation systems effluents.
2. Doses due to long-term releases are modeled using five-year historical average dispersion and deposition values per the guidance of Reg. Guides 1.109 and 1.111, and NUREGs 0133 and 0472.

c. Short-term Releases

1. These releases are defined as those which occur:
 - For a total of 500 hours or less in a calendar year.
 - Not more than 150 hours in any quarter.
2. Per NUREG 0133, and based on an operational history that has demonstrated short-term gaseous releases may be characterized as random in both time of day and duration, five-year historical average atmospheric dispersion and deposition values are used to model doses due to short-term releases.

5.2.3 Gas Effluent Concentration Limits

a. Philosophy of Concentration Limits

1. Dose Rate Limits

- a) The radiological effluent controls restrict, at all times, the dose rate due to radioactive materials released in gaseous effluents from the site to areas at or beyond the site boundary to the following:
 - 1) For noble gases:
 - Less than or equal to 500 mrem/yr to the total body
 - Less than or equal to 3000 mrem/yr to the skin
 - 2) For iodine-131, iodine-133, tritium, and for all radionuclides in particulate form with half-lives greater than 8 days:
 - Less than or equal to 1500 mrem/yr to any organ
- b) These dose rate limits act to restrict, at all times, the instantaneous concentrations of radionuclides in gaseous effluents at the site boundary.

2. Allocation Factors

- a) The limits set forth by CY2.ID1, Attachment 6, are site limits which require the setpoint methodology ensures simultaneous releases do not exceed the off-site dose rate limits.
- b) The DCPD high alarm setpoint (HASP) methodology uses an allocation factor (AF) which may be adjusted based on operational requirements with the following restrictions:
 - The sum of the AFs for RE-14 (plant vent noble gas monitor), the SGBD tank vents, and miscellaneous gaseous release points from both units shall be less than or equal to 1.
 - AFs for RE-22 (waste gas decay tanks) and RE-44 (containment purge) may be adjusted based on operational requirements with the restriction that the sum of the AFs for RE-22 and RE-44 shall be less than or equal to the AF for RE-14.
 - AFs for RE-24 (plant vent iodine monitor) and RE-28 (plant vent particulate monitor) are set equal to the AF for RE-14.

Discharge Pathway	Radiation Monitor	Allocation Factor (AF)
Plant Vent - Noble gas monitor	RE-14	0.48
Plant Vent - Iodine monitor	RE-24	0.48
Plant Vent - Particulate monitor	RE-28	0.48
Waste Gas Decay Tank	RE-22	0.10
Containment Purge	RE-44	0.38
SGBD Tank Vent	N/A	0.01
Miscellaneous	N/A	0.01

3. Safety Factor

- a) An additional level of conservatism in the HASP methodology is implemented by using a safety factor (SF).

b. Gaseous Effluent Radiation Monitor Setpoint Calculations

1. HASP Methodology for RE-14/RE-14R: Plant Vent Noble Gas Monitors

- a) Redundant radiation monitors, RE-14 and RE-14R, monitor the plant vent effluent stream noble gas concentration.
- b) The HASP provides alarm function only. However, when RE-14 reaches an over-range condition, its processor will turn off RE-14 and turn on RE-87 (plant vent high range noble gas monitor). RE-14R does not have this over-range feature.
- c) The HASP methodology for RE-14/RE-14R is given by eq 20 and is based on the assumption that the total body dose rate limit is most limiting.

$${}^{14}\text{Max}C_T(\text{NG}) = (\text{AF})(\text{SF}) \left(\frac{500}{(472)(F_{\text{pv}})(\overline{\chi/Q})_{\text{Max}} (294)} \right) \quad (\text{eq 20})$$

Where:

${}^{14}\text{Max}C_T(\text{NG})$ = maximum allowable total concentration of noble gas in the plant vent ($\mu\text{Ci/cc}$)

AF = plant vent allocation factor for one unit from Table 2

SF = safety factor (0.9)

500 = site total body dose rate limit for instantaneous releases (mrem/yr)

472 = conversion constant to cc/sec from cfm

F_{pv} = total flowrate in the plant vent (cfm)
[Maximum plant vent flowrate = 263,000 cfm]

$(\overline{\chi/Q})_{\text{Max}}$ = maximum site boundary dispersion factor from Attachment 2, based on 5-year historical averages derived from the meteorological database

294 = whole body dose factor (mrem/yr per $\mu\text{Ci/m}^3$) for Xe-133 from Attachment 3
[For plant vent HASP, release is assumed to be all Xe-133.]

2. Plant Vent Noble Gas Monitor - RE-14/RE-14R Scaling

- a) To correlate RE-14 readings to noble gas concentration during periods between samplings, the concentration is scaled per eq 21:

$$C_T = \frac{CPM_T}{CPM_S} \times C_S \quad (\text{eq 21})$$

Where:

CPM_T = RE-14 time weighted arithmetic mean (cpm)

CPM_S = RE-14 gross count rate at the time of sampling (cpm)

C_S = noble gas concentration corresponding to CPM_S , based on noble gas grab sample ($\mu\text{Ci/cc}$)

C_T = scaled concentration of noble gas ($\mu\text{Ci/cc}$)

3. HASP Methodology for RE-24/RE-24R: Plant Vent Iodine Monitor

- a) Redundant radiation monitors, RE-24 and RE-24R, monitor the plant vent effluent stream iodine concentration.
- b) The HASP provides alarm function only.
- c) The alarm setpoint methodology:
- Assumes the monitors respond only to I-131.
 - Presumes a release mixture based on the RCS source term.

d) The RE-24/RE-24R HASP is given by eq 22:

$${}^{24}\text{Max}C_{T(I)} = (AF)(SF)(f_{I-131}) \left(\frac{1500}{(472)(F_{pv})(\overline{\chi/Q})_{\text{Max}} \left(\sum_i P_i^w f_i \right)} \right) \quad (\text{eq 22})$$

Where:

${}^{24}\text{Max}C_{T(I)}$ = maximum allowable I-131 concentration in the plant vent ($\mu\text{Ci/cc}$)
 AF = plant vent allocation factor for one unit from Table 2
 SF = safety factor (0.9)
 f_{I-131} = fraction of the total non-noble gas concentration due to I-131 defined as:

$$\frac{C_{I-131}}{\sum_i C_i} \quad (\text{eq 23})$$

1500 = site organ dose rate limit for I-131, for I-133, for tritium, and for all radioactive materials in particulate form with half-lives greater than 8 days (mrem/yr)
 472 = conversion constant to cc/sec from cfm
 F_{pv} = total flowrate in the plant vent (cfm)
 [Maximum plant vent flowrate = 263,000 cfm]
 $(\overline{\chi/Q})_{\text{Max}}$ = maximum site boundary dispersion factor from Attachment 2, based on 5-year historical averages derived from the meteorological database
 P_i^w = inhalation dose factor for radionuclide "i" (mrem/yr per $\mu\text{Ci/m}^3$) from Attachment 4 for child age group for worst case organ
 [Dose factors are based on NUREG 0133 methodology. Inhalation dose conversion factors are from Reg. Guide 1.109, Rev 1, Table E-9, with the following exceptions: H-3, Sb-124, and Sb-125 inhalation dose conversion factors from NUREG/CR-4013.]
 f_i = fraction of total non-noble gas concentration (excluding tritium) due to radionuclide "i" defined as:

$$\frac{C_i}{\sum_i C_i} \quad (\text{eq 24})$$

4. HASP Methodology for RE-28/RE-28R: Plant Vent Particulate Monitor
 - a) Redundant radiation monitors, RE-28 and RE-28R, monitor the plant vent effluent stream particulate concentration.
 - b) The HASP provides alarm function only.
 - c) The alarm setpoint methodology assumes:
 - 5% cross-talk from the iodine channel which is due to the retention of a small portion of iodine on the particulate filter.
 - A release mixture based on the RCS source term.

d) The RE-28/RE-28R HASP methodology is given by eq 25:

$${}^{28} \text{Max } C_T(\text{Part}) = (\text{AF})(\text{SF}) \left((0.05) \sum_{\text{Iodines}} f_{\text{Iodines}} + \sum_{\text{Particulates}} f_{\text{Particulates}} \right) \left(\frac{1500}{(472)(F_{\text{pv}}) \left(\overline{\chi/Q} \right)_{\text{Max}} \left(\sum_i P_i^w f_i \right)} \right) \quad (\text{eq 25})$$

Where:

- ${}^{28} \text{Max } C_T(\text{Part})$ = maximum allowable particulate concentration in the plant vent ($\mu\text{Ci/cc}$)
- AF = plant vent allocation factor for one unit from Table 2
- SF = safety factor (0.9)
- 0.05 = fraction of total iodine activity retained on the particulate filter
- f_{Iodines} = fraction of the total non-noble gas concentration due to iodines
- $f_{\text{Particulates}}$ = fraction of the total non-noble gas concentration due to particulates
- 1500 = site organ dose rate limit for I-131, for I-133, for tritium, and for all radioactive materials in particulate form with half-lives greater than 8 days (mrem/yr)
- 472 = conversion constant to cc/sec from cfm
- F_{pv} = total flowrate in the plant vent (cfm)
[Maximum plant vent flowrate = 263,000 cfm]
- $\left(\overline{\chi/Q} \right)_{\text{Max}}$ = maximum site boundary dispersion factor from Attachment 2, based on 5-year historical averages derived from the meteorological database
- P_i^w = inhalation dose factor for radionuclide "i" (mrem/yr per $\mu\text{Ci/m}^3$) from Attachment 4 for child age group for worst case organ
[Dose factors are based on NUREG 0133 methodology. Inhalation dose conversion factors are from Reg. Guide 1.109, Rev 1, Table E-9, with the following exceptions: H-3, Sb-124, and Sb-125 inhalation dose conversion factors taken from NUREG/CR-4013.]
- f_i = fraction of total non-noble gas concentration (excluding tritium) due to radionuclide "i" defined as:
$$\frac{C_i}{\sum_i C_i} \quad (\text{eq 24})$$

5. HASP Methodology for RE-22: Waste Gas Decay Tank Monitor

- a) Radiation monitor RE-22 monitors waste gas decay tank (GDT) effluent releases and provides alarm and automatic release termination functions.
- b) The HASP methodology for RE-22 assumes that the skin dose rate limit is most limiting and is given by eq 26:

$${}^{22\text{Max}}C_T(\text{NG}) = (\text{AF})(\text{SF}) \left(\frac{3000}{(472)(F_{\text{gdt}})(\overline{\chi/Q})_{\text{Max}} (1.34 \times 10^3)} \right) \quad (\text{eq 26})$$

Where:

${}^{22\text{Max}}C_T(\text{NG})$ = maximum allowable total concentration of noble gas in the GDT exhaust line ($\mu\text{Ci/cc}$)

AF = GDT allocation factor for one unit from Table 2

SF = safety factor (0.9)

3000 = site skin dose rate limit for instantaneous releases (mrem/yr)

472 = conversion constant to cc/sec from cfm

F_{gdt} = maximum flowrate for the GDT system (31 cfm)

$(\overline{\chi/Q})_{\text{Max}}$ = maximum site boundary dispersion factor from Attachment 2, based on 5 year historical averages derived from the meteorological database

1.34×10^3 = skin dose factor for Kr-85 (mrem/yr per $\mu\text{Ci/m}^3$) from Attachment 3

6. HASP Methodology for RE-44A/RE-44B: Containment Purge
 - a) Redundant radiation monitors, RE-44A/RE-44B, monitor the containment purge and provide alarm and automatic release termination functions.
 - b) The containment purge HASP methodology limits the noble gas dose rate for skin and total body exposure by:
 - 1) Calculating the following two setpoints:
 - One setpoint per eq 27, which is based on limiting the total body dose rate
 - A second setpoint per eq 28, which is based on limiting the skin dose rate
 - 2) Using the more limiting of the two setpoints calculated.

c) Limiting Concentration Based on Total Body Dose

$${}^{44}\text{A/BMax} C_{\text{T}}(\text{NG}) = (\text{AF})(\text{SF}) \left(\frac{500}{(472)(F_{\text{ct}}) \left(\overline{(\chi/Q)}_{\text{Max}} \right) \left(\sum K_i f_i \right)} \right) \quad (\text{eq 27})$$

Where:

- ${}^{44}\text{A/BMax} C_{\text{T}}(\text{NG})$ = maximum allowable total concentration of noble gas in the containment purge exhaust line ($\mu\text{Ci/cc}$)
- AF = containment purge allocation factor for one unit from Table 2
- SF = safety factor (0.9)
- 500 = site total body dose rate limit for instantaneous releases (mrem/yr)
- 472 = conversion constant to cc/sec from cfm
- F_{ct} = maximum flowrate in the containment purge system
[Maximum containment purge flowrate = 55,000 cfm]
- $\left(\overline{(\chi/Q)}_{\text{Max}} \right)$ = maximum site boundary dispersion factor from Attachment 2, based on 5 year historical averages derived from the meteorological database
- K_i = whole body dose factor (mrem/yr per $\mu\text{Ci/m}^3$) for radionuclide "i" from Attachment 3
- f_i = fraction of the concentration of the individual noble gas radionuclide "i" in the total mix of noble gas effluents in the containment purge line defined as:

$$\frac{C_i}{\sum_i C_i} \quad (\text{eq 24})$$

- d) Limiting Concentration Based on Skin Dose
- 1) Skin dose should be calculated whenever an RCS sample contains a significant fraction of Kr-85.
 - 2) The concentration limit calculated by this method should then be compared to the concentration limit calculated for total body dose. The smaller concentration should be used as the limiting concentration for the HASP.

$${}^{44\text{A}/\text{BMax}}\text{C}_{\text{T}}(\text{NG}) = (\text{AF})(\text{SF}) \left(\frac{3000}{(472)(F_{\text{ct}}) \left(\overline{\chi/Q} \right)_{\text{Max}} \left(\sum_i (L_i + 1.1M_i) f_i \right)} \right) \quad (\text{eq 28})$$

Where:

- ${}^{44\text{A}/\text{BMax}}\text{C}_{\text{T}}(\text{NG})$ = maximum allowable total concentration of noble gas in the plant vent ($\mu\text{Ci}/\text{cc}$)
- AF = containment purge allocation factor for one unit from Table 2
- SF = safety factor (0.9).
- 3000 = site skin dose rate limit for instantaneous releases (mrem/yr)
- 472 = conversion constant to cc/sec from cfm
- F_{ct} = total flowrate in the containment purge system (cfm)
[Maximum containment purge flowrate = 55,000 cfm]
- $\left(\overline{\chi/Q} \right)_{\text{Max}}$ = maximum site boundary dispersion factor from Attachment 2, based on 5-year historical averages derived from the meteorological database
- L_i = skin dose factor (mrem/yr per $\mu\text{Ci}/\text{m}^3$) for isotope "i" from Attachment 3
- 1.1 = conversion factor mrem/mrad; converts air dose to skin dose
- M_i = gamma air dose factor (mrad/yr per $\mu\text{Ci}/\text{m}^3$) for radionuclide "i" from Attachment 3
- f_i = fraction of the concentration of the individual noble gas radionuclide "i" in the total mix of noble gas effluents in the containment purge line defined as:

$$\frac{C_i}{\sum_i C_i} \quad (\text{eq 24})$$

c. Mode 6 Particulate Activity

1. The HASP calculation specified in this section based on noble gas effluent limitations conservatively bounds the TS requirement for particulate activity in Mode 6.
2. The FSAR expected case accident for Mode 6 is a containment fuel handling accident which does not include a particulate release. Therefore, the HASP for RM-44 in this section conservatively satisfies the TS.^{Ref 7.8}

5.2.4 Gaseous Dose Rate Calculation Methodology

a. Total Body Noble Gas Dose Rate Methodology

1. The dose rate to the total body due to immersion in a cloud of noble gases is given by:

$$\left(\overline{\chi/Q}\right)_{\text{Max}} \sum_i K_i \dot{Q}_i \leq 500 \text{ mrem/year} \quad (\text{eq 29})$$

Where:

\dot{Q}_i = release rate of radionuclide "i" ($\mu\text{Ci}/\text{sec}$)
(Other terms are as previously defined.)

b. Skin Dose Rate Methodology

1. The dose rate to the skin due to immersion in a cloud of noble gases is given by:

$$\left(\overline{\chi/Q}\right)_{\text{Max}} \left(\sum_i (L_i + 1.1M_i) \dot{Q}_i \right) \leq 3000 \text{ mrem/year} \quad (\text{eq 30})$$

(Where terms are as previously defined.)

c. Radioiodine, Tritium, and Particulate Dose Rate Methodology

1. The dose rate to organ "o" due to radioiodines, tritium, and particulates released in gaseous effluents is given by:

$$\left(\overline{\chi/Q}\right)_{\text{Max}} \left(\sum_i P_{io} \dot{Q}_i \right) \leq 1500 \text{ mrem/year} \quad (\text{eq 31})$$

Where:

$$P_{io} = K'(\text{BR})\text{DFA}_{io}$$

$$\text{Where: } K' = 10^6 \text{ pCi}/\mu\text{Ci}$$

BR = breathing rate of the child age group (m^3/yr)
[The default value of $3700 \text{ m}^3/\text{yr}$ is from Reg. Guide 1.109, Table E-5.]

DFA_i = inhalation dose factor for organ "o" for the child age group for radionuclide "i" (mrem/pCi) from Reg. Guide 1.109, Table E-9, with the following exceptions: H-3, Sb-124 and Sb-125 inhalation dose conversion factors from NUREG/CR4013.

(Other terms are as previously defined. Values for P_{io} are listed in Attachment 4.)

5.2.5 Noble Gas Air Dose Calculation Methodology

a. Gamma Air Dose

1. The gamma air dose due to immersion in a cloud of noble gases is given by:

$$D_{\text{ay}} = (3.17 \times 10^{-8}) (\overline{\chi/Q})_{\text{Max}} \left(\sum_i M_i \tilde{Q}_i \right) \quad (\text{eq 32})$$

Where:

D_{ay} = gamma air dose (mrad)

3.17×10^{-8} = conversion constant yr/sec

M_i = gamma air dose factor for radionuclide "i"
(mrad/yr per $\mu\text{Ci}/\text{m}^3$) from Attachment 3

\tilde{Q}_i = total release of noble gas radionuclide "i" (μCi)

(Other terms are as previously defined.)

b. Beta Air Dose

1. The beta air dose due to immersion in a cloud of noble gases is given by:

$$D_{\text{a}\beta} = (3.17 \times 10^{-8}) (\overline{\chi/Q})_{\text{Max}} \left(\sum_i N_i \tilde{Q}_i \right) \quad (\text{eq 33})$$

Where:

$D_{\text{a}\beta}$ = beta air dose (mrad)

N_i = beta air dose factor for radionuclide "i" (mrad/yr per $\mu\text{Ci}/\text{m}^3$)
from Attachment 3

(Other terms are as previously defined.)

5.2.6 Dose to Critical Receptor Due to Radioiodines, Tritium, Carbon-14, and Particulates Released in Gaseous Effluents

a. Calculation Methodology

1. The dose to an individual (critical receptor) due to radioiodines, tritium, carbon-14 (C-14), and particulates released in gaseous effluents with half-lives greater than 8 days is calculated based on the methodology described in NUREG 0133. This methodology makes use of the maximum individual concept described in Reg. Guide 1.109.

a) Maximum Individual

- 1) The maximum individual is characterized as maximum with regard to food consumption, occupancy, and other usage parameters. This concept models those individuals within the local population with habits representing reasonable deviations from the average.
- 2) In all physiological and metabolic respects, the maximum individual is assumed to have those characteristics that represent the average for the age group of interest.

b) Critical Receptor

- 1) The concept of critical receptor is introduced as a further refinement of the maximum individual.
- 2) The critical receptor concept is applied at that location where the combination of dispersion (χ/Q), deposition (D/Q), existing pathways, occupancy time, receptor age group, and effluent source term indicates the maximum potential exposure.

c) Exposure Pathways

- 1) The inhalation and ground plane exposure pathways are considered to exist at all locations.
- 2) The grass-cow-milk, grass-cow-meat, grass-wild game-meat and vegetation pathways are considered based on their actual existence in the vicinity of the plant.
- 3) The dose pathways that have been shown to actually exist at DCPD are the ground plane, inhalation, and the vegetation pathways.
- 4) These dose pathways are reviewed yearly and updated based on the annual land use census survey to ensure that actual exposure to an individual will not be substantially underestimated.
- 5) The locations of the pathways and descriptions are listed in Attachment 2.

b. Dose Calculation

- The dose contributions to the total body and each individual organ (bone, liver, thyroid, kidney, lung, and GI-LLI) of the maximum exposed individual (critical receptor) due to radioactive gaseous effluent releases are calculated for all radionuclides identified in gaseous effluents released to unrestricted areas using the following expression:

$$D_{apo} = (3.17 \times 10^{-8})(\overline{W}_{CR}) \left(\sum_i R_{aipo} \tilde{Q}_i \right) \quad (\text{eq 34})$$

Where:

- D_{apo} = dose to critical receptor for age group "a," pathway "p," and organ "o" (mrem)
[Dose due to C-14 may be reported separately from other isotopes within reports.]
- \overline{W}_{CR} = critical receptor $\overline{\chi}/Q$ for immersion, inhalation, and all tritium and C-14 pathways (seconds/m³) from Attachment 2
- = critical receptor \overline{D}/Q for ground plane and all ingestion pathways (1/m²) from Attachment 2
- R_{aipo} = site-specific dose factor for age group "a," radionuclide "i," pathway "p" and organ "j" (mrem/yr per $\mu\text{Ci}/\text{m}^3$ for inhalation, tritium, and C-14 pathways; mrem/yr per $\mu\text{Ci}/\text{sec m}^2$ for ground plane and ingestion pathways).
[These dose factors are listed in attachments 5 through 12. Special circumstance dose factors may be calculated on a case-by-case basis, and documented in the corrective action program.]
[Site-specific dose factors are calculated based on NUREG 0133 methodology. All dose conversion factors are from Reg. Guide 1.109, Rev 1, Tables E6-E14, with the following exceptions: H-3, Sb-124 and Sb-125 dose conversion factors from NUREG/CR-4013.]

NOTE: C-14 total release calculations are made per step 5.2.6b.1.a).

\tilde{Q}_i = total release of radionuclide "i" (μCi)

NOTE: The release of C-14 takes into consideration production, percent released in gaseous form and chemical form, per the methodology in Reference 7.22. While the EPRI document provides recommended parameters, site-specific information is evolving, which will likely result in year-to-year changes.

- a) The total C-14 release per unit per year is calculated as follows:

$$\tilde{Q}_{C-14\text{Tot}} = \mu\text{Ci}_{C-14\text{Rx}} \times F_{\text{cap}} \times \text{FR}_{\text{gas}} \quad (\text{inhalation path})$$

$$\tilde{Q}_{C-14\text{CO}_2} = \mu\text{Ci}_{C-14\text{Rx}} \times F_{\text{cap}} \times \text{FR}_{\text{gas}} \times \text{FF}_{\text{CO}_2} \quad (\text{ingestion path})$$

Where:

$$\tilde{Q}_{C-14\text{Tot}} = \text{total C-14 released from unit in gaseous form during a calendar year } (\mu\text{Ci})$$

$$\tilde{Q}_{C-14\text{CO}_2} = \text{total C-14 released from unit in gaseous form as CO}_2 \text{ during a calendar year } (\mu\text{Ci})$$

$$\mu\text{Ci}_{C-14\text{Rx}} = \text{microcuries produced in the reactor per unit per effective full-power year} \\ [\text{This value is calculated per Reference 7.22.}]$$

$$F_{\text{cap}} = \text{unit's operating capacity factor } (\leq 1.0) \text{ during the year}$$

$$\text{FR}_{\text{gas}} = \text{fraction of produced C-14 assumed to be released in gaseous form based on site-specific values or values recommended by Reference 7.22.} \\ [\text{This takes into consideration factors such as disposal of C-14 in solid radwaste.}]$$

$$\text{FF}_{\text{CO}_2} = \text{fraction of produced C-14 assumed to be released in the gaseous, inorganic form (CO}_2\text{) based on site-specific values or values recommended by Reference 7.22.}$$

5.2.7 GRW Batch Release Noble Gas Percent Release Rate Limits (PRRLs)

- a. The PRRL for noble gas releases for each unit based on the 500 mrem/yr whole body dose rate limit is calculated per eq 35:

$$PRRL = \frac{\left(\overline{\chi/Q}\right)_{Max} \left(\sum_i K_i \dot{Q}_i\right)}{(0.48)(500 \text{ mrem/yr})} \times 100\% \quad (\text{eq 35})$$

Where:

- $\left(\overline{\chi/Q}\right)_{Max}$ = maximum site boundary dispersion factor from Attachment 2, based on 5 year historical averages derived from the meteorological database
- K_i = whole body dose factor (mrem/yr per $\mu\text{Ci}/\text{m}^3$) for radionuclide "i" from Attachment 3
- \dot{Q}_i = total release rate of radionuclide "i" ($\mu\text{Ci}/\text{sec}$) from all sources discharged through this release point
- 0.48 = plant vent allocation factor for one unit from Table 2
- 500 mrem/yr = site noble gas dose rate limit

5.2.8 Noble Gas GRW Batch Release Expected Reading (ER)

- a. If the ER exceeds the existing HASP setting, no release should be made until one of the following is performed:
 - 1. The HASP is raised above the ER (per CY2.DC1)
 - 2. Release conditions (e.g., flowrate) are changed so that the ER is below the HASP
- b. The ER for RE-22 is given by eq 36:

$$ER_{RE-22} = BKGD_{RE-22} + \sum_i k_{RE-22i} C_{RE-22i} \quad (\text{eq 36})$$

Where:

ER_{RE-22} = expected reading on monitor RE-22 ($\mu\text{Ci/cc}$)

$BKGD_{RE-22}$ = RE-22 background

k_{RE-22i} = RE-22 response factor for radionuclide "i"

C_{RE-22i} = concentration of radionuclide "i" seen by RE-22

- c. The ER for RE-44A/RE-44B is given by eq 37:

$$ER_{RE-44} = BKGD_{RE-44} + (CCSP_{RE-44}) \sum_i k_{RE-44i} C_{RE-44i} \quad (\text{eq 37})$$

Where:

ER_{RE-44} = expected reading on monitor RE-44 ($\mu\text{Ci/cc}$)

$BKGD_{RE-44}$ = RE-44 background

$CCSP_{RE-44}$ = conversion constant setpoint for RE-44

k_{RE-44i} = RE-44 response factor for radionuclide "i"

C_{RE-44i} = concentration of radionuclide "i" seen by RE-44

d. The ER for RE-14/RE-14R is given by eq 38:

$$ER_{RE-14} = BKGD_{RE-14} + (CCSP_{RE-14}) \left(\sum_i k_{RE-14i} C_{RE-14i} \right) \quad (\text{eq 38})$$

Where:

ER_{RE-14} = expected reading on monitor RE-14 ($\mu\text{Ci}/\text{cc}$)

$BKGD_{RE-14}$ = RE-14 background

$CCSP_{RE-14}$ = conversion constant setpoint for RE-14

k_{RE-14i} = RE-14 response factor for radionuclide "i"

C_{RE-14i} = concentration of radionuclide "i" seen by RE-14

5.2.9 GRW Batch Release Iodine, Particulate, Tritium PRRL

- a. The PRRL for radioiodines, particulates, and tritium for each unit is calculated based on the 1500 mrem/yr organ dose rate limit.
- b. The dose rate is calculated per eq 39 for the inhalation pathway to the child age group using the highest (worst case) organ dose factor for nuclide.

$$PRRL_o = \frac{(\overline{\chi/Q})_{Max} \sum_i P_i^w \dot{Q}_i}{(0.48)(1500\text{mrem/yr})} \times 100\% \quad (\text{eq 39})$$

Where:

- $(\overline{\chi/Q})_{Max}$ = maximum site boundary dispersion factor from Attachment 2, based on 5 year historical averages derived from the meteorological database
- P_i^w = inhalation dose factor for radionuclide "i" (mrem/yr per $\mu\text{Ci}/\text{m}^3$) from Attachment 4 for child age group for worst case organ
[Dose factors are based on NUREG 0133 methodology. Inhalation dose conversion factors are from Reg. Guide 1.109, Rev 1, Table E-9, with the following exceptions: H-3, Sb-124 and Sb-125 inhalation dose conversion factors from NUREG/CR-4013.]
- \dot{Q}_i = release rate of radionuclide "i" ($\mu\text{Ci}/\text{sec}$)
- 0.48 = plant vent allocation factor for one unit from Table 2
- 1500 mrem/yr = site radioiodine, particulate, and tritium dose rate limit

5.2.10 Alternate Dose Methodologies

- a. For routine gaseous effluent dose assessment, the methodology of NUREG 0133 (described in Section 5.2.6) shall be used.
- b. For special purposes (e.g., evaluation of potential new gaseous effluent dose pathways or critical receptors), DCPD may elect to use the dose methodologies of Regulatory Guide 1.109 or the GASPARD computer code.

5.2.11 Gas Effluent Dose Projection

NOTE: The Radioactive Effluent Management System (REMS) computer program is used to calculate the dose projection.

- a. The projected dose contributions from each reactor unit due to gaseous effluents for the current calendar month, quarter, and current calendar year shall be calculated per the methodology and parameters in the ODCP at least once per 31 days.
 1. By the first day of the year, the following tables in REMS shall be updated:
 - GRW dose receptor
 - GRW dose rate receptor
 - GRW external dose select
 - GRW external occupancy
 - GRW internal dose select
 - GRW internal occupancy
 2. The purpose of dose projections is to determine whether appropriate treatment of gaseous radioactive materials in relation to maintaining releases "as low as reasonably achievable" is necessary.
- b. The projected dose from each reactor unit is given by eq 12:

$$D_P = D_{P,U} + \frac{1}{2} D_{P,Com} \quad (\text{eq 12})$$

Where:

D_P = projected dose

$D_{P,U}$ = projected dose attributed to reactor unit, U

$D_{P,Com}$ = projected dose common to both reactor units

- c. The 31-day projected dose is calculated per eq 13:

$$D_P^M = 31 \left(\frac{D_A^{PM} + d_A^{CM} + d_P^{CB}}{T + t} \right) \quad (\text{eq 13})$$

Where:

D_P^M = projected dose for the next 31-day period

D_A^{PM} = previous month's actual dose

d_A^{CM} = current month actual dose to date

d_P^{CB} = projected dose from current batch release

T = number of days in the previous month

t = number of days into the present month

- d. The projected quarterly doses are calculated per eq 14:

$$D_P^{CQ} = d_A^{CQ} + (92 - t) \left(\frac{D_A^{PQ} + d_A^{CQ} + d_P^{CB}}{T + t} \right) \quad (\text{eq 14})$$

Where:

D_P^{CQ} = projected dose for the current calendar quarter

d_A^{CQ} = current quarter to date actual dose

D_A^{PQ} = previous quarter's actual dose

d_P^{CB} = projected dose as a result of the current batch release

T = number of days in the previous quarter

t = number of days into the present quarter

e. Projected yearly doses are calculated per eq 15:

$$D_P^{CY} = d_A^{CY} + (366 - t) \left(\frac{D_A^{PY} + d_A^{CY} + d_P^{CB}}{(T + t)} \right) \quad (\text{eq 15})$$

Where:

D_P^{CY} = projected dose for the current calendar year

d_A^{CY} = current year to date actual dose

D_A^{PY} = previous year's actual dose

d_P^{CB} = projected dose as a result of the current batch release

T = number of days in the previous year

t = number of days into the present year

5.2.12 Unplanned Gaseous Releases (Abnormal Releases)

a. Unmonitored, Unplanned Release

1. Write a report (normally performed by the radiochemistry effluents engineer) describing the event with a calculation, if possible, of the percent of release rate limit listed in CY2.ID1.
2. Forward this report to PSRC for review.
3. Describe the release in the Annual Radioactive Effluent Release Report.

b. Monitored, Unplanned Releases

1. Releases Exceeding 1% of CY2.ID1 Release Rate Limit

- a) Write a report (normally performed by the radiochemistry effluents engineer) describing the event.
- b) Forward this report to PSRC for review.
- c) Describe the release in the Annual Radioactive Effluent Release Report.
- d) For purposes of classification only, unplanned release puffs through the plant vent may use one hour integrated resolution times.

5.3 40 CFR 190 Dose Calculations

5.3.1 Pathway

- a. 40 CFR 190, "Environmental Radiation Protection Standards for Nuclear Power Operations," is applicable to operations which are part of a nuclear fuel cycle which result in both of the following:
 - Radiation doses received by members of the public in the general environment
 - Radioactive materials introduced into the general environment
- b. The annual dose equivalent to any member of the public from planned discharges of radioactive materials to the general environment and to radiation from these operations shall not exceed the following:
 - 25 millirems to the whole body
 - 75 millirems to the thyroid
 - 25 millirems to any other organ
- c. For DCCP, the contributions from liquid and gaseous effluents, as well as direct radiation from selected outside storage tanks, storage buildings, and the Independent Spent Fuel Storage Installation (ISFSI), shall be included.
- d. The total uranium fuel cycle dose to any member of the public will be calculated by summing the following doses:
 - Direct radiation dose
 - Liquid effluent dose
 - Noble gas dose
 - Radioiodine, tritium, C-14, and particulate gaseous effluent dose

5.3.2 Methodology

a. Direct Radiation Dose

1. Routine determination of direct radiation dose from selected outside storage tanks, storage buildings, and the ISFSI may be made by:
 - Direct survey measurements.
 - Derived from area TLD data.
 - Calculated by shielding code.
2. The direct radiation dose shall also take into account residence times near the site based on land use census information.
3. Direct radiation dose is calculated using environmental TLD data per eq 40.

$$D'_{sb} = \left(\frac{r_{adj}}{r_{sb}} \right)^2 (D'_{ro})(B)(e^{-\mu_o \times r_{sb}}) \quad (\text{eq 40})$$

Where:

D'_{sb} = dose rate at the site boundary (mrem)

D'_{ro} = dose rate from the dosimetry reading (mrem)

r_{adj} = distance from the point source to the dosimetry (m)

r_{sb} = distance from the point source to site boundary (m)

$$B = \text{buildup factor} = 1 + (\mu)(r_{sb}) \left(\frac{\mu_a + \mu_s}{\mu_a} \right)$$

Where: μ_a = total absorption coefficient

$$= 0.001 \times e^{(1.34 - (0.105 \times (\ln(10 \times \bar{E}) - 1.57)^2))} \times (273^\circ\text{K}/T^\circ\text{K})$$

μ_s = total Compton scatter coefficient

$$= 0.001 \times e^{(3.10 - (0.089 \times (\ln(10 \times \bar{E}) + 1.89)^2))} \times (273^\circ\text{K}/T^\circ\text{K})$$

μ_o = total attenuation coefficient

$$= \mu_a + \mu_s$$

\bar{E} = external effective average gamma energy per disintegration of the source (Mev)

$T^\circ\text{K}$ = average absolute temperature (Kelvin)

b. Noble Gas Dose

1. The noble gas skin dose and total body dose contributions to the total uranium fuel cycle dose to a member of the public shall be calculated as shown in eq 41 and eq 42:

$$\text{Noble gas total body dose} = (3.17 \times 10^{-8}) \left(\overline{\chi/Q} \right)_R \left(\sum_i K_i \tilde{Q}_i \right) \quad (\text{eq 41})$$

$$\text{Noble gas skin dose} = (3.17 \times 10^{-8}) \left(\overline{\chi/Q} \right)_R \left(\sum_i (L_i + 1.1M_i) \tilde{Q}_i \right) \quad (\text{eq 42})$$

Where:

3.17×10^{-8} = conversion constant yr/sec

$\left(\overline{\chi/Q} \right)_R$ = maximum historical dispersion factor for the receptor of interest from Attachment 2, based on 5 year historical averages derived from the meteorological database

K_i = whole body dose factor for radionuclide "i" (mrem/yr per $\mu\text{Ci}/\text{m}^3$) from Attachment 3

L_i = skin dose factor for radionuclide "i" (mrem/yr per $\mu\text{Ci}/\text{m}^3$) from Attachment 3

1.1 = conversion factor mrem/mrad; converts air dose to skin dose

M_i = gamma air dose factor for radionuclide "i" (mrad/yr per $\mu\text{Ci}/\text{m}^3$) from Attachment 3

\tilde{Q}_i = total release of noble gas radionuclide "i" ($\mu\text{Ci}/\text{sec}$)

c. Liquid and Gaseous Effluent Dose

1. Doses shall be calculated as follows:
 - Dose from liquid effluents per eq 1
 - Dose from radioiodines, tritium, and particulates in gaseous effluents per eq 34
2. For purposes of calculating the dose required by the radiological effluent controls, more realistic assumptions concerning the liquid and gaseous effluent dose pathways shall be used based on the most recent land use census data as well as the latest environmental monitoring information.
 - a) These assumptions may include, but not be limited to:
 - More realistic liquid dilution factors
 - Location and age of actual individuals
 - Site-specific food pathway parameters
 - Documentation of true food consumption
 - b) Other assumptions may be used provided they may be substantiated by census or direct measurement.

5.4 On-Site Dose to Members of the Public

5.4.1 Access to the Site

- a. Members of the public are occasionally granted access within the site boundary, but only in the owner controlled area up to the protected area boundary.
- b. The most common public access activities are:
 - Tours to the simulator (training building)
 - Law enforcement using the shooting range (most frequent activity)
 - Cattle drives through to adjacent properties
 - Visits by Native Americans to on-site burial grounds (closest to the plant)

5.4.2 Exposure Pathways

- a. Exposure due to liquid releases while on-site is highly unlikely and therefore not addressed.
- b. Exposure due to gaseous releases and direct radiation are credible and therefore are considered.

5.4.3 Dose Calculations

- a. Dose to members of the public during on-site activities will be primarily calculated based on:
 - The duration of the on-site visitation time.
 - The closest proximity to the plant.
- b. For gaseous releases, the doses are calculated per:
 - eq 41 (noble gas total body dose)
 - eq 42 (noble gas skin dose)
 - eq 34 (dose from radioiodines, tritium, C-14, and particulates)
 1. The "Ri" in eq 34:
 - a) Considers only the inhalation and ground plane pathway.
 - b) Excludes the infant age group.

5.4.4 The χ/Q and D/Q values are modified using logarithmic extrapolation from the site boundary (SB) to the on-site location of interest as shown in eq 43 and eq 44:

$$\log\left(\frac{\chi}{Q}\right)_{\text{on-site}} \approx \left(\frac{\log\left(\frac{\chi}{Q}\right)_{\text{SB}} - \log\left(\frac{\chi}{Q}\right)_{\text{loc}}}{\log(\text{dist})_{\text{SB}} - \log(\text{dist})_{\text{loc}}} \right) (\log(\text{dist})_{\text{on-site}} - \log(\text{dist})_{\text{SB}}) + \log\left(\frac{\chi}{Q}\right)_{\text{SB}} \quad (\text{eq 43})$$

$$\log\left(\frac{D}{Q}\right)_{\text{on-site}} \approx \left(\frac{\log\left(\frac{D}{Q}\right)_{\text{SB}} - \log\left(\frac{D}{Q}\right)_{\text{loc}}}{\log(\text{dist})_{\text{SB}} - \log(\text{dist})_{\text{loc}}} \right) (\log(\text{dist})_{\text{on-site}} - \log(\text{dist})_{\text{SB}}) + \log\left(\frac{D}{Q}\right)_{\text{SB}} \quad (\text{eq 44})$$

- a. Based on Reg. Guide 1.111, these equations may be expected to provide reasonable dispersion and deposition estimates for distances as close as 200 meters.
- b. Determination of direct radiation dose from the reactor units and from outside storage tanks, storage building, and the ISFSI may be made by:
 - Direct survey measurements.
 - Derived from environmental TLD data.
 - Calculated by shielding code.
- c. A distance of 200 meters from the plant (both units) equidistant from the plant vent is arbitrarily selected as the closest perimeter for which on-site doses will be calculated.

5.4.5 On-Site Locations

- a. The activities of the members-of-the-public while on-site (described in step 5.4.1) are at or beyond 200 meters.
- b. Table 3 details the types of on-site activities that members-of-the-public might be expected to participate in at DCP.
- c. The sectors and closest distances in which they may visit as well as expected visitation duration are also shown (based on security section information).

Table 3: Expected On-Site Distances and Visitation Times for Members of the Public			
On-Site Member of the Public	Sector of Visitation	Closest Point of Approach to the Plant	Average Expected Visitation (Time per Year)
Law enforcement at shooting range	SE	700m	208 hours
<u>Tour Participants</u>			
Simulator Bldg	S (SE)	310m	4 hours
Overlook	E	210m	1 hour
Native Americans at burial grounds	NW	200m	96 hours
	NNW	200m	96 hours
Ranch hands driving cattle around site	NW	250m	1 hour
	NNW	350m	1 hour
	N	320m	1 hour
	NNE	450m	1 hour
	NE	630m	1 hour

6. RECORDS

- 6.1 Submit the basis documents generated per CAP A-8 for the following to the Records Management System (RMS) per CY1.DC1, "Analytical Data Processing Responsibilities":
- Meteorological parameters
 - Abnormal discharges documentation
 - Determination of release rate and dose parameters methodology
 - Dose projections

7. REFERENCES

- 7.1 CAP A-5, "Liquid Radwaste Discharge Management"
- 7.2 CAP A-6, "Gaseous Radwaste Discharge Management"
- 7.3 CAP A-8, "Off-Site Dose Calculation," Revision 10 (direct radiation calculation)
- 7.4 CAP D-15, "Steam Generator Leak Rate Determination"
- 7.5 CAP D-19, "Correlation of Rad Monitors of Radioactivity"
- 7.6 CY2.DC1, "Radiation Monitoring System High Alarm Setpoint Control Procedure"
- 7.7 CY2.ID1, "Radiological Effluent and Controls Program"
- 7.8 "Setpoint Calculation for Containment Ventilation Exhaust Monitor," Calc # NSP-1&2-39-44, 10/92 and 11/92 and Action Request (AR) A0430610
- 7.9 AR A0619600, "Rad Effluent Sampling of Ni-63"
- 7.10 AR A0619601, "Include Tc-99M In ODCM and ARER Reports"
- 7.11 License Amendment 67/66, January 22, 1992
- 7.12 NUREG-0172, "Age-Specific Radiation Dose Commitment Factors for a One-Year Chronic Intake," November 1977
- 7.13 NUREG 2919, "Computer Code XOQDOQ," Revision 2, September, 1982
- 7.14 NUREG No. 0133, "Preparation of Radiological Effluent Tech Specs for Nuclear Power Plants," October 1978
- 7.15 NUREG No. 0543, "Methods for Demonstrating LWR Compliance with the EPA Uranium Fuel Cycle Standard 40 CFR 190," January 1980
- 7.16 NUREG/CR-4013, "LADTAP II - Technical Reference and User Guide"
- 7.17 Regulatory Guide 1.109, "Calculation of Annual Doses to Man From Routine Releases of Reactor Effluents for the Purpose of Evaluating Compliance with 10 CFR 50, Appendix I," Rev. 0, March 1976

- 7.18 Regulatory Guide 1.109, "Calculation of Annual Doses to Man From Routine Releases of Reactor Effluents for the Purpose of Evaluating Compliance with 10 CFR 50, Appendix I," Rev. 1, October 1977
- 7.19 Regulatory Guide, 1.111, "Methods for Estimating Atmospheric Transport and Dispersion of Gaseous Effluents in Routine Releases from Light-Water-Cooled Reactors," Rev. 1, July, 1977
- 7.20 Review and Expansion of USNRC Regulatory Guide 1.109 Models for Computing Dose Conversion Factors, F.W. Boone and John M. Palms, Report No. EMP-155, February 1983
- 7.21 "Radioactive Decay Data Tables," David C. Kocher. DOE/TIC-11026, 1981
- 7.22 "Estimation of Carbon-14 in Nuclear Power Plant Gaseous Effluents," EPRI Technical Report 1021106, December 2010
- 7.23 Meteorology Services Report Number 420DC.11.18, April 2011 (XOQDOQ data)
- 7.24 "DRADCALC.xls Computer Program Verification and Validation Report", Revision 0, June 1997

LRW Composite Dose Factors

U1&2 Attachment 1: Page 1 of 3

LRW Composite Dose Factors, A _{io} , for Adults at a Saltwater Site to Organ "o" (mrem/hour per µCi/mL) (1)							
Nuclide	Tot Body	Thyroid	Kidney	Lung	GI-LLI	Bone	Liver
H-3	1.61E-01	1.61E-01	1.61E-01	1.61E-01	1.61E-01	0.00E+00	1.61E-01
Na-24	4.57E-01	4.57E-01	4.57E-01	4.57E-01	4.57E-01	4.57E-01	4.57E-01
Cr-51	5.58E+00	3.34E+00	1.23E+00	7.40E+00	1.40E+03	0.00E+00	0.00E+00
Mn-54	1.35E+03	0.00E+00	2.10E+03	0.00E+00	2.16E+04	0.00E+00	7.06E+03
Mn-56	3.15E+01	0.00E+00	2.26E+02	0.00E+00	5.67E+03	0.00E+00	1.78E+02
Fe-55	8.23E+03	0.00E+00	0.00E+00	1.97E+04	2.03E+04	5.11E+04	3.53E+04
Fe-59	7.27E+04	0.00E+00	0.00E+00	5.30E+04	6.32E+05	8.06E+04	1.90E+05
Co-57	2.36E+02	0.00E+00	0.00E+00	0.00E+00	3.59E+03	0.00E+00	1.42E+02
Co-58	1.35E+03	0.00E+00	0.00E+00	0.00E+00	1.22E+04	0.00E+00	6.03E+02
Co-60	3.82E+03	0.00E+00	0.00E+00	0.00E+00	3.25E+04	0.00E+00	1.73E+03
Ni-63	1.67E+03	0.00E+00	0.00E+00	0.00E+00	7.18E+02	4.96E+04	3.44E+03
Ni-65	1.20E+01	0.00E+00	0.00E+00	0.00E+00	6.65E+02	2.02E+02	2.62E+01
Cu-64	1.01E+02	0.00E+00	5.40E+02	0.00E+00	1.83E+04	0.00E+00	2.14E+02
Zn-65	2.32E+05	0.00E+00	3.43E+05	0.00E+00	3.23E+05	1.61E+05	5.13E+05
Zn-69	4.56E+01	0.00E+00	4.26E+02	0.00E+00	9.85E+01	3.43E+02	6.56E+02
As-76	4.42E+01	0.00E+00	8.72E+01	0.00E+00	0.00E+00	0.00E+00	4.62E+01
Br-82	4.07E+00	0.00E+00	0.00E+00	0.00E+00	4.67E+00	0.00E+00	0.00E+00
Br-84	9.39E-02	0.00E+00	0.00E+00	0.00E+00	7.37E-07	0.00E+00	0.00E+00
Rb-86	2.91E+02	0.00E+00	0.00E+00	0.00E+00	1.23E+02	0.00E+00	6.24E+02
Rb-88	9.49E-01	0.00E+00	0.00E+00	0.00E+00	2.47E-11	0.00E+00	1.79E+00
Rb-89+D	8.34E-01	0.00E+00	0.00E+00	0.00E+00	6.89E-14	0.00E+00	1.19E+00
Sr-89+D	1.43E+02	0.00E+00	0.00E+00	0.00E+00	8.00E+02	4.99E+03	0.00E+00
Sr-90+D	2.83E+03	0.00E+00	0.00E+00	0.00E+00	3.55E+03	1.41E+05	0.00E+00
Sr-91+D	3.71E+00	0.00E+00	0.00E+00	0.00E+00	4.37E+02	9.18E+01	0.00E+00
Sr-92+D	1.51E+00	0.00E+00	0.00E+00	0.00E+00	6.90E+02	3.48E+01	0.00E+00
Y-90	1.63E-01	0.00E+00	0.00E+00	0.00E+00	6.42E+04	6.06E+00	0.00E+00
Y-91m+D	2.22E-03	0.00E+00	0.00E+00	0.00E+00	1.68E-01	5.73E-02	0.00E+00
Y-92	1.56E-02	0.00E+00	0.00E+00	0.00E+00	9.32E+03	5.32E-01	0.00E+00
(1) Dose factors are based on NUREG 0133 methodology.							

LRW Composite Dose Factors

U1&2 Attachment 1: Page 2 of 3

LRW Composite Dose Factors, A _{io} , for Adults at a Saltwater Site to Organ "o" (mrem/hour per µCi/mL) (1)							
Nuclide	Tot Body	Thyroid	Kidney	Lung	GI-LLI	Bone	Liver
Zr-95+D	3.46E+00	0.00E+00	8.02E+00	0.00E+00	1.62E+04	1.59E+01	5.11E+00
Zr-97+D	8.13E-02	0.00E+00	2.68E-01	0.00E+00	5.51E+04	8.81E-01	1.78E-01
Nb-95	1.34E+02	0.00E+00	2.46E+02	0.00E+00	1.51E+06	4.47E+02	2.49E+02
Mo-99+D	2.43E+01	0.00E+00	2.89E+02	0.00E+00	2.96E+02	0.00E+00	1.28E+02
Tc-101	1.88E-01	0.00E+00	3.46E-01	9.81E-03	5.77E-14	1.33E-02	1.92E-02
Ru-103+D	4.60E+01	0.00E+00	4.07E+02	0.00E+00	1.25E+04	1.07E+02	0.00E+00
Ru-105+D	3.51E+00	0.00E+00	1.15E+02	0.00E+00	5.44E+03	8.89E+00	0.00E+00
Ru-106+D	2.01E+02	0.00E+00	3.06E+03	0.00E+00	1.03E+05	1.59E+03	0.00E+00
Ag-110m+D	8.60E+02	0.00E+00	2.85E+03	0.00E+00	5.91E+05	1.56E+03	1.45E+03
Sn-113	3.53E+03	9.85E+02	0.00E+00	0.00E+00	0.00E+00	6.06E+04	1.66E+03
Sn-117m	8.76E+02	2.52E+02	0.00E+00	0.00E+00	0.00E+00	3.02E+03	3.41E+02
Sb-122	6.65E+00	3.09E-01	0.00E+00	1.18E+01	0.00E+00	2.19E+01	4.47E-01
Sb-124	1.09E+02	6.70E-01	0.00E+00	2.15E+02	7.84E+03	2.76E+02	5.22E+00
Sb-125	4.20E+01	1.79E-01	0.00E+00	1.36E+02	1.94E+03	1.77E+02	1.97E+00
Te-125m	2.91E+01	6.51E+01	8.82E+02	0.00E+00	8.66E+02	2.17E+02	7.86E+01
Te-129m+D	1.47E+02	3.20E+02	3.89E+03	0.00E+00	4.69E+03	9.31E+02	3.47E+02
Te-129	6.19E-01	1.95E+00	1.07E+01	0.00E+00	1.92E+00	2.54E+00	9.55E-01
Te-131m+D	5.71E+01	1.08E+02	6.94E+02	0.00E+00	6.80E+03	1.40E+02	6.85E+01
Te-131+D	5.03E-01	1.31E+00	6.99E+00	0.00E+00	2.26E-01	1.59E+00	6.66E-01
Te-132+D	1.24E+02	1.46E+02	1.27E+03	0.00E+00	6.24E+03	2.04E+02	1.32E+02
I-131+D	1.79E+02	1.02E+05	5.35E+02	0.00E+00	8.23E+01	2.18E+02	3.12E+02
I-132	9.96E+00	9.96E+02	4.54E+01	0.00E+00	5.35E+00	1.06E+01	2.85E+01
I-133+D	3.95E+01	1.90E+04	2.26E+02	0.00E+00	1.16E+02	7.45E+01	1.30E+02
I-134	5.40E+00	2.62E+02	2.40E+01	0.00E+00	1.32E-02	5.56E+00	1.51E+01
I-135+D	2.24E+01	4.01E+03	9.75E+01	0.00E+00	6.87E+01	2.32E+01	6.08E+01
Cs-134	1.33E+04	0.00E+00	5.27E+03	1.75E+03	2.85E+02	6.84E+03	1.63E+04
Cs-136	2.04E+03	0.00E+00	1.57E+03	2.16E+02	3.21E+02	7.16E+02	2.83E+03
Cs-137+D	7.85E+03	0.00E+00	4.07E+03	1.35E+03	2.32E+02	8.77E+03	1.20E+04
Cs-138	5.94E+00	0.00E+00	8.81E+00	8.70E-01	5.12E-05	6.07E+00	1.20E+01
(1) Dose factors are based on NUREG 0133 methodology.							

LRW Composite Dose Factors

U1&2 Attachment 1: Page 3 of 3

LRW Composite Dose Factors, A_{io} , for Adults at a Saltwater Site to Organ "o" (mrem/hour per $\mu\text{Ci/mL}$) (1)							
Nuclide	Tot Body	Thyroid	Kidney	Lung	GI-LLI	Bone	Liver
Ba-139	2.30E-01	0.00E+00	5.23E-03	3.17E-03	1.39E+01	7.85E+00	5.59E-03
Ba-140+D	1.08E+02	0.00E+00	7.02E-01	1.18E+00	3.38E+03	1.64E+03	2.06E+00
Ba-141+D	1.29E-01	0.00E+00	2.68E-03	1.63E-03	1.80E-09	3.81E+00	2.88E-03
La-140	2.10E-01	0.00E+00	0.00E+00	0.00E+00	5.83E+04	1.57E+00	7.94E-01
La-142	9.13E-03	0.00E+00	0.00E+00	0.00E+00	2.68E+02	8.06E-02	3.67E-02
Ce-141	2.63E-01	0.00E+00	1.08E+00	0.00E+00	8.86E+03	3.43E+00	2.32E+00
Ce-143+D	4.94E-02	0.00E+00	1.97E-01	0.00E+00	1.67E+04	6.04E-01	4.46E+02
Ce-144+D	9.59E+00	0.00E+00	4.43E+01	0.00E+00	6.04E+04	1.79E+02	7.47E+01
Pr-144	9.64E-04	0.00E+00	4.44E-03	0.00E+00	2.73E-09	1.90E-02	7.87E-03
Nd-147+D	2.74E-01	0.00E+00	2.68E+00	0.00E+00	2.20E+04	3.96E+00	4.58E+00
Pu-238	2.07E+03	0.00E+00	8.87E+03	0.00E+00	8.85E+03	7.62E+04	9.66E+03
Pu-239	2.31E+03	0.00E+00	9.83E+03	0.00E+00	8.07E+03	8.79E+04	1.06E+04
Pu-240	2.31E+03	0.00E+00	9.82E+03	0.00E+00	8.23E+03	8.76E+04	1.05E+04
Pu-241+D	4.01E+01	0.00E+00	1.85E+02	0.00E+00	1.70E+02	1.90E+03	9.03E+01
Pu-242	2.23E+03	0.00E+00	9.46E+03	0.00E+00	7.91E+03	8.13E+04	1.02E+04
U-233+D	1.56E+03	0.00E+00	6.02E+03	0.00E+00	1.86E+03	2.58E+04	0.00E+00
U-234	1.53E+03	0.00E+00	5.90E+03	0.00E+00	1.82E+03	2.48E+04	0.00E+00
U-235+D	1.44E+03	0.00E+00	5.54E+03	0.00E+00	2.31E+03	2.37E+04	0.00E+00
U-236	1.47E+03	0.00E+00	5.66E+03	0.00E+00	1.71E+03	2.37E+04	0.00E+00
U-238+D	1.35E+03	0.00E+00	5.19E+03	0.00E+00	1.63E+03	2.27E+04	0.00E+00
W-187	2.68E+00	0.00E+00	0.00E+00	0.00E+00	2.51E+03	9.16E+00	7.66E+00
Np-239	1.91E-03	0.00E+00	1.08E-02	0.00E+00	7.11E+02	3.53E-02	3.47E-03
(1) Dose factors are based on NUREG 0133 methodology.							

Summary of Land Use Census Evaluation

U1&2 Attachment 2: Page 1 of 1

Sector	Receptor Description	Distance (miles)	X/Q	D/Q	Comments
N	None				No receptors within 5 miles
NNE	Residence + garden	4.4	4.80E-08	7.80E-11	Full-time occupancy Critical receptor ingestion dose assessed at this location
	Residence	3.3	7.40E-08	1.30E-10	Trailer - limited use
	Residence	3.2	7.70E-08	1.40E-10	Cabin - limited use
NE	Residence	4.9	3.30E-08	5.50E-11	Full-time occupancy
ENE	Residence	4.4	3.60E-08	6.50E-11	Full-time occupancy
	Residence	5.0	3.00E-08	5.20E-11	Full-time occupancy
E	Residence	4.0	5.30E-08	1.30E-10	Cabin - limited use
	Residence	3.7	5.90E-08	1.50E-10	Part-time occupancy
	Residence + garden	4.5	4.50E-08	1.00E-10	Full-time occupancy
ESE	Oat hay farming	3.3	1.80E-07	1.20E-09	Less than 10 farm workers present periodically during growing season. Normally one planting per year.
SE	None				No receptors within 5 miles
SSE	None				Over water
S	None				Over water
SSW	None				Over water
SW	None				Over water
WSW	None				Over water
W	None				Over water
WNW	None				Over water
NW	Highest site boundary dispersion value	0.5	5.30E-06	1.70E-08	Gas effluent dose rates, PRRLs, and HASPs evaluated at this location.
	Residence	1.2	1.20E-06	4.00E-09	Trailer - limited use
	Residence	3.6	2.10E-07	5.80E-10	Full-time occupancy
NNW	Residence	1.5	6.50E-07	2.00E-09	Full-time occupancy (trailer) Critical receptor ground plane and inhalation dose assessed at this location
	Public campground	4.6	1.20E-07	2.70E-10	
	Ranger Station	4.6	1.20E-07	2.70E-10	Occupied during normal work hours

GRW Dose Parameters: Noble Gas Dose Factors

U1&2 Attachment 3: Page 1 of 1

GRW Dose Factors for Noble Gases (mrem/yr per $\mu\text{Ci}/\text{m}^3$) (1)				
Radionuclide	Whole Body Dose Factor, K_i	Skin Dose Factor, L_i	Gamma Air Dose Factor, M_i	Beta Air Dose Factor, N_i
Kr-83m	7.56E-02	----	1.93E+01	2.88E+02
Kr-85m	1.17E+03	1.46E+03	1.23E+03	1.97E+03
Kr-85	1.61E+01	1.34E+03	1.72E+01	1.95E+03
Kr-87	5.92E+03	9.73E+03	6.17E+03	1.03E+04
Kr-88	1.47E+04	2.37E+03	1.52E+04	2.93E+03
Kr-89	1.66E+04	1.01E+04	1.73E+04	1.06E+04
Kr-90	1.56E+04	7.29E+03	1.63E+04	7.83E+03
Xe-131m	9.15E+01	4.76E+02	1.56E+02	1.11E+03
Xe-133m	2.51E+02	9.94E+02	3.27E+02	1.48E+03
Xe-133	2.94E+02	3.06E+02	3.53E+02	1.05E+03
Xe-135m	3.12E+03	7.11E+02	3.36E+03	7.39E+02
Xe-135	1.81E+03	1.86E+03	1.92E+03	2.46E+03
Xe-137	1.42E+03	1.22E+04	1.51E+03	1.27E+04
Xe-138	8.83E+03	4.13E+03	9.21E+03	4.75E+03
Ar-41	8.84E+03	2.69E+03	9.30E+03	3.28E+03

(1) From Table B-1 of Regulatory Guide 1.109 (Rev. 1, Oct. 1977)

Child Inhalation Pathway Dose Factors for Worst Case Organ

Radionuclide	P_i^w
H-3	6.40E+02
Cr-51	1.70E+04
Mn-54	1.58E+06
Fe-59	1.27E+06
Co-58	1.11E+06
Co-60	7.07E+06
Zn-65	9.95E+05
Rb-86	1.98E+05
Sr-89	2.16E+06
Y-90	2.68E+05
Sr-90	3.85E+07
Zr-95	2.23E+06
Nb-95	6.14E+05
Ru-103	6.62E+05
Ru-106	1.43E+07
Ag-110M	5.48E+06
Sb-124	3.24E+06
Sb-125	2.32E+06
Te-129M	1.76E+06
I-131	1.62E+07
I-133	3.85E+06
Cs-134	1.01E+06
Cs-136	1.71E+05
Cs-137	9.07E+05
Ba-140	1.74E+06
Ce-141	5.44E+05
Ce-144	1.20E+07
Nd-147	3.28E+05

GRW Dose Parameters: Ground Plane Dose Factors

U1&2 Attachment 5: Page 1 of 1

Ground Plane Dose Factors GRW Dose Parameters, $R_{i,GP}$, for Radioiodines, Radioactive Particulates, and any Radionuclide other than Noble Gas (IPT), Gaseous Effluents (GRW), any Age Group, Ground Plane Pathway (mrem/yr per $\mu\text{Ci}/(\text{sec m}^2)$) (1)							
Nuclide	Bone	Liver	T Body	Thyroid	Kidney	Lung	GI-LLI
H-3	0.00E+00	0.00E+00	0.00E+00	0.00E+00	0.00E+00	0.00E+00	0.00E+00
C-14	0.00E+00	0.00E+00	0.00E+00	0.00E+00	0.00E+00	0.00E+00	0.00E+00
Cr-51	4.65E+06	4.65E+06	4.65E+06	4.65E+06	4.65E+06	4.65E+06	4.65E+06
Mn-54	1.38E+09	1.38E+09	1.38E+09	1.38E+09	1.38E+09	1.38E+09	1.38E+09
Fe-59	2.73E+08	2.73E+08	2.73E+08	2.73E+08	2.73E+08	2.73E+08	2.73E+08
Co-58	3.80E+08	3.80E+08	3.80E+08	3.80E+08	3.80E+08	3.80E+08	3.80E+08
Co-60	2.15E+10	2.15E+10	2.15E+10	2.15E+10	2.15E+10	2.15E+10	2.15E+10
Zn-65	7.46E+08	7.46E+08	7.46E+08	7.46E+08	7.46E+08	7.46E+08	7.46E+08
Rb-86	8.98E+06	8.98E+06	8.98E+06	8.98E+06	8.98E+06	8.98E+06	8.98E+06
Sr-89	2.16E+04	2.16E+04	2.16E+04	2.16E+04	2.16E+04	2.16E+04	2.16E+04
Y-90	4.50E+03	4.50E+03	4.50E+03	4.50E+03	4.50E+03	4.50E+03	4.50E+03
Sr-90	0.00E+00	0.00E+00	0.00E+00	0.00E+00	0.00E+00	0.00E+00	0.00E+00
Zr-95	2.45E+08	2.45E+08	2.45E+08	2.45E+08	2.45E+08	2.45E+08	2.45E+08
Nb-95	1.37E+08	1.37E+08	1.37E+08	1.37E+08	1.37E+08	1.37E+08	1.37E+08
Ru-103	1.08E+08	1.08E+08	1.08E+08	1.08E+08	1.08E+08	1.08E+08	1.08E+08
Ru-106	4.20E+08	4.20E+08	4.20E+08	4.20E+08	4.20E+08	4.20E+08	4.20E+08
Ag-110M	3.45E+09	3.45E+09	3.45E+09	3.45E+09	3.45E+09	3.45E+09	3.45E+09
Sb-124	5.99E+08	5.99E+08	5.99E+08	5.99E+08	5.99E+08	5.99E+08	5.99E+08
Sb-125	2.34E+09	2.34E+09	2.34E+09	2.34E+09	2.34E+09	2.34E+09	2.34E+09
Te-129M	1.98E+07	1.98E+07	1.98E+07	1.98E+07	1.98E+07	1.98E+07	1.98E+07
I-131	1.72E+07	1.72E+07	1.72E+07	1.72E+07	1.72E+07	1.72E+07	1.72E+07
I-133	2.45E+06	2.45E+06	2.45E+06	2.45E+06	2.45E+06	2.45E+06	2.45E+06
Cs-134	6.90E+09	6.90E+09	6.90E+09	6.90E+09	6.90E+09	6.90E+09	6.90E+09
Cs-136	1.51E+08	1.51E+08	1.51E+08	1.51E+08	1.51E+08	1.51E+08	1.51E+08
Cs-137	1.03E+10	1.03E+10	1.03E+10	1.03E+10	1.03E+10	1.03E+10	1.03E+10
Ba-140	2.05E+07	2.05E+07	2.05E+07	2.05E+07	2.05E+07	2.05E+07	2.05E+07
Ce-141	1.37E+07	1.37E+07	1.37E+07	1.37E+07	1.37E+07	1.37E+07	1.37E+07
Ce-144	6.96E+07	6.96E+07	6.96E+07	6.96E+07	6.96E+07	6.96E+07	6.96E+07
Nd-147	8.39E+06	8.39E+06	8.39E+06	8.39E+06	8.39E+06	8.39E+06	8.39E+06
(1) Dose factors are based on NUREG 0133 methodology.							

GRW Dose Parameters for Radioiodines, Radioactive Particulates, and any Radionuclide other than Noble Gas (IPT), Gaseous Effluents (GRW), Infant Age Group, Inhalation Pathway Organ "O" (mrem/yr per $\mu\text{Ci}/\text{m}^3$) $R_{i,\text{Inhal}}$ (1)							
Nuclide	Bone	Liver	T Body	Thyroid	Kidney	Lung	GI-LLI
H-3	0.00E+00	3.68E+02	3.68E+02	3.68E+02	3.68E+02	3.68E+02	3.68E+02
C-14	2.65E+04	5.31E+03	5.31E+03	5.31E+03	5.31E+03	5.31E+03	5.31E+03
Cr-51	0.00E+00	0.00E+00	8.95E+01	5.75E+01	1.32E+01	1.28E+04	3.57E+02
Mn-54	0.00E+00	2.53E+04	4.98E+03	0.00E+00	4.98E+03	1.00E+06	7.06E+03
Fe-59	1.36E+04	2.35E+04	9.48E+03	0.00E+00	0.00E+00	1.02E+06	2.48E+04
Co-58	0.00E+00	1.22E+03	1.82E+03	0.00E+00	0.00E+00	7.77E+05	1.11E+04
Co-60	0.00E+00	8.02E+03	1.18E+04	0.00E+00	0.00E+00	4.51E+06	3.19E+04
Zn-65	1.93E+04	6.26E+04	3.11E+04	0.00E+00	3.25E+04	6.47E+05	5.14E+04
Rb-86	0.00E+00	1.90E+05	8.82E+04	0.00E+00	0.00E+00	0.00E+00	3.04E+03
Sr-89	3.98E+05	0.00E+00	1.14E+04	0.00E+00	0.00E+00	2.03E+06	6.40E+04
Y-90	3.29E+03	0.00E+00	8.82E+01	0.00E+00	0.00E+00	2.69E+05	1.04E+05
Sr-90	1.55E+07	0.00E+00	3.12E+05	0.00E+00	0.00E+00	1.12E+07	1.31E+05
Zr-95	1.15E+05	2.79E+04	2.03E+04	0.00E+00	3.11E+04	1.75E+06	2.17E+04
Nb-95	1.57E+04	6.43E+03	3.78E+03	0.00E+00	4.72E+03	4.79E+05	1.27E+04
Ru-103	2.02E+03	0.00E+00	6.79E+02	0.00E+00	4.24E+03	5.52E+05	1.61E+04
Ru-106	8.68E+04	0.00E+00	1.09E+04	0.00E+00	1.07E+05	1.16E+07	1.64E+05
Ag-110M	9.98E+03	7.22E+03	5.00E+03	0.00E+00	1.09E+04	3.67E+06	3.30E+04
Sb-124	3.79E+04	5.56E+02	1.20E+04	1.01E+02	0.00E+00	2.65E+06	5.91E+04
Sb-125	5.17E+04	4.77E+02	1.09E+04	6.23E+01	0.00E+00	1.64E+06	1.47E+04
Te-129M	1.41E+04	6.09E+03	2.23E+03	5.47E+03	3.18E+04	1.68E+06	6.90E+04
I-131	3.79E+04	4.44E+04	1.96E+04	1.48E+07	5.18E+04	0.00E+00	1.06E+03
I-133	1.32E+04	1.92E+04	5.60E+03	3.56E+06	2.24E+04	0.00E+00	2.16E+03
Cs-134	3.96E+05	7.03E+05	7.45E+04	0.00E+00	1.90E+05	7.97E+04	1.33E+03
Cs-136	4.83E+04	1.35E+05	5.29E+04	0.00E+00	5.64E+04	1.18E+04	1.43E+03
Cs-137	5.49E+05	6.12E+05	4.55E+04	0.00E+00	1.72E+05	7.13E+04	1.33E+03
Ba-140	5.60E+04	5.60E+01	2.90E+03	0.00E+00	1.34E+01	1.60E+06	3.84E+04
Ce-141	2.77E+04	1.67E+04	1.99E+03	0.00E+00	5.25E+03	5.17E+05	2.16E+04
Ce-144	3.19E+06	1.21E+06	1.76E+05	0.00E+00	5.38E+05	9.84E+06	1.48E+05
Nd-147	7.94E+03	8.13E+03	5.00E+02	0.00E+00	3.15E+03	3.22E+05	3.12E+04
(1) Dose factors are based on NUREG 0133 methodology.							

GRW Dose Parameters for Radioiodines, Radioactive Particulates, and any Radionuclide other than Noble Gas (IPT), Gaseous Effluents (GRW), Child Age Group, Inhalation Pathway Organ "O" (mrem/yr per $\mu\text{Ci}/\text{m}^3$) $R_{i,\text{Inhal}}$ (1)							
Nuclide	Bone	Liver	T Body	Thyroid	Kidney	Lung	GI-LLI
H-3	0.00E+00	6.40E+02	6.40E+02	6.40E+02	6.40E+02	6.40E+02	6.40E+02
C-14	3.59E+04	6.73E+03	6.73E+03	6.73E+03	6.73E+03	6.73E+03	6.73E+03
Cr-51	0.00E+00	0.00E+00	1.54E+02	8.55E+01	2.43E+01	1.70E+04	1.08E+03
Mn-54	0.00E+00	4.29E+04	9.51E+03	0.00E+00	1.00E+04	1.58E+06	2.29E+04
Fe-59	2.07E+04	3.34E+04	1.67E+04	0.00E+00	0.00E+00	1.27E+06	7.07E+04
Co-58	0.00E+00	1.77E+03	3.16E+03	0.00E+00	0.00E+00	1.11E+06	3.44E+04
Co-60	0.00E+00	1.31E+04	2.26E+04	0.00E+00	0.00E+00	7.07E+06	9.62E+04
Zn-65	4.26E+04	1.13E+05	7.03E+04	0.00E+00	7.14E+04	9.95E+05	1.63E+04
Rb-86	0.00E+00	1.98E+05	1.14E+05	0.00E+00	0.00E+00	0.00E+00	7.99E+03
Sr-89	5.99E+05	0.00E+00	1.72E+04	0.00E+00	0.00E+00	2.16E+06	1.67E+05
Y-90	4.11E+03	0.00E+00	1.11E+02	0.00E+00	0.00E+00	2.62E+05	2.68E+05
Sr-90	3.85E+07	0.00E+00	7.66E+05	0.00E+00	0.00E+00	1.48E+07	3.43E+05
Zr-95	1.90E+05	4.18E+04	3.70E+04	0.00E+00	5.96E+04	2.23E+06	6.11E+04
Nb-95	2.35E+04	9.18E+03	6.55E+03	0.00E+00	8.62E+03	6.14E+05	3.70E+04
Ru-103	2.79E+03	0.00E+00	1.07E+03	0.00E+00	7.03E+03	6.62E+05	4.48E+04
Ru-106	1.36E+05	0.00E+00	1.69E+04	0.00E+00	1.84E+05	1.43E+07	4.29E+05
Ag-110M	1.69E+04	1.14E+04	9.14E+03	0.00E+00	2.12E+04	5.48E+06	1.00E+05
Sb-124	5.74E+04	7.40E+02	2.00E+04	1.26E+02	0.00E+00	3.24E+06	1.64E+05
Sb-125	9.84E+04	7.59E+02	2.07E+04	9.10E+01	0.00E+00	2.32E+06	4.03E+04
Te-129M	1.92E+04	6.85E+03	3.04E+03	6.33E+03	5.03E+04	1.76E+06	1.82E+05
I-131	4.81E+04	4.81E+04	2.73E+04	1.62E+07	7.88E+04	0.00E+00	2.84E+03
I-133	1.66E+04	2.03E+04	7.70E+03	3.85E+06	3.38E+04	0.00E+00	5.48E+03
Cs-134	6.51E+05	1.01E+06	2.25E+05	0.00E+00	3.30E+05	1.21E+05	3.85E+03
Cs-136	6.51E+04	1.71E+05	1.16E+05	0.00E+00	9.55E+04	1.45E+04	4.18E+03
Cs-137	9.07E+05	8.25E+05	1.28E+05	0.00E+00	2.82E+05	1.04E+05	3.62E+03
Ba-140	7.40E+04	6.48E+01	4.33E+03	0.00E+00	2.11E+01	1.74E+06	1.02E+05
Ce-141	3.92E+04	1.95E+04	2.90E+03	0.00E+00	8.55E+03	5.44E+05	5.66E+04
Ce-144	6.77E+06	2.12E+06	3.61E+05	0.00E+00	1.17E+06	1.20E+07	3.89E+05
Nd-147	1.08E+04	8.73E+03	6.81E+02	0.00E+00	4.81E+03	3.28E+05	8.21E+04
(1) Dose factors are based on NUREG 0133 methodology.							

GRW Dose Parameters for Radioiodines, Radioactive Particulates, and any Radionuclide other than Noble Gas (IPT), Gaseous Effluents (GRW), Teen Age Group, Inhalation Pathway Organ "o" (mrem/yr per $\mu\text{Ci}/\text{m}^3$) $R_{i,\text{inhal}}$ (1)							
Nuclide	Bone	Liver	T Body	Thyroid	Kidney	Lung	GI-LLI
H-3	0.00E+00	7.25E+02	7.25E+02	7.25E+02	7.25E+02	7.25E+02	7.25E+02
C-14	2.60E+04	4.87E+03	4.87E+03	4.87E+03	4.87E+03	4.87E+03	4.87E+03
Cr-51	0.00E+00	0.00E+00	1.35E+02	7.50E+01	3.07E+01	2.10E+04	3.00E+03
Mn-54	0.00E+00	5.11E+04	8.40E+03	0.00E+00	1.27E+04	1.98E+06	6.68E+04
Fe-59	1.59E+04	3.70E+04	1.43E+04	0.00E+00	0.00E+00	1.53E+06	1.78E+05
Co-58	0.00E+00	2.07E+03	2.78E+03	0.00E+00	0.00E+00	1.34E+06	9.52E+04
Co-60	0.00E+00	1.51E+04	1.98E+04	0.00E+00	0.00E+00	8.72E+06	2.59E+05
Zn-65	3.86E+04	1.34E+05	6.24E+04	0.00E+00	8.64E+04	1.24E+06	4.66E+04
Rb-86	0.00E+00	1.90E+05	8.40E+04	0.00E+00	0.00E+00	0.00E+00	1.77E+04
Sr-89	4.34E+05	0.00E+00	1.25E+04	0.00E+00	0.00E+00	2.42E+06	3.71E+05
Y-90	2.98E+03	0.00E+00	8.00E+01	0.00E+00	0.00E+00	2.93E+05	5.59E+05
Sr-90	3.31E+07	0.00E+00	6.66E+05	0.00E+00	0.00E+00	1.65E+07	7.65E+05
Zr-95	1.46E+05	4.58E+04	3.15E+04	0.00E+00	6.74E+04	2.69E+06	1.49E+05
Nb-95	1.86E+04	1.03E+04	5.66E+03	0.00E+00	1.00E+04	7.51E+05	9.68E+04
Ru-103	2.10E+03	0.00E+00	8.96E+02	0.00E+00	7.43E+03	7.83E+05	1.09E+05
Ru-106	9.84E+04	0.00E+00	1.24E+04	0.00E+00	1.90E+05	1.61E+07	9.60E+05
Ag-110M	1.38E+04	1.31E+04	7.99E+03	0.00E+00	2.50E+04	6.75E+06	2.73E+05
Sb-124	4.30E+04	7.94E+02	1.68E+04	9.76E+01	0.00E+00	3.85E+06	3.98E+05
Sb-125	7.38E+04	8.08E+02	1.72E+04	7.04E+01	0.00E+00	2.74E+06	9.92E+04
Te-129M	1.39E+04	6.58E+03	2.25E+03	4.58E+03	5.19E+04	1.98E+06	4.05E+05
I-131	3.54E+04	4.91E+04	2.64E+04	1.46E+07	8.40E+04	0.00E+00	6.49E+03
I-133	1.22E+04	2.05E+04	6.22E+03	2.92E+06	3.59E+04	0.00E+00	1.03E+04
Cs-134	5.02E+05	1.13E+06	5.49E+05	0.00E+00	3.75E+05	1.46E+05	9.76E+03
Cs-136	5.15E+04	1.94E+05	1.37E+05	0.00E+00	1.10E+05	1.78E+04	1.09E+04
Cs-137	6.70E+05	8.48E+05	3.11E+05	0.00E+00	3.04E+05	1.21E+05	8.48E+03
Ba-140	5.47E+04	6.70E+01	3.52E+03	0.00E+00	2.28E+01	2.03E+06	2.29E+05
Ce-141	2.84E+04	1.90E+04	2.17E+03	0.00E+00	8.88E+03	6.14E+05	1.26E+05
Ce-144	4.89E+06	2.02E+06	2.62E+05	0.00E+00	1.21E+06	1.34E+07	8.64E+05
Nd-147	7.86E+03	8.56E+03	5.13E+02	0.00E+00	5.02E+03	3.72E+05	1.82E+05
(1) Dose factors are based on NUREG 0133 methodology.							

GRW Dose Parameters: Adult, Inhalation Pathway

U1&2 Attachment 9: Page 1 of 1

GRW Dose Parameters for Radioiodines, Radioactive Particulates, and any Radionuclide other than Noble Gas (IPT), Gaseous Effluents (GRW), Adult Age Group, Inhalation Pathway Organ "o" (mrem/yr per $\mu\text{Ci}/\text{m}^3$) $R_{i,\text{Inhal}}$ (1)							
Nuclide	Bone	Liver	T Body	Thyroid	Kidney	Lung	GI-LLI
H-3	0.00E+00	7.18E+02	7.18E+02	7.18E+02	7.18E+02	7.18E+02	7.18E+02
C-14	1.82E+04	3.41E+03	3.41E+03	3.41E+03	3.41E+03	3.41E+03	3.41E+03
Cr-51	0.00E+00	0.00E+00	1.00E+02	5.95E+01	2.28E+01	1.44E+04	3.32E+03
Mn-54	0.00E+00	3.96E+04	6.30E+03	0.00E+00	9.84E+03	1.40E+06	7.74E+04
Fe-59	1.18E+04	2.78E+04	1.06E+04	0.00E+00	0.00E+00	1.02E+06	1.88E+05
Co-58	0.00E+00	1.58E+03	2.07E+03	0.00E+00	0.00E+00	9.28E+05	1.06E+05
Co-60	0.00E+00	1.15E+04	1.48E+04	0.00E+00	0.00E+00	5.97E+06	2.85E+05
Zn-65	3.24E+04	1.03E+05	4.66E+04	0.00E+00	6.90E+04	8.64E+05	5.34E+04
Rb-86	0.00E+00	1.35E+05	5.90E+04	0.00E+00	0.00E+00	0.00E+00	1.66E+04
Sr-89	3.04E+05	0.00E+00	8.72E+03	0.00E+00	0.00E+00	1.40E+06	3.50E+05
Y-90	2.09E+03	0.00E+00	5.61E+01	0.00E+00	0.00E+00	1.70E+05	5.06E+05
Sr-90	2.87E+07	0.00E+00	5.77E+05	0.00E+00	0.00E+00	9.60E+06	7.22E+05
Zr-95	1.07E+05	3.44E+04	2.33E+04	0.00E+00	5.42E+04	1.77E+06	1.50E+05
Nb-95	1.41E+04	7.82E+03	4.21E+03	0.00E+00	7.74E+03	5.05E+05	1.04E+05
Ru-103	1.53E+03	0.00E+00	6.58E+02	0.00E+00	5.83E+03	5.05E+05	1.10E+05
Ru-106	6.91E+04	0.00E+00	8.72E+03	0.00E+00	1.34E+05	9.36E+06	9.12E+05
Ag-110M	1.08E+04	1.00E+04	5.94E+03	0.00E+00	1.97E+04	4.63E+06	3.02E+05
Sb-124	3.12E+04	5.89E+02	1.24E+04	7.55E+01	0.00E+00	2.48E+06	4.06E+05
Sb-125	5.34E+04	5.95E+02	1.26E+04	5.40E+01	0.00E+00	1.74E+06	1.01E+05
Te-129M	9.76E+03	4.67E+03	1.58E+03	3.44E+03	3.66E+04	1.16E+06	3.83E+05
I-131	2.52E+04	3.58E+04	2.05E+04	1.19E+07	6.13E+04	0.00E+00	6.28E+03
I-133	8.64E+03	1.48E+04	4.52E+03	2.15E+06	2.58E+04	0.00E+00	8.88E+03
Cs-134	3.73E+05	8.48E+05	7.28E+05	0.00E+00	2.87E+05	9.76E+04	1.04E+04
Cs-136	3.90E+04	1.46E+05	1.10E+05	0.00E+00	8.56E+04	1.20E+04	1.17E+04
Cs-137	4.78E+05	6.21E+05	4.28E+05	0.00E+00	2.22E+05	7.52E+04	8.40E+03
Ba-140	3.90E+04	4.90E+01	2.57E+03	0.00E+00	1.67E+01	1.27E+06	2.18E+05
Ce-141	1.99E+04	1.35E+04	1.53E+03	0.00E+00	6.26E+03	3.62E+05	1.20E+05
Ce-144	3.43E+06	1.43E+06	1.84E+05	0.00E+00	8.48E+05	7.78E+06	8.16E+05
Nd-147	5.27E+03	6.10E+03	3.65E+02	0.00E+00	3.56E+03	2.21E+05	1.73E+05
(1) Dose factors are based on NUREG 0133 methodology.							

GRW Dose Parameters for Radioiodines, Radioactive Particulates, and any Radionuclide other than Noble Gas (IPT), Gaseous Effluents (GRW), Child Age Group, Vegetation Pathway Organ "o" (mrem/yr per $\mu\text{Ci}/(\text{sec m}^2)$) $R_{i,\text{Vegi}}$ (1)							
Nuclide	Bone	Liver	T Body	Thyroid	Kidney	Lung	GI-LLI
H-3 (2)	0.00E+00	2.29E+03	2.29E+03	2.29E+03	2.29E+03	2.29E+03	2.29E+03
C-14 (2)	3.50E+06	7.01E+05	7.01E+05	7.01E+05	7.01E+05	7.01E+05	7.01E+05
Cr-51	0.00E+00	0.00E+00	1.17E+05	6.49E+04	1.77E+04	1.18E+05	6.20E+06
Mn-54	0.00E+00	6.65E+08	1.77E+08	0.00E+00	1.86E+08	0.00E+00	5.58E+08
Fe-59	3.97E+08	6.42E+08	3.20E+08	0.00E+00	0.00E+00	1.86E+08	6.69E+08
Co-58	0.00E+00	6.45E+07	1.97E+08	0.00E+00	0.00E+00	0.00E+00	3.76E+08
Co-60	0.00E+00	3.78E+08	1.12E+09	0.00E+00	0.00E+00	0.00E+00	2.10E+09
Zn-65	8.12E+08	2.16E+09	1.35E+09	0.00E+00	1.36E+09	0.00E+00	3.80E+08
Rb-86	0.00E+00	4.54E+08	2.79E+08	0.00E+00	0.00E+00	0.00E+00	2.92E+07
Sr-89	3.59E+10	0.00E+00	1.03E+09	0.00E+00	0.00E+00	0.00E+00	1.39E+09
Y-90	2.31E+04	0.00E+00	6.18E+02	0.00E+00	0.00E+00	0.00E+00	6.57E+07
Sr-90	1.87E+12	0.00E+00	3.77E+10	0.00E+00	0.00E+00	0.00E+00	1.67E+10
Zr-95	3.86E+06	8.50E+05	7.56E+05	0.00E+00	1.22E+06	0.00E+00	8.86E+08
Nb-95	4.12E+05	1.61E+05	1.15E+05	0.00E+00	1.51E+05	0.00E+00	2.97E+08
Ru-103	1.53E+07	0.00E+00	5.89E+06	0.00E+00	3.86E+07	0.00E+00	3.96E+08
Ru-106	7.45E+08	0.00E+00	9.30E+07	0.00E+00	1.01E+09	0.00E+00	1.16E+10
Ag-110M	3.21E+07	2.17E+07	1.74E+07	0.00E+00	4.04E+07	0.00E+00	2.58E+09
Sb-124	3.52E+08	4.57E+06	1.23E+08	7.78E+05	0.00E+00	1.96E+08	2.20E+09
Sb-125	4.99E+08	3.85E+06	1.05E+08	4.62E+05	0.00E+00	2.78E+08	1.19E+09
Te-129M	8.40E+08	2.35E+08	1.30E+08	2.71E+08	2.47E+09	0.00E+00	1.02E+09
I-131	1.43E+08	1.44E+08	8.17E+07	4.75E+10	2.36E+08	0.00E+00	1.28E+07
I-133	3.52E+06	4.36E+06	1.65E+06	8.09E+08	7.26E+06	0.00E+00	1.76E+06
Cs-134	1.60E+10	2.63E+10	5.55E+09	0.00E+00	8.16E+09	2.93E+09	1.42E+08
Cs-136	8.18E+07	2.25E+08	1.46E+08	0.00E+00	1.20E+08	1.79E+07	7.90E+06
Cs-137	2.39E+10	2.29E+10	3.38E+09	0.00E+00	7.46E+09	2.68E+09	1.43E+08
Ba-140	2.77E+08	2.43E+05	1.62E+07	0.00E+00	7.90E+04	1.45E+05	1.40E+08
Ce-141	6.55E+05	3.27E+05	4.85E+04	0.00E+00	1.43E+05	0.00E+00	4.08E+08
Ce-144	1.27E+08	3.98E+07	6.78E+06	0.00E+00	2.21E+07	0.00E+00	1.04E+10
Nd-147	7.27E+04	5.89E+04	4.56E+03	0.00E+00	3.23E+04	0.00E+00	9.33E+07
(1) Dose factors are based on NUREG 0133 methodology.							
(2) For tritium and carbon-14, the dose parameter units are mrem/yr per $\mu\text{Ci}/\text{m}^3$ for all pathways, and they shall be multiplied by χ/Q .							

GRW Dose Parameters for Radioiodines, Radioactive Particulates, and any Radionuclide other than Noble Gas (IPT), Gaseous Effluents (GRW), Teen Age Group, Vegetation Pathway Organ "o" (mrem/yr per $\mu\text{Ci}/(\text{sec m}^2)$) $R_{i,\text{Vegi}}$ (1)							
Nuclide	Bone	Liver	T Body	Thyroid	Kidney	Lung	GI-LLI
H-3 (2)	0.00E+00	1.47E+03	1.47E+03	1.47E+03	1.47E+03	1.47E+03	1.47E+03
C-14 (2)	1.45E+06	2.91E+05	2.91E+05	2.91E+05	2.91E+05	2.91E+05	2.91E+05
Cr-51	0.00E+00	0.00E+00	6.16E+04	3.42E+04	1.35E+04	8.79E+04	1.03E+07
Mn-54	0.00E+00	4.54E+08	9.01E+07	0.00E+00	1.36E+08	0.00E+00	9.32E+08
Fe-59	1.79E+08	4.18E+08	1.61E+08	0.00E+00	0.00E+00	1.32E+08	9.89E+08
Co-58	0.00E+00	4.37E+07	1.01E+08	0.00E+00	0.00E+00	0.00E+00	6.02E+08
Co-60	0.00E+00	2.49E+08	5.60E+08	0.00E+00	0.00E+00	0.00E+00	3.24E+09
Zn-65	4.24E+08	1.47E+09	6.86E+08	0.00E+00	9.41E+08	0.00E+00	6.23E+08
Rb-86	0.00E+00	2.75E+08	1.29E+08	0.00E+00	0.00E+00	0.00E+00	4.06E+07
Sr-89	1.51E+10	0.00E+00	4.33E+08	0.00E+00	0.00E+00	0.00E+00	1.80E+09
Y-90	1.24E+04	0.00E+00	3.35E+02	0.00E+00	0.00E+00	0.00E+00	1.02E+08
Sr-90	9.22E+11	0.00E+00	1.84E+10	0.00E+00	0.00E+00	0.00E+00	2.11E+10
Zr-95	1.72E+06	5.44E+05	3.74E+05	0.00E+00	7.99E+05	0.00E+00	1.26E+09
Nb-95	1.93E+05	1.07E+05	5.90E+04	0.00E+00	1.04E+05	0.00E+00	4.58E+08
Ru-103	6.82E+06	0.00E+00	2.91E+06	0.00E+00	2.40E+07	0.00E+00	5.69E+08
Ru-106	3.09E+08	0.00E+00	3.90E+07	0.00E+00	5.97E+08	0.00E+00	1.48E+10
Ag-110M	1.52E+07	1.44E+07	8.73E+06	0.00E+00	2.74E+07	0.00E+00	4.03E+09
Sb-124	1.55E+08	2.85E+06	6.03E+07	3.51E+05	0.00E+00	1.35E+08	3.11E+09
Sb-125	2.14E+08	2.34E+06	5.01E+07	2.05E+05	0.00E+00	1.88E+08	1.67E+09
Te-129M	3.61E+08	1.34E+08	5.72E+07	1.17E+08	1.51E+09	0.00E+00	1.36E+09
I-131	7.68E+07	1.08E+08	5.78E+07	3.14E+10	1.85E+08	0.00E+00	2.13E+07
I-133	1.93E+06	3.28E+06	1.00E+06	4.58E+08	5.75E+06	0.00E+00	2.48E+06
Cs-134	7.10E+09	1.67E+10	7.75E+09	0.00E+00	5.31E+09	2.03E+09	2.08E+08
Cs-136	4.35E+07	1.71E+08	1.15E+08	0.00E+00	9.31E+07	1.47E+07	1.38E+07
Cs-137	1.01E+10	1.35E+10	4.69E+09	0.00E+00	4.59E+09	1.78E+09	1.92E+08
Ba-140	1.38E+08	1.69E+05	8.90E+06	0.00E+00	5.74E+04	1.14E+05	2.13E+08
Ce-141	2.83E+05	1.89E+05	2.17E+04	0.00E+00	8.89E+04	0.00E+00	5.40E+08
Ce-144	5.27E+07	2.18E+07	2.83E+06	0.00E+00	1.30E+07	0.00E+00	1.33E+10
Nd-147	3.67E+04	4.00E+04	2.39E+03	0.00E+00	2.35E+04	0.00E+00	1.44E+08
(1)	Dose factors are based on NUREG 0133 methodology.						
(2)	For tritium and carbon-14, the dose parameter units are mrem/yr per $\mu\text{Ci}/\text{m}^3$ for all pathways, and they shall be multiplied by χ/Q .						

GRW Dose Parameters: Adult, Vegetation Pathway

U1&2 Attachment 12: Page 1 of 1

GRW Dose Parameters for Radioiodines, Radioactive Particulates, and any Radionuclide other than Noble Gas (IPT), Gaseous Effluents (GRW), Adult Age Group, Vegetation Pathway Organ "o" (mrem/yr per $\mu\text{Ci}/(\text{sec m}^2)$) $R_{i,\text{Vegi}}$ (1)							
Nuclide	Bone	Liver	T Body	Thyroid	Kidney	Lung	GI-LLI
H-3 (2)	0.00E+00	1.29E+03	1.29E+03	1.29E+03	1.29E+03	1.29E+03	1.29E+03
C-14 (2)	8.97E+05	1.79E+05	1.79E+05	1.79E+05	1.79E+05	1.79E+05	1.79E+05
Cr-51	0.00E+00	0.00E+00	4.64E+04	2.77E+04	1.02E+04	6.15E+04	1.17E+07
Mn-54	0.00E+00	3.13E+08	5.97E+07	0.00E+00	9.31E+07	0.00E+00	9.58E+08
Fe-59	1.26E+08	2.96E+08	1.13E+08	0.00E+00	0.00E+00	8.27E+07	9.87E+08
Co-58	0.00E+00	3.08E+07	6.90E+07	0.00E+00	0.00E+00	0.00E+00	6.24E+08
Co-60	0.00E+00	1.67E+08	3.69E+08	0.00E+00	0.00E+00	0.00E+00	3.14E+09
Zn-65	3.17E+08	1.01E+09	4.56E+08	0.00E+00	6.75E+08	0.00E+00	6.36E+08
Rb-86	0.00E+00	2.20E+08	1.03E+08	0.00E+00	0.00E+00	0.00E+00	4.34E+07
Sr-89	9.95E+09	0.00E+00	2.86E+08	0.00E+00	0.00E+00	0.00E+00	1.60E+09
Y-90	1.33E+04	0.00E+00	3.57E+02	0.00E+00	0.00E+00	0.00E+00	1.41E+08
Sr-90	6.95E+11	0.00E+00	1.40E+10	0.00E+00	0.00E+00	0.00E+00	1.75E+10
Zr-95	1.18E+06	3.77E+05	2.55E+05	0.00E+00	5.92E+05	0.00E+00	1.20E+09
Nb-95	1.43E+05	7.95E+04	4.27E+04	0.00E+00	7.86E+04	0.00E+00	4.83E+08
Ru-103	4.77E+06	0.00E+00	2.05E+06	0.00E+00	1.82E+07	0.00E+00	5.57E+08
Ru-106	1.93E+08	0.00E+00	2.44E+07	0.00E+00	3.72E+08	0.00E+00	1.25E+10
Ag-110M	1.05E+07	9.75E+06	5.79E+06	0.00E+00	1.92E+07	0.00E+00	3.98E+09
Sb-124	1.04E+08	1.96E+06	4.11E+07	2.52E+05	0.00E+00	8.08E+07	2.95E+09
Sb-125	1.37E+08	1.53E+06	3.25E+07	1.39E+05	0.00E+00	1.05E+08	1.50E+09
Te-129M	2.51E+08	9.37E+07	3.97E+07	8.62E+07	1.05E+09	0.00E+00	1.26E+09
I-131	8.07E+07	1.15E+08	6.62E+07	3.78E+10	1.98E+08	0.00E+00	3.05E+07
I-133	2.08E+06	3.62E+06	1.10E+06	5.32E+08	6.31E+06	0.00E+00	3.25E+06
Cs-134	4.67E+09	1.11E+10	9.08E+09	0.00E+00	3.59E+09	1.19E+09	1.94E+08
Cs-136	4.25E+07	1.68E+08	1.21E+08	0.00E+00	9.33E+07	1.28E+07	1.90E+07
Cs-137	6.36E+09	8.70E+09	5.70E+09	0.00E+00	2.95E+09	9.81E+08	1.68E+08
Ba-140	1.29E+08	1.61E+05	8.42E+06	0.00E+00	5.49E+04	9.24E+04	2.65E+08
Ce-141	1.97E+05	1.33E+05	1.51E+04	0.00E+00	6.19E+04	0.00E+00	5.09E+08
Ce-144	3.29E+07	1.38E+07	1.77E+06	0.00E+00	8.16E+06	0.00E+00	1.11E+10
Nd-147	3.37E+04	3.90E+04	2.33E+03	0.00E+00	2.28E+04	0.00E+00	1.87E+08
(1) Dose factors are based on NUREG 0133 methodology.							
(2) For tritium and carbon-14, the dose parameter units are mrem/yr per $\mu\text{Ci}/\text{m}^3$ for all pathways, and they shall be multiplied by χ/Q .							

Liquid Discharges Monitored for Radioactivity

U1&2 Attachment 13: Page 1 of 1

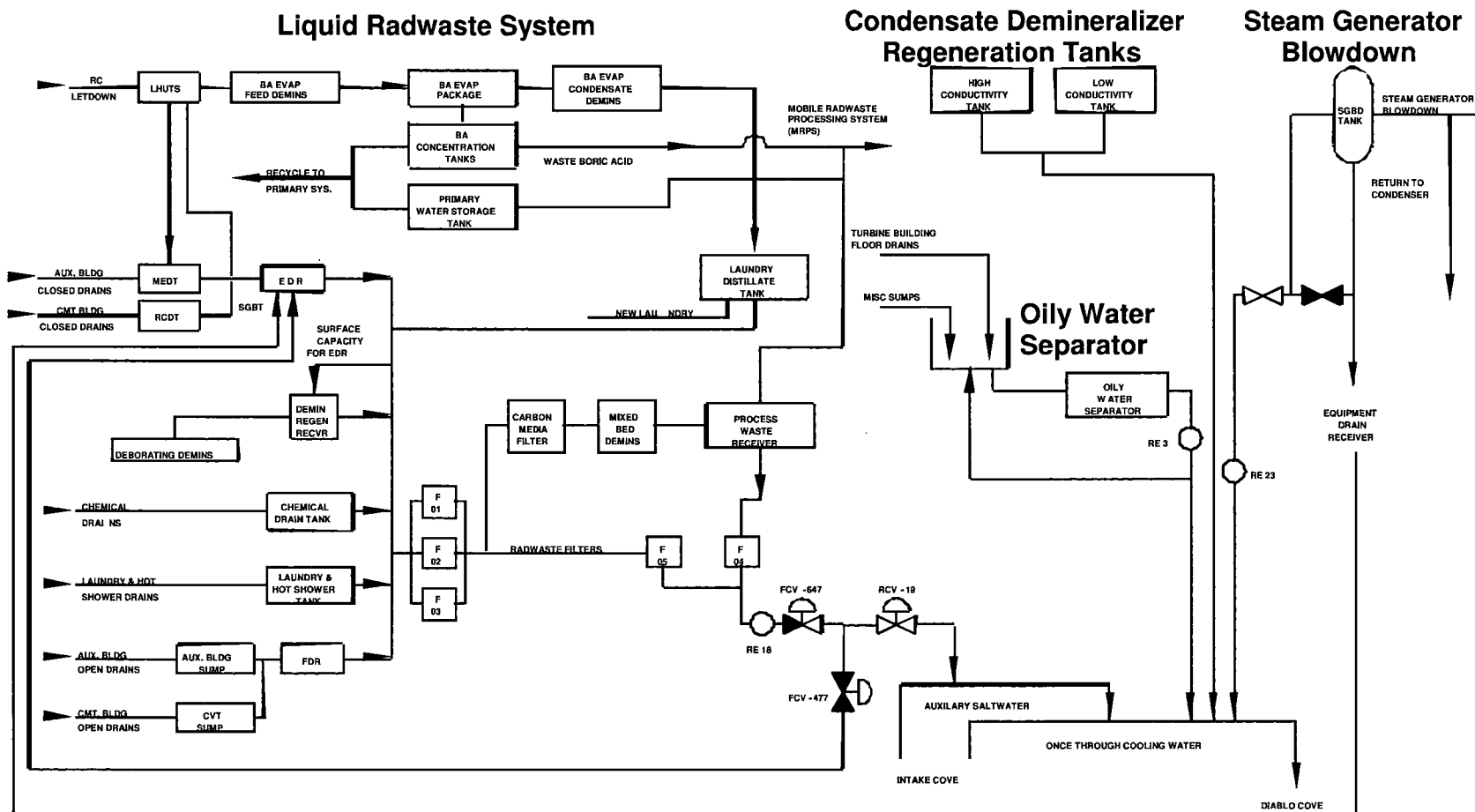

Gaseous Releases Monitored for Radioactivity

U1&2 Attachment 14: Page 1 of 1

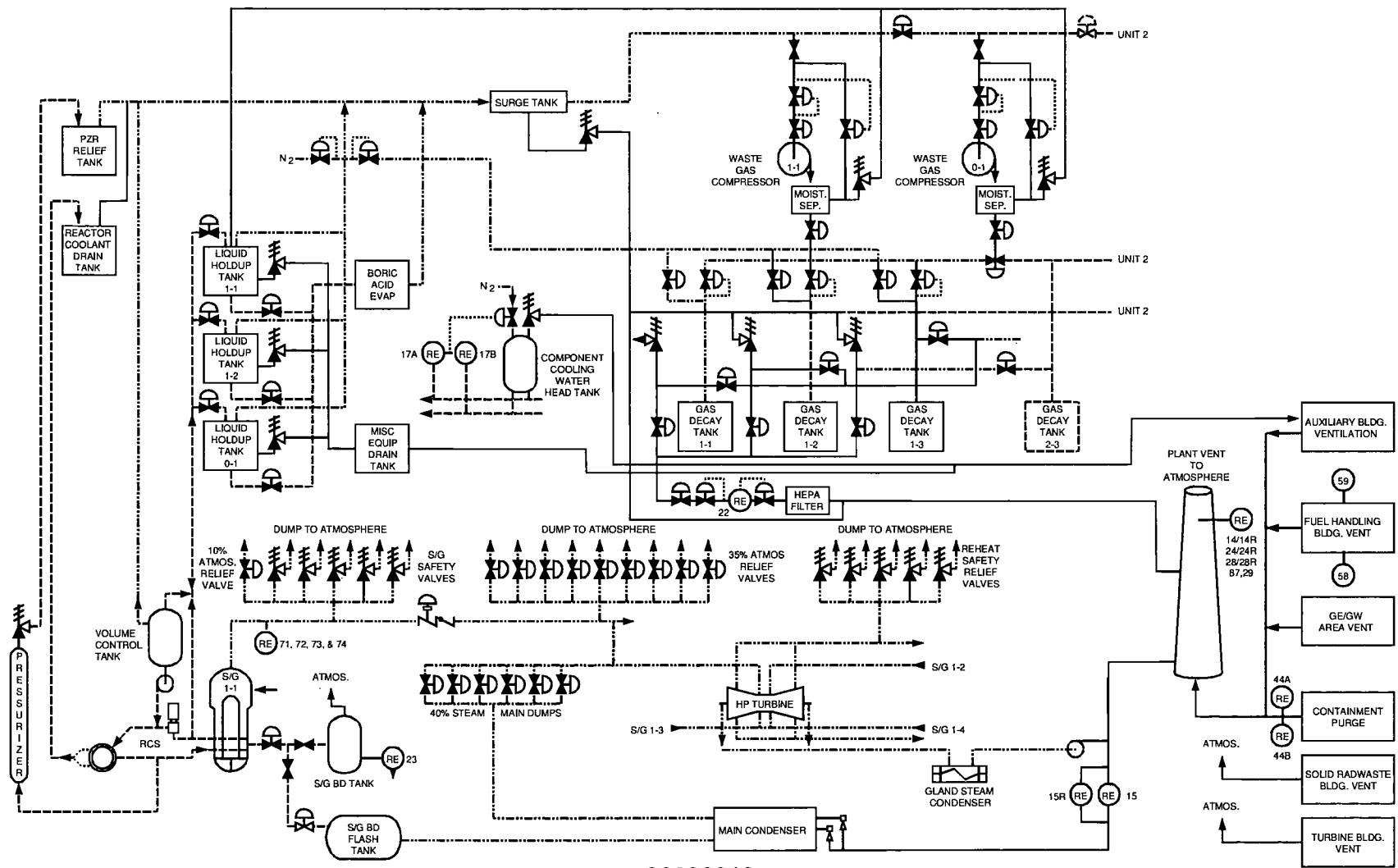

00692319

A N A

Attachment 6

**Diablo Canyon Power Plant Departmental Administrative Procedure,
RP2.DC2, "Radwaste Solidification Process Control Program," Revision 15**

Radwaste Solidification Process Control Program

04/14/09
Effective Date

QUALITY RELATED

Table of Contents

1.	SCOPE	1
2.	DISCUSSION.....	1
3.	DEFINITIONS	2
4.	RESPONSIBILITIES	2
5.	INSTRUCTIONS	3
5.1	General.....	3
5.2	Wet Waste	3
5.3	Oily Waste	6
5.4	Special Cases	6
5.5	Remedial Actions	6
5.6	Vendor Reports ^{T32288}	7
5.7	Vendor Procedures	7
6.	RECORDS.....	8
7.	REFERENCES	8
8.	Major Change to the Solid Radwaste Treatment System Evaluation.....	9

ATTACHMENTS:

1. Form 69-10350, Process Control Program (PCP) Verification, 03/20/09

1. SCOPE

- 1.1 The purpose of the Radwaste Solidification Process Control Program (PCP) is to define the necessary program guidance used at the plant to ensure that activities to solidify wet radioactive waste for disposal, conform to the code of Federal and State regulations and the Waste Burial Site License criteria.

2. DISCUSSION

- 2.1 Solidification is the conversion of wet radioactive wastes into a form that meets shipping and burial ground requirements.
- 2.2 This procedure implements the requirements of 10 CFR 50.36a and General Design Criterion 60 of Appendix A to 10 CFR Part 50. The process parameters included in establishing the PROCESS CONTROL PROGRAM may include, but are not limited to, waste type, waste pH, waste/liquid/SOLIDIFICATION agent/catalyst ratios, waste oil content, waste principal chemical constituents, and mixing and curing times.

-
- 2.3 This procedure contains the individual procedures necessary to perform PCP sample solidifications.
 - 2.4 Cement solidification will not be utilized to stabilize resin or floor drain sludges. Only NRC approved binders, state approved binders or binders submitted for state approval (e.g., Advanced Polymer) may be used to solidify resin or floor drain sludges to meet waste form stability.

3. DEFINITIONS

None

4. RESPONSIBILITIES

- 4.1 The Station Director has overall responsibility for the solid radioactive waste activities and approves changes to the PCP.
- 4.2 Radiation protection manager is responsible for implementing the requirements of this procedure.
- 4.3 Radwaste engineer is responsible for the developing and reviewing procedures relating to the requirements of this procedure.
- 4.4 The radwaste foreman is responsible for the implementing procedures relating to the requirements of this procedure.
- 4.5 Quality is responsible for verifying compliance with the program requirements.

5. INSTRUCTIONS

5.1 General

NOTE: It is the policy of the company to conscientiously apply emphasis and attention to those activities associated with generation, processing, packaging, storage and disposal of radioactive waste generated at the plant and to maintain a high level of assurance that radioactive waste forms meet or exceed the applicable federal and state regulations and the radioactive waste burial site license criteria.

5.1.1 Changes to this program requires submission to the US NRC in the annual Radioactive Effluent Release report for the period in which the changes were made.

5.1.2 Any major change to the solid radwaste treatment system shall be reported to the US NRC in the annual Radioactive Effluent Release report for the period in which the change was approved.

- a. The discussion of each system change shall contain the items listed in Section 8, "Major Change to the Solid Radwaste Treatment System Evaluation."
- b. This information may be submitted as part of the annual FSAR update in lieu of the annual Radioactive Effluent Release report.

5.2 Wet Waste

5.2.1 Liquid/Wet Waste

- a. Liquid/wet wastes shall be processed to a condition meeting shipping and disposal criteria.
 1. These criteria include requirements for immobilization, stability and limits on free standing water (FSW).
 2. Specific instructions on processing and required FSW limits are contained in plant procedures and/or qualified vendor procedures.

5.2.2 Containers, Shipping Casks and Packaging

- a. Solid radioactive waste shall be processed, packaged and shipped per plant procedures and/or qualified vendor procedures.
 1. These procedures provide specific instructions which ensure the container, shipping casks, and packaging methods comply with the applicable code of federal regulations, state regulations and the radioactive waste burial site license criteria.

5.2.3 Shipping and Disposal

- a. Solid radioactive waste shall be prepared, loaded and shipped to a federal and/or state licensed radioactive waste disposal facility (burial ground) per plant procedures and/or qualified vendor procedures.
 - 1. These procedures provide specific instructions which ensure the shipments meet the intended burial site license requirements as well as applicable federal and state regulations.

5.2.4 Specimen Samples

- a. Qualified vendor procedures, approved by the Station Director, shall provide written instructions on sampling, processing and handling waste for the determination of process parameters prior to the actual full scale solidification.
 - 1. These procedures contain the description of the laboratory mixing methods used for specimen sample solidification.

5.2.5 Solidification Process

- a. Qualified vendors used for radioactive waste solidification shall provide a Process Control program and written procedures.
 - 1. These procedures and changes thereto shall be approved by the Station Director prior to use.
 - 2. The vendors shall have an NRC topical report, CRCPD E-5 committee approval or submittal for state approval on the waste forms which will be solidified. These documents should include:
 - a) Description of the solidification process.
 - b) Type of solidification used.
 - c) Process control parameters.
 - d) Parameter boundary conditions.
 - e) Proper waste form properties.
 - f) Specific instructions to ensure the systems are operated within established process parameters.

5.2.6 Sampling Program for Solidification^{T32288}

- a. Vendors, utilized for radioactive waste solidification, shall include in their approved procedures, requirements to sample at least every tenth batch of the same waste type to ensure solidification and to provide actions to be taken if a sample fails to verify solidification.
 1. After a test specimen failure, initial test specimens from three consecutive batches of that waste type must demonstrate solidification before testing requirements of every tenth batch can be resumed.
 2. Verification of such sampling is to be accomplished by completing form 69-10350, "Process Control Program (PCP) Verification."
 3. These forms will be maintained by radiation protection and in the Records Management System (RMS).
 4. These procedures and changes thereto shall be approved by the Station Director prior to use.

5.2.7 Waste Form Verification

Vendors utilized to process wet wastes shall include in their procedures provisions to verify that the solidification and/or FSW criteria in the federal and state regulations and the burial site license are met for the specific type of waste being processed.

5.2.8 Corrective Actions for Free Standing Water

Vendors utilized to process wet wastes shall include in their approved procedures provisions for correcting processed waste in which free standing water in excess of the FSW criteria is detected.

5.2.9 Exothermic Processes

Vendors utilized for radioactive waste solidification that use an exothermic solidification method shall include in their approved procedures:

- a. Waste/binder temperature monitoring to mitigate the consequence of adverse exothermic reactions which may occur in the full scale solidification but might not be noticeable in the specimen tests.
- b. Specific process control parameters that shall be met before capping the container.

5.3 Oily Waste

5.3.1 Oily wastes shall be shipped to off-site processor for treatment.

- a. These processors provide the proper methods to treat oily wastes to comply with federal and state regulations and applicable burial site license criteria.

5.4 Special Cases

<p>NOTE: Based upon previous industry experience, the plant foresees the potential for situations arising that may be beyond existing plant capabilities.</p>
--

5.4.1 Anticipating this possibility, provisions to accommodate such situations in a timely manner by using special techniques or processes are allowed. These special cases shall be controlled as follows:

- a. Implementing procedures shall be developed comparable to those used for normal plant solid waste activities based on the guidance of this PCP and incorporating the applicable provisions for process control and testing.
- b. The implementing procedure shall receive Station Director approval prior to use.
- c. Use of this provision and supporting information shall be included in the next annual Radioactive Effluent Release report to the NRC.

5.5 Remedial Actions

5.5.1 For waste forms which do not meet federal, state and burial site regulations and requirements, suspension of shipment of the inadequately processed waste and correction of the PCP, procedures or processing equipment shall be performed as necessary to prevent recurrence.

5.5.2 For waste forms not prepared per the PCP, testing of the waste to verify shipping and burial site requirements shall be performed and appropriate administrative action taken to prevent recurrence.

5.6 Vendor Reports^{T32288}

- 5.6.1 The following is located in vendor binder TK 9400/ES-1 maintained by the RP radwaste engineer.
- a. US DOE Waste Form Report INEEL/EXT-04-01501, Low-Level Waste Form Qualification Testing of the NUKEM Macro encapsulation Cartridge Filters Waste Form, December 2005.
- 5.6.2 The following is located in vendor binder TK 94001 DTI-1 maintained by the RP radwaste engineer.
- a. US DOE Waste Form Report INEEL/EXT-04-01505, Low-Level Waste Form Qualification Testing of the Diversified Technologies Polymer Waste Form, January 2004.
 - b. US DOE Waste Form Report INEEL/EXT-04-01505 Addendum, Low-Level Waste Form Qualification Testing of the Diversified Technologies Polymer Waste Form - APS ENCAP Application, February 2009.
 - c. Topical Report DTI-VERI-100-NP-A, VERI™ (Vinyl Ester Resin In Situ) Solidification Process for Low-Level Radioactive Waste, Rev 1.
 - d. Topical Report DT-VERI-100-NP-A, Addendum 1, ENCAP Encapsulation Utilizing the VERI Solidification Process.
 - e. Topical Report DNS-RSS-200-NP, The Dow Waste Solidification Process for Low-Level Radioactive Waste (Docket Number WM-82).

5.7 Vendor Procedures

A roster of the currently approved vendor Process Control Program procedures is located in NPG Library/Radiation Protection/RadWaste/RW Vendor Waste Form Procedures.

6. RECORDS

- 6.1 Records of PCP specimen results and form 69-10350 shall be submitted to the Records Management System on a shipment basis by container per RCP RW-4.

7. REFERENCES

- 7.1 RP2.DC3, "Radwaste Dewatering Process Control Program"
- 7.2 Cement Encapsulation of Cartridge Filters to Provide Waste Form Stability Basis Document, Rev. 1, PG&E NRS Log 0087
- 7.3 Encapsulation of Cartridge Filters In Vinyl Ester Styrene (VES) to Provide Waste Form Stability Basis Document, Rev. 0, PG&E NRS Log 0072
- 7.4 NRC Information Notice 88-08, Chemical Reactions with Radioactive Waste Solidification Agents
- 7.5 NUREG 0472 and 0473
- 7.6 NUREG-0800, 11.4 US NRC Standard Review Plan Solid Waste Management Systems
- 7.7 Technical Position on Waste Form, Revision 1, US NRC, January 1991
- 7.8 Title 10 Code of Federal Regulations

8. Major Change to the Solid Radwaste Treatment System Evaluation

- 8.1 A summary of the evaluation that led to the determination that the change could be made per 10 CFR 50.59.
- 8.2 Sufficient detailed information to totally support the reason for the change without benefit of additional or supplemental information.
- 8.3 A detailed description of the equipment, components and processes involved and the interfaces with other plant systems.
- 8.4 An evaluation of the change which shows the predicted releases of radioactive materials in liquid and gaseous effluents and/or quantity of solid waste that differ from those previously predicted in the License application and amendments thereto.
- 8.5 An evaluation of the change which shows the expected maximum exposures to a MEMBER OF THE PUBLIC in the UNRESTRICTED AREA and to the general population that differ from those previously estimated in the License application and amendments thereto.
- 8.6 A comparison of the predicted releases of radioactive materials, in liquid and gaseous effluent and in solid waste, to the actual releases for the period prior to when the changes are to be made.
- 8.7 An estimate of the exposure to plant operating personnel as a result of the change.
- 8.8 Documentation of the fact that the change was reviewed and found acceptable.

Attachment 7

**Diablo Canyon Power Plant Departmental Administrative Procedure,
RP2.DC3, "Radwaste Dewatering Process Control Program," Revision 9**

Radwaste Dewatering Process Control Program

10/05/10
Effective Date

QUALITY RELATED

Table of Contents

1.	SCOPE	1
2.	DISCUSSION.....	1
3.	DEFINITIONS	1
4.	RESPONSIBILITIES	2
5.	INSTRUCTIONS	2
5.1	General	2
5.2	Required Specific Instructions for the Dewatering Procedures	3
5.3	General Control Parameters	3
5.4	Reports and HIC Certifications	4
6.	RECORDS	4
7.	REFERENCES	4

1. SCOPE

- 1.1 The purpose of the Radwaste Dewatering Process Control Program is to assure that the waste form resulting from the dewatering of vendor containers meets State and Federal regulations as well as Burial Site Criteria for Free Standing Water (FSW).
- 1.2 This Dewatering Process Control Program applies to all vendor dewatering liners and High Integrity Containers (HICs) containing ion exchange and filter media.

2. DISCUSSION

- 2.1 The dewatering system consists of a pump with necessary hoses for connection to the liner or HIC and to the plant interface piping. Liners or HICs supplied by a vendor are preassembled with a hub and/or lateral assembly for dewatering retention of media. Procedures for dewatering are dependent on the waste media to be dewatered and/or the container type.
- 2.2 These procedures, specific to the container and waste material, provide instruction for the pumping and settling time sequences as well as; pump rate, total times pumped, and acceptance criteria. Additional contingencies are provided for vessels or liners requiring further steps to meet acceptance criteria and the means of verification of compliance. Methods for recording container and dewatering data are included in the specific procedures.

3. DEFINITIONS

None

4. **RESPONSIBILITIES**

- 4.1 The Station Director shall approve changes to this program.
- 4.2 The radwaste engineer is responsible for developing and reviewing procedures relating to the requirements of this program.
- 4.3 The radwaste foreman is responsible for implementing the procedures relating to the requirements of this program.
- 4.4 Quality organization is responsible for verifying compliance with the quality requirements of the dewatering procedures.

5. **INSTRUCTIONS**

5.1 General

- 5.1.1 In order to stabilize a dewatered wet waste an NRC approved HIC may be utilized.
- 5.1.2 Polyethylene HICs which are approved by the disposal site state may be used to provide waste stability provided they are disposed of in a concrete overpack as a compensatory measure for their structural deficiency.
- 5.1.3 Changes to the Dewatering Control Program which affect any waste form parameters (e.g., type of HIC) require submission to the US NRC in the annual Radioactive Effluent Release report for the period in which the changes were made.
- 5.1.4 Any container of dewatered ion exchange media placed in interim storage shall undergo a dewatering verification prior to shipment for disposal.
- 5.1.5 No NRC topical or vendor dewatering test report for spent cartridge filters currently exists. Spent cartridge filters may be loaded into HICs and dewatered for storage.
 - a. These containers shall not be shipped for disposal prior to encapsulation of the contents or dewatering by an as yet to be determined verifiable process to meet free standing water criteria.
- 5.1.6 The Dewatering Control Program consists of:
 - Dewatering test reports
 - HIC certifications
 - Dewatering procedures
 - a. Changes to the Dewatering Control Program shall be approved by the Station Director.

5.2 Required Specific Instructions for the Dewatering Procedures

- 5.2.1 Pumping time cycles.
- 5.2.2 Pump rate.
- 5.2.3 Total time to be pumped.
- 5.2.4 Temperature monitoring.
- 5.2.5 Acceptance criteria of FSW.
- 5.2.6 Pressure monitoring when gas generation is suspected.^{T34960}
- 5.2.7 Documentation and records of dewatering activities.
- 5.2.8 These procedures shall also specify the type of container and waste media that may be dewatered.
 - a. Contingencies shall be provided for additional steps that may be necessary to meet FSW criteria.
- 5.2.9 A roster of the currently approved vendor dewatering procedures is located in NPG Library/Radiation Protection/RadWaste/RW Vendor Procedures.doc.

5.3 General Control Parameters

- 5.3.1 Carbon steel liners for direct disposal at Clive, UT shall not to be loaded with material that exceeds Class A after concentration averaging.
- 5.3.2 Waste temperature should be monitored to mitigate exothermic chemical reactions which are possible when dewatering organic ion exchange materials used for chemical decontamination.
- 5.3.3 At the end of the appropriate pump cycle a measurement of displaced liquid shall be made for containers sent directly to disposal.
- 5.3.4 Records shall be maintained for all dewatered containers prior to shipment.
 - a. Copies shall be delivered to the radwaste foreman for indexing with radwaste container paper work.

5.4 Reports and HIC Certifications

- 5.4.1 The following are located in vendor binder TK 9400/ES-1 maintained by the RP radwaste engineer.
- a. Test Report: Scientific Ecology Group, Inc. EN-005, Summary Test Report for Dewatering Tests on Durasil 70, DT-80 and other media Dewatering Testing, Rev. C.
 - b. State of South Carolina Department of Health and Environmental Control, Certificate of Compliance - High Integrity Container.
 1. Certification Number DHEC-PL-010
- 5.4.2 The following is located in vendor binder TK 94001/DTI-2 maintained by the RP radwaste engineer.
- a. Diversified Technologies, High Velocity Vacuum (HVV) Dewatering Test Report, Rev 1.
 - b. Diversified Technology Services, Process Control Parameters PCP-02, High Velocity Vacuum (HVV) Dewatering, Rev 0, 08/16/90.

6. RECORDS

- 6.1 Records of dewatering activities shall be submitted to the Records Management System by container per RCP RW-4.

7. REFERENCES

- 7.1 RCP RW-4, "Solid Radioactive Waste Shipment"
- 7.2 NRC Information Notice No. 83-14: Dewatered Spent Ion Exchange Resin Susceptibility to Exothermic Chemical Reaction
- 7.3 NRC Information Notice No. 89-27: Limitations on the Use of Waste Forms and High Integrity Containers for the Disposal of Low-Level Radioactive Waste
- 7.4 NRC Information Notice No. 90-50: Minimization of Methane Gas in Plant Systems and Radwaste Shipping Containers
- 7.5 Polyethylene HIC and Concrete Overpack Disposal Basis Document, Rev 1, PG&E NRS Log 0041

Attachment 8

2014 DCPD Land Use Census

2014 DCPD Land Use Census

Diablo Canyon Power Plant (DCPP) was owned and operated by Pacific Gas & Electric (PG&E) Company. PG&E owned and provided environmental stewardship to approximately 14 miles of Pacific Ocean coastline and approximately 13,000 acres surrounding the 1,000 acre DCPP site. The PG&E property extended roughly from Avila Beach to Montana de Oro State Park. DCPP was located approximately seven miles WNW of Avila Beach and approximately four miles SSE of Montana de Oro State Park.

Diablo Canyon Power Plant (DCPP) Radiological Environmental Monitoring Program (REMP) personnel conducted a land use census in the vicinity of DCPP for 2014. The land use census was based on Nuclear Regulatory Commission (NRC) Regulatory Guide 4.8, "Environmental Technical Specifications for Nuclear Power Plants". The land use census also provided compliance with 10 CFR 50 Appendix I Section IV (B)(3); "Identify changes in the use of unrestricted areas (e.g., for agricultural purposes) to permit modifications in monitoring programs for evaluating doses to individuals from principal pathways of exposure".

DCPP Program Directive CY2, "Radiological Monitoring and Controls Program" required performance of a land use census. DCPP procedure RP1.ID11, "Environmental Radiological Monitoring Procedure", required identification of the nearest milk animal, nearest residence, and the nearest broadleaf producing garden greater than 50 square meters (500 square feet) in each of the landward meteorological sectors within a radial distance of 8 kilometers (5 miles) of the Unit One Containment (CTMT) structure. A land use census was conducted at least once per year during the growing season (between Feb 15 and Dec 1) for the Diablo Canyon environs.

The 2014 land use census was conducted via a helicopter over-flight and landowner telephone interviews. The helicopter over-flight was conducted on October 3rd, 2014. Telephone interviews were conducted August 26th through November 19th, 2014. Nine individual landowners or tenants were contacted.

Milk:

No milk animals were identified within the first 8 kilometers (5 miles) of any sector.

Residences:

The nearest residence, relative to all sectors, was a small trailer located in the NNW sector about 2.42 kilometers (1.5 miles) from the plant. In 2013, this structure was identified as a small trailer in the NW sector at 1.93 km. This trailer was moved to the newly reported NNW location in 2014. One ranch worker occupied this BLANCHARD trailer approximately 1 day per week (midweek) during the year.

A total of seventeen structures were identified within the 8-kilometer (5-mile) radius of the plant, which were confirmed or appear to have been occupied in 2014. A new structure (5th wheel trailer) was identified in the NNE sector at 5.34 km. Six abandoned structures were identified during the land use census. The nearest residence in each sector was summarized in Table 1.

Gardens:

The land use census identified two household gardens greater than 50 square meters (500 square feet) that produced broadleaf vegetation. The READ garden (REMP station 3C1) was approximately ¼ acre and located in the NNE sector at 7.13 kilometers (4.43 miles). The KOONZE garden (REMP station 6C1) was approximately 500 square feet and located in the E sector at 7.43 kilometers (4.62 miles).

MELLO managed a farm in the ESE sector along the southern site access road coastal plateau. The farm started at approximately 4.8 km (3 mi) and extended to 7.8 km (4.8 mi) from the site. This commercial farm produced no broadleaf vegetation. The farm area was about 100 acres of land with rotational planting. Commercial crops consisted of about 100% cereal grass (oat hay) and straw grass. Less than 10 farm workers periodically occupied this area during the growing season.

Additional Land Use:

It should be noted that the term "site-boundary" referred to the area within a radius of approximately 1.2 km (0.74 mi) from the Unit One CTMT structure. Much of the area outside the site-boundary was routinely used for rotational cattle grazing by five separate cattle operations. For purposes of this land use census, the five cattle ranches were called BLANCHARD, SINSHEIMER, READ, ANDRE, and MELLO.

BLANCHARD did not graze any cattle, goats, or sheep within 8 km (5 miles) of DCPD in 2014 due to extreme drought conditions in San Luis Obispo County. All of BLANCHARD's livestock were located in Cayucos California at "Old Creek Ranch" in 2014.

Additionally, BLANCHARD's livestock were sold under the "Old Creek Ranch" label at local farmer's markets in 2014. "Old Creek Ranch" labeled meats were sampled quarterly by REMP personnel in 2014 for background analytical data trending purposes. The REMP station codes were BCM, BGM, and BSM.

SINSHEIMER had about 100 cattle outside the plant site-boundary in the NNE sector. These cattle were allowed to breed and about 90 calves were sold to mass market in 2014.

READ had about 72 adult cattle and 68 calves outside the plant site-boundary in the NNE sector. About 68 yearling cattle were sold under the "Old Creek Ranch" label at local farmer's markets in 2014. "Old Creek Ranch" labeled meats were sampled quarterly by REMP personnel in 2014 for background analytical data trending purposes.

ANDRE had about 80 cattle outside the plant site-boundary in the ENE sector. About 80 calves were sold to mass market in 2014. ANDRE did not slaughter any cattle in 2014 for personal consumption.

MELLO managed about 800 cattle outside the plant site-boundary in the E, ESE, and SE sectors. Harris Ranch Beef Corporation owned these cattle and sold all of them to mass market in 2014. MELLO did not slaughter any cattle in 2014 for personal consumption.

Two landowners (JOHE and ANDRE) harvested wild game for personal consumption outside the plant site-boundary in the NNE, NE, and ENE sectors. This wild game consisted of approximately two deer per landowner.

There was a California State Park Ranger Office in the NNW sector at 7.48 kilometers (4.65 miles) from the site. Approximately three State Parks staff personnel occupied this office from 1000 to 1500 each day (365 days per year).

There was a public campground (Islay Creek Campground) located in the NNW sector at Montana de Oro State Park at 7.36 kilometers (4.57 miles). This campground was near Spooner's Cove.

Approximately 713,000 people visited Montana de Oro State Park via day-use permit.

Approximately 22,000 people spent the night at Islay Creek Campground.

There was public access to hiking trails at the north and south ends of the PG&E property in 2014.

The Point Buchon Trail was located at the north end of PG&E property and had about 18,000 visitors in 2014. The trail traversed about 3.5 miles of coastline from Coon Creek to Crowbar Canyon. The trail was open to the public for day hikes Thursday thru Monday from approximately 0800-1700. Two to three people from California Land Management occupied the trail head booth near Coon Creek during operational days from 0700 to 1730. This trail was originally opened to the public on July 13, 2007.

The Pecho Coast Trail was located at the south end of PG&E property and had about 3,000 visitors in 2014. The trail was approximately 3.7 miles long and led from the Avila Beach DCPD entrance gate to the Point San Luis Lighthouse property and up the coastline to Rattlesnake Canyon. Access was controlled (via web-site reservation permission only) and conducted by docents. This trail was just slightly outside the 5 mile radius of the site. Pecho Coast Trail hikes were only available on Wednesdays (about 20 people) and Saturdays (about 40 people).

Thirty to forty Port San Luis Lighthouse keepers occupied the lighthouse grounds on Tuesdays, Thursdays, and Saturdays from 0800-1600. Special events were also held at the lighthouse throughout the year (e.g. weddings, fundraisers, reunions, etc). The lighthouse property was owned by the Port San Luis Harbor District.

Groundwater Protection Initiative (GPI) Review:

There were no site construction activities or spills that warranted changes to GPI monitoring frequencies, monitoring locations, contract lab analytical capabilities, or analytical detection thresholds in 2014.

From April to December of 2014, additional Independent Spent Fuel Storage Installation (ISFSI) pad construction occurred. New ISFSI pad locations were excavated to a depth of approximately 15 feet and concrete pads were constructed. Construction activities did not indicate any subsurface aquifers and no groundwater sources were encountered.

There were no changes in on-site or near site groundwater usage. Groundwater beneath the site power block was not used as a source of drinking water.

Additional On-site Information:

The Old Steam Generator Storage Facility (OSGSF) was located within the site-boundary in the ENE sector (68.3 degrees) at 0.99 km (0.61 mi) from Unit One CTMT.

The following plant equipment was placed into the Old Steam Generator Storage Facility for the duration of the plant operating license on the dates indicated below.

- Unit One old steam generators (4 total) : 2/14/2009
- Unit Two old steam generators (4 total) : 3/2/2008
- Unit One old reactor head (1 total) : 10/23/2010
- Unit Two old reactor head (1 total) : 11/6/2009

The on-site Independent Spent Fuel Storage Installation (ISFSI) pad was located within the site-boundary in the ENE sector (58.47 degrees) at 0.36 km (0.22 mi) from Unit One CTMT.

DCPP loaded its first ISFSI dry cask onto the pad on 6/23/2009.

There were no ISFSI (dry cask) loading campaigns in 2014.

Table 1 summarizes the nearest residence location in each meteorological sector.

The Land Use Figure shows the location of the residences and gardens in the vicinity of DCPP.

Table 1
Land Use Census 2014

**Distance in Kilometers (and Miles) from the center point of U-1 CTMT
Nearest Milk Animal, Residence, and Vegetable Garden**

22½ Degree (a) Radial Sector	Nearest Milk Animal	Nearest Residence km (mi)	Residence Azimuth Degree	Nearest Vegetable Garden km (mi)
NW	None	5.76 (3.58)	325.2	None
NNW	None	2.42 (1.5) ^(b)	332.1	None
N	None	None	—	None
NNE	None	5.18 (3.22)	21.5	7.13 (4.4) ^(c)
NE	None	7.94 (4.94)	36.4	None
ENE	None	7.15 (4.45)	63.8	None
E	None	5.97 (3.71)	89.9	7.43 (4.6) ^(d)
ESE	None	None	—	5.31 (3.3) ^(e)
SE	None	None	—	None

Table Notation:

- (a) Sectors not shown contain no land (other than islets not used for the purposes indicated in this table) beyond the site-boundary.
- (b) BLANCHARD trailer is the residence used for critical receptor calculations.
- (c) The READ (station 3C1) vegetable garden is located in the NNE sector and located at the 20.24 azimuth degree. There is also a limited use residence at this location.
- (d) The KOONZE (station 6C1) vegetable garden is located in the E sector and located at the 97.52 azimuth degree. There is also a full time residence at this location.
- (e) The MELLO garden is the commercial farm along the westward side of the site access road; however, it does not produce broadleaf vegetation. This farm extends from 4.8 km to 7.8 km (3 to 4.8 miles) from the plant.

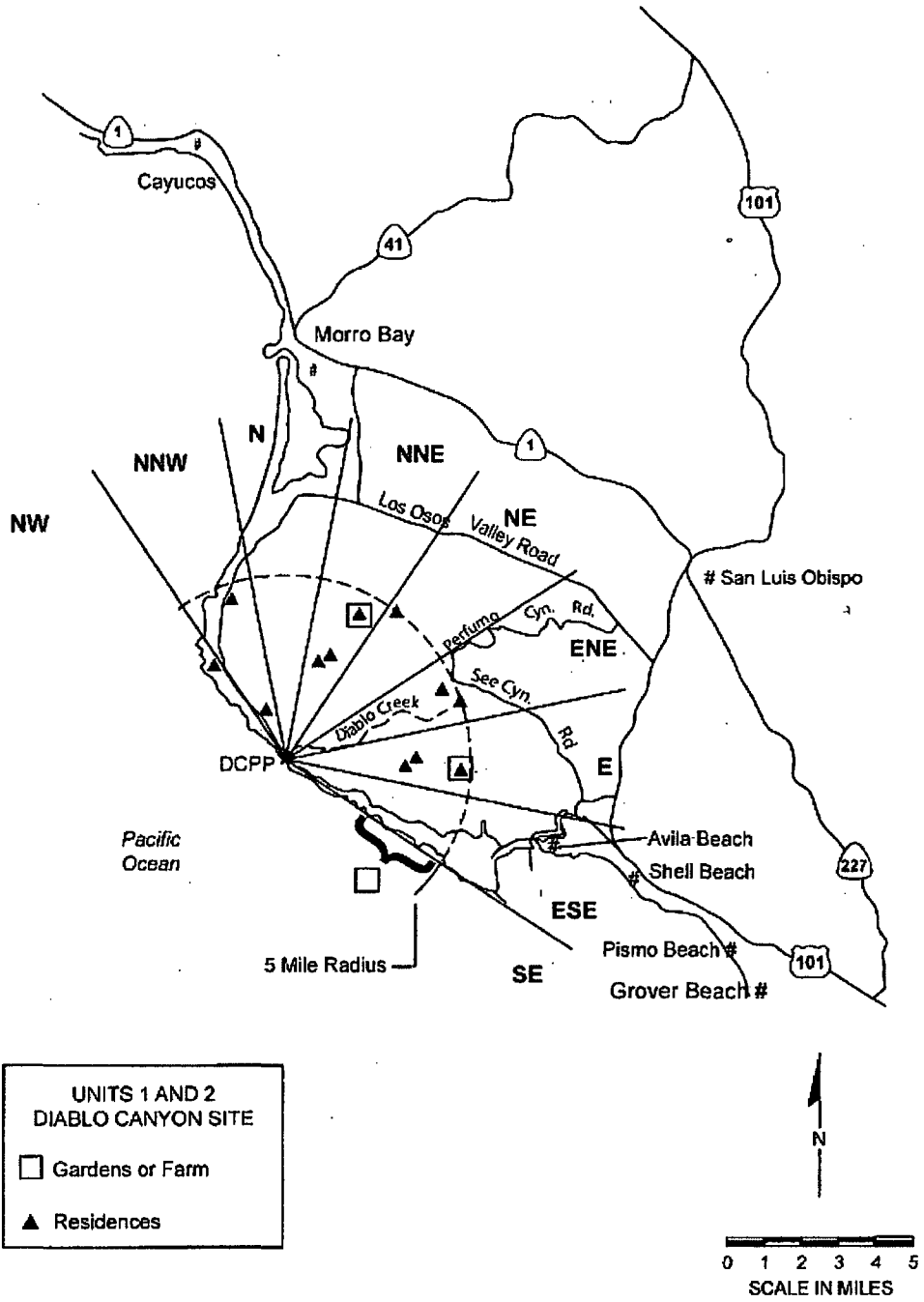

Units 1 and 2 Diablo Canyon Power Plant Land Use Census.

Enclosure 2
Diablo Canyon Power Plant
Meteorological Data

