

Oyster Creek Generating Station
Route 9 South
PO Box 388
Forked River, NJ 08731

www.exeloncorp.com

10 CFR 50.36a(a)(2)
10 CFR 72.44 (d)(3)
Technical Specification 6.9.1.d

RA-11-002

April 30, 2011

U. S. Nuclear Regulatory Commission
Attn: Document Control Desk
Washington, DC 20555 - 0001

Oyster Creek Nuclear Generating Station
Renewed Facility Operating License No. DPR-16
NRC Docket No. 50-219

Independent Spent Fuel Storage Facility
NRC Docket No. 72-15

Subject: Annual Radioactive Effluent Release Report for 2010

Enclosed with this cover letter is the Annual Radioactive Effluent Release Report for the period January 1 to December 31, 2010. This report includes the Oyster Creek Nuclear Generating Station Independent Spent Fuel Storage Facility. One revision (Revision 5) was made to the OCNCS Offsite Dose Calculation Manual during the calendar year 2010 and is enclosed.

If any further information or assistance is needed, please contact Mike Ford, Chemistry Manager, at 609-971-2432.

Sincerely,



Michael J. Massaro
Vice President – Oyster Creek Nuclear Generating Station

Enclosure: 2010 Annual Radioactive Effluent Release Report

cc: Administrator, USNRC Region I (w/o attachment)
USNRC Senior Project Manager, Oyster Creek (w/o attachment)
USNRC Senior Resident Inspector, Oyster Creek (w/o attachment)
Craig Stewart, American Nuclear Insurers
File No. 11002 (w/o attachment)

A009
JE48
LIMSS26

Exelon

Nuclear

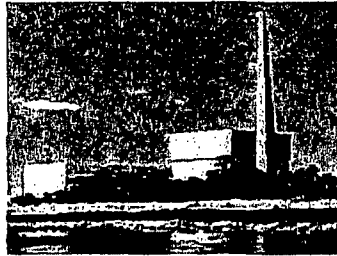

Annual Radioactive Effluent Release Report

2010

Oyster Creek Generating Station

Oyster Creek 2010 Annual Radioactive Effluent Release Report

ANNUAL RADIOACTIVE EFFLUENT RELEASE REPORT

January 1, 2010 through December 31, 2010

EXELON GENERATION COMPANY, LLC

OYSTER CREEK GENERATING STATION

DOCKET NO. 50-219 (Oyster Creek Generating Station)

DOCKET NO. 72-15 (Independent Spent Fuel Storage Facility)

**Submitted to
The United States Nuclear Regulatory Commission
Pursuant to
Renewed Facility Operating License DPR-16**

TABLE OF CONTENTS

SECTION	PAGE
EXECUTIVE SUMMARY	1
1. Introduction	3
2. Supplemental Information	4
A Regulatory Limits	4
B Effluent Concentration Limits	5
C Average Energy	5
D Measurements and Approximations of Total Radioactivity	5
E Batch Releases	9
F Abnormal Releases	9
G Revisions to the ODCM	9
H Radiation Effluent Monitors Out of Service More Than 30 Days	10
I Releases from the Independent Spent Fuel Storage Facility	10
J Program Deviations	11
 Appendix A – Effluent and Waste Disposal Summary	 12
Appendix B – Solid Waste and Irradiated Fuel Shipments	19
Appendix C – Radiological Impact to Man	24
Appendix D – Meteorological Data	27
Appendix E – ODCM Revisions	85
Appendix F – ERRATA	86

Oyster Creek 2010 Annual Facility Effluent Release Report

(Page Intentionally Left Blank)

Oyster Creek 2010 Annual Radioactive Effluent Release Report

EXECUTIVE SUMMARY

Effluents are strictly monitored to ensure that radioactivity released to the environment is as low as reasonably achievable and does not exceed regulatory limits. Effluent control includes the operation of monitoring systems, in-plant and environmental sampling and analyses programs, quality assurance programs for effluent and environmental programs, and procedures covering all aspects of effluent and environmental monitoring.

Both radiological environmental and effluent monitoring indicate that the operation of Oyster Creek Generating Station (OCGS) does not result in significant radiation exposure of the people or the environment surrounding OCGS and is well below the applicable levels set by the Nuclear Regulatory Commission (NRC) and the Environmental Protection Agency (EPA).

There were liquid radioactive effluent releases during 2010 of concentrations of tritium too low to detect at an LLD of 200 picocuries per liter (pCi/L) at the NJPDES permitted main condenser outfall. The releases were part of nearly continuous pumping of groundwater at approximately 70 gpm containing low levels of tritium and no detectable gamma. Exelon and the State of New Jersey Department of Environmental Protection (NJDEP) agreed to this remediation action instead of natural attenuation to address concentrations of tritium in groundwater above the environmental LLD of 2,000 pCi/L. Well 73 and supporting equipment and piping were installed to pump groundwater to the intake structure at the inlet of the main circulating water pumps. Provisions were established for both batch and continuous releases of groundwater. Batch releases started October 21, 2010 and continuous releases commenced on November 17, 2010. Releases continued until the end of 2010 with a total of 4.56E+06 gallons of groundwater pumped resulting in 2.67E-01 Ci of tritium released to the discharge canal. The dose to the most limiting member of the public due to the release of groundwater was 2.55E-06 mrem.

There were no liquid or gaseous abnormal releases during 2010.

The maximum hypothetical calculated organ dose (GI-LLI) from iodines, tritium, carbon-14 (C-14), and particulates to any individual due to gaseous effluents was 4.71E-01 mrem, which was approximately 3.14E+00 percent of the annual limit of 15 mrem. C-14 was included as a principal nuclide for the first time in this report. The relative increase in organ dose from gaseous effluents compared to previous years was due to C-14. The maximum calculated gamma air dose in the UNRESTRICTED AREA due to noble gas effluents was 2.13E-01 mrem, which was 2.13E+00 percent of the annual 10 CFR 50 Appendix I, As Low As Reasonably Achievable (ALARA) limit of 10 mrem.

For comparison, the background radiation dose averages approximately 300 mrem per year in the Central New Jersey area, which includes approximately 200 mrem from naturally occurring radon gas and 100 mrem from background radiation.

The Independent Spent Fuel Storage Installation (ISFSI) is a closed system and the only exposure is due to direct radiation. Based on offsite TLD readings, dose due to direct radiation from the ISFSI was less than 1 mrem for 2010. Because it is a sealed unit, no radioactive material was released.

Oyster Creek 2010 Annual Radioactive Effluent Release Report

On April 7, 2010, the main stack Radioactive Gaseous Effluent Monitoring System (RAGEMS) sample line was discovered separated at a Swagelok union at the 260 foot elevation. The sample line was disconnected with the two ends separated by a distance of several inches, such that the sample line was open to the atmosphere. Subsequent investigations revealed a second sample line separation at a Swagelok union lower in the stack. The tubing was held in place by the insulation and the heat trace. A root cause analysis concluded that the sample line was first separated about January 1, 2006. Since the insulation was in place, the sample line continued to provide a partial sample of the stack gas. Over the four years, the data indicates that the sample line separation increased slowly. The root cause concluded that the lack of data trending as required by Regulatory Guide 4.15, Quality Assurance for Radiological Monitoring Programs (Normal Operations) – Effluent Streams and the Environment, was the cause of the failure to recognize the sample line failure. Corrective actions have been taken to address the performance deficiency.

Comparison of environmental sampling results to iodine and particulate gaseous effluents released, showed no radioactivity attributable to the operation of OCGS. Both elevated and ground-level release paths were considered in this review, with total iodines released of $3.40\text{E-}02$ Ci and total particulates with half-lives greater than 8 days released of $3.07\text{E-}02$ Ci.

Joint Frequency Tables of meteorological data, per Pasquill Category, as well as for all stability classes, are included. All data was collected from the on-site Meteorological Facility. Data recoveries for the 380-foot data and the 33-foot data were 99.1 percent and 99.1 percent, respectively. The UFSAR commits to Regulatory Guide (RG) 1.23 for Meteorological Facility data recovery. RG 1.23 requires data recovery of at least 90% on an annual basis.

Effluents are strictly monitored to ensure that radioactivity released to the environment is as low as reasonably achievable and does not exceed regulatory limits. Effluent control includes the operation of monitoring systems, in-plant and environmental sampling and analyses programs, quality assurance programs for effluent and environmental programs, and procedures covering all aspects of effluent and environmental monitoring.

Both radiological environmental and effluent monitoring indicate that the operation of OCGS does not result in significant radiation exposure of the people or the environment surrounding OCGS and is well below the applicable levels set by the Nuclear Regulatory Commission (NRC) and the EPA.

Oyster Creek 2010 Annual Radioactive Effluent Release Report

1. Introduction

In accordance with the reporting requirements of Technical Specification 6.9.1.d applicable during the reporting period, this report summarizes the effluent release data for OCGS for the period January 1, 2010 through December 31, 2010. This submittal complies with the format described in Regulatory Guide 1.21, "Measuring, Evaluating and Reporting Radioactivity in Solid Wastes and Releases of Radioactive Materials in Liquid and Gaseous Effluents from Light-Water Cooled Nuclear Power Plants", Revision 1, June, 1974.

Meteorological data was reported in the format specified in Regulatory Guide 1.23, Revision 1, "Meteorological Monitoring Programs for Nuclear Power Plants".

All vendor results were received and included in the report calculations. Therefore the 2010 report is complete.

Oyster Creek 2010 Annual Radioactive Effluent Release Report

2. Supplemental Information

Oyster Creek Generating Station

Exelon Generation Company, LLC

A. Regulatory Limits:

	Limit	Units	Receptor	ODCM and 10 CFR 50, Appendix I Design Objective Limits
1. Noble Gases:				
a.	≤ 500	mrem/yr	Total Body	ODCM Control 3.11.2.1
	≤ 3000	mrem/yr	Skin	
b.	≤ 5	mrad	Air Gamma	Quarterly air dose limits ODCM Control 3.11.2.2
	≤ 10	mrad	Air Beta	
c.	≤ 10	mrad	Air Gamma	Yearly air dose limits ODCM Control 3.11.2.2
	≤ 20	mrad	Air Beta	
d.	< 5	mrem	Total Body (Gamma)	10 CFR 50, Appendix I, Section II.B.2(b)
	< 15	mrem	Skin (Beta)	
2. Iodines, Tritium, Particulates with Half Life > 8 days:				
a.	≤ 1500	mrem/yr	Any Organ	ODCM Control 3.11.2.1
b.	≤ 7.5	mrem	Any Organ	Quarterly dose limits ODCM Control 3.11.2.3
c.	≤ 15	mrem	Any Organ	Yearly dose limits ODCM Control 3.11.2.3
3. Liquid Effluents				
a.	Concentration 10 CFR 20, Appendix B, Table 2 Column 2			ODCM Control 3.11.1.1
b.	≤ 1.5	mrem	Total Body	Quarterly dose limits ODCM Control 3.11.1.2
	≤ 5	mrem	Any Organ	
c.	≤ 3	mrem	Total Body	Yearly dose limits ODCM Control 3.11.1.2
	≤ 10	mrem	Any Organ	

Oyster Creek 2011 Annual Radioactive Effluent Release Report

B. Effluent Concentration Limits:

Gaseous dose rates rather than effluent concentrations are used to calculate permissible release rates for gaseous releases. The maximum permissible dose rates for gaseous releases are defined in ODCM Controls 3.11.2.1.

The Effluent Concentration Limit (ECL) specified in 10 CFR 20, Appendix B, Table 2, Column 2 for identified nuclides, were used to calculate permissible release rates and concentrations for liquid release per ODCM Controls 3.11.1.1. The total activity concentration at the Route 9 bridge for all dissolved or entrained gases was limited to $< 2E-04 \mu\text{Ci/ml}$.

C. Average Energy (\bar{E}):

The Oyster Creek ODCM limits the instantaneous dose equivalent rates due to the release of noble gases to less than or equal to 500 mrem/year to the total body and less than or equal to 3000 mrem/year to the skin. The average beta and gamma energies (\bar{E}) of the radionuclide mixture in releases of fission and activation gases as described in Regulatory Guide 1.21, "Measuring, Evaluation, and Reporting Radioactivity in Solid Wastes and Releases of Radioactive Materials in Liquid and Gaseous Effluents from Light-Water-Cooled Nuclear Power Plants," may be used to calculate doses in lieu of more sophisticated software. The Oyster Creek radioactive effluent program employs the methodologies presented in U.S. NRC Regulatory Guide 1.109 "Calculation of Annual Doses to Man from Routine Releases of Reactor Effluents for the Purpose of Evaluating Compliance with 10 CFR Part 50, Appendix I," Revision 1, October 1977. Therefore, average energy (\bar{E}) as described in Regulatory Guide 1.21 is not applicable to Oyster Creek.

D. Measurements and Approximations of Total Radioactivity:

1. Fission and Activation Gases

The method used for Gamma Isotopic Analysis is the Canberra Gamma Spectroscopy System with a gas Marinelli beaker. Airborne effluent gaseous activity was continuously monitored and recorded in accordance with ODCM Table 4.11.2.1.2-1. Additional grab samples were taken from the stack RAGEMS sample point and ground-level release sample points and analyzed at least monthly to determine the isotopic mixture of noble gas activity released for the month. If activity was found in the grab isotopic analysis, the results are entered into Simplified Environmental Effluent Dosimetry System (SEEDS) to calculate dose and dose rates. If no activity is detected in the grab samples, post treatment or Off Gas Isotopic Analysis data may be used.

The release rates of fission and activation gases for the time period that the stack sample line was degraded were estimated based on the releases rates for May through October 2010. Releases rates were adjusted for known plant variables such as AOG system availability, plant power level and off gas release rates.

2. Iodines

The method used for Gamma Isotopic Analysis is the Canberra Gamma Spectroscopy System with a charcoal cartridge. Iodine activity was continuously sampled and analyzed in accordance with ODCM Table 4.11.2.1.2-1. Charcoal samples are taken from the stack RAGEMS sample point and ground-level release sample points and analyzed at least weekly to determine the total activity released from the plant based on the average vent flow rates recorded for the sampling period.

The release rates of iodines for the time period that the stack sample line was degraded were estimated based on the releases rates for May through October 2010. Releases rates were adjusted for known plant variables such as AOG system availability, plant power level and off gas release rates.

3. Particulates (half-lives > 8 days)

The method used for Gamma Isotopic Analysis is the Canberra Gamma Spectroscopy System with a particulate filter (47 mm). Particulate activity was continuously sampled and analyzed in accordance with ODCM Table 4.11.2.1.2-1. Particulate samples are taken from the stack RAGEMS sample point and ground-level release sample points and analyzed at least weekly to determine the total activity released from the plant based on the average vent flow rates recorded for the sampling period.

The release rates of particulate for the time period that the stack sample line was degraded were estimated based on the releases rates for May through October 2010. Releases rates were adjusted for known plant variables such as AOG system availability, plant power level and off gas release rates.

4. Tritium

A. Gaseous Effluents

Air from stack effluents was passed through a desiccant column and distilled to remove the moisture collected. An aliquot of the water from the distillate was analyzed for tritium using a liquid scintillation counter.

The release rate of tritium for the time period that the stack sample line was degraded was estimated based on the releases rates for May through October 2010.

B. Liquid Effluents

Water from liquid effluents was filtered and analyzed for tritium using a liquid scintillation counter.

5. Gross Alpha

Gross alpha was measured by an off-site vendor for both the gas and liquid effluent composite samples.

6. Carbon-14 (C-14)

The amount of C-14 (Ci) released was estimated using the guidance from EPRI Technical Report 1021106, Estimation of Carbon-14 in Nuclear Power Plant Gaseous Effluents. The C-14 was released primarily through the stack (97%) with a small amount (3%) released through plant vents. The activity in liquid effluents was determined to not be significant.

The offsite dose from C-14 was calculated using SEEDS, which uses approved ODCM methodologies. The resulting annual dose to a child from gaseous releases of C-14 is about 4.26E-01 mrem to the bone.

7. Liquid Effluents

Groundwater containing tritium was released during 2010. For batch releases, tritium and principal gamma emitters were determined for each batch prior to release. For continuous releases, tritium and principal gamma emitters were determined for a composite sample daily. The concentration of tritium is limited to ensure concentrations were less than 200 pCi/l in the discharge canal. The gamma emitters were limited to less than detectable concentrations.

The leaks into the groundwater were reported in the 2009 Annual Radioactive Effluent Release Report as abnormal releases. Estimates of the curies of the tritium releases were reported. Doses due to the release of the groundwater to the discharge canal were included in the report. To ensure that amount of activity discharge is accurate and limiting, the activity and doses as a result of discharges during 2010 from the groundwater remediation project are included in this report.

8. Estimated Total Error Present

Procedure CY-AA-170-2100, Estimated Errors of Effluent Measurements, provides the methodology to obtain an overall estimate of the error associated with radioactive effluents.

9. Composite Samples and Lower Limit of Detection (LLD)

Particulate air samples were composited monthly and analyzed for gross alpha, Sr-89 and Sr-90. Groundwater batch and continuous releases were composited at least monthly and analyzed for gross alpha, Sr-89, Sr-90, Fe-55 and Ni-63. These composites are submitted to an offsite vendor laboratory for analysis. The ODCM required LLD for liquid and airborne releases are as follows:

Liquid:	LLD
Principal Gamma Emitters (Mn-54, Fe-59, Co-58, Co-60, Zn-65, Mo-99, I-131, Ce-141, Cs-134, Cs-137)	5E-07 µCi/ml
Principal Gamma Emitters (Ce-144)*	1E-05/5E-06 µCi/ml
Dissolved and Entrained Gases	1E-05 µCi/ml
H-3	1E-05 µCi/ml
Gross Alpha	1E-07 µCi/ml
Sr-89 and Sr-90	5E-08 µCi/ml
Fe-55 and Ni-63	1E-06 µCi/ml
Airborne	LLD
Principal Gamma Emitters (Kr-87, Kr-88, Xe-133, Xe-133m, Xe-135, Xe-138)	1E-04 µCi/ml
H-3	1E-06 µCi/ml
I-131	1E-12 µCi/ml
I-133	1E-10 µCi/ml
Principal Gamma Emitters (Mn-54, Fe-59, Co-58, Co-60, Zn-65, Mo-99, Cs-134, Cs-137, Ce-141, Ce-144)	1E-11 µCi/ml
Gross Alpha	1E-11 µCi/ml
Sr-89, Sr-90	1E-11 µCi/ml

* Liquid LLD for Ce-144 was revised in ODCM revision in 2010

Oyster Creek 2010 Annual Radioactive Effluent Release Report

E. Batch Releases:

1. Liquid

	Qtr 1	Qtr 2	Qtr 3	Qtr 4
Number of Batch Releases	0.00E+00	0.00E+00	0.00E+00	7.00E+00
Total time period for batch releases (min)	0.00E+00	0.00E+00	0.00E+00	3.20E+02
Maximum time period for batch release (min)	0.00E+00	0.00E+00	0.00E+00	5.20E+01
Average time period for batch release (min)	0.00E+00	0.00E+00	0.00E+00	4.57E+01
Minimum time period for batch release (min)	0.00E+00	0.00E+00	0.00E+00	3.90E+01
Average Stream flow during period of release (gpm)	N/A	N/A	N/A	7.99E+05

2. Gaseous

There were no batch releases of gaseous effluents during 2010.

F. Abnormal Releases:

There were no abnormal liquid or gaseous releases during 2010.

G. Revisions to the ODCM:

Revision 5 of CY-OC-170-301, Offsite Dose Calculation Manual was approved during October, 2010. The revision was primarily required to support the groundwater remediation project. A complete copy, along with detailed information justifying the changes, a determination that the changes did not reduce the accuracy or reliability of dose calculations or setpoint determination, and documentation of review and approval, is included in this report.

H. Radiation Effluent Monitors Out of Service More Than 30 Days

Per ODCM Control 3.3.3.10, "Radioactive Liquid Effluent Monitoring Instrumentation" and 3.3.3.11, Radioactive Gaseous Effluent Monitoring Instrumentation requires:

With less than the minimum number of radioactive liquid effluent monitoring instrumentation channels OPERABLE, take the ACTION shown in Table 3.3.3.10-1. Make every reasonable effort to return the instrument to OPERABLE status within 30 days and, if unsuccessful, explain in the next Radioactive Effluent Release Report why the inoperability was not corrected in a timely manner.

The following is a discussion of instrumentation out of service for greater than 30 days:

1. From January 1, 2006 to April 20, 2010 the stack noble gas monitors, stack iodine sampler, and stack particulate sampler were not able to perform their specified function accurately due to the degraded/separated sample line. The release rates for the time period January 1, 2010 to April 15, 2010 were estimated based on the releases rates for May through October 2010. The release rates for the time period April 15, 2010 to April 20, 2010 were measured by an alternate sampling plan that measured the inputs to the stack by grab samples.
2. The Service Water radiation monitor was out of service from 12/27/2009 to 4/18/2010 and 6/15/2010 to 7/16/2010. The monitor experienced low flow due to the position of the sample line on the process pipe. The position of the sample line has been corrected and sample flow returned to normal. The cause of the monitor not being returned to service in a timely manner was due to the modification process required to move the sample line.
3. The stack effluent flow and sample flow monitors were out of service from June 29, 2010 to August 9, 2010. The likely cause of the malfunction is a response to electromagnetic interference from lightning in the area. Flows were estimated as required by ODCM Table 3.3.3.1.1-1. The flow monitors experienced a new type of failure.

I. Releases from the Independent Spent Fuel Storage Facility:

The ISFSI is a closed system and the only exposure would be due to direct radiation. This includes iodines, particulates, and noble gases. Based on offsite TLD readings, dose due to direct radiation from the ISFSI was less than 1 mrem for 2010. Because it is a sealed unit, no radioactive material was released.

J. Program Deviations:

1. Procedure 621.3.037, Turbine Building RAGEMS Noble Gas Monitor – Functional Test was not performed at the frequency required by ODCM Table 4.3.3.11-1. The test was required to be performed by November 13, 2010 and was completed on December 2, 2010.
2. The groundwater remediation composite sampler was found out of service for less than one day on November 30, 2010. The composite sampler is required by ODCM Table 4.11.1.1.1-1, Radioactive Liquid Waste Sampling and Analysis Program. A grab sample was taken as a compensatory measure and the composite sample was immediately returned to service.
3. On December 18, 2010 at 04:00 the stack monitor noble gas monitor count rate was discovered to be much lower than expected. A valve was found to be out of position causing a dilution in the sample concentration. Based on the stack monitor noble gas monitor readings, the valve had been open for 15 hours. The valve was placed in the correct, closed position, immediately and the count rate returned to normal.
4. The stack sample line was discovered separated on April 7, 2010. A root cause analysis concluded that the sample line was first separated about January 1, 2006. The sample line was returned to service on April 20, 2010.

Appendix A
Effluent and Waste Disposal Summary

Oyster Creek 2011 Annual Radioactive Effluent Release Report

LIST OF TABLES

	PAGE
Table A - 1 Gaseous Effluents – Summation of All Releases	14
Table A - 2 Gaseous Effluents Release Point: Elevated Release	15
Table A - 3 Gaseous Effluents Release Point: Ground Level Releases	16
Table A - 4 Liquid Effluents – Summation of All Releases	17
Table A – 5 Liquid Release Point: Groundwater Remediation	18

Oyster Creek 2010 Annual Radioactive Effluent Release Report

Table A - 1 Gaseous Effluents – Summation of All Releases

Period: January 1, 2010 through December 31, 2010

Unit: Oyster Creek

A. Fission & Activation Gases	Units	Quarter 1	Quarter 2	Quarter 3	Quarter 4	Est. Total Error %
1. Total Release	Ci	1.34E+02	7.74E+01	7.85E+01	1.09E+02	25.00%
2. Average Release Rate for Period	µCi/sec	1.73E+01	9.85E+00	9.88E+00	1.37E+01	
3. Gamma Air Dose	mrad	2.17E-02	4.24E-03	1.69E-01	4.44E-02	
4. Beta Air Dose	mrad	6.86E-03	4.74E-03	3.35E-02	9.05E-03	
5. Percent of ODCM Limit						
- Gamma Air Dose	%	4.34E-01	8.48E-02	3.38E+00	8.88E-01	
- Beta Air Dose	%	6.86E-02	4.74E-02	3.35E-01	9.05E-02	

B. Iodines

1. Total – I-131	Ci	6.99E-03	1.37E-02	8.14E-03	5.17E-03	25.00%
2. Average Release Rate for Period	µCi/sec	8.99E-04	1.75E-03	1.02E-03	6.51E-04	
3. Percent of ODCM limit	%	*	*	*	*	

C. Particulate

1. Particulates with T 1/2 > 8 days	Ci	7.82E-03	5.22E-03	7.91E-03	9.73E-03	25.00%
2. Average Release Rate for Period	µCi/sec	1.01E-03	6.64E-04	9.96E-04	1.22E-03	
3. Percent of ODCM limit	%	*	*	*	*	

D. Tritium

1. Total Release	Ci	1.87E+01	2.01E+01	1.71E+01	7.39E+00	25.00%
2. Average Release Rate for Period	µCi/sec	2.40E+00	2.55E+00	2.15E+00	9.30E-01	
3. Percent of ODCM limit	%	*	*	*	*	

E. Gross Alpha

1. Total Release	Ci	1.90E-06	2.96E-07	3.48E-06	<LLD	25.00%
2. Average Release Rate for Period	µCi/sec	2.44E-07	3.76E-08	4.38E-07	<LLD	
3. Percent of ODCM limit	%	*	*	*	*	

F. Carbon-14

1. Total Release	Ci	2.46E+00	2.49E+00	2.53E+00	2.53E+00	
2. Average Release Rate for Period	µCi/sec	3.17E-01	3.17E-01	3.18E-01	3.18E-01	

G. Iodine 131 & 133, Tritium, Carbon-14 & Particulate

1. Organ Dose	mrem	2.53E-02	1.35E-01	1.66E-01	1.45E-01	
2. Percent of ODCM Limit	%	3.37E-01	1.80E+00	2.21E+00	1.93E+00	

* ODCM Limit is for combined Iodine, tritium, Carbon-14 and particulate only, which is shown in Item G.

Oyster Creek 2010 Annual Radioactive Effluent Release Report

Table A - 2 Gaseous Effluents Release Point: Elevated Release

Period: January 1, 2010 through December 31, 2010

Unit: Oyster Creek

Nuclides Released	Unit	Continuous Mode				Batch Mode			
		Quarter 1	Quarter 2	Quarter 3	Quarter 4	Quarter 1	Quarter 2	Quarter 3	Quarter 4
1. Fission gases									
Kr-85	Ci	<LLD	<LLD	<LLD	<LLD	<LLD	<LLD	<LLD	<LLD
Kr-85m	Ci	3.51E+00	2.05E+00	3.54E+00	6.23E+00	<LLD	<LLD	<LLD	<LLD
Kr-87	Ci	1.57E+01	1.08E+01	1.28E+01	2.24E+01	<LLD	<LLD	<LLD	<LLD
Kr-88	Ci	1.02E+01	5.00E+00	4.85E+00	1.99E+01	<LLD	<LLD	<LLD	<LLD
Xe-133	Ci	<LLD	6.69E-02	<LLD	1.02E+00	<LLD	<LLD	<LLD	<LLD
Xe-135	Ci	5.88E+01	5.66E+01	5.01E+01	5.21E+01	<LLD	<LLD	<LLD	<LLD
Xe-135m	Ci	9.68E+00	1.12E-01	<LLD	5.24E+00	<LLD	<LLD	<LLD	<LLD
Xe-137	Ci	<LLD	1.16E+00	<LLD	1.45E-02	<LLD	<LLD	<LLD	<LLD
Xe-138	Ci	3.64E+01	4.16E-01	<LLD	<LLD	<LLD	<LLD	<LLD	<LLD
Ar-41	Ci	<LLD	2.65E-01	<LLD	<LLD	<LLD	<LLD	<LLD	<LLD
Total for Period	Ci	1.34E+02	7.65E+01	7.13E+01	1.07E+02	<LLD	<LLD	<LLD	<LLD
2. Iodines									
I-131	Ci	2.11E-03	2.18E-03	2.41E-03	1.77E-03	<LLD	<LLD	<LLD	<LLD
I-133	Ci	4.87E-03	1.15E-02	5.70E-03	3.28E-03	<LLD	<LLD	<LLD	<LLD
I-135	Ci								
Total for Period	Ci	6.98E-03	1.37E-02	8.11E-03	5.05E-03	<LLD	<LLD	<LLD	<LLD
3. Particulates									
Sr-89	Ci	1.73E-03	1.11E-03	2.18E-03	7.35E-04	<LLD	<LLD	<LLD	<LLD
Sr-90	Ci	6.10E-06	1.16E-05	<LLD	2.58E-06	<LLD	<LLD	<LLD	<LLD
Cs-134	Ci	<LLD	<LLD	<LLD	<LLD	<LLD	<LLD	<LLD	<LLD
Cs-137	Ci	2.81E-05	5.61E-05	2.11E-05	6.16E-05	<LLD	<LLD	<LLD	<LLD
Ba-140	Ci	2.79E-03	1.11E-03	2.51E-03	2.99E-03	<LLD	<LLD	<LLD	<LLD
La-140	Ci	<LLD	<LLD	<LLD	<LLD	<LLD	<LLD	<LLD	<LLD
Cr-51	Ci	<LLD	<LLD	<LLD	<LLD	<LLD	<LLD	<LLD	<LLD
Mn-54	Ci	8.73E-04	9.14E-04	8.42E-04	5.45E-04	<LLD	<LLD	<LLD	<LLD
Co-58	Ci	4.89E-04	4.23E-04	4.87E-04	2.00E-04	<LLD	<LLD	<LLD	<LLD
Co-60	Ci	1.31E-03	1.12E-03	1.42E-03	7.85E-04	<LLD	<LLD	<LLD	<LLD
Mo-99	Ci	2.10E-04	1.57E-04	2.00E-04	1.37E-04	<LLD	<LLD	<LLD	<LLD
Ag-110m	Ci	<LLD	<LLD	<LLD	<LLD	<LLD	<LLD	<LLD	<LLD
Ce-141	Ci	<LLD	1.19E-06	<LLD	<LLD	<LLD	<LLD	<LLD	<LLD
Ce-144	Ci	<LLD	<LLD	<LLD	<LLD	<LLD	<LLD	<LLD	<LLD
Fe-59	Ci	<LLD	<LLD	<LLD	<LLD	<LLD	<LLD	<LLD	<LLD
Zn-65	Ci	2.68E-04	2.59E-04	2.02E-04	2.48E-04	<LLD	<LLD	<LLD	<LLD
Total for Period	Ci	7.70E-03	5.16E-03	7.86E-03	9.68E-03	<LLD	<LLD	<LLD	<LLD
4. Tritium									
H-3	Ci	1.55E+01	1.51E+01	1.64E+01	6.96E+00	<LLD	<LLD	<LLD	<LLD
5. Gross Alpha									
Gross Alpha	Ci	1.90E-06	2.96E-07	3.48E-06	<LLD	<LLD	<LLD	<LLD	<LLD
6. Carbon-14									
C-14	Ci	2.39E+00	2.42E+00	2.45E+00	2.45E+00	<LLD	<LLD	<LLD	<LLD

Oyster Creek 2010 Annual Radioactive Effluent Release Report

Table A - 3 Gaseous Effluents Release Point: Ground Level Releases

Period: January 1, 2010 through December 31, 2010

Unit: Oyster Creek

Nuclides Released	Unit	Continuous Mode				Batch Mode			
		Quarter 1	Quarter 2	Quarter 3	Quarter 4	Quarter 1	Quarter 2	Quarter 3	Quarter 4
1. Fission gases									
Kr-85	Ci	<LLD	<LLD	<LLD	<LLD	<LLD	<LLD	<LLD	<LLD
Kr-85m	Ci	<LLD	1.63E-03	<LLD	<LLD	<LLD	<LLD	<LLD	<LLD
Kr-87	Ci	<LLD	<LLD	<LLD	<LLD	<LLD	<LLD	<LLD	<LLD
Kr-88	Ci	<LLD	5.22E-03	7.23E+00	1.81E+00	<LLD	<LLD	<LLD	<LLD
Xe-133	Ci	<LLD	<LLD	<LLD	<LLD	<LLD	<LLD	<LLD	<LLD
Xe-135	Ci	<LLD	9.50E-01	<LLD	<LLD	<LLD	<LLD	<LLD	<LLD
Xe-135m	Ci	<LLD	<LLD	<LLD	<LLD	<LLD	<LLD	<LLD	<LLD
Xe-138	Ci	<LLD	<LLD	<LLD	<LLD	<LLD	<LLD	<LLD	<LLD
Ar-41	Ci	<LLD	<LLD	<LLD	<LLD	<LLD	<LLD	<LLD	<LLD
Total for Period	Ci	<LLD	9.57E-01	7.23E+00	1.81E+00	<LLD	<LLD	<LLD	<LLD
2. Iodines									
I-131	Ci	9.18E-06	1.85E-05	1.12E-05	8.92E-05	<LLD	<LLD	<LLD	<LLD
I-133	Ci	4.41E-06	2.19E-05	1.65E-05	3.20E-05	<LLD	<LLD	<LLD	<LLD
I-135	Ci								
Total for Period	Ci	1.36E-05	4.04E-05	2.77E-05	1.21E-04	<LLD	<LLD	<LLD	<LLD
3. Particulates									
Sr-89	Ci	<LLD	<LLD	<LLD	<LLD	<LLD	<LLD	<LLD	<LLD
Sr-90	Ci	<LLD	<LLD	<LLD	<LLD	<LLD	<LLD	<LLD	<LLD
Cs-134	Ci	<LLD	<LLD	<LLD	<LLD	<LLD	<LLD	<LLD	<LLD
Cs-137	Ci	<LLD	<LLD	<LLD	<LLD	<LLD	<LLD	<LLD	<LLD
Ba-140	Ci	<LLD	<LLD	<LLD	<LLD	<LLD	<LLD	<LLD	<LLD
La-140	Ci	<LLD	<LLD	<LLD	<LLD	<LLD	<LLD	<LLD	<LLD
Cr-51	Ci	<LLD	<LLD	<LLD	<LLD	<LLD	<LLD	<LLD	<LLD
Mn-54	Ci	3.91E-06	2.51E-05	1.10E-05	9.47E-06	<LLD	<LLD	<LLD	<LLD
Co-58	Ci	1.94E-06	4.26E-06	6.29E-06	7.74E-06	<LLD	<LLD	<LLD	<LLD
Co-60	Ci	1.05E-04	2.07E-05	2.78E-05	2.51E-05	<LLD	<LLD	<LLD	<LLD
Mo-99	Ci	<LLD	<LLD	1.41E-06	3.28E-06	<LLD	<LLD	<LLD	<LLD
Ag-110m	Ci	<LLD	<LLD	<LLD	<LLD	<LLD	<LLD	<LLD	<LLD
Ce-141	Ci	<LLD	<LLD	<LLD	<LLD	<LLD	<LLD	<LLD	<LLD
Ce-144	Ci	<LLD	<LLD	<LLD	<LLD	<LLD	<LLD	<LLD	<LLD
Fe-59	Ci	<LLD	<LLD	<LLD	<LLD	<LLD	<LLD	<LLD	<LLD
Zn-65	Ci	<LLD	5.35E-06	5.86E-06	2.70E-06	<LLD	<LLD	<LLD	<LLD
Total for Period	Ci	1.11E-04	5.54E-05	5.24E-05	4.83E-05	<LLD	<LLD	<LLD	<LLD
4. Tritium									
H-3	Ci	3.18E+00	4.97E+00	6.75E-01	4.29E-01	<LLD	<LLD	<LLD	<LLD
5. Gross Alpha									
Gross Alpha	Ci	<LLD	<LLD	<LLD	<LLD	<LLD	<LLD	<LLD	<LLD
6. Carbon-14									
C-14	Ci	7.40E-02	7.48E-02	7.56E-02	7.56E-02	<LLD	<LLD	<LLD	<LLD

Oyster Creek 2010 Annual Radioactive Effluent Release Report

Table A - 4 Liquid Effluents – Summation of All Releases

Period: January 1, 2010 through December 31, 2010

Unit: Oyster Creek

A. Fission & Activation Products	Units	Quarter 1	Quarter 2	Quarter 3	Quarter 4	Est. Total Error %
1. Total Release not including tritium, gases, alpha	Ci	<LLD	<LLD	<LLD	<LLD	25.00%
2. Average Diluted concentration during period	µCi/ml	<LLD	<LLD	<LLD	<LLD	
3. Total Body Dose	mrem	<LLD	<LLD	<LLD	2.55E-06	
4. Organ Dose	mrem	<LLD	<LLD	<LLD	2.55E-06	
3. Percent of ODCM Limit						
-Total Body Dose	%	<LLD	<LLD	<LLD	1.70E-04	
-Organ Dose	%	<LLD	<LLD	<LLD	1.70E-04	

B. Tritium

	Units	Quarter 1	Quarter 2	Quarter 3	Quarter 4	Est. Total Error %
1. Total Release	Ci	<LLD	<LLD	<LLD	2.66E-01	25.00%
2. Average diluted concentration during period	µCi/ml	<LLD	<LLD	<LLD	1.51E-09	
3. Percent of 10CFR20 limit	%	<LLD	<LLD	<LLD	1.51E-04	

C. Dissolved and Entrained Gases

	Units	Quarter 1	Quarter 2	Quarter 3	Quarter 4	Est. Total Error %
1. Total Release	Ci	<LLD	<LLD	<LLD	<LLD	25.00%
2. Average diluted concentration	µCi/ml	<LLD	<LLD	<LLD	<LLD	
3. Percent of ODCM limit	%	<LLD	<LLD	<LLD	<LLD	

D. Gross Alpha Activity

	Units	Quarter 1	Quarter 2	Quarter 3	Quarter 4	Est. Total Error %
1. Total Release	Ci	<LLD	<LLD	<LLD	<LLD	25.00%

E. Volume of Waste Released prior to dilution	Liters	0.00E+00	0.00E+00	0.00E+00	1.73E+07
--	--------	----------	----------	----------	----------

F. Volume of Dilution Water Used During Period	Liters	N/A	N/A	N/A	1.76E+11
---	--------	-----	-----	-----	----------

Oyster Creek 2010 Annual Radioactive Effluent Release Report

Table A – 5 Liquid Release Point: Groundwater Remediation

Period: January 1, 2010 through December 31, 2010

Unit: Oyster Creek

Nuclides Released	Unit	Continuous Mode				Batch Mode			
		Quarter 1	Quarter 2	Quarter 3	Quarter 4	Quarter 1	Quarter 2	Quarter 3	Quarter 4
Fission & Activation Products									
Sr-89	Ci	<LLD	<LLD	<LLD	<LLD	<LLD	<LLD	<LLD	<LLD
Sr-90	Ci	<LLD	<LLD	<LLD	<LLD	<LLD	<LLD	<LLD	<LLD
Cs-134	Ci	<LLD	<LLD	<LLD	<LLD	<LLD	<LLD	<LLD	<LLD
Cs-137	Ci	<LLD	<LLD	<LLD	<LLD	<LLD	<LLD	<LLD	<LLD
I-131	Ci	<LLD	<LLD	<LLD	<LLD	<LLD	<LLD	<LLD	<LLD
Co-58	Ci	<LLD	<LLD	<LLD	<LLD	<LLD	<LLD	<LLD	<LLD
Co-60	Ci	<LLD	<LLD	<LLD	<LLD	<LLD	<LLD	<LLD	<LLD
Fe-59	Ci	<LLD	<LLD	<LLD	<LLD	<LLD	<LLD	<LLD	<LLD
Zn-65	Ci	<LLD	<LLD	<LLD	<LLD	<LLD	<LLD	<LLD	<LLD
Mn-54	Ci	<LLD	<LLD	<LLD	<LLD	<LLD	<LLD	<LLD	<LLD
Cr-51	Ci	<LLD	<LLD	<LLD	<LLD	<LLD	<LLD	<LLD	<LLD
Zr-95	Ci	<LLD	<LLD	<LLD	<LLD	<LLD	<LLD	<LLD	<LLD
Nb-95	Ci	<LLD	<LLD	<LLD	<LLD	<LLD	<LLD	<LLD	<LLD
Mo-99	Ci	<LLD	<LLD	<LLD	<LLD	<LLD	<LLD	<LLD	<LLD
Tc-99m	Ci	<LLD	<LLD	<LLD	<LLD	<LLD	<LLD	<LLD	<LLD
Ba-140	Ci	<LLD	<LLD	<LLD	<LLD	<LLD	<LLD	<LLD	<LLD
La-140	Ci	<LLD	<LLD	<LLD	<LLD	<LLD	<LLD	<LLD	<LLD
Ce-141	Ci	<LLD	<LLD	<LLD	<LLD	<LLD	<LLD	<LLD	<LLD
Ag-110m	Ci	<LLD	<LLD	<LLD	<LLD	<LLD	<LLD	<LLD	<LLD
Fe-55	Ci	<LLD	<LLD	<LLD	<LLD	<LLD	<LLD	<LLD	<LLD
Ce-144	Ci	<LLD	<LLD	<LLD	<LLD	<LLD	<LLD	<LLD	<LLD
Total for Period	Ci	<LLD	<LLD	<LLD	<LLD	<LLD	<LLD	<LLD	<LLD
Dissolved Entrained Gases									
X-133	Ci	<LLD	<LLD	<LLD	<LLD	<LLD	<LLD	<LLD	<LLD
Xe-135	Ci	<LLD	<LLD	<LLD	<LLD	<LLD	<LLD	<LLD	<LLD
Tritium									
H-3	Ci	<LLD	<LLD	<LLD	2.66E-01	<LLD	<LLD	<LLD	2.22E-04
Gross Alpha									
Gross Alpha	Ci	<LLD	<LLD	<LLD	<LLD	<LLD	<LLD	<LLD	<LLD

Oyster Creek 2010 Annual Radioactive Effluent Release Report

Appendix B Solid Waste and Irradiated Fuel Shipments - 2010

Oyster Creek 2010 Annual Reactor Effluent Release Report

A. Solid waste shipped offsite for burial or disposal (not irradiated fuel)

1. Type of waste

Types of Waste	Total Quantity (m ³)	Total Activity (Ci)	Period	Est. Total Error%
a. Spent resins, filter sludges, evaporator bottom, etc	5.67E+01	3.11E+01	2010	2.50E+01
b. Dry compressible waste, contaminated equip, etc	6.37E+02	1.14E+00	2010	2.50E+01
c. Irradiated components, control rods, etc	0.00E+00	0.00E+00	2010	2.50E+01
d. Other	1.78E+02	1.88E-01	2010	2.50E+01

Oyster Creek 2000 Annual Radioactive Effluent Release Report

1. Estimate of Major Nuclide Composition (By Waste Type)

Category A – Spent Resin, Filters, Sludges, Evaporator Bottoms, etc.

Isotope	Waste Class A		Waste Class C	
	Curies	Percent	Curies	Percent
H-3	5.19E-02	3.90E-01	5.86E-02	3.29E-01
C-14	6.70E-01	5.04E+00	3.68E+00	2.07E+01
Mn-54	3.24E-01	2.44E+00	1.16E-01	6.52E-01
Fe-55	8.04E+00	6.05E+01	1.09E+01	6.13E+01
Fe-59			1.00E-16	5.62E-16
Co-57	5.06E-04	3.80E-03		
Co-58	1.04E-04	7.82E-04	8.54E-12	4.80E-11
Co-60	2.90E+00	2.18E+01	2.28E+00	1.28E+01
Ni-63	1.13E-01	8.50E-01	1.21E-01	6.80E-01
Zn-65	8.43E-02	6.34E-01	1.03E-02	5.79E-02
Sr-89	3.79E-06	2.85E-05		
Sr-90	5.02E-03	3.77E-02	1.45E-03	8.15E-03
Nb-95			1.52E-21	8.54E-21
Tc-99	1.17E-03	8.80E-03		
Ag-110m	3.80E-03	2.86E-02	5.88E-03	3.31E-02
Sb-125	4.88E-03	3.67E-02	3.51E-02	1.97E-01
Cs-134	4.30E-03	3.23E-02	4.73E-03	2.66E-02
Cs-137	1.08E+00	8.12E+00	3.77E-01	2.12E+00
Ce-144	4.41E-03	3.32E-02	1.56E-03	8.77E-03
Pu-238	1.36E-04	1.02E-03	8.28E-03	4.65E-02
Pu-239	4.64E-05	3.49E-04	1.99E-03	1.12E-02
Pu-240	9.91E-06	7.45E-05		
Pu-241	4.88E-03	3.67E-02	1.72E-01	9.67E-01
Am-241	5.76E-03	4.33E-02	3.66E-03	2.06E-02
Cm-242	1.92E-05	1.44E-04	4.34E-07	2.44E-06
Cm-243	3.57E-04	2.68E-03		
Cm-244	4.04E-04	3.04E-03	1.10E-02	6.18E-02
Totals	1.33E+01	1.00E+02	1.78E+01	1.00E+02

Oyster Creek 2010 Annual Site Environmental Report

Category B – Dry Compressible Waste, Contaminated Equipment, etc.

Isotope	Waste Class A	
	Curies	Percent Abundance %
H-3	1.00E-05	8.78E-04
C-14	3.59E-05	3.15E-03
Mn-54	6.18E-02	5.43E+00
Fe-55	7.18E-01	6.31E+01
Co-58	8.12E-05	7.13E-03
Co-60	1.66E-01	1.46E+01
Ni-63	7.23E-03	6.35E-01
Zn-65	6.32E-02	5.55E+00
Sr-90	4.81E-04	4.22E-02
Tc-99	9.97E-05	8.76E-03
Cs-134	6.93E-04	6.09E-02
Cs-137	1.17E-01	1.03E+01
Ce-144	3.80E-03	3.34E-01
Pu-238	5.66E-06	4.97E-04
Pu-239	1.90E-06	1.67E-04
Pu-241	2.15E-04	1.89E-02
Am-241	8.12E-06	7.13E-04
Cm-242	6.69E-07	5.88E-05
Cm-243	4.96E-06	4.36E-04
Cm-244	4.95E-06	4.35E-04
Totals	1.14E+00	1.00E+02

Category C – Irradiated components, control rods, etc.

No Irradiated components, control rods, etc. shipped

Oyster Creek 2010 Annual Radioactive Effluent Release Report

Category D - Other - Scrap Metal

Isotope	Waste Class A	
	Curies	Percent Abundance %
H-3	5.24E-02	2.79E+01
C-14	9.49E-07	5.06E-04
Mn-54	1.31E-02	6.98E+00
Fe-55	6.04E-02	3.22E+01
Co-58	1.43E-03	7.62E-01
Co-60	3.35E-02	1.79E+01
Ni-63	1.03E-03	5.49E-01
Zn-65	9.42E-03	5.02E+00
Sr-89	8.66E-05	4.62E-02
Sr-90	1.00E-04	5.33E-02
Nb-95	8.53E-06	4.55E-03
Cs-134	5.87E-05	3.13E-02
Cs-137	1.54E-02	8.21E+00
Ce-144	6.32E-04	3.37E-01
Pb-214	1.98E-91	1.06E-88
Pu-238	4.81E-07	2.56E-04
Pu-239	1.62E-07	8.64E-05
Pu-240	1.76E-05	9.38E-03
Am-241	6.01E-07	3.20E-04
Cm-242	4.38E-08	2.33E-05
Cm-243	3.72E-07	1.98E-04
Cm-244	3.72E-07	1.98E-04
Totals	1.88E-01	1.00E+02

2. Solid Waste (Disposition)

Number of Shipments	Mode of Transportation	Destination
10	Hittman Transport Co.	Barnwell Disposal Facility
17	Hittman Transport Co.	Duratek - Bear Creek
1	Southern Pines	Duratek - Bear Creek
4	Hittman Transport Co.	Duratek Radwaste Processing, Inc.

B. Irradiated Fuel Shipments (disposition).

There were no irradiated fuel shipments

C. Changes to the Process Control Program

There were no changes to the Process Control Plan in 2010.

**Appendix C
Radiological Impact to Man**

Oyster Creek 2010 Annual Radioactive Effluent Release Report

Per ODCM Administrative Control 6.2, an assessment of radiation doses to the likely most exposed MEMBER OF THE PUBLIC from reactor releases and other nearby uranium fuel cycle sources (including doses from primary effluent pathways and direct radiation) for the previous calendar year must be made to show conformance with 40 CFR Part 190, Environmental Radiation Protection Standards for Nuclear Power Operation. For purposes of this calculation the following assumptions were made:

Gaseous

- Nearest resident was SE sector at 925 meters
- Actual 2010 meteorology and measured gaseous effluent releases were used
- All significant pathways were assumed to be present
- Occupancy factor was considered 100%.

Liquid

- Doses calculated in the discharge canal at the Route 9 bridge
- Fish, shellfish and shoreline pathways doses calculated

40 CFR Part 190 Compliance

- Thermoluminescence Dosimetry (TLD) measurements (minus average of control stations) measured direct radiation for the nearest resident
- The highest calculated dose for gamma air dose and liquid total body were summed for total body dose
- The highest calculated dose for gamma air dose, child bone and liquid organ were summed for organ dose
- The limits for Kr-85, I-129, Pu-239 and other alpha-emitting transuranic radionuclides with half-lives greater than one year were not exceeded

The ODCM does not require total body doses to the population and average doses to individuals in the population from gaseous effluents to a distance of 50 miles from the site to be calculated.

New Jersey State Police or National Guard were not present full time at the plant entrance.

Oyster Creek 2010 Annual Radioactive Effluent Release Report

A summary of gaseous and liquid radiation doses to most likely exposed MEMBER OF THE PUBLIC was as follows:

Effluent	Applicable Organ	Estimated Dose	Age Group	Location		% of Applicable Limit	Limit	Unit
				Distance (meters)	Direction (toward)			
Noble Gas	Gamma - Air Dose	2.13E-01	All	430	ESE	2.13E+00	10	mrad
Noble Gas	Beta - Air Dose	4.90E-02	All	430	ESE	2.45E-01	20	mrad
Noble Gas	Total Body (Gamma)	4.17E-02	All	925	SE	8.34E-01	5	mrem
Noble Gas	Skin (Beta)	5.73E-02	All	925	SE	3.82E-01	15	mrem
Iodine, Particulate, Carbon-14 & Tritium	Bone	4.71E-01	Child	925	SE	3.14E+00	15	mrem
Liquid	Total body	2.55E-06	All	South Route 9 Bridge		8.50E-05	3	mrem
Liquid	Organ	2.55E-06	All			2.55E-05	10	mrem
Direct Radiation	Total Body	<LLD	All	644	SE	<LLD	25	mrem

40 CFR Part 190 Compliance								
Total Dose	Total Body	2.13E-01	All	925	SE	8.52E-01	25	mrem
Total Dose	Bone	6.84E-01	All	925	SE	2.74E+00	25	mrem
Total Dose	Thyroid	6.84E-01	All	925	SE	9.12E-01	75	mrem

Appendix D
Meteorological Data

Oyster Creek 2010 Annual Radioactive Effluent Release Report

LIST OF METEOROLOGICAL DATA TABLES		PAGE
Table D – 1	Wind Speed by Direction Measured at 33 Feet for various Stability Classes for the Oyster Creek Generating Station, January – March, 2010	29
Table D – 2	Wind Speed by Direction Measured at 380 Feet for various Stability Classes for the Oyster Creek Generating Station, January – March, 2010	36
Table D – 3	Wind Speed by Direction Measured at 33 Feet for various Stability Classes for the Oyster Creek Generating Station, April – June, 2010	43
Table D – 4	Wind Speed by Direction Measured at 380 Feet for various Stability Classes for the Oyster Creek Generating Station, April – June, 2010	50
Table D – 5	Wind Speed by Direction Measured at 33 Feet for various Stability Classes for the Oyster Creek Generating Station, July – September, 2010	57
Table D – 6	Wind Speed by Direction Measured at 380 Feet for various Stability Classes for the Oyster Creek Generating Station, July – September, 2010	64
Table D – 7	Wind Speed by Direction Measured at 33 Feet for various Stability Classes for the Oyster Creek Generating Station, October – December, 2010	71
Table D – 8	Wind Speed by Direction Measured at 380 Feet for various Stability Classes for the Oyster Creek Generating Station, October – December, 2010	78

Oyster Creek 2010 Annual Radioactive Effluent Release Report

Table D - 1 Wind Speed by Direction Measured at 33 Feet for various Stability Classes for the Oyster Creek Generating Station, January - March, 2010

Oyster Creek Alpha

Period of Record: January - March 2010
 Stability Class - Extremely Unstable - 150Ft-33Ft Delta-T (F)
 Winds Measured at 33 Feet

Wind Direction	Wind Speed (in mph)						Total
	1-3	4-7	8-12	13-18	19-24	> 24	
N	0	4	30	2	0	0	36
NNE	1	3	2	1	0	0	7
NE	0	8	8	3	0	0	19
ENE	1	15	4	0	0	0	20
E	0	3	2	0	0	0	5
ESE	0	4	5	0	0	0	9
SE	0	4	7	2	0	0	13
SSE	0	1	2	0	0	0	3
S	0	1	3	4	0	0	8
SSW	0	1	0	1	0	0	2
SW	0	2	0	0	0	0	2
WSW	0	2	2	1	0	0	5
W	0	7	22	6	0	0	35
WNW	0	6	54	21	1	0	82
NW	0	4	41	1	0	0	46
NNW	0	5	15	7	0	0	27
Variable	0	0	0	0	0	0	0
Total	2	70	197	49	1	0	319

Hours of calm in this stability class: 0
 Hours of missing wind measurements in this stability class: 1
 Hours of missing stability measurements in all stability classes: 62

Oyster Creek 2010 Annual Radioactive Effluent Release Report

Table D – 1 Wind Speed by Direction Measured at 33 Feet for various Stability Classes for the Oyster Creek Generating Station, January – March, 2010

Oyster Creek Alpha

Period of Record: January - March 2010
Stability Class - Moderately Unstable - 150Ft-33Ft Delta-T (F)
Winds Measured at 33 Feet

Wind Direction	Wind Speed (in mph)						Total
	1-3	4-7	8-12	13-18	19-24	> 24	
N	0	4	3	1	0	0	8
NNE	0	0	3	0	0	0	3
NE	0	5	2	0	0	0	7
ENE	0	7	0	0	0	0	7
E	0	1	1	0	0	0	2
ESE	0	3	0	0	0	0	3
SE	0	1	3	1	0	0	5
SSE	0	1	2	0	0	0	3
S	0	0	2	1	0	0	3
SSW	0	1	1	0	0	0	2
SW	0	2	0	0	0	0	2
WSW	0	1	4	0	0	0	5
W	0	3	6	5	0	0	14
WNW	0	6	15	4	0	0	25
NW	0	5	7	4	0	0	16
NNW	0	3	5	2	0	0	10
Variable	0	0	0	0	0	0	0
Total	0	43	54	18	0	0	115

Hours of calm in this stability class: 0
 Hours of missing wind measurements in this stability class: 0
 Hours of missing stability measurements in all stability classes: 62

Oyster Creek 2010 Annual Radioactive Effluent Release Report

Table D – 1 Wind Speed by Direction Measured at 33 Feet for various Stability Classes for the Oyster Creek Generating Station, January – March, 2010

Oyster Creek Alpha

Period of Record: January - March 2010
Stability Class - Slightly Unstable - 150Ft-33Ft Delta-T (F)
Winds Measured at 33 Feet

Wind Direction	Wind Speed (in mph)						Total
	1-3	4-7	8-12	13-18	19-24	> 24	
N	0	1	2	0	0	0	3
NNE	0	0	0	0	0	0	0
NE	0	1	0	0	0	0	1
ENE	0	0	0	0	0	0	0
E	0	1	0	0	0	0	1
ESE	1	0	0	0	0	0	1
SE	0	1	0	0	0	0	1
SSE	0	0	1	0	0	0	1
S	0	0	2	1	0	0	3
SSW	0	0	0	0	0	0	0
SW	0	0	0	0	0	0	0
WSW	0	1	1	0	0	0	2
W	0	1	3	0	1	0	5
WNW	0	2	12	2	1	0	17
NW	0	2	3	0	0	0	5
NNW	0	2	1	2	0	0	5
Variable	0	0	0	0	0	0	0
Total	1	12	25	5	2	0	45

Hours of calm in this stability class: 0
Hours of missing wind measurements in this stability class: 0
Hours of missing stability measurements in all stability classes: 62

Oyster Creek 2010 Annual Inactive Effluent Release Report

Table D – 1 Wind Speed by Direction Measured at 33 Feet for various Stability Classes for the Oyster Creek Generating Station, January – March, 2010

Oyster Creek Alpha

Period of Record: January - March 2010
 Stability Class - Neutral - 150Ft-33Ft Delta-T (F)
 Winds Measured at 33 Feet

Wind Direction	Wind Speed (in mph)						Total
	1-3	4-7	8-12	13-18	19-24	> 24	
N	1	14	21	5	0	0	41
NNE	2	18	12	3	0	0	35
NE	10	21	15	3	0	0	49
ENE	2	4	0	0	0	0	6
E	2	4	0	0	0	0	6
ESE	0	4	4	0	0	0	8
SE	1	6	5	8	0	0	20
SSE	0	4	2	1	0	0	7
S	0	9	11	1	0	0	21
SSW	0	2	1	1	0	0	4
SW	1	5	2	0	0	0	8
WSW	3	6	3	0	0	0	12
W	0	4	36	4	0	0	44
WNW	8	18	41	27	1	0	95
NW	5	14	22	17	0	0	58
NNW	6	18	14	5	0	0	43
Variable	0	0	0	0	0	0	0
Total	41	151	189	75	1	0	457

Hours of calm in this stability class: 0
 Hours of missing wind measurements in this stability class: 5
 Hours of missing stability measurements in all stability classes: 62

Oyster Creek 2010 Annual Radioactive Effluent Release Report

Table D – 1 Wind Speed by Direction Measured at 33 Feet for various Stability Classes for the Oyster Creek Generating Station, January – March, 2010

Oyster Creek Alpha

Period of Record: January - March 2010
Stability Class - Slightly Stable - 150Ft-33Ft Delta-T (F)
Winds Measured at 33 Feet

Wind Direction	Wind Speed (in mph)						Total
	1-3	4-7	8-12	13-18	19-24	> 24	
N	7	40	17	2	0	0	66
NNE	3	5	19	1	0	0	28
NE	7	10	21	12	0	0	50
ENE	5	3	7	3	0	0	18
E	2	5	3	0	0	0	10
ESE	0	8	2	0	0	0	10
SE	1	3	3	5	0	0	12
SSE	1	10	10	7	2	0	30
S	2	8	6	3	1	0	20
SSW	1	5	7	4	0	0	17
SW	0	7	2	0	0	0	9
WSW	5	48	6	0	0	0	59
W	3	69	35	0	0	0	107
WNW	5	60	58	3	0	0	126
NW	9	45	38	0	0	0	92
NNW	9	20	17	6	0	0	52
Variable	0	0	0	0	0	0	0
Total	60	346	251	46	3	0	706

Hours of calm in this stability class: 0
Hours of missing wind measurements in this stability class: 0
Hours of missing stability measurements in all stability classes: 62

Oyster Creek 2010 Annual Radioactive Effluent Release Report

Table D – 1 Wind Speed by Direction Measured at 33 Feet for various Stability Classes for the Oyster Creek Generating Station, January – March, 2010

Oyster Creek Alpha

Period of Record: January - March 2010
Stability Class - Moderately Stable - 150Ft-33Ft Delta-T (F)
Winds Measured at 33 Feet

Wind Direction	Wind Speed (in mph)						Total
	1-3	4-7	8-12	13-18	19-24	> 24	
N	2	10	0	0	0	0	12
NNE	0	1	0	0	0	0	1
NE	1	0	0	0	0	0	1
ENE	1	0	0	0	0	0	1
E	1	2	0	0	0	0	3
ESE	1	0	0	0	0	0	1
SE	1	1	0	0	0	0	2
SSE	2	0	0	0	0	0	2
S	1	1	0	0	0	0	2
SSW	4	2	0	0	0	0	6
SW	7	18	0	0	0	0	25
WSW	12	28	0	0	0	0	40
W	9	35	0	0	0	0	44
WNW	6	19	0	0	0	0	25
NW	11	19	0	0	0	0	30
NNW	4	28	0	0	0	0	32
Variable	1	0	0	0	0	0	1
Total	64	164	0	0	0	0	228

Hours of calm in this stability class: 0
 Hours of missing wind measurements in this stability class: 0
 Hours of missing stability measurements in all stability classes: 62

Oyster Creek 2010 Annual Radioactive Effluent Release Report

Table D – 1 Wind Speed by Direction Measured at 33 Feet for various Stability Classes for the Oyster Creek Generating Station, January – March, 2010

Oyster Creek Alpha

Period of Record: January - March 2010
 Stability Class - Extremely Stable - 150Ft-33Ft Delta-T (F)
 Winds Measured at 33 Feet

Wind Direction	Wind Speed (in mph)						Total
	1-3	4-7	8-12	13-18	19-24	> 24	
N	2	3	0	0	0	0	5
NNE	3	0	0	0	0	0	3
NE	2	0	0	0	0	0	2
ENE	2	0	0	0	0	0	2
E	1	0	0	0	0	0	1
ESE	1	0	0	0	0	0	1
SE	1	0	0	0	0	0	1
SSE	1	0	0	0	0	0	1
S	0	0	0	0	0	0	0
SSW	5	0	0	0	0	0	5
SW	12	6	0	0	0	0	18
WSW	35	23	0	0	0	0	58
W	31	8	0	0	0	0	39
WNW	12	5	0	0	0	0	17
NW	19	27	0	0	0	0	46
NNW	8	15	0	0	0	0	23
Variable	0	0	0	0	0	0	0
Total	135	87	0	0	0	0	222

Hours of calm in this stability class: 0
 Hours of missing wind measurements in this stability class: 0
 Hours of missing stability measurements in all stability classes: 62

Oyster Creek 2010 Annual Radiocesium Effluent Release Report

Table D – 2 Wind Speed by Direction Measured at 380 Feet for various Stability Classes for the Oyster Creek Generating Station, January – March, 2010

Oyster Creek Alpha

Period of Record: January - March 2010
Stability Class - Extremely Unstable - 380Ft-33Ft Delta-T (F)
Winds Measured at 380 Feet

Wind Direction	Wind Speed (in mph)						Total
	1-3	4-7	8-12	13-18	19-24	> 24	
N	0	0	3	8	0	0	11
NNE	0	0	1	1	0	0	2
NE	0	0	0	2	0	0	2
ENE	0	0	0	2	0	0	2
E	0	0	0	1	0	0	1
ESE	0	0	0	0	0	0	0
SE	0	0	0	0	0	0	0
SSE	0	0	0	0	0	0	0
S	0	0	0	0	0	0	0
SSW	0	0	0	0	0	0	0
SW	0	0	0	0	0	0	0
WSW	0	0	0	0	0	0	0
W	0	0	0	0	0	0	0
WNW	0	0	0	0	0	3	3
NW	0	0	0	0	0	2	2
NNW	0	0	0	0	0	0	0
Variable	0	0	0	0	0	0	0
Total	0	0	4	14	0	5	23

Hours of calm in this stability class: 0
 Hours of missing wind measurements in this stability class: 0
 Hours of missing stability measurements in all stability classes: 62

Oyster Creek 2010 Annual Radiologically Active Effluent Release Report

Table D – 2 Wind Speed by Direction Measured at 380 Feet for various Stability Classes for the Oyster Creek Generating Station, January – March, 2010

Oyster Creek Alpha

Period of Record: January - March 2010
Stability Class - Moderately Unstable - 380Ft-33Ft Delta-T (F)
Winds Measured at 380 Feet

Wind Direction	Wind Speed (in mph)						Total
	1-3	4-7	8-12	13-18	19-24	> 24	
N	0	0	1	6	0	1	8
NNE	0	0	2	1	0	0	3
NE	0	0	3	1	0	0	4
ENE	0	0	2	0	0	0	2
E	0	0	1	0	0	0	1
ESE	0	0	0	0	0	0	0
SE	0	0	0	0	0	0	0
SSE	0	0	0	0	0	0	0
S	0	0	0	1	1	0	2
SSW	0	1	0	0	0	0	1
SW	0	0	0	0	0	0	0
WSW	0	0	1	0	0	0	1
W	0	0	2	3	0	0	5
WNW	0	0	3	7	7	3	20
NW	0	0	4	16	11	2	33
NNW	0	0	1	1	1	0	3
Variable	0	0	0	0	0	0	0
Total	0	1	20	36	20	6	83

Hours of calm in this stability class: 0
 Hours of missing wind measurements in this stability class: 0
 Hours of missing stability measurements in all stability classes: 62

Oyster Creek 2010 Annual Radioactive Effluent Release Report

Table D – 2 . Wind Speed by Direction Measured at 380 Feet for various Stability Classes for the Oyster Creek Generating Station, January – March, 2010

Oyster Creek Alpha

Period of Record: January - March 2010
Stability Class - Slightly Unstable - 380Ft-33Ft Delta-T (F)
Winds Measured at 380 Feet

Wind Direction	Wind Speed (in mph)						Total
	1-3	4-7	8-12	13-18	19-24	> 24	
N	0	0	1	5	4	5	15
NNE	0	0	3	3	1	0	7
NE	0	0	4	1	0	2	7
ENE	0	3	9	0	0	1	13
E	0	1	2	0	0	0	3
ESE	0	0	1	0	0	0	1
SE	0	0	3	2	1	1	7
SSE	0	1	1	1	0	0	3
S	0	0	0	1	0	0	1
SSW	0	0	1	1	3	0	5
SW	0	0	1	0	0	0	1
WSW	0	1	1	0	1	0	3
W	0	0	1	3	0	2	6
WNW	0	1	5	14	16	11	47
NW	0	0	1	11	18	6	36
NNW	0	1	4	6	3	2	16
Variable	0	0	0	0	0	0	0
Total	0	8	38	48	47	30	171

Hours of calm in this stability class: 0
 Hours of missing wind measurements in this stability class: 1
 Hours of missing stability measurements in all stability classes: 62

Oyster Creek 2010 Annual Radioactive Effluent Release Report

Table D – 2 Wind Speed by Direction Measured at 380 Feet for various Stability Classes for the Oyster Creek Generating Station, January – March, 2010

Oyster Creek Alpha

Period of Record: January - March 2010
Stability Class - Neutral - 380Ft-33Ft Delta-T (F)
Winds Measured at 380 Feet

Wind Direction	Wind Speed (in mph)						Total
	1-3	4-7	8-12	13-18	19-24	> 24	
N	1	3	16	45	13	12	90
NNE	0	2	6	20	18	7	53
NE	1	8	12	21	28	33	103
ENE	2	12	11	1	2	1	29
E	0	7	4	2	0	2	15
ESE	0	2	7	6	0	0	15
SE	0	5	4	9	2	8	28
SSE	0	5	7	10	1	0	23
S	0	2	5	9	3	0	19
SSW	0	2	4	9	15	8	38
SW	0	0	3	6	2	0	11
WSW	0	0	5	3	2	0	10
W	0	1	8	13	20	8	50
WNW	0	1	6	28	65	38	138
NW	0	4	13	31	53	53	154
NNW	0	3	14	26	13	24	80
Variable	0	0	0	0	0	0	0
Total	4	57	125	239	237	194	856

Hours of calm in this stability class: 0
 Hours of missing wind measurements in this stability class: 4
 Hours of missing stability measurements in all stability classes: 62

Oyster Creek 2010 Annual Radioactive Effluent Release Report

Table D – 2. Wind Speed by Direction Measured at 380 Feet for various Stability Classes for the Oyster Creek Generating Station, January – March, 2010

Oyster Creek Alpha

Period of Record: January - March 2010
Stability Class - Slightly Stable - 380Ft-33Ft Delta-T (F)
Winds Measured at 380 Feet

Wind Direction	Wind Speed (in mph)						Total
	1-3	4-7	8-12	13-18	19-24	> 24	
N	0	4	12	27	16	8	67
NNE	2	3	7	8	7	0	27
NE	0	6	2	1	2	4	15
ENE	0	3	7	5	1	9	25
E	0	6	5	1	4	4	20
ESE	0	1	3	4	1	0	9
SE	0	0	2	3	1	0	6
SSE	0	0	2	3	4	17	26
S	0	1	1	5	4	5	16
SSW	0	0	1	6	6	1	14
SW	0	1	2	1	2	0	6
WSW	0	0	0	3	7	1	11
W	0	1	3	19	50	3	76
WNW	0	0	2	25	85	11	123
NW	0	1	4	27	42	9	83
NNW	0	0	5	4	34	3	46
Variable	0	0	0	0	0	0	0
Total	2	27	58	142	266	75	570

Hours of calm in this stability class: 0
 Hours of missing wind measurements in this stability class: 2
 Hours of missing stability measurements in all stability classes: 62

Oyster Creek 2010 Annual Radioactive Effluent Release Report

Table D – 2 Wind Speed by Direction Measured at 380 Feet for various Stability Classes for the Oyster Creek Generating Station, January – March, 2010

Oyster Creek Alpha

Period of Record: January - March 2010
Stability Class - Moderately Stable - 380Ft-33Ft Delta-T (F)
Winds Measured at 380 Feet

Wind Direction	Wind Speed (in mph)						Total
	1-3	4-7	8-12	13-18	19-24	> 24	
N	0	0	2	4	18	15	39
NNE	0	0	3	6	7	0	16
NE	0	1	4	2	0	0	7
ENE	0	0	3	2	0	0	5
E	0	1	4	2	0	0	7
ESE	0	0	1	0	0	0	1
SE	0	0	2	2	0	0	4
SSE	0	0	0	0	0	0	0
S	0	0	0	0	0	0	0
SSW	0	0	1	1	1	0	3
SW	0	0	0	3	3	4	10
WSW	0	0	2	4	1	3	10
W	0	0	3	11	14	2	30
WNW	0	0	2	17	19	6	44
NW	0	0	1	12	13	1	27
NNW	0	1	1	15	19	5	41
Variable	0	0	0	0	0	0	0
Total	0	3	29	81	95	36	244

Hours of calm in this stability class: 0
Hours of missing wind measurements in this stability class: 0
Hours of missing stability measurements in all stability classes: 62

Oyster Creek 2010 Annual Discharge Efficiency Release Report

Table D – 2 Wind Speed by Direction Measured at 380 Feet for various Stability Classes for the Oyster Creek Generating Station, January – March, 2010

Oyster Creek Alpha

Period of Record: January - March 2010
Stability Class - Extremely Stable - 380Ft-33Ft Delta-T (F)
Winds Measured at 380 Feet

Wind Direction	Wind Speed (in mph)						Total
	1-3	4-7	8-12	13-18	19-24	> 24	
N	0	1	2	3	0	5	11
NNE	0	0	2	1	1	0	4
NE	1	0	1	1	0	0	3
ENE	1	0	1	0	0	0	2
E	0	1	2	0	0	0	3
ESE	0	0	4	1	0	0	5
SE	0	1	3	0	0	0	4
SSE	0	1	2	0	0	0	3
S	0	1	2	0	0	0	3
SSW	0	1	1	1	3	0	6
SW	0	4	3	5	4	6	22
WSW	2	1	2	4	7	5	21
W	0	4	3	5	10	0	22
WNW	0	0	0	2	1	3	6
NW	0	0	0	2	7	1	10
NNW	0	0	4	8	6	1	19
Variable	0	0	0	0	0	0	0
Total	4	15	32	33	39	21	144

Hours of calm in this stability class: 0
 Hours of missing wind measurements in this stability class: 0
 Hours of missing stability measurements in all stability classes: 62

Oyster Creek 2010 Annual Radioactive Effluent Release Report

Table D – 3 Wind Speed by Direction Measured at 33 Feet for various Stability Classes for the Oyster Creek Generating Station; April – June, 2010

Oyster Creek Alpha

Period of Record: April - June 2010
Stability Class - Extremely Unstable - 150Ft-33Ft Delta-T (F)
Winds Measured at 33 Feet

Wind Direction	Wind Speed (in mph)						Total
	1-3	4-7	8-12	13-18	19-24	> 24	
N	0	2	2	0	0	0	4
NNE	1	8	0	0	0	0	9
NE	0	12	11	0	0	0	23
ENE	0	21	16	0	0	0	37
E	0	22	9	0	0	0	31
ESE	0	30	33	0	0	0	63
SE	0	18	50	0	0	0	68
SSE	1	6	33	3	0	0	43
S	0	9	28	19	0	0	56
SSW	0	14	12	0	0	0	26
SW	1	8	24	3	0	0	36
WSW	1	15	44	2	0	0	62
W	0	12	32	18	2	0	64
WNW	1	13	38	21	0	0	73
NW	0	15	53	5	0	0	73
NNW	0	8	12	0	0	0	20
Variable	0	0	0	0	0	0	0
Total	5	213	397	71	2	0	688

Hours of calm in this stability class: 0
 Hours of missing wind measurements in this stability class: 0
 Hours of missing stability measurements in all stability classes: 8

Oyster Creek 2010 Annual Performance Report Release Report

Table D – 3 Wind Speed by Direction Measured at 33 Feet for various Stability Classes for the Oyster Creek Generating Station, April – June, 2010

Oyster Creek Alpha

Period of Record: April - June 2010
Stability Class - Moderately Unstable - 150Ft-33Ft Delta-T (F)
Winds Measured at 33 Feet

Wind Direction	Wind Speed (in mph)						Total
	1-3	4-7	8-12	13-18	19-24	> 24	
N	1	1	0	0	0	0	2
NNE	0	3	0	0	0	0	3
NE	1	10	1	0	0	0	12
ENE	0	4	3	0	0	0	7
E	0	0	2	0	0	0	2
ESE	0	1	0	0	0	0	1
SE	0	8	1	0	0	0	9
SSE	0	3	6	0	0	0	9
S	0	3	7	2	0	0	12
SSW	0	1	1	1	0	0	3
SW	0	2	2	1	0	0	5
WSW	0	3	4	2	0	0	9
W	1	3	3	0	0	0	7
WNW	0	5	3	2	0	0	10
NW	0	1	4	0	0	0	5
NNW	1	3	0	0	0	0	4
Variable	0	0	0	0	0	0	0
Total	4	51	37	8	0	0	100

Hours of calm in this stability class: 0
 Hours of missing wind measurements in this stability class: 0
 Hours of missing stability measurements in all stability classes: 8

Oyster Creek 2010 Annual Radioactive Effluent Release Report

Table D – 3 Wind Speed by Direction Measured at 33 Feet for various Stability Classes for the Oyster Creek Generating Station, April – June, 2010

Oyster Creek Alpha

Period of Record: April - June 2010
 Stability Class - Slightly Unstable - 150Ft-33Ft Delta-T (F)
 Winds Measured at 33 Feet

Wind Direction	Wind Speed (in mph)						Total
	1-3	4-7	8-12	13-18	19-24	> 24	
N	0	0	0	0	0	0	0
NNE	0	3	0	0	0	0	3
NE	0	2	0	0	0	0	2
ENE	1	0	0	0	0	0	1
E	0	0	0	0	0	0	0
ESE	0	4	0	0	0	0	4
SE	0	2	0	0	0	0	2
SSE	0	2	1	0	0	0	3
S	0	2	1	0	0	0	3
SSW	0	1	0	0	0	0	1
SW	0	0	1	0	0	0	1
WSW	0	2	1	0	0	0	3
W	1	5	3	1	0	0	10
WNW	0	0	1	0	0	0	1
NW	1	2	1	0	0	0	4
NNW	0	1	1	0	0	0	2
Variable	0	0	0	0	0	0	0
Total	3	26	10	1	0	0	40

Hours of calm in this stability class: 0
 Hours of missing wind measurements in this stability class: 0
 Hours of missing stability measurements in all stability classes: 8

Oyster Creek 2010 Annual Radiological Effluent Release Report

Table D – 3 Wind Speed by Direction Measured at 33 Feet for various Stability Classes for the Oyster Creek Generating Station, April – June, 2010

Oyster Creek Alpha

Period of Record: April - June 2010
 Stability Class - Neutral - 150Ft-33Ft Delta-T (F)
 Winds Measured at 33 Feet

Wind Direction	Wind Speed (in mph)						Total
	1-3	4-7	8-12	13-18	19-24	> 24	
N	3	4	1	0	0	0	8
NNE	2	11	6	0	0	0	19
NE	8	33	7	0	0	0	48
ENE	1	12	1	0	0	0	14
E	1	12	3	0	0	0	16
ESE	1	12	4	0	0	0	17
SE	2	11	6	0	0	0	19
SSE	3	13	6	0	0	0	22
S	4	40	20	1	0	0	65
SSW	3	26	13	2	0	0	44
SW	2	14	6	0	0	0	22
WSW	2	13	9	0	0	0	24
W	4	13	7	2	0	0	26
WNW	3	16	19	8	0	0	46
NW	5	13	5	0	0	0	23
NNW	4	7	3	1	0	0	15
Variable	0	0	0	0	0	0	0
Total	48	250	116	14	0	0	428

Hours of calm in this stability class: 0
 Hours of missing wind measurements in this stability class: 0
 Hours of missing stability measurements in all stability classes: 8

Oyster Creek 2010 Annual Radioactive Effluent Release Report

Table D – 3 Wind Speed by Direction Measured at 33 Feet for various Stability Classes for the Oyster Creek Generating Station, April – June, 2010

Oyster Creek Alpha

Period of Record: April - June 2010
 Stability Class - Slightly Stable - 150Ft-33Ft Delta-T (F)
 Winds Measured at 33 Feet

Wind Direction	Wind Speed (in mph)						Total
	1-3	4-7	8-12	13-18	19-24	> 24	
N	2	9	1	0	0	0	12
NNE	0	9	2	0	0	0	11
NE	5	8	5	1	0	0	19
ENE	1	3	1	3	0	0	8
E	2	1	0	0	0	0	3
ESE	2	2	1	0	0	0	5
SE	7	3	0	0	0	0	10
SSE	9	13	1	0	0	0	23
S	12	36	3	3	0	0	54
SSW	11	56	27	1	0	0	95
SW	10	60	7	0	0	0	77
WSW	13	35	3	0	0	0	51
W	6	21	5	1	0	0	33
WNW	4	17	6	0	0	0	27
NW	9	19	2	0	0	0	30
NNW	3	5	0	0	0	0	8
Variable	0	0	0	0	0	0	0
Total	96	297	64	9	0	0	466

Hours of calm in this stability class: 0
 Hours of missing wind measurements in this stability class: 0
 Hours of missing stability measurements in all stability classes: 8

Oyster Creek 2010 Annual Effluent Release Report

Table D – 3 Wind Speed by Direction Measured at 33 Feet for various Stability Classes for the Oyster Creek Generating Station, April – June, 2010

Oyster Creek Alpha

Period of Record: April - June 2010
 Stability Class - Moderately Stable - 150Ft-33Ft Delta-T (F)
 Winds Measured at 33 Feet

Wind Direction	Wind Speed (in mph)						Total
	1-3	4-7	8-12	13-18	19-24	> 24	
N	2	2	0	0	0	0	4
NNE	0	0	0	0	0	0	0
NE	1	0	0	0	0	0	1
ENE	0	0	0	0	0	0	0
E	0	0	0	0	0	0	0
ESE	0	0	0	0	0	0	0
SE	5	0	0	0	0	0	5
SSE	2	0	0	0	0	0	2
S	4	1	0	0	0	0	5
SSW	9	9	1	0	0	0	19
SW	11	14	1	0	0	0	26
WSW	18	33	0	0	0	0	51
W	13	14	0	0	0	0	27
WNW	11	8	0	0	0	0	19
NW	6	10	0	0	0	0	16
NNW	5	3	0	0	0	0	8
Variable	0	0	0	0	0	0	0
Total	87	94	2	0	0	0	183

Hours of calm in this stability class: 0
 Hours of missing wind measurements in this stability class: 0
 Hours of missing stability measurements in all stability classes: 8

Oyster Creek 2010 Air Quality Active Effluent Release Report

Table D – 3 Wind Speed by Direction Measured at 33 Feet for various Stability Classes for the Oyster Creek Generating Station, April – June, 2010

Oyster Creek Alpha

Period of Record: April - June 2010
 Stability Class - Extremely Stable - 150Ft-33Ft Delta-T (F)
 Winds Measured at 33 Feet

Wind Direction	Wind Speed (in mph)						Total
	1-3	4-7	8-12	13-18	19-24	> 24	
N	4	0	0	0	0	0	4
NNE	0	0	0	0	0	0	0
NE	1	0	0	0	0	0	1
ENE	0	0	0	0	0	0	0
E	0	0	0	0	0	0	0
ESE	2	0	0	0	0	0	2
SE	3	0	0	0	0	0	3
SSE	2	2	0	0	0	0	4
S	3	0	0	0	0	0	3
SSW	10	0	0	0	0	0	10
SW	9	2	0	0	0	0	11
WSW	51	31	0	0	0	0	82
W	53	18	0	0	0	0	71
WNW	31	8	0	0	0	0	39
NW	27	9	0	0	0	0	36
NNW	2	1	0	0	0	0	3
Variable	0	0	0	0	0	0	0
Total	198	71	0	0	0	0	269

Hours of calm in this stability class: 2
 Hours of missing wind measurements in this stability class: 0
 Hours of missing stability measurements in all stability classes: 8

Oyster Creek 2010 Annual Radioactive Effluent Release Report

Table D – 400: Wind Speed by Direction Measured at 380 Feet for various Stability Classes for the Oyster Creek Generating Station, April – June, 2010

Oyster Creek Alpha

Period of Record: April - June 2010
Stability Class - Extremely Unstable - 380Ft-33Ft Delta-T (F)
Winds Measured at 380 Feet

Wind Direction	Wind Speed (in mph)						Total
	1-3	4-7	8-12	13-18	19-24	> 24	
N	0	0	0	1	0	0	1
NNE	0	0	3	0	0	0	3
NE	0	0	0	5	0	0	5
ENE	0	0	2	3	0	0	5
E	0	0	5	0	0	0	5
ESE	0	1	6	0	0	0	7
SE	0	1	2	2	0	0	5
SSE	0	0	2	0	0	0	2
S	0	0	3	0	0	0	3
SSW	0	0	0	0	0	0	0
SW	0	0	2	1	0	0	3
WSW	0	0	0	9	8	0	17
W	0	1	1	14	8	9	33
WNW	0	0	2	5	9	8	24
NW	0	0	2	17	17	2	38
NNW	0	0	1	4	1	0	6
Variable	0	0	0	0	0	0	0
Total	0	3	31	61	43	19	157

Hours of calm in this stability class: 0
 Hours of missing wind measurements in this stability class: 0
 Hours of missing stability measurements in all stability classes: 7

Oyster Creek 2010 Annual Radioactive Effluent Release Report

Table D – 4 Wind Speed by Direction Measured at 380 Feet for various Stability Classes for the Oyster Creek Generating Station; April – June, 2010

Oyster Creek Alpha

Period of Record: April - June 2010
Stability Class - Moderately Unstable - 380Ft-33Ft Delta-T (F)
Winds Measured at 380 Feet

Wind Direction	Wind Speed (in mph)						Total
	1-3	4-7	8-12	13-18	19-24	> 24	
N	0	1	0	0	0	0	1
NNE	0	1	1	0	0	0	2
NE	0	1	3	1	0	0	5
ENE	0	0	9	1	0	0	10
E	0	2	7	1	0	0	10
ESE	0	1	8	0	0	0	9
SE	0	0	18	6	0	0	24
SSE	0	0	9	6	1	0	16
S	0	0	3	7	2	0	12
SSW	0	0	0	4	4	0	8
SW	0	0	1	5	0	0	6
WSW	0	1	4	5	2	1	13
W	0	0	1	6	4	2	13
WNW	0	0	4	7	2	4	17
NW	0	0	6	10	7	2	25
NNW	0	0	2	6	0	0	8
Variable	0	0	0	0	0	0	0
Total	0	7	76	65	22	9	179

Hours of calm in this stability class: 0
 Hours of missing wind measurements in this stability class: 0
 Hours of missing stability measurements in all stability classes: 7

Oyster Creek 2010 Annual Radioactive Effluent Release Report

Table D – 4: Wind Speed by Direction Measured at 380 Feet for various Stability Classes for the Oyster Creek Generating Station, April – June, 2010

Oyster Creek Alpha

Period of Record: April - June 2010
Stability Class - Slightly Unstable - 380Ft-33Ft Delta-T (F)
Winds Measured at 380 Feet

Wind Direction	Wind Speed (in mph)						Total
	1-3	4-7	8-12	13-18	19-24	> 24	
N	0	1	0	0	0	0	1
NNE	0	1	0	0	0	0	1
NE	0	2	2	1	0	0	5
ENE	0	2	7	1	0	0	10
E	0	2	6	0	0	0	8
ESE	0	3	6	1	0	0	10
SE	0	2	14	3	0	0	19
SSE	0	2	9	7	1	0	19
S	0	0	5	8	1	0	14
SSW	0	0	5	4	6	3	18
SW	0	1	6	1	2	0	10
WSW	0	1	3	6	3	0	13
W	0	1	1	5	0	0	7
WNW	0	3	3	4	6	4	20
NW	0	4	2	7	8	4	25
NNW	0	2	1	4	0	0	7
Variable	0	0	0	0	0	0	0
Total	0	27	70	52	27	11	187

Hours of calm in this stability class: 0
 Hours of missing wind measurements in this stability class: 0
 Hours of missing stability measurements in all stability classes: 7

Oyster Creek 2010 Annual Radioactive Effluent Release Report

Table D – 4 Wind Speed by Direction Measured at 380 Feet for various Stability Classes for the Oyster Creek Generating Station, April – June, 2010

Oyster Creek Alpha

Period of Record: April - June 2010
 Stability Class - Neutral - 380Ft-33Ft Delta-T (F)
 Winds Measured at 380 Feet

Wind Direction	Wind Speed (in mph)						Total
	1-3	4-7	8-12	13-18	19-24	> 24	
N	1	2	4	6	0	0	13
NNE	0	9	15	1	7	0	32
NE	1	16	25	17	4	0	63
ENE	0	12	14	14	5	9	54
E	0	4	7	5	0	0	16
ESE	0	4	14	2	3	0	23
SE	0	10	19	9	7	0	45
SSE	0	5	24	9	1	0	39
S	0	5	37	23	3	0	68
SSW	1	4	26	36	7	6	80
SW	0	2	8	18	5	0	33
WSW	0	5	10	24	13	4	56
W	1	1	11	16	4	3	36
WNW	0	2	13	30	9	15	69
NW	1	3	8	11	16	7	46
NNW	1	4	8	15	2	2	32
Variable	0	0	0	0	0	0	0
Total	6	88	243	236	86	46	705

Hours of calm in this stability class: 0
 Hours of missing wind measurements in this stability class: 0
 Hours of missing stability measurements in all stability classes: 7

Oyster Creek 2010 Annual Inertive Effluent Release Report

Table D – 4 Wind Speed by Direction Measured at 380 Feet for various Stability Classes for the Oyster Creek Generating Station, April – June, 2010

Oyster Creek Alpha

Period of Record: April - June 2010
Stability Class - Slightly Stable - 380Ft-33Ft Delta-T (F)
Winds Measured at 380 Feet

Wind Direction	Wind Speed (in mph)						Total
	1-3	4-7	8-12	13-18	19-24	> 24	
N	0	1	6	5	2	0	14
NNE	1	0	4	3	0	0	8
NE	0	2	4	4	1	0	11
ENE	0	2	4	4	0	0	10
E	0	3	3	2	0	0	8
ESE	0	0	2	1	0	0	3
SE	0	2	3	2	0	0	7
SSE	0	0	4	3	2	0	9
S	0	2	13	19	1	0	35
SSW	1	5	20	35	16	2	79
SW	0	3	8	44	50	10	115
WSW	0	5	3	21	13	3	45
W	1	5	3	15	12	1	37
WNW	0	2	8	10	13	2	35
NW	1	2	2	12	7	0	24
NNW	0	3	4	7	8	0	22
Variable	0	0	0	0	0	0	0
Total	4	37	91	187	125	18	462

Hours of calm in this stability class: 0
Hours of missing wind measurements in this stability class: 0
Hours of missing stability measurements in all stability classes: 7

Oyster Creek 2010 Annual Radiologically Active Effluent Release Report

Table D-4 Wind Speed by Direction Measured at 380 Feet for various Stability Classes for the Oyster Creek Generating Station, April - June, 2010

Oyster Creek Alpha

Period of Record: April - June 2010
Stability Class - Moderately Stable - 380Ft-33Ft Delta-T (F)
Winds Measured at 380 Feet

Wind Direction	Wind Speed (in mph)						Total
	1-3	4-7	8-12	13-18	19-24	> 24	
N	0	0	4	15	9	0	28
NNE	0	0	1	2	1	0	4
NE	0	0	2	2	0	0	4
ENE	0	0	0	1	0	0	1
E	0	0	0	0	0	0	0
ESE	0	1	0	0	0	0	1
SE	0	1	0	0	0	0	1
SSE	0	1	0	4	0	0	5
S	2	2	4	2	0	0	10
SSW	1	2	7	11	2	1	24
SW	0	0	1	11	18	15	45
WSW	0	1	0	4	20	6	31
W	0	1	3	14	18	6	42
WNW	0	1	3	14	10	6	34
NW	0	1	6	4	11	0	22
NNW	0	0	1	11	17	1	30
Variable	0	0	0	0	0	0	0
Total	3	11	32	95	106	35	282

Hours of calm in this stability class: 0
 Hours of missing wind measurements in this stability class: 0
 Hours of missing stability measurements in all stability classes: 7

Oyster Creek 2010 Annual Radioactive Effluent Release Report

Table D – 4 Wind Speed by Direction Measured at 380 Feet for various Stability Classes for the Oyster Creek Generating Station, April – June, 2010

Oyster Creek Alpha

Period of Record: April - June 2010
Stability Class - Extremely Stable - 380Ft-33Ft Delta-T (F)
Winds Measured at 380 Feet

Wind Direction	Wind Speed (in mph)						Total
	1-3	4-7	8-12	13-18	19-24	> 24	
N	0	2	3	5	8	0	18
NNE	0	1	3	2	0	0	6
NE	0	2	4	3	0	0	9
ENE	0	3	2	0	0	0	5
E	1	1	0	2	0	0	4
ESE	1	1	0	0	0	0	2
SE	0	0	0	1	0	0	1
SSE	0	2	3	2	0	0	7
S	1	0	5	5	0	0	11
SSW	0	2	1	0	2	0	5
SW	1	1	1	9	2	2	16
WSW	0	1	1	10	8	3	23
W	0	0	4	9	6	6	25
WNW	1	1	6	4	9	5	26
NW	2	1	10	11	10	0	34
NNW	1	1	4	4	2	1	13
Variable	0	0	0	0	0	0	0
Total	8	19	47	67	47	17	205

Hours of calm in this stability class: 0
Hours of missing wind measurements in this stability class: 0
Hours of missing stability measurements in all stability classes: 7

Oyster Creek 2010 Annual Radioactive Effluent Release Report

Table D – 5 Wind Speed by Direction Measured at 33 Feet for various Stability Classes for the Oyster Creek Generating Station, July – September, 2010

Oyster Creek Alpha

Period of Record: July - September 2010
 Stability Class - Extremely Unstable - 150Ft-33Ft Delta-T (F)
 Winds Measured at 33 Feet

Wind Direction	Wind Speed (in mph)						Total
	1-3	4-7	8-12	13-18	19-24	> 24	
N	1	6	4	0	0	0	11
NNE	0	12	2	0	0	0	14
NE	1	8	2	0	0	0	11
ENE	1	25	25	0	0	0	51
E	0	20	26	0	0	0	46
ESE	0	21	24	0	0	0	45
SE	0	12	41	1	0	0	54
SSE	0	11	50	3	0	0	64
S	1	4	39	16	0	0	60
SSW	0	9	10	0	0	0	19
SW	1	14	22	0	0	0	37
WSW	3	12	19	7	0	0	41
W	0	17	31	4	0	0	52
WNW	0	19	50	1	0	0	70
NW	3	23	19	0	0	0	45
NNW	2	16	16	0	0	0	34
Variable	0	0	0	0	0	0	0
Total	13	229	380	32	0	0	654

Hours of calm in this stability class: 0
 Hours of missing wind measurements in this stability class: 0
 Hours of missing stability measurements in all stability classes: 1

Oyster Creek 2010 Annual Inertive Effluent Release Report

Table D – 5 : Wind Speed by Direction Measured at 33 Feet for various Stability Classes for the Oyster Creek Generating Station, July – September, 2010

Oyster Creek Alpha

Period of Record: July - September 2010
Stability Class - Moderately Unstable - 150Ft-33Ft Delta-T (F)
Winds Measured at 33 Feet

Wind Direction	Wind Speed (in mph)						Total
	1-3	4-7	8-12	13-18	19-24	> 24	
N	1	1	0	0	0	0	2
NNE	0	1	1	0	0	0	2
NE	1	2	3	0	0	0	6
ENE	0	0	1	0	0	0	1
E	0	2	3	0	0	0	5
ESE	1	1	1	0	0	0	3
SE	0	4	0	0	0	0	4
SSE	1	6	3	2	0	0	12
S	0	3	12	2	0	0	17
SSW	0	2	6	0	0	0	8
SW	0	0	0	0	0	0	0
WSW	0	2	3	0	0	0	5
W	0	5	3	0	0	0	8
WNW	1	1	2	0	0	0	4
NW	0	10	2	0	0	0	12
NNW	2	1	1	0	0	0	4
Variable	0	0	0	0	0	0	0
Total	7	41	41	4	0	0	93

Hours of calm in this stability class: 0
Hours of missing wind measurements in this stability class: 0
Hours of missing stability measurements in all stability classes: 1

Oyster Creek 2010 Annual Radioactive Effluent Release Report

Table D – 5 Wind Speed by Direction Measured at 33 Feet for various Stability Classes for the Oyster Creek Generating Station, July – September, 2010

Oyster Creek Alpha

Period of Record: July - September 2010
Stability Class - Slightly Unstable - 150Ft-33Ft Delta-T (F)
Winds Measured at 33 Feet

Wind Direction	Wind Speed (in mph)						Total
	1-3	4-7	8-12	13-18	19-24	> 24	
N	1	2	2	0	0	0	5
NNE	0	2	2	0	0	0	4
NE	0	0	0	0	0	0	0
ENE	0	0	2	0	0	0	2
E	0	0	3	0	0	0	3
ESE	0	3	1	0	0	0	4
SE	0	1	0	0	0	0	1
SSE	0	4	2	5	0	0	11
S	0	1	6	1	0	0	8
SSW	0	0	1	0	0	0	1
SW	1	1	3	0	0	0	5
WSW	1	2	1	0	0	0	4
W	0	1	1	0	0	0	2
WNW	0	1	2	0	0	0	3
NW	1	4	0	0	0	0	5
NNW	0	0	1	0	0	0	1
Variable	0	0	0	0	0	0	0
Total	4	22	27	6	0	0	59

Hours of calm in this stability class: 0
Hours of missing wind measurements in this stability class: 0
Hours of missing stability measurements in all stability classes: 1

Oyster Creek 2010 Annual Radioactive Effluent Release Report

Table D – 5 Wind Speed by Direction Measured at 33-Feet for various Stability Classes for the Oyster Creek Generating Station, July – September, 2010

Oyster Creek Alpha

Period of Record: July - September 2010
 Stability Class - Neutral - 150Ft-33Ft Delta-T (F)
 Winds Measured at 33 Feet

Wind Direction	Wind Speed (in mph)						Total
	1-3	4-7	8-12	13-18	19-24	> 24	
N	3	16	2	0	0	0	21
NNE	2	7	8	0	0	0	17
NE	1	4	12	0	0	0	17
ENE	1	1	7	0	0	0	9
E	0	16	12	0	0	0	28
ESE	0	27	2	0	0	0	29
SE	2	19	12	0	0	0	33
SSE	2	12	20	10	0	0	44
S	3	21	22	5	0	0	51
SSW	3	17	21	0	0	0	41
SW	4	11	3	0	0	0	18
WSW	3	12	2	0	0	0	17
W	1	11	1	0	0	0	13
WNW	3	12	3	0	0	0	18
NW	4	10	1	0	0	0	15
NNW	2	9	2	0	0	0	13
Variable	0	0	0	0	0	0	0
Total	34	205	130	15	0	0	384

Hours of calm in this stability class: 0
 Hours of missing wind measurements in this stability class: 0
 Hours of missing stability measurements in all stability classes: 1

Oyster Creek 2010 Annual Radioactive Effluent Release Report

Table D – 5 Wind Speed by Direction Measured at 33 Feet for various Stability Classes for the Oyster Creek Generating Station, July – September, 2010

Oyster Creek Alpha

Period of Record: July - September 2010
Stability Class - Slightly Stable - 150Ft-33Ft Delta-T (F)
Winds Measured at 33 Feet

Wind Direction	Wind Speed (in mph)						Total
	1-3	4-7	8-12	13-18	19-24	> 24	
N	6	14	0	0	0	0	20
NNE	1	9	0	0	0	0	10
NE	3	4	0	0	0	0	7
ENE	1	17	1	0	0	0	19
E	0	10	0	0	0	0	10
ESE	4	8	1	0	0	0	13
SE	7	13	0	1	0	0	21
SSE	16	17	7	1	0	0	41
S	13	43	4	0	0	0	60
SSW	9	42	20	0	0	0	71
SW	10	42	5	0	0	0	57
WSW	23	53	0	0	0	0	76
W	9	18	1	0	0	0	28
WNW	8	20	3	0	0	0	31
NW	16	21	0	0	0	0	37
NNW	11	14	2	0	0	0	27
Variable	0	0	0	0	0	0	0
Total	137	345	44	2	0	0	528

Hours of calm in this stability class: 0
 Hours of missing wind measurements in this stability class: 1
 Hours of missing stability measurements in all stability classes: 1

Oyster Creek 2010 Annual Radiative Effluent Release Report

Table D – 5 Wind Speed by Direction Measured at 33 Feet for various Stability Classes for the Oyster Creek Generating Station, July – September, 2010

Oyster Creek Alpha

Period of Record: July - September 2010
 Stability Class - Moderately Stable - 150Ft-33Ft Delta-T (F)
 Winds Measured at 33 Feet

Wind Direction	Wind Speed (in mph)						Total
	1-3	4-7	8-12	13-18	19-24	> 24	
N	2	1	0	0	0	0	3
NNE	1	0	0	0	0	0	1
NE	0	3	0	0	0	0	3
ENE	0	1	0	0	0	0	1
E	0	1	0	0	0	0	1
ESE	1	1	0	0	0	0	2
SE	2	0	0	0	0	0	2
SSE	3	0	0	0	0	0	3
S	7	2	0	0	0	0	9
SSW	7	3	0	0	0	0	10
SW	11	10	0	0	0	0	21
WSW	14	22	0	0	0	0	36
W	21	5	0	0	0	0	26
WNW	16	7	0	0	0	0	23
NW	11	11	0	0	0	0	22
NNW	0	3	0	0	0	0	3
Variable	0	0	0	0	0	0	0
Total	96	70	0	0	0	0	166

Hours of calm in this stability class: 0
 Hours of missing wind measurements in this stability class: 0
 Hours of missing stability measurements in all stability classes: 1

Oyster Creek 2010 Annual Report - Inactive Effluent Release Report

Table D – 5 Wind Speed by Direction Measured at 33 Feet for various Stability Classes for the Oyster Creek Generating Station, July – September, 2010

Oyster Creek Alpha

Period of Record: July - September 2010
 Stability Class - Extremely Stable - 150Ft-33Ft Delta-T (F)
 Winds Measured at 33 Feet

Wind Direction	Wind Speed (in mph)						Total
	1-3	4-7	8-12	13-18	19-24	> 24	
N	3	0	0	0	0	0	3
NNE	0	0	0	0	0	0	0
NE	1	0	0	0	0	0	1
ENE	0	0	0	0	0	0	0
E	1	0	0	0	0	0	1
ESE	0	0	0	0	0	0	0
SE	0	0	0	0	0	0	0
SSE	1	0	0	0	0	0	1
S	1	0	0	0	0	0	1
SSW	5	0	0	0	0	0	5
SW	12	2	0	0	0	0	14
WSW	70	20	0	0	0	0	90
W	83	11	0	0	0	0	94
WNW	51	9	0	0	0	0	60
NW	31	14	0	0	0	0	45
NNW	5	2	0	0	0	0	7
Variable	0	0	0	0	0	0	0
Total	264	58	0	0	0	0	322

Hours of calm in this stability class: 0
 Hours of missing wind measurements in this stability class: 0
 Hours of missing stability measurements in all stability classes: 1

Oyster Creek 2010 Annual Radioactive Effluent Release Report

Table D – 6. Wind Speed by Direction Measured at 380 Feet for various Stability Classes for the Oyster Creek Generating Station, July – September, 2010

Oyster Creek Alpha

Period of Record: July - September 2010
Stability Class - Extremely Unstable - 380Ft-33Ft Delta-T (F)
Winds Measured at 380 Feet

Wind Direction	Wind Speed (in mph)						Total
	1-3	4-7	8-12	13-18	19-24	> 24	
N	0	0	0	0	0	0	0
NNE	0	0	0	0	0	0	0
NE	0	0	0	1	0	0	1
ENE	0	0	0	1	1	0	2
E	0	0	7	0	0	0	7
ESE	0	0	3	2	0	0	5
SE	0	0	0	6	0	0	6
SSE	0	0	0	1	0	0	1
S	0	0	1	6	1	0	8
SSW	0	0	1	1	0	0	2
SW	0	0	0	4	0	0	4
WSW	0	0	0	3	1	0	4
W	0	0	1	5	7	2	15
WNW	0	0	0	9	1	0	10
NW	0	0	2	6	5	0	13
NNW	0	0	1	0	0	0	1
Variable	0	0	0	0	0	0	0
Total	0	0	16	45	16	2	79

Hours of calm in this stability class: 0
 Hours of missing wind measurements in this stability class: 0
 Hours of missing stability measurements in all stability classes: 6

Oyster Creek 2010 Annual Radioactive Effluent Release Report

Table D – 6 Wind Speed by Direction Measured at 380 Feet for various Stability Classes for the Oyster Creek Generating Station, July – September, 2010

Oyster Creek Alpha

Period of Record: July - September 2010
Stability Class - Moderately Unstable - 380Ft-33Ft Delta-T (F)
Winds Measured at 380 Feet

Wind Direction	Wind Speed (in mph)						Total
	1-3	4-7	8-12	13-18	19-24	> 24	
N	0	0	1	5	0	0	6
NNE	0	0	0	0	0	0	0
NE	0	0	1	0	0	0	1
ENE	0	0	7	4	2	0	13
E	0	0	5	3	0	0	8
ESE	0	0	5	4	0	0	9
SE	0	0	8	3	0	0	11
SSE	0	0	4	8	0	0	12
S	0	0	4	16	0	0	20
SSW	0	0	3	4	2	0	9
SW	0	0	4	5	1	0	10
WSW	0	0	3	7	1	0	11
W	0	0	0	2	5	0	7
WNW	0	0	6	7	2	0	15
NW	0	0	5	12	0	1	18
NNW	0	0	2	5	0	0	7
Variable	0	0	0	0	0	0	0
Total	0	0	58	85	13	1	157

Hours of calm in this stability class: 0
 Hours of missing wind measurements in this stability class: 0
 Hours of missing stability measurements in all stability classes: 6

Oyster Creek 2010 Annual Inertive Effluent Release Report

Table D – 6 Wind Speed by Direction Measured at 380 Feet for various Stability Classes for the Oyster Creek Generating Station, July – September, 2010

Oyster Creek Alpha

Period of Record: July - September 2010
Stability Class - Slightly Unstable - 380Ft-33Ft Delta-T (F)
Winds Measured at 380 Feet

Wind Direction	Wind Speed (in mph)						Total
	1-3	4-7	8-12	13-18	19-24	> 24	
N	0	1	5	4	0	0	10
NNE	0	2	3	1	2	0	8
NE	0	0	3	1	0	0	4
ENE	0	1	9	1	0	1	12
E	0	1	5	5	0	0	11
ESE	0	4	16	0	0	0	20
SE	0	0	15	3	0	0	18
SSE	0	1	9	16	0	0	26
S	0	0	5	10	5	0	20
SSW	0	0	6	8	3	1	18
SW	0	0	5	2	0	0	7
WSW	0	0	2	3	2	0	7
W	0	0	4	5	3	1	13
WNW	0	0	7	9	0	0	16
NW	0	0	3	11	2	0	16
NNW	0	1	2	2	0	0	5
Variable	0	0	0	0	0	0	0
Total	0	11	99	81	17	3	211

Hours of calm in this stability class: 0
 Hours of missing wind measurements in this stability class: 0
 Hours of missing stability measurements in all stability classes: 6

Oyster Creek 2010 Annual Radioactive Effluent Release Report

Table D – 6 Wind Speed by Direction Measured at 380 Feet for various Stability Classes for the Oyster Creek Generating Station, July – September, 2010

Oyster Creek Alpha
 Period of Record: July - September 2010
 Stability Class - Neutral - 380Ft-33Ft Delta-T (F)
 Winds Measured at 380 Feet

Wind Direction	Wind Speed (in mph)						Total
	1-3	4-7	8-12	13-18	19-24	> 24	
N	0	8	2	16	1	0	27
NNE	2	6	15	23	1	0	47
NE	0	4	10	12	8	0	34
ENE	1	7	8	3	10	0	29
E	0	2	16	13	12	0	43
ESE	0	7	38	9	0	0	54
SE	0	5	32	12	2	0	51
SSE	0	11	27	22	13	16	89
S	0	4	28	33	16	0	81
SSW	0	6	16	50	20	2	94
SW	1	5	12	13	4	0	35
WSW	3	8	1	18	5	0	35
W	1	7	14	18	4	0	44
WNW	1	4	13	10	0	0	28
NW	3	5	17	23	5	1	54
NNW	0	8	13	14	1	0	36
Variable	0	0	0	0	0	0	0
Total	12	97	262	289	102	19	781

Hours of calm in this stability class: 0
 Hours of missing wind measurements in this stability class: 0
 Hours of missing stability measurements in all stability classes: 6

Oyster Creek 2010 Annual Radioactive Effluent Release Report

Table D – 6: Wind Speed by Direction Measured at 380 Feet for various Stability Classes for the Oyster Creek Generating Station, July – September, 2010

Oyster Creek Alpha

Period of Record: July - September 2010
Stability Class - Slightly Stable - 380Ft-33Ft Delta-T (F)
Winds Measured at 380 Feet

Wind Direction	Wind Speed (in mph)						Total
	1-3	4-7	8-12	13-18	19-24	> 24	
N	1	6	10	6	0	0	23
NNE	0	4	6	11	0	0	21
NE	2	4	4	0	0	0	10
ENE	0	1	1	10	0	0	12
E	1	1	3	11	0	0	16
ESE	1	3	11	2	0	0	17
SE	0	4	9	3	0	1	17
SSE	0	3	13	5	1	1	23
S	0	4	10	16	0	0	30
SSW	0	1	14	45	9	1	70
SW	1	1	4	39	38	0	83
WSW	0	3	15	21	15	1	55
W	1	2	6	17	8	4	38
WNW	0	0	3	20	11	2	36
NW	0	2	2	13	13	0	30
NNW	1	1	8	13	8	0	31
Variable	0	0	0	0	0	0	0
Total	8	40	119	232	103	10	512

Hours of calm in this stability class: 0
 Hours of missing wind measurements in this stability class: 1
 Hours of missing stability measurements in all stability classes: 6

Oyster Creek 2010 Annual Radioactive Effluent Release Report

Table D – 6 Wind Speed by Direction Measured at 380 Feet for various Stability Classes for the Oyster Creek Generating Station, July – September, 2010

Oyster Creek Alpha
 Period of Record: July - September 2010
 Stability Class - Moderately Stable - 380Ft-33Ft Delta-T (F)
 Winds Measured at 380 Feet

Wind Direction	Wind Speed (in mph)						Total
	1-3	4-7	8-12	13-18	19-24	> 24	
N	0	0	3	19	14	0	36
NNE	0	0	5	2	0	0	7
NE	0	2	3	0	0	0	5
ENE	0	1	1	3	0	0	5
E	0	1	0	0	0	0	1
ESE	0	2	0	0	0	0	2
SE	0	1	1	0	0	0	2
SSE	0	3	5	1	0	0	9
S	0	2	8	3	0	0	13
SSW	1	1	6	2	0	0	10
SW	0	2	3	10	15	1	31
WSW	0	0	2	10	10	2	24
W	0	1	1	12	5	4	23
WNW	0	0	6	6	15	1	28
NW	0	0	1	12	12	1	26
NNW	0	0	7	13	10	0	30
Variable	0	0	0	0	0	0	0
Total	1	16	52	93	81	9	252

Hours of calm in this stability class: 0
 Hours of missing wind measurements in this stability class: 0
 Hours of missing stability measurements in all stability classes: 6

Oyster Creek 2010 Annual Performance Efficiency Report

Table D – 6 Wind Speed by Direction Measured at 380 Feet for various Stability Classes for the Oyster Creek Generating Station, July – September, 2010

Oyster Creek Alpha

Period of Record: July - September 2010
Stability Class - Extremely Stable - 380Ft-33Ft Delta-T (F)
Winds Measured at 380 Feet

Wind Direction	Wind Speed (in mph)						Total
	1-3	4-7	8-12	13-18	19-24	> 24	
N	0	2	10	19	7	0	38
NNE	1	2	10	6	0	0	19
NE	0	3	5	1	0	0	9
ENE	0	0	2	0	0	0	2
E	0	0	1	0	0	0	1
ESE	0	3	2	0	0	0	5
SE	0	4	2	0	0	0	6
SSE	1	1	7	0	0	0	9
S	0	1	1	1	0	0	3
SSW	0	1	2	2	0	0	5
SW	0	0	4	2	2	0	8
WSW	0	4	2	4	8	1	19
W	0	3	2	13	8	0	26
WNW	0	1	3	4	7	0	15
NW	0	0	5	11	7	0	23
NNW	0	0	3	15	3	0	21
Variable	0	0	0	0	0	0	0
Total	2	25	61	78	42	1	209

Hours of calm in this stability class: 0
 Hours of missing wind measurements in this stability class: 0
 Hours of missing stability measurements in all stability classes: 6

Oyster Creek 2010 Annual Radioactive Effluent Release Report

Table D-7 Wind Speed by Direction Measured at 33 Feet for various Stability Classes for the Oyster Creek Generating Station, October - December, 2010

Oyster Creek Alpha

Period of Record: October - December 2010
Stability Class - Extremely Unstable - 150Ft-33Ft Delta-T (F)
Winds Measured at 33 Feet

Wind Direction	Wind Speed (in mph)						Total
	1-3	4-7	8-12	13-18	19-24	> 24	
N	0	10	2	0	0	0	12
NNE	0	7	9	0	0	0	16
NE	0	5	0	0	0	0	5
ENE	0	10	6	0	0	0	16
E	0	4	1	0	0	0	5
ESE	1	6	0	0	0	0	7
SE	0	6	6	0	0	0	12
SSE	0	1	1	0	0	0	2
S	0	2	8	0	0	0	10
SSW	0	3	5	1	0	0	9
SW	0	11	5	0	0	0	16
WSW	0	14	27	1	0	0	42
W	0	9	25	23	0	0	57
WNW	1	15	45	23	0	0	84
NW	0	28	39	18	4	0	89
NNW	0	11	11	1	0	0	23
Variable	0	0	0	0	0	0	0
Total	2	142	190	67	4	0	405

Hours of calm in this stability class: 0
 Hours of missing wind measurements in this stability class: 0
 Hours of missing stability measurements in all stability classes: 6

Oyster Creek 2010 Annual Radioactive Effluent Release Report

Table D - 7 Wind Speed by Direction Measured at 33 Feet for various Stability Classes for the Oyster Creek Generating Station, October - December, 2010

Oyster Creek Alpha

Period of Record: October - December 2010
 Stability Class - Moderately Unstable - 150Ft-33Ft Delta-T (F)
 Winds Measured at 33 Feet

Wind Direction	Wind Speed (in mph)						Total
	1-3	4-7	8-12	13-18	19-24	> 24	
N	0	1	2	0	0	0	3
NNE	2	0	4	0	0	0	6
NE	0	1	1	0	0	0	2
ENE	0	2	0	0	0	0	2
E	2	2	0	0	0	0	4
ESE	1	1	1	0	0	0	3
SE	0	0	1	0	0	0	1
SSE	0	4	0	0	0	0	4
S	0	1	3	0	0	0	4
SSW	0	0	0	0	0	0	0
SW	0	3	5	0	0	0	8
WSW	2	5	7	0	0	0	14
W	1	7	4	4	0	0	16
WNW	1	8	18	3	0	0	30
NW	0	6	5	1	0	0	12
NNW	1	4	0	0	0	0	5
Variable	0	0	0	0	0	0	0
Total	10	45	51	8	0	0	114

Hours of calm in this stability class: 0
 Hours of missing wind measurements in this stability class: 0
 Hours of missing stability measurements in all stability classes: 6

Oyster Creek 2010 Annual Radioactive Effluent Release Report

Table D-7 Wind Speed by Direction Measured at 33 Feet for various Stability Classes for the Oyster Creek Generating Station, October - December, 2010

Oyster Creek Alpha

Period of Record: October - December 2010
 Stability Class - Slightly Unstable - 150Ft-33Ft Delta-T (F)
 Winds Measured at 33 Feet

Wind Direction	Wind Speed (in mph)						Total
	1-3	4-7	8-12	13-18	19-24	> 24	
N	1	1	1	0	0	0	3
NNE	0	0	0	0	0	0	0
NE	0	0	0	0	0	0	0
ENE	0	0	0	0	0	0	0
E	0	0	0	0	0	0	0
ESE	0	1	1	0	0	0	2
SE	0	2	1	0	0	0	3
SSE	0	0	0	0	0	0	0
S	0	0	1	0	0	0	1
SSW	0	0	1	0	0	0	1
SW	0	1	0	0	0	0	1
WSW	0	0	2	1	0	0	3
W	2	1	5	1	0	0	9
WNW	0	1	11	4	0	0	16
NW	0	5	4	1	1	0	11
NNW	1	3	3	1	0	0	8
Variable	0	0	0	0	0	0	0
Total	4	15	30	8	1	0	58

Hours of calm in this stability class: 0
 Hours of missing wind measurements in this stability class: 0
 Hours of missing stability measurements in all stability classes: 6

Oyster Creek 2010 Annual Radioactive Effluent Release Report

Table D – 7. Wind Speed by Direction Measured at 33 Feet for various Stability Classes for the Oyster Creek Generating Station, October – December, 2010

Oyster Creek Alpha

Period of Record: October - December 2010
 Stability Class - Neutral - 150Ft-33Ft Delta-T (F)
 Winds Measured at 33 Feet

Wind Direction	Wind Speed (in mph)						Total
	1-3	4-7	8-12	13-18	19-24	> 24	
N	1	6	2	0	0	0	9
NNE	1	2	11	0	0	0	14
NE	3	0	8	0	0	0	11
ENE	1	0	1	0	0	0	2
E	3	1	6	1	0	0	11
ESE	0	11	7	0	0	0	18
SE	1	1	14	9	0	0	25
SSE	2	6	1	2	0	0	11
S	0	5	17	2	0	0	24
SSW	0	4	20	0	0	0	24
SW	1	5	3	0	0	0	9
WSW	7	10	10	0	0	0	27
W	3	12	32	5	0	0	52
WNW	2	36	48	12	0	0	98
NW	10	22	44	12	0	0	88
NNW	1	13	17	1	0	0	32
Variable	0	0	0	0	0	0	0
Total	36	134	241	44	0	0	455

Hours of calm in this stability class: 0
 Hours of missing wind measurements in this stability class: 0
 Hours of missing stability measurements in all stability classes: 6

Oyster Creek 2010 Annual Radioactive Effluent Release Report

Table D – 7 Wind Speed by Direction Measured at 33 Feet for various Stability Classes for the Oyster Creek Generating Station, October – December, 2010

Oyster Creek Alpha

Period of Record: October - December 2010
Stability Class - Slightly Stable - 150Ft-33Ft Delta-T (F)
Winds Measured at 33 Feet

Wind Direction	Wind Speed (in mph)						Total
	1-3	4-7	8-12	13-18	19-24	> 24	
N	6	5	0	0	0	0	11
NNE	4	1	6	0	0	0	11
NE	6	0	8	0	0	0	14
ENE	3	6	1	0	0	0	10
E	3	8	0	0	0	0	11
ESE	1	5	0	1	0	0	7
SE	1	3	4	3	2	0	13
SSE	1	2	2	2	2	0	9
S	2	10	7	5	0	0	24
SSW	6	27	9	0	0	0	42
SW	3	34	11	0	0	0	48
WSW	8	69	8	0	0	0	85
W	19	66	25	0	0	0	110
WNW	17	66	11	1	0	0	95
NW	7	44	13	0	0	0	64
NNW	3	15	1	0	0	0	19
Variable	0	0	0	0	0	0	0
Total	90	361	106	12	4	0	573

Hours of calm in this stability class: 0
Hours of missing wind measurements in this stability class: 3
Hours of missing stability measurements in all stability classes: 6

Oyster Creek 2010 Annual Predictive Effluent Release Report

Table D – 7 Wind Speed by Direction Measured at 33 Feet for various Stability Classes for the Oyster Creek Generating Station, October – December, 2010

Oyster Creek Alpha

Period of Record: October – December 2010
 Stability Class - Moderately Stable - 150Ft-33Ft Delta-T (F)
 Winds Measured at 33 Feet

Wind Direction	Wind Speed (in mph)						Total
	1-3	4-7	8-12	13-18	19-24	> 24	
N	3	0	0	0	0	0	3
NNE	0	0	1	0	0	0	1
NE	0	0	1	0	0	0	1
ENE	2	1	0	0	0	0	3
E	2	1	0	0	0	0	3
ESE	2	0	0	0	0	0	2
SE	2	1	0	0	0	0	3
SSE	2	2	0	0	0	0	4
S	0	1	0	0	0	0	1
SSW	6	3	1	0	0	0	10
SW	5	16	0	0	0	0	21
WSW	17	45	0	0	0	0	62
W	18	28	0	0	0	0	46
WNW	4	27	0	0	0	0	31
NW	3	18	0	0	0	0	21
NNW	6	3	0	0	0	0	9
Variable	0	0	0	0	0	0	0
Total	72	146	3	0	0	0	221

Hours of calm in this stability class: 0
 Hours of missing wind measurements in this stability class: 0
 Hours of missing stability measurements in all stability classes: 6

Oyster Creek 2010 Annual Baseline Effluent Release Report

Table D-7 Wind Speed by Direction Measured at 33 Feet for various Stability Classes for the Oyster Creek Generating Station, October - December, 2010

Oyster Creek Alpha

Period of Record: October - December 2010
Stability Class - Extremely Stable - 150Ft-33Ft Delta-T (F)
Winds Measured at 33 Feet

Wind Direction	Wind Speed (in mph)						Total
	1-3	4-7	8-12	13-18	19-24	> 24	
N	3	1	0	0	0	0	4
NNE	0	0	0	0	0	0	0
NE	1	0	0	0	0	0	1
ENE	3	0	0	0	0	0	3
E	0	0	0	0	0	0	0
ESE	3	0	0	0	0	0	3
SE	0	0	0	0	0	0	0
SSE	2	0	0	0	0	0	2
S	1	0	0	0	0	0	1
SSW	2	1	0	0	0	0	3
SW	18	2	0	0	0	0	20
WSW	75	42	0	0	0	0	117
W	94	16	0	0	0	0	110
WNW	31	9	0	0	0	0	40
NW	27	28	0	0	0	0	55
NNW	5	8	0	0	0	0	13
Variable	0	0	0	0	0	0	0
Total	265	107	0	0	0	0	372

Hours of calm in this stability class: 1
 Hours of missing wind measurements in this stability class: 0
 Hours of missing stability measurements in all stability classes: 6

Oyster Creek 2010 Annual Inactive Effluent Release Report

Table D – 8 Wind Speed by Direction Measured at 380 Feet for various Stability Classes for the Oyster Creek Generating Station, October – December, 2010

Oyster Creek Alpha

Period of Record: October - December 2010
 Stability Class - Extremely Unstable - 380Ft-33Ft Delta-T (F)
 Winds Measured at 380 Feet

Wind Direction	Wind Speed (in mph)						Total
	1-3	4-7	8-12	13-18	19-24	> 24	
N	0	0	0	0	0	0	0
NNE	0	0	0	0	0	0	0
NE	0	0	1	1	0	0	2
ENE	0	0	0	0	0	0	0
E	0	0	0	0	0	0	0
ESE	0	0	0	0	0	0	0
SE	0	0	0	0	0	0	0
SSE	0	0	0	0	0	0	0
S	0	0	0	0	0	0	0
SSW	0	0	0	0	0	0	0
SW	0	0	0	0	0	0	0
WSW	0	0	0	0	0	0	0
W	0	0	0	2	0	0	2
WNW	0	0	0	0	2	0	2
NW	0	0	0	1	2	0	3
NNW	0	0	0	0	1	0	1
Variable	0	0	0	0	0	0	0
Total	0	0	1	4	5	0	10

Hours of calm in this stability class: 0
 Hours of missing wind measurements in this stability class: 0
 Hours of missing stability measurements in all stability classes: 7

Oyster Creek 2010 Annual Radioactive Effluent Release Report

Table D – 8 Wind Speed by Direction Measured at 380 Feet for various Stability Classes for the Oyster Creek Generating Station, October – December, 2010

Oyster Creek Alpha

Period of Record: October - December 2010
Stability Class - Moderately Unstable - 380Ft-33Ft Delta-T (F)
Winds Measured at 380 Feet

Wind Direction	Wind Speed (in mph)						Total
	1-3	4-7	8-12	13-18	19-24	> 24	
N	0	0	0	0	0	0	0
NNE	0	0	2	0	0	0	2
NE	0	0	2	1	0	0	3
ENE	0	0	4	0	0	0	4
E	0	0	0	0	0	0	0
ESE	0	0	0	0	0	0	0
SE	0	0	1	0	0	0	1
SSE	0	0	0	0	0	0	0
S	0	0	0	0	0	0	0
SSW	0	0	0	0	0	0	0
SW	0	0	0	0	0	0	0
WSW	0	0	0	4	0	0	4
W	0	0	2	6	3	0	11
WNW	0	0	0	2	7	3	12
NW	0	2	2	8	17	12	41
NNW	0	0	1	1	4	1	7
Variable	0	0	0	0	0	0	0
Total	0	2	14	22	31	16	85

Hours of calm in this stability class: 0
 Hours of missing wind measurements in this stability class: 0
 Hours of missing stability measurements in all stability classes: 7

Oyster Creek 2010 Annual Radioactive Effluent Release Report

Table D – 8 Wind Speed by Direction Measured at 380 Feet for various Stability Classes for the Oyster Creek Generating Station, October – December, 2010

Oyster Creek Alpha

Period of Record: October – December 2010
 Stability Class - Slightly Unstable - 380Ft-33Ft Delta-T (F)
 Winds Measured at 380 Feet

Wind Direction	Wind Speed (in mph)						Total
	1-3	4-7	8-12	13-18	19-24	> 24	
N	0	2	4	0	0	0	6
NNE	0	0	1	1	0	0	2
NE	0	0	5	2	0	0	7
ENE	0	0	1	1	0	0	2
E	0	0	6	0	0	0	6
ESE	0	0	0	0	0	0	0
SE	0	2	3	1	0	0	6
SSE	0	0	0	1	0	0	1
S	0	0	0	0	0	0	0
SSW	0	0	1	8	0	0	9
SW	0	1	1	0	1	0	3
WSW	0	0	8	12	1	0	21
W	0	0	3	10	4	3	20
WNW	0	0	5	6	7	16	34
NW	0	0	11	10	13	12	46
NNW	0	1	6	3	4	0	14
Variable	0	0	0	0	0	0	0
Total	0	6	55	55	30	31	177

Hours of calm in this stability class: 0
 Hours of missing wind measurements in this stability class: 0
 Hours of missing stability measurements in all stability classes: 7

Oyster Creek 2010 Annual Radioactive Effluent Release Report

Table D – 8 Wind Speed by Direction Measured at 380 Feet for various Stability Classes for the
Oyster Creek Generating Station, October – December, 2010

Oyster Creek Alpha							
Period of Record: October - December 2010							
Stability Class - Neutral - 380Ft-33Ft Delta-T (F)							
Winds Measured at 380 Feet							
Wind Direction	Wind Speed (in mph)						Total
	1-3	4-7	8-12	13-18	19-24	> 24	
N	0	4	10	12	7	4	37
NNE	1	3	7	11	0	0	22
NE	0	0	4	6	16	8	34
ENE	0	2	1	1	2	0	6
E	1	4	6	0	1	0	12
ESE	3	4	5	6	0	0	18
SE	1	6	2	5	6	3	23
SSE	0	8	2	2	0	6	18
S	0	0	5	8	4	4	21
SSW	0	1	3	6	28	3	41
SW	0	0	9	7	8	0	24
WSW	0	1	10	17	6	1	35
W	0	7	6	22	28	11	74
WNW	0	7	10	37	56	39	149
NW	1	7	14	30	37	63	152
NNW	2	3	10	20	19	8	62
Variable	0	0	0	0	0	0	0
Total	9	57	104	190	218	150	728

Hours of calm in this stability class: 0
Hours of missing wind measurements in this stability class: 2
Hours of missing stability measurements in all stability classes: 7

Oyster Creek 2010 Annual Radioactive Effluent Release Report

Table D – 8. Wind Speed by Direction Measured at 380 Feet for various Stability Classes for the Oyster Creek Generating Station, October – December, 2010

Oyster Creek Alpha

Period of Record: October - December 2010
Stability Class - Slightly Stable - 380Ft-33Ft Delta-T (F)
Winds Measured at 380 Feet

Wind Direction	Wind Speed (in mph)						Total
	1-3	4-7	8-12	13-18	19-24	> 24	
N	0	2	7	11	2	0	22
NNE	0	1	5	3	1	0	10
NE	2	1	6	1	1	4	15
ENE	2	1	3	0	0	0	6
E	0	2	3	3	2	1	11
ESE	0	5	3	6	2	6	22
SE	0	7	3	2	5	14	31
SSE	0	3	4	6	3	7	23
S	0	3	4	5	2	3	17
SSW	0	0	4	4	9	1	18
SW	0	1	4	17	26	6	54
WSW	0	1	3	19	31	2	56
W	0	2	2	11	50	1	66
WNW	0	3	5	34	54	7	103
NW	0	5	8	39	65	9	126
NNW	0	1	5	19	38	1	64
Variable	0	0	0	0	0	0	0
Total	4	38	69	180	291	62	644

Hours of calm in this stability class: 0
 Hours of missing wind measurements in this stability class: 1
 Hours of missing stability measurements in all stability classes: 7

Oyster Creek 2010 Annual Radioactive Effluent Release Report

Table D – 8 Wind Speed by Direction Measured at 380 Feet for various Stability Classes for the Oyster Creek Generating Station, October – December, 2010

Oyster Creek Alpha

Period of Record: October - December 2010
Stability Class - Moderately Stable - 380Ft-33Ft Delta-T (F)
Winds Measured at 380 Feet

Wind Direction	Wind Speed (in mph)						Total
	1-3	4-7	8-12	13-18	19-24	> 24	
N	0	0	5	12	18	0	35
NNE	0	1	4	1	0	0	6
NE	0	0	0	1	1	0	2
ENE	0	4	1	0	0	0	5
E	0	2	0	1	0	0	3
ESE	0	2	5	1	0	0	8
SE	0	0	2	2	0	0	4
SSE	0	1	0	1	0	0	2
S	0	1	3	0	0	0	4
SSW	0	1	2	3	1	0	7
SW	0	1	3	2	1	1	8
WSW	1	1	6	6	11	2	27
W	0	0	1	5	15	5	26
WNW	0	1	2	5	32	6	46
NW	0	0	1	15	26	11	53
NNW	0	1	3	7	4	0	15
Variable	0	0	0	0	0	0	0
Total	1	16	38	62	109	25	251

Hours of calm in this stability class: 0
Hours of missing wind measurements in this stability class: 0
Hours of missing stability measurements in all stability classes: 7

Oyster Creek 2010 Annual Radioactive Effluent Release Report

Table D – 8 Wind Speed by Direction Measured at 380 Feet for various Stability Classes for the Oyster Creek Generating Station, October – December, 2010

Oyster Creek Alpha

Period of Record: October - December 2010
 Stability Class - Extremely Stable - 380Ft-33Ft Delta-T (F)
 Winds Measured at 380 Feet

Wind Direction	Wind Speed (in mph)						Total
	1-3	4-7	8-12	13-18	19-24	> 24	
N	0	3	10	12	8	0	33
NNE	2	4	8	22	7	0	43
NE	2	3	5	10	1	0	21
ENE	1	4	1	0	0	0	6
E	1	4	2	0	0	0	7
ESE	1	2	4	1	0	0	8
SE	2	3	5	8	0	0	18
SSE	0	1	0	0	0	0	1
S	1	2	0	0	0	0	3
SSW	0	1	3	1	1	0	6
SW	0	0	8	1	0	0	9
WSW	2	4	5	6	7	1	25
W	0	3	4	6	4	3	20
WNW	3	2	4	10	19	8	46
NW	1	1	2	17	13	1	35
NNW	0	5	5	7	5	0	22
Variable	0	0	0	0	0	0	0
Total	16	42	66	101	65	13	303

Hours of calm in this stability class: 0
 Hours of missing wind measurements in this stability class: 0
 Hours of missing stability measurements in all stability classes: 7

Appendix E
ODCM Revisions

Approval Documentation

ODCM Change Determination

CY-OC-170-301 Revision 5

Document Site Approval Form
Page 1 of 2

AD-AA-101-F-01
Revision 3

See AD-AA-101 for the procedural requirements associated with this Form.
Desktop Instruction available on Intranet or through AD functional area.

Facility: OCGS

Document Number: CY-OC-170-301 Revision: 5

Title: Offsite Dose Calculation Manual for Oyster Creek Generating Station

Superseded Documents: N/A or List:
 Check this box if superseding a document containing commitments, notify the Commitment Tracking Coordinator per LS-AA-110 so the CTD can be updated as appropriate.

Environmental Review Applicability – Is an Environmental Review applicable per EN-AA-103? No or Yes
If Yes, then attach Environmental Review documentation required per EN-AA-103.

Is this a Fleet Standard Document being processed with form AD-AA-101-F-09? No or Yes If yes, then attach the completed form AD-AA-101-F-09, skip the following section, and go to Continuation A.

Batch – Are multiple document creations/revisions/cancelations being issued to add/revise/cancel them for similar requirements? No or Yes If Yes, then identify the highest level Document and Issue Type below.

Check only one Document Type: Level 1 - Continuous Use Procedure <input type="checkbox"/> Level 2 - Reference Use Procedure <input type="checkbox"/> Level 3 - Information Use Procedure <input checked="" type="checkbox"/> T&RM <input type="checkbox"/> Form <input type="checkbox"/>	Check only one Issue Type: New <input type="checkbox"/> Revision <input checked="" type="checkbox"/> Cancel Document <input type="checkbox"/> Cancel Revision <input type="checkbox"/> Non-Permanent <input type="checkbox"/> Editorial Revision <input type="checkbox"/>	Incorporated Site Items (EC, AR, PCR, etc): _____ _____ _____
--	--	---

Revision Summary: Groundwater Remediation Project
(Attach additional description if required)

CONFIRM that **no** commitments (i.e., those steps annotated with CM-X) have been changed or deleted unless evaluated via completion of LS-AA-110 commitment change/deletion form and INITIAL [Preparer]: DLD

Preparer Dennis Oltmans 10-15-10 2588
Print Date Extension

Validation – Is substantiating this document's usability via mockup, simulated performance, field walkdown, or bench top review required? No or Yes If Yes, then attach validation documentation.
If Yes, then print name & sign for completed validation: _____

NOS Review – Excluding NDE, ISI, Peer Inspection or Independent Verification, is this document used to perform independent inspection for acceptance (including field installation inspections, fabrication inspections, receipt inspections, new fuel inspection, etc.), or for certification of inspection personnel? No or Yes
If Yes, then NOS Reviewer to print name & sign for acceptance: _____

Continuation A - Is this a T&RM, Form, or Editorial Revision? No or Yes If yes, then skip the following section and go Continuation B.

Impact on Operating and Design Margins – N/A or explain: _____
(Attach additional description if required)

<input checked="" type="checkbox"/> No <input type="checkbox"/> Yes 10CFR50.59 Applicable?	Tracking Number: _____
<input checked="" type="checkbox"/> No <input type="checkbox"/> Yes 10CFR72.48 Applicable?	
<input type="checkbox"/> No <input checked="" type="checkbox"/> Yes Other Regulatory Process Applicable?	Other Regulatory Process Number: <u>CY-AA-170-3100</u>
<input checked="" type="checkbox"/> No <input type="checkbox"/> Yes Potential security impact per SY-AA-500-127?	If Yes, then Security Reviewer acceptance documented by cross discipline review below
<input checked="" type="checkbox"/> No <input type="checkbox"/> Yes Surveillance Coordinator Review Required?	If Yes, then Surveillance Coordinator Review documented by cross discipline review below

Cross Discipline Reviews: (list below)

<u>Jack McInally</u> Print	<u>[Signature]</u> Signature	<u>10/15/2010</u> Date	<u>RP</u> Discipline or Org.
_____ Print	_____ Signature	_____ Date	_____ Discipline or Org.
_____ Print	_____ Signature	_____ Date	_____ Discipline or Org.

Attach additional if req'd

SQR Approval indicates that all required Cross-Disciplinary reviews have been performed and the reviewers have signed this form. This procedure is technically and functionally accurate for all functional areas. (See AD-AA-102)

SQR Approval: Jerome P. Chrisman 10/15/10 Chemistry
Print and Sign Date Discipline

Document Site Approval Form
Page 2 of 2

AD-AA-101-F-01
Revision 3

Continuation B - Is this a T&RM, or Form? No or Yes If yes, then skip the following section and go to Continuation C.

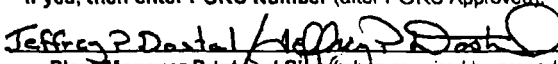
PORC Required:	If yes, then enter PORC Number (after PORC Approved):	10-8	
<input type="checkbox"/> No <input checked="" type="checkbox"/> Yes	 Jeffrey P. Dostal Plant Manager Print and Sign (when required by procedure)	10-20-10	Date

Continuation C - Is this an Editorial Revision? No or Yes If yes, then skip the following section and go to Continuation D.

Applicable Site Contact/Site Change Agents (SME): <u>Dennis Oltmans</u>			
- Responsible for Change Management information in <input checked="" type="checkbox"/> this form or <input type="checkbox"/> HU-AA-1101 Checklist (attached)			
- Responsible to shepherd the document through site review, approval/authorization, and implementation.			
Affected Functional Area(s) or Individuals:			
Print	Signature	Date	Affected FA
Print	Signature	Date	Affected FA
Print	Signature	Date	Affected FA
Attach additional if req'd			
Resources needed to Implement Change: <u>N/A</u> (Only list, if other than Level of Effort.)			
For ongoing impacts, estimate number of Full Time Equivalents (FTE). If additional resources are needed go to HU-AA-1101.			
Communication Plan: <u>Yes</u> (e.g., e-mail, Site Paper, <u>Supervisor Briefing</u> , <u>Voice Mail</u> , etc.) & <u>Q & A</u>			
Training Required / Qualifications affected: <input type="checkbox"/> No <input checked="" type="checkbox"/> Yes If yes, list: <u>JIT for Operations and Chemistry</u> (e.g., Supervisory Briefing, Tailgate Briefing, Required Reading, <u>Formal Training</u> recertification etc.)			
Update to information infrastructure (e.g. PassPort, PIMS, <u>EDMS</u> workflows, or Lotus Notes, etc.) required to support implementation (including updated forms loaded into PassPort): _____			
Records retention and document distribution requirements to be addressed with Records Management: _____			

Continuation D - If all procedurally required activities associated with this document revision have been completed and the document is ready for implementation, then SFAM to print name, sign & date for authorization to implement. Provide implementation date or, enter N/A then implementation will be upon the issuance by Records Management per RM requirements. Authorization below indicates the SFAM or a designee of the SFAM has verified the document does not alter or negatively impact compliance with regulatory requirements or station commitments.

		Interim Chg # :	<u>N/A</u>
Site Authorization:	 Mike Ford SFAM Print and Sign	10/20/10	10/20/10
		Date	Impl. Date
			Exp. Date

Progeny

Document Site Approval Form
Page 1 of 2

AD-AA-101-F-01
Revision 3

See AD-AA-101 for the procedural requirements associated with this Form.
Desktop instruction available on Intranet or through AD functional area.

Facility: OYSTER

Document Number: CY-OC-170-301 Revision:

Title: OYSTER CREEK OFF-SITE DOSE CALCULATION MANUAL

Superseded Documents: N/A or List:

Check this box if superseding a document containing commitments, notify the Commitment Tracking Coordinator per LS-AA-110 so the CTD can be updated as appropriate.

Environmental Review Applicability - Is an Environmental Review applicable per EN-AA-103? No or Yes
If Yes, then attach Environmental Review documentation required per EN-AA-103.

Is this a Fleet Standard Document being processed with form AD-AA-101-F-09? No or Yes If yes, then attach the completed form AD-AA-101-F-09, skip the following section, and go to Continuation A.

Batch - Are multiple document creations/revisions/cancellations being issued to add/revise/cancel them for similar requirements? No or Yes If Yes, then identify the highest level Document and Issue Type below.

Check only one Document Type: Level 1 - Continuous Use Procedure <input type="checkbox"/> Level 2 - Reference Use Procedure <input checked="" type="checkbox"/> Level 3 - Information Use Procedure <input type="checkbox"/> T&RM <input type="checkbox"/> Form <input type="checkbox"/>	Check only one Issue Type: New <input type="checkbox"/> Revision <input checked="" type="checkbox"/> Cancel Document <input type="checkbox"/> Cancel Revision <input type="checkbox"/> Non-Permanent <input type="checkbox"/> Editorial Revision <input type="checkbox"/>	Incorporated Site Items (EC, AR, PCR, etc):
--	--	--

Revision Summary: TO SUPPORT TRITIUM PLUME REMEDIATION
(Attach additional description if required)

CONFIRM that no commitments (i.e., those steps annotated with CM-X) have been changed or deleted unless evaluated via completion of LS-AA-110 commitment change/deletion form and INITIAL [Preparer]:

Preparer D. OLTMAUS
Print Date Extension

Validation - Is substantiating this document's usability via mockup, simulated performance, field walkdown, or bench top review required? No or Yes If Yes, then attach validation documentation.
If Yes, then print name & sign for completed validation:

NOS Review - Excluding NDE, ISI, Peer Inspection or Independent Verification, is this document used to perform independent inspection for acceptance (including field installation inspections, fabrication inspections, receipt inspections, new fuel inspection, etc.), or for certification of inspection personnel? No or Yes
If Yes, then NOS Reviewer to print name & sign for acceptance:

Continuation A - Is this a T&RM, Form, or Editorial Revision? No or Yes If yes, then skip the following section and go Continuation B.

Impact on Operating and Design Margins - N/A or explain: _____
(Attach additional description if required)

<input type="checkbox"/> No <input type="checkbox"/> Yes 10CFR50.59 Applicable?	Tracking Number: _____
<input type="checkbox"/> No <input type="checkbox"/> Yes 10CFR72.48 Applicable?	
<input type="checkbox"/> No <input type="checkbox"/> Yes Other Regulatory Process Applicable?	Other Regulatory Process Number: _____
<input type="checkbox"/> No <input type="checkbox"/> Yes Potential security impact per SY-AA-500-127?	If Yes, then Security Reviewer acceptance documented by cross discipline review below
<input type="checkbox"/> No <input type="checkbox"/> Yes Surveillance Coordinator Review Required?	If Yes, then Surveillance Coordinator Review documented by cross discipline review below

Cross Discipline Reviews: (list below)

<u>F. LEONE</u> Print	<u>[Signature]</u> Signature	<u>15 OCT 10</u> Date	<u>ENV.</u> Discipline or Org.
_____ Print	_____ Signature	_____ Date	_____ Discipline or Org.
_____ Print	_____ Signature	_____ Date	_____ Discipline or Org.

Attach additional if req'd

SQR Approval indicates that all required Cross-Disciplinary reviews have been performed and the reviewers have signed this form. This procedure is technically and functionally accurate for all functional areas. (See AD-AA-102)

SQR Approval: _____
Print and Sign Date Discipline

ODCM Change Determination

Station: Oyster Creek Generating Station

Page 1 of 15

ODCM Revision No. 5

Determination Identifier A & B

I. Determination Questions (Check correct response)

1. Does the ODCM change maintain the level of radioactive effluent control required by 10CFR20.1301? YES NO

Explain:

10 CFR 20.1301 establishes the dose limits for individual members of the public. The current limit is 100 mrem in a year. In addition 10 CFR 20.1301.d establishes that a licensee must meet the requirements of 40 CFR 190. 40 CFR 190 establishes annual limits to a real individual of 25 mrem to the total body or any organ other than thyroid and 75 mrem to the thyroid.

The changes marked with an "A" in the "Change Type" column are administrative in nature and therefore have no negative impact on exceeding these limits.

The Groundwater Remediation Project has the determination identifier B. The objective of the project is to pump groundwater into the plant intake to reduce the concentration of tritium in the groundwater. The groundwater will be discharged to the discharge canal by either a batch mode or a continuous mode. Groundwater will be pumped at a rate of 30-50 gpm to draw the contaminated water out of the Cape May and Cohansey aquifers, diluted with circ water to less than detectable levels of tritium and discharged into Barnegat Bay. This plume resulted from a condensate transfer piping leaks in April 2009 and August 2009. These leaks were reported in the 2009 Annual Radiological Effluent Release Report as an unplanned release. The total activity for both leaks was estimated to be 8.43 Ci of tritium.

The groundwater discharge has a composite sampler. The composite sample will be analyzed daily for gamma emitting radionuclides and H-3. The daily samples will be composited monthly and analyzed for gross alpha, Sr-89, Sr-90, Fe-55 and Ni-63. Doses will be calculated based on the sample results using existing methodologies in the ODCM.

Since the changes are similar to current practices, there will be no change to the level of radioactive effluent control required by 10CFR20.1301.

2. Does the ODCM change maintain the level of radioactive effluent control required by 10CFR20.1302? YES NO

Explain:

10CFR20.1302 compliance with dose limits for individual members of the public requires that surveys of radiation levels in unrestricted and controlled areas and radioactive materials in effluents released to unrestricted and controlled areas to

demonstrate compliance with the dose limits for individual members of the public in §20.1301. The licensee shall show compliance to the annual dose limit in §20.1301 by demonstrating by measurement or calculation that the total effective dose equivalent to the individual likely to receive the highest dose...does not exceed the annual dose limit; or demonstrate that the annual average concentrations of radioactive material released in gaseous and liquid effluents at the boundary of the unrestricted area do not exceed the values specified in Table 2 of Appendix B to Part 20; and if an individual were continuously present in an unrestricted area, the dose from external sources would not exceed 0.002 rem (0.02mSv) in an hour and 0.05 rem (0.5mSv) in a year.

The changes marked with an "A" in the "Change Type" column are administrative in nature and therefore have no negative impact on the requirements of 10CFR20.1302.

The sampling provided by this ODCM change ensures that the ground water remediation activity is monitored in a manner similar to the current batch and continuous liquid release paths. The additional sampling provides frequencies, required analysis, and lower limits of detections (LLD) for the groundwater remediation project. The requirements are similar to the requirements of NUREG-1302, Offsite Dose Calculation Manual Guidance: Standard Radiological Effluent Controls for Boiling Water Reactors for continuous liquid releases with the following exemptions. The requirement to sample and analyze for dissolved and entrained gases is not required since dissolved and entrained gases are not reasonably expected to be present in ground water. I-131 is not listed as a separate radionuclide since the LLD is the same as other Principal Gamma Emitters. The analysis for Ni-63 is not required by NUREG-1302 but has been detected in 10CFR61 analysis. The inclusion of Ni-63 is a conservative practice.

Since the changes are similar to current practices, the level of radioactive effluent control required by 10CFR20.1302 is maintained.

3. Does the ODCM change maintain the level of radioactive effluent control required by 40CFR190 and 10CFR72.104? YES NO

Explain:

40CFR190 requires the annual dose equivalent not exceed 25 millirems to the whole body, and 75 millirems to the thyroid, and 25 millirems to any other organ of any member of the public as the result of exposures to planned discharges of radioactive materials, radon and its daughters excepted, to the general environment from uranium fuel cycle operations and to radiation from these operations.

10CFR72.104 has the same limits with the following requirements: Operational restrictions must be established to meet as low as is reasonably achievable objectives for radioactive materials in effluents and direct radiation levels associated with ISFSI and Operational limits must be established for radioactive materials in effluents and direct radiation levels associated with ISFSI.

The changes marked with an "A" in the "Change Type" column are administrative in nature and therefore have no negative impact on requirements of 40CFR190 or 10CFR72.104.

The additional sampling provided by this ODCM change ensures that the ground water remediation activity is monitored in a manner similar to the current batch and continuous liquid release paths. The additional sampling provides frequencies, required analysis, and lower limits of detections (LLD) for the groundwater remediation project. The requirements meet the requirements of NUREG-1302, Offsite Dose Calculation Manual Guidance: Standard Radiological Effluent Controls for Boiling Water Reactors for continuous liquid releases with the following exemptions. The requirement to sample and analyze for dissolved and entrained gases is not required since dissolved and entrained gases are not reasonably expected to be present in ground water. I-131 is not listed as a separate radionuclide since the LLD is the same as other Principal Gamma Emitters. The analysis for Ni-63 is not required by NUREG-1302 but has been detected in 10CFR61 analysis. The inclusion of Ni-63 is a conservative practice.

With the controls established by this ODCM change, the groundwater remediation activities will not challenge or exceed the limits or controls established by 40CFR190. The ISFSI is not affected by this ODCM change; therefore the level of radioactive effluent control required by 10CFR72.104 will not be changed.

4. Does the ODCM change maintain the level of radioactive effluent control required by 10CFR50.36a? YES NO

Explain:

10CFR50.36a requires that nuclear power reactors keep releases of radioactive materials to unrestricted areas during normal conditions, including expected occurrences, as low as is reasonably achievable by establishing operating procedures developed pursuant to §50.34a(c) for the control of effluents and that the radioactive waste system, pursuant to §50.34a, be maintained and used....(b) in establishing and implementing the operating procedures described in paragraph (a) of this section, the licensee shall be guided by the following considerations: Experience with the design, construction, and operation of nuclear power reactors indicates that compliance with the technical specifications described in this section will keep average annual releases of radioactive material in effluents and their resultant committed effective dose equivalents at small percentages of the dose limits specified in §20.1301 and in the license. At the same time, the licensee is permitted the flexibility of operation, compatible with considerations of health and safety...It is expected that in using this flexibility under unusual conditions, the licensee will exert its best efforts to keep levels of radioactive material in effluents as low as is reasonably achievable.

The changes marked with an "A" in the "Change Type" column are administrative in nature and therefore have no negative impact on the requirements of 10CFR50.36a.

The additional sampling provided by this ODCM change ensures that the ground water remediation activity is monitored in a manner similar to the current continuous liquid release paths. The additional sampling provides frequencies, required analysis, and lower limits of detections (LLD) for the groundwater remediation project. The requirements meet the requirements of NUREG-1302, Offsite Dose Calculation Manual Guidance: Standard Radiological Effluent Controls for Boiling Water Reactors for continuous liquid releases with the following exemptions. The requirement to sample and analyze for dissolved and entrained gases is not required since dissolved and entrained gases are not reasonably expected to be present in ground water. The analysis for Ni-63 is not required by NUREG-1302 but has been detected in spent resin. The inclusion of Ni-63 is a more conservative practice.

This change will not reduce the station's ability to keep releases of radioactive materials to unrestricted areas as low as reasonably achievable as required by 10CFR50.36a.

5. Does the ODCM change maintain the level of radioactive effluent control required by Appendix I to 10CFR50? YES NO

Explain:

Appendix I to 10CFR50 requires that

- A. The calculated annual total quantity of all radioactive material above background to be released from each light-water-cooled nuclear power reactor to unrestricted areas will not result in an estimated annual dose or dose commitment from liquid effluents for any individual in an unrestricted area from all pathways of exposure in excess of 3 millirems to the total body or 10 millirems to any organ.

The changes marked with an "A" in the "Change Type" column are administrative in nature and therefore have no negative impact on exceeding these limits.

The ODCM change only affects doses due to liquid releases. The ODCM change will not reduce the level of control required by 10CFR50 Appendix I. Doses will be calculated and reported if the water discharged exceeds the curies that were reported in 2009. Doses will be calculated and reported if the water discharged contains any plant produced radionuclides other than tritium.

The additional sampling provided by this ODCM change ensures that the ground water remediation activity is monitored in a manner similar to the current batch and continuous liquid release paths. The additional sampling provides frequencies, required analysis, and lower limits of detections (LLD) for the groundwater remediation project. The dose due to liquid effluents will be calculated in accordance with current ODCM methodology. The actual doses resulting from the groundwater remediation activity will be a small fraction of 10CFR50Appendix I limits and will be documented in accordance with the existing ODCM requirements.

The expected doses are expected to be well below the design objectives established in 10CFR50 Appendix I.

6. Does the ODCM change maintain the accuracy or reliability of YES NO effluent, dose, or setpoint calculations?

Explain:

The changes marked with an "A" in the "Change Type" column are administrative in nature and therefore have no negative impact on accuracy or reliability of effluent dose or setpoints.

Dose calculations will be performed using the Simplified Environmental Effluent Dosimetry System software (SEEDS). The SEEDS software has been previously approved for use at Oyster Creek and employs the calculations and methodology established in the ODCM.

There were no changes to the methodology used to calculate dose, so there will be no negative impact on accuracy or reliability of effluent dose. There were no changes to the methodology used to calculate setpoints, so there will be no negative impact on accuracy or reliability of setpoints calculations.

7. Does the ODCM change maintain the accuracy of radioactive YES NO effluent control required by the SAR?

Explain:

The changes marked with an "A" in the "Change Type" column are administrative in nature and therefore have no negative impact on the accuracy of radioactive effluent control required by SAR.

UFSAR Chapters 3,6,9,11 and 12 were reviewed.

UFSAR 11.2.3.2 –Release Points and 11.5.2.2 – Process Liquid Monitoring Subsystems were revised to include the impact of the temporary groundwater remediation activity as described below and documented in Passport action # 1126203-01.

UFSAR 11.2.3.2 "Release Points"

Temporary groundwater remediation activities, where contaminated groundwater from the area between the turbine building and intake structure is pumped into the intake canal at the suction of the circulating water pumps, will constitute a liquid radioactive release path. This plume resulting from condensate transfer piping leaks in April and August 2009 has been characterized as having only tritium contamination. Analyses of monitoring well samples have shown no plant produced gamma-emitters or hard-to-detects. Calculations have determined that regulatory limits would not be exceeded even in the event of an instantaneous release of the entire plume. Composite sampling of the water being released is necessary to obtain a representative sample of the liquid to confirm the validity of the characterization of the plume.

11.5.2.2 "Process Liquid Monitoring Subsystems"

The composite sampler and flow monitor in the discharge path that releases groundwater into the intake will be used to determine the total quantity of plant-produced radioactive nuclides released via this pathway. Existing methodology in the ODCM will be used to calculate doses.

The ODCM change does not reduce the accuracy of the radiological controls required by the SAR.

II. If all questions are answered YES, then complete the ODCM Change Determination and implement the Change per this procedure.

III. If any question is answered NO, then a change to the ODCM is not permitted

IV. Signoffs:

See AD-AA-101-F-01

ODCM Change Summary Matrix

Administrative Changes - Determination A				
Ground Water Remediation - Determination B				
Item No.	(old) Rev. 4 Page No.	(New) Rev. 5 Page No.	Determination Identifier	Description of Change
1	All	All	A	Change Revision 4 to Revision 5
2	All	All	A	Change footer from 092909 to 101810
3	3	3	A	6.1 Change REOR to AREOR
4	3	3	A	6.2 Change RERR to ARERR
5	4	4	A	Change 1.5.5 to ...EXAMPLE 1
6	4	4	A	Add 1.5.3.1 SHORELINE DOSE CALCULATION EXAMPLE 2
7	4	4	A	Change 1.5.3 to ...EXAMPLE 1
8	4	4	A	Add 1.5.5.1 INGESTION DOSE CALCULATION EXAMPLE 2
9	7	7	A	Add Figure D-1-1c: Groundwater Remediation System
10	8	8	A	Add "and discharge points" to ...and the liquid and gaseous waste treatment systems.
11	14	13	A	In 1.51 SEMI-INFINITE PLUME MODEL change Dose assessment model which is based on the assumption that the travel in air. to Dose assessment model with the following assumptions.
12	18	18	A	In 4.3.3.10 change CHANNL to CHANNEL
13	19	19	A	Changed ACTION 110 to N/A
14	19	19	A	Changed ACTION 114 to N/A
15	19	19	A	Changed ACTION 113 to N/A
16	19	19	B	Add to FLOW RATE MEASUREMENT DEVICES b. Groundwater Remediation Release Path with 1 Channel Required OPERABLE and ACTION 115
17	20	20	A	IR 1091620-02 Change ACTION 112 to "With no channels OPERABLE, effluent releases via this pathway may continue provided that, at least once per 24 hours, grab samples are collected and analyzed for radioactivity at a limit of detection specified by Table 4.11.1.1.1-1"
18	20	20	B	Add ACTION 115 With no channel OPERABLE, effluent releases via this pathway may continue provided the flow rate is estimated at least once per 4 hours during actual releases. Pump performance curves generated in place may be used to

				estimate flow.
19	21	21	B	Add to FLOW RATE MEASUREMENT DEVICES b. Groundwater Remediation Release Path with a daily Channel Check and once per 18 months Calibration
20	22	22	B	Add foot note f. While actively discharging through this pathway.
21	31	31	A	Change A. Batch Waste Release Tanks to 1. Batch Waste Release Tanks
22	31	31	A	Change B. Reactor Building, New Radwaste and AOG Service Water Effluent to 2. Continuous Release a. Reactor Building Service Water Effluent b. New Radwaste Service Water Effluent c. AOG Service Water Effluent
23	31	31	B	Add 3. Groundwater Remediation Pathway a. Continuous b. Batch Release Tank
24	31	31	B	Added Continuous Composite sample to be analyzed daily for Principal Gamma Emitters and H-3
25	31	31	B	Add note h to Continuous Sampling Frequency
26	31	31	B	Changed Composite ^d to Composite ^g
27	31	31	B	Added monthly composite of continuous release path for analysis of Gross Alpha, Sr-89, Sr-90, Fe-55 and Ni-63
28	31	31	B	Added Grab Sample for each batch to be analyzed for Principal Gamma Emitters and H-3
29	31	31	B	Added monthly composite of batch release path for analysis of Gross Alpha, Sr-89, Sr-90, Fe-55 and Ni-63
30	32	32	A	Change footnote paragraph to "Analyses shall be performed in such a manner that the stated LLDs will be achieved under routine conditions with typical values of E, V, Y, and t for the radionuclides Mn-54, Fe-59, Co-58, Co-60, Zn-65, Mo-99, Ce-141, Cs-134, Cs-137; and an LLD of 5E-6 µCi/ml should typically be achieved for Ce-144."
31	33	33	A	Changed words to be consistent with item 27
32	33	33	B	Added footnote h. Aliquot sampling shall at least hourly to be representative of the quantities and concentrations of radioactive materials in liquid effluent. Prior to analyses, all samples taken for the composite shall be thoroughly mixed in order for the composite samples to be

				representative of the effluent release.
33	49	49	A	IR1092075-02 Change Table 3.12-1 3.c. TYPE AND FREQUENCY OF ANALYSIS to "Grab Sample weekly, combine into a 2 week composite if I-131 analysis is required; composite monthly otherwise."
34	56	56	A	Change I-131 Air Particulate and Air Iodine to 0.07 ⁽⁵⁾
35	56	56	A	Change Cs-134 Air Particulate and Air Iodine to 0.05 ⁽⁵⁾
36	56	56	A	Change Cs-137 Air Particulate and Air Iodine to 0.06 ⁽⁵⁾
	56	56	A	Added note 7 to Ba-140 LLD
37	58	58	A	Added footnote 7 (7) Ba-140 and La-140 are in equilibrium
38	61	61	A	Change ACTION c. to b.
39	64	64	A	In BASES 3/4.11.1.1 change Sr-89,90 to Sr-89/90
40	64	64	B	In BASES 3/4.11.1.1 Added While discharging groundwater via the continuous release remediation pathway, the composite sample will be analyzed daily for principal gamma emitters and tritium. A monthly composite sample is analyzed for gross alpha, Sr-89/90, Fe-55, and Ni-63. While discharging groundwater via the batch release mode remediation pathway, a grab sample is collected from each tank and analyzed for principal gamma emitters and tritium, a composite sample is analyzed monthly for gross alpha, Sr-89/90, Fe-55, and Ni-63.
41	70	71	A	IR 1086231-02 In 6.1 changed (REOR) to (AREOR)
42	71	72	A	IR 1086231-02 In 6.2 changed (RERR) to (ARERR)
43	71	73	A	In step 6.2.2.5, delete ", and 3.2" in second line
44	71	72	A	In 6.2.2.5 add and 3.2. to end.
45	73	74	A	In 1.1 (1) Changed <u>Alarm (Only)</u> to (1) <u>Reactor Building Service Water Effluent</u>
46	73	74	B	In 1.1 (1) Figures D-1-1a and D-1-1b was changed to Figures D-1-1a, D-1-1b, and D-1-1c.
47	77	78	A	1.5.3 Changed EXAMPLE to EXAMPLE 1
48	77	78	A	In step 1.5.3, Change λl to λi
49	78	79	B	Added 1.5.3.1 SHORELINE DOSE EXAMPLE 2

				<p>The following provides an example of the liquid dose calculation for groundwater remediation discharge:</p> <p>Initial parameters:</p> <p>Canal flow rate 1E6gpm (typical of normal full power operation) Release: 50 gpm for 7 days at 1E-8 µCi/ml Co-60</p> <p>Problem: Calculate shoreline whole body dose</p> <p>Uap = 67 (teenager) hours W = 0.1 M = 3.76 F = 2228 [1E6 gpm * 3785 ml / gal / (60 sec/min * 28316 ml/ft3) = 2228 CFS] Qi = 1.91 E-5 Ci [1E-08 µCi/ml*50gpm*7days*24hr/day*60 min/hr*3785ml/gal/1E+6 µCi/ml/Ci. = 1.91E-5 Ci] Ti = 1930 [5.27 years*365.25 days/yr = 1.93E+03 days] □i = 1.31E-1 [0.693 / (5.27 yrs)] Tb = 30 years Daipj = 1.7E-8 mrem/hr / pCi/m2 External Dose factor</p> <p>Calculate Rapj for a = Teen, j = total body, p = shoreline dose for one isotope</p>
50	78	80	A	1.5.5 Changed EXAMPLE to EXAMPLE 1
51	79	81	B	<p>Added 1.5.5.1 INGESTION DOSE CALCULATION EXAMPLE 2</p> <p>The following provides an example of the liquid dose calculation for ground water remediation discharge:</p> <p>Initial parameters:</p> <p>Canal flow rate 1E6 gpm (typical of normal full power operation) Release: 50 gpm for 7 days at 700,000 pCi/l H-3</p> <p>Problem: calculate teen whole body dose from saltwater fish ingestion</p> <p>Uap = 16 (teenager) Kg M = 3.76 F = 2228 [1E6 gpm * 3785 ml / gal / (60</p>

				<p>sec/min * 28316 ml/ft3) = 2228 CFS] $Q_i = 1.34 \text{ Ci}$ $[7E+5 \text{ pCi/l} * 50 \text{ gpm} * 7 \text{ days} * 24 \text{ hr/day} * 60 \text{ min/hr} * 3.785 \text{ l/gal} / 1E+12 \text{ pCi/Ci} = 1.34 \text{ Ci}]$ $B_{ip} = 0.90$ (Regulatory Guide 1.109, Table A-1) $D_{aipj} = 1.06E-07 \text{ mrem / pCi}$ Calculate R_{apj} for a = Teen, j = total body, p = fish ingestion dose for one isotope</p>
52	86	88	A	In step 2.3.1.4, change 1.36E-5-5 to 1.36E-5
53	89	91	A	In Table 2.4.1-1 change mad to mrad
54	89	91	A	In step 2.4.1.1, Dose γ from (mrem) to (mrad)
55	91	93	A	In step 2.4.1.2, change 1.63E-3-3 to 1.63E-3
56	92	94	A	In step 2.4.1.3, changed Dose _{set} to Dose(t)
57	92	94	A	In step 2.4.1.3, changed Doses to Dose(s)
58	92	94	A	In step 2.4.1.3, change Doses from (mrad) to (mrem)
59	105	109	A	3.1 Change RERR to ARERR
60	109	111	A	In Table A-3 change $A_{\alpha io}$ $A_{\beta i}$
61	110	112	A	Table A-4, Change nearest resident from 966 to 925 meters SE of the OCGS.
62	125	127	B	Added FIGURE D-1-1c: GRIUNDWATER REMEDIATION SYSTEM drawing
63	127	130	A	IR 1091590-02 Figure D-2-2, Added gland seal exhauster as input to stack
64	130	135	A	Changed DW Station Code from 1 to 1S and 1N
65	136	139	A	Add new sample medium to Table E-1 DW Station Code 114 Distance 0.8 miles Azimuth 267, Well at Bldg 25 on Forked River site
66	136	139	A	Add new sample medium to Table E-1 VEG Station Code 115 Distance miles Azimuth 90 ,east of Route 9 and North of the Discharge Canal
67	140	143	B	Added Liquid Release Point (Intake) to Figure E-4

OFFSITE DOSE CALCULATION MANUAL

FOR

OYSTER CREEK GENERATING STATION

Revision of this document requires PORC approval and changes are controlled
by CY-AA-170-3100

TABLE OF CONTENTS

INTRODUCTION

PART 1 - RADIOLOGICAL EFFLUENT CONTROLS

- 1.0 DEFINITIONS
- 3.0 APPLICABILITY
- 3.3 INSTRUMENTATION
 - 3.3.3.10 RADIOACTIVE LIQUID EFFLUENT MONITORING INSTRUMENTATION
 - 3.3.3.11 RADIOACTIVE GASEOUS EFFLUENT MONITORING INSTRUMENTATION
- 3.11.1 LIQUID EFFLUENTS
 - 3.11.1.1 CONCENTRATION
 - 3.11.1.2 DOSE
 - 3.11.1.3 LIQUID WASTE TREATMENT SYSTEM
- 3.11.2 GASEOUS EFFLUENTS
 - 3.11.2.1 DOSE RATE
 - 3.11.2.2 DOSE NOBLE GASES
 - 3.11.2.3 DOSE - IODINE -131, IODINE - 133, TRITIUM, AND RADIONUCLIDES IN PARTICULATE FORM
 - 3.11.2.4 GASEOUS RADWASTE TREATMENT
- 3.11.3 MARK I CONTAINMENT
- 3.11.4 TOTAL DOSE
- 3.12 RADIOLOGICAL ENVIRONMENTAL MONITORING
 - 3.12.1 MONITORING PROGRAM
 - 3.12.2 LAND USE CENSUS
 - 3.12.3 INTERLABORATORY COMPARISON PROGRAM
 - 3.12.4 METEOROLOGICAL MONITORING PROGRAM

BASES FOR SECTIONS 3.0 AND 4.0

3.3 INSTRUMENTATION

- 3.3.3.10 RADIOACTIVE LIQUID EFFLUENT MONITORING INSTRUMENTATION
- 3.3.3.11 RADIOACTIVE GASEOUS EFFLUENT MONITORING INSTRUMENTATION

3.11 RADIOACTIVE EFFLUENTS

3.11.1 LIQUID EFFLUENTS

- 3.11.1.1 CONCENTRATION
- 3.11.1.2 DOSE
- 3.11.1.3 LIQUID RADWASTE TREATMENT

3.11.2 GASEOUS EFFLUENTS

- 3.11.2.1 DOSE RATES
- 3.11.2.2 DOSE-NOBLE GAS
- 3.11.2.3 DOSE – IODINE-131, IODINE-133, TRITIUM, AND RADIONUCLIDES IN PARTICULATE FORM
- 3.11.2.4 AUGMENTED OFFGAS TREATMENT SYSTEM

3.11.4 TOTAL DOSE

3.12 RADIOLOGICAL ENVIRONMENTAL MONITORING

- 3.12.1 MONITORING PROGRAM
- 3.12.2 LAND USE CENSUS
- 3.12.3 INTERLABORATORY COMPARISON PROGRAM

5.0 DESIGN FEATURES/SITE MAP

6.0 ADMINISTRATIVE CONTROLS

- 6.1 ANNUAL RADIOLOGICAL ENVIRONMENTAL OPERATING REPORT (AREOR)
- 6.2 ANNUAL RADIOACTIVE EFFLUENT RELEASE REPORT (ARERR)
- 6.3 RESPONSIBILITIES

PART II – CALCULATIONAL METHODOLOGIES

- 1.0 LIQUID EFFLEUNTS
- 1.1 RADIATION MONITORING INSTRUMENTATION AND CONTROLS
- 1.2 LIQUID EFFLUENT MONITOR SETPOINT DETERMINATION
 - 1.2.1 LIQUID EFFLUENT MONITORS
 - 1.2.2 SAMPLE RESULT SETPOINTS
 - 1.2.3 ASSUMED DISTRIBUTION SETPOINTS

BATCH RELEASES

- 1.3 CONTINUOUS RELEASES
- 1.4 LIQUID EFFLUENT DOSE CALCULATION – 10CFR50
 - 1.5.1 MEMBER OF THE PUBLIC DOSE – LIQUID EFFLUENTS
 - 1.5.2 SHORELINE DEPOSIT DOSE
 - 1.5.3 SHORELINE DOSE EXAMPLE 1
 - 1.5.3.1 SHORELINE DOSE EXAMPLE 2
 - 1.5.4 INGESTION DOSE – LIQUID
 - 1.5.5 INGESTION DOSE CALCULATION EXAMPLE 1
 - 1.5.5.1 INGESTION DOSE CALCULATION EXAMPLE 2
 - 1.5.6 PROJECTED DOSE – LIQUID
- 1.5 REPRESENTATIVE SAMPLES
- 2.0 GASEOUS EFFLUENTS
- 2.1 RADIATION MONITORING INSTRUMENTATION AND CONTROLS
- 2.2 GASEOUS EFFLUENT MONITOR SETPOINT DETERMINATION
 - 2.2.1 PLANT VENT
 - 2.2.2 OTHER RELEASE POINTS
 - 2.2.3 RADIONUCLIDE MIX FOR SETPOINTS
- 2.3 GASEOUS EFFLUENT INSTANTANEOUS DOSE RATE CALCULATIONS 10CFR20
 - 2.3.1 SITE BOUNDARY DOSE RATE – NOBLE GASES

- 2.3.1.1 TOTAL BODY DOSE RATE
- 2.3.1.2 EXAMPLE TOTAL BODY DOSE RATE
- 2.3.1.3 SKIN DOSE RATE
- 2.3.1.4 EXAMPLE SKIN DOSE RATE
- 2.3.2 SITE BOUNDARY DOSE RATE – RADIOIODINE AND PARTICULATES
 - 2.3.2.1 METHOD – SITE BOUNDARY DOSE RATE – RADIOIODINE AND PARTICULATES
 - 2.3.2.2 EXAMPLE IODINE AND PARTICULATES DOSE RATE CALCULATION
- 2.4 NOBLE GAS EFFLUENT DOSE CALCULATION - 10CFR50
 - 2.4.1 UNRESTRICTED AREA DOSE – NOBLE GASES
 - 2.4.1.1 AIR DOSE METHOD
 - 2.4.1.2 EXAMPLE NOBLE GAS AIR DOSE CALCULATION
 - 2.4.1.3 INDIVIDUAL PLUME DOSE METHOD
- 2.5 RADIOIODINE PARTICULATE AND OTHER RADIONUCLIDES DOSE CALCULATIONS – 10CFR50
 - 2.5.1 INHALATION OF RADIOIODINES, TRITIUM, PARTICULATES, AND OTHER RADIONUCLIDES
 - 2.5.2 EXAMPLE CALCULATION - INHALATION OF RADIOIODINES, TRITIUM, PARTICULATES, AND OTHER RADIONUCLIDES
 - 2.5.3 INGESTION OF RADIOIODINES, PARTICULATES AND OTHER RADIONUCLIDES
 - 2.5.3.1 CONCENTRATION OF THE RADIONUCLIDE IN ANIMAL FORAGE AND VEGETATION – OTHER THAN TRITIUM
 - 2.5.3.2 EXAMPLE CALCULATION OF CONCENTRATION OF THE RADIONUCLIDE IN ANIMAL FORAGE AND VEGETATION – OTHER THAN TRITIUM
 - 2.5.3.3 CONCENTRATION OF TRITIUM IN ANIMAL FORAGE AND VEGETATION
 - 2.5.3.4 EXAMPLE CALCULATION OF CONCENTRATION OF TRITIUM IN ANIMAL FORAGE AND VEGETATION
 - 2.5.3.5 CONCENTRATION OF THE RADIONUCLIDE IN MILK AND MEAT

- 2.5.3.6 EXAMPLE CALCULATION OF CONCENTRATION OF THE RADIONUCLIDE IN MILK AND MEAT
- 2.5.3.7 DOSE FROM CONSUMPTION OF MILK, MEAT, AND VEGETABLES
- 2.5.3.8 EXAMPLE CALCULATION – DOSE FROM CONSUMPTION OF MILK, MEAT, AND VEGETABLES

2.5.4 GROUND PLANE DEPOSITION IRRADIATION

- 2.5.4.1 GROUND PLANE CONCENTRATION
- 2.5.4.2 EXAMPLE GROUND PLANE CONCENTRATION CALCULATION
- 2.5.4.3 GROUND PLANE DOSE
- 2.5.4.4 EXAMPLE GROUND PLANE DOSE

2.6 PROJECTED DOSES - GASEOUS

3.0 TOTAL DOSE TO MEMBERS OF THE PUBLIC– 40CFR190

- 3.1 EFFLUENT DOSE CALCULATIONS
- 3.2 DIRECT EXPOSURE DOSE DETERMINATION

4.0 RADIOLOGICAL ENVIRONMENTAL MONITORING PROGRAM

APPENDIX A – DERIVED DOSE FACTORS AND RECEPTOR LOCATIONS

- Table A-1: Dose Conversion Factors for Deriving Radioactive Noble Gas Radionuclide-To-Dose Equivalent Rate Factors
- Table A-2: Noble Gas Radionuclide-To-Dose Equivalent Rate Factors
- Table A-3: Air Dose Conversion Factors for Effluent Noble Gas
- Table A-4: Locations Associated with Maximum Exposure of a Member of The Public
- Table A-5: Critical Receptor Noble Gas Dose Conversion Factors

APPENDIX B – MODELING PARAMETERS

- Table B-1 :OCGS Usage Factors for Individual Dose Assessment
- Table B-2: Monthly Average Absolute Humidity

APPENDIX C – REFERENCES

- TABLE C-1: REFERENCES

APPENDIX D – SYSTEM DRAWINGS

Figure D-1-1a: Liquid Radwaste Treatment Chem Waste and Floor
Drain System
Figure D-1-1b: Liquid Radwaste Treatment – High Purity and Equipment
Drain System
Figure D-1-1c: Groundwater Remediation System
Figure D-1-2: Solid Radwaste Processing System
Figure D-2-1: Gaseous Radwaste Treatment – Augmented Offgas System
Figure D-2-2: Ventilation System

APPENDIX E – RADIOLOGICAL ENVIRONMENTAL MONITORING PROGRAM – SAMPLE TYPE AND LOCATION

Table E-1: REMP Sample Locations
Figure E-1: Locations of REMP Stations within a 1-mile radius of the
Oyster Creek Generating Station.
Figure E-2: Locations of REMP Stations within a 1 to 5-mile radius of the
Oyster Creek Generating Station.
Figure E-3: Locations of REMP stations greater than 5 miles from the
Oyster Creek Generating Station

OYSTER CREEK GENERATING STATION OFF SITE DOSE CALCULATION MANUAL

INTRODUCTION

The Oyster Creek Off Site Dose Calculation Manual (ODCM) is an implementing document to the Oyster Creek Technical Specifications. The previous Limiting Conditions for Operations that were contained in the Radiological Effluent Technical Specifications (RETS) are now included in the ODCM as Radiological Effluent Controls (REC). The ODCM contains two parts: Part I – Radiological Effluent Controls, and Part II – Calculational Methodologies.

Part I includes the following:

- The Radiological Effluent Controls and the Radiological Environmental Monitoring Programs required by Technical Specifications 6.8.4
- Descriptions of the information that should be included in the Annual Radioactive Effluent Release Report and the Annual Radiological Environmental Operating Report required by Technical Specifications 6.9.1.d and 6.9.1.e, respectively.

Part II describes methodologies and parameters used for:

- The calculation of radioactive liquid and gaseous effluent monitoring instrumentation alarm/trip set points; and
- The calculation of radioactive liquid and gaseous concentrations, dose rates, cumulative yearly doses, and projected doses.

Part II also contains a list and graphical description of the specific sample locations for the radiological environmental monitoring program (REMP), and the liquid and gaseous waste treatment systems and discharge points.

PART I - RADIOLOGICAL EFFLUENT CONTROLS

1.0 DEFINITIONS

The following terms are defined so that uniform interpretation of these CONTROLS may be achieved. The defined terms appear in capitalized type and are applicable throughout these CONTROLS.

1.1 OPERABLE – OPERABILITY

A system, subsystem, train, component or device shall be OPERABLE or have OPERABILITY when it is capable of performing its specified function(s). Implicit in the definition shall be the assumption that all necessary attendant instrumentation, controls, normal and emergency electrical power sources, cooling or seal water, lubrication or other auxiliary equipment that are required for the system, subsystem, train, component or device to perform its function(s) are also capable of performing their related support function(s).

A verification of OPERABILITY is an administrative check, by examination of appropriate plant records (logs, surveillance test records) to determine that a system, subsystem, train, component or device is not inoperable. Such verification does not preclude the demonstration (testing) of a given system, subsystem, train, component or device to determine OPERABILITY.

1.2 ACTION

ACTION shall be that part of a CONTROL that prescribes remedial measures required under designated conditions.

1.4 CHANNEL CALIBRATION

A CHANNEL CALIBRATION shall be the adjustment, as necessary, of the channel output such that it responds, with acceptable range and accuracy, to known values of the parameter that the channel monitors. The CHANNEL CALIBRATION shall encompass the entire channel, including equipment actuation, alarm, or trip.

1.5 CHANNEL CHECK

A CHANNEL CHECK shall be a qualitative determination of acceptable operability by observation of channel behavior during operation. This determination shall include, where possible, comparison of the channel with other independent channels measuring the same variable.

1.6 CHANNEL FUNCTIONAL TEST

CHANNEL FUNCTIONAL TEST shall be the injection of a simulated signal into the channel to verify its proper response including, where applicable, alarm and/or trip initiating actions.

1.9 CONTROL

The Limiting Conditions for Operation (LCOs) that were contained in the Radiological Effluent Technical Specifications were transferred to the OFF SITE DOSE CALCULATION MANUAL (ODCM) and were renamed CONTROLS. This is to distinguish between those LCOs that were retained in the Technical Specifications and those LCOs or CONTROLS that were transferred to the ODCM.

1.13 FREQUENCY NOTATION

The FREQUENCY NOTATION specified for the performance of Surveillance Requirements shall correspond to the intervals defined in Table 1.1.

1.30 REPORTABLE EVENT

A REPORTABLE EVENT shall be any of those conditions specified Section 50.73 to 10CFR Part 50.

1.33 SOURCE CHECK

SOURCE CHECK shall be the qualitative assessment of channel response when the channel sensor is exposed to a source of increased radioactivity.

1.34 AUGMENTED OFF GAS SYSTEM (AOG)

The AUGMENTED OFF GAS SYSTEM is designed and installed to holdup and/or process radioactive gases from the main condenser off gas system for the purpose of reducing the radioactive material content of the gases before release to the environs.

1.35 MEMBER (S) OF THE PUBLIC

MEMBER (S) OF THE PUBLIC shall include all persons who are not occupationally associated with Exelon Generation and who do not normally frequent the Oyster Creek Generating Station site. This category does not include employees of the utility, its contractors, contractor employees, vendors, or persons who enter the site to make deliveries, to service equipment, work on site or for other purposes associated with plant functions. This category does include persons who use portions of the site

for recreational, occupational, or other purposes not associated with the plant. An individual is not a member of the public during any period in which the individual receives an occupational dose.

1.36 OFF SITE DOSE CALCULATION MANUAL (ODCM)

The OFF SITE DOSE CALCULATION MANUAL (ODCM) shall contain the methodology and parameters used in the calculation of Off Site doses due to radioactive gaseous and liquid effluents, in the calculation of gaseous and liquid effluent monitoring Alarm/Trip Set points, and in the conduct of the Radiological Environmental Monitoring Program. The ODCM shall also contain (1) the Radioactive Effluent Controls and Radiological Environmental Monitoring Programs required by Technical Specification Section 6.8.4 and (2) descriptions of the information that should be included in the Annual Radioactive Effluent Release Report AND Annual Radiological Environmental Operating Report required by Technical Specification Sections 6.9.1.d and 6.9.1.e, respectively.

1.37 PURGE – PURGING

PURGE or PURGING shall be the controlled process of discharging air or gas from a confinement and replacing it with air or gas.

1.38 SITE BOUNDARY

The SITE BOUNDARY shall be the perimeter line around OCGS beyond which the land is neither owned, leased, nor otherwise subject to control by Exelon Generation. The area outside the SITE BOUNDARY is termed OFF SITE or UNRESTRICTED AREA.

1.39 OFF SITE

The area that is beyond the site boundary where the land is neither owned, leased nor otherwise subject to control by Exelon Generation. Can be interchanged with UNRESTRICTED AREA.

1.40 UNRESTRICTED AREA

An UNRESTRICTED AREA shall be any area at or beyond the SITE BOUNDARY, access to which is not controlled by the licensee for purposes of protection of individuals from exposure to radiation and radioactive materials, or any area within the SITE BOUNDARY used for residential quarters or for industrial, commercial, institutional, and/or recreational purposes. Can be interchanged with OFF SITE.

1.41 DOSE EQUIVALENT I-131

DOSE EQUIVALENT I-131 shall be that concentration of I-131 (micro curies per gram), which alone would produce the same thyroid dose as the quantity and isotopic mixture of I-131, I-132, I-133, I-134, and I-135 actually present. The thyroid dose conversion factors used for this calculation shall be those listed in Table E-7 of Regulatory Guide 1.109, "Calculation of Annual Doses to Man from Routine Releases of Reactor Effluences for the Purpose of Evaluating Compliance with 10CFR Part 40 Appendix I."

1.42 DEPOSITION (D/Q)

The direct removal of gaseous and particulate species on land or water surfaces. DEPOSITION is expressed as a quantity of material per unit area (e.g. m^{-2}).

1.43 DOSE CONVERSION FACTOR (DCF)

A parameter calculated by the methods of internal dosimetry, which indicates the committed dose equivalent (to the whole body or organ) per unit activity inhaled or ingested. This parameter is specific to the isotope and the dose pathway. DOSE CONVERSION FACTORS are commonly tabulated in units of mrem/hr per picocurie/ m^3 in air or water. They can be found in Reg Guide 1.109 appendices.

1.44 EFFLUENT CONCENTRATION (EC)

The liquid and air concentration levels which, if inhaled or ingested continuously over the course of a year, would produce a total effective dose equivalent of 0.05 rem. LEC refers to liquid EFFLUENT CONCENTRATION.

1.45 ELEVATED (STACK) RELEASE

An airborne effluent plume whose release point is higher than twice the height of the nearest adjacent solid structure and well above any building wake effects so as to be essentially unentrained. Regulatory Guide 1.111 is the basis of the definition of an ELEVATED RELEASE. Elevated releases generally will not produce any significant ground level concentrations within the first few hundred yards of the source. ELEVATED RELEASES generally have less dose consequence to the public due to the greater downwind distance to the ground concentration maximum compared to ground releases. All main stack releases at the OCGS are ELEVATED RELEASES.

1.46 FINITE PLUME MODEL

Atmospheric dispersion and dose assessment model which is based on the assumption that the horizontal and vertical dimensions of an effluent

plume are not necessarily large compared to the distance that gamma rays can travel in air. It is more realistic than the semi-infinite plume model because it considers the finite dimensions of the plume, the radiation build-up factor, and the air attenuation of the gamma rays coming from the cloud. This model can estimate the dose to a receptor who is not submerged in the radioactive cloud. It is particularly useful in evaluating doses from an elevated plume or when the receptor is near the effluent source.

1.47 GROUND LEVEL (VENT) RELEASE

An airborne effluent plume which contacts the ground essentially at the point of release either from a source actually located at ground elevation or from a source well above the ground elevation which has significant building wake effects to cause the plume to be entrained in the wake and driven to the ground elevation. GROUND LEVEL RELEASES are treated differently than ELEVATED RELEASES in that the X/Q calculation results in significantly higher concentrations at the ground elevation near the release point.

1.48 OCCUPATIONAL DOSE

The dose received by an individual in a RESTRICTED AREA or in the course of employment in which the individual's assigned duties involve exposure to radiation and to radioactive material from licensed and unlicensed sources of radiation, whether in the possession of the licensee or other person. Occupational dose does not include dose received from background radiation, as a patient from medical practices, from voluntary participation in medical research programs, or as a member of the general public

1.49 "OPEN DOSE"

A routine effluent dosimetry computer program that uses Reg. Guides 1.109 and 1.111 methodologies.

1.50 RAGEMS (RADIOACTIVE EMISSIONS MONITORING SYSTEM)

A plant system that monitors gaseous effluent releases from monitored release points. There is a RAGEMS system for the main stack (RAGEMS I) and one for the turbine building (RAGEMS II). They monitor particulates, iodine's, and noble gases.

1.51 SEMI-INFINITE PLUME MODEL

Dose assessment model with the following assumptions. The ground is considered to be an infinitely large flat plate and the receptor is located at

the origin of a hemispherical cloud of infinite radius. The radioactive cloud is limited to the space above the ground plane. The semi-infinite plume model is limited to immersion dose calculations.

1.52 SOURCE TERM

The activity release rate, or concentration of an actual release or potential release. The common units for the source term are curies, curies per second, and curies per cubic centimeter, or multiples thereof (e.g., micro curies).

1.53 X/Q - ("CHI over Q")

The dispersion factor of a gaseous release in the environment calculated by a point source Gaussian dispersion model. Normal units of X/Q are sec/m^3 . The X/Q is used to determine environmental atmospheric concentrations by multiplying the source term, represented by Q (in units of $\mu\text{Ci}/\text{sec}$ or Ci/sec). Thus, the plume dispersion, X/Q (seconds/cubic meter) multiplied by the source term, Q ($\mu\text{Ci}/\text{seconds}$) yields an environmental concentration, X ($\mu\text{Ci}/\text{m}^3$). X/Q is a function of many parameters including wind speed, stability class, release point height, building size, and release velocity.

1.54 SEEDS (Simplified Effluent Environmental Dosimetry System)

A routine effluent dosimetry computer program that uses Reg. Guides 1.109 and 1.111 methodologies.

TABLE 1.1: SURVEILLANCE FREQUENCY NOTATION *

<u>NOTATION</u>	<u>FREQUENCY</u>
S	At least once per 12 hours.
D	At least once per 24 hours.
W	At least once per 7 days.
M	At least once per 31 days.
Q	At least once per 92 days.
SA	At least once per 184 days.
A	At least once per 366 days.

R	At least once per 18 months (550 days).
1/24	At least once per 24 months (refueling cycle)
S/U	Prior to each reactor startup.
P	Prior to each radioactive release.
N.A.	Not applicable.

* Each surveillance requirement shall be performed within the specified time interval with a maximum allowable extension not to exceed 25% of the surveillance interval.

3/4 CONTROLS AND SURVEILLANCE REQUIREMENTS

3/4.0 APPLICABILITY

CONTROLS

3.0.1 Compliance with the CONTROLS contained in the succeeding CONTROLS is required during the OPERATIONAL CONDITIONS or other conditions specified therein; except that upon failure to meet the CONTROL, the associated ACTION requirements shall be met.

3.0.2 Noncompliance with a CONTROL shall exist when the requirements of the CONTROL and associated ACTION requirements are not met within the specified time intervals. If the CONTROL is restored prior to expiration of the specified time intervals, completion of the ACTION requirements is not required.

3.0.3 Except as provided in the associated ACTION requirements, when a CONTROL is not met or the associated ACTION requirements cannot be satisfied, action shall be initiated to place the unit into COLD SHUTDOWN within the following 30 hours.

Where corrective measures are completed that permit operation under the ACTION requirements, the ACTION may be taken in accordance with the specified time limits as measured from the time of failure to meet the CONTROL. Exceptions to these requirements are stated in the individual CONTROLS.

This CONTROL is not applicable in COLD SHUTDOWN or REFUELING.

3.0.4 Entry into an OPERATIONAL CONDITION or other specified condition shall not be made when the conditions of the CONTROLS are not met and the associated ACTION requires a shutdown if they are not met within a specified time interval. Entry into an OPERATIONAL CONDITION or other specified condition may be made in accordance with ACTION requirements when conformance to them permits continued operation of the facility for an unlimited period of time. This provision shall not prevent passage through or to OPERATIONAL CONDITIONS as required to comply with ACTION requirements. Exceptions to these requirements are stated in the individual CONTROLS.

3.0.5 Equipment removed from service or declared inoperable to comply with ACTIONS may be returned to service under administrative control solely to perform testing to demonstrate its OPERABILITY or the OPERABILITY of other equipment. This is an exception to CONTROL 3.0.2 for the system returned to service under administrative control to perform the testing required to demonstrate OPERABILITY.

3 /4.0 APPLICABILITY

SURVEILLANCE REQUIREMENTS

4.0.1 Surveillance Requirements shall be met during the OPERATIONAL CONDITIONS or other conditions specified for individual CONTROLS unless otherwise stated in an individual Surveillance Requirement.

4.0.2 Each Surveillance Requirement shall be performed within the specified surveillance interval with a maximum allowable extension not to exceed 25 percent of the specified surveillance interval.

4.0.3 Failure to perform a Surveillance Requirement within the allowed surveillance interval, defined by CONTROL 4.0.2, shall constitute a failure to meet the OPERABILITY requirements for a CONTROL. The time limits of the ACTION requirements are applicable at the time it is identified that a Surveillance Requirement has not been performed. The ACTION requirements may be delayed for up to 24 hours to permit the completion of the surveillance when the allowed outage time limits of the ACTION requirements are less than 24 hours. Surveillance Requirements do not have to be performed on inoperable equipment.

4.0.4 Entry into an OPERATIONAL CONDITION or other specified applicable condition shall not be made unless the Surveillance Requirement(s) associated with the CONTROLS have been performed within the applicable surveillance interval or as otherwise specified. This provision shall not prevent passage through or to OPERATIONAL CONDITIONS as required to comply with ACTION requirements.

3/4.3 INSTRUMENTATION

3/4.3.3.10 RADIOACTIVE LIQUID EFFLUENT MONITORING INSTRUMENTATION

CONTROLS

3.3.3.10 In accordance with Oyster Creek Technical Specifications 6.8.4.a.1, the radioactive liquid effluent monitoring instrumentation channels shown in Table 3.3.3.10-1 shall be OPERABLE with their Alarm/Trip set points set to ensure that the limits of CONTROL 3.11.1.1 are not exceeded. The Alarm/Trip set points of these channels shall be determined and adjusted in accordance with the methodology and parameters in the ODCM Part II section 1.2.1.

APPLICABILITY: During all liquid releases via these pathways.

ACTION:

- a. With a radioactive liquid effluent monitoring instrumentation channel Alarm/Trip set point less conservative than required by the above CONTROL, immediately suspend the release of radioactive liquid effluents monitored by the affected channel, or declare the channel inoperable, or change the set point so it is acceptably conservative, or provide for manual initiation of the Alarm/Trip function(s).
- b. With less than the minimum number of radioactive liquid effluent monitoring instrumentation channels OPERABLE, take the ACTION shown in Table 3.3.3.10-1. Make every reasonable effort to return the instrument to OPERABLE status within 30 days and, if unsuccessful, explain in the next Radioactive Effluent Release Report pursuant to Technical Specification 6.9.1.d why the inoperability was not corrected in a timely manner.
- c. The provisions of CONTROL 3.0.3 and 3.0.4 are not applicable. Report all deviations in the Radioactive Effluent Release Report.

SURVEILLANCE REQUIREMENTS

4.3.3.10 Each radioactive liquid effluent monitoring instrumentation channel shall be demonstrated OPERABLE by performance of the CHANNEL CHECK, SOURCE CHECK, CHANNEL CALIBRATION, and CHANNEL FUNCTIONAL TEST at the Frequencies shown in Table 4.3.3.10-1.

TABLE 3.3.3.10-1: RADIOACTIVE LIQUID EFFLUENT MONITORING INSTRUMENTATION

INSTRUMENT	MINIMUM CHANNELS OPERABLE	ACTION
1. RADIOACTIVITY MONITORS PROVIDING ALARM AND AUTOMATIC TERMINATION OF RELEASE		
a. Liquid Radwaste Effluent Line (DELETED)	N/A	N/A
b. Turbine Building Sump No. 1-5 (DELETED)	N/A	N/A
2. RADIOACTIVITY MONITORS PROVIDING ALARM BUT NOT PROVIDING AUTOMATIC TERMINATION OF RELEASE		
a. Reactor Building Service Water System Effluent Line	1	112
3. FLOW RATE MEASUREMENT DEVICES		
a. Liquid Radwaste Effluent Line (DELETED)	N/A	N/A
b. Groundwater Remediation Release Path	1	115

TABLE 3.3.3.10-1 (Continued)

TABLE NOTATIONS

- ACTION 110** With no channels OPERABLE, effluent releases via this pathway may continue provided that:
- a. At least two independent samples are taken, one prior to discharge and one near the completion of discharge and analyzed in accordance with SURVEILLANCE REQUIREMENT 4.11.1.1.1.
 - b. Before initiating a release, at least two technically qualified members of the Facility Staff independently verify the release rate calculations and discharge line valving;
- Otherwise, suspend release of radioactive effluents via this pathway.
- ACTION 112** With no channels OPERABLE, effluent releases via this pathway may continue provided that, at least once per 24 hours, grab samples are collected and analyzed for radioactivity at a limit of detection specified by Table 4.11.1.1.1-1.
- ACTION 113** With no channel OPERABLE, effluent releases via the affected pathway may continue provided the flow is estimated with the pump curve or change in tank level, at least once per batch during a release.
- ACTION 114** With no channel OPERABLE effluent may be released provided that before initiating a release:
1. A sample is taken and analyzed in accordance with SURVEILLANCE REQUIREMENT 4.11.1.1.1.
 2. Qualified personnel determine and independently verify the acceptable release rate.
- ACTION 115** With no channel OPERABLE, effluent releases via this pathway may continue provided the flow rate is estimated at least once per 4 hours during actual releases. Pump performance curves may be used to estimate flow.

TABLE 4.3.3.10-1: RADIOACTIVE LIQUID EFFLUENT MONITORING INSTRUMENTATION SURVEILLANCE REQUIREMENTS^a

<u>INSTRUMENT</u>	<u>CHANNEL CHECK</u>	<u>SOURCE CHECK</u>	<u>CHANNEL CALIBRATION</u>	<u>CHANNEL FUNCTIONAL TEST</u>
1. RADIOACTIVITY MONITORS PROVIDING ALARM AND AUTOMATIC TERMINATION OF RELEASE				
a. Liquid Radwaste Effluent Line (DELETED)	N/A	N/A	N/A	N/A
b. Turbine Building Sump No. 1-5 (DELETED)	N/A	N/A	N/A	N/A
2. RADIOACTIVITY MONITORS PROVIDING ALARM BUT NOT PROVIDING AUTOMATIC TERMINATION OF RELEASE				
a. Reactor Building Service Water System Effluent Line	D	M	R ^e	Q ^d
3. FLOW RATE MEASUREMENT DEVICES				
a. Liquid Radwaste Effluent Line (DELETED)	N/A	N/A	N/A	N/A
b. Groundwater Remediation Release path	D ^f	N/A	R ^f	N/A

TABLE 4.3.3.10-1 (Continued)

TABLE NOTATIONS

- a. Instrumentation shall be **OPERABLE** and in service except that a channel may be taken out of service for the purpose of a check, calibration, test or maintenance without declaring it to be inoperable.
- d. The **CHANNEL FUNCTIONAL TEST** shall also demonstrate that Control Room alarm annunciation occurs if any of the following conditions exists:
 - 1. Instrument indicates measured levels above the alarm set point.
 - 2. Instrument indicates a downscale failure.
 - 3. Instrument controls not set in operate mode.
 - 4. Instrument electrical power loss.
- e. The **CHANNEL CALIBRATION** shall be performed according to established calibration procedures.
- f. While actively discharging through this pathway.

3/4.3 INSTRUMENTATION

3/4.3.3.11 RADIOACTIVE GASEOUS EFFLUENT MONITORING INSTRUMENTATION CONTROLS

3.3.3.11 In accordance with Oyster Creek Technical Specifications 6.8.4.a.1, the radioactive gaseous effluent monitoring instrumentation channels shown in Table 3.3.3.11-1 shall be OPERABLE with their alarm/trip set points set to ensure that the limits of CONTROL 3.11.2.1 are not exceeded. The alarm/trip set points of these channels meeting CONTROLS 3.11.2.1 shall be determined and adjusted in accordance with the methodology and parameters in the ODCM Part II Section 2.2.

APPLICABILITY: As shown in Table 3.3.3.11-1

ACTION:

- a. With a radioactive gaseous effluent monitoring instrumentation channel alarm/trip set point less conservative than required by the above CONTROL, immediately suspend the release of radioactive gaseous effluents monitored by the affected channel, or declare the channel inoperable, or change the set point so it is acceptably conservative.
- b. With less than the minimum number of radioactive gaseous effluent monitoring instrumentation channels OPERABLE, take the ACTION shown in Table 3.3.3.11-1. Exert best efforts to return the instrument to OPERABLE status within 30 days and, if unsuccessful, explain in the next Radioactive Effluent Release Report pursuant to Technical Specification 6.9.1.d why this inoperability was not corrected in a timely manner.
- c. The provisions of CONTROLS 3.0.3 and 3.0.4 are not applicable. Report all deviations in the Radioactive Effluent Release Report.

SURVEILLANCE REQUIREMENTS

4.3.3.11 Each radioactive gaseous effluent monitoring instrumentation channel shall be demonstrated OPERABLE by performance of the CHANNEL CHECK, SOURCE CHECK, CHANNEL CALIBRATION, and CHANNEL FUNCTIONAL TEST operations at the frequencies shown in Table 4.3.3.11-1.

TABLE 3.3.3.11-1: RADIOACTIVE GASEOUS EFFLUENT MONITORING INSTRUMENTATION

<u>INSTRUMENT</u>	<u>MINIMUM CHANNELS OPERABLE^a</u>	<u>APPLICABILITY</u>	<u>ACTION</u>
1. DELETED			
2. STACK MONITORING SYSTEM			
a. Radioactive Noble Gas Monitor (Low Range)	1	b,e	124
b. Iodine Sampler	1	b,e	127
c. Particulate Sampler	1	b,e	127
d. Effluent Flow Measuring Device	1	b	122
e. Sample Flow Measuring Device	1	b	128
3. TURBINE BUILDING VENTILATION MONITORING SYSTEM			
a. Radioactive Noble Gas Monitor (Low Range)	1	b	123
b. Iodine Sampler	1	b	127
c. Particulate Sampler	1	b	127
d. Effluent Flow Measuring Device	1	b	122
e. Sample Flow Measuring Device	1	b	128

TABLE 3.3.3.11-1(Continued)

RADIOACTIVE GASEOUS EFFLUENT MONITORING INSTRUMENTATION

<u>INSTRUMENT</u>	<u>MINIMUM CHANNELS OPERABLE^a</u>	<u>APPLICABILITY</u>	<u>ACTION</u>
4. AUGMENTED OFF GAS BUILDING EXHAUST VENTILATION MONITORING SYSTEM			
a. Radioactive Noble Gas Monitor	1	b	123
b. Iodine Sampler	1	b	127
c. Particulate Sampler	1	b	127
d. Sample Flow Measuring Device	1	b	128

TABLE 3.3.3.11-1 (Continued)

TABLE NOTATIONS

- a. Channels shall be OPERABLE and in service as indicated except that a channel may be taken out of service for the purpose of a check, calibration, test maintenance or sample media change without declaring the channel to be inoperable.
- b. During releases via this pathway
- e. Monitor / sampler or an alternate shall be OPERABLE to monitor / sample Stack effluent whenever the drywell is being purged.

- ACTION 122 With no channel OPERABLE, effluent releases via this pathway may continue provided the flow rate is estimated whenever the exhaust fan combination in this system is changed.
- ACTION 123 With no channel OPERABLE, effluent releases via this pathway may continue provided a grab sample is taken at least once per 48 hours and is analyzed for gross radioactivity within 24 hours thereafter or provided an alternate monitoring system with local display is utilized.
- ACTION 124 With no channel OPERABLE, effluent releases via this pathway may continue provided a grab sample is taken at least once per 8 hours and analyzed for gross radioactivity within 24 hours or provided an alternate monitoring system with local display is utilized. Drywell purge is permitted only when the radioactive noble gas monitor is operating.
- ACTION 127 With no channel OPERABLE, effluent releases via this pathway may continue provided the required sampling is initiated with auxiliary sampling equipment as soon as reasonable after discovery of inoperable primary sampler(s).
- ACTION 128 With no channel OPERABLE, effluent releases via the sampled pathway may continue provided the sampler air flow is estimated and recorded at least once per day.

TABLE 4.3.3.11-1: RADIOACTIVE GASEOUS EFFLUENT MONITORING INSTRUMENTATION SURVEILLANCE REQUIREMENTS

<u>INSTRUMENT</u>	<u>CHANNEL CHECK</u>	<u>SOURCE CHECK</u>	<u>CHANNEL CALIBRATION</u>	<u>CHANNEL FUNCTIONAL TEST</u>	<u>MODES IN WHICH SURVEILLANCE REQUIRED^a</u>
1. DELETED					
2. MAIN STACK MONITORING SYSTEM					
a. Radioactive Noble Gas Monitor (Low Range)	D	M	1/24 ^f	Q ^h	b
b. Iodine Sampler	W	N.A.	N.A.	N.A.	b
c. Particulate Sampler	W	N.A.	N.A.	N.A.	b
d. Effluent Flow Measuring Device	D	N.A.	1/24	Q	b
e. Sample Flow Measuring Device	D	N.A.	R	Q	b
3. TURBINE BUILDING VENTILATION MONITORING SYSTEM					
a. Radioactive Noble Gas Monitor (Low Range)	D	M	1/24 ^f	Q ⁱ	b
b. Iodine Sampler	W	N.A.	N.A.	N.A.	b
c. Particulate Sampler	W	N.A.	N.A.	N.A.	b
d. Effluent Flow Measuring Device	D	N.A.	1/24	Q	b
e. Sample Flow Measuring Device	D	N.A.	R	Q	b

TABLE 4.3.3.11-1(Continued)

RADIOACTIVE GASEOUS EFFLUENT MONITORING INSTRUMENTATION SURVEILLANCE REQUIREMENTS

<u>INSTRUMENT</u>	<u>CHANNEL CHECK</u>	<u>SOURCE CHECK</u>	<u>CHANNEL CALIBRATION</u>	<u>CHANNEL FUNCTIONAL TEST</u>	<u>MODES IN WHICH SURVEILLANCE IS REQUIRED^a</u>
4. AUGMENTED OFF GAS BUILDING EXHAUST VENTILATION MONITORING SYSTEM					
a. Radioactive Noble Gas Monitor	D	M	R ^f	Q ^e	b
b. Iodine Sampler	W	N.A.	N.A.	N.A.	b
c. Particulate Sampler	W	N.A.	N.A.	N.A.	b
d. Sample Flow Measuring Device	D	N.A.	R	N.A.	b

TABLE 4.3.3.11-1 (Continued)

TABLE NOTATIONS

- a. Instrumentation shall be OPERABLE and in service except that a channel may be taken out of service for the purpose of a check calibration, test or maintenance without declaring it to be inoperable.
- b. During releases via this pathway.
- e. The CHANNEL FUNCTIONAL TEST shall also demonstrate that control room alarm annunciation occurs if any of the following conditions exist:
 - 1. Instrument indicates measured levels above the alarm set point.
 - 2. Instrument indicates a downscale failure.
 - 3. Instrument controls not set in operate mode.
 - 4. Instrument electrical power loss.
- f. The CHANNEL CALIBRATION shall be performed according to established calibration procedures.
- h. The CHANNEL FUNCTIONAL TEST shall also demonstrate that control room alarm annunciation occurs if any of the following conditions exists:
 - 1. Instrument indicates measured levels above the alarm set point.
 - 2. Instrument indicates a low count rate/monitor failure.
 - 3. Switch cover alarm shall be verified to alarm when the cover is opened; and clear when the cover is closed after the faceplate switches are verified in their correct positions.
- i. The CHANNEL FUNCTIONAL TEST shall also demonstrate that control room alarm annunciation occurs if any of the following conditions exists:
 - 1. Instrument indicates measured levels above the alarm set point.
 - 2. Instrument indicates a low count rate/monitor failure.

3/4.11 RADIOACTIVE EFFLUENTS

3/4.11.1 LIQUID EFFLUENTS

3/4.11.1.1 CONCENTRATION

CONTROLS

3.11.1.1 In accordance with the Oyster Creek Technical Specifications 6.8.4.a.2 and 3, the concentration of radioactive material, other than noble gases, in liquid effluent in the discharge canal at the Route 9 bridge (See Figure E-3) shall not exceed the concentrations specified in 10 CFR Part 20, Appendix B, Table 2, Column 2. The concentration of noble gases dissolved or entrained in liquid effluent in the discharge canal at the Route 9 bridge shall not exceed 2E-4 microcuries/milliliter.

APPLICABILITY: At all times.

ACTION:

- a. In the event the concentration of radioactive material in liquid effluent released into the Off Site area beyond the Route 9 bridge exceeds either of the concentration limits above, reduce the release rate without delay to bring the concentration below the limit.
- b. The provisions of CONTROLS 3.0.3, 3.0.4 and Technical Specification 6.9.2 are not applicable.

SURVEILLANCE REQUIREMENTS

4.11.1.1.1 Radioactive liquid wastes shall be sampled and analyzed according to the sampling and analysis program in Table 4.11.1.1.1-1.

Alternately, pre-release analysis of batches(es) of radioactive liquid waste may be by gross beta or gamma counting provided a maximum concentration limit of 1E-8 $\mu\text{Ci/ml}$ in the discharge canal at the Route 9 bridge is applied.

4.11.1.1.2 The results of the radioactivity analyses shall be used in accordance with the methodology and parameters in the ODCM Part II Section 1.2 to assure that the concentrations at the point of release are maintained within the limits of CONTROL 3.11.1.1 and 3.11.1.2.

4.11.1.1.3 The alarm or trip set point of each radioactivity monitoring channel in Table 3.3.3.10-1 shall be determined on the basis of sampling and analyses results obtained according to Table 4.11.1.1.1-1 and the set point method in ODCM Part II 1.2.1 and set to alarm or trip before exceeding the limits of CONTROL 3.11.1.1.

TABLE 4.11.1.1.1-1: RADIOACTIVE LIQUID WASTE SAMPLING AND ANALYSIS PROGRAM

Liquid Release Type	Sampling Frequency	Minimum Analysis Frequency	Type of Activity Analysis	Lower Limit Detection ^a (LLD) ($\mu\text{Ci/ml}$)
1. Batch Waste Release Tanks	P Each Batch ^b	P ^c Each Batch	Principal Gamma Emitters	5E-07
			I-131	5E-07
	P One Batch/M ^b	M	Dissolved and Entrained Gases (Gamma Emitters)	1E-05
			H-3	1E-05
	P Each Batch ^b	M Composite ^d	Gross Alpha	1E-07
			Sr-89, Sr-90	5E-08
P Each Batch ^b	Q Composite ^d	Fe-55	1E-06	
2. Continuous Release a. Reactor Building Service Water Effluent b. New Radwaste Service Water Effluent c. AOG Service Water Effluent	W Grab Sample ^e	W	Principal Gamma Emitters	5E-07
			I-131	5E-07
	(note f)	M Composite ^g	H-3	1E-05
			Gross Alpha	1E-07
			Fe-55	1E-06
3. Groundwater Remediation Pathway a. Continuous	Continuous ^h	D Composite	Principal Gamma Emitters	5E-07
			H-3	1E-05
	M	M Composite ^g	Gross Alpha	1E-07
			Sr-89, Sr-90	5E-08
			Fe-55	1E-06
			Ni-63	1E-06
b. Batch Release Tank	P Each Batch ^b	P Each Batch	Principal Gamma Emitters	5E-07
			H-3	1E-05
	P Each Batch ^b	M Composite ^d	Gross Alpha	1E-07
			Sr-89, Sr-90	5E-08
			Fe-55	1E-06
			Ni-63	1E-06

TABLE 4.11.1.1-1 (CONTINUED)

TABLE NOTATIONS

- a. The Lower Limit of Detection (LLD) is defined, for purposes of these specifications, as the smallest concentration of radioactive material in a sample that will yield a net count, above system background, that will be detected with 95 percent probability with only 5 percent probability of falsely concluding that a blank observation represents a "real" signal.

The LLD is applicable to the capability of a measurement system under typical conditions and not as a limit for the measurement of a particular sample in the radioactive liquid waste sampling and analyses program.

For a particular measurement system, which may include radiochemical separation:

$$LLD = \frac{4.66 * S_b}{E * V * 2.22E6 * Y * \exp(-\lambda \Delta t)}$$

Where:

LLD is the lower limit of detection as defined above (microcurie per unit mass or volume),

S_b is the standard deviation of the background counting rate or of the counting rate of a blank sample as appropriate (counts per minute),

E is the counting efficiency,

V is the sample size (units of mass or volume),

2.22E+6 is the number of disintegrations per minute per microcurie,

Y is the fractional radiochemical yield, when applicable,

λ is the radioactive decay constant for the particular radionuclide, and

Δt is the elapsed time between the end of the sample collection and the time of counting.

Analyses shall be performed in such a manner that the stated LLDs will be achieved under routine conditions with typical values of E, V, Y, and t for the radionuclides Mn-54, Fe-59, Co-58, Co-60, Zn-65, Mo-99, Ce-141, Cs-134, Cs-137; and an LLD of 5E-6 μ Ci/ml should typically be achieved for Ce-144.

TABLE 4.11.1.1.1-1 (CONTINUED)

TABLE NOTATIONS

Occasionally, background fluctuations, interfering radionuclides, or other uncontrollable circumstances may render these LLD's unachievable.

When calculating the LLD for a radionuclide determined by gamma ray spectrometry, the background may include the typical contributions of other radionuclides normally present in the sample. The background count rate of a semiconductor detector (e.g. HPGe) is determined from background counts that are determined to be within the full width of the specific energy band used for the quantitative analysis for the radionuclide.

The principal gamma emitters for which the LLD specification will apply are exclusively the following radionuclides: Mn-54, Fe-59, Co-58, Co-60, Zn-65, Mo-99, Cs-134, Cs-137, Ce-141, and Ce-144. This list does not mean that only these nuclides are to be detected and reported. Other peaks that are measurable and identifiable, together with the above nuclides, shall be identified and reported. The LLD for Ce-144 is $5E-6$ $\mu\text{Ci/mL}$ whereas the LLD for Mo-99 and the other gamma emitters is $5E-7$ $\mu\text{Ci/mL}$. Nuclides that are below the LLD for the analysis should not be reported.

- b. A batch release is the discharge of liquid wastes of a discrete volume. Before sampling for analysis, each batch should be thoroughly mixed.
- c. In the event a gross radioactivity analysis is performed in lieu of an isotopic analysis before a batch is discharged, a sample will be analyzed for principal gamma emitters afterwards.
- d. A composite sample is one in which the quantity of liquid sampled is proportional to the quantity of liquid waste discharged and in which the method of sampling employed results in a specimen which is representative of the liquids released.
- e. Analysis may be performed after release.
- f. In the event a grab sample contains more than $5E-7$ $\mu\text{Ci/mL}$ of I-131 and principal gamma emitters or in the event the Reactor Building Service Water radioactivity monitor indicates more than $5E-7$ $\mu\text{Ci/mL}$ radioactivity in the effluent, as applicable, sample the elevated activity effluent daily until analysis confirms the activity concentration in the effluent does not exceed $5E-7$ $\mu\text{Ci/mL}$. In addition a composite sample must be made up for further analysis for all samples taken when the activity was $> 5E-7$ $\mu\text{Ci/mL}$.
- g. A composite sample is produced combining grab samples, each having a defined volume, collected routinely from the sump or stream being sampled
- h. Aliquot sampling shall be at least hourly to be representative of the quantities and concentrations of radioactive materials in liquid effluent. Prior to analyses, all samples taken for the composite shall be thoroughly mixed in order for the composite samples to be representative of the effluent release.

3/ 4.11 RADIOACTIVE EFFLUENTS

3/ 4.11.1.2 DOSE

CONTROLS

3.11.1.2 In accordance with Oyster Creek Technical Specifications 6.8.4.a.4 and 5, the dose or dose commitment to a MEMBER OF THE PUBLIC from radioactive materials in liquid effluents released to UNRESTRICTED AREAS (see Figure E-4) shall be limited:

- a. During any calendar quarter to less than or equal to 1.5 mrem to the Total Body and to less than or equal to 5 mrem to any body organ, and
- b. During any calendar year to less than or equal to 3 mrem to the Total Body and to less than or equal to 10 mrem to any body organ.

APPLICABILITY: At all times.

ACTION:

- a. With the calculated dose from the release of radioactive materials in liquid effluents exceeding any of the above limits, prepare and submit to the Commission within 30 days from the end of the quarter, pursuant to Technical Specification 6.9.2, a Special Report that identifies the cause(s) for exceeding the limit(s) and defines the corrective actions that have been taken and/or will be taken to reduce the releases and the proposed corrective actions to be taken to assure that subsequent releases will be in compliance with the above limits.
- b. The provisions of CONTROL 3.0.3 and 3.0.4 are not applicable.

SURVEILLANCE REQUIREMENTS

4.11.1.2 Cumulative dose contributions from liquid effluents for the current calendar quarter and the current calendar year shall be determined in accordance with the methodology and parameters in the ODCM Part II Section 1.5 at least once per 31 days in accordance with Technical Specification 6.8.4.a.5.

3/4.11 RADIOACTIVE EFFLUENTS

3/4.11.1.3 LIQUID WASTE TREATMENT SYSTEM

CONTROLS

3.11.1.3 In accordance with the Oyster Creek Technical Specifications 6.8.4.a.6, the liquid radwaste treatment system shall be OPERABLE and appropriate portions of the system shall be used to reduce releases of radioactivity when projected doses due to the liquid effluent to UNRESTRICTED AREAS (see Figure E-4) would exceed 0.06 mrem to the Total Body or 0.2 mrem to any organ in a 31 day period.

APPLICABILITY: At all times.

ACTION:

a. With radioactive liquid waste being discharged without treatment and in excess of the above, prepare and submit to the Commission within 30 days, pursuant to Technical Specification 6.9.2, a Special Report that includes the following information:

1. Explanation of why liquid radwaste was being discharged without treatment, identification of any inoperable equipment or subsystems, and the reason for the inoperability,
2. Action(s) taken to restore the inoperable equipment to OPERABLE status, and
3. Summary description of action(s) taken to prevent a recurrence.

b. The provisions of CONTROL 3.0.3 and 3.0.4 are not applicable.

SURVEILLANCE REQUIREMENTS

4.11.1.3.1 Doses due to liquid releases to UNRESTRICTED AREAS shall be projected at least once per 31 days in accordance with the methodology and parameters in the ODCM Part II Section 1.5 in accordance with Technical Specifications 6.8.4.a.5.

4.11.1.3.2 The installed liquid radwaste treatment system shall be demonstrated OPERABLE by meeting CONTROLS 3.11.1.1, 3.11.1.2, and 3.11.1.3.

3/4.11 RADIOACTIVE EFFLUENTS

3/4.11.2 GASEOUS EFFLUENTS

3/4.11.2.1 DOSE RATE

CONTROLS

3.11.2.1 In accordance with the Oyster Creek Technical Specifications 6.8.4.a.5 and 7, the dose rate due to radioactive materials released in gaseous effluents in the UNRESTRICTED AREA (see Figure E-3) shall be limited to the following:

- a. For noble gases: Less than or equal to 500 mrem/yr to the total body and less than or equal to 3000 mrem/yr to the skin, and
- b. For iodine-131, iodine-133, tritium, and for all radionuclides in particulate form with half-lives greater than 8 days: Less than or equal to 1500 mrem/yr to any body organ.

APPLICABILITY: At all times.

ACTION:

- a. With the dose rate(s) exceeding the above limits, immediately restore the release rate to within the above limit(s).
- b. If the gaseous effluent release rate cannot be reduced to meet the above limits, the reactor shall be in at least SHUTDOWN CONDITION within 48 hours unless corrective actions have been completed and the release rate restored to below the above limit.

SURVEILLANCE REQUIREMENTS

4.11.2.1.1 The dose rate due to noble gases in gaseous effluents shall be determined to be within the above limits in accordance with the methodology and parameters in the ODCM Part II Section 2.3.1.

4.11.2.1.2 The dose rate due to iodine-131, iodine-133, tritium, and all radionuclides in particulate form with half-lives greater than 8 days in gaseous effluents shall be determined to be within the above limits in accordance with the methodology and parameters in the ODCM Part II Section 2.3.2 by obtaining representative samples and performing analyses in accordance with the sampling and analysis program specified in Table 4.11.2.1.2-1.

4.11.2.1.3 Dose rates due to tritium, Sr-89, Sr-90, and alpha-emitting radionuclides are averaged over no more than 3 months and the dose rate due to other radionuclides is averaged no more than 31 days.

TABLE 4.11.2.1.2-1: RADIOACTIVE GASEOUS WASTE SAMPLING AND ANALYSIS PROGRAM

Gaseous Release Type	Sampling Frequency	Minimum Analysis Frequency	Type of Activity Analysis	Lower Limit Detection ^a (LLD) ($\mu\text{Ci/ml}$)
Stack; Turbine Building Exhaust Vents; Augmented Off gas Building Vent	Q Grab Sample ^f	Q	H-3	1E-06
	M Grab Sample c,d,f	M	Principal Gamma Emitters ^b (Noble Gases)	1E-04
	Continuous ^f	W Charcoal Sample	I-131	1E-12
			I-133	1E-10
	Continuous ^f	W Particulate Sample	Principal Gamma Emitters ^b (particulates)	1E-11
	Continuous ^f	M ^e Composite Particulate Sample	Gross Alpha	1E-11
	Continuous	Q ^e Composite Particulate Sample	Sr-89, Sr-90	1E-11
	Continuous	Noble Gas Monitor	Noble Gases Gamma Radioactivity	1E-06

TABLE 4.11.2.1.2-1 (Continued)

TABLE NOTATIONS

- a. The Lower Limit of Detection (LLD) is defined, for purposes of these specifications, as the smallest concentration of radioactive material in a sample that will yield a net count, above system background, that will be detected with 95 percent probability with only 5 percent probability of falsely concluding that a blank observation represents a "real" signal.

The LLD is applicable to the capability of a measurement system under typical conditions and not as a limit for the measurement of a particular sample in the radioactive liquid waste sampling and analyses program.

For a particular measurement system, which may include radiochemical separation:

$$LLD = \frac{4.66 * S_b}{E * V * 2.22E6 * Y * \exp(-\lambda \Delta t)}$$

Where:

LLD is the lower limit of detection as defined above (microcurie per unit mass or volume),

S_b is the standard deviation of the background counting rate or of the counting rate of a blank sample as appropriate (counts per minute),

E is the counting efficiency,

V is the sample size (units of mass or volume),

2.22E+6 is the number of disintegrations per minute per microcurie,

Y is the fractional radiochemical yield, when applicable,

λ is the radioactive decay constant for the particular radionuclide, and

Δt is the elapsed time between the end of the sample collection and the time of counting.

Analyses shall be performed in such a manner that the stated LLD's will be achieved under routine conditions with typical values of E, V, Y, and t for the radionuclides Mn-54, Fe-59, Co-58, Co-60, Zn-65, Cs-134, Cs-137, and Ce-141. Occasionally background fluctuations, or other uncontrollable circumstances may render these LLD's unachievable.

When calculating the LLD for a radionuclide determined by gamma ray spectrometry, the background may include the typical contributions of other radionuclides normally present in the

TABLE 4.11.2.1.2-1 (Continued)

TABLE NOTATIONS

samples. The background count rate of a HpGe detector is determined from background counts that are determined to be within the full width of the specific energy band used for the quantitative analysis for that radionuclide

- b. The principal gamma emitters for which the LLD specification applies exclusively are the following radionuclides: Kr-87, Kr-88, Xe-133, Xe-133m, Xe-135 and Xe-138 for gaseous emissions and Mn-54, Fe-59, Co-58, Co-60, Zn-65, Mo-99, Cs-134, Cs-137, Ce-141, and Ce-144 for particulate emissions. This list does not mean that only these nuclides are to be considered. Other gamma peaks that are identifiable, together with those of the above nuclides, shall also be analyzed and reported in the Annual Radioactive Effluent Release Report consistent with CONTROL 3.11.2.1. The LLD for Mo-99 and Ce-144 is $1E-10$ $\mu\text{Ci/ml}$ whereas the LLD for other principal gamma emitting particulates is $1E-11$ $\mu\text{Ci/ml}$. Radionuclides which are below the LLD for the analysis should not be reported.
- c. The noble gas radionuclides in gaseous effluent may be identified by taking a grab sample of effluent and analyzing it.
- d. In the event the reactor power level increases more than 15 percent in one hour and the Stack noble gas radioactivity monitor shows an activity increase of more than a factor of three after factoring out the effect due to the change in reactor power, a grab sample of Stack effluent shall be collected and analyzed.
- e. A composite particulate sample shall include an equal fraction of at least one particulate sample collected during each week of the compositing period.
- f. In the event a sample is collected for 24 hours or less, the LLD may be increased by a factor of 10.

3/4.11 RADIOACTIVE EFFLUENTS

3/4.11.2.2 DOSE - NOBLE GASES

CONTROLS

3.11.2.2 In accordance with the Oyster Creek Technical Specification 6.8.4.a.5 and 8, the air dose due to noble gases released in gaseous effluents in the UNRESTRICTED AREA (see Figure E-3) shall be limited to the following:

- a. During any calendar quarter: Less than or equal to 5 mrad for gamma radiation and less than or equal to 10 mrad for beta radiation and,
- b. During any calendar year: Less than or equal to 10 mrad for gamma radiation and less than or equal to 20 mrad for beta radiation.

APPLICABILITY: At all times.

ACTION:

- a. With the calculated air dose from radioactive noble gases in gaseous effluents exceeding any of the above limits, prepare and submit to the Commission within 30 days from the end of the quarter during which the release occurred, pursuant to Technical Specification 6.9.2, a Special Report that identifies the cause(s) for exceeding the limit(s) and defines the corrective actions that have been taken to reduce the release and the proposed corrective actions to be taken to assure that subsequent releases will be in compliance with the above limits.
- b. The provisions of CONTROLS 3.0.3 and 3.0.4 are not applicable.

SURVEILLANCE REQUIREMENTS

4.11.2.2 Cumulative dose contributions for the current calendar quarter and current calendar year for noble gases shall be determined in accordance with the methodology and parameters in the ODCM Part II Section 2.4.1 at least once per 31 days in accordance with Technical Specification 6.8.4.a.5.

3/4.11 RADIOACTIVE EFFLUENTS

3/4.11.2.3 DOSE - IODINE-131, IODINE-133, TRITIUM, AND RADIONUCLIDES IN PARTICULATE FORM

CONTROLS

3.11.2.3 In accordance with Oyster Creek Technical Specification 6.8.4.a.5 and 9, the dose to a MEMBER OF THE PUBLIC from iodine-131, iodine-133, tritium, and all radionuclides in particulate form with half-lives greater than 8 days in gaseous effluents released in the UNRESTRICTED AREA (see Figure E-3) shall be limited to the following:

- a. During any calendar quarter: Less than or equal to 7.5 mrem to any body organ and,
- b. During any calendar year: Less than or equal to 15 mrem to any body organ.

APPLICABILITY: At all times.

ACTION:

- a. With the calculated dose from the release of iodine-131, iodine-133 and radionuclides in particulate form with half-lives greater than 8 days, in gaseous effluents exceeding any of the above limits, prepare and submit to the Commission within 30 days, pursuant to Technical Specification 6.9.2, a Special Report that identifies the cause(s) for exceeding the limit and defines the corrective actions that have been taken to reduce the releases and the proposed corrective actions to be taken to assure that subsequent releases will be in compliance with the above limits.
- b. The provisions of CONTROLS 3.0.3 and 3.0.4 are not applicable.

SURVEILLANCE REQUIREMENTS

4.11.2.3 Cumulative dose contributions for the current calendar quarter and current calendar year for iodine-131, iodine-133, tritium, and radionuclides in particulate form with half-lives greater than 8 days shall be determined in accordance with the methodology and parameters in the ODCM Part II Section 2.5 at least once per 31 days in accordance with Technical Specification 6.8.4.a.5.

3/4.11 RADIOACTIVE EFFLUENTS

3/4.11.2.4 GASEOUS RADWASTE TREATMENT

CONTROLS

- 3.11.2.4 The AUGMENTED OFF GAS SYSTEM shall be in operation to reduce releases of radioactivity when the projected doses in 31 days due to gaseous effluent releases to areas at and beyond the SITE BOUNDARY (see Figure E-4) would exceed:
- 0.2 mrad to air from gamma radiation, or
 - 0.4 mrad to air from beta radiation, or
 - 0.3 mrem to any body organ

APPLICABILITY: Whenever the main condenser steam jet air ejector is in operation except during startup or shutdown with reactor power less than 40 percent of rated. In addition, the AUGMENTED OFF GAS SYSTEM need not be in operation during end of cycle coast-down periods when the system can no longer function due to low off gas flow.

ACTION:

- Every reasonable effort shall be made to maintain and operate charcoal absorbers in the AUGMENTED OFF GAS SYSTEM to treat radioactive gas from the main condenser air ejectors.
- With gaseous radwaste from the main condenser air ejector system being discharged without treatment for more than 30 consecutive days and either CONTROL 3.11.2.1 or 3.11.2.4 exceeded, prepare and submit to the Commission within 30 days from the end of the quarter during which release occurred, pursuant to Technical Specification 6.9.2, a Special Report that includes the following information:
 - Identification of any inoperable equipment or subsystems, and the reason for the inoperability,
 - Action(s) taken to restore the inoperable equipment to OPERABLE status, and
 - Summary description of action(s) taken to prevent a recurrence.
- The provisions of CONTROL 3.0.3 and 3.0.4 are not applicable.

SURVEILLANCE REQUIREMENTS

4.11.2.4.1 Operation of the Augmented Off gas System charcoal absorbers shall be verified by verifying the AOG System bypass valve, V-7-31, alignment or alignment indication closed at least once every 12 hours whenever the main condenser air ejector is operating.

4.11.2.4.2 Doses due to gaseous releases to UNRESTRICTED AREAS shall be projected at least once per 31 days in accordance with the methodology and parameters in the ODCM Part II Section 1.5 in accordance with Technical Specifications 6.8.4.a.5.

3/4.11 RADIOACTIVE EFFLUENTS

3/4.11.3. MARK I CONTAINMENT

CONTROLS

3.11.3.1 Venting or purging of the containment Drywell may be through normal Reactor Building Ventilation if the following requirements are met:

APPLICABILITY:

If the Station year-to-date radiological effluent releases (either iodine or noble gas) are less than 10% of the ODCM limit, then Standby Gas Treatment is NOT required for purging the contents of the Drywell.

ACTION:

If the Station year-to-date radiological effluent releases (either iodine or noble gas) are greater than 10% of the ODCM limit, then the Standby Gas Treatment System must be used for purging the contents of the Drywell.

SURVEILLANCE REQUIREMENTS

4.11.3.1 The Standby Gas Treatment System is OPERABLE and available whenever the purge system is in use.

3/4.11 RADIOACTIVE EFFLUENTS

3/4.11.4 TOTAL DOSE

CONTROLS

3.11.4.1 In accordance with Oyster Creek Technical Specifications 6.8.4.a.10, the annual (calendar year) dose commitment to any MEMBER OF THE PUBLIC due to radioactive material in the effluent and direct radiation from the OCGS in the UNRESTRICTED AREA shall be limited to less than or equal to 75 mrem to the thyroid or less than or equal to 25 mrem to the total body or any other organ.

APPLICABILITY: At all times

ACTION:

- a. With the calculated doses from the release of radioactive materials in liquid or gaseous effluents exceeding twice the limits of CONTROLS 3.11.1.2a, 3.11.1.2b, 3.11.2.2a, 3.11.2.2b, 3.11.2.3a, or 3.11.2.3b, perform an assessment to determine whether the limits of CONTROL 3.11.4.1 have been exceeded. If such is the case, prepare and submit to the Commission within 30 days, pursuant to Technical Specification 6.9.2; a Special Report that defines the corrective action to be taken to reduce subsequent releases to prevent recurrence of exceeding the above limits and includes the schedule for achieving conformance with the above limits. This Special Report shall include information specified in 10CFR20.2203. If the estimated dose(s) exceeds the above limits, and if the release condition resulting in violation of 40 CFR Part 190 has not already been corrected, the Special Report shall include a request for a variance in accordance with the provisions of 40 CFR Part 190. Submittal of the report is considered a timely request, and a variance is granted until staff action on the request is complete.
- b. The provisions of CONTROLS 3.0.3 and 3.0.4 are not applicable.

SURVEILLANCE REQUIREMENTS

4.11.4.1 Cumulative dose contributions from liquid and gaseous effluents shall be determined in accordance with SURVEILLANCE REQUIREMENT 4.11.1.2, 4.11.2.2, 4.11.2.3, and in accordance with the methodology and parameters in the ODCM Part II Section 3.0 at least once per year.

4.11.4.2 Cumulative dose contributions from direct radiation from the facility shall be determined in accordance with the methodology and parameters in the ODCM Part II Section 3.2. This requirement is applicable only under conditions set forth in CONTROL 3.11.4, ACTION a.

3/4.12 RADIOLOGICAL ENVIRONMENTAL MONITORING

3/4.12.1 MONITORING PROGRAM

CONTROLS

3.12.1. In accordance with Oyster Creek Technical Specifications 6.8.4.b, the radiological environmental monitoring program shall be conducted as specified in Table 3.12.1-1. For specific sample locations see Table E-1. Revisions to the non-ODCM required portions of the program may be implemented at any time. Non-ODCM samples are those taken in addition to the minimum required samples listed in Table 3.12.1-1.

APPLICABILITY: At all times.

ACTION:

- a. With the radiological environmental monitoring program not being conducted as specified in Table 3.12.1-1, prepare and submit to the Commission, in the Annual Radiological Environmental Operating Report required by Technical Specification 6.9.1.e, a description of the reasons for not conducting the program as required and the plans for preventing a recurrence.
- b. With the level of radioactivity as the result of plant effluents in an environmental sampling medium at a specified location exceeding the reporting levels of Table 3.12.1-2 when averaged over any calendar quarter, prepare and submit to the Commission within 60 days of the end of the quarter, pursuant to Technical Specification 6.9.2, a Special Report that identifies the cause(s) for exceeding the limit(s) and defines the corrective actions to be taken to reduce radioactive effluents so that the potential annual dose* to a MEMBER OF THE PUBLIC is less than the calendar year limits of CONTROLS 3.11.1.2, 3.11.2.2, and 3.11.2.3. When more than one of the radionuclides in Table 3.12.1-2 are detected in the sampling medium, this report shall be submitted if:

$$\frac{\text{concentration (1)}}{\text{reporting level (1)}} + \frac{\text{concentration (2)}}{\text{reporting level (2)}} + \dots \geq 1.0$$

When radionuclides other than those in Table 3.12.1-2 are detected and are the result of plant effluents, this report shall be submitted if the potential annual dose* to a MEMBER OF THE PUBLIC from all radionuclides is equal to or greater than the calendar year limits of CONTROLS 3.11.1.2, 3.11.2.2, and 3.11.2.3. This report is not required if the measured level of radioactivity was not the result of plant effluents; however, in such an event, the condition shall be reported and described in the Annual Radiological Environmental Operating Report pursuant to Section 6.1.2.1.

*The methodology used to estimate the potential annual dose to a MEMBER OF THE PUBLIC shall be indicated in this report.

3/4.12 RADIOLOGICAL ENVIRONMENTAL MONITORING

3/4.12.1 MONITORING PROGRAM

CONTROLS (Continued)

ACTION: (Continued)

- c. If garden vegetation samples are unobtainable due to any legitimate reason, it is NOT ACCEPTABLE to substitute vegetation from other sources. The missed sample will be documented in the annual report, with no further actions necessary. If a permanent sampling location becomes unavailable, follow Table 3.12.1-1 Table Notation (1) to replace the location.
- d. The provisions of CONTROLS 3.0.3, 3.0.4 and Technical Specification 6.9.2 are not applicable.

SURVEILLANCE REQUIREMENTS

- 4.12.1 The radiological environmental monitoring samples shall be collected pursuant to Table 3.12.1-1 from the specific locations given in Table E-1, and shall be analyzed pursuant to the requirements of Table 3.12.1-1, and the detection capabilities required by Table 4.12.1-1.

TABLE 3.12.1-1: RADIOLOGICAL ENVIRONMENTAL MONITORING PROGRAM

<u>EXPOSURE PATHWAY AND/OR SAMPLE</u>	<u>NUMBER OF REPRESENTATIVE SAMPLES AND SAMPLE LOCATIONS⁽¹⁾</u>	<u>SAMPLING AND COLLECTION FREQUENCY</u>	<u>TYPE AND FREQUENCY OF ANALYSIS</u>
1. DIRECT RADIATION ⁽²⁾	<p>Routine monitoring stations with two or more dosimeters placed as follows:</p> <p>An inner ring of stations one in each meteorological sector in the general area of the SITE BOUNDARY (At least 16 locations);</p> <p>An outer ring of stations, one in each land-based meteorological sector in the approximately 6- to 8-km range from the site (At least 14 locations); and</p> <p>At least 8 stations to be placed in special interest areas such as population centers, nearby residences, schools, and in one or two areas to serve as control stations.</p>	Quarterly	Gamma dose quarterly

TABLE 3.12.1-1(Cont'd)

RADIOLOGICAL ENVIRONMENTAL MONITORING PROGRAM

<u>EXPOSURE PATHWAY AND/OR SAMPLE</u>	<u>NUMBER OF REPRESENTATIVE SAMPLES AND SAMPLE LOCATIONS⁽¹⁾</u>	<u>SAMPLING AND COLLECTION FREQUENCY</u>	<u>TYPE AND FREQUENCY OF ANALYSIS</u>
<p>2. AIRBORNE</p> <p>Radioiodine and Particulates</p>	<p>Samples from 5 locations:</p> <p>Three samples from close to the SITE BOUNDARY in different sectors of the highest calculated annual average ground-level D/Q.</p> <p>One sample from the vicinity of a community having the highest calculated annual average ground-level D/Q; and</p> <p>One sample from a control location, as for example 15-30 km distant and in the least prevalent wind direction ⁽⁶⁾.</p>	<p>Continuous sampler operation with sample collection weekly or more frequently if required by dust loading.</p>	<p><u>Radioiodine Canister:</u> I-131 analysis weekly.</p> <p><u>Particulate Sampler</u> Gross beta radioactivity analysis following filter change⁽³⁾;</p> <p>Gamma isotopic analysis⁽⁴⁾ of composites (by location) quarterly.</p>

TABLE 3.12.1-1(Cont'd)
RADIOLOGICAL ENVIRONMENTAL MONITORING PROGRAM

<u>EXPOSURE PATHWAY AND/OR SAMPLE</u>	<u>NUMBER OF REPRESENTATIVE SAMPLES AND SAMPLE LOCATIONS⁽¹⁾</u>	<u>SAMPLING AND COLLECTION FREQUENCY</u>	<u>TYPE AND FREQUENCY OF ANALYSIS</u>
3. WATERBORNE			
a. Surface	One sample upstream One sample downstream	Grab sample weekly, Combine into monthly composite.	Gamma isotopic and tritium analysis ⁽⁴⁾ .
b. Ground ⁽⁵⁾	Samples from one or two sources if likely to be affected.	Grab sample quarterly.	Gamma isotopic and tritium analysis ⁽⁴⁾ .
c. Drinking	1 sample of each of 1 to 3 of the nearest water supplies that could be affected by its discharge.	Grab sample weekly, combine into a 2-week composite if I-131 analysis is required; composite monthly otherwise.	Gross beta, gamma isotopic and tritium analysis monthly ⁽⁴⁾⁽⁷⁾ .
	One sample from a background location.		

TABLE 3.12.1-1(Cont'd)

RADIOLOGICAL ENVIRONMENTAL MONITORING PROGRAM

<u>EXPOSURE PATHWAY AND/OR SAMPLE</u>	<u>NUMBER OF REPRESENTATIVE SAMPLES AND SAMPLE LOCATIONS⁽¹⁾</u>	<u>SAMPLING AND COLLECTION FREQUENCY</u>	<u>TYPE AND FREQUENCY OF ANALYSIS</u>
d. Sediment	One sample from downstream area with existing or potential recreational value.	Semiannually.	Gamma isotopic analysis ⁽⁴⁾ semiannually.

TABLE 3.12.1-1(Cont'd)

RADIOLOGICAL ENVIRONMENTAL MONITORING PROGRAM

<u>EXPOSURE PATHWAY AND/OR SAMPLE</u>	<u>NUMBER OF REPRESENTATIVE SAMPLES AND SAMPLE LOCATIONS⁽¹⁾</u>	<u>SAMPLING AND COLLECTION FREQUENCY</u>	<u>TYPE AND FREQUENCY OF ANALYSIS</u>
4. INGESTION a. Milk ⁽⁶⁾	No milking animals If milk animals are identified: Samples from milking animals in three locations within 5km having the highest dose potential. If there are none, then one sample from milking animals in each of three areas between 5 an 8 km distant where doses are calculated to be greater than 1 mrem per year. One sample from milking animal at a control location 15 to 30 km distant and in the least prevalent wind direction	Semimonthly when on pasture; monthly at other times	Gamma isotopic ⁽⁴⁾ and Iodine -131 semimonthly when animals are on pasture; monthly at other times
b. Fish	One sample of available species consumed by man in plant discharge canal. One sample of available species consumed by man not influenced by plant discharge.	Semiannually, when available	Gamma isotopic analysis ⁽⁴⁾ on edible portions.

TABLE 3.12.1-1(Cont'd)

RADIOLOGICAL ENVIRONMENTAL MONITORING PROGRAM

<u>EXPOSURE PATHWAY AND/OR SAMPLE</u>	<u>NUMBER OF REPRESENTATIVE SAMPLES AND SAMPLE LOCATIONS⁽¹⁾</u>	<u>SAMPLING AND COLLECTION FREQUENCY</u>	<u>TYPE AND FREQUENCY OF ANALYSIS</u>
c. Clams	One sample of available species consumed by man within the influence of the facility discharge.	Semiannually, when available	Gamma isotopic analysis ⁽⁴⁾ on edible portions.
	One sample of available species consumed by man not influenced by plant discharge.		
d. Vegetation ⁽⁸⁾	3 samples of broad leaf vegetation grown nearest each of two different Off Site locations of highest predicted annual average combined elevated and ground level release D/Q	Monthly during growing season	Gamma isotopic analysis ⁽⁴⁾ and I-131 on edible portion.
	One sample of each of the similar broad leaf vegetation grown at least 15 to 30 km (9.3-18.6 miles) distant in the least prevalent wind direction.		

TABLE 3.12.1-1 (Continued)

TABLE NOTATIONS

- (1) Specific parameters of distance and direction sector from the centerline of the reactor, and additional description where pertinent, are provided for each and every sample location in Table 3.12.1-1 and Table E-1. Deviations are permitted from the required sampling schedule if specimens are unobtainable due to circumstances such as hazardous conditions, seasonal unavailability, malfunction of automatic sampling equipment, and other legitimate reasons. If specimens are unobtainable due to sampling equipment malfunction, effort shall be made to complete corrective action prior to the end of the next sampling period. All deviations from the sampling schedule shall be documented in the Annual Radiological Environmental Operating Report pursuant to CONTROL 6.1.2.4. It is recognized that, at times, it may not be possible or practicable to continue to obtain samples of the media of choice at the most desired location or time. In these instances suitable specific alternative media and locations may be chosen for the particular pathway in question and appropriate substitutions made within 30 days in the Radiological Environmental Monitoring Program given in the ODCM. Pursuant to Technical specification 6.19, submit in the next Radioactive Effluent Release Report documentation for a change in the ODCM including revised figure(s) and table for the ODCM reflecting the new location(s) with supporting information identifying the cause of the unavailability of samples for the pathway and justifying the selection of the new location(s) for obtaining samples. This applies to changes/deletions/additions of permanent sampling locations. This does not apply to one-time deviations from the sampling schedule. In those cases, it is NOT ACCEPTABLE to substitute sample media from other sources. The missed sample will be documented in the annual report, with no further actions necessary.
- (2) One or more instruments, such as pressurized ion chamber, for measuring and recording dose rate continuously may be used in place of, or in addition to, integrating dosimeters. For the purposes of this table, a thermoluminescent dosimeter (TLD) is considered to be one phosphor; two or more phosphors in a packet are considered as two or more dosimeters. The number of direct radiation monitoring stations has been reduced from the NUREG 1302 recommendation due to geographical limitations; e.g., some sectors are over water and some sectors cannot be reached due to lack of highway access, therefore the number of dosimeters has been reduced accordingly.
- (3) Airborne particulate sample filters shall be analyzed for gross beta radioactivity 24 hours or more after sampling to allow for radon and thoron daughter decay. If gross beta activity in air particulate is greater than ten times the yearly mean of control samples, gamma isotopic analysis shall be performed on the individual samples.
- (4) Gamma isotopic analysis means the identification and quantification of gamma-emitting radionuclides that may be attributable to the effluents from the facility.

- (5) Groundwater samples shall be taken when this source is tapped for drinking or irrigation purposes in areas where the hydraulic gradient or recharge properties are suitable for contamination. Extensive studies of geology and groundwater in the vicinity of the OCGS (Reference 21 and 31) have demonstrated that there is no plausible pathway for effluents from the facility to contaminate offsite groundwater, including the local drinking water supplies. Samples of groundwater, including local drinking water wells, are collected in order to provide assurance to the public that these water resources are not impacted.
- (6) The purpose of this sample is to obtain background information. If it is not practical to establish control locations in accordance with the distance and wind direction criteria, other sites which provide valid background data may be substituted.
- (7) I-131 analysis on each composite when the dose calculated for the consumption of the water is greater than 1 mrem per year.
- (8) If garden vegetation samples are unobtainable due to any legitimate reason (see (1) above), it is NOT ACCEPTABLE to substitute vegetation from other sources. The missed sample will be documented in the annual report, with no further actions necessary.

TABLE 3.12.1-2: REPORTING LEVELS FOR RADIOACTIVITY CONCENTRATIONS IN ENVIRONMENTAL SAMPLES - REPORTING LEVELS

Analysis	Surface and Ground Water(pCi/l)	Airborne Particulate and Iodine (pCi/m ³)	Fish (pCi/Kg, wet)	Milk (pCi/l)	Vegetation (pCi/Kg, wet)
H-3	20000*				
Mn-54	1000		30000		
Fe-59	400		10000		
Co-58	1000		30000		
Co-60	300		10000		
Zn-65	300		20000		
Zr-Nb-95	400				
I-131	2**	0.9		3	100
Cs-134	30	10	1000	60	1000
Cs-137	50	20	2000	70	2000
Ba-La-140	200			300	

*For drinking water samples (this is the 40 CFR Part 141 value).
If no drinking water pathway exists, a value of 30,000 pCi/L may be used.

**If no drinking water pathway exists, a value of 20 pCi/L may be used.

TABLE 4.12.1-1: DETECTION CAPABILITIES FOR ENVIRONMENTAL SAMPLE ANALYSIS^{(1),(2)} - LOWER LIMITS OF DETECTION (LLD)⁽³⁾

Analysis	Surface and Ground Water (pCi/l)	Air Particulate and Air Iodine (pCi/m ³)	Vegetation (pCi/Kg, wet)	Sediment (pCi/Kg, dry)	Fish and Clams (pCi/Kg, wet)
Gross Beta	4	0.01			
H-3	2000 ⁽⁴⁾				
Mn-54	15				130
Fe-59	30				260
Co-58, 60	15				130
Zn-65	30				260
Zr-95	30				
Nb-95	15				
I-131	1 ⁽⁴⁾	0.07 ⁽⁵⁾	60		
Cs-134	15	0.05 ⁽⁶⁾	60	150	130
Cs-137	18	0.06 ⁽⁶⁾	80	180	150
La-140	15				
Ba-140	60 ⁽⁷⁾				

TABLE 4.12.1-1: (Continued)

TABLE NOTATIONS

- (1) This list does not mean that only these nuclides are to be considered. Other peaks that are identifiable, together with those of the above nuclides, shall also be analyzed and reported in the Annual Radiological Environmental Operating Report pursuant to CONTROL 6.1.2.3.
- (2) Required detection capabilities for thermoluminescent dosimeters used for environmental measurements shall be in accordance with the recommendations of Regulatory Guide 4.13.
- (3) The LLD is defined, for purposes of these CONTROLS as the smallest concentration of radioactive material in a sample that will yield a net count, above system background, that will be detected with 95% probability with only 5% probability of falsely concluding that a blank observation represents a "real" signal.

For a particular measurement system, which may include radiochemical separation:

$$LLD = \frac{4.66 * Sb}{E * V * 2.22 * Y * \exp(-\lambda \Delta t)}$$

Where:

LLD is the "a priori" lower limit of detection as defined above, as picocuries per unit mass or volume,

Sb is the standard deviation of the background counting rate or of the counting rate of a blank sample as appropriate, as counts per minute,

E is the counting efficiency, as counts per disintegration,

V is the sample size in units of mass or volume,

2.22 is the number of disintegrations per minute per Pico curie,

Y is the fractional radiochemical yield, when applicable,

λ is the radioactive decay constant for the particular radionuclide (sec^{-1}), and

Δt for environmental samples is the elapsed time between sample collection, or end of the sample collection period, and time of counting (sec).

Typical values of E, V, Y, and Δt should be used in the calculation.

TABLE 4.12.1-1 (Continued)

TABLE NOTATIONS

It should be recognized that the LLD is defined as an a priori (before the fact) limit representing the capability of a measurement system and not as an a posteriori (after the fact) limit for a particular measurement. Analyses shall be performed in such a manner that the stated LLDs will be achieved under routine conditions. Occasionally, background fluctuations, unavoidable small sample sizes, the presence of interfering nuclides, or other uncontrollable circumstances may render these LLDs unachievable. In such cases, the contributing factors shall be identified and described in the Annual Radiological Environmental Operating Report pursuant Technical Specification 6.9.1.e and Control 6.1.2.6.4.

- (4) If no drinking water pathway exists, a value of 3000 pCi/L for tritium and 15 pCi/L for iodine-131 may be used.
- (5) For the air iodine sample.
- (6) For the air particulate sample.
- (7) Ba-140 and La-140 are in equilibrium

3/4.12 RADIOLOGICAL ENVIRONMENTAL MONITORING

3/4.12.2 LAND USE CENSUS

CONTROLS

3.12.2 In accordance with the Oyster Creek Technical Specifications 6.8.4.b, a land use census shall be conducted and shall identify within a distance of 5 miles the location in each of the 16 meteorological sectors of the nearest milk animal, the nearest residence and the nearest garden* of greater than 500 ft² producing broad leaf vegetation. The census shall also identify within a distance of 3 miles the location in each of the 16 meteorological sectors all milk animal and all gardens greater than 500 square feet producing broadleaf vegetation.

APPLICABILITY: At all times.

ACTION:

- a. With a land use census identifying a location(s) that yields a calculated dose or dose commitment greater than the values currently being calculated in SURVEILLANCE REQUIREMENT 4.11.2.3, identify the new location(s) in the next Radioactive Effluent Release Report, pursuant to Control 6.2.2.4.
- b. With a land use census identifying a location(s) that yields a calculated dose or dose commitment (via the same exposure pathway) 20 percent greater than at a location from which samples are currently being obtained in accordance with CONTROL 3.12.1, add the new location(s) to the radiological environmental monitoring program within 30 days. The sampling location(s), excluding the control station location, having the lowest calculated dose or dose commitment(s), via the same exposure pathway, may then be deleted from this monitoring. Pursuant to CONTROL 6.2.2.4, identify the new location(s) in the next Radioactive Effluent Release Report and also include in the report a revised figure(s) and table for the ODCM reflecting the new location(s).
- c. The provisions of CONTROLS 3.0.3 and 3.0.4 are not applicable.

SURVEILLANCE REQUIREMENTS

4.12.2 The land use census shall be conducted during the growing season at least once per 12 months using that information that will provide the best results, such as by door-to-door survey, visual survey, aerial survey, or by consulting local agriculture authorities. The results of the land use census shall be included in the Annual Radiological Environmental Operating Report pursuant to CONTROL 6.1.2.2.

*Broad leaf vegetation sampling of at least three different kinds of vegetation may be performed at the SITE BOUNDARY in each of two different direction sectors with the highest predicted elevated release D/Q's in lieu of the garden census. Controls for broadleaf vegetation sampling in Table 3.12.1-1, Part 4.c shall be followed, including analysis of control samples.

3/4.12 RADIOLOGICAL ENVIRONMENTAL MONITORING

3/4.12.3 INTERLABORATORY COMPARISON PROGRAM

CONTROLS

3.12.3 In accordance with Oyster Creek Technical Specifications 6.8.b.3, analyses shall be performed on radioactive materials supplied as part of an Interlaboratory comparison program which has been approved by the Commission:

APPLICABILITY: At all times.

ACTION:

- a. With analyses not being performed as required above, report the reason and corrective actions taken to prevent a recurrence to the Commission in the Annual Radiological Environmental Operating Report pursuant to CONTROL 6.1.2.6.3.
- b. The provisions of CONTROLS 3.0.3 and 3.0.4 are not applicable.

SURVEILLANCE REQUIREMENTS

4.12.3 A summary of the results obtained as part of the above-required Interlaboratory Comparison Program shall be included in the Annual Radiological Environmental Operating Report pursuant to CONTROL 6.1.2.6.3.

3/4 .12 RADIOLOGICAL ENVIRONMENTAL MONITORING

3/4.12.4 METEOROLOGICAL MONITORING PROGRAM

CONTROLS

3.12.4 The meteorological monitoring instrumentation channels shown in Table 3.12.4.-1 shall be operable.

APPLICABILITY: At all times.

ACTION:

- a. With less than the minimum required instrumentation channels OPERABLE for more than 7 days, initiate an Issue Report outlining the cause of the malfunction and the plans for restoring the instrumentation to OPERABLE status.
- b. The provisions of CONTROLS 3.0.3 and 3.0.4 are not applicable.

TABLE 3.12.4-1

METEOROLOGICAL MONITORING INSTRUMENTATION

INSTRUMENT	ELEVATION	MINIMUM INSTRUMENT OPERABLE
1. Wind Speed		
a.	380 feet	1
b.	150 feet	1
c.	33 feet	1
2. Wind Direction		
a.	380 feet	1
b.	150 feet	1
c.	33 feet	1
3. ΔT		
a.	380-33	1
b.	150-33	1

BASES FOR SECTIONS 3.0 AND 4.0

CONTROLS AND SURVEILLANCE REQUIREMENTS

NOTE: The BASES contained in the succeeding pages summarize the reasons for the CONTROLS of Sections 3.0 and 4.0, but are not considered a part of these CONTROLS.

3/4.3 INSTRUMENTATION

BASES

3/4.3.3.10 RADIOACTIVE LIQUID EFFLUENT MONITORING INSTRUMENTATION

The radioactive liquid effluent instrumentation is provided to monitor and control, as applicable, the releases of radioactive materials in liquid effluents during actual or potential releases of liquid effluents. The reactor service water system discharge line radioactivity monitor initiates an alarm in the Control Room when the alarm set point is exceeded. The alarm/trip set points for these instruments shall be calculated and adjusted in accordance with the methodology and parameters in the ODCM to ensure that the alarm/trip will occur prior to exceeding the limits of 10 CFR Part 20. The OPERABILITY and use of this instrumentation is consistent with the requirements of General Design Criteria 60, 63, and 64 of Appendix A to 10 CFR Part 50.

3/4.3.3.11 RADIOACTIVE GASEOUS EFFLUENT MONITORING INSTRUMENTATION

The radioactive gaseous effluent instrumentation is provided to monitor and control, as applicable, the releases of radioactive materials in gaseous effluents during actual or potential releases of gaseous effluents. The alarm/trip set points for each of the noble gas monitors shall be calculated and adjusted in accordance with the methodology and parameters in the ODCM. This will ensure the alarm/trip will occur prior to exceeding the limits of 10 CFR Part 20. The radioactive gas monitors for the stack effluent and the Augmented Off gas Building exhaust ventilation have alarms which report in the Reactor Control Room. The OPERABILITY and use of this instrumentation is consistent with the requirements of General Design Criteria 60, 63, and 64 of Appendix A to 10 CFR Part 50.

3/4.11 RADIOACTIVE EFFLUENTS

BASES

3/4.11.1 LIQUID EFFLUENTS

3/4.11.1.1 CONCENTRATION

This CONTROL is provided to ensure that the concentration of radioactive materials released in liquid waste effluents to UNRESTRICTED AREAS will be less than the concentration levels specified in 10 CFR Part 20, Appendix B, Table 2, Column 2. This limitation provides additional assurance that the levels of radioactive materials in bodies of water in UNRESTRICTED AREAS will result in exposures within (1) the Section II.A design objectives of Appendix I, 10 CFR Part 50, to a MEMBER OF THE PUBLIC and (2) the limits of 10 CFR Part 20.106(a) to the population. The concentration limit for dissolved or entrained noble gases is based upon the assumption that Xe-135 is the controlling radioisotope and its concentration limit in air (submersion) was converted to an equivalent concentration in water using the methods described in International Commission on Radiological Protection (ICRP) Publication 2.

The value 1E-8 is the limit for unidentified gross gamma or beta releases as per 10 CFR 20 Appendix B, Table 2, Column 2 "any single radionuclide...other than alpha or spontaneous fission ...half life greater than 2 hours". This provides operational flexibility while providing reasonable assurance that dose will remain less than 0.1 rem/yr.

The required detection capabilities for radioactive materials in liquid waste samples are tabulated in terms of the lower limits of detection (LLDs). Detailed discussion of the LLD, and other detection limits can be found in references 25, 26, and 27.

Weekly grab samples for Service Water Effluents are composited for monthly tritium and gross alpha analysis and quarterly Sr-89/90 and Fe-55 analysis if activity is detected. New Radwaste and AOG Service Water Effluents have no continuous radiation monitors. Weekly grab samples are performed to detect leaks. Plant design does not include composite samplers, so the weekly grab sample frequency is considered adequate.

While discharging groundwater via the continuous release remediation pathway, the composite sample will be analyzed daily for principal gamma emitters and tritium. A monthly composite sample is analyzed for gross alpha, Sr-89/90, Fe-55, and Ni-63.

While discharging groundwater via the batch release mode remediation pathway, a grab sample is collected from each tank and analyzed for principal gamma emitters and tritium, a composite sample is analyzed monthly for gross alpha, Sr-89/90, Fe-55, and Ni-63.

Circulating Water Effluent is not included in Table 4.11.1.1-1, Radioactive Liquid Waste Sampling and Analysis Program since the Circulating Water is sampled as part of the

Radiological Environmental Monitoring Program, Table 3.12.1-1, 3a, Waterborne, Surface downstream sample.

3/4.11.1.2 DOSE

This CONTROL is provided to implement the requirements of Sections II.A, III.A, and IV.A of Appendix I, 10 CFR Part 50. The CONTROL implements the guides set forth in Section II.A of Appendix I. The ACTION statements provide the required operating flexibility and at the same time implement the guides set forth in Section IV.A of Appendix I to assure that the releases of radioactive material in liquid effluents to UNRESTRICTED AREAS will be kept "as low as is reasonably achievable." The dose calculation methodology and parameters in the ODCM implement the requirements in Section III.A of Appendix I that conformance with the guides of Appendix I be shown by calculational procedures based on models and data, such that the actual exposure of a MEMBER OF THE PUBLIC through appropriate pathways is unlikely to be substantially underestimated. The equations specified in the ODCM for calculating the doses due to the actual release rates of radioactive materials in liquid effluents are consistent with the methodology provided in Regulatory Guide 1.109 and Regulatory Guide 1.113.

3/4.11.1.3 LIQUID RADWASTE TREATMENT

The OPERABILITY of the liquid radwaste treatment system ensures that this system will be available for use whenever liquid effluents require treatment prior to their release to the environment. The requirement that the appropriate portions of this system be used, when specified, provides assurance that the releases of radioactive materials in liquid effluents will be kept "as low as is reasonably achievable". This CONTROL implements the requirements of General Design Criterion 60 of Appendix A to 10 CFR Part 50 and the design objective given in Section II.D of Appendix I to 10 CFR Part 50. The specified limits governing the use of appropriate portions of the liquid radwaste treatment system were specified as a suitable fraction of the dose design objectives set forth in Section II.A of Appendix I, 10 CFR Part 50, for liquid effluents. Figure D-1-1a, Liquid Radwaste Treatment Chem Waste and Floor Drain System and Figure D-1-1b, Liquid Radwaste Treatment – High Purity and Equipment Drain System provides details of the Liquid Radwaste Treatment system.

3/4.11.2 GASEOUS EFFLUENTS

3/4.11.2.1 DOSE RATE

This CONTROL is provided to ensure that the dose at any time at and beyond the SITE BOUNDARY from gaseous effluents will be within the annual dose limits of 10 CFR Part 20 to UNRESTRICTED AREAS. The annual dose limits are the doses associated with the concentrations of 10 CFR Part 20, Appendix B, Table 2, Column 1. These limits provide reasonable assurance that radioactive material discharged in gaseous effluents will not result in the exposure of a MEMBER OF THE PUBLIC in an UNRESTRICTED AREA either within or outside the SITE BOUNDARY, to annual average concentrations exceeding the limits specified

in Appendix B, Table 2 of 10 CFR Part 20. For MEMBERS OF THE PUBLIC who may at times be within the SITE BOUNDARY, the occupancy of the individual will usually be sufficiently low to compensate for any increase in the atmospheric diffusion factor above that for the SITE BOUNDARY. Examples of calculations for such MEMBERS OF THE PUBLIC with the appropriate occupancy factors shall be given in the ODCM. The specified release rate limits restrict, at all times, the corresponding gamma and beta dose rates above background to a MEMBER OF THE PUBLIC at or beyond the SITE BOUNDARY to less than or equal to 500 mrem/year to the total body or to less than or equal to 3000 mrem/yr to the skin. These release rate limits also restrict, at all times, the corresponding thyroid dose rate above background to a child via the inhalation pathway to less than or equal to 1500 mrem/year.

The required detection capabilities for radioactive materials in liquid waste samples are tabulated in terms of the lower limits of detection (LLDs). Detailed discussion of the LLD, and other detection limits can be found in references 25, 26 and 27.

Tritium is sampled quarterly for gaseous effluents. Based on the consistency of the data from the quarterly sampling, the sampling frequency is adequate.

3/4.11.2.2 DOSE - NOBLE GASES

This CONTROL is provided to implement the requirements of Section II.B, III.A and IV.A of Appendix I, 10 CFR Part 50. The CONTROL implements the guides set forth in Section II.B of Appendix I. The ACTION statements provide the required operating flexibility and at the same time implement the guides set forth in Section IV.A of Appendix I to assure that the releases of radioactive material in gaseous effluents will be kept "as low as is reasonably achievable." The SURVEILLANCE REQUIREMENTS implement the requirements in Section III.A of Appendix I that conformance with the guides of Appendix I be shown by calculational procedures based on models and data such that the actual exposure of a MEMBER OF THE PUBLIC through appropriate pathways is unlikely to be substantially underestimated. The dose calculation methodology and parameters established in the ODCM for calculating the doses due to the actual release rates of radioactive noble gases in gaseous effluents are consistent with the methodology provided in Regulatory Guide 1.109 and Regulatory Guide 1.111. The ODCM equations provided for determining the air doses at and beyond the SITE BOUNDARY are based upon the historical average atmospheric conditions.

3/4.11.2.3 DOSE - IODINE-131, IODINE-133, TRITIUM, AND RADIONUCLIDES IN PARTICULATE FORM

This CONTROL is provided to implement the requirements of Section II.C, III.A and IV.A of Appendix I, 10 CFR Part 50. The CONTROLS are the guides set forth in Section II.C of Appendix I. The ACTION statements provide the required operating flexibility and at the same time implement the guides set forth in Section IV.A of Appendix I to assure that the releases of radioactive material in gaseous effluents to UNRESTRICTED AREAS will be kept "as low as is reasonably achievable." The ODCM calculational methods specified in SURVEILLANCE REQUIREMENTS implement the requirements in Section III.A of Appendix I that conformance with the guides of Appendix I be shown by calculational procedures based on models and data such that the actual exposure of a MEMBER OF THE PUBLIC through appropriate pathways is unlikely to be substantially underestimated. The ODCM calculational methodology and

parameters for calculating the doses due to the actual release rates of the subject materials are consistent with the methodology provided in Regulatory Guide 1.109, and Regulatory Guide 1.111. These equations also provide for determining the actual doses based upon the historical average atmospheric conditions. The release rate controls for iodine-131, iodine-133, tritium, and radionuclides in particulate form with half-life greater than 8 days are dependent on the existing radionuclide pathways to man, in the areas at and beyond the SITE BOUNDARY. The pathways that were examined in the development of these calculations were: 1) individual inhalation of airborne radionuclides, 2) deposition of radionuclides onto green leafy vegetation with subsequent consumption by man, 3) deposition onto grassy areas where milk animals and meat producing animals graze with consumption of the milk and meat by man, and 4) deposition on the ground with subsequent exposure of man.

3/4.11.2.4 AUGMENTED OFF GAS TREATMENT SYSTEM

The OPERABILITY of the AUGMENTED OFF GAS TREATMENT SYSTEM (AOG) ensures that the system will be available for use whenever gaseous effluents require treatment prior to release to the environment. The requirement that the appropriate portions of these systems be used, when specified, provides reasonable assurance that the releases of radioactive materials in gaseous effluents will be kept "as low as is reasonably achievable." This CONTROL implements the requirements of General Design Criterion 60 of Appendix A to 10 CFR Part 50, and the design objectives given in Section II.D of Appendix I to 10 CFR Part 50. The specified limits governing the use of appropriate portions of the systems were specified as a suitable fraction of the dose design objectives set forth in Section II.B and II.C of Appendix I, 10 CFR Part 50, for gaseous effluents. Figure D-2-1, Gaseous Radwaste Treatment – Augmented Off Gas System, Figure D-2-2, Ventilation System provide details of the Augmented Off Gas Treatment System and Figure D-2-3, AOG Ventilation System.

3/4.11.4 TOTAL DOSE

This CONTROL is provided to meet the dose limitations of 40 CFR Part 190 that have now been incorporated into 10 CFR Part 20 by 46 FR 18525. The CONTROL requires the preparation and submittal of a Special Report whenever the calculated doses from plant radioactive effluents exceed 25 mrem to the total body or any organ, except the thyroid, which shall be limited to less than or equal to 75 mrem. It is highly unlikely that the resultant dose to a MEMBER OF THE PUBLIC will exceed the dose limits of 40 CFR Part 190 if the doses remain within twice the dose design objectives of Appendix I, and if direct radiation doses from the unit, including outside storage tanks, etc. are kept small. The Special Report will describe a course of action that should result in the limitation of the annual dose to a MEMBER OF THE PUBLIC to within the 40 CFR Part 190 limits. For purposes of the Special Report, it may be assumed that the dose commitment to the MEMBER OF THE PUBLIC from other uranium fuel cycle sources is negligible. If the dose to any MEMBER OF THE PUBLIC is estimated to exceed the requirements of 40 CFR Part 190, the Special Report with a request for a variance (provided the release conditions resulting in violation of 40 CFR Part 190 have not already been corrected), in accordance with the provisions of 40 CFR Part 190 and 10 CFR Part 20, is considered to be a timely request and fulfills the requirements of 40 CFR Part 190 until NRC staff action is completed. The variance only relates to the limits of 40 CFR Part 190, and does

3/4.12 RADIOLOGICAL ENVIRONMENTAL MONITORING

BASES

3/4.12.1 MONITORING PROGRAM

The radiological environmental monitoring program required by this CONTROL provides representative measurements of radiation and of radioactive materials in those exposure pathways and for those radionuclides that lead to the highest potential radiation exposures of MEMBERS OF THE PUBLIC resulting from the station operation. This monitoring program implements Section IV.B.2 of Appendix I to 10 CFR Part 50 and thereby supplements the radiological effluent monitoring program by verifying that the measurable concentrations of radioactive materials and levels of radiation are not higher than expected on the basis of the effluent measurements and the modeling of the environmental exposure pathways. Guidance for this monitoring program is provided by the Radiological Assessment Branch Position on Environmental Monitoring, Revision 1, November 1979.

The required detection capabilities for environmental sample analyses are tabulated in terms of the lower limits of detection (LLDs). The LLDs required by Table 4.12.1-1 are considered optimum for routine environmental measurements in industrial laboratories. It should be recognized that the LLD is defined as an a priori (before the fact) limit representing the capability of a measurement system and not as an a posteriori (after the fact) limit for a particular measurement.

Detailed discussion of the LLD, and other detection limits can be found in references 25, 26, and 27.

Site-specific research, which included the installation of a groundwater monitoring well network, has demonstrated that the groundwater pathway is not a potential pathway to man from the OCGS. The surface water into which the OCGS discharges is a marine estuary containing saline water that is not used as drinking water or irrigation water by man.

3/4.12.2 LAND USE CENSUS

This CONTROL is provided to ensure that changes in the use of areas at and beyond the SITE BOUNDARY are identified and that modifications to the radiological environmental monitoring program are made if required by the results of this census. The best information from the door-to-door survey, from aerial survey, from visual survey or consulting with local agricultural authorities shall be used. This census satisfies the requirements of Section IV.B.3 of Appendix I to 10 CFR Part 50. Restricting the census to gardens of greater than 50 m² (500 ft²) provides assurance that significant exposure pathways via leafy vegetables will be identified and monitored since a garden of this size is the minimum required to produce the quantity (26 kg/year) of leafy vegetables assumed in Regulatory Guide 1.109 for consumption by a child. To determine this minimum garden size, the following assumptions were made: 1) 20% of the garden was used for growing broad leaf vegetation (i.e., similar to lettuce and cabbage), and 2) a vegetation yield of 2 kg/m².

3/4.12 RADIOLOGICAL ENVIRONMENTAL MONITORING

BASES

3/4.12.3 INTERLABORATORY COMPARISON PROGRAM

The requirement for participation in an approved Interlaboratory Comparison Program is provided to ensure that independent checks on the precision and accuracy of the measurements of radioactive material in environmental sample matrices are performed as part of the quality assurance program for environmental monitoring in order to demonstrate that the results are valid for the purposes of Section IV.B.2 of Appendix I to 10 CFR Part 50.5.0

5.0 DESIGN FEATURES / SITE MAP

(Provided FOR INFORMATION ONLY. Technical Specifications are controlling.)

5.1 Site map which will allow identification of structures and release points shall be as shown in Figure E-4.

6.0 ADMINISTRATIVE CONTROLS

6.1 ANNUAL RADIOLOGICAL ENVIRONMENTAL OPERATING REPORT (AREOR)

6.1.1 In accordance with Oyster Creek Technical Specifications 6.9.1.e, a routine radiological environmental operating report covering the operation of the unit during the previous calendar year shall be submitted prior to May 1 of the following year.

6.1.2 The Annual Radiological Environmental Operating Reports shall include:

6.1.2.1 Summaries, interpretations, and an analysis of trends of the results of the radiological environmental surveillance activities (Radiological Environmental Monitoring Program –REMP) for the report period. This will include a comparison with preoperational studies, with operational controls (as appropriate), and with previous environmental surveillance reports, and an assessment of the observed impacts of the plant operation on the environment.

6.1.2.2 The reports shall also include the results of land use censuses required by CONTROL 3.12.2. If harmful effects or evidence of irreversible damage are detected by the monitoring, the report shall provide an analysis of the problem and a planned course of action to alleviate the problem.

6.1.2.3 The Annual Radiological Environmental Operating Reports shall include summarized and tabulated results similar in format to that in Regulatory Guide 4.8, December 1975 of all the radiological environmental samples taken during the report period.

6.1.2.4 Deviations from the sampling program identified in CONTROL 3.12.1 shall be reported.

6.1.2.5 In the event that some individual results are not available for inclusion with the report, the report shall be submitted noting and explaining the reasons for the missing results. The missing data shall be submitted as soon as possible in a supplementary report.

6.1.2.6 The reports shall also include the following:

6.1.2.6.1 A summary description of the radiological environmental monitoring Program;

6.1.2.6.2 Map(s), covering sampling locations, keyed to a table giving distances and directions from the reactor;

6.1.2.6.3 The results of licensee participation in the Inter-laboratory Comparison Program, as required by CONTROL 3.12.3;

6.1.2.6.4 Identification of environmental samples analyzed when the analysis instrumentation was not capable of meeting the detection capabilities in Table 4.12.1-1.

6.2 ANNUAL ROUTINE RADIOACTIVE EFFLUENT RELEASE REPORT (ARERR)

6.2.1 Routine radioactive effluent release reports covering the operation of the unit shall be submitted prior to May 1 of each year and in accordance with the requirements of 10CFR50.36a and section IV.B.1 of 10CFR 50 Appendix I.

6.2.2 The Radioactive Effluent Release Report shall include:

6.2.2.1 A summary of the quantities of radioactive liquid and gaseous effluents and solid waste released from the unit as outlined in Regulatory Guide 1.21, "Measuring, Evaluating, and Reporting Radioactivity in Solid Wastes and Releases of Radioactive Materials in Liquid and Gaseous Effluents from Light-Water-Cooled Nuclear Power Plants," Revision 1, June 1974, with data summarized on a quarterly basis following the format of Appendix B thereof.

6.2.2.2 An annual summary of hourly meteorological data collected over the previous year. This annual summary may be in the form of joint frequency distributions of wind speed, wind direction, and atmospheric stability. Alternatively, summary meteorological data may be retained and made available to the NRC upon request.

6.2.2.3 An assessment of the radiation doses due to the radioactive liquid and gaseous effluents released from the unit or station during the previous calendar year. The historical annual average meteorology or the meteorological conditions concurrent with the time of release of radioactive materials in gaseous effluents (as determined by sampling frequency and measurement) shall be used for determining the gaseous pathway doses. The assessment of radiation doses shall be performed in accordance with this OFF SITE DOSE CALCULATION MANUAL (ODCM).

6.2.2.4 Identify those radiological environmental sample parameters and locations where it is not possible or practicable to continue to obtain samples of the media of choice at the most desired location or time. In addition, the cause of the unavailability of samples for the pathway and the new location(s) for obtaining replacement samples should be identified. The report should also include a revised figure(s) and table(s) for the ODCM reflecting the new location(s).

6.2.2.5 An assessment of radiation doses to the likely most exposed MEMBER OF THE PUBLIC from reactor releases and other nearby uranium fuel cycle sources (including doses from primary effluent pathways and direct radiation) for the previous calendar year to show conformance with 40 CFR Part 190, Environmental Radiation Protection Standards for Nuclear Power Operation. The assessment of radiation doses shall be performed in accordance with this OFF SITE DOSE CALCULATION MANUAL (ODCM) Part II Sections 1.5, 2.4, 2.5 and 3.2.

- 6.2.2.6 The Radioactive Effluent Release Reports shall include the following information for each class of solid waste (as defined by 10 CFR Part 61) shipped Off Site during the report period (see Figure D-1-2):
 - a. Total volume shipped
 - b. Total curie quantity (specify whether determined by measurement or estimate),
 - c. Principal radionuclides (specify whether determined by measurement or estimate),
 - d. Type of waste (e.g., dewatered spent resin, compacted dry waste, evaporator bottoms)
- 6.2.2.7 Unplanned releases from the site to UNRESTRICTED AREAS of radioactive materials in gaseous and liquid effluents on a quarterly basis.
- 6.2.2.8 Changes to the PROCESS CONTROL PROGRAM (PCP)
- 6.2.2.9 Changes to the OFF SITE DOSE CALCULATION MANUAL (ODCM) in the form of a complete, legible copy of the ODCM.

6.3 RESPONSIBILITIES:

- 6.3.1 Chemistry / Radwaste - Responsible for:
 - 6.3.1.1 Implementing approval.
 - 6.3.1.2 Compliance with specifications regarding routine dose assessment.
 - 6.3.1.3 Radiological Environmental Monitoring Program
 - 6.3.1.4 Technical consultation and review
- 6.3.2 Operations - Responsible for compliance with specifications regarding operation of the OCGS.
- 6.3.3 Engineering - Responsible for compliance with specifications regarding set point determination and implementation
- 6.3.4 Radiological Engineering - Responsible for technical consultation and review.

PART II - CALCULATIONAL METHODOLOGIES

1.0 LIQUID EFFLUENTS

1.1 RADIATION MONITORING INSTRUMENTATION AND CONTROLS

The liquid effluent monitoring instrumentation and controls at Oyster Creek for controlling and monitoring normal radioactive material releases in accordance with the Oyster Creek Radiological Effluent Technical Specifications are summarized as follows:

- (1) Reactor Building Service Water Effluent - The Reactor Building Service Water Effluent Line Monitor provides an alarm function only for releases into the environment.

Liquid radioactive waste flow diagrams are presented in Figures D-1-1a, D-1-1b, and D-1-1c.

1.2 LIQUID EFFLUENT MONITOR SET POINT DETERMINATION

Per the requirements of CONTROL 3.3.3.10, alarm set points shall be established for the liquid monitoring instrumentation to ensure that the release concentration limits of CONTROL 3.11.1.1 are met (i.e., the concentration of radioactive material released in liquid effluents to UNRESTRICTED AREAS at the U.S. route 9 bridge over the discharge canal shall not exceed the concentrations specified in 10 CFR 20 Appendix B, Table 2, Column 2, for radionuclides and 2.0E-04 $\mu\text{Ci/ml}$ for dissolved or entrained noble gases).

1.2.1 LIQUID EFFLUENT MONITORS

The set points for the liquid effluent monitors at the Oyster Creek Generating Station are determined by the following equation:

$$S = \frac{A}{FLEC} g \frac{F_2}{F_1} + BKG$$

Where:

- S = radiation monitor alarm set point (cpm)
- A = activity concentration ($\mu\text{Ci/ml}$) of sample in laboratory: $A = \sum C_i$
- g = the primary conversion factor for the instrument – the ratio of effluent radiation monitor counting rate to laboratory activity concentration in a sample of liquid (cpm per $\mu\text{Ci/mL}$).
- F₁ = flow in the batch release line (e.g. gal/min). Value not greater than the discharge line flow alarm maximum set point.

F_2 = flow in the discharge canal (e.g. gal/min). Value not less than the discharge canal minimum flow.

BKG = Monitoring instrument background (cpm)

FLEC = fraction or multiple of unrestricted area LEC in aqueous effluent based on sample analysis. FLEC is the ratio between the LEC_i and C_i . FLEC is unitless. For example: LEC for Co-60 is $3E-6$ $\mu\text{Ci/mL}$. If the concentration in a expected release is $6E-6$ $\mu\text{Ci/mL}$; then FLEC is $6E-6/3E-6 = 2$.

The term $\frac{A}{FLEC}$ represents the count rate of a solution having the same nuclide distribution as the sample and the LEC of that mixture.

C_i = concentration of radionuclide i in effluent, i.e., in a liquid radwaste sample tank, in reactor building service water ($\mu\text{Ci/mL}$).

LEC_i = The unrestricted area liquid effluent concentration (LEC) of radionuclide i , i.e., 10 CFR 20, Appendix B, Table 2, Column 2 quantity for radionuclide i ($\mu\text{Ci/mL}$).

In the event gross radioactivity analysis alone is used to determine the radioactivity in an effluent stream or batch, FLEC is $C/1E-8$ (see 4.11.1.1.1),

Where:

C = The gross radioactivity concentration in effluent ($\mu\text{Ci/mL}$).

$1E-8$ = The unrestricted area LEC for unidentified radionuclides ($\mu\text{Ci/mL}$) from 4.11.1.1.1.

If the gross activity concentration, C , is below the lower limit of detection for gross activity, the value, $1E-8$ $\mu\text{Ci/mL}$, or the equivalent counting rate (cpm/mL) may be substituted for the factor

$\frac{A}{FLEC}$

$$\frac{A}{FLEC} = 1E-8 \mu\text{Ci/mL}$$

1.2.2 SAMPLE RESULT SET POINTS

Usually, when the concentration of specific radionuclides is determinable in a sample(s), i.e., greater than the LLD, the alarm/trip set point of each liquid effluent radioactivity monitor is based upon the measurement of radioactive material in a batch of liquid to be released or in a continuous aqueous discharge.

1.2.3 ASSUMED DISTRIBUTION SET POINTS

Alternatively, a radionuclide distribution that represents the distribution expected to be in the effluent if the concentration were high enough to be detectable, i.e., greater than the LLD, may be assumed. The representative distribution may be

based upon past measurements of the effluent stream or upon a computed distribution.

1.3 BATCH RELEASES

A sample of each batch of liquid radwaste is analyzed for I-131 and other principal gamma emitters or for gross beta or gross gamma activity before release. The result of the analysis is used to calculate the trip set point of the radioactivity monitor on the liquid radwaste effluent line to apply to release of the batch.

1.4 CONTINUOUS RELEASES

The Reactor Building Service Water Effluent is sampled and analyzed weekly for I-131, other principal gamma emitters. Results of analyses for the preceding week or for a period as long as the preceding 3 months are used to calculate the alarm/trip set point of the corresponding effluent radioactivity monitor in order to determine a representative value. In each case, whether batch or continuous, the monitor alarm/trip set point may be set at lower activity concentration than the calculated set point.

1.5 LIQUID EFFLUENT DOSE CALCULATION - 10 CFR 50

Doses resulting from the release of radioiodines and particulates must be calculated to show compliance with Appendix I of 10CFR50. Calculations will be performed at least monthly for all liquid effluents as stated in SURVEILLANCE REQUIREMENT 4.11.1.2 and SURVEILLANCE REQUIREMENT 4.11.1.3.1 to verify that the dose to MEMBERS OF THE PUBLIC is maintained below the limits specified in CONTROL 3.11.1.2

The maximum dose to an individual from radioiodines, tritium, and radioactive particulates with half-lives of greater than eight days in liquid effluents released to unrestricted areas is determined as described in Reg. Guide 1.109. Environmental pathways that radioiodine, tritium, and particulates in liquid effluent follow to the maximally exposed MEMBER OF THE PUBLIC are assumed to be: exposure to shoreline deposits, ingestion of fish, and ingestion of shellfish. To assess compliance with CONTROL 3.11.1.2, the dose due to radioactive iodine, tritium, and particulates in liquid effluent is calculated to a person at the Route 9 bridge who consumes fish and shellfish harvested at that location.

1.5.1 MEMBER OF THE PUBLIC DOSE - LIQUID EFFLUENTS

CONTROL 3.11.1.2 limits the dose or dose commitment to MEMBERS OF THE PUBLIC from radioactive materials in liquid effluents from Oyster Creek Generating Station to those listed in Table 1.5.1-1.

TABLE 1.5.1-1 LIQUID PATHWAY DOSE LIMITS

<u>During Any Calendar Quarter</u>	<u>During Any Calendar Year</u>
≤ 1.5 mrem to total body	≤ 3.0 mrem to total body
≤ 5.0 mrem to any organ	≤ 10.0 mrem to any organ

Per the SURVEILLANCE REQUIREMENTS of 4.11.1.2, the following calculation methods shall be used for determining the dose or dose commitment due to the liquid radioactive effluents from Oyster Creek. Applicable liquid pathways to man for Oyster Creek include shoreline exposure, and ingestion of saltwater fish and shellfish. The receptor location is provided in Table A-4.

1.5.2 SHORELINE DEPOSIT DOSE

The shoreline exposure pathway dose is calculated generally in the form (based on Reg. Guide 1.109):

$$Rapj = 110000 \frac{UapWM}{F} \sum_i QiTiDaipj(1 - \exp(-\lambda iTb))$$

Where:

110000 = a constant that accounts for time and flow conversions

Rapj = the annual dose to organ j (including the total body), through pathway p, to age group a

Uap = the age dependent usage factor for the specific pathway. Usage factors for shoreline exposure are residence time on the shoreline (hours). Usage factors are provided in Reg. Guide 1.109 Table E-5. Usage factors specifically selected for Oyster Creek are presented in Table B-1.

W = the shore width factor. This adjusts the infinite plane gamma or beta dose factors for the finite size and shape of the shoreline. Different factors apply to different bodies of water. A factor of 0.1 is used for OC for 'discharge canal bank'.

M = the recirculation factor. The recirculation factor is a multiplier of 3.76 to account for recirculation of discharge water back into the intake. Although this occurs infrequently, it is assumed to occur for each liquid release.

F = the flow rate in the discharge canal in cubic feet per second

- Q_i = the activity of the i th isotope in the release in curies
 T_i = the half life of the i th isotope in days
 Da_{ipj} = the age a , isotope i , pathway p , and organ j , specific dose conversion factor. Pathway, isotope, age, and organ specific dose factors are obtained from Regulatory Guide 1.109 Appendix E, Tables E-6 through E-14
 λ_i = the decay constant of the i th isotope in years
 T_b = the long term buildup time, assumed to be 30 years

Note: λ_i and T_b can use any time units as long as they are both the same. No transit delay (T_p from Reg. Guide 1.109) is assumed.

1.5.3 SHORELINE DOSE EXAMPLE 1

The following provides an example of the liquid dose calculation:

Initial parameters:

Canal flow rate 1E6 gpm (typical of normal full power operation)
Release: 10,000 gallons of water at 1E-3 μ Ci/ml Co-60

Problem: calculate shoreline whole body dose

- U_{ap} = 67 (teenager) hours
 W = 0.1
 M = 3.76
 F = 2228 [1E6 gpm * 3785 ml / gal / (60 sec/min * 28316 ml/ft³) = 2228 CFS]
 Q_i = 0.03785 Ci [1E-3 μ Ci/ml * 10000gal * 3785ml/gal = 0.03785 Ci]
 T_i = 1930 [5.27 years*365.25days/yr = 1.93E3 days]
 λ_i = 1.31E-1 [0.693 / (5.27 yrs)]
 T_b = 30 years
 Da_{ipj} = 1.7E-8 mrem/hr / pCi/m² Gamma dose factor

Calculate R_{apj} for a = Teen, j = total body, p = shoreline dose for one isotope

$$R_{apj} = 110000 \frac{67 * 0.1 * 3.76}{2228} \sum_i 0.03785 * 1930 * 1.7E-8 * (1 - \exp(-1.3E-1 * 30))$$

$$R_{apj} = 1.5E-3 \text{ mrem:teen:wholebody}$$

1.5.3.1 SHORELINE DOSE EXAMPLE 2

The following provides an example of the liquid dose calculation for groundwater remediation discharge:

Initial parameters:

Canal flow rate 1E6gpm (typical of normal full power operation)
Release: 50 gpm for 7 days at 1E-8 μ Ci/ml Co-60

Problem: Calculate shoreline whole body dose

U_{ap} = 67 (teenager) hours

W = 0.1

M = 3.76

F = 2228

[1E6 gpm * 3785 ml / gal / (60 sec/min * 28316 ml/ft³) = 2228 CFS]

Q_i = 1.91 E-5 Ci

[1E-08 μ Ci/ml*50gpm*7days*24hr/day*60 min/hr*3785ml/gal/1E+6 μ Ci/ml/Ci. = 1.91E-5 Ci]

T_i = 1930 [5.27 years*365.25 days/yr = 1.93E+03 days]

λ_i = 1.31E-1 [0.693 / (5.27 yrs)]

T_b = 30 years

Da_{ipj} = 1.7E-8 mrem/hr / pCi/m² External Dose factor

Calculate R_{apj} for a = Teen, j = total body, p = shoreline dose for one isotope

$$R_{apj} = 110000 \frac{67 * 0.1 * 3.76}{2228} \sum_i 1.91E-5 * 1930 * 1.7E-8 * (1 - \exp(-1.31E-1 * 30))$$

$$R_{apj} = 7.64E-7 \text{ mrem:teen:wholebody}$$

1.5.4 INGESTION DOSE - LIQUID

Ingestion dose pathway calculations are similar to those for the shoreline dose, with minor changes in constants, removal of the shore width factor, and inclusion of the bioaccumulation factor:

$$R_{apj} = 1100 \frac{U_{ap} M}{F} \sum_i Q_i B_{ip} D_{a_{ipj}}$$

Where:

B_{ip} = the stable element bioaccumulation factor for pathway p for the ith isotope

No transit delay is assumed

Pathway, isotope, age, and organ specific dose factors are obtained from Regulatory Guide 1.109 Appendix E Tables E-7 through E-14. Bioaccumulation factors are provided in Reg. Guide 1.109 Table A-1. Usage factors are provided in Reg. Guide 1.109 Table E-5. Usage factors specifically selected for Oyster Creek are presented in Table B-1.

The radionuclides included in the periodic dose assessment per the requirements of CONTROL 3/4.11.1.2 are those as identified by gamma spectral analysis of the liquid waste samples collected and analyzed per the requirements of CONTROL 3/4.11.1.1, Table 4.11.1.1-1.

Radionuclides requiring radiochemical analysis (e.g., Sr-89 and Sr-90) will be added to the dose analysis at a frequency consistent with the required minimum analysis frequency of Table 4.11.1.1-1.

1.5.5 INGESTION DOSE CALCULATION EXAMPLE 1

The following provides an example of the liquid dose calculation:

Initial parameters:

Canal flow rate 1E6 gpm (typical of normal full power operation)

Release: 10000 gallons of water at 1E-3 μ Ci/mL Co-60

Problem: calculate teen whole body dose from saltwater fish ingestion

$$Rapj = 1100 \frac{UapM}{F} \sum_i QiBipDaipj$$

Uap = 16 (teenager) Kg

M = 3.76

F = 2228

[1E6 gpm * 3785 ml / gal / (60 sec/min * 28316 ml/ft³) = 2228 CFS]

Qi = 0.03785 Ci [1E-3 μ Ci/mL * 10000 * 3785 = 0.03785 Ci]

Bip = 100

Daipj = 6.33E-6 mrem / pCi

Calculate Rapj for a = Teen, j = total body, p = fish ingestion dose for one isotope

$$Rapj = 1100 \frac{16 * 3.76}{2228} \sum_i 0.03785 * 100 * 6.33 E - 6$$

$$Rapj = 7.12 E - 4 \text{ mrem : teen : wholebody}$$

1.5.5.1 INGESTION DOSE CALCULATION EXAMPLE 2

The following provides an example of the liquid dose calculation for ground water remediation discharge:

Initial parameters:

Canal flow rate 1E6 gpm (typical of normal full power operation)

Release: 50 gpm for 7 days at 700,000 pCi/l H-3

Problem: calculate teen whole body dose from saltwater fish ingestion

$$Rapj = 1100 \frac{UapM}{F} \sum_i QiBipDaipj$$

$Uap = 16$ (teenager) Kg

$M = 3.76$

$F = 2228$ [$1E6 \text{ gpm} * 3785 \text{ ml / gal} / (60 \text{ sec/min} * 28316 \text{ ml/ft}^3) = 2228 \text{ CFS}$]

$Qi = 1.34 \text{ Ci}$

[$7E+5 \text{ pCi/l} * 50 \text{ gpm} * 7 \text{ days} * 24 \text{ hr/day} * 60 \text{ min/hr} * 3.785 \text{ l/gal} / 1E+12 \text{ pCi/Ci} = 1.34 \text{ Ci}$]

$Bip = 0.90$ (Regulatory Guide 1.109, Table A-1)

$Daipj = 1.06E-07 \text{ mrem / pCi}$

Calculate $Rapj$ for $a = \text{Teen}$, $j = \text{total body}$, $p = \text{fish ingestion dose for one isotope}$

$$Rapj = 1100 \frac{16 * 3.76}{2228} \sum_i 1.34 * 0.9 * 1.06 E - 7$$

$$Rapj = 3.80 E - 6 \text{ mrem : teen : wholebody}$$

1.5.6 PROJECTED DOSE – LIQUID

The projected doses in a 31 day period are equal to the calculated doses from the current 31 day period.

1.6 REPRESENTATIVE SAMPLES

A sample should be representative of the bulk stream or volume of effluent from which it is taken. Prior to sampling, large volumes of liquid waste should be mixed in as short a time interval as practicable to assure that any sediments or particulate solids are distributed uniformly in the waste mixture. Recirculation pumps for liquid waste tanks (collection or sample test tanks) should be capable of recirculating at a rate of not less than two tank volumes in eight hours. Minimum recirculation times and methods of recirculation are controlled by specific plant procedures.

2.0 GASEOUS EFFLUENTS

2.1 RADIATION MONITORING INSTRUMENTATION AND CONTROLS

The gaseous effluent monitoring instrumentation and controls at Oyster Creek for controlling and monitoring normal radioactive material releases in accordance with the Radiological Effluent CONTROLS are summarized as follows:

(1) Main Stack

The main stack receives normal ventilation flow from the reactor building, new radwaste, old radwaste, process discharge flow from the augmented off gas system (AOG), condenser off gas flow if AOG is not in service, and normal ventilation flow from portions of the turbine building, predominantly the condenser bay area. Reactor building and turbine building flow is not normally processed or filtered. Reactor Building flow may be manually or automatically directed through the Standby Gas Treatment System (SBGTS) which has particulate and charcoal filtration. Off gas flow is processed through AOG or through a 30-minute delay pipe prior to release. Flow from the 'new' and 'old' radwaste buildings is HEPA filtered. Releases through the main stack are monitored for noble gases using the RAGEMS I system and sampled for iodine, particulates and tritium. The plant stack is considered to be a true elevated release point.

(2) Turbine Building Vent

The Turbine building vent is monitored for noble gases by the RAGEMS II system and sampled for iodine, particulates and tritium. It discharges on the west side of the turbine building approximately at roof height and is considered to be a ground level release. It ventilates the turbine floor and other areas of the turbine building. Flow through this release point is not filtered.

(3) Feed Pump Room Vent

The feed pump room vent is monitored by RAGEMS II. It discharges on the east side of the turbine building below roof height and is considered to be a ground level release. It ventilates the reactor feed pump room. Flow through this release point is not filtered.

(4) Augmented Off Gas Building Vent

Off gas Building HVAC is released through a ground level release from the building. Off Gas process flow is not released through the building ventilation, but is routed To the stack plant. A ventilation monitoring system monitors for noble gas and samples for particulate and iodine.

(5) Isolation Condensers

The isolation condensers are a ground level release. The predominant isotope through this potential release point is tritium as a consequence of the forced evaporation of condensate transfer water when the isolation condensers are initiated. Releases are neither monitored nor is the release process flow sampled. Releases of tritium are evaluated based on liquid samples of the input and the volume used.

Gaseous radioactive waste flow diagrams with the applicable, associated radiation monitoring instrumentation controls are presented in Figures D-2-1 and D-2-2.

2.2 GASEOUS EFFLUENT MONITOR SET POINT DETERMINATION

2.2.1 PLANT VENT

Per the requirements of CONTROL 3.3.3.11, alarm set points shall be established for the gaseous effluent monitoring instrumentation to ensure that the release rate of noble gases does not exceed the limits of CONTROL 3.11.2.1, which corresponds to a dose rate at the SITE BOUNDARY of 500 mrem/year to the total body or 3000 mrem/year to the skin. Based on a grab sample analysis of the applicable release (i.e., of the Stack, Off gas process flow, etc.), the radiation monitoring alarm set points may be established by the following calculation methods. A set point of a monitor of an elevated release, e.g., from the stack, may be calculated using the equation:

$$S = 1.06 \left(\frac{h}{f} \right) \frac{\sum C_i}{\sum (C_i D F S_i)} + Bkg$$

where :

S = the alarm set point (cpm)

h = primary conversion factor of the instrument - monitor response to activity concentration of effluent being monitored, cpm/($\mu\text{Ci}/\text{cm}^3$). Each monitoring channel has a unique response, h, which is determined by the instrument calibration.

C_i = relative concentration of noble gas radionuclide i in effluent at the point of monitoring ($\mu\text{Ci}/\text{cm}^3$)

1.06 = 500 mrem/year /472 (conversion of cfm to cc/sec)

D F S_i = factor converting elevated release rate of radionuclide i to total body dose equivalent rate at the location of potential exposure. Units are: mrem/(yr($\mu\text{Ci}/\text{sec}$)). From Table A-1.

f = flow of gaseous effluent stream being monitored, i.e., stack flow, vent flow, etc. (ft^3/min)

BKG = Monitoring instrument background (cpm or mR/hr)

2.2.2 OTHER RELEASE POINTS

The set point of a monitor of a ground-level or split-wake release, e.g., from the turbine building vent or the AOG building, may be calculated with the equation:

$$S = 1.06 \left(\frac{h}{f \frac{X}{Q}} \right) \frac{\sum C_i}{\sum (C_i DFV_i)} + Bkg$$

Where:

DFVi = factor converting ground-level or split wake release of radionuclide i to the total body dose equivalent rate at the location of potential exposure. Units are: mrem/(yr(μCi/m³

X/Q = atmospheric dispersion from point of ground-level or split-wake release to the location of potential exposure (sec/m³) from Table 2.2.2-1.

The atmospheric dispersion, X/Q, and the dose conversion factor, DFSi, depend upon local conditions. For the purpose of calculating radioactive noble gas effluent monitor alarm set points appropriate for the OCGS, the locations of maximum potential Off Site exposure and the reference atmospheric dispersion factors applicable to the derivation of set points are given in Table 2.2.2-1.

Symbols for this equation were defined in Section 2.2.1.

TABLE 2.2.2-1 RECEPTOR LOCATIONS AND DISPERSION FOR GASEOUS MONITOR SET POINTS

Discharge Point	Receptor Location		Atm. Dispersion (sec/m ³)
	Sector	Distance(m)	
Ground-level or vent	SE	522	1.36 E-5
Stack	SE	522	1.09 E-8

2.2.3 RADIONUCLIDE MIX FOR SET POINTS

For the purpose of deriving a set point, the distribution of radioactive noble gases in an effluent stream may be determined in one of the following ways:

2.2.3.1.1 Preferably, the radionuclide distribution is obtained by gamma isotopic analysis of identifiable noble gases in effluent gas samples. Results of the analyses of one or more samples may be averaged to obtain a representative spectrum.

2.2.3.2 In the event a representative distribution is unobtainable from recent measurements by the radioactive gaseous waste sampling and analysis program, it may be based upon past measurements.

2.2.3.3 Alternatively, the total activity concentration of radioactive noble gases may be assumed to be Xenon-133 as found in Reg Guide 1.97.

2.3 GASEOUS EFFLUENT INSTANTANEOUS DOSE RATE CALCULATIONS - 10 CFR 20

2.3.1 SITE BOUNDARY DOSE RATE - NOBLE GASES

CONTROL 3.11.2.1a limits the dose rate at the SITE BOUNDARY due to noble gas releases to ≤ 500 mrem/yr, total body and ≤ 3000 mrem/yr, skin. Radiation monitor alarm set points are established to ensure that these release limits are not exceeded. In the event any gaseous releases from the station results in an alarm set point (as determined in Section 2.2) being exceeded, an evaluation of the SITE BOUNDARY dose rate resulting from the release shall be performed.

2.3.1.1 TOTAL BODY DOSE RATE

The total body dose equivalent rate from radioactive noble gases discharged from an elevated point (stack above building wake) is calculated with the equation:

$$DG = \sum_i Q_i P_{\gamma} S_i$$

From a ground-level release (building vent) the total body dose equivalent rate is:

$$DG = \frac{X}{Q_v} \sum_i Q_i P_{\gamma} V_i$$

where:

DG = total body dose equivalent rate due to irradiation by radioactive noble gas (mrem/hr)

Q_i = average discharge rate of noble gas radionuclide i released during the averaging time (μCi/hr)

P_γV_i = factor converting time integrated ground-level concentration of noble gas nuclide i to total body dose $\frac{\text{mrem} \cdot \text{m}^3}{\mu\text{Ci} \cdot \text{sec}}$. See Table A-2.

$\frac{X}{Q_v}$ = atmospheric dispersion factor from the OCGS to the Off Site location of interest
(sec/m³) from Table 2.3.1.3-1

$P_{\gamma Si}$ = factor converting unit noble gas nuclide *i* stack release to total body dose at ground level received outdoors from the overhead plume (mrem/μCi). See Table A-2

The noble gas plume gamma-to-total body dose factors, $P_{\gamma Si}$ at designated locations are derived from meteorological dispersion data with the USNRC RABFIN software computer code or similar computer program implementing Reg Guide 1.109, Appendix B. The noble gas semi-infinite cloud gamma-to-total body dose factors, $P_{\gamma Si}$, are derived from Reg Guide 1.109, Revision 1, Table B-1, Column 5.

2.3.1.2 EXAMPLE TOTAL BODY DOSE RATE

Calculate the dose from a release of 100 Ci of Xe133 in 1 hour from a ground level release

$$DG = \frac{X}{Q_v} \sum_i Q_i P_{\gamma Vi}$$

X/Q_v = 1.36E-5 sec/m³ (Table 2.3.1.3-1)

Q_i = 1E8 μCi/hr [100Ci*1E6 μCi/Ci]

$P_{\gamma Vi}$ = 9.33E-6 mrem-m³ / μCi-sec

$$DG = 1.36 E - 5 \sum_i 1 E 8 * 9.33 E - 6$$

$$DG = 0.013 \text{ mrem / hr}$$

2.3.1.3 SKIN DOSE RATE

The dose equivalent rate to skin from radioactive noble gases is calculated by assuming a person at ground level is immersed in and irradiated by a semi-infinite cloud of the noble gases originating in airborne effluent. It is calculated for each air effluent discharge point with the equation:

$$DB = \frac{X}{Q} \sum_i Q_i (S B_i + 1.11 A \gamma V_i)$$

where:

DB = dose rate to skin from radioactive noble gases (mrem/hr)

$\frac{X}{Q}$ = Atmospheric dispersions from gaseous effluent discharge point to ground-level location of interest (sec/m³) from Table 2.3.1.3-1.

Q_i = discharge rate of noble gas radionuclide i ($\mu\text{Ci/hr}$)

SB_i = factor converting time integrated ground-level concentration of noble gas radionuclide i to skin dose from beta radiation $\frac{\text{mrem} \cdot \text{m}^3}{\mu\text{Ci} \cdot \text{sec}}$ from Table A-2.

$A_{\gamma V_i}$ = factor for converting time integrated, semi-infinite concentration of noble gas radionuclide i to air dose from its gamma $\frac{\text{mrad} \cdot \text{m}^3}{\mu\text{Ci} \cdot \text{sec}}$ from Table A-2.

The noble gas beta radiation-to-skin-dose factors, SB_i and the noble gas gamma-to-air dose factors, $A_{\gamma V_i}$, are derived from Reg Guide 1.109, Revision 1, Table B-1, columns 3 and 4 respectively. A tabulation of these factors used to compute noble gas-to-dose equivalent rate at 522 meters SE of the OCGS is in Table A-2.

The dose equivalent rate is calculated with the meteorological dispersion data given in Table 2.3.1.3-1.

TABLE 2.3.1.3-1 RECEPTOR LOCATIONS AND DISPERSION FOR SITE BOUNDARY DOSE RATES

Discharge Point	Receptor Location		Atm. Dispersion (sec/m ³)
	Sector	Distance (m)	
Ground Level or Vent	SE	522	1.36 E-5
Stack	SE	522	1.09 E-8

Alternatively, an approved computer code (e.g., "SEEDS" or "Open EMS") that implements the requirements of Regulatory Guide 1.109 may be used.

Actual meteorological conditions concurrent with the release period or the default, annual average dispersion parameters as presented above may be used for evaluating the gaseous effluent dose rate.

2.3.1.4 EXAMPLE SKIN DOSE RATE

Calculate the skin dose from a release of 100 Ci of Xe133 in 1 hour from a ground level release:

$$DB = \frac{X}{Q} \sum_i Q_i (S B_i + 1.11 A \gamma V_i)$$

X/Q = 1.36 E-5 sec/m³

Q_i = 1E8 μCi/hr

S B_i = 9.71E-6

AγV_i = 1.12E-5

$$DB = 1.36E - 5 \sum_i 1E8(9.71E - 6 + 1.11 * 1.12E - 5)$$

$$DB = 0.0030 \text{ mrad / hr}$$

2.3.2 SITE BOUNDARY DOSE RATE - RADIOIODINE AND PARTICULATES

2.3.2.1 METHOD - SITE BOUNDARY DOSE RATE - RADIOIODINE AND PARTICULATES

The dose rate Off Site due to the airborne release of I-131, I-133, tritium, and particulates with half-lives greater than 8 days is limited to no more than 1500 mrem/yr to any organ in CONTROL 3.11.2.1b. Evaluation of compliance with CONTROL 3.11.2.1b is based on the sampling and analyses specified in TABLE 4.11.2.1.2-1. Since the dose rate cannot be resolved within less than the sample integration or compositing time, the contribution of each radionuclide to the calculated dose rate will be averaged no more than 3 months for H-3, Sr-89, Sr-90, and alpha-emitting radionuclides and no more than 31 days for other radionuclides. These are their usual sample

integration or compositing times. The equation used to assess compliance of radioiodine, tritium, and radioactive particulate releases with the dose rate limit is:

$$DR_p = 1E6 \sum_e \sum_i^n Ra DFAija Q_{ei} \frac{\overline{X}}{Q_e}$$

where:

1E6 = conversion pCi/μCi

DR_p = the average dose rate to an organ via exposure pathway, p (mrem/yr).

DFAija = inhalation dose factors due to intake of radionuclide i, to organ j age group a (mrem/pCi) from Reg. Guide 1.109 Appendix E.

Ra = age group dependent inhalation respiratory rate (usage factor) m³/yr from Table B-1

$\frac{\overline{X}}{Q_e}$ = annual average relative airborne concentration at an Off Site location due to a release from either the Stack or a vent, i.e. release point, e (sec/m³) from Table 2.3.2.1-1.

Q_{ei} = release rate of radionuclide i from release point, e during the period of interest (μCi/sec).

For real-time meteorology and on an annual average basis, the location of the maximum ground-level concentration originating from a vent release will differ from the maximum ground-level concentration from a stack release. When assessing compliance with CONTROL 3.11.2.1b for tritium, iodine, and particulate, the air dispersion (X/Q) values are provided in Table 2.3.2.1-1.

TABLE 2.3.2.1-1 LOCATION OF MAXIMUM EXPOSURE RE BY INHALATION

Discharge Point	Receptor Location		Atm. Dispersion (sec/m3)
	Sector	Distance (m)	
Ground Level or Vent	SE	522	1.36 E-5
Stack	SE	522	1.09 E-8
Alternatively, inhalation exposure to effluent from the stack may be evaluated at the closest hypothetical individual located at:			
Stack	SE	966m	1.19 E-8

Alternatively, an approved computer code (e.g., "SEEDS" or "Open EMS") that implements the methods of Regulatory Guide 1.109, may be used.

2.3.2.2 EXAMPLE IODINE AND PARTICULATES DOSE RATE CALCULATION

Calculate the child thyroid dose rate from a release of 100 $\mu\text{Ci/hr}$ of I131 from a ground level release:

$$DRp = 1E6 \sum_e \sum_i^n Ra D F A i j a Q e i \frac{X}{Qe}$$

$Ra = 3700 \text{ m}^3/\text{yr}$

$DFAija = 4.39E-3$

$Qei = 0.028 \mu\text{Ci/sec}$ [100 $\mu\text{Ci/hr}$ / 3600 sec/hr = 0.02778]

$X/Qe = 1.36 E-5$

$$DRp = 1E6 \sum_i^n 3700 * 4.39E - 3 * 0.028 * 1.36E - 5$$

$$DRp = 6.2 \text{ mrem / yr}$$

2.4 NOBLE GAS EFFLUENT DOSE CALCULATIONS - 10 CFR 50

Doses resulting from the release of noble gases must be calculated to show compliance with Appendix I of 10CFR50. Calculations will be performed at least monthly for all gaseous effluents as stated in SURVEILLANCE REQUIREMENT 4.11.2.2 to verify that the dose to air is kept below the limits specified in CONTROL 3.11.2.2 and the dose to MEMBERS OF THE PUBLIC is maintained below the limits specified in CONTROL 3.11.2.3.

2.4.1 UNRESTRICTED AREA DOSE - NOBLE GASES

CONTROL 3.11.2.2 requires a periodic assessment of releases of noble gases to evaluate compliance with the quarterly air dose limits shown in Table 2.4.1-1.

TABLE 2.4.1-1 ANNUAL AIR DOSE LIMITS

<u>During any calendar quarters</u>	<u>During any calendar year</u>
≤ 5 mrad gamma-air	≤ 10 mrad gamma-air
≤ 10 mrad beta-air	≤ 20 mrad beta-air

The method used to calculate the air dose at the critical location due to noble gas is described by the following equations. The limits are provided in CONTROL 3.11.2.2 for air dose Off Site due to gamma and beta radiations from effluent noble gas.

2.4.1.1 AIR DOSE METHOD

a: For Gamma Radiation:

$$Dose \gamma = \sum_{i=1}^n A\gamma V_i \frac{\bar{X}_v}{Q} Q_{vi} + A\gamma S_i Q_{si}$$

b: For Beta Radiation

$$Dose \beta = \sum_e \sum_{i=1}^n A\beta_i \frac{\bar{X}_e}{Q} Q_{ei}$$

where:

Dose γ = the gamma dose during any specified time period (mrad).

Dose β = the beta dose during any specified time period (mrad).

$A\gamma V_i$ = the air dose factor due to ground level gamma emissions for each identified noble gas radionuclide, i; (mrad/yr per $\mu\text{Ci}/\text{m}^3$). Table A-2

$A\gamma S_i$ = the factor for air dose at ground level due to irradiation for an airborne plume resulting from a Stack release (mrad per μCi), Table A-3.

$A\beta_i$ = the air dose factor due to beta emissions for each identified noble gas radionuclide, i (mrad/yr per $\mu\text{Ci}/\text{m}^3$). Table A-3

$\frac{\bar{X}_v}{Q}$ or $\frac{\bar{X}_e}{Q}$ = the annual average relative concentration for areas at or beyond the site boundary for releases from either the Stack or ground vent at the critical location (sec/m^3), Table 2.4.1.1-1

Q_{vi} = amount of radionuclide i released from vents (μCi).

Q_{si} = amount of radionuclide i released from the Stack (μCi).

Q_{ei} = amount of radionuclide i released from release point e (μCi).

Noble gases may be released from the ground level vents and stack. The quantity of noble gas radionuclides released will be determined from the continuous noble gas monitors and periodic isotopic analyses. The maximum Off Site gamma radiation dose rate to air from noble gases discharged from either the stack or from building vents occurs at 522 meters SE of the OCGS. Values of $A_{\gamma Si}$ depend upon the meteorological conditions and the location of exposure and are calculated using the NRC RABFIN code or similar one in accordance with Reg. Guide 1.109, Appendix B, Section 1. $A_{\gamma Vi}$ and AB_i are derived from Reg. Guide 1.109, Table B-1 for a semi-infinite cloud, independent of meteorology or location. Values of $A_{\gamma Si}$, $A_{\gamma Vi}$ and AB_i used to calculate the noble gas radiation dose to air at 522 meters SE of the OCGS are in Table A-3. Reference atmospheric dispersion from the OCGS to 522 meters SE is given in Table 2.4.1.1-1.

TABLE 2.4.1.1-1 RECEPTOR LOCATIONS AND DISPERSION FOR AIR DOSE

Discharge Point	Receptor Location		Atm. Dispersion (sec/m ³)
	Sector	Distance (m)	
Ground Level or Vent	SE	522	1.36 E-5
Stack	SE	522	1.09 E-8

Alternatively, an approved computer code (e.g., "SEEDS" or "Open EMS") that implements the requirements of Reg. Guide 1.109 may be used.

2.4.1.2 EXAMPLE NOBLE GAS AIR DOSE CALCULATION

Calculate the gamma air dose from a release of 1 Ci per hour of Xe133 for 10 hours from a ground level release and 100Ci per hour for 10 hours from an elevated release:

$$Dose_{\gamma} = \sum_{i=1}^n A_{\gamma} V_i \frac{\bar{X}}{Q} v Q_{vi} + A_{\gamma} S_i Q_{si}$$

$$A_{\gamma} V_i = 1.12E-5 \text{ mrad} - \text{m}^3 / \mu\text{Ci} - \text{sec}$$

$$X/Q = 1.36 E-5$$

$$Q_{vi} = 1E7 \mu\text{Ci} \quad [1\text{Ci/hr} \cdot 10\text{hrs} \cdot 1E6 \mu\text{Ci/Ci}]$$

$$A_{\gamma} S_i = 5.45E-13 \text{ mrad} / \mu\text{Ci}$$

$$Q_{si} = 1E9 \mu\text{Ci} \quad [100\text{Ci/hr} \cdot 10\text{hrs} \cdot 1E6 \mu\text{Ci/Ci}]$$

$$Dose_{\gamma} = \sum_{i=1}^n 1.12E-5 * 1.36E-5 * 1E7 + 5.45E-13 * 1E9$$

$$Dose_{\gamma} = \sum_{i=1}^n 1.63E-3 + 5.45E-4$$

$$Dose_{\gamma} = 2.2E-3 \text{ mrad}$$

Note how the ground level portion has a higher dose contribution per unit activity than the elevated portion.

2.4.1.3 INDIVIDUAL PLUME DOSE METHOD

The method for dose to an individual from noble gases is essentially identical with the air dose method except that different dose factors apply. Also, since dose to the skin combines the contribution from gamma and beta emissions, the gamma dose must be added to the beta dose to obtain a total skin dose.

a: For Total Body:

$$Dose(t) = \sum_{i=1}^n P\gamma V_i \frac{\bar{X}}{Q} v Q_{vi} + P\gamma S_i Q_{si}$$

b: For Skin

$$Dose(s) = \sum_e \sum_{i=1}^n S\beta_i \frac{\bar{X}}{Q} e Q_{ei} + Dose(t)$$

where:

Dose(t) = the total body dose during any specified time period (mrem).

Dose(s) = the skin dose during any specified time period (mrem).

$P\gamma V_i$ = the plume dose factor due to ground level gamma emissions for each identified noble gas radionuclide, i; (mrad/yr per $\mu\text{Ci}/\text{m}^3$). Table A-5.

$P\gamma S_i$ = the factor for plume dose at ground level due to irradiation for an airborne plume resulting from a Stack release (mrad per μCi), Table A-5.

$S\beta_i$ = the skin dose factor due to beta emissions for each identified noble gas radionuclide, i (mrad/yr per $\mu\text{Ci}/\text{m}^3$) from Table A-5.

$\frac{\bar{X}}{Q^e}$ or $\frac{\bar{X}}{Q^v}$ = the annual average relative concentration for areas at or beyond the site

boundary for releases from either the Stack or ground vent at the critical location (sec/m^3) from Table 2.5.1.

Q_{vi} = amount of radionuclide i released from vents (μCi).

Q_{si} = amount of radionuclide i released from the Stack (μCi).

Q_{ei} = amount of radionuclide i released from release point e (μCi).

2.5 RADIOIODINE, PARTICULATE AND OTHER RADIONUCLIDES DOSE CALCULATIONS - 10 CFR 50

Doses resulting from the release of radioiodines and particulates must be calculated to show compliance with Appendix I of 10CFR50. Calculations will be performed at least monthly for all gaseous effluents as stated in SURVEILLANCE REQUIREMENT 4.11.2.2 and SURVEILLANCE REQUIREMENT 4.11.2.3 to verify that the dose to air is kept below the limits specified in CONTROL 3.11.2.2 and the dose to MEMBERS OF THE PUBLIC is maintained below the limits specified in CONTROL 3.11.2.3.

The maximum dose to an individual from radioiodines, tritium, and radioactive particulates with half-lives of greater than eight days in gaseous effluents released to unrestricted areas is determined as described in Reg. Guide 1.109. Environmental pathways that radioiodine, tritium, and particulates in airborne effluent follow to the maximally exposed MEMBER OF THE PUBLIC as determined by the annual land use survey and reference meteorology will be evaluated. The seasonality of exposure pathways may be considered. For instance, if the most exposed receptor has a garden, fresh and stored vegetables are assumed to be harvested and eaten during April through October. Fresh vegetables need not be considered as an exposure pathway during November through March. To assess compliance with CONTROL 3.11.2.3, the dose due to radioactive iodine, tritium, and particulates in airborne effluent is calculated to a person residing 966 meters SE of the OCGS. Reference atmospheric dispersion and deposition factors are given in Table 2.5-1.

TABLE 2.5-1 DISPERSION FOR 10CFR50 DOSES

Discharge Point	Dispersion X/Q (sec/m ³)	Deposition D/Q(1/m ²)
Ground Level or Vent.	4.86 E-6	1.41 E-8
Stack	1.19 E-8	1.74 E-9

The environmental pathways of exposure to be evaluated are: inhalation, irradiation from ground deposition, and ingestion of milk (cow and goat are treated separately), meat, and vegetables. Eight organs are considered: Bone, Liver, Total Body, Thyroid, Kidney, Lung, GI-LLI (Gastro-Intestinal tract / Lower Large Intestine), and Skin. Four different age groups are considered: Infants, Children, Teens, and Adults. Doses are calculated to a 'receptor' – a person who inhales the airborne activity and resides in a location with ground deposition, and eats and drinks the foodstuffs produced. The maximally exposed individual is conservatively assumed to reside at the location of the highest sum of the inhalation and ground plane doses, while eating and drinking foodstuffs transported from the locations that are highest for those pathways. Receptor locations are provided in Table A-4.

Alternatively, an approved computer code (e.g., "SEEDS" or "Open EMS") that implements the requirements of Reg Guide 1.109 may be used.

2.5.1 INHALATION OF RADIOIODINES, TRITIUM, PARTICULATES, AND OTHER RADIONUCLIDES.

Dose from the inhalation pathway is generally in the form:

$$D_{ja} = RaT \sum \frac{X}{Q} Q_i D_{FAija} \text{Exp}(-\lambda_i Tr)$$

Where:

D_{ja} = the dose to the organ j (of eight) of age group a (of four)

Ra = the respiration rate for age group a from Table B-1

T = the duration of the release in fraction of a year

$\frac{X}{Q}$ = The atmospheric dispersion to the point of interest (the 'receptor') in sec/m^3 from Table 2.5-1

Q_i = The release rate of radionuclide i (pCi/sec)

D_{FAija} = The inhalation dose conversion factor (mrem per pCi) for radionuclide i to organ j of age group a from Reg. Guide 1.109 Appendix E.

λ_i = decay constant of isotope i: $0.693/\text{Half life in years}$

Tr = plume transit time from release to receptor in years

λ_i and Tr may be in any time units as long as they are the same

Note that a 'depleted X/Q' (dX/Q) is applicable to particulates only, which accounts for the natural settling and lack of surface reflection of particulates to estimate the downwind concentration accounting for these removal processes. Depleted X/Q will be slightly smaller than the X/Q. This is not used in the ODCM for simplicity. Using the X/Q is therefore slightly conservative compared to the dX/Q .

2.5.2 EXAMPLE CALCULATION - INHALATION OF RADIOIODINES, TRITIUM, PARTICULATES, AND OTHER RADIONUCLIDES

Calculate the dose to child lung from inhalation from a ground level release of 100 μCi of Co-60 in 10 hours. Plume transit decay time is ignored ($\exp(-\lambda t) = 1$).

$$D_{ja} = 3700 * 0.00114 * 1.53E - 5 * 2.78E3 * 1.91E - 3$$

$$D_{ja} = 3.4E - 4 \text{ mrem}$$

$$D_{ja} = RaT \sum_i \frac{X}{Q} Q_i D F A_{ija}$$

- D_{ja} = the dose to the organ j (of eight) of age group a (of four)
- Ra = 3700 m^3/yr
- T = 0.00114 yrs [10 hrs / 8760 hrs / yr]
- $\frac{X}{Q}$ = 1.53 E-5 sec/ m^3
- Q_i = 2.78E3 pCi/sec [100 μCi * 1E6 pCi/ μCi / (10 hrs*3600 sec / hr)]
- DFA_{ija} = 1.91E-3 mrem / pCi

2.5.3 INGESTION OF RADIOIODINES, PARTICULATES AND OTHER RADIONUCLIDES

Dose from the ingestion pathways is more complex and is broken out here into multiple steps:

2.5.3.1 CONCENTRATION OF THE RADIONUCLIDE IN ANIMAL FORAGE AND VEGETATION – OTHER THAN TRITIUM

The concentration of a radionuclide in a foodstuff (other than tritium – see section 2.5.3.3 for tritium) is dependent on the atmospheric deposition, the biological uptake into the food, various decay times (plume travel, harvest to table, etc.) and is generally of the form:

Where:

C_{iv} = the concentration (pCi/kg) of radionuclide i in vegetation

Q_i = the release rate of isotope i in pCi/hr

$\frac{D}{Q}$ = The atmospheric deposition to the point of interest (the 'receptor') in $1/\text{m}^2$ from

Table 2.5-1.

$$C_{iv} = \frac{D}{Q} Q_i \left\{ \frac{r(1 - \text{EXP}(-\lambda E_i T_e))}{Y_v \lambda E_i} + \frac{B_{iv}(1 - \text{EXP}(-\lambda_i T_b))}{P \lambda_i} \right\} \text{EXP}(-\lambda_i T_h) \text{EXP}(-\lambda_i T_r)$$

- r = the retention coefficient for deposition onto vegetation surfaces (1.0 for iodines, 0.2 for particulates)
- λ_i = the decay constant of radionuclide i; 0.693/half life in hours
- λE_i = the effective removal constant which is the sum of $\lambda_i + \lambda_w$ where λ_w is the weathering constant, 0.0021/hr
- T_e = duration of crop exposure during the growing season in hours. This is not the entire duration of the growing season, and is different for leafy vegetable and fruit/grain/vegetables. Provided in Table E-15 of Reg. Guide 1.109 or Table B-1.
- Y_v = agricultural yield Kg of vegetation per m^2 , typically 0.7 kg/m^2
- B_{iv} = soil uptake concentration factor for transfer of the radionuclide i from the soil to the vegetation through normal root uptake processes in pCi/kg in vegetation per pCi/Kg in soil. Values are provided in Reg. Guide 1.109 Table E-1.
- T_b = the length of time the soil is exposed to contaminated inputs – nominally 30 years (2.63E5 hr)
- P = effective soil density in kg/m^2 normally 240 kg/m^2
- T_h = holdup time, the time the foodstuff is in transit between harvest and consumption in hours
- T_r = plume transit time from release to receptor in hours

2.5.3.2 EXAMPLE CALCULATION OF CONCENTRATION OF THE RADIONUCLIDE IN ANIMAL FORAGE AND VEGETATION – OTHER THAN TRITIUM.

Calculate the forage and vegetation concentration from a ground level release of 100 μCi of Co-60 in 10 hours (plume transit time is ignored $T_r=0$, $\text{EXP}(-\lambda_i T_r)=1$):

- D/Q = 1.41E-8 m^2
- Q_i = 1E7 pCi/hr [100 μCi * 1E6 pCi/ μCi / 10 hr]
- r = 0.2
- λ_i = 1.5E-5/hr [0.693 / (5.27yr * 8760 hr/yr)]
- λE_i = 2.1E-3 /hr [1.5E-5 + 0.0021]
- T_e = 720 hr [grass-cow-milk-man pathway value]
- Y_v = 0.7 kg/m^2
- B_{iv} = 9.4E-3

$$C_{iv} = \frac{D}{Q} Q_i \left\{ \frac{r(1 - \text{EXP}(-\lambda E_i T_e))}{Y_v \lambda E_i} + \frac{B_{iv}(1 - \text{EXP}(-\lambda_i T_b))}{P \lambda_i} \right\} \text{EXP}(-\lambda_i T_h) \text{EXP}(-\lambda_i T_r)$$

$$C_{iv} = 1.41E-8 * 1E7 \left\{ \frac{\frac{0.2 * (1 - \text{EXP}(-2.1E-3 * 720))}{0.7 * 2.1E-3} + \frac{9.4E-3 * (1 - \text{EXP}(-1.5E-5 * 2.63E5))}{240 * 1.5E-5}}{240 * 1.5E-5} \right\} \text{EXP}(-1.5E-5 * 0)$$

$$C_{iv} = 1.41E-8 * 1E7 \left\{ \frac{\frac{0.2 * (1 - \text{EXP}(-1.52))}{1.47E-3} + \frac{9.4E-3 * (1 - \text{EXP}(-3.95))}{3.6E-3}}{3.6E-3} \right\} \text{EXP}(-0)$$

$$C_{iv} = 1.41E-1 \left\{ \frac{106 * 1 +}{2.56} \right\} * 1$$

$$C_{iv} = 15.3 \text{ pCi / Kg}$$

T_b = 2.63E5 hr

P = 240 kg/m²

T_h = 0 hr (consumption of pasture grass directly by animals)

2.5.3.3 CONCENTRATION OF TRITIUM IN ANIMAL FORAGE AND VEGETATION

Since tritium is assumed to be released as tritiated water (HTO), the concentration of tritium in a foodstuff is dependent on atmospheric dispersion like a gas, rather than particulate deposition as for other radionuclides for foodstuff uptake. Further, the concentration of tritium in food is assumed to be based on equilibrium between the concentration of the tritium in the atmospheric water and the concentration of tritium in the water in the food. Concentration of tritium in vegetation can be calculated generally in the form (a plume transit decay term: EXP(-λ_iT_r) is ignored since plume travel times are very short compared to the half life):

$$C_{tv} = 1000 Q_t \frac{X}{Q} * 0.75 * \frac{0.5}{H}$$

Where:

C_{tv} = the concentration (pCi/kg) of tritium in vegetation

1000= g per kg

Q_t = the release rate of the tritium in pCi/ sec

X/Q = the atmospheric dispersion at the vegetation point, sec/m³ from Table 2.5-1

0.75 = the fraction of vegetation that is water

0.5 = the effective ratio between the atmospheric water concentration and the vegetation concentration

H = the absolute humidity g/m³. Absolute humidity is seasonally dependent, varying from as little as 1 in the winter to as much as 20 in the summer. Monthly average values derived from historical data are provided in Table B-2.

2.5.3.4 EXAMPLE CALCULATION OF CONCENTRATION OF TRITIUM IN ANIMAL FORAGE AND VEGETATION.

Calculate the forage and vegetation concentration from a ground level release of 100 μ Ci of H-3 in 10 hours. Plume transit decay time is ignored ($\exp(-\lambda t_r)=1$):

$$C_{tv} = 1000Q_t \frac{X}{Q} * 0.75 * \frac{0.5}{H}$$

Q_t = 2778 pCi/sec [100uCi * 1E6 pCi/uCi / (10hrs*3600sec/hr)]

X/Q = 4.86E-6 sec/m³

H = 5 g/m³ (assumed for this example)

$$C_{tv} = 2778 * 1000 * 4.86E - 6 * 0.75 * \frac{0.5}{5}$$

$$C_{tv} = 1.0 pCi/kg$$

2.5.3.5 CONCENTRATION OF THE RADIONUCLIDE IN MILK AND MEAT

Meat and milk animals are assumed to eat both pasture grass and stored feed. During a fraction of the year, they may be assumed to be exclusively on stored feed, outside of the growing season. If using annual average release, the fraction of stored and fresh feed must be accounted for with fractions, otherwise (as in this ODCM), the fresh pasture pathway is turned on or off depending on the growing season.

The concentration of a radionuclide in the animal feed is calculated as follows:

$$C_{iv} = F_p C_{is} + (1 - F_p) C_{is} (1 - F_s) + C_{ip} F_s (1 - F_p)$$

Where:

F_p = the growing season pasture factor: 1 if not growing season, 0 if in growing season

F_s = the fraction of the daily feed from fresh pasture from Table B-1 or Exhibit E-15 from Reg. Guide 1.109.

C_{ip} = the concentration in the fresh pasture feed (C_{iv} from section 2.5.3.2 with $T_h = 0$ for immediate consumption)

C_{is} = the concentration in stored feed (C_{iv} from section 2.5.3.2 with $T_h = 90$ days)

The concentration in the milk is then based on this feed concentration:

$$C_{im} = F_m C_{iv} Q_f \text{EXP}(-\lambda_i T_f)$$

Where;

C_{im} = the concentration in milk pCi/l

F_m = the transfer coefficient of intake to concentration in the milk (d/l) from Reg. Guide 1.109 Table E-1.

Q_f = feed intake rate Kg/d from Reg. Guide 1.109 Table E-3.

λ_i = radionuclide i decay constant in 1/days

T_f = transport time from milk production to consumption (2 days for milk)

The Goat milk pathway may be similarly evaluated:

$$C_{im} = F_g C_{iv} Q_f \text{EXP}(-\lambda_i T_f)$$

Where

F_g = the transfer coefficient of intake to concentration in the milk (d/l) for goats from Reg. Guide 1.109 Table E-2.

And for meat:

$$C_{if} = F_f C_{iv} Q_f \text{EXP}(-\lambda_i T_s)$$

Where:

F_f = the transfer coefficient of intake to concentration in the meat d/kg from Reg. Guide 1.109 Table E-1.

T_s = The transport time from slaughter to consumption (20 days)

2.5.3.6 EXAMPLE CALCULATION OF CONCENTRATION OF THE RADIONUCLIDE IN MILK AND MEAT

Calculate the concentration in cow milk from a ground level release of 100 μCi of Co-60 in 10 hours. Plume transit decay time is ignored ($\exp(-\lambda_i T_r)=1$):

$$C_{iv} = F_p C_{is} + (1 - F_p) C_{is} (1 - F_s) + C_{ip} F_s (1 - F_p)$$

Assume animals are on pasture and receive half of their food from stored feed.

$C_{ip} = 18.4 \text{ pCi/kg}$ as previously calculated in section 2.5.3.2

$F_p = 0$

$F_s = 0.5$

C_{is} is calculated by applying a 90 day decay term to the C_{ip} value previously calculated, since the previous decay correction was for 0 time as shown in 2.5.3.2.

$$C_{is} = 18.4 * (\exp(-0.693 * 90 / (5.27 * 365.25)))$$

$$C_{is} = 17.8 \text{ pCi / kg}$$

C_{iv} is then:

$$C_{iv} = 0 * 17.8 + (1 - 0.5) 17.8 * (1 - 0) + 18.4 * .5 * (1 - 0)$$

$$C_{iv} = 18.1 \text{ pCi / kg}$$

The concentration in milk is given by:

$$C_{im} = F_m C_{iv} Q_f \text{EXP}(-\lambda_i T_f)$$

$F_m = 1.0\text{E-}3 \text{ d/l}$

$Q_f = 50 \text{ Kg/d}$

$\lambda_i = 3.6\text{E-}4/\text{d} [0.693 / (5.27\text{yrs} * 365.25\text{days/yr})]$

$$C_{im} = 1.0\text{E-}3 * 18.1 * 50 * \text{EXP}(-3.6\text{E-}4 * 2)$$

$$C_{im} = 0.90 \text{ pCi / l}$$

The concentration in meat given by:

$$C_{if} = F_f C_{iv} Q_f \text{EXP}(-\lambda_i T_f)$$

$F_f = 1.3\text{E-}2 \text{ d/kg}$

$Q_f = 50 \text{ Kg/d}$

$\Delta_i = 3.6\text{E-}4/\text{d}$

$$C_{if} = 1.3\text{E-}2 * 18.1 * 50 * \text{EXP}(-3.6\text{E-}4 * 20)$$

$$C_{if} = 11.7 \text{ pCi / kg}$$

2.5.3.7 DOSE FROM CONSUMPTION OF MILK, MEAT, AND VEGETABLES

The environmental pathway ingestion dose is the sum of the milk, meat, and vegetation ingestion pathways. There are two separate pathways for vegetation: fresh leafy vegetables and a combination of fruits, non-leafy vegetables, and grains. These differ only in the decay and buildup processes applied to account for the environmental exposure, and transportation delay decay represented by T_e and T_h as shown in section 2.5.3.1. For long half-life isotopes (e.g. Co-60) the decay differences have little impact on the dose.

Dose from the environmental ingestion pathways is generally of the form:

$$D_{ja} = T \sum_i DF_{Iija} [U_{av} F_g C_{iv} + U_{am} C_{im} + U_{af} C_{if} + U_{al} F_l C_{il}]$$

Where:

D_{ja} = the dose to organ j of age group a - mrem

T = fraction of year of release duration

DF_{Iija} = the ingestion dose factor for isotope i to organ j for age group a - mrem/pCi from Reg. Guide 1.109 Appendix E

U_{av} = Ingestion rate (usage factor) for non-leafy vegetables, grains, and fruits for age group a from Reg. Guide 1.109 Table E-5 or Table B-1.

F_g = the fraction of vegetables, grains, and fruits from the location of interest : 0.76 in Reg. Guide 1.109.

C_{iv} = the concentration of isotope i in the vegetables, fruits, and grains calculated from section 2.5.3.2.

U_{am} = Ingestion rate (usage factor) for milk for age group a : from Table B-1 or Reg. Guide 1.109 Table E-5.

C_{im} = the concentration of isotope i in milk calculated from section 2.5.3.5.

U_{af} = the ingestion rate for meat for age group a : from Table B-1 or Reg. Guide 1.109 Table E-5.

C_{if} = the concentration of isotope i in meat calculated from section 2.5.3.2.

U_{al} = the ingestion rate for leafy vegetables for age group a : from Table B-1 or Reg. Guide 1.109 Table E-5.

FI = the fraction of annual leafy vegetable ingestion from the location of interest : 1.0 in Reg. Guide 1.109.

Cil = concentration of isotope i in the leafy vegetables for direct human consumption:
Civ calculated from section 2.5.3.2 with Th=0.

2.5.3.8 EXAMPLE CALCULATION - DOSE FROM CONSUMPTION OF MILK, MEAT, AND VEGETABLES

Calculate the ingestion dose to child whole body from a ground level release of 100 μ Ci of Co-60 in 10 hours. Plume transit decay time is ignored ($\exp(-\lambda t_r)=1$):

$$D_{ja} = T \sum_i DF_{Iija} [U_{av} F_g C_{iv} + U_{am} C_{im} + U_{af} C_{if} + U_{al} F_l C_{il}]$$

T = .00114 [10hrs / 8760 hrs/yr]
DF_{Iija} = 1.56E-5 mrem/pCi
U_{av} = 520
F_g = 0.76
C_{iv} = 18.0 [18.4*EXP(- λ *60) using 60 day delay for ingestion]
U_{am} = 330
C_{im} = 0.9
U_{af} = 41
C_{if} = 11.7
U_{al} = 26
F_l = 1
C_{il} = 18.4

$$D_{ja} = .00114 \sum_i 1.56E - 5 [520 * 0.76 * 18 + 330 * 0.9 + 41 * 11.7 + 26 * 1 * 18.4]$$

$$D_{ja} = .00114 \sum_i 1.56E - 5 [7114 + 297 + 480 + 478]$$

$$D_{ja} = 1.5E - 4 \text{ mrem: child: wholebody}$$

2.5.4 GROUND PLANE DEPOSITION IRRADIATION

Dose from ground plane deposition is estimated by determining the surface activity resulting from the release.

2.5.4.1 GROUND PLANE CONCENTRATION

The ground surface activity is estimated as:

$$C_{ig} = \frac{D Q_i}{Q \lambda_i} (1 - \text{EXP}(-\lambda_i T_b))$$

Where:

C_{ig} = ground plane concentration of radionuclide i in pCi/m²

$\frac{D}{Q}$ = local atmospheric release deposition factor in 1/m² from Table 2.5-1

Q_i = release rate in pCi/sec

λ_i = radiological decay constant in 1/sec

T_b = long term buildup time 30 years (9.46E8 sec)

Note: Q_i , λ_i and T_b can utilize any time units as long as they are all the same

2.5.4.2 EXAMPLE GROUND PLANE CONCENTRATION CALCULATION

Calculate the ground plane concentration from a 100 μ Ci release of Co-60 over 10 hours from a ground level release point.

$$C_{ig} = \frac{D}{Q} \frac{Q_i}{\lambda_i} (1 - \text{EXP}(-\lambda_i T_b))$$

$$\frac{D}{Q} = 1.41E-8 / \text{m}^2$$

$$Q_i = 2778 \text{ pCi/sec} \quad [100 \mu\text{Ci}/10\text{hrs}/3600\text{sec/hr}]$$

$$\lambda_i = 4.17E-9/\text{sec} \quad [0.693/(5.27\text{yr} * 8760\text{hr/yr} * 3600\text{sec/hr})]$$

$$T_b = 9.46E8 \text{ sec}$$

$$C_{ig} = 1.41E-8 \frac{2778}{4.17E-9} (1 - \text{EXP}(-4.17E-9 * 9.46E8))$$

$$C_{ig} = 1.41E-8 \frac{2778}{4.17E-9} (1 - \text{EXP}(-4.17E-9 * 9.46E8))$$

$$C_{ig} = 1.11E4 \text{ pCi/m}^2$$

2.5.4.3 GROUND PLANE DOSE

Annual dose from the ground plane deposition is of the form:

$$D_{jg} = 8760 * T * S_f \sum_i C_{ig} D F G_{ij}$$

Where:

D_{jg} = the annual dose (mrem) from ground plane pathway (g) to the total body or skin (j)

8760 = hours in a year

T = fraction of year release is in progress

Sf = shielding factor accounting for shielding from dwelling from Table B-1

DFGij = Ground plane dose factor for skin or total body (j) for radionuclide i from Table E-6 of Reg. Guide 1.109 in mrem/hr / pCi/m².

2.5.4.4 EXAMPLE GROUND PLANE DOSE

Calculate the ground plane Total Body dose from a 100 µCi release of Co-60 over 10 hours from a ground level release point.

$$\text{Given: } D_{jg} = 8760 * T * Sf \sum C_{ig} DFG_{ij}$$

$$T = 0.00114 [10/8760]$$

$$Sf = 0.7$$

$$DFG_{ij} = 1.7E-8$$

$$D_{jg} = 8760 * 0.00114 * 0.7 \sum 9729 * 1.7E-8$$

$$D_{jg} = 1.15E-3 \text{ mrem Total Body}$$

2.6 PROJECTED DOSES – GASEOUS

The projected doses in a 31 day period are equal to the calculated doses from the current 31 day period.

3.0 TOTAL DOSE TO MEMBERS OF THE PUBLIC - 40 CFR 190

The Radiological Environmental Monitoring Report (REMP) submitted by May 1st of each year shall include an assessment of the radiation dose to the likely most exposed MEMBER OF THE PUBLIC for reactor releases and other nearby uranium fuel cycle sources (including dose contributions from effluents and direct radiation from on-site sources). For the likely most exposed MEMBER OF THE PUBLIC in the vicinity of Oyster Creek, the sources of exposure need only consider the Oyster Creek Generating Station. No other fuel cycle facilities would contribute significantly to the MEMBER OF THE PUBLIC dose for the Oyster Creek vicinity, however, both plant operation and ISFSI sources must be included in the dose assessment.

To assess compliance with CONTROL 3.11.4, calculated organ and total body doses from effluents from liquid pathways and atmospheric releases as well as any dose from direct radiation will be summed.

As appropriate for demonstrating/evaluating compliance with the limits of CONTROL 3.11.4 (40 CFR 190), the results of the environmental monitoring program may be used for providing data on actual measured levels of radiation and / or radioactive

material and resultant dose to the MEMBER OF THE PUBLIC in the actual pathways of exposure.

3.1 EFFLUENT DOSE CALCULATIONS

For purposes of implementing the surveillance requirements of CONTROL 3/4.11.4 and the reporting requirements of Technical Specification 6.9.1.d (ARERR), dose calculations for the Oyster Creek Generating Station may be performed using the calculation methods contained within the ODCM; the conservative controlling pathways and locations from the ODCM or the actual pathways and locations as identified by the land use census (CONTROL 3/4.12.1) may be used. Average annual meteorological dispersion parameters provided herein or meteorological conditions concurrent with the release period under evaluation may be used.

3.2 DIRECT EXPOSURE DOSE DETERMINATION

Any potentially significant direct exposure contribution to off-site individual doses may be evaluated based on the results of environmental measurements (e.g., TLD) and/or by the use of radiation transport and shielding calculation methodologies.

4.0 RADIOLOGICAL ENVIRONMENTAL MONITORING PROGRAM

The operational phase of the Radiological Environmental Monitoring Program (REMP) is conducted in accordance with the requirements of CONTROL 3.12.1. The objectives of the program are:

- To determine whether any significant increases occur in the concentration of radionuclides in the critical pathways of exposure in the vicinity of Oyster Creek
- To determine if the operation of the Oyster Creek Generating Station has resulted in any increase in the inventory of long lived radionuclides in the environment;
- To detect any changes in the ambient gamma radiation levels; and
- To verify that OCGS operations have no detrimental effects on the health and safety of the public or on the environment.

The REMP sample locations are presented in Appendix E.

Table A-1 Dose Conversion Factors for Deriving Radioactive Noble Gas Radionuclide-to-Dose Equivalent Rate Factors*

<u>Radionuclide</u>	<u>Factor DFSi for Stack Release*</u>	<u>Factor DFVi for Ground-level or Split-Wake Release**</u>
	$\frac{\text{mrem-sec}}{\mu\text{Ci-year}}$	$\frac{\text{mrem-m}^3}{\mu\text{Ci-year}}$
Kr83m	1.47E-09	7.56E-02
Kr85m	9.12E-05	1.17E+03
Kr85	1.47E-06	1.61E+01
Kr87	4.80E-04	5.92E+03
Kr88	1.18E-03	1.47E+04
Kr89	1.17E-03	1.66E+04
Kr90	-	1.56E+04
Xe131m	2.10E-05	9.15E+01
Xe133m	1.64E-05	2.51E+02
Xe133	1.57E-05	2.94E+02
Xe135m	2.77E-04	3.12E+03
Xe135	1.51E-04	1.81E+03
Xe137	1.06E-04	1.42E+03
Xe138	7.63E-04	8.83E+03
Xe139	1.44E-04	5.02E+03
Ar41	9.11E-04	8.84E+03

* Based on reference meteorology applicable at 522 meters SE of stack.

** For exposure to a semi-infinite cloud of noble gas.

Table A-2 Noble Gas Radionuclide-to-Dose Equivalent Rate Factors*

<u>Radionuclide</u>	$P_{\gamma}Si^{**}$ <u>mrem</u> μCi	$P_{\gamma}Vi^{***}$ <u>mrem-m³</u> $\mu Ci\text{-sec (K}_i)$	$A_{\gamma}Vi^{***}$ <u>mrads-m³</u> $\mu Ci\text{-sec (M}_i)$	SBi^{***} <u>mrem-m³</u> $\mu Ci\text{-sec (L}_i)$
Kr83m	4.66E-17	2.40E-09	6.13E-07	-
Kr85m	2.91E-12	3.71E-05	3.90E-05	4.63E-05
Kr85	4.66E-14	5.11E-07	5.46E-07	4.25E-05
Kr87	1.52E-11	1.88E-04	1.96E-04	3.09E-04
Kr88	3.73E-11	4.67E-04	4.83E-04	7.52E-05
Kr89	3.70E-11	5.27E-04	5.49E-04	3.21E-04
Kr90	-	4.95E-04	5.17E-04	2.31E-04
Xe131m	6.65E-13	2.90E-06	4.95E-06	1.51E-05
Xe133m	5.20E-13	7.97E-06	1.04E-05	3.16E-05
Xe133	4.97E-13	9.33E-06	1.12E-05	9.71E-06
Xe135m	8.78E-12	9.90E-05	1.07E-04	2.26E-05
Xe135	4.78E-12	5.75E-05	6.10E-05	5.90E-05
Xe137	3.36E-12	4.51E-05	4.79E-05	3.87E-04
Xe138	2.42E-11	2.80E-04	2.92E-04	1.31E-04
Xe139	4.56E-12	-	-	-
Ar41	2.89E-11	2.81E-04	2.95E-04	8.54E-05

* All of these dose factors apply out-of-doors.

** Based on reference meteorology at 522 meters SE of effluent stack.

*** Derived from Reg Guide 1.109, Revision 1, Table B-1.

Table A-3 Air Dose Conversion Factors for Effluent Noble Gas

<u>Radionuclide</u>	<u>A_γSi**</u> <u>mrad</u> <u>μCi</u>	<u>A_γVi***</u> <u>mrad-m3</u> <u>μCi-sec(M_i)</u>	<u>A_βi***</u> <u>mrad-m3</u> <u>μCi-sec (N_i)</u>
Kr83m	9.35E-15	6.13E-07	9.14E-06
Kr85m	3.03E-12	3.90E-05	6.25E-05
Kr85	4.94E-14	5.46E-07	6.19E-05
Kr87	1.60E-11	1.96E-04	3.27E-04
Kr88	3.93E-11	4.83E-04	9.30E-05
Kr89	3.90E-11	5.49E-04	3.37E-04
Kr90	-	5.17E-04	2.49E-04
Xe131m	7.26E-13	4.95E-06	3.52E-05
Xe133m	5.86E-13	1.04E-05	4.70E-05
Xe133	5.45E-13	1.12E-05	3.33E-05
Xe135m	9.32E-12	1.07E-04	2.35E-05
Xe135	6.18E-12	6.10E-05	7.81E-05
Xe137	3.55E-12	4.79E-05	4.03E-04
Xe138	2.54E-11	2.92E-04	1.51E-04
Xe139	4.82E-12	-	-
Ar41	3.03E-11	2.95E-04	1.04E-04

** Based on reference meteorology at 522 meters SE of effluent stack.

*** Derived from Reg Guide 1.109, Revision 1, Table B-1.

Table A-4 Locations Associated with Maximum Exposure of a Member of the Public*

<u>Effluent</u>	<u>Distance</u> (meters)	<u>Location</u>	<u>Direction</u> (to)
Liquid		U.S. Route 9 Bridge at Discharge Canal	
Airborne Iodine and Particulates	925		SE
Tritium	925		SE
Noble Gases	925		SE
Irradiation by OCGS		Site Boundary	All
Noble Gas g Air Dose	925		SE
Noble Gas B Air Dose	925		SE

Note: the nearby resident experiencing the maximum exposure to airborne effluent and to gamma radiation directly from the Station is located 925 meters SE of the OCGS. The most exposed member of the public is assumed to be exposed by irradiation from the OCGS, by inhaling airborne effluent, by irradiation by the airborne effluent, by irradiation by the airborne plume of the noble gas, by radionuclides deposited onto the ground, by irradiation by shoreline deposits, and by eating fish and shellfish caught in the discharge canal.

*The age group of the most exposed member of the public is based on Reg. Guide 1.109, Revision 1.

Table A-5 Critical Receptor Noble Gas Dose Conversion Factors*

Radionuclide	$P_{\gamma Si}^{**}$ mrem μCi	$P_{\gamma Vi}^{***}$ mrem-m ³ $\mu Ci\text{-sec}(K_i)$	$A_{\gamma Vi}^{***}$ mrad-m ³ $\mu Ci\text{-sec}(M_i)$	$A_{\gamma Si}^{**}$ mrad μCi	S_{Bi}^{***} mrem-m ³ $\mu Ci\text{-sec}(L_i)$
Kr83m	3.76E-17	2.40E-09	6.13E-07	9.66E-15	-
Kr85m	1.68E-12	3.71E-05	3.90E-05	1.75E-12	4.63E-05
Kr85	2.60E-14	5.11E-07	5.46E-07	2.75E-14	4.25E-05
Kr87	8.37E-12	1.88E-04	1.96E-04	8.81E-12	3.09E-04
Kr88	2.08E-11	4.67E-04	4.83E-04	2.18E-11	7.52E-05
Kr89	1.83E-11	5.27E-04	5.49E-04	1.93E-11	3.21E-04
Kr90	-	4.95E-04	5.17E-04	-	2.31E-04
Xe131m	3.99E-13	2.90E-06	4.95E-06	4.44E-13	1.51E-05
Xe133m	3.10E-13	7.97E-06	1.04E-05	3.58E-13	3.16E-05
Xe133	3.11E-13	9.33E-06	1.12E-05	3.42E-13	9.71E-06
Xe135m	4.71E-12	9.90E-05	1.07E-04	5.01E-12	2.26E-05
Xe135	2.73E-12	5.75E-05	6.10E-05	2.87E-12	5.90E-05
Xe137	1.65E-12	4.51E-05	4.79E-05	1.75E-12	3.87E-04
Xe138	1.33E-11	2.80E-04	2.92E-04	1.40E-11	1.31E-04
Xe139	-	-	1.61E-12	-	-
Ar41	1.58E-11	2.81E-04	2.95E-04	1.66E-11	8.54E-05

* All of these dose factors apply out-of-doors.

** Based on reference meteorology at 522 meters SE of effluent stack.

*** Derived from Reg Guide 1.109, Revision 1, Table B-1

APPENDIX B - MODELING PARAMETERS.

Table B-1- OCGS Usage Factors For Individual Dose Assessment

<u>Effluent Ingestion Parameters</u>	<u>Usage Factor</u>
Fraction Of Produce From Local Garden	7.6E-1
Soil Density In Plow Layer (Kg/m ²)	2.4E+2
Fraction Of Deposited Activity Retained On Vegetation	2.5E-1
Shielding Factor For Residential Structures	7.0E-1
Period Of Buildup Of Activity In Soil (hr)	1.31E+5
Period Of Pasture Grass Exposure to Activity (hr)	7.2E+2
Period Of Crop Exposure to Activity (hr)	1.44E+3
Delay Time For Ingestion Of Stored Feed By Animals (hr)	2.16E+3
Delay Time For Ingestion Of Leafy Vegetables By Man (hr)	2.4E+1
Delay Time For Ingestion Of Other Vegetables By Man (hr)	1.44E+3
Transport Time Milk-Man (hr)	4.8E+1
Time Between Slaughter and Consumption of Meat Animal (hr)	4.8E+2
Grass Yield Wet Weight (Kg/m ²)	7.0E-1
Other Vegetation Yield Wet-Weight (Kg/m ²)	2.0
Weathering Rate Constant For Activity on Veg. (hr ⁻¹)	2.1E-3
Milk Cow Feed Consumption Rate (Kg/day)	5.0E+1
Goat Feed Consumption Rate (Kg/day)	6.0
Beef Cattle Feed Consumption Rate (Kg/day)	5.0E+1
Milk Cow Water Consumption Rate (L/day)	6.0E+1
Goat Water Consumption Rate (L/day)	8.0
Beef Cattle Water Consumption Rate (L/day)	5.0E+1
Environmental Transit Time For Water Ingestion (hr)	1.2E+1
Environmental Transit Time For Fish Ingestion (hr)	2.4E+1
Environmental Transit Time For Shore Exposure (hr)	0
Environmental Transit Time For Invertebrate Ingestion (hr)	2.4E+1

Table B-1(Continued)
OCGS Usage Factors For Individual Dose Assessment

<u>Effluent Ingestion Parameters</u>	<u>Usage Factor</u>
Water Ingestion (L/yr)	
a. Adult	7.3E+2
b. Teen	5.1E+2
c. Child	5.1E+2
d. Infant	3.3E+2
Shore Exposure (hr/yr)	
a. Adult	1.2E+1
b. Teen	6.7E+1
c. Child	1.4E+1
d. Infant	0
Salt Water Sport Fish Ingestion (Kg/yr)	
a. Adult	2.1E+1
b. Teen	1.6E+1
c. Child	6.9
d. Infant	0
Salt Water Commercial Fish Ingestion (Kg/yr)	
a. Adult	2.1E+1
b. Teen	1.6E+1
c. Child	6.9
d. Infant	0
Salt Water Invertebrate Ingestion (Kg/yr)	
a. Adult	5.0
b. Teen	3.8
c. Child	1.7
d. Infant	0
Irrigated Leafy Vegetable Ingestion (Kg/yr)	
a. Adult	6.4E+1
b. Teen	4.2E+1
c. Child	2.6E+1
d. Infant	0

Table B-1 (Continued)
OCGS Usage Factors For Individual Dose Assessment

<u>Effluent Ingestion Parameters</u>	<u>Usage Factor</u>
Irrigated Other Vegetable Ingestion (Kg/yr)	
a. Adult	5.2E+2
b. Teen	6.3E+2
c. Child	5.2E+2
d. Infant	0
Irrigated Root Vegetable Ingestion (Kg/yr)	
a. Adult	5.2E+2
b. Teen	6.3E+2
c. Child	5.2E+2
d. Infant	0
Irrigated Cow and Goat Milk Ingestion (L/yr)	
a. Adult	3.1E+2
b. Teen	4.0E+2
c. Child	3.3E+2
d. Infant	3.3E+2
Irrigated Beef Ingestion (Kg/yr)	
a. Adult	1.1E+2
b. Teen	6.5E+1
c. Child	4.1E+1
d. Infant	0
Inhalation (m³/yr)	
a. Adult	8.0E+3
b. Teen	8.0E+3
c. Child	3.7E+3
d. Infant	1.4E+3
Cow and Goat Milk Ingestion (L/yr)	
a. Adult	3.1E+2
b. Teen	4.0E+2
c. Child	3.3E+2
d. Infant	3.3E+2
Meat Ingestion (Kg/yr)	
a. Adult	1.1E+2
b. Teen	6.5E+1
c. Child	4.1E+1
d. Infant	0

Table B-1 (Continued)
OCGS Usage Factors For Individual Dose Assessment

<u>Effluent Ingestion Parameters</u>	<u>Usage Factor</u>
Leafy Vegetable Ingestion (Kg/yr)	
a. Adult	6.4E+1
b. Teen	4.2E+1
c. Child	2.6E+1
d. Infant	0
Fruits, Grains, & Other Vegetable Ingestion (Kg/yr)	
a. Adult	5.2E+2
b. Teen	6.3E+2
c. Child	5.2E+2
d. Infant	0

Table B-2 Monthly Average Absolute Humidity g/m³
(derived from historical climatological data)

<u>Month</u>	<u>Average Absolute Humidity (g/m³)</u>
January	3.3
February	3.3
March	4.5
April	6.1
May	9.4
June	12.8
July	15.2
August	15.6
September	12.4
October	7.9
November	5.9
December	3.8

APPENDIX C - REFERENCES

APPENDIX C - REFERENCES

1. [Faint, illegible text]

2. [Faint, illegible text]

3. [Faint, illegible text]

4. [Faint, illegible text]

5. [Faint, illegible text]

6. [Faint, illegible text]

7. [Faint, illegible text]

8. [Faint, illegible text]

9. [Faint, illegible text]

10. [Faint, illegible text]

11. [Faint, illegible text]

12. [Faint, illegible text]

13. [Faint, illegible text]

14. [Faint, illegible text]

15. [Faint, illegible text]

16. [Faint, illegible text]

17. [Faint, illegible text]

18. [Faint, illegible text]

19. [Faint, illegible text]

20. [Faint, illegible text]

21. [Faint, illegible text]

22. [Faint, illegible text]

23. [Faint, illegible text]

24. [Faint, illegible text]

25. [Faint, illegible text]

26. [Faint, illegible text]

27. [Faint, illegible text]

28. [Faint, illegible text]

29. [Faint, illegible text]

30. [Faint, illegible text]

31. [Faint, illegible text]

32. [Faint, illegible text]

33. [Faint, illegible text]

34. [Faint, illegible text]

35. [Faint, illegible text]

36. [Faint, illegible text]

37. [Faint, illegible text]

38. [Faint, illegible text]

39. [Faint, illegible text]

40. [Faint, illegible text]

41. [Faint, illegible text]

42. [Faint, illegible text]

43. [Faint, illegible text]

44. [Faint, illegible text]

45. [Faint, illegible text]

46. [Faint, illegible text]

47. [Faint, illegible text]

48. [Faint, illegible text]

49. [Faint, illegible text]

50. [Faint, illegible text]

51. [Faint, illegible text]

52. [Faint, illegible text]

53. [Faint, illegible text]

54. [Faint, illegible text]

55. [Faint, illegible text]

56. [Faint, illegible text]

57. [Faint, illegible text]

58. [Faint, illegible text]

59. [Faint, illegible text]

60. [Faint, illegible text]

61. [Faint, illegible text]

62. [Faint, illegible text]

63. [Faint, illegible text]

64. [Faint, illegible text]

65. [Faint, illegible text]

66. [Faint, illegible text]

67. [Faint, illegible text]

68. [Faint, illegible text]

69. [Faint, illegible text]

70. [Faint, illegible text]

71. [Faint, illegible text]

72. [Faint, illegible text]

73. [Faint, illegible text]

74. [Faint, illegible text]

75. [Faint, illegible text]

76. [Faint, illegible text]

77. [Faint, illegible text]

78. [Faint, illegible text]

79. [Faint, illegible text]

80. [Faint, illegible text]

81. [Faint, illegible text]

82. [Faint, illegible text]

83. [Faint, illegible text]

84. [Faint, illegible text]

85. [Faint, illegible text]

86. [Faint, illegible text]

87. [Faint, illegible text]

88. [Faint, illegible text]

89. [Faint, illegible text]

90. [Faint, illegible text]

91. [Faint, illegible text]

92. [Faint, illegible text]

93. [Faint, illegible text]

94. [Faint, illegible text]

95. [Faint, illegible text]

96. [Faint, illegible text]

97. [Faint, illegible text]

98. [Faint, illegible text]

99. [Faint, illegible text]

100. [Faint, illegible text]

Table C-1 - REFERENCES

- 1) Oyster Creek Updated Final Safety Analysis Report
- 2) Oyster Creek Facility Description and Safety Analysis Report
- 3) Oyster Creek Operating License and Technical Specifications
- 4) NUREG 1302 "Off Site Dose Calculation Manual Guidance: Standard Radiological Effluent Controls for Boiling Water Reactors" – Generic Letter 89-10, Supplement No. 1, April 1991
- 5) Reg Guide 1.21 "Measuring, Evaluating, and Reporting Radioactivity in Solid Wastes and Releases of radioactive materials in Liquid and Gaseous Effluents from Light-Water-Cooled Nuclear Power Plants" Rev.1, June 1974
- 6) Reg Guide 1.23
- 7) Reg Guide 1.97
- 8) Reg Guide 1.109 "Calculation of Annual Doses to Man from Routine Releases of Reactor Effluents for the Purpose of Evaluating Compliance With 10 CFR 50, Appendix I", Rev 1, October, 1977
- 9) Reg Guide 1.111 "Methods for Estimating Atmospheric Transport and Dispersion of Gaseous Effluents in Routine Releases From Light-Water-Cooled Reactors", Rev.1, July, 1977
- 10) Reg Guide 4.8 " Environmental Technical Specifications for Nuclear Power Plants"
- 11) NRC Radiological Assessment Branch Technical Position, Rev 1, November 1979 (Appendix A to NUREG1302)
- 12) NUREG-0016
- 13) NUREG-0133
- 14) Licensing Application, Amendment 13, Meteorological Radiological Evaluation for the Oyster Creek Nuclear Power Station Site.
- 15) Licensing Application, Amendment 11, Question IV-8.
- 16) Evaluation of the Oyster Creek Nuclear Generating Station to Demonstrate Conformance to the Design Objectives of 10CFR50, Appendix I, May, 1976, Tables 3-10

- 17) XOQDOQ Output Files for Oyster Creek Meteorology, Murray and Trettle, Inc.
- 18) Hydrological Information and Liquid Dilution Factors Determination to Conform with Appendix I Requirements: Oyster Creek, correspondence from T. Potter, Pickard, Lowe and Garrick, Inc. to Oyster Creek, July, 1976.
- 19) Carpenter, J. J. "Recirculation and Effluent Distribution for Oyster Creek Site", Pritchard-Carpenter Consultants, Baltimore, Maryland, 1964.
- 20) Nuclear Regulatory Commission, Generic Letter 89-01, "Implementation of Programmatic Controls for Radiological Effluent Technical Specifications in the Administrative Controls Section and Relocation of the Procedural Details of RETS to the ODCM or PCP", January, 1989.
- 21) Ground Water Monitoring System (Final Report), Woodward-Clyde Consultants, March, 1984.
- 22) Meteorology and Atomic Energy, Department of Energy, 1981.
- 23) SEEDS Code Documentation through V & V of Version 98.8F (Radiological Engineering Calculation No. 2820-99-005, Dated 3/23/99)
- 24) Lynch, Giuliano, and Associates, Inc., Drawing Entitled, "Minor Subdivision, Lots 4 and 4.01 Block 1001", signed 13 Sep 99.
- 25) Currie, L. A., "Lower Limit of Detection: Definition and Elaboration of a Proposed Position for Radiological Effluent and Environmental Measurements" .
- 26) NUREG/CR-4007 (September 1984).
- 27) HASL Procedures Manual, HASL-300 (revised annually).
- 28) Regulatory Guide 1.113, "Estimating Aquatic Dispersion of Effluents from Accidental and Routine Reactor Releases for the Purposes of Implementing Appendix I," April 1977
- 29) Reg. Guide 4.13
- 30) 10CFR20, Appendix B, Table 2, Annual Limits on Intake (ALIs) and Derived Air Concentrations (DACs) of Radionuclides for Occupational Exposure; Effluent Concentrations; Concentrations for Release to Sewerage

- 31) Conestoga Rovers and Associates, Hydrogeologic Investigation Report, Fleet wide Assessment, Oyster Creek Generating Station, Forked River, New Jersey, Ref. No. 045136(18), September, 2006.

APPENDIX D – SYSTEM DRAWINGS



FIGURE D-1-1a: LIQUID RADWASTE TREATMENT CHEM WASTE AND FLOOR DRAIN SYSTEM

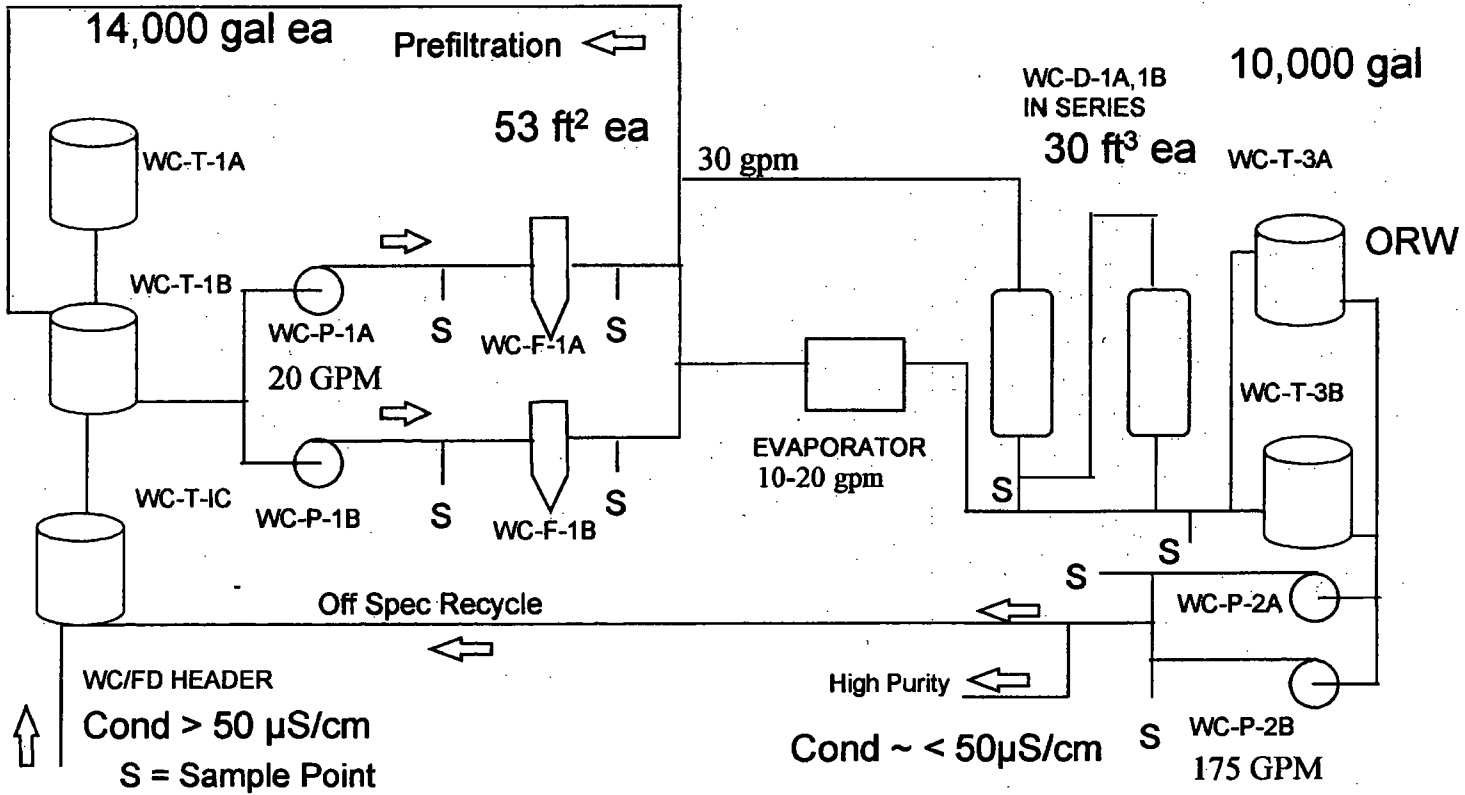

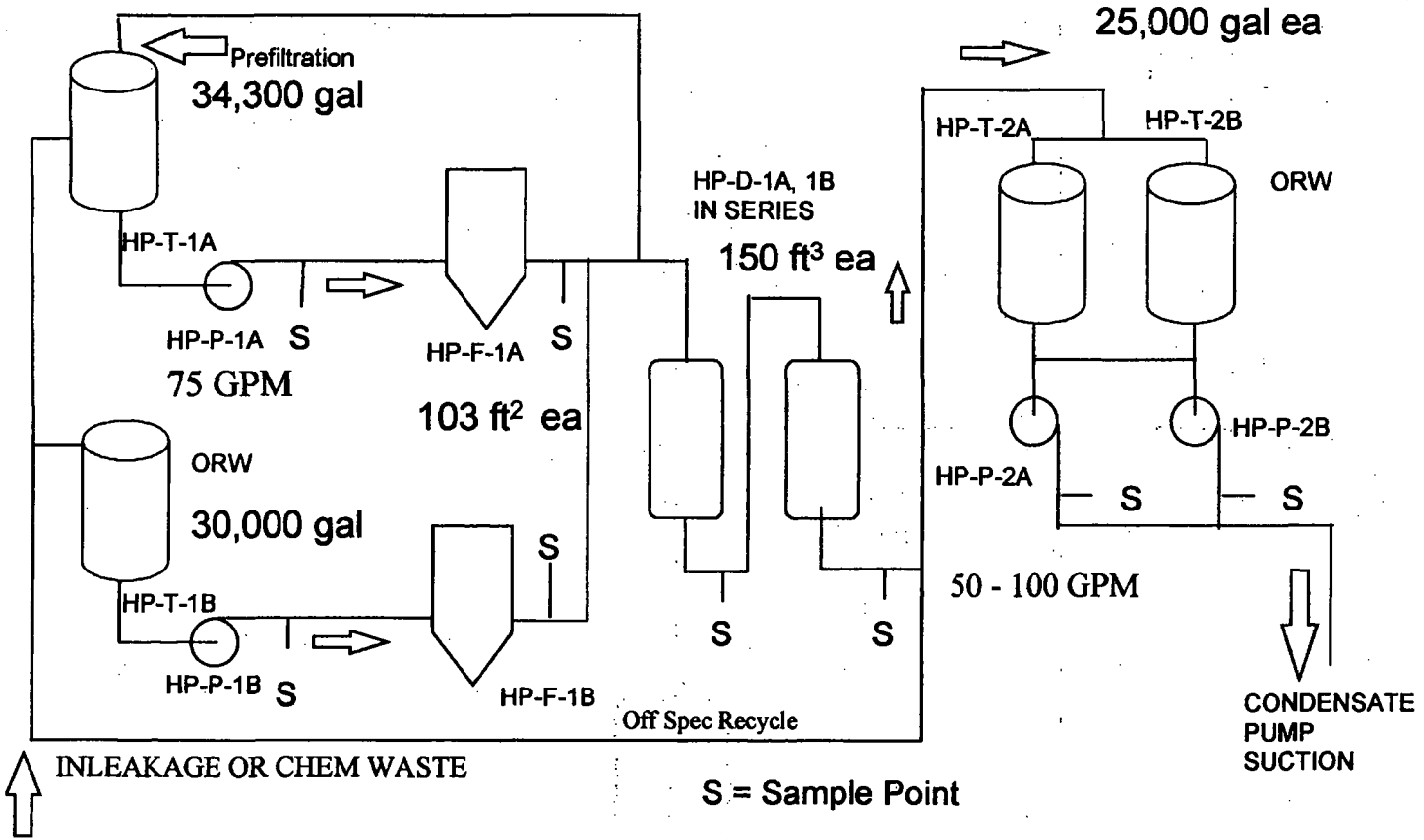

FIGURE D-1-1b: LIQUID RADWASTE TREATMENT - HIGH PURITY AND EQUIPMENT DRAIN SYSTEM

FIGURE D-1-1c: GROUNDWATER REMEDIATION SYSTEM

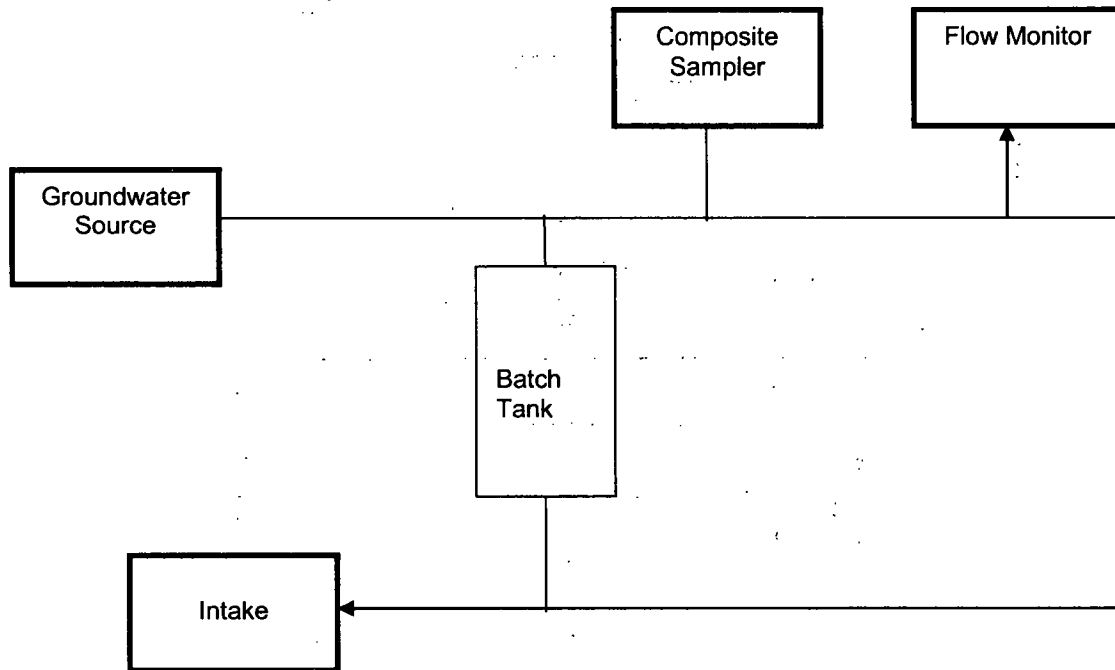

FIGURE D-1-2: SOLID RADWASTE PROCESSING SYSTEM

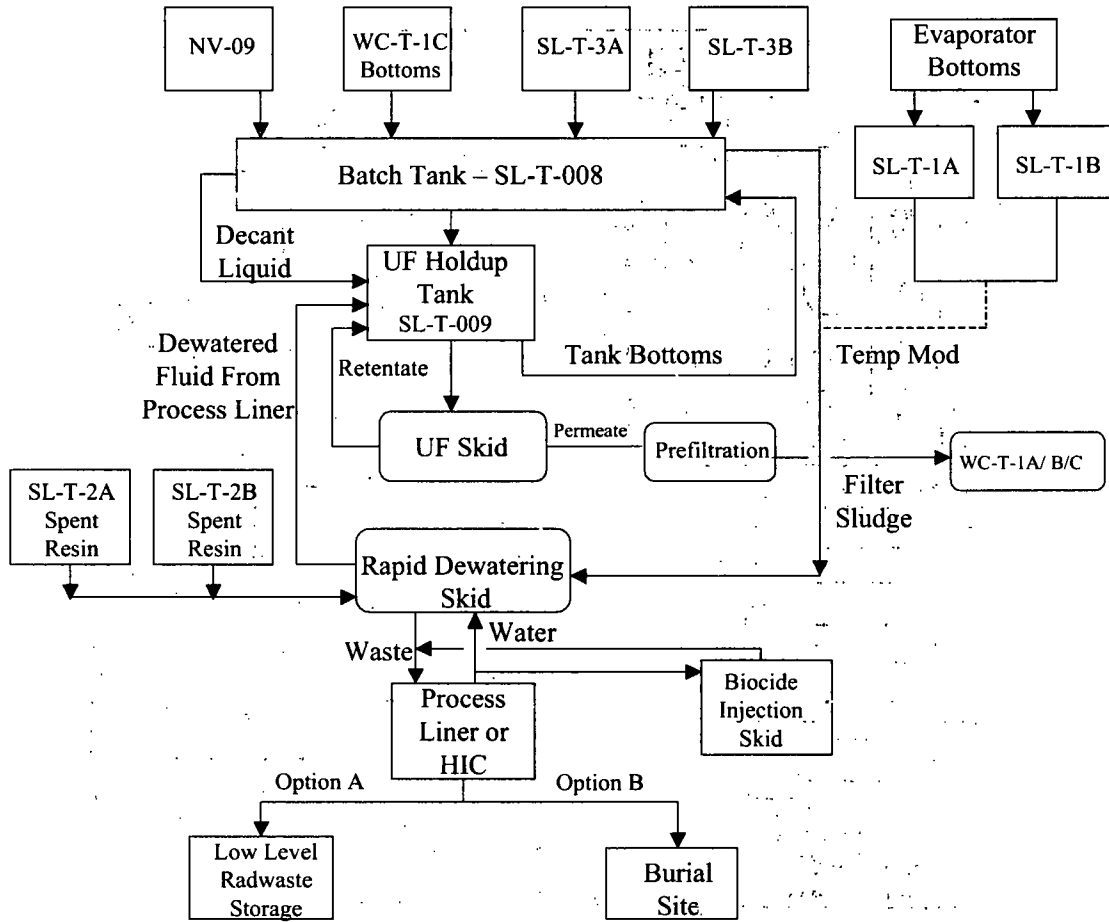
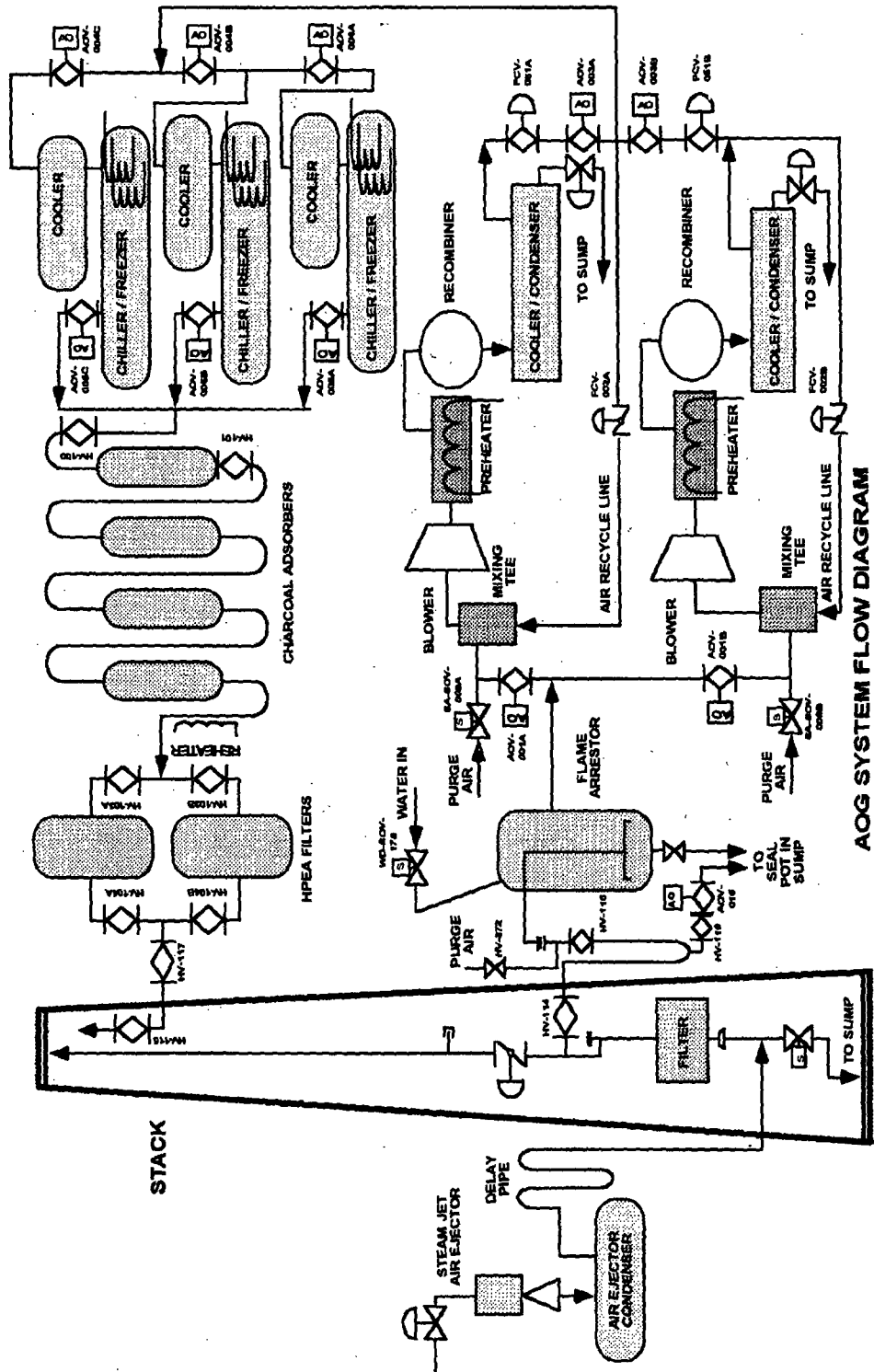

FIGURE D-2-1: GASEOUS RADWASTE TREATMENT - AUGMENTED OFF GAS SYSTEM



AOG SYSTEM FLOW DIAGRAM

FIGURE D-2-2: VENTILATION SYSTEM

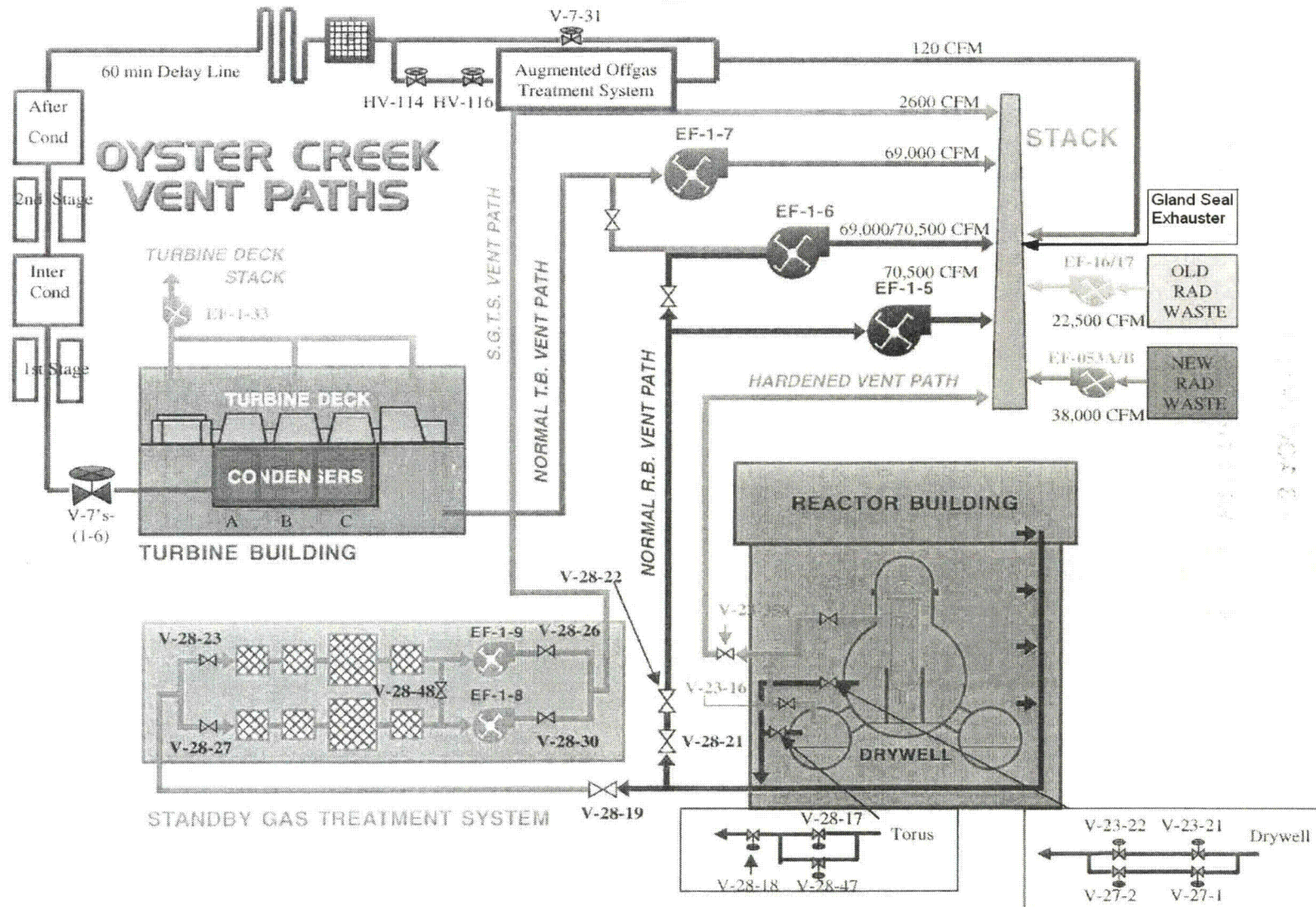

Figure D-2-3 AOG Ventilation System

Error! Objects cannot be created from editing field codes.

APPENDIX E - RADIOLOGICAL ENVIRONMENTAL MONITORING PROGRAM - SAMPLE TYPE AND LOCATION

All sampling locations and specific information about the individual locations are given in Table E-1. Figures E-1, E-2 and E-3 show the locations of sampling stations with respect to the site. Figure E-4 shows the site layout.

TABLE E-1: REMP SAMPLE LOCATIONS ⁽¹⁾

<u>Sample Medium</u>	<u>Station Code</u>	<u>Distance (miles)</u>	<u>Azimuth (degrees)</u>	<u>Description</u>
TLD	1	0.4	219	SW of site at OCGS Fire Pond, Forked River, NJ (Inner Ring)
DW	1S	0.1	209	On-site southern domestic well at OCGS, Forked River, NJ
	1N	0.2	349	On-site northern domestic well at OCGS, Forked River, NJ Either the southern or northern well is sampled.
APT, AIO, TLD	3	6.0	97	East of site, near old Coast Guard Station, Island Beach State Park TLD – Special Interest Area
TLD	4	4.6	213	SSW of Site, Garden State Parkway and Route 554, Barnegat, NJ (Outer Ring)
TLD	5	4.2	353	North of Site, Garden State Parkway Rest Area, Forked River, NJ (Outer Ring)
TLD	6	2.1	13	NNE of site, Lane Place, behind St. Pius Church, Forked River, NJ (Outer Ring)
TLD	8	2.3	177	South of site, Route 9 at the Waretown Substation, Waretown, NJ (Outer Ring)
TLD	9	2.0	230	SW of site, where Route 532 and the Garden State Parkway meet, Waretown, NJ (Outer Ring)
APT, AIO, TLD	C	24.7	313	NW of site, JCP&L office in rear parking lot, Cookstown, NJ (Background Station)
TLD	11	8.2	152	SSE of site, 80 th and Anchor Streets, Harvey Cedars, NJ (Special Interest Area)
TLD	14	20.8	2	North of site, Larrabee Substation on Randolph Road, Lakewood, NJ (Background Station)
APT, AIO	20	0.7	95	East of site, on Finninger Farm on south side of access road, Forked River, NJ
TLD	22	1.6	145	SE of site, on Long John Silver Way, Skippers Cove, Waretown, NJ (Outer Ring)
SWA, CLAM,	23	3.6	64	ENE of site, Barnegat Bay off Stouts Creek,

TABLE E-1: REMP SAMPLE LOCATIONS ⁽¹⁾

<u>Sample Medium</u>	<u>Station Code</u>	<u>Distance (miles)</u>	<u>Azimuth (degrees)</u>	<u>Description</u>
AQS				approximately 400 yards SE of "Flashing Light 1"
SWA, CLAM, AQS	24	2.1	101	East of site, Barnegat Bay, approximately 250 yards SE of "Flashing Light 3"
SWA, AQS, FISH	33	0.4	123	ESE of site, east of Route 9 Bridge in OCGS Discharge Canal
VEG	35	0.4	111	ESE of site, east of Route 9 and north of the OCGS Discharge Canal, Forked River, NJ
VEG	36	23.1	319	NW of site, at "U-Pick" Farm, New Egypt, NJ (Background Station)
DW	37	2.2	18	NNE of Site, off Boox Road at Lacey MUA Pumping Station, Forked River, NJ (Background Station)
DW	38	1.6	197	SSW of Site, on Route 532, at Ocean Township MUA Pumping Station, Waretown, NJ
DW	39	3.5	353	N of Site, Trenton Ave. off Lacey Road Lacey Twp., MUA Pump Station, Forked River, NJ (Background Station)
TLD	46	5.6	323	NW of Site, on Lacey Road adjacent to Utility Pole BT 259 65 (Outer Ring)
TLD	47	4.6	26	NNE of Site, Route 9 and Harbor Inn Road, Berkeley Township, NJ (Outer Ring)
TLD	48	4.5	189	South of Site, Intersection of Brook and School Streets, Barnegat, NJ (Outer Ring)
TLD	51	0.4	358	North of site, on the access road to Forked River Site, Forked River, NJ (Inner Ring)
TLD	52	0.3	333	NNW of site, on the access road to Forked River Site, Forked River, NJ (Inner Ring)
TLD	53	0.3	309	NW of site, at sewage lift station on the access road to the Forked River Site,

TABLE E-1: REMP SAMPLE LOCATIONS ⁽¹⁾

<u>Sample Medium</u>	<u>Station Code</u>	<u>Distance (miles)</u>	<u>Azimuth (degrees)</u>	<u>Description</u>
TLD	54	0.3	288	Forked River, NJ (Inner Ring) WNW of site, on the access road to Forked River Site, Forked River, NJ (Inner Ring)
TLD	55	0.3	263	West of site, on Southern Area Stores security fence, west of OCGS Switchyard, Forked River, NJ (Inner Ring)
TLD	56	0.3	249	WSW of site, on utility pole east of Southern Area Stores, west of the OCGS Switchyard, Forked River, NJ (Inner Ring)
TLD	57	0.2	206	SSW of site, on Southern Area Stores access road, Forked River, NJ (TLD - ODCM Required - Inner Ring)
TLD	58	0.2	188	South of site, on Southern Area Stores access road, Forked River, NJ (Inner Ring)
TLD	59	0.3	166	SSE of site, on Southern Area Stores access road, Waretown, NJ (Inner Ring)
TLD	61	0.3	104	ESE of site, on Route 9 south of OCGS Main Entrance, Forked River, NJ (Inner Ring)
TLD	62	0.2	83	East of site, on Route 9 at access road to OCGS Main Gate, Forked River, NJ (Inner Ring)
TLD	63	0.2	70	ENE of site, on Route 9, between main gate and OCGS North Gate access road, Forked River, NJ (Inner Ring)
TLD	64	0.3	42	NE of site, on Route 9 North at entrance to Finninger Farm, Forked River, NJ (Inner Ring)

TABLE E-1: REMP SAMPLE LOCATIONS (Continued)

<u>Sample Medium</u>	<u>Station Code</u>	<u>Distance (miles)</u>	<u>Azimuth (degrees)</u>	<u>Description</u>
TLD	65	0.4	19	NNE of site, on Route 9 at Intake Canal Bridge, Forked River, NJ (Inner Ring)
APT, AIO, TLD, VEG	66	0.4	133	SE of site, east of Route 9 and south of the OCGS Discharge Canal, inside fence, Waretown, NJ (TLD - Inner Ring)
TLD	68	1.3	266	West of site, on Garden State Parkway North at mile marker 71.7, Lacey Township, NJ (Outer Ring)
APT, AIO, TLD	71	1.6	164	SSE of site, on Route 532 at the Waretown Municipal Building, Waretown, NJ (TLD - Special Interest Area)
APT, AIO, TLD	72	1.9	25	NNE of site, on Lacey Road at Knights of Columbus Hall, Forked River, NJ (TLD - Special Interest Area)
APT, AIO, TLD	73	1.8	108	ESE of site, on Bay Parkway, Sands Point Harbor, Waretown, NJ (TLD - Outer Ring)
TLD	74	1.8	88	East of site, Orlando Drive and Penguin Court, Forked River, NJ (Outer Ring)
TLD	75	2.0	71	ENE of site, Beach Blvd. and Maui Drive, Forked River, NJ (Outer Ring)
TLD	78	1.8	2	North of site, 1514 Arient Road, Forked River, NJ (Outer Ring)
TLD	79	2.9	160	SSE of site, Hightide Drive and Bonita Drive, Waretown, NJ (Outer Ring)
TLD	81	3.5	201	SSW of site, on Rose Hill Road at intersection with Barnegat Boulevard, Barnegat, NJ (Special Interest Area)

TABLE E-1: REMP SAMPLE LOCATIONS (Continued)

Sample Medium	Station Code	Distance (miles)	Azimuth (degrees)	Description
TLD	82	4.4	36	NE of site, Bay Way and Clairmore Avenue, Lanoka Harbor, NJ (Outer Ring)
TLD	84	4.4	332	NNW of site, on Lacey Road, 1.3 miles west of the Garden State Parkway on siren pole, Lacey Township, NJ (Outer Ring)
TLD	85	3.9	250	WSW of site, on Route 532, just east of Wells Mills Park, Waretown, NJ (Outer Ring)
TLD	86	5.0	224	SW of site, on Route 554, 1 mile west of the Garden State Parkway, Barnegat, NJ (Outer Ring)
TLD	88	6.6	125	SE of site, eastern end of 3 rd Street, Barnegat Light, NJ (Special Interest Area)
TLD	89	6.1	108	ESE of site, Job Francis residence, Island Beach State Park (Special Interest Area)
TLD	90	6.3	75	ENE of site, parking lot A-5, Island Beach State Park (Special Interest Area)
TLD	92	9.0	46	NE of site, at Guard Shack/Toll Booth, Island Beach State Park (Special Interest Area)
FISH, CRAB	93	0.1	242	WSW of site, OCGS Discharge Canal between Pump Discharges and Route 9, Forked River, NJ
SWA, AQS, CLAM, FISH	94	20.0	198	SSW of site, in Great Bay/Little Egg Harbor (Background Station)
TLD	98	1.6	318	NW of site, on Garden State Parkway at mile marker 73.0, Lacey Township, NJ (Outer Ring)

TABLE E-1: REMP SAMPLE LOCATIONS (Continued)

<u>Sample Medium</u>	<u>Station Code</u>	<u>Distance (miles)</u>	<u>Azimuth (degrees)</u>	<u>Description</u>
TLD	99	1.5	310	NW of site, on Garden State Parkway at mile marker 72.8, Lacey Township, NJ (Outer Ring)
TLD	100	1.4	43	NE of site, Yacht Basin Plaza South off Lakdeside Dr., Lacey Township, NJ (Outer Ring)
TLD	101	1.7	49	NE of site, end of Lacey Rd., East, Lacey Township, NJ (Outer Ring)
TLD	102	1.6	344	NNW of site, end of Sheffield Dr., Barnegat Pines, Lacey Township, NJ (Outer Ring)
TLD	103	2.4	337	NNW of site, Llewellyn Parkway, Barnegat Pines, Lacey Township, NJ (Outer Ring)
TLD	104	1.8	221	SW of site, Rt. 532 West, before Garden State Parkway, Ocean Township, NJ (Outer Ring)
TLD	105	2.8	222	SW of site, Garden State Parkway North, beside mile marker 69.6, Ocean Township, NJ (Outer Ring)
TLD	106	1.2	288	NW of site, Garden State Parkway North, beside mile marker 72.2 Lacey Township, NJ (Outer Ring)
TLD	107	1.3	301	NW of Site, Garden State Parkway North, beside mile marker 72.5, Lacey Township, NJ (Outer Ring)
TLD	109	1.2	141	SE of site, Lighthouse Dr., Waretown, Ocean Township, NJ (Outer Ring)
TLD	110	1.5	127	SE of site, Tiller Drive and Admiral Way, Waretown, Ocean Township, NJ (Outer Ring)
APT, AIO	111	0.3	64	ENE of site, Finninger Farm property along access road, Lacey Township, NJ
TLD	112	0.2	178	S of site, along Southern access road, Lacey Township, NJ (Inner Ring)
TLD	113	0.3	90	E of site, along Rt. 9 North, Lacey Township, NJ (Inner Ring)
TLD	T1	0.4	219	SW of site, at OCGS Fire Pond, Lacey Township, NJ (Inner Ring)
GW	W-3C	0.4	112	ESE of site on Finninger Farm adjacent to Station 35, Lacey Township, NJ

<u>Sample Medium</u>	<u>Station Code</u>	<u>Distance (miles)</u>	<u>Azimuth (degrees)</u>	<u>Description</u>
GW	MW-24-3A	0.8	97	E of site on Finninger Farm on South side of access road, Lacey Township, NJ
DW	114	0.8	267	Well at Bldg 25 on Forked River site
VEG	115	0.3	96	East of Site, on Finninger Farm

SAMPLE MEDIUM IDENTIFICATION KEY

APT = Air Particulate	SWA = Surface Water	TLD = Thermoluminescent Dosimeter
AIO = Air Iodine	AQS = Aquatic Sediment	FISH = Fish
VEG = Vegetables	CLAM = Clams	CRAB =Crab
	DW = Drinking Water	GW = Ground Water

(1) Samples may not be collected from some locations listed in this table, as long as the minimum number of samples listed in Table 3.12.1-1 is collected.

FIGURE E-1

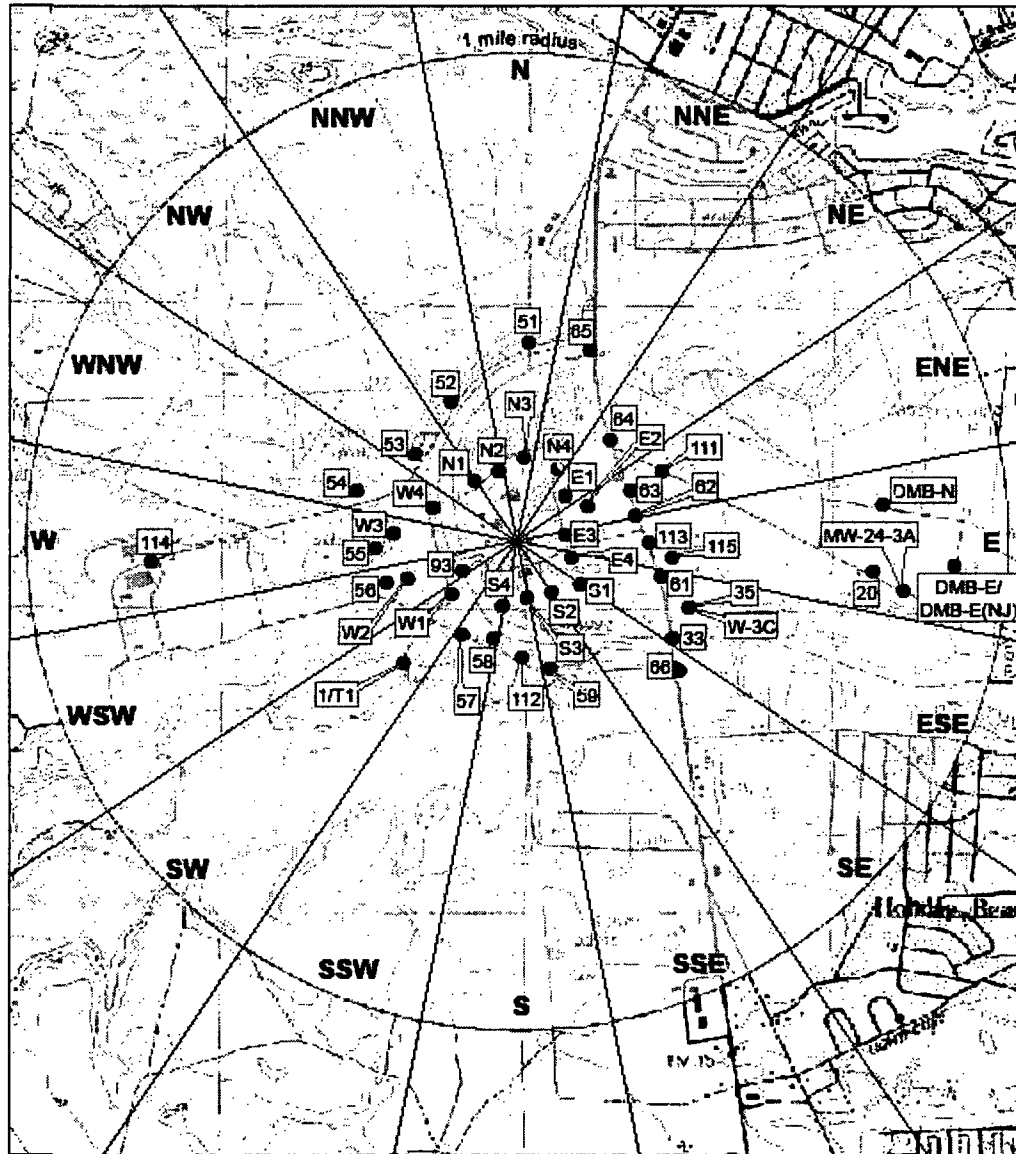

Oyster Creek Generating Station REMP Stations
 within a 1 mile radius
 2010



NORMANDEAU ASSOCIATES
 ENVIRONMENTAL CONSULTANTS
 450 Co. Road 200, Suite 101, Stuart, FL 34988

date: 10/10/10
 prepared by: a. sherman
 project: 20577

rev date:
 checked by: a. sherman
 file name: CC_REISP_2010_1.mxd

FIGURE E-2

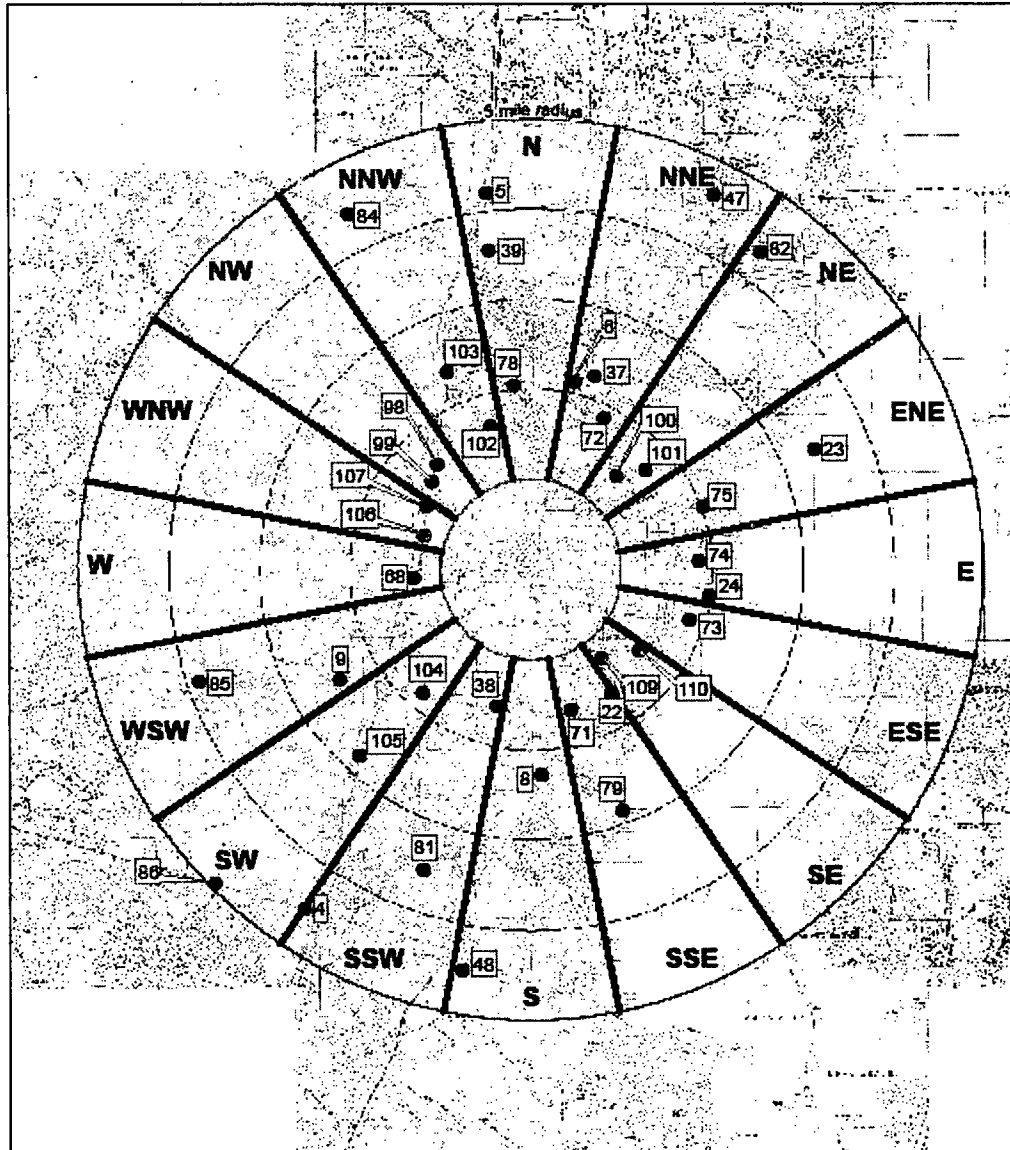

7,300 3,650 0 7,300 Feet



Oyster Creek Generating Station REMP Stations
 within a 1 to 5 mile radius
 2010



NORMANDEAU ASSOCIATES
 ENVIRONMENTAL CONSULTANTS
 60 Old Meeting Place, Bag A, Suite 101, Dover, PA 17814

date: 10/08/10
 prepared by: a.sherman
 project: 25677

svr: ddb
 checked by: d.sherman
 file name: OC_REMP_2010_5.mxd

FIGURE E-3

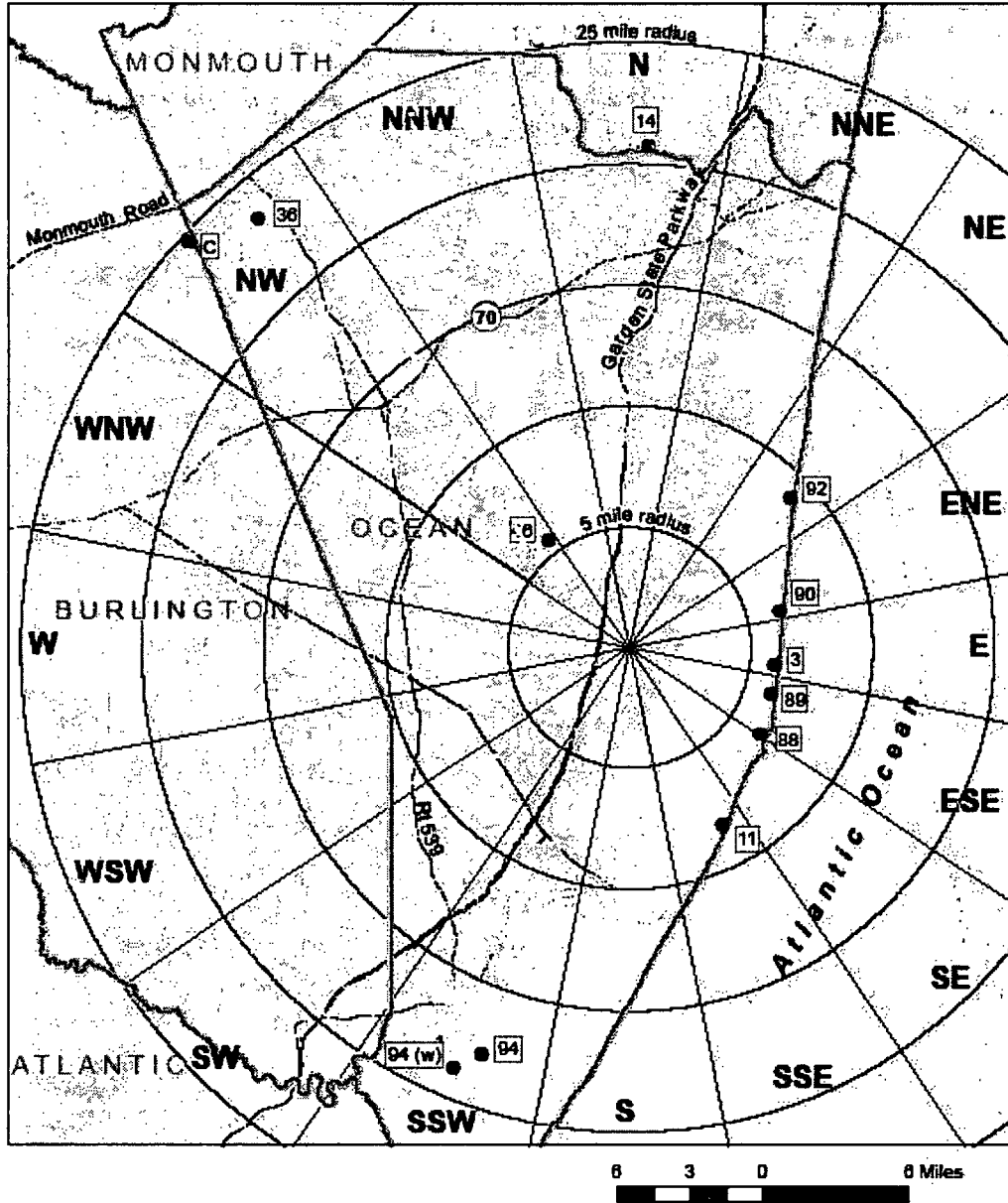



<p>Oyster Creek Generating Station REMP Stations greater than 5 mile radius 2010</p>	<p>N</p> 		<p>NORMANDEAU ASSOCIATES ENVIRONMENTAL CONSULTANTS</p>
		<p>date: 10/20/10 prepared by: a. sherman project: 30677</p>	<p>rev date: checked by: e. mohan file name: OC_2010_o-ecrsta.mxd</p>

FIGURE E-4

AREA PLOT PLAN OF SITE

SITE MAP DEFINING UNRESTRICTED AREAS AND SITE BOUNDARY FOR RADIOACTIVE
GASEOUS AND LIQUID EFFLUENTS

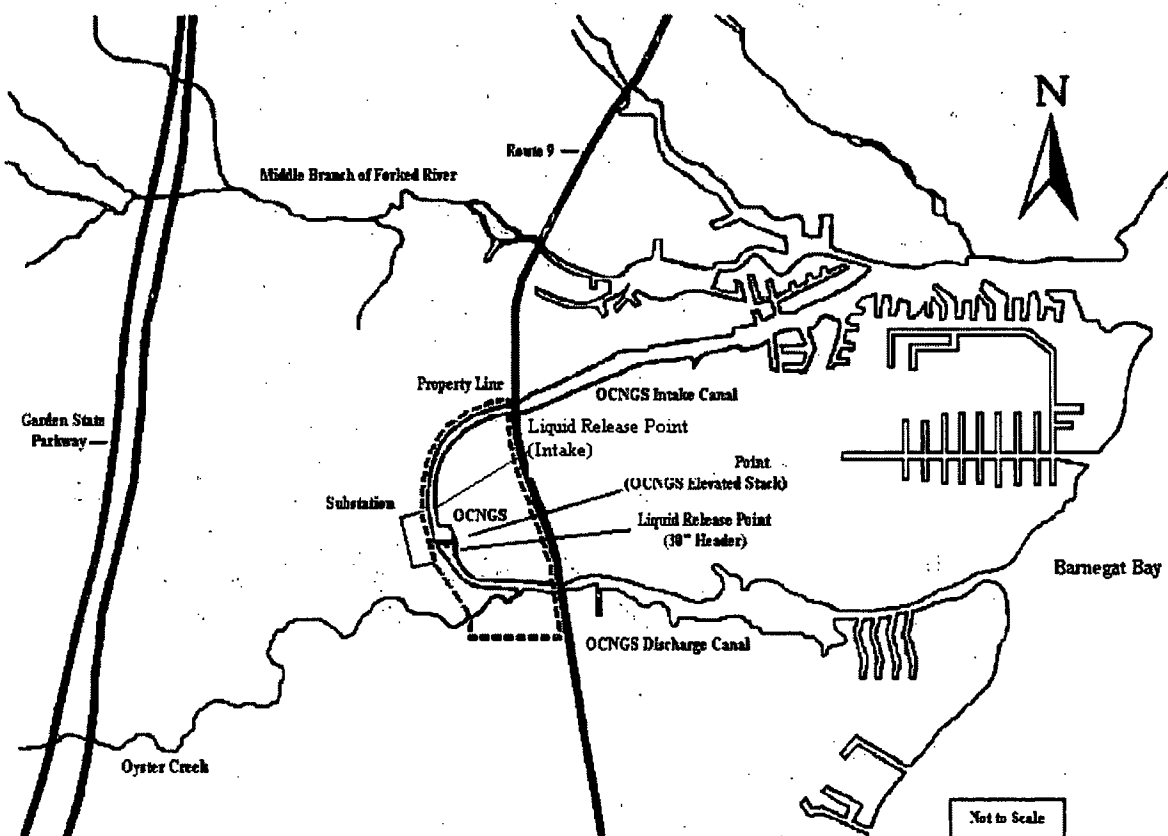

Oyster Creek 2010 Annual Radioactive Effluent Release Report

Appendix F ERRATA

Revised Annual Radioactive Effluent Release Reports for 2006, 2007, 2008 and 2009 will be submitted under separate cover. The reports are being revised to correct the stack release data that was incorrect due to the stack sample line separation.