

# Research Activities FY 2010-FY 2011



## AVAILABILITY OF REFERENCE MATERIALS IN NRC PUBLICATIONS

### NRC Reference Material

As of November 1999, you may electronically access NUREG-series publications and other NRC records at NRC's Public Electronic Reading Room at <http://www.nrc.gov/reading-rm.html>.

Publicly released records include, to name a few, NUREG-series publications; *Federal Register* notices; applicant, licensee, and vendor documents and correspondence; NRC correspondence and internal memoranda; bulletins and information notices; inspection and investigative reports; licensee event reports; and Commission papers and their attachments.

NRC publications in the NUREG series, NRC regulations, and *Title 10, Energy*, in the Code of *Federal Regulations* may also be purchased from one of these two sources.

1. The Superintendent of Documents  
U.S. Government Printing Office  
Mail Stop SSOP  
Washington, DC 20402-0001  
Internet: [bookstore.gpo.gov](http://bookstore.gpo.gov)  
Telephone: 202-512-1800  
Fax: 202-512-2250
2. The National Technical Information Service  
Springfield, VA 22161-0002  
[www.ntis.gov](http://www.ntis.gov)  
1-800-553-6847 or, locally, 703-605-6000

A single copy of each NRC draft report for comment is available free, to the extent of supply, upon written request as follows:

Address: U.S. Nuclear Regulatory Commission  
Office of Administration  
Mail, Distribution and Messenger Team  
Washington, DC 20555-0001  
E-mail: [DISTRIBUTION@nrc.gov](mailto:DISTRIBUTION@nrc.gov)  
Facsimile: 301-415-2289

Some publications in the NUREG series that are posted at NRC's Web site address <http://www.nrc.gov/reading-rm/doc-collections/nuregs> are updated periodically and may differ from the last printed version. Although references to material found on a Web site bear the date the material was accessed, the material available on the date cited may subsequently be removed from the site.

### Non-NRC Reference Material

Documents available from public and special technical libraries include all open literature items, such as books, journal articles, and transactions, *Federal Register* notices, Federal and State legislation, and congressional reports. Such documents as theses, dissertations, foreign reports and translations, and non-NRC conference proceedings may be purchased from their sponsoring organization.

Copies of industry codes and standards used in a substantive manner in the NRC regulatory process are maintained at—

The NRC Technical Library  
Two White Flint North  
11545 Rockville Pike  
Rockville, MD 20852-2738

These standards are available in the library for reference use by the public. Codes and standards are usually copyrighted and may be purchased from the originating organization or, if they are American National Standards, from—

American National Standards Institute  
11 West 42<sup>nd</sup> Street  
New York, NY 10036-8002  
[www.ansi.org](http://www.ansi.org)  
212-642-4900

Legally binding regulatory requirements are stated only in laws; NRC regulations; licenses, including technical specifications; or orders, not in NUREG-series publications. The views expressed in contractor-prepared publications in this series are not necessarily those of the NRC.

The NUREG series comprises (1) technical and administrative reports and books prepared by the staff (NUREG-XXXX) or agency contractors (NUREG/CR-XXXX), (2) proceedings of conferences (NUREG/CP-XXXX), (3) reports resulting from international agreements (NUREG/IA-XXXX), (4) brochures (NUREG/BR-XXXX), and (5) compilations of legal decisions and orders of the Commission and Atomic and Safety Licensing Boards and of Directors' decisions under Section 2.206 of NRC's regulations (NUREG-0750).

---

# Research Activities FY 2010-FY 2011



NUREG-1925, Rev. 1

Manuscript Completed: October 2010

Date Published: December 2010

U.S. Nuclear Regulatory Commission  
Office of Nuclear Regulatory Research (RES)  
Washington, D.C. 20555-0001

[www.nrc.gov](http://www.nrc.gov)



---

# Abstract

The Office of Nuclear Regulatory Research (RES) supports the regulatory mission of the U.S. Nuclear Regulatory Commission (NRC) by providing technical advice, tools, and information to identify and resolve safety issues, make regulatory decisions, and issue regulations and guidance. This includes conducting confirmatory experiments and analyses; developing technical bases that support the NRC's safety decisions; and preparing the agency for the future by evaluating the safety aspects of new technologies and designs for nuclear reactors, materials, waste, and security.

The NRC faces challenges as the industry matures, including potential new safety issues, the availability of new technologies, technical issues associated with the deployment of new reactor designs, and knowledge management. The NRC focuses its research primarily on near-term needs related to the oversight of operating reactors, as well as to new and advanced reactor designs. RES develops technical tools, analytical models, and experimental data to allow the agency to assess safety and regulatory issues. The RES staff develops these tools, models, and data through contracts with commercial entities, national laboratories, and universities or in collaboration with international organizations.

This NUREG presents research conducted across a wide variety of disciplines, ranging from fuel behavior under accident conditions to seismology to health physics. At times, this research also provides the technical bases for regulatory decisions and confirms licensee analyses. RES works closely with the NRC's licensing offices in the review and analysis of high-risk events and provides its expertise to support licensing. RES has organized this collection of information sheets by business lines and topical areas that summarize projects currently in progress. Each sheet provides the RES technical staff and division that can be contacted for additional information.

# Foreword

## A Message from the Director



The Office of Nuclear Regulatory Research (RES) is a major U.S. Nuclear Regulatory Commission (NRC) program office, mandated by Congress. The office plans, recommends, and implements a program of nuclear regulatory research, standards development, and resolution of generic safety issues for nuclear power plants and other facilities regulated by the NRC. RES partners with other NRC program offices, federal agencies, industry research organizations, and international organizations. This NUREG provides a general overview of numerous key projects and their status including long-term research.

In fiscal year (FY) 2009, the staff completed resolution of Generic Issue (GI) 163, “Multiple Steam Generator Tube Leakage,” and GI 191, “Assessment of Debris Accumulation on PWR Sump Performance.”

In addition, RES made significant progress on other GIs, such as GI 199, “Implications of Updated Probabilistic Seismic Hazard Estimates in Central and Eastern U.S. for Existing Plants.” Some of the highlighted FY2010–2011 projects include state-of-the-art reactor consequence analysis (Chapter 3), the analysis of cancer risk in populations living near nuclear facilities (Chapter 4), new and advanced reactor research (Chapter 11), probabilistic risk assessment (Chapter 5), and human reliability analysis activities (Chapter 6). RES and the regulatory offices also continue to focus on aging-related materials issues, such as dissimilar metal weld cracking and mitigation, cyber security and digital instrumentation and control, and the agency’s Fire Protection Stabilization Plan. These are simply a few of the critical research projects contained in this report and expected to continue over the next several years.

To accomplish these projects, the office’s annual budget is approximately \$70 million. The funding allocation is shown in Figure iv.1.

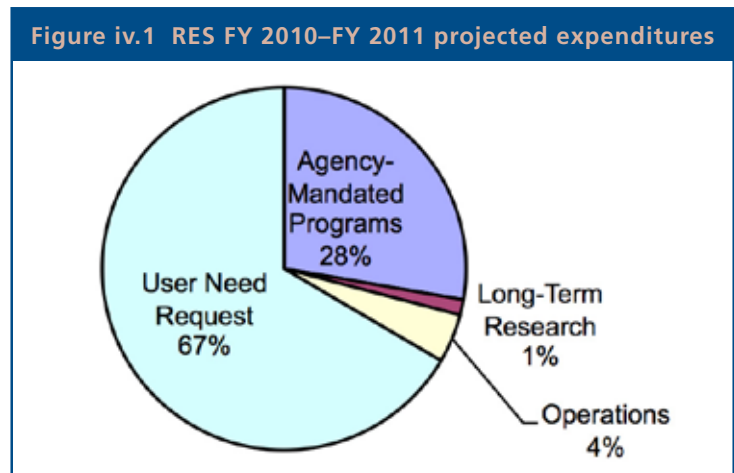

- The needs of regulatory offices drive two-thirds of RES activities (user need requests).
- The Commission drives one-third of RES activities (agency-mandated programs).
- A small amount of long-term research focuses on subjects expected to be critical in 5 to 10 years.

Currently, RES has about 265 staff members. This staff continues to reflect diversity in academic degrees, demographics, and technical disciplines. The wide range of engineering and scientific disciplines includes expertise in nuclear materials, human factors and human reliability, health physics, fire protection, seismology, and probabilistic risk assessment.

Along with the numerous technical projects, RES continues its management initiative, detailed in “RES Focus Areas 2010–2011” (Figure iv.2), which identifies office improvement priorities, creates management focus groups to implement specific activities for employee self-development and well-being, and optimizes fiscal and project management.

In summary, RES appreciates your interest in these activities and will continue to issue updates of this NUREG for your information. Additional questions or comments on the content should be directed to the technical staff or the division noted on each specific project summary sheet.



*Brian W. Sheron, Director*  
Office of Nuclear Regulatory Research

### Promote Best Practices in Project Management

- ▶ Develop & maintain an electronic PM Handbook
- ▶ Update Project Management Office Instructions
- ▶ Develop & conduct training for Project Managers

**Leads:** Sean Peters & Teresa Granconovitz

**Executive Sponsor:** Mary Muesle

### Maintain High Technical Quality

- ▶ Develop process map for RES products
- ▶ Improve quality review throughout the process
- ▶ Institutionalize quality feedback

**Lead:** Mirela Gavrilas

**Executive Sponsor:** Kathy Halvey Gibson

### Promote Self-Development and Well-Being

- ▶ Promote the use of IDPs, mentoring, & rotations
- ▶ Explore a qualification program for RES staff
- ▶ Encourage diversity

**Lead:** Stephanie Bush-Goddard

**Executive Sponsor:** Stu Richards

### Stay Connected and Maintain Relationships w/Stakeholders

- ▶ Reach out to customers to overcome distance
- ▶ Utilize technology to maintain relationships
- ▶ Share success stories & best practices

**Lead:** Andrea Valentin

**Executive Sponsor:** Doug Coe

### Foster Knowledge Management

- ▶ Expand Expertise Exchange program
- ▶ Continue to support Communities of Practice
- ▶ Champion NUREG/KM series development

**Lead:** Leslie Donaldson

**Executive Sponsor:** Jim Lyons

### Promote an Open Collaborative Work Environment

- ▶ Identify factors contributing to open collaboration
- ▶ Train on agency & government programs
- ▶ Communicate best practices

**Lead:** Tom Kardaras

**Executive Sponsor:** Mike Case



## Focus Areas 2010-2011





# Table of Contents

<b>Abstract</b> .....	iii	Report to Congress on Abnormal Occurrences.....	65
<b>Foreword</b> .....	iv	Analysis of Cancer Risk in Populations Living Near Nuclear Facilities .....	67
<b>Figures</b> .....	viii	Radiological Toolbox.....	68
<b>Abbreviations and Acronyms</b> .....	xii	Phantom w/ltH Moving Arms and Legs (PIMAL).....	70
<b>Chapter 1: Regulatory Support</b> .....	1	VARSKIN Skin Dose Computer Code.....	72
Regulatory Guides.....	2	Accelerator-Enhanced Gemstones .....	74
Consensus Codes and Standards.....	3	<b>Chapter 5: Risk Analysis</b> .....	77
Generic Issues Program .....	4	Comprehensive Site Level 3 Probabilistic Risk Assessment .....	78
Fuel Cycle Oversight Process .....	6	Risk Assessment Standardization Project .....	81
Knowledge Management in the Office of Nuclear Regulatory Research .....	8	Probabilistic Risk Assessment Quality and Standards.....	83
<b>Chapter 2: Reactor Safety Codes and Analysis</b> .....	11	Reactor Operating Experience Data Collection and Analysis .....	85
Code Application and Maintenance Program (CAMP) .....	12	Accident Sequence Precursor Program.....	87
Thermal-Hydraulic Simulations of Operating Reactors .....	14	SPAR Model Development Program .....	89
TRAC/RELAP Advanced Computational Engine (TRACE) Thermal-Hydraulics Code.....	16	Thermal-Hydraulic Level 1 Probabilistic Risk Assessment Success Criteria .....	92
Symbolic Nuclear Analysis Package (SNAP) Computer Code Applications.....	19	Advancing Modeling Techniques in Level 2 and Level 3 Probabilistic Risk Assessment .....	94
Nuclear Analysis and the SCALE Code .....	21	Risk-Informing Emergency Preparedness - Probabilistic Risk Analysis of Emergency Action Levels .....	96
Fission Products Burnup Credit .....	22	Risk-Informing Security.....	97
High-Burnup Light-Water Reactor Fuel .....	24	Design-Basis Flood Determinations at Nuclear Power Plants.....	98
Spent Fuel Pool Criticality Analysis.....	26	Assessment of Debris Accumulation on Emergency Core Cooling System Suction Strainer Performance .....	99
<b>Chapter 3: Severe Accident Research and Consequence Analysis</b> .....	27	<b>Chapter 6: Human Factors and Reliability Research</b> .....	101
State-of-the-Art Reactor Consequence Analysis .....	28	Human Reliability Analysis Data Repository .....	102
Severe Accidents and the MELCOR Code .....	29	Human Reliability Analysis Model Differences.....	103
MELCOR Accident Consequence Code System and Its New Graphical User Interface: WinMACCS .....	32	Improving Human Reliability Analysis Methods by Using Simulator Runs .....	104
Melt Coolability and Concrete Interaction Follow-On Program .....	34	Pilot Testing of Human Reliability Analysis-Informed Training and Job Aid for NRC Staff Involved with Medical Applications of Byproduct Materials .....	106
Zirconium Fire Research .....	36	Qualitative Human Reliability Analysis for Spent Fuel Handling .....	107
Aerosol Trapping in a Steam Generator (ARTIST) .....	37	Human Performance for Advanced Control Room Design.....	108
Containment Analyses.....	39	Support for Implementation of 10 CFR Part 26 Fitness-for-Duty Programs .....	110
Containment Iodine Behavior .....	40	Safety Culture .....	112
Source Term Analysis.....	42	<b>Chapter 7: Fire Safety Research</b> .....	113
Phébus-Fission Products and Phébus-International Source Term Program.....	44	Fire Probabilistic Risk Assessment Methodology for Nuclear Power Facilities .....	114
Fission Product Release and Transport Modeling for High-Temperature Gas-Cooled Reactors.....	46	Fire Human Reliability Analysis Methods Development.....	116
Environmental Transport Research Program.....	48	Fire Modeling Activities .....	118
Integrated Ground Water Monitoring and Modeling .....	50	Cable Heat Release, Ignition and Spread in Tray Installations During Fire (CHRISTIFIRE).....	120
In Situ Bioremediation of Uranium in Ground Water .....	52	Direct Current Electrical Shorting in Response to Exposure Fire (DESIREEFIRE) .....	122
<b>Chapter 4: Health Effects</b> .....	55	Fire Effects on Electrical Cables and Impact on Nuclear Power Plant System Performance: Phenomena Identification and Ranking Table (PIRT) and Expert Elicitation Programs .....	124
Health Effects Program .....	56	Beyond-Design-Basis Fires for Spent Fuel Transportation: Shipping Cask Seal Performance Testing .....	125
Regulatory Basis for NRC Standards for Protection Against Ionizing Radiation .....	58		
Participation in National and International Radiation Protection Activities .....	60		
Radiation Exposure Information and Reporting System (REIRS) .....	63		

Training Programs for Fire Probabilistic Risk Assessment, Human Reliability Analysis, and Fire Modeling.....	126
Fire Research and Regulation Knowledge Management .....	128

**Chapter 8: Seismic and Structural Research** ..... 131

Advances in Seismic Hazard Assessment for the Central and Eastern United States.....	132
Tsunami Research Program .....	134
Seismic Isolation Technology Regulatory Research .....	135
Risk-Informed Assessment of Containment Degradation .....	137

**Chapter 9: Materials Performance Research** ..... 139

Extremely Low Probability of Rupture .....	140
Research to Support Regulatory Decisions Related to Second and Subsequent License Renewal Applications .....	142
Steam Generator Tube Integrity.....	144
Consequential Steam Generator Tube Rupture Program.....	146
Reactor Pressure Vessel Integrity.....	148
Environmentally Assisted Fatigue of Components Exposed to the Reactor Water Environment.....	149
Degradation of Reactor Vessel Internals from Neutron Irradiation.....	151
Primary Water Stress-Corrosion Cracking .....	153
Primary Water Stress-Corrosion Cracking Mitigation Evaluations and Weld Residual Stress Validation Programs.....	155
Nondestructive Examination .....	157
International Nondestructive Examination Round Robin Testing .....	159
Containment Liner Corrosion.....	161
Atmospheric Stress Corrosion Cracking of Dry Cask Storage Systems .....	163
High-Density Polyethylene Piping Research Program.....	165
Neutron Absorbers in Spent Fuel Pools .....	166

**Chapter 10: Digital Instrumentation and Control and Electrical Research**..... 167

Digital Instrumentation and Control .....	168
Digital Instrumentation and Control Probabilistic Risk Assessment .....	170
Analytical Assessment of Digital Instrumentation and Control Systems .....	172
Cyber Security for Digital Instrumentation and Control Systems .....	174
Susceptibility of Nuclear Stations to External Faults .....	176
Evaluation of Equipment Qualification Margins to Extend Service Life.....	177
Charging Current as an Indicator of a Fully Charged Battery .....	178

**Chapter 11: New and Advanced Reactor Research**... 179

Thermal-Hydraulic Analyses of New Reactors .....	180
Computational Fluid Dynamics in Regulatory Applications .....	182
Advanced Reactor Research Program.....	183
Next Generation Nuclear Plant .....	185
Materials Issues for High Temperature Gas-Cooled Reactors .....	187
Confirmatory Analysis Tool for Structural Integrity Evaluation of Creep and Creep-Fatigue Crack Growth in Next Generation Nuclear Plant Metallic Components.....	189

**Chapter 12: International Cooperative and Long-Term Research** ..... 191

Cooperative International Research Activities and Agreements .....	192
The Organization for Economic Cooperation and Development Halden Reactor Project .....	193
The Organization for Economic Cooperation and Development/Nuclear Energy Agency PKL2 Project .....	195
The Organization for Economic Cooperation and Development ROSA-2 Program .....	196
Studsvik Cladding Integrity Project.....	197
International Cooperative Research on Impact Testing.....	198
Round Robin Analysis of Containment Performance under Severe Accidents—Collaboration Between the U.S. Nuclear Regulatory Commission and the Atomic Energy Regulatory Board of India .....	200
Agency Forward-Looking and Long-Term Research .....	201

**Figures**

iv.1	RES FY 2010–FY 2011 projected expenditures .....	iv
iv.2	RES Focus Areas 2010–2011 .....	v
1.1	Time to complete the GI screening process .....	4
1.2	Breakdown of resolution products for GIs .....	5
1.3	The nuclear fuel cycle .....	6
1.4	Typical uranium enrichment facility, part of the nuclear fuel cycle .....	6
1.5	Typical fuel fabrication facility, part of the nuclear fuel cycle ..	7
1.6	Photo from the 2010 KM Fair .....	8
1.7	Governor Dick Thornburgh (PA) at an RES seminar on the accident at TMI in 1979 .....	9
2.1	TRACE, an advanced, best-estimate reactor system code used to model the T/H performance of nuclear power plants. ....	14
2.2	Steady-state conditions in a BWR (SNAP animation) .....	15
2.3	Key primary coolant T/H components, including reactor vessel pumps, and steam generator, for a two-loop PWR depicted with SNAP .....	15
2.4	Simplified plant model nodalization .....	16
2.5	TRACE architecture .....	17
2.6	Creating input models using SNAP .....	19
2.7	Animating analysis results using SNAP .....	19
2.8	Plotting analysis results using SNAP .....	20
2.9	Updated model editor display capabilities .....	20
2.10	Coupled reactor and fuel cycle nuclear analyses .....	21
2.11	NRC nuclear analysis codes for reactor physics .....	21
2.12	Comparison of typical reactivity decrements associated with actinides only and with a combination of actinides and fission products .....	22
2.13	The acceptable loading inventory for a generic burnup credit rail cask design with 32 PWR assemblies, enhanced from 30% of the PWR SNF inventory to almost 90% of the inventory if credit for fission products can be obtained in the safety evaluation .....	23
2.14	Increasing the inventory that can be put in high-capacity burnup credit casks to enable at least 625 fewer shipments and provide a savings of about \$156M .....	23
2.15	Integral LOCA test equipment operating at 1,200 °C, at Studsvik laboratory in Sweden, where tests will be conducted on high-burnup, irradiated fuel rods .....	25

2.16	Metallographic images of irradiated cladding material showing hydride precipitates (a) with $\sim 318 \pm 30$ wppm, predominantly oriented in the cladding circumferential direction; (b) with $425 \pm 77$ wppm, oriented in both the radial and circumferential directions. . . . .	25	4.16	Diagram of iridium-192 wire . . . . .	66
2.17	Commercial spent fuel pool . . . . .	26	4.17	Locations of operating nuclear power facilities . . . . .	67
3.1	Iodine release for unmitigated cases . . . . .	28	4.18	Radiological Toolbox . . . . .	68
3.2	MELCOR modeling capabilities . . . . .	29	4.19	Radiological Toolbox graphical user interface . . . . .	69
3.3	MELCOR plant modeling approach . . . . .	29	4.20	Mathematical-based human phantom with articulating arms and legs . . . . .	70
3.4	EPR simulation model . . . . .	30	4.21	Voxel-based phantom with articulating arms and legs. . . . .	70
3.5	ABWR core heatup and degradation . . . . .	30	4.22	Geometrical setting for patient-physician modeling with a realistic postures (right) using PIMAL . . . . .	70
3.6	EPR user interface model. . . . .	31	4.23	Point source geometry screen . . . . .	72
3.7	Graphical view of WinMACCS (network evacuation model is shown) . . . . .	32	4.24	Enhanced gemstones . . . . .	74
3.8	SSWICS test stand. . . . .	34	4.25	Rhodotron high-energy electron beam accelerator . . . . .	74
3.9	osttest debris from CCI tests . . . . .	35	4.26	Diagram of electron beam accelerator and batch of natural clear topaz . . . . .	75
3.10	Single fuel assembly for Phase 1 testing in construction stage with a closeup view of an installed thermocouple . . . . .	36	5.1	Factors affecting the scope of PRAs for operating nuclear power plants. . . . .	78
3.11	ARTIST facility . . . . .	37	5.2	Three sequential levels of risk analysis in PRAs for nuclear power plants. . . . .	79
3.12	Sample of results obtained from ARTIST-II. . . . .	38	5.3	Site accident risk and approximate scope of NUREG-1150 . . . . .	80
3.13	ESBWR long-term containment cooling . . . . .	39	5.4	Relationship of regulations, RGs, and standards for risk-informed activities . . . . .	84
3.14	Hypothesized mechanism for gaseous iodine source in the Phébus-FP tests . . . . .	40	5.5	Source and uses of operational data and analyses in NRC regulatory programs . . . . .	86
3.15	BIP irradiation vessel with sample coupons . . . . .	41	5.6	Occurrence rate of all precursors . . . . .	88
3.16	EPICUR experimental setup (one of the experiments under the Phébus-ISTP program). . . . .	41	5.7	Occurrence rate of precursors with high safety significance . . . . .	88
3.17	Use of source term and relation to other factors in dose calculations . . . . .	42	5.8	Example of SDP analysis results with SAPHIRE Version 8. . . . .	90
3.18	Phébus reactor and the test loop (top view) . . . . .	44	5.9	Example of LOOP SPAR model event tree display with SAPHIRE Version 8. . . . .	91
3.19	VERDON 2-cell FP release experimental facility (one of the experimental facilities constructed under the Phébus-ISTP program). . . . .	45	5.10	A definition of Level 1 probabilistic risk assessment success criteria . . . . .	92
3.20	TRISO fuel particle. . . . .	46	5.11	High-level overview of success criteria process . . . . .	93
3.21	Cesium concentration profile . . . . .	47	5.12	The three levels of PRA . . . . .	94
3.22	Cesium release fraction. . . . .	47	5.13	The spectrum of approach classes . . . . .	94
3.23	Conceptual visualization of contaminant pathways . . . . .	48	5.14	Sample high-level code coupling scheme . . . . .	95
3.24	Flow chart of the integrated monitoring strategy . . . . .	50	6.1	Diagram illustrating the concept of using empirical data to inform the human error probabilities of human failure events . . . . .	102
3.25	Illustration of a conceptual model of a complex field site and complex sources for which monitoring can facilitate decisionmaking for remediation. . . . .	51	6.2	One conceptualization of an advanced control room design. . . . .	108
3.26	Microbial mediation of Fe(III) reduction . . . . .	52	7.1	Simplified fire PRA event tree representing different sets of fire damage and plant response. . . . .	114
4.1	Formation of a regulation. . . . .	56	7.2	Operators in a NPP control room . . . . .	116
4.2	Enhanced gemstones . . . . .	57	7.3	NUREG-1921 cover page . . . . .	117
4.3	Planned exposure situations . . . . .	58	7.4	Measured vs. predicted hot gas layer temperature rise. . . . .	118
4.4	Biokinetic model . . . . .	59	7.5	Graphical output from FDS/Smokeview fire model . . . . .	119
4.5	Biokientic Model . . . . .	60	7.6	Pyrolysis combustion flow calorimeter . . . . .	120
4.6	Background radiation exposure from NRC Report No. 160 . . . . .	60	7.7	ISO/TS 1970 tube furnace. . . . .	120
4.7	Occupational radiation exposure workers. . . . .	61	7.8	Cone calorimeter . . . . .	121
4.8	Russian whole-body counting facility. . . . .	61	7.9	Radiant panel cable tray fire test. . . . .	121
4.9	Map of Mayak Facility in Russia. . . . .	62	7.10	Burning cables during cable tray fire test . . . . .	121
4.10	Sample data from REIRS database . . . . .	63	7.11	Cables in tray . . . . .	121
4.11	Process for submitting licensee exposure reports. . . . .	64	7.12	Direct current electrical cable hot short . . . . .	122
4.12	Event assessment for AOs. . . . .	65	7.13	Intermediate-scale dc fire tests . . . . .	123
4.13	Gamma stereotactic radiosurgery unit (gamma knife). . . . .	66	7.14	Battery bank for dc fire tests . . . . .	123
4.14	Diagram of the cranial nerves. . . . .	66	7.15	A typical PIRT panel discussion. . . . .	124
4.15	High-dose rate prostate brachytherapy . . . . .	66	7.16	Pictures of the small-scale test vessel after 800°C exposure for 9 hours . . . . .	125

7.17	Photo from the 2008 NRC-RES/EPRI fire PRA workshop .	126	9.22	Schematic showing a cross-section of a reinforced concrete containment structure with embedded foreign material from original construction and corrosion penetration of the steel containment liner .	162
7.18	NUREG/CP-0194, Volume 1 of 3, cover page .	127	9.23	ISFSI locations .	163
7.19	Screenshot of “The Browns Ferry Nuclear Plant (BFN) Fire of 1975 and the History of NRC Fire Regulations” (DVD main menu) .	128	9.24	Dry storage system designs .	163
8.1	Current projects supporting seismic hazard assessment .	132	9.25	Cross-section of a Type 304 U-bend specimen showing intergranular cracks after testing for 16 weeks at 40 °C (104 °F) .	164
8.2	Example source zones from the CEUS SSC for nuclear facilities project .	133	9.26	Corrosion and biofouling of carbon steel service water system piping .	165
8.3	Computed maximum tsunami wave amplitude in the Atlantic Basin generated by a Mw 8.8 scenario earthquake in the Caribbean source zone .	134	9.27	Installation of underground Class 3 safety-related HDPE piping .	165
8.4	Schematic figures showing typical design of a seismically isolated structural system (above) and a typical rubber-bearing style isolator (below) .	135	9.28	Blistering on the aluminum cladding of Boral neutron absorber .	166
8.5	Example of reinforced concrete containment leak paths for postulated corrosion degradation (NUREG/CR-6920) .	137	9.29	Degradation of the composite matrix in Boraflex neutron absorber .	166
9.1	xLPR organizational development structure .	140	10.1	Highly integrated control room .	168
9.2	Pressurizer surge nozzle illustration .	141	10.2	Condensed Markov state transition model for quantifying DFWCS failure frequency from hardware failures .	170
9.3	Years of commercial operation (2010) .	142	10.3	Integrating different types of evidence to demonstrate that a system is safe .	173
9.4	Recirculating steam generator tube bundle .	144	10.4	Graphic of United States showing infrastructure of various utilities .	174
9.5	Tube integrity research schematic .	144	10.5	NRC staff reviewing the first set of batteries that the contractor has received before commencing confirmatory battery testing .	178
9.6	Fatigue S–N behavior for carbon steel .	149	11.1	AP1000 .	180
9.7	Cracking of a baffle bolt in a PWR .	151	11.2	U.S. APWR .	180
9.8	PWSCC cracks in the Alloy 182 J-groove weld in North Anna-2 Nozzle 31. .	153	11.3	EPR .	180
9.9	Photograph showing extensive boric acid corrosion in the low-alloy steel Davis-Besse reactor pressure vessel head. Reactor coolant leaked from PWSCC cracks in the Alloy 600 control rod drive mechanism nozzle and the nozzle J-groove weld .	153	11.4	ESBWR .	181
9.10	Cutaway view of a carbon steel nozzle DM weld and stainless steel piping typical in a light water cooled nuclear power plant .	155	11.5	ABWR .	181
9.11	Cross section of nozzle to pipe weld highlighting weld bead pattern .	155	11.6	IPWR .	181
9.12	Stress magnitude distribution in a nozzle to pipe weld configuration .	156	11.7	Temperature contours of a ventilated dry cask that uses ambient air to passively cool the spent fuel stored inside the canister surrounded by a concrete overpack .	182
9.13	Pressurizer surge nozzle DM weld mockup being measured for WRS .	156	11.8	During a particular severe accident scenario, hot gases from the core circulate through the hot legs and steam generator in a counter-current flow pattern. The risk of induced failures is considered .	182
9.14	Sectioning of reactor vessel head penetrations from WNP-1, a cancelled plant .	157	11.9	The advanced accumulator (b) is a water storage tank with a flow damper in it that switches the flow rate of cooling water injected into a reactor vessel from a large (a) to small (c) flow rate .	182
9.15	Nondestructive and destructive examination of salvaged CRDM penetrations and J-groove welds from North Anna, Unit 2 .	157	11.10	Schematic of NRC HTGR accident analysis evaluation model concept .	183
9.16	Sample illustrating the coarse grain microstructure of centrifugally cast stainless steel .	157	11.11	Artist’s rendition of an NGNP plant .	185
9.17	Schematic view of flaw detection at the far side of a weld, using a phased array ultrasonic (PA-UT) technique. PA-UT improves flaw detection in coarse-grained metals and welds .	158	11.12	TRISO fuel for NGNP .	185
9.18	Organization of PINC .	159	11.13	Influence of material behavior, inspection, flaw evaluation, and component integrity assessment on risk assessment .	187
9.19	Test Block 2.10 from Swedish Radiation Safety Authority Qualification Center .	159	11.14	Roadmap for development of a confirmatory analysis tool for creep and creep-fatigue flaw evaluation of the NGNP metallic components .	190
9.20	Information technology tool—PINC Atlas .	160	12.1	HBWR test reactor .	194
9.21	Photograph of the through-wall corrosion detected at Beaver Valley, 2009. A piece of wood embedded in the concrete during original construction was found behind the corroded area of the steel containment liner. The area was identified by a large paint blister which was filled with steel corrosion products .	161	12.2	HAMMLAB control room simulator .	194
			12.3	TRACE nodalization and schematic of PKL facility .	195
			12.4	Size comparison of ROSA/LSTF to a four-loop PWR .	196
			12.5	LSTF primary system TRACE model used for 17% intermediate hot-leg break .	196

---

12.6	FRAPCON-3.4 predicted minus measured permanent hoop strain as a function of burnup, indicating an underprediction at high burnups. . . . .	198
12.7	Hard missile impact on reinforced concrete slab: (a) impact face and (b) back face (VTT) . . . . .	199
12.8	Soft missile impact on reinforced concrete slab (VTT) . . . . .	199
12.9	Displacement contours for simulated missile impact on vertical wall. . . . .	200
12.10	Completed prestressed concrete containment vessel ¼-scale model at SNL. . . . .	201





---

# Abbreviations And Acronyms

## Numerals

$\Delta$ CDP	change in core damage probability
4S	Toshiba Super Safe, Small and Simple reactor

## A

ABAQUS	Suite of software applications for finite element analysis and computer-aided engineering
ABWR	advanced boiling-water reactor
ac	alternating current
ACRS	Advisory Committee on Reactor Safeguards
ADAMS	Agencywide Documents Access and Management System (NRC)
AEA	Atomic Energy Act
AEC	U.S. Atomic Energy Commission
AECL	Atomic Energy of Canada Ltd.
AERB	Atomic Energy Regulatory Board (India)
AES	Advanced Environmental Solutions, LLC
ALARA	as low as reasonably achievable
AMP	aging management program
AMPX	Advanced Module for Processing Cross Sections
ANL	Argonne National Laboratory
ANS	American Nuclear Society
AO	abnormal occurrence
AP1000	Advanced Passive 1000 Megawatt
APEX	Advanced Power Extraction
API	application programming interface
APWR	U.S. Advanced Pressurized Water Reactor (Mitsubishi)
ARRP	Advanced Reactor Research Program
ARTIST	Aerosol Trapping In Steam generator
ASCI	American Standard Code for Information Interchange
ASEP	Accident Sequence Evaluation Program
ASME	American Society of Mechanical Engineers
ASME S&T LLC	Limited Liability Company
ASP	accident sequence precursor
ASTM	American Society for Testing and Materials
ATHEANA	A Technique for Human Event Analysis
ATWS	anticipated transient without scram

## B

BADGER	Boron-10 Areal Density Gauge for Evaluating Racks
BAM	German Federal Institute for Materials Research and Testing

BETHSY	loop for the study of thermal-hydraulic system
BFBT	BWR full-size fine-mesh bundle test
BFN	Browns Ferry Nuclear
BIP	Behavior of Iodine Project (CSNI)
BNL	Brookhaven National Laboratory
BRIIE	Baseline Risk Index for Initiating Events
BWR	boiling-water reactor

## C

C	Celsius
C-SGTR	consequential steam generator tube rupture
Cal/g	calorie per gram
CAMP	Code Application and Maintenance Program
CAROLFIRE	Cable Response to Live Fire
CBDT	cause-based decision tree
CCDP	conditional core damage probability
CCF	common-cause failure
CCI	core-concrete interaction
CDA	critical digital asset
CDF	core damage frequency
CE	Combustion Engineering
CEUS	Central and Eastern United States
CEUS SSC	Central and Eastern United States Seismic Source Characterization
CFAST	Consolidated Fire Growth and Smoke Transport Model
CFD	computational fluid dynamics
CFR	Code of Federal Regulations
CHRISTI-FIRE	Cable Heat Release, Ignition, and Spread in Tray Installations during Fire
COL	combined license
CONOPS	concepts of operations
CONTAIN	Containment Analysis Code
CP	computerized procedure
CPLD	complex programmable logic device
CR	control room
CRAC	Calculation of Reactor Accident Consequences
CRDM	control rod drive mechanism
CRPPH	International Commission on Radiation Protection
CRT	crew response tree
CRUD	Chalk River Unidentified Deposit
CSARP	Cooperative Severe Accident Research Program (NRC)
CSAU	Code Scaling, Applicability, and Uncertainty
CSM	conceptual site model
CSNI	Committee on the Safety of Nuclear Installations
CTP	crack-tip parameter





HEP	human error probability	IST	Integrated System Test
HERA	Human Event Repository and Analysis	ISTP	International Source Term Program
HF	human factors	IT	information technology
HFE	human factors engineering	ITP	Industry Trends Program
HFE	human failure event		
HGL	hot gas layer	<b>J</b>	
HHA	hierarchical hazard assessment	JAEA	Japanese Atomic Energy Agency
HMR	hydrometeorology report	JAERI	Japan Atomic Energy Research Institute
HPP	human performance profile	JCCRER	Joint Coordinating Committee for Radiation Effects Research
HQ	headquarters		
HRA	human reliability analysis	<b>K</b>	
HRP	Halden Reactor Project	KM	knowledge management
HRR	heat release rate		
HRRPUA	heat release rate per unit area	<b>L</b>	
HSI	human-system interface	LANL	Los Alamos National Laboratory
HTGR	high-temperature gas-cooled reactor	LAR	licensee amendment request
		LBB	leak before break
<b>I</b>		LER	licensee event report
IA		LERF	large early release frequency
IAEA	International Atomic Energy Agency	LLW	low-level waste
IASCC	irradiation-assisted stress-corrosion cracking	LOCA	loss-of-coolant accident
I&C	instrumentation and control	LOFW	loss of feedwater
ICAP	International Code Assessment and Application Program	LOOP	loss of offsite power
ICRP	International Commission on Radiological Protection	LPSD	low-power/shutdown
IEEE	Institute of Electrical and Electronics Engineers	LRA	license renewal application
IFE	Institut for Energiteknikk	LSTF	large-scale test facility
IFRAM	International Forum for Reactor Aging Management	LWR	light-water reactor
		<b>M</b>	
IHX	Intermediate Heat Exchanger	MACCS	MELCOR Accident Consequence Code System
INL	Idaho National Laboratory	MAG	modeling application guide
IPEEE	individual plant examination of external events	MAGIC	fire modeling tool
IPWR	Integral Pressurized Water Reactor	MARIAFIRES	Methods for Applying Risk Analysis to Fire Scenarios
IRIS	International Reactor Innovative and Secure Light Water Reactor (Westinghouse)	MARSAME	Multi-Agency Radiation Survey and Assessment of Materials and Equipment Manual
IROFS	items relied on for safety	MARSSIM	Multi-Agency Radiological Survey and Site Investigation Manual
IRSN	Institut de Radioprotection et de Sûreté Nucléaire (French Institute for Radiological Protection and Nuclear Safety)	MASLWR	Multi-Application Light Water Reactor
ISA	integrated safety analysis	MATLAB	MATrix LABoratory
ISEMIR	Information System on Occupational Exposure in Medicine, Industry, and Research	MCAP	MELCOR Code Assessment Program
ISFSI	independent spent fuel storage installation	MCCI	Melt Coolability and Concrete Interaction
ISG	interim staff guidance	MCNP	Monte Carlo N-Particle Transport Code
ISI	inservice inspection	MD	monitoring device
ISL	in situ leach	MD	management directive
ISOE	Information System on Occupational Exposure	MELCOR	computer code for analyzing severe accidents in NPPs

MgO	magnesium oxide
MIC	microbiologically induced corrosion
MIRD	medical internal radiation dose
MOR	monthly operating report
MOST	Method of Splitting Tsunami
MOU	memorandum of understanding
MOX	mixed oxide
MOX FFF	Mixed Oxide Fuel Fabrication Facility
MP	monitoring point
MRP	Materials Reliability Project
MSIP	Mechanical Stress Improvement Process
MSLB	main steamline break
MSPI	Mitigating Systems Performance Index
MTO	Man-Technology-Organization
MW	megawatt

## N

NAS	U.S. National Academy of Sciences
NCI	U.S. National Cancer Institute
NCRP	National Council of Radiation Protection and Measurements
NDE	nondestructive examination
NEA	Nuclear Energy Agency
NEI	Nuclear Energy Institute
NERC	North American Electric Reliability Corporation
NFPA	National Fire Protection Association
NGA	next generation attenuation
NGNP	Next Generation Nuclear Plant
NGO	Non-Governmental Organization
NIST	National Institute of Standards and Technology
NMSS	Office of Nuclear Material Safety and Safeguards
NOAA	National Oceanic and Atmospheric Administration (U.S. Department of Commerce)
NPP	nuclear power plant
NPP FIRE MAG	Nuclear Power Plant Fire Modeling Application Guide
NRC	U.S. Nuclear Regulatory Commission
NRO	Office of New Reactors
NRR	Office of Nuclear Reactor Regulation
NSIR	Office of Nuclear Security and Incident Response
NUPEC	Nuclear Power Engineering Corporation (Japan)
NUREG	NRC technical report designation
NUREG/CR	NRC technical report designation/contractor report
NUREG/IA	NRC technical report designation/international agreement
NWS	National Weather Service

## O

OECD	Organization for Economic Cooperation and Development
OIG	Office of the Inspector General
ORNL	Oak Ridge National Laboratory

## P

PA	performance assessment
PARENT	Program to Assess Reliability of Emerging Non-destructive Techniques
PANDA	Passive Non-Destructive Assay of Nuclear Materials
PARCS	Purdue's Advanced Reactor Core Simulator
PA-UT	phased array ultrasonic
PBMR	pebble bed modular reactor
PBP	paper-based procedure
PBPM	planning, budgeting, and management (process)
PBR	pebble bed reactor
PCCV	Prestressed Concrete Containment Vessel
PCFC	pyrolysis combustion flow calorimeter
PEER	Pacific Earthquake Engineerin Research (Center)
PFM	probabilistic fracture mechanics
Phébus-FP	Phébus-Fission Products
Phébus-ISTP	Phébus-International Source Term Program
PI	performance indicator
PIMAL	phantom with moving arms and legs
PINC	Program for the Inspection of Nickel-Alloy Components
PIRT	Phenomena Identification and Ranking Table
PKL	Primärkreislauf-Versuchsanlage (German for primary coolant loop test facility)
PM	project manager
PMDA	Proactive Materials Degradation Assessment
PMMD	Proactive Management of Materials Degradation
PMP	probable maximum precipitation
PMR	prismatic modular reactor
PNNL	Pacific Northwest National Laboratory
POS	plant operating state
PPS	Package Performance Study
PRA	probabilistic risk assessment or probabilistic risk analysis
PSA8	Probabilistic Safety Conference 2008
PSHA	probabilistic seismic hazard assessment
PSI	Paul Scherrer Institut
PTS	pressurized thermal shock
PUMA	Purdue University Multi-Dimensional Integral Test Assembly
PWR	pressurized-water reactor

PWSCC	primary water stress-corrosion cracking	SECY	Office of the Secretary
<b>Q</b>		SERF	small early release frequency
QA	quality assurance	SFR	sodium-cooled fast reactor
QHO	quantitative health objective	SFP	spent fuel pool
<b>R</b>		SG	steam generator
RACKLIFE	software calculation package used for mapping of degradation	SGAP	Steam Generator Action Plan
RADS	Reliability and Availability Data System	SGTR	steam generator tube rupture
RADTRAD	Radionuclide Transport, Removal, and Dose code	SKC	susceptibility, knowledge, and confidence
RAMONA		SI Units	International System of Units (abbreviated SI from the French <i>Le Systeme International</i> )
RASP	Risk Assessment Standardization Project	SMAW	shielded metal arc welding
RCC-MR	French Code	SNAP	Symbolic Nuclear Analysis Package
RCS	reactor coolant system	SNF	spent nuclear fuel
R&D	research and development	SNFT	spent nuclear fuel transportation
REIRS	Radiation Exposure Information and Reporting System	SNL	Sandia National Laboratories
RELAP5	Reactor Excursion and Leak Analysis Program	SOARCA	State-of-the-Art Reactor Consequence Analysis
REMIX	Regional Mixing Model	SPAR	Standardized Plant Analysis Risk
RES	Office of Nuclear Regulatory Research	SPAR-H	Standardized Plant Analysis Risk—Human Reliability Analysis Method
RG	regulatory guide	SPE	standard problem exercise
RIC	Regulatory Information Conference	SRM	staff requirements memorandum
RIDM	risk-informed decisionmaking	SRP	Standard Review Plan
RIM	Reliability and Integrity Management	SS	stainless steel
RIS	regulatory issue summary	SSC	structure, system, and component
RMIEP	Risk Methods Integration and Evaluation Program	SSHAC	Senior Seismic Hazard Analysis Committee
ROE	red oil excursion	SSU	safety system unavailability
ROP	Reactor Oversight Process	SSWICS	small-scale water ingress and crust strength
ROSA	Rig of Safety Assessment	STAR	computer code used for CFD
RPV	reactor pressure vessel	STCP	Source Term Code Package
RSICC	Radiation Safety Information Computational Center	STSET	Source Term Separate Effects Test Project
RuO <sub>4</sub>	ruthenium tetroxide	S/U	sensitivity/uncertainty
RV	reactor vessel	<b>T</b>	
<b>S</b>		T/H	thermal-hydraulic
SAIC	Science Applications International Corporation	TEPCO	Tokyo Electric Power Company
SAPHIRE	Systems Analysis Programs for Hands-on Integrated Reliability Evaluation	THERP	Technique for Human Error Rate Prediction
SBO	station blackout	THIEF	Thermally-Induced Electrical Failure
SCALE	Standardized Computer Analyses for Licensing Evaluations	TMI	Three Mile Island (Nuclear Power Plant)
SCIP	Studsвик Cladding Integrity Project	TRAC	Transient Reactor Analysis Code
SCC	stress-corrosion cracking	TRACE	TRAC/RELAP Advanced Computational Engine
SDP	Significance Determination Process	TRISO	Tristructural-Isotropic
SEASET	Separate Effects and Systems Effects Tests	TWG	task working group
		<b>U</b>	
		U	uranium
		UO <sub>2</sub>	uranium dioxide
		U.S. APWR	U.S. Advanced Pressurized-Water Reactor (Mitsubishi)

---

USEGC U.S. east and gulf coasts

USGS U.S. Geological Survey

## **V**

V&V verification and validation

VARSKIN code used to model and calculate skin dose

VEGA Verification Experiments of radionuclides Gas/  
Aerosol release

VERCORS French test program

VHTR very-high-temperature gas-cooled reactor

VTT Technical Research Center of Finland

## **W**

WEP wired equivalent privacy

WGRisk OECD/NEA/CSNI Working Group on Risk

WIR waste-incident-to-reprocessing

wppm weight parts per million

WRS Weld Residual Stresses

## **X**

xLPR extremely low probability of rupture

## **Z**

ZIRLO fuel rod cladding material





---

# Chapter 1: Regulatory Support

Regulatory Guides

Consensus Codes and Standards

Generic Issues Program

Fuel Cycle Oversight Process

Knowledge Management in the  
Office of Nuclear Regulatory Research

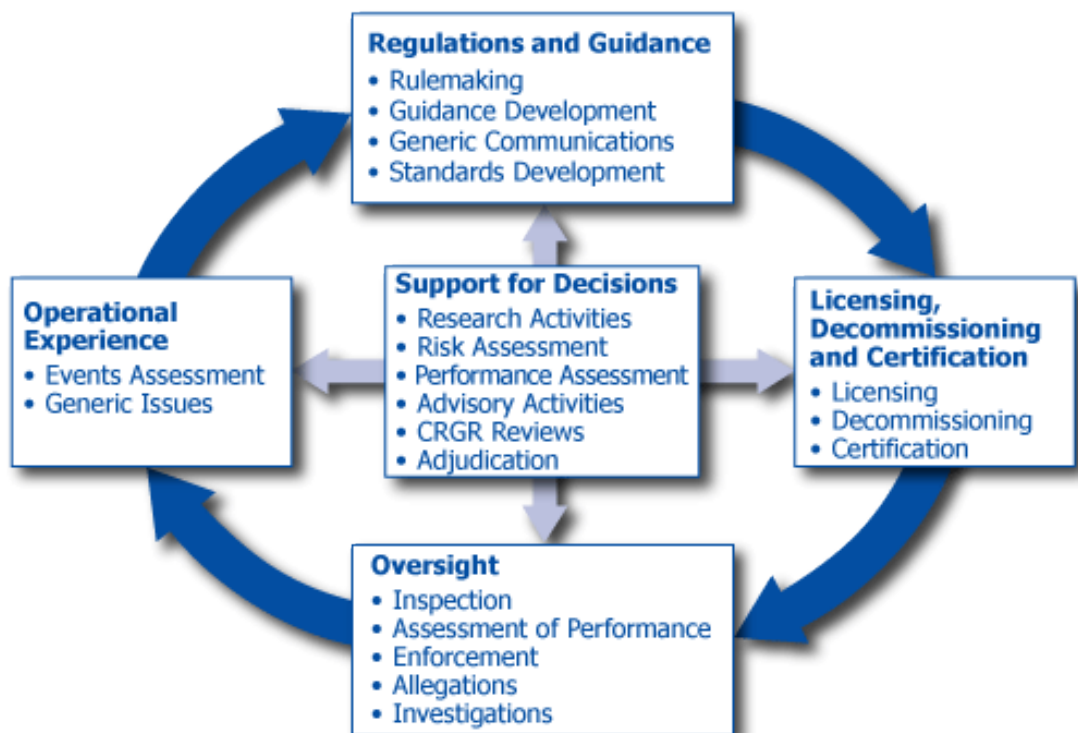

---

# Regulatory Guides

## Scope

The U.S. Nuclear Regulatory Commission (NRC) issues regulatory guides for public use to present approaches that the staff considers acceptable in implementing the agency's regulations.

The regulatory guides are grouped into 10 broad divisions to facilitate access to the information:

- Division 1—Power Reactors
- Division 2—Research and Test Reactors
- Division 3—Fuels and Materials Facilities
- Division 4—Environmental and Siting
- Division 5—Materials and Plant Protection
- Division 6—Products
- Division 7—Transportation
- Division 8—Occupational Health
- Division 9—Antitrust and Financial Review
- Division 10—General

## Development Process

The NRC staff develops regulatory guides with input from external stakeholders and updates them to incorporate new staff technical positions, revised industry standards, and lessons learned from practical experience. The NRC initially issues each regulatory guide as a draft guide for public comment for a specific period of time before its publication as a final guide. The NRC Web site at <http://www.nrc.gov/reading-rm/doc-collections/reg-guides/> lists the agency's regulatory guides. Draft guides that are available for public comment can be accessed by following the links from this Web page.

The staff reviews and addresses public comments and changes the draft guide as necessary. The NRC's Advisory Committee on Reactor Safeguards receives copies of proposed regulatory guides and may choose to discuss them before and after the public comment period.

Comments and suggestions are encouraged in connection with improvements to published regulatory guides and the development of new guides. The NRC staff revises existing guides, as appropriate, to accommodate comments and to reflect new information or experience.

## Application

The NRC staff uses regulatory guides in its review of applications, while the nuclear industry uses them to understand the staff's expectations. Regulatory guides are not substitutes for regulations, and compliance with them is not required. Licensees may present alternative methods and solutions that differ from those set forth in regulatory guides. The staff will evaluate alternative methods and solutions and accept those that provide a basis for the staff's determinations of adequate safety and security.

### **For More Information**

Contact John Ridgely, RES/DE, at 301-251-7458 or [John.Ridgely@nrc.gov](mailto:John.Ridgely@nrc.gov)



---

# Consensus Codes and Standards

## Background

The Nuclear Regulatory Commission (NRC) cooperates with professional organizations that develop consensus standards associated with systems, structures, equipment, or materials used by the nuclear industry. A standard contains technical requirements, safety requirements, guidelines, characteristics, and recommended practices for performance. The consensus standards process is based on openness, balance of interests, due process with written records, and consensus—more than a majority but not necessarily unanimity. Codes are standards or groups of standards that have been incorporated by reference into the regulations of one or more governmental bodies and have the force of law.

For example, the American Society of Mechanical Engineers (ASME) developed the Boiler and Pressure Vessel Code, which is widely acknowledged as an acceptable set of standards used to design, construct, and inspect pressure-retaining components, including nuclear vessels, piping, pumps, and valves. Similarly, the National Fire Protection Association (NFPA) has developed a series of consensus standards to define acceptable methods to design, install, inspect, and maintain fire protection systems. The NRC has incorporated into its regulations both the ASME Boiler and Pressure Vessel Code and a key NFPA standard, with some limitations.

## Objective

The objective of this program is to optimize the NRC's development and use of consensus codes and standards as part of its regulatory framework and in voluntary compliance with Public Law 104-113, the "National Technology Transfer and Advancement Act of 1995."

## Approach

The NRC's use of consensus standards is consistent with the requirements of this Act in the Office of Management and Budget's Circular A-119, "Federal Agency Participation in the Development and Use of Voluntary Consensus Standards and in Conformity Assessment Activities." Participation of the NRC staff in consensus standards development is essential, because the codes and standards are an integral part of the agency's regulatory framework. The benefits of this active involvement include cost savings, improved efficiency and transparency, and regulatory requirements of high technical quality. The agency acknowledges

the broad range of technical expertise and experience of the individuals who belong to the many consensus standards organizations. Thus, participation in standards development minimizes the expenditure of NRC resources that would otherwise be necessary to provide guidance with the technical depth and level of detail of consensus standards.

In 2009, over 180 NRC staff members participated in over 300 standards activities, such as membership on a standards-writing committee. The organizations governing these committees include ASME, NFPA, the Institute of Electrical and Electronics Engineers, the American Concrete Institute, and many others.

In addition to regulations that incorporate consensus standards, the NRC staff issues guidance on acceptable methods for complying with its regulations, such as regulatory guides. These guidance documents frequently reference consensus standards as acceptable methods for compliance with NRC regulations. A principal reason for using standards is to provide the regulatory stability and predictability desired by stakeholders.

Most codes and standards evolve over time, through a process that includes the development of new standards and the revision of existing ones. For example, work is underway with standards-developing organizations to update voluntary consensus standards that may be applied to license renewal or new nuclear plant construction, including advanced reactor technologies.

In 2009, in cooperation with other Federal agencies, the NRC helped establish a new information exchange forum called the Nuclear Energy Standards Coordinating Cooperative. The group is open to all stakeholders in the development and application of standards related to nuclear energy technology, including operating and proposed new power plants. Its goals are to identify standards needs, prioritize standards for development or revision, and initiate or support collaboration in writing standards.

The NRC staff is also evaluating international standards, such as documents published by the International Standards Organization and the International Electrotechnical Commission, as well as guidance issued by the International Atomic Energy Agency. Where applicable, these documents are referenced for information or guidance. The NRC staff is exploring the possibility of future endorsement of international standards within the agency's regulatory framework.

### For more information

Contact Carol E. Moyer, RES/DE, at 301-251-7641 or [carol.moyer@nrc.gov](mailto:carol.moyer@nrc.gov)

# Generic Issues Program

## Background

The Generic Issues Program (GIP) addresses those issues that have significant generic implications for risk or security and that cannot be more effectively handled by other regulatory programs and processes. The NRC staff developed GIP in response to Commission and Congressional directives in 1976 and 1977, respectively. The program included identifying GIs, assigning priorities, developing detailed action plans, projecting costs, providing continuous high-level management oversight of progress, and disseminating information to the public related to the issues as they progressed. The program has identified more than 850 GIs to date, resulting in a variety of regulatory products.

## Approach

Various reports, office letters, Commission papers, and Management Directive (MD) 6.4, “Generic Issues Program,” revised in November 2009, describe the process used to resolve the issues. Since 1999, the guidance in MD 6.4 has provided a consistent framework for handling, tracking, and defining the minimum documentation associated with processing GIs. Different stages of the program are defined by this procedure. However, because of the varying technical disciplines and levels of difficulty, flexibility is built into the program.

As explained in MD 6.4, the GIP process consists of five stages: (1) identification, (2) acceptance review, (3) screening, (4) safety or risk assessment, and (5) regulatory assessment. The GIP staff members apply a graded approach (i.e., as an issue proceeds through the program, it is analyzed with more rigor, and more resources are devoted to it). Similarly, issues with greater safety significance receive more resources and priority than less significant issues.

## Recent Improvements in the GIP Process

An interoffice working group proposed improvements to the GIP in SECY-07-0022, “Status Report on Proposed Improvements to the Generic Issues Program,” dated January 30, 2007, to ensure comprehensive and timely resolution of future GIs. These changes have significantly improved the timeliness and effectiveness of the program. Recent performance (since January 2007) indicates the success of these changes. As an example of these improvements, Figure 1.1 shows the time needed to complete the screening process for issues identified at two different periods.

## GIP Products

GIP has contributed significantly to the NRC’s mission; because of the diverse nature of topics that have become GIs, the NRC has developed a variety of products to resolve them.

GIs that have not failed any of the screening criteria or historically were prioritized with significant rankings could lead to a regulatory product. About 300 issues reached the resolution stage and could have resulted in a regulatory product. These products are divided into four broad categories: (1) new policies and rules, (2) generic communications, (3) regulatory guidance, and (4) no direct requirement but with associated actions that allowed their resolution. In addition, the NRC resolved a portion of the issues with no requirements. Figure 1.2 shows a breakdown of resolution products for GIs processed under GIP from 1983 to 2009.

Approximately two-thirds of the issues prioritized from 1983 to 1999 or screened after 1999 were not pursued further for resolution. These issues were either integrated with other issues, their safety concerns were addressed by other issues, or their prospect of safety improvements was not substantial and worthwhile. Although a large number of issues did not need to be pursued to the resolution stage and, consequently, their disposition did not result in a formal regulatory product, completing the prioritization or screening stages provided an in-depth insight as to their risk and safety significance. Figure 1.2 does not include these issues because the NRC did not pursue them to the resolution stage.

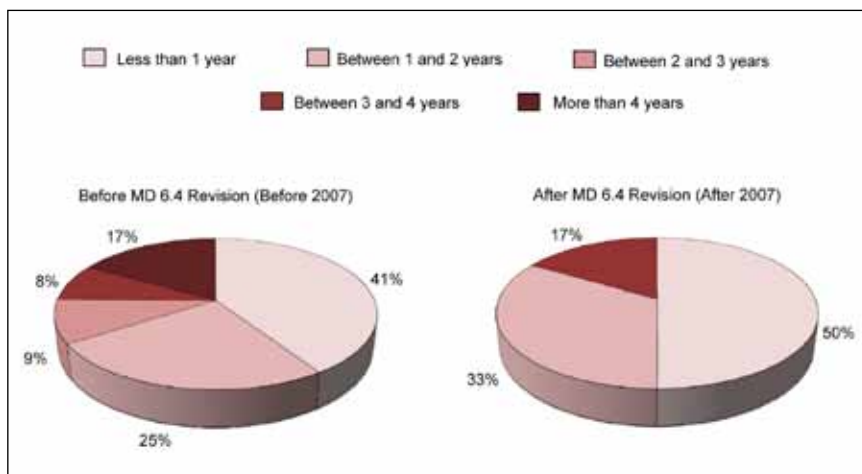

Figure 1.1 Time to complete the GI screening process.

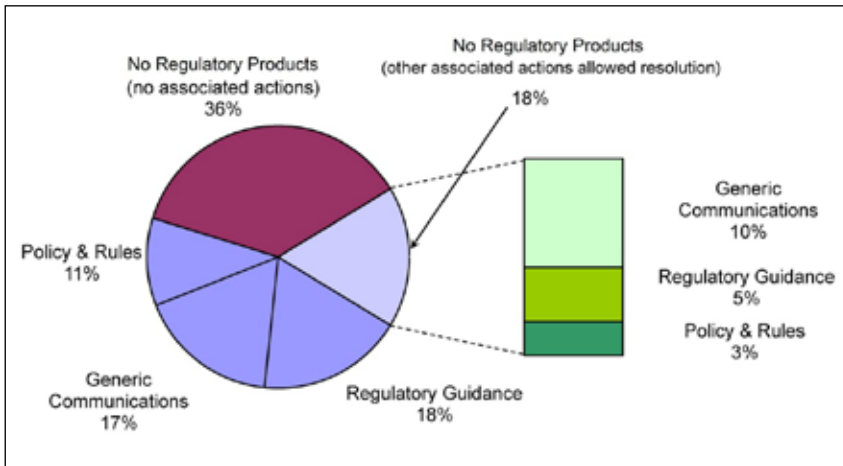

Figure 1.2 Breakdown of resolution products for GIs.

## List of Active Generic Issues

- GI-186: “Potential Risk and Consequences of Heavy Load Drops in Nuclear Power Plants”
- GI-189: “Susceptibility of Ice Condenser and Mark III Containments to Early Failure from Hydrogen Combustion during a Severe Accident”
- GI-191: “Assessment of Debris Accumulation on PWR Sump Performance”
- GI-193: “BWR ECCS Suction Concerns”
- GI-199: “Implications of Updated Probabilistic Seismic Hazard Estimates in Central and Eastern United States on Existing Plants”

### For More Information

Contact Mehdi Reisi-Fard, RES/DRA at 301-251-7490 or [Mehdi.Reisifard@nrc.gov](mailto:Mehdi.Reisifard@nrc.gov)

# Fuel Cycle Oversight Process

## Background

In 2000, the NRC revised Title 10 of the Code of Federal Regulations (10 CFR) Part 70, “Domestic Licensing of Special Nuclear Material,” for fuel cycle facilities to require an integrated safety analysis (ISA) and resulting items relied on for safety (IROFS). At that same time, the NRC staff also began considering a risk-informed Fuel Cycle Oversight Process (FCOP), using elements from the Reactor Oversight Process (ROP). Figure 1.3 provides an overview of the activities involved in the nuclear fuel cycle. The Commission directed the staff (Staff Requirements Memorandum SECY-00-0222) to proceed with the proposed new FCOP, cautioning that the effort should not negatively affect the implementation of the revised 10 CFR Part 70. The staff engaged stakeholders in public meetings on the development of the new FCOP; however, the Executive Director for Operations (EDO), in a memorandum dated March 18, 2002, suggested deferring development of the new FCOP until after the licensees completed ISAs and the NRC had reviewed them.

The Office of the Inspector General (OIG), in its report, “Audit of the NRC’s Regulation of the Nuclear Fuel Cycle Facilities” (OIG-07-A-06), dated January 10, 2007, recommended that the staff fully implement a framework for fuel cycle oversight consistent with a structured process, such as the ROP. In a February 13, 2007, memorandum in response to the audit, the Deputy Executive Director for Materials, Research, State, and Compliance Programs stated that, as more experience is gained with the ISA process, the NRC will make appropriate enhancements to the inspection and/or licensing procedures to establish a more structured program, similar to the ROP. The memorandum also noted that, because various fuel cycle facilities possess different operational characteristics, the ultimate structure of the FCOP would use more qualitative assessments of performance. Figures 1.4 and 1.5 illustrate two different types of fuel cycle facilities.

SECY-07-0191, “Implementation and Update of the Risk-Informed and Performance-Based Plan,” dated October 31, 2007, outlined plans to revise the FCOP to make it more risk informed and performance based.

In early 2009, the Executive Director for Operations directed the staff to revise the FCOP to improve its objectivity, predictability, transparency, and consistency and to incorporate risk-informed and performance-based tools. To comply with this direction, the staff formed a steering committee of NRC senior managers to provide guidance and feedback, identify policy issues, and advise on technical, regulatory, and policy issues.

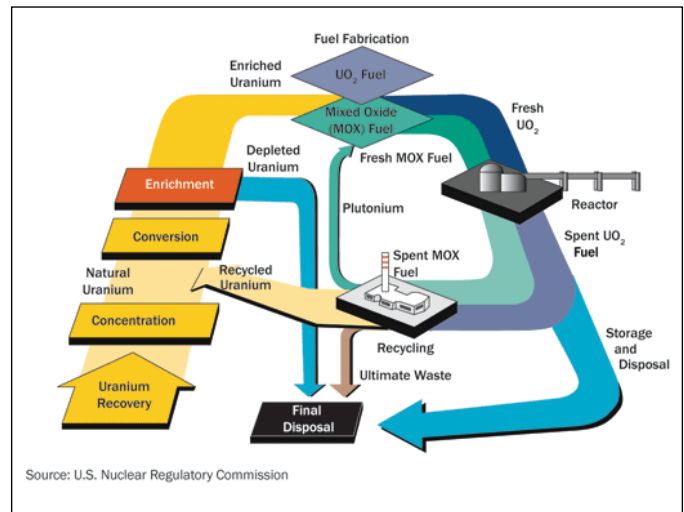

Figure 1.3 The nuclear fuel cycle.

In SECY-010-0031, “Revising the Fuel Cycle Oversight Process,” dated March 19, 2010, the staff proposed one qualitative and one quantitative option for continuing to revise the FCOP. However, the Commission directed the staff to prepare a SECY paper comparing ISAs used in fuel facilities to probabilistic risk assessment (PRA) methods used in nuclear power plants (NPPs).

In the August 4, 2010, staff requirements memorandum (SRM) related to SECY-010-0031, the Commission disapproved the staff’s plan to develop a revised FCOP and directed it to continue making modest adjustments to the existing FCOP to enhance its efficiency and efficacy.

## Objective

The objective of this project is to support the Office of Nuclear Materials Safety and Safeguards (NMSS) in evaluating differences between an ISA and a PRA and in developing tools and guidance for the FCOP.



Figure 1.4 Typical uranium enrichment facility, part of the nuclear fuel cycle.

## Approach

RES has contracted with Brookhaven National Laboratory (BNL) to support NMSS in improving the FCOP with PRA insights and tools. The near-term task is to support the FCOP in developing the paper comparing an ISA to a PRA, as directed by the Commission. Longer term tasks include developing tools and guidance for chemical safety, criticality safety, and human reliability, and undertaking a pilot project to develop cornerstones that the NRC could apply to the FCOP.

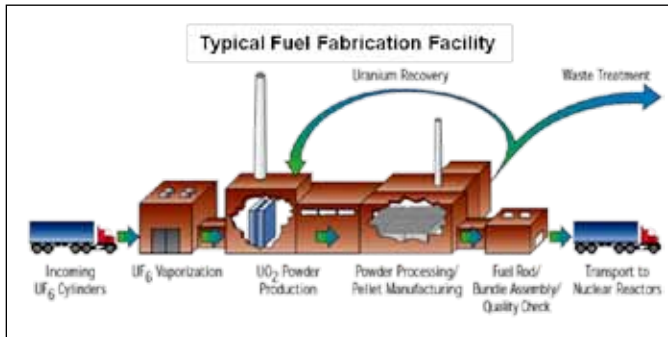

Figure 1.5 Typical fuel fabrication facility, part of the nuclear fuel cycle.

## Future Work

The NRC will continue to improve its Fuel Cycle Oversight Processes with Risk Insights and PRA as it continues to mature. Future work will be determined based on the results of the current work, available resources, and future needs.

### For More Information Contact:

Felix E. Gonzalez, RES/DRA at 301-251-7596, or  
Felix.Gonzalez@nrc.gov

Michelle Gonzalez, RES/DRA at 301-251-7591, or  
Michelle.Gonzalez@nrc.gov

Brian Wagner, RES/DRA at 301-251-7595, or  
Brian.Wagner@nrc.gov



# Knowledge Management in the Office of Nuclear Regulatory Research

## Background

The mission of the Office of Nuclear Regulatory Research (RES) is to support the regulatory mission of the NRC by providing technical advice, technical tools, and information for identifying and resolving safety issues, performing the research necessary to support regulatory decisions, and promulgating regulations and guidance. RES's principal product is knowledge; thus, knowledge management (KM) is an integral part of the RES mission.

## Objective

RES's objective is to capture, preserve, and transfer key knowledge among employees and stakeholders. The body of knowledge can be used when making regulatory and policy decisions and ensures that issues are viewed and analyzed within a historical context.

## Approach

RES KM activities fall into several categories as described below.

### Agency-Level KM Steering Committee

The NRC has a KM Steering Committee where senior-level managers listen to new KM ideas and discuss future plans. The meetings cultivate an awareness of the value of KM initiatives agencywide and support staff with KM-oriented projects and goals.

RES is a member of the committee and sends a representative to the meetings, which occur a few times a year. The office presents KM ideas and concepts for discussion.

The KM Steering Committee also sponsors large, agencywide events. In 2010, the KM Committee organized a KM Fair (see Figure 1.6) to highlight KM-oriented activities in each office. Every office was invited to set up a display booth featuring individual KM activities. RES staff members set up booths to share information with their colleagues on fire protection; high-temperature gas-cooled reactors (HTGRs); the reactor safety databank; structural, geotechnical, and seismic engineering; and RES seminars.



Figure 1.6 Photo from the 2010 KM Fair.

### RES KM Focus Area Group

RES identifies “focus areas” each year to pool additional attention and resources on high-priority issues. One of the focus areas for 2010–2011 is KM. A working group was formed to set the following goals for this focus area:

- Expand Expertise Exchange Program.
- Continue to support communities of practice (CoPs).
- Champion NUREG/KM series development.

### RES Seminars

For several years, RES has sponsored monthly seminars on technical topics of broad agency interest. RES also sponsors special indepth technical symposia on topics such as the Three Mile Island (TMI) accident, Chernobyl, and the September 11, 2001, attack on the World Trade Center (WTC) Twin Towers and Building 7. These events include staff presentations and may also feature special guests who have unique knowledge of the topic. For example, for the TMI seminar in 2009, speakers included Governor Richard Thornburgh of Pennsylvania (see Figure 1.7) and Ed Frederick who was an operator on shift at the time of the accident in 1979. The two September 11 seminars (WTC Twin Towers and WTC Building 7) were presented by the scientists and researchers from the National Institute of Standards and Technology as mandated by Congress to determine why the structures collapsed.



**Figure 1.7** Governor Dick Thornburgh (PA) at a RES seminar on the 1979 accident at Three Mile Island.

### Communities of Practice

To be successful, the NRC staff must have access to existing sources of technical information. A key aspect of the RES KM Program is the development of virtual CoPs where RES staff members can share and collect information in their area of interest. RES now has several CoPs on such topics as human factors; HTGRs; liquid metal cooled reactors; fire protection; health effects; and structural, geotechnical, and seismic engineering.

### Publications—NUREGS

Official NRC publications are called NUREGs. RES is the agency leader for publishing KM-focused NUREGs that compile historic information, video, and references. The Fire Research Branch in particular has contributed much to the office, agency, and industry through its KM efforts. The following NUREGs from the Fire Research Branch are publicly available:

- NUREG/BR-0465, Revision 1, “Fire Protection and Fire Research Knowledge Management Digest.”
- NUREG/BR-0175, “A Short History of Nuclear Regulation, 1946–1990.”
- NUREG/BR-0364, “A Short History of Fire Safety Research Sponsored by the U.S. NRC, 1975–2008.”
- NUREG/BR-0361, “The Browns Ferry Nuclear Plant Fire of 1975 and the History of NRC Fire Regulations.”

In 2010, RES proposed a new publication series focused exclusively on collecting and interpreting historical information on technical topics for the benefit of future generations of NRC professionals. A publication in the proposed NUREG series would be called a NUREG/KM.

### Expertise Exchange Program

The Expertise Exchange Program matches seasoned professionals with newer employees or those who want to learn more to facilitate information sharing. The program provides a means to preserve institutional knowledge, expertise, and opinions gained through on-the-job experiences. It is also a goal for the office’s KM Focus Area Group.

The general approach of the program includes exposing employees to key topic areas, which are recorded in a formal knowledge transfer plan. Employees gain exposure to key topic areas and become known to management through attendance at selected internal meetings and management briefings. Knowledge is also gained through attendance at select conferences when possible. Finally, in addition to well-defined short-term and long-term tasks, employees may be asked provide support to other offices to build their skill set and familiarity with their subject area.

### For More Information

Contact Leslie Donaldson, RES/PMDDA at 301-251-7964 or [Leslie.Donaldson@nrc.gov](mailto:Leslie.Donaldson@nrc.gov)





# Chapter 2: Reactor Safety Codes and Analysis

Code Application and Maintenance Program (CAMP)

Thermal-Hydraulic (T/H) Simulations of Operating Reactors

TRAC/RELAP Advanced Computational Engine (TRACE) T/H Code

Symbolic Nuclear Analysis Package (SNAP) Computer Code Applications

Nuclear Analysis and the SCALE Code

Fission Products Burnup Credit

High-Burnup Light-Water Reactor Fuel

Spent Fuel Pool Criticality Analysis

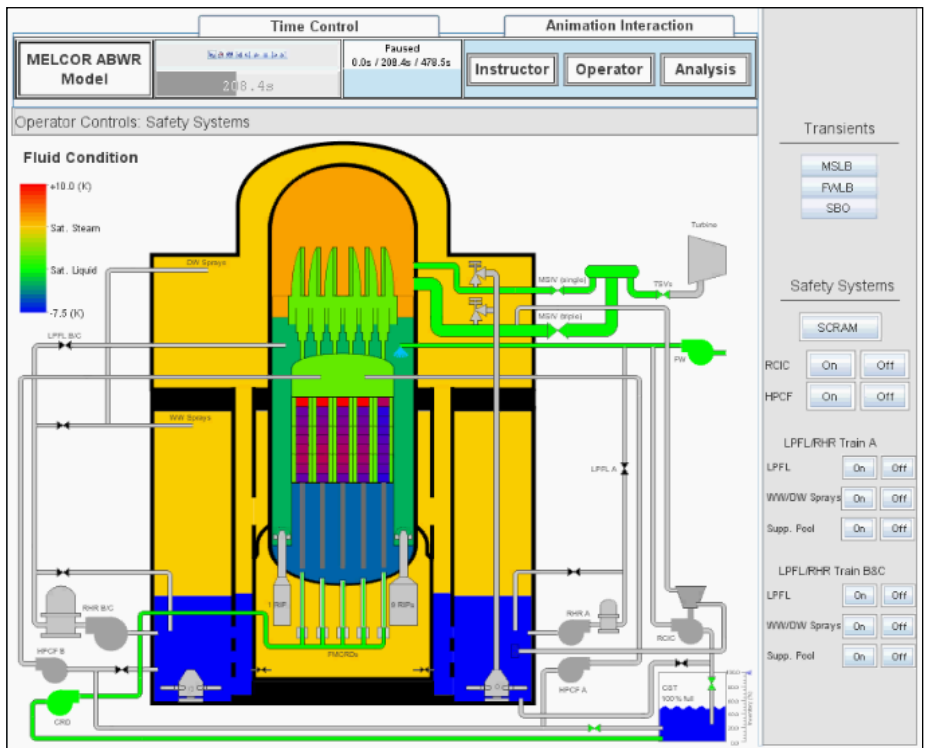

Animating analysis results using SNAP

---

# Code Application and Maintenance Program (CAMP)

## Background

In 1985, the U.S. Nuclear Regulatory Commission (NRC) developed the International Code Assessment and Application Program (ICAP) to assess and improve its thermal-hydraulic (T/H) transient computer codes. Approximately 14 nations signed bilateral cooperative agreements with the United States, providing contributions in the form of model development, code assessment, and information generated from applying the codes to operating nuclear power plants. ICAP members held 14 management and specialist meetings between 1985 and 1991. During this time, the NRC published approximately 130 NUREG/IA reports on ICAP work in a number of areas, including core reflood, stratification in horizontal pipes, vertical stratification, postcritical heat flux, and blowdown and quench. ICAP used a variety of test facilities to assess the codes independently. The information generated from this cooperative international work helped the NRC to improve the accuracy, reliability, and speed of its T/H codes. Input from the program also supported the development and application of the Code Scaling, Applicability, and Uncertainty code evaluation methodology in the late 1980s.

In the early 1990s, ICAP developed into CAMP. The CAMP agreement involved monetary contributions, in addition to in-kind technical contributions. The technical contributions include, among other things, (1) sharing code experience and identifying areas for code and model improvements, and (2) developing expertise in the use of the codes.

CAMP holds two meetings each year, one in the United States and the other abroad.

## Approach

The CAMP program provides members with RELAP5, TRACE, Purdue's Advanced Reactor Core Simulator (PARCS), and SNAP codes. The RELAP5 and TRACE codes are the NRC's primary T/H reactor system analysis codes. TRACE is the new consolidated code. PARCS is a multidimensional reactor kinetics code that can be coupled to TRACE and RELAP5. SNAP is a graphical user interface (GUI) to the codes and provides preprocessing, runtime control, and postprocessing capabilities. These codes are then used to analyze accidents and transients in operating reactors, support the resolution of generic issues, evaluate emergency procedures and accident management strategies, confirm licensees' analyses, test the fidelity of NRC simulators, provide training exercises for NRC staff, and support

the certification of advanced reactor designs.

During the biannual CAMP meetings, the members have an opportunity to present their technical findings to the NRC. More specifically, the members (1) share experience with NRC T/H computer codes to identify errors, perform assessments, and identify areas for additional experiments, model development, and improvement, (2) maintain and improve user expertise, (3) develop and improve user application guidelines, (4) develop a well-documented T/H code assessment database, and (5) share experience in the use of the codes to resolve safety and other technical issues (e.g., scalability and uncertainty).

## Accomplishments

The CAMP and ICAP programs have provided more than 200 NUREG/IAs that contributed to the development, assessment, and application of the NRC T/H analysis codes. Technical areas span the entire range of accident and transient analysis. These include low-pressure, low-power transients; advanced reactor design applications; coupling between the primary system and containment; operation of passive core cooling systems during accidents; boron dilution transients; neutronics coupling; reflood; and condensation with noncondensables. The reports document the contributions made to assessment, plant analysis, and physical model development.

In several recent cases, contributions made to the CAMP program provided important code improvements and saved the NRC time and money. For example, analyses of proposed supercritical water reactor designs by CAMP members identified problems in the RELAP5 water properties near the critical point, an area now being improved. (TRACE also uses the RELAP5 water properties.)

Although the NRC is not currently analyzing supercritical water reactors, water properties near the critical point are important in calculations regarding pressurized-water reactor (PWR) anticipated transients without scram (ATWS). Another example of efficiency is the Republic of Korea's in-kind contributions on CANDU reactors, which were used during ACR 700 T/H code development. This in-kind contribution allowed the NRC to start analyzing the ACR 700 during the preapplication review, sooner than it could have without the Korean contributions. Korean modeling of the advanced accumulator in the AP1400 reactor design has helped guide NRC efforts to model the advanced accumulator of the U.S. Advanced Pressurized-Water Reactor (APWR), which has similar design features and which the NRC's Office of New Reactors is currently reviewing for design certification.

---

## Future Work

At the start of the CAMP agreement, the NRC used four primary T/H and reactor kinetics codes specifically designed for modeling transient and accident behavior in PWRs and boiling-water reactors (BWRs). The codes used 1980-era computer languages and T/H modeling. In the late 1990s, the NRC began a code consolidation effort to merge the features of these codes into a new code, using a modern software architecture that would more easily support the addition of modern T/H models and be easily portable to new computer hardware and operating systems. The new code would also reduce the personnel resources and money needed to maintain and improve multiple codes and the associated training costs.

TRACE is the primary T/H code the NRC uses to review and audit license amendments for operating reactors, advanced reactor license applications, generic safety issues, and power uprate requests.

CAMP members, who are experts in using and evaluating T/H codes, will continue to play a major role as an independent group with the necessary technical expertise to evaluate TRACE. Several CAMP members have started to use TRACE for in-kind technical contributions. CAMP members have shown good results in TRACE assessments of the ROSA and PKL integral test facilities, in separate effects condensation tests, and in the BFBT BWR single-channel steady-state and transient tests. Members have also demonstrated coupling TRACE to computational fluid dynamics (CFD). As TRACE matures, CAMP will become an important contributor to its future development and assessment. CAMP contributions will provide information to the NRC code development staff to improve the speed, accuracy, robustness, and usability of TRACE, thus improving the NRC's reviews, analyses, and audits of licensee products and its protection of public health and safety.

### **For More Information**

Contact Antony Calvo, DSA at 301-251-7677 or [Antony.Calvo@nrc.gov](mailto:Antony.Calvo@nrc.gov)

# Thermal-Hydraulic Simulations of Operating Reactors

## Background

The Office of Nuclear Regulatory Research (RES) provides the tools and methods used by NRC program offices to review licensee submittals and evaluate and resolve safety issues. For thermal-hydraulic (T/H) analyses, the NRC uses the TRACE computer code to perform the following:

- confirmatory calculation reviews of licensee submissions, such as those for extended power uprates
- exploratory calculations to establish the technical bases for rule changes, such as the proposed redefinition of the emergency core cooling system rule in Title 10 of the Code of Federal Regulations (10 CFR) 50.46, “Acceptance Criteria for Emergency Core Cooling Systems for Light-Water Nuclear Power Reactors”
- exploratory calculations for the resolution of generic safety issues, such as Generic Safety Issue 191, “Assessment of Debris Accumulation on PWR Sump Performance”

RES is developing a library of TRACE input decks for simulating currently operating pressurized-water reactors (PWR) and boiling-water reactors (BWR).

## Approach

TRACE plant input decks exist for specific simulations. These can be design-basis loss-of-coolant accidents (LOCAs), anticipated operational occurrences, ATWS, and other transients. Depending on the simulations to be performed, the size and complexity of plant input decks can range from single-system components to the entire nuclear steam supply system. TRACE is able to simulate the multifaceted evolution of these events, capturing all of the major system operations and T/H processes that unfold (see Figure 2.1).

Each physical piece of equipment in a plant can be represented as some type of TRACE component, and each component can be further nodalized into a number of physical volumes—also called cells—over which the fluid, conduction, and kinetics equations are averaged. TRACE input decks representing entire plants consist of an array of one-dimensional and three-dimensional TRACE components arranged and sized to match plant specifications.

Because of the modeling flexibility available to the user, the “TRACE Users Guide” (Ref. 1) contains the best-practice modeling guidelines. The user guide shows modelers the most effective methods to arrange generic one-dimensional components to depict particular systems and to employ function-specific components, such as the PWR accumulator and pressurizer and the BWR jetpump and channel components, to achieve the desired results.

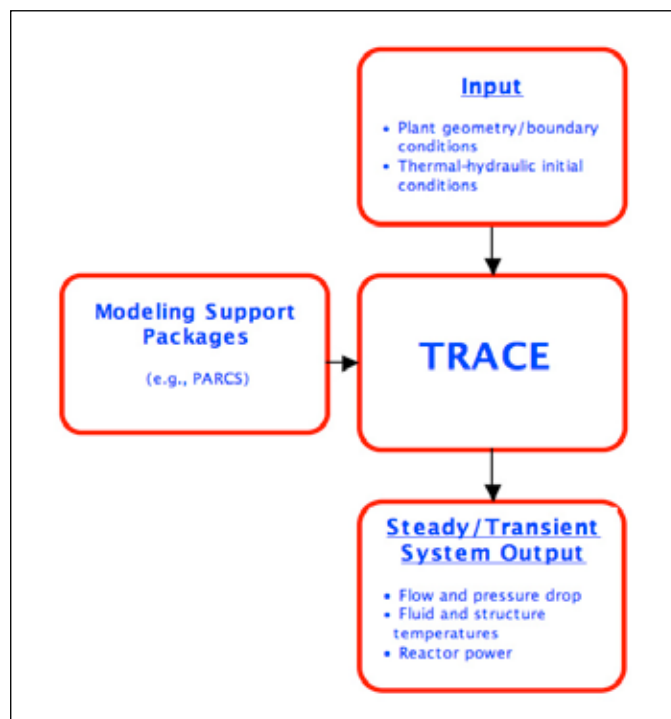

Figure 2.1 TRACE, an advanced, best-estimate reactor system code used to model the T/H performance of nuclear power plants

User input includes plant geometry and process conditions (e.g., temperature, flow). The code supports integration with detailed modeling packages (e.g., the three-dimensional kinetics code, PARCS), used to model specific performance issues, including neutronics.

Once the arrangement of the plant deck is complete and each component is set with initial values for normal operating pressures, temperatures, and flow conditions, TRACE is run in steady-state mode for a period of time to test the model and to develop appropriate steady-state initial conditions for the specified operating state and boundary conditions. TRACE models transients and accidents by simulating an initiating event after steady initial conditions have been reached. Developmental assessments support the applicability of TRACE in modeling these events (Ref. 2).

Recently, the NRC updated plant input decks developed for other system codes and converted them into TRACE to support the licensing reviews of extended power uprate applications.

It uses these models to assess the effects of increased power on system behavior and safety margins.

### BWR Models

The NRC has developed representative LOCA and design-basis accident input decks for most General Electric-type BWRs, including the BWR3, BWR4, and BWR5 plants (see Figure 2.2). TRACE significantly enhanced component-specific features to improve the modeling of containment pressurization and feedback during design-basis events.

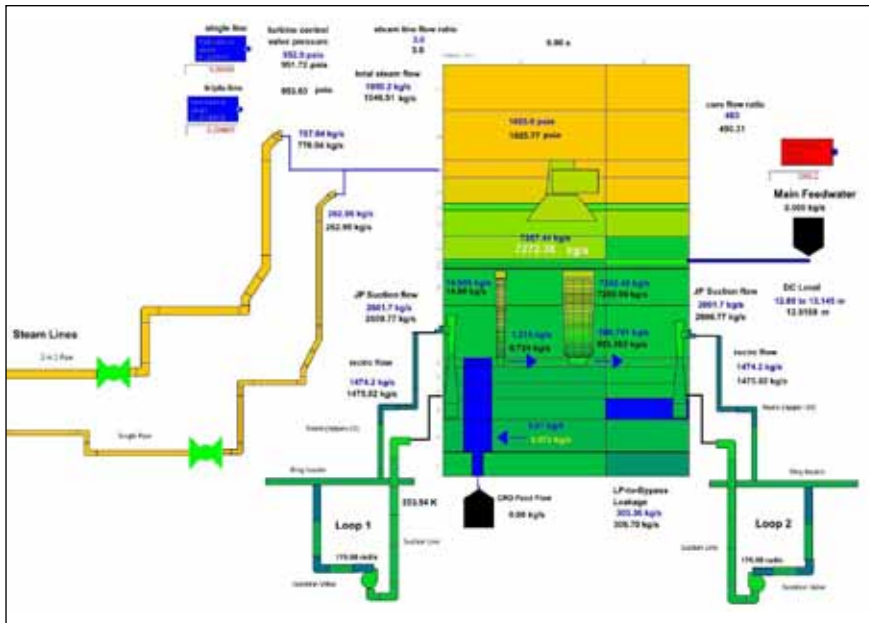

Figure 2.2 Steady-state conditions in a BWR (SNAP animation)

### PWR Models

Representative LOCA and design-basis accident models exist for Westinghouse PWRs with two, three, and four loops, several Combustion Engineering plants, and two Babcock and Wilcox plants (see Figure 2.3).

Building a comprehensive library of plant input decks will enhance the ability of the NRC staff to perform timely and defensible confirmatory analyses in support of regulatory decisions.

## References

1. TRACE 5.0 User's Manual, Volume 2: Modeling Guidelines (ML071720510),
2. TRACE 5.0 Assessment Manual – Main Report (ML071200505)

### For More Information

Contact Istvan (Steve) Frankl, RES/DSA at 301-251-7901 or [Istvan.Frankl@nrc.gov](mailto:Istvan.Frankl@nrc.gov)

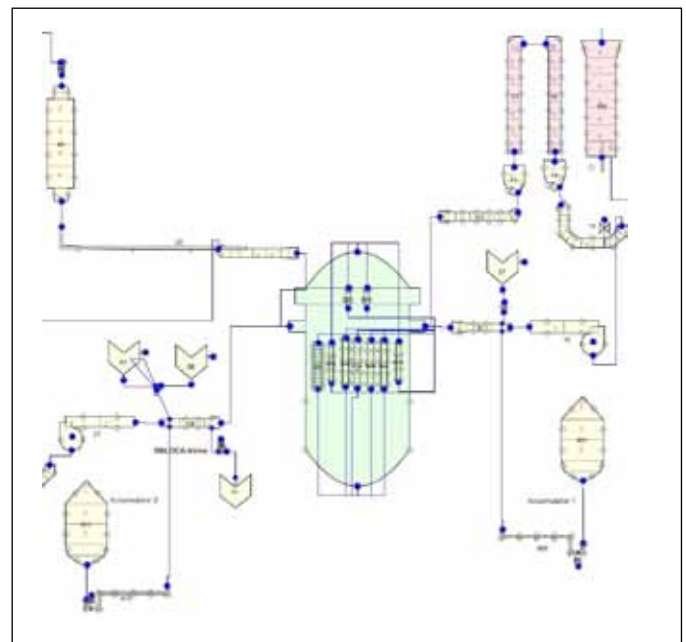

Figure 2.3 Key primary coolant T/H components, including reactor vessel, pumps, and steam generator, for a two-loop PWR depicted with SNAP

# TRAC/RELAP Advanced Computational Engine (TRACE) Thermal-Hydraulics Code

## Background

The NRC uses thermal-hydraulic (T/H) codes to perform operational and accident transient analyses. Before the late 1990s, the NRC developed and used four system computer codes—RELAP5, TRAC-PWR, TRAC-BWR and RAMONA—to perform independent safety analyses of pressurized-water reactors (PWR) and boiling-water reactors (BWR) nuclear power plants. These computer codes used architecture and modeling methods developed in the 1970s. The NRC decided that it would be more cost effective to maintain a single modernized computer code that could be used to analyze all the reactor designs and operational conditions addressed by the four older computer codes.

Over the last 10 years, in an effort to meet this goal, the NRC decided to consolidate the above four analysis codes into a single modernized computational platform. The code consolidation project began with the vision “to have the capability to perform thermal-hydraulic safety analysis in the future that allows for solutions to the full spectrum of important nuclear safety problems in an efficient and effective manner, taking complete advantage of state-of-the-art modeling, hardware, and software capabilities.” In other words, the NRC must be able to do more with less:

**LESS:** The NRC must be able to reduce and consolidate personnel resources needed for solving any given problem and for maintaining code capability by developing or improving:

- ease-of-use
- speed
- robustness
- flexibility
- maintainability and upgradability

**MORE:** The NRC must be able to accommodate the new challenges and demands for best-estimate T/H analysis, coupled to related capabilities:

- accuracy
- flexibility

- maintainability and upgradability
- simplicity
- expanded scope of capabilities
- quality assurance

Version 5.0 of TRACE is the culmination of that effort. It can analyze operational and safety transients, such as small- and large-break loss-of-coolant accidents (LOCA) in PWRs and BWRs, as well as the interactions between the related neutronic and T/H systems.

The T/H and neutronic capabilities of TRACE V5.0 enable the NRC to make independent evaluations of transients for existing and new reactor designs. The NRC uses these capabilities to perform sensitivity assessments of system hardware and phenomena, which can be modeled using different analytical or modeling approaches.

## Approach

Development and assessment is an ongoing process. During 2008, the NRC addressed modeling issues identified during (1) an independent peer review, completed in 2008, (2) the development of input models used to support the licensing of new and operating reactors, and (3) code assessment activities leading up to the release of Version 5.0. These efforts ultimately led to the release of TRACE V5.0 Patch 2 in June 2010.

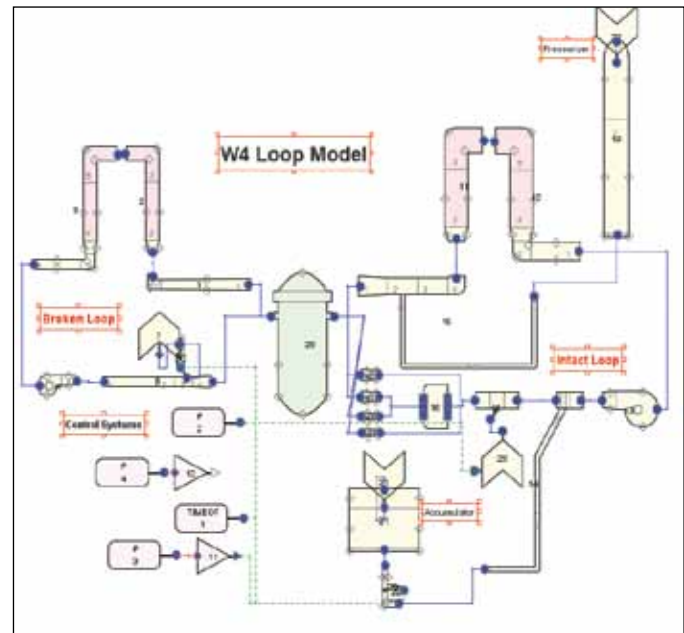

Figure 2.4 Simplified plant model nodalization



## Modeling Capabilities

The code features a two-fluid, compressible, nonequilibrium hydrodynamics model that can be solved across a one-, two-, or three-dimensional mesh topology. It also features a three-dimensional reactor kinetics capability through coupling with PARCS. The code is capable of performing any type of reactor analysis previously performed by each of the predecessor codes and has component models and mesh connectivity that allow a full reactor and containment system to be easily modeled. (Figure 2.4 shows an example of a simplified reactor system nodalization for TRACE.)

The NRC added a significant number of new features to the code as a result of the consolidation project. The most notable achievements include the addition of a plethora of BWR-specific component types; a single junction component (to capture RELAP5-style mesh connectivity); 3D-kinetics (through coupling with PARCS); a new heat structure component; an improved set of constitutive models for reflood, condensation, and other basic phenomena; an improved level tracking model; numerous usability enhancements; and countless bug fixes.

A significant advance in the modeling capability of TRACE is the addition of a parallel processing capability that allows the code to communicate with itself or other codes. This feature is known as the exterior communications interface (ECI). The ECI is a request-driven interface that allows TRACE to communicate with any code that implements the ECI, without actually having to make any modifications to TRACE. The ECI has allowed TRACE to be easily coupled to codes such as SNAP, CONTAIN, REMIX, and MATLAB. The interface should allow TRACE to be coupled to CFD or other special purpose codes in the future.

## TRACE Development

TRACE uses a modern code architecture that is portable, easy to maintain, and easy to extend with new models to address future safety issues (a graphical representation of this is shown below in Figure 2.5). TRACE has run successfully on multiple operating systems, including Windows NT/2000/XP, Linux, and Mac OSX.

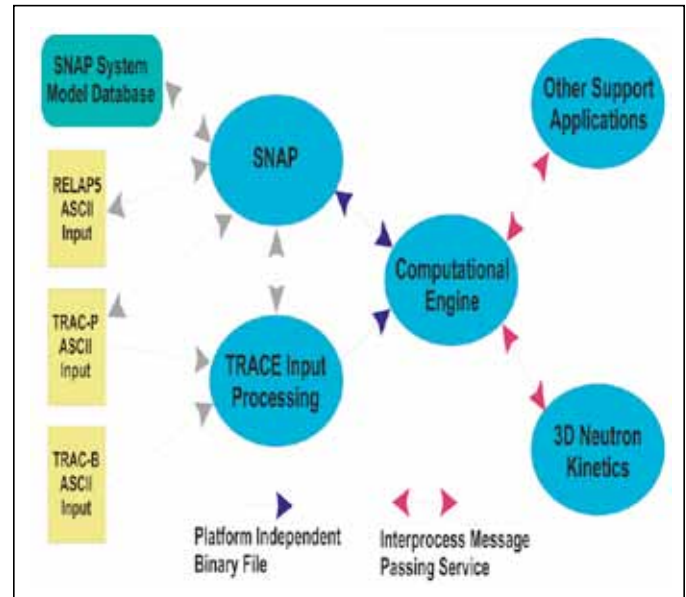

Figure 2.5 TRACE architecture

Code quality is the goal of a stringent development process. Some of the principal elements of this process include:

- configuration control
- establishment and strict enforcement of coding guidelines and development standards
- documented development process
  - software requirements document
  - software design/implementation
  - test plan
  - completion report
- three-tiered testing process
  - comprehensive regression set
  - automated robustness testing
  - automated code assessments
- multiplatform testing
- automated bug-tracking system

The final stage before any periodic official release of TRACE involves a thorough developmental assessment to identify any deficiencies in its physical models and correlations. The NRC may develop new physical models when it identifies a need for them.

---

The current assessment test matrix for TRACE contains more than 500 cases. The TRACE assessment test matrix contains a comprehensive set of fundamental, separate effects, and integral tests. These tests range from 1/1000th scale to full scale and include new and advanced plant-specific experiments for both BWRs and PWRs. In addition to data from NRC-funded experiments, the assessment matrix includes experimental data that was obtained through international collaboration. Among these are experiments at the BETHSY, ROSA, and PANDA facilities. The set of experimental data against which TRACE has been validated is more comprehensive than any other NRC T/H code in terms of scope, quantity, and quality.

Improvements underway for future versions of TRACE are focused on enhancing capabilities related to the simulation of advanced reactor designs, such as the APWR, the U.S. Evolutionary Power Reactor, and the AP1000, as well as small-scale modular reactors. Significant efforts are also directed towards fixing bugs, addressing peer review findings, and improving code robustness and run-time performance. The TRACE development team recently released V5.0 Patch 2 to address some of the issues identified to date, and additional patch releases are planned. TRACE will provide a robust and extensible platform for safety analyses well into the future.

**For More Information**

Contact Chris Hoxie, DSA at 301-251-7562 or  
Chris.Hoxie@nrc.gov



# Symbolic Nuclear Analysis Package (SNAP) Computer Code Applications

## Background

The NRC recognizes that analytical capability and expertise are essential to ensure design adequacy and safe operation of nuclear power plants. This mission is, in part, accomplished by analyzing operational and accident transients using thermal-hydraulic (T/H) modeling software. The NRC has developed and uses several computer codes to perform safety analyses of pressurized-water reactors (PWR) and boiling-water reactors (BWR). The input models for most of these codes are text based, requiring the user to write an input file (or deck) in a text editor and then run the analysis program. These input files are often very complex, difficult to read, and time consuming to prepare. Additionally, each computer code uses different input formats and variable names. This adds to the burden on the analysts, who usually use more than one of these modeling programs to perform a review. To lessen this model development burden, the NRC decided that it would be cost effective to develop a single, standardized graphical user interface (GUI) that could be extended for use with any analytical code.

An NRC analyst reviewing, for example, a power plant modification, must perform several analyses using NRC T/H computer codes. The NRC analyst needs to perform this analysis as efficiently and as error free as possible. Until the development of SNAP, the most efficient way for analysts to accomplish their work was to learn several cumbersome input formats. They also needed several different software packages to display and interpret the results. The analyst was forced to spend a significant amount of time preparing text-based input files and transferring information from one application to another. These efforts were very prone to errors, which could affect results.

SNAP removes the need for analysts to use the text-based entry methods and to transfer or replicate data among several different packages. It does this by providing a powerful, flexible, and easy-to-use GUI, both to prepare analytical models and to interpret results. Since the core look and feel of SNAP is the same for different programs, the analyst does not have to learn and remember several different interfaces and, therefore, is less likely to make an error based on differences in input formats. Currently SNAP has interfaces for RELAP5, TRACE, CONTAIN, MELCOR, RADTRAD, and FRAPCON3 (see Figures 2.6, 2.7, 2.8, 2.9).

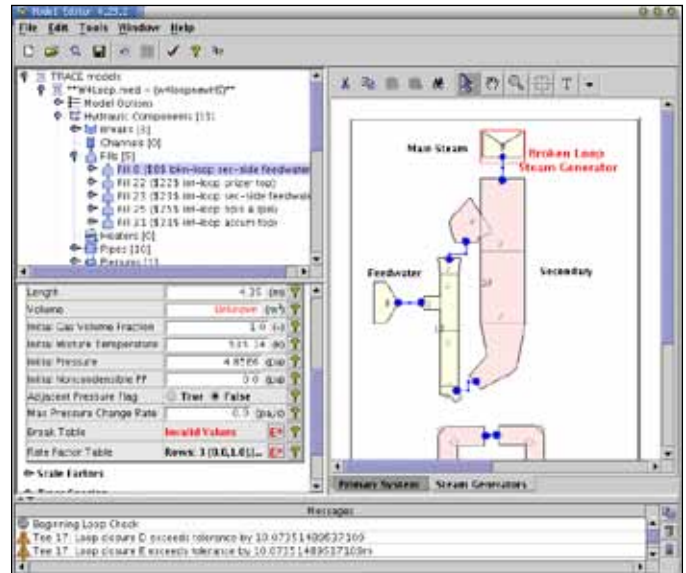

Figure 2.6 Creating input models using SNAP

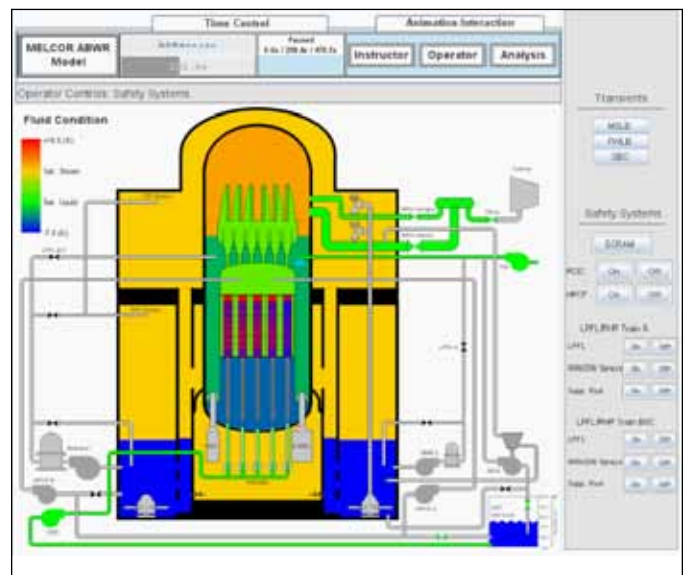

Figure 2.7 Animating analysis results using SNAP

## Approach

### Development

Development in 2009 focused on improving the simulator capabilities of SNAP. Most notable changes in the simulator area were made to better support the MELCOR 2.x code development efforts (see Figure 2.9 below). However, because of the object-based architecture of SNAP, the changes made to support MELCOR 2.x are now also available to the other SNAP-supported codes (most notably, TRACE and RELAP5).

Other improvements to SNAP during 2010 are as follows:

- A new supported code, RADTRAD, is a code the NRC Office of Nuclear Reactor Regulation uses to review licensees' offsite dose calculations. RADTRAD was rewritten in 2009 as a plug-in to SNAP. Note that the entire RADTRAD code is now in SNAP. A SNAP plug-in normally provides only a GUI to an analytical code, but, in this case, the code itself resides in the plug-in.
- The NRC maintained compatibility with the current versions of TRACE during the recent TRACE development efforts. Most notably, it added a vessel-junction pseudo-component to support vessel-to-vessel junctions in TRACE. The vessel-junction component greatly reduces visual clutter on a TRACE model graphical display.
- The NRC has invested significant work on three new plug-ins. The first is the job-stream plug-in, which permits chaining code runs together in a definable sequence, allowing analysts to design and automate whole analytical processes. The job-stream plug-in, used along with other new plug-ins, will further simplify running complex restart cases, uncertainty-quantification jobs, and other multistage analyses involving multiple analytical codes.
- The second is the uncertainty-quantification plug-in, which will use an existing uncertainty quantification toolkit known as DAKOTA (Design Analysis Kit for Optimization and Terascale Applications), developed by Sandia National Laboratories. DAKOTA provides tools for sensitivity analysis and optimization as well as uncertainty quantification; the NRC is likely to extend the SNAP interface to DAKOTA to cover these features as well.
- The third is the engineering template plug-in. The engineering-template feature allows analysts to modify their code input models using macro capabilities available in the SNAP model-editor. For instance, massive model changes could be preprogrammed and executable with a single button on the input model display.

## Application

SNAP has now been adopted by a large number of analysts using TRACE and, to a lesser extent, by analysts using RELAP5, CONTAIN, MELCOR, RADTRAD, and FRAPCON3. SNAP continues to gain greater acceptance and use throughout the agency, as well as in other organizations involved with nuclear analysis.

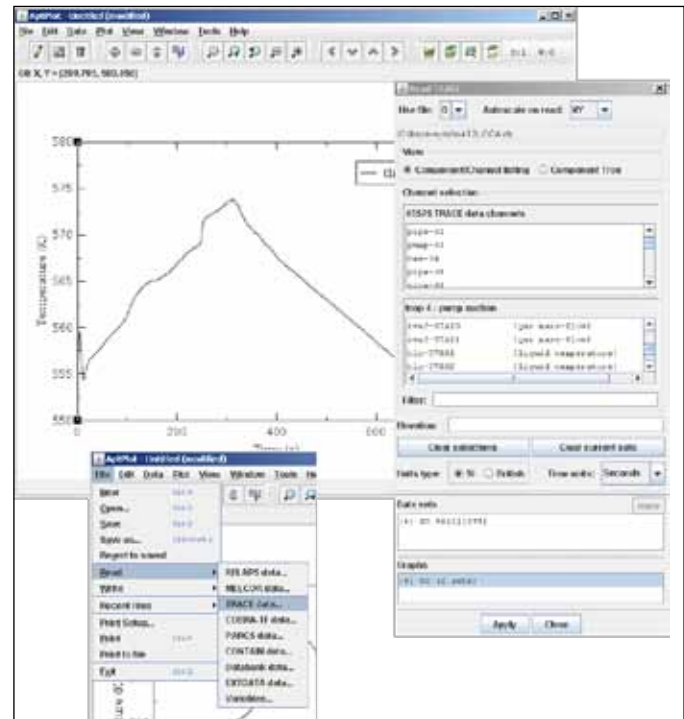

Figure 2.8 Plotting analysis results using SNAP

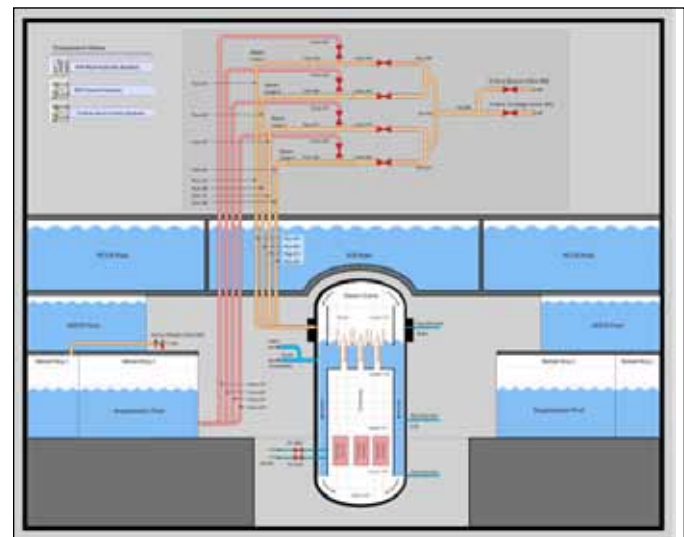

Figure 2.9 Updated model editor display capabilities

### For More Information

Contact Chester Gingrich RES/DSA at 301-251-7535 or [Chester.Gingrich@nrc.gov](mailto:Chester.Gingrich@nrc.gov)

# Nuclear Analysis and the SCALE Code

## Background

As used here, the term nuclear analysis describes the use of analytical tools and experimental data to predict and understand the interactions of nuclear radiation and matter within various nuclear systems. Nuclear analysis thus encompasses the analyses of (1) fission reactor neutronics, both steady state and dynamic, (2) nuclide generation and depletion, as applied to predicting in-reactor and spent-fuel decay heat power, fixed radiation sources, and radionuclide inventories potentially available for release, (3) radiation transport and attenuation, as applied to the evaluation of material damage fluence, material dosimetry, material activation, radiation detection, and radiation protection, and (4) nuclear criticality safety (i.e., the prevention and mitigation of self-sustaining fission chain reactions outside reactors).

## Objective

The RES objective is to maintain NRC staff expertise and analytical tools to perform independent neutronics and criticality analyses for nuclear power plants, spent fuel pools (SFPs), and spent fuel storage and transportation casks.

## Approach

### Overview

Nuclear analysis efforts support the staff's ongoing and anticipated nuclear safety evaluation activities for the licensing and oversight of (1) existing reactors, front-end fuel cycle activities, and spent fuel storage, transport, and disposal systems, and (2) proposed new and advanced reactors (see Figures 2.10 and 2.11) and their associated front-end and back-end fuel cycle activities. The primary nuclear analysis tools used for these activities are (1) the PARCS core neutronics simulator code, (2) the SCALE 6 modular code system, and (3) the AMPX code for processing fundamental nuclear data in the Evaluated Nuclear Data File (ENDF) into code-usable libraries of continuous-energy or fine-group nuclear cross sections and related nuclear data. When appropriate, RES integrates planned nuclear analysis activities into larger NRC research plans for the respective applications.

### Identification of Issues and Needs

An example of the need for additional data for current and near-term activities is in the area of burnup credit for the criticality safety analysis of spent fuel casks. Operating and new reactors need experimental data to validate codes and reduce uncertainties. Such validation currently relies on limited data or code-to-code comparisons. The NRC has validated nuclear

codes for partial mixed-oxide fueling in pressurized-water reactors (PWR) and is validating codes against plant operating and test data for use in steady-state and transient analyses of modern boiling-water reactor (BWR) cores, including the Economic Simplified BWR.

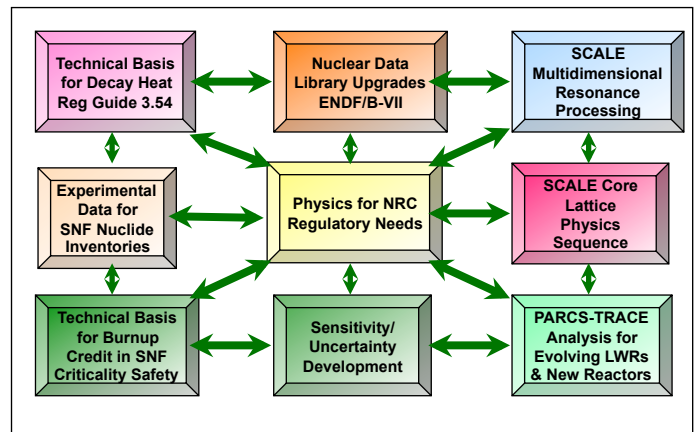

Figure 2.10 Coupled reactor and fuel cycle nuclear analyses

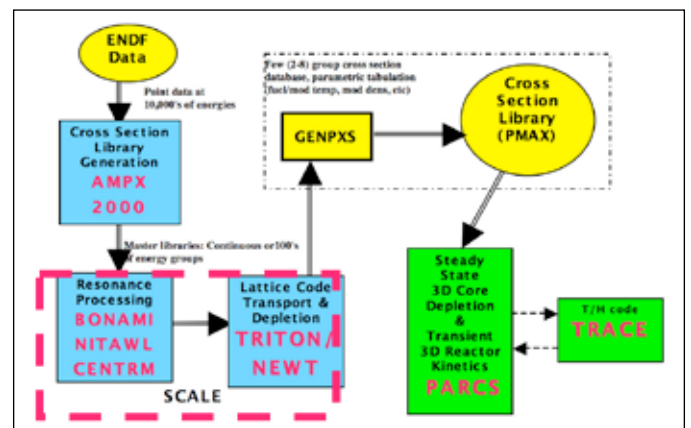

Figure 2.11 NRC nuclear analysis codes for reactor physics

The NRC is currently modifying and extending codes to accommodate different fuel, core, and control configurations and operating features of high-temperature, gas-cooled reactors. Major modifications include those associated with cross section processing of the reactors' coated particle fuel double-heterogeneity and code architecture changes to allow parallel processing of SCALE analysis sequences that currently require high execution times. In addition, the NRC is updating the radiation shielding codes for application to high-capacity spent fuel cask systems and advanced reactor systems.

### For More Information

Contact Dr. Mourad Aissa, RES/DSA at 301-251-7511 or [Mourad.Aissa@nrc.gov](mailto:Mourad.Aissa@nrc.gov)

# Fission Products Burnup Credit

## Background

The purpose of this research is to develop a technical basis to support the allowance of full (fission product and actinides) burnup credit for transportation and storage casks.

Spent nuclear fuel (SNF) refers to uranium-bearing fuel elements that have been used at commercial nuclear reactors and are no longer producing enough energy to sustain a nuclear reaction. The fission process has stopped once the spent fuel is removed from the reactor, but the spent fuel assemblies still generate significant amounts of radiation and heat. Because of the residual hazard, spent fuel must be stored or shipped in containers or casks that shield and contain the radioactivity and dissipate the heat. Further, the SNF storage or shipping system needs to support subcriticality (i.e., the neutron chain reactions cannot be maintained in the system), thereby preventing criticality accidents.

Our nation stores SNF at a variety of sites (e.g., in reactor SFPs or in dry cask storage at reactor sites). Over the last 30 years, thousands of shipments of commercially generated SNF have been made over highways, through towns, and along railroads in the United States without causing any radiological releases to the environment or harm to the public. It is also crucial to have no criticality accidents during storage and transportation.

Most of these spent fuel shipments occur between reactors owned by the same utility, to share storage space, or spent fuel may be shipped to a research facility to perform tests on the spent fuel itself. To minimize the number of such shipments, as much nuclear material as possible is loaded into each shipment without violating criticality safety.

## Objective

The RES objective is to conduct research to develop the technical basis to support revising the document of the Office of Nuclear Materials Safety and Safeguards (NMSS), Interim Staff Guidance (ISG) 8, “Burnup Credit in the Criticality Safety Analyses of PWR Spent Fuel in Transport and Storage Casks,” Revision 2, dated September 27, 2002, to include fission-product burnup credit.

## Approach

### The need

The regulation for transportation and storage of spent fuel is in 10 CFR Part 71, “Packaging and Transportation of Radioactive

Material,” and 10 CFR Part 72, “Licensing Requirements for the Independent Storage of Spent Nuclear Fuel, High-Level Radioactive Waste, and Reactor-Related Greater than Class C Waste.” In reviewing transportation and storage packages for compliance with the regulation, NMSS issued the ISG concerning issues not currently addressed in a standard review plan (SRP) or where clarification of SRP text is necessary. This guidance is intended to ensure consistent reviews by the NMSS staff and will be incorporated into the next periodic update of the applicable SRP.

ISG 8, Revision 2, provides full-actinides burnup credit. Burnup credit refers to a reduction in reactivity that occurs in fuel burnup caused by the change in concentration (net reduction) of fissile nuclides and the production of parasite neutron-absorbing nuclides (nonfissile actinides and fission products). Roughly two-thirds of the reactivity reduction is due to the major actinides, and the remaining one-third is due to the fission products and minor actinides (see Figure 2.12).

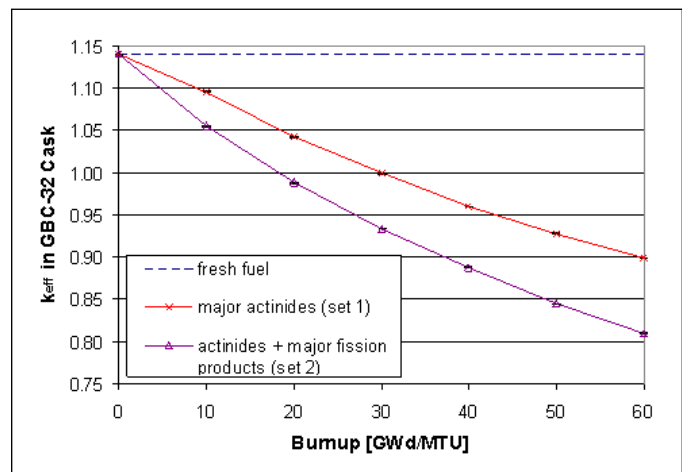

Figure 2.12 Comparison of typical reactivity decrements associated with actinides only and with a combination of actinides and fission products

## Research Activities

The development of the technical information and analysis approaches included (1) application of a sensitivity/uncertainty method to support recommendations of appropriate critical experiments for use in the validation of criticality safety code, (2) recommendation on criteria for preshipment measurement, (3) SCALE 6 analysis of sensitivity/uncertainty-recommended critical experiments and recently acquired assay data to provide a generic estimate of bias and uncertainty for full burnup credit, (4) investigation to recommend modeling approaches for full burnup credit, including a best estimate prediction of any additional reactivity margin, (5) evaluation of the generation processes and accuracy of reactor records for spent fuel assemblies, (6) evaluation of a nuclear data uncertainty propagation method to generate bias and bias uncertainty values



for those fission products for which limited or no validation data exists (7) evaluation of alternative methods to poolside assembly burnup measurement, and (8) technical support for the ISG 8 revision. This research supports the agency's goals on effectiveness and safety. The Oak Ridge National Laboratory does the research.

## Applications

The existing ISG 8, Revision 2, will allow about 30 percent of the SNF assemblies in PWRs to be loaded into high-capacity casks. Including fission products (based on appropriate experimental data for model validation) and giving fission product burnup credit would allow 80–90 percent of the PWR SNF assemblies to be loaded into such casks (see Figure 2.13). The potential savings to the industry (as a result of having fewer shipments) is conservatively estimated at \$156 million (see Figure 2.14).

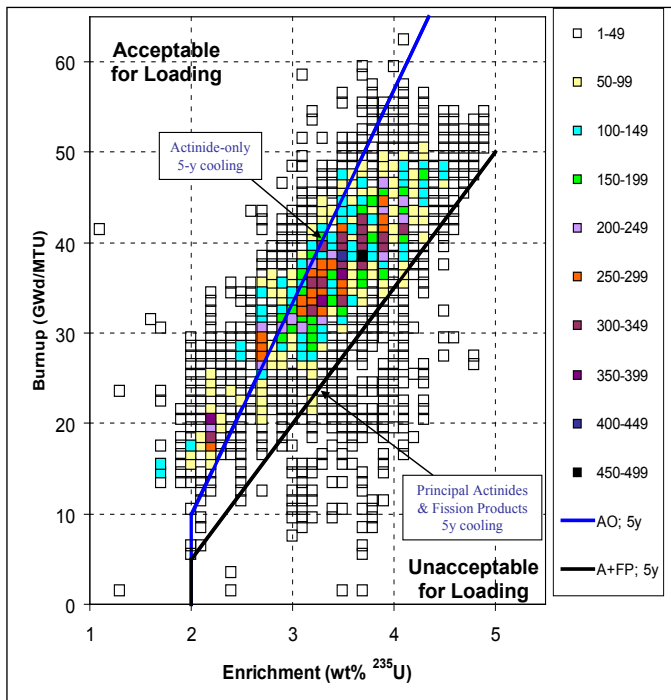

**Figure 2.13** The acceptable loading inventory for a generic burnup credit rail cask design with 32 PWR assemblies, enhanced from 30% of the PWR SNF inventory to almost 90% of the inventory, if credit for fission products can be obtained in the safety evaluation

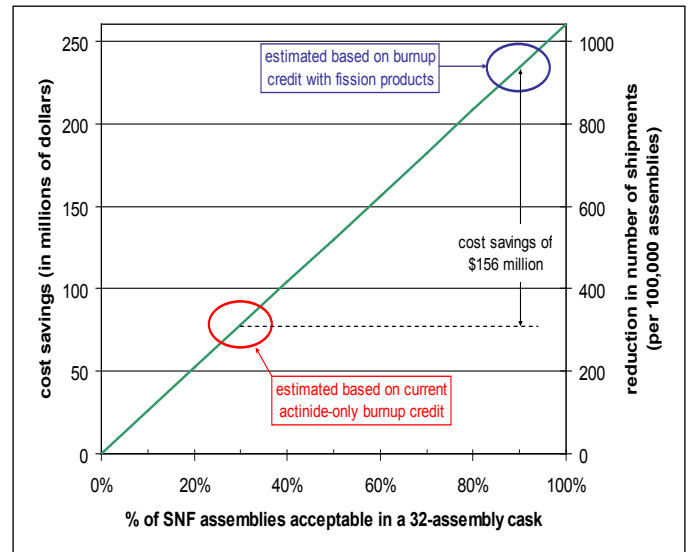

**Figure 2.14** Increasing the inventory that can be put in high-capacity burnup credit casks to enable at least 625 fewer shipments and provide a savings of about \$156 million

### For More Information

Contact Dr. Mourad Aissa, RES/DSA at (301) 251-7511 or [Mourad.Aissa@nrc.gov](mailto:Mourad.Aissa@nrc.gov)

---

# High-Burnup Light-Water Reactor Fuel

## Background

Fuel rod cladding is the first barrier for retention of fission products, and the structural integrity of the cladding ensures a coolable geometry during hypothetical reactor transients and accidents. Ensuring cladding integrity also allows simplifying assumptions to be made in spent fuel cask criticality calculations. Regulations and regulatory guidance documents contain fuel and cladding damage criteria. Licensees compare the criteria to predictions of fuel rod behavior during reactor operation and following discharge during spent fuel transportation and storage.

The fuel damage criteria were originally developed from a data base of unirradiated and low-burnup fuel with Zircaloy cladding. From more recent test data, it became clear that extrapolation from a low-burnup data base was not satisfactory for regulatory purposes, and the NRC initiated a high-burnup fuel research program to address this issue.

## Objective

The current research program is designed to provide information in the following areas:

- Embrittlement Criteria and Oxidation Correlations for Loss-of-Coolant Accidents (LOCA) 10 CFR 50.46(b); Regulatory Guide 1.157, “Best-Estimate Calculations of Emergency Core Cooling System Performance”
- Coolability Criteria and Threshold Failure Correlations for Reactivity-Initiated Accidents (Regulatory Guide 1.77, “Assumptions Used for Evaluating a Control Rod Ejection Accident for Pressurized Water Reactors”; NUREG-0800 section 4.2, “Fuel System Design”)
- Fuel Rod Properties for Transportation and Storage Analysis (10 CFR 71.55, “General Requirements for Fissile Material Packages”; 10 CFR 72.122, “Overall Requirements”)
- Fuel Rod Computer Codes, used to audit licensees’ evaluation models that demonstrate compliance with criteria and to analyze test data (10 CFR Part 50, “Domestic Licensing of Production and Utilization Facilities,” Appendix K, “ECCS Evaluation Models”; Regulatory Guide 1.183, “Alternative Radiological Source Terms for Evaluating Design-Basis Accidents at Nuclear Power Reactors”)

## Approach

Argonne National Laboratory, Oak Ridge National Laboratory, and Studsvik Nuclear AB hot cell laboratory (Sweden) are conducting a large experimental program with the active cooperation of the U.S. nuclear fuel industry, including the Electric Power Research Institute, Areva, Global Nuclear Fuel, and Westinghouse. The Pacific Northwest National Laboratory is conducting a modest support program for NRC’s fuel rod computer codes, along with a code users’ group consisting of 24 U.S. and international participants.

Other research with partial support from the NRC is conducted by the Halden Reactor Project (Norway), the Institute for Radiological and Nuclear Safety (France), the Japan Atomic Energy Agency, and Studsvik Nuclear AB. Additional arrangements exist with Finland and Spain that provide a mechanism to exchange technical data and analytical results.

### Loss-of-Coolant Accidents

During a postulated LOCA, the fuel rod cladding would experience very high temperatures and severe oxidation. The NRC’s regulations specify limits for temperature and oxidation to preserve ductility and thereby ensure a coolable geometry following this postulated accident. However, additional phenomena occur with high-burnup fuel that the original embrittlement criteria do not address. Nevertheless, current plant operations provide adequate assurance of safety, largely through the use of conservative methods.

Based on its research (Research Information Letter 0801, “Technical Basis for Revision of Embrittlement Criteria in 10 CFR 50.46,” dated May 30, 2008 (Agencywide Documents Access and Management System Accession Number ML081350225), the NRC is developing new performance-based criteria to account for high-burnup phenomena and to permit the use of new cladding materials without requiring license exemptions.

With the loss of reactor pressure and high temperatures experienced during a LOCA, some fuel rods will deform outwards and burst or rupture. The NRC is conducting a confirmatory research program aimed particularly at the behavior of the ballooned and burst region of high-burnup fuel under LOCA conditions. Figure 2.15 shows the integral LOCA test equipment that Studsvik laboratory in Sweden will use to test high-burnup irradiated rods.



Figure 2.15 Integral LOCA test equipment operating at 1,200C, at Studsvik laboratory in Sweden, where tests will be conducted on high-burnup, irradiated fuel rods

### Reactivity-Initiated Accidents

Following an accidental control rod ejection in a pressurized-water reactor (PWR) or control blade drop in a boiling-water reactor (BWR), the fuel rod cladding would experience very large stresses at relatively low temperatures. The NRC requirements specify limits on the energy deposited in these events to avoid cladding failure or dispersal of hot fuel particles with the potential for energetic fuel coolant interactions, core damage, and loss of coolability. However, additional phenomena occur with high-burnup fuel that lower the cladding's ductility and substantially reduce the amount of deposited energy that can be tolerated. Although some confirmatory work is continuing in France, using the CABRI reactor, and in Japan, using the Nuclear Safety Research Reactor, most of this research is complete and new criteria are being developed based on these results. Meanwhile, current plant operations provide adequate assurance of safety, largely as the result of the voluntary use of conservative methods.

### Transportation and Storage

During transportation and storage of spent fuel, the fuel rod cladding experiences higher temperatures and pressure differences than during full-power operation, and the fuel rods experience large impact loads in postulated accidents. Because of the fuel rod cladding's reduced ductility at high burnup, its mechanical properties and failure conditions are substantially altered.

Testing on high-burnup specimens of most commercial cladding types will provide the mechanical properties that are needed for safety analyses.

Storage conditions can also lead to changes in the morphology of hydrogen precipitates, leading to changes in the fracture properties of cladding material. Hydrogen is absorbed in the cladding during the burnup-related corrosion process under normal operation and typically precipitates in hydrides oriented in the cladding circumferential direction, as shown in Figure 2.16a below. Under storage conditions, the hydride precipitates may reorient in the cladding radial direction, as shown in Figure 2.16b, resulting in a reduction in cladding ductility. The NRC is currently conducting a research program aimed at identifying the conditions under which this reorientation takes place.

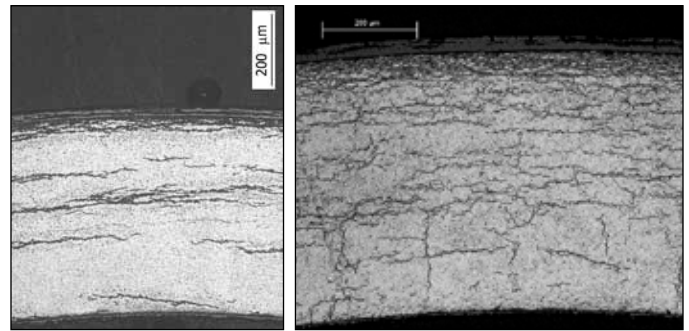

a.

b.

Figure 2.16 Metallographic images of irradiated cladding material showing hydride precipitates (a) with  $\sim 318 \pm 30$  wppm, predominantly oriented in the cladding circumferential direction; (b) with  $425 \pm 77$  wppm, oriented in both the radial and circumferential directions after heating cycle with stress.

### Fuel Rod Computer Codes

The NRC maintains computer codes for the analysis of both steady-state and transient conditions. The agency uses these codes to evaluate experimental data and to audit licensees' safety analyses. As new cladding alloys are introduced (e.g., Areva's M5 and Westinghouse's Optimized ZIRLO), burnable poisons are changed (e.g., high concentrations of gadolinia), and higher burnups are sought (beyond 62 gigawatt day per ton), the materials' properties and models in the codes must be revised. In-reactor tests are often used to obtain data for these changes. Halden results are particularly valuable. The ability to perform quantitative analyses of fuel rod behavior is an essential part of the NRC's assessment of safety in reactor operations and spent fuel transportation and storage.

### For More Information

Contact Harold Scott, RES/DSA at 301-251-7557 or [Harold.Scott@nrc.gov](mailto:Harold.Scott@nrc.gov)

Michelle Flanagan, RES/DSA at 301-251-7547 or [Michelle.Flanagan@nrc.gov](mailto:Michelle.Flanagan@nrc.gov)



# Spent Fuel Pool Criticality Analysis

## Background

Criticality analyses of spent fuel pools (SFP) inherently include some form of depletion analysis to characterize the composition of the spent fuel (an example of a SFP is shown in Figure 2.17). During irradiation, the fissile content of the uranium 235 isotope, in the uranium dioxide fuel, and the content of the embedded neutron absorbers are reduced. At the same time, the content of other fissile isotopes increases because of nonfission neutron capture. In addition, the fission process produces isotopes that are neutron absorbers.

The overall effect is a reduction of the fuel's ability to produce commercially viable amounts of power. Accounting for this depletion effect in the criticality analysis of spent nuclear fuel (SNF) is generally referred to as burnup credit.

To effectively use burnup credit, SFP analysis requires that the computer code used to calculate the reactivity of the SFP be validated over the range of interested nuclides. This validation is performed by benchmarking the code against experimental data. This results in a bias and uncertainty, for the code, which are used in the analysis to determine the SNF reactivity at a 95 percent probability level with 95 percent confidence, as codified in 10 CFR 50.68, "Criticality Accident Requirements."

## Objective

The RES objective is to establish a technical basis for SFP criticality safety evaluations and perform a validation of the SCALE 6 NRC neutronics analysis code suite to yield a code-independent methodology that licensees could use to perform a complete validation of their criticality codes.

## Approach

### The need

Currently, in the absence of an experimentally determined isotopic depletion uncertainty, the NRC reviewers use the guidance provided by the internal memorandum issued on August 19, 1998, known as the "Kopp Letter": An uncertainty equal to 5 percent of the reactivity decrement to the burnup of interest. The technical basis for this depletion uncertainty is not documented and is believed to be engineering judgment.

The need, therefore, is to develop a code-independent methodology that will result in the determination of depletion

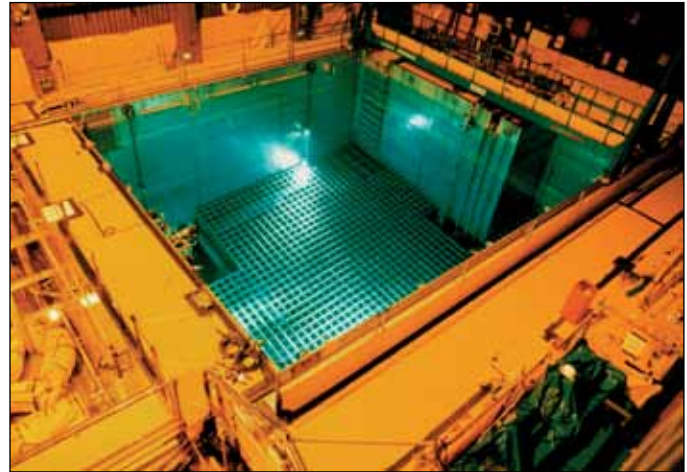

Figure 2.17 Commercial spent fuel pool

and criticality analysis code bias and bias uncertainties for the crediting of actinides and fission products (FP) in SFP criticality safety assessments.

## Research Activities

The development of the technical basis and analysis approaches include (1) the determination of SCALE 6 depletion sequence bias and bias uncertainty for depletion analysis crediting actinides only, FP only, and both actinides and FP, (2) the determination of the sensitivity of the SCALE 6 depletion sequence bias and bias uncertainty to SFP parameters, (3) the determination of SCALE 6 criticality analysis sequence bias and bias uncertainty for K-effective crediting actinides only, FP only, and both actinides and FP.

## Applications

The NRC has received increasingly complex license amendment requests with regard to the SFP. These have involved an ever decreasing center-to-center spacing between storage cells and the potential placement of more reactive fuel assemblies, among other differences. These license amendment requests have raised questions about the bases for and applicability of previously accepted assumptions, including some contained in staff guidance.

The results of the research will form a firm technical basis to define a recommended approach for SFP criticality analysis.

### For More Information

Contact Don Algama, RES/DSA at (301) 251-7940 or [Don.Algama@nrc.gov](mailto:Don.Algama@nrc.gov)

---

# Chapter 3: Severe Accident Research and Consequence Analysis

State-of-the-Art Reactor Consequence Analysis

Severe Accidents and the MELCOR Code

MELCOR Accident Consequence Code System and Its New Graphical User Interface: WinMACCS

Melt Coolability and Concrete Interaction Follow-On Program

Zirconium Fire Research

Aerosol Trapping in a Steam Generator (ARTIST)

Containment Analyses

Containment Iodine Behavior

Source Term Analysis

Phébus-Fission Products and Phébus-International Source Term Program

Fission Product Release and Transport Modeling for High-Temperature Gas-Cooled Reactor

Environmental Transport Research Program

Integrated Ground Water Monitoring and Modeling

In Situ Bioremediation of Uranium in Ground Water



Single zirconium fuel assembly under construction prior to fire testing.

# State-of-the-Art Reactor Consequence Analysis

## Background

The U.S. Nuclear Regulatory Commission (NRC) is conducting research to estimate the possible public health and safety consequences in the unlikely event of a commercial nuclear power plant accident releasing radioactive material into the environment. The agency has used accident assessment tools since its creation in the 1970s to help focus attention on the reactor design and operational features that are most important to safety. The State-of-the-Art Reactor Consequence Analysis (SOARCA) takes maximum advantage of hundreds of millions of dollars of national and international reactor safety research and reflects improved plant design, operation, and accident management implemented over the past 25 years. Using computer models and simulation tools, the NRC is developing a set of realistic consequence estimates of very unlikely accidents at an initial set of two U.S. reactor sites representative of different reactor and containment designs used in the United States. This kind of research into accident phenomena, such as core damage and containment performance, has provided the basis for industry procedures to mitigate such accidents.

## Approach

### SOARCA Plant-Specific Basis

Researchers from the NRC and Sandia National Laboratory are analyzing accident progression and consequences for two reactor and containment designs in use in the United States: a General Electric boiling-water reactor (BWR) with a Mark I containment (Peach Bottom) and a Westinghouse pressurized-water reactor (PWR) with a dry, subatmospheric containment (Surry).

### SOARCA Process And Schedule

This study uses state-of-the-art information and calculation tools to develop best estimates of radioactive material released into the environment based on the reactor and containment classes. The study assesses those releases to determine best estimates of offsite radiological consequences, including uncertainties in those results.

These new assessments consider areas such as: (1) design-specific reactor accident sequence progression; (2) design-specific containment failure timing, location, and size; (3) site-specific emergency planning assumptions, including evacuation and sheltering; (4) credit for operator actions; and (5) site-specific meteorological conditions and updated population data.

The project uses standardized plant analysis risk models or other available probabilistic risk analyses to determine the sequences and initiating events (internal and external) that should be considered for inclusion in the study. Scenario selection is based on an estimated core damage frequency of greater than  $10^{-6}$  per reactor-year (one in 1 million) or greater than  $10^{-7}$  per reactor-year (one in 10 million) for accidents which may bypass containment features. The project also incorporates insights gained from NRC research programs on containment performance and severe accident phenomena. Researchers are using a computer code that models accident progression (MELCOR) to estimate the radioactive material released into the environment for each scenario. Finally, MELCOR Accident Consequence Code System, Version 2 (MACCS2) is a computer code that models offsite consequences. MACCS2 is being used to generate site-specific consequence estimates that account for site-specific weather conditions, population distribution, and emergency planning assumptions.

### SOARCA Status

Of the initial scope of no more than eight plants, the NRC staff was able to secure three volunteers: Peach Bottom, Surry, and Sequoyah. (Analysis for Sequoyah began but was then deferred until completion of analyses for Peach Bottom and Surry.) Analyses have now been completed for Peach Bottom and Surry, and an external peer-review of the results has been completed. The NRC plans to initiate an uncertainty study in 2010 and expects to release the results from these two plants in early 2011 for public review and comment. Preliminary results shown in Figure 3.1 demonstrate that current predictions differ dramatically from those of previous studies.

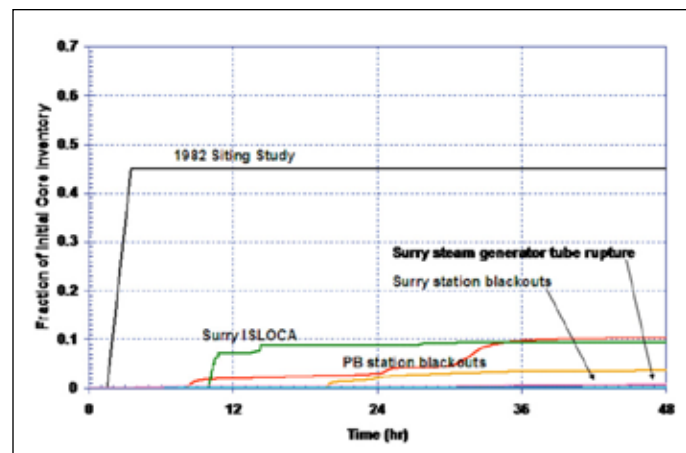

Figure 3.1 Iodine release for unmitigated cases

### For More Information

Contact Richard Chang, RES/DSA at 301-251-7980 or [Richard.Chang@nrc.gov](mailto:Richard.Chang@nrc.gov).

# Severe Accidents and the Melcor Code

## Background

The risk to the public from nuclear power generation arises if an accident progresses to the point at which fuel degradation occurs, and large quantities of radioactive materials are released into the environment. The NRC has invested heavily in the investigation of severe reactor accidents and has developed computer codes for the analysis of severe accident phenomena and progression. Expertise on severe accident phenomenological behavior and a quantitative predictive capability for simulating the response of nuclear power systems to severe accidents are essential to the NRC's mission. The role of such expertise and analytical capability is potentially wide ranging in the regulatory environment, which includes the transition to a more risk-informed regulatory framework and to the study of vulnerabilities of nuclear power plants. MELCOR represents the current state of the art in severe accident analysis, which has developed through NRC and international research performed since the accident at Three Mile Island in 1979.

## Objective

The objective of this research is to maintain NRC staff expertise on severe accident phenomenological behavior and a computer code for analysis of nuclear power plants' response to severe accidents.

## Approach

The MELCOR code is a fully integrated, engineering-level computer code whose primary purpose is to model the progression of postulated accidents in light-water reactors (LWRs), as well as in nonreactor systems (e.g., spent fuel pool (SFP) and dry cask). MELCOR is a modular code consisting of three general types of packages: (1) basic physical phenomena (i.e., hydrodynamics—control volume and flowpaths, heat and mass transfer to structures, gas combustion, aerosol and vapor physics), (2) reactor-specific phenomena (i.e., decay heat generation, core degradation and relocation, ex-vessel phenomena, engineering safety systems), and (3) support functions (i.e., thermodynamics, equations of state, material properties, data-handling utilities, equation solvers). These packages model the major systems of a nuclear power plant and their associated interactions (see Figures 3.2. and 3.3). MELCOR 1.8.6 (Fortran 77) was released in September 2005; the code modernization effort resulted in the release of MELCOR 2.0 (Fortran 95) in September 2006. The latest version (MELCOR 2.1) was released in September 2008.

Current activities will include development and implementation of new and improved models to predict the severe accident behavior of advanced non-LWR reactor designs.

Severe accident competency is needed to evaluate new generic severe accident issues and to address risk-informed regulatory initiatives and operating reactor issues associated with plant changes, as in the case of steam generator tube integrity. Licensees will continue to pursue plant modifications that require assessment of incremental risk impacts that will necessitate analysis of phenomena related to severe accidents.

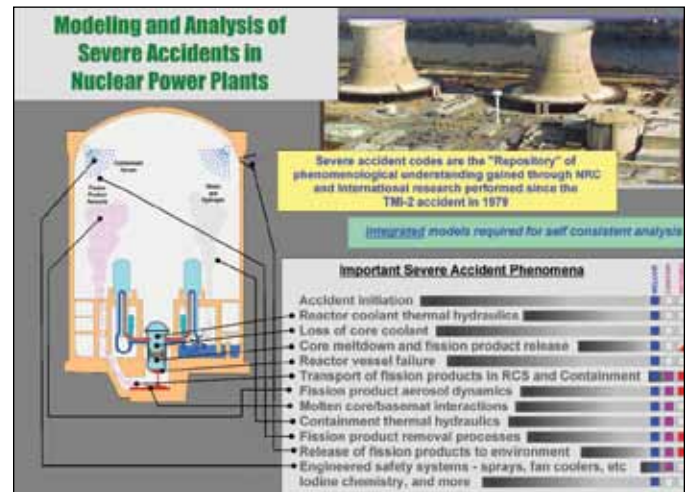

Figure 3.2 MELCOR modeling capabilities

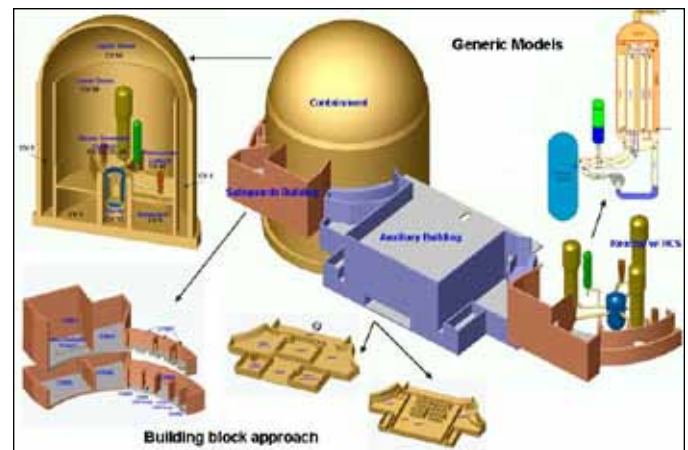

Figure 3.3 MELCOR plant modeling approach

## Applications

The improved understanding of phenomenological behavior and modeling in severe accidents and their implementation in MELCOR directly impacted the analytical methods and criteria adopted for design-basis accidents (e.g., source term research and the revised source term). The development of best-estimate severe accident models in the future is expected to improve the licensing evaluation models. The development of best-estimate



models reveals, quantitatively, margins in existing models. Activities associated with the development, assessment, and applications of MELCOR include the following:

- safety analysis and risk decisionmaking
  - revision of the NRC’s alternative source term (NUREG-1465, “Accident Source Terms for Light-Water Nuclear Power Plants,” issued February 1995) for high-burnup fuel and mixed-oxide (MOX) fuel
  - new reactor certification (Advanced Passive 1000 Megawatt (AP1000), Economic Simplified Boiling-Water Reactor (ESBWR), U.S. Evolutionary Power Reactor (EPR), U.S. Advanced Pressurized-Water Reactor (U.S. APWR), Advanced Boiling-Water Reactor (ABWR))
- experimental analyses and code validation activities
- nuclear power plant beyond-design-basis accidents
- aerosol transport and deposition in steam generators during bypass accidents
- risk of steam generator tube rupture induced by a severe accident
- effects of air ingress on fission product release
- vulnerabilities of SFP to accidents
- state-of-the-art consequence analysis

National laboratories, universities (e.g., Texas A&M), and international organizations (e.g., Paul Scherrer Institute in Switzerland) are involved in the MELCOR code development effort.

A Symbolic Nuclear Analysis Package (SNAP) plug-in has been developed for MELCOR, and the integration of MELCOR and SNAP provides a more user friendly system for input deck preparation and accident simulation. The accident simulation models for new reactor designs, including the EPR (see Figures 3.4 and 3.6), ABWR (see Figure 3.5), U.S. APWR, AP1000, and ESBWR, are

under development. The models run in severe accident and design-basis accident modes (containment peak pressure and source term). The models provide a convenient display system for the user to define an accident sequence by introducing system malfunctions (e.g., loss-of-coolant accident (LOCA)) and controls (e.g., emergency core cooling system (ECCS)) to mitigate the consequences of the accident. In addition, the user can visually see the progression of an accident (e.g., core heatup and degradation) as the calculation is progressing. The following figures illustrate examples of the simulation models for the EPR and ABWR, including core degradation and available system interfaces.

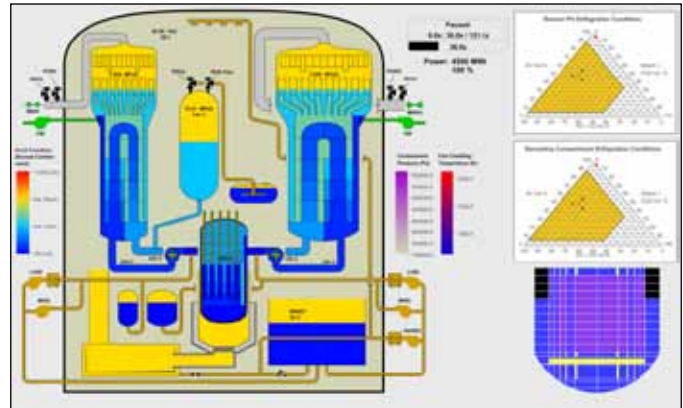

Figure 3.4 EPR simulation model

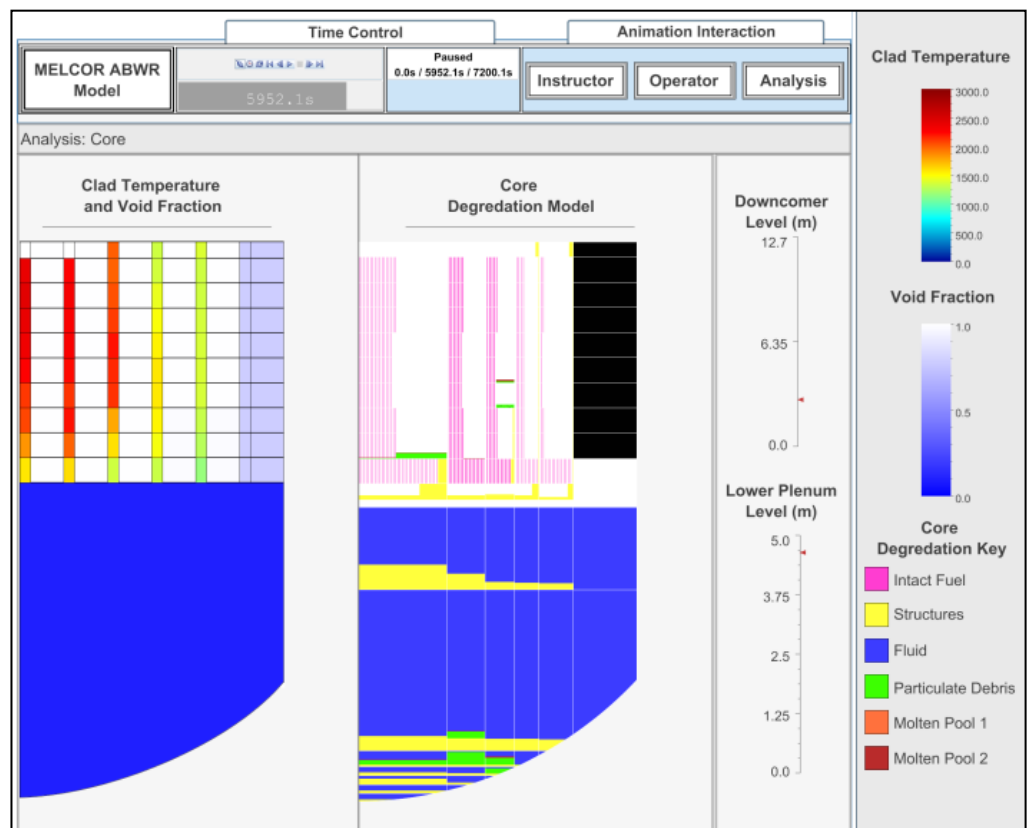

Figure 3.5 ABWR core heatup and degradation

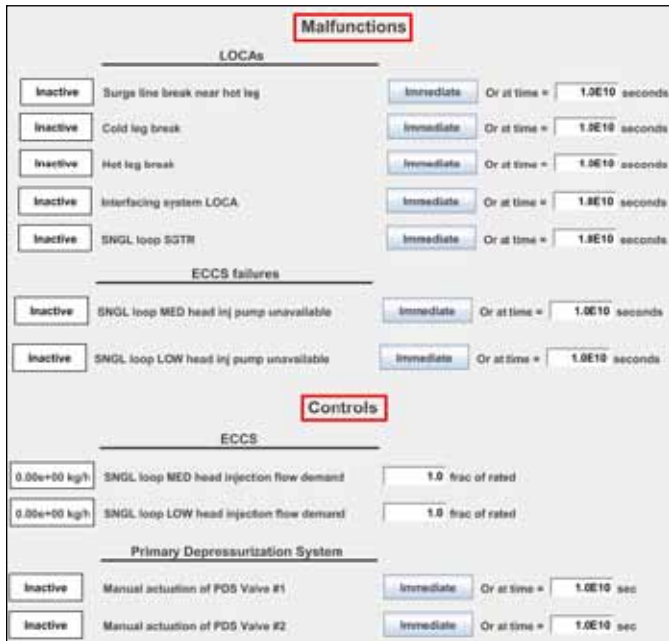

Figure 3.6 EPR user interface model

## International Collaborations

The following examples of international collaborations resulted in MELCOR improvements:

- NRC Cooperative Severe Accident Research Program (CSARP)
- MELCOR Code Assessment Program (MCAP)
- Phébus-Fission Products (Phébus FP), VERCORS (a French test program), and follow-on program (Phébus-Source Term Separate Effects Test Project (STSET)), French Institute for Radiological Protection and Nuclear Safety (IRSN): This project investigates fission product releases and degradation of uranium dioxide (UO<sub>2</sub>) fuel (including burnup greater than 40 gigawatt day per metric ton) and MOX fuel under severe accident conditions, and the effects of air ingress on core degradation and fission product release. Results are used to validate the NUREG-1465 source term and MELCOR code.
- German QUENCH experiment program to investigate overheated fuel.
- ARTIST, Paul Scherrer Institute (Switzerland): This project investigates experimentally the potential mitigation of radioactive material releases through the secondary side of a steam generator. Results from this research would allow the NRC to decide whether improved source term bypass models are needed.
- Molten Core Concrete Interaction Program, Organization for Economic Cooperation and Development (OECD) and Argonne National Laboratory (U.S.): This project consists

of separate effects experiments to further address the ex-vessel debris coolability issue. The results will be used to develop coolability models.

- Behavior of Iodine Project (BIP), Nuclear Energy Agency, Committee on the Safety of Nuclear Installations (France): Experimental investigations of iodine behavior in containment during conditions following a severe accident for computer code model development and validation. BIP addresses the uncertainties related to iodine behavior (especially with respect to iodine interactions with paints). Together with complementary testing at Atomic Energy of Canada Ltd. (AECL) and IRSN, this project advances and quantifies the state of the art on modeling of iodine behavior in the containment. Adequate modeling of iodine behavior is crucial in determining the need for pH control in containment sump. The proposed research will complement the ongoing IRSN projects of France Phébus-FP and follow-on program, Phébus STSET.

### For More Information

Contact Hossein Esmaili, RES/DSA at 301-251-7554 or Hossein.Esmaili@nrc.gov

# Melcor Accident Consequence Code System and its New Graphical User Interface, WinMACCS

## MACCS

The NRC uses the MELCOR Accident Consequence Code System (MACCS) to estimate the offsite consequences from radioactive material released into the atmosphere. The MACCS code, first released in 1987, was developed to remedy limitations in Calculation of Reactor Accident Consequences (CRAC), a code developed in the 1970s for the WASH-1400 study, entitled, "The Reactor Safety Study." This study was a probabilistic risk assessment (PRA) of hypothetical nuclear power plant accidents. The MACCS code has evolved through the years into a more complex and realistic set of models for offsite consequences. The improved version of the MACCS code was named MACCS2.

## MACCS2 and its Graphical User Interface: WinMACCS

Recently, a new Version 2.4 of MACCS2 has been released, along with the graphical user interface, WinMACCS Version 3.4 (see Figure 3.7).

Meteorological sampling capabilities have been maintained from the earliest version of the code (CRAC). Now, uncertainty in source term and in many other parameters, including parameters related to emergency response, can be easily input through WinMACCS. The two most important improvements implemented in MACCS2/WinMACCS are the ability to easily evaluate the impact of parameter uncertainty and the ability to model alternative dose-response relationships for latent cancer fatality evaluation (e.g., the Health Physics Society type of threshold for latent cancer).

### Other Improvements in Maccs Version 2.4

- more cohorts for evacuation (20)

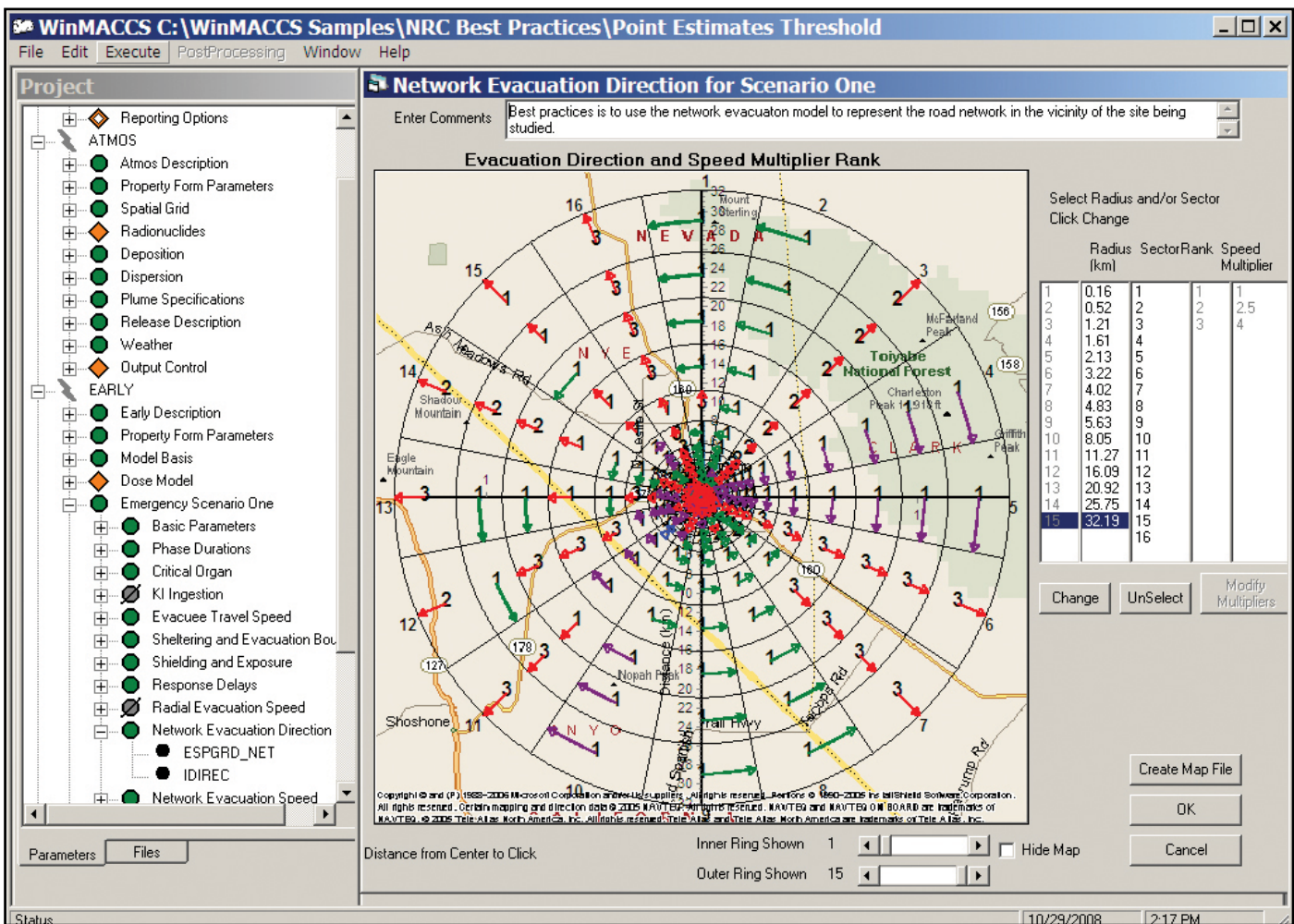

Figure 3.7 Graphical view of WinMACCS (network evacuation model is shown)



- potassium iodine ingestion model
- more compass directions (up to 64)
- more plume segments (up to 200)
- more aerosol bins and chemical groups (20)
- multiple meteorological data intervals (15, 30, or 60 minutes)
- diurnal mixing-height model
- long-range, lateral plume spread model
- improved Briggs plume rise model
- plume meander based on Regulatory Guide 1.145, “Atmospheric Dispersion Models for Potential Accident Consequence Assessments at Nuclear Power Plants”
- dynamic memory allocation

### Features of WinMACCS Version 3.4

- cyclic handling of MELCOR source terms
- graphical manipulation of MACCS2 network evacuation parameters (e.g., direction and speed)
- editing of grand mean and arbitrary quantile levels for uncertainty calculations
- option to remove food pathway

## MACCS2/WinMACCS Uses

Offsite consequence evaluations are used to evaluate the consequences of severe radiological accidents as part of the environmental reports and environmental impact statements for early site permits, to support plant-specific evaluation of severe accident mitigation alternatives required as part of the environmental assessment for license renewal, to assist in emergency planning, and to provide input to cost/benefit analyses.

## New Work

Work is ongoing to update the MACCS2 code based on current technology.

The new work will develop and implement a more detailed and up-to-date economic model and an approach for treating complex wind patterns. Other modifications will allow additional flexibility in specifying population groups (i.e., at a specific location in a defined grid area and with a finer resolution) as a function of distance from the release location.

For uncertainty analyses, capabilities are being implemented to sample dose conversion factor values and distribute numerous MACCS2 runs into a computer network cluster; this effort will include postprocessing of the results.

The current schedule envisions a new version of MACCS2/WinMACCS by December 2011.

### For More Information

Contact Carlos Navarro, RES/DSA at 301-251-7485 or [Carlos.Navarro@nrc.gov](mailto:Carlos.Navarro@nrc.gov)

# Melt Coolability and Concrete Interaction Follow-on Program

## Background

The goal of the Melt Coolability and Concrete Interaction Follow-on (MCCI-2) research program is to conduct reactor material experiments and associated analysis to achieve the following two technical objectives: (1) resolve the ex-vessel debris coolability issue through a program that focuses on providing both confirmatory evidence and test data for coolability mechanisms identified in earlier integral tests and (2) address remaining uncertainties related to long-term, two-dimensional core-concrete interactions (CCIs) under both wet and dry cavity conditions. Achievement of these objectives will demonstrate the efficacy of severe accident management guidelines for existing plants and provide the technical basis for better containment designs.

## Approach

The risk to the public from nuclear power generation arises if an accident progresses to the point where fuel degradation occurs. In the most extreme postulated event sequences, molten fuel could hypothetically fail the reactor vessel, leading to melt discharge into the containment. The NRC has computer codes that simulate the progression of severe accidents. The agency uses these codes to evaluate the consequences of beyond-design-basis accidents; thus, they are an important tool in the transition to a more risk-informed regulatory framework.

The improved understanding of phenomenological behavior under both design- and beyond-design-basis accident sequences has direct implications for the analytical methods. The improved models for debris coolability and molten CCI gained from the MCCI program will reduce uncertainties when applied to risk assessments of the current fleet and new plant designs.

In terms of the ex-vessel debris coolability, two types of separate effects tests were conducted to provide data on key cooling mechanisms. In the original MCCI program, the melt eruption test focused on providing data on the melt entrainment coefficient under well-controlled experimental conditions. The entrainment rate data provided coefficient estimates that can be used in models for evaluating the effect of melt ejection on mitigation of accident sequences. The small-scale water ingress and crust strength (SSWICS) tests provide data on the ability of water to ingress into core material, thereby augmenting the otherwise conduction-limited heat transfer process (see Figure 3.8). These tests showed that the dry-out limit is a strong



Figure 3.8 SSWICS test stand

function of melt composition, but weakly dependent on system pressure. Crust strength data obtained as part of this work verified the concept of sustained melt/crust contact as the result of crust instability in the typical cavity span of most power plants.

With regard to CCI, the approach was to conduct integral effect tests that replicate as closely as possible the conditions at plant scale, thereby providing data that can be used to verify and validate the codes directly. To augment the amount of information gathered from these tests, the experiments were flooded from above after a predefined concrete ablation depth was reached to provide debris coolability data under conditions involving late-phase flooding. The input power levels for the tests were selected so that the heat fluxes from the melt to concrete surfaces and the upper atmosphere were initially in the range of the heat flux expected early in the accident sequence. The results of these tests indicate that the directional power split is a strong function of concrete characteristics; the split is approximately unity for limestone/common sand concrete, whereas the split is significantly larger than unity for siliceous concrete.

In terms of the applicability to plant conditions, the tests provided information that contributes to the database for reducing modeling uncertainties related to two-dimensional, molten CCI under both wet and dry cavity conditions. Data from these and other test series form a technical basis for developing and validating models of the various cavity erosion and debris cooling mechanisms. These models can then be deployed in integral codes that are able to link the interrelated



Figure 3.9 Posttest debris from CCI tests

phenomenological effects, thereby forming the technical basis for extrapolating the results to plant conditions. Furthermore, current experiments are designed to address special mitigation features that can enhance coolability in new reactor designs. For example, an integral test will be conducted to investigate the effect of cooling the molten corium from the bottom through a system of pipes, which is expected to expedite stabilization.

As part of the project, analytical models were upgraded to include the experimental findings related to debris coolability and to scope out an approximate debris coolability envelope for the two concrete types that the program evaluated. The results for limestone/common sand concrete indicate that melt stabilization may be achievable in under 1 meter of axial ablation as long as the cavity is flooded before the melt concrete content exceeds 15 weight percent for initial melt depths ranging up to 40 centimeters. For siliceous concrete, stabilization may not be achieved in under 1 meter of ablation unless the initial melt depth is fairly shallow (i.e., less than 20 centimeters), and the cavity is flooded before the melt concrete content exceeds 10 weight percent.

As a whole, the results of the CCI tests indicate trends in the ablation front progression that cannot be fully explained on the basis of the current understanding of the phenomenology involved with this type of physical process (see Figure 3.9). These trends are currently under investigation, and data acquired in the MCCI-2 program will allow analysts to extrapolate experimental results to plant scale with higher confidence.

#### For More Information

Contact Annie Ramirez, RES/DSA at 301-251-7537 or [Annie.Ramirez@nrc.gov](mailto:Annie.Ramirez@nrc.gov)

# Zirconium Fire Research

## Background

In 2001, the NRC staff performed an evaluation of the potential accident risk in a spent fuel pool (SFP) at decommissioning plants in the United States. NUREG 1738, “Technical Study of Spent Fuel Pool Accident Risk at Decommissioning Nuclear Power Plants,” describes a modeling approach for a typical decommissioning plant with design assumptions and industry commitments, the thermal-hydraulic (T/H) analyses performed to evaluate spent fuel stored in the SFP at decommissioning plants, the risk assessment of SFP accidents, the consequence calculations, and the implications for decommissioning regulatory requirements. Some of the assumptions in the accident progression in NUREG-1738 were known to be necessarily conservative, especially the estimation of the fuel damage. The NRC continued SFP accident research by applying best-estimate computer codes to predict the severe accident progression following various postulated accident initiators. The best-estimate computer code studies identified various modeling and phenomenological uncertainties that prompted a need for experimental confirmation. The NRC undertook the present experimental program to address T/H issues associated with complete loss-of-coolant accidents (LOCA) in pressurized-water reactor (PWR) SFPs. The NRC also plans to expand the study to include accidents in the SFPs of operating power plants.

## Objective

The objective of this project is to provide basic T/H data associated with an SFP complete LOCA. The accident conditions of interest for the SFP were simulated in a full-scale prototypic fashion (electrically heated, prototypic assemblies in a prototypic SFP rack) so that the experimental results closely represent actual fuel assembly responses. A major impetus for this work is to facilitate code validation (primarily MELCOR) and reduce modeling uncertainties within the code.

## Testing Approach

The study will be conducted in two phases. Phase 1 will focus on axial heating and burn propagation. A single full-length test assembly will be constructed with zirconium-alloy clad heater rods (see Figure 3.10). As demonstrated in the previous study for boiling-water reactors (BWR), the thermal mass of the compacted magnesium oxide (MgO) powder used to make the electric heater is an excellent match to spent fuel. The assembly will be characterized in two different-sized storage cells and conclude with an ignition test to determine where in the assembly ignition first occurs and the nature of the burn along the axis of the assembly. The insulated

boundary conditions will experimentally represent a “hot neighbor” situation, which is an important bounding scenario.

Phase 2 will address radial heating and burn propagation and will include effects of fuel rod ballooning. Five full-length assemblies will be constructed in which the center assembly will be of the same heated design as used in Phase 1. The four peripheral assemblies will be unheated but highly prototypic, incorporating prototypic fuel tubes and end plugs. These boundary conditions experimentally represent a “cold neighbor” situation, which complements the bounding scenario covered by Phase 1. The peripheral fuel rods will be filled with high density MgO ceramic, sized to precisely match the thermal mass of spent fuel. Studies using this test assembly will conclude with a fire test in which the center assembly is heated to ignition, which eventually propagates radially to the peripheral assemblies. All of the fuel rods in two of the four peripheral assemblies will be pressurized with helium so that these fuel rods will balloon when the zirconium-alloy cladding reaches a high enough temperature. The two peripheral assemblies without pressurized rods will serve as a control for evaluating the effect of ballooning.

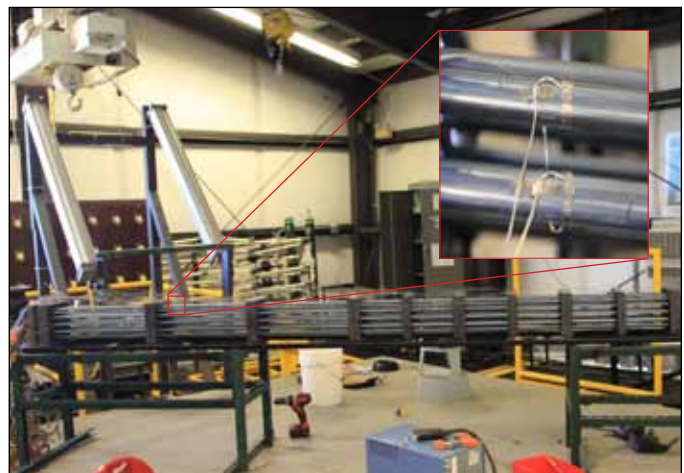

Figure 3.10 Single fuel assembly for Phase 1 testing in construction stage with a closeup view of an installed thermocouple

## Analysis Support

As in the previous BWR study, all stages of testing will use MELCOR modeling results. Pretest MELCOR modeling results will be used to guide the experimental test assembly design and instrumentation. MELCOR modeling results will also be used to choose experimental operating parameters, such as the applied assembly power. At each step in the testing, improvements will be made to the MELCOR model to continually increase confidence in the modeling validity.

### For More Information

Contact Ghani Zigh, RES/DSA at 301-251-7505 or [Ghani.Zigh@nrc.gov](mailto:Ghani.Zigh@nrc.gov)



# Aerosol Trapping in a Steam Generator (ARTIST)

## Background

Risk analyses often find containment bypass accidents to be risk dominant, even though such accidents may not have particularly large predicted frequencies. Because the release of radioactivity from the core is not to the containment but to the secondary side of the steam generator, less opportunity exists for natural and engineered systems to attenuate the release.

NUREG-1150, “Severe Accident Risks: An Assessment for Five U.S. Nuclear Power Plants,” identifies the attenuation of radionuclide release in the secondary side of a steam generator as an important uncertainty. The NUREG-1150 study predicted low, but very uncertain, decontamination factors for radionuclide release to the secondary side of steam generators. Subsequent analyses by industrial investigators suggested that much higher natural decontamination was possible in steam generators even if these generators could not be reflooded. The discrepancy in analysis results was, in part, the result of differences in the aerosol particle sizes assumed in the NUREG-1150 study and in the industrial analysis. Differences in aerosol behavior correlations were also responsible for some of the discrepancies.

The original Aerosol Trapping In a Steam Generator (ARTIST) experimental project was designed to determine the amount of aerosol retention that could occur on the secondary side of a pressurized-water reactor (PWR) steam generator in the event of a steam generator tube rupture (SGTR) accident that progressed to core damage and the release of significant quantities of radioactivity (see Figure 3.11). Such postulated SGTR accidents are part of a class of accidents that allow radioactive effluent produced during core-damaging accidents to bypass the reactor containment. A seven-phase international project (2003–2007) conducted at the Paul Scherrer Institut (PSI) in Switzerland investigated aerosol and droplet retention in a model steam generator under dry, wet, and accident management conditions. This collaborative international research was part of a larger effort to make MELCOR, the NRC’s accident analysis computer code, yield realistic results. The NRC used the data to develop and validate the model for attenuation of radioactive aerosols in the steam generator secondary side.



Figure 3.11 ARTIST facility

Data from the integral tests, together with data from several separate-effects tests, were used to refine correlations for the decontamination of aerosol-laden gas used in the MELCOR accident analysis code. The objectives of the ARTIST project have largely been met.

The original ARTIST tests strongly suggested that particles composed of agglomerates of primary particles can break up in high-velocity flows through steam generators. The tests also suggest that conglomerates will disintegrate to about 0.8 micrometers. The experimental program also noted evidence of particle resuspension, particle bounce, and likely saltation.

## Objective

The NRC’s objective in this experimental program is to develop models for aerosol bounce, breakup, and resuspension to better predict fission product release during postulated reactor accidents.

## Approach

The ARTIST-II project is an international research project. In this project, PSI will conduct further experiments of aerosol retention under the following conditions:

- in the primary side of a steam generator tube containing a break
- in the secondary side of a dry steam generator bundle
- in a flooded bundle
- in a flooded separator

Experimental parameters were changed over those conducted in ARTIST-I. Changes were made to aerosol concentration and material, including the use of liquid aerosols. Additional instrumentation was also added to the facilities. A sample of the results obtained from ARTIST II is provided at right (see Figure 3.12).

One experimental phase added in ARTIST-II is a thermodynamic study of flashing to determine the droplet mass flux and size distribution that one would get from flashing in an SGTR. A literature review is in progress. Models are planned to be entered in MELCOR using control functions.

The various participants in this international project also contribute to the project. In-kind participant contributions include both experimental and theoretical work. Analytical contributions include simulating experiments and modeling of phenomena. Experimental contributions include aerosol retention in bundles and scrubbing of aerosols from exhaust gases, as well as an analysis of agglomerate bounce and breakup.

The NRC's primary focus for, and contribution to, the ARTIST-II project centers on the modeling of aerosol bounce, breakup, and resuspension. Agency researchers are applying deterministic and probabilistic models for bounce and breakup found in literature to the modeling. Furthermore, aerosols were numerically grown in a manner representing diffusion processes. Discrete element simulations have been conducted on these generated aerosols to provide insight into the experimental research. These simulations consist of adding adhesion models to the simulation code, impacting the virtual particles into a virtual wall, and observing the fragmentation following impact. Analyses vary impact velocity and interparticle adhesion forces and may vary wall rigidity and particle-wall forces.

Theoretical work underway on breakup suggests that aerosol particles in the steam generator secondary side will not grow to large sizes.

## Applications

Data from this experimental program are used to develop and improve models for the NRC MELCOR severe accident code. The MELCOR code is used in the risk and vulnerability assessment of operating nuclear power plants and certification of new reactor designs.

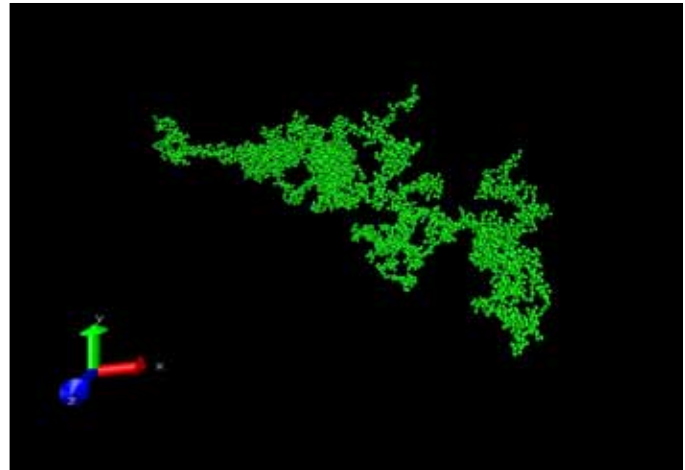

Figure 3.12 Sample of results obtained from ARTIST-II

### For More Information

Contact Michael Salay, RES/DSA at 301-251-7543 or [Michael.Salay@nrc.gov](mailto:Michael.Salay@nrc.gov)



# Containment Analyses

## Background

The containment encloses the reactor system and is the final barrier against the release of radioactive fission products in the event of a breach of either the primary or secondary coolant system. Evaluations entail a variety of postulated design-basis and beyond-design-basis (including core melt) events involving accident progression and radiological source term calculations. Computer codes, such as CONTAIN and MELCOR, are used in licensing reviews (including new reactor designs), in addressing regulatory safety issues (e.g., generic safety issues, risk-informing regulations), and in responding to changes in containment safety margins. These computer codes serve as a repository of accumulated knowledge in the area of containment and severe accident research and will be improved as new information is collected and disseminated.

## Objective

The objective of this research is to maintain NRC staff expertise and analytical tools on design-basis and beyond-design-basis containment analysis for current light-water reactors (LWR) and new reactor designs.

## Approach

CONTAIN and MELCOR are state-of-the-art lumped parameter codes which offer a greater robustness in analyzing a broader array of reactor containment designs (see Figure 3.13).

### For More Information

Contact Allen Notafrancesco, RES/DSA at 301-251-7560 or [Allen.Notafrancesco@nrc.gov](mailto:Allen.Notafrancesco@nrc.gov)

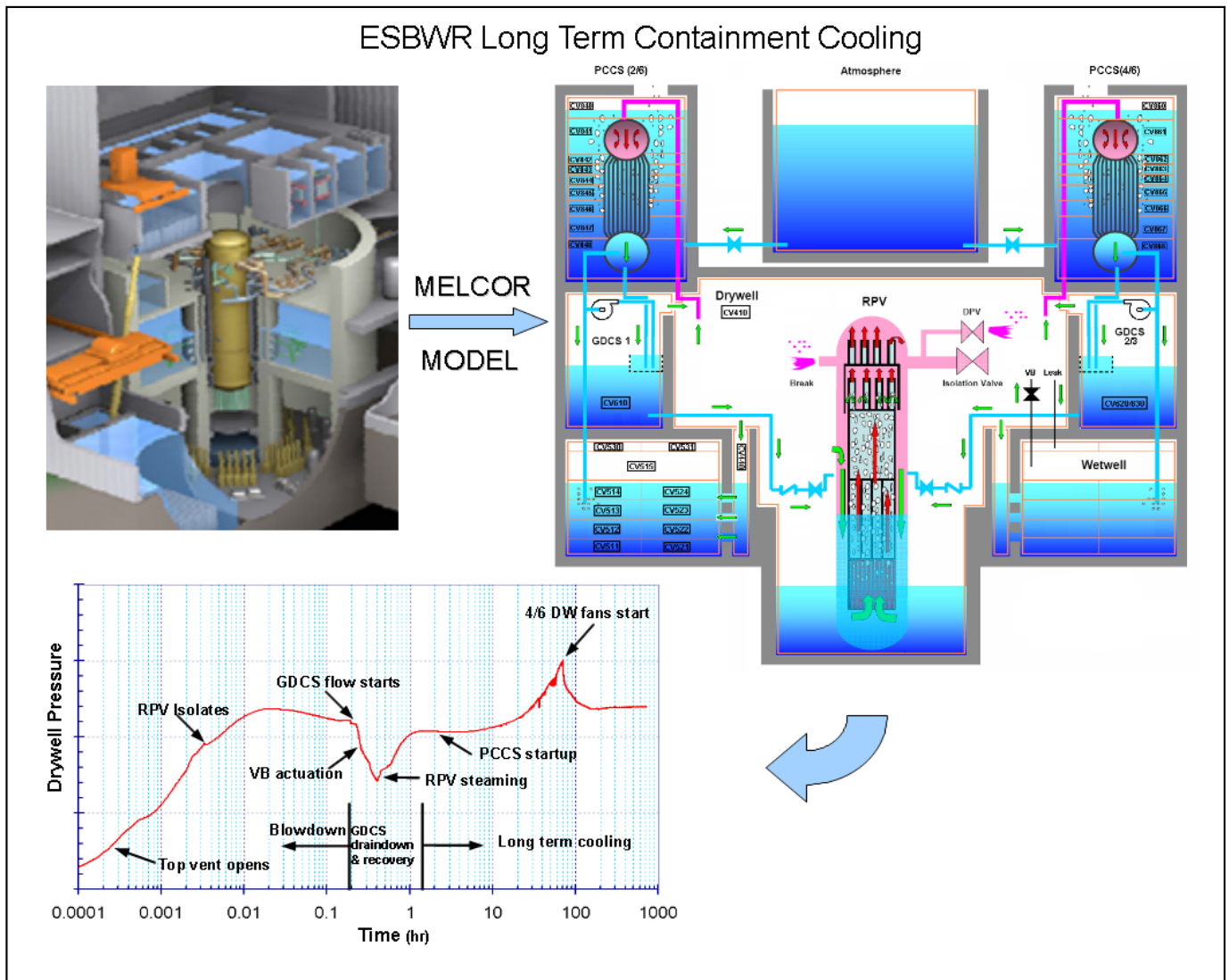

Figure 3.13 ESBWR long-term containment cooling

# Containment Iodine Behavior

## Background

The integral Phébus-FP experiments provided an opportunity to test code predictions of overall severe accident behavior. One aspect that could be improved was the prediction of containment iodine behavior. Previously conducted pure water benchtop experiments suggested that preventing PWR sump water from becoming acidic is necessary and sufficient to prevent significant gaseous iodine from evolving in a reactor containment following an accident involving core damage. However, the observations of the Phébus FP experiments, the complexity of which more closely matches prototypic severe accident behavior, show that this may not necessarily be the case for power reactors.

Iodine is one of the major contributors to dose in analyses of postulated reactor accidents and therefore merits more attention than less dose-important elements. Because iodine's dose contribution results from gaseous and particulate fission products contained in gas leaking from the reactor and containment, reducing the amount of airborne fission products reduces the contribution to dose. To minimize the iodine dose, pressurized-water reactor (PWR) sumps are buffered to keep the sump water alkaline, thus preventing the iodine that reaches the sump from converting to volatile forms which can then be released to the containment atmosphere.

The results of the Phébus-FP tests indicate that controlling the sump pH may not significantly impact the development of a gaseous iodine concentration in the reactor containment in the immediate aftermath of an accident involving core degradation. Two aspects of the Phébus-FP experiments that influenced this iodine behavior were the presence of condensing surfaces and the presence of additional materials in the sump. Liquid films developing on surfaces are not affected by the buffer in the sump; therefore, they do not remain alkaline and thus do not prevent the iodine in these films from converting to volatile forms which may subsequently be released to the containment atmosphere.

In addition to iodine, other fission products and structural materials released from the degrading test bundle reached the sump in the Phébus-FP experiments. Consequently, the Phébus-FP sump chemistry far better represents that of a prototypic reactor than previous experiments did. In the Phébus-FP experiments, which used silver-indium-cadmium control rods, the silver that reached the sump reacted with iodine to form a precipitate which

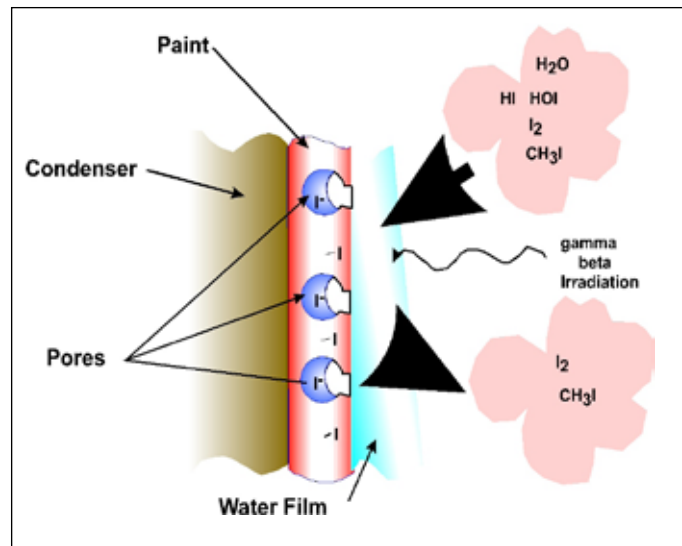

Figure 3.14 Hypothesized mechanism for gaseous iodine source in the Phébus-FP tests

effectively prevented iodine in the sump from being released to the containment atmosphere, even when the sump water was acidic.

The iodine concentrations observed in the Phébus-FP experiments cannot be directly applied to reactor containments since the facility was not scaled for gaseous iodine behavior. To scale this iodine behavior to power reactor containments, it is necessary to account for differences between the Phébus-FP facility and power reactors. Relevant differences include higher dose rates, different containment surface-to-volume ratio and fractional sump settling area, different surface materials, different airborne materials (e.g., from radiolytic destruction of cables), different materials present in sumps, and paint aging. Properly accounting for these differences will require mechanistic models of iodine behavior.

## Objective

The objective of this research is to develop mechanistic models of the phenomena governing the containment iodine behavior observed in the Phébus-FP experiments so that this observed behavior can be scaled to operating power reactors.

## Approach

The overall approach for resolving the iodine issue is as follows:

- Test hypotheses against experiments.
- Develop models and validate models with further experiments.
- Simulate the Phébus-FP experiment.

- Simulate power plants.
- Evaluate sensitivities and uncertainty.
- Peer review models and analyses.
- Make recommendations related to gaseous iodine behavior.

The approach for developing models to scale the iodine behavior of the Phébus-FP experiments has been to systematically test various working hypotheses describing the persistent gaseous iodine behavior (see Figure 3.14).

To obtain data to test hypotheses for gaseous behavior and validate the developed models, RES is participating in two international separate effects research programs: (1) BIP, which is organized by OECD and conducted by AECL (see Figure 3.15), and (2) the Experimental Program for Iodine Chemistry Under Radiation (EPICUR), which is part of the Phébus-International Source Term Program (Phébus-ISTP) follow-on to the Phébus-FP experiments conducted by IRSN (see Figure 3.16).

For a steady-state concentration of gaseous iodine to exist, sources of gaseous iodine must balance the sinks of gaseous iodine. The experimental work and modeling is directed towards identifying and characterizing the sources and sinks of gaseous iodine. Based on observations of the Phébus-FP experiments, the results of additional separate-effects experiments, and analyses, it is believed that the source of the persistent gaseous iodine in the Phébus-FP experiments was the containment surfaces upon which iodine deposited. Figure 3.14 shows a schematic of the hypothesized mechanism for this source. The general mechanism can be described as follows:

- Particulate and gaseous iodine is released to the containment from the reactor coolant system.
- Particles deposit and gases adsorb on surfaces in containment.
- Particles decompose and gases absorb into paint.
- Irradiation releases iodine vapors.
- Vapors react in atmosphere to form iodine oxide particles.

Development of standalone models to predict the gaseous iodine behavior is currently under way. This modeling will be used to guide further experimental testing.

## Applications

A simplified subset of the developed models will be included in the MELCOR severe accident code. The MELCOR code is used for safety analysis and risk-informed decisionmaking. The results of the iodine modeling and analyses conducted with these models will provide the technical basis for a recommendation on the need for buffering in PWR sumps. The modeling is expected to affect assumptions made in future dose calculations.



Figure 3.15 BIP irradiation vessel with sample coupons

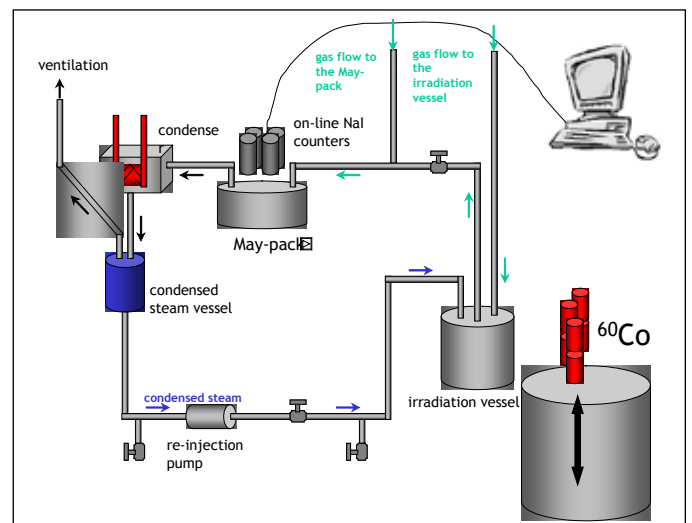

Figure 3.16 EPICUR experimental setup (one of the experiments under the Phébus-ISTP program)

### For More Information

Contact Michael Salay, RES/DSA at 301-251-7543 or Michael.Salay@nrc.gov

# Source Term Analysis

## Background

The use of postulated accidental releases of radioactive materials is an integral part of defining the NRC's regulatory policy and practices. The regulations in Title 10 of the Code of Federal Regulations (10 CFR) Part 100, "Reactor Site Criteria," require that, for licensing purposes, an accidental fission product release resulting from "substantial meltdown" of the core into the containment be postulated to occur. The regulations also require evaluation of the potential radiological consequences of such a release, assuming that the containment remains intact but leaks at its maximum allowable leak rate. Radioactive material escaping from the containment is often referred to as the "radiological release to the environment." The radiological release is obtained from the containment leak rate and knowledge of the airborne radioactive inventory in the containment atmosphere. The radioactive inventory within containment is referred to as the "in-containment accident source term."

Regulatory source terms provide a prescription of fission product release magnitude and timings that represents a broad range of accident scenarios. In addition to site suitability, the regulatory applications of this source term (in conjunction with the dose calculation methodology) affect the design of a wide range of plant systems.

Most of the currently operating power reactors in the United States were designed and licensed based on the source term described in Technical Information Document (TID)-14844, "Calculation of Distance Factors for Power and Test Reactors," issued by the Atomic Energy Commission in 1962. This source term, based on the results of experiments involving the heatup of irradiated fuel fragments in a furnace, was assumed to be instantly available in the containment. Half of the iodine was assumed to deposit in route to the containment. The source to the environment was found by assuming the design-basis leakage rate for the containment and attenuation of the radioactive material available for release by the plant's engineered safety features (e.g., sprays, suppression pools, ice beds).

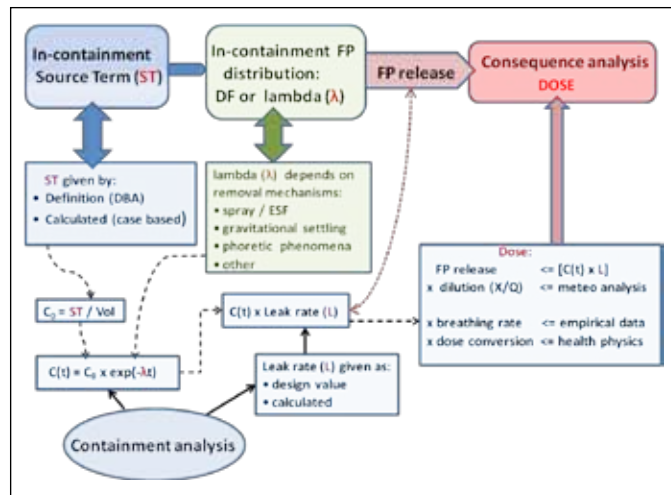

Figure 3.17 Use of source term and relation to other factors in dose calculations

Following the accident at Three Mile Island, it was evident that radionuclide release did not closely follow the pattern that might be expected based on the TID-14844 source term. Pressure arose from the nuclear industry for a more realistic source term. Since insufficient data were available to define a new source term, research was undertaken to obtain necessary data and define a new source term.

The route to a more realistic accident source term, as defined by RES, was to develop a mechanistic linkage of radionuclide behavior, including release from fuel and transport to the containment to reactor accident phenomena (see Figure 3.17). This effort led to the development of the Source Term Code Package (STCP), a suite of standalone computer codes linked together to mechanistically predict, for a variety of accidents, the source term to the reactor containment and the attenuation of the inventory of radionuclides in the containment as a result of natural and engineered processes. This first phase of the NRC's study of mechanistic reactor accident source terms culminated in the publication of improved source terms for use in regulatory processes (NUREG-1465) and publication of a Level III analysis of accident risks at representative U.S. nuclear power plants (NUREG 1150).

## Objective

The objective of this research is to extend the source term described in NUREG 1465 to cover both light-water reactors (LWR) with high burnup cores and LWRs with mixed oxide (MOX) fuel.



---

## Approach

In 2001–2002, the NRC convened an expert panel to develop revisions to the reactor accident source term described in NUREG 1465. The undertaking was prompted by interest in having source terms applicable to conventional reactor fuel taken to high burnups (55 to 75 gigawatt days per ton (GWd/t)) and to MOX made with weapons-grade plutonium dioxide. In formulating the revisions, the peer reviewers drew attention to the changes in understanding that have come about because of major experimental investigations of fission product behavior under reactor accident conditions, such as the Phébus-FP program, the VERCORS tests, and the Verification Experiments of Radionuclides Gas/Aerosol Release (VEGA) tests. The assessments for that effort were performed, however, without the benefit of accident sequence analyses and without mathematical models validated against the pertinent experiments with high burnup or MOX fuel. Members of the expert panel developing the revisions to the NUREG-1465 source term attempted to mentally integrate the results of the applicable tests to predict source terms during accidents at nuclear power plants. They extrapolated the phenomenology of source terms from fuel burned to levels in excess of about 60 GWd/t. The panel members also extrapolated the behaviors of conventional fuels with conventional Zircaloy cladding to estimate the behavior of MOX fuel with zirconium-niobium (M5) cladding. The limitations of the analysis and databases available to the expert panel made research to confirm the panel's estimates necessary.

Confirmatory research has been conducted for both high burnup and MOX fuels in both BWRs and PWRs. This research was performed by analyzing risk-significant sequences with a version of the MELCOR severe accident code modified for and validated against recent fission product release and transport experiments including experiments involving high burnup and MOX fuels. The integrated systems-level analysis MELCOR code replaced the STCP code suite.

This research analyzed source terms for boiling-water reactors (BWR) with high burnup fuel, pressurized-water reactors (PWR) with high burnup fuel, and PWRs with MOX fuel. Tables generated by the expert panels were updated using the results of this research. It became apparent during the course of the research that advances in modeling of severe accident progression would result in changes from the low enrichment source terms provided in NUREG-1465. It was also observed that the changes between the NUREG-1465 source terms and those generated for high burnup and MOX fuels during this research resulted predominantly from the advances in modeling and not from differences between the different fuel types. The

most notable change is the reduction of the rate of degradation phenomena resulting from improvements to heat transfer modeling. A synthesis report of this research and its findings has recently been completed and is undergoing peer review.

## Applications

The reactor accident source term arises in two distinct ways in the U.S. regulatory process. The first is the release of radioactive material to the environment during a hypothetical reactor accident. This source term is an input to models of radionuclide dispersal and accident consequences. It drives measures taken for emergency preparedness and accident response. It is a crucial element of Level III PRAs and is also important consideration in the cost-benefit analyses of safety improvements that go beyond regulatory requirements to provide adequate protection of public health and safety.

The second source term used in the regulatory process is the release of radioactive material to the reactor containment. This source term is used in the analysis of plant sites. It is a defense-in-depth measure to assess the adequacy of reactor containments and engineered safety systems. This source term also figures in the environmental qualification of equipment within the containment that must function following a design-basis accident.

TID-14844, NUREG 1465, and any updates to this source term are examples of the latter source term. Improvements made to the MELCOR code in the areas of core degradation, fission product release, and fission product transport benefit the former source term whenever the updated code is used to calculate fission product releases.

### For More Information

Contact Michael Salay, RES/DSA at 301-251-7543 or [Michael.Salay@nrc.gov](mailto:Michael.Salay@nrc.gov)

# Phébus-Fission Products and Phébus-International Source Term Program

## Background

In the unlikely event of a commercial nuclear power plant accident, the NRC has developed computer codes for the analysis of severe accident phenomena and progression. The NRC maintains its analytical tool to evaluate severe accident risk in the transition to a more risk-informed regulatory framework and for use in the study of vulnerabilities of nuclear power plants.

Future needs include development of insights into the severe accident behavior of advanced reactor designs and extending the expertise acquired on current reactor designs to address future design-specific considerations.

The improved understanding of phenomenological behavior and modeling in severe accidents has had direct implications for the analytical methods and criteria adopted for design-basis accidents (e.g., source term research and the revised source term described in NUREG-1465). The development of improved severe accident, best-estimate models in the future will also be likely to influence the improvement of licensing evaluation models since the development of best-estimate modeling reveals, quantitatively, margins in existing modeling.

## Objective

The purpose of the Phébus-FP program is to conduct integral tests to study the processes governing the transport, retention, and chemistry of fission products under severe accident conditions in light-water reactors (LWR) and to provide data of integral severe accident behavior to validate severe accident computer codes.

The aim of the follow-on program, Phébus-ISTP, is to conduct separate-effects experiments in various experimental facilities to resolve the findings from Phébus-FP, as well as to continue the investigation done in Phébus-FP (e.g., research into air ingress and fission product chemistry, fission product release from high burnup fuel and mixed oxide (MOX) fuel, iodine chemistry, and control rod oxidation and degradation). The follow-on program will also provide data for the improvement of physical models of phenomena in the Phébus-FP experiments that were not well predicted by codes.

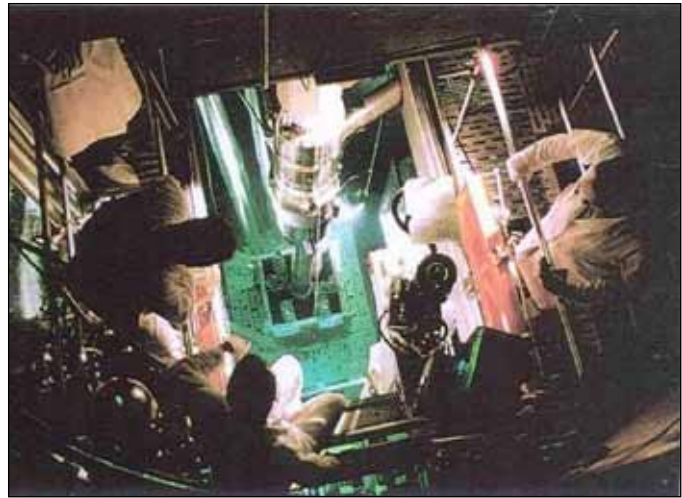

Figure 3.18 Phébus reactor and the test loop (top view)

## Approach

The key features of the Phébus-FP Program include the following:

- The program uses a loop-type test reactor with a low enrichment driver core of 20 to 40 megawatt power, using fuel rod elements (see Figure 3.18).
- Core cooling and moderation are achieved by demineralized light water.
- Light water and graphite are used as reflectors.
- Tests (four out of five) primarily involve a cluster of 20 fuel rods (about 10 kilograms), 1 meter long, located in the central hole of the driver core of the Phébus-FP reactor. One test (FPT-4) consists of a rubble bed instead of fuel rods.
- The facility is instrumented to measure fission product release, deposition in the primary circuit, and release to the containment.
- The facility includes a representative primary circuit, including a steam generator tube, containment, and sump.

The Phébus-ISTP program includes several experimental series, each with its own facility. The experiments cover fission product release, air-cladding oxidation, oxidation of B4C-steel mixtures by steam, and behavior of iodine both in the reactor coolant system and in containment.



## Applications

The Phébus-FP integral experimental data support the assessment and development of new MELCOR models (e.g., iodine chemistry, iodine behavior in containment, and fuel degradation). The improved MELCOR is used for safety analysis and risk-informed decisionmaking. The data were also used to confirm many of the important features of the NRC's revised/alternative source term specified in NUREG-1465, such as the finding that iodine release is predominantly in aerosol form, with allowance for small fractions (5 percent) in gaseous form.

The results of the Phébus-FP tests indicate that controlling the sump pH may not significantly impact the development of a gaseous iodine concentration in the reactor containment in the immediate aftermath of an accident involving core degradation. Moreover, interactions between the chemicals used to control sump pH and some insulation materials dispersed to the sump can increase viscosity of the solution rendering it more difficult to pump.

The Phébus-ISTP is expected to provide prototypical experimental data on air ingress, fission product chemistry, and fission product release from high-burnup fuel and MOX fuel for MELCOR code assessment and development (see Figure 3.19). The data will enable the NRC to address the issue of ruthenium behavior under accident conditions in an air environment. Situations in which this could occur include a spent fuel pool accident or a reactor accident involving fuel damage in which air enters the reactor vessel. Unlike fuel degradation in steam which produces relatively non-volatile ruthenium dioxide ( $\text{RuO}_2$ ), fuel degradation in air can result in the production of the more-volatile ruthenium tetroxide ( $\text{RuO}_4$ ) resulting in a greater overall release of ruthenium. If the ruthenium release is significant, it will impact the evaluation of early and latent health effects under 10 CFR Part 100. In addition, assessments will be made of the separate-effects results on NUREG-1465 (the NRC's revised/alternative source term). NUREG 1465 is used for design-basis accident analysis in operating plants and in new reactor design certification reviews under 10 CFR Part 100.

### For More Information

Contact Michael Salay, RES/DSA at 301-251-7543 or [Michael.Salay@nrc.gov](mailto:Michael.Salay@nrc.gov)

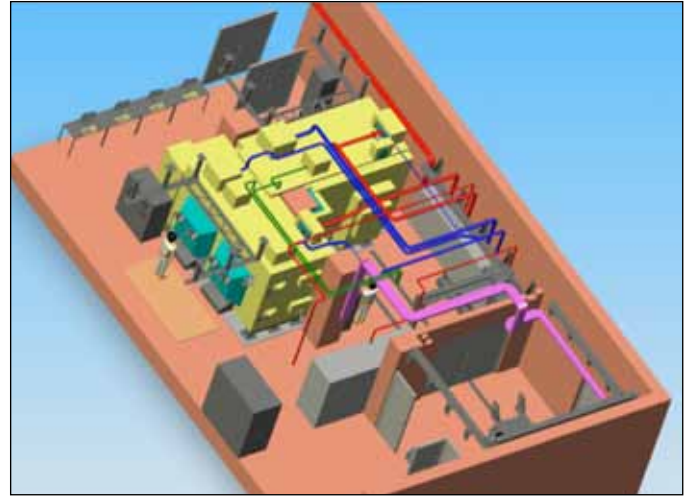

Figure 3.19 VERDON 2-cell FP release experimental facility (one of the experimental facilities constructed under the Phébus-ISTP program)

# Fission Product Release and Transport Modeling for High-Temperature Gas-Cooled Reactors

## Background

High-temperature gas-cooled reactors (HTGRs) use fuel in the form of TRISO-coated fuel particles embedded in a graphitized matrix (see Figure 3.20). TRISO fuel particles for both the pebble bed reactor (PBR) and prismatic modular reactor (PMR) designs consist of a fuel kernel surrounded by four coating layers: a buffer layer of porous pyrolytic carbon, a dense inner pyrolytic carbon layer, a dense silicon carbide layer, and a dense outer pyrolytic carbon layer. The HTGR evaluation model relies primarily on MELCOR to provide an independent analytical capability for fission product (FP) release and source term. MELCOR is a fully integrated, engineering-level computer code that was originally developed to model the progression of LWR severe accidents. The code is being modified to include models for HTGR confirmatory safety analysis. The HTGR fission product model for MELCOR is being developed to calculate the fractional release and distribution of fission products during normal operation and during accidents. The fission product release and transport model considers the important phenomena for fission product behavior in HTGRs, including the recoil and release of fission products from the fuel kernel, transport through the coating layers, transport through the surrounding fuel matrix, release into circulating helium coolant, settling and plateout on structural surfaces, adsorption by graphite dust in the primary system, and resuspension.

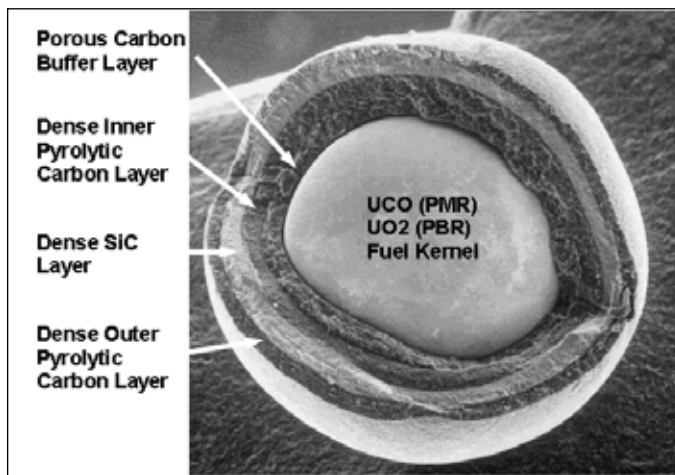

Figure 3.20 TRISO fuel Particle

## Objective

The objective of this research is to develop a MELCOR fission product release model and address FP transport issues unique to HTGR designs.

## Approach

The approach for the MELCOR fission product release model was developed based on considerations of the important phenomena for fission product behavior in HTGRs. The fission product release models in MELCOR are based on the diffusion of radionuclides through the different coating layers of the fuel particle, the graphite matrix, and the graphite fuel elements (prismatic design). The model accounts for the release during normal operation and accidents using empirically determined diffusion coefficients and fuel failure fraction as a function of temperature and burnup. MELCOR models intact fuel particles (kernel with all layers), failed particles (kernel only), and fuel particles without the silicon carbide layer.

For intact particles, the gaseous fission products released are assumed to accumulate in the buffer; for failed particles, fission products are assumed to go directly to the graphitized matrix. Diffusion-based release models calculate the condensable (metallic) and noncondensable (gaseous) fission product release. This calculation is performed during normal operation to determine the partition of the fission product inventory between the kernel and the buffer layer and the amount released from failed particles. In general, release from the fuel particle is described by the diffusion equation:

$$\frac{\partial C_i}{\partial t} = \frac{1}{r^2} \frac{\partial}{\partial r} \left( r^2 D_i \frac{\partial C_i}{\partial r} \right) - \lambda_i C_i + \beta_i$$

where

- $C$  = Concentration of nuclide (mole per cubic meter (mol/m<sup>3</sup>))
- $D$  = Diffusion coefficient (square meter per second (m<sup>2</sup>/s))
- $r$  = Radial dimension (meter (m))
- $\lambda$  = Decay constant (1/second (s))
- $\beta$  = Generation rate (mole per cubic meter per second (mol/m<sup>3</sup>-s))

The evolution of concentration profiles for cesium, as calculated by a finite difference code, for steady-state conditions at 1,200 Kelvin, and for the fractional release from the intact fuel particle are shown below (see Figures 3.21 and 3.22).

During the accident, the core temperature rises, resulting in increased particle failures from the higher temperatures and increased diffusional release from intact and failed particles. Particles fail at various times during the accident, so the total fission product release must account for these different failure times. The releases from failed particles versus time are the integrated result of particle failures over the course of the accident, which is expressed as a convolution integral.

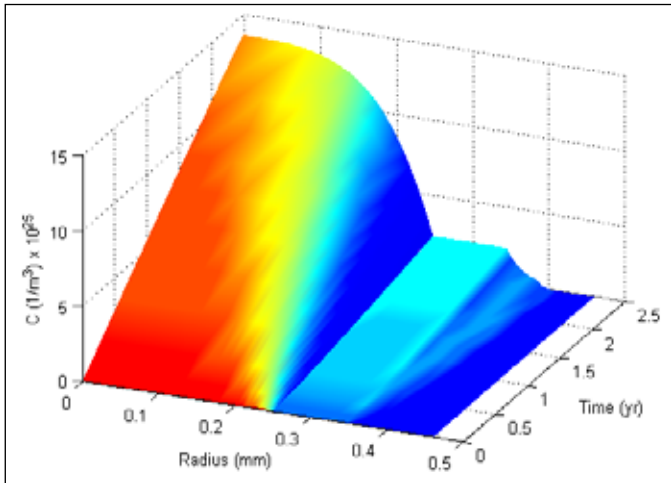

Figure 3.21 Cesium concentration profile

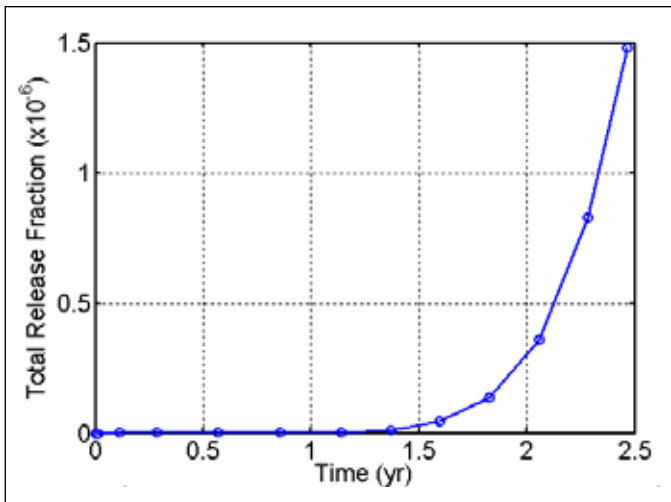

Figure 3.22 Cesium release fraction

MELCOR models a wide range of phenomena involving fission product transport as aerosols or vapors, including particle agglomeration, FP condensation and evaporation, chemisorption (e.g., cesium on metal surfaces), and FP deposition by various processes including gravitational settling, Brownian diffusion, thermophoresis, and diffusiophoresis. In addition, MELCOR has models for engineered safety features, including decontamination by water pool scrubbing and filters. Some of these models need to be extended for use with HTGRs, and additional models need to be developed. Fission products are not just present in the fuel; they may also accumulate, via

adsorption, in graphite dust that is generated and subsequently distributed in the reactor system, and via plateout in the primary system. Existing MELCOR aerosol transport models can provide the framework for calculation of dust and fission product transport in the HTGR reactor system. A liftoff model for the dust and fission products will be developed. A turbulent deposition model needs to be developed to estimate deposition in pipes and impacts on HTGR components, such as heat exchangers and turbomachinery. The dynamic and collision shape factors in the aerosol agglomeration models need to be modified and made size dependent.

**For More Information**

Contact Hossein Esmaili, RES/DSA at 301-251-7554 or Hossein.Esmaili@nrc.gov

# Environmental Transport Research Program

## Background

Many activities that are part of nuclear fuel cycles have the potential to expose the environment or the public to low levels of contamination from nuclear materials (see Figure 3.23). Environmental assessment and protection address the vulnerability of environmental resources and public health to potential chronic exposure to radionuclides associated with nuclear facilities, including nuclear reactor, fuel cycle, waste disposal, and decommissioned facilities.



Figure 3.23 Conceptual visualization of contaminant pathways

## Technical Issues

Monitoring and modeling of environmental systems at nuclear facilities are evolving in response to changing needs, increased understanding of environmental systems, and advances in technology. Issues associated with environmental monitoring include identification of potential sources and measurable indicators of system performance that can be coupled to regulatory requirements. Traditional analyses have often involved conservative assumptions that often led to costly solutions. One goal of the research on environmental transport is to increase realism in current environmental assessments.

### Specific Regulatory Needs

The program explicitly addresses needs imposed by risk-informed regulation. Individual research activities address needs identified by current regulatory programs, including the new reactor licensing program, the advanced reactors program, the decommissioning and uranium recovery program, and the reprocessing program.

The NRC licensing staff needs updated or new technical bases for reviewing site characterization, monitoring, modeling, and remediation programs submitted by current and prospective

licensees. Regulatory guidance is needed on environmental assessments and performance monitoring associated with new reactors and the decommissioning of nuclear facilities.

## Principal Research Activities

### Release of Radionuclides from Wastes or Engineered Structures and Advanced Sampling and Monitoring of Radionuclide Releases

The potential for chronic releases of radionuclides to the environment from nuclear facilities must be understood to ensure compliance with NRC regulations. Assessing long-term releases under varying chemical and physical conditions is a difficult but important aspect of ensuring that current or planned nuclear facilities conform to regulatory goals. Thus, research activities are being conducted to monitor, characterize, and model the behavior of radionuclide-containing materials in the environment, including assessment of in situ sensors for real-time monitoring of radionuclides in the environment and field lysimeter studies at waste disposal sites. The relationship among short-term leach tests, leaching models, and the long-term behavior of radioactive waste is being assessed.

### Long-Term Behavior of Engineered Materials

The expectation of future use of engineered materials to isolate radioactive wastes or environmental contaminants results in a need for analytical tools to assess the design and performance of cement, concrete, and natural earth materials in engineered structures. Research activities include obtaining field-scale properties of soil and composite material covers that use geosynthetics to isolate radioactive waste to better understand the mechanics of contaminant release. Research is also underway to understand the long-term effectiveness of cementitious materials both for nuclear reactor and waste isolation applications. Research into the performance of reinforced-concrete or cement barriers supports assessment of reactor life extension and the performance of engineered disposal facilities.

In the area of cementitious materials performance, the environmental transport research program has a cooperative interaction and research program with the objective of developing the next generation of simulation tools to evaluate the structural, hydraulic, and chemical performance of cementitious barriers used in nuclear applications over extended timeframes (e.g., more than 100 years for operating facilities and greater than 1,000 years for waste management applications). The program, the Cementitious Barriers Partnership, is a multidisciplinary, multiinstitutional collaboration of Federal, academic, private sector, and international expertise formed to accomplish the project objectives.

---

## **Geotechnical Considerations for New and Advanced Nuclear Power Plants**

The recognition that design and construction of new or next-generation facilities can increase or inhibit the release, migration, and isolation of materials in the geosphere is addressed by research activities to improve the understanding, modeling, and monitoring of the performance of engineered features of new facilities. All of these activities involve the performance of soil-based subsurface components of the foundation system to mitigate the release of contaminants to the environment.

## **Advanced Modeling for Environmental Assessment**

Advances in computational facilities are enabling research to incorporate additional realism in the assessment of geochemical and biochemical processes that enhance or retard radionuclide transport. Additional realism significantly enhances the prospects for meaningful validation of system or subsystem models used for environmental assessment. Research on computational tools is focused on a generic framework for linking databases, models, and other analytic tools for flexible problem solving.

## **Decision Support for Ground Water Remediation**

Technologies for the remediation of subsurface contamination have advanced significantly in recent years. Likewise, advances in understanding and manipulating subsurface biota are leading to advances in exploiting the ability of biota to remediate subsurface contamination. Research is being conducted to examine the efficacy of long-term performance of these remediation technologies and to provide tools to assist in remediation planning.

## **Regulatory Basis in Support of Fuel Reprocessing Facilities**

A commercial nuclear fuel reprocessing plant has not been licensed in the United States for over 35 years; consequently, the NRC's regulatory framework needs to be updated to support the licensing of such a facility. In light of recent initiatives by the U.S. Department of Energy (DOE) and commercial industry interest in developing such facilities, a multioffice working group is developing a regulatory basis in support of rulemaking for reprocessing. The document will address a number of issues related to reprocessing, including waste management and risk. Research activities planned to support this effort include an assessment of source term phenomena and code development.

## **Collaborative Efforts and Opportunities**

The environmental transport research program leverages resources through cooperative interactions and special research agreements, such as the Memorandum of Understanding on Research and Development of Multimedia Environment Models (see <http://sites.google.com/a/environmental-modeling.org/environmental-modeling/>) with other national and international research organizations pursuing related work. The technical objective is to collaborate on or gain access to technologies, databases, computer software, lessons learned, and methods that support the NRC's regulatory activities. Collaborators include other Federal agencies (e.g., the U.S. Department of Agriculture's Agricultural Research Service, U.S. Geological Survey, National Institute of Standards and Technology, U.S. Environmental Protection Agency, U.S. Army Corps of Engineers), DOE national laboratories, universities, National Academies, professional societies (e.g., American Nuclear Society, American Geophysical Union, International Association of Hydrological Sciences, National Ground Water Association, American Society for Testing and Materials), and international organizations (e.g., the Nuclear Energy Agency of the Organization for Economic Cooperation and Development and the International Atomic Energy Agency).

These cooperative ventures help to identify important research findings, datasets, and lessons learned for use in evaluating and testing multimedia environmental models, examining the role of engineered barrier systems in waste disposal, and evaluating the practicality of modeling chemical sorption in environmental systems. Interactions with professional societies assist in developing guidance and training programs. Knowledge management also profits from interactions with other Federal and professional organizations and from their information sources (e.g., technical journals, Web sites, and monographs).

## **For More Information**

Contact William Ott, RES/DRA at 301-251-7407 or [William.Ott@nrc.gov](mailto:William.Ott@nrc.gov)



# Integrated Ground Water Monitoring and Modeling

## Background

RES is working with NRC licensing offices (the Office of Federal and State Materials and Environmental Management Programs (FSME), the Office of New Reactors (NRO), and the Office of Nuclear Reactor Regulation (NRR)), as well as its regional offices, to develop guidance for reviewing ground water monitoring programs, as required in 10 CFR 20.1406(a) and 10 CFR 20.1406(b); 10 CFR 50.75(g); Appendix A, “Criteria Relating to the Operation of Uranium Mills and the Deposition of Tailings or Wastes Produced by the Extraction or Concentration of Source Material from Ores Processed Primarily for Their Source Material Content,” to 10 CFR Part 40, “Domestic Licensing of Source Material”; 10 CFR 61.53, “Environmental Monitoring”; and 10 CFR 63.131, “General Requirements.” In November 2007, RES issued NUREG/CR-6948, “Integrated Ground-Water Monitoring Strategy for NRC-Licensed Facilities and Sites,” which provides the technical bases for this guidance. Also in 2007, the Nuclear Energy Institute (NEI) issued its industry initiative on ground water protection that includes onsite ground water monitoring at all nuclear reactor sites. NEI funded the Electric Power Research Institute (EPRI) to develop guidelines for ground water protection that were issued in January 2008. NRC Regional inspectors, working with NRR and RES staff, have used the RES-developed information to review these new programs in conjunction with existing offsite radiological environmental monitoring programs. This monitoring is needed to detect radionuclide releases and to evaluate the need for and selection of remediation approaches.

NUREG/CR-6948 documents the development and testing of an integrated ground water monitoring strategy. It integrates conceptual site model (CSM) confirmation with ground water monitoring through the use of performance indicators (PIs) (e.g., concentrations, water fluxes in the unsaturated and saturated zones). It outlines procedures for selecting, locating, and calibrating field instruments and methods to detect radionuclide releases in the subsurface and to determine the need and effective approaches for remediation.

## Objective

The objective of this research is to provide the NRC with a technical basis for assessing licensees’ monitoring programs and applicants’ planned monitoring programs.

## Approach

The strategy provides an integrated and systematic approach for monitoring subsurface flow and transport beginning at the land surface and extending through the unsaturated zone to the underlying water table aquifer (see Figure 3.24). The strategy is robust and useful for reviewing site- and facility-specific ground water monitoring programs to do the following:

- Assess the effectiveness of contaminant isolation systems and remediation activities.
- Communicate to decisionmakers and stakeholders the monitored PIs through effective data management, analysis, and visualization techniques.
- Detect and identify the presence of contaminant plumes and preferential ground water transport pathways.
- Test alternative conceptual and numerical flow and transport models.
- Aid in the confirmation of the assumptions of the CSM and, hence, the performance of the facility through monitoring of PIs.

The documented strategy provides the technical bases, along with identified guidance and analytical tools, for assessing the completeness and efficacy of an integrated ground water monitoring program. It focuses on quantifying uncertainties in the hydrologic features, events, and processes using “real-time, near-continuous” monitoring data to confirm the CSM. The strategy links the ground water monitoring program to the detection level required for early warning of releases.

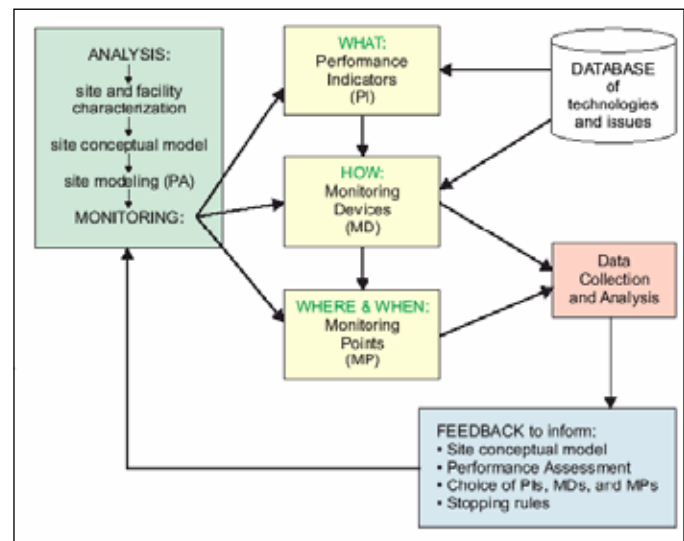

Figure 3.24 Flow chart of the integrated monitoring strategy



RES and its contractor, Advanced Environmental Solutions, LLC (AES), developed and tested the strategy to demonstrate how to identify and monitor PIs of the subsurface flow and transport system behavior. Using field case studies, the strategy illustrates how these methods coupled to the CSM models can provide early detection of releases. The strategy was tested for a range of complex hydrogeologic settings using field monitoring datasets to demonstrate its validity and usefulness for reviewing nuclear facility issues.

## Research Activities

AES examined the state of the practice in ground water monitoring of radionuclides for confirming CSM models. Figure 3.25 shows the natural and engineered complexities that can affect subsurface flow and radionuclide transport. Monitoring strategies need to consider these complexities in the development and testing of conceptual models. Monitoring involves detection and sampling both above (i.e., in the unsaturated zone) and below the water table and, as illustrated in the figure, must not introduce inadvertent pathways. AES drew lessons learned from field case studies involving site-specific contaminant sources, release modes, and hydrogeologic and geochemical conditions affecting transport. AES tested these field studies using trend analyses and statistical methods to determine the frequency and duration of monitoring to confirm regulatory criteria. The testing also evaluated ground water flow and transport modeling assumptions in the CSMs for the various field examples. AES examined which technical bases in monitoring are useful for determining the need for remediation and ways to confirm the efficacy of remediation in interdicting and mitigating ground water contamination in the unsaturated and saturated zones.

In documenting the strategy, AES outlined the logic for selecting the appropriate sensors and geophysical technologies, monitoring locations and frequency, and analysis methods to confirm the CSMs and their assumptions. The tools and technical bases developed emphasize relevancy to decommissioning nuclear waste and new reactor facilities. AES presented technology transfer seminars to the NRC staff and Agreement State regulators on the strategy and case studies relevant to radionuclide transport assessments. The revised Regulatory Guide 1.21, "Measuring, Evaluating, and Reporting Radioactive Material in Liquid and Gaseous Effluents and Solid Waste," and Regulatory Guide 4.1, "Radiological Environmental Monitoring for Nuclear Power Plants," reference the strategy.

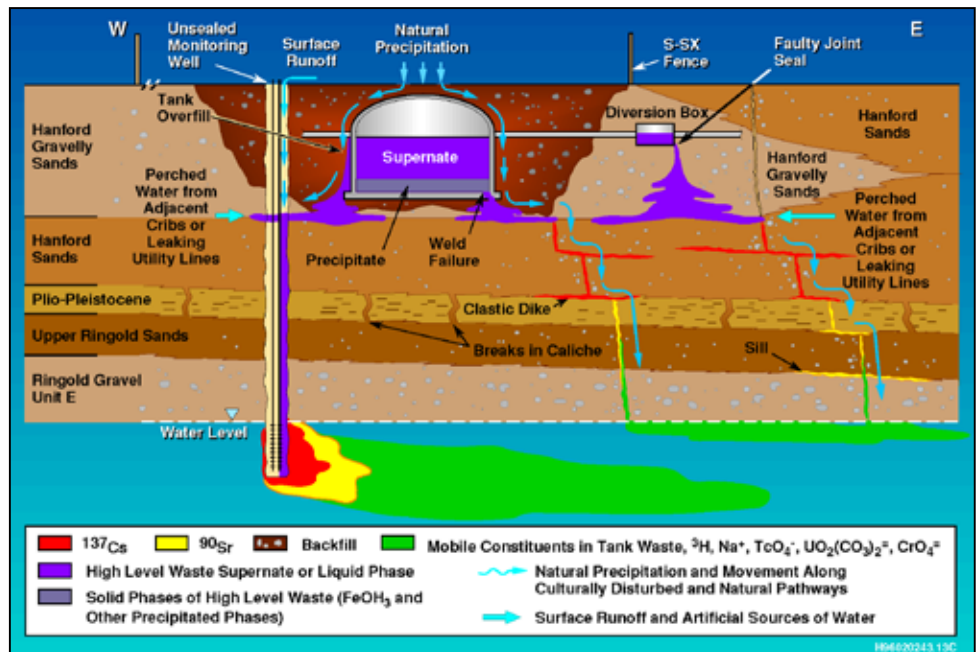

Figure 3.25 Illustration of a conceptual model of a complex field site and complex sources for which monitoring can facilitate decisionmaking for remediation (Ward et al. "A Comprehensive Analysis of Contaminant Transport in the Vadose Zone Beneath Tank SX-109," PNL-11463. Richland, Washington, February 1997.)

### For More Information

Contact Thomas Nicholson, RES/DRA at 301-251-7498 or [Thomas.Nicholson@nrc.gov](mailto:Thomas.Nicholson@nrc.gov)

# In Situ Bioremediation of Uranium in Ground Water

## Background

The NRC has received license applications and decommissioning plans referring to the use of in situ bioremediation of ground water at two types of sites: (1) shallow plumes of uranium that originated with waste disposal operations and (2) in situ leach (ISL) uranium recovery sites that have been depleted and require ground water remediation in accordance with Appendix A to 10 CFR Part 40. In both cases, the original remediation methods have not reduced aqueous uranium concentrations to acceptable levels. These results have led to the proposal of a new approach using in situ manipulation of native bacterial populations to alter geochemical conditions.

In this remediation technique, electron donors (e.g., acetate, lactate) are injected through wells into the contaminated aquifer where bacterial activity is expected to increase and generate reducing conditions. In this process iron [Fe (III)] and uranium [U (VI)] is reduced, and uranium precipitated from solution (Figure 3.26). This is a relatively new remediation approach with potential applications at many other nuclear facilities. (For a review of the technology, see LBNL-42995, 2003). However, it is important to note that the uranium is left in place. Eventually, many sites that have been bioremediated will likely be exposed to oxidizing conditions. This is especially so at shallow sites. The NRC staff must be able to confirm the long-term ability of bioremediation to sequester uranium from ground water.

## Objective

The objective of this research is to provide the NRC with a technically defensible understanding of the long-term behavior of the residual uranium in remediated systems as they return to oxidizing conditions.

## Approach

To assess the behavior of bioremediated systems, two approaches are being used for each of the two types of sites: shallow uranium plumes and ISL units. The two approaches, laboratory scale experimental work and advanced modeling, will complement each other. The U.S. Geological Survey is conducting the laboratory work in a project entitled, "Uranium Sequestration and Solid Phase Behavior during and after Bioremediation." Pacific Northwest National Laboratory is conducting the modeling project, which is entitled, "Modeling the Long-Term Behavior of Uranium during and after Bioremediation."

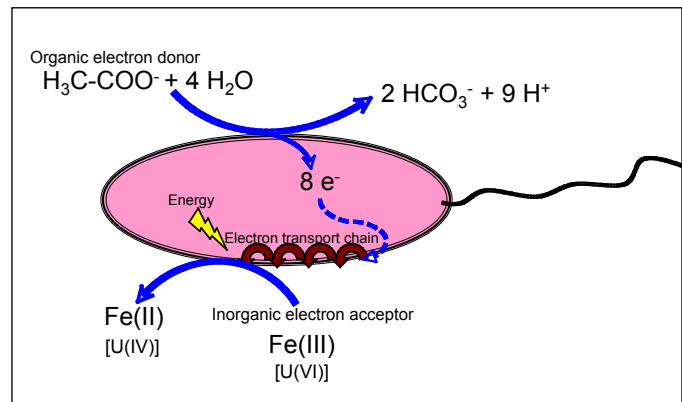

Figure 3.26 Microbial mediation of Fe(III) reduction (Original concept from Lovley et al, 1991. Figure from NUREG/CR-6973 (Long et al., 2008.)

U(VI) is the mobile valence state of uranium, whereas reduced uranium, U(IV), has very low solubility as uraninite. Addition of acetate as an electron donor stimulates dissimilar metal-reducing microorganisms. U(VI) is reduced concurrently with Fe(III).

## Experimental Approach

For the experimental program, sediment representing the two types of sites is placed in columns and reducing conditions are established by biostimulation. Especially important to long-term performance is the stability of the solid phase uranium and iron minerals generated by bioremediation as they are leached by various site-specific ground waters. The behavior of uranium and other elements is being followed in both the aqueous phase during reduced conditions and then as oxygen-containing water is introduced into the columns. Solid phase analysis includes synchrotron-based methods, such as x-ray absorption spectroscopy, to determine the oxidation state of uranium and iron, as well as their microscale distributions under the reduced and oxidized conditions of the columns. Changes in the microbial community and important community members are being assessed by two deoxyribonucleic-acid-based methods over the course of the column experiments.

After oxidizing conditions begin to return to the site, other processes will control the distribution of uranium between the solid and liquid phases, potentially remobilizing uranium. Licensees contend that uranium will readily adsorb on iron oxides that form in place after the remediated soil is oxidized. It is unknown if this is a viable process or if the chemistry of reoxidation (i.e., acid generation) will inhibit adsorption.

Sediment from a mined ISL site has been sampled and found to have a bacterial population very depleted in Geobacteraceae, the family of common soil bacteria that is generally active in reducing a variety of metals including Fe(III) and U(VI). How this may influence the efficacy of bioremediation of ISLs is currently being examined.

A series of questions define this research. While it is well known that uranium precipitates under reducing conditions, does it always precipitate as a discrete mineral or is some uranium distributed as amorphous or very small (nanoscale) particles? During bioremediation does uranium also coprecipitate with minerals such as mackinawite, siderite, and calcite? If so, in what oxidation state is the uranium? If aqueous uranium enters the system, how does it react with these new solids? How do major differences in microbial populations alter the processes and reagents (e.g., electron donors) needed to precipitate uranium? The experimental program will provide answers to these questions, providing details needed to estimate the long-term behavior of uranium.

### Modeling Approach

The objective of the modeling work is to identify, assess, and model short- and long-term chemical processes caused by in situ bioremediation. It will focus on processes controlling uranium sequestration and changes in uranium mobility during and after bioremediation. The approach will use coupled models of biological, geochemical, and transport processes to determine how the chemistry in these systems changes and what the effects will be on parameters that can be monitored in the field.

The modeling effort iterates through key parameters such as flow rates, uranium concentrations, mass of iron available, carbonate concentrations, biological kinetics, alkalinity, and oxygen and uranium input. For uranium in shallow ground water, NUREG/CR-7014, "Processes, Properties, and Conditions Controlling In Situ Bioremediation of Uranium in Shallow, Alluvial Aquifers," issued in 2010 (Yabusaki et al., 2010), reports one- and two-dimensional modeling. The report examines the response of parameters to transient and dynamic processes and events (such as floods) that influence geochemical conditions. In addition, the report describes expected behavior of monitored parameters (e.g., uranium concentrations, pH, oxidation-reduction potential) to these events as determined by model calculations. Key results are discussed that can be used to assess proposed bioremediation applications.

Modeling of ISL uranium recovery sites is beginning and is based, in part, on ground water data from several ISLs as well as the experiments conducted by the U.S. Geological Survey. Efforts will include modeling of incursion of lixiviant (the oxygen enriched solution used to extract uranium from the ore) from other operating cells and changes in ground water elevation.

Products of the modeling work will include a guidance document that describes approaches, criteria, and methods to predict the stability of biorestored ISL sites and shallow plumes to help staff in licensing reviews. It will provide modeling-based

information on changes in parameters that can be expected as a result of changing conditions in the subsurface system. Ultimately, both the experimental and modeling approaches will allow the NRC to (1) assess the geochemical, microbial, and ground water conditions and processes that affect uranium transport and its potential long-term sequestration; (2) provide the technical basis to predict long-term performance (e.g., 1,000 to 10,000 years performance periods) for decommissioning, particularly during reoxidation following bioremediation treatments; and (3) evaluate bioremediation design, performance, and stability for uranium recovery and related financial surety costs.

## References

- Yabusaki, S.B., Y. Fang, P.E. Long, C.T. Resch, A.D. Peacock, J. Komlos, P.R. Jaffe, S.J. Morrison, R.D. Dayvault, D.C. White, and R.T. Anderson. (2007). "Uranium Removal from Ground-water via In Situ Biostimulation: Field-Scale Modeling of Transport and Biological Processes." *Journal of Contaminant Hydrology* 93(1-4): 216–235.
- Long, P.E. S.B. Yabusaki, P.D. Meyer, C.J. Murray, and A.L. N'Guessan. (2008). "Technical Basis for Assessing Uranium Bioremediation Performance," NUREG/CR-6973.
- Lovely, D.R., E.J. Phillips, Y.A. Gorby, and E.R. Landa. (1991). "Microbial Reduction of Uranium," *Nature* 350(6317): 413–416.
- LBNL-42595. (2003). "Bioremediation of Metals and Radionuclides... What It Is and How It Works," 2nd Edition, Lawrence Berkeley National Laboratory.
- Yabusaki, S.B., Y. Fang, S.R. Waichler, and P.E. Long. (2010). "Processes, Properties, and Conditions Controlling In Situ Bioremediation of Uranium in Shallow, Alluvial Aquifers," NUREG/CR 7014.

### For More Information

Contact Dr. Mark Fuhrmann, RES/DRA at 301-251-7472 or Mark.Fuhrmann@nrc.gov



---

# Chapter 4: Health Effects

Health Effects Program

Regulatory Basis for NRC Standards for Protection Against Ionizing Radiation

Participation in National and International Radiation Protection Activities

Radiation Exposure Information and Reporting System (REIRS)

Report to Congress on Abnormal Occurrences

Analysis of Cancer Risk in Populations Living Near Nuclear Facilities

Radiological Toolbox

Phantom with Moving Arms and Legs (PIMAL)

VARSKIN Skin Dose Computer Code

Accelerator-Enhanced Gemstones

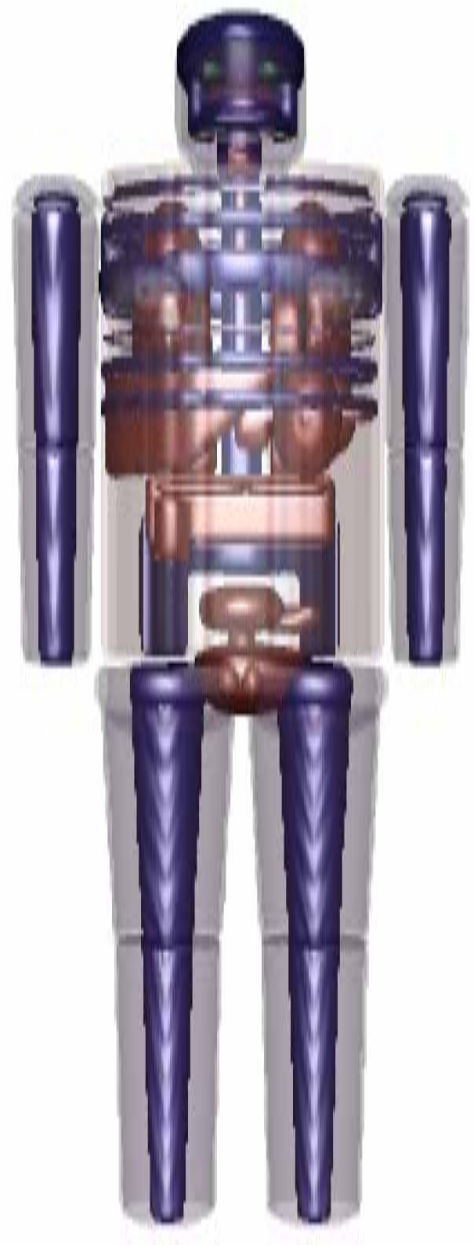



# Health Effects Program

## Background

The U.S. Nuclear Regulatory Commission's (NRC's) Health Effects Program is an agencywide resource that provides technical support in the areas of radiation protection, dose assessment, and assessment of human health effects for reactor and nuclear materials licensing, emergency preparedness, and nuclear security activities.

The program's scope includes the following:

- technical basis for radiation protection regulations
- exposure and abnormal occurrence reports
- computer codes and databases development
- health effects and dosimetry research

## FOUNDATION OR BASIS FOR REGULATORY PROGRAM



Figure 4.1 Formation of a regulation

## Technical and Regulatory Projects

- internal dosimetry research
- monitoring national and international scientific organizations related to radiation protection
- radiation protection regulatory guides
- VARSKIN
- Phantom with Moving Arms and Legs (PIMAL)
- gemstones

- Report to Congress on Abnormal Occurrences
- Radiation Exposure Information and Reporting System (REIRS)

## Internal Dosimetry Research

The Health Effects Branch (HEB) provides technical resources to the NRC by conducting radiation dosimetry research for regulatory applications. This research improves the agency's capability to model radiation interactions within humans, evaluate internal dosimetry codes for estimating radiation exposures, and assess worker or public exposures from licensed activities or incidents.

## National and International Activities

One of the benefits of the Health Effects Program is the promotion of consistency in regulatory applications of radiation protection and health effects research among NRC programs, as well as those of other Federal and State regulatory agencies. The Health Effects Program staff collaborates with national and international experts in health physics at national laboratories, universities, and other organizations, including the following:

- Interagency Steering Committee on Radiation Standards
- National Council on Radiation Protection and Measurements
- National Academies
- Nuclear Energy Agency (NEA) Information System on Occupational Exposure
- International Commission on Radiological Protection
- International Atomic Energy Agency
- French Institute for Radiological Protection and Nuclear Safety

## Radiation Protection Regulatory Guides

Developing and updating regulatory guides on occupational health and other radiation protection-related topics provides licensees with better methods for maintaining compliance with NRC regulations. Regulatory guides describe NRC-approved methods of meeting regulatory requirements.

## VARSKIN

The NRC funded the development of the VARSKIN computer code in the 1980s to facilitate skin-dose calculations. Since then, the code has been upgraded to make it more efficient and easier to use. The NRC is currently developing a more sophisticated replacement for the code's existing photon dose algorithm, as well as further enhancements to the code's functionality.

## PIMAL

The Office of Nuclear Regulatory Research (RES) and Oak Ridge National Laboratory have developed a computational “phantom” with moving arms and legs (i.e., the PIMAL) to assess the radiation dose for realistic exposure geometries. PIMAL is based on the Oak Ridge National Laboratory mathematical phantom and can bend arms from the shoulder and elbow, and legs from the hip and knee. An accompanying graphical user interface has also been developed to assist the user with dose assessments and reduce the analyst’s time.

## Gemstones

Exposing gemstones to radiation is a known method of enhancing and deepening the gemstone color. The bombardment of radiation hitting the gemstone deposits energy that creates color centers, causing a gemstone such as topaz, naturally colorless, to turn blue. Other gemstones are irradiated with other color enhancements. Gemstone color enhancement using radiation can be performed using a nuclear reactor (neutron bombardment), an accelerator (electron-particle beam exposure), or a cobalt irradiator (gamma rays). This technique of color enhancement by irradiation is widely used for gemstones such as topaz, tourmaline, quartz, beryl, zircon, diamond, and, more recently, labradorite.



Figure 4.2 Enhanced gemstones

## Report to Congress on Abnormal Occurrences

The NRC annually publishes the Abnormal Occurrence (AO) Report to Congress. An AO is defined as an unscheduled incident or event that the NRC determines to be significant from the standpoint of public health or safety. The AO process helps to identify deficiencies and ensure that corrective actions are taken to prevent recurrence. An accident or event will be considered an AO if it involves a major reduction in the degree of protection of public health or safety. This type of incident or event would have a moderate or more severe impact on public health or safety. The AO report contains event details from both NRC and Agreement State-licensed facilities that meet the AO criteria published by the Commission.

## Radiation Exposure Information and Reporting System

The NRC’s REIRS collects information on occupational radiation exposures to workers from certain NRC-licensed activities. The data collected in the REIRS database are used to evaluate licensee as-low-as-reasonably-achievable (ALARA) programs and is shared with national and international research counterparts. The REIRS database is also used to compile the annual report, NUREG0713, “Radiation Exposure at Commercial Nuclear Power Reactors and Other Facilities.”

## Analysis of Cancer Risk in Populations Living Near Nuclear Facilities

The NRC requested that the U.S. National Academy of Sciences (NAS) conduct a study that analyzes the cancer risk of populations living near NRC-licensed facilities. This study will be used to update the 1990 National Cancer Institute (NCI) report, “Cancer in Populations Living Near Nuclear Facilities.” The NRC staff has used the 1990 NCI study as a valuable risk communication tool for addressing stakeholder concerns about cancer mortality attributable to the operation of nuclear facilities.

## Future Goals: Strengthen the NRC’s Health Physics Capabilities

The Health Effects Program seeks to be an agencywide resource for technical and regulatory health physics information, including development of implementation tools for state-of-the-art techniques in radiation protection and recommendations on health physics policy.

### For More Information

Contact Stephanie Bush-Goddard, RES/DSA at 3012517528 or [Stephanie.Bush-Goddard@nrc.gov](mailto:Stephanie.Bush-Goddard@nrc.gov)

# Regulatory Basis for NRC Standards for Protection Against Ionizing Radiation

## Background

In Title 10 of the *Code of Federal Regulations* (10 CFR) Part 20, “Standards for Protection Against Radiation,” the NRC provides the fundamental radiological protection criteria for use by NRC licensees. The last major revision to 10 CFR Part 20 was completed in 1991 and was based primarily on the 1977 recommendations contained in International Commission on Radiological Protection (ICRP) Publication 26, “Recommendations of the International Commission on Radiological Protection.”

Since 1991, the NRC has made minor revisions to 10 CFR Part 20, such as a reduced public dose limit that incorporates the recommendations of ICRP Publication 60, “1990 Recommendations of the International Commission on Radiological Protection.” However, in other NRC regulations, such as Appendix I, “Numerical Guides for Design Objectives and Limiting Conditions for Operation to Meet the Criterion ‘As Low as is Reasonably Achievable’ for Radioactive Material in Light-Water-Cooled Nuclear Power Reactor Effluents,” to 10 CFR Part 50, “Domestic Licensing of Production and Utilization Facilities,” some radiation dose criteria are based primarily on ICRP Publications 1 and 2 (the 1958 and 1959 “Recommendations of the International Commission on Radiological Protection”). In addition, NRC fuel cycle licensees have received authorization, on a case-by-case basis, to use the newer ICRP methodology (ICRP Publication 66, “Human Respiratory Tract Model for Radiological Protection,” issued January 1995 and beyond) in their licensed activities. The Agreement States have requirements for their licensees that are essentially identical to 10 CFR Part 20. As a result, three different sets of ICRP recommendations are in use today by various licensees.

## Approach

In December 2008, the NRC staff provided the Commission with a summary of regulatory and technical options for moving—or not moving—toward a greater alignment of NRC’s radiation protection regulatory framework with ICRP Publication 103. The Commission subsequently directed the NRC staff to begin engagement with stakeholders and interested parties to initiate development of a regulatory basis for possible revision of the NRC’s radiation protection regulations, as adequate and appropriate where scientifically justified, to achieve greater alignment with the recommendations in ICRP

Publication 103, “Recommendations of the ICRP,” issued February 2008.<sup>1</sup>

## Current Activities

As part of this effort, the Health Effects Branch (HEB) is developing technical information on the benefits and burdens associated with revising the NRC’s radiation protection regulatory framework. HEB will consider (1) impacts on licensees, (2) impacts on public confidence, (3) cost-benefit issues, (4) backfit issues, (5) impacts on the NRC’s materials program, and (6) other benefits and burdens of adopting ICRP Publication 103 recommendations. Currently, development of this regulatory basis comprises the four technical areas described below.

### Impacts of Changing Occupational Dose Limits and Using Dose Constraints

The purpose of this task is to collect and analyze information about the actual dose distributions from industrial and medical licensees and to determine the impact of reduced dose limits from 50 to 20 millisievert (5 rem to 2 rem) per year both on an annual basis and averaged over 5 years. The staff plans to develop a report that provides technical information and a policy synopsis for agencywide use.

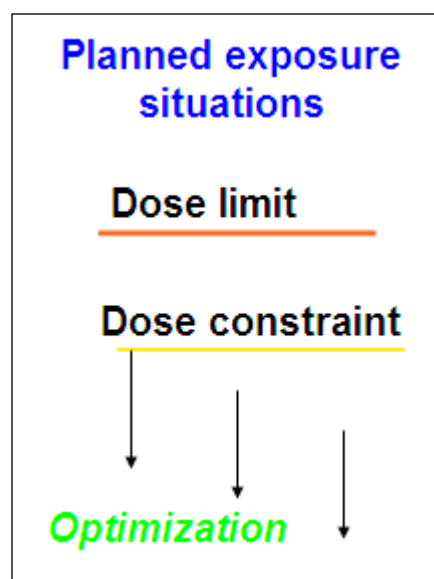

Figure 4.3 Planned exposure situations

### Occupational Dose Information and Evaluation of Potential Compliance Issues

This analysis will address potential changes to the occupational dose limit, the dose limit to an embryo or fetus of a declared pregnant woman, and the use of dose constraints. Currently, there is minimal information on occupational exposures at

<sup>1</sup> SRM-SECY-08-0197, April 2, 2009, ADAMS Accession No. ML090920103

Agreement State-licensed facilities, medical institutions, or for exposures to the embryo or fetus. Extensive outreach to external stakeholders is planned to obtain the supporting information.

### **Support Development of New Biokinetic and Dosimetric Models and Dose Coefficients for Occupational and Public Exposure**

The purpose of this task is to support and monitor work being conducted by Oak Ridge National Laboratory on the development of biokinetic and dosimetric models and dose coefficients for occupational and public exposure to radionuclides that are based on ICRP Publication 103 recommendations. This is a multiyear effort that will continue until ICRP finalizes the numerical values associated with ICRP Publication 103.

RES staff is working closely with other Federal agencies to share the cost of funding Oak Ridge National Laboratory for related work.



Figure 4.4 Biokinetic model

### **Costs and Impacts of Implementing ICRP Publication 60 in the United States**

To estimate the potential costs of implementing ICRP Publication 103, the NRC is seeking information from domestic and international sources on costs and strategies for implementing ICRP Publication 60. The NRC staff is

obtaining resource and implementation information from the U.S. Department of Energy's revision of 10 CFR Part 835, "Occupational Radiation Protection," to incorporate ICRP Publication 60 recommendations.

Also, the NRC staff will obtain information from European and Asian regulatory agencies and radiation protection organizations on the adoption of some or all of the recommendations of ICRP Publication 60.

### **Use of Research Results**

The work conducted under this project will support the NRC staff in developing a policy paper that delineates options for and impacts of moving the NRC's radiation protection standards toward greater alignment with the recommendations outlined in ICRP Publication 103. The current effort will not provide all of the necessary information to proceed with rulemaking, and future Commission policy decisions may change the scope of this work.

### **For More Information**

Contact Tony Huffert, RES/DSA at 301-251-7506  
Anthony.Huffert@nrc.gov

# Participation in National and International Radiation Protection Activities

## Introduction

One of the benefits of the Health Effects Branch (HEB) program is the promotion of consistency and coherence in regulatory applications of radiation protection and health effects research among NRC programs, as well as those of other Federal and State regulatory agencies. To that end, HEB staff is actively engaged in monitoring and participating in the influential organizations described below.

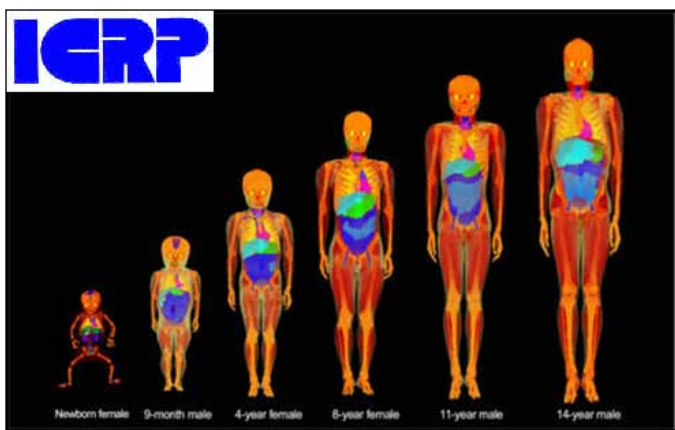

Figure 4.5 Biokientic model

## Participation

### ICRP—International Commission on Radiological Protection (Terry Brock, PhD)

ICRP is an independent registered charity, established to advance for the public benefit the science of radiological protection, in particular by providing recommendations and guidance on all aspects of protection against ionizing radiation. HEB collaborates with ICRP and stakeholders to ensure consistency in the application of radiation protection standards and dosimetry modeling.

### NCRP—National Council on Radiation Protection and Measurements (Casper Sun, PhD, CHP)

The NCRP seeks to formulate and disseminate information, guidance, and recommendations on radiation protection and measurements that represent the consensus of leading scientific thinking. The Council seeks out areas in which the development and publication of NCRP materials can make an important contribution to the public interest.

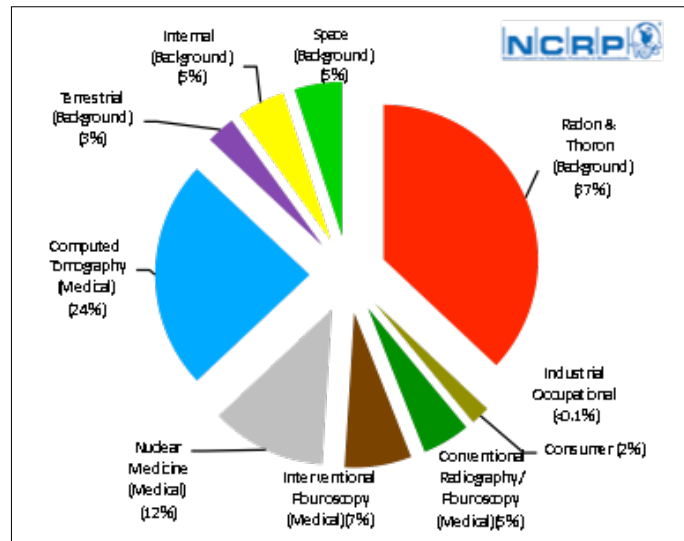

Figure 4.6 Background radiation exposure  
Source: NCRP Report No. 160

### CRPPH—NEA Committee on Radiation Protection and Public Health (Stephanie Bush-Goddard, PhD)

The NEA's CRPPH is a valuable resource for its member countries. The committee is made up of regulators and radiation protection experts with the broad mission of providing timely identification of new and emerging issues, analyzing their possible implications, and recommending or taking action to address these issues to further enhance radiation protection regulation and implementation. The HEB participates in the regulatory and operational consensus developed by the CRPPH on these emerging issues, supports policy and regulation development in member countries, and disseminates good practice.

### EGOE—Expert Group on Occupational Exposure (Tony Huffert, CHP)

EGOE is an international working group established under the NEA's CRPPH. EGOE will build on operational and regulatory experience in NEA member countries to identify where and how operational experience can support the review and development of occupational radiological protection guidance and good practice. The group will explore the promotion of safety and as low as reasonably achievable (ALARA) radiation exposure culture in new and growing industries, regulatory and self-assessment of ALARA programs, current experience and evolution in stakeholder involvement (especially workers) in occupational radiation protection, and practical approaches to itinerant worker management. HEB will work with EGOE to examine applying radiological protection optimization, setting dose constraint values, using collective dose limits in occupational radiological protection, and assessing stakeholder aspects of radiological protection optimization.



**ISOE—Information System on Occupational Exposure (Doris Lewis)**

ISOE was created in 1992 to provide a forum for radiation protection professionals from nuclear electricity utilities and national regulatory authorities worldwide to share dose reduction information, operational experience, and information to improve the optimization of radiological protection at nuclear power plants. Radiation Exposure Information and Reporting System (REIRS), managed by HEB, provides exposure information of domestic occupational workers for an increasingly international and global market.



Figure 4.7 Occupational radiation exposure workers

**ISEMIR—INFORMATION SYSTEM ON OCCUPATIONAL EXPOSURE IN MEDICINE, INDUSTRY, AND RESEARCH (Doris Lewis)**

ISEMIR was created in 2008 by the IAEA as a complimentary working group to NEA’s ISOE. The purpose of ISEMIR is to develop a global occupational exposure database of radiation exposures for global workers at nonnuclear electric utilities. The participation of the REIRS project manager in this international working group provides information on the development, implementation, and use of a database for trend analysis on the optimization of radiological protection at nonnuclear electric utilities.

**IRSN—INSTITUT DE RADIOPROTECTION ET DE SÛRETÉ NUCLÉAIRE (Tony Huffert, CHP)**

IRSN is a French public authority that conducts industrial and commercial activities. It is under the joint authority of the Ministry for Ecology, Energy, Sustainable Development and Town and Country Planning, the Ministry for the Economy, Industry and Employment, the Ministry for Higher Education and Research, the Ministry of Defense, and the Ministry for Health and Sports.

**JCCRER—JOINT COORDINATING COMMITTEE FOR RADIATION EFFECTS RESEARCH (Terry Brock, PhD)**

JCCRER is a bilateral government committee representing agencies from the United States and the Russian Federation tasked with coordinating scientific research on the health effects of exposure to ionizing radiation in the Russian Federation from the production of nuclear weapons. Jointly conducting radiation research with the Russian Federation provides a unique opportunity to learn more about possible risks to groups of people from long-term exposure to radiation. The HEB representative serves on the JCCRER Executive Committee, which is tasked with ensuring direct communication among the partners within the Agreement, coordinating the work of national organizations, and ensuring the effective and efficient implementation of JCCRER goals and objectives.

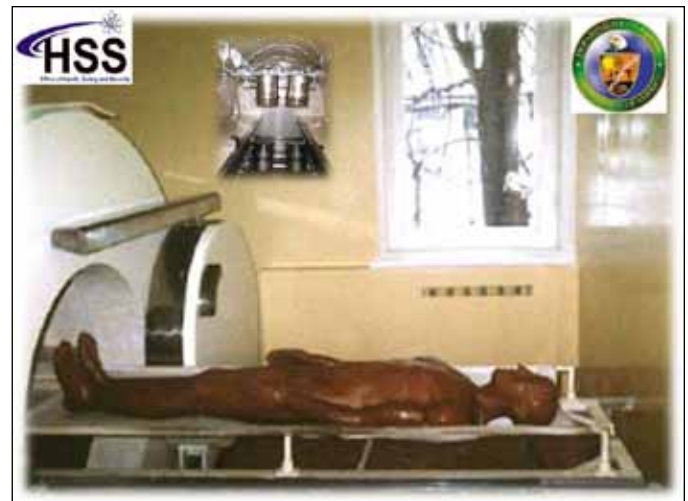

Figure 4.8 Russian Federation whole-body counting facility



Figure 4.9 Map of Mayak facility in the Russian Federation

**For More Information**

Contact Stephanie Bush-Goddard, RES/DSA, at 301-251-7528 or [Stephanie.Bush-Goddard@nrc.gov](mailto:Stephanie.Bush-Goddard@nrc.gov)

# Radiation Exposure Information and Reporting System (REIRS)

## Background

The REIRS project collects and analyzes the occupational radiation exposure records submitted by NRC licensees under 10 CFR 20.2206, “Reports of Individual Monitoring.”

Each year, approximately 200,000 radiation exposure reports are submitted by five categories of NRC licensees:

1. industrial radiography
2. manufacturers and distributors of byproduct material
3. commercial nuclear power reactors
4. independent spent fuel storage installations
5. fuel processors, fabricators, and reprocessors

The NRC does not receive radiation exposure reports from the remaining two licensee categories, low-level waste disposal facilities and geologic repository for high-level waste, because these facilities are either not under NRC jurisdiction or not currently in operation.

## Approach

To maintain compliance with 10 CFR 20.2206, NRC licensees must submit their occupational radiation exposure data to the NRC by April 30 of each year. Licensees can submit this data either electronically or on paper, using either NRC Form 5, “Occupational Dose Record for a Monitoring Period,” or a Form 5 equivalent.

The objective of the REIRS database is to provide NRC staff with occupational exposure data for evaluating trends in licensee performance in radiation protection and for research and epidemiological studies. The exposure reports in this database can provide facts about routine occupational exposures to radiation and radioactive material that can occur in connection with certain NRC-licensed activities.

The analysis of REIRS data is published annually in NUREG-0713, “Radiation Exposure at Commercial Nuclear Power Reactors and Other Facilities.”

## Application

The radiation exposure reports submitted by NRC licensees are used to meet the following NRC regulatory goals:

- evaluating the effectiveness of licensee’s as low as reasonably achievable (ALARA) programs at commercial nuclear power plants
- evaluating the radiological risk associated with certain categories of NRC-licensed activities
- comparing occupational radiation risks with potential public risks
- establishing priorities for the use of NRC health physics resources, such as research and development of standards and regulatory guidance
- answering congressional and public inquiries
- providing radiation exposure history reports to current and former occupational radiation workers who were exposed to radiation or radioactive materials at NRC-licensed or regulated facilities
- conducting occupational epidemiological studies

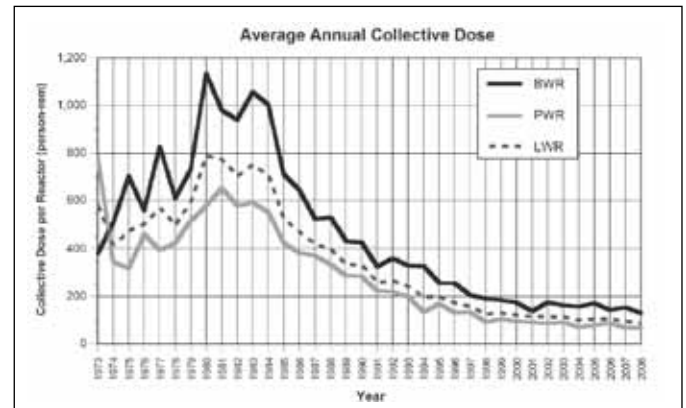

Figure 4.10 Sample data from REIRS database

## Web site

The annual NUREG-0713 reports are available on the NRC’s public Web site at [www.nrc.gov](http://www.nrc.gov) or the REIRS Web page at [www.reirs.com](http://www.reirs.com).

## REIRS Software

REMIT is a software package that allows licensees to maintain and report their exposure records to the REIRS database. REMIT allows for the electronic exchange of records from one licensee to another and the importing of records from the licensee’s dosimetry processor. REIRView is another NRC-developed software package that allows licensees to validate their

annual electronic submittals to the REIRS database. This saves licensees and the NRC considerable processing time because the licensee can identify and correct problems before submitting the information to the REIRS database.

**For More Information**

Contact Doris Lewis, RES/DSA at 301-251-7559 or Doris.Lewis@nrc.gov

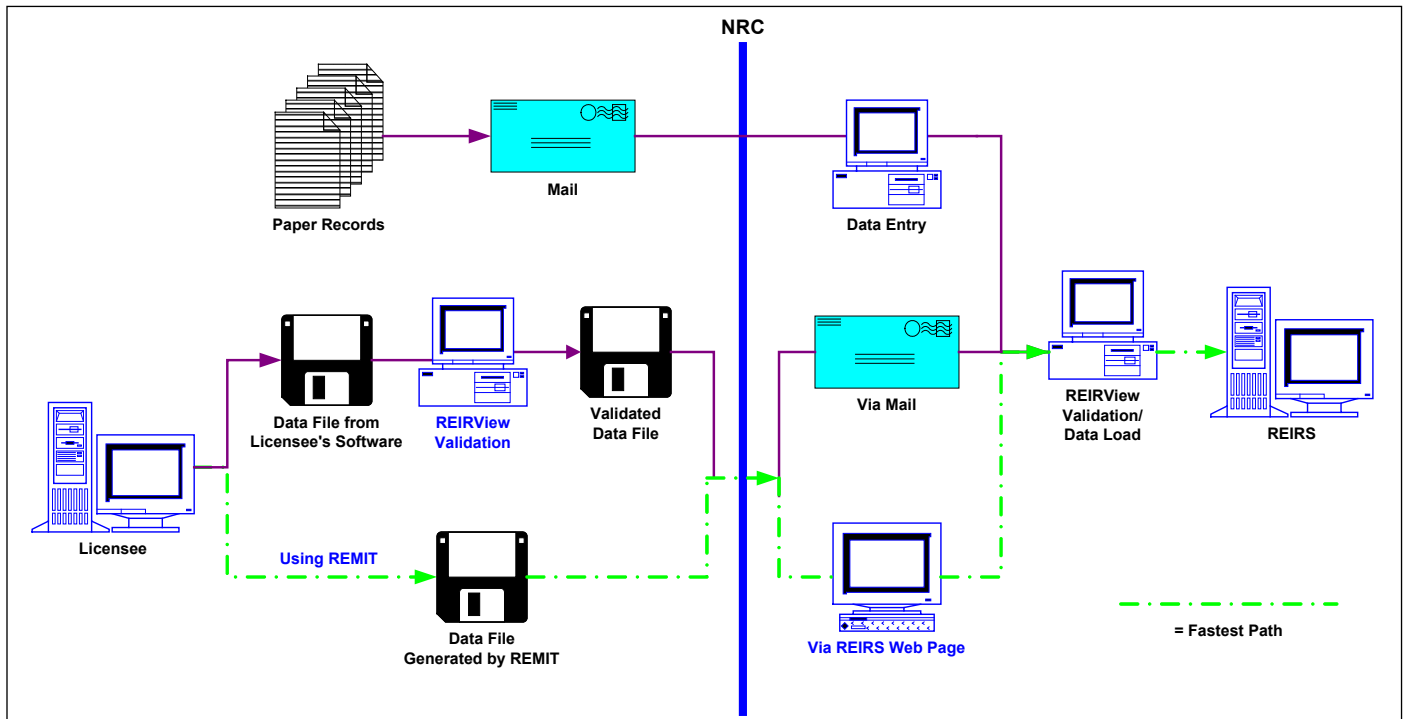

Figure 4.11 Process for submitting licensee exposure reports

# Report to Congress on Abnormal Occurrences

## Background

Section 208 of the Energy Reorganization Act of 1974 defines an abnormal occurrence (AO) as an unscheduled incident or event that the NRC determines to be significant from the standpoint of public health or safety.

The Federal Reports Elimination and Sunset Act of 1995 (Public Law 10466) requires the NRC to report AOs to Congress annually. The NRC initially promulgated the AO criteria in a policy statement published in the *Federal Register* on February 24, 1977 (42 FR 10950), followed by several revisions in subsequent years.

The NRC published its most recent revision to the AO criteria in the *Federal Register* on October 12, 2006 (71 FR 60198); it took effect on October 1, 2007.

## Approach

The AO process helps to identify deficiencies and ensure that corrective actions are taken to prevent recurrence. An accident or event will be considered an AO if it involves a major reduction in the degree of protection of public health or safety. This type of incident or event would have a moderate or more severe impact on public health or safety and could include, but need not be limited to, the following:

- moderate exposure to, or release of, radioactive material licensed by or otherwise regulated by the Commission
- major degradation of essential safety-related equipment
- major deficiencies in design, construction, use of, or management controls for facilities or radioactive material licensed by or otherwise regulated by the Commission

## Application

When an incident or event occurs, the NRC uses a generic event assessment process to assess it. This generic event assessment process includes the following actions:

- internal coordination with NRC offices
- systematic review of the cause of the event
- followup with the reporting licensee
- outreach to external stakeholders, as appropriate
- communication of lessons learned

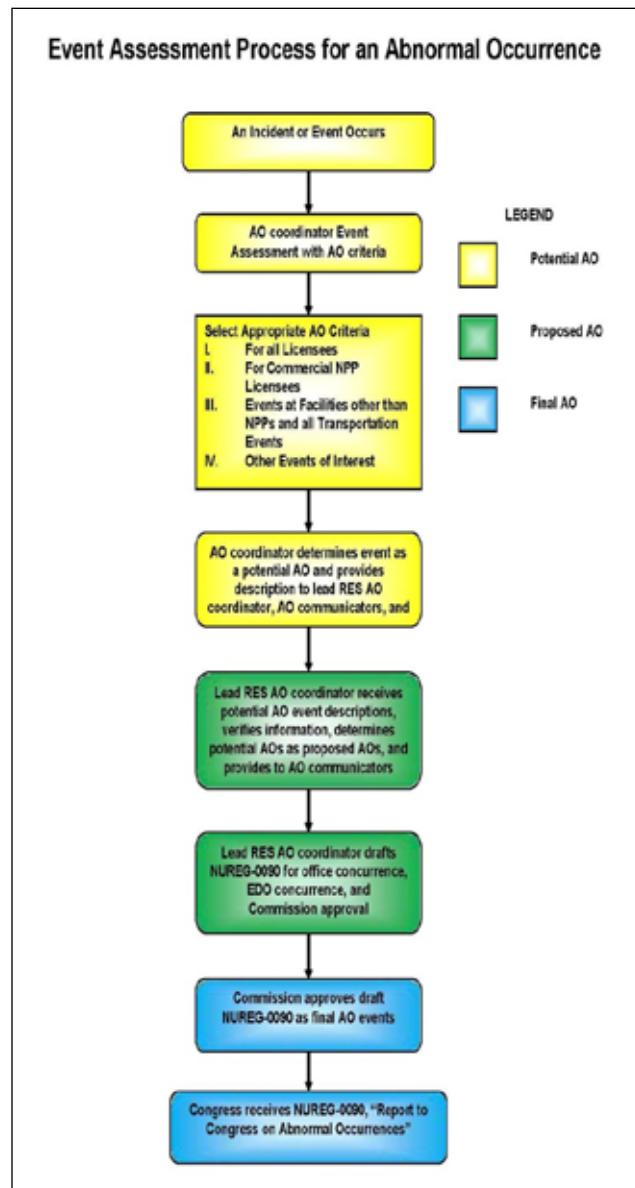

Figure 4.12 Event assessment for abnormal occurrences

## Examples of AO Events

### Medical Event at Presbyterian Hospital of Dallas Involving Gamma Stereotactic Radiosurgery Unit for Trigeminal Neuralgia

Presbyterian Hospital of Dallas notified the NRC of a medical event that occurred during a gamma stereotactic radiosurgery unit ("gamma knife"; see Figure 4.13) treatment for trigeminal neuralgia. The procedure prescribed the use of radiation from the cobalt60 source to treat the patient's fifth intracranial (trigeminal) nerve. An error in entry of information into the treatment planning system caused the wrong nerve to receive treatment (the seventh instead of the fifth intracranial nerve; see Figure 4.14).





Figure 4.13 Gamma stereotactic radiosurgery unit (gamma knife)  
(Source US NRC TTC-TN)

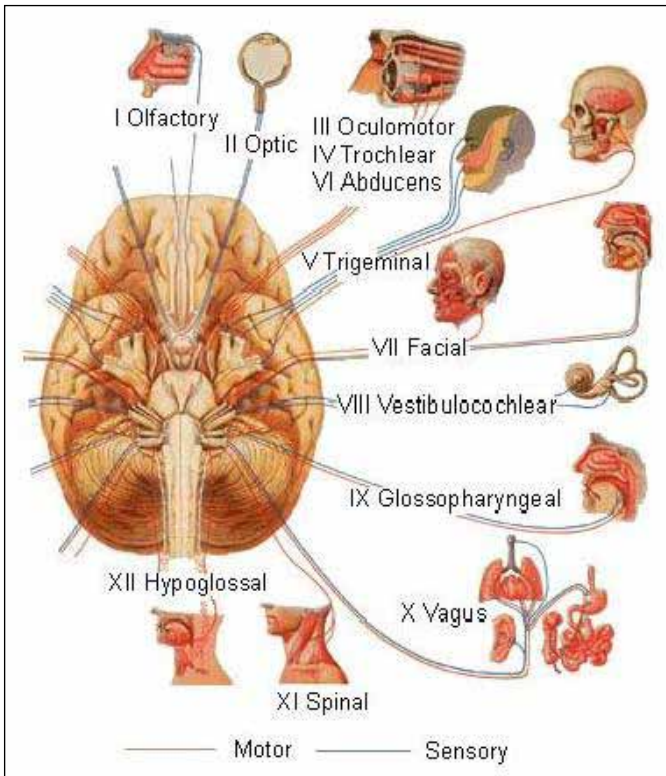

Figure 4.14 Diagram of the cranial nerves

### Medical Event at Cancer Care Northwest PET Center Involving Treatment for Prostate Cancer

Cancer Care Northwest PET Center notified the NRC of a medical event that occurred with a high dose rate brachytherapy treatment (Figure 4.15) for prostate cancer containing iridium192. During patient treatment, the aluminum connector to one of the needles (Figure 4.16) became detached from the plastic guide tube and a dose was delivered to a small area of the patient's inner thigh, the wrong treatment site

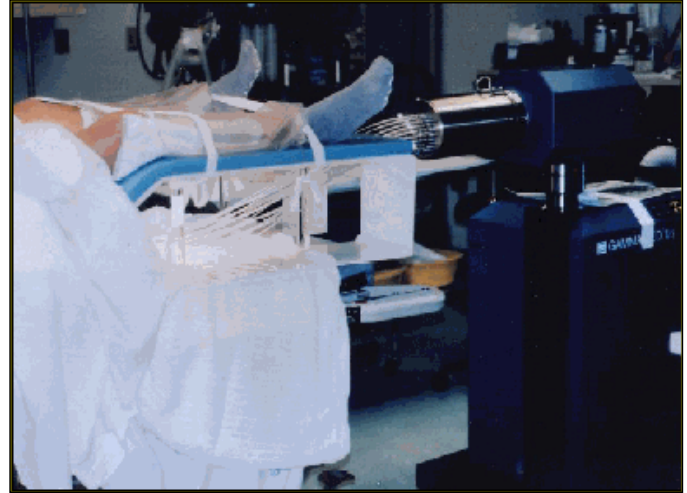

Figure 4.15 High dose rate prostate brachytherapy  
(Source US NRC TTC-TN)

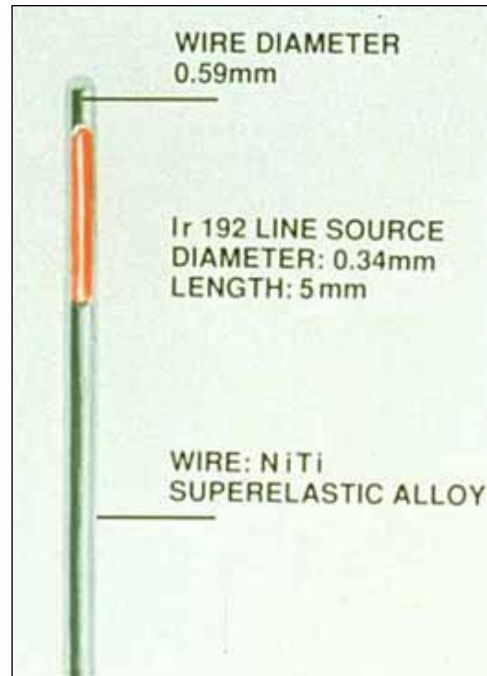

Figure 4.16 Diagram of iridium192 wire

### For More Information

Contact John Tomon, RES/DSA at 301-251-7904 or [John.Tomon@nrc.gov](mailto:John.Tomon@nrc.gov)

# Analysis of Cancer Risk in Populations Living Near Nuclear Facilities

## Background

On April 7, 2010, the U.S. Nuclear Regulatory Commission (NRC) requested that the U.S. National Academy of Sciences (NAS) conduct a study analyzing the cancer risk of populations living near NRC-licensed facilities. This study will be used to update the 1990 U.S. National Cancer Institute (NCI) report, “Cancer in Populations Living Near Nuclear Facilities.” The NAS is a nongovernmental organization chartered by the U.S. Congress to advise the Nation on issues of science, technology, and medicine. Through the National Research Council and Institute of Medicine, it carries out studies independent of the government using processes designed to promote transparency, objectivity, and technical rigor. More information on its methods for performing studies is available at <http://www.nationalacademies.org/studycommitteprocess.pdf>.

The NRC staff has used the 1990 NCI study as a valuable risk communication tool for addressing stakeholder concerns about cancer mortality attributable to the operation of nuclear facilities. Stakeholders often ask the staff about perceived elevated cancer rates in populations working or residing near NRC-licensed nuclear facilities, including power reactors and fuel cycle facilities (e.g., fuel enrichment and fabrication plants). The NCI study was produced in response to concerns about elevated risk of childhood leukemia to persons near a British nuclear facility (Sellafield). NCI researchers studied more than 900,000 cancer deaths, using county mortality records collected from 1950 to 1984. Changes in mortality rates for 16 types of cancer were evaluated. The NCI report concluded that cancer mortality rates are generally not elevated for people living in the 107 U.S. counties containing or closely adjacent to 62 nuclear facilities. However, the population data used in the NCI report is now more than 20 years old and is ready to be updated.

Today, stakeholder interest continues about perceived elevated cancer rates in populations near reactors, including cancer incidence (i.e., being diagnosed with cancer but not necessarily dying from the disease). The NRC is asking NAS to conduct this study to provide up-to-date information on cancer risks in populations near nuclear facilities.

## Approach

The proposed study will be performed in two phases: (1) preparing a scoping study to determine the best methodology, the best approach, and the potential limitations for performing the cancer incidence and mortality epidemiology study, and (2) performing the actual study. The NRC’s objective is to determine whether or not the cancer risks to populations living near or adjacent to nuclear facilities are different from the cancer risks to the average population and, if they differ, whether these risks should be attributed to the nuclear facility or to other causes. The study also will evaluate whether the risks are different for various age groups, including children.

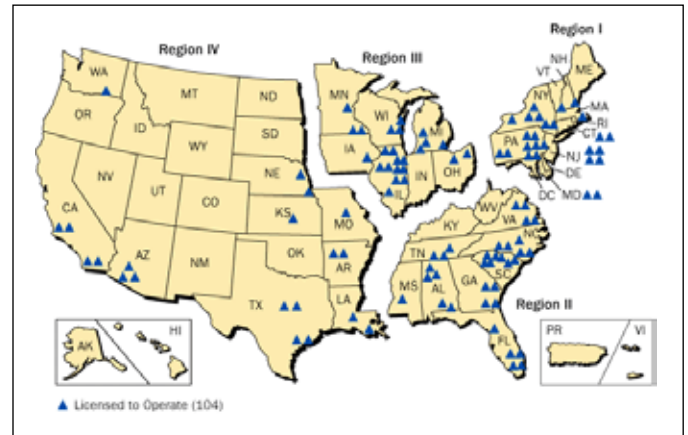

Figure 4.17 Locations of operating nuclear power facilities

## Study Status

NAS will hold public meetings to solicit public comment on the study approach and final deliverables. Notification of forthcoming public meetings at NAS is available at <http://dels.nas.edu/nrsb/meetings.shtml>.

The NCI fact sheet on the original 1990 study is available at <http://www.cancer.gov/cancertopics/factsheet/Risk/nuclear-facilities>

The press release on the NRC’s request to NAS is available at <http://www.nrc.gov/reading-rm/doc-collections/news/2010/10-060.html>

### For More Information

Contact Terry Brock, RES/DSA at 301-251-7487 or [Terry.Brock@nrc.gov](mailto:Terry.Brock@nrc.gov)

# Radiological Toolbox

## Background

The NRC, in conjunction with Oak Ridge National Laboratory, developed the Radiological Toolbox (hereafter referred to as the “Rad Toolbox” or “toolbox”) as a means to quickly access databases needed for radiation protection, shielding, and dosimetry calculations.

The toolbox is essentially an electronic handbook. It contains data of interest to health physicists, radiological engineers, and others working in fields involving radiation. Examples of data contained in the toolbox include the following:

- radioactive decay data
- biokinetic data
- internal and external dose coefficients
- elemental composition of many materials
- radiation interaction coefficients
- kerma coefficients
- other tabular data of interest

The toolbox includes a means to export the tabular data to an Excel worksheet for use in other calculations. It operates in a Windows environment.

## Approach

The Rad Toolbox is a computer application that provides access to physical, chemical, anatomical, physiological, and mathematical data (and models) relevant to the protection of workers and the public from exposures to ionizing radiation.

A graphical interface enables viewing of the data and the means to extract data for further use in computations and analysis. The numerical data, for the most part, are stored in International System (SI) units. However, the user can display and extract the data using non-SI units.

The data are stored in Microsoft Access databases and in flat ASCII files. The toolbox features additional computational capabilities and numerical data of interest.

The toolbox includes the following data elements:

- nuclear decay data—ICRP Publication 38, “Radionuclide Transformations” (ICRP 1983), and the Japan Atomic Energy Research Institute (Endo 1999, 2001)

- dose coefficients for photon and neutron fields—ICRP Publication 74, “Conversion Coefficients for Use in Radiological Protection against External Radiation” (ICRP 1996b)
- organ masses values (ICRP Publication 72, “Age-Dependent Doses to the Members of the Public from Intake of Radionuclides, Part 5, Compilation of Ingestion and Inhalation Coefficients”) and reference values (ICRP Publication 89, “Basic Anatomical and Physiological Data for Use in Radiological Protection: Reference Values”)
- radiation workers—ICRP Publications 30, “Limits for Intakes of Radionuclides by Workers, Part 3,” and 68, “Dose Coefficients for Intakes of Radionuclides by Workers” (ICRP 1978, 1994)
- members of the public—ICRP Publication 72 (ICRP 1996a)
- external irradiation—Federal Guidance Report 12, “External Exposure to Radionuclides in Air, Water, and Soil” (U.S. Environmental Protection Agency, 1993)

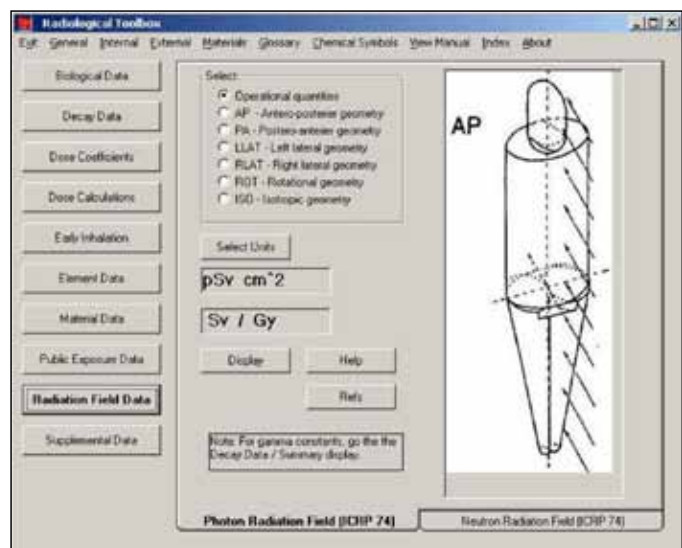

Figure 4.18 Radiological Toolbox

For the most part, the Rad Toolbox accesses numerical databases and converts the requested values to the units specified by the users.

Computational modules are included to calculate inhalation dose coefficients for deterministic effects over the time period specified by the user and to compute radiation interaction coefficients for materials based on their elemental composition.

The software’s help files provide access to textual information on topics ranging from general information to the details of models describing the fate of radionuclides in the body.

## Toolbox Content

When the toolbox is initiated, a user screen appears.

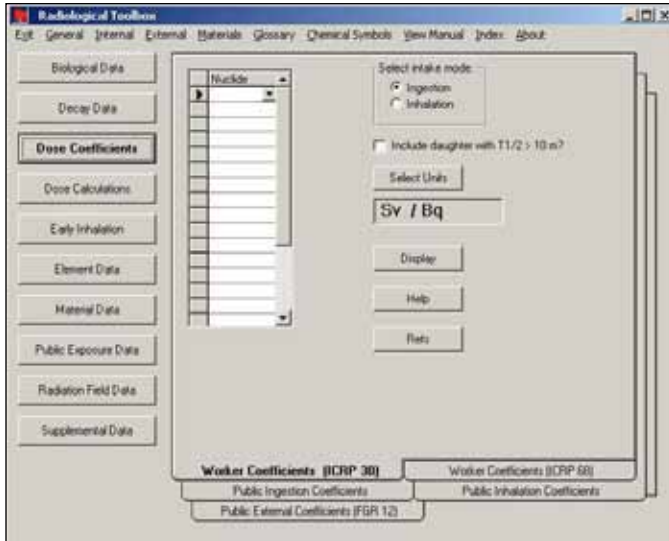

Figure 4.19 Radiological Toolbox graphical user interface

The menu bar at the top of the screen allows access to the software help files in addition to other standard functions.

The menu bar at the left of the screen allows access to all data elements that are included in the toolbox.

For example, the “Dose Coefficients” section of the toolbox provides access to the following sets of nuclide-specific dose coefficients:

- external dose rate coefficients for 826 radionuclides from Federal Guidance Report 12 (EPA 1993)
- committed dose coefficients for inhalation and ingestion intakes of 738 radionuclides by workers from ICRP Publications 30 and 68 (ICRP 1978, 1994)
- age-dependent committed dose coefficients for the inhalation and ingestion intakes of 738 radionuclides by members of the public (six ages at intake) from ICRP Publication 72 (ICRP 1996a)

For each set of coefficients, it is possible to display up to 20 nuclides at a time for a chosen route of exposure or intake.

## Future Updates

Further revisions of the toolbox are planned as the NRC staff and other users identify the need for additional data.

The program and user manual can be downloaded from the NRC public Web site at <http://www.nrc.gov/about-nrc/regulatory/research/radiological-toolbox.html>

### For More Information

Contact Elijah Dickson, RES/DSA at 301-251-7519 or [Elijah.Dickson@nrc.gov](mailto:Elijah.Dickson@nrc.gov)

## References

Endo, A., T. Tamura, and Y. Yamaguchi. *Compilation of Nuclear Decay Data Used for Dose Calculation Revised Data for Radionuclides Not Listed in ICRP Publication 38*, JAERI-Data/Code 99-035. 1999.

Endo, A., and Y. Yamaguchi. *Compilation of Nuclear Decay Data Used for Dose Calculation Revised Data for Radionuclides Listed in ICRP Publication 38*, JAERI-Data/Code 2001-004. 2001.

U.A. Environmental Protection Agency. *External Exposure to Radionuclides in Air, Water, and Soil*. Federal Guidance Report 12. U.S. Environmental Protection Agency, Washington, DC, 1993.

International Commission on Radiological Protection. *Limits for Intakes of Radionuclides by Workers*. ICRP Publication 30. Annals of the ICRP Vol. 2. International Commission on Radiological Protection, Pergamon Press, New York, NY, 1978.

International Commission on Radiological Protection (ICRP). *Dose Coefficients for Intakes of Radionuclides by Workers*. ICRP Publication 68. Annals of the ICRP 24(4). International Commission on Radiological Protection, Pergamon Press, New York, NY, 1994.

International Commission on Radiological Protection (ICRP). *Age-dependent Doses to the Members of the Public from Intake of Radionuclides: Part 5 Compilation of Ingestion and Inhalation Coefficients*. ICRP Publication 72. International Commission on Radiological Protection, Pergamon Press, New York, NY, 1996a.

International Commission on Radiological Protection (ICRP). *Conversion Coefficients for Use in Radiological Protection Against External Radiation*. ICRP Publication 74. International Commission on Radiological Protection, Pergamon Press, New York, 1996b.



# Phantom with Moving Arms and Legs (PIMAL)

## Background

Modeling scenarios of radiation exposure to the human body, either internal or external, requires an extensive knowledge of both fundamental particle physics and complex radionuclide biokinetics. To aid the NRC staff in developing exposure models and performing the necessary dosimetry calculations for an individual, RES has developed humanoid phantom models (“phantoms with moving arms and legs” or PIMALs) now considered essential tools for radiation dose assessment.

## Approach

RES has partnered with Oak Ridge National Laboratory to develop two types of phantoms important for radiation dose assessment. One type, often referred to as a mathematical

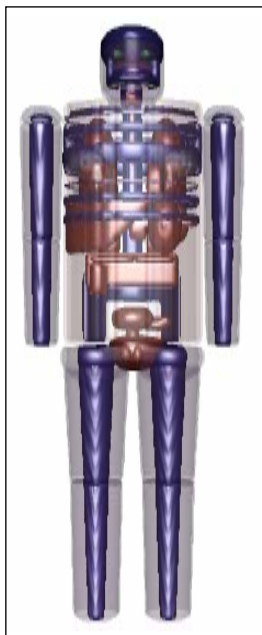

**Figure 4.20** Mathematically-based human phantom with articulating arms and legs

phantom, is an update of the Medical Internal Radiation Dose (MIRD) phantom with the substitution of movable arms and legs for the fixed ones in MIRD. Development of this updated phantom, with a graphical user interface (GUI), is near completion. A second type, now under consideration, is to be a hybrid with the same arms and legs as those on the mathematical phantom but with a voxelized torso. The GUI is used to graphically set the arms and legs to the desired orientation, develop the Monte Carlo NParticle Transport Code (MCNP) input file, and display a table of organ doses and effective dose at the end of the run. The GUI allows users with only basic MCNP user skills to perform calculations using the phantom.

phantom, is an update of the Medical Internal Radiation Dose (MIRD) phantom with the substitution of movable arms and legs for the fixed ones in MIRD. Development of this updated phantom, with a graphical user interface (GUI), is near completion. A second type, now under consideration, is to be a hybrid with the same arms and legs as those on the mathematical phantom but with a voxelized torso. The GUI is used to graphically set the arms and legs to the desired orientation, develop the Monte Carlo NParticle Transport Code (MCNP) input file, and display a table of organ doses and effective dose at the end of the run. The GUI allows users with only basic MCNP user skills to perform calculations using the phantom.

In the case of voxelized phantoms, the organs are defined by individual volumetric elements or pixels, referred to as voxels, which, depending on the resolution, may each measure a few

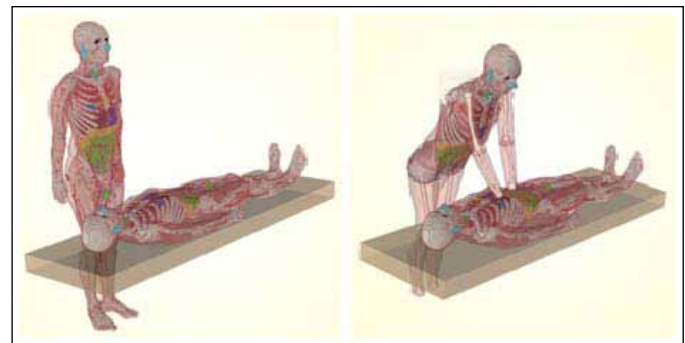

**Figure 4.21** voxel-based phantom with articulating arms and legs

millimeters on a side. Each part of the body is defined by an identifiable group of these pixels. Millions are required to compose a single humanoid model.

Voxel-based phantoms are excellent in applications when extremely accurate dosimetry is needed. However, their complexity makes them computationally expensive to execute. Figure 4.21 graphically represents the male voxel phantom.

The NRC staff experience using PIMAL has clearly demonstrated that state-of-the-art phantoms and a user-friendly GUI greatly ease the burden of setting up and executing a radiation transport problem and retrieving the dosimetry results.



**Figure 4.22** Geometrical setting for patient-physician modeling with a realistic posture (right) using PIMAL

## Current Status

Work has been completed to update the 1974 MIRD5 phantom and original PIMAL GUI. Additional work to develop new mathematical and voxel-based phantoms is ongoing. An example of ongoing work is implementation of the new ICRP103 tissue weighting factors, in addition to those from ICRP26 and ICRP30, into the GUI to calculate the effective dose. The next phase of this project is to test the phantoms in a variety of exposure situations and incorporate improvements and additions to increase their utility and ease of use. Beyond this stage, the



---

NRC will consider whether or not conversion to hybrid male and female voxel phantoms would be a significant addition to the MIRD set. One important advantage of such hybrids would be that they can be designed to the same specifications as the recently adopted ICRP male and female voxel phantoms, which then serve as benchmarks for NRC's phantoms and calculations.

**For More Information**

Contact Mohammad Saba, RES/DSA at 301-251-7558 or [mohammad.saba@nrc.gov](mailto:mohammad.saba@nrc.gov)

# Varskin Skin Computer Code

## Background

The computer code VARSKIN 3 is currently used to model and calculate skin dose from skin or protective clothing contamination for regulatory requirements under 10 CFR Part 20.

The NRC sponsored the development of the VARSKIN code to assist licensees in demonstrating compliance with 10 CFR 20.1201(c). This regulation requires licensees to have an approved radiation protection program that includes established protocols for calculating and documenting the dose attributable to radioactive contamination of the skin.

## Approach

### Original VARSKIN code

The initial version of the code, developed in the 1980s, fulfilled the regulatory requirement but was limited to point sources or infinitely thin disk sources directly on the skin. Soon after the initial release of VARSKIN, the industry encountered a new type of skin contaminant, which consisted of discrete microscopic radioactive particles, called “hot particles.”

These hot particles differ radically from uniform skin contamination in that they have a thickness, and that many of the exposures result from particles on the outside of protective clothing. Therefore, the code required further modifications.

### VARSKIN Mod 2

VARSKIN Mod 2, developed in the early 1990s, significantly enhanced the code by adding the ability to model three-dimensional sources (cylinders, spheres, and slabs) with materials placed between the source and skin (including air gaps that attenuate the beta particles).

The code also modeled hot particle photon doses in certain cases. In addition, VARSKIN Mod 2 incorporated a user interface that greatly simplified data entry and increased efficiency in calculating skin dose.

### VARSKIN 3

VARSKIN 3, released in 2004, operates in a Microsoft Windows environment and is designed to be significantly easier to learn and use than VARSKIN Mod 2.

In addition, this release enables users to calculate the skin dose (from both beta and gamma sources) attributable to radioactive contamination of skin or protective clothing.

The code also offers the ability to compute the dose at any skin depth or skin volume, with point, disk, cylindrical, spherical, or slab (rectangular) sources. It even enables users to compute doses from multiple sources.

Figure 4.23 shows a typical VARSKIN 3 input screen for point source geometry.

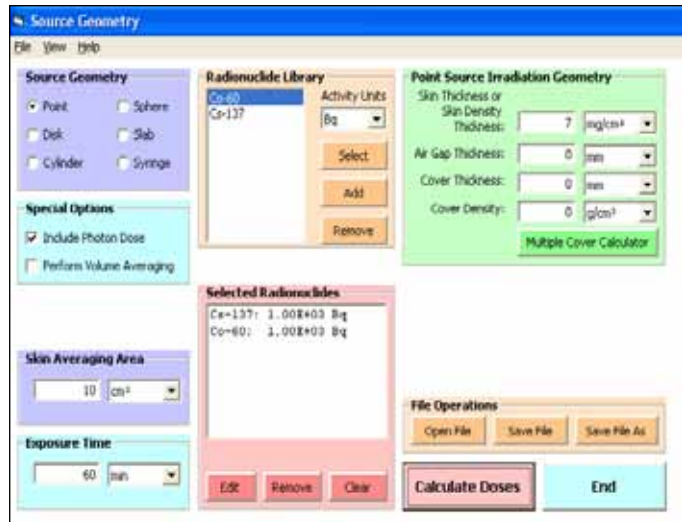

Figure 4.23 Point source geometry screen

The input data file was also modified for VARSKIN 3 to reflect current physical data, include the dose contribution from internal conversion and Auger electrons, and to allow a correction for low-energy electrons.

## Current Status

Since the release of VARSKIN 3, the NRC staff has compared its dose calculations, for various energies and at various skin depths, with doses calculated by the Monte Carlo N-Particle Transport Code System (MCNP) developed by the Los Alamos National Laboratory. The comparison shows that VARSKIN 3 overestimates the dose with increasing photon energy.

For that reason, the NRC is currently sponsoring further enhancement of the code to replace the existing photon dose algorithm and to develop quality assurance methods for this model.

Upgrades to VARSKIN will include the following:

- an enhanced photon dosimetry model that is based on Monte Carlo simulations of hot-particle contamination
- mathematical formulations rather than look-up tables to drive the estimation of dose
- dose averaging to provide efficient convergence of the solution

- 
- incorporation of parameters for energy, attenuation, dose-averaging area, and air gap
  - protective clothing thickness, as well as simple volumetric sources

Code developers have also addressed deficiencies in the current code by creating the capability to calculate dose while accounting for attenuation and by correcting the assumption that used the same effective-Z for all materials.

## Future Updates

- Correct technical issues with the beta dose model reported by the code users.
- Develop a quality assurance program for beta dose model.
- Develop a training module for using the code.

VARSKIN 3 is available from the Radiation Safety Information Computational Center. For additional information, see NUREG/CR-6918, “VARSKIN 3: A Computer Code for Assessing Skin Dose from Skin Contamination,” issued October 2006. This document can be found in the Agency Documents Access and Management System (ADAMS), ML063320348.

### For More Information

Contact Mohammad Saba, RES/DSA at 301-251-7558 or [Mohammad.Saba@NRC.gov](mailto:Mohammad.Saba@NRC.gov)

# Accelerator-Enhanced Gemstones

## Background

Exposing gemstones to radiation is a method of enhancing and deepening the gemstone color. The bombardment of radiation hitting the gemstone deposits energy that creates color centers. For example, radiation can cause a naturally clear topaz to turn blue. Other gemstones are irradiated with other color enhancements (Figure 4.24). Gemstone color enhancement using radiation can be performed using a nuclear reactor (neutron bombardment), an accelerator (electron-particle beam exposure) (Figure 4.25), or a cobalt irradiator (gamma rays). Color enhancement by irradiation is currently widely used on gemstones such as topaz, tourmaline, quartz, beryl, zircon, diamond, and, more recently, labradorite.



Figure 4.24 Enhanced gemstones (Reference 1)

As a high-energy electron approaches another charged particle, such as an atomic nucleus, the electron will deflect because of the electric field; as a result, it will also release energy in the form of an X-ray. If the X-ray has enough energy, known as threshold energy, it can enter a nucleus and cause a photoneutron or photoproton reaction. The resulting atom with one less nucleon may be stable or radioactive. The neutron can then activate another nuclide within the gemstone, creating a daughter that could possibly be radioactive. The impurities in the gemstones are what become activated, making the gemstone radioactive.

Generally, photoneutron reactions occur in gemstones from electron beams with energies greater than 10 million electron volts. Gemstones treated at a low energy in an electron accelerator may not actually become radioactive. Thus, electron-irradiated gemstones do not produce byproduct materials unless the electron energy exceeds the threshold energy for activation of the gemstone impurities.

## Approach

Section 651(e) of the Energy Policy Act expanded the definition of byproduct material as defined in Section 11e of the Atomic Energy Act of 1954, as amended. This change placed certain naturally occurring and accelerator-produced radioactive materials under the NRC's jurisdiction. NRC regulations provide exemptions from the usual requirements for an NRC license to persons who receive, possess, use, transfer, own, or acquire byproduct material in exempt distribution quantities or concentrations. Each initial distributor of irradiated gemstones that holds one of these NRC-issued "exempt distributions licenses" is required to ensure that its gemstones are tested to preclude the possibility of the gemstones reaching the public before the activity induced in the gemstone is at or below exempt concentrations.

In the United States, only the initial distributor of the gemstones must be licensed under 10 CFR 32.11, "Introduction of Byproduct Material in Exempt Concentrations into Products or Materials, and Transfer of Ownership or Possession: Requirements for License." The exemptions are set forth in 10 CFR 30.14, "Exempt Concentrations," and 10 CFR 30.18, "Exempt Quantities." Persons who have this NRC license are authorized to distribute exempt products to persons who do not require an NRC license.



Figure 4.25 Rhodotron high-energy electron beam accelerator (Reference 1)

## Current Status

The goal of research on this topic is to provide the NRC with the current practices and data from the electron beam accelerator-irradiated gemstone industry, for the purpose of making sound regulatory decisions regarding the issuance of exempt distribution licenses.

Gemstones are irradiated in batches (Figure 4.26). Exempt distribution licensees typically conduct batch analysis to demonstrate that gemstones are at or below maximum exempt concentration levels upon release. Batch analysis in lieu of single-gemstone analysis is performed for efficiency and productivity. The batch size is usually dictated by the physical limitations of the analysis equipment. It is not clear that individual gemstones with radioactivity levels above the exempt concentration limits are always identified in a batch analysis release. At present, there is no guidance demonstrating the efficacy of batch survey methodologies.

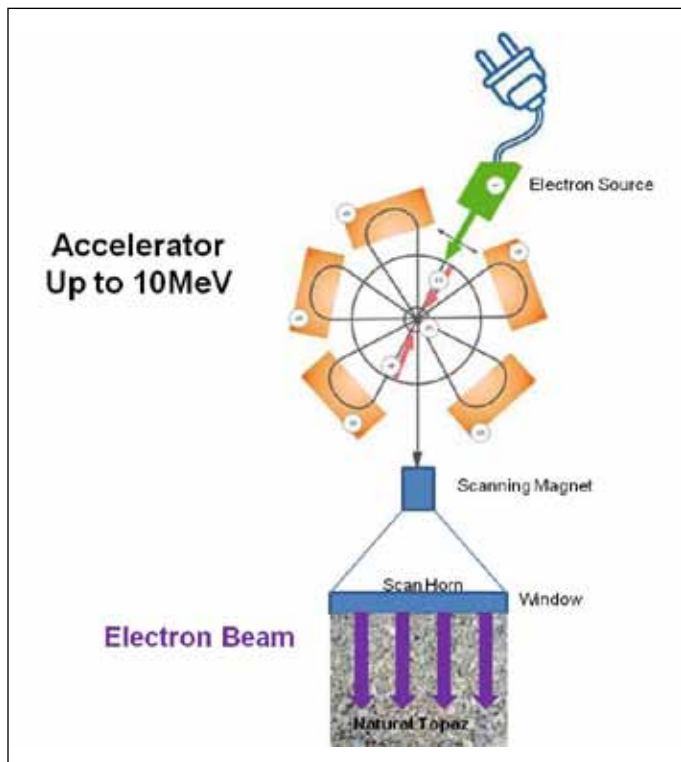

Figure 4.26 Diagram of electron beam accelerator and batch of natural clear topaz (Reference 1)

## References

1. Yves Jongen, “Industrial Applications of Accelerators: Traditional and New” (presentation at Accelerators for America’s Future Washington, October 26, 2009).

### For More Information

Contact John Tomon, RES/DSA at 301-251-7904 or [John.Tomon@nrc.gov](mailto:John.Tomon@nrc.gov)





# Chapter 5: Risk Analysis

Comprehensive Site Level 3 Probabilistic Risk Assessment

Risk Assessment Standardization Project

Probabilistic Risk Assessment Quality and Standards

Reactor Operating Experience Data Collection and Analysis

Accident Sequence Precursor Program

SPAR Model Development Program

Thermal-Hydraulic Level 1 Probabilistic Risk Assessment Success Criteria

Advancing Modeling Techniques in Level 2 and Level 3 Probabilistic Risk Assessment

Risk-Informing Emergency Preparedness: Probabilistic Risk Analysis of Emergency Action Levels

Risk-Informing Security

Design-Basis Flood Determinations at Nuclear Power Plants

Assessment of Debris Accumulation on ECCS Suction Strainer Performance

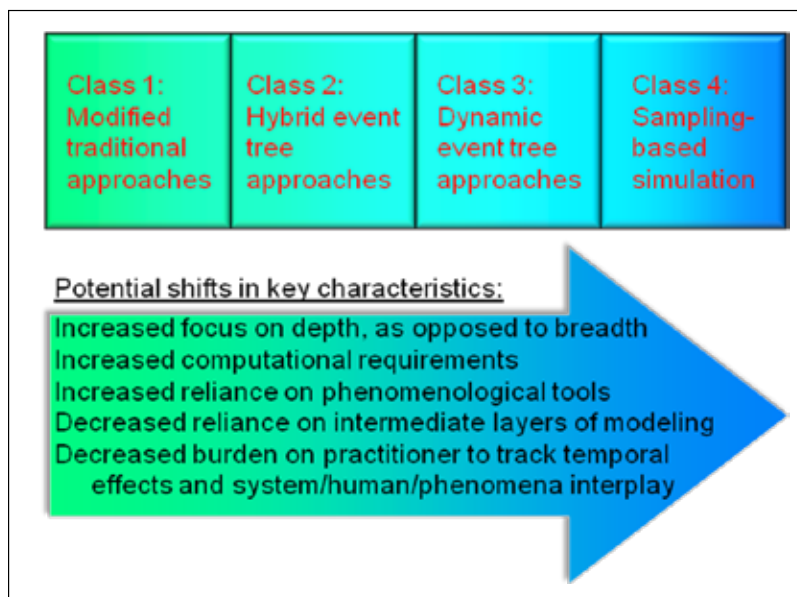

Diagram illustrating the spectrum of approach classes associated with advanced modeling techniques in Level 2 and Level 3 probabilistic risk assessment (PRA)

# Comprehensive Site Level 3 Probabilistic Risk Assessment

## Background

### Risk and Probabilistic Risk Assessment

According to the traditional definition, risk is the product of the likelihood and consequences of an adverse event. Probabilistic risk assessment (PRA) is a systematic analysis tool consisting of specific technical elements that provide both qualitative insights and a quantitative assessment of risk by addressing the following questions, commonly referred to as the “risk triplet”: (1) What can go wrong? (2) How likely is it? and (3) What are the consequences? Modern PRAs have also incorporated uncertainty analyses to address a fourth question: How confident are we in our answers to these three questions? In this way, PRAs allow the identification, prioritization, and mitigation of significant contributors to risk to improve nuclear power plant safety.

PRAs for nuclear power plants can vary in scope, depending on their intended use. The scope of a PRA is defined by the degree of coverage of the following five factors: (1) radiological hazards, (2) population exposed to hazards, (3) plant operating states, (4) initiating event hazards, and (5) level of risk characterization. Figure 5.1 summarizes the various scoping options for each factor.

### The Importance of Level 3 PRA

Figure 5.2 illustrates that PRAs for nuclear power plants can estimate risk measures at three different levels of characterization using sequential analyses in which the output from one level serves as a conditional input to the next. Using event trees and fault trees, a Level 1 PRA models various plant and operator responses to initiating events that challenge plant operation to identify accident sequences that result in reactor core damage. The estimated frequencies for all core damage accident sequences are summed to calculate the total core damage frequency (CDF) for the analyzed plant.

Factor	Scoping Options for Operating Nuclear Power Plants
Radiological hazards	Reactor core Spent fuel Other Radioactive Sources
Population exposed to hazards	Onsite population Offsite population
Plant operating states	At-Power Low Power/Shutdown
Initiating event hazards	Internal events Traditional internal events (transients, loss-of-coolant accidents) Internal floods Internal fires
	External events Seismic events (earthquakes) High winds Other external hazards
Level of risk characterization	Level 1 PRA: Core damage frequency Level 2 PRA: e.g., Large early release frequency Level 3 PRA: Early fatality risk Latent cancer fatality risk

**Figure 5.1 Factors affecting the scope of PRAs for operating nuclear power plants**

A Level 2 PRA models and analyzes the progression of “severe accidents”—those Level 1 PRA accident sequences that result in reactor core damage—by considering how the reactor coolant and other relevant systems respond, as well as how the containment responds to the accident. This analysis is based on both the initial status of structures and systems and their ability to withstand the harsh accident environment. Once the system and containment response is characterized, the frequency, type, amount, timing, and energy content of the radioactivity released to the environment—also known as source term characteristics—can be determined.

A Level 3 PRA models the release and transport of radioactive material in a severe accident and estimates the health and economic impact in terms of the following offsite consequence measures: (1) early fatalities and injuries and latent cancer fatalities resulting from the radiation doses to the surrounding population, and (2) economic costs associated with evacuation, relocation, property loss, and decontamination. Offsite consequences are estimated based on the Level 2 PRA source term characteristics, and on several other factors affecting the transport and impact of the radioactive material, including meteorology, demographics, emergency response, and land use. Combining the results of the Level 1 and Level 2 PRAs with the results of this consequence analysis, only the Level 3 PRA estimates the integrated risk (likelihood times consequences) to the public for the analyzed nuclear power plant. In fact, only a Level 3 PRA can estimate the two high-level quantitative health objectives related to early and latent cancer fatality risks that the

U.S. Nuclear Regulatory Commission (NRC) identified in a 1986 safety goal policy statement on determining what level of risk is acceptable to ensure adequate protection of public health and safety.

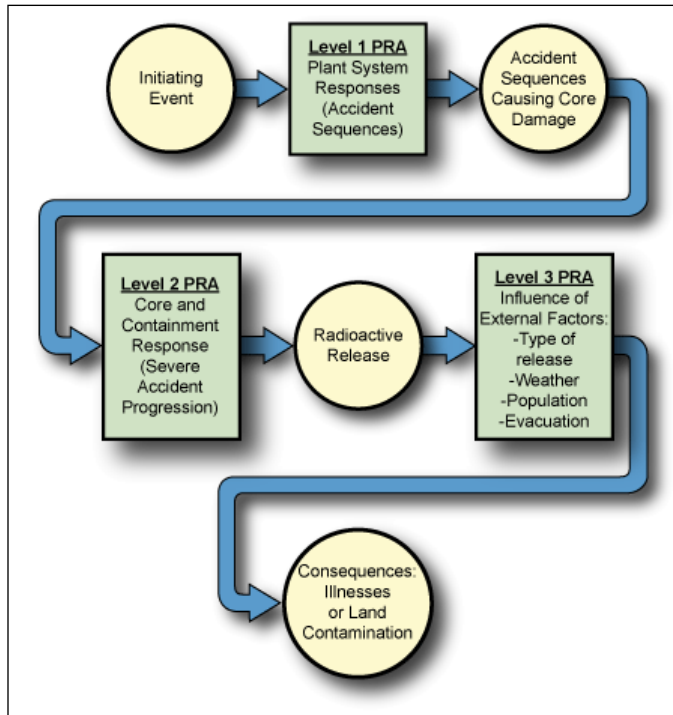

Figure 5.2 Three sequential levels of risk analysis in PRAs for nuclear power plants (Source: www.nrc.gov)

### NUREG-1150: A Landmark Study

Although Level 3 PRAs are required to directly estimate the risk to the public from nuclear power plant accidents, the NRC does not routinely use them in risk-informed regulation. In fact, NRC-sponsored Level 3 PRAs have not been conducted since the late 1980s—over 20 years ago. These Level 3 PRAs were documented in a collection of NUREG/CR reports and a single corresponding summary document, NUREG-1150, “Severe Accident Risks: An Assessment for Five U.S. Nuclear Power Plants,” issued October 1990. NUREG-1150 provides a set of PRA models and a snapshot-in-time (circa 1988) assessment of the severe accident risks associated with five commercial nuclear power plants of different reactor and containment designs. The NRC has used the landmark NUREG-1150 results and perspectives in a variety of regulatory applications, including development of PRA policy statements, support of risk-informed rulemaking, prioritization of generic issues and research, and establishment of numerical risk acceptance guidelines for the use of CDF and large early-release frequency (LERF) as surrogate risk metrics for early and latent cancer fatality risks.

Since then, the NRC has ensured safety primarily by using results obtained from Level 1 and limited Level 2 PRAs—both less

expensive than Level 3 PRAs—and how they relate to lower level subsidiary safety goals based on CDF and LERF to risk-inform regulatory decisionmaking.

### The Need For a New Comprehensive Site Level 3 PRA

There are several compelling reasons for conducting a new comprehensive site Level 3 PRA. First, in the two decades since the publication of NUREG-1150, there have been substantial developments that may affect the results and risk perspectives that have influenced many regulatory applications. In addition to risk-informed regulations implemented to improve safety (e.g., the Station Blackout and Maintenance Rules), there have been plant modifications that may affect risk (e.g., the addition or improvement of plant safety systems, changes to technical specifications, power uprates, and the development of improved accident management strategies). Along with NRC and industry acquisition of over 20 years of operating experience, there have also been significant advances in PRA methods, models, tools, and data—collectively referred to as “PRA technology”—and in information technology. Finally, the State-of-the-Art Reactor Consequence Analysis (SOARCA) study, which leveraged many of the same safety improvements and technological advances, integrates and analyzes two of the essential technical elements of a Level 3 PRA for some of the more likely reactor accident sequences—the severe accident progression and offsite consequence analyses. A new level 3 PRA could therefore seek to leverage the methods, models, and tools used in the SOARCA analysis and capitalize on the insights gained from the application of state-of-the-art practices.

In addition to these developments, the Level 3 PRAs documented in NUREG-1150 are incomplete in scope. Figure 5.3 illustrates the scope of a complete site accident risk analysis, with the approximate scope of the NUREG-1150 PRAs shown by the gray-shaded region. These PRAs were limited to the assessment of single-unit reactor accidents initiated primarily by internal events occurring during full-power operations. The partial coverage of external events indicates that a limited set of external events (fires and earthquakes) were considered for only two of the five analyzed nuclear power plants.

To update and improve its understanding of reactor accident risks, the NRC is considering evaluating accidents that might occur during any plant operating state, that are initiated by all possible internal events and external events, and that may simultaneously affect multiple units per site. Moreover, for a comprehensive site accident risk analysis, the NRC is also considering analyzing the risk from other site radiological hazards, such as spent fuel and radioactive waste streams. Because corresponding surrogate risk metrics that can be meaningfully integrated with and compared to CDF and LERF do not exist for these other radiological hazards, this analysis can only be accomplished in Level 3 space.

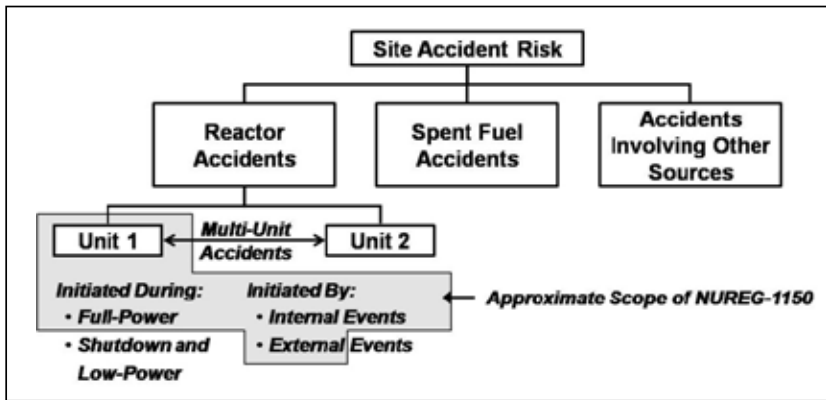

Figure 5.3 Site accident risk and approximate scope of NUREG-1150  
(Source: Marty Stutzke)

### For More Information

Contact the Project Manager:

Dan Hudson, RES/DRA at 301-251-7919 or

Daniel.Hudson@nrc.gov

or

Senior Technical Advisor:

Marty Stutzke, RES/DRA at 301-251-7614 or

Martin.Stutzke@nrc.gov

## Objective

For these reasons, the NRC staff has identified three specific objectives for a potential new comprehensive site Level 3 PRA project. The first objective is to update and improve staff understanding of site accident risk by (1) incorporating plant safety improvements, insights from SOARCA, and advances in PRA technology that have occurred in the two decades since NUREG-1150, and (2) integrating the risk from additional radiological hazards using consistent assumptions, methods, and tools to enable a meaningful comparison and ranking of risk contributors to focus the NRC's safety mission. Second is to upgrade and disseminate information about the NRC's PRA technology, using 21<sup>st</sup>-century information technology in a comprehensive risk analysis toolbox that will enhance the NRC's ability to risk-inform current and future regulatory decisionmaking. Third is to develop PRA expertise by training a new generation of risk analysts who will gain state-of-the-art knowledge and experience.

## Approach

Following an Office of Nuclear Regulatory Research (RES) briefing on the need for a new comprehensive site Level 3 PRA, the Commission expressed conditional support and directed the staff to continue internal coordination efforts and engage external stakeholders in formulating a plan and scope for future Level 3 PRA activities. In response, the RES Division of Risk Analysis (DRA) has initiated a scoping study to identify various options for the following elements of a pilot study: (1) site selection, (2) project scope, (3) PRA technology to be used, (4) new research needed to accomplish the project's objectives, and (5) resource estimates and information needs to better understand and address potential challenges. The staff will present the results of this scoping study, along with a specific recommendation for a Level 3 PRA pilot project, to the Commission for consideration in 2011.



---

# Risk Assessment Standardization Project

## Background

In the NRC's Reactor Oversight Process, the NRC staff performs risk assessments of inspection findings and reactor incidents to determine their significance for appropriate regulatory response. Currently, several NRC groups are performing these risk assessments for Accident Sequence Precursor (ASP) and Significance Determination Process (SDP) Phase 3 analyses, and for Incident Investigation Program assessments under Management Directive (MD) 8.3, "NRC Incident Investigation Program," issued March 2001. Because each NRC program has different objectives, the NRC staff initiated the Risk Assessment Standardization Project (RASP) to establish standard procedures, improve the methods, and enhance risk models that are used in risk assessment in various risk-informed regulatory applications.

## Approach

### Project Objectives

The primary objective of RASP is to provide standard methods and tools for risk analysis of inspection findings or reactor incidents for the ASP program, Phase 3 analysis of the SDP, and Incident Investigation Program, while recognizing differences in purpose among the programs. By using these standard methods and tools, NRC analysts from various Headquarters and regional offices will achieve more consistent results when performing risk assessments of operational events and licensee performance issues.

### Rasp Activities

Major RASP activities include the following:

- developing standard procedures and methods for the analysis of internal events, internal fire and flooding events, external events, and shutdown events
- providing enhanced-quality, integrated NRC Standardized Plant Analysis Risk (SPAR) models for internal and external events, including shutdown events
- enhancing the Systems Analysis Programs for Hands-on Integrated Reliability Evaluation (SAPHIRE) code for SPAR model analyses
- providing readily available technical support to SDP analysts

The NRC staff in the RES Division of Risk Analysis is performing these RASP activities as part of a multiyear project expected to result in the revision and development of procedures to consolidate and streamline risk analysis. Staff from the Office

of Nuclear Reactor Regulation Division of Risk Assessment and Division of Inspection and Regional Support as well as regional senior reactor analysts provide detailed peer review of RASP-related products, as well as feedback for future enhancements.

Specific details of the proposed work on each RASP activity are discussed below.

### Development of Risk Assessment of Operational Events Handbook

The NRC staff issued the "Risk Assessment of Operational Events Handbook" ("RASP handbook") for risk assessment of internal and external events at U.S. commercial nuclear power plants. This handbook is in the form of a practical, how-to guide to the methods, best practices, examples, tips, and precautions for using SPAR models to evaluate the risk of inspection findings and reactor incidents. The handbook represents best practices based on feedback and experience from the analyses of over 600 precursors in the ASP program (since 1969) and many SDP Phase 3 analyses (since 2000).

The handbook consists of three volumes designed to address internal events analysis (Volume 1), external events analysis (Volume 2), and SPAR model reviews (Volume 3). A fourth volume is currently under internal review for shutdown events analysis. The scope of each of these volumes is described below.

***Development of Standard Guidance for Internal Events Analysis.*** Volume 1 of the RASP handbook, "Internal Events," provides guidance on generic methods and processes to estimate the risk significance of initiating events (e.g., reactor trip, loss of offsite power) and degraded conditions (e.g., a failed high-pressure injection pump, failed emergency power system) that may have occurred at a nuclear power plant. Specifically, this volume provides guidance on the following analysis methods: exposure time determination and modeling, failure determination and modeling, mission time modeling, test and maintenance outage modeling, recovery modeling of failed equipment, and multiunit considerations modeling.

Volume 1 also contains an appendix that provides guidance on the process for performing risk analysis of operational events. Appendix A, "Roadmap: Risk Analysis of Operational Events," provides an overview of the risk analysis process and detailed steps on how to perform a risk analysis of an operational event.

Future revisions of Volume 1 of the RASP handbook will include additional method guides, such as common-cause failure analysis in event assessment, application of SPAR-Human Reliability Analysis Method (SPAR-H) and associated human reliability analysis (HRA) technical issues in event assessment, estimation of site- and season-specific frequency of tornados and hurricanes, and the use of support-system initiating event models in event assessment.

---

***Development of Standard Guidance for Evaluating Internal Fires and Flooding Events, External Events.*** Volume 2 of the RASP handbook, “External Events,” provides methods and guidance for the risk analysis of initiating events and conditions associated with external events. External events include internal fire, internal flooding, seismic events, and other external events such as external flooding, external fire, high winds, tornado, hurricane, and other extreme weather-related events. This volume is intended to complement Volume 1 for internal events. The guidance for risk analysis of external events provides a systematic process to initiate and complete a preliminary analysis, including examples and worksheets for the required steps of the analysis method. Specifically, this volume provides guidance on the following analysis methods: internal fire modeling and fire risk quantification, internal flood modeling and risk quantification, seismic event modeling and seismic risk quantification, and other external event modeling and risk quantification.

***Development of Standard Guidance for Reviews of SPAR Model Modifications.*** Volume 3 of the RASP Handbook, “SPAR Model Reviews,” provides analysts and SPAR model developers with additional guidance to ensure that the SPAR models used in the risk analysis of operational events represent the as-built, asoperated plant to the extent needed to support the analyses. This volume provides checklists that can be used following modifications to the SPAR models for performing risk analysis of operational events. These checklists are based on NUREG/CR-3485, “PRA Review Manual,” issued September 1985; Regulatory Guide (RG) 1.200, “An Approach for Determining the Technical Adequacy of Probabilistic Risk Assessment Results for Risk-Informed Activities”; and experiences and lessons learned from SDP and ASP analyses.

***Development of Standard Guidance for Evaluating Shutdown Events.*** Volume 4 of the RASP handbook, “Shutdown Events,” will provide methods and practical guidance for modeling shutdown scenarios and quantifying their core damage frequency using SPAR models and SAPHIRE software. The current scope includes the following plant operating states for boiling-water reactors and pressurized-water reactors (PWRs): hot shutdown, cold shutdown, refueling outage, and mid-loop operations (PWR only). A draft version of this handbook has been issued for internal trial use. The NRC expects to issue the final version in early 2011.

Enhancements to SPAR Models and the SAPHIRE Interface for SPAR Model Analyses

This activity involves enhancing SPAR models and the SAPHIRE interface to ensure that quality risk assessment tools are readily available to NRC staff performing risk assessments. The expected enhancements will include improvements in the fidelity

of SPAR models for risk analysis of internal events, external events, and shutdown events. Additional description of SPAR model enhancement and development activities appears in the information sheet, “SPAR Model Development Program,” in this chapter.

SAPHIRE Version 8 was made available to the staff in April 2010. This new version of the SAPHIRE software provides enhanced user interface tools, as well as improved modeling and analysis methods that support the development and use of the SPAR models.

### **Technical Support for SDP Analysts**

This activity involves providing technical support to SDP analysts on the efficient use of the various RASP products, such as guidance for standard risk assessment methods, enhanced SPAR models, new software tools, and the Web-based toolbox. The expected technical support will include the maintenance of RASP products and their quality, as-requested enhancements to risk assessment methods and SPAR models, and peer reviews of SDP Phase 3 analyses. Peer reviews of SDP Phase 3 analyses will focus on unique and complex cases to ensure consistency and scrutability of analysis results.

For more information, please see S.M. Wong et al., “Risk Assessment Standardization Project (RASP) Handbook for Risk Assessment of Operational Events,” *ANS PSA 2008 Topical Meeting*, Knoxville, TN, September 7–11, 2008.

### **For More Information**

Contact Don Marksberry, RES/DRA at 301-251-7593 or [Don.Marksberry@nrc.gov](mailto:Don.Marksberry@nrc.gov)

---

# Probabilistic Risk Assessment Quality and Standards

## Background

The NRC recognizes that probabilistic risk assessment (PRA) has evolved to the point where it can be used as a tool in regulatory decisionmaking. Consequently, confidence in the information derived from a PRA is an important issue. The accuracy of the technical content must be sufficient to justify the specific results and insights that are used to support the decision under consideration.

In 1995, the NRC issued a policy statement on the use of PRA, encouraging its use in all regulatory matters. That policy statement directs that “the use of PRA technology should be increased to the extent supported by the state-of-the-art in PRA methods and data and in a manner that complements the NRC’s deterministic approach.” Since the NRC issued its PRA policy statement, the agency has added a number of risk-informed activities to the NRC regulatory structure (i.e., regulation and guidance, licensing and certification, oversight, and operational experience). The NRC has also developed technical documents to provide guidance on the use of PRA information to support these activities.

## Objective

The PRA quality program’s objective is to define PRA quality (or technical acceptability) so that there is the needed confidence in the results being used for risk-informed regulatory decisionmaking, and so that the defined technical acceptability is commensurate with the activity (or decision) under consideration.

## Approach

To establish the definition of PRA quality, the NRC issued Regulatory Guide (RG) 1.200, “An Approach for Determining the Technical Adequacy of Probabilistic Risk Assessment Results for Risk-Informed Activities,” which provides the staff position on one acceptable approach for determining the technical acceptability of a PRA. RG 1.200 provides guidance on the technical acceptability of PRA in the following manner:

- Establishes the attributes and characteristics of a technically acceptable PRA.
- Endorses consensus PRA standards and the industry peer review process.
- Demonstrates technical acceptability in support of a regulatory application.

The staff position in RG 1.200 on PRA technical acceptability accomplishes the following:

- Defines the scope of a base PRA to include Level 1, 2, and 3 analyses, at-power, low-power, and shutdown operating conditions, internal and external hazards to support operating reactors and new light water reactors (LWRs).
- Defines a set of technical elements and associated attributes that need to be addressed in a technically acceptable base PRA.
- Provides guidance to ensure that a PRA model represents the plant down to the component-level of detail, incorporates plant-specific experience, and reflects a realistic analysis of plant responses.
- Includes a process to develop, maintain, and upgrade a PRA to ensure that the model represents the as-built, as-operated (or as-designed) plant.

The staff position in RG 1.200 on consensus PRA standards and the industry peer review process does the following:

- Allows the use of consensus PRA standards and peer reviews (as endorsed by the NRC in RG 1.200) to demonstrate the technical acceptability of a base PRA.
- Provides guidance for an acceptable peer review process and peer reviewer qualifications.
- Endorses the American Society of Mechanical Engineers/American Nuclear Society (ASME/ANS) PRA standard and the Nuclear Energy Institute (NEI) peer review guidance documents. The endorsement of the standard consists of staff objections and proposed resolutions. An application PRA needs to address the staff objections in RG 1.200, where applicable, if the PRA standard is to be considered met.

The staff position in RG 1.200 on PRA technical acceptability in support of a regulatory application does the following:

- Recognizes that the needed PRA scope (i.e., risk characterization, level of detail, plant specificity and realism) is commensurate with the specific risk-informed application under consideration.
- Some applications (e.g., extension of diesel generator allowed outage time) may only use a portion of the base PRA, whereas other applications (e.g., safety significance categorization of structures, systems, and components) may require the complete model.
- Demonstrates one approach for technical acceptability of a PRA, independent of application. Inherent in this definition

is the concept that a PRA need only have the scope and level of detail necessary to support the application for which it is being used, but it always needs to be technically acceptable.

RG 1.200 is also a supporting document to other NRC RGs that address risk-informed activities. Figure 5.4 shows the relationship of this RG with risk-informed activities in regulations, application-specific guidance in associated RGs, consensus PRA standards, and industry programs.

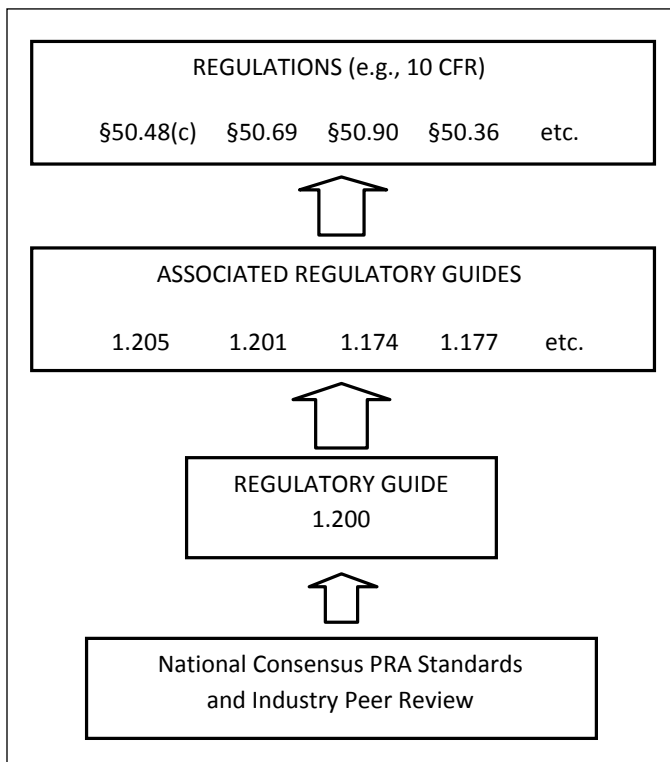

**Figure 5.4** Relationship of regulations, RGs, and standards for risk-informed activities

When used in support of an application, a major goal of RG 1.200 is to obviate the need for an in-depth review of the base PRA by NRC reviewers, allowing them to focus their review on key assumptions and areas identified by peer reviewers as being of concern and relevant to the application. Consequently, RG 1.200 is meant to provide for a more focused and consistent review process.

## Status

The status of the standards, peer review guidance, and RG 1.200 are as follows:

ASME/ANS have published ASME/ANS RA-Sa-2009 to support a PRA for operating LWRs. The scope of the standard includes a Level 1 LERF PRA for at-power conditions addressing both internal and external hazards. An addendum to this

standard is expected to be published in late 2010 or early 2011. This addendum will address issues with internal events, internal flood, internal fires, and seismic events. Extending ASME/ANS RA-Sa-2009 to address low-power shutdown conditions and to support new LWRs is underway. Further, PRA standards for Level 2 and Level 3 are under development, along with a PRA standard for non-LWRs.

NEI has published NEI-00-02, “Probabilistic Risk Assessment Peer Review Process Guidance”; NEI-05-04, “Process for Performing Follow-on PRA Peer Reviews Using the ASME PRA Standard”; and NEI-07-12, Fire Probabilistic Risk Assessment (FPRA) Peer Review Process Guidelines,” which include a peer review process for Level 1 LERF PRA for internal events and internal floods, PRA updates and upgrades, and fire PRA, respectively. NEI revised NEI-07-12 in June 2010. Revision 2 to RG 1.200 provides staff endorsement of ASME/ANS RA-Sa-2009 and the NEI peer review guidance documents. Revision 3 to RG 1.200 is expected to be published in mid-2011 to endorse Addendum B to ASME/ANS RA-Sa-2009 and the new revision to NEI-07-12.

### For More Information

Contact Mary Drouin, RES/DRA at 301-251-7574 or [Mary.Drouin@nrc.gov](mailto:Mary.Drouin@nrc.gov)

---

# Reactor Operating Experience Data Collection and Analysis

## Background

The collection and analysis of nuclear power plant operational data are important activities in the NRC's risk-informed regulatory programs. The results of the data collection efforts are primarily used to estimate and monitor the risk of accidents at U.S. commercial nuclear power plants. Data and information reported to the NRC are reviewed, evaluated, and coded into databases that form the basis for estimates of reliability parameters used in probabilistic risk assessment (PRA) models.

These models permit the NRC to do the following:

- Perform state-of-the-art risk assessments of operating events and conditions.
- Assess licensee risk-related performance.
- Conduct special studies of risk-related issues, such as station blackout risk, as part of the Special Reliability Studies Project.
- Determine trends, develop performance indicators based on operating data, and perform reliability studies for risk-significant systems and equipment.

## Approach

The NRC maintains a set of PRA models for all operating U.S. commercial nuclear power plants. The staff uses these Standardized Plant Analysis Risk (SPAR) models to support risk-informed decisionmaking. For example, the Accident Sequence Precursor (ASP) program uses the SPAR models in analyses to help identify potential precursors, to support the agency's Significance Determination Process (SDP), and to confirm licensee risk analyses submitted in support of license amendment requests.

To maintain current SPAR models, RES collects and analyzes operating data from all nuclear power plants. The data are used to estimate the inputs required for the models. Examples of basic model inputs are initiating event frequencies, component failure probabilities, component failure rates, maintenance unavailabilities, common-cause failure parameters, and human failure probabilities.

The Reactor Operating Experience Data for Risk Applications Project collects data on the operation of nuclear power plants as reported in licensee event reports (LERs), licensees' monthly

operating reports, and the Institute of Nuclear Power Operations Equipment Performance and Information Exchange System (EPIX) (see Figure 5.5). The data collected include component and system failures, demands on safety systems, initiating events, fire events, common-cause failures, and system/train unavailabilities. The data are stored in discrete database systems, such as the Reliability and Availability Data System (RADS), Common-Cause Failure Database, and ASP Events Database.

Data input into the RADS database are used to verify and validate information used in the Mitigating Systems Performance Index (MSPI) Program. RADS data are used to review the efficiency and effectiveness of the MSPI and to suggest improvements to the index.

LERs can be individually searched by using the LERSearch program, accessible through the NRC's public Web site at:<https://nrcoe.inel.gov/secure/lersearch/index.cfm>

The Computational Support for Risk Applications Project also uses the data to periodically update PRA parameters, such as initiating event frequencies, component reliabilities, maintenance unavailabilities, and common-cause failure parameters, for input into the plant-specific SPAR models. In general, the NRC uses the data to support its established regulatory programs, which help identify potential safety issues, such as the Industry Trends Program (ITP), the ASP program for evaluation of the risk associated with operating events, and the Reactor Oversight Process.

For example, RES supports the ITP by trending operating experience data and making that information available on the RES internal and public Web sites. Examples of trends that are regularly updated include thresholds for initiating events; system, component, and common-cause failures; and ASP events.

ASP analyses and the SDP use component failure probability estimates and initiating event frequencies to determine the risk significance of inspection findings. The results are then used to decide the allocation and characterization of inspection resources, the initiation of an inspection team, and the need for further analysis by other agency organizations.

The Reactor Operating Experience Results and Databases Web site (<http://nrcoe.inel.gov/results/>) makes current operating experience information available to the NRC staff and the public. The site also contains results from a variety of previously published studies that include initiating events, system performance, component performance, common-cause failures, fire events, and loss of offsite power.



Finally, RES also supports the Baseline Risk Index for Initiating Events, a measure used to provide a risk-informed performance indicator for the initiating events “Cornerstone of Safety.” This type of information helps the Office of Nuclear Reactor Regulation affirm that operating reactor safety is being maintained and also enhances the NRC’s inspections of significant safety systems.

**For More Information**

Contact John C. Lane, RES/DRA at 301-251-7446 or John.Lane@nrc.gov

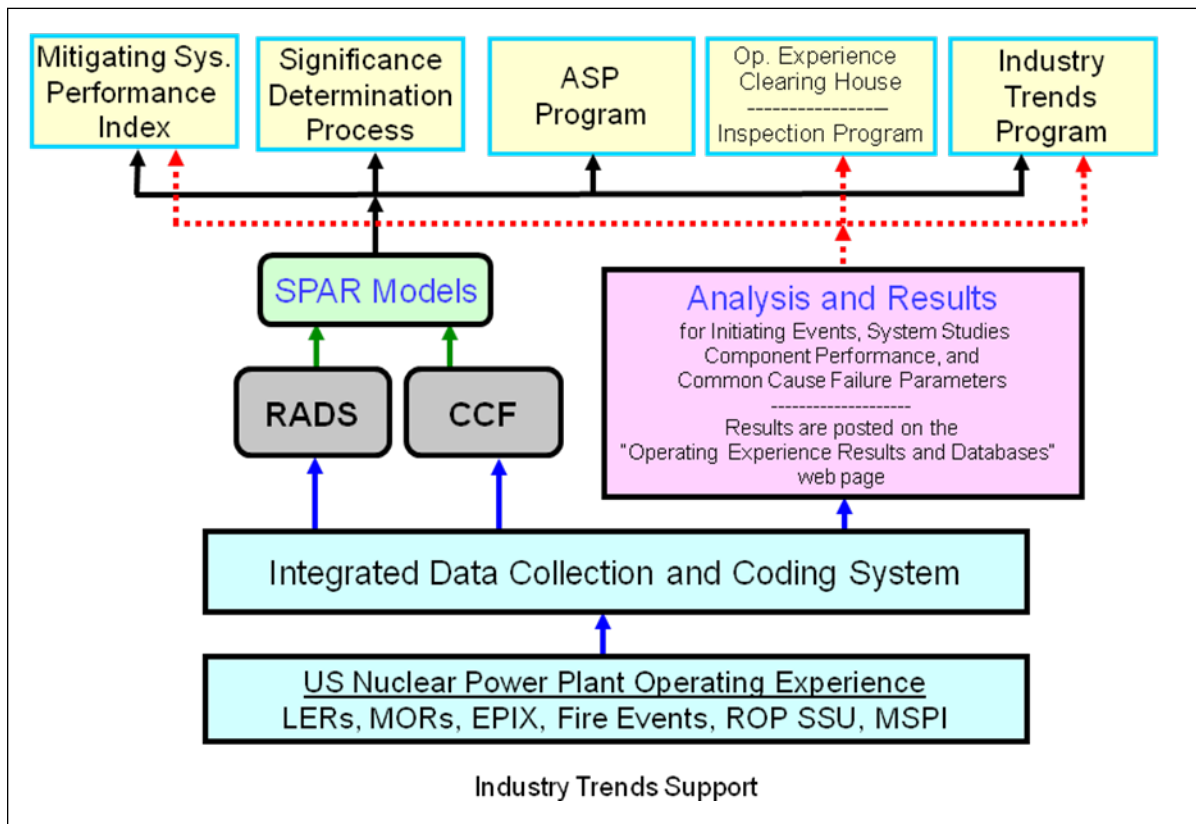

Figure 5.5 Sources and uses of operating data and analyses in NRC regulatory programs

---

# Accident Sequence Precursor Program

## Background

The NRC established the Accident Sequence Precursor (ASP) Program in 1979 in response to NUREG/CR-0400, “Risk Assessment Review Group Report,” issued September 1978. The ASP Program systematically evaluates U.S. nuclear power plant operating experience to identify, document, and rank the operating events most likely to lead to inadequate core cooling and severe core damage (precursors), given the likelihood of additional failures.

The ASP Program is one of three NRC programs that assess the risk significance of issues and events (the other two are the Significance Determination Process SDP and the Incident Investigation Program defined in Management Directive 8.3). Compared to the other two programs, the ASP Program assesses additional scope of operating experience at U.S. nuclear power plants. For example, the ASP Program analyzes initiating events as well as degraded conditions where no identified deficiency occurred in the licensee’s performance. The ASP Program scope also includes events with concurrent, multiple degraded conditions.

## Objective

The ASP Program has the following objectives:

- Provide a comprehensive, risk-informed view of nuclear power plant operating experience and a measure for trending core damage risk.
- Provide a partial check on dominant core damage scenarios predicted by probabilistic risk assessments.
- Provide feedback to regulatory activities.

The NRC also uses the ASP Program to monitor performance against the safety goal established in the agency’s strategic plan. Specifically, the program provides input to the following performance measures:

- Zero events per year identified as a significant precursor of a nuclear reactor accident (i.e., conditional core damage probability (CCDP) or change in core damage probability ( $\Delta$ CDP) greater than or equal to  $1 \times 10^{-3}$ )

- No more than one significant adverse trend in industry safety performance (determination principally made from the Industry Trends Program but supported by ASP results).

## Approach

To identify potential precursors, the NRC staff reviews plant events from licensee event reports and inspection reports. The staff then analyzes any identified potential precursors by calculating the probability of an event leading to a core damage state. A plant event can be of one of two types: (1) an occurrence of an initiating event, such as a reactor trip or a loss of offsite power event with any subsequent equipment unavailability or degradation, or (2) a degraded plant condition indicated by unavailability or degradation of equipment without the occurrence of an initiating event.

For the first type, the staff calculates a CCDP. This metric represents a conditional probability that a core damage state is reached, given an occurrence of an initiating event with any subsequent equipment failure or degradation.

For the second type, the staff calculates the  $\Delta$ CDP. This metric represents the change in the probability of reaching a core damage state for the period that a piece of equipment or a combination of equipment is deemed unavailable or degraded from a nominal core damage probability for the same period for which the nominal failure or unavailability probability is assumed for the subject equipment.

The ASP Program considers an event with a CCDP or  $\Delta$ CDP greater than or equal to  $1 \times 10^{-6}$  to be a precursor. The program defines a significant precursor as an event with a CCDP or  $\Delta$ CDP greater than or equal to  $1 \times 10^{-3}$ .

## Recent Results

- No significant precursors were identified for FY 2010. The last significant precursor identified was the event at Davis-Besse, which involved multiple degraded conditions (FY 2002).
- The mean occurrence rate of all precursors does not exhibit a trend that is statistically significant for the period from FY 2001 to FY 2009 (see Figure 5.6).

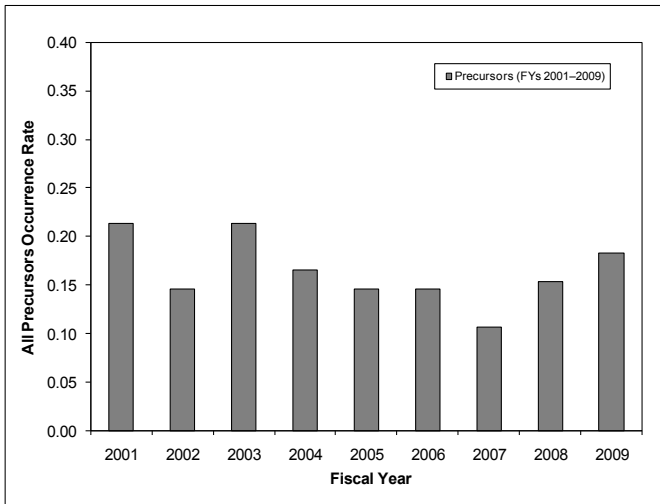

### For More Information

Contact Christopher Hunter, RES/DRA at 301-251-7575 or Christopher.Hunter@nrc.gov

Figure 5.6 Occurrence rate of all precursors

- Statistically significant decreasing trends were detected in the occurrence rate of precursors with high safety significance (i.e., CCDP or  $\Delta$ CDP greater than or equal to  $1 \times 10^{-4}$ ) and precursors occurring at pressurized-water reactors (see Figure 5.7).

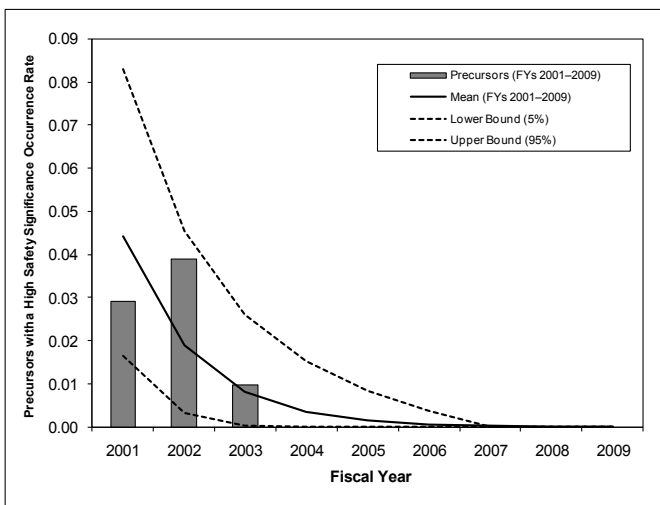

Figure 5.7 Occurrence rate of precursors with high safety significance

- No statistically significant trends were detected for precursors involving initiating events, degraded conditions, losses of offsite power, and precursors occurring at boiling-water reactors.

### Annual Summary of Results

Updated results from the ASP Program are published in an annual paper to the Commission. The most recent paper, SECY090143, “Status of the Accident Sequence Precursor Program and the Standardized Plant Analysis Risk Models,” was issued on September 29, 2009.

---

# SPAR Model Development Program

## Background

For assessing public safety and developing regulations for nuclear reactors and materials, the NRC traditionally used a deterministic approach that asked “What can go wrong?” and “What are the consequences?” Now, the development of risk assessment methods and tools allows the NRC to also ask “How likely is it that something will go wrong?” These risk tools also allow the NRC to consider multiple hazards and combinations of equipment and human failures that go beyond what is traditionally considered. By making the regulatory process risk-informed (through the use of risk insights to focus on those items most important to protecting public health and safety), the NRC can focus its attention on the design and operational issues most important to safety.

In the reactor safety arena, risk-informed activities occur in five broad categories: (1) rulemaking, (2) licensing process, (3) Reactor Oversight Process, (4) regulatory guidance, and (5) development of risk analysis tools, methods, and data. Activities within these categories include revisions to technical requirements in the regulations; risk-informed technical specifications; a new framework for inspection, assessment, and enforcement actions; guidance on risk-informed inservice inspections; and improved Standardized Plant Analysis Risk (SPAR) models.

The SPAR models, Systems Analysis Programs for Hands-on Integrated Reliability Evaluation (SAPHIRE) software, and the Risk Assessment Standardization Project (RASP) handbook, developed by the Office of Nuclear Regulatory Research (RES), provide the staff with the probabilistic risk assessment (PRA) tools to support these risk-informed activities.

## Objective: SPAR Model Applications

SPAR models and the SAPHIRE software are used to support the following activities.

### Inspection Program (e.g., Significance Determination Process Phase 3)

The SPAR models and the SAPHIRE software help determine the risk significance of inspection findings or of events in order to decide the allocation and characterization of inspection resources, the initiation of an inspection team, or the need for further analysis or action by other agency organizations.

### Management Directive 8.3, “NRC Incident Investigation Program”

The SPAR models and the SAPHIRE software help estimate the risk significance of events and conditions at operating plants so that the agency can analyze and evaluate the implications of plant operating experience in order to compare the operating experience with the results of the licensees’ risk analysis, identify risk conditions that need additional regulatory attention, identify risk insignificant conditions that need less regulatory attention, and evaluate the impact of regulatory or licensee programs on risk.

### Accident Sequence Precursor Program

The SPAR models and the SAPHIRE software help to screen and analyze operating experience data in a systematic manner in order to identify those events or conditions that are precursors to severe accident sequences.

### Generic Safety Issues

The SPAR models and the SAPHIRE software provide the capability for resolution of generic safety issues, both for screening (or prioritization) and conducting more rigorous analysis to determine if licensees should be required to make a change to their plant or to assess if the agency should modify or eliminate an existing regulatory requirement.

### License Amendment Reviews

The SPAR models and the SAPHIRE software enable the staff to make risk-informed decisions on plant-specific changes to the licensing basis, as proposed by licensees, and provide risk perspectives in support of the agency’s reviews of licensees’ submittals.

### Performance Indicators Verification (e.g., Mitigating System Performance Index, NUREG-1816)

The SPAR models and the SAPHIRE software assist in the identification of threshold values for risk-based performance indicators and in the development of an integrated performance indicator.

### Special Studies (e.g., Loss Of Offsite Power And Station Blackout, NUREG/CR-6890 Volumes 1 & 2)

The SPAR models and the SAPHIRE software help staff perform various studies in support of regulatory decisions as requested by the Commission, Office of Nuclear Reactor Regulation (NRR), and other NRC offices.

## Approach

The NRC staff uses SPAR models and the SAPHIRE software in support of risk-informed activities related to the inspection program, incident investigation program, license amendment

reviews, performance indicator verification, accident sequence precursor program, generic safety issues, and special studies. These tools also support and provide rigorous and peer-reviewed evaluations of operating experience, thereby demonstrating the agency's ability to analyze operating experience independently of licensees' risk assessments and enhancing the technical credibility of the agency.

The SPAR models integrate systems analysis, accident scenarios, component failure likelihoods, and human reliability analysis into a coherent model that reflects the design and operation of the plant. The SPAR model gives risk analysts the capability to quantify the expected risk of a nuclear power plant in terms of core damage frequency and the change in that risk given an event, an anomalous condition, or a change in the design of the plant. More importantly, the model provides the analyst with the ability to identify and understand the attributes that significantly contribute to the risk and insights on how to manage that risk.

Currently, 78 SPAR models representing the 104 operating commercial nuclear plants in the United States are used for analysis of the core damage risk (i.e., Level 1 analysis) from internal events at operating power. The Level 1 SPAR model includes core damage risk resulting from general transients (including anticipated transients without scram), transients induced by loss of a vital alternating current or direct current bus, transients induced by a loss of cooling (service) water, loss-of-coolant accidents, and loss of offsite power. The SPAR models use a standard set of event trees for each plant design class and standardized input data for initiating event frequencies, equipment performance, and human performance, although these input data may be modified to be more plant- and event-specific, when needed. The system fault trees contained in the SPAR models are generally not as detailed as those contained in licensees' PRA models.

In FY 2010, the NRC revised and augmented the 78 SPAR models to take advantage of the new features and capabilities of SAPHIRE Version 8. SAPHIRE Version 8 was made available to the staff in April 2010. This new version of the SAPHIRE software provides enhanced user interface tools, as well as improved modeling and analysis methods that support the development and use of the SPAR models. Figure 5.8 provides an example output from the new SAPHIRE user interface intended to support the Significance Determination Process (SDP). Model enhancements included improved modeling of common-cause failure events, handling of recovery rule linking, analysis documentation, and parameter data updates.

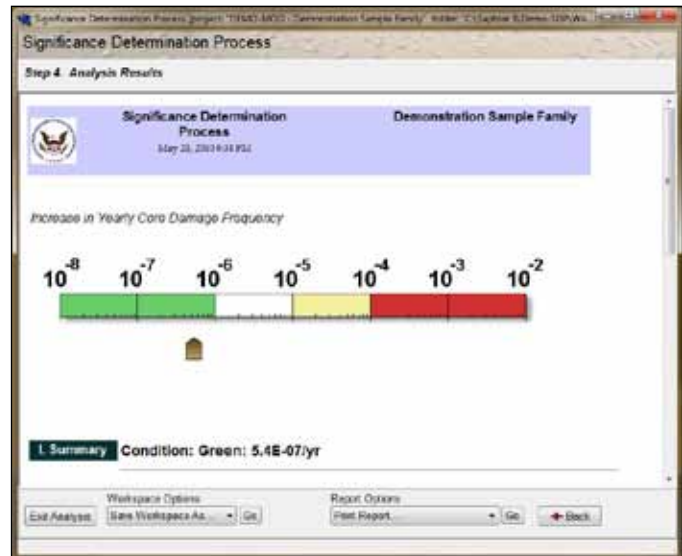

Figure 5.8 Example of SDP analysis results with SAPHIRE Version 8

To more accurately model plant operation and configuration and to identify the significant differences between the licensee's PRA and SPAR logic, the staff performed detailed cut-set level reviews on all 78 models. In addition to the internal event at-power models, the staff developed 15 external event models based on the licensee responses to Generic Letter 8820, Supplement 4, "Individual Plant Examination of External Events (IPEEE) for Severe Accident Vulnerabilities," issued in 1991; seven low-power/shutdown models; and three extended Level 1 models supporting large early release frequency (LERF) and Level 2 modeling. These models are used to support a variety of regulatory programs, including the SDP. In addition, the external event models were recently used to support the NRC's State-of-the-Art Reactor Consequence Analysis (SOARCA) Project and to evaluate severe accident sequences for the Consequential Steam Generator Tube Rupture Project in support of the NRC's Steam Generator Action Plan.

One significant upcoming activity is the incorporation into the SPAR models of internal fire scenarios from the National Fire Protection Association (NFPA) 805, "Performance-Based Standard for Fire Protection for Light Water Reactor Electric Generating Plants," pilot applications. In addition, the staff continues to provide technical support for SPAR model users and risk-informed programs. The staff also completes about a dozen routine SPAR model updates annually.

The staff is also developing design-specific internal events SPAR models for new reactor designs. The AP1000 model was completed in February 2010. The model has been optimized for SAPHIRE Version 8 and has been transitioned to a routine maintenance status. A first draft of the advanced boiling-water reactor model was provided to the Office of New Reactors



(NRO) for review and is currently going through validation. The staff is also developing a design-specific internal events SPAR model for the U.S. Advanced Pressurized Water Reactor. Because design standardization is a key aspect of the new plants, it should only be necessary to develop one SPAR model for each of the new designs.

The NRC implemented a formal SPAR model quality assurance plan in September 2006. Limited scope validation and verification is accomplished by comparisons to licensee PRA models (as available) and to NRC NUREGs and analyses. Limited scope peer reviews consist of internal quality assurance review by NRC contractors, NRC PRA staff, and regional senior reactor analysts (as available). Improvements to the models on a continuing basis result from staff user feedback, peer reviews from licensees, and insights gained from special studies, such as identification of threshold values during Mitigating Systems Performance Index (MSPI) reviews and the study on loss of offsite power (LOOP) and station blackout. In 2007, the NRC began a cooperative effort with the Electric Power Research Institute (EPRI) to improve PRA quality and address several key technical issues common to both the SPAR models and industry models. This cooperation resulted in the joint publication of EPRI Report 1016741, "Support System Initiating Events: Identification and Quantification Guideline," in 2008. This report documents current methods to identify and quantify support system initiating events using PRAs. Other cooperative projects include improvements to LOOP modeling (a typical LOOP event tree model is shown in Figure 5.9) and emergency core cooling system performance following boiling-water reactor (BWR) containment failure. In addition, the staff, with the cooperation of industry experts, performed a peer review of a representative BWR SPAR model and pressurized-water reactor (PWR) SPAR model in accordance with American National Standards Institute / American Society of Mechanical Engineers (ANSI)/ASME RAS-2002, "Probabilistic Risk Assessment for Nuclear Power Plant Applications," and RG 1.200. The staff reviewed the peer review comments and initiated projects to address these comments where appropriate. The staff is also reevaluating certain success criteria in the SPAR models using state-of-the-art thermal-hydraulic modeling tools.

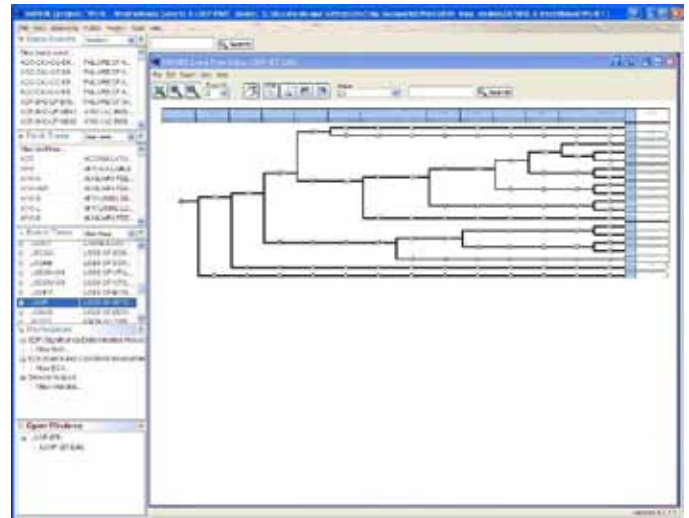

**Figure 5.9 Example of LOOP SPAR model event tree display with SAPHIRE Version 8**

### **For More Information**

Internal Events:

Contact Peter Appignani, RES/DRA at 301-251-7608 or Peter.Appignani@nrc.gov

External Events and Low-Power/Shutdown Models:

Contact Selim Sancaktar, RES/DRA at 301-251-7572 or Selim.Sancaktar@nrc.gov

New Reactor Models and Routine SPAR Model Updates:

Contact Michelle Gonzalez, RES/DRA, at 301-251-7591 or Michelle.Gonzalez@nrc.gov

SAPHIRE:

Contact Daniel O'Neal, RES/DRA at 301-251-7599 or Daniel.ONeal@nrc.gov

Jeffery Wood, RES/DRA at 301-251-7588 or

Jeffery.Wood@nrc.gov

# Thermal-Hydraulic Level 1 Probabilistic Risk Assessment Success Criteria

## Background

The NRC uses its Standardized Plant Analysis Risk (SPAR) models to support a number of risk-informed initiatives. The fidelity and realism of these models is ensured through a number of processes, including cross-comparison with industry models, review and use by a wide range of technical experts, and confirmatory analysis. One ongoing activity is to use one of the agency's mature accident simulation tools (MELCOR) to perform analyses that can be used to confirm or support the update of specific aspects of the SPAR models. The aspects under consideration are the so-called, "success criteria," as well as the timing of certain key events (e.g., the depletion of a water source) that affect the estimation of the probability of success for operator actions. Figure 5.10 provides a definition of success criteria.

### What are success criteria?

*"criteria for establishing the minimum number of combinations of systems or components required to operate, or minimum levels of performance per component during a specific period of time, to ensure that the safety functions are satisfied."*

Source: American Society of Mechanical Engineers/American Nuclear Society, *Standard for Level 1/ Large Early Release Frequency Probabilistic Risk Assessment for Nuclear Power Plant Applications*, ASME/ANS RA-Sa-2009

Figure 5.10 A definition of Level 1 probabilistic risk assessment success criteria

## Objectives

The objectives of this research activity are:

- to perform thermal-hydraulic analyses that can update or confirm specific underlying assumptions in the agency's probabilistic risk assessment (PRA) models (SPAR models) related to postulated accident evolution and timing
- to enhance in-house expertise and knowledge transfer, for the purpose of improving the ability of the Office of Nuclear Regulatory Research (RES) to consult with the program offices and Regions on PRA modeling issues
- to promote collaboration between thermal-hydraulic and PRA analysts.

## Approach

Using a mixture of in-house and contractor capabilities, specific modeling aspects are identified, scoped, and analyzed. These analyses are then used as the technical basis for making changes (as needed) to the PRA models themselves. Figure 5.11 depicts the high-level framework for this process. This figure shows the basic steps in the analysis, which include the translation of the actual plant design and operating features to a computer model representation, the performance of analytical studies and the generation of results, and the distillation of these results in to findings that can be used to confirm or alter the PRA model representation of the plant.

The types of issues that have been investigated to date include the following:

- small-break loss-of-coolant accidents—dependency on aligning the emergency core cooling system water source to the containment sump
- feed-and-bleed decay heat removal—the minimum number of pressurizer power-operated relief valves and high-head pumps needed
- spontaneous steam generator tube rupture—time available for operators to mitigate the accident before core damage
- station blackout—time available to recover power
- medium and large loss-of-coolant accidents—minimum equipment needed to prevent core damage

## Ongoing and Future Plans

As of autumn 2010, the NRC staff's ongoing and near-term plans include the following:

- developing a NUREG documenting the analyses performed for a Mark I boiling-water reactor and a 3-loop Westinghouse plant with a subatmospheric containment
- implementing the first round of analyses into the SPAR models
- developing an additional MELCOR input model for a 4-loop Westinghouse plant with a large, dry containment for future success criteria analyses
- investigating Level 1 PRA end-state issues, such as the relative conservatism in common core damage surrogates (e.g., core uncover versus peak clad temperature of 1,204 degrees Celsius (2,200 degrees Fahrenheit))
- increasingly collaborating with external stakeholders

**For More Information**

Contact Don Helton, RES/DRA at 301-251-7594 or Donald.Helton@nrc.gov

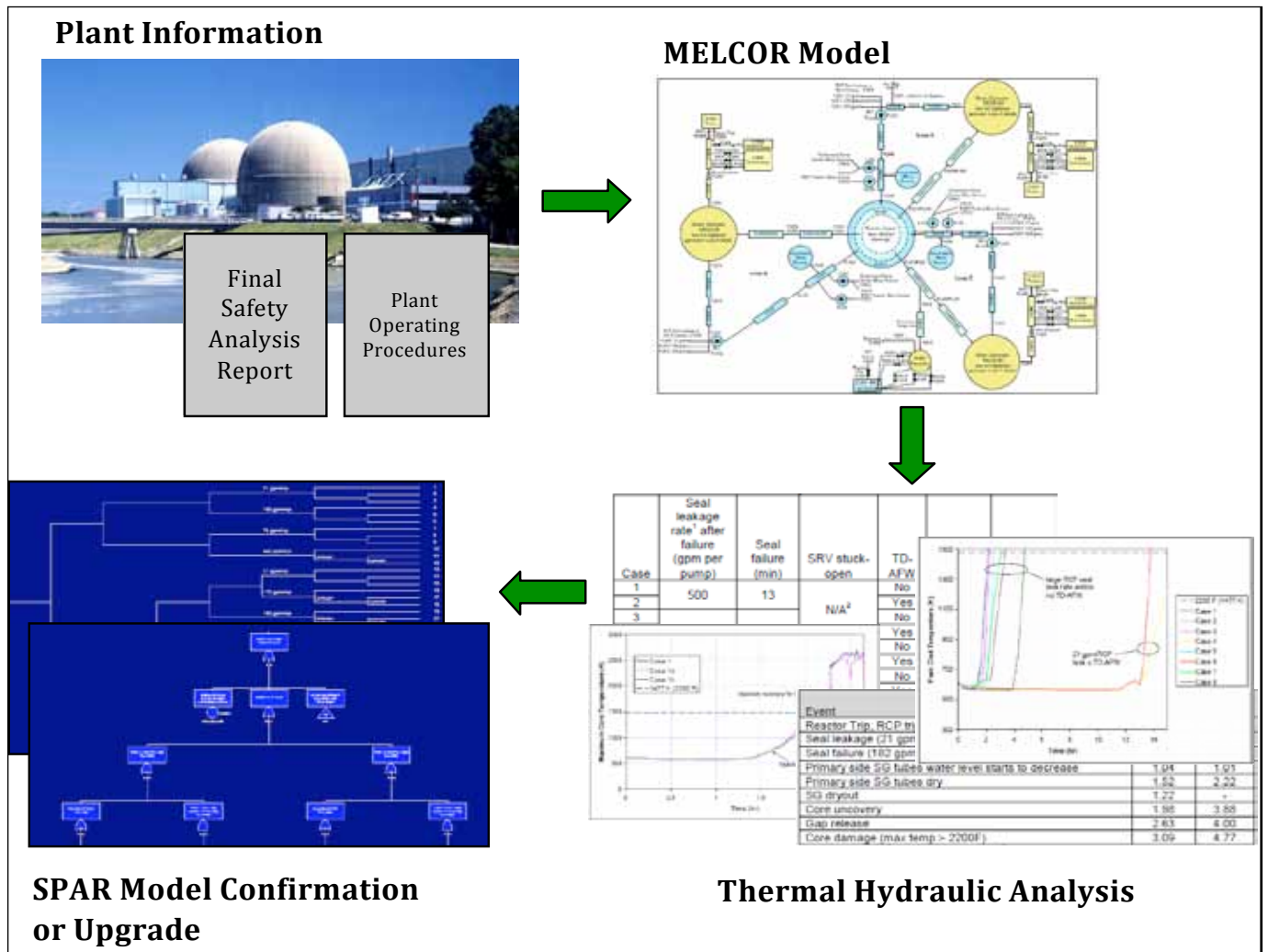

Figure 5.11 High-level overview of success criteria process

# Advancing Modeling Techniques in Level 2 and Level 3 Probabilistic Risk Assessment

## Background

As part of its strategic long-term research planning efforts, the NRC has identified Level 2 and Level 3 probabilistic risk assessment (PRA) as areas that would benefit from examination of advanced methods. Figure 5.12 defines the three levels of PRA.

Level 1 PRA – initiating event to the onset of core degradation or achievement of a safe state
Level 2 PRA – onset of core degradation to the release of fission products to the environment
Level 3 PRA – offsite consequences

Figure 5.12 The three levels of PRA

In 2009, the project began with an internal scoping study to evaluate both methodological and implementation-oriented issues associated with the advancement of Level 2 and 3 PRA modeling techniques. The scoping study created a taxonomy of approach classes, depicted in Figure 5.13. This figure depicts four classes of methodological approaches and how the migration across this spectrum might affect the key characteristics. This effort included a meeting with targeted external stakeholders, and was fully documented in a May 2009 report, “Scoping Study on Advancing Modeling Techniques for Level 2/3 PRA” (ADAMS Accession No. ML091320454).

## Objective

The objective of this activity is to investigate the feasibility of using advanced methods to achieve specific improvements in the current state-of-practice in Level 2 and Level 3 PRA. The specific attributes of a desirable advancement include the following:

- Reduces reliance on unnecessary modeling simplifications and surrogates (i.e., more phenomenological).
- Addresses methodological shortcomings identified by the State-of-the-Art Reactor Consequence Analysis (SOARCA) project.
- Improves treatment of human interaction and mitigation.
- Makes process and results more scrutable.

- Leverages advances in computational capabilities and technology developments but is computationally tractable.
- Allows for ready production of uncertainty characterizations.

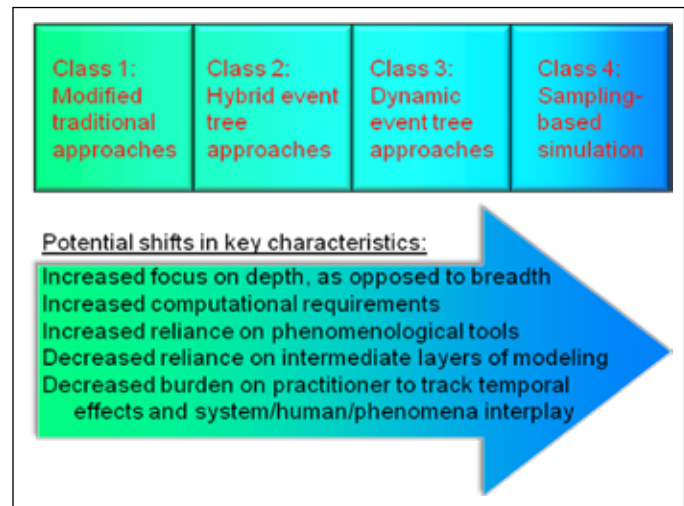

Figure 5.13 The spectrum of approach classes

## Approach

Following on the heels of the 2009 scoping study, the next phase of work began with the initiation of a methods development project at Sandia National Laboratories (SNL). This phase of the work, which started in July 2009, focuses on a dynamic event tree approach (see Figure 5.14) that uses the MELCOR accident analysis program in conjunction with a dynamic operator response model. (Figure 5.14 illustrates a potential scheme for combining existing computer programs in a manner that facilitates dynamic accident simulation.) To accomplish this, the NRC and SNL are collaborating with the University of Maryland and Ohio State University. The initial method development, including application of the approaches to a demonstration problem, is scheduled to be completed in 2011.

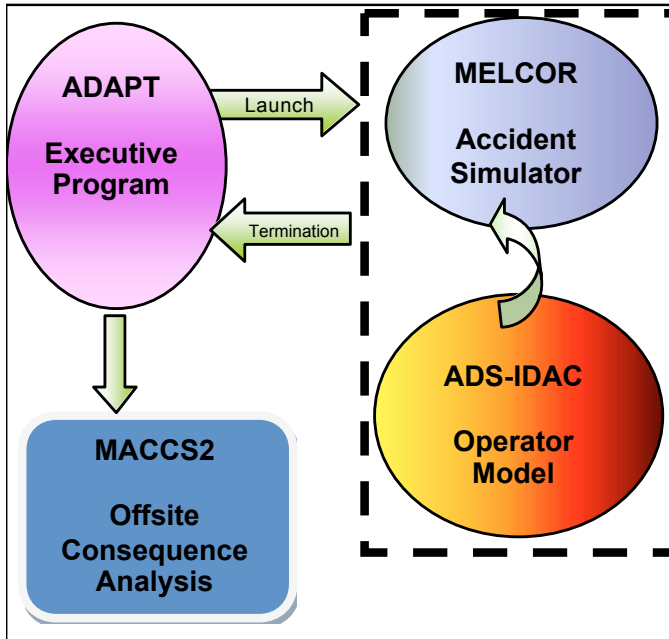

Figure 5.14 Sample high-level code coupling scheme

**For More Information**

Contact Don Helton, RES/DRA at 301-251-7594 or Donald.Helton@nrc.gov

**The building blocks:**

MELCOR—an NRC-developed computer code that deterministically models the progression of severe accidents in nuclear power plants

MACCS2 (MELCOR Accident Consequence Code System 2)—an NRC-developed offsite consequence computer code that models the atmospheric transport and dispersion of radioactive material and the associated offsite effects

ADS-IDAC (Accident Dynamics Simulator Using Information, Decisions, and Actions in a Crew Context)—a discrete dynamic event tree computer code developed by the University of Maryland that dynamically treats accident evolution, in concert with a simulator such as MELCOR, with a focus on the cognitive representation of the operators

ADAPT (Analysis of Dynamic Accident Progression Trees)—a discrete dynamic event tree computer code developed by Ohio State University that dynamically treats accident evolution, in concert with a simulator such as MELCOR, with a focus on component and phenomenological behavior



---

# Risk-Informing Emergency Preparedness: Probabilistic Risk Analysis of Emergency Action Levels

## Background

The current emergency action levels (EALs) harken back to those developed in the post-Three Mile Island era and documented in NUREG-0654, “Criteria for Preparation and Evaluation of Radiological Emergency Response Plans and Preparedness in Support of Nuclear Power Plants.” Although the more current approach in NEI-99-01, “Methodology for Development of Emergency Action Levels,” is a significant improvement, the basic EALs and the associated emergency classes are largely unchanged from those identified in NUREG-0654. Because EALs originated from the informed judgment of staff in the early 1980s, there has never been a “first principles” analysis of damage states represented by the EALs to determine internal consistency.

In September 2008, the Commission directed the staff in staff requirements memorandum (SRM) COMDEK-08-0005, “FY2010 NRC Performance Budget Proposal,” to begin the next major enhancement in quantifying the protection that emergency preparedness plans should provide and codifying them in regulations that are transparent. This scope of work will explore the feasibility of applying risk-informed methodology to emergency response elements. If successful, this effort can result in the ability to quantify the risk associated with the different EALs, improving the NRC’s ability to evaluate the licensee’s emergency preparedness plans.

In May 2010, a user need request originating from the Office of Nuclear Security and Incident Response (NSIR) asked the Office of Nuclear Regulatory Research (RES) to support a project to risk inform EALs.

## Objective

The project objective is to evaluate the degradation of safety margin that results when a nuclear plant is in the damage state represented by an EAL. This would allow the staff to determine if the EALs for a given emergency classification level (ECL)—for example, site area emergency—present a similar level of safety margin degradation. The results of the evaluation would be used as a technical basis for correcting any outliers identified and for reducing or increasing the associated emergency class.

## Approach

The initial analysis is based on Peach Bottom and Surry as surrogates for boiling-water reactor and pressurized-water reactor plants. Current Standardized Plant Analysis Risk (SPAR) models are used to analyze the potential reactor core damage probability for a given set of initiating conditions that are described in an EAL for a given ECL. The analysis is akin to that performed in the Accident Sequence Precursor (ASP) program to determine the risk significance of an event. The main figure of merit to be used is conditional core damage probability. However, the study will focus on identifying any inconsistencies between EALs for the same ECL rather than on the quantified probabilities.

The resulting reactor core damage potential for that ECL would then be compared to similar scenarios in different EALs. Once the analysis of Peach Bottom and Surry is completed, the staff will determine if there is any inconsistency in any of the ECLs for a given EAL.

Using the risk insights from the two surrogate plants, the staff will perform further analysis for other plants to verify the results and to gain more useful risk-informed insights for future emergency planning.

### For More Information

Contact Sandra Lai, RES/DRA at 301-251-7607 or [Sandra.Lai@nrc.gov](mailto:Sandra.Lai@nrc.gov)

---

# Risk-Informing Security

## Background

To date, the NRC has made considerable progress in risk-informing its safety-related regulatory processes (licensing, regulation, oversight, and event assessment). Less progress has been made on security-related applications. In a March 2010 review of the NRC's safety research program, the Advisory Committee on Reactor Safeguards (ACRS) stated the following:

PRA [probabilistic risk assessments] contain a wealth of information regarding the ways undesirable plant states, such as core damage and large release of radioactivity, can occur. This information is not utilized in formulating security requirements to evaluate their benefit and their impact on safety. The ACRS recommends that RES [the Office of Nuclear Regulatory Research] establish a research project to explore the possibility of risk informing security requirements and building on PRAs to create a unified framework for the evaluation of both safety and security.

Traditionally, the NRC has not formally used risk information in the development of security regulations, licensing actions, and inspection activities. Security policy is largely based on a conditional risk associated with an attack on a facility or material in transport, as well as attempts to divert or steal nuclear or radioactive material. Resources are diverted to the areas with the highest potential consequences or conditional risks. Initial event frequencies are generally not quantified.

In May 2010, a user need request originating from the Office of Nuclear Security and Incident Response (NSIR) asked RES to assist "in identifying opportunities to better risk inform the regulatory approach to security at the U.S. Nuclear Regulatory Commission (NRC)."

## Objective

The overall objective of this program is to identify potential areas in which increased application of risk information could enhance security. Risk-informing processes more broadly can help ensure that the level of protection is commensurate with the risk.

## Approach

To accomplish this task, RES held a workshop to receive expert input on how risk assessment or risk management processes could better inform the NRC security process. The workshop was attended by RES and NSIR staff, risk and security experts from several national laboratories, and representatives from other

government agencies. This workshop was held September 14 and 15, 2010 at Sandia National Laboratories (SNL) in Albuquerque, New Mexico.

The Risk-Informed Security Regulations Workshop had the following objectives:

Discuss current approaches in risk assessment for security applications and the use of the results of such assessments in security-related, risk-informed decisionmaking.  
Identify issues, failures, benefits, and other lessons learned when conducting security-related risk assessments; and implementing risk-informed processes and procedures.  
Identify opportunities to apply risk-informed approaches to regulating security. The goal is to understand where risk information might be useful in the NRC's regulatory processes.

A report will be completed that summarizes findings and identifies paths forward. This report may recommend further analysis of risk-informing one or more areas of security regulation and potentially a follow-up workshop to focus on specific issues.

### For More Information

Contact Brian Wagner, RES/DRA at 301-251-7595 or [Brian.Wagner@nrc.gov](mailto:Brian.Wagner@nrc.gov)

---

# Design-Basis Flood Determinations at Nuclear Power Plants

## Background

In 1977, the NRC issued Regulatory Guide (RG) 1.59, “Design Basis Flood for Nuclear Power Plants,” which detailed 1970s-era methods for determining design-basis floods at nuclear power plants. Flooding mechanisms that may need to be considered at nuclear power plants included local intense precipitation, river flooding, dam breach or failure, storm surge, seiche, tsunami, ice jams, or at least some of the 120 combinations of these processes. Since RG 1.59 was last updated in the late 1970s, the technical basis (data sources, tools, and analytic methods) for flood assessment has evolved considerably, and the Office of Nuclear Regulatory Research (RES) Environmental Transport Branch (ETB) is preparing to revise the guide.

## Objective

The objective of the research described here is to develop a technical basis for revising RG 1.59.

## Approach

Contracted research activities in support of revising RG 1.59 fall into three categories: (1) overall technical basis, (2) extreme precipitation, and (3) storm surge. Staff activities include understanding climate change and its possible impacts on floods and considering policy questions concerned with the revised guidance.

## Technical Basis

Research in this area focuses on identifying the appropriate tools (conceptual models, mathematical models, modeling software, and data sources) for conducting design-basis flood determinations. Much of this work has concentrated on developing a hierarchical hazard assessment (HHA) methodology. HHA provides a roadmap for applying a hierarchy of conceptual and mathematical models for the efficient determination of design-basis flood mechanisms and levels. The NRC is also investigating the appropriate blend of deterministic and probabilistic methods and the analysis of combined events.

## Extreme Precipitation

This work addresses data and methods for estimating probable maximum precipitation (PMP). Generalized PMP estimates for various areas and durations have been published in National Weather Service hydrometeorology reports. However, these estimates for much of the eastern United States have not been

updated since the 1970s and do not reflect storms that have occurred since the early to mid-1970s. This is important, because the basic PMP approach begins with a catalogue of historical storms. Current efforts are focused on a two-state pilot region comprising North Carolina and South Carolina. Although the pilot is using the basic approach used in the National Weather Service hydrometeorology reports, it is also investigating new extreme storm data sets and individual storm analysis techniques for this region. Methods for addressing uncertainties and confidence intervals are also being investigated.

## Storm Surge Modeling

This research is investigating the application of advanced storm surge modeling methods, developed in the aftermath of hurricane Katrina, to coastal nuclear power plant sites. The methods combine (1) high-resolution data sets for local bathymetry and topography, (2) coupled models for hurricane winds, wind driven waves, and storm surge, and (3) probabilistic treatment of parameters that are input to the models. The focus is on efficient determination of probable maximum surge levels that account for local bathymetry and topography, and on realistic parameterizations for large storms impacting particular regions.

## Climate Change

The ETB staff has been reviewing the current state of climate science and the scientific arguments about increased global warming and climate change over the next 90 years. The staff is assessing the possible impacts of climate change on flooding and methods for flood analysis.

## Policy Issues

Through a technical advisory group on floods, the ETB staff has been working with its counterparts in the Office of New Reactors (NRO) on policy questions related to the revision of RG 1.59. These questions concern the balance between deterministic and probabilistic approaches to be recommended in the guide, the validity and utility of the concept of probable maximum events versus analyses using extreme-value probability distributions, and whether to participate in the revision of the American Nuclear Society (ANS) 1992 flood standard (currently an appendix to RG 1.59) or to incorporate parts of the standard into the RG.

## For More Information

Contact John Randall, RES/DRA at 301-251-7456 or [John.Randall@nrc.gov](mailto:John.Randall@nrc.gov)

Joseph Kanney, RES/DRA at 301-251-7600 or [Joseph.Kanney@nrc.gov](mailto:Joseph.Kanney@nrc.gov)

Thomas Nicholson, RES/DRA at 301-251-7498 or [Thomas.Nicholson@nrc.gov](mailto:Thomas.Nicholson@nrc.gov)

---

# Assessment of Debris Accumulation on Emergency Core Cooling System Suction Strainer Performance

## Background

The NRC has sponsored extensive research to provide information and develop guidance for evaluating the performance of the emergency core cooling system (ECCS) following a loss-of-coolant (LOCA) accident to support resolution of Generic Safety Issue (GSI)-191, “Assessment of Debris Accumulation on PWR Sump Performance.” The NRC has published over 30 NRC technical reports documenting this effort. The current research is focused on completing the documentation of the results of this work.

## Approach

To better understand the effects of debris accumulation on ECCS sump strainers, the staff initiated research in four primary areas: (1) post-LOCA chemistry, (2) sump screen head-loss, (3) downstream effects, and (4) coating debris transport.

In 2006 and 2007, an external peer review and a phenomena identification and ranking table exercise were completed. The purpose of these tasks was to identify if there were any chemical effects, not currently being considered, on the performance of the ECCS. NUREG-1861, “Peer Review of GSI-191 Chemical Effects Research Program,” issued December 2006; NUREG-1918, “Phenomena Identification and Ranking Table Evaluation of Chemical Effects Associated with Generic Safety Issue 191,” issued February 2009; and NUREG/CR-6988 “Final Report—Evaluation of Chemical Effects Phenomena in Post-LOCA Coolant,” issued January 2009, documented these studies. The evaluation and disposition of the chemical effects issues identified in those reports is scheduled to be completed by the end of FY 2010.

In addition, the NRC is revising regulatory guides (RGs) that provide guidance related to ECCS suction strainer performance to incorporate the lessons learned and is also preparing a comprehensive state-of-the-art knowledge base report.

RG 1.82, draft Revision 4, “Water Sources for Long-Term Recirculation Cooling Following a Loss-of-Coolant-Accident,” has been issued for public comment. This draft revision

incorporates the lessons learned during resolution of GSI191 and also reformats the document for easier use.

RG 1.54, draft Revision 2, “Service Level I, II and III Protective Coatings applied to Nuclear Power Plants,” has been prepared and is near final approval. This revision incorporates lessons learned from resolution of GSI-191 applicable to protective coatings. It also endorses, with limitations, the latest applicable ASTM standards.

The NRC is preparing a comprehensive state-of-the-art report to document the ECCS strainer performance knowledge base. The intent of this report is to summarize all of the NRC research activities and technical reports completed to resolve GSI-191. This report will also summarize the NRC staff positions on research activities and topical reports performed by industry and licensees.

This project has two phases. First, the NRC will prepare a NUREG-series report for the domestic fleet of plants. This report is scheduled to be complete in FY 2011. Second, the NRC will participate on an international team to develop a Nuclear Energy Agency/Committee for the Safety of Nuclear Installations-series report for the international community. This task is planned to begin in FY 2011.

### For More Information

Contact John Burke, RES/DE at 301-251-7628 or [John.Burke@nrc.gov](mailto:John.Burke@nrc.gov)





# Chapter 6: Human Factors and Reliability Research

Human Reliability Analysis Data Repository

Human Reliability Analysis Model Differences

Improving Human Reliability Analysis Methods by Using Simulator Runs

Pilot Testing of Human Reliability Analysis-Informed Training and Job Aid for NRC Staff Involved with Medical Applications of Byproduct Materials

Qualitative Human Reliability Analysis for Spent Fuel Handling

Human Performance for Advanced Control Room Design

Support for Implementation of 10 CFR Part 26 Fitness-for-Duty Programs

Safety Culture

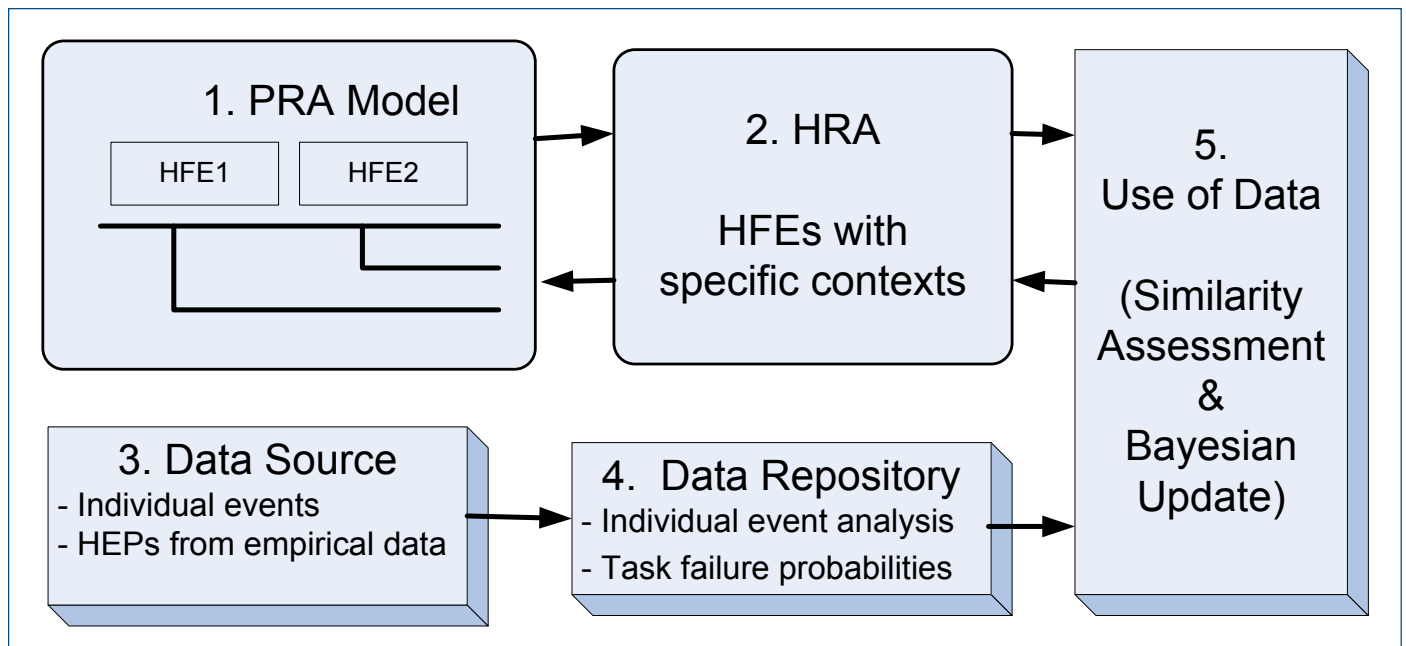

Diagram illustrating the concept of using empirical data to inform the human error probabilities of human failure events

# Human Reliability Analysis Data Repository

## Background

Consistent with the NRC's policy statements on the use of probabilistic risk assessment (PRA) and for achieving an appropriate PRA quality for NRC risk-informed regulatory decisionmaking, the NRC has established a phased approach to probabilistic risk assessment quality (see SECY-04-0118, "Plan for the Implementation of the Commission's Phased Approach to Probabilistic Risk Assessment Quality," issued July 2004, and SECY-07-0042, "Status of the Plan for the Implementation of the Commission's Phased Approach to Probabilistic Risk Assessment Quality," issued March 2007). The phased approach to PRA quality includes an action plan for stabilizing the PRA quality expectation and requirements to address PRA technical issues. Human reliability analysis (HRA) is an important PRA element. Data are key to HRA quality. The Commission identified the need for HRA data in staff requirements memorandum (SRM)-M061020, "HRA Model Differences," dated November 8, 2006, and SRM-M090204B, dated February 18, 2009.

Currently, the Office of Nuclear Regulatory Research (RES) maintains the Human Event Repository and Analysis (HERA) system to provide HRA data. The HERA data source relies on analyzing past events and simulator exercises. In order to more effectively support human error probability (HEP) estimates, enhancements to the current HERA are necessary in such areas as data collection methodology, data sources, and the use of collected data to inform HRA. A data framework providing enhancements to these areas has been proposed and is under discussion for development.

## Objective

This project seeks to develop a method to effectively use empirical data to support HRA, with emphasis on HEP estimates.

## Approach

The NRC staff's approach is to use the similarity-matching concept to identify the empirical data that can be used to inform the HEPs of the human failure events (HFEs) of interest.

Unlike hardware reliability studies and because of the variability of the HFEs, it is not practical to collect the total number of successes and failures when calculating HEPs. One solution involves grouping together empirical data on tasks with similar

human performance characteristics to inform the HEPs. This approach could significantly increase the usability of the empirical data collected.

The staff's approach is to use the six functional elements in most HRA methods for calculating HEPs to form a human performance profile (HPP). The six elements are task analysis (or task decomposition), generic tasks, error modes or error mechanisms, performance-shaping factors, task dependency, and recovery from human failure. The HPP will be used to characterize empirical data and the HFE of interest and to measure the similarity between the HFE of interest and the empirical data. Figure 6.1 illustrates this concept.

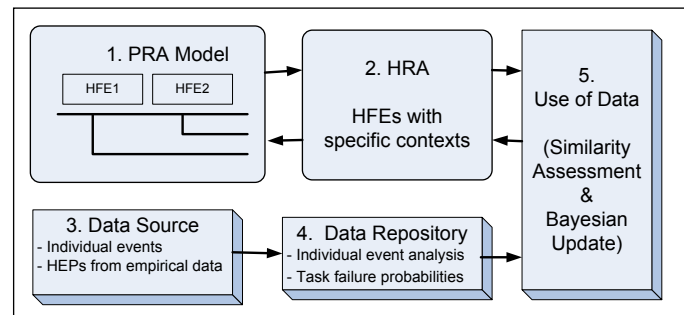

**Figure 6.1** Diagram illustrating the concept of using empirical data to inform the human error probabilities of human failure events

In the upper portion of Figure 6.1, the HFEs are specified in PRA or HRA (Blocks 1 and 2). Based on the contextual information provided in PRA or HRA, the HPP of the HFE can be specified. The lower portion of Figure 6.1 shows the likely data types (Block 3). These include analyses of individual events (by identifying the key tasks and corresponding human performance in the events) and task failure probabilities. Each instance of success or failure in performing key tasks in past events and each task failure probability are considered as a data point. Each data point is characterized by the HPP and stored in a data repository (Block 4). The data points with similar HPPs to HFEs of interest can be identified from the repository to inform the HFE's HEP.

Key technical challenges to the approach include developing the HPP, similarity measurements, and use of imperfect data.

### For More Information

Contact Y. James Chang, RES/DRA, at 301-251-7589 or [James.Chang@nrc.gov](mailto:James.Chang@nrc.gov)

---

# Human Reliability Analysis Model Differences

## Background

The NRC's Office of Nuclear Regulatory Research (RES) is supporting the Advisory Committee on Reactor Safeguards (ACRS) to address the November 8, 2006, staff requirements memorandum (SRM-M061020) in which the Commission directed the ACRS to "work with the staff and other stakeholders to evaluate different human reliability models in an effort to propose a single model for the agency to use or guidance on which model(s) should be used in specific circumstances." RES is addressing this issue through collaborative work with EPRI (Electric Power Research Institute), initiated under the RES memorandum of understanding with EPRI on PRA.

## Approach

To address the issue, the project is pursuing a formalization approach and a quantification tool capable of performing HRA in a consistent and efficient manner. The formalization approach aims to build a foundation for HRA that uses the current understanding of human performance and is consistent with the overall PRA framework from the perspective of both failure modeling and estimation of failure probabilities. This approach introduces the crew response tree (CRT) concept, which depicts human failure events in a manner parallel to the PRA event tree process. CRTs provide a structure for identifying the context associated with the human failure events under analysis and use a human information processing model as a platform to identify potential failures.

This approach incorporates behavioral science knowledge by providing the decompositions of human failures, failure mechanisms, and failure factors from both a top-down and bottom-up perspective. The bottom-up approach reflects findings from scientific papers documenting theories, models, and data of interest. The CRT structure and associated lower level models provide a roadmap for incorporating the phenomena with which crews would be dealing, the plant characteristics (e.g., design, indications, procedures, training), and the plant's human performance capabilities (understanding, decision, action). The work aims to create rules, and potentially template-based guidance, for a consistent, efficient, and effective analysis.

For quantification, the formalization approach uses the typical PRA conditional probability expression, delineated to a level adequate for associating the probability of a human failure event with conditional probabilities of the associated contexts,

failure mechanisms, and underlying factors (e.g., performance-shaping factors). This mathematical formulation can be used to directly estimate HEPs using various data sources (e.g., expert estimations, anchor values, simulator data, historical data) or can be modified to interface with existing quantification approaches. However, the quantification approach is still under exploration.

The staff anticipates that the methodology will be developed and available for public review and comment by November 2011.

The NRC's costs represent only a fraction of the actual costs for both the international empirical study and the collaborative work with EPRI for addressing SRM-M061020 on HRA model differences. Through these collaborative efforts, the NRC is also able to take advantage of extensive domestic and international PRA and HRA expertise from recognized academics and practitioners.

## For More Information

Contact Erasmia Lois, RES/DRA at 301-251-7573 or [Erasmia.Lois@nrc.gov](mailto:Erasmia.Lois@nrc.gov)

---

# Improving Human Reliability Analysis Methods by Using Simulator Runs

## Background

As part of its efforts to improve human reliability analysis (HRA), the Office of Nuclear Regulatory Research (RES) participates in and supports the International HRA Empirical Study to benchmark HRA models by comparing HRA results to empirical data generated through crew simulator runs. Although the documentation of this study is not yet complete, its findings indicate areas for improvement in HRA methods and practices. But because the study is based on the results of simulator runs using European crews at the Halden Reactor Project (HRP) simulator, the issue of the applicability of the study results to U.S. nuclear power plant crews has been raised.

In its February 2009 staff requirements memorandum (SRM-M090204B), the Commission directed the staff to work with industry and international partners to test the performance of U.S. nuclear power plant operating crews and to keep the Commission informed of the status of its HRA data and benchmarking projects. RES's benchmarking work is responsive to SRM-M090204B.

The NRC established a memorandum of understanding with a U.S. utility that volunteered to participate in this study and offered simulator facilities, crews, and expertise to support the design and execution of the experimental runs. As a result, a new study was initiated that the HRP staff supports with expertise in the design and execution of simulator runs, as well as the collection and interpretation of crew performance data.

The objective of this new study is to evaluate a specific set of HRA methods used in regulatory applications by comparing HRA predictions to crew performance in simulator experiments performed at a U.S. nuclear power plant. The results will be used to accomplish the following:

- Determine the potential limitations of data collected in non-U.S. simulators when used to evaluate U.S. applications.
- Improve the insights developed from the International HRA Empirical Study.

## Approach

The study approach consists of the following four steps:

### 1. Experimental Design and Performance of Simulated Scenarios

The experimental design is focused on collecting information on the predictive power and consistency of HRA methods—A Technique for Human Error Analysis (ATHEANA), Standardized Plant Analysis Risk—Human Reliability Analysis Method (SPAR-H), Technique for Human Error Rate Prediction/Accident Sequence Evaluation Program (THERP/ASEP), and Cause-Based Decision Tree (CBDT) in particular—through analysis of crew performance in simulated nuclear power plant accident scenarios. It stipulates the collection of information to be used by HRA analysts to evaluate the human failure events (HFEs) involved in the scenarios and to estimate the human error probabilities (HEPs).

The design includes three accident scenarios. The design addresses the plant status before the initiating event, the initiating event, and the associated plant design capabilities and operational characteristics to deal with the event, including procedural guidance; the predetermination and definition of the HFEs to be analyzed for each scenario and associated success criteria; the identification of human performance metrics; the development of crew performance collection protocols and questionnaires to support documentation of observed crew performance; and the development of an information package containing basic probabilistic risk assessment (PRA) and HRA information to be provided to the HRA teams.

The actual experiment consists of the running of the scenarios and the collection and documentation of observations about plant behavior and crew performance by experts (typically plant trainers and PRA/HRA experts). In addition to live observations, crew performance observations are collected through videotapes and debriefings of both the crews and the plant experts who observed the runs.

The experimenters evaluate crew performance by analyzing the information collected during the experiment according to predefined protocols and performance metrics. This part of the study is supported by the staff of the HRP.

---

## 2. Information Collection and Evaluation of HEPs by HRA teams

Each HRA method is applied by two or three HRA teams composed of NRC and contractor staff. The HRA teams visit the plant to interview plant personnel, view simulator runs (other than the study simulations), and collect relevant plant information. On the basis of the information collected, the teams use their selected HRA methods to perform predictive analysis and to estimate HEPs for the HFEs involved in the simulated scenarios, document the results, and submit them for review and evaluation.

One goal of the study is to understand the types of information considered by HRA teams in performing HRA analysis using a given method. Documenting this information provides insights about differences and commonalities among HRA methods; in particular, it helps staff to develop an understanding of how methods (or analysts) are using the collected information and of how the different ways of using information affect consistency among methods or analysts. Documenting information use also allows comparisons with crew simulator performance to examine if the appropriate factors are being considered by the teams using the different HRA methods.

## 3. Evaluation of the HRA submittals

An independent group of experts reviews the submitted analyses and compares them to the observed simulator data. These experts perform method-to-method and HRA team-to-team comparisons to determine if and how method differences and analyst differences influence the HRA results. Their analysis includes both qualitative and quantitative comparisons.

Qualitative comparisons examine the extent to which HRA analysts, using their methods, were able to identify key drivers (such as misdiagnosis of equipment failures or lack of adequate procedural guidance for performing the required actions) that could influence the crew's capability to accomplish the required actions. Through such comparisons, the experts identify (1) method limitations with regard to guiding analysts to identify important drivers of human performance, and (2) method limitations with regard to ensuring a consistent use of the method by different analysts (intra-analyst consistency).

Quantitative comparisons involve (1) the ranking of the estimated HEPs, (2) the ranking of the human actions in terms of the level of difficulty that crews appear to have experienced during the simulation, and (3) comparison of the resulting ranking in (1) and (2). These comparisons allow the experts to examine whether or not inconsistencies in ranking stem from the following causes:

- the extent to which the quantification tool can incorporate the important drivers of human performance identified through the qualitative analysis (e.g., the tool allows the use of only a few performance shaping factors in the estimation of HEPs)
- the extent to which the quantification tool can provide a consistent and traceable process to estimate HEPs
- the analysts' capability to correctly apply the tool.

## 4. Documentation of the Results

A NUREG report will (1) document the results for each method tested, including the performance characteristics of each method and potential implications for regulatory applications, and (2) assess the consistency of the methods and identify how practitioners can achieve better consistency in HRA.

RES expects this study to be completed by September 2011.

### For More Information

Contact Erasmia Lois, RES/DRA at 301-251-7573 or [Erasmia.Lois@nrc.gov](mailto:Erasmia.Lois@nrc.gov)



---

# Pilot Testing of Human Reliability Analysis-Informed Training and Job Aid for NRC Staff Involved with Medical Applications of Byproduct Materials

## Background

In 2003, the Office of Nuclear Material Safety and Safeguards (NMSS) provided the Office of Nuclear Regulatory Research (RES) with a user need for developing human reliability analysis (HRA) capability specific to materials and waste applications (NMSS-2003-003). In this memorandum, NMSS requested two phases of work. Both phases were completed in December 2008.

The Phase 1 work consisted of feasibility studies for developing NMSS capability in HRA. The feasibility study for materials applications addressed both medical and industrial applications.

The Phase 2 work focused on the recommendations from the feasibility study, namely, the development of job aids (e.g., HRA-informed decisionmaking aids) and associated training for NRC staff on HRA-informed issues in human performance in medical applications.

The final products of the Phase 2 work, a prototype HRA-informed job aid (i.e., a database of risk-relevant human performance issues and historical errors, related to treatment steps) and associated training materials for medical applications (gamma-knife based), were presented to staff in the Office of Federal and State Materials and Environmental Management Programs (FSME) and delivered to the NRC in December 2008.

Follow-up work to pilot the HRA-informed job aid and training materials began in spring 2010.

## Approach

The overall objective is to develop HRA-informed job aids and associated training for NRC staff involved with medical applications of byproduct materials. Although prototypes of the HRA-informed job aid and training materials have been developed, instructions on how to use these tools for specific NRC tasks (e.g., inspections, license reviews) were not developed. Consequently, interaction with NRC staff from the regions, as well as the continued involvement of staff at NRC Headquarters is required in this pilot testing phase of development.

RES is currently making plans for pilot testing of both products at NRC Region I.

### PILOT TESTING TASKS

The following are the expected tasks for the pilot testing of the HRA-informed job aid and associated training:

- initial updates to HRA-informed training and job aid (with respect to recent events and new gamma knife technology)
- initial interactions with NRC Region I staff
- onsite HRA-informed training
- onsite demonstration of HRA-informed job aid
- selection of candidates for trial use of HRA-informed job aid
- trial use of HRA-informed job aid
- feedback on trial use
- updates to HRA-informed job aid and associated training (based on feedback)

By the end of calendar year 2010, the first two tasks should be complete and preparations started for Task 3.

### For More Information

Contact Susan Cooper, RES/DRA at 301-251-7604 or [Susan.Cooper@nrc.gov](mailto:Susan.Cooper@nrc.gov)

---

# Qualitative Human Reliability Analysis for Spent Fuel Handling

## Background

In 2003, the Office of Nuclear Material Safety and Safeguards (NMSS) provided the Office of Nuclear Regulatory Research (RES) with a user need for developing human reliability analysis (HRA) capability specific to materials and waste applications (NMSS-2003-003). In this memorandum, NMSS requested two phases of work, the first of which is completed.

Phase 1 work consisted of feasibility studies for developing NMSS capability in HRA. The feasibility study for waste applications (performed by NRC staff) addressed high-level waste, spent fuel storage, fuel cycle, and decommissioning applications. This study identified the following needs for potential NMSS-specific HRA development that were common to more than one waste application:

- development of HRA methods specific to NMSS needs
- guidance for evaluating the effectiveness of administrative controls
- guidance on good practices for implementing HRA
- guidance for reviewing HRAs
- assistance in incident significance assessments

Initial Phase 2 work on this project began investigating development of HRA methods specific to NMSS needs and guidance on good practices for implementing HRA.

Additionally, NMSS and RES identified new priorities, resulting in project efforts focused on the development of HRA insights for spent fuel handling. Such activities include investigation of both spent fuel misloads and cask drops.

## Approach

The first step in developing HRA capability for NMSS was to develop a qualitative understanding of the important human performance issues for spent fuel handling that need to be addressed by HRA.

To this end, this project has completed the following work:

- identification and review of literature relevant to understanding human performance in spent fuel handling

- interviews of subject-matter experts in spent fuel handling
- evaluation and use of relevant literature and interviews of experts to perform qualitative HRA tasks for spent fuel handling

The result of this work was a July 2006 Sandia National Laboratories (SNL) letter report describing potential vulnerabilities and possible scenarios that could lead to misloads and cask drops.

Currently, the project is developing further HRA-informed insights on cask drops. It is expected that this work will provide useful input to future NRC inspections and reviews.

The current schedule for deliverables for both efforts is the following:

- draft NUREG/CR on initial efforts for misloads and cask drops—September 2010
- draft NUREG/CR on recent expanded efforts on cask drops—September 2010
- preparation of both final NUREG/CRs—December 2010

Continued interactions between NMSS and RES staff are planned as these deliverables are completed.

### For More Information

Contact Susan Cooper, RES/DRA at 301-251-7604 or [Susan.Cooper@nrc.gov](mailto:Susan.Cooper@nrc.gov)

# Human Performance for Advanced Control Room Design

## Background

With the renewed interest in nuclear energy, there are plans to begin constructing new plants within the next several years. The new generation of plants will differ from the existing fleet in several important ways, including the design of the reactors, the instrumentation and control (I&C), and the human-system interface (HSI). Figure 6.2 illustrates one conceptualization of an advanced control room (CR) design. Taken together, these technological advances will lead to concepts of operation that are different from those found in currently operating nuclear power plants. The potential benefits of the new technologies should result in more efficient operations and maintenance. However, if the technologies are poorly designed and implemented, there is the potential they will reduce human reliability, increase errors, and negatively impact human performance—resulting in a detrimental effect on safety. To address these concerns, the NRC sponsored a study to identify human performance research that may be needed to support the review of licensee’s implementation of new technology in new and advanced nuclear power plants.

## Approach

To identify the research issues, current industry trends and developments were evaluated in the areas of reactor technology, I&C technology, HSI integration technology, and human factors engineering (HFE) methods and tools. These four research issues were then organized into seven HFE topic areas: (1) role of personnel and automation, (2) staffing and training, (3) normal operations management, (4) disturbance and emergency management, (5) maintenance and change management, (6) plant design and construction, and (7) HFE methods and tools. Next, a panel of independent subject-matter experts representing various disciplines (e.g., HFE, I&C) and backgrounds (e.g., vendors, utilities, research organizations) prioritized the issues. Sixty-four issues were distributed among four categories, with 20 research issues placed into the top priority category.

NUREG/CR-6947, “Human Factors Considerations with Respect to Emerging Technology in Nuclear Power Plants,” issued October 2008, documents the results of the study. The report contains a summary of the high-level topic areas, the research issues in each topic area, the priorities for each issue, and a human performance rationale that describes the reason why each research issue is relevant. The findings from this study

are being used to develop a long-term research plan addressing human performance within these technology areas for the purpose of establishing a technical basis from which regulatory review guidance can be generated.

Of the 20 research projects identified as having a priority 1 research need, four have been completed, five are currently underway, and an additional three projects are scheduled to begin this year. Descriptions of the five projects that are underway are provided below.



Figure 6.2 One conceptualization of an advanced control room design

## Advances in Human Factors Engineering Methods and Tools

The methods and tools used to design, analyze, and evaluate the HFE aspects of nuclear power plants are rapidly changing. A previous study identified the current trends in the use of HFE methodologies and tools, identified their applicability to nuclear power plant design and evaluation, and determined their role in safety reviews conducted by the NRC. The study identified seven categories of methods and tools for which additional review guidance may be needed, including (1) application of human performance models, (2) use of virtual environments and visualizations, (3) analysis of cognitive tasks, (4) rapid development engineering, (5) integration of HFE methods and tools, (6) computer-aided design, and (7) computer applications for performing traditional analyses. One outcome of this project to date has been the development of detailed guidance for applying human performance models to the evaluation of nuclear power plant designs. The next phase of the study will provide human factors (HF) guidance for an additional two methods and tool categories.

## Roles of Automation and Complexity in Control Rooms

The overall level of automation in advanced nuclear power plants is expected to be much higher than in plants currently operating in the United States. It is important that the staff be cognizant of current practices and trends in the use of automation in nuclear power plant CRs and understand the influences of automation on CR design, human performance, and conduct of operations. A previous study, “Human-System Interfaces (HSIs)

---

to Automatic Systems,” developed a general framework for characterizing automation systems and developed HFE criteria for evaluating automation designs. The present study will further the state of the art by examining the impact of automation on CR design, specifically the impact of automation on (1) operator performance during normal, abnormal, and emergency operations; (2) the reliability of operator’s use of automation systems, including existing methods for assessing impacts; and (3) operator performance when the automation fails or is in a degraded state.

### **Human Factors Guidance for the Assessment of Computerized Procedures**

Applicants for new and advanced reactor design certifications are proposing to incorporate computer-based procedure capabilities as part of their main CR designs. The potential forms of implementation can range from basic applications that are limited to displaying static representations of procedures to those that provide dynamic displays of procedures in conjunction with relevant plant status and process data, context-dependent decision aids, soft controls, and the capability to implement automated sequences of procedure steps. Although the challenges and human factors considerations increase with the level of functionality of these applications, even the most basic application requires consideration of how it will be integrated with other elements of the CR design, how the implementation might affect the roles and responsibilities of the operating crew and standards for conduct of operations, how the operators will transition to backup procedures upon loss of a computer-based procedure system, what the potential failure modes of the application will be, and how those failure modes will be addressed to ensure that acceptable levels of human performance will be maintained. This project will review applicable research literature and operating experience and develop a technical basis document for the development of review guidance that addresses the key issues associated with the use of CR computerized procedures.

### **Human Factors Aspects in Concepts of Operations for Modular Designs**

Advances in nuclear power plant technology have set the stage for changes to traditional concepts of operations (CONOPS). The CONOPS of new reactor designs introduce such safety-critical performance considerations as the operation of multiple reactors by a reduced crew. The objective of this project is to examine the human factors aspects associated with the monitoring and control of multimodular plants and to provide a technical basis for evaluating the impacts of evolving CONOPS on human performance. The regulatory documents for reviewing modular designs will also be assessed to identify areas that need additional technical basis or guidance to facilitate the staff review of CONOPS for modular reactor designs.

### **Update Existing Human Factors Engineering Regulatory Guidance**

The NRC staff reviews the HFE aspects of nuclear power plants in accordance with the guidance presented in NUREG-0800, “Standard Review Plan for the Review of Safety Analysis Reports for Nuclear Power Plants.” Detailed design review procedures for the HFE programs of applicants for construction permits, operating licenses, standard design certifications, combined operating licenses, and license amendments are provided in NUREG-0711, Revision 2, “Human Factors Engineering Program Review Mode.” As part of the review process, the interfaces between plant personnel and plant systems and components are evaluated for conformance with the guidance contained in NUREG-0700, Revision 2, “Human-System Interface Design Review Guidelines.” NUREG-0711 and NUREG-0700 were last updated in 2004 and 2002, respectively. This study will update NUREG-0711 and NUREG-0700 with HFE criteria developed from the most recent and best available technical bases. The availability of up-to-date HFE review guidance will help to ensure that the NRC staff has the latest knowledge, information, and tools to safely and efficiently perform its regulatory tasks.

### **For More Information**

Contact Stephen Fleger, RES/DRA at 301-251-7905 or [Stephen.Fleger@nrc.gov](mailto:Stephen.Fleger@nrc.gov)

---

# Support For Implementation of 10 CFR Part 26 Fitness-for-Duty Programs

## Background

To ensure the safety and security of nuclear facilities, the NRC has developed regulations to standardize and ensure effective implementation of fitness-for-duty (FFD) programs that apply to personnel who engage in certain safety- and security-related activities. For example, certain personnel at commercial nuclear power plants who have unescorted access to the plant's protected areas and those who transport strategic special nuclear materials must be subject to an FFD program. The NRC requires FFD programs to provide reasonable assurance that nuclear facility personnel are trustworthy and will perform their tasks in a reliable manner.

In Title 10 of the *Code of Federal Regulations* (10 CFR) Part 26, "Fitness for Duty Programs," the NRC describes the scientific and technical requirements for FFD programs that address illegal drug use, alcohol abuse, misuse of legal drugs, impairment from fatigue, and any other mental or physical conditions that could impair job performance. At the time that 10 CFR Part 26 was first published in the *Federal Register* (54 FR 24468; June 7, 1989) and subsequently, the Commission directed the NRC staff to continue to analyze FFD programs, assess the effectiveness and efficiency of the rule, and recommend appropriate improvements or changes.

Most recently, the NRC, with extensive stakeholder input, published an amended, reorganized, and updated rule. The amended 10 CFR Part 26 was published in the *Federal Register* on March 31, 2008. It is organized into 12 subparts that group together related requirements. The NRC permitted licensees and other entities to defer implementation of the majority of the rule's requirements until March 31, 2009, and granted an additional 6 months to implement the rule's new fatigue management requirements.

## Approach

The Office of Nuclear Regulatory Research (RES) participates in a multidisciplinary team of NRC staff that is supporting a myriad of agency initiatives and efforts to facilitate education about the rule and its implementation.

## Fatigue Regulatory Guide

RES worked closely with other NRC staff and stakeholders to publish guidance for implementing the fatigue management requirements of 10 CFR Part 26. Specific requirements for nuclear power plant licensees to manage worker fatigue are a new addition to 10 CFR Part 26. As guidance on the new rules, the NRC published Regulatory Guide (RG) 5.73, "Fatigue Management for Nuclear Power Plant Personnel," in March 2009.

## Training Development

To ensure that implementation efforts among the regions and various offices are coordinated and consistent, RES staff and its contractors have developed training materials for inspectors and other NRC staff involved in implementing 10 CFR Part 26. To date, the training has been developed, pilot-tested, and supplemented with computer-based training specifically focused on the fatigue management requirements.

## FFD Web Site Update

Transparency is an important NRC goal. Toward that end, the NRC staff maintains a public Web site to provide one location for stakeholders to access information and submit questions about the rule and any implementation concerns. The Web site includes the history of the 10 CFR Part 26 rulemaking, frequently asked questions about 10 CFR Part 26 and its implementation, FFD program reports from licensees, and related documents and resources.

## Inspection Procedures

RES supports other NRC offices in developing inspection procedures that are used to evaluate the effectiveness of FFD programs and to verify licensee compliance with the rule's requirements.

## Technical Bases for Alternate Specimens and Fatigue Technologies

The science and technologies for assuring personnel fitness for duty continue to advance. Consistent with the Commission's direction to continue assessing the effectiveness and efficiency of FFD programs, RES is identifying scientific and technological advances that may enhance FFD programs. For example, 10 CFR Part 26 currently requires the use of urine, breath, and saliva testing for drugs and alcohol. However, new drug testing technologies are being developed that rely on alternate specimens, including hair and sweat. New methods to manage fatigue in the workplace and technologies for assessing fatigue and other possible types of impairment are also of interest. Finally, RES is evaluating other readiness-to-perform technologies, as these tests have implications for effective job and task performance.



---

### **Future Updates to 10 CFR Part 26**

The Commission directed the NRC staff to initiate a new 10 CFR Part 26 rulemaking after publication of the March 31, 2008, amended and revised rule. The Commission asked the NRC staff to review specific elements of the rule related to the technical basis and to evaluate including licensee quality control, quality verification, and quality assurance personnel in the fatigue provisions of 10 CFR Part 26. The RES staff is continuing to provide its technical expertise to staff engaged in the new rulemaking.

### **For More Information**

Contact Valerie Barnes, RES/DRA at 301-251-7585 or [Valerie.Barnes@nrc.gov](mailto:Valerie.Barnes@nrc.gov)

---

# Safety Culture

## Background

The culture of an organization affects the performance of the people in it. Weaknesses in an organization's safety culture may set the stage for equipment failures and human errors that can have an adverse impact on safe performance.

### Goal of Safety Culture Activities

The initial goal of the NRC's 2006 safety culture initiative was to enhance the Reactor Oversight Process (ROP) to more fully consider safety culture in the NRC's assessments of inspection findings and overall nuclear power plant performance. More recently, the Commission directed the NRC staff to (1) consider the need for an agencywide safety culture policy statement that would apply to all entities regulated by the NRC and (2) recommend whether and how to better integrate security culture considerations into the NRC's safety and security oversight activities.

The Office of Nuclear Regulatory Research (RES) is providing technical expertise related to human and organizational performance to support the agency's safety culture activities. The RES staff participates in the Safety Culture Working Group, the Safety Culture Policy Statement Task Force, and the Safety Culture Policy Statement Steering Committee.

### Industry Safety Culture Assessment Initiative

Concurrent with the NRC staff's activities, the nuclear power industry, led by the Nuclear Energy Institute (NEI), is developing a standardized safety culture assessment methodology and performance indicators. NEI has indicated that the assessment methodology will be used by nuclear power plant licensees for biennial self-assessments and, with modifications, to reply to NRC requests for independent or third-party safety culture assessments under the ROP. The performance indicators will be used to provide ongoing monitoring of safety culture trends. RES staff will assist the Office of Nuclear Reactor Regulation (NRR) in evaluating the industry's new approach.

### For More Information

Contact Valerie Barnes, RES/DRA at 301-251-7585 or [Valerie.Barnes@nrc.gov](mailto:Valerie.Barnes@nrc.gov)

# Chapter 7: Fire Safety Research

Fire Probabilistic Risk Assessment Methodology for Nuclear Power Facilities

Fire Human Reliability Analysis Methods Development

Fire Modeling Activities

Cable Heat Release, Ignition, and Spread in Tray Installations During Fire (CHRISTIFIRE)

Direct Current Electrical Shorting in Response to Exposure Fire (DESIREEFIRE)

Fire Effects on Electrical Cables and Impact on Nuclear Power Plant System Performance: Phenomena Identification and Ranking Table (PIRT) and Expert Elicitation Programs

Beyond-Design-Basis Fires for Spent Fuel Transportation: Shipping Cask Seal Performance Testing

Training Programs for Fire Probabilistic Risk Assessment, Human Reliability Analysis, and Fire Modeling

Fire Research and Regulation Knowledge Management



NUREG/BR-0465



---

## Future Work

A revision to the joint report is in the planning stages as the methodology continues to mature.

### **For More Information**

Contact J.S. Hyslop, RES/DRA at 301-251-7611 or  
JS.Hyslop@nrc.gov



# Fire Human Reliability Analysis Methods Development

## Background

The Individual Plant Examination of External Events (IPEEE) program and the experience from actual fire events found that, depending on design and operational conditions, fire can be a significant or dominant contributor to nuclear power plant (NPP) risk. Human errors have been shown to be a significant contributor to overall plant risk (including the risk from fires) because of the significant role that operators play in the fire protection strategy on reactor safety. Figure 7.2 illustrates operators in an NPP control room. Human reliability analysis (HRA) is the tool used to assess the implications of various aspects of human performance on risk. Currently, the NRC is expanding existing HRA methods to evaluate the impact of human failures in the fire protection defense-in-depth safety strategy.

In 2004, the NRC amended its fire protection requirements to allow existing reactor licensees to voluntarily adopt the risk-informed, performance-based rule, 10 CFR 50.48(c). This rule endorses National Fire Protection Association (NFPA) Standard 805, “Performance Based Standard for Fire Protection for Light Water Reactor Electric Generating Plants,” as an alternative to the existing prescriptive fire protection requirements. To realize the full benefits of making the transition to the risk-informed, performance-based standard, plants will need to have a fire probabilistic risk assessment (PRA) that includes quantitative HRA for post-fire mitigative human actions modeled in a fire PRA.

The Electric Power Research Institute (EPRI) and NRC’s Office of Nuclear Regulatory Research (RES) embarked on a cooperative project to improve the state of the art in fire risk assessment to support this new risk-informed environment in fire protection. This project produced a consensus document, NUREG/CR-6850 (EPRI 1011989), “Fire PRA Methodology for Nuclear Power Facilities,” that addresses fire risk for at-power operations. This report provides high-level qualitative guidance and quantitative screening guidance for conducting a fire HRA. However, this document does not provide a detailed quantitative methodology to develop best-estimate human error probabilities (HEPs) for human failure events under fire-generated conditions.

## Objective

The overall objective of the effort is to develop fire HRA methods beyond what is currently in NUREG/CR-6850 (EPRI 1011989)

and develop an HRA methodology and approach suitable for use in a fire PRA.

The fire HRA guidance developed through this effort is intended to support plants making the transition to 10 CFR 50.48(c), as well as NRC reviewers evaluating the adequacy of submittals from licensees making that transition. It may also be employed as a general fire PRA tool for HRA.



Figure 7.2 Operators in a NPP control room

## Approach

RES has worked collaboratively with EPRI to develop a methodology and associated guidance for performing quantitative HRAs for post-fire mitigative human actions modeled in a fire PRA. The NRC issued NUREG-1921 (EPRI 1019196), “EPRI/NRC-RES Fire Human Reliability Analysis Guidelines” (see Figure 7.3), as a draft for public comment in December 2009. It provides three approaches to quantification: screening, scoping, and detailed HRA. Screening is based on the guidance in NUREG/CR-6850 (EPRI 1011989), with some additional guidance for scenarios with long time windows. Scoping is a new approach to quantification developed specifically to support the iterative nature of fire PRA quantification. Scoping is intended to provide less conservative HEPs than screening but requires fewer resources than a detailed HRA. For detailed HRA quantification, the NRC has developed guidance on how to apply existing methods to assess post-fire HEPs.

The NRC plans to release NUREG-1921 (EPRI 1019196) as a final report in spring 2011.

---

## Future Work

The NRC has added a new HRA module to the NRC-RES/EPRI Fire PRA Workshop to provide training on the use of this methodology. The joint fire HRA methodology development team is scheduled to deliver the fire HRA training at the 2010 workshops, as well as at future fire PRA workshops.

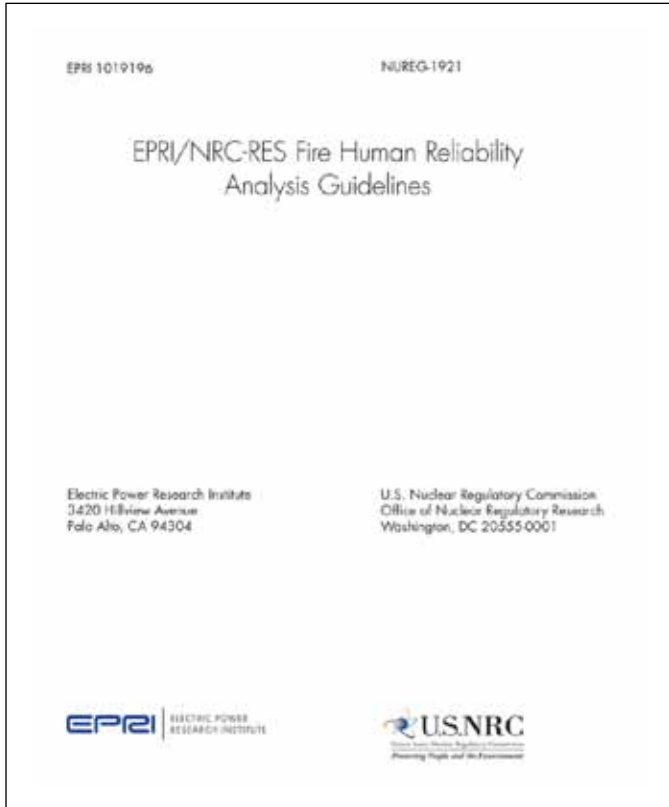

Figure 7.3 NUREG-1921 cover page

### For More Information

Contact Kendra Hill, RES/DRA at 301-251-3300 or [Kendra.Hill@nrc.gov](mailto:Kendra.Hill@nrc.gov)

# Fire Modeling Activities

## Background

The results of the Individual Plant Examination of External Events (IPEEE) program and actual fire events indicate that fire can be a significant contributor to nuclear power plant (NPP) risk, depending on design and operational conditions. Fire models can evaluate fire scenarios in risk assessments, determine damage to cables and other systems and components important to safety, and characterize the progression of fire beyond initial targets. Used in these ways, fire models are important tools in determining the contribution of fire to the overall risk in NPPs.

## Objective

The objective of this program is to provide methodologies, tools, and support for the use of fire modeling in NPP applications.

## Approach

In 2004, the NRC amended its fire protection requirements to allow existing reactor licensees to voluntarily adopt the fire protection requirements contained in National Fire Protection Association (NFPA) Standard 805, which allows licensees to use fire models as part of their fire protection programs. However, the fire models are subject to verification and validation (V&V) and must be acceptable to the NRC to ensure the quality and integrity of the modeling. To this end, the NRC Office of Nuclear Regulatory Research (RES), along with the Electric Power Research Institute (EPRI) and the National Institute of Standards and Technology (NIST), conducted an extensive V&V study of fire models used to analyze NPP fire scenarios. This study resulted in the seven-volume report NUREG-1824, “Verification and Validation of Selected Fire Models for Nuclear Power Plant Applications,” issued May 2007.

The NRC and its licensees use the results in NUREG-1824 to provide confidence in the predictive capabilities of the various models evaluated. For example, although engineering calculations have limited capabilities, they provide reasonable estimates of certain phenomena when used within limitations (see Figure 7.4). These insights are valuable to fire model users who are developing analyses to support a transition to NFPA 805, to justify exemptions from existing prescriptive regulatory requirements, and to conduct significance determination process (SDP) reviews under the Reactor Oversight Process (ROP).

The NRC completed a Phenomena Identification and Ranking Table (PIRT) study of fire modeling (NUREG/CR-6978, “A Phenomena Identification and Ranking Table (PIRT) Exercise

for Nuclear Power Plant Fire Modeling Applications”), issued November 2008, which identified important fire-modeling capabilities needed to improve the NRC’s confidence in the results. This study helps define future research priorities in fire modeling.

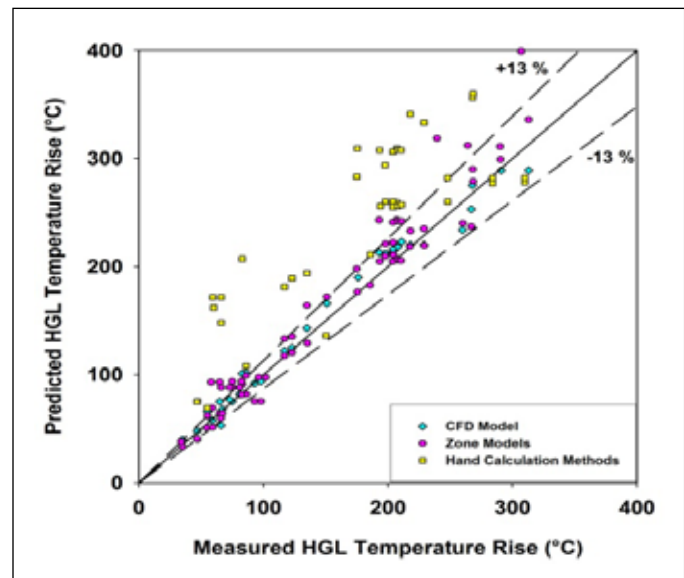

Figure 7.4 Measured vs. predicted hot gas layer temperature rise. The models evaluated provide reasonable estimates of actual temperature rise.

Fire risk assessments often need to determine when cables will fail during a fire in NPPs. In the past, cable-damage models have been crude and have not been validated. Recently, as part of the Cable Response to Live Fire (CAROLFIRE) program, the NRC and NIST have developed a simple cable damage model named Thermally-Induced Electrical Failure (THIEF). This model uses empirical information about cable failure temperatures and calculations of the thermal response of a cable to predict the time to cable damage. The NRC benchmarked and validated the THIEF model against real cable failure and thermal data acquired during the CAROLFIRE program.

NIST used the THIEF model in both two-zone and computational fluid dynamics (CFD) models. In addition, the NRC incorporated the THIEF model in its fire dynamics tools spreadsheets (NUREG-1805, “Fire Dynamics Tools (FDTs) Quantitative Fire Hazard Analysis Methods for the U.S. Nuclear Regulatory Commission Fire Protection Inspection Program,” issued December 2004). The THIEF spreadsheet is a useful tool for inspectors and licensees to quickly determine the likelihood of cable damage, given a fire, or to indicate the need for further analysis.

Currently, the NRC is again working with EPRI and NIST to develop technical guidance to assist those who conduct fire-modeling analyses of NPPs. This guidance will continue to expand on NUREG-1824 by providing users with best practices

from experts in fire modeling and NPP fire safety.

This application guide contains five commonly available fire modeling tools (FDTs, Fire-Induced Vulnerability Evaluation (FIVE)-Rev1, Consolidated Fire Growth and Smoke Transport Model (CFAST), MAGIC, and Fire Dynamics Simulator (FDS)) that were developed by nuclear power stakeholders or that were applied to NPP fire scenarios. Previously, RES, EPRI, and NIST used these same models in the V&V study documented in NUREG-1824. Figure 7.5 illustrates a isometric view of a room in an NPP showing the temperature profile above an electrical cabinet fire in a fire dynamics simulation.

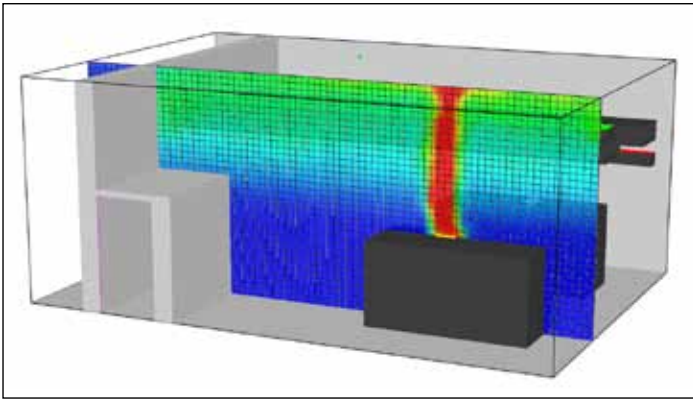

**Figure 7.5** Graphical output from FDS/Smokeview fire model

The NRC released draft NUREG-1934, “Nuclear Power Plant Fire Modeling Application Guide (NPP FIRE MAG),” for public comment in early 2010. It received numerous comments and suggestions during the public comment period on ways to expand and improve it to better support the model users and reviewers. The NRC is currently working with EPRI and NIST on revising the draft and expects to publish it in early 2011. This report will assist both the user performing the calculation and the reviewers; it includes guidance on selecting appropriate models for a given fire scenario and on understanding the levels of confidence that can be attributed to the model results. The report will also form the foundation for future fire model training being developed by RES and EPRI.

## Future Work

The NRC is continuing to update the fire modeling tools, expand the V & V effort, and develop additional model input data.

### For More Information

Contact David Stroup, RES/DRA at 301-251-7609 or [David.Stroup@nrc.gov](mailto:David.Stroup@nrc.gov)

# Cable Heat Release, Ignition, and Spread in Tray Installations During Fire (CHRISTIFIRE)

## Background

Fire can be a significant contributor to nuclear power plant (NPP) risk. In 1975, a serious fire involving electrical cables occurred at the Browns Ferry Nuclear Power Plant (BFN) operated by the Tennessee Valley Authority (TVA). NPPs typically contain hundreds of miles of electrical cables. The burning behavior of cables in a fire depends on a number of factors, including their constituent materials and construction, as well as their location and installation geometry. Burning cables can propagate flames from one area to another, or they can add to the amount of fuel available for combustion. Burning cables also produce smoke containing toxic and corrosive gases. The lower the heat exposure required to ignite the electrical cables, the greater the fire hazard in terms of ignition and flame spread. Electrical cables exposed to fire can lose physical integrity (i.e., melting of the insulation) and insulation resistance, leading to electrical breakdown or short-circuiting or the spread of fire to other cables or combustibles.

The amount of experimental evidence and analytical tools available to calculate the effects of cable tray fires is relatively small when compared to the vast number of possible fire scenarios. Many of the large-scale fire tests conducted with cables are qualification tests, in which the materials are tested in a relatively realistic configuration and qualitatively ranked on a comparative basis. This type of test typically does not address the details of fire growth and spread and does not provide useful data for realistic fire-risk and fire-model calculations.

## Objective

The CHRISTIFIRE (Cable Heat Release, Ignition, and Spread in Tray Installations during Fire) experimental program is an effort to quantify the mass and energy released from burning electrical cables. The program includes fire tests on grouped electrical cables to enable better understanding of the fire hazard characteristics, including heat release rate (HRR) and flame spread. The NRC will use this type of quantitative information to develop more realistic models of cable fires for use in fire probabilistic risk assessment (PRA) analyses, such as those performed using the methods of NUREG/CR-6850 “Fire PRA Methodology for Nuclear Power Facilities” in NFPA 805 applications.

## Approach

Phase 1 of CHRISTIFIRE included experiments ranging from microscale to full-scale. Small samples of cable jackets and insulation were burned within a calorimeter to measure the heat of combustion, pyrolysis temperature, heat release capacity, and residue yield (see Figure 7.6). Meter-long cable segments were slowly fed through a small tube furnace and a variety of spectrometric techniques measured the composition of the effluent (see Figure 7.7). The standard cone calorimeter test (see Figure 7.8) measured the heat release rate per unit area for a variety of cable types at several external heat fluxes.

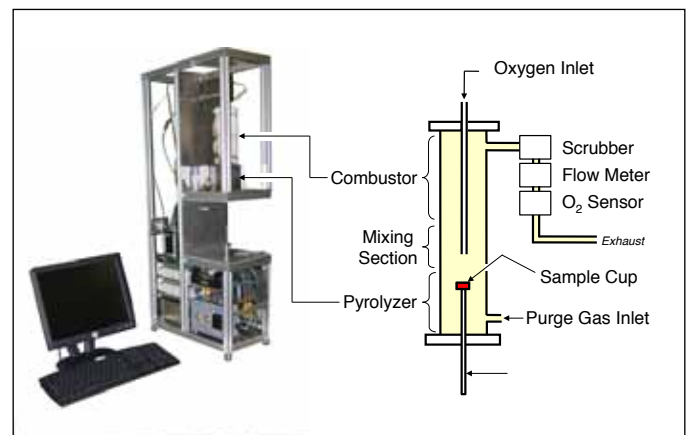

Figure 7.6 Pyrolysis combustion flow calorimeter (Photograph and diagram from ASTM D 7390)

A large radiant panel apparatus (see Figure 7.9), specially designed for this test program, measured the burning rate of cables when installed in ladder-back trays. Finally, a series of 26 multiple-tray, full-scale experiments assessed the effect of changing the vertical tray spacing, tray width, and tray fill (see Figures 7.10 and 7.11).



Figure 7.7 ISO/TS 1970 tube furnace (Photograph of test apparatus used for one set of microscale tests)

In addition, a simple model of flame spread in horizontal tray configurations, referred to as FLASH-CAT (Flame Spread over Horizontal Cable Trays), makes use of semi-empirical estimates of lateral and vertical flame spread, and measured values of combustible mass, heat of combustion, heat release rate per unit area, and char yield.



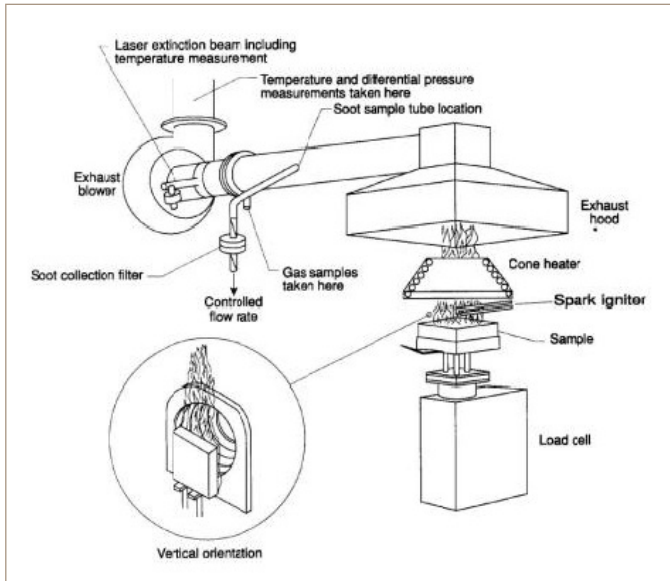

Figure 7.8 Cone calorimeter  
(From ASTM D611303; diagram of the cone calorimeter test apparatus)



Figure 7.11 Cables in tray  
(Cables placed in trays before fire test)



Figure 7.9 Radiant panel cable tray fire test (Side view of burning cables in a tray exposed to a radiant heat source)



Figure 7.10 Burning cables during cable tray fire test  
(Side view of burning cables in trays during a multi-tray test after ignition using a small gas burner)

## Future Work

CHRISTIFIRE was the first attempt at developing a more realistic understanding of the burning behavior of grouped cables. Based on its success, future phases of the project will examine the burning behavior of cables installed in vertical trays and the effectiveness of various methods of protection. The FLASH-CAT model will be validated and extended to other configurations.

### For More Information

Contact David Stroup, RES/DRA at 301-251-7609 or [David.Stroup@nrc.gov](mailto:David.Stroup@nrc.gov)

# Direct Current Electrical Shorting in Response to Exposure Fire (DESIREEFIRE)

## Background

The Individual Plant Examination of External Events (IPEEE) program results and actual fire events indicate that fire can be a significant contributor to nuclear power plant (NPP) risk. The question of how to determine risk resulting from fire damage to electrical cables in NPPs has been of concern since the Browns Ferry NPP (BFN) fire in 1975. In earlier years, it was generally believed that any system that depended on electric cables passing through a compartment damaged by fire would be unavailable for its intended safety function. The BFN fire and recent testing have prompted wider understanding that short circuits involving an energized conductor can pose considerably greater risk. The resultant “hot shorts” (see Figure 7.12) can cause systems to malfunction so as to inadvertently reposition motor-operated valves and start or stop plant equipment. Plant safety analyses should account for this risk.

A consensus regarding the likelihood of hot shorts given fire-damaged cables did not exist in the late 1990s. The Nuclear Energy Institute (NEI) and the Electric Power Research Institute (EPRI) conducted a testing program in 2001, and the NRC conducted one in its [Cable Response to Live Fire \(CAROLFIRE\)](#) program in 2006. Volumes 1–3 of NUREG/CR-6931, “Cable Response to Live Fire (CAROLFIRE),” document the CAROLFIRE results. These programs produced a vast amount of data and knowledge related to fire-induced circuit failures of alternating current (ac) circuits. However, none of the previous testing explicitly explored the fire-induced circuit failure phenomena for direct current (dc). Both current operating plants and the proposed new reactor designs use dc circuits to operate numerous safety-related systems.

Some recent tests performed by industry indicate that the results for ac circuits may not be fully representative of what might occur from fire-induced damage to dc circuits. Because of the differences in the operating voltages and circuit design between ac and dc, the previous data gathered for ac circuits may not be applicable to dc circuits.

## Objective

The [Direct Current Electrical Shorting in Response to Exposure Fire \(DESIREEFIRE\)](#) testing (see Figures 7.12 and 7.13 for examples of tests) of risk-significant dc circuits will allow the fire

protection community to better understand dc circuit-failure characteristics.

## Approach

The NRC staff elected to perform fire testing of dc circuits using configurations that are representative of safety-significant circuits and components used in NPPs to better understand the probability of spurious actuations and the duration of those actuations in dc circuits.

The DESIREEFIRE testing program used small- and intermediate-scale tests to evaluate the response of dc circuits to fire conditions. Tests include several different circuits:

- dc motor starters
- pilot solenoid-operated valve coils
- medium-voltage circuit-breaker control
- instrumentation circuit

The DESIREEFIRE project is another RES Fire Research Branch working under collaborative research agreement with EPRI. This agreement has provided various components and cabling to the DESIREEFIRE testing program at little or no cost to the NRC.



Figure 7.12 Direct current electrical cable hot short

It also provided expert advice on the various aspects of the dc power system and circuit design. Testing is complete, and the NRC plans to issue the report in near future.



Figure 7.13 Intermediate-scale dc fire tests



Figure 7.14 Battery bank for dc fire tests

## Future Work

The determination for future cable testing programs will be based upon the outcome of the Fire Effects on Electrical Cables and impact on Nuclear Power Plant System Performance Phenomena Identification and Ranking Table (PIRT) and Expert Elicitations.

### For More Information

Contact Gabriel Taylor, RES/DRA at 301-251-7576 or [Gabriel.Taylor@nrc.gov](mailto:Gabriel.Taylor@nrc.gov)

# Fire Effects on Electrical Cables and Impact on Nuclear Power Plant System Performance: Phenomena Identification and Ranking Table (PIRT) and Expert Elicitation Programs

## Background

Beginning in 1997, the NRC staff noticed a series of Licensee Event Reports (LERs) related to potential plant-specific problems involving fire-induced electrical cable circuit failures. The staff issued Information Notice 99-17, “Problems Associated with Post-Fire Safe-Shutdown Circuit Analysis,” in June 1999, to alert the industry. The industry, under the leadership of the Nuclear Energy Institute (NEI), performed a joint series of fire tests with the Electric Power and Research Institute (EPRI) to better understand the issue. The industry used an expert elicitation to review the results and provide recommendations with regard to their use in probabilistic risk assessments (PRAs). EPRI 1003326, “Characterization of Fire-Induced Circuit Faults—Results of Cable Fire Testing,” issued December 2002, documented the testing and expert panel results.

On February 19, 2003, the NRC sponsored a facilitated public workshop to discuss the results of the NEI/EPRI tests. Following the workshop, the NRC issued Regulatory Issue Summary (RIS) 2004-03, “Risk-Informed Approach for Post-Fire Safe-Shutdown Circuit Inspections,” in December 2004. In that document, the staff identified a number of areas requiring additional testing. The NRC Office of Nuclear Regulatory Research (RES) initiated the Cable Response to Live Fire (CAROLFIRE) test program to address these concerns and documented the results in the three volumes of NUREG/CR-6931 “CAROLFIRE” report, which was published in April 2008. In 2006, a licensee performed independent testing of ungrounded direct current (dc) circuits and obtained unexpected results.

In 2009–2010, the NRC, along with EPRI, initiated the “Direct Current Electrical Shorting in Response to Exposure Fire” (DESIREEFIRE) testing program to better understand the performance of dc circuits. This testing program used small- and intermediate-scale tests to evaluate the response of dc electric cables and circuits to fire conditions. Several different circuits were tested, including dc motor starters, pilot solenoid-operated valve coils, medium-voltage circuit-breaker controls, and instrumentation circuits.

## Objective

Following the development in 2005 of circuit failure probabilities in NUREG/CR-6850, “EPRI/NRC-RES Fire PRA Methodology for Nuclear Power Facilities,” the NRC added two additional major fire testing programs regarding cable hot shorting: CAROLFIRE in 2008 and DESIREEFIRE in 2011. The objective of these Phenomena Identification and Ranking Table (PIRT) and expert elicitation programs is to improve the state of the art related to understanding and predicting hot shorting when cables are exposed to fire conditions.

## Approach

The NRC plans to convene two separate expert panels. The first will be comprised of electrical engineering experts to review all currently available testing data. This panel will follow the NRC’s PIRT process to determine the state of the art in predicting hot shorting when cables are exposed to fire conditions.

The second expert panel will be comprised of fire PRA experts to explore and advance the state of the art in determining realistic probabilities of hot shorting when cables are exposed to fire conditions.

Figure 7.15 below illustrates a typical PIRT panel discussion in progress.



Figure 7.15 A typical PIRT panel discussion

## Future Work

The determination for future cable testing will be based upon these PIRT and Expert Elicitation.

### For More Information

Contact Gabriel Taylor, RES/DRA at 301-251-7576, or [Gabriel.Taylor@nrc.gov](mailto:Gabriel.Taylor@nrc.gov)



# Beyond-Design-Basis Fires for Spent Fuel Transportation: Shipping Cask Seal Performance Testing

## Background

The NRC needs data to determine the performance of seals in spent fuel transportation packages during beyond-design-basis fires, similar to the Baltimore Tunnel Fire in 2001. The performance of the package seals is important for determining the potential release of radioactive material from a package during a beyond-design-basis accident. The seals have lower temperature limits than other package components and are a vital part of the containment barrier between the environment and the cask contents.

NUREG/CR-6886, “Spent Fuel Transportation Package Response to the Baltimore Tunnel Fire Scenario,” describes in detail an evaluation of the potential release of radioactive materials from three different spent fuel transportation packages. This evaluation used estimates of temperatures resulting from the 2001 Baltimore Tunnel Fire as boundary conditions for finite element models to determine the temperature of various components of the packages, including the seals. For two of the packages, the model-estimated temperatures of the seals exceeded their continuous-use rated service temperature, meaning the release of radioactive material could not be ruled out with available information. However, for both of those packages, the analysis determined, by a bounding calculation, that the maximum expected release would be well below the regulatory safety requirements given in 10 CFR Part 71, “Packaging and Transportation of Radioactive Material,” for a release from a spent fuel package during hypothetical accident conditions.

In 2008, a National Institute of Standards and Technology (NIST) study, “Possible Methods for Determination of the Performance of a Transportation Cask in a Beyond-Design-Basis Fire,” determined different testing approaches for evaluating package seal performance for containing Chalk River Unidentified Deposit (CRUD) released from the surface of fuel assemblies being transported.

## Objective

The objective of the package seal test is to determine its performance in beyond-design-basis fire scenarios and to provide the physical data needed to better understand the likelihood of a radioactive material release.

## Approach

The Office of Nuclear Regulatory Research (RES) has contracted with NIST to conduct small-scale thermal testing to obtain experimental data regarding the performance of seals during beyond-design-basis fires.

The experimental testing consists of a fabricated small-scale pressure vessel with an American Society of Mechanical Engineers (ASME) flange design (see Figure 7.16), using metallic seals from a selected manufacturer similar to those that might be used on an actual spent nuclear fuel transportation package. The vessel will be heated in an electrical oven to temperatures as high as 800 degrees Celsius (C), which far exceeds the rated temperature of the seals in question. NIST will measure the temperature at different points in the test sample and will also monitor the internal pressure of the vessel to determine if any leaks from the test sample occur.

## Future Work

Future Testing will be determined based upon the outcome of this test series.



**Figure 7.16** Pictures of the small-scale test vessel after 800°C exposure for 9 hours (small-scale test vessel (top left), vessel head after disassembly (top right), and vessel body and metallic seal after disassembly (bottom left and bottom right))

## For More Information

Contact Felix E. Gonzalez, RES/DRA at 301-251-7596 or [Felix.Gonzalez@nrc.gov](mailto:Felix.Gonzalez@nrc.gov)



# Training Programs for Fire Probabilistic Risk Assessment, Human Reliability Analysis, and Fire Modeling

## Background

In 1995, the NRC adopted a policy statement on probabilistic risk assessment (PRA) that was intended to increase the use of PRA technology in all regulatory matters to the extent supported by the technical merit of the PRA methods and data. In 2004, the NRC amended its fire protection requirements to allow existing reactor licensees to voluntarily adopt the risk-informed, performance-based 10 CFR 50.48(c) rule, which endorses National Fire Protection Association (NFPA) Standard 805, “Performance Based Standard for Fire Protection for Light Water Reactor Electric Generating Plants”, as an alternative to current prescriptive fire protection requirements. Approximately one-half of the current licensed nuclear power plants (NPPs) plan to make the transition to this new rule. In order to realize the full benefits of making the transition to the risk-informed, performance-based standard, plants will need to perform a fire PRA. The fire protection inspection program also uses fire PRAs to perform other regulatory activities, such as the Significance Determination Process (SDP) for inspection findings. Many NPPs use the joint Electric Power Research Institute (EPRI) and NRC document NUREG/CR-6850 (EPRI 1011989), “Fire PRA Methodology for Nuclear Power Facilities,” to create fire PRAs for at-power operations. The NRC staff uses it to support reviews of the licensee amendment request (LAR) that a licensee submits when transitioning their fire protection program to NFPA 805. As part of the pilot plants’ transition to 10 CFR 50.48(c), the NRC and EPRI have jointly produced interim solutions to fire PRA issues that have been raised concerning the implementation of NUREG/CR-6850 in NFPA 805’s frequently-asked-questions (FAQ) program.

The staff is also publishing NUREG-1921 (EPRI 1019196), “EPRI/NRC-RES Fire Human Reliability Analysis Guidelines,” which it anticipates will be used to develop human reliability analysis (HRA) components of fire PRAs. At the present time, RES, in partnership with EPRI, has drafted NUREG-1934 (EPRI 1019195), “Nuclear Power Plant Fire Model Application Guide” (NPP FIRE MAG). When the NRC issues the final report, it will provide the basis for future fire model training.

## Objective

This program supports the NRC’s policy to increase the use of PRA technology by providing training for 10 CFR 50.48(c) and

other fire protection programs in fire PRA, circuit analysis, HRA, and fire modeling.

## Approach

Since 2005, the NRC and EPRI have jointly conducted training sessions in fire PRA. These sessions, hosted in alternate years by RES and EPRI, are available at no charge to all interested stakeholders. In 2005 and 2006, 3 days of general training covered fire PRA topical areas: PRA, fire models, and fire circuit analysis. Training in 2007 was expanded to 2 weeks per year. The courses offered detailed discussions and hands-on examples for each topical area in parallel for 4 days per week. The 2008 training sessions (Figure 7.17) were video recorded and documented along with their training materials in the three-volume NUREG/CP-0194, “Methods for Applying Risk Analysis to Fire Scenarios (MARIAFIRES)” (Figure 7.18), thus enabling self-study for persons unable to attend the course. This detailed instruction continued through 2009, when it was expanded in 2010 to provide an introduction to fire HRA in NUREG-1921.

In 2009, the NRC endorsed the American Society of Mechanical Engineers/American Nuclear Society (ASME/ANS) PRA standard in Regulatory Guide (RG) 1.200, “An Approach for Determining the Technical Adequacy of Probabilistic Risk Assessment Results for Risk-Informed Activities.” Therefore, the 2010 training has also been updated to include the relationship between NUREG/CR-6850 and the fire PRA standard. In addition, the 2010 training includes HRA as a separate topical area to complement existing areas. Overall, this joint work is producing a higher level of understanding of fire PRA methods, which is expected to enhance the efficiency of NRC and industry efforts in fire PRA.



Figure 7.17 Photo from the 2008 NRC-RES/EPRI fire PRA workshop

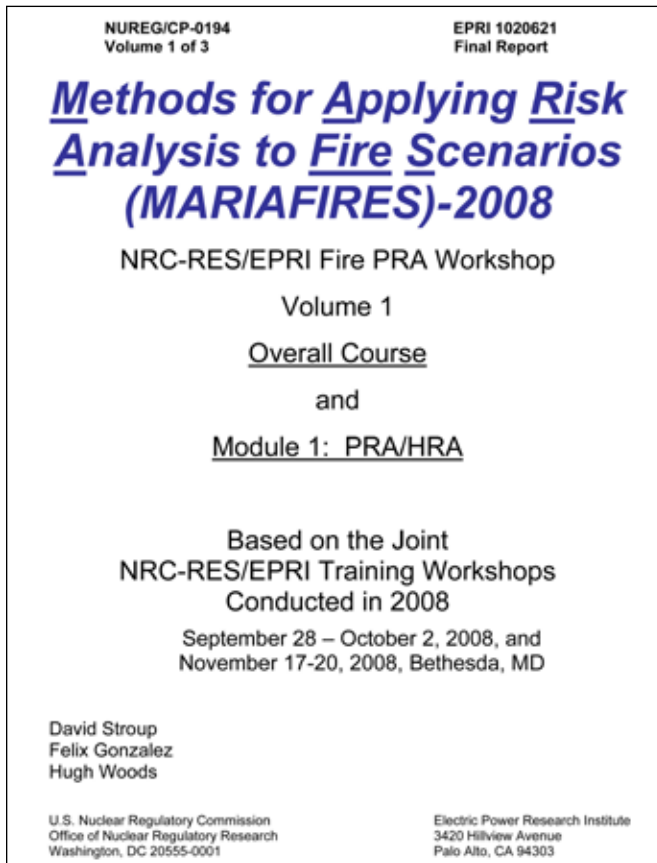

Figure 7.18 NUREG/CP-0194, Volume 1 of 3, cover page  
(Video recordings of the training sessions covered in each volume are included on a DVD in that volume)

## Future Work

The Fire PRA, HRA, and Fire Modeling Programs are scheduled to continue into the future. A MARIAFIRES-2010 is also in the planning stages. A Fire Modeling Training Program is expected to be jointly developed by NRC and EPRI after the completion of NUREG-1934, “Nuclear Power Plant Fire Modeling Application Guide (NPP FIRE-MAG)”

### For More Information

#### Contact:

Fire PRA:

J.S. Hyslop, RES/DRA at 301-251-7611 or  
JS.Hyslop@nrc.gov

Fire HRA:

Kendra Hill, RES/DRA at 301-251-3300 or  
Kendra.Hill@nrc.gov

Fire Modeling:

David Stroup, RES/DRA at 301-251-7609 or  
David.Stroup@nrc.gov

# Fire Research and Regulation Knowledge Management

## Background

The results of the Individual Plant Examination of External Events (IPEEE) program and actual fire events indicate that fire can be a significant contributor to nuclear power plant (NPP) risk, depending on design and operational conditions. During the last 30 years, the NRC has undertaken many studies to better understand fire hazards, fire events, and fire risk in NPPs. The Fire Research Branch (FRB) in the Office of Nuclear Regulatory Research (RES) initiated the Fire Research and Regulation Knowledge Base Project to assemble the collection of NRC fire-related publications issued over the past 30 years. FRB has also undertaken a similar project to document and preserve the history of the influential Browns Ferry NPP (BFN) fire of 1975, and has assembled a Short History of Fire Safety Research to document the agency's research activities.

## Objective

The objective of this research is to support the NRC's knowledge management initiative in the fire protection area by identifying relevant information to be documented.

## Approach

### NUREG/BR-0465: Fire Protection And Fire Research Knowledge Management Digest

The Fire Research and Regulation Knowledge Base is a user-friendly database that provides information needed during such activities as inspections and reviews. The database includes publicly available documents, such as 10 CFR Part 50, "Domestic Licensing of Production and Utilization Facilities"; guidelines for fire protection in NPPs; fire inspection manuals; fire inspection procedures; generic letters; bulletins; information notices; circulars; administrative letters; regulatory issue summaries; and regulatory guides. The technical knowledge includes NRC technical publications (i.e., NUREGs) that serve as background information to the regulatory documents. It includes reports of NRC-sponsored fire experiments, studies, and probabilistic risk assessments (PRAs). These documents often provide the technical bases and insights for fire protection requirements and guidelines.

### NUREG/BR-0361: The Browns Ferry Nuclear (BFN) Plant Fire of 1975 and the History of NRC Fire Regulations

In 1975, a fire occurred at BFN that challenged the operators' ability to safely shut the plant down. The fire prompted a new series of fire protection regulations and is a formative event in the history of fire protection regulations for NPPs. The brochure and DVD on the BFN plant fire of 1975 (see Figure 7.19) contain all major public documents, publications, regulations, and presentations pertaining to the BFN fire in a one-stop information resource with a user-friendly format, to provide a well-informed perspective about the BFN fire. Combined, these sources create a well-rounded picture of the event for varied types and levels of users; individually, they paint a detailed picture of specific aspects of the event.



Figure 7.19 Screenshot of "The Browns Ferry Nuclear Plant (BFN) Fire of 1975 and the History of NRC Fire Regulations" (DVD main menu)

### NUREG/BR-0364: A Short History of Fire Safety Research

The knowledge management program includes "A Short History of Fire Safety Research Sponsored by the U.S. NRC, 1975-2008," which covers its four phases:

- 1975–1987—the Fire Protection Research Program (FPRP) investigated the effectiveness of changes made to NRC's fire protection regulations after the 1975 Browns Ferry NPP fire
- 1987–1993—early fire PRAs were conducted (e.g., the LaSalle Risk Methods Integration and Evaluation Program (RMIEP))
- 1993–1998—incremental improvements were made to the RMIEP methods
- 1998–present—methods were developed to better apply the Commission's PRA technology policy to fire risk technology (to be used where practical in all regulatory matters).

---

## Future Work

An update to NUREG/BR-0361, “The Browns Ferry Nuclear (BFN) Plant Fire of 1975 and the History of NRC Fire Regulations”, and NUREG/BR-0465, “Fire Protection and Fire Research Knowledge Management Digest,” are in the planning stages.

### **For More Information**

Contact Hugh (“Roy”) Woods, RES/DRA at 301-251-7577 or [Hugh.Woods@nrc.gov](mailto:Hugh.Woods@nrc.gov)

David Stroup, RES/DRA at 301-251-7609 or [David.Stroup@nrc.gov](mailto:David.Stroup@nrc.gov)

Felix Gonzalez, RES/DRA at 301-251-7596 or [Felix.Gonzalez@nrc.gov](mailto:Felix.Gonzalez@nrc.gov)





# Chapter 8: Seismic and Structural Research

Advances in Seismic Hazard Assessment for the  
Central and Eastern United States

Tsunami Research Program

Seismic Isolation Technology Regulatory Research

Risk-Informed Assessment of Containment  
Degradation

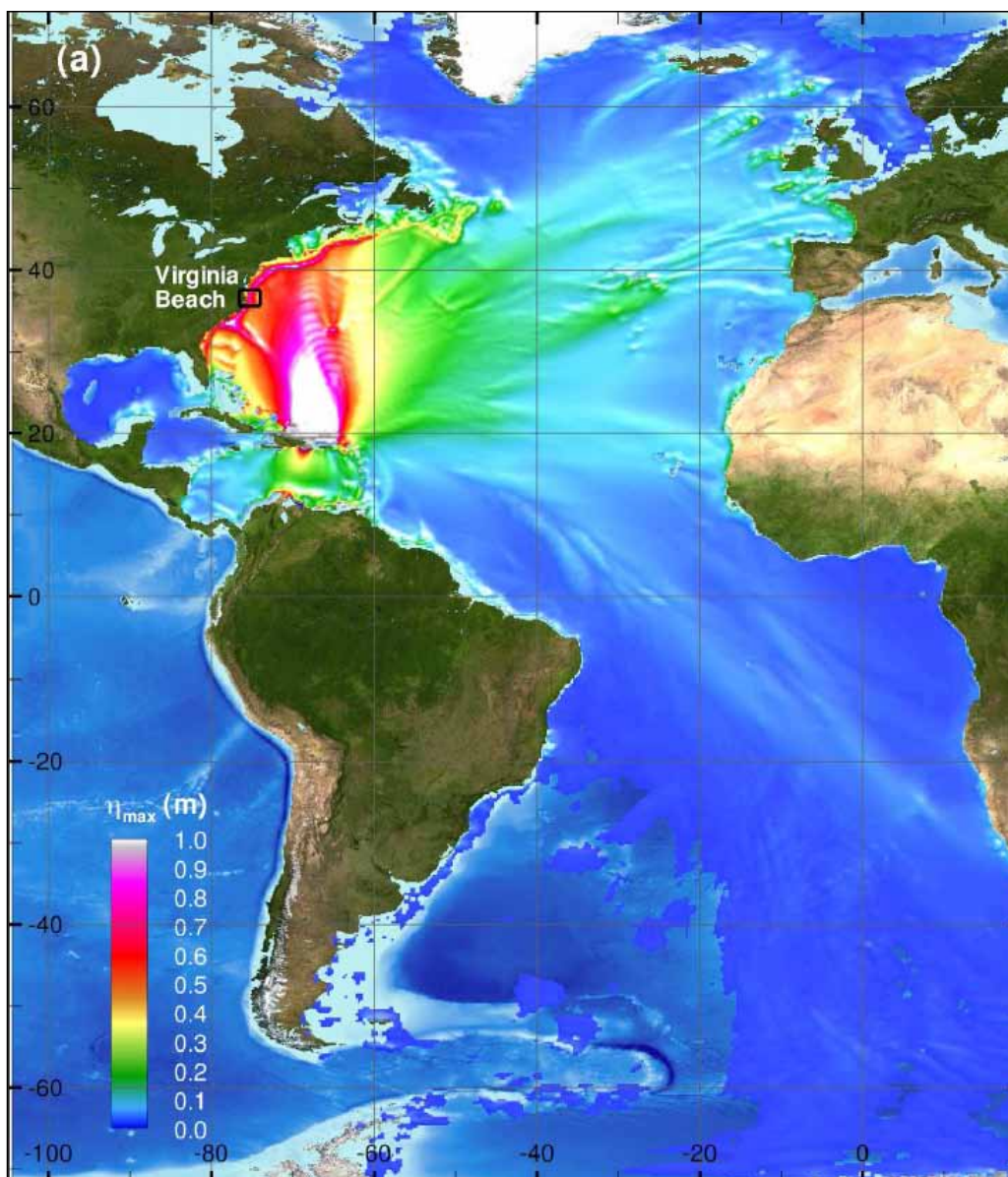

Computed maximum tsunami wave amplitude in the Atlantic Basin generated by a Mw 8.8 earthquake in the Caribbean source zone

# Advances in Seismic Hazard Assessment for the Central and Eastern United States

## Background

Seismic safety in the design and operation of nuclear facilities has been evolving since the development of the first rules and guidance for seismic design by the Atomic Energy Commission. In 1998, the U.S. Nuclear Regulatory Commission (NRC) issued a policy decision to move towards a risk-informed and performance-based regulatory framework. Risk-informed frameworks use probabilistic methods to assess not only what can go wrong, but also how likely it is to go wrong. Over the last decades, significant advances have been made in the ability to assess seismic hazard. The NRC is currently sponsoring several projects in support of both an updated assessment of seismic hazard in the Central and Eastern United States (CEUS) and an enhancement of the overall framework under which the hazard characterizations are developed. Figure 8.1 outlines three of the projects supporting the assessment of seismic hazard. The products of these projects will be used in the determination of seismic hazard design levels.

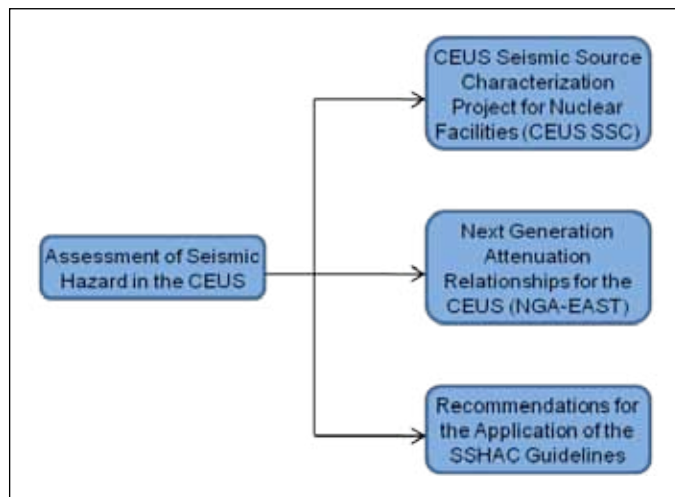

Figure 8.1 Current projects supporting seismic hazard assessment

## Research Projects

### The Ceus Seismic Source Characterization for Nuclear Facilities

The objective of the CEUS seismic source characterization (SSC) project is to develop an up-to-date seismic source characterization for the CEUS (see Figure 8.2) that includes (1) full assessment and incorporation of uncertainties, (2) a range of diverse technical interpretations from the informed scientific community, (3) an up-to-date earthquake database,

(4) proper and appropriate documentation, and (5) a peer review. Accordingly, the project is being conducted using a process described as a Level 3 project in the Senior Seismic Hazard Analysis Committee (SSHAC) guidance (NUREG/CR-6372, “Senior Seismic Hazard Analysis Committee (SSHAC) Recommendations for Probabilistic Seismic Hazard Analysis: Guidance on Uncertainty and Use of Experts”). The NRC, along with the U.S. Department of Energy (DOE), and the Electric Power Research Institute (EPRI), cooperatively sponsor this project, which is scheduled to be completed in 2010.

### Next Generation Attenuation Relationship Development for the CEUS

A probabilistic seismic hazard analysis (PSHA) requires the prediction of ground motions for an earthquake with a given magnitude and distance. This research program will develop new state-of-the-art ground motion prediction equations for the CEUS by following up on the successful multiinvestigator project, known as the Next Generation Attenuation (NGA) Relationship project, which focused on the western United States and which the Pacific Earthquake Engineering Research (PEER) Center coordinated. The NRC, DOE, EPRI, and the U.S. Geological Survey (USGS) have cooperatively undertaken this project, which is expected to end in 2014.

### Practical Procedures for Implementing the SSHAC Guidelines and Updating Existing PSHAS

In an effort to standardize PSHAs, the NRC sponsored the development of NUREG/CR-6372. While the SSHAC guidelines provide a robust framework for undertaking PSHAs of different levels of complexity, they do not provide detailed guidance on how to implement PSHAs within the framework. This project will result in a NUREG-series report to complement the SSHAC guidelines by providing practical guidelines for implementing the SSHAC framework, by capturing lessons learned during recent SSHAC Level 3 and 4 projects, and by providing practical guidelines for updating SSHAC-based PSHAs when new information becomes available. This project is scheduled to be completed in early 2011.

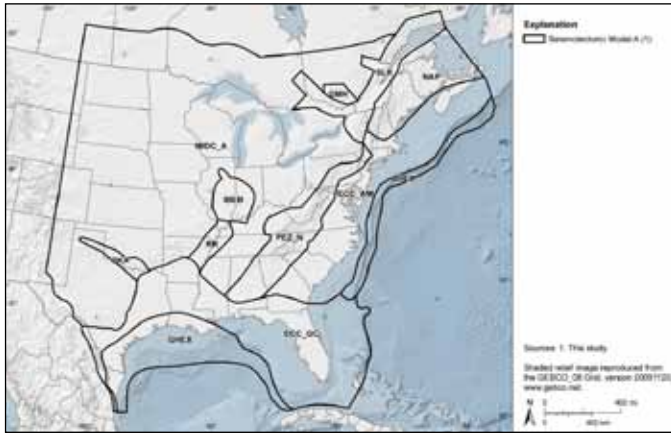

Figure 8.2 Example source zones from the CEUS SSC for nuclear facilities project

**For More Information**

Contact Annie Kammerer, RES/DE at 301-251-7695 or [Annie.Kammerer@nrc.gov](mailto:Annie.Kammerer@nrc.gov)

# Tsunami Research Program

## Background

Since the 2004 Indian Ocean tsunami, significant advances have been made in the ability to assess tsunami hazard globally. The Nuclear Regulatory Commission's (NRC's) current tsunami research program was initiated in 2006 and focuses on bringing the latest technical advances to the regulatory process and exploring topics unique to nuclear facilities. The tsunami research program focuses on several key areas: landslide-induced tsunami hazard assessments, support activities associated with the licensing of new nuclear power plants in the United States, development of probabilistic methods, and development of the technical basis for new NRC guidance.

This program, which includes cooperative work with the United States Geological Survey (USGS) and the National Oceanic and Atmospheric Administration (NOAA), has already resulted in several important publications on tsunami hazard assessments on the Atlantic Coast of the United States.

## Approach

### Tsunamigenic Source Characterization

The NRC tsunami research program includes assessment of both seismic- and landslide-based tsunamigenic sources in both the near and the far fields. The inclusion of tsunamigenic landslides, an important category of sources that impact tsunami hazard levels for the Atlantic and Gulf Coasts, is a key difference between this program and most previous tsunami hazard assessment programs. The USGS conducted the initial phase of work related to source characterization, which consisted of collection, interpretation, and analysis of available offshore data, with significant effort focused on characterizing offshore near-field landslides and analyzing their tsunamigenic potential and properties. A publicly-available USGS report to the NRC, titled "Evaluation of Tsunami Sources with the Potential to Impact the U.S. Atlantic and Gulf Coasts," ten Brink et al., 2008 (ADAMS Accession No. ML082960196), which is currently being used by both NRC staff and industry, summarizes this work. In addition, eight papers have been published in a special edition of *Marine Geology* dedicated to the results of the NRC research program ("Tsunami Hazard along the U.S. Atlantic Coast," *Marine Geology*, Volume 264, Issues 1–2, 2009). In the current phase of research, additional field investigations are being conducted in key locations of interest and additional analysis of the data is being undertaken.

### Tsunami Generation and Propagation Modeling

The USGS database is now used both for reviews of individual plant applications and as input for tsunami generation and

propagation modeling being conducted by the experts at USGS and Texas A&M University. The goal of this modeling is to better understand the possible impacts that the identified sources could have on the coasts.

To undertake modeling of the impact of a flank failure landslide of the La Palma volcano in the Canary Islands, NOAA's Method of Splitting Tsunami (MOST) tsunami generation and propagation model has been coupled with the impact Simplified Arbitrary Lagrangean Eulerian (iSALE) code, which can be used for modeling landslide-based tsunamigenic mechanisms. MOST is also being used to investigate the impact of the seismic tsunamigenic sources identified and characterized by the USGS (see Figure 8.3).

The final phases of the program will also explore acceptable probabilistic tsunami hazard assessment methods.

### New Regulatory Guidance

Regulatory Guide 1.59, "Design Basis Floods for Nuclear Power Plants," issued in 1977, briefly discussed tsunami as a source of flooding. The NRC is currently updating this regulatory guide. However, the update of this guide will not include tsunami-induced flooding. The NRC staff is currently preparing a new regulatory guide focused on tsunami hazard assessment and risk. The staff also contributed to tsunami information in draft International Atomic Energy Agency (IAEA) Safety Standard DS-417, "Meteorological and Hydrological Hazards in Site Evaluation for Nuclear Installations."

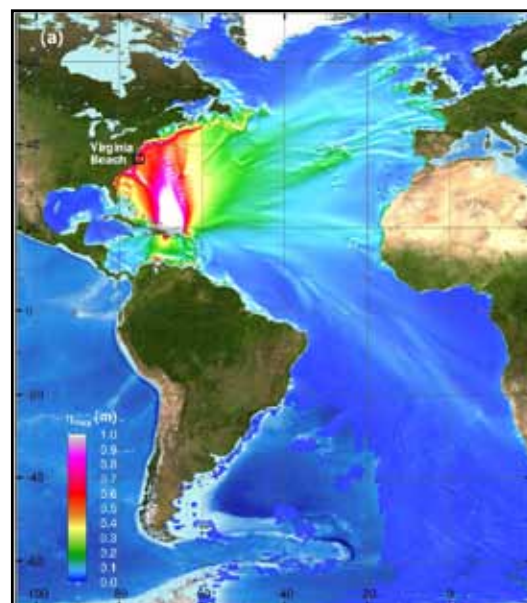

Figure 8.3 Computed maximum tsunami wave amplitude in the Atlantic Basin generated by a  $M_w$  8.8 scenario earthquake in the Caribbean source zone

### For More Information

Contact Annie Kammerer, RES/DE at 301-251-7695 or [Annie.Kammerer@nrc.gov](mailto:Annie.Kammerer@nrc.gov)



# Seismic Isolation Technology Regulatory Research

## Background

Seismic isolation technologies (also called base isolation technologies) are components and systems that isolate a structure from the motion of the ground during an earthquake. Modern seismic isolation devices and components were principally developed in the 1970s and 1980s, and thousands of conventional buildings, industrial structures, and bridges have been seismically isolated in the United States and abroad (see examples in Figure 8.4). Seismic isolation has been used to design and construct nuclear facility structures in France and South Africa. The renaissance of nuclear energy is leading to an exploration of the use of seismic isolation technologies in U.S. nuclear facilities. Several new advanced reactor designs are expected to include seismic isolation systems. To prepare for the possible use of these technologies in nuclear plant design, the NRC has initiated a program to identify and investigate these technical areas.

## Approach

### Development of NUREG/CR on the Use of Seismic Isolation Systems in Nuclear Power Plants

The NRC, working with Lawrence Berkeley National Laboratory, is addressing a range of technical considerations for analysis and design of safety-related nuclear facility structures using seismic isolation. An associated NUREG/CR under development is intended to serve as a reference for engineers engaged in the design of structures using seismic isolation systems, as well as NRC staff charged with reviewing applications utilizing these technologies. Typically, the seismic isolation components are treated as a civil or structural subsystem of a nuclear power plant whose risk-informed design is governed by specific performance objectives. The treatment of seismic isolation in existing building codes and regulations is being explored as a starting point. The NUREG/CR will discuss the behavior, mechanical properties, modeling, structural response analysis, and design issues for seismic isolation design using the most commonly used seismic isolation devices.

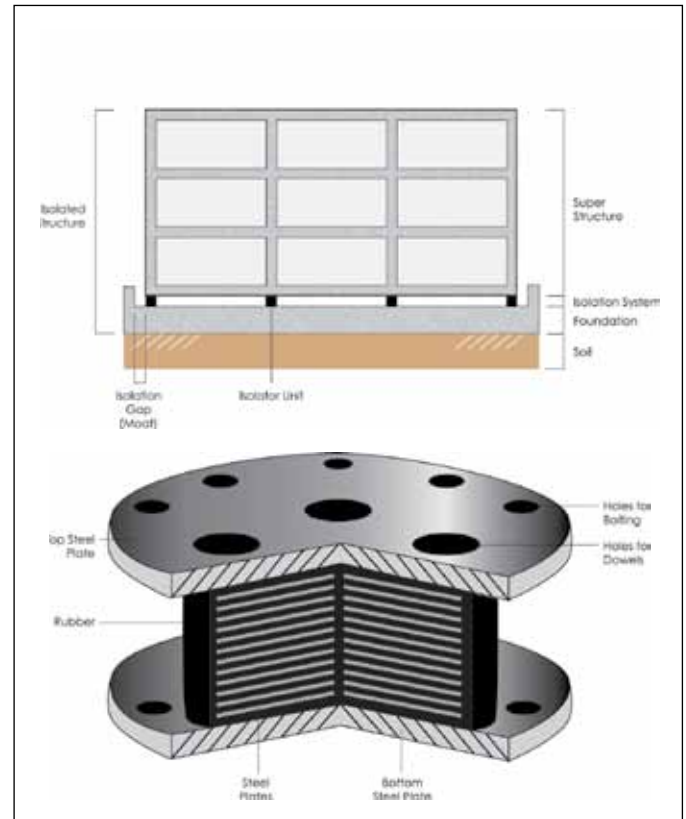

Figure 8.4 Schematic figures showing typical design of a seismically isolated structural system (above) and a typical rubber-bearing style isolator (below)

### Upcoming Investigation of Nuclear-Plant-Specific Issues

Further research is required in a number of technical areas. Some of these issues, such as the response to vertical excitation and soil-structure interaction, are already considered for non-isolated nuclear power plant designs such that current guidance could be applicable. Other issues, such as an evaluation of the consequences of impact of the structure against sidewalls during horizontal motion or impact from isolator uplift are new issues for the NRC. An important conclusion from the ongoing work is that base isolation is a viable technology for use in nuclear power plants. Additional research to investigate these critical areas will soon begin to identify acceptable means and methods of analysis and to establish a regulatory basis for review.

### Additional Plant Specific Issues

Additional topics of interest include the following:

- evaluation of isolator displacement capacity and beyond-design-basis events
- evaluation of the effect of differences among the mechanical properties of base isolation devices
- evaluation of the likelihood and possible consequences of rocking of the isolated superstructure on the base isolation devices;



- 
- investigation of the beyond-design-basis aircraft impact load on the base isolation devices
  - development, verification and validation of computer simulation models of base isolation devices under multidirectional excitation;
  - aging and testing of the base isolation devices
  - investigation of the interaction between the base isolation layer, the foundation, and any underlying soil

**For More Information**

Contact Annie Kammerer, RES/DE at 301-251-7695 or [Annie.Kammerer@nrc.gov](mailto:Annie.Kammerer@nrc.gov)

# Risk-Informed Assessment of Containment Degradation

## Background

Over time, degradation has been observed in the containment vessels of a number of operating nuclear power plants in the United States. Forms of degradation include corrosion of the steel shell or liner, corrosion of reinforcing bars, loss of prestressing, and corrosion of bellows. The containment vessel serves as the ultimate barrier against the release of radioactive material into the environment. Because of this role, compromising the containment could increase the risk of a large release in the unlikely event of an accident. Previous work in this area assessed the effects of degradation on the pressure-retaining capacity of the containment vessel through structural analyses that account for degradation. These analyses provided useful information about the effects of the degradation on the structural capacity of the containment in both deterministic and probabilistic fashions. However, additional studies are still required to identify adequate metrics and related methods that can be used to examine the effects of degradation in specific cases.

## Approach

The NRC is sponsoring research at Sandia National Laboratories (SNL) to assess the effects of containment vessel degradation in containment vessels in a risk-informed manner. Goals for the research include supporting license renewal reviews and inspections by providing methods to examine, on a case-by-case basis, potential degradation effects from aging and repairs. Initially, the study evaluated the effects of degradation on several types of containments with respect to the guidelines given in Regulatory Guide 1.174, “An Approach for Using Probabilistic Risk Assessment in Risk-Informed Decisions on Plant-Specific Changes to the Licensing Basis.” The study integrated fragility curves developed for nondegraded and postulated degraded conditions using structural analysis with preexisting probabilistic risk assessment models used in NUREG-1150, “Severe Accident Risks: An Assessment for Five U.S. Nuclear Power Plants.” That phase of the study concluded that several cases of postulated degradation involving corrosion of the liner (see Figure 8.5) or shell showed small increases, no increases, or even decreases in the large early release frequency (LERF). Rather than leading to a containment rupture, the postulated liner degradation causes the containment to fail by leakage, with an increase in small early release frequency (SERF).

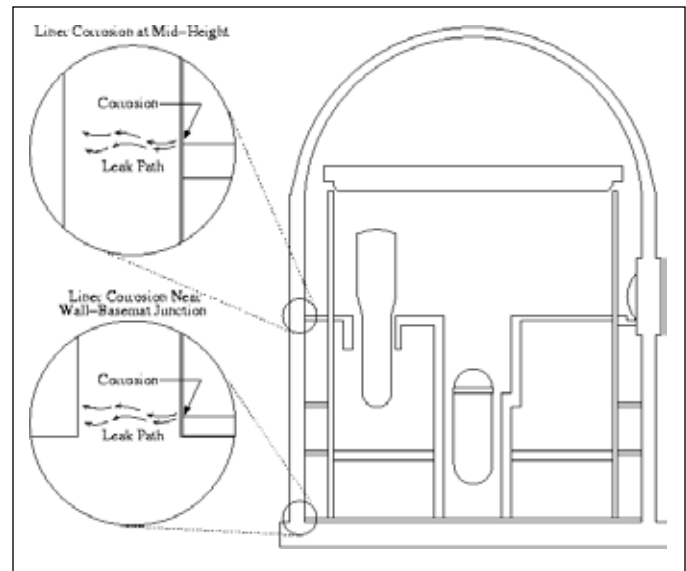

**Figure 8.5** Example of reinforced concrete containment leak paths for postulated corrosion degradation (NUREG/CR-6920)

Since Regulatory Guide 1.174 does not provide guidance on the limits of SERF, additional deterministic analyses were performed to assess the effects of degradation on consequences to evaluate the feasibility of using metrics other than LERF. The study is continuing to assess the extent of corrosion, other containment types, and other degradation modes. Because most U.S. power plants have unique designs, a research goal is to develop results, approaches, and metrics that can be used for case-by-case examination of degradation effects.

## For More Information

Contact Dr. Jose Pires, RES/DE at 301-251-7696 or [Jose.Pires@nrc.gov](mailto:Jose.Pires@nrc.gov)



---

# Chapter 9: Materials Performance Research

Extremely Low Probability of Rupture

Research To Support Regulatory Decisions Related to Second and Subsequent License

Renewal Applications

Steam Generator Tube Integrity

Consequential Steam Generator Tube Rupture Program

Reactor Pressure Vessel Integrity

Environmentally Assisted Fatigue of Components Exposed to the Reactor Water Environment

Degradation of Reactor Vessel Internals from Neutron Irradiation

Primary Water Stress-Corrosion Cracking

Primary Water Stress-Corrosion Cracking Mitigation Evaluations and Weld Residual Stress Validation Programs

Nondestructive Examination

International Nondestructive Examination Round Robin Testing

Containment Liner Corrosion

Atmospheric Stress-Corrosion Cracking of Dry Cask Storage Systems

High-Density Polyethylene Piping Research Program

Neutron Absorbers in Spent Fuel Pools

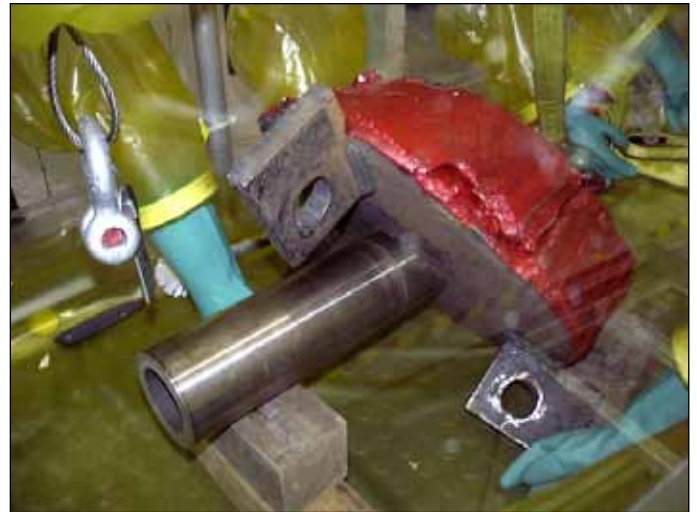

Nondestructive and destructive examination of salvaged control rod drive mechanism penetrations and J-groove welds from North Anna, Unit 2

# Extremely Low Probability of Rupture

## Background

The staff of the U.S. Nuclear Regulatory Commission (NRC) describes in Standard Review Plan (SRP) Section 3.6.3, “Leak-Before-Break (LBB) Evaluation Procedures,” acceptable analysis and assessment methodologies. Specifically, the SRP outlines a deterministic assessment procedure that can be used to demonstrate compliance with the requirement of General Design Criterion (GDC) 4, “Environmental and Dynamic Effects Design Bases,” in Appendix A, “General Design Criteria for Nuclear Power Plants,” to Title 10 of the *Code of Federal Regulations* (10 CFR) Part 50, “Domestic Licensing of Production and Utilization Facilities,” for primary system pressure piping to exhibit an extremely low probability of rupture. SRP Section 3.6.3 does not allow for assessment of piping systems with active degradation mechanisms. However, it is known that primary water stress-corrosion cracking (PWSCC) is occurring in systems that have been granted LBB exemptions to remove pipe-whip restraints and jet impingement shields.

To address this issue, the NRC has determined through a qualitative approach that these LBB-approved systems remain in compliance (see NRC Regulatory Issue Summary 10-07, “Regulatory Requirements for Application of Weld Overlays and Other Migration techniques in Piping Systems Approved for Leak-Before-Break,” dated June 8, 2010). This approach includes the following:

- As a qualitative rationale, the great majority of observed cracking is of limited extent and of shallow depth. These factors tend to mitigate the risk of piping rupture.
- PWSCC mitigation activities have been implemented (e.g., stress improvement and material replacement with overlays, mechanical stress improvement, inlays, onlays).

While such actions are prudent, timely, and warranted, they fail to resolve the clear deficiencies in the SRP Section 3.6.3 assessment paradigm, revealing continued need for a new and comprehensive piping system assessment methodology. To address this need, a program has been proposed with the long-term goal of developing an assessment tool that can be used to directly assess compliance with the probabilistic acceptance criterion of GDC 4. This tool would properly model the effects of active degradation mechanisms, inservice inspection protocols, and associated mitigation activities. The probabilistic tool will be comprehensive with respect to known challenges, vetted with respect to the scientific adequacy of models and inputs, flexible enough to permit analysis of a variety of inservice situations, and sufficiently adaptable to accommodate evolving and improving knowledge and additional degradation modes.

## Approach

As part of the effort for quantitatively ensuring the long-term extremely low probability of rupture, in accordance with GDC 4, the Office of Nuclear Regulatory Research (RES) is embarking on an effort to develop a modular-based computer code for the determination of the probability of failure for reactor coolant system (RCS) components. In doing so, RES has sought the support of national laboratories and commercial contractors and communicates with the domestic nuclear industry under the auspice of the Electric Power Research Institute (EPRI). This computer code will be capable of considering all degradation mechanisms that may contribute to low probability failure events while properly handling the uncertainty in the failure process. The code will be structured in a modular fashion so that, as additional operational experiences arise, additions or modifications can be easily incorporated without code restructuring. The first arm of the modular code to be developed deals directly with primary piping integrity and is coined xLPR for “extremely low probability of rupture.”

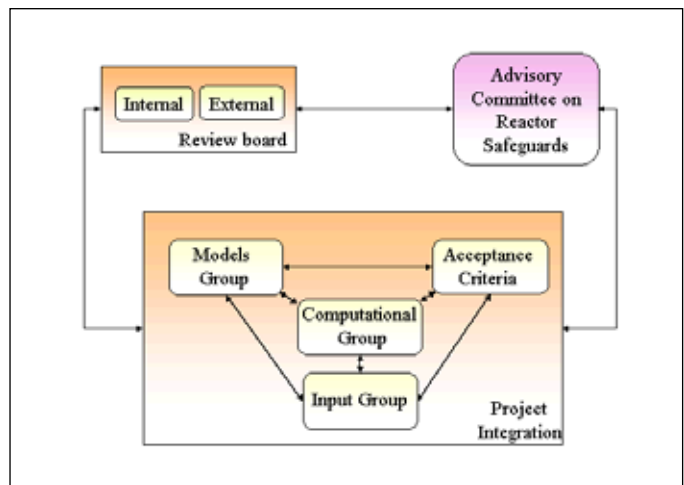
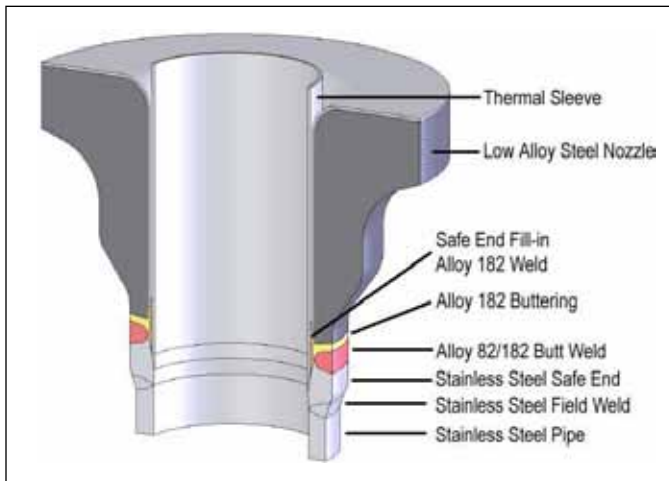

Figure 9.1 xLPR organizational development structure

As part of the ongoing 2-year pilot study effort, RES developed a group of teams as shown in Figure 9.1, each with specific long-term and short-term technical objectives. These teams will develop the quantification of extremely low probability of rupture. As part of the pilot study, the team effort will be focused on a particular problem. (i.e., the failure of a pressurizer surge nozzle dissimilar metal weld as seen in Figure 9.2 with a circumferential crack.)





**Figure 9.2 Pressurizer surge nozzle illustration**

As the pilot study draws to a close, an initial version of the xLPR code (Version 1.0) is complete and will be used to demonstrate the feasibility of conducting these calculations using a fully verified, vetted, document controlled code. The pilot study outcome will be a demonstration of the feasibility of this process, both computationally and organizationally, to develop a complex fracture mechanics based code to calculate the probability of rupture for primary piping systems. In addition, an understanding of the limitations associated with these codes, and a firm basis for developing a more robust modular-type code will be developed. In the long term, focus shifts to the more generic problems associated with RCS integrity. The long-term outcome will be a modular computer code based with verified and validated methodologies for predicting low probability of failure events.

## Schedule

The planned schedule for the xLPR program is as follows:

xLPR pilot study complete – December 2010

xLPR modular code – 1<sup>st</sup> Quarter 2013

Long Term – Generic modular code – 1<sup>st</sup> Quarter 2015

### For More Information

Contact David L. Rudland, RES/DE at 301-251-7622 or [David.Rudland@nrc.gov](mailto:David.Rudland@nrc.gov)

# Research to Support Regulatory Decisions Related to Second and Subsequent License Renewal Applications

## Background

Materials degradation phenomena, if not appropriately managed, have the potential to adversely impact the functionality and safety margins of nuclear power plant (NPP) systems, structures, and components (SSCs), especially as they continue to operate for longer periods. The Office of Nuclear Regulatory Research (RES) has initiated a multiyear research program to develop an improved understanding of materials degradation failure mechanisms to better predict potential impacts on the long-term operability of NPP SSCs, to provide necessary technical data to support regulatory decisions, and to inform the development of aging management programs (AMPs) to ensure continued safe plant operation.

operating period. The agency permits requests for a subsequent license renewal under Title 10 of the *Code of Federal Regulations* (10 CFR) Part 54, “Requirements for Renewal of Operating Licenses for Nuclear Power Plants.” However, potential technical challenges from aging effects on passive SSCs may need to be resolved before the licensee enters into an operating period beyond 60 years, including aging effects on the reactor pressure vessel (RPV), the RPV internals, primary piping, safety-related secondary piping, buried and submerged structures, electric cable insulation, and concrete exposed to high temperature and radiation.

To ensure that the NRC is prepared for a timely review of possible LRAs for a subsequent renewal, research to support the agency’s regulatory decisionmaking on such LRAs is needed to ensure the availability of the necessary technical information.

## Objective

The objective of this research is to provide a sound technical basis to support timely reviews of potential subsequent LRAs.

## Approach

The NRC and industry have already expended considerable resources over the last several decades to better understand the safety implications and risk associated with aging of SSCs. Key activities have included an assessment of the technical basis for an alternate pressurized thermal shock (PTS) rule (10 CFR 50.61a, “Alternate Fracture Toughness Requirements for Protection against Pressurized Thermal Shock Events”), aging of electrical cables, and environmentally assisted cracking (EAC) of materials. Further, in February 2008, the NRC and the U.S. Department of Energy (DOE) cosponsored a “Workshop on U.S. Nuclear Power Plant Life Extension Research and Development,” which requested stakeholder input into aging management research areas for “Life Beyond 60.” (A summary of the workshop proceedings is provided in the Agencywide Documents Access and Management System (ADAMS) at Accession No. ML080570419.) Based on the results of this workshop, and the staff’s long-term research plan, potential additional areas of focus for a subsequent license renewal include aging management of reactor vessel and internal materials, cable insulation, buried and submerged structures, and concrete exposed to high temperature and radiation.

The NRC staff is presently expanding the original NUREG/CR-6923, “Expert Panel Report on Proactive Materials Degradation Assessment,” issued February 2007, to include longer timeframes (i.e., 80 or more years) and passive long-lived SSCs beyond the primary piping and core internals, such as the concrete containment building and cable insulation. This will allow the staff to (1) identify significant knowledge gaps

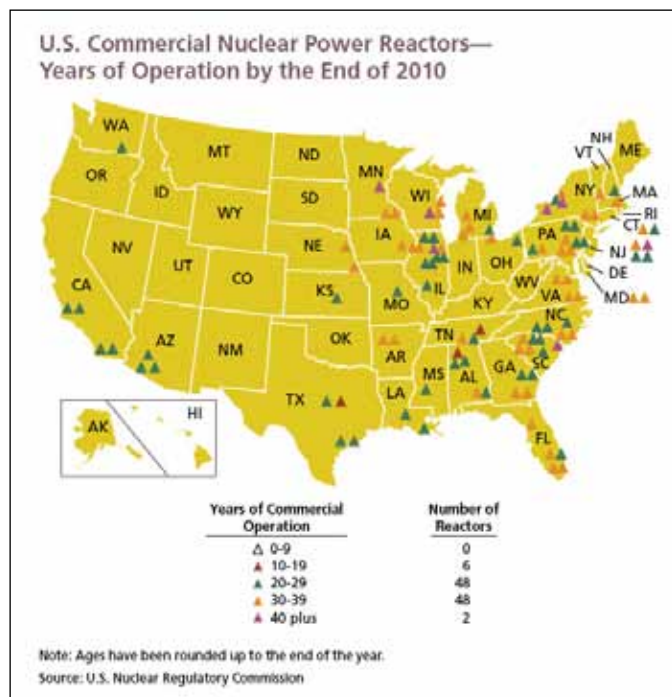

Figure 9.3 Years of commercial operation (2010)

As shown in Figure 9.3, several NPPs have entered into the first period of extended operation, and to date over half (59) have been granted an initial license extension of 40–60 years.

The U.S. commercial nuclear power industry has publicly informed the NRC staff of its intentions to submit, in the 2015–2019 timeframe, license renewal applications (LRAs) for a subsequent license renewal, which will cover a potential 80-year

---

and any new forms of degradation that may have arisen since the original proactive materials degradation assessment report was developed; (2) capture the current knowledge base on materials degradation mechanisms; and, (3) prioritize materials degradation research needs and directions for future efforts. This effort is being accomplished through a collaborative effort with a complementary DOE program—the LWR Sustainability (LWRS) program.

In recent years, there have been a variety of related research initiatives, such as the creation of the Materials Aging Institute by the Electric Power Research Institute (EPRI), Électricité de France (EDF), Tokyo Electric Power Company (TEPCO), and others, as well as the development of networks and technical meetings focused on some elements of proactive management of materials degradation (PMMD). However, no forum currently exists to bring together these diverse activities and provide coordinated information exchange and prioritization of PMMD topics. The NRC is working with other national regulators and nongovernmental organizations (NGOs) to implement an International Forum for Reactor Aging Management (IFRAM) that would create a network of international experts who would exchange information on operating experience, best practices, and emerging knowledge. These experts would work jointly to leverage the separate efforts of existing national programs into a coordinated research activity. This coordination enables a pooling of technical expertise and avoids unnecessary redundant efforts. The participants would share responsibility, accountability, resources, and rewards from this coordinated activity.

The staff will also be holding recurrent NRC/industry workshops on the status of operating experience from the initial renewal term and industry research activities to address aging management of technical issues for a subsequent license renewal term. This is a followup to the initial February 2008 workshop; the next workshop is planned for the first quarter of 2011.

In a related activity, RES is initiating an effort to collect the results from implementation of AMPs committed to by licensees for the initial license renewal period, along with any information from other licensee activities that will provide greater insights to materials aging phenomena in the renewed license operating period. This information and improved understanding will be used to identify any need for enhancements to AMPs for plant operation out to 80 years.

**For More Information**

Contact C.E. (“Gene”) Carpenter, Jr., RES/DE at 301-251-7632 or [Gene.Carpenter@nrc.gov](mailto:Gene.Carpenter@nrc.gov)

# Steam Generator Tube Integrity

## Background

Steam generator (SG) tubes (see Figure 9.4) are an integral part of the reactor coolant system (RCS) pressure boundary. They serve as a barrier to isolate the radiological fission products in the primary coolant from the secondary coolant and the environment. The understanding of SG tube degradation phenomena is continually evolving to keep pace with advances in SG designs and materials. To date, many modes of degradation have been observed in SG tubes, including bulk corrosion and wastage, crevice corrosion, pitting, denting, stress-corrosion cracking, and intergranular corrosion attack. Flaws have developed on both the primary and the secondary side of SG tubes. If such flaws go undetected or unmitigated, they can lead to tube rupture and possible radiological release to the environment.



Figure 9.4 Recirculating steam generator tube bundle

## Overview

The main objective of this research program is to develop a technical basis for SG tube integrity evaluations. This basis is needed to ensure that SG tubes continue to be inspected appropriately, flaw evaluations continue to be conducted correctly, and repair or plugging criteria are implemented appropriately. To aid in regulatory decisions and to assess code applications, as depicted in Figure 9.5, this research program addresses the following areas:

- assessment of inspection reliability
- evaluation of inservice inspection technology
- evaluation and experimental validation of tube integrity and integrity prediction modeling
- evaluation and experimental validation of degradation modes

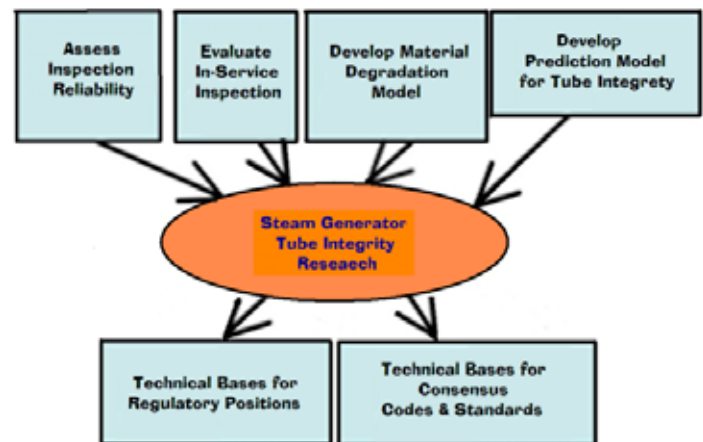

Figure 9.5 Tube integrity research schematic

## Approach

The research is intended to formulate and document a comprehensive technical basis that will contribute directly to the safety, openness, and effectiveness of the NRC's regulatory actions related to SGs. The key elements of the program are best described by technical area

### Assessing Inspection Reliability

In this area, research aims to assess the reliability of current inspection methods based on the flaws observed in the field and to evaluate any new and emerging inspection methods as they arise. For example, one task in this area involves assessing the capabilities and limitations of automated eddy current analysis. The task will utilize the Argonne National Laboratory SG tube flaw mockup facility, which contains a variety of flaws typically found in the field. Results of automated eddy current analysis will be compared to a previous eddy current round robin test,

---

which studied the reliability of human analysts. In this way, the staff can assess the reliability of automated eddy current analysis techniques.

### **Inservice Inspection Technology**

Advanced nondestructive examination (NDE) techniques are used to evaluate SG tube integrity. During inservice inspections, NDE is used to detect and characterize tube flaws. Research in this area aims to evaluate the reliability of NDE techniques for both original and repaired SG tubes. For eddy current inspection, this research will evaluate correlations of signal voltage to flaw morphology and structural integrity. A technical report on this research will present an evaluation of the differences and limitations between various eddy current methods including bobbin coil, rotating pancake, and xprobe.

### **Research on Tube Integrity And Performance Modeling**

When a flaw is detected in an SG tube, its potential for leaking or bursting must be assessed. Tube integrity is assessed using models that predict leak rates and burst pressures that a particular flaw might exhibit during normal operation or design-basis accidents. While models exist to predict flaw behavior, they require that complex flaw morphology be simplified. One means of simplifying a complex crack is to use a rectangular crack profile. Ongoing research will continue to assess the use of the rectangular crack method for estimating failure pressure and leak rate for complex crack geometries.

Research will also continue to examine the leak rate from postulated tube flaws in the region of the tubesheet under postulated severe accident conditions. Experimental tests will be conducted to calibrate and validate the leak models.

Another ongoing study examines the consequences of exposing RCS materials to high temperatures during severe accident scenarios. Such accidents may challenge the integrity of SG tubes, so analyses are being conducted to determine whether certain RCS components may fail before SG tubes. Such a scenario would be preferable to an initial release through SG tubes, because RCS leaks would leak into containment, while SG tube leaks could lead to a radiation release to the outside environment.

### **Research On Degradation Modes**

Analytical models exist to predict potential degradation behavior in SG tubes during normal operating conditions. Research in this area seeks to evaluate and experimentally validate those models. This will require a better understanding of crevice conditions and stress-corrosion crack initiation, evolution, and growth. The NRC has already conducted considerable research

in these areas, which has established a better understanding of the nature of crevice behavior. A NUREG report will describe the research in this area.

### **International Cooperation**

The NRC is currently administering the fourth, 5-year term of the International Steam Generator Tube Integrity Program (ISG-TIP-4). In this program, regulators and researchers from member countries conduct and share research on tube integrity and inspection technologies. Current participants include organizations from Canada, France, Japan, Korea, and the United States.

### **For More Information**

Contact Charles Harris, RES/DE at 301-251-7637 or [Charles.Harris@nrc.gov](mailto:Charles.Harris@nrc.gov)



---

# Consequential Steam Generator Tube Rupture Program

## Background

The NRC and the nuclear power industry have expended considerable resources over the last two decades to better understand the safety implications and risk associated with consequential steam generator tube rupture (C-SGTR) events (i.e., events in which steam generator (SG) tubes leak or fail as a consequence of the high differential pressures or SG tube temperatures, or both, predicted to occur in certain accident sequences). Key activities included an assessment of temperature-induced creep-rupture of the reactor coolant system (RCS) components in the NUREG-1150 study entitled, “Severe Accident Risks: An Assessment for Five U.S. Nuclear Power Plants, issued December 1990; a representative analysis of the potential for induced containment bypass by an ad hoc NRC staff working group in NUREG-1570, “Risk Assessment of Severe Accident-Induced Steam Generator Tube Rupture” issued 1998, and recent thermal-hydraulic (T/H) analyses and risk analyses as part of the steam generator action plan (SGAP). Severe accident analyses performed as part of the state-of-the-art reactor consequence analyses (SOARCA) project provide additional insights into the likelihood and impact of subsequent failure of the reactor hot leg shortly following a C-SGTR event.

Prior investigations of a Westinghouse plant concluded that the contribution of C-SGTR events to the overall containment bypass frequency is at best at the same order of magnitude, if not lower than, the containment bypass fraction associated with other internal events for most pressurized-water reactors (PWRs). Thus, plant risk assessments should consider and monitor the risk associated with C-SGTR in a manner commensurate with its expected importance at each plant. Although important conclusions were made, these investigations identified certain limitations of scope, as well as a lack of thorough RCS component modeling with advanced simulation tools. It is important to address these limitations to advance our understanding of associated risks and to develop an enhanced risk assessment tool for C-SGTR events.

## Objectives

To close the technical gaps and to develop an enhanced risk assessment procedure for C-SGTR, the current RES program will attempt to fulfill the following objectives:

- Update computational fluid dynamics (CFD) and system code models for Combustion Engineering (CE) plants.

- Evaluate the impact of in-core instrument tube failures on natural circulation.
- Update SG flow distributions.
- Complete structural analyses of CE and Westinghouse RCS components.
- Develop a user-friendly methodology for assessing the risk associated with consequential tube rupture and leakage in design-basis accidents and severe accident events.
- Conduct a reassessment of the conditional probabilities of C-SGTR based on updated flow distributions and updated T/H analyses.

Compile and summarize key research, building upon NUREG-1570 (work performed as part of SGAP activities).

## Approach

### CE Thermal-Hydraulic and Severe Accident Analysis

The updated modeling approach and lessons learned from these most recent Westinghouse plant predictions will be applied to a CE plant model in order to improve the T/H predictions. This effort will update the hot-leg flow and mixing model, as well as hot-leg thermal radiation modeling.

The CE CFD model will be updated to include a simplified upper plenum, hot leg, surge line, and the SG primary side. This model will be used to predict hot leg and inlet plenum mixing rates, as well as the variations in temperature of the flow entering the hottest tubes in the SG.

The system code modeling effort will include the development of a MELCOR CE plant model which incorporates all of the lessons learned from the recent Westinghouse predictions completed in support of the SGAP. The modeling will also incorporate the updated CE CFD model predictions.

### Assess Impact of In-Core Instrument Tube Failures

In December 2009, RES completed a study on the impact of the consequences of instrumentation tube failure during severe accidents, which is detailed in ERI/NRC-09-206, “Analysis of the Impact of Instrumentation Tube Failure on Natural Circulation During Severe Accidents” (ADAMS Accession No. ML100130402). This work assesses the impact of instrumentation tube failures for Three Mile Island, Unit 2 (TMI-2) (a Babcock & Wilcox (B&W) design with a once through SG), and Zion (a 4-loop Westinghouse design with a U-tube SG). After a thorough review of this work, a detailed assessment of in-core instrument failures will be prepared.

### Updated Steam Generator Flow Distributions

To assess the probability of an induced SGTR, detailed knowledge of the characteristics of SG tube flaws is needed

---

with the tube temperature and stress profile during postulated accidents. For statistical analysis, flaw density distribution data as a function of size, shape, orientation, location, and type are needed. The potential for failure depends primarily on the upper tail of the size distribution (i.e., the most severe flaws) for a given flaw type and location. A verification process will also be used to confirm that the flaw distributions are consistent with operating experience for observed leakage rates.

By means of an existing memorandum of understanding addendum between the NRC and EPRI, RES will work with the industry to update flaw distributions originally developed in the mid-1990s. This update will include (1) evaluating the effect of improved inspection techniques on flaw density distributions; (2) developing distributions for both crack-like and wear-like defects; (3) accounting for flaws in the SG tube within the tubesheet regions; and (4) identifying any changes in flaw distribution caused by new tube materials, new SG designs, or new inspection techniques.

### **Structural Analysis of CE And Westinghouse RCS Components for Prediction of RCS Piping Failure**

RES structural analyses will build upon the latest T/H and severe accident analyses to include specific RCS components for Westinghouse and CE plants (e.g., hot-leg nozzle and hot leg-to-surge line nozzle). The failure analysis will consider uncertainty resulting from the shape, size, and location of potential flaws in the RCS components.

RES plans to identify, characterize, and model relevant RCS nozzles to assess their potential for failure during severe accidents for Westinghouse and CE plants. Two-dimensional axisymmetric and three-dimensional models will be developed, addressing variables such as nozzle geometries and configurations, boundary conditions, loading conditions, fabrication effects, stress-corrosion cracking mitigations, and degraded conditions. These models will be used to determine the time to failure for each analyzed component and the associated sensitivity to loadings and flaw geometry. Because of the importance of incorporating uncertainty, RES will develop a semiempirical methodology, based on numerical experiments, to predict failure of critical RCS components. The resulting methodology is expected to be more conducive to the procedure adopted in the C-SGTR risk assessment method developed as part of the program.

### **Simplified Method for Assessing the Risk Associated With C-SGTR**

In March 2009, RES provided the NRC's Office of Nuclear Reactor Regulation (NRR) with a report describing a method for assessing C-SGTR risk (ADAMS Accession No. ML083540412). RES intends to extend the methods described in this previous report to incorporate a number of enhancements. These

enhancements will include consideration of the updated T/H conditions, SG flaw distribution, and RCS component analyses. Additionally, C-SGTR risk assessment methods described in previous NRC, Electric Power Research Institute (EPRI), and industry reports will be reviewed to identify useful insights and modeling approaches for use with the new simplified method. RES anticipates that the level of analysis in the new approach will be comparable to that of the previous RES C-SGTR risk report and the earlier NUREG-1570 study. Consistent with previous C-SGTR risk assessment work, the new simplified method will consider both pressure-induced and thermally induced SG tube failures.

### **Reevaluation of C-SGTR Conditional Probabilities**

In support of SGAP, RES previously developed an SG tube failure probability calculator tool. RES plans to extend the framework and modeling approaches used in this tool, including pressure- and temperature-induced challenges. Consequently, this program will focus on further validation of the detailed modeling used in the calculator, extension of calculator capabilities, updates to basic data and parameters (including provisions for future data updates), improvements in calculator usability, and development of supporting documentation.

## **Deliverables**

The following deliverables are anticipated at the completion of the C-SGTR program:

- probabilistic risk assessment report
- risk assessment tool
- draft regulatory guidance on risk-informed decision making regarding C-SGTR
- draft Risk Assessment Standardization Project (RASP) handbook section on assessment of CSGTR suitable to support revisions to the Inspection Manual Chapter 0609 appendices supporting the Significance Determination Process (SDP).
- summary report compiling key research results

### **For More Information**

Contact Raj Mohan Iyengar, RES/DE at 301-251-7907 or [Raj.Iyengar@nrc.gov](mailto:Raj.Iyengar@nrc.gov)

---

# Reactor Pressure Vessel Integrity

## Background

One aspect to the safe operation of a nuclear power plant is maintaining the structural integrity of the reactor pressure vessel (RPV) during both routine operations (i.e., heat up, cool down, and hydro test) and during postulated accident scenarios (e.g., pressurized thermal shock (PTS)). To do this, procedures are needed to estimate and compare the driving force for structural failure to the resistance of the structure to this driving force (and the effect of radiation on this resistance). Current statutory procedures for these estimates are found in Title 10 of the *Code of Federal Regulations* (10 CFR) Part 50.61, “Fracture Toughness Requirements for Protection against Pressurized Thermal Shock Events (i.e., the PTS rule); Appendix G, “Fracture Toughness Requirements,” to 10 CFR Part 50; Appendix H, “Reactor Vessel Material Surveillance Program Requirements,” to 10 CFR Part 50; Regulatory Guide 1.99, “Radiation Embrittlement of Reactor Vessel Materials;” and Regulatory Guide 1.161, “Evaluation of Reactor Pressure Vessels with Charpy Upper Shelf Energy Less Than 50 ft-lb.” While these methods generally depend on empirically based engineering methods, they are known to incorporate large implicit conservatisms adopted to address state-of-knowledge deficiencies that existed at the time of their promulgation. When coupled with the deterministic basis of current regulations, these conservatisms may unnecessarily reduce the possibility for continued operation and potential license renewals.

## Objectives

1. Integration of the advances in the state of knowledge, empirical data, and computational power that has occurred in the 20+ years since the adoption of the current regulatory requirements to develop the technical bases for state-of-the-science and risk-informed revisions to the statutory procedures that regulate the structural integrity of the current operational boiling and pressurized reactor fleets.
2. Use of the advances in the state of knowledge and empirical data that have accumulated over 20+ years of structural materials research by the nuclear community to develop, validate, and refine physically based predictive models of material deformation and failure behavior to include the effects of radiation embrittlement.

An additional objective is to apply insights from probabilistic structural integrity assessment gained from the first objective and the predictive material models developed in the second objective to develop and validate a modular probabilistic computer code

that can be used to assess the structural integrity assessment of any pressurized structure in a nuclear power plant.

## Approach

RES has recently completed a multiyear study conducted in cooperation with the Oak Ridge National Laboratory (ORNL), other national laboratories and Government contractors, and the domestic nuclear power industry under the auspices of the Electric Power Research Institute (EPRI) Materials Reliability Project (MRP) to develop the technical basis for a risk-informed revision to the PTS rule. The Office of Nuclear Reactor Regulation (NRR) has used this technical basis to develop a voluntary alternative to the PTS rule which relaxes many of the conservatisms in the current rule without impacting the public health and safety. The NRC completed this voluntary alternative rule in 2010.

Also in the coming years, RES will publish and make available for public comment a revised version of Regulatory Guide 1.99, along with its technical basis. This revision is based on over five times the quantity of empirical data used to develop the current regulatory guide. The insights gained from these activities provide a large part of the work needed as the technical bases to support revisions to Appendices G and H to 10 CFR Part 50, which are both scheduled for completion in 2011.

In the next 5–10 years, RES will pursue the following two major initiatives to ensure the structural integrity of the pressurized nuclear power plant components in the existing fleet during the period of license extension and in the new reactor fleet:

- Development and validation of a method capable of identifying embrittlement mechanisms in reactor materials before they occur in commercial reactor service.
- Development and validation of a modular computational tool to perform probabilistic structural integrity assessments of passive primary reactor pressure boundary components.

### For More Information

Contact Mark Kirk, RES/DE at 301-251-7631 or [Mark.Kirk@nrc.gov](mailto:Mark.Kirk@nrc.gov)

# Environmentally Assisted Fatigue of Components Exposed to the Reactor Water Environment

## Background

Environmentally assisted fatigue (EAF) deals with the effects that reactor coolant environments have on the fatigue life of components exposed to those environments. The American Society of Mechanical Engineers (ASME) Code, Section III, design fatigue curves, which were developed based on air testing of laboratory specimens, do not explicitly address EAF, and test data indicate that the ASME Code fatigue curves may not always be adequate for coolant environments (see Figure 9.6).

EAF of components exposed to the reactor water environment was first identified as a part of the NRC's Fatigue Action Plan, which was completed in 1995 (SECY-95-245, "Completion of the Fatigue Action Plan," dated September 25, 1995). By memorandum dated December 26, 1999, the NRC identified the need to evaluate environmental fatigue for nuclear power plants pursuing license renewal as a part of the close out of Generic Safety Issue (GSI) 190, "Fatigue Evaluation of Metal Components for 60-Year Plant Life." NUREG-1801, Revision 1, "Generic Aging Lessons Learned (GALL) Report," provides guidance for licensees. Specifically Chapter X.M1, "Metal Fatigue of Reactor Coolant Pressure Boundary," recommends the use of the methodology contained in NUREG/CR-6583, "Effects of Light-Water Reactor (LWR) Coolant Environments on Fatigue Design Curves of Carbon and Low-Alloy Steels," for carbon and low-alloy steels and NUREG/CR-5704, "Effects of LWR Coolant Environments on Fatigue Design Curves of Austenitic Stainless Steels," for austenitic stainless steels.

The NRC also identified the need to evaluate environmental fatigue for new reactors in Regulatory Guide 1.207, "Guidelines for Evaluating Fatigue Analyses Incorporating the Life Reduction of Metal Components Due to the Effects of the Light Water Reactor Environment for New Reactors," with associated methodology documented in NUREG/CR-6909, "Effect of LWR Coolant Environments on the Fatigue Life of Reactor Materials." This methodology is also allowed for use by license renewal applicants.

The NRC must make additional effort in this area to facilitate the future review of licensees' environmental fatigue evaluations submitted to the agency for review and approval by both license renewal and new reactor applicants.

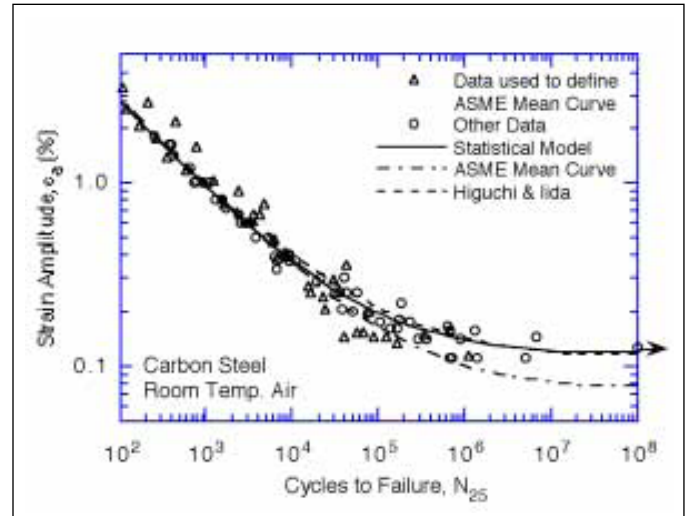

Figure 9.6 Fatigue S-N behavior for carbon steel

## Objective

Discussions among the Office of Nuclear Reactor Regulation (NRR), RES, and the Office of New Reactors (NRO) identified several further efforts necessary to address EAF:

- a transient stress evaluation software tool for rapidly determining thermal transient stresses in reactor components
- an ASME Code, Section III, fatigue calculation software tool for estimating fatigue usage factors in reactor components
- revised fatigue cumulative usage factor (CUF) evaluation criteria for postulated high-energy line break (HELB) locations
- technical support from Argonne National Laboratory (ANL) to update existing environmental fatigue methodology and develop application techniques

RES has planned activities for the time period of August 2009 through December 2011 to address these needs.

## Planned Tasks

The specifics of the RES tasks planned for this topic are as follows:

### 1. Transient Stress Evaluation Software Tool

In this task, a software "mathematical integrator" tool will be developed and benchmarked that performs Duhamel integration for any user-specified input thermal transient using a unit stress response to develop thermal transient stress histories. The concept behind this approach is to utilize established mathematical integration techniques

---

to simplify the stress evaluation of thermal transients. Guidance will also be provided regarding the finite element evaluation that is needed to develop the unit stress response necessary for use of this software. A technical/user report will also be developed for this software.

## 2. Section III Fatigue Calculation Software Tool

In this task, a software tool will be developed and benchmarked that performs fatigue evaluation in accordance with ASME Code, Section III, as follows:

- user-inputs consisting of a six stress-component tensor time-history for a point on a RPV component for thermal transients (including pressure and mechanical loadings).
- scaling and combination of the above stresses, as appropriate, into a total stress time-history tensor for the location being evaluated
- stress-range pairing of the time-history tensor and conversion to principal stress ranges
- cycle counting of the stress ranges
- calculation of alternating stress intensities
- calculation of CUF
- calculation of environmental CUF in accordance with Regulatory Guide 1.207

A technical/user report will also be developed for this software.

## 3. Develop a Technical Basis for Postulated HELB Locations

The outcome of this task will be a technical report which documents the available background for this issue and any available information that was used to establish the previous CUF limit, the essential elements of refined fatigue analyses that could be performed for plants operating beyond 40 years to satisfy a revised CUF limit, the essential elements of a flaw tolerance approach that could be used in lieu of the current CUF limit for the operating reactor fleet, and a technical basis for a CUF limit to be used in HELB evaluations for affected piping systems in new reactors and plants operating to 60 years.

## 4. Technical Consulting from ANL

This task includes technical and consulting support from ANL (with whom the NRC contracted for much of its earlier work on this subject) in the following areas:

- reviewing proposed ASME Code Cases on environmental fatigue
- reviewing data to determine the impact of strain threshold and holdtime effects
- reviewing additional available laboratory data collected over the past decade to determine whether revision of Regulatory Guide 1.207 is necessary
- investigating several practical issues associated with application of the Regulatory Guide 1.207 methodology
- providing technical support to NRC staff in addressing environmental fatigue issues related to license renewal and new reactor design and providing NRC staff with knowledge transfer and subject matter turnover.

### **For More Information**

Contact Gary L. Stevens, RES/DE at 301-251-7569 or [Gary.Stevens@nrc.gov](mailto:Gary.Stevens@nrc.gov)



# Degradation of Reactor Vessel Internals from Neutron Irradiation

## Background

The internal components of light-water reactor (LWR) pressure vessels are fabricated primarily with austenitic stainless steels because of their relatively high strength, ductility, and fracture toughness in their unirradiated state. During normal reactor operational conditions, the internal components are exposed to high-energy neutron irradiation and high-temperature reactor coolant. Prolonged exposure to neutron irradiation changes both the microstructure and microchemistry of these stainless steel components and increases their strength and their susceptibility to irradiation-assisted stress-corrosion cracking (IASCC). Exposure also decreases their ductility and fracture toughness. Cracks caused by IASCC have been found in a number of internal components in LWRs, including control rod blades, core shrouds, and bolts (see Figure 9.7).

As nuclear power plants age and neutron irradiation dose increases, the degradation of the vessel internals becomes more likely and potentially more severe. Preliminary data suggest that the significance of LWR vessel internals degradation could increase during both the license extension period (i.e., 40 to 60 years) and during even longer term operation of nuclear power plants.

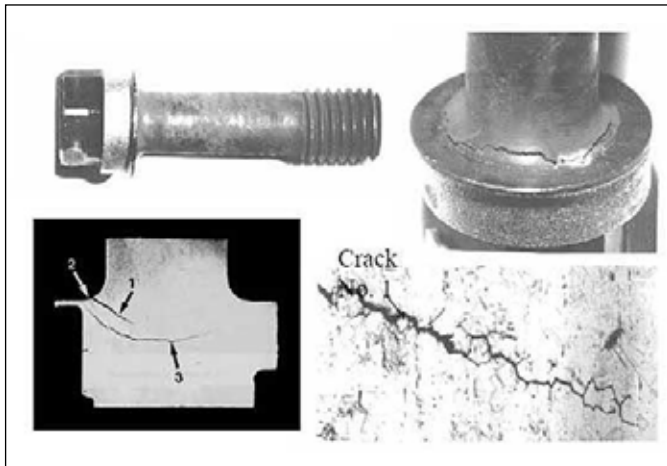

Figure 9.7 Cracking of a baffle bolt in a pressure water reactor (PWR).

## Objective

The NRC has developed a broad research plan to address the degradation of reactor vessel internals from neutron radiation. The results of the research will be used to provide insights into the causes and mechanisms of IASCC in boiling-water reactors (BWRs) and PWRs and to inform regulatory decisions regarding the reliability of reactor vessel internals during long-term operation.

## Approach

The NRC has been conducting research to characterize and evaluate irradiation-induced degradation by doing the following:

- defining a threshold neutron dose above which irradiation begins to affect material properties
- evaluating the adequacy of data used to estimate cyclic fatigue and IASCC growth rates for both the BWR and PWR vessel internal materials
- assessing the significance of void swelling and irradiation stress relaxation/creep on the structural and functional integrity of PWR internal components.

Test specimens have been and will be irradiated over a broad range of prototypical exposure levels to evaluate the expected performance of plant materials. In addition, the research plan includes the harvesting of internal structural materials from decommissioned nuclear reactors, such as the Zorita reactor in Spain. Materials from the Zorita reactor have higher levels of radiation exposure than experimental samples and would provide information on the expected behavior of domestic BWR and PWR components during long-term operation. The plan also provides for participation in other collaborative research efforts that will leverage resources, extend knowledge acquired from previous research, and utilize unique testing facilities within the international community.

Presently, a systematic research effort is underway to determine the causes of IASCC, establish a fracture toughness degradation threshold, and investigate saturation effects in BWR and PWR internals. Representative reactor internal materials are being irradiated at the Halden Nuclear Reactor facility in Norway, and experimental testing is being carried out at Argonne National Laboratory (ANL). Specifically, within BWR environments, the effects on IASCC and fracture toughness from the hydrogen concentration in the reactor coolant and the concentration of light elements, such as sulfur and oxygen, within the steels are being evaluated. This portion of the work is nearing completion. In the next phase, the effects of neutron dose on IASCC and fracture toughness and the synergistic effects of neutron and thermal embrittlement on fracture toughness are

---

being investigated for PWR environments. Longer term research will focus on effects expected during plant operation beyond 60 years.

As previously indicated, the NRC staff is completing a multiyear study of the effect of BWR environments on IASCC of austenitic stainless steel vessel internals. The products of this program have been used to evaluate licensee submittals related to managing degradation of these components and to inform other aspects of the regulatory process, such as inspection requirements and responses to relief requests. This program's results have led to the resolution of regulatory issues, as well as the development, validation, and improvement of regulations and regulatory guidelines.

**For more information**

Contact Dr. Appajosula S. Rao, RES/DE at 301-251-7636 or [Appajosula.Rao@nrc.gov](mailto:Appajosula.Rao@nrc.gov)

# Primary Water Stress-Corrosion Cracking

## Background

Primary water stress corrosion cracking (PWSCC) in primary pressure boundary components composed of nickel-based alloy is a degradation mechanism that can affect the operational safety of pressurized water reactors (PWRs). PWSCC cracks found in control rod drive mechanism (CRDM) nozzle J-groove welds at North Anna Unit 2 are shown in Figure 9.8. The narrow cracks are often located in complex structures either within or adjacent to welds and are difficult to detect and characterize. Undetected PWSCC has led to reactor pressure boundary leaks and subsequent boric acid corrosion of the low-alloy steel reactor pressure vessel head at Davis-Besse in 2002 (see Figure 9.9).

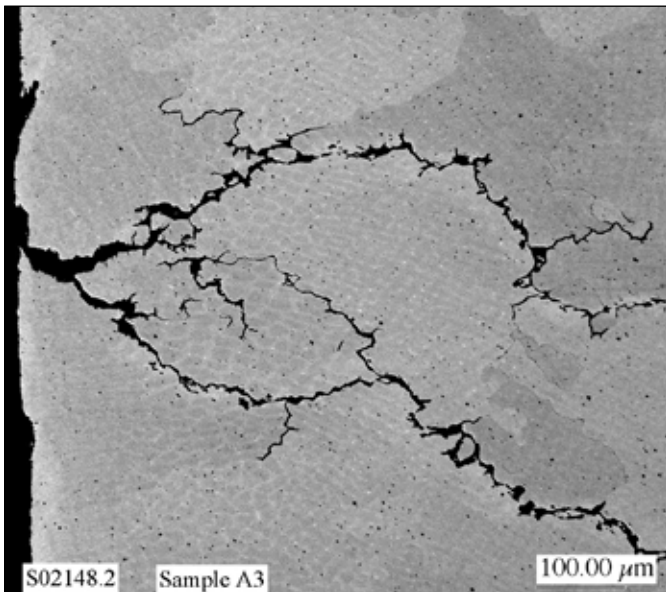

Figure 9.8 PWSCC cracks in the Alloy 182 Jgroove weld in North Anna-2 Nozzle 31

Alloy 690 and associated weld metals, Alloy 52 and 152, which have nominal chromium concentrations of 30 percent, have been used in replacement components, including steam generators, PWR replacement heads, reactor coolant system piping, nozzles, and instrument penetrations. PWSCC mitigation of the more susceptible alloys has been conducted using Alloy 52 and 152 weld overlays. To be successful, an improved understanding of the complex interrelations between stresses in the affected components, material microstructure, and the aggressive nature of the PWR environment is necessary.

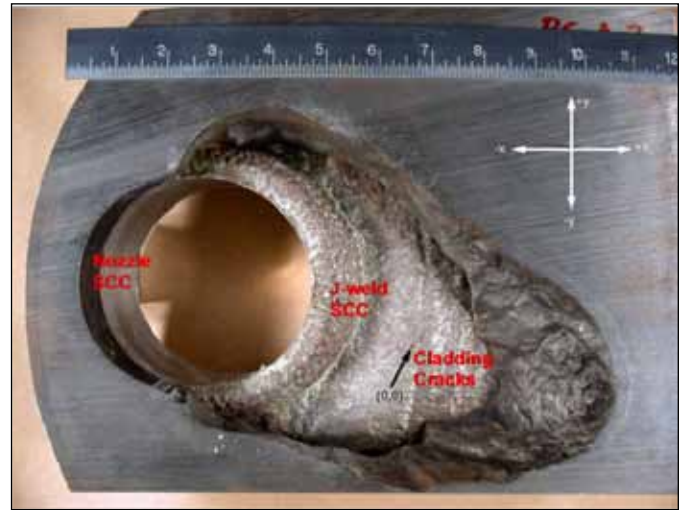

Figure 9.9 Photograph showing extensive boric acid corrosion in the low-alloy steel Davis-Besse reactor pressure vessel head. Reactor coolant leaked from PWSCC cracks in the Alloy 600 control rod drive mechanism nozzle and the nozzle J-groove weld.

## Objective

The objectives of this program are to evaluate the PWSCC susceptibility of high-chromium Alloy 690 and its weld metals, Alloys 152/52 and their variations, and to determine the relationship between PWSCC susceptibility and metallurgical characteristics of the chromium-containing nickel-based alloys used in replacement and new construction components. The work will also provide valuable information to assess potential mitigation methods for the lower chromium nickel-based alloys (600/182/82) originally used in PWRs and known to be susceptible to PWSCC.

Information obtained will be used to develop regulatory guidance and establish inservice inspection requirements necessary to ensure continued safe operation of PWRs.

## Approach

The NRC is sponsoring confirmatory research consisting of crack growth rate measurements on nickel-based alloys in simulated PWR environments, as well as microstructural and fracture surface analyses of test materials. The NRC is also participating in an international cooperative effort to evaluate factors that influence the PWSCC susceptibility of nickel-based alloys.

## NRC-Sponsored Research

The NRC has ongoing research activities on the PWSCC susceptibility of nickel-based alloys. Specific tests are being conducted to evaluate the importance of the following:

- 
- fabrication processes and thermal treatments on Alloy 690
  - shielded metal arc welding (SMAW) and gas tungsten arc welding (GTAW) processes
  - heat-affected zones adjacent to SMAW and GTAW welds
  - weld defects, including hot cracking and ductility dip cracking
  - dilution zones in dissimilar metal welds

Examination of test specimen fracture morphology, along with metallurgical analyses and crack tip characterizations of test specimens and actual plant components which have been removed from service, will provide data to determine how the microstructural features affect PWSCC growth rates.

Results obtained from the NRC-sponsored research have shown that possible combinations of cold work and thermal treatments can significantly affect the PWSCC susceptibility of Alloy 690. High-chromium weld filler alloys are generally more resistant to PWSCC; however, higher susceptibility of some welds is still being investigated.

### **PWSCC International Cooperation**

The NRC is also participating in an international cooperative effort that includes representatives from the Electric Power Research Institute (EPRI), industry, and licensees. This cooperative effort has led to the development of PWSCC testing protocols and analysis methods, evaluation of representative plant materials, and testing of newly developed weld alloys. The cooperative effort provides a forum for the dissemination and discussion of research results which benefits all participants.

### **For More Information**

Contact Darrell S. Dunn, RES/DE at 301-251-7621 or [Darrell.Dunn@nrc.gov](mailto:Darrell.Dunn@nrc.gov)

# Primary Water Stress-Corrosion Cracking Mitigation Evaluations and Weld Residual Stress Validation Programs

## Background

In pressurized-water reactor (PWR) coolant systems, nickel-based dissimilar metal (DM) welds are typically used to join carbon steel components, including the reactor pressure vessel (RPV), steam generators (SGs), and the pressurizer, to stainless steel piping. Figures 9.10 and 9.11 show a representative nozzle to piping connection cross-section, including the dissimilar metal (DM) weld. The DM weld is fabricated by sequentially depositing weld beads as high-temperature molten metal that cools, solidifies, and contracts, retaining stresses that approach or, potentially, exceed the material's yield strength.

These DM welds are susceptible to primary water stress-corrosion cracking (PWSCC) as an active degradation mechanism that has led to RCS pressure boundary leakage. PWSCC is driven by tensile weld residual stresses (WRS) and other applied loads within the susceptible DM weld material. Hence, proper assessment of these stresses is essential to accurately predict PWSCC flaw growth and ensuring component integrity.

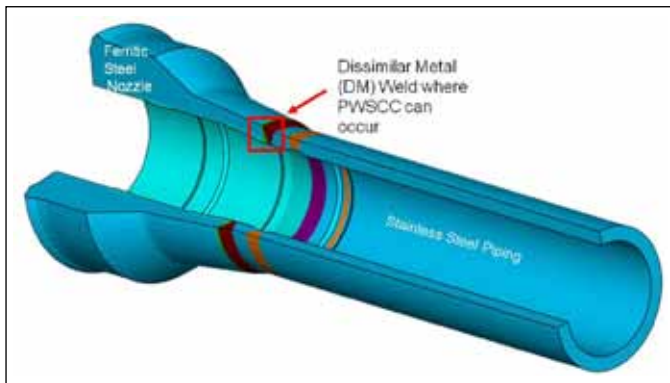

Figure 9.10 Cutaway view of a carbon steel nozzle DM weld and stainless steel piping typical in a light-water cooled nuclear power plant

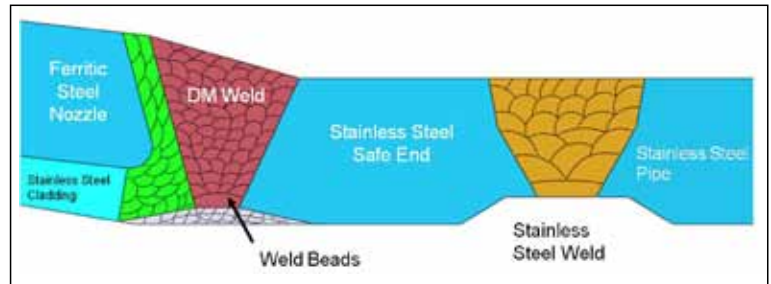

Figure 9.11 Cross-section of nozzle to pipe weld highlighting weld bead pattern

The nuclear power industry has developed several PWSCC mitigation techniques for DM welds that are currently being implemented in the PWR fleet. Examples include the following:

- full structural and optimized weld overlays, in which replacement material less susceptible to PWSCC is welded onto the outer diameter of the affected joint that also imparts a stress improvement to the susceptible joint
- weld inlays, in which a layer of replacement material less susceptible to PWSCC is welded to the inner diameter to act as a barrier between the corrosive reactor coolant and the DM weld material (e.g., similar to cladding)
- Mechanical Stress Improvement Processes (MSIP) in which the pipe is squeezed using a large hydraulically driven clamp that imparts a stress improvement to the susceptible joint

Weld overlays and MSIP reduce, and in some cases reverse, tensile residual stresses in DM welds, decreasing the driving force for crack growth. However, weld inlays have been shown to increase tensile WRSs, potentially increasing PWSCC initiation and growth, but, of the less susceptible replacement material.

## Validation Program

Recent improvements in computational capabilities have facilitated advances in WRS predictions using finite element analysis (FEA). Although no universally accepted methodology exists to model WRS using FEA, Electric Power Research Institute (EPRI) has developed draft guidelines for streamlining these procedures. The assumptions and estimation techniques vary from analyst to analyst, causing variability in the predicted WRS profiles.

RES is supporting the Office of Nuclear Reactor Regulation (NRR) in developing appropriate regulatory requirements to address PWSCC in reactor coolant piping systems. A portion of this effort includes the Weld Residual Stress Validation Program aimed at refining and validating the FEA procedures for modeling WRS and characterizing the uncertainties in the resulting predictions. The WRS Validation Program is being



conducted cooperatively with EPRI under a memorandum of understanding addendum.

Figure 9.12 shows a typical WRS FEA performed using the ABAQUS software for a RPV-to-pipe nozzle DM weld. The distribution in stresses shows where a flaw may initiate (typically on the inner diameter of the DM weld), propagate, and cause leakage or structural instability. The results of this analysis are being validated through comparison of predicted temperature, thermal strain, and residual stress fields with a variety of physical measurements performed on actual and representative plant components and mockups.

The Weld Residual Stress Validation Program has enjoyed a number of successes thus far, including the following:

- evaluations of various PWSCC mitigation techniques (full structural weld overlays, optimized weld overlays, MSIP, and inlays)
- safety evaluation report technical basis development provided to NRR for approving several PWSCC mitigation techniques for use by the PWR fleet
- input to ASME Code Case reviews
- multiple plant-specific PWSCC flaw evaluations for NRR review

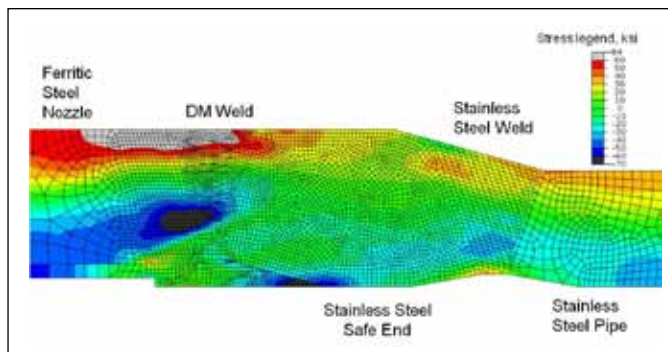

Figure 9.12 Stress magnitude distribution in a nozzle to pipe weld configuration

## Remaining Work

RES, RES contractors, and in cooperation with the nuclear power industry through an NRC/EPRI memorandum of understanding addendum, are currently completing a multiphase program to validate predictions of WRSs based on FEA. A major element of this program involves the International Weld Residual Stress Round Robin, in which 15 organizations are blindly and independently analyzing the WRSs in a representative pressurizer surge nozzle DM weld mockup, as seen in Figure 9.13. RES is conducting a blind validation of this



Figure 9.13 Pressurizer surge nozzle DM weld mockup being measured for WRS

mockup by measuring WRS and comparing the measurements to blindly conducted FEA predictions.

Once completed, the WRS Validation Program will facilitate improvements in the following:

- WRS FEA predictive methodologies
- PWSCC flaw evaluation procedures and NRR staff review of licensee submittals
- determining estimates for the uncertainty and distribution of WRS, which are needed in probabilistic analyses (e.g., xLPR Code).

Figures 9.10–9.12 courtesy of Dr. Lee Fredette of Battelle Memorial Institute, Columbus, OH.

### For more information

Contact Howard J. Rathbun, RES/DE at 301-251-7647 or [Howard.Rathbun@nrc.gov](mailto:Howard.Rathbun@nrc.gov)

# Nondestructive Examination

## Background

As required by Title 10 of the *Code of Federal Regulations* (10 CFR) Part 50.55(a), “Codes and Standards”, licensees must inspect structures, systems, and components (SSCs) to ensure that their safety function is performed and that the requirements of the ASME Code are met. Research on nondestructive examination (NDE) of light-water reactor (LWR) components and structures provides the technical basis for regulatory decision-making related to these requirements. Results from the NDE of these components and structures are also used to assess models developed to predict the effects of materials degradation mechanisms and as initial conditions for component-specific fracture mechanics calculations. The Pacific Northwest National Laboratory (PNNL) is conducting this work.

## Regulatory Needs

Areas of concern addressed by NDE research include the following:

- quantification of the accuracy and reliability of NDE techniques used for inservice inspection (ISI) of LWR systems and components
- support for NRC rulemaking efforts in materials reliability such as the PTS rule
- improvement of the effectiveness and adequacy of the ISI requirements proscribed in the ASME Code
- development of a technical basis for the evaluation of proposed NDE methods and ISI programs for new and advanced reactor licensing

The four specific project areas highlighted below address these regulatory needs.

## Approach

### Evaluation of NDE Reliability and ISI Techniques

Research activities include NDE of fabrication flaws and destructive verification. The research objectives are to (1) determine the relationships among preservice inspection methods, inservice degradation (cracking, aging), and ISI practice and results; and (2) evaluate the effectiveness, accuracy, and reliability of new techniques expected to be applied by licensees in current, new, and advanced reactors. Certain materials, degradation mechanisms, and locations are difficult to inspect in the current fleet of reactors and will most likely remain challenging for new reactors. The NRC is using fabricated mockups and components removed from reactors, including

some canceled plants and some operating reactors, to determine the effectiveness of existing and emerging NDE techniques (see Figures 9.14 and 9.15).



Figure 9.14 Sectioning of reactor vessel head penetrations from WNP-1, a cancelled plant

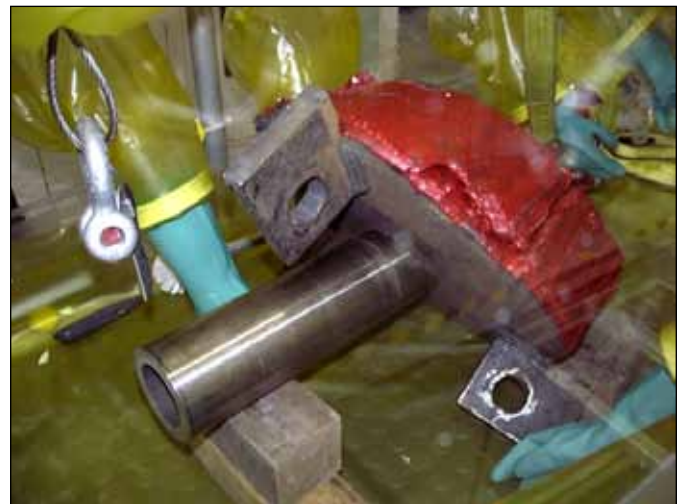

Figure 9.15 Nondestructive and destructive examination of salvaged CRDM penetrations and J-groove welds from North Anna, Unit 2

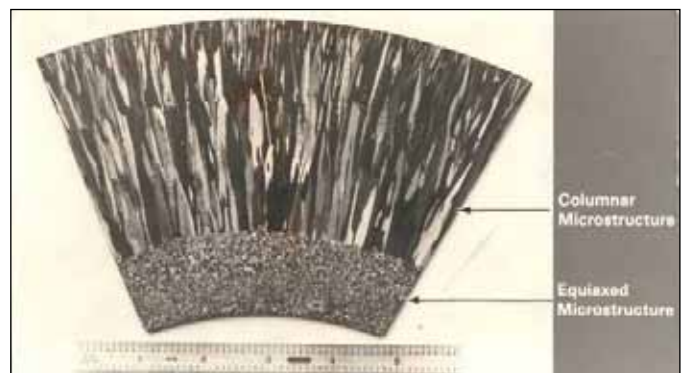

Figure 9.16 Sample illustrating the coarse grain microstructure of centrifugally cast stainless steel

The NRC performs some of this work under cooperative agreements to help defray costs and to gain access to the expertise of other organizations. For example, the ability to detect and characterize PWSCC in LWR components is being evaluated under an NRC-initiated international project known as the Program for the Inspection of Nickel-Alloy Components (PINAC). This program is linking NDE performance to crack morphology and is developing NDE reliability data of advanced ultrasonics and other new NDE methods. Eight organizations participate in PINAC and exchange information and test results from their related research.

The NRC is directing, under its current program at PNNL, research on the inspection of coarse-grained austenitic alloys and welds (see Figures 9.16 and 9.17). NDE of these components is difficult because of signal attenuation and reflections. In these materials, grain boundaries and other microstructural features appear similar to cracks. Research findings will support appropriate inspection requirements for these components so as to ensure safety.

### Enhanced Signal Processing and Analysis Systems

Modern NDE systems (Figure 9.17) produce a significant amount of data that must be examined during ISIs. Automated data analysis algorithms reduce the processing time for large amounts of NDE data and thus improve ISI reliability by allowing more extensive inspections. Computer-aided data analysis methods may further improve NDE reliability by reducing or eliminating operator-related errors. Advanced processing techniques also support the use of alternative NDE techniques (e.g., high-resolution eddy current and phased array inspections). The research is focused on determining the accuracy and reliability of advanced NDE for complicated defects in comparison with conventional techniques, confirmed by destructive examination.

### Advanced Inspection for Fabricated Components

Proposals to increase the use of high-density polyethylene piping with welds and joints present a significant challenge to the nuclear industry and the NRC because there is little experience with using these materials in nuclear power plants. Furthermore, the application of NDE to these joints presents new technical issues. The initial efforts of this research focus on evaluation of relevant inspection techniques deployed in other industries and the review of research results on these techniques. This information will be used in developing licensing requirements for licensee ISI programs for such materials.

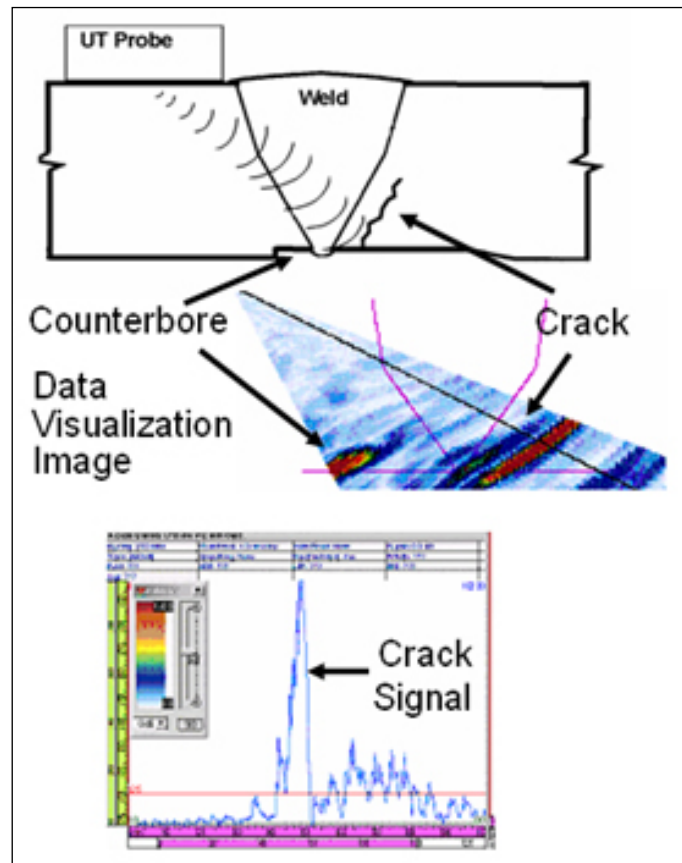

Figure 9.17 Schematic view of flaw detection at the far side of a weld, using a phased array ultrasonic (PA-UT) technique. PA-UT improves flaw detection in coarse-grained metals and welds

### In Situ Material and Stress-State Characterization

Material characterization using NDE is being developed to produce more accurate, in situ evaluation of structural integrity of degraded components and radiation damage. This is promising work because many NDE methods are sufficiently sensitive to the presence of residual stress, while also being sensitive to microstructural material variations that usually accompany residual stresses and aging. The NRC will perform research to determine the effectiveness of the various techniques as they are developed in the industry.

## Summary

The NRC is conducting research to determine the accuracy and reliability of NDE techniques used to identify and characterize flaws in LWR structures and components stemming from aging-related degradation or induced during fabrication or repair processes. International cooperative programs help to defray the cost of this research and allow the NRC to learn from other organizations.

### For More Information

Contact Aladar Csontos, RES/DE at 301-251-7640 or [Aladar.Csontos@nrc.gov](mailto:Aladar.Csontos@nrc.gov)



# International Nondestructive Examination Round Robin Testing

## Background

Between November 2000 and March 2001, leaks were discovered in Alloy 600 control rod drive mechanism (CRDM) nozzles and associated Alloy 182 J-groove attachment welds in several pressurized water reactors (PWRs). Destructive examination of several CRDMs showed that the leaks resulted from primary water stress corrosion cracking (PWSCC). By mid-2002, over 30 leaking CRDM nozzles had been reported in the United States. Moreover, during this same time, a circumferential hairline crack was detected in the first weld between the reactor vessel nozzle and the A-loop hot-leg piping at another PWR that was subsequently determined to be PWSCC. Such events, both domestic and international, made it apparent that additional research was necessary to address PWSCC in dissimilar metal welds.

The NRC executed agreements with organizations from Japan, Sweden, South Korea, Finland, and the United States to establish the Program for the Inspection of Nickel-Alloy Components (PINC). Pacific Northwest National Laboratory (PNNL) assisted the NRC with the coordination of this program. Figure 9.18 depicts the organization of PINC.

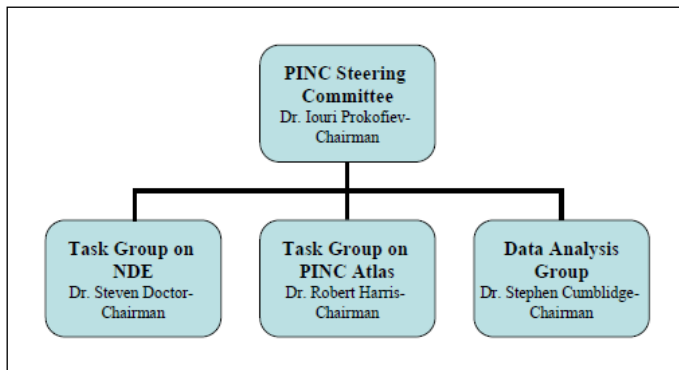

Figure 9.18 Organization of PINC

## Objective

The purpose of this program is to compile a knowledge base (archived through the information technology tool, PINC Atlas) on cracking in Alloy 600 and similar nickel-based alloys in nuclear power plants, including the crack morphology and nondestructive examination (NDE) responses. In addition, the program will identify and quantitatively assess the capabilities of current NDE techniques to detect, size, and characterize tight defects using NDE mockups with simulated PWSCC-like cracks.

## Approach

As part of their international collaboration, PINC participants identified, ranked, and determined which component configurations should be considered for the study.

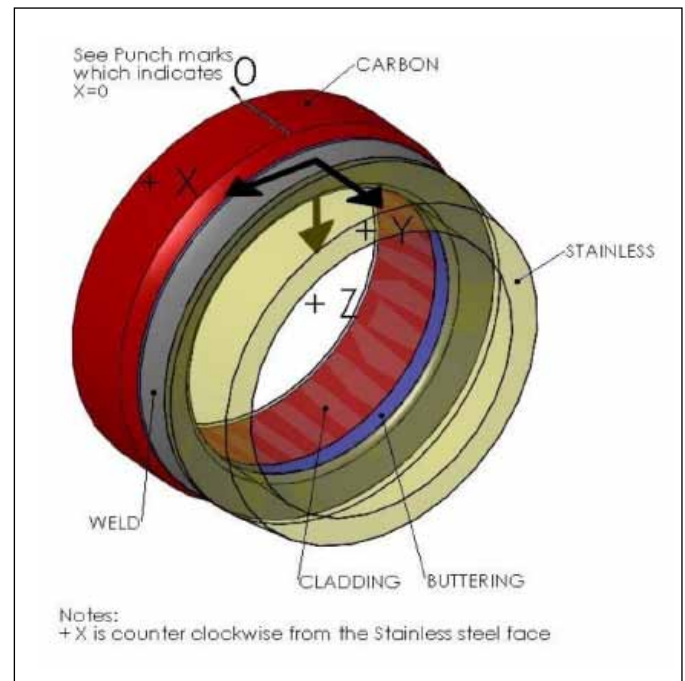

Figure 9.19 Test Block 2.10 from Swedish Radiation Safety Authority Qualification Center

A series of test blocks with cracks were then designed and fabricated by different contributors (such as shown in Figure 9.19) to simulate the selected component configurations. NUREG/CR-7019, “Results of the Program for the Inspection of Nickel Alloy Components,” issued August 2010, describes the results of the round robin tests that were performed to assess the NDE effectiveness and reliability.

The primary objective of the study was to produce an electronic resource on PWSCC in nickel-based alloys. This included documenting the material generated in support of an improved understanding of (1) PWSCC morphology, (2) NDE responses to PWSCC, and (3) the capability of NDE to reliably detect and accurately size PWSCC.

With regard to the second objective (i.e., investigate the capability of various NDE methods to detect and size the through-wall extent of PWSCC), NUREG/CR-7019 describes the efforts of the PINC participants to detect and measure the lengths of cracks. The surface conditions, access to both sides of the weld, and inspection conditions for the PINC specimens provided the inspectors with less challenging conditions than would be expected in field inspections of PWR components. Although the inspection conditions were less challenging,

team performance was highly variable. This finding supports continuation of performance demonstration efforts in the nuclear industry to ensure adequate qualification of inspectors. The variability in team performance should be factored into the decisionmaking process when applying the results of this study.

Other key insights from the report include the following:

- Eddy current inspection from the cracked surface demonstrated the highest probability of detection for the examination of the dissimilar metal weld specimens.
- None of the NDE techniques in this round robin study demonstrated the capability to accurately measure the depths of flaws in dissimilar metal welds to ASME Code, Section XI, requirements.
- The study suggests that, in certain situations, examinations would be improved through the use of several NDE techniques to ensure adequate flaw detection and sizing.

### Program to Assess Reliability of Emerging Nondestructive Techniques

The results from PINC helped substantiate the fact that current NDE technology is sufficient to detect damage during only its final stages. Thus, the need for follow-on confirmatory research on emerging techniques for earlier detection of damage to plant components was clear.

In 2010, the NRC began an additional international cooperative project with a two-fold objective of early detection and prediction. Early detection will involve subjecting samples to temperature and stress and studying the damage in situ using, for example, acoustic emission. Predictions will involve developing NDE techniques to detect susceptibility of materials to damage.

The new Program to Assess Reliability of Emerging Nondestructive Techniques (PARENT) for dissimilar metal welds will focus on tight cracks, including PWSCC and hot cracks, in welds in piping and in other nuclear power plant components. It will assess the reliability of emerging NDE techniques to detect and characterize PWSCC in nickel-based primary reactor coolant system components.

The result of inspections on NDE test specimens containing representative simulated and fabrication flaws using more advanced, emerging techniques will be relevant to weld inlay and overlay repairs for existing reactors and to fabrication welds in new reactors. The Atlas information tool with PWSCC crack morphology and corresponding NDE results, developed under the PINC program, will be reviewed, applied, and extended to support inservice inspectors (see Figure 9.20).



Figure 9.20 Information technology tool—PINC Atlas

#### For More Information

Contact Dr. Iouri Prokofiev RES/DE at 301-251-7655 or [Iouri.Prokofiev@nrc.gov](mailto:Iouri.Prokofiev@nrc.gov)



# Containment Liner Corrosion

## Background

Commercial nuclear power plant containment buildings are designed to act as a barrier to prevent radioactive release under severe accident conditions. Many nuclear power plants have containment buildings constructed with either reinforced or posttensioned concrete in contact with a thin steel containment liner, which serves as a leaktight membrane. Although the integrity of containment liners is assessed by leak rate tests and NRC-required inspections, three instances of through-wall corrosion of the liner have occurred since 1999. In all cases, liner corrosion was associated with foreign material embedded in the concrete during original construction (see Figure 9.21). Prior leak tests or inspections detected neither the foreign material nor the corrosion-related material loss. Active corrosion was identified after penetration of the liner had occurred.



**Figure 9.21** Photograph of the through-wall corrosion detected at Beaver Valley, 2009. A piece of wood embedded in the concrete during original construction was found behind the corroded area of the steel containment liner. The area was identified by a large paint blister which was filled with steel corrosion products.

## Objective

The objectives of this program are to evaluate historical information about liner corrosion events, determine the mechanisms for through-wall corrosion, and determine whether plant designs and construction practices influence the susceptibility to liner corrosion. The results of the program will be used to assess the current methods of inspecting the liner and possible methods to mitigate liner corrosion. Knowledge gained will also be applied to the effects of plant aging on the integrity of the containment structure and the steel liner.

## Approach

Historical information on incidents of liner corrosion was gathered from several sources, including the following:

- In-service Inspection (ISI) reports and leak rate test results
- NRC inspection reports
- Licensee event reports
- International operating experience

Information is being analyzed to determine the relationships between liner corrosion incidents and plant design, operational parameters, and the presence of construction defects. The analysis conducted will be used to identify whether additional research or regulatory action is needed.

## Results

Review of historical information showed that containment liner corrosion initiating on the inside surface of containment liners as a result of degraded or damaged coatings and water collection behind moisture barriers occurs more frequently than corrosion at the liner-concrete interface. Although damage to moisture barriers and coating are more frequent, NRC-required inspections have resulted in early detection and mitigation of these incidents.

Operating experience indicates construction defects, such as fragments of wood present from the time of original construction, are a major contributor to liner corrosion at the concrete-liner interface. For containment structures designed so that the liner is in contact with the concrete (Figure 9.22), a foreign material in contact with the steel may retain moisture, promote crevice corrosion, and be the source of acidic decomposition products.

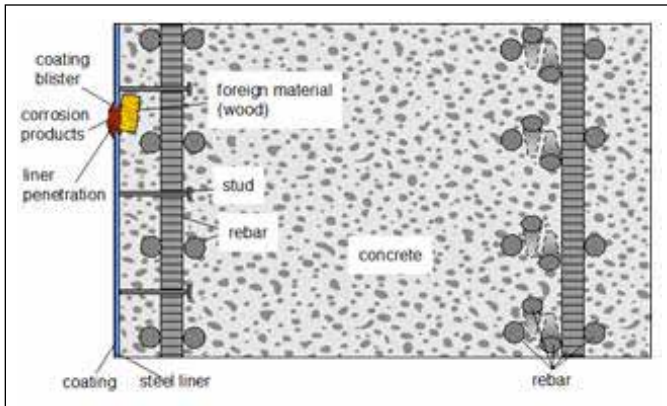

**Figure 9.22** Schematic showing a cross-section of a reinforced concrete containment structure with embedded foreign material from original construction and corrosion penetration of the steel containment liner

## Future Efforts

The efficacy of current inspection methods and the value gained from augmented inspections will be assessed. Testing and modeling efforts may be beneficial to understand the effects of construction defects on corrosion of the steel containment liner and the potential benefits of coatings, sealants, concrete overlays, inhibitors, and cathodic protection systems as mitigation methods for concrete degradation and liner corrosion. Evaluation of the aging and degradation of these passive components will be necessary as nuclear power plants age and enter extended operation beyond 40 and 60 years of service.

### For More Information

Contact Darrell S. Dunn, RES/DE at 301-251-7621 or [Darrell.Dunn@nrc.gov](mailto:Darrell.Dunn@nrc.gov)

# Atmospheric Stress Corrosion Cracking of Dry Cask Storage Systems

## Background

Commercial nuclear power plants refuel every 18 to 24 months. Fuel removed from the core is placed in spent fuel pools for a minimum of 5 years. Independent spent fuel storage installations (ISFSIs), licensed under Title 10 of the Code of Federal Regulations Part 72, “Licensing Requirements for the Independent Storage of Spent Nuclear Fuel, High-Level Radioactive Waste, and Reactor-Related Greater Than Class C Waste,” are used when spent fuel pools have reached capacity (see Figure 9.23 for map of ISFSI locations). ISFSIs are initially licensed for 20 years, and license renewals for 40 years were recently completed for three ISFSI sites.

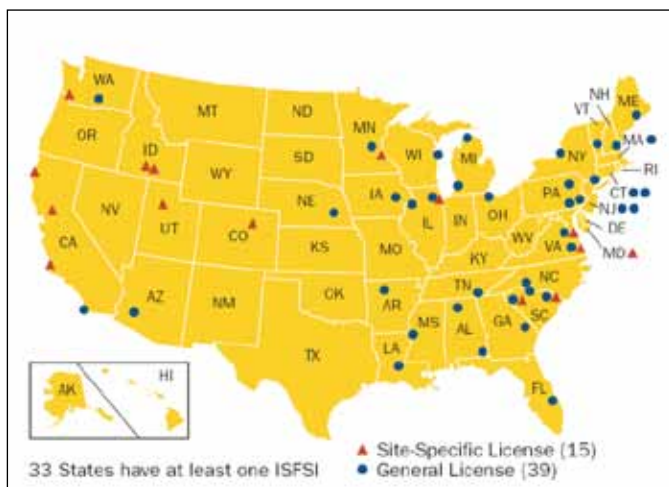

Figure 9.23 ISFSI locations

Dry storage systems at operating ISFSIs consist of canisters constructed using austenitic Type 304/304L/316/316L stainless steels (see Figure 9.24). Some of the current and possibly future ISFSI sites are located in coastal atmospheres where chloride containing salt as an airborne aerosol may deposit on the canister surfaces. A review of previous research provided little insight on the possible effects of salt accumulation over the expected range of operating temperatures for dry storage system canisters. Understanding the environmental conditions and material factors that influence atmospheric chloride stress-corrosion cracking (SCC) of austenitic stainless steel is necessary to evaluate the long-term operation of dry cask storage systems.

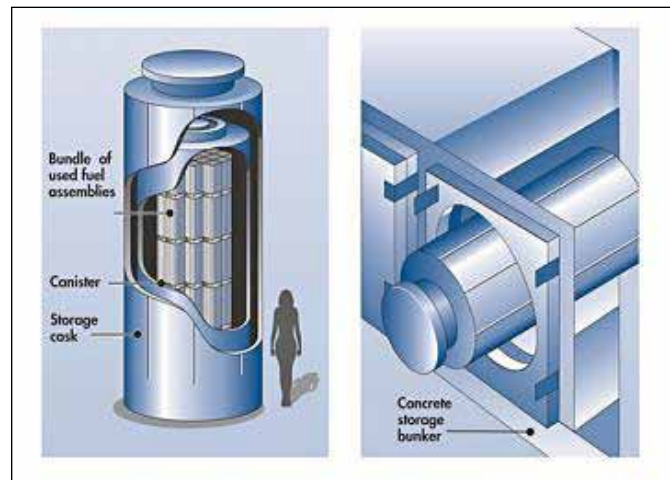

Figure 9.24 Dry storage system designs

## Objective

The objective of this research was to evaluate the potential for canister degradation at ISFSIs, including the deposition and accumulation of sea salts that may induce SCC. Evaluation of SCC susceptibility must consider the time-dependent changes in the environmental conditions on the surfaces of the stainless steel canisters, canister construction materials, and fabrication effects. Information obtained will help identify potential issues and regulatory requirements for long-term ISFSI operation in coastal atmospheres.

## Approach

The NRC sponsored research to evaluate the chloride SCC susceptibility of austenitic stainless steel dry storage systems exposed to coastal atmospheres. Accelerated laboratory tests were conducted using standardized U-bend test specimens produced from stainless steel Types 304, 304L, and 316L base metals, as well as 304/308, 304L/308L, and 316L/316L gas tungsten arc welded (GTAW) alloys. Accelerated atmospheric testing was conducted by placing the test specimens in an atmospheric chamber and heating the specimens to 40, 85, and 120 degrees Celsius (104, 185, and 248 degrees Fahrenheit (F)). Dry sea salt deposited on specimens over a 2-week period was equivalent to an 18-month exposure in a coastal atmosphere. Environmental conditions inside the test chamber were controlled with alternating high and low relative humidity intervals to simulate daily fluctuations. Test specimens were examined after exposure periods of 4, 16, 32, and 52 weeks.

## Results

As illustrated in Figure 9.25, the high relative humidity led to the formation of chloride-containing solutions and chloride SCC on all specimens tested at 40 degrees C (104 degrees F).

Type 316L stainless steel was found to be slightly more resistant to chloride SCC as compared to Types 304 and 304L. SCC was observed on the Type 304 and 304L specimens after only 4 weeks of accelerated testing, whereas SCC on the Type 316L specimens occurred after 32 weeks. SCC was observed on U-bend specimens with and without welds. No SCC occurred on specimens tested at 85 and 120 degrees C (185 and 248 degrees F). Lower relative humidity at the higher temperatures precluded the formation of chloride-containing solutions.

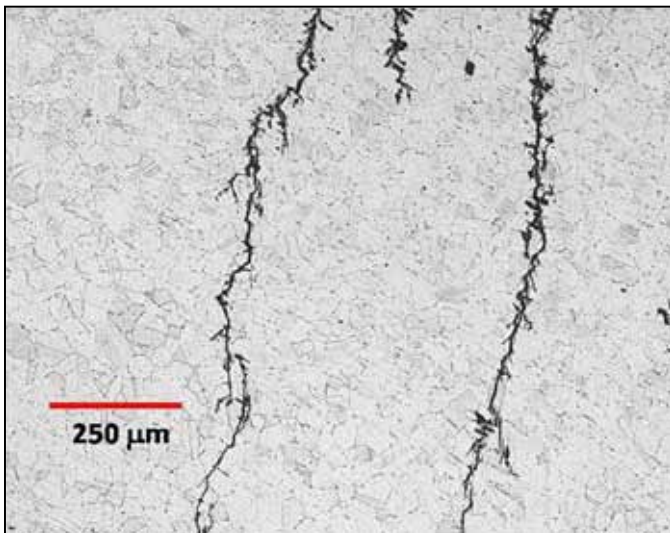

Figure 9.25 Cross-section of a Type 304 U-bend specimen showing intergranular cracks after testing for 16 weeks at 40 °C (104 °F)

## Summary and Future Work

- Results of accelerated testing under conservative conditions indicate that deposited sea salts can form chloride-containing solutions at high relative humidity values and promote SCC in austenitic stainless steels.
- Higher temperatures and lower relative humidity prevent the formation of chloride-containing solutions that can promote SCC.
- The implications of this research suggest that the SCC of ISFSI storage casks appears to be limited to a narrow range of conditions but may be more likely during extended operation as the storage canister surface temperatures decrease.
- The NRC will share the results of this research with industry as part of the ongoing cooperative efforts to address the safe long-term storage of spent fuel.

### For More Information

Contact Darrell S. Dunn, RES/DE at 301-251-7621 or [Darrell.Dunn@nrc.gov](mailto:Darrell.Dunn@nrc.gov)



# High-Density Polyethylene Piping Research Program

## Background

As seen in Figure 9.26, carbon steel piping used for nuclear power plant Class 3 safety-related service water systems have experienced general corrosion, microbiologically induced corrosion (MIC), and biofouling resulting in leakage and flow restriction.



**Figure 9.26** Corrosion and biofouling of carbon steel service water system piping

As a result, the nuclear power industry has proposed to replace buried carbon steel piping service water systems with high-density polyethylene (HDPE). HDPE piping is typically immune to general corrosion, MIC, and biofouling; is less costly to install; and has a potential service life exceeding 50 years. HDPE piping is used extensively in natural gas distribution systems, as well as in municipal water piping systems, with great success. The mining and oil drilling industries offer examples of other applications of HDPE piping.

ASME Code, Section III, governs the design and installation of Class 3 safety-related service water piping systems. However, the ASME Code does not include the design and installation of HDPE piping systems. The ASME Section III/XI Special Working Group—Polyethylene Piping developed Code Case N-755, which provides rules for the design and installation of HDPE piping systems. Code Case N-755 addresses many of the issues related to using HDPE piping in Class 3 safety-related buried piping systems, but the NRC identified several issues related to the allowable service life conditions, pipe fusion, and inspection that need resolution before the agency will allow its general use by licensees. ASME is working to resolve these issues.

Since the NRC has not approved Code Case N-755, licensees have submitted relief requests for the substitution of carbon steel piping with HDPE piping for Class 3 safety-related applications. The agency has granted two such relief requests, which relied heavily on Code Case N-755, but the NRC imposed several additional requirements to help ensure piping and fusion joint integrity (see Figure showing HDPE piping installed at a nuclear power plant).



**Figure 9.27** Installation of underground Class 3 safety-related HDPE piping

## Regulatory Needs

The objective of this program is to conduct confirmatory research to assess the service life, design, fabrication, and inspection requirements proposed in Code Case N-755. Since HDPE is a new material for safety-related applications at nuclear power plants, data and analyses are needed to independently verify the requirements in Code Case N-755 and its application to existing and new nuclear power plants.

## Approach

RES is performing confirmatory tests and analyses on HDPE piping to evaluate the following:

- allowable service life conditions for pipe and fusion joints
- piping system design requirements
- fusion procedure qualification requirements
- nondestructive testing methods and procedure qualification requirements

RES is active in ASME Code activities related to HDPE piping and coordinates HDPE piping issues with the Office of Nuclear Reactor Regulation (NRR) and the Office of New Reactors (NRO) for eventual ASME resolution.

### For More Information

Contact Eric Focht, RES/DE at 301-251-7649 or [Eric.Focht@nrc.gov](mailto:Eric.Focht@nrc.gov)



# Neutron Absorbers in Spent Fuel Pools

## Background

After use in a nuclear reactor, fuel bundles are stored in the spent fuel pool in cells formed by a stainless steel rack structure. Subcriticality in the pool is often credited to panels of boron-10 containing neutron absorber materials which are placed within the rack walls. In the past 30 years, neutron absorber materials have shown various types of degradation, such as blistering or matrix degradation (see Figures 9.28 and 9.29). Incidents of excessive degradation are summarized in Information Notice 09-26, “Degradation of Neutron-Absorbing Materials in the Spent Fuel Pool,” dated October 28, 2009. Degradation of credited neutron absorber panels may invalidate the geometric and areal density assumptions used for the original criticality calculations of record and challenge the requirement for  $k_{\text{eff}}$  to be less than 0.95 as specified by Title 10 of the *Code of Federal Regulations* (10 CFR) Part 50.68, “Criticality Accident Requirements”.

Currently, plants assess the neutron absorption capabilities of these materials by three means: (1) mapping of degradation through software calculation packages, such as RACKLIFE; (2) direct in situ measurement of neutron absorption, such as Boron-10 Areal Density Gauge for Evaluating Racks (BADGER) testing; and (3) analysis of test coupons positioned in the pool. If significant degradation is detected, plants may reduce  $k_{\text{eff}}$  by reracking existing bundles and replacing or adding neutron absorber panels/inserts. However, as extended plant operations produce more and more spent fuel bundles, which need to be placed into previously unoccupied cells, and as neutron absorber materials age further, reracking and panel/insert addition or replacement have become more difficult.

## Objective

In light of these new concerns, the NRC staff is initiating a research program to catalog plants’ current use of neutron absorbers and evaluate the efficacy of current surveillance programs. Results of the program will guide future regulatory decisions pertaining to spent fuel pools.

## Approach

### Compilation of Existing Data

The NRC staff is currently collecting available historical data concerning spent fuel pools and absorbers from public licensing and relicensing documents. The staff is also collaborating with industry groups to obtain additional information. A complete databank of neutron absorber information will allow the staff to

identify degradation trends as a function of factors such as panel age, fluence, or pool environment.

### Evaluation of Surveillance Methods and Programs

Over the next 2 years, the staff is planning to conduct research to verify the accuracy of the BADGER testing and the RACKLIFE degradation modeling program. The staff is also studying mechanisms and rates of neutron panel degradation to determine whether these or other surveillance methods and programs can detect loss of neutron absorber capability and if such detection will occur in a timely manner.

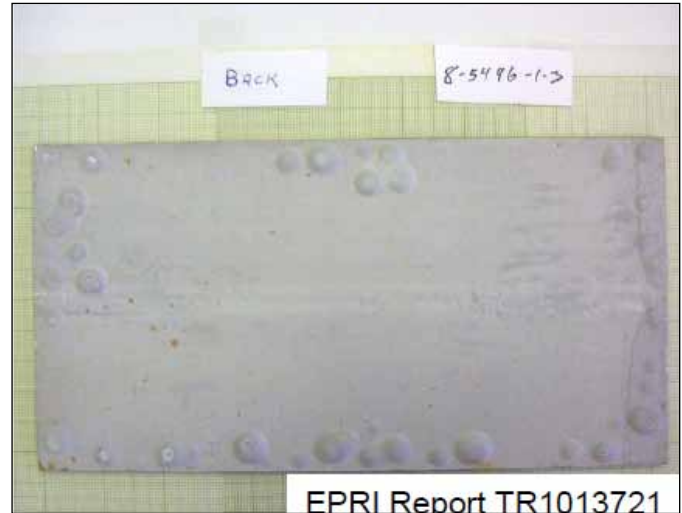

Figure 9.28 Blistering on the aluminum cladding of Boral neutron absorber



Figure 9.29 Degradation of the composite matrix in Boraflex neutron absorber

### For More Information

Contact April Pulvirenti, RES/DE at 301-251-7976 or [April.Pulvirenti@nrc.gov](mailto:April.Pulvirenti@nrc.gov)

# Chapter 10: Digital Instrumentation and Control and Electrical Research

Digital Instrumentation and Control

Digital Instrumentation and Control Probabilistic Risk Assessment

Analytical Assessment of Digital Instrumentation and Control Systems

Cyber Security for Digital Instrumentation and Control Systems

Susceptibility of Nuclear Stations to External Faults

Evaluation of Equipment Qualification Margins to Extend Service Life

Charging Current as an Indicator of a Fully Charged Battery



# Digital Instrumentation and Control

## Background

The digital instrumentation and control (I&C) area continues to evolve as the technology changes and the U.S. Nuclear Regulatory Commission (NRC) continues to refine its regulatory approach. Current control rooms are dominated by analog equipment, such as electromechanical switches, annunciators, chart recorders, and panel-mounted meters. However, as operating nuclear power plants (NPPs) upgrade their control rooms, analog equipment is being replaced with modern digital equipment, including flat screen operator interfaces and soft controls. Future plants will have highly integrated control rooms similar to those in Figure 10.1. The NRC has seen a substantial increase in the proposed use of digital systems for new reactors and retrofits in operating reactors. As a result, the NRC continues to update applicable licensing criteria and regulatory guidance and perform research to support licensing these new digital I&C systems.

In the 1990s, the NRC developed guidance to support the review of digital systems in NPPs. Since that time, the NRC has been effectively using the current licensing guidance for review of applications of digital technology in operating reactors and in certification of new reactor designs. In an effort to continually improve the licensing process, the NRC commissioned the National Academy of Sciences' National Research Council to review issues associated with the use of digital systems. The National Research Council issued its report, "Digital Instrumentation and Control Systems in Nuclear Power Plants," and made several recommendations, which included a recommendation to update the NRC research program to balance short-term regulatory needs and long-term anticipatory research needs. The Advisory Committee on Reactor Safeguards (ACRS) has also encouraged research in the digital I&C area to keep pace with the ever-changing technology.

## Overview

In 2005, the Office of Nuclear Regulatory Research (RES) developed a comprehensive 5-year Digital System Research Program Plan, which defined the I&C research programs to support the regulatory needs of the agency. In 2007, the NRC formed a Digital I&C Steering Committee and seven task working groups (TWGs) to work with the nuclear industry in improving regulatory guidance for digital I&C system upgrades in operating reactors, support design certification submittals for new reactors, and support review of digital I&C systems in fuel cycle facilities. The TWGs issued new interim staff guidance to address specific digital I&C regulatory issues. In 2010, the agency developed an updated Digital System Research Plan with input from several sources, including the National Research

Council's report on digital I&C systems at nuclear power plants, ACRS, external stakeholders, and the NRC staff. The updated research plan consists of five research program areas: (1) safety aspects of digital systems, (2) security aspects of digital systems, (3) advanced nuclear power concepts, (4) knowledge management, and (5) carryover projects. The products of these research programs include technical review guidance, information to support regulatory-based acceptance criteria, assessment tools and methods, standardization, and knowledge management initiatives.



Figure 10.1 Highly integrated control room

## Research Program

RES is currently conducting research in several key technical areas that support licensing of operating reactors, new reactors, and advanced reactors.

Work in the area of safety aspects of digital systems includes analytical assessment research to support safety evaluations of digital I&C systems. Ongoing research is developing an inventory and classification for NPP digital systems, elicitation of expert opinions on the state of the art in analysis of safety critical systems, failure mode and operational experience analysis, and a safety demonstration framework. This research will improve the understanding of how digital systems may fail and develop the commensurate criteria to ensure that these systems will not compromise their safety functions and not affect NPP safety adversely. Other research projects are investigating fault-tolerant testing techniques and advanced diagnostics and prognostics. The NRC and the industry are interested in risk-informing digital safety system licensing reviews. One of the major challenges to risk-informing digital system reviews is developing an acceptable method for modeling digital system reliability. The staff examined a number of reliability and risk methods that have been developed in other industries, such as aerospace, defense, and telecommunications. Based on its review of these techniques and available failure data, the staff performed benchmark studies

---

of digital system modeling methods, including traditional event-tree/fault-tree and dynamic methods. Internal staff and ACRS reviews of the studies challenged the viability of the methods and availability of data needed. Further research on the failure modes of digital systems and quantitative software reliability is being pursued.

With respect to the security aspects of digital systems, the staff developed a new Regulatory Guide 5.71, “Cyber Security Programs for Nuclear Facilities,” in support of Title 10 of the *Code of Federal Regulations* (10 CFR) 73.54, “Protection of Digital Computer and Communication Systems and Networks.” The staff is actively engaged in ongoing cyber research to explore cyber vulnerabilities in digital systems and networks, including wireless networks that are expected to be deployed in NPPs. This research will ultimately provide improved regulatory guidance and tools for evaluating digital systems and networks for cyber vulnerabilities, including potential vulnerabilities arising from safety and nonsafety system interconnections.

The staff is also staying abreast of advanced nuclear power concepts in the digital systems area. In support of the U.S. Department of Energy’s advanced reactor design programs, Next Generation Nuclear Plant, and the proposed license applications for small modular reactors, research projects to investigate unique regulatory aspects for advanced I&C are underway.

In the knowledge management area, collaborative research efforts in the United States and internationally support sharing regulatory standards and research data for digital systems. There are ongoing efforts to share operational experience data and analysis techniques with industry via the Electric Power Research Institute; with other Government agencies, such as the National Aeronautics and Space Administration, and with research organizations in other countries. Research supports international NPP digital system standards harmonization and NRC knowledge management and regulatory efficiency improvements.

**For More Information**

Contact Russell Sydnor, RES/DE at 301-251-7405 or [Russell.Sydnor@nrc.gov](mailto:Russell.Sydnor@nrc.gov)



# Digital Instrumentation and Control Probabilistic Risk Assessment

## Background

Nuclear power plants have traditionally relied on analog systems for their monitoring, control, and protection functions. With a shift in technology to digital systems with their functional advantages, existing plants have begun to replace current analog systems, while new plant designs fully incorporate digital systems. Since digital instrumentation and control (I&C) systems are expected to play an increasingly important role in nuclear power plant safety, the NRC has developed a digital I&C research plan that defines a coherent set of research programs to support its regulatory needs.

The current licensing process for digital I&C systems is based on deterministic engineering criteria. In its 1995 policy statement on probabilistic risk assessment (PRA), the Commission encouraged the use of PRA technology in all regulatory matters to the extent supported by the state of the art in PRA methods and data (Volume 60, page 42622, of the *Federal Register*). Although many activities have been completed in the area of risk-informed regulation, the risk-informed analysis process for digital I&C systems has not yet been satisfactorily developed. Since, at present, no consensus methods exist for quantifying the reliability of digital I&C systems, one of the programs included in the NRC digital I&C research plan addresses risk assessment methods and data for digital I&C systems. The objective of this research is to identify and develop methods, analytical tools, and regulatory guidance to support (1) nuclear power plant licensing decisions using information on the risks of digital systems and (2) inclusion of models of digital systems in PRAs of nuclear power plants.

## Approach

Previous and current Office of Nuclear Regulatory Research (RES) projects have identified a set of desirable characteristics for reliability models of digital systems and have applied various probabilistic reliability modeling methods to an example digital system (i.e., a digital feedwater control system (DFWCS)). Figure 10.2 provides an illustration of one of these modeling methods. Several NUREG/CR reports, which have received extensive internal and external stakeholder review, document this work. The results of these benchmark studies have been compared to the set of desirable characteristics to identify areas where additional research might improve the capabilities of the methods. One specific area currently being pursued by

RES is the quantification of software reliability. To examine the substantial differences in PRA modeling of software (versus conventional nuclear power plant components), in May 2009, RES convened a workshop involving a team of experts with collective knowledge of software reliability and/or nuclear power plant PRA. At the workshop, the experts established a philosophical basis for modeling software failures in a reliability model. RES is now reviewing quantitative software reliability methods and plans to develop one or two technically sound approaches to modeling and quantifying software failures in terms of failure rates and probabilities. Assuming such approaches can be developed, they will then be applied to an example software-based protection system in a proof-of-concept study.

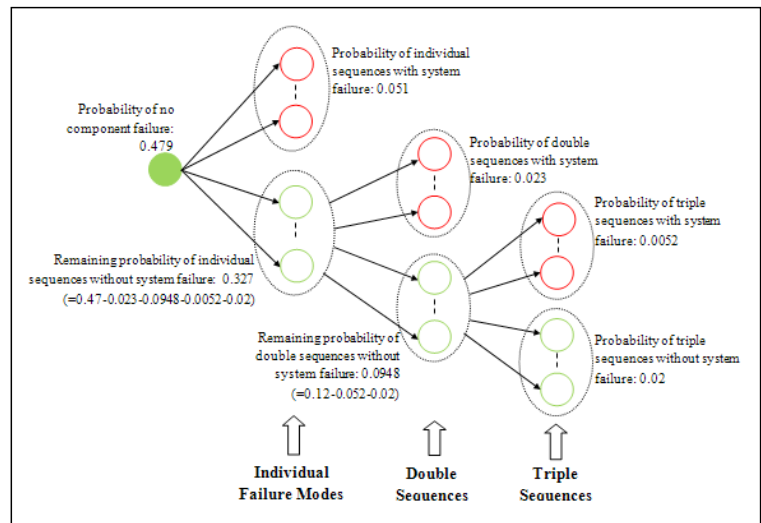

Figure 10.2 Condensed Markov state transition model for quantifying DFWCS failure frequency from hardware failures

The results of the benchmark studies have also highlighted the following areas for which enhancement in the state of the art for PRA modeling of digital systems is needed:

- approaches for defining and identifying failure modes of digital systems and determining the effects of their combinations on the system
- methods and parameter data for modeling self-diagnostics, reconfiguration, and surveillance, including using other components to detect failures
- better data on hardware failures of digital components, including addressing the potential issue of double-crediting fault-tolerant features, such as self-diagnostics
- better data on the common-cause failures (CCFs) of digital components
- methods for modeling software CCF across system boundaries (e.g., when there is common support software)
- methods for addressing modeling uncertainties in modeling digital systems



- 
- methods for human reliability analysis associated with digital systems
  - process for determining if and when a dynamic model of controlled plant processes is necessary in developing a reliability model of a digital system

Even if an acceptable method is established for modeling digital systems in a PRA and progress is made in the above areas, (1) the level of effort and expertise required to develop and quantify the models will need to be practical for vendors and licensees and (2) the level of uncertainty associated with the quantitative results will need to be sufficiently constrained so that the results are useful for regulatory applications.

### International Collaboration

In October 2008, RES staff led a technical meeting on digital I&C risk modeling for the working group on risk (WGRisk) of the Organization for Economic Cooperation and Development (OECD), Nuclear Energy Agency (NEA), Committee on the Safety of Nuclear Installations (CSNI). The objectives of this meeting were to make recommendations regarding current methods and information sources used for quantitative evaluation of the reliability of digital I&C systems for PRAs of nuclear power plants, and identify, where appropriate, the near- and long-term developments necessary to improve modeling and evaluation of the reliability of these systems. While the meeting did not produce specific recommendations of the methods or information sources that should be used for quantitative evaluation of the reliability of digital I&C systems for PRAs of nuclear power plants, it did provide a useful forum for the participants to share and discuss their experience with modeling these systems. The report documenting the meeting is available on the NEA Web site at <http://www.nea.fr/nsd/docs/2009/csni-r2009-18.pdf>. A follow-on WGRisk activity is now getting underway that will focus on development of a failure mode taxonomy for digital I&C systems for use when incorporating digital I&C systems into PRAs of nuclear power plants.

### References

NUREG/CR-6962, "Traditional Probabilistic Risk Assessment Methods for Digital Systems," October 2008.

NUREG/CR-6997, "Modeling a Digital Feedwater Control System Using Traditional Probabilistic Risk Assessment Methods," September 2009.

Chu, T.L., et al., "Workshop on Philosophical Basis for Incorporating Software Failures into a Probabilistic Risk Assessment," Brookhaven National Laboratory, Technical Report, BNL-90571-2009-IR, November 2009 (Agencywide Documents Access and Management System (ADAMS) Accession No. ML092780607).

### For More Information

Contact Alan Kuritzky, RES/DRA at 301-251-7587 or [Alan.Kuritzky@nrc.gov](mailto:Alan.Kuritzky@nrc.gov)

---

# Analytical Assessment of Digital Instrumentation and Control Systems

## Background

New and proposed digital instrumentation and control (I&C) systems in nuclear power plants (NPPs) pervade and affect nearly all plant equipment, with increasing interdependencies (e.g. through interconnections, resource sharing, and data exchanges), complexity is increasing. These interdependencies are becoming increasingly difficult to identify, analyze, and understand. Configurations of these networked systems tend to have plant-specific differences, such that no two systems are identical. The operating history of such systems is relatively short and, by the very nature of the systems and expected changes, is not likely to become statistically significant. In addition, unanticipated failure modes could create very confusing situations that might place the plant, or lead operators to place the plant, in unexpected or unanalyzed configurations. Under these conditions, evaluation for licensing has become very challenging. The Advisory Committee on Reactor Safeguards has also observed these concerns.

## Overview

This research project, which addresses these concerns, is driven by a combination of the Commission's staff requirements memoranda (SRM)-M070607 and SRM-M080605B and the needs expressed by the regulatory offices through the fiscal year (FY) 2010–FY 2014 NRC Digital Systems Research Plan (ADAMS Accession No. ML100541484).

Using existing theoretical knowledge in the fields of software and systems engineering for high-confidence, real-time control systems, this research will develop a framework of knowledge about how and why digital I&C systems may fail. The framework will allow continuous enrichment with new knowledge gained from operating experience and other research inside and outside the NPP application domain.

## Objectives

In support of the safety evaluation of digital I&C systems, this research will improve the understanding of how systems may fail and develop the commensurate criteria to ensure that these systems will not compromise their safety functions and affect NPP safety adversely.

Knowledge in the form of a causality framework will be useful in improving root-cause analysis of operating experience and will serve to inform companion research in PRA. Knowledge about modes of degradation will also inform research in the effects of degraded I&C on human performance.

## Approach

Based on an inventory of current and future digital I&C devices and systems in NPPs, the three preapproved digital I&C platforms, and emerging trends in digital technology, this research will characterize the NPP application domain and, for this bounded domain, it will identify credible failure and fault modes and analyze their effects, including the operating crew, the plant, and other affected systems. Since the limited failure modes of mature technology hardware components is relatively well understood and the practice of their application is relatively mature, the scope of this research focuses on understanding the failure modes of systems and systems of systems, the causes of such failures, and the criteria or conditions to avoid or prevent such failures. Of particular interest are the system failures caused by complex logic, whether implemented in the form of software, a field-programmable gate array, or a complex programmable logic device.

To acquire relevant knowledge outside the NPP industry, the NRC reached out to the world's leading researchers in safety-critical software and systems engineering and pursued an elicitation process culminating in a two-day clinic. The results from this expertise elicitation activity have shaped the direction of some of the research described below.

## Inventory and Classification of Digital Instrumentation and Controls Systems

In cooperation with the nuclear industry, this study will establish an inventory of current and future digital I&C devices and systems in NPPs. The purpose is to understand the scope and nature of the systems on which safety assessment research should be focused. The inventory will include enough information to allow characterization of the domains of applications in NPPs (the digital I&C devices and systems and their relationships to their environments) and clustering the inventoried items into classes of similarities. Example elements of information include: (1) the role or NPP function in which the item is applied, (2) whether the item stands alone or is interconnected, (3) various aspects and indicators of the complexity of the item, (4) the degree of verification or qualification, (5) properties of its architecture, and (6) properties of its development process to the extent that these elements or information are available. The intent of such characterization is to facilitate the understanding of possible adverse behaviors and approaches to ensure freedom from adverse behaviors.

## Digital Instrumentation and Control Failure and Fault Modes Research

This study will establish an analytical framework for organizing knowledge about how and why digital I&C systems may fail. The scope of the study will be limited to the domain of digital I&C devices and systems (e.g., classes of devices and systems represented in the existing inventory, NRC preapproved platforms, and trends in new licensing applications). The scope includes an analysis of systems with tightly coupled integration of traditionally decoupled or loosely coupled functions, applications (e.g., reactor trip system, engineered safety features actuation system), signals, and infrastructural services, as exemplified in new licensing applications.

Knowledge about failures, faults, and their causes will be organized in a reusable manner. Coupled with causal knowledge will be research on criteria or conditions to avoid or prevent such faults (e.g., constraints on the architecture and the development process).

## Knowledge Elicitation from Experts

To acquire relevant knowledge outside the NPP industry, the NRC reached out to the world's leading researchers in safety-critical software and systems engineering and pursued an elicitation process culminating in a two-day clinic held in January 2010 to identify the following:

- current limitations in the assurance of complex logic and areas of uncertainties
- evidence needed for effective assurance
- areas in need of research and development

The pool of experts represented a broad diversity in cultural backgrounds, application domains, and thought processes. Countries of origin included the United Kingdom, Sweden, Germany, Australia, New Zealand, Canada, and the United States. Application domains included defense, space flight, commercial aviation, medical devices, automobiles, telecommunications, and railways.

Through a chain of referrals by the experts, the NRC built a candidate pool of over 75, of which more than 30 experts were available for individual interviews. Based on common patterns emerging from the collective interviews, the NRC drafted a reference position to confirm with the experts the areas of general agreement and to identify areas for deeper discussion. While certain findings confirmed NRC staff positions, other findings revealed opportunities to improve the rigor and depth of NRC reviews. For example, the experts confirmed that the safety assessment for a digital I&C system will continue to require high caliber judgment from a diverse team, commensurate with the complexity of the system and its development process

and environment, such as in systems containing complex software or other manifestations of complex logic. To exercise reasonable judgment, the review team will require a variety of complementary types of evidence, integrated with reasoning to demonstrate that the remaining uncertainties will not affect system safety adversely. The experts recommended that, in the absence of such demonstration, there should be diverse defensive measures, independent from digital safety systems using complex software or other implementations of complex logic or products of software-intensive tools.

## Safety Demonstration Framework

In accordance with recommendations from the experts, as mentioned above, the NRC is investigating the application of the evidence-argument-claim structure (variously known as an assurance case or a safety case) to systematize the safety evaluation of a complex digital I&C system (see Figure 10.3). Although the NRC has a comprehensive regulatory guidance framework, certification or licensing applications submitted for review tend to address the various requirements and guidelines separately, rather than in a safety-goal-oriented integrative manner. This research will explore mapping the NRC's regulatory guidance framework into a safety-goal-oriented evidence-argument-claim framework.

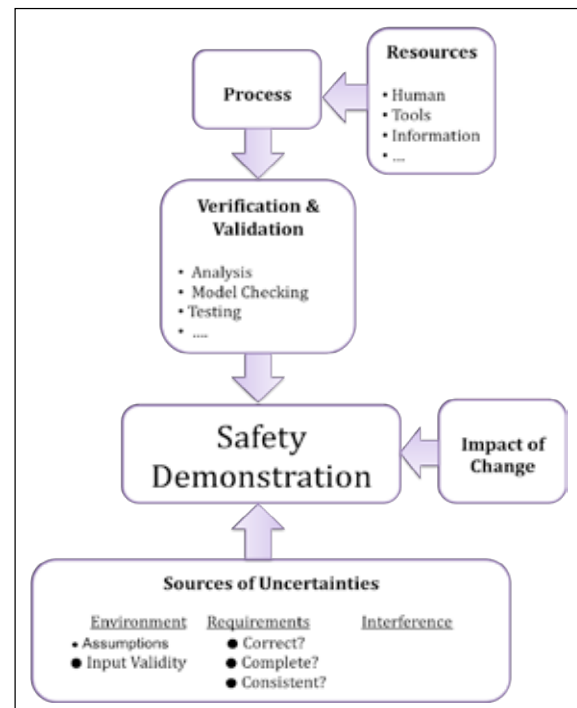

Figure 10.3 Integrating different types of evidence to demonstrate that a system is safe

### For More Information

Contact Luis Betancourt, RES/DE at 301-251-7409 or Luis.Betancourt@nrc.gov

# Cyber Security for Digital Instrumentation and Control Systems

## Background

As the nuclear industry continues to integrate modern digital technology into control and protection systems, new challenges and issues arise with ensuring that the critical functions at NPPs are protected from both malicious and unintentional acts through computer-based resources and communication networks. In 2009, the NRC issued a new cyber security rule in Title 10 of the Code of Federal Regulations (CFR) 73.54, which requires licensees to provide high degree of assurance that digital systems and networks are adequately protected from cyber threats up to and including the design-basis threat. In January 2010, the NRC office of research (RES) issued an accompanying Regulatory Guide 5.71, “Cyber Security Program for Nuclear Facilities,” which provides guidance to licensees on how to comply with the recently issued cyber security rule.

## Objective

The Digital Instrumentation and Controls Branch within RES has been actively involved in cyber security research for several years. One objective of this research is to ensure that NRC’s regulatory framework is appropriately updated to consider the anticipated increase of digital technology in existing and new reactors. This objective is covered by several cyber security research projects outlined in the Digital System Research Plan for FY 2010–FY 2014 and by establishing new regulatory guidance, such as Regulatory Guide 5.71.

## Issuance of Regulatory Guide 5.71

The cyber security rule (10 CFR 73.54) requires licensees to protect digital computer and communication systems and networks associated with safety-related functions, important to safety functions, security functions, emergency preparedness functions, and relevant support systems and equipment. Regulatory Guide 5.71 provides a performance-based approach that the NRC staff believes is acceptable for complying with 10 CFR 73.54. The approach outlined in Regulatory Guide 5.71 provides guidance to formulate a viable cyber security plan, identify critical digital assets (CDAs), and apply extensive National Institute of Standards and Technology (NIST) cyber security controls tailored specifically for NPPs.

The NIST cyber security standards (Special Publication 800-53, “Recommended Security Controls for Federal Information Systems,” and Special Publication 800-82, “Guide to Industrial

Control Systems (ICS) Security”) were adapted for use in nuclear facilities by considering some of the unique challenges posed by the intersection of industrial control systems and traditional information technology (IT) systems.

Since Regulatory Guide 5.71 provides a comprehensive approach to securing digital systems and networks, ongoing cyber security research seeks to produce tools and processes to better facilitate reviews of the cyber security plans, inspections of the cyber security plans, and technical reviews for future digital safety systems.



Figure 10.4 Graphic of United States showing infrastructure of various utilities

## Digital Safety System Vulnerability Assessments

Potential interactions between safety and security are an identified concern for digital upgrades in existing reactors and all-digital control and protection architectures for new reactors. The purpose of vulnerability assessments is to identify potential platform-based weaknesses. A critical digital safety system, such as a digital reactor protection system, may consist of several CDAs and could have multiple potential access points that might weaken the security posture if exploited by an adversary, such as a disgruntled insider. This project aims to first identify weaknesses, or vulnerabilities, in generic digital safety systems and then identify appropriate controls or practices that could mitigate or eliminate the identified vulnerabilities.

The approach for the digital safety systems vulnerability assessment is based on the Sandia National Laboratories’ red teaming process, which is a planned vulnerability assessment performed from the perspective of a postulated adversary. The red teaming process is adapted to model a defined adversary threat level and to observe the test systems’ response to attack progressions performed in a safe laboratory environment. This project will support development of regulatory positions on cyber security. The deliverables will also provide the NRC staff

---

with enhanced processes and tools for identifying and assessing security vulnerabilities. Deliverables from the digital safety system vulnerability assessments could also assist NRC staff reviews of cyber security plans, aid in training for regional cyber security inspections, and inform technical reviews for safety requirements.

## Network Security

The network security project supports regulatory priorities discussed with the NRC's Nuclear Security and Incident Response Office by identifying generic protection and mitigation measures appropriate to NPP environments. The project will support the review of digital I&C system upgrades in currently operating nuclear plants and future plants. This project also supports the Advanced Reactor Research Program.

Networking (both wireless and wired) is the interconnection of components (e.g., controllers, actuators, and sensors) with the objective of communicating among the associated subsystems. This networking of subsystems within a larger system framework can present security vulnerabilities in the system as a result of weaknesses in the network design that could be exploited during a cyber attack propagated through a vulnerable subsystem. These vulnerabilities could be inherent in the system features or could be incorporated into the system features during system development or before system installation.

The network security research project addresses secure network design techniques for networks yet to be installed in nuclear facilities. This research will obtain from digital industry security experts information regarding cyber vulnerability mitigation strategies that can be built into or added onto digital system architecture designs during the network design and development phase. The research also will identify strengths and weaknesses of various network architecture designs, including built-in and added-on cyber vulnerability mitigation strategies. The areas to be addressed will include preferred practices that prevent or mitigate insider cyber attack vectors, outsider cyber attack vectors, and developer cyber attack vectors.

## Wireless Network Security

In wireless communications, a signal is transmitted through a shared medium instead of a controlled conductive path, such as wires. Irrespective of the transmission medium, wired or wireless, many established security controls, such as those identified in Regulatory Guide 5.71, apply to any network. If a wireless network is not directly associated with a critical system at an NPP, it could provide a pathway to wired assets, which would qualify it as a wireless CDA according to guidance in Regulatory Guide 5.71.

Because wireless communications travel through air, and not a controllable path, interference from the environment, surrounding equipment, and structures becomes a dominant security and performance issue. The use of a shared transmission medium makes wireless network architecture and security implementation different from that of the wired network. Past research (e.g., NUREG/CR-6882, "Assessment of Wireless Technologies and Their Application at Nuclear Facilities," issued July 2006) has identified and assessed numerous security-related issues associated with implementing wireless systems, such as denial of service, wired equivalent privacy encryption, wireless telephony, and unsecured access points. Examples of the combinations of defensive measures to be explored in this project include password protection, encryption, administrative controls, network diversity and segmentation, firewalls, access point management (roaming), signal/noise/strength level monitoring, effects of wireless sensor usage, signal strength management, and even signal direction management. These security considerations are identified and addressed in a deliverable for the Wireless Network Security project being led by experts from the Oak Ridge National Laboratories.

### For More Information

Contact Jeanne Dion, RES/DE at 301-251-7482 or [Jeanne.Dion@nrc.gov](mailto:Jeanne.Dion@nrc.gov)



---

# Susceptibility of Nuclear Stations to External Faults

## Background

Offsite power is considered to be the most reliable electrical source for safe operation and accident mitigation in Nuclear Power Plants (NPPs). It is also the preferred source of power for normal and emergency NPP shutdown. When offsite power is lost, emergency diesel generators provide onsite power. Consequently, if both power sources are lost, a total loss of alternating current power could occur, resulting in station blackout, which is one of the significant contributors to core damage frequency.

In August 2003, an electrical power disturbance in the northeastern part of the United States caused nine NPPs to experience a loss-of-offsite power (LOOP) event. This event, which was initiated by an overgrown tree touching electrical transmission lines, resulted in cascading outages, caused trips of NPP stations, and disabled offsite power supplies. Thus, the design and maintenance practices for NPP switchyard protection systems can affect the reliability and availability of the plants' offsite power sources.

Since the deregulation of the electric power industry, NPP switchyards may have become more vulnerable to external faults because most of those switchyards are no longer owned, operated, or maintained by companies that have an ownership interest in the NPPs. Instead, the switchyards are maintained by local transmission and distribution companies, which may not fully appreciate the issues associated with NPP safety and security. Maintenance practices may also be inconsistent among these companies. In addition, circuit breaker components (i.e., relays, contacts, and opening/closing mechanisms) have begun to show age-related degradation. Improper maintenance of these components could affect the detection and mitigation of faults, which could, in turn, delay protective actions at NPPs.

At Catawba Nuclear Station on May 20, 2006, both units tripped automatically from 100 percent power following a LOOP event. (See the licensee event report for Event Number 41322006001, "Loss of Offsite Power Event Resulted in Reactor Trip of Both Catawba Units from 100% Power.") That event began when a fault occurred within a current transformer associated with one of the switchyard power circuit breakers. A second current transformer failure, along with the actuation of differential relays associated with both switchyard buses, deenergized both buses and separated the units from the grid.

## Objective

The NRC staff initiated a research project to develop a better understanding of the current power system protection in electrical switchyards and identify the system vulnerabilities that contribute to electrical fault propagation into nuclear facilities.

## Approach

This research project comprises multiple tasks. First, the contractor will review the operation of electrical protection systems associated with events that resulted in plant trips and LOOPs (e.g., Palo Verde, Catawba, and Peach Bottom). The contractor will then identify the root causes of the propagation of external electrical faults into the NPP switchyards, assess the level of protection of current NPP switchyard breaker arrangements and relay schemes used for protection, and coordinate this study with the North American Electric Reliability Corporation (NERC) and Federal Energy Regulatory Commission (FERC) and its assessments of switchyard protection. Lastly, the contractor will illustrate through analysis and modeling how an actual fault outside an NPP switchyard will affect an operating NPP station and will compare existing NPP switchyard designs with modeling and analysis of the settings and identify the desirable level of protection offered for responding to external faults.

## Products

Upon completion of this research project, the NRC may develop a NUREG-series report to provide an assessment of the NPP switchyard protection designs in its response to external electrical faults and will consider publishing a regulatory guide, in coordination with NERC and FERC, to address the desirable level of protection acceptable for NPP switchyards.

### For More Information

Contact Darrell Murdock, RES/DE at 301-251-7629 or [Darrell.Murdock@nrc.gov](mailto:Darrell.Murdock@nrc.gov)

---

# Evaluation of Equipment Qualification Margins to Extend Service Life

## Background

According to Title 10 of the *Code of Federal Regulations* Part 50 Section 49 (10 CFR 50.49), “Environmental Qualification of Electric Equipment Important to Safety for Nuclear Power Plants,” Class 1E electrical equipment located in a harsh environment must be environmentally qualified to perform its safety-related function during and following a design-basis event such as a loss-of-coolant accident.

In particular, 10 CFR 50.49, known as the Environmental Qualification (EQ) Rule, states that “margins must be applied to account for unquantified uncertainty, such as effects of product variations and inaccuracies in test instruments.”

The Institute of Electrical and Electronics Engineers (IEEE) Standard (Std.) 323-1974, “IEEE Standard for Qualifying Class 1E Equipment for Nuclear Power Generating Stations,” defines margin as the difference between the most severe specified service conditions of the plant and the conditions used in type testing.

Furthermore, Section 6.3.1.5 of IEEE Std. 323-1974 lists suggested factors for licensees and equipment manufacturers to apply to service conditions for type testing, including temperature, pressure, radiation, voltage, frequency, time, vibration, and environmental transients.

The margins, as indicated in IEEE Std. 323-1974, are utilized in the test profiles to determine the qualified life of equipment. However, the margins are expected to account for the following:

- manufacturing tolerances and measurement uncertainties
- lack of sufficient oxygen in the test chamber
- lack of simultaneous age conditioning (temperature and radiation)
- high dose rate for radiation aging
- license renewal to extend the life of equipment to 60 years
- inconsistencies in activation energy values used in the Arrhenius equation<sup>1</sup> for thermal aging

---

<sup>1</sup> The Arrhenius equation is a methodology for addressing time-temperature aging effects, where the key assumption is that material thermal degradation is dominated by a single chemical reaction whose rate is determined by the temperature of the material and a material constant called the activation energy.

Since manufacturing tolerances and measurement uncertainties cannot be readily quantified when establishing qualified life, margins are added to ensure that the equipment can perform its safety function. The lack of oxygen in the test chamber during accelerated aging could impact the qualified life since the equipment could have greater degradation because of the oxidation effects. As a result, equipment testing does not consider the effects of oxygen, and the margins account for this phenomena. Furthermore, recent data have shown that simultaneous aging (radiation and thermal) may produce synergistic effects that reduce the qualified life when compared to sequential aging. The same margins are also used to account for any variations between sequential and simultaneous aging. Using a smaller dose rate for the radiation aging of cables would more adequately result in showing radiation degradation effects, but the margin is also credited for the use of a high radiation dose rate. The existing margin is applied to extend the life of equipment to 60 years for license renewal, but when an imprecise activation energy is utilized, the impact on the time needed for thermal aging can be affected. Therefore, to correct for any errors in activation energy, margins are added. As a result, the margins are used to account for a variety of factors, as opposed to only production variations.

The regulatory use for this research will be to establish the technical basis for assessing the qualified life of electrical equipment in light of the uncertainties identified following the initial qualification testing.

## Approach

Through this research, the staff aims to (1) confirm whether EQ requirements for electrical equipment are being met throughout the current and renewed license periods of operating reactors, (2) quantify the margin, and (3) verify its adequacy to address the uncertainties discussed above. This research will assess the existing margins and evaluate its adequacy in light of known problems. The contractor will perform a background literature search and include the review of several key reports on the aging of cables. The NRC will publish a NUREG/CR report at the completion of this project outlining the margin available to address the known uncertainties when qualifying electrical equipment.

### For More Information

Contact Sheila Ray, RES/DE at 301-251-7644 or [Sheila.Ray@nrc.gov](mailto:Sheila.Ray@nrc.gov)

# Charging Current as an Indicator of a Fully Charged Battery

## Background

The NRC is sponsoring confirmatory battery testing research to determine whether charging current is a suitable indicator of a fully charged condition for lead-calcium batteries, to evaluate the impact of overcharging on battery capacity and service life, and to simulate battery aging and monitor its impact on battery life and performance. The research program will determine the level of current monitoring needed to ensure a fully charged condition and maintain operational readiness while in standby mode.

## Approach

Traditionally, the typical plant technical specifications required the measurement of specific gravity to determine if the battery was fully charged. To overcome the uncertainties in specific gravity measurements to assess the state of charge, the industry developed an alternate technique to measure charging current as an indicator. The Institute of Electrical and Electronics Engineers (IEEE) revised IEEE Standard (Std.) 450-1975, "IEEE Recommended Practice for Maintenance, Testing, and Replacement of Large Lead Storage Batteries for Generating Stations and Substations," to accommodate this new method. IEEE Std. 450-2002, "Recommended Practice for Maintenance, Testing, and Replacement of Vented Lead-Acid Batteries for Stationary Applications," recommends measuring the battery's charging current in lieu of specific gravity for determining a vented lead-calcium battery's state-of-charge. The standard provides the recommended practices, test schedules, and testing procedures, including recommended methods for determining a battery's state of charge to maintain permanently installed vented lead-acid storage batteries (typically of the lead-calcium type) for their standby power applications. The NRC staff endorsed this new standard and issued Regulatory Guide 1.129, Revision 2, "Maintenance, Testing, and Replacement of Vented Lead-Acid Storage Batteries for Nuclear Power Plants."

To confirm that the battery has the capability to perform its design function, the staff initiated the research and arranged the testing of batteries to be performed in three phases:

- (1) evaluation of charging current as a monitoring technique,
- (2) evaluation of the use of charging current to monitor battery capacity, and
- (3) impact of overcharging on batteries.

The approach for this research project will involve testing of lead-acid batteries from three different types of vendors to obtain a good sample of what is currently being used at the Nuclear

Power Plants (NPPs) (see Figure 10.5). The batteries will be installed in a configuration similar to that used in the plants and will be subjected to deep discharge/charge cycles to simulate an expected service life for the batteries. All testing will be performed in accordance with IEEE Std. 450-2002, along with a quality assurance plan developed specifically to meet the needs of the project in order to ensure an acceptable level of quality for the test results.

Upon the completion of the testing, the NRC will issue a NUREG-series report to document the assessment of the new test methods involving charging current. In addition, the NRC will consider issuing regulatory guidance to describe the various battery cell metallurgies and the best methods to verify the operational readiness of battery systems in NPPs.



Figure 10.5 NRC staff reviewing the first set of batteries that the contractor has received before commencing confirmatory battery testing

### For More Information

Contact Liliana Ramadan, RES/DE at 301-251-7642 or [Liliana.Ramadan@nrc.gov](mailto:Liliana.Ramadan@nrc.gov)

---

# Chapter 11: New and Advanced Reactor Research

Thermal-Hydraulic Analyses of New Reactors

Computational Fluid Dynamics in Regulatory Applications

Advanced Reactor Research Program

Next Generation Nuclear Plant

Materials Issues for High-Temperature Gas-Cooled Reactors

Confirmatory Analysis Tool for Structural Integrity  
Evaluation of Creep and Creep-Fatigue Crack  
Growth in Next Generation Nuclear Plant Metallic  
Components

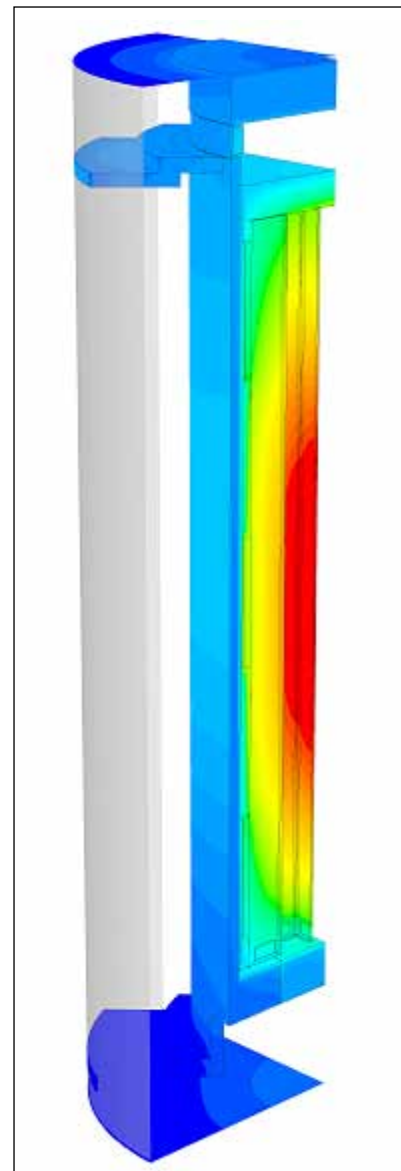

Temperature contours of a ventilated dry cask that uses ambient air to passively cool the spent fuel stored inside the canister surrounded by a concrete overpack



# Thermal-Hydraulic Analyses of New Reactors

## Background

The U.S. Nuclear Regulatory Commission (NRC) uses the Transient Reactor Analysis Code/Reactor Excursion and Leak Analysis Program (TRAC/RELAP) Advanced Computational Engine (TRACE) code to perform confirmatory calculations in support of design certification and combined operating license reviews for all new reactors—the Advanced Passive 1000 Megawatt (AP1000), U.S. Advanced Pressurized-Water Reactor (U.S. APWR), the U.S. Evolutionary Power Reactor (EPR), the Economic Simplified Boiling-Water Reactor (ESBWR), and the Advanced Boiling-Water Reactor (ABWR). The modeling of various integral pressurized-water reactor (IPWR) designs has been undertaken to assess the applicability of NRC codes in anticipation of confirmatory analyses.

New reactor designs include evolutionary advances in light-water reactor technology and thus pose unique modeling challenges as a result of novel systems and operating conditions. Many of these modeling challenges are associated with passive systems that rely on phenomena such as gravity, pressure differentials, natural convection, or the inherent response of certain materials to temperature changes. Most developmental assessments conducted for currently operating light-water reactors cover the phenomenology necessary in thermal-hydraulic simulations for new reactor designs. However, the modeling of some of the novel systems and operating conditions of new reactors requires further code development and additional assessments against specific experimental data.

## New Reactor Designs

### AP1000

The AP1000 (see Figure 11.1) relies extensively on passive safety systems. Passive systems are used for core cooling, containment cooling, main control room emergency habitability, and



Figure 11.1 AP1000

containment isolation. These systems challenge system codes in predicting fluid flow induced by small driving heads. The applicability of TRACE to simulate AP1000 transients was

demonstrated through comparisons with data from relevant integral and separate-effects test facilities.

### U.S. APWR

Most of the major components of the U.S. APWR (see Figure 11.2) are very similar to those of existing pressurized-water reactors (PWRs). The major exception is the advanced accumulator that eliminates the need for pumped low-pressure safety injection. The ability of TRACE to predict the behavior of advanced accumulators has been demonstrated with separate-effects data. Furthermore, detailed three-dimensional phenomena, such as cavitation, nitrogen ingress, and mass flow rate, have been modeled using computational fluid dynamics tools, and the results were coupled as needed with system code simulations.



Figure 11.2 U.S. APWR

### EPR

The EPR (see Figure 11.3) is an evolutionary PWR design that uses rapid secondary-side depressurization for mitigation of loss-of-coolant accidents (LOCAs). This increases the emphasis on the ability of TRACE to predict reflux condensation in steam generator tubes. To demonstrate the applicability of TRACE to the EPR, code predictions were assessed against data acquired from separate and integral test facilities, such as Advanced Power Extraction (APEX), Full-Length Emergency Cooling Heat Transfer-Separate Effects and Systems Effects Tests (FLECHT-SEASET), Rig of Safety Assessment (ROSA)-IV, and ROSA-V.



Figure 11.3 U.S. EPR



## ESBWR

The ESBWR (see Figure 11.4) has a passively driven containment cooling system and a gravity-driven cooling system. Both of these systems rely entirely on natural phenomena for the convection of mass and energy. The prediction of void distributions and two-phase natural circulation is very important for the ESBWR. Integral test data from the Purdue University Multi-Dimensional Integral Test Assembly (PUMA) and Passive Non-Destructive Assay of Nuclear Materials (PANDA) facilities were used to assess the code for this application. In addition, proper modeling of film condensation in the presence of noncondensable gases at low power levels posed a significant challenge in the ESBWR analysis. Improved models in TRACE predicted these phenomena very well.

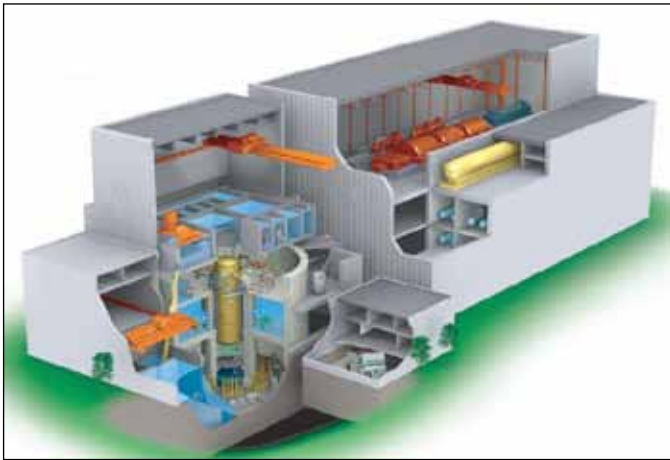

Figure 11.4 ESBWR

## ABWR

The ABWR (see Figure 11.5) is an evolutionary boiling-water reactor that includes such design enhancements as recirculation pumps internal to the reactor vessel and digital controls.



Figure 11.5 ABWR

TRACE will be used to simulate the plant response to LOCAs, as well as to anticipated operational occurrences and other transients. Modeling internal pumps and incorporating the logic needed for digital controls will pose potential challenges to the code.

## IPWR

The current IPWR designs (see Figure 11.6) eliminate the external reactor coolant piping and integrate the steam generator and pressurizer into the reactor vessel as one integral primary system. The NuScale IPWR design uses helical tube steam generators, and the mPower IPWR design uses once-through tube steam generators to produce superheated steam in the secondary system. Test data from the Multi-Application Light Water Reactor (MASLWR) and integrated system test (IST) facilities are being used to assess the NRC codes for applicability to these designs. Proper modeling of helical tube heat transfer, film condensation, and natural circulation are the main challenges for TRACE simulation.

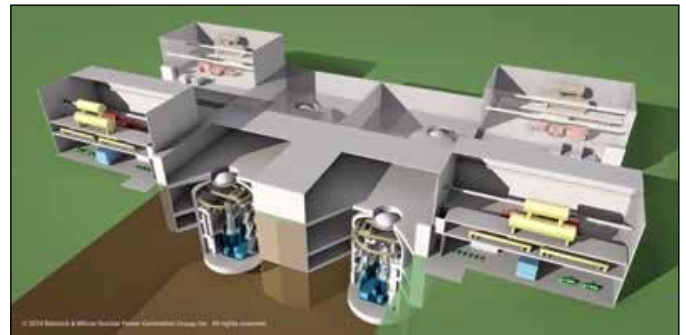

Figure 11.6 IPWR

### For more information

Contact Jaclyn Dorn, RES/DSA 301-251-7565 or [Jaclyn.Dorn@nrc.gov](mailto:Jaclyn.Dorn@nrc.gov)

# Computational Fluid Dynamics in Regulatory Applications

## Background

Computational fluid dynamics (CFD) has reached the maturity necessary to play an increased role in the nuclear power generation industry. CFD provides detailed three-dimensional fluid flow information not available from system code thermal-hydraulic simulations. These multidimensional details can enhance the understanding of certain phenomena and thus play a role in reducing uncertainty and improving the technical bases for licensing decisions.

The NRC's Office of Nuclear Regulatory Research (RES) has developed a state-of-the-art CFD capability that supports multiple offices within the agency. RES uses the commercial CFD codes from ANSYS Inc. (FLUENT) and CD-adapco (STAR-CCM+) and has supported the development of multiphase modeling capabilities in research codes. The office maintains a Linux cluster with over 200 processors to provide the capability needed to solve the large-scale problems that are characteristic in the nuclear industry. RES staff is actively involved in national and international CFD programs and maintains a high level of expertise in the field. This state-of-the-art capability provides a robust infrastructure for both confirmatory and exploratory CFD computations.

## Applications

### Spent Fuel Transportation And Storage

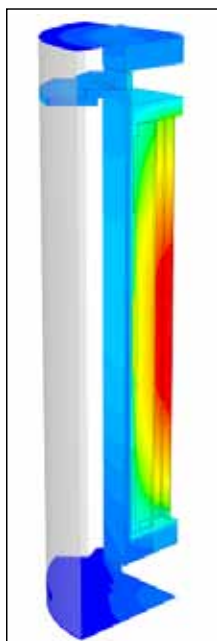

RES works closely with the Office of Nuclear Material Safety and Safeguards in areas concerning the analysis of spent fuel storage cask designs.

The CFD approach has been used to study cask designs under a variety of external conditions, such as fires, reduced ventilation, and hotter fuels. This work supports dry cask certification efforts by improving the agency's technical bases for licensing decisions (see Figure 11.7).

**Figure 11.7** Temperature contours of a ventilated dry cask that uses ambient air to passively cool the spent fuel stored inside the canister surrounded by a concrete overpack

### Operating Reactors

CFD predictions have also aided in understanding detailed fluid behavior for broad-scope analyses, such as pressurized thermal shock, induced steam generator tube failures, boron dilution and transport, and spent fuel pool analyses. In most cases, CFD results are used iteratively with system code predictions, or they provide boundary or initial conditions for other simulations (see Figure 11.8).

### New And Advanced Reactors

The agency has used CFD to confirm the distribution of injected boron in the ESBWR. In the design certification of the U.S. APWR, CFD was used to investigate the performance of an advanced accumulator (see Figure 11.9). The phenomena of interest are cavitation and nitrogen ingress, which exceed typical system code capabilities. The validation of the CFD simulation against experimental data was particularly challenging for this application, especially because CFD results were also used to examine possible scale effects.

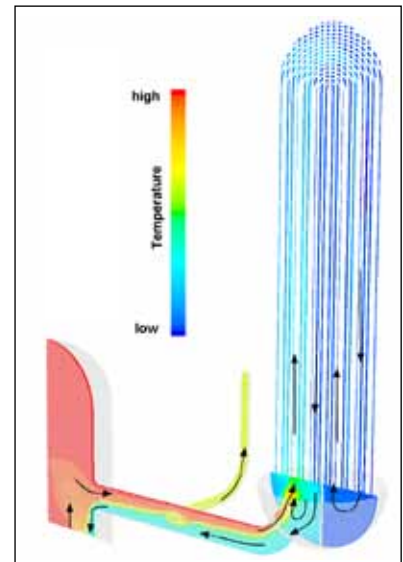

**Figure 11.8** During a particular severe accident scenario, hot gases from the core circulate through the hot legs and steam generator in a counter-current flow pattern. The risk of induced failures is considered.

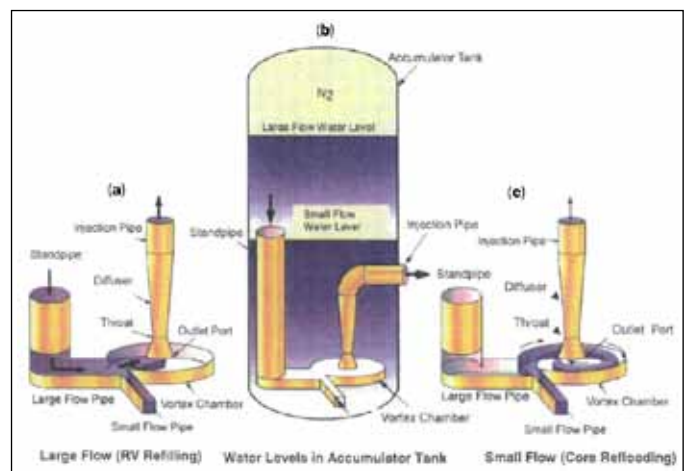

**Figure 11.9** The advanced accumulator (b) is a water storage tank with a flow damper in it that switches the flow rate of cooling water injected into a reactor vessel from a large (a) to small (c) flow rate

### For More Information

Contact Kenneth Armstrong, RES/DSA, at 301-251-7551 or [Kenneth.Armstrong@nrc.gov](mailto:Kenneth.Armstrong@nrc.gov)

# Advanced Reactor Research Program

## Background

RES has updated the NRC's Advanced Reactor Research Program (ARRP). The original ARRP was forwarded to the Commission on April 18, 2003, as Enclosures 1 and 2 to SECY-03-0059, "NRC's Advanced Reactor Research Program." The revised ARRP focuses on advanced nonlight-water reactor (non-LWR) designs involving high- (and very-high-) temperature, graphite-moderated, gas-cooled reactors. The high-temperature gas-cooled reactor (HTGR) and very-high-temperature gas-cooled reactor (VHTR) research infrastructure assessment and related NRC research and development (R&D) plans rebaseline the earlier HTGR research infrastructure assessment and R&D plans documented in SECY-03-0059.

## Overview

The revised ARRP documents the NRC's current assessment of its research infrastructure needs and the agency's planned safety research to support its review of HTGR and VHTR licensing applications. These include a combined license (COL) application for a VHTR to be constructed at the Idaho National Laboratory (INL) in connection with the Next Generation Nuclear Plant (NGNP) Project, as directed by the Energy Policy Act of 2005 (EPAct) (Public Law 109-58), and a potential design certification application for the pebble bed modular reactor.

The update also includes a high-level survey of the technical infrastructure development and initial safety research that the NRC would need to conduct to prepare for its review of a potential sodium-cooled fast reactor (SFR) licensing application. Such licensing applications include a near-term application for design approval for the Toshiba Super Safe, Small and Simple (4S) reactor and a longer term licensing application for a commercial advanced fast-burner reactor being developed by the U.S. Department of Energy (DOE) for nuclear fuel recycling. The SFR research infrastructure survey was conducted at a higher level than the HTGR and VHTR reassessment. The survey identifies the key technical, safety, and research issues associated with SFR licensing. The survey provides a framework for a potential follow-on in-depth SFR research infrastructure assessment similar in scope to the HTGR and VHTR assessment. As an example, the NRC HTGR accident analysis evaluation model concept schematic shown in Figure 11.10 demonstrates the applicability of research results to reactor plant systems analysis.

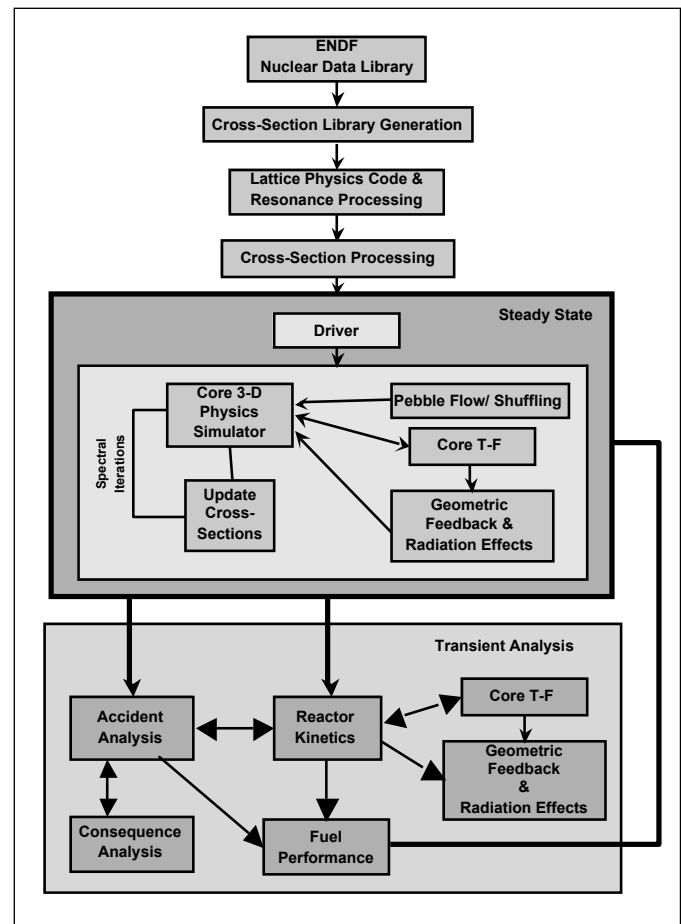

Figure 11.10 Schematic of NRC HTGR accident analysis evaluation model concept

The updated ARRP also includes technical infrastructure development and associated NRC safety research needs that are generically applicable to all advanced reactor designs. Generic advanced reactor arenas include human performance, advanced digital instrumentation and controls, and probabilistic risk assessment.

The revised ARRP reflects the results of phenomena identification and ranking table reviews conducted for the NGNP VHTR. The revision also reflects comments received from DOE and INL on a draft revision of the ARRP update, as well as technical information provided by DOE and INL on the R&D being conducted by the DOE national laboratories in support of the design, development, and licensing of the NGNP VHTR. The ARRP also considers technical information received from other national and international organizations involved in HTGR safety R&D.

The current update recognizes that some of the technical infrastructure issues and NRC safety research plans documented in the 2003 ARRP were subsequently included in the R&D plans of selected foreign or domestic HTGR or VHTR design, development, or research organizations. The updated ARRP

---

reflects completion of selected high-priority HTGR-specific and generic safety R&D described in the 2003 ARRPP.

The scope of the reassessment does not include the technical infrastructure development and safety research that may be needed to support the review of licensing applications for advanced LWRs (e.g., the AREVA EPR, General Electric ESBWR, Westinghouse International Reactor Innovative and Secure (IRIS) LWR, Mitsubishi U.S. APWR, and NuScale MASLWR). The staff will document these R&D needs separately on an advanced LWR design-specific basis.

The NRC will assign priorities to R&D tasks for developing the agency's VHTR technical infrastructure development and safety research consistent with the NGNP VHTR technology selection and COL application schedule. Priorities will be similarly assigned to the generic NRC R&D tasks. NRC technical infrastructure development to support the agency's safety review of these designs will involve the development of staff expertise, analytic tools and methods, experimental facilities, and data. In the near term, the staff expects the highest priority NGNP VHTR-specific technical infrastructure development and safety research to be in the areas of materials analysis, fuel performance analysis, nuclear and thermal-fluid analysis, accident analysis, and technical review infrastructure.

The ARRPP HTGR and VHTR infrastructure assessment and SFR infrastructure survey identify, respectively, the gaps in the NRC's technical information and data and independent technical capabilities for conducting licensing application reviews for HTGRs and SFRs.

## Summary

The VHTR and HTGR infrastructure technical needs assessment activities are linked to the following nine key safety research arenas:

1. technical review infrastructure (including draft regulatory review guidance for applying probabilistic risk information in establishing licensing basis events; classification of systems, structures, and components; and defense in depth)
2. accident analysis (including probabilistic risk assessment methods and assessment guidance, human performance, and instrumentation and control)
3. reactor/plant systems analysis (including thermal-fluid analysis, nuclear analysis, mechanistic source term analysis, and fission product transport analysis)
4. fuel performance analysis (including fuel performance mechanistic analysis and fuel fission product transport analysis)
5. materials analysis (including nuclear graphite component and metallic component performance)

6. structural analysis (including reactor building civil structure and reactor core internals structural performance) and reactor safety hazards posed by a connected nearby hydrogen production or process heat facility
7. consequence analysis (including dose calculations and environmental impact studies)
8. nuclear materials safety (including enrichment, fabrication, and transport) and waste safety (including storage, transport, and disposal)
9. nuclear safeguards and security

Human performance and instrumentation and controls are considered generic arenas applicable to all advanced reactor designs and technologies. The SFR infrastructure survey addressed reactor/plant systems analysis (including thermal-fluid dynamics, nuclear analysis, and severe accident and source term analysis), fuels analysis, materials analysis, and structural analysis.

### For More Information

Contact Tarek Zaki, RES/DSA at 301-251-7986 or [Tarek.Zaki@nrc.gov](mailto:Tarek.Zaki@nrc.gov)



# Next Generation Nuclear Plant

## Background

The Next Generation Nuclear Plant (NGNP) is an advanced reactor concept for generating electricity and producing hydrogen using the process heat from the reactor outlet. Title VI, Subtitle C, Section 641, of the EPA Act directs the DOE Secretary to develop an NGNP prototype for operation by 2021. Furthermore, Title VI, Subtitle C, Section 644(a), provides the NRC with the licensing authority for the NGNP prototype, and Section 644(b) requires that the Secretary of DOE and the Chairman of the NRC jointly develop a licensing strategy for the NGNP to submit to the U.S. Congress by August 2008.

## Approach

The scope of the NGNP licensing strategy development project addresses all elements of the NGNP licensing strategy as described in Section 644(b) of the EPA Act:

- NGNP licensing approach (i.e., a description of the ways in which current light-water reactor (LWR) licensing requirements need to be adapted for the types of reactors considered for the NGNP project)
- analytical tools needed by the NRC to independently verify the NGNP design and its safety performance in order to license an NGNP
- other R&D that the NRC will need to conduct for the review of an NGNP license application
- resource requirements to implement the licensing strategy

DOE has determined that the NGNP nuclear reactor will be a very-high-temperature gas-cooled reactor (VHTR) for the production of electricity, process heat, and hydrogen (see Figure 11.11). The VHTR can provide high-temperature process heat (up to 950 degrees Celsius) that can be used as a substitute for the burning of fossil fuels for a wide range of commercial applications. Since the VHTR is a new and unproven reactor design, the NRC will need to adapt its licensing requirements and processes, which have historically evolved around LWR designs, for licensing the NGNP nuclear reactor.

### NGNP Reactor Technology

NGNP reactor technology differs from that of commercial LWRs. Hence, to develop a licensing approach, an NGNP technology envelope needs to be defined, considering key project assumptions and uncertainties that are relevant to evaluating licensing options and establishing technical requirements.

These aspects may include, but are not limited to, technology options being considered; potential prototype plant parameter envelope (e.g., licensed power level, fuel type and performance characteristics, power conversion cycle, hydrogen cogeneration technology, spent fuel management, safety and security issues); and plans and schedules for technology development, design development, and licensing.

The final design of a prototype NGNP will be realized some time in the future; however, the two concepts in the forefront of technology development are the pebble bed reactor and the prismatic core reactor.



Figure 11.11 Artist's rendition of an NGNP plant

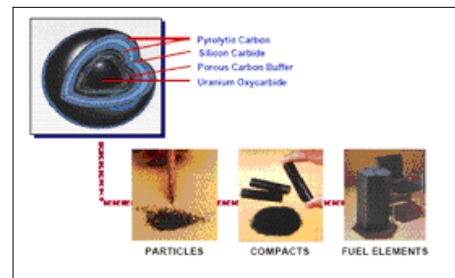

Figure 11.12 TRISO fuel for NGNP

### NGNP Licensing Requirements

Many of the regulatory requirements and supporting review guidance for LWRs are technology neutral; that is, they are applicable to non-LWR designs as well as to LWR designs. However, certain LWR requirements may not apply to the unique aspects of an NGNP design. Accordingly, in developing the NGNP licensing strategy, the NRC and DOE considered the various options available to the NRC staff for adapting current NRC LWR licensing requirements for the NGNP VHTR. These options related to legal, process, technical, research, and regulatory infrastructure matters and included an examination of historical licensing activities. These considerations led to selection of a licensing strategy that would best comply with the considerations identified in the EPA Act.

The licensing strategy developed jointly by the NRC and DOE has two distinct aspects. The first is a recommended approach for how the NRC will adapt the current LWR licensing



---

technical requirements to apply to an NGNP. The second is a recommended licensing process alternative that identifies which of the procedural alternatives in the NRC regulations would be best for licensing the NGNP. To arrive at these recommendations, the NRC and DOE evaluated a number of options and alternatives.

### **Analytical Tools Development and Other R&D**

Certain analytical tools will likely need to be developed or modified in different technical areas to enable the review of the NGNP license application, evaluate the safety case, and assess the safety margin. Given the early stage of the NGNP program, the development needs should be considered preliminary projections to be reevaluated on an ongoing basis.

To address regulatory and safety issues for an NGNP design in major technical areas, and, in particular to identify important safety-relevant phenomena associated with these design concepts and to assess the knowledge base, a phenomena identification and ranking table (PIRT) exercise was conducted in 2007. The PIRT process involved assembling groups of experts in each of the identified major areas, facilitating focused discussions among the experts in these areas, annotating expert deliberations and finally, assessing the knowledge gaps in these areas based on expert deliberations.

The PIRT exercise was conducted in the following major topical areas associated with the NGNP:

- thermal fluids and accident analysis
- high-temperature materials including graphite
- process heat and hydrogen cogeneration
- fission product transport (FPT) and dose
- tristructural isotropic (TRISO)-coated fuel particles (see Figure 11.12)

The NRC plans to use existing analytical tools to the extent feasible, with appropriate modifications for the intended purpose. For LWR safety analysis, the NRC traditionally uses its system-level MELCOR code, which is capable of performing thermal-fluid and accident analysis, including FPT and release. This code will be modified for the NGNP. Also, as needed, CFD models and associated tools will be developed to investigate certain thermal-fluids phenomena in greater detail so as to reduce uncertainties in predictive capability.

The NRC uses Purdue's Advanced Reactor Core Simulator (PARCS), among other codes, for neutronic calculations, which provide initial and boundary conditions to accident analysis codes such as MELCOR. The neutronic codes can be modified as appropriate for NGNP confirmatory analysis. The agency

will use a fuel performance code to provide fuel-related initial and boundary conditions to accident analysis codes. DOE has ongoing R&D activities to support development of such a code. The NRC will explore inclusion of this code or, at a minimum, the fuel performance models in the code, in the agency's suite of codes.

In other technical areas (notably, high-temperature materials and graphite performance and fuel performance), the development strategy for confirmatory analysis tools will utilize various sources of information to the maximum extent feasible. Current R&D activities funded by DOE, as well as international cooperative R&D programs, are addressing many of these areas. To the extent that data and tools are available from these activities, the NRC will use this information in the development of its independent confirmatory analysis capability. The NRC will also make extensive use of experimental data generated by an applicant and provided to the agency as part of the license submittal, as well as data from domestic and international programs and other sources available in the open literature.

### **Project Status**

The NGNP Licensing Strategy report was submitted to the U.S. Congress in August 2008. Work is currently in progress to implement various elements of the licensing strategy.

#### **For More Information**

Contact Sudhamay Basu, RES/DSA at 301-251-7521 or [Sudhamay.Basu@nrc.gov](mailto:Sudhamay.Basu@nrc.gov)

# Materials Issues for High-Temperature Gas-Cooled Reactors

## Background

High Temperature Gas-Cooled Reactors (HTGRs) operate in an environment quite different from that of Light Water Reactors (LWRs). Challenges to the pressure boundary metallic materials and graphite and other ceramic core components are considerably more severe. The HTGR coolant does not change phase and the graphite core components (GCCs) are exposed to very high temperatures and neutron fluence.

The integrity of metallic and graphite components is important to maintaining safety. Integrity of components is necessary to avoid air, water, or steam ingress into the pressure boundary and to maintain core geometry. The pressure boundary also acts as a barrier to release of radioactivity. A sound technical basis is necessary for evaluating the integrity and failure modes of components.

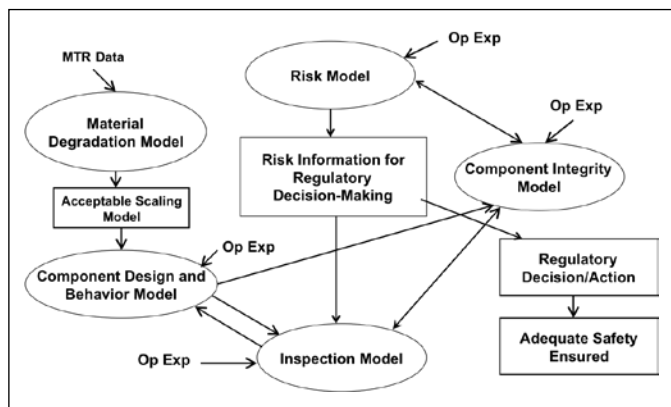

Figure 11.13 Influence of material behavior, inspection, flaw evaluation, and component integrity assessment on risk assessment

As illustrated in Figure 11.13, information from various aspects of materials research, such as degradation mechanisms, inspection efficacy, stress analysis, and component integrity assessment, obtained from probability of failure estimate, is needed for conducting probabilistic risk assessments resulting from the failure of these components to perform their intended functions. Note that failure probability data are not available from experience; therefore, large uncertainty information may be developed from research to identify and quantify degradation processes

The EPAAct established the NGNP to demonstrate the generation of electricity or hydrogen, or both, with an HTGR. The NRC is responsible for licensing and regulatory oversight of the NGNP. A combined construction and operating license application for the NGNP is presently scheduled for submittal to NRC in fiscal

year (FY) 2013.

As of summer 2010, the design of the NGNP HTGR is still conceptual, and final component specification and material selection have yet to be determined. Therefore, the NRC continues to research generic component performance requirements. Candidate materials for specific applications are being evaluated to identify potential qualification and acceptance gaps.

The staff expects the HTGR applicant to provide complete data with the COL or design certification (DC) application. This will include technical bases to support the designed functions of high-temperature materials and GCCs. The staff evaluation of the design will rely on the applicant-provided information. During reactor operation, the licensee will confirm designed performance of GCC via periodic inspections and coupon tests.

The NRC began to develop a research plan during 2003 on materials issues related to HTGR and has updated it on an annual basis. The research plan has been coordinated with the Office of New Reactors (NRO) and has been presented periodically to the Advisory Committee on Reactor Safeguards (ACRS). The research plan identified the lack of consensus codes and standards for high-temperature materials and graphite as a leading hurdle for staff review of an HTGR license application. A number of research projects have been conducted since then.

## High-Temperature Materials Research

For metallic materials, the staff analyzed the limitations involved in extending the known properties at lower temperatures to the HTGR operating temperature. The agency published the results of this analysis, conducted by Argonne National Laboratory (ANL), as NUREG/CR-6816, "Review and Assessment of Codes and Procedures for HTGR Components." Seven codes and procedures were analyzed, including five American Society of Mechanical Engineers (ASME) codes (Section III, Subsection NB, and Subsection NH) and Code Cases (N-499-1, N-201-4, and the draft Code Case for Alloy 617); one French code (RCCMR); and one British procedure. The report concluded the following:

- Most of the materials needed for HTGR were not included in the code cases; therefore, new code cases are needed for these materials.
- Codes and code cases did not provide specific guidelines for environmental effects, especially the effect of impure helium, on the high temperature behavior (e.g., creep and creep-fatigue) of the materials considered.
- Data on environmental effects should be collected or generated, if not available, so that the specific guidelines for these effects can be developed.

---

ANL also examined in considerable detail high-temperature material properties of relevance to HTGR and published the results in NUREG/CR-6824, “Materials Behavior in HGTR Environments.” The report identified the materials used for structural applications (such as pressure vessel and reactor primary circuit components, including internals) and for the power conversion system, with emphasis on gas-turbine-based HTGRs.

The NRC staff has been participating in ASME Code, Section III, Subsection NH, development activities to ensure that code cases consider in sufficient detail the environmental effects on important alloying elements and their distribution and affected properties whose degradation will influence the design margin for maintaining the integrity of the coolant pressure boundary.

The NRC also jointly participated with DOE in sponsoring ASME S&T LLC in developing a roadmap for updating the Subsection NH Code to be applicable to the NGNP HTGR. The following key issues continue to be addressed:

- flaw evaluation for design margin assessment
- component classifications
- development of risk-informed inspection program, including reliability and integrity management (RIM) of passive metallic components

During 2010, a research contract was placed at Pacific Northwest National Laboratory (PNNL) to determine a suite of reliable flaw evaluation techniques for HTGR high-temperature materials, including acoustic emission. In addition, PNNL staff will review the documents currently being generated by the ASME Code Division 5 Section XI Special Working Group for HTGR inservice inspection (ISI) requirements. PNNL will identify additional information needed to evaluate the applicant’s design and to review licensee-proposed ISI programs.

During 2007, the NRC conducted a PIRT exercise with a panel of high-temperature materials experts to determine data needs which have high importance to safety and low knowledge. The exercise identified five phenomena in this category. NUREG/CR-6944, “Next Generation Nuclear Plant Phenomena Identification and Ranking Tables (PIRTs),” Volume 4, “High-Temperature Materials PIRTs,” issued March 2008, contains the results of the PIRT exercise. Of these five phenomena, the NRC decided to focus research on the development of a time-dependent creep and creep-fatigue crack growth predictive methodology that will be integrated into the modular probabilistic fracture mechanics (PFM) computer code. This work, being conducted at Oak Ridge National Laboratory (ORNL), is the subject of a separate information sheet.

## Nuclear Graphite—Research

Consistent with the graphite research plan, the NRC, in cooperation with DOE, conducted a PIRT exercise with an international panel of nuclear graphite experts. NUREG/CR-6944, Volume 5, “Graphite PIRTs,” issued March 2008, presents the results of this effort. Of the several phenomena identified, five were ranked to be of high importance and low knowledge. During 2009, the NRC conducted a technical information gap analysis international workshop and identified specific technical areas which are not addressed by the HTGR applicants’ and other current worldwide research. To conduct effective technical review, the workshop panel recommended that the NRC staff develop a broad knowledge base in nuclear graphite technology and actively participate in the development of irradiation data, behavior modeling and interpretation, and codes and standards development.

In 2010, the NRC initiated independent research in two major areas. The first is exploratory research on the release of stored (Wigner) energy of irradiated graphite when it is heated subsequently to temperatures greater than the irradiation temperature. Such a scenario is possible, for example, in a LOCA, leading to excessive heat generation and loss of graphite with potential release of radionuclides. The second is research to develop a confirmatory finite element stress analysis (FEA) tool, which will provide the staff an independent capability to conduct time (dose)-integrated, nonlinear, three-dimensional FEA for GCC. The input data for model and procedure development will originate from DOE/INL/ORNL and other worldwide research. The model and the procedures will be validated and verified using the ASME Code and DOE and other vendor data and benchmark calculations on idealized core component shapes. The staff can use this FEA tool, projected to be available by 2013, to confirm applicant assumptions, stresses, design factors of safety, and the retention of design margin over the reactor life. The staff will also use this tool to perform confirmatory analyses of applicant designed deformation limits for GCC.

## Ceramic and Carbon-Carbon Composites

The NRC currently has not planned any specific research on these materials because of the paucity of specific information on these materials from NGNP designers, especially with respect to the design envelope, expected material interactions with the environment, and safety classification. The staff expects that safety concerns pertaining to nuclear graphite will generally apply to these materials.

### For More Information:

Contact Dr. Makuteswara Srinivasan, RES/DE at 301-251-7630 or makuteswara.srinivasan@nrc.gov

---

# Confirmatory Analysis Tool for Structural Integrity Evaluation of Creep and Creep-Fatigue Crack Growth in Next Generation Nuclear Plant Metallic Components

## Background

The Energy Policy Act of 2005 (EPAAct) established the Next Generation Nuclear Plant (NGNP) to demonstrate the generation of electricity or hydrogen, or both, with an HGTR. The NRC is responsible for licensing and regulatory oversight of the NGNP. A combined construction and operating license application for the NGNP is planned for submittal to the NRC in fiscal year (FY) 2014.

Creep and creep-fatigue crack growth of preexisting flaws or flaws that are initiated early in service life of metallic components (e.g., intermediate heat exchanger (IHX), cross vessel (CV)/ duct, steam generators (SG), reactor pressure vessel (RPV)) in the NGNP, a very high temperature reactor (VHTR), are of particular concern if they are not detected during in-service inspection (ISI) because of accessibility or other issues. A macroscopic crack might grow to a critical size that triggers other structural failure modes, such as creep rupture due to reduced section thickness or brittle fracture of ferritic steel components during heatup or cooldown. A crack might also grow through the wall thickness, leading to a breach of the pressure boundary or the primary/secondary boundary and causing fission product release and/or air/steam/water ingress. Oak Ridge National Laboratories (ORNL) is conducting this work.

The NRC has identified subcritical crack growth from creep and creep-fatigue loading of NGNP high-temperature metallic components as a phenomenon that has a high importance ranking and a low knowledge level (NUREG/CR-6944, Volume 4). Time-dependent creep and creep-fatigue crack growth evaluation methodologies and analysis tools are necessary to support the independent assessment of the structural integrity of NGNP pressure boundary metallic components under normal operating conditions, design-basis accident and beyond-design-basis conditions, and other conditions that result in significant component degradation and failure.

## Objective

The objective of this research is to develop a confirmatory analysis tool to perform independent structural integrity evaluation of NGNP metallic components operating in high-

temperature range where creep or creep-fatigue deformation is significant.

## Approach

The focus is on development of a validated time-dependent creep and creep-fatigue crack growth predictive methodology that will be integrated into a modular probabilistic fracture mechanics (PFM) computer code that the NRC is currently developing. The evaluation model consists of three modules, as shown in Figure 11.14 and described in the text below. This independent confirmatory capability is planned to be completed in FY 2014 to support NRC licensing reviews of the NGNP metallic components.

### Methods Development

The development of time-dependent crack-tip parameters (CTPs) is the main focus of this group of efforts. The NGNP candidate metallic materials exhibit three stages of creep behavior (primary, secondary, and tertiary). The approach to the development of CTPs is to perform crack-tip singularity analysis for each of the three creep deformation regimes. Once the time-dependent fracture mechanics methodology is developed, a data analysis procedure would be available to determine the correlation between the CTPs and the creep crack growth rate data.

### NGNP-Specific Crack Growth Correlations

This module is involved with the development of crack growth correlations specifically for the materials of construction for the NGNP IHX, CV/duct, SG, RPV, and other components. The evaluation model development will include both base metal and weldments. The required NGNP-specific crack growth correlations and material constants will be developed from confirmatory or new crack growth test data.

### Model Implementation into PFM Code

This module is involved with the implementation of the deterministic flaw evaluation procedure in the computer program module. It is anticipated that flaw evaluations using either best-estimate or statistical upper limits for the crack growth rates could be performed by the computer program. After completion of verification and validation, the deterministic flaw evaluation computer program will be incorporated into NRC's modular PFM computer code upon inclusion of various sources of aleatory and epistemic uncertainties in the data and models.

## Data Needs

A set of scoping tests to generate creep and creep-fatigue crack growth data will be needed to develop creep and creep-fatigue crack growth correlations. Judging from the available information in the literature, representative nickel-based Alloy



800H and its associated weldment are good candidates for the scoping tests since Alloy 800H has creep behavior similar to the materials being considered for the NGNP in a temperature range of 750–800 degrees Celsius. A list of data needs and the dates they are needed has been provided to the Department of Energy/Idaho National Laboratories NGNP project. Confirmatory NGNP-specific crack growth data will also be needed to validate creep crack growth correlations and to support NGNP license review. While the environment that these materials will be exposed to during service is impure helium, and possibly steam, the test data will be generated primarily in the air environment. Thus, any potential material degradation mechanisms in impure helium, and possibly in steam, that could accelerate the crack growth rates as compared with those in the air environment will need to be addressed through additional limited number of confirmatory environmental tests.

**For More Information:**

Contact Dr. Shah Malik, RES/DE at 301-251-7657 or Shah.Malik@nrc.gov

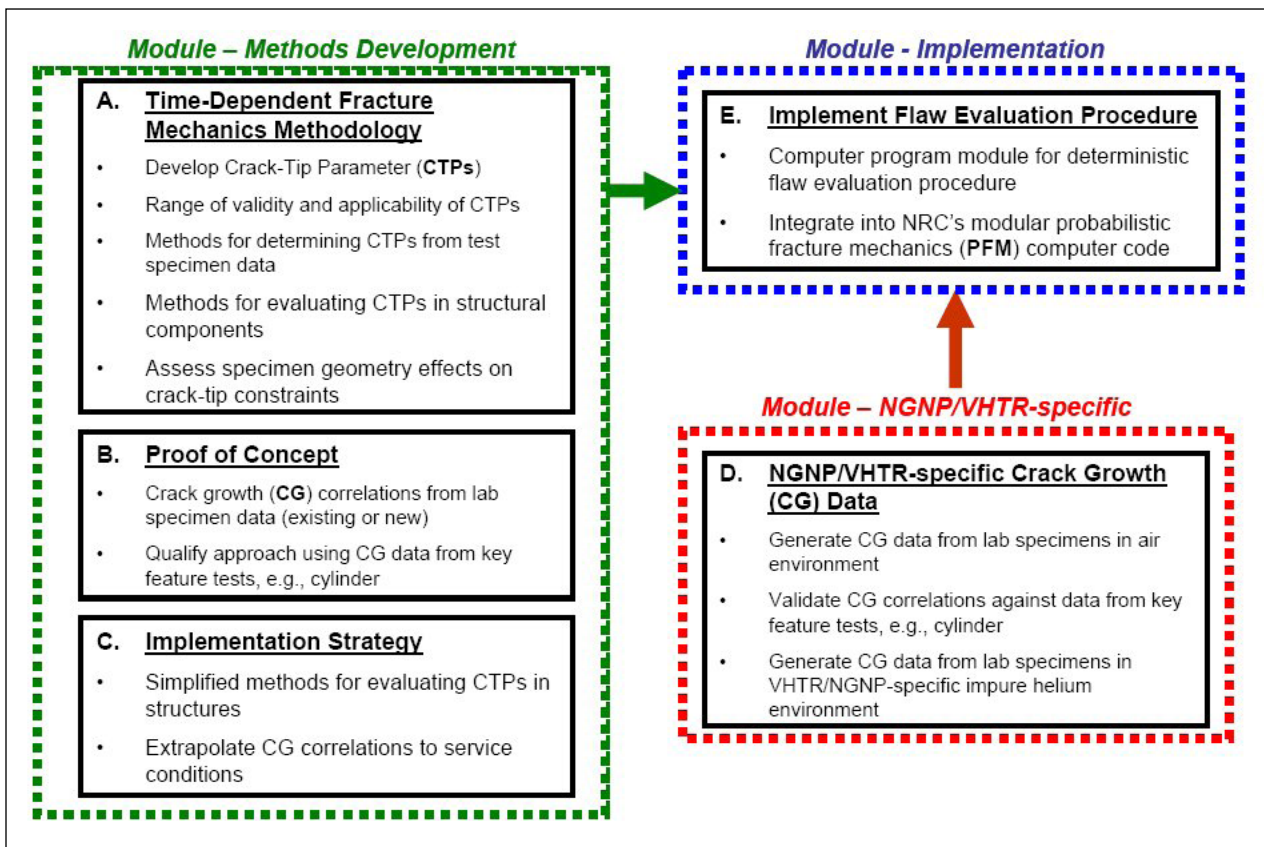

Figure 11.14 Roadmap for development of a confirmatory analysis tool for creep and creep-fatigue flaw evaluation of the NGNP metallic components



---

# Chapter 12: International Cooperative and Long-Term Research

## Cooperative International Research Activities and Agreements

The Organization for Economic Cooperation and Development Halden Reactor Project

The Organization for Economic Cooperation and Development/Nuclear Energy Agency PKL2 Project

The Organization for Economic Cooperation and Development ROSA-2 Program

Studsвик Cladding Integrity Project

International Cooperative Research on Impact Testing

Round Robin Analysis of Containment Performance under Severe Accident—Collaboration between the U.S. Nuclear Regulatory Commission and the Atomic Energy Regulatory Board (India)

Agency Forward-Looking and Long-Term Research



Completed prestressed concrete containment vessel 1/4-scale model at Sandia National Laboratories

---

# Cooperative International Research Activities and Agreements

## Cooperative Research Agreements

The U.S. Nuclear Regulatory Commission's (NRC's) Office of Nuclear Regulatory Research (RES) has implemented 100+ bilateral or multilateral agreements with 20+ countries and the Organization for Economic Cooperation and Development (OECD). These agreements cover a wide range of activities and technical disciplines, including severe accidents, thermal-hydraulic (T/H) code assessment and application, digital instrumentation and control (I&C), nuclear fuels analysis, seismic safety, fire protection, human reliability, and more.

## Bilateral, Multilateral and Code User Groups

Many of the agreements are established bilaterally with a foreign regulator or research institution for participation in one of the two largest nuclear safety computer code sharing programs. The Code Applications and Maintenance Program (CAMP) includes thermal-hydraulic code analysts from 20+ member nations. The Cooperative Severe Accident Research Program (CSARP) includes about 20 member nations who focus on the analysis of severe accidents using the MELCOR code. Both programs include user group meetings at which participants share experience with the NRC codes; identify code errors; perform code assessments; and identify areas for additional improvement, experiments, and model development.

The OECD's Nuclear Energy Agency (NEA) coordinates most of the NRC's multilateral research agreements. A few examples show how diverse the agreements can be. Large-scale experiments include the Halden Reactor Project (HRP) based in Norway and the domestically based Sandia Fuel Pool project. The OECD Piping Failure Data Exchange Project database is a different sort of shared resource for participants. RES applies a set of established criteria when considering cooperative research program proposals it receives. Considerations include cost, benefit, timeliness of expected results for current and expected regulatory uses, and more.

NRC participation in these agreements allows broader sharing of data obtained from physical facilities not available in the United States. As a result, NRC tools, data, and safety knowledge stay current and are state of the art. This enhances the NRC's ability to soundly make realistic regulatory and safety decisions based upon worldwide scientific knowledge and promotes the effective and efficient use of agency resources. Data obtained are used to

develop new analytical models; to validate NRC safety codes; to enhance assessments of plant risk, including decisionmaking, fire, and human performance and reliability; and to develop risk-informed approaches to regulation.

## NEA Activities

The NRC plays a very active role at the OECD/NEA, with RES maintaining leadership roles in the Committee on the Safety of Nuclear Installations (CSNI) (including the CSNI's seven working groups and three joint task groups) and the Committee on Radiation Protection and Public Health (CRPPH). The RES Director serves on the CSNI Bureau and on the Halden Reactor Project's Board of Management.

## IAEA Activities

RES also serves as the agency lead on codes and standards. By acting as the agency lead in the International Atomic Energy Agency's (IAEA's) Nuclear Safety Standards Committee, RES coordinates NRC contributions to the many IAEA safety standards guides. RES also participates in two "extra-budgetary programs" within IAEA entitled, "Protection against Tsunamis and Post Earthquake Consideration in the External Zone," and "Seismic Safety of Existing Nuclear Power Plants," which feeds into the IAEA's International Seismic Safety Center.

## Bilateral Information Exchange

RES also actively seeks international cooperation to obtain technical information on safety issues that require test facilities not available domestically and would require substantial resources to duplicate in the United States. RES will often propose modifications to a project sponsor so that the proposed project can better meet the NRC's needs. In addition, the NRC may propose to sponsor cooperative international participation in research projects conducted by the NRC.

RES has long been a leader in the area of enhancing domestic resources with international knowledge, skills, and use of foreign facilities. The staff has worked, and continues to work, to ensure that the international activities in which it participates have direct relevance to the NRC's regulatory program.

## For more information

Contact Donna-Marie Sangimino, RES/PMDA at 301-251-7673 or [Donna-Marie.Sangimino@nrc.gov](mailto:Donna-Marie.Sangimino@nrc.gov)

---

# The Organization for Economic Cooperation and Development Halden Reactor Project

## Background

The NRC and its predecessor, the U.S. Atomic Energy Commission (AEC), have been participating in the Organization for Economic Cooperation and Development (OECD) Nuclear Energy Agency (NEA) Halden Reactor Project (HRP) since its inception in 1958. During this period, the NRC has used numerous research products from this internationally funded cooperative effort, which is located in Halden, Norway, and managed by the Norwegian Institute for Energy Technology (Institutt for Energiteknikk (IFE)). For example, Halden tests on high-burnup fuel under loss-of-coolant accident (LOCA) conditions supported an NRC research information letter on cladding embrittlement. As another example, Halden's human factors research has supported regulatory guidance in areas such as alarm systems, hybrid control rooms, display navigation, and guidance for the review of proposed staffing configurations in computer-based control rooms.

## Facilities and Activities

### Fuels and Materials Research

The Halden Boiling-Water Reactor (HBWR) (see Figure 12.1), which currently operates at 18 to 20 megawatts, is fully dedicated to instrumented in-reactor testing of fuel and reactor materials. Since its initial startup, the reactor facility has been progressively updated and is now one of the most versatile test reactors in the world. The HRP fuels and materials program focuses on the performance of fuel and structural materials under normal or accident conditions using the numerous experimental channels in the core that are capable of handling many test rigs simultaneously.

Recent NRC reviews of industry fuel behavior codes have directly employed data from the HRP fuels program. These data are also essential for updating the NRC's fuel codes and materials properties library, which are used to audit industry analyses. Currently, the NRC is particularly interested in the previously mentioned LOCA tests, which are investigating such phenomena as axial gas flow, maintaining or breaking fuel-to-cladding bonding, fuel axial relocation, and fuel fragment spillage through cladding burst opening.

Regarding the HRP's nuclear reactor materials testing program, the HRP has, over the years, provided fundamental technical information to support the understanding of the

performance of irradiated reactor pressure vessel (RPV) materials and supplemented results generated under NRC research programs. Recently, the HRP has been an essential partner in evaluating the irradiation-assisted stress-corrosion cracking (IASCC) of light-water reactor (LWR) materials. The HRP has irradiated materials that were later tested under the NRC's research program at Argonne National Laboratory to measure crack initiation, fracture toughness, and crack growth rate under representative LWR conditions. The HRP's ongoing work on IASCC and other areas (e.g., irradiation-induced stress relaxation) supplements NRC-sponsored research and addresses existing knowledge gaps. The NRC staff is using this information to inform reviews of licensee aging management programs.

### Man-Technology-Organization Laboratory

IFE's Halden facility also includes the IFE Man-Technology-Organization (MTO) Laboratory. The Halden Man-Machine Laboratory (HAMMLAB) (see Figure 12.2) is one of the principal experimental facilities in this laboratory. HAMMLAB uses a reconfigurable simulator control room that facilitates research into instrumentation and control (I&C), human factors, and human reliability analysis (HRA). Currently, HAMMLAB has hardware and software enabling it to simulate the Fessenheim pressurized-water reactor (PWR) plant in France, the Forsmark-3 boiling-water reactor (BWR) plant in Sweden, and the Ringhals-3 PWR plant in Sweden.

Many of the HAMMLAB experiments are performed with the control room configured as a prototype advanced control room with an integrated surveillance and control system. This setup is used to explore the impacts of automation and advanced human-system interfaces on operator performance. HAMMLAB has extensive data collection capabilities and typically uses qualified nuclear power plant operators (who are familiar with the plants being simulated) as test subjects.

Recently, HRP-designed and executed HAMMLAB experiments provided the foundation for the International Empirical HRA Study, a multinational study aimed at developing an empirically based understanding of the performance, strengths, and weaknesses of HRA methods used in risk-informed regulatory applications. The NRC will be using the study's results to address outstanding HRA technical issues, including those related to HRA model differences identified in a November 8, 2006, staff requirements memorandum (SRM). Currently, ongoing HRP experiments are addressing a number of topics of interest to the NRC, including control room staffing strategies, the role and effects of automation in advanced control room designs, and aids to improve control room teamwork. The NRC expects that this research will contribute to the technical basis for human factors guidance, especially for new reactor designs.

The IFE MTO Laboratory also includes a virtual environment center and an integrated operations laboratory. The former is used to perform research involving mixed reality applications (e.g., training), and the latter is used to address issues associated with remote operations.

Finally, the MTO Laboratory also conducts research on I&C systems. Past efforts include work in the area of instrumentation surveillance and monitoring techniques based on advanced decision algorithms. A number of HRP-developed systems have been evaluated for use by U.S. plants.

The current HRP digital systems research activities contribute to three phases of a system lifecycle:

- Development, assurance and deployment of high integrity software important to nuclear power plant safety,
- Condition monitoring and maintenance support, where engineering and technical support teams are the intended beneficiaries of the research results. This research will improve accuracy and usability of current methods and develop novel techniques to improve diagnostics and condition-based maintenance.
- Development and application of software systems for operational support, where plant operators are the intended beneficiaries of the research results. The research program includes interaction of advanced control systems with human operators and issues related to the implementation and use of operational procedures.

## Summary

The HRP has provided and continues to provide valuable information to the NRC. Much of this information addresses gaps that are otherwise not being addressed by current NRC research activities, and some of this information is foundational to NRC's efforts to improve the technical basis of key models, methods, and tools. Furthermore, because the NRC is one of several contributors to the HRP budget, the HRP enables the NRC staff to significantly leverage its resources.

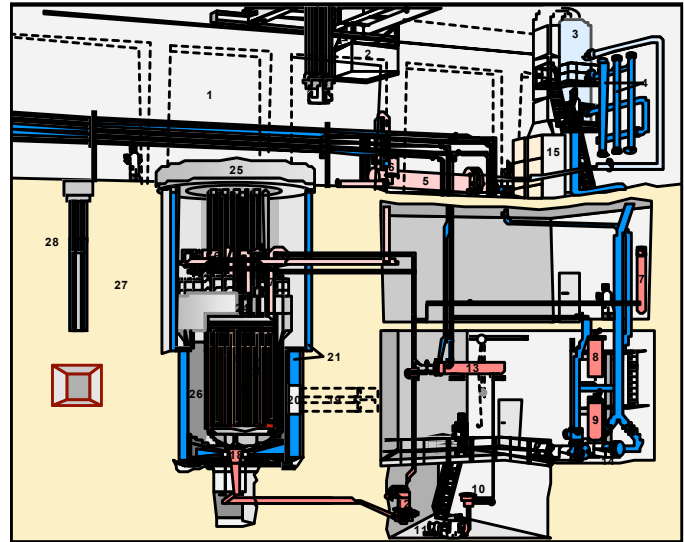

Figure 12.1 HBWR test reactor



Figure 12.2 HAMMLAB control room simulator

### For More Information

Contact Alysia Bone, RES/DRA at 301-251-7602 or [Alysia.Bone@nrc.gov](mailto:Alysia.Bone@nrc.gov)



# The Organization for Economic Cooperation and Development/ Nuclear Energy Agency PKL2 Project

## Background

Since 2001, the NRC has been involved in a series of Organization for Economic Cooperation and Development (OECD)-fostered programs that use the Primärkreisläufe (PKL) facility to investigate safety-related issues relevant to current and new pressurized-water reactor (PWR) designs. The latest of such programs is the OECD/Nuclear Energy Agency (NEA) PKL2 Project (PKL2), a 3.5-year program that focuses on complex heat transfer mechanisms in steam generators (SGs) and boron precipitation processes under postulated accident conditions. Participation in this program is expected to help reduce known uncertainties in the area of thermal-hydraulics and provide data for use in assessing and enhancing the applicability of the NRC's Transient Reactor Analysis Code/Reactor Excursion and Leak Analysis Program (TRAC/RELAP) Advanced Computational Engine (TRACE) code.

Designed and built in the 1970s by AREVA NP GmbH (formally Siemens/KWU), the PKL facility is a full-height, 1:145 volume-scaled replica of a German PWR. Configured for enhanced realism, the facility has four identical reactor coolant loops arranged symmetrically around a reactor pressure vessel that contains a simulated core. Each of the four loops is equipped with a fully functional SG and a reactor coolant pump, and the core is simulated using 314 electrically heated rods. Each SG contains 30 U-tubes of original size and material, and each reactor coolant pump is equipped with an active speed controller to enable the simulation of different pump characteristics. The bundle of rods representing the core are capable of generating 2.5 megawatts (MW) of core power, which is equivalent to 10 percent of the nominal power rating of the 1,300-MW PWR used as the basis for the facility's design.

## Approach

For PKL2, 19 of the 28 OECD member countries have agreed to the following program of experimentation:

- G1: Systematic investigation of the heat transfer mechanisms in SGs containing nitrogen, steam, and water (2 tests)
- G2: Cooldown procedures with SGs isolated and emptied on the secondary side

- G3: Fast cooldown transients (e.g., main steamline break (MSLB))
- G4: Systematic study of heat transfer in SGs under reflux condenser conditions
- G5: Boron precipitation processes after large-break loss-of-coolant accident (LBLOCA)
- G6/G7: Subjects yet to be determined

Before an experiment is conducted, its scope and configuration are discussed and agreed upon during biannual review meetings. These meetings also allow members to review results from completed tests, exchange information on modeling best practices, and compare computer code results from posttest calculations.

The first TRACE posttest calculation performed during PKL2 was of the Test G3 MSLB. To perform the calculation, a TRACE model representing each of the major components and control systems present in the facility was developed (Figure 12.3). The TRACE results showed that the code was capable of predicting all of the key phenomena reasonably well. The results also made apparent the uniqueness of the four-loop data in illuminating the asymmetric effects of the test, which proved to be a challenge for the code to simulate.

As more tests are completed, similar calculations will be performed and analyzed to assess the applicability of TRACE and provide further insight into safety-related issues. Of particular interest is the boron-precipitation test, Test G5, which will investigate the factors affecting boron precipitation during long-term cooling and help determine the adequacy of modeling techniques employed by licensees to simulate the phenomena.

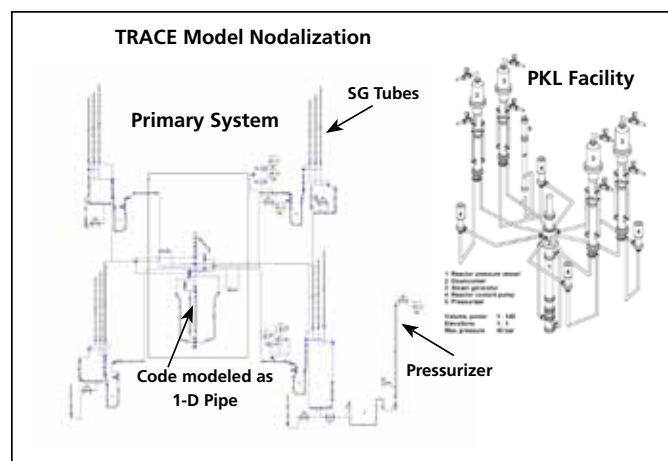

Figure 12.3 TRACE nodalization and schematic of PKL facility

## For More Information

Contact Shawn O. Marshall, RES/DSA at 301-251-7523 or [Shawn.Marshall@nrc.gov](mailto:Shawn.Marshall@nrc.gov)



# The Organization for Economic Cooperation and Development ROSA-2 Program

## Background

The NRC has been participating in the Rig of Safety Assessment (ROSA) program for many years under the Organization for Economic Cooperation and Development/Nuclear Energy Agency. The ROSA-2 program is the latest phase of the program to conduct thermal-hydraulic (T/H) accident experiments in PWRs. The ROSA-2 program started in 2009 and is scheduled to be completed in 2012.

## Approach

The ROSA programs use the Large Scale Test Facility (LSTF) operated by the Japanese Atomic Energy Agency (JAEA) to conduct T/H accident experiments (see Figures 12.4 and 12.5). The LSTF, which has been in use since 1985, is an instrumented full height, 1/48 volumetrically scaled test facility intended to perform system integral experiments simulating the T/H response at full-pressure conditions of existing and

investigate the following safety issues:

Three intermediate-break LOCAs, including risk-informed break size definition and verification of safety analysis codes, will be performed.

Improvements and new proposals for accident management mitigation and emergency operation will be investigated. Two tests, focused on the recovery from a steam generator tube rupture (SGTR), one with and the second without a main steam line break (MSLB), will be performed.

A counterpart test with the *Primärkreislauf-Versuchsanlage* (primary coolant loop test facility) PKL test facility is being developed. The PKL facility in Erlangen, Germany, is operated by AREVA NP. Counterpart testing at the ROSA-2/LSTF and PKL facilities will provide test data that reflect the design scaling of the two facilities and produce two sets of test data for computer code validation. Program participants will finalize the description of the counterpart ROSA-2/LSTF-PKL test in the near future.

The NRC staff members participating in this international project investigate unresolved safety issues relevant to current PWRs and new PWR designs. The ROSA-2 test data will be used to validate the TRACE computer code and expand the usefulness of the code as an audit tool.

The ROSA-2 test program has already completed testing of a 17-percent intermediate hot-leg break and a 17-percent intermediate cold-leg break; however, only preliminary test data are currently available. The NRC staff has developed a TRACE model of the primary and secondary sides of the LSTF test facility to analyze these two tests. Preliminary test data for these

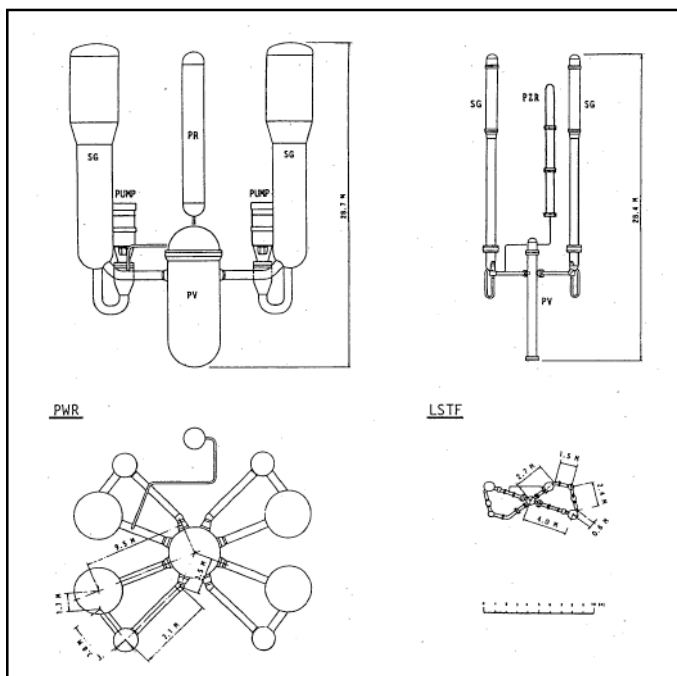

next generation PWR designs during loss-of-coolant accidents (LOCAs) and other operational and abnormal transients.  
**Figure 12.4** Size comparison of ROSA/LSTF to a four-loop PWR

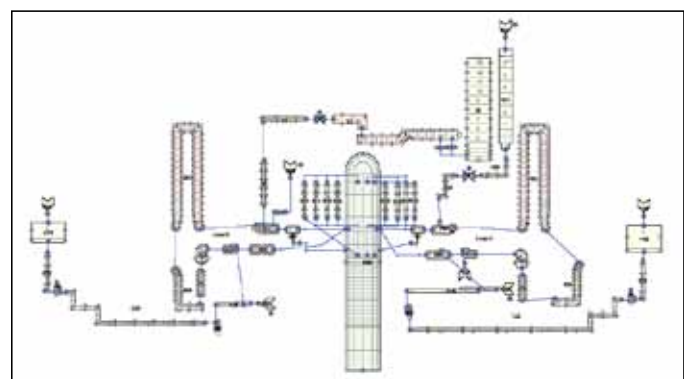

two tests have been compared to TRACE blind and posttest predictions.

**Figure 12.5** LSTF primary system TRACE model used for 17% intermediate hot-leg break

Six tests are planned for the ROSA-2 program. As part of the ROSA-2 program, testing at the LSTF facility will specifically

## For More Information

---

Contact William Krotiuk, RES/DSA at 301-251-7541 or  
William.Krotiuk@nrc.gov

# Studsvik Cladding Integrity Project

## Background

The Studsvik Cladding Integrity Project (SCIP) is an Organization for Economic Cooperation and Development/ Nuclear Energy Agency supported international program launched in 2004 and now extended to 2014, with participants from Europe, Japan, the United States, Russia, and Korea. The participants represent four categories: those who supply and manufacture the fuel, the power companies themselves, regulators, and laboratories with similar assignments to Studsvik's.

## Objective

SCIP is focused on improving the ability to predict mechanisms that can cause damage to cladding under normal operation and during transients. The program is conducted in the form of experiments, studies of fundamental mechanisms, development of suitable testing methods, and knowledge transfer.

The SCIP experiments and studies of fundamental mechanisms enable the understanding and quantification of key parameters important to hydrogen-induced failures, stress-corrosion cracking failures, and pellet-cladding mechanical interaction failures. This work provides valuable information for the development of operating restrictions.

The development of testing methods includes in-cell and out-of-cell mechanical testing techniques, as well as postirradiation analysis methods. This work enables the characterization of changes in cladding and pellets that take place with irradiation and provides valuable and unique characterization of advanced cladding and fuel pellet designs.

## Approach

Multiple laboratories are performing the technical work in SCIP II. Power transient testing is conducted in the Halden Boiling-Water Reactor (HBWR). Studies of the irradiated rods are then made at the Studsvik Hot Cell Laboratory, leading to a series of mechanical tests in other laboratories at Studsvik.

## Use Of Scip Data In The Integral Assessment Of Fuel Rod Computer Codes

As part of the NRC's fuel performance code development effort, new code versions are exercised to assess the integral code predictions to measured data for various performance parameters. The documentation of the integral assessment is

publicly available and serves to demonstrate the code's ability to accurately predict integral fuel response under normal and off-normal conditions. As new data are generated, new assessment cases are added to the integral assessment suite.

The latest integral assessment added 10 SCIP ramps to the assessment suite. The ramps were modeled to assess the ability of FRAPCON 3.4 to predict cladding hoop strain during power ramps. Peak node plastic strain values from SCIP ramp data were compared to predicted values. Measured versus predicted values of plastic strain were compared as a function of burnup and ramp terminal level. These ramp tests were the first ramp tests that FRAPCON 3.4 was compared to with burnup greater than 45 gigawatt day per metric ton of uranium (GWd/MTU).

The comparison of predicted to the measured values in these ramp tests provided valuable insight into FRAPCON's ability to predict fuel and cladding response during power ramps. In this comparison effort, it was noted that FRAPCON 3.4 underpredicted the measured hoop strain in high burnup rods. The underprediction was most severe for those ramp tests with long hold times, as can be seen in Figure 12.6. The NRC is now revisiting the FRAPCON 3.4 strain model to investigate the source of this underprediction, and, if possible, to improve the modeling capabilities of FRAPCON.

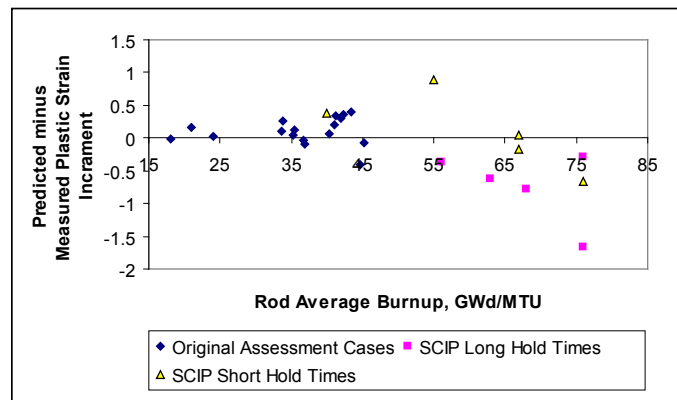

Figure 12.6 FRAPCON 3.4 predicted minus measured permanent hoop strain as a function of burnup, indicating an underprediction at high burnups

### For More Information

Contact Michelle Flanagan, RES/DSA at 301-251-7547 or [Michelle.Flanagan@nrc.gov](mailto:Michelle.Flanagan@nrc.gov)

# International Cooperative Research on Impact Testing

## Background and Objectives

The NRC believes that it is prudent for nuclear power plant designers to take into account the potential effects of the impact of a large, commercial aircraft on nuclear facilities. RES has been conducting research in the area of impact loads on nuclear power plant structures that contributes to maintaining and developing critical skills needed to carry out the agency's mission of ensuring the safety of nuclear installations. Currently, the NRC participates in two international collaborative research programs in this area—one with the Technical Research Center of Finland (VTT) and one with the Nuclear Energy Agency (NEA) Committee on the Safety of Nuclear Installations (CSNI's) Working Group on Integrity and Aging of Components and Structures (IAGE-WG) Concrete Subgroup. The expected benefits of these programs are (1) to benchmark the various computer codes that the NRC staff and its contractors utilize in impact assessments against experiments and (2) to synthesize the results of benchmarking into recommendations for good practices. These collaborative programs also provide opportunities to interact and exchange information with nuclear regulators abroad and with international nuclear safety organizations, ensuring NRC cognizance of ongoing impact research in various countries.

Anticipated benefits to the NRC from its participation in these programs include (1) reducing uncertainty associated with assessments of impact loads on nuclear installations and (2) ensuring that the assessments performed for U.S. reactors represent the state of the art in ensuring the safety of the public and protection of the environment.

## Approach

### Impact Test Agreement with the Technical Research Center of Finland

The NRC, the VTT, and nuclear regulators and nuclear safety research organizations in other countries participate in a multiyear international experimental research program, called IMPACT, to collect and analyze new data on the performance of reinforced and prestressed concrete walls subject to impact loads. All testing data under this program are provided by VTT using unique testing facilities not readily available elsewhere in the world, while the technical work of the NRC and the other participants focuses on analytical efforts.

Specific aims of the project include (1) obtaining new data on the time-varying hydrodynamic shock pressures from the impact on rigid structures of empty tanks, tanks filled with concrete (i.e., hard missiles; see Figure 12.7), and tanks filled with liquids

(i.e., soft missiles; see Figure 12.8); (2) collecting new data on the response of reinforced concrete walls (e.g., displacements, strains) to these impact loads; (3) use of the new data to develop insights on the behavior of structures under impact conditions; and (4) use of the new data to benchmark computer simulation codes.

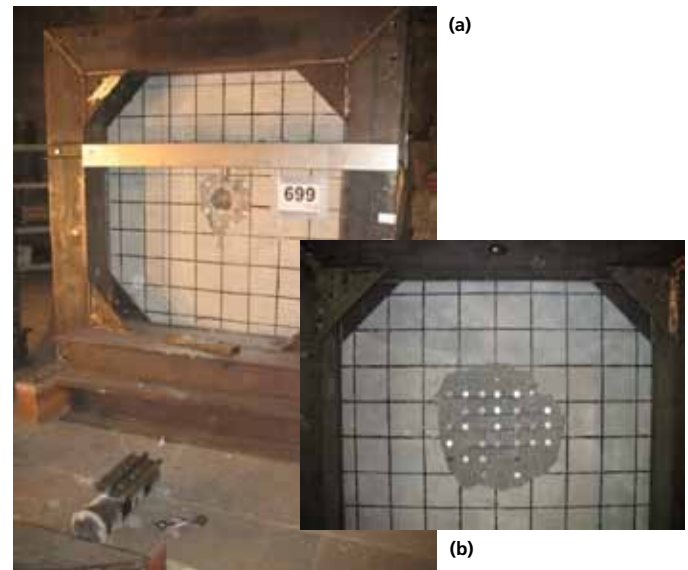

Figure 12.7 Hard missile impact on reinforced concrete slab: (a) impact face and (b) back face (VTT)

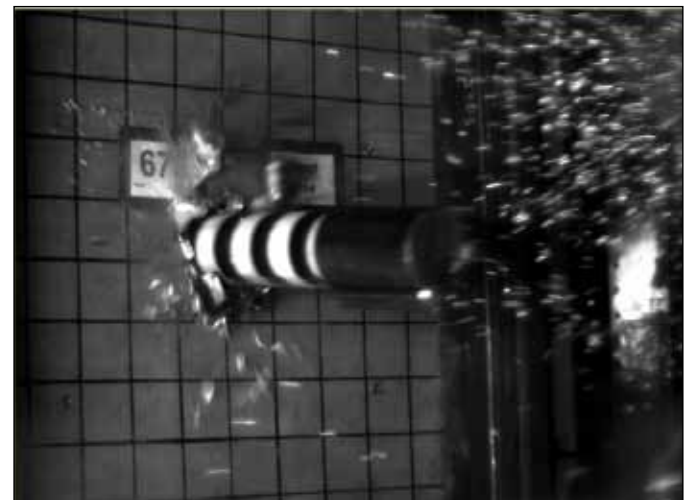

Figure 12.8 Soft missile impact on reinforced concrete slab (VTT)

VTT tests for the IMPACT program assess various reinforcement conditions, including prestressing, support conditions, slab thickness, impact speeds, and missile hardness. The first phase of the program tested over 20 impacts on concrete slabs, and a similar number of tests is planned for the second phase of the program already underway.

The IMPACT program includes regular workshops in which the participants exchange information on benchmarking, including benchmarking being done by RES staff (see Figure 12.9).

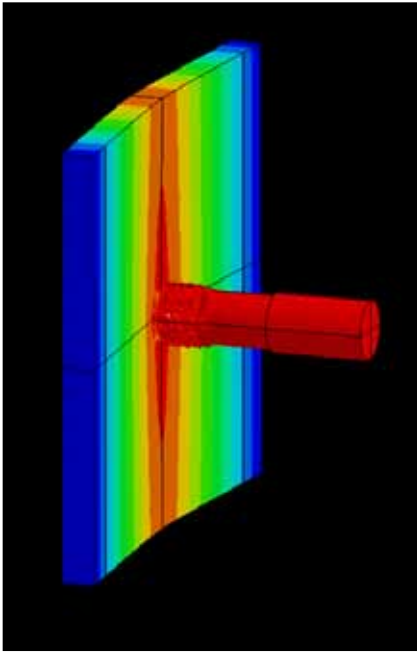

Figure 12.9 Displacement contours for simulated missile impact on vertical wall

## Research to Support the CSNI Project on Impact Assessment

The CSNI IAGE-WG Concrete Subgroup, developed a round robin benchmark exercise entitled, “Improving Robustness Assessment Methodologies for Structures Impacted by Missiles.” The purpose of this project is to develop guidance that outlines effective methods of evaluating the integrity of structures impacted by missiles and to compare various methods in a round robin study of impact data. The project will use publicly available data from simple, reduced-scale tests and will reinterpret previous tests with newly available data, modeling capabilities, and results. The exercise will consider several types of structures ranging from structural components and box-shaped structures of reduced size to reactor building-like structures of reduced size. The project is expected to produce a state-of-the-art report collecting the contributions and proposing synthesis and recommendations for good practices.

To support its participation in this program, the NRC contracted Sandia National Laboratories (SNL) to benchmark different types of numerical simulation tools and to develop improved insights on modeling and damage criteria aimed at increasing confidence in numerical simulations for the assessment of existing and planned facilities.

### For More Information

Contact Dr. Syed Ali, RES/DE 301-251-7658 or [Syed.Ali@nrc.gov](mailto:Syed.Ali@nrc.gov)



# Round Robin Analysis of Containment Performance Under Severe Accidents— Collaboration Between the U.S. Nuclear Regulatory Commission and the Atomic Energy Regulatory Board of India

## Background

As part of the Indo-U.S. Civilian Nuclear Agreement, the NRC and the Atomic Energy Regulatory Board (AERB) of India are working together through the USNRC-AERB Nuclear Safety Co-Operation Program. As a result of this program, the two agencies met and discussed areas of mutually beneficial areas of study. The two agencies agreed to cooperate in the following areas: (1) new reactor designs, (2) probabilistic risk assessment (PRA) methods and applications and severe accident analysis and management, (3) proactive material degradation program, (4) digital systems reliability and qualification, and (5) operating experience feedback in India and the United States.

Also through this program, the NRC and AERB agreed to organize and participate in the Standard Problem Exercise #3 (SPE #3) round robin analyses. The SPE #3 will build on the previous round robin analysis of the NRC and the Nuclear Power Engineering Corporation of Japan (NUPEC) 1:4-Scale Prestressed Concrete Containment Vessel (PCCV) model tests conducted at the Sandia National Laboratories (SNL). The aim of SPE #3 is to undertake an analytical exercise on concrete containment structural performance. This will be accomplished by the benchmarking of the SNL PCCV model test to develop a consensus on modeling approach to assess pressure versus leakage behavior and to determine ultimate load behavior (see Figure 12.10).

Research into the integrity of containment structures for nuclear power plants has been conducted in both national and international Round Robin analyses. While the contributions of each of these efforts to the understanding of the role of containment in ensuring the safe operation of nuclear power plants is important, the most comprehensive experimental effort has been conducted at SNL, primarily under the sponsorship of the NRC. NUREG/CR-6906, “Containment Integrity Research at Sandia National Laboratories: An Overview,” summarizes the major results of the experimental efforts and the observations and insights gained from the analytical efforts of more than 25 years of containment integrity research at SNL. Before pressure

testing the scale models, a number of regulatory and research organizations were invited to participate in a pretest round robin analysis to perform predictive modeling of the response of scale models to overpressurization. Seventeen organizations responded and agreed to participate in the pretest round robin analysis activities. The purpose of the SNL containment integrity research was to provide a forum for researchers in the area to apply current state-of-the-art analysis methodologies to predict the capacity of steel, reinforced, and prestressed concrete containment vessels. The SPE #3 organized by the NRC and AERB progresses from these past efforts. In addition to the NRC and AERB, other international organizations from France, Finland, Korea, Sweden, Germany, and the United Kingdom are participating in SPE #3. The exercise is expected to produce a joint report describing the exercise and summarizing the results of the analyses performed.



Figure 12.10 Completed prestressed concrete containment vessel ¼-scale model at SNL



### For More Information

Contact Herman Graves, RES/DE at 301-251-7625 or [Herman.Graves@nrc.gov](mailto:Herman.Graves@nrc.gov)

---

# Agency Forward-Looking and Long-Term Research

## Background

### Forward-Looking Research

The NRC currently identifies, as a matter of routine, long-term, or forward-looking, research activities which support potential regulatory needs over the longer term (within the next few years). The agency identifies and pursues these forward-looking research activities during the normal course of planning and budgeting processes.

### Long-Term Research

Each year since 2007, the staff has prepared Commission papers on long-term research activities. The papers discuss candidate long-term research topics and estimate funding needs for use in budget preparation. For the purposes of the annual Commission papers, long-term research is defined as research that is not already funded or otherwise being worked on that will provide the fundamental insights and technical information needed to address potential technical issues or identified gaps to support anticipated NRC needs in the future (more than 5 years).

## Approach

The NRC performs regulatory research to support the achievement of the goals identified in its Strategic Plan. These goals ensure protection of public health and safety and the environment; ensure the secure use and management of radioactive materials; ensure openness in the NRC's regulatory processes; ensure that NRC actions are effective, efficient, realistic, and timely; and ensure excellence in agency management.

The objectives of forward-looking and long-term research are to identify the research required to support related regulatory decisionmaking, to help determine whether research should be conducted by the NRC or by the industry, and to identify collaborative opportunities with domestic and international partners. The identified research could be exploratory, in support of possible new program areas, in support of the development of technical bases for a range of anticipated regulatory decisions, to address emerging technologies that could have future regulatory applications, or to develop plans to implement needed research.

The agency has established the following exploratory long-term research strategies:

1. Ensure that the NRC regulations and regulatory processes have sound technical bases.
2. Prepare the agency for anticipated changes in nuclear technology that could have safety, security, or environmental implications.
3. Develop improved methods by which the agency can carry out its regulatory responsibilities.
4. Develop and maintain an infrastructure of expertise, facilities, analytical capabilities, and data to support regulatory decisionmaking.

The process for determining the projects that should be funded under the aegis of the long-term research plan includes soliciting input from the regulatory and regional offices on the exploratory long-term research activities that the agency should consider undertaking. In addition, RES staff reviews previously suggested long-term exploratory research activities, including those not funded in previous budget years, for inclusion in the candidate list. Moreover, the process establishes a review committee composed of seven senior-level system staff members from RES and the regulatory offices. The committee reviews, evaluates, and rates activities that resulted from new suggestions and those remaining from previous proposal processes. The committee's charter specifies five evaluation criteria and their weighting factors to provide a rating, or score, for each activity. The five criteria include leveraging resources, advancing the state of the art, providing an independent tool to the NRC, applying to more than one program area, and addressing gaps created by technology advancements.

The committee forwards the results of the review to the RES Office Director and posts the results on an internal Web site. In this way, the review committee's ratings are available to the staff as feedback on the input suggestions. Since 2010, during the planning, budgeting, and performance management process (PBPM), the RES Office Director, along with the directors of the agency's regulatory offices, agree on those long-term research projects that should receive a "high" priority and should be actively supported through those phases of the PBPM process under their control.

### For More Information

Contact Patricia Santiago, RES/DSA at 301-251-7982 or [Patricia.Santiago@nrc.gov](mailto:Patricia.Santiago@nrc.gov)

<p><b>NRC FORM 335</b> (9-2004) NRCMD 3.7</p> <p style="text-align: center;"><b>U.S. NUCLEAR REGULATORY COMMISSION</b></p> <p style="text-align: center;"><b>BIBLIOGRAPHIC DATA SHEET</b> <i>(See instructions on the reverse)</i></p>	<p><b>1. REPORT NUMBER</b> (Assigned by NRC, Add Vol., Supp., Rev., and Addendum Numbers, if any.)</p> <p style="text-align: center;">NUREG-1925, Rev. 1</p>				
<p><b>2. TITLE AND SUBTITLE</b></p> <p>Research Activities FY2010 - FY2011 U.S. Nuclear Regulatory Commission</p>	<p><b>3. DATE REPORT PUBLISHED</b></p> <table border="1" style="width: 100%;"> <tr> <td style="text-align: center;">MONTH</td> <td style="text-align: center;">YEAR</td> </tr> <tr> <td style="text-align: center;">12</td> <td style="text-align: center;">2010</td> </tr> </table> <p><b>4. FIN OR GRANT NUMBER</b></p>	MONTH	YEAR	12	2010
MONTH	YEAR				
12	2010				
<p><b>5. AUTHOR(S)</b></p> <p>Patricia A. Santiago, Brett Rini, Ken Armstrong, Dan Hudson</p>	<p><b>6. TYPE OF REPORT</b></p> <p style="text-align: center;">NUREG</p> <p><b>7. PERIOD COVERED (Inclusive Dates)</b></p> <p style="text-align: center;">2010-2011</p>				
<p><b>8. PERFORMING ORGANIZATION - NAME AND ADDRESS</b> <i>(If NRC, provide Division, Office or Region, U.S. Nuclear Regulatory Commission, and mailing address; if contractor, provide name and mailing address.)</i></p> <p>Office of Nuclear Regulatory Research U.S. Nuclear Regulatory Commission Mail Stop C6D20M Washington, DC 20555-0001</p>					
<p><b>9. SPONSORING ORGANIZATION - NAME AND ADDRESS</b> <i>(If NRC, type "Same as above"; if contractor, provide NRC Division, Office or Region, U.S. Nuclear Regulatory Commission, and mailing address.)</i></p> <p>same as above</p>					
<p><b>10. SUPPLEMENTARY NOTES</b></p>					
<p><b>11. ABSTRACT</b> <i>(200 words or less)</i></p> <p>The Office of Nuclear Regulatory Research (RES) develops technical tools, analytical models, and experimental data with which the agency assesses safety and regulatory issues for operating reactors as well as for new and advanced reactor designs. RES staff develops these tools, models, and data through contracts with commercial entities, national laboratories, and universities, or in collaboration with international organizations.</p> <p>RES conducts research across a wide variety of disciplines, ranging from fuel behavior under accident conditions to seismology to health physics. This research at times also provides the technical bases for regulatory decisions and confirms licensee analyses. RES works closely with the NRC's licensing offices in the review and analysis of high-risk events and provides its expertise to support licensing. RES also develops regulatory guides and is responsible for resolving generic safety issues.</p> <p>This NUREG provides a collection of information sheets, organized by topical areas and specific projects, that summarize programs currently in progress.</p>					
<p><b>12. KEY WORDS/DESCRIPTORS</b> <i>(List words or phrases that will assist researchers in locating the report.)</i></p> <p>Digital Instrumentation and Control Research, Fire Safety Research, Human Factors and Reliability Research, Materials Performance Research, New and Advanced Reactors, Radiation Protection, Reactor Safety Codes and Analysis, Generic Issues, Risk and Consequence Analysis, Seismic and Structural Research, Severe Accident Research, MELCOR, WinMACCS, Phebus-Fission Products, Zirconium Fire Research, SPAR Model, TRACE, SOARCA, VARSKIN, PRA, Vessel Integrity, Tube Integrity, Materials Degradation</p>	<p><b>13. AVAILABILITY STATEMENT</b></p> <p style="text-align: center;">unlimited</p> <p><b>14. SECURITY CLASSIFICATION</b></p> <p><i>(This Page)</i></p> <p style="text-align: center;">unclassified</p> <p><i>(This Report)</i></p> <p style="text-align: center;">unclassified</p> <p><b>15. NUMBER OF PAGES</b></p> <p><b>16. PRICE</b></p>				



[www.nrc.gov](http://www.nrc.gov)  
NUREG-1925, Rev. 1  
December 2010