



International Agreement Report

RELAP5/MOD3.3 Assessment against New PMK Experiments

Prepared by:
P. Kral

Nuclear Research Institute Rez
Husinec-Rez 130
250 68 Rez, Czech Republic

A. Calvo, NRC Project Manager

**Office of Nuclear Regulatory Research
U.S. Nuclear Regulatory Commission
Washington, DC 20555-0001**

June 2010

Prepared as part of
The Agreement on Research Participation and Technical Exchange
Under the International Code Assessment and Maintenance Program (CAMP)

**Published by
U.S. Nuclear Regulatory Commission**

AVAILABILITY OF REFERENCE MATERIALS IN NRC PUBLICATIONS

NRC Reference Material

As of November 1999, you may electronically access NUREG-series publications and other NRC records at NRC's Public Electronic Reading Room at <http://www.nrc.gov/reading-rm.html>. Publicly released records include, to name a few, NUREG-series publications; *Federal Register* notices; applicant, licensee, and vendor documents and correspondence; NRC correspondence and internal memoranda; bulletins and information notices; inspection and investigative reports; licensee event reports; and Commission papers and their attachments.

NRC publications in the NUREG series, NRC regulations, and *Title 10, Energy*, in the Code of *Federal Regulations* may also be purchased from one of these two sources.

1. The Superintendent of Documents
U.S. Government Printing Office
Mail Stop SSOP
Washington, DC 20402-0001
Internet: bookstore.gpo.gov
Telephone: 202-512-1800
Fax: 202-512-2250
2. The National Technical Information Service
Springfield, VA 22161-0002
www.ntis.gov
1-800-553-6847 or, locally, 703-605-6000

A single copy of each NRC draft report for comment is available free, to the extent of supply, upon written request as follows:

Address: U.S. Nuclear Regulatory Commission
Office of Administration
Reproduction and Mail Services Branch
Washington, DC 20555-0001

E-mail: DISTRIBUTION@nrc.gov
Facsimile: 301-415-2289

Some publications in the NUREG series that are posted at NRC's Web site address <http://www.nrc.gov/reading-rm/doc-collections/nuregs> are updated periodically and may differ from the last printed version. Although references to material found on a Web site bear the date the material was accessed, the material available on the date cited may subsequently be removed from the site.

Non-NRC Reference Material

Documents available from public and special technical libraries include all open literature items, such as books, journal articles, and transactions, *Federal Register* notices, Federal and State legislation, and congressional reports. Such documents as theses, dissertations, foreign reports and translations, and non-NRC conference proceedings may be purchased from their sponsoring organization.

Copies of industry codes and standards used in a substantive manner in the NRC regulatory process are maintained at—

The NRC Technical Library
Two White Flint North
11545 Rockville Pike
Rockville, MD 20852-2738

These standards are available in the library for reference use by the public. Codes and standards are usually copyrighted and may be purchased from the originating organization or, if they are American National Standards, from—

American National Standards Institute
11 West 42nd Street
New York, NY 10036-8002
www.ansi.org
212-642-4900

Legally binding regulatory requirements are stated only in laws; NRC regulations; licenses, including technical specifications; or orders, not in NUREG-series publications. The views expressed in contractor-prepared publications in this series are not necessarily those of the NRC.

The NUREG series comprises (1) technical and administrative reports and books prepared by the staff (NUREG-XXXX) or agency contractors (NUREG/CR-XXXX), (2) proceedings of conferences (NUREG/CP-XXXX), (3) reports resulting from international agreements (NUREG/IA-XXXX), (4) brochures (NUREG/BR-XXXX), and (5) compilations of legal decisions and orders of the Commission and Atomic and Safety Licensing Boards and of Directors' decisions under Section 2.206 of NRC's regulations (NUREG-0750).

DISCLAIMER: This report was prepared under an international cooperative agreement for the exchange of technical information. Neither the U.S. Government nor any agency thereof, nor any employee, makes any warranty, expressed or implied, or assumes any legal liability or responsibility for any third party's use, or the results of such use, of any information, apparatus, product or process disclosed in this publication, or represents that its use by such third party would not infringe privately owned rights.

NUREG/IA-0229



International Agreement Report

RELAP5/MOD3.3 Assessment against New PMK Experiments

Prepared by:
P. Kral

Nuclear Research Institute Rez
Husinec-Rez 130
250 68 Rez, Czech Republic

A. Calvo, NRC Project Manager

**Office of Nuclear Regulatory Research
U.S. Nuclear Regulatory Commission
Washington, DC 20555-0001**

June 2010

Prepared as part of
The Agreement on Research Participation and Technical Exchange
Under the International Code Assessment and Maintenance Program (CAMP)

**Published by
U.S. Nuclear Regulatory Commission**

Abstract

The results of RELAP5 post-test analysis of 3 tests performed on the PMK integral test facility are presented and discussed. The Hungarian facility PMK is a scaled-down model of NPP with VVER-440/213 reactor. The code version RELAP5/MOD3.3 Path02 has been assessed against the experimental data from the tests T2.1, T2.2, and T2.3. The tests were focused on medium-break LOCA without HPSI. Generally, RELAP5 predictions are in very good agreement with the measured data.

FOREWORD

The RELAP5 is a very important computational tool for increasing nuclear safety also of the VVER reactors, especially in the Czech Republic. The Nuclear Research Institute (NRI) Rez has assessed the code against numerous experiments and consequently applied it to safety analyses of Czech NPP. The presented report documents one of the assessment works.

CONTENTS

	<u>Page</u>
ABSTRACT	III
FOREWORD	V
CONTENTS	VII
LIST OF FIGURES	VIII
LIST OF TABLES	VIII
EXECUTIVE SUMMARY	IX
ACKNOWLEDGMENTS	X
ABBREVIATIONS, GREEK LETTERS	XI
1. INTRODUCTION	1
2. DESCRIPTION OF THE PMK FACILITY	3
3. UJV INPUT MODEL OF PMK FACILITY	7
4. POST-TEST ANALYSIS OF T2.1 EXPERIMENT	9
4.1 Experiment description	9
4.2 Results of calculation	12
4.3 Comparison of results	14
5. POST-TEST ANALYSIS OF T2.2 EXPERIMENT	17
5.1 Experiment description	17
5.2 Results of calculation	20
5.3 Comparison of results	22
6. POST-TEST ANALYSIS OF T2.3 EXPERIMENT	25
6.1 Experiment description	25
6.2 Results of calculation	28
6.3 Comparison of results	30
7. CONCLUSIONS	33
8. REFERENCES	35
APPENDIX A LISTING OF UJV INPUT DECK OF PMK	A-1
APPENDIX B LISTING OF STRIP FILE	B-1
APPENDIX C COMPLETE SET OF COMPARISON PLOTS FOR CASE T2.1	C-1
APPENDIX D COMPLETE SET OF COMPARISON PLOTS FOR CASE T2.2	D-1
APPENDIX E COMPLETE SET OF COMPARISON PLOTS FOR CASE T2.3	E-1

LIST OF FIGURES

	<u>Page</u>
Figure 1 Elevation diagram	5
Figure 2 Flow diagram of the PMK facility	6
Figure 3 Nodalization scheme of PMK for RELAP5	8
Figure 4 Primary pressure (T2.1)	11
Figure 5 Secondary pressure (T2.1)	11
Figure 6 Core inlet temperature (T2.1)	13
Figure 7 Cladding temperature (T2.1)	13
Figure 8 Collapsed level in reactor (T2.1)	15
Figure 9 Collapsed level in hydroaccumulator SIT-1 (T2.1)	16
Figure 10 Integrated break mass flow rate (T2.1)	16
Figure 11 Primary pressure (T2.2)	19
Figure 12 Secondary pressure (T2.2)	19
Figure 13 Core inlet temperature (T2.2)	21
Figure 14 Cladding temperature (T2.2)	21
Figure 15 Collapsed level in reactor (T2.2)	23
Figure 16 Collapsed level in hydroaccumulator SIT-1 (T2.2)	24
Figure 17 Integrated break mass flow rate (T2.2)	24
Figure 18 Primary pressure (T2.3)	27
Figure 19 Secondary pressure (T2.3)	27
Figure 20 Core inlet temperature (T2.3)	29
Figure 21 Cladding temperature (T2.3)	29
Figure 22 Collapsed level in reactor (T2.3)	31
Figure 23 Collapsed level in hydroaccumulator SIT-1 (T2.3)	32
Figure 24 Integrated break mass flow rate (T2.3)	32

LIST OF TABLES

	<u>Page</u>
Table 1 Initial conditions of test T2.1	10
Table 2 Boundary conditions of test T2.1	10
Table 3 Timing of main events of test T2.1	12
Table 4 Initial conditions of test T2.2	18
Table 5 Boundary conditions of test T2.2	18
Table 6 Timing of main events of test T2.2	20
Table 7 Initial conditions of test T2.3	26
Table 8 Boundary conditions of test T2.3	26
Table 9 Timing of main events of test T2.3	28

EXECUTIVE SUMMARY

The PMK-2 facility [3] is a scaled down model of the VVER-440/213 and it had been primarily designed for investigation of small-break loss of coolant accidents (SBLOCA) and transient processes of this type of NPP. Nowadays the facility is also widely used for assessment of advanced computer code, that are used for safety analysis in VVER-operating countries.

One of the most important and world-widespread computer codes is the RELAP5 code. In the Czech Republic, the RELAP5 is installed under agreement between US NRC and Czech regulatory body (SONS). The main user of the code is the Nuclear Research Institute (NRI, UJV) Rez, where the code is widely assessed and applied to NPP safety analyses.

The tests used in this report for assessment of RELAP5/MOD3.3 computer code are medium-break LOCA accidents without HPSI and with operator interventions (secondary bleed, primary bleed). Also the effect of lower hydroaccumulator pressure is studied.

Comparison of the measured test data and the RELAP5/MOD3.3 results showed very good overall agreement of all major system parameters as primary pressure, reactor level, reactor coolant and clad temperature etc.

The work is focused not only on the computer code assessment – it also gives important conclusions for the Emergency Operating Procedures (EOP) that have been lastly improved at the VVER power plants.

ACKNOWLEDGMENTS

The authors acknowledge the support of the Czech regulatory body - the State Office of Nuclear Safety (SONS) - in acquiring the advanced thermal hydraulic codes. We also acknowledge the support of the Ministry of Industry and Trade of the Czech Republic within the national programs and grants focused on increase of the nuclear safety and the level of knowledge in branch of thermal hydraulics.

ABBREVIATIONS, GREEK LETTERS

BE	best-estimate
CL	cold leg
D	diameter
DC	downcomer
ECCS	Emergency Core Cooling System
EOP	Emergency Operating Procedures
HA	hydroaccumulator
HL	hot leg
HPIS	High Pressure Injection System
HPSI	high pressure safety injection
ID	inner diameter
LOCA	loss-of-coolant accident
LOOP	loss-of-offsite power
LPIS	Low Pressure Injection System
LPSI	low pressure safety injection
MBLOCA	medium-break LOCA
N/A	not applicable
EOP	emergency operating procedures
PCT	peak clad temperature
PRZ	pressurizer
RCP	reactor coolant pump
SBLOCA	small-break LOCA
SCRAM	reactor trip ("safety control rod ax man")
SG	steam generator
SIT	safety injection tank
UP	upper plenum
VVER	Russian type of PWR (with horizontal SGs)

1. INTRODUCTION

The tests used in this report for assessment of RELAP5/MOD3.3 computer code were carried out in frame of the IMPAM-VVER project. The project was focused on different problems encountered during the development of EOPs for VVER reactors. The participants of the project performed both pre- and post-test analyses of the test with computer codes CATHARE, ATHLET and RELAP. UJV Rez participated in the assessment part of the project mainly with the ATHLET code [4].

Objective the work presented in this report is additional assessment of RELAP5/MOD3.3 against selected tests performed at the PMK facility in frame of IMPAM project. The tests are medium-break LOCA accidents without HPSI and with operator interventions (secondary bleed, primary bleed). Also the effect of lower hydroaccumulator pressure is studied.

The following PMK tests will be post-analyzed in this report:

- Test 2.1 reproducing the EOP steps for larger SB-LOCA. A reduced number of hydro-accumulators is assumed to be available. Since no HPIS is working, core overheating will occur after emptying of the hydro-accumulators. Secondary bleed and primary bleed and feed will be started following the procedures. The aim is to investigate whether LPIS injection can be started before renewed core overheating occurs.
- Test 2.2 reproducing Test 2.1, but bleed and feed start earlier.
- Test 2.3 starting from lower parameters (attempt to make a counter-part test with PACTEL facility) and investigating the effect of reduced initial pressure and higher level in hydroaccumulators.

The work is focused not only on the computer code assessment – it gives important conclusions also for the Emergency Operating Procedures (EOP), that have been lastly improved at the VVER power plants.

2. DESCRIPTION OF THE PMK FACILITY

The PMK-2 facility [3] is a scaled down model of the VVER-440/213 and it was primarily designed for investigating small-break loss of coolant accidents (SBLOCA) and transient processes of this type of NPP. The specific features of VVER-440/213 are as follows: 6-loop primary circuit, horizontal steam generators, loop seal in hot and cold legs, safety injection tank (SIT) set-point pressure higher than secondary pressure (nowadays modified at majority of VVER-440/213), the coolant from SITs directly injected to the upper plenum and downcomer. As a consequence of the differences the transient behavior of such a reactor system should be different from the usual PWR system behavior.

The volume and power scaling of PMK facility are 1:2070. Transients can be started from nominal operating conditions. The ratio of elevations is 1:1 except for the lower plenum and pressurizer. The six loops of the plant are modeled by a single active loop. In the secondary side of the steam generator the steam/water volume ratio is maintained. The coolant is water under the same operating conditions as in the nuclear power plant.

The core model consists of 19 electrically heated rods, with uniform power distribution. Core length, elevation and flow area are the same as in the Paks NPP.

In the modeling of the steam generator primary side, the tube diameter, length and number were determined by the requirement of keeping the 1:2070 ratio of the product of the overall heat transfer coefficient and the equivalent heat transfer area. The elevations of tube rows and the axial surface distribution of tubes are the same as in the reference system. On the secondary side the water level and the steam to water volume ratios are kept. The temperature and pressure are the same as in the NPP. The horizontal design of the VVER steam generator affects the primary circuit behavior during a small break LOCA in quite a different way to the usual vertical steam generators.

Cold and hot legs are volume scaled and care was taken to reproduce the correct elevations of the loop seals in both the cold and the hot legs. Cold and hot leg cross section areas if modeled according to volume scaling principles would have produced much too high pressure drops. Since, for practical reasons, length could not be maintained 1:1, relatively large cross sections were chosen for the PMK loop. On the one hand this results in smaller cold and hot leg frictional pressure drops than in the NPP, on the other hand, however, it improves the relatively high surface to volume ratio of the PMK pipework. As to the former effect, the small frictional pressure drop of the PMK cold and hot legs will have a negligible effect on small-break processes. However, the pressure drop is increased using orifices around the loop.

For the pressurizer the volume scaling, the water to steam volume ratio and the elevation of the water level is kept. For practical reasons the diameter and length ratios cannot be realized. The pressurizer is connected to the same point of the hot leg as in the reference system. Electrical heaters are installed in the model and the provision of the spray cooling is similar to that of Paks NPP.

For the hydroaccumulators, the volume scaling and elevation is kept. They are connected to the downcomer and upper plenum similar to those of the reference system. The four hydroaccumulators of the VVER-440/213 are modeled by 2 SIT vessels.

The HPIS and LPIS systems are modeled by controlling the coolant flow rate in the lines by control valves. The flow rates measured during the start-up period of the Paks NPP are used to control the valves.

The main circulating pump of the PMK serves to produce the nominal operating conditions corresponding to that of the NPP prior to break initiation as well as to simulate the flow coast-down following pump trip early in the transient. For this reason the pump is accommodated in a by-pass line. Flow coast-down is modeled by closing a control valve in an appropriate manner and if flow rate is reduced to that of natural circulation, the valve in the by-passed cold leg part is opened while the pump line is simultaneously closed.

PMK Test Facility Characteristics:

Reference NPP:

Paks Nuclear Power Plant with VVER-440/213 (6 loops)
1375 MWt - hexagonal fuel arrangement

General Scaling factor:

Power, volumes: 1/2070, loops 1/345
Elevations: 1/1

Primary coolant system (1 loop representation):

- Pressure: 12.3 MPa (nominal), 16 MPa (max.)
- Nominal core inlet temperature: 540K
- Nominal core power: 664 kW
- Nominal flow rate: 4.5 kg/s

Special features:

- 19 heater rods, uniform axial and radial power distribution
- 2.5 m heated length
- External downcomer
- Pump is accommodated in by-pass line
 - flow rate 0 to nominal value
 - NPP pump coast down simulation
- Loop piping: 46 mm ID

Secondary system:

- Pressure: 4.6 MPa, feed water temperature: 496 K
- Nominal steam and feed water mass flow: 0.36 kg/s

Special features:

- Horizontal steam generator
- Controlled heat removal system

Safety injection systems:

- High Pressure Injection System (HPIS) and Low Pressure Injection System (LPIS)
- Safety Injection Tanks (SITs)
- Emergency feed water

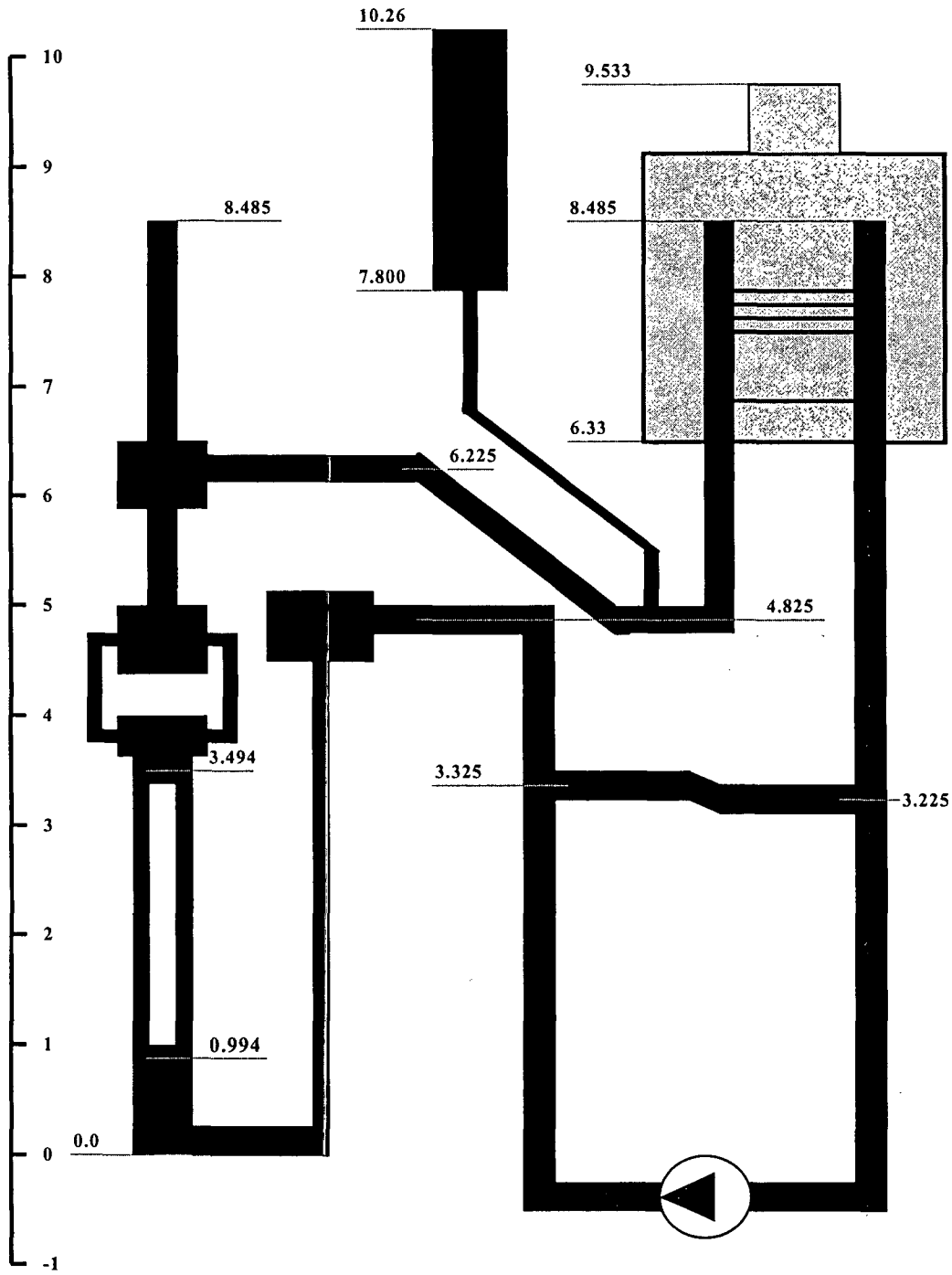

Figure 1 Elevation diagram

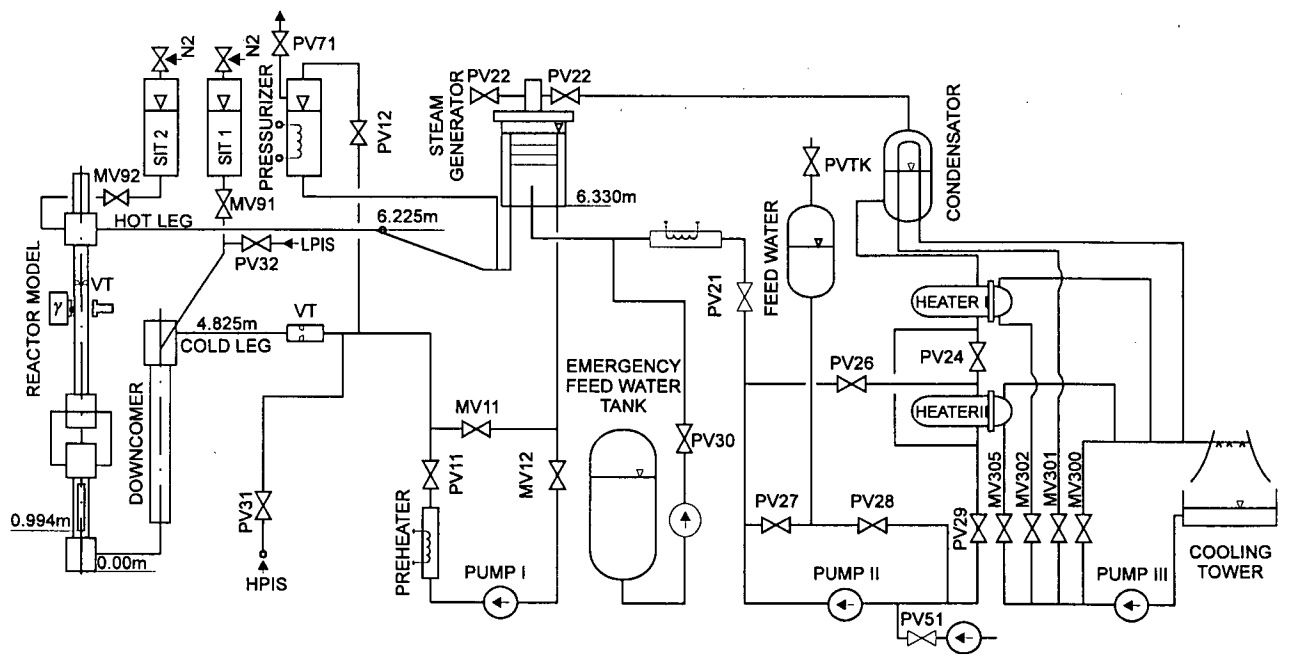

Figure 2 Flow diagram of the PMK facility

3. UJV INPUT MODEL OF PMK FACILITY

The RELAP5 input deck of PMK used for the post-test analyses is a modified version of our older deck [1, 2] used for modeling of PMK-NVH in early 90-ties, when we analyzed the IAEA organized SPE tests.

The modeling approach used in development of PMK model is similar to the approach applied in development of input models of Czech NPPs with VVER reactors. Generally, geometry and nodalization of primary circuit except of SG is very similar to those of standard PWR. There are only 3 major specific features of VVER-440/213, that should be reflected in nodalization – horizontal SG (reflected in multi-layer nodalization of SG tubing), loop seal in hot leg (reflected in detailed nodalization of HL), and direct HA/LPIS injection to reactor (we don't expect any multi-dimensional effects in small-scale facility like PMK, so simple 1-D modeling of reactor vessel was used).

Our RELAP5 input model of PMK experimental facility consists of:

- 134 volumes
- 144 junctions
- 126 heat structures (with 553 mesh points)
- 62 control variables
- 68 trips

Nodalization scheme can be seen in **Figure 3**. Comparing to our „old“ model of PMK-NVH [1, 2], the major modifications of PMK nodalization implemented during work on this report, are as follows: more exact modeling of lower plenum, remodeled core outlet and upper plenum, and modified nodalization of PRZ and PRZ surge line (incl. location of PRZ surge line connection to the hot leg).

Listing of the current version of the PMK input deck used for the presented analyses (specifically T2.3) can be found in the Appendix I.

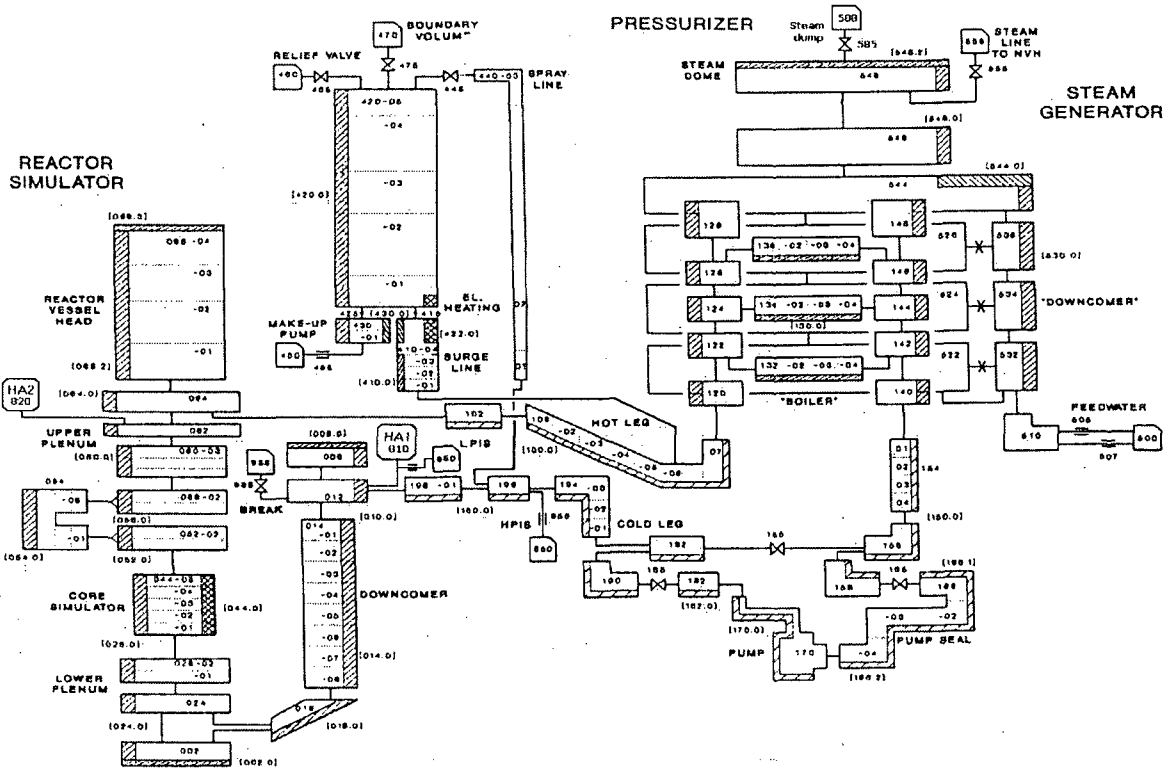

Figure 3 Nodalization scheme of PMK for RELAP5

4. POST-TEST ANALYSIS OF T2.1 EXPERIMENT

4.1 Experiment description

The Test 2.1 (T2.1-BF) [5, 6] experiment simulates a primary loss-of-coolant accident without high pressure injection and the basic question is whether the primary pressure can be reduced to the shut-off head of the pumps of the LPI systems. Earlier PMK tests indicate that in these situations it is too late to start bleed and feed at superheated core outlet temperature if the SITs are no longer available. The significant loss of primary coolant may lead to core overheating before the system pressure decreases to the activation pressure of LPI systems.

The test is defined by the following steps:

- Experiment started from nominal operating parameters of the loop by opening the 7.4% break in the cold leg (break orifice D3 mm corresponding with D135 mm break size in VVER-440);
actually break line is connected not directly to the cold leg, but to the reactor downcomer top, close to reactor inlet from cold leg;
- SCRAM actuation simultaneously;
- Secondary side isolation simultaneously;
- Pressurizer heaters off simultaneously;
- Pump coast down simultaneously,
- 1 SIT to the upper plenum and 2 SITs to the downcomer,
- Secondary bleed starts at $T_{clad} > 350\text{ }^{\circ}\text{C}$
(plus we applied here additional condition of „time > 900 s (15 min)“ to avoid too early initiation of sec. bleed by temperature peaks in first hundreds of seconds and to be realistic as for timing of first operator interventions),
- Primary bleed starts at $T_{clad} > 500\text{ }^{\circ}\text{C}$,
- LPIS starts at $p < 0,7\text{ MPa}$,
- Power to core simulator off if $T_{clad} > 600\text{ }^{\circ}\text{C}$,
- Test terminated if $T_{clad} > 650\text{ }^{\circ}\text{C}$.

The main objective of the test is to get experimental evidence on the effectiveness of the secondary bleed and the primary bleed and feed to reduce the primary pressure to the setpoint pressure of LPIS without core damage. Further on it will help to assess the predictive capabilities of codes in the calculation of the complex transient scenario and identification of key events.

The initial conditions of the test are nearly the same as the nominal operating parameters of the plant considering the scaling ratio. In **Table 1** below these conditions are given. Specified data are compared with measured data and the steady-state calculation results.

Table 1 Initial conditions of test T2.1

	Unit	Specified	Measured	Calculation NRI
Primary system pressure (PR21)	MPa	12.3	12.377	12.425
Primary loop flow (FL53)	kg/s	4.5	4.34	4.34
Core inlet temperature (TE63)	K	541	541.8	542.1
Core power (PW01)	kW	664	665.1	665.5
Coolant level in PRZ (LE71)	m	9.2	9.22	9.20
SIT-1 initial pressure (PR91)	MPa	5.8	5.82	5.82
SIT-2 initial pressure (PR92)	MPa	5.8	5.90	5.90
SIT-1 initial level (LE91)	m	9.62	9.64	9.644
SIT-2 initial level (LE92)	m	10.03	10.05	10.052
Secondary pressure (PR81)	MPa	4.6	4.84	4.84
Feedwater flow (FL81)	kg/s	0.35	0.43	0.43
Feedwater temperature (TE81)	K	496	491.4	491.4
Coolant level in SG (LE81)	m	8.2	8.62	8.630

As boundary conditions it was decided to have the SCRAM, the RCP trip and the secondary side isolation together with the opening of the break valve. The secondary bleed starts when the heater rod surface temperature is more than 350°C (plus we used additional condition "not before 900 s" in our calculation), the primary bleed starts when the fuel surface temperature is more than 500°C and LPIS starts when the primary pressure is less than 0,7 MPa. The boundary conditions are listed in **Table 2** below.

Table 2 Boundary conditions of test T2.1

	Unit	Specified	Measured	Calculation NRI
Break orifice diameter	mm	3.0	3.0	3.0
Secondary bleed valve diameter	mm	4.0	4.0	4.0
Primary bleed valve diameter	mm	1.0	1.0	1.0
Break opens at	s	0.0	1.0	0.0
SCRAM is initiated at	s	0.0	2.0	2.0
Isolation of feedwater and steam lines	s	0.0	0.0	0.0
RCP coast-down initiated at	s	0.0	4.0	4.0
Steam dump valve opens at	MPa	5.3	5.37	5.3
Steam dump valve closes at	MPa	4.9	4.89	4.9
Secondary bleed initiated at T _{clad} >	°C	350	347	350 *
Primary bleed initiated at T _{clad} >	°C	500	504	500
LPIS injection starts if primary pressure	MPa	0.7	0.7	0.7
LPIS flow rate (1 system assumed)	kg/s	0.042	0.07	0.07
SIT-1 injection ended at	m	8.22	8.22	8.22
SIT-2 injection ended at	m	9.33	9.25	9.25

* Note: For start of operator initiated secondary bleed we applied additional condition of „time > 900 s (15 min)“ to avoid its too early initiation by clad temperature peaks in first hundreds of seconds (and to be realistic as for timing of first operator interventions).

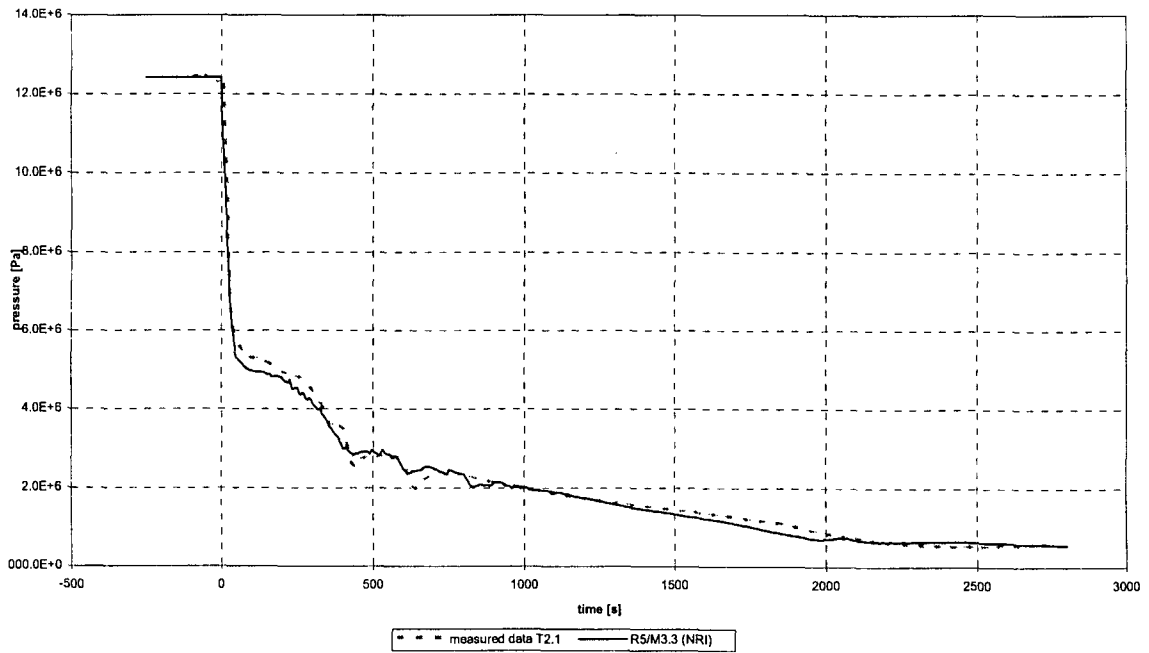

Figure 4 Primary pressure (T2.1)

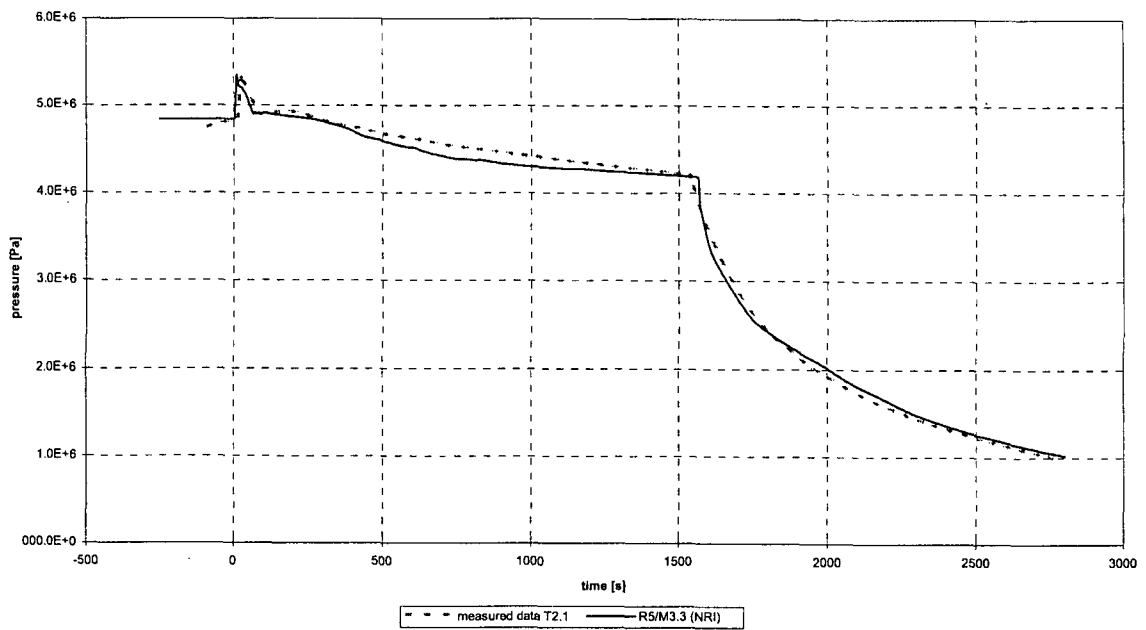

Figure 5 Secondary pressure (T2.1)

4.2 Results of calculation

The main events of the Test 2.1 and the RELAP5 calculations are listed in **Table 3** below:

Table 3 Timing of main events of test T2.1

Event	Timing [s]		Comment
	Measured	Calculation NRI	
Break valve opening	1.0	0.0	Break diameter is 3 mm (i.e. 7.4% of CL flow area)
Isolation of feedwater and steam lines initiated	0.0	0.0	Closing of valves: 4 s
SCRAM actuated	3.0	3.0	timing of effective power decrease
RCP trip	4.0	4.0	
Steam dump valve opening	24	11	At sec. press. 5.3 MPa
SIT-1, SIT-2 injection start	48	38	
Steam dump valve closing	79	66	At sec. press 4.9 MPa
First reversal of heat transfer at SG	not measured	99	
First clad overheating	245-325 (320 °C)	200-230 (339 °C)	
SIT-1 injection to downcomer end	629	830	
SIT-2 injection to upper plenum end	637	1020	
Final fuel rod overheating (TW01) start	1414	1495	
Secondary bleed initiation	1534	1565	After clad temp 350 °C (+ in calculation additional condition t > 900 s)
Primary bleed initiation	1706	1680	After clad temp 500 °C
Core power switching off	1861	1756	Protection from 600 °C
Time of fuel rod temperature maximum	1863 (601 °C)	1756 (600 °C)	
LPIS injection starts at	2114	1965	
Core fully flooded	2250	2055	
Transient end	2763	2800	

The defined LOCA scenario starts with opening of the break valve at reactor downcomer top and with coincident loss of offsite power (LOOP) simulation. Major consequences of LOOP are the immediate trip of RCP, reactor SCRAM, and isolation of SG secondary side.

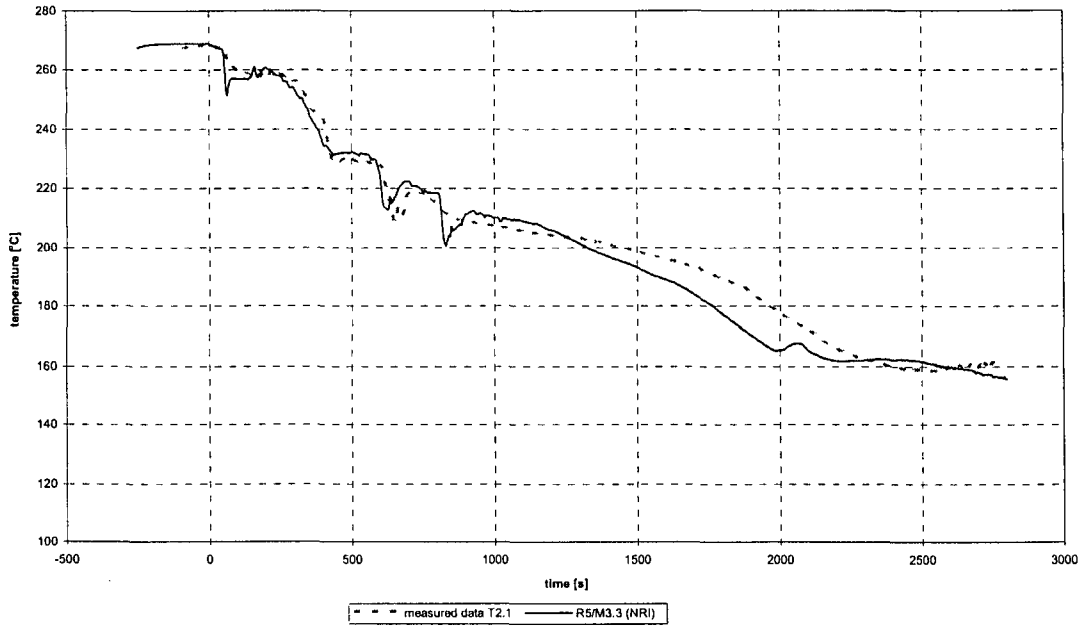

Figure 6 Core inlet temperature (T2.1)

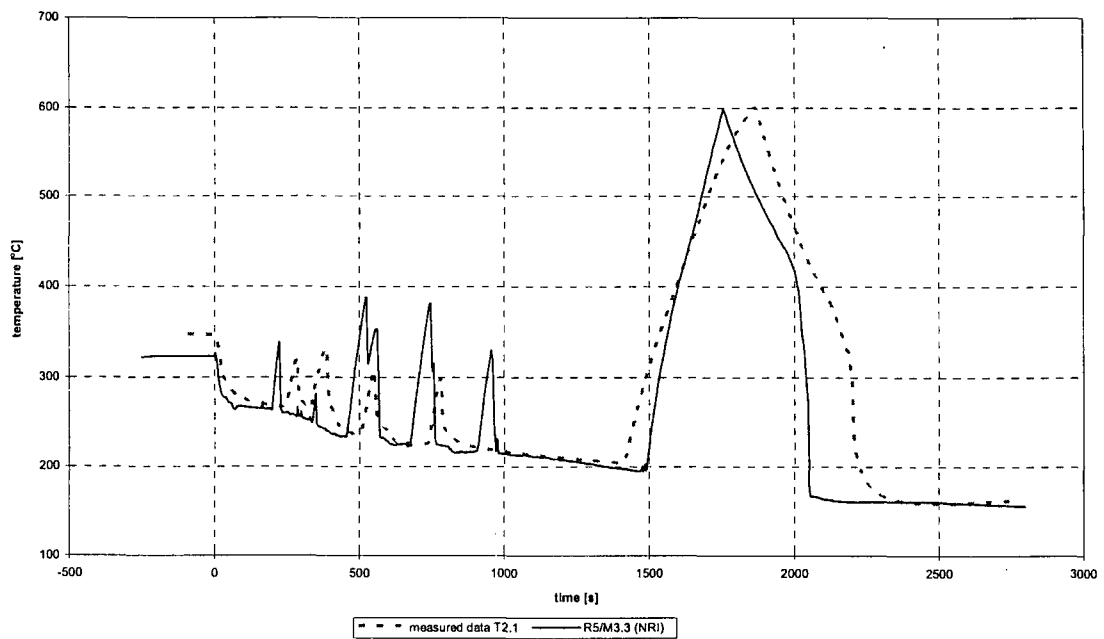

Figure 7 Cladding temperature (T2.1)

Due to the isolation of the secondary side, the steam generator pressure increases fast, reaching the steam dump opening setpoint 5.3 MPa. In the calculation, the steam dump occurs in time interval 11-66 s. After closing of the valve (at 4.9 MPa), the secondary pressure is stabilized and slowly decreases due to heat losses and drop of parameters in primary circuit (reversed heat transfer at SG after 99 s).

Outflow of primary coolant through break with equivalent diameter 3 mm (7.4% of cold leg flow area) leads to fast decrease of primary pressure. After dropping under 6.0 MPa, the hydroaccumulators start to inject cold water into UP and DC.

As there is no HPIS available in the test T2.1, end of HA injection (at time 1020 s, with primary pressure about 2 MPa, i.e. high above LPIS shut-off head of 0.7 MPa) means further decrease of primary inventory and finally core uncover and heat-up.

After reaching of cladding temperature level 350 °C secondary bleed is initiated (note: in the calculation we applied additional condition for secondary bleed initiation: „time > 900 s (15 min)“ to avoid its too early initiation by clad temperature peaks in first hundreds of seconds and to be realistic as for timing of first operator interventions). Unfortunately, both the experiment and the calculation show that the secondary bleed had almost no effect on the heater rod temperature.

So the core heat-up continues and when clad temperature reaches 500 °C, primary bleed is initiated. Again it had minimal effect on behavior of the system and core cooling (both in experiment and in calculation).

So ultimately, the PMK facility core protection stops the core power after clad temperature reaches set-point 600 °C and the same (a measure not “available” at real NPP with nuclear fuel and decay heat production after SCRAM) is modeled in the RELAP5 calculation. After that, clad temperatures and other primary parameters starts to decrease. The clad temperature decrease is strongly accelerated by start of LPIS injection into DC (after primary pressure drop under 0.7 MPa).

4.3 Comparison of results

The most important comparison plots of the measured data and the post-test UJV calculations are shown in **Figure 4 - Figure 10**. Complete set of comparison plots can be found in Appendix III.

Most calculated parameters is in very good agreement with measured data, especially the most important system parameters like primary and sec. pressure, coolant and clad temperature etc. The integrated break flow is slightly overpredicted in the first 300 s of the transient and on the contrary, substantially underpredicted after 400 s. The difference between measured and calculated leak is after 800 s more or less constant and amounts approximately 20 kg (15% of steady state inventory).

Initial increase of secondary pressure is faster in calculation than in experiment (see the timing of the steam dump), which could be caused by not modeling of steam pipes between SG and valves. Overall agreement between measured and computed course of secondary pressure is however very good.

As the prediction of primary pressure course is very good, also the step-wise injection from the HAs is predicted well by the code, but there is some difference in the timing and the amount injected in the different steps. In the facility the HA valves are opened by the primary pressure signal and they remain then open, after a discharge phase significant backflow from the primary can be seen in the measured HA level curves. In the RELAP hydroaccumulator model, that valve is a check valve, which does not enable any reverse flow in the hydroaccumulator line. In PMK these reverse flows bring warmer water into subcooled HA (subcooled by gas expansion) and warms it up, which consequently accelerates HA injection. Thus the HA injection in experiment is naturally little bit faster than injection predicted in calculation.

Both the experiment and calculations show that in this LOCA scenario the Accident Management can't reduce the primary pressure fast enough to prevent substantial overheating of the core.

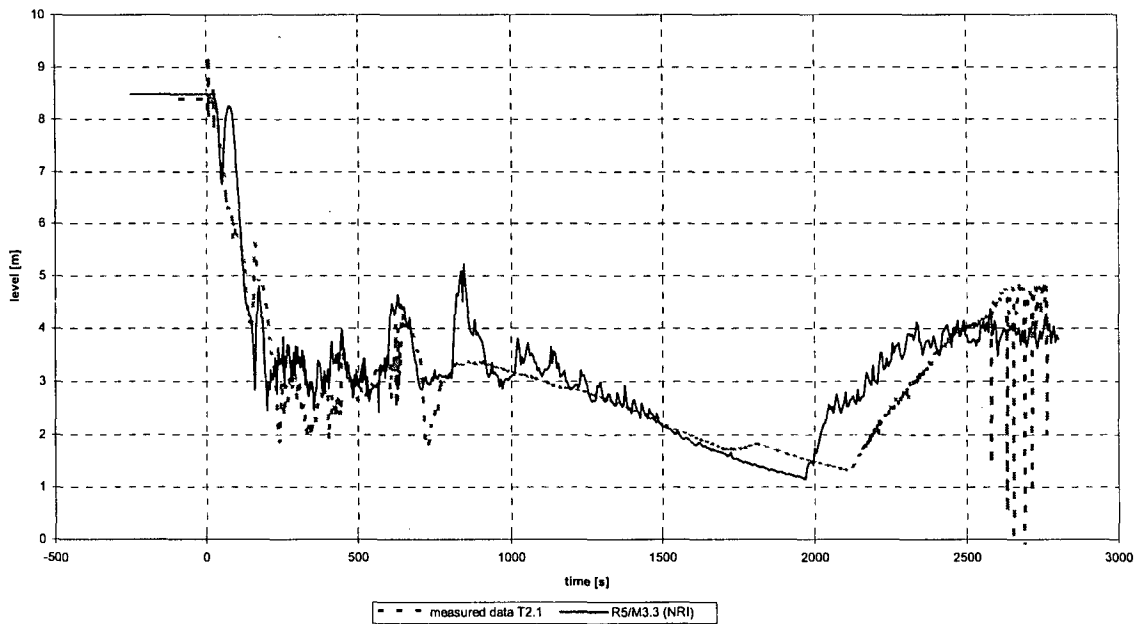

Figure 8 Collapsed level in reactor (T2.1)

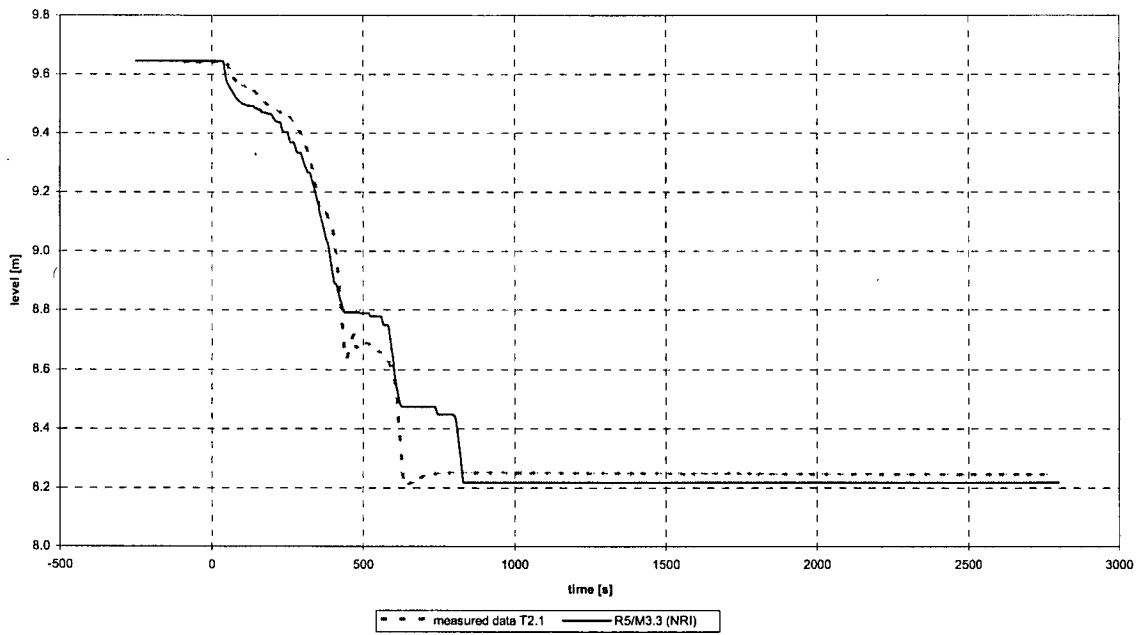

Figure 9 Collapsed level in hydroaccumulator SIT-1 (T2.1)

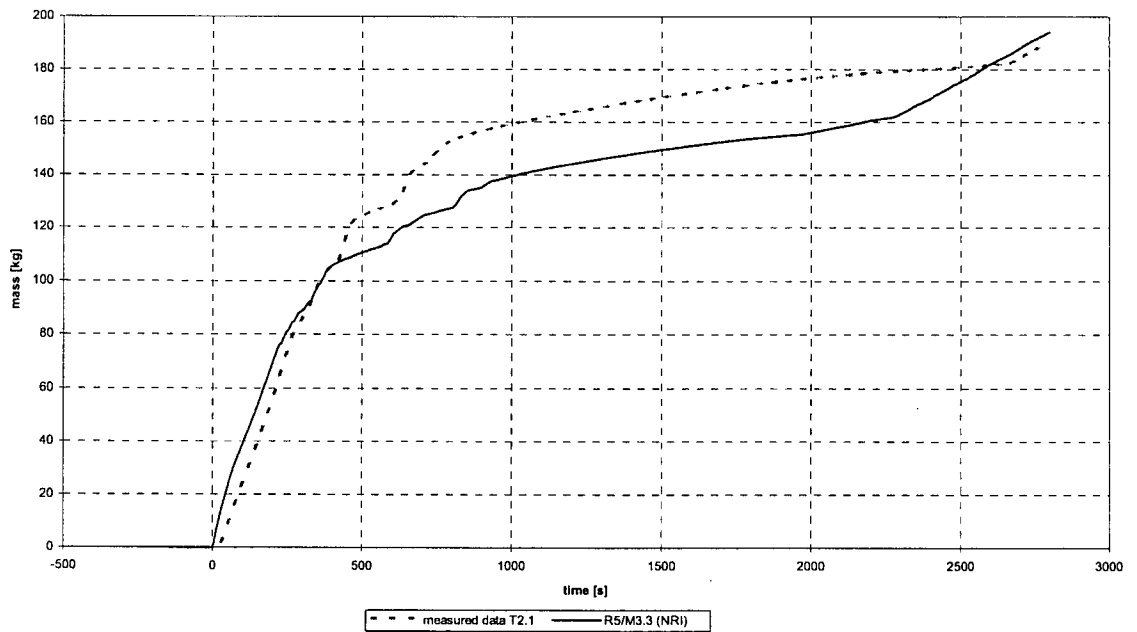

Figure 10 Integrated break mass flow rate (T2.1)

5. POST-TEST ANALYSIS OF T2.2 EXPERIMENT

5.1 Experiment description

The Test 2.2 (T2.2-BF) [5, 6] experiment simulated a primary loss-of-coolant accident without high pressure injection and the basic question is whether in case of very early operator initiated depressurization of the system, the primary pressure can be reduced to the shut-off head of the pumps of the LPI systems. Earlier PMK tests had indicated that in these situations it is too late to start bleed and feed at superheated core outlet temperature if the SITs are no longer available. The significant loss of primary coolant may lead to core overheating before the system pressure decreases to the activation pressure of LPI system.

This test followed Test 2.1. The only difference was that the bleed and feed interventions were started earlier to get the setpoint pressure of LPI systems. Secondary system depressurization in here in T2.2 started at 900 s before start of ultimate core heat up (in T2.1 it was started by 350 °C cladding temp., i.e. at about 1500 s) and primary system depressurization is here started when core heat up lead to clad temperature 300 °C (while in T2.1 is was started at 500 C).

The test scenario was defined by the following steps:

- Experiment started from nominal operating parameters of the loop by opening the 7.4% break in the cold leg (actually break line is connected not directly to the cold leg, but to the reactor downcomer top, close to cold leg inlet);
- SCRAM actuation simultaneously;
- Secondary side isolation simultaneously;
- Pressurizer heaters off simultaneously;
- Pump (RCP) coast down simultaneously,
- 1 SIT to the upper plenum and 2 SITs to the downcomer,
- Secondary bleed starts at 900 s,
- Primary bleed starts at $T_{clad} > 300$ °C, (plus we applied here again additional condition of „time > time of sec. bleed + 5 min = 1200 s “ to be realistic as for timing of the operator interventions sequence),
- LPIS starts at $p < 0,7$ MPa,
- Power to core simulator off if $T_{clad} > 600$ °C,
- Test terminated if $T_{clad} > 650$ °C.

The main objective of the test is to get experimental evidence on the effectiveness of the secondary bleed and the primary bleed and feed to reduce the primary pressure to the setpoint pressure of LPIS without core damage. Further on it will help to assess the predictive capabilities of codes in the prediction of the complex transient scenario and identification of key events.

The initial conditions of the test are nearly the same as the nominal operating parameters of the plant considering the scaling ratio. In the **Table 4** below these conditions are given. Specified values are compared with measured data and the steady-state calculation results.

Table 4 Initial conditions of test T2.2

	Unit	Specified	Measured	Calculation NRI
Primary system pressure (PR21)	MPa	12.3	12.37	12.370
Primary loop flow (FL53)	kg/s	4.5	4.40	4.34
Core inlet temperature (TE63)	K	541	541.4	541.62
Core power (PW01)	kW	664	667	665
Coolant level in PRZ (LE71)	m	9.2	9.19	9.20
SIT-1 initial pressure (PR91)	MPa	5.8	5.83	5.83
SIT-2 initial pressure (PR92)	MPa	5.8	5.87	5.87
SIT-1 initial level (LE91)	m	9.62	9.64	9.64
SIT-2 initial level (LE92)	m	10.03	10.04	10.05
Secondary pressure (PR81)	MPa	4.6	4.80	4.80
Feedwater flow (FL81)	kg/s	0.35	0.423	0.34
Feedwater temperature (TE81)	K	496	478.8	478.8
Coolant level in SG (LE81)	m	8.2	8.65	8.63

As boundary conditions it was decided to have the SCRAM, the RCP trip and the secondary side isolation together with the opening of the break valve. The secondary bleed starts when the heater rod surface temperature is more than 350°C (plus we used additional condition "not before 900 s" in our calculation), the primary bleed starts when the fuel surface temperature is more than 500 °C and LPIS starts when the primary pressure is less than 0,7 MPa.

Table 5 Boundary conditions of test T2.2

	Unit	Specified	Measured	Calculation NRI
Break orifice diameter	mm	3.0	3.0	3.0
Secondary bleed valve diameter	mm	4.0	4.0	4.0
Primary bleed valve diameter	mm	1.0	1.0	1.0
Break opens at	s	0.0	0.0	0.0
SCRAM is initiated at	s	0.0	2.0	2.0
Isolation of feedwater and steam lines	s	0.0	2.0	0.0
RCP coast-down initiated at	s	0.0	0.0	0.0
RCP coast-down time	s	150	117	147.5
Steam dump valve opens at	MPa	5.3	5.37	5.3
Steam dump valve closes at	MPa	4.9	4.89	4.9
Secondary bleed initiated at time	s	900	889	889
Primary bleed initiated at T _{clad} >	°C	300	295	295
LPIS injection starts if primary pressure	MPa	0.7	0.73	0.73
LPIS flow rate (1 system assumed)	kg/s	0.042	0.042	0.042
SIT-1 injection ended at	m	8.275	8.221	8.23
SIT-2 injection ended at	m	9.360	9.278	9.28

* Note: For start of operator initiated primary bleed we applied additional condition of „time > time of sec. bleed + 5 min (1200 s)“ to avoid its too early initiation by clad temperature peaks in first hundreds of seconds and to be realistic as for timing of the operator interventions sequence.

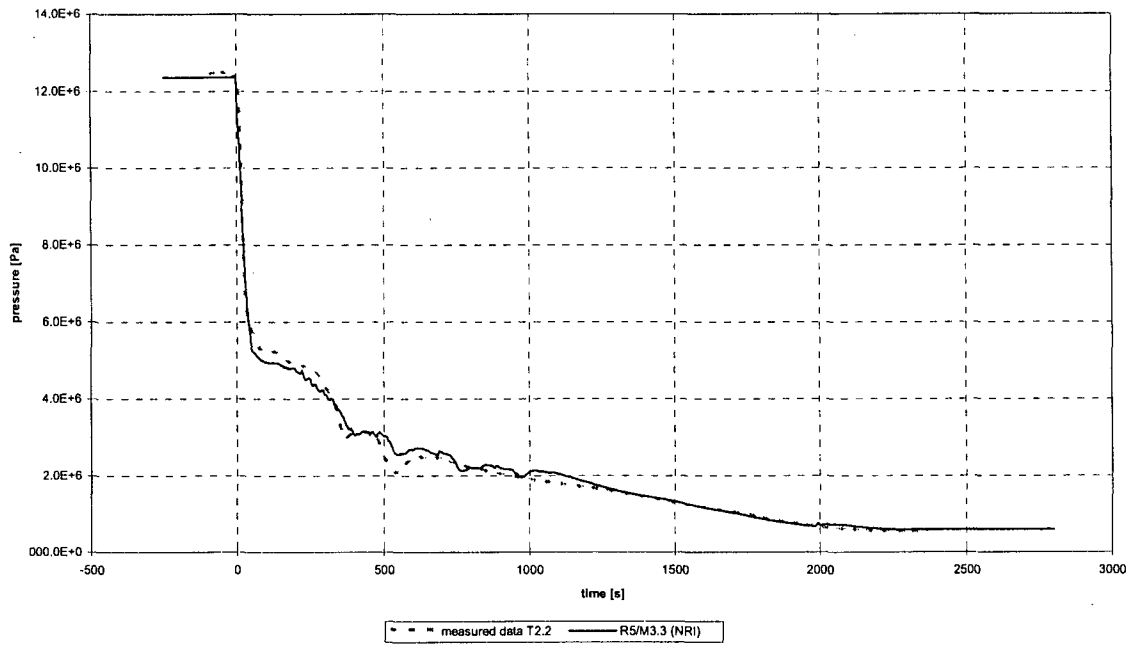

Figure 11 Primary pressure (T2.2)

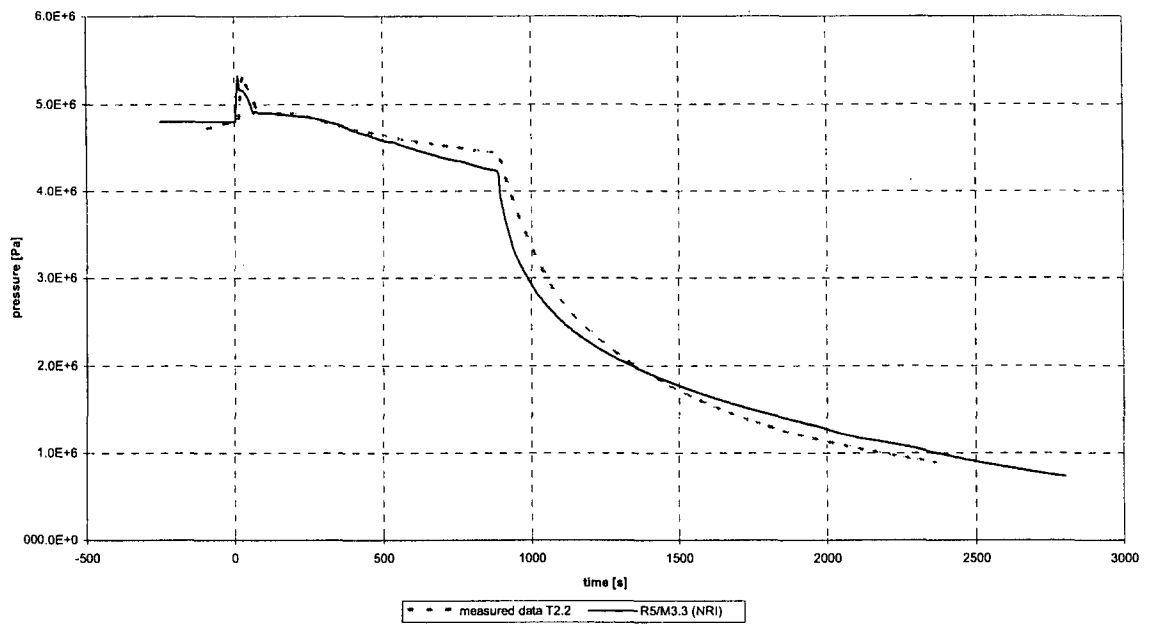

Figure 12 Secondary pressure (T2.2)

5.2 Results of calculation

The main events of the test T2.2 and the RELAP5 calculations are listed in **Table 6** below:

Table 6 Timing of main events of test T2.2

Event	Timing [s]		Comment
	Measured	Calculation NRI	
Break valve opening	0.0	0.0	Break diameter is 3 mm (i.e. 7.4% of CL flow area)
RCP trip	0.0	0.0	
SCRAM actuated	2.0	2.0	
Isolation of feedwater and steam lines initiated	2.0	0.0	Closing time of MSIV/FW equals to 4 s
Steam dump valve opening	29	11	At sec. press. 5.3 MPa
SIT-1, SIT-2 injection start	46	42	
Steam dump valve closing	79	65	At sec. press 4.9 MPa
First reversal of heat transfer at SG	not measured	97	
First clad overheating	235-275	200-225	
SIT-1 injection to upper plenum end	536	950	
SIT-2 injection to downcomer end	538	965	
Secondary bleed initiation	889	889	Predefined
Final fuel rod overheating (TW01) start	1212	1460	
Primary bleed initiation	1277	1503	After final clad heat up to clad temp 300 (295) °C
Core power switching off	1756	1726	Protection from 600 °C
Time of fuel rod temperature maximum	1759 (605 °C)	1725 (600 °C)	
LPIS injection starts at	1920	1909	
Reactor level minimum	1938 (1.02 m)	1910 (1.13 m)	
Core fully flooded	2150	2035	
Transient end	2370	2800	

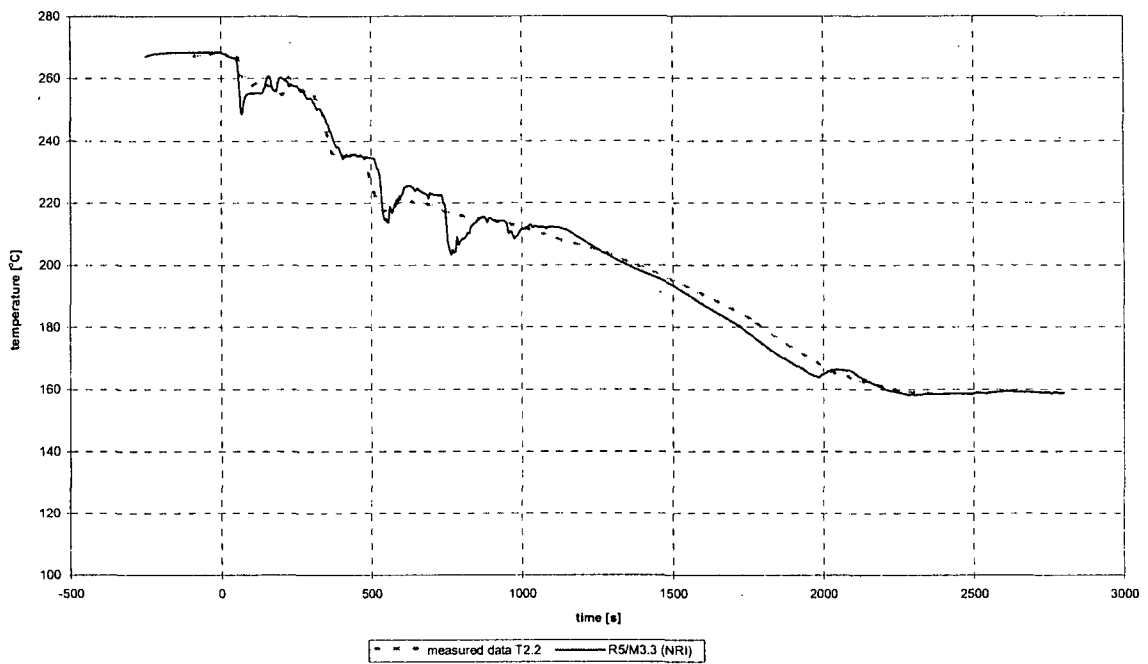

Figure 13 Core inlet temperature (T2.2)

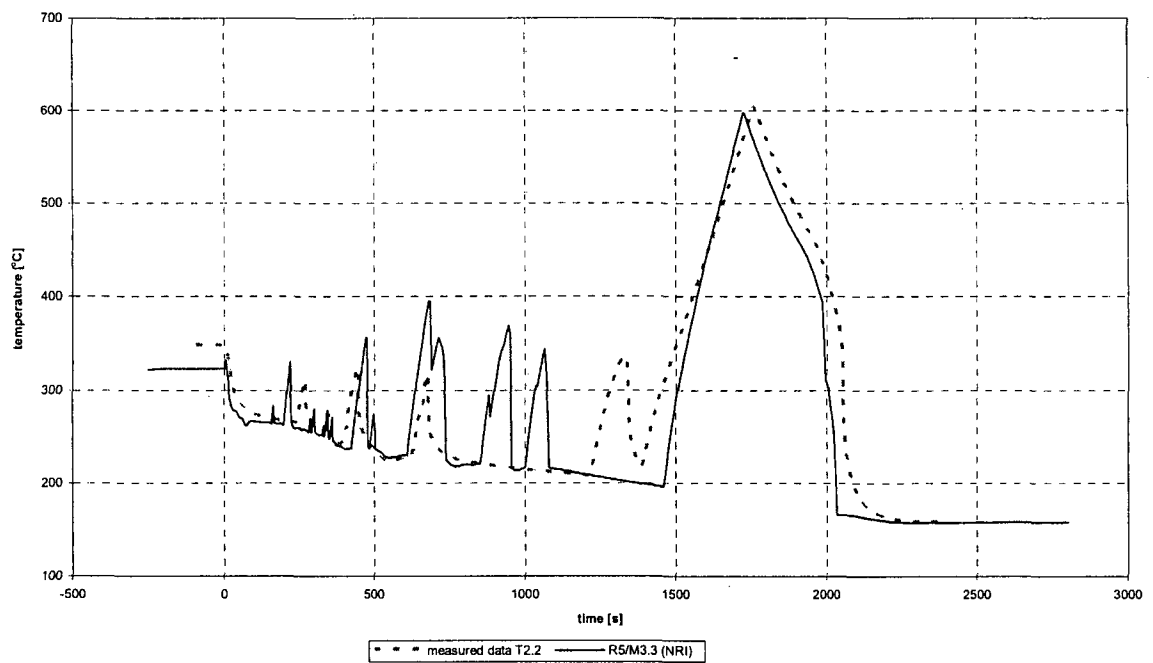

Figure 14 Cladding temperature (T2.2)

The defined medium-break LOCA scenario starts with opening of the break valve at reactor downcomer top and with coincident loss of offsite power (LOOP) simulation. Major consequences of LOOP are the immediate trip of RCP, reactor SCRAM, and isolation of SG secondary side.

Due to the closing of MSIV, the SG pressure increases fast, reaching the steam dump opening setpoint 5.3 MPa. In the calculation, the steam dump occurs in time interval 11-65 s. After closing of the valve (at 4.9 MPa), the secondary pressure is stabilized and slowly decreases due to heat losses and drop of parameters in primary circuit (reversed heat transfer at SG after 97 s).

Outflow of primary coolant through break with equivalent diameter 3 mm (7.4% of cold leg flow area) leads to fast decrease of primary pressure. After getting under 6.0 MPa, the hydroaccumulators start to inject cold water into UP and DC.

As there is no HPIS available in the test T2.2, end of HA injection (at 965 s, with primary pressure about 2 MPa, i.e. substantially higher than LPIS shut-off head of 0.7 MPa) means further decrease of primary inventory and finally deep core uncover and heat-up. At time 900 s secondary bleed initiation is predefined. Unfortunately, both the experiment and the calculation show that the secondary bleed had almost no effect on the heater rod temperature. Primary pressure is about 2 MPa and its decrease towards LPIS pump shut-off head (0.7 MPa) is very slow.

So the primary inventory depletion continues and at 1460 s of calculation the final core uncover and heat up starts (there were some temporary heat-ups before in earlier phase of the process). Consequently, when the clad temperature reaches 300 °C, primary bleed is initiated by operator. However opening of PRZ relief valve has also minimal effect on behavior of the system and core cooling (both in experiment and in calculation).

So ultimately, the PMK facility core protection stops the core power after clad temperature reaches setpoint 600 °C and the same measure is modeled in the RELAP5 calculation. After that, clad temperatures and other primary parameters starts to decrease. After primary pressure decrease to 0.7 MPa the clad temperature decrease is strongly accelerated by start of LPIS injection into DC.

5.3 Comparison of results

The most important comparison plots of the measured data and the post-test UJV calculations are shown in **Figure 11 - Figure 17**. Complete set of comparison plots can be found in Appendix IV.

Most of the calculated parameters is in very good agreement with measured data, especially the most important system parameters like primary and sec. pressure, clad temperature etc. The integrated break flow is slightly overpredicted in the first 300 s of the transient and on the contrary, substantially underpredicted after 400 s. The difference between measured and calculated leak is after 800 s more or less constant and amounts approximately 20 kg (15% of steady state inventory).

As the prediction of primary pressure course is pretty good, also the step-wise injection from the HAs is predicted well by the code, but there is some difference in the timing and the amount injected in the different steps. In the facility the HA valves are opened by the primary pressure

signal and they remain then open, after a discharge phase significant reverse flows from the primary can be seen in the measured HA level curves. In the RELAP hydroaccumulator model, that valve is a check valve, which does not enable reverse flow in the hydroaccumulator line.

The reverse flow brings warmer water into HA that would warm up very cold HAs (subcooled by gas expansion) and thus accelerate later HA injection. So the HA injection in experiment is naturally little bit faster than injection predicted in calculation.

Both the experiment and calculations show that in this LOCA scenario the Accident Management measures can't reduce the primary pressure fast enough to prevent substantial overheating of the reactor core.

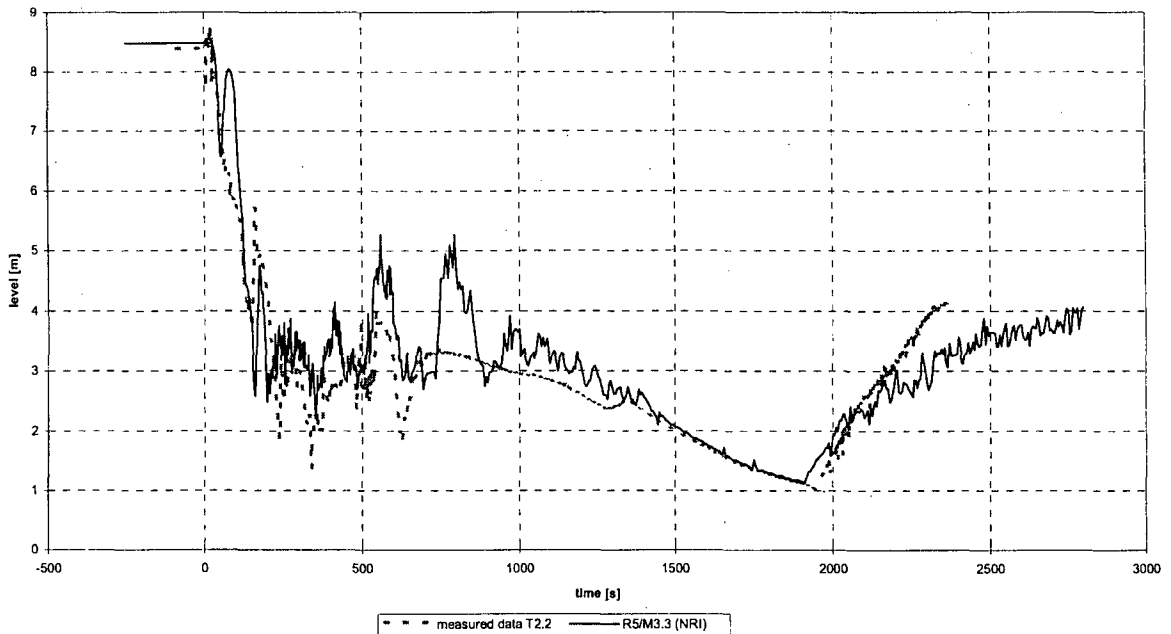

Figure 15 Collapsed level in reactor (T2.2)

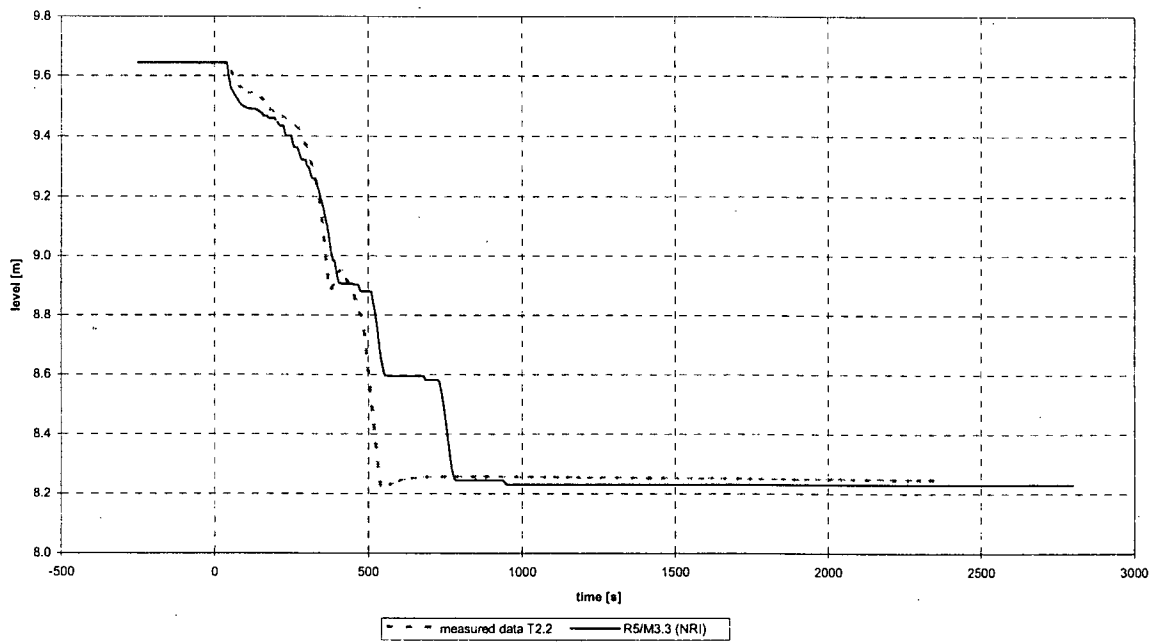

Figure 16 Collapsed level in hydroaccumulator SIT-1 (T2.2)

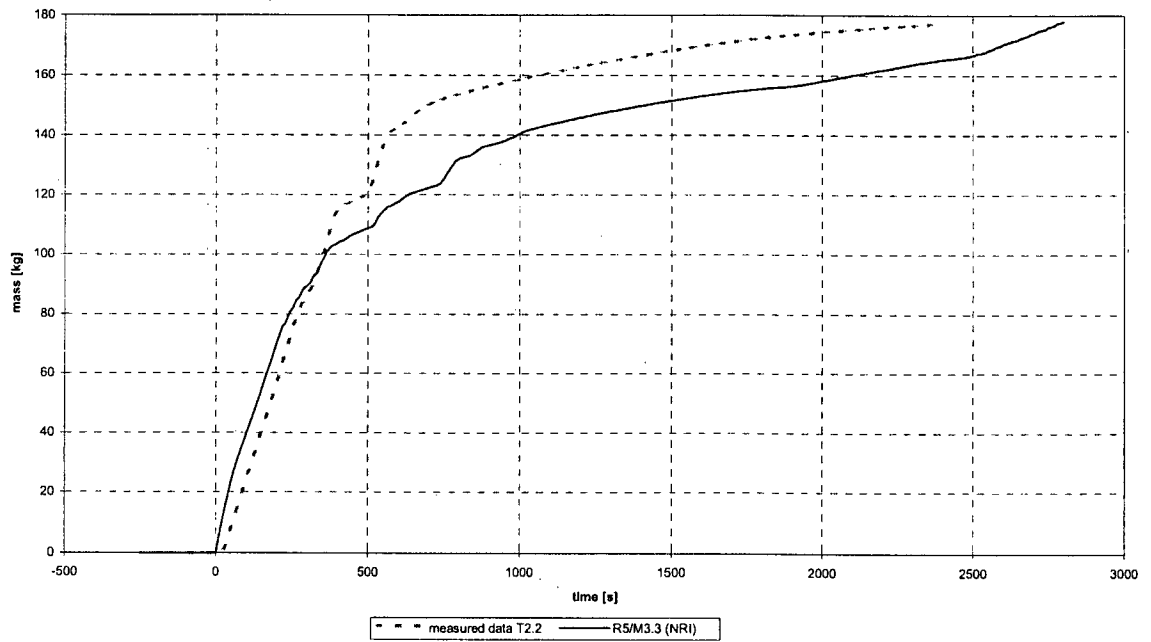

Figure 17 Integrated break mass flow rate (T2.2)

6. POST-TEST ANALYSIS OF T2.3 EXPERIMENT

6.1 Experiment description

The Test 2.3 (T2.3-BF) [5, 6] experiment simulated a medium-break LOCA without high pressure injection and the basic question was whether the primary pressure can be reduced to the shut-off head of the pumps of the LPI systems. Earlier PMK tests had indicated that in these situations it is too late to start bleed and feed at superheated core outlet temperature if the SITs are no longer available. The significant loss of primary coolant may lead to core overheating before the system pressure decreases to the shut-off head of LPI systems. The specific features of the experiment is that the test is a counterpart test with PACTEL facility and that modified hydroaccumulator parameters were used.

The test is defined by the following steps:

- Experiment started from lower operating parameters of the facility by opening the 7.4% break in the cold leg (actually break line is connected not directly to the cold leg, but to the reactor downcomer top, close to cold leg inlet);
- SCRAM actuation simultaneously;
- Secondary side isolation simultaneously;
- Pressurizer heaters off simultaneously;
- Pump coast down simultaneously;
- 1 SIT to the upper plenum and 2 SITs to the downcomer, with reduced pressure 3.5 MPa;
- Secondary bleed starts at $T_{clad} > 350$ °C;
- Primary bleed starts at $T_{clad} > 400$ °C;
- LPIS starts at $p < 0,7$ MPa;
- Test is terminated at $T_{clad} > 450$ °C.

The main objective of the test was to get experimental evidence on the effectiveness of the secondary bleed and the primary bleed and feed to reduce the primary pressure to the setpoint pressure of LPIS without core damage. Further objectives were as follows:

- Assessment of the predictive capabilities of codes in the prediction of the complex transient scenario and identification of key events;
- Effect of initiation of secondary bleed and primary bleed and feed;
- Effect of reduced hydroaccumulator pressure;
- Effect of scaling ratio, PMK/PACTEL = 1:6,78.

The initial conditions of the test T2.3 at PMK were "synchronized" with PACTEL facility (esp. PACTEL limitation to max. primary pressure 8 MPa). In the table below these conditions are given. Specified data are compared with measured data and the steady-state calculation results.

Table 7 Initial conditions of test T2.3

	Unit	Specified	Measured	Calculation NRI
Primary system pressure (PR21)	MPa	7.7	7.71	7.69
Primary loop flow (FL53)	kg/s	1.1	1.21	1.21
Core inlet temperature (TE63)	K	528	524.3	518.1
Core power (PW01)	kW	138	136.2	136.3
Coolant level in PRZ (LE71)	m	9.1	8.93	8.95
SIT-1 initial pressure (PR91)	MPa	3,5	3.55	3.55
SIT-2 initial pressure (PR92)	MPa	3,5	3.56	3.56
SIT-1 initial level (LE91)	m	9,811	9.835	9.84
SIT-2 initial level (LE92)	m	10,128	10.118	10.13
Secondary pressure (PR81)	MPa	4,2	3.34	3.34
Feedwater flow (FL81)	kg/s	0,11	0.11	0.11
Feedwater temperature (TE81)	K	498	390.6	390.6
Coolant level in SG (LE81)	m	8,4	8.41	8.416

As boundary conditions it was decided to have the SCRAM, the RCP trip and the secondary side isolation together with the opening of the break valve. The secondary bleed starts when the heater rod surface temperature is more than 350°C (plus we used additional condition "not before 900 s" in our calculation), the primary bleed starts when the fuel surface temperature is more than 500°C and LPIS starts when the primary pressure is less than 0,7 MPa. The boundary conditions are listed in **Table 8** below:

Table 8 Boundary conditions of test T2.3

	Unit	Specified	Measured	Calculation NRI
Break orifice diameter	mm	3.0	3.0	3.0
Break valve opens at	s	0.0	2.0	2.0
Scram is initiated at	s	0.0	2.0	2.0
Isolation of feedwater and steam lines	s	0.0	3.0	3.0
Pump coast-down initiated at	s	0.0	7.0	7.0
Pump coast-down	s	150	120	150
Secondary bleed initiated at $T_{wall} >$	°C	350	349.5	350 *
Primary bleed initiated at $T_{wall} >$	°C	400	399.5	400
LPIS injection starts if primary pressure	MPa	0.7	0.7	0.7
LPIS flow rate (1 system assumed)	kg/s	0.042	0.0432	0.0432
SIT-1 injection ended at	m	8.24	8.22	8.22
SIT-2 injection ended at	m	9.34	9.26	9.28

* Note: For start of operator initiated secondary bleed we applied additional condition of „time > 1200 s“ to avoid its too early initiation by clad temperature peaks in first hundreds of seconds and to be realistic as for timing of first operator interventions.

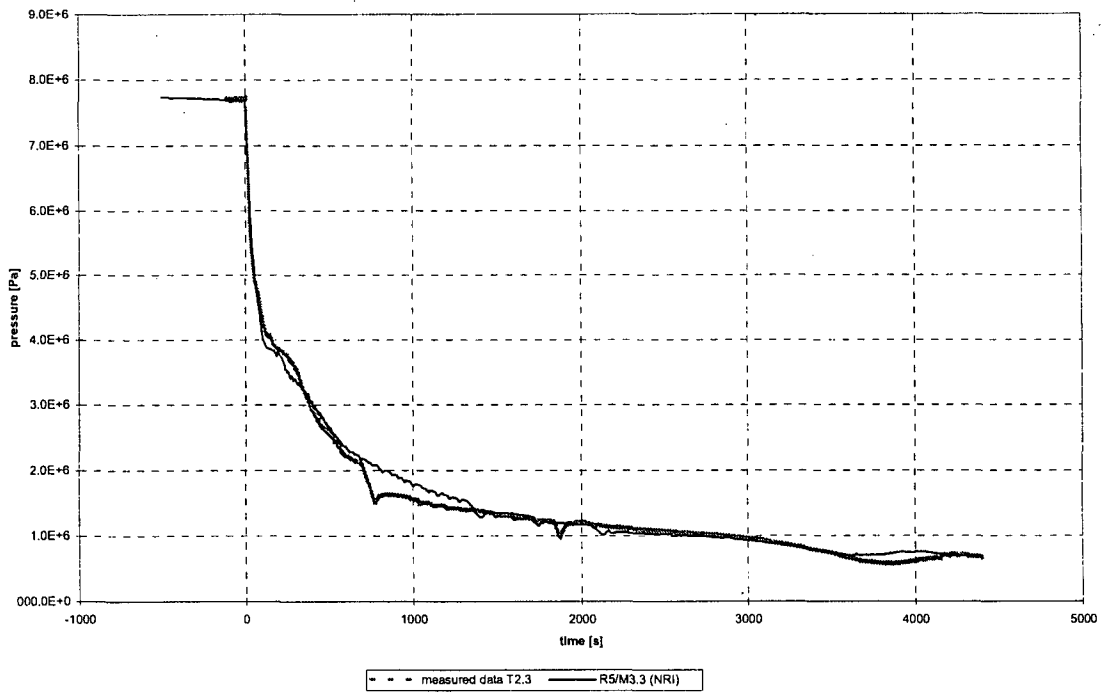

Figure 18 Primary pressure (T2.3)

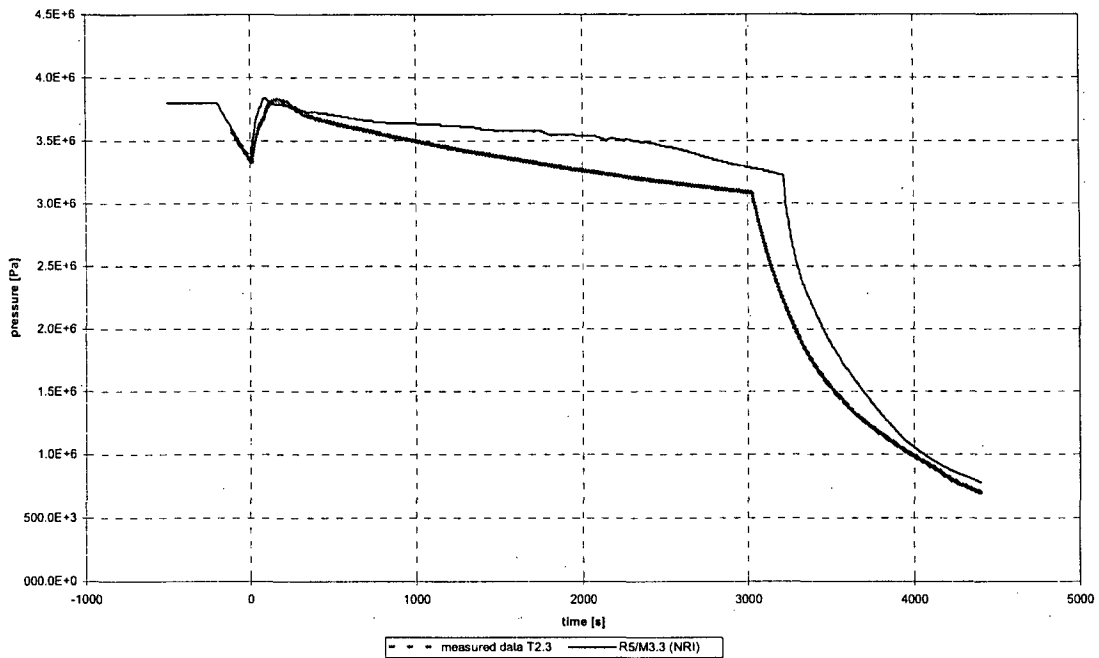

Figure 19 Secondary pressure (T2.3)

6.2 Results of calculation

The main events of the Test T2.3 and the RELAP5 calculations are listed in **Table 9** below:

Table 9 Timing of main events of test T2.3

Event	Timing [s]		Comment
	Measured	Calculation NRI	
Break valve opening	2	2	Break diameter is 3 mm (i.e. 7.4% of CL flow area)
SCRAM actuated	2	2	
Isolation of feedwater and steam lines initiated	3	3	
RCP trip	7	7	
Steam dump valve opening	-	-	No pressure increase to 5.3 MPa
Culmination of sec. pressure	90 (3.88 MPa)	170 (3.85 MPa)	
First clad overheating	235-270	175-195	
First reversal of heat transfer at SG	not measured	224	
SIT-1, SIT-2 injection start	314	235	
SIT-1 injection to upper plenum end	1865	2140	
SIT-2 injection to downcomer end	1868	2550	
Final fuel rod overheating (TW01) start	2880	3120	
Secondary bleed initiation	3030	3220	At clad temp. 350 °C
Primary bleed initiation	3101	3260	At clad temp. 400 °C
Core power switching off	-	-	No temperature increase to 600°C
LPIS injection starts at	3533	3610	
Time of fuel rod temperature maximum	3540 (465 °C)	3630 (528 °C)	
Reactor level minimum	3530 (1.64 m)	3630 (1.31 m)	
Core fully flooded	3625	3650	
Transient end	4400	4400	

The PMK test T2.3 starts from specific initial conditions (parameters reduced due to parallel test with PACTEL facility: 20% power level, lower primary and sec. pressure, lower reactor flow etc.). The initial conditions are not fully stabilized before 0 s - see the course of measured sec. pressure, core inlet temperature etc. In our calculation we tried to simulate as good as possible this "dynamic" start of transient.

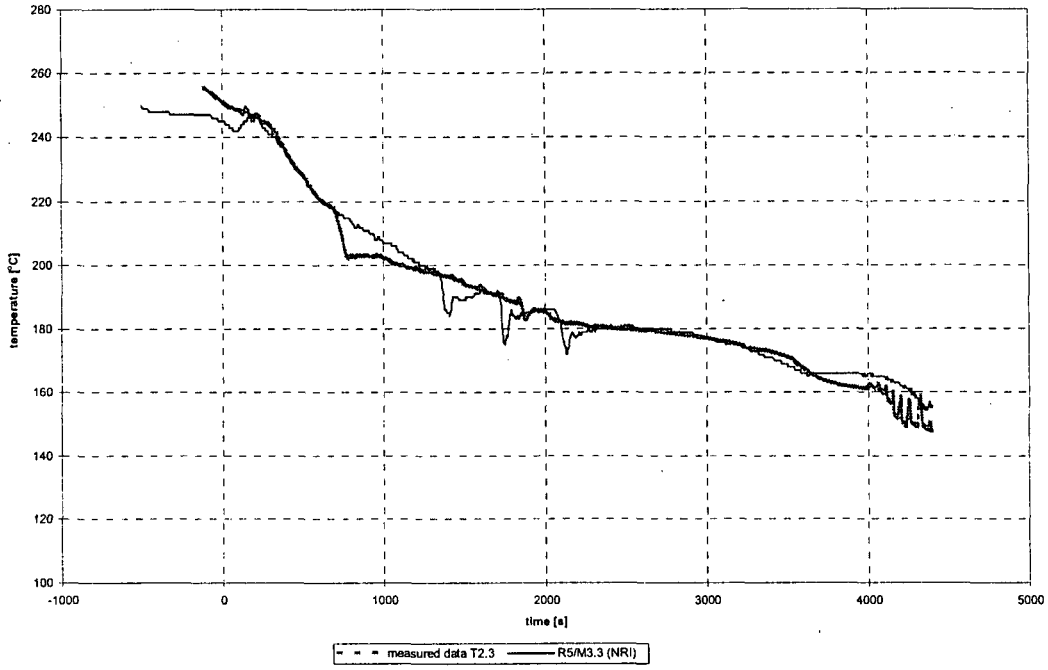

Figure 20 Core inlet temperature (T2.3)

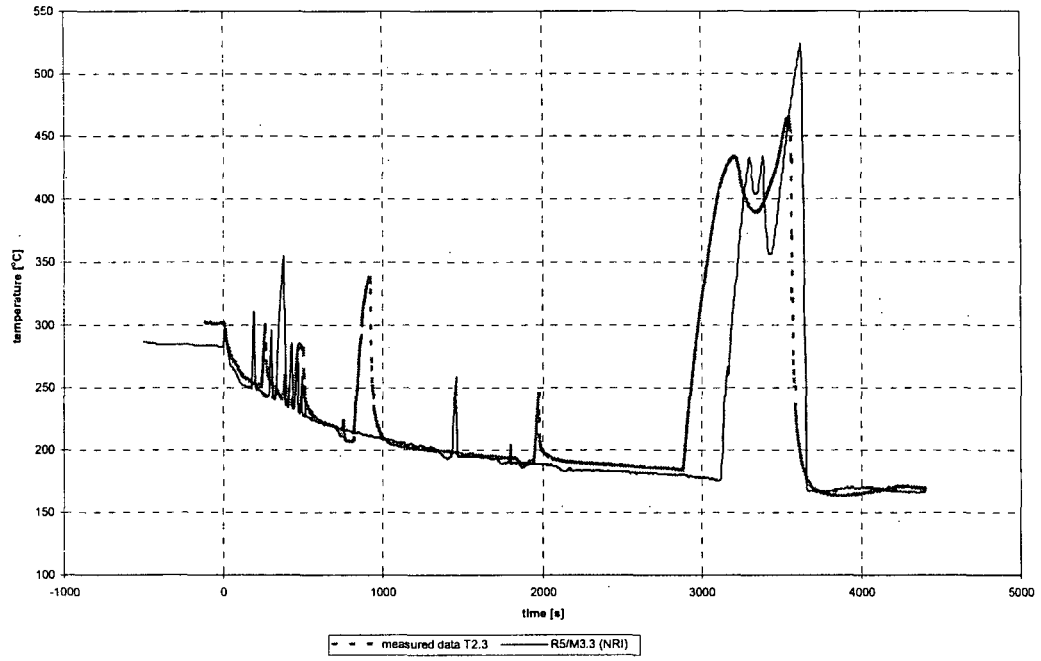

Figure 21 Cladding temperature (T2.3)

The selected medium-break LOCA scenario started with opening of the break valve (break diameter is 3 mm - i.e. 7.4% of CL flow area) at reactor downcomer top and with coincident loss of offsite power (LOOP) simulation. Major consequences of LOOP are the nearly immediate reactor SCRAM, and isolation of SG secondary side, and trip of RCP.

Due to the closing of MSIV, the SG pressure increases at first and after culmination at about 3.85 MPa (90 s in calc.) slowly decreases due to heat losses from SG secondary and due to drop of parameters in primary circuit. Heat transfer at SG tubing occurs at 224 s (in calc.). Outflow of primary coolant through break with equivalent diameter 3 mm (7.4% of cold leg flow area) leads to fast decrease of primary pressure. After getting under 3.5 MPa, the hydroaccumulators start to inject cold water into UP and DC (at 314 s of calc.).

There are some short-time core heat-up in first hundreds of seconds due to reactor level depressions and/or liquid hold up in UP. However the PCT in this period culminates in quite "low" temperature range 250-350 °C.

As there is no HPIS available in the test T2.3, the end of HA injection (at primary pressure about 1.2 MPa, i.e. higher than LPIS shut-off head of 0.7 MPa) means further decrease of primary inventory and finally a deeper core uncover and heat-up.

The final core uncover and heat-up starts at about 3000 s. After reaching of cladding temperature level 350 °C secondary bleed is initiated by opening of relief valve at SG top. Unfortunately, both the experiment and the calculation show that the secondary bleed had minimal or no effect on the core cooling.

So the core heat-up continued and when clad temperature reaches 400 °C, primary bleed was initiated. Shortly after that (circa 100 s in both exp. and calc.) the clad temperature course experienced a temporary partial decrease (by some 50 °C). But after another approximately 100 s the clad temperature returns to increase. The temporary reactor level increase and improvement of core cooling was caused by "draining" of hot leg after PRZ relief valve opening, so decreasing of delta-p at primary loop and relaxing level in inner reactor. There could be also minor influence of coolant flashing in lower plenum, but as the pressure decrease was slow, this phenomena was not so important.

Primary pressure decrease ("supported" by both sec. and prim. bleed) leads at about 3600 s to start of LPIS injection and consequently to ultimate core reflooding (3650 s). After that core cooling is stabilized and at 4400 s the post-test calculation was terminated.

6.3 Comparison of results

The most important comparison plots of the measured data and the post-test UJV calculations are shown in **Figure 18 - Figure 24**. Complete set of comparison plots can be found in Appendix V.

Most of the calculated parameters is in very good agreement with measured data, especially the most important system parameters like primary pressure, reactor inlet temperature, clad temperature, reactor vessel level etc.

The integrated break flow is slightly overpredicted in the first 200 s of the transient and on the contrary, substantially underpredicted after 700 s. The difference between measured and calculated leak is after 800 s more or less constant and amounts approximately 20 kg (15% of steady state inventory).

As the prediction of primary pressure course is pretty good, also the step-wise injection from the HAs is predicted well by the code, but there is some difference in the timing and the amount injected in the different steps. In the PMK facility the HA valves are opened by the primary pressure signal and they remain then open, after a discharge phase significant reverse flows from the primary can be seen in the measured HA level curves. In the RELAP hydroaccumulator model, that valve is a check valve, which does not enable reverse flow in the hydroaccumulator line. The reverse flow in experiment brings warmer water into HA that would warm up very cold HAs (subcooled by gas expansion) and thus accelerate later HA injection. So the HA injection in experiment is naturally little bit faster than injection predicted in calculation.

Both the experiment and calculations show that in this LOCA scenario without HPIS the Accident Management measures can reduce the primary pressure fast enough to initiate LPIS injection and prevent substantial overheating of the reactor core.

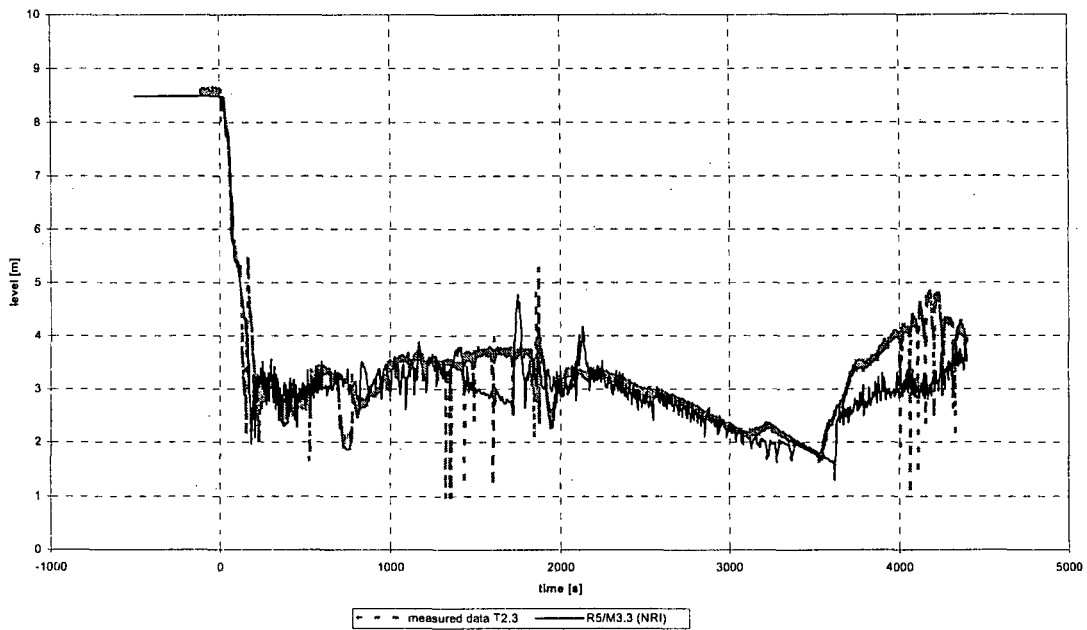

Figure 22 Collapsed level in reactor (T2.3)

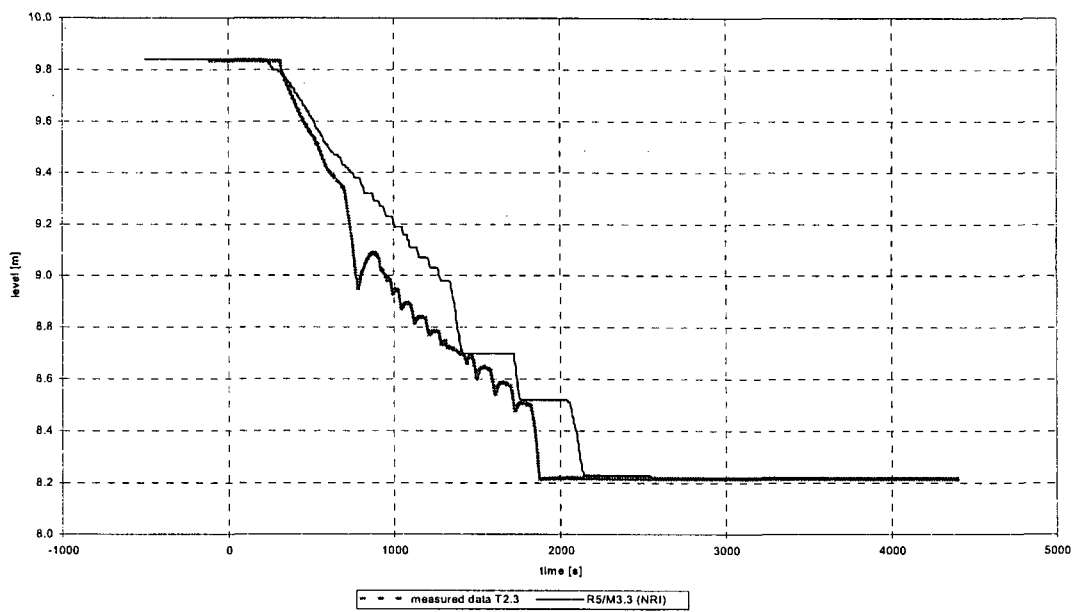

Figure 23 Collapsed level in hydroaccumulator SIT-1 (T2.3)

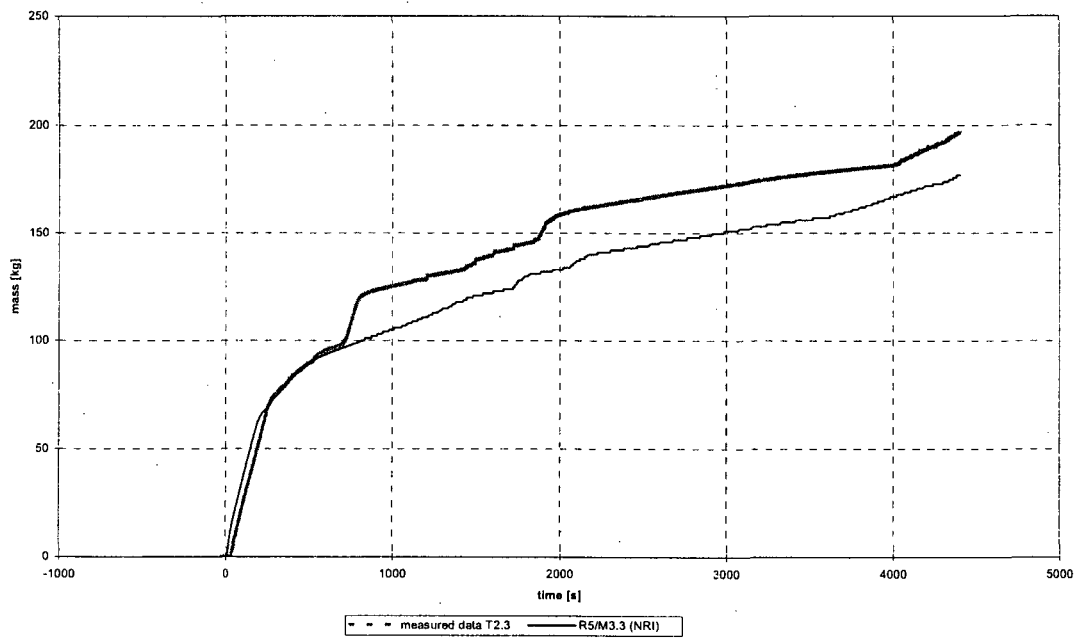

Figure 24 Integrated break mass flow rate (T2.3)

7. CONCLUSIONS

As a part of assessment of new version of RELAP5 (the MOD3.3) in UJV Rez, we have performed a set of post-test analyses of new PMK experiments. The analyzed tests T2.1, T2.2, and T2.3 were performed in 2003-2004 in frame of the IMPAM-VVER project.

The PMK facility is a scaled down model of the VVER-440/213 and it was primarily designed for investigating small-break loss of coolant accidents (SBLOCA) and transient processes of this type of NPP. The volume and power scaling of PMK facility are 1:2070. Transients can be started from nominal operating conditions. The ratio of elevations is 1:1 except for the lower plenum and pressurizer. The six loops of the plant are modeled by a single active loop. In the secondary side of the steam generator the steam/water volume ratio is maintained. The coolant is water under the same operating conditions as in the nuclear power plant.

All three tests T2.1, T2.2, and T2.3 were focused on medium-break LOCA without HPSI. Individual tests differentiated in initial conditions of primary and secondary system, hydroaccumulator parameters and timing of operator interventions. The issue of the tests was the core cooling problem in small and medium-break LOCA without HPSI, where after end of HA injection and before primary pressure drop under LPIS pumps shut-off head, there is a period without any ECCS, that could result in core uncover and heat-up. The experiment studied effectiveness of operator interventions (secondary bleed and primary bleed) with various timing, that should accelerate decrease of pressure in RCS and so shorten the period without ECCS injection. In two tests the operator interventions were not fully successful (i.e. clad temperature rose above 600 °C, what is limiting value for PMK core simulator), in the last test the interventions were successful, i.e. LPSI was effectively initiated before overheating of the core simulator.

The RELAP5 input deck used for the post-test analyses is a modified version of the older UJV input deck used for modeling of PMK-NVH in early 90-ties, when we analyzed the IAEA organized SPE tests. Listing of the current version of the deck used for the presented analyses is in the Appendix I.

Comparison of the measured test data and the calculation results showed very good overall agreement of all major system parameters as primary pressure, reactor level, reactor coolant and clad temperature etc.

As for the revealed shortcomings of our RELAP5 simulation, in all three tests one can see certain overprediction of the break flow in the first 200-300 s and on the contrary break flow underprediction in period 700-800 s. Later on the difference between measured and calculated integrated leak is more or less constant and amounts approximately 20 kg (15% of steady state inventory). We used as default the Henry-Fauske critical flow model, but also with the original RELAP5 break flow model, the results showed similar trends. As the same discrepancy was shown in calculation of other participants of the IMPAM project with different computer codes, one can conclude, that the problem could be connected with complicated geometry of section "downcomer top", where are connected 3 important piping's – break valve piping, cold leg inlet and hydroaccumulator line.

As the prediction of primary pressure course was pretty good in all 3 tests, also the step-wise injection from the HAs was predicted well by the code, but there were some differences in the timing and the amount injected in the different steps. Here the explanation is quite simple. In the PMK facility the HA valves are opened by the primary pressure signal and they remain then open even in case when a reverse flows from the primary circuit occurs (as can be seen in the measured HA level curves). However, in the RELAP hydroaccumulator model, that valve is a check valve, which does not enable reverse flow in the hydroaccumulator line. This difference between object and model causes probably the small disagreement in results - the reverse flows in experiment bring warmer water into HA that warms up partially the very cold HA (subcooled by gas expansion) and thus accelerate consequent HA injection. So the HA injection in experiment is naturally little bit faster than injection predicted in calculation.

Additional notes to EOP:

Although the results of experiments T2.1 and T2.2 gave very pessimistic answer to the question if operator intervention, i.e. secondary and primary bleed initiated after start of core heat-up start, can be effective in situation of larger-small or medium break LOCA without HPSI, the issue is no so critical.

We made additional analyses without switch-off of core power at T_{clad} 600 °C and the results showed, that the cladding temperature wouldn't probably exceed 1200 °C in any of these tests. The PCT in these special analyses of T2.1 and T2.2 was 995 °C and 920 °C, respectively.

8. REFERENCES

1. Král, P.: Introductory Calculation with RELAP5/MOD2 Computer Code - Analysis of Primary-to-Secondary Leak Test Performed in PMK-NVH Facility, UJV-9393T, UJV Rez, June 1993.
2. Král, P.: RELAP5/MOD2 Post-Test Analysis of PMK-NVH Cold Leg 7.4% Loss of Coolant Accident – Depth of Nodalization Parametric Study, UJV-9429T, UJV Rez, August 1991.
3. Szabados, L. et al: PMK-2 HANDBOOK, Technical Specification of the Hungarian Integral Test Facility for VVER-440/213 Safety Analysis. KFKI Atomic Energy Research Institute. Budapest, 1996.
4. Lahovský, F.: Pre-Test Calculation for PMK-2 Test 2.2 with ATHLET code: 7.4% Cold Leg Break with Secondary Bleed and Primary Bleed and Feed. Rež, April 2003.
5. Guba, A. et al: Analyses of PMK Experiments – Summary Report, IMPAM-VVER Project, KFKI-AEKI, February 2005.
6. Tóth, I. et al: PMK Experiments – Summary Report, IMPAM-VVER project, KFKI-AEKI, May 2005.
7. Král, P.: Results of RELAP5 Calculations of LOCA for VVER-1000, IMPAM-VVER, UJV Rez, 2005.
8. Král, P.: Results of RELAP5 Calculations of LOCA D136 and D60 mm for VVER-440/213, IMPAM-VVER, UJV Rez, 2005.

APPENDIX A LISTING OF UJV INPUT DECK OF PMK

```

#####
*#
*# RELAP5 INPUT MODEL OF PMK-NVH FACILITY
*# NUCLEAR RESEARCH INSTITUTE REZ
*#
#####
*
=id-pmk-51u.nrc ... fine-node ID of PMK2 test T2.3
*
#####
*#miscellaneous control cards #
#####
*
* options card
001 * no spec. options
*
* problem type and option
* pr.type pr.option
100 new transnt
*
* input check or run option [opt.]
* option
101 run
*
* restart input file control card [not for "new"]
* rest.numb.
*103
*
* restart-plot file control card [not for "plot" and "redit"]
* act.or
*104 none
*
* noncondensable gas type (max.5 norm.words)
* type
110 nitrogen
*
* initial mass fraction for each noncondensable gas type [opt.]
* fraction
115 1.
121 002010000 0.095 h2o "Prim-sys"
122 522010000 6.635 h2o "Sec-sys"
*
#####
*#time stop control cards #
#####
*
* initial time value
* ini.time
200 0.
*
* time step control
* set.end min. max.st. ctrl. mined majed rst
201 990. 1.-8 0.4 00003 25 250 250
202 1000. 1.-8 0.4 00003 15 50000 50000
203 1100. 1.-8 1.0 00003 1 50000 50000
204 1600. 1.-8 1.0 00003 2 100 100
205 2000. 1.-8 1.0 00003 5 100 100
206 5400. 1.-8 1.0 00003 5 100 100
*
*
=====
*

```

```

* run trip end
*
410 time 0 ge null 0 2000. 1
410 htemp 044000604 ge null 0 1473. 1
600 410
*
=====
*
*
*
#####
*# minor edits #
#####
*
=====
* mass flows
=====
*
0000301 dt 0
*
0000302 dtcrnt 0
*
0000303 emass 0
*
* Loop flow (CL end)
0000304 mflowj 198010000
*
* Break flow
0000305 mflowj 935000000
*
* HPIS flow
0000306 mflowj 855000000
*
* LPIS flow
0000307 mflowj 865000000
*
* HA1 (to DC) flow
0000308 mflowj 810010000
*
* HA2 (to UP) flow
0000309 mflowj 820010000
*
=====
*
=====
*
* UP plenum pressure
0000310 p 052010000
*
* SG secondary pressure
0000311 p 548010000
*
* liquid level in sg secondary
0000312 cntrlvar 528
0000313 cntrlvar 828
*
* FW flow
0000314 mflowj 505000000
0000315 mflowj 507000000
*
* MSL flow
0000316 mflowj 555000000
*
=====
* liquid levels
=====
*
* liquid level in reactor model
0000317 cntrlvar 817
0000318 cntrlvar 818
0000319 cntrlvar 819
*

```

* level in hot leg loop seal (reactor side)
0000320 cntrlvar 823

* level in sg primary + hot leg
0000321 cntrlvar 824

* level in sg primary + cold leg
0000322 cntrlvar 822

0000323 cntrlvar 400 * PRZ level

* liquid level in reactor downcomer
0000324 cntrlvar 825

=====

* slabs temperatures

=====

* heater rod 5 part surface temperature
0000327 htemp 044000604
0000328 htemp 044000504
0000329 htemp 044000404
0000330 htemp 044000104

* wall of downcomer upper part
0000331 htemp 014000104

0000332 htemp 064000104

0000333 htemp 044000601

=====

* volume temperatures

=====

* core inlet temperature
0000334 tempf 026020000

* core outlet temp.
0000335 tempf 052010000

0000336 tempf 014010000

0000340 tempf 140010000

0000341 tempf 524010000

0000342 tempg 052010000

0000343 tempg 140010000

=====

* miscellaneous

=====

0000346 cputime 0

0000347 dt 0

* core heat production
0000352 cntrlvar 044

* sg tubing heat transfer
0000353 cntrlvar 520*

0000357 voidf 420010000

0000358 voidg 044060000

0000359 voidg 062010000

0000360 voidg 064010000

```

*
0000361 voidg 068010000
*
**
***
#####
*#trip input data #
#####
*
* 500 always true
* 501 always false
* 601 transient initiation
* 602 scram
* 603 pump trip
* 604 steam valve opens
* 605 steam valve closes
* 606 hpis
* 609 pump trip
* 610 (pump table off)
* 617 transient trip neg
* 644 prz relief valve open
* 648 prz spray valve open
* 658 prz el.heater in operation
*
=====
*
* always true trip
500 time 0 ge null 0 -6.0 l
*
* always false trip
501 time 0 lt null 0 -6.0 l
*
* stop of prz "make-up"
509 time 0 lt null 0 990.0 n
*
=====
*
* transient initialization
401 time 0 ge null 0 1000. l
601 500 and 401 l
*
* stationary state run - controllers in action
617 -601 and 500 n
618 617 and 617 n
*
* long stdy controllers (up to 900 ss):
418 time 0 le null 0 900. n
*
*
=====
*
* break opening trip
466 time 0 ge null 0 1002. l
666 500 and 466 l
*
=====
*
* scram
402 p 052010000 le null 0 11.6e6 l
602 402 and 601 l *opt*= after pressure drop
602 601 and 601 l *opt*= at 0. s
*
*
=====
*
* full power off trip (overheat protection)
590 cntrlvar 933 ge null 0 873. n
690 590 and 401 l
*
=====
*
* RCP trip

```

```

403 p      052010000 le      null  0      9.47e6 |
404 time  0      ge      null  0      1000. |
404 time  0      ge      null  0      1007. |

603 403    and      601    | *opt*= after pressure drop
603 601    and      601    | *opt*= at 0. s
603 404    and      404    | *opt*= at predefined time

```

=====

```

*
*
* hpis
406 time  0      ge      timeof 402    60.0 |
606 406    and      601    | *opt*= BE
606 501    and     -501    | *opt*= Deactivated

```

=====

```

*
*
* ACCUMs stop trips:
407 cntrivar 810    ge      null  0      8.221  n
407 cntrivar 810    ge      null  0      8.23   n
407 cntrivar 810    ge      null  0      8.22   n
607 407      and     601    n

408 cntrivar 812    ge      null  0      9.25   n
408 cntrivar 812    ge      null  0      9.278  n
408 cntrivar 812    ge      null  0      9.26   n
408 cntrivar 812    ge      null  0      9.28   n
608 408      and     601    n

```

=====

```

*
*
* LPSI
411 p      064010000 lt      null  0      0.73+6 n
411 p      064010000 lt      null  0      0.7+6  n
611 411    and     601    |

```

=====

```

*
*
* pump trip
409 time  0      ge      timeof 403    147.5 |
409 time  0      ge      timeof 403    147.5 |
609 409    and     601    |
610 -603   and     500    n

```

=====

```

*
*
* temperary expanded FW source
521 time  0      ge      null  0      710.0  n
522 time  0      le      null  0      990.0  n
522 time  0      le      null  0      1010.0 n
522 time  0      le      null  0      1000.0 n
626 521    and     522    n
627 626    and     626    n

```

=====

```

*
*
* MSIV closing (SG isolation at steam side):
431 time  0      ge      timeof 601    12.    n *opt*
431 time  0      ge      timeof 601    0.     n *opt*
431 time  0      ge      timeof 601    3.     n *opt*
631 431    and     601    |

```

```

*
*
* Normal FW isolation:

```

433 time 0 ge timeof 601 12. n *opt*
 433 time 0 ge timeof 601 0. n *opt*
 433 time 0 ge timeof 601 3. n *opt*
 633 433 and 601 l

* Normal FW on
 634 -633 and -633 n

=====

* prz relief valve
 540 p 420050000 gt null 0 12.84+6 n
 541 p 420050000 ge null 0 12.32+6 n
 640 540 or 644 n
 644 541 and 640 n

* Operator opening if Tclad high:
 546 cntrlvar 933 ge null 0 773. n *opt*= 500 C
 546 cntrlvar 933 ge null 0 573. n *opt*= 300 C
 546 cntrlvar 933 ge null 0 568. n *opt*= 295 C
 546 cntrlvar 933 ge null 0 673. n *opt*= 400 C

547 time 0 ge null 0 3500.0 n *= time conditioning

643 546 and 547 l * high temp .and. time cond.

* Final opening trip for PRZ RV:
 646 644 or 643 n

=====

* prz boundary valve (in action from trip "508" to 1000 s)
 670 401 or 618 n
 671 -670 or -670 n

=====

* prz make-up pump in action
 673 617 and 618 n *= only in STDY

=====

* prz spray valve
 542 p 052010000 gt null 0 12.6509+6 n
 543 p 052010000 ge null 0 12.6507+6 n
 645 542 or 648 n
 648 543 and 645 n

=====

* prz heater
 550 p 052010000 gt null 0 12.6502+6 n
 551 p 052010000 ft null 0 12.6500+6 n
 650 551 or 651 n
 651 -550 and 650 n

552 cntrlvar 400 ge null 0 8.3 n
 657 651 and 552 n
 658 657 and 618 n

=====

* Sec. side relief valve
 421 p 548010000 gt null 0 5.37+6 n
 421 p 548010000 gt null 0 5.3+6 n
 422 p 548010000 ge null 0 4.89+6 n
 422 p 548010000 ge null 0 4.9+6 n

```

621 422 and 622 n
*
622 421 and -421 n *opt*= Deactivated autom. operation
622 421 or 621 n *opt*= BE autom. operation
*
423 cntrlvar 933 ge null 0 623. n *= depress. by 350 C
*
424 time 0 ge null 0 1900.0 n *= time conditioning
424 time 0 ge null 0 1889.0 n *= time conditioning
424 time 0 ge null 0 3500.0 n *= time conditioning
*
624 424 and 424 | *opt*= activated only from time
624 423 and 424 | *opt*= activated from high temp .and. time
*
625 624 or 624 n *= deactivated autom.opening (only operator)
625 501 and -501 n *= fully deactivated
625 622 or 624 n *= BE final opening trip (automatics + operator)
*
629 -422 and -625 n *= final closing trip
*
*
*
#####
*#interactive input data #
#####
*
* var.name ini.val. convers.f. alph.part integr.part
*0000801
*
*0000802
*
*
#####
*#hydrodynamic component #
#####
*
*
*=====
*=====
* = reactor vessel
*=====
*=====
*
*=====
* downcomer top - upper part
*=====
*
* component name and type
* comp.name comp.type
0080000 r-input branch
*
* branch information card
* numb.of.jun. ctrl. [ or 0 -> w1,w2 of 010n2..=ini.vel.]
0080001 1 1
*
* branch volume geometry cards
* area length vol. az.ang. inc.ang. elv.chng.
0080101 2.01-2 0.112 0. 0. -90. -0.112
*
* rough. h.diam. flags
0080102 3.-5 0.16 00
*
* branch volume initial conditions
* ctrl. (p) (temp) bor.con.[if]
*
0080200 103 12.772+6 537.7
*
* branch junction geometry cards

```

```

*      from      to      area loss.c. rev.loss.c. flags
0081101 008010002 012010001 0.  0.  0.  00000
*
*      branch junction initial conditions [according to 0100001]
*      ini.f.flw. ini.g.flw. interf.vel.
*
0081201 0.0  0.  0.
***
=====
* input branch
* -----
=====
*
*      component name and type
*      comp.name comp.type
0120000 r-input  branch
*
*      branch information card
*      numb.of.jun. ctrl. [ or 0 -> w1,w2 of 012n2..=ini.vel.]
0120001 2  1
*
*      branch volume geometry cards
*      area length vol. az.ang. inc.ang. elv.chng.
0120101 0.0201 0.116 0.  0.  -90.  -0.116
*
*      rough. h.diam. flags
0120102 3.-5 .16  00
*
*      branch volume initial conditions
*      ctrl. (p) (temp) bor.con.[if]
*
0120200 103 12.772+6 537.7
*
*      branch junction geometry cards
*      from      to      area loss.c. rev.loss.c. flags
0121101 198020002 012010003 1.7-3 10.  10.  00001
*
0122101 012010002 014010001 0.  0.5  0.5  100100
*
*      branch junction initial conditions [according to 0120001]
*      ini.f.flw. ini.g.flw. interf.vel.
*
0121201 4.73  0.  0.
0122201 4.73  0.  0.
***
=====
* downcomer
* -----
=====
*
*      component name and type
*      comp.name comp.type
0140000 r-downc  pipe
*
*      pipe information card
*      numb.of.vol.
0140001 8
*
*      pipe volume flow areas
*      area vol.numb.  ->  ->
0140101 2.63-3 8
*
*      (internal) pipe junction flow areas [opt.]
*      area jun.numb.  ->
*140201 2.63-3 7  *>= 2.6 in 5-volume downcomer
*
*      pipe volume lengths
*      lengh vol.numb.  ->  ->
0140301 0.5695 1  0.5225 8
*
*      pipe volume volumes
*      vol. vol.numb.  ->  ->

```

```

0140401
*
* pipe volume vertical angles
* inc.ang. vol.num. ____->____ ____->____
0140601 -90. 8
*
* pipe volume elevation change [opt.]
* elev.chng. vol.num. ____->____ ____->____
0140701 -0.5695 1 -0.5225 8
*
* pipe volume friction data
* rough. h.diam. vol.num.
0140801 3.-5 5.755-2 8
*
* (internal) pipe junction loss coefficients [opt.]
* loss.c. rev.loss.c. jun.num.
0140901 0. 0. 7
*
* pipe volume control flags
* flags vol.num. ____->____ ____->____
0141001 00 8
*
* pipe junction control flags
* flags jun.num. ____->____ ____->____
0141101 00100 7
*
* pipe volume initial conditions
* ctrl. (w4 or 0.) vol.num.
0141201 103 12.52+6 537.7 0. 0. 0. 8
*
* pipe junction conditions control word [opt.]
* ctrl. [ _ or 0 -> w1,w2 of 01413..=ini.vel.]
0141300 1
*
* pipe junction initial conditions
* ini.f.flw. ini.g.flw. intrf.vel. jun.num.
0141301 4.73 0. 0. 7
***
=====
* downcomer bottom connection
* =====
*
* component name and type
* comp.name comp.type
0180000 r-down-c branch
*
* branch information card
* numb.of.jun. ctrl. [ _ or 0 -> w1,w2 of 018n2..=ini.vel.]
0180001 3 1
*
* branch volume geometry cards
* area length vol. az.ang. inc.ang. elv.chng.
0180101 1.7-3 0.834 0. 0. -10. -0.35
*
* rough. h.diam. flags
0180102 3.-5 4.654-2 00
*
* branch volume initial conditions
* ctrl. (p) (temp) bor.con.[if]
0180200 103 12.52+6 537.7
*
* branch junction geometry cards
* from to area loss.c. rev.loss.c. flags
0181101 014080002 018010001 1.7-3 0.2 0.2 00100
*
0182101 018010002 024010001 0.9-3 14. 14.5 00000
*
0183101 018010002 002010002 0.8-3 15. 14.5 00000

```

```

*
*   branch junction initial conditions [according to 0180001]
*   ini.f.flw.  ini.g.flw.  interf.vel.
*
0181201  4.73    0.    0.
*
0182201  3.00    0.    0.
***
0183201  2.24    0.    0.
***
*
=====
* lower plenum bottom part
*
=====
*
*   component name and type
*   comp.name  comp.type
0020000  r-lp-b   branch
*
*   branch information card
*   numb.of.jun.  ctrl. [ _ or 0 -> w1,w2 of 002n2..=ini.vel.]
0020001  1        1
*
*   branch volume geometry cards
*   area length vol. az.ang. inc.ang. elv.chng.
0020101  7.3-3 0.19  0.  0.  90.  0.19
*
*   rough. h.diam. flags
0020102  3.-5  0.1088  00
*
*   branch volume initial conditions
*   ctrl. (p)  (temp)  bor.con.[if]
*
0020200  103  12.73+6  537.7
*
*   branch junction geometry cards
*   from to area loss.c. rev.loss.c. flags
0021101  002010002  024010001  0.  0.1  0.1  00100
*
*   branch junction initial conditions [according to 0020001]
*   ini.f.flw.  ini.g.flw.  interf.vel.
*
0021201  2.24    0.    0.
***
*
=====
* lower plenum middle part
*
=====
*
*   component name and type
*   comp.name  comp.type
0240000  r-lp-b   branch
*
*   branch information card
*   numb.of.jun.  ctrl. [ _ or 0 -> w1,w2 of 024n2..=ini.vel.]
0240001  1        1
*
*   branch volume geometry cards
*   area length vol. az.ang. inc.ang. elv.chng.
0240101  7.3-3 0.19  0.  0.  90.  0.19
*
*   rough. h.diam. flags
0240102  3.-5  0.1088  00
*
*   branch volume initial conditions
*   ctrl. (p)  (temp)  bor.con.[if]
*
0240200  103  12.73+6  537.7
*
*   branch junction geometry cards
*   from to area loss.c. rev.loss.c. flags

```

0241101 024010002 026010001 0. 1. 1. 00100
0241101 024010002 026010001 0. 0.2 0.2 00100

* branch junction initial conditions [according to 0240001]
* ini.f.flw. ini.g.flw. interf.vel.

0241201 4.73 0. 0.

=====

* lower plenum upper part

=====

* component name and type
* comp.name comp.type
0260000 r-lp-u pipe

* pipe information card
* numb.of.vol.
0260001 2

* pipe volume flow areas
* area vol.numb. ____-> ____-> ____
0260101 7.3-3 2

* (internal) pipe junction flow areas [opt.]
* area jun.numb. ____-> ____
0260201 * = 2.6 in 5-volume downcomer

* pipe volume lengths
* length vol.numb. ____-> ____-> ____
0260301 0.307 2

* pipe volume volumes
* vol. vol.numb. ____-> ____-> ____
0260401 0. 2

* pipe volume vertical angles
* inc.ang. vol.numb. ____-> ____-> ____
0260601 +90. 2

* pipe volume elevation change [opt.]
* elev.chng. vol.numb. ____-> ____-> ____
0260701 +0.307 2

* pipe volume friction data
* rough. h.diam. vol.numb.
0260801 3.-5 0.1003 2

* (internal) pipe junction loss coefficients [opt.]
* loss.c. rev.loss.c. jun.numb.
0260901 0. 0. 1

* pipe volume control flags
* flags vol.numb. ____-> ____-> ____
0261001 00 2

* pipe junction control flags
* flags jun.numb. ____-> ____-> ____
0261101 01000 1

* pipe volume initial conditions
* ctrl. (w4 or 0.) vol.numb.
0261201 103 12.52+6 537.7 0. 0. 0. 2

* pipe junction conditions control word [opt.]
* ctrl. [] or 0 -> w1,w2 of 02613..=ini.vel.]
0261300 1

* pipe junction initial conditions
* ini.f.flw. ini.g.flw. intrf.vel. jun.numb.

```

*
0261301 4.73 0. 0. 1
***
*=====
* lower plenum - core connection
*=====
*
* component name and type
* comp.name comp.type
0350000 upc-con sngljun
*
* single junction geometry cards
* from to area loss rev.loss. flgs.
0350101 026020002 044010001 0. 1. 1. 00100
*
* single junction initial conditions [w1=0 -> w2,w3=vel.]
* ctrl ini.f.flw. ini.g.flw. interf.vel.
0350201 1 4.73 0. 0.
***
*=====
* reactor core
*=====
*
* component name and type
* comp.name comp.type
0440000 r-core pipe
*
* pipe information card
* numb.of.vol.
0440001 6
*
* pipe volume flow areas
* area vol.num. -> ->
0440101 1.5-3 6
*
* pipe volume lengths
* lengh vol.num. -> ->
0440301 0.5 4
0440302 0.25 6
*
* pipe volume volumes
* vol. vol.num. -> ->
0440401 0. 6
*
* pipe volume vertical angles
* inc.ang. vol.num. -> ->
0440601 90. 6
*
* pipe volume elevation change [opt.]
* elev.chng. vol.num. -> ->
0440701 +0.5 4
0440702 +0.25 6
*
* pipe volume friction data
* rough. h.diam. vol.num.
0440801 3.-5 9.307-2 6
*
* (internal) pipe junction loss coefficients [opt.]
* loss.c. rev.loss.c. jun.num.
0440901 1. 1. 3
0440902 0.5 0.5 5
*
* pipe volume control flags
* flags vol.num. -> ->
0441001 00000 6
0441001 00100 6
*
* pipe junction control flags
* flags jun.num. -> ->

```

```

0441101 100100 5
*
* pipe volume initial conditions
*   ctrl.      (w4 or 0.)      vol.numb.
*   ----      ----      ----
0441201 103 12.52+6 543.0 0. 0. 0. 1
*
0441202 103 12.52+6 548.3 0. 0. 0. 2
*
0441203 103 12.52+6 553.5 0. 0. 0. 3
*
0441204 103 12.52+6 558.6 0. 0. 0. 4
*
0441205 103 12.52+6 563.6 0. 0. 0. 6
*
* pipe junction conditions control word [opt.]
*   ctrl. [ _ or 0 -> w1,w2 of 04413..=ini.vel.]
0441300 1
*
* pipe junction initial conditions
*   ini.f.flw. ini.g.flw. intrf.vel. jun.numb.
*   ----      ----
0441301 4.73 0. 0. 5
***
*=====
* core outlet connections
*=====
*
0490000 upc-con1 sngljun
0490101 044060002 052010001 0. 1. 1. 100100
0490201 1 4.73 0. 0.
*
*=====
*
0520000 core-out pipe
0520001 2
0520101 7.3-3 2

0520301 0.260 1
0520302 0.190 2

0520401 0. 2 *= 6.105e-3.

0520601 90. 2

0520801 3.-5 9.307-2 2
0520902 0. 0. 1

0521001 00000 2
0521101 100000 1
0521201 103 12.65+6 563.0 0. 0. 0. 2
0521300 1
0521301 4.73 0. 0. 1
***
*=====
* UP bottom connections
*=====
*
0510000 upc-con1 sngljun
0510101 052010002 054010001 0.01-3 5.555 5.555 100002
0510201 1 0.73 0. 0.
**
0530000 upc-con2 sngljun
0530101 052020001 054010001 3.29-3 0.09 0.09 100002
0530201 1 4. 0. 0.
**
*=====
*
0540000 r-core pipe

```

```

0540001 6
0540101 3.3-3 6

0540301 0.212 4
0540302 0.455 5
0540303 0.455 6

0540301 0.212 2
0540302 0.455 4
0540303 0.212 6

0540401 0. 6 *= 6.105e-3

0540601 0. 2
0540602 90. 4
0540603 0. 6

0540801 3.-5 0.046 6
0540902 0. 0. 5

0541001 00000 6
0541101 100000 5
0541201 103 12.52+6 563.0 0. 0. 0. 6
0541300 1
0541301 4.73 0. 0. 5
***
*****
* UP bottom connections
* -----
* -----
*
0550000 upc-con sngljun
0550101 054060002 058010002 3.3-3 0.125 0.125 100001
0550101 054060002 058010002 3.0-3 0.125 0.125 100001
0550101 054060002 058010002 1.515-3 0.125 0.125 100001
0550101 054060002 058010002 3.15-3 0.125 0.125 100001
0550201 1 4.0 0. 0.
*
0570000 upc-con sngljun
0570101 054060002 058020001 1.515-3 0.125 0.125 100001
0570101 054060002 058020001 0.15-3 0.125 0.125 100001
0570201 1 0.73 0. 0.
**
*
*****
* upper plenum - lowermost part
* -----
* -----
*
* component name and type
* comp.name comp.type
0580000 r-up-bb pipe
*
* pipe information card
* numb.of.vol.
0580001 2
*
* pipe volume flow areas
* area vol.num. -> ->
0580101 4.2-3 2
*
* pipe volume lengths
* lengh vol.num. -> ->
0580301 0.17 2
*
* pipe volume volumes
* vol. vol.num. -> ->
0580401 0. 2
*
* pipe volume vertical angles
* inc.ang. vol.num. -> ->
0580601 90. 2

```



```

*
* pipe volume friction data
* rough. h.diam. vol.numb.
0580801 3.5 0.0 2
*
* (internal) pipe junction loss coefficients [opt.]
* loss.c. rev.loss.c. jun.numb.
0580901 0. 0. 1
*
* pipe volume control flags
* flags vol.numb. ____->____ ____->____
0581001 00 2
*
* pipe junction control flags
* flags jun.numb. ____->____
0581101 100100 1
*
* pipe volume initial conditions
* ctrl. w4 or 0. -> -> vol.numb.
0581201 103 12.52+6 563.5 0. 0. 0. 2
*
* pipe junction conditions control word [opt.]
* ctrl. [ _ or 0 -> w1,w2 of 06013..=ini.vel.]
0581300 1
*
* pipe junction initial conditions
* ini.f.flw. ini.g.flw. intrf.vel. jun.numb.
0581301 4.73 0. 0. 1
***
=====
* UP connection
*
=====
*
* component name and type
* comp.name comp.type
0590000 upc-con sngljun
*
* single junction geometry cards
* from to area loss rev.loss. flgs.
0590101 058020002 060010001 1.66-3 0. 0. 100000
*
* single junction initial conditions [w1=0 -> w2,w3=vel.]
* ctrl ini.f.flw. ini.g.flw. interf.vel.
0590201 1 4.73 0. 0.
**
*
=====
* upper plenum - bottom part
*
=====
*
* component name and type
* comp.name comp.type
0600000 r-up-b pipe
*
* pipe information card
* numb.of.vol.
0600001 3
*
* pipe volume flow areas
* area vol.numb. ____->____ ____->____
0600101 1.66-3 2
0600102 4.2-3 3
*
*
* pipe volume lengths
* lengh vol.numb. ____->____ ____->____
0600301 0.503 2

```

```

*
0600301 0.586 2
*
0600301 0.5 2
0600302 0.333 3
*
* pipe volume volumes
* vol. vol.num. ____-> ____ -> ____
0600401 0. 3
*
* pipe volume vertical angles
* inc.ang. vol.num. ____-> ____ -> ____
0600601 90. 3
*
* pipe volume friction data
* rough. h.diam. vol.num.
0600801 3-5 0.046 2
0600802 3-5 0.073 3
*
* (internal) pipe junction loss coefficients [opt.]
* loss.c. rev.loss.c. jun.num.
0600901 0. 0. 2
*
* pipe volume control flags
* flags vol.num. ____-> ____ -> ____
0601001 00 3
*
* pipe junction control flags
* flags jun.num. ____-> ____
0601101 100100 2
*
* pipe volume initial conditions
* ctrl. w4 or 0. -> -> vol.num.
*
0601201 103 12.52+6 563.5 0. 0. 0. 3
*
* pipe junction conditions control word [opt.]
* ctrl. [ ] or 0 -> w1,w2 of 06013..=ini.vel.]
0601300 1
*
* pipe junction initial conditions
* ini.f.flw. ini.g.flw. intrf.vel. jun.num.
*
0601301 4.73 0. 0. 2
***
*=====
* upper plenum - middle part
*=====
*
* component name and type
* comp.name comp.type
0620000 r-up-m branch
*
* branch information card
* numb.of.jun. ctrl. [ ] or 0 -> w1,w2 of 062n2..=ini.vel.]
0620001 1 1
*
* branch volume geometry cards
* area length vol. az.ang. inc.ang. elv.chng.
0620101 1.22-2 0.448 0. 0. 90. 0.448
0620101 5.1-3 0.448 0. 0. 90. 0.448
0620101 2.01-2 0.058 0. 0. 90. 0.058
*
* rough. h.diam. flags
0620102 3-5 0.160 00
*
* branch volume initial conditions
* ctrl. (p) (temp) bor.con.[if]
*
0620200 103 12.52+6 563.5
*

```

```

*   branch junction geometry cards
*   from   to   area loss.c. rev.loss.c. flags
0621101 060030002 062010001 4.2-3 0. 0. 100100
*
*   branch junction initial conditions [according to 0620001]
*   ini.f.flw. ini.g.flw. interf.vel.
*   ---      ---      ---
0621201 5.24 0. 0.
***
=====
* upper plenum - middle part
* -----
*
*   component name and type
*   comp.name comp.type
0640000 r-up-m branch
*
*   branch information card
*   numb.of.jun. ctrl. [ or 0 -> w1,w2 of 064n2..=ini.vel.]
0640001 3 1
*
*   branch volume geometry cards
*   area length vol. az.ang. inc.ang. elv.chng.
0640101 1.22-2 0.448 0. 0. 90. 0.448
0640101 5.1-3 0.448 0. 0. 90. 0.448
0640101 2.01-2 0.170 0. 0. 90. 0.170
*
*   rough. h.diam. flags
0640102 3.-5 0.160 00
*
*   branch volume initial conditions
*   ctrl. (p) (temp) bor.con.[if]
*   --- --- ---
0640200 103 12.52+6 563.5
*
*   branch junction geometry cards
*   from   to   area loss.c. rev.loss.c. flags
0641101 062010002 064010001 2.01-2 0. 0. 100100
*
0642101 064010002 068010001 4.2-3 0. 0. 000100
*
0643101 064010001 102010001 1.66-3 2. 2. 000000
*
*   branch junction initial conditions [according to 0640001]
*   ini.f.flw. ini.g.flw. interf.vel.
*   ---      ---      ---
0641201 5.24 0. 0.
*
0642201 0. 0. 0.
*
0643201 5.24 0. 0.
***
=====
* upper plenum - top part
* -----
*
*   component name and type
*   comp.name comp.type
0680000 r-up-t pipe
*
*   pipe information card
*   numb.of.vol.
0680001 4
*
*   pipe volume flow areas
*   area vol.numb.  ->  ->
0680101 5.1-3 3
0680101 4.2-3 4
*
*   (internal) pipe junction flow areas [opt.]

```

```

*      area jun.num.  ____-> ____
*680201
*
*      pipe volume lenghts
*      lengh vol.num.  ____-> ____  ____-> ____
0680301 0.680 3
0680301 0.5225 4
*
*      pipe volume volumes
*      vol. vol.num.  ____-> ____  ____-> ____
0680401 0. 4
*
*      pipe volume vertical angles
*      inc.ang. vol.num.  ____-> ____  ____-> ____
0680601 90. 4
*
*      pipe volume elevation change [opt.]
*      elev.chng. vol.num.  ____-> ____  ____-> ____
0680701 0.680 3
0680701 0.5225 4
*
*      pipe volume friction data
*      rough. h.diam. vol.num.
*
0680802 3.-5 73.00-3 4
*
*      (internal) pipe junction loss coefficients [opt.]
*      loss.c. rev.loss.c. jun.num.
0680901 0. 0. 3
*
*      pipe volume control flags
*      flags vol.num.  ____-> ____  ____-> ____
0681001 00 4
*
*      pipe junction control flags
*      flags jun.num.  ____-> ____
0681101 00100 3
*
*      pipe volume initial conditions
*      ctrl. w4 or 0. -> -> vol.num.
*
0681201 103 12.52+6 544.0 0. 0. 0. 1
*
0681202 103 12.52+6 540.0 0. 0. 0. 2
*
0681203 103 12.52+6 536.0 0. 0. 0. 3
*
0681204 103 12.52+6 532.0 0. 0. 0. 4
*
*
*      pipe junction conditions control word [opt.]
*      ctrl. [ _ or 0 -> w1,w2 of 06813..=ini.vel.]
0681300 1
*
*      pipe junction initial conditions
*      ini.f.flw. ini.g.flw. intrf.vel. jun.num.
*
0681301 0. 0. 0. 3
*
*
*=====
*=====
* = hot leg
* =
*=====
*=====
*
*=====
* HL first part
* =
*=====

```

```

*
* component name and type
* comp.name comp.type
1020000 hl1 branch
*
* branch information card
* numb.of.jun. ctrl. [ or 0 -> w1,w2 of 102n2..=ini.vel.]
1020001 1 1
*
* branch volume geometry cards
* area length vol. az.ang. inc.ang. elv.chng.
1020101 1.7-3 0.75 0. 0. 0. 0.
*
* rough. h.diam. flags
1020102 3.5 4.654-2 00
*
* branch volume initial conditions
* ctrl. (p) (temp) bor.con.[if]
1020200 103 12.52+6 563.0
*
* branch junction geometry cards
* from to area loss.c. rev.loss.c. flags
1021101 102010002 106010001 1.7-3 0.1 0.1 00100
*
* branch junction initial conditions [according to 1020001]
* ini.f.flw. ini.g.flw. interf.vel.
1021201 4.73 0. 0.
***
=====
* hot leg from prz connection to sg inlet
*
=====
*
* component name and type
* comp.name comp.type
1060000 hl-pipe pipe
*
* pipe information card
* numb.of.vol.
1060001 7
*
* pipe volume flow areas
* area vol.numb. -> ->
1060101 1.7-3 7
*
* -> ->
1060102
*
* pipe volume lengths
* lengh vol.numb. -> ->
1060301 0.560 5 0.502 6 0.770 7
*
* -> ->
*1060302
*
* pipe volume volumes
* vol. vol.numb. -> ->
1060401 0. 7
*
* pipe volume vertical angles
* inc.ang. vol.numb. -> ->
1060601 -30. 5 0. 6 90. 7
*
* pipe volume elevation change [opt.]
* elev.chng. vol.numb. -> ->
1060701 -0.28 5 0. 6 0.77 7
*
* -> ->
*1060702
*

```

```

* pipe volume friction data
* rough. h.diam. vol.num.
1060801 3.-5 4.654-2 7
*
* (internal) pipe junction loss coefficients [opt.]
* loss.c. rev.loss.c. jun.num.
1060901 0. 0. 5
1060902 0.2 0.2 6
*
* pipe volume control flags
* flags vol.num. ____-> ____ ____-> ____
1061001 00 7
*
* pipe junction control flags
* flags jun.num. ____-> ____ ____-> ____
1061101 00100 6
*
* pipe volume initial conditions
* ctrl. ____ (w4 or 0.) ____ vol.num.
1061201 103 12.52+6 563.0 0. 0. 7
*
* pipe junction conditions control word [opt.]
* ctrl. [ _ or 0 -> w1,w2 of 10613..=ini.vel.]
1061300 1
*
* pipe junction initial conditions
* ini.f.flw. ini.g.flw. intrf.vel. jun.num.
1061301 4.73 0. 0. 6
***
*
*=====
*=====
*= sg primary side
*=====
*=====
*
*=====
* sg primary side inlet
*=====
*
* component name and type
* comp.name comp.type
1200000 sgp-inl branch
*
* branch information card
* numb.of.jun. ctrl. [ _ or 0 -> w1,w2 of 120n2..=ini.vel.]
1200001 2 1
*
* branch volume geometry cards
* area length vol. az.ang. inc.ang. elv.chng.
1200101 4.2-3 0.77 0. 0. 90. 0.77
*
* rough. h.diam. flags
1200102 3.-5 7.3-2 00
*
* branch volume initial conditions
* ctrl. (p) (temp) ____ ____ bor.con.[if]
1200200 103 12.598+6 563.0
*
* branch junction geometry cards
* from to area loss.c. rev.loss.c. flags
1201101 106070002 120010001 1.7-3 0.4 0.4 00100
*
1202101 120010002 122010001 3.8-3 0. 0. 00100
*
* branch junction initial conditions [according to 1200001]

```

```

*      ini.f.flw. ini.g.flw. interf.vel.
*      ---      ---
1201201 4.73    0.    0.
*
1202201 4.73    0.    0.
***
=====
* inlet collector - lower level
*
=====
*
*      component name and type
*      comp.name comp.type
1220000 sgp-ic-b branch
*
*      branch information card
*      numb.of.jun. ctrl. [ or 0 -> w1,w2 of 122n2..=ini.vel.]
1220001 2      1
*
*      branch volume geometry cards
*      area length vol. az.ang. inc.ang. elv.chng.
1220101 4.2-3 0.61 0. 0. 90. 0.61
*
*      rough. h.diam. flags
1220102 3.-5 7.315-2 00
*
*      branch volume initial conditions
*      ctrl. (p) (temp) bor.con.[if]
*      --- --- --- ---
1220200 103 12.52+6 562.5
*
*      branch junction geometry cards
*      from to area loss.c. rev.loss.c. flags
1221101 122010002 124010001 0. 0. 0. 00100
*
1222101 122010001 132010001 0. 10. 3. 00100
*
*      branch junction initial conditions [according to 1220001]
*      ini.f.flw. ini.g.flw. interf.vel.
*      --- ---
1221201 4.24    0.    0.
*
1222201 1.    0.    0.
***
=====
* inlet collector - middle level
*
=====
*
*      component name and type
*      comp.name comp.type
1240000 sgp-ic-m branch
*
*      branch information card
*      numb.of.jun. ctrl. [ or 0 -> w1,w2 of 124n2..=ini.vel.]
1240001 2      1
*
*      branch volume geometry cards
*      area length vol. az.ang. inc.ang. elv.chng.
1240101 4.2-3 0.61 0. 0. 90. 0.61
*
*      rough. h.diam. flags
1240102 3.-5 7.315-2 00
*
*      branch volume initial conditions
*      ctrl. (p) (temp) bor.con.[if]
*      --- --- --- ---
1240200 103 12.52+6 562.5
*
*      branch junction geometry cards
*      from to area loss.c. rev.loss.c. flags
1241101 124010002 126010001 0. 0. 0. 00100

```

```

*
1242101 124010001 134010001 0. 10. 8. 00100
*
*   branch junction initial conditions [according to 1240001]
*   ini.f.flw. ini.g.flw. interf.vel.
*
1241201 3.24 0. 0.
*
1242201 1. 0. 0.
***
=====
* inlet collector - upper level
*
=====
*
*   component name and type
*   comp.name comp.type
1260000 sgp-ic-u branch
*
*   branch information card
*   numb.of.jun. ctrl. [ or 0 -> w1,w2 of 126n2.=ini.vel.]
1260001 2 1
*
*   branch volume geometry cards
*   area length vol. az.ang. inc.ang. elv.chng.
1260101 4.2-3 0.61 0. 0. 90. 0.61
*
*   rough. h.diam. flags
1260102 3.-5 7.315-2 00
*
*   branch volume initial conditions
*   ctrl. (p) (temp) bor.con.[if]
1260200 103 12.52+6 561.5
*
*   branch junction geometry cards
*   from to area loss.c. rev.loss.c. flags
1261101 126010002 128010001 0. 0. 0. 00100
*
1262101 126010002 136010001 0. 10. 12.5 00100
*
*   branch junction initial conditions [according to 1260001]
*   ini.f.flw. ini.g.flw. interf.vel.
*
1261201 0. 0. 0.
*
1262201 3.24 0. 0.
***
=====
* inlet collector - blind end
*
=====
*
*   component name and type
*   comp.name comp.type
1280000 sgp-ic-t branch
*
*   branch information card
*   numb.of.jun. ctrl. [ or 0 -> w1,w2 of 128n2.=ini.vel.]
1280001 0 1
*
*   branch volume geometry cards
*   area length vol. az.ang. inc.ang. elv.chng.
1280101 4.2-3 0.249 0. 0. 90. 0.249
*
*   rough. h.diam. flags
1280102 3.-5 7.315-2 00
*
*   branch volume initial conditions
*   ctrl. (p) (temp) bor.con.[if]
1280200 103 12.52+6 560.5

```



```

*280200 104. 12.52+6 533.7 0.1
*
* branch junction geometry cards
* from to area loss.c. rev.loss.c. flags
*
* branch junction initial conditions [according to 1280001]
* ini.f.flw. ini.g.flw. interf.vel.
*
***

```

```

=====
* sg tubing - lower section
=====

```

```

* component name and type
* comp.name comp.type
1320000 sgp-tub1 pipe
*
* pipe information card
* numb.of.vol.
1320001 4
*
* pipe volume flow areas
* area vol.num. ____-> ____ ____-> ____
1320101 5.65-4 4
*
* (internal) pipe junction flow areas [opt.]
* area jun.num. ____-> ____
1320201
*
* pipe volume lengths
* lengh vol.num. ____-> ____ ____-> ____
1320301 0.978 4
1320301 0.929 4
*
* pipe volume volumes
* vol. vol.num. ____-> ____ ____-> ____
1320401 0. 4
*
* pipe volume vertical angles
* inc.ang. vol.num. ____-> ____ ____-> ____
1320601 0. 4
*
* pipe volume elevation change [opt.]
* elev.chng. vol.num. ____-> ____ ____-> ____
1320701 0. 4
*
* pipe volume friction data
* rough. h.diam. vol.num.
1320801 3.-5 6.-3 4
1320801 3.-5 0. 4 *=along sirkia
*
* (internal) pipe junction loss coefficients [opt.]
* loss.c. rev.loss.c. jun.num.
1320901 0.1 0.1 3 *=along sirkia
*1320901 0.1 0.1 3
*
* pipe volume control flags
* flags vol.num. ____-> ____ ____-> ____
1321001 00 4
*
* pipe junction control flags
* flags jun.num. ____-> ____
1321101 00100 3
*
* pipe volume initial conditions
* ctrl. ____ ____ ____ ____ w4 or 0. -> -> vol.num.
1321201 103 12.52+6 552. 0. 0. 0. 1
*
1321202 103 12.52+6 545. 0. 0. 0. 2
*

```

```

1321203 103 12.52+6 541. 0. 0. 0. 3
*
1321204 103 12.52+6 538. 0. 0. 0. 4
*
* pipe junction conditions control word [opt.]
*   ctrl. [ 1 or 0 -> w1,w2 of 13213..=ini.vel.]
1321300 1
*
* pipe junction initial conditions
*   ini.f.flw. ini.g.flw. intrf.vel. jun.numb.
*
1321301 1. 0. 0. 3
***
=====
* sg tubing - middle section
*
=====
*
* component name and type
*   comp.name comp.type
1340000 sgp-tub2 pipe
*
* pipe information card
*   numb.of.vol.
1340001 4
*
* pipe volume flow areas
*   area vol.numb. ____-> ____ -> ____
1340101 8.48-4 4
*
* (internal) pipe junction flow areas [opt.]
*   area jun.numb. ____-> ____
1340201
*
* pipe volume lengths
*   lengh vol.numb. ____-> ____ -> ____
1340301 0.929 4
*
* pipe volume volumes
*   vol. vol.numb. ____-> ____ -> ____
1340401 0. 4
*
* pipe volume vertical angles
*   inc.ang. vol.numb. ____-> ____ -> ____
1340601 0. 4
*
* pipe volume elevation change [opt.]
*   elev.chng. vol.numb. ____-> ____ -> ____
1340701 0. 4
*
* pipe volume friction data
*   rough. h.diam. vol.numb.
1340801 3.-5 6.-3 4
1340801 3.-5 0. 4 *=sirkia
*
* (internal) pipe junction loss coefficients [opt.]
*   loss.c. rev.loss.c. jun.numb.
1340901 0.1 0.1 3
*
* pipe volume control flags
*   flags vol.numb. ____-> ____ -> ____
1341001 00 4
*
* pipe junction control flags
*   flags jun.numb. ____-> ____
1341101 00100 3
*
* pipe volume initial conditions
*   ctrl. ____ w4 or 0. -> -> vol.numb.
*
1341201 103 12.52+6 552. 0. 0. 0. 1
*

```

```

1341202 103 12.52+6 545. 0. 0. 0. 2
*
1341203 103 12.52+6 541. 0. 0. 0. 3
*
1341204 103 12.52+6 538. 0. 0. 0. 4
*

```

```

* pipe junction conditions control word [opt.]
*   ctrl. [ _ or 0 -> w1,w2 of 13413..=ini.vel.]
1341300 1
*

```

```

* pipe junction initial conditions
*   ini.f.flw. ini.g.flw. intrf.vel. jun.numb.
*
1341301 1. 0. 0. 3
***

```

```

=====
* sg tubing - upper section
*
=====

```

```

* component name and type
*   comp.name comp.type
1360000 sgp-tub3 pipe
*

```

```

* pipe information card
*   numb.of.vol.
1360001 4
*

```

```

* pipe volume flow areas
*   area vol.numb. ____->____ ____->____
1360101 8.48-4 4
*

```

```

* (internal) pipe junction flow areas [opt.]
*   area jun.numb. ____->____
1360201
*

```

```

* pipe volume lengths
*   lengh vol.numb. ____->____ ____->____
1360301 0.929 4
*

```

```

* pipe volume volumes
*   vol. vol.numb. ____->____ ____->____
1360401 0. 4
*

```

```

* pipe volume vertical angles
*   inc.ang. vol.numb. ____->____ ____->____
1360601 0. 4
*

```

```

* pipe volume elevation change [opt.]
*   elev.chng. vol.numb. ____->____ ____->____
1360701 0. 4
*

```

```

* pipe volume friction data
*   rough. h.diam. vol.numb.
1360801 3.-5 6.-3 4
1360801 3.-5 0. 4
*

```

```

* (internal) pipe junction loss coefficients [opt.]
*   loss.c. rev.loss.c. jun.numb.
1360901 0.1 0.1 3
*

```

```

* pipe volume control flags
*   flags vol.numb. ____->____ ____->____
1361001 00 4
*

```

```

* pipe junction control flags
*   flags jun.numb. ____->____
1361101 00100 3
*

```

```

* pipe volume initial conditions
*   ctrl. ____ w4 or 0. -> -> vol.numb.
*   ____ -> ->

```

```

1361201 103 12.52+6 550. 0. 0. 0. 1
*
1361202 103 12.52+6 543. 0. 0. 0. 2
*
1361203 103 12.52+6 539. 0. 0. 0. 3
*
1361204 103 12.52+6 538. 0. 0. 0. 4
*
* pipe junction conditions control word [opt.]
*   ctrl. [ _ or 0 -> w1,w2 of 13613..=ini.vel.]
1361300 1
*
* pipe junction initial conditions
*   ini.f.flw. ini.g.flw. intrf.vel. jun.numb.
*
1361301 3.24 0. 0. 3
***
=====
* outlet collector - blind end
*
=====
*
* component name and type
*   comp.name comp.type
1480000 sgp-oc-t branch
*
* branch information card
*   numb.of.jun. ctrl. [ _ or 0 -> w1,w2 of 148n2..=ini.vel.]
1480001 1 1
*
* branch volume geometry cards
*   area length vol. az.ang. inc.ang. elv.chng.
1480101 4.2-3 0.249 0. 0. -90. -0.249
*
*   rough. h.diam. flags
1480102 3.-5 7.315-2 00
*
* branch volume initial conditions
*   ctrl. (p) (temp) bor.con.[if]
*
1480200 103 12.52+6 532.
*
* branch junction geometry cards
*   from to area loss.c. rev.loss.c. flags
1481101 148010002 146010001 0. 0. 0. 00100
*
* branch junction initial conditions [according to 1480001]
*   ini.f.flw. ini.g.flw. interf.vel.
*
1481201 0. 0. 0.
***
=====
* outlet collector - upper level
*
=====
*
* component name and type
*   comp.name comp.type
1460000 sgp-oc-u branch
*
* branch information card
*   numb.of.jun. ctrl. [ _ or 0 -> w1,w2 of 146n2..=ini.vel.]
1460001 2 1
*
* branch volume geometry cards
*   area length vol. az.ang. inc.ang. elv.chng.
1460101 4.2-3 0.61 0. 0. -90. -0.61
*
*   rough. h.diam. flags
1460102 3.-5 7.315-2 00
*
* branch volume initial conditions

```

```

*      ctrl. (p)  (temp)                bor.con.[if]
*      ----  ----  ----  ----
1460200 103  12.52+6 538.0
*
*      branch junction geometry cards
*      from   to   area loss.c. rev.loss.c. flags
1461101 136040002 146010001 0.  10.  12.5  00100
*
1462101 146010002 144010001 0.  0.  0.  00100
*
*      branch junction initial conditions [according to 1460001]
*      ini.f.flw. ini.g.flw. interf.vel.
*      ---  ---
1461201 3.24  0.  0.
*
1462201 3.24  0.  0.
***
=====
* outlet collector - middle level
* -----
*
*      component name and type
*      comp.name comp.type
1440000 sgp-oc-m branch
*
*      branch information card
*      numb.of.jun. ctrl. [ or 0 -> w1,w2 of 144n2..=ini.vel.]
1440001 2  1
*
*      branch volume geometry cards
*      area length vol. az.ang. inc.ang. elv.chng.
1440101 4.2-3 0.61 0. 0. -90. -0.61
*
*      rough. h.diam. flags
1440102 3.5 7.315-2 00
*
*      branch volume initial conditions
*      ctrl. (p)  (temp)                bor.con.[if]
*      ----  ----  ----  ----
1440200 103  12.52+6 538.0
*
*      branch junction geometry cards
*      from   to   area loss.c. rev.loss.c. flags
1441101 134040002 144010002 0.  10.  8.  00100
*
1442101 144010002 142010001 0.  0.  0.  00100
*
*      branch junction initial conditions [according to 1440001]
*      ini.f.flw. ini.g.flw. interf.vel.
*      ---  ---
1441201 1.  0.  0.
*
1442201 4.24  0.  0.
***
=====
* outlet collector - lower level
* -----
*
*      component name and type
*      comp.name comp.type
1420000 sgp-oc-l branch
*
*      branch information card
*      numb.of.jun. ctrl. [ or 0 -> w1,w2 of 142n2..=ini.vel.]
1420001 2  1
*
*      branch volume geometry cards
*      area length vol. az.ang. inc.ang. elv.chng.
1420101 4.2-3 0.61 0. 0. -90. -0.61
*

```

```

*      rough. h.diam. flags
1420102 3-5 7.315-2 00
*
*      branch volume initial conditions
*      ctrl. (p) (temp)          bor.con.[if]
*
1420200 103 12.52+6 538.0
*
*      branch junction geometry cards
*      from to area loss.c. rev.loss.c. flags
1421101 132040002 142010002 0. 10. 3. 00100
*
1422101 142010002 140010001 0. 0. 0. 00100
*
*      branch junction initial conditions [according to 1420001]
*      ini.f.flw. ini.g.flw. interf.vel.
*
1421201 1. 0. 0.
*
1422201 4.24 0. 0.
***
=====
* sg primary side outlet
*
=====
*
*      component name and type
*      comp.name comp.type
1400000 sgp-out branch
*
*      branch information card
*      numb.of.jun. ctrl. [ or 0 -> w1,w2 of 140n2..=ini.vel.]
1400001 1 1
*
*      branch volume geometry cards
*      area length vol. az.ang. inc.ang. elv.chng.
1400101 4.2-3 0.77 0. 0. -90. -0.77
*
*      rough. h.diam. flags
1400102 3-5 7.3-2 00
*
*      branch volume initial conditions
*      ctrl. (p) (temp)          bor.con.[if]
*
1400200 103 12.598+6 538.
*
*      branch junction geometry cards
*      from to area loss.c. rev.loss.c. flags
1401101 140010002 154010001 1.7-3 0. 0. 00100
*
*      branch junction initial conditions [according to 1400001]
*      ini.f.flw. ini.g.flw. interf.vel.
*
1401201 4.73 0. 0.
***
=====
*
*      cold leg
*
=====
*
*      part from sg outlet to "before rcp" branching
*
=====
*
*      component name and type
*      comp.name comp.type
1540000 cl-1p-1 pipe
*

```

```

* pipe information card
*   numb.of.vol.
1540001 4
*
* pipe volume flow areas
*   area vol.num. ____-> ____ ____-> ____
1540101 1.7-3 4
*
* (internal) pipe junction flow areas [opt.]
*   area jun.num. ____-> ____
1540201
*
* pipe volume lengths
*   length vol.num. ____-> ____ ____-> ____
1540301 0.5925 4
*
* pipe volume volumes
*   vol. vol.num. ____-> ____ ____-> ____
1540401 0. 4
*
* pipe volume vertical angles
*   inc.ang. vol.num. ____-> ____ ____-> ____
1540601 -90. 4
*
* pipe volume friction data
*   rough. h.diam. vol.num.
1540801 3.-5 4.654-2 4
*
* (internal) pipe junction loss coefficients [opt.]
*   loss.c. rev.loss.c. jun.num.
1540901 0. 0. 3
*
* pipe volume control flags
*   flags vol.num. ____-> ____ ____-> ____
1541001 00 4
*
* pipe junction control flags
*   flags jun.num. ____-> ____
1541101 00100 3
*
* pipe volume initial conditions
*   ctrl. ____ w4 or 0. -> -> vol.num.
1541201 103 12.52+6 538. 0. 0. 0. 4
*
* pipe junction conditions control word [opt.]
*   ctrl. [_ or 0 -> w1,w2 of 15413..=ini.vel.]
1541300 1
*
* pipe junction initial conditions
*   ini.f.flw. ini.g.flw. intrf.vel. jun.num.
1541301 4.73 0. 0. 3
***
=====
* "before rcp" branching
* =====
*
* component name and type
*   comp.name comp.type
1560000 cl-1p-2 branch
*
* branch information card
*   numb.of.jun. ctrl. [_ or 0 -> w1,w2 of 154n2..=ini.vel.]
1560001 1 1
*
* branch volume geometry cards
*   area length vol. az.ang. inc.ang. elv.chng.
1560101 1.7-3 0.605 0. 0. 90. 0.1
*
*   rough. h.diam. flags

```

```

1560102 3.-5 4.654-2 00
*
*   branch volume initial conditions
*   ctrl. (p)   (temp)           bor.con.[if]
*
1560200 103 12.547+6 538.
*
*   branch junction geometry cards
*   from   to   area loss.c. rev.loss.c. flags
1561101 154040002 156010001 0. 0. 0. 00100
*
*   branch junction initial conditions [according to 1560001]
*   ini.f.flw. ini.g.flw. interf.vel.
*
1561201 4.73 0. 0.
*
=====
* by-pass valve
*
=====
*
*   component name and type
*   comp.name comp.type
1550000 cl-v-by1 valve
*
*   valve junction geometry cards
*   from   to   area loss rev.loss flgs.
1550101 156010002 192010001 1.5-3 0. 0. 00100
*
*   valve junction initial conditions
*   ctrl. ini.f.flw. ini.g.flw. interf.vel.
*
1550201 1 0. 0. 0.
*
*   valve type card
*   type
1550300 mtrvlv
*
*   valve data and initial conditions [according to 1550300]
*   open close
*
1550301 609 501 0.5 0.
*
***
=====
* part before valve "165"
*
=====
*
*   component name and type
*   comp.name comp.type
1580000 cl-1p-3 branch
*
*   branch information card
*   numb.of.jun. ctrl. [ or 0 -> w1,w2 of 154n2..=ini.vel.]
1580001 1 1
*
*   branch volume geometry cards
*   area length vol. az.ang. inc.ang. elv.chng.
1580101 4.2-3 0.71 0. 0. -90. -0.703
*
*   rough. h.diam. flags
1580102 3.-5 0. 00
*
*   branch volume initial conditions
*   ctrl. (p)   (temp)           bor.con.[if]
*
1580200 103 12.547+6 538.
*
*   branch junction geometry cards
*   from   to   area loss.c. rev.loss.c. flags
1581101 154040002 158010001 0. 0. 0. 00100

```



```

*
* branch junction initial conditions [according to 1580001]
*   ini.f.flw.  ini.g.flw.  interf.vel.
1581201  4.73    0.      0.
*
=====
* "pre-pump" valve
*
=====
*
* component name and type
*   comp.name  comp.type
1650000  cl-v-pre  valve
*
* valve junction geometry cards
*   from      to      area  loss  rev.loss  figs.
1650101  158010002  166010001  1.5-3  0.      0.      00100
*
* valve junction initial conditions
*   ctrl.  ini.f.flw.  ini.g.flw.  interf.vel.
1650201  1      4.73      0.      0.
*
* valve type card
*   type
1650300  mtrvlv
*
* valve data and initial conditions [according to 1650300]
*   open  close
*   ----  ----  ----  ----  ----  ----
1650301  501    609    0.5    1.
***
*
=====
* suction leg
*
=====
*
* component name and type
*   comp.name  comp.type
1660000  cl-suc  pipe
*
* pipe information card
*   numb.of.vol.
1660001  4
*
* pipe volume flow areas
*   area  vol.numb.  ->  ->
1660101  4.2-3  3      8.-3  4
*
* (internal) pipe junction flow areas [opt.]
*   area  jun.numb.  ->  ->
1660201  4.2-3  3
*
* pipe volume lengths
*   lengh  vol.numb.  ->  ->
1660301  1.767  1      1.5  3      1.62  4
*
*1660302 ->  ->
*
* pipe volume volumes
*   vol.  vol.numb.  ->  ->
1660401  0.  4
*
* pipe volume vertical angles
*   inc.ang.  vol.numb.  ->  ->
1660601  -90.  4
*
* pipe volume elevation change [opt.]
*   elev.chng.  vol.numb.  ->  ->
1660701  -0.495  1      -0.51  2      -0.85  3

```

```

*
*
*----->----->
1660702 -0.985 4
*
* pipe volume friction data
* rough. h.diam. vol.numb.
1660801 3.-5 7.315-2 3
*
1660802 3.-5 0.101 4
*
*1660803
*
* (internal) pipe junction loss coefficients [opt.]
* loss.c. rev.loss.c. jun.numb.
1660901 0. 0. 3
*
* pipe volume control flags
* flags vol.numb. ----->----->----->
1661001 00 4
*
* pipe junction control flags
* flags jun.numb. ----->----->----->
1661101 00100 3
*
* pipe volume initial conditions
* ctrl. (w4 or 0.) vol.numb.
1661201 103 12.52+6 538. 0. 0. 0. 4
*
* pipe junction conditions control word [opt.]
* ctrl. [ or 0 -> w1,w2 of 16613..=ini.vel.]
1661300 T
*
* pipe junction initial conditions
* ini.f.flw. ini.g.flw. intrf.vel. jun.numb.
1661301 4.73 0. 0. 3
***
*=====
* pump
*-----
*=====
*
* component name and type
* comp.name comp.type
1700000 cl-pump pump
*
* pump volume geometry cards
* area length vol. az.ang. incl.ang. el.chng. flgs.
1700101 1.66-3 0. 7.529-3 0. 90. 1.85 00
*
* pump inlet (suction) junction card
* con.vol. area loss rev.loss flgs.
1700108 166040002 1.7-3 0.8 0.8 00000
*
* pump outlet (discharge) junction card
* con.vol. area loss rev.loss flgs.
1700109 182010001 1.7-3 1.3 1.3 00000
*
* pump volume initial conditions
* ctrl. bor.con.[if]
1700200 103 12.52+6 538.
*
* pump inlet junction initial conditions [ if w1=1 -> flw. ]
* ctrl. ini.f.flw. ini.g.flw. interf.vel.
1700201 1 4.73 0. 0.
*
* pump outlet junction initial conditions [ "-" ]
* ctrl. ini.f.flw. ini.g.flw. interf.vel.

```

```

1700202 1 4.73 0. 0.
*
* pump index and option card
* indic. t.ph.index dif.in. torq.in. vel.in. tr.n. rev.ind.
1700301 0 0 0 -1 0 603 0
*
* pump description card
* vel. vel.ratio flow head torque inertia
1700302 155. 1. 5.8-3 100. 100. 100.
*
* dens. m.torq. fric.c.tf2 tf0 tf1 tf3
1700303 780. 747.3 0. 0. 0. 0.
*
* pump variable inertia card [if not w6 of 1700302]
* rel.sp. i3 i2 i1 i0
*1700308
*
* pump-shaft connection card [if]
* shaft.num. discon.trip
*1700309
*
* pump stop data card
* time max.vel. max.rev.vel.
1700310 0. 890.118 -890.118
*
*****
* single phase head curves
*****
*
* head 1
1701100 1 1
1701101 0.0 1.055
1701102 0.05 1.064
1701103 0.10 1.079
1701104 0.20 1.102
1701105 0.30 1.120
1701106 0.40 1.131
1701107 0.50 1.131
1701108 0.60 1.123
1701109 0.70 1.104
1701110 0.80 1.0785
1701111 0.90 1.043
1701112 1.00 1.00
*
* head 2
1701200 1 2
1701201 0.0 -0.780
1701202 0.10 -0.6285
1701203 0.20 -0.478
1701204 0.30 -0.323
1701205 0.31 -0.308
1701206 0.35 -0.248
1701207 0.40 -0.169
1701208 0.45 -0.084
1701209 0.5015 0.0
1701210 0.55 0.082
1701211 0.6 0.173
1701213 0.70 0.365
1701214 0.75 0.461
1701215 0.80 0.556
1701217 0.90 0.7680
1701218 0.95 0.881
1701219 1.0 1.000
*
* head 3
1701300 1 3
1701301 -1.0 2.110
1701302 -0.90 1.9270
1701303 -0.80 1.759
1701304 -0.70 1.6105
1701305 -0.60 1.489
1701306 -0.50 1.380

```

1701307	-0.40	1.282
1701308	-0.30	1.2000
1701309	-0.20	1.133
1701310	-0.10	1.0805
1701311	-0.05	1.0615
1701312	0.0	1.055

*
* head 4

1701400	1	4
1701401	-1.0	2.110
1701402	-0.90	1.862
1701403	-0.80	1.650
1701404	-0.70	1.474
1701405	-0.60	1.332
1701406	-0.50	1.212
1701407	-0.40	1.105
1701408	-0.30	1.002
1701409	-0.20	0.911
1701410	-0.10	0.830
1701411	0.0	0.761

*
* head 5

1701500	1	5
1701501	0.00	0.424
1701502	0.10	0.489
1701503	0.20	0.543
1701504	0.30	0.603
1701505	0.40	0.6600
1701506	0.50	0.7095
1701507	0.60	0.7495
1701508	0.70	0.777
1701509	0.80	0.804
1701510	0.90	0.861
1701511	1.0	0.948

*
* head 6

1701600	1	6
1701601	0.0	0.761
1701602	0.10	0.710
1701603	0.20	0.664
1701604	0.30	0.644
1701605	0.40	0.653
1701606	0.50	0.6795
1701607	0.60	0.707
1701608	0.70	0.746
1701609	0.80	0.799
1701610	0.90	0.861
1701611	1.00	0.948

*
* head 7

1701700	1	7
1701701	-1.0	-1.300
1701702	-0.90	-0.85
1701703	-0.60	-0.283
1701704	-0.50	-0.147
1701705	-0.45	-0.081
1701706	-0.384	0.0
1701707	-0.35	0.041
1701708	-0.30	0.106
1701709	-0.25	0.17
1701710	-0.20	0.233
1701711	-0.15	0.290
1701712	-0.10	0.3395
1701713	-0.05	0.384
1701714	0.00	0.424

*
* head 8

1701800	1	8
1701801	-1.0	-1.300
1701802	-0.8	-1.29
1701803	-0.50	-1.20
1701804	-0.20	-1.00

1701805 0.00 -0.780

*

* single phase torque curves

*

*

* torque 1

1701900	2	1
1701901	0.0	0.439
1701902	0.05	0.442
1701903	0.10	0.460
1701904	0.20	0.515
1701905	0.30	0.5825
1701906	0.40	0.647
1701907	0.50	0.706
1701908	0.60	0.764
1701909	0.70	0.823
1701910	0.80	0.882
1701911	0.90	0.9415
1701912	1.0	1.0

* torque 2

1702000	2	2
1702001	0.0	-0.518
1702002	0.10	-0.350
1702003	0.20	-0.184
1702004	0.30	-0.0180
1702005	0.31	0.0
1702006	0.35	0.066
1702007	0.40	0.151
1702008	0.45	0.238
1702009	0.5015	0.320
1702010	0.55	0.396
1702011	0.6000	0.464
1702013	0.70	0.5985
1702016	0.75	0.666
1702017	0.80	0.731
1702019	0.90	0.864
1702020	0.95	0.9305
1702021	1.0	1.000

* torque 3

1702100	2	3
1702101	-1.0	1.182
1702102	-0.90	1.0370
1702103	-0.80	0.911
1702104	-0.70	0.804
1702105	-0.60	0.712
1702106	-0.50	0.632
1702107	-0.40	0.567
1702108	-0.30	0.513
1702109	-0.20	0.473
1702110	-0.10	0.4495
1702111	-0.05	0.441
1702112	0.00	0.439

* torque 4

1702200	2	4
1702201	-1.0	1.182
1702202	-0.90	1.120
1702203	-0.80	1.093
1702204	-0.70	1.104
1702205	-0.60	1.240
1702206	-0.50	1.323
1702207	-0.40	1.340
1702208	-0.30	1.256
1702209	-0.20	1.122
1702210	-0.10	1.041
1702211	0.00	0.948

* torque 5

1702300	2	5
1702301	0.0	-0.569
1702302	0.10	-0.439
1702303	0.20	-0.318
1702304	0.30	-0.202

```

1702305 0.40 -0.098
1702306 0.50 0.013
1702307 0.60 0.121
1702308 0.70 0.229
1702309 0.80 0.345
1702310 0.90 0.474
1702311 1.0 0.630
* torque 6
1702400 2 6
1702401 0.0 0.984
1702402 0.10 0.9505
1702403 0.20 0.929
1702404 0.30 0.905
1702405 0.40 0.873
1702406 0.50 0.840
1702407 0.60 0.802
1702408 0.70 0.761
1702409 0.80 0.7205
1702410 0.90 0.678
1702411 0.95 0.653
1702412 1.00 0.630
* torque 7
1702500 2 7
1702501 -1.0 -2.200
1702502 -0.6 -1.59
1702503 -0.5 -1.39
1702507 -0.45 -1.297
1702509 -0.384 -1.18
1702510 -0.35 -1.1205
1702511 -0.30 -1.04
1702512 -0.25 -0.956
1702513 -0.20 -0.870
1702514 -0.15 -0.7905
1702515 -0.10 -0.716
1702516 -0.05 -0.640
1702517 0.0 -0.569
* torque 8
1702600 2 8
1702601 -1.0 -2.200
1702602 0.0 -0.518
*
*****
* two-phase multiplier data
*****
*
* head
1703000 0
1703001 0.0 0.0
1703002 0.20 0.0
1703003 0.43 1.00
1703004 0.86 1.00
1703005 1.00 0.0
* torque
1703100 0
1703101 0.0 0.0
1703102 1.0 0.0
*
*****
* two-phase difference data
*****
*
* head 1
1704100 1 1
1704101 0.0 0.165
1704102 0.05 0.774
1704103 0.1 0.81
1704104 0.3 0.773
1704105 0.5 0.804
1704106 0.7 0.828
1704108 1.0 0.816
* head 2
1704200 1 2

```

1704201	0.0	0.22
1704202	0.1	0.2285
1704203	0.3	0.248
1704205	0.5	0.331
1704206	0.7	0.487
1704208	1.0	0.816
* head 3		
1704300	1	3
1704301	-1.0	-0.82
1704302	-0.8	-1.491
1704303	-0.7	-1.6695
1704304	-0.5	-1.78
1704305	-0.3	-1.50
1704306	-0.2	-1.137
1704307	-0.1	-0.5895
1704308	0.0	0.165
* head 4		
1704400	1	4
1704401	-1.0	-0.82
1704402	-0.9	-0.538
1704403	-0.8	-0.33
1704404	-0.6	-0.098
1704405	-0.4	-0.045
1704406	-0.2	-0.039
1704407	0.0	-0.039
* head 5		
1704500	1	5
1704501	0.0	-0.046
1704503	0.2	-0.366
1704505	0.4	-0.58
1704507	0.6	-0.6805
1704509	0.8	-0.676
1704511	1.0	-0.482
* head 6		
1704600	1	6
1704601	0.0	-0.039
1704603	0.2	-0.066
1704605	0.4	-0.097
1704607	0.6	-0.173
1704609	0.8	-0.331
1704611	1.0	-0.482
* head 7		
1704700	1	7
1704701	-1.0	0.8
1704705	-0.6	0.797
1704707	-0.4	0.51
1704709	-0.2	0.233
1704711	0.0	-0.046
* head 8		
1704800	1	8
1704801	-1.0	0.8
1704806	-0.5	0.45
1704809	-0.2	0.29
1704811	0.0	0.22
* torque 1		
1704900	2	1
1704901	0.0	0.0
1704902	1.0	0.0
* torque 2		
1705000	2	2
1705001	0.0	0.0
1705002	1.0	0.0
* torque 3		
1705100	2	3
1705101	-1.0	0.0
1705102	0.0	0.0
* torque 4		
1705200	2	4
1705201	-1.0	0.0
1705202	0.0	0.0
* torque 5		
1705300	2	5

```

1705301 0.0 0.0
1705302 1.0 0.0
* torque 6
1705400 2 6
1705401 0.0 0.0
1705402 1.0 0.0
* torque 7
1705500 2 7
1705501 -1.0 0.0
1705502 0.0 0.0
* torque 8
1705600 2 8
1705601 -1.0 0.0
1705602 0.0 0.0
*
* pump velocity table
*
1706100 610 cntrivar 902
*
1706101 0. 0.
*
1706102 300. 300.
*
=====
* pump discharge (heater)
*
=====
*
* component name and type
* comp.name comp.type
1820000 cl-heat snglvol
*
* single volume geometry cards
* area length vol. az.ang. inc.ang. elv.ch
1820101 4.735-3 1.795 0. 0. 0. 0.
*
* rough. h.diam. flags
1820102 3.-5 0.1022 00
*
* single volume initial conditions
* ctrl. bor.con.[if]
1820200 103 12.52+6 538.
***
=====
* pump discharge valve
*
=====
*
* component name and type
* comp.name comp.type
1850000 cl-v-p0s valve
*
* valve junction geometry cards
* from to area loss rev.loss flgs.
1850101 182010002 190010001 1.5-3 0. 0. 00100
*
* valve junction initial conditions
* ctrl. ini.f.flw. ini.g.flw. interf.vel.
1850201 1 4.73 0. 0.
*
* valve type card
* type
1850300 .srvvlv
*
* valve data and initial conditions [according to 1850300]
*
* -----
1850301 191
***
=====

```



```

* volume from "post" valve
* =====
*
* component name and type
* comp.name comp.type
1900000 cl-2p-1 snglvol
*
* snglvol volume geometry cards
* area length vol. az.ang. inc.ang. elv.chng.
1900101 1.622-2 2.354 0. 0. 90. 1.793
*
* rough. h.diam. flags
1900102 3.-5 4.789-2 00
*
* snglvol volume initial conditions
* ctrl. (p) (temp) bor.con.[if]
1900200 103 12.52+6 538.
***
* =====
* volume from "by-pass" valve
* =====
*
* component name and type
* comp.name comp.type
1920000 cl-2p-2 branch
*
* branch information card
* numb.of.jun. ctrl. [ or 0 -> w1,w2 of 192n2..=ini.vel.]
1920001 2 1
*
* branch volume geometry cards
* area length vol. az.ang. inc.ang. elv.chng.
1920101 1.7-3 0.95 0. 0. 0. 0.
*
* rough. h.diam. flags
1920102 3.-5 4.654-2 00
*
* branch volume initial conditions
* ctrl. (p) (temp) bor.con.[if]
1920200 103 12.52+6 538.
*
* branch junction geometry cards
* from to area loss.c. rev.loss.c. flags
1921101 190010002 192010002 0. 0. 0. 00100
*
1922101 192010002 194010001 0. 0. 0. 00100
*
* branch junction initial conditions [according to 1920001]
* ini.f.flw. ini.g.flw. interf.vel.
1921201 4.73 0. 0.
*
1922201 4.73 0. 0.
***
* =====
* cold leg - part3
* =====
*
* component name and type
* comp.name comp.type
1940000 cl-2p-3 pipe
*
* pipe information card
* numb.of.vol.
1940001 4
*
* pipe volume flow areas

```

```

*   area vol.numb.  ___->___  ___->___
1940101 1.7-3 4
*
*   pipe volume lenghts
*   lengh vol.numb.  ___->___  ___->___
1940301 0.5 3 0.555 4
*
*   pipe volume volumes
*   vol. vol.numb.  ___->___  ___->___
1940401 0. 4
*
*   pipe volume vertical angles
*   inc.ang. vol.numb.  ___->___  ___->___
1940601 90. 3 0. 4
*
*   pipe volume elevation change [opt.]
*   elev.chng. vol.numb.  ___->___  ___->___
1940701 0.5 3 0. 4
*
*   pipe volume friction data
*   rough. h.diam. vol.numb.
1940801 3.-5 4.654-2 4
*
*   (internal) pipe junction loss coefficients [opt.]
*   loss.c. rev.loss.c. jun.numb.
1940901 0. 0. 3
*
*   pipe volume control flags
*   flags vol.numb.  ___->___  ___->___
1941001 00 4
*
*   pipe junction control flags
*   flags jun.numb.  ___->___
1941101 00100 3
*
*   pipe volume initial conditions
*   ctrl. w4 or 0. -> -> vol.numb.
*
1941201 103 12.52+6 538. 0. 0. 0. 4
*
*   pipe junction conditions control word [opt.]
*   ctrl. [ or 0 -> w1,w2 of 19413..=ini.vel.]
1941300 T
*
*   pipe junction initial conditions
*   ini.f.flw. ini.g.flw. intrf.vel. jun.numb.
*
1941301 4.73 0. 0. 3
***
=====
* cold leg - part with eccs and prz spray line connections
*
=====
*
*   component name and type
*   comp.name comp.type
1960000 cl-con branch
*
*
*   branch information card
*   numb.of.jun. ctrl. [ or 0 -> w1,w2 of cccn2..=ini.vel.]
1960001 3 1
*
*   branch volume geometry cards
*   area length vol. az.ang. inc.ang. elv.chng.
1960101 1.7-3 0.561 0. 0. 0. 0.
*
*   rough. h.diam. flags
1960102 3.-5 4.654-2 00
*
*   branch volume initial conditions
*   ctrl. (p) (temp) bor.con.[if]

```

```

*
* -----
1960200 103 12.52+6 538.
*
* branch junction geometry cards
* from to area loss.c. rev.loss.c. flags
1961101 194040002 196010001 0. 0.1 0.1 00100
*
1962101 196010002 198010001 0. 0.1 0.1 00100
*
1963101 196010002 440010001 0. 2.2 2.2 00102
*
* branch junction initial conditions [according to 1960001]
* ini.f.flw. ini.g.flw. interf.vel.
*
1961201 4.73 0. 0.
*
1962201 4.73 0. 0.
*
1963201 0. 0. 0.
***
=====
* cold leg - last part
*
=====
*
* component name and type
* comp.name comp.type
1980000 cl-end pipe
*
* pipe information card
* numb.of.vol.
1980001 2
*
* pipe volume flow areas
* area vol.num. ____-> ____ -> ____
1980101 1.7-3 2
*
* pipe volume lengths
* lengh vol.num. ____-> ____ -> ____
1980301 0.56 2
*
* pipe volume volumes
* vol. vol.num. ____-> ____ -> ____
1980401 0. 2
*
* pipe volume vertical angles
* inc.ang. vol.num. ____-> ____ -> ____
1980601 0. 2
*
* pipe volume elevation change [opt.]
* elev.chng. vol.num. ____-> ____ -> ____
1980701
*
* pipe volume friction data
* rough. h.diam. vol.num.
1980801 3.-5 4.654-2 2
*
* (internal) pipe junction loss coefficients [opt.]
* loss.c. rev.loss.c. jun.num.
1980901 0. 0. 1
*
* pipe volume control flags
* flags vol.num. ____-> ____ -> ____
1981001 00 2
*
* pipe junction control flags
* flags jun.num. ____-> ____
1981101 00100 1
*
* pipe volume initial conditions
* ctrl. w4 or 0. -> -> vol.num.
*
* -----

```

```

1981201 103 12.52+6 538. 0. 0. 0. 2
*
* pipe junction conditions control word [opt.]
*   ctrl. [  or 0 -> w1,w2 of 19813..=ini.vel.]
1981300 1
*
* pipe junction initial conditions
*   ini.f.flw. ini.g.flw. intrf.vel. jun.numb.
*
1981301 4.73 0. 0. 1
***
*
*=====
*
* prz= pressurizer
*=====
*
**=====
*
* prz-HL connection
*=====
*
* component name and type
*   comp.name comp.type
4070000 prz-con sngljun
*
* single junction geometry cards
*   from to area loss rev.loss. flgs.
4070101 106060001 410010001 4.15-4 2.55 2.55 00102
*
* single junction initial conditions [w1=0 -> w2,w3=vel.]
*   ctrl ini.f.flw. ini.g.flw. interf.vel.
*
4070201 1 0. 0. 0.
*
*=====
*
* prz-hot leg connection pipe
*=====
*
* component name and type
*   comp.name comp.type
4100000 prz-con pipe
*
* pipe information card
*   numb.of.vol.
4100001 6
*
* pipe volume flow areas
*   area vol.numb. -> ->
4100101 4.15-4 1
4100102 3.80-4 4
4100103 6.61-4 5
4100104 14.7-3 6
*
* pipe volume lengths
*   lengh vol.numb. -> ->
4100301 0.15 1
4100302 0.76 2
4100303 1.57 3
4100304 1.57 4
4100305 0.350 5
4100306 0.250 6
*
* pipe volume volumes
*   vol. vol.numb. -> ->
4100401 0. 6
*
* pipe volume vertical angles
*   inc.ang. vol.numb. -> ->

```

```

4100601 0. 1
4100602 90. 2
4100603 45. 4
4100604 0. 5
4100605 90. 6
*
* pipe volume elevation change [opt.]
* elev.chng. vol.num. ____->____ ____->____
4100701 0. 1
4100702 0.76 2
4100703 1.069 3
4100704 1.069 4
4100705 0.0 5
4100706 0.250 6
*
* pipe volume friction data
* rough. h.diam. vol.num.
4100801 3.-5 0.023 1
4100802 3.-5 0.022 4
4100803 3.-5 0.029 5
4100804 3.-5 0.025 6
*
* (internal) pipe junction loss coefficients [opt.]
* loss.c. rev.loss.c. jun.num.
4100901 0.5 0.5 5
*
* pipe volume control flags
* flags vol.num. ____->____ ____->____
4101001 00 6
*
* pipe junction control flags
* flags jun.num. ____->____
4101101 00100 5
*
* pipe volume initial conditions
* ctrl. w4 or 0. -> -> vol.num.
*
4101201 103 12.45+6 555. 0. 0. 0. 5
4101202 103 12.40+6 599. 0. 0. 0. 6
*
* pipe junction conditions control word [opt.]
* ctrl. [ or 0 -> w1,w2 of 41013..=ini.vel.]
4101300 1
*
* pipe junction initial conditions
* ini.f.flw. ini.g.flw. intrf.vel. jun.num.
*
4101301 0. 0. 0. 5
*
=====
* PRZ surge line - vessel connection
*
=====
*
* component name and type
* comp.name comp.type
4150000 prz-con sngljun
*
* single junction geometry cards
* from to area loss rev.loss. flgs.
4150101 410060002 420010001 0. 0.5 1.0 00100
*
* single junction initial conditions [w1=0 -> w2,w3=vel.]
* ctrl ini.f.flw. ini.g.flw. interf.vel.
*
4150201 1 0. 0. 0.
***
=====
* pressurizer vessel
*
=====

```

```

*
* component name and type
* comp.name comp.type
4200000 prz-ves pipe
*
* pipe information card
* numb.of.vol.
4200001 5
*
* pipe volume flow areas
* area vol.numb. ____-> ____ ____-> ____
4200101 8.01-3 5
*
* pipe volume lengths
* length vol.numb. ____-> ____ ____-> ____
4200301 0.225 1
*
4200302 0.557 2
*
4200303 0.600 4
*
4200304 0.305 5
*
* pipe volume volumes
* vol. vol.numb. ____-> ____ ____-> ____
4200401 0. 5
*
* pipe volume vertical angles
* inc.ang. vol.numb. ____-> ____ ____-> ____
4200601 90. 5
*
* pipe volume friction data
* rough. h.diam. vol.numb.
4200801 3-5 0.101 5
*
* (internal) pipe junction loss coefficients [opt.]
* loss.c. rev.loss.c. jun.numb.
4200901 0. 0. 4
*
* pipe volume control flags
* flags vol.numb. ____-> ____ ____-> ____
4201001 00 5
*
* pipe junction control flags
* flags jun.numb. ____-> ____ ____-> ____
4201101 00100 4
*
* pipe volume initial conditions
* ctrl. (w4 or 0.) vol.numb.
*
4201201 102 12.39+6 0. 0. 0. 0. 1
4201202 102 12.39+6 0. 0. 0. 0. 2
4201203 102 12.39+6 0. 0. 0. 0. 3
4201204 102 12.39+6 0.1 0. 0. 0. 4
4201204 102 12.39+6 1. 0. 0. 0. 5
*
* pipe junction conditions control word [opt.]
* ctrl. [ ] or 0 -> w1,w2 of 42013..=ini.vel.]
4201300 T
*
* pipe junction initial conditions
* ini.f.flw. ini.g.flw. intrf.vel. jun.numb.
*
4201301 0. 0. 0. 4
*
=====
* prz inner connection
*
=====
*
* component name and type
* comp.name comp.type

```

```

4250000 prz-con sngljun
*
* single junction geometry cards
* from to area loss rev.loss. flgs.
4250101 430020002 420010001 0. 0.1 0.1 00100
*
* single junction initial conditions [w1=0 -> w2,w3=vel.]
* ctrl ini.f.flw. ini.g.flw. interf.vel.
4250201 1 0. 0. 0.
***
=====
* pressurizer vessel
* =====
*
* component name and type
* comp.name comp.type
4300000 prz-ves pipe
*
* pipe information card
* numb.of.vol.
4300001 2
*
* pipe volume flow areas
* area vol.num. -> ->
4300101 6.1-3 2
*
* pipe volume lengths
* length vol.num. -> ->
4300301 0.150 1
4300302 0.085 2
*
* pipe volume volumes
* vol. vol.num. -> ->
4300401 0. 2
*
* pipe volume vertical angles
* inc.ang. vol.num. -> ->
4300601 90. 2
*
* pipe volume elevation change [opt.]
* elev.chng. vol.num. -> ->
4300701 0.150 1
4300702 0.085 2
*
* pipe volume friction data
* rough. h.diam. vol.num.
4300801 3.-5 0. 2
*
* (internal) pipe junction loss coefficients [opt.]
* loss.c. rev.loss.c. jun.num.
4300901 0. 0. 1
*
* pipe volume control flags
* flags vol.num. -> ->
4301001 00 2
*
* pipe junction control flags
* flags jun.num. -> ->
4301101 00100 1
*
* pipe volume initial conditions
* ctrl. (w4 or 0.) vol.num.
4301201 102 12.39+6 0. 0. 0. 0. 1
4301202 102 12.39+6 0. 0. 0. 0. 2
*
* pipe junction conditions control word [opt.]
* ctrl. [ or 0 -> w1,w2 of 43013..=ini.vel.]
4301300 1
*

```

```

* pipe junction initial conditions
* ini.f.flw. ini.g.flw. intrf.vel. jun.numb.
*
4301301 0. 0. 0. 1
*
=====
* PRZ spray line
*
=====
*
* component name and type
* comp.name comp.type
4400000 spray-l pipe
*
* pipe information card
* numb.of.vol.
4400001 3
*
* pipe volume flow areas
* area vol.numb. ____-> ____ ____-> ____
4400101 7.85-5 3
*
* (internal) pipe junction flow areas [opt.]
* area jun.numb. ____-> ____
4400201 7.85-5 2
*
* pipe volume lengths
* length vol.numb. ____-> ____ ____-> ____
4400301 1.412 1 3.5 2 0.8 3 ____
*
* pipe volume volumes
* vol. vol.numb. ____-> ____ ____-> ____
4400401 0. 3
*
* pipe volume vertical angles
* inc.ang. vol.numb. ____-> ____ ____-> ____
4400601 90. 3
*
* pipe volume elevation change [opt.]
* elev.chng. vol.numb. ____-> ____ ____-> ____
4400701 1.412 1 3.5 2 0.523 3 ____
*
* pipe volume friction data
* rough. h.diam. vol.numb.
4400801 3-5 0.01 3
*
* (internal) pipe junction loss coefficients [opt.]
* loss.c. rev.loss.c. jun.numb.
4400901 0.1 0.1 1
4400902 0.3 0.3 2
*
* pipe volume control flags
* flags vol.numb. ____-> ____ ____-> ____
4401001 00 3
*
* pipe junction control flags
* flags jun.numb. ____-> ____
4401101 00100 2
*
* pipe volume initial conditions
* ctrl. ____ ____ ____ ____ ____ ____ ____ ____ ____ ____ ____ ____
* w4 or 0. -> -> vol.numb.
4401201 103 12.52+6 534. 0. 0. 0. 3
*
* pipe junction conditions control word [opt.]
* ctrl. [ _ or 0 -> w1,w2 of 44013..=ini.vel.]
4401300 1
*
* pipe junction initial conditions
* ini.f.flw. ini.g.flw. intrf.vel. jun.numb.

```



```

*
4401301 0. 0. 0. 2
*
=====
* prz spray valve
*
=====
*
* component name and type
* comp.name comp.type
4450000 prz-topv valve
*
* valve junction geometry cards
* from to area loss rev.loss flgs.
4450101 440030002 420050002 7.8-5 20. 500. 00100
*
* valve junction initial conditions
* ctrl. ini.f.flw. ini.g.flw. interf.vel.
4450201 1 0. 0. 0.
*
* valve type card
* type
4450300 trpvlv
*
* valve data and initial conditions [according to 4350300]
*
* -----
4450301 501
*
=====
* aux. make-up water
*
=====
*
* component name and type
* comp.name comp.type
4500000 auxwater tmdpvol
*
* time dependent volume geometry cards
* area length vol. az.ang. inc.ang. elv.ch
4500101 8.-3 0.615 0. 0. 90. 0.615
*
* rough. h.diam. flags
4500102 0.3-5 0.101 00
*
* time dependent volume data control word
* ctrl.
4500200 102
*
* time dependent volume cards [according to 4500200 ctrl.]
* var. bor.con.[if]
*
4500201 0. 12.585+6 0.
4500201 0. 7.6+6 0.
***
=====
* aux. make-up water pump - steady state controller
* #####
*
*
* component name and type
* comp.name comp.type
4550000 aux-pump tmdpjun
*
* tmdpjun geometry card
* from to area
4550101 450000000 430010001 6.6-4
*
* tmdpjun control word
* ctrl. trip.num. alph.part num.part
4550200 1 673 cntrivar 400 *opt*= BE

```

4550200 1 418 cntrlvar 400 *opt*= long STDY

*
* tmpdjun data [according to 4550200 ctrl.]
* var. f. g. int.vel.(=0.)
*

4550201 -1.+75 0. 0. 0.
4550202 0. 0. 0. 0.
4550203 7.8 100. 0. 0.
4550204 9.33 0. 0. 0.
4550205 10.26 -100. 0. 0.

4550201 -1.+75 0. 0. 0.
4550202 0. 0. 0. 0.
4550203 7.7 100. 0. 0.
4550204 9.1 0. 0. 0.
4550205 9.7 -100. 0. 0.

=====
* prz relief valve
*
=====

4650000 prz-topv valve

4650101 420050003 460000000 6.6-4 0. 0. 00100
4650101 420050002 460000000 0. 0. 0. 00100
4650101 420050002 460000000 1.77-4 0. 0. 00100
4650101 420050002 460000000 0.785-6 0. 0. 00100
4650101 420040002 460000000 0.785-6 0. 0. 00100

4650201 1 0. 0. 0.
4650300 trpvlv
4650301 644 *opt*= BE (old)
4650301 501 *opt*= Deactivated
4650301 646 *opt*= BE (new)

=====
* prz dump volume
*
=====

* component name and type
* comp.name comp.type
4600000 prz-topv tmpdvol

* time dependent volume geometry cards
* area length vol. az.ang. inc.ang. elv.ch
4600101 0.1 0.615 0. 0. 90. 0.615

* rough. h.diam. flags
4600102 3.-5 0.101 00

* time dependent volume data control word
* ctrl. trip
4600200 102 603

* time dependent volume cards [according to 4600200 ctrl.]
* var. bor.con.[if]

4600201 -1. 1.+5 0.250
4600202 0.0 1.+5 0.250
4600203 1.000 1.+5 0.197
4600204 2.500 1.+5 0.153
4600205 5.000 1.+5 0.124
4600206 8.500 1.+5 0.103
4600207 13.00 1.+5 0.088
4600208 18.00 1.+5 0.080
4600209 23.50 1.+5 0.070
4600210 29.50 1.+5 0.063
4600211 37.00 1.+5 0.056
4600212 44.50 1.+5 0.051
4600213 53.00 1.+5 0.045

4600214	62.00	1.+5	0.041
4600215	72.00	1.+5	0.037
4600216	82.00	1.+5	0.034
4600217	92.00	1.+5	0.029
4600218	102.0	1.+5	0.026
4600219	112.0	1.+5	0.024
4600220	122.0	1.+5	0.020
4600221	132.0	1.+5	0.018
4600222	142.0	1.+5	0.014
4600223	147.5	1.+5	0.000

=====

* artificial prz boundary volume

*(required pressure in upper plenum is 12.65 mpa)

=====

*
 4700000 prz-cntr tmdpvol
 4700101 8.-3 0.615 0. 0. 90. 0.615
 4700102 3.-5 0.101 00
 4700200 102

4700201 0. 12.5957+6 1.

4700201 0. 12.37+6 1.

4700201 0. 12.315+6 1.

4700201 0. 12.315+6 1.

4700202 400. 12.315+6 1.

4700203 500. 7.70+6 1.

4700204 1000. 7.645+6 1.

*
 4750000 prz-topv valve
 4750101 470000000 420050002 0. 0. 0. 00100
 4750201 1 0. 0. 0.
 4750300 trpvlv
 4750301 618

=====

*= Emergency Core Cooling System (ECCS)

=====

* HPIS

=====

8500000 hpis-tv tmdpvol
 8500101 4.5-3 0.34 0. 0. 0. 0.
 8500102 3.-5 7.571-2 00
 8500200 101
 8500201 0. 293. 0.

8550000 hpis-tj tmdpjun
 8550101 850000000 196010001 7.85-5
 8550200 1 606
 8550201 -1. 0. 0. 0.
 8550202 0. 0.028 0. 0.
 8550203 3000. 0.028 0. 0.

** LPIS

=====

8600000 Lpis-tv tmdpvol
8600101 4.5-3 0.34 0. 0. 0. 0.
8600102 3.-5 7.571-2 00
8600200 101
8600201 0. 293. 0.

*
8650000 Lpis-tj tmdpjun
8650101 860000000 012010003 7.85-5

8650200 1 611
8650201 -1. 0. 0. 0.
8650202 0. 0.0432 0. 0.
8650203 3000. 0.0432 0. 0.

8650200 1 611
8650201 -1. 0. 0. 0.
8650202 0. 0.07 0. 0.
8650203 3000. 0.07 0. 0.

*=====

* accumulator no.1 (inserted into downcomer)

*=====

* component name and type
* comp.name comp.type
8100000 accu-1 accum

* volume geometry cards
* area length vol. az.ang. inc.ang. elev.chng.
8100101 3.048-2 2.47 0. 0. 90. 2.47

* roug. h.diam. flgs.
8100102 4.-5 0. 00

* accumulator tank initial thermodynamic conditions
* press. temp. boron
8100200 3.55+6 293. 0.

* accumulator junction geometry cards
* to area loss rev.loss. flgs.
8101101 012010003 7.85-5 15.6 2000. 00001

* accumulator tank initial conditions, standpipe line length/
* elevation and tank wall heat transfer terms
* f.vol. lev. leng. elev. thick. flg. dens. cap. trip
8102200 0. 1.86 5.167 3.15 0.011 0 7800. 620. 607 *opt*= BE

*=====

* accumulator no.2 (inserted into upper plenum)

*=====

* component name and type
* comp.name comp.type
8200000 accu-2 accum

* volume geometry cards
* area length vol. az.ang. inc.ang. elev.chng.
8200101 3.048-2 2.47 0. 0. 90. 2.47

* roug. h.diam. flgs.
8200102 4.-5 0. 00

* accumulator tank initial thermodynamic conditions
* press. temp. boron
8200200 3.56+6 293. 0.

* accumulator junction geometry cards
* to area loss rev.loss. flgs.
8201101 062010002 7.85-5 14.4 2000. 00000

```

*
* accumulator tank initial conditions, standpipe line length/
* elevation and tank wall heat transfer terms
* f.vol. lev. leng. elev. thick. flg. dens. cap. trip
8202200 0. 2.153 4.8 1.75 0.011 0 7800. 620. 608 *opt*= BE
*
*=====
*=====
* auxiliary systems
*=====
*=====
*
*=====
* ambient volumes
*-----
*=====
*
* component name and type
* comp.name comp.type
9800000 amb-room snglvol
*
* single volume geometry cards
* area length vol. az.ang. inc.ang. elv.ch
9800101 100. 10. 0. 0. 0. 0.
*
* rough. h.diam. flags
9800102 3.-5 0. 00
*
* single volume initial conditions
* ctrl. bor.con.[if]
9800200 101 293. 0.
***
*=====
* artificial junction
*-----
*=====
*
* component name and type
* comp.name comp.type
9850000 art-jun tmdpjun
*
* tmdpjun geometry card
* from to area
9850101 980000000 002010001 0.0001
*
* tmdpjun control word
* ctrl. trip.num. alph.part num.part
9850200 1
*
* tmdpjun data [according to 9850200 ctrl.]
* var. f. g. int.vel.(=0.)
*
9850201 0. 0. 0. 0.
*
*=====
*=====
* steam generator - secondary side
*=====
*=====
*
*=====
* feed water source
*-----
*=====
*
5000000 sgs-fwt tmdpvol
5000101 0.01 0.5 0. 0. 0. 0.
5000102 3.-5 7.571-2 00

```

```

5000200 003
5000201 0. 5.0+6 491.4 *opt*
5000201 0. 5.0+6 478.8 *opt*
5000201 0. 5.0+6 390.6 *opt*
*
5020000 sgs-wv-l branch
5020001 1 0
5020101 0.01 0.5 0. 0. 0. 0.
5020102 3.-5 0.04 00
5020200 003 5.0+6 491.8
5021101 500010002 502010001 0. 0.35 0.35 00100
5021201 6.36-2 0.36 0.

```

```

=====
* feedwater pump
*
=====

```

```

* component name and type
* comp.name comp.type
5050000 sgs-fwp tmdpjun
*
* tmdpjun geometry card
* from to area
5050101 502010002 510000000 0.
*
* tmdpjun control word
* ctrl. trip.numb. alph.part num.part
*
5050200 1 634 cntrivar 828
5050201 -1. 0. 0. 0.
5050202 0. 0.11 0. 0.
5050203 8.41 0.11 0. 0.
5050204 8.42 0. 0. 0.
5050205 9. 0. 0. 0.

```

```

=====
* feedwater pump - steady state controller proper level = 8.58m
* ----- ##### 2.25m
*
=====

```

```

5060000 sgs-fwt tmdpv0l
5060101 0.01 0.5 0. 0. 0. 0.
5060102 3.-5 7.571-2 00
*
5060200 002 0 p 532010000
5060201 4.0+6 4.0+6 0.
+ 6.0+6 6.0+6 0.
*
5060200 003
5060201 0. 5.0+6 491.8
*
5060200 003
5060201 0. 5.0+6 390.6

```

```

-----
*
5070000 sgs-fwp tmdpjun
5070101 506000000 532000000 0.
*
5070200 1 627 cntrivar 828 *= Deactivated (zero flow)
5070201 -1. 0. 0. 0.
5070202 0. 0. 0. 0.
5070203 8.62 0. 0. 0.
5070204 8.63 0. 0. 0.
5070205 9.4 0. 0. 0.
*
5070200 1 627 cntrivar 828
5070201 -1. 0. 0. 0.
5070202 0. 5. 0. 0.
5070203 8.41 0.3 0. 0.
5070204 8.42 0. 0. 0.

```

```

5070205 9.4 0. 0. 0.
*
=====
* feedwater pipe
*
=====
*
* component name and type
* comp.name comp.type
5100000 sgs-fwpi branch
*
* branch information card
* numb.of.jun. ctrl. [ or 0 -> w1,w2 of 518n2..=ini.vel.]
5100001 1 1
*
* branch volume geometry cards
* area length vol. az.ang. inc.ang. elv.chng.
5100101 5.-4 3. 0. 0. 90. 3.
*
* rough. h.diam. flags
5100102 3.-5 2.524-2 00
*
* branch volume initial conditions
* ctrl. (p) (temp) bor.con.[if]
5100200 102 4.67+6 0.
*
* branch junction geometry cards
* from to area loss.c. rev.loss.c. flags
5101101 510010002 532010002 5.-4 0.2 2.0 00100
*
* branch junction initial conditions [according to 5180001]
* ini.f.flw. ini.g.flw. interf.vel.
5101201 0.377 0. 0.
***
=====
* sg water volume - lower part
*
=====
*
* component name and type
* comp.name comp.type
5220000 sgs-wv-l branch
*
* branch information card
* numb.of.jun. ctrl. [ or 0 -> w1,w2 of 522n2..=ini.vel.]
5220001 1 0
*
* branch volume geometry cards
* area length vol. az.ang. inc.ang. elv.chng.
5220101 0.108 0.61 0. 0. 90. 0.61
*
* rough. h.diam. flags
5220102 3.-5 0.04 00100
*
* branch volume initial conditions
* ctrl. (p) (quale) bor.con.[if]
5220200 102 4.67+6 2.44-3
*
* branch junction geometry cards
* from to area loss.c. rev.loss.c. flags
5221101 522010002 524010001 0. 0.35 0.35 00100
*
* branch junction initial conditions [according to 5220001]
* ini.f.vel. ini.g.vel. interf.vel.
5221201 6.36-2 0.36 0.
***
=====
* sg water volume - middle part

```

```

* -----
* =====
*
* component name and type
* comp.name comp.type
5240000 sgs-wv-m branch
*
* branch information card
* numb.of.jun. ctrl. [ or 0 -> w1,w2 of 524n2..=ini.vel.]
5240001 1 0
*
* branch volume geometry cards
* area length vol. az.ang. inc.ang. elv.chng.
5240101 0.108 0.61 0. 0. 90. 0.61
*
* rough. h.diam. flags
5240102 3.-5 0.04 00100
*
* branch volume initial conditions
* ctrl. (p) (quale) bor.con.[if]
5240200 102 4.67+6 8.40-3
*
* branch junction geometry cards
* from to area loss.c. rev.loss.c. flags
5241101 524010002 526010001 0. 0.35 0.35 00100
*
* branch junction initial conditions [according to 5240001]
* ini.f.vel. ini.g.vel. interf.vel.
5241201 9.55-2 0.35 0.
***
* =====
* sg water volume - lower part
* -----
* =====
*
* component name and type
* comp.name comp.type
5260000 sgs-wv-u branch
*
* branch information card
* numb.of.jun. ctrl. [ or 0 -> w1,w2 of 526n2..=ini.vel.]
5260001 0 1
*
* branch volume geometry cards
* area length vol. az.ang. inc.ang. elv.chng.
5260101 0.108 0.61 0. 0. 90. 0.61
*
* rough. h.diam. flags
5260102 3.-5 0.04 00100
*
* branch volume initial conditions
* ctrl. (p) (quale) bor.con.[if]
5260200 102 4.67+6 9.35-3
*
* branch junction geometry cards
* from to area loss.c. rev.loss.c. flags
*
* branch junction initial conditions [according to 5260001]
* ini.f.vel. ini.g.vel. interf.vel.
*
* =====
* SG volume above TB
* -----
* =====
*
5280000 sgs-wv-u branch
5280001 1 1
5280101 0.108 0.2 0. 0. 90. 0.2

```



```

5280102 3.-5 0.04 00100
5280200 102 4.67+6 9.35-3
5281101 526010002 528010001 0. 0.35 0.35 00100
5281201 9.55-2 0.35 0.

```

```

*=====
* SG volume above DC
*=====

```

```

*
5380000 sgs-wv-u branch
5380001 1 1
5380101 0.066 0.2 0. 0. -90. -0.2
5380102 3.-5 0.04 00100
5380200 102 4.67+6 9.35-3
5381101 538010002 536010001 0. 0.35 0.35 00100
5381201 9.55-2 0.35 0.

```

```

*=====
* sg downcomer - upper part
*=====

```

```

*
* component name and type
* comp.name comp.type
5360000 sgs-down branch
*
* branch information card
* numb.of.jun. ctrl. [ or 0 -> w1,w2 of 536n2..=ini.vel.]
5360001 2 0
*
* branch volume geometry cards
* area length vol. az.ang. inc.ang. elv.chng.
5360101 0.054 0.61 0. 0. -90. -0.61
*
* rough. h.diam. flags
5360102 3.-5 0. 00
*
* branch volume initial conditions
* ctrl. (p) bor.con.[if]
5360200 102 4.67+6 7.66-3
*
* branch junction geometry cards
* from to area loss.c. rev.loss.c. flags
5361101 536010002 534010001 0. 0.3 1.02 00100
*
5362101 536010003 526010003 0.486 16. 16. 00003
*
* branch junction initial conditions [according to 5360001]
* ini.f.vel. ini.g.vel. interf.vel.
5361201 0.65 0.45 0.
*
5362201 -1.6-2 -2.5-2 0.

```

```

*=====
* sg downcomer - middle part
*=====

```

```

*
* component name and type
* comp.name comp.type
5340000 sgs-down branch
*
* branch information card
* numb.of.jun. ctrl. [ or 0 -> w1,w2 of 534n2..=ini.vel.]
5340001 2 0
*
* branch volume geometry cards
* area length vol. az.ang. inc.ang. elv.chng.
5340101 0.054 0.61 0. 0. -90. -0.61

```

```

*
*   rough. h.diam. flags
5340102 3.-5 0. 00
*
*   branch volume initial conditions
*   ctrl. (p)          bor.con.[if]
*
5340200 102 4.67+6 7.69-3
*
*   branch junction geometry cards
*   from to area loss.c. rev.loss.c. flags
5341101 534010002 532010001 0. 0.3 1.02 00100
*
5342101 534010003 524010003 0.496 14. 14. 00003
*
*   branch junction initial conditions [according to 5340001]
*   ini.f.vel. ini.g.vel. interf.vel.
*
5341201 0.50 0.18 0.
*
5342201 6.3-3 1.04-2 0.
*
=====
* sg downcomer - lower part
* -----
*
*   component name and type
*   comp.name comp.type
5320000 sgs-down branch
*
*   branch information card
*   numb.of.jun. ctrl. [ or 0 -> w1,w2 of 532n2..=ini.vel.]
5320001 2 0
*
*   branch volume geometry cards
*   area length vol. az.ang. inc.ang. elv.chng.
5320101 0.054 0.61 0. 0. -90. -0.61
*
*   rough. h.diam. flags
5320102 3.-5 0. 00
*
*   branch volume initial conditions
*   ctrl. (p) (temp)          bor.con.[if]
*
5320200 102 4.67+6 2.91-3
*
*   branch junction geometry cards
*   from to area loss.c. rev.loss.c. flags
5321101 532010002 522010001 0. 0.3 1.02 00100
*
5322101 532010003 522010003 0.596 12. 12. 00003
*
*   branch junction initial conditions [according to 5320001]
*   ini.f.vel. ini.g.vel. interf.vel.
*
5321201 0.75 0.74 0.
*
5322201 -9.7-3 -1.7-2 0.
*
=====
* sg separator part
* -----
*
*   component name and type
*   comp.name comp.type
5440000 sgs-sep separatr
5440000 sgs-sep branch
*
*   separator information card
*   numb.of.jun. ctrl. [ or 0 -> w1,w2 of 544n2..=ini.vel.]

```

```

5440001 3      0
*
* separator volume geometry cards
* area length vol. az.ang. inc.ang. elv.chng.
5440101 0.174 0.195 0. 0. 90. 0.195
*
* rough. h.diam. flags
5440102 3.5 0.4373 00
*
* separator volume initial conditions
* ctrl. (p) (quale) bor.con.[if]
*
5440200 102 4.67+6 2.10-2
*
* separator junction geometry cards
* from to area loss rev.loss flags w7
5441101 544010002 546010001 0. 0.35 0.35 00000 *0.5
*
5442101 544010001 538010001 0. 0.35 0.35 00000 *0.15
*
5443101 528010002 544010001 0. 0.35 0.35 00000
*
* separator junction initial conditions [according to 5440001]
* ini.f.vel. ini.g.vel. interf.vel.
*
5441201 1.8-3 1.10 0.
*
5442201 0.38 -.25 0.
*
5443201 4.1-2 0.41 0.
***
*=====
* sg steam volume - middle part
*=====
*
5460000 spray-l pipe
5460001 2
5460101 3.05-2 2
5460301 0.38 1 0.385 2
5460401 0. 2
5460601 90. 2
5460801 3.5 0.198 2
5460901 0.1 0.1 1
5461001 00000 2
5461101 00100 1
5461201 102 4.67+6 2.92-2 0. 0. 0. 2
5461300 1
5461301 0. 1.02 0. 1
*
*=====
* sg steam volume - top part
*=====
*
5480000 sgs-s-t branch
5480001 1 0
5480101 3.05-2 0.228 0. 0. 90. 0.228
5480102 3.5 0. 00
5480200 102 4.67+6 0.99
5481101 546020002 548010001 0. 0. 0. 00100
5481201 1.9-3 1.02 0.
*
*
*
*=====
* secondary side - steam part
*=====
*=====

```

```

=====
*
=====
* steam line valve
*
=====
*
* component name and type
* comp.name comp.type
5550000 ss-sl-va valve
*
* valve junction geometry cards
* from to area loss rev.loss flgs.
5550101 548010002 558000000 4.5-5 0. 0. 00100
5550101 548010002 558000000 4.6-3 0. 0. 00100
5550101 548010001 558000000 4.6-3 0. 0. 00100
*
* valve junction initial conditions
* ctrl. ini.f.vel. ini.g.vel. interf.vel.
5550201 0 0.26 0.46 0.
*
* valve type card
* type
5550300 mtrvlv
*
* valve data and initial conditions [according to 5550300]
* open close rate ini
5550301 501 631 0.25 1.
***
=====
* steam line boundary
*
=====
*
* component name and type
* comp.name comp.type
5580000 ss-sl-tv tmdpvol
*
* time dependent volume geometry cards
* area length vol. az.ang. inc.ang. elv.ch
5580101 0.1 0.34 0. 0. 0. 0.
*
* rough. h.diam. flags
5580102 3.-5 7.571-2 00
*
* time dependent volume data control word
* ctrl. trip
5580200 102
*
* time dependent volume cards [according to 5580200 ctrl.]
* var. bor.con.[if]
5580201 0. 4.79973+6 1.
5580202 200. 4.79973+6 1.
5580203 400. 3.8+6 1.
5580204 800. 3.8+6 1.
5580205 1000. 3.34+6 1.
=====
* MSS relief valve
*
=====
*
5850000 sec-RV valve
5850101 548010002 588000000 0.1257-4 0.5 0.5 00100 *= D4mm
5850102 1.0 1.0
5850201 1 0. 0. 0.
5850300 mtrvlv
5850301 625 629 0.435 0. *= opening time 2.3 s (closing 1.9 s)

```

```

*
*
*
5880000 ss-savab tmdpvol
5880101 4.5-3 0.34 0. 0. 0.
5880102 3.-5 7.571-2 00
5880200 102
5880201 0. 1.0+5 1.
*
*
=====
*
* break simulation
*
=====
*
*
*
=====
*
* break valve cross-connection
*
=====
*
*
9350000 breakvlv valve
9350101 012010002 938000000 7.0686e-6 0.0 0.0 00102
9350102 1.15 0.14
9350201 1 0.0 0.0 0.0
9350300 trpvlv
9350301 666
*
*
=====
*
* break boundary volume
*
=====
*
*
9380000 containm tmdpvol
9380101 1.666-3 0.348 0.000 0.000 0.000 0.000
9380102 .3000e-4 4.6-2 00
9380200 102 601
9380201 -1.0 1.0e+5 1.000
9380202 0.0 0.5e6 1.000
9380203 3.0 0.7e6 1.000
9380204 7.0 0.7e6 1.000
9380205 10.0 0.68e6 1.000
9380206 20.0 0.53e6 1.000
9380207 30.0 0.39e6 1.000
9380208 50.0 0.37e6 1.000
9380209 100.0 0.36e6 1.000
9380210 150.0 0.40e6 1.000
9380211 210.0 0.38e6 1.000
9380212 220.0 0.22e6 1.000
9380213 400.0 0.20e6 1.000
9380214 410.0 0.12e6 1.000
9380215 996.0 0.12e6 1.000
*
*
*
#####
*#heat structures
#####
*
*
=====
*
* downcomer top - upper plate
*
=====
*
*
*
* general hs data
* ax.str. rd.mesh gm.type ini.fl. lft.bnd. 3*refl.w[opt]
10080000 1 4 1 1 0.0
*
*
*
* hs mesh flags
* mesh.loc.flg. mesh.form.flg.

```

```

10080100 0      1
*
*   hs mesh interval data (format 1 is used)
*   numb.of.int.  rght.coor. --->.....
10080101 3      40.0e-3
*
*   hs composition data
*   compos.  int.numb. --->.....
10080201 1      3
*
*   hs source distribution data
*   format 1 [if w1 of 1cccg100=0.]
*   gam.a.c. mesh.int.numb. --->.....
10080301 0.0    3
*
*   initial temperature data [according to 1cccg400]
*   temp.
*   ----
10080401 530.0  4
*
*   left boundary condition cards
*   bnd.vol. incr. type  ar.code area  hsnumb.
10080501 008010000 0    1    1    2.1-2  1
*
*   right boundary condition cards
*   " " " " " " " " " "
10080601 980010000 0    3933  1    2.1-2  1
*
*   source data cards
*   type multipl. dir.heat.for.lft.bnd. for.right heat.str.numb.
10080701 0      0.0    0.0    0.0    1
*
*   additional left boundary cards
*   flgs. ht.trn.h.diam. heated.eq.diam. length ht.str.numb.
10080801 0      0.0    0.0    0.0    1
*
**
*   lf.h.dh. heated.lengths grid.lengths grid.losses boil.f. HS.no.
*   w1  w2  w3  w4  w5  w6  w7  w8  w9
10080801 0.   10.  10.  0.   0.   0.   0.   1.   1
*
*=====
*   downcomer top - cylinder
*=====
*
*   general hs data
*   ax.str. rd.mesh gm.type ini.fl. lft.bnd. 3*refl.w[opt]
10100000 2      4      2      1      80.0e-3
*
*   hs mesh flags
*   mesh.loc.flg. mesh.form.flg.
10100100 0      1
*
*   hs mesh interval data (format 1 is used)
*   numb.of.int.  rght.coor. --->.....
10100101 3      130.0e-3
*
*   hs composition data
*   compos.  int.numb. --->.....
10100201 1      3
*
*   hs source distribution data
*   format 1 [if w1 of 1cccg100=0.]
*   gam.a.c. mesh.int.numb. --->.....
10100301 0.0    3
*
*   initial temperature data [according to 1cccg400]
*   temp.
*   ----
10100401 560.0  4
*

```

```

* left boundary condition cards
* bnd.vol. incr. type ar.code area hsnumb.
10100501 008010000 0 1 1 0.112 1 *(200)+hattu

```

```

10100502 012010000 0 1 1 0.116 2

```

```

* right boundary condition cards
* _ _ _ _ _
10100601 980010000 0 3933 1 0.112 1

```

```

10100602 980010000 0 3933 1 0.116 2

```

```

* source data cards
* type multipl. dir.heat.for.lft.bnd. for.right heat.str.numb.
10100701 0 0.0 0.0 0.0 2

```

```

* additional left boundary cards
* flgs. ht.trn.h.diam. heated.eq.diam. length ht.str.numb.
10100801 0 0.0 0.0 0.0 2

```

```

**
* lf.h.dh. heated.lengths grid.lengths grid.losses boil.f. HS.no.
* w1 w2 w3 w4 w5 w6 w7 w8 w9
10100801 0. 10. 10. 0. 0. 0. 0. 1. 2

```

```

=====
* downcomer
=====

```

```

* general hs data
* ax.str. rd.mesh gm.type ini.fl. lft.bnd. 3*refl.w[opt]
10140000 8 4 2 1 36.5e-3

```

```

* hs mesh flags
* mesh.loc.flg. mesh.form.flg.
10140100 0 1

```

```

* hs mesh interval data (format 1 is used)
* numb.of.int. rght.coor. --->.....
10140101 3 44.5e-3

```

```

* hs composition data
* compos. int.numb. --->.....
10140201 1 3

```

```

* hs source distribution data
* format 1 [if w1 of 1cccg100=0.]
* gam.a.c. mesh.int.numb. --->.....
10140301 0.0 3

```

```

* initial temperature data [according to 1cccg400]
* temp.
* ----
10140401 560.0 4

```

```

* left boundary condition cards
* bnd.vol. incr. type ar.code area hsnumb.
10140501 014010000 10000 1 1 0.5225 8

```

```

* right boundary condition cards
* _ _ _ _ _
10140601 980010000 0 3933 1 0.5225 8

```

```

* source data cards
* type multipl. dir.heat.for.lft.bnd. for.right heat.str.numb.
10140701 0 0.0 0.0 0.0 8

```

```

* additional left boundary cards
* flgs. ht.trn.h.diam. heated.eq.diam. length ht.str.numb.
10140801 0 0.0 0.0 0.0 8

```

```

**
*   If.h.dh. heated.lengths grid.lengths grid.losses boil.f. HS.no.
*   w1   w2   w3   w4   w5   w6   w7   w8   w9
10140801 0.   10.  10.  0.   0.   0.   0.   1.   8
*
*=====
*   downcomer bottom
*=====
*
*   general hs data
*   ax.str. rd.mesh gm.type ini.fl. lft.bnd. 3*refl.w[opt]
10180000 1   4   2   1   23.0e-3
*
*   hs mesh flags
*   mesh.loc.flg. mesh.form.flg.
10180100 1000
*
*   initial temperature flag
*   ini.temp.flg.
10180400 1000
*
*   left boundary condition cards
*   bnd.vol. incr. type ar.code area hsnumb.
10180501 018010000 0   1   1   0.836 1
*
*   right boundary condition cards
*   " " " " " " " " " "
10180601 980010000 0   3933 1   0.836 1
*
*   source data cards
*   type multipl. dir.heat.for.lft.bnd. for.right heat.str.numb.
10180701 0   0.0  0.0  0.0  0.0  1
*
*   additional left boundary cards
*   flgs. ht.trn.h.diam. heated.eq.diam. length ht.str.numb.
10180801 0   0.0  0.0  0.0  0.0  1
**
*   If.h.dh. heated.lengths grid.lengths grid.losses boil.f. HS.no.
*   w1   w2   w3   w4   w5   w6   w7   w8   w9
10180801 0.   10.  10.  0.   0.   0.   0.   1.   1
*
*=====
*   lower plenum - bottom plate
*=====
*
*   general hs data
*   ax.str. rd.mesh gm.type ini.fl. lft.bnd. 3*refl.w[opt]
10020000 1   4   1   1   0.0
*
*   hs mesh flags
*   mesh.loc.flg. mesh.form.flg.
10020100 0   1
*
*   hs mesh interval data (format 1 is used)
*   numb.of.int. rght.coor. --->.....
10020101 3   15.0e-3
*
*   hs composition data
*   compos. int.numb. --->.....
10020201 1   3
*
*   hs source distribution data
*   format 1 [if w1 of 1cccg100=0.]
*   gam.a.c. mesh.int.numb. --->.....
10020301 0.0  3
*
*   initial temperature data [according to 1cccg400]
*   temp.
*   ---

```



```

10020401 530.0 4
*
* left boundary condition cards
* bnd.vol. incr. type ar.code area hsnumb.
10020501 002010000 0 1 1 9.5-3 1
*
* right boundary condition cards
* _ _ _ _ _ _ _ _
10020601 980010000 0 3930 1 9.5-3 1
*
* source data cards
* type multipl. dir.heat.for.lft.bnd. for.right heat.str.numb.
10020701 0 0.0 0.0 0.0 1
*
* additional left boundary cards
* flgs. ht.trn.h.diam. heated.eq.diam. length ht.str.numb.
10020801 0 0.0 0.0 0.0 1
**
* lf.h.dh. heated.lengths grid.lengths grid.losses boil.f. HS.no.
* w1 w2 w3 w4 w5 w6 w7 w8 w9
10020801 0. 10. 10. 0. 0. 0. 0. 1. 1
*
=====
* lower plenum
=====
*
*
* general hs data
* ax.str. rd.mesh gm.type ini.fl. lft.bnd. 3*refl.w[opt]
10220000 2 4 2 1 50.5e-3
*
* hs mesh flags
* mesh.loc.flg. mesh.form.flg.
10220100 0 1
*
* hs mesh interval data (format 1 is used)
* numb.of.int. right.coor. --->.....
10220101 3 157.0e-3
*
* hs composition data
* compos. int.numb. --->.....
10220201 1 3
*
* hs source distribution data
* format 1 [if w1 of 1cccg100=0.]
* gam.a.c. mesh.int.numb. --->.....
10220301 0.0 3
*
* initial temperature data [according to 1cccg400]
* temp.
* ----
10220401 560.0 4
*
* left boundary condition cards
* bnd.vol. incr. type ar.code area hsnumb.
10220501 002010000 0 1 1 0.190 1
10220502 024010000 0 1 1 0.190 2
*
* right boundary condition cards
* _ _ _ _ _ _ _ _
10220601 980010000 0 3930 1 0.190 2
*
* source data cards
* type multipl. dir.heat.for.lft.bnd. for.right heat.str.numb.
10220701 0 0.0 0.0 0.0 2
*
* additional left boundary cards
* flgs. ht.trn.h.diam. heated.eq.diam. length ht.str.numb.
10220801 0 0.0 0.0 0.0 2
*

```

```

**
*   lf.h.dh. heated.lengths grid.lengths grid.losses boil.f. HS.no.
*   w1   w2   w3   w4   w5   w6   w7   w8   w9
10220801 0.   10.  10.  0.   0.   0.   0.   1.   2

```

```

=====
*   core barrel
=====

```

```

*   general hs data
*   ax.str. rd.mesh gm.type ini.fl. lft.bnd. 3*refl.w[opt]
10260000 8   7   2   1   30.0e-3

```

```

*   hs mesh flags
*   mesh.loc.flg. mesh.form.flg.
10260100 0   1

```

```

*   hs mesh interval data (format 1 is used)
*   numb.of.int. rght.coor. --->.....
10260101 3   100.0e-3
10260102 3   133.0e-3

```

```

*   hs composition data
*   compos. int.numb. --->.....
10260201 2   3
10260202 1   6

```

```

*   hs source distribution data
*   format 1 [if w1 of 1cccg100=0.]
*   gam.a.c. mesh.int.numb. --->.....
10260301 0.0   6

```

```

*   initial temperature data [according to 1cccg400]
*   temp.
*   ----
10260401 560.0   7

```

```

*   left boundary condition cards
*   bnd.vol. incr. type ar.code area hsnumb.
10260501 026010000 0   1   1   0.340 1
10260502 026020000 0   1   1   0.340 2
10260503 044010000 0   1   1   0.500 3
10260504 044020000 0   1   1   0.500 4
10260505 044030000 0   1   1   0.500 5
10260506 044040000 0   1   1   0.500 6
10260507 044050000 0   1   1   0.250 7
10260508 044060000 0   1   1   0.250 8

```

```

*   right boundary condition cards
*   " " " " " " " "
10260601 980010000 0   3930 1   0.340 1
10260602 980010000 0   3930 1   0.340 2
10260603 980010000 0   3930 1   0.500 3
10260604 980010000 0   3930 1   0.500 4
10260605 980010000 0   3930 1   0.500 5
10260606 980010000 0   3930 1   0.500 6
10260607 980010000 0   3930 1   0.250 7
10260608 980010000 0   3930 1   0.250 8

```

```

*   source data cards
*   type multipl. dir.heat.for.lft.bnd. for.right heat.str.numb.
10260701 0   0.0   0.0   0.0   8

```

```

*   additional left boundary cards
*   flgs. ht.trn.h.diam. heated.eq.diam. length ht.str.numb.
10260801 0   0.0   0.0   0.0   8

```

```

**
*   lf.h.dh. heated.lengths grid.lengths grid.losses boil.f. HS.no.
*   w1   w2   w3   w4   w5   w6   w7   w8   w9
10260801 0.   10.  10.  0.   0.   0.   0.   1.   8

```

```

*
*=====
*   core simulator
*=====
*
*
*   general hs data
*   ax.str. rd.mesh gm.type ini.fl. lft.bnd. 3*refl.w[opt]
10440000 6   4   2   1   3.55e-3
*
*   hs mesh flags
*   mesh.loc.flg. mesh.form.flg.
10440100 0   1
*
*   hs mesh interval data (format 1 is used)
*   numb.of.int. rght.coor. --->.....
10440101 3   4.550e-3
*
*   hs composition data
*   compos. int.numb. --->.....
10440201 1   3
*
*   hs source distribution data
*   format 1 [if w1 of 1cccg100=0.]
*   gam.a.c. mesh.int.numb. --->.....
10440301 1.0 3
*
*   initial temperature data [according to 1cccg400]
*   temp.
*   ----
10440401 575.0 4
*
*   left boundary condition cards
*   bnd.vol. incr. type ar.code area hsnumb.
10440501 0   0   0   1   9.5   4
10440502 0   0   0   1   4.75  6
*
*   right boundary condition cards
*   " " " " " " " " " "
10440601 044010000 10000 1   1   9.5   4
10440602 044050000 10000 1   1   4.75  6
*
*   source data cards
*   type multipl. dir.heat.for.lft.bnd. for.right heat.str.numb.
10440701 10095 0.2 0.0 0.0 1
10440702 10095 0.2 0.0 0.0 2
10440703 10095 0.2 0.0 0.0 3
10440704 10095 0.2 0.0 0.0 4
10440705 10095 0.1 0.0 0.0 5
10440706 10095 0.1 0.0 0.0 6
*
*   additional right boundary cards
*   " " " " " " " "
10440901 0   8.6e-3 0.0 0.0 6
**
*   rg.h.dh. heated.lengths grid.lengths grid.losses boil.f. HS.no.
*   w1 w2 w3 w4 w5 w6 w7 w8 w9
10440901 0. 10. 10. 0. 0. 0. 0. 1. 6
*
*=====
*   upper plenum - core outlet
*=====
*
*
*   general hs data
*   ax.str. rd.mesh gm.type ini.fl. lft.bnd. 3*refl.w[opt]
10520000 2   4   2   1   50.5e-3
*
*   hs mesh flags
*   mesh.loc.flg. mesh.form.flg.
10520100 0   1

```

```

*
*   hs mesh interval data (format 1 is used)
*   numb.of.int.  rght.coor. --->.....
10520101 3      157.0e-3
*
*   hs composition data
*   compos.  int.numb. --->.....
10520201 1      3
*
*   hs source distribution data
*   format 1 [if w1 of 1cccg100=0.]
*   gam.a.c.  mesh.int.numb. --->.....
10520301 0.0    3
*
*   initial temperature data [according to 1cccg400]
*   temp.
*   ----
10520401 560.0  4
*
*   left boundary condition cards
*   bnd.vol.  incr.  type  ar.code  area  hsnumb.
10520501 052010000 0      1      1      0.26  1
10520502 052020000 0      1      1      0.19  2
*
*   right boundary condition cards
*   _" _" _" _" _" _"
10520601 980010000 0      3930  1      0.26  1
10520602 980010000 0      3930  1      0.19  2
*
*   source data cards
*   type  multipl.  dir.heat.for.lft.bnd.  for.right  heat.str.numb.
10520701 0      0.0  0.0  0.0  2
*
*   additional left boundary cards
*   flgs.  ht.tn.h.diam.  heated.eq.diam.  length  ht.str.numb.
10520801 0      0.0  0.0  0.0  2
*
**
*   lf.h.dh.  heated.lengths  grid.lengths  grid.losses  boil.f.  HS.no.
*   w1  w2  w3  w4  w5  w6  w7  w8  w9
10520801 0.  10.  10.  0.  0.  0.  0.  1.  2
*
=====
*   upper plenum  u-pipes
=====
*
*   general hs data
*   ax.str.  rd.mesh  gm.type  ini.fl.  lft.bnd.  3*refl.w[opt]
10540000 6      4      2      1      23.0e-3
*
*   hs mesh flags
*   mesh.loc.flg.  mesh.form.flg.
10540100 1000
*
*   initial temperature flag
*   ini.temp.flg.
10540400 1000
*
*   left boundary condition cards
*   bnd.vol.  incr.  type  ar.code  area  hsnumb.
10540501 054010000 10000  1      1      0.212  2
10540502 054030000 10000  1      1      0.455  4
10540503 054050000 10000  1      1      0.212  6
*
*   right boundary condition cards
*   _" _" _" _" _" _"
10540601 980010000 0      3930  1      0.212  2
10540602 980010000 0      3930  1      0.455  4
10540603 980010000 0      3930  1      0.212  6
*
*   source data cards

```

```

*      type multipl. dir.heat.for.lft.bnd. for.right heat.str.numb.
10540701 0      0.0  0.0  0.0  0.0  6
*
*      additional left boundary cards
*      flgs. ht.trn.h.diam. heated.eq.diam. length ht.str.numb.
10540801 0      0.0  0.0  0.0  0.0  6
**
*      lf.h.dh. heated.lengths grid.lengths grid.losses boil.f. HS.no.
*      w1   w2   w3   w4   w5   w6   w7   w8   w9
10540801 0.    10.  10.  0.   0.   0.   0.   1.   6
*
*=====
*      upper plenum  bottom part
*=====
*
*
*      general hs data
*      ax.str. rd.mesh gm.type ini.fl. lft.bnd. 3*refl.w[opt]
10560000 2      4      2      1      36.5e-3
*
*      hs mesh flags
*      mesh.loc.flg. mesh.form.flg.
10560100 0      1
*
*      hs mesh interval data (format 1 is used)
*      numb.of.int. rght.coor. --->.....
10560101 3      127.0e-3
*
*      hs composition data
*      compos. int.numb. --->.....
10560201 1      3
*
*      hs source distribution data
*      format 1 [if w1 of 1cccg100=0.]
*      gam.a.c. mesh.int.numb. --->.....
10560301 0.0    3
*
*      initial temperature data [according to 1cccg400]
*      temp.
*      ----
10560401 560.0  4
*
*      left boundary condition cards
*      bnd.vol. incr. type ar.code area hsnumb.
10560501 058010000 10000 1      1      0.170  2
*
*      right boundary condition cards
*      "_  "_  "_  "_  "_  "_
10560601 980010000 0      3930  1      0.170  2
*
*      source data cards
*      type multipl. dir.heat.for.lft.bnd. for.right heat.str.numb.
10560701 0      0.0  0.0  0.0  0.0  2
*
*      additional left boundary cards
*      flgs. ht.trn.h.diam. heated.eq.diam. length ht.str.numb.
10560801 0      0.0  0.0  0.0  0.0  2
**
*      lf.h.dh. heated.lengths grid.lengths grid.losses boil.f. HS.no.
*      w1   w2   w3   w4   w5   w6   w7   w8   w9
10560801 0.    10.  10.  0.   0.   0.   0.   1.   2
*
*=====
*      upper plenum  tube 57x5.5 mm
*=====
*
*
*      general hs data
*      ax.str. rd.mesh gm.type ini.fl. lft.bnd. 3*refl.w[opt]
10600000 2      4      2      1      23.0e-3

```

```

*
*   hs mesh flags
*   mesh.loc.flg. mesh.form.flg.
10600100 0      1
*
*   hs mesh interval data (format 1 is used)
*   numb.of.int. rght.coor. --->.....
10600101 3      28.5e-3
*
*   hs composition data
*   compos. int.numb. --->.....
10600201 1      3
*
*   hs source distribution data
*   format 1 [if w1 of 1cccg100=0.]
*   gam.a.c. mesh.int.numb. --->.....
10600301 0.0    3
*
*   initial temperature data [according to 1cccg400]
*   temp.
*   ----
10600401 560.0  4
*
*   left boundary condition cards
*   bnd.vol. incr. type ar.code area hsnumb.
10600501 060010000 10000 1 1 0.5 2
*
*   right boundary condition cards
*   " " " " " " " " " "
10600601 980010000 0 3930 1 0.5 2
*
*   source data cards
*   type multipl. dir.heat.for.lft.bnd. for.right heat.str.numb.
10600701 0 0.0 0.0 0.0 2
*
*   additional left boundary cards
*   flgs. ht.trn.h.diam. heated.eq.diam. length ht.str.numb.
10600801 0 0.0 0.0 0.0 2
*
**
*   If.h.dh. heated.lengths grid.lengths grid.losses boil.f. HS.no.
*   w1 w2 w3 w4 w5 w6 w7 w8 w9
10600801 0. 10. 10. 0. 0. 0. 0. 1. 2
*
*=====
*   upper plenum tube Di=73 mm
*=====
*
*
*   general hs data
*   ax.str. rd.mesh gm.type ini.fl. lft.bnd. 3*refl.w[opt]
10610000 1 4 2 1 36.5e-3
*
*   hs mesh flags
*   mesh.loc.flg. mesh.form.flg.
10610100 0      1
*
*   hs mesh interval data (format 1 is used)
*   numb.of.int. rght.coor. --->.....
10610101 3      56.5e-3 *= estimate incl. flange
*
*   hs composition data
*   compos. int.numb. --->.....
10610201 1      3
*
*   hs source distribution data
*   format 1 [if w1 of 1cccg100=0.]
*   gam.a.c. mesh.int.numb. --->.....
10610301 0.0    3
*
*   initial temperature data [according to 1cccg400]
*   temp.

```

```

*
*-----
10610401 560.0 4
*
* left boundary condition cards
* bnd.vol. incr. type ar.code area hsnumb.
10610501 060030000 0 1 1 0.333 1
*
* right boundary condition cards
* _ _ _ _ _ _ _ _ _ _
10610601 980010000 0 3930 1 0.333 1
*
* source data cards
* type multipl. dir.heat.for.lft.bnd. for.right heat.str.numb.
10610701 0 0.0 0.0 0.0 1
*
* additional left boundary cards
* flgs. ht.trn.h.diam. heated.eq.diam. length ht.str.numb.
10610801 0 0.0 0.0 0.0 1
**
* lf.h.dh. heated.lengths grid.lengths grid.losses boil.f. HS.no.
* w1 w2 w3 w4 w5 w6 w7 w8 w9
10610801 0. 10. 10. 0. 0. 0. 0. 1. 1
*
*=====
* upper plenum outlet part with d=160 mm
*=====
*
*
* general hs data
* ax.str. rd.mesh gm.type ini.fl. lft.bnd. 3*refl.w[opt]
10640000 2 4 2 1 80.0e-3
*
* hs mesh flags
* mesh.loc.flg. mesh.form.flg.
10640100 0 1
*
* hs mesh interval data (format 1 is used)
* numb.of.int. rght.coor. --->.....
10640101 3 130.0e-3
*
* hs composition data
* compos. int.numb. --->.....
10640201 1 3
*
* hs source distribution data
* format 1 [if w1 of 1cccg100=0.]
* gam.a.c. mesh.int.numb. --->.....
10640301 0.0 3
*
* initial temperature data [according to 1cccg400]
* temp.
*-----
10640401 560.0 4
*
* left boundary condition cards
* bnd.vol. incr. type ar.code area hsnumb.
10640501 062010000 0 1 1 0.105 1
10640502 064010000 0 1 1 0.170 2
*
* right boundary condition cards
* _ _ _ _ _ _ _ _ _ _
10640601 980010000 0 3935 1 0.105 1
10640602 980010000 0 3935 1 0.170 2
*
* source data cards
* type multipl. dir.heat.for.lft.bnd. for.right heat.str.numb.
10640701 0 0.0 0.0 0.0 2
*
* additional left boundary cards

```

```

*   flgs. ht.trn.h.diam. heated.eq.diam. length ht.str.numb.
10640801 0 0.0 0.0 0.0 2
*
**
*   lf.h.dh. heated.lengths grid.lengths grid.losses boil.f. HS.no.
*   w1 w2 w3 w4 w5 w6 w7 w8 w9
10640801 0. 10. 10. 0. 0. 0. 0. 1. 2
*
=====
*   upper plenum top part with d=73 mm
=====
*
*
*   general hs data
*   ax.str. rd.mesh gm.type ini.fl. lft.bnd. 3*refl.w[opt]
10682000 4 4 2 1 36.5e-3 1 0 4
*
*   hs mesh flags
*   mesh.loc.flg. mesh.form.flg.
10682100 0 1
*
*   hs mesh interval data (format 1 is used)
*   numb.of.int. rght.coor. --->.....
10682101 3 44.50e-3
*
*   hs composition data
*   compos. int.numb. --->.....
10682201 1 3
*
*   hs source distribution data
*   format 1 [if w1 of 1cccg100=0.]
*   gam.a.c. mesh.int.numb. --->.....
10682301 0.0 3
*
*   initial temperature data [according to 1cccg400]
*   temp.
*   ----
10682401 560.0 4
*
*   left boundary condition cards
*   bnd.vol. incr. type ar.code area hsnumb.
10682501 068010000 0 1 1 0.5225 1
10682502 068020000 0 1 1 0.5225 2
10682503 068030000 0 1 1 0.5225 3
10682504 068040000 0 1 1 0.5225 4
*
*   right boundary condition cards
*   " " " " " "
10682601 980010000 0 3935 1 0.5225 1
10682602 980010000 0 3935 1 0.5225 2
10682603 980010000 0 3935 1 0.5225 3
10682604 980010000 0 3935 1 0.5225 4
*
*   source data cards
*   type multipl. dir.heat.for.lft.bnd. for.right heat.str.numb.
10682701 0 0.0 0.0 0.0 4
*
*   additional left boundary cards
*   flgs. ht.trn.h.diam. heated.eq.diam. length ht.str.numb.
10682801 0 0.0 0.0 0.0 4
*
**
*   lf.h.dh. heated.lengths grid.lengths grid.losses boil.f. HS.no.
*   w1 w2 w3 w4 w5 w6 w7 w8 w9
10682801 0. 10. 10. 0. 0. 0. 0. 1. 4
*
=====
*   upper plenum - top plate
=====
*
*
*   general hs data

```



```

*   ax.str. rd.mesh gm.type ini.fl. lft.bnd. 3*refl.w[opt]
10683000 1   4   1   1   0.0
*
*   hs mesh flags
*   mesh.loc.flg. mesh.form.flg.
10683100 0   1
*
*   hs mesh interval data (format 1 is used)
*   numb.of.int. rght.coor. --->.....
10683101 3   30.0e-3
*
*   hs composition data
*   compos. int.numb. --->.....
10683201 1   3
*
*   hs source distribution data
*   format 1 [if w1 of 1cccg100=0.]
*   gam.a.c. mesh.int.numb. --->.....
10683301 0.0   3
*
*   initial temperature data [according to 1cccg400]
*   temp.
*   ----
10683401 560.0   4
*
*   left boundary condition cards
*   bnd.vol. incr. type ar.code area hsnumb.
10683501 068040000 0   1   1   6.22-3   1
*
*   right boundary condition cards
*   _ _ _ _ _ _ _ _ _ _ _ _ _ _ _ _
10683601 980010000 0   3935   1   6.22-3   1
*
*   source data cards
*   type multipl. dir.heat.for.lft.bnd. for.right heat.str.numb.
10683701 0   0.0   0.0   0.0   1
*
*   additional left boundary cards
*   flgs. ht.trn.h.diam. heated.eq.diam. length ht.str.numb.
10683801 0   0.0   0.0   0.0   1
*
**
*   lf.h.dh. heated.lengths grid.lengths grid.losses boil.f. HS.no.
*   w1 w2 w3 w4 w5 w6 w7 w8 w9
10683801 0. 10. 10. 0. 0. 0. 0. 1. 1
*
*
*=====
*   hot leg
*=====
*
*   general hs data
*   ax.str. rd.mesh gm.type ini.fl. lft.bnd. 3*refl.w[opt]
11000000 8   4   2   1   23.0e-3
*
*   hs mesh flags
*   mesh.loc.flg. mesh.form.flg.
11000100 0   1
*
*   hs mesh interval data (format 1 is used)
*   numb.of.int. rght.coor. --->.....
11000101 3   28.5e-3
*
*   hs composition data
*   compos. int.numb. --->.....
11000201 1   3
*
*   hs source distribution data
*   format 1 [if w1 of 1cccg100=0.]
*   gam.a.c. mesh.int.numb. --->.....
11000301 0.0   3
*

```

```

*   initial temperature data [according to 1cccg400]
*   temp.
*   ----
11000401 560.0  4
*
*   left boundary condition cards
*   bnd.vol. incr. type ar.code area hsnumb.
11000501 102010000 0 1 1 0.750 1
11000502 106010000 0 1 1 0.572 2
11000503 106020000 0 1 1 0.572 3
11000504 106030000 0 1 1 0.572 4
11000505 106040000 0 1 1 0.572 5
11000506 106050000 0 1 1 0.572 6
11000507 106060000 0 1 1 0.450 7
11000508 106070000 0 1 1 0.770 8
*
*   right boundary condition cards
11000601 980010000 0 3910 1 0.750 1
11000602 980010000 0 3910 1 0.572 2
11000603 980010000 0 3910 1 0.572 3
11000604 980010000 0 3910 1 0.572 4
11000605 980010000 0 3910 1 0.572 5
11000606 980010000 0 3910 1 0.572 6
11000607 980010000 0 3910 1 0.450 7
11000608 980010000 0 3910 1 0.770 8
*
*   source data cards
*   type multipl. dir.heat.for.lft.bnd. for.right heat.str.numb.
11000701 0 0.0 0.0 0.0 8
*
*   additional left boundary cards
*   flgs. ht.trn.h.diam. heated.eq.diam. length ht.str.numb.
11000801 0 0.0 0.0 0.0 8
**
*   lf.h.dh. heated.lengths grid.lengths grid.losses boil.f. HS.no.
*   w1 w2 w3 w4 w5 w6 w7 w8 w9
11000801 0. 10. 10. 0. 0. 0. 0. 1. 8
*
*=====
*   pressurizer surge line
*=====
*
*   general hs data
*   ax.str. rd.mesh gm.type ini.fl. lft.bnd. 3*refl.w[opt]
14100000 5 4 2 1 14.5e-3
*
*   hs mesh flags
*   mesh.loc.flg. mesh.form.flg.
14100100 0 1
*
*   hs mesh interval data (format 1 is used)
*   numb.of.int. rght.coor. --->.....
14100101 3 19.0e-3
*
*   hs composition data
*   compos. int.numb. --->.....
14100201 1 3
*
*   hs source distribution data
*   format 1 [if w1 of 1cccg100=0.]
*   gam.a.c. mesh.int.numb. --->.....
14100301 0.0 3
*
*   initial temperature data [according to 1cccg400]
*   temp.
*   ----
14100401 560.0  4
*
*   left boundary condition cards

```

```

*      bnd.vol. incr. type ar.code area hsnumb.
14100501 410010000 0 1 1 0.15 1
14100502 410020000 0 1 1 0.76 2
14100503 410030000 0 1 1 1.57 3
14100504 410040000 0 1 1 1.57 4
14100505 410050000 0 1 1 0.15 5
*
*      right boundary condition cards
*      _" _" _" _" _" _"
14100601 980010000 0 3940 1 0.15 1
14100602 980010000 0 3940 1 0.76 2
14100603 980010000 0 3940 1 1.57 3
14100604 980010000 0 3940 1 1.57 4
14100605 980010000 0 3940 1 0.15 5
*
*      source data cards
*      type multipl. dir.heat.for.lft.bnd. for.right heat.str.numb.
14100701 0 0.0 0.0 0.0 5
*
*      additional left boundary cards
*      flgs. ht.trn.h.diam. heated.eq.diam. length ht.str.numb.
14100801 0 0.0 0.0 0.0 5
**
*      lf.h.dh. heated.lengths grid.lengths grid.losses boil.f. HS.no.
*      w1 w2 w3 w4 w5 w6 w7 w8 w9
14100801 0. 10. 10. 0. 0. 0. 0. 1. 5

```

```

=====
*      pressurizer, 420 - 426
=====

```

```

*
*      general hs data
*      ax.str. rd.mesh gm.type ini.fl. lft.bnd. 3*refl.w[opt]
14200000 7 4 2 1 50.5e-3
*
*      hs mesh flags
*      mesh.loc.flg. mesh.form.flg.
14200100 0 1
*
*      hs mesh interval data (format 1 is used)
*      numb.of.int. rght.coor. --->.....
14200101 3 66.5e-3
*
*      hs composition data
*      compos. int.numb. --->.....
14200201 1 3
*
*      hs source distribution data
*      format 1 [if w1 of 1cccg100=0.]
*      gam.a.c. mesh.int.numb. --->.....
14200301 0.0 3
*
*      initial temperature data [according to 1cccg400]
*      temp.
*      ----
14200401 595.0 4

```

```

*      left boundary condition cards
*      bnd.vol. incr. type ar.code area hsnumb.
14200501 430010000 0 1 1 0.150 1
14200502 430020000 0 1 1 0.085 2
14200503 420010000 0 1 1 0.225 3
14200504 420020000 0 1 1 0.557 4
14200505 420030000 0 1 1 0.6 5
14200506 420040000 0 1 1 0.6 6
14200507 420050000 0 1 1 0.305 7

```

```

*      right boundary condition cards
*      _" _" _" _" _" _"
14200601 980010000 0 3940 1 0.150 1

```

```

14200602 980010000 0      3940  1      0.085  2
14200603 980010000 0      3940  1      0.225  3
14200604 980010000 0      3940  1      0.557  4
14200605 980010000 0      3940  1      0.6    5
14200606 980010000 0      3940  1      0.6    6
14200607 980010000 0      3940  1      0.305  7
*
*   source data cards
*   type multipl. dir.heat.for.lft.bnd. for.right heat.str.numbr.
14200701 0  0.0  0.0      0.0  7
*
*   additional left boundary cards
*   flgs. ht.trn.h.diam. heated.eq.diam. length ht.str.numbr.
14200801 0  0.0  0.0      0.0  7
*
**
*   lf.h.dh. heated.lengths grid.lengths grid.losses boil.f. HS.no.
*   w1  w2  w3  w4  w5  w6  w7  w8  w9
14200801 0.  10.  10.  0.  0.  0.  0.  1.  7
*
=====
*   prz heater simulator
=====
*
*
*   general hs data
*   ax.str. rd.mesh gm.type ini.fl. lft.bnd. 3*refl.w[opt]
14220000 2  4  2  1  0.
*
*   hs mesh flags
*   mesh.loc.flg. mesh.form.flg.
14220100 0  1
*
*   hs mesh interval data (format 1 is used)
*   numb.of.int. rght.coor. --->.....
14220101 3  12.5-3
*
*   hs composition data
*   compos. int.numb. --->.....
14220201 1  3
*
*   hs source distribution data
*   format 1 [if w1 of 1cccg100=0.]
*   gam.a.c. mesh.int.numb. --->.....
14220301 1.0  3
*
*   initial temperature data [according to 1cccg400]
*   temp.
*   ----
14220401 600.0  4
*
*   left boundary condition cards
*   bnd.vol. incr. type ar.code area hsnumbr.
14220501 0  0  0  1  0.255  1
*
14220502 0  0  0  1  0.225  2
*
*   right boundary condition cards
*   " " " " " "
14220601 410060000 0  1  1  0.255  1
*
14220602 420010000 0  1  1  0.225  2
*
*   source data cards
*   type multipl. dir.heat.for.lft.bnd. for.right heat.str.numbr.
14220701 422 0.  0.  0.3  1
*
14220702 422 0.  0.  0.7  2
*
*   additional right boundary cards
*   flgs. ht.trn.h.diam. heated.eq.diam. length ht.str.numbr.
14220901 0  0.  0.0  0.0  2

```

```

*
**
*   rg.h.dh. heated.lengths grid.lengths grid.losses boil.f. HS.no.
*   w1   w2   w3   w4   w5   w6   w7   w8   w9
14220901 0.   10.  10.  0.   0.   0.   0.   1.   2
*
=====
*   pressurizer - well between bottom blind end and surge line
=====
*
*   general hs data
*   ax.str. rd.mesh gm.type ini.fl. lft.bnd. 3*refl.w[opt]
14300000 2   4   2   1   2.4-2
*
*   hs mesh flags
*   mesh.loc.flg. mesh.form.flg.
14300100 0   1
*
*   hs mesh interval data (format 1 is used)
*   numb.of.int. rght.coor. --->.....
14300101 3   2.5-2
*
*   hs composition data
*   compos. int.numb. --->.....
14300201 1   3
*
*   hs source distribution data
*   format 1 [if w1 of 1cccg100=0.]
*   gam.a.c. mesh.int.numb. --->.....
14300301 0.0  3
*
*   initial temperature data [according to 1cccg400]
*   temp.
*   ----
14300401 560.0  4
*
*   left boundary condition cards
*   bnd.vol. incr. type ar.code area hsnumb.
14300501 410060000 0   1   1   0.150  1
*
14300502 410060000 0   1   1   0.085  2
*
*   right boundary condition cards
*   " " " " " " " "
14300601 430010000 0   1   1   0.150  1
*
14300602 430020000 0   1   1   0.085  2
*
*   source data cards
*   type multipl. dir.heat.for.lft.bnd. for.right heat.str.numb.
14300701 0   0.0  0.0  0.0  0.0  2
*
*   additional left boundary cards
*   flgs. ht.trn.h.diam. heated.eq.diam. length ht.str.numb.
14300801 0   0.0  0.0  0.0  2
*
*   additional right boundary cards
*   flgs. ht.trn.h.diam. heated.eq.diam. length ht.str.numb.
14300901 0   0.   0.0  0.0  2
*
**
*   lf.h.dh. heated.lengths grid.lengths grid.losses boil.f. HS.no.
*   w1   w2   w3   w4   w5   w6   w7   w8   w9
14300801 0.   10.  10.  0.   0.   0.   0.   1.   2
*
*   rg.h.dh. heated.lengths grid.lengths grid.losses boil.f. HS.no.
*   w1   w2   w3   w4   w5   w6   w7   w8   w9
14300901 0.   10.  10.  0.   0.   0.   0.   1.   2
*
=====
*   sg inlet collector slab

```

```

=====
*
*   general hs data
*   ax.str. rd.mesh gm.type ini.fl. lft.bnd. 3*refl.w[opt]
11200000 5   4   2   1   36.5e-3
*
*   hs mesh flags
*   mesh.loc.flg. mesh.form.flg.
11200100 0   1
*
*   hs mesh interval data (format 1 is used)
*   numb.of.int. rght.coor. --->.....
11200101 3   44.5e-3
*
*   hs composition data
*   compos. int.numb. --->.....
11200201 1   3
*
*   hs source distribution data
*   format 1 [if w1 of 1cccg100=0.]
*   gam.a.c. mesh.int.numb. --->.....
11200301 0.0  3
*
*   initial temperature data [according to 1cccg400]
*   temp.
*   ----
11200401 560.0  4
*
*
*   left boundary condition cards
*   bnd.vol. incr. type ar.code area hsnumb.
11200501 120010000 0   1   1   0.620  1
11200502 122010000 0   1   1   0.710  2
11200503 124010000 0   1   1   0.610  3
11200504 126010000 0   1   1   0.610  4
11200505 128010000 0   1   1   0.300  5
*
*   right boundary condition cards
*   " " " " " " " "
11200601 980010000 0   3910  1   0.620  1
11200602 522010000 0   1   1   0.710  2
11200603 524010000 0   1   1   0.610  3
11200604 526010000 0   1   1   0.610  4
11200605 544010000 0   1   1   0.300  5
*
*   source data cards
*   type multipl. dir.heat.for.lft.bnd. for.right heat.str.numb.
11200701 0   0.0  0.0  0.0  0.0  5
*
*   additional left boundary cards
*   flgs. ht.trn.h.diam. heated.eq.diam. length ht.str.numb.
11200801 0   0.0  0.0  0.0  0.0  5
*
*   additional right boundary cards
*   flgs. ht.trn.h.diam. heated.eq.diam. length ht.str.numb.
11200901 0   0.0  0.0  0.0  0.0  5
*
**
*   lf.h.dh. heated.lengths grid.lengths grid.losses boil.f. HS.no.
*   w1 w2 w3 w4 w5 w6 w7 w8 w9
11200801 0.  10.  10.  0.  0.  0.  0.  1.  5
*
*   rg.h.dh. heated.lengths grid.lengths grid.losses boil.f. HS.no.
*   w1 w2 w3 w4 w5 w6 w7 w8 w9
11200901 0.  10.  10.  0.  0.  0.  0.  1.  5
*
=====
* lower section of sg tubing
=====
*

```

```

* general hs data
* ax.str. rd.mesh gm.type ini.fl. lft.bnd. 3*refl.w[opt]
11320000 4 4 2 1 3.0e-3
*
* hs mesh flags
* mesh.loc.flg. mesh.form.flg.
11320100 0 1
*
* hs mesh interval data (format 1 is used)
* numb.of.int. rght.coor. --->.....
11320101 3 4.0e-3
*
* hs composition data
* compos. int.num. --->.....
11320201 1 3
*
* hs source distribution data
* format 1 [if w1 of 1cccg100=0.]
* gam.a.c. mesh.int.num. --->.....
11320301 0.0 3
*
* initial temperature data [according to 1cccg400]
* temp.
*
11320401 530.0 4
*
* left boundary condition cards
* bnd.vol. incr. type ar.code area hsnumb.
11320501 132010000 10000 1 1 19.96 4 *=changed
*
* right boundary condition cards
* _ _ _ _ _ _ _ _
11320601 522010000 0 1 1 19.96 4
*
* source data cards
* type multipl. dir.heat.for.lft.bnd. for.right heat.str.num.
11320701 0 0.00 0.0 0.0 4
*
* additional left boundary cards
* flgs. ht.trn.h.diam. heated.eq.diam. length ht.str.num.
11320801 0 6.0e-3 0.0 0.0 4
*
* additional right boundary cards
* _ _ _ _ _ _ _ _
11320901 0 40.e-3 0.0 0.0 4 *=original
**
* lf.h.dh. heated.lengths grid.lengths grid.losses boil.f. HS.no.
* w1 w2 w3 w4 w5 w6 w7 w8 w9
11320801 0. 10. 10. 0. 0. 0. 0. 1. 4
*
* rg.h.dh. heated.lengths grid.lengths grid.losses boil.f. HS.no.
* w1 w2 w3 w4 w5 w6 w7 w8 w9
11320901 0. 10. 10. 0. 0. 0. 0. 1. 4
*
*=====
* middle section of sg tubing
*=====
*
* general hs data
* ax.str. rd.mesh gm.type ini.fl. lft.bnd. 3*refl.w[opt]
11340000 4 4 2 1 3.0e-3
*
* hs mesh flags
* mesh.loc.flg. mesh.form.flg.
11340100 0 1
*
* hs mesh interval data (format 1 is used)
* numb.of.int. rght.coor. --->.....
11340101 3 4.0e-3

```

```

*
* hs composition data
*   compos. int.numb. --->.....
11340201 1   3
*
*   hs source distribution data
*   format 1 [if w1 of 1cccg100=0.]
*   gam.a.c. mesh.int.numb. --->.....
11340301 0.0   3
*
*   initial temperature data [according to 1cccg400]
*   temp.
*   ----
11340401 530.0   4
*
*   left boundary condition cards
*   bnd.vol. incr. type ar.code area hsnumb.
11340501 134010000 10000   1   1   29.93 4   *=changed
*
*   right boundary condition cards
*   " " " " " " " " " "
11340601 524010000 0   1   1   29.93 4
*
*   source data cards
*   type multipl. dir.heat.for.lft.bnd. for.right heat.str.numb.
11340701 0   0.00   0.0   0.0   4
*
*   additional left boundary cards
*   flgs. ht.trn.h.diam. heated.eq.diam. length ht.str.numb.
11340801 0   6.0e-3   0.0   0.0   4
*
*   additional right boundary cards
*   " " " " " " " " " "
11340901 0   40.e-3   0.0   0.0   4   *=original
**
*   lf.h.dh. heated.lengths grid.lengths grid.losses boil.f. HS.no.
*   w1 w2 w3 w4 w5 w6 w7 w8 w9
11340801 0.   10.   10.   0.   0.   0.   0.   1.   4
*
*   rg.h.dh. heated.lengths grid.lengths grid.losses boil.f. HS.no.
*   w1 w2 w3 w4 w5 w6 w7 w8 w9
11340901 0.   10.   10.   0.   0.   0.   0.   1.   4
*
*
*=====
* upper section of sg tubing
*=====
*
*   general hs data
*   ax.str. rd.mesh gm.type ini.fl. lft.bnd. 3*refl.w[opt]
11360000 4   4   2   1   3.0e-3
*
*   hs mesh flags
*   mesh.loc.flg. mesh.form.flg.
11360100 0   1
*
*   hs mesh interval data (format 1 is used)
*   numb.of.int. rght.coor. --->.....
11360101 3   4.0e-3
*
*   hs composition data
*   compos. int.numb. --->.....
11360201 1   3
*
*   hs source distribution data
*   format 1 [if w1 of 1cccg100=0.]
*   gam.a.c. mesh.int.numb. --->.....
11360301 0.0   3
*
*   initial temperature data [according to 1cccg400]
*   temp.

```



```

*
* -----
11360401 530.0 4
*
* left boundary condition cards
* bnd.vol. incr. type ar.code area hsnumb.
11360501 136010000 10000 1 1 31.93 4 *=changed
*
* right boundary condition cards
* " " " " " " " "
11360601 526010000 0 1 1 31.93 4
*
* source data cards
* type multipl. dir.heat.for.lft.bnd. for.right heat.str.numb.
11360701 0 0.00 0.0 0.0 4
*
* additional left boundary cards
* flgs. ht.frn.h.diam. heated.eq.diam. length ht.str.numb.
11360801 0 6.0e-3 0.0 0.0 4
*
* additional right boundary cards
* " " " " " " " "
11360901 0 40.e-3 0.0 0.0 4 *=original
**
* lf.h.dh. heated.lengths grid.lengths grid.losses boil.f. HS.no.
* w1 w2 w3 w4 w5 w6 w7 w8 w9
11360801 0. 10. 10. 0. 0. 0. 0. 1. 4
*
* rg.h.dh. heated.lengths grid.lengths grid.losses boil.f. HS.no.
* w1 w2 w3 w4 w5 w6 w7 w8 w9
11360901 0. 10. 10. 0. 0. 0. 0. 1. 4
*
* =====
* sg outlet collector slab
* =====
*
* general hs data
* ax.str. rd.mesh gm.type ini.fl. lft.bnd. 3*refl.w[opt]
11400000 5 4 2 1 36.5e-3
*
* hs mesh flags
* mesh.loc.flg. mesh.form.flg.
11400100 0 1
*
* hs mesh interval data (format 1 is used)
* numb.of.int. rght.coor. --->.....
11400101 3 44.5e-3
*
* hs composition data
* compos. int.numb. --->.....
11400201 1 3
*
* hs source distribution data
* format 1 [if w1 of 1cccg100=0.]
* gam.a.c. mesh.int.numb. --->.....
11400301 0.0 3
*
* initial temperature data [according to 1cccg400]
* temp.
*
* -----
11400401 530.0 4
*
* left boundary condition cards
* bnd.vol. incr. type ar.code area hsnumb.
11400501 140010000 0 1 1 0.620 1
11400502 142010000 0 1 1 0.710 2
11400503 144010000 0 1 1 0.610 3
11400504 146010000 0 1 1 0.610 4
11400505 148010000 0 1 1 0.300 5
*
* right boundary condition cards

```

```

*      "-      "-      "-      "-      "-      "-
11400601 980010000 0      3920 1      0.620 1
11400602 522010000 0      1      1      0.710 2
11400603 524010000 0      1      1      0.610 3
11400604 526010000 0      1      1      0.610 4
11400605 544010000 0      1      1      0.300 5
*
* source data cards
* type multipl. dir.heat.for.lft.bnd. for.right heat.str.numb.
11400701 0 0.0 0.0 0.0 5
*
* additional left boundary cards
* flgs. ht.trn.h.diam. heated.eq.diam. length ht.str.numb.
11400801 0 0.0 0.0 0.0 5
*
* additional right boundary cards
* flgs. ht.trn.h.diam. heated.eq.diam. length ht.str.numb.
11400901 0 0.0 0.0 0.0 5
**
* lf.h.dh. heated.lengths grid.lengths grid.losses boil.f. HS.no.
* w1 w2 w3 w4 w5 w6 w7 w8 w9
11400801 0. 10. 10. 0. 0. 0. 0. 1. 5
*
* rg.h.dh. heated.lengths grid.lengths grid.losses boil.f. HS.no.
* w1 w2 w3 w4 w5 w6 w7 w8 w9
11400901 0. 10. 10. 0. 0. 0. 0. 1. 5
*
*=====
* cold leg
*=====
*
* general hs data
* ax.str. rd.mesh gm.type ini.fl. lft.bnd. 3*refl.w[opt]
11500000 13 4 2 1 23.0e-3
*
* hs mesh flags
* mesh.loc.flg. mesh.form.flg.
11500100 0 1
*
* hs mesh interval data (format 1 is used)
* numb.of.int. rght.coor. --->.....
11500101 3 28.5e-3
*
* hs composition data
* compos. int.numb. --->.....
11500201 1 3
*
* hs source distribution data
* format 1 [if w1 of 1cccg100=0.]
* gam.a.c. mesh.int.numb. --->.....
11500301 0.0 3
*
* initial temperature data [according to 1cccg400]
* temp.
* ----
11500401 530.0 4
*
* left boundary condition cards
* bnd.vol. incr. type ar.code area hsnumb.
11500501 154010000 0 1 1 0.540 1
11500502 154020000 0 1 1 0.540 2
11500503 154030000 0 1 1 0.540 3
11500504 154040000 0 1 1 0.540 4
11500505 156010000 0 1 1 0.789 5
11500506 192010000 0 1 1 0.950 6
11500507 194010000 0 1 1 0.500 7
11500508 194020000 0 1 1 0.500 8
11500509 194030000 0 1 1 0.500 9
11500510 194040000 0 1 1 0.555 10

```

```

11500511 196010000 0 1 1 0.561 11
11500512 198010000 0 1 1 0.560 12
11500513 198020000 0 1 1 0.560 13

```

```
* right boundary condition cards
```

```

*
*
11500601 980010000 0 3920 1 0.540 1
11500602 980010000 0 3920 1 0.540 2
11500603 980010000 0 3920 1 0.540 3
11500604 980010000 0 3920 1 0.540 4
11500605 980010000 0 3920 1 0.789 5
11500606 980010000 0 3920 1 0.950 6
11500607 980010000 0 3920 1 0.500 7
11500608 980010000 0 3920 1 0.500 8
11500609 980010000 0 3920 1 0.500 9
11500610 980010000 0 3920 1 0.555 10
11500611 980010000 0 3920 1 0.561 11
11500612 980010000 0 3920 1 0.560 12
11500613 980010000 0 3920 1 0.560 13

```

```
* source data cards
```

```

* type multipl. dir.heat.for.lft.bnd. for.right heat.str.numb.
11500701 0 0.0 0.0 0.0 0.0 13

```

```
* additional left boundary cards
```

```

* flgs. ht.trn.h.diam. heated.eq.diam. length ht.str.numb.
11500801 0 0.0 0.0 0.0 0.0 13

```

```
** lf.h.dh. heated.lengths grid.lengths grid.losses boil.f. HS.no.
```

```

* w1 w2 w3 w4 w5 w6 w7 w8 w9
11500801 0. 10. 10. 0. 0. 0. 0. 1. 13

```

```
=====
* pump seal, 165-168
=====
```

```
* general hs data
```

```

* ax.str. rd.mesh gm.type ini.fl. lft.bnd. 3*refl.w[opt]
11661000 4 4 2 1 36.5e-3

```

```
* hs mesh flags
```

```

* mesh.loc.flg. mesh.form.flg.
11661100 0 1

```

```
* hs mesh interval data (format 1 is used)
```

```

* numb.of.int. rght.coor. --->.....
11661101 3 44.5e-3

```

```
* hs composition data
```

```

* compos. int.numb. --->.....
11661201 1 3

```

```
* hs source distribution data
```

```

* format 1 [if w1 of 1cccg100=0.]
* gam.a.c. mesh.int.numb. --->.....
11661301 0.0 3

```

```
* initial temperature data [according to 1cccg400]
```

```

* temp. ----
11661401 540.0 4

```

```
* left boundary condition cards
```

```

* bnd.vol. incr. type ar.code area hsnumb.
11661501 158010000 0 1 1 0.810 1
11661502 166010000 0 1 1 1.767 2
11661503 166020000 0 1 1 1.500 3
11661504 166030000 0 1 1 1.500 4

```

```
* right boundary condition cards
```

```

*      "-  "-  "-  "-  "-  "-
11661601 980010000 0      3920  1      0.810  1
11661602 980010000 0      3920  1      1.767  2
11661603 980010000 0      3920  1      1.500  3
11661604 980010000 0      3920  1      1.500  4
*
*      source data cards
*      type multipl. dir.heat.for.lft.bnd. for.right heat.str.numb.
11661701 0  0.0  0.0      0.0  4
*
*      additional left boundary cards
*      flgs. ht.trn.h.diam. heated.eq.diam. length ht.str.numb.
11661801 0  0.0  0.0      0.0  4
*
**
*      lf.h.dh. heated.lengths grid.lengths grid.losses boil.f. HS.no.
*      w1  w2  w3  w4  w5  w6  w7  w8  w9
11661801 0.  10.  10.  0.  0.  0.  0.  1.  4
*
*=====
*      pump seal, 169
*=====
*
*      general hs data
*      ax.str. rd.mesh gm.type ini.fl. lft.bnd. 3*refl.w[opt]
11662000 1  4  2  1  50.5e-3
*
*      hs mesh flags
*      mesh.loc.flg. mesh.form.flg.
*
*      hs mesh flags
*      mesh.loc.flg. mesh.form.flg.
11662100 0  1
*
*      hs mesh interval data (format 1 is used)
*      numb.of.int. right.coor. --->.....
11662101 3  66.5e-3
*
*      hs composition data
*      compos. int.numb. --->.....
11662201 1  3
*
*      hs source distribution data
*      format 1 [if w1 of 1cccg100=0.]
*      gam.a.c. mesh.int.numb. --->.....
11662301 0.0  3
*
*      initial temperature data [according to 1cccg400]
*      temp.
*      ----
11662401 540.0  4
*
*      left boundary condition cards
*      bnd.vol. incr. type ar.code area hsnumb.
11662501 166040000 0  1  1  1.620  1
*
*      right boundary condition cards
*      "-  "-  "-  "-  "-  "-
11662601 980010000 0      3920  1      1.620  1
*
*      source data cards
*      type multipl. dir.heat.for.lft.bnd. for.right heat.str.numb.
11662701 0  0.0  0.0      0.0  1
*
*      additional left boundary cards
*      flgs. ht.trn.h.diam. heated.eq.diam. length ht.str.numb.
11662801 0  0.0  0.0      0.0  1
*
**
*      lf.h.dh. heated.lengths grid.lengths grid.losses boil.f. HS.no.
*      w1  w2  w3  w4  w5  w6  w7  w8  w9

```

```

11662801 0. 10. 10. 0. 0. 0. 0. 1. 1
*
=====
*   pump delivery line, 170 & 190
=====
*
*   general hs data
*   ax.str. rd.mesh gm.type ini.fl. lft.bnd. 3*refl.w[opt]
11700000 2 4 2 1 23.9e-3
*
*   hs mesh flags
*   mesh.loc.flg. mesh.form.flg.
11700100 1500
*
*   initial temperature flag
*   ini.temp.flg.
11700400 1500
*
*   left boundary condition cards
*   bnd.vol. incr. type ar.code area hsnumb.
11700501 170010000 0 1 1 3.115 1
11700502 190010000 0 1 1 2.354 2
*
*   right boundary condition cards
*   " " " " " " " "
11700601 980010000 0 3920 1 3.115 1
11700602 980010000 0 3920 1 2.354 2
*
*   source data cards
*   type multipl. dir.heat.for.lft.bnd. for.right heat.str.numb.
11700701 0 0.0 0.0 0.0 2
*
*   additional left boundary cards
*   flgs. ht.trn.h.diam. heated.eq.diam. length ht.str.numb.
11700801 0 0.0 0.0 0.0 2
**
*   lf.h.dh. heated.lengths grid.lengths grid.losses boil.f. HS.no.
*   w1 w2 w3 w4 w5 w6 w7 w8 w9
11700801 0. 10. 10. 0. 0. 0. 0. 1. 2
*
=====
*   preheater 182
=====
*
*   general hs data
*   ax.str. rd.mesh gm.type ini.fl. lft.bnd. 3*refl.w[opt]
11820000 1 4 2 1 51.0e-3
*
*   hs mesh flags
*   mesh.loc.flg. mesh.form.flg.
11820100 0 1
*
*   hs mesh interval data (format 1 is used)
*   numb.of.int. rght.coor. --->.....
11820101 3 63.5e-3
*
*   hs composition data
*   compos. int.numb. --->.....
11820201 1 3
*
*   hs source distribution data
*   format 1 [if w1 of 1cccg100=0.]
*   gam.a.c. mesh.int.numb. --->.....
11820301 0.0 3
*
*   initial temperature data [according to 1cccg400]
*   temp.
*   ----
11820401 540.0 4

```

```

*
* left boundary condition cards
*   bnd.vol. incr. type ar.code area hsnumb.
11820501 182010000 0 1 1 2.170 1
*
* right boundary condition cards
*   " " " " " " " "
11820601 980010000 0 3920 1 2.170 1
*
* source data cards
*   type multipl. dir.heat.for.lft.bnd. for.right heat.str.numb.
11820701 0 0.0 0.0 0.0 1
*
* additional left boundary cards
*   flgs. ht.trn.h.diam. heated.eq.diam. length ht.str.numb.
11820801 0 0.0 0.0 0.0 1
**
* lf.h.dh. heated.lengths grid.lengths grid.losses boil.f. HS.no.
*   w1 w2 w3 w4 w5 w6 w7 w8 w9
11820801 0. 10. 10. 0. 0. 0. 0. 1. 1

```

```

=====
* steam generatorm - big cylinder
=====

```

```

*
* general hs data
*   ax.str. rd.mesh gm.type ini.fl. lft.bnd. 3*refl.w[opt]
15300000 5 7 2 1 235.0e-3
*
* hs mesh flags
*   mesh.loc.flg. mesh.form.flg.
15300100 0 1
*
* hs mesh interval data (format 1 is used)
*   numb.of.int. right.coor. --->.....
15300101 1 238.0e-3
*
15300102 3 254.0e-3
*
15300103 2 314.0e-3
*
* hs composition data
*   compos. int.numb. --->.....
15300201 1 1
*
15300202 3 4
*
15300203 4 6
*
* hs source distribution data
*   format 1 [if w1 of 1cccg100=0.]
*   gam.a.c. mesh.int.numb. --->.....
15300301 0.0 6
*
* initial temperature data [according to 1cccg400]
*   temp.
15300401 560.0 7

```

```

* left boundary condition cards
*   bnd.vol. incr. type ar.code area hsnumb.
15300501 544010000 0 1 1 0.190 1
15300502 538010000 0 1 1 0.200 2
15300503 532010000 0 1 1 0.610 3
15300504 534010000 0 1 1 0.610 4
15300505 536010000 0 1 1 0.610 5
*
* right boundary condition cards
*   bnd.vol. incr. type ar.code area hsnumb.
15300601 980010000 0 3950 1 0.190 1

```

```

15300602 980010000 0      3950  1      0.200  2
15300603 980010000 0      3950  1      0.610  3
15300604 980010000 0      3950  1      0.610  4
15300605 980010000 0      3950  1      0.610  5
*
*   source data cards
*   type multipl. dir.heat.for.lft.bnd. for.right heat.str.numb.
15300701 0      0.0  0.0  0.0  5
*
*   additional left boundary cards
*   flgs. ht.trn.h.diam. heated.eq.diam. length ht.str.numb.
15300801 0      0.0  0.0  0.0  5
**
*   lf.h.dh. heated.lengths grid.lengths grid.losses boil.f. HS.no.
*   w1 w2 w3 w4 w5 w6 w7 w8 w9
15300801 0.  10. 10. 0.  0.  0.  0.  1.  5
*
*=====
*   steam generator - top plate
*=====
*
*   general hs data
*   ax.str. rd.mesh gm.type ini.fl. lft.bnd. 3*refl.w[opt]
15440000 1      6      1      1      0.0
*
*   hs mesh flags
*   mesh.loc.flg. mesh.form.flg.
15440100 0      1
*
*   hs mesh interval data (format 1 is used)
*   numb.of.int. rght.coor. --->.....
15440101 3      95.0e-3
15440102 2      155.0e-3
*
*   hs composition data
*   compos. int.numb. --->.....
15440201 3      3
15440202 4      5
*
*   hs source distribution data
*   format 1 [if w1 of 1cccg100=0.]
*   gam.a.c. mesh.int.numb. --->.....
15440301 0.0  5
*
*   initial temperature data [according to 1cccg400]
*   temp.
*   ----
15440401 560.0  6
*
*   left boundary condition cards
*   bnd.vol. incr. type ar.code area hsnumb.
15440501 544010000 0      1      1      0.234  1
*
*   right boundary condition cards
*   " " " " " " " "
15440601 980010000 0      3950  1      0.234  1
*
*   source data cards
*   type multipl. dir.heat.for.lft.bnd. for.right heat.str.numb.
15440701 0      0.0  0.0  0.0  1
*
*   additional left boundary cards
*   flgs. ht.trn.h.diam. heated.eq.diam. length ht.str.numb.
15440801 0      0.0  0.0  0.0  1
**
*   lf.h.dh. heated.lengths grid.lengths grid.losses boil.f. HS.no.
*   w1 w2 w3 w4 w5 w6 w7 w8 w9
15440801 0.  10. 10. 0.  0.  0.  0.  1.  1
*

```

```

=====
*
*   steam generator - bottom plate
*
=====
*
*
*   general hs data
*   ax.str. rd.mesh gm.type ini.fl. lft.bnd. 3*refl.w[opt]
15220000 1   6   1   1   0.0
*
*   hs mesh flags
*   mesh.loc.flg. mesh.form.flg.
15220100 0   1
*
*   hs mesh interval data (format 1 is used)
*   numb.of.int. rght.coor. --->.....
15220101 3   95.0e-3
15220102 2   155.0e-3
*
*   hs composition data
*   compos. int.numb. --->.....
15220201 3   3
15220202 4   5
*
*   hs source distribution data
*   format 1 [if w1 of 1cccg100=0.]
*   gam.a.c. mesh.int.numb. --->.....
15220301 0.0   5
*
*   initial temperature data [according to 1cccg400]
*   temp.
*   ----
15220401 560.0   6
*
*   left boundary condition cards
*   bnd.vol. incr. type ar.code area hsnumb.
15220501 522010000 0   1   1   0.385   1
*
*   right boundary condition cards
*   " " " " " " " " " " " "
15220601 980010000 0   3950   1   0.385   1
*
*   source data cards
*   type multipl. dir.heat.for.lft.bnd. for.right heat.str.numb.
15220701 0   0.0   0.0   0.0   1
*
*   additional left boundary cards
*   flgs. ht.trn.h.diam. heated.eq.diam. length ht.str.numb.
15220801 0   0.0   0.0   0.0   1
*
**
*   lf.h.dh. heated.lengths grid.lengths grid.losses boil.f. HS.no.
*   w1 w2 w3 w4 w5 w6 w7 w8 w9
15220801 0. 10. 10. 0. 0. 0. 0. 1. 1
*
=====
*
*   steam generator - small cylinder
*
=====
*
*
*   general hs data
*   ax.str. rd.mesh gm.type ini.fl. lft.bnd. 3*refl.w[opt]
15480000 3   6   2   1   98.5e-3
*
*   hs mesh flags
*   mesh.loc.flg. mesh.form.flg.
15480100 0   1
*
*   hs mesh interval data (format 1 is used)
*   numb.of.int. rght.coor. --->.....
15480101 3   109.5e-3
15480102 2   169.5e-3
*

```



```

* hs composition data
*   compos.  int.numb.  --->.....
15480201 3      3
15480202 4      5
*
*   hs source distribution data
*   format 1 [if w1 of 1cccg100=0.]
*   gam.a.c. mesh.int.numb. --->.....
15480301 0.0    5
*
*   initial temperature data [according to 1cccg400]
*   temp.
*   ----
15480401 560.0  6
*
*   left boundary condition cards
*   bnd.vol.  incr.  type  ar.code  area  hsnumb.
15480501 546010000 10000  1      1      0.38  2
*
15480502 548010000 0      1      1      0.228 3
*
*   right boundary condition cards
*   " " " " " " " " " "
15480601 980010000 0      3950  1      0.38  2
*
15480602 980010000 0      3950  1      0.228 3
*
*   source data cards
*   type  multipl.  dir.heat.for.lft.bnd.  for.right  heat.str.numb.
15480701 0      0.0  0.0  0.0  3
*
*   additional left boundary cards
*   flgs.  ht.trn.h.diam.  heated.eq.diam.  length  ht.str.numb.
15480801 0      0.0  0.0  0.0  3
**
*   lf.h.dh.  heated.lengths  grid.lengths  grid.losses  boil.f.  HS.no.
*   w1  w2  w3  w4  w5  w6  w7  w8  w9
15480801 0.  10.  10.  0.  0.  0.  0.  1.  3
*
*
*
*#####
*#####
* heat structure thermal property data
*#####
*
*   composition type and data format
*   mat.type  con.flg.  cap.flg.
20100100 tbl/fctn 1      1      * stainless steel
20100200 tbl/fctn 1      1      * isolation material in the core
20100300 tbl/fctn 1      1      * mn-steel
20100400 tbl/fctn 1      1      * insulation material for piping etc.
*
*=====
*
*   stainless steel thermal conductivity
*=====
*
*   thermal conductivity data
*   temp.  cond.(or mole fract.)
20100101 293.  14.7
20100102 473.  17.3
20100103 773.  21.0
20100104 973.  21.0
*=====
*
*   stainless steel heat capacity
*=====
*
*   volumetric heat capacity data
*   temp.  cap.
20100151 293.  .3900e+7

```

20100152 773. .4836e+7
20100153 973. .4836e+7 *= ad-hoc extended

*
*=====

* core isolation material thermal conductivity
*=====

* thermal conductivity data
* temp. cond.(or mole fract.)
20100201 273. 2.558
20100202 473. 2.558
20100203 773. 2.558
*=====

* core isolation material heat capacity
*=====

* volumetric heat capacity data
* temp. cap.
20100251 293. .2146e+7
20100252 773. .2484e+7
*
*=====

* mn-steel thermal conductivity
*=====

* thermal conductivity data
* temp. cond.(or mole fract.)
20100301 373. 51.1
20100302 473. 47.7
20100303 573. 44.2
20100304 773. 42.2
*=====

* mn-steel heat capacity
*=====

* volumetric heat capacity data
* temp. cap.
20100351 293. .3900e+7
20100352 773. .3900e+7
*
*=====

**=====

* system insulation material thermal conductivity
*=====

* thermal conductivity data
* temp. cond.(or mole fract.)
20100401 273. 2.558
20100402 473. 2.558
20100403 773. 2.558
*=====

* volumetric heat capacity data
* temp. cap.
20100451 293. .2146e+7
20100452 773. .2484e+7
*
*=====

*#####
* general tables
*#####
*
*=====

* pressurizer heater
*=====

*
*=====

* table type and multiplier data
* tab.type tab.trip number factors
20242200 power 658 1. 1.
*
*=====

* general table data
 * arg.val. func.val.
 20242201 -1.0 0.

20242202 0.0 3200.
 20242202 0.0 2000.

=====

* core simulator power

=====

* table type and multiplier data
 * tab.type tab.trip.number factors
 20290000 power 602 1. 1000.

* general table data
 * arg.val. func.val.

20290001 -1.0 654.0 * SPE1 power curve
 20290002 0.0 654.0
 20290003 1.0 577.2
 20290004 2.0 496.6
 20290005 3.0 421.3
 20290006 4.0 398.4
 20290007 5.0 371.5
 20290008 7.0 234.0
 20290009 7.001 234.0
 20290010 10.0 147.6
 20290011 14.0 88.0
 20290012 19.0 58.5
 20290013 24.0 47.5
 20290014 30.0 41.4
 20290015 60.0 34.6
 20290016 100.0 30.3
 20290017 200.0 23.2
 20290018 400.0 19.3
 20290019 800.0 15.0
 20290020 1000.0 15.0

* T2.1 power curve
 20290001 -1.0 665.5
 20290002 0.0 665.5
 20290003 1.0 665.5
 20290004 2.97 665.
 20290005 3.95 637.3
 20290006 4.94 574.8
 20290007 6.92 421.3
 20290008 9.89 261.9
 20290009 11.8 187.9
 20290010 14.9 119.9
 20290011 19.8 65.1
 20290012 24.7 44.3
 20290013 30.6 35.2
 20290014 50.4 31.3
 20290015 100.0 25.3
 20290016 200.0 19.5
 20290017 400.0 15.4
 20290018 800.0 15.4
 20290019 1050.0 15.0
 20290020 1500.0 15.0
 20290021 1800.0 15.6

* T2.3 power curve
 20290001 -1.0 136.3
 20290002 0.0 136.3
 20290003 1.0 136.1
 20290004 2.97 135.6
 20290005 3.95 121.7
 20290006 4.94 109.2
 20290007 6.92 84.0
 20290008 9.89 61.6
 20290009 11.8 51.6
 20290010 14.9 42.8
 20290011 19.8 36.5

20290012	24.7	34.2
20290013	30.6	33.4
20290014	50.4	30.4
20290015	100.0	25.5
20290016	200.0	19.5
20290017	400.0	16.2
20290018	800.0	15.7
20290019	1050.0	15.6
20290020	1500.0	15.5
20290021	1800.0	15.6
20290022	2500.0	15.4
20290023	3550.0	15.4
20290024	4000.0	15.0
20290025	4452.0	15.0
20290026	4454.0	0.0

=====
 * hot leg - heat transfer coefficient
 =====

*
 * table type and multiplier data
 * tab.type tab.trip.number factors
 20291000 htc-t

*
 * general table data
 * arg.val. func.val.
 20291001 0. 25.

=====
 * cold leg - heat transfer coefficient
 =====

*
 * table type and multiplier data
 * tab.type tab.trip.number factors
 20292000 htc-t

*
 * general table data
 * arg.val. func.val.
 20292001 0. 7.8

=====
 * reactor downcomer - heat transfer coefficient
 =====

*
 * table type and multiplier data
 * tab.type tab.trip.number factors
 20293300 htc-t

*
 * general table data
 * arg.val. func.val.
 20293301 0. 6.

=====
 * reactor vessel - heat transfer coefficient
 =====

*
 * table type and multiplier data
 * tab.type tab.trip.number factors
 20293000 htc-t

*
 * general table data
 * arg.val. func.val.
 20293001 0. 2.
 20293001 0. 5.
 20293001 0. 2.8

=====
 * reactor vessel upper part - heat transfer coefficient
 =====

*
 * table type and multiplier data
 * tab.type tab.trip.number factors

```

20293500 htc-t
*
*   general table data
*   arg.val. func.val.
20293501 0.    2.8
*
*
=====
* pressurizer - heat transfer coefficient
=====
*
*   table type and multiplier data
*   tab.type tab.trip.number factors
20294000 htc-t
*
*   general table data
*   arg.val. func.val.
20294001 0.    8.2
***
*
=====
* steam generator secondary - heat transfer coefficient
=====
*
*   table type and multiplier data
*   tab.type tab.trip.number factors
20295000 htc-t
*
*   general table data
*   arg.val. func.val.
20295001 0.    2.1
*
*
#####
*# control system
#####
*
=====
* c.v. for core power
=====
*-----1-----2-----3-----4-----5-----6-----7
20509000 pow1 function 1.0 665.5 1
20509001 time 0 900
*
*-----1-----2-----3-----4-----5-----6-----7
20509100 pow-off tripunit 1. 1. 1
20509101 -690
*
*-----1-----2-----3-----4-----5-----6-----7
20509500 sumpTQ20 mult 1. 665.5 1
20509501 cntrivar 90
+ cntrivar 91

*
*
*
*
=====
* control variables for coast-down simulation valves
=====
*
*
*
=====
* c.v. for valve "155"
=====
*
*
*   control component type card
*   name type scal. ini.val. in.fl. lim.ctrl.
20519000 mv11na constant 0.0
*

```

```

*
*
* control component type card
* name type scal. ini.val. in.fl. lim.ctrl.
*0519000 mv11na sum 1.0 0.0 1 3 0.0 1.0
*
*0519001 0.0
*
=====
* c.v. for valve "185"
=====
*
* control component type card
* name type scal. ini.val. in.fl. lim.ctrl.
20519100 pv11na sum 1.0 0.25 0
*
* control component data card
*
20519101 0.0 1.0 quale 460010000
*
=====
* c.v. for valve "165"
=====
*
* control component type card
* name type scal. ini.val. in.fl. lim.ctrl.
20519200 mv12na constant 1.0
*
*
* control component type card
* name type scal. ini.val. in.fl. lim.ctrl.
*0519000 mv11na sum 1.0 0.0 1 3 0.0 1.0
*
* control component data card
*
*0519001 0.0
*
=====
*= steady state control system
=====
*
=====
* primary coolant pump speed controllers
=====
*
* calculate mass flow error
*
* control component type card
* name type scal. ini.val. in.fl. lim.ctrl.
20590100 mflowerr sum 1.0 0.0 1
*
* control component data card
*
* -----
20590101 4.7300 -1.0 mflowj 170010000
20590101 4.400 -1.0 mflowj 170010000
20590101 4.3400 -1.0 mflowj 170010000
20590101 1.210 -1.0 mflowj 170010000
* sp xxxxxx
* sp - cold leg mass flow setpoint
*
*
* pump speed
*
* control component type card
* name type scal. ini.val. in.fl. lim.ctrl.
20590200 pcpspeed integral 8.2 155.0 1

```

```

*
20590201 cntrlvar 901
*
*
*
*=====
*   pressurizer liquid level
**=====
*
*   control component type card
*   name   type   scal. ini.val. in.fl. lim.ctrl.
20540000 presqlv sum   1.0   9.33   1
*
*   control component data card
*
20540001 7.95   0.085   voidf  430020000
20540002     0.225   voidf  420010000
20540003     0.557   voidf  420020000
20540004     0.600   voidf  420030000
20540005     0.600   voidf  420040000
*
*
*=====
*   pressure difference in prz vessel
*=====
*
*   control component type card
*   name   type   scal. ini.val. in.fl. lim.ctrl.
20541000 ko-p-dif sum   1.0   1.+4   1
*
*   control component data card
*
20541001 0.    1.    p    430020000
*
20541002 -1.    p    420050000
*
*
*=====
*   prz level along pressure difference ... repaired
*=====
*
*   control component type card
*   name   type   scal. ini.val. in.fl. lim.ctrl.
20542000 ko-p-lev sum   1.    9.33   1
*
*   control component data card
*
20542001 7.95   1.30688-4 cntrlvar 410
20542001 7.95   1.50291-4 cntrlvar 410
*
*
*=====
*
*=====
*   control variables for parameters to be calculated
*=====
*
*=====
*   Time in seconds after transient start
*   1-----2-----3-----4-----5-----6-----7
20513300 tran-sec sum   1.0   0.0   1
20513301 -1000.  1.    time   0
*
*=====
*   pressure drop in the core
*=====
*
*   control component type card

```

```

*   name   type   scal.  ini.val. in.fl. lim.ctrl.
20581300 dpcore  sum    1.0    0.0    1
*
*   control component data card
*
20581301 0.0    1.0    p     026020000
20581302 -1.0    p     052010000
*
=====
* pressure drop in sg's primery part
*
=====
*   control component type card
*   name   type   scal.  ini.val. in.fl. lim.ctrl.
20581400 dpsgprim sum    1.0    0.0    1
*
*   control component data card
*
20581401 0.0    1.0    p     120010000
*
20581402 -1.0    p     140010000
*
=====
* pressure difference between break point and steam dome
*
=====
*   control component type card
*   name   type   scal.  ini.val. in.fl. lim.ctrl.
20581500 dpbreak sum    1.0    0.0    1
*
*   control component data card
*
20581501 0.0    1.0    p     128010000
*
20581502 -1.0    p     548010000
*
*
=====
* liquid level in ACCUMs
*
=====
*   control component type card
*   name   type   scal.  ini.val. in.fl. lim.ctrl.
20581000 L-SIT1dc sum    1.000  9.64  0
20581001 7.975  2.47  voidf  810010000
*
20581200 L-SIT2up sum    1.000  10.05 0
20581201 7.975  2.47  voidf  820010000
*
*
=====
* liquid level in "reactor" vessel
*
=====
20581600 L-LP    sum    1.000  0.0    1
20581601 0.0    0.190  voidf  002010000
20581602 0.190  voidf  024010000
20581603 0.307  voidf  026010000
20581604 0.307  voidf  026020000
*
20581700 L-core  sum    1.000  0.0    1
20581701 0.0    0.500  voidf  044010000
20581702 0.500  voidf  044020000
20581703 0.500  voidf  044030000
20581704 0.500  voidf  044040000
20581705 0.25   voidf  044050000
20581706 0.25   voidf  044060000
*
20581800 L-UP    sum    1.000  0.0    1

```



```

20581801 0.0 0.26 voidf 052010000
20581802 0.455 voidf 054030000
+ 0.455 voidf 054040000
20581803 0.17 voidf 058020000
20581804 0.5 voidf 060010000
+ 0.5 voidf 060020000
+ 0.333 voidf 060030000
20581806 0.058 voidf 062010000
20581807 0.170 voidf 064010000
20581808 0.5225 voidf 068010000
20581809 0.5225 voidf 068020000
20581810 0.5225 voidf 068030000
20581811 0.5225 voidf 068040000

```

```

20581900 L-RV sum 1.000 8.485 1
20581901 0.0 1. cntrlvar 816
20581902 1. cntrlvar 817
20581903 1. cntrlvar 818

```

```

*=====
* liquid level in head of "reactor" vessel
*=====

```

```

* control component type card
* name type scal. ini.val. in.fl. lim.ctrl.
20582000 upliqlvl sum 1.000 8.485 0
* control component data card

```

```

20582001 6.167 0.058 voidf 062010000
20582002 0.170 voidf 064010000
20582003 0.5225 voidf 068010000
20582004 0.5225 voidf 068020000
20582005 0.5225 voidf 068030000
20582006 0.5225 voidf 068040000

```

```

*=====
* sg's outlet primary collector + adjacent part of cold leg liquid l.
*=====

```

```

* control component type card
* name type scal. ini.val. in.fl. lim.ctrl.
20582200 clloopsl sum 1.0 8.445 0
* control component data card

```

```

20582201 3.202 0.1100 voidf 156010000
20582202 0.5400 voidf 154010000
20582203 0.5400 voidf 154020000
20582204 0.5400 voidf 154030000
20582205 0.5400 voidf 154040000
20582206 0.7700 voidf 140010000
20582207 0.6100 voidf 142010000
20582208 0.6100 voidf 144010000
20582209 0.6100 voidf 146010000
20582210 0.2490 voidf 148010000

```

```

*=====
* liquid level in the middle part of the hot leg
*=====

```

```

* control component type card
* name type scal. ini.val. in.fl. lim.ctrl.
20582300 hillsreac sum 1.0 6.202 0
* control component data card

```

```

20582301 4.802 0.28 voidf 106010000
20582302 0.28 voidf 106020000

```

```

20582303      0.28 voidf 106030000
20582304      0.28 voidf 106040000
20582305      0.28 voidf 106050000

```

```

*=====
* sg's inlet primary collector + adjacent part of hot leg liquid level
*=====

```

```

* control component type card
* name type scal. ini.val. in.fl. lim.ctrl.
20582400 hllssgin sum 1.06875 9.000 0

```

```

* control component data card
20582401 4.802 0.770 voidf 106070000
20582402      0.770 voidf 120010000
20582403      0.610 voidf 122010000
20582404      0.610 voidf 124010000
20582405      0.610 voidf 126010000
20582406      0.249 voidf 128010000

```

```

*=====
* liquid level in the "reactor" downcomer
*=====

```

```

* control component type card
* name type scal. ini.val. in.fl. lim.ctrl.
20582500 dcliqlvl sum 1.0 4.995 0

```

```

* control component data card
20582501 0.190 0.112 voidf 008010000
20582502      0.116 voidf 012010000
20582503      0.5695 voidf 014010000
20582504      0.5225 voidf 014020000
20582505      0.5225 voidf 014030000
20582506      0.5225 voidf 014040000
20582507      0.5225 voidf 014050000
20582508      0.5225 voidf 014060000
20582509      0.5225 voidf 014070000
20582510      0.5225 voidf 014080000
20582511      0.350 voidf 018010000

```

```

*=====
* water level in sg
*=====

```

```

* control component type card
* name type scal. ini.val. in.fl. lim.ctrl.
20582800 sgliqlvl sum 1. 8.58 1

```

```

20582801 6.33 1.0 cntrivar 528

```

```

*=====
* liquid level in "reactor" part of cold leg
*=====

```

```

* control component type card
* name type scal. ini.val. in.fl. lim.ctrl.
20582900 cllopslr sum 1.0 4.705 0

```

```

* control component data card
20582901 3.202 0.5000 voidf 194010000
20582902      0.5000 voidf 194020000
20582903      0.5000 voidf 194030000

```

```

*=====

```

* total (approximate) heat transfer in core simulator

```
=====
*
20504200 q-core sum 1.0 654.5+3 0
20504201 0. 1. q 044010000
20504202 1. q 044020000
20504203 1. q 044030000
20504204 1. q 044040000
20504205 1. q 044050000
20504206 1. q 044060000
*
```

```
**=====
20504400 Q-core sum 1.0 654.5+3 1
20504401 0.0 1.0 cntrlvar 042
20504402 1.0 cntrlvar 545
*
```

* heat transfer in sg tubing and collectors

```
=====
*
* control component type card
* name type scal. ini.val. in.fl. lim.ctrl.
20552000 q-sg-tub sum 1.0 0. 1
*
* control component data card
*
20552001 0. 1. q 522010000
20552002 1. q 524010000
20552003 1. q 526010000
*
```

* heat loss at steam generator secondary

```
=====
*
* control component type card
* name type scal. ini.val. in.fl. lim.ctrl.
20553000 Qout-SG sum 1.0 0. 1
*
* control component data card
*
20553001 0. 1. q 532010000
20553002 1. q 534010000
20553003 1. q 536010000
20553004 1. q 544010000
20553005 1. q 546010000
20553006 1. q 546020000
20553007 1. q 548010000
20553008 1. q 538010000
*
```

* heat losses from PRZ

```
=====
*
20554000 Qout-PRZ sum 1.0 0. 1
20554001 0. 0.0476 htrnr 420000100
+ 0.0270 htrnr 420000200
+ 0.0714 htrnr 420000300
+ 0.1767 htrnr 420000400
+ 0.1904 htrnr 420000500
+ 0.1904 htrnr 420000600
+ 0.0968 htrnr 420000700
*
```

* heat losses from HL

```
=====
*
20554100 Qout-HL sum 1.0 0. 1
20554101 0. 1. q 106010000
20554102 1. q 106020000
20554103 1. q 106030000
*
```

20554104	1.	q	106040000
20554105	1.	q	106050000
20554106	1.	q	106060000
20554107	1.	q	106070000

20554108	1.	q	102010000
20554109	1.	q	120010000

=====
* heat losses from CL
=====

20554200	Qout-aux	sum	1.0	0.	1
20554201	0.	1.	q	140010000	

20554202	1.	q	154010000
+	1.	q	154020000
+	1.	q	154030000
+	1.	q	154040000

20554203	1.	q	156010000
----------	----	---	-----------

20554204	1.	q	158010000
----------	----	---	-----------

20554205	1.	q	166010000
+	1.	q	166020000
+	1.	q	166030000
+	1.	q	166040000

20554300	Qout-CL	sum	1.0	0.	1
20554301	0.	1.	cntrlvar	542	

20554306	1.	q	170010000
----------	----	---	-----------

20554307	1.	q	182010000
----------	----	---	-----------

20554308	1.	q	190010000
+	1.	q	192010000
+	1.	q	194010000
+	1.	q	194020000
+	1.	q	194030000
+	1.	q	194040000

20554309	1.	q	196010000
+	1.	q	198010000
+	1.	q	198020000

=====
* heat losses from DC
=====

20554400	Qout-DC	sum	1.0	0.	1
20554401	0.	1.	q	008010000	
+	1.	q	012010000		

20554402	1.	q	014010000
+	1.	q	014020000
+	1.	q	014030000
+	1.	q	014040000
+	1.	q	014050000
+	1.	q	014060000
+	1.	q	014070000
+	1.	q	014080000

20554403	1.	q	018010000
----------	----	---	-----------

=====
* heat losses from reactor upward part
=====

20554500	Qout-cor	sum	1.0	0.	1
20554501	0.	0.0942	htrnr	026000300	

```

+      0.0942 htrnr 026000400
+      0.0942 htrnr 026000500
+      0.0942 htrnr 026000600
+      0.0471 htrnr 026000700
+      0.0471 htrnr 026000800

```

```

=====
20554600 Qout-COR sum      1.0  0.  1
20554601 0.  1.  q      002010000
20554602 1.  1.  q      024010000
+      1.  q      026010000
+      1.  q      026020000
20554603 1.  1.  cntrlvar 545
20554604 1.  1.  q      052010000
+      1.  q      052020000
+      1.  q      054010000
+      1.  q      054020000
+      1.  q      054030000
+      1.  q      054040000
+      1.  q      054050000
+      1.  q      054060000

```

```

=====
* heat losses from reactor upward part
=====

```

```

20554700 Qout-UP sum      1.0  0.  1
20554701 0.  1.  q      058010000
+      1.  q      058020000

20554705 1.  1.  q      060010000
+      1.  q      060020000
+      1.  q      060030000
+      1.  q      062010000
+      1.  q      064010000

20554706 1.  1.  q      068010000
+      1.  q      068020000
+      1.  q      068030000
+      1.  q      068040000

```

```

=====
* total heat losses from primary loop (i.e. not SG and not PRZ)
=====

```

```

20554800 Qout-RCS sum      1.0  0.  1
20554801 0.  1.  cntrlvar 541 * HL
+      1.  cntrlvar 543 * CL
+      1.  cntrlvar 544 * DC
+      1.  cntrlvar 546 * Core+
+      1.  cntrlvar 547 * UP

```

```

=====
* total heat losses from the system (prim + sec)
=====

```

```

20554900 Qout-ALL sum      1.0  0.  1
20554901 0.  1.  cntrlvar 530 * SG sec
20554902 1.  1.  cntrlvar 540 * PRZ
20554903 1.  1.  cntrlvar 548 * R+loop

```

```

=====
* water level in sg - pure value
=====

```

```

* control component type card
* name type scal. ini.val. in.fl. lim.ctrl.
20552800 sgliqlvl sum      1.  2.25  1
*
20552801 0.  0.41 voidf 522010000
+      0.2 voidf 532010000
20552802 0.  0.41 voidf 524010000
+      0.2 voidf 534010000

```

```

20552803      0.41 voidf 526010000
+             0.2 voidf 536010000
20552804      0.195 voidf 544010000
+             0.2 voidf 538010000
20552805      0.38 voidf 546010000
+             0.385 voidf 546020000
20552806      0.228 voidf 548010000

```

```

*=====
* time of scram
*=====

```

```

* control component type card
* name type scal. ini.val. in.fl. lim.ctrl.
20560200 scram-t tripdlay 1. 4.3 1

```

```

* control component data card

```

```

20560201 602

```

```

*=====
* time of pump cost-down
*=====

```

```

* control component type card
* name type scal. ini.val. in.fl. lim.ctrl.
20560300 pump-t tripdlay 1. 12.0 1

```

```

* control component data card

```

```

20560301 603

```

```

*=====
* time of pump cost-down
*=====

```

```

* control component type card
* name type scal. ini.val. in.fl. lim.ctrl.
20565800 pump-t tripunit 1. 0. 1

```

```

* control component data card

```

```

20565801 658

```

```

*=====
* integrated mass flow through prz spray valve
*=====

```

```

* control component type card
* name type scal. ini.val. in.fl. lim.ctrl.
20591100 int-leak integral 1. 0. 0

```

```

* control component data card

```

```

20591101 mflowj 445000000

```

```

*=====
* integrated break flow
*=====

```

```

20591300 int-leak integral 1. 0. 0
20591301 mflowj 935000000

```

```

*=====
* total ECCS flow CCs
*=====

```

```

20591900 mf-ACCs sum 1.000 0.0 1
20591901 0.0 1.0 mflowj 810010000

```

```

20591902      1.0   mflowj  820010000
20592000 mf-ECCS sum      1.000  0.0  1
20592001 0.0    1.0   mflowj  855000000
20592002      1.0   mflowj  865000000
20592003      1.0   cntrlvar 919
20592200 ma-ECCS integral 1.  0.  0
20592201 cntrlvar 920

```

```

=====
*
* Maximum clad temperature
*-----1-----2-----3-----4-----5-----6-----7
20593300 TmaxCLAD stdfnctn 1.  0.  1
20593301 max   httemp  044000104
+           httemp  044000204
+           httemp  044000304
+           httemp  044000404
+           httemp  044000504
+           httemp  044000604

```

```

=====
*
* Maximum "fuel" temperature
*-----1-----2-----3-----4-----5-----6-----7
20594400 TmaxFUEL stdfnctn 1.  0.  1
20594401 max   httemp  044000101
+           httemp  044000201
+           httemp  044000301
+           httemp  044000401
+           httemp  044000501
+           httemp  044000601

```

..... e n d

APPENDIX B LISTING OF STRIP FILE

```

#####
#####
*
=stri.p07 ... stripping of PMK2 calculation results
*
=====
*
100 strip fmtout
*
103 0 ncompress
103 0 * ncompress
*
=====
*
=====
* Common and "quick-overview" strips:
*
=====
1001 time 0 * calculation time
1002 cntrlvar 133 * transient time
1003 cputime 0
1004 emass 0
1005 dt 0
1006 dtcrnt 0

1007 cntrlvar 913 * integrated break flow
1008 cntrlvar 920 * total ECCS
1009 cntrlvar 922 * integrated ECCS flow

1010 p 052010000 * upper plenum pressure
1011 p 548010000 * sg secondary pressure

1012 mflowj 935000000 * break flow
1013 mflowj 855000000 * HPSI
1014 mflowj 865000000 * LPIS
1015 cntrlvar 919 * HAs injection

1016 mflowj 198010000 * CL flow
1017 mflowj 026010000 * R (LP) flow

1018 mflowj 505000000 * FW flow
1019 mflowj 555000000 * MSLIV flow
*

1020 cntrlvar 819 * liquid level in reactor model
1021 cntrlvar 820 * level in reactor UH
1022 cntrlvar 825 * liquid level in reactor downcomer

1023 cntrlvar 823 * level in hot leg loop seal (reactor side)
1024 cntrlvar 824 * level in sg primary + hot leg
1025 cntrlvar 822 * level in sg primary + cold leg

1026 cntrlvar 400 * liquid level in the PRZ
1027 cntrlvar 420 * PRZ level acc. to delta-p

1028 cntrlvar 528 * SG level
1029 cntrlvar 828 * SG level (with scaling 1.008x)

1030 tempf 026020000 * core inlet temperature

```

1031	tempf	052010000	* core outlet temp.
1032	tempf	056010000	* core outlet temp.
1033	tempf	014010000	* DC top temp.
1034	tempf	140010000	* SG prim. outlet temp.
1035	tempf	524010000	* SG sec. temp.
1036	tempg	052010000	* steam temp at core outlet (UP bottom)
1037	tempg	056010000	* core outlet temp.
1038	tempg	140010000	* steam temp at SG prim. outlet
1039	sattemp	052010000	* sat. temp. in UP
1040	httemp	044000604	* heater rod 5.part surface temperature
1041	httemp	044000504	*
1042	httemp	044000404	*
1043	httemp	044000304	*
1044	httemp	044000204	*
1045	httemp	044000104	*
1046	httemp	014000104	* wall of downcomer upper part
1047	httemp	064000104	*
1048	cntrlvar	933	* max clad temp
1049	cntrlvar	944	* max fuel centre temp
*			
1051	cntrlvar	044	* core heat production
1052	cntrlvar	520	* sg tubing heat transfer
1058	mflowj	465000000	* PRZ RV flow
1059	mflowj	585000000	* SDA flow
*			
1060	voidf	420010000	*
1061	voidg	044050000	*
1062	voidg	062010000	*
1063	voidg	064010000	*
1064	voidg	068010000	*
*			
1070	cntrlvar	810	* level in SIT1
1071	cntrlvar	812	* level in SIT2
1072	mflowj	810010000	* SIT1 flow
1073	mflowj	820010000	* SIT2 flow
1074		*	
1075	cntrlvar	817	* level in core
1076	cntrlvar	818	* level in UP
*			
1080	cntrlvar	822	* level in CLsg
1081	cntrlvar	823	* level in HLr
1082	cntrlvar	824	* level in HLsg
1083	cntrlvar	829	* level in CLrcp
1089	tempg	060010000	* core outlet temp. 2
*			
*			
**			

**			
*			

.. end of strip input .

**APPENDIX C COMPLETE SET OF COMPARISON PLOTS FOR
CASE T2.1**

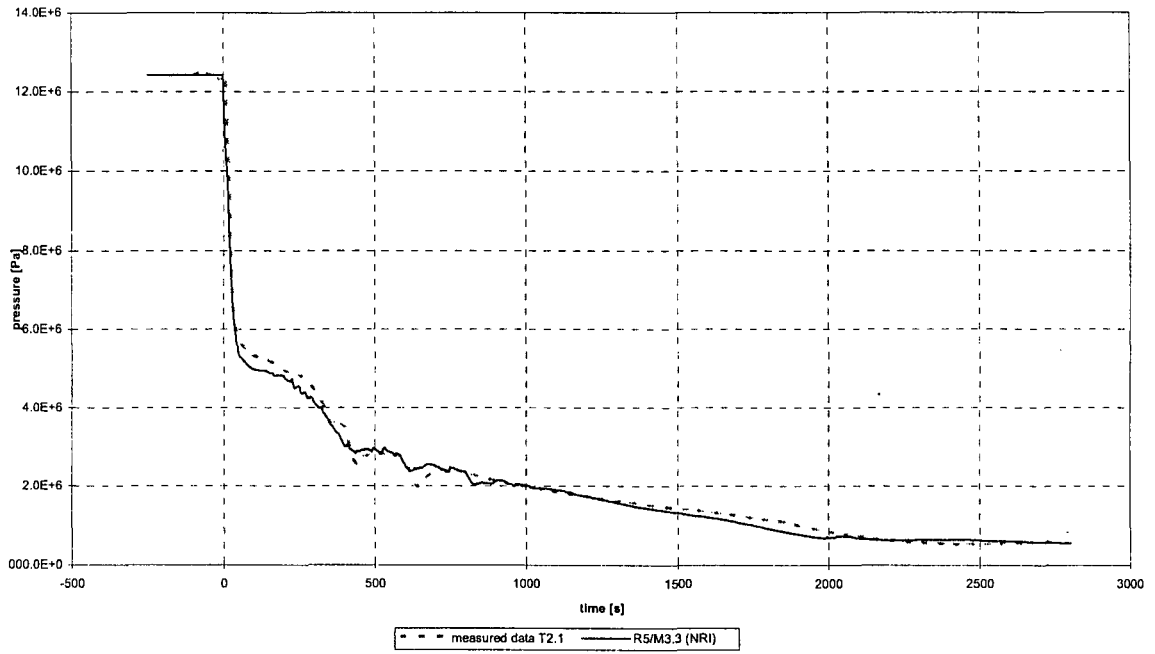

Fig.C-1 Primary pressure (T2.1)

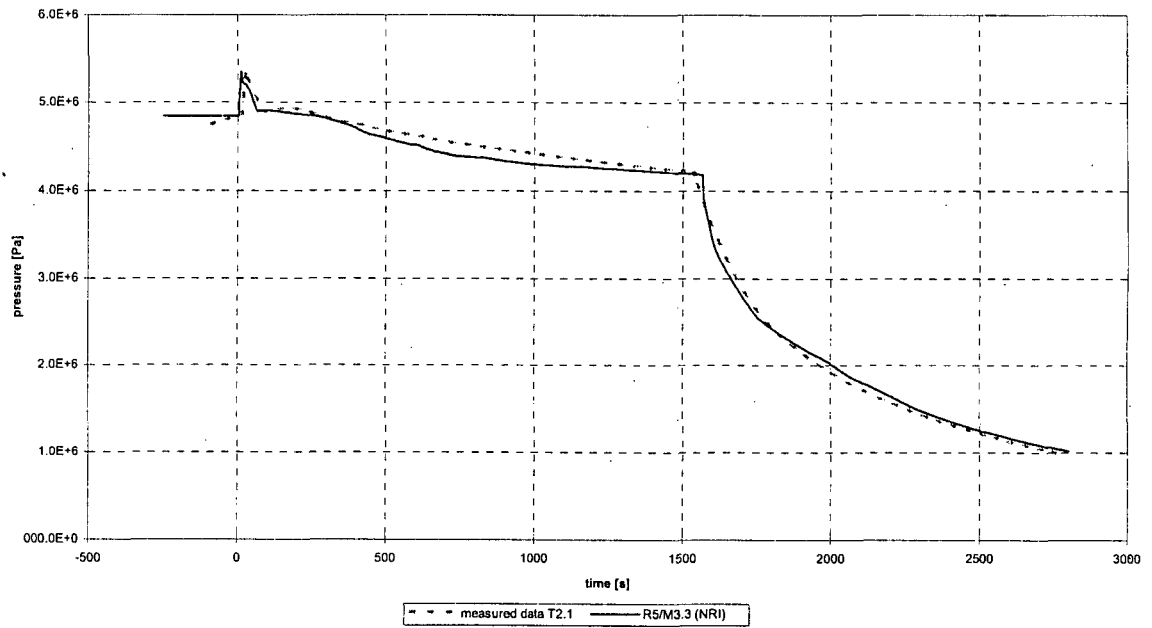

Fig.C-2 Secondary pressure (T2.1)

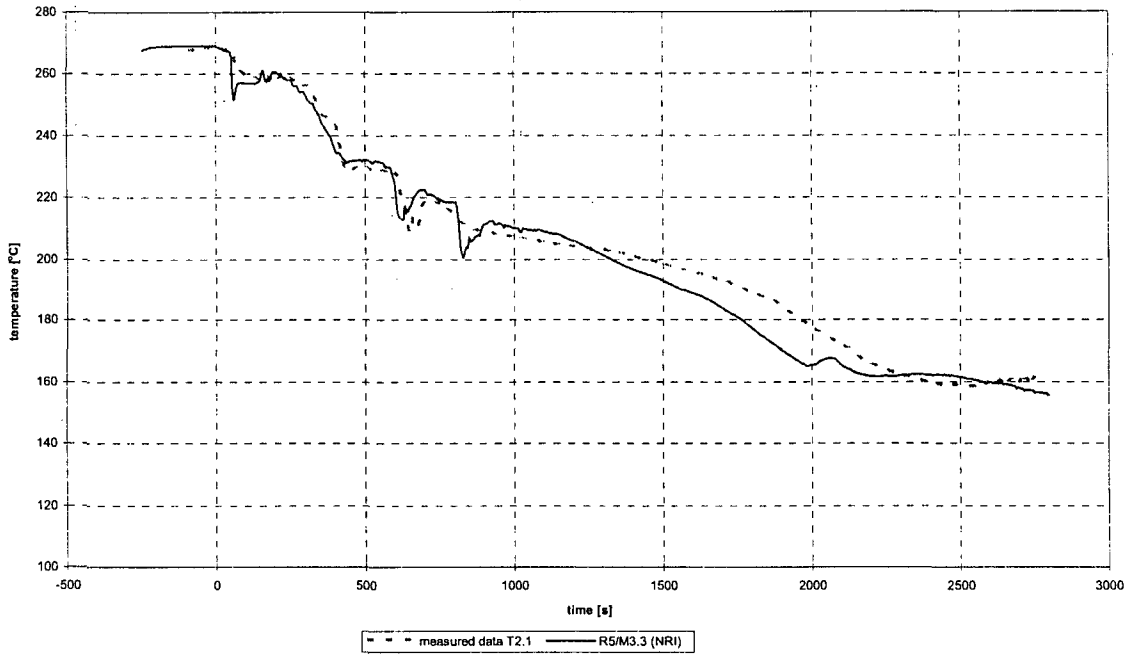

Fig.C-3 Core inlet temperature (T2.1)

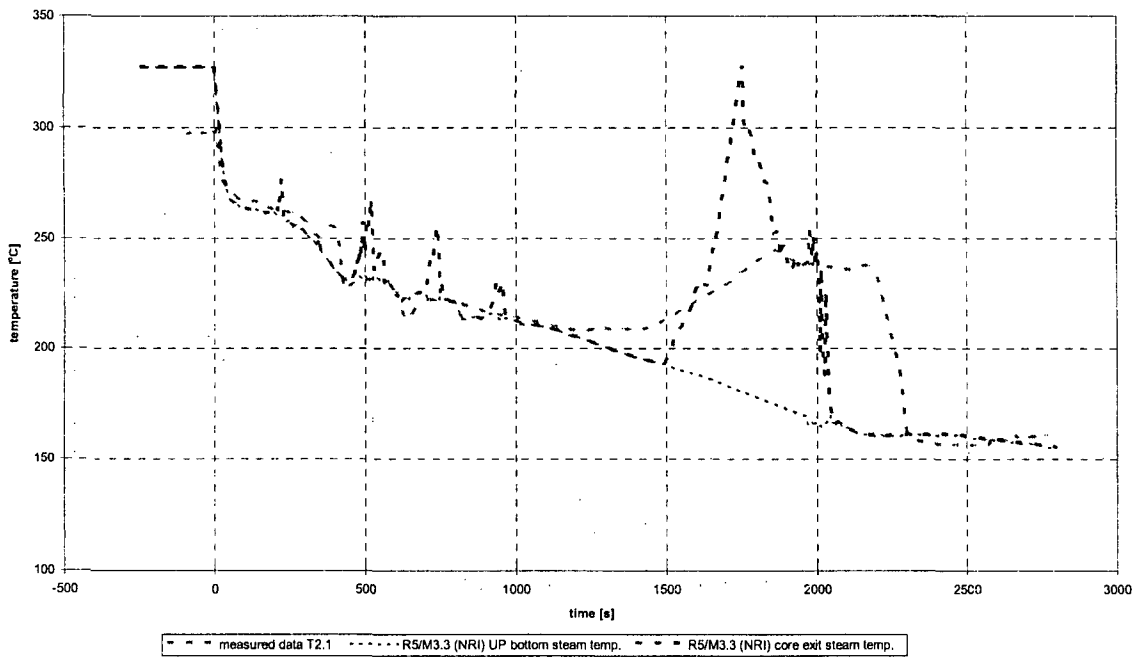

Fig.C-4 Core outlet temperature (T2.1)

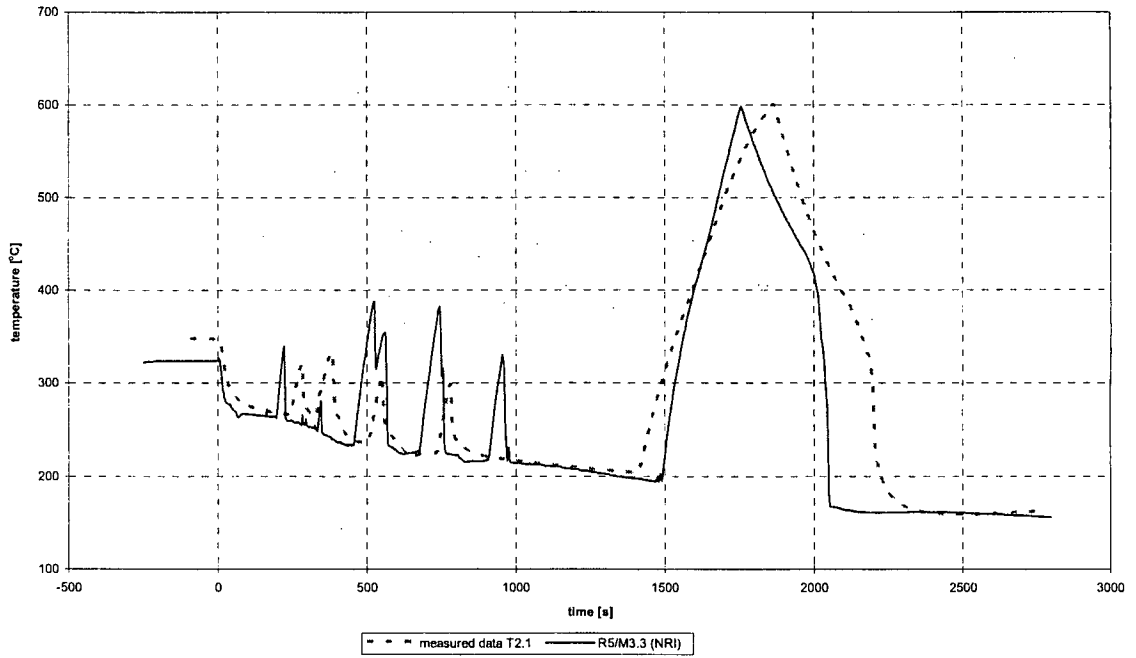

Fig.C-5 Cladding temperature (T2.1)

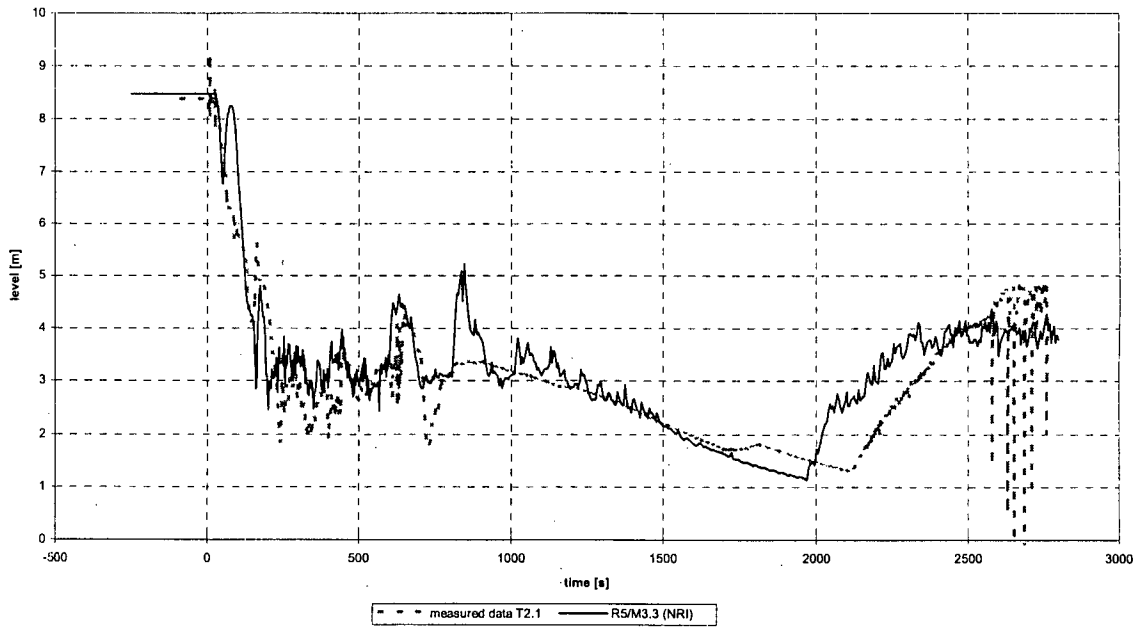

Fig.C-6 Collapsed level in reactor (T2.1)

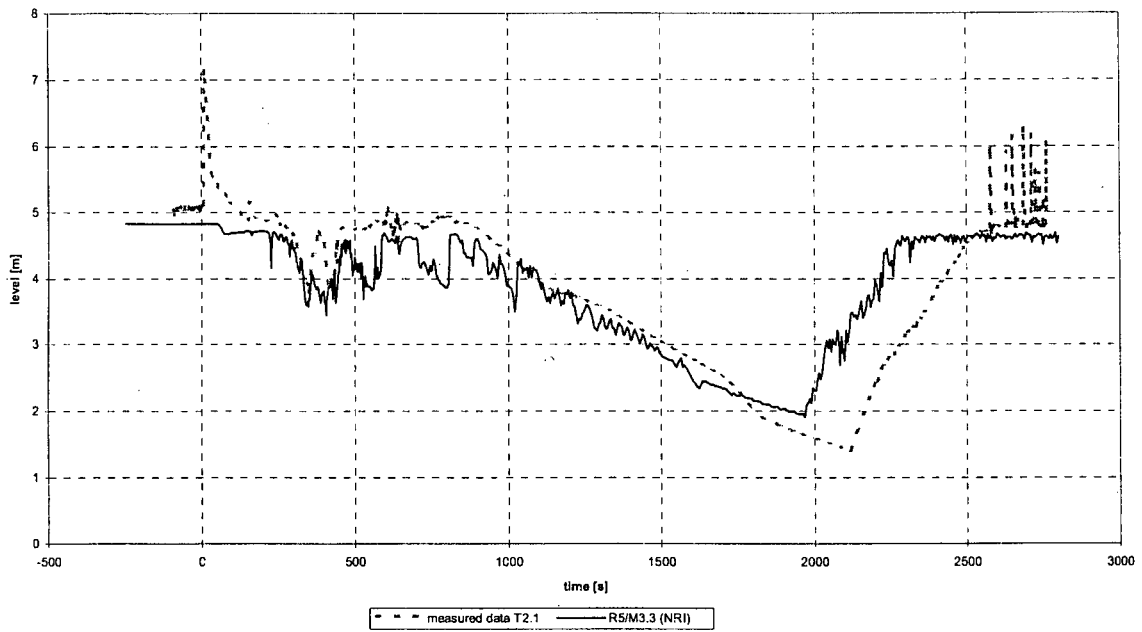

Fig.C-5 Collapsed level in reactor downcomer (T2.1)

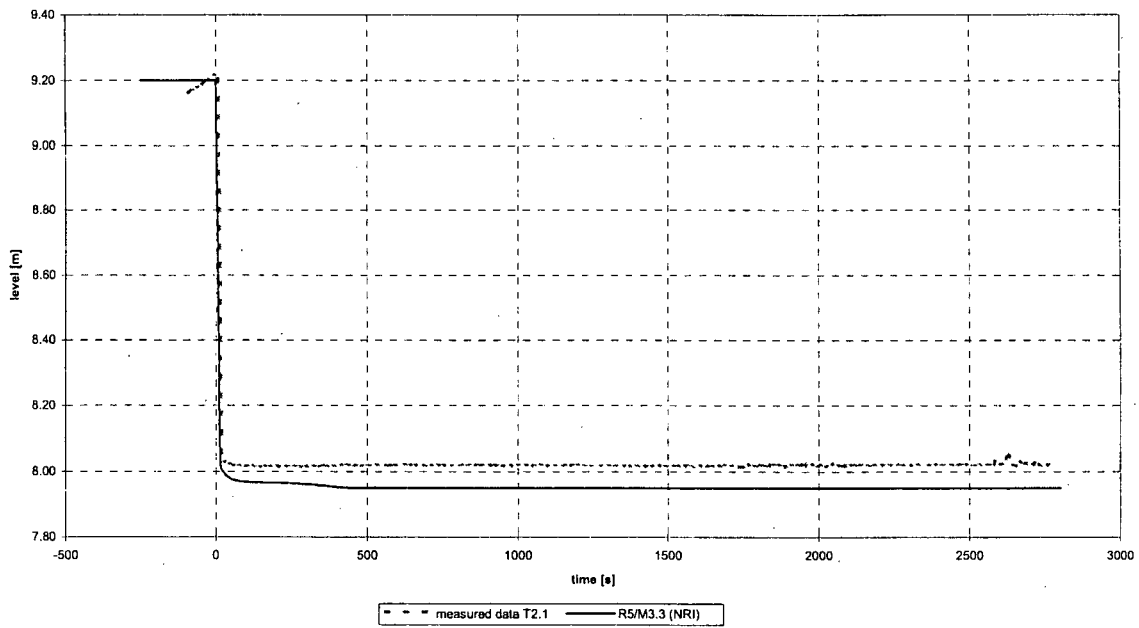

Fig.C-8 Collapsed level in PRZ (T2.1)

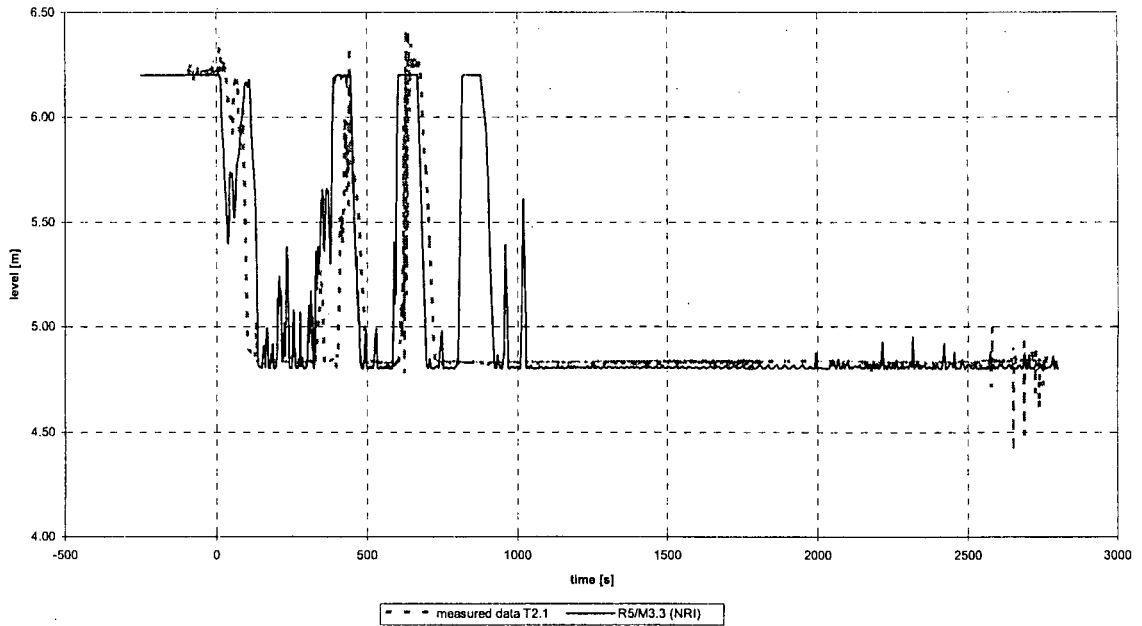

Fig.C-9 Collapsed level in hot leg loop seal – reactor side (T2.1)

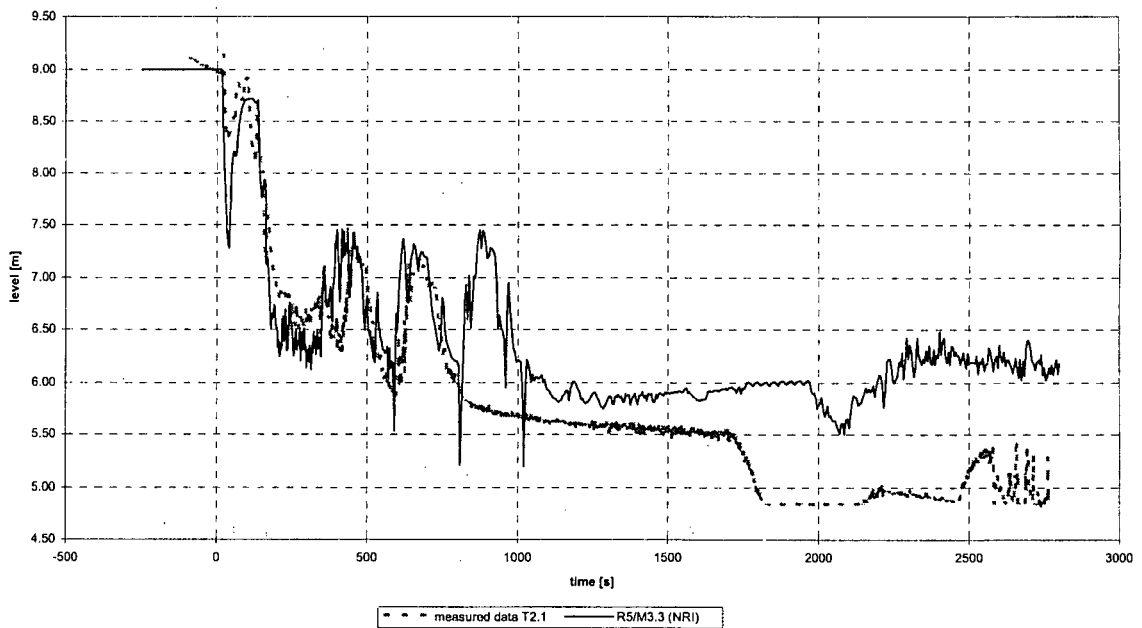

Fig.C-10 Collapsed level in hot leg loop seal – SG side (T2.1)

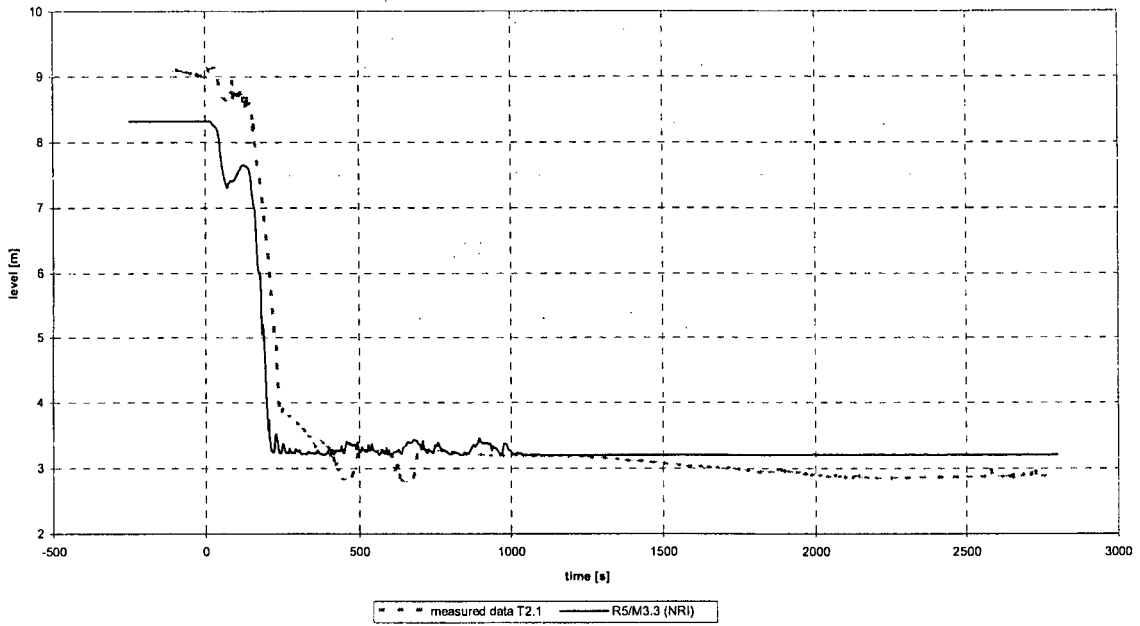

Fig.C-11 Collapsed level in cold leg loop seal – SG side (T2.1)

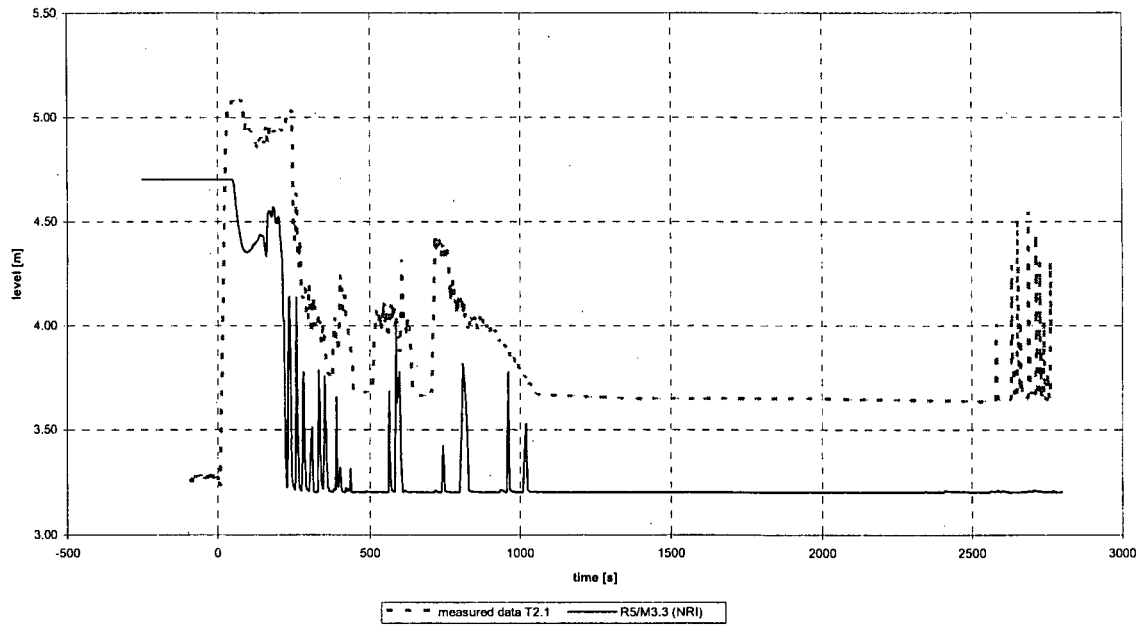

Fig.C-12 Collapsed level in cold leg loop seal – reactor side (T2.1)

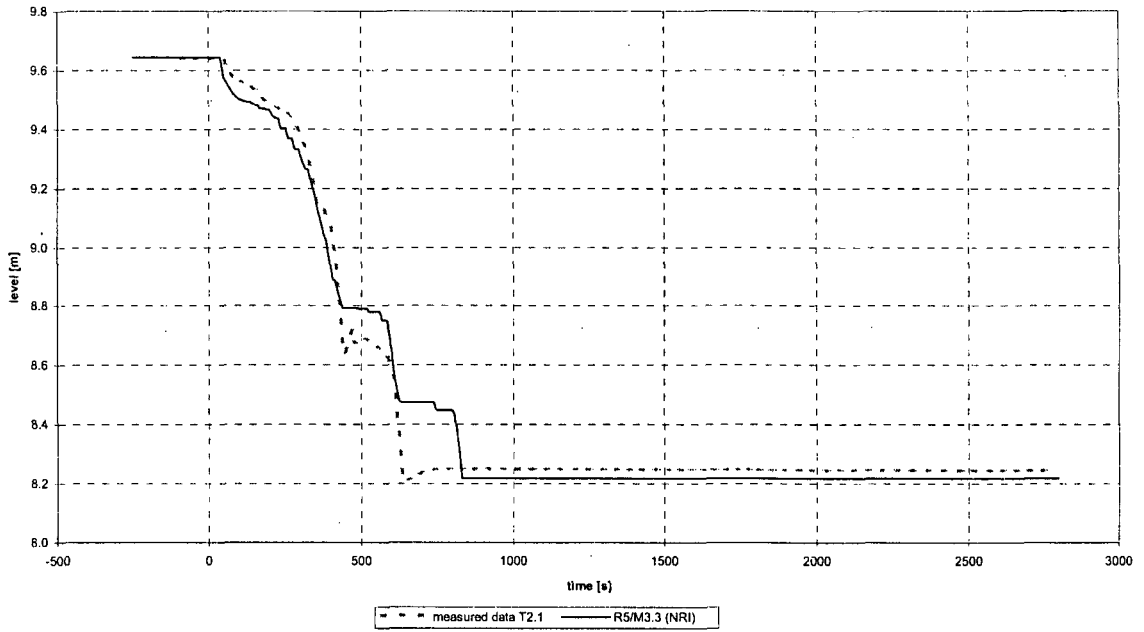

Fig.C-13 Collapsed level in hydroaccumulator SIT-1 (T2.1)

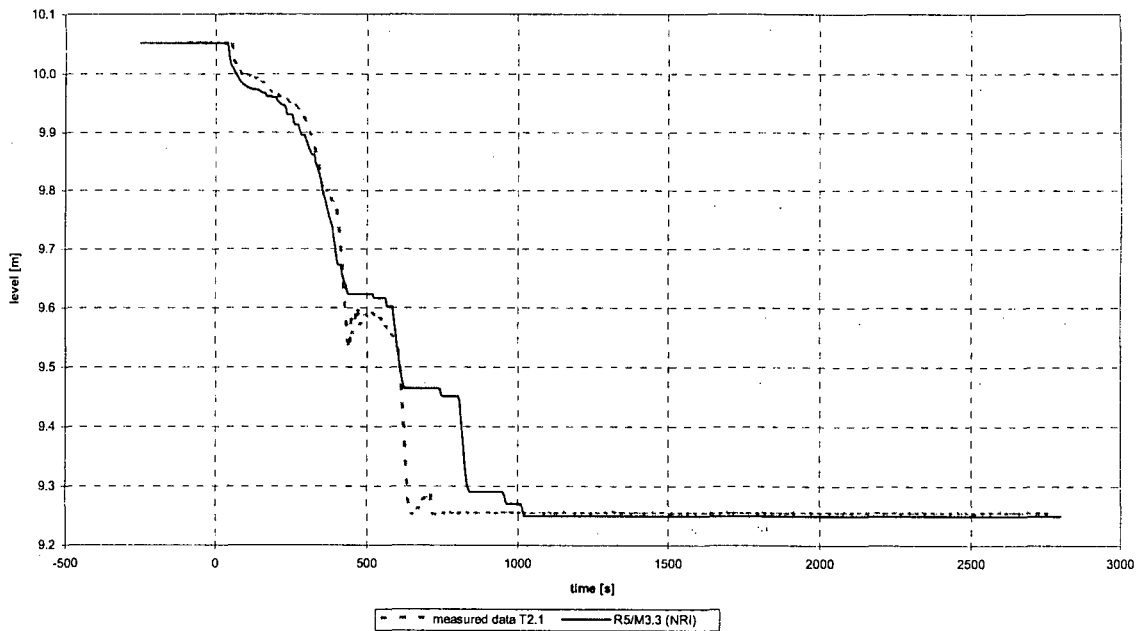

Fig.C-14 Collapsed level in hydroaccumulator SIT-2 (T2.1)

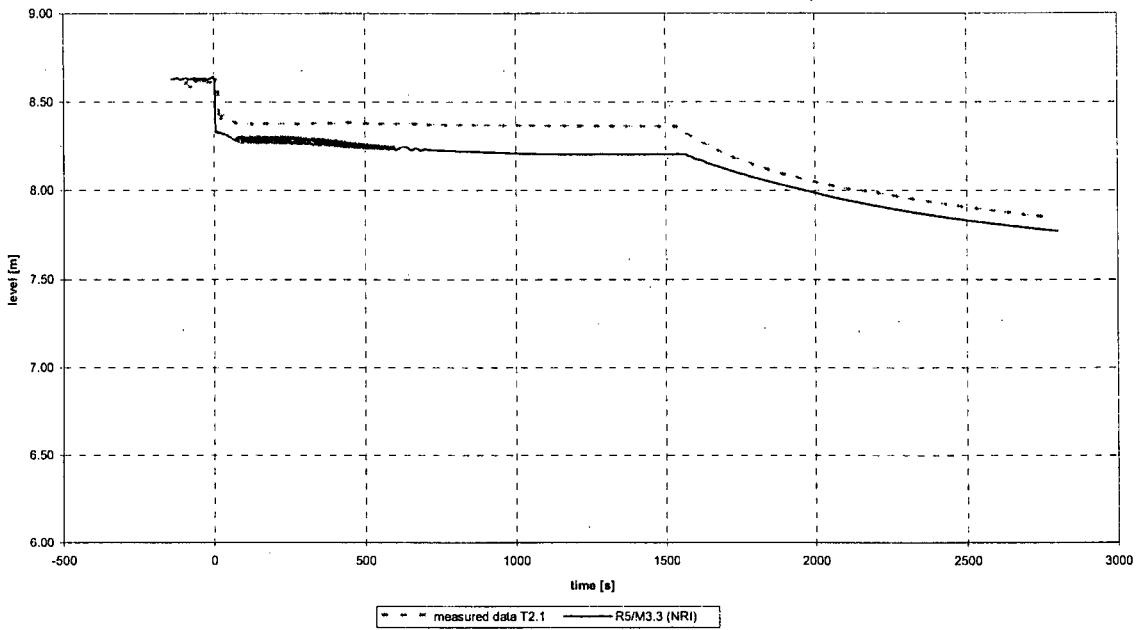

Fig.C-15 Collapsed level in SG secondary side (T2.1)

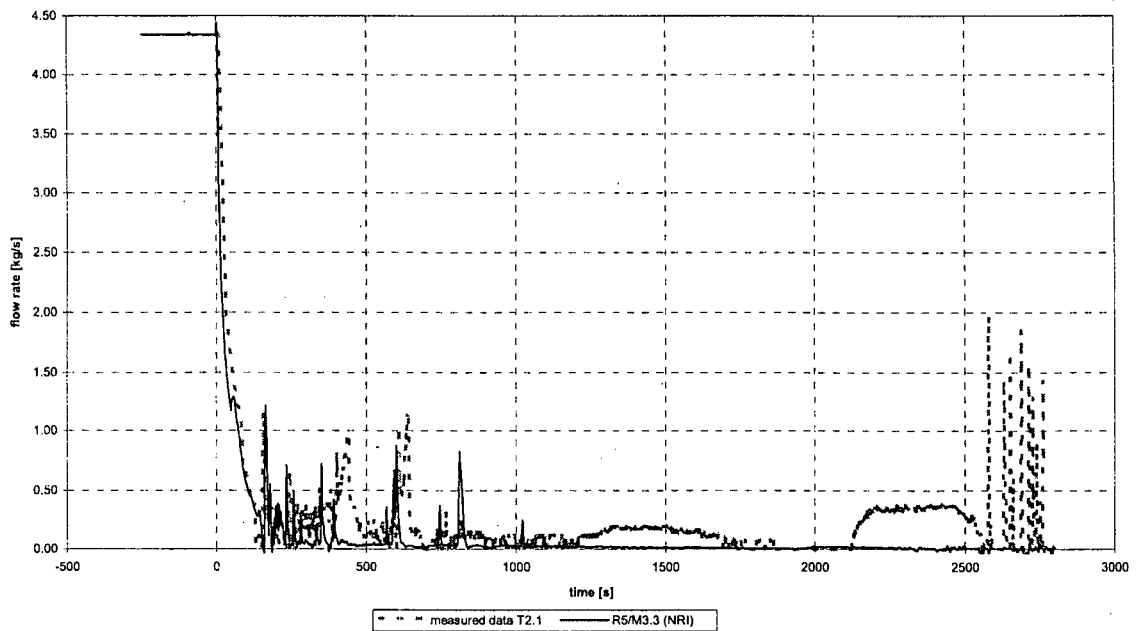

Fig.C-16 Loop mass flow rate (T2.1)

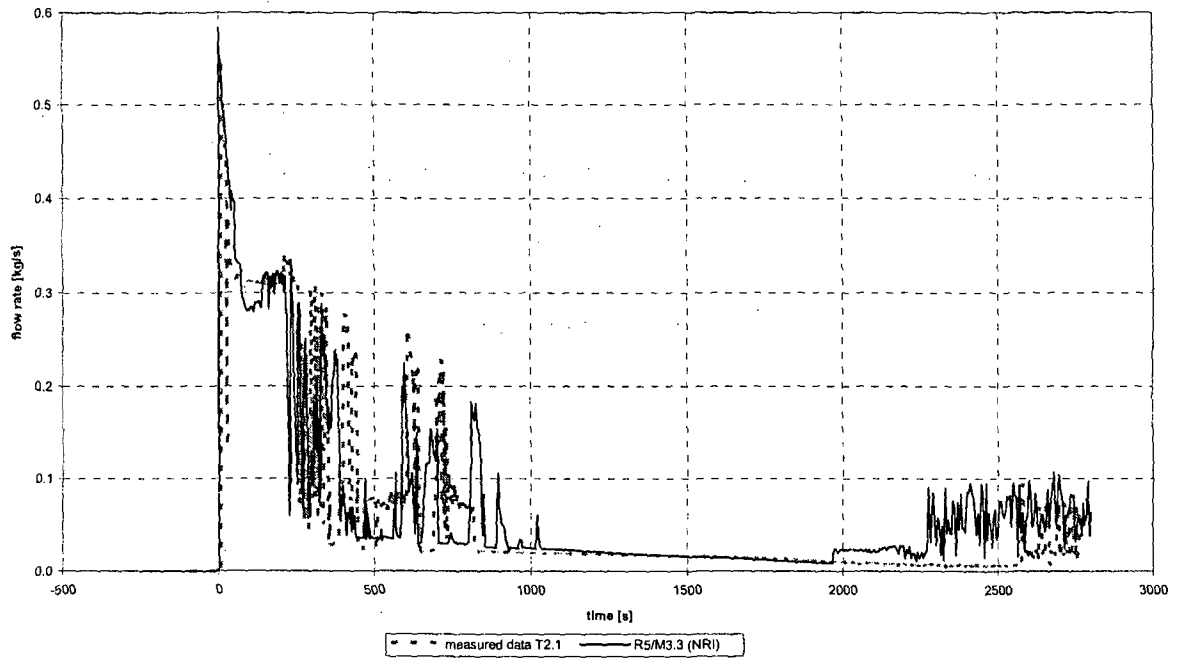

Fig.C-17 Break mass flow rate (T2.1)

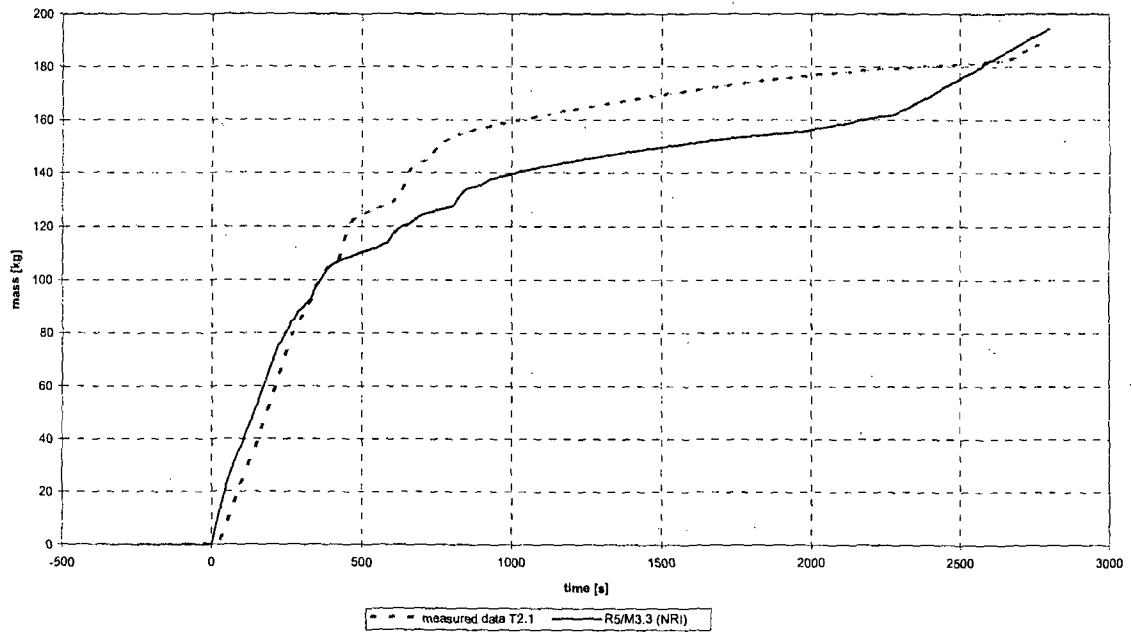

Fig.C-18 Integrated break mass flow rate (T2.1)

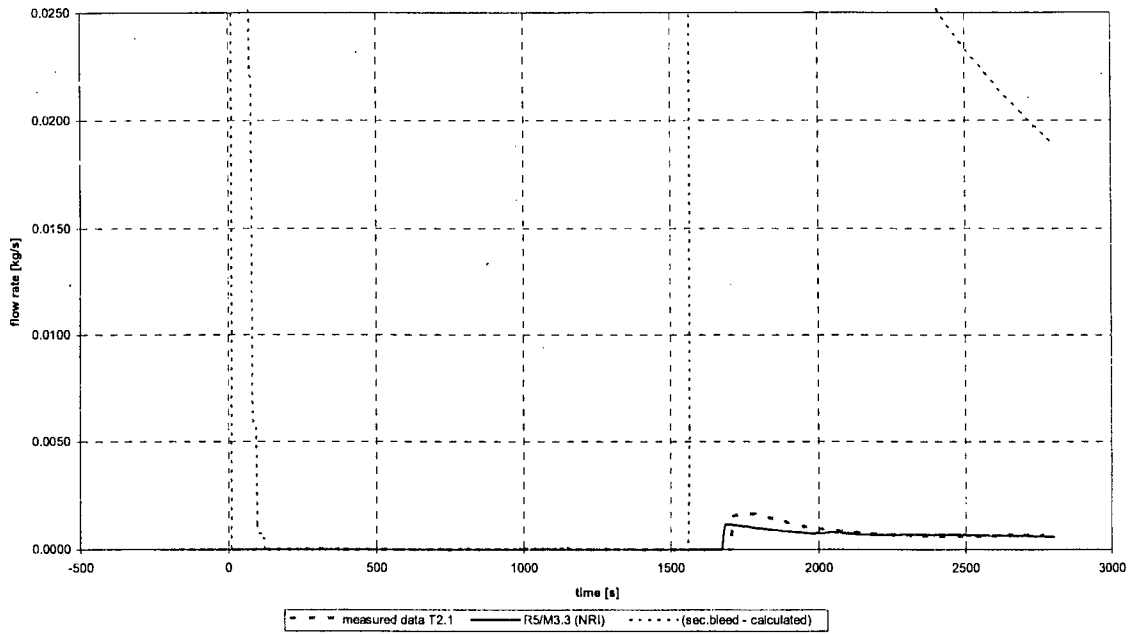

Fig.C-19 PRZ relief valve flow rate (T2.1)

**APPENDIX D COMPLETE SET OF COMPARISON PLOTS FOR
CASE T2.2**

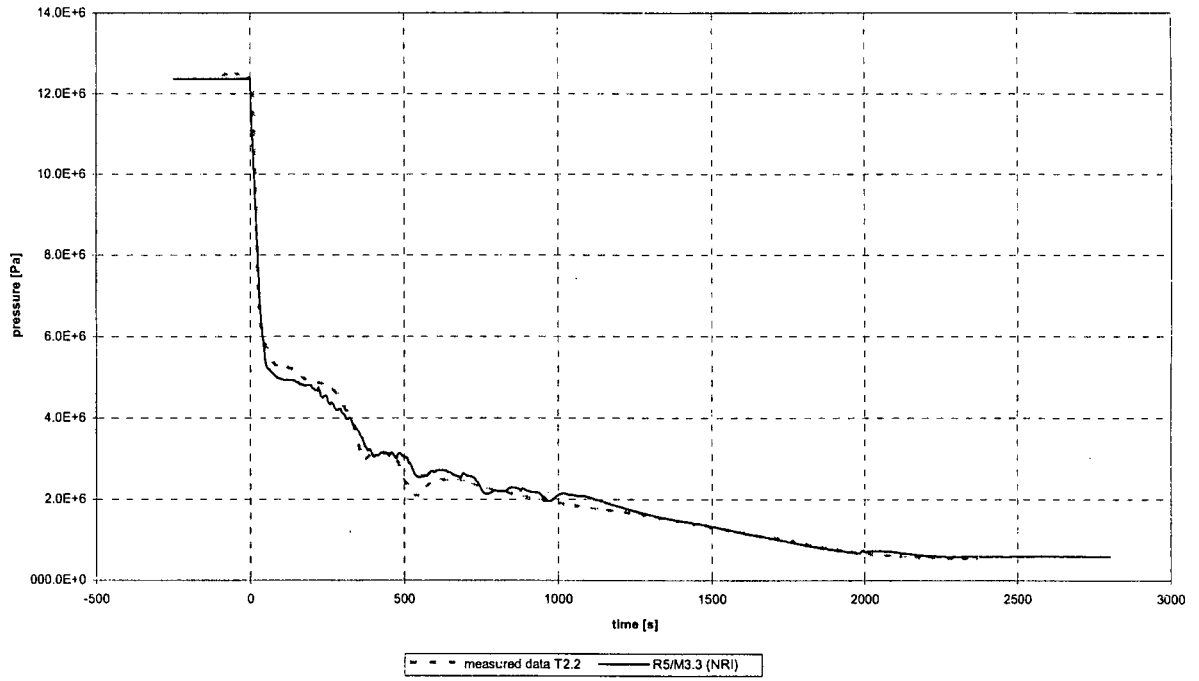

Fig.D-1 Primary pressure (T2.2)

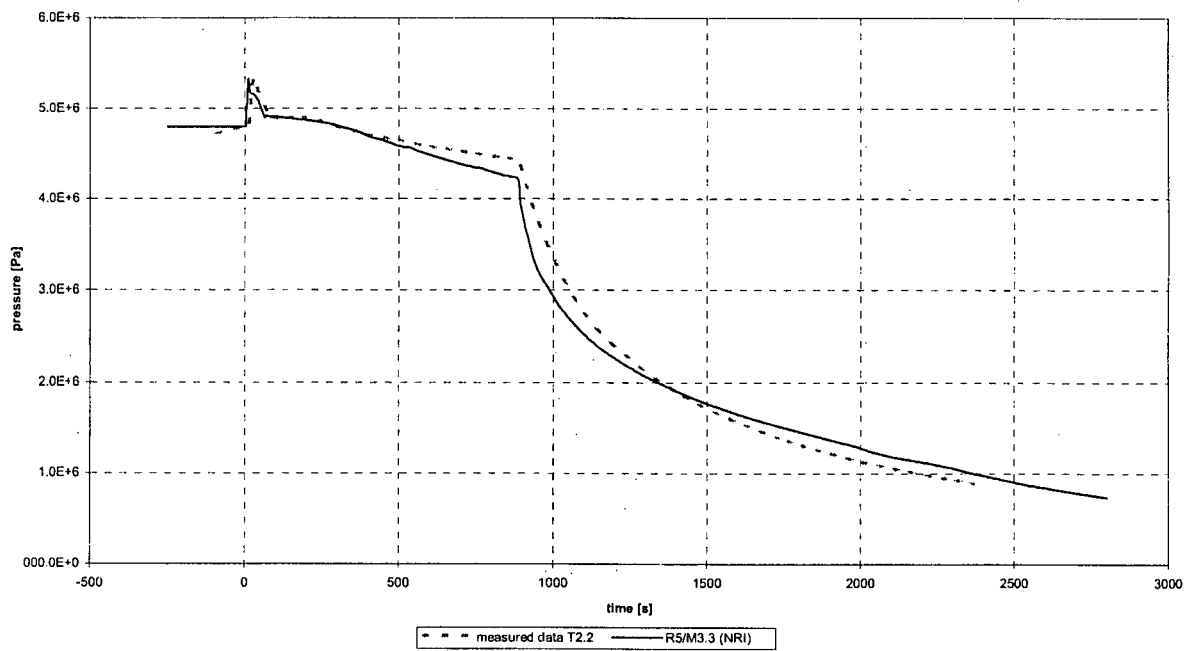

Fig.D-2 Secondary pressure (T2.2)

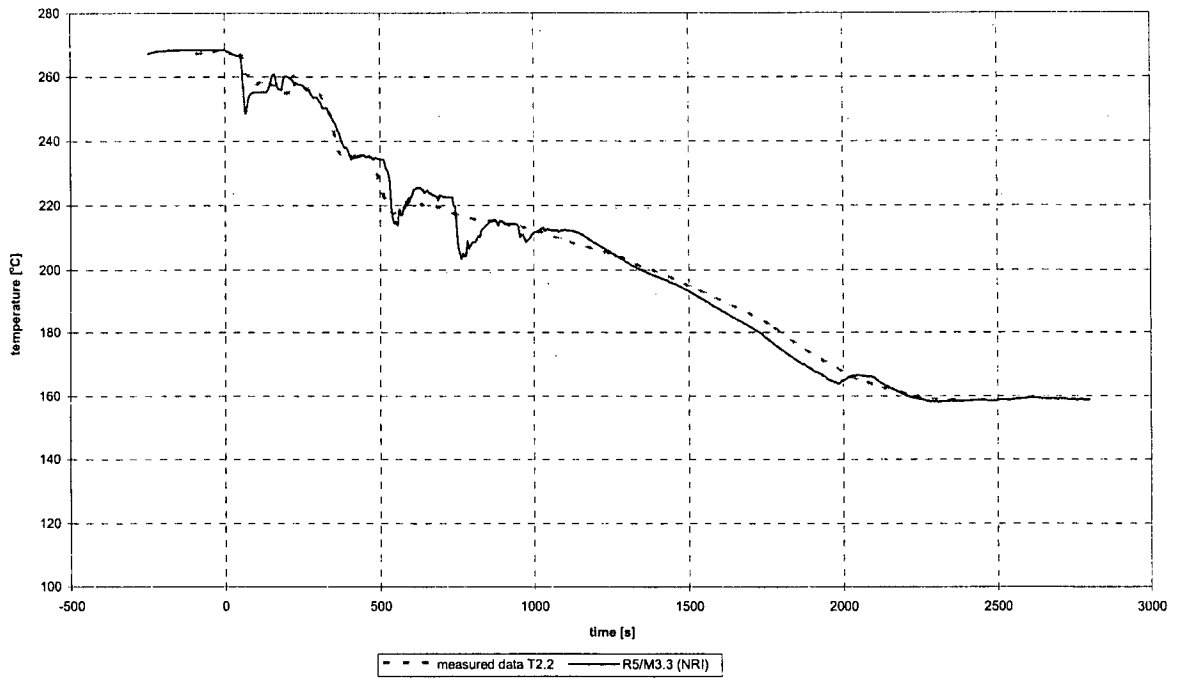

Fig.D-3 Core inlet temperature (T2.2)

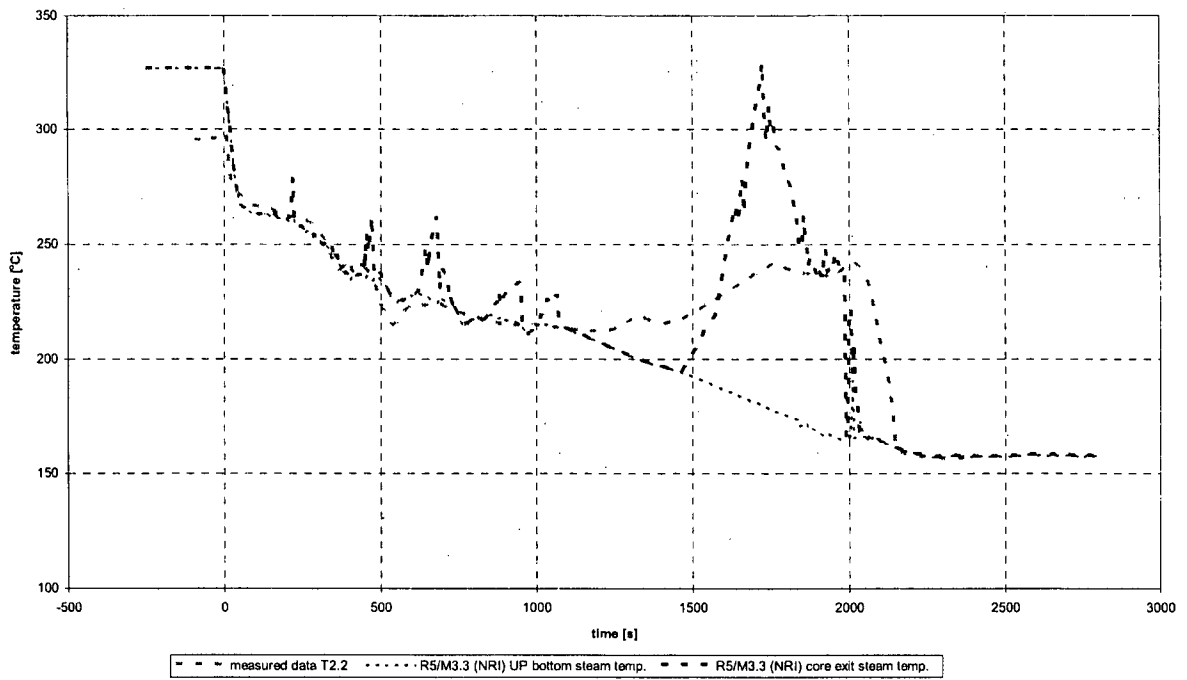

Fig.D-4 Core outlet temperature (T2.2)

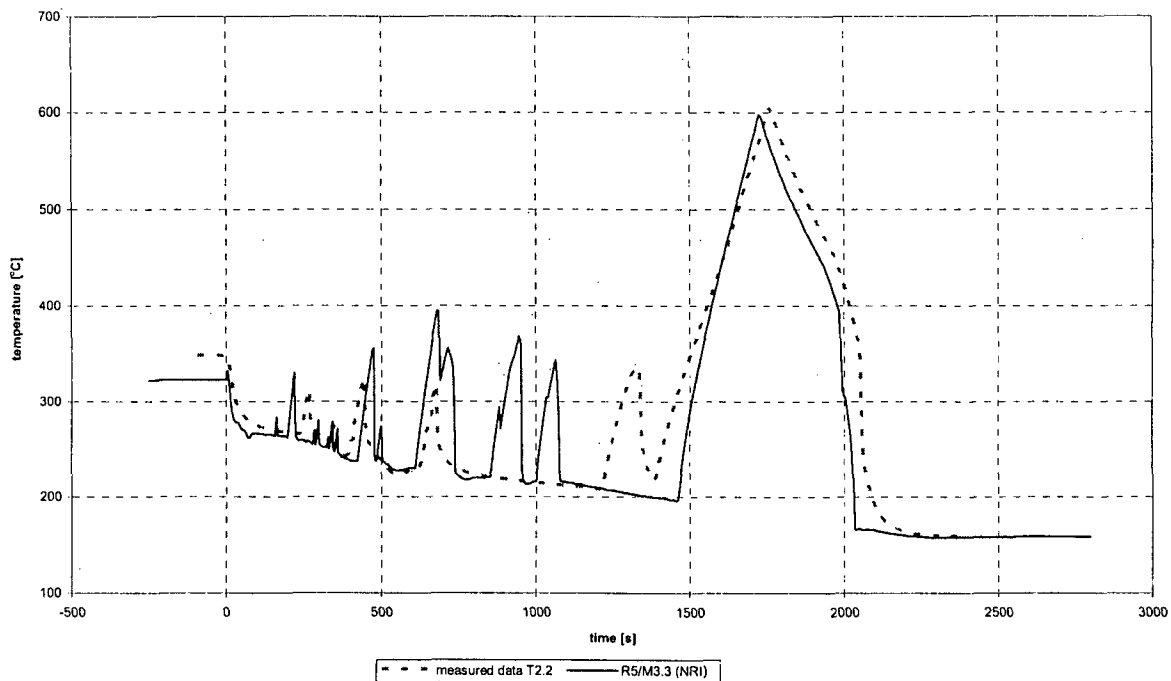

Fig.D-5 Cladding temperature (T2.2)

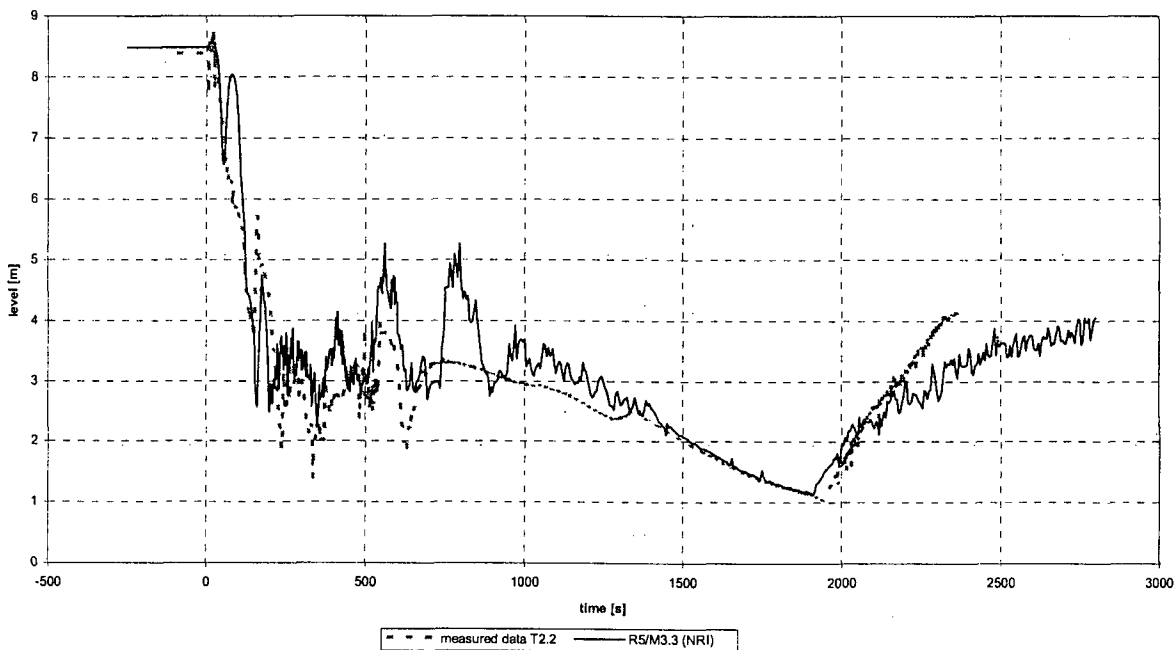

Fig.D-6 Collapsed level in reactor (T2.2)

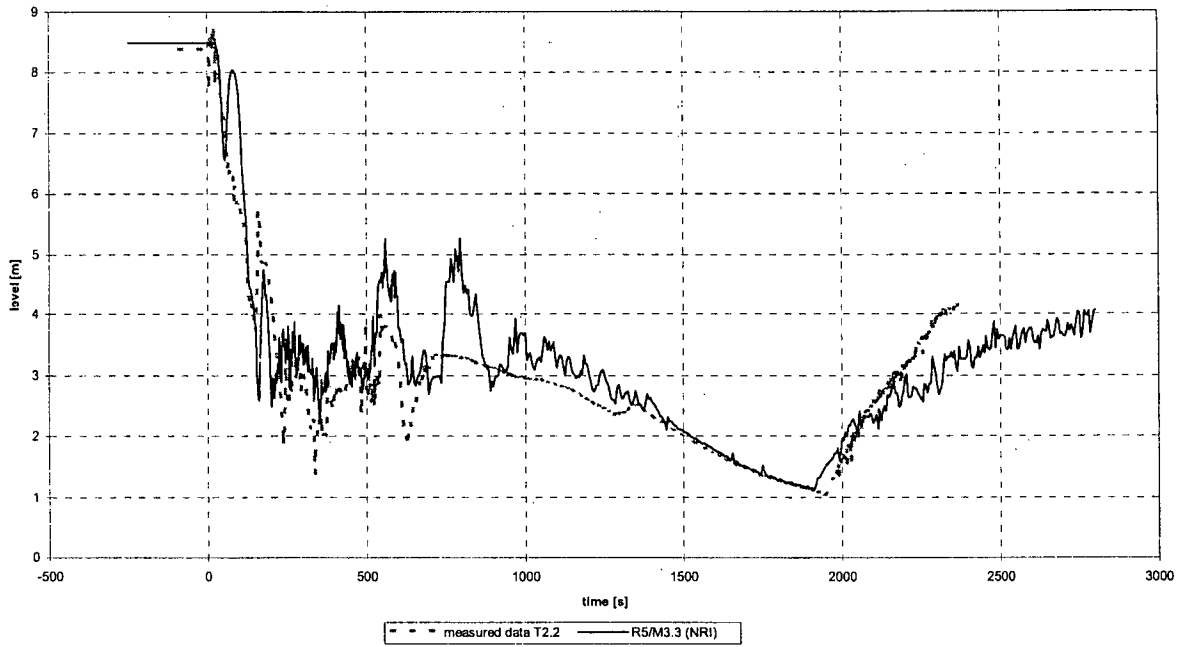

Fig.D-7 Collapsed level in reactor downcomer (T2.2)

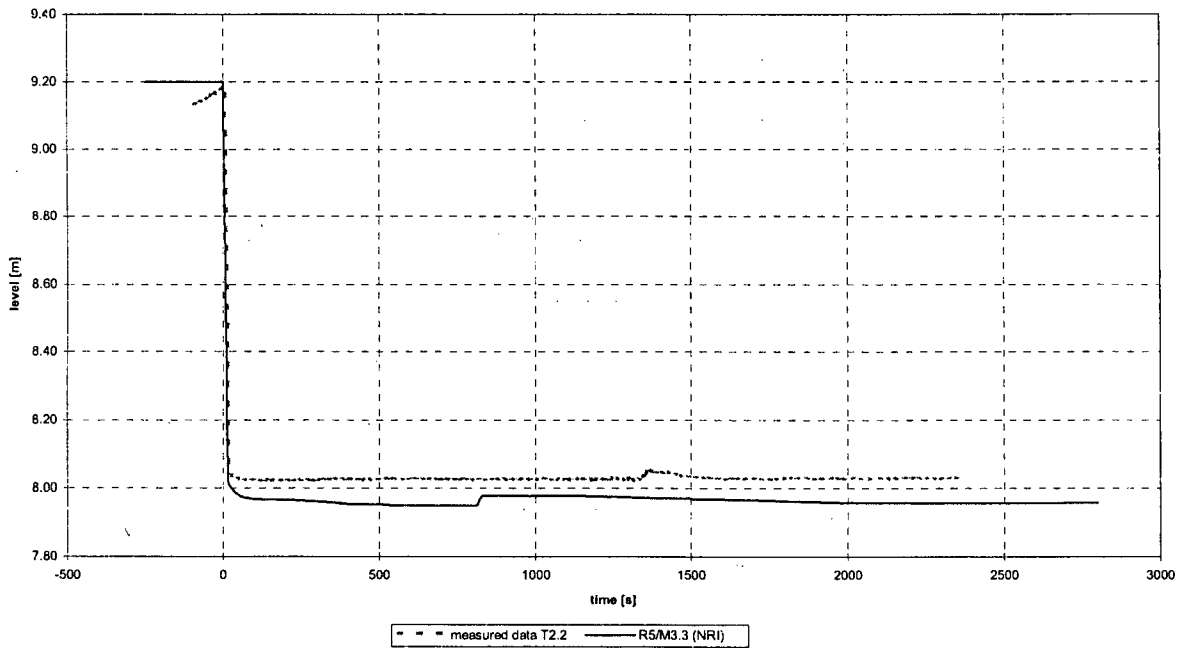

Fig.D-8 Collapsed level in PRZ (T2.2)

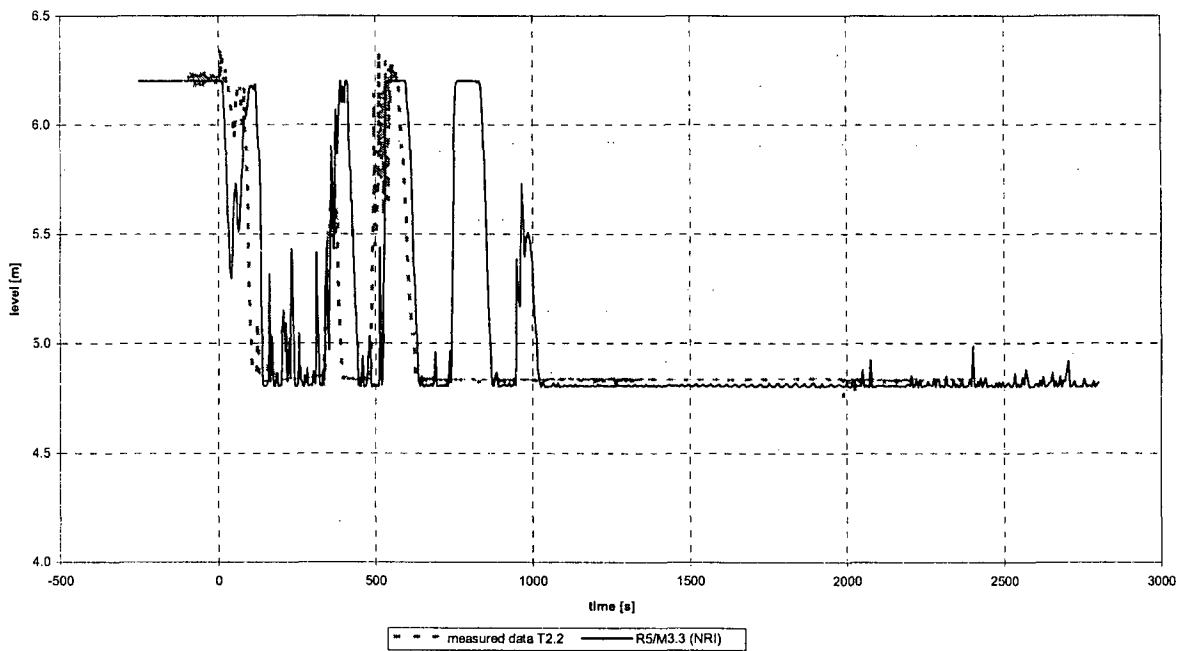

Fig.D-9 Collapsed level in hot leg loop seal – reactor side (T2.2)

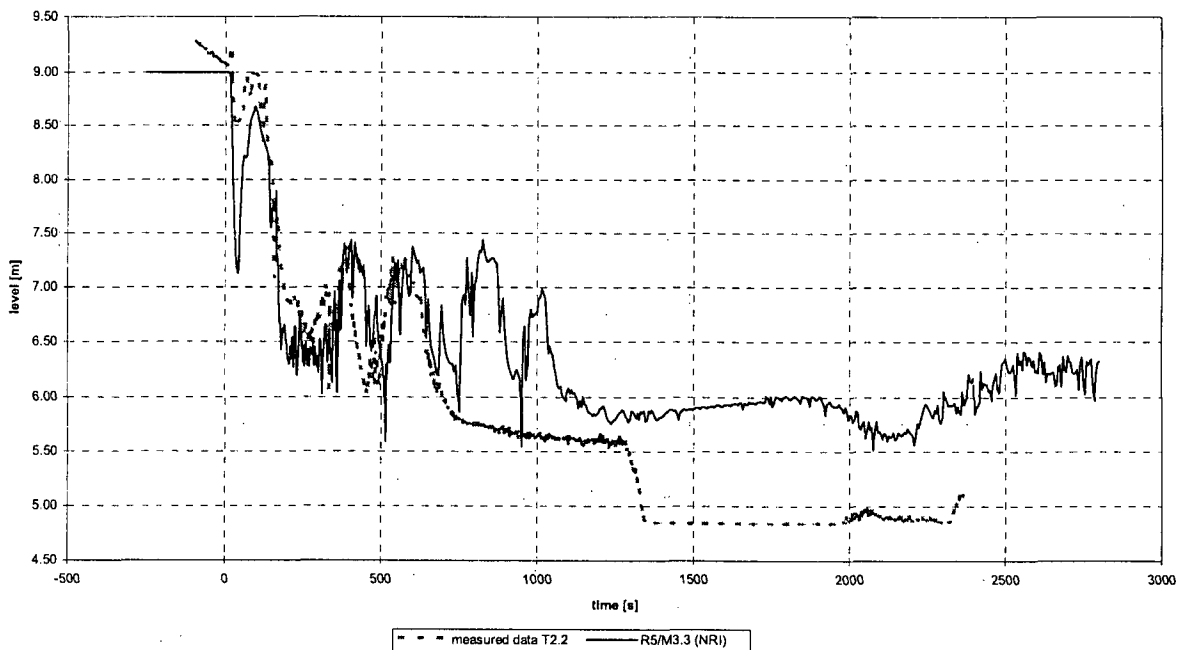

Fig.D-10 Collapsed level in hot leg loop seal – SG side (T2.2)

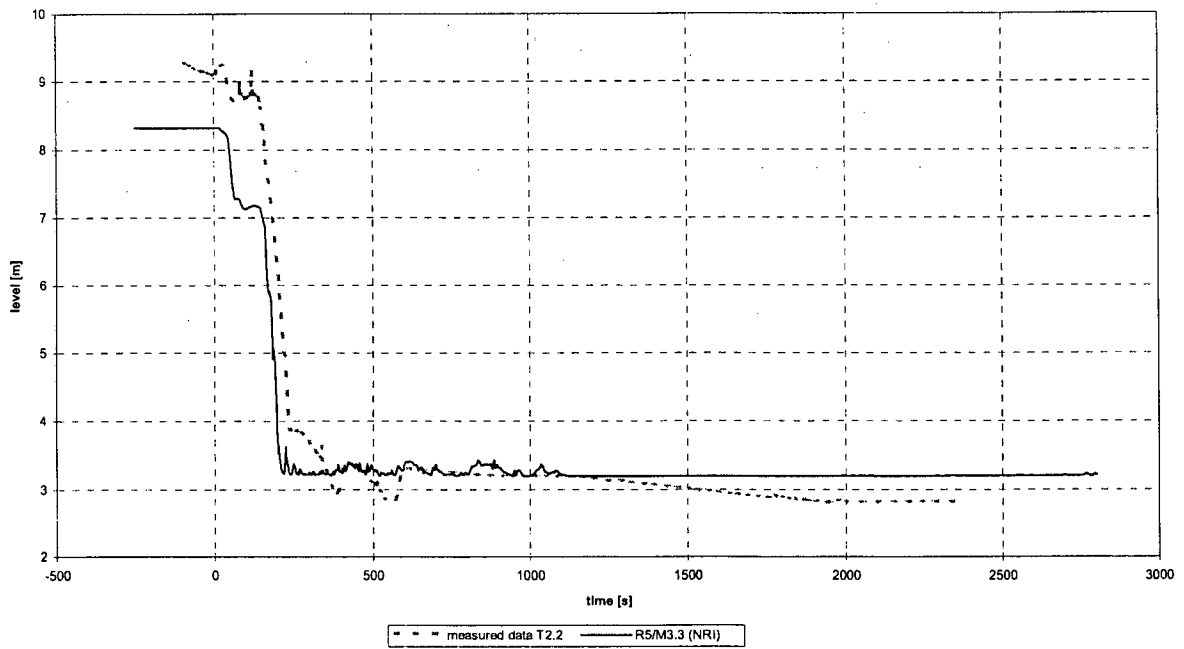

Fig.D-11 Collapsed level in cold leg loop seal – SG side (T2.2)

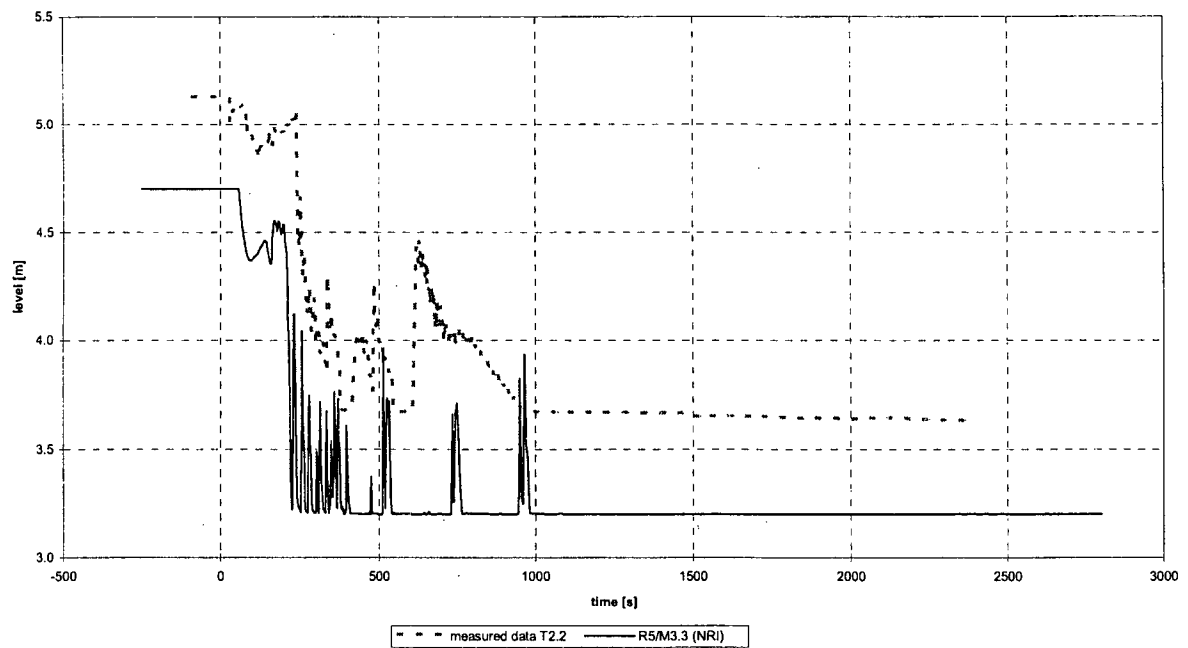

Fig.D-11 Collapsed level in cold leg loop seal – reactor side (T2.2)

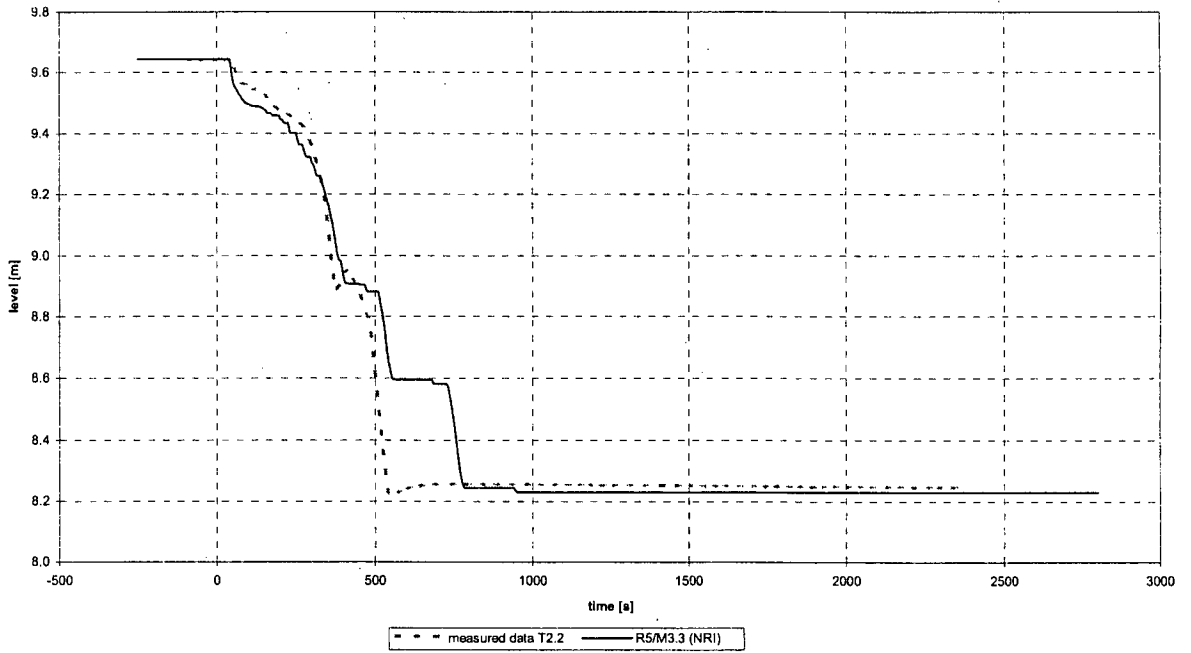

Fig.D-13 Collapsed level in hydroaccumulator SIT-1 (T2.2)

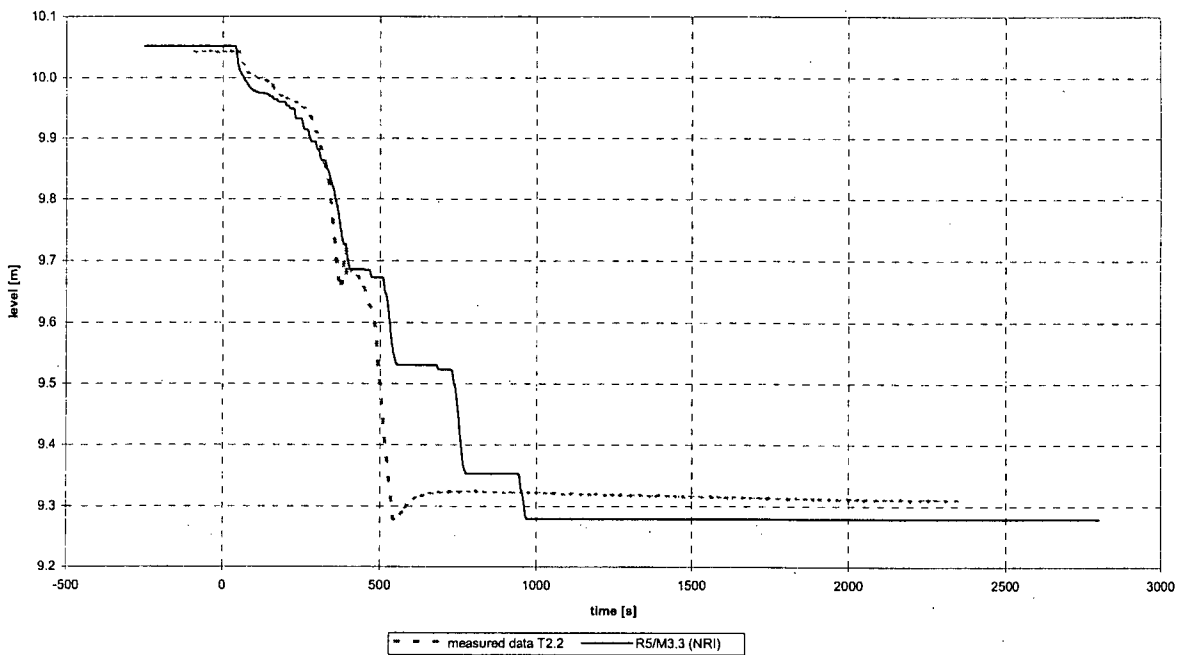

Fig.D-14 Collapsed level in hydroaccumulator SIT-2 (T2.2)

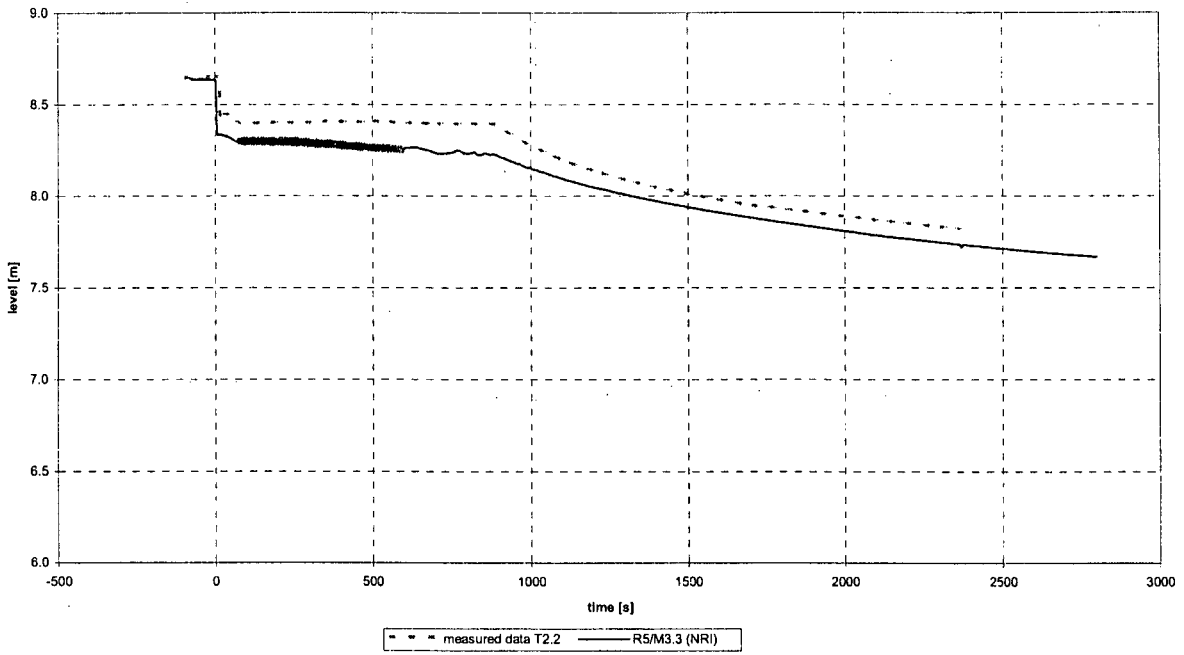

Fig.D-15 Collapsed level in SG secondary side (T2.2)

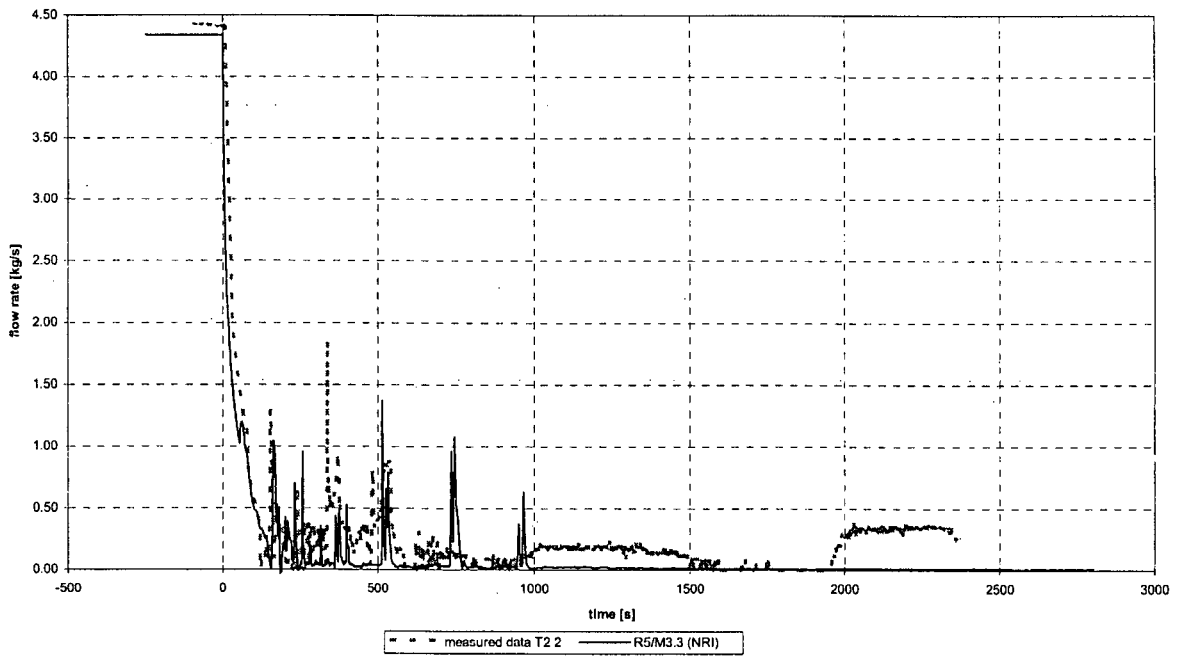

Fig.D-16 Loop mass flow rate (T2.2)

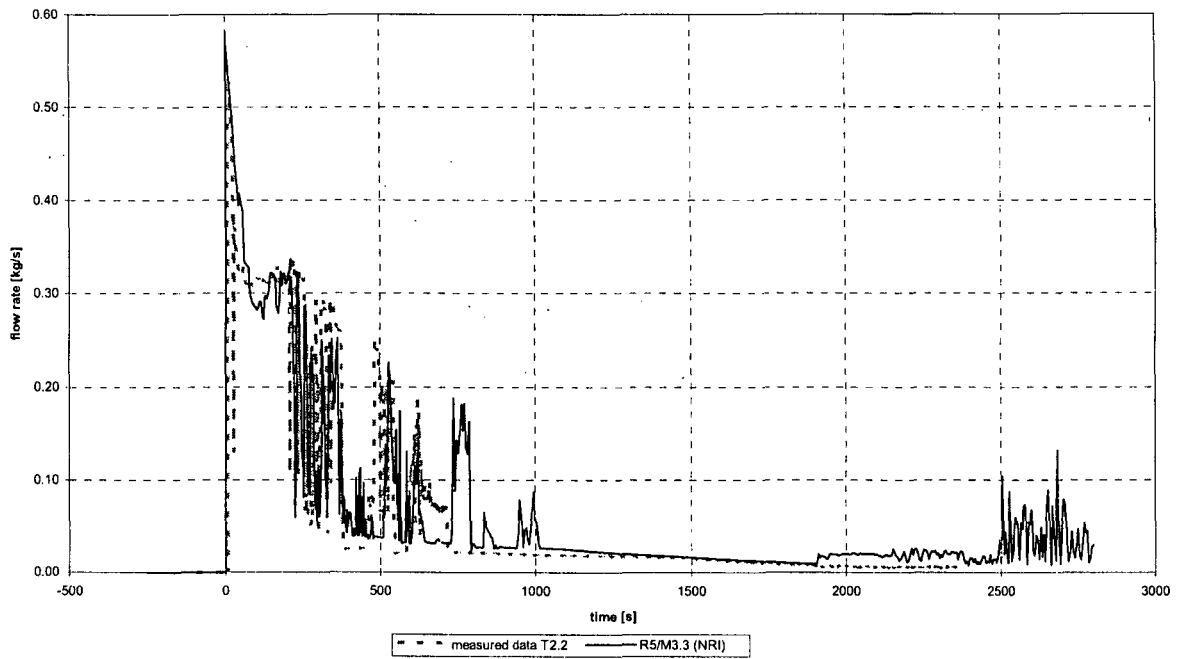

Fig.D-17 Break mass flow rate (T2.2)

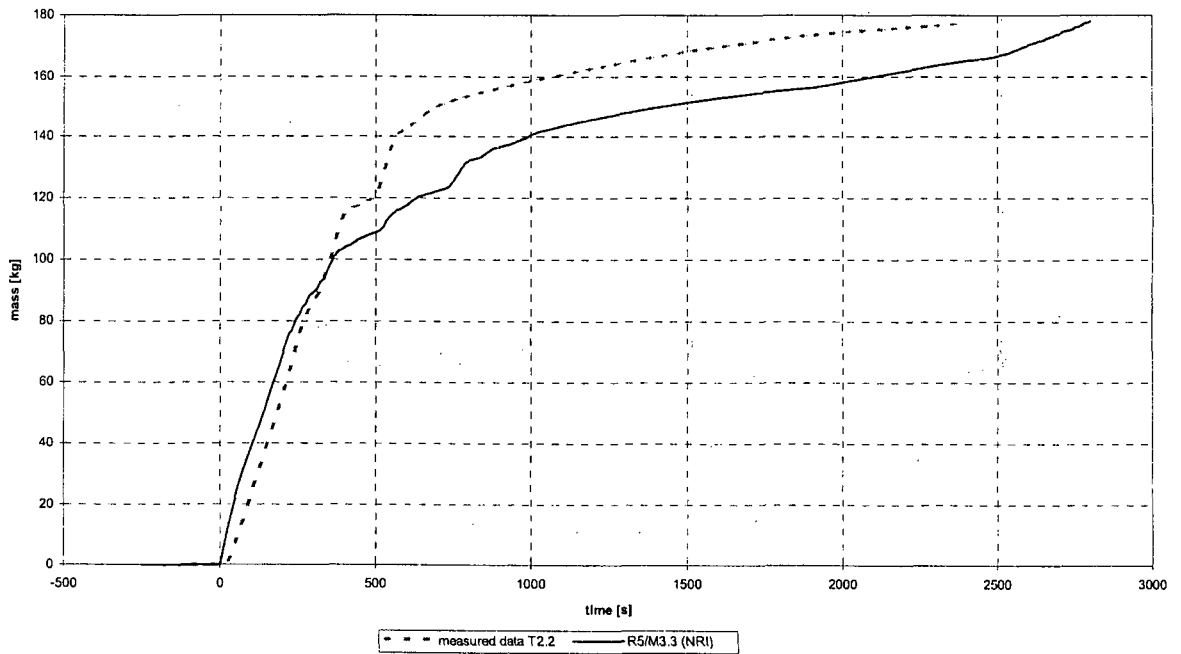

Fig.D-18 Integrated break mass flow rate (T2.2)

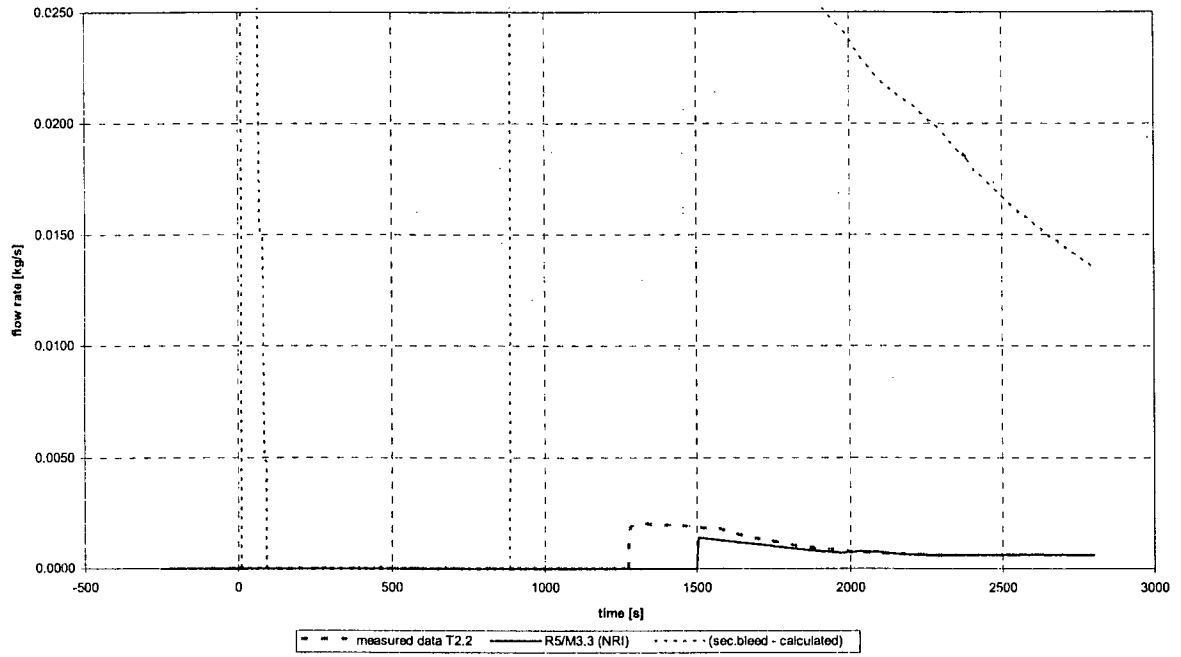

Fig.D-19 PRZ relief valve flow rate (T2.2)

**APPENDIX E COMPLETE SET OF COMPARISON PLOTS FOR
CASE T2.3**

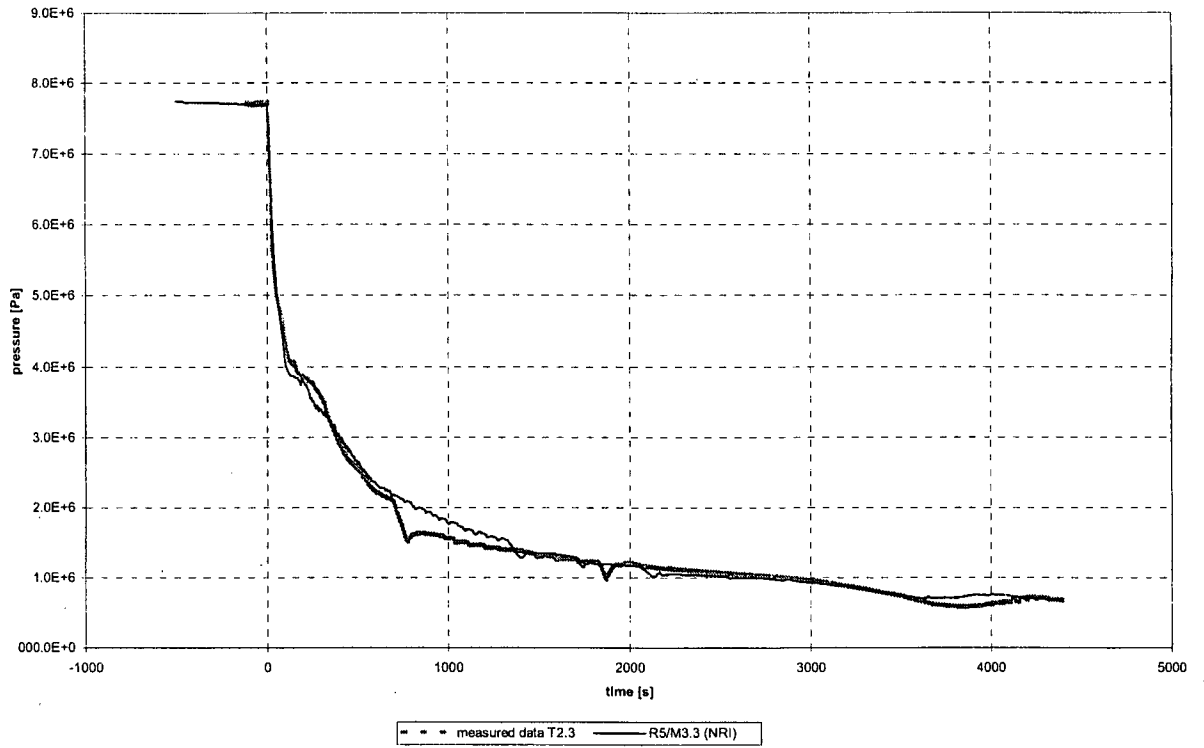

Fig.E-1 Primary pressure (T2.3)

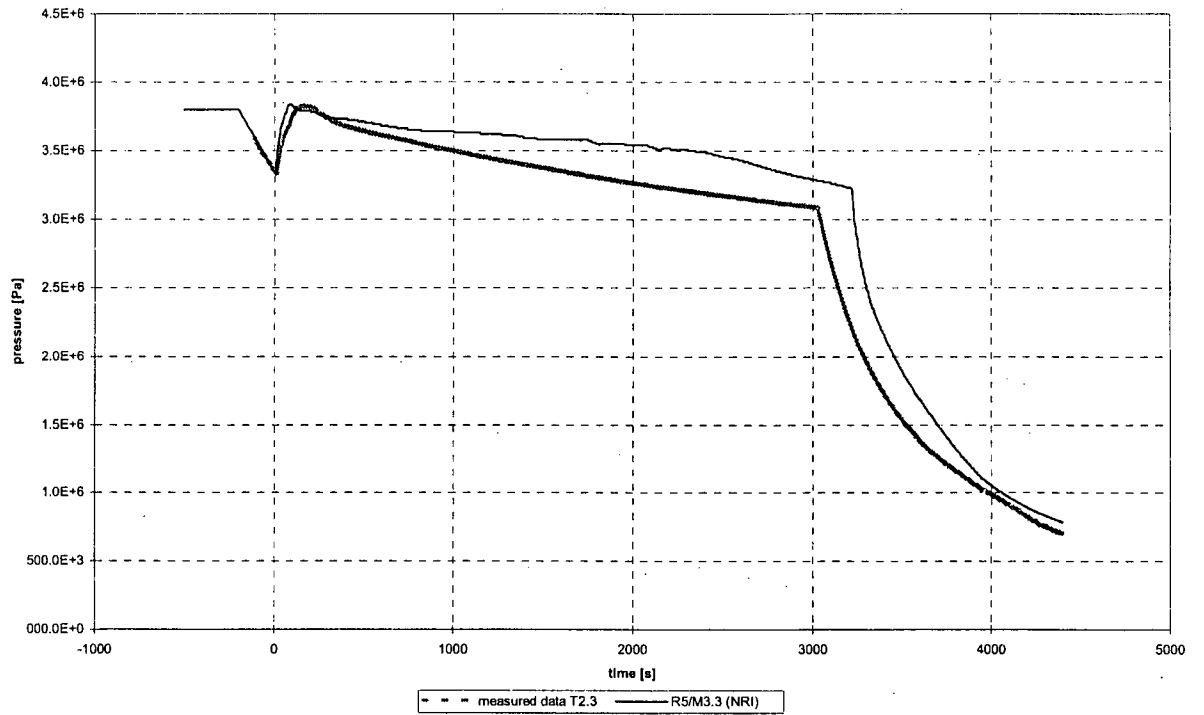

Fig.E-2 Secondary pressure (T2.3)

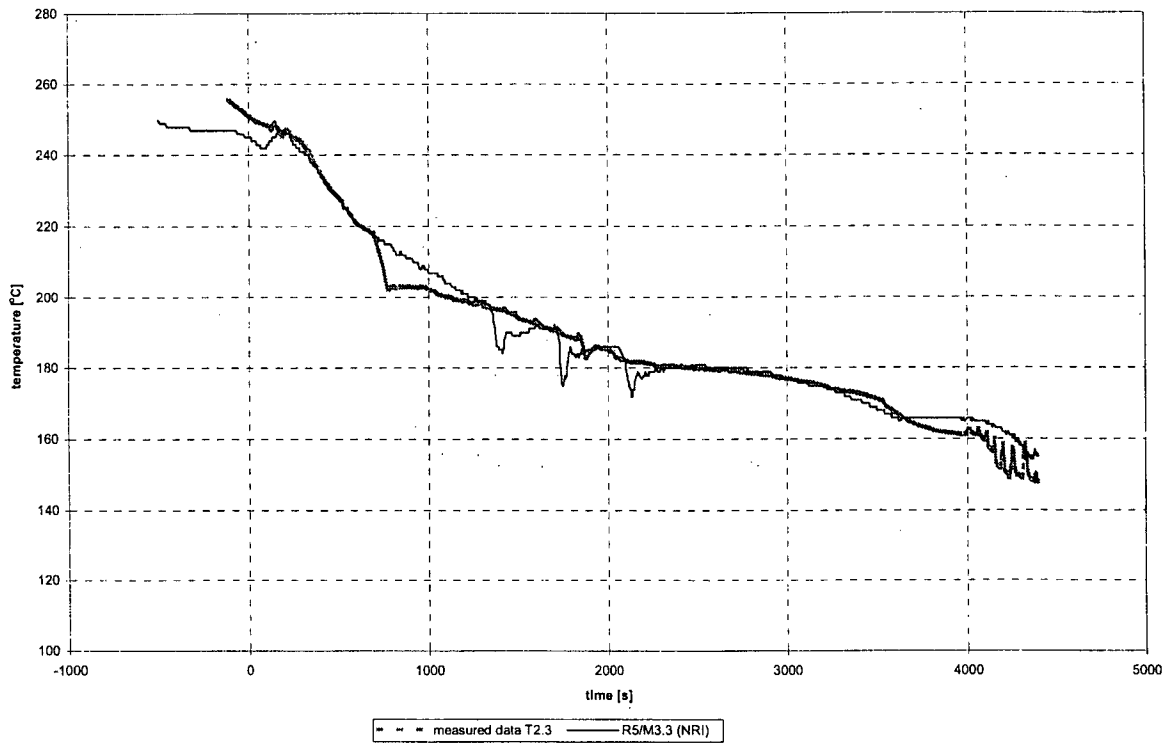

Fig.E-3 Core inlet temperature (T2.3)

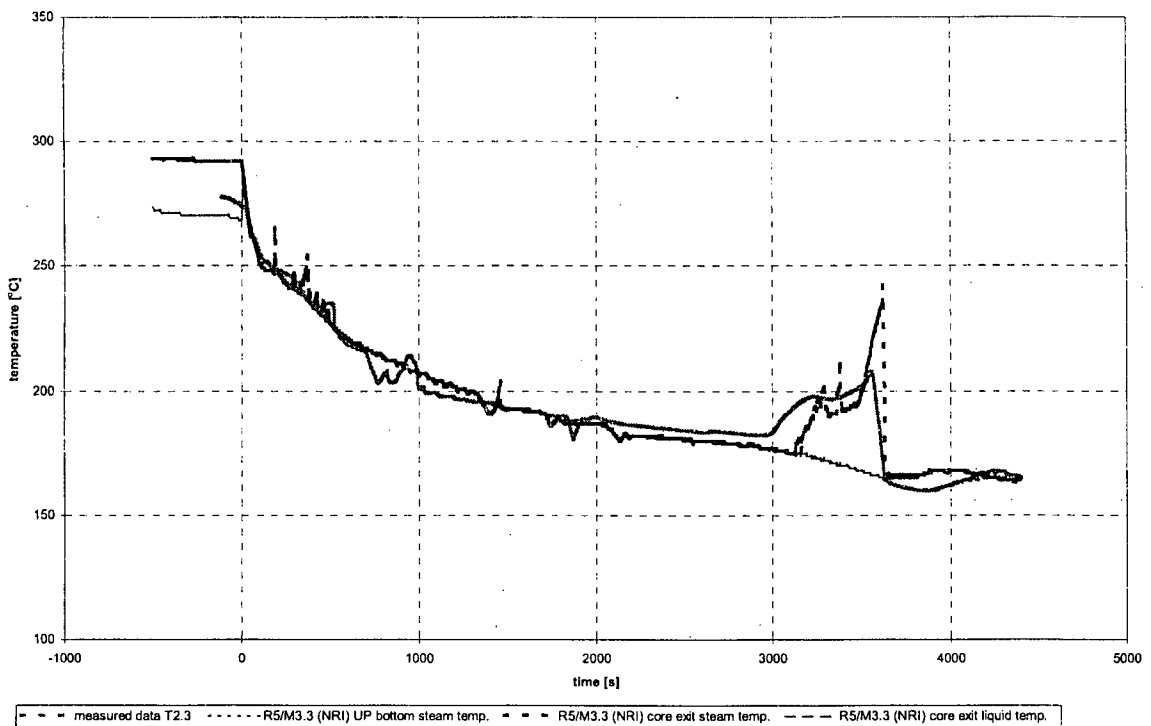

Fig.E-4 Core outlet temperature (T2.3)

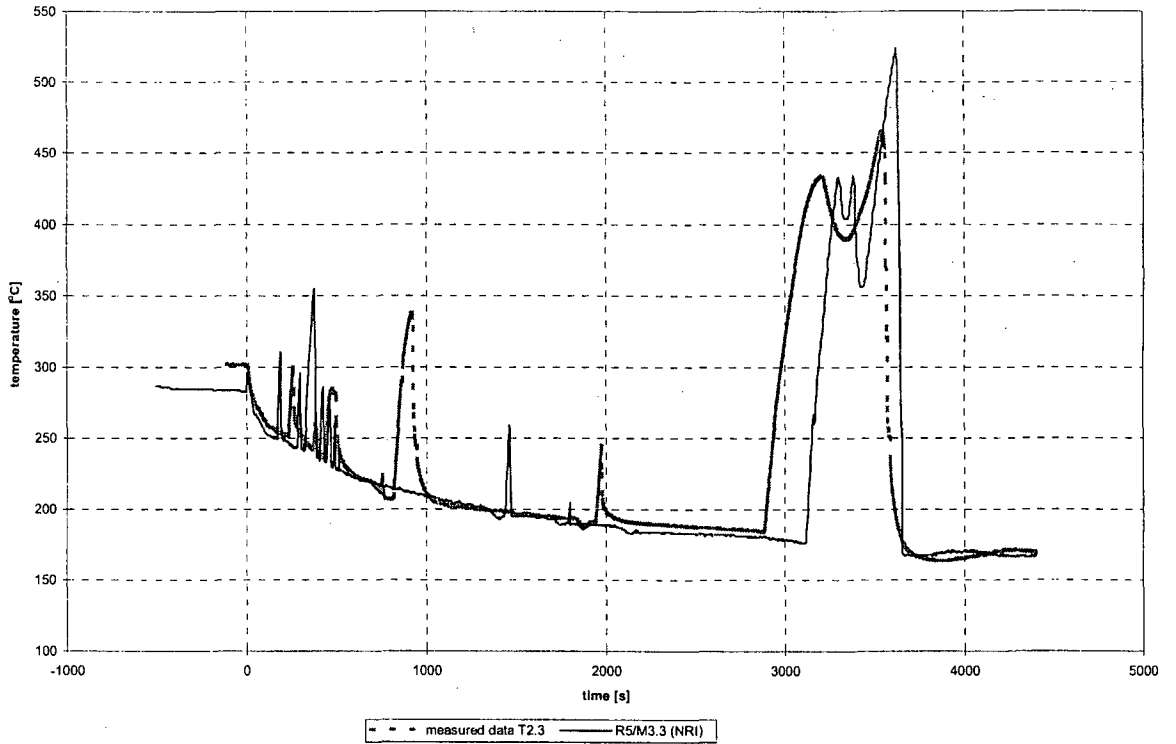

Fig.E-5 Cladding temperature (T2.3)

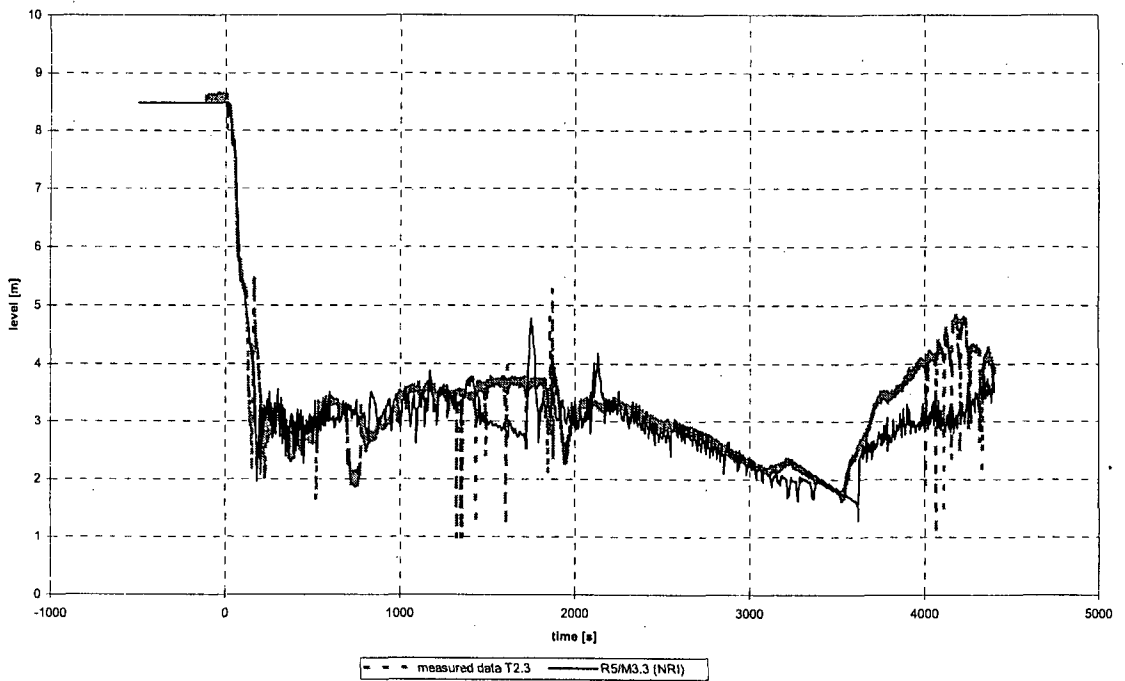

Fig.E-6 Collapsed level in reactor (T2.3)

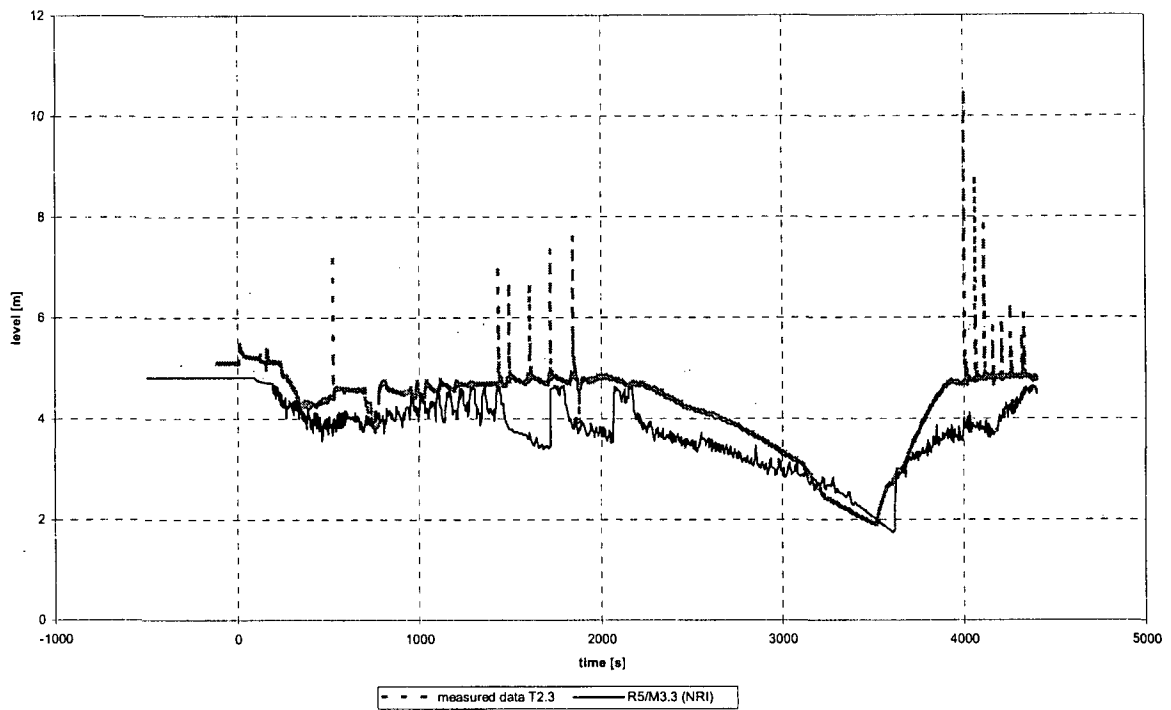

Fig.E-7 Collapsed level in reactor downcomer (T2.3)

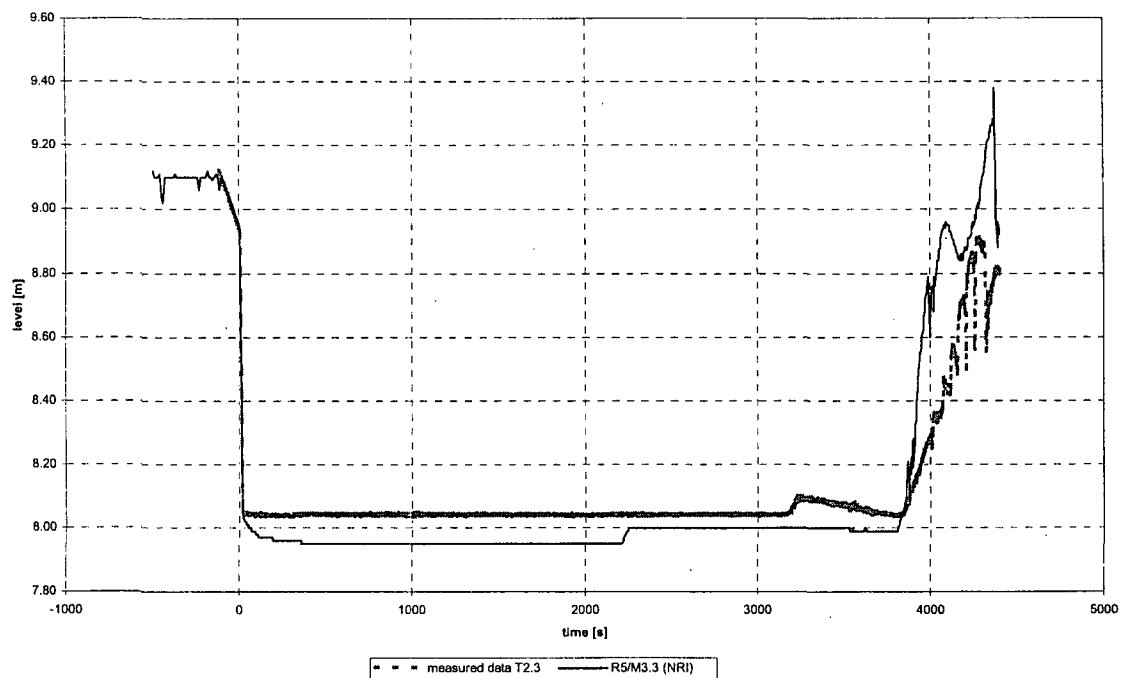

Fig.E-8 Collapsed level in PRZ (T2.3)

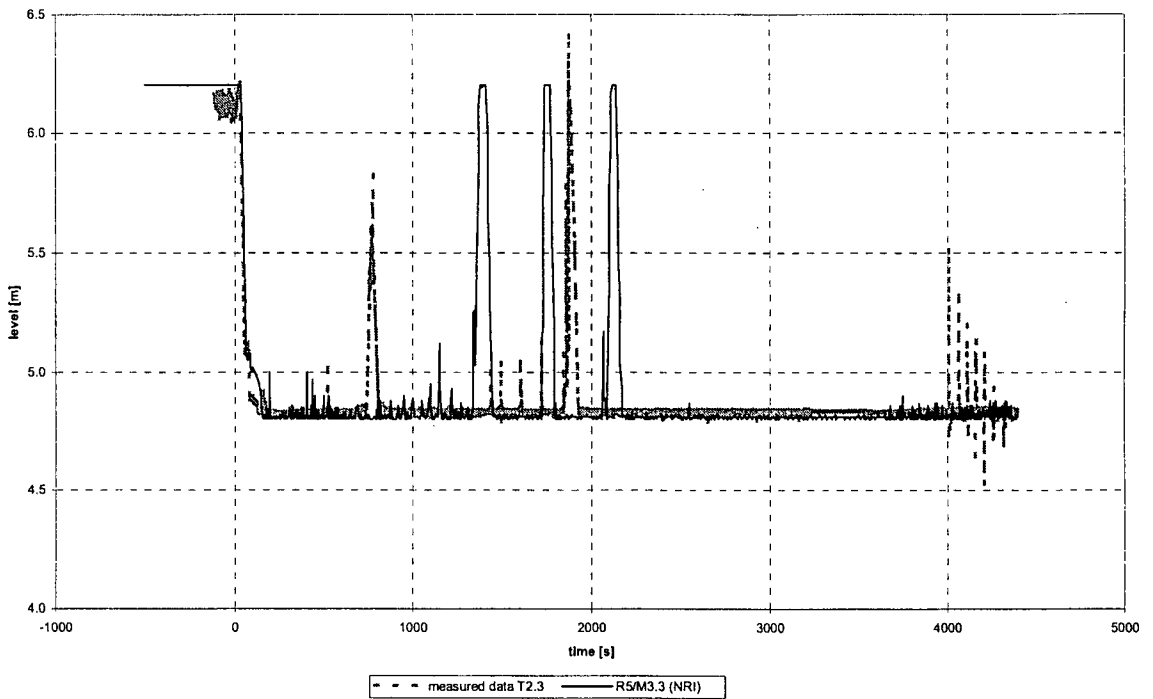

Fig.E-9 Collapsed level in hot leg loop seal – reactor side (T2.3)

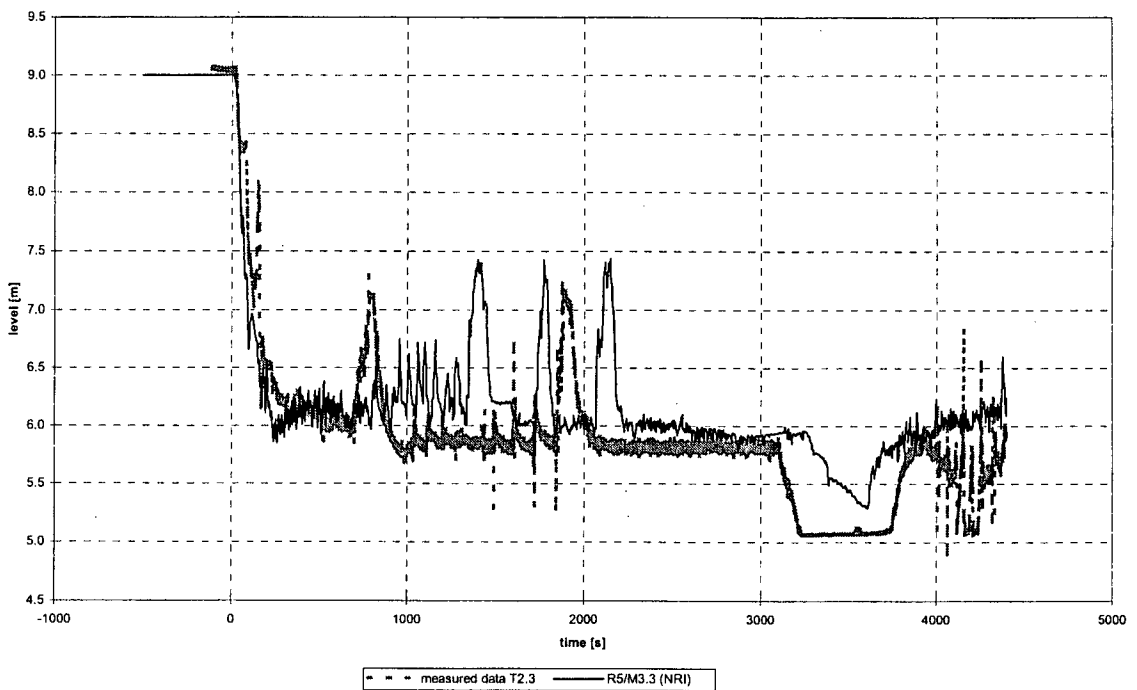

Fig.E-10 Collapsed level in hot leg loop seal – SG side (T2.3)

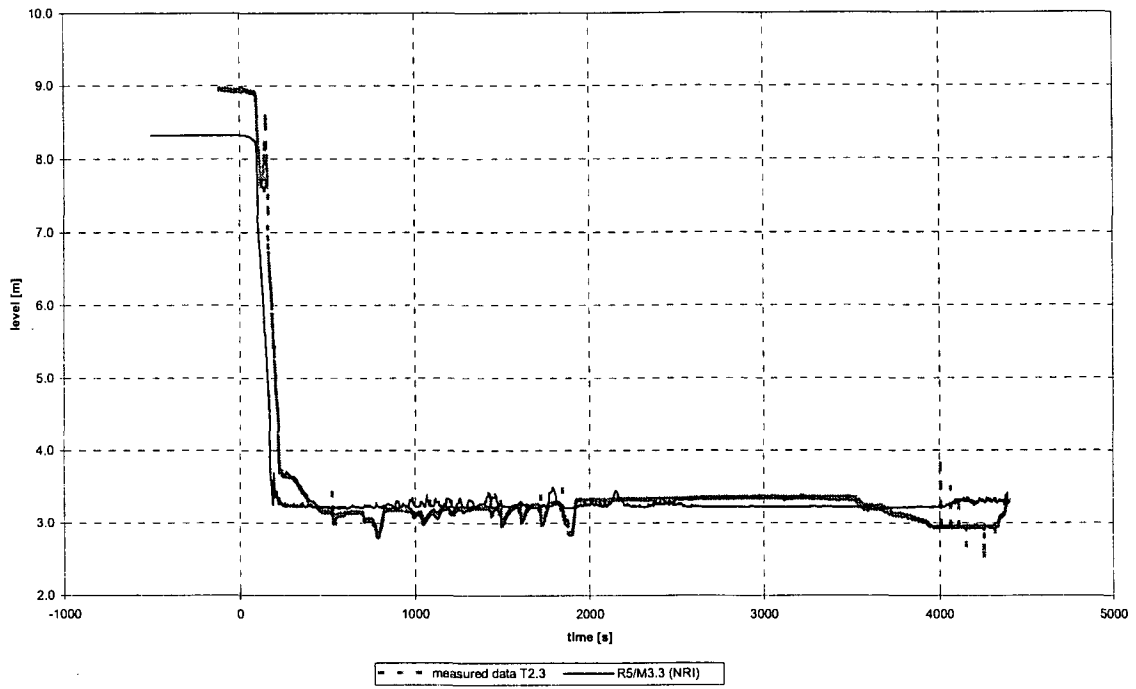

Fig.E-11 Collapsed level in cold leg loop seal – SG side (T2.3)

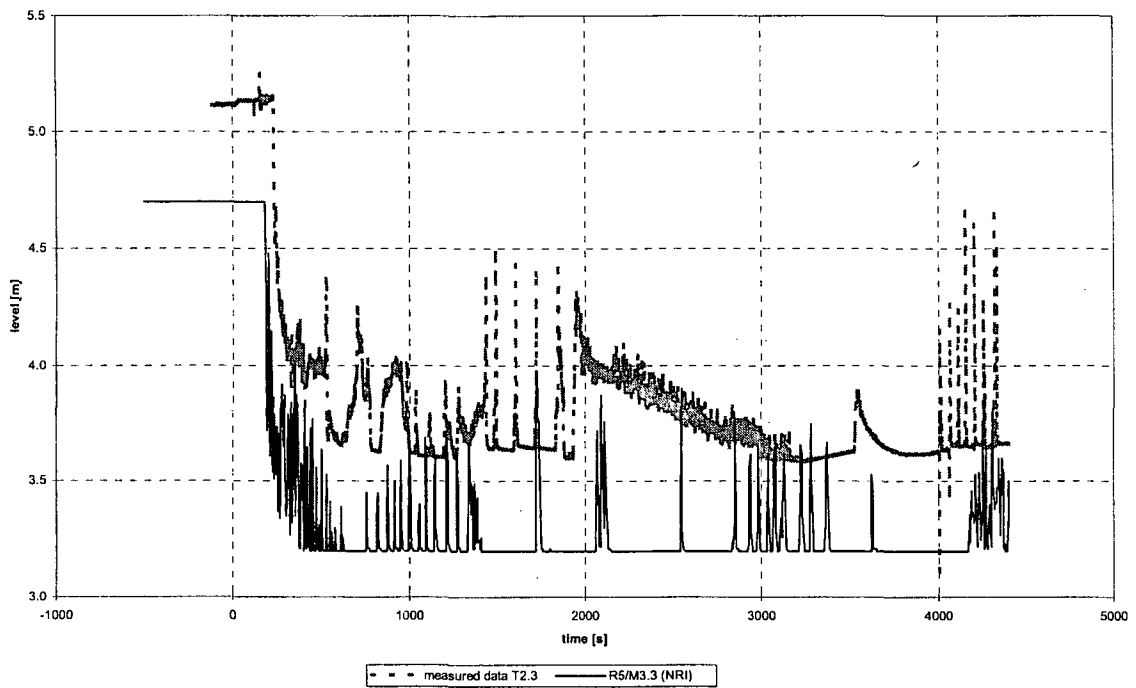

Fig.E-12 Collapsed level in cold leg loop seal – reactor side (T2.3)

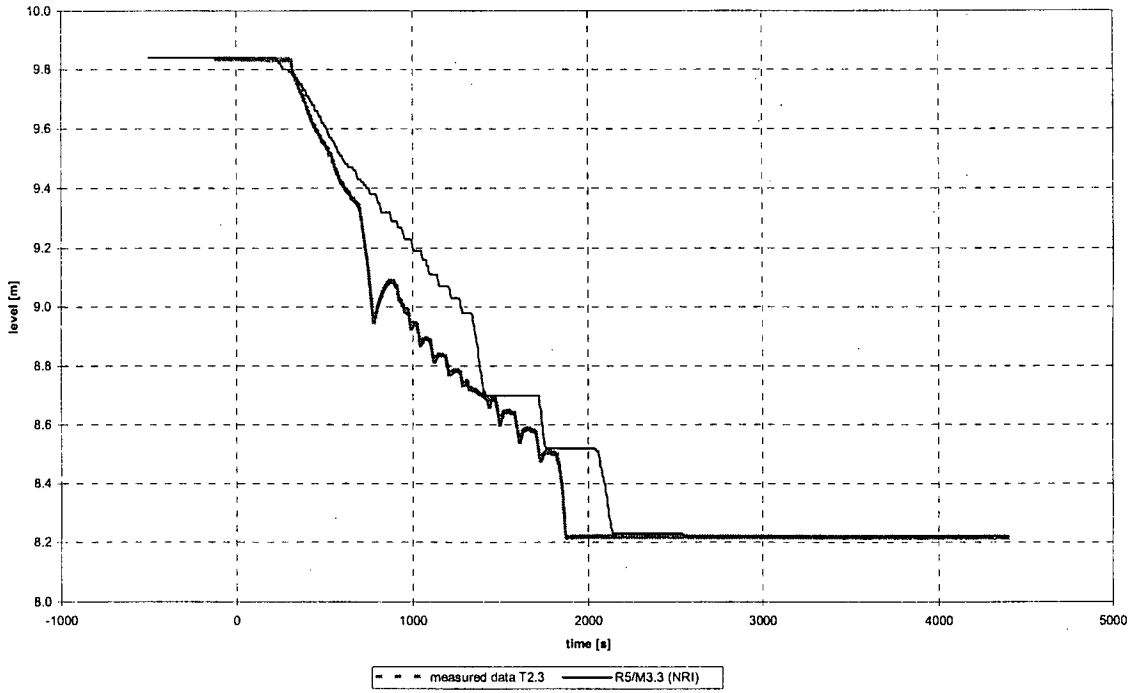

Fig.E-13 Collapsed level in hydroaccumulator SIT-1 (T2.3)

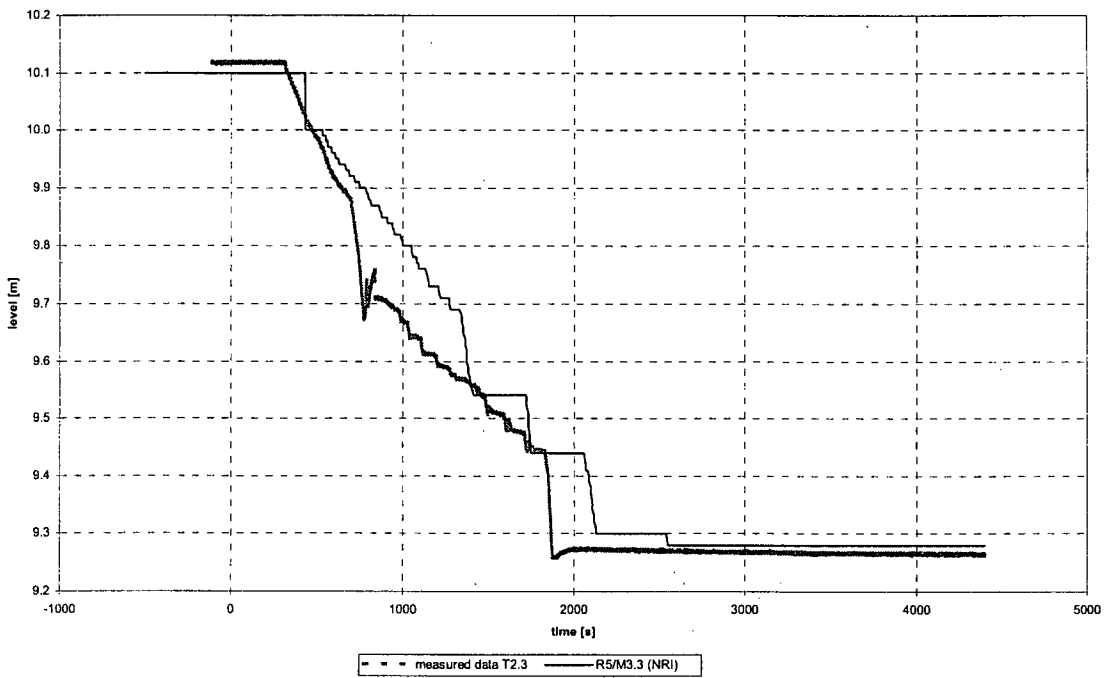

Fig.E-14 Collapsed level in hydroaccumulator SIT-2 (T2.3)

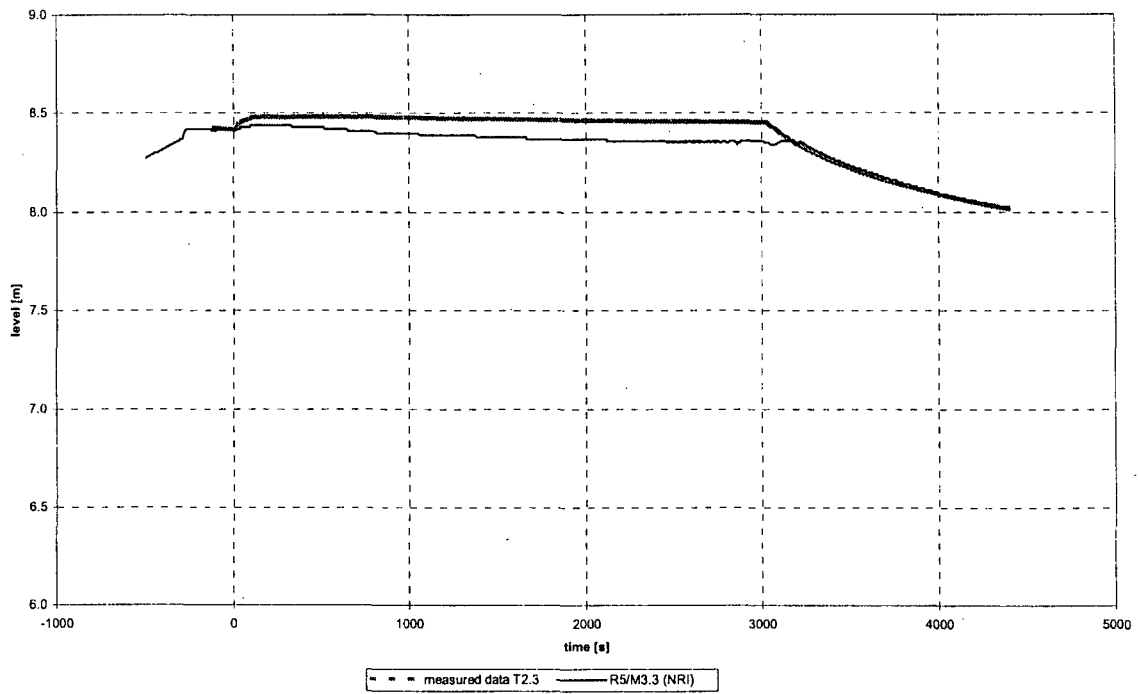

Fig.E-15 Collapsed level in SG secondary side (T2.3)

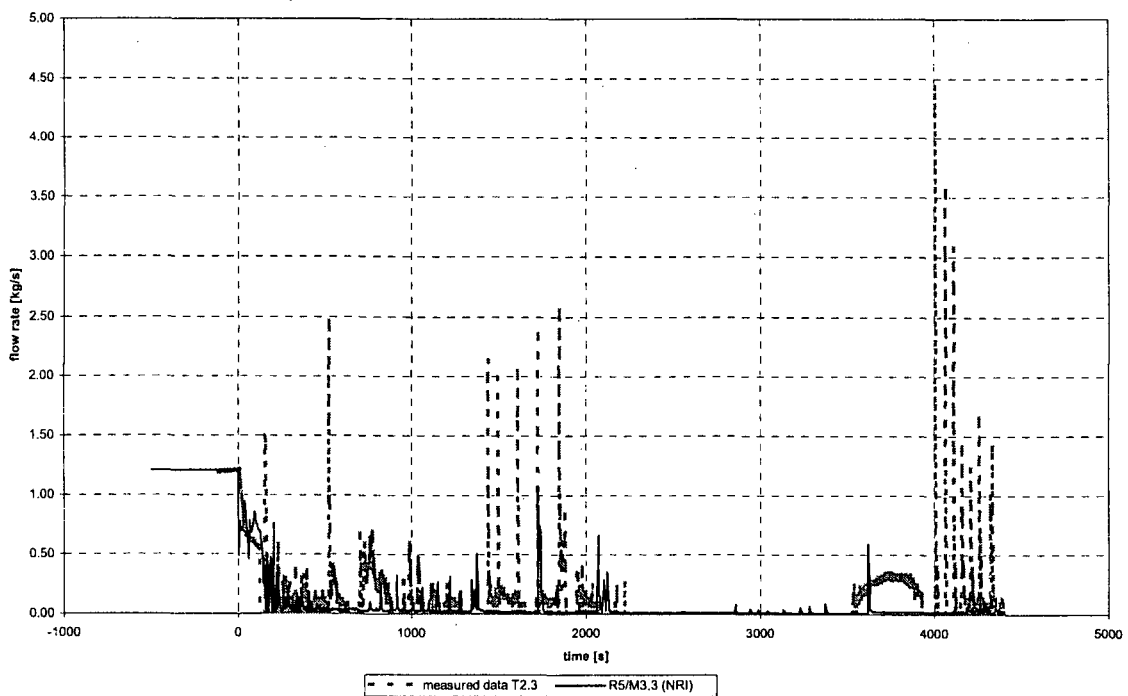

Fig.E-16 Loop mass flow rate (T2.3)

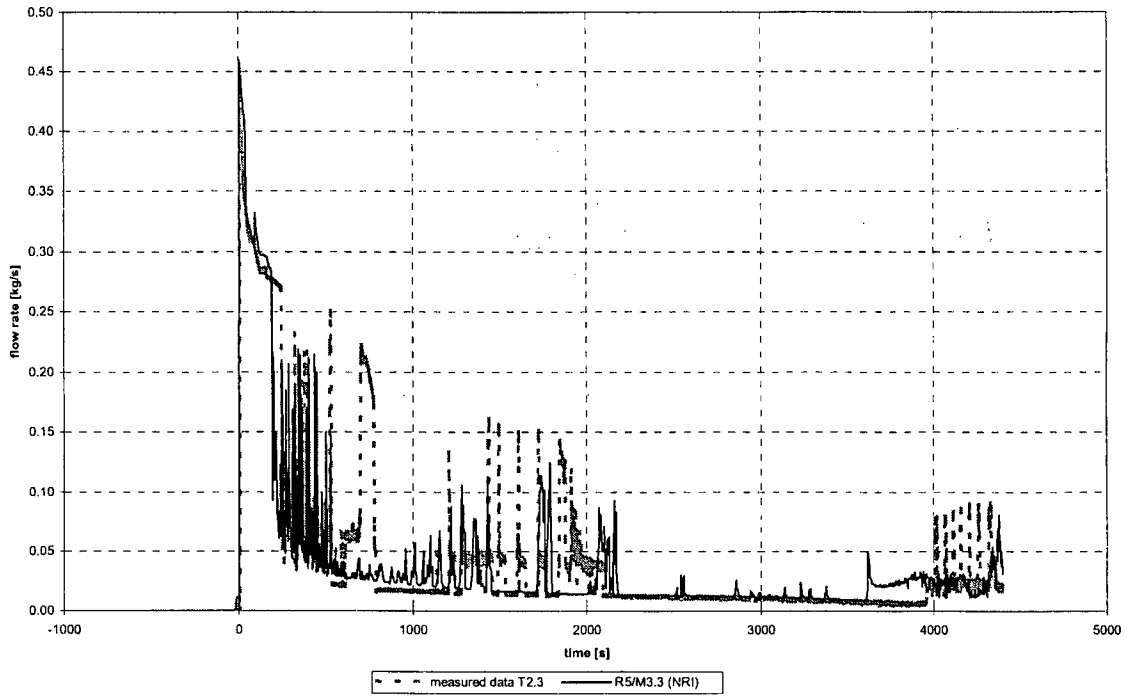

Fig.E-17 Break mass flow rate (T2.3)

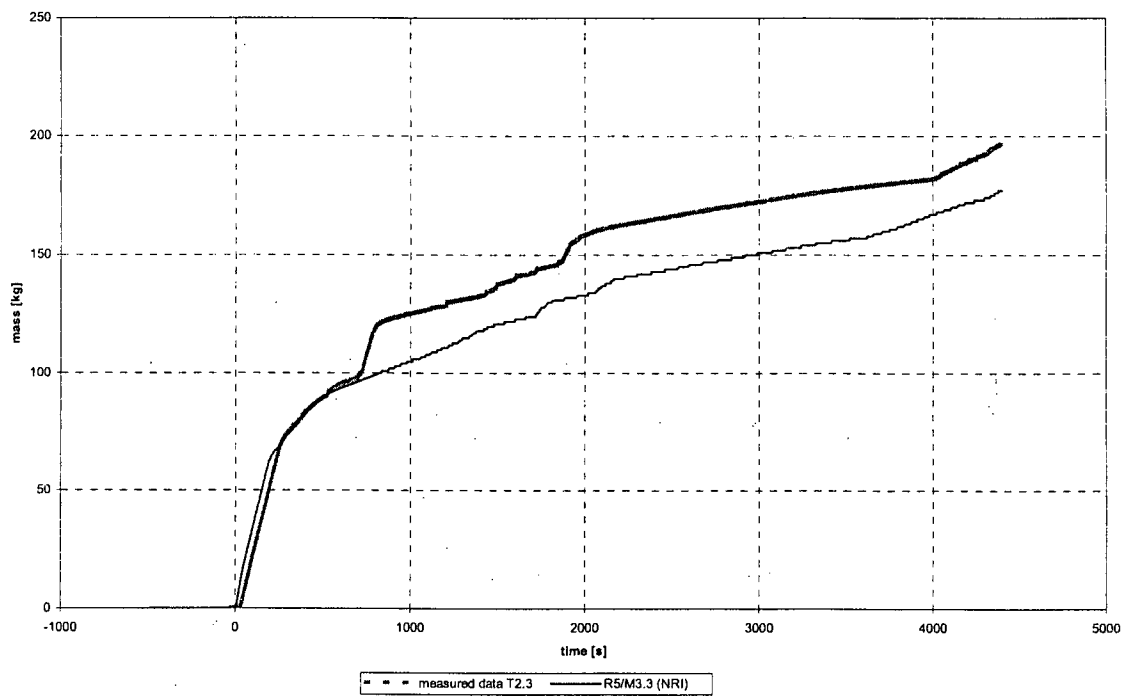

Fig.E-18 Integrated break mass flow rate (T2.3)

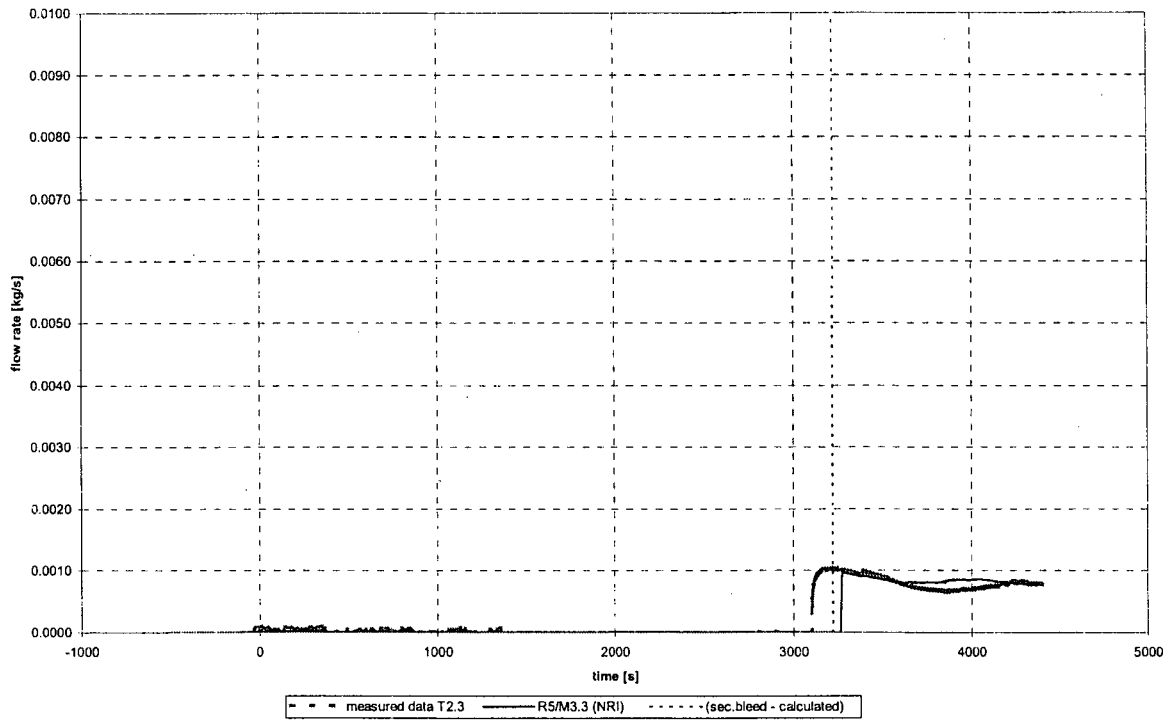

Fig.E-19 PRZ relief valve flow rate (T2.3)

BIBLIOGRAPHIC DATA SHEET

(See instructions on the reverse)

2. TITLE AND SUBTITLE
RELAP5/MOD3.3 Assessment against New PMK Experiments

3. DATE REPORT PUBLISHED

MONTH	YEAR
June	2010

4. FIN OR GRANT NUMBER

5. AUTHOR(S)
Pavel Kral

6. TYPE OF REPORT
Technical

7. PERIOD COVERED (Inclusive Dates)

8. PERFORMING ORGANIZATION - NAME AND ADDRESS (If NRC, provide Division, Office or Region, U.S. Nuclear Regulatory Commission, and mailing address; if contractor, provide name and mailing address.)

Nuclear Research Institute Rez
Husinec-Rez 130
250 68 Rez, Czech Republic

9. SPONSORING ORGANIZATION - NAME AND ADDRESS (If NRC, type "Same as above"; if contractor, provide NRC Division, Office or Region, U.S. Nuclear Regulatory Commission, and mailing address.)

Division of Systems Analysis
Office of Nuclear Regulatory Research
U.S. Nuclear Regulatory Commission
Washington, DC 20555-0001

10. SUPPLEMENTARY NOTES

A. Calvo, NRC Project Manager

11. ABSTRACT (200 words or less)

The results of RELAP5 post-test analysis of 3 tests performed on the PMK integral test facility are presented and discussed. The Hungarian facility PMK is a scaled-down model of NPP with VVER-440/213 reactor. The code version RELAP5/MOD3.3 Path02 has been assessed against the experimental data from the tests T2.1, T2.2, and T2.3. The tests were focused on medium-break LOCA without HPSI. Generally, RELAP5 predictions are in very good agreement with the measured data.

12. KEY WORDS/DESCRIPTORS (List words or phrases that will assist researchers in locating the report.)

RELAP5 post-test analysis
Thermal hydraulic code calculations
The Nuclear Research Institute (NRI) Rez
VVER reactors,
Czech Republic
Small-break loss of coolant accidents (SBLOCA)
Czech regulatory body (SONS)
RELAP5/MOD3.3 computer code
Emergency Operating Procedures (EOP)

13. AVAILABILITY STATEMENT
unlimited

14. SECURITY CLASSIFICATION

(This Page)
unclassified

(This Report)
unclassified

15. NUMBER OF PAGES

16. PRICE



Federal Recycling Program



UNITED STATES
NUCLEAR REGULATORY COMMISSION
WASHINGTON, DC 20555-0001

OFFICIAL BUSINESS