



**Pacific Gas and Electric Company®**

**James R. Becker**  
Site Vice President

Diablo Canyon Power Plant  
Mail Code 104/5/601  
P. O. Box 56  
Avila Beach, CA 93424

805.545.3462  
Internal: 691.3462  
Fax: 805.545.6445

April 24, 2009

PG&E Letter DCL-09-025

U.S. Nuclear Regulatory Commission  
ATTN: Document Control Desk  
Washington, DC 20555-0001

Docket No. 50-275, OL-DPR-80  
Docket No. 50-323, OL-DPR-82  
Diablo Canyon Units 1 and 2  
2008 Annual Radioactive Effluent Release Report

Dear Commissioners and Staff:

Pacific Gas and Electric Company is submitting the enclosed 2008 Annual Radioactive Effluent Release Report in accordance with 10 CFR 50.36a (a)(2), and Section 5.6.3 of the Diablo Canyon Power Plant Technical Specifications.

The report describes the quantities of radioactive gaseous and liquid effluents released from the plant, and the solid radioactive waste shipments made during the period of January 1, through December 31, 2008.

Recommendations are made as a result of this submittal.

One compact disk is being sent with the report. The disk contains meteorological data. If you have any questions, please contact Jeff Gardner of my staff at (805) 545-4385.

Sincerely,

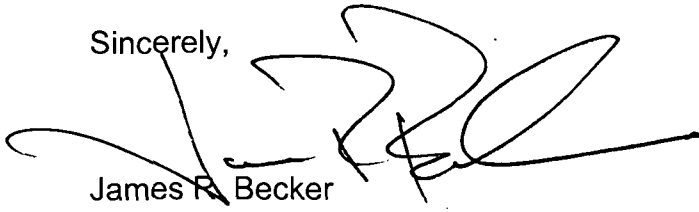

James R. Becker

swh/64002712

Enclosure

cc/enc: Edgar D. Bailey, DHS  
Roger W. Briggs, Executive Officer, CRWQCB  
Elmo E. Collins, Regional Administrator, Region IV  
William A. Nestel, INPO  
Michael S. Peck, NRC Senior Resident Inspector  
Gregory Thomas, MD, San Luis Obispo County Health Officer  
Alan B. Wang, NRC Project Manager, NRR  
Diablo Distribution

*JE48*  
*NRR*

**DIABLO CANYON POWER PLANT  
2008 ANNUAL RADIOACTIVE EFFLUENT RELEASE REPORT**



---

January 1 - December 31, 2008

---



## DIABLO CANYON POWER PLANT

### Annual Radioactive Effluent Release Report January 1, 2008, Through December 31, 2008

#### Table of Contents

	Introduction	1
I.	Supplemental Information	2
II.	Major Changes to Liquid, Gaseous, and Solid Radwaste Systems	9
III.	Changes to the Offsite Dose Calculation Manual	11
IV.	Land Use Census	14
V.	Gaseous and Liquid Effluents	14
	Table 1 - Gaseous Effluents – Summation of All Releases	15
	Table 2 - Gaseous Effluents – Ground-Level Releases	18
	Table 3 - Gaseous Effluents – Lower Limits of Detection	22
	Table 4 – Liquid Effluents – Summation of All Releases	24
	Table 5 – Liquid Effluents – Nuclides Releases	27
	Table 6 – Liquid Effluents – Lower Limit of Detection (LLD)	33
VI.	Solid Waste Shipments	36
VII.	Radiation Dose due to Gaseous and Liquid Effluents	38
	Table 7 – Radiation Dose Due to the Release of Radioactive Liquid Effluents	41
	Table 8 – Radiation Dose Due to the Release of Radioactive Gaseous Effluents	42
	Table 9 – Percent of Technical Specification Limits for Radioactive Liquid	45
	Table 10 – Percent of Technical Specification Limits for Radioactive Gaseous Effluents	46
	Table 11 – Onsite Dose to Members of the Public	48
VII.	Meteorological Data	53

**DIABLO CANYON POWER PLANT**

**Annual Radioactive Effluent Release Report  
January 1, 2008 Through December 31, 2008**

**Attachments**

1. License Basis Impact Evaluation 2008-001, "Auxiliary Control Board Replacement - Phase 2"
2. Nuclear Power Generation Program Directive Procedure, CY2, "Radiological Monitoring and Controls Program," Revision 6
3. Nuclear Power Generation Interdepartmental Administrative Procedure (IDAP), CY2.ID1, "Radioactive Effluent Controls Program," Revision 9
4. IDAP RP1.ID11, "Environmental Radiological Monitoring Procedure," Revision 8
5. Diablo Canyon Power Plant Chemical Analysis Procedure, CAP A-8, "Off-Site Dose Calculation Procedure," Revision 32
6. Diablo Canyon Power Plant Administrative Procedure, RP2.DC2, "Radwaste Solidification Process Control Program," Revision 14
7. 2008 Land Use Census



## **DIABLO CANYON POWER PLANT**

### **2008 Annual Radioactive Effluent Release Report**

#### **Introduction**

The 2008 Annual Radioactive Effluent Release Report summarizes gaseous and liquid effluent releases from Diablo Canyon Power Plant's (DCPP) Units 1 and 2. The report includes the dose due to release of radioactive liquid and gaseous effluents and summarizes solid radwaste shipments. The report contains information required by Units 1 and 2 Technical Specification (TS) 5.6.3, and is presented in the general format of Regulatory Guide 1.21, "Measuring, Evaluating, and Reporting Radioactivity in Solid Wastes and Releases of Radioactive Materials in Liquid and Gaseous Effluents from Light-Water Nuclear Power Plants," Appendix B, "Effluent and Waste Disposal Report." Procedure revisions, which implement the Off-Site Dose Calculation Manual (ODCM), and one compact disk containing meteorological data, are attached.

In all cases, the plant effluent releases were well below TS limits for the report period.

**I. Supplemental Information**

**A. Regulatory Limits**

**1. Gaseous Effluents**

**a. Noble Gas Dose Rate Limit**

The dose rate in areas at or beyond the site boundary due to radioactive noble gases released in gaseous effluents is limited to less than or equal to 500 millirem (mR) per year to the total body, and less than or equal to 3000 mR per year to the skin. (Radioactive Effluent Controls Program [RECP], 6.1.6.1.a.)

**b. Particulate and Iodine Dose Rate Limit**

The dose rate in areas at or beyond the site boundary due to iodine-131, iodine-133, tritium, and all radionuclides in particulate form with half-lives greater than 8 days in gaseous effluents, is limited to less than or equal to 1500 mR per year to any organ. (RECP 6.1.6.1.b)

**c. Noble Gas Dose Limit**

The air dose due to noble gases released in gaseous effluents from each reactor unit to areas at or beyond the site boundary is limited to the following:

Radiation Type	Calendar Quarter Limit RECP 6.1.7.1.a	Calendar Year Limit RECP 6.1.7.1.b
Gamma	5 millirad	10 millirad
Beta	10 millirad	20 millirad

**d. Particulate and Iodine Dose Limit**

The dose to an individual from iodine-131, iodine-133, tritium, and all radionuclides in particulate form with half-lives greater than 8 days in gaseous effluents released from each reactor unit to areas at or beyond the site boundary is limited to less than or equal to 7.5 mR to any organ in any calendar quarter, and less than or equal to 15 mR to any organ during a calendar year. (RECP 6.1.8.1)

2. Liquid Effluents

a. Concentration

The concentration of radioactive material released from the site is limited to the concentrations specified in 10 CFR 20, Appendix B, Table 2, Column 2, for radionuclides other than dissolved or entrained noble gases. For dissolved or entrained noble gases, the concentration is limited to  $2 \times 10^{-4}$  microcuries/milliliter ( $\mu\text{Ci/ml}$ ) total activity. (RECP 6.1.3.1)

b. Dose

The dose or dose commitment to a member of the public from radioactive materials in liquid effluents released from each reactor unit to areas at or beyond the site boundary is limited to the following:

Dose Type	Calendar Quarter Limit RECP 6.1.4.1.a	Calendar Year Limit RECP 6.1.4.1.b
Total Body	1.5 millirem	3 millirem
Any Organ	5 millirem	10 millirem

B. Maximum Permissible Concentrations

1. Gaseous Effluents

Maximum permissible concentrations are not used for determining allowable release rates for gaseous effluents at DCP.

2. Liquid Effluents

The concentrations listed in 10 CFR 20, Appendix B, Table 2, Column 2, for radionuclides other than dissolved or entrained noble gases are used for determining the allowable release concentration at the point of discharge from the site for liquid effluents. For dissolved or entrained noble gases, the allowable release concentration at the point of discharge is limited to  $2 \times 10^{-4} \mu\text{Ci/ml}$  total activity for liquid effluents.

C. Measurements and Approximations of Total Radioactivity

1. Gaseous Effluents

a. Fission and Activation Gases

A pair of offline monitors equipped with beta scintillator detectors monitors the gaseous radioactivity released from the plant vent. The monitor readings are correlated to isotopic concentration based on laboratory isotopic analysis of grab samples using a germanium detector.

For plant vent noble gas releases, grab sample results are used to quantify releases. The individual batch release data are used to quantify the radioactivity discharged from the gas decay tanks and containment.

A noble gas grab sample is obtained and analyzed at least weekly. The isotopic mixture is assumed to remain constant between grab sample analyses.

Containment purges, gas decay tank releases, and air ejector discharges are released via the plant vent.

The gaseous radioactivity released from the steam generator blowdown tank vent is measured by analyzing liquid or steam condensate grab samples with a germanium detector. A factor  $R$ , a ratio of unit masses between water flashing to steam and water entering the tank, is used to calculate the activity. The isotopic concentrations are assumed to remain constant between grab samples.

Other potential pathways for releasing gaseous radioactivity are periodically monitored by collecting grab samples and analyzing these samples with a germanium detector system.

b. Iodines

Radioiodines released from the plant vent are monitored by continuous sample collection on silver zeolite cartridges. The cartridges are changed at least weekly and analyzed with a germanium detector. The radioiodine releases are averaged over the period of cartridge sample collection.

Other potential pathways for releasing radioiodines are periodically monitored by collecting samples using charcoal

or silver zeolite cartridges and analyzing with a germanium detector.

Radioactive materials in particulate form released from the plant vent are monitored by continuous sample collection on particulate filters. The filters are changed at least weekly and analyzed with a germanium detector. The particulate radioactivity is averaged over the period of particulate filter sample collection. Each filter is analyzed for alpha emitters using an internal proportional counter. Plant vent particulate filters collected during a quarter are used for the composite analysis for strontium-89 and -90, the analysis of which is performed by a contract laboratory.

Other potential pathways for releasing radioactive particulate are periodically monitored by collecting samples using particulate filters and analyzing these filters with a germanium detector.

c. Tritium

Tritium released from the plant vent is monitored by passing a measured volume of plant vent sample through a water column and determining the tritium increase in the water. An aliquot of the water is counted in a liquid scintillation spectrometer. The minimum routine sample frequency for tritium is weekly. The tritium concentration is assumed to remain constant between samples.

d. Estimations of Overall Error

Sources of error considered for batch release are: (1) calibration source, (2) calibration counting, (3) sampling, (4) sample counting, and (5) gas decay tank pressure gauge/containment exhaust fan flow rate.

Sources of error for continuous release are: (1) calibration source, (2) calibration counting, (3) sampling, (4) sample counting, (5) process monitor (RE-14) reading (fission gases only), and (6) plant vent exhaust fan flow rate.

$$\text{Total error} = (\sigma_1^2 + \sigma_2^2 + \sigma_3^2 + \dots + \sigma_i^2)^{1/2}$$

Where  $\sigma_i$  = error associated with each component.

2. Liquid Effluents

a. Batch Releases

Each tank of liquid radwaste is analyzed for principal gamma emitters using a germanium detector prior to release. A monthly prerelease analysis includes dissolved and entrained gases. Volume proportional monthly and quarterly composites are prepared from aliquots of each tank volume discharged. The monthly composite is analyzed for tritium using a liquid scintillation spectrometer and gross alpha radioactivity using an internal proportional counter. The quarterly composite is analyzed for iron-55 and for strontium-89 and -90 by a contract laboratory. The monthly composite for discharges from the auxiliary building are also analyzed for nickel-63, uranium-233/234/235/236/238 and plutonium-238/239/240/241/242 by a contract laboratory.

b. Continuous Releases

For the continuous liquid releases of the steam generator blowdown tank and turbine building sump oily water separator, daily grab samples are collected, and aliquots are proportioned for weekly, monthly, and quarterly composites.

The oily water separator weekly composite is analyzed for principal gamma emitters using a germanium detector. The steam generator blowdown tank weekly composite is analyzed for principal gamma emitters and iodine-131.

The steam generator blowdown tank monthly composite is analyzed for tritium using a liquid scintillation spectrometer, and for gross alpha using an internal proportional counter.

The steam generator blowdown tank quarterly composite is analyzed for iron-55 and for strontium-89 and strontium-90 by a contract laboratory. The results for each of the composites are averaged over the period of the composite.

In addition, one grab sample of the steam generator blowdown tank is analyzed monthly for dissolved and entrained gases using a germanium detector. The results of

this analysis are assumed to remain constant over the period of one month.

A grab sample of the steam generator blowdown is collected at least weekly and analyzed for gamma activity using a germanium detector. This analysis is used to monitor activity, however, is not used in effluent calculations unless a significant change is detected.

Note on dilution volume:

Tables 4A, 4B, and 4C, "Liquid Effluents - Summation of All Releases," Item F, lists the, "Volume of circulating saltwater used during release periods," in liters. This value is calculated by multiplying the discharge duration by the circulating water flow rate. The values listed in the Tables are the summation of the circulating water discharge volume calculated for each individual batch and continuous discharge period. Therefore, in the case where two or more simultaneous discharges into the same circulating water are occurring, the calculated volume of circulating water is duplicated, and therefore the sum of the dilution volumes for the batch releases and continuous releases are greater than the actual dilution volume since each discharge incorporates the circulating discharge flow rate in its own dose calculation.

c. Estimation of Overall Error

Sources of error considered are: (1) calibration source error, (2) calibration counting error, (3) sampling error, (4) sample counting error, and (5) volume of waste release error.

These sources of error are independent; therefore the total error is calculated according to the following formula:

$$\text{Total error} = (\sigma_1^2 + \sigma_2^2 + \sigma_3^2 + \dots + \sigma_i^2)^{1/2}$$

Where  $\sigma_i$  = error associated with each component.

D. Batch Releases

1. Liquid

a. Number of batch releases.....	606
b. Total time period for batch releases.....	2622 hours
c. Maximum time period for a batch release.....	168 hours
d. Average time period for a batch release.....	4.33 hours
e. Minimum time period for a batch release.....	0.15 hours
f. Average saltwater flow during batch releases.....	9.16E+05 gallons per minute (gpm)

2. Gaseous

a. Number of batch releases.....	140
b. Total time period for batch releases.....	1942 hours
c. Maximum time period for a batch release.....	72.00 hours
d. Average time period for a batch release.....	13.87 hours
e. Minimum time period for a batch release.....	1.00 hours

E. Abnormal Release (Gaseous and Liquid)

No abnormal releases occurred during 2008.



## II. Major Changes to Liquid, Gaseous, and Solid Radwaste Treatment System

An design change was implemented in 2008 that affected the gaseous radwaste treatment system.

The Auxiliary Building Control Board for Diablo Canyon Power Plant (DCPP) provides an Operator Station to control the receiving, storage, treatment, and discharge of liquid and gaseous radwaste products generated by both Units. The obsolete pneumatic fluidic logic system was replaced by a digital control system. This change is documented in Design Change Package (DCP) J-49855.

Changes to the following sections of the FSAR have been approved:

7.7.1.11.3, 11.2.2.2, 11.2.2.3, 11.3.2 and 15.4.7.1.

DCPP Procedure CY2.ID1, "Radioactive Effluent Controls Program," requires that the following be contained in the discussion of a change such as DCP J-49855.

- A. Evaluation that led to the determination that the change could be made in accordance with 10 CFR 50.59:

A copy of the 10 CFR 50.59 Evaluation is included in Appendix 1.

- B. Information to totally support the reason for the change without benefit of additional or supplemental information:

A digital control system replaced an obsolete pneumatic fluidic logic system. The system controls the operation of various control valves for the waste gas collection, processing, storage, and disposal system. The design function and administrative controls for gaseous radwaste releases has not changed.

The control board panel configurations and indications needed improvements, from a human factors standpoint. Many of the panel instruments and controllers were air operated and no longer available. The original vendor no longer manufactures replacement parts. A replacement vendor for parts is not available.

As a pneumatic dependent system, tubing and control elements were susceptible to leaks.

The overall objective was to replace the obsolete control board system with a new digital control system. The new system was designed with redundant networking systems and independent power sources. The new digital control system is also designed to enhance the ability for operations

to control and monitor processes. The new system consolidates needed information onto a display that provides much more effective view of system operation. Although there is a fundamental change to the way information is presented and how controls are interacted with the operator, the control capability requirements have not been impacted.

C. Description of the equipment, components, and processes involved and the interfaces with other plant systems:

The overall scope of the design change established the following:

- Data acquisition and control system (DACS)
- Redundant controller/communication chassis
- Three remote input/output chassis, each with independent power supplies.
- An auxiliary maintenance terminal
- Network connections to DACS
- System upgrade to controls/indications:
  - Fluidic logic replacement/gas decay tanks
  - Waste gas compressor
  - Miscellaneous equipment drain tank/auxiliary building sump level controls
  - Boric acid concentrates holding tank 0-2
  - Annunciation alarms
  - Oxygen analyzer 2 percent alarms and 4 percent trip
  - Selected annunciation at other panels

D. Evaluation of the change which shows the predicted releases of radioactive materials in gaseous effluent that differ from those previously predicted in the license application:

*No change was made in the function or administrative controls. Therefore, this design change is not intended to change the quantity of gaseous radioactive material releases.*

E. Evaluation which shows the expected maximum exposure to a member of the public in the unrestricted area and to the general population that differ from those previously estimated in license application:

*No change was made in the function or administrative controls. Therefore, this design change is not intended to change the expected dose due to the release of gaseous radioactive material.*

- F. Comparison of the predicted releases of radioactive material, in liquid effluents and solid waste, to the actual releases for the period prior to when the change are to be made.

*No change was made in the function or administrative controls. Therefore, this design change is not intended to change the quantity of gaseous radioactive material releases.*

- G. Estimate of the exposure to plant operating personnel as a result of the change:

*No change was made in the function or administrative controls. Therefore, this design change is not expected to change the exposure to plant operating personnel.*

### III. Changes to the Offsite Dose Calculation Manual (ODCM)

The DCPD ODCM is made up of the following procedures:

- Nuclear Power Generation Program Directive Procedure, CY2, "Radiological Monitoring and Controls Program" (RMCP)
- Nuclear Power Generation Interdepartmental Administrative Procedure (IDAP), CY2.ID1, "Radioactive Effluent Controls Program" (RECP)
- IDAP RP1.ID11, "Environmental Radiological Monitoring Procedure (ERMP)
- DCPD Chemical Analysis Procedure, CAP A-8, "Offsite Dose Calculation Procedure" (ODCP)

Changes made to these procedures during the reporting period are described below. A copy of each revision made during the reporting period is included as an attachment.

If no changes were made to a particular procedure during the reporting period, the most recent revision is included as an attachment in order to provide a complete, current copy of the ODCM used during the reporting period.

Also included is a description of the changes made to DCPD Administrative Procedure, RP2.DC2, "Radwaste Solidification Process Control Program," (PCP).

#### A. Changes to the RMCP

1. Figure 1: The figure's title and box formatting were edited. No information was changed.
2. Section 3, "DEFINITIONS:" Hyphens were replaced with colons at the end of each item.

3. Section 4.3: The "Example" was revised. The previous example referred to a group that has since been changed.
4. Section 5, "RESPONSIBILITIES:"
  - a. The responsibilities of the "plant services vice president" were moved to the "chief nuclear officer" [CNO]. The "plant services vice president" position no longer exists. A variety of groups formerly under that position now report directly to the CNO. Rather than listing many of them, the responsibility was rolled up to the CNO.
  - b. The "plant operations vice president" was changed to "site vice president and station director."
  - c. The "plant services vice president" was deleted. Its responsibilities were added to the "chief nuclear officer."
  - d. The "station director" was changed to "senior director operations services." The groups most involved with the radiological monitoring and controls program report directly to this position (Chemical and Environmental Operations, Radiation Protection [RP], Operation Services).
  - e. The "engineering director" was changed to "senior director engineering services."
  - f. The "licensing director" was changed to "quality verification director."
5. Section 12, "SPONSOR:" This section was deleted to conform to current format guidance.
6. Revision 6 was approved by the CNO on May 28, 2008. See Attachment 2.

B. Changes to the RECP

1. References to "TES" [Technical & Ecological Services] was deleted from the procedure. This company organization no longer exists. The responsibilities this group maintained for Radiological Environmental Monitoring Program (REMP) now reside with the plant's RP section.
2. The Plant Safety Review Committee (PSRC) no longer approves major changes to the radwaste treatment system. Therefore, a step was deleted that required evidence should be provided in the annual rad effluent report showing PSRC approval of major changes to the radwaste treatment system.

3. Clarifications were made to Tables 6.1.1-1, 6.1.3-1, and 6.1.6-1.
4. Revision 9 was approved by the Station Director on July 10, 2008. See Attachment 3.

C. Changes to ERMP

1. Editorial changes were made to identify the change in name of the "California Department of Health Services" to "California Department of Public Health."
2. Responsibilities for the REMP engineer and vendor lab were revised.
3. Monitoring of the old steam generator storage facility (OSGSF) was added.
4. Several Action Requests (problem reports) were added to "REFERENCES."
5. Some station codes were updated.
6. Some additional sampling at certain locations, and by the State, were added.
7. Laboratory Sr-89/90 LLD values were updated.
8. Revision 8 was approved by the Station Director on June 20, 2008. See Attachment 4.

D. Changes to the ODCP

1. Two position titles were updated in the "RESPONSIBILITIES" section.
2. Added Te-125m to the liquid radwaste list of isotope dose factors.
3. Updated the X/Q and D/Q values based upon the 2003-2007 5-year average values calculated by PG&E's Meteorological Services.
4. Revision 32 was approved by the Station Director on July 13, 2008. See Attachment 5.

E. Changes to PCP

IDAP RP2.DC2 was not revised during the reporting period. See Attachment 6.

**IV. Land Use Census**

Changes to the Land Use Census Program are included as Attachment 7.

**V. Gaseous and Liquid Effluents**

Tables 1 through 3 describe gaseous effluents. Tables 4 through 6 describe liquid effluents.

**DIABLO CANYON POWER PLANT  
ANNUAL RADIOACTIVE EFFLUENT RELEASE REPORT 2008  
TABLE 1A  
GASEOUS EFFLUENTS - SUMMATION OF ALL RELEASES**

Units	First Quarter	Second Quarter	Est. Total Error %
-------	---------------	----------------	--------------------

A. Fission and activation gases

1. Total release	Ci	5.14E+1	1.84E-1	41%
2. Average release rate for period	μCi/sec	6.53E+0	2.34E-2	
3. Percent of technical specification limit <sup>1</sup>	%	3.35E-3	2.70E-5	

B. Iodines

1. Total iodine-131	Ci	4.99E-3	MDA	24%
2. Average release rate for period	μCi/sec	6.35E-4	MDA	
3. Percent of technical specification limit <sup>1</sup>	%	3.49E-3	MDA	

C. Particulates

1. Particulates with half-lives >8 days	Ci	4.13E-5	8.54E-8	24%
2. Average release rate for period	μCi/sec	5.25E-6	1.09E-8	
3. Percent of technical specification limit <sup>1</sup>	%	2.25E-6	1.51E-7	
4. Gross alpha radioactivity	Ci	6.86E-7	4.29E-7	

D. Tritium

1. Total release	Ci	5.66E+1	3.35E+1	13%
2. Average release rate for period	μCi/sec	7.20E+0	4.27E+0	
3. Percent of technical specification limit <sup>1</sup>	%	1.66E-5	9.83E-6	

MDA = Less than the "a posteriori" minimum detectable activity (microcuries per unit mass or volume). This note applies to all tables.

<sup>1</sup> RECP 6.1.6.1 Limit

**DIABLO CANYON POWER PLANT  
ANNUAL RADIOACTIVE EFFLUENT RELEASE REPORT 2008**

**TABLE 1B  
GASEOUS EFFLUENTS - SUMMATION OF ALL RELEASES**

Units	Third Quarter	Fourth Quarter	Est.Total Error %
-------	------------------	-------------------	----------------------

A. Fission and activation gases

1. Total release	Ci	2.20E+0	2.76E-2	41%
2. Average release rate for period	μCi/sec	2.77E-1	3.48E-3	
3. Percent of technical specification limit <sup>1</sup>	%	7.50E-5	3.32E-5	

B. Iodines

1. Total iodine-131	Ci	MDA	MDA	24%
2. Average release rate for period	μCi/sec	MDA	MDA	
3. Percent of technical specification limit <sup>1</sup>	%	MDA	MDA	

C. Particulates

1. Particulates with half-lives >8 days	Ci	MDA	MDA	24%
2. Average release rate for period	μCi/sec	MDA	MDA	
3. Percent of technical specification limit <sup>1</sup>	%	MDA	MDA	
4. Gross alpha radioactivity	Ci	1.43E-7	6.53E-8	

D. Tritium

1. Total release	Ci	3.96E+1	2.98E+1	13%
2. Average release rate for period	μCi/sec	4.98E+0	3.75E+0	
3. Percent of technical specification limit <sup>1</sup>	%	1.15E-5	8.63E-6	

MDA = Less than the "a posteriori" minimum detectable activity (microcuries per unit mass or volume). This note applies to all tables.

<sup>1</sup> RECP 6.1.6.1 Limit



**DIABLO CANYON POWER PLANT  
 ANNUAL RADIOACTIVE EFFLUENT RELEASE REPORT 2008  
 TABLE 1C  
 GASEOUS EFFLUENTS - SUMMATION OF ALL RELEASES**

Units	Annual Total
-------	--------------

A. Fission and activation gases

1. Total release	Ci	5.38E+1
2. Average release rate for period	μCi/sec	1.70E+0
3. Percent of technical specification limit <sup>1</sup>	%	8.66E-4

B. Iodines

1. Total iodine-131	Ci	4.99E-3
2. Average release rate for period	μCi/sec	1.58E-4
3. Percent of technical specification limit <sup>1</sup>	%	8.69E-4

C. Particulates

1. Particulates with half-lives >8 days	Ci	4.14E-5
2. Average release rate for period	μCi/sec	1.31E-6
3. Percent of technical specification limit <sup>1</sup>	%	5.96E-7
4. Gross alpha radioactivity	Ci	1.32E-6

D. Tritium

1. Total release	Ci	1.60E+2
2. Average release rate for period	μCi/sec	5.04E+0
3. Percent of technical specification limit <sup>1</sup>	%	1.16E-5

<sup>1</sup> RECP.6.1.6.1 Limit

**DIABLO CANYON POWER PLANT  
ANNUAL RADIOACTIVE EFFLUENT RELEASE REPORT 2008  
TABLE 2A  
GASEOUS EFFLUENTS - GROUND LEVEL RELEASES**

Nuclides Released	Units	First Quarter		Second Quarter	
		Continuous Mode	Batch Mode	Continuous Mode	Batch Mode

1. Fission gases

argon-41	Ci	MDA	1.09E+0	MDA	2.19E-2
krypton-85	Ci	MDA	2.03E-2	MDA	1.61E-1
krypton-85m	Ci	MDA	MDA	MDA	MDA
krypton-87	Ci	MDA	MDA	MDA	MDA
krypton-88	Ci	MDA	MDA	MDA	MDA
xenon-131m	Ci	MDA	1.54E-4	MDA	MDA
xenon-133	Ci	2.64E+1	2.39E+1	MDA	1.29E-3
xenon-133m	Ci	MDA	MDA	MDA	MDA
xenon-135	Ci	MDA	5.31E-5	MDA	MDA
xenon-135m	Ci	MDA	MDA	MDA	MDA
xenon-138	Ci	MDA	MDA	MDA	MDA
TOTAL FOR PERIOD	Ci	2.64E+1	2.50E+1	MDA	1.84E-1

2. Iodines

iodine-131	Ci	4.71E-3	MDA
iodine-133	Ci	2.85E-4	MDA
iodine-135	Ci	MDA	MDA
TOTAL FOR PERIOD	Ci	4.99E-3	MDA

MDA = Less than the "a posteriori" minimum detectable activity (microcuries per unit mass or volume). This note applies to all tables.

**DIABLO CANYON POWER PLANT  
ANNUAL RADIOACTIVE EFFLUENT RELEASE REPORT 2008  
TABLE 2A (Continued)  
GASEOUS EFFLUENTS - GROUND LEVEL RELEASES**

Nuclides Released	Units	Continuous Mode	
		First Quarter	Second Quarter

3. Particulates

barium-140	Ci	MDA	MDA
cesium-134	Ci	MDA	MDA
cesium-137	Ci	MDA	MDA
cerium-141	Ci	MDA	MDA
cerium-144	Ci	MDA	MDA
chromium-51	Ci	MDA	MDA
cobalt-57	Ci	MDA	MDA
cobalt-58	Ci	4.12E-5	MDA
cobalt-60	Ci	MDA	MDA
iron-59	Ci	MDA	MDA
lanthanum-140	Ci	MDA	MDA
manganese-54	Ci	MDA	MDA
molybdenum-99	Ci	MDA	MDA
ruthenium-103	Ci	MDA	MDA
strontium-89	Ci	MDA	MDA
strontium-90	Ci	8.66E-8	8.54E-8
zinc-65	Ci	MDA	MDA
zirconium-95	Ci	MDA	MDA
TOTAL FOR PERIOD	Ci	4.13E-5	8.54E-8

MDA = Less than the "a posteriori" minimum detectable activity (microcuries per unit mass or volume).  
This note applies to all tables.

**DIABLO CANYON POWER PLANT  
ANNUAL RADIOACTIVE EFFLUENT RELEASE REPORT 2008**

**TABLE 2B  
GASEOUS EFFLUENTS - GROUND LEVEL RELEASES**

Nuclides Released	Units	Third Quarter		Fourth Quarter	
		Continuous Mode	Batch Mode	Continuous Mode	Batch Mode

1. Fission gases

argon-41	Ci	MDA	2.14E-2	MDA	2.76E-2
krypton-85	Ci	MDA	9.98E-1	MDA	MDA
krypton-85m	Ci	MDA	MDA	MDA	MDA
krypton-87	Ci	MDA	MDA	MDA	MDA
krypton-88	Ci	MDA	MDA	MDA	MDA
xenon-131m	Ci	MDA	1.62E-3	MDA	MDA
xenon-133	Ci	MDA	1.18E+0	MDA	4.06E-5
xenon-133m	Ci	MDA	2.26E-4	MDA	MDA
xenon-135	Ci	MDA	1.38E-4	MDA	MDA
xenon-135m	Ci	MDA	MDA	MDA	MDA
xenon-138	Ci	MDA	MDA	MDA	MDA
TOTAL FOR PERIOD	Ci	MDA	2.20E+0	MDA	2.76E-2

2. Iodines

iodine-131	Ci	MDA	MDA
iodine-133	Ci	MDA	MDA
iodine-135	Ci	MDA	MDA
TOTAL FOR PERIOD	Ci	MDA	MDA

MDA = Less than the "a posteriori" minimum detectable activity (microcuries per unit mass or volume). This note applies to all tables.

**DIABLO CANYON POWER PLANT  
 ANNUAL RADIOACTIVE EFFLUENT RELEASE REPORT 2008  
 TABLE 2B (Continued)  
 GASEOUS EFFLUENTS - GROUND LEVEL RELEASES**

Nuclides Released	Units	Continuous Mode	
		Third Quarter	Fourth Quarter

3. Particulates

barium-140	Ci	MDA	MDA
cesium-134	Ci	MDA	MDA
cesium-137	Ci	MDA	MDA
cerium-141	Ci	MDA	MDA
cerium-144	Ci	MDA	MDA
chromium-51	Ci	MDA	MDA
cobalt-57	Ci	MDA	MDA
cobalt-58	Ci	MDA	MDA
cobalt-60	Ci	MDA	MDA
iron-59	Ci	MDA	MDA
lanthanum-140	Ci	MDA	MDA
manganese-54	Ci	MDA	MDA
molybdenum-99	Ci	MDA	MDA
ruthenium-103	Ci	MDA	MDA
strontium-89	Ci	MDA	MDA
strontium-90	Ci	MDA	MDA
zinc-65	Ci	MDA	MDA
zirconium-95	Ci	MDA	MDA
TOTAL FOR PERIOD	Ci	MDA	MDA

MDA = Less than the "a posteriori" minimum detectable activity (microcuries per unit mass or volume).  
 This note applies to all tables.

**DIABLO CANYON POWER PLANT  
ANNUAL RADIOACTIVE EFFLUENT RELEASE REPORT 2008**

**TABLE 3  
GASEOUS EFFLUENTS - LOWER LIMITS OF DETECTION**

Nuclide	Units	Continuous Mode	Batch Mode	
			Containment Purge	Gas Decay Tank

1. Fission gases

argon-41	μCi/ml	2.86E-8	2.86E-8	7.15E-6
krypton-85	μCi/ml	2.99E-6	2.99E-6	1.20E-3
krypton-85m	μCi/ml	6.92E-9	6.92E-9	3.61E-6
krypton-87	μCi/ml	3.64E-8	3.64E-8	9.03E-6
krypton-88	μCi/ml	3.70E-8	3.70E-8	9.16E-6
xenon-131m	μCi/ml	1.92E-7	1.92E-7	1.08E-4
xenon-133	μCi/ml	2.02E-8	2.02E-8	8.35E-6
xenon-133m	μCi/ml	5.32E-8	5.32E-8	2.55E-5
xenon-135	μCi/ml	8.93E-9	8.93E-9	3.01E-6
xenon-135m	μCi/ml	2.98E-7	2.98E-7	2.37E-5
xenon-138	μCi/ml	5.47E-7	5.47E-7	6.28E-5

2. Tritium

hydrogen-3	μCi/ml	4.18E-9	4.18E-9	N/A
------------	--------	---------	---------	-----

3. Iodines

iodine-131	μCi/ml	5.59E-13	N/A
iodine-133	μCi/ml	5.75E-13	N/A
iodine-135	μCi/ml	1.29E-12	N/A

**DIABLO CANYON POWER PLANT  
 ANNUAL RADIOACTIVE EFFLUENT RELEASE REPORT 2008  
 TABLE 3 (Continued)  
 GASEOUS EFFLUENTS - LOWER LIMITS OF DETECTION**

Nuclide	Units	Continuous Mode
---------	-------	-----------------

4. Particulates

barium-140	μCi/ml	1.75E-12
cesium-134	μCi/ml	4.92E-13
cesium-137	μCi/ml	5.38E-13
cerium-141	μCi/ml	4.87E-13
cerium-144	μCi/ml	1.41E-12
chromium-51	μCi/ml	3.30E-12
cobalt-57	μCi/ml	2.57E-13
cobalt-58	μCi/ml	6.39E-13
cobalt-60	μCi/ml	5.48E-13
iron-59	μCi/ml	1.15E-12
lanthanum-140	μCi/ml	6.80E-13
manganese-54	μCi/ml	5.04E-13
molybdenum-99	μCi/ml	2.91E-13
ruthenium-103	μCi/ml	4.57E-13
strontium-89	μCi/ml	8.98E-16
strontium-90	μCi/ml	4.71E-16
zinc-65	μCi/ml	1.52E-12
zirconium-95	μCi/ml	9.75E-13
gross alpha	μCi/ml	4.64E-15

**DIABLO CANYON POWER PLANT  
 ANNUAL RADIOACTIVE EFFLUENT RELEASE REPORT 2008**

**TABLE 4A  
 LIQUID EFFLUENTS - SUMMATION OF ALL RELEASES**

Units	First Quarter	Second Quarter	Est.Total Error %
-------	---------------	----------------	-------------------

A. Fission and activation products

1. Total release (not including tritium, gases, alpha)	Ci	8.23E-3	8.63E-3	24%
2. Average diluted concentration during period	μCi/ml	4.68E-12	3.26E-12	
3. Percent of applicable limit <sup>1</sup>	%	4.43E-5	1.18E-5	

B. Tritium

1. Total release	Ci	4.70E+2	2.85E+2	13%
2. Average diluted concentration during period	μCi/ml	2.67E-7	1.07E-7	
3. Percent of applicable limit <sup>1</sup>	%	2.67E-2	1.07E-2	

C. Dissolved and entrained gasses

1. Total release	Ci	2.26E-1	1.87E-2	24%
2. Average diluted concentration during period	μCi/ml	1.28E-10	7.08E-12	
3. Percent of applicable limit <sup>1</sup>	%	6.42E-5	3.54E-6	

D. Gross Alpha

1. Total release	Ci	MDA	MDA	61%
------------------	----	-----	-----	-----

E. Volume of waste release (prior to dilution)	liters	6.44E+7	8.73E+7	5%
--	--------	---------	---------	----

F. Volume of circulating saltwater used during release periods	liters	1.76E+12	2.65E+12	7%
--	--------	----------	----------	----

MDA = Less than the "a posteriori" minimum detectable activity (microcuries per unit mass or volume). This note applies to all tables.

<sup>1</sup> RECP 6.1.6.1 Limit



**DIABLO CANYON POWER PLANT  
ANNUAL RADIOACTIVE EFFLUENT RELEASE REPORT 2008**

**TABLE 4B  
LIQUID EFFLUENTS - SUMMATION OF ALL RELEASES**

Units	Third Quarter	Fourth Quarter	Est.Total Error %
-------	---------------	----------------	-------------------

A. Fission and activation products

1. Total release (not including tritium, gases, alpha)	Ci	4.58E-3	7.47E-3	24%
2. Average diluted concentration during period	μCi/ml	1.80E-12	2.79E-12	
3. Percent of applicable limit <sup>1</sup>	%	1.45E-5	1.39E-5	

B. Tritium

1. Total release	Ci	9.15E+2	7.36E+2	13%
2. Average diluted concentration during period	μCi/ml	3.60E-7	2.75E-7	
3. Percent of applicable limit <sup>1</sup>	%	3.60E-2	2.75E-2	

C. Dissolved and entrained gasses

1. Total release	Ci	4.05E-3	4.65E-4	24%
2. Average diluted concentration during period	μCi/ml	1.60E-12	1.74E-13	
3. Percent of applicable limit <sup>1</sup>	%	7.98E-7	8.70E-8	

D. Gross Alpha

1. Total release	Ci	MDA	MDA	61%
------------------	----	-----	-----	-----

E. Volume of waste release (prior to dilution)	liters	7.64E+7	7.85E+7	5%
--	--------	---------	---------	----

F. Volume of circulating saltwater used during release periods	liters	2.54E+12	2.67E+12	7%
--	--------	----------	----------	----

MDA = Less than the "a posteriori" minimum detectable activity (microcuries per unit mass or volume). This note applies to all tables.

<sup>1</sup> RECP 6.1.6.1 Limit

**DIABLO CANYON POWER PLANT  
ANNUAL RADIOACTIVE EFFLUENT RELEASE REPORT 2008**

**TABLE 4C  
LIQUID EFFLUENTS - SUMMATION OF ALL RELEASES**

	Units	Annual Total
--	-------	--------------

A. Fission and activation products

1. Total release (not including tritium, gases, alpha)	Ci	2.89E-2
2. Average diluted concentration during period	$\mu\text{Ci/ml}$	3.01E-12
3. Percent of applicable limit <sup>1</sup>	%	1.90E-5

B. Tritium

1. Total release	Ci	2.40E+3
2. Average diluted concentration during period	$\mu\text{Ci/ml}$	2.50E-7
3. Percent of applicable limit <sup>1</sup>	%	2.50E-2

C. Dissolved and entrained gasses

1. Total release	Ci	2.49E-1
2. Average diluted concentration during period	$\mu\text{Ci/ml}$	2.59E-11
3. Percent of applicable limit <sup>1</sup>	%	1.29E-5

D. Gross Alpha

1. Total release	Ci	MDA
------------------	----	-----

E. Volume of waste release (prior to dilution)	liters	3.07E+8
--	--------	---------

F. Volume of circulating saltwater used during release periods	liters	9.62E+12
--	--------	----------

MDA = Less than the "a posteriori" minimum detectable activity (microcuries per unit mass or volume).  
This note applies to all tables.

<sup>1</sup> RECP 6.1.6.1 Limit

**DIABLO CANYON POWER PLANT  
ANNUAL RADIOACTIVE EFFLUENT RELEASE REPORT 2008**

**TABLE 5A  
LIQUID EFFLUENTS - NUCLIDES RELEASED**

Nuclides Released	Units	First Quarter		Second Quarter	
		Continuous Mode	Batch Mode	Continuous Mode	Batch Mode
antimony-122	Ci	MDA	MDA	MDA	MDA
antimony-124	Ci	MDA	MDA	MDA	MDA
antimony-125	Ci	MDA	2.28E-4	MDA	2.29E-4
barium-140	Ci	MDA	MDA	MDA	MDA
beryllium-7	Ci	MDA	MDA	MDA	MDA
bromine-82	Ci	MDA	MDA	MDA	MDA
cerium-141	Ci	MDA	MDA	MDA	MDA
cerium-143	Ci	MDA	MDA	MDA	MDA
cerium-144	Ci	MDA	MDA	MDA	MDA
cesium-134	Ci	MDA	2.35E-6	MDA	MDA
cesium-136	Ci	MDA	MDA	MDA	MDA
cesium-137	Ci	MDA	2.25E-6	MDA	MDA
cesium-138	Ci	MDA	MDA	MDA	MDA
chromium-51	Ci	MDA	2.75E-5	MDA	MDA
cobalt-57	Ci	MDA	1.48E-5	MDA	MDA
cobalt-58	Ci	MDA	1.65E-3	MDA	1.57E-3
cobalt-60	Ci	MDA	1.28E-3	MDA	4.50E-4
iron-55	Ci	MDA	1.76E-3	MDA	2.57E-3
iron-59	Ci	MDA	MDA	MDA	2.92E-5
lanthanum-140	Ci	MDA	MDA	MDA	MDA

MDA = Less than the "a posteriori" minimum detectable activity (microcuries per unit mass or volume). This note applies to all tables.

**DIABLO CANYON POWER PLANT  
 ANNUAL RADIOACTIVE EFFLUENT RELEASE REPORT 2008**

**TABLE 5A (CONTINUED)  
 LIQUID EFFLUENTS - NUCLIDES RELEASED**

Nuclides Released	Units	First Quarter		Second Quarter	
		Continuous Mode	Batch Mode	Continuous Mode	Batch Mode
lanthanum-142	Ci	MDA	MDA	MDA	MDA
manganese-54	Ci	MDA	8.72E-6	MDA	8.42E-7
manganese-56	Ci	MDA	MDA	MDA	MDA
molybdenum-99	Ci	MDA	1.79E-6	MDA	MDA
nickel-63	Ci	MDA	2.36E-3	MDA	1.62E-3
niobium-95	Ci	MDA	1.66E-7	MDA	1.11E-5
neodymium-147	Ci	MDA	MDA	MDA	MDA
plutonium-238	Ci	MDA	MDA	MDA	MDA
plutonium-239/240	Ci	MDA	MDA	MDA	MDA
plutonium-241	Ci	MDA	MDA	MDA	MDA
plutonium-242	Ci	MDA	MDA	MDA	MDA
rubidium-89	Ci	MDA	MDA	MDA	MDA
ruthenium-103	Ci	MDA	MDA	MDA	MDA
silver-110m	Ci	MDA	MDA	MDA	MDA
sodium-24	Ci	MDA	6.19E-7	MDA	MDA
strontium-89	Ci	MDA	MDA	MDA	MDA
strontium-90	Ci	MDA	MDA	MDA	MDA
strontium-91	Ci	MDA	MDA	MDA	MDA
strontium-92	Ci	MDA	MDA	MDA	MDA
tellurium-125m	Ci	MDA	MDA	MDA	2.08E-3
tellurium-129m	Ci	MDA	MDA	MDA	MDA
tellurium-131	Ci	MDA	MDA	MDA	MDA

MDA = Less than the "a posteriori" minimum detectable activity (microcuries per unit mass or volume). This note applies to all tables.

**DIABLO CANYON POWER PLANT  
ANNUAL RADIOACTIVE EFFLUENT RELEASE REPORT 2008  
TABLE 5A (CONTINUED)  
LIQUID EFFLUENTS - NUCLIDES RELEASED**

Nuclides Released	Units	First Quarter		Second Quarter	
		Continuous Mode	Batch Mode	Continuous Mode	Batch Mode
tellurium-132	Ci	MDA	3.04E-5	MDA	MDA
tin-113	Ci	MDA	MDA	MDA	MDA
tin-117m	Ci	MDA	MDA	MDA	3.70E-5
tungsten-187	Ci	MDA	MDA	MDA	MDA
uranium-233/234	Ci	MDA	MDA	MDA	MDA
uranium-235/236	Ci	MDA	MDA	MDA	MDA
uranium-238	Ci	MDA	MDA	MDA	MDA
zinc-65	Ci	MDA	7.99E-4	MDA	5.50E-5
zirconium-95	Ci	MDA	MDA	MDA	MDA
iodine-131	Ci	MDA	5.48E-5	MDA	1.96E-5
iodine-132	Ci	MDA	2.58E-5	MDA	MDA
iodine-133	Ci	MDA	7.58E-6	MDA	MDA
iodine-134	Ci	MDA	MDA	MDA	MDA
iodine-135	Ci	MDA	3.96E-6	MDA	MDA
TOTAL FOR PERIOD	Ci	MDA	8.23E-3	MDA	8.63E-3

**DISSOLVED AND ENTRAINED GASES**

xenon-133	Ci	MDA	2.14E-1	MDA	6.28E-4
xenon-133m	Ci	MDA	8.53E-4	MDA	MDA
xenon-135	Ci	MDA	9.30E-5	MDA	2.91E-5
krypton-85	Ci	MDA	1.05E-2	MDA	1.81E-2
krypton-87	Ci	MDA	MDA	MDA	MDA
krypton-88	Ci	MDA	MDA	MDA	MDA
TOTAL FOR PERIOD	Ci	MDA	2.26E-1	MDA	1.87E-2

MDA = Less than the "a posteriori" minimum detectable activity (microcuries per unit mass or volume). This note applies to all tables.

**DIABLO CANYON POWER PLANT  
ANNUAL RADIOACTIVE EFFLUENT RELEASE REPORT 2008**

**TABLE 5B  
LIQUID EFFLUENTS - NUCLIDES RELEASED**

Nuclides Released	Units	Third Quarter		Fourth Quarter	
		Continuous Mode	Batch Mode	Continuous Mode	Batch Mode
antimony-122	Ci	MDA	MDA	MDA	MDA
antimony-124	Ci	MDA	MDA	MDA	MDA
antimony-125	Ci	MDA	9.37E-4	MDA	3.52E-4
barium-140	Ci	MDA	MDA	MDA	MDA
beryllium-7	Ci	MDA	MDA	MDA	MDA
bromine-82	Ci	MDA	MDA	MDA	MDA
cerium-141	Ci	MDA	MDA	MDA	MDA
cerium-143	Ci	MDA	MDA	MDA	MDA
cerium-144	Ci	MDA	MDA	MDA	MDA
cesium-134	Ci	MDA	MDA	MDA	MDA
cesium-136	Ci	MDA	MDA	MDA	MDA
cesium-137	Ci	MDA	MDA	MDA	MDA
cesium-138	Ci	MDA	MDA	MDA	MDA
chromium-51	Ci	MDA	2.19E-5	MDA	MDA
cobalt-57	Ci	MDA	MDA	MDA	8.73E-6
cobalt-58	Ci	MDA	8.41E-4	MDA	9.37E-4
cobalt-60	Ci	MDA	6.67E-4	MDA	7.21E-4
iron-55	Ci	MDA	9.52E-4	MDA	2.54E-3
iron-59	Ci	MDA	MDA	MDA	MDA
lanthanum-140	Ci	MDA	MDA	MDA	MDA

MDA = Less than the "a posteriori" minimum detectable activity (microcuries per unit mass or volume). This note applies to all tables.

**DIABLO CANYON POWER PLANT  
 ANNUAL RADIOACTIVE EFFLUENT RELEASE REPORT 2008  
 TABLE 5B (CONTINUED)  
 LIQUID EFFLUENTS - NUCLIDES RELEASED**

Nuclides Released	Units	Third Quarter		Fourth Quarter	
		Continuous Mode	Batch Mode	Continuous Mode	Batch Mode
lanthanum-142	Ci	MDA	MDA	MDA	MDA
manganese-54	Ci	MDA	1.29E-6	MDA	3.34E-7
manganese-56	Ci	MDA	MDA	MDA	MDA
molybdenum-99	Ci	MDA	4.76E-5	MDA	MDA
nickel-63	Ci	MDA	8.28E-4	MDA	2.82E-3
niobium-95	Ci	MDA	MDA	MDA	5.14E-7
neodymium-147	Ci	MDA	MDA	MDA	MDA
plutonium-238	Ci	MDA	MDA	MDA	MDA
plutonium-239/240	Ci	MDA	MDA	MDA	MDA
plutonium-241	Ci	MDA	MDA	MDA	MDA
plutonium-242	Ci	MDA	MDA	MDA	MDA
rubidium-89	Ci	MDA	MDA	MDA	MDA
ruthenium-103	Ci	MDA	MDA	MDA	MDA
silver-110m	Ci	MDA	MDA	MDA	MDA
sodium-24	Ci	MDA	MDA	MDA	MDA
strontium-89	Ci	MDA	MDA	MDA	MDA
strontium-90	Ci	MDA	MDA	MDA	MDA
strontium-91	Ci	MDA	MDA	MDA	MDA
strontium-92	Ci	MDA	MDA	MDA	MDA
tellurium-125m	Ci	MDA	MDA	MDA	MDA
tellurium-129m	Ci	MDA	MDA	MDA	MDA
tellurium-131	Ci	MDA	MDA	MDA	MDA

MDA = Less than the "a posteriori" minimum detectable activity (microcuries per unit mass or volume). This note applies to all tables.

DIABLO CANYON POWER PLANT  
 ANNUAL RADIOACTIVE EFFLUENT RELEASE REPORT 2008

TABLE 5B (CONTINUED)  
 LIQUID EFFLUENTS - NUCLIDES RELEASED

Nuclides Released	Units	Third Quarter		Fourth Quarter	
		Continuous Mode	Batch Mode	Continuous Mode	Batch Mode
tellurium-132	Ci	MDA	4.73E-5	MDA	MDA
tin-113	Ci	MDA	MDA	MDA	MDA
tin-117m	Ci	MDA	MDA	MDA	MDA
tungsten-187	Ci	MDA	MDA	MDA	MDA
uranium-233/234	Ci	MDA	MDA	MDA	MDA
uranium-235/236	Ci	MDA	MDA	MDA	MDA
uranium-238	Ci	MDA	MDA	MDA	MDA
zinc-65	Ci	MDA	2.33E-4	MDA	8.95E-5
zirconium-95	Ci	MDA	MDA	MDA	MDA
iodine-131	Ci	MDA	MDA	MDA	MDA
iodine-132	Ci	MDA	5.19E-5	MDA	MDA
iodine-133	Ci	MDA	MDA	MDA	MDA
iodine-134	Ci	MDA	MDA	MDA	MDA
iodine-135	Ci	MDA	MDA	MDA	MDA
TOTAL FOR PERIOD	Ci	MDA	4.58E-3	MDA	7.47E-3

DISSOLVED AND ENTRAINED GASES

xenon-133	Ci	MDA	2.58E-3	MDA	4.65E-4
xenon-133m	Ci	MDA	MDA	MDA	MDA
xenon-135	Ci	MDA	MDA	MDA	MDA
krypton-85	Ci	MDA	1.47E-3	MDA	MDA
krypton-87	Ci	MDA	MDA	MDA	MDA
krypton-88	Ci	MDA	MDA	MDA	MDA
TOTAL FOR PERIOD	Ci	MDA	4.05E-3	MDA	4.65E-4

MDA = Less than the "a posteriori" minimum detectable activity (microcuries per unit mass or volume). This note applies to all tables.



**DIABLO CANYON POWER PLANT  
ANNUAL RADIOACTIVE EFFLUENT RELEASE REPORT 2008**

**TABLE 6  
LIQUID EFFLUENTS - LOWER LIMITS OF DETECTION**

Nuclide	Units	LLD
antimony-122	μCi/ml	5.32E-8
antimony-124	μCi/ml	4.65E-8
antimony-125	μCi/ml	1.46E-7
barium-140	μCi/ml	1.97E-7
beryllium-7	μCi/ml	3.62E-7
bromine-82	μCi/ml	5.04E-8
cerium-141	μCi/ml	4.75E-8
cerium-143	μCi/ml	6.65E-8
cerium-144	μCi/ml	2.27E-7
cesium-134	μCi/ml	3.93E-8
cesium-136	μCi/ml	5.49E-8
cesium-137	μCi/ml	4.59E-8
cesium-138	μCi/ml	3.17E-7
chromium-51	μCi/ml	2.89E-7
cobalt-57	μCi/ml	2.99E-8
cobalt-58	μCi/ml	5.98E-8
cobalt-60	μCi/ml	5.24E-8
iron-55	μCi/ml	7.44E-7
iron-59	μCi/ml	6.50E-8
lanthanum-140	μCi/ml	6.95E-8
lanthanum-142	μCi/ml	1.20E-7
manganese-54	μCi/ml	6.21E-8
manganese-56	μCi/ml	2.93E-7
molybdenum-99	μCi/ml	2.21E-8
nickel-63	μCi/ml	8.01E-8
niobium-95	μCi/ml	5.81E-8

**DIABLO CANYON POWER PLANT  
ANNUAL RADIOACTIVE EFFLUENT RELEASE REPORT 2008  
TABLE 6 (CONTINUED)  
LIQUID EFFLUENTS - LOWER LIMITS OF DETECTION**

Nuclide	Units	LLD
neodymium-147	μCi/ml	1.22E-7
plutonium-238	μCi/ml	2.53E-8
plutonium-239/240	μCi/ml	1.40E-8
plutonium-241	μCi/ml	4.78E-8
plutonium-242	μCi/ml	3.34E-9
rubidium-89	μCi/ml	1.82E-5
ruthenium-103	μCi/ml	3.46E-8
silver-110m	μCi/ml	3.32E-8
sodium-24	μCi/ml	6.97E-8
strontium-89	μCi/ml	6.02E-7
strontium-90	μCi/ml	3.38E-6
strontium-91	μCi/ml	8.87E-8
strontium-92	μCi/ml	8.54E-8
tellurium-125m	μCi/ml	7.79E-6
tellurium-129m	μCi/ml	1.80E-6
tellurium-131	μCi/ml	2.14E-7
tellurium-132	μCi/ml	2.67E-8
tin-113	μCi/ml	4.49E-8
tin-117m	μCi/ml	2.48E-8
tungsten-187	μCi/ml	1.18E-7
uranium-233/234	μCi/ml	1.78E-8
uranium-235/236	μCi/ml	1.65E-8
uranium-238	μCi/ml	1.47E-8
zinc-65	μCi/ml	1.09E-7
zirconium-95	μCi/ml	7.53E-8
gross alpha	μCi/ml	9.80E-8
hydrogen-3	μCi/ml	4.93E-6

**DIABLO CANYON POWER PLANT  
ANNUAL RADIOACTIVE EFFLUENT RELEASE REPORT 2008  
TABLE 6 (CONTINUED)  
LIQUID EFFLUENTS - LOWER LIMITS OF DETECTION**

Nuclide	Units	LLD
iodine-131	$\mu\text{Ci/ml}$	4.82E-8
iodine-132	$\mu\text{Ci/ml}$	5.59E-8
iodine-133	$\mu\text{Ci/ml}$	4.87E-8
iodine-134	$\mu\text{Ci/ml}$	9.68E-8
iodine-135	$\mu\text{Ci/ml}$	2.07E-7
xenon-133	$\mu\text{Ci/ml}$	1.29E-7
xenon-133m	$\mu\text{Ci/ml}$	2.79E-7
xenon-135	$\mu\text{Ci/ml}$	2.57E-8
krypton-85	$\mu\text{Ci/ml}$	1.28E-5
krypton-87	$\mu\text{Ci/ml}$	1.11E-7
krypton-88	$\mu\text{Ci/ml}$	1.41E-7

## VI. Solid Radwaste Shipments

### Solid Waste and Irradiated Fuel Shipment

#### A. Solid Waste Shipped Off-site for Burial or Disposal (Not irradiated fuel)

1. Type of Waste	Unit	12 Month Period	Est. Total Error, %
a. Spent Resins, Filter Sludges, Evaporator Bottoms, etc.	m <sup>3</sup> Ci	5.85E+00 1.89E+02	9.00E+0
b. Dry Compressible Waste, Contaminated Equipment, etc.	m <sup>3</sup> Ci	3.15 E+01 9.93E+00	9.00E+0
c. Irradiated Components, Control Rods, etc.	m <sup>3</sup> Ci	8.83E-01 1.68E+00	0.00E+0
d. Other	m <sup>3</sup> Ci	0.00E+0 0.00E+0	0.00E+0

#### 2. Estimate of Major Nuclide Composition (by type of waste)

a.	Ni-63	%	4.11E+01
	Co-60	%	2.49E+01
	Fe-55	%	1.59E+01
	Zn-65	%	1.22E+00
	Sb-125	%	1.34E+00
b.	Fe-55	%	5.95E+01
	Co-60	%	1.34E+01
	Ni-63	%	7.90E+00
	H-3	%	3.37E+00
	Zn-65	%	1.25E+00
c.	Not Applicable	%	N/A
d.	Not Applicable	%	N/A

**Solid Waste and Irradiated Fuel Shipment (Continued)**

**3. Solid Waste Disposition**

Number of Shipments	Mode of Transportation	Destination
3	Truck	Barnwell, SC
13	Truck	Clive, UT
7	Rail	Clive, UT

**4. Supplemental Information Required by former TS 6.9.1.6**

Solidification Agent	Type of Container	Number of Containers	10 CFR 61 Waste Class	Shipping Type
Cement	IP1	1	C	IP2 - LSAII
Polymer	IP1	1	B	Type B
Cement	IP1	1	B	IP1 - LSA
None	IP1	28	AU	IP1 - LSA

**B. Irradiated Fuel Shipments (Disposition)**

Number of Shipments	Mode of Transportation	Destination
None	N/A	N/A

## VII. Radiation Dose Due to Gaseous and Liquid Effluents

### Radiation Doses

#### A. Radiation Doses from Radioactive Liquid Effluents

The radiation dose contributions due to releases of radioactive liquid effluents to the total body and each individual organ for the maximum exposed adult have been calculated in accordance with the methodology in the ODCP. Dose contributions listed in Table 7 show conformance to RECP 6.1.4.1.

#### B. Radiation Doses from Radioactive Gaseous Effluents

The radiation dose contributions due to radioactive gaseous effluents at the site boundary for the land sectors have been calculated in accordance with the calculation methodology in the ODCP. Each unit's dose contribution has been calculated separately. The latest five-year historical average meteorology conditions were used in these calculations. In addition to the site boundary doses, the dose to an individual (critical receptor) due to radioiodines, tritium, and particulates released in gaseous effluents with half-lives greater than eight days is determined in accordance with the methodology in the ODCP based on the methodology described in NUREG-0133. Dose contributions listed in Table 8, which represents the maximum dose for age groups, organs, and geographic locations for the report period, show conformance to RECP 6.1.6.1, 6.1.7.1, and 6.1.8.1.

#### C. Radiation Doses from Direct Radiation (Line-of-Sight Plus Sky-Shine) - Closest Site Boundary

For the report period, the radiation dose is evaluated to be  $6.19\text{E-}01$  mR, assuming 24-hour per day exposure, due to the presence of:

- Radioactive waste containers outside of plant buildings
- The storage of contaminated tools and equipment inside plant buildings
- OSGSF, which loaded with Unit 2 old steam generators for the first time in 2008.

#### D. Radiation Doses from Chemistry Laboratory Radioactive Gaseous Effluents - Closest Site Boundary (800m)

The radiation dose due to chemistry laboratory radioactive gaseous effluents for the report period is evaluated to be  $4.62\text{E-}06$  mR.

**E. Radiation Doses from Post Accident Sampling System Radioactive Gaseous Effluents - Closest Site Boundary (800m)**

The radiation doses due to post accident sampling system radioactive gaseous effluents for the report period is evaluated to be 1.15E-6 mR.

**F. 40 CFR 190 Considerations**

The release of radioactivity in liquid and gaseous effluents resulted in doses that are small percentages of the TS limits as shown in Tables 9 and 10. This, coupled with the fact that there are no other uranium fuel cycle sources within eight kilometers of the DCPP, shows conformance to 40 CFR 190.

**G. Radiation Doses from Radioactive Liquid and Gaseous Effluents to Members of the Public Due To Their Activities Inside The Site Boundary**

1. Liquid Effluents

The radiation dose to members of the public within the site boundary due to the release of radioactive liquid effluents is negligible because the discharge piping for liquid radwaste is mostly imbedded in concrete, located in remote or inaccessible areas, or is underground. In addition, the quantity of radioactivity released was very low.

2. Gaseous Effluents

The radiation dose to members of the public within the site boundary due to the release of radioactive gaseous effluents are listed in Table 11.

**H. Radiation Dose from Radioactive Gaseous Effluents to Individual Due to Consumption of Grazing Animals on Property Surrounding the Site.**

The Land Use Census identified that during 2008, ranchers in the area around the plant slaughtered goat, sheep, deer, wild pig and cattle for personal consumption. As part of the DCPP REMP, samples of cow, goat, deer, and sheep meat were analyzed for radioactivity. Results of those analyses are available in the 2008 REMP report

Based upon the isotopes discharged in gaseous form during 2008, the maximum calculated dose due to these identified meat pathways is 1.55E-01 mrem.

**I. Subsurface Water Radioactive Contamination**

Recent industry events have identified equipment leaks containing low levels of radioactivity, resulting in contaminated ground water and storm water radioactivity concentrations that may leave the plant sites.

Suspected plant equipment leaks that could result in such an event at DCPD are documented in the corrective action program. Analysis of samples of subsurface water at DCPD has indicated the presence of tritium. At this time, we have no reason to point to plant system leakage as the source for this tritium.

Sampling and analysis of the Auxiliary building roof drains, auxiliary building drywell, and the containment structure observation wells have identified detectable tritium activity. This tritium is most likely coming from the rain wash-out of gaseous tritium exiting the plant vent system. This tritium is being accounted for in the plant vent release, and rain water tritium is being accounted for per plant approved procedures. This practice will continue until such time that new industry guidance is provided to account for this pathway in a different manner.

Refer to the 2008 REMP report for the data that has been evaluated to date for the sampling locations.



**DIABLO CANYON POWER PLANT  
 ANNUAL RADIOACTIVE EFFLUENT RELEASE REPORT 2008**

**TABLE 7  
 RADIATION DOSE DUE TO THE RELEASE OF RADIOACTIVE LIQUID EFFLUENTS**

	millirem				
	First Quarter	Second Quarter	Third Quarter	Fourth Quarter	Annual Total
Total Body	1.89E-04	4.71E-05	1.14E-04	8.72E-05	4.37E-04
Bone	2.42E-04	1.19E-04	6.74E-05	1.47E-04	5.76E-04
Liver	3.68E-04	9.44E-05	1.61E-04	1.37E-04	7.60E-04
Thyroid	5.88E-05	2.59E-05	7.86E-05	6.14E-05	2.25E-04
Kidney	2.26E-04	3.55E-05	1.20E-04	7.69E-05	4.58E-04
Lung	8.07E-05	5.25E-05	8.87E-05	8.72E-05	3.09E-04
G.I. LLI	2.89E-04	9.92E-05	1.47E-04	1.23E-04	6.57E-04

**DIABLO CANYON POWER PLANT  
 ANNUAL RADIOACTIVE EFFLUENT RELEASE REPORT 2008**

**TABLE 8A**

**RADIATION DOSE<sup>1</sup> DUE TO THE RELEASE OF RADIOACTIVE GASEOUS EFFLUENTS (UNIT 1)**

		First Quarter Dose	Second Quarter Dose	Third Quarter Dose	Fourth Quarter Dose	Annual Total Dose
<b>Site Boundary</b>						
<b>Noble Gas</b>						
Gamma Air Dose	mrad	7.97E-5	1.58E-5	1.67E-5	1.56E-5	1.28E-4
Beta Air Dose	mrad	1.97E-4	5.90E-5	5.88E-6	5.52E-6	2.68E-4
<b>Nearest Residence-NNW</b>						
<u>I, P, T<sup>2,3</sup></u>						
Critical Receptor (Highest Organ)	mrem	3.26E-4	2.74E-4	2.54E-4	2.56E-4	1.11E-3
<b>Nearest Vegetable Garden - ESE</b>						
<u>I, P, T<sup>2,4</sup></u>						
Critical Receptor (Highest Organ)	mrem	2.68E-4	1.90E-4	1.76E-4	1.77E-4	8.11E-4

DIABLO CANYON POWER PLANT  
 ANNUAL RADIOACTIVE EFFLUENT RELEASE REPORT 2008

TABLE 8B

RADIATION DOSE<sup>1</sup> DUE TO THE RELEASE OF RADIOACTIVE GASEOUS EFFLUENTS (UNIT 2)

		First Quarter Dose	Second Quarter Dose	Third Quarter Dose	Fourth Quarter Dose	Annual Total Dose
<b>Site Boundary</b>						
<b>Noble Gas</b>						
Gamma Air Dose	mrad	4.68E-3	1.97E-5	9.17E-5	2.83E-5	4.82E-3
Beta Air Dose	mrad	9.45E-3	7.15E-6	5.52E-4	9.99E-6	1.00E-2

		First Quarter Dose	Second Quarter Dose	Third Quarter Dose	Fourth Quarter Dose	Annual Total Dose
<b>Nearest Residence-NNW</b>						
<u>I, P, T<sup>2,3</sup></u>						
Critical Receptor (Highest Organ)	mrem	3.05E-3	2.20E-4	3.33E-4	1.82E-4	3.79E-3

		First Quarter Dose	Second Quarter Dose	Third Quarter Dose	Fourth Quarter Dose	Annual Total Dose
<b>Nearest Vegetable Garden - ESE</b>						
<u>I, P, T<sup>2,4</sup></u>						
Critical Receptor (Highest Organ)	mrem	1.03E-2	1.52E-4	2.23E-4	1.26E-4	1.08E-2

**Notes for Tables 8A and 8B**

1. This represents the maximum dose of age groups, organs, and geographic locations for the quarter and the year.
2. Radioiodines, radioactive material in particulate form, and radionuclides other than noble gases with half-lives greater than eight days.
3. The inhalation and ground plane pathways are included for this location.
4. The inhalation, ground plane, and vegetable pathways are included for this location. An occupancy factor of 0.5 was used for the inhalation and ground plane pathways. The teenage group had the highest calculated dose for this location.

DIABLO CANYON POWER PLANT  
 ANNUAL RADIOACTIVE EFFLUENT RELEASE REPORT 2008

TABLE 9  
 PERCENT OF TECHNICAL SPECIFICATION LIMITS<sup>1</sup> FOR RADIOACTIVE LIQUID EFFLUENTS

	Percent				
	First Quarter	Second Quarter	Third Quarter	Fourth Quarter	Annual Total
Total Body	1.26E-02	3.14E-03	7.57E-03	5.81E-03	1.46E-02
Bone	4.84E-03	2.39E-03	1.35E-03	2.93E-03	5.76E-03
Liver	7.36E-03	1.89E-03	3.22E-03	2.74E-03	7.60E-03
Thyroid	1.18E-03	5.17E-04	1.57E-03	1.23E-03	2.25E-03
Kidney	4.51E-03	7.10E-04	2.40E-03	1.54E-03	4.58E-03
Lung	1.61E-03	1.05E-03	1.77E-03	1.74E-03	3.09E-03
G.I. LLI	5.78E-03	1.98E-03	2.93E-03	2.45E-03	6.57E-03

**NOTE:**

<sup>1</sup>RECP 6.1.4.1

DIABLO CANYON POWER PLANT  
ANNUAL RADIOACTIVE EFFLUENT RELEASE REPORT 2008

TABLE 10A

PERCENT OF TECHNICAL SPECIFICATION LIMITS<sup>1</sup> FOR RADIOACTIVE GASEOUS EFFLUENTS (UNIT 1)

		First Quarter % of TS Limit	Second Quarter % of TS Limit	Third Quarter % of TS Limit	Fourth Quarter % of TS Limit	Annual Total % of TS Limit
<b>Site Boundary</b>						
<u>Noble Gas</u>						
Gamma Air Dose	mrad	1.59E-3	3.16E-4	3.33E-4	3.13E-4	1.28E-3
Beta Air Dose	mrad	1.97E-3	5.90E-4	5.88E-5	5.52E-5	1.34E-3
<b>Nearest Residence - NNW</b>						
<u>I, P, T</u>						
Critical Receptor (Highest Organ)	mrem	4.35E-3	3.66E-3	3.39E-3	3.41E-3	7.40E-3
<b>Nearest Vegetable Garden - ESE</b>						
<u>I, P, T</u>						
Critical Receptor (Highest Organ)	mrem	3.58E-3	2.53E-3	2.34E-3	2.36E-3	5.41E-3

**NOTE:**

<sup>1</sup>RECP 6.1.6.1, 6.1.7.1 and 6.1.8.1

DIABLO CANYON POWER PLANT  
ANNUAL RADIOACTIVE EFFLUENT RELEASE REPORT 2008

TABLE 10B

PERCENT OF TECHNICAL SPECIFICATION LIMITS<sup>1</sup> FOR RADIOACTIVE GASEOUS EFFLUENTS (UNIT 2)

		First Quarter % of TS Limit	Second Quarter % of TS Limit	Third Quarter % of TS Limit	Fourth Quarter % of TS Limit	Annual Total % of TS Limit
<b>Site Boundary</b>						
<b>Noble Gas</b>						
Gamma Air Dose	mrad	9.37E-2	3.94E-4	1.83E-3	5.66E-4	4.82E-2
Beta Air Dose	mrad	9.45E-2	7.15E-5	5.52E-3	9.99E-5	5.01E-2
<b>Nearest Residence-NNW</b>						
<b>I, P, T</b>						
Critical Receptor (Highest Organ)	mrem	4.07E-2	2.93E-3	4.44E-3	2.43E-3	2.52E-2
<b>Nearest Vegetable Garden - ESE</b>						
<b>I, P, T (ESE)</b>						
Critical Receptor (Highest Organ)	mrem	1.38E-1	2.02E-3	2.98E-3	1.68E-3	7.22E-2

**NOTE:**

<sup>1</sup>RECP 6.1.6.1, 6.1.7.1 and 6.1.8.1

**DIABLO CANYON POWER PLANT  
ANNUAL RADIOACTIVE EFFLUENT RELEASE REPORT 2008  
TABLE 11A  
RADIATION DOSE DUE TO RELEASE OF RADIOACTIVE GASEOUS EFFLUENTS  
FIRST QUARTER, 2008  
ON-SITE DOSE TO MEMBERS OF THE PUBLIC (SPECIAL INTEREST GROUPS)**

Specific Activity	Exposure Location (Sectors)	Exposure Closest Dist. (meters)	Exposure Time (Hours)	External Dose		Internal Dose	
				Noble Gas		Iodines, Particulates, and Tritium	
				Whole Body	Skin	Ground Plane	Inhalation
Police at Shooting Range	SE	700	52.0	1.54E-4	3.10E-4	6.08E-6	7.20E-4
Tour Participants							
(a) Simulator Bldg.	S	310	1.00	2.02E-6	4.06E-6	4.22E-8	9.44E-6
(b) Bio Lab	SSE	460	1.50	3.04E-6	6.09E-6	9.59E-8	1.42E-5
(c) Overlook	E	210	0.25	1.41E-6	2.83E-6	1.38E-8	6.57E-6
American Indians at Burial Grounds	NW	200	24.0	5.59E-4	1.12E-3	6.28E-6	2.61E-3
	NNW	200	24.0	3.91E-4	7.85E-4	3.58E-6	1.82E-3
Ranch Hands driving cattle around site	NW	250	0.25	3.90E-6	7.83E-6	4.61E-8	1.82E-5
	NNW	350	0.25	1.49E-6	3.00E-6	1.56E-8	6.97E-6
	N	320	0.25	9.92E-7	1.99E-6	7.83E-9	4.63E-6
	NNE	450	0.25	3.88E-7	7.79E-7	3.37E-9	1.81E-6
	NE	630	0.25	1.97E-7	3.96E-7	2.07E-9	9.21E-7

NOTE: All doses are in mrem.



**DIABLO CANYON POWER PLANT  
ANNUAL RADIOACTIVE EFFLUENT RELEASE REPORT 2008  
TABLE 11B  
RADIATION DOSE DUE TO RELEASE OF RADIOACTIVE GASEOUS EFFLUENTS  
SECOND QUARTER, 2008  
ON-SITE DOSE TO MEMBERS OF THE PUBLIC (SPECIAL INTEREST GROUPS)**

Specific Activity	Exposure Location (Sectors)	Exposure Closest Dist. (meters)	Exposure Time (Hours)	External Dose		Internal Dose	
				Noble Gas		Iodines, Particulates, and Tritium	
				Whole Body	Skin	Ground Plane	Inhalation
Police at Shooting Range	SE	700	52.0	1.25E-6	3.18E-6	0.00E+0	1.36E-4
Tour Participants							
(a) Simulator Bldg.	S	310	1.00	1.64E-8	4.17E-8	0.00E+0	1.78E-6
(b) Bio Lab	SSE	460	1.50	2.45E-8	6.26E-8	0.00E+0	2.67E-6
(c) Overlook	E	210	0.25	1.14E-8	2.90E-8	0.00E+0	1.24E-6
American Indians at Burial Grounds	NW	200	24.0	4.52E-6	1.15E-5	0.00E+0	4.92E-4
	NNW	200	24.0	3.16E-6	8.06E-6	0.00E+0	3.45E-4
Ranch Hands driving cattle around site	NW	250	0.25	3.15E-8	8.04E-8	0.00E+0	3.44E-6
	NNW	350	0.25	1.21E-8	3.08E-8	0.00E+0	1.32E-6
	N	320	0.25	8.02E-9	2.05E-8	0.00E+0	8.74E-7
	NNE	450	0.25	3.14E-9	8.00E-9	0.00E+0	3.42E-7
	NE	630	0.25	1.60E-9	4.07E-9	0.00E+0	1.74E-7

NOTE: All doses are in mrem.

**DIABLO CANYON POWER PLANT  
ANNUAL RADIOACTIVE EFFLUENT RELEASE REPORT 2008  
TABLE 11C  
RADIATION DOSE DUE TO RELEASE OF RADIOACTIVE GASEOUS EFFLUENTS  
THIRD QUARTER, 2008  
ON-SITE DOSE TO MEMBERS OF THE PUBLIC (SPECIAL INTEREST GROUPS)**

Specific Activity	Exposure Location (Sectors)	Exposure Closest Dist. (meters)	Exposure Time (Hours)	External Dose		Internal Dose	
				Noble Gas		Iodines, Particulates, and Tritium	
				Whole Body	Skin	Ground Plane	Inhalation
Police at Shooting Range	SE	700	52.0	3.50E-6	1.55E-5	0.00E+0	1.61E-4
Tour Participants							
(a) Simulator Bldg.	S	310	1.00	4.59E-8	2.04E-7	0.00E+0	2.11E-6
(b) Bio Lab	SSE	460	1.50	6.88E-8	3.06E-7	0.00E+0	3.16E-6
(c) Overlook	E	210	0.25	3.19E-8	1.42E-7	0.00E+0	1.47E-6
American Indians	NW	200	24.0	1.27E-5	5.63E-5	0.00E+0	5.81E-4
at Burial Grounds	NNW	200	24.0	8.87E-6	3.94E-5	0.00E+0	4.07E-4
Ranch Hands driving	NW	250	0.25	8.84E-8	3.93E-7	0.00E+0	4.06E-6
cattle around site	NNW	350	0.25	3.39E-8	1.50E-7	0.00E+0	1.55E-6
	N	320	0.25	2.25E-8	9.99E-8	0.00E+0	1.03E-6
	NNE	450	0.25	8.80E-9	3.91E-8	0.00E+0	4.04E-7
	NE	630	0.25	4.48E-9	1.99E-8	0.00E+0	2.05E-7

NOTE: All doses are in mrem.

**DIABLO CANYON POWER PLANT  
ANNUAL RADIOACTIVE EFFLUENT RELEASE REPORT 2008  
TABLE 11D  
RADIATION DOSE DUE TO RELEASE OF RADIOACTIVE GASEOUS EFFLUENTS  
FOURTH QUARTER, 2008  
ON-SITE DOSE TO MEMBERS OF THE PUBLIC (SPECIAL INTEREST GROUPS)**

Specific Activity	Exposure Location (Sectors)	Exposure Closest Dist. (meters)	Exposure Time (Hours)	External Dose		Internal Dose	
				Whole Body	Skin	Iodines, Particulates, and Tritium	
						Ground Plane	Inhalation
Police at Shooting Range	SE	700	52.0	1.55E-6	2.26E-6	0.00E+0	1.21E-4
Tour Participants							
(a) Simulator Bldg.	S	310	1.00	2.03E-8	2.96E-8	0.00E+0	1.58E-6
(b) Bio Lab	SSE	460	1.50	3.04E-8	4.44E-8	0.00E+0	2.38E-6
(c) Overlook	E	210	0.25	1.41E-8	2.06E-8	0.00E+0	1.10E-6
American Indians at Burial Grounds	NW	200	24.0	5.60E-6	8.17E-6	0.00E+0	4.37E-4
	NNW	200	24.0	3.92E-6	5.72E-6	0.00E+0	3.06E-4
Ranch Hands driving cattle around site	NW	250	0.25	3.91E-8	5.70E-8	0.00E+0	3.05E-6
	NNW	350	0.25	1.50E-8	2.18E-8	0.00E+0	1.17E-6
	N	320	0.25	9.94E-9	1.45E-8	0.00E+0	7.76E-7
	NNE	450	0.25	3.89E-9	5.67E-9	0.00E+0	3.04E-7
	NE	630	0.25	1.98E-9	2.89E-9	0.00E+0	1.54E-7

NOTE: All doses are in mrem.

**DIABLO CANYON POWER PLANT  
ANNUAL RADIOACTIVE EFFLUENT RELEASE REPORT 2008  
TABLE 11E  
RADIATION DOSE DUE TO RELEASE OF RADIOACTIVE GASEOUS EFFLUENTS  
ANNUAL TOTAL, 2008  
ON-SITE DOSE TO MEMBERS OF THE PUBLIC (SPECIAL INTEREST GROUPS)**

Specific Activity	Exposure Location (Sectors)	Exposure Closest Dist. (meters)	Exposure Time (Hours)	External Dose		Internal Dose	
				Noble Gas		Iodines, Particulates, and Tritium	
				Whole Body	Skin	Ground Plane	Inhalation
Police at Shooting Range	SE	700	208.0	1.51E-4	3.07E-4	6.08E-6	1.14E-3
Tour Participants							
(a) Simulator Bldg.	S	310	4.00	1.97E-6	4.02E-6	4.22E-8	1.49E-5
(b) Bio Lab	SSE	460	6.00	2.96E-6	6.04E-6	9.59E-8	2.24E-5
(c) Overlook	E	210	1.00	1.37E-6	2.80E-6	1.38E-8	1.04E-5
American Indians at Burial Grounds	NW	200	96.0	5.45E-4	1.11E-3	6.28E-6	4.12E-3
	NNW	200	96.0	3.81E-4	7.78E-4	3.58E-6	2.88E-3
Ranch Hands driving cattle around site	NW	250	1	3.80E-6	7.76E-6	4.61E-8	2.87E-5
	NNW	350	1	1.46E-6	2.97E-6	1.56E-8	1.10E-5
	N	320	1	9.68E-7	1.97E-6	7.83E-9	7.31E-6
	NNE	450	1	3.79E-7	7.72E-7	3.37E-9	2.86E-6
	NE	630	1	1.93E-7	3.93E-7	2.07E-9	1.45E-6

NOTE: All doses are in mrem.

### VIII. Meteorological Data

#### Meteorological Data

The hour-by-hour listing of wind speed, wind direction, atmospheric stability, and precipitation is contained on compact disc with this submittal.

#### Compact Diskette Information

Filename	Sensitivity	File Size	Description
NRC05	Non-SGI	1.3 Mb	Diablo Canyon Primary Meteorological Data

Special Instructions: The CD-R media are read-only, 700MB compact diskettes.

On May 21, 2008, the primary meteorological tower was damaged by crane operations. The primary meteorological tower was replaced during the third quarter of 2008. Due to this event, meteorological data shows a higher frequency of west-northwest wind direction when compared to previous periods. This change in frequency is due to substitution of data from the 10 meter level from the backup meteorological tower during the summer months while repair were made to the out-of-service primary meteorological tower.

**Attachment 1**

**License Basis Impact Evaluation 2008-001  
Auxiliary Control Board Replacement - Phase 2  
DCP J-49855**

**LBIE - Section 0 - General Information and Summary**

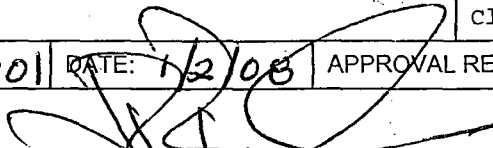
LBIE TITLE: Auxiliary Control Board Replacement -Phase 2	
LBIE NUMBER: 2008-001	
IMPLEMENTING DOCUMENT NO.: DCP J-49855	DOC. REV. NO.: 0
IMPLEMENTING DOCUMENT TITLE: Aux Cont Brd Replace-Ph 2	
SPONSORING ORGANIZATION: PGPE	SPONSOR PRINT LAST NAME: Clint Miller
PSRC MEETING NO.: 2008-001	DATE: 1/2/08
APPROVAL RECOMMENDED: <input checked="" type="checkbox"/> Y <input type="checkbox"/> N	
STATION DIRECTOR APPROVAL: 	DATE: 1 3 08

As a result of the LBIE Screen (Forms 69-10430 and 69-21097), indicate which sections of the LBIE have been completed and are attached. Refer to TS3.ID2 to complete each evaluation.

- 10 CFR 50.59 and/or  10 CFR 72.48 Evaluation (check one or both if applicable)
- Fire Protection Program, Attachment 8.4, Form 69-20174
- Safety Assessment, Attachment 8.5, Form 69-20175
- Environmental Protection, Attachment 8.6, Form 69-20176
- Emergency Plan, Attachment 8.7, Form 69-20177
- Security Plan, Attachment 8.8, Form 69-20178

**Summary:** For 10 CFR 50.59 and/or 10 CFR 72.48 evaluations, this information will be used for preparation of the biennial reports submitted pursuant to 10 CFR 50.59(d)(2) or 10 CFR 72.48(d)(2). Refer to the 10 CFR 50.59 Resource Manual or 10 CFR 72.48 Resource Manual for instructions.

Activity Description:

**This LBIE for Auxiliary Building Control Board Replacement (Phase 2) applies to both Units 1&2.**

Per LBIE screen section 9.2.2.a & 9.2.2.B, this design change is treated as a digital upgrade and guidance from EPRI TR-102348 revision 1 is followed. This guidance provided meaningful evaluation information to the response to LBIE questions 1 and 2. Since the control system is Design Class II, non-safety-related, the response to questions 3 thru 8 were answered using the guidance provided in the 10 CFR 50.59 Resource Manual Rev. 3, November 2005.

The overall mission is to replace the obsolete Auxiliary Building Control Board control system with a new control system. The Auxiliary Building Control Board Replacement (Phase 2) design change will replace existing controls and integrate the functions of the Gaseous Radwaste (GRW), MEDT, Aux Building Sump and BA Concentrates Holding Tank 0-2 into a hybrid digital control system. The overall scope of Phase 2 Auxiliary control Board Replacement design change will establish the following,

- Data Acquisition and control System (DACS-Controllogix)
- Two (2) redundant controller/communication chassis will be installed at 73' panel PAXBIO.
- Three (3) remote I/O chassis (each having redundant power supplies). Two (2) remote I/O will be installed at 73' panel PAXBIO. One (1) remote I/O will be installed at panel POWE.
- One (1) Auxiliary Maintenance Terminal at 73' panel PAXBIO.
- Network Connections to DACS
  - Ethernet/fiber for local area network
  - ControlNet for DACS
  - 24 VDC power Distribution between panels PAXBNET, PAXBIO, PAXBPNO and POWE.
- System upgrade to Controls/Indication
  - GRW-Fluidic Logic replacement/Gas Decay Tanks
  - GRW-Waste Gas Compressor
  - LRW-MEDT/Aux Building Sump (ABS) level controls

REFERENCE DOCUMENT NO.: DCP J-49855

DOC. REV. NO.: 0

- o CVCS-Boric Acid Concentrates Holding tank (BACHT 0-2)
- o POWE annunciation alarms
- o O2 analyzer 2% alarm and 4% trip
- o Selected Annunciation at other panels

Phase 2 design change scope will be completed as two separate design change packages (DCP J-49855 & J-49877). The scoping for this DCP J-49855 replaces and upgrades the Auxiliary Control Board system with a new digital control system. DCP J-49877 was approved and removes abandoned-in-place (AIP), unused components, and power receptacles and relocates waste gas compressor relays to support the main digital upgrade DCP J-49855.

Summary of Evaluation:

This design change does not require prior NRC approval. There is no adverse impact to any radwaste design function described in the FSARU. All electrical and instrument control schemes being replaced or modified provide a non-safety related (Design Class II) function. All control schemes are supplied by non-vital power. The associated systems are non safety related and not relied upon for the safe shutdown of the plant. The design change replaces the existing obsolete Gaseous Radwaste Fluidic Logic control system and other components to increase system reliability and availability.

The new system will be designed with redundant networking systems and independent power sources. The redundant power supplies are derived from independent (Unit 1&2) power sources to protect the system in the event of a loss power. Having the infrastructure designed to have redundant network systems, HMI control stations and power supplies improves reliability and minimizes down time. Also integrating some of the old instruments into the new hybrid control system will minimize maintenance.

The automatic and manual functions will be integrated into the hybrid digital control system. The new digital control system will be designed to enhance the ability for operations to control and monitor the process. The existing Aux Building Control Board annunciator alarm functions will be integrated into the hybrid digital display as alarms. Handswitches used for automatic/manual control of waste gas compressors, pumps and valves will be integrated into the control system. The new control system consolidates needed information onto display screens (HMIs) that provide much more effective view of system operation. The new system will provide a MIMIC as part of the HMI display to replace the old board MIMIC. The new system will save time for an operator to seek meter readings or other indications. The new control features will not adversely increase time required to perform the control actions from the HMI display. Cautions and warnings can be displayed to prevent potential errors. Although there is a fundamental change to the way information is presented and controls are interacted with the operator, the control capability requirements are not impacted.

Also GDT Fill, vent and purge activity functions are maintained and integrated into the new control system. Failure mode for the GDT control valves to fail closed upon loss of power or air is maintained. The ability to control tank quantities including the GDT cross-over valve (FCV-417) is maintained. The key operated switch for FCV-417 was replaced with a cut out switch to maintain "defense in depth" measures. The ability for the flow control vent waste gas valve (FCV-410) providing the means for redundant isolation and manual operation to initiate valve opening will not be affected. The key operated switch for FCV-410 is removed since it requires manual operation to open the valve and establish venting. Also FCV-410 has a common "redundant" relationship to both the upstream dedicated GDT vent valves (FCV-404, 405 & 406) and the downstream vent header radiation monitor control valve RCV-17. This requires independent action to open the GDT vent valves to avoid inadvertent venting. Also added features such as administrative controls within the digital controls will require a minimum of a two step function to initiate venting. The RM-22 radiation monitor, signals to EARS, control circuit for RCV-17 and valve RCV-17 will be unaffected and maintained independent of the new control system except for



REFERENCE DOCUMENT NO.: DCP J-49855

DOC. REV. NO.: 0

the existing HI radiation alarm signal fed to the new Aux Building Control Board. RCV-17 downstream of FCV-410 will close automatically in the event of high radiation. A new feature of the new digital system processes is a HI radiation alarm that provides an interlock to automatically close GDT vent valves FCV-404, 405, 406 & common vent header valve FCV-410.

A Functional Requirements Specification (FRS), 663195-31 has been written to specify specific programming and design functional requirements for the digital controller and HMIs. The FRS provides the basis for the plant software QA program and configuration management of the reactor makeup control system.

In general, the new system improves the control and provides human factor enhancements to better support operator tasks and reduce risk of errors.

References (including documents implementing credited actions or compensatory measures):

10CFR 50.59 Resource Manual Revision 3, dated November 2005, Q-List, Tech Spec (3.1, 3.3, 3.4, 3.5, 3.7, 5.5.12), ECGs (8.1-8.8, 19.1, 24.1, 24.2, 24.3), FSAR sections (7.7.1.11.3, 7.7.1.11.4, Fig 7.7-31, 8, 9.3, 11.2, 11.3, 11.4, 15.4.7 & 16), DCM S-8, S-19, S-24, S-33, S-65, S-25A, M-43, S-78, T-24, Regulatory Guide 1.97 R3 (Instrumentation for Light Water Cooled Nuclear Power Plants to Assess Plant and Environs Conditions During and Following an Accident), Regulatory Guide 1.180 R1 (Guidelines for Evaluating Electromagnetic and Radio-Frequency Interference in Safety-Related Instrumentation and Control Systems), EPRI TR-10238 Revision 1 (NEI 01-01 Guideline on Licensing Digital Upgrades), FCC Part 15 (Sub Parts A&B) ISA standard TR-91.00.02-2003, setpoint calculations NSP-1/2-24-8A, NSP-1/2-24-11A, NSP-1/2-24-17, Seismic calculation ES96, ES102, Action Requests: AR A0683887, A0581789.

## LBIE - Section 1 - 10 CFR 50.59 and/or 10 CFR 72.48 Evaluation

IMPLEMENTING DOCUMENT NO.: DCP J-49855	DOC. REV. NO.: 0
--	------------------

**NOTES:** A response justifying the answer to each question below must be provided. The 10 CFR 50.59 Resource Manual or 10 CFR 72.48 Resource Manual (RM) should be used to determine the content of each response (see Section 6.2 for additional guidance). Identify references used to perform evaluation (either in a single list or within the written responses).

If the answer to any of the 10 CFR 50.59 and/or 10 CFR 72.48 questions is "YES," then the proposed activity may not be implemented until a License Amendment has been obtained from the NRC.

Throughout this evaluation, FSARU refers to the current *FSAR as updated* per 10 CFR 50.71 or 10 CFR 72.70, approved changes to the FSAR which have not yet been submitted to the NRC by amendment and documents incorporated into the FSAR by reference.

The following is a  10 CFR 50.59 and/or  10 CFR 72.48 Evaluation (check one or both)

### EFFECTS ON ACCIDENTS AND MALFUNCTIONS PREVIOUSLY EVALUATED IN THE FSARU

1. Does the proposed activity result in more than a minimal increase in the frequency of occurrence of an accident previously evaluated in the FSARU? (See Section 6.2.1 of the RM.)  Y  N

Justification:

The Auxiliary Building Control Board referenced per (UFSAR Section 7.7.1.11.3). The liquid radwaste system (LRS) collects and processes the radioactive liquid wastes generated during plant operation (UFSAR Section 11.2). The gaseous radwaste system (GRS) provides controlled handling and disposal of gaseous wastes generated during plant operation (UFSAR Section 11.3). Also SAR Section 15.4.7 describes cause and events of a rupture of a waste gas decay tank.

The accident analysis in FSAR Chapters 6 & 15 are unaffected by this change.

*a. Does the new equipment installed with the upgrade exhibit performance characteristics, or have design features, that give an increased frequency of a system malfunction resulting in an accident? EPRI TR-102348 r.1, Appendix A.*

The accident evaluated in the FSARU 15.4.7 is concerning a rupture of a waste gas decay tank. This low probability accident scenario would rely on a combination of inadvertent operator errors and equipment malfunctions or failures and is considered highly unlikely. The control system installed per this design change is highly reliable and does not change the failure mode of any valve on loss of power or instrument air.

The new system will integrate redundant work stations, HMIs and servers. Also the new digital control system will have redundant power supplies derived from independent (Unit 1&2) power sources to protect the system in the event of a loss power. An additional INSQL Historian server and a network link to the PDN system are provided. Also a third HMI at the 73' elevation will be used as a maintenance work station for programming and troubleshooting. Having the infrastructure designed to have redundant network systems, HMI control stations and power supplies improves reliability and minimizes down time. Also integrating some of the old instruments into the new hybrid control system will reduce maintenance.

GDT Fill, vent and purge activity functions are maintained and integrated into the new control system. The ability to control tank quantities including the GDT cross-over valve (FCV-417) is maintained. The key operated switch for FCV-417 was replaced with a cut out switch to maintain "defense in depth" measures. The ability for the flow control vent valve (FCV-410) providing the means for redundant isolation and manual operation to initiate valve opening will not be affected. The key operated switch for

IMPLEMENTING DOCUMENT NO.: DCP J-49855

DOC. REV. NO.: 0

FCV-410 is removed since the new system maintains manual operation to open the valve and establish venting. Also FCV-410 has a common "redundant" relationship to both the upstream dedicated GDT vent valves (FCV-404, 405 & 406) and the downstream vent header radiation monitor control valve RCV-17. This requires independent action to open the GDT vent valves to avoid inadvertent venting. Also added features such as administrative controls within the digital controls will require a minimum of a two step function to initiate venting. The RM-22 radiation monitor, signals to EARS, control circuit for RCV-17 and valve RCV-17 will be unaffected and maintained independent of the new control system except for the existing HI radiation alarm signal fed to the new Aux Building Control Board. RCV-17 downstream of FCV-410 will close automatically in the event of high radiation. A new feature of the new digital system processes a HI radiation alarm and provides interlock to automatically close GDT vent valves FCV-404, 405, 406 & common vent header valve FCV-410.

The design change will not affect the ability of the explosive gas monitoring instruments channels (ANR-75 & 76) to provide a 2% alarm or 4% alarm/compressor trip signal. The O2 analyzer 2% alarm or 4% alarm/compressor trip signal will be input and controlled by the digital control system.

All of the system circuit cards can be replaced on line with the power applied. Power isolation devices are provided and/or maintained for associated compressors, pumps and control valves for ease of operations and maintenance. The new system will have Field Termination Panels (FTP) and a cable management system that connects the digital controller with the analog and digital input/outputs (I/O). The FTPs will provide fuse protection for digital I/Os. Also dedicated manual isolation valves are provided on the pneumatic control lines to the associated control valves.

The new digital control system has an internal flash memory storage card backup to ensure control conditions, variable values and configuration programs are retained. The system is further backed by a battery.

Functional Requirements Specification (FRS) will specify specific programming and design functional requirements. The FRS provides the basis for the plant software QA program and configuration management of the reactor makeup control system.

The instrument controls being modified provide a non safety-related function and will not affect the portions of the control system that are safety related.

*b. Does the system exhibit performance characteristics that increase the need for operator intervention or increase operator burden to support operation of the system in normal or off-normal conditions? Could this increase the frequency of an accident previously evaluated? EPRI TR-102348 r.1, Appendix A.*

The accident previously evaluated is a rupture of a waste gas decay tank (FSARU 15.4.7). Then answer to both of these questions is 'No'. No increase to operator interface is required. The new system will provide improved reliability, better support of operator tasks and reduces risk of errors.

*c. Is the system compatible with the installed environment (e.g., temperature, humidity, seismic, EMI/RFI emissions, airborne particulates) such that system performance will not be degraded compared to the system being replaced? EPRI TR-102348 r.1, Appendix A.*

Yes. The replacement materials are compatible for use in the system application.

The associated control schemes do not require environmental qualification. This design change involves modification to Class II (QA Class S) panels POWE, POEC, POCV1&2. The panels are seismically

IMPLEMENTING DOCUMENT NO.: DCP J-49855

DOC. REV. NO.: 0

qualified to protect fuses required for RG 1.97 circuits. The design change does not affect any RG 1.97 circuits or fuses.

The new digital control system (electronics) is located in a mild environment.

The Allen-Bradley Controllogix digital control systems have been independently tested for EMI/RFI by the United States Navy in accordance with MIL Spec standards. The MIL Spec standards MIL-STD-462D & 461E is endorsed by Reg Guide 1.180 and considered one of the most stringent standards. The Allen Bradley Controllogix has been approved by the Navy for use in their surface combatants, on aircraft carriers, destroyers and mine sweepers.

Electromechanical devices, such as relays, can produce low frequency waves (30 MHz or less) of conducted emissions. Appropriate grounding and shielding practices will be used to minimize noise. Allen-Bradley can provide noise filtering on various control inputs as needed. This design change provides a redundant power source to the Allen-Bradley controls to allow a stable and reliable voltage supply. The digital outputs are rated to meet the process electrical loads.

Based upon the above considerations, electromagnetic interferences to other components or susceptibility to EMI/RFI emissions is considered unlikely. The effect due to EMI/RFI is considered insignificant since the digital control system is designed to replace and/or interface with the existing Class II Auxiliary Building Control Board instrumentation and control systems. The digital system will be associated with non-safety related applications that are not relied upon for the safe shutdown of the plant. Occurrence of system failure is highly unlikely due to the redundant architecture built into the new digital system.

Based upon the above considerations, electromagnetic interferences to other components or susceptibility to EMI/RFI emissions is considered unlikely.

*d. Can the system have an adverse impact on the installed environment (e.g., temperature, humidity, seismic, EMI/RFI emissions, airborne particulates) such that performance of an existing system used for accident detection will be more than minimally degraded compared to existing requirements? EPRI TR-102348 r.1, Appendix A.*

No. The bulk of the digital control (electronics) is located in Area K of the 85' Auxiliary Building Control Board control room and 73' Area K Auxiliary Building. The heat dissipation from these new devices is considered insignificant and will not affect the HVAC loading or degrade the ability of any accident detection equipment.

Refer to previous EMI/RFI evaluation in 1.c. Electromagnetic interferences to other components or susceptibility to EMI/RFI emissions is considered unlikely.

Conclusion:

Therefore, the new system will not result in more than minimal increase in the frequency of occurrence of a rupture of a waste gas decay tank accident previously evaluated in the FSAR 15.4.7

2. Does the proposed activity result in more than a minimal increase in the likelihood of occurrence of a malfunction of an SSC important to safety previously evaluated in the FSARU? (See Section 6.2.2 of the RM.)  Y  N

Justification:

The Auxiliary Building Control Board referenced per (UFSAR Section 7.7.1.11.3). The liquid radwaste system (LRS) collects and processes the radioactive liquid wastes generated during plant operation (UFSAR Section 11.2). The gaseous radwaste system (GRS) provides controlled handling and disposal of

IMPLEMENTING DOCUMENT NO.: DCP J-49855

DOC. REV. NO.: 0

gaseous wastes generated during plant operation (UFSAR Section 11.3). Also SAR Section 15.4.7 describes cause and events of a rupture of a waste gas decay tank.

*a. Does the modified system meet the required plant environmental and seismic envelopes? EPRI 102348 rev. 1*

Yes. The equipment is compatible with the required plant environment and seismic envelopes. The associated control schemes do not require environmental qualification. This design change involves modification to Class II (QA Class S) panels POWE, POEC, POCV1&2. The panels are seismically qualified to protect fuses required for RG 1.97 circuits. The design change does not affect any RG 1.97 circuits or fuses. All electrical and I&C control schemes associated with the Phase 2 Auxiliary Building Control Board Design are Class II. The electrical circuits are fed from non-vital sources.

*b. Could the environment in which the upgraded equipment operates cause an increase in the likelihood of a failure (e.g., electromagnetic susceptibility in higher frequency range)? Could the new system create an environment (e.g., temperature, humidity, seismic, EMI/RFI emissions, airborne particulates) which adversely affects other equipment and increased the probability of occurrence of a malfunction? EPRI 102348 rev. 1*

The answer is 'No' to both questions. The bulk of the digital control (electronics) is located in Area K of the 85' Auxiliary Building Control Board control room and 73' Area K Auxiliary Building. The heat dissipation from these new devices is considered insignificant and will not affect the HVAC loading or increase the probability of a malfunction to other equipment.

Electromagnetic interferences to other components or susceptibility to EMI/RFI emissions is considered unlikely. Refer to previous evaluation per 1.c.

*c. Have potential interactions between safety-related and non-safety-related systems been addressed? EPRI 102348 rev. 1*

Yes. The design change mounts non safety related panels, raceway and tubing on adjacent Class I concrete wall or floors to allow installation. This design change also modifies electrical raceway to accommodate field routing of cable and fiber. The addition of the new panels and electrical raceways is within building allowances and does not adversely impact any structural integrity of any civil structures.

*d. Are the electrical loads associated with the upgraded system addressed in the design? EPRI 102348 rev. 1*

Yes. This issue has been addressed in the design. Refer to the DCE associated with this design change under the heading, "Electrical Design Considerations".

*e. Does the HVAC have adequate capacity for the thermal loads of the upgraded system? EPRI 102348 rev. 1*

Yes. The amount of heat dissipation for the new devices is considered insignificant as a HVAC heat load. This issue has been addressed in the design. Refer to the DCE associated with this design change under the heading, "HVAC Design Considerations".

*f. Does the upgraded system meet applicable requirements for separation, independence, and grounding? EPRI 102348 rev. 1*

Yes. Design Class I to Class II separation and independence are not issues within the associated Design Class II systems.

*g. Does the upgraded system have adequate cabinet cooling? EPRI 102348 rev. 1*

IMPLEMENTING DOCUMENT NO.: DCP J-49855

DOC. REV. NO.: 0

Yes. The amount of heat dissipation for the new control system is considered insignificant for the wattage being removed and installed. Refer to the DCE associated with this design change under the heading, "HVAC Design Considerations". All panels associated with this design change are not equipped with fans and will not require the addition of cabinet cooling.

*h. Could a common cause failure result in a system-level failure based on the failure analysis (also see item (i))? EPRI 102348 rev. 1*

No. It can be postulated that a software error causing an adverse system failure beyond the existing system failure modes is highly unlikely. The new control system including the software will be verified by a pre-installation and post-modification acceptance test in accordance with the Functional Requirements Specification (FRS) 663195-31. The FRS provides the basis for the plant software QA program and configuration management of the reactor makeup control system.

*i.1. Is there reasonable assurance that the dependability of the system is sufficient (i.e. the likelihood of failure is significantly below that of single, active, failures)? EPRI 102348 rev. 1*

Yes. The Allen Bradley Controllogix system has a Safety Integration Level (SIL) certification of SIL2. Per ISA standard TR-91.00.02-2003, a SIL2 digital system is considered a highly reliable (non-redundant) system and has reliability rating of greater than 99.99%.

*i.2. Was the application software developed under a 10 CFR 50 Appendix B, QA program using a documented life cycle development process? EPRI 102348 rev. 1*

No. The Allen Bradley software platform SIL2 rating was certified by TUV, an internationally recognized and credited test facility; however, this specific application software was not developed under a 10 CFR 50 Appendix B, QA program. The digital control system is Design Class II. The system has redundant power supplies and network system. The robust design of the system and pre- and post-installation testing ensure that design objectives are met and the possibility of a failure to the system is negligible.

*i.3. Does the design comply with industry and regulatory standards? EPRI 102348 rev. 1*

Yes. This issue has been addressed in the design. Refer to the DCE associated with this design change under the heading, "DESIGN BASES/SUMMARY REQUIREMENTS, items 4 (Regulatory Guides) and item 5 (Industry Codes and Standards).

*i.4. Is there prior operating history for the digital device(s) and their firmware? EPRI 102348 rev. 1*

Yes. Allen Bradley digital control systems are used all over the world for critical processes. They are one (if not the) most widely used digital control supplier in the industry. The Allen Bradley Controllogix series controllers have been approved by the Navy for use in their surface combatants, on aircraft carriers, destroyers and mine sweepers.

*i.5. Has the platform been pre-qualified through NRC review? EPRI 102348 rev. 1*

No. This design change does not require prior NRC approval. The new digital control system is Design Class II. The new control system integrates the radwaste controls using redundant power supplies and network system which provides improved reliability.

*i.6. Does the design include features to detect, annunciate, and/or mitigate faults? EPRI 102348 rev. 1*

Yes. The Auxiliary Building Control Board annunciator and MIMIC board displays will be integrated into the new control system and displayed at the HMI control terminals. Alarm functions going to the main control room annunciator will not be affected.

*i.7. Has the system been tested under all normal and abnormal conditions? EPRI 102348 rev. 1*

IMPLEMENTING DOCUMENT NO.: DCP J-49855

DOC. REV. NO.: 0

Yes. Normal and abnormal conditions including failure modes will be tested. A pre-installation acceptance test per the Functional Requirements Specification (FRS) and the post modification testing will provide assurance that the new control system meets the design requirements and is reliable.

*j. Is there a clear trend toward increasing the likelihood of malfunction of the SSC(s)? EPRI 102348 rev. 1*  
No. The DCP testing program will verify that the system and software are properly configured for the application.

Conclusion:

Therefore, the new system will not result in more than minimal increase in the likelihood of a malfunction of an SSC important to safety that is evaluated in the FSAR.

3. Does the proposed activity result in more than a minimal increase in the consequences of an accident previously evaluated in the FSARU?  Y  N  
(See Section 6.2.3 of the RM.)

Justification: The Auxiliary Building Control Board referenced per (UFSAR Section 7.7.1.11.3). The liquid radwaste system (LRS) collects and processes the radioactive liquid wastes generated during plant operation (UFSAR Section 11.2). The gaseous radwaste system (GRS) provides controlled handling and disposal of gaseous wastes generated during plant operation (UFSAR Section 11.3). Also SAR Section 15.4.7 describes cause and events of a rupture of a waste gas decay tank.

The FSARU 15.4.7 evaluation concerning a rupture of a waste gas decay tank is considered a low probability accident scenario and is highly unlikely based per response to 1.a.. This design change does not impact the conclusion of the previous analysis.

Conclusion:

Therefore, the new system will not result in any increase in the consequences of an accident previously evaluated in the FSAR.

4. Does the proposed activity result in more than a minimal increase in the consequences of a malfunction of an SSC important to safety previously evaluated in the FSARU? (See Section 6.2.4 of the RM.)  Y  N

Justification: Same response as question 3. Therefore, the new system will not result in any increase in the consequences of a malfunction of an SSC important to safety previously evaluated in the FSAR.

IMPLEMENTING DOCUMENT NO.: DCP J-49855

DOC. REV. NO.: 0

POTENTIAL FOR CREATION OF A NEW TYPE OF EVENT NOT PREVIOUSLY EVALUATED IN THE FSARU

5. Does the proposed activity create a possibility for an accident of a different type than any previously evaluated in the FSARU? (See Section 6.2.5 of the RM.)  Y  N

Justification:

A thorough failure modes and effects analysis has been performed per the design change DCE under the heading, "Failure Modes and Effects Analysis (FMEA)". As explained in the FMEA and in question 3 above, this design change does nothing to invalidate the previous analyses. Hence, this design change does not create a possibility for an accident of a different type than any previously evaluated in the FSARU.

6. Does the proposed activity create a possibility for a malfunction of an SSC important to safety with a different result than any previously evaluated in FSARU? (See Section 6.2.6 of the RM.)  Y  N

Justification:

As discussed in the response to question 5, the postulated failures are bounded by the existing failure analyses. Hence, the replacement of the control system does not result in a malfunction of an SSC important to safety with a different result than previously evaluated in the FSARU.

IMPACT ON FISSION PRODUCT BARRIERS AS DESCRIBED IN THE FSARU

7. Does the proposed activity result in a design basis limit for a fission product barrier as described in the FSARU being exceeded or altered? (See Section 6.2.7 of the RM.)  Y  N

Justification:

The design functional requirements of the system are maintained and does not alter, change, or challenge to any fission product barrier.

IMPACT ON EVALUATION METHODOLOGIES DESCRIBED IN THE FSARU

8. Does the proposed activity result in a departure from a method of evaluation described in the FSARU used in establishing the design bases or in the safety analyses? (See Section 6.2.8 of the RM.)  Y  N

Justification:

FSAR sections will be updated to clarify and/or reflect the function/features of the Auxiliary Building Control Board rather than specific hardware or actions. This design change will require the following FSARU updates:

- FSAR section 7.7.1.11.3 (Auxiliary Building Control Board) states that that the current board contains annunciation and mimic for the associated systems. The proposed digital control system eliminates the annunciation and mimic panel and includes their function as alarms and mimic within the new digital display. SAR section 7.7.1.11.3 will be updated to generically reflect the functions of the Auxiliary Building Control Board rather than specific hardware.
- Update FSAR section 11.2.2.2 for MEDT High alarm function. The SAR states that a high alarm to the main annunciator is provided. However, the alarm function is actually provided to the



IMPLEMENTING DOCUMENT NO.: DCP J-49855

DOC. REV. NO.: 0

Auxiliary Building Control Board annunciator. Similar corrections were made to the SAR sections for the equipment drain receivers (11.2.2.2) and Auxiliary Building Sump (11.2.2.3). The SAR will be updated to clarify and reflect the alarm functions of the Auxiliary Building Control Board rather than specific hardware.

- Update FSAR section 11.3.2 for the Gaseous Radwaste System (Description). The fluidic logic system and reference to key operated switching for the gas decay tank vent line common flow control valve is described. The SAR will be updated to generically describe the control system in terms of function rather than use of specific hardware. Also reference to the common flow control vent valve providing the means for redundant isolation and manual operation for venting will be stated.
- SAR section 15.4.7.1 (Rupture of a Waste Gas Decay Tank) discusses the use of radioactive waste gas decay tanks to permit decay of radioactive gases as a means of reducing or preventing the release of radioactive materials to the atmosphere. A number of combinations of inadvertent operator errors and equipment malfunctions or failures could be identified that might result in a release of some or all of the activity stored in these tanks. This section will be updated to reduce confusion by changing "Interlock Procedures" to "Operating Procedures" to reduce probability of release in which Operating Procedures are defined as the basis for controlling the Gaseous Radwaste System per FSAR section 11.3.3. There are no modifications being proposed to the GDT, valves or associated piping. The new control system maintains the ability for redundant isolation and manual operation to allow operators to terminate a release on the vent line. The radiation monitor (RM-22) is unaffected and allows early detection and the ability to isolate the release. SAR section 15.4.7 does not go into any level of detail of the new control system.
- It should be noted that SAR reference figure 7.7-31 (Arrangement of Auxiliary Building Control Panel) is not included as part of the FSAR change request since updates based on corresponding engineering drawing 330557-1 figure are periodically performed. Also radiation monitor RM-22 (Gas Decay Tank Discharge Gas Monitor) per SAR sections 11.2 & 11.3 are unaffected.

The above changes do not depart from any method of evaluation described in the SAR used in establishing the design bases or in the safety analysis.

IMPLEMENTING DOCUMENT NO.: DCP J-49855	DOC. REV. NO.: 0
--	------------------

**CONCLUSION**

Based on the above, the preparer and ITR have determined that prior NRC approval:

- is required.
- is not required.

If the answer to any question is "yes," NRC approval is required prior to implementing the activity.

PREPARER SIGNATURE: (Qual: TLBIEV) <i>[Signature]</i>	DATE: 12-10-07	PRINT LAST NAME: Kinoshita
ITR SIGNATURE: (Qual: TLBIEV) <i>[Signature]</i>	DATE: 12/19/07	PRINT LAST NAME: Hicks

**Attachment 2**

**Nuclear Power Generation Program Directive Procedure,  
CY2, "Radiological Monitoring and Controls Program," Revision 6**

\*\*\* ISSUED FOR USE BY: \_\_\_\_\_ DATE: \_\_\_\_\_ EXPIRES: \_\_\_\_\_ \*\*\*  
 PACIFIC GAS AND ELECTRIC COMPANY NUMBER CY2  
 NUCLEAR POWER GENERATION REVISION 6  
 PROGRAM DIRECTIVE PAGE 1 OF 12

TITLE: Radiological Monitoring and Controls Program

6-2-08  
 EFFECTIVE DATE

CLASSIFICATION: QUALITY RELATED  
 SPONSORING ORGANIZATION: CHEMISTRY

TABLE OF CONTENTS

<u>SECTION</u>	<u>PAGE</u>
PROGRAM OVERVIEW .....	1
APPLICABILITY .....	2
DEFINITIONS .....	3
PROGRAM OBJECTIVES AND REQUIREMENTS .....	3
Program Objectives.....	3
Program Requirements.....	4
Radiological Environmental Monitoring Program .....	4
Radioactive Effluent Control Program .....	4
Offsite Dose Calculation Procedures.....	7
Environmental Radiological Monitoring Procedure.....	7
Radwaste Treatment Systems .....	7
Quality Assurance Requirements.....	7
RESPONSIBILITIES .....	8
KEY IMPLEMENTING DOCUMENTS .....	8
Inter-Departmental Administrative Procedures (IDAPs).....	8
Department-Level Administrative Procedures (DLAPs).....	8
CLOSELY RELATED PROGRAMS .....	9
RECORDS .....	10
APPENDICES .....	10
ATTACHMENTS.....	10
REFERENCES .....	10

1. PROGRAM OVERVIEW

- 1.1 It is the policy of nuclear generation that the release of radioactive materials to the environment be in compliance with Federal regulations and be "As Low As Reasonably Achievable" (ALARA). The overall objectives are to protect the health and safety of the public from undue radiation exposure and to minimize the amount of radioactive effluents resulting from the operation of the plant.
- 1.2 This PD defines the overall policies and general requirements related to the Radiological Monitoring and Controls Program (RMCP). This includes the Radiological Environmental Monitoring Program (REMP), and the Radioactive Effluent Controls Program (RECP).

**TITLE: Radiological Monitoring and Controls Program**

---

- 1.3 The scope of this PD is focused on the control of releases of radioactive material to the environment, and minimizing radiological impact on the general public. Radiation protection of plant workers and visitors within the restricted area of the plant is within the scope of RP1, "Radiation Protection."
- 1.4 Figure 1 illustrates the hierarchy of procedures associated with this PD.

Figure 1: CY2 Hierarchy of Procedures

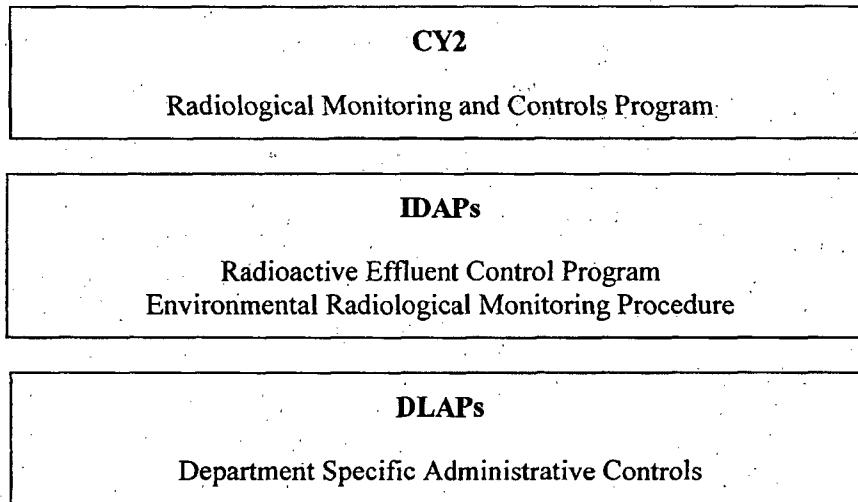

2. APPLICABILITY

This PD is applicable to all persons involved in radioactive effluent control, monitoring, and management activities. This includes all nuclear generation personnel, personnel matrixed to nuclear generation from other company organizations, personnel in other company organizations that are engaged in activities in support of nuclear generation, and contractor personnel that are working under nuclear generation supervision.

TITLE: Radiological Monitoring and Controls Program

---

3. DEFINITIONS

- 3.1 ALARA (acronym for "as low as reasonably achievable"): A term that means making every reasonable effort to maintain exposures to radiation as far below the dose limits of 10 CFR 20 as is practical consistent with the purpose for which the licensed activity is undertaken, taking into account the state of technology, the economics of improvements in relation to state of technology, the economics of improvements in relation to benefits to the public health and safety, and in relation to utilization of nuclear energy and licensed materials in the public interest. The specific objectives of achieving ALARA effluents are based on those described in 10 CFR 50, Appendix I.
- 3.2 The Radiological Monitoring and Controls Program (RMCP): Contains the Radioactive Effluent Controls and Radiological Environmental Monitoring Programs required by Technical Specifications 5.5.1 and 5.5.4 and descriptions of the information that should be included in the Annual Radiological Environmental Operating and Annual Radioactive Effluent Release Reports required by Technical Specifications 5.6.2 and 5.6.3.
- 3.3 Offsite Dose Calculation Procedure (ODCP): Contains the methodology and parameters used in the calculation of offsite doses due to radioactive gaseous and liquid effluents and in the calculation of gaseous and liquid effluent monitoring Alarm/Trip Setpoints.
- 3.4 Environmental Radiological Monitoring Procedure (ERMP): Contains a description of sample locations, types of sample locations, methods and frequency of analysis, and reporting requirements.

4. PROGRAM OBJECTIVES AND REQUIREMENTS

4.1 Program Objectives

The nuclear generation radiological monitoring and controls program is established to meet the following objectives:

- 4.1.1 Ensure that systems, methods, and controls are established to meet applicable regulatory requirements and objectives for release of radioactive effluents.

Liquid and gaseous radioactive waste processing systems provide the means for controlling radioactive releases. It is also important to establish administrative controls with clear delineation of responsibilities to ensure that monitoring, measurement, and release activities are properly sequenced, authorized, and controlled.

TITLE: Radiological Monitoring and Controls Program

---

4.2 Program Requirements

The basic requirement for the radiological monitoring and controls program shall be to maintain radioactive releases to the unrestricted areas surrounding the plant in conformance with applicable Federal regulations and ALARA. The following sections provide additional requirements for various elements of the program.

4.2.1 Changes to the RMCP (including ODCP, ERMP and RECP) shall be processed in accordance with the requirements of the plant Technical Specification Section 5.5.1.

4.2.2 Radiological Environmental Monitoring Program

a. A Radiological Environmental Monitoring Program (REMP) shall be established and maintained to comply with the plant Technical Specification 5.5.1, Radiological Environmental Monitoring Program requirements. The program shall be provided to monitor the radiation and radionuclides in the environs of the plant, and shall address the following:

1. Monitoring, sampling, analysis, and reporting of radiation and radionuclides in the environment in accordance with the methodology and parameters in the Environmental Radiological Monitoring Procedure (ERMP),
2. A Land Use Census to ensure that changes in the use of areas at and beyond the SITE BOUNDARY are identified and that modifications to the monitoring program are made if required by the results of this census, and
3. Participation in an Interlaboratory Comparison Program to ensure that independent checks on the precision and accuracy of the measurements of radioactive materials in the environmental sample matrices are performed as part of the quality assurance program for environmental monitoring.

4.2.3 Radioactive Effluent Control Program

a. Monitoring requirements shall be established and maintained for all major and potentially significant paths for release of radioactive material during normal plant operation, including anticipated operational occurrences, to comply with Regulatory Guide 1.21, Revision 1, June 1974, requirements.

TITLE: Radiological Monitoring and Controls Program

---

- b. Procedures shall be established and maintained to define the methods and requirements for control of liquid and gaseous radioactive discharges within the limits of the plant Technical Specification Section 5.5.4. These procedures shall address the following:
1. Limitations on the operability of radioactive liquid and gaseous monitoring instrumentation including surveillance requirements and setpoint determination in accordance with methodology in the Offsite Dose Calculation Procedure, (ODCP),
  2. Limitations on the concentrations of radioactive material released in liquid effluents to UNRESTRICTED AREAS conforming to 10 CFR Part 20, Appendix B, Table 2, Column 2,
  3. Monitoring, sampling, and analysis of radioactive liquid and gaseous effluents in accordance with 10 CFR 20.1302 and with the methodology and parameters in the ODCP,
  4. Limitations on the annual and quarterly doses or dose commitment to a MEMBER OF THE PUBLIC from radioactive materials in liquid effluents released from each unit to UNRESTRICTED AREAS conforming to Appendix I to 10 CFR Part 50,
  5. Determination of cumulative and projected dose contributions from radioactive effluents for the current calendar quarter and current calendar year in accordance with the methodology and parameters in the ODCP at least every 31 days,
  6. Limitations on the operability and use of the liquid and gaseous effluent treatment systems to ensure that the appropriate portions of these systems are used to reduce releases of radioactivity when the projected doses in a 31-day period would exceed 2 percent of the guidelines for the annual dose or dose commitment conforming to Appendix I to 10 CFR Part 50,
  7. Limitations on the dose rate resulting from radioactive material released in gaseous effluents from the site to areas at or beyond the SITE BOUNDARY shall be limited to the following:
    - a) For noble gases: Less than or equal to a dose rate of 500 mrem/yr to the whole body and less than or equal to a dose rate of 3000 mrem/yr to the skin, and
    - b) For Iodine-131, for Iodine-133, for tritium, and for all radionuclides in particulate form with half-lives greater than 8 days: Less than or equal to a dose rate of 1500 mrem/yr to any organ.



**TITLE: Radiological Monitoring and Controls Program**

---

8. Limitations on the annual and quarterly air doses resulting from noble gases released in gaseous effluents from each unit to areas beyond the SITE BOUNDARY conforming to Appendix I to 10 CFR Part 50,
  9. Limitations on the annual and quarterly doses to MEMBERS OF THE PUBLIC from Iodine-131, Iodine-133, tritium, and all radionuclides in particulate form with half-lives greater than 8 days in gaseous effluents released from each unit to areas beyond the SITE BOUNDARY conforming to Appendix I to 10 CFR Part 50, and
  10. Limitations on the annual dose or dose commitment to any MEMBER OF THE PUBLIC due to releases of radioactivity and to radiation from uranium fuel cycle sources conforming to 40 CFR Part 190.
  11. The provisions of SR 3.0.2 and SR 3.0.3 are applicable to the Radioactive Effluent Controls Program Surveillance Frequency.
- c. Sampling and analysis methods associated with effluent monitoring activities shall be controlled in accordance with a department level administrative procedure that controls material and equipment used for analysis for the chemistry and radiochemistry programs.
  - d. Systems that are known pathways for radioactive releases shall be explicitly addressed. Periodic sampling of systems with the potential of becoming radioactively contaminated should also be addressed.
  - e. An onsite meteorological program shall be established and maintained in accordance with the requirements of Regulatory Guide 1.23, February 1972, to provide sufficient data for the performance of dose assessments.
  - f. The collection and processing of technical data required to support the Annual Radioactive Effluent Release Report and non-routine reports to the NRC to comply with the plant Technical Specification 5.6.3 shall be defined as part of this program. The processing of these reports shall be performed in accordance with XI1, "Regulatory Interface."

**TITLE: Radiological Monitoring and Controls Program**

---

4.2.4 Offsite Dose Calculation Procedures

- a. Offsite Dose Calculation Procedures (ODCP) shall be established and maintained to define and control the methods for determining offsite doses. NRC Regulatory Guide 1.109, Revision 1, October 1977, as well as its interpretation through NUREG 0133, should be used as guidance for establishing acceptable methods. These procedures shall address the following:
  1. Methods for determining monitoring instrumentation alarm setpoints are addressed in accordance with a Department-Level Administrative Procedure (DLAP) under CY2.
  2. Methods for determining effluent concentrations.
  3. Methods for calculating doses to persons in unrestricted areas surrounding the plant from all exposure pathways.
- b. Changes to the ODCP shall be processed in accordance with the requirements of Technical Specification 5.5.1.

4.2.5 Environmental Radiological Monitoring Procedure

- a. An Environmental Radiological Monitoring Procedure (ERMP) shall be established and shall contain a description of sample locations, types of sample locations, methods and frequency of analysis, and reporting requirements.

4.2.6 Radwaste Treatment Systems

- a. Radwaste Treatment Systems shall be provided to control the processing and release of radioactive materials in gaseous and liquid effluent in compliance with Technical Specification requirements. The design of these systems shall be controlled in accordance with CF3, "Design Control," and the requirements of Regulatory Guide 1.143, October 1979.
- b. Approval of changes to the radwaste treatment systems shall be processed in accordance with the requirements of CF4, "Modification Control."

4.2.7 Quality Assurance Requirements

In addition to requirements specified in earlier sections and those requirements utilizing procedures in the Section 6.2 of this PD, the control program shall be subject to the quality assurance requirements specified in CY1, "Chemistry/Radiochemistry."

TITLE: Radiological Monitoring and Controls Program

---

4.3 Support by the Company Departments

Departments outside of nuclear generation may be called upon to support nuclear generation activities associated with the Radioactive Monitoring Controls Program. The contract or agreement between nuclear generation and other departments shall ensure the support is performed in accordance with the requirements of this PD.

EXAMPLE: Meteorological Services may perform annual meteorological data reviews and calculate dispersion and deposition factors for use the radioactive effluents control program.

5. RESPONSIBILITIES

- 5.1 The Chief Nuclear Officer is responsible for establishing the policy and general requirements for the Radiological Monitoring and Controls Program, for providing management support and guidance for the program's implementation, and ensuring compliance with all regulatory requirements is maintained. The chief nuclear officer is also responsible for ensuring that support from reporting departments is provided for the Radiological Monitoring and Controls Program.
- 5.2 The Site Vice President and Station Director is responsible for the overall development, implementation, and maintenance of the Radiological Monitoring and Controls Program in accordance with the requirements of this PD.
- 5.3 The senior director operations services is responsible for the direct implementation of the Radiological Monitoring and Controls Program with the exception of the design of radwaste treatment and effluent monitoring systems.
- 5.4 The senior director engineering services is responsible for maintaining the design bases for installed plant radwaste treatment and effluent monitoring systems, structures, and components and providing technical support to the plant for the operation and maintenance of these systems.
- 5.5 The quality verification director is responsible for auditing the Radiological Monitoring and Controls Program as outlined in step 3.10 of Appendix 9.1.
- 5.6 The maintenance services director is responsible for maintaining the radiation monitoring systems and the hardware and software for the Rad Effluent program.

6. KEY IMPLEMENTING DOCUMENTS

6.1 Inter-Departmental Administrative Procedures (IDAPs)

Inter-Department Administrative Procedures shall be developed to address the following aspects of the Radiological Monitoring and Controls Program:

- 6.1.1 An IDAP shall be developed to define the requirements and responsibilities associated with the Radioactive Effluent Control Program.
- 6.1.2 An IDAP shall be developed to define the requirements and responsibilities associated with the Environmental Radiological Monitoring Procedure.

6.2 Department-Level Administrative Procedures (DLAPs)

Departments responsible for performing activities related to the Radioactive Effluent Control program shall develop DLAPs as appropriate to control program activities.

TITLE: Radiological Monitoring and Controls Program

---

7. CLOSELY RELATED PROGRAMS

7.1 Interfaces

This section describes each of the principal interfaces and boundaries between this Program Directive and other management processes.

7.1.1 AD10, "Records"

"Records" provides for the retention of Radiological Monitoring and Controls Program records.

7.1.2 CF3, "Design Control"

"Design Control" addresses the implementation of design activities for installed radwaste treatment and effluent monitoring systems in accordance with the requirements of NRC Regulatory Guide 1.143.

7.1.3 CF4, "Modification Control"

"Modification Control" addresses the implementation of modification activities for installed effluent monitoring systems.

7.1.4 CY1, "Chemistry/Radiochemistry"

"Chemistry/Radiochemistry" addresses the methods for chemistry/radiochemistry sampling and analysis of liquid and gaseous radioactive effluents in support of this PD.

7.1.5 OM7, "Problem Resolution"

"Problem Resolution" addresses deficiencies identified during the implementation of the radioactive effluent control program. OM7 also addresses evaluating nonconformances for reportability in accordance with Technical Specifications.

7.1.6 TQ1, "Personnel Training and Qualification"

"Personnel Training and Qualification" identifies training and qualification requirements for personnel.

7.1.7 XI1, "Regulatory Interface"

"Regulatory Interface" addresses the process for required reporting and communication with outside agencies.

7.1.8 CY2.ID1, "Radioactive Effluent Controls Program"

"Radioactive Effluent Controls Program" contains the general program requirements to ensure the requirements of 10 CFR Part 20 and 10 CFR Part 50, Appendix I, are met.

TITLE: Radiological Monitoring and Controls Program

---

8. RECORDS

None

9. APPENDICES

9.1 Graded Quality Assurance Requirements for Radiological Monitoring and Controls Program

10. ATTACHMENTS

None

11. REFERENCES

- 11.1 Title 10, Code of Federal Regulations,
  - 11.1.1 Part 20, "Standards for Protection Against Radiation"
  - 11.1.2 Part 50, Appendix I,
  - 11.1.3 Part 50, Appendix A, GDC 60, 64,
  - 11.1.4 Part 50.36a, "Technical Specifications on Effluents from Nuclear Power Reactors"
- 11.2 Title 40, Code of Federal Regulations, "Environmental Radiation Protection Standards for Nuclear Power Operations."
- 11.3 Regulatory Guide 1.109, Revision 1, October 1977, "Calculation of Annual Doses to Man From Routine Releases of Reactor Effluents for the Purpose of Evaluating Compliance with 10 CFR Part 50 Appendix I."
- 11.4 Regulatory Guide 1.143, October 1979, "Design Guidance for Radioactive Waste Management Systems, Structures, and Components Installed in Light-Water-Cooled Nuclear Power Plants."
- 11.5 Regulatory Guide 1.21, Revision 1, June 1974, "Measuring, Evaluating, and Reporting Radioactivity in Solid Wastes and Releases of Radioactive Materials in Liquid and Gaseous Effluent from Light-Water-Cooled Nuclear Power Plants."
- 11.6 Regulatory Guide 1.23, February 1972, "Onsite Meteorological Programs."
- 11.7 Regulatory Guide 4.15, Revision 1, February 1979, "Quality Assurance For Radiological Monitoring Programs (Normal Operations) - Effluent Streams and the Environment."
- 11.8 Regulatory Guide 4.1, Revision 1, April 1975, "Programs for Monitoring Radioactivity in the Environs of Nuclear Power Plants."
- 11.9 Diablo Canyon Nuclear Power Plant Facility Operating Licenses (Unit 1, Unit 2)
- 11.10 QA Commitment: FSAR Chapter 17.2.
- 11.11 QA Commitment: Regulatory Guide 1.33.

TITLE: Radiological Monitoring and Controls Program

---

APPENDIX 9.1

GRADED QA REQUIREMENTS  
FOR RADIOLOGICAL MONITORING AND CONTROLS PROGRAM

The basis for these Graded QA requirements is to comply with the regulations of 10 CFR 20, 10 CFR 50, 40 CFR 190, the Technical Specifications and Regulatory Guides 1.21, and 4.15.

1. GRADED ITEMS

Radioactive Effluent monitoring instruments are classified as Category 2 or Category 3 items per Regulatory Guide 1.97, "Instrumentation for Light-Water-Cooled Nuclear Power Plants to Assess Plant and Environs Conditions During and Following an Accident." These instruments are used for detection and assessment of releases and possibly detection of containment breach with accomplishment of mitigation of the breach. These items fall under Graded QA requirements.

2. GRADED ACTIVITIES

- 2.1 Installed radiation monitors required per Technical Specification 3.3.3 for monitoring radioactive effluents during plant operations or accidents shall be calibrated at prescribed intervals.
- 2.2 Sampling and analysis of liquid and gaseous effluents shall be performed in accordance with CY1, "Chemistry/Radiochemistry."
- 2.3 Calculations, computer programs, and procedures for evaluating the dose associated with radioactive effluents shall be performed in accordance with approved quality related procedures.

3. GRADED REQUIREMENTS

- 3.1 Effluent releases shall be maintained ALARA and shall be performed in accordance with the requirements of this Program Directive (CY2) to limit the concentrations, doses and doserates as specified in DCCP Technical Specification 5.5.4, NRC regulations 10 CFR 20, 10 CFR 50 Appendix I, and EPA regulation 40 CFR 190.
- 3.2 The Annual Radiological Environmental Operating Report shall be developed in accordance with Technical Specification 5.6.2.
- 3.3 The Annual Radioactive Effluent Release Report shall be developed in accordance with Technical Specification 5.6.3.
- 3.4 Records that support and document the Radiological Monitoring and Controls Program shall be controlled in accordance with AD10, "Records."
- 3.5 Personnel involved in direct implementation of chemistry/radiochemistry, operations, or radiation protection activities in support of the Radiological Monitoring and Controls Program are qualified in accordance with the requirements of TQ1, "Personnel Training and Qualification." In addition, personnel involved in direct implementation of activities in support of the Radiological Environmental Monitoring Program are qualified in accordance with the requirements of an interdepartmental administrative procedure for Environmental Radiological Monitoring (ERMP).

TITLE: Radiological Monitoring and Controls Program

---

APPENDIX 9.1 (Continued)

- 3.6 Notifications and reports to and correspondence with regulatory agencies shall be done in accordance with XII, "Regulatory Interface."
- 3.7 Written plans, procedures and instructions for implementing Radiological Monitoring and Controls Program shall be prepared, processed, and controlled in accordance with AD1, "Administrative Control Program."
- 3.8 Procurement of quality-related equipment or services shall be in accordance with written procedures. Applicable regulatory requirements, design bases, and any other requirements necessary to assure adequate quality shall be included in or invoked by reference in documents for procurement of items or services. Test or acceptance requirements and documentation to be submitted by the supplier shall be identified in the procurement documents. Receipt inspection requirements, if required, shall be identified in the procurement documents.
- 3.9 Deficiencies identified during implementation of this program shall be documented and controlled in accordance with OM7, "Problem Resolution."
- 3.10 FSAR Chapter 17.18, "Audits," prescribes the audit frequency for various portions of the RMCP:
  - 3.10.1 The performance of activities required by the quality assurance program for the Radioactive Effluents Control Program shall be audited at least once per 24 months unless specified otherwise.
  - 3.10.2 The Radiological Environmental Monitoring Program, implementing procedures, and program results shall be audited at least once per 24 months.
  - 3.10.3 The Offsite Dose Calculation Procedure and its implementing procedures shall be audited at least once per 24 months.

**Attachment 3**

**Nuclear Power Generation Interdepartmental Administrative Procedure,  
CY2.ID1, "Radioactive Effluent Controls Program," Revision 9**



TITLE:    Radioactive Effluent Controls Program

11-25-08  
EFFECTIVE DATE

---

PROCEDURE CLASSIFICATION: QUALITY RELATED  
SPONSORING ORGANIZATION: CHEMISTRY

TABLE OF CONTENTS

<u>SECTION</u>	<u>PAGE</u>
SCOPE.....	1
DISCUSSION.....	1
RESPONSIBILITIES.....	2
INSTRUCTIONS.....	3
Administrative Requirements.....	3
Reporting Requirements.....	3
Revisions to the RECP.....	6
Major Changes to Liquid, Gaseous, and Solid Radwaste Treatment Systems.....	7
RECORDS.....	7
APPENDICES.....	7
REFERENCES.....	7

1.    SCOPE

1.1    This procedure contains the general program requirements of the Radioactive Effluent Controls Program. This program ensures that the requirements of 10 CFR Part 20 and 10 CFR Part 50 Appendix I are met.

2.    DISCUSSION

2.1    This procedure provides the general requirements for Radioactive Effluent Controls Program in accordance with the Technical Specifications and the implementation Generic Letter 89-01, "Implementation of Programmatic Controls for Radiological Effluent Technical Specifications in the Administrative Controls Section of the Technical Specifications and the Relocation of Procedural Details of RETS to the Off-Site Dose Calculation Manual or to the Process Control Program."

2.2    The following Technical Specification definitions are applicable: T.S. Section 5.5.1

2.2.1    The Off-site Dose Calculation Manual (ODCM) shall contain the methodology and parameters used in the calculation of off-site doses resulting from radioactive gaseous and liquid effluents, in the calculation of gaseous and liquid effluent monitoring alarm and trip setpoints, and in the conduct of radiological environmental monitoring program; and

2.2.2    The ODCM shall contain the radioactive effluent controls and radiological environmental monitoring activities, and the description of the information that should be included in the Annual Radiological Environmental Operating, and the Radioactive Effluent Release Reports required by Technical Specification 5.6.2 and 5.6.3.

TITLE: Radioactive Effluent Controls Program

---

2.2.3 The Diablo Canyon ODCM is made up of the following procedures:

- CAP A-8, "Off-site Dose Calculation Procedure"
- CY2.ID1, "Radioactive Effluent Controls Program"
- RP1.ID11, "Environmental Radiological Monitoring Procedure"
- CY2, "Radiological Monitoring and Controls Program"

Changes to each of these procedures shall be processed in accordance with the requirements of Technical Specification Section 5.5.1.

2.3 The specific methodology and parameters used in the calculation of off-site doses resulting from radioactive gaseous and liquid effluents and in the calculation of gaseous and liquid effluent monitoring Alarm/Trip Setpoints, is contained in CAP A-8, "Off-Site Dose Calculations Procedure (ODCP)." As such, CAP A-8 is incorporated in this procedure by reference. Therefore, the requirements for revisions to this procedure also apply to CAP A-8.

3. RESPONSIBILITIES

3.1 The chemistry manager is responsible for:

- 3.1.1 Implementation of the Off-Site Dose Calculation Procedure in a manner that meets regulatory requirements and preparing the Annual Radiological Effluent Release Report.
- 3.1.2 Providing direction to the Operations Staff in the processing of radioactive waste streams.
- 3.1.3 Ensuring that a comparison of the Annual Radioactive Effluent Release Report and the Annual Radiological Environmental Operating Report is performed.
- 3.1.4 Ensuring that dose commitment increases due to the Land Use Census in accordance with Commitment 6.1.12.1 are determined and communicated promptly to radiation protection.

3.2 The radiation protection manager is responsible for:

- 3.2.1 Ensuring the performance of the annual land use census and that the results are provided to chemistry so that chemistry can establish the dose requirements of Commitment 6.1.12.1.
- 3.2.2 Ensuring that the results of the annual Land Use Census are included in the Annual Radiological Environmental Operating Report.
- 3.2.3 Ensuring that changes to the Environmental Radiological Monitoring Procedure are provided to chemistry for inclusion in the Annual Radiological Effluent Release Report.
- 3.2.4 Ensuring preparation, review and approval of the Nonroutine Radiological Environmental Operating Report when required by Commitment 6.1.11.1

TITLE: Radioactive Effluent Controls Program

---

4. INSTRUCTIONS

4.1 Administrative Requirements

- 4.1.1 It is the intent of the Radioactive Effluent Control Program to monitor all significant release pathways from the power plant. A pathway is considered significant if a conservative evaluation yields an additional dose increment equal to or more than 10 percent of the total from all pathways considered in this program.
- 4.1.2 At times, minor release pathways occur from the power plant due to plant maintenance activities. An example of this is air leaving Containment when the equipment hatch or door is open. These minor release pathways are usually negligible from a radioactive effluents control program release and dose perspective, and are well within the margin of error of the significant monitored pathway and dose models.
- 4.1.3 Appendix 6.1 of this procedure contains the operational requirements of the Radioactive Effluent Controls Program.
- 4.1.4 The operational requirements are implemented by equipment control guidelines (reference OPI.DC16), CAP A-8, and XI1.ID2, "Regulatory Reporting Requirements and Reporting Process."
  - a. The Equipment Control Guidelines implement those requirements that are related to equipment and have specific allowed outage times or operator actions.
  - b. CAP A-8 includes the methodology and parameters used in the calculation of off-site doses resulting from radioactive gaseous and liquid effluents and in the calculation of gaseous and liquid effluent monitoring alarm/trip setpoints.
  - c. XI1.ID2 implements the reporting requirements.

4.2 Reporting Requirements

4.2.1 Annual Radioactive Effluent Release Report

- a. Report Schedule
  - 1. Annual Radioactive Effluent Release Reports covering the operation of the unit during the previous calendar year shall be submitted before May 1 of each year, in accordance with 10 CFR 50.36a.

TITLE: Radioactive Effluent Controls Program

---

- b. The Annual Radioactive Effluent Release Reports shall include:
1. A summary of the quantities of radioactive liquid and gaseous effluents and solid waste released from the unit as outlined in Regulatory Guide 1.21, "Measuring, Evaluating, and Reporting Radioactivity in Solid Wastes and Releases of Radioactive Materials in Liquid and Gaseous Effluents from Light-Water-Cooled Nuclear Power Plants," Revision 1, June 1974, with data summarized on a quarterly basis following the format of Appendix B thereof. For solid wastes, the format for Table 3 in Appendix B shall be supplemented with three additional categories; class of solid wastes (as defined by 10 CFR Part 61), type of container (e.g., LSA, Type A, Type B, Large Quantity) and SOLIDIFICATION agent or absorbent (e.g., cement, urea formaldehyde);
  2. A list and description of unplanned releases as defined in ODCP from the site to UNRESTRICTED AREAS of radioactive materials in gaseous and liquid effluents made during the reporting period;
  3. Changes to the ODCM.
    - a) Pursuant to Technical Specification 5.5.1, changes to the following procedures made during the reporting period shall be included as described below:
      - 1) RP2.DC2, "Radwaste Solidification Process Control Program (PCP)"

**NOTE:** An FSAR update may be used in lieu of the ARERR for communicating changes to the NRC, regarding the PCP.
      - 2) CY2.ID1, "Radioactive Effluent Controls Program (RECP)"
      - 3) CY2, "Radiological Monitoring and Controls Program (RMCP)"
      - 4) RP1.ID11, "Environmental Radiological Monitoring Program (ERMP)"
      - 5) CAP A-8, "Off-Site Dose Calculations (ODC)"
    - b) If a change is made to any of these procedures, include a legible copy of each procedure in the report. This provides a complete copy of the ODC in the report.
    - c) If multiple changes to any one procedure are made during the reporting period, include a copy of each revision.

TITLE: Radioactive Effluent Controls Program

---

- d) Each procedure change shall be identified by markings in the margin of the affected pages, clearly indicating the area of the page that was changed.
  - e) The date the change was implemented shall be indicated (e.g., the first page of the procedure should indicate the implementation date).
4. A listing of new locations for dose calculations and/or environmental monitoring identified by the Land Use Census pursuant to Appendix 6.1.
  5. An explanation as to why the inoperability of liquid or gaseous effluent monitoring instrumentation was not corrected within the time specified in Appendix 6.1; and
  6. Description of the events leading to liquid holdup tanks or gas storage tanks exceeding the limits of ECG 19.1 or ECG 24.3.
- c. A discussion of major changes to the Radwaste Treatment Systems (liquid, gaseous and solid). The discussion of each change shall contain:
1. A summary of the evaluation that led to the determination that the change could be made in accordance with 10 CFR 50.59;
  2. Sufficient detailed information to totally support the reason for the change without benefit of additional or supplemental information;
  3. A detailed description of the equipment, components and processes involved and the interfaces with other plant systems;
  4. An evaluation of the change which shows the predicted releases of radioactive materials in liquid and gaseous effluents and/or quantity of solid waste that differ from those previously predicted in the License application and amendments thereto;
  5. An evaluation of the change which shows the expected maximum exposures to a MEMBER OF THE PUBLIC in the UNRESTRICTED AREA and to the general population that differ from those previously estimated in the License application and amendments thereto;
  6. A comparison of the predicted releases of radioactive materials, in liquid and gaseous effluents and in solid waste, to the actual releases for the period prior to when the changes are to be made;
  7. An estimate of the exposure to plant operating personnel as a result of the change; and
  8. Otherwise the above information may be submitted as part of the annual FSAR update.

**TITLE: Radioactive Effluent Controls Program**

---

- d. In addition, the Annual Radioactive Effluent Release Report shall also include:
1. An annual summary of hourly meteorological data collected over the previous year. This annual summary may be either in the form of an hour-by-hour listing on magnetic tape/hard disk or other media of wind speed, wind direction, atmospheric stability, and precipitation (if measured), or in the form of joint frequency distributions of wind speed, wind direction, and atmospheric stability or the licensee has the option of retaining this summary of required meteorological data on site in a file that shall be provided to the NRC upon request;
  2. An assessment of the radiation doses due to the radioactive liquid and gaseous effluents released from the unit or station during the previous calendar year;
  3. An assessment of the radiation doses from radioactive liquid and gaseous effluents to MEMBERS OF THE PUBLIC due to their activities inside the SITE BOUNDARY (see FSAR Figure 2.1-2) during the report period;
  4. All assumptions used in making these assessments, i.e., specific activity, exposure time and location. The meteorological conditions concurrent with the time of release of radioactive materials in gaseous effluents, as determined by sampling frequency and measurement, shall be used for determining the gaseous pathway doses. The assessment of radiation doses shall be performed in accordance with the methodology and parameters in the OFF-SITE DOSE CALCULATIONS (ODC); and
  5. An assessment of radiation doses to the likely most exposed MEMBER OF THE PUBLIC from reactor releases and other nearby uranium fuel cycle sources, including doses from primary effluent pathways and direct radiation, for the previous calendar year to show conformance with 40 CFR Part 190, "Environmental Radiation Protection Standards for Nuclear Power Operation." Acceptable methods for calculating the dose contribution from liquid and gaseous effluents are given in Regulatory Guide 1.109, Rev. 1, October 1977.
- e. A single submittal may be made for a multiple unit plant. The submittal should combine those sections that are common to all units at the plant; however, for units with separate radwaste system, the submittal shall specify the releases of radioactive material from each unit.

4.3 Revisions to the RECP

- 4.3.1 The requirements for revision to the RECP also apply to CAP A-8.
- 4.3.2 The requirements are provided in Technical Specification 5.5.1.

**TITLE: Radioactive Effluent Controls Program**

---

- 4.4 Major Changes to Liquid, Gaseous, and Solid Radwaste Treatment Systems
  - 4.4.1 Major changes to the liquid, gaseous, and solid radwaste treatment systems shall become effective upon review and acceptance provided the change could be made in accordance with 10 CFR 50.59.

5. RECORDS

- 5.1 Data Sheets and records will be maintained in the Records Management System (RMS) in accordance with CY1.DC1, "Analytical Data Processing Responsibilities."

6. APPENDICES

- 6.1 Operational Requirements of the Radioactive Effluent Controls Program
- 6.2 High Alarm Setpoints for Fuel Building and Control Room Ventilation Systems Actuation Instrumentation

7. REFERENCES

- 7.1 CAP A-8, "Off-site Dose Calculations (ODC)"
- 7.2 CAP A-5, "Liquid Radwaste Discharge Management"
- 7.3 CAP A-6, "Gaseous Radwaste Discharge Management"
- 7.4 RP1.ID11, "Environmental Radiological Monitoring Procedure"
- 7.5 OP1.DC16, "Control of Plant Equipment Not Required by the Technical Specifications"
- 7.6 XII.ID2, "Regulatory Reporting Requirements and Reporting Process"
- 7.7 Regulatory Guide 1.21, Revision 1, June 1974
- 7.8 Regulatory Guide 1.109, Revision 1, October 1977
- 7.9 License Amendment Request 93-04
- 7.10 10 CFR 20.1302
- 7.11 40 CFR 190
- 7.12 10 CFR 50.36a
- 7.13 10 CFR 50 Appendix I
- 7.14 CY2, "Radiological Monitoring and Controls Program"
- 7.15 QA Commitment: FSAR Chapter 17.2
- 7.16 QA Commitment: Reg Guide 4.15
- 7.17 License Amendment 67/66, January 22, 1992
- 7.18 License Amendment 184/186, January 3, 2006
- 7.19 Action Request A0581581, "Track LAR Revising Fuel Handling Requirements per TSTF-51"
- 7.20 Action Request A0619600, "Rad Effluent Sampling of Ni-63"
- 7.21 Action Request A0660441, "ODCM Change Identification Discrepancies"

TITLE: Radioactive Effluent Controls Program

---

#### APPENDIX 6.1

##### Operational Requirements of the Radioactive Effluent Controls Program

###### 6.1.1 Radioactive Liquid Effluent Monitoring Instrumentation (Also covered by ECG 39.3)

###### Commitment for Operation

6.1.1.1 The radioactive liquid effluent monitoring instrumentation channels shown in Table 6.1.1-1 shall be OPERABLE with their Alarm/Trip Setpoints set to ensure that the limits of Commitment 6.1.3.1 are not exceeded. The Alarm/Trip Setpoints of these channels shall be determined in accordance with the methodology and parameters in the OFF-SITE DOSE CALCULATIONS (ODC).

Applicability: At all times.

###### Action:

- a. With a radioactive liquid effluent monitoring instrumentation channel Alarm/Trip Setpoint less conservative than required by the above Commitment, immediately suspend the release of radioactive liquid effluents monitored by the affected channel or declare the channel inoperable.
- b. With less than the minimum number of radioactive liquid effluent monitoring instrumentation channels OPERABLE, take the ACTION shown in Table 6.1.1-1. Restore the inoperable instrumentation to OPERABLE status within the time specified in the ACTION, or explain in the next Annual Radioactive Effluent Release Report why this inoperability was not corrected within the time specified.

###### Surveillance Requirements

- 6.1.1.2 Each radioactive liquid effluent monitoring instrumentation channel shall be demonstrated OPERABLE by performance of the CHANNEL CHECK, SOURCE CHECK, CHANNEL CALIBRATION and CHANNEL FUNCTIONAL TEST at the frequencies shown in Table 6.1.1-2.
- 6.1.1.3 At least one saltwater pump shall be determined operating and providing dilution to the discharge structure at least once per 4 hours whenever dilution is required to meet the limits of Commitment 6.1.3.1.



TITLE: Radioactive Effluent Controls Program

APPENDIX 6.1 (continued)

TABLE 6.1.1-1

Radioactive Liquid Effluent Monitoring Instrumentation

	<u>INSTRUMENT</u>	<u>MINIMUM CHANNELS OPERABLE</u>	<u>ACTION</u>
1.	Radioactivity Monitors Providing Alarm and Automatic Termination of Release		
a.	Liquid Radwaste Effluent Line (RM-18)#	1	1
b.	Steam Generator Blowdown Tank (RM-23)	1	2
2.	Flow Rate Measurement Devices		
a.	Liquid Radwaste Effluent Line (FR-20)#	1	4
b.	Steam Generator Blowdown Effluent Lines (FR-53)	1	4
c.	Oily Water Separator Effluent Line (FR-251)#	1	4
3.	Radioactivity Monitor Not Providing Automatic Termination of Release		
	Oily Water Separator Effluent Line (RM-3)#	1	3

# This Radioactive Liquid Effluent Monitoring Instrumentation is common to both units.

TITLE: Radioactive Effluent Controls Program

---

APPENDIX 6.1 (continued)

TABLE 6.1.1-1 (continued)

Action Statements

- ACTION 1** With the number of channels OPERABLE less than required by the Minimum Channels OPERABLE requirement, effluent releases via this pathway may continue for up to 14 days provided that prior to initiating a release:
- a. At least two independent samples are analyzed in accordance with Commitment 6.1.3.2.
  - b. At least two technically qualified members of the facility staff independently verify the release rate calculations and discharge line valvings.
- Otherwise, suspend release of radioactive effluents via this pathway.
- ACTION 2** With the number of channels OPERABLE less than required by the Minimum Channels OPERABLE requirement, effluent releases via this pathway may continue for up to 30 days provided grab samples are analyzed for radioactivity (beta or gamma) at a lower limit of detection of no more than  $10^{-7}$  microcuries/ml (reference A0702694):
- a. At least once per 12 hours when the specific activity of the secondary coolant is greater than 0.01 microcuries/gram DOSE EQUIVALENT I-131, or
  - b. At least once per 24 hours when the specific activity of the secondary coolant is less than or equal to 0.01 microcuries/gram DOSE EQUIVALENT I-131.
- ACTION 3** With the number of channels OPERABLE less than required by the Minimum Channels OPERABLE requirement, effluent releases via this pathway may continue for up to 30 days provided that, at least once per 12 hours, grab samples are collected and analyzed for radioactivity (beta or gamma) at a lower limit of detection of no more than  $10^{-7}$  microcuries/ml (reference A0702694) or transfer the oily water separator effluent to the Liquid Radwaste Treatment System.
- ACTION 4** With the number of channels OPERABLE less than required by the Minimum Channels OPERABLE requirement, effluent releases via this pathway may continue for up to 30 days provided the flow rate is estimated at least once per 4 hours during actual releases. Pump performance curves may be used to estimate flow.

TITLE: Radioactive Effluent Controls Program

APPENDIX 6.1 (continued)

TABLE 6.1.1-2

Radioactive Liquid Effluent Monitoring Instrumentation Surveillance Requirements

<u>Instrument</u>	<u>Channel Check</u>	<u>Source Check</u>	<u>Channel Calibration</u>	<u>Channel Functional Test</u>
1. Radioactivity Monitors Providing Alarm and Automatic Termination of Release				
a. Liquid Radwaste Effluent Line (RM-18)	D	P	R(3)	Q(1)
b. Steam Generator Blowdown Tank (RM-23)	D	M	R(3)	Q(1)
2. Flow Rate Measurement Devices				
a. Liquid Radwaste Effluent Line (FR-20)	D(4)	N.A.	R	Q
b. Steam Generator Blowdown Effluent Line (FR-53)	D(4)	N.A.	R	Q
c. Oily Water Separator Effluent Line (FR-251)	Daily(4)	N.A.	R	Q
3. Radioactivity Monitor Not Providing Automatic Termination of Release				
Oily Water Separator Effluent Line (RM-3)	D	M	R(3)	Q(2)

TITLE: Radioactive Effluent Controls Program

---

APPENDIX 6.1 (continued)

TABLE 6.1.1-2

Table Notation

- (1) The CHANNEL FUNCTIONAL TEST shall also demonstrate that automatic isolation of this pathway and Control Room alarm annunciation occurs if any of the following conditions exists:
  - a. Instrument indicates measured levels above the Alarm/Trip Setpoint (isolation and alarm),  
or
  - b. Relay control circuit failure (isolation only), or
  - c. Instrument indicates a downscale failure (alarm only), or
  - d. Instrument controls not set in operate mode (alarm only).
- (2) The CHANNEL FUNCTIONAL TEST shall also demonstrate that Control Room alarm annunciation occurs if any of the following conditions exist:
  - a. Instrument indicates measured levels above the Alarm Setpoint, or
  - b. Circuit failure, or
  - c. Instrument indicates a downscale failure, or
  - d. Instrument controls not set in operate mode.
- (3) The initial CHANNEL CALIBRATION shall be performed using one or more of the reference standards certified by the National Bureau of Standards (NBS) or using standards that have been obtained from suppliers that participate in measurement assurance activities with NBS. These standards shall permit calibrating the system over its intended range of energy and measurement range. For subsequent CHANNEL CALIBRATION, sources that have been related to the initial calibration shall be used.
- (4) CHANNEL CHECK shall consist of verifying indication of flow during periods of release. CHANNEL CHECK for FR-251 shall be made once per calendar day\*, and for FR-20 and FR-53 shall be made at least once per 24 hours on days on which continuous, periodic, or batch releases are made.
- (5) Frequency Notation

<u>Notation</u>	<u>Frequency</u>
D	At least once per 24 hours
Daily	At least once per calendar day*
M	At least once per 31 days
Q	At least once per 92 days
R	At least once per 18 months
P	Completed prior to each release
N.A.	Not Applicable

\* The frequency "once per calendar day" could result in two successive channel checks nearly 48 hours apart over a two day period. This frequency is different from and should not be confused with the frequency notation "D" (at least once per 24 hours) defined in Technical Specifications.

TITLE: Radioactive Effluent Controls Program

---

APPENDIX 6.1 (continued)

6.1.2 Radioactive Gaseous Effluent Monitoring Instrumentation (Also covered by ECG 39.4)

Commitment for Operation

6.1.2.1 The radioactive gaseous effluent monitoring instrumentation channels shown in Table 6.1.2-1 shall be OPERABLE with their Alarm/Trip Setpoints set to ensure that the limits of Commitment 6.1.6.1 is not exceeded. The Alarm/Trip Setpoints of these channels meeting Commitment 6.1.6.1 shall be determined and adjusted in accordance with the methodology and parameters in the ODCP.

Applicability: As shown in Table 6.1.2-1.

Action:

- a. With a radioactive gaseous effluent monitoring instrumentation channel Alarm/Trip Setpoint less conservative than required by the above Commitment, immediately suspend the release of radioactive gaseous effluents monitored by the affected channel, or declare the channel inoperable.
- b. With the number of OPERABLE radioactive gaseous effluent monitoring instrumentation channels less than the Minimum Channels OPERABLE, take the ACTION shown in Table 6.1.2-1. Restore the inoperable instrumentation to OPERABLE status within the time specified in the ACTION or explain in the next Annual Radioactive Effluent Release Report why this inoperability was not corrected within the time specified.

Surveillance Requirements

6.1.2.2 Each radioactive gaseous effluent monitoring instrumentation channel shall be demonstrated OPERABLE by performance of the CHANNEL CHECK, SOURCE CHECK, CHANNEL CALIBRATION and CHANNEL FUNCTIONAL TEST at the frequencies shown in Table 6.1.2-2.

TITLE: Radioactive Effluent Controls Program

APPENDIX 6.1 (continued)

TABLE 6.1.2-1

Radioactive Gaseous Effluent Monitoring Instrumentation

<u>Instrument</u>	<u>Minimum Channel Operable</u>	<u>Applicability</u>	<u>Action</u>
1. Gaseous Radwaste System			
Noble Gas Activity Monitor - Providing Alarm and Automatic Termination of Release (RM-22)	1	*	5
2. Plant Vent system			
a. Noble Gas Activity Monitor Providing Alarm (RM-14 or RM-14R)	1	*	7
b. Iodine Sampler	1	*	9
c. Particulate Sampler	1	*	9
d. Flow Rate Monitor (FR-12)	1	*	6
e. Iodine Sampler Flow Rate Monitor	1	*	6
3. Containment Purge System			
Noble Gas Activity Monitor - Providing Alarm and Automatic Termination of Release (RM-44A or 44B)	2 <sup>(1)</sup>	**	8

<sup>(1)</sup> 2 channels required in Modes 1, 2, 3 and 4. Only 1 channel required during movement of recently irradiated fuel assemblies within containment.

TITLE: Radioactive Effluent Controls Program

---

APPENDIX 6.1 (continued)

TABLE 6.1.2-1 (continued)

Table Notations

\* At all times.

\*\* MODES 1-4; also MODE 6 during CORE ALTERATIONS or movement of irradiated fuel within containment.

ACTION 5 With the number of channels OPERABLE less than required by the Minimum Channels OPERABLE requirement, the contents of the tank(s) may be released to the environment for up to 14 days provided that prior to initiating the release:

- a. At least two independent samples of the tank's contents are analyzed, and
- b. At least two technically qualified members of the facility staff independently verify the release rate calculations and discharge valve lineup.

Otherwise, suspend release of radioactive effluents via this pathway.

ACTION 6 With the number of channels OPERABLE less than required by the Minimum Channels OPERABLE requirement, effluent releases via this pathway may continue for up to 30 days provided the flow rate is estimated at least once per 4 hours.

ACTION 7 With the number of channels OPERABLE less than required by the Minimum Channels OPERABLE requirement, effluent releases via this pathway may continue for up to 30 days provided grab samples are taken at least once per 12 hours and these samples are analyzed for radioactivity within 24 hours.

ACTION 8 With the number of channels OPERABLE less than required by the Minimum Channels OPERABLE requirement, immediately suspend containment PURGING of radioactive effluents via this pathway.

ACTION 9 With the number of channels OPERABLE less than required by the Minimum Channels OPERABLE requirement, effluent releases via the affected pathway may continue for up to 30 days provided samples are continuously collected with auxiliary sampling equipment as required in Commitment Table 6.1.6-1.

**NOTE FOR ACTION 9:** To respond to the low flow alarm, determine that a simple fix cannot be made and that an auxiliary sampler is needed. Move the sampler in, hook up and verify operation, a maximum of two hours is considered a reasonable time. Over two hours should be considered as exceeding the time limitation of the commitment for operation (ECG 39.4).

TITLE: Radioactive Effluent Controls Program

APPENDIX 6.1 (continued)

TABLE 6.1.2-2

Radioactive Gaseous Effluent Monitoring Instrumentation Surveillance Requirements

<u>Instrument</u>	<u>Channel Check</u>	<u>Source Check</u>	<u>Channel Calibration</u>	<u>Channel Functional Test</u>	<u>Modes for Which Surveillance Is Required</u>
1. Gaseous Radwaste System					
Noble Gas Activity Monitor - Providing					
Alarm and Automatic Termination of Release (RM-22)	P	P	R(3)	Q(1)	*
2. Plant Vent System					
a. Noble Gas Activity Monitor Providing Alarm (RM-14 or RM-14R)	D	M	R(3)	Q(2)	*
b. Iodine Sampler	W(4)	N.A.	N.A.	N.A.	*
c. Particulate Sampler	W(4)	N.A.	N.A.	N.A.	*
d. Flow Rate Monitor (FR-12)	D	N.A.	R	Q	*
e. Iodine Sampler Flow Rate Monitor	D	N.A.	R	Q	*
3. Containment Purge System					
Noble Gas Activity Monitor - Providing Alarm and Automatic Termination of Release (RM-44A or 44B)	D	P	R(3)	Q(1)	**



TITLE: Radioactive Effluent Controls Program

---

APPENDIX 6.1 (continued)

TABLE 6.1.2-2 (continued)

Table Notations

\* At all times.

\*\* MODES 1-4; also MODE 6 during CORE ALTERATIONS or movement of irradiated fuel within containment.

- (1) The CHANNEL FUNCTIONAL TEST shall also demonstrate that automatic isolation of this pathway and control room alarm annunciation occurs if any of the following conditions exists:
  - a. Instrument indicates measured levels above the Alarm/Trip Setpoint (isolation and alarm),  
or
  - b. Instrument indicates a downscale failure (alarm only), or
  - c. Instrument controls not set in operate mode (alarm only).
- (2) The CHANNEL FUNCTIONAL TEST shall also demonstrate that control room alarm annunciation occurs if any of the following conditions exist:
  - a. Instrument indicates measured levels above the Alarm Setpoint, or
  - b. Circuit failure, or
  - c. Instrument indicates a downscale failure, or
  - d. Instrument controls not set in operate mode.
- (3) The initial CHANNEL CALIBRATION shall be performed using one or more of the reference standards certified by the National Bureau of Standards (NBS) or using standards that have been obtained from suppliers that participate in measurement assurance activities with NBS. These standards shall permit calibrating the system over its intended range of energy and measurement range. For subsequent CHANNEL CALIBRATION, sources that have been related to the initial calibration shall be used.
- (4) The CHANNEL CHECK shall consist of verifying that the iodine cartridge and particulate filter are installed in the sample holders.

(5) Frequency Notation

<u>Notation</u>	<u>Frequency</u>
D	At least once per 24 hours
W	At least once per 7 days
M	At least once per 31 days
Q	At least once per 92 days
R	At least once per 18 months
P	Completed prior to each release
N.A.	Not Applicable

TITLE: Radioactive Effluent Controls Program

---

APPENDIX 6.1 (continued)

6.1.3 Liquid Effluents - CONCENTRATION

Commitment for Operation

- 6.1.3.1 The concentration of radioactive material released in liquid effluents to UNRESTRICTED AREAS (see TS Figure 5.1-3) shall be limited to the concentrations specified in 10 CFR Part 20, Appendix B, Table 2, Column 2 for radionuclides other than dissolved or entrained noble gases. For dissolved or entrained noble gases, the concentration shall be limited to  $2 \times 10^{-4}$  microcurie/ml total activity.

Applicability: At all times.

Action:

With the concentration of radioactive material released in liquid effluents to UNRESTRICTED AREAS exceeding the above limits, immediately restore the concentration to within the above limits.

Surveillance Requirements

- 6.1.3.2 Radioactive liquid wastes shall be sampled and analyzed according to the sampling and analysis program of Table 6.1.3-1.
- 6.1.3.3 The results of the radioactivity analyses shall be used in accordance with the methodology and parameters in the ODCP to assure that the concentrations at the point of release are maintained within the limits of Commitment 6.1.3.1.

TITLE: Radioactive Effluent Controls Program

APPENDIX 6.1 (continued)

TABLE 6.1.3-1

Radioactive Liquid Waste Sampling and Analysis Program

Liquid Release Type	Sampling Frequency	Minimum Analysis Frequency	Type Of Activity Analysis	Lower Limit of Detection (LLD) ( $\mu\text{Ci/ml}$ ) <sup>(1)</sup>	
1. Batch Waste Release Tanks <sup>(4)</sup>	P Each Batch	P Each Batch	Principal Gamma Emitters <sup>(6)</sup>	$5 \times 10^{-7}$	
			I-131	$1 \times 10^{-6}$	
	P One Batch/M	M	Dissolved and Entrained Gases (Gamma emitters)		$1 \times 10^{-5}$
			P Each Batch	M Composite <sup>(2)</sup>	H-3
	Gross Alpha	$1 \times 10^{-7}$			
	P Each Batch	Q Composite <sup>(2)</sup>	Sr-89, Sr-90	$5 \times 10^{-8}$	
			Fe-55	$1 \times 10^{-6}$	
			Pu-238, Pu-239, Pu-240, Pu-241, Pu-242	$5 \times 10^{-8}$	
			U-233, U-234, U-235, U-236, U-238	$5 \times 10^{-8}$	
				Ni-63	$1 \times 10^{-6}$
2. Continuous Releases <sup>(5)</sup>  Steam Generator Blowdown Tank	D Grab Sample	W Composite <sup>(3)</sup>	Principal Gamma Emitters <sup>(6)</sup>	$5 \times 10^{-7}$	
			I-131	$1 \times 10^{-6}$	
	M Grab Sample	M	Dissolved and Entrained Gases (Gamma emitters)		$1 \times 10^{-5}$
			D Grab Sample	M Composite <sup>(3)</sup>	H-3
	Gross Alpha	$1 \times 10^{-7}$			
	D Grab Sample	Q Composite <sup>(3)</sup>	Sr-89, Sr-90	$5 \times 10^{-8}$	
			Fe-55	$1 \times 10^{-6}$	
	3. Continuous Releases <sup>(5)</sup>  Oily Water Separator Effluent	D Grab Sample	W Composite <sup>(3)</sup>	Principal Gamma Emitters <sup>(6)</sup>	$5 \times 10^{-7}$

TITLE: Radioactive Effluent Controls Program

---

APPENDIX 6.1 (continued)

TABLE 6.1.3-1 (continued)

Table Notations

- (1) The LLD is defined, for the purposes of these specifications, as the smallest concentration of radioactive material in a sample that will yield a net count, above system background, that will be detected with 95% probability with only 5% probability of falsely concluding that a blank observation represents a "real" signal.

For a particular measurement system, which may include radiochemical separation:

$$LLD = \frac{4.66s_b}{E * V * 2.22 \times 10^6 * Y * \exp(-\lambda\Delta t)}$$

Where:

- LLD = the "a priori" lower limit of detection (microcuries per unit mass or volume),  
s<sub>b</sub> = the standard deviation of the background counting rate or of the counting rate of a blank sample as appropriate (counts per minute),  
E = the counting efficiency (counts per disintegration),  
V = the sample size (units of mass or volume),  
2.22 x 10<sup>6</sup> = the number of disintegrations per minute per microcurie,  
Y = the fractional radiochemical yield, when applicable,  
λ = the radioactive decay constant for the particular radionuclide (sec<sup>-1</sup>), and  
Δt = the elapsed time between the midpoint of sample collection and the time of counting (sec).

Typical values of E, V, Y, and Δt should be used in the calculation.

It should be recognized that the LLD is defined as an a priori (before the fact) limit representing the capability of a measurement system and not as an a posteriori (after the fact) limit for a particular measurement.

- (2) A composite sample is one in which the quantity of liquid sampled is proportional to the quantity of liquid waste discharged and in which the method of sampling employed results in a specimen which is representative of the liquids released.
- (3) To be representative of the quantities and concentrations of radioactive materials in liquid effluents, samples shall be composited in proportion to the rate of flow of the effluent stream. Prior to analyses, all samples taken for the composite shall be thoroughly mixed in order for the composite sample to be representative of the effluent release.
- (4) A batch release is the discharge of liquid wastes of a discrete volume. Prior to sampling for analyses, each batch shall be isolated, and then thoroughly mixed, by a method described in the ODCP, to assure representative sampling.

TITLE: Radioactive Effluent Controls Program

---

APPENDIX 6.1 (continued)

TABLE 6.1.3-1 (continued)

Table Notations

- (5) A continuous release is the discharge of liquid wastes of a nondiscrete volume; e.g., from a volume of system that has an input flow during the continuous release.
- (6) The principal gamma emitters for which the LLD specification applies include the following radionuclides: Mn-54, Fe-59, Co-58, Co-60, Zn-65, Mo-99, Cs-134, Cs-137, and Ce-141. Ce-144 shall also be measured but with an LLD of  $5 \times 10^{-6}$ . This list does not mean that only these nuclides are to be considered. Other gamma peaks that are identifiable, together with those of the above nuclides, shall also be analyzed and reported in the Annual Radioactive Effluent Release Report. If two or more redundant sample and analysis results of the same discharge pathway indicate slight differences in low level isotopic mixture, the analysis resulting in higher calculated dose should be used. The isotopes chosen to represent the discharge shall be reported.

- (7) Frequency Notation:

<u>Notation</u>	<u>Frequency</u>
D	At least once per 24 hours.
W	At least once per 7 days.
M	At least once per 31 days.
Q	At least once per 92 days.
P	Completed prior to each release.

6.1.4 Liquid Effluents - Dose

Commitment for Operation

6.1.4.1 The dose or dose commitment to a MEMBER OF THE PUBLIC from radioactive materials in liquid effluents released, from each unit, to UNRESTRICTED AREAS (see FSAR Figure 5.1-3) shall be limited:

- a. During any calendar quarter to less than or equal to 1.5 mrem to the whole body and to less than or equal to 5 mrem to any organ, and
- b. During any calendar year to less than or equal to 3 mrem to the whole body and to less than or equal to 10 mrem to any organ.

Applicability: At all times.

Action:

- a. With the calculated dose from the release of radioactive materials in liquid effluents exceeding any of the above limits, prepare and submit to the Commission within 30 days, pursuant to 10 CFR 50.4, a Special Report that identifies the cause(s) for exceeding the limit(s) and defines the corrective actions that have been taken to reduce the releases and the proposed corrective actions to be taken to assure that subsequent releases will be in compliance with the above limits.

TITLE: Radioactive Effluent Controls Program

---

APPENDIX 6.1 (continued)

Surveillance Requirements

6.1.4.2 Cumulative dose contributions from liquid effluents for the current calendar quarter and the current calendar year shall be determined in accordance with the methodology and parameters in the ODCP at least once per 31 days.

6.1.5 Liquid Radwaste Treatment System

Commitment for Operation

6.1.5.1 The Liquid Radwaste Treatment System\* shall be OPERABLE and appropriate portions of the system shall be used to reduce the radioactive materials in liquid wastes prior to their discharge when the projected doses due to the liquid effluent, from each unit, to UNRESTRICTED AREAS (see FSAR Figure 2.1-2) would exceed 0.06 mrem to the whole body or 0.2 mrem to any organ in a 31-day period.

Applicability: At all times.

Action:

- a. With any portion of the Liquid Radwaste Treatment System not in operation and with radioactive liquid waste being discharged without treatment and in excess of the above limits, prepare and submit to the Commission within 30 days, pursuant to 10 CFR 50.4, a Special Report which includes the following information:
1. Explanation of why liquid radwaste was being discharged without treatment, identification of any inoperable equipment or subsystems, and the reason for the inoperability,
  2. Action(s) taken to restore the inoperable equipment to OPERABLE status, and
  3. Summary description of action(s) taken to prevent a recurrence.

Surveillance Requirements

6.1.5.2 Doses due to liquid releases from each unit to UNRESTRICTED AREAS shall be projected at least once per 31 days, in accordance with the methodology and parameters in the ODCP when Liquid Radwaste Treatment Systems are not being fully utilized.

6.1.5.3 The installed Liquid Radwaste Treatment System shall be considered OPERABLE by meeting Commitments 6.1.3.1 and 6.1.4.1.

---

\* The Liquid Radwaste Treatment System is common to both units.

TITLE: Radioactive Effluent Controls Program

---

APPENDIX 6.1 (continued)

6.1.6 Gaseous Effluents - Dose Rate

Commitment for Operation

6.1.6.1 The dose rate due to radioactive materials released in gaseous effluents from the site to areas at or beyond the SITE BOUNDARY (see FSAR Figure 2.1-2) shall be limited to the following:

- a. For noble gases: Less than or equal to 500 mrem/yr to the whole body and less than or equal to 3000 mrem/yr to the skin, and
- b. For Iodine-131, for Iodine-133, for tritium, and for all radionuclides in particulate form with half-lives greater than 8 days: Less than or equal to 1500 mrem/yr to any organ.

Applicability: At all times.

Action:

With the dose rate(s) exceeding the above limits, immediately decrease the release rate to within the above limit(s).

Surveillance Requirements

6.1.6.2 The dose rate due to noble gases in gaseous effluents shall be determined to be within the above limits in accordance with the methodology and procedures of the ODCP.

6.1.6.3 The dose rate due to Iodine-131, Iodine-133, tritium, and all radionuclides in particulate form with half-lives greater than 8 days in gaseous effluents shall be determined to be within the above limits in accordance with the methodology and procedures of the ODCP by obtaining representative samples and performing analyses in accordance with the sampling and analysis program specified in Table 6.1.6-1.

TITLE: Radioactive Effluent Controls Program

APPENDIX 6.1 (continued)

TABLE 6.1.6-1

Radioactive Gaseous Waste Sampling and Analysis Program

Gaseous Release Type	Sampling Frequency	Minimum Analysis Frequency	Type of Activity Analysis	Lower Limit of Detection (LLD) ( $\mu\text{Ci/ml}$ ) <sup>(1)</sup>
1. Waste Gas Decay Tank	P Each Tank Grab Sample	P Each Tank	Principal Gamma Emitters <sup>(7)</sup> (noble gases)	$1 \times 10^{-4}$
2. Containment Purge	P Each Purge <sup>(2)</sup> Grab Sample	P Each Purge <sup>(2)</sup>	Principal Gamma Emitters <sup>(7)</sup> (noble gases)	$1 \times 10^{-4}$
			I-131, I-133	$1 \times 10^{-9}$
			Principal Gamma Emitters (particulates)	$1 \times 10^{-9}$
			H-3	$1 \times 10^{-6}$
3. Plant Vent	M <sup>(2)</sup> Grab Sample	M <sup>(2)</sup>	Principal Gamma Emitters <sup>(7)</sup> (noble gases)	$1 \times 10^{-4}$
	W <sup>(3)(5)</sup> Grab Sample	W	H-3	$1 \times 10^{-6}$
4. All Release Types as listed in 1., 2., 3., above, at the plant vent	Continuous <sup>(6)</sup>	W <sup>(4)</sup> Charcoal Sample	I-131	$1 \times 10^{-12}$
			I-133	$1 \times 10^{-10}$
	Continuous <sup>(6)</sup>	W <sup>(4)</sup> Particulate Sample	Principal Gamma Emitters <sup>(7)</sup>	$1 \times 10^{-11}$
	Continuous <sup>(6)</sup>	M Composite Particulate Sample	Gross Alpha	$1 \times 10^{-11}$
5. Steam Generator Blowdown Tank Vent	M <sup>(8)</sup>	M <sup>(8)</sup>	Principal Gamma Emitters <sup>(7)</sup> (noble gases)	$1 \times 10^{-4}$
			Q Composite Particulate Sample	Sr-89, Sr-90



TITLE: Radioactive Effluent Controls Program

---

APPENDIX 6.1 (continued)

TABLE 6.1.6-1 (continued)

Table Notations

- (1) The LLD is defined, for purposes of these specifications, as the smallest concentration of radioactive material in a sample that will yield a net count, above system background, that will be detected with 95% probability with only 5% probability of falsely concluding that a blank observation represents a "real" signal.

For a particular measurement system, which may include radiochemical separation:

$$LLD = \frac{4.66s_b}{E * V * 2.22 \times 10^6 * Y * \exp(-\lambda\Delta t)}$$

Where:

- LLD = the "a priori" lower limit of detection (microcuries per unit mass or volume),  
 $s_b$  = the standard deviation of the background counting rate or of the counting rate of a blank sample as appropriate (counts per minute),  
E = the counting efficiency (counts per disintegration),  
V = the sample size (units of mass or volume),  
 $2.22 \times 10^6$  = the number of disintegrations per minute per microcurie,  
Y = the fractional radiochemical yield, when applicable,  
 $\lambda$  = the radioactive decay constant for the particular radionuclide ( $\text{sec}^{-1}$ ), and  
 $\Delta t$  = the elapsed time between the midpoint of sample collection and the time of counting (sec).

Typical values of E, V, Y, and  $\Delta t$  should be used in the calculation.

It should be recognized that the LLD is defined as an a priori (before the fact) limit representing the capability of a measurement system and not as an a posteriori (after the fact) limit for a particular measurement.

- (2) Sampling and analyses shall also be performed following shutdown, startup, or a THERMAL POWER change exceeding 15% of the RATED THERMAL POWER within a 1-hour period.
- (3) Tritium grab samples shall be taken a least once per 24 hours when the refueling canal is flooded.

TITLE: Radioactive Effluent Controls Program

---

APPENDIX 6.1 (continued)

TABLE 6.1.6-1 (continued)

Table Notations (continued)

- (4) Samples shall be changed at least once per 7 days and analyses shall be completed within 48 hours after changing or after removal from sampler. Sampling shall also be performed at least once per 24 hours for at least 7 days following each shutdown, startup or THERMAL POWER change exceeding 15% of RATED THERMAL POWER within a 1-hour period and analyses shall be completed within 48 hours of changing. When samples collected for 24 hours are analyzed, the corresponding LLD's may be increased by a factor of 10. This requirement does not apply if: (1) analysis shows that the DOSE EQUIVALENT I-131 concentration in the reactor coolant has not increased more than a factor of 3; and (2) the noble gas monitor shows that effluent activity has not increased more than a factor of 3.

- (5) Tritium grab samples shall be taken at least once per 7 days from the ventilation exhaust from the spent fuel pool area, whenever spent fuel is in the spent fuel pool.

- (6) The ratio of the sample flow rate to the sampled stream flow rate shall be known for the time period covered by each dose or dose rate calculation made in accordance with Commitments 6.1.6.1, 6.1.7.1, and 6.1.8.1.

- (7) The principal gamma emitters for which the LLD specification applies include the following radionuclides: Kr-87, Kr-88, Xe-133, Xe-133m, Xe-135, and Xe-138 in noble gas releases and Mn-54, Fe-59, Co-58, Co-60, Zn-65, Mo-99, I-131, Cs-134, Cs-137, Ce-141, and Ce-144 in Iodine and particulate releases. This list does not mean that only these nuclides are to be considered. Other gamma peaks that are identifiable, together with those of the above nuclides, shall also be analyzed and reported in the Annual Radioactive Effluent Release Report.

If two or more redundant sample and analysis results of the same discharge pathway indicate slight differences in low level isotopic mixture, the analysis resulting in higher calculated dose should be used. The isotopes chosen to represent the discharge shall be reported

- (8) Grab samples shall be taken and analyzed at least once per 31 days whenever there is flow through the steam generator blowdown tank. Releases of radioiodines shall be estimated based on secondary coolant concentration and partitioning factors during releases or shall be measured.

- (9) Frequency Notation

<u>Notation</u>	<u>Frequency</u>
W	At least once per 7 days
M	At least once per 31 days
Q	At least once per 92 days
P	Completed prior to each release

TITLE: Radioactive Effluent Controls Program

---

APPENDIX 6.1 (continued)

6.1.7 Dose - Noble Gases

Commitment for Operation

6.1.7.1 The air dose due to noble gases released in gaseous effluents, from each unit, to areas at or beyond the SITE BOUNDARY (see TS Figure 5.1-3) shall be limited to the following:

- a. During any calendar quarter: Less than or equal to 5 mrad for gamma radiation and less than or equal to 10 mrad for beta radiation, and
- b. During any calendar year: Less than or equal to 10 mrad for gamma radiation and less than or equal to 20 mrad for beta radiation.

Applicability: At all times.

Action:

- a. With the calculated air dose from radioactive noble gases in gaseous effluents exceeding any of the above limits, prepare and submit to the Commission within 30 days, pursuant to 10 CFR 50.4, a Special Report that identifies the cause(s) for exceeding the limit(s), defines the corrective actions that have been taken to reduce the releases and the proposed corrective actions to be taken to assure that subsequent releases will be in compliance with the above limits.

Surveillance Requirements

6.1.7.2 Cumulative dose contributions for the current calendar quarter and current calendar year for noble gases shall be determined in accordance with the methodology and parameters in the ODCP at least once per 31 days.

6.1.8 Dose - Iodine-131, Iodine-133, Tritium, and Radioactive Material in Particulate Form

Commitment for Operation

6.1.8.1 The dose to a MEMBER OF THE PUBLIC from Iodine-131, Iodine-133, tritium and all radionuclides in particulate form with half-lives greater than 8 days in gaseous effluents released, from each unit, to areas at and beyond the SITE BOUNDARY (see TS Figure 5.1-3) shall be limited to the following:

- a. During any calendar quarter: Less than or equal to 7.5 mrem to any organ and,
- b. During any calendar year: Less than or equal to 15 mrem to any organ.

Applicability: At all times.

TITLE: Radioactive Effluent Controls Program

---

APPENDIX 6.1 (continued)

Action:

- a. With the calculated dose from the release of Iodine-131, Iodine-133, tritium, and radionuclides in particulate form with half-lives greater than 8 days, in gaseous effluents exceeding any of the above limits, prepare and submit to the Commission within 30 days, pursuant to 10 CFR 50.4, a Special Report that identifies the cause(s) for exceeding the limit(s), defines the corrective actions that have been taken to reduce the releases and the proposed actions to be taken to assure that subsequent releases will be in compliance with the above limits.

Surveillance Requirements

- 6.1.8.2 Cumulative dose contributions for the current calendar quarter and current calendar year for Iodine-131, Iodine-133, tritium, and radionuclides in particulate form with half-lives greater than 8 days shall be determined in accordance with the methodology and parameters in the ODCP at least once per 31 days.

6.1.9 Gaseous Radwaste Treatment System

Commitment for Operation

- 6.1.9.1 The GASEOUS RADWASTE SYSTEM and the VENTILATION EXHAUST TREATMENT SYSTEM shall be OPERABLE. The appropriate portions of these systems shall be used to reduce releases of radioactivity when the projected doses in 31 days due to gaseous effluent releases, from each unit, to areas at and beyond the SITE BOUNDARY (see FSAR Figure 2.1-2), would exceed 0.2 mrad to air from gamma radiation or 0.4 mrad to air from beta radiation or 0.3 mrem to any organ of a MEMBER OF THE PUBLIC.

Applicability: At all times.

Action:

- a. With radioactive gaseous waste being discharged without treatment and in excess of the above limits, prepare and submit to the Commission within 30 days, pursuant to 10 CFR 50.4, a Special Report that includes the following information:
1. Identification of the inoperable equipment or subsystems and the reason for inoperability,
  2. Action(s) taken to restore the inoperable equipment to OPERABLE status, and
  3. Summary description of action(s) taken to prevent a recurrence.

TITLE: Radioactive Effluent Controls Program

---

APPENDIX 6.1 (continued)

Surveillance Requirements

6.1.9.2 Doses due to gaseous releases from each unit to areas at and beyond the SITE BOUNDARY shall be projected at least once per 31 days, in accordance with the methodology and parameters in the ODCP when Gaseous Radwaste Treatment Systems are not being fully utilized.

6.1.9.3 The installed VENTILATION EXHAUST TREATMENT SYSTEM and GASEOUS RADWASTE SYSTEM shall be considered OPERABLE by meeting Commitments 6.1.6.1 and 6.1.7.1 or 6.1.8.1.

6.1.10 Total Dose

Commitment for Operation

6.1.10.1 The annual (calendar year) dose or dose commitment to any MEMBER OF THE PUBLIC due to releases of radioactivity and to radiation from uranium fuel cycle sources shall be limited to less than or equal to 25 mrems to the whole body or any organ, except the thyroid, which shall be limited to less than or equal to 75 mrems.

Applicability: At all times.

Action:

- a. With the calculated doses from the release of radioactive materials in liquid or gaseous effluents exceeding twice the limits of Commitments 6.1.4.1.a, 6.1.4.1.b, 6.1.7.1.a, 6.1.7.1.b, 6.1.8.1.a, or 6.1.8.1.b, calculations shall be made including direct radiation contributions from the units and from outside storage tanks to determine whether the above limits of Regulatory Commitment 6.1.10.1 have been exceeded. If such is the case, prepare and submit to the Commission within 30 days, pursuant to 10 CFR 50.4, a Special Report that defines the corrective action to be taken to reduce subsequent releases to prevent recurrence of exceeding the above limits and includes the schedule for achieving conformance with the above limits. This Special Report, as defined in 10 CFR 20.2203(a), shall include an analysis that estimates the radiation exposure (dose) to a MEMBER OF THE PUBLIC from uranium fuel cycle sources, including all effluent pathway and direct radiation, for the calendar year that includes the release(s) covered by this report. It shall also describe levels of radiation and concentrations of radioactive material involved, and the cause of the exposure levels or concentrations. If the estimated dose(s) exceeds the above limits, and if the release condition resulting in violation of 40 CFR Part 190 has not already been corrected, the Special Report shall include a request for a variance in accordance with the provisions of 40 CFR Part 190. Submittal of the report is considered a timely request, and a variance is granted until staff action on the request is complete.

TITLE: Radioactive Effluent Controls Program

---

APPENDIX 6.1 (continued)

Surveillance Requirements

- 6.1.10.2 Cumulative dose contributions from liquid and gaseous effluents shall be determined in accordance with Commitments 6.1.4.2, 6.1.7.2, and 6.1.8.2, and in accordance with the methodology and parameters in the ODCP.
- 6.1.10.3 Cumulative dose contributions from direct radiation from the units and from outside storage tanks shall be determined in accordance with the methodology and parameters in the ODCP. This requirement is applicable only under conditions set forth in ACTION a. of Commitment 6.1.10.1.

6.1.11 Radiological Environmental Monitoring

- 6.1.11.1 Commitment for Operation - The Radiological Environmental Monitoring Program shall be conducted as specified in RP1.ID11, "Environmental Radiological Monitoring Procedure."

Applicability: At all times.

Action:

- a. With the confirmed level of radioactivity as the result of plant effluents in an environmental sampling medium at a specified location exceeding the "Reporting Levels for Nonroutine Operating Reports" in RP1.ID11 when averaged over any calendar quarter, prepare and submit to the Commission within 30 days from the end of the quarter, pursuant to 10 CFR 50.4, a Nonroutine Radiological Environmental Operating Report that identifies the cause(s) for exceeding the limit(s) and defines the corrective actions to be taken to reduce radioactive effluents so that the potential annual dose to a MEMBER OF THE PUBLIC is less than the calendar year limits of Commitment 6.1.4.1, 6.1.7.1, or 6.1.8.1. A confirmatory reanalysis of the original, a duplicate, or a new sample may be desirable, as appropriate. The results of the confirmatory analysis shall be completed at the earliest time consistent with the analysis, but in any case within 30 days. When more than one of the radionuclides from "Reporting Levels for Nonroutine Operating Reports" in RP1.ID11 are detected in the sampling medium, this report shall be submitted if:

$$\frac{\text{concentration}(1)}{\text{reportinglevel}(1)} + \frac{\text{concentration}(2)}{\text{reportinglevel}(2)} + \dots \geq 1.0$$

When radionuclides other than those in the "Reporting Levels for Nonroutine Operating Reports" in RP1.ID11 are detected and are the result of plant effluents, a Nonroutine Radiological Environmental Operating Report shall be submitted if the potential annual dose to a MEMBER OF THE PUBLIC from all radionuclides is equal to or greater than the calendar year limits of Commitment 6.1.4.1, 6.1.7.1, or 6.1.8.1. This report shall include an evaluation of any release conditions, environmental factors, or other aspects necessary to explain the anomalous result.

TITLE: Radioactive Effluent Controls Program

---

APPENDIX 6.1 (continued)

6.1.12 LAND USE CENSUS

6.1.12.1 A Land Use Census shall be conducted as specified in RP1.ID11, "Environmental Radiological Monitoring Procedure."

Applicability: At all times.

Action:

- a. With a Land Use Census identifying a location(s) that yields a calculated dose or dose commitment greater than the values currently being calculated in Commitment 6.1.8.2, identify the new location(s) in the next Annual Radioactive Effluent Release Report.
- b. With a Land Use Census identifying a location(s) that yields a calculated dose or dose commitment (via the same exposure pathway) 20% greater than at a location from which samples are currently being obtained in accordance with Commitment 6.1.11.1, add the new location(s) within 30 days to the Radiological Environmental Monitoring Program given in the ERMP. The sampling location(s), excluding the control station location, having the lowest calculated dose or dose commitment(s), via the same exposure pathway, may be deleted from this monitoring program after October 31 of the year in which this Land Use Census was conducted. Submit in the next Annual Radioactive Effluent Release Report documentation for a change in the ERMP including a revised figure(s) and table(s) for the ERMP reflecting the new location(s) with information supporting the change in sampling locations.

Bases

6.1.1 Radioactive Liquid Effluent Monitoring Instrumentation

The radioactive liquid effluent instrumentation is provided to monitor and control, as applicable, the releases of radioactive materials in liquid effluents during actual or potential releases of liquid effluents. The Alarm/Trip Setpoints for these instruments shall be calculated and adjusted in accordance with the methodology and parameters in the ODCP to ensure that the alarm/trip will occur prior to exceeding the limits of 10 CFR Part 20. The OPERABILITY and use of this instrumentation is consistent with the requirements of General Design Criteria 60, 63, and 64 of Appendix A to 10 CFR Part 50.

6.1.2 Radioactive Gaseous Effluent Monitoring Instrumentation

The radioactive gaseous effluent instrumentation is provided to monitor and control, as applicable, the releases of radioactive materials in gaseous effluents during actual or potential releases of gaseous effluents. The Alarm/Trip Setpoints for these instruments shall be calculated and adjusted in accordance with the methodology and parameters in the ODCP to ensure that the alarm/trip will occur prior to exceeding the limits of NUREG 0133. The OPERABILITY and use of this instrumentation is consistent with the requirements of General Design Criteria 60, 63, and 64 of Appendix A to 10 CFR Part 50. The sensitivity of any noble gas activity monitors used to show compliance with the gaseous effluent release requirements of Regulatory Commitment 6.1.7.1 shall be such that concentrations as low as  $1 \times 10^{-5}$   $\mu\text{Ci/ml}$  are measurable.

TITLE: Radioactive Effluent Controls Program

---

APPENDIX 6.1 (continued)

6.1.3 Liquid Effluents - Concentration

This Regulatory Commitment is provided to ensure that the concentration of radioactive materials released in liquid waste effluents to UNRESTRICTED AREAS will be less than the concentration levels specified in 10 CFR Part 20, Appendix B, Table 2, Column 2. This limitation provides additional assurance that the levels of radioactive materials in bodies of water in UNRESTRICTED AREAS will result in exposures within: (1) the Section II.A design objectives of Appendix I, 10 CFR Part 50, to a MEMBER OF THE PUBLIC, and (2) the limits of 10 CFR 20.1301(e) to the population. The concentration limit for dissolved or entrained noble gases is based upon the assumption that Xe-135 is the controlling radioisotope and its Effluent Concentration Limit (ECL) in air (submersion) was converted to an equivalent concentration in water using the methods described in International Commission on Radiological Protection (ICRP) Publication 2.

This Regulatory Commitment applies to the release of radioactive materials in liquid effluents from all units at the site.

The required detection capabilities for radioactive materials in liquid waste samples are tabulated in terms of the lower limits of detection (LLDs). Detailed discussion of the LLD, and other detection limits can be found in Currie, L.A., "Lower Limit of Detection: Definition and Elaboration of a Proposed Position for Radiological Effluent and Environmental Measurements," NUREG/CR-4007 (September 1984), and in the HASL Procedures Manual, HASL-300 (revised annually).

6.1.4 Liquid Effluents - Dose

This Regulatory Commitment is provided to implement the requirements of Sections II.A, III.A and IV.A of Appendix I, 10 CFR Part 50. The Limiting Condition for Operation implements the guides set forth in Section II.A of Appendix I. The ACTION statements provide the required operating flexibility and at the same time implement the guides set forth in Section IV.A of Appendix I to assure that the releases of radioactive material in liquid effluents to UNRESTRICTED AREAS will be kept "as low as is reasonably achievable." The dose calculation methodology and parameters in the ODCP implement the requirements in Section III.A of Appendix I that conformance with the guides of Appendix I be shown by calculational procedures based on models and data, such that the actual exposure of a MEMBER OF THE PUBLIC through appropriate pathways is unlikely to be substantially underestimated. The equations specified in the ODCP for calculating the doses due to the actual release rates of radioactive materials in liquid effluents are consistent with the methodology provided in Regulatory Guide 1.109, "Calculation of Annual Doses to Man from Routine Releases of Reactor Effluents for the Purpose of Evaluating Compliance with 10 CFR Part 50, Appendix I," Revision 1, October 1977 and Regulatory Guide 1.113, "Estimating Aquatic Dispersion of Effluents from Accidental and Routine Reactor Releases for the Purpose of Implementing Appendix I," April 1977.

This Regulatory Commitment applies to the release of radioactive materials in liquid effluents from each unit at the site. For units with shared Radwaste Treatment Systems, the liquid effluents from the shared system are to be proportioned among the units sharing that system.



TITLE: Radioactive Effluent Controls Program

---

APPENDIX 6.1 (continued)

6.1.5 Liquid Radwaste Treatment System

The OPERABILITY of the Liquid Radwaste Treatment System ensures that this system will be available for use whenever liquid effluents require treatment prior to release to the environment. The requirement that the appropriate portions of this system be used when specified provides assurance that the releases of radioactive materials in liquid effluents will be kept "as low as is reasonably achievable." This specification implements the requirements of 10 CFR 50.36a, General Design Criterion 60 of Appendix A to 10 CFR Part 50 and the design objective given in Section II.D of Appendix I to 10 CFR Part 50. The specified limits governing the use of appropriate portions of the Liquid Radwaste Treatment System were specified as a suitable fraction of the dose design objectives set forth in Section II.A of Appendix I, 10 CFR Part 50, for liquid effluents.

This Regulatory Commitment applies to the release of radioactive materials in liquid effluents from each unit at the site. For units with shared Radwaste Treatment Systems, the liquid effluents from the shared system are to be proportioned among the units sharing that system.

6.1.6 Gaseous Effluents - Dose Rate

This Regulatory Commitment is provided to ensure that the dose at any time at and beyond the SITE BOUNDARY from gaseous effluents from all units on the site will be within the annual dose limits of NUREG 0133 to UNRESTRICTED AREAS. The annual dose limits are the doses to be associated with the concentrations of 10 CFR Part 20, Appendix B, Table 2, Column 1. These limits provide reasonable assurance that radioactive material discharged in gaseous effluents will not result in the exposure of a MEMBER OF THE PUBLIC in an UNRESTRICTED AREA, either within or outside the SITE BOUNDARY, to average concentrations exceeding the limits to be specified in Appendix B, Table 2 of 10 CFR Part 20 (10 CFR Part 20.1302(c)). For MEMBERS OF THE PUBLIC who may at times be within the SITE BOUNDARY, the occupancy of that MEMBER OF THE PUBLIC will usually be sufficiently low to compensate for any increase in the atmospheric diffusion factor above that for the SITE BOUNDARY. Examples of calculations for such MEMBERS OF THE PUBLIC, with the appropriate occupancy factors, shall be given in the ODCP. The specified release rate limits of NUREG 0133 restrict, presently, the corresponding gamma and beta dose rates above background to a MEMBER OF THE PUBLIC at or beyond the SITE BOUNDARY to less than or equal to 500 mrem/year to the whole body or to less than or equal to 3000 mrem/year to the skin. These release rate limits also restrict, at all times, the corresponding thyroid dose rate above background to a child via the inhalation pathway to less than or equal to 1500 mrem/year.

This Regulatory Commitment applies to the release of radioactive materials in gaseous effluents from all units at the site.

The required detection capabilities for radioactive material in gaseous waste samples are tabulated in terms of the lower limits of detection (LLDs). Detailed discussion of the LLD, and other detection limits can be found in Currie, L.A., "Lower Limit of Detection: Definition and Elaboration of a Proposed Position for Radiological Effluent and Environmental Measurements," NUREG/CR-4007 (September 1984), and in the HASL Procedures Manual, HASL-300 (revised annually).

**TITLE:** Radioactive Effluent Controls Program

---

APPENDIX 6.1 (continued)

6.1.7 Dose - Noble Gases

This Regulatory Commitment is provided to implement the requirements of Sections II.B, III.A and IV.A of Appendix I, 10 CFR Part 50. The Limiting Condition for Operation implements the guides set forth in Section II.B of Appendix I. The ACTION statements provide the required operation flexibility and at the same time implement the guides set forth in Section IV.A of Appendix I to assure that the releases of radioactive material in gaseous effluents to UNRESTRICTED AREAS will be kept "as low as is reasonably achievable." The Surveillance Requirements implement the requirements in Section III.A of Appendix I that conformance with the guides of Appendix I be shown by calculational procedures based on models and data such that the actual exposure of a MEMBER OF THE PUBLIC through appropriate pathways is unlikely to be substantially underestimated. The dose calculation methodology and parameters established in the ODCP for calculating the doses due to the actual release rates of radioactive noble gases in gaseous effluents are consistent with the methodology provided in Regulatory Guide 1.109, "Calculation of Annual Doses to Man from Routine Releases of Reactor Effluents for the Purpose of Evaluating Compliance with 10 CFR Part 50, Appendix I," Revision 1, October 1977 and Regulatory Guide 1.111, "Methods for Estimating Atmospheric Transport and Dispersion of Gaseous Effluents in Routine Releases from Light-Water-Cooled Reactors," Revision 1, July 1977. The ODCP equations provided for determining the air doses at and beyond the SITE BOUNDARY are based upon the historical average atmospheric conditions.

This Regulatory Commitment applies to the release of radioactive materials in gaseous effluents from each unit at the site. For units with shared Radwaste Treatment Systems, the gaseous effluents from the shared system are proportioned among the units sharing the system.

TITLE: Radioactive Effluent Controls Program

---

APPENDIX 6.1 (continued)

6.1.8 Dose - Iodine-131, Iodine-133, Tritium, and Radioactive Material in Particulate Form

This Regulatory Commitment is provided to implement the requirements of Sections II.C, III.A, and IV.A of Appendix I, 10 CFR Part 50. The Limiting Conditions for Operation are the guides set forth in Section II.C of Appendix I. The ACTION statements provide the required operating flexibility and at the same time implement the guides set forth in Section IV.A of Appendix I to assure that the releases of radioactive materials in gaseous effluents to UNRESTRICTED AREAS will be kept "as low as is reasonably achievable." The ODCP calculational methods specified in the Surveillance Requirements implement the requirements in Section III.A of Appendix I that conformance with the guides of Appendix I be shown by calculational procedures based on models and data, such that the actual exposure of a MEMBER OF THE PUBLIC through appropriate pathways is unlikely to be substantially underestimated. The ODCP calculational methodology and parameters for calculating the doses due to the actual release rates of the subject materials are consistent with the methodology provided in Regulatory Guide 1.109, "Calculation of Annual Doses to Man from Routine Releases of Reactor Effluents for the Purpose of Evaluating Compliance with 10 CFR Part 50, Appendix I," Revision 1, October 1977 and Regulatory Guide 1.111, "Methods for Estimating Atmospheric Transport and Dispersion of Gaseous Effluents in Routine Releases from Light-Water-Cooled Reactors," Revision 1, July 1977. These equations also provide for determining the actual doses based upon the historical average atmospheric conditions. The release rate specifications for Iodine-131, Iodine-133, tritium, and radionuclides in particulate form with half-lives greater than 8 days are dependent upon the existing radionuclide pathways to man in the areas at and beyond the SITE BOUNDARY. The pathways that were examined in the development of the calculations were: (1) individual inhalation of airborne radionuclides, (2) deposition of radionuclides onto green leafy vegetation with subsequent consumption by man, (3) deposition onto grassy areas where milk animals and meat-producing animals graze with consumption of the milk and meat by man, and (4) deposition on the ground with subsequent exposure of man.

This Regulatory Commitment applies to the release of radioactive materials in gaseous effluents from each unit at the site. For units with shared Radwaste Treatment Systems, the gaseous effluents from the shared system are proportioned among the units sharing that system.

6.1.9 Gaseous Radwaste Treatment System

The OPERABILITY of the GASEOUS RADWASTE SYSTEM and the VENTILATION EXHAUST TREATMENT SYSTEM ensures that the systems will be available for use whenever gaseous effluents require treatment prior to release to the environment. The requirement that the appropriate portions of these systems be used, when specified, provides reasonable assurance that the releases of radioactive materials in gaseous effluents will be kept "as low as is reasonably achievable." This specification implements the requirements of 10 CFR 50.36a, General Design Criterion 60 of Appendix A to 10 CFR Part 50 and the design objectives given in Section II.D of Appendix I to 10 CFR Part 50. The specified limits governing the use of appropriate portions of the systems were specified as a suitable fraction of the dose design objectives set forth in Sections II.B and II.C of Appendix I, 10 CFR Part 50, for gaseous effluents.

This Regulatory Commitment applies to the release of radioactive materials in gaseous effluents from each unit at the site. For units with shared Radwaste Treatment Systems, the gaseous effluents from the shared system are proportioned among the units sharing that system.

TITLE: Radioactive Effluent Controls Program

---

APPENDIX 6.1 (continued)

6.1.10 Total Dose

This Regulatory Commitment is provided to meet the dose limitations of 40 CFR Part 190 that have been incorporated into 10 CFR Part 20 by 46 FR 18525. The specification requires the preparation and submittal of a Special Report whenever the calculated doses due to releases of radioactivity and to radiation from uranium fuel cycle sources exceed 25 mrems to the whole body or any organ, except the thyroid, which shall be limited to less than or equal to 75 mrems. For sites containing up to four reactors, it is highly unlikely that the resultant dose to a MEMBER OF THE PUBLIC will exceed the dose limits of 40 CFR Part 190 if the individual reactors remain within twice the dose design objectives of Appendix I, and if direct radiation doses from the units and from outside storage tanks are kept small. The Special Report will describe a course of action that should result in the limitation of the annual dose to a MEMBER OF THE PUBLIC to within the 40 CFR Part 190 limits. For the purposes of the Special Report, it may be assumed that the dose commitment to the MEMBER OF THE PUBLIC from other uranium fuel cycle sources is negligible, with the exception that dose contribution from other nuclear fuel cycle facilities at the same site or within a radius of 8 km must be considered. If the dose to any MEMBER OF THE PUBLIC is estimated to exceed the requirements of 40 CFR Part 190, the Special Report with a request for a variance (provided the release conditions resulting in violation of 40 CFR Part 190 have not already been corrected), in accordance with the provisions of 40 CFR 190.11 and 10 CFR 20.2203(a), is considered to be a timely request and fulfills the requirements of 40 CFR Part 190 until NRC staff action is completed. The variance only relates to the limits of 40 CFR Part 190, and does not apply in any way to the other requirements for dose limitation of 10 CFR Part 20, as addressed in Regulatory Commitment 6.1.3.1 and 6.1.6.1. An individual is not considered a MEMBER OF THE PUBLIC during any period in which he/she is engaged in carrying out any operation that is part of the nuclear fuel cycle.

TITLE: Radioactive Effluent Controls Program

---

APPENDIX 6.2

High Alarm Setpoints for Fuel Building and  
Control Room Ventilation Systems Actuation Instrumentation

6.2.1 Fuel Building Ventilation System (FBVS) Instrumentation, RE-58 and RE-59

6.2.1.1 RE-58 Nominal Setpoint  $\leq 75$  mr/hr

Bases

6.2.1.2 Fuel Handling Accident in Fuel Handling Building

- a. The basis for the RE-58 high alarm setpoint is to initiate actions to mitigate offsite dose consequences from air borne releases resulting from a fuel handling accident in the Spent Fuel Pool area. Routing ventilation exhaust from the Spent Fuel Pool area through the charcoal filter, thus stripping halogens (principally iodine isotopes) mitigates off-site dose consequences. The rerouting of the ventilation is accomplished automatically upon receipt of a RE-58 high alarm. Receipt of the high alarm also signals personnel to evacuate the area. PG&E performed a calculation (RA-90-1-0 "High and Alert Alarm Setpoint for RE-58") to base the high alarm setpoint of RE-58 on the airborne radioactivity concentration in the fuel Handling Building for the FSAR Update Expected Case accident release during a fuel handling accident. The Expected Case Accident consequence presented in the FSAR Update is a less severe, but more probable accident than the FSAR Update Design Basis Case fuel handling accident. This resulted in a more conservative (lower) setpoint than that for the Design Basis Accident Case. This calculation analyzed the detector sensitivity to the various release nuclides as presented in the FSAR Update.
- b. The high alarm setpoint is set to a value more consistent with the Expected Case Accident dose rates which eliminates spurious ESF actuation while limiting the off-site consequences due to this accident. A  $\leq 75$ mr/hr setpoint equates to a site boundary whole body dose of 1.46mr for the duration of the accident, which has been evaluated as being acceptable.

6.2.1.3 Inadvertent Criticality in the Spent Fuel Pool

- a. The high density Spent Fuel Pool racks were redesigned to assure that a  $K_{eff}$  equal to or less than 0.95 is maintained with the racks fully loaded with fuel of the highest anticipated reactivity in each of two regions, and flooded with unborated water at a temperature corresponding to the highest reactivity. PG&E submitted PG&E Letter No. DCL-85-30, "Re-racking of Spent Fuel Pools," on September 19, 1985. The results of the criticality analysis for normal and abnormal operations were evaluated in this report. LAR 85-13 (PG&E Letter No. DCL-85-333) was submitted on October 30, 1985, and summarized the results of the Spent Fuel Pool re-racking report. Postulated events that could potentially involve accidental criticality were examined and it was concluded that the limiting value for criticality ( $K_{eff}$  of 0.95) would not be exceeded. Therefore, an inadvertent criticality in the Spent Fuel Pool is not considered a credible accident and an evaluation of the effect of raising the actuation setpoint on RE-58 was not required.

TITLE: Radioactive Effluent Controls Program

---

APPENDIX 6.2 (continued)

- b. Radiation monitor RE-59, which monitors the new fuel storage vault area, also provides indication of inadvertent criticality and changes in dose rate for radiation protection purposes.

6.2.1.4 RE-59 Nominal Setpoint  $\leq 15\text{mr/hr}$

- a. In DCCP FSAR update in Chapter 12, Table 12.1-1, "Plant Zone Classifications," the Fuel Handling Building areas in which RE-59 is located is classified as Zone III, "Controlled Assess Requiring Short-Term Occupancy" as indicated in Design Criteria Memorandum DCM-T20.
- b. The Zone III design maximum dose rate is  $\leq 15\text{mr/hr}$ . If the radiation flux reaches this value, the high alarm will be actuated and the ventilation mode will change as indicated above with the RE-58 high alarm actuation.

6.2.2 Control Room Ventilation System (CRVS) Instrumentation, RS-25A and RS-26A

6.2.2.1 RS-25A/RS-26A Nominal Setpoint  $\leq 2\text{ mr/hr}$

Bases

6.2.2.2 Per calculations DV-1-23 and DV-2-23 attachment 2:

- a. The applicable NRC requirement for the radiation exposure (dose) to personnel in the Main Control Room is 10 CFR 20.105 "Permissible Level of Radiation in Unrestricted Areas" (superseded). Section b(1) of 10 CFR 20.105 limits the radiation dose for unrestricted areas to  $2\text{mr/hr}$  and Section b(2) limits the dose to  $100\text{mr}$  in seven consecutive days. If an operator works in the control room for 48 hours per week (12 hours per day and 4 days per week, a normal operator work week) during a  $2\text{mr/hr}$  dose rate, the operator will receive a  $96\text{mr}$  dose. This is less than the  $100\text{mr/week}$  dose limit of 10 CFR 20.105 (superseded). Thus, a setpoint of  $\leq 2\text{ mr/hr}$  has been established for the Control Room Air Inlet Radiation Monitors. If the radiation flux reaches this value at any of the detectors, a change in the ventilation to Mode 4 will be initiated.
- b. 10 CFR 20.105 has been superseded and any changes to this setpoint will require a basis change to reflect the requirements of 10 CFR 50 Appendix A Criterion 19.

- 6.2.3 All of the setpoints are controlled by the setpoint control program CF6.ID1 and require a design change vehicle (request per CF4.ID1) to change. Actual field setpoints are set more conservative to account for instrument errors.

**Attachment 4**

**Nuclear Power Generation Interdepartmental Administrative Procedure,  
RP1.ID11, "Environmental Radiological Monitoring Procedure," Revision 8**

TITLE: Environmental Radiological Monitoring Procedure

7-7-08  
EFFECTIVE DATE

---

PROCEDURE CLASSIFICATION: QUALITY RELATED

1. SCOPE

1.1 This procedure constitutes the Environmental Radiological Monitoring Procedure (ERMP) and implements the requirements of the Radiological Environmental Monitoring Program (REMP) for the plant per Technical Specification 5.5.1 and 5.6.2. This procedure is part of the Offsite Dose Calculation Manual (ODCM).

2. DISCUSSION

2.1 The purpose of a Radiological Environmental Monitoring Program is to provide a basis for evaluating concentrations of radioactive materials and radiation levels in the environment from radiological releases once a reactor is operational.

2.2 This procedure describes the supplemental and minimum required program, describing sample locations, types of sample locations, methods and frequency of analysis, reporting requirements, performance of land use census, and participation in an interlaboratory comparison program.

2.3 This procedure also contains the state of California Department of Public Health (CDPH) cross-check program.

2.4 The program described by this procedure provides measurements of radiation and of radioactive materials in those exposure pathways and for those nuclides that lead to the highest potential radiation exposures of members of the public resulting from plant operation. This monitoring program implements section IV.B.2, IV.B.3 and IV.C of Appendix I to 10 CFR 50 and supplements the Radioactive Effluent Control Program. Guidance for this monitoring program is provided by the Radiological Assessment Branch Technical Position on Radiological Environmental Monitoring, revision 1, November, 1979.

3. DEFINITIONS

3.1 Broadleaf Vegetation: The leafy portion of plants such as lettuce, cabbage, spinach, or other similar leafy plants, typically used for human consumption.

3.2 Supplemental Sample: Samples that should be collected when available, but when they are not available, they are not subject to the substitution requirements of Table 1, Note 1 (Appendix 7.1). These types of samples are specifically designated as "supplemental" in Table 1 (Appendix 7.1).



TITLE: Environmental Radiological Monitoring Procedure

---

4. RESPONSIBILITIES

- 4.1 The radiation protection manager is responsible for ensuring implementation of this procedure, including:
  - 4.1.1 Approval of the Annual Radiological Environmental Operating Report (AREOR) prior to its submittal to the NRC. This should be a signature page at the front of the AREOR.
- 4.2 The REMP Engineer is responsible for the following:
  - 4.2.1 Identifying and evaluating the significant pathways of radiological impact to man and biota (e.g. food vectors, recreational use, water use) and subsequent updating of the REMP.
  - 4.2.2 Ensuring the performance of the annual land use census and that the results are provided to chemistry so that chemistry can establish the dose requirements of Appendix 6.1.12.1 of CY2.ID1, "Radioactive Effluent Controls Program."
  - 4.2.3 Preparation of the Annual Radiological Environmental Operating Report (AREOR).
  - 4.2.4 Ensuring that changes to the ERMP are provided to chemistry for inclusion in the Annual Radiological Effluent Release Report.
  - 4.2.5 Ensuring the required REMP sampling and monitoring are performed.
  - 4.2.6 Ensuring that the environmental TLD program is maintained.
  - 4.2.7 Contract implementation and communication with the environmental vendor lab (REMP).
  - 4.2.8 Ensuring that the personnel responsible for the management and for the implementation of the REMP receive training on the changes to the REMP at least annually. Such training consists of topics related to the changes in the plant's REMP procedures, industry events, any changes in technology that pertain to REMP sampling techniques or to the analysis of REMP samples and the nature and goals of the quality assurance program. Proficiency of personnel who perform activities affecting the quality of the REMP can be maintained by retraining, reexamining, recertifying, or by periodic performance reviews as appropriate. Initial training is provided on an as needed basis to new personnel responsible for quality related REMP activities.

**TITLE: Environmental Radiological Monitoring Procedure**

---

- 4.3 The REMP environmental lab vendor is responsible for the following:
- 4.3.1 Ensuring analysis is performed for the samples as required by the ERMP.
  - 4.3.2 Ensuring that participation is maintained in an interlaboratory comparison program sufficient to satisfy step 5.5.1 of this procedure.
  - 4.3.3 Ensuring that ERMP sample results exceeding the criteria of Appendix 6.1.11.1 of CY2.ID1, "Radioactive Effluent Controls Program," are communicated promptly as per the contract (to the chemistry manager and the radiation protection manager at the plant).
  - 4.3.4 Ensuring communication with DCPD per the contract. Examples are as follows:
    - a. sample results not meeting the contract "a-priori" LLDs
    - b. exceeding contract notification levels
    - c. problems with lab REMP sample analyses
    - d. problems with sample shipments
    - e. interlaboratory comparison program issues
  - 4.3.5 Ensuring that appropriate procedures are established and maintained for sample handling, sample analysis and all associated laboratory equipment.
  - 4.3.6 Ensuring qualifications and training of vendor lab personnel.
  - 4.3.7 Ensuring contract compliance.
- 4.4 The DCPD regulatory services department is responsible for ensuring that reports required by the ERMP are submitted to the appropriate recipients per XI1.ID2, "Regulatory Reporting Requirements and Reporting Process."

5. INSTRUCTIONS

Sampling and Monitoring

- 5.1 Environmental samples shall be collected and analyzed according to Table 1 at the locations shown in Table 5 (Appendix 7.5) and Figure 1, (Attachment 8.1) and Figure 2 (Attachment 8.2). Analytical techniques used will be such that the detection capabilities in Table 2 (Appendix 7.2) are routinely achieved. The sampling frequencies specified in Table 1 (Appendix 7.1) are allowed an extension of 25 percent (NUREG 1301, Page 16, Section 4.0.2).
- 5.2 The Old Steam Generator Storage Facility (OSGSF) inspection sumps shall be monitored quarterly to ensure there is no standing water in the sumps (on vaults containing equipment). If water is found; the corrective action process will be initiated, isotopic analysis for plant related isotopes will be performed, and the water dispositioned per plant protocols.
- 5.3 Sampling procedures for the REMP pathways and OSGSF sump monitoring are controlled in the DCPD plant manual, Volume 7 "Radiation Protection-Radiation Control Procedures," "RCP EM" series of procedures.

TITLE: Environmental Radiological Monitoring Procedure

---

5.4 Land Use Census

5.4.1 This census satisfies the requirements of section IV.B.3 of Appendix I to 10 CFR 50. Restricting the census to gardens of greater than 500 square feet provides assurance that significant exposure pathways via broadleaf vegetation will be identified and monitored as necessary. The size of the garden is the minimum to produce the quantity of 26 kg/year of broadleaf assumed in Regulatory Guide 1.109 for consumption by a child.

5.4.2 A Land Use Census will be conducted at least once per year, during the growing season (between February 15 and December 1), which will determine the locations in each of the 16 meteorological sectors within a distance of 8 km (5 mi) for:

- a. The nearest milk animal.
- b. The nearest residence.
- c. The nearest garden of greater than 50 square meters (500 sq. ft.) producing broadleaf vegetation.

**NOTE:** Broadleaf vegetation sampling may be performed at the site boundary in a sector with the highest D/Q in lieu of the garden census portion of the land use census.

5.4.3 The land use census will be conducted using that information which will provide the best results, which typically consists of discussions with landowners/tenants in conjunction with an aerial survey. Local agricultural authorities may also be consulted.

5.4.4 If the land use census identifies a location(s) that yields a calculated dose or dose commitment greater than the values currently being calculated per CY2.ID1, Appendix 6.1.12, the new location(s) shall be identified in the next Annual Radioactive Effluent Release Report.

5.4.5 If the land use census identifies a location(s) that yields a calculated dose or dose commitment (via the same exposure pathway) 20 percent greater than at a location from which samples are currently being obtained per Appendix 6.1.11 of CY2.ID1, add the new location(s) within 30 days to the radiological environmental monitoring program given in this ERMP. The sampling location(s), excluding the control station location, having the lowest calculated dose or dose commitment(s), via the same exposure pathway, may be deleted from this monitoring program after October 31 of the year in which this land use census was conducted. Documentation for a change in the ERMP will be submitted in the next Annual Radioactive Effluent Release Report including a revised figure(s) and table(s) for the ERMP reflecting the new location(s) with information supporting the change in sampling locations.

TITLE: Environmental Radiological Monitoring Procedure

---

- 5.5 Cross-check Programs
- 5.5.1 Participation will be maintained in an interlaboratory comparison program. This participation will include each of the determinations (sample medium-radionuclide combination) as described in Table 1 (Appendix 7.1) to ensure independent checks on the precision and accuracy of the measurements of radioactive materials in the ERMP samples.
- 5.5.2 Participation will be maintained in a split-sampling program with the State of California Department of Public Health (CDPH) as required by CDPH. The program will consist of radiological analyses of duplicate (split) samples or replicate analyses of the same sample by both the REMP environmental lab vendor and CDPH. The sample results from the REMP environmental lab vendor are available to CDPH in the DCPD Annual Radiological Environmental Operating Report (AREOR) or as requested by CDPH. The sample types, analyses performed, and frequencies of collection are given in Table 6 (Appendix 7.6).
- 5.6 Annual Radiological Environmental Operating Report (AREOR)
- 5.6.1 A report on the radiological environmental monitoring program will be prepared annually and submitted to the NRC prior to May 1 of the following year per DCPD Tech Spec 5.6.2.
- 5.6.2 The Annual Radiological Environmental Operating Report shall include:
- a. Summaries, interpretations, and an analysis of trends of the results of the radiological environmental monitoring program activities for the report period.
  - b. A comparison with preoperational studies, operational controls (as appropriate), and previous environmental surveillance reports.
  - c. An assessment of the observed impacts of the plant operation on the environment.
  - d. The results of the land use census.
  - e. The results of analyses of all radiological environmental samples and of all environmental radiation measurements taken during the period pursuant to the locations specified in tables and figures in this ERMP as well as summarized and tabulated results of these analyses and measurements in the format of Table 3 (Appendix 7.3) or equivalent.
  - f. A summary description of the radiological environmental monitoring program.
  - g. Legible maps covering all sampling locations keyed to a table giving distances and directions from the centerline between both reactors.

**TITLE: Environmental Radiological Monitoring Procedure**

---

- h. The results of licensee or REMP analysis lab vendor participation in the interlaboratory comparison program and the corrective action taken if the specified program is not being performed as required.
- i. The reason for not conducting the radiological environmental monitoring program as required, and discussion of all deviations from the sampling schedule of Table 1 (Appendix 7.1), including plans for preventing a recurrence.
- j. A discussion of environmental sample measurements that exceed the reporting levels of Table 4 (Appendix 7.4), but are not the result of plant effluents (i.e., demonstrated by comparison with a control station or with preoperational data).
- k. A discussion of all analyses in which the LLD required by Table 2 (Appendix 7.2) was not achievable.
- l. A description of any significant onsite radioactive leaks/spills into groundwater for the calendar year.
- m. Signature approval of the AREOR by the DCPD RP manager.
- n. Results of the Old Steam Generator Storage Facility (OSGSF) quarterly sump monitoring for standing water in vaults containing equipment. Report plant related isotopic activity detected and disposition of water.

5.7 Nonroutine Reports

5.7.1 Supplementary Report

- a. In the event that some results are not available for inclusion with the report, the report shall be submitted noting and explaining the reasons for the missing results. The missing data shall be submitted as soon as possible in a supplementary report.

5.7.2 Nonroutine Radiological Environmental Operating Report

- a. If a measured radionuclide concentration resulting from plant effluents in an environmental sampling medium, averaged over any calendar quarter sampling period, exceeds the reporting level given in Table 4 (Appendix 7.4), or when radionuclides other than those in Table 4 (Appendix 7.4) are detected and are the result of plant effluents where the potential annual dose to a member of the public from all radionuclides is equal to or greater than the calendar year limits of Appendix I of 10 CFR 50, a nonroutine radiological environmental operating report shall be prepared per CY2.ID1. This report is not required if the measured level of radioactivity was not the result of plant effluents, however, in such an event, the condition shall be reported and described in the annual radiological environmental operating report.

**TITLE: Environmental Radiological Monitoring Procedure**

---

- 5.7.3 Notification
    - a. Make informal notification as soon as practicable to appropriate State/Local officials, with follow-up notification to the NRC, as appropriate, regarding significant onsite radioactive leaks/spills into groundwater.
    - b. Make informal notification as soon as practicable to appropriate State/Local officials, with follow-up notification to the NRC (as appropriate) regarding onsite or offsite groundwater sample results exceeding the reporting criteria of Appendix 7.4 (Table 4) and meeting the reporting/notification criteria of the NEI Groundwater Protection Initiative (or subsequent NUREG).
  - 5.8 The Annual Radiological Environmental Operating Report (AREOR) shall be distributed to the following agencies.<sup>Ref 9.15</sup> The May 1<sup>st</sup> deadline for submittal applies to the NRC only.
    - 5.8.1 Nuclear Regulatory Commission (NRC)
    - 5.8.2 Chief, Radiological Health Services Branch, California Department of Public Health (CDPH).
    - 5.8.3 Executive Officer, Regional Water Quality Control Board, Central Coast Region
    - 5.8.4 Executive Officer, San Luis Obispo County Air Pollution Control District
    - 5.8.5 San Luis Obispo County Health Officer (Environmental Health Department)
  - 5.9 ERMP Changes
    - 5.9.1 Changes to this procedure shall be processed per the requirements of the plant Technical Specification Section 5.5.1.
    - 5.9.2 Notification of Sample Unavailability
      - a. If milk or vegetation sampling is not being performed as required by Table 1 (Appendix 7.1), identify specific locations for obtaining replacement samples and add them within 30 days to the radiological environmental monitoring program given in the ERMP. The specific locations from which samples were unavailable may then be deleted from the monitoring program. Submit in the next Annual Radioactive Effluent Release Report documentation for a change in the ERMP including a revised figure(s) and table for the ERMP reflecting the new location(s) with supporting information identifying the cause of the unavailability of samples and justifying the selection of the new location(s) for obtaining samples.
- NOTE:** The currently approved ERMP allows for substitution of milk and broadleaf vegetation sampling with additional air sampling in two sectors.

TITLE: Environmental Radiological Monitoring Procedure

---

6. RECORDS

- 6.1 Performance of the land use census shall be documented, including as a minimum the names of persons contacted and dates of contact. This documentation does not need to appear in the required reports, but should be entered into the records management system for the duration of the plant license.
- 6.2 Changes to the ERMP shall be retained in the records management system for the duration of the plant operating license.
- 6.3 REMP training shall be documented and recorded in PIMS or SAP (electronic plant management system). Training records shall also be placed in the Records Management System (RMS) for the duration of the plant operating license.

7. APPENDICES

- 7.1 Table 1: Radiological Environmental Monitoring Program
- 7.2 Table 2: Detection Capabilities (LLD's) for Environmental Sample Analysis
- 7.3 Table 3: Environmental Radiological Monitoring Program Summary
- 7.4 Table 4: Reporting Levels for Radioactivity Concentrations in Environmental Samples
- 7.5 Table 5: Distances and Directions to Environmental Monitoring Stations
- 7.6 Table 6: Summary of Cross-Check Program with State of California

8. ATTACHMENTS

- 8.1 "DCPP Offsite ERMP Stations (Figure 1)," 06/18/08
- 8.2 "DCPP Offsite ERMP Stations (Figure 2)," 06/18/08
- 8.3 "DCPP Onsite ERMP Stations Satellite Map (Figure 3)," 06/18/08

TITLE: Environmental Radiological Monitoring Procedure

---

9. REFERENCES

- 9.1 CY2, "Radiological Monitoring and Controls Program"
- 9.2 CY2.ID1, "Radioactive Effluent Control Program"
- 9.3 10 CFR 50 Appendix I
- 9.4 DCCP, Units 1 & 2, Plant Manual, Licenses, Amendments & Tech Specs, Volume 4A
- 9.5 RMS RLOC 001157-1162 & 001157-1163, "State Acceptance Letter"
- 9.6 NCR N0001947, "REMP program weakness"
- 9.7 AR A0419386, "Implementation of RP1.ID11 may violate FSAR Chapter 11"
- 9.8 AR A0419371, "Lack of prescribed REMP training program"
- 9.9 AR A0471782, "RP1.ID11 non compliance with AD1.ID1"
- 9.10 PCD T04341, T12344, T34940, T35262, T03114, T03131, T03133, T04076, T19000, T31239, T32015, T05246, T01437, T01438
- 9.11 AR A0564876, "2000 & 2001 Land Use Census outside dates specified in FSAR"
- 9.12 AR A0566312, "REMP audit dates and numbers, important document locations"
- 9.13 AR A0580124, "Verification of FSAR update 2.1.4.5 IAW AD1.ID2 Section 4.8"
- 9.14 AR A0584392, "Evaluate mussel growth at REMP sample point PON"
- 9.15 AR A0619597, "Inconsistencies or improvements to RP1.ID11"
- 9.16 AR A0642975 Eval 35, "SGRP – Old Steam Generator Storage Facility"
- 9.17 AR A0658602, "Coordinate radiological sampling of groundwater wells"
- 9.18 AR A0719469, "Establish quarterly monitoring of Old Steam Generator Storage Facility"



**TITLE: Environmental Radiological Monitoring Procedure**

APPENDIX 7.1

Table 1: Radiological Environmental Monitoring Program

Exposure Pathway and/or Sample Type	Number of Representative Samples and Sample Locations <sup>1</sup>	Sampling Stations	Collection Frequency	Type of Analysis	Required or Supplemental
1. Direct Radiation <sup>2</sup>	Thirty-one routine monitoring stations containing thermo luminescent dosimeters (TLDs) such that at least two (2) phosphors are present at each station, placed as follows:				
	An inner ring of stations, one in each terrestrial meteorological sector in the general area of the SITE BOUNDARY;	0S1, 0S2, WN1, 1S1, 2S1, 3S1, 4S1, 5S1, 6S1, 7S1, 8S1, 9S1, 8S2, 5S3, and MT1	Quarterly	Gamma Dose	Required
	An outer ring of stations, one in each terrestrial meteorological sector in the 2.5 to 12 km range from the site; and	1A1, 0B1, 1C1, 2D1, 3D1, 4C1, 5C1, 6D1, and 7C1	Quarterly	Gamma Dose	Required
	One or two areas to serve as control stations; and	4D1, 5F1	Quarterly	Gamma Dose	Required
	The balance of the stations to be placed in special interest areas such as population centers, nearby residences, or schools.	7D1, 7D2, 5F3, 7F1, and 7G2	Quarterly	Gamma Dose	Required
2. Airborne Radioiodine	Samples from five locations:				
	Three samples from close to the three SITE BOUNDARY locations, in different sectors, of the highest calculated annual average ground level D/Q:	MT1, 0S2, and 8S1 (historically). 1S1 & 8S2 (Note 5)	Continuous sampler operation with sample collection weekly, or more frequently if required by dust loading.	I-131 analysis	Required
	One sample from the vicinity of a community having the highest calculated annual average ground level D/Q;	7D1	Continuous sampler operation with sample collection weekly, or more frequently if required by dust loading.	I-131 analysis	Required
	One sample from a control location.	5F1	Continuous sampler operation with sample collection weekly, or more frequently if required by dust loading.	I-131 analysis	Required

TITLE: Environmental Radiological Monitoring Procedure

APPENDIX 7.1 (continued)

Exposure Pathway and/or Sample Type	Number of Representative Samples and Sample Locations <sup>1</sup>	Sampling Stations	Collection Frequency	Type of Analysis	Required or Supplemental
3. Airborne Particulate	Samples from five locations:				
	Three samples from close to the three SITE BOUNDARY locations, in different sectors, of the highest calculated annual average ground level D/Q:	MT1, 0S2, and 8S1 (historically). 1S1 & 8S2 (note 5).	Continuous sampler operation with sample collection weekly, or more frequently if required by dust loading.	Weekly gross beta radioactivity analysis following filter change <sup>3</sup> . Quarterly gamma isotopic analysis <sup>4</sup> of composite consisting of approx 12 filters (by location).	Required
	One sample from the vicinity of a community having the highest calculated annual average ground level D/Q;	7D1	Continuous sampler operation with sample collection weekly, or more frequently if required by dust loading.	Weekly gross beta radioactivity analysis following filter change <sup>3</sup> . Quarterly gamma isotopic analysis <sup>4</sup> of composite consisting of approx 12 filters (by location).	Required
	One sample from a control location.	5F1	Continuous sampler operation with sample collection weekly, or more frequently if required by dust loading.	Weekly gross beta radioactivity analysis following filter change <sup>3</sup> . Quarterly gamma isotopic analysis <sup>4</sup> of composite consisting of approx 12 filters (by location).	Required

TITLE: Environmental Radiological Monitoring Procedure

APPENDIX 7.1 (continued)

Exposure Pathway and/or Sample Type	Number of Representative Samples and Sample Locations <sup>1</sup>	Sampling Stations	Collection Frequency	Type of Analysis	Required or Supplemental
4. Waterborne					
a. Surface Ocean Water	One sample from the plant Outfall, Diablo Cove, and an area not influenced by plant discharge.	OUT, DCM, and 7C2	Monthly (grab sample)	Gamma isotopic <sup>4</sup> and tritium analysis.	Required
	One sample from the plant Outfall, Diablo Cove, and an area not influenced by plant discharge.	OUT, DCM, and 7C2	Quarterly (grab sample)	Gross Beta, Sr-89, Sr/Y-90, Fe-55, and Ni-63	Supplemental
b. Drinking Water	One sample from the plant drinking water, one sample from Diablo Creek (upstream of plant), and one control sample.	DW1 and 5S2 OEL (control)	Monthly (grab sample)	Gamma isotopic <sup>4</sup> , I-131, and tritium analysis.	Required
	One sample from the plant drinking water, one sample from Diablo Creek (upstream of plant), and one control sample.	DW1 and 5S2 OEL (control)	Quarterly (grab sample)	Gross Beta, Sr-89, Sr/Y-90, Fe-55, and Ni-63	Supplemental
	One sample from Diablo Creek (downstream of plant) and one sample from Blanchard Spring.	WN2 and 1A2	Quarterly (grab sample)	Gamma isotopic <sup>4</sup> , tritium, I-131, gross beta, Sr-89, Sr/Y-90, Fe-55, and Ni-63	Supplemental
c. Groundwater	One sample from wells located under the plant power block.	OW1, OW2, and DY1	Quarterly (grab sample, when available)	Gamma isotopic <sup>4</sup> , tritium, gross beta, Sr-89, Sr/Y-90, Fe-55, and Ni-63	Supplemental
	One sample from a well located outside the plant power block (control sample).	WW2	Quarterly (grab sample, when available)	Gamma isotopic <sup>4</sup> , tritium, gross beta, Sr-89, Sr/Y-90, Fe-55, and Ni-63	Supplemental
d. Sediment	One sample of offshore ocean sediment from Diablo Cove and Rattlesnake Canyon.	DCM and 7C2	Annual (grab sample)	Gamma isotopic <sup>4</sup>	Required
	One sample of offshore ocean sediment from Diablo Cove and Rattlesnake Canyon.	DCM and 7C2	Annual (grab sample)	Sr-89, Sr/Y-90, Fe-55, and Ni-63	Supplemental
	One sample from each of five local recreational beaches.	AVA, MDO, PMO, CYA, and CBA	Semi-Annual (grab sample)	Gamma isotopic <sup>4</sup> , Sr-89, Sr/Y-90, Fe-55, and Ni-63	Supplemental
e. Marine Flora	One sample of kelp	DCM, PON, POS, and 7C2	Quarterly (when available)	Gamma isotopic <sup>4</sup>	Supplemental
	One sample of intertidal algae	DCM and 7C2	Quarterly (when available)	Gamma isotopic <sup>4</sup>	Supplemental

TITLE: Environmental Radiological Monitoring Procedure

APPENDIX 7.1 (continued)

Exposure Pathway and/or Sample Type	Number of Representative Samples and Sample Locations <sup>1</sup>	Sampling Stations	Collection Frequency	Type of Analysis	Required or Supplemental
5. Ingestion					
a. Milk	Samples from milking animals in three locations within 5 km distance having the highest dose potential. If there are none, then one sample from milking animals in each of three areas between 5 to 8 km distance where doses are calculated to be greater than 1 mrem per year. One sample from milking animals at a control location 15 to 30 km distant and in the least prevalent wind direction. <b>NOTE:</b> The sample (5F2) should be taken monthly even if there are no indicator samples available.	5F2	Semimonthly when animals are on pasture; monthly at other times.	Gamma isotopic <sup>4</sup> and I-131 analysis.	Supplemental
b. Fish and Invertebrates	One sample of rock fish (family Sebastes) and one sample of perch (family Embiotocidae)	DCM and 7C2	Quarterly (grab sample)	Gamma isotopic <sup>4</sup> analysis on edible portions of each sample.	Required
	One sample of rock fish (family Sebastes) and one sample of perch (family Embiotocidae)	PON and POS	Quarterly (grab sample)	Gamma isotopic <sup>4</sup> analysis on edible portions of each sample.	Supplemental
	One sample of mussel (family Mytilus)	DCM and 7C2	Quarterly (grab sample)	Gamma isotopic <sup>4</sup> analysis on edible portions of each sample.	Required
	One sample of mussel (family Mytilus)	PON	Annual (grab sample)	Gamma isotopic <sup>4</sup> analysis on edible portions of each sample.	Supplemental
	One sample of mussel (family Mytilus)	POS	Quarterly (grab sample)	Gamma isotopic <sup>4</sup> analysis on edible portions of each sample.	Supplemental
	One sample of locally harvested market fish.	7D3 OR 2F1 (should alternate between locations)	Quarterly (grab sample)	Gamma isotopic <sup>4</sup> analysis on edible portions of each sample.	Supplemental

TITLE: Environmental Radiological Monitoring Procedure

APPENDIX 7.1 (continued)

Exposure Pathway and/or Sample Type	Number of Representative Samples and Sample Locations <sup>1</sup>	Sampling Stations	Collection Frequency	Type of Analysis	Required or Supplemental
c. Broadleaf Vegetation <sup>5</sup>	Three samples of broadleaf vegetation grown nearest off-site locations of highest calculated annual average ground level D/Q IF milk sampling is not performed.		Monthly (when available)	Gamma isotopic <sup>4</sup> analysis (that includes I-131) on edible portion.	Required (see notation #5)
	One sample of each of the similar broadleaf vegetation grown 15 to 30 km distant in the least prevalent wind direction IF milk sampling is not performed.		Monthly (when available)	Gamma isotopic <sup>4</sup> analysis (that includes I-131) on edible portion.	Required (see notation #5)
d. Vegetative Crops	One sample of broadleaf vegetation or vegetables or fruit	5F2, 7C1, and 7G1	Monthly (when available)	Gamma isotopic <sup>4</sup> analysis on edible portion.	Supplemental
	One sample of broadleaf vegetation or vegetables or fruit.	6C1	Quarterly (when available)	Gamma isotopic <sup>4</sup> analysis on edible portion.	Supplemental
e. Meat sample	One sample of each species (cow, goat, sheep, deer, or pig) of edible meat portion slaughtered for personal consumption (not mass market).	BCM, BGM, BSM, JDM, JPM, ACM, ADM, APM	Quarterly (when available and provided by land owners within 8 km of plant site)	Gamma isotopic <sup>4</sup> analysis, Sr-89, and Sr/Y-90 on edible portion.	Supplemental

TITLE: Environmental Radiological Monitoring Procedure

---

APPENDIX 7.1 (continued)

Table Notations

1. Deviations are permitted from the required sampling schedule if specimens are unobtainable due to circumstances such as hazardous conditions, seasonal unavailability, malfunction of automatic sampling equipment and other legitimate reasons. If specimens are unobtainable due to sampling equipment malfunction, effort shall be made to complete corrective action prior to the end of the next sampling period. All deviations from the sampling schedule shall be documented in the Annual Radiological Environmental Operating Report. It is recognized that, at times, it may not be possible or practicable to continue to obtain samples of the media of choice at the most desired location or time. In these instances, suitable specific alternative media and locations may be chosen for the particular pathway in question and appropriate substitutions made within 30 days in the Radiological Environmental Monitoring Program, and submitted in the next Annual Radioactive Effluent Release Report, including a revised figure(s) and table for the ERMP reflecting the new location(s) with supporting information identifying the cause of the unavailability of samples for that pathway and justifying the selection of the new location(s) for obtaining samples.
2. For the purposes of this table, a thermoluminescent dosimeter (TLD) is considered to be one phosphor. There are normally three calcium sulfate phosphors in an environmental TLD BADGE. Film badges shall not be used as dosimeters for measuring direct radiation.
3. Airborne particulate sample filters shall be analyzed for gross beta radioactivity 24 hours or more after sampling to allow for radon and thoron daughter decay. If gross beta activity in air particulate samples is greater than 10 times the yearly mean of control samples, gamma isotopic analysis shall be performed on the individual samples.
4. Gamma isotopic analysis means the identification and quantification of gamma-emitting radionuclides that may be attributable to the effluents from the facility.
5. If food products are unavailable, additional air sampling as specified in Table 1, Parts 2 & 3 will be done in the SE (Station 8S2) and NNW (station 1S1) sectors.
6. The Branch Technical Position (Nov 79) states, "Any location from which milk can no longer be obtained may be dropped from the surveillance program after notifying the NRC in writing that they are no longer obtainable at that location". Although the milk sampling performed at 5F2 is outside the 5-mile radius and is supplemental to the REMP, this notification should take place if 5F2 milk sampling ceases.

TITLE: Environmental Radiological Monitoring Procedure

APPENDIX 7.2

Table 2: Detection Capabilities for Environmental Sample Analysis <sup>(1)(2)</sup>  
 Lower Limits of Detection (LLD) <sup>(3)</sup>

Analysis	Water (pCi/L)	Airborne Particulate or Gases (pCi/m <sup>3</sup> )	Fish (pCi/kg, wet)	Milk (pCi/L)	Food Products (pCi/kg, wet)	Sediment (pCi/kg, dry)
Gross beta	4	0.01				
H-3	400					
Mn-54	15		130			
Fe-59	30		260			
Co-58, 60	15		130			
Zn-65	30		260			
Zr-Nb-95	15					
Sr-89	5			5	0.5 pCi/g	2 pCi/g
Sr/Y-90	1			1	0.5 pCi/g	2 pCi/g
I-131	1*	0.07		1	60	
Cs-134	15	0.05	130	15	60	150
Cs-137	18	0.06	150	18	80	180
Ba-La-140	15			15		

Table Notations

- (1) This list does not mean that only these nuclides are to be considered. Other peaks that are identifiable, together with those of the above nuclides, shall also be analyzed and reported in the Annual Radiological Environmental Operating Report.
- (2) Required detection capabilities for thermoluminescent dosimeters used for environmental measurements shall be per the recommendations of Regulatory Guide 4.13, Revision 1, July 1977.
- (3) The LLD is defined, for purposes of these specifications, as the smallest concentration of radioactive material in a sample that will yield a net count, above system background, that will be detected with 95 percent probability with only 5 percent probability of falsely concluding that a blank observation represents a "real" signal.

\* If no drinking water pathway exists, a value of 15 pCi/L may be used.

TITLE: Environmental Radiological Monitoring Procedure

---

APPENDIX 7.2 (Continued)

Table 2 (Continued)

Table Notations

For a particular measurement system, which may include radiochemical separation:

$$LLD = \frac{4.66s_b}{E \times V \times 2.22 \times Y \times \exp(-\lambda t)}$$

Where:

- LLD = the "a priori" the lower limit of detection as defined above (as pCi per unit mass or volume)
- $S_b$  = the standard deviation of the background counting rate or of the counting rate of a blank sample as appropriate (as counts per minute)
- E = the counting efficiency (as counts per transformation)
- V = the sample size (in units of mass or volume)
- 2.22 = the number of transformations per minute per picocurie
- Y = the fractional radiochemical yield (when applicable)
- $\lambda$  = the radioactive decay constant for the particular radionuclide
- t = the elapsed time between sample collection (or end of the sample collection period) and time of counting

The value of  $S_b$  used in the calculation of the LLD for a detection system will be based on the actual observed variance of the background counting rate or of the counting rate of the blank samples (as appropriate) rather than on an unverified theoretically predicted variance. In calculating the LLD for a radionuclide determined by gamma-ray spectrometry, the background will include the typical contributions of other radionuclides normally present in the samples (e.g., potassium-40 in milk samples).

Analyses will be performed in such a manner that the stated LLDs will be achieved under routine conditions. Occasionally background fluctuations, unavoidably small sample sizes, the presence of interfering nuclides, or other uncontrollable circumstances may render these LLDs unachievable. In such cases, the contributing factors will be identified and described in the Annual Environmental Radiological Operating Report.

Typical values of E, V, Y and t should be used in the calculation. It should be recognized that the LLD is defined as a priori (before the fact) limit representing the capability of a measurement system and not as a posteriori (after the fact) limit for a particular measurement.



TITLE: Environmental Radiological Monitoring Procedure

APPENDIX 7.3

Table 3: Environmental Radiological Monitoring Program Summary

Name of Facility \_\_\_\_\_ Docket No. \_\_\_\_\_  
 Location of Facility \_\_\_\_\_ Reporting Period \_\_\_\_\_  
 (County, State)

Medium or Pathway Sampled (Unit of Measurement)	Type and Total Number of Analyses Performed	Lower Limit of Detection(a) (LLD)	Location with Highest Annual Mean		All Indicator Locations Mean (1)(b) Range (b)	Control Locations Mean(1)(b) Range(b)	Number of Reportable Occurrences
			Name, Distance and Direction	Mean (1)(b) Range (b)			

(a) Unless indicated the LLDs specified in Table 2 were met.

(b) Mean and the range based upon detectable measurements only. Fraction of detectable measurements at specified locations is indicated in parentheses (1); e.g., (10/12) means that 10 out of 12 samples contained detectable activity.

TITLE: Environmental Radiological Monitoring Procedure

APPENDIX 7.4

Table 4: Reporting (Notification) Levels for Radioactivity Concentrations in Environmental Samples

Analysis	Water (pCi/L)	Airborne Particulate or Gases (pCi/m <sup>3</sup> )	Fish (pCi/kg, wet)	Milk (pCi/L)	Food Products (pCi/kg, wet)
H-3	20,000*				
Mn-54	1,000		30,000		
Fe-59	400		10,000		
Co-58	1,000		30,000		
Co-60	300		10,000		
Zn-65	300		20,000		
Sr-89	20				
Sr/Y-90	8				
Zr-Nb-95	400				
I-131	2**	0.9		3	100
Cs-134	30	10	1,000	60	1,000
Cs-137	50	20	2,000	70	2,000
Ba-La-140	200			300	

\* For drinking water samples. This is the 40 CFR 141 value. If no drinking water pathway exists, a value of 30,000 pCi/L may be used.

\*\* If no drinking water pathway exists, a value of 20 pCi/L may be used.

TITLE: Environmental Radiological Monitoring Procedure

APPENDIX 7.5

Table 5: Distances and Directions to Environmental Monitoring Stations  
 (Stations are shown on Attachments 8.1 and 8.2)

Station Code*	Station Name	Radial Direction (True Heading) (Degrees)	Radial Distance from Plant km (Miles)	
0S1	Exclusion Fence-Northwest Corner	320	0.16	(0.1)
0S2	North Gate	320	0.8	(0.5)
1S1	Wastewater Pond	330	0.64	(0.4)
2S1	Back Road-300 m North of Plant	0	0.32	(0.2)
3S1	Road NW of 230 kV Switchyard	23	0.64	(0.4)
4S1	Back Road Between Switchyards	43	0.8	(0.5)
5S1	500 kV Switchyard	58	0.64	(0.4)
5S2	Diablo Creek Weir	65	0.96	(0.6)
5S3	Microwave Tower Road	70	1.02	(0.7)
6S1	Microwave Tower	94	0.8	(0.5)
7S1	Overlook Road	112	0.48	(0.3)
8S1	Target Range	125	0.8	(0.5)
8S2	Southwest Site Boundary	128	1.76	(1.1)
9S1	South Cove	167	0.64	(0.4)
MT1	Meteorological Tower	185	0.32	(0.2)
DCM	Diablo Cove Marine	270	0.32	(0.2)
WN1	Northwest Guard Shack	290	0.32	(0.2)
WN2	Diablo Creek Outlet	283	0.25	(0.15)
1A1	Crowbar Canyon	327	2.56	(1.6)
1A2	Blanchard Spring	331	2.4	(1.5)
0B1	Point Buchon	325	5.76	(3.6)
1C1	Montana de Oro Campground	336	7.52	(4.7)
4C1	Clark Valley Gravel Pit	45	9.28	(5.8)
5C1	Junction Prefumo/See Canyon Roads	64	7.52	(4.7)
6C1	Household Garden	98	7.24	(4.5)
7C1	Pecho Creek Ruins (Mello Farm)	120	6.56	(4.1)
7C2	Rattlesnake Canyon	124	7.52	(4.7)
2D1	Sunnyside School	10	11.04	(6.9)
3D1	Clark Valley	24	9.92	(6.2)
4D1	Los Osos Valley Road	36	12.16	(7.6)
6D1	Junction See/Davis Canyon Roads	89	12.0	(7.5)
7D1	Avila Gate	118	10.56	(6.6)
7D2	Avila Beach	110	12.16	(7.6)
7D3	Avila Pier	120	11.0	(6.9)
2F1	Morro Bay (Commercial Landing)	0	17.44	(10.9)
5F1	SLO OEL	79	16.41	(10.2)
5F2	Cal Poly Farm	60	20.16	(12.6)
5F3	SLO County Health Department	70	20.32	(12.7)
7F1	Shell Beach	110	17.28	(10.8)

TITLE: Environmental Radiological Monitoring Procedure

APPENDIX 7.5 (Continued)

Table 5 (continued)

Station Code*	Station Name	Radial Direction (True Heading) (Degrees)	Radial Distance from Plant km (Miles)	
7G1	Arroyo Grande (Kawaoka Farm)	115	26.88	(16.8)
7G2	Oceano Substation	118	27.68	(17.3)
AVA	Avila Beach (near pier)	109	11.75	(7.3)
CBA	Cambria Moonstone Beach	330	45.86	(28.5)
CYA	Cayucos Beach (near pier)	350	26.87	(16.7)
DY1	Drywell 115'	77	0.041	(0.026)
DW1	Drinking Water from Plant Potable Water System	161	0.59	(0.37)
MDO	Montana de Oro (Spooners Cove)	336	7.56	(4.7)
OW1	Observation Well 01	336	0.07	(0.046)
OW2	Observation Well 02	157	0.07	(0.045)
OEL	Offsite Emergency Lab	79	16.41	(10.2)
OUT	Plant Outfall	270	0.32	(0.2)
PMO	Pismo Beach (near pier)	113	20.76	(12.9)
PON	Pacific Ocean North of Diablo Cove	305	2.4	(1.5)
POS	Pacific Ocean South of Diablo Cove	145	1.28	(0.8)
WW2	Water Well 02	70	1.02	(0.63)

\* Station Code (XYZ):

X - First number (0-9) represents the radial sector in which the station is located:

- |                     |                     |
|---------------------|---------------------|
| 0 - Northwest       | 5 - East-northeast  |
| 1 - North-northwest | 6 - East            |
| 2 - North           | 7 - East-southeast  |
| 3 - North-northeast | 8 - Southeast       |
| 4 - Northeast       | 9 - South-southeast |

Y - Letter (S, A-H) represents the distance from the plant:

- S - On-site
- A - 0-2 miles from plant (but off-site)
- B - 2-4 miles from plant
- C - 4-6 miles from plant
- D - 6-8 miles from plant
- E - 8-10 miles from plant
- F - 10-15 miles from plant
- G - 15-20 miles from plant
- H - Greater than 20 miles from plant

Z - Second number represents the station number within the zone.

\* Station Codes exceptions:

The following stations do not follow the coding system: Diablo Cove Marine (DCM), Meteorological Tower (MT1), Northwest guard shack (WN1), Diablo Creek outlet (WN2), Pacific Ocean North (PON), Pacific Ocean South (POS), Offsite Emergency Lab (OEL), Plant outfall (OUT), Drinking water (DW1), Water Well 02 (WW2), Observation Well 01 (OW1), Observation Well 02 (OW2), Drywell 115 (DY1), Avila Beach (AVA), Montana de Oro - Spooners Cove (MDO), Pismo Beach (PMO), Cayucos Beach (CYA), Cambria Moonstone Beach (CBA), Blanchard Cow Meat (BCM), Blanchard Goat Meat (BGM), Blanchard Sheep Meat (BSM), Johe Deer Meat (JDM), Johe Pig Meat (JPM), Andre Cow Meat (ACM), Andre Deer Meat (ADM), Andre Pig Meat (APM).

TITLE: Environmental Radiological Monitoring Procedure

APPENDIX 7.6

Table 6: Summary of Cross-Check Program with State of California

Sample Type	Station No.	Frequency*	Radioanalyses
Milk (supplemental)	5F2	Monthly	Gamma Isotopic (incl. I-131 and K-40)
Drinking Water	DW1	Monthly	Gamma Isotopic (incl. I-131), H-3
Outfall Water	OUT	Monthly	Gamma Isotopic, H-3
Diablo Creek	5S2	Monthly	Gamma Isotopic, H-3
Vegetative Crops (supplemental)	7G1	Quarterly	Gamma Isotopic
Fish or Invertebrate	DCM	Quarterly	Gamma Isotopic
Air Particulates and Radioiodine	5F1 (at SLO Health Dept), 7D1	Weekly Quarterly	Gross Beta, I-131 Gamma Isotopic (composite airborne particulate samples)
Sediment	DCM	Annually	Gamma Isotopic
Direct Radiation (TLD)	MT1, 1A1, 1C1, 4D1, 5F3, 5S1, 7D1, 7C1, 7F1, 8S2	Quarterly	Gamma Exposure (mR)
Kelp (supplemental)	DCM	Quarterly	Gamma Isotopic

\* When available

TITLE: DCPP Offsite ERMP Stations (Figure 1)

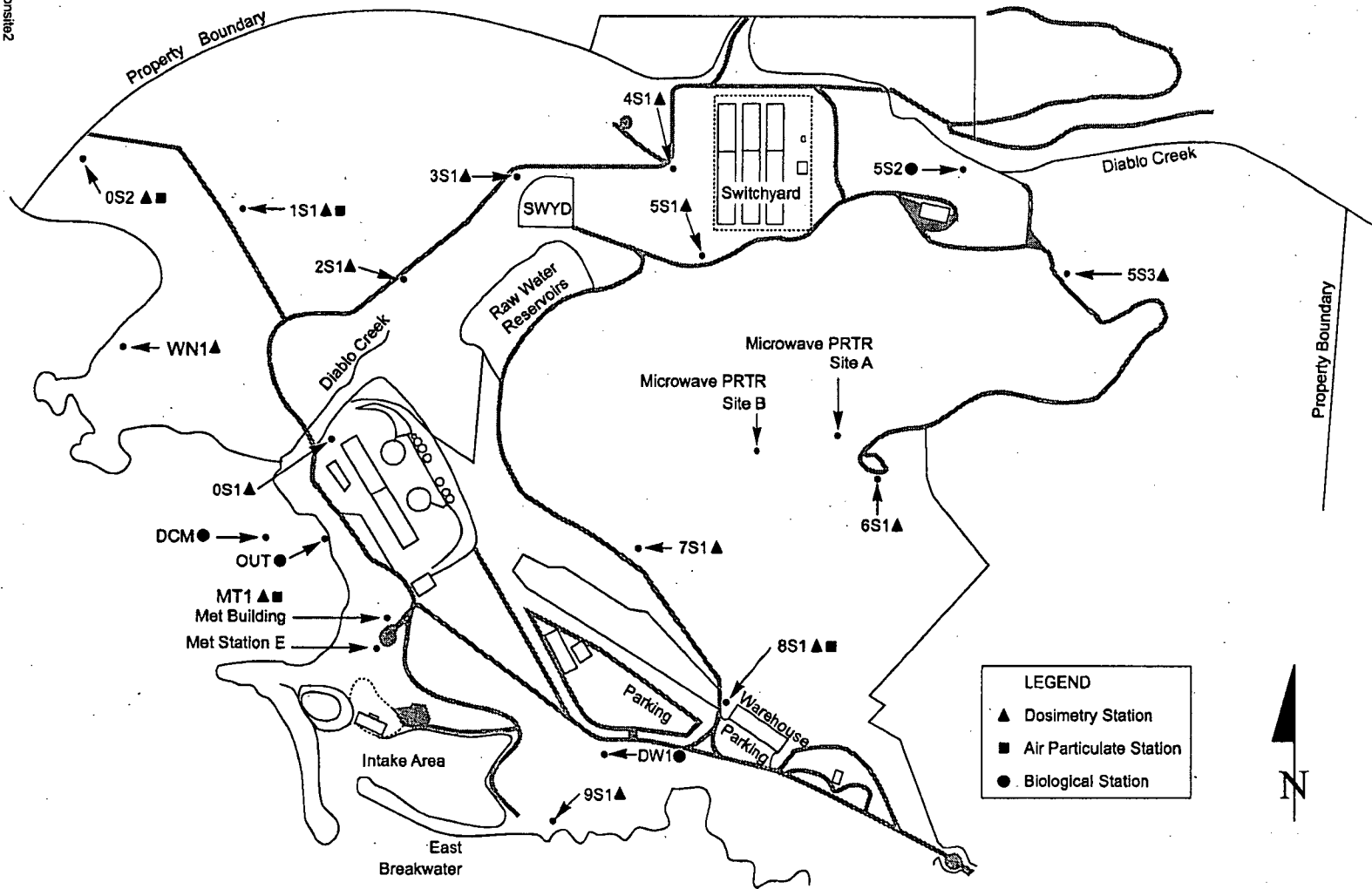

**LEGEND**

- ▲ Dosimetry Station
- Air Particulate Station
- Biological Station



Figure 1 - DCPP Onsite ERMP Stations

970338/onsite2

RP1.ID11.08.DOC 01A

0618.1138

NUCLEAR POWER GENERATION  
RP1.ID11  
ATTACHMENT 8.2

TITLE: DCCP Offsite ERMP Stations (Figure 2)

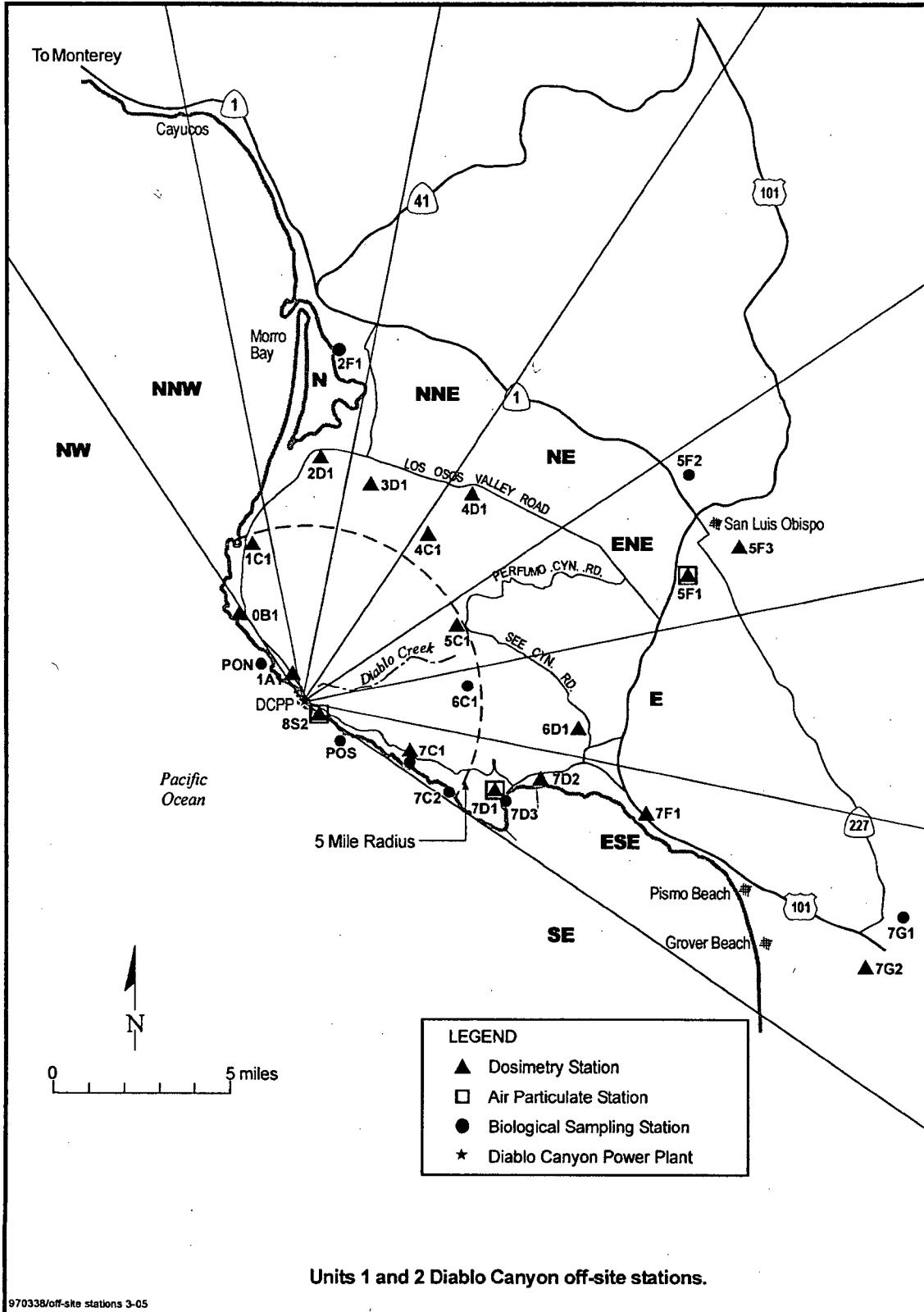

06/18/08

NUCLEAR POWER GENERATION

RP1.ID11

ATTACHMENT 8.3

TITLE: DCCP Onsite ERM/PS Stations Satellite Map (Figure 3)

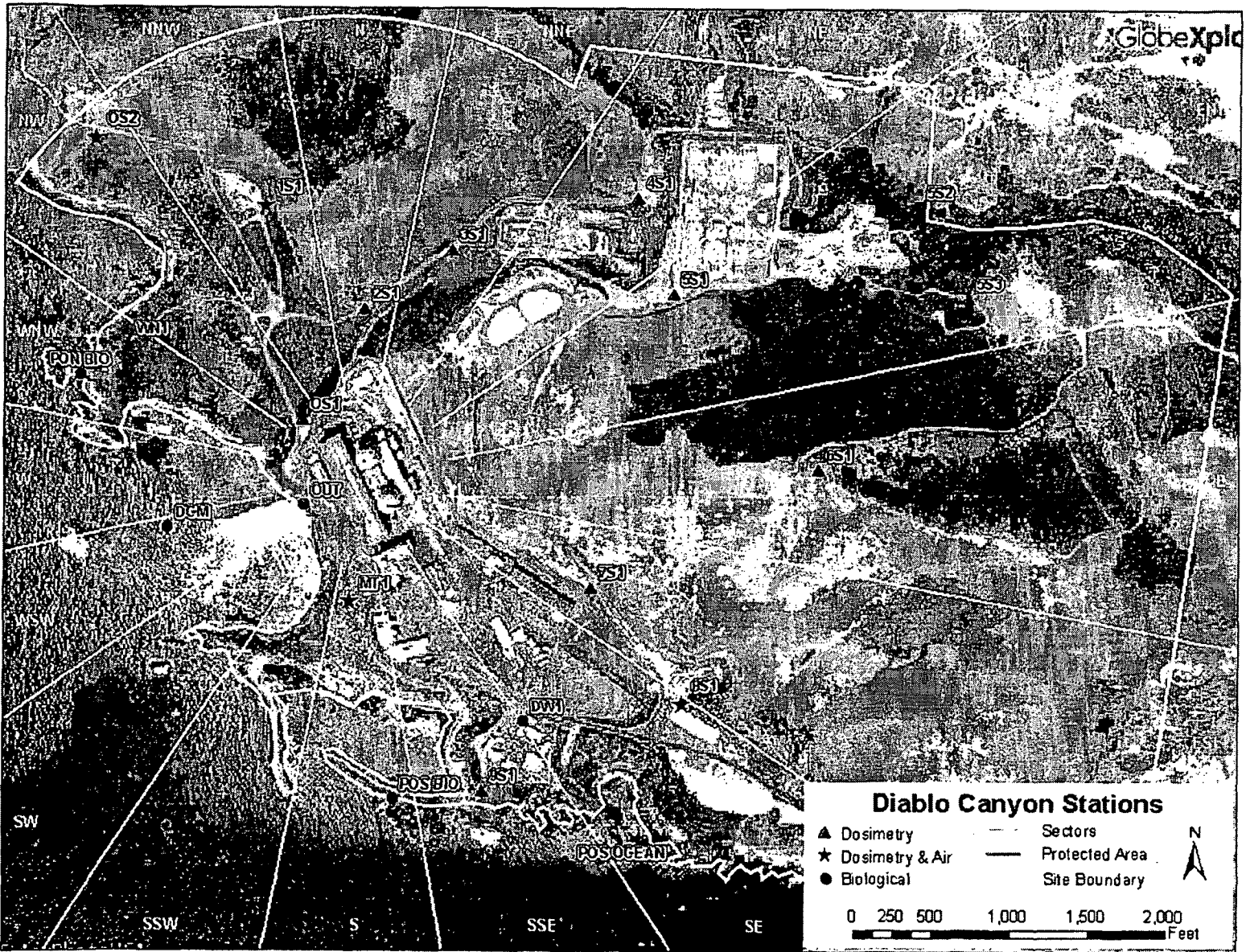



**Attachment 5**

**Diablo Canyon Power Plant Chemical Analysis Procedure,  
CAP A-8, "Offsite Dose Calculation Procedure," Revision 32**

\*\*\* ISSUED FOR USE BY \_\_\_\_\_ DATE \_\_\_\_\_ EXPIRES \_\_\_\_\_ \*\*\*  
 PACIFIC GAS AND ELECTRIC COMPANY NUMBER CAP A-8  
 NUCLEAR POWER GENERATION REVISION 32  
 DIABLO CANYON POWER PLANT PAGE 1 OF 62  
 CHEMICAL ANALYSIS PROCEDURE UNITS

TITLE Off-Site Dose Calculations

**1 AND 2**  
11-25-08  
 EFFECTIVE DATE

PROCEDURE CLASSIFICATION QUALITY RELATED

TABLE OF CONTENTS

<u>SECTION</u>	<u>PAGE</u>
SCOPE	2
DISCUSSION	3
RESPONSIBILITIES	3
PREREQUISITES	3
PRECAUTIONS	4
INSTRUCTIONS	4
Liquid Effluents	4
Liquid Effluents - Dose Calculation	4
10 CFR 20, Appendix B, Table 2, Column 2, Effluent (Liquid) Concentration Limit (ECL) Calculation	6
Liquid Effluent Radiation Monitor Set Point Methodology	7
Dose Projection (for Liquid Effluents)	13
Liquid Limiting Flow Rate Methodology - ECL Based	15
Liquid Limiting Flow Rates - LLD Based	16
Gaseous Effluents	18
Plant Vent Noble Gas Monitor - RE-14 HASP	21
Containment Purge - RE-44 HASP	28
Dose To Critical Receptor Due To Radioiodines, Tritium and Particulates Released in Gaseous Effluents	34
40 CFR 190 Dose Calculations	42
ACCEPTANCE CRITERIA	47
REFERENCES	47
RECORDS	48
APPENDICES	48
ATTACHMENTS	48
Table 6 1- Typical Liquid Effluent Discharge Pathway Allocation Factors	8
Table 6 2- Typical Gaseous Effluent Discharge Pathway Allocation Factors	20
Table 6 3- Expected On-Site Distance and Visitation Times for Members of the Public	46

TITLE Off-Site Dose Calculations

1 SCOPE

This procedure describes the methodology for the following

Effluent Type	RECP or Tech Spec	RECP or Tech Spec Surveillance Requirement	Implements
Liquids	6 1 1 1 (RECP) 6 1 3 1 (RECP)	Determination of alarm/trip setpoints for RE-18, RE-23, and RE-3	10 CFR 20 App B Table 2, Col 2
Gases	6 1 2 1 (RECP) 6 1 6 1 (RECP)	Determination of alarm/trip setpoints for RE-22, RE-14, and RE-14R	NUREG 0133
Liquids	6 1 3 2 (RECP) 6 1 3 3 (RECP)	Prerelease analyses of effluents Post release analysis of effluents	10 CFR 20 App B Table 2, Col 2
Liquids	6 1 4 2 (RECP)	Dose calculations	10 CFR 50 App I
Liquids	6 1 5 2 (RECP)	Dose projections	10 CFR 50 App I
Gases	6 1 6 2	Dose Rate calculations, Noble Gases, Total Body and Skin	NUREG 0133
Gases	6 1 6 3	Dose Rate calculations, Iodines, Particulates and Radionuclides other than Noble Gases, per organ, per age group	NUREG 0133
Gases	6 1 7 2 (RECP)	Noble Gas Air Dose Calculations	10 CFR 50 App I
Gases	6 1 8 2 (RECP)	Iodines, Particulates, and Radionuclides other than Noble Gases Organ Dose Calculations per age group	10 CFR 50 App I
Gases	6 1 9 2 (RECP)	Noble Gases, Iodines, Particulates, and Radionuclides other than Noble Gases, Dose Projection	10 CFR 50 App I
Liquids and Gases	6 1 10 2 (RECP) 4 4 2 b 1 (RECP)	Cumulative Dose from Liquids, Noble Gases, Iodines, Particulates, and Radionuclides other than Noble Gases per age group, per organ	40 CFR 190
Direct Radiation	6 1 10 3 (RECP)	Direct Radiation Dose Rate and Dose Calculations to unrestricted areas due to plant and high radwaste storage sky-shine	40 CFR 190

The calculational methodology for doses are based on models and data that make it unlikely to substantially underestimate the actual exposure of an individual through any of the appropriate pathways. Tables containing the values for the various parameters used in these expressions are also included.

TITLE Off-Site Dose Calculations

---

2 DISCUSSION

- 2 1 This procedure is used in support of the Radiological Monitoring and Controls Program (RMCP), and Radioactive Effluent Controls Program (RECP), and the portion that deals with routine radioactive liquid and gaseous releases to the unrestricted area. Limits are based on the dose commitment to a member of the general public related to the release of radionuclides through either direct or indirect exposure (e.g., submersion in a cloud of radioactive Noble Gases, radionuclides deposited on the ground, direct radiation from radionuclides stored on-site, inhalation of radionuclides or ingestion of radionuclides via a food pathway such as milk, meat, vegetable or fish, etc.)
- 2 2 The conduct of the Environmental Radiological Monitoring Procedure (ERMP) is found in RP1 ID11
- 2 3 Changes to CAP A-8 shall be processed in accordance with the requirements of DCCP Technical Specification Section 5.5.1

3 RESPONSIBILITIES

- 3 1 The manager, chemistry is the overseeing authority of responsibility for ensuring that the off-site dose calculational procedure (ODCP) meets all RECP and Tech Spec requirements with regards to calculated doses delivered by the plant to the unrestricted area surrounding the site
- 3 2 The senior radiochemistry engineer assumes the overall responsibility for ensuring that this procedure's program is followed and implemented where appropriate, especially in regards to RECP or Tech Spec requirements
- 3 3 The radiochemistry effluents engineer has the responsibility of correct and timely implementation of all the procedure's calculational methodology, where appropriate, for each radioactive effluent released. Furthermore this engineer is responsible for reviewing the results, cross (spot) checking the calculations, and maintaining an updated archive of post release calculated doses for annual report purposes
- 3 4 The digital systems group assures that any supporting computer software is maintained current and compatible with the procedure's calculational methodology and that the computer hardware is maintained operable at all times
- 3 5 The radiochemistry staff engineer provides an oversight of the effluents program's ODCP to confirm compliance with RECP or Tech Specs, provide technical support, recommend or design improvements to the dose calculational methodology and the effluent program control, and investigate long-term planning toward effluent related activities and their associated dose calculations
- 3 6 Responsibilities as described in CY1, "Chemistry and Radiochemistry," and CY1 DC1, "Analytical Data Processing Responsibilities," apply

4 PREREQUISITES

None

TITLE Off-Site Dose Calculations

5 PRECAUTIONS

None

6 INSTRUCTIONS

6 1 Liquid Effluents

6 1 1 Liquid Effluents - Dose Calculation

The dose contributions to the total body and each individual organ (bone, liver, thyroid, kidney, lung and GI-LLI) of the maximum exposed individual (adult) due to consumption of saltwater fish and saltwater invertebrate is calculated for all radionuclides identified in liquid effluents released to unrestricted areas using the following expression

$$D_o = F_t \Delta t \sum_i A_{io} C_i e^{-\lambda_i t_m} \quad (1)$$

Where

$D_o$  = The dose commitment to organ, o, in mrem

$F_t$  = Near field average dilution factor during the period of the release It is defined as

$$F_t = \frac{\text{Waste Flow}}{\text{Dilution Flow} \times Z} \quad (2)$$

Where

$Z$  =  $Z$  is the site specific factor for the mixing effect of the discharge structure Specifically, it is the credit taken for dilution which occurs between the discharge structure and the body of water which contaminates fish or invertebrates in the liquid ingestion pathway For DCCP  $Z = 5$

$\Delta t$  = The time period for the release in hours

$A_{io}$  = The site specific ingestion dose commitment factor to organ, o, due to radionuclide, i, in mrem/hr per  $\mu\text{Ci/ml}$  as defined by Equation 3

$C_i$  = Concentration of radionuclide, i, in the undiluted liquid effluent, in  $\mu\text{Ci/ml}$

$\lambda_i$  = Decay constant of radionuclide, i

$t_m$  = Time interval between end of sampling and midpoint of release

TITLE Off-Site Dose Calculations

The site specific ingestion dose commitment factor,  $A_{io}$ , is defined as

$$A_{io} = k_o (U_F BF_i + U_I BI_i) DF_i \quad (3)$$

Where

- $k_o$  = Units conversion factor of  $1.4 \times 10^5$  in units of  $\rho Ci / \mu Ci \times ml/l \times yr/hr$
- $U_F$  = Saltwater fish consumption rate in kilograms of fish per year DCPD value for this parameter is 21 kg/yr and is taken from NUREG 0133, Section 4.3.1
- $BF_i$  = Saltwater bioaccumulation factor for nuclide,  $i$ , in fish flesh in units of  $\rho Ci/Kg$  per  $\rho Ci/l$ . Values for  $BF_i$  are taken from Table A-1 of Reg. Guide 1.109, except uranium and plutonium, which were taken from NUREG/CR-4013
- $U_I$  = Saltwater invertebrate consumption rate in kilograms per years DCPD value for this parameter is 5 kg/yr and is taken from NUREG 0133, Section 4.3.1
- $BI_i$  = Saltwater bioaccumulation factor for nuclide,  $i$ , in invertebrate flesh in units of  $\rho Ci/Kg$  per  $\rho Ci/l$ . Values for  $BI_i$  are taken from Table A-1 of Reg. Guide 1.109, except uranium and plutonium, which were taken from NUREG-4013
- $DF_i$  = Adult ingestion dose conversion factor for nuclide,  $i$ , in mrem per  $\rho Ci$  ingested, from Table E-11 of Regulatory Guide 1.109, with exceptions detailed below
- $DF_i$  exceptions H-3, Br-82, Sb-124, Sb-125, Pu-238, Pu-239, Pu-240, Pu-241 and Pu-242, ingestion dose conversion factors are taken from EMP-155  
 As-76, Sn-113, Sn-117m and Sb-122 ingestion dose conversion factors were calculated by ORNL using ICRP-2 methodology  
 U-233, U-234, U-235, U-236 and U-238 ingestion dose conversion factors are taken from NUREG-0172

The site specific values for  $A_{io}$  are listed in Table 10.1. When necessary, these factors were corrected for the ingrowth of daughter radionuclides following ingestion of the parent. All radionuclides treated in this manner are followed by a "+D". Reference NUREG-0172, "Age-Specific Radiation Dose Commitment Factors for a One-Year Chronic Intake," and A0619601

Units 1 and 2 share a common liquid radwaste (LRW) treatment system. The effluent doses due to releases discharged via the common LRW are apportioned between the units with 50% credited to Unit 1 and 50% credited to Unit 2.

TITLE Off-Site Dose Calculations

6 1 2 10 CFR 20, Appendix B, Table 2, Column 2, Effluent (Liquid) Concentration Limit (ECL) Calculation

- a The ECL for the identified mixture of radionuclides in the "j<sup>th</sup>" batch of liquids is calculated as follows

$$ECL_j = \frac{\sum_{i=1}^n C_{ij}}{\sum_{i=1}^n ECL_{ij}} \quad (4)$$

Where

$ECL_j$  = The unrestricted area total undiluted ECL for the "j<sup>th</sup>" particular mixture of identified radionuclides, in  $\mu\text{Ci/ml}$

$C_{ij}$  = The concentration of radionuclide "i," in  $\mu\text{Ci/ml}$  for the "j<sup>th</sup>" mixture

$ECL_{ij}$  = The ECL in unrestricted area water for radionuclide "i," in general, in  $\mu\text{Ci/ml}$  (from 10 CFR 20, Appendix B, Table 2, Column 2)

b The overall ECL for simultaneous discharges is given by Equation 5

$$ECL_{overall} = \frac{\sum_{j=1}^n \Phi_j C_j}{\sum_{j=1}^n \frac{\Phi_j C_j}{ECL_j}} \quad (5)$$

Where

- $ECL_{overall}$  = The unrestricted area ECL for the current radionuclide mixture for concurrent "j" discharges (in  $\mu\text{Ci/ml}$ )
- $C_j$  = The total activity concentration for the "j<sup>th</sup>" individual stream in  $\mu\text{Ci/ml}$
- $ECL_j$  = The total ECL for the "j<sup>th</sup>" individual mixture (or stream) determined as defined in Equation 4, in  $\mu\text{Ci/ml}$
- $\Phi_j$  = The ratio of an individual discharge "j<sup>th</sup>" pathway flowrate to the sum total of all individual undiluted pathway flowrates as defined by

$$\Phi_j = \frac{f_j}{\sum_j f_j} \quad (6)$$

Where

- $f_j$  = Undiluted effluent flowrate for pathway, "j"

### 6 1 3 Liquid Effluent Radiation Monitor Set Point Methodology

#### a Introduction

The DCCP radiological effluent controls program requires that the liquid effluent monitors be operable with their alarm/trip set points set to ensure that the effluent concentration limits of 10 CFR 20 are not exceeded

The alarm/trip set point for the liquid effluent radiation monitors is derived from the concentration limit set forth in Appendix B, Table 2, Column 2 of 10 CFR 20 1001-2404

The alarm/trip set points are applied at the unrestricted area boundary. The set points take into account appropriate factors for dilution, dispersion, or decay of radioactive materials that may occur between the point of discharge and the unrestricted area boundary.



b Allocation and Safety Factors

The limits of RECP 6 1 3 1 are site limits which require that the set point methodology must ensure simultaneous releases do not exceed the liquid effluent concentration limits of 10 CFR 20 in the unrestricted area. The DCPH High Alarm Set Point (HASP) methodology makes use of an Allocation Factor (AF) to limit the effluent concentrations from simultaneous liquid discharges. The Allocation Factors can be adjusted based upon operational requirements with the restriction that the sum of the Allocation Factors must be less than or equal to 1.

Typical Allocation Factors are shown

Table 6 1

Typical Liquid Effluent Discharge Pathway Allocation Factors

Discharge Pathway	Rad Monitor	Allocation Factor (AF)
Oily Water Separator	RE-3	0 01
Liquid Radwaste System	RE-18	0 90
Steam Generator Blow Down (Unit 1)	RE-23 (U1)	0 04
Steam Generator Blow Down (Unit 2)	RE-23 (U2)	0 04
Miscellaneous	none	0 01

An additional level of conservatism in the HASP methodology is implemented by the use of a Safety Factor (SF). The Safety Factor is defined as 0 9 and provides for a High Alarm Set Point at 90% of the 10 CFR 20 concentration limits.

c Tritium Correction Factor

As result of an aggressive liquid radwaste treatment program, the liquid effluents at DCPH typically contain very low levels of gamma emitters. In order to reduce the over all volume of liquid waste discharged, DCPH also recycles waste water. This recycling results in higher tritium concentration in liquid effluents when compared with the low gamma emitter concentrations. As a result, standard HASP methodology results in very low set points. In some cases the calculated set points are barely above the monitor background.

The liquid HASP methodology used by DCPH uses a Tritium Correction Factor (TCF) which assumes a constant, but conservative tritium concentration in the liquid effluent. This results in an operationally reasonable set point while ensuring that the liquid effluent concentrations released to the unrestricted areas do not exceed the limits of 10 CFR 20.

The Tritium Correction Factor is defined as shown in Equation 7

$$TCF = \left[ 1 - \left( \frac{C_{H3}/ECL_{H3}}{F/f} \right) \right] \quad (7)$$

Where

- $ECL_{H3}$  = effluent concentration limit of tritium  
 $C_{H3}$  = concentration of tritium in the release mix, pre-dilution ( $\mu\text{Ci/ml}$ )  
 $F$  = conservative dilution flow rate (gpm)  
 $f$  = conservative undiluted effluent flow rate (gpm)

The concentration of tritium,  $C_{H3}$ , is conservatively estimated

d Liquid Effluent Radiation Monitor Set Point Calculations

The High Alarm Set Point (HASP) are calculated to ensure that the liquid effluent concentration limits of 10 CFR 20 are not exceeded. The set points represent the maximum operational set point. The actual set point used by operations will be equal to or less than the actual value as determined by the HASP methodology described in this section.

1 Set Point Methodology for RE-3 HASP Oily Water Separator

Under normal conditions, the Oily Water Separator stream does not contain any radioactive material. Only in the event that there is primary to secondary leakage does this become a potential liquid effluent discharge point. In order to insure that no unplanned or unmonitored releases take place by way of the Oily Water Separator, RE-3 serves to monitor the discharge even when no activity has been identified in the effluent. When no significant primary to secondary leakage is taking place or when no activity has been identified in the Oily Water Separator, the High Alarm Set Point for RE-3 is calculated as shown in Equation 8.

$$HASP_{RE-3} = 3 \times BKGD_{RE-3} \quad (8)$$

In the event that primary to secondary leakage results in activity being detected in the Oily Water Separator, Equation 9 will be used to calculate a High Alarm Set Point value. The greater HASP value as determined by Equation 8 or Equation 9 will be used.

$$HASP_{RE-3} = BKGD_{RE-3} + (AF)(SF) \times \sum_{\gamma} k_{\gamma} C_{\gamma} \left[ \frac{F/f}{\sum_{i \neq H3} C_i / ECL_i} \right] \times TCF \quad (9)$$

Where

- HASP<sub>RE-3</sub> = high alarm setpoint for RE-3 (cpm)
- BKGD<sub>RE-3</sub> = background reading for RE-3 (cpm)
- (AF) = allocation factor for the oily water separator effluent system from Table 6.1
- (SF) = safety factor for RE-3 (0.9)
- k<sub>γ</sub> = monitor response factor (cpm/μCi/ml)
- C<sub>γ</sub> = concentration of gamma emitting isotopes in the release mix, pre-dilution (μCi/ml)
- F = dilution flow rate (gpm)
- f = undiluted effluent flow rate (gpm)
- C<sub>i</sub> = concentration of isotope "i," in the release mix, pre-dilution (μCi/ml)
- ECL<sub>i</sub> = effluent concentration limit of isotope "i"
- TCF = tritium correction factor as defined by Equation 7

2 Set Point Methodology for RE-18 HASP Liquid Radwaste System

The High Alarm Set Point for the RE-18 Liquid Radwaste System liquid effluent radiation monitor is calculated as shown in Equation 10

$$HASP_{RE-18} = BKGD_{RE-18} + (AF)(SF) \times \sum_{\gamma} k_{\gamma} C_{\gamma} \left[ \frac{F/f}{\sum_{i \neq H3} C_i / ECL_i} \right] \times TCF \quad (10)$$

Where

$HASP_{RE-18}$  = high alarm setpoint for RE-18 (cpm)

$BKGD_{RE-18}$  = background reading for RE-18 (cpm)

(AF) = allocation factor for the liquid radwaste effluent system from Table 6.1

(SF) = safety factor for RE-18 (0.9)

$k_{\gamma}$  = monitor response factor (cpm/ $\mu$ Ci/ml)

$C_{\gamma}$  = concentration of gamma emitting isotopes in the release mix, pre-dilution ( $\mu$ Ci/ml)

F = dilution flow rate (gpm)

f = undiluted effluent flow rate (gpm)

$C_i$  = concentration of isotope "i," in the release mix, pre-dilution ( $\mu$ Ci/ml)

$ECL_i$  = effluent concentration limit of isotope "i"

TCF = tritium correction factor as defined by Equation 7

TITLE Off-Site Dose Calculations

3 Set Point Methodology for RE-23 HASP Steam Generator  
 Blowdown Tank

The High Alarm Set Point for the RE-23, Steam Generator  
 Blowdown Tank liquid effluent radiation monitor, is calculated as  
 shown in Equation 11

$$HASP_{RE-23} = BKGD_{RE-23} + (AF)(SF) \times \sum_{\gamma} k_{\gamma} C_{\gamma} \left[ \frac{F/f}{\sum_{i \neq H3} C_i / ECL_i} \right] \times TCF \quad (11)$$

Where

$HASP_{RE-23}$  = high alarm setpoint for RE-23 (cpm)

$BKGD_{RE-23}$  = background reading for RE-23 (cpm)

(AF) = allocation factor for the steam generator  
 blowdown effluent system for each unit from  
 Table 6.1

(SF) = safety factor for RE-23 (0.9)

$k_{\gamma}$  = monitor response factor (cpm/ $\mu$ Ci/ml)

$C_{\gamma}$  = concentration of gamma emitting isotopes in  
 the release mix, pre-dilution ( $\mu$ Ci/ml)

F = dilution flow rate (gpm)

f = undiluted effluent flow rate (gpm)

$C_i$  = concentration of isotope "i," in the release  
 mix, pre-dilution ( $\mu$ Ci/ml)

$ECL_i$  = effluent concentration limit of isotope "i"

TCF = tritium correction factor as defined by  
 Equation 7

6 1 4 Dose Projection (for Liquid Effluents)

The projected dose contributions from each reactor unit due to liquid effluents for the current calendar month, quarter and current calendar year must be determined in accordance with the methodology and parameters in the ODCP at least once per 31 days

The purpose of this is to determine if appropriate treatment of liquid radioactive materials in relation to maintaining releases "as low as reasonably achievable," is necessary

The projected dose from each reactor unit is given by

$$D_P = D_{P U} + \frac{1}{2} D_{P Com} \quad (12)$$

Where

- $D_P$  = Projected Dose
- $D_{P U}$  = Projected dose attributed to reactor unit, U
- $D_{P Com}$  = Projected dose common to both reactor units

The 31-day projected dose is calculated by Equation 13

$$D_P^M = 31 \times \frac{D_A^{PM} + d_A^{CM} + d_P^{CB}}{(T + t)} \quad (13)$$

Where

- $D_P^M$  = Monthly Projected Dose
- $D_A^{PM}$  = Previous Month's Actual Dose
- $d_A^{CM}$  = Current Month Actual Dose to date
- $d_P^{CB}$  = Projected Dose from Current Batch Release
- T = Number of days in the previous month
- t = Number of days into the present month

TITLE Off-Site Dose Calculations

Projected quarterly doses are determined by Equation 14

$$D_P^{CQ} = d_A^{CQ} + (92 - t) \frac{D_A^{PQ} + d_A^{CQ} + d_P^{CB}}{(T + t)} \quad (14)$$

Where

$D_P^{CQ}$  = Projected dose for the current calendar quarter

$d_A^{CQ}$  = Current quarter to date actual dose

$D_A^{PQ}$  = Previous quarter's actual dose

$d_P^{CB}$  = Projected dose as a result of the current batch release

T = Number of days in the previous quarter

t = Number of days into the present quarter

Projected yearly doses are determined by Equation 15

$$D_P^{CY} = d_A^{CY} + (366 - t) \frac{D_A^{PY} + d_A^{CY} + d_P^{CB}}{(T + t)} \quad (15)$$

Where

$D_P^{CY}$  = Projected dose for the current calendar year

$d_A^{CY}$  = Current year to date actual dose

$D_A^{PY}$  = Previous year's actual dose

$d_P^{CB}$  = Projected dose as a result of the current batch release

T = Number of days in the previous year

t = Number of days into the present year

6 1 5 Liquid Limiting Flow Rate Methodology - ECL Based

The maximum effluent flow rate through monitors RE-3, RE-18, and RE-23 as well as for releases from the Condensate Demineralizer Regenerate waste tank or miscellaneous release points is established in order to provide further control over the effluent releases. The release rate limit is determined by the effluent concentration and the 10 CFR 20 Effluent Concentration Limits (ECLs) as shown in Equation 16

$$f = \frac{F(AF)(SF)(TCF)}{\sum_{i=H-3} \frac{C_i}{ECL_i}} \quad (16)$$

Where

- f = Maximum operational undiluted liquid radwaste effluent discharge flow rate (gpm)
- F = Expected dilution flow rate (gpm)
- AF = allocation factor for the liquid radwaste effluent source from Table 6 1
- SF = safety factor (0 9)
- TCF = tritium correction factor as defined by Equation 7
- C<sub>i</sub> = concentration of isotopes "i" in the release mix, pre-dilution (μCi/ml)
- ECL<sub>i</sub> = effluent concentration limit of isotope "i" (μCi/ml)

When the term  $\sum_{i=H-3} \frac{C_i}{ECL_i} = 0$  then the Limiting Flow Rate is calculated by

$$f = F(AF)(SF)(TCF) \quad (17)$$

Where the terms are as previously defined



TITLE Off-Site Dose Calculations

6 1 6 Liquid Limiting Flow Rates - LLD Based

When there is no primary to secondary leakage, the Oily Water Separator and various miscellaneous release points are assumed to be uncontaminated. Furthermore, in order to establish practical operational flow rate limits for any sources when they are considered uncontaminated, Equation 18 is used. While no activity may be present, Equation 18 assumes a concentration equal to the Lower Limit of Detection for the nuclides listed in CY2 ID1, Appendix 6 1, Table 6 1 3-1.

$$f = \frac{F(AF)(SF)}{4.3} \quad (18)$$

Where

- f = Maximum operational undiluted liquid radwaste effluent discharge flow rate (gpm)
- F = Expected dilution flow rate (gpm)
- AF = allocation factor for the liquid radwaste effluent source from Table 6 1
- SF = safety factor (0.9)
- 4.3 = Total ECL fraction as given by

$$\sum_i \frac{LLD_i}{ECL_i}$$

Where

- LLD<sub>i</sub> = Lower limit of detection for isotope "i" from CY2 ID1, Appendix 6 1, Table 6 1 3-1 (μCi/ml)
- ECL<sub>i</sub> = effluent concentration limit of isotope "i" (μCi/ml)

TITLE Off-Site Dose Calculations

---

6 1 7 Unplanned Liquid Releases (Abnormal Releases)

An unplanned release is an unexpected and potentially unmonitored release to the environment due to operational error or equipment malfunctions

- a Unmonitored unplanned releases shall have a report written by the Radiochemistry Effluents Engineer describing the event with a calculation, if possible, of the percent of Tech Spec release rate limit. This will then be forwarded to PSRC for review. Describe these unplanned releases in the Annual Radioactive Effluent Release Report.
- b Monitored unplanned releases which exceed 1% of the RECP release rate limit will also have a report written describing the event and must be forwarded to the PSRC for review. Describe these unplanned releases in the Annual Radioactive Effluent Release Report.

6 2 Gaseous Effluents

The only significant path for gaseous radioactive releases to the environment during normal operations is via the plant vent. This source is used for calculating dose rates and real-time doses to the unrestricted area due to noble gases, vaporous radioiodines and airborne radio-particulates. The plant vent also has redundant monitoring for these types of gaseous releases.

Other paths such as the steam generator blowdown tank vent, the chemistry lab fume hood, the main condenser Nash vacuum pump discharge, hot machine shop vent, etc., are considered miscellaneous release sources. These miscellaneous release sources are not continuously monitored but can have dose rates and dose calculated for their path to the unrestricted area.

6 2 1 Meteorological Methodology

The equations for determining gaseous effluent concentration limits, high alarm setpoints, dose rates, and critical receptor doses make use of the historical average atmospheric conditions in accordance with methodologies of Regulatory Guides 1 109 and 1 111 and NUREGs 0133 and 0472. The historical average dispersion ( $\chi/Q$ ) and deposition ( $D/Q$ ) values are derived from the methodology of Regulatory Guide 1 111 as implemented by NUREG 2919 (computer code XOQDOQ). The DCPD dispersion and deposition values are based on the latest five years of meteorological data and are updated when the value of  $\chi/Q$  or  $D/Q$  changes by more than ten percent. The present values are listed in Table 10 2.

Long-term releases are characterized as those that are generally continuous and stable in release rate, such as normal ventilation systems effluents. Doses due to long-term releases are modeled using historical annual average dispersion and deposition values in accordance with the guidance of Regulatory Guide 1 109, Regulatory Guide 1 111, NUREG 0133 and NUREG 0472.

Short-term releases are defined as those which occur for a total of 500 hours or less in a calendar year but not more than 150 hours in any quarter. In accordance with NUREG 0133 and based upon an operational history that has demonstrated short term gaseous releases can be characterized as random in both time of day and duration, historical average atmospheric dispersion and deposition values are used to model doses due to short-term releases.

6 2 2 Gas Effluent Concentration Limits

a Philosophy of Concentration Limits

The radiological effluent controls restrict at all times the dose rate due to radioactive materials released in gaseous effluents from the site to areas at or beyond the site boundary for noble gases to less than or equal to 500 mrem/yr to the total body and 3000 mrem/yr to the skin. For iodine-131, iodine-133, tritium and for all radionuclides in particulate form with half-lives greater than 8 days, the dose rate is limited to less than or equal to 1500 mrem/yr. to any organ.

These dose rate limits act to restrict at all times the instantaneous concentrations of radionuclides in gaseous effluents at the site boundary.

1 Allocation and Safety Factors

The limits set forth by RECP 6 1 6 1 are site limits which require that the set point methodology must ensure simultaneous releases do not exceed the off-site dose rate limits set forth by RECP 6 1 6 1(a) and 6 1 6 1(b). The DCP High Alarm Set Point methodology makes use of an Allocation Factor (AF) to limit the noble gas effluent dose rate from simultaneous atmospheric releases.

The Allocation Factors can be adjusted based upon operational requirements with the following restrictions:

- The sum of the Allocation Factors for RE-14 (plant vent noble gas monitor), the SGBD tank vents, and miscellaneous release points from both units must be less than or equal to 1.
- The Allocation Factors for RE-22 (Waste Gas Decay Tanks) and RE-44 (Containment Purge) can also be adjusted based upon operational requirements with restriction that the sum of the Allocation Factors for RE-22 and RE-44 must be less than or equal to the Allocation Factor for RE-14.
- The Allocation Factors for RE-24 (Plant Vent Iodine Monitor) and RE-28 (Plant Vent Particulate Monitor) are set equal to the Allocation Factor for RE-14.

TITLE Off-Site Dose Calculations

Typical Allocation Factors are shown

Table 6 2

Typical Gaseous Effluent Discharge Pathway Allocation Factors

Discharge Pathway	Rad Monitor	Allocation Factor (AF)
Plant Vent - NG Monitor	RE-14	0 48
Plant Vent Iodine Monitor	RE-24	0 48
Plant Vent Part Monitor	RE-28	0 48
Waste Gas Decay Tank	RE-22	0 10
Containment Purge	RE-44	0 38
SGBD Tank Vent		0 01
Miscellaneous		0 01

An additional level of conservatism in the HASP methodology is implemented by the use of a Safety Factor (SF) The Safety Factor is defined as 0 9 and provides for a High Alarm Set Point at 90% of the dose rate limits

b Gaseous Effluent Radiation Monitor Set Points

1 PLANT VENT NOBLE GAS MONITOR - RE-14 HASP

The Plant Vent effluent stream is monitored by rad monitor RE-14  
 RE-14 provides alarm function only

The High Alarm Set Point methodology for RE-14 is given by  
 Equation 19, which is based upon the assumption that the total body  
 dose rate limit is most limiting

$${}^{14\text{Max}}C_T(\text{NG}) = AF \times SF \times \frac{500}{472 \times F_{pv} \times (\overline{\chi/Q})_{\text{Max}} \times 294} \quad (19)$$

Where

- ${}^{14\text{Max}}C_T(\text{NG})$  = the maximum allowable total concentration of noble gas in the plant vent, in  $\mu\text{Ci/cc}$
- AF = the allocation factor for the plant vent for one unit from Table 6 2
- SF = a safety factor to ensure that dose rate limits of the radiological effluent controls are not exceeded (0 9)
- 500 = (mrem/yr) the site Total Body dose rate limit for instantaneous releases
- 472 = the conversion constant to cc/sec from cfm
- $F_{pv}$  = total flow rate in the plant vent, in cfm (maximum plant vent flow rate is 263,000 cfm)
- $(\overline{\chi/Q})_{\text{Max}}$  = the maximum historical site boundary dispersion factor, based on 5 year averages derived from the meteorological data base, from Table 10 2
- 294 = the whole body dose factor (mrem/yr/ $\mu\text{Ci/m}^3$ ) for Xe-133 as presented in Table 10 3, (for the plant vent HASP, the release is assumed to be all Xe-133)

2 PLANT VENT NOBLE GAS MONITOR - RE-14 SCALING

In order to correlate the readings of RE-14 to noble gas concentration during periods between samplings, the concentration is scaled according to Equation 20

$$C_T = \frac{CPM_T}{CPM_S} \times C_S \quad (20)$$

Where

$CPM_T$  = RE-14 time weighted arithmetic mean (cpm)

$CPM_S$  = RE-14 gross count rate at the time of sampling (cpm)

$C_S$  = Concentration of noble gas corresponding to  $CPM_S$ , based upon noble gas grab sample ( $\mu\text{Ci/cc}$ )

$C_T$  = Scaled concentration of noble gas ( $\mu\text{Ci/cc}$ )

3 PLANT VENT IODINE MONITOR - RE-24

The Plant Vent Iodine concentration is monitored by rad monitor RE-24. RE-24 provides alarm function only. The alarm setpoint methodology is based upon the assumption that RE-24 responds only to I-131. The methodology also presumes a release mixture based upon the RCS source term.

The High Alarm Set Point methodology of RE-24 is given by Equation 21

$${}^{24\text{Max}}C_T(\text{Iodine}) = SF \times AF \times f_{I-131} \frac{1500}{472 \times F_{pv} \times (\chi/Q)_{\text{Max}} \sum_i P_i^w f_i} \quad (21)$$

Where

${}^{24\text{Max}}C_T(\text{Iodine})$  = the maximum allowable concentration of I-131 in the plant vent

AF = The allocation factor for the plant vent for one unit from Table 6.2

SF = A safety factor to insure that the dose rate limits of the radiological effluent controls are not exceeded (0.9)

$f_{I-131}$  = fraction of the total non-noble gas concentration that is due to I-131. Defined as

$$f_{I-131} = \frac{C_{I-131}}{\sum_i C_i} \quad (22)$$



TITLE Off-Site Dose Calculations

1500 = (mrem/yr) the site organ dose rate limit for Iodine-131, for Iodine-133, for tritium, and for all radioactive materials in particulate form with half-lives greater than 8 days

472 = the conversion constant to cc/sec from cfm

$F_{pv}$  = total flowrate in the plant vent, in cfm (maximum plant vent flowrate is 263,000 cfm)

$(\overline{x/Q})_{Max}$  = maximum historical site boundary dispersion factor, based on 5 year averages derived from the meteorological database, from Table 10 2

$P_i^w$  = Inhalation dose factor for nuclide "i" (mrem/yr/ $\mu\text{Ci}/\text{m}^3$ ) for child age group for worst case organ, from Table 10 4 Dose factors are based upon NUREG 0133 methodology Inhalation dose conversion factors are taken from Reg Guide 1 109, Rev 1, Table E-9, with the following exceptions H-3, Sb-124 and Sb-125 inhalation dose conversion factors taken from NUREG/CR-4013

$f_i$  = fraction of total non-noble gas concentration (excluding tritium) that is due to nuclide, i, and defined as

$$f_i = \frac{C_i}{\sum_i C_i} \quad (23)$$

4 PLANT VENT PARTICULATE MONITOR - RE-28

The Plant Vent Particulate concentration is monitored by rad monitor RE-28. The alarm setpoint methodology is based upon the assumption of a 5% cross talk from the iodine channel. This is due to the retention of a small portion of iodine on the particulate filter. A release mixture based upon the RCS source term is also assumed.

The High Alarm Set Point methodology for RE-28 is given by Equation 24

$$\begin{aligned}
 {}^{28\text{Max}}C_T(\text{Particulates}) = & AF \times SF \times \left( 0.05 \times \sum_{\text{Iodines}} f_{\text{Iodines}} + \sum_{\text{Particulates}} f_{\text{Particulates}} \right) \\
 & \times \frac{1500}{472 \times F_{pv} \times (\chi/Q)_{\text{Max}} \sum_i P_i^w f_i} \quad (24)
 \end{aligned}$$

Where

- ${}^{28\text{Max}}C_T(\text{Particulate})$  = Maximum allowable particulate concentration in the plant vent
- AF = The allocation factor for the plant vent for one unit from Table 6.2
- SF = A safety factor to insure that the dose rate limits of the radiological effluent controls are not exceeded (0.9)
- 0.05 = Fraction of total iodine activity retained on particulate filter
- $f_{\text{Iodines}}$  = Fraction of the total non-noble gas concentration that is due to iodines
- $f_{\text{Particulates}}$  = Fraction of the total non-noble gas concentration that is due to particulates
- 1500 = (mrem/yr) the site organ dose rate limit for Iodine-131, for Iodine-133, for tritium, and for all radioactive materials in particulate form with half-lives greater than 8 days
- 472 = Conversion constant to cc/sec from cfm
- $F_{pv}$  = Total flowrate in the plant vent, in cfm (maximum plant vent flowrate is 263,000 cfm)

TITLE Off-Site Dose Calculations

$(\overline{\chi/Q})_{Max}$  = Maximum historical site boundary dispersion factor, based on 5 year averages derived from the meteorological database, from Table 10 2

$P_1^w$  = Inhalation dose factor for nuclide "1" (mrem/yr/ $\mu\text{Ci}/\text{m}^3$ ) for child age group for worst case organ, from Table 10 4 Dose factors are based upon NUREG 0133 methodology Inhalation dose conversion factors are taken from Reg Guide 1 109, Rev 1, Table E-9, with the following exceptions H-3, Sb-124 and Sb-125 inhalation dose conversion factors taken from NUREG/CR-4013

$f_1$  = Fraction of total non-noble gas concentration (excluding tritium) that is due to nuclide, 1, as defined by Equation 23

5 WASTE GAS DECAY TANK MONITOR - RE-22 HASP

Effluent releases from the Waste Gas Decay Tank are monitored by rad monitor RE-22. RE-22 provides alarm and automatic release termination functions.

The High Alarm Set Point methodology for RE-22 is given by Equation 25, which is based upon the assumption that the skin dose rate limit is most limiting.

$${}^{22\text{Max}}C_T(\text{NG}) = AF \times SF \times \frac{3000}{472 \times F_{\text{gd}} \times (\overline{\chi/Q})_{\text{Max}} \times 1.34 \times 10^3} \quad (25)$$

Where

- ${}^{22\text{Max}}C_T(\text{NG})$  = the maximum allowable total concentration of noble gas in the gas decay tank exhaust line, in  $\mu\text{Ci/cc}$
- AF = the allocation factor for the waste gas decay tank for one unit from Table 6.2
- SF = safety factor to ensure that dose rate limits of the radiological effluent controls are not exceeded (0.9)
- 3000 = (mrem/yr) the site skin dose rate limit for instantaneous releases
- 472 = the conversion constant to cc/sec from cfm
- $F_{\text{gd}}$  = maximum flow rate for the gas decay tank system (31 cfm)
- $(\overline{\chi/Q})_{\text{Max}}$  = the maximum historical site boundary dispersion factor, based on 5 year averages derived from the meteorological data base from Table 10.2
- $1.34 \times 10^3$  = the skin dose factor for Kr-85 (mrem/yr/  $\mu\text{Ci/m}^3$ , from Table 10.3)

6 CONTAINMENT PURGE - RE-44 HASP

The Containment Purge is monitored by rad monitor RE-44 RE-44 provides alarm and automatic release termination functions.

The HASP for RE-44 must limit the noble gas dose rate for skin and total body exposure. In order to address this, two set points are calculated. One set point is calculated based upon limiting the total body dose rate and the other limits the skin dose rate. The more limiting set point is used. The High Alarm Set Point methodology for RE-44 is given by Equations 26 and 27.

a) Limiting Concentration Based on Total Body Dose

$${}^{44A/B}C_T(NG) = AF \times SF \times \frac{500}{472 \times F_{ct} \times (\overline{\chi/Q})_{Max} \times \sum K_i f_i} \quad (26)$$

Where

- ${}^{44A/B}C_T(NG)$  = the maximum allowable total concentration of noble gas in the containment purge exhaust line, in  $\mu Ci/cc$
- AF = the allocation factor for the containment purge for one unit from Table 6.2
- SF = safety factor to ensure that dose rate limits of radiological effluent controls are not exceeded (0.9)
- 500 = (mrem/yr) the site Total Body dose rate limit for instantaneous releases
- 472 = the conversion constant to cc/sec from cfm
- $F_{ct}$  = maximum flow rate in the containment purge system (maximum containment purge flowrate is 55,000 cfm)
- $(\overline{\chi/Q})_{Max}$  = the maximum historical site boundary dispersion factor, based on 5 year averages derived from the meteorological data base averages, from Table 10.2

TITLE Off-Site Dose Calculations

$K_i$  = whole body dose factor (mrem/yr/ $\mu\text{Ci}/\text{m}^3$ ) for isotope "i" Dose factors are presented in Table 10 3

$f_i$  = the fraction of the concentration of the individual noble gas radionuclide, "i," in the total mix of noble gas effluents in the containment purge line

b) Limiting Concentration Based on Skin Dose

Skin dose should be calculated whenever an RCS sample contains a significant fraction of Kr-85

The concentration limit calculated by this method should then be compared to the concentration limit calculated for total body dose The smaller concentration should be selected as the limiting concentration for the HASP

$${}^{44}\text{A}/\text{BMax} C_T(\text{NG}) = \text{AF} \times \text{SF} \times \frac{3000}{472 \times F_{ct} \times (\overline{\chi/Q})_{\text{Max}} \times \sum (L_i + 1 M_i) f_i} \quad (27)$$

Where

${}^{44}\text{A}/\text{BMax} C_T(\text{NG})$  = the maximum allowable total concentration of noble gas in the plant vent in  $\mu\text{Ci}/\text{cc}$

AF = the allocation factor for the containment purge for one unit from Table 6 2

SF = safety factor to ensure that dose rate limits of the radiological effluent controls are not exceeded (0 9)

3000 = (mrem/yr) the site skin dose rate limit for instantaneous releases

472 = the conversion constant to cc/sec from cfm

$F_{ct}$  = total flow rate in the containment purge system, in cfm (maximum containment purge flow rate is 55,000 cfm)

$(\overline{\chi/Q})_{\text{Max}}$  = the maximum historical site boundary dispersion factor, based on 5 year averages derived from the meteorological data base averages, from Table 10 2

TITLE Off-Site Dose Calculations

- 
- $L_i$  = the skin dose factor (mrem/yr per  $\mu\text{Ci}/\text{m}^3$ ) for isotope "i" Dose factors are presented in Table 10.3
- $I_i$  = Conversion factor mrem/mrad Converts air dose to skin dose
- $M_i$  = the gamma air dose factor (mrad/yr per  $\mu\text{Ci}/\text{m}^3$ ) for isotope "i" Dose factors are presented in Table 10.3
- $f_i$  = the fraction of the concentration of the individual noble gas radionuclide, "i," in the total mix of noble gas effluents in the containment purge line

c Mode 6 Particulate activity

The HASP calculation specified in this section based upon Noble Gas effluent limitations conservatively bounds the Tech Spec requirement for particulate activity in Mode 6. The FSAR expected case accident for Mode 6 is a containment fuel handling accident which does not include a particulate release. Therefore, the HASP for RM-44 in this section conservatively satisfies the Tech Spec (Ref. 8.15).

TITLE Off-Site Dose Calculations

6 2 3 Gaseous Dose Rate Calculation Methodology

a Total Body Noble Gas Dose Rate Methodology

The dose rate to the total body due to immersion in a cloud of noble gases is given by

$$\left(\overline{\chi/Q}\right)_{Max} \sum_1 K_i Q_i \leq 500 \text{ mrem/year} \quad (28)$$

Where

$Q_i$  = The release rate of radionuclide  $i$  in units of  $\mu\text{Ci}/\text{sec}$

All other terms are as previously defined

b Skin Dose Rate Methodology

The dose rate to the skin due to immersion in a cloud of noble gases is given by

$$\left(\overline{\chi/Q}\right)_{Max} \sum_1 (L_i + 1 M_i) Q_i \leq 3000 \text{ mrem/year} \quad (29)$$

Where the terms are as previously defined



TITLE Off-Site Dose Calculations

c Radioiodine, Tritium and Particulate Dose Rate Methodology

The dose rate to organ, o, due to radioiodines, tritium and particulates released in gaseous effluents is given by

$$\left(\frac{\chi}{Q}\right)_{Max} \sum P_{i0} Q_i \leq 1500 \text{ mrem/year} \quad (30)$$

Where

$$P_{i0} = K'(BR)DFA_{i0}$$

and

$$K' = 10^6 \rho C_1 / \mu C_1$$

BR = The breathing rate of the a child age group in m<sup>3</sup>/yr  
The default value of 3700 m<sup>3</sup>/yr is taken from Table E-5 of Reg Guide 1 109

DFA<sub>i</sub> = The inhalation dose factor for organ o, for the child age group for radionuclide, i, from Table E-9 of Reg Guide 1 109 in mrem/ρC<sub>1</sub>, with the following exceptions H-3, Sb-124 and Sb-125 inhalation dose conversion factors taken from NUREG/CR4013

All other terms are as previously defined

Values for P<sub>i0</sub> are listed in Table 10 6

TITLE Off-Site Dose Calculations

6 2 4 Noble Gas Air Dose Calculation Methodology

a Gamma Air Dose

The gamma air dose due to immersion in a cloud of noble gases is given by

$$D_{ay} = 3.17 \times 10^{-8} (\overline{\lambda/Q})_{Max} \sum_1 M_i \tilde{Q}_i \quad (31)$$

Where

$D_{ay}$  = Gamma air dose in mrad

$3.17 \times 10^{-8}$  = Conversion constant yr/sec

$M_i$  = Gamma air dose factor for nuclide  $i$ , in mrad/yr per  $\mu\text{Ci}/\text{m}^3$ . Values are listed in Table 10.3

$\tilde{Q}_i$  = Total release of noble gas radionuclide,  $i$ , in  $\mu\text{Ci}$

All other terms are as previously defined

b Beta Air Dose

The beta air dose due to immersion in a cloud of noble gases is given by

$$D_{a\beta} = 3.17 \times 10^{-8} (\overline{\lambda/Q})_{Max} \sum_1 N_i \tilde{Q}_i \quad (32)$$

Where

$D_{a\beta}$  = Beta air dose in mrad

$N_i$  = Beta air dose factor for nuclide  $i$ , in mrad/yr per  $\mu\text{Ci}/\text{m}^3$ . Values are listed in Table 10.3

All other terms are as previously defined

6 2 5 Dose To Critical Receptor Due To Radioiodines, Tritium and Particulates Released in Gaseous Effluents

a Calculation Methodology

The dose to an individual (critical receptor) due to radioiodines, tritium and particulates released in gaseous effluents with half-lives greater than 8 days is determined based upon the methodology described in NUREG 0133. This methodology makes use of the maximum individual concept described in Regulatory Guide 1.109. The maximum individual is characterized as maximum with regard to food consumption, occupancy, and other usage parameters. This concept therefore models those individuals within the local population with habits representing reasonable deviations from the average. In all physiological and metabolic respects, the maximum individual is assumed to have those characteristics that represent the average for the age group of interest.

The concept of critical receptor is introduced as a further refinement of the maximum individual. The critical receptor is defined as that individual that receives the largest dose based upon the combination of dose pathways that have been shown to actually exist. The critical receptor concept is applied at that location where the combination of dispersion ( $\chi/Q$ ), deposition ( $D/Q$ ), existing pathways, occupancy time, receptor age group, and effluent source term indicates the maximum potential exposure. The inhalation and ground plane exposure pathways are considered to exist at all locations. The grass-cow-milk, grass-cow-meat, and vegetation pathways are considered based on their actual existence in the vicinity of the plant.

The dose pathways that have been shown to actually exist at DCP are the ground plane, inhalation and the vegetation pathways. These dose pathways are reviewed yearly and updated based upon the annual land use census survey in order to insure that actual exposure to an individual will not be substantially underestimated.

The locations of the pathways and descriptions are listed in Table 10.2.

b Dose Calculation

The dose contributions to the total body and each individual organ (bone, liver, thyroid, kidney, lung and GI-LLI) of the maximum exposed individual (Critical Receptor) due to radioactive gaseous effluent releases is calculated for all radionuclides identified in gaseous effluents released to unrestricted areas using the following expression

$$D_{apo} = 3.17 \times 10^{-8} \bar{W}_{CR} \sum_i R_{aipo} \tilde{Q}_i \quad (33)$$

Where

$D_{apo}$  = Dose to the critical receptor for age group a, pathway p, and organ o, in mrem

$\bar{W}_{CR}$  = Critical receptor  $\bar{\chi}/\bar{Q}$  for immersion, inhalation and all tritium pathways (seconds/m<sup>3</sup>) from Table 10.2

= Critical receptor  $\bar{D}/\bar{Q}$  for ground plane and all ingestion pathways (1/m<sup>2</sup>) from Table 10.2

$R_{aipo}$  = Site specific dose factor for age group a, radionuclide i, pathway p, and organ j (mrem/yr per  $\mu\text{Ci}/\text{m}^3$  for inhalation and tritium pathways - mrem/yr per  $\mu\text{Ci}/(\text{sec m}^2)$  for ground plane and ingestion pathways) These dose factors are listed in Table 10.6

The site specific dose factors are calculated based upon NUREG 0133 methodology. All dose conversion factors are taken from Reg. Guide 1.109, Rev. 1, Tables E6-E14, with the following exceptions: H-3, Sb-124 and Sb-125 dose conversion factors taken from NUREG/CR-4013.

$\tilde{Q}_i$  = The total release of radionuclide i, in units of  $\mu\text{Ci}$

TITLE Off-Site Dose Calculations

6 2 6 Noble Gas Gaseous Radioactive Waste (GRW) Batch Release Percent Release Rate Limits (PRRLs) and Expected Reading (ER)

The Percent Release Rate Limit (PRRL) for noble gas releases for each unit is calculated based upon the 500 mrem/yr whole body dose rate limit, and is given by Equation 34

$$PRRL = \frac{(\overline{\chi/Q})_{Max} \sum K_i Q_i}{(0.48)(500 \text{ mrem/yr})} \times 100\% \quad (34)$$

Where

$(\overline{\chi/Q})_{Max}$  = The maximum site boundary dispersion factor based on 5 year averages from Table 10 2

$K_i$  = Whole body dose factor (mrem/yr per  $\mu\text{Ci}/\text{m}^3$ ) for isotope "i" Dose factors are presented in Table 10 3

$Q_i$  = Total release rate of isotope "i" from all sources discharged through this release point in  $\mu\text{Ci}/\text{sec}$

0.48 = Plant vent allocation factor for one unit from Table 6 2

500 mrem/yr = Site noble gas dose rate limit

The Expected Reading (ER) is the anticipated monitor response based upon the known plant vent concentration and the monitor response factors. The Expected Readings for RE-22, RE-44, RE-14 are given by Equations 35, 36, and 37

$$ER_{(RE-22)} = BKG_{(RE-22)} + \sum_i k_{(RE-22),i} C_{(RE-22),i} \quad (35)$$

Where

- $ER_{(RE-22)}$  = Expected reading on monitor RE-22 in  $\mu\text{Ci/cc}$
- $BKG_{(RE-22)}$  = Monitor background
- $k_{(RE-22),i}$  = Noble gas monitor response factor for nuclide "i" for monitor RE-22
- $C_{(RE-22),i}$  = Concentration of nuclide "i" seen by RE-22

$$ER_{(RE-44)} = BKG_{(RE-44)} + CCSP_{(RE-44)} \sum_i k_{(RE-44),i} C_{(RE-44),i} \quad (36)$$

Where

- $ER_{(RE-44)}$  = Expected reading on monitor RE-44 in  $\mu\text{Ci/cc}$
- $BKG_{(RE-44)}$  = Monitor background
- $CCSP_{(RE-44)}$  = Conversion constant setpoint for monitor RE-44
- $k_{(RE-44),i}$  = Noble gas monitor response factor for nuclide "i" for monitor RE-44
- $C_{(RE-44),i}$  = Concentration of nuclide "i" seen by monitor RE-44

$$ER_{(RE-14)} = BKG_{(RE-14)} + CCSP_{(RE-14)} \sum_i k_{(RE-14),i} C_{(RE-14),i} \quad (37)$$

Where

- $ER_{(RE-14)}$  = Expected reading on monitor RE-14 in  $\mu\text{Ci/cc}$
- $BKG_{(RE-14)}$  = Monitor background
- $CCSP_{(RE-14)}$  = Conversion constant setpoint for monitor RE-14

$k_{(RE-14)_i}$  = Noble gas monitor response factor for nuclide "i" for monitor RE-14

$C_{(RE-14)_i}$  = Concentration of nuclide "i" seen by monitor RE-14

Generally if the Expected Reading (ER) is greater than the existing HASP setting (an "administrative limit" as set by CY2 DC1) then no release should be made until a calculation shows that the HASP (Admin Limit) can be raised so the release can be legally discharged. On the other hand should the ER be less than the existing HASP (Admin Limit), then the release can be discharged.

6 2 7 IPT - PRRL

The Percent Release Rate Limit (PRRL) for radioiodines, tritium and particulates for each unit is calculated based upon the 1500 mrem/yr organ dose rate limit. The dose rate is calculated for the inhalation pathway to the child age group using the highest (worst case) organ dose factor for nuclide. The Percent Release Rate Limit based on the worst case organ is given by Equation 38.

$$PRRL_o = \frac{(\overline{\chi/Q})_{Max} \sum_i P_i^w Q_i}{(0.48)(1500 \text{ mrem/yr})} \times 100\% \quad (38)$$

Where

$(\overline{\chi/Q})_{Max}$  = The maximum site boundary dispersion factor based on 5 year averages from Table 10.2

$P_i^w$  = Inhalation dose factor for nuclide "i" (mrem/yr/ $\mu\text{Ci}/\text{m}^3$ ) for child age group for worst case organ, from Table 10.4. Dose factors are based upon NUREG 0133 methodology. Inhalation dose conversion factors are taken from Reg. Guide 1.109, Rev 1, Table E-9, with the following exceptions: H-3, Sb-124 and Sb-125 inhalation dose conversion factors taken from NUREG/CR-4013.

$Q_i$  = Release rate of isotope "i" in  $\mu\text{Ci}/\text{sec}$

0.48 = Plant vent location factor for one unit from Table 6.2

1500 mrem/yr = Site radioiodine, tritium and particulate dose rate limit

TITLE Off-Site Dose Calculations

6 2 8 Alternate Dose Methodologies

For purposes of routine gaseous effluent dose assessment, the methodology of NUREG 0133 (described in Section 6 2 5) will be used. However, DCPD may elect to utilize the dose methodologies of Regulatory Guide 1 109 or the GASPAR computer code for special purposes such as evaluation of potential new gaseous effluent dose pathways or critical receptors.

6 2 9 Gas Effluent Dose Projection

The projected dose contributions from each reactor unit due to gaseous effluents for the current calendar month, quarter and current calendar year must be determined in accordance with the methodology and parameters in the ODCP at least once per 31 days.

The computer program, Radioactive Effluent Management System (REMS), is used for this projection. Therefore, by the first day of the year, the following tables in REMS need to be updated:

- GRW dose receptor
- GRW dose rate receptor
- GRW external dose select
- GRW external occupancy
- GRW internal dose select
- GRW internal occupancy

The purpose of this is to determine if appropriate treatment of gaseous radioactive materials in relation to maintaining releases "as low as reasonably achievable," is necessary.

The projected dose from each reactor unit is given by

$$D_p = D_{pU} + \frac{1}{2} D_{pCom} \quad (39)$$

Where

$D_p$  = Projected Dose

$D_{pU}$  = Projected dose attributed to reactor unit, U

$D_{pCom}$  = Projected dose common to both reactor units



The 31 day projected dose is calculated by Equation 40

$$D_P^M = 31 \times \frac{D_A^{PM} + d_A^{CM} + d_P^{CB}}{(T + t)} \quad (40)$$

Where

- $D_P^M$  = Projected Dose for the next 31 day period
- $D_A^{PM}$  = Previous Month's Actual Dose
- $d_A^{CM}$  = Current Month Actual Dose to date
- $d_P^{CB}$  = Projected Dose from Current Batch Release
- T = Number of days in the previous month
- t = Number of days into the present month

Projected quarterly doses are determined by Equation 41

$$D_P^{CQ} = d_A^{CQ} + (92 - t) \frac{D_A^{PQ} + d_A^{CQ} + d_P^{CB}}{(T + t)} \quad (41)$$

Where

- $D_P^{CQ}$  = Projected dose for the current calendar quarter
- $d_A^{CQ}$  = Current quarter to date actual dose
- $D_A^{PQ}$  = Previous quarter's actual dose
- $d_P^{CB}$  = Projected dose as a result of the current batch release
- T = Number of days in the previous quarter
- t = Number of days into the present quarter

Projected yearly doses are determined by Equation 42

$$D_P^{CY} = d_A^{CY} + (366 - t) \frac{D_A^{PY} + d_A^{CY} + d_P^{CB}}{(T + t)} \quad (42)$$

Where

- $D_P^{CY}$  = Projected dose for the current calendar year  
 $d_A^{CY}$  = Current year to date actual dose  
 $D_A^{PY}$  = Previous year's actual dose  
 $d_P^{CB}$  = Projected dose as a result of the current batch release  
T = Number of days in the previous year  
t = Number of days into the present year

6 2 10 Unplanned Gaseous Releases (Abnormal Releases)

- a An unplanned release is an unexpected and potentially unmonitored release to the environment due to operational error or equipment malfunctions
- 1 Unmonitored unplanned releases shall have a report written by the Radiochemistry Effluents Engineer describing the event with a calculation, if possible, of the percent of RECP limit. This will then be forwarded to PSRC for review. Describe these unplanned releases in the Annual Radioactive Effluent Release Report.
  - 2 Monitored unplanned releases which exceed 1% of the RECP limit will also have a report written describing the event and must be forwarded to the PSRC for review. Describe these unplanned releases in the Annual Radioactive Effluent Release Report. For purposes of classification only, unplanned release puffs through the plant vent may use one hour integrated resolution times.

63 40 CFR 190 Dose Calculations

631 Pathways

Calculation of total uranium fuel cycle dose for purposes of demonstrating compliance with 40 CFR 190 requires the contributions from liquid and gaseous effluent as well as direct radiation from the units and outside storage tanks to be considered. The total uranium fuel cycle dose to any member of the public will be calculated by summing the following doses

- Direct Radiation Dose
- Liquid Effluent Dose
- Noble Gas Dose
- Radioiodine, Tritium and Particulate Gaseous Effluent Dose

632 Methodology

a Direct Radiation Dose

Determination of direct radiation dose from the reactor units and from outside storage tanks may be made by direct survey measurements, derived from environmental TLD data, or calculated by shielding code

The direct radiation dose will also take into account residence times near the site based upon land use census information

The direct radiation determination using environmental TLD is given by equation 43

$$D'_{sb} = \left[ \frac{radj}{800} \right]^2 D'_{ro} \times (9.57) \times e^{-(6.38)} \quad (43)$$

where

$D'_{sb}$  = the dose rate at the site boundary, in mrem

$D'_{ro}$  = the dose rate from the dosimetry reading, in mrem

radj = the distance from the point source to the dosimetry, in meter

800 = the distance from the point source to site boundary, in meter

b Noble Gas Dose

The noble gas skin dose and total body dose contributions to the total uranium fuel cycle dose to a member of the public will be determined as shown in Equations 44 and 45

$$\text{Noble Gas Total Body Dose} = 3.17 \times 10^{-8} (\bar{x/Q})_R \sum_i K_i \tilde{Q}_i \quad (44)$$

$$\text{Noble Gas Skin Dose} = 3.17 \times 10^{-8} (\bar{x/Q})_R \sum_i (L_i + 1.1 M_i) \tilde{Q}_i \quad (45)$$

Where

- $3.17 \times 10^{-8}$  = Conversion constant yr/sec
- $(\bar{x/Q})_R$  = Maximum historical dispersion factor for receptor of interest, based on 5 year averages from Table 10.2
- $K_i$  = Whole body dose factor for nuclide  $i$ , in mrem/yr per  $\mu\text{Ci}/\text{m}^3$ . Values are listed in Table 6.3
- $L_i$  = Skin dose factor for nuclide  $i$ , in mrem/yr per  $\mu\text{Ci}/\text{m}^3$ . Values are listed in Table 6.3
- 1.1 = Conversion factor mrem/mrad. Converts air dose to skin dose
- $M_i$  = Gamma air dose factor for nuclide  $i$ , in mrad/yr per  $\mu\text{Ci}/\text{m}^3$ . Values are listed in Table 10.3
- $\tilde{Q}_i$  = Total release of noble gas radionuclide, " $i$ ", in  $\mu\text{Ci}/\text{sec}$

TITLE Off-Site Dose Calculations

---

c Liquid and Gaseous Effluent Dose

The doses from liquid effluents and radioiodines, tritium and particulates in gaseous effluents will be determined by Equations 1 and 33, respectively

For purposes of calculating the dose required by the radiological effluent controls, more realistic assumptions concerning the liquid and gaseous effluent dose pathways will be used, based upon the most recent land use census data as well as the latest environmental monitoring information

These assumptions may include, but not be limited to more realistic liquid dilution factors, location and age of actual individuals, site specific food pathway parameters, and documentation of true food consumption. Other assumptions may be used provided they can be substantiated by census or direct measurement

64 On-Site Dose to Members of the Public

Members of the public are occasionally granted access within the site boundary, but only in the owner controlled area up to the protected area boundary. The most common public access activities are tours to the simulator (training building) or Bio Lab, policemen using the shooting range (most frequent activity), cattle drives through to adjacent properties, and visits of American Indians to on-site burial grounds (closest to the plant).

Exposure to members of the public due to liquid releases while on-site is highly unlikely and therefore not addressed. Exposure due to gaseous releases and direct radiation are credible and therefore are considered.

The dose to members of the public during on-site activities will be primarily determined by the duration of the on-site visitation time and by the closest proximity to the plant.

For gaseous releases the doses are calculated using Equations 44, 45 and 33. The R<sub>i</sub>'s in Equation 33 consider only the inhalation and ground plane pathway and exclude the infant age group.

The X/Q and D/Q values are modified using logarithmic extrapolation from the site boundary to the on-site location of interest as shown in Equations 46 and 47.

$$\log[X/Q]_{on\ site} \approx \frac{\log[X/Q]_{S\ B} - \log[X/Q]_{loc}}{\log(dist\ S\ B) - \log(dist\ loc)} [\log(dist\ on - site) - \log(dist\ S\ B)] + \log[X/Q]_{S\ B} \quad (46)$$

$$\log[D/Q]_{on\ site} \approx \frac{\log[D/Q]_{S\ B} - \log[D/Q]_{loc}}{\log(dist\ S\ B) - \log(dist\ loc)} [\log(dist\ on - site) - \log(dist\ S\ B)] + \log[D/Q]_{S\ B} \quad (47)$$

Based upon Regulatory Guide 1.111, these equations can be expected to provide reasonable dispersion and deposition estimates for distances as close as 200 meters.

Determination of direct radiation dose from the reactor units and from outside storage tanks may be made by direct survey measurements, derived from environmental TLD data, or calculated by shielding code.

A distance of 200 meters from the plant (both units) equidistant from the plant vent is arbitrarily selected as the closest perimeter for which on-site doses will be calculated.

TITLE Off-Site Dose Calculations

The activities of the members-of-the-public while on-site (described above), are at or beyond 200 meters Table 6 3 details the types of on-site activities that members-of-the-public might be expected to participate in at DCPP The sectors and closest distances in which they may visit as well as expected visitation duration are also shown (based on Security Section information)

Table 6 3

Expected On-Site Distances and Visitation Times for Members of the Public

ONSITE MEMBER OF THE PUBLIC	SECTOR OF VISITATION	CLOSEST POINT OF APPROACH TO PLANT	AVERAGE EXPECTED VISITATION TIME PER YEAR
Police at shooting range	SE	700m	208 hours
Tour Participants			
Simulator Bldg	S (SE)	310m	4 hours
Overlook	E	210m	1 hours
American Indians at burial grounds	NW NNW	200m 200m	96 hours 96 hours
Ranch hands driving cattle around site	NW NNW N NNE NE	250m 350m 320m 450m 630m	1 hour 1 hour 1 hour 1 hour 1 hour

TITLE Off-Site Dose Calculations

7 ACCEPTANCE CRITERIA

7 1 There is no quantitative acceptance for this procedure. If the task or analysis has been accomplished within the bounds of this procedure, it is considered acceptable.

8 REFERENCES

- 8 1 License Amendment 67/66, January 22, 1992
- 8 2 Calculation of Annual Doses to Man From Routine Releases of Reactor Effluents for the Purpose of Evaluating Compliance with 10 CFR 50, Appendix I, Regulatory Guide 1 109, Rev 0, March 1976
- 8 3 Calculation of Annual Doses to Man From Routine Releases of Reactor Effluents for the Purpose of Evaluating Compliance with 10 CFR 50, Appendix I, Regulatory Guide 1 109, Rev 1, October 1977
- 8 4 Preparation of Radiological Effluent Tech Specs for Nuclear Power Plants, NUREG No 0133, October 1978
- 8 5 LADTAP II - Technical Reference and User Guide, NUREG/CR-4013
- 8 6 Methods for Demonstrating LWR Compliance with the EPA Uranium Fuel Cycle Standard 40 CFR 190, NUREG No 0543, January 1980
- 8 7 Methods for Estimating Atmospheric Transport and Dispersion of Gaseous Effluents in Routine Releases from Light-Water-Cooled Reactors, Regulatory Guide, 1 111, Rev 1, July, 1977
- 8 8 Radioactive Decay Data Tables, David C Kocher DOE/TIC-11026, 1981
- 8 9 CAP A-6, "Gaseous Radwaste Discharge Management "
- 8 10 CAP A-5, "Liquid Radwaste Discharge Management "
- 8 11 CAP D-15, "Steam Generator Leak Rate Determination "
- 8 12 CAP D-19, "Correlation of Rad Monitors to Radioactivity "
- 8 13 CY2 DC1, "Radiation Monitoring System High Alarm Setpoint Control Procedure "
- 8 14 CY2 ID1, "Radiological Effluent and Controls Program" (RECP)
- 8 15 "Setpoint Calculation for Containment Ventilation Exhaust Monitor,"  
Calc # NSP-1&2-39-44, 10/92 and 11/92 and AR A0430610
- 8 16 NUREG 2919, Computer Code XOQDOQ, Revision 2, September, 1982
- 8 17 Meteorology Services Report Number 420DC 08 15, March 2008 (XOQDOQ data)
- 8 18 Age-Specific Radiation Dose Commitment Factors for a One-Year Chronic Intake, NUREG-0172, November 1977



TITLE Off-Site Dose Calculations

- 8 19 Include Tc-99M In ODCM and ARER Reports, Action Request A0619601
- 8 20 Rad Effluent Sampling of Ni-63, Action Request A0619600
- 8 21 Review and Expansion of USNRC Regulatory Guide 1 109 Models for Computing Dose Conversion Factors, F W Boone and John M Palms, Report No EMP-155, February 1983

9 RECORDS

- 9 1 Data Sheets and records will be maintained in the Records Management System (RMS) in accordance with CY1 DC1, "Analytical Data Processing Responsibilities "

10 APPENDICES

- 10 1 LRW Composite Dose Factors,  $A_{10}$ , For Adults At A Saltwater Site (mrem/hour per  $\mu\text{Ci/ml}$ ) organ "O"
- 10 2 Summary Of Land Use Census Evaluation
- 10 3 GRW Dose Factors For Noble Gases
- 10 4 Child Inhalation Pathway Dose Factors For Worst Case Organ
- 10 5 Ground Plane Dose Factors
- 10 6 GRW Dose Parameters For Radioiodines, Radioactive Particulates, and Any Radionuclide Other Than Noble Gas (IPT), Gaseous Effluents (GRW)
  - 10 6 1 Infant Age Group, Inhalation Pathway Organ "O" (mrem/yr per  $\mu\text{Ci/m}^3$ )  
 $R_{i, \text{Inhal}}$
  - 10 6 2 Child Age Group, Inhalation Pathway Organ "O" (mrem/yr per  $\mu\text{Ci/m}^3$ )  
 $R_{i, \text{Inhal}}$
  - 10 6 3 Teen Age Group, Inhalation Pathway Organ "O" (mrem/yr per  $\mu\text{Ci/m}^3$ )  $R_{i, \text{Inhal}}$
  - 10 6 4 Adult Age Group, Inhalation Pathway Organ "O" (mrem/yr per  $\mu\text{Ci/m}^3$ )  
 $R_{i, \text{Inhal}}$
  - 10 6 5 Child Age Group, Vegetation Pathway Organ "O" (mrem/yr per  $\mu\text{Ci}/(\text{sec m}^2)$ )  $R_{i, \text{Vegi}}$
  - 10 6 6 Teen Age Group, Vegetation Pathway Organ "O"  
(mrem/yr per  $\mu\text{Ci}/(\text{sec m}^2)$ )  $R_{i, \text{Vegi}}$
  - 10 6 7 Adult Age Group, Vegetation Pathway Organ "O"  
(mrem/yr per  $\mu\text{Ci}/(\text{sec m}^2)$ )  $R_{i, \text{Vegi}}$

11 ATTACHMENTS

- 11 1 "Liquid Discharges (LRW) Monitored for Radioactivity," 10/04/00
- 11 2 "Gaseous Releases (GRW) Monitored for Radioactivity," 10/31/00

TITLE Off-Site Dose Calculations

Table 101

LRW Composite Dose Factors<sup>1</sup>, A<sub>10</sub>,  
 for Adults at a Saltwater Site  
 (mrem/hour per μCi/ml)  
 organ "O"

Nuclide	Tot Body	Thyroid	Kidney	Lung	GI-LLI	Bone	Liver
H-3	1 61E-01	1 61E-01	1 61E-01	1 61E-01	1 61E-01	0 00E+00	1 61E-01
Na-24	4 57E-01	4 57E-01	4 57E-01	4 57E-01	4 57E-01	4 57E-01	4 57E-01
Cr-51	5 58E+00	3 34E+00	1 23E+00	7 40E+00	1 40E+03	0 00E+00	0 00E+00
Mn-54	1 35E+03	0 00E+00	2 10E+03	0 00E+00	2 16E+04	0 00E+00	7 06E+03
Mn-56	3 15E+01	0 00E+00	2 26E+02	0 00E+00	5 67E+03	0 00E+00	1 78E+02
Fe-55	8 23E+03	0 00E+00	0 00E+00	1 97E+04	2 03E+04	5 11E+04	3 53E+04
Fe-59	7 27E+04	0 00E+00	0 00E+00	5 30E+04	6 32E+05	8 06E+04	1 90E+05
Co-57	2 36E+02	0 00E+00	0 00E+00	0 00E+00	3 59E+03	0 00E+00	1 42E+02
Co-58	1 35E+03	0 00E+00	0 00E+00	0 00E+00	1 22E+04	0 00E+00	6 03E+02
Co-60	3 82E+03	0 00E+00	0 00E+00	0 00E+00	3 25E+04	0 00E+00	1 73E+03
Ni-63	1 67E+03	0 00E+00	0 00E+00	0 00E+00	7 18E+02	4 96E+04	3 44E+03
Ni-65	1 20E+01	0 00E+00	0 00E+00	0 00E+00	6 65E+02	2 02E+02	2 62E+01
Cu-64	1 01E+02	0 00E+00	5 40E+02	0 00E+00	1 83E+04	0 00E+00	2 14E+02
Zn-65	2 32E+05	0 00E+00	3 43E+05	0 00E+00	3 23E+05	1 61E+05	5 13E+05
Zn-69	4 56E+01	0 00E+00	4 26E+02	0 00E+00	9 85E+01	3 43E+02	6 56E+02
As-76	4 42E+01	0 00E+00	8 72E+01	0 00E+00	0 00E+00	0 00E+00	4 62E+01
Br-82	4 07E+00	0 00E+00	0 00E+00	0 00E+00	4 67E+00	0 00E+00	0 00E+00
Br-84	9 39E-02	0 00E+00	0 00E+00	0 00E+00	7 37E-07	0 00E+00	0 00E+00
Rb-86	2 91E+02	0 00E+00	0 00E+00	0 00E+00	1 23E+02	0 00E+00	6 24E+02
Rb-88	9 49E-01	0 00E+00	0 00E+00	0 00E+00	2 47E-11	0 00E+00	1 79E+00
Rb-89+D	8 34E-01	0 00E+00	0 00E+00	0 00E+00	6 89E-14	0 00E+00	1 19E+00
Sr-89+D	1 43E+02	0 00E+00	0 00E+00	0 00E+00	8 00E+02	4 99E+03	0 00E+00
Sr-90+D	2 83E+03	0 00E+00	0 00E+00	0 00E+00	3 55E+03	1 41E+05	0 00E+00
Sr-91+D	3 71E+00	0 00E+00	0 00E+00	0 00E+00	4 37E+02	9 18E+01	0 00E+00
Sr-92+D	1 51E+00	0 00E+00	0 00E+00	0 00E+00	6 90E+02	3 48E+01	0 00E+00
Y-90	1 63E-01	0 00E+00	0 00E+00	0 00E+00	6 42E+04	6 06E+00	0 00E+00
Y-91m+D	2 22E-03	0 00E+00	0 00E+00	0 00E+00	1 68E-01	5 73E-02	0 00E+00
Y-92	1 56E-02	0 00E+00	0 00E+00	0 00E+00	9 32E+03	5 32E-01	0 00E+00
Zr-95+D	3 46E+00	0 00E+00	8 02E+00	0 00E+00	1 62E+04	1 59E+01	5 11E+00
Zr-97+D	8 13E-02	0 00E+00	2 68E-01	0 00E+00	5 51E+04	8 81E-01	1 78E-01
Nb-95	1 34E+02	0 00E+00	2 46E+02	0 00E+00	1 51E+06	4 47E+02	2 49E+02
Mo-99+D	2 43E+01	0 00E+00	2 89E+02	0 00E+00	2 96E+02	0 00E+00	1 28E+02
Tc-101	1 88E-01	0 00E+00	3 46E-01	9 81E-03	5 77E-14	1 33E-02	1 92E-02
Ru-103+D	4 60E+01	0 00E+00	4 07E+02	0 00E+00	1 25E+04	1 07E+02	0 00E+00
Ru-105+D	3 51E+00	0 00E+00	1 15E+02	0 00E+00	5 44E+03	8 89E+00	0 00E+00
Ru-106+D	2 01E+02	0 00E+00	3 06E+03	0 00E+00	1 03E+05	1 59E+03	0 00E+00
Ag-110m+D	8 60E+02	0 00E+00	2 85E+03	0 00E+00	5 91E+05	1 56E+03	1 45E+03
Sn-113	3 53E+03	9 85E+02	0 00E+00	0 00E+00	0 00E+00	6 06E+04	1 66E+03
Sn-117m	8 76E+02	2 52E+02	0 00E+00	0 00E+00	0 00E+00	3 02E+03	3 41E+02
Sb-122	6 65E+00	3 09E-01	0 00E+00	1 18E+01	0 00E+00	2 19E+01	4 47E-01
Sb-124	1 09E+02	6 70E-01	0 00E+00	2 15E+02	7 84E+03	2 76E+02	5 22E+00
Sb-125	4 20E+01	1 79E-01	0 00E+00	1 36E+02	1 94E+03	1 77E+02	1 97E+00

TITLE Off-Site Dose Calculations

Table 101 (continued)

LRW Composite Dose Factors<sup>1</sup>, A<sub>10</sub>,  
 for Adults at a Saltwater Site  
 (mrem/hour per µCi/ml)  
 organ "O"

Nuclide	Tot Body	Thyroid	Kidney	Lung	GI-LLI	Bone	Liver
Te-125m	2.91E+01	6.51E+01	8.82E+02	0.00E+00	8.66E+02	2.17E+02	7.86E+01
Te-129m+D	1.47E+02	3.20E+02	3.89E+03	0.00E+00	4.69E+03	9.31E+02	3.47E+02
Te-129	6.19E-01	1.95E+00	1.07E+01	0.00E+00	1.92E+00	2.54E+00	9.55E-01
Te-131m+D	5.71E+01	1.08E+02	6.94E+02	0.00E+00	6.80E+03	1.40E+02	6.85E+01
Te-131+D	5.03E-01	1.31E+00	6.99E+00	0.00E+00	2.26E-01	1.59E+00	6.66E-01
Te-132+D	1.24E+02	1.46E+02	1.27E+03	0.00E+00	6.24E+03	2.04E+02	1.32E+02
I-131+D	1.79E+02	1.02E+05	5.35E+02	0.00E+00	8.23E+01	2.18E+02	3.12E+02
I-132	9.96E+00	9.96E+02	4.54E+01	0.00E+00	5.35E+00	1.06E+01	2.85E+01
I-133+D	3.95E+01	1.90E+04	2.26E+02	0.00E+00	1.16E+02	7.45E+01	1.30E+02
I-134	5.40E+00	2.62E+02	2.40E+01	0.00E+00	1.32E-02	5.56E+00	1.51E+01
I-135+D	2.24E+01	4.01E+03	9.75E+01	0.00E+00	6.87E+01	2.32E+01	6.08E+01
Cs-134	1.33E+04	0.00E+00	5.27E+03	1.75E+03	2.85E+02	6.84E+03	1.63E+04
Cs-136	2.04E+03	0.00E+00	1.57E+03	2.16E+02	3.21E+02	7.16E+02	2.83E+03
Cs-137+D	7.85E+03	0.00E+00	4.07E+03	1.35E+03	2.32E+02	8.77E+03	1.20E+04
Cs-138	5.94E+00	0.00E+00	8.81E+00	8.70E-01	5.12E-05	6.07E+00	1.20E+01
Ba-139	2.30E-01	0.00E+00	5.23E-03	3.17E-03	1.39E+01	7.85E+00	5.59E-03
Ba-140+D	1.08E+02	0.00E+00	7.02E-01	1.18E+00	3.38E+03	1.64E+03	2.06E+00
Ba-141+D	1.29E-01	0.00E+00	2.68E-03	1.63E-03	1.80E-09	3.81E+00	2.88E-03
La-140	2.10E-01	0.00E+00	0.00E+00	0.00E+00	5.83E+04	1.57E+00	7.94E-01
La-142	9.13E-03	0.00E+00	0.00E+00	0.00E+00	2.68E+02	8.06E-02	3.67E-02
Ce-141	2.63E-01	0.00E+00	1.08E+00	0.00E+00	8.86E+03	3.43E+00	2.32E+00
Ce-143+D	4.94E-02	0.00E+00	1.97E-01	0.00E+00	1.67E+04	6.04E-01	4.46E+02
Ce-144+D	9.59E+00	0.00E+00	4.43E+01	0.00E+00	6.04E+04	1.79E+02	7.47E+01
Pr-144	9.64E-04	0.00E+00	4.44E-03	0.00E+00	2.73E-09	1.90E-02	7.87E-03
Nd-147+D	2.74E-01	0.00E+00	2.68E+00	0.00E+00	2.20E+04	3.96E+00	4.58E+00
Pu-238	2.07E+03	0.00E+00	8.87E+03	0.00E+00	8.85E+03	7.62E+04	9.66E+03
Pu-239	2.31E+03	0.00E+00	9.83E+03	0.00E+00	8.07E+03	8.79E+04	1.06E+04
Pu-240	2.31E+03	0.00E+00	9.82E+03	0.00E+00	8.23E+03	8.76E+04	1.05E+04
Pu-241+D	4.01E+01	0.00E+00	1.85E+02	0.00E+00	1.70E+02	1.90E+03	9.03E+01
Pu-242	2.23E+03	0.00E+00	9.46E+03	0.00E+00	7.91E+03	8.13E+04	1.02E+04
U-233+D	1.56E+03	0.00E+00	6.02E+03	0.00E+00	1.86E+03	2.58E+04	0.00E+00
U-234	1.53E+03	0.00E+00	5.90E+03	0.00E+00	1.82E+03	2.48E+04	0.00E+00
U-235+D	1.44E+03	0.00E+00	5.54E+03	0.00E+00	2.31E+03	2.37E+04	0.00E+00
U-236	1.47E+03	0.00E+00	5.66E+03	0.00E+00	1.71E+03	2.37E+04	0.00E+00
U-238 D	1.35E+03	0.00E+00	5.19E+03	0.00E+00	1.63E+03	2.27E+04	0.00E+00
W-187	2.68E+00	0.00E+00	0.00E+00	0.00E+00	2.51E+03	9.16E+00	7.66E+00
Np-239	1.91E-03	0.00E+00	1.08E-02	0.00E+00	7.11E+02	3.53E-02	3.47E-03

<sup>1</sup> Dose factors are based upon NUREG 0133 methodology

TITLE Off-Site Dose Calculations

Table 10 2  
 Summary of Land Use Census Evaluation

Sector	Receptor Description	Distance (miles)	X/Q	D/Q	Comments
N	none				no receptors within 5 miles
NNE	residence + garden	4 4	4 50E-8	8 80E-11	full time occupancy
	residence	3 3	6 80E-08	1 50E-10	trailer - limited use
	residence	3 2	7 10E-08	1 50E-10	cabin - limited use
NE	residence	4 9	3 20E-08	6 20E-11	full time occupancy
ENE	residence	4 4	2 70E-08	6 90E-11	full time occupancy
	residence	5 0	2 30E-08	5 50E-11	full time occupancy
E	residence	4 0	4 20E-08	1 30E-10	cabin - limited use
	residence	3 7	4 80E-08	1 50E-10	part time occupancy
	residence + garden	4 5	3 60E-08	1 00E-10	full time occupancy
ESE	oat hay and sugar peas	3 3	1 60E-07	9 70E-10	field workers present only during the day - critical receptor ground plane, inhalation, and vegetation ingestion dose assessed at this location
SE	none				no receptors within 5 miles
SSE	none				over water
S	none				over water
SSW	none				over water
SW	none				over water
WSW	none				over water
W	none				over water
WNW	none				over water
NW	highest site boundary dispersion value	0 5	5 40E-6	1 90E-8	Gas effluent dose rates PRRs and HASPs evaluated at this location
	residence	1 2	1 20E-6	4 30E-9	trailer - limited use
	residence	3 6	2 20E-7	6 20E-10	full time occupancy
NNW	residence	1 5	6 40E-07	2 10E-09	full time occupancy (trailer) - critical receptor ground plane and inhalation dose assessed at this location
	Public campground	4 6	1 20E-7	2 90E-10	Occupied during normal work hours
	Ranger Station	4 6	1 20E-07	2 90E-10	

TITLE Off-Site Dose Calculations

Table 103  
 GRW Dose Factors for Noble Gases<sup>1</sup>

Radionuclide	Whole Body Dose Factor $K_1$ (mrem/yr per $\mu\text{Ci}/\text{m}^3$ )	Skin Dose Factor $L_1$ (mrem/yr per $\mu\text{Ci}/\text{m}^3$ )	Gamma Air Dose Factor $M_1$ (mrad/yr per $\mu\text{Ci}/\text{m}^3$ )	Beta Air Dose Factor $N_1$ (mrad/yr per $\mu\text{Ci}/\text{m}^3$ )
Kr-83m	7.56E-02	----	1.93E+01	2.88E+02
Kr-85m	1.17E+03	1.46E+03	1.23E+03	1.97E+03
Kr-85	1.61E+01	1.34E+03	1.72E+01	1.95E+03
Kr-87	5.92E+03	9.73E+03	6.17E+03	1.03E+04
Kr-88	1.47E+04	2.37E+03	1.52E+04	2.93E+03
Kr-89	1.66E+04	1.01E+04	1.73E+04	1.06E+04
Kr-90	1.56E+04	7.29E+03	1.63E+04	7.83E+03
Xe-131m	9.15E+01	4.76E+02	1.56E+02	1.11E+03
Xe-133m	2.51E+02	9.94E+02	3.27E+02	1.48E+03
Xe-133	2.94E+02	3.06E+02	3.53E+02	1.05E+03
Xe-135m	3.12E+03	7.11E+02	3.36E+03	7.39E+02
Xe-135	1.81E+03	1.86E+03	1.92E+03	2.46E+03
Xe-137	1.42E+03	1.22E+04	1.51E+03	1.27E+04
Xe-138	8.83E+03	4.13E+03	9.21E+03	4.75E+03
Ar-41	8.84E+03	2.69E+03	9.30E+03	3.28E+03

<sup>1</sup> From Table B-1 of Regulatory Guide 1.109 (Rev. 1, Oct. 1977)

TITLE Off-Site Dose Calculations

Table 104

Child Inhalation Pathway Dose Factors for Worst Case Organ

Radionuclide	$P_i^w$
H-3	6.40E+02
CR-51	1.70E+04
MN-54	1.58E+06
FE-59	1.27E+06
CO-58	1.11E+06
CO-60	7.07E+06
ZN-65	9.95E+05
RB-86	1.98E+05
SR-89	2.16E+06
Y-90	2.68E+05
SR-90	3.85E+07
ZR-95	2.23E+06
NB-95	6.14E+05
RU-103	6.62E+05
RU-106	1.43E+07
AG-110M	5.48E+06
SB-124	3.24E+06
SB-125	2.32E+06
TE-129M	1.76E+06
I-131	1.62E+07
I-133	3.85E+06
CS-134	1.01E+06
CS-136	1.71E+05
CS-137	9.07E+05
BA-140	1.74E+06
CE-141	5.44E+05
CE-144	1.20E+07
ND-147	3.28E+05

TITLE Off-Site Dose Calculations

Table 10 5  
 Ground Plane Dose Factors

GRW Dose Parameters<sup>1</sup>,  $R_{1,GP}$  for Radioiodines, Radioactive  
 Particulates, and any Radionuclide Other Than  
 Noble Gas (IPT), Gaseous Effluents (GRW),  
 any Age Group, Ground Plane Pathway  
 (mrem/yr per  $\mu\text{Ci}/(\text{sec m}^2)$ )

Nuclide	Bone	Liver	T Body	Thyroid	Kidney	Lung	GI-LLI
H-3	0 00E+00	0 00E+00	0 00E+00	0 00E+00	0 00E+00	0 00E+00	0 00E+00
CR-51	4 65E+06	4 65E+06	4 65E+06	4 65E+06	4 65E+06	4 65E+06	4 65E+06
MN-54	1 38E+09	1 38E+09	1 38E+09	1 38E+09	1 38E+09	1 38E+09	1 38E+09
FE-59	2 73E+08	2 73E+08	2 73E+08	2 73E+08	2 73E+08	2 73E+08	2 73E+08
CO-58	3 80E+08	3 80E+08	3 80E+08	3 80E+08	3 80E+08	3 80E+08	3 80E+08
CO-60	2 15E+10	2 15E+10	2 15E+10	2 15E+10	2 15E+10	2 15E+10	2 15E+10
ZN-65	7 46E+08	7 46E+08	7 46E+08	7 46E+08	7 46E+08	7 46E+08	7 46E+08
RB-86	8 98E+06	8 98E+06	8 98E+06	8 98E+06	8 98E+06	8 98E+06	8 98E+06
SR-89	2 16E+04	2 16E+04	2 16E+04	2 16E+04	2 16E+04	2 16E+04	2 16E+04
Y-90	4 50E+03	4 50E+03	4 50E+03	4 50E+03	4 50E+03	4 50E+03	4 50E+03
SR-90	0 00E+00	0 00E+00	0 00E+00	0 00E+00	0 00E+00	0 00E+00	0 00E+00
ZR-95	2 45E+08	2 45E+08	2 45E+08	2 45E+08	2 45E+08	2 45E+08	2 45E+08
NB-95	1 37E+08	1 37E+08	1 37E+08	1 37E+08	1 37E+08	1 37E+08	1 37E+08
RU-103	1 08E+08	1 08E+08	1 08E+08	1 08E+08	1 08E+08	1 08E+08	1 08E+08
RU-106	4 20E+08	4 20E+08	4 20E+08	4 20E+08	4 20E+08	4 20E+08	4 20E+08
AG-110M	3 45E+09	3 45E+09	3 45E+09	3 45E+09	3 45E+09	3 45E+09	3 45E+09
SB-124	5 99E+08	5 99E+08	5 99E+08	5 99E+08	5 99E+08	5 99E+08	5 99E+08
SB-125	2 34E+09	2 34E+09	2 34E+09	2 34E+09	2 34E+09	2 34E+09	2 34E+09
TE-129M	1 98E+07	1 98E+07	1 98E+07	1 98E+07	1 98E+07	1 98E+07	1 98E+07
I-131	1 72E+07	1 72E+07	1 72E+07	1 72E+07	1 72E+07	1 72E+07	1 72E+07
I-133	2 45E+06	2 45E+06	2 45E+06	2 45E+06	2 45E+06	2 45E+06	2 45E+06
CS-134	6 90E+09	6 90E+09	6 90E+09	6 90E+09	6 90E+09	6 90E+09	6 90E+09
CS-136	1 51E+08	1 51E+08	1 51E+08	1 51E+08	1 51E+08	1 51E+08	1 51E+08
CS-137	1 03E+10	1 03E+10	1 03E+10	1 03E+10	1 03E+10	1 03E+10	1 03E+10
BA-140	2 05E+07	2 05E+07	2 05E+07	2 05E+07	2 05E+07	2 05E+07	2 05E+07
CE-141	1 37E+07	1 37E+07	1 37E+07	1 37E+07	1 37E+07	1 37E+07	1 37E+07
CE-144	6 96E+07	6 96E+07	6 96E+07	6 96E+07	6 96E+07	6 96E+07	6 96E+07
ND-147	8 39E+06	8 39E+06	8 39E+06	8 39E+06	8 39E+06	8 39E+06	8 39E+06

<sup>1</sup> Dose factors are based upon NUREG 0133 methodology

Table 106

GRW Dose Parameters for Radioiodines, Radioactive Particulates, and any Radionuclide Other Than Noble Gas (IPT), Gaseous Effluents (GRW)



TITLE Off-Site Dose Calculations

Table 1061

GRW Dose Parameters<sup>1</sup> for Radioiodines, Radioactive Particulates, and any Radionuclide Other Than Noble Gas (IPT), Gaseous Effluents (GRW), Infant Age Group, Inhalation Pathway Organ "O"  
 (mrem/yr per  $\mu\text{Ci}/\text{m}^3$ )  $R_{i, \text{Inhal}}$

Nuclide	Bone	Liver	T Body	Thyroid	Kidney	Lung	GI-LLI
H-3	0 00E+00	3 68E+02	3 68E+02	3 68E+02	3 68E+02	3 68E+02	3 68E+02
CR-51	0 00E+00	0 00E+00	8 95E+01	5 75E+01	1 32E+01	1 28E+04	3 57E+02
MN-54	0 00E+00	2 53E+04	4 98E+03	0 00E+00	4 98E+03	1 00E+06	7 06E+03
FE-59	1 36E+04	2 35E+04	9 48E+03	0 00E+00	0 00E+00	1 02E+06	2 48E+04
CO-58	0 00E+00	1 22E+03	1 82E+03	0 00E+00	0 00E+00	7 77E+05	1 11E+04
CO-60	0 00E+00	8 02E+03	1 18E+04	0 00E+00	0 00E+00	4 51E+06	3 19E+04
ZN-65	1 93E+04	6 26E+04	3 11E+04	0 00E+00	3 25E+04	6 47E+05	5 14E+04
RB-86	0 00E+00	1 90E+05	8 82E+04	0 00E+00	0 00E+00	0 00E+00	3 04E+03
SR-89	3 98E+05	0 00E+00	1 14E+04	0 00E+00	0 00E+00	2 03E+06	6 40E+04
Y-90	3 29E+03	0 00E+00	8 82E+01	0 00E+00	0 00E+00	2 69E+05	1 04E+05
SR-90	1 55E+07	0 00E+00	3 12E+05	0 00E+00	0 00E+00	1 12E+07	1 31E+05
ZR-95	1 15E+05	2 79E+04	2 03E+04	0 00E+00	3 11E+04	1 75E+06	2 17E+04
NB-95	1 57E+04	6 43E+03	3 78E+03	0 00E+00	4 72E+03	4 79E+05	1 27E+04
RU-103	2 02E+03	0 00E+00	6 79E+02	0 00E+00	4 24E+03	5 52E+05	1 61E+04
RU-106	8 68E+04	0 00E+00	1 09E+04	0 00E+00	1 07E+05	1 16E+07	1 64E+05
AG-110M	9 98E+03	7 22E+03	5 00E+03	0 00E+00	1 09E+04	3 67E+06	3 30E+04
SB-124	3 79E+04	5 56E+02	1 20E+04	1 01E+02	0 00E+00	2 65E+06	5 91E+04
SB-125	5 17E+04	4 77E+02	1 09E+04	6 23E+01	0 00E+00	1 64E+06	1 47E+04
TE-129M	1 41E+04	6 09E+03	2 23E+03	5 47E+03	3 18E+04	1 68E+06	6 90E+04
I-131	3 79E+04	4 44E+04	1 96E+04	1 48E+07	5 18E+04	0 00E+00	1 06E+03
I-133	1 32E+04	1 92E+04	5 60E+03	3 56E+06	2 24E+04	0 00E+00	2 16E+03
CS-134	3 96E+05	7 03E+05	7 45E+04	0 00E+00	1 90E+05	7 97E+04	1 33E+03
CS-136	4 83E+04	1 35E+05	5 29E+04	0 00E+00	5 64E+04	1 18E+04	1 43E+03
CS-137	5 49E+05	6 12E+05	4 55E+04	0 00E+00	1 72E+05	7 13E+04	1 33E+03
BA-140	5 60E+04	5 60E+01	2 90E+03	0 00E+00	1 34E+01	1 60E+06	3 84E+04
CE-141	2 77E+04	1 67E+04	1 99E+03	0 00E+00	5 25E+03	5 17E+05	2 16E+04
CE-144	3 19E+06	1 21E+06	1 76E+05	0 00E+00	5 38E+05	9 84E+06	1 48E+05
ND-147	7 94E+03	8 13E+03	5 00E+02	0 00E+00	3 15E+03	3 22E+05	3 12E+04

<sup>1</sup> Dose factors are based upon NUREG 0133 methodology

TITLE Off-Site Dose Calculations

Table 10 6 2

GRW Dose Parameters<sup>1</sup> for Radioiodines, Radioactive Particulates, and any Radionuclide Other Than Noble Gas (IPT), Gaseous Effluents (GRW), Child Age Group, Inhalation Pathway Organ "O"  
 (mrem/yr per  $\mu\text{Ci}/\text{m}^3$ )  $R_{i, \text{Inhal}}$

Nuclide	Bone	Liver	T Body	Thyroid	Kidney	Lung	GI-LLI
H-3	0 00E+00	6 40E+02	6 40E+02	6 40E+02	6 40E+02	6 40E+02	6 40E+02
CR-51	0 00E+00	0 00E+00	1 54E+02	8 55E+01	2 43E+01	1 70E+04	1 08E+03
MN-54	0 00E+00	4 29E+04	9 51E+03	0 00E+00	1 00E+04	1 58E+06	2 29E+04
FE-59	2 07E+04	3 34E+04	1 67E+04	0 00E+00	0 00E+00	1 27E+06	7 07E+04
CO-58	0 00E+00	1 77E+03	3 16E+03	0 00E+00	0 00E+00	1 11E+06	3 44E+04
CO-60	0 00E+00	1 31E+04	2 26E+04	0 00E+00	0 00E+00	7 07E+06	9 62E+04
ZN-65	4 26E+04	1 13E+05	7 03E+04	0 00E+00	7 14E+04	9 95E+05	1 63E+04
RB-86	0 00E+00	1 98E+05	1 14E+05	0 00E+00	0 00E+00	0 00E+00	7 99E+03
SR-89	5 99E+05	0 00E+00	1 72E+04	0 00E+00	0 00E+00	2 16E+06	1 67E+05
Y-90	4 11E+03	0 00E+00	1 11E+02	0 00E+00	0 00E+00	2 62E+05	2 68E+05
SR-90	3 85E+07	0 00E+00	7 66E+05	0 00E+00	0 00E+00	1 48E+07	3 43E+05
ZR-95	1 90E+05	4 18E+04	3 70E+04	0 00E+00	5 96E+04	2 23E+06	6 11E+04
NB-95	2 35E+04	9 18E+03	6 55E+03	0 00E+00	8 62E+03	6 14E+05	3 70E+04
RU-103	2 79E+03	0 00E+00	1 07E+03	0 00E+00	7 03E+03	6 62E+05	4 48E+04
RU-106	1 36E+05	0 00E+00	1 69E+04	0 00E+00	1 84E+05	1 43E+07	4 29E+05
AG-110M	1 69E+04	1 14E+04	9 14E+03	0 00E+00	2 12E+04	5 48E+06	1 00E+05
SB-124	5 74E+04	7 40E+02	2 00E+04	1 26E+02	0 00E+00	3 24E+06	1 64E+05
SB-125	9 84E+04	7 59E+02	2 07E+04	9 10E+01	0 00E+00	2 32E+06	4 03E+04
TE-129M	1 92E+04	6 85E+03	3 04E+03	6 33E+03	5 03E+04	1 76E+06	1 82E+05
I-131	4 81E+04	4 81E+04	2 73E+04	1 62E+07	7 88E+04	0 00E+00	2 84E+03
I-133	1 66E+04	2 03E+04	7 70E+03	3 85E+06	3 38E+04	0 00E+00	5 48E+03
CS-134	6 51E+05	1 01E+06	2 25E+05	0 00E+00	3 30E+05	1 21E+05	3 85E+03
CS-136	6 51E+04	1 71E+05	1 16E+05	0 00E+00	9 55E+04	1 45E+04	4 18E+03
CS-137	9 07E+05	8 25E+05	1 28E+05	0 00E+00	2 82E+05	1 04E+05	3 62E+03
BA-140	7 40E+04	6 48E+01	4 33E+03	0 00E+00	2 11E+01	1 74E+06	1 02E+05
CE-141	3 92E+04	1 95E+04	2 90E+03	0 00E+00	8 55E+03	5 44E+05	5 66E+04
CE-144	6 77E+06	2 12E+06	3 61E+05	0 00E+00	1 17E+06	1 20E+07	3 89E+05
ND-147	1 08E+04	8 73E+03	6 81E+02	0 00E+00	4 81E+03	3 28E+05	8 21E+04

<sup>1</sup> Dose factors are based upon NUREG 0133 methodology

TITLE Off-Site Dose Calculations

Table 1063

GRW Dose Parameters<sup>1</sup> for Radioiodines, Radioactive Particulates, and any Radionuclide Other Than Noble Gas (IPT), Gaseous Effluents (GRW), Teen Age Group, Inhalation Pathway Organ "O"  
 (mrem/yr per  $\mu\text{Ci}/\text{m}^3$ )  $R_{i, \text{inhal}}$

Nuclide	Bone	Liver	T Body	Thyroid	Kidney	Lung	GI-LLI
H-3	0 00E+00	7 25E+02	7 25E+02	7 25E+02	7 25E+02	7 25E+02	7 25E+02
CR-51	0 00E+00	0 00E+00	1 35E+02	7 50E+01	3 07E+01	2 10E+04	3 00E+03
MN-54	0 00E+00	5 11E+04	8 40E+03	0 00E+00	1 27E+04	1 98E+06	6 68E+04
FE-59	1 59E+04	3 70E+04	1 43E+04	0 00E+00	0 00E+00	1 53E+06	1 78E+05
CO-58	0 00E+00	2 07E+03	2 78E+03	0 00E+00	0 00E+00	1 34E+06	9 52E+04
CO-60	0 00E+00	1 51E+04	1 98E+04	0 00E+00	0 00E+00	8 72E+06	2 59E+05
ZN-65	3 86E+04	1 34E+05	6 24E+04	0 00E+00	8 64E+04	1 24E+06	4 66E+04
RB-86	0 00E+00	1 90E+05	8 40E+04	0 00E+00	0 00E+00	0 00E+00	1 77E+04
SR-89	4 34E+05	0 00E+00	1 25E+04	0 00E+00	0 00E+00	2 42E+06	3 71E+05
Y-90	2 98E+03	0 00E+00	8 00E+01	0 00E+00	0 00E+00	2 93E+05	5 59E+05
SR-90	3 31E+07	0 00E+00	6 66E+05	0 00E+00	0 00E+00	1 65E+07	7 65E+05
ZR-95	1 46E+05	4 58E+04	3 15E+04	0 00E+00	6 74E+04	2 69E+06	1 49E+05
NB-95	1 86E+04	1 03E+04	5 66E+03	0 00E+00	1 00E+04	7 51E+05	9 68E+04
RU-103	2 10E+03	0 00E+00	8 96E+02	0 00E+00	7 43E+03	7 83E+05	1 09E+05
RU-106	9 84E+04	0 00E+00	1 24E+04	0 00E+00	1 90E+05	1 61E+07	9 60E+05
AG-110M	1 38E+04	1 31E+04	7 99E+03	0 00E+00	2 50E+04	6 75E+06	2 73E+05
SB-124	4 30E+04	7 94E+02	1 68E+04	9 76E+01	0 00E+00	3 85E+06	3 98E+05
SB-125	7 38E+04	8 08E+02	1 72E+04	7 04E+01	0 00E+00	2 74E+06	9 92E+04
TE-129M	1 39E+04	6 58E+03	2 25E+03	4 58E+03	5 19E+04	1 98E+06	4 05E+05
I-131	3 54E+04	4 91E+04	2 64E+04	1 46E+07	8 40E+04	0 00E+00	6 49E+03
I-133	1 22E+04	2 05E+04	6 22E+03	2 92E+06	3 59E+04	0 00E+00	1 03E+04
CS-134	5 02E+05	1 13E+06	5 49E+05	0 00E+00	3 75E+05	1 46E+05	9 76E+03
CS-136	5 15E+04	1 94E+05	1 37E+05	0 00E+00	1 10E+05	1 78E+04	1 09E+04
CS-137	6 70E+05	8 48E+05	3 11E+05	0 00E+00	3 04E+05	1 21E+05	8 48E+03
BA-140	5 47E+04	6 70E+01	3 52E+03	0 00E+00	2 28E+01	2 03E+06	2 29E+05
CE-141	2 84E+04	1 90E+04	2 17E+03	0 00E+00	8 88E+03	6 14E+05	1 26E+05
CE-144	4 89E+06	2 02E+06	2 62E+05	0 00E+00	1 21E+06	1 34E+07	8 64E+05
ND-147	7 86E+03	8 56E+03	5 13E+02	0 00E+00	5 02E+03	3 72E+05	1 82E+05

<sup>1</sup> Dose factors are based upon NUREG 0133 methodology

TITLE Off-Site Dose Calculations

Table 1064

GRW Dose Parameters<sup>1</sup> for Radioiodines, Radioactive Particulates, and any Radionuclide Other Than Noble Gas (IPT), Gaseous Effluents (GRW), Adult Age Group, Inhalation Pathway Organ "O"  
 (mrem/yr per  $\mu\text{Ci}/\text{m}^3$ )  $R_{i, \text{Inhal}}$

Nuclide	Bone	Liver	T Body	Thyroid	Kidney	Lung	GI-LLI
H-3	0 00E+00	7 18E+02	7 18E+02	7 18E+02	7 18E+02	7 18E+02	7 18E+02
CR-51	0 00E+00	0 00E+00	1 00E+02	5 95E+01	2 28E+01	1 44E+04	3 32E+03
MN-54	0 00E+00	3 96E+04	6 30E+03	0 00E+00	9 84E+03	1 40E+06	7 74E+04
FE-59	1 18E+04	2 78E+04	1 06E+04	0 00E+00	0 00E+00	1 02E+06	1 88E+05
CO-58	0 00E+00	1 58E+03	2 07E+03	0 00E+00	0 00E+00	9 28E+05	1 06E+05
CO-60	0 00E+00	1 15E+04	1 48E+04	0 00E+00	0 00E+00	5 97E+06	2 85E+05
ZN-65	3 24E+04	1 03E+05	4 66E+04	0 00E+00	6 90E+04	8 64E+05	5 34E+04
RB-86	0 00E+00	1 35E+05	5 90E+04	0 00E+00	0 00E+00	0 00E+00	1 66E+04
SR-89	3 04E+05	0 00E+00	8 72E+03	0 00E+00	0 00E+00	1 40E+06	3 50E+05
Y-90	2 09E+03	0 00E+00	5 61E+01	0 00E+00	0 00E+00	1 70E+05	5 06E+05
SR-90	2 87E+07	0 00E+00	5 77E+05	0 00E+00	0 00E+00	9 60E+06	7 22E+05
ZR-95	1 07E+05	3 44E+04	2 33E+04	0 00E+00	5 42E+04	1 77E+06	1 50E+05
NB-95	1 41E+04	7 82E+03	4 21E+03	0 00E+00	7 74E+03	5 05E+05	1 04E+05
RU-103	1 53E+03	0 00E+00	6 58E+02	0 00E+00	5 83E+03	5 05E+05	1 10E+05
RU-106	6 91E+04	0 00E+00	8 72E+03	0 00E+00	1 34E+05	9 36E+06	9 12E+05
AG-110M	1 08E+04	1 00E+04	5 94E+03	0 00E+00	1 97E+04	4 63E+06	3 02E+05
SB-124	3 12E+04	5 89E+02	1 24E+04	7 55E+01	0 00E+00	2 48E+06	4 06E+05
SB-125	5 34E+04	5 95E+02	1 26E+04	5 40E+01	0 00E+00	1 74E+06	1 01E+05
TE-129M	9 76E+03	4 67E+03	1 58E+03	3 44E+03	3 66E+04	1 16E+06	3 83E+05
I-131	2 52E+04	3 58E+04	2 05E+04	1 19E+07	6 13E+04	0 00E+00	6 28E+03
I-133	8 64E+03	1 48E+04	4 52E+03	2 15E+06	2 58E+04	0 00E+00	8 88E+03
CS-134	3 73E+05	8 48E+05	7 28E+05	0 00E+00	2 87E+05	9 76E+04	1 04E+04
CS-136	3 90E+04	1 46E+05	1 10E+05	0 00E+00	8 56E+04	1 20E+04	1 17E+04
CS-137	4 78E+05	6 21E+05	4 28E+05	0 00E+00	2 22E+05	7 52E+04	8 40E+03
BA-140	3 90E+04	4 90E+01	2 57E+03	0 00E+00	1 67E+01	1 27E+06	2 18E+05
CE-141	1 99E+04	1 35E+04	1 53E+03	0 00E+00	6 26E+03	3 62E+05	1 20E+05
CE-144	3 43E+06	1 43E+06	1 84E+05	0 00E+00	8 48E+05	7 78E+06	8 16E+05
ND-147	5 27E+03	6 10E+03	3 65E+02	0 00E+00	3 56E+03	2 21E+05	1 73E+05

<sup>1</sup> Dose factors are based upon NUREG 0133 methodology

TITLE Off-Site Dose Calculations

Table 10 6 5

GRW Dose Parameters<sup>1</sup> for Radioiodines, Radioactive Particulates, and any Radionuclide Other Than Noble Gas (IPT), Gaseous Effluents (GRW), Child Age Group, Vegetation Pathway Organ "O"  
 (mrem/yr per  $\mu\text{Ci}/(\text{sec m}^2)$ )  $R_{\text{veg}}$

Nuclide	Bone	Liver	T Body	Thyroid	Kidney	Lung	GI-LLI
H-3 <sup>2</sup>	0 00E+00	2 29E+03	2 29E+03	2 29E+03	2 29E+03	2 29E+03	2 29E+03
CR-51	0 00E+00	0 00E+00	1 17E+05	6 49E+04	1 77E+04	1 18E+05	6 20E+06
MN-54	0 00E+00	6 65E+08	1 77E+08	0 00E+00	1 86E+08	0 00E+00	5 58E+08
FE-59	3 97E+08	6 42E+08	3 20E+08	0 00E+00	0 00E+00	1 86E+08	6 69E+08
CO-58	0 00E+00	6 45E+07	1 97E+08	0 00E+00	0 00E+00	0 00E+00	3 76E+08
CO-60	0 00E+00	3 78E+08	1 12E+09	0 00E+00	0 00E+00	0 00E+00	2 10E+09
ZN-65	8 12E+08	2 16E+09	1 35E+09	0 00E+00	1 36E+09	0 00E+00	3 80E+08
RB-86	0 00E+00	4 54E+08	2 79E+08	0 00E+00	0 00E+00	0 00E+00	2 92E+07
SR-89	3 59E+10	0 00E+00	1 03E+09	0 00E+00	0 00E+00	0 00E+00	1 39E+09
Y-90	2 31E+04	0 00E+00	6 18E+02	0 00E+00	0 00E+00	0 00E+00	6 57E+07
SR-90	1 87E+12	0 00E+00	3 77E+10	0 00E+00	0 00E+00	0 00E+00	1 67E+10
ZR-95	3 86E+06	8 50E+05	7 56E+05	0 00E+00	1 22E+06	0 00E+00	8 86E+08
NB-95	4 12E+05	1 61E+05	1 15E+05	0 00E+00	1 51E+05	0 00E+00	2 97E+08
RU-103	1 53E+07	0 00E+00	5 89E+06	0 00E+00	3 86E+07	0 00E+00	3 96E+08
RU-106	7 45E+08	0 00E+00	9 30E+07	0 00E+00	1 01E+09	0 00E+00	1 16E+10
AG-110M	3 21E+07	2 17E+07	1 74E+07	0 00E+00	4 04E+07	0 00E+00	2 58E+09
SB-124	3 52E+08	4 57E+06	1 23E+08	7 78E+05	0 00E+00	1 96E+08	2 20E+09
SB-125	4 99E+08	3 85E+06	1 05E+08	4 62E+05	0 00E+00	2 78E+08	1 19E+09
TE-129M	8 40E+08	2 35E+08	1 30E+08	2 71E+08	2 47E+09	0 00E+00	1 02E+09
I-131	1 43E+08	1 44E+08	8 17E+07	4 75E+10	2 36E+08	0 00E+00	1 28E+07
I-133	3 52E+06	4 36E+06	1 65E+06	8 09E+08	7 26E+06	0 00E+00	1 76E+06
CS-134	1 60E+10	2 63E+10	5 55E+09	0 00E+00	8 16E+09	2 93E+09	1 42E+08
CS-136	8 18E+07	2 25E+08	1 46E+08	0 00E+00	1 20E+08	1 79E+07	7 90E+06
CS-137	2 39E+10	2 29E+10	3 38E+09	0 00E+00	7 46E+09	2 68E+09	1 43E+08
BA-140	2 77E+08	2 43E+05	1 62E+07	0 00E+00	7 90E+04	1 45E+05	1 40E+08
CE-141	6 55E+05	3 27E+05	4 85E+04	0 00E+00	1 43E+05	0 00E+00	4 08E+08
CE-144	1 27E+08	3 98E+07	6 78E+06	0 00E+00	2 21E+07	0 00E+00	1 04E+10
ND-147	7 27E+04	5 89E+04	4 56E+03	0 00E+00	3 23E+04	0 00E+00	9 33E+07

<sup>1</sup> Dose factors are based upon NUREG 0133 methodology

<sup>2</sup> For Tritium the units of the dose parameters are mrem/yr per  $\mu\text{Ci}/\text{m}^3$  for all pathways, and they must be multiplied by X/Q

TITLE Off-Site Dose Calculations

Table 1066

GRW Dose Parameters<sup>1</sup> for Radioiodines, Radioactive Particulates, and any Radionuclide Other Than Noble Gas (IPT), Gaseous Effluents (GRW), Teen Age Group, Vegetation Pathway Organ "O"  
 (mrem/yr per  $\mu\text{Ci}/(\text{sec m}^2)$ )  $R_{i, \text{veg}}$

Nuclide	Bone	Liver	T Body	Thyroid	Kidney	Lung	GI-LLI
H-3 <sup>2</sup>	0 00E+00	1 47E+03	1 47E+03	1 47E+03	1 47E+03	1 47E+03	1 47E+03
CR-51	0 00E+00	0 00E+00	6 16E+04	3 42E+04	1 35E+04	8 79E+04	1 03E+07
MN-54	0 00E+00	4 54E+08	9 01E+07	0 00E+00	1 36E+08	0 00E+00	9 32E+08
FE-59	1 79E+08	4 18E+08	1 61E+08	0 00E+00	0 00E+00	1 32E+08	9 89E+08
CO-58	0 00E+00	4 37E+07	1 01E+08	0 00E+00	0 00E+00	0 00E+00	6 02E+08
CO-60	0 00E+00	2 49E+08	5 60E+08	0 00E+00	0 00E+00	0 00E+00	3 24E+09
ZN-65	4 24E+08	1 47E+09	6 86E+08	0 00E+00	9 41E+08	0 00E+00	6 23E+08
RB-86	0 00E+00	2 75E+08	1 29E+08	0 00E+00	0 00E+00	0 00E+00	4 06E+07
SR-89	1 51E+10	0 00E+00	4 33E+08	0 00E+00	0 00E+00	0 00E+00	1 80E+09
Y-90	1 24E+04	0 00E+00	3 35E+02	0 00E+00	0 00E+00	0 00E+00	1 02E+08
SR-90	9 22E+11	0 00E+00	1 84E+10	0 00E+00	0 00E+00	0 00E+00	2 11E+10
ZR-95	1 72E+06	5 44E+05	3 74E+05	0 00E+00	7 99E+05	0 00E+00	1 26E+09
NB-95	1 93E+05	1 07E+05	5 90E+04	0 00E+00	1 04E+05	0 00E+00	4 58E+08
RU-103	6 82E+06	0 00E+00	2 91E+06	0 00E+00	2 40E+07	0 00E+00	5 69E+08
RU-106	3 09E+08	0 00E+00	3 90E+07	0 00E+00	5 97E+08	0 00E+00	1 48E+10
AG-110M	1 52E+07	1 44E+07	8 73E+06	0 00E+00	2 74E+07	0 00E+00	4 03E+09
SB-124	1 55E+08	2 85E+06	6 03E+07	3 51E+05	0 00E+00	1 35E+08	3 11E+09
SB-125	2 14E+08	2 34E+06	5 01E+07	2 05E+05	0 00E+00	1 88E+08	1 67E+09
TE-129M	3 61E+08	1 34E+08	5 72E+07	1 17E+08	1 51E+09	0 00E+00	1 36E+09
I-131	7 68E+07	1 08E+08	5 78E+07	3 14E+10	1 85E+08	0 00E+00	2 13E+07
I-133	1 93E+06	3 28E+06	1 00E+06	4 58E+08	5 75E+06	0 00E+00	2 48E+06
CS-134	7 10E+09	1 67E+10	7 75E+09	0 00E+00	5 31E+09	2 03E+09	2 08E+08
CS-136	4 35E+07	1 71E+08	1 15E+08	0 00E+00	9 31E+07	1 47E+07	1 38E+07
CS-137	1 01E+10	1 35E+10	4 69E+09	0 00E+00	4 59E+09	1 78E+09	1 92E+08
BA-140	1 38E+08	1 69E+05	8 90E+06	0 00E+00	5 74E+04	1 14E+05	2 13E+08
CE-141	2 83E+05	1 89E+05	2 17E+04	0 00E+00	8 89E+04	0 00E+00	5 40E+08
CE-144	5 27E+07	2 18E+07	2 83E+06	0 00E+00	1 30E+07	0 00E+00	1 33E+10
ND-147	3 67E+04	4 00E+04	2 39E+03	0 00E+00	2 35E+04	0 00E+00	1 44E+08

<sup>1</sup> Dose factors are based upon NUREG 0133 methodology

<sup>2</sup> For Tritium the units of the dose parameters are mrem/yr per  $\mu\text{Ci}/\text{m}^3$  for all pathways, and they must be multiplied by X/Q

TITLE Off-Site Dose Calculations

Table 1067

GRW Dose Parameters<sup>1</sup> for Radioiodines, Radioactive Particulates, and any Radionuclide Other Than Noble Gas (IPT), Gaseous Effluents (GRW), Adult Age Group, Vegetation Pathway Organ "O"  
 (mrem/yr per  $\mu\text{Ci}/(\text{sec m}^2)$ )  $R_{i, \text{veg}}$

Nuclide	Bone	Liver	T Body	Thyroid	Kidney	Lung	GI-LLI
H-3 <sup>2</sup>	0 00E+00	1 29E+03	1 29E+03	1 29E+03	1 29E+03	1 29E+03	1 29E+03
CR-51	0 00E+00	0 00E+00	4 64E+04	2 77E+04	1 02E+04	6 15E+04	1 17E+07
MN-54	0 00E+00	3 13E+08	5 97E+07	0 00E+00	9 31E+07	0 00E+00	9 58E+08
FE-59	1 26E+08	2 96E+08	1 13E+08	0 00E+00	0 00E+00	8 27E+07	9 87E+08
CO-58	0 00E+00	3 08E+07	6 90E+07	0 00E+00	0 00E+00	0 00E+00	6 24E+08
CO-60	0 00E+00	1 67E+08	3 69E+08	0 00E+00	0 00E+00	0 00E+00	3 14E+09
ZN-65	3 17E+08	1 01E+09	4 56E+08	0 00E+00	6 75E+08	0 00E+00	6 36E+08
RB-86	0 00E+00	2 20E+08	1 03E+08	0 00E+00	0 00E+00	0 00E+00	4 34E+07
SR-89	9 95E+09	0 00E+00	2 86E+08	0 00E+00	0 00E+00	0 00E+00	1 60E+09
Y-90	1 33E+04	0 00E+00	3 57E+02	0 00E+00	0 00E+00	0 00E+00	1 41E+08
SR-90	6 95E+11	0 00E+00	1 40E+10	0 00E+00	0 00E+00	0 00E+00	1 75E+10
ZR-95	1 18E+06	3 77E+05	2 55E+05	0 00E+00	5 92E+05	0 00E+00	1 20E+09
NB-95	1 43E+05	7 95E+04	4 27E+04	0 00E+00	7 86E+04	0 00E+00	4 83E+08
RU-103	4 77E+06	0 00E+00	2 05E+06	0 00E+00	1 82E+07	0 00E+00	5 57E+08
RU-106	1 93E+08	0 00E+00	2 44E+07	0 00E+00	3 72E+08	0 00E+00	1 25E+10
AG-110M	1 05E+07	9 75E+06	5 79E+06	0 00E+00	1 92E+07	0 00E+00	3 98E+09
SB-124	1 04E+08	1 96E+06	4 11E+07	2 52E+05	0 00E+00	8 08E+07	2 95E+09
SB-125	1 37E+08	1 53E+06	3 25E+07	1 39E+05	0 00E+00	1 05E+08	1 50E+09
TE-129M	2 51E+08	9 37E+07	3 97E+07	8 62E+07	1 05E+09	0 00E+00	1 26E+09
I-131	8 07E+07	1 15E+08	6 62E+07	3 78E+10	1 98E+08	0 00E+00	3 05E+07
I-133	2 08E+06	3 62E+06	1 10E+06	5 32E+08	6 31E+06	0 00E+00	3 25E+06
CS-134	4 67E+09	1 11E+10	9 08E+09	0 00E+00	3 59E+09	1 19E+09	1 94E+08
CS-136	4 25E+07	1 68E+08	1 21E+08	0 00E+00	9 33E+07	1 28E+07	1 90E+07
CS-137	6 36E+09	8 70E+09	5 70E+09	0 00E+00	2 95E+09	9 81E+08	1 68E+08
BA-140	1 29E+08	1 61E+05	8 42E+06	0 00E+00	5 49E+04	9 24E+04	2 65E+08
CE-141	1 97E+05	1 33E+05	1 51E+04	0 00E+00	6 19E+04	0 00E+00	5 09E+08
CE-144	3 29E+07	1 38E+07	1 77E+06	0 00E+00	8 16E+06	0 00E+00	1 11E+10
ND-147	3 37E+04	3 90E+04	2 33E+03	0 00E+00	2 28E+04	0 00E+00	1 87E+08

<sup>1</sup> Dose factors are based upon NUREG 0133 methodology

<sup>2</sup> For Tritium the units of the dose parameters are mrem/yr per  $\mu\text{Ci}/\text{m}^3$  for all pathways, and they must be multiplied by X/Q

DIABLO CANYON POWER PLANT  
CAP A-8  
ATTACHMENT 11 1

1 AND 2

TITLE Liquid Discharges (LRW) Monitored for Radioactivity

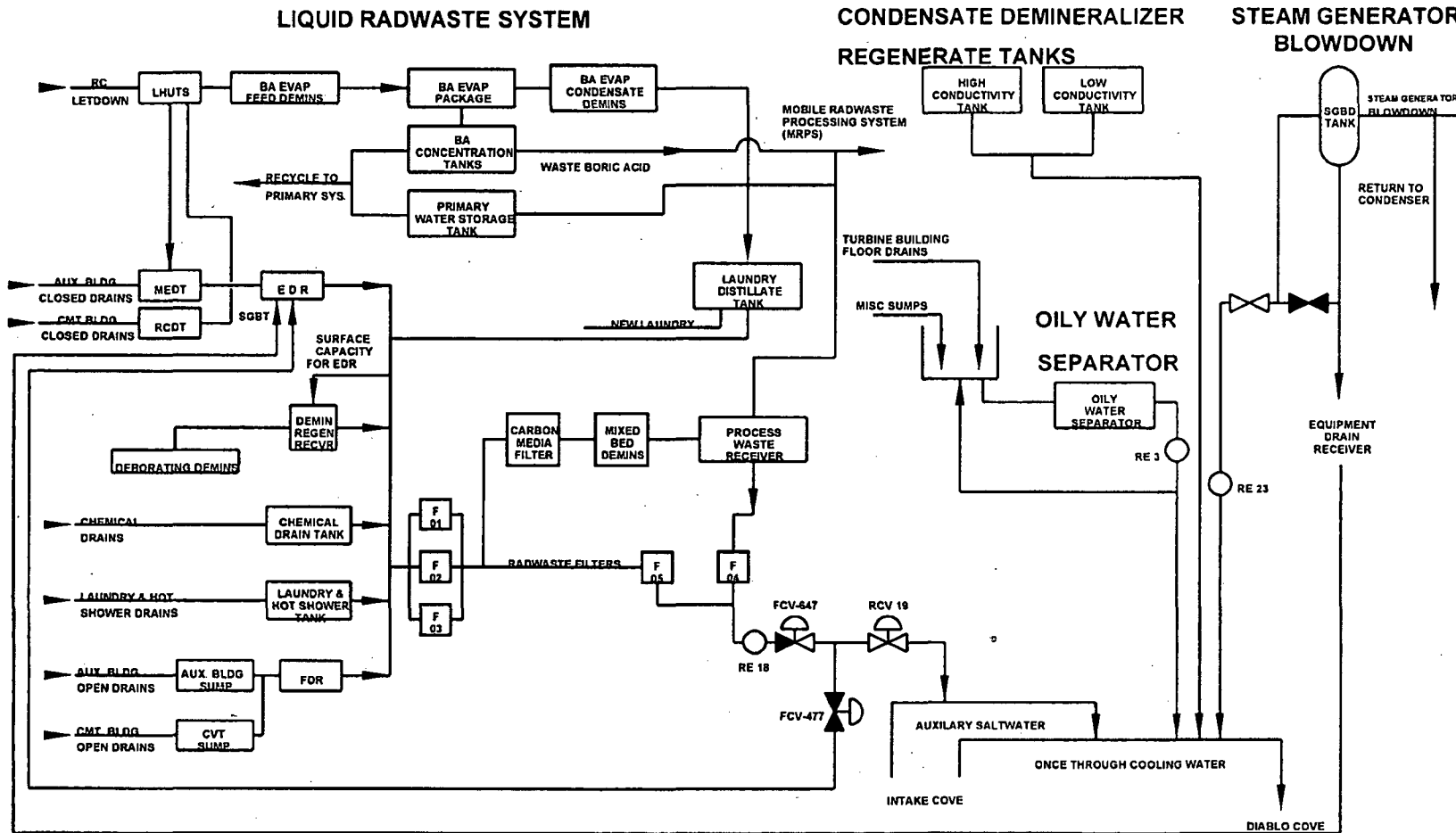

00692302



DIABLO CANYON POWER PLANT  
CAP A-8  
ATTACHMENT 11 2

# 1 AND 2

TITLE Gaseous Releases (GRW) Monitored for Radioactivity

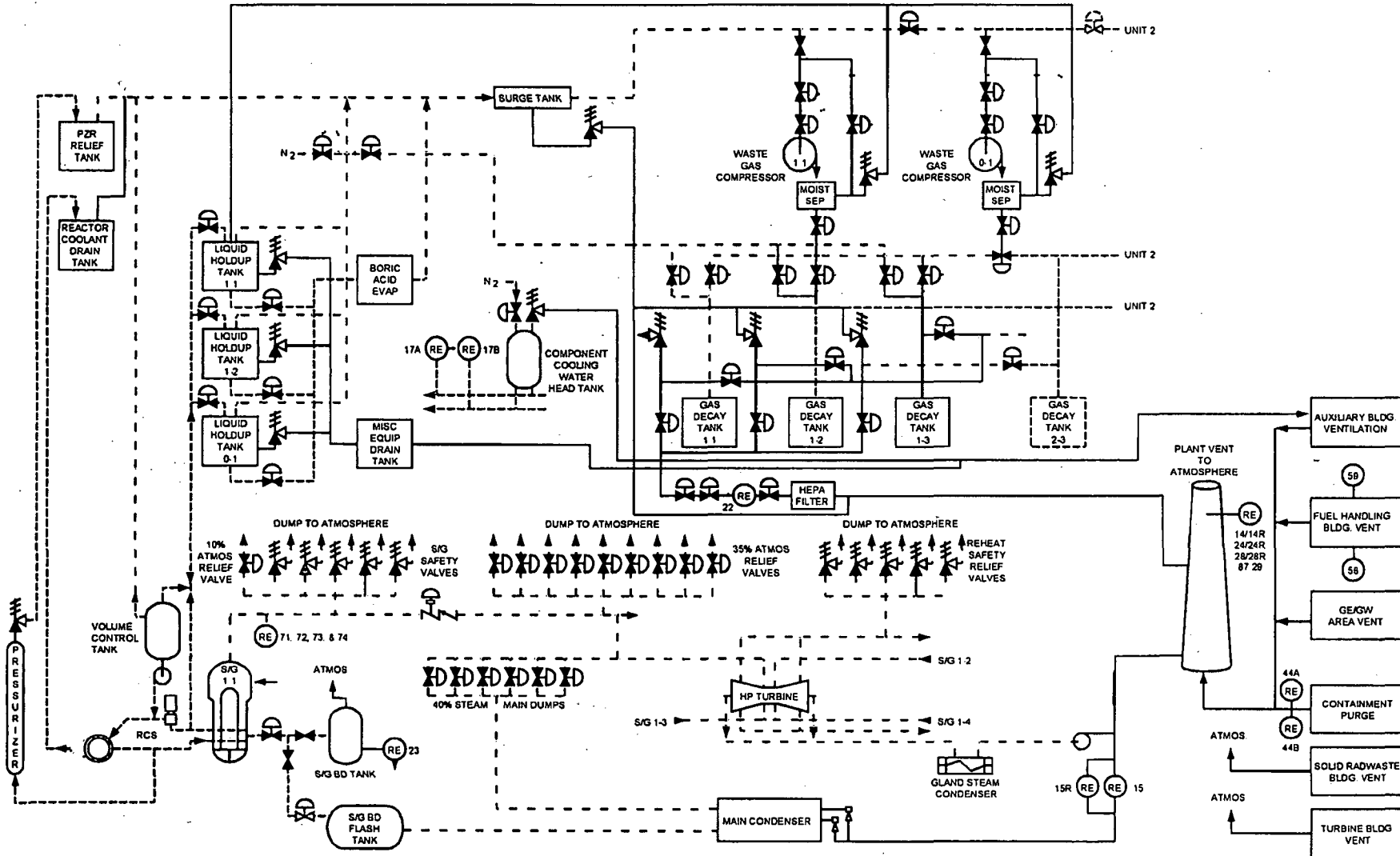

**Attachment 6**

**Diablo Canyon Power Plant Administrative Procedure,  
RP2.DC2, "Radwaste Solidification Process Control Program," Revision 14**

\*\*\* ISSUED FOR USE BY: \_\_\_\_\_ DATE: \_\_\_\_\_ EXPIRES: \_\_\_\_\_ \*\*\*  
PACIFIC GAS AND ELECTRIC COMPANY NUMBER RP2.DC2  
NUCLEAR POWER GENERATION REVISION 14  
DIABLO CANYON POWER PLANT PAGE 1 OF 5  
ADMINISTRATIVE PROCEDURE

TITLE: Radwaste Solidification Process Control Program

11/28/05  
EFFECTIVE DATE

---

PROCEDURE CLASSIFICATION: QUALITY RELATED  
SPONSORING ORGANIZATION: RADIATION PROTECTION  
REVIEW LEVEL: "A"

1. SCOPE

1.1 The purpose of the Radwaste Solidification Process Control Program (PCP) is to define the necessary program guidance used at the plant to ensure that activities to solidify wet radioactive waste for disposal, conform to the code of Federal and State regulations and the Waste Burial Site License criteria.

2. DISCUSSION

2.1 Solidification is the conversion of wet radioactive wastes into a form that meets shipping and burial ground requirements.

2.2 This procedure implements the requirements of 10 CFR 50.36a and General Design Criterion 60 of Appendix A to 10 CFR Part 50. The process parameters included in establishing the PROCESS CONTROL PROGRAM may include, but are not limited to, waste type, waste pH, waste/liquid/SOLIDIFICATION agent/catalyst ratios, waste oil content, waste principal chemical constituents, and mixing and curing times.

2.3 This procedure contains the individual procedures necessary to perform PCP sample solidifications.

2.4 Cement solidification will not be utilized to stabilize resin or floor drain sludges. Only NRC approved binders, state approved binders or binders submitted for state approval (e.g., Advanced Polymer) may be used to solidify resin or floor drain sludges to meet waste form stability.

3. RESPONSIBILITIES

3.1 Station director has the overall responsibility for the solid radioactive waste activities and approves changes to the PCP.

3.2 Radiation protection manager is responsible for the implementation of the requirements of this procedure.

3.3 Radwaste engineer is responsible for the development and review of procedures relating to the requirements of this procedure.

3.4 The radwaste foreman is responsible for the implementation of procedures relating to the requirements of this procedure.

3.5 Quality is responsible for verification of compliance with the program requirements.

TITLE: Radwaste Solidification Process Control Program

---

4. INSTRUCTIONS

4.1 GENERAL

It is the policy of the company to conscientiously apply emphasis and attention to those activities associated with generation, processing, packaging, storage and disposal of radioactive waste generated at the plant and to maintain a high level of assurance that radioactive waste forms meet or exceed the applicable federal and state regulations and the radioactive waste burial site license criteria.

4.1.1 Changes to this program requires submission to the US NRC in the annual Radioactive Effluent Release report for the period in which the changes were made.

4.1.2 Any major change to the solid radwaste treatment system shall be reported to the US NRC in the annual Radioactive Effluent Release report for the period in which the change was approved. The discussion of each system change shall contain the items listed in Attachment 6.2. This information may be submitted as part of the annual FSAR update in lieu of the annual Radioactive Effluent Release report.

4.2 WET WASTE

4.2.1 LIQUID/WET WASTE

Liquid/wet wastes are processed to a condition meeting shipping and disposal criteria. These criteria include requirements for immobilization, stability and limits on free standing water (FSW). Specific instructions on processing and required FSW limits are contained in plant procedures and/or qualified vendor procedures.

4.2.2 CONTAINERS, SHIPPING CASKS AND PACKAGING

Solid radioactive waste is processed, packaged and shipped in accordance with plant procedures and/or qualified vendor procedures. These procedures provide specific instructions which ensure the container, shipping casks, and packaging methods comply with the applicable code of federal regulations, state regulations and the radioactive waste burial site license criteria.

4.2.3 SHIPPING AND DISPOSAL

Solid radioactive waste is prepared, loaded and shipped to a federal and/or state licensed radioactive waste disposal facility (burial ground) in accordance with plant procedures and/or qualified vendor procedures. These procedures provide specific instructions which ensure the shipments meet the intended burial site license requirements as well as applicable federal and state regulations.

4.2.4 SPECIMEN SAMPLES

Qualified vendor procedures, approved by the station director, provide written instructions on sampling, processing and handling waste for the determination of process parameters prior to the actual full scale solidification. These procedures contain the description of the laboratory mixing methods used for specimen sample solidification.

**TITLE: Radwaste Solidification Process Control Program**

---

4.2.5 SOLIDIFICATION PROCESS

Qualified vendors used for radioactive waste solidification are required to provide the Process Control program and written procedures. These procedures and changes thereto must be approved by the station director prior to use. Further, the vendors are required to have an NRC topical report, state approval or submittal for state approval on the waste forms which will be solidified. These documents should include:

- a. Description of the solidification process.
- b. Type of solidification used.
- c. Process control parameters.
- d. Parameter boundary conditions.
- e. Proper waste form properties.
- f. Specific instructions to ensure the systems are operated within established process parameters.

4.2.6 SAMPLING PROGRAM FOR SOLIDIFICATION T32288

Vendors, utilized for radioactive waste solidification, are required to include in their approved procedures, requirements to sample at least every tenth batch of the same waste type to ensure solidification and to provide actions to be taken if a sample fails to verify solidification. After a test specimen failure, initial test specimens from three consecutive batches of that waste type must demonstrate solidification before testing requirements of every tenth batch can be resumed. Verification of such sampling is to be accomplished by completing Form 69-10350, "Processing Control Program (PCP) Verification." (See Attachment 6.1.) These forms will be maintained by radiation protection and in the Records Management System (RMS). These procedures and changes thereto must be approved by the station director prior to use.

4.2.7 WASTE FORM VERIFICATION

Vendors utilized to process wet wastes are required to include in their procedures provisions to verify that the solidification and/or FSW criteria in the federal and state regulations and the burial site license are met for the specific type of waste being processed.

4.2.8 CORRECTIVE ACTIONS FOR FREE STANDING WATER

Vendors utilized to process wet wastes are required to include in their approved procedures provisions for correcting processed waste in which free standing water in excess of the FSW criteria is detected.

TITLE: Radwaste Solidification Process Control Program

---

4.2.9 EXOTHERMIC PROCESSES

Vendors utilized for radioactive waste solidification that use an exothermic solidification method are required to include in their approved procedures:

- a. Waste/binder temperature monitoring to mitigate the consequence of adverse exothermic reactions which may occur in the full scale solidification but might not be noticeable in the specimen tests.
- b. Specific process control parameters that shall be met before capping the container.

4.3 OILY WASTE

Oily wastes are shipped to off-site processor for treatment. These processors provide the proper methods to treat oily wastes to comply with federal and state regulations and applicable burial site license criteria.

4.4 SPECIAL CASES

Based upon previous industry experience, the plant foresees the potential for situations arising that may be beyond existing plant capabilities. Anticipating this possibility, provisions are made herein to accommodate such situations in a timely manner by using special techniques or processes. These special cases would be controlled as follows:

- 4.4.1 Implementing procedures would be developed comparable to those used for normal plant solid waste activities based on the guidance of this PCP and incorporating the applicable provisions for process control and testing.
- 4.4.2 The implementing procedure would receive station director approval prior to use.
- 4.4.3 Use of this provision and supporting information would be included in the next annual Radioactive Effluent Release report to the NRC.

4.5 REMEDIAL ACTIONS

- 4.5.1 For waste forms which do not meet federal, state and burial site regulations and requirements, suspension of shipment of the inadequately processed waste and correction of the PCP, procedures or processing equipment shall be performed as necessary to prevent recurrence.
- 4.5.2 For waste forms not prepared in accordance with the PCP, testing of the waste to verify shipping and burial site requirements shall be performed and appropriate administrative action taken to prevent recurrence.

4.6 VENDOR REPORTS <sup>T32288</sup>

- 4.6.1 The following are maintained in Document Control Master File, Catalog No. TK 9400/NUKEM-1.
  - a. US DOE Waste Form Report INEEL/EXT-04-01501, Low-Level Waste Form Qualification Testing of the NUKEM Macro encapsulation Cartridge Filters Waste Form, January 2004.
  - b. Topical Report TR-002, 10 CFR 61 Qualified Radioactive Waste Forms, Rev. 1.

**TITLE: Radwaste Solidification Process Control Program**

---

- 4.6.2 The following are maintained in Document Control Master File, Catalog No. TK 94001 DTI-1.
- a. US DOE Waste Form Report INEEL/EXT-04-01505, Low-Level Waste Form Qualification Testing of the Diversified Technologies Polymer Waste Form, January 2004.
  - b. Topical Report DTI-VERI-100-NP-A, VERI™ (Vinyl Ester Resin In Situ) Solidification Process for Low-Level Radioactive Waste, Rev 1.
  - c. Topical Report DT-VERI-100-NP-A, Addendum1.ENCAP Encapsulation Utilizing the VERI Solidification Process.
  - d. Topical Report DNS-RSS-200-NP, The Dow Waste Solidification Process for Low-Level Radioactive Waste (Docket Number WM-82).

4.7 **VENDOR PROCEDURES**

A roster of the currently approved vendor Process Control Program procedures is located in NPG Library/Radiation Protection/RadWaste/RW Vendor Waste Form Procedures.

5. **RECORDS**

- 5.1 Records of PCP specimen results and Form 69-10350 shall be submitted to the Records Management System on a shipment basis by container per RCP RW-4.

6. **ATTACHMENTS**

- 6.1 Form 69-10350, "Process Control Program (PCP) Verification," 06/03/93  
6.2 "Major Change to the Solid Radwaste Treatment System Evaluation," 05/24/01

7. **REFERENCES**

- 7.1 Title 10 Code of Federal Regulations.  
7.2 NUREG 0472 and 0473.  
7.3 NUREG-0800, 11.4 US NRC Standard Review Plan Solid Waste Management Systems.  
7.4 RP2.DC3, "Radwaste Dewatering Process Control Program."  
7.5 NRC Information Notice 88-08, Chemical Reactions with Radioactive Waste Solidification Agents.  
7.6 Technical Position on Waste Form, Revision 1, US NRC, January 1991.  
7.7 Cement Encapsulation of Cartridge Filters to Provide Waste Form Stability Basis Document, Rev. 1, PG&E NRS Log 0087.  
7.8 Encapsulation of Cartridge Filters In Vinyl Ester Styrene (VES) to Provide Waste Form Stability Basis Document, Rev. 0, PG&E NRS Log 0072.

DIABLO CANYON POWER PLANT  
 RP2.DC2  
 ATTACHMENT 6.1

TITLE: Process Control Program (PCP) Verification

DATE	WASTE BATCH		PCP		NOTES	OPERATOR	VERIFIER
	Number	Type	Passed	Failed			



DIABLO CANYON POWER PLANT  
RP2.DC2  
ATTACHMENT 6.2

TITLE: Major Change to the Solid Radwaste Treatment System Evaluation

1. A summary of the evaluation that led to the determination that the change could be made in accordance with 10 CFR 50.59;
2. Sufficient detailed information to totally support the reason for the change without benefit of additional or supplemental information;
3. A detailed description of the equipment, components and processes involved and the interfaces with other plant systems;
4. An evaluation of the change which shows the predicted releases of radioactive materials in liquid and gaseous effluents and/or quantity of solid waste that differ from those previously predicted in the License application and amendments thereto;
5. An evaluation of the change which shows the expected maximum exposures to a MEMBER OF THE PUBLIC in the UNRESTRICTED AREA and to the general population that differ from those previously estimated in the License application and amendments thereto;
6. A comparison of the predicted releases of radioactive materials, in liquid and gaseous effluent and in solid waste, to the actual releases for the period prior to when the changes are to be made;
7. An estimate of the exposure to plant operating personnel as a result of the change; and
8. Documentation of the fact that the change was reviewed and found acceptable.

**Attachment 7**

**2008 Land Use Census**

## 2008 DCPD LAND USE CENSUS

Diablo Canyon Power Plant (DCPP) Radiological Environmental Monitoring Program (REMP) personnel conducted a Land Use Census in the vicinity of DCPD for 2008. The land use census is based on Nuclear Regulatory Commission Regulatory Guide 8, "Environmental Technical Specifications for Nuclear Power Plants" and 10 CFR 50 Appendix I, Section IV, B. 3. DCPD Program Directive CY2, "Radiological Monitoring and Controls Program" requires performance of a land use census.

DCPP IDAP RP1.ID11, "Environmental Radiological Monitoring Procedure," requires identification of the nearest milk animal, nearest residence, and the nearest broadleaf producing garden greater than 50 square meters (500 square feet) in each of the landward meteorological sectors within a distance of 8 kilometers (5 miles) of the plant. The land use census is conducted at least once per year during the growing season (between Feb 15 and Dec 1) for the Diablo Canyon environs.

The 2008 Land Use Census was conducted via a helicopter overflight and landowner telephone interviews. The helicopter over-flight was conducted on September 3, 2008. The telephone interviews were conducted November 12 through November 20, 2008. Thirteen individual landowners or tenants were contacted.

### **Milk**

No milk animals were identified within the first 8 kilometers (5 miles) of any sector.

### **Residences**

The nearest residence, relative to all sectors, is a small trailer located in the NW sector about 1.93 kilometers (1.2 miles) from the plant. Ranch workers occupy this Blanchard residence approximately 1 month per year during cattle round-ups.

A total of 16 residences were identified within the 8-kilometer (5-mile) radius of the plant, which were confirmed or appear to be occupied during 2008. Two abandoned structures are located in each of the NNW and NNE sectors.

The nearest residence in each sector is summarized in Table 1.

### **Gardens**

The land use census identified two household gardens greater than 50 square meters (500 square feet) that produce broadleaf vegetation. The Read garden is approximately 1/4 acre, and located in the NNE sector at 7.08 kilometers (4.41 miles). The Koonze garden is approximately 500 square feet, and located in the E sector at 7.24 kilometers (4.5 miles).

Mello manages a farm on the coastal plateau, along the site access road, in the ESE sector. The farm starts at approximately 4.8 km and extends to 7.2 km (3 to 4.5 miles) from the plant. This commercial farm produces no broadleaf vegetation. The farm area is about 100 acres of land with 6 to 10 rotational plantings per year (not all 100 acres planted at any one time). Commercial crops consist of about 10 percent squash and 90 percent cereal grass (oat hay). Less than 10 farm workers periodically occupy this area during the growing season.

### **Additional Land Use**

Much of the area outside the plant site-boundary is used for rotational cattle grazing by five separate cattle operations. For purposes of this census, the five cattle ranches are called Blanchard, Sinsheimer, Read, Andre, and Mello.

Blanchard has about 120 cattle outside the plant site-boundary and utilizes the NW, NNW, N, and NNE sectors. About 80 yearling cattle were sold to mass market in 2008. Blanchard slaughtered two cattle in 2008 for personal consumption.

Additionally, Blanchard managed about 200 goats that were used for weed abatement in all landward sectors within the plant site-boundary. During 2008, approximately 100 baby goats were born and then taken to Santa Margarita California where they are grass fed for 1 year. After 1 year, the 100 yearling goats are then to be sold to mass-market. Blanchard slaughtered one goat in 2008 for personal consumption.

Blanchard also managed about 100 sheep outside the plant site-boundary in the NW and NNW sectors. These sheep were allowed to breed and the yearlings were sold to mass market. Blanchard slaughtered one sheep in 2008 for personal consumption.

Blanchard meats were sampled by REMP personnel.

Sinsheimer has about 100 cattle outside the plant site-boundary in the NNE sector. These cattle were allowed to breed and about 90 calves were sold to mass market in 2008. Sinsheimer did not slaughter any cattle for personal consumption in 2008.

Read has about 150 cattle outside the plant site-boundary in the NNE sector.

Andre has about 80 cattle outside the plant site-boundary in the ENE sector. About 80 calves were sold to mass market in 2008. Andre did not slaughter any cattle in 2008 for personal consumption.

Mello manages about 1000 cattle outside the plant site-boundary in the E, ESE, and SE sectors. Harris Ranch Beef Corporation owned these cattle and sold all of them to mass market in 2008. Mello did not slaughter any cattle in 2008 for personal consumption.

Two landowners (Johe and Andre) take wild game for personal consumption outside the plant site-boundary in the NNE, NE, and ENE sectors. This wild game consists of approximately two deer and four wild pigs per landowner.

There is a California State Park Ranger Office in the NNW sector at 7.483 kilometers (4.65 miles) from the plant. Approximately 3 people occupy this office from 1000 to 1500 each day per week.

There is a public campground located in the NNW sector at Montana de Oro State Park at 7.387 kilometers (4.59 miles). This campground is near Spooner's Cove.

### **Groundwater Impacts**

On November 17, 2008, DCPD ceased make-up water usage from Diablo Creek (REMP station 5S2). The lower dam was breached due to Coastal Commission requirements for the Old Steam Generator Storage Facility building permit. Prior to November 17, DCPD used approximately 80 gallons per minute (gpm) of creekwater as a makeup source to the 100K tank which provided water to the plant makeup reservoir, and the 30K tank which provided water to the plant fire suppression system.

To replace the creek makeup water source, DCPD refurbished Water Well 02 (REMP station WW2). Prior to November 2008, this WW2 provided aquifer water at approximately 10 gpm to DCPD makeup systems. After November 2008, WW2 is expected to supply approximately 100 gpm to the 100K and 30K tanks.

WW2 was refurbished to be a production well 350 ft deep with a 10-inch casing. Test results verified the well could sustain more than 150 gpm even during drought conditions. Drawdown test data show the WW2 pump ground elevation at 333 ft above sea level with the maximum drawdown of the well during normal operation at 133 ft above sea level. Therefore, this aquifer resides at an elevation of approximately 133 ft above sea level. With the DCPD power block located at approximately 115 ft to 50 ft above sea level, there is little chance of plant power block communication with the WW2 aquifer.

In support of this WW2 refurbishment, two additional exploration wells were drilled and permitted for testing only. One well is Water Well 04, which is 506 ft deep and is located southwest of WW2. Another test well is Water Well 05, which is 409 ft deep and is located northeast of WW2 in the paved area behind the document storage

building (near the maintenance garage). Both wells are over 1/2 mile to the east of the plant power block. Water Well 04 and Water Well 05 have been capped and are no longer available.

An old 13K water tank is located directly east of the 500 kV switchyard and near Water Well 01 (WW1). This old 13K water tank historically received water from the pre-November 2008 WW2. During these makeup water construction changes, a new 13K water tank was constructed near the actual physical location of WW2. The old 13K was abandoned. The makeup water flow from WW2 is now to this new 13K tank (acting as a surge tank) which then feeds into the 100K tank.

Aquifer testing was conducted by Environmental and Natural Resource Management Consultants, and the final report submitted to DCPD (dated August 22, 2008).

Table 1 summarizes the nearest residence location in each meteorological sector.

Figure 3 shows the location of the residences and gardens in the vicinity of DCPD.

Table 1

**Land Use Census 2008**  
**Distance in Kilometers (and Miles) from the Point Located Centrally Between**  
**both Units Nearest Milk Animal, Residence, and Vegetable Garden**

<b>22½ Degree (a) Radial Sector</b>	<b>Nearest Milk Animal</b>	<b>Nearest Residence Km (mi)</b>	<b>Residence Azimuth Degree</b>	<b>Nearest Vegetable Garden km (mi)</b>
NW	None	1.93 (1.2)	319.5	None
NNW	None	2.41 (1.5) <sup>(b)</sup>	331	None
N	None	None	—	None
NNE	None	5.21 (3.2)	019.8	7.08 (4.4) <sup>(c)</sup>
NE	None	7.89 (4.9)	036	None
ENE	None	7.08 (4.4)	063.5	None
E	None	5.95 (3.7)	097.5	7.24 (4.5) <sup>(d)</sup>
ESE	None	None	—	5.31 (3.3) <sup>(e)</sup>
SE	None	None	—	None

Table Notation:

- (a) Sectors not shown contain no land (other than islets not used for the purposes indicated in this table) beyond the site-boundary.
- (b) Blanchard residence is the full-time residence for critical receptor calculations.
- (c) The Read vegetable garden is located in the NNE sector and located at the 020 azimuth degree. There is also a full time residence at this location.
- (d) The Koonze vegetable garden is located in the E sector and located at the 098 azimuth degree. There is also a full time residence at this location.
- (e) The Mello garden is the commercial farm along the westward side of the site access road; however, it does not produce broadleaf vegetation. This farm extends from 4.8 km to 7.2 km (3 to 4.5 miles) from the plant.

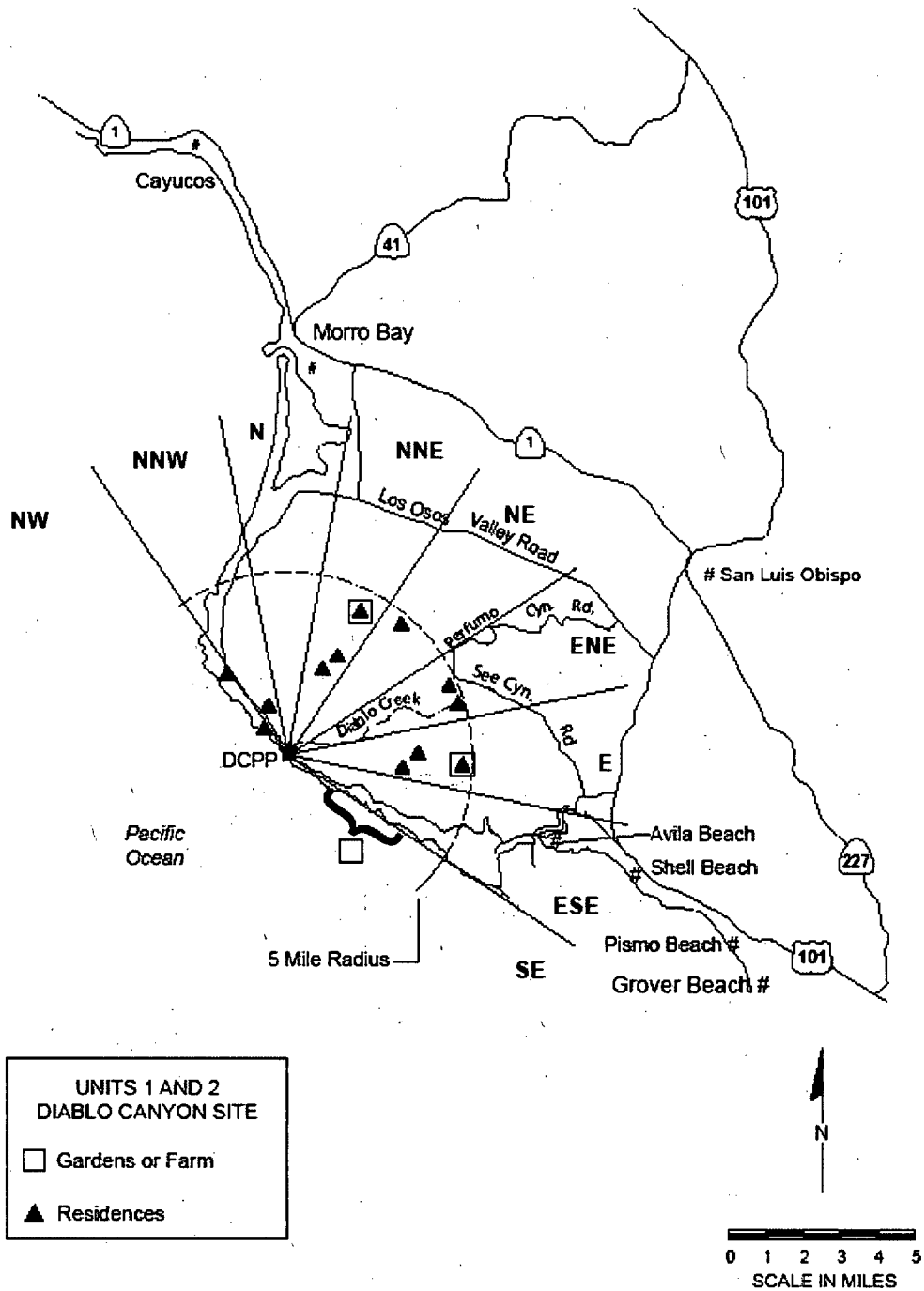

Figure 3. Units 1 and 2 Diablo Canyon Power Plant Land Use Census.