

BSC

**Study Cover Sheet**

QA: N/A

**YUCCA MOUNTAIN PROJECT**

Concepts for Waste Retrieval and Alternate Storage of Radioactive Waste  
(Study Title)

Page 1 of 32

DOE Contract No.:  
DE-AC28-01RW12101

007	1/9/08	Update to Cover Sheet, Footers, Figure 4, and References. Identified as an informal study in Section 3.1	K. Draper <i>Kate D. Draper</i>	M. Johnson <i>Mark Johnson</i>	M. Johnson <i>Mark Johnson</i>	N/A
006	10/23/2007	Update to Figure 4, and references.	M.D. Voegele	M. Johnson	M. Johnson	N/A
005	9/5/2007	Update to Figure 2, 4, and references.	M.D. Voegele	R. Thornley	M. Johnson	N/A
004	5/31/2007	Issued to resolve CR 10652	M.D. Voegele	R. Thornley	M. Johnson	N/A
003	5/18/2007	Complete Revision to align with new retrieval equipment and strategy. No change bars shown.	M.D. Voegele	R. Thornley	M. Prytherch	N/A
002	3/29/2005	Minor changes made to align with SAR Section 1.11.	F. Bierich		M. Prytherch	N/A
001	10/6/2004	Changed discussion from multiple locomotives to a single locomotive. Made editorial changes throughout to address clarity and readability. Changed QA designator of the document. Updated to reflect changes in recovery strategies and concepts for off-normal retrieval. Revision bars identify changes.	J. Heineman		M. Prytherch	N/A
000	2/24/2004	Initial issue	F. Bierich A.D. Krug		M. Prytherch	N/A
Rev.	Date	Reason for Revision	By Print Name and Sign	EGS/Lead Print Name and Sign	PE/RM Print Name and Sign	DEM Print Name and Sign

Document No.:  
800-30R-HER0-00100-000

Rev.:  
007

**DISCLAIMER**

This study was prepared as an account of work sponsored by an agency of the United States Government. Neither the United States Government nor any agency thereof, nor any of their employees, nor any of their contractors, subcontractors or their employees, makes any warranty, express or implied, or assumes any legal liability or responsibility for the accuracy, completeness, or any third party's use or the results of such use of any information, apparatus, product, or process disclosed, or represents that its use would not infringe privately owned rights. Reference herein to any specific commercial product, process, or service by trade name, trademark, manufacturer, or otherwise, does not necessarily constitute or imply its endorsement, recommendation, or favoring by the United States Government or any agency thereof or its contractors or subcontractors. The views and opinions of authors expressed herein do not necessarily state or reflect those of the United States Government or any agency thereof.

## CONTENTS

1	INTRODUCTION .....	5
1.1	PURPOSE .....	5
1.2	SCOPE .....	5
2	REFERENCES .....	6
2.1	DOCUMENTS CITED .....	6
2.2	CODES, STANDARDS, REGULATIONS, AND PROCEDURES.....	7
3	QUALITY.....	7
3.1	QUALITY ASSURANCE.....	7
3.2	USE OF COMPUTER SOFTWARE.....	7
4	TIMELINE FOR RETRIEVAL.....	7
4.1	WINDOW OF TIME TO INITIATE RETRIEVAL .....	7
4.2	DURATION OF THE RETRIEVAL PERIOD .....	8
5	ACCESS TO THE SUBSURFACE REPOSITORY .....	8
5.1	GENERAL DESCRIPTION OF THE SUBSURFACE REPOSITORY.....	8
5.2	EMPLACEMENT DRIFT PANEL DESCRIPTIONS .....	9
6	WASTE RETRIEVAL OPERATIONS.....	11
6.1	CONCEPT OF OPERATIONS FOR WASTE RETRIEVAL.....	11
6.2	RETRIEVAL OPERATIONS .....	11
6.3	POTENTIAL RETRIEVAL PROBLEMS .....	15
7	ALTERNATE STORAGE FACILITY .....	19
7.1	SCOPE .....	19
7.2	CONCEPT OF OPERATIONS .....	20
7.3	SITE LOCATION AND DESCRIPTION.....	20
7.4	FACILITIES .....	21
8	RADIATION PROTECTION .....	29
8.1	RETRIEVAL OPERATION-HAZARDS ANALYSES AND PRECLOSURE SAFETY .....	29
8.2	ALTERNATE STORAGE FACILITY OPERATIONS-HAZARDS ANALYSES AND PRECLOSURE SAFETY ASSESSMENTS.....	30
8.3	OPERATION-OCCUPATIONAL DOSE ESTIMATES AND ENGINEERING AND ADMINISTRATIVE CONTROLS (ALARA).....	30
9	COMPATIBILITY OF RETRIEVAL WITH RELATED REPOSITORY OPERATIONS.....	31
9.1	PERFORMANCE CONFIRMATION .....	31
9.2	DRIP SHIELD REMOVAL .....	31
9.3	BACKFILLING OF EMPLACEMENT DRIFTS.....	31
10	SUMMARY .....	32

## FIGURES

	<b>Page</b>
1: Retrieval Timeline .....	8
2: Subsurface Layout .....	10
3: TEV Concept .....	18
4: Possible Scenario 1 Site - Alternate Storage Facility .....	23
5: Scenario 1 Conceptual Operations Mechanical Flow .....	24
6: Alternate Storage Facility Scenario 1 Conceptual Layout.....	25
7: Waste Retrieval Transfer Building Scenario 1 Conceptual Design.....	26
8: Concrete Storage Unit Scenario 1 Concept .....	27
9: Mobile Lifting Gantry Conceptual Design .....	28
10: Modular Concrete Storage Pad Scenario 1 Conceptual Design .....	29

## ACRONYMS AND ABBREVIATIONS

ALARA	as low as is reasonably achievable
BSC	Bechtel SAIC Company, LLC
CCC	central control center
CFR	code of federal regulations
CSU	concrete storage unit
DOE	U.S. Department of Energy
HEMF	Heavy Equipment Maintenance Facility
kW/m	kilowatt(s) per meter
MTHM	metric tons of heavy metal
NRC	U.S. Nuclear Regulatory Commission
SSC	structure, system, or component
TEV	Transport and Emplacement Vehicle

# 1 INTRODUCTION

## 1.1 PURPOSE

The primary purpose of this study is to present:

- Concepts for retrieval operations
- Equipment to be used
- Scenarios under which waste retrieval operations will take place
- Methods for responding to potential retrieval problems
- Compliance with the preclosure performance objectives of 10 CFR 63.111(a) and (b) (Reference 2.2.1) during the retrieval of waste packages from the subsurface repository.

If a decision for retrieval is made for any or all of the waste, the waste to be retrieved would be dispositioned in accordance with the regulations applicable at the time.

The secondary purpose is to present concepts for the design, construction, and operation of an alternate storage facility. The alternate storage facility would serve to temporarily house the retrieved waste until final disposition of the waste is established. The concept presented is consistent with current practices and regulations for protection of public health and safety and the environment and demonstrates the feasibility of such a facility, if required.

## 1.2 SCOPE

The basis for this study is the assumption that retrieval can be generally conducted in a reversed order from emplacement using the same equipment. Consequently, the methods and procedures developed for the emplacement process are assumed to be applicable and are used for retrieval. The scope of this study is primarily limited to the consideration of retrieval under normal operating conditions. Off-normal recovery scenarios for individual waste packages or small numbers of waste packages are discussed only to illustrate that there are no foreseeable events that would prevent the retrieval of emplaced waste. The discussion of retrieval presented in this study is an adaptation of previous studies of retrieval and alternate storage of radioactive waste and does not represent new technical analysis. The findings of those studies were considered in the development of the approaches presented in this study.

Recovery is used in this document to indicate the return from an off-normal condition to a normal operating regime. Retrieval is defined in 10 CFR 63.2 (Reference 2.2.1) and is used in this document as “the act of permanently removing radioactive waste from the underground location at which the waste had been previously emplaced for disposal.” Retrieval may be implemented on the basis of a policy decision to (non-inclusive): protect public health and safety, address environmental concerns, recover economically valuable constituents of the spent fuel, or approach disposal in a different manner. Until a decision is made to permanently close the repository, the design must preserve the option to retrieve the emplaced nuclear waste as required in 10 CFR 63.111(e) (Reference 2.2.1). The design approach to satisfy this requirement is that nothing in the repository design or the emplacement process shall preclude the retrieval of any or all waste packages.

## 2 REFERENCES

### 2.1 DOCUMENTS CITED

- 2.1.1 BSC 2003 *Radiological Releases Due to Air and Silica Dust Activation in Emplacement Drifts*. 800-00C-EBS0-00100-000-00A. Las Vegas, Nevada: Bechtel SAIC Company. ACC: ENG.20030509.0001; ENG.20050816.0006. (DIRS 164562)
- 2.1.2 BSC 2007. *Underground Layout Configuration for LA*. 800-KMC-SS00-00200-000-00B. Las Vegas, Nevada: Bechtel SAIC Company. ACC: ENG.20070727.0004; ENG.20071214.0002. (DIRS 179640)
- 2.1.3 BSC 2005. *Categorization of Event Sequences for License Application*. 000-00C-MGR0-00800-000-00C. Las Vegas, Nevada: Bechtel SAIC Company. ACC: ENG.20050808.0003; ENG.20050929.0003. (DIRS 174467)
- 2.1.4 BSC 2007. *Geologic Repository Operations Area Overall Site Plan*. 000-C00-MGR0-00201-000 REV 00D. Las Vegas, Nevada: Bechtel SAIC Company. ACC: ENG.20071116.0003. (DIRS 184213)
- 2.1.5 BSC 2004. *Performance Confirmation Plan*. TDR-PCS-SE-000001 REV 05. Las Vegas, Nevada: Bechtel SAIC Company. ACC: DOC.20041122.0002. (DIRS 172452)
- 2.1.6 BSC 2004. *Ventilation Model and Analysis Report*. ANL-EBS-MD-000030 REV 04. Las Vegas, Nevada: Bechtel SAIC Company. ACC: DOC.20041025.0002. (DIRS 169862)
- 2.1.7 CRWMS M&O 1999. *Repository Surface Design Engineering Files Report*. BCB000000-01717-5705-00009 REV 003. Las Vegas, Nevada: CRWMS M&O. ACC: MOL.19990615.0238. (DIRS 104508)
- 2.1.8 BSC 2007. *Project Design Criteria Document*. 000-3DR-MGR0-00100-000-007. Las Vegas, Nevada: Bechtel SAIC Company. ACC: ENG.20071016.0005; ENG.20071108.0001; ENG.20071220.0003; ENG.20080107.0001; ENG.20080107.0002; ENG.20080107.0016; ENG.20080107.0017. (DIRS 179641)
- 2.1.9 Edwards, T.A. and Yuan, Y. 2003. *Recommended Surface Contamination Levels for Waste Packages Prior to Placement in the Repository*. 000-30R-OSS0-00100-000-000. Las Vegas, Nevada: Bechtel SAIC Company. ACC: ENG.20030903.0001. (DIRS 164177)
- 2.1.10 Williams, N.H. 2003. "Contract No. DE-AC28-01RW12101 – Licensing Position-034, Preclosure Period Duration." Letter from N.H. Williams (BSC) to J.D. Ziegler (DOE/ORD), December 15, 2003, 1209039726, with enclosure. ACC: MOL.20040107.0059. (DIRS 166503)
- 2.1.11 BSC 2007. *Basis of Design for the TAD Canister-Based Repository Design Concept*. 000-3DR-MGR0-00300-000-001. Las Vegas, Nevada: Bechtel SAIC Company. ACC: ENG.20071002.0042; ENG.20071026.0033; ENG.20071108.0002; ENG.20071109.0001; ENG.20071120.0023; ENG.20071126.0049; ENG.20071214.0009; ENG.20071213.0005; ENG.20071227.0018. (DIRS 182131)
- 2.1.12 BSC 2007. *Strategies for Recovery After an Off-Normal Event to the Waste Package Transport and Emplacement Vehicle*. 800-30R-HE00-01800-000 REV 000. Las Vegas, Nevada: Bechtel SAIC Company. ACC: ENG.20070531.0043. (DIRS 182303)

## **2.2 CODES, STANDARDS, REGULATIONS, AND PROCEDURES**

- 2.2.1 10 CFR 63. 2007. Energy: Disposal of High-Level Radioactive Wastes in a Geologic Repository at Yucca Mountain, Nevada. Internet Accessible. (DIRS 180319)
- 2.2.2 66 FR 55732. Disposal of High-Level Radioactive Wastes in a Proposed Geologic Repository at Yucca Mountain, NV, Final Rule. 10 CFR Parts 2, 19, 20, 21, 30, 40, 51, 60, 61, 63, 70, 72, 73, and 75. ACC: MOL.20050324.0102; MOL.20050418.0124. (DIRS 156671)
- 2.2.3 EG-PRO-3DP-G04B-00016 Rev 004, *Engineering Studies*. Las Vegas, Nevada: Bechtel SAIC Company.
- 2.2.4 IT-PRO-0011, Rev. 7. *Software Management*. Las Vegas, Nevada: Bechtel SAIC Company.

## **3 QUALITY**

### **3.1 QUALITY ASSURANCE**

This informal study was prepared in accordance with EG-PRO-3DP-G04B-00016, *Engineering Studies*.

### **3.2 USE OF COMPUTER SOFTWARE**

No computer software subject to IT-PRO-0011, *Software Management* was used in the development of this document. Graphic figures are presented for illustrative purposes only and were not used for any computations.

## **4 TIMELINE FOR RETRIEVAL**

### **4.1 WINDOW OF TIME TO INITIATE RETRIEVAL**

The Code of Federal Regulations (10 CFR 63.111(e)(1)) (Reference 2.2.1) states that:

“The geologic repository operations area must be designed to preserve the option of waste retrieval throughout the period during which wastes are being emplaced and thereafter, until the completion of a performance confirmation program and Commission review of the information obtained from such a program. To satisfy this objective, the geologic repository operations area must be designed so that any or all of the emplaced waste could be retrieved on a reasonable schedule starting at any time up to 50 years after waste emplacement operations are initiated, unless a different time period is approved or specified by the Commission.”

Currently the design includes a 50-year period of forced ventilation following the completion of waste emplacement and prior to closure of the repository (Reference 2.1.6). (The 50-year ventilation period only applies to a 1.45 kW/m thermal loading of the emplacement drifts. A different ventilation period may be appropriate for a different loading scenario.) Consequently, since the Performance Confirmation program will run through this period of forced ventilation, the option to retrieve must be preserved until the completion of the ventilation program (Reference 2.1.10).

The current repository program schedule is that waste package emplacement will begin in 2017 and continue for 24 to 30 years. The waste retrieval option must be preserved for an additional 50 years to complete the ventilation program. During this time, Commission review of the

performance confirmation information would occur. DOE schedule reassessments may affect the retrieval period, as well.

The anticipated period of retrievability will extend until the decision is made to perform permanent closure. This period envelopes the 50-year period specified in 10 CFR 63.111(e)(1) and is consistent with the 100-year maximum period required for retrieval equipment maintainability and replacement (Reference 2.1.11, *Section 2.2.2.7*).

## 4.2 DURATION OF THE RETRIEVAL PERIOD

The Code of Federal Regulations (10 CFR 63.111(e)(3)) (Reference 2.2.1) states that:

“...a reasonable schedule for retrieval is one that would permit retrieval in about the same time as that required to construct the geologic repository operations area and emplace waste.”

Any new construction needed for retrieval would need to be completed in time to support completion of retrieval in a period equivalent to the planned schedule for construction of the repository and emplacement of waste.

A conceptual timeline of retrieval activities is presented in Figure 1. This timeline reflects estimates of timeframes involved in the standard license amendment process with the engineering, procurement, and construction activities needed to support retrieval operations.

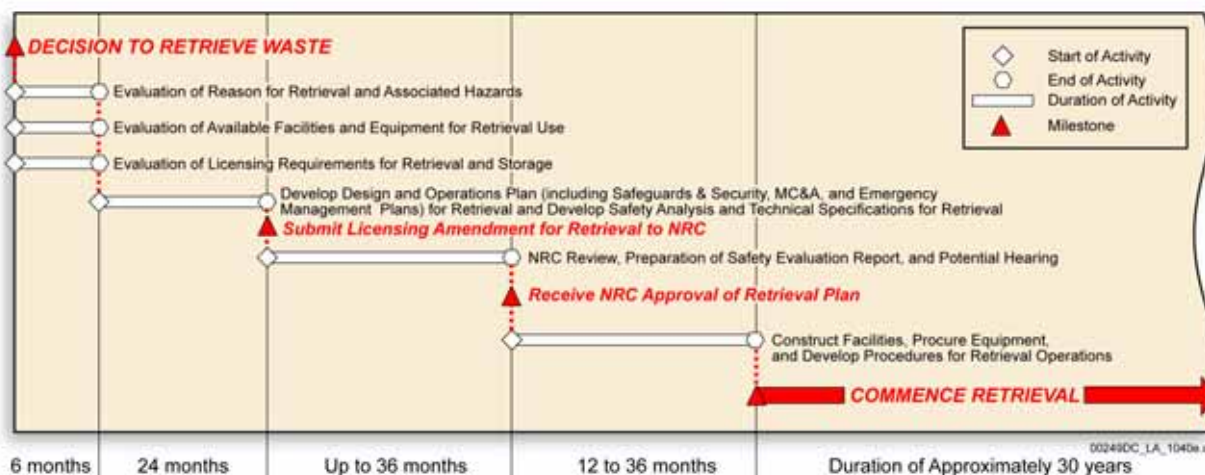

Figure 1: Retrieval Timeline

## 5 ACCESS TO THE SUBSURFACE REPOSITORY

### 5.1 GENERAL DESCRIPTION OF THE SUBSURFACE REPOSITORY

The layout of the underground repository consists of four panels as shown in Figure 2. These panels will accommodate a total of 70,000 metric tons of heavy metal (MTHM) of spent nuclear fuel and high-level radioactive waste. Access to the individual emplacement drifts for each of these panels is discussed in the following section.

Access to the subsurface repository starts with the North Portal (Figure 2) and the north ramp that leads to the access mains and the individual emplacement drifts in each drift panel. All waste package transportation for waste retrieval will be through the North Portal, north ramp,



and connecting access mains. The south ramp and the north construction ramp are used for purposes of construction and ventilation of the subsurface repository but not for waste retrieval.

The panels are to be constructed sequentially in the order numbered, e.g., Panel 1 will be constructed first and Panel 4 will be the last to be constructed. As the drifts within each panel are completed, emplacement will follow in the same order.

## **5.2 EMPLACEMENT DRIFT PANEL DESCRIPTIONS**

The initial emplacement will be in Panel 1, located within the central section of the overall layout as shown in Figure 2. The size of the panel is relatively small in comparison to the other panels in the repository. The path to the emplacement drifts for waste emplacement and retrieval equipment will be through the north ramp and the Panel 1 access main (Figure 2).

Panel 2 is located to the south of Panel 1. Entry to the emplacement drifts for waste emplacement and retrieval will be through the Panel 1 access main to the Panel 2 access main.

Panel 3, located to the north of Panel 1, is divided into two zones, the east and west. Entry to the emplacement drifts for waste emplacement and retrieval will be through the Panel 3 access main.

Panel 4 is located to the west of Panel 3. Entry to the emplacement drifts for waste emplacement and retrieval will be through the Panel 1 access main to the Panel 4 access main.

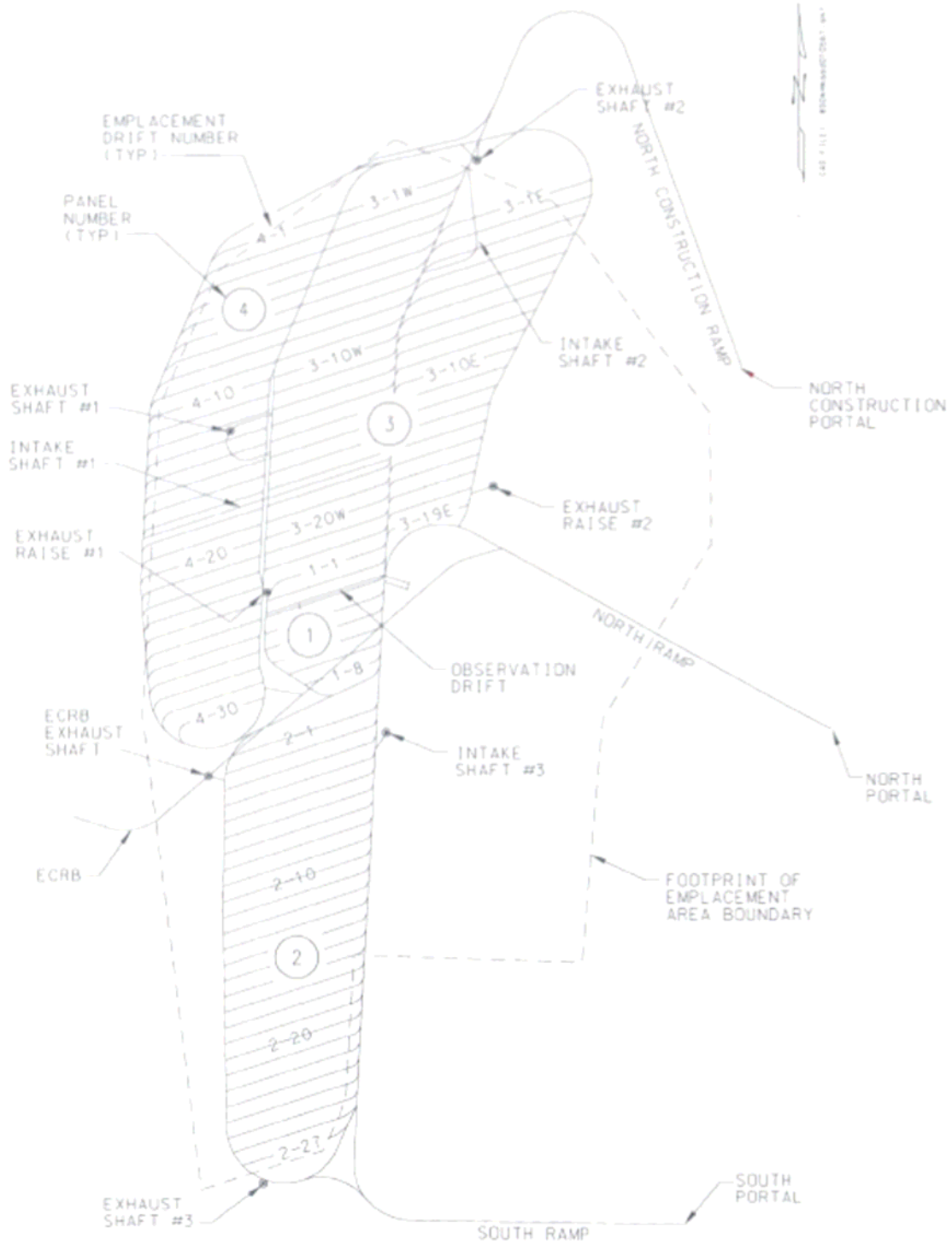

Source: Reference 2.1.2 (Figure 1).

**Figure 2: Subsurface Layout**

## **6 WASTE RETRIEVAL OPERATIONS**

### **6.1 CONCEPT OF OPERATIONS FOR WASTE RETRIEVAL**

Conditions within the repository during the preclosure period are expected to be normal (systems, structures, and components (SSCs) function as designed under operational conditions). Significant SSCs that make up the subsurface facility would be operating normally and capable of performing in accordance with their intended functions. The operational concept for retrieving the waste packages would be to perform those steps executed in the waste emplacement process in reverse order. Operational interferences that may be expected are the same as those encountered during emplacement operations. Off-normal conditions, if any, will require an assessment to identify specific conditions and determine an appropriate retrieval strategy.

### **6.2 RETRIEVAL OPERATIONS**

#### **6.2.1 Preparatory Operations at Surface Facilities**

This section of the document discusses preparatory surface operations that are necessary to support the waste retrieval process. Included are descriptions of maintenance activities that will be performed for the mobile equipment. Formal maintenance plans will be developed during detail design to address each aspect of waste retrieval operations.

#### **6.2.2 TEV Description**

The TEV is an electrically powered, remotely controlled, rail based vehicle. The conceptual design maintains as wide as practicable rail gauge and center of gravity, while remaining within the emplacement drift-envelope. This design configuration ensures vehicle stability and minimizing the potential for tipover. This low center of gravity also reduces the maximum waste package drop height. The maximum drop height requirement applies only when the TEV's shielded enclosure is raised to its maximum height and its' shielded base plate has been retracted from underneath.

Major TEV components include a radiological shielded enclosure with two swinging front shield doors, a vertically moving rear shield door and a horizontally retractable-shielded base plate forming a shielded enclosure base. The shielded enclosure's internal construction includes a structural configuration that locates and lifts a waste package and emplacement pallet using only integral emplacement pallet lifting features. The shielded enclosure's moving portions will feature electrically operated mechanical locks, and electrical or mechanical interlocks whichever is practicable. The shielded enclosure is surrounded on three sides by a structural chassis that provides location and support for horizontally pivoted wheel blocks. The current concept provides two wheel blocks per vehicle side with each wheel block consisting of two wheels. The wheel blocks have a horizontal pivot center distance between both wheels. Horizontal pivots ensure equal wheel to rail loadings improving vehicle traction and braking efficiency. Only two wheels, on one side of the vehicle only, one at the front and one at the back, will be double flanged to provide vehicle guidance. The six remaining wheels shall be flangeless, plain wheels to provide load support functions only. Each wheel will have an independent drive system consisting of a high ratio gearbox with integral brake motor. High ratio gearboxes ensure that following motor failure, vehicle linear movement is stopped because wheel rotation cannot back-drive a gearbox. Drive motors will feature integral brakes that will ensure, with a loss of electrical power, that spring actuated motor brakes will automatically be applied and the

vehicle's linear movement will be prevented. Motors or gearbox drive shafts will also feature rotary encoders and speed detection devices to provide constant feed back and confirmation to the on-board vehicle's programmable logic control system and the Central Control Center regarding the vehicle's position and speed.

The vehicle chassis will provide mountings for the shielded enclosure lift system responsible for the shielded enclosure raising and lowering. The current conceptual design indicates six motorized screw jacks, three jacks per vehicle side. Screw jacks are based upon upright, machine screw, rotating screw types. These jacks are selected because of the ability to self-lock in the event of drive failure, thus preventing load drop. The current design utilizes four corner-lifting devices to perform normal operations and two centrally positioned lifting devices perform off-normal event recovery operations. The lifting drive system includes positional, speed, and load monitoring devices to provide constant feed back and confirmation to the on-board programmable logic control system and to the Central Control Center on the condition, position, and speed of the lifting devices during operations. In addition to the lifting systems, there are a number of chassis-mounted electrically driven positional lock bolts that, when energized, drive load bearing bolts into the shielded enclosure location features to provide positional confirmation of shielded enclosure maximum height and to provide shielded enclosure positive support during vehicle movement. These will enable the lifting features to be back-driven to an extent that no load remains on any lifting system components. This will ensure that vibrations and shock loadings from rails and wheels will not be transmitted into the lifting feature components during vehicle travel and will assist in improving their longevity.

The vehicle chassis will also provide mountings for a shielded base plate drive system and base plate linear bearing support system. The base plate will have additional support from wheels, running on the main vehicle rails. These wheels will be mounted at the extreme rear end of the base plates and will provide support to the base plate when the base plate is in its fully extended position. The current design indicates a potential for a gap between the shielded enclosure rear wall under-face and the base plate top face. To prevent a radiological shine path in this area, a vertically moving rear shield door is mounted to the shielded enclosure's rear shield wall. When the main shielded enclosure is in its raised position and the shielded enclosure base plate is fully retracted underneath, the rear vertical shield door will be lowered to cover this potential gap. This feature will also provide a simple mechanical interlock in that the base plate cannot be extended until the door is raised; therefore, the shielded enclosure cannot be lowered until the shield door is raised and the base plate is fully extended. A similar mechanical interlock will exist between the front shield doors and the base plate. With the swinging doors in their closed position and the base plate fully retracted underneath, locking features attached to internal faces of the doors will engage with locking features mounted to the base plate. Only when the doors swing open will these features disengage. This will prevent the base plate from being retracted until the front shield doors are in their open position. Another mechanical interlock will be introduced by mounting swinging door hinges to the vehicle chassis and not to the shielded enclosure end faces. By incorporating in the door faces a multi-stepped internal profile that interlocks with the similar multi stepped profiles in the shielded enclosure end faces; the shielded enclosure is prevented from lowering until the shielded enclosure swinging doors are opened.

The shielded enclosure back end will feature an enclosure of the same profile used to house all on-board electrical equipment. Positioning this enclosure behind the shielded enclosure will ensure that electrical components mounted inside will be radiologically shielded. The rear

electrical enclosure will feature temperature control and ventilation systems to maintain a temperature that will assist in prolonging an active life of electrical components located inside. The enclosure will also contain fire detection and suppression systems to be automatically activated if an internal electrical fire occurs.

The vehicle chassis also provides a mounting for conventional rail clamps that will prevent vehicle movement when it is in a parked position and during off-normal seismic activities. These rail clamps will not clamp to the crane rails sides, but will exert a vertical force to the top of the rails that will prevent further vehicle movement. The clamps are electrically powered off and spring-applied on and will activate automatically during an electrical power loss. They will also function as parking brakes.

When the TEV is not in use, it is anticipated that it will be housed in a site support facility located on the surface, most likely the heavy equipment maintenance facility (HEMF). Within the HEMF, routine maintenance will be performed to ensure the TEV remains operational.

Routine maintenance could include:

1. Lubrication
2. Confirmation of operations
3. Drive system maintenance
4. Calibration of instrumentation
5. Verification of control system operation
6. Camera and communications devices

These activities will be completed on a scheduled basis determined during the detailed design and fabrication of the TEV

### **6.2.3 TEV Retrieval Operations**

To retrieve a waste package the TEV would start at the HEMF and travel to top of the north ramp. After inspections the TEV would travel down the ramp to the subsurface, and continue on the selected drift. The TEV would travel into the drift past the access doors and approach the waste package. The location of the waste package would be known due to the location verifications performed during emplacement. The TEV would approach the waste package at 1.5 ft per minute with the front shield doors open, the base plate extended, and the main shielding enclosure lowered. Cameras would be used to identify any potential concerns. Once the TEV has engaged the waste package cameras would verify waste package position in the TEV, and the shielded enclosure would be used to lift the waste package. The base plate and the front and rear shield doors would be closed, and the TEV could return to the access main through the turnout. Once in the access main the TEV would take the waste package to its new location.

### **6.2.4 System Interfaces**

The waste retrieval system must interface with a number of systems to safely accomplish the task of retrieving waste. The waste retrieval system interfaces with the digital control and management information and communication systems for the transmission of data to and from the retrieval equipment, and for the remote control of the equipment when necessary. The waste retrieval system also interfaces with the subsurface ventilation system for the emplacement drift-operating environment and for travel through the emplacement access doors. The retrieval equipment will travel exclusively on rails and receive electrical power through a third rail. These interfaces are presented in the following subsections to discuss the significance of each interface.

#### **6.2.4.1 Digital Control and Management Information System Interface**

The digital control and management information system provides observation and manual override capability of the TEV. The digital control and management information system provides data communications, data processing, managerial reports, data storage, and data analysis.

#### **6.2.4.2 Subsurface Ventilation System Interface**

The retrieval equipment will require entry and exit from the emplacement drifts. The only way for this equipment to get into and out of the drifts will be through the emplacement access doors that are part of the subsurface ventilation system. The operators in the CCC will be monitoring/controlling the retrieval equipment and will therefore be aware that entry into the drift is necessary. The sequence of operations and how the interfaces will work is envisioned as follows:

- The subsurface ventilation system will notify the digital control and management information system once the ventilation system is ready for the emplacement access doors to open.
- If the conditions are acceptable, the digital control and management information system will direct the subsurface ventilation system that it is permissible for the emplacement access doors to open.
- The subsurface ventilation system will issue commands for the emplacement access doors to open.
- The retrieval equipment enters the turnout
- When retrieval equipment is sufficiently clear of the emplacement access doors, the digital control and management information system will direct the subsurface ventilation system that it is permissible for the emplacement access doors to close.
- The subsurface ventilation system will issue commands for the emplacement access doors to close.

As shown above, emplacement access door operation will be an integral component of the waste retrieval process that will be coordinated by the digital control and management information system. The only direct interface between the subsurface ventilation system and the waste retrieval system is that the doors are appropriately sized to permit the equipment to pass through.

During retrieval operations, the ventilation system will be responsible for controlling the temperature in the emplacement drifts to ensure operability of the equipment involved in the operation.

#### **6.2.4.3 Emplacement Transportation System and Power Interfaces**

The retrieval equipment will be rail based and is the same equipment that is used for emplacement. The layout of the rail must include provisions for the retrieval equipment to orient itself in the proper direction. The layout of the track on the surface will be designed to allow for reversing the direction of travel of the waste retrieval equipment.

Similar to the rail requirements, electrical service must also be provided to the retrieval equipment. To provide power to equipment a conductor bar or third rail electrical distribution system will be used. The distribution systems will be designed so the required voltage, at sufficient capacity, will be provided to the equipment wherever it is operating within the repository.

The retrieval equipment will utilize the same rail and electrical power facilities used for emplacement. If alternate surface facilities are constructed the rail and electrical power facilities would need to be expanded to support the new facilities.

### **6.3 METHODOLOGIES FOR IDENTIFYING AND ANALYZING POTENTIAL RETRIEVAL PROBLEMS**

Waste retrieval will be a reversal of the waste emplacement operations. Due to the fact that the subsurface repository will be maintained over the full length of the preclosure period, no major impacts to operational processes are expected. If any retrieval problems occur, they would be evaluated on a case by case basis to identify specific conditions and determine an appropriate recovery and remedial action strategy.

Some of the potential events or issues that could possibly occur during waste retrieval operations are addressed in the following subsections. Detailed strategy for recovery from off-normal events is discussed in the *Strategies for Recovery After an Off-Normal Event to the Waste Package Transport and Emplacement Vehicle* (Reference 2.1.12) document.

Although each off-normal event will be evaluated in detail, the strategy for recovery to allow continuation of retrieval will include:

1. Assessing the immediate status of an involved waste package for personnel safety.
2. Notification and reporting to the NRC and other appropriate jurisdictions based on the significance of the event.
3. Developing a detailed recovery plan which will include:
  - Assessing radiological and industrial safety conditions to ensure recovery is implemented in accordance with ALARA and industrial safety requirements
  - Assessing security impacts during retrieval
  - Assessing impacts of retrieval on the environment at or near the site
  - Establishing access control and isolating the event area from continued operations, if required to ensure worker safety
  - Confining contamination, if present
  - Collecting technical data
  - Formulating a mitigation plan
  - Designing and providing any additional specialized equipment needed for mitigation.
4. Obtaining approval for the recovery plan.
5. Completing actions in accordance with the recovery plan and returning the repository to normal operations.

### **6.3.1 Repository Conditions**

At the time the decision is made to retrieve waste, one of the first assessments to be made will be the condition of the facilities and needs for reconditioning and/or upgrade of facilities and equipment to support retrieval. This effort will include the subsurface facility, mobile equipment, surface facilities and alternate storage facilities necessary for waste retrieval. These facilities and equipment will be accessed, including a safety hazards analysis, and appropriate measures taken to ensure support for planned retrieval operations.

#### **6.3.1.1 Surface Facilities**

At the time a decision is made to retrieve waste the condition of the surface facilities will be determined by a number of factors, including:

- The status of emplacement operations.
- The availability of facilities for retrieval operations.
- The status of the equipment within the facilities with regard to being serviceable and usable for retrieval operations.

#### **6.3.1.2 Mobile Equipment**

An assessment of mobile equipment will also be needed similar to that for the surface facilities. Reconditioning and upgrade of mobile equipment (TEV) will be determined by the results of the assessment.

#### **6.3.1.3 Subsurface Facility**

The subsurface facility is designed to facilitate retrieval operations. The design bases, operations, and inspection and maintenance programs work together to maintain access and functionality of the equipment necessary to support retrieval operations. In general, the subsurface facility will be maintained until closure. During the period between the completion of emplacement and closure, several activities that require access and use of the facilities will continue. These activities could include the performance confirmation program, installation of drip shields, backfilling, where applicable, and sealing openings as part of closure. The same maintenance programs that will be in place for emplacement will be carried forward for retrieval and therefore are not repeated here. No adverse subsurface maintenance conditions are expected that would impact retrieval and storage.

As part of the Performance Confirmation Program, during repository operations, selected emplacement drifts will be monitored for environmental conditions and waste package condition. Monitoring may be accomplished utilizing instrumentation and remotely operated vehicles, with on-board cameras and sensors, to detect rockfalls, for visual inspections, and for material sampling. Monitoring and inspection activities will provide the necessary information for evaluating drift degradation effects, as well as required maintenance and repair of the ground support components. Ground support components may be needed to provide continued accessibility to the emplacement drifts for possible waste retrieval operations (Reference 2.1.5, Section 3.3).



## **6.4 POTENTIAL CONTINGENCY MEASURES**

A number of unlikely events could happen during retrieval that could complicate operations. The following sections discuss some potential events and the associated conceptual recovery actions. After appropriate actions are implemented to recover from these events, it is expected that waste packages will still ultimately be retrievable from the repository through the use of a closed and shielded conveyance vehicle, such as the TEV. This transport method will protect the surrounding workers from loose contamination or direct radiation associated with the waste package.

The events discussed in the following sections are representative, and similar, to the events that might be encountered during normal emplacement operations. Experience gained during normal emplacement will be applied in implementing recovery actions. Event occurrences will be assessed to identify specific event conditions and to determine an appropriate approach for recovery and remediation. Analyses of events that are potentially adverse to retrieval will continue through operations until permanent closure.

### **6.4.1 Emplacement Access Doors are Damaged**

The emplacement access doors could be damaged by abnormal events, impacting the surrounding infrastructure, or by an impact with mobile equipment during waste retrieval operations. Consequently, the doors may not open or close properly. A recovery plan will be developed using the methodology discussed in section 6.3. As this is a low dose area the fix would not be complicated.

### **6.4.2 TEV Cannot Retrieve Waste Package**

A TEV may not be able to retrieve a waste package from an emplacement drift. One possible scenario would be when a TEV, operating within an emplacement drift, is unable to engage an emplacement pallet for retrieval. The causes for this scenario may vary, but could be due to misalignment of a waste package and emplacement pallet within the emplacement drift.

Scenarios where a TEV is unable to retrieve a waste package from an emplacement drift and the mitigation concepts for these will be evaluated using the generic recovery process discussed in section 6.3. Possible solutions would be to use remote equipment to realign the waste package and pallet, or use a winching system to maneuver the waste package and emplacement pallet to a more accessible area.

### **6.4.3 Rockfall or Ground Support Failure**

A portion of the ground support could fail within the emplacement drift causing a blockage within the drift. To make the scenario more severe it can be postulated that the waste package retrieval has begun, waste packages are present, a loaded TEV is in the area of the rockfall, and the TEV is partially buried. In addition, repository infrastructure components, including the ground support, rail tracks, and the electric third rail are severely damaged and inoperable downstream of the area of the rockfall. Data communications and associated video signals from the TEV would be lost, putting the operators in a temporary information and control blackout condition.

The recovery actions for this scenario would begin with the generic steps discussed in section 6.3. Remote equipment would be used to remove any debris that is in the way. Winching or towing devices would be used to recover stuck equipment.

While no significant rockfall events are expected during preclosure operations, studies indicate that fallen material from an emplacement drift rockfall can be safely and effectively removed to allow resumption of operations.

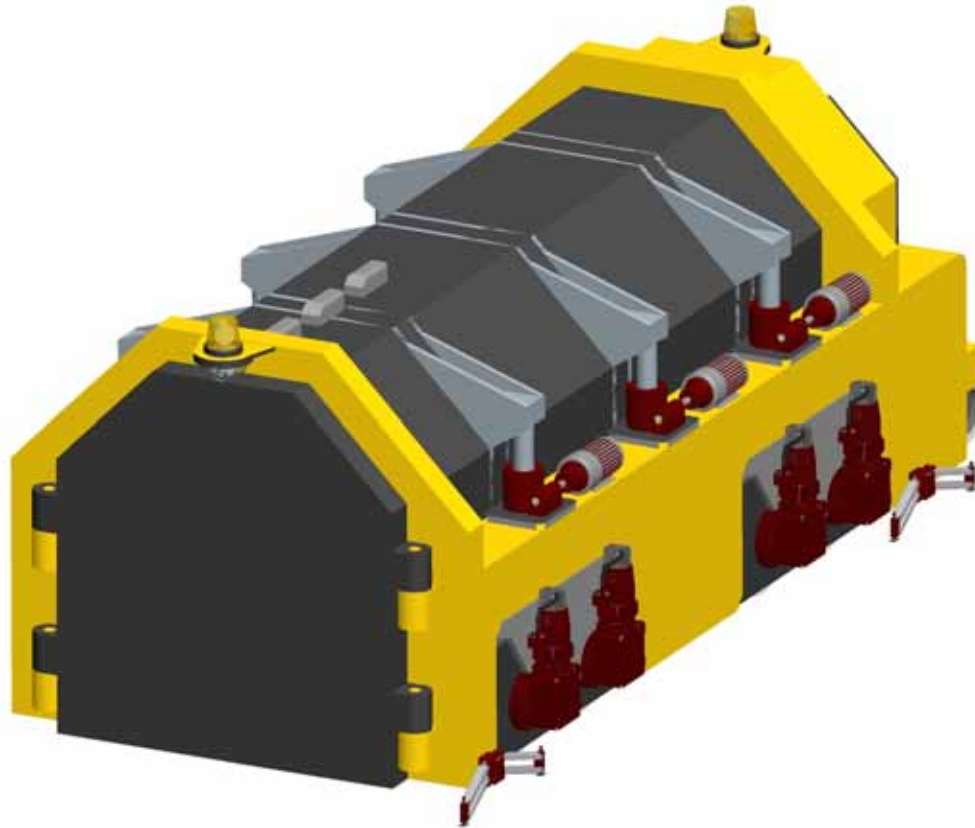

**Figure 3: TEV Concept**

## 7 ALTERNATE STORAGE FACILITY

### 7.1 SCOPE

If waste is retrieved from the subsurface repository, one of two options is likely to be proposed:

- The waste will be retrieved and put into long-term surface storage at Yucca Mountain
- The waste will be held in short-term storage at Yucca Mountain, pending further processing or transfer to some offsite location.

The specific design and operational plan for the disposition of the retrieved waste will depend upon the reason for retrieval,

- The final disposition of the waste,
- Consideration of associated hazards,
- Applicable regulations (to be established in the future)
- The licensing process enacted for retrieval.

If the waste is to be put into long-term surface storage at Yucca Mountain, one of the three following scenarios is likely to occur:

Scenario 1—Retrieval occurs after all waste has been emplaced and the existing surface facilities have been decommissioned. In this scenario, the concept of operations is that the retrieved waste packages must be delivered to a new facility, the Alternate Storage Facility, for processing and storage. This activity would include placing the waste packages into suitable surface storage containers and placing them in an Alternate Storage Facility.

Scenario 2—Retrieval occurs after all the waste has been emplaced in the subsurface repository but before the surface facilities are decommissioned. In this case a redesign and modification of the surface facilities would be undertaken. The scope of the redesign would be limited to the concept of operations described in Scenario 1.

Scenario 3—In this scenario retrieval occurs before all of the waste has been received on site and has been emplaced. It is likely that waste will continue to be shipped to the site. In this case it is assumed that the existing surface facilities will still be needed. The redesign and modification of the existing surface facilities would need to consider these complications and still satisfy the concept of operations described in Scenario 1.

The reason for retrieval may be such that the capacity of the surface facility would be significantly less than the subsurface waste inventory. For example, if the waste is to be shipped offsite, the size of the surface facility would be limited to that required for short-term storage and preparation for shipment in licensed shipping casks. Those casks may receive the entire waste package or the waste may have to be removed from the waste package and repackaged for off-site transport. A detailed evaluation of the storage area requirements and the storage system configuration would be performed during the comprehensive assessment of an Alternate Storage Facility.

At this time it is premature to consider specific designs for any of these possible scenarios since the reason for retrieval is not known and there are no regulations that would provide licensing and design guidance. Therefore, only one concept has been selected to be representative of the

above noted scenarios and illustrates the flow of activities that would take place for these alternative scenarios. The one selected is Scenario 1, the option that the waste is to be placed in long-term surface storage at Yucca Mountain. This concept illustrates the flow of accepting the waste package at a surface facility, unloading it from the TEV, reloading it into a new container and moving it to a storage area. These activities will be similar for the other two scenarios, differing only in details. This should be interpreted as conceptual and does not represent a design that is to be implemented, without further evaluation. As is the case for the facility size, handling operations of the Alternate Storage Facility will also depend on the amount of waste already received at the site at the time of the decision.

## **7.2 CONCEPT OF OPERATIONS**

The specific design and operational plan for the surface facilities depend upon the specific needs for the storage and hazards encountered in the retrieval process. Modifications to facilities existing at the site may be appropriate or new facilities may be needed. This planning would commence should retrieval be necessary. The storage concepts considered here are based on documented assumptions, engineering studies, and regulatory requirements. Studies on storage facility concepts are presented in *Repository Surface Design Engineering Files Report*, (Reference 2.1.7, Attachment I).

A comprehensive repository assessment, operational analysis, and detailed design for the Alternate Storage Facility will be performed should the decision to retrieve be made. This effort will include ALARA and criticality considerations and may lead to other concepts of operations. For example, a horizontal waste package handling and storage system may be preferred, but other orientations will be considered as well. The nature of the waste package handling system and the size and configuration for the storage area will be evaluated in the comprehensive assessment.

During retrieval, it is assumed that waste packages are removed from the emplacement drifts, moved to the surface, and transported to the Alternate Storage Facility, which stores the retrieved waste in a manner that protects the health and safety of the public and workers, and maintains the quality of the environment. The Alternate Storage Facility consists of a Waste Retrieval Transfer Building, support facilities, and a number of reinforced concrete storage pads located near the repository's North Portal. The facility is equipped for waste package unloading from the TEV, transfer to a vertical concrete storage unit (CSU), and transport of each CSU to a dry concrete storage pad location.

## **7.3 SITE LOCATION AND DESCRIPTION**

A possible site for the Alternate Storage Facility is in the Midway Valley near the repository North Portal as shown in Figure 4. The area contains approximately 240 acres (Reference 2.1.7, Attachment I, Section 3). Figure 4 also shows the locations identified for on-site aging facilities that can accommodate up to 40,000 MTHM. This capacity includes 19,000 MTHM in contingency aging at an area located directly north of the site facilities. The aging areas could be used for alternate storage, if necessary. As shown in Figure 4, the proposed alternate waste retrieval storage facility has been located in Midway Valley adjacent to the 20,000 MTHM aging area that is northwest of the site facilities. This new area of approximately 240 acres overlays the future contingency expansion location of the additional 19,000 MTHM aging area and is sufficient to store up to 70,000 MTHM, if needed. Use of this area for retrieval storage would require appropriate characterization, siting studies and site preparation activities.

Site selection criteria to be considered in Scenario 1 for the Alternate Storage Facility include:

- Proximity to the repository North Portal
- Retrieval of all repository waste in the allocated timeframe
- Adequate site space for dry storage of retrieved waste
- Locating the waste at one location or storing it at several smaller locations
- Identification of environmental conditions (seismic, hydrological, meteorological, etc.)
- Security concerns.

## **7.4 FACILITIES**

### **7.4.1 Alternate Storage Facility**

The anticipated flow of operations is shown in Figure 5, based on Scenario 1. Figure 6 shows a conceptual layout of the proposed Alternate Storage Facility. The waste storage area is configured for modular storage pads. Each modular concrete storage pad provides space for transport and storage of CSUs. Positions are provided on each side of the transport aisle used for moving the CSU into position. The selection of concrete storage units is only for illustrative purposes and does not reflect a commitment to this design concept.

The Alternate Storage Facility (Figure 6) contains space for a Waste Retrieval Transfer Building, a TEV queuing yard, a CSU staging area, the modular CSU storage area, site support facility, an inspection gatehouse, and an administrative and security complex.

The Alternate Storage Facility site is furnished with both rail and road access. A new rail line may be needed from the existing repository main gate to the Alternate Storage Facility.

The Alternate Storage Facility, including the concrete storage pad areas, is enclosed with a double security fence. One buffer is provided between the CSUs and the double security fence and a second buffer is provided between the double security fence and the site boundary, located a substantial distance from the Alternate Storage Facility.

### **7.4.2 Waste Retrieval Transfer Building**

A conceptual design of the Waste Retrieval Transfer Building is shown in Figure 7. The empty CSUs are delivered by rail to the site, unloaded in the CSU staging area, transported to the Waste Retrieval Transfer Building, and staged in the CSU loading bay. The upper and lower sections of the cask, cask loading plates and cask shield lids are transferred into the shielded portion of the building for waste package loading.

TEVs are received at the Alternate Storage Facility, staged in the TEV queuing yard, and moved into the Waste Retrieval Transfer Building. The waste package and associated emplacement pallet are remotely transferred from the TEV to a waste package transfer cart and then lifting fixtures (to be determined) are installed. The transfer cart moves the waste package to a tilting station, where the waste package is rotated to a vertical orientation. The waste package is then transferred directly to the base or lower portion of the CSU (Figure 8) or to one of three available waste package staging areas. Once the CSU shield or upper portion of the CSU is installed over the waste package, the CSU lid, cover, and locking plates are remotely installed. The CSU is then ready for transport to a concrete storage pad.

A CSU mobile lifting gantry is used to transport the loaded CSU to its storage pad. Figure 9 shows the conceptual design of the mobile lifting gantry. The remotely operated mobile lifting

gantry straddles the CSU, engages the CSU lifting bails, lifts the CSU and waste package, transports the loaded CSU to its storage pad, positions the CSU on the pad (see Figure 10), and lowers the CSU onto the pad.

The Waste Retrieval Transfer Building has two wings, one for waste package receipt and transfer and one for CSU loading and handling. The two wings are perpendicular to each other. The Waste Retrieval Transfer Building also includes a CSU loading bay for staging and transfer of unloaded CSUs and an adjacent support facility.

### **7.4.3 Concrete Storage Unit**

The CSU concept is shown in Figure 8. The CSU consists of an annular vertical cylinder and base. The inside diameter provides a gap between the CSU and the waste package for natural circulation cooling of the waste package. Based on the design of the CSU, multiple sizes may be needed to accommodate the various waste package sizes. The CSU includes concrete shielding for radiation protection to reduce gamma and neutron doses. When the CSU is assembled and loaded with a waste package, a shielded lid and cover are installed.

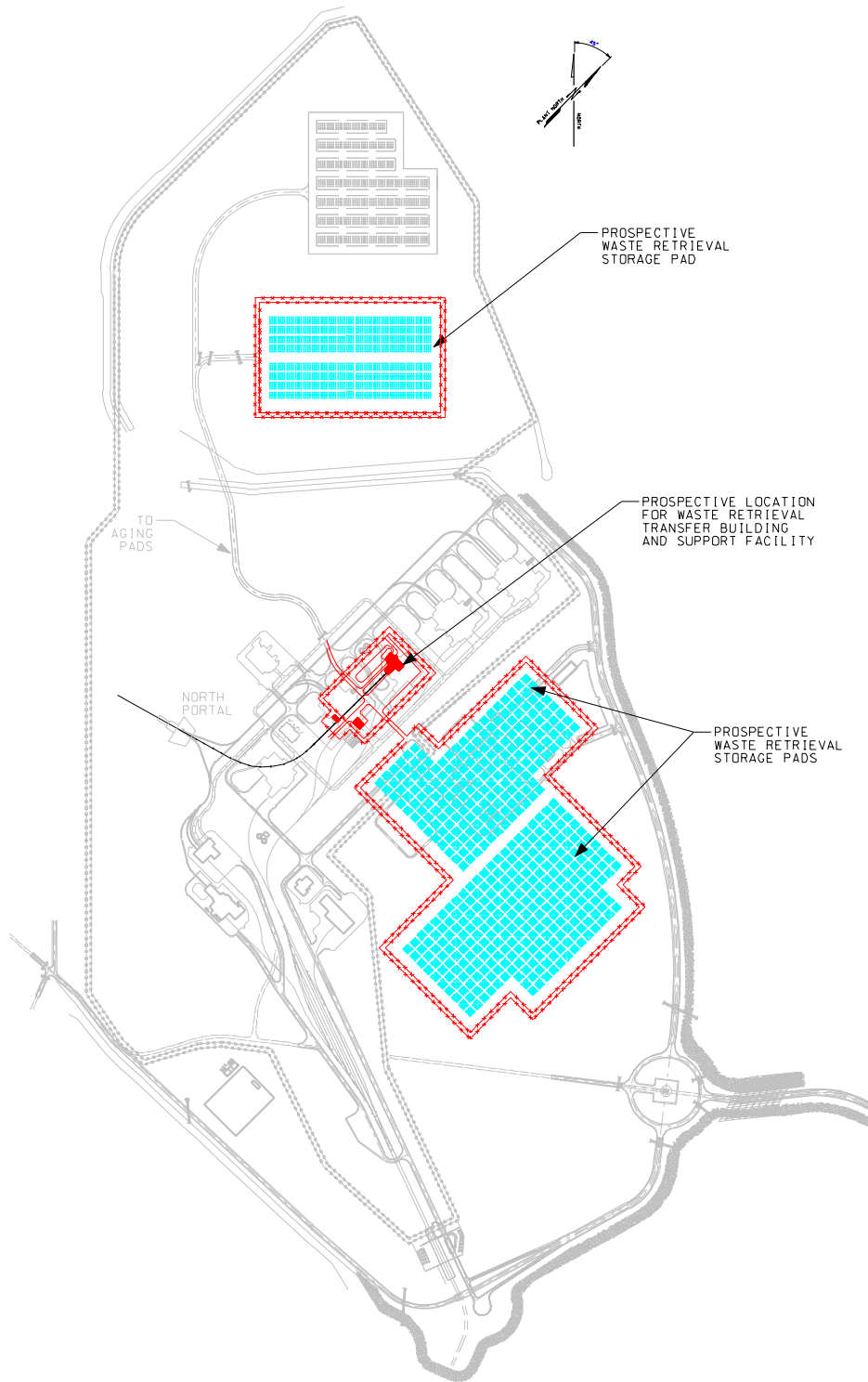

Source: Adapted from Reference 2.1.4.

Note: This figure shows an overlay of the potential Alternate Storage Facility over a portion of the currently proposed waste aging areas.

**Figure 4. Possible Scenario 1 Site - Alternate Storage Facility**

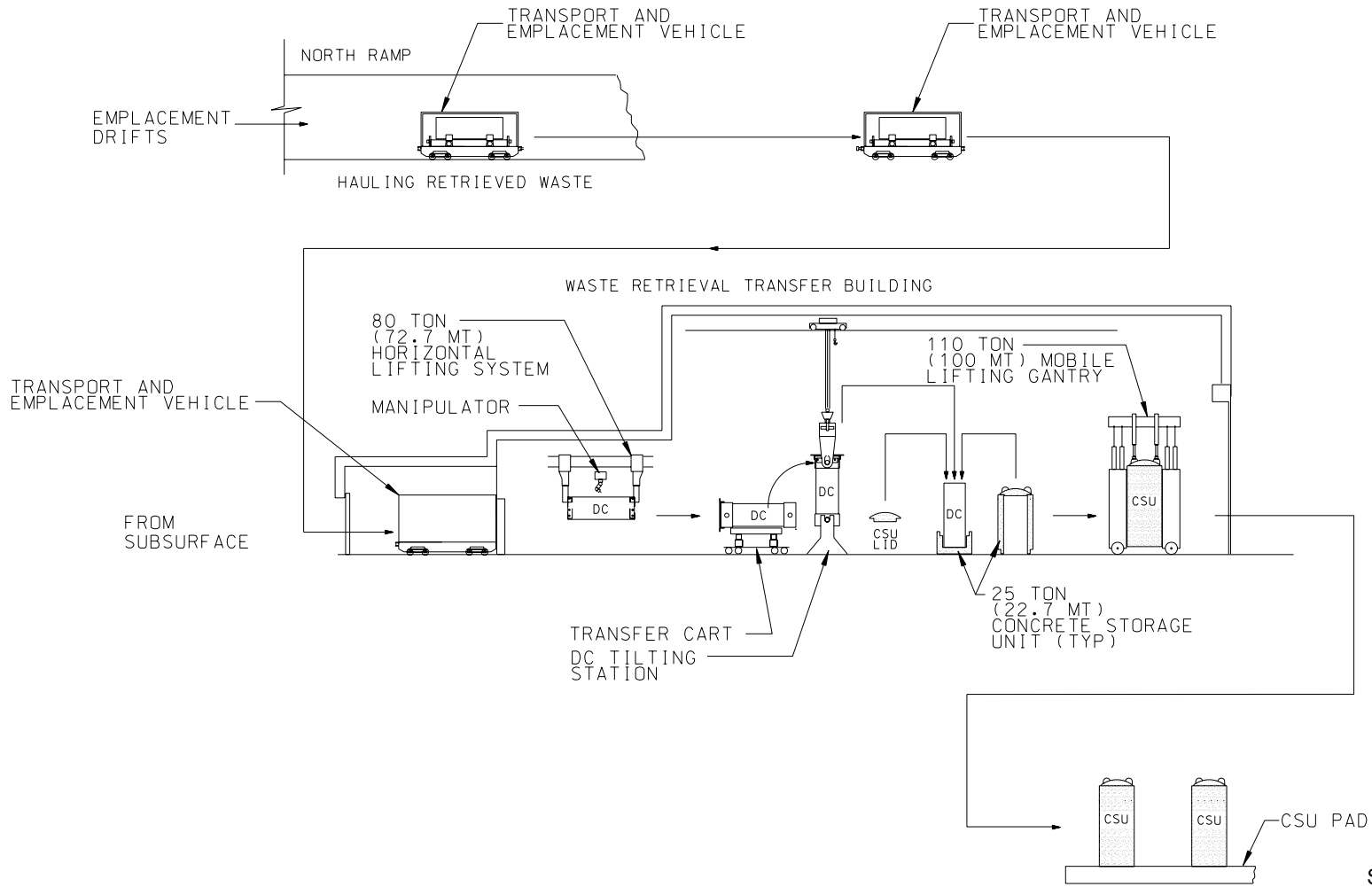

Source: Adapted

From Adapted from Reference 2.1.7 (Figure I-5).

Figure 5: Scenario 1 Conceptual Operations Mechanical Flow



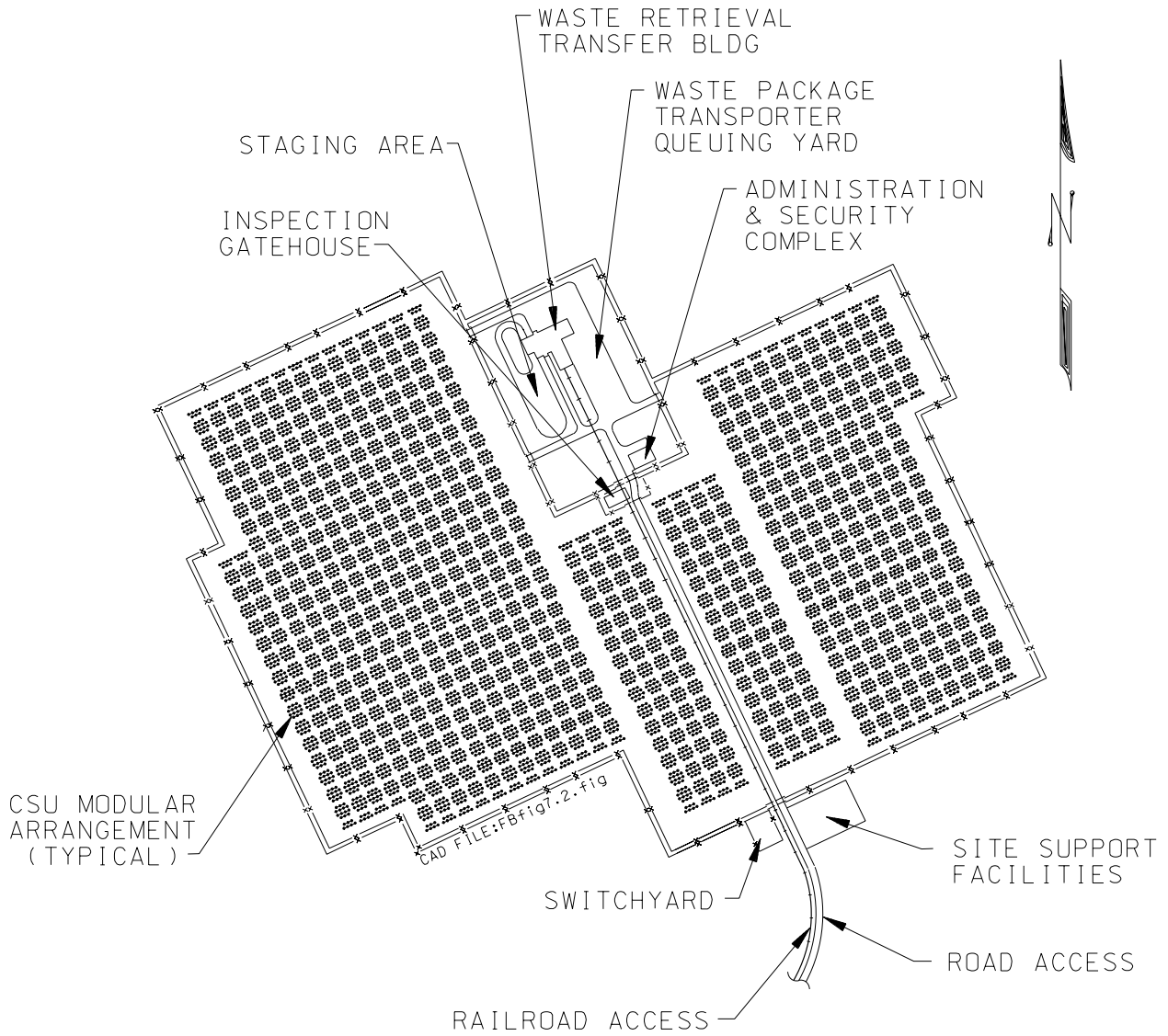

Source: Adapted from Reference 2.1.7 (Figure I-2).

**Figure 6: Alternate Storage Facility Scenario 1 Conceptual Layout**

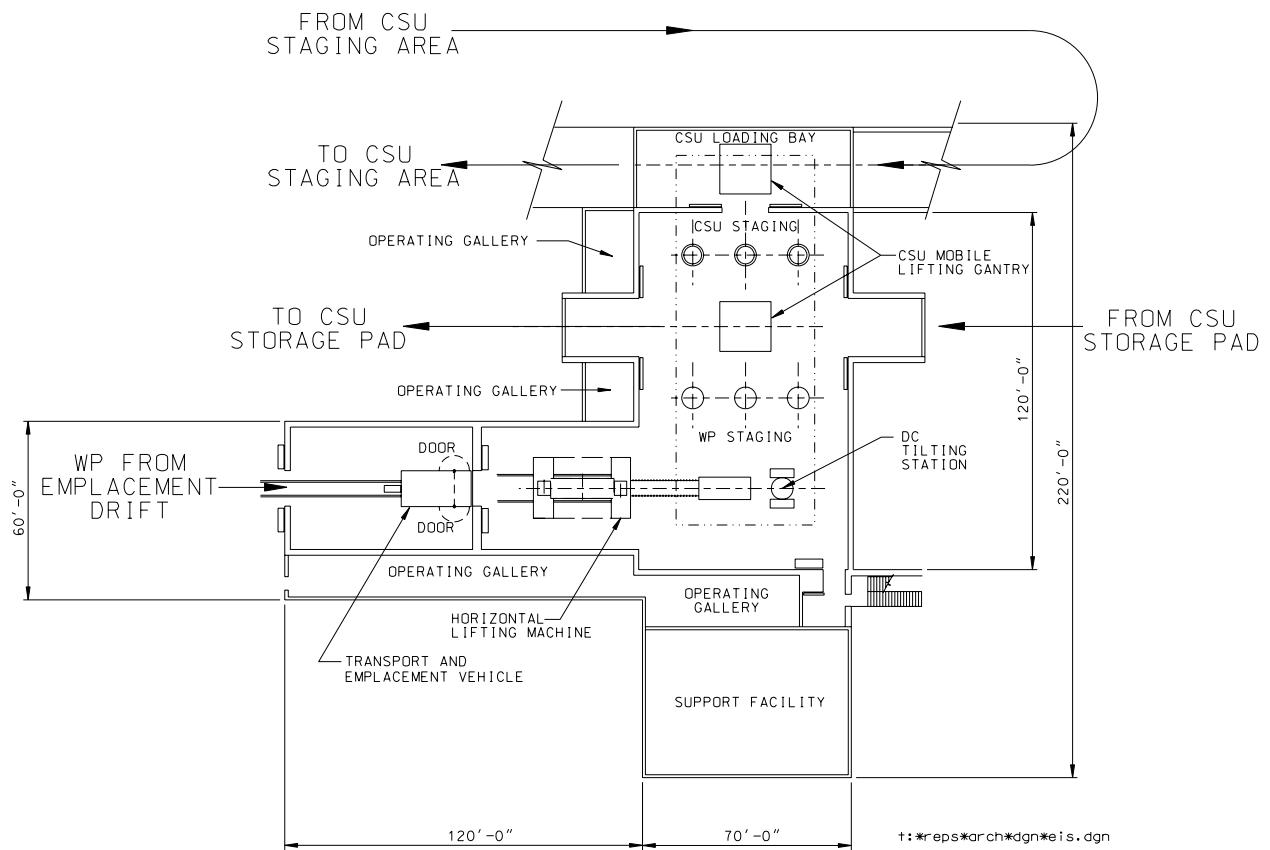

Source: Adapted from Reference 2.1.7 (Figure I-6).

**Figure 7: Waste Retrieval Transfer Building Scenario 1 Conceptual Design**

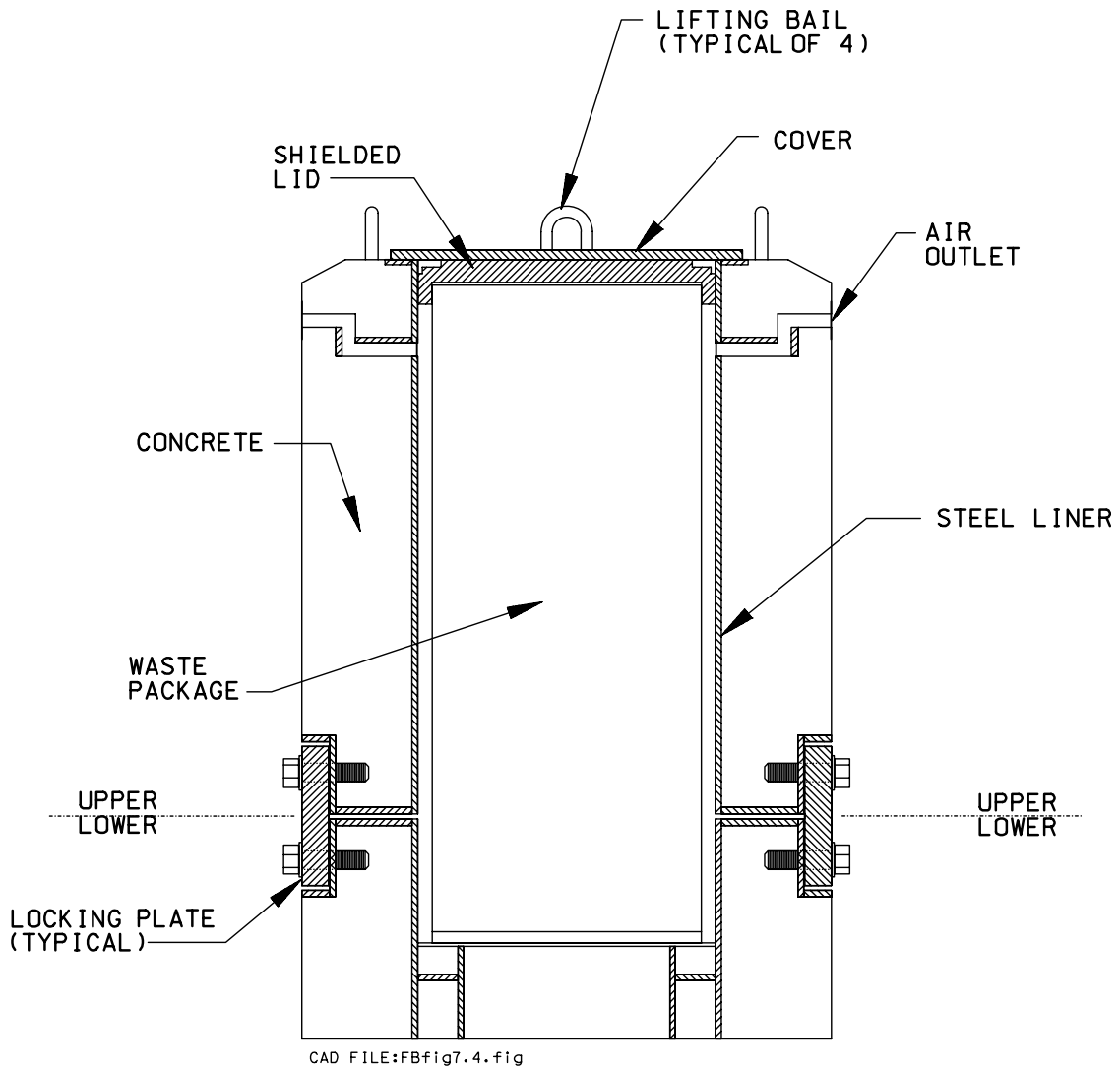

Source: Adapted from Reference 2.1.7 (Figure I-4).

**Figure 8: Concrete Storage Unit Scenario 1 Concept**

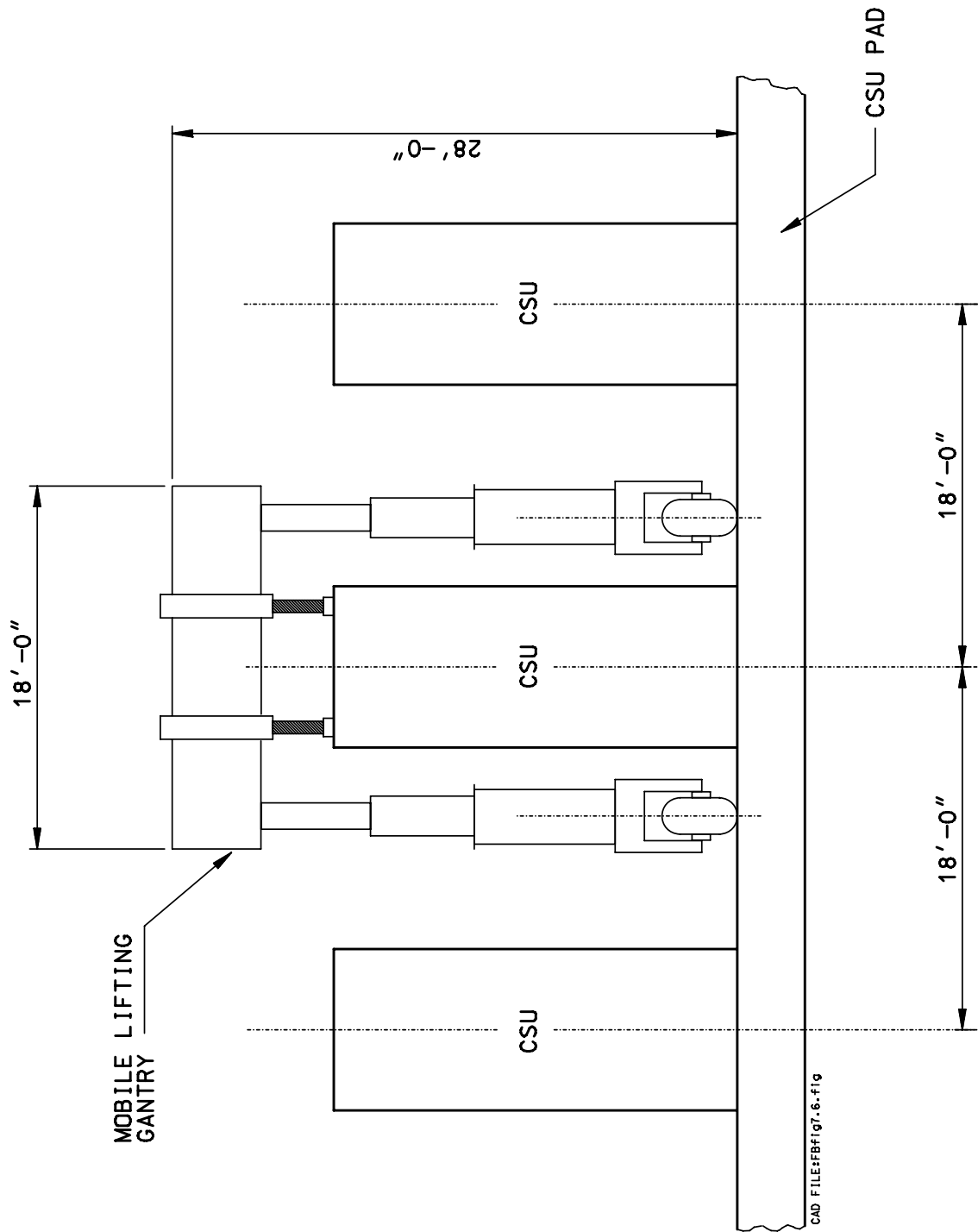

Source: Adapted from Reference 2.1.7 (Figure I-7).

**Figure 9: Mobile Lifting Gantry Conceptual Design**

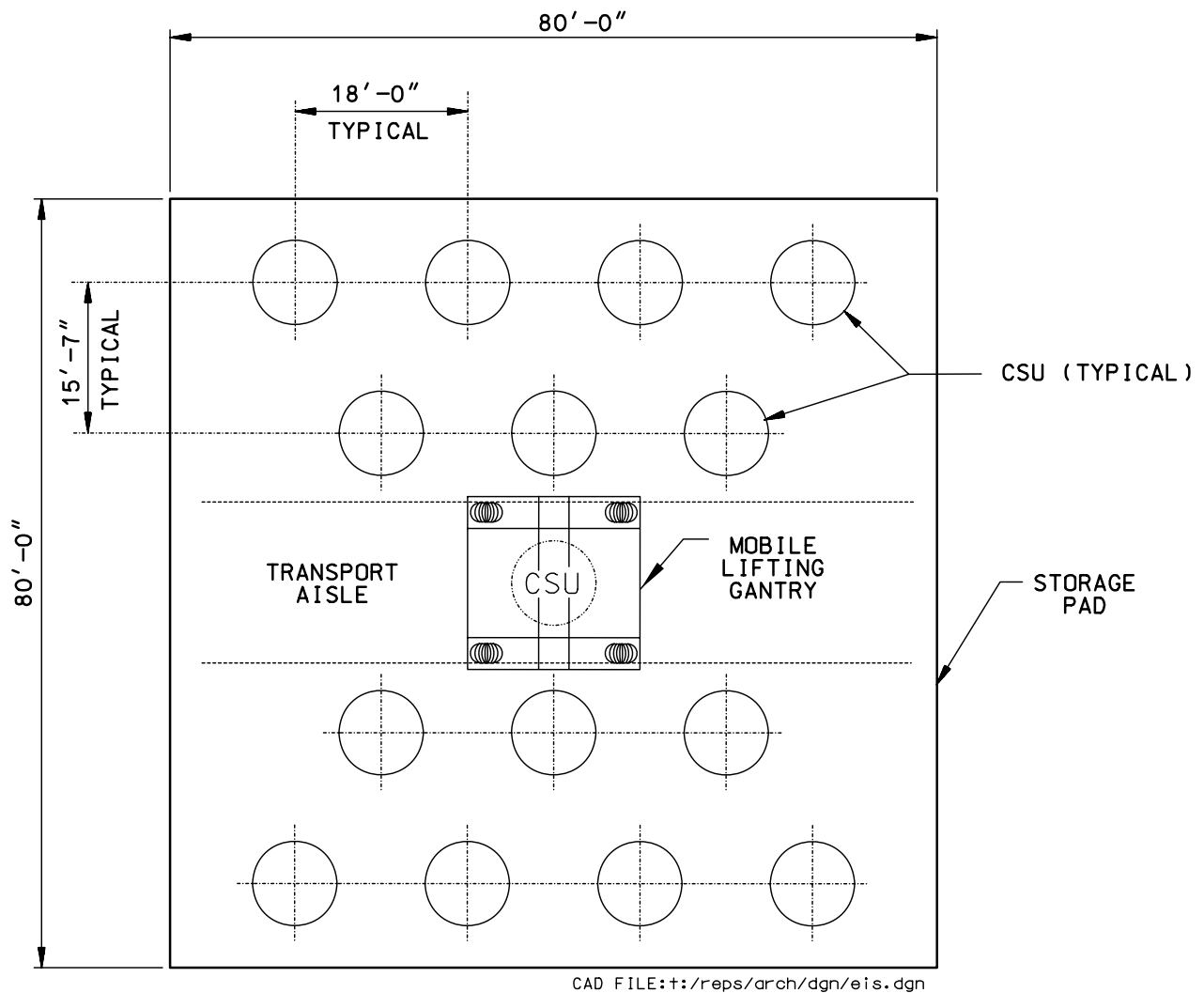

Source: Adapted from Reference 2.1.7 (Figure I-3).

**Figure 10: Modular Concrete Storage Pad Scenario 1 Conceptual Design**

## 8 RADIATION PROTECTION

### 8.1 RETRIEVAL OPERATION-HAZARDS ANALYSES AND PRECLOSURE SAFETY

*Categorization of Event Sequences for License Application* (Reference 2.1.3, Section 6.3.6.1) describes the events associated with the waste package subsurface transport and emplacement. While retrieval is beyond the scope of that document, these events are assumed to be applicable for retrieval because of the assumption that retrieval is largely the reverse of emplacement. Should retrieval be required, additional calculation of doses for Category 1 and Category 2 event

sequences associated with retrieval, will be developed prior to initiating retrieval operations to ensure that any potential event sequences are considered.

## **8.2 ALTERNATE STORAGE FACILITY OPERATIONS-HAZARDS ANALYSES AND PRECLOSURE SAFETY ASSESSMENTS**

An operations hazard analysis and a preclosure safety assessment have not been made for the Alternate Storage Facility because of the conceptual nature of the design. These activities will be conducted during the design stage, should the retrieval decision be made.

## **8.3 OPERATION-OCCUPATIONAL DOSE ESTIMATES AND ENGINEERING AND ADMINISTRATIVE CONTROLS (ALARA)**

Occupational dose estimates have not been made specifically for retrieval of waste packages from the repository. The radiation exposure considerations applicable for emplacement operation will also apply for retrieval, along with any additional considerations based on pre-retrieval radiological survey activities.

The design of the surface facilities is aimed at eliminating or reducing waste package radioactive contamination during emplacement. Surveying the waste packages before emplacement in the repository will control the contamination level at the surface of the waste packages. A limit on the surface contamination has been established based on dose consequences of radionuclide releases from the repository exhausts in *Recommended Surface Contamination Levels for Waste Packages Prior to Placement in the Repository* (Reference 2.1.9). If the waste package surface contamination level exceeds the recommended level it will be decontaminated and then sent to subsurface only after ensuring that the contamination is within the established limit. Another source of radiation that may contribute dose through ingestion and submersion is the activation products generated in air and host rock surrounding waste packages due to neutron exposure. Neutron activation of host rock and silica dust has been quantified in *Radiological Releases due to Air and Silica Dust Activation in Emplacement Drifts* (Reference 2.1.1) to be significantly less than 10 CFR 20 limits for airborne releases. The potential for activated dust to affect the surface contamination levels of a waste package will also be considered. The ventilation system is designed to minimize the spread of contamination into occupied areas. The retrieval of waste packages from the drifts will be done by using remote technology to eliminate the presence of occupational workers in high radiation areas. Further administrative controls, such as surveying and monitoring, will be used in conjunction with engineering controls to reduce individual, as well as collective, dose to occupational workers during retrieval operation. The regulatory requirements for conducting surveys and monitoring contamination levels and radiation doses will be followed.

A combination of management controls, radiation safety considerations, and regulatory requirements and guidance will be employed in the design and operation of waste retrieval to implement as low as is reasonably achievable dose principles.

## **9 COMPATIBILITY OF RETRIEVAL WITH RELATED REPOSITORY OPERATIONS**

### **9.1 PERFORMANCE CONFIRMATION**

The scope of the Performance Confirmation program is to include monitoring for retrieval, specifically as stated by the U.S. Nuclear Regulatory Commission in 66 FR 55732 (Reference 2.2.2, Section III, Section 2.3, page 55744) on performance confirmation:

“it is important that the general requirements also include consideration of operational aspects of repository performance, for example, the ability to retrieve waste as required at 10 CFR 63.111(e). An organized program of collecting subsurface information during repository construction and operation that confirms the design assumptions regarding the ability to retrieve waste is therefore an important performance confirmation activity.”

As stated in 10 CFR 63.111(e)(1) (Reference 2.2.1):

“The geologic repository operations area must be designed to preserve the option of waste retrieval throughout the period during which wastes are being emplaced and thereafter, until the completion of a performance confirmation program and Commission review of the information obtained from such a program...”

The relationship between retrieval and the Performance Confirmation Program is discussed in the *Performance Confirmation Plan* (Reference 2.1.5). Performance confirmation activities will be performed to ensure that the option to retrieve the waste remains viable.

### **9.2 DRIP SHIELD REMOVAL**

Limited design analysis has shown that, on a conceptual level, drip shield placement is feasible with current technology and equipment. It is possible that retrieval could be ordered after drip shields have been installed. Should this be the case, the same equipment that placed the drip shields could remove them in advance of waste package retrieval. The duration of the retrieval period may be affected, since drip shield removal would require additional time to perform. The retrieval analyses conducted in preparation for waste retrieval would assess actions based on whether or not drip shields had been previously installed and what impacts, if any would be imposed on the retrieval schedule (Timeline for Retrieval, Section 4).

### **9.3 BACKFILLING OF EMPLACEMENT DRIFTS**

Currently the program baseline does not include the backfilling of the emplacement drifts, although this option cannot be precluded. Accordingly, the current approach for retrieval does not consider the need for removal of backfill at the time of retrieval. Based on previous studies of events, such as drift collapse (Section 6.3.2.6), removal of backfill would require a comprehensive evaluation of safety and operating conditions and a detailed implementation plan that included identification of appropriate equipment. If the decision to backfill the emplacement drifts is made, it is possible that retrieval could be ordered after placement of the backfill has been initiated. The proposed schedule for retrieval (Section 4) does not provide additional time for backfill removal.

## 10 SUMMARY

The Code of Federal Regulations (10 CFR 63.111(e)(1)) (Reference 2.2.1) requires the design to preserve the option of waste retrieval throughout the period during which wastes are being emplaced and thereafter, until the completion of a Performance Confirmation Program. Currently the design includes a 50-year period of forced ventilation following the completion of waste emplacement (Reference 2.1.6). Consequently, since the Performance Confirmation Program will run through this period of forced ventilation the option to retrieve must be preserved until the completion of the ventilation program.

10 CFR 63.111(e)(3) (Reference 2.2.1) states that a reasonable schedule for retrieval is one that would permit retrieval in about the same time as that required for constructing the geologic repository operations area and emplacing waste.

Waste retrieval can be accomplished by a reversal of the emplacement process. The TEV will remove a waste package from an emplacement drift and return the waste package to the surface.

The reasons for waste retrieval would dictate specific surface facility designs and activities. The Alternate Storage Facility would accept waste packages from the subsurface, repack them in a concrete storage cask, and house the retrieved waste packages until a final disposition is made as to their future. Regulatory actions would be required for final disposition of the waste.

An initial retrieval decision would include the preparation of retrieval plans. The retrieval plan development process would include the following steps:

- The following activities would be conducted concurrently: Evaluate hazards associated with retrieval; Evaluate facilities and equipment available for use in retrieval operations; Evaluate licensing requirements of retrieval, applicable at the time of retrieval.
- Following those activities, a License Amendment request would be developed to include: A design with supporting safety analysis and technical specifications to implement an operational retrieval plan.
- The NRC would perform its review, attendant with any other regulatory actions,
- Following NRC approval of the amendment, any needed facilities would then be constructed and started-up, procedures developed governing the retrieval process, and retrieval would be commenced.

The concepts presented in this study are not to be used as the basis for design, construction, or procurement.

If and when a decision is made to retrieve, revised regulations may be in place or may be needed to address retrieval and storage. Design of systems, equipment, and processes would comply with these regulations. As guidance does not currently exist in 10 CFR Part 63 (Reference 2.2.1) for the execution of retrieval and storage of radioactive waste, this study discusses concepts consistent with preserving public safety and waste isolation.

A conceptual evaluation of potential off-normal subsurface events indicates that while an off-normal event may temporarily interrupt retrieval operations, no postulated off-normal event could ultimately prevent a successful retrieval operation.