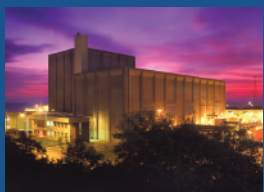
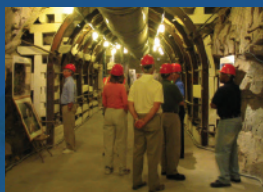


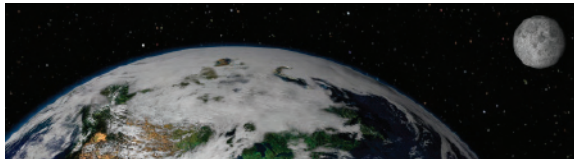


2008-2009

# Information Digest







2008-2009

# Information Digest

NUREG-1350, Volume 20  
Manuscript Completed: August 2008  
Date Published: August 2008

Office of Public Affairs  
U.S. Nuclear Regulatory Commission  
Washington, DC 20555-0001

[www.nrc.gov](http://www.nrc.gov)



*Protecting People and the Environment*

*Front Cover: (clockwise from upper left corner)*

1. Gamma Knife® headframe used for treating brain tumors with focused radiation beams. (Photo Courtesy of Elekta.)
2. Limerick nuclear power plant located near Philadelphia, PA. (Photo courtesy of Exelon Corp.)
3. Satellite image of Earth.
4. NRC headquarters in Rockville, MD.
5. Background image of entrance to NRC headquarters.

*Inside Cover: (from left to right)*

1. Control room at a nuclear plant.
2. Inside the proposed nuclear waste facility at Yucca Mountain, NV.
3. Fuel assembly components for a nuclear power plant.
4. Pilgrim nuclear power plant near Plymouth, MA. (Photo courtesy of Entergy Nuclear.)



## ABSTRACT

The U.S. Nuclear Regulatory Commission (NRC) 2008–2009 Information Digest provides a summary of information about the NRC. It describes the agency’s regulatory responsibilities and licensing activities and also provides general information on nuclear energy.

To create the Information Digest, the agency compiled and organized NRC and industry-related data into a quick reference on the agency and the industry it regulates. Data include activities through 2007 or the most current data available at manuscript completion. (In this edition, adjustments were made to figures previously based on preliminary data. All information is final unless otherwise noted.)

The NRC reviewed information from industry sources but did not perform an independent verification.

Also in this edition, some changes reflect the data-driven characteristics of the digest. They include the following: development of a new section titled “Security and Emergency Preparedness” to reflect our mission and strategic plan goals, development of an NRC Web Link Index of URL addresses that lead to more information on major topics, and creation of a tear-out reference sheet called NRC Facts at a Glance.

The agency welcomes comments or suggestions on the Information Digest. Please contact Ivonne Couret, Office of Public Affairs, U.S. Nuclear Regulatory Commission, Washington, DC 20555-0001.



## TABLE OF CONTENTS

Abstract	iii
<b>NRC: AN INDEPENDENT REGULATORY AGENCY</b>	<b>1</b>
Mission	2
Major Activities	3
Organizations and Functions	5
Budget	10
<b>U.S. AND WORLDWIDE ENERGY</b>	<b>13</b>
U.S. Electricity Capacity and Generation	14
Average Production Expenses	19
U.S. Electricity Generated by Commercial Nuclear Power	19
Worldwide Electricity Generated by Commercial Nuclear Power	23
Worldwide Nuclear Production	24
International Activities	28
<b>OPERATING NUCLEAR REACTORS</b>	<b>31</b>
U.S. Commercial Nuclear Power Reactors	32
Oversight of U.S. Commercial Nuclear Power Reactors	38
New Commercial Nuclear Power Reactor Licensing	43
Reactor License Renewal	47
Nuclear Research and Test Reactors	50
Nuclear Regulatory Research	51
<b>NUCLEAR MATERIALS</b>	<b>55</b>
Fuel Cycle Facilities	56
Uranium Milling	61
Materials Licenses	63
Medical and Academic	65
Industrial	67
Material Security	69
<b>RADIOACTIVE WASTE</b>	<b>71</b>
Low-Level Radioactive Waste Disposal	72
High-Level Radioactive Waste Management	74
Transportation	83
Decommissioning	85
<b>SECURITY AND EMERGENCY PREPAREDNESS</b>	<b>87</b>
Overview	88
Facilities Security	88
Materials Security	89
Emergency Preparedness	89
Incident Response	90

<b>APPENDICES</b>	<b>95</b>
Abbreviations Used in Appendices	96
Appendix A: U.S. Commercial Nuclear Power Reactors	98
Appendix B: U.S. Commercial Nuclear Power Reactors Formerly Licensed to Operate (Permanently Shut Down)	113
Appendix C: Canceled U.S. Commercial Nuclear Power Reactors	115
Appendix D: U.S. Commercial Nuclear Power Reactors by Operating Utility Company	121
Appendix E: U.S. Nuclear Research and Test Reactors (Operating) Regulated by the NRC	123
Appendix F: U.S. Nuclear Research and Test Reactors (under Decommissioning) Regulated by the NRC	125
Appendix G: Industry Performance Indicators: Annual Industry Averages	126
Appendix H: Dry Spent Fuel Storage Designs: NRC-Approved for Use by General Licensees	127
Appendix I: Dry Spent Fuel Storage Licensees	128
Appendix J: Nuclear Power Units by Nation	132
Appendix K: Nuclear Power Units by Reactor Type, Worldwide	133
Appendix L: Top 50 Reactors by Capacity Factor, Worldwide	134
Appendix M: Top 50 Reactors by Generation, Worldwide	136
Appendix N: Quick-Reference Metric Conversion Tables	138
Glossary	141
Web Link Index	160
Information Digest Index	166
NRC Facts at a Glance	169

## FIGURES

### **NRC: AN INDEPENDENT REGULATORY AGENCY**

1. U.S. Nuclear Regulatory Commission Organization Chart	6
2. NRC Regions	9
3. NRC Budget Authority	10
4. NRC Personnel Ceiling	10
5. Distribution of NRC FY 2008 Budget Authority and Staff	11
6. Recovery of NRC Budget	12

### **U.S. AND WORLDWIDE ENERGY**

7. U.S. Electric Existing Capacity by Energy Source	14
8. Power Upgrades: Past, Current, and Future	15
9. Projected Electric Capacity Dependent on License Renewals	15
10. U.S. Electric Net Generation by Energy Source	16
11. Net Electricity Generated in Each State by Nuclear Power	18
12. U.S. Net Electric Generation by Energy Source	20



13. U.S. Average Nuclear Reactor and Coal-Fired and Fossil Steam Plant Production Expenses	21
14. Net Generation of U.S. Nuclear Electricity	22
15. Operating Nuclear Power Plants Worldwide	24
16. Gross Nuclear Electric Power as a Percent of World Nuclear Generation	26
17. Total Domestic Electricity Generation	26

**OPERATING NUCLEAR REACTORS**

18. U.S. Operating Commercial Nuclear Power Reactors	33
19. Typical Pressurized-Water Reactor	34
20. Typical Boiling-Water Reactor	35
21. U.S. Commercial Nuclear Power Reactor Operating Licenses — Issued by Year	36
22. NRC Inspection Effort at Operating Reactors	37
23. Industry Performance Indicators: Annual Industry Averages	39
24. New Reactor Licensing Schedule of Applications by Design	45
25. U.S. Commercial Nuclear Power Reactors — Years of Operation	47
26. U.S. Commercial Nuclear Power Reactor Operating Licenses — Expiration Date by Year Assuming Construction Recapture	48
27. U.S. Nuclear Research and Test Reactors	50
28. NRC Research Funding	52

**NUCLEAR MATERIALS**

29. Locations of Fuel Cycle Facilities	57
30. The Nuclear Fuel Cycle	58
31. Enrichment Processes	59
32. Simplified Fuel Fabrication Process	60
33. Locations of Uranium Milling Sites	62
34. Agreement States	63
35. Cross-Section of Fixed Fluid Gauge	67
36. Commercial Irradiator	69
37. Life Cycle Approach to Source Security	70

**RADIOACTIVE WASTE**

38. Storage of Commercial Spent Fuel by State through 2007	74
39. Spent Fuel Generation and Storage after Use	76
40. Licensed/Operating Independent Spent Fuel Storage Installations	79
41. Independent Spent Fuel Storage Installation Growth with Time	80
42. Proposed Yucca Mountain Repository	81
43. Dry Storage of Spent Nuclear Fuel	84

**SECURITY AND EMERGENCY PREPAREDNESS**

44. Industry Performance Indicators: Annual Industry Percentages	91
--	----

## TABLES

### U.S. AND WORLDWIDE ENERGY

1. Electric Generating Capacity and Electric Generation in Each State by Nuclear Power	17
2. U.S. Net Electric Generation by Energy Source	20
3. U.S. Average Nuclear Reactor, Coal-Fired, and Fossil-Steam Plant Production Expenses	21
4. U.S. Nuclear Power Reactor Average Net Capacity Factor and Net Generation	22
5. U.S. Commercial Nuclear Power Reactor Average Capacity Factor by Vendor and Reactor Type	23
6. Commercial Nuclear Power Reactor Average Gross Capacity Factor and Gross Generation by Selected Country	27
7. Commercial Nuclear Power Reactor Average Gross Capacity Factor by Selected Country	27
8. Bilateral Information Exchange and Cooperation Programs with the United States	28

### OPERATING NUCLEAR REACTORS

9. U.S. Commercial Nuclear Power Reactor Operating Licenses — Issued by Year	36
10. Expected New Nuclear Power Plant Applications	46
11. U.S. Commercial Nuclear Power Reactor Operating Licenses — Expiration Date by Year, 2009–2046	48

### NUCLEAR MATERIALS

12. Major U.S. Fuel Cycle Facility Sites	57
13. Locations of Uranium Milling Facilities	62
14. U.S. Materials Licenses by State	64

### RADIOACTIVE WASTE

15. U.S. Low-Level Radioactive Waste Compacts	73
16. U.S. State-by-State Commercial Nuclear Used Fuel and Payments to the Nuclear Waste Fund	75
17. Complex Decommissioning Sites	86

*NRC headquarters in Rockville, MD.*



## **NRC: AN INDEPENDENT REGULATORY AGENCY**

## MISSION

The U.S. Nuclear Regulatory Commission (NRC) is an independent agency created by Congress. The mission of the NRC is to license and regulate the Nation's civilian use of byproduct, source, and special nuclear materials in order to protect public health and safety, promote the common defense and security, and protect the environment.

The NRC's regulations are designed to protect both the public and workers against radiation hazards from industries that use radioactive materials.

The NRC's scope of responsibility includes regulation of commercial nuclear power plants; research, test, and training reactors; nuclear fuel cycle facilities; medical, academic, and industrial uses of radioactive materials; and the transport, storage, and disposal of radioactive materials and wastes.

In addition, the NRC licenses the import and export of radioactive materials and works to enhance nuclear safety and security throughout the world.

## Values

The NRC adheres to the principles of good regulation—*independence, openness, efficiency, clarity, and reliability*. The agency puts these principles into practice with effective, realistic, and timely regulatory actions.

## Strategic Goals

**Safety:** Ensure adequate protection of public health and safety and the environment.

**Security:** Ensure adequate protection in the secure use and management of radioactive materials.

## Strategic Outcomes

- Prevent the occurrence of any nuclear reactor accidents.
- Prevent the occurrence of any inadvertent criticality events.
- Prevent the occurrence of any acute radiation exposures resulting in fatalities.
- Prevent the occurrence of any releases of radioactive materials that result in significant radiation exposures.
- Prevent the occurrence of any releases of radioactive materials that cause significant adverse environmental impacts.
- Prevent any instances where licensed radioactive materials are used domestically in a manner hostile to the United States.

## Statutory Authority

The NRC was established by the Energy Reorganization Act of 1974 to oversee the commercial nuclear industry. The agency took over regulation formerly carried out by the Atomic Energy Commission and began operations on January 18, 1975. As noted earlier, it is the



NRC's job to regulate the civilian commercial, industrial, academic, and medical uses of nuclear materials. This enables the Nation to use radioactive materials for beneficial civilian purposes while protecting the American people and their environment.

The NRC's regulations are contained in Title 10 of the *Code of Federal Regulations* (10 CFR). The following principal statutory authorities govern the NRC's work and can be found on the NRC Web site (see Web Link Index):

- Atomic Energy Act of 1954, as Amended (P.L. 83-703)
- Energy Reorganization Act of 1974, as Amended (P.L. 93-438)
- Uranium Mill Tailings Radiation Control Act of 1978, as Amended (P.L. 95-604)
- Nuclear Non-Proliferation Act of 1978 (P.L. 95-242)
- West Valley Demonstration Project Act of 1980 (P.L. 96-368)
- Nuclear Waste Policy Act of 1982, as Amended (P.L. 97-425)
- Low-Level Radioactive Waste Policy Act amendments of 1985 (P.L. 99-240)
- Diplomatic Security and Anti-Terrorism Act of 1986 (P.L. 107-56)
- Solar, Wind, Waste, and Geothermal Power Production Incentives Act of 1990
- Energy Policy Act of 1992
- Energy Policy Act of 2005

The NRC, the Agreement States (see Glossary), and licensees—those who hold licenses to use radioactive materials—share a common responsibility to protect public health and safety and the environment. Federal regulations and the NRC regulatory program are important elements in the protection of the public. However, because licensees are the ones using radioactive material, they bear the primary responsibility for safely handling these materials.

## MAJOR ACTIVITIES

The NRC fulfills its responsibilities through the following licensing and regulatory activities:

- Licenses the design, construction, operation, and decommissioning of nuclear plants and other nuclear facilities, such as nuclear fuel facilities, uranium enrichment facilities, and research and test reactors.
- Licenses the possession, use, processing, handling, and importing and exporting of nuclear materials.
- Licenses the siting, design, construction, operation, and closure of low-level radioactive waste disposal sites under NRC jurisdiction and the construction, operation, and closure of a proposed geologic repository for high-level radioactive waste.

- Licenses the operators of civilian nuclear reactors.
- Inspects licensed and certified facilities and activities.
- Certifies privatized uranium enrichment facilities.
- Conducts light-water reactor safety research, using independent research, data, and expertise, to develop regulations and anticipate potential safety problems.
- Collects, analyzes, and disseminates information about the operational safety of commercial nuclear power reactors and certain nonreactor activities.
- Establishes rules, regulations, and orders that govern licensed nuclear activities.
- Investigates nuclear incidents and allegations concerning any matter regulated by the NRC.
- Enforces NRC regulations and the conditions of NRC licenses.
- Conducts public hearings on matters of nuclear and radiological safety, environmental concern, and common defense and security.
- Develops effective working relationships with State and Tribal Governments regarding reactor operations and the regulation of nuclear materials.
- Develops policy and provides direction on security issues at nuclear facilities and interacts with other Federal agencies, including the U.S. Department of Homeland Security, on safety and security issues.
- Directs the NRC program for response to incidents involving licensees and conducts a program of emergency preparedness and response for licensed nuclear facilities.
- Provides opportunities for public involvement in the regulatory process that include the following: holding open meetings, conferences, and workshops; issuing rules, regulations, petitions, and technical reports for public comment; responding to requests for NRC documents under the Freedom of Information Act; reporting safety concerns; and providing access to thousands of NRC documents through the NRC Web site.



*The NRC hosted the annual Regulatory Information Conference (RIC) attended by more than 2,300 people including representatives from more than 25 foreign countries, the nuclear industry, and congressional staff.*



Chairman  
Dale E. Klein



Commissioner  
Gregory B. Jaczko



Commissioner  
Peter B. Lyons



Commissioner  
Kristine L. Svinicki

**Commissioner Term Expiration**

Commissioner	Expiration of Term
Dale E. Klein, Chairman	June 30, 2011
Gregory B. Jaczko	June 30, 2013
Peter B. Lyons	June 30, 2009
Kristine L. Svinicki	June 30, 2012

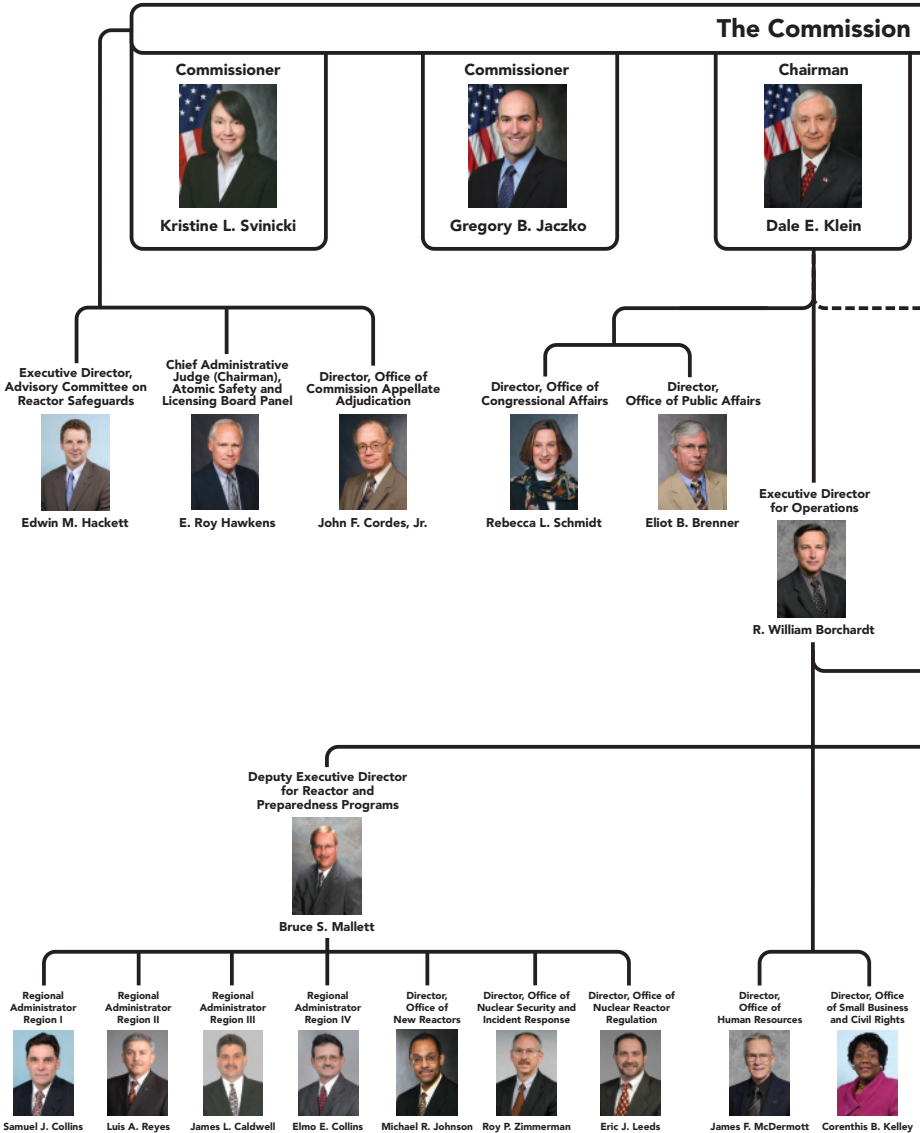
**ORGANIZATIONS AND FUNCTIONS**

The NRC’s Commission is composed of five members nominated by the President and confirmed by the U.S. Senate for a 5-year term. The President designates one member to serve as Chairman, principal executive officer, and spokesperson of the Commission. The members’ terms are normally staggered so that one

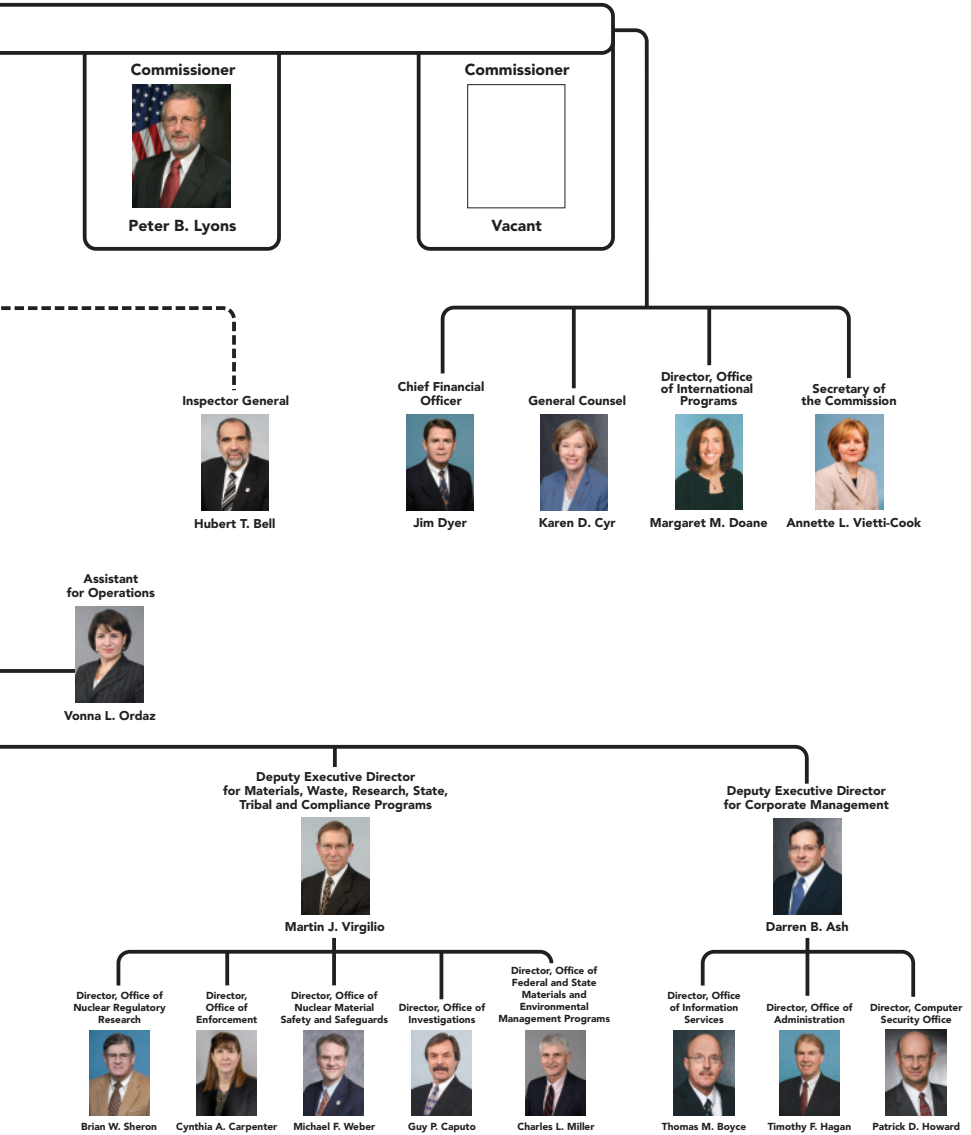
Commissioner’s term expires on June 30 every year. No more than three Commissioners can belong to the same political party. The members of the Commission (as of August 2008) are shown above. There is currently one vacancy.

The Commission as a whole formulates policies and regulations governing nuclear reactor and materials safety, issues orders to licensees, and adjudicates legal

Figure 1. U.S. Nuclear Regulatory Commission Organization Chart







matters brought before it. The Executive Director for Operations (EDO) carries out the policies and decisions of the Commission and directs the activities of the program and regional offices (see Figures 1 and 2).

The NRC's major program offices are as follows:

- **Office of Nuclear Reactor Regulation**

Handles all licensing and inspection activities associated with the operation of both nuclear power reactors and research and test reactors.

- **Office of New Reactors**

Provides safety oversight of the design, siting, licensing, and construction of new commercial nuclear power reactors.

- **Office of Nuclear Material Safety and Safeguards**

Regulates activities that provide for the safe and secure production of nuclear fuel used in commercial nuclear reactors; the safe storage, transportation, and disposal of high-level radioactive waste and spent nuclear fuel; and the transportation of radioactive materials regulated under the Atomic Energy Act of 1954.

- **Office of Federal and State Materials and Environmental Management Programs**

Develops and oversees the regulatory framework for the safe

and secure use of nuclear materials, industrial, commercial, and medical applications, uranium recovery activities, low-level radioactive waste sites, and the decommissioning of previously operating nuclear facilities and power plants.

- **Office of Nuclear Regulatory Research**

Provides independent expertise and information for making timely regulatory judgments, anticipating problems of potential safety significance, and resolving safety issues. Helps develop technical regulations and standards as well as collecting, analyzing, and disseminating information about the operational safety of commercial nuclear power plants and certain nuclear materials activities.

- **Office of Nuclear Security and Incident Response**

Oversees agency policy and activities involving security at nuclear facilities. Provides a safeguards and security interface with other Federal agencies and maintains the agency emergency preparedness and response program.

- **Regional Offices**

Conduct inspection, enforcement, investigation, licensing, and emergency response programs for nuclear reactors, fuel facilities, and materials licensees.

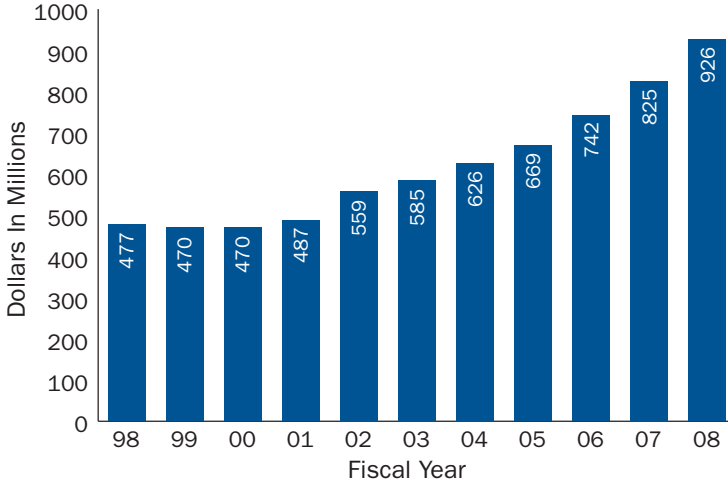


**BUDGET**

For fiscal year (FY) 2008  
(October 1, 2007–September 30,  
2008) Congress appropriated

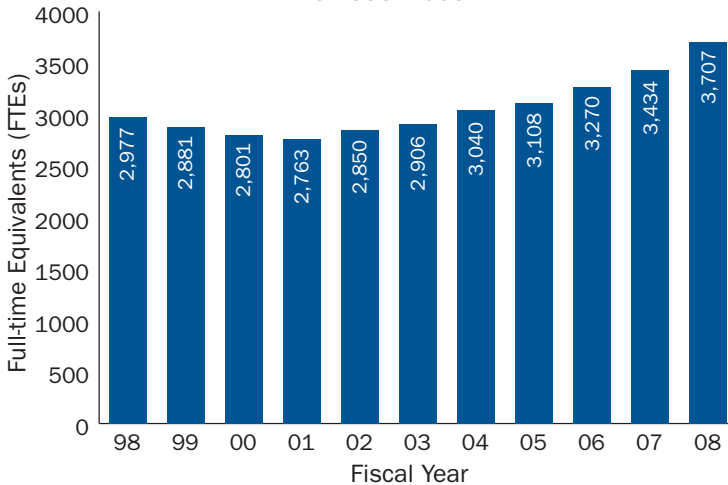
\$926 million to the NRC. The  
NRC’s FY 2008 personnel ceiling  
is 3,707 full-time equivalent (FTE)  
staff (see Figures 3 and 4).

**Figure 3. NRC Budget Authority,  
FYs 1998–2008**



Note: Dollars are rounded to the nearest million.  
Source: U.S. Nuclear Regulatory Commission

**Figure 4. NRC Personnel Ceiling,  
FYs 1998–2008**



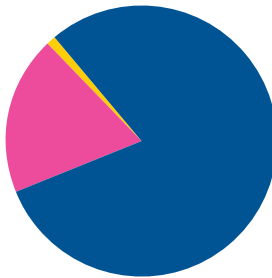
Source: U.S. Nuclear Regulatory Commission

The Office of the Inspector General (OIG) received its own appropriation. The amount is included in the NRC budget.

The NRC allocated funds and staff to Nuclear Reactor Safety and Nuclear Materials and Waste Safety programs and the OIG (see Figure 5).

**Figure 5. Distribution of NRC FY 2008 Budget Authority and Staff (Dollars in Millions)**

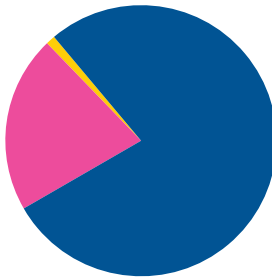
Total Authority: \$926 Million



Programs

- Nuclear Reactor Safety (\$740.6 M) 80%
- Nuclear Materials and Waste Safety (\$176.7 M) 19%
- Inspector General (\$8.7 M) 1%

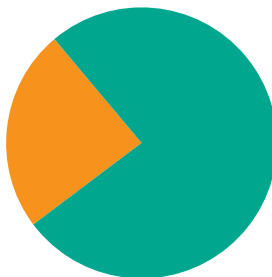
Total Staff: 3,707 FTE



Programs

- Nuclear Reactor Safety (2,886 FTE) 78%
- Nuclear Materials and Waste Safety (770 FTE) 21%
- Inspector General (51 FTE) 1%

Staff by Location



Staff Location

- Headquarters (2,818 FTE) 76%
- Regions (889 FTE) 24%

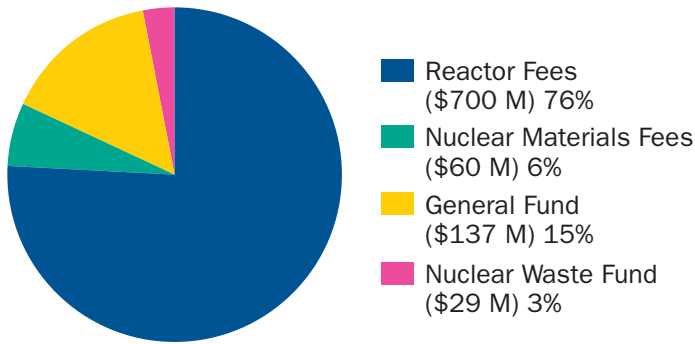
Note: Dollars and percentages are rounded to the nearest whole number.  
Source: U.S. Nuclear Regulatory Commission

By law, the NRC must recover, through fees billed to licensees, approximately 90 percent of its budget authority for FY 2008, less the amounts appropriated from the Nuclear Waste Fund for high-level radioactive waste activities and from general funds for waste-

incidental-to-recycling and generic homeland security activities. Fees are to be collected each year by September 30. The total amount to be recovered in FY 2008 is approximately \$760.7 million. This amount reflects some administrative adjustments (see Figure 6).

**Figure 6. Recovery of NRC Budget, FY 2008\***

Total Authority: \$926 Million



<u>Class of Licensee</u>	<u>Annual Fees</u>
Operating Power Reactor	\$4,167,000**
Fuel Facility	\$341,000 to \$3,007,000
Uranium Recovery Facility	\$10,300
Materials User	\$590 to \$24,400

\* Based on the final FY 2008 fee rule.

\*\* Includes spent fuel storage/reactor decommissioning FY 2008 annual fee of \$135,000.

Note: Percentages are rounded to the nearest whole number.

Source: U.S. Nuclear Regulatory Commission

*The Earth and moon from space.*



## **U.S. AND WORLDWIDE ENERGY**



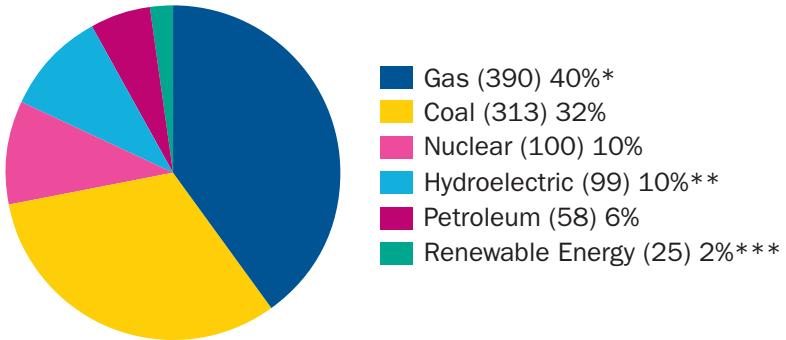
**U.S. ELECTRICITY CAPACITY AND GENERATION**

U.S. electric generating capacity totaled approximately 986 gigawatts in 2006 (see Figure 7), up slightly from 2005 at 978 gigawatts. The existing nuclear generating capacity totaled 100 gigawatts, which translates to 10 percent of total capacity. This increase was due to modifications and authorized power increases (uprates) at existing nuclear units, bringing nuclear energy production to its highest capacity level since 1996.

U.S. utilities have used power uprates since the 1970s as a way to generate more electricity from their nuclear plants. By January 2008, the NRC had approved 116 power uprates, resulting in a gain of approximately 5,200 megawatts electric (MWe) at existing plants. Collectively, these uprates have added the equivalent of five new reactors worth of generation activity at existing plants. The NRC is reviewing or anticipating uprate applications totaling another 2,500 MWe (see Figures 8 and 9).

**Figure 7. U.S. Electric Existing Capacity by Energy Source, 2006**

Total Existing Capacity: 986 gigawatts



\* Gas includes natural gas, blast furnace gas, propane gas, and other manufactured and waste gases derived from fossil fuel.

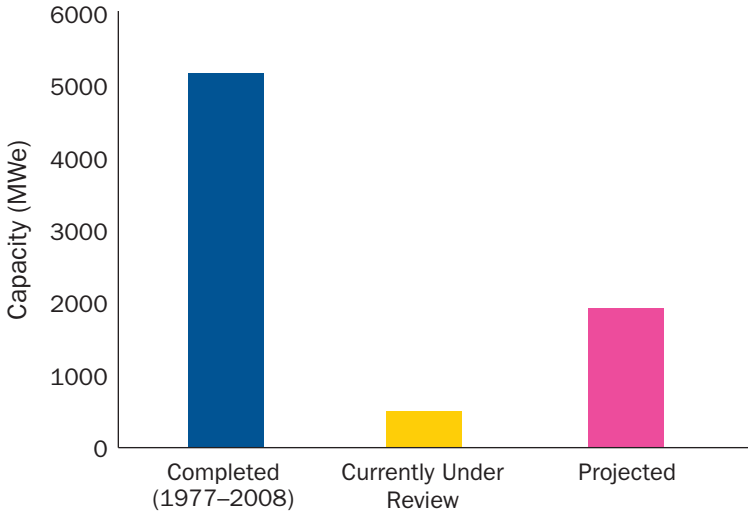
\*\* Hydroelectric includes conventional hydroelectric and hydroelectric pumped storage.

\*\*\* Renewable energy includes geothermal, wood and nonwood waste, wind, and solar energy.

Note: Totals may not equal sum of components because of rounding.

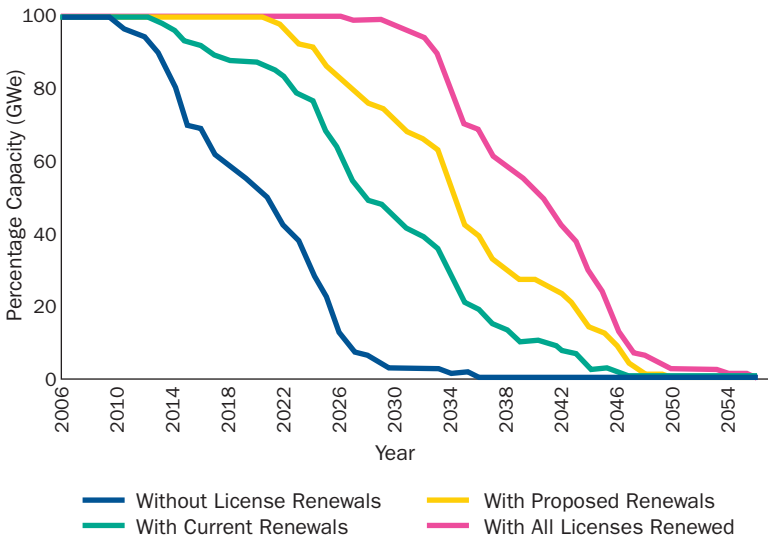
Source: DOE/EIA Electric Power Annual 2006, Existing Capacity by Energy Source, Table 2.2, [www.eia.doe.gov](http://www.eia.doe.gov)

**Figure 8. Power Uprates: Past, Current, and Future**



Note: Power uprates have added the equivalent of five new reactors to the U.S. power grid.  
 Source: U.S. Nuclear Regulatory Commission

**Figure 9. Projected Electric Capacity Dependent on License Renewals**



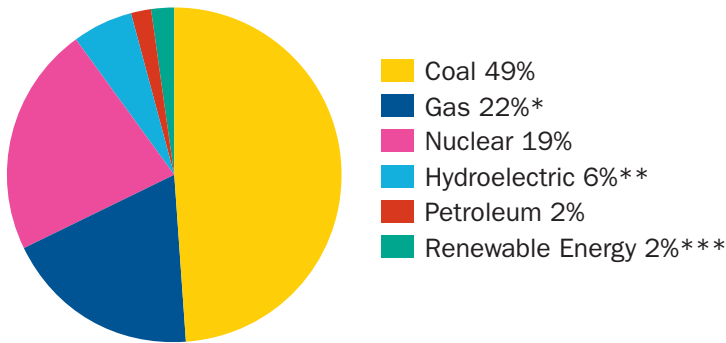
Source: U.S. Nuclear Regulatory Commission

U.S. net electric generation (see Glossary) totaled approximately 4,160 billion kilowatthours in 2007. Nuclear energy accounted for approximately 19 percent of this generation at 806 billion kilowatthours (KWh) (see Figure 10). In 2007, 104 nuclear reactors licensed to operate in 31 States generated approximately one-fifth of the Nation's electricity.

As of 2006, three States (New Jersey, South Carolina, and Vermont) relied on nuclear power for more than 50 percent of their electricity. The percentages cited reflect the percentages of the total net generation in these States that were from nuclear sources. An additional 13 States relied on nuclear power for 25 to 50 percent of their electricity (see Table 1 and Figure 11).

**Figure 10. U.S. Electric Net Generation by Energy Source, 2007**

Total Net Generation: 4,160 billion kilowatthours



\* Gas includes natural gas, blast furnace gas, propane gas, and other manufactured and waste gases derived from fossil fuel.

\*\* Hydroelectric includes conventional hydroelectric and hydroelectric pumped storage.

\*\*\* Renewable energy includes geothermal, wood and nonwood waste, wind, and solar energy.

Note: Percentages are rounded to the nearest whole number.

Source: DOE/EIA Monthly Energy Review, March 2008, Table 7.2a, [www.eia.doe.gov](http://www.eia.doe.gov)

**Table 1. Electric Generating Capacity and Electric Generation in Each State by Nuclear Power, 2006**

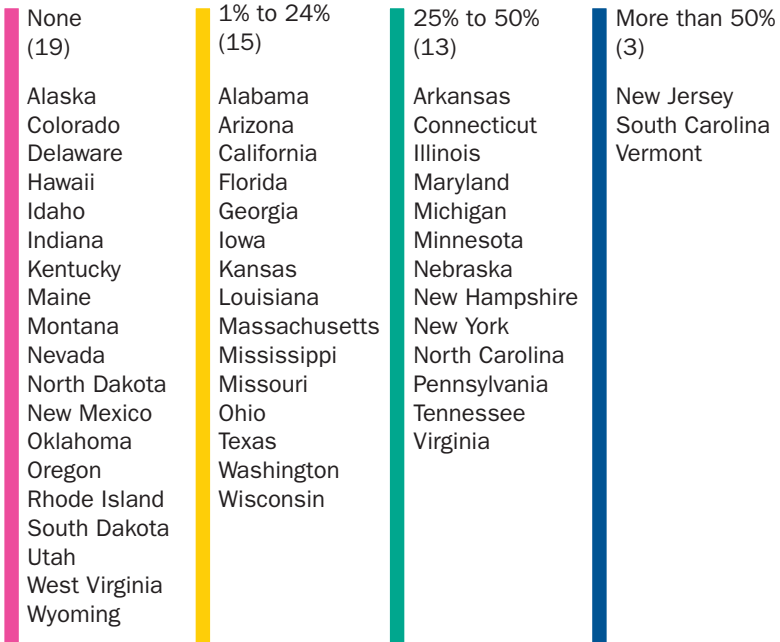
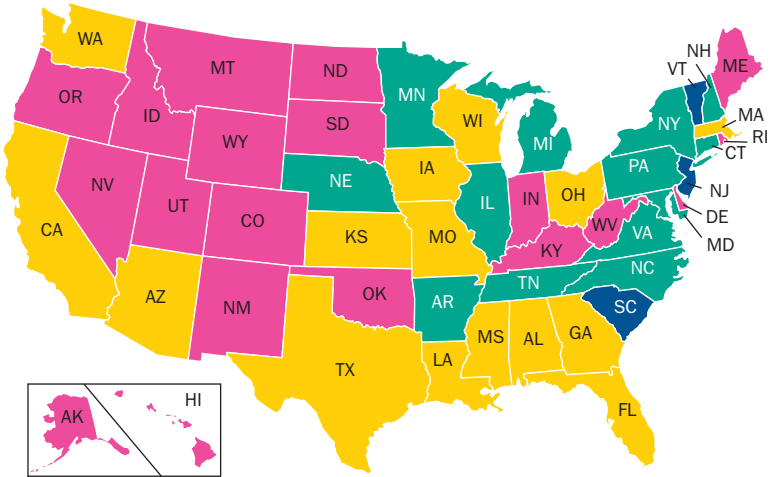
State	Nuclear Percentage of		State	Nuclear Percentage of	
	Net Capacity	Net Generation		Net Capacity	Net Generation
Alabama	16	23	Missouri	6	11
Arizona	15	23	Nebraska	17	28
Arkansas	13	29	New Hampshire	29	43
California	7	15	New Jersey	21	54
Connecticut	26	48	New York	13	30
Florida	7	14	North Carolina	18	32
Georgia	11	23	Ohio	6	11
Illinois	27	49	Pennsylvania	20	34
Iowa	5	11	South Carolina	28	51
Kansas	10	21	Tennessee	16	26
Louisiana	8	18	Texas	5	10
Maryland	14	28	Vermont	55	72
Massachusetts	5	13	Virginia	15	38
Michigan	13	26	Washington	4	9
Minnesota	13	25	Wisconsin	10	20
Mississippi	8	23	USA	10	19
			Others*	0	0

\* The District of Columbia and 19 States have no nuclear generating capability.

Note: Net capacity reflects net summer capacity data and percentages are rounded to the nearest whole number.

Source: DOE/EIA State Electricity Profiles 2006, [www.eia.doe.gov](http://www.eia.doe.gov)

**Figure 11. Net Electricity Generated in Each State by Nuclear Power, 2006**



Note: Percentages are rounded to the nearest whole number.  
 Source: DOE/EIA State Electricity Profiles 2006, [www.eia.doe.gov](http://www.eia.doe.gov)

Since 1996, net nuclear electric generation has increased by 19 percent, and coal-fired electric generation has increased by 13 percent (see Figure 12 and Table 2). All other electricity-generating sources have increased by 37 percent.

### AVERAGE PRODUCTION EXPENSES

The production expense data presented here include all nuclear, fossil, and coal-fired utility-owned steam electric plants (see Table 3 and Figure 13).

In 2006, production expenses averaged \$19.46 each megawatthour for nuclear power plants and \$29.59 each megawatthour for fossil fuel plants.

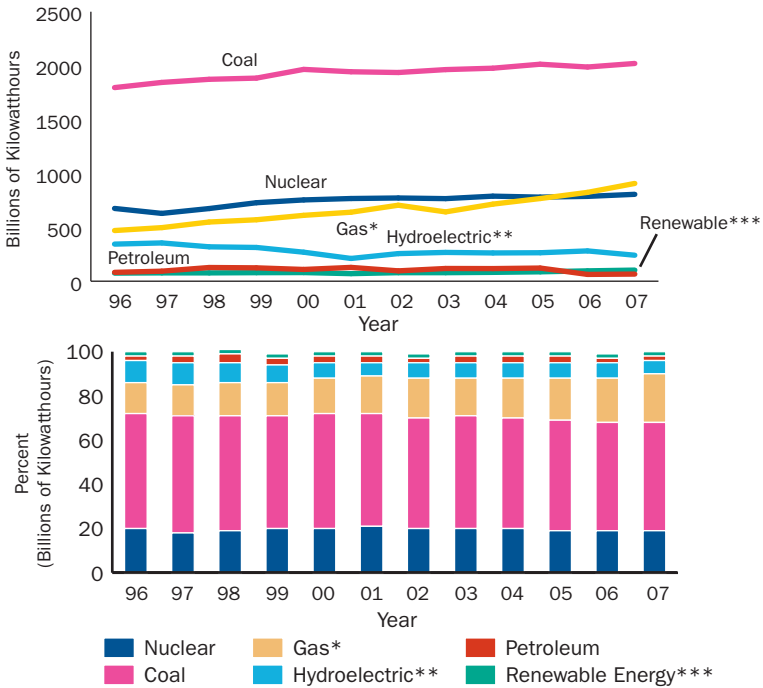
### U.S. ELECTRICITY GENERATED BY COMMERCIAL NUCLEAR POWER

In 2007, net nuclear-based electric generation in the United States produced a total of 806 billion kilowatthours (see Table 4 and Figure 14).

In 2006, the average U.S. net capacity factor was 90 percent. It increased to 92 percent in 2007. Since 1996, the average capacity factor has increased approximately 16 percent. The net capacity factor is the ratio of electricity generated to the amount of energy that could have been generated.

- In 2007, 98 percent of U.S. commercial nuclear reactors operated above a capacity factor of 70 percent.
- In 2007, Westinghouse Electric reactors had the highest average capacity factor compared to those of the other three vendors. The 50 Westinghouse Electric reactors had an average capacity factor of 94 percent. The other three vendors had the following average capacity factors: 7 Babcock & Wilcox reactors—92 percent, 12 Combustion Engineering reactors—92 percent, and 35 General Electric reactors—89 percent (see Table 5).

Figure 12. U.S. Net Electric Generation by Energy Source, 1996–2007



\* Gas includes natural gas, blast furnace gas, propane gas, and other manufactured and waste gases derived from fossil fuel.  
 \*\* Hydroelectric includes conventional hydroelectric and hydroelectric pumped storage.  
 \*\*\* Renewable energy includes geothermal, wood and nonwood waste, wind, and solar energy.  
 Source: DOE/EIA Monthly Energy Review, March 2008, Table 7.2a, www.eia.doe.gov

Table 2. U.S. Net Electric Generation by Energy Source, 1996–2007 (Billion Kilowatthours)

Year	Coal	Petroleum	Gas*	Hydroelectric**	Nuclear	Renewable*** Energy
1996	1,795	81	469	344	675	76
1997	1,845	92	493	352	629	77
1998	1,873	128	545	319	674	77
1999	1,881	118	570	313	728	79
2000	1,966	111	614	270	754	81
2001	1,904	125	648	208	769	71
2002	1,933	95	702	256	780	79
2003	1,973	119	665	267	764	79
2004	1,977	120	726	260	788	83
2005	2,013	122	774	264	782	87
2006	1,990	64	829	283	787	96
2007†	2,021	66	909	241	806	103

Note: See footnotes for Figure 12. † Based on preliminary data.  
 Source: DOE/EIA Monthly Energy Review, March 2008, Table 7.2a, www.eia.doe.gov



**Table 3. U.S. Average Nuclear Reactor, Coal-Fired, and Fossil-Steam Plant Production Expenses, 1996–2006 (Dollars per Megawatthour)**

Year	Operation and Maintenance	Fuel	Total Production Expenses	Year	Operation and Maintenance	Fuel	Total Production Expenses
<b>Nuclear</b>				<b>Coal-Fired</b>			
1996	15.15	5.50	20.65	1996	4.74	16.51	21.25
1997*	17.92	5.42	23.33	1997*	4.65	16.80	21.45
1998	15.77	5.39	21.16	<b>Fossil-Steam**</b>			
1999	14.06	5.17	19.23	1998	4.58	15.94	20.52
2000	13.34	4.95	18.28	1999	4.59	15.62	20.22
2001	13.31	4.67	17.98	2000	4.76	17.69	22.44
2002	13.58	4.60	18.18	2001	5.01	18.13	23.14
2003	14.09	4.60	18.69	2002	5.22	16.11	21.32
2004	13.68	4.58	18.26	2003	5.23	17.35	22.59
2005	13.62	4.54	18.16	2004	5.64	18.21	23.85
2006	14.61	4.85	19.46	2005	5.93	21.77	27.69
				2006	6.42	23.17	29.59

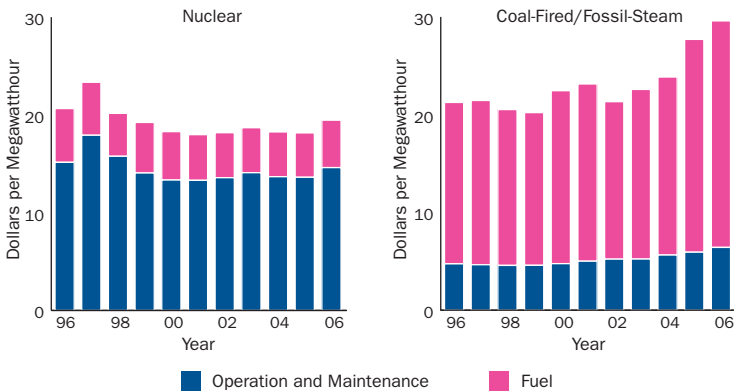
U.S. AND WORLDWIDE ENERGY

\* Data for 1997 and prior years were obtained from Utility Data Institute, Inc.

\*\* Includes coal and fossil fuel. Plant production expenses are no longer available exclusively for coal-fired fuel.

Source: Federal Energy Regulatory Commission, FERC Form 1, "Annual Report of Major Electric Utilities, Licensees and Others," DOE/EIA Electric Power Annual 2006, www.eia.doe.gov

**Figure 13. U.S. Average Nuclear Reactor and Coal-Fired and Fossil-Steam Plant Production Expenses, 1996–2006**



Source: Federal Energy Regulatory Commission, FERC Form 1, "Annual Report of Major Electric Utilities, Licensees and Others," DOE/EIA Electric Power Annual 2006, www.eia.doe.gov

**Table 4. U.S. Nuclear Power Reactor Average Net Capacity Factor and Net Generation, 1996–2007**

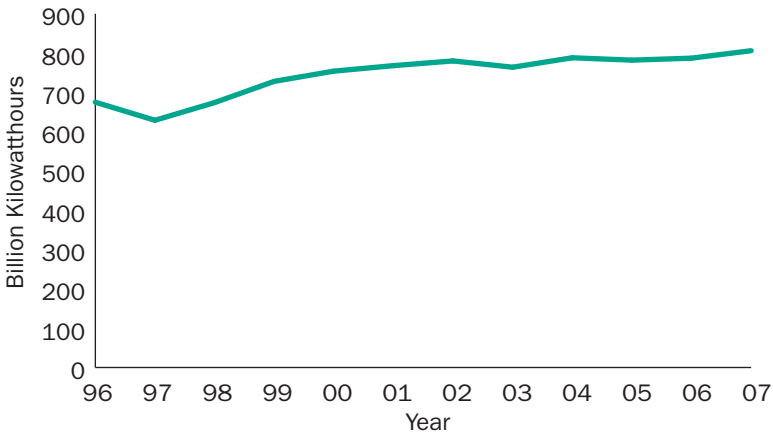
Year	Number of Operating Reactors	Average Annual Capacity Factor (Percent)	Net Generation of Electricity	
			Billions of Kilowatt-hours	Percent of Total U.S. Capacity
1996	109	76	675	19.6
1997	107	71	629	18.0
1998	104	78	674	18.6
1999	104	85	728	19.7
2000	104	88	754	19.8
2001	104	89	769	20.6
2002	104	90	780	20.2
2003	104	88	764	19.7
2004	104	90	788	19.9
2005	104	89	782	19.3
2006	104	90	787	19.4
2007*	104	92	806	19.4

\* Based on preliminary data.

Note: Average annual capacity factor is based on net maximum dependable capacity. See Glossary for definition.

Source: Based on March 2008 DOE/EIA Monthly Energy Review Table 7.2a, [www.eia.doe.gov](http://www.eia.doe.gov), and licensee data as compiled by the U.S. Nuclear Regulatory Commission

**Figure 14. Net Generation of U.S. Nuclear Electricity, 1996–2007**



Source: Based on March 2008 DOE/EIA Monthly Energy Review Table 7.2.a, [www.eia.doe.gov](http://www.eia.doe.gov), and licensee data as compiled by the U.S. Nuclear Regulatory Commission

**Table 5. U.S. Commercial Nuclear Power Reactor Average Capacity Factor by Vendor and Reactor Type, 2005–2007**

Capacity Factor	Licensed to Operate			Percent of Net Nuclear Generated		
	2005	2006	2007	2005	2006	2007*
Above 70 Percent	99	101	101	99	99	98
50 to 70 Percent	4	1	2	1	1	1
Below 50 Percent	1	2	1	>1	>1	>1

Vendor	Licensed to Operate			Average Capacity Factor (Percent)		
	2005	2006	2007	2005	2006	2007*
Babcock & Wilcox	7	7	7	91	90	92
Combustion Engineering	12	12	12	92	96	92
General Electric	35	35	35	86	95	89
Westinghouse Electric	50	50	50	91	92	94
Total	104	104	104	N/A	N/A	N/A

Reactor Type	Licensed to Operate			Average Capacity Factor (Percent)		
	2005	2006	2007	2005	2006	2007*
Boiling-Water Reactor	35	35	35	88	90	90
Pressurized-Water Reactor	69	69	69	90	90	93
Total	104	104	104	N/A	N/A	N/A

U.S. AND WORLDWIDE ENERGY

\*Based on preliminary data.

Note: Average capacity factor is based on net maximum dependable capacity. See Glossary for definition. Refer to Appendix A for the 2002–2007 average capacity factors for each reactor. Percentages are rounded to the nearest whole number.

Source: Licensee data as compiled by the U.S. Nuclear Regulatory Commission

### WORLDWIDE ELECTRICITY GENERATED BY COMMERCIAL NUCLEAR POWER

As of 2007, there were 437 operating reactors in 30 countries and Taiwan with a total installed capacity of 371,855 gigawatts electric (GWe) (see Figure 15). In addition, five nuclear power plants were in long-term shutdown, and

35 nuclear power plants were under construction.

- Refer to Appendix J for a list of the number of nuclear power reactors in the world and Appendix K for nuclear power units by reactor type, worldwide. The two top producers of nuclear electricity during 2007 were the United States and France.

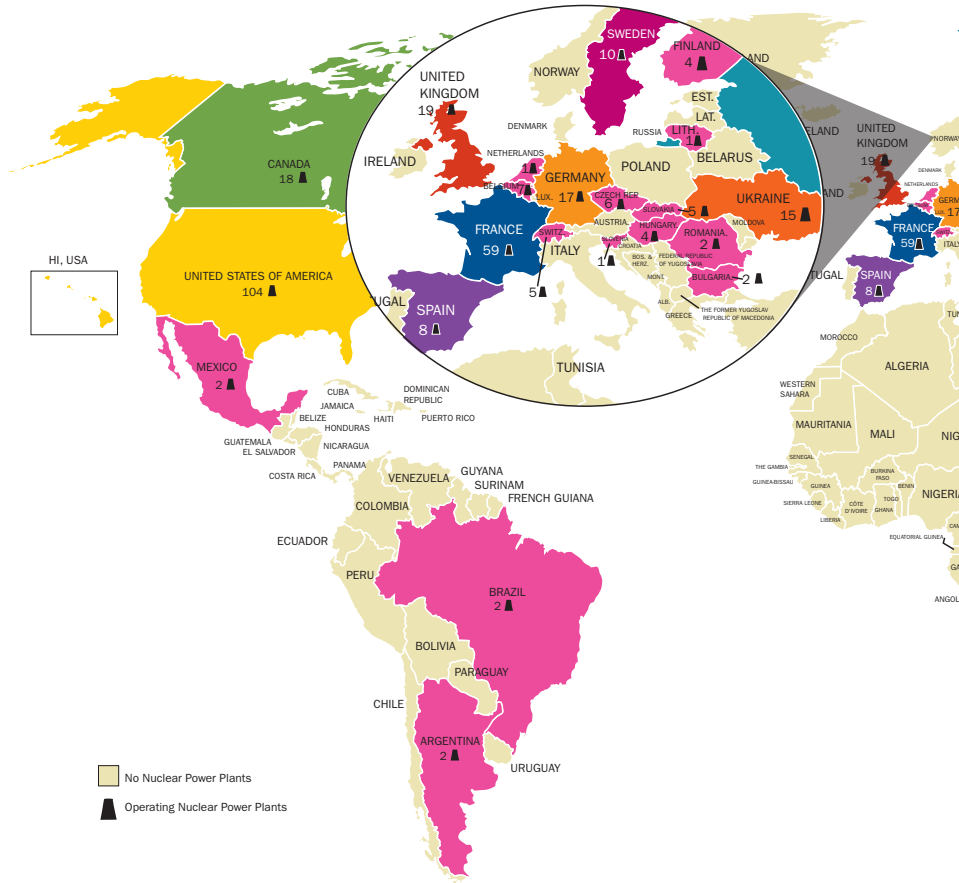
**WORLDWIDE NUCLEAR PRODUCTION**

The U.S. produced approximately 32 percent of the world’s gross nuclear-generated electricity in 2007 (see Figure 16). France was the next highest producer at 16 percent. Based on preliminary data in 2006, France had the highest nuclear portion (79%) of total energy generated. In the

United States, nuclear energy accounted for 19 percent of the energy generation (see Figure 17).

Countries with the highest average gross capacity factor for nuclear reactors in 2007 include the United States at 91 percent, the Republic of Korea at 88 percent, Sweden at 80 percent, and Germany at 73 percent (see Table 6).

**Figure 15. Operating Nuclear**



Note: There are no commercial reactors in Alaska or Hawaii. Refer to Appendix J for a world list of the number of nuclear power reactors.

Source: *Nucleonics Week*® and International Atomic Energy Agency

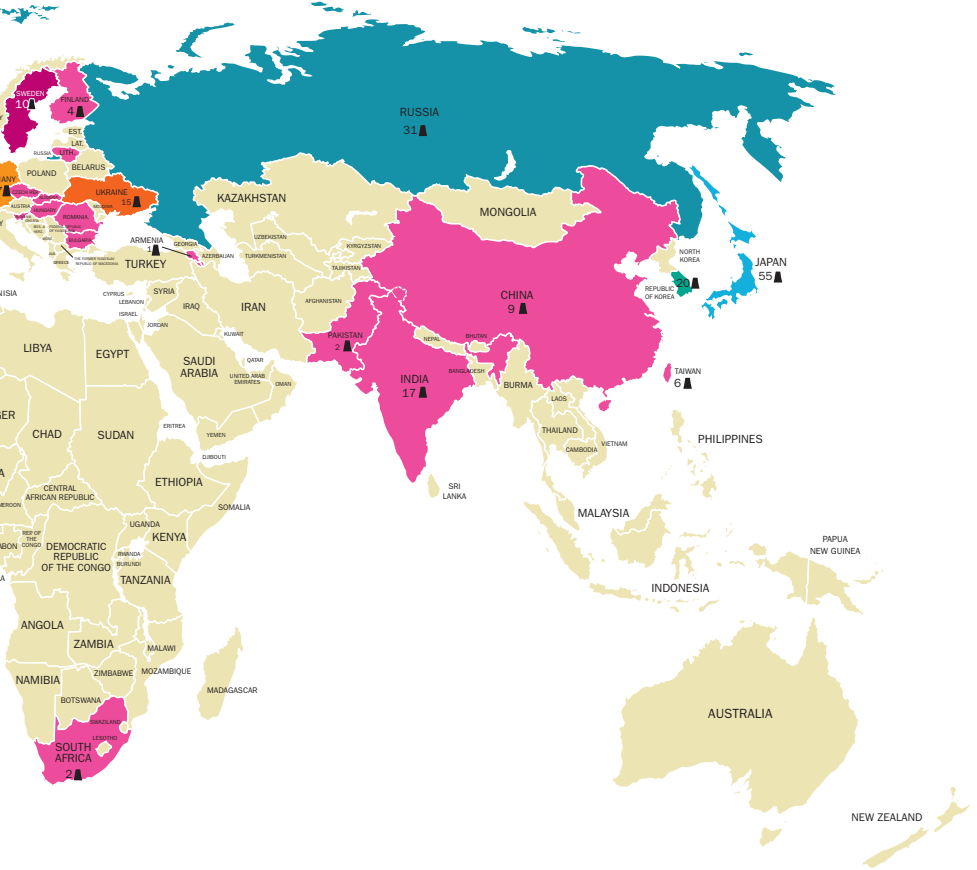
Reactors in the United States had the greatest gross nuclear generation at 843 billion kilowatthours. France was the next highest producer at 439 billion kilowatthours (see Table 6).

Refer to Appendix L for a list of the top 50 units by gross capacity factor worldwide, and refer to Appendix M for a list of the top

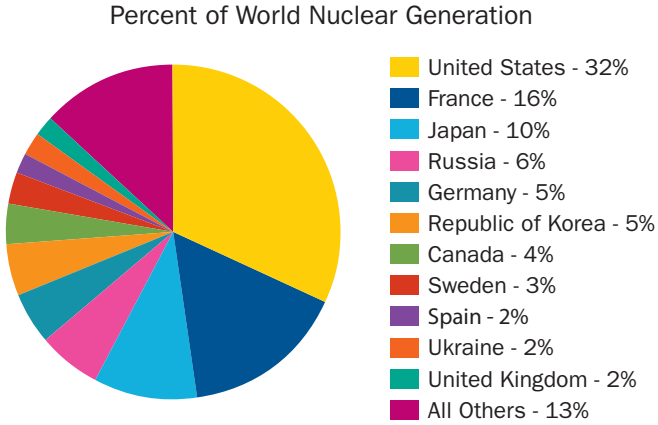
50 units by gross generation worldwide.

Over the past 10 years, the average annual gross capacity factor has increased 15 percent in the United States, 3 percent in France, and 2 percent in Sweden. In the same period, the average annual gross capacity factor has decreased 19 percent in Japan and 6 percent in Germany (see Table 7).

**Power Plants Worldwide, 2007**



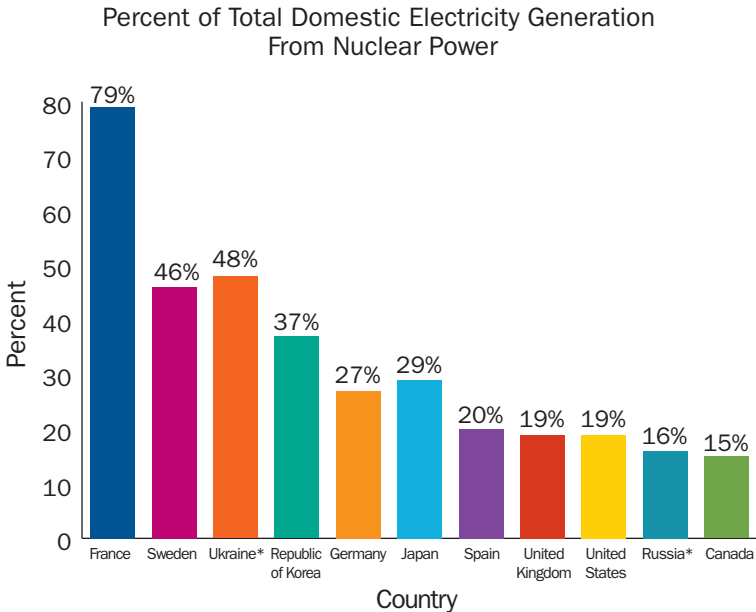
**Figure 16. Gross Nuclear Electric Power as a Percent of World Nuclear Generation, 2007**



Total World Gross Nuclear Electricity Generation:  
2,667 billion kilowatthours

Source: *Nucleonics Week*®, February 14, 2008, by McGraw-Hill, Inc. Reproduced by permission. Further reproduction prohibited.

**Figure 17. Total Domestic Electricity Generation, 2006**



\* Based on total electric preliminary figures for 2005. Data from 2006 are unavailable.

Source: Energy Information Administration, Office of Energy Markets and End Use, International Energy Statistics Team

**Table 6. Commercial Nuclear Power Reactor Average Gross Capacity Factor and Gross Generation by Selected Country, 2007**

Country	Number of Operating Reactors	Average Gross Capacity Factor (in percent)	Total Gross Nuclear Generation (in billions of kWh)	Number of Operating Reactors in Top 50 by Capacity Factor	Number of Operating Reactors in Top 50 by Generation
Canada	21	67	94	3	0
France	58	76	439	0	13
Germany	17	73	140	0	9
Japan	55	64	279	5	2
Republic of Korea	20	88	143	2	0
Russia	31	71	158	0	0
Sweden	10	80	67	0	0
Ukraine	15	78	48	0	0
United States	104	91	843	32	22

Note: The United States gross capacity factor and generation includes estimates based on net MWh for 4 of the 104 U.S. units.

Source: Excerpted from *Nucleonics Week*®, February 14, 2008, by McGraw-Hill, Inc. Reproduced by permission. Further reproduction prohibited.

**Table 7. Commercial Nuclear Power Reactor Average Gross Capacity Factor by Selected Country, 1998–2007**

## Annual Gross Average Capacity Factor (Percent)

Country	1998	1999	2000	2001	2002	2003	2004	2005	2006	2007*
Canada	50	52	50	53	53	54	64	66	71	67
France	73	71	72	73	75	75	77	78	77	76
Germany	79	88	87	87	83	84	87	86	89	73
Japan	83	79	79	79	77	59	70	69	70	64
Republic of Korea	—	88	90	93	93	94	92	95	93	88
Russia	—	61	67	67	67	70	68	66	70	71
Sweden	78	78	66	84	75	77	89	87	82	80
Ukraine	—	65	69	74	75	78	76	72	74	78
United States	76	85	87	88	89	87	90	87	88	91
	{78	86	88	90	91	89	91	89	90	92}**

\* 2007 based on preliminary data.

\*\* For comparison, the U.S. average net capacity factor is used. The 2007 U.S. average net capacity factor is 92 percent. Brackets { } denote average net capacity factor.

Note: Percentages are rounded to the nearest whole number.

Source: Excerpted from *Nucleonics Week*®, February 14, 2008, by McGraw-Hill, Inc. Reproduced by permission. Further reproduction prohibited. Licensee data as compiled by the U.S. Nuclear Regulatory Commission.



**INTERNATIONAL ACTIVITIES**

The U.S. Nuclear Regulatory Commission must perform certain legislatively mandated international duties. These include licensing the import and export of nuclear materials and equipment and participating in activities supporting U.S. Government compliance with international treaties and agreement obligations. The NRC has bilateral programs of assistance or coopera-

tion with 36 countries and Taiwan (see Table 8). The NRC has also supported U.S. Government nuclear safety initiatives with countries such as India, Pakistan, Georgia, and Azerbaijan. In addition, the NRC actively cooperates with multinational organizations, such as the International Atomic Energy Agency (IAEA) and the Nuclear Energy Agency (NEA), a part of the Organisation for Economic

**Table 8. Bilateral Information Exchange and Cooperation Programs with the United States**

Country	Agreement Renewal Date	Country	Agreement Renewal Date
Argentina	2012	Japan	2008
Armenia	2012	Kazakhstan	2009
Australia	2008	Lithuania	2010
Belgium	2010	Mexico	2012
Brazil	2009	The Netherlands	2008
Bulgaria	2011	Peru	Open-Ended
Canada	2012	Philippines	Open-Ended
China	2013	Republic of Korea	2010
Czech Republic	2010	Romania	2010
Egypt	1991	Russia	2001
Finland	2011	Slovakia	2010
France	2008	Slovenia	2010
Germany	2012	South Africa	2010
Greece	2008	Spain	2010
Hungary	2012	Sweden	2011
Indonesia	2008	Switzerland	2007
Israel	2010	Ukraine	2011
Italy	2010	United Kingdom	2013

Note: The NRC also provides support to the American Institute in Taiwan.



*Commissioner Lyons, Chairman Klein, Director of International Programs Margaret Doane, and then-Executive Director for Operations Luis Reyes participate in the International Atomic Energy Agency's conference in Vienna, Austria, September 2007.*

Co-operation and Development. The NRC also has a robust international cooperative research program.

Since its inception, the agency has hosted over 300 foreign nationals in on-the-job training assignments at NRC headquarters and the regional offices. NRC's Foreign Assignee Program helps instill regulatory awareness, capabilities, and commitments in foreign assignees. It also helps to enhance regulatory expertise of both the foreign assignee and NRC staff. Additionally, the program improves international channels of communication by opening interaction with the international nuclear community and developing relationships with key personnel in foreign regulatory agencies.

Through its export/import authority, the NRC upholds the U.S. Government goals of not only

limiting the proliferation of materials that could be used in weapons but also the malicious use of radioactive materials. In addition to its direct export/import licensing role, the NRC consults with other U.S. Government agencies on international nuclear commerce activities falling under their authority. The NRC continues to work to strengthen the export/import regulations of nuclear equipment and materials, and to improve communication between domestic and international

stakeholders (see Web Link Index).

The NRC assists in implementing the U.S. Government's international nuclear policies through developing legal instruments that address nuclear nonproliferation, safety, safeguards, physical protection, radiation protection, spent fuel and waste management, and liability. Among the international treaties and agreements that the NRC has helped to develop are the Nuclear Non-Proliferation Treaty; U.S. bilateral agreements for peaceful nuclear cooperation under Section 123 of the U.S. Atomic Energy Act of 1954, as amended; and international conventions on nuclear safety, the safety of spent fuel and radioactive waste management, and the physical protection of nuclear material. The NRC also ensures licensee compliance with the U.S. Voluntary Safeguards

Offer agreement with the IAEA. This agreement will be amended when the President signs the document entitled “Protocol Additional to the U.S.–International Atomic Energy Agency Agreement for the Application of Safeguards in the United States.”

The NRC also participates in a wide range of mutually beneficial international exchange programs that enhance the safety and security of peaceful nuclear activities worldwide. These low-cost, high-impact programs provide safety and security information through participation in joint cooperative activities and assistance to other countries to develop and improve regulatory organizations and overall nuclear safety and security. The NRC engages in the following activities:

- Ensures prompt notification to foreign partners of U.S. safety issues, notifies NRC program offices about foreign safety issues, and shares security information with selected countries.
- Assists other countries to develop and improve regulatory programs through training, workshops, peer review of regulatory documents, working group meetings, technical information, and specialist exchanges.
- Initiates bilateral discussions with countries which have recently built facilities or have vendors of equipment that may be imported to the United States during the anticipated construction of new nuclear power plants.
- Participates in the multinational programs of the IAEA and the NEA concerned with safety research and regulatory matters, radiation protection, risk assessment, emergency preparedness, waste management, transportation, safeguards, physical protection, security, standards development, training, and technical assistance.
- Participates in the Multinational Design Evaluation Program (MDEP), which leverages the resources of interested regulatory authorities to review designs of new power reactors.
- Hosts the International Nuclear Regulators Association (INRA) meetings on a rotating basis with other members. Two meetings are held each year. INRA was established to influence and enhance nuclear safety from the regulatory perspective and its members are the most senior officials of well-established independent national nuclear regulatory organizations. Current members are Canada, France, Germany, Japan, the Republic of Korea, Spain, Sweden, the United Kingdom, and the United States.
- Participates in joint cooperative research programs through approximately 100 multilateral agreements with 23 countries to leverage access to foreign test facilities not otherwise available in the United States. Access to foreign test facilities expands the NRC’s knowledge base and contributes to the efficient and effective use of the NRC’s resources in conducting research on high-priority safety issues.

*Limerick Generating Station, located near Philadelphia, PA.*



Courtesy of Exelon Generation Co. LLC

## OPERATING NUCLEAR REACTORS

## U.S. COMMERCIAL NUCLEAR POWER REACTORS

As of August 2008, there were 104 commercial nuclear power reactors licensed to operate in 31 States (see Figure 18 and Appendix A). The reactors are characterized by the following:

- 4 different reactor vendors
- 26 operating companies
- 80 different designs
- 65 sites

Courtesy: FPL



Turkey Point Nuclear Plant, Homestead, FL

## Diversity

Although there are many similarities, each reactor design can be considered unique. A typical pressurized-water reactor is shown in Figure 19, and a typical boiling-water reactor is shown in Figure 20.

## Experience

During 2007, reactors accumulated approximately 2,663 years of operational experience (see Figure 21 and Table 9). An additional 385 years of experience have been accumulated by permanently shut-down reactors.

Courtesy: Dominion Generation



North Anna Power Station, Mineral, VA

Courtesy: Pacific Gas & Electric



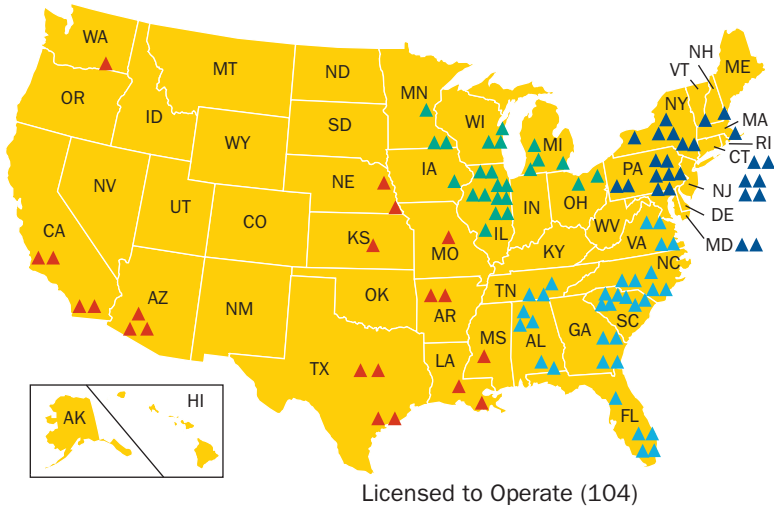
Diablo Canyon Nuclear Power Plant, San Luis Obispo, CA

Courtesy: Dominion Nuclear Corp.



Millstone Power Station, New London, CT

Figure 18. U.S. Operating Commercial Nuclear Power Reactors



OPERATING NUCLEAR REACTORS

**REGION I**

**CONNECTICUT**

- ▲ Millstone 2 and 3

**MARYLAND**

- ▲ Calvert Cliffs 1 and 2

**MASSACHUSETTS**

- ▲ Pilgrim 1

**NEW HAMPSHIRE**

- ▲ Seabrook 1

**NEW JERSEY**

- ▲ Hope Creek 1
- ▲ Oyster Creek
- ▲ Salem 1 and 2

**NEW YORK**

- ▲ James A. FitzPatrick
- ▲ Ginna
- ▲ Indian Point 2 and 3
- ▲ Nine Mile Point 1 and 2

**PENNSYLVANIA**

- ▲ Beaver Valley 1 and 2
- ▲ Limerick 1 and 2
- ▲ Peach Bottom 2 and 3
- ▲ Susquehanna 1 and 2
- ▲ Three Mile Island 1

**VERMONT**

- ▲ Vermont Yankee

**REGION II**

**ALABAMA**

- ▲ Browns Ferry 1, 2, and 3
- ▲ Joseph M. Farley 1 and 2

**FLORIDA**

- ▲ Crystal River 3
- ▲ St. Lucie 1 and 2
- ▲ Turkey Point 3 and 4

**GEORGIA**

- ▲ Edwin I. Hatch 1 and 2
- ▲ Vogtle 1 and 2

**NORTH CAROLINA**

- ▲ Brunswick 1 and 2
- ▲ McGuire 1 and 2
- ▲ Shearon Harris 1

**SOUTH CAROLINA**

- ▲ Catawba 1 and 2
- ▲ Oconee 1, 2, and 3
- ▲ H.B. Robinson 2
- ▲ Summer

**TENNESSEE**

- ▲ Sequoyah 1 and 2
- ▲ Watts Bar 1

**VIRGINIA**

- ▲ North Anna 1 and 2
- ▲ Surry 1 and 2

**REGION III**

**ILLINOIS**

- ▲ Braidwood 1 and 2
- ▲ Byron 1 and 2
- ▲ Clinton
- ▲ Dresden 2 and 3
- ▲ La Salle County 1 and 2
- ▲ Quad Cities 1 and 2

**IOWA**

- ▲ Duane Arnold

**MICHIGAN**

- ▲ D.C. Cook 1 and 2
- ▲ Fermi 2
- ▲ Palisades

**MINNESOTA**

- ▲ Monticello
- ▲ Prairie Island 1 and 2

**OHIO**

- ▲ Davis-Besse
- ▲ Perry 1

**WISCONSIN**

- ▲ Kewaunee
- ▲ Point Beach 1 and 2

**REGION IV**

**ARKANSAS**

- ▲ Arkansas Nuclear 1 and 2

**ARIZONA**

- ▲ Palo Verde 1, 2, and 3

**CALIFORNIA**

- ▲ Diablo Canyon 1 and 2
- ▲ San Onofre 2 and 3

**KANSAS**

- ▲ Wolf Creek 1

**LOUISIANA**

- ▲ River Bend 1
- ▲ Waterford 3

**MISSISSIPPI**

- ▲ Grand Gulf

**MISSOURI**

- ▲ Callaway

**NEBRASKA**

- ▲ Cooper
- ▲ Fort Calhoun

**TEXAS**

- ▲ Comanche Peak 1 and 2
- ▲ South Texas Project 1 and 2

**WASHINGTON**

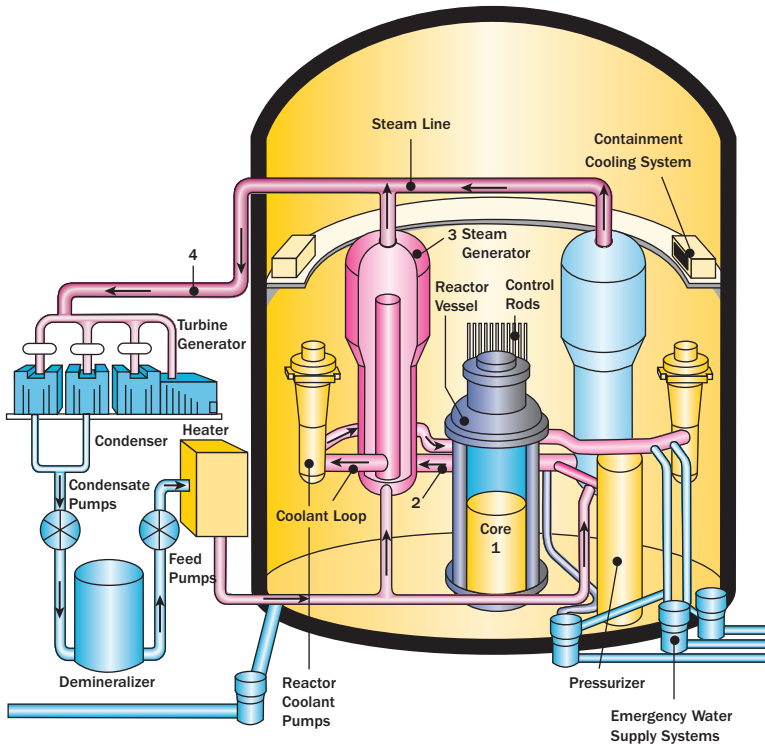
- ▲ Columbia

Source: U.S. Nuclear Regulation Commission

Figure 19. Typical Pressurized-Water Reactor

How Nuclear Reactors Work

In a typical commercial pressurized light-water reactor (1) the core inside the reactor vessel creates heat, (2) pressurized water in the primary coolant loop carries the heat to the steam generator, (3) inside the steam generator, heat from the primary coolant loop vaporizes the water in a secondary loop producing steam, and (4) the steam line directs the steam to the main turbine, causing it to turn the turbine generator, which produces electricity. The unused steam is exhausted to the condenser where it is condensed into water. The resulting water is pumped out of the condenser with a series of pumps, reheated, and pumped back to the steam generator. The reactor's core contains fuel assemblies that are cooled by water circulated using electrically powered pumps. These pumps and other operating systems in the plant receive their power from the electrical grid. If offsite power is lost, emergency cooling water is supplied by other pumps, which can be powered by onsite diesel generators. Other safety systems, such as the containment cooling system, also need electric power. Pressurized-water reactors contain between 150–200 fuel assemblies.



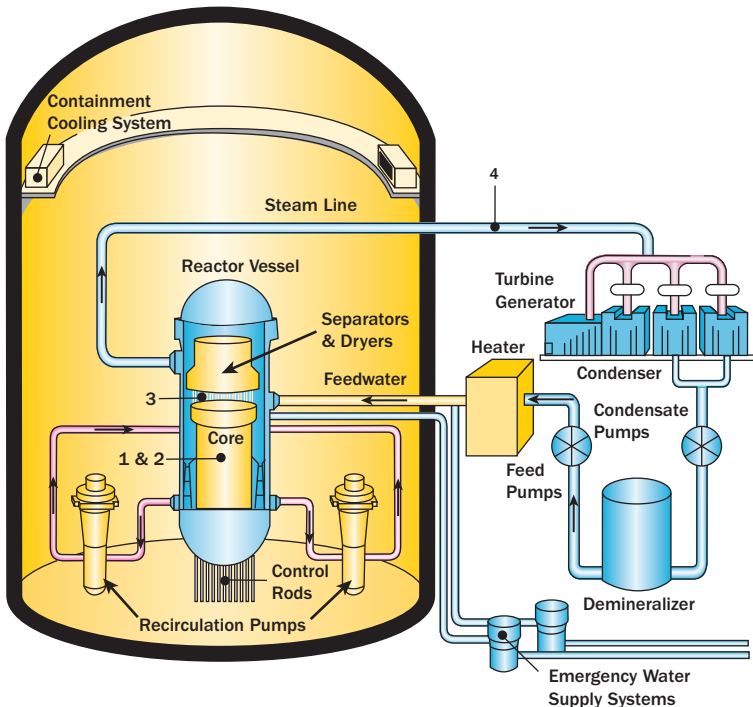
Source: U.S. Nuclear Regulatory Commission



### Figure 20. Typical Boiling-Water Reactor

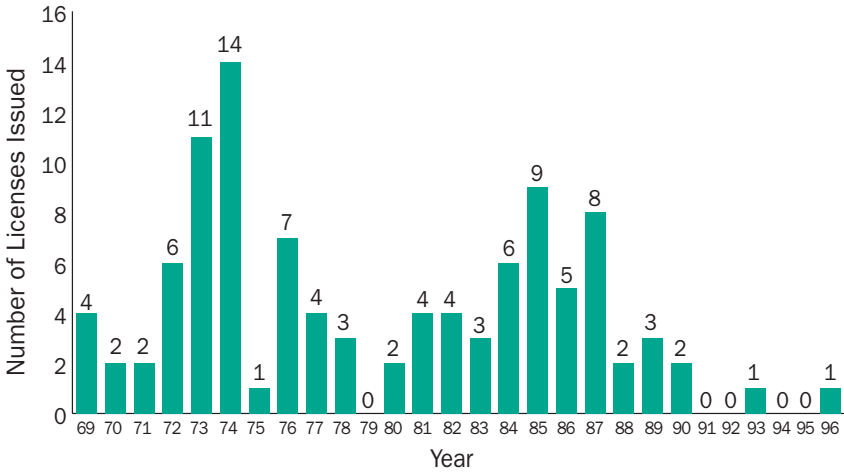
#### How Nuclear Reactors Work

In a typical commercial boiling-water reactor, (1) the core inside the reactor vessel creates heat, (2) a steam-water mixture is produced when very pure water (reactor coolant) moves upward through the core, absorbing heat, (3) the steam-water mixture leaves the top of the core and enters the two stages of moisture separation where water droplets are removed before the steam is allowed to enter the steam line, and (4) the steam line directs the steam to the main turbine, causing it to turn the turbine generator, which produces electricity. The unused steam is exhausted to the condenser where it is condensed into water. The resulting water is pumped out of the condenser with a series of pumps, reheated, and pumped back to the reactor vessel. The reactor's core contains fuel assemblies that are cooled by water circulated using electrically powered pumps. These pumps and other operating systems in the plant receive their power from the electrical grid. If offsite power is lost, emergency cooling water is supplied by other pumps, which can be powered by onsite diesel generators. Other safety systems, such as the containment cooling system, also need electric power. Boiling-water reactors contain between 370–800 fuel assemblies.



Source: U.S. Nuclear Regulatory Commission

**Figure 21. U.S. Commercial Nuclear Power Reactor Operating Licenses—Issued by Year**



Note: No licenses were issued after 1996.  
 Source: U.S. Nuclear Regulatory Commission

**Table 9. U.S. Commercial Nuclear Power Reactor Operating Licenses—Issued by Year**

1969	Dresden 2 Ginna Nine Mile Point 1 Oyster Creek	1974	Arkansas Nuclear 1 Browns Ferry 2 Brunswick 2 Calvert Cliffs 1 Cooper D.C. Cook 1 Duane Arnold Edwin I. Hatch 1 James A. FitzPatrick Oconee 3 Peach Bottom 3 Prairie Island 1 Prairie Island 2 Three Mile Island 1	1981	Joseph M. Farley 2 McGuire 1 Salem 2 Sequoyah 2	1987	Beaver Valley 2 Braidwood 1 Byron 2 Clinton Nine Mile Point 2 Palo Verde 3 Shearon Harris 1 Vogtle 1
1970	H.B. Robinson 2 Point Beach 1	1975	Millstone 2	1982	La Salle County 1 San Onofre 2 Summer Susquehanna 1	1988	Braidwood 2 South Texas Project 1
1971	Dresden 3 Monticello	1976	Beaver Valley 1 Browns Ferry 3 Brunswick 1 Calvert Cliffs 2 Indian Point 3 Salem 1 St. Lucie 1	1983	McGuire 2 San Onofre 3 St. Lucie 2	1989	Limerick 2 South Texas Project 2 Vogtle 2
1972	Palisades Pilgrim 1 Quad Cities 1 Quad Cities 2 Surry 1 Turkey Point 3	1977	Crystal River 3 Davis-Besse D.C. Cook 2 Joseph M. Farley 1	1984	Callaway Diablo Canyon 1 Grand Gulf 1 La Salle County 2 Susquehanna 2 Washington Nuclear Project 2 (Columbia)	1990	Comanche Peak 1 Seabrook 1
1973	Browns Ferry 1 Fort Calhoun Indian Point 2 Kewaunee Oconee 1 Oconee 2 Peach Bottom 2 Point Beach 2 Surry 2 Turkey Point 4 Vermont Yankee	1978	Arkansas Nuclear 2 Edwin I. Hatch 2 North Anna 1	1985	Byron 1 Catawba 1 Diablo Canyon 2 Fermi 2 Limerick 1 Palo Verde 1 River Bend 1 Waterford 3 Wolf Creek 1	1993	Comanche Peak 2
		1980	North Anna 2 Sequoyah 1	1986	Catawba 2 Hope Creek 1 Millstone 3 Palo Verde 2 Perry 1	1996	Watts Bar 1

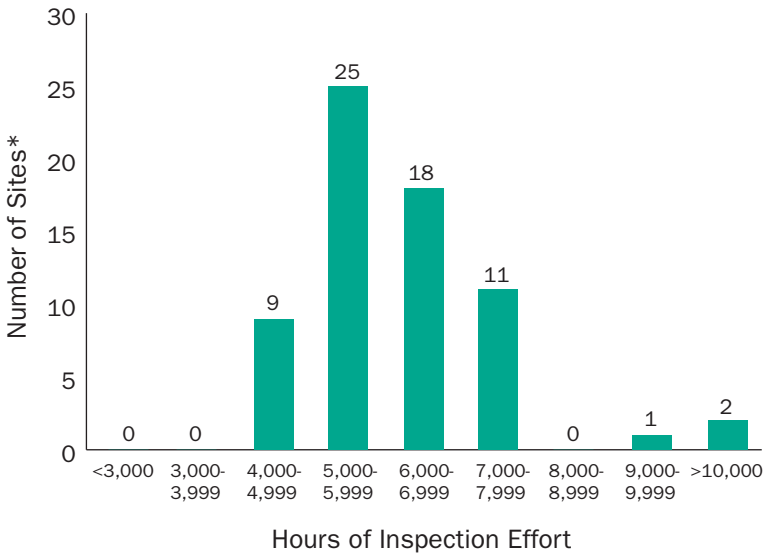
Note: Limited to reactors licensed to operate. Year is based on the date the initial full-power operating license was issued.  
 Source: U.S. Nuclear Regulatory Commission

### Principal Licensing and Inspection Activities

The NRC conducts a variety of licensing and inspection activities.

- Typically about 15 separate license changes are requested per power reactor each year. The NRC completed more than 1,540 separate reviews in FY 2007.
- The NRC has licensed approximately 4,500 reactor operators. Each operator must qualify every 2 years and apply for license renewal every 6 years.
- On average, the NRC expended approximately 6,340 hours of inspection effort at each operating reactor site during 2007 (see Figure 22).
- The NRC reviews approximately 3,000 licensed facility documents concerning events annually.
- The NRC oversees the decommissioning of nuclear power reactors. Refer to Appendices B and F for their decommissioning status.

**Figure 22. NRC Inspection Effort at Operating Reactors, 2007**



Note: Data include regular and nonregular hours for all activities related to baseline, plant-specific, generic safety issues, and allegation inspections (does not include effort) for performance assessment. Data are presented for calendar year (CY) 2007.

\* 66 total sites (Indian Point 2 and 3, Hope Creek, and Salem are treated as separate sites for inspection effort.)

Source: U.S. Nuclear Regulatory Commission

### OVERSIGHT OF U.S. COMMERCIAL NUCLEAR POWER REACTORS

The NRC does not operate nuclear power plants. Rather, it regulates the operation of the Nation's 104 nuclear power plants by establishing regulatory requirements for their design, construction, and operation. To ensure that the plants are operated safely within these requirements, the NRC licenses the plants to operate, licenses the plant operators, and establishes technical specifications for the operation of each plant.

#### Reactor Oversight Process

The NRC provides continuous oversight of plants through its Reactor Oversight Process (ROP) to verify that they are being operated in accordance with NRC rules and regulations. The NRC has full authority to take action to protect public health and safety. It may demand immediate licensee action, up to and including a plant shutdown.

The ROP is described on the NRC's Web site and in NUREG-1649, Revision 4, "Reactor Oversight Process," December 2006. In general terms, the ROP uses both NRC inspection findings and performance indicators (PIs) from licensees to assess the safety performance of each plant. The

ROP recognizes that issues of very low safety significance inevitably occur, and plants are expected to address these issues effectively. The NRC performs an intensive baseline level of inspection at each plant. The NRC may perform supplemental inspections and take additional actions to ensure that significant performance issues are addressed. The latest plant-specific inspection findings and PI information can be found on the NRC's Web site (see Web Link Index).

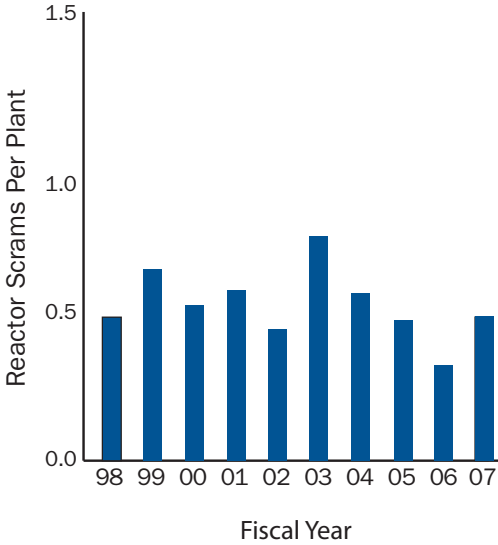
The ROP takes into account improvements in the performance of the nuclear industry over the past 25 years and improved approaches to inspecting and evaluating the safety performance of NRC-licensed plants. The improvements in plant performance can be attributed both to efforts within the nuclear industry and to successful regulatory oversight.

#### Industry Performance Indicators

In addition to evaluating the performance of each individual plant, the NRC compiles data on overall reactor industry performance using various industry-level performance indicators (see Figure 23 and Appendix G). The industry PIs provide additional data for assessing trends in overall industry performance.

**Figure 23. Industry Performance Indicators:  
Annual Industry Averages, FY 1998–2007**

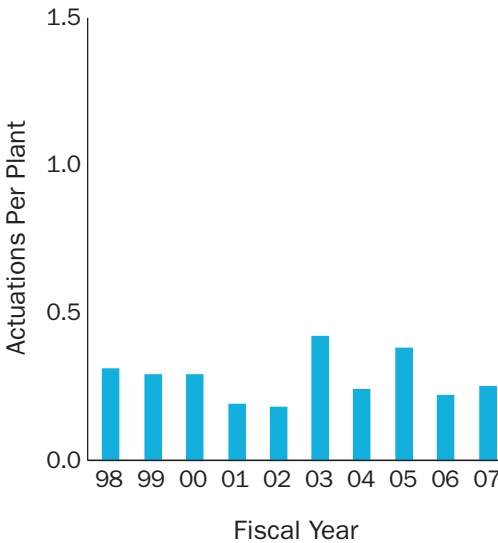
Automatic Scrams While Critical



A reactor is said to be “critical” when it achieves a self-sustaining nuclear chain reaction, as when the reactor is operating. The sudden shutting down of a nuclear reactor by rapid insertion of control rods, either automatically or manually by the reactor operator, is referred to as a “scram.” This indicator measures the number of unplanned automatic scrams that occurred while the reactor was critical.

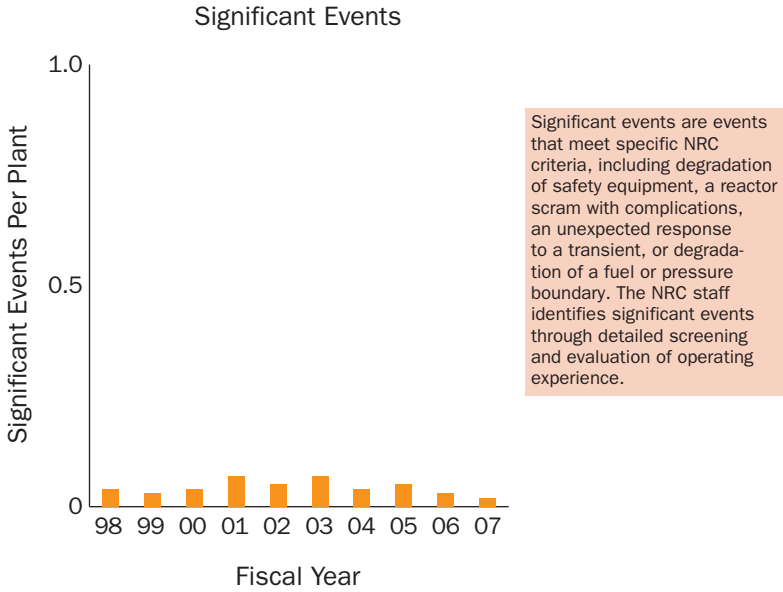
OPERATING NUCLEAR REACTORS

Safety System Actuations

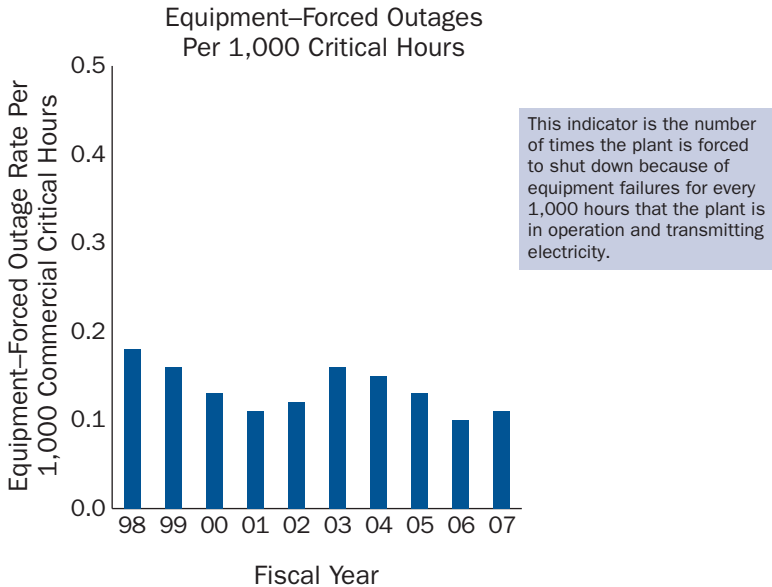
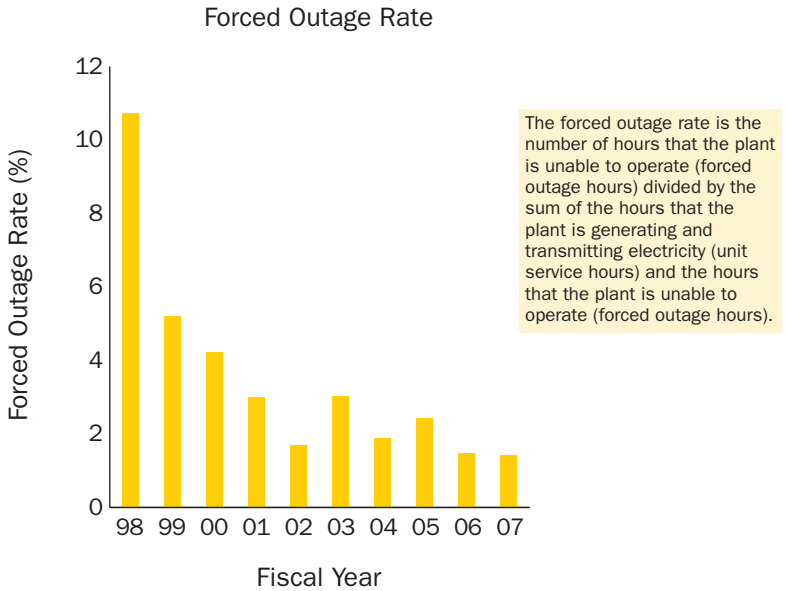


Safety system actuations are certain manual or automatic engagements of the logic or equipment of the emergency core cooling systems (ECCS) or emergency power systems. These systems are specifically designed to either remove heat from the reactor fuel rods if the normal core cooling system fails or provide emergency electrical power if the normal electrical systems fail.

**Figure 23. Industry Performance Indicators:  
Annual Industry Averages, FY 1998–2007 (Continued)**

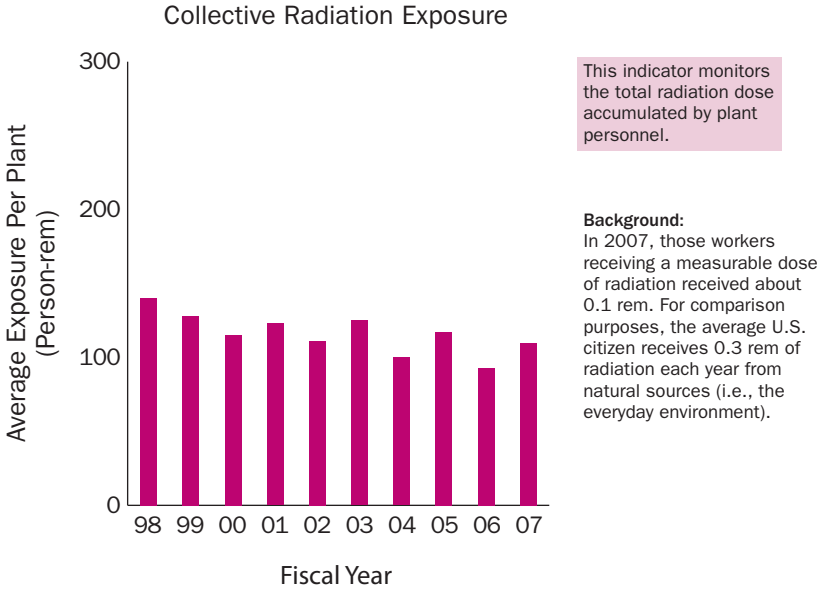


**Figure 23. Industry Performance Indicators:  
Annual Industry Averages, FY 1998–2007 (Continued)**



OPERATING NUCLEAR REACTORS

**Figure 23. Industry Performance Indicators:  
Annual Industry Averages, FY 1998–2007 (Continued)**



Note: Data represent annual industry averages, with plants in extended shutdown excluded. Data are rounded for display purposes. These data may differ slightly from previously published data as a result of refinements in data quality.  
Source: Licensee data as compiled by the U.S. Nuclear Regulatory Commission



*There are at least two full-time NRC inspectors at each plant site to ensure facilities are meeting NRC regulations.*



## NEW COMMERCIAL NUCLEAR POWER REACTOR LICENSING

The NRC continues to interact with vendors and utilities regarding prospective new reactor applications and licensing activities. The new licensing process is a substantial improvement over the system used in the 1970s, 1980s, and 1990s. The NRC expects to receive a significant number of new combined construction and operating license (COL) applications for reactors over the next several years and is developing the infrastructure to support the necessary technical reviews. The NRC will increase staffing levels to accommodate up to 23 COL applications for a total of 34 new nuclear units over the next few years (see Figure 24, Table 10, and the Web Link Index).

As of August 1, 2008, the NRC had received 11 COL applications:

- Calvert Cliffs (MD)
- South Texas Project (TX)
- Bellefonte (AL)
- North Anna (VA)
- William States Lee III (SC)
- Shearon Harris (NC)
- Grand Gulf (MS)
- Vogtle (GA)
- V.C. Summer (SC)
- Callaway (MO)
- Levy County (FL)

The staff expects to receive an additional seven COL applications by the end of 2008. For a current schedule of received and expected

new reactor licensing applications, see Figure 24, Table 11, and the Web Link Index.

The NRC has tailored its new reactor licensing activities to handle new applications effectively. These activities include the following:

- Revising regulations governing combined license applications in 10 CFR Part 52 that cover early site permits, standard design approvals, standard design certifications, combined licenses, and manufacturing licenses.
- Adopting an optimized approach for reviewing applications through a design-centered licensing review.
- Revising limited work authority regulations to allow some preconstruction activities without NRC approval, such as site clearing, road building, and transmission line routing.
- Developing Regulatory Guide 1.206, “Combined License Applications for Nuclear Power Plants—LWR Edition.”

The NRC has issued three early site permits (ESPs) to the following applicants:

- System Energy Resources, Inc. (Entergy), for the Grand Gulf site in Mississippi
- Exelon Generation Company, LLC, for the Clinton site in Illinois

- Dominion Nuclear North Anna, LLC, for the North Anna site in Virginia

The agency is currently reviewing an ESP application submitted by Southern Nuclear Operating Company for the Vogtle site in Georgia. The staff expects to receive three additional ESP applications between 2010 and 2012. An ESP provides for early resolution of site safety, environmental protection, and emergency preparedness issues independent of a specific nuclear plant review. Mandatory adjudicatory hearings associated with the ESPs are conducted after the completion of the NRC staff's technical review.

The NRC has issued design certifications (DCs) for four reactor designs that can be referenced in an application for a nuclear power plant. These designs are:

- General Electric (GE) Nuclear Energy's Advanced Boiling-Water Reactor (ABWR)
- Westinghouse's System 80+
- Westinghouse's AP600
- Westinghouse's AP1000

The NRC is currently performing certification reviews of these designs:

- GE's Economic Simplified Boiling-Water Reactor (ESBWR)
- Westinghouse's AP1000 DC Amendment

- AREVA's Evolutionary Power Reactor (EPR)
- Mitsubishi's U.S. Advanced Pressurized-Water Reactor (USAPWR)

The NRC's future activities will include inspecting licensee construction to ensure that the as-built facility conforms to its COL conditions and that the construction meets the regulations for quality control and assurance. The agency also inspects vendor facilities to ensure that products and services furnished to new U.S. reactors meet quality and other regulatory requirements. To meet demand, the NRC opened a special construction inspection office in Atlanta, GA.

The NRC staff will examine a licensee's operational programs, such as security, radiation protection, and operator training and qualification, to ensure that the licensee is ready to operate the plant once it is built. The agency's construction site inspectors will devote significant resources to verifying a licensee's completion of inspections, tests, analyses, and acceptance criteria. The NRC will use these direct inspections and other methods to confirm the licensee has completed these actions and has met the acceptance criteria included in a COL prior to allowing startup of the plant.

In addition, the NRC will dispatch several full-time inspectors to a site during the construction phase to



**Table 10. Expected New Nuclear Power Plant Applications  
(as of August 1, 2008)**

Company (Project/Docket#)	Date of Application	Design	Date Accepted	Site Under Consideration	State	Existing Op. Plant
<b>CY 2007 Applications</b>						
<input checked="" type="checkbox"/> NRG Energy (52-012/013)	9/20/07	ABWR	11/29/07	South Texas Project (2 units)	TX	Y
<input checked="" type="checkbox"/> NuStart Energy (52-014/015)	10/30/07	AP1000	1/18/08	Bellefonte (2 units)	AL	N
<input checked="" type="checkbox"/> UNISTAR (52-016)	7/13/07 (Env.), 3/13/08 (Safety)	EPR	1/25/08	Calvert Cliffs (1 unit)	MD	Y
<input checked="" type="checkbox"/> Dominion (52-017)	11/27/07	ESBWR	1/29/08	North Anna (1 unit)	VA	Y
<input checked="" type="checkbox"/> Duke (52-018/019)	12/13/07	AP1000	2/25/08	William Lee Nuclear Station (2 units)	SC	N
<b>2007 TOTAL NUMBER OF APPLICATIONS = 5 TOTAL NUMBER OF UNITS = 8</b>						
<b>CY 2008 Applications</b>						
<input checked="" type="checkbox"/> Progress Energy (52-022/023)	2/19/08	AP1000	4/17/08	Harris (2 units)	NC	Y
<input checked="" type="checkbox"/> NuStart Energy (52-024)	2/27/08	ESBWR	4/17/08	Grand Gulf (1 unit)	MS	Y
<input checked="" type="checkbox"/> Southern Nuclear Operating Co. (755)	3/31/08	AP1000	5/30/08	Vogtle (2 units)	GA	Y
<input checked="" type="checkbox"/> South Carolina Electric & Gas (743)	3/31/08	AP1000	7/31/08	Summer (2 units)	SC	Y
<input type="checkbox"/> AmerenUE (750)	7/24/08	EPR		Callaway (1 unit)	MO	Y
<input type="checkbox"/> Progress Energy (756)	7/30/08	AP1000		Levy County (2 units)	FL	N
Entergy (745)		ESBWR		River Bend (1 unit)	LA	Y
Exelon (761)		ESBWR		Victoria County (2 units)	TX	N
PPL Generation (763)		EPR		Bell Bend (1 unit)	PA	Y
UNISTAR (759)		EPR		Nine Mile Point (1 unit)	NY	Y
Luminant Power (754)		USAPWR		Comanche Peak (2 units)	TX	Y
Detroit Edison (757)		ESBWR		Fermi (1 unit)	MI	Y
Alternate Energy Holdings (765)		EPR		Bruneau (1 unit)	ID	N
<b>2008 TOTAL NUMBER OF APPLICATIONS = 13 TOTAL NUMBER OF UNITS = 19</b>						
<b>CY 2009 Applications</b>						
Florida Power and Light (763)		AP1000		Turkey Point (2 units)	FL	Y
Amarillo Power (752)		EPR		Vicinity of Amarillo (2 units)	TX	UNK
<b>2009 TOTAL NUMBER OF APPLICATIONS = 2 TOTAL NUMBER OF UNITS = 4</b>						
<b>CY 2010 Applications</b>						
Blue Castle Project		TBD		Utah	UT	N
Unannounced		TBD		TBD	TBD	UNK
Unannounced		TBD		TBD	TBD	UNK
<b>2010 TOTAL NUMBER OF APPLICATIONS = 3 TOTAL NUMBER OF UNITS = 3</b>						
<b>2007 - 2010 Total Number of Applications = 23 Total Number of Units = 34</b>						

- Acceptance Review Ongoing     - Accepted/Docketed    UNK - Unknown

oversee day-to-day activities of the licensee and its contractors.

More information on the NRC’s new reactor licensing activities is available on the NRC Web site (see Web Link Index).

### REACTOR LICENSE RENEWAL

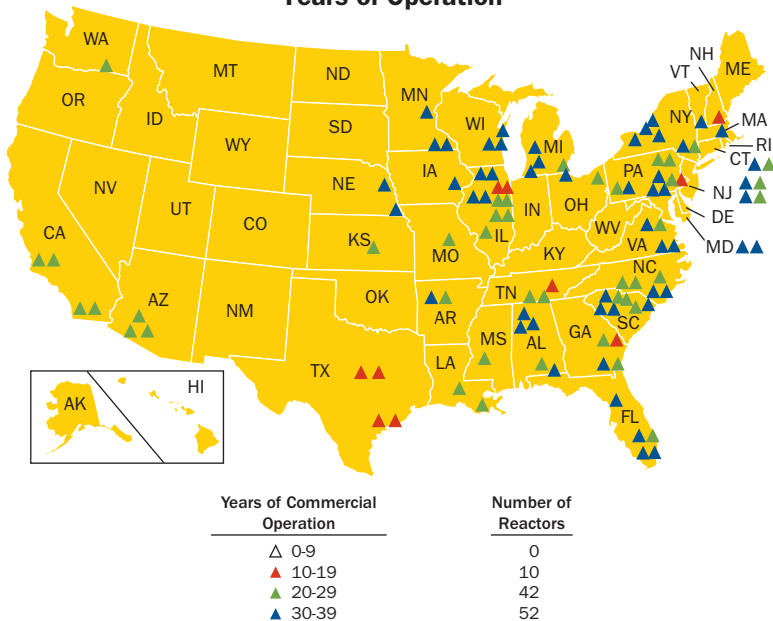
Based on the Atomic Energy Act of 1954, the NRC issues licenses for commercial power reactors to operate for 40 years and can allow licenses to be renewed for up to an additional 20 years.

Economic and antitrust considerations, not limitations of nuclear

technology, determined the original 40-year term for reactor licenses. However, due to this selected time period, some systems, structures, and components may have been engineered on the basis of an expected 40-year service life.

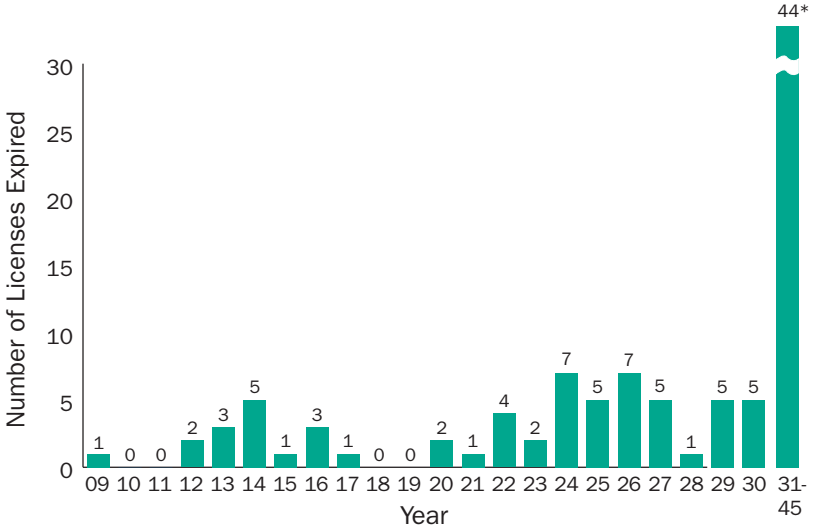
As of February 2008, approximately half of the licensed reactor units have either received or are under review for license renewal. Of these, 48 units (26 sites) have received renewed licenses. Figure 25 illustrates the ages of operating reactors. Figure 26 and Table 11 show the expiration dates of operating commercial nuclear licenses.

**Figure 25. U.S. Commercial Nuclear Power Reactors—Years of Operation**



Source: U.S. Nuclear Regulatory Commission

**Figure 26. U.S. Commercial Nuclear Power Reactor Operating Licenses—Expiration Date by Year Assuming Construction Recapture**



\*Data exceed graph parameters.  
Source: U.S. Nuclear Regulatory Commission

**Table 11. U.S. Commercial Nuclear Power Reactor Operating Licenses—Expiration Date by Year, 2009–2046**

2009	Oyster Creek	2024	Byron 1	2030	Comanche Peak 1	2036	Browns Ferry 3
2012	Pilgrim 1		Callaway		Monticello		Brunswick 1
	Vermont Yankee		Diablo Canyon 1		Point Beach 1		Calvert Cliffs 2
2013	Indian Point 2		Grand Gulf 1		Robinson 2	2037	St. Lucie 1
	Kewaunee		Limerick 1	2031	Seabrook 1		D.C. Cook 2
	Prairie Island 1		Susquehanna 2		Palisades	2038	Joseph M. Farley 1
2014	Cooper		Waterford 3	2032	Quad Cities 1		Arkansas Nuclear 2
	Duane Arnold	2025	Diablo Canyon 2		Quad Cities 2		Edwin Hatch 2
	James A. FitzPatrick		Fermi 2		Surry 1	2040	North Anna 1
	Prairie Island 2		Palo Verde 1	2033	Turkey Point 3		North Anna 2
	Three Mile Island 1		River Bend 1		Browns Ferry 1	2041	Joseph M. Farley 2
2015	Indian Point 3		Wolf Creek 1		Comanche Peak 2	2042	McGuire 1
2016	Beaver Valley 1	2026	Braidwood 1		Fort Calhoun	2043	Summer
	Crystal River 3		Byron 2		Oconee 1		Catawba 1
	Salem 1		Clinton		Oconee 2		Catawba 2
2017	Davis-Besse		Palo Verde 2		Peach Bottom 2	2045	McGuire 2
2020	Salem 2		Hope Creek 1		Point Beach 2		St. Lucie 2
	Sequoyah 1		Perry 1	2033	Surry 2	2046	Millstone 3
2021	Sequoyah 2		Shearon Harris 1		Turkey Point 4		Nine Mile Point 2
2022	La Salle County 1	2027	Beaver Valley 2		Arkansas Nuclear 1		
	San Onofre 2		Braidwood 2	2034	Browns Ferry 2		
	San Onofre 3		Palo Verde 3		Brunswick 2		
	Susquehanna 1		South Texas Project 1		Calvert Cliffs 1		
2023	Columbia Generating St.		Vogtle 1		D.C. Cook 1		
	La Salle County 2	2028	South Texas Project 2		Edwin Hatch 1		
		2029	Dresden 2		Oconee 3		
			Ginna	2035	Peach Bottom 3		
			Limerick 2		Millstone 2		
			Nine Mile Point 1		Watts Bar 1		
			Vogtle 2				

Year assumes that the maximum number of years for construction recapture has been added to the current expiration date.

Note: Limited to reactors licensed to operate.

Source: Data as of December 2007 compiled by the U.S. Nuclear Regulatory Commission

The decision whether to seek license renewal rests entirely with nuclear power plant owners and typically is based on the plant's economic situation and on whether it can meet NRC requirements.

The NRC will only renew a license if it determines that a currently operating plant will continue to maintain the required level of safety.

Over the plant's life, this level of safety has been enhanced through maintenance of the licensing basis, with appropriate adjustments to address new information from industry operating experience. In addition, the NRC's regulatory activities have provided ongoing assurance that the current licensing basis will provide an acceptable level of safety. The agency developed the license renewal review process to provide continued assurance that the licensee will maintain this level of safety for the period of extended operation.

The NRC has issued regulations establishing clear requirements for license renewal to ensure safe plant operation for extended plant life codified in Title 10 of the *Code of Federal Regulations* (10 CFR) Part 51, "Environmental Protection Regulations for Domestic Licensing and Related Regulatory Functions," and 10 CFR Part 54, "Requirements for Renewal of Operating Licenses for Nuclear Power Plants." The review of a renewal application proceeds

along two paths—one for the review of safety issues and the other for environmental issues. An applicant must provide the NRC with an evaluation that addresses the technical aspects of plant aging and describes the ways those effects will be managed. The applicant must also prepare an evaluation of the potential impact on the environment if the plant operates for up to an additional 20 years. The NRC reviews the application and verifies the safety evaluation through inspections.

### Public Involvement

Public participation is an important part of the license renewal process. There are several opportunities for members of the public to question how aging will be managed during the period of extended operation. Information provided by the applicant is made available to the public. The NRC holds a number of public meetings. All of the agency's technical and environmental review results are fully documented and made publicly available. Concerns may be litigated in an adjudicatory hearing if any party that would be adversely affected requests a hearing and submits an admissible contention.

The NRC provides information on the license renewal process, plants that have received renewed licenses, and those under review on the NRC Web site (see Web Link Index).

## NUCLEAR RESEARCH AND TEST REACTORS

Nuclear research and test reactors are designed and used for research, testing, and education in physics, chemistry, biology, medicine, materials sciences, and related fields. These reactors help prepare people for nuclear-related careers in the fields of electric power, national defense, health services, research, and education.

There are 44 licensed research and test reactors:

- 32 research and test reactors operating in 22 States (see Figure 27)

- 12 reactors shut down and in various stages of decommissioning

Refer to Appendix E for a list of the 32 operating research and test reactors regulated by the NRC.

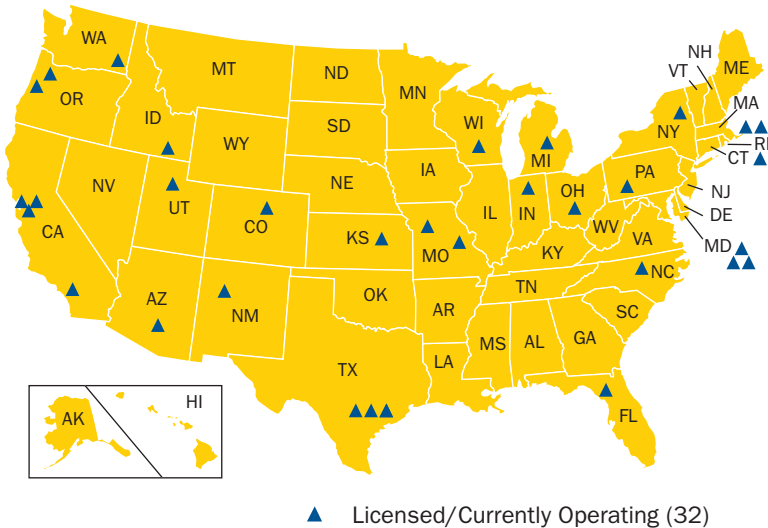
Since 1958, 82 licensed research and test reactors have been decommissioned.

Refer to Appendix F for a list of the 12 research and test reactors regulated by the NRC that are in the process of decommissioning.

Principal licensing and inspection activities include the following:

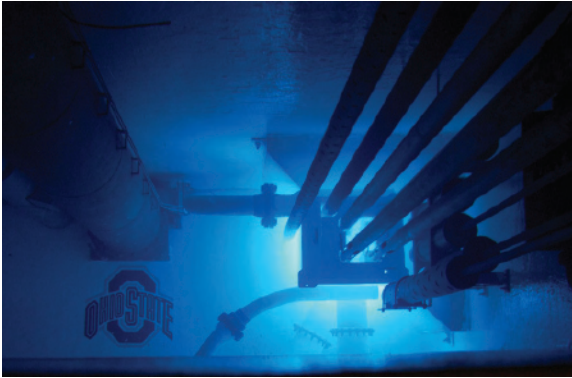
- Licensing approximately 300 research and test reactor operators.

**Figure 27. U.S. Nuclear Research and Test Reactors**



Source: U.S. Nuclear Regulatory Commission





*A blue glow of radiation, known as the "Cerenkov effect," from nuclear fuel in the Ohio State Research/Test Reactor*

- Requalifying each operator before renewal of his or her 6-year license.
- Conducting approximately 45 research and test reactor inspections each year.

## NUCLEAR REGULATORY RESEARCH

The NRC's research program supports the agency's regulatory mission by providing technical advice, tools, and information to identify and resolve safety issues, make regulatory decisions, and promulgate regulations and guidance. This includes conducting confirmatory experiments and analyses; developing technical bases that support the NRC's safety decisions; and preparing the agency for the future by evaluating the safety aspects of new technologies and designs for nuclear reactors, materials, waste, and security. The NRC faces challenges as the industry matures, including potential new safety issues, the availability of new technologies, technical issues associated with the deployment of

new reactor designs, and knowledge management.

The NRC focuses its research primarily on near-term needs related to oversight of operating light-water reactors, the technology currently used in the United States. However, recent applications for advanced light-water reactors and preapplication activity regarding non light-water reactor vendors have prompted the agency to consider longer-term research needs.

The NRC ensures protection of public health, safety, and the environment through research programs that do the following:

- Examine technical issues such as:
  - material degradation issues (e.g., stress-corrosion cracking and boric acid corrosion)
  - new and evolving technologies (e.g., new reactor technology, mixed oxide fuel performance)

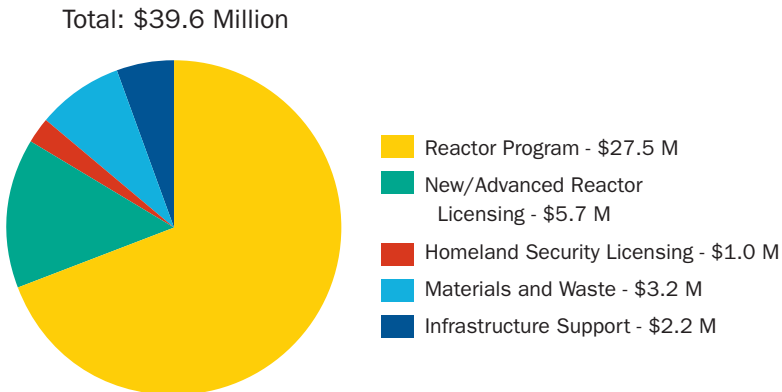
- experience gained from operating reactors
- probabilistic risk assessment (PRA) methods
- Develop and improve computer codes as computational abilities expand and additional experimental and operational data allow for more realistic simulation. These computer codes analyze a wide spectrum of technical areas, including the following:
  - severe accidents
  - radionuclide transport through the environment
  - health effects of radioactive releases
  - nuclear criticality
  - fire conditions in nuclear facilities
  - thermal hydraulic performance of reactors

- reactor fuel performance
- PRA of each nuclear power reactor
- Ensure the secure use and management of nuclear facilities and radioactive materials by investigating potential security vulnerabilities and possible compensatory actions.

The NRC dedicates seven percent of its personnel and 10 percent of its contracting funds to research. This research enables the NRC's highly skilled, experienced experts to formulate sound technical solutions and to support timely and realistic regulatory decisions.

The NRC research budget for FY 2008 is nearly \$40 million. This includes contracts with national laboratories, universities, and other research organizations for greater expertise and access to research facilities. The primary areas of research are illustrated in Figure 28.

**Figure 28. NRC Research Funding, FY 2008**



Source: U.S. Nuclear Regulatory Commission

## Fire Protection Testing



*Inspection of electrical cable insulation following fire tests*



*Simulation of water flow from a fire hose that may be used to extinguish a cable insulation fire*



*Assembly of insulated electrical cables being lowered into a furnace that reaches 1700° F for a 1-hour test*

About two-thirds of the research program is directed toward maintaining the safety of existing operating reactors. An increasing amount is being directed to new and advanced reactors as new reactor applications are received. Radioactive waste programs and security also are focus areas for research. Infrastructure support includes information technology and human resources.

The NRC also has cooperative agreements with universities and

nonprofit organizations to research specific areas of interest to the agency.

These cooperative agreements and grants include the following organizations:

- Electric Power Research Institute for work on fire risk and advancing probabilistic risk assessments
- Pennsylvania State University for research on spacer grid thermal hydraulics and nuclear fuel cladding behavior

- University of Tennessee for work on sparse radiation survey data
- Ohio State University for research on the risk importance of digital systems
- Massachusetts Institute of Technology for work on advanced nuclear technologies

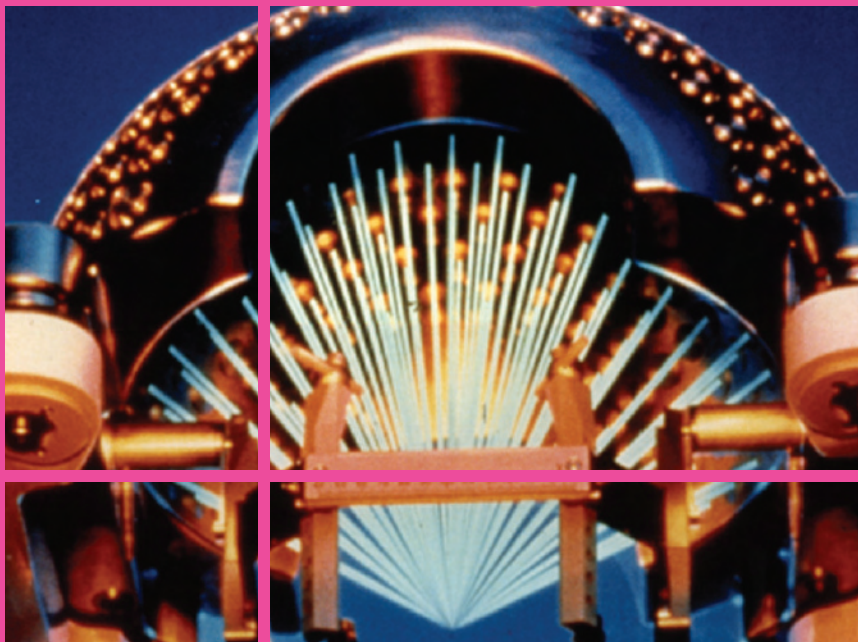
The NRC collaborates with the international research community on non light-water reactor technologies. This collaboration helps the agency initiate activities focused on new technologies using minimal resources. Collaboration is aided by the agency's leadership role in the standing committees and senior advisory groups of international

organizations, such as the International Atomic Energy Agency and the Nuclear Energy Agency.

The NRC also has research agreements with foreign governments for international cooperative research that include the following projects:

- Halden Reactor Project in Norway for research and development of fuel, reactor internals, plant control and monitoring, and human factors
- Phebus-2K project in France for severe accident phenomena
- Studsvik Cladding Integrity Project in Sweden for nuclear fuels research

*A Gamma Knife® headframe uses radiation beams to treat people with brain cancer.*



**NUCLEAR MATERIALS**

## FUEL CYCLE FACILITIES

Anticipated growth in the nuclear industry has created renewed interest in uranium enrichment—the process of transforming uranium ore into reactor fuel. The NRC licenses and inspects all commercial nuclear fuel facilities involved in uranium enrichment and nuclear fuel fabrication (see Figures 29–32). Once ore has been mined and milled (processed), it goes to enrichment and fuel fabrication facilities (see “Uranium Milling,” page 61).

There are seven licensed major fuel fabrication and production facilities and four uranium enrichment facilities in the United States. Two of the enrichment facilities use a process called gaseous diffusion and two use gas centrifuge technology. For the latter two facilities, the NRC issued one license to Louisiana Energy Services in June 2006, for a facility near Eunice, NM. The other license went to USEC Inc., in April 2007, for a facility at the U.S. Department of Energy (DOE) complex near Piketon, OH. Both facilities are under construction (see Table 12).

At least three other fuel fabrication facilities may be constructed. The NRC is currently reviewing an application for an operating license for a DOE mixed oxide (MOX) (see Glossary) fuel fabrication facility at its Savannah River Site in Aiken, SC. That facility, which will be operated by Shaw AREVA MOX Services, LLC, is under construction. AREVA, a French multinational energy conglomerate, has notified the NRC of its intent to apply for a license for a gas

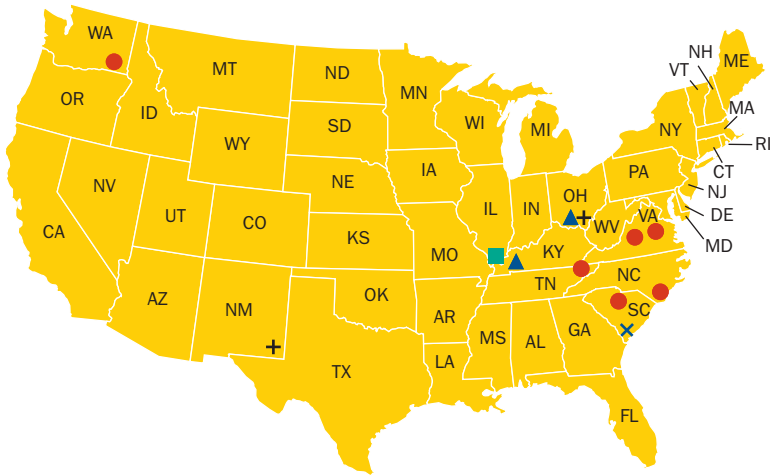
centrifuge enrichment plant, tentatively planned for Idaho Falls, ID. General Electric-Hitachi Nuclear Energy has also announced plans to apply for a license for an enrichment plant with laser technology in Wilmington, NC.

Once nuclear fuel is fabricated and then used to generate nuclear energy, it becomes spent nuclear fuel. In the United States, spent nuclear fuel is stored securely either at a nuclear power plant or at a special storage facility away from a plant. Some countries recycle their spent nuclear fuel and use it to generate more energy. One problem with recycling spent nuclear fuel is the risk that countries without nuclear weapons may be able to use recycling technology to create a nuclear weapons program. To address this problem, DOE has proposed the Global Nuclear Energy Partnership (GNEP). This program aims to expand nuclear energy worldwide by using recycling technology that renders spent nuclear fuel usable for nuclear power but useless for weapons. As part of the GNEP project, the NRC would license any proposed commercial spent fuel recycling facility and advanced recycling reactor. The NRC has completed a first-order analysis of the existing regulatory framework to identify any gaps, issued annual reports to DOE, and established the GNEP Steering Committee.

### Domestic Safeguards Program

The NRC’s domestic safeguards program for fuel cycle facilities and transportation is aimed at ensuring that special nuclear material (such as plutonium, uranium-233,

**Figure 29. Locations of Fuel Cycle Facilities**



- × Mixed Oxide Fuel Fabrication Facility (1)
- ▲ Gaseous Diffusion Enrichment Facility (2)
- Uranium Fuel Fabrication Facility (6)
- + Gas Centrifuge Enrichment Facility (2)
- Uranium Hexafluoride Production Facility (1)

Note: There are no fuel cycle facilities in Alaska or Hawaii.  
 Source: U.S. Nuclear Regulatory Commission

**Table 12. Major U.S. Fuel Cycle Facility Sites**

Uranium Hexafluoride Production Facilities	
Honeywell International, Inc.	Metropolis, IL
Uranium Fuel Fabrication Facilities	
Global Nuclear Fuels-Americas, LLC	Wilmington, NC
Westinghouse Electric Company, LLC Columbia Fuel Fabrication Facility	Columbia, SC
Nuclear Fuel Services, Inc.	Erwin, TN
AREVA NP, Inc. Mt. Athos Road Facility	Lynchburg, VA
BWX Technologies Nuclear Products Division	Lynchburg, VA
AREVA NP, Inc.	Richland, WA
Gaseous Diffusion Uranium Enrichment Facilities	
USEC Inc.	Paducah, KY
USEC Inc.	Piketon, OH* (in cold standby)
Gas Centrifuge Uranium Enrichment Facilities	
USEC Inc.	Piketon, OH (in construction)
Louisiana Energy Services	Eunice, NM (in construction)
Mixed Oxide Fuel Fabrication Facilities	
Shaw AREVA MOX Services, LLC	Aiken, SC (in review)

Note: The NRC regulates nine other facilities that possess significant quantities of special nuclear material (other than reactors) or process source material (other than uranium recovery facilities).

\* Currently in cold shutdown and not used for enrichment.

Source: U.S. Nuclear Regulatory Commission

NUCLEAR MATERIALS



or uranium enriched in the isotopes uranium-233 or uranium-235) is not stolen for possible use in an improvised weapon. It also works to ensure that such material does not pose an unreasonable risk to the public from radiological sabotage.

The NRC verifies through licensing and inspection activities that licensees apply safeguards to protect special nuclear material. Additionally, the NRC and DOE developed the Nuclear Materials Management and Safeguards System (NMMSS) to track transfers and inventories of special nuclear material, source material from abroad, and other material.

The NRC has issued licenses to approximately 180 facilities authorizing them to possess plutonium and enriched uranium in quantities ranging from a single kilogram to multiple tons. These licensees verify and document their inventories in the NMMSS database. There are

also several hundred additional sites licensed by the NRC or State governments that possess plutonium and enriched uranium in smaller quantities (typically ranging from one gram to tens of grams).

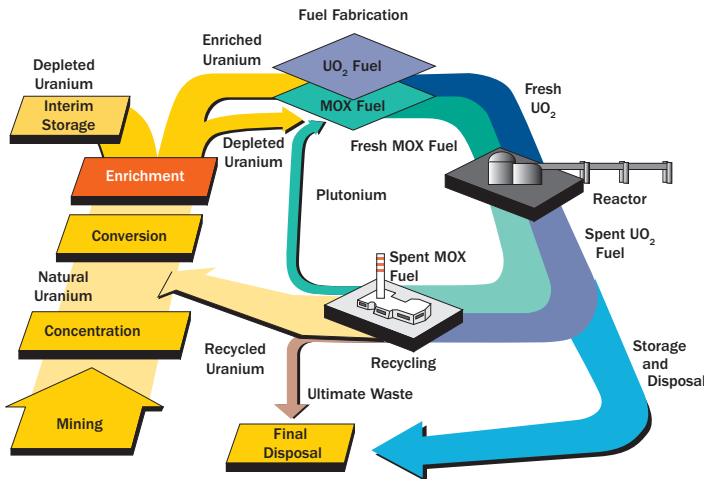
The NRC is currently working with these licensees to confirm the accuracy of their inventories, thus increasing confidence in the location and quantity of plutonium and enriched uranium held by the NRC and Agreement State licensees.

**Principal Licensing and Inspection Activities**

On average, the NRC completes approximately 80 new licenses, license renewals, license amendments, and safety and safeguards reviews for fuel cycle facilities annually.

The NRC routinely conducts safety, safeguards, and environmental protection inspections at all fuel cycle facilities.

**Figure 30. The Nuclear Fuel Cycle**

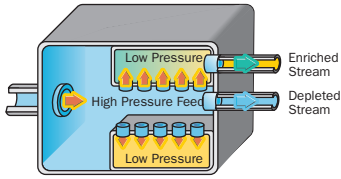


Source: U.S. Nuclear Regulatory Commission



Figure 31. Enrichment Processes

## A. Gas Diffusion Process



The gaseous diffusion process uses molecular diffusion to separate a gas from a two-gas mixture. The isotopic separation is accomplished by diffusing uranium, which has been combined with fluorine to form uranium hexafluoride ( $\text{UF}_6$ ) gas, through a porous membrane (barrier) and using the different molecular velocities of the two isotopes to achieve separation.

The gas centrifuge process uses a large number of rotating cylinders in series and parallel configurations. Gas is introduced and rotated at high speed, concentrating the component of higher molecular weight towards the outer wall of the cylinder and the lower molecular weight component toward the center. The enriched and the depleted gas are removed by scoops.

## B. Gas Centrifuge Process

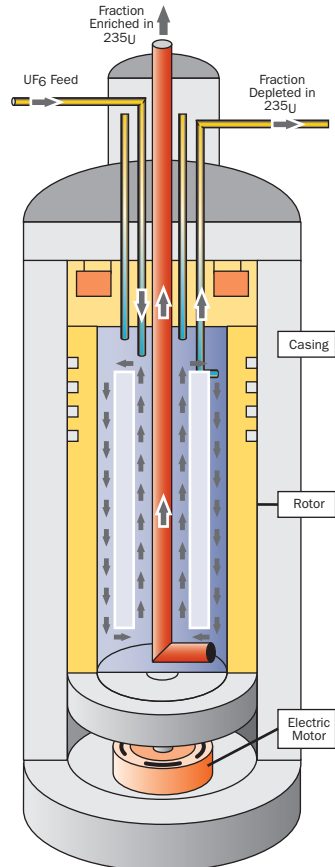
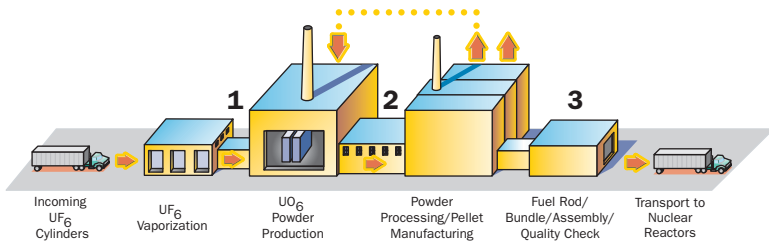


Figure 32. Simplified Fuel Fabrication Process



Fabrication is the final step in the process used to produce uranium fuel. Fuel fabrication facilities mechanically and chemically process the enriched uranium into nuclear reactor fuel.

Fabrication begins with the conversion of enriched  $UF_6$  gas to a uranium dioxide ( $UO_2$ ) solid. Nuclear fuel must maintain both its chemical and physical properties under the extreme conditions of heat and radiation present inside an operating reactor vessel. Fabrication of commercial light-water reactor fuel consists of the following three basic steps:

- (1) the chemical conversion of  $UF_6$  to uranium dioxide ( $UO_2$ ) powder
- (2) a ceramic process that converts uranium dioxide powder to small ceramic pellets

- (3) a mechanical process that loads the fuel pellets into rods and constructs finished fuel assemblies.

After the  $UF_6$  is chemically converted to  $UO_2$ , the powder is blended, milled, and pressed into ceramic fuel pellets about the size of a fingertip. The pellets are stacked into long tubes made of material called “cladding” (such as zirconium alloys). After careful inspection, the resulting fuel rods are bundled into fuel assemblies for use in reactors. The cladding material provides one of several barriers to contain the radioactive fission products produced during the nuclear chain reaction.

Following final assembly operations, the completed fuel assembly, about 3.7 meters long (12 feet), is washed, inspected, and finally stored in a special rack until it is ready for shipment to a nuclear power plant site.

## URANIUM MILLING

To make fuel for reactors, uranium ore is recovered or extracted from the ground, converted, and enriched into fuel pellets.

A conventional uranium mill is a chemical plant that extracts uranium from mined ore. The mined ore is brought by truck to the milling facility where it is crushed. Sulfuric acid then leaches the soluble components, including 90 to 95 percent of the uranium, from the ore. Alkaline leaching agents can also be used. The uranium is then separated from the leach solution. Conventional mills are typically located in areas of low population density, and they process ores from mines within about 50 kilometers (30 miles) of the mill. Most conventional mills in the United States are in the process of closing.

In-situ leaching (ISL, also referred to as in-situ recovery) is another means of extracting uranium from underground ore. ISL facilities recover uranium from low-grade ores that may not be economically recoverable by other methods. In this process, a leaching agent, such as oxygen with sodium carbonate, is injected through wells into the ore to dissolve the uranium. The leach solution is pumped from the rock formation, and the uranium is then separated from the solution. About 12 such ISL facilities exist in the United States. Of these, four are licensed by the NRC, and the rest are licensed by Texas, an Agreement State (States authorized by the NRC to regulate certain

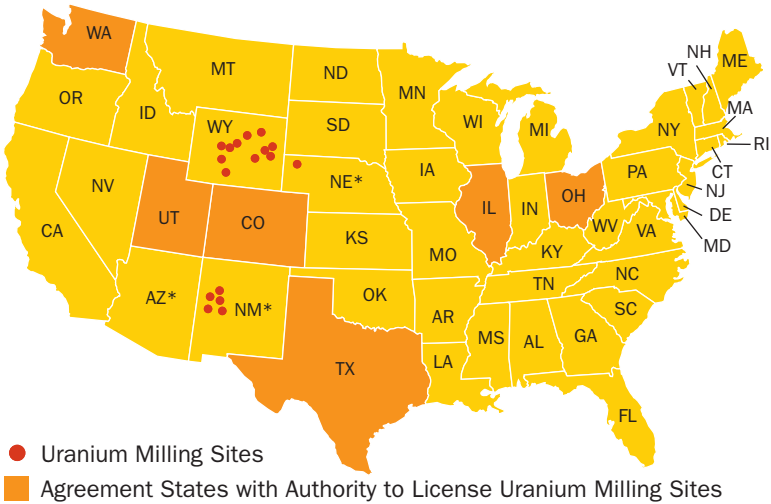
nuclear materials within the State) (see Figure 33).

The NRC does not regulate traditional mining, but it does regulate the processing of uranium ore. It has jurisdiction over mills and in-situ leaching facilities. In both processes, the final product of uranium milling is “yellowcake,” so named because of its yellowish color. The yellowcake is sent to a conversion facility for processing in the next step in the manufacture of nuclear fuel.

Because of the resurgence of interest in the construction of new nuclear power plants, the agency anticipates as many as 17 applications for new milling facilities and several applications to expand or restart existing milling facilities in the next few years. As of July 2008, the agency had received three applications for new facilities and three applications to expand or restart an existing facility. The current status of applications can be found on the NRC’s Web site (see Web Link Index). Existing facilities and new potential sites are located in Wyoming, New Mexico, Nebraska, South Dakota, and Arizona, and in the Agreement States of Texas, Colorado, and Utah (see Figure 33 and Table 13). The NRC plans to work closely with stakeholders, including Native American Tribal Government, to address concerns with the licensing of future uranium recovery facilities.

The NRC has a well-established regulatory framework for ensuring

**Figure 33. Locations of Uranium Milling Sites**



\*Agreement States where the NRC has retained authority to license uranium milling  
 Source: U.S. Nuclear Regulatory Commission

**Table 13. Locations of Uranium Milling Facilities**

LICENSEE	SITE NAME, LOCATION
<b>In-Situ Leach Facilities</b>	
Cogema Mining, Inc.°	Irigaray/Christensen Ranch, WY
Crow Butte Resources, Inc.	Crow Butte, NE*
Hydro Resources, Inc.	Crownpoint, NM
Power Resources, Inc.°	Smith Ranch and Highlands, WY*
<b>Conventional Uranium Milling Facilities</b>	
American Nuclear Corp. †	Gas Hills, WY
Bear Creek Uranium Co. †	Bear Creek, WY
Exxon Mobil Corp. †	Highlands, WY
Homestake Mining Co. †	Homestake, NM
Kennecott Uranium Corp.	Sweetwater, WY
Pathfinder Mines Corp. †	Lucky Mc, WY
Pathfinder Mines Corp. †	Shirley Basin, WY
Rio Algom Mining, LLC †	Ambrosia Lake, NM
Umetco Minerals Corp.†	Gas Hills, WY
United Nuclear Corp. †	Church Rock, NM
Western Nuclear, Inc. †	Split Rock, WY

Note: The facilities listed are under the authority of the NRC.

\* There are satellite facilities located within the State.

° Sites not currently operating

† Sites undergoing decommissioning

that uranium recovery facilities are appropriately licensed, operated, decommissioned, and monitored to protect public health and safety. Through the regulatory framework, the NRC is responsible for the following activities:

- Inspection and oversight of both active and inactive mills
- Siting and design features of tailings impoundments that minimize disturbance by natural forces and minimize the release of radon
- Comprehensive reclamation and decommissioning requirements to ensure adequate cleanup of active and formerly active mills
- Stringent financial assurance requirements to ensure funds are available for decommissioning

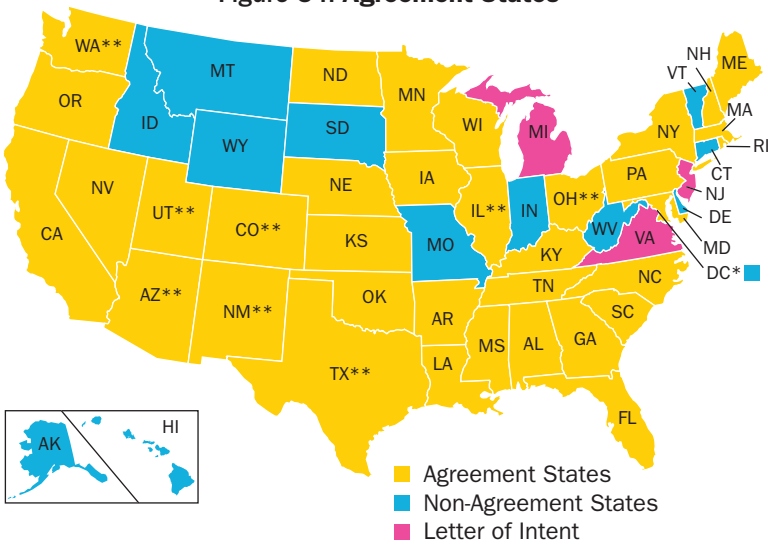
- Requirements for below-grade disposal of mill tailings and liners for tailings impoundments (see Glossary)
- Ground water monitoring to prevent ground water contamination
- Long-term monitoring and oversight of decommissioned facilities

### MATERIALS LICENSES

The NRC and Agreement States have issued approximately 22,300 licenses for medical, academic, industrial, and general uses of nuclear materials (see Figure 34 and Table 14).

- NRC administers approximately 3,800 licenses.
- 35 Agreement States administer approximately 18,500 licenses.

Figure 34. Agreement States



\* Other Non-Agreement States include major U.S. territories such as Puerto Rico, Virgin Islands, and Guam.  
 \*\* The NRC has maintained authority to license uranium milling.  
 Source: U.S. Nuclear Regulatory Commission

NUCLEAR MATERIALS

**Table 14. U.S. Materials Licenses by State**

State	Number of Licenses	
	NRC	Agreement States
Alabama	17	468
Alaska	56	0
Arizona	10	396
Arkansas	6	233
California	47	2,018
Colorado	23	351
Connecticut	192	0
Delaware	60	0
District of Columbia	43	0
Florida	15	1,700
Georgia	15	515
Hawaii	59	0
Idaho	81	0
Illinois	39	741
Indiana	277	0
Iowa	2	172
Kansas	11	315
Kentucky	11	432
Louisiana	11	560
Maine	2	127
Maryland	74	632
Massachusetts	25	511
Michigan	538	0
Minnesota	12	187
Mississippi	6	333
Missouri	303	0
Montana	77	0

State	Number of Licenses	
	NRC	Agreement States
Nebraska	4	158
Nevada	6	266
New Hampshire	4	80
New Jersey	496	0
New Mexico	15	193
New York	34	1,508
North Carolina	19	681
North Dakota	8	64
Ohio	49	773
Oklahoma	23	241
Oregon	4	481
Pennsylvania	85	665
Rhode Island	1	59
South Carolina	16	375
South Dakota	41	0
Tennessee	22	605
Texas	42	1,666
Utah	10	197
Vermont	38	0
Virginia	387	0
Washington	18	444
West Virginia	184	0
Wisconsin	24	335
Wyoming	80	0
Others*	148	0
Total	3,770	18,482

 Agreement State

\* Others include major U.S. territories.

Note: Agreement States data are the latest available as of September 13, 2007; the NRC data are the latest available as of March 2008.

Reactor- and accelerator-produced radionuclides are used extensively throughout the United States for civilian and military industrial applications; basic and applied research; manufacture of consumer products; academic studies; and medical diagnosis, treatment, and research. The NRC and Agreement State regulatory programs are designed to ensure that licensees safely use these materials and do not endanger public health and safety or cause damage to the environment.

## MEDICAL AND ACADEMIC

In both medical and academic settings, the NRC reviews the facilities, personnel, program controls, and equipment to ensure the safety of the public, patients, and workers who might be exposed to radiation.

### Medical

The NRC and Agreement States issue licenses to hospitals and physicians for the use of radioactive material in medical treatments. In addition, the NRC develops guidance and regulations for use by licensees and maintains a committee of medical experts to obtain advice about the use of byproduct materials in medicine. The Advisory Committee on the Medical Uses of Isotopes is comprised of physicians, scientists, and other health care professionals who provide advice to the NRC staff on initiatives in the medical uses of radioactive materials.

About one-third of all patients admitted to hospitals are diagnosed or treated using radioactive materials. Radioactive materials are used in various medical treatments. This branch of medicine is known as nuclear medicine, and the radioactive materials for treatment are called radiopharmaceuticals. Doctors of nuclear medicine use radiopharmaceuticals to diagnose patients using in vivo tests (direct administration of radiopharmaceuticals to patients) or in vitro tests (the addition of radioactive materials to lab samples taken from patients). Doctors also use radio-pharmaceuticals and radiation-producing devices to treat conditions such as hyperthyroidism and certain forms of cancer and to ease bone pain caused by cancer.

### Diagnostic Procedures

For most diagnostic nuclear medicine procedures, a small amount of radioactive material, known as a radiopharmaceutical, is administered, either by injection, inhalation, or oral administration. The radiopharmaceutical collects in the organ or area being evaluated, where it emits photons. These photons can be detected by a device known as a gamma camera. The gamma camera produces images that provide information about the organ function and composition.

### Radiation Therapy

The primary objective of radiation therapy is to deliver an accurately

prescribed dose of radiation to the target site while minimizing the radiation dose to surrounding healthy tissue. Radiation therapy can be used to treat cancer or to relieve symptoms associated with certain diseases. Treatments often involve multiple exposures spaced over a period of time for maximum therapeutic effect. When used to treat malignant diseases, radiation therapy is often delivered in combination with surgery or chemotherapy.

There are three main categories of radiation therapy:

- External beam therapy (also called teletherapy) is a beam of radiation directed to the target tissue. There are several different categories of external beam therapy units. The type of treatment machine that is regulated by the NRC contains a high-activity radioactive source (usually cobalt-60) that emits photons to treat the target site.
- In brachytherapy treatments, sealed radioactive sources are permanently or temporarily placed near or on a body surface, in a body cavity, directly to a surface within a cavity, or directly on the cancerous tissue. The radiation dose is delivered at a distance of up to a few centimeters from the target area.
- Therapeutic radiopharmaceuticals are large amounts of unsealed radioactive materials that localize in a specific region

or organ system to deliver a large radiation dose.

### Academic

The NRC issues licenses to academic institutions for educational and research purposes. For example, qualified instructors use radioactive materials in classroom demonstrations. Scientists in a wide variety of disciplines use radioactive materials for laboratory research.

### Industrial

The NRC and Agreement States license users of radioactive material for the specific type, quantity, and location of material that may be used. Radionuclides are used in a number of industrial and commercial applications, including industrial radiography, gauges, well logging, and manufacturing. For example, radiography uses radiation sources to find structural defects in metallic castings and welds. Gauges use radiation sources to determine the thickness of paper products, fluid levels in oil and chemical tanks, and the moisture and density of soils and material at construction sites. Gas chromatography uses low-energy radiation sources for identifying the chemical elements in an unknown substance. Gas chromatography can determine the components of complex mixtures, such as petroleum products, smog, and cigarette smoke, and can be used in biological and medical research to identify the



components of complex proteins and enzymes. Well-logging devices use a radioactive source and detection equipment to make a record of geological formations down a bore hole. This process is used extensively for oil, gas, coal, and mineral exploration.

## INDUSTRIAL

### Nuclear Gauges

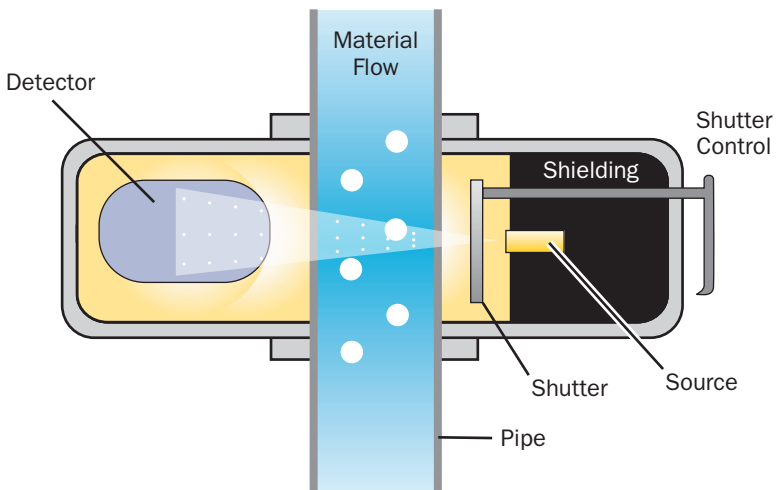
Nuclear gauges are used as nondestructive devices to measure the physical properties of products and industrial processes as a part of quality control. There are fixed and portable gauges.

A fixed gauge consists of a radioactive source that is contained in a source holder. When the user

opens the container's shutter, a beam of radiation hits the material or product being processed or controlled. A detector mounted opposite the source measures the radiation passing through the product. The gauge readout or computer monitor shows the measurement. The selection of the type, energy, and strength of radiation is determined by the material and process being monitored.

The diagram below shows a fixed fluid gauge installed on a pipe (see Figure 35). The beverage, food, plastics, and chemical industries use such devices to measure the densities, flow rates, levels, thicknesses, and weights of a wide variety of materials and surfaces.

**Figure 35. Cross-Section of Fixed Fluid Gauge**



Source: U.S. Nuclear Regulatory Commission

A portable gauge is a radioactive source and detector mounted together in a portable shielded device. When the device is used, it is placed on the object to be measured, and the source is either inserted into the object or the gauge relies on a reflection of radiation from the source to bounce back to the bottom of the gauge. The detector in the gauge measures the radiation, either directly from the inserted source or from the reflected radiation.

The radiation measurement indicates the thickness, density, moisture content, or some other property that is displayed on a gauge readout or on a computer monitor. The top of the gauge has sufficient shielding to protect the operator while the source is exposed. When the measuring process is completed, the source is retracted or a shutter closes, minimizing exposure from the source.

### Commercial Irradiators

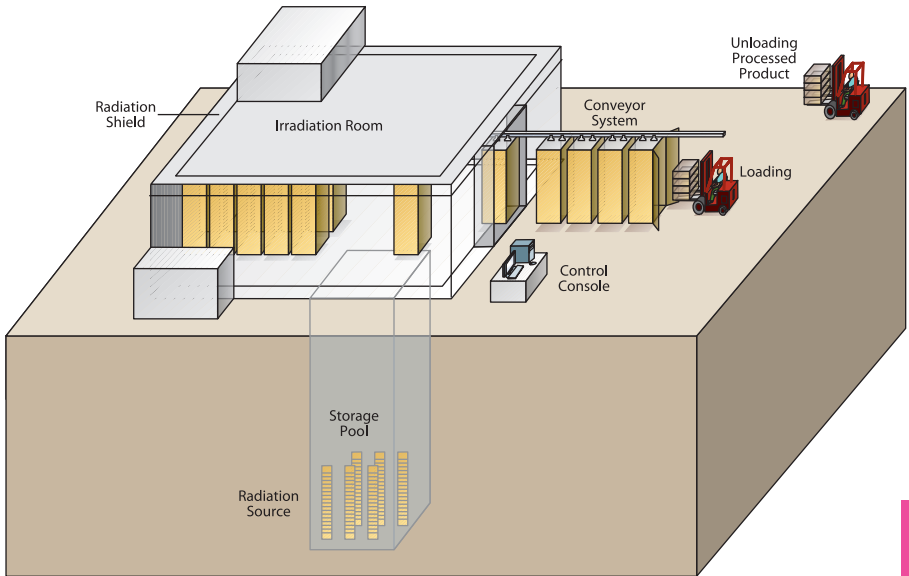
Commercial irradiators expose products such as food, food containers, spices, medical supplies, and wood flooring to radiation to eliminate harmful bacteria, germs, and insects, or for hardening or other purposes. The gamma radiation does not leave any radioactive residue or cause any of the treated products to become radioactive themselves. The source of that radiation can be radioactive materials (e.g., cobalt-60), an X-ray tube, or an electron beam.

There are approximately 50 commercial irradiators nationwide that are licensed by the NRC and Agreement States. For the past 40 years, the U.S. Food and Drug Administration and other agencies have approved the irradiation of meat and poultry, as well as other foods, including fresh fruits and vegetables (see Figure 36). The amount of radioactive material in the devices can range from 1 to 10 million curies.

There are generally two types of irradiators that use radioactive material in operation in the United States: underwater and wet-source-storage panoramic models.

- In the case of underwater irradiators, the sealed sources (radioactive material encased inside a capsule, sometimes called “sealed sources”) that provide the radiation remain in the water at all times, providing shielding for workers and the public. The product to be irradiated is placed in a watertight container, lowered into the pool, irradiated, and then removed.
- With wet-source-storage panoramic irradiators, the radioactive sealed sources are also stored in the water, but they are raised into the air to irradiate products that are automatically moved into the room on a conveyor system. Sources are then lowered back to the bottom of the pool. For this type of irradiator, thick concrete walls

Figure 36. Commercial Irradiator



or steel provide protection for workers and the public when the sources are lifted from the pool.

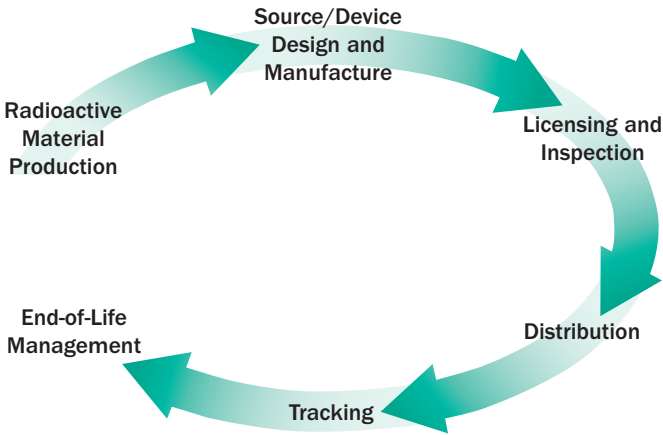
### MATERIAL SECURITY

The NRC and Agreement States currently use a database to track the most security-significant radioactive sources used in medicine and industry. The database is useful in that it provides snapshots of data; however, a new National Source Tracking System (NSTS) is under development that will allow NRC and Agreement State licensees to record, in real time, transfers of

this material directly over a secure Web-based system via the Internet.

Deployment of the NSTS is expected in January 2009. In addition, a proposed rule to expand the NSTS to lower-risk sources is expected to be finalized in early 2009. There are also improved coordination and communications with security and intelligence agencies. Together, these activities will make potentially dangerous radioactive sources even more secure and less vulnerable to terrorists (see Figure 37).

Figure 37. Life Cycle Approach to Source Security



**Principal Licensing and Inspection Activities**

The NRC issues approximately 2,700 new licenses, license renewals, or license amendments for materials licenses each year.

The NRC conducts approximately 1,250 health and safety and security inspections of its nuclear materials licensees each year.

*Empty storage/transport container for radioactive waste delivered at a reactor site.*



## RADIOACTIVE WASTE

## LOW-LEVEL RADIOACTIVE WASTE DISPOSAL

Low-level radioactive waste (LLW) includes items that have become contaminated with radioactive material or have become radioactive through exposure to neutron radiation. This waste typically consists of contaminated protective shoe covers and clothing, wiping rags, mops, filters, reactor water treatment residues, equipment and tools, medical tubes, swabs, injection needles, syringes, and laboratory animal carcasses and tissue.

The radioactivity can range from just-above-background levels found in nature to very high levels as from the parts inside the reactor vessel in a nuclear power plant. Low-level radioactive waste is typically stored onsite by licensees until it has decayed away. Then it can be disposed of as ordinary trash or until amounts are large enough for shipment to a low-level radioactive waste disposal site in containers approved by the U.S. Department of Transportation or the U.S. Nuclear Regulatory Commission (NRC).

Commercial LLW is disposed of in facilities licensed by either the NRC or Agreement States in accordance with health and safety requirements. The facilities are designed, constructed, and operated to meet safety standards. The operator of the facility also extensively characterizes the site on which the facility is located and analyzes how the facility will perform in the future.

Current LLW disposal uses shallow land disposal sites with or without concrete vaults. The low-level radioactive waste will sit there safely for thousands of years.

The NRC has developed a classification system for low-level radioactive waste based on its potential hazards. It has specified disposal and waste requirements for each of the three classes of waste—Class A, B, and C. These classes have progressively higher levels of concentrations of radioactive material, with A having the lowest and C having the highest level. Class A waste accounts for approximately 96 percent of the total volume of low-level radioactive waste. Determination of the classification of waste is a complex process.

The volume and radioactivity of waste vary from year to year based on the types and quantities of waste shipped each year. Waste volumes currently include several million cubic feet each year from reactor facilities undergoing decommissioning and cleanup of contaminated sites.

The Low-Level Radioactive Waste Policy Amendments Act of 1985 gave the States responsibility for the disposal of their LLW. It authorized States to do the following:

- Form 10 regional compacts with each compact to establish an LLW disposal site (see Table 15).
- Exclude waste generated outside a compact.

Active LLW licensed disposal facilities include the following:

- **Barnwell**, located in Barnwell, SC—Previously, Barnwell accepted waste from all U.S. generators. As of July 2008, Barnwell only accepts waste from the Atlantic Compact States (Connecticut, New Jersey, and South Carolina). Barnwell is licensed by the State of South

Carolina to receive all classes of LLW.

- **Energy Solutions**, located in Clive, UT—Energy Solutions accepts waste from all regions of the United States. It is licensed by the State of Utah for Class A waste only.
- **Hanford**, located in Hanford, WA—Hanford accepts waste

**Table 15. U.S. Low-Level Radioactive Waste Compacts**

<b>Appalachian</b>	<b>Rocky Mountain</b>
Delaware	Colorado
Maryland	Nevada
Pennsylvania	New Mexico
West Virginia	<b>Southeast</b>
<b>Atlantic</b>	Alabama
Connecticut	Florida
New Jersey	Georgia
South Carolina*	Mississippi
<b>Central</b>	Tennessee
Arkansas	Virginia
Kansas	<b>Southwestern</b>
Louisiana	Arizona
Oklahoma	California
<b>Central Midwest</b>	North Dakota
Illinois	South Dakota
Kentucky	<b>Texas</b>
<b>Midwest</b>	Texas
Indiana	Vermont
Iowa	<b>Unaffiliated</b>
Minnesota	Maine
Missouri	Massachusetts
Ohio	Michigan
Wisconsin	Nebraska
<b>Northwest</b>	New Hampshire
Alaska	New York
Hawaii	North Carolina
Idaho	Rhode Island
Montana	
Oregon	
Utah*	
Washington*	
Wyoming	

Note: Data as of May 2008

\*There are three active LLW disposal facilities.

RADIOACTIVE WASTE

Source: U.S. Nuclear Regulatory Commission

from the Northwest and Rocky Mountain compacts. Hanford is licensed by the State of Washington to receive all classes of LLW.

Closed LLW disposal facilities:

- Beatty, NV, closed 1993
- Sheffield, IL, closed 1978
- Maxey Flats, KY, closed 1977
- West Valley, NY, closed 1975

## HIGH-LEVEL RADIOACTIVE WASTE MANAGEMENT

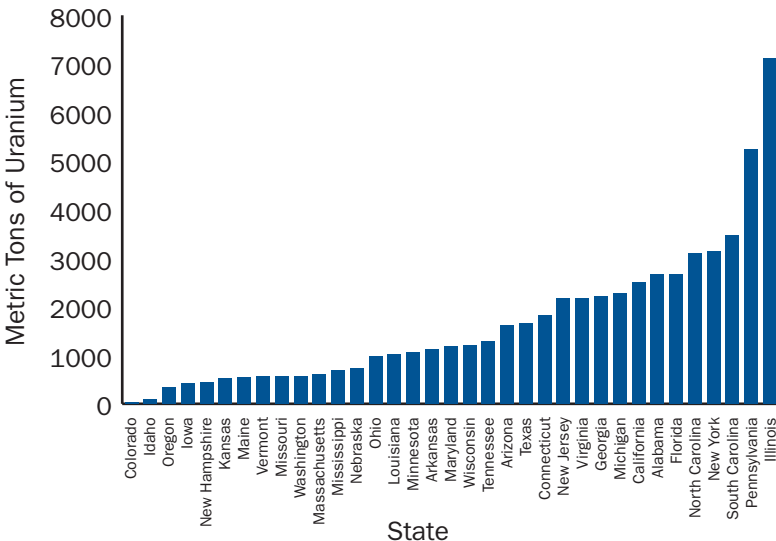
### Spent Nuclear Fuel Storage

A survey conducted by the U.S. Energy Information Administration in 2002 found that U.S. commercial nuclear power plants were storing approximately 46,000 metric tons of spent nuclear fuel onsite. By early

2008, the amount of commercial spent fuel in storage at commercial nuclear power plants had grown to an estimated 57,000 metric tons. With no long-term waste storage or disposal facility available, the amount of spent fuel in storage at individual commercial nuclear power plants is increasing at a rate of approximately 2,000 metric tons per year. As with all civilian uses of nuclear materials, the NRC licenses and regulates the storage of spent fuel, both at commercial nuclear power plants and at storage facilities located away from reactors.

Commercial spent nuclear fuel is currently being stored in 35 States (see Figure 38 and Table 16). This includes 31 States with operating nuclear power reactors, where spent fuel is being stored

Figure 38. Storage of Commercial Spent Fuel by State through 2007



Note: Idaho is holding used fuel from Three Mile Island, Unit 2. Data are rounded up to the nearest 10 tons. Source: ACI Nuclear Energy Solutions and U.S. Department of Energy. Updated February 2008.



**Table 16. U.S. State-by-State Commercial Nuclear Used Fuel and Payments to the Nuclear Waste Fund**

State	Metric Tons of Uranium	Nuclear Waste Fund Contributions (\$ M)
Alabama	2,660	684.1
Arizona	1,620	483.4
Arkansas	1,120	271.6
California	2,510	764.2
Colorado	30	0.2
Connecticut	1,830	337.1
Florida	2,660	716.7
Georgia	2,210	630.9
Idaho	90	NA
Illinois	7,120	1,617.2
Iowa	430	103.7
Kansas	530	172.0
Louisiana	1,010	294.8
Maine	550	65.5
Maryland	1,180	329.5
Massachusetts	610	151.7
Michigan	2,280	473.7
Minnesota	1,060	363.3
Mississippi	690	185.0
Missouri	570	178.3
Nebraska	740	242.2
New Hampshire	440	136.3
New Jersey	2,180	544.5
New York	3,130	721.5
North Carolina	3,100	763.8
Ohio	980	273.3
Oregon	350	75.5
Pennsylvania	5,240	1,428.4
South Carolina	3,460	1,147.6
Tennessee	1,280	331.8
Texas	1,660	540.2
Vermont	560	85.3
Virginia	2,180	645.8
Washington	570	144.9
Wisconsin	1,200	413.4
Other	NA	7.6
Total	57,650	15,325.0

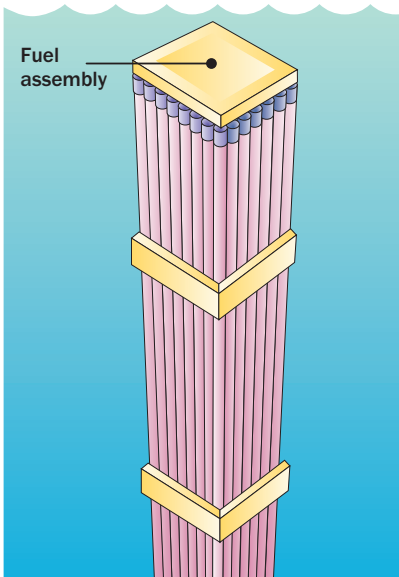
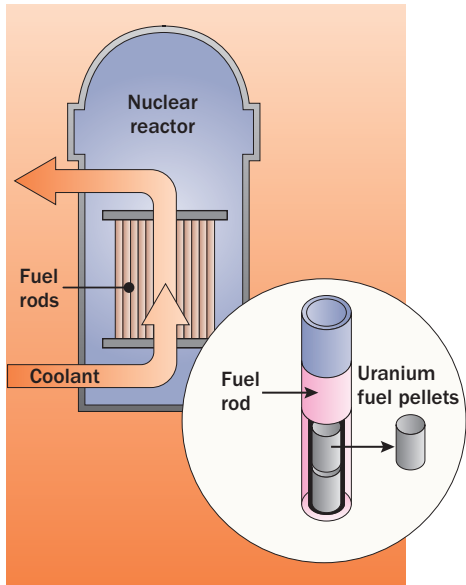
Note: Idaho is holding used fuel from Three Mile Island, Unit 2.

Used fuel data are rounded up to the nearest 10 tons and is current as of January 2008. Nuclear waste fund contributions are current as of June 30, 2007.

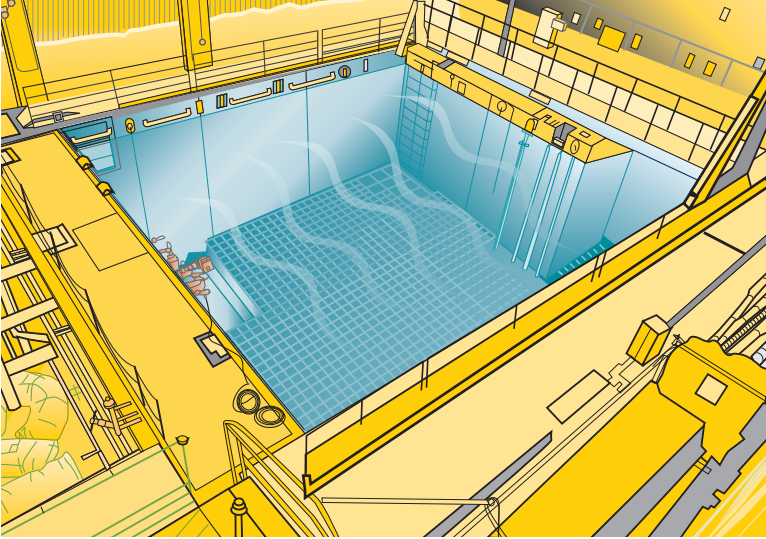
Source: ACI Nuclear Energy Solutions and U.S. Department of Energy

**Figure 39. Spent Fuel Generation and Storage after Use**

**1** A nuclear reactor is powered by enriched uranium-235 fuel. Fission (splitting of atoms) generates heat, which produces steam that turns turbines to produce electricity. A reactor rated at several hundred megawatts may contain 100 or more tons of fuel in the form of bullet-sized pellets loaded into long metal rods that are bundled together into fuel assemblies. Pressurized-water reactors (PWRs) contain between 150–200 fuel assemblies. Boiling-water reactors (BWRs) contain between 370–800 fuel assemblies.



**2** After about 6 years, spent fuel assemblies—typically 14 feet long and containing nearly 200 fuel rods for PWRs and 80–100 fuel rods for BWRs—are removed from the reactor and allowed to cool in storage pools for a few years. At this point, the 900-pound assemblies contain only about one-fifth the original amount of uranium-235.



- 3** Commercial light-water nuclear reactors store spent radioactive fuel in a steel-lined, seismically designed concrete pool under about 40 feet of water that provides shielding from radiation. Water pumps supply continuously flowing water to cool the spent fuel. Extra water for the pool is provided by other pumps that can be powered from an onsite emergency diesel generator. Support features, such as water-level monitors and radiation detectors, are also in the pool. Spent fuel is stored in the pool until it can be transferred to dry casks onsite or transported offsite to a high-level radioactive waste disposal site.

Source: U.S. Department of Energy and the Nuclear Energy Institute

onsite in spent fuel pools and in dry casks. The remaining four States—Colorado, Idaho, Maine, and Oregon—do not have operating power reactors but are also storing spent fuel at storage facilities.

Most reactor facilities were not designed to store the full amount of spent fuel that the reactor would generate during its operational life. Facilities originally planned to store spent fuel temporarily in deep pools of continuously chilled and circulating water that cool the spent fuel assemblies and provide shielding from radiation. After a few years, the facilities expected to send the spent fuel to a recycling plant. However, the Federal Government declared a moratorium on recycling spent fuel in 1977. Although the ban was later lifted, recycling was not pursued. To cope with the spent fuel they were generating, facilities expanded their storage capacity by using high-density storage racks in their spent fuel pools. However, spent fuel pools are not a permanent storage solution (see Figure 39).

To supplement storage of spent fuel, some licensees have decided to store some portion of their spent fuel inventories in dry cask storage onsite. These facilities are called independent spent fuel storage installations (ISFSI) and are licensed by the NRC. These large casks are typically made of leak-tight, welded, and bolted steel and concrete surrounded by another layer of steel or concrete. The spent fuel bundle sits in the center of the nested canisters in an inert gas. Dry

cask storage serves the following two functions: it shields people and the environment from radiation, and it keeps the spent fuel inside dry and nonreactive.

The NRC authorizes storage of spent fuel at an ISFSI under two licensing options:

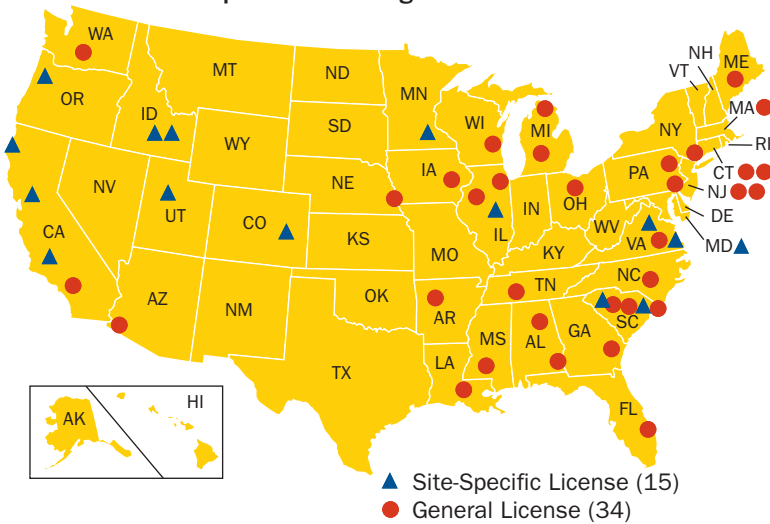
- Site-specific licensing
- General licensing

Currently, there are 49 licensed ISFSIs in the United States (see Figure 40). As of 2007, NRC-licensed ISFSIs were storing approximately 34,000 spent fuel assemblies in about 950 storage casks. To meet storage needs, the use of ISFSIs has increased and is expected to continue to grow (see Figure 41).

Under a site-specific license, an applicant submits a license application to the NRC, and the NRC performs a technical review of the safety aspects of the proposed ISFSI. If the agency finds that the ISFSI is safe, it approves the application and issues a license. A spent fuel storage license contains technical requirements and operating conditions for the ISFSI and specifies what the licensee is authorized to store at the site. The license term for an ISFSI is 20 years from the date of issuance. However, licenses may be renewed.

A general license from the NRC authorizes a licensee who operates a nuclear power reactor to store spent fuel onsite in dry storage casks. The NRC documents its approval by issuing a certificate of compliance to the cask vendor

Figure 40. Licensed/Operating Independent Spent Fuel Storage Installations



**ALABAMA**

- Browns Ferry
- Farley

**ARIZONA**

- Palo Verde

**ARKANSAS**

- Arkansas Nuclear

**CALIFORNIA**

- ▲ Diablo Canyon
- ▲ Rancho Seco
- San Onofre
- ▲ Humboldt Bay

**COLORADO**

- ▲ Fort St. Vrain

**CONNECTICUT**

- Haddam Neck
- Millstone

**FLORIDA**

- St. Lucie

**GEORGIA**

- Hatch

**IDAHO**

- ▲ DOE: TMI-2 (Fuel Debris)
- ▲ Idaho Spent Fuel Facility

**ILLINOIS**

- ▲ GE Morris (Wet)
- Dresden
- Quad Cities

**IOWA**

- Duane Arnold

**LOUISIANA**

- River Bend

**MAINE**

- Maine Yankee

**MARYLAND**

- ▲ Calvert Cliffs

**MASSACHUSETTS**

- Yankee Rowe

**MICHIGAN**

- Big Rock Point
- Palisades

**MINNESOTA**

- ▲ Prairie Island

**MISSISSIPPI**

- Grand Gulf

**NEBRASKA**

- Ft. Calhoun

**NEW JERSEY**

- Hope Creek
- Oyster Creek

**NEW YORK**

- James A. FitzPatrick
- Indian Point

**NORTH CAROLINA**

- McGuire

**OHIO**

- Davis-Besse

**OREGON**

- ▲ Trojan

**PENNSYLVANIA**

- Susquehanna
- Peach Bottom

**SOUTH CAROLINA**

- ▲ Oconee
- ▲ H.B. Robinson
- Catawba

**TENNESSEE**

- Sequoyah

**UTAH**

- ▲ Private Fuel Storage

**VIRGINIA**

- ▲ Surry
- ▲ North Anna

**WASHINGTON**

- Columbia

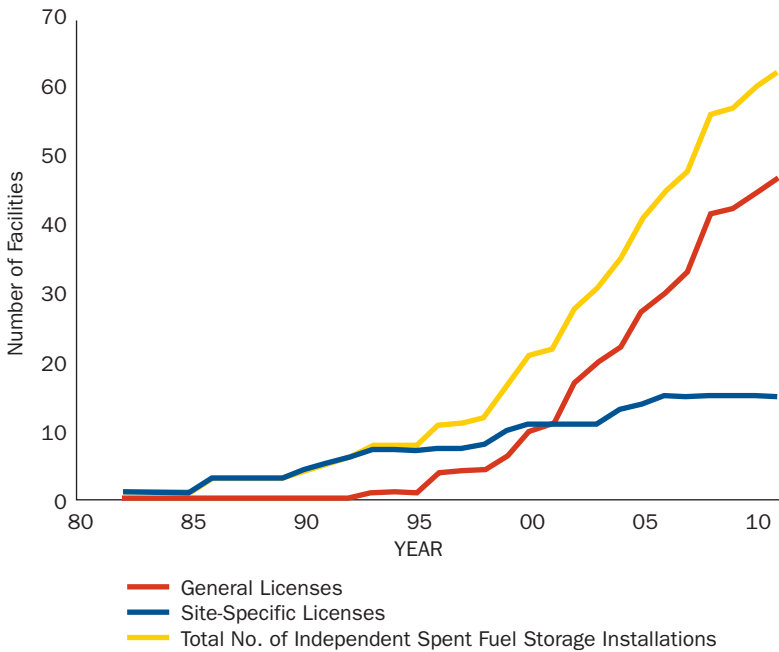
**WISCONSIN**

- Point Beach

Note: Data are current as of March 2008.  
Source: U.S. Nuclear Regulatory Commission

RADIOACTIVE WASTE

Figure 41. Independent Spent Fuel Storage Installation Growth with Time



Source: U.S. Nuclear Regulatory Commission

through rulemaking. Several dry storage cask designs have received certificates. Refer to Appendix H for a list of dry spent fuel storage systems that are approved for use with a general license.

The general license terminates 20 years after the date that the cask is first used for storage. If the NRC renews the cask’s certificate, the general license terminates 20 years after the certificate renewal date. Thirty days before the certificate expiration date, the cask vendor may apply for reapproval. In the event that the cask vendor does not apply for reapproval, a general licensee may apply for reapproval.

Before using the cask, general licensees are required to perform

written evaluations that establish that the cask meets the conditions in the certificate, that the concrete pads underneath the casks can adequately support the static and dynamic loads, and that the level of radioactive materials in effluents and direct radiation meet NRC standards.

The public can participate in decisions about spent fuel storage, as they can in many licensing and rulemaking decisions. The Atomic Energy Act of 1954, as amended, and the NRC’s own regulations, require public hearings for site-specific licensing actions and for commenting on certificate rulemakings. Interested members of the public may also file petitions for rulemaking.

Appendix I lists dry spent fuel storage licensees.

Additional information on ISFSIs is available on the NRC Web site (see Web Link Index).

### Proposed Yucca Mountain Repository

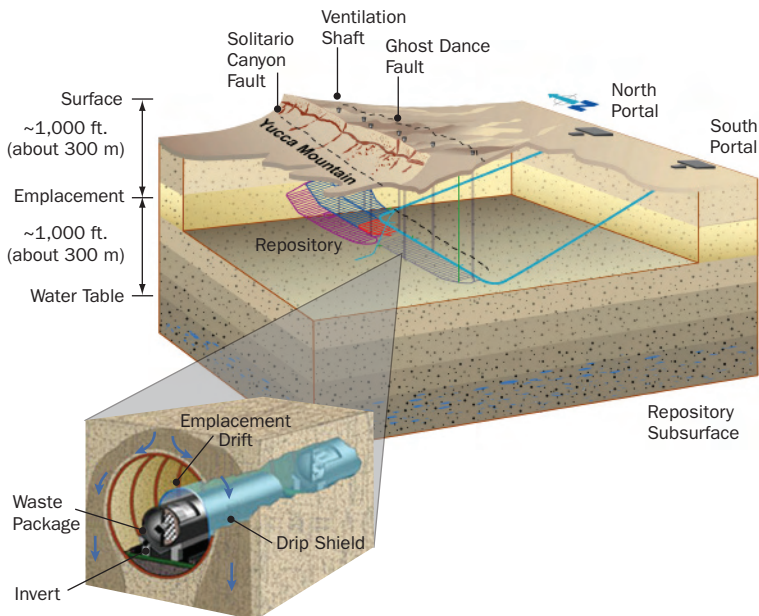
U.S. policies governing permanent disposal of high-level radioactive waste (HLW) are defined by the Nuclear Waste Policy Act of 1982, as amended, and the Energy Policy Act of 1992. These acts specify that high-level radioactive waste will be disposed of underground, in a deep geologic repository. The Nuclear

Waste Policy Act of 1982, amended in 1987, names Yucca Mountain, a desert ridgeline in Nevada, as the single candidate site for this potential geologic repository (see Figure 42).

If an application is approved, three Federal agencies will perform key roles in the disposal of spent nuclear fuel and other high-level radioactive waste.

- The U.S. Department of Energy (DOE) will construct and operate the repository for spent fuel and other high-level radioactive waste, if its application is approved.

**Figure 42. Proposed Yucca Mountain Repository**



This cutaway image of Yucca Mountain details its planned network of repository surface facilities, ramps, tunnels, and cask emplacement.

Source: U.S. Department of Energy

- The U.S. Environmental Protection Agency (EPA) will issue environmental standards that the NRC will use to evaluate the safety of a geologic repository.
- The NRC will issue regulations that implement the EPA's standards. It will also review DOE's application and decide whether to license the proposed repository. If the NRC grants the license, it must ensure that DOE safely constructs, operates, and eventually closes the repository.

For many years, both DOE and the NRC have engaged in prelicense application discussions in public meetings to help ensure a complete and high-quality license application from DOE.

On February 15, 2002, after receiving a recommendation from the Secretary of Energy, the President notified Congress that he considered Yucca Mountain qualified for a construction permit application. Congress approved the recommendation, and on July 23, 2002, the President signed a joint congressional resolution directing the DOE to prepare an application for constructing a repository at Yucca Mountain. The DOE submitted a license application to the NRC on June 3, 2008.

Decisions about licensing a geologic repository will occur in three phases—

- (1) licensing repository construction,
- (2) licensing the opening of the constructed repository, and

- (3) once the repository is full, licensing its closing or decommissioning.

In the first phase, DOE must submit a license application to the NRC. If after reviewing the application for quality, the NRC accepts the application, it has 3–4 years by law to make a decision. Within that time, the NRC will complete its safety review, conduct a public hearing before an independent licensing board, and decide whether to authorize construction of the repository.

Should the NRC authorize construction, the process enters the second phase. As construction of the repository nears completion, DOE must update its license application. The NRC must again complete a safety review and conduct a public hearing before an independent licensing board, in order to decide whether DOE can safely receive and dispose of waste at the repository. If the NRC grants the license to receive and possess high-level radioactive waste, DOE could begin placing high-level radioactive waste in the repository.

The third phase would begin once the repository becomes full. DOE would update its application again and apply for a license amendment to decommission repository surface facilities and permanently close the repository.

Information on HLW can be found on the NRC Web site (see Web Link Index).



## TRANSPORTATION

About 3 million packages of radioactive materials are shipped each year in the United States, either by road, rail, air, or water. This figure may seem high, but it actually represents less than 1 percent of the Nation's yearly hazardous material shipments. Regulating the safety of commercial radioactive material shipments is the joint responsibility of the NRC and the U.S. Department of Transportation.

The NRC ensures transportation safety by reviewing and certifying shipping packages for the commercial transport of large quantities of radioactive materials and fissile materials. In addition, the NRC certifies shipping package designs for DOE's noncommercial transuranic waste shipments to the Waste Isolation Pilot Plant in New Mexico and for DOE-proposed spent fuel shipments to Yucca Mountain in Nevada. Shipping packages can range from a relatively light design to something like a large steel and concrete dry cask (see Figure 43).

In order for the NRC to certify a transportation package, the package must be tested and/or computer analyzed. Several tests in a sequence will show if the package is strong enough to withstand a series of accidents and still safely hold radioactive material.

Aside from assuring the strength of the package, the NRC also ensures

safety by regulating the operating procedures that control the package and the vehicle carrying it. The agency also conducts spot inspections to ensure that the packages are fabricated and used according to regulations.

The NRC inspectors verify the following:

- Transportation package users have taken the appropriate radiation measurements around the package to ensure that the package does not exceed maximum radiation levels.
- Transportation package users have performed package inspections for criteria such as leak-tightness.
- Bolts and other equipment are intact and the packages are in good condition.

Both the NRC and DOE continue joint operation of a national database and information support system to track the movement of domestic and foreign nuclear materials under safeguards control.

### Principal Licensing and Inspection Activities

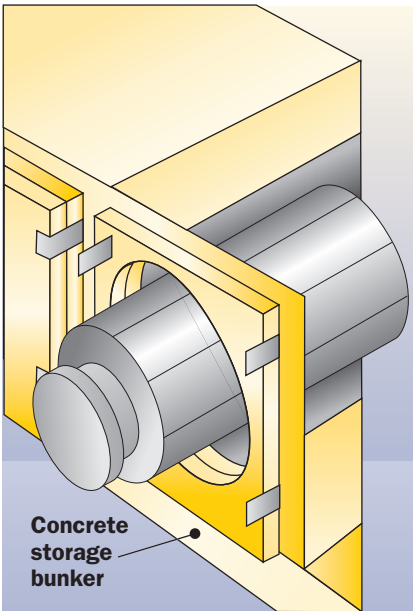
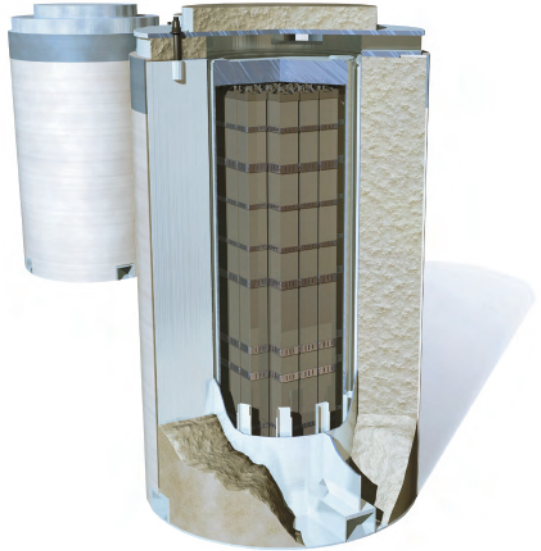
The NRC conducts about 1,000 transportation safety inspections of fuel, reactor, and materials licensees annually.

The NRC reviews, evaluates, and certifies approximately 80 new, renewal, or amended package design applications for the transport of nuclear materials annually.

**Figure 43. Dry Storage of Spent Nuclear Fuel**

At some nuclear reactors across the country, spent fuel is kept onsite, typically above ground, in systems basically similar to the ones shown here.

**1** Once the spent fuel has cooled, it is loaded into special canisters that are designed to hold nuclear fuel assemblies. Water and air are removed. The canister is filled with inert gas, welded shut, and rigorously tested for leaks. It is then placed in a cask for storage or transportation. The NRC has approved the storage of up to 40 pressurized-water reactor assemblies and up to 68 boiling-water reactor assemblies in each canister. The dry casks are then loaded onto the concrete pads.



**2** The canisters can also be stored in aboveground concrete bunkers, each of which is about the size of a one-car garage.

**3** Eventually the canisters shown in (1) or (2) may be placed inside a transportation package for shipment.

The NRC inspects about 20 dry storage and transport package licensees annually.

The NRC reviews and evaluates approximately 150 license applications for the import or export of nuclear materials annually.

Additional information on materials transportation is available on the NRC Web site (see Web Link Index).

## DECOMMISSIONING

Decommissioning is the safe removal of a facility from service and reduction of residual radioactivity to a level that permits release of the property and termination of the license. The NRC rules on decommissioning establish site-release criteria and provide for unrestricted and, under certain conditions, restricted release of a site.

The NRC regulates the decontamination and decommissioning of materials and fuel cycle facilities, nuclear power plants, research and test reactors, and uranium recovery facilities, with the ultimate goal

of license termination. Approximately 200 materials licenses are terminated each year. Most of these license terminations are routine, and the sites require little, if any, remediation to meet the NRC's release criteria for unrestricted access. The decommissioning program focuses on the termination of licenses that are not routine because the sites involve more complex decommissioning activities.

Currently, there are 14 nuclear power reactors, 11 research and test reactors, 19 complex decommissioning materials facilities, 1 fuel cycle facility, and 32 uranium recovery facilities decommissioning or in safe storage under NRC jurisdiction. Table 17 and Appendices B and F list complex decommissioning sites and permanently shutdown and decommissioning nuclear power, research, and test reactors. The 2007 Annual Report, "Status of the NRC Decommissioning Program," February 2008, provides additional information on the decommissioning programs of the NRC and Agreement States. More information is on the NRC Web site (see Web Link Index).

**Table 17. Complex Decommissioning Sites**

Company	Location
AAR Manufacturing, Inc. (Brooks & Perkins)	Livonia, MI
ABC Laboratories	Columbia, MO
Army, Department of, Jefferson Proving Ground	Madison, IN
Army, Department of, Ft. McClellan	Ft. McClellan, AL
Babcock & Wilcox SLDA	Vandergrift, PA
Battelle Columbus Laboratories	Columbus, OH
ABB Prospects	Windsor, CT
Englehard Minerals	Great Lakes, IL
Fansteel, Inc.	Muskogee, OK
Homer Laughlin China	Newell, WV
Kerr-McGee	Cimarron, OK
Mallinckrodt	St. Louis, MO
NWI Breckenridge	Breckenridge, MI
Salmon River	Salmon, ID
Shieldalloy Metallurgical Corporation	Newfield, NJ
Stepan Chemical Corporation	Maywood, NJ
UNC Naval Products	New Haven, CT
Westinghouse Electric Corporation — Hematite	Festus, MO
West Valley Demonstration Project	West Valley, NY

Source: U.S. Nuclear Regulatory Commission

*A guard in a bullet-resistant enclosure at a nuclear power plant.*



## SECURITY AND EMERGENCY PREPAREDNESS

### OVERVIEW

Nuclear security is a high priority for the U.S. Nuclear Regulatory Commission. For the last several decades, effective NRC regulation and strong partnerships with a variety of Federal, State, and local authorities, have ensured security at nuclear power plants across the country. In fact, nuclear plants likely represent the best protected private sector facilities in the United States. However, in a post-9/11 security climate, the agency recognizes the need for even higher levels of security.

In recent years, the NRC has undertaken comprehensive enhancements to bolster the security of our nation's nuclear facilities and radioactive materials. Because nuclear power plants are inherently robust structures, these additional security upgrades largely focus on the following improvements:

- Well-trained and armed security officers
- High-tech equipment and physical barriers
- Greater standoff distances for vehicle checks
- Intrusion detection and surveillance systems
- Tested emergency preparedness and response plans
- Restrictive site access control, including background checks and fingerprinting

Additional layers of protection to public security are provided by coordinating and sharing threat information among the U.S. Department of Homeland Security, the U.S. Federal Bureau of Investigation, intelligence agencies, the U.S. Department of Defense, and local law enforcement.

### FACILITIES SECURITY

Nuclear power plants and fuel fabrication facilities must be able to defend successfully against a set of hypothetical threats that the agency calls the design basis threat (DBT). These hypothetical adversaries include threats that challenge a plant's physical security, personnel security, and cyber security. The NRC does not make details of the DBT public due to security concerns. However, the agency continuously evaluates this set of hypothetical threats against real-world intelligence to ensure the agency remains current and prepared.

To test the adequacy of a nuclear power plant licensee's defenses against the DBT, the NRC oversees rigorous "force-on-force" drills. During these exercises, a highly trained mock adversary force "attacks" a nuclear facility. Beginning in 2004, the NRC began holding more challenging and realistic force-on-force exercises that also occur more frequently.

The NRC focuses considerable effort towards ensuring that facilities meet its security requirements.

As part of the Reactor Oversight Process, the NRC performs a baseline level of inspection at a plant. In 2000, NRC inspectors spent about 1,600 hours directly inspecting plant security (this excludes force-on-force inspections). Today, highly qualified NRC inspectors spend more than 8,000 hours a year directly scrutinizing nuclear power plants security through inspection. Publicly available portions of the security-related inspection reports for 2007 can be found on the NRC Web site (see Web Link Index).

## MATERIALS SECURITY

The security of radioactive materials is important for a number of reasons. For example, terrorists could use some materials to make a so-called “dirty bomb.” The NRC works with its Agreement States, Federal agencies, the International Atomic Energy Agency, and licensees to protect radioactive material from theft or diversion. The agency has made improvements and upgrades to the joint NRC-Department of Energy database that tracks the movement and location of certain forms and quantities of “special” nuclear material. NRC tracks high-risk radioactive sources by means of a database. The NRC will replace this database with the new National Source Tracking System, which is being developed to track radioactive sources on a continuous, real-time basis. Other improvements allow U.S. Customs and Border Protection agents to promptly vali-

date whether radioactive materials coming into the United States are properly licensed by the NRC.

## EMERGENCY PREPAREDNESS

Good emergency preparedness ensures that a nuclear power plant operator can protect public health and safety in the event of an emergency.

The NRC staff participates in emergency preparedness exercises, some of which include security and terrorism scenarios. As part of these exercises, the NRC works with licensees, Federal agencies, State and local officials, and first responders to form a coordinated system of emergency preparedness and response. This system includes public information, preparations for evacuation, instructions for sheltering, and other actions to protect the residents near nuclear power plants in the event of a serious incident.

As a condition of their license, operators of nuclear power plants develop and maintain effective emergency preparedness plans to protect the public. The NRC inspects plants to ensure they are meeting security requirements for emergencies and evaluates the implementation of those requirements. In addition, the agency monitors certain performance indicators related to emergency preparedness. Increased public confidence in public protection is obtained through the combined



inspection of Emergency Preparedness (EP) requirements and the evaluation of their implementation, as well as by monitoring performance indicators submitted by plants (see Figure 44).

The NRC assesses the ability of nuclear power plant operators to protect the public by requiring full-scale emergency preparedness exercises at least once every 2 years. These exercises maintain the skills of the emergency responders and identify and correct any weaknesses. The NRC and Federal Emergency Management Agency (FEMA) evaluate the exercises. Between these 2-year exercises, nuclear power plant operators conduct additional emergency preparedness drills that are evaluated by NRC inspectors.

Additional information on emergency preparedness is available on the NRC Web site (see Web Link Index).

## INCIDENT RESPONSE

Sharing information quickly among the NRC, other Federal agencies, and the nuclear industry is critical to preventing a terrorist attack. The NRC staff supports several important Federal anti-terrorism centers for integrated assessments of security-related information. The NRC Headquarters Operations Center, located in the agency's headquarters in Rockville, MD, is staffed around-the-clock to disseminate information and coordinate responses. To ensure the timely distribution of threat information, the NRC continuously reviews intelligence and assesses suspicious activity.

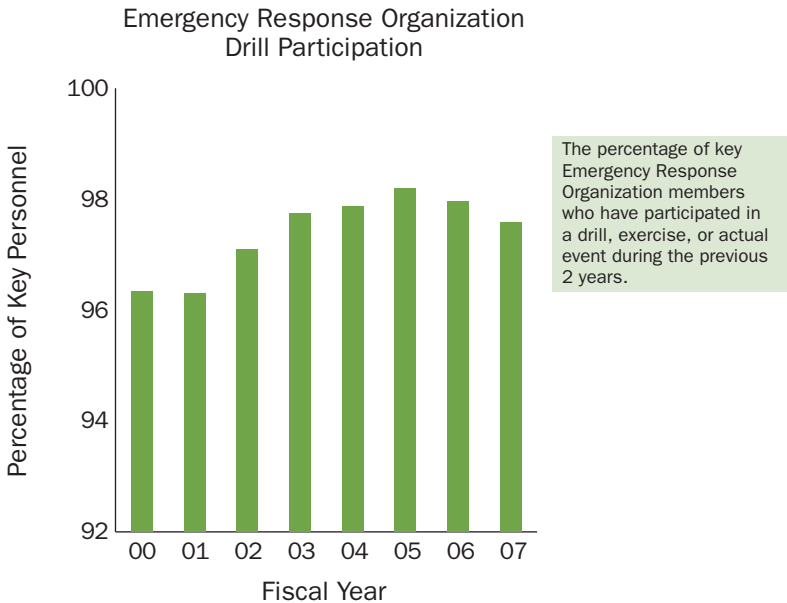
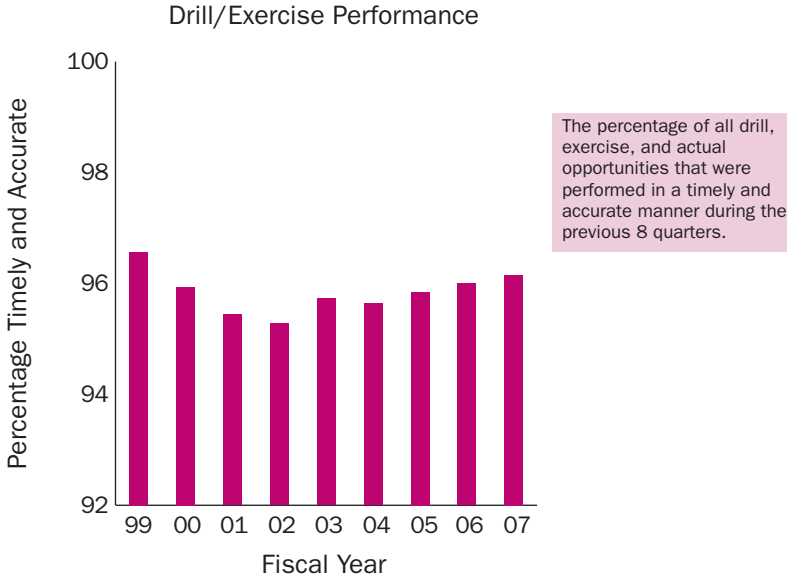
As described in the national response plans, the NRC is the coordinating agency for events occurring at NRC-licensed facilities and those involving radioactive materials either licensed by



*During an EP exercise the NRC staff briefs Commissioner Lyons (center) on the current status.*

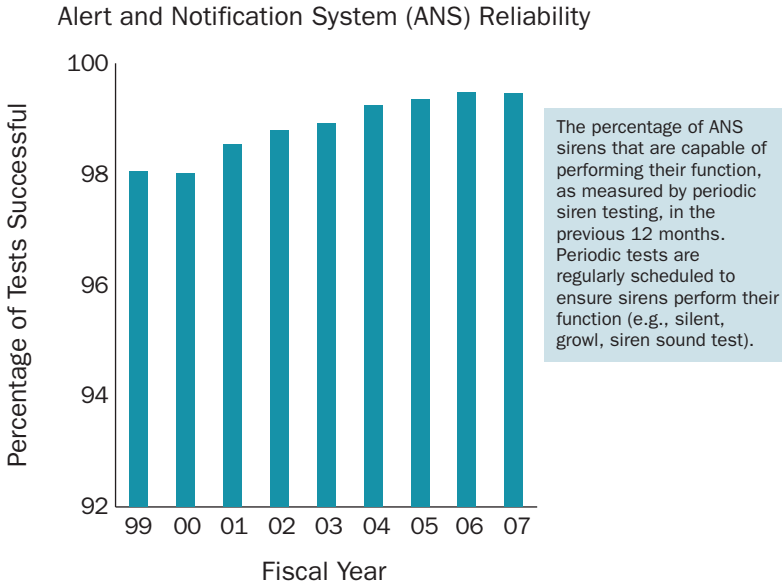


**Figure 44. Industry Performance Indicators:  
Annual Industry Percentages, FY 1999–2007**



Note: Complete Fiscal Year 1999 data are not available.

**Figure 44. Industry Performance Indicators:  
Annual Industry Percentages, FY 1999–2007 (Continued)**



Source: Licensee data as compiled by the U.S. Nuclear Regulatory Commission

NRC or by an Agreement State. In this role, the NRC has technical leadership for the Federal Government’s response to the event. As the severity of an event worsens, the U.S. Department of Homeland Security coordinates the Federal response to the event.

In response to a possible emergency involving radioactive materials, the NRC activates its incident response program at its Headquarters Operations Center and one of its four Regional Incident Response Centers. Teams of

specialists assemble at the Centers to evaluate event information and assess the potential impact on public health and safety. The NRC staff provides expert consultation, support, and assistance to State and local public safety officials. Scientists and engineers at the centers analyze the event and evaluate possible recovery strategies. Meanwhile, other experts evaluate the effectiveness of protective actions that have been recommended by the licensee and implemented by State and local officials. If needed, the NRC will dispatch a team of

technical experts from the closest regional office to the site of the emergency. The team serves as the NRC's onsite eyes and ears, allowing a firsthand assessment and face-to-face communications with all participants. The Headquarters Operations Center continues to provide round-the-clock Federal

communications, logistical support, and technical analysis throughout the response.

Additional information is available on incident response in NUREG-0728, Rev. 4, April 2005, "NRC Incident Response Plan" (see Web Link Index).



*Gary Holahan, Deputy Director of Office of New Reactors, participates in the Waterford Nuclear Exercise full-scale emergency response with licensee.*



## APPENDICES

**ABBREVIATIONS USED IN APPENDICES**

<b>AC</b>	Allis Chalmers
<b>AE</b>	Architect-Engineer
<b>AI</b>	Atomics International
<b>B&amp;R</b>	Burns & Roe
<b>B&amp;W</b>	Babcock & Wilcox
<b>BECH</b>	Bechtel
<b>BLH</b>	Baldwin Lima Hamilton
<b>BRRT</b>	Brown & Root
<b>BWR</b>	Boiling-Water Reactor
<b>CE</b>	Combustion Engineering
<b>COMM. OP.</b>	Date of Commercial Operation
<b>CON TYPE</b>	Containment Type
<b>DRYAMB</b>	Dry, Ambient Pressure
<b>DRYSUB</b>	Dry, Subatmospheric
<b>HTG</b>	High-Temperature Gas-Cooled
<b>ICECND</b>	Wet, Ice Condenser
<b>LMFB</b>	Liquid Metal Fast Breeder
<b>MARK 1</b>	Wet, Mark I
<b>MARK 2</b>	Wet, Mark II
<b>MARK 3</b>	Wet, Mark III
<b>CP</b>	Construction Permit
<b>CP ISSUED</b>	Date of Construction Permit Issuance
<b>CWE</b>	Commonwealth Edison Company
<b>DANI</b>	Daniel International
<b>DBDB</b>	Duke & Bechtel
<b>DOE</b>	Department of Energy
<b>DPR</b>	Demonstration Power Reactor
<b>DUKE</b>	Duke Power Company
<b>EVESR</b>	ESADA (Empire States Atomic Development Associates) Vallecitos Experimental Superheat Reactor
<b>EBSO</b>	Ebasco
<b>EXP. DATE</b>	Expiration Date of Operating License

<b>FLUR</b>	Fluor Pioneer
<b>G&amp;H</b>	Gibbs & Hill
<b>GA</b>	General Atomic
<b>GE</b>	General Electric
<b>GHDR</b>	Gibbs & Hill & Durham & Richardson
<b>GIL</b>	Gilbert Associates
<b>GPC</b>	Georgia Power Company
<b>HWR</b>	Pressurized Heavy-Water Reactor
<b>JONES</b>	J.A. Jones
<b>KAIS</b>	Kaiser Engineers
<b>kW</b>	Kilowatt
<b>LLP</b>	B&W Lowered Loop
<b>LR ISSUED</b>	License Renewal Issued
<b>MHI</b>	Mitsubishi Heavy Industries, Ltd.
<b>MW</b>	Megawatts
<b>MWe</b>	Megawatts Electrical
<b>MWh</b>	Megawatthour
<b>MWt</b>	Megawatts Thermal
<b>NIAG</b>	Niagara Mohawk Power Corporation
<b>NPF</b>	Nuclear Power Facility
<b>NSP</b>	Northern States Power Company
<b>NSSS</b>	Nuclear Steam System Supplier & Design Type
<b>GE 1</b>	GE Type 1
<b>GE 2</b>	GE Type 2
<b>GE 3</b>	GE Type 3
<b>GE 4</b>	GE Type 4
<b>GE 5</b>	GE Type 5
<b>GE 6</b>	GE Type 6
<b>WEST 2LP</b>	Westinghouse Two-Loop
<b>WEST 3LP</b>	Westinghouse Three-Loop
<b>WEST 4LP</b>	Westinghouse Four-Loop
<b>OL</b>	Operating License
<b>OL ISSUED</b>	Date of Latest Full Power Operating License
<b>OL-FP</b>	Operating License-Full Power
<b>OL-LP</b>	Operating License-Low Power

<b>PG&amp;E</b>	Pacific Gas & Electric Company	<b>TNPG</b>	The Nuclear Power Group
<b>PSE</b>	Pioneer Services & Engineering	<b>TRIGA</b>	Training Reactor and Isotopes Production, General Atomics
<b>PTHW</b>	Pressure Tube Heavy Water	<b>TVA</b>	Tennessee Valley Authority
<b>PUBS</b>	Public Service Electric & Gas Company	<b>UE&amp;C</b>	United Engineers & Constructors
<b>PWR</b>	Pressurized-Water Reactor	<b>USEC</b>	U.S. Enrichment Corporation
<b>RLP</b>	B&W Raised Loop	<b>WDCO</b>	Westinghouse Development Corporation
<b>S&amp;L</b>	Sargent & Lundy	<b>WEST</b>	Westinghouse Electric
<b>S&amp;W</b>	Stone & Webster	<b>WMT</b>	Waste Management Tank
<b>SSI</b>	Southern Services Incorporated		
<b>STP</b>	South Texas Project		

**State and Territory Abbreviations**

<u>State/Possession</u>	<u>Abbreviation</u>	<u>State/Possession</u>	<u>Abbreviation</u>
Alabama	AL	Montana	MT
Alaska	AK	Nebraska	NE
Arizona	AZ	Nevada	NV
Arkansas	AR	New Hampshire	NH
California	CA	New Jersey	NJ
Colorado	CO	New Mexico	NM
Connecticut	CT	New York	NY
Delaware	DE	North Carolina	NC
District of Columbia	DC	North Dakota	ND
Florida	FL	Ohio	OH
Georgia	GA	Oklahoma	OK
Guam	GU	Oregon	OR
Hawaii	HI	Pennsylvania	PA
Idaho	ID	Puerto Rico	PR
Illinois	IL	Rhode Island	RI
Indiana	IN	South Carolina	SC
Iowa	IA	South Dakota	SD
Kansas	KS	Tennessee	TN
Kentucky	KY	Texas	TX
Louisiana	LA	Utah	UT
Maine	ME	Vermont	VT
Maryland	MD	Virgin Islands	VI
Massachusetts	MA	Virginia	VA
Michigan	MI	Washington	WA
Minnesota	MN	West Virginia	WV
Mississippi	MS	Wisconsin	WI
Missouri	MO	Wyoming	WY

ABBREVIATIONS  
USED IN APPENDICES

APPENDIX A  
U.S. Commercial Nuclear Power Reactors

Unit Licensee, Operating Utility Co. Location Docket Number Web Address	NRC Region	Con Type NSSS AE Constructor	Licensed MWt	Net Summer Capacity (MW)*	CP Issued OL Issued Comm. Op. LR Issued Exp. Date	License Type & Number	2002- 2007** Capacity Factor (Percent)
Arkansas Nuclear One 1 Entergy Nuclear Operations, Inc. † 6 miles WNW of Russellville, AR 050-00313	IV	PWR-DRYAMB B&W LLP BECH BECH	2568	836	12/06/1968 05/21/1974 12/19/1974 06/20/2001 05/20/2034	OL-FP DPR-51	88.5 92.0 92.4 78.3 102.1 94.0
<a href="http://www.entropy-nuclear.com/plant_information/ano.aspx">www.entropy-nuclear.com/plant_information/ano.aspx</a>							
Arkansas Nuclear One 2 Entergy Nuclear Operations, Inc. † 6 miles WNW of Russellville, AR 050-00368	IV	PWR-DRYAMB CE BECH BECH	3026	998	12/06/1972 09/01/1978 03/26/1980 06/30/2005 07/17/2038	OL-FP NPF-6	98.2 90.4 98.6 91.0 89.6 99.4
<a href="http://www.entropy-nuclear.com/plant_information/ano.aspx">www.entropy-nuclear.com/plant_information/ano.aspx</a>							
Beaver Valley 1 FirstEnergy Nuclear Operating Company † 17 miles W of McCandless, PA 050-00334	I	PWR-DRYAMB WEST 3LP S&W S&W	2900	849	06/26/1970 07/02/1976 10/01/1976 N/A 01/29/2016	OL-FP DPR-66	98.5 83.2 92.6 101.4 78.3 94.9
<a href="http://www.firstenergycorp.com">www.firstenergycorp.com</a>							
Beaver Valley 2 FirstEnergy Nuclear Operating Company † 17 miles W of McCandless, PA 050-00412	I	PWR-DRYAMB WEST 3LP S&W S&W	2900	832	05/03/1974 08/14/1987 11/17/1987 N/A 05/27/2027	OL-FP NPF-73	90.7 91.2 100.2 92.9 86.6 102.5
<a href="http://www.firstenergycorp.com">www.firstenergycorp.com</a>							
Braidwood 1 Exelon Corp. Exelon Generation Co., LLC 20 miles SSW of Joliet, IL 050-00456	III	PWR-DRYAMB WEST 4LP S&L CWE	3586.6	1178	12/31/1975 07/02/1987 07/29/1988 N/A 10/17/2026	OL-FP NPF-72	102.2 97.2 94.8 99.6 96.4 92.3
<a href="http://www.exeloncorp.com/ourcompanies/powergen/nuclear/braidwood/">www.exeloncorp.com/ourcompanies/powergen/nuclear/braidwood/</a>							
Braidwood 2 Exelon Corp. Exelon Generation Co., LLC 20 miles SSW of Joliet, IL 050-00457	III	PWR-DRYAMB WEST 4LP S&L CWE	3586.6	1152	12/31/1975 05/20/1988 10/17/1988 N/A 12/18/2027	OL-FP NPF-77	91.7 96.3 100.8 94.3 95.4 100.4
<a href="http://www.exeloncorp.com/ourcompanies/powergen/nuclear/braidwood/">www.exeloncorp.com/ourcompanies/powergen/nuclear/braidwood/</a>							
Browns Ferry 1 Tennessee Valley Authority † 10 miles NW of Decatur, AL 050-00259	II	BWR-MARK 1 GE 4 TVA TVA	3458	1065	05/10/1967 12/20/1973 08/01/1974 05/04/2006 12/20/2033	OL-FP DPR-33	– – – – – 48.6
<a href="http://www.tva.gov/power/nuclear/brownsferry.htm">www.tva.gov/power/nuclear/brownsferry.htm</a>							



## APPENDIX A

### U.S. Commercial Nuclear Power Reactors (continued)

Unit Licensee, Operating Utility Co. Location Docket Number Web Address	NRC Region	Con Type NSSS AE Constructor	Licensed MWt	Net Summer Capacity (MW)*	CP Issued OL Issued Comm. Op. LR Issued Exp. Date	License Type & Number	2002- 2007** Capacity Factor (Percent)
Browns Ferry 2 Tennessee Valley Authority † 10 miles NW of Decatur, AL 050-00260	II	BWR-MARK 1 GE 4 TVA TVA	3458	1118	05/10/1967 08/02/1974 03/01/1975 05/04/2006 06/28/2034	OL-FP DPR-52	91.4 85.5 99.6 89.9 94.3 77.7
<a href="http://www.tva.gov/power/nuclear/brownsferry.htm">www.tva.gov/power/nuclear/brownsferry.htm</a>							
Browns Ferry 3 Tennessee Valley Authority † 10 miles NW of Decatur, AL 050-00296	II	BWR-MARK 1 GE 4 TVA TVA	3458	1114	07/31/1968 08/18/1976 03/01/1977 05/04/2006 07/02/2036	OL-FP DPR-68	95.0 95.6 88.9 93.8 88.5 93.1
<a href="http://www.tva.gov/power/nuclear/brownsferry.htm">www.tva.gov/power/nuclear/brownsferry.htm</a>							
Brunswick 1 Carolina Power & Light Co. Progress Energy 2 miles N of Southport, NC 050-00325	II	BWR-MARK 1 GE 4 UE&C BRRT	2923	938	02/07/1970 11/12/1976 03/18/1977 06/26/2006 09/08/2036	OL-FP DPR-71	93.3 100.8 86.1 94.4 87.4 95.9
<a href="http://www.progress-energy.com/aboutenergy/powerplants/nuclearplants/brunswick.asp">www.progress-energy.com/aboutenergy/powerplants/nuclearplants/brunswick.asp</a>							
Brunswick 2 Carolina Power & Light Co. Progress Energy 2 miles N of Southport, NC 050-00324	II	BWR-MARK 1 GE 4 UE&C BRRT	2923	900	02/07/1970 12/27/1974 11/03/1975 06/26/2006 12/27/2034	OL-FP DPR-62	99.6 98.9 98.1 86.0 89.7 87.0
<a href="http://www.progress-energy.com/aboutenergy/powerplants/nuclearplants/brunswick.asp">www.progress-energy.com/aboutenergy/powerplants/nuclearplants/brunswick.asp</a>							
Byron 1 Exelon Generation Co., LLC Exelon Corp. 17 miles SW of Rockford, IL 050-00454	III	PWR-DRYAMB WEST 4LP S&L CWE	3586.6	1164	12/31/1975 02/14/1985 09/16/1985 N/A 10/31/2024	OL-FP NPF-37	94.0 94.2 101.5 94.2 91.4 98.3
<a href="http://www.exeloncorp.com/ourcompanies/powergen/nuclear/byron_generating_station.htm">www.exeloncorp.com/ourcompanies/powergen/nuclear/byron_generating_station.htm</a>							
Byron 2 Exelon Generation Co., LLC Exelon Corp. 17 miles SW of Rockford, IL 050-00455	III	PWR-DRYAMB WEST 4LP S&L CWE	3586.6	1136	12/31/1975 01/30/1987 08/02/1987 N/A 11/06/2026	OL-FP NPF-66	93.7 101.1 96.4 95.7 102.2 88.7
<a href="http://www.exeloncorp.com/ourcompanies/powergen/nuclear/byron_generating_station.htm">www.exeloncorp.com/ourcompanies/powergen/nuclear/byron_generating_station.htm</a>							
Callaway AmerenUE Union Electric Company 25 miles ENE of Jefferson City, MO 050-00483	IV	PWR-DRYAMB WEST 4LP BECH DANI	3565	1190	04/16/1976 10/18/1984 12/19/1984 N/A 10/18/2024	OL-FP NPF-30	83.8 97.4 78.4 77.0 97.0 89.9
<a href="http://www.ameren.com/aboutus/adc_au_Callaway.asp">www.ameren.com/aboutus/adc_au_Callaway.asp</a>							

APPENDIX A  
**U.S. Commercial Nuclear Power Reactors (continued)**

Unit Licensee, Operating Utility Co. Location Docket Number Web Address	NRC Region	Con Type NSSS AE Constructor	Licensed MWt	Net Summer Capacity (MW)*	CP Issued OL Issued Comm. Op. LR Issued Exp. Date	License Type & Number	2002- 2007** Capacity Factor (Percent)
Calvert Cliffs 1 Constellation Energy † 40 miles S of Annapolis, MD 050-00317	I	PWR-DRYAMB CE BECH BECH	2700	873	07/07/1969 07/31/1974 05/08/1975 03/23/2000 07/31/2034	OL-FP DPR-53	62.8 101.8 91.5 99.5 84.2
<a href="http://www.constellation.com/portal/site/constellation/menuitem.0275303d670d51908d84ff10025166a0/">www.constellation.com/portal/site/constellation/menuitem.0275303d670d51908d84ff10025166a0/</a>							
Calvert Cliffs 2 Constellation Energy † 40 miles S of Annapolis, MD 050-00318	I	PWR-DRYAMB CE BECH BECH	2700	862	07/07/1969 08/13/1976 04/01/1977 03/23/2000 08/13/2036	OL-FP DPR-69	101.7 81.9 99.9 93.9 97.9
<a href="http://www.constellation.com/portal/site/constellation/menuitem.0275303d670d51908d84ff10025166a0/">www.constellation.com/portal/site/constellation/menuitem.0275303d670d51908d84ff10025166a0/</a>							
Catawba 1 Duke Energy Carolinas, LLC † 6 miles NNW of Rock Hill, SC 050-00413	II	PWR-ICECND WEST 4LP DUKE DUKE	3411	1129	08/07/1975 01/17/1985 06/29/1985 N/A 12/05/2043	OL-FP NPF-35	95.9 82.7 97.9 92.8 82.1
<a href="http://www.duke-energy.com/power-plants/nuclear/catawba.asp">www.duke-energy.com/power-plants/nuclear/catawba.asp</a>							
Catawba 2 Duke Energy Carolinas, LLC † 6 miles NNW of Rock Hill, SC 050-00414	II	PWR-ICECND WEST 4LP DUKE DUKE	3411	1129	08/07/1975 05/15/1986 08/19/1986 N/A 12/05/2043	OL-FP NPF-52	102.9 94.2 89.1 102.1 88.8
<a href="http://www.duke-energy.com/power-plants/nuclear/catawba.asp">www.duke-energy.com/power-plants/nuclear/catawba.asp</a>							
Clinton Exelon Generating Co., LLC Exelon Corp. 6 miles E of Clinton, IL 050-00461	III	BWR-MARK 3 GE 6 S&L BALD	3473	1043	02/24/1976 04/17/1987 11/24/1987 N/A 09/29/2026	OL-FP NPF-62	86.0 96.8 87.5 94.3 90.1
<a href="http://www.exeloncorp.com/ourcompanies/powergen/nuclear/Clinton_Power_Station.htm">www.exeloncorp.com/ourcompanies/powergen/nuclear/Clinton_Power_Station.htm</a>							
Columbia Generating Station (Formerly Washington Nuclear) Energy Northwest † 12 miles NW of Richland, WA 050-00397	IV	BWR-MARK 2 GE 5 B&R BECH	3486	1131	03/19/1973 04/13/1984 12/13/1984 N/A 12/20/2023	OL-FP NPF-21	93.2 78.5 91.1 83.2 94.2
<a href="http://www.energy-northwest.com/generation/cgs/index.php">www.energy-northwest.com/generation/cgs/index.php</a>							
Comanche Peak 1 Luminant Generation Company, LLC † 4 miles N of Glen Rose, TX 050-00445	IV	PWR-DRYAMB WEST 4LP G&H BRRT	3458	1150	12/19/1974 04/17/1990 08/13/1990 N/A 02/08/2030	OL-FP NPF-87	81.9 101.4 89.5 91.5 102.2
<a href="http://www.luminant.com/plants/comanche_peak.aspx">www.luminant.com/plants/comanche_peak.aspx</a>							

## APPENDIX A

### U.S. Commercial Nuclear Power Reactors (continued)

Unit Licensee, Operating Utility Co. Location Docket Number Web Address	NRC Region	Con Type NSSS AE Constructor	Licensed MWt	Net Summer Capacity (MW)*	CP Issued OL Issued Comm. Op LR Issued Exp. Date	License Type & Number	2002- 2007** Capacity Factor (Percent)
Comanche Peak 2 Luminant Generation Company, LLC † 4 miles N of Glen Rose, TX 050-00446	IV	PWR-DRYAMB WEST 4LP BECH BRRT	3458	1150	12/19/1974 04/06/1993 08/03/1993 N/A 02/02/2033	OL-FP NPF-89	89.3 82.5 99.2 91.6 95.3 101.7
<a href="http://www.luminant.com/plants/comanche_peak.aspx">www.luminant.com/plants/comanche_peak.aspx</a>							
Cooper Nebraska Public Power District † 23 miles S of Nebraska City, NE 050-00298	IV	BWR-MARK 1 GE 4 B&R B&R	2381	760	06/04/1968 01/18/1974 07/01/1974 N/A 01/18/2014	OL-FP DPR-46	95.1 67.8 92.9 88.5 88.7 100.2
<a href="http://www.nppd.com/About_Us/Energy_Facilities/facilities/cns.asp">www.nppd.com/About_Us/Energy_Facilities/facilities/cns.asp</a>							
Crystal River 3 Florida Power Corporation Progress Energy 7 miles NW of Crystal River, FL 050-00302	II	PWR-DRYAMB B&W LLP GIL JONES	2609	838	09/25/1968 01/28/1977 03/13/1977 N/A 12/03/2016	OL-FP DPR-72	99.0 89.6 99.2 86.5 94.7 90.9
<a href="http://www.progress-energy.com/aboutenergy/powerplants/nuclearplants/crystalriver.asp">www.progress-energy.com/aboutenergy/powerplants/nuclearplants/crystalriver.asp</a>							
Davis-Besse FirstEnergy Nuclear Operating Co. † 21 miles ESE of Toledo, OH 050-00346	III	PWR-DRYAMB B&W RLP BECH	2772	889	03/24/1971 04/22/1977 07/31/1978 N/A 04/22/2017	OL-FP NPF-3	11.6 (-0.9) 74.6 93.6 81.8 98.5
<a href="http://www.firstenergycorp.com">www.firstenergycorp.com</a>							
Diablo Canyon 1 Pacific Gas & Electric Co. † 12 miles WSW of San Luis Obispo, CA 050-00275	IV	PWR-DRYAMB WEST 4LP PG&E PG&E	3411	1122	04/23/1968 11/02/1984 05/07/1985 N/A 11/02/2024	OL-FP DPR-80	73.7 100.7 75.6 87.3 100.7 99.2
<a href="http://www.pge.com/myhome/edusafety/systemworks/diablo canyon/">www.pge.com/myhome/edusafety/systemworks/diablo canyon/</a>							
Diablo Canyon 2 Pacific Gas & Electric Co. † 12 miles WSW of San Luis Obispo, CA 050-00323	IV	PWR-DRYAMB WEST 4LP PG&E PG&E	3411	1118	12/09/1970 08/26/1985 03/13/1986 N/A 08/20/2025	OL-FP DPR-82	97.5 80.9 84.0 99.2 86.8 99.2
<a href="http://www.pge.com/myhome/edusafety/systemworks/diablo canyon/">www.pge.com/myhome/edusafety/systemworks/diablo canyon/</a>							
Donald C. Cook 1 Indiana/Michigan Power Co. † 11 miles S of Benton Harbor, MI 050-00315	III	PWR-ICECND WEST 4LP AEP AEP	3304	1029	03/25/1969 10/25/1974 08/28/1975 N/A 10/25/2034	OL-FP DPR-58	88.4 73.8 99.0 90.5 80.9 102.6
<a href="http://www.aep.com">www.aep.com</a>							

APPENDIX A  
**U.S. Commercial Nuclear Power Reactors (continued)**

Unit Licensee, Operating Utility Co. Location Docket Number Web Address	NRC Region	Con Type NSSS AE Constructor	Licensed MWt	Net Summer Capacity (MW)*	CP Issued OL Issued Comm. Op. LR Issued Exp. Date	License Type & Number	2002- 2007** Capacity Factor (Percent)
Donald C. Cook 2 † Indiana/Michigan Power Co. 11 miles S of Benton Harbor, MI 050-00316 <a href="http://www.aep.com">www.aep.com</a>	III	PWR-HCECND WEST 4LP AEP AEP	3468	1077	03/25/1969 12/23/1977 07/01/1978 10/03/2005 12/23/2037	OL-FP DPR-74	82.8 75.4 83.9 99.8 88.9 86.1
Dresden 2 Exelon Generation Co., LLC Exelon Corp. 9 miles E of Morris, IL 050-00237 <a href="http://www.exeloncorp.com/ourcompanies/powergen/nuclear/dresden_generating_station.htm">www.exeloncorp.com/ourcompanies/powergen/nuclear/dresden_generating_station.htm</a>	III	BWR-MARK 1 GE 3 S&L UE&C	2957	867	01/10/1966 02/20/1991 06/09/1970 10/28/2004 12/22/2029	OL-FP DPR-19	101.1 90.2 77.6 86.8 95.7 91.8
Dresden 3 Exelon Generation Co., LLC Exelon Corp. 9 miles E of Morris, IL 050-00249 <a href="http://www.exeloncorp.com/ourcompanies/powergen/nuclear/dresden_generating_station.htm">www.exeloncorp.com/ourcompanies/powergen/nuclear/dresden_generating_station.htm</a>	III	BWR-MARK 1 GE 3 S&L UE&C	2957	867	10/14/1966 01/12/1971 11/16/1971 10/28/2004 01/12/2031	OL-FP DPR-25	81.4 93.5 84.5 92.6 94.4 99.5
Duane Arnold FPL Energy Duane Arnold, LLC Florida Power and Light Co. 8 miles NW of Cedar Rapids, IA 050-00331 <a href="http://www.fpl.com/environment/nuclear/about_duane_arnold.shtml">www.fpl.com/environment/nuclear/about_duane_arnold.shtml</a>	III	BWR-MARK 1 GE 4 BECH BECH	1912	581	06/22/1970 02/22/1974 02/01/1975 N/A 02/21/2014	OL-FP DPR-49	92.3 81.0 99.8 89.2 100.2 88.8
Edwin I. Hatch 1 Southern Nuclear Operating Co. † 11 miles N of Baxley, GA 050-00321 <a href="http://www.southerncompany.com/southernnuclear/hatch.asp">www.southerncompany.com/southernnuclear/hatch.asp</a>	II	BWR-MARK 1 GE 4 BECH GPC	2804	876	09/30/1969 10/13/1974 12/31/1975 01/05/2002 08/06/2034	OL-FP DPR-57	88.4 95.3 90.3 91.1 83.6 97.7
Edwin I. Hatch 2 Southern Nuclear Operating Co. † 11 miles N of Baxley, GA 050-00366 <a href="http://www.southerncompany.com/southernnuclear/hatch.asp">www.southerncompany.com/southernnuclear/hatch.asp</a>	II	BWR-MARK 1 GE 4 BECH GPC	2804	883	12/27/1972 06/13/1978 09/05/1979 N/A 06/13/2038	OL-FP NPF-5	97.4 90.0 97.0 87.0 98.8 87.3
Fermi 2 The Detroit Edison Co. † 25 miles NE of Toledo, OH 050-00341 <a href="http://www.dteenergy.com">www.dteenergy.com</a>	III	BWR-MARK 1 GE 4 S&L DANI	3430	1122	09/26/1972 07/15/1985 01/23/1988 N/A 03/20/2025	OL-FP NPF-43	95.6 83.4 86.6 90.0 76.1 84.6

## APPENDIX A

### U.S. Commercial Nuclear Power Reactors (continued)

Unit Licensee, Operating Utility Co. Location Docket Number Web Address	NRC Region	Con Type NSSS AE Constructor	Licensed MWt	Net Summer Capacity (MW)*	CP Issued OL Issued Comm. Op. LR Issued Exp. Date	License Type & Number	2002- 2007** Capacity Factor (Percent)
Fort Calhoun Omaha Public Power District † 19 miles N of Omaha, NE 050-00285 <a href="http://www.oppd.com">www.oppd.com</a>	IV	PWR-DRYAMB CE GHDR GHDR	1500	478	06/07/1968 08/09/1973 09/26/1973 11/04/2003 08/09/2033	OL-FP DPR-40	91.3 84.0 97.3 69.5 73.8 104.4
R.E. Ginna Constellation Energy † 20 miles NE of Rochester, NY 050-00244 <a href="http://www.constellation.com/portal/site/constellation/menuitem.385c7a188817d1908d84ff10025166a0/">www.constellation.com/portal/site/constellation/menuitem.385c7a188817d1908d84ff10025166a0/</a>	I	PWR-DRYAMB WEST 2LP GIL BECH	1775	498	04/25/1966 09/19/1969 07/01/1970 05/19/2004 09/18/2029	OL-FP DPR-18	87.7 88.6 98.6 91.7 94.5 113.1
Grand Gulf 1 Entergy Nuclear Operations, Inc. † 52 miles S of Vicksburg, MS 050-00416 <a href="http://www.entropy-nuclear.com/plant_information/grand_gulf.aspx">www.entropy-nuclear.com/plant_information/grand_gulf.aspx</a>	IV	BWR-MARK 3 GE 6 BECH BECH	3898	1266	09/04/1974 11/01/1984 07/01/1985 N/A 11/01/2024	OL-FP NPF-29	93.3 98.5 91.7 90.6 93.9 84.4
H.B. Robinson 2 Carolina Power & Light Co. Progress Energy 26 miles from Florence, SC 050-00261 <a href="http://www.progress-energy.com/aboutenergy/powerplants/nuclearplants/robinson.asp">www.progress-energy.com/aboutenergy/powerplants/nuclearplants/robinson.asp</a>	II	PWR-DRYAMB WEST 3LP EBSO EBSO	2339	710	04/13/1967 09/23/1970 03/07/1971 04/19/2004 07/31/2030	OL-FP DPR-23	90.1 103.5 92.1 92.8 103.9 92.3
Hope Creek 1 PSEG Nuclear, LLC † 18 miles SE of Wilmington, DE 050-00354 <a href="http://www.pseg.com/companies/fossil/plants/hopecreek.jsp">www.pseg.com/companies/fossil/plants/hopecreek.jsp</a>	I	BWR-MARK 1 GE 4 BECH BECH	3840	1061	11/04/1974 07/25/1986 12/20/1986 N/A 04/11/2026	OL-FP NPF-57	96.2 79.0 65.4 82.6 92.3 87.2
Indian Point 2 Entergy Nuclear Operations, Inc. † 24 miles N of New York City, NY 050-00247 <a href="http://www.entropy-nuclear.com/plant_information/indian_point.aspx">www.entropy-nuclear.com/plant_information/indian_point.aspx</a>	I	PWR-DRYAMB WEST 4LP UE&C WDCO	3216	1020	10/14/1966 09/28/1973 08/01/1974 N/A 09/28/2013	OL-FP DPR-26	88.6 99.1 87.5 99.1 89.4 99.0
Indian Point 3 Entergy Nuclear Operations, Inc. † 24 miles N of New York City, NY 050-00286 <a href="http://www.entropy-nuclear.com/plant_information/indian_point.aspx">www.entropy-nuclear.com/plant_information/indian_point.aspx</a>	I	PWR-DRYAMB WEST 4LP UE&C WDCO	3216	1025	08/13/1969 12/12/1975 08/30/1976 N/A 12/12/2015	OL-FP DPR-64	97.8 88.2 100.5 89.5 99.9 86.8

APPENDIX A  
**U.S. Commercial Nuclear Power Reactors (continued)**

Unit Licensee, Operating Utility Co. Location Docket Number Web Address	NRC Region	Con Type NSSS AE Constructor	Licensed MWt	Net Summer Capacity (MW)*	CP Issued OL Issued Comm. Op. LR Issued Exp. Date	License Type & Number	2002- 2007** Capacity Factor (Percent)
James A. FitzPatrick Entergy Nuclear Operations, Inc. † 8 miles NE of Oswego, NY 050-00333	I	BWR-MARK 1 GE 4 S&W S&W	2536	852	05/20/1970 10/17/1974 07/28/1975 N/A 10/17/2014	OL-FP DPR-59	89.5 96.4 87.1 94.5 90.5 92.7
<a href="http://www.entropy-nuclear.com/plant_information/fitzPatrick.aspx">www.entropy-nuclear.com/plant_information/fitzPatrick.aspx</a>							
Joseph M. Farley 1 Southern Nuclear Operating Co. † 18 miles SE of Dothan, AL 050-00348	II	PWR-DRYAMB WEST 3LP SSI DANI	2775	851	08/16/1972 06/25/1977 12/01/1977 05/12/2005 06/25/2037	OL-FP NPF-2	99.0 90.5 85.9 99.3 86.1 87.5
<a href="http://www.southerncompany.com/southernnuclear/farley.asp">www.southerncompany.com/southernnuclear/farley.asp</a>							
Joseph M. Farley 2 Southern Nuclear Operating Co. † 18 miles SE of Dothan, AL 050-00364	II	PWR-DRYAMB WEST 3LP SSI BECH	2775	860	08/16/1972 03/31/1981 07/30/1981 05/12/2005 03/31/2041	OL-FP NPF-8	87.6 100.0 89.0 84.1 101.2 87.2
<a href="http://www.southerncompany.com/southernnuclear/farley.asp">www.southerncompany.com/southernnuclear/farley.asp</a>							
Kewaunee Power Station Dominion Energy Kewaunee, Inc. Dominion Generation 27 miles E of Green Bay, WI 050-00305	III	PWR-DRYAMB WEST 2LP PSE PSE	1772	556	08/06/1968 12/21/1973 06/16/1974 N/A 12/21/2013	OL-FP DPR-43	102.4 88.1 78.8 62.6 75.4 95.0
<a href="http://www.dom.com/about/stations/nuclear/kewaunee/index.jsp">www.dom.com/about/stations/nuclear/kewaunee/index.jsp</a>							
La Salle County 1 Exelon Generation Co., LLC Exelon Corp. 11 miles SE of Ottawa, IL 050-00373	III	BWR-MARK 2 GE 5 S&L CWE	3489	1118	09/10/1973 04/17/1982 01/01/1984 N/A 04/17/2022	OL-FP NPF-11	91.7 92.4 92.2 100.2 92.8 98.7
<a href="http://www.exeloncorp.com/ourcompanies/powergen/nuclear/lasalle_county_generating_station.htm">www.exeloncorp.com/ourcompanies/powergen/nuclear/lasalle_county_generating_station.htm</a>							
La Salle County 2 Exelon Generation Co., LLC Exelon Corp. 11 miles SE of Ottawa, IL 050-00374	III	BWR-MARK 2 GE 5 S&L CWE	3489	1120	09/10/1973 12/16/1983 10/19/1984 N/A 12/16/2023	OL-FP NPF-18	90.9 91.0 101.0 90.7 102.1 94.9
<a href="http://www.exeloncorp.com/ourcompanies/powergen/nuclear/lasalle_county_generating_station.htm">www.exeloncorp.com/ourcompanies/powergen/nuclear/lasalle_county_generating_station.htm</a>							
Limerick 1 Exelon Generation Co., LLC Exelon Corp. 21 miles NW of Philadelphia, PA 050-00352	I	BWR-MARK 2 GE 4 BECH BECH	3458	1134	06/19/1974 08/08/1985 02/01/1986 N/A 10/26/2024	OL-FP NPF-39	93.5 100.9 95.1 99.2 93.2 100.6
<a href="http://www.exeloncorp.com/ourcompanies/powergen/nuclear/limerick_generating_station.htm">www.exeloncorp.com/ourcompanies/powergen/nuclear/limerick_generating_station.htm</a>							

## APPENDIX A

### U.S. Commercial Nuclear Power Reactors (continued)

Unit Licensee, Operating Utility Co. Location Docket Number Web Address	NRC Region	Con Type NSSS AE Constructor	Licensed MWt	Net Summer Capacity (MW)*	CP Issued OL Issued Comm. Op. LR Issued Exp. Date	License Type & Number	2002- 2007** Capacity Factor (Percent)
Limerick 2 Exelon Generation Co., LLC † Exelon Corp. 21 miles NW of Philadelphia, PA 050-00353 <a href="http://www.exeloncorp.com/ourcompanies/powergen/nuclear/limerick_generating_station.htm">www.exeloncorp.com/ourcompanies/powergen/nuclear/limerick_generating_station.htm</a>	I	BWR-MARK 2 GE 4 BECH BECH	3458	1134	06/19/1974 08/25/1989 01/08/1990 06/22/2029	OL-FP NPF-85	100.7 94.4 99.2 91.2 100.1 91.2
McGuire 1 Duke Energy Power Company, LLC † 17 miles N of Charlotte, NC 050-00369 <a href="http://www.duke-energy.com/power-plants/nuclear/mcguire.asp">www.duke-energy.com/power-plants/nuclear/mcguire.asp</a>	II	PWR-HCECND WEST 4LP DUKE DUKE	3411	1100	02/23/1973 07/08/1981 12/01/1981 12/05/2003 06/12/2041	OL-FP NPF-9	94.4 102.9 85.3 93.1 103.4 79.4
McGuire 2 Duke Energy Power Company, LLC † 17 miles N of Charlotte, NC 050-00370 <a href="http://www.duke-energy.com/power-plants/nuclear/mcguire.asp">www.duke-energy.com/power-plants/nuclear/mcguire.asp</a>	II	PWR-HCECND WEST 4LP DUKE DUKE	3411	1100	02/23/1973 05/27/1983 03/01/1984 12/05/2003 03/03/2043	OL-FP NPF-17	92.6 93.7 103.4 88.7 87.4 103.4
Millstone 2 Dominion Nuclear Connecticut, Inc. Dominion Generation 3.2 miles WSW of New London, CT 050-00336 <a href="http://www.dom.com/about/stations/nuclear/millstone/index.jsp">www.dom.com/about/stations/nuclear/millstone/index.jsp</a>	I	PWR-DRYAMB COMB CE BECH BECH	2700	882	12/11/1970 09/26/1975 12/26/1975 11/28/2005 07/31/2035	OL-FP DPR-65	81.3 80.3 97.8 88.2 84.1 99.5
Millstone 3 Dominion Nuclear Connecticut, Inc. Dominion Generation 3.2 miles WSW of New London, CT 050-00423 <a href="http://www.dom.com/about/stations/nuclear/millstone/index.jsp">www.dom.com/about/stations/nuclear/millstone/index.jsp</a>	I	PWR-DRYSUB WEST 4LP S&W S&W	3411	1155	08/09/1974 01/31/1986 04/23/1986 11/28/2005 11/25/2045	OL-FP NPF-49	87.7 100.8 88.3 86.4 99.7 86.0
Monticello Nuclear Management Co. † 30 miles NW of Minneapolis, MN 050-00263 <a href="http://www.nmcco.com/about_us/locations/monticello.htm">www.nmcco.com/about_us/locations/monticello.htm</a>	III	BWR-MARK 1 GE 3 BECH BECH	1775	572	06/19/1967 01/09/1981 06/30/1971 11/08/2006 09/08/2030	OL-FP DPR-22	95.9 91.8 100.7 89.3 101.2 83.7
Nine Mile Point 1 Constellation Energy † 6 miles NE of Oswego, NY 050-00220 <a href="http://www.constellation.com/portal/site/constellation/menuitem.487e3f1fe004e1908d84ff10025166a0/">www.constellation.com/portal/site/constellation/menuitem.487e3f1fe004e1908d84ff10025166a0/</a>	I	BWR-MARK 1 GE 2 NIAG S&W	1850	621	04/12/1965 12/26/1974 12/01/1969 10/31/2006 08/22/2029	OL-FP DPR-63	90.5 80.4 91.7 84.6 98.4 87.6

APPENDIX A  
**U.S. Commercial Nuclear Power Reactors (continued)**

Unit Licensee, Operating Utility Co. Location Docket Number Web Address	NRC Region	Con Type NSSS AE Constructor	Licensed MWt	Net Summer Capacity (MW)*	CP Issued OL Issued Comm. Op. LR Issued Exp. Date	License Type & Number	2002- 2007** Capacity Factor (Percent)
Nine Mile Point 2 Constellation Energy † 6 miles NE of Oswego, NY 050-00410	I	BWR-MARK 2 GE 5 S&W S&W	3467	1135	06/24/1974 07/02/1987 03/11/1988 10/31/2006 10/31/2046	OL-FP NPF-69	83.7 95.5 86.3 99.7 90.4
<a href="http://www.constellation.com/portal/site/constellation/menuitem.487e3f1fe004e1908d84ff10025166a0/">www.constellation.com/portal/site/constellation/menuitem.487e3f1fe004e1908d84ff10025166a0/</a>							
North Anna 1 Virginia Electric & Power Co. Dominion Generation 40 miles NW of Richmond, VA 050-00338	II	PWR-DRYSUB WEST 3LP S&W S&W	2893	924	02/19/1971 04/01/1978 06/06/1978 03/20/2003 04/01/2038	OL-FP NPF-4	100.8 80.5 91.3 95.1 88.2
<a href="http://www.dom.com/about/stations/nuclear/northanna/index.jsp">www.dom.com/about/stations/nuclear/northanna/index.jsp</a>							
North Anna 2 Virginia Electric & Power Co. Dominion Generation 40 miles NW of Richmond, VA 050-00339	II	PWR-DRYSUB WEST 3LP S&W S&W	2893	910	02/19/1971 08/21/1980 12/14/1980 03/20/2003 08/21/2040	OL-FP NPF-7	68.6 90.4 91.7 87.0 99.7
<a href="http://www.dom.com/about/stations/nuclear/northanna/index.jsp">www.dom.com/about/stations/nuclear/northanna/index.jsp</a>							
Oconee 1 Duke Energy Power Company, LLC † 30 miles W of Greenville, SC 050-00269	II	PWR-DRYAMB B&W LLP DBDB DUKE	2568	846	11/06/1967 02/06/1973 07/15/1973 05/23/2000 02/06/2033	OL-FP DPR-38	89.2 70.8 97.7 90.7 78.5
<a href="http://www.duke-energy.com/power-plants/nuclear/oconee.asp">www.duke-energy.com/power-plants/nuclear/oconee.asp</a>							
Oconee 2 Duke Energy Power Company, LLC † 30 miles W of Greenville, SC 050-00270	II	PWR-DRYAMB B&W LLP DBDB DUKE	2568	846	11/06/1967 10/06/1973 09/09/1974 05/23/2000 10/06/2033	OL-FP DPR-47	89.2 102.1 76.3 89.9 99.7
<a href="http://www.duke-energy.com/power-plants/nuclear/oconee.asp">www.duke-energy.com/power-plants/nuclear/oconee.asp</a>							
Oconee 3 Duke Energy Power Company, LLC † 30 miles W of Greenville, SC 050-00287	II	PWR-DRYAMB B&W LLP DBDB DUKE	2568	846	11/06/1967 07/19/1974 12/16/1974 05/23/2000 07/19/2034	OL-FP DPR-55	100.7 85.2 77.2 97.7 90.5
<a href="http://www.duke-energy.com/power-plants/nuclear/oconee.asp">www.duke-energy.com/power-plants/nuclear/oconee.asp</a>							
Oyster Creek 1 AmerGen Energy Co., LLC Exelon Corp. 9 miles S of Toms River, NJ 050-00219	I	BWR-MARK 1 GE 2 B&R B&R	1930	619	12/15/1964 07/02/1991 12/01/1969 N/A 04/09/2009	OL-FP DPR-16	94.9 96.9 89.3 99.1 85.7
<a href="http://www.exeloncorp.com/ourcompanies/powergen/nuclear/oyster_creek_generating_station.htm">www.exeloncorp.com/ourcompanies/powergen/nuclear/oyster_creek_generating_station.htm</a>							



## APPENDIX A

### U.S. Commercial Nuclear Power Reactors (continued)

Unit Licensee, Operating Utility Co. Location Docket Number Web Address	NRC Region	Con Type NSSS AE Constructor	Licensed MWt	Net Summer Capacity (MW)*	CP Issued OL Issued Comm. Op. LR Issued Exp. Date	License Type & Number	2002- 2007** Capacity Factor (Percent)
Palisades Entergy Nuclear Operations, Inc. † 5 miles S of South Haven, MI 050-00255	III	PWR-DRYAMB CE BECH BECH	2565	778	03/14/1967 02/21/1971 12/31/1971 01/17/2007 03/24/2031	OL-FP DPR-20	36.8 94.6 91.6 79.3 97.5 85.5
<a href="http://www.entropy-nuclear.com/plant_information/palisades.aspx">www.entropy-nuclear.com/plant_information/palisades.aspx</a>							
Palo Verde 1 Arizona Public Service Company † 36 miles W of Phoenix, AZ 050-00528	IV	PWR-DRYAMB CE80-2L BECH BECH	3990	1314	05/25/1976 06/01/1985 01/28/1986 N/A 06/01/2025	OL-FP NPF-41	89.1 97.2 84.6 62.7 42.4 77.0
<a href="http://www.aps.com/general_info/AboutAPS_18.html">www.aps.com/general_info/AboutAPS_18.html</a>							
Palo Verde 2 Arizona Public Service Company † 36 miles W of Phoenix, AZ 050-00529	IV	PWR-DRYAMB CE80-2L BECH BECH	3990	1314	05/25/1976 04/24/1986 09/19/1986 N/A 04/24/2026	OL-FP NPF-51	92.0 72.2 92.4 81.9 85.2 95.2
<a href="http://www.aps.com/general_info/AboutAPS_18.html">www.aps.com/general_info/AboutAPS_18.html</a>							
Palo Verde 3 Arizona Public Service Company † 36 miles W of Phoenix, AZ 050-00530	IV	PWR-DRYAMB COMB CE80-2L BECH BECH	3990	1247	05/25/1976 11/25/1987 01/08/1988 N/A 11/25/2027	OL-FP NPF-74	102.0 87.5 75.0 83.9 85.5 63.9
<a href="http://www.aps.com/general_info/AboutAPS_18.html">www.aps.com/general_info/AboutAPS_18.html</a>							
Peach Bottom 2 Exelon Generating Co., LLC Exelon Corp. 17.9 miles S of Lancaster, PA 050-00277	I	BWR-MARK 1 GE 4 BECH BECH	3514	1112	01/31/1968 10/25/1973 07/05/1974 N/A 08/08/2033	OL-FP DPR-44	92.3 95.4 90.6 98.2 92.8 101.3
<a href="http://www.exeloncorp.com/ourcompanies/powergen/nuclear/peach_bottom">www.exeloncorp.com/ourcompanies/powergen/nuclear/peach_bottom</a>							
Peach Bottom 3 Exelon Generating Co., LLC Exelon Corp. 17.9 miles S of Lancaster, PA 050-00278	I	BWR-MARK 1 GE 4 BECH BECH	3514	1112	01/31/1968 07/02/1974 12/23/1974 05/07/2003 07/02/2034	OL-FP DPR-56	100.8 91.3 102.1 90.6 101.5 92.7
<a href="http://www.exeloncorp.com/ourcompanies/powergen/nuclear/peach_bottom">www.exeloncorp.com/ourcompanies/powergen/nuclear/peach_bottom</a>							
Perry 1 FirstEnergy Nuclear Operating Co. † 35 miles NE of Cleveland, OH 050-00440	III	BWR-MARK 3 GE 6 GIL KAIS	3758	1231	05/03/1977 11/13/1986 11/18/1987 N/A 03/18/2026	OL-FP NPF-58	92.0 79.0 94.3 70.9 97.1 74.7
<a href="http://www.firstenergycorp.com">www.firstenergycorp.com</a>							

APPENDIX A  
**U.S. Commercial Nuclear Power Reactors (continued)**

Unit Licensee, Operating Utility Co. Location Docket Number Web Address	NRC Region	Con Type NSSS AE Constructor	Licensed MWt	Net Summer Capacity (MW)*	CP Issued OL Issued Comm. Op. LR Issued Exp. Date	License Type & Number	2002- 2007** Capacity Factor (Percent)
Pilgrim 1 Entergy Nuclear Operations, Inc. † 4 miles SE of Plymouth, MA 050-00293	I	BWR-MARK 1 GE 3 BECH BECH	2028	685	08/26/1968 09/15/1972 12/01/1972 N/A 06/08/2012	OL-FP DPR-35	98.7 83.0 98.7 91.3 97.2 85.4
<a href="http://www.entropy-nuclear.com/plant_information/pilgrim.aspx">www.entropy-nuclear.com/plant_information/pilgrim.aspx</a>							
Point Beach 1 FPL Energy Point Beach, LLC Florida Power and Light Co. 13 miles NNW of Manitowoc, WI 050-00266	III	PWR-DRYAMB WEST 2LP BECH BECH	1540	512	07/19/1967 10/05/1970 12/21/1970 12/22/2005 10/05/2030	OL-FP DPR-24	89.9 96.8 80.7 81.2 99.6 85.2
<a href="http://www.nmcco.com/about_us/locations/locations.htm">www.nmcco.com/about_us/locations/locations.htm</a>							
Point Beach 2 FPL Energy Point Beach, LLC Florida Power & Light Co. 13 miles NNW of Manitowoc, WI 050-00301	III	PWR-DRYAMB WEST 2LP BECH BECH	1540	514	07/25/1968 03/08/1973 10/01/1972 12/22/2005 03/08/2033	OL-FP DPR-27	90.2 82.5 97.1 71.8 90.9 99.1
<a href="http://www.fpl.com/environment/nuclear/nuclear_power_serves_you.shtml">www.fpl.com/environment/nuclear/nuclear_power_serves_you.shtml</a>							
Prairie Island 1 Nuclear Management Co. † 28 miles SE of Minneapolis, MN 050-00282	III	PWR-DRYAMB WEST 2LP FLUR NSP	1650	551	06/25/1968 04/05/1974 12/16/1973 N/A 08/09/2013	OL-FP DPR-42	95.1 100.5 78.5 98.6 84.9 92.3
<a href="http://www.nmcco.com/about_us/locations/prairie_island.htm">www.nmcco.com/about_us/locations/prairie_island.htm</a>							
Prairie Island 2 Nuclear Management Co. † 28 miles SE of Minneapolis, MN 050-00306	III	PWR-DRYAMB WEST 2LP FLUR NSP	1650	545	06/25/1968 10/29/1974 12/21/1974 N/A 10/29/2014	OL-FP DPR-60	93.9 92.7 101.6 84.0 84.0 93.3
<a href="http://www.nmcco.com/about_us/locations/prairie_island.html">www.nmcco.com/about_us/locations/prairie_island.html</a>							
Quad Cities 1 Exelon Generating Co., LLC Exelon Corp. 20 miles NE of Moline, IL 050-00254	III	BWR-MARK 1 GE 3 S&L UE&C	2957	867	02/15/1967 12/14/1972 02/18/1973 N/A 12/14/2032	OL-FP DPR-29	85.5 89.9 85.4 82.7 88.8 91.5
<a href="http://www.exeloncorp.com/ourcompanies/powergen/nuclear/quad_cities_generating_station.htm">www.exeloncorp.com/ourcompanies/powergen/nuclear/quad_cities_generating_station.htm</a>							
Quad Cities 2 Exelon Generating Co., LLC Exelon Corp. 20 miles NE of Moline, IL 050-00265	III	BWR-MARK 1 GE 3 S&L UE&C	2957	867	02/15/1967 12/14/1972 03/10/1973 10/28/2004 12/14/2032	OL-FP DPR-30	87.5 92.0 81.1 92.7 86.4 98.8
<a href="http://www.exeloncorp.com/ourcompanies/powergen/nuclear/quad_cities_generating_station.htm">www.exeloncorp.com/ourcompanies/powergen/nuclear/quad_cities_generating_station.htm</a>							

## APPENDIX A

### U.S. Commercial Nuclear Power Reactors (continued)

Unit Licensee, Operating Utility Co. Location Docket Number Web Address	NRC Region	Con Type NSSS AE Constructor	Licensed MWt	Net Summer Capacity (MW)*	CP Issued OL Issued Comm. Op. LR Issued Exp. Date	License Type & Number	2002- 2007** Capacity Factor (Percent)
River Bend 1 Entergy Nuclear Operations, Inc. 24 miles NNW of Baton Rouge, LA 050-00458	IV	BWR-MARK 3 GE 6 S&W S&W	3091	967	03/25/1977 11/20/1985 06/16/1986 N/A 08/29/2025	OL-FP NPF-47	98.6 89.2 87.3 93.2 88.1 84.8
<a href="http://www.entropy-nuclear.com/plant_information/river_bend.aspx">www.entropy-nuclear.com/plant_information/river_bend.aspx</a>							
Salem 1 PSEG Nuclear, LLC † 18 miles S of Wilmington, DE 050-00272	I	PWR-DRYAMB WEST 4LP PUBS UE&C	3459	1174	09/25/1968 08/13/1976 06/30/1977 N/A 08/13/2016	OL-FP DPR-70	88.6 93.5 72.0 92.0 99.3 89.1
<a href="http://www.pseg.com/companies/nuclear/salem.jsp">www.pseg.com/companies/nuclear/salem.jsp</a>							
Salem 2 PSEG Nuclear, LLC † 18 miles S of Wilmington, DE 050-00311	I	PWR-DRYAMB WEST 4LP PUBS UE&C	3459	1130	09/25/1968 05/20/1981 10/13/1981 N/A 04/18/2020	OL-FP DPR-75	86.1 81.9 88.4 89.8 92.2 97.7
<a href="http://www.pseg.com/companies/nuclear/salem.jsp">www.pseg.com/companies/nuclear/salem.jsp</a>							
San Onofre 2 Southern California Edison Co. † 4 miles SE of San Clemente, CA 050-00361	IV	PWR-DRYAMB CE BECH BECH	3438	1070	10/18/1973 02/16/1982 08/08/1983 N/A 02/16/2022	OL-FP NPF-10	90.7 103.6 85.7 95.3 72.0 88.5
<a href="http://www.sce.com/PowerandEnvironment/PowerGeneration/SanOnofreNuclearGeneratingStation">www.sce.com/PowerandEnvironment/PowerGeneration/SanOnofreNuclearGeneratingStation</a>							
San Onofre 3 Southern California Edison Co. † 4 miles SE of San Clemente, CA 050-00362	IV	PWR-DRYAMB CE BECH BECH	3438	1080	10/18/1973 11/15/1982 04/01/1984 N/A 11/15/2022	OL-FP NPF-15	100.9 90.9 73.6 100.1 72.1 94.1
<a href="http://www.sce.com/PowerandEnvironment/PowerGeneration/SanOnofreNuclearGeneratingStation">www.sce.com/PowerandEnvironment/PowerGeneration/SanOnofreNuclearGeneratingStation</a>							
Seabrook 1 FPL Energy Seabrook, LLC Florida Power & Light Co. 13 miles S of Portsmouth, NH 050-00443	I	PWR-DRYAMB WEST 4LP UE&C UE&C	3648	1244	07/07/1976 03/15/1990 08/19/1990 N/A 03/15/2030	OL-FP NPF-86	91.4 91.3 99.9 88.5 86.2 98.8
<a href="http://www.fpl.com/environment/nuclear/about_seabrook_station.shtml">www.fpl.com/environment/nuclear/about_seabrook_station.shtml</a>							
Sequoyah 1 Tennessee Valley Authority † 9.5 miles NE of Chattanooga, TN 050-00327	II	PWR-ICECND WEST 4LP TVA TVA	3455	1150	05/27/1970 09/17/1980 07/01/1981 N/A 09/17/2020	OL-FP DPR-77	100.9 72.9 92.0 100.0 90.2 86.9
<a href="http://www.tva.gov/power/nuclear/sequoyah.htm">www.tva.gov/power/nuclear/sequoyah.htm</a>							

APPENDIX A  
**U.S. Commercial Nuclear Power Reactors (continued)**

Unit Licensee, Operating Utility Co. Location Docket Number Web Address	NRC Region	Con Type NSSS AE Constructor	Licensed MWt	Net Summer Capacity (MW)*	CP Issued OL Issued Comm. Op. LR Issued Exp. Date	License Type & Number	2002- 2007** Capacity Factor (Percent)
Sequoyah 2 Tennessee Valley Authority † 9.5 miles NE of Chattanooga, TN 050-00328	II	PWR-HECND WEST 4LP TVA TVA	3455	1127	05/27/1970 09/15/1981 06/01/1982 N/A 09/15/2021	OL-FP DPR-79	86.6 83.6 95.6 90.4 90.3 100.2
<a href="http://www.tva.gov/power/nuclear/sequoyah.htm">www.tva.gov/power/nuclear/sequoyah.htm</a>							
Shearon Harris 1 Carolina Power & Light Co. Progress Energy 20 miles SW of Raleigh, NC 050-00400	II	PWR-DRYAMB WEST 3LP EBSO DANI	2900	900	01/27/1978 01/12/1987 05/02/1987 N/A 10/24/2026	OL-FP NPF-63	99.4 91.8 88.7 100.6 89.2 93.9
<a href="http://www.progress-energy.com/aboutenergy/powerplants/nuclearplants/harris.asp">www.progress-energy.com/aboutenergy/powerplants/nuclearplants/harris.asp</a>							
South Texas Project 1 STP Nuclear Operating Co. † 12 miles SSW of Bay City, TX 050-00498	IV	PWR-DRYAMB WEST 4LP BECH EBSO	3853	1280	12/22/1975 03/22/1988 08/25/1988 N/A 08/20/2027	OL-FP NPF-76	98.1 60.6 98.5 88.0 90.5 105.3
<a href="http://www.stpnoc.com/index.html">www.stpnoc.com/index.html</a>							
South Texas Project 2 STP Nuclear Operating Co. † 12 miles SSW of Bay City, TX 050-00499	IV	PWR-DRYAMB WEST 4LP BECH EBSO	3853	1280	12/22/1975 03/28/1989 06/19/1989 N/A 12/15/2028	OL-FP NPF-80	73.9 79.3 91.6 88.5 100.1 92.5
<a href="http://www.stpnoc.com/index.html">www.stpnoc.com/index.html</a>							
St. Lucie 1 Florida Power & Light Co. † 12 miles SE of Ft. Pierce, FL 050-00335	II	PWR-DRYAMB COMB CE EBSO EBSO	2700	839	07/01/1970 03/01/1976 12/21/1976 10/02/2003 03/01/2036	OL-FP DPR-67	94.1 102.1 85.8 82.8 101.5 84.8
<a href="http://www.fpl.com/environment/nuclear/about_st_lucie.shtml">www.fpl.com/environment/nuclear/about_st_lucie.shtml</a>							
St. Lucie 2 Florida Power & Light Co. † 12 miles SE of Ft. Pierce, FL 050-00335	II	PWR-DRYAMB COMB CE EBSO EBSO	2700	839	05/02/1977 06/10/1983 08/08/1983 10/02/2003 04/06/2043	OL-FP NPF-16	100.8 80.1 92.0 85.5 82.3 70.1
<a href="http://www.fpl.com/environment/nuclear/about_st_lucie.shtml">www.fpl.com/environment/nuclear/about_st_lucie.shtml</a>							
Surry 1 Dominion Generation † 17 miles NW of Newport News, VA 050-00280	II	PWR-DRYSUB WEST 3LP S&W S&W	2546	799	06/25/1968 04/06/1983 12/22/1972 03/20/2003 05/25/2032	OL-FP DPR-32	100.8 76.4 92.0 96.4 90.2 100.2
<a href="http://www.dom.com/about/stations/nuclear/surry/index.jsp">www.dom.com/about/stations/nuclear/surry/index.jsp</a>							

## APPENDIX A

### U.S. Commercial Nuclear Power Reactors (continued)

Unit Licensee, Operating Utility Co. Location Docket Number Web Address	NRC Region	Con Type NSSS AE Constructor	Licensed MWt	Net Summer Capacity (MW)*	CP Issued OL Issued Comm. Op. LR Issued Exp. Date	License Type & Number	2002- 2007** Capacity Factor (Percent)
Surry 2 Dominion Generation † 17 miles NW of Newport News, VA 050-00281	II	PWR-DRYSUB WEST 3LP S&W S&W	2546	799	06/25/1968 01/29/1973 05/01/1973 03/20/2003 01/29/2033	OL-FP DPR-37	91.4 78.6 100.5 92.6 88.4 88.5
<a href="http://www.dom.com/about/stations/nuclear/surry/index.jsp">www.dom.com/about/stations/nuclear/surry/index.jsp</a>							
Susquehanna 1 PPL Susquehanna, LLC † 7 miles NE of Berwick, PA 050-00387	I	BWR-MARK 2 GE 4 BECH BECH	3952	1135	11/02/1973 11/12/1982 06/08/1983 N/A 07/17/2022	OL-FP NPF-14	83.3 96.3 80.3 94.6 86.2 101.2
<a href="http://www.pplweb.com/ppl+generation/ppl+susquehanna.htm">www.pplweb.com/ppl+generation/ppl+susquehanna.htm</a>							
Susquehanna 2 PPL Susquehanna, LLC † 7 miles NE of Berwick, PA 050-00388	I	BWR-MARK 2 GE 4 BECH BECH	3952	1140	11/02/1973 06/27/1984 02/12/1985 N/A 03/23/2024	OL-FP NPF-22	95.6 85.5 100.0 88.7 92.5 95.1
<a href="http://www.pplweb.com/ppl+generation/ppl+susquehanna.htm">www.pplweb.com/ppl+generation/ppl+susquehanna.htm</a>							
Three Mile Island 1 AmerGen Energy Co., LLC Exelon Corp. 10 miles SE of Harrisburg, PA 050-00289	I	PWR-DRYAMB B&W LLP GIL UE&C	2568	786	05/18/1968 04/19/1974 09/02/1974 N/A 04/19/2014	OL-FP DPR-50	102.3 90.0 102.2 98.1 105.0 87.9
<a href="http://www.exeloncorp.com/ourcompanies/powergen/nuclear/three_mile_island_unit_-_1.htm">www.exeloncorp.com/ourcompanies/powergen/nuclear/three_mile_island_unit_-_1.htm</a>							
Turkey Point 3 Florida Power & Light Co. † 25 miles S of Miami, FL 050-00250	II	PWR-DRYAMB WEST 3LP BECH BECH	2300	693	04/27/1967 07/19/1972 12/14/1972 06/06/2002 07/19/2032	OL-FP DPR-31	102.4 89.7 77.7 95.5 91.9 96.5
<a href="http://www.fpl.com/environment/nuclear/about_turkey_point.shtml">www.fpl.com/environment/nuclear/about_turkey_point.shtml</a>							
Turkey Point 4 Florida Power & Light Co. † 25 miles S of Miami, FL 050-00251	II	PWR-DRYAMB WEST 3LP BECH BECH	2300	693	04/27/1967 04/10/1973 09/07/1973 06/06/2002 04/10/2033	OL-FP DPR-41	96.4 91.6 99.9 69.8 88.6 100.1
<a href="http://www.fpl.com/environment/nuclear/about_turkey_point.shtml">www.fpl.com/environment/nuclear/about_turkey_point.shtml</a>							
V.C. Summer South Carolina Electric & Gas Co. † 26 miles NW of Columbia, SC 050-00395	II	PWR-DRYAMB WEST 3LP GIL DANI	2900	966	03/21/1973 11/12/1982 01/01/1984 04/23/2004 08/06/2042	OL-FP NPF-12	85.5 86.9 97.2 88.3 88.9 84.8
<a href="http://www.sceg.com/en">www.sceg.com/en</a>							

APPENDIX A  
**U.S. Commercial Nuclear Power Reactors (continued)**

Unit Licensee, Operating Utility Co. Location Docket Number Web Address	NRC Region	Con Type NSSS AE Constructor	Licensed MWt	Net Summer Capacity (MW)*	CP Issued OL Issued Comm. Op. LR Issued Exp. Date	License Type & Number	2002- 2007** Capacity Factor (Percent)
Vermont Yankee Entergy Nuclear Operations, Inc. † 5 miles S of Brattleboro, VT 050-00271	I	BWR-MARK 1 GE 4 EBSO EBSO	1912	620	12/11/1967 02/28/1973 11/30/1972 N/A 03/21/2012	OL-FP DPR-28	88.7 100.3 86.8 91.9 115.2 86.6
<a href="http://www.entropy-nuclear.com/plant_information/vermont_yankee.aspx">www.entropy-nuclear.com/plant_information/vermont_yankee.aspx</a>							
Vogtle 1 Southern Nuclear Operating Co. † 26 miles SE of Augusta, GA 050-00424	II	PWR-DRYAMB WEST 4LP SBEC GPC	3625	1152	06/28/1974 03/16/1987 06/01/1987 N/A 01/16/2027	OL-FP NPF-68	85.9 93.3 100.4 91.4 85.9 98.7
<a href="http://www.southerncompany.com/southernnuclear/vogtle.asp">www.southerncompany.com/southernnuclear/vogtle.asp</a>							
Vogtle 2 Southern Nuclear Operating Co. † 26 miles SE of Augusta, GA 050-00425	II	PWR-DRYAMB WEST 4LP SBEC GPC	3625	1149	06/28/1974 03/31/1989 05/20/1989 N/A 02/09/2029	OL-FP NPF-81	83.6 96.7 90.8 85.4 92.2 82.8
<a href="http://www.southerncompany.com/southernnuclear/vogtle.asp">www.southerncompany.com/southernnuclear/vogtle.asp</a>							
Waterford 3 Entergy Nuclear Operations, Inc. † 25 miles W of New Orleans, LA 050-00382	IV	PWR-DRYAMB COMB CE EBSO EBSO	3716	1152	11/14/1974 03/16/1985 09/24/1985 N/A 12/18/2024	OL-FP NPF-38	92.5 88.9 101.1 77.6 91.9 98.0
<a href="http://www.entropy-nuclear.com/plant_information/waterford_3.aspx">www.entropy-nuclear.com/plant_information/waterford_3.aspx</a>							
Watts Bar 1 Tennessee Valley Authority † 10 miles S of Spring City, TN 050-00390	II	PWR-ICECND WEST 4LP TVA TVA	3459	1121	01/23/1973 02/07/1996 05/27/1996 N/A 11/09/2035	OL NPF-90	91.1 87.1 100.1 89.7 68.0 102.3
<a href="http://www.tva.gov/power/nuclear/wattsbar.htm">www.tva.gov/power/nuclear/wattsbar.htm</a>							
Wolf Creek 1 Wolf Creek Nuclear Operating Corp. † 3.5 miles NE of Burlington, KS 050-00482	IV	PWR-DRYAMB WEST 4LP BECH DANI	3565	1166	05/31/1977 06/04/1985 09/03/1985 N/A 03/11/2025	OL-FP NPF-42	88.2 87.1 98.9 86.4 91.5 101.5
<a href="http://www.kcpl.com/about/wcnoc.html">www.kcpl.com/about/wcnoc.html</a>							

\* Data calculations compiled by Nuclear Energy Institute (NEI).  
 \*\* Average capacity factor is listed in year order starting with 2002.  
 † Licensee and Operating Utility company are the same.  
 Source: NRC-compiled data from EIA/DOE data and NEI

**APPENDIX B**  
**U.S. Commercial Nuclear Power Reactors Formerly**  
**Licensed to Operate (Permanently Shut Down)**

Unit Location	Reactor Type WmT	NSSS Vendor	OL Issued Shut Down	Decommissioning Alternative Selected Current Status
Big Rock Point Charlevoix, MI	BWR 240	GE	05/01/1964 08/29/1997	DECON DECON Completed
GE Bonus* Punta Higuera, PR	BWR 50	CE	04/02/1964 06/01/1968	ENTOMB ENTOMB
CVTR** Parr, SC	PTHW 65	WEST	11/27/1962 01/01/1967	SAFSTOR SAFSTOR
Dresden 1 Morris, IL	BWR 700	GE	09/28/1959 10/31/1978	SAFSTOR SAFSTOR
Elk River* Elk River, MN	BWR 58	AC/S&L	11/06/1962 02/01/1968	DECON DECON Completed
Fermi 1 Newport, MI	SCF 200	CE	05/10/1963 09/22/1972	SAFSTOR SAFSTOR
Fort St. Vrain Platteville, CO	HTG 842	GA	12/21/1973 08/18/1989	DECON DECON Completed
GE VBWR Sunol, CA	BWR 50	GE	08/31/1957 12/09/1963	SAFSTOR SAFSTOR
Haddam Neck Meriden, CT	PWR 1825	WEST	12/27/1974 12/05/1996	DECON DECON Completed
Hallam* Hallam, NE	SCGM 256	BLH	01/02/1962 09/01/1964	ENTOMB ENTOMB
NS Savannah, GA	PWR 74	B&W	08/1965 11/1970	SAFSTOR SAFSTOR
Humboldt Bay 3 Eureka, CA	BWR 200	GE	08/28/1962 07/02/1976	DECON DECON In Progress
Indian Point 1 Buchanan, NY	PWR 615	B&W	03/26/1962 10/31/1974	SAFSTOR SAFSTOR
La Crosse Genoa, WI	BWR 165	AC	07/03/1967 04/30/1987	SAFSTOR SAFSTOR
Maine Yankee Wiscasset, ME	PWR 2700	CE	06/29/1973 12/06/1996	DECON DECON Completed
Millstone 1 Waterford, CT	BWR 2011	GE	10/31/1986 07/21/1998	SAFSTOR SAFSTOR
Pathfinder Sioux Falls, SD	BWR 190	AC	03/12/1964 09/16/1967	DECON DECON Completed
Peach Bottom 1 Peach Bottom, PA	HTG 115	GA	01/24/1966 10/31/1974	SAFSTOR SAFSTOR

**APPENDIX B**  
**U.S. Commercial Nuclear Power Reactors Formerly**  
**Licensed To Operate (Permanently Shut Down) (continued)**

Unit Location	Reactor Type WMT	NSSS Vendor	OL Issued Shut Down	Decommissioning Alternative Selected Current Status
Piqua* Piqua, OH	OCM 46	AI	08/23/1962 01/01/1966	ENTOMB ENTOMB
Rancho Seco Herald, CA	PWR 2772	B&W	08/16/1974 06/07/1989	DECON DECON In Progress
San Onofre 1 San Clemente, CA	PWR 1347	WEST	03/27/1967 11/30/1992	DECON DECON In Progress
Saxton Saxton, PA	PWR 23.5	WEST	11/15/1961 05/01/1972	DECON DECON Completed
Shippingport* Shippingport, PA	PWR 236	WEST	N/A 1982	DECON DECON Completed
Shoreham Wading River, NY	BWR 2436	GE	04/21/1989 06/28/1989	DECON DECON Completed
Three Mile Island 2 Londonderry Township, PA	PWR 2770	B&W	02/08/1978 03/28/1979	(1)
Trojan Rainier, OR	PWR 3411	WEST	11/21/1975 11/09/1992	DECON DECON Completed
Yankee-Rowe Franklin County, MA	PWR 0600	WEST	12/24/1963 10/01/1991	DECON DECON Completed
Zion 1 Zion, IL	PWR 3250	WEST	10/19/1973 02/21/1997	SAFSTOR SAFSTOR
Zion 2 Zion, IL	PWR 3250	WEST	11/14/1973 09/19/1996	SAFSTOR SAFSTOR

\* AEC/DOE owned; not regulated by the U.S. Nuclear Regulatory Commission (NRC).

\*\* Holds byproduct license from the State of South Carolina.

Notes: See Glossary for definitions of decommissioning alternatives.

(1) Three Mile Island 2 has been placed in a postdefueling monitored storage mode until Unit 1 permanently ceases operation, at which time both units are planned to be decommissioned.

Source: DOE Integrated Database for 1990; U.S. Spent Fuel and Radioactive Waste, Inventories, Projections, and Characteristics (DOE/RW-0006, Rev. 6), and U.S. Nuclear Regulatory Commission, Nuclear Power Plants in the World, Edition #6



## APPENDIX C

### Canceled U.S. Commercial Nuclear Power Reactors

Unit Utility Location	Con Type MWe per Unit	Canceled Date Status
Allens Creek 1 Houston Lighting & Power Company 4 miles NW of Wallis, IN	BWR 1150	1982 Under CP Review
Allens Creek 2 Houston Lighting & Power Company 4 miles NW of Wallis, IN	BWR 1150	1976 Under CP Review
Atlantic 1 & 2 Public Service Electric & Gas Company Floating Plants off the Coast of NJ	PWR 1150	1978 Under CP Review
Bailly 1 Northern Indiana Public Service Company 12 miles NNE of Gary, IN	BWR 645	1981 With CP
Barton 1 & 2 Alabama Power & Light 15 miles SE of Clanton, AL	BWR 1159	1977 Under CP Review
Barton 3 & 4 Alabama Power & Light 15 miles SE of Clanton, AL	BWR 1159	1975 Under CP Review
Bellefonte 1 & 2 Tennessee Valley Authority 6 miles NE of Scottsboro, AL	PWR 1235	2006 With CP
Black Fox 1 & 2 Public Service Company of Oklahoma 3.5 miles S of Inola, OK	BWR 1150	1982 Under CP Review
Blue Hills 1 & 2 Gulf States Utilities Company SW tip of Toledo Bend Reservoir, County, TX	PWR 918	1978 Under CP Review
Callaway 2 Union Electric Company 10 miles SE of Fulton, MO	PWR 1150	1981 With CP
Cherokee 1 Duke Power Company 6 miles SSW of Blacksburg, SC	PWR 1280	1983 With CP
Cherokee 2 & 3 Duke Power Company 6 miles SSW of Blacksburg, SC	PWR 1280	1982 With CP

**APPENDIX C**  
**Canceled U.S. Commercial Nuclear Power Reactors (continued)**

Unit Utility Location	Con Type MWe per Unit	Canceled Date Status
Clinch River Project Management Corp., DOE, TVA 23 miles W of Knoxville, in Oak Ridge, TN	LMFB 350	1983 Under CP Review
Clinton 2 Illinois Power Company 6 miles E of Clinton, IL	BWR 933	1983 With CP
Davis-Besse 2 & 3 Toledo Edison Company 21 miles ESE of Toledo, OH	PWR 906	1981 Under CP Review
Douglas Point 1 & 2 Potomac Electric Power Company 5.7 miles SSE of Quantico, VA	BWR 1146	1977 Under CP Review
Erie 1 & 2 Ohio Edison Company Berlin, OH	PWR 1260	1980 Under CP Review
Forked River 1 Jersey Central Power & Light Company 2 miles S of Forked River, NJ	PWR 1070	1980 With CP
Fort Calhoun 2 Omaha Public Power District 19 miles N of Omaha, NE	PWR 1136	1977 Under CP Review
Fulton 1 & 2 Philadelphia Electric Company 17 miles S of Lancaster, PA	HTG 1160	1975 Under CP Review
Grand Gulf 2 Entergy Operations, Inc. 25 miles S of Vicksburg, MS	BWR 1250	1990 With CP
Greene County Power Authority of the State of NY 20 miles N of Kingston, MS	PWR 1191	1980 Under CP Review
Greenwood 2 & 3 Detroit Edison Company Greenwood Township, MS	PWR 1200	1980 Under CP Review
Hartsville A1 & A2 Tennessee Valley Authority 5 miles SE of Hartsville, TN	BWR 1233	1984 With CP

**APPENDIX C**  
**Canceled U.S. Commercial Nuclear Power Reactors (continued)**

Unit Utility Location	Con Type MWe per Unit	Canceled Date Status
Hartsville B1 & B2 Tennessee Valley Authority 5 miles SE of Hartsville, TN	BWR 1233	1982 With CP
Haven 1 (formerly Koshkonong) Wisconsin Electric Power Company 4.2 miles SSW of Fort Atkinson, WI	PWR 900	1980 Under CP Review
Haven 2 (formerly Koshkonong) Wisconsin Electric Power Company 4.2 miles SSW of Fort Atkinson, WI	PWR 900	1978 Under CP Review
Hope Creek 2 Public Service Electric & Gas Company 18 miles SE of Washington, DE	BWR 1067	1981 With CP
Jamesport 1 & 2 Long Island Lighting Company 65 miles E of New York City, NY	PWR 1150	1980 With CP
Marble Hill 1 & 2 Public Service of Indiana 6 miles NE of New Washington, IN	PWR 1130	1985 With CP
Midland 1 Consumers Power Company S of City of Midland, MI	PWR 492	1986 With CP
Midland 2 Consumers Power Company S of City of Midland, MI	PWR 818	1986 With CP
Montague 1 & 2 Northeast Nuclear Energy Company 1.2 miles SSE of Turners Falls, MA	BWR 1150	1980 Under CP Review
New England 1 & 2 New England Power Company 8.5 miles E of Westerly, RI	PWR 1194	1979 Under CP Review
New Haven 1 & 2 New York State Electric & Gas Corporation	PWR 1250	1980 Under CP Review
North Anna 3 Virginia Electric & Power Company 40 miles NW of Richmond, VA	PWR 907	1982 With CP

**APPENDIX C**  
**Canceled U.S. Commercial Nuclear Power Reactors (continued)**

Unit Utility Location	Con Type MWe per Unit	Canceled Date Status
North Anna 4 Virginia Electric & Power Company 40 miles NW of Richmond, VA	PWR 907	1980 With CP
North Coast 1 Puerto Rico Water Resources Authority 4.7 miles ESE of Salinas, PR	PWR 583	1978 Under CP Review
Palo Verde 4 & 5 Arizona Public Service Company 36 miles W of Phoenix, AZ	PWR 1270	1979 Under CP Review
Pebble Springs 1 & 2 Portland General Electric Company 55 miles WSW of Tri Cities (Kenewick-Pasco-Richland), OR	PWR 1260	1982 Under CP Review
Perkins 1, 2, & 3 Duke Power Company 10 miles N of Salisbury, NC	PWR 1280	1982 Under CP Review
Perry 2 Cleveland Electric Illuminating Co. 7 miles NE of Painesville, OH	BWR 1205	1994 Under CP Review
Phipps Bend 1 & 2 Tennessee Valley Authority 15 miles SW of Kingsport, TN	BWR 1220	1982 With CP
Pilgrim 2 Boston Edison Company 4 miles SE of Plymouth, MA	PWR 1180	1981 Under CP Review
Pilgrim 3 Boston Edison Company 4 miles SE of Plymouth, MA	PWR 1180	1974 Under CP Review
Quanicassee 1 & 2 Consumers Power Company 6 miles E of Essexville, MI	PWR 1150	1974 Under CP Review
River Bend 2 Gulf States Utilities Company 24 miles NNW of Baton Rouge, LA	BWR 934	1984 With CP
Seabrook 2 Public Service Co. of New Hampshire 13 miles S of Portsmouth, NH	PWR 1198	1988 With CP

**APPENDIX C**  
**Canceled U.S. Commercial Nuclear Power Reactors (continued)**

Unit Utility Location	Con Type MWe per Unit	Canceled Date Status
Shearon Harris 2 Carolina Power & Light Company 20 miles SW of Raleigh, NC	PWR 900	1983 With CP
Shearon Harris 3 & 4 Carolina Power & Light Company 20 miles SW of Raleigh, NC	PWR 900	1981 With CP
Skagit/Hanford 1 & 2 Puget Sound Power & Light Company 23 miles SE of Bellingham, WA	PWR 1277	1983 Under CP Review
Sterling Rochester Gas & Electric Corporation 50 miles E of Rochester, NY	PWR 1150	1980 With CP
Summit 1 & 2 Delmarva Power & Light Company 15 miles SSW of Wilmington, DE	HTG 1200	1975 Under CP Review
Sundesert 1 & 2 San Diego Gas & Electric Company 16 miles SW of Blythe, CA	PWR 974	1978 Under CP Review
Surry 3 & 4 Virginia Electric & Power Company 17 miles NW of Newport News, VA	PWR 882	1977 With CP
Tyrone 1 Northern States Power Company 8 miles NE of Durond, WI	PWR 1150	1981 Under CP Review
Tyrone 2 Northern States Power Company 8 miles NE of Durond, WI	PWR 1150	1974 With CP
Vogtle 3 & 4 Georgia Power Company 26 miles SE of Augusta, GA	PWR 1113	1974 With CP
Washington Nuclear 1 Energy Northwest 10 miles E of Aberdeen, WA	PWR 1266	1995 With CP
Washington Nuclear 3 Energy Northwest 16 miles E of Aberdeen, WA	PWR 1242	1995 With CP

**APPENDIX C**  
**Canceled U.S. Commercial Nuclear Power Reactors (continued)**

Unit Utility Location	Con Type MWe per Unit	Canceled Date Status
Washington Nuclear 4 Energy Northwest 10 miles E of Aberdeen, WA	PWR 1218	1982 With CP
Washington Nuclear 5 Energy Northwest 16 miles E of Aberdeen, WA	PWR 1242	1982 With CP
Yellow Creek 1 & 2 Tennessee Valley Authority 15 miles E of Corinth, MS	BWR 1285	1984 With CP
Zimmer 1 Cincinnati Gas & Electric Company 25 miles SE of Cincinnati, OH	BWR 810	1984 With CP

Note: Cancellation is defined as public announcement of cancellation or written notification to the NRC.  
 Only docketed applications are indicated.

(1) Watts Bar 2 has not been formally cancelled; however, TVA has stopped construction and is presently evaluating options (e.g., cancellation or completion).

Source: DOE/EIA Commercial Nuclear Power 1991 (DOE/EIA-0438 (91)), Appendix E (page 105) and U.S. Nuclear Regulatory Commission

## APPENDIX D

## U.S. Commercial Nuclear Power Reactors by Operating Utility Company

Utility	Unit
AmerenUE <a href="http://www.ameren.com">www.ameren.com</a>	Callaway*
Arizona Public Service Company <a href="http://www.aps.com">www.aps.com</a>	Palo Verde 1, 2, & 3*
Constellation Energy <a href="http://www.constellation.com">www.constellation.com</a>	Calvert Cliffs 1 & 2 Ginna Nine Mile Point 1 & 2
Detroit Edison Company <a href="http://www.dteenergy.com">www.dteenergy.com</a>	Fermi 2
Dominion Generation <a href="http://www.dom.com">www.dom.com</a>	Kewaunee Millstone 2 & 3 North Anna 1 & 2 Surry 1 & 2
Duke Energy Carolinas, LLC <a href="http://www.duke-energy.com">www.duke-energy.com</a>	Catawba 1 & 2 McGuire 1 & 2 Oconee 1, 2, & 3
Energy Northwest <a href="http://www.energy-northwest.com">www.energy-northwest.com</a>	Columbia Generating Station
Entergy Nuclear Operations, Inc. <a href="http://www.entergy-nuclear.com">www.entergy-nuclear.com</a>	Arkansas Nuclear 1 & 2 James A. FitzPatrick Grand Gulf 1 Indian Point 2 & 3 Palisades Pilgrim 1 River Bend 1 Vermont Yankee Waterford 3
Exelon Corporation, LLC <a href="http://www.exeloncorp.com">www.exeloncorp.com</a>	Braidwood 1 & 2 Byron 1 & 2 Clinton Dresden 2 & 3 La Salle County 1 & 2 Limerick 1 & 2 Oyster Creek Peach Bottom 2 & 3 Quad Cities 1 & 2 Three Mile Island 1
FirstEnergy Nuclear Operating Company <a href="http://www.firstenergycorp.com">www.firstenergycorp.com</a>	Beaver Valley 1 & 2 Davis-Besse Perry 1

APPENDIX D

**U.S. Commercial Nuclear Power Reactors by Operating Utility Company  
(continued)**

Utility	Unit
Florida Power & Light Company <a href="http://www.fpl.com">www.fpl.com</a>	Duane Arnold Point Beach 1 & 2 Seabrook 1 St. Lucie 1 & 2 Turkey Point 3 & 4
Indiana/Michigan Power Company <a href="http://www.indianamichiganpower.com">www.indianamichiganpower.com</a>	D.C. Cook 1 & 2
Luminant Generation Company, LLC <a href="http://www.luminant.com">www.luminant.com</a>	Comanche Peak 1 & 2*
Nebraska Public Power District <a href="http://www.nppd.com">www.nppd.com</a>	Cooper
Nuclear Management Company, LLC <a href="http://www.nmcco.com">www.nmcco.com</a>	Monticello Prairie Island 1 & 2
Omaha Public Power District <a href="http://www.oppd.com">www.oppd.com</a>	Fort Calhoun
Pacific Gas & Electric Company <a href="http://www.pge.com">www.pge.com</a>	Diablo Canyon 1 & 2*
PPL Susquehanna, LLC <a href="http://www.pplweb.com">www.pplweb.com</a>	Susquehanna 1 & 2
Progress Energy <a href="http://www.progress-energy.com">www.progress-energy.com</a>	Brunswick 1 & 2 Crystal River 3 H.B. Robinson 2 Shearon Harris 1
PSEG Nuclear, LLC <a href="http://www.pseg.com">www.pseg.com</a>	Hope Creek 1 Salem 1 & 2
South Carolina Electric & Gas Company <a href="http://www.sceg.com">www.sceg.com</a>	Summer
Southern California Edison Company <a href="http://www.sce.com">www.sce.com</a>	San Onofre 2 & 3
Southern Nuclear Operating Company <a href="http://www.southerncompany.com">www.southerncompany.com</a>	Edwin I. Hatch 1 & 2 Joseph M. Farley 1 & 2 Vogtle 1 & 2
STP Nuclear Operating Company <a href="http://www.stpnoc.com">www.stpnoc.com</a>	South Texas Project 1 & 2*
Tennessee Valley Authority <a href="http://www.tva.gov">www.tva.gov</a>	Browns Ferry 1, 2, & 3 Sequoyah 1 & 2 Watts Bar 1
Wolf Creek Nuclear Operating Corporation <a href="http://www.wcnoc.com">www.wcnoc.com</a>	Wolf Creek 1*

\*These plants have a joint program called the Strategic Teaming and Resource Sharing (STARS) group. They share resources for refueling outages and to develop some shared licensing applications.

Source: U.S. Nuclear Regulatory Commission



**APPENDIX E**  
**U.S. Nuclear Research and Test Reactors (Operating)**  
**Regulated by the NRC**

Licensee Location	Reactor Type OL Issued	Power Level (kW)	Licensee Number Docket Number
Aerotest San Ramon, CA	TRIGA (Indus) 07/02/1965	250	R-98 50-228
Armed Forces Radiobiology Research Institute Bethesda, MD	TRIGA 06/26/1962	1,100	R-84 50-170
Dow Chemical Company Midland, MI	TRIGA 07/03/1967	300	R-108 50-264
General Electric Company Sunol, CA	Nuclear Test 10/31/1957	100	R-33 50-73
Idaho State University Pocatello, ID	AGN-201 #103 10/11/1967	0.005	R-110 50-284
Kansas State University Manhattan, KS	TRIGA 10/16/1962	250	R-88 50-188
Massachusetts Institute of Technology Cambridge, MA	HWR Reflected 06/09/1958	5,000	R-37 50-20
National Institute of Standards & Technology Gaithersburg, MD	Nuclear Test 05/21/1970	20,000	TR-5 50-184
North Carolina State University Raleigh, NC	Pulstar 08/25/1972	1,000	R-120 50-297
Ohio State University Columbus, OH	Pool 02/24/1961	500	R-75 50-150
Oregon State University Corvallis, OR	TRIGA Mark II 03/07/1967	1,100	R-106 50-243
Pennsylvania State University University Park, PA	TRIGA 07/08/1955	1,100	R-2 50-5
Purdue University West Lafayette, IN	Lockheed 08/16/1962	1	R-87 50-182
Reed College Portland, OR	TRIGA Mark I 07/02/1968	250	R-112 50-288
Rensselaer Polytechnic Institute Troy, NY	Critical Assembly 07/03/1964	0.1	CX-22 50-225
Rhode Island Atomic Energy Commission Narragansett, RI	GE Pool 07/23/1964	2,000	R-95 50-193

**APPENDIX E**  
**U.S. Nuclear Research and Test Reactors (Operating)**  
**Regulated by the NRC (continued)**

Licensee Location	Reactor Type OL Issued	Power Level (kW)	Licensee Number Docket Number
Texas A&M University College Station, TX	AGN-201M #106 08/26/1957	0.005	R-23 50-59
Texas A&M University College Station, TX	TRIGA 12/07/1961	1,000	R-128 50-128
U.S. Geological Survey Denver, CO	TRIGA Mark I 02/24/1969	1,000	R-113 50-274
University of Arizona Tucson, AZ	TRIGA Mark I 12/05/1958	110	R-52 50-113
University of California/Davis Sacramento, CA	TRIGA 08/13/1998	2,300	R-130 50-607
University of California/Irvine Irvine, CA	TRIGA Mark I 11/24/1969	250	R-116 50-326
University of Florida Gainesville, FL	Argonaut 05/21/1959	100	R-56 50-83
University of Maryland College Park, MD	TRIGA 10/14/1960	250	R-70 50-166
University of Massachusetts/Lowell Lowell, MA	GE Pool 12/24/1974	1,000	R-125 50-223
University of Missouri/Columbia Columbia, MO	Tank 10/11/1966	10,000	R-103 50-186
University of Missouri/Rolla Rolla, MO	Pool 11/21/1961	200	R-79 50-123
University of New Mexico Albuquerque, NM	AGN-201M #112 09/17/1966	0.005	R-102 50-252
University of Texas Austin, TX	TRIGA Mark II 01/17/1992	1,100	R-92 50-602
University of Utah Salt Lake City, UT	TRIGA Mark I 09/30/1975	100	R-126 50-407
University of Wisconsin Madison, WI	TRIGA 11/23/1960	1,000	R-74 50-156
Washington State University Pullman, WA	TRIGA 03/06/1961	1,000	R-76 50-27

Source: U.S. Nuclear Regulatory Commission

## APPENDIX F

**U.S. Nuclear Research and Test Reactors  
(under Decommissioning) Regulated by the NRC**

Licensee Location	Reactor Type Power Level (kW)	OL Issued Shutdown	Decommissioning Alternative Selected Current Status
General Atomics San Diego, CA	TRIGA Mark F 1,500	07/01/60 09/07/94	DECON SAFSTOR
General Atomics San Diego, CA	TRIGA Mark I 250	05/03/58 12/17/96	DECON SAFSTOR
General Electric Company Sunol, CA	GETR (Tank) 50,000	01/07/59 06/26/85	SAFSTOR SAFSTOR
General Electric Company Sunol, CA	EVESR 17,000	11/12/63 02/01/67	SAFSTOR SAFSTOR
National Aeronautics and Space Administration Sandusky, OH	Test 60,000	05/02/62 07/07/73	DECON DECON In Progress
National Aeronautics and Space Administration Sandusky, OH	Mockup 100	06/14/61 07/07/73	DECON DECON In Progress
University of Buffalo Buffalo, NY	Pulstar 2,000	03/24/61 07/23/96	DECON SAFSTOR
University of Illinois Urbana-Champaign, IL	TRIGA 1,500	07/22/69 04/12/99	DECON DECON In Progress
University of Michigan Ann Arbor, MI	Pool 2,000	09/13/57 01/29/04	DECON DECON In Progress
Veterans Administration Omaha, NE	TRIGA 20	06/26/59 11/05/01	DECON SAFSTOR
Viacom Waltz Mill, PA	Tank 20,000	06/19/59 03/25/63	DECON DECON In Progress
Worcester Polytechnic Institute Worcester, MA	GE 10	12/16/59 06/30/07	DECON DECON Pending

Source: U.S. Nuclear Regulatory Commission

**APPENDIX G**  
**Industry Performance Indicators:**  
**Annual Industry Averages, FYs 1998–2007**

Indicator	1998	1999	2000	2001	2002	2003	2004	2005	2006	2007
Automatic Scrams	0.48	0.64	0.52	0.57	0.44	0.75	0.56	0.47	0.32	0.48
Safety System Actuations	0.25	0.29	0.29	0.19	0.18	0.41	0.24	0.38	0.22	0.25
Significant Events	0.02	0.03	0.04	0.07	0.05	0.07	0.04	0.05	0.03	0.02
Safety System Failures	0.65	1.68	1.40	0.82	0.88	0.96	0.78	0.99	0.59	0.65
Forced Outage Rate	1.43	5.20	4.24	3.00	1.70	3.04	1.88	2.44	1.47	1.43
Equipment-Forced Outage Rate	0.11	0.16	0.13	0.11	0.12	0.16	0.15	0.13	0.10	0.11
Collective Radiation Exposure	110.00	128.00	115.00	123.00	111.00	125.00	100.00	117.00	93.00	110.00
Drill/Exercise Performance	–	96.57	95.94	95.44	95.28	95.73	95.64	95.85	96.00	98.15
ERO Drill Participation	–	–	96.34	96.30	97.10	97.74	97.87	98.20	97.96	97.58
Alert and Notification System Reliability	–	98.05	98.02	98.53	98.79	98.92	99.24	99.34	99.48	99.45

Note: Drills and exercises were piloted in 1999 and became standard practice for all plants in 2000.

Source: Licensee data as compiled by the U.S. Nuclear Regulatory Commission

**APPENDIX H**  
**Dry Spent Fuel Storage Designs:**  
**NRC-Approved for Use by General Licensees**

Vendor	Docket #	Storage Design Model
General Nuclear Systems, Inc.	72-1000	CASTOR V/21
NAC International, Inc.	72-1002	NAC S/T
	72-1003	NAC-C28 S/T
	72-1015	NAC-UMS
	72-1025	NAC-MPC
Holtec International	72-1008	HI-STAR 100
	72-1014	HI-STORM 100
BNG Fuel Solutions Corporation	72-1007	VSC-24
	72-1026	Fuel Solutions (WSNF-220, -221, -223)
		W-150 Storage Cask
		W-100 Transfer Cask W-21, W-74 Canisters
Transnuclear, Inc.	72-1005	TN-24
	72-1027	TN-68
	72-1021	TN-32, 32A, 32B
	72-1004	Standardized NUHOMS-24P, 24PHB, 24PTH, 52B, 61BT, 32PT
		Standardized Advanced NUHOMS-24PT1, 24PT4
	72-1030	NUHOMS HD-32PTH

Source: U.S. Nuclear Regulatory Commission data as of January 2008

**APPENDIX I**  
**Dry Spent Fuel Storage Licensees**

Reactor Utility	Date Issued	Vendor	Storage Model	Docket #
Surry 1, 2 Virginia Electric & Power Company (Dominion Gen.)	07/02/1986	General Nuclear Systems, Inc. Transnuclear, Inc. NAC International, Inc. Westinghouse, Inc.	CASTOR V/21 TN-32 NAC-128 CASTOR X/33 MC-10	72-2
H.B. Robinson 2 Carolina Power & Light Company	08/13/1986 Under General License 09/06/2005	Transnuclear, Inc. Transnuclear, Inc.	NUHOMS-7P NUHOMS-24P	72-3 72-60
Oconee 1, 2, 3 Duke Energy Company	01/29/1990 Under General License 03/05/1999	Transnuclear, Inc.	NUHOMS-24P	72-4 72-40
Fort St. Vrain* U.S. Department of Energy	11/04/1991	FW Energy Applications, Inc.	Modular Vault Dry Store	72-9
Calvert Cliffs 1, 2 Calvert Cliffs Nuclear Power Plant	11/25/1992	Transnuclear, Inc.	NUHOMS-24P NUHOMS-32P	72-8
Palisades Nuclear Management Company, LLC	Under General License 05/11/1993	BNG Fuel Solutions Transnuclear, Inc.	VSC-24 NUHOMS-32PT	72-7
Prairie Island 1, 2 Nuclear Management Company, LLC	10/19/1993	Transnuclear, Inc.	TN-40	72-10
Point Beach 1, 2 Nuclear Management Company, LLC	Under General License 05/26/1996	BNG Fuel Solutions Transnuclear, Inc.	VSC-24 NUHOMS-32PT	72-5
Davis-Besse First Energy Nuclear Operating Company	Under General License 01/01/1996	Transnuclear, Inc.	NUHOMS-24P	72-14
Arkansas Nuclear 1, 2 Entergy Operations, Inc.	Under General License 12/17/1996	BNG Fuel Solutions Holtec International	VSC-24 HI-STORM 100	72-13
North Anna Virginia Electric & Power Company (Dominion Gen.)	06/30/1998	Transnuclear, Inc.	TN-32	72-16
Trojan Portland General Electric Corp.	03/31/1999	Holtec International	HI-STORM 100	72-17

**APPENDIX I**  
**Dry Spent Fuel Storage Licensees (continued)**

<b>Reactor Utility</b>	<b>Date Issued</b>	<b>Vendor</b>	<b>Storage Model</b>	<b>Docket #</b>
INEEL ISFSI TMI-2 Fuel Debris, U.S. Department of Energy	03/19/1999	Transnuclear, Inc.	NUHOMS-12T	72-20
Susquehanna Pennsylvania Power & Light	Under General License 10/18/1999	Transnuclear, Inc.	NUHOMS-52B NUHOMS-61BT	72-28
Peach Bottom 2, 3 Exelon Generating Company	Under General License 06/12/2000	Transnuclear, Inc.	TN-68	72-29
Hatch 1, 2 Southern Nuclear Operating	Under General License 07/06/2000	Holtec International	HI-STAR 100 HI-STORM 100	72-36
Dresden 1, 2, 3 Exelon Generating	Under General License 07/10/2000	Holtec International	HI-STAR 100 HI-STORM 100	72-37
Rancho Seco Sacramento Municipal Utility District	06/30/2000	Transnuclear, Inc.	NUHOMS-24P	72-11
McGuire Duke Power	Under General License 02/01/2001	Transnuclear, Inc.	TN-32	72-38
Big Rock Point Consumers Energy	Under General License 11/18/2002	BNG Fuel Solutions	Fuel Solutions W74	72-43
James A. FitzPatrick Entergy Nuclear Operations, Inc.	Under General License 04/25/2002	Holtec International	HI-STORM 100	72-12
Maine Yankee Maine Yankee Atomic Power Company	Under General License 08/24/2002	NAC International, Inc.	NAC-UMS	72-30
Columbia Generating Station Energy Northwest	Under General License 09/02/2002	Holtec International	HI-STORM 100	72-35
Oyster Creek AmeriGen Energy Company	Under General License 04/11/2002	Transnuclear, Inc.	NUHOMS-61BT	72-15
Yankee Rowe Yankee Atomic Electric	Under General License 06/26/2002	NAC International, Inc.	NAC-MPC	72-31

**APPENDIX I  
Dry Spent Fuel Storage Licensees (continued)**

<b>Reactor Utility</b>	<b>Date Issued</b>	<b>Vendor</b>	<b>Storage Model</b>	<b>Docket #</b>
Duane Arnold Nuclear Management Corporation	Under General License 09/01/2003	Transnuclear, Inc.	NUHOMS-61BT	72-32
Palo Verde Arizona Public Service Company	Under General License 03/15/2003	NAC International, Inc.	NAC-UMS	72-44
San Onofre Southern California Edison Company	Under General License 10/03/2003	Transnuclear, Inc.	NUHOMS-24PT	72-41
Diablo Canyon Pacific Gas & Electric Co.	03/22/2004	Holtec International	HI-STORM 100	72-26
Haddam Neck CT Yankee Atomic Power	Under General License 05/21/2004	NAC International, Inc.	NAC-MPC	72-39
Sequoyah Tennessee Valley Authority	Under General License 07/13/2004	Holtec International	HI-STORM 100	72-34
Idaho Spent Fuel Facility Facility Foster Wheeler Environmental Corp.	11/30/2004	Multiple	Multiple	72-25
Humboldt Bay Pacific Gas & Electric Co.	11/30/2005	Holtec International	HI-STORM 100HB	72-27
Private Fuel Storage Facility	02/21/2006	Holtec International	HI-STORM 100	72-22
Browns Ferry Tennessee Valley Authority	Under General License 08/21/2005	Holtec International	HI-STORM 100S	72-52
Joseph M. Farley Southern Nuclear Operating Co.	Under General License 08/25/2005	Transnuclear, Inc.	NUHOMS-32PT	72-42
Millstone Dominion Generation	Under General License 02/15/2005	Transnuclear, Inc.	NUHOMS-32PT	72-47
Quad Cities Exelon	Under General License 12/02/2005	Holtec International	HI-STORM 100S	72-53
River Bend Entergy	Under General License 12/29/2005	Holtec International	HI-STORM 100S	72-49



**APPENDIX I**  
**Dry Spent Fuel Storage Licensees (continued)**

Reactor Utility	Date Issued	Vendor	Storage Model	Docket #
Fort Calhoun Standardized, Inc.	Under General License 7/29/2006	Transnuclear	NUHOMS-32PT	72-54
Grand Gulf 1	Under General License 11/18/2006	Holtec International	HI-STORM 100S-B	72-50
Hope Creek/Salem	Under General License 12/08/2006	Holtec International	HI-STORM 100	72-48
Fort Calhoun Omaha Public Power District	07/29/2006	Transnuclear, Inc.	NUHOMS-32PT	72-54
Hope Creek Public Service Electric and Gas Company	11/10/2006	Holtec International	HI-STORM 100	72-48
Grand Gulf Entergy Operations, Inc.	11/18/2006	Holtec International	HI-STORM 100S	72-50
Catawba Duke Energy Corporation	07/30/2007	NAC International, Inc.	NAC-UMS	72-45
Surry Virginia Electric & Power Company (Dominion Gen.)	08/06/2007	Transnuclear, Inc.	NUHOMS-HD	72-55
Indian Point	01/11/2008	Holtec International	HI-STORM 100	72-51
St. Lucie Florida Power and Light Company	03/14/2008	Transnuclear, Inc.	NUHOMS-HD	72-61

\*Fort St. Vrain plant is undergoing decommissioning and was transferred to DOE on June 4, 1999.

Source: U.S. Nuclear Regulatory Commission

APPENDIX J  
Nuclear Power Units by Nation

Country	In Operation		Under Construction, or on Order as of December 31, 2007*		Total MWh Gross 2007	Shutdown
	Number of Units	Capacity MWe Gross	Number of Units	Capacity Net		
Argentina	2	1,005	1	692	7,217,228	0
Armenia	1	408	0	0	2,553,416	1 <sup>P</sup>
Belgium	7	6,101	0	0	48,227,373	1 <sup>P</sup>
Brazil	2	2,007			12,365,339	0
Bulgaria*	2	3,000	2	1,906	3,906	4 <sup>P</sup>
Canada*	18	13,393	0	0	15,164	2 <sup>P</sup> & 2 <sup>L</sup>
China*	9	9,014	6	5,220	62,862,000	0
Taiwan	6	4,884	2	2,600	7,484	0
Czech Republic	6	3,760	0	0	26,123,793	0
Finland	4	2,800	1	1,600	23,423,221	0
France	59	66,130	1	1,330	439,102,649	11 <sup>P</sup>
Germany	17	21,457	0	0	140,533,026	19 <sup>P</sup>
Hungary	4	1,910	0	0	14,676,914	0
India	17	4,120	6	2,708	17,807,226	0
Iran	0	0	1	915	0	4 <sup>P</sup>
Italy	0	0	0	0	0	0
Japan	55	49,580	1	866	278,708,640	3 <sup>P</sup> & 1 <sup>L</sup>
Kazakhstan	0	0	0	0	0	0
Lithuania	1	1,500	0	0	9,832,800	1 <sup>P</sup>
Mexico	2	1,350	0	0	10,420,725	0
Netherlands	1	512	0	0	4,223,322	1 <sup>P</sup>
Pakistan	2	462	1	300	2,521,032	0
Republic of Korea	20	16,810	3	2,880	142,943,153	0
Romania	2	1,412			6,967,162	0
Russia	31	23,266	7	4,789	158,281,670	5 <sup>P</sup>
Slovakia	5	2,200			2,881,188	2 <sup>P</sup>
Slovenia	1	727	0	0	5,695,020	0
South Africa	2	1,930	0	0	13,189,078	0
Spain	8	7,735	0	0	55,039,426	2 <sup>P</sup>
Sweden	10	9,356	0	0	66,921,607	3

## APPENDIX J

### Nuclear Power Units by Nation (continued)

Country	In Operation		Under Construction, or on Order as of December 31, 2007*		Total MWh Gross 2007	Shutdown
	Number of Units	Capacity Net	Number of Units	Capacity Net MWe		
Switzerland	5	3,352	0	0	27,699,164	0
Ukraine	15	13,880	2	900	47,671,499	4 <sup>P</sup>
United Kingdom	19	12,540	0	0	6,794,000	26
United States	104	106,476	1	1,165	674,768,882	28

P = Permanent Shutdown

L = Long-term Shutdown

\* Construction information from International Atomic Energy Agency—Power Reactor Information System.

Note: Operable, under construction, or on order as of December 31, 2007.

Source: *Nucleonics Week*<sup>®</sup> and International Atomic Energy Agency analysis compiled by the U.S. Nuclear Regulatory Commission. Operation generation data information is from *Nucleonics Week*<sup>®</sup>, February 14, 2008.

## APPENDIX K

### Nuclear Power Units by Reactor Type, Worldwide

Reactor Type	In Operation	
	Number of Units	Net MWe
Pressurized light-water reactors (PWR)	265	243,332
Boiling light-water reactors (BWR)	94	85,044
Gas-cooled reactors, all types (GCR)	18	9,034
Heavy-water reactors, all types (HWR)	44	22,355
Graphite-moderated light-water reactors (LWGR)	16	11,404
Liquid metal cooled fast-breeder reactors (FBR)	2	690
<b>Total</b>	<b>439</b>	<b>371,860</b>

Note: MWe values rounded to the nearest whole number.

Source: International Atomic Energy Agency—Power Reactor Information System Database, [www.iaea.org/programmes/az/index.html](http://www.iaea.org/programmes/az/index.html). Data as compiled by the U.S. Nuclear Regulatory Commission. Data available as of March 2008.

**APPENDIX L**  
**Top 50 Reactors by Capacity Factor, Worldwide**

Nation	Unit	Reactor Type	Vendor	2007 Gross Generation (MWh)	2007 Gross Capacity Factor (Percent)
United States	Calvert Cliffs-1	PWR	CE	7,978,267	102.33
United States	Limerick-1	BWR	GE	10,400,300	102.09
United States	Point Beach-2	PWR	West.	4,728,500	101.85
Japan	Ohi-3	PWR	MHI	10,495,844	101.53
Japan	Genkai-4	PWR	MHI	10,419,833	100.79
United States	Catawba-1	PWR	West.	10,605,263	100.47
Japan	Ikata-2	PWR	MHI	4,976,304	100.35
United States	Braidwood-2	PWR	West.	10,616,040	100.12
United States	Comanche Peak-2	PWR	West.	10,648,862	100.05
United States	Summer	PWR	West.	8,810,490	100.03
United States	Wolf Creek	PWR	West.	10,741,943	100.02
United States	South Texas-1	PWR	West.	12,364,817	99.89
Japan	Hamaoka-3	BWR	Tosh.	9,621,122	99.83
United States	Surry-2	PWR	West.	7,411,529	99.83
United States	Watts Bar-1	PWR	West.	10,571,119	99.73
Republic of Korea	Yonggwang-5	PWR	KHIC-CE	9,123,910	99.56
United States	Dresden-3	BWR	GE	7,923,279	99.50
United States	Millstone-2	PWR	CE	7,974,743	99.22
Spain	Almaraz-1	PWR	West.	8,510,105	99.13
United States	Fort Calhoun	PWR	CE	4,567,284	99.11
United States	Ginna	PWR	West.	5,178,111	99.01
Belgium	Doel-4	PWR	Acecowen	9,014,345	98.85
United States	Davis-Besse	PWR	B&W	8,110,973	98.78
United States	Sequoyah-2	PWR	West.	10,205,348	98.64
United States	Beaver Valley-2	PWR	West.	7,877,622	98.62
United States	Salem-2	PWR	West.	10,089,888	98.45
United States	LaSalle-1	BWR	GE	10,054,798	98.44
Belgium	Tihange-2	PWR	Fram.	9,096,230	98.42
United States	Peach Bottom-2	BWR	GE	10,178,900	98.31
Taiwan	Chinshan-2	BWR	GE	5,472,600	98.22
United States	Cooper	BWR	GE	6,884,580	98.12
United States	Quad Cities-2	BWR	GE	7,834,899	98.07
United States	Vogtle-1	PWR	West.	10,430,556	98.00

**APPENDIX L**  
**Top 50 Reactors by Capacity Factor, Worldwide (continued)**

Nation	Unit	Reactor Type	Vendor	2007 Gross Generation (MWh)	2007 Gross Capacity Factor (Percent)
Taiwan	Maanshan-2	PWR	West.	8,166,221	97.93
United States	Indian Point-2	PWR	West.	9,133,852	97.72
United States	Hatch-1	BWR	GE	7,792,394	97.64
Finland	Olkiluoto-1	BWR	Asea	7,602,830	97.52
United States	Byron-1	PWR	West.	10,592,002	97.35
United States	Diablo Canyon-2	PWR	West.	10,204,220	97.32
Canada	Bruce-7	PHWR	AECL	7,421,647	97.15
Romania	Cernavoda-1	PHWR	AECL	6,005,176	97.10
Japan	Tomari-2	PWR	MHI	4,917,731	96.95
Canada	Darlington-1	PHWR	AECL	7,913,984	96.72
Canada	Bruce-5	PHWR	AECL	7,150,330	96.59
United States	Cook-1	PWR	West.	9,559,146	96.48
Republic of Korea	Kori-3	PWR	West.	8,480,797	96.42
United States	McGuire-2	PWR	West.	10,338,055	96.34
Switzerland	Goesgen	PWR	KWU	8,602,966	96.28
United States	Waterford-3	PWR	CE	10,304,998	96.27
United States	Prairie Island-2	PWR	West.	4,719,950	96.22

Source: Excerpted from *Nucleonics Week*®, February 14, 2008 by McGraw Hill, Inc. Reproduced by permission. Further reproduction prohibited.

**APPENDIX M**  
**Top 50 Reactors by Generation, Worldwide**

Nation	Unit	Reactor Type	Vendor	2007 Gross Generation (MWh)	2007 Gross Capacity Factor (Percent)
United States	South Texas-2	PWR	West.	12,364,817	99.89
Germany	Brokdorf	PWR	KWU	12,012,812	95.23
Germany	Isar-2	PWR	KWU	12,009,087	92.94
Germany	Philippsburg-2	PWR	Siemens	11,776,690	92.21
Germany	Emsland	PWR	KWU	11,594,166	94.54
United States	Palo Verde-2	PWR	CE	11,539,361	92.25
Germany	Grohnde	PWR	KWU	11,459,545	91.48
France	Chooz-B2	PWR	Fram.	11,432,850	83.66
France	Nogent-1	PWR	Fram.	11,274,204	94.42
Germany	Neckar-2	PWR	KWU	11,113,680	90.62
Germany	Gundremmingen-B	BWR	KWU	11,052,931	93.88
Germany	Grafenrheinfelf	PWR	KWU	10,900,554	92.52
France	St. Alban/St. Maurice-2	PWR	Fram.	10,895,259	90.06
United States	South Texas-2	PWR	West.	10,843,548	88.60
France	Chooz-B1	PWR	Fram.	10,802,405	79.05
United States	Wolf Creek	PWR	West.	10,741,943	100.02
United States	Comanche Peak-2	PWR	West.	10,648,862	100.05
United States	Braidwood-2	PWR	West.	10,616,040	100.12
United States	Catawba-1	PWR	West.	10,605,263	100.47
United States	Byron-1	PWR	West.	10,592,002	97.35
United States	Watts Bar-1	PWR	West.	10,571,119	99.73
Japan	Ohi-3	PWR	MHI	10,495,844	101.53
France	Civaux-2	PWR	Fram.	10,435,556	76.31
United States	Vogtle-1	PWR	West.	10,430,556	98.00
Japan	Genkai-4	PWR	MHI	10,419,833	100.79
United States	Limerick-1	BWR	GEL	10,400,300	102.09
Germany	Gundremmingen-C	BWR	KWU	10,353,237	87.94
United States	McGuire-2	PWR	West.	10,338,055	96.34
France	Golfech-2	PWR	Fram.	10,307,088	86.32
United States	Waterford-3	PWR	CE	10,304,998	96.27
France	Nogent-2	PWR	Fram.	10,298,233	86.25
France	Cattenom-1	PWR	Fram.	10,210,924	85.58

**APPENDIX M**  
**Top 50 Reactors by Generation, Worldwide (continued)**

Nation	Unit	Reactor Type	Vendor	2007 Gross Generation (MWh)	2007 Gross Capacity Factor (Percent)
United States	Sequoyah-2	PWR	West.	10,205,348	98.64
United States	Diablo Canyon-2	PWR	West.	10,204,220	97.32
United States	Peach Bottom-2	BWR	GE	10,178,900	98.31
United States	Salem-2	PWR	West.	10,089,888	98.45
United States	LaSalle-1	BWR	GE	10,054,798	98.44
France	Flamanville-1	PWR	Fram.	10,013,946	82.72
France	Cattenom-3	PWR	Fram.	10,008,756	83.89
France	Cattenom-2	PWR	Fram.	9,994,072	83.76
United States	Braidwood-1	PWR	West.	9,974,027	91.67
France	Golfech-1	PDR	Fram.	9,950,409	83.34
Switzerland	Leibstadt	BWR	GE	9,912,102	94.29
France	Belleville-2	PWR	Fram.	9,900,951	82.92
Lithuania	Ignalina-2	RBMK	MAE	9,832,800	74.82
United States	Susquehanna-1	BWR	GE	9,829,164	93.35
United States	Callaway	PWR	West.	9,795,581	87.44
United States	Nine Mile Point-2	BWR	GE	9,780,349	92.65
United States	Grand Gulf-2	BWR	GE	9,768,073	84.48
Brazil	Angra-2	PWR	KWU	9,656,675	81.65

Source: Excerpted from *Nucleonics Week*®, February 14, 2008 by McGraw Hill, Inc. Reproduced by permission. Further reproduction prohibited.

**APPENDIX N**  
**Quick-Reference Metric Conversion Tables**

**SPACE AND TIME**

Quantity	From Inch-Pound Units	To Metric Units	Multiply by
Length	mi (statute)	km	1.609 347
	yd	m	*0.914 4
	ft (int)	m	*0.304 8
	in	cm	*2.54
Area	mi <sup>2</sup>	km <sup>2</sup>	2.589 998
	acre	m <sup>2</sup>	4 046.873
	yd <sup>2</sup>	m <sup>2</sup>	0.836 127 4
	ft <sup>2</sup>	m <sup>2</sup>	*0.092 903 04
	in <sup>2</sup>	cm <sup>2</sup>	*6.451 6
Volume	acre foot	m <sup>3</sup>	1 233.489
	yd <sup>3</sup>	m <sup>3</sup>	0.764 554 9
	ft <sup>3</sup>	m <sup>3</sup>	0.028 316 85
	ft <sup>3</sup>	L	28.316 85
	gal	L	3.785 412
	fl oz	mL	29.573 53
	in <sup>3</sup>	cm <sup>3</sup>	16.387 06
Velocity	mi/h	km/h	1.609 347
	ft/s	m/s	*0.304 8
Acceleration	ft/s <sup>2</sup>	m/s <sup>2</sup>	*0.304 8

**NUCLEAR REACTION AND IONIZING RADIATION**

Quantity	From Inch-Pound Units	To Metric Units	Multiply by
Activity (of a radionuclide)	curie (Ci)	MBq	*37,000.0
	dpm	Becquerel (Bq)	0.016 667
Absorbed dose	rad	Gray (Gy)	*0.01
	rad	cGy	*1.0
Dose equivalent	rem	Sievert (Sv)	*0.01
	rem	mSv	*10.0
	mrem	mSv	*0.01
	mrem	μSv	*10.0
Exposure (X-rays and gamma rays)	roentgen (R)	C/kg (coulomb)	0.000 258



## APPENDIX N

### Quick-Reference Metric Conversion Tables (continued)

#### HEAT

Quantity	From Inch-Pound Units	To Metric Units	Multiply by
Thermodynamic temperature	°F	K	*K = (°F + 59.67)/1.8
Celsius temperature	°F	°C	*°C = (°F-32)/1.8
Linear expansion coefficient	1/°F	1/K or 1/°C	*1.8
Thermal conductivity	(Btu · in)/(ft <sup>2</sup> · h · °F)	W/(m · °C)	0.144 227 9
Coefficient of heat transfer	Btu / (ft <sup>2</sup> · h · °F)	W/(m <sup>2</sup> · °C)	5.678 263
Heat capacity	Btu/°F	kJ/°C	1.899 108
Specific heat capacity	Btu/(lb · °F)	kJ/(kg · °C)	*4.186 8
Entropy	Btu/°F	kJ/°C	1.899 108
Specific entropy	Btu/(lb · °F)	kJ/(kg · °C)	*4.186 8
Specific internal energy	Btu/lb	kJ/kg	*2.326

#### MECHANICS

Quantity	From Inch-Pound Units	To Metric Units	Multiply by
Mass (weight)	ton (short)	t (metric ton)	*0.907 184 74
	lb (avdp)	kg	*0.453 592 37
Moment of mass	lb · ft	kg · m	0.138 255
Density	ton (short)/yd <sup>3</sup>	t/m <sup>3</sup>	1.186 553
	lb/ft <sup>3</sup>	g/m <sup>3</sup>	16.018 46
Concentration (mass)	lb/gal	g/L	119.826 4
Momentum	lb · ft/s	kg · m/s	0.138 255
Angular momentum	lb · ft <sup>2</sup> /s	kg · m <sup>2</sup> /s	0.042 140 11
Moment of inertia	lb · ft <sup>2</sup>	kg · m <sup>2</sup>	0.042 140 11
Force	kip (kilopound)	kN (kilonewton)	4.448 222
	lbf	N (newton)	4.448 222
Moment of force, torque	lbf · ft	N · m	1.355 818
	lbf · in	N · m	0.122 984 8
Pressure	atm (std)	kPa (kilopascal)	*101.325
	bar	kPa	*100.0
	lbf/in <sup>2</sup> (formerly psi)	kPa	6.894 757
	inHg (32 °F)	kPa	3.386 38
	ftH <sub>2</sub> O (39.2 °F)	kPa	2.988 98
	inH <sub>2</sub> O (60 °F)	kPa	0.248 84
	mmHg (0 °C)	kPa	0.133 322

**APPENDIX N**  
**Quick-Reference Metric Conversion Tables (continued)**

MECHANICS (continued)			
Quantity	From Inch-Pound Units	To Metric Units	Multiply by
Stress	kip/in <sup>2</sup> (formerly ksi)	MPa	6.894 757
	lbf/in <sup>2</sup> (formerly psi)	MPa	0.006 894 757
	lbf/in <sup>2</sup> (formerly psi)	kPa	6.894 757
	lbf/ft <sup>2</sup>	kPa	0.047 880 26
Energy, work	kWh	MJ	*3.6
	cal <sup>th</sup>	J (joule)	*4.184
	Btu	kJ	1.055 056
	ft · lbf	J	1.355 818
	therm (US)	MJ	105.480 4
Power	Btu/s	kW	1.055 056
	hp (electric)	kW	*0.746
	Btu/h	W	0.293 071 1

Note: The information contained in this table is intended to familiarize NRC personnel with commonly used SI units and provide a quick reference to aid in the understanding of documents containing SI units. The conversion factors provided have not been approved as NRC guidelines for development of licensing actions, regulations, or policy.

To convert from metric units to inch-pound units, divide the metric unit by the conversion factor.

\* Exact conversion factors

Source: Federal Standard 376A (May 5, 1983), "Preferred Metric Units for General Use by the Federal Government"; and International Commission of Radiation Units and Measurements, ICRU Report 33 (1980), "Radiation Quantities and Units"

## GLOSSARY (ABBREVIATIONS AND TERMS DEFINED)

**10 CFR – TITLE 10, CODE OF FEDERAL REGULATIONS (10 CFR):** The U.S. Nuclear Regulatory Commission’s (NRC’s) regulations, sometimes called rules, that impose requirements that licensees must meet to obtain or retain a license or certificate to use nuclear materials or operate a nuclear facility. These regulations govern the transportation of materials; the use of materials at such nuclear facilities as power plants, research reactors, uranium mills, fuel facilities, and waste repositories; and the use of materials for medical, industrial, and academic purposes. The process of developing regulations is called rulemaking.

**AGREEMENT STATE:** A State that has signed an agreement under which the State regulates the use of byproduct, source, and small quantities of special nuclear materials in that State.

**ATOMIC ENERGY:** Energy released in nuclear reactions. Of particular interest is the energy released when a neutron initiates the breaking up of an atom’s nucleus into smaller pieces (fission) or when two nuclei are joined together under millions of degrees of heat (fusion). It is more correctly called nuclear energy.

**BACKGROUND RADIATION:** Radiation that is always present in the environment and is produced by natural sources such as cosmic rays, radioactive elements in the ground, building materials, and the human body. It includes radon gas (except as a decay product of source or special nuclear material). It does not include radiation from source, byproduct, or special nuclear materials regulated by the NRC. The typical average individual exposure in the United States from background radiation is about 300 millirems per year.

**BOILING-WATER REACTOR:** A reactor in which water, used as both coolant and moderator, is allowed to boil in the core. The resulting steam can be used directly to drive a turbine and electrical generator, thereby producing electricity.

**BRACHYTHERAPY:** Radiotherapy in which the source of radiation is placed (as by implantation) in or close to the area being treated.

**BYPRODUCT:** Any radioactive material (except special nuclear material) yielded in, or made radioactive by, exposure to the radiation incident to the process of producing or using special nuclear material (as in a reactor). This includes the tailings or wastes produced by the extraction or concentration of uranium or thorium from ore.

**CANISTER:** See *Dry Cask Storage*.

**CAPABILITY:** The maximum load that a generating unit, generating station, or other electrical apparatus can carry under specified conditions for a given period of time without exceeding approved limits of temperature and stress.

**CAPACITY:** The amount of electric power delivered or required for which a generator, turbine, transformer, transmission circuit, station, or system is rated by the manufacturer.

**CAPACITY CHARGE:** An element in a two-part pricing method used in capacity transactions (energy charge is the other element). The capacity charge, sometimes called demand charge, is assessed on the amount of capacity being purchased.

**CAPACITY FACTOR:** The ratio of the electrical energy produced by a generating unit for the period of time considered to the electrical energy that could have been produced at continuous full-power operation during the same period.

**CAPACITY FACTOR (GROSS):** The ratio of the gross electricity generated, for the time considered, to the energy that could have been generated at continuous full-power operation during the same period.

**CAPACITY UTILIZATION:** Capacity utilization is computed by dividing production by productive capacity and multiplying by 100.

**CASK:** A heavily shielded container used to store and/or ship radioactive materials. Lead and steel are common materials in casks.

**CLASSIFIED INFORMATION:** At the NRC and at the facilities it regulates, classified information is primarily of two types. National Security Information is information classified by an executive order, whose compromise would cause some degree of damage to the national security. Restricted data is information classified by the Atomic Energy Act, whose compromise would assist in the design, manufacture, or utilization of nuclear weapons. The lowest level of classified information is Confidential, the next higher is Secret, and the highest is Top Secret.

**COMBINED LICENSE (COL):** A combined license authorizes construction, and with conditions, operation of a nuclear power plant at a specific site and in accordance with laws and customs.

**COMMERCIAL SECTOR:** The commercial sector is generally defined as nonmanufacturing business establishments, including hotels, motels, restaurants, wholesale businesses, retail stores, and health, social, and educational institutions. The utility may classify commercial service as all consumers whose demand or annual use exceeds some specified limit. The limit may be set by the utility based on the rate schedule of the utility.

**COMPACT:** A group of two or more States formed to dispose of low-level radioactive waste on a regional basis. Forty-four States have formed 10 compacts.

**CONSTRUCTION RECAPTURE:** The maximum number of years that could be added to the license expiration date to recover the period from the construction permit to the date when the operating license was granted. A licensee is required to submit an application for such a change.

**CONTAINMENT STRUCTURE:** An enclosure, usually a dome made of steel-reinforced concrete, around a nuclear reactor to confine fission products that otherwise might be released to the atmosphere in the event of an accident.

**CONTAMINATION:** The deposition of unwanted radioactive material on the surfaces of structures, areas, objects, or personnel.

**CRITICALITY:** A term used in reactor physics to describe the state when the number of neutrons released by fission is exactly balanced by the neutrons being absorbed (by the fuel and reaction-damping material called “poisons”) and escaping the reactor core. A reactor is said to be “critical” when it achieves a self-sustaining nuclear chain reaction, as when the reactor is operating.

**DECAY, RADIOACTIVE:** The decrease in the amount of any radioactive material with the passage of time due to the spontaneous emission from the atomic nuclei of either alpha or beta particles, often accompanied by gamma radiation.

**DECOMMISSION:** Safely removing a facility from service and reducing residual radioactivity to a level that permits the release of the property for unrestricted and, under certain conditions, restricted use.

**DECOMMISSIONING:** The process of closing down a facility followed by reducing residual radioactivity to a level that permits the release of the property for unrestricted use.

**DECON:** A method of decommissioning in which the equipment, structures, and portions of a facility and site containing radioactive contaminants are removed or decontaminated to a level that permits the property to be released for unrestricted use shortly after cessation of operations.

**DECONTAMINATION:** The reduction or removal of contaminated radioactive material from a structure, area, object, or person. Decontamination may be accomplished by (1) treating the surface to remove or decrease the contamination, (2) letting the material stand so that the radioactivity is decreased as a result of natural radioactive decay, or (3) covering the contamination to shield the radiation emitted.

**DEFENSE IN DEPTH:** A design and operational philosophy that uses multiple layers of protection to prevent and mitigate accidents. It includes access controls, physical barriers, redundant and diverse key safety functions, and emergency response.

**DEPARTMENT OF ENERGY (DOE):** The overarching mission of the U.S. DOE is to advance the national, economic, and energy security of the United States; to promote scientific and technological innovation in support of that mission; and to ensure the environmental cleanup of the national nuclear weapons complex.

**DEPARTMENT OF HOMELAND SECURITY (DHS):** Homeland Security leverages resources within Federal, State, and local Governments, coordinating the transition of multiple agencies and programs into a single, integrated agency

focused on protecting the American people and their homeland. DHS has many major department components. The following are a few of the agencies that interact with the NRC—Directorate for Science and Technology, Office of Intelligence and Analysis, Domestic Nuclear Detection Office, Transportation Security Administration (TSA), Customs and Border Protection (CBP), and Federal Emergency Management (FEMA).

**DEPLETED URANIUM:** Uranium having a percentage of uranium-235 smaller than the 0.7 percent found in natural uranium. It is obtained from spent (used) fuel elements or as byproduct tailings, or residues, from uranium isotope separation.

**DESIGN-BASIS THREAT (DBT):** A profile of the type, composition, and capabilities of an adversary. The NRC and its licensees use the DBT as a basis for designing security systems to protect against acts of radiological sabotage and to prevent the theft of special nuclear material. The DBT is described in detail in 10 CFR 73 “Physical Protection of Plants and Materials.” This term is applied to clearly identify for a licensee the expected capability of its facility to withstand a threat.

**DESIGN CERTIFICATION:** The NRC may approve and certify a standard nuclear plant design through a rulemaking, independent of a specific site. The design certification is valid for 15 years.

**DRY CASK STORAGE:** An above ground storage system for spent fuel that has cooled and has been loaded into special canisters. Each canister is designed to hold approximately two to six dozen spent fuel assemblies, depending on the type of assembly. Water and air are removed. The canister is filled with inert gas and sealed (welded or bolted shut). Some canisters are designed to be placed vertically in robust above-ground concrete or steel structures. Some canisters are designed to be stored horizontally in above-ground concrete bunkers, each of which is about the size of a one-car garage.

**EARLY SITE PERMIT (ESP):** An ESP resolves site safety, environmental protection, and emergency preparedness issues independent of a specific nuclear plant design.

**ECONOMIC SIMPLIFIED BOILING-WATER REACTOR (ESBWR):**

A nuclear reactor that has passive safety features and uses natural circulation with no recirculation pumps or associated piping.

**EFFICIENCY, PLANT:** The percentage of the total energy content of a power plant’s fuel that is converted into electricity. The remaining energy is lost to the environment as heat.

**ELECTRIC POWER:** The rate at which electric energy is transferred. Electric power is measured by capacity and is commonly expressed in megawatts (MW).

**ELECTRIC POWER GRID:** A system of synchronized power providers and consumers connected by transmission and distribution lines and operated by one or more control centers. In the continental United States, the electric power grid consists of three systems—the Eastern Interconnect, the Western Interconnect, and

the Texas Interconnect. In Alaska and Hawaii, several systems encompass areas smaller than the State (e.g., the interconnect serving Anchorage, Fairbanks, and the Kenai Peninsula; individual islands).

**ELECTRIC POWER PLANT:** A station with electric generators and auxiliary equipment for converting mechanical, chemical, and/or fission energy into electric energy.

**ELECTRIC UTILITY:** A corporation, person, agency, authority, or other legal entity or instrumentality that owns and/or operates facilities within the United States, its territories, or Puerto Rico for the generation, transmission, distribution, or sale of electric energy primarily for use by the public and files forms listed in 18 CFR Part 141, “Statements and Reports (Schedules).” Facilities that qualify as cogenerators or small power producers under the Public Utility Regulatory Policies Act (PURPA) are not considered electric utilities.

**EMERGENCY CLASSIFICATIONS:** An Emergency classification is a set of plant conditions which indicate a level of risk to the public. Both nuclear power plants and research and test reactors use the four emergency classifications listed below in order of increasing severity.

- Unusual Event – Under this category, events are in progress or have occurred which indicate potential degradation in the level of safety of the plant. No release of radioactive material requiring offsite response or monitoring is expected unless further degradation occurs.
- Alert – Events are in progress or have occurred which involve an actual or potential substantial degradation in the level of safety of the plant. Any releases of radioactive material from the plant are expected to be limited to a small fraction of the Environmental Protection Agency (EPA) Protective Action Guides (PAGs).
- Site Area Emergency – Events are in progress or have occurred that result in actual or likely major failures of plant functions needed for protection of the public. Any releases of radioactive material are not expected to exceed the EPA PAGs except near the site boundary.
- General Emergency – There is actual or imminent substantial core damage or melting of reactor fuel with the potential for loss of containment integrity. Radioactive releases during a general emergency can reasonably be expected to exceed the EPA PAGs for more than the immediate site area.

The following are emergency classifications for nuclear materials and fuel cycle facility licensees:

- Alert – Events may occur, are in progress, or have occurred that could lead to a release of radioactive material, but the release is not expected to require a response by an offsite response organization to protect people offsite.
- Site Area Emergency – Events may occur, are in progress, or have occurred that could lead to a significant release of radioactive material, and the release could require a response by offsite response organizations to protect people offsite.

**EMERGENCY PREPAREDNESS (EP):** Establishing the plans, training, exercises, and resources necessary to achieve readiness for an emergency and all hazards.

**ENERGY INFORMATION ADMINISTRATION (EIA):** The statistical agency within DOE that provides policy-neutral data, forecasts, and analyses to promote sound policymaking, efficient markets, and public understanding regarding energy and its interaction with the economy and the environment.

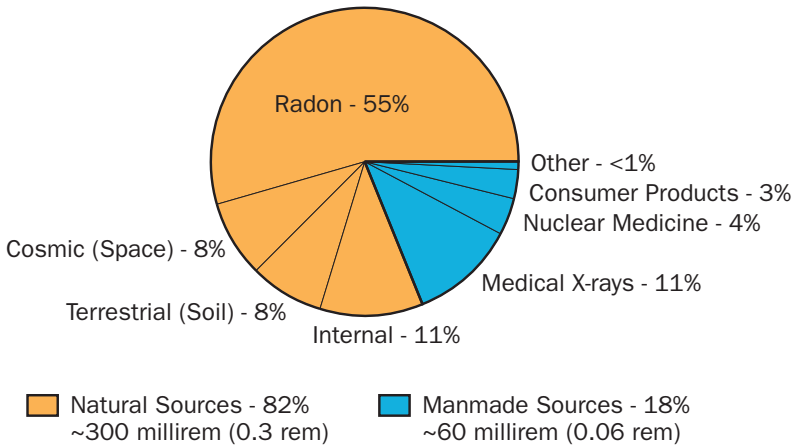
**ENTOMB:** A method of decommissioning in which radioactive contaminants are encased in a structurally long-lived material, such as concrete. The entombment structure is appropriately maintained and continually checked until the radioactivity decays to a level permitting unrestricted release of the property.

**ENVIRONMENTAL PROTECTION AGENCY (EPA):** Federal agency that leads the Nation’s environmental science, research, education, and assessment efforts.

**EVENT NOTIFICATION (EN) SYSTEM:** An internal NRC automated event tracking system used by the NRC Operations Center to track information on incoming notifications of the occurrence of significant material events that have or may affect public health and safety. Significant material events are reported to the NRC Operations Center by NRC licensees, staff of the Agreement States, other Federal agencies, and the public.

**EXPOSURE:** Being exposed to ionizing radiation or to radioactive material. The maximum permissible yearly dose for a person working with or around nuclear material is 5 rem.

**Sources of Radiation Exposure in the United States**





**FEDERAL EMERGENCY MANAGEMENT AGENCY (FEMA):** A component organization of the Department of Homeland Security that prepares the nation for hazards, manages Federal response and recovery efforts following any national incident, and administers the National Flood Insurance Program.

**FEDERAL ENERGY REGULATORY COMMISSION (FERC):** An independent regulatory agency having jurisdiction over interstate transmission of electricity, natural gas, and oil. It also has oversight of building liquefied natural gas terminals and interstate natural gas pipelines and licensing of hydropower projects.

**FISCAL YEAR (FY):** The 12-month period, from October 1 through September 30, used by the Federal Government in budget formulation and execution. The fiscal year is designated by the calendar year in which it ends.

**FISSILE:** Material that will fission after absorbing a slow neutron.

**FISSION (FISSIONING):** The splitting of a nucleus into at least two other nuclei and the release of a relatively large amount of energy. Two or three neutrons are usually released during this type of transformation.

**FORCE ON FORCE (FOF):** These exercises test a nuclear plant's ability to defend against the design basis threat. A full FOF exercise, spanning 2 weeks, includes tabletop drills and simulated combat between a mock commando-type adversary force and the nuclear plant security force. During the attack, the mock adversary force tries to simulate damage to key safety systems and components that protect the reactor core or the spent nuclear fuel pool. The plant's security force, in turn, seeks to stop the adversaries from causing a radiation release. These exercises involve a wide array of Federal, State, local law enforcement, emergency planning officials, plant operators, and NRC personnel.

**FOREIGN ASSIGNEE PROGRAM:** An on-the-job training program at the NRC for assignees from other countries, usually from their regulatory organizations, operating under the aegis of bilateral information exchange arrangements.

**FREEDOM OF INFORMATION ACT (FOIA):** The United States law that provides any person the right, enforceable in court, to obtain access to Federal agency records.

**FUEL ASSEMBLY:** A bundle of fuel rods (or plates). Many fuel assemblies make up a reactor core.

**FUEL CYCLE:** The series of steps involved in supplying fuel for nuclear power reactors. It can include mining, milling, isotopic enrichment, fabrication of fuel elements, use in a reactor, chemical recycling to recover the fissionable material remaining in the spent fuel, reenrichment of the fuel material, refabrication into new fuel elements, and waste disposal.

**FUEL RECYCLING (REPROCESSING):** The processing of reactor fuel to separate the unused fissionable material from waste material.

**FUEL ROD:** A long, slender tube that holds fissionable material (fuel) for nuclear reactor use. Fuel rods are assembled into bundles called fuel assemblies, which are loaded individually into the reactor core.

**FULL-TIME EQUIVALENT:** A measurement equal to one staff person working a full-time work schedule for 1 year.

**GAS CENTRIFUGE:** A uranium enrichment process that uses a large number of rotating cylinders in a series. These series of centrifuge machines, called trains, are interconnected to form cascades. In this process, uranium hexafluoride gas is placed in a drum or cylinder and rotated at high speed. This rotation creates a strong gravitational field so that the heavier gas molecules (containing uranium-238) move toward the outside of the cylinder and the lighter gas molecules (containing uranium-235) collect closer to the center. The stream that is slightly enriched in uranium-235 is withdrawn and fed into the next higher stage, while the slightly depleted stream is recycled back into the next lower stage.

**GAS CHROMATOGRAPHY:** A technique for separating chemical substances in which the sample is carried by a moving gas stream through a tube packed with a finely divided solid that may be coated with a film of a liquid. Because of its simplicity, sensitivity, and effectiveness in separating components of mixtures, gas chromatography devices are useful in the analysis of air pollutants, alcohol in blood, essential oils, and food products.

**GASEOUS DIFFUSION PLANT:** A facility where uranium hexafluoride gas is filtered. Uranium-235 is separated from uranium-238, increasing the percentage of uranium-235 from 1 to 3 percent. The process requires enormous amounts of electric power.

**GAUGING DEVICES:** Devices used to measure, monitor, and control the thickness of sheet metal, textiles, paper napkins, newspaper, plastics, photographic film, and other products as they are manufactured. Nonportable gauging devices (i.e., gauges mounted in fixed locations) are designed for measurement or control of material density, flow, level, thickness, or weight. The gauges contain sealed sources that radiate through the substance being measured to a readout or controlling device. Portable gauging devices, such as moisture density gauges, are used at field locations. These gauges contain a gamma-emitting sealed source, usually cesium-137, or a sealed neutron source, usually americium-241 or beryllium.

**GENERATION (Gross):** The total amount of electric energy produced by a generating station as measured at the generator terminals.

**GENERATION (Net):** The gross amount of electric energy produced minus the electric energy consumed at a generating station for station use. Measured in wathours except as noted otherwise.

**GENERATOR CAPACITY:** The maximum output, commonly expressed in megawatts (MW), that generating equipment can supply to system load, adjusted for ambient conditions.

**GENERATOR NAMEPLATE CAPACITY:** The maximum rated output of a generator under specific conditions designated by the manufacturer. Generator nameplate capacity is usually indicated in units of kilovolt-amperes (kVA) and in kilowatts (kW) on a nameplate physically attached to the generator.

**GEOLOGICAL REPOSITORY:** A mine-like facility for disposal of radioactive waste that uses waste packages and the natural geology as barriers to isolate waste.

**GIGAWATT:** One billion watts.

**GIGAWATTHOUR:** One billion watthours.

**GLOBAL NUCLEAR ENERGY PARTNERSHIP (GNEP):** The Partnership is cooperation of those nations that share the common vision of the necessity of the expansion of nuclear energy for peaceful purposes worldwide in a safe and secure manner. It aims to accelerate development and deployment of advanced fuel cycle technologies to encourage clean development and prosperity worldwide, improve the environment, and reduce the risk of nuclear proliferation.

**GRID:** The layout of an electrical distribution system.

**HALF-LIFE:** The time in which one half of the atoms of a particular radioactive substance disintegrate into another nuclear form. Measured half-lives vary from millionths of a second to billions of years. Also called physical or radiological half-life.

**HEALTH PHYSICS:** The science concerned with the recognition, evaluation, and control of health and environmental hazards that may arise from the use and application of ionizing radiation.

**HIGH-ENRICHED URANIUM:** Uranium enriched to 20 percent or greater in the isotope uranium-235.

**HIGH-LEVEL RADIOACTIVE WASTE (HLW):** This type of radioactive waste includes (1) irradiated (spent) reactor fuel; (2) liquid waste resulting from the operation of the first cycle solvent extraction system, and the concentrated wastes from subsequent extraction cycles, in a facility for recycling irradiated reactor fuel; and (3) solids into which such liquid wastes have been converted. HLW is primarily in the form of spent fuel discharged from commercial nuclear power reactors. It also includes some recycled HLW from defense activities and a small quantity of recycled commercial HLW.

**IN-SITU LEACH (ISL):** A process using a leaching solution to extract uranium from underground ore bodies in place (in other words, in situ). The leaching agent, which contains an oxidant such as oxygen with sodium carbonate, is injected through wells into the ore body in a confined aquifer to dissolve the uranium. This solution is then pumped via other wells to the surface for processing.

**INCIDENT RESPONSE (IR):** Activities that address the short-term, direct effects of an occurrence or event, natural or human caused, which requires an emergency response to protect life or property.

**INDEPENDENT SPENT FUEL STORAGE INSTALLATION (ISFSI):** A complex designed and constructed for the interim storage of spent nuclear fuel, solid reactor-related greater than Class C (GTCC) waste, and other radioactive materials associated with spent fuel and reactor-related GTCC waste storage. An ISFSI which is located on the site of another facility licensed by the NRC or a facility licensed under 10 CFR Part 50, "Domestic Licensing of Production and

Utilization Facilities,” and which shares common utilities and services with that facility or is physically connected with that other facility may still be considered independent.

**INTERNATIONAL ATOMIC ENERGY AGENCY (IAEA):** The IAEA is the world center of cooperation in the nuclear field. It was set up as the “Atoms for Peace” organization in 1957 within the United Nations family. The agency works with its member States and multiple partners worldwide to promote safe, secure, and peaceful nuclear technologies.

**INTERNATIONAL NUCLEAR REGULATORS ASSOCIATION (INRA):** The INRA, a group of international nuclear regulators formed in January 1997 to provide regulators a forum to discuss nuclear safety. Countries represented include Canada, France, Japan, Spain, Republic of Korea, Sweden, the United Kingdom, and the United States.

**IRRADIATION:** Exposure to radiation.

**ISOTOPE:** Any two or more forms of an element having identical or very closely related chemical properties and the same atomic number but different atomic weights or mass numbers.

**KILOWATT (KW):** One thousand watts.

**LICENSED MATERIAL:** Source material, special nuclear material, or byproduct material received, possessed, used, transferred, or disposed of under a general or specific license issued by the NRC.

**LICENSEES:** An entity that is licensed.

**LICENSING BASIS:** The collection of documents or technical criteria that provides the basis upon which the NRC issues a license to possess radioactive materials, conduct operations involving emission of radiation, use special nuclear materials, or dispose of radioactive waste.

**LOW-LEVEL RADIOACTIVE WASTE (LLW):** LLW generally refers to a wide range of wastes. Industries; hospitals and medical, educational, or research institutions; private or Government laboratories; and nuclear fuel cycle facilities (e.g., nuclear power reactors and fuel fabrication plants) using radioactive materials generate LLW as part of their normal operations. These wastes are generated in many physical and chemical forms and levels of contamination.

**MAXIMUM DEPENDABLE CAPACITY (Gross):** Dependable main-unit gross capacity, winter or summer, whichever is smaller. The dependable capacity varies because the unit efficiency varies during the year because of temperature variations in cooling water. It is the gross electrical output as measured at the output terminals of the turbine generator during the most restrictive seasonal conditions (usually summer). Measured in watts except as noted otherwise.

**MAXIMUM DEPENDABLE CAPACITY (Net):** Gross maximum dependable capacity minus the normal station service loads. Measured in watts except as noted otherwise.

**MEGAWATT (MW):** One million watts.

**MEGAWATTHOUR (MWh):** One million watthours.

**METRIC TON:** Approximately 2,200 pounds.

**MILL TAILINGS:** Naturally radioactive residue from the processing of uranium ore into yellowcake in a mill. Although the milling process recovers about 93 percent of the uranium, the residues, or tailings, contain several naturally occurring radioactive elements, including uranium, thorium, radium, polonium, and radon. Mill tailings are often confined within an enclosure known as a "tailings impoundment."

**MIXED OXIDE (MOX) FUEL:** A fuel made of plutonium dioxide and depleted uranium dioxide.

**MONITORING OF RADIATION:** Periodic or continuous determination of the amount of ionizing radiation or radioactive contamination present in a region, used as a safety measure, for the purpose of health or environmental protection. Bioassay, alpha scans, and other methods monitor air, surface water and ground water, soil and sediment, equipment surfaces, and personnel, (e.g., bioassay or alpha scans).

**NATIONAL RESPONSE FRAMEWORK (NRF):** The framework presents the guiding principles for responders in order to provide a unified national response to disasters and emergencies. It describes how communities, Tribes, States, the Federal Government, the private sector, and nongovernmental partners work together to coordinate national response. The framework, which became effective March 22, 2008, builds upon the National Incident Management System (NIMS), which provides a consistent template for managing incidents.

**NATIONAL SOURCE TRACKING SYSTEM (NSTS):** A secure Web-based system that will allow NRC licensees to record certain types of radioactive source transfers directly over the Internet. Until the NSTS becomes available, the NRC and Agreement States will continue using an interim database to record snapshots of data. The interim database has been in use since 2004 and currently meets the U.S. Government's commitment to implement a national source registry.

**NATURAL URANIUM:** Uranium as found in nature. It contains 0.7 percent uranium-235, 99.3 percent uranium-238, and a trace amount of uranium-234 by weight.

**NET ELECTRIC GENERATION:** The amount of gross electric energy generation less the electrical energy consumed at the generating station(s) for station service or auxiliaries. *Note:* Electricity required for pumping at pumped-storage plants is regarded as electricity for station service and is deducted from gross generation.

**NET SUMMER CAPABILITY:** The steady hourly output that generating equipment is expected to supply to system load exclusive of auxiliary power, as demonstrated by tests at the time of summer peak demand. Measured in watts except as noted otherwise.

**NONPOWER REACTOR:** A nuclear reactor used for research, training, or test purposes and for the production of radioisotopes for medical and industrial uses.

**NRC OPERATIONS CENTER:** Located in Rockville, MD, serves as the focal coordination point for communicating with NRC licensees, State agencies, and other Federal agencies about operating events in both the nuclear reactor and nuclear material industry. The Operations Center is staffed 24 hours a day by NRC Headquarters Operations Officers (HOO), who are trained to receive, evaluate, and respond to events reported to the Operations Center.

**NUCLEAR ENERGY:** See *Atomic Energy*.

**NUCLEAR ENERGY AGENCY (NEA):** NEA is a specialized agency within the Organisation for Economic Co-operation and Development (OECD), an intergovernmental organization of industrialized countries, based in Paris, France.

**NUCLEAR FUEL:** Fissionable materials that have been enriched to such a composition that, when placed in a nuclear reactor, will support a self-sustaining fission chain reaction, producing heat in a controlled manner for process use.

**NUCLEAR MATERIALS:** See *Special Nuclear Material*, *Source Material*, and *Byproduct*.

**NUCLEAR MATERIAL MANAGEMENT AND SAFEGUARDS SYSTEM (NMMSS):** The U.S. Government's information system containing current and historic data on the possession, use, and shipment of nuclear materials. This centralized database contains information collected from Government and commercial nuclear facilities and provides output reports to those facilities and other interested parties, primarily U.S. Government offices charged with the management and safeguarding of nuclear materials.

**NUCLEAR POISON (also called a neutron poison):** A substance with a large capacity for neutron absorption. Although this effect may be undesirable in some applications, neutron-absorbing materials, also called poisons, are intentionally inserted into some types of reactors in order to lower the high reactivity of their initial fresh fuel load. Some of these poisons deplete as they absorb neutrons during reactor operation, while others remain relatively constant.

**NUCLEAR POWER PLANT:** A facility in which heat produced in a reactor by the fissioning of nuclear fuel is used to drive a steam turbine.

**NUCLEAR/RADIOLOGICAL INCIDENT ANNEX:** This annex to the National Response Framework provides an organized, integrated, and coordinated response by Federal agencies to terrorist incidents involving nuclear or radioactive materials, and accidents or incidents involving such material. This annex covers radiological dispersal devices (RDDs) or improvised nuclear devices (INDs) as well as reactor plant accidents (commercial or weapons production facilities), lost radioactive material sources, transportation accidents involving radioactive material, and foreign accidents involving nuclear or radioactive material.

**NUCLEAR REACTOR:** A device in which nuclear fission may be sustained and controlled in a self-supporting nuclear reaction. The varieties are many, but all incorporate certain features, including fissionable material or fuel, a moderating material (unless the reactor is operated on fast neutrons), a reflector to conserve

escaping neutrons, provisions for removal of heat, measuring and controlling instruments, and protective devices. The reactor is the heart of a nuclear power plant.

**NUCLEAR WASTE:** A particular type of radioactive waste that is produced as part of the nuclear fuel cycle (i.e., those activities needed to produce nuclear fission, or splitting of the atom). These activities include extraction of uranium from ore, concentration of uranium, processing into nuclear fuel, and disposal of byproducts. Radioactive waste is a broader term that includes all waste that contains radioactivity. Residues from water treatment, contaminated equipment from oil drilling, and tailings from the processing of metals such as vanadium and copper also contain radioactivity but are not considered “nuclear waste” because they are produced outside of the nuclear fuel cycle. The NRC generally regulates only those wastes produced in the nuclear fuel cycle (e.g., uranium mill tailings, depleted uranium, and spent fuel rods).

**OCCUPATIONAL DOSE:** The dose received by an individual in the course of employment in which the individual’s assigned duties involve exposure to radiation or to radioactive material from licensed and unlicensed sources of radiation, whether in the possession of the licensee or other person. Occupational dose does not include dose received from background radiation, from any medical administration the individual has received, from exposure to individuals administered radioactive materials and released in accordance with 10 CFR 35.75, “Release of Individuals Containing Unsealed Byproduct Material or Implants Containing Byproduct Material,” from voluntary participation in medical research programs, or as a member of the general public.

**ORGANISATION FOR ECONOMIC CO-OPERATION AND DEVELOPMENT (OECD):** The OECD brings together the governments of countries committed to democracy and the market economy from around the world to support sustainable economic growth, boost employment, raise living standards, maintain financial stability, assist other countries’ economic development, and contribute to growth in world trade. The OECD also shares expertise and exchanges views with more than 100 other countries and economies, from Brazil, China, and Russia to the least developed countries in Africa.

**ORPHAN SOURCES (UNWANTED RADIOACTIVE MATERIAL):** Sealed sources of radioactive material contained in a small volume (but not radioactively contaminated soils and bulk metals) in any one or more of the following conditions—(1) in an uncontrolled condition that requires removal to protect public health and safety from a radiological threat, (2) controlled or uncontrolled, but for which a responsible party cannot be readily identified, (3) controlled, but the material’s continued security cannot be assured, (4) if held by a licensee, the licensee has few or no options for, or is incapable of providing for, the safe disposition of the material, (5) in the possession of a person, not licensed to possess the material, who did not seek to possess the material, or (6) in the possession of a State radiological protection program for the sole purpose of mitigating a radiological threat because of one of the above conditions, and for which the State does not have a means to provide for the material’s appropriate disposition.

**OUTAGE:** The period during which a generating unit, transmission line, or other facility is out of service.

**OUTAGE (FORCED):** The shutdown of a generating unit, transmission line, or other facility for emergency reasons or a condition in which the generating equipment is unavailable for load due to unanticipated breakdown.

**OUTAGE (FULL FORCED):** The net capability of main generating units that are unavailable for load for emergency reasons.

**OUTAGE (SCHEDULED):** The shutdown of a generating unit, transmission line, or other facility for inspection or maintenance, in accordance with an advance schedule.

**PELLET, FUEL:** As used in pressurized-water reactors and boiling-water reactors, a pellet is a small cylinder approximately 3/8-inch in diameter and 5/8-inch in length, consisting of uranium fuel in a ceramic form, uranium dioxide. Typical fuel pellet enrichments in nuclear power reactors range from 2.0 percent to 4.9 percent uranium-235.

**PERFORMANCE-BASED REGULATION:** Regulation focused on results or outcomes of performance, rather than a prescriptive process, technique, or procedure.

**PERFORMANCE INDICATOR:** A performance indicator is a quantitative measure of a particular attribute of licensee performance that indicates how well a plant is performing when measured against established thresholds. Licensees submit these data quarterly, and the NRC regularly performs verification inspections of their submittals. As previously mentioned, the NRC uses its analysis of these data with its own inspection data for assessment of a plant's performance.

**POSSESSION-ONLY LICENSE:** A form of license that allows possession but not operation.

**POWER UPRATE:** The process of increasing the maximum power level at which a commercial nuclear power plant may operate.

**PRESSURIZED-WATER REACTOR (PWR):** A nuclear reactor in which heat is transferred from the core to a heat exchanger via water kept under high pressure without boiling the water.

**PROBABILISTIC RISK ANALYSIS (PRA):** A systematic method for addressing the risk triplet as it relates to the performance of a complex system to understand likely outcomes, sensitivities, areas of importance, system interactions, and areas of uncertainty. The risk triplet is the set of three questions that the NRC uses to define "risk"—(1) What can go wrong? (2) How likely is it? (3) What are the consequences? The NRC identifies important scenarios from such an assessment.

**PRODUCTION EXPENSE:** Production expenses are a component of generation expenses and include costs associated with operation, maintenance, and fuel.

**RAD:** The special unit for radiation-absorbed dose, which is the amount of energy from any type of ionizing radiation (e.g., alpha, beta, gamma, neutrons) deposited in any medium (e.g., water, tissue, air). A dose of one rad means the absorption of 100 ergs (a small but measurable amount of energy) per gram of absorbing tissue (100 rad = 1 gray). For gamma rays and beta particles, 1 rad of exposure results in 1 rem of dose.



**RADIATION (IONIZING RADIATION):** Alpha particles, beta particles, gamma rays, X-rays, neutrons, high-speed electrons, high-speed protons, and other particles capable of producing ions. Radiation, as used in 10 CFR Part 20, “Standards for Protection against Radiation,” does not include nonionizing radiation, such as radio-waves or microwaves, or visible, infrared, or ultraviolet light.

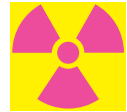
**RADIATION, NUCLEAR:** Particles (alpha, beta, neutrons) or photons (gamma) emitted from the nucleus of unstable radioactive atoms as a result of radioactive decay.

**RADIATION SOURCE:** Usually a sealed source of radiation used in teletherapy and industrial radiography, as a power source for batteries (as in use in space craft), or in various types of industrial gauges. Machines, such as accelerators and radioisotope generators, and natural radionuclides may be considered sources.

**RADIATION STANDARDS:** Exposure standards, permissible concentrations, rules for safe handling, regulations for transportation, regulations for industrial control of radiation, and control of radioactive material by legislative means.

**RADIATION THERAPY (RADIOTHERAPY):** The treatment of disease by exposure to a radioactive substance.

**RADIATION WARNING SYMBOL:** An officially prescribed symbol (a magenta or black trefoil) on a yellow background that must be displayed where certain quantities of radioactive materials are present or where certain doses of radiation could be received.



**RADIOACTIVE CONTAMINATION:** Deposition of radioactive material in any place where it may harm persons or equipment.

**RADIOACTIVE DECAY:** Large unstable atoms can become more stable by emitting radiation. This process is called radioactive decay. This radiation can be emitted in the form of a positively charged alpha particle, a negatively charged beta particle, or gamma rays or X-rays.

**RADIOACTIVITY:** The spontaneous emission of radiation, generally alpha or beta particles, often accompanied by gamma rays, from the nucleus of an unstable isotope. Also, the rate at which radioactive material emits radiation. Measured in units of becquerels or disintegrations per second.

**RADIOGRAPHY:** The making of a shadow image on photographic film by the action of ionizing radiation.

**RADIOISOTOPE:** An unstable isotope of an element that decays or disintegrates spontaneously, emitting radiation. Approximately 5,000 natural and artificial radioisotopes have been identified.

**RADIONUCLIDE:** A chemical substance that exhibits radioactivity.

**RADIOPHARMACEUTICAL:** Any of a number of radioactive drugs used diagnostically or therapeutically.

**REACTOR CORE:** Part of a nuclear reactor containing the fuel assemblies where fission takes place.

**REACTOR OVERSIGHT PROCESS (ROP):** The NRC process that uses both inspection findings and performance indicators (PIs) to assess the safety performance of each plant.

**REGULATION:** The governmental function of controlling or directing economic entities through the process of rulemaking and adjudication.

**REGULATORY INFORMATION CONFERENCE (RIC):** The RIC is a joint presentation of the NRC's Offices of Nuclear Reactor Regulation and Nuclear Regulatory Research. The conference brings together the NRC staff, regulated utilities, materials users, and other interested stakeholders to discuss nuclear safety topics and significant and timely regulatory activities through informal dialogue to ensure an open regulatory process.

**REM:** Roentgen equivalent man is a standard unit that measures the amount of radiation absorbed by the human body.

**RENEWABLE RESOURCES:** Natural, but flow-limited resources that can be replenished. They are virtually inexhaustible in duration but limited in the amount of energy that is available per unit of time. Some (such as geothermal and biomass) may be stock limited in that stocks are depleted by use, but on a time scale of decades, or perhaps centuries, they can probably be replenished. Renewable energy resources include biomass, hydro, geothermal, solar, and wind. In the future, they could also include the use of ocean thermal, wave, and tidal action technologies. Utility renewable resource applications include bulk electricity generation, onsite electricity generation, distributed electricity generation, nongrid-connected generation, and demand-reduction (energy efficiency) technologies. The Information Digest has included conventional hydroelectric and storage hydroelectric in a separate category from other resources identified.

**RISK:** The combined answer to the following three questions: (1) What can go wrong? (2) How likely is it to go wrong? (3) What are the consequences if it goes wrong?

**RISK-BASED DECISIONMAKING:** An approach to regulatory decisionmaking in which such decisions are made solely based on the results of a probabilistic risk analysis.

**RISK-INFORMED DECISIONMAKING:** An approach to decisionmaking in which insights from probabilistic risk analyses are considered with other engineering insights.

**RISK-INFORMED REGULATION:** Risk-informed regulation incorporates an assessment of safety significance or relative risk in NRC regulatory actions. This approach ensures that the regulatory burden imposed by individual regulations or processes is commensurate with the importance of that regulation or process to protecting public health and safety and the environment.

**RISK SIGNIFICANT:** When used to qualify an object, such as a system, structure, component, accident sequence, or cut set, this term identifies that object as exceeding a predetermined criterion related to its contribution to the risk from the

facility being addressed. This term is also associated with a level of risk that exceeds a predetermined significance criterion.

**SAFEGUARDS:** Safeguards encompass the use of material control and accounting programs to verify that all special nuclear material is properly controlled and accounted for, as well as the physical protection (also referred to as physical security) equipment and security forces. As used by the International Atomic Energy Agency (IAEA), this term also means verifying that the peaceful use commitments made in binding nonproliferation agreements, both bilateral and multilateral, are honored.

**SAFEGUARDS INFORMATION (SGI):** A special category of sensitive unclassified information authorized to be protected. Safeguards information concerns the physical protection of operating power reactors, spent fuel shipments, strategic special nuclear material, or other radioactive material.

**SAFETY RELATED:** In the regulatory arena, this term applies to systems, structures, components, procedures, and controls of a facility or process that are relied upon to remain functional during and following design-basis events. Their functionality ensures that key regulatory criteria, such as levels of radioactivity released, are met. Examples of safety-related functions include shutting down a nuclear reactor and maintaining it in a safe shutdown condition.

**SAFETY-SIGNIFICANT:** When used to qualify an object, such as a system, structure, component, or accident sequence, this term identifies that object as having an impact on safety, whether determined through risk analysis or other means, that exceeds a predetermined significance criterion.

**SAFSTOR:** A method of decommissioning in which the nuclear facility is placed and maintained in such condition that the nuclear facility can be safely stored and subsequently decontaminated (deferred decontamination) to levels that permit release for unrestricted use.

**SCRAM:** The sudden shutting down of a nuclear reactor, usually by rapid insertion of control rods, either automatically or manually by the reactor operator. May also be called a reactor trip. It is actually an acronym for “safety control rod axe man,” the worker assigned to insert the emergency rod on the first reactor (the Chicago Pile) in the United States.

#### **SENSITIVE UNCLASSIFIED NONSAFEGUARDS INFORMATION**

**(SUNSI):** This information is generally not publicly available and encompasses a wide variety of categories, such as proprietary information, personal and private information, or information subject to attorney-client privilege.

**SHUTDOWN:** A decrease in the rate of fission (and heat production) in a reactor (usually by the insertion of control rods into the core).

**SOURCE MATERIAL:** Uranium or thorium, or any combination thereof, in any physical or chemical form or ores that contain by weight 1/20 of one percent (0.05 percent) or more of (1) uranium, (2) thorium, or (3) any combination thereof. Source material does not include special nuclear material.

**SPECIAL FORM RADIOACTIVE MATERIAL:** Radioactive material that satisfies the following conditions (1) it is either a single solid piece or is contained in a sealed capsule that can be opened only by destroying the capsule, (2) the piece or capsule has at least one dimension not less than 5 millimeters (0.2 inch), and (3) it satisfies the requirements of 10 CFR 71.75, "Qualification of Special Form Radioactive Material." A special form encapsulation designed in accordance with the requirements of 10 CFR 71.4, "Definitions," in effect on June 30, 1983, and constructed before July 1, 1985, and a special form encapsulation designed in accordance with the requirements of 10 CFR 71.4 in effect on March 31, 1996, and constructed before April 1, 1998, may continue to be used. Any other special form encapsulation must meet the specifications of this definition.

**SPECIAL NUCLEAR MATERIAL:** Plutonium, uranium-233, or uranium enriched in the isotopes uranium-233 or uranium-235.

**SPENT (DEPLETED OR USED) FUEL:** Nuclear reactor fuel that has been used to the extent that it can no longer effectively sustain a chain reaction.

**SPENT FUEL POOL:** An underwater storage and cooling facility for spent (used) fuel assemblies that have been removed from a reactor.

**SUBCRITICALITY:** The condition of a nuclear reactor system when the rate of production of fission neutrons is lower than the rate of production in the previous generation because of increased neutron leakage and poisons.

**TELE THERAPY:** Treatment in which the source of the therapeutic agent (e.g., radiation) is at a distance from the body. Called also external beam radiotherapy.

**TRANSIENT:** A change in the reactor coolant system temperature and/or pressure due to a change in power output of the reactor. Transients can be caused by (1) adding or removing neutron poisons, (2) increasing or decreasing electrical load on the turbine generator, or (3) accident conditions.

**TRANSURANIC WASTE:** Material contaminated with transuranic elements that is produced primarily from recycling spent fuel and from use of plutonium in fabrication of nuclear weapons.

**TRITIUM:** A radioactive isotope of hydrogen (one proton, two neutrons). Because it is chemically identical to natural hydrogen, tritium can easily be taken into the body by any ingestion path. It decays by beta emission. It has a radioactive half-life of about 12.5 years.

**UPRATE:** See *Power Uprate*.

**URANIUM:** A radioactive element with the atomic number 92 and, as found in natural ores, an atomic weight of approximately 238. The two principal natural isotopes are uranium-235 (0.7 percent of natural uranium), which is fissile, and uranium-238 (99.3 percent of natural uranium), which is fissionable by fast neutrons and is fertile, meaning that it becomes fissile after absorbing one neutron. Natural uranium also includes a minute amount of uranium-234.

**URANIUM FUEL FABRICATION FACILITY:** A facility that converts enriched uranium hexafluoride (UF<sub>6</sub>) into fuel for nuclear reactors, primarily commercial light-water power reactors and research and test reactors. The UF<sub>6</sub>, in solid form in containers, is heated to gaseous form, and then chemically processed to form uranium dioxide (UO<sub>2</sub>) powder. This powder is processed into ceramic pellets and loaded into metal tubes, which are then bundled into fuel assemblies..

**URANIUM HEXAFLUORIDE PRODUCTION FACILITY:** A facility that receives natural uranium in the form of ore concentrate and converts it into uranium hexafluoride.

**VIABILITY ASSESSMENT:** A DOE decisionmaking process to judge the prospects for geologic disposal of HLW at Yucca Mountain based on (1) specific design work on the critical elements of the repository and waste package, (2) a total system performance assessment that will describe the probable behavior of the repository, (3) a plan and cost estimate for the work required to complete a license application, and (4) an estimate of the costs to construct and operate the repository.

**WASTE, RADIOACTIVE:** Radioactive materials at the end of a useful life cycle or in a product that is no longer useful and should be properly disposed.

**WASTE CLASSIFICATION (CLASSES OF WASTE):** LLW is classified according to its radiological hazard. The classes of waste include Class A, Class B, and Class C with Class A being the least hazardous and accounting for 96 percent of LLW. As the waste class and hazard increases, NRC's regulations require greater controls to ensure that public health and the environment are protected.

**WATT:** An international system unit of power equal to one joule per second. In electricity, a watt is equal to current (in amperes) multiplied by voltage (in volts).

**WATTHOUR:** An electrical energy unit of measure equal to 1 watt of power supplied to, or taken from, an electrical circuit steadily for 1 hour.

**WELL-LOGGING:** All operations involving the lowering and raising of measuring devices or tools that contain licensed material or are used to detect licensed materials in wells for the purpose of obtaining information about the well or adjacent formations that may be used in oil, gas, mineral, groundwater, or geological exploration.

**WHEELING SERVICE:** The movement of electricity from one system to another over transmission facilities of intervening systems. Wheeling service contracts can be established between two or more systems.

**YELLOWCAKE:** Yellowcake is the product of the uranium extraction (milling) process; early production methods resulted in a bright yellow compound, hence the name yellowcake. The material is a mixture of uranium oxides that can vary in proportion and in color from yellow to orange to dark green (blackish) depending at which temperature the material was dried (level of hydration and impurities). Higher drying temperatures produce a darker, less soluble material. Yellowcake is commonly referred to as U<sub>3</sub>O<sub>8</sub> and is assayed as pounds U<sub>3</sub>O<sub>8</sub> equivalent. This fine powder is packaged in drums and sent to a conversion plant that produces uranium hexafluoride as the next step in the manufacture of nuclear fuel.

## WEB LINK INDEX

### NRC: AN INDEPENDENT REGULATORY AGENCY

#### Mission, Goals, and Statutory Authority

Strategic Plan FY 2008-2013

[www.nrc.gov/reading-rm/doc-collections/nuregs/staff/sr1614/v4/sr1614v4.pdf](http://www.nrc.gov/reading-rm/doc-collections/nuregs/staff/sr1614/v4/sr1614v4.pdf)

Statutory Authority

[www.nrc.gov/about-nrc/governing-laws.html](http://www.nrc.gov/about-nrc/governing-laws.html)

#### Major Activities

Public Involvement

[www.nrc.gov/public-involve.html](http://www.nrc.gov/public-involve.html)

Freedom of Information Act (FOIA)

[www.nrc.gov/reading-rm/foia/foia-privacy.html](http://www.nrc.gov/reading-rm/foia/foia-privacy.html)

Agency Rulemaking Actions

[www.regulations.gov](http://www.regulations.gov)

#### Organizations and Functions

Organization Chart

[www.nrc.gov/about-nrc/organization/nrcorg.pdf](http://www.nrc.gov/about-nrc/organization/nrcorg.pdf)

The Commission

[www.nrc.gov/about-nrc/organization/commfuncdesc.html](http://www.nrc.gov/about-nrc/organization/commfuncdesc.html)

Commission Direction-Setting and Policymaking Activities

[www.nrc.gov/about-nrc/policymaking.html](http://www.nrc.gov/about-nrc/policymaking.html)

NRC Regions

[www.nrc.gov/about-nrc/locations.html](http://www.nrc.gov/about-nrc/locations.html)

#### NRC Budget

Performance Budget: Fiscal Year 2009 (NUREG-1100, Vol. 24)

[www.nrc.gov/reading-rm/doc-collections/nuregs/staff/sr1100/v24/](http://www.nrc.gov/reading-rm/doc-collections/nuregs/staff/sr1100/v24/)

### U.S. AND WORLDWIDE ENERGY

#### U.S. Electricity

Energy Information Administration

Official Energy Statistics from the U.S. Government

[www.eia.doe.gov](http://www.eia.doe.gov)

#### Worldwide Electricity and Nuclear Power

International Atomic Energy Agency (IAEA)

[www.iaea.org](http://www.iaea.org)

IAEA Power Reactor Information System (PRIS)

[www.iaea.org/programmes/a2](http://www.iaea.org/programmes/a2)

Nuclear Energy Agency (NEA)  
[www.nea.fr/](http://www.nea.fr/)

World Nuclear Association (WNA)  
[www.world-nuclear.org/](http://www.world-nuclear.org/)

World Nuclear Power Reactors 2006-08 and Uranium Requirements  
[www.world-nuclear.org/info/reactors.html](http://www.world-nuclear.org/info/reactors.html)

WNA Reactor Database  
[www.world-nuclear.org/reference/default.aspx](http://www.world-nuclear.org/reference/default.aspx)

WNA Global Nuclear Reactors Map  
[www.wano.org.uk/WANO\\_Documents/WANO\\_Map/WANO\\_Map.pdf](http://www.wano.org.uk/WANO_Documents/WANO_Map/WANO_Map.pdf)

NRC Office of International Programs  
[www.nrc.gov/about-nrc/organization/oipfuncdesc.html](http://www.nrc.gov/about-nrc/organization/oipfuncdesc.html)

NRC 20th Regulatory Information Conference (RIC)  
[www.nrc.gov/public-involve/conference-symposia/ric/](http://www.nrc.gov/public-involve/conference-symposia/ric/)

### International Activities

Treaties and Conventions  
[www.nrc.gov/about-nrc/ip/treaties-conventions.html](http://www.nrc.gov/about-nrc/ip/treaties-conventions.html)

## OPERATING NUCLEAR REACTORS

### U.S. Commercial Nuclear Power Reactors

Commercial Reactors  
[www.nrc.gov/info-finder/reactor/](http://www.nrc.gov/info-finder/reactor/)

### Oversight of U.S. Commercial Nuclear Power Reactors

Reactor Oversight Process (ROP)  
[www.nrc.gov/NRR/OVERSIGHT/ASSESS/index.html](http://www.nrc.gov/NRR/OVERSIGHT/ASSESS/index.html)

NUREG-1649  
[www.nrc.gov/reading-rm/doc-collections/nuregs/staff/sr1649/r4/](http://www.nrc.gov/reading-rm/doc-collections/nuregs/staff/sr1649/r4/)

ROP Performance Indicators Summary  
[www.nrc.gov/NRR/OVERSIGHT/ASSESS/pi\\_summary.html](http://www.nrc.gov/NRR/OVERSIGHT/ASSESS/pi_summary.html)

### Future U.S. Commercial Nuclear Power Reactor Licensing

New Reactor License Process  
[www.nrc.gov/reactors/new-reactor-op-lic/licensing-process.html#licensing](http://www.nrc.gov/reactors/new-reactor-op-lic/licensing-process.html#licensing)

### New Reactors

New Reactor Licensing  
[www.nrc.gov/reactors/new-reactor-licensing.html](http://www.nrc.gov/reactors/new-reactor-licensing.html)

### Reactor License Renewal

Reactor License Renewal Process  
[www.nrc.gov/reactors/operating/licensing/renewal/process.html](http://www.nrc.gov/reactors/operating/licensing/renewal/process.html)

10 CFR Part 51

[www.nrc.gov/reading-rm/doc-collections/cfr/part051/](http://www.nrc.gov/reading-rm/doc-collections/cfr/part051/)

10 CFR Part 54

[www.nrc.gov/reading-rm/doc-collections/cfr/part054/](http://www.nrc.gov/reading-rm/doc-collections/cfr/part054/)

Status of License Renewal Applications and Industry Activities

[www.nrc.gov/reactors/operating/licensing/renewal/applications.html](http://www.nrc.gov/reactors/operating/licensing/renewal/applications.html)

### U.S. Nuclear Research and Test Reactors

Research and Test Reactors

[www.nrc.gov/reactors/non-power.html](http://www.nrc.gov/reactors/non-power.html)

### Nuclear Regulatory Research

Nuclear Reactor Safety Research

[www.nrc.gov/about-nrc/regulatory/research/reactor-rsch.html](http://www.nrc.gov/about-nrc/regulatory/research/reactor-rsch.html)

State-of-the-Art Reactor Consequence Analyses (SOARCA)

[www.nrc.gov/about-nrc/regulatory/research/soar.html](http://www.nrc.gov/about-nrc/regulatory/research/soar.html)

Risk Assessment in Regulation

[www.nrc.gov/about-nrc/regulatory/risk-informed.html](http://www.nrc.gov/about-nrc/regulatory/risk-informed.html)

Digital Instrumentation and Controls

[www.nrc.gov/about-nrc/regulatory/research/digital.html](http://www.nrc.gov/about-nrc/regulatory/research/digital.html)

Computer Codes

[www.nrc.gov/about-nrc/regulatory/research/comp-codes.html](http://www.nrc.gov/about-nrc/regulatory/research/comp-codes.html)

Generic Issues Program

[www.nrc.gov/about-nrc/regulatory/gen-issues.html](http://www.nrc.gov/about-nrc/regulatory/gen-issues.html)

The Committee To Review Generic Requirements (CRGR)

[www.nrc.gov/about-nrc/regulatory/crgr.html](http://www.nrc.gov/about-nrc/regulatory/crgr.html)

## NUCLEAR MATERIALS

### U.S. Fuel Cycle Facilities

U.S. Fuel Cycle Facilities

[www.nrc.gov/info-finder/materials/fuel-cycle/](http://www.nrc.gov/info-finder/materials/fuel-cycle/)

### Uranium Milling

Uranium Milling/Recovery

[www.nrc.gov/materials/fuel-cycle-fac/ur-milling.html](http://www.nrc.gov/materials/fuel-cycle-fac/ur-milling.html)

### U.S. Materials Licenses

Materials Licensees Toolkits

[www.nrc.gov/materials/miau/mat-toolkits.html](http://www.nrc.gov/materials/miau/mat-toolkits.html)

### Medical Applications

Medical Applications

[www.nrc.gov/materials/medical.html](http://www.nrc.gov/materials/medical.html)



**Medical Uses**

Medical Uses  
[www.nrc.gov/materials/miau/med-use.html](http://www.nrc.gov/materials/miau/med-use.html)

**Nuclear Gauges and Commercial Product Irradiators**

General Licenses Uses  
[www.nrc.gov/materials/miau/general-use.html](http://www.nrc.gov/materials/miau/general-use.html)

**Industrial Uses of Nuclear Material**

Industrial Applications  
[www.nrc.gov/materials/miau/industrial.html](http://www.nrc.gov/materials/miau/industrial.html)  
 Exempt Consumer Products  
[www.nrc.gov/materials/miau/consumer-pdts.html](http://www.nrc.gov/materials/miau/consumer-pdts.html)

**RADIOACTIVE WASTE****U.S. Low-Level Radioactive Waste Disposal**

Low-Level Radioactive Waste  
[www.nrc.gov/waste/low-level-waste.html](http://www.nrc.gov/waste/low-level-waste.html)

**U.S. High-Level Radioactive Waste Management: Disposal and Storage**

High-Level Radioactive Waste  
[www.nrc.gov/waste/high-level-waste.html](http://www.nrc.gov/waste/high-level-waste.html)

**Spent Nuclear Fuel Storage**

Spent Nuclear Fuel Storage  
[www.nrc.gov/waste/spent-fuel-storage.html](http://www.nrc.gov/waste/spent-fuel-storage.html)

**U.S. Nuclear Materials Transportation**

Nuclear Materials Transportation  
[www.nrc.gov/materials/transportation.html](http://www.nrc.gov/materials/transportation.html)

**Decommissioning**

Decommissioning  
[www.nrc.gov/about-nrc/regulatory/decommissioning.html](http://www.nrc.gov/about-nrc/regulatory/decommissioning.html)

**NUCLEAR SECURITY AND EMERGENCY PREPAREDNESS**

Nuclear Security  
[www.nrc.gov/security.html](http://www.nrc.gov/security.html)

**Domestic Safeguards**

Domestic Safeguards  
[www.nrc.gov/security/domestic.html](http://www.nrc.gov/security/domestic.html)

**Information Security**

Information Security  
[www.nrc.gov/security/info-security.html](http://www.nrc.gov/security/info-security.html)

Assuring the Security of Radioactive Material  
[www.nrc.gov/security/byproduct.html](http://www.nrc.gov/security/byproduct.html)

### Emergency Preparedness and Response

Emergency Preparedness and Response  
[www.nrc.gov/about-nrc/emerg-preparedness.html](http://www.nrc.gov/about-nrc/emerg-preparedness.html)

### Research and Test Reactor Emergency Preparedness

Research and Test Reactors  
[www.nrc.gov/about-nrc/emerg-preparedness/protect-public/research-test.html](http://www.nrc.gov/about-nrc/emerg-preparedness/protect-public/research-test.html)

### Stakeholder Meetings and Workshops

[www.nrc.gov/public-involve/public-meetings/stakeholder-mtngs-wksp.html](http://www.nrc.gov/public-involve/public-meetings/stakeholder-mtngs-wksp.html)

### Emergency Action Level Development

[www.nrc.gov/about-nrc/emerg-preparedness/emerg-action-level-dev.html](http://www.nrc.gov/about-nrc/emerg-preparedness/emerg-action-level-dev.html)

### Hostile Action Based Emergency Preparedness (EP) Drill

[www.nrc.gov/about-nrc/emerg-preparedness/respond-to-emerg/hostile-action.html](http://www.nrc.gov/about-nrc/emerg-preparedness/respond-to-emerg/hostile-action.html)

### Exercise Schedules

NRC Participation Exercise Schedule  
[www.nrc.gov/about-nrc/emerg-preparedness/exercise-schedules.html](http://www.nrc.gov/about-nrc/emerg-preparedness/exercise-schedules.html)

Biennial FEMA-Graded Exercise Schedule  
[www.nrc.gov/about-nrc/emerg-preparedness/exercise-schedules/bi-annual-ex-schedule.html](http://www.nrc.gov/about-nrc/emerg-preparedness/exercise-schedules/bi-annual-ex-schedule.html)

## OTHER WEB LINKS

### Employment Opportunities

NRC—*A Great Place to Work*  
[www.nrc.gov/about-nrc/employment.html](http://www.nrc.gov/about-nrc/employment.html)

### Glossary

NRC Basic References  
[www.nrc.gov/reading-rm/basic-ref/glossary/full-text.html](http://www.nrc.gov/reading-rm/basic-ref/glossary/full-text.html)

### Glossary of Electricity Terms

[www.eia.doe.gov/cneaf/electricity/epav1/glossary.html](http://www.eia.doe.gov/cneaf/electricity/epav1/glossary.html)

### Glossary of Security Terms

<https://hseep.dhs.gov/DHSResource/Glossary.aspx>

## Public Involvement

Electronic Reading Room

[www.nrc.gov/reading-rm.html](http://www.nrc.gov/reading-rm.html)

Freedom of Information & Privacy Act

[www.nrc.gov/reading-rm/foia/foia-privacy.html](http://www.nrc.gov/reading-rm/foia/foia-privacy.html)

Agencywide Documents Access Management System (ADAMS)

[www.nrc.gov/reading-rm/adams.html](http://www.nrc.gov/reading-rm/adams.html)

Public Meeting Schedule

[www.nrc.gov/public-involve/public-meetings/index.cfm](http://www.nrc.gov/public-involve/public-meetings/index.cfm)

Documents for Comments

[www.nrc.gov/public-involve/doc-comment.html](http://www.nrc.gov/public-involve/doc-comment.html)

## Small Business and Civil Rights

Contracting Opportunities for Small Businesses

[www.nrc.gov/about-nrc/contracting/small-business.html](http://www.nrc.gov/about-nrc/contracting/small-business.html)

Workplace Diversity

[www.nrc.gov/about-nrc/employment/diversity.html](http://www.nrc.gov/about-nrc/employment/diversity.html)

Discrimination Complaint Activity

[www.nrc.gov/about-nrc/civil-rights/dca.html](http://www.nrc.gov/about-nrc/civil-rights/dca.html)

Equal Employment Opportunity Program

[www.nrc.gov/about-nrc/civil-rights/eo.html](http://www.nrc.gov/about-nrc/civil-rights/eo.html)

Limited English Proficiency

[www.nrc.gov/about-nrc/civil-rights/limited-english.html](http://www.nrc.gov/about-nrc/civil-rights/limited-english.html)

Minority Serving Institutions Program

[www.nrc.gov/about-nrc/grants.html#msip](http://www.nrc.gov/about-nrc/grants.html#msip)

NRC Comprehensive Diversity Management Plan brochure

[www.nrc.gov/reading-rm/doc-collections/nuregs/brochures/br0316](http://www.nrc.gov/reading-rm/doc-collections/nuregs/brochures/br0316)

NRC Mentoring Program

[www.nrc.gov/about-nrc/employment/diversity.html/](http://www.nrc.gov/about-nrc/employment/diversity.html/)

**INDEX**

**A**

Academic 2, 3, 63, 65, 66, 141, 170

Agreement States 3, 58, 61, 62–65, 66, 68, 69, 72, 85, 89, 92, 141, 146, 151, 170

Appropriation 10

Atomic Energy Act 3, 8, 29, 47, 80, 142, 169

**B**

Bilateral programs 28–30, 147, 157

Boiling-Water Reactor 23, 32, 35, 44, 76, 84, 96, 133, 141, 144, 154, 169

Byproduct 2, 65, 114, 141, 144, 150, 152, 153, 169

**C**

Capacity 14, 15, 17, 19, 22–25, 27, 78, 98–112, 132–137, 139, 141, 142, 148, 150, 152, 170

Cask 77, 78, 80, 81, 83, 84, 127, 141, 142, 144

Coal-fired 14, 16, 19–21

**D**

Decommissioning 3, 8, 12, 37, 50, 62, 63, 72, 82, 85, 86, 113, 114, 125, 131, 143, 146, 157, 163, 169, 170

Disposal 2, 3, 8, 58, 63, 72–74, 77, 81, 82

**E**

Energy Reorganization Act 2, 3, 169

Enrichment 3, 4, 56–59, 97, 147, 148, 154, 170

Environmental issues 2, 4, 8, 44, 49, 58, 82, 143, 144, 146, 149, 151, 169, 170

**F**

Fabrication 56–58, 60, 88, 147, 150, 158, 159, 170

Fuel facilities 3, 8, 56, 141

Fuel rods 39, 60, 76, 147, 153

**G**

Gaseous diffusion 56, 57, 59, 148, 170

Gauges 66–68, 148, 155, 163

Gross generation 25–27, 134–137, 148, 151

**H**

Hexafluoride 57, 59, 148, 159, 170

High-Level Radioactive Waste 3, 8, 9, 74–82, 149, 163, 170

**I**

Industrial 2, 3, 8, 57, 97, 141, 151, 155, 163

In-situ leach 61, 150, 170

Inspection 8, 37, 38, 44, 49–51, 53, 57, 58, 63, 70, 83, 89–90, 97, 154, 156, 169, 170

**L**

Licensing 3, 8, 28, 29, 37, 43, 45, 47, 49, 50, 52, 58, 61, 70, 78, 80, 82, 83, 122, 140, 150, 161, 162, 169, 170

Low-Level Radioactive Waste 3, 8,  
72, 73, 142, 150, 163, 169, 170

## M

Materials 2–5, 8, 11, 12, 28, 29,  
50–52, 55, 57–70, 74, 80, 83, 85,  
88–90, 92, 141, 142, 143, 150,  
152, 153, 155, 156, 159, 162, 163,  
169, 170

Medical 2, 3, 8, 63, 65, 66, 68, 72,  
141, 146, 150, 151, 153, 162, 163,  
170

Milling 61–63, 147, 151, 159, 162,  
169

Mission 2, 3, 169

Mixed Oxide 51, 56, 57, 151, 170

## N

Nuclear Waste Policy Act 3, 81,  
169, 170

## O

Operating reactors 23, 37, 47, 52,  
53, 169

## P

Personnel 10, 52, 65, 88, 91

Pressurized-Water Reactor 23, 32,  
34, 44, 76, 84, 154, 169

Probabilistic Risk Assessment 52,  
53, 154, 156

Public participation 49

## R

Radiation exposure 2, 42, 146, 150

Radioactive waste 3, 8, 12, 29, 53,  
71–86, 142, 149, 150, 153, 163,

169, 170

Radionuclide 52, 65, 66, 138, 155

Reactor Oversight Process 38, 89,  
156, 161

Rulemaking 45, 80, 141, 144, 156,  
160, 169

Rules 4, 38, 141, 155

## S

Safety 2–5, 8, 11, 28–30, 34, 35,  
38–40, 44, 49, 51, 53, 58, 63, 65,  
70, 72, 78, 82, 83, 89, 92, 126,  
157, 162, 169, 170

Security 2, 3, 4, 8, 12, 30, 44,  
51–53, 69–70, 87–93, 142–144,  
147, 153, 157, 163, 164

Significant Events 40

Spent fuel 29, 56, 74, 76–81, 83,  
84, 127–131, 144, 147, 149, 150,  
153, 157, 158, 163, 169, 170

Statutory authority 2, 160

## U

Uranium 3, 4, 8, 12, 56–63, 74–76,  
85, 97, 141, 144, 148, 149, 150,  
151, 153, 154, 157–159, 161, 162,  
169, 170

## W

Waste 2, 8, 9, 11, 12, 51–53, 58,  
71–77, 81–83, 97, 114, 141, 142,  
147, 149, 150, 153, 158, 159, 163,  
169, 170

## Y

Yellowcake 61, 151, 159

Yucca Mountain 81–83, 159, 170

<b>NRC FORM 335</b> (8-2004) NRCMD 3.7	<b>U.S. NUCLEAR REGULATORY COMMISSION</b>	<b>1. REPORT NUMBER</b> (Assigned by NRC, Add Vol., Supp., Rev., and Addendum Numbers, if any.)
<b>BIBLIOGRAPHIC DATA SHEET</b> <i>(See instructions on the reverse)</i>		NUREG-1350, Vol. 20
<b>2. TITLE AND SUBTITLE</b>  U.S. Nuclear Regulatory Commission Information Digest 2008-2009 Edition	<b>3. DATE REPORT PUBLISHED</b>	
	MONTH  August	YEAR  2008
<b>5. AUTHOR(S)</b>  Ivonne Couret	<b>4. FIN OR GRANT NUMBER</b>  n/a	
	<b>6. TYPE OF REPORT</b>  Annual	
<b>8. PERFORMING ORGANIZATION - NAME AND ADDRESS</b> <i>(If NRC, provide Division, Office or Region, U.S. Nuclear Regulatory Commission, and mailing address; if contractor, provide name and mailing address.)</i>  Public Affairs Staff Office of Public Affairs U.S. Nuclear Regulatory Commission Washington, DC 20555-0001	<b>7. PERIOD COVERED</b> <i>(Inclusive Dates)</i>  2007	
	<b>9. SPONSORING ORGANIZATION - NAME AND ADDRESS</b> <i>(If NRC, type "Same as above"; if contractor, provide NRC Division, Office or Region, U.S. Nuclear Regulatory Commission, and mailing address.)</i>  Same as 8, above	
<b>10. SUPPLEMENTARY NOTES</b>		
<b>11. ABSTRACT</b> <i>(200 words or less)</i>  The U.S. Nuclear Regulatory Commission (NRC) 2008-2009 Information Digest provides a summary of information about the NRC. It describes the agency's regulatory responsibilities and licensing activities and also provides general information on nuclear energy. To create the Information Digest, the agency compiled and organized NRC and industry-related data into a quick reference on the agency and the industry it regulates. Data include activities through 2007 or the most current data available at manuscript completion. (In this edition, adjustments were made to figures previously based on preliminary data. All information is final unless otherwise noted.) The NRC reviewed information from industry sources but did not perform an independent verification. Also in this edition, some changes reflect the data-driven characteristics of the digest. They include the following: development of a new section titled "Security and Emergency Preparedness" to reflect our mission and strategic plan goals; development of an NRC Web Link Index of URL addresses that lead to more information on major topics; and creation of a tear-out reference sheet called Facts at a Glance.		
<b>12. KEY WORDS/DESCRIPTORS</b> <i>(List words or phrases that will assist researchers in locating the report.)</i>  Information Digest 2008-2009 Edition NRC Facts Nuclear Regulatory Commission	<b>13. AVAILABILITY STATEMENT</b>  unlimited	
	<b>14. SECURITY CLASSIFICATION</b> <i>(This Page)</i>  unclassified	
	<i>(This Report)</i>  unclassified	
	<b>15. NUMBER OF PAGES</b>  180	
<b>16. PRICE</b>		

## MISSION

The mission of the U.S. Nuclear Regulatory Commission is to license and regulate the Nation's civilian use of byproduct, source, and special nuclear materials to ensure adequate protection of public health and safety, to promote the common defense and security, and to protect the environment.

## COMMISSION

Chairman Dale E. Klein

Term expires June 30, 2011

Commissioner Gregory B. Jaczko

Term expires June 30, 2013

Commissioner Peter B. Lyons

Term expires June 30, 2009

Commissioner Kristine L. Svinicki

Term expires June 30, 2012

## NRC BUDGET

- Total authority: \$926 million
- Total staff: 3,707
- Total budget expected to be recovered by annual fees to licensees: \$760.7 million
- NRC research program support: \$39.6 million

## NRC REGULATORY ACTIVITIES

- Regulation and guidance—rulemaking
- Policymaking
- Licensing, decommissioning, and certification
- Research
- Oversight
- Emergency preparedness and response
- Support of decisions

## NRC GOVERNING LEGISLATION

The NRC was established by the Energy Reorganization Act of 1974. A summary of laws that govern the agency's operations is provided below. The text of other laws may be found in NUREG-0980, "Nuclear Regulatory Legislation."

## FUNDAMENTAL LAWS GOVERNING CIVILIAN USES

### Nuclear Materials and Facilities

- Atomic Energy Act of 1954, as amended
- Energy Reorganization Act of 1974

### Radioactive Waste

- Nuclear Waste Policy Act of 1982, as amended
- Low-Level Radioactive Waste Policy Amendments Act of 1985
- Uranium Mill Tailings Radiation Control Act of 1978

### Non-Proliferation

- Nuclear Non-Proliferation Act of 1978

## FUNDAMENTAL LAWS GOVERNING THE PROCESSES OF REGULATORY AGENCIES

- Administrative Procedure Act (5 U.S.C. Chapters 5 through 8)
- National Environmental Policy Act
- Diplomatic Security and Anti-Terrorism Act of 1986
- Solar, Wind, Waste, and Geothermal Power Production Incentives Act of 1990
- Energy Policy Act of 1992 Provisions
- Energy Policy Act of 2005

## TREATIES AND AGREEMENTS

- Nuclear Non-Proliferation Treaty
- International Atomic Energy Agency/U.S. Safeguards Agreement
- Convention on the Physical Protection of Nuclear Material
- Convention on Early Notification of a Nuclear Accident
- Convention on Assistance in Case of a Nuclear Accident and Radiological Emergency
- Convention on Nuclear Safety
- Convention on Supplemental Liability and Safety of Spent Fuel Management and on the Safety of Radioactive Waste Management

## U.S. COMMERCIAL NUCLEAR POWER REACTORS

- 20 percent of Nation's electrical use generated by nuclear power plants
- 104 nuclear power plants "licensed to operate" in the United States
  - 69 pressurized-water reactors (PWRs)
  - 35 boiling-water reactors (BWRs)
- 4 reactor fuel vendors
- 26 operating companies
- 80 different designs
- 65 commercial reactor sites
- 14 decommissioning power reactors
- Total inspection hours: 6,340 in calendar year 2007 at operating reactors; approximately 3,000 source documents concerning events reviewed

### Reactor License Renewal

Commercial power reactor operating licenses are valid for 40 years and may be renewed for up to an additional 20 years.

- 26 sites and 48 units with renewal licenses issued at operating nuclear plants
- 12 sites with license renewal applications in review
- 17 sites with letters of intent for renewal licenses applications

## NEW REACTOR LICENSE PROCESS

### Early Site Permit (ESP)

- 3 ESPs issued
- 1 ESP application in review

### Construction and Operating License (COL)

- 9 COL applications received/docketed
- 2 COL applications in acceptance review
- 10 letters of intent to submit COL applications

### Reactor Design Certification (DC)

- 4 DCs issued
- 4 DCs in review

## Nuclear Research and Test Reactors

- 50 licensed research reactors and test reactors
  - 32 reactors operating in 22 States
  - 12 reactors permanently shut down and in various stages of decommissioning (Since 1958, a total of 82 licensed research and test reactors have been decommissioned.)

# NRC FACTS AT A GLANCE (Continued)

## NUCLEAR SECURITY AND SAFEGUARDS

- Once every 2 years, each nuclear power plant performs full-scale emergency preparedness exercises.
- Plants also conduct additional emergency drills in between exercises. The NRC evaluates all emergency exercises and drills.

## PUBLIC MEETINGS AND INVOLVEMENT

- The NRC conducts 900 public meetings annually.
- The NRC hosts both the Regulatory Information Conference (RIC) and the Fuel Cycle Information Exchange (FCIX) where participants discuss the latest technical issues.

## NEWS AND INFORMATION

NRC news releases are available through a free listserv subscription at [www.nrc.gov/public-involve/listserv.html](http://www.nrc.gov/public-involve/listserv.html).

## NUCLEAR MATERIALS

- Approximately 22,300 licenses are issued for medical, academic, industrial, and general uses of nuclear materials.
- Approximately 3,800 licenses are administered by the NRC.
- Approximately 18,500 licenses are administered by the 35 Agreement States.

### 15 Uranium Milling Sites

- 4 in-situ leaching
- 11 conventional milling
- 3 applications for new milling sites
- 3 applications for restart/expand of milling sites

### 12 Fuel Cycle Facilities

- 1 uranium hexafluoride production facility
- 6 uranium fuel fabrication facilities
- 2 gaseous diffusion uranium enrichment facilities (1 in cold standby)
- 2 gas centrifuge uranium enrichment facilities (under construction)
- 1 mixed oxide fuel fabrication facility (under review)
- 180 NRC-licensed facilities authorized to possess plutonium and enriched uranium with inventory registered in the Nuclear Materials Management and Safeguards System database

## RADIOACTIVE WASTE

### Low-Level Radioactive Waste

- 10 regional compacts (exclusion of waste generated outside a compact)
- 2 active licensed disposal facilities (post-Barnwell)
- 4 closed disposal facilities

## High-Level Radioactive Waste Management

### Disposal and Storage

- On June 3, 2008, the U.S. Department of Energy (DOE) submitted a license application to the NRC. DOE is seeking authorization to construct a deep geologic repository for disposal of spent nuclear fuel and high-level radioactive waste at Yucca Mountain, NV. The NRC will review that application and evaluate a wide range of technical and scientific issues. The NRC will issue a construction authorization only if DOE can demonstrate that it can safely construct and operate the repository in compliance with the NRC's regulations. The review process is expected to take up to 4 years.
- The Nuclear Waste Policy Act of 1982, as amended, defines the roles of the three Federal agencies responsible for nuclear waste. DOE is responsible for developing permanent disposal capacity for spent fuel and other high-level radioactive waste. The U.S. Environmental Protection Agency (EPA) is responsible for developing environmental standards to evaluate the safety of a geologic repository. The NRC is responsible for developing regulations to implement the EPA safety standards and for licensing the repository.

### Spent Nuclear Fuel Storage

- 49 licensed/operating Independent Spent Fuel Storage Installations
- 15 site-specific licenses
- 34 general licenses

### Transportation – Principal Licensing and Inspection Activities

- The NRC examines transport-related safety during approximately 1,000 safety inspections of fuel, reactor, and materials licensees annually.
- The NRC reviews, evaluates, and certifies approximately 80 new, renewal, or amended container-design applications for the transport of nuclear materials annually.
- The NRC reviews and evaluates approximately 150 license applications for the import/export of nuclear materials from the United States annually.
- The NRC inspects about 20 dry storage and transport package licensees annually.

### Decommissioning

Approximately 200 material licenses are terminated each year. NRC's decommissioning program focuses on the termination of licenses that are not routine and that require complex activities.

- 14 nuclear power reactors
- 12 research and test reactors
- 19 complex decommissioning materials facilities
- 1 fuel cycle facility (partial decommissioning)
- 32 uranium recovery facilities in safe storage under NRC jurisdiction



## AVAILABILITY OF REFERENCE MATERIALS IN NRC PUBLICATIONS

### NRC Reference Material

As of November 1999, you may electronically access NUREG-series publications and other NRC records at NRC's Public Electronic Reading Room at <http://www.nrc.gov/reading-rm.html>.

Publicly released records include, to name a few, NUREG-series publications; *Federal Register* notices; applicant, licensee, and vendor documents and correspondence; NRC correspondence and internal memoranda; bulletins and information notices; inspection and investigative reports; licensee event reports; and Commission papers and their attachments.

NRC publications in the NUREG series, NRC regulations, and *Title 10, Energy*, in the Code of *Federal Regulations* may also be purchased from one of these two sources.

1. The Superintendent of Documents  
U.S. Government Printing Office  
Mail Stop SSOP  
Washington, DC 20402-0001  
Internet: [bookstore.gpo.gov](http://bookstore.gpo.gov)  
Telephone: 202-512-1800  
Fax: 202-512-2250
2. The National Technical Information Service  
Springfield, VA 22161-0002  
[www.ntis.gov](http://www.ntis.gov)  
1-800-553-6847 or, locally, 703-605-6000

A single copy of each NRC draft report for comment is available free, to the extent of supply, upon written request as follows:

Address: U.S. Nuclear Regulatory Commission  
Office of Administration  
Mail, Distribution and Messenger Team  
Washington, DC 20555-0001

E-mail: [DISTRIBUTION@nrc.gov](mailto:DISTRIBUTION@nrc.gov)  
Facsimile: 301-415-2289

Some publications in the NUREG series that are posted at NRC's Web site address <http://www.nrc.gov/reading-rm/doc-collections/nuregs> are updated periodically and may differ from the last printed version. Although references to material found on a Web site bear the date the material was accessed, the material available on the date cited may subsequently be removed from the site.

### Non-NRC Reference Material

Documents available from public and special technical libraries include all open literature items, such as books, journal articles, and transactions, *Federal Register* notices, Federal and State legislation, and congressional reports. Such documents as theses, dissertations, foreign reports and translations, and non-NRC conference proceedings may be purchased from their sponsoring organization.

Copies of industry codes and standards used in a substantive manner in the NRC regulatory process are maintained at—

The NRC Technical Library  
Two White Flint North  
11545 Rockville Pike  
Rockville, MD 20852-2738

These standards are available in the library for reference use by the public. Codes and standards are usually copyrighted and may be purchased from the originating organization or, if they are American National Standards, from—

American National Standards Institute  
11 West 42<sup>nd</sup> Street  
New York, NY 10036-8002  
[www.ansi.org](http://www.ansi.org)  
212-642-4900

Legally binding regulatory requirements are stated only in laws; NRC regulations; licenses, including technical specifications; or orders, not in NUREG-series publications. The views expressed in contractor-prepared publications in this series are not necessarily those of the NRC.

The NUREG series comprises (1) technical and administrative reports and books prepared by the staff (NUREG-XXXX) or agency contractors (NUREG/CR-XXXX), (2) proceedings of conferences (NUREG/CP-XXXX), (3) reports resulting from international agreements (NUREG/IA-XXXX), (4) brochures (NUREG/BR-XXXX), and (5) compilations of legal decisions and orders of the Commission and Atomic and Safety Licensing Boards and of Directors' decisions under Section 2.206 of NRC's regulations (NUREG-0750).

Office of Public Affairs  
U.S. Nuclear Regulatory Commission



NUREG-1350, Volume 20  
August 2008