

ATTACHMENT 1
Procedure Approval Form
Page 1 of 1

6

AD-AA-101-1002
Revision 10

Document Number: <u>CY-OC-170-301</u>		Revision: <u>2</u>	
Title: <u>Offsite Dose Calculation Manual for Oyster Creek Generating Station</u>			
<input type="checkbox"/> New	<input type="checkbox"/> Cancel Document	<input type="checkbox"/> Cancel Revision	<input checked="" type="checkbox"/> Revision
EC#: _____		PCR#: _____	PPIS#: _____
<input type="checkbox"/> Editorial		ER#: _____	AR#: _____
<input type="checkbox"/> Batch		#: <u>567226-09-11</u>	
<input type="checkbox"/> Supersede corporate document(s) List: <u>None</u>			
Revision Summary: <u>Attachment 1 of ODCM Summary Matrix (CY-AA-170-3100) has changes</u>			
Attach add'l descript, if req'd			
Impact on Operating and Design Margins: <input checked="" type="checkbox"/> N/A			
Attach add'l descript, if req'd			
CONFIRM that no commitments (i.e., those steps annotated with CM-X) have been changed or deleted unless evaluated via completion of LS-AA-110 commitment change/deletion form and INITIAL [Preparer]: <u>RA</u>			
Preparer: <u>Robert Artz</u>		<u>03/26/07</u>	<u>OC-4006</u>
Print		Date	Location/Ext
Applicable Site Contacts	BR <input type="checkbox"/>	DR <input type="checkbox"/>	QC <input type="checkbox"/>
	BY <input type="checkbox"/>	LA <input type="checkbox"/>	CL <input type="checkbox"/>
Check box and provide name	PB <input type="checkbox"/>	OC <input checked="" type="checkbox"/> <u>Robert Artz</u>	LG <input type="checkbox"/>
	TMI <input type="checkbox"/>	ZN <input type="checkbox"/>	Other <input type="checkbox"/>
	SA <input type="checkbox"/>	HC <input type="checkbox"/>	Other <input type="checkbox"/>
Validation Req'd: <input checked="" type="checkbox"/> No <input type="checkbox"/> Yes (attach)		Common Training Req'd: <input checked="" type="checkbox"/> No <input type="checkbox"/> Yes	
(Validation requirement see AD-AA-101)		Site Specific Training Req'd: <input checked="" type="checkbox"/> No <input type="checkbox"/> Yes	
Change Management: <input type="checkbox"/> HU-AA-1101 Change Checklist Attached		<input type="checkbox"/> Document Traveler <input checked="" type="checkbox"/> None Required	
Level of Use: <input type="checkbox"/> Level 1 - Continuous Use		<input type="checkbox"/> Level 2 - Reference Use <input checked="" type="checkbox"/> Level 3 - Information Use	
Approval			
CFAM (Standard Procedures)	Print/Sign	Date	Location/Ext:
Approval Location: <u>Oyster Creek</u>	Site Document(s) to be superseded: <u>None</u>		
Use additional sheets as necessary. Assure that all pending changes are dispositioned.			
<input type="checkbox"/> Temp. Change	<input type="checkbox"/> Interim Change	Temp or Interim Change #:	Interim Change expiration:
10CFR50.59 Applicable: <input type="checkbox"/> No <input checked="" type="checkbox"/> Yes (Or applicable regulatory process reviews)		<u>OC-S-2007-0073</u>	<input type="checkbox"/> Exempt per
10CFR72.48 Applicable: <input checked="" type="checkbox"/> No <input type="checkbox"/> Yes		Tracking Number	
PORC Required: <input type="checkbox"/> No <input checked="" type="checkbox"/> Yes		PORC Number (after PORC Approved): <u>07-07</u>	
<input type="checkbox"/> If superseding a document containing commitments, notify the Commitment Tracking Coordinator per LS-AA-110 so the CTD can be updated as appropriate.			
Cross Discipline Reviews: (list below)		Surveillance Coordinator Review Req'd <input checked="" type="checkbox"/> No <input type="checkbox"/> Yes	
<u>MARCIA Pruskowski</u>	<u>M Pruskowski</u>	<u>3/26/07</u>	<u>Chem</u>
Print	Signature	Date	Discipline or Org.
<u>Patrick Boyle</u>	<u>M Pruskowski for Boyle (email)</u>	<u>3/28/07</u>	<u>Coep Chem</u>
Print	Signature	Date	Discipline or Org.
Print	Signature	Date	Discipline or Org.
Attach additional if req'd			
Temp Change Authorization Only	SRO Print/Sign/Date	SQR Print/Sign/Date	Impl. Date Exp. Date
SQR Approval indicates that all required Cross-Disciplinary reviews have been performed and the reviewers have signed this form. This procedure is technically and functionally accurate for all functional areas.			
SQR Approval:	<u>JF MURPHY</u>	<u>4-1-07</u>	<u>RAO PRO</u>
	Print/Sign	Date	Discipline or Org.
Site Authorization:	<u>JK Schuster</u>	<u>4-5-07</u>	<u>4-13-07</u>
	SFAM Print/Sign	Date	Impl. Date
	<u>JAMES J RANDICH</u>	<u>4-12-07</u>	
	Plant Manager Print/Sign (when required by procedure)	Date	

50.59 REVIEW COVERSHEET FORM

LS-AA-104-1001

Revision 2

Page 1 of 3

Station: Oyster Creek

Activity/Document Number: CY-OC-170-301

Revision Number: 2

Title: Offsite Dose Calculation Manual for Oyster Creek Generating Station

NOTE: For 50.59 Evaluations, information on this form will provide the basis for preparing the biennial summary report submitted to the NRC in accordance with the requirements of 10 CFR 50.59(d)(2).

Description of Activity:

This activity is a revision of the Oyster Creek ODCM, procedure CY-OC-170-301. The changes are.

- Addition of statement: "Revision of this document requires PORC approval and changes are controlled by CY-AA-170-3100."
- Font changed to Ariel 12.
- Added section 3/4.11.3: "Ventilation Exhaust Treatment System" to bring ODCM into line with CY-AA-170-300.
- Added section 3/4.11.3.1 "Mark I Containment" to bring ODCM into line with CY-AA-170-300.
- Added comma behind word "Operable" in Action 124.
- Changed LLDs for principal gamma emitters and I-131 to $5E-7$ $\mu\text{Ci/mL}$ that are values in Standard Technical Specifications.
- Section 4.11.2.13 changed the word "is" to "are."
- In Table 4.11.2.1.2-1 deleted a line in the Table separating the words "Principal Gamma" and the word "Emitters."
- Deleted words "interfering radionuclides" as interfering radionuclides do not interfere with counting.
- Changed "GeLi" to "HpGe" as this is correct terminology.
- In definition of Daipj term for Shoreline Deposit Dose, Table E-7 is corrected to Table E-6 and Tb term is changed from 15 years to 30 years to be more conservative. This change also changes the example calculation result from $1.3 E-3$ mrem to $1.5E-3$ mrem.
- Added numerous enhancements to Table 3.12.1 to bring the Table in line with the Branch Technical Position (BTP) and NUREG 1302. Specifically, eight special interest stations are specified for direct radiation. For airborne, term "close to site boundary" is changed to "offsite." For Waterborne, clarified type and frequency for gamma isotopic and tritium. For clams, changed words "discharge canal" to "within influence of the facility discharge." Revised footnote 6 to refer to background information.
- Added Section 3/4.12.4 and Table 3.12.4-1 on meteorological monitoring instrumentation.
- The factor $P_{\gamma}V_i$ has units corrected to $\text{mrem}\cdot\text{m}^3/\mu\text{Ci}\cdot\text{sec}$ in the example calculation. The answer and units to the sample calculation are unchanged.
- Reference to non-existent table deleted. Also reference to "Open EMS" added to line under Table 2.3.2.1-1.
- Reference to "Open EMS" added to second paragraph under Table 2.5-1.
- Tb time changed from 15 years to 30 years in two locations in 2.5.3.1 and 2.5.3.2 and changes to calculation result on from 18.5 pCi/kg to 18.4 pCi/kg.
- Unit for gram is corrected to "g" in definition of H, the absolute humidity.
- Tb time is also changed in from 15 to 30 years in 2.5.4.1 and example calculation 2.5.4.2. This changes the calculation result from 9729 pCi/m² to $1.11E4$ pCi/m².
- Symbols used by Open EMS software: K_i , M_i , L_i added to Table A-2.
- Symbol N_i used by Open EMS software added to Table A-3.
- Symbols used by Open EMS software: K_i , M_i , L_i added to Table A-5.
- Table 3.12.1-1 Radiological Environmental Monitoring Program, section d. Added the words "elevated release" before "D/Q", and the words "and most prevalent wind direction frequency" after "D/Q". For control location, added the words "location of lowest predicted annual average elevated release" before "D/Q", and the words "and least prevalent wind direction frequency" after "D/Q".
- Table 3.12.1-1 Table Notations has number (7) added and it reads as follows: "Due to the fact that greater than 90% of all gaseous effluents releases are elevated, it is appropriate to use the D/Q factors generated from elevated release meteorological data, as the primary driver for environmental sample location placement".
- Table 3.3.3.10-1, added "DELETED" after 1.b Turbine Building Sump No. 1-5, and "N/A" to Minimum Channels Operable for same monitor.
- Table 4.3.3.10.1-1, added "DELETED" after 1.b Turbine Building Sump No. 1-5, and "N/A" for all channel checks for same monitor.
- Table 4.11.1.1.1-1, B., deleted "and Turbine Bldg. Sump No. 1-5".
- Table 4.11.1.1.1-1, Table Notations, f., deleted "or sample Turbine Building Sump 1-5 each discharge".
- Bases 3/4.3.3.10, deleted sentence referring to Turbine Building sump 1-5.
- Part II, 1.1, deleted section (1), which refers to the Turbine Building 1-5 Sump Monitor. Renumbered section 1.1.

50.59 REVIEW COVERSHEET FORM

LS-AA-104-1001

Revision 2

Page 2 of 3

Station: Oyster Creek

Activity/Document Number: CY-OC-170-301

Revision Number: 2

Title: Offsite Dose Calculation Manual for Oyster Creek Generating Station

- Section 1.2.1, in Ci definition, deleted reference to Sump No. 1-5.
- Section 1.4, deleted reference to Turbine Building 1-5 Sump.
- Added footnote (8) to Table 3.12.1-1 Table Notations, "If garden vegetation samples are unobtainable due to any legitimate reason, it is NOT ACCEPTABLE to substitute vegetation from other sources. The missed sample will be documented in the annual report, with no further actions necessary."
- Section 3/4.12.1, c., paragraph deleted and replaced with "If garden vegetation samples are unobtainable due to any legitimate reason, it is NOT ACCEPTABLE to substitute vegetation from other sources. The missed sample will be documented in the annual report, with no further actions necessary. If a permanent sampling location becomes unavailable, follow Table 3.12.1-1 Table Notation (1) to replace the location."
- Section 3.12.1, added the following at the end of the paragraph, "Revisions to the non-ODCM required portions of the program may be implemented at any time. Non-ODCM samples are those taken in addition to the minimum required samples listed in Table 3.12.1-1."
- Table 3.12.1-1 Table Notations, added the following to the end of notation (1), "This applies to changes/deletions/additions of permanent sampling locations. This does not apply to one-time deviations from the sampling schedule. In those cases, it is NOT ACCEPTABLE to substitute sample media from other sources. The missed sample will be documented in the annual report, with no further actions necessary."
- Add footnote (1) to Table E-1: "Revisions to the non-ODCM required portions of the program may be implemented at any time. Non-ODCM samples are those taken in addition to the minimum required samples listed in Table 3.12.1-1."
- Table C-1 References, added reference 30) 10CFR20, Appendix B, Table 2, Annual Limits on Intake (ALIs) and Derived Air Concentrations (DACs) of Radionuclides for Occupational Exposure; Effluent Concentrations; Concentrations for Release to Sewage.
- Updated Solid Radwaste Processing System diagram, Figure D-1-2. Added tanks to drawing.

Reason for Activity:

This activity is being performed in accordance with CY-AA-170-3100, "Offsite Dose Calculation Manual Revisions," a process by which changes to the ODCM are made. These changes are based upon input from various sources including a consultant familiar with more up-to-date ODCMs throughout the industry. In addition, IR 394581 was written to correct the sampling and analysis frequency for tritium in surface and groundwater to match the BPT requirements. Furthermore IR 438356 was written to address minimum monitoring requirements to meet NRC guidance in the Branch Technical Position (BTP) for Radiological Environmental Monitoring Programs. These changes include:

- Administrative changes
- Formatting IAW CY-AA-170-300: "Offsite Dose Calculation Manual Administration"
- Incorporation of various IRs (394581, 394607, 438356, 477051, 567276)

Effect of Activity:

This change updates the ODCM and consolidates action tracking items that identified differences between the previous revision (rev 1) and the BTP. Plant operations are not affected by any of the changes outlined in the bulleted items under "Description of Activity." Furthermore, design bases or safety analyses as described in the UFSAR are not affected by changes to this document.

Summary of Conclusion for the Activity's 50.59 Review:

(Provide justification for the conclusion, including sufficient detail to recognize and understand the essential arguments leading to the conclusion. Provide more than a simple statement that a 50.59 Screening, 50.59 Evaluation, or a License Amendment Request, as applicable, is not required.)

Screening indicates that 50.59 is NOT applicable to the changes outlined above in "Description of Activity." Question 8 in the Applicability Review Form was answered YES since this is a program controlled by the "...Technical Specifications (such as the ODCM). The document change may be implemented without prior NRC approval, as the intent of the procedure has not changed. However, in compliance with CY-AA-170-3100, "Offsite Dose Calculation Manual Revisions," the revised ODCM will be forwarded to the NRC with the submission of the next Annual Radiological Effluents Release Report.

50.59 REVIEW COVERSHEET FORM

LS-AA-104-1001
Revision 2
Page 3 of 3

Station: Oyster Creek

Activity/Document Number: CY-OC-170-301

Revision Number: 2

Title: Offsite Dose Calculation Manual for Oyster Creek Generating Station

Attachments:

Attach all 50.59 Review forms completed, as appropriate.

(NOTE: if both a Screening and Evaluation are completed, no Screening No. is required.)

Forms Attached: (Check all that apply.)

<input checked="" type="checkbox"/>	Applicability Review			
<input checked="" type="checkbox"/>	50.59 Screening	50.59 Screening No.	<u>OC-2007-S-0073</u>	Rev. <u>0</u>
<input type="checkbox"/>	50.59 Evaluation	50.59 Evaluation No.	_____	Rev. _____

50.59 APPLICABILITY REVIEW FORM

LS-AA-104-1002

Revision 2

Page 1 of 1

Activity/Document Number: CY-OC-170-301

Revision Number: 2

Address the questions below for all aspects of the Activity. If the answer is yes for any portion of the Activity, apply the identified process(es) to that portion of the Activity. Note that it is not unusual to have more than one process apply to a given Activity. See Section 4 of the Resource Manual (RM) for additional guidance.

I. Does the proposed Activity involve a change:		
1. Technical Specifications or Operating License (10CFR50.90)?	X NO __ YES	See Section 4.2.1.1 of the RM
2. Conditions of License Quality Assurance program (10CFR50.54(a))? Security Plan (10CFR50.54(p))? Emergency Plan (10CFR50.54(q))?	X NO __ YES X NO __ YES X NO __ YES	See Section 4.2.1.2 of the RM
3. Codes and Standards IST Program Plan (10CFR50.55a(f))? ISI Program Plan (10CFR50.55a(g))?	X NO __ YES X NO __ YES	See Section 4.2.1.3 of the RM
4. ECCS Acceptance Criteria (10CFR50.46)?	X NO __ YES	See Section 4.2.1.4 of the RM
5. Specific Exemptions (10CFR50.12)?	X NO __ YES	See Section 4.2.1.5 of the RM
6. Radiation Protection Program (10CFR20)?	X NO __ YES	See Section 4.2.1.6 of the RM
7. Fire Protection Program (applicable UFSAR or operating license condition)?	X NO __ YES	See Section 4.2.1.7 of the RM
8. Programs controlled by the Operating License or the Technical Specifications (such as the ODCM).	__ NO <u>X</u> YES	See Section 4.2.1.7 of the RM
9. Environmental Protection Program	X NO __ YES	See Section 4.2.1.7 of the RM
10. Other programs controlled by other regulations.	X NO __ YES	See Section 4.2.1 of the RM
II. Does the proposed Activity involve maintenance which restores SSCs to their original condition or involve a temporary alteration supporting maintenance that will be in effect during at-power operations for 90 days or less?		
	X NO __ YES	See Section 4.2.2 of the RM
III. Does the proposed Activity involve a change to the:		
1. UFSAR (including documents incorporated by reference) that is excluded from the requirement to perform a 50.59 Review by NEI 96-07 or NEI 98-03?	X NO __ YES	See Section 4.2.3 of the RM
2. Managerial or administrative procedures governing the conduct of facility operations (subject to the control of 10CFR50, Appendix B)	X NO __ YES	See Section 4.2.4 of the RM
3. Procedures for performing maintenance activities (subject to 10CFR50, Appendix B)?	X NO __ YES	See Section 4.2.4 of the RM
4. Regulatory commitment not covered by another regulation based change process (see NEI 99-04)?	X NO __ YES	See Section 4.2.3/4.2.4 of the RM
IV. Does the proposed Activity involve a change to the Independent Spent Fuel Storage Installation (ISFSI) (subject to control by 10 CFR 72.48)		
	X NO __ YES	See Section 4.2.6 of the RM

Check one of the following:

- If all aspects** of the Activity are controlled by one or more of the above processes, then a 50.59 Screening is not required and the Activity may be implemented in accordance with its governing procedure.
- If any portion** of the Activity is not controlled by one or more of the above processes, then process a 50.59 Screening for the portion not covered by any of the above processes. The remaining portion of the activity should be implemented in accordance with its governing procedure.

Signoff:

50.59 Screener 50.59 Evaluator:
(Circle One)

Robert Artz
(Print name)

Sign:

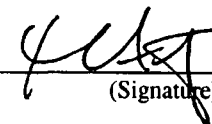
(Signature)

Date: 03/26/07

50.59 SCREENING FORM

LS-AA-104-1003

Revision 1

Page 1 of 2

50.59 Screening No.

OC-2007-S-0073

Rev. No. 0

Activity/Document Number: CY-OC-170-301

Revision Number: 2

I. 50.59 Screening Questions (Check correct response and provide separate written response providing the basis for the answer to each question)(See Section 5 of the Resource Manual (RM) for additional guidance):

1. Does the proposed Activity involve a change to an SSC that adversely affects an UFSAR described design function? (See Section 5.2.2.1 of the RM) ___ YES x NO
2. Does the proposed Activity involve a change to a procedure that adversely affects how UFSAR described SSC design functions are performed or controlled? (See Section 5.2.2.2 of the RM) ___ YES x NO
3. Does the proposed Activity involve an adverse change to an element of a UFSAR described evaluation methodology, or use of an alternative evaluation methodology, that is used in establishing the design bases or used in the safety analyses? (See Section 5.2.2.3 of the RM) ___ YES x NO
4. Does the proposed Activity involve a test or experiment not described in the UFSAR, where an SSC is utilized or controlled in a manner that is outside the reference bounds of the design for that SSC or is inconsistent with analyses or descriptions in the UFSAR? (See Section 5.2.2.4 of the RM) ___ YES x NO
5. Does the proposed Activity require a change in the Technical Specifications or Operating License? (See Section 5.2.2.5 of the RM) ___ YES x NO

II. List the documents (e.g., UFSAR, Technical Specifications, other licensing basis, technical, commitments, etc.) reviewed, including sections numbers where relevant information was found (if not identified in the response to each question).
ODCM (CY-OC-170-301), CY-AA-170-3100 – “Offsite Dose Calculation Manual Revisions,” CY-AA-170-300 “Offsite Dose Calculation Manual Administration,” CY-AA-170-2000 – “Annual Radioactive Effluent Release Report.”
USFAR (See next page).

III. Select the appropriate conditions:

- | | |
|-------------------------------------|--|
| <input checked="" type="checkbox"/> | If all questions are answered NO, then complete the 50.59 Screening and implement the Activity per the applicable governing procedure. |
| <input type="checkbox"/> | If question 1, 2, 3, or 4 is answered YES and question 5 is answered NO, then a 50.59 Evaluation shall be performed. |
| <input type="checkbox"/> | If questions 1, 2, 3, and 4 are answered NO and question 5 is answered YES, then a License Amendment is required prior to implementation of the Activity. |
| <input type="checkbox"/> | If question 5 is answered YES for any portion of an Activity, then a License Amendment is required prior to implementation of that portion of the Activity. In addition, if question 1, 2, 3, or 4 is answered YES for the remaining portions of the Activity, then a 50.59 Evaluation shall be performed for the remaining portions of the Activity. |

IV. Screening Signoffs:

50.59 Screener:

Robert Antz
(Print name)

Sign:

[Signature]
(Signature)

Date: 03/26/07

50.59 Reviewer:

Marcia Huskanski
(Print name)

Sign:

[Signature]
(Signature)

Date: 3/26/07

50.59 SCREENING FORM

LS-AA-104-1003

Revision 1

Page 2 of 2

50.59 Screening No.

OC-2007-S-0073

Rev. No. 0

Activity/Document Number: CY-OC-170-301

Revision Number: 2

1. The proposed activity, is a change to procedure CY-OC-170-301 "Offsite Dose Calculation Manual for Oyster Creek Generating Station." This change in no way changes the Annual Radioactive Effluent Release Report or any other requirement in the USFAR. Therefore, the activity does not involve a change that will adversely affect an UFSAR described SSC design function.
2. The proposed activity, the revision of the ODCM consists of numerous changes (see Review Coversheet) and brings Oyster Creek's ODCM in line with Corporate Procedures, NUREG 1302 and the Branch Technical Position (BTP). It does not involve a change to a procedure that adversely affects how UFSAR described SSC design functions are performed or controlled. Therefore, this activity in no way adversely affects how UFSAR described SSC design functions are performed or controlled.
3. The proposed activity, the revision of the Oyster Creek ODCM brings the document in line with the BTP in terms of tritium sampling, referencing new radiological effluents software and numerous corrections to tables and calculations. This change does not affect represent reporting requirements delineated in the UFSAR and these changes do not require revising or replacing an UFSAR described evaluation methodology that is used in establishing the design bases or used in safety analyses for a SSC.
4. The changes in the ODCM are neither experiments nor tests as described in the UFSAR where the SSC is utilized or controlled in a manner that is outside the reference bounds of SSC design or is inconsistent with analyses or descriptions in the UFSAR.
5. The proposed activity is not discussed in the Technical Specifications although it is discussed in the ODCM. This activity in no way alters or changes any other license requirement. Therefore, this activity will not require a change to either the Operating License or Technical Specifications.

References:

UFSAR

- 1.9.24 Sampling and Analysis of Plant Effluents
- 2.1.1 Effluent Dose Limits
- 2.4.10 Release of Liquid Effluents
- 3.1.51 Release of Radioactive Materials to the Environment
- 3.1.54 Monitoring Fuel and Waste Storage
- 9.2.1.2.3 System Description of NRW and AOG
- 11.2.3.3 Dilution Factor for Radioactive Releases
- 11.5.2.2 Process Liquid Monitoring
- Table 11.2.26 Population Doses from Liquid Effluents
- 11.3 Gaseous Waste Management System
- Table 11.3.12 Population Doses

ATTACHMENT 1
ODCM Change Summary Matrix

Radiological Effluent Controls Changes – Determination A

REMP Changes – Determination B

Item No.	(old) Rev. 1 page No.	(new) Rev. 2 page No.	Determination Identifier	Description of Change
1.	1.0	1		Added "Revision of this document requires PORC approval and changes are controlled by CY-AA-170-3100.
2.	All	All		Changed font to Ariel 12.
3.	2	2	A	Added Section 3/4.11.3 "Mark I Containment" to bring ODCM into line with CY-AA- 170-300.
4.	22	25	A	Added comma behind word "OPERABLE" in Action 124.
5.	27	30	A	LLDs for principal gamma emitters and I-131 in Standard Technical Specifications are 5E-7 µCi/mL. Value changed from 1E-6 to 5E-7.
6.	32	35	A	Section 4.11.2.1.3 changed the word "is" to "are."
7.	33	37	A/B	In Table 4.11.2.1.2-1 deleted a line in the table separating the words "Principal Gamma" and word "Emitters."
8.	34	38	A/B	Deleted words "interfering radionuclides" as interfering radionuclides should NOT interfere with counting.
9.	34	39	A/B	Changed "GeLi" to "HpGe" as this is the correct terminology.
10.		43	A	Added a section on Mark I Containment per CY-AA-170-300.
11.	65	78	A	In definition of Daipj term, Table E-7 is corrected to Table E-6.
12.	42 to 47	47 to 54	B	Added numerous enhancements to Table 3.12.1 to bring the Table in line with the Branch Technical Position (BTP) and NUREG 1302. Specifically, eight special interest stations are specified for direct radiation. For airborne, term "close to site boundary" is changed to "offsite." For Waterborne, clarified type and frequency for gamma isotopic and tritium. For clams, changed words "discharge canal" to "within influence of the facility discharge." Revised footnote 6 to refer to background information.
13.		61 to 62	A/B	Added Section 3/4.12-4 and Table 3.12.4-1 on meteorological monitoring instrumentation.
14.	65	78	A	In definition of Tb term the long-term buildup time is changed to 30 years to be more conservative.
15.	66	78	A	In example calculation of shoreline dose, the changing of Tb to 30 years appears in this calculation and changes the result from 1.3E-3 mrem to 1.5E-3 mrem.
16.	71	84	A	The factor P _γ V _i has units corrected to mrem-m ³ /µCi-sec. The answer and units to the sample calculation are unchanged.
17.	74	89	A	Reference to non-existent table deleted. Also reference to "Open EMS" added to line under Table 2.3.2.1-1.
18.	78	94	A	Reference to "Open EMS" added to second paragraph under Table 2.5-1.
19.	81	97 to 98	B	Tb time changed to 30 years (2.63E5 hours) in two places on pages 97 and 98, and changes calculation result on page 98 from 18.4 pCi/kg to 18.5 pCi/kg.
20.	82	99	B	Unit for gram is corrected to "g" in definition of H, the absolute humidity.
21.	87	104	A/B	Tb term changed to 30 years (9.46E8 seconds) and also changed in example calculation on same page. This changes the calculation result from 9729 pCi/m ² to 1.11E4 pCi/m ² .
22.	92	109	A/B	Symbols used by Open EMS: K _i , M _i , L _i added to terms in Table A-2.

ATTACHMENT 1 ODCM Change Summary Matrix

23.	93	110	A/B	Symbols M _i and N _i used by Open EMS added to term in Table A-3.
24.	95	112	A/B	Symbols used by Open EMS: K _i , M _i , L _i added to terms in Table A-5.
25.	47	52	B	Table 3.12.1-1 Radiological Environmental Monitoring Program, section d. Added the words "elevated release" before "D/Q", and the words "and most prevalent wind direction frequency" after "D/Q". For control location, added the words "location of lowest predicted annual average elevated release" before "D/Q", and the words "and least prevalent wind direction frequency" after "D/Q".
26.	48	53, 55	B	Table 3.12.1-1 Table Notations has number (7) added and it reads as follows: "Due to the fact that greater than 90% of all gaseous effluents releases are elevated, it is appropriate to use the D/Q factors generated from elevated release meteorological data, as the primary driver for environmental sample location placement".
27.	15	19	A	Table 3.3.3.10-1, added "DELETED" after 1.b Turbine Building Sump No. 1-5, and "N/A" to Minimum Channels Operable for same monitor.
28.	17	21	A	Table 4.3.3.10.1-1, added "DELETED" after 1.b Turbine Building Sump No. 1-5, and "N/A" for all channel checks for same monitor.
29.	27	31	A	Table 4.11.1.1.1-1, B., deleted "and Turbine Bldg. Sump No. 1-5".
30.	29	33	A	Table 4.11.1.1.1-1, Table Notations, f., deleted "or sample Turbine Building Sump 1-5 each discharge".
31.	54	64	A	Bases 3/4.3.3.10, deleted sentence referring to Turbine Building sump 1-5.
32.	62	74	A	Part II, 1.1, deleted section (1), which refers to the Turbine Building 1-5 Sump Monitor. Renumbered section 1.1.
33.	63	75	A	Section 1.2.1, in Ci definition, deleted reference to Sump No. 1-5.
34.	64	76	A	Section 1.4, deleted reference to Turbine Building 1-5 Sump.
35.	47, 48	53, 55	B	Added footnote (8) to Table 3.12.1-1 Table Notations, "If garden vegetation samples are unobtainable due to any legitimate reason, it is NOT ACCEPTABLE to substitute vegetation from other sources. The missed sample will be documented in the annual report, with no further actions necessary."
36.	41	47	B	Section 3/4.12.1, c., paragraph deleted and replaced with "If garden vegetation samples are unobtainable due to any legitimate reason, it is NOT ACCEPTABLE to substitute vegetation from other sources. The missed sample will be documented in the annual report, with no further actions necessary. If a permanent sampling location becomes unavailable, follow Table 3.12.1-1 Table Notation (1) to replace the location."
37.	40	46	B	Section 3.12.1, added the following at the end of the paragraph, "Revisions to the non-ODCM required portions of the program may be implemented at any time. Non-ODCM samples are those taken in addition to the minimum required samples listed in Table 3.12.1-1."
38.	48	54	B	Table 3.12.1-1 Table Notations, added the following to the end of notation (1), "This applies to changes/deletions/additions of permanent sampling locations. This does not apply to one-time deviations from the sampling schedule. In those cases, it is NOT ACCEPTABLE to substitute sample media from other sources. The missed sample will be documented in the annual report, with no further actions necessary."
39.	112, 116	129 to 134	B	Add footnote (1) to Table E-1: "Revisions to the non-ODCM required portions of the program may be implemented at any time. Non-ODCM samples are those taken in addition to the minimum required samples listed in Table 3.12.1-1."
40.	104	121	B	Table C-1 References, added reference 30, 10CFR20, Appendix B, Table 2, Annual Limits on Intake (ALIs) and Derived Air Concentrations (DACs) of Radionuclides for Occupational Exposure; Effluent Concentrations; Concentrations for Release to Sewerage.
41.	108	125	A/B	Updated Solid Radwaste Processing System diagram, Figure D-1-2. Added tanks to drawing.
42.	53	60	A/B	Added the words "elevated release" prior "D/Q" in the last paragraph on the page.
43.	49	54	B	Added note: "If no drinking water pathway exists, a value of 20 pCi/L may be used."

ATTACHMENT 1
ODCM Change Summary Matrix

44.	72	86	A	Added reference to alternate computer code Open EMS below Table 2.3.1.3-1.
45.	52	57	B	Revised footnote (5) to quote the limits if no drinking water pathway exists.

ATTACHMENT 2
ODCM Change Determination

Station: Oyster Creek

ODCM Revision No. 2

Determination No. OC-2007-D-0001

I. Determination Questions (Check correct response)

1. Does the ODCM change maintain the level of radioactive effluent control required by 10CFR20.1301? X YES ___ NO

Explain: The changes as outlined in Attachment 1 do NOT affect the level of radioactive effluent control required by 10CFR20.1301. These changes are relatively small changes that affect hand-calculations, terminology (GeLi to HpGe), how Mark 1 containment systems are vented, terms added to tables and a few grammatical corrections.

2. Does the ODCM change maintain the level of radioactive effluent control required by 10CFR20.1302? X YES ___ NO

Explain: 10CFR20.1302 deals with compliance with dose limits for individual members of the public. As stated above, the changes to the ODCM do not affect dose to the public. There are subtle changes to the example calculations but these are example calculations and are not part of the actual dose to the public.)

3. Does the ODCM change maintain the level of radioactive effluent control required by 40CFR190? X YES ___ NO

Explain: 40CFR190 deals with radiation doses received by members of the public in the general environment and to radioactive materials introduced into the general environment as a result of operations that are Part of the nuclear fuel cycle. The requirement is an Environmental Protection Agency regulation. Doses to the public are not calculated by the above criteria.

4. Does the ODCM change maintain the level of radioactive effluent control required by 10CFR50.36a? X YES ___ NO

Explain: 10CFR50.36a deals with Technical Specifications on effluents from nuclear power reactors. The section also deals with the plant operator developing operating procedures for dealing with operating the radioactive waste system at the plant. More specifically, for radiological effluents, 50.36a also deals with the Annual Radiological Effluents Release Report (ARERR). The only change affecting the ARERR is the requirement to submit the report within 90 days of January 1 of each year. The Technical Specification change to allow this change is being addressed separately.

ATTACHMENT 2
ODCM Change Determination

5. Does the ODCM change maintain the level of radioactive effluent control required by Appendix I to 10CFR50? YES NO

Explain: 10CFR50 Appendix I deals with dose limits as calculated for the Annual Radiological Effluents Release Report (ARERR). We are not changing the affected sections to the ODCM which are Section 3.11.2.1, 3.11.2.2, 3.22.2.3 or 3.11.4. Section 3.11.2.1 spells out the limits to whole body, skin and organ dose. Section 3.11.2.2b addresses annual air dose limits. Section 3.11.2.3 addresses dose due to radioactive iodine, tritium and particulates. Section 3.11.4 deals with calculated organ doses and total whole body doses from effluents.

6. Does the ODCM change maintain the accuracy or reliability of effluent, dose, or setpoint calculations? YES NO

Explain: Set point calculations are not changed. Furthermore, dose calculations are performed by a validated and verified computer program called SEEDS (Simplified Environmental Effluent Dosimetry System) controlled by Procedure CY-OC-130-501 and the changes to the ODCM as proposed do not involve any changes to these items.

7. Does the ODCM change maintain the accuracy of radioactive effluent control required by the SAR? YES NO

Explain: The UFSAR was searched and the following items were reviewed in terms of the proposed ODCM changes. In no case is the accuracy or integrity of the radioactive effluent control affected by these ODCM changes:

- 1.9.24 Sampling and Analysis of Plant Effluents
- 2.1.1 Effluent Dose Limits
- 9.2.1.2.3 System Description of NRW and AOG
- 11.2.3.3 Dilution factor for Radioactive releases
- 11.5.2.2 Process Liquid Monitoring
- Table 11.2.26 Population Doses from Liquid Effluents
- 11.3 Gaseous Waste Management System
- 11.3.12 Population Doses

II. If all questions are answered YES, then complete the ODCM Change Determination and implement the Change per this procedure.

III. If any question is answered NO, then a change to the ODCM is not permitted

IV. Signoffs:

Determination Preparer: Robert Artz [Signature] Date: 03/26/07
(Printed Name) (Signature)

Reviewer: Marecia Prunka [Signature] Date: 03/26/07
(Printed Name) (Signature)

PORC ITEM SUMMARY COVER SHEET

SUBJECT: Revision 2 of the Offsite Dose Calculation Manual (ODCM)

PREPARED BY: Robert Artz

IS A 50.59/72.48 SAFETY EVALUATION REQUIRED? [] Yes [X] No

ISSUE SUMMARY: Revision 2 of the Station's ODCM (CY-OC-170-301) involves numerous changes, mostly of the administrative nature. Several involve bringing the ODCM into line with the NRC's Branch Technical Position (BTP), correcting old terminology such as GeLi and gm to HpGe and g respectively, and explicit instructions on what to do with REMP garden sampling if vegetation samples are unavailable.

SAFETY IMPACT: These changes do NOT affect the level of radioactive effluent control required by 10CFR20.1301. The changes do affect hand-calculations, terminology (GeLi to HpGe), how Mark 1 containment systems are vented, terms added to tables to be aligned with the NRC's BTP, and a few grammatical corrections. Plant operations are not affected by any of the changes proposed under this revision to the ODCM. Furthermore, design bases or safety analyses as described in the UFSAR are not affected by changes to this document.

The Presentation Material is Ready for PORC Review

Presenter's Signature

04/02/07
Date

Supervisor's Signature

04/02/07
Date

PORC MEETING (07-07) REPORT

PORC QUORUM: R. Zacholski (C), J. Magee (P), J. Renda (P),
T. Schuster (P), S. Hutchins (A)
(C) = Chairman, (P) = Primary Member, (A) = Alternate Member

OTHER PARTICIPANTS: K. Poletti, L. Baker (Presenters, Item 1)
M. Pruskowski, B. Artz (Presenters, Item 2)
R. Milos (PORC Coordinator)

Meeting 07-07 of the Oyster Creek Plant Operations Review Committee (PORC) was convened at 3:00 PM on Thursday, April 5, 2007, in the OCAB Board Room. The Chairman verified that a quorum with the necessary expertise was present. Two items were on the agenda for PORC meeting 07-07:

(1) EP-OC-1010, Oyster Creek Emergency Plan, Rev. 9

PORC reviewed the latest changes to Revision 9 of the Emergency Plan, EP-OC-1010. PORC reviewed the Mode Applicability changes to the four EALs and the update to the PAR as detailed in the attachment. The Issue Summary, Safety Impact, and PORC Comments from today's meeting are provided in Attachment A to this report. All PORC questions / comments were adequately addressed at the meeting. The Chairman polled the voting members. All voting members agreed that there were no safety concerns preventing approval of Revision 9 to the Emergency Plan. The PORC disposition is: **Approval Recommended.**

(2) CY-OC-170-301, Oyster Creek Offsite Dose Calculation Manual, Rev. 2

PORC reviewed Revision 2 to CY-OC-170-301, Oyster Creek Offsite Dose Calculation Manual. Revision 2 includes numerous changes, mostly editorial and clarifications. This revision also addresses the issue, which caused PORC to remand the ODCM revision last July. The Issue Summary, Safety Significance, and PORC Comments from today's meeting are provided in Attachment B to this report. Most PORC questions / comments were addressed at the meeting, however, PORC required Engineering to provide additional information to the Chemistry Manager regarding the status of the sump 1-5 mod. The Chairman polled the voting members. All voting members agreed that there were no safety concerns preventing approval PORC of the ODCM revision pending review of the requested information from Engineering. The PORC disposition is: **Approval Recommended with Comment.**

Subsequent to the meeting, the PORC Chairman determined that the Engineering response to PORC's comment was satisfactory. There are no open items.

Additionally, in accordance with section 4.3.2 of LS-AA-106, a PORC Subcommittee reviewed two procedures (SY-AA-101-104, Rev 7 and SY-AA-101-016, Rev. 8) and determined that these revisions to the procedures did not have nuclear safety significance, and therefore did not have to be reviewed by the full PORC. The LS-AA-106, Attachment 3 forms, documenting these determinations by the Subcommittee are attached to this report.

R Milos 4-5-2007

Submitted: R. Milos, PORC Coordinator

R. Zacholski 4/6/07

Minutes Approved: R. Zacholski, PORC Chairman

Janis Randich 4/10/07

Recommendation Approved: J. Randich, Plant Manager

ATTACHMENT A

PORC 07-07 Meeting Notes EP-OC-1010, Oyster Creek Emergency Plan, Rev. 9

Presenters: K. Poletti, L. Baker

50.59 Safety Evaluation Yes No

Disposition:

- Approval Recommended
- Approval Recommended with Conditions (see below)
- Remanded
- Review Only

Issue Summary:

Oyster Creek is expanding the Mode Applicability and adding a Note to four new Cold Shutdown EALs approved by the NRC to implement NEI 99-01. This change does not alter the intent of the four EALs as defined by NEI 99-01 and approved by the NRC in the SER. The EALs being revised by this evaluation are MS9, MU9, MS8 and MU8.

Oyster Creek does not utilize the same Modes as defined by standard technical specifications. It should be noted that Oyster Creek's technical specification for Modes does not include the statement "*one or more vessel head bolts less than fully tensioned*" for the Refuel Mode as described in NEI guidance. Without the use of this qualifier in the EAL Mode description, and since it is different from Oyster Creek's technical specification definition of Modes, the four EALs might not be classified in a timely manner. To include this qualifier in the definition of Modes, the Emergency Plan definition would have been different than the technical specification definition and could have lead to confusion.

To satisfy the intent of NEI 99-01, Oyster Creek is revising the four EALs (MS8, MU8, MS9 and MU9) to make the Mode Applicability be both Modes 3 and 4 with a qualifying Note added describing the status of the vessel head bolts. These changes are being done for clarity to ensure a misclassification does not arise due to a difference in the Emergency Plan and technical specification definitions of 'Refuel'.

The addition of the changes does not alter the EAL intent and ensures the EALs are classified based on the applicability requirements of the NEI guidance for which the EALs were approved in the SER. This EAL revision from the SER approved EALs for MS8, MU8, MS9 and MU9 would not result in either fewer or delayed classifications. This change therefore would not result in a decrease of effectiveness in the Emergency Plan.

In addition to the above EAL changes, Oyster Creek is updating the Protective Action Recommendation flow chart to reflect the approved change from 'Child Thyroid' to 'Adult Thyroid'. As part of the conversion to NEI 99-01, and in agreement with the State of New Jersey, Oyster Creek revised their existing EAL for Radiological Effluents to be based on Adult Thyroid CDE instead of Child Thyroid. This change aligned Oyster Creek with the guidance provided in NEI 99-01 and EPA-400 guidelines and approved by the NRC in SER dated January 17, 2007. As a result of this change the Protective Action Recommendation for use of Shelter during a controlled release was revised to reflect the new GE EAL thresholds.

However, the state of New Jersey still requires KI issued to the public should the release exceed 5 Rem Child Thyroid. To remove possible confusion the Child Thyroid CDE was converted to Adult Thyroid CDE. The dose level requirement for recommending KI to the general public was not changed. Since these changes do not affect the present Protective Action Recommendations established in conjunction with the State of New Jersey and approved with the conversion to NEI 99-01 EALs, they are considered administrative in nature and would not constitute a decrease in the effectiveness of Oyster Creek's Emergency Plan.

The only pages changed in the document are: Table D-1 (Page D-24, D-25) and page J-8 and the associated basis pages D-110, D-114, D-115, D-118

Safety Impact:

A 50.54(q) Program Evaluation and Effectiveness Review was completed and determined these changes maintain equivalent or establish an improved capability to respond to an emergency or meet actions or other requirements described in the Emergency Plan, in protecting the health and safety of plant personnel and the general public in the event of an emergency and in implementation of a federal regulation or requirement or formal commitment.

Significant Questions / Comments by PORC, including Resolutions:

PORC discussed the Mode Applicability changes to the four EALs and the update to the PAR detailed above. PORC required that the presentation documents be reviewed and made clear that no Tech Spec change will be required as a result of this Plan revision. The review and clarification has been accomplished. PORC also received assurance that no Operations procedures are affected by this revision.

PORC Open Items:

None

ATTACHMENT B

PORC 07-07 Meeting Notes CY-OC-170-301, Rev 2, Oyster Creek Offsite Dose Calculation Manual

Presenters: M. Pruskowski, B. Artz

50.59 Safety Evaluation Yes No

Disposition:

- Approval Recommended
- Approval Recommended with Conditions (see below)
- Remanded
- Review only

Summary of Changes:

Revision 2 of the Station's ODCM (CY-OC-170-301) involves numerous changes, mostly administrative in nature. Several involve bringing the ODCM into line with the NRC's Branch Technical Position (BTP), correcting old terminology such as GeLi and gm to HpGe and g respectively, and explicit instructions on what to do with REMP garden sampling if vegetation samples are unavailable.

Summary of Safety Significance:

CY-OC-170-301 is an administrative document (Offsite Dose Calculation Manual) and this revision has no impact on nuclear safety, plant operations, or any design bases / safety analysis, as described in the UFSAR. A 10CFR50.59 Screening or Evaluation for this revision was not required. The revision was processed in accordance with procedure CY-AA-170-3100, Offsite Dose Calculation Manual Revisions.

Significant Questions / Comments by PORC, including Resolutions:

PORC reviewed the additional information on gaseous effluents on page 44 of the revision, which addresses the cause of PORC's remand of the ODCM proposed revision on July 18, 2006 at PORC Meeting 06-11. PORC was satisfied with the additional information provided today.

PORC required that Engineering provide a summary of the status on the sump 1-5 mod and the sequencing of events to implement the mod. The information will be provided to the Chemistry Manager for review. This information was subsequently reviewed and is satisfactory.

PORC Open Items:

None

ATTACHMENT 3
Nuclear Safety Significance Assessment Form
Page 1 of 1

Item Title: <u>REVISION, CONTROL, AND DISTRIBUTION OF SECURITY PLANS AND IMPLEMENTING PROCEDURES/TEAM</u>		
Item Number: <u>SY-AA-101-104</u> Revision No. <u>7</u>		
Does the proposed change:		YES NO
1	Result in a change to a procedure affecting Technical Specifications, ECCS, ESF, or PRA risk significant equipment or systems?	<input type="checkbox"/> <input checked="" type="checkbox"/>
2	Result in a modification or change to a ECCS, ESF, or PRA risk significant system?	<input type="checkbox"/> <input checked="" type="checkbox"/>
3	Consist of a major change to the facility and/or a major test or experiment?	<input type="checkbox"/> <input checked="" type="checkbox"/>
4	Consist of a major change to a plant process?	<input type="checkbox"/> <input checked="" type="checkbox"/>
5	Change the qualification or operational characteristics of installed components or systems classified as safety related.	<input type="checkbox"/> <input checked="" type="checkbox"/>
6	Change the nuclear safety response of the plant to normal evolutions, anticipated operational occurrences, or design basis accidents?	<input type="checkbox"/> <input checked="" type="checkbox"/>
7	Have the potential to reduce the ability of the operator to assess or control the nuclear safety status of the plant?	<input type="checkbox"/> <input checked="" type="checkbox"/>
8	Result from investigations of significant operational abnormalities including accidental unplanned or uncontrolled radioactive releases?	<input type="checkbox"/> <input checked="" type="checkbox"/>
9	Increase the potential for a plant trip or present a challenge to safety systems?	<input type="checkbox"/> <input checked="" type="checkbox"/>
10	Require NRC approval prior to implementation, e.g., TS, Security Plan, Emergency Plan?	<input type="checkbox"/> <input checked="" type="checkbox"/>
11	10 CFR 50.59/10 CFR 72.48 written evaluation be prepared?	<input type="checkbox"/> <input checked="" type="checkbox"/>
If any answer to the above questions is "Yes", a full PORC review is required. If all questions are answered "No", a full PORC review is not required. Assumptions must be documented in the Comments Section below.		
COMMENTS		
(Use additional pages as necessary)		
Circle as applicable THIS ITEM DOES/DOES NOT REQUIRE FULL PORC REVIEW.		
PORC Member's Name <u>Sevend. Kehine</u> Department: <u>Engineering</u>		
Print		
PORC Member's <u>[Signature]</u> Date: <u>03/26/2007</u>		
Signature		

RICHARD MILOS / Richard Milos / REG ASSURANCE / 3-26-07
Paul F. Ccevental / Paul Ccevental / 10/15 / 3/26/07

ATTACHMENT 3
Nuclear Safety Significance Assessment Form
Page 1 of 1

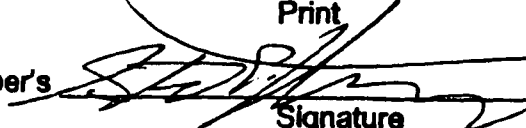
Item Title: <u>CONTROL AND CLASSIFICATION OF SAFEGUARDS INFORMATION</u>				
Item Number: <u>SY-AA-101-106</u>		Revision No. <u>8</u>		
Does the proposed change:			YES	NO
1	Result in a change to a procedure affecting Technical Specifications, ECCS, ESF, or PRA risk significant equipment or systems?			X
2	Result in a modification or change to a ECCS, ESF, or PRA risk significant system?			X
3	Consist of a major change to the facility and/or a major test or experiment?			X
4	Consist of a major change to a plant process?			X
5	Change the qualification or operational characteristics of installed components or systems classified as safety related.			X
6	Change the nuclear safety response of the plant to normal evolutions, anticipated operational occurrences, or design basis accidents?			X
7	Have the potential to reduce the ability of the operator to assess or control the nuclear safety status of the plant?			X
8	Result from investigations of significant operational abnormalities including accidental unplanned or uncontrolled radioactive releases?			X
9	Increase the potential for a plant trip or present a challenge to safety systems?			X
10	Require NRC approval prior to implementation, e.g., TS, Security Plan, Emergency Plan?			X
11	10 CFR 50.59/10 CFR 72.48 written evaluation be prepared?			X
<p>If any answer to the above questions is "Yes", a full PORC review is required. If all questions are answered "No", a full PORC review is not required. Assumptions must be documented in the Comments Section below.</p>				
COMMENTS				
(Use additional pages as necessary)				
<p>Circle as applicable THIS ITEM DOES/DOES NOT REQUIRE FULL PORC REVIEW.</p>				
PORC Member's Name <u>Steven P. Hutchins</u>		Department: <u>Engineering</u>		
Print				
PORC Member's 		Date: <u>03/26/2007</u>		
Signature				

RICHARD MILOS / Richard Milos / REG ASSURANCE / 3-26-07
PAUL F. CERVENKA / Paul C / ORS / 3/27

U777JMM

Microsoft Word – Chemistry – Day in the Field 04-
04/11/08 03:33 PM



Day in the Field Guidance

Bold selected observation choice:

- ◆ **Observe an entire activity from beginning to end**

Observed the backwash of condensate pre-filters.

Safety

Safety was discussed at the observed pre-job briefs. One improvement opportunity was noted. A chem. Tech was carrying a small nitrogen bottle without proper gloves on. Stopped and coached tech and had the cylinder moved with gloves on. FMS entry made.

Briefs

Attended the overall job pre job brief conducted by the shift supervisor and the chemistry brief held for the mini- module back flush. The overall job brief was conducted by the shift supervisor. All required personnel attended. Good brief conducted. All parties were engaged asked questions and gave insights where needed. Talked about personal opex. The supervisor stressed all the proper human performance tools needed to perform the job safely with no errors. No time pressure, who was in charge, roles and responsibilities, stop work criteria, and the key questions.

The chemistry brief was given by the primary chemist. Safety and procedure adherence were stressed. The procedure was walked thru and a good understanding was achieved about what to expect and roles and responsibilities.

2 Minute Drill Understanding and Usage

Drill was used appropriately at both job sites.

FLS Standards

Shift Supervisor was engaged coaching and directing operators. The shift manager came to the job site and was intrusive asking questions and coaching. He questioned the operator showing the trainees how to perform the operation to insure it was qualified operator performing the tasks and not the trainees. The chemist was involved coaching and directing the techs.

Configuration control

Proper procedure use and adherence was observed at both jobs. Touch Star and peer check were also observed. No configuration control issues identified.

Procedure Use and Adherence

Excellent use of procedure adherence was observed at both job sites. Place keeping was used and no deficiencies were noted.

Differences in Standards between Paired Organizations (you observation compared to FLS or Managers observation)

None Noted

Lack of Clarity of Standards

None noted.

Anything One Observer Taught Another

None noted.

Day in the Field Guidance

Contamination Control

The chem. Techs used gloves appropriately for crossing rad boundaries while back flushing and sampling the mini modules. The chem techs wiped up area after sampling and no contamination was noted.

Alara note: The rad tech requested I move to a lower dose area during my observation.

Leak Identification and Management

Non noted.

Cross-Functional Teamwork

Excellent cross functional teamwork and coordination. There were operators, operators in training, chemists, chemistry techs, I and C techs, rad techs, project engineer, system engineer, and vendors working on this backwash. Great communication was observed. There was a clear understanding of roles and responsibilities. Operations were the lead and made sure everything was done according to the proper procedures. There was great ownership observed from chemistry and engineering. FMS entries were made.

OFFSITE DOSE CALCULATION MANUAL

FOR

OYSTER CREEK GENERATING STATION

Revision of this document requires PORC approval and changes are controlled
by CY-AA-170-3100

TABLE OF CONTENTS

INTRODUCTION

PART 1 - RADIOLOGICAL EFFLUENT CONTROLS

1.0 DEFINITIONS

3.0 APPLICABILITY

3.3 INSTRUMENTATION

3.3.3.10 RADIOACTIVE LIQUID EFFLUENT MONITORING INSTRUMENTATION

3.3.3.11 RADIOACTIVE GASEOUS EFFLUENT MONITORING INSTRUMENTATION

3.11.1 LIQUID EFFLUENTS

3.11.1.1 CONCENTRATION

3.11.1.2 DOSE

3.11.1.3 LIQUID WASTE TREATMENT SYSTEM

3.11.2 GASEOUS EFFLUENTS

3.11.2.1 DOSE RATE

3.11.2.2 DOSE NOBLE GASES

3.11.2.3 DOSE - IODINE -131, IODINE - 133, TRITIUM, AND RADIONUCLIDES IN PARTICULATE FORM

3.11.2.4 GASEOUS RADWASTE TREATMENT

3.11.3 MARK I CONTAINMENT

3.11.4 TOTAL DOSE

3.12 RADIOLOGICAL ENVIRONMENTAL MONITORING

3.12.1 MONITORING PROGRAM

3.12.2 LAND USE CENSUS

3.12.3 INTERLABORATORY COMPARISON PROGRAM

3.12.4 METEOROLOGICAL MONITORING PROGRAM

BASES FOR SECTIONS 3.0 AND 4.0

3.3 INSTRUMENTATION

3.3.3.10 RADIOACTIVE LIQUID EFFLUENT MONITORING
INSTRUMENTATION

3.3.3.11 RADIOACTIVE GASEOUS EFFLUENT MONITORING
INSTRUMENTATION

3.11 RADIOACTIVE EFFLUENTS

3.11.1 LIQUID EFFLUENTS

3.11.1.1 CONCENTRATION

3.11.1.2 DOSE

3.11.1.3 LIQUID RADWASTE TREATMENT

3.11.2 GASEOUS EFFLUENTS

3.11.2.1 DOSE RATES

3.11.2.2 DOSE-NOBLE GAS

3.11.2.3 DOSE – IODINE-131, IODINE-133, TRITIUM,
AND RADIONUCLIDES IN PARTICULATE FORM

3.11.2.4 AUGMENTED OFFGAS TREATMENT SYSTEM

3.11.4 TOTAL DOSE

3.12 RADIOLOGICAL ENVIRONMENTAL MONITORING

3.12.1 MONITORING PROGRAM

3.12.2 LAND USE CENSUS

3.12.3 INTERLABORATORY COMPARISON PROGRAM

5.0 DESIGN FEATURES/SITE MAP

6.0 ADMINISTRATIVE CONTROLS

6.1 ANNUAL RADIOLOGICAL ENVIRONMENTAL OPERATING
REPORT (REOR)

6.2 ANNUAL RADIOACTIVE EFFLUENT RELEASE REPORT (RERR)

6.3 RESPONSIBILITIES

PART II – CALCULATIONAL METHODOLOGIES

- 1.0 LIQUID EFFLEUNTS
- 1.1 RADIATION MONITORING INSTRUMENTATION AND CONTROLS
- 1.2 LIQUID EFFLUENT MONITOR SETPOINT DETERMINATION
 - 1.2.1 LIQUID EFFLUENT MONITORS
 - 1.2.2 SAMPLE RESULT SETPOINTS
 - 1.2.3 ASSUMED DISTRIBUTION SETPOINTS
- 1.3 BATCH RELEASES
- 1.4 CONTINUOUS RELEASES
- 1.5 LIQUID EFFLUENT DOSE CALCULATION – 10CFR50
 - 1.5.1 MEMBER OF THE PUBLIC DOSE – LIQUID EFFLUENTS
 - 1.5.2 SHORELINE DEPOSIT DOSE
 - 1.5.3 SHORELINE DOSE EXAMPLE
 - 1.5.4 INGESTION DOSE – LIQUID
 - 1.5.5 INGESTION DOSE CALCULATION EXAMPLE
- 1.6 REPRESENTATIVE SAMPLES
- 2.0 GASEOUS EFFLUENTS
- 2.1 RADIATION MONITORING INSTRUMENTATION AND CONTROLS
- 2.2 GASEOUS EFFLUENT MONITOR SETPOINT DETERMINATION
 - 2.2.1 PLANT VENT
 - 2.2.2 OTHER RELEASE POINTS
 - 2.2.3 RADIONUCLIDE MIX FOR SETPOINTS
- 2.3 GASEOUS EFFLUENT INSTANTANEOUS DOSE RATE CALCULATIONS 10CFR20
 - 2.3.1 SITE BOUNDARY DOSE RATE – NOBLE GASES
 - 2.3.1.1 TOTAL BODY DOSE RATE
 - 2.3.1.2 EXAMPLE TOTAL BODY DOSE RATE
 - 2.3.1.3 SKIN DOSE RATE
 - 2.3.1.4 EXAMPLE SKIN DOSE RATE

- 2.3.2 SITE BOUNDARY DOSE RATE – RADIOIODINE AND PARTICULATES
 - 2.3.2.1 METHOD – SITE BOUNDARY DOSE RATE – RADIOIODINE AND PARTICULATES
 - 2.3.2.2 EXAMPLE IODINE AND PARTICULATES DOSE RATE CALCULATION
- 2.4 NOBLE GAS EFFLUENT DOSE CALCULATION - 10CFR50
 - 2.4.1 UNRESTRICTED AREA DOSE – NOBLE GASES
 - 2.4.1.1 AIR DOSE METHOD
 - 2.4.1.2 EXAMPLE NOBLE GAS AIR DOSE CALCULATION
 - 2.4.1.3 INDIVIDUAL PLUME DOSE METHOD
- 2.5 RADIOIODINE PARTICULATE AND OTHER RADIONUCLIDES DOSE CALCULATIONS – 10CFR50
 - 2.5.1 INHALATION OF RADIOIODINES, TRITIUM, PARTICULATES, AND OTHER RADIONUCLIDES
 - 2.5.2 EXAMPLE CALCULATION - INHALATION OF RADIOIODINES, TRITIUM, PARTICULATES, AND OTHER RADIONUCLIDES
 - 2.5.3 INGESTION OF RADIOIODINES, PARTICULATES AND OTHER RADIONUCLIDES
 - 2.5.3.1 CONCENTRATION OF THE RADIONUCLIDE IN ANIMAL FORAGE AND VEGETATION – OTHER THAN TRITIUM
 - 2.5.3.2 EXAMPLE CALCULATION OF CONCENTRATION OF THE RADIONUCLIDE IN ANIMAL FORAGE AND VEGETATION – OTHER THAN TRITIUM
 - 2.5.3.3 CONCENTRATION OF TRITIUM IN ANIMAL FORAGE AND VEGETATION
 - 2.5.3.4 EXAMPLE CALCULATION OF CONCENTRATION OF TRITIUM IN ANIMAL FORAGE AND VEGETATION
 - 2.5.3.5 CONCENTRATION OF THE RADIONUCLIDE IN MILK AND MEAT
 - 2.5.3.6 EXAMPLE CALCULATION OF CONCENTRATION OF THE RADIONUCLIDE IN MILK AND MEAT

- 2.5.3.7 DOSE FROM CONSUMPTION OF MILK,
MEAT, AND VEGETABLES
- 2.5.3.8 EXAMPLE CALCULATION – DOSE FROM
CONSUMPTION OF MILK, MEAT, AND
VEGETABLES

2.5.4 GROUND PLANE DEPOSITION IRRADIATION

- 2.5.4.1 GROUND PLANE CONCENTRATION
- 2.5.4.2 EXAMPLE GROUND PLANE
CONCENTRATION CALCULATION
- 2.5.4.3 GROUND PLANE DOSE
- 2.5.4.4 EXAMPLE GROUND PLANE DOSE

3.0 TOTAL DOSE TO MEMBERS OF THE PUBLIC– 40CFR190

- 3.1 EFFLUENT DOSE CALCULATIONS
- 3.2 DIRECT EXPOSURE DOSE DETERMINATION

4.0 RADIOLOGICAL ENVIRONMENTAL MONITORING PROGRAM

APPENDIX A – DERIVED DOSE FACTORS AND RECEPTOR LOCATIONS

- Table A-1: Dose Conversion Factors for Deriving Radioactive Noble
Gas Radionuclide-To-Dose Equivalent Rate Factors
- Table A-2: Noble Gas Radionuclide-To-Dose Equivalent Rate Factors
- Table A-3: Air Dose Conversion Factors for Effluent Noble Gas
- Table A-4: Locations Associated with Maximum Exposure of a Member of
The Public
- Table A-5: Critical Receptor Noble Gas Dose Conversion Factors

APPENDIX B – MODELING PARAMETERS

- Table B-1 :OCGS Usage Factors for Individual Dose Assessment
- Table B-2: Monthly Average Absolute Humidity

APPENDIX C – REFERENCES

- TABLE C-1: REFERENCES

APPENDIX D – SYSTEM DRAWINGS

- Figure D-1-1a: Liquid Radwaste Treatment Chem Waste and Floor
Drain System

Figure D-1-1b: Liquid Radwaste Treatment – High Purity and Equipment
Drain System
Figure D-1-2: Solid Radwaste Processing System
Figure D-2-1: Gaseous Radwaste Treatment – Augmented Offgas System
Figure D-2-2: Ventilation System

APPENDIX E – RADIOLOGICAL ENVIRONMENTAL MONITORING PROGRAM – SAMPLE
TYPE AND LOCATION

Table E-1: REMP Sample Locations
Figure E-1: REMP Sampling Locations Within 2 miles
Figure E-2: REMP Sampling Locations Outside 2 miles
Figure E-3: Area Plot Plan of Site

OYSTER CREEK GENERATING STATION OFF SITE DOSE CALCULATION MANUAL

INTRODUCTION

The Oyster Creek Off Site Dose Calculation Manual (ODCM) is an implementing document to the Oyster Creek Technical Specifications. The previous Limiting Conditions for Operations that were contained in the Radiological Effluent Technical Specifications (RETS) are now included in the ODCM as Radiological Effluent Controls (REC). The ODCM contains two parts: Part I – Radiological Effluent Controls, and Part II – Calculational Methodologies.

Part I includes the following:

- The Radiological Effluent Controls and the Radiological Environmental Monitoring Programs required by Technical Specifications 6.8.4
- Descriptions of the information that should be included in the Annual Radioactive Effluent Release Report and the Annual Radiological Environmental Operating Report required by Technical Specifications 6.9.1.d and 6.9.1.e, respectively.

Part II describes methodologies and parameters used for:

- The calculation of radioactive liquid and gaseous effluent monitoring instrumentation alarm/trip set points; and
- The calculation of radioactive liquid and gaseous concentrations, dose rates, cumulative yearly doses, and projected doses.

Part II also contains a list and graphical description of the specific sample locations for the radiological environmental monitoring program (REMP), and the liquid and gaseous waste treatment systems.

PART I - RADIOLOGICAL EFFLUENT CONTROLS

1.0 DEFINITIONS

The following terms are defined so that uniform interpretation of these CONTROLS may be achieved. The defined terms appear in capitalized type and are applicable throughout these CONTROLS.

1.1 OPERABLE – OPERABILITY

A system, subsystem, train, component or device shall be OPERABLE or have OPERABILITY when it is capable of performing its specified function(s). Implicit in the definition shall be the assumption that all necessary attendant instrumentation, controls, normal and emergency electrical power sources, cooling or seal water, lubrication or other auxiliary equipment that are required for the system, subsystem, train, component or device to perform its function(s) are also capable of performing their related support function(s).

A verification of OPERABILITY is an administrative check, by examination of appropriate plant records (logs, surveillance test records) to determine that a system, subsystem, train, component or device is not inoperable. Such verification does not preclude the demonstration (testing) of a given system, subsystem, train, component or device to determine OPERABILITY.

1.2 ACTION

ACTION shall be that part of a CONTROL that prescribes remedial measures required under designated conditions.

1.4 CHANNEL CALIBRATION

A CHANNEL CALIBRATION shall be the adjustment, as necessary, of the channel output such that it responds, with acceptable range and accuracy, to known values of the parameter that the channel monitors. The CHANNEL CALIBRATION shall encompass the entire channel, including equipment actuation, alarm, or trip.

1.5 CHANNEL CHECK

A CHANNEL CHECK shall be a qualitative determination of acceptable operability by observation of channel behavior during operation. This determination shall include, where possible, comparison of the channel with other independent channels measuring the same variable.

1.6 CHANNEL FUNCTIONAL TEST

CHANNEL FUNCTIONAL TEST shall be the injection of a simulated signal into the channel to verify its proper response including, where applicable, alarm and/or trip initiating actions.

1.9 CONTROL

The Limiting Conditions for Operation (LCOs) that were contained in the Radiological Effluent Technical Specifications were transferred to the OFF SITE DOSE CALCULATION MANUAL (ODCM) and were renamed CONTROLS. This is to distinguish between those LCOs that were retained in the Technical Specifications and those LCOs or CONTROLS that were transferred to the ODCM.

1.13 FREQUENCY NOTATION

The FREQUENCY NOTATION specified for the performance of Surveillance Requirements shall correspond to the intervals defined in Table 1.1.

1.30 REPORTABLE EVENT

A REPORTABLE EVENT shall be any of those conditions specified Section 50.73 to 10CFR Part 50.

1.33 SOURCE CHECK

SOURCE CHECK shall be the qualitative assessment of channel response when the channel sensor is exposed to a source of increased radioactivity.

1.34 AUGMENTED OFF GAS SYSTEM (AOG)

The AUGMENTED OFF GAS SYSTEM is designed and installed to holdup and/or process radioactive gases from the main condenser off gas system for the purpose of reducing the radioactive material content of the gases before release to the environs.

1.35 MEMBER (S) OF THE PUBLIC

MEMBER (S) OF THE PUBLIC shall include all persons who are not occupationally associated with AmerGen Energy Company, LLC and who do not normally frequent the Oyster Creek Generating Station site. This category does not include employees of the utility, its contractors, contractor

employees, vendors, or persons who enter the site to make deliveries, to service equipment, work on site or for other purposes associated with plant functions. This category does include persons who use portions of the site for recreational, occupational, or other purposes not associated with the plant. An individual is not a member of the public during any period in which the individual receives an occupational dose.

1.36 OFF SITE DOSE CALCULATION MANUAL (ODCM)

The OFF SITE DOSE CALCULATION MANUAL (ODCM) shall contain the methodology and parameters used in the calculation of Off Site doses due to radioactive gaseous and liquid effluents, in the calculation of gaseous and liquid effluent monitoring Alarm/Trip Set points, and in the conduct of the Radiological Environmental Monitoring Program. The ODCM shall also contain (1) the Radioactive Effluent Controls and Radiological Environmental Monitoring Programs required by Technical Specification Section 6.8.4 and (2) descriptions of the information that should be included in the Annual Radioactive Effluent Release Report AND Annual Radiological Environmental Operating Report required by Technical Specification Sections 6.9.1.d and 6.9.1.e, respectively.

1.37 PURGE – PURGING

PURGE or PURGING shall be the controlled process of discharging air or gas from a confinement and replacing it with air or gas.

1.38 SITE BOUNDARY

The SITE BOUNDARY shall be the perimeter line around OCGS beyond which the land is neither owned, leased, nor otherwise subject to control by AmerGen Energy Company, LLC. The area outside the SITE BOUNDARY is termed OFF SITE or UNRESTRICTED AREA.

1.39 OFF SITE

The area that is beyond the site boundary where the land is neither owned, leased nor otherwise subject to control by AmerGen Energy Company, LLC. Can be interchanged with UNRESTRICTED AREA.

1.40 UNRESTRICTED AREA

An UNRESTRICTED AREA shall be any area at or beyond the SITE BOUNDARY, access to which is not controlled by the licensee for purposes of protection of individuals from exposure to radiation and radioactive

materials, or any area within the SITE BOUNDARY used for residential quarters or for industrial, commercial, institutional, and/or recreational purposes. Can be interchanged with OFF SITE.

1.41 DOSE EQUIVALENT I-131

DOSE EQUIVALENT I-131 shall be that concentration of I-131 (micro curies per gram), which alone would produce the same thyroid dose as the quantity and isotopic mixture of I-131, I-132, I-133, I-134, and I-135 actually present. The thyroid dose conversion factors used for this calculation shall be those listed in Table E-7 of Regulatory Guide 1.109, "Calculation of Annual Doses to Man from Routine Releases of Reactor Effluences for the Purpose of Evaluating Compliance with 10CFR Part 40 Appendix I."

1.42 DEPOSITION (D/Q)

The direct removal of gaseous and particulate species on land or water surfaces. DEPOSITION is expressed as a quantity of material per unit area (e.g. m^{-2}).

1.43 DOSE CONVERSION FACTOR (DCF)

A parameter calculated by the methods of internal dosimetry, which indicates the committed dose equivalent (to the whole body or organ) per unit activity inhaled or ingested. This parameter is specific to the isotope and the dose pathway. DOSE CONVERSION FACTORS are commonly tabulated in units of mrem/hr per picocurie/ m^3 in air or water. They can be found in Reg Guide 1.109 appendices.

1.44 EFFLUENT CONCENTRATION (EC)

The liquid and air concentration levels which, if inhaled or ingested continuously over the course of a year, would produce a total effective dose equivalent of 0.05 rem. LEC refers to liquid EFFLUENT CONCENTRATION.

1.45 ELEVATED (STACK) RELEASE

An airborne effluent plume whose release point is higher than twice the height of the nearest adjacent solid structure and well above any building wake effects so as to be essentially unentrained. Regulatory Guide 1.111 is the basis of the definition of an ELEVATED RELEASE. Elevated releases generally will not produce any significant ground level concentrations within the first few hundred yards of the source.

ELEVATED RELEASES generally have less dose consequence to the public due to the greater downwind distance to the ground concentration maximum compared to ground releases. All main stack releases at the OCGS are ELEVATED RELEASES.

1.46 FINITE PLUME MODEL

Atmospheric dispersion and dose assessment model which is based on the assumption that the horizontal and vertical dimensions of an effluent plume are not necessarily large compared to the distance that gamma rays can travel in air. It is more realistic than the semi-infinite plume model because it considers the finite dimensions of the plume, the radiation build-up factor, and the air attenuation of the gamma rays coming from the cloud. This model can estimate the dose to a receptor who is not submerged in the radioactive cloud. It is particularly useful in evaluating doses from an elevated plume or when the receptor is near the effluent source.

1.47 GROUND LEVEL (VENT) RELEASE

An airborne effluent plume which contacts the ground essentially at the point of release either from a source actually located at ground elevation or from a source well above the ground elevation which has significant building wake effects to cause the plume to be entrained in the wake and driven to the ground elevation. GROUND LEVEL RELEASES are treated differently than ELEVATED RELEASES in that the X/Q calculation results in significantly higher concentrations at the ground elevation near the release point.

1.48 OCCUPATIONAL DOSE

The dose received by an individual in a RESTRICTED AREA or in the course of employment in which the individual's assigned duties involve exposure to radiation and to radioactive material from licensed and unlicensed sources of radiation, whether in the possession of the licensee or other person. Occupational dose does not include dose received from background radiation, as a patient from medical practices, from voluntary participation in medical research programs, or as a member of the general public

1.49 "OPEN DOSE"

A routine effluent dosimetry computer program that uses Reg. Guides 1.109 and 1.111 methodologies.

1.50 RAGEMS (RADIOACTIVE EMISSIONS MONITORING SYSTEM)

A plant system that monitors gaseous effluent releases from monitored release points. There is a RAGEMS system for the main stack (RAGEMS I) and one for the turbine building (RAGEMS II). They monitor particulates, iodine's, and noble gases.

1.51 SEMI-INFINITE PLUME MODEL

Dose assessment model which is based on the assumption that the travel in air. The ground is considered to be an infinitely large flat plate and the receptor is located at the origin of a hemispherical cloud of infinite radius. The radioactive cloud is limited to the space above the ground plane. The semi-infinite plume model is limited to immersion dose calculations.

1.52 SOURCE TERM

The activity release rate, or concentration of an actual release or potential release. The common units for the source term are curies, curies per second, and curies per cubic centimeter, or multiples thereof (e.g., micro curies).

1.53 X/Q - ("CHI over Q")

The dispersion factor of a gaseous release in the environment calculated by a point source Gaussian dispersion model. Normal units of X/Q are sec/m^3 . The X/Q is used to determine environmental atmospheric concentrations by multiplying the source term, represented by Q (in units of $\mu\text{Ci}/\text{sec}$ or Ci/sec). Thus, the plume dispersion, X/Q (seconds/cubic meter) multiplied by the source term, Q ($\mu\text{Ci}/\text{seconds}$) yields an environmental concentration, X ($\mu\text{Ci}/\text{m}^3$). X/Q is a function of many parameters including wind speed, stability class, release point height, building size, and release velocity.

1.54 SEEDS (Simplified Effluent Environmental Dosimetry System)

A routine effluent dosimetry computer program that uses Reg. Guides 1.109 and 1.111 methodologies.

TABLE 1.1: SURVEILLANCE FREQUENCY NOTATION *

<u>NOTATION</u>	<u>FREQUENCY</u>
S	At least once per 12 hours.
D	At least once per 24 hours.
W	At least once per 7 days.
M	At least once per 31 days.
Q	At least once per 92 days.
SA	At least once per 184 days.
A	At least once per 366 days.
R	At least once per 18 months (550 days).
1/24	At least once per 24 months (refueling cycle)
S/U	Prior to each reactor startup.
P	Prior to each radioactive release.
N.A.	Not applicable.

* Each surveillance requirement shall be performed within the specified time interval with a maximum allowable extension not to exceed 25% of the surveillance interval.

3/4 CONTROLS AND SURVEILLANCE REQUIREMENTS

3/4.0 APPLICABILITY

CONTROLS

3.0.1 Compliance with the CONTROLS contained in the succeeding CONTROLS is required during the OPERATIONAL CONDITIONS or other conditions specified therein; except that upon failure to meet the CONTROL, the associated ACTION requirements shall be met.

3.0.2 Noncompliance with a CONTROL shall exist when the requirements of the CONTROL and associated ACTION requirements are not met within the specified time intervals. If the CONTROL is restored prior to expiration of the specified time intervals, completion of the ACTION requirements is not required.

3.0.3 Except as provided in the associated ACTION requirements, when a CONTROL is not met or the associated ACTION requirements cannot be satisfied, action shall be initiated to place the unit into COLD SHUTDOWN within the following 30 hours.

Where corrective measures are completed that permit operation under the ACTION requirements, the ACTION may be taken in accordance with the specified time limits as measured from the time of failure to meet the CONTROL. Exceptions to these requirements are stated in the individual CONTROLS.

This CONTROL is not applicable in COLD SHUTDOWN or REFUELING.

3.0.4 Entry into an OPERATIONAL CONDITION or other specified condition shall not be made when the conditions of the CONTROLS are not met and the associated ACTION requires a shutdown if they are not met within a specified time interval. Entry into an OPERATIONAL CONDITION or other specified condition may be made in accordance with ACTION requirements when conformance to them permits continued operation of the facility for an unlimited period of time. This provision shall not prevent passage through or to OPERATIONAL CONDITIONS as required to comply with ACTION requirements. Exceptions to these requirements are stated in the individual CONTROLS.

3.0.5 Equipment removed from service or declared inoperable to comply with ACTIONS may be returned to service under administrative control solely to perform testing to demonstrate its OPERABILITY or the OPERABILITY of other equipment. This is an exception to CONTROL 3.0.2 for the system returned to service under administrative control to perform the testing required to demonstrate OPERABILITY.

3 /4.0 APPLICABILITY

SURVEILLANCE REQUIREMENTS

4.0.1 Surveillance Requirements shall be met during the OPERATIONAL CONDITIONS or other conditions specified for individual CONTROLS unless otherwise stated in an individual Surveillance Requirement.

4.0.2 Each Surveillance Requirement shall be performed within the specified surveillance interval with a maximum allowable extension not to exceed 25 percent of the specified surveillance interval.

4.0.3 Failure to perform a Surveillance Requirement within the allowed surveillance interval, defined by CONTROL 4.0.2, shall constitute a failure to meet the OPERABILITY requirements for a CONTROL. The time limits of the ACTION requirements are applicable at the time it is identified that a Surveillance Requirement has not been performed. The ACTION requirements may be delayed for up to 24 hours to permit the completion of the surveillance when the allowed outage time limits of the ACTION requirements are less than 24 hours. Surveillance Requirements do not have to be performed on inoperable equipment.

4.0.4 Entry into an OPERATIONAL CONDITION or other specified applicable condition shall not be made unless the Surveillance Requirement(s) associated with the CONTROLS have been performed within the applicable surveillance interval or as otherwise specified. This provision shall not prevent passage through or to OPERATIONAL CONDITIONS as required to comply with ACTION requirements.

3/4.3 INSTRUMENTATION

3/4.3.3.10 RADIOACTIVE LIQUID EFFLUENT MONITORING INSTRUMENTATION

CONTROLS

3.3.3.10 In accordance with Oyster Creek Technical Specifications 6.8.4.a.1, the radioactive liquid effluent monitoring instrumentation channels shown in Table 3.3.3.10-1 shall be OPERABLE with their Alarm/Trip set points set to ensure that the limits of CONTROL 3.11.1.1 are not exceeded. The Alarm/Trip set points of these channels shall be determined and adjusted in accordance with the methodology and parameters in the ODCM Part II section 1.2.1.

APPLICABILITY: During all liquid releases via these pathways.

ACTION:

- a. With a radioactive liquid effluent monitoring instrumentation channel Alarm/Trip set point less conservative than required by the above CONTROL, immediately suspend the release of radioactive liquid effluents monitored by the affected channel, or declare the channel inoperable, or change the set point so it is acceptably conservative, or provide for manual initiation of the Alarm/Trip function(s).
- b. With less than the minimum number of radioactive liquid effluent monitoring instrumentation channels OPERABLE, take the ACTION shown in Table 3.3.3.10-1. Make every reasonable effort to return the instrument to OPERABLE status within 30 days and, if unsuccessful, explain in the next Radioactive Effluent Release Report pursuant to Technical Specification 6.9.1.d why the inoperability was not corrected in a timely manner.
- c. The provisions of CONTROL 3.0.3 and 3.0.4 are not applicable. Report all deviations in the Radioactive Effluent Release Report.

SURVEILLANCE REQUIREMENTS

4.3.3.10 Each radioactive liquid effluent monitoring instrumentation channel shall be demonstrated OPERABLE by performance of the CHANNEL CHECK, SOURCE CHECK, CHANNEL CALIBRATION, and CHANNEL FUNCTIONAL TEST at the Frequencies shown in Table 4.3.3.10-1.

TABLE 3.3.3.10-1: RADIOACTIVE LIQUID EFFLUENT MONITORING INSTRUMENTATION

INSTRUMENT	MINIMUM CHANNELS OPERABLE	ACTION
1. RADIOACTIVITY MONITORS PROVIDING ALARM AND AUTOMATIC TERMINATION OF RELEASE		
a. Liquid Radwaste Effluent Line (DELETED)	N/A	110
b. Turbine Building Sump No. 1-5 (DELETED)	N/A	114
2. RADIOACTIVITY MONITORS PROVIDING ALARM BUT NOT PROVIDING AUTOMATIC TERMINATION OF RELEASE		
a. Reactor Building Service Water System Effluent Line	1	112
3. FLOW RATE MEASUREMENT DEVICES		
a. Liquid Radwaste Effluent Line (DELETED)	N/A	113

TABLE 3.3.3.10-1 (Continued)

TABLE NOTATIONS

- ACTION 110 With no channels OPERABLE, effluent releases via this pathway may continue provided that:
- a. At least two independent samples are taken, one prior to discharge and one near the completion of discharge and analyzed in accordance with SURVEILLANCE REQUIREMENT 4.11.1.1.1.
 - b. Before initiating a release, at least two technically qualified members of the Facility Staff independently verify the release rate calculations and discharge line valving;
- Otherwise, suspend release of radioactive effluents via this pathway.
- ACTION 112 With no channels OPERABLE, effluent releases via this pathway may continue provided that, at least once per 24 hours during the release, grab samples are collected and analyzed for gross radioactivity (beta or gamma) at a limit of detection of at least $1E-6 \mu\text{Ci/ml}$.
- ACTION 113 With no channel OPERABLE, effluent releases via the affected pathway may continue provided the flow is estimated with the pump curve or change in tank level, at least once per batch during a release.
- ACTION 114 With no channel OPERABLE effluent may be released provided that before initiating a release:
1. A sample is taken and analyzed in accordance with SURVEILLANCE REQUIREMENT 4.11.1.1.1.
 2. Qualified personnel determine and independently verify the acceptable release rate.

TABLE 4.3.3.10-1: RADIOACTIVE LIQUID EFFLUENT MONITORING INSTRUMENTATION SURVEILLANCE REQUIREMENTS^a

<u>INSTRUMENT</u>	<u>CHANNEL CHECK</u>	<u>SOURCE CHECK</u>	<u>CHANNEL CALIBRATION</u>	<u>CHANNEL FUNCTIONAL TEST</u>
1. RADIOACTIVITY MONITORS PROVIDING ALARM AND AUTOMATIC TERMINATION OF RELEASE				
a. Liquid Radwaste Effluent Line (DELETED)	N/A	N/A	N/A	N/A
b. Turbine Building Sump No. 1-5 (DELETED)	N/A	N/A	N/A	N/A
2. RADIOACTIVITY MONITORS PROVIDING ALARM BUT NOT PROVIDING AUTOMATIC TERMINATION OF RELEASE				
a. Reactor Building Service Water System Effluent Line	D	M	R ^e	Q ^d
3. FLOW RATE MEASUREMENT DEVICES				
a. Liquid Radwaste Effluent Line (DELETED)	N/A	N/A	N/A	N/A

TABLE 4.3.3.10-1 (Continued)

TABLE NOTATIONS

- a. Instrumentation shall be **OPERABLE** and in service except that a channel may be taken out of service for the purpose of a check, calibration, test or maintenance without declaring it to be inoperable.

- d. The **CHANNEL FUNCTIONAL TEST** shall also demonstrate that Control Room alarm annunciation occurs if any of the following conditions exists:
 - 1. Instrument indicates measured levels above the alarm set point.
 - 2. Instrument indicates a downscale failure.
 - 3. Instrument controls not set in operate mode.
 - 4. Instrument electrical power loss.

- e. The **CHANNEL CALIBRATION** shall be performed according to established calibration procedures.

3/4.3 INSTRUMENTATION

3/4.3.3.11 RADIOACTIVE GASEOUS EFFLUENT MONITORING INSTRUMENTATION

CONTROLS

3.3.3.11 In accordance with Oyster Creek Technical Specifications 6.8.4.a.1, the radioactive gaseous effluent monitoring instrumentation channels shown in Table 3.3.3.11-1 shall be OPERABLE with their alarm/trip set points set to ensure that the limits of CONTROL 3.11.2.1 are not exceeded. The alarm/trip set points of these channels meeting CONTROLS 3.11.2.1 shall be determined and adjusted in accordance with the methodology and parameters in the ODCM Part II Section 2.2.

APPLICABILITY: As shown in Table 3.3.3.11-1

ACTION:

- a. With a radioactive gaseous effluent monitoring instrumentation channel alarm/trip set point less conservative than required by the above CONTROL, immediately suspend the release of radioactive gaseous effluents monitored by the affected channel, or declare the channel inoperable, or change the set point so it is acceptably conservative.
- b. With less than the minimum number of radioactive gaseous effluent monitoring instrumentation channels OPERABLE, take the ACTION shown in Table 3.3.3.11-1. Exert best efforts to return the instrument to OPERABLE status within 30 days and, if unsuccessful, explain in the next Radioactive Effluent Release Report pursuant to Technical Specification 6.9.1.d why this inoperability was not corrected in a timely manner.
- c. The provisions of CONTROLS 3.0.3 and 3.0.4 are not applicable.

SURVEILLANCE REQUIREMENTS

4.3.3.11 Each radioactive gaseous effluent monitoring instrumentation channel shall be demonstrated OPERABLE by performance of the CHANNEL CHECK, SOURCE CHECK, CHANNEL CALIBRATION, and CHANNEL FUNCTIONAL TEST operations at the frequencies shown in Table 4.3.3.11-1.

TABLE 3.3.3.11-1: RADIOACTIVE GASEOUS EFFLUENT MONITORING INSTRUMENTATION

INSTRUMENT	MINIMUM CHANNELS OPERABLE ^a	APPLICABILITY	ACTION
1. DELETED			
2. STACK MONITORING SYSTEM			
a. Radioactive Noble Gas Monitor (Low Range)	1	b,e	124
b. Iodine Sampler	1	b,e	127
c. Particulate Sampler	1	b,e	127
d. Effluent Flow Measuring Device	1	b	122
e. Sample Flow Measuring Device	1	b	128
3. TURBINE BUILDING VENTILATION MONITORING SYSTEM			
a. Radioactive Noble Gas Monitor (Low Range)	1	b	123
b. Iodine Sampler	1	b	127
c. Particulate Sampler	1	b	127
d. Effluent Flow Measuring Device	1	b	122
e. Sample Flow Measuring Device	1	b	128

TABLE 3.3.3.11-1(Continued)

RADIOACTIVE GASEOUS EFFLUENT MONITORING INSTRUMENTATION

<u>INSTRUMENT</u>	<u>MINIMUM CHANNELS OPERABLE^a</u>	<u>APPLICABILITY</u>	<u>ACTION</u>
4. AUGMENTED OFF GAS BUILDING EXHAUST VENTILATION MONITORING SYSTEM			
a. Radioactive Noble Gas Monitor	1	b	123
b. Iodine Sampler	1	b	127
c. Particulate Sampler	1	b	127
d. Sample Flow Measuring Device	1	b	128

TABLE 3.3.3.11-1 (Continued)

TABLE NOTATIONS

- a. Channels shall be OPERABLE and in service as indicated except that a channel may be taken out of service for the purpose of a check, calibration, test maintenance or sample media change without declaring the channel to be inoperable.
- b. During releases via this pathway
- e. Monitor / sampler or an alternate shall be OPERABLE to monitor / sample Stack effluent whenever the drywell is being purged.

- ACTION 122 With no channel OPERABLE, effluent releases via this pathway may continue provided the flow rate is estimated whenever the exhaust fan combination in this system is changed.
- ACTION 123 With no channel OPERABLE, effluent releases via this pathway may continue provided a grab sample is taken at least once per 48 hours and is analyzed for gross radioactivity within 24 hours thereafter or provided an alternate monitoring system with local display is utilized.
- ACTION 124 With no channel OPERABLE, effluent releases via this pathway may continue provided a grab sample is taken at least once per 8 hours and analyzed for gross radioactivity within 24 hours or provided an alternate monitoring system with local display is utilized. Drywell purge is permitted only when the radioactive noble gas monitor is operating.
- ACTION 127 With no channel OPERABLE, effluent releases via this pathway may continue provided the required sampling is initiated with auxiliary sampling equipment as soon as reasonable after discovery of inoperable primary sampler(s).
- ACTION 128 With no channel OPERABLE, effluent releases via the sampled pathway may continue provided the sampler air flow is estimated and recorded at least once per day.

TABLE 4.3.3.11-1: RADIOACTIVE GASEOUS EFFLUENT MONITORING INSTRUMENTATION SURVEILLANCE REQUIREMENTS

<u>INSTRUMENT</u>	<u>CHANNEL CHECK</u>	<u>SOURCE CHECK</u>	<u>CHANNEL CALIBRATION</u>	<u>CHANNEL FUNCTIONAL TEST</u>	<u>MODES IN WHICH SURVEILLANCE REQUIRED^a</u>
1. DELETED					
2. MAIN STACK MONITORING SYSTEM					
a. Radioactive Noble Gas Monitor (Low Range)	D	M	1/24 ^f	Q ^h	b
b. Iodine Sampler	W	N.A.	N.A.	N.A.	b
c. Particulate Sampler	W	N.A.	N.A.	N.A.	b
d. Effluent Flow Measuring Device	D	N.A.	1/24	Q	b
e. Sample Flow Measuring Device	D	N.A.	R	Q	b
3. TURBINE BUILDING VENTILATION MONITORING SYSTEM					
a. Radioactive Noble Gas Monitor (Low Range)	D	M	1/24 ^f	Q ⁱ	b
b. Iodine Sampler	W	N.A.	N.A.	N.A.	b
c. Particulate Sampler	W	N.A.	N.A.	N.A.	b
d. Effluent Flow Measuring Device	D	N.A.	1/24	Q	b
e. Sample Flow Measuring Device	D	N.A.	R	Q	b

TABLE 4.3.3.11-1(Continued)

RADIOACTIVE GASEOUS EFFLUENT MONITORING INSTRUMENTATION SURVEILLANCE REQUIREMENTS

<u>INSTRUMENT</u>	<u>CHANNEL CHECK</u>	<u>SOURCE CHECK</u>	<u>CHANNEL CALIBRATION</u>	<u>CHANNEL FUNCTIONAL TEST</u>	<u>MODES IN WHICH SURVEILLANCE IS REQUIRED^a</u>
4. AUGMENTED OFF GAS BUILDING EXHAUST VENTILATION MONITORING SYSTEM					
a. Radioactive Noble Gas Monitor	D	M	R ^f	Q ^e	b
b. Iodine Sampler	W	N.A.	N.A.	N.A.	b
c. Particulate Sampler	W	N.A.	N.A.	N.A.	b
d. Sample Flow Measuring Device	D	N.A.	R	N.A.	b

TABLE 4.3.3.11-1 (Continued)

TABLE NOTATIONS

- a. Instrumentation shall be OPERABLE and in service except that a channel may be taken out of service for the purpose of a check calibration, test or maintenance without declaring it to be inoperable.
- b. During releases via this pathway.
- e. The CHANNEL FUNCTIONAL TEST shall also demonstrate that control room alarm annunciation occurs if any of the following conditions exist:
 - 1. Instrument indicates measured levels above the alarm set point.
 - 2. Instrument indicates a downscale failure.
 - 3. Instrument controls not set in operate mode.
 - 4. Instrument electrical power loss.
- f. The CHANNEL CALIBRATION shall be performed according to established calibration procedures.
- h. The CHANNEL FUNCTIONAL TEST shall also demonstrate that control room alarm annunciation occurs if any of the following conditions exists:
 - 1. Instrument indicates measured levels above the alarm set point.
 - 2. Instrument indicates a low count rate/monitor failure.
 - 3. Switch cover alarm shall be verified to alarm when the cover is opened; and clear when the cover is closed after the faceplate switches are verified in their correct positions.
- i. The CHANNEL FUNCTIONAL TEST shall also demonstrate that control room alarm annunciation occurs if any of the following conditions exists:
 - 1. Instrument indicates measured levels above the alarm set point.
 - 2. Instrument indicates a low count rate/monitor failure.

3/4.11 RADIOACTIVE EFFLUENTS

3/4.11.1 LIQUID EFFLUENTS

3/4.11.1.1 CONCENTRATION

CONTROLS

3.11.1.1 In accordance with the Oyster Creek Technical Specifications 6.8.4.a.2 and 3, the concentration of radioactive material, other than noble gases, in liquid effluent in the discharge canal at the Route 9 bridge (See Figure E-3) shall not exceed the concentrations specified in 10 CFR Part 20, Appendix B, Table 2, Column 2. The concentration of noble gases dissolved or entrained in liquid effluent in the discharge canal at the Route 9 bridge shall not exceed 2E-4 microcuries/milliliter.

APPLICABILITY: At all times.

ACTION:

- a. In the event the concentration of radioactive material in liquid effluent released into the Off Site area beyond the Route 9 bridge exceeds either of the concentration limits above, reduce the release rate without delay to bring the concentration below the limit.
- b. The provisions of CONTROLS 3.0.3, 3.0.4 and Technical Specification 6.9.2 are not applicable.

SURVEILLANCE REQUIREMENTS

4.11.1.1.1 Radioactive liquid wastes shall be sampled and analyzed according to the sampling and analysis program in Table 4.11.1.1.1-1.

Alternately, pre-release analysis of batches(es) of radioactive liquid waste may be by gross beta or gamma counting provided a maximum concentration limit of 1E-8 $\mu\text{Ci/ml}$ in the discharge canal at the Route 9 bridge is applied.

4.11.1.1.2 The results of the radioactivity analyses shall be used in accordance with the methodology and parameters in the ODCM Part II Section 1.2 to assure that the concentrations at the point of release are maintained within the limits of CONTROL 3.11.1.1 and 3.11.1.2.

4.11.1.1.3 The alarm or trip set point of each radioactivity monitoring channel in Table 3.3.3.10-1 shall be determined on the basis of sampling and analyses results obtained according to Table 4.11.1.1.1-1 and the set point method in ODCM Part II 1.2.1 and set to alarm or trip before exceeding the limits of CONTROL 3.11.1.1.

TABLE 4.11.1.1.1-1: RADIOACTIVE LIQUID WASTE SAMPLING AND ANALYSIS PROGRAM

Liquid Release Type	Sampling Frequency	Minimum Analysis Frequency	Type of Activity Analysis	Lower Limit Detection ^a (LLD) ($\mu\text{Ci}/\text{ml}$)
A. Batch Waste Release Tanks	P	P ^c	Principal Gamma Emitters	5E-07
	Each Batch ^b	Each Batch	I-131	5E-07
	P	M	Dissolved and Entrained Gases (Gamma Emitters)	1E-05
	One Batch/M ^b			
	P	M	H-3	1E-05
	Each Batch ^b	Composite ^d	Gross Alpha	1E-07
B. Reactor Building Service Water Effluent	P	Q	Sr-89, Sr-90	5E-08
	Each Batch ^b	Composite ^d	Fe-55	1E-06
	W	W	Principal Gamma Emitters	5E-07
	Grab Sample ^e		I-131	5E-07
	(note f)	M	H-3	1E-05
		Composite ^g	Gross Alpha	1E-07
(note f)	Q	Sr-89, Sr-90	5E-08	
	Composite ^g	Fe-55	1E-06	

TABLE 4.11.1.1.1 (CONTINUED)

TABLE NOTATIONS

- a. The Lower Limit of Detection (LLD) is defined, for purposes of these specifications, as the smallest concentration of radioactive material in a sample that will yield a net count, above system background, that will be detected with 95 percent probability with only 5 percent probability of falsely concluding that a blank observation represents a "real" signal.

The LLD is applicable to the capability of a measurement system under typical conditions and not as a limit for the measurement of a particular sample in the radioactive liquid waste sampling and analyses program.

For a particular measurement system, which may include radiochemical separation:

$$LLD = \frac{4.66 * S_b}{E * V * 2.22E6 * Y * \exp(-\lambda\Delta t)}$$

Where:

LLD is the lower limit of detection as defined above (microcurie per unit mass or volume),

S_b is the standard deviation of the background counting rate or of the counting rate of a blank sample as appropriate (counts per minute),

E is the counting efficiency,

V is the sample size (units of mass or volume),

2.22E+6 is the number of disintegrations per minute per microcurie,

Y is the fractional radiochemical yield, when applicable,

λ is the radioactive decay constant for the particular radionuclide, and

Δt is the elapsed time between the end of the sample collection and the time of counting.

Analyses shall be performed in such a manner that the stated LLDs will be achieved under routine conditions with typical values of E, V, Y, and t for the radionuclides Mn-54, Fe-59, Co-58, Co-60, Zn-65, Ce-141, Cs-134, Cs-137; and an LLD of 1E-5 μ Ci/ml should typically be achieved for Mo-99 and Ce-144.

TABLE 4.11.1.1.1-1 (CONTINUED)TABLE NOTATIONS

Occasionally, background fluctuations, interfering radionuclides, or other uncontrollable circumstances may render these LLD's unachievable.

When calculating the LLD for a radionuclide determined by gamma ray spectrometry, the background may include the typical contributions of other radionuclides normally present in the sample. The background count rate of a semiconductor detector (e.g. HPGe) is determined from background counts that are determined to be within the full width of the specific energy band used for the quantitative analysis for the radionuclide.

The principal gamma emitters for which the LLD specification will apply are exclusively the following radionuclides: Mn-54, Fe-59, Co-58, Co-60, Zn-65, Mo-99, Cs-134, Cs-137, Ce-141, and Ce-144. This list does not mean that only these nuclides are to be detected and reported. Other peaks that are measurable and identifiable, together with the above nuclides, shall be identified and reported. The LLD for Mo-99 and Ce-144 is $1E-5 \mu\text{Ci/mL}$ whereas the LLD for the other gamma emitters is $5E-7 \mu\text{Ci/mL}$. Nuclides that are below the LLD for the analysis should not be reported.

- b. A batch release is the discharge of liquid wastes of a discrete volume. Before sampling for analysis, each batch should be thoroughly mixed.
- c. In the event a gross radioactivity analysis is performed in lieu of an isotopic analysis before a batch is discharged, a sample will be analyzed for principal gamma emitters afterwards.
- d. A composite sample is one in which the quantity of liquid sampled is proportional to the quantity of liquid waste discharged and in which the method of sampling employed results in a specimen which is representative of the liquids released.
- e. Analysis may be performed after release.
- f. In the event a grab sample contains more than $5E-7 \mu\text{Ci/mL}$ of I-131 and principal gamma emitters or in the event the effluent radioactivity monitor indicates more than $5E-7 \mu\text{Ci/mL}$ radioactivity in the effluent, as applicable, sample Reactor Building Service Water effluent daily until analysis confirms the activity concentration in the effluent does not exceed $5E-7 \mu\text{Ci/mL}$. In addition a composite sample must be made up for further analysis for all samples taken when the activity was $> 5E-7 \mu\text{Ci/mL}$.
- g. A composite sample is produced combining grab samples, each having a defined volume, collected routinely from the sump or stream being sampled

3/ 4.11 RADIOACTIVE EFFLUENTS

3/ 4.11.1.2 DOSE

CONTROLS

3.11.1.2 In accordance with Oyster Creek Technical Specifications 6.8.4.a.4 and 5, the dose or dose commitment to a MEMBER OF THE PUBLIC from radioactive materials in liquid effluents released to UNRESTRICTED AREAS (see Figure E-3) shall be limited:

- a. During any calendar quarter to less than or equal to 1.5 mrem to the Total Body and to less than or equal to 5 mrem to any body organ, and
- b. During any calendar year to less than or equal to 3 mrem to the Total Body and to less than or equal to 10 mrem to any body organ.

APPLICABILITY: At all times.

ACTION:

- a. With the calculated dose from the release of radioactive materials in liquid effluents exceeding any of the above limits, prepare and submit to the Commission within 30 days from the end of the quarter, pursuant to Technical Specification 6.9.2, a Special Report that identifies the cause(s) for exceeding the limit(s) and defines the corrective actions that have been taken and/or will be taken to reduce the releases and the proposed corrective actions to be taken to assure that subsequent releases will be in compliance with the above limits.
- b. The provisions of CONTROL 3.0.3 and 3.0.4 are not applicable.

SURVEILLANCE REQUIREMENTS

4.11.1.2 Cumulative dose contributions from liquid effluents for the current calendar quarter and the current calendar year shall be determined in accordance with the methodology and parameters in the ODCM Part II Section 1.5 at least once per 31 days in accordance with Technical Specification 6.8.4.a.5.

3/4.11 RADIOACTIVE EFFLUENTS

3/4.11.1.3 LIQUID WASTE TREATMENT SYSTEM

CONTROLS

3.11.1.3 In accordance with the Oyster Creek Technical Specifications 6.8.4.a.6, the liquid radwaste treatment system shall be OPERABLE and appropriate portions of the system shall be used to reduce the radioactive materials in liquid wastes prior to their discharge when the radioactivity concentration, exclusive of tritium and dissolved noble gases, in the batch exceeds 0.001 $\mu\text{Ci/mL}$.

APPLICABILITY: At all times.

ACTION:

a. With radioactive liquid waste being discharged without treatment and in excess of the above, prepare and submit to the Commission within 30 days, pursuant to Technical Specification 6.9.2, a Special Report that includes the following information:

1. Explanation of why liquid radwaste was being discharged without treatment, identification of any inoperable equipment or subsystems, and the reason for the inoperability,
2. Action(s) taken to restore the inoperable equipment to OPERABLE status, and
3. Summary description of action(s) taken to prevent a recurrence.

b. The provisions of CONTROL 3.0.3 and 3.0.4 are not applicable.

SURVEILLANCE REQUIREMENTS

4.11.1.3.1 Doses due to liquid releases to UNRESTRICTED AREAS shall be determined at least once per 31 days in accordance with the methodology and parameters in the ODCM Part II Section 1.5 in accordance with Technical Specifications 6.8.4.a.5.

4.11.1.3.2 The installed liquid radwaste treatment system shall be demonstrated OPERABLE by meeting CONTROLS 3.11.1.1, 3.11.1.2, and 3.11.1.4.

3/4.11 RADIOACTIVE EFFLUENTS

3/4.11.2 GASEOUS EFFLUENTS

3/4.11.2.1 DOSE RATE

CONTROLS

3.11.2.1 In accordance with the Oyster Creek Technical Specifications 6.8.4.a.5 and 7, the dose Equivalent rate due to radioactive materials released in gaseous effluents in the UNRESTRICTED AREA (see Figure E-3) shall be limited to the following:

- a. For noble gases: Less than or equal to 500 mrem/yr to the total body and less than or equal to 3000 mrem/yr to the skin, and
- b. For iodine-131, iodine-133, tritium, and for all radionuclides in particulate form with half-lives greater than 8 days: Less than or equal to 1500 mrem/yr to any body organ.

APPLICABILITY: At all times.

ACTION:

- a. With the dose rate(s) exceeding the above limits, immediately restore the release rate to within the above limit(s).
- b. If the gaseous effluent release rate cannot be reduced to meet the above limits, the reactor shall be in at least SHUTDOWN CONDITION within 48 hours unless corrective actions have been completed and the release rate restored to below the above limit.

SURVEILLANCE REQUIREMENTS

4.11.2.1.1 The dose rate due to noble gases in gaseous effluents shall be determined to be within the above limits in accordance with the methodology and parameters in the ODCM Part II Section 2.3.1.

4.11.2.1.2 The dose rate due to iodine-131, iodine-133, tritium, and all radionuclides in particulate form with half-lives greater than 8 days in gaseous effluents shall be determined to be within the above limits in accordance with the methodology and parameters in the ODCM Part II Section 2.3.2 by obtaining representative samples and performing analyses in accordance with the sampling and analysis program specified in Table 4.11.2.1.2-1.

4.11.2.1.3 Dose rates due to tritium, Sr-89, Sr-90, and alpha-emitting radionuclides are averaged over no more than 3 months and the dose rate due to other radionuclides is averaged no more than 31 days.

4.11.2.1.4 Doses due to gaseous releases to UNRESTRICTED AREAS shall be determined at least once per 31 days in accordance with the methodology and parameters in the ODCM Part II Section 2.4.1 in accordance with Technical Specification 6.8.4.a.5.

TABLE 4.11.2.1.2-1: RADIOACTIVE GASEOUS WASTE SAMPLING AND ANALYSIS PROGRAM

Gaseous Release Type	Sampling Frequency	Minimum Analysis Frequency	Type of Activity Analysis	Lower Limit Detection ^a (LLD) ($\mu\text{Ci/ml}$)
Stack	Q Grab Sample ^f	Q	H-3	1E-06
Stack; Turbine Building Exhaust Vents; Augmented Off gas Building Vent	M Grab Sample c,d,f	M	Principal Gamma Emitters ^b (Noble Gases)	1E-04
	Continuous ^f	W Charcoal Sample	I-131	1E-12
			I-133	1E-10
	Continuous ^f	W Particulate Sample	Principal Gamma Emitters ^b (particulates)	1E-11
	Continuous ^f	M ^e Composite Particulate Sample	Gross Alpha	1E-11
	Continuous	Q ^e Composite Particulate Sample	Sr-89, Sr-90	1E-11
	Continuous	Noble Gas Monitor	Noble Gases Gamma Radioactivity	1E-06

TABLE 4.11.2.1.2-1 (Continued)TABLE NOTATIONS

- a. The Lower Limit of Detection (LLD) is defined, for purposes of these specifications, as the smallest concentration of radioactive material in a sample that will yield a net count, above system background, that will be detected with 95 percent probability with only 5 percent probability of falsely concluding that a blank observation represents a "real" signal.

The LLD is applicable to the capability of a measurement system under typical conditions and not as a limit for the measurement of a particular sample in the radioactive liquid waste sampling and analyses program.

For a particular measurement system, which may include radiochemical separation:

$$LLD = \frac{4.66 * S_b}{E * V * 2.22E6 * Y * \exp(-\lambda \Delta t)}$$

Where:

LLD is the lower limit of detection as defined above (microcurie per unit mass or volume),

S_b is the standard deviation of the background counting rate or of the counting rate of a blank sample as appropriate (counts per minute),

E is the counting efficiency,

V is the sample size (units of mass or volume),

2.22E+6 is the number of disintegrations per minute per microcurie,

Y is the fractional radiochemical yield, when applicable,

λ is the radioactive decay constant for the particular radionuclide, and

Δt is the elapsed time between the end of the sample collection and the time of counting.

Analyses shall be performed in such a manner that the stated LLD's will be achieved under routine conditions with typical values of E, V, Y, and t for the radionuclides Mn-54, Fe-59, Co-58, Co-60, Zn-65, Cs-134, Cs-137, and Ce-141. Occasionally background fluctuations, or other uncontrollable circumstances may render these LLD's unachievable.

When calculating the LLD for a radionuclide determined by gamma ray spectrometry, the background may include the typical contributions of other radionuclides normally present in the

TABLE 4.11.2.1.2-1 (Continued)

TABLE NOTATIONS

samples. The background count rate of a HpGe detector is determined from background counts that are determined to be within the full width of the specific energy band used for the quantitative analysis for that radionuclide

- b. The principal gamma emitters for which the LLD specification applies exclusively are the following radionuclides: Kr-87, Kr-88, Xe-133, Xe-133m, Xe-135 and Xe-138 for gaseous emissions and Mn-54, Fe-59, Co-58, Co-60, Zn-65, Mo-99, Cs-134, Cs-137, Ce-141, and Ce-144 for particulate emissions. This list does not mean that only these nuclides are to be considered. Other gamma peaks that are identifiable, together with those of the above nuclides, shall also be analyzed and reported in the Annual Radioactive Effluent Release Report consistent with CONTROL 3.11.2.1. The LLD for Mo-99 and Ce-144 is $1\text{E-}10$ $\mu\text{Ci/ml}$ whereas the LLD for other principal gamma emitting particulates is $1\text{E-}11$ $\mu\text{Ci/ml}$. Radionuclides which are below the LLD for the analysis should not be reported.
- c. The noble gas radionuclides in gaseous effluent may be identified by taking a grab sample of effluent and analyzing it.
- d. In the event the reactor power level increases more than 15 percent in one hour and the Stack noble gas radioactivity monitor shows an activity increase of more than a factor of three after factoring out the effect due to the change in reactor power, a grab sample of Stack effluent shall be collected and analyzed.
- e. A composite particulate sample shall include an equal fraction of at least one particulate sample collected during each week of the compositing period.
- f. In the event a sample is collected for 24 hours or less, the LLD may be increased by a factor of 10.

3/4.11 RADIOACTIVE EFFLUENTS

3/4.11.2.2 DOSE - NOBLE GASES

CONTROLS

3.11.2.2 In accordance with the Oyster Creek Technical Specification 6.8.4.a.5 and 8, the air dose due to noble gases released in gaseous effluents in the UNRESTRICTED AREA (see Figure E-3) shall be limited to the following:

- a. During any calendar quarter: Less than or equal to 5 mrad for gamma radiation and less than or equal to 10 mrad for beta radiation and,
- b. During any calendar year: Less than or equal to 10 mrad for gamma radiation and less than or equal to 20 mrad for beta radiation.

APPLICABILITY: At all times.

ACTION:

- a. With the calculated air dose from radioactive noble gases in gaseous effluents exceeding any of the above limits, prepare and submit to the Commission within 30 days from the end of the quarter during which the release occurred, pursuant to Technical Specification 6.9.2, a Special Report that identifies the cause(s) for exceeding the limit(s) and defines the corrective actions that have been taken to reduce the release and the proposed corrective actions to be taken to assure that subsequent releases will be in compliance with the above limits.
- b. The provisions of CONTROLS 3.0.3 and 3.0.4 are not applicable.

SURVEILLANCE REQUIREMENTS

4.11.2.2 Cumulative dose contributions for the current calendar quarter and current calendar year for noble gases shall be determined in accordance with the methodology and parameters in the ODCM Part II Section 2.4.1 at least once per 31 days in accordance with Technical Specification 6.8.4.a.5.

3/4.11 RADIOACTIVE EFFLUENTS

3/4.11.2.3 DOSE - IODINE-131, IODINE-133, TRITIUM, AND RADIONUCLIDES IN PARTICULATE FORM

CONTROLS

3.11.2.3 In accordance with Oyster Creek Technical Specification 6.8.4.a.5 and 9, the dose to a MEMBER OF THE PUBLIC from iodine-131, iodine-133, tritium, and all radionuclides in particulate form with half-lives greater than 8 days in gaseous effluents released in the UNRESTRICTED AREA (see Figure E-3) shall be limited to the following:

- a. During any calendar quarter: Less than or equal to 7.5 mrem to any body organ and,
- b. During any calendar year: Less than or equal to 15 mrem to any body organ.

APPLICABILITY: At all times.

ACTION:

- a. With the calculated dose from the release of iodine-131, iodine-133 and radionuclides in particulate form with half-lives greater than 8 days, in gaseous effluents exceeding any of the above limits, prepare and submit to the Commission within 30 days, pursuant to Technical Specification 6.9.2, a Special Report that identifies the cause(s) for exceeding the limit and defines the corrective actions that have been taken to reduce the releases and the proposed corrective actions to be taken to assure that subsequent releases will be in compliance with the above limits.
- b. The provisions of CONTROLS 3.0.3 and 3.0.4 are not applicable.

SURVEILLANCE REQUIREMENTS

4.11.2.3 Cumulative dose contributions for the current calendar quarter and current calendar year for iodine-131, iodine-133, tritium, and radionuclides in particulate form with half-lives greater than 8 days shall be determined in accordance with the methodology and parameters in the ODCM Part II Section 2.5 at least once per 31 days in accordance with Technical Specification 6.8.4.a.5.

3/4.11 RADIOACTIVE EFFLUENTS

3/4.11.2.4 GASEOUS RADWASTE TREATMENT

CONTROLS

3.11.2.4 In accordance with Oyster Creek Technical Specifications 6.8.4.a.6, the AUGMENTED OFF GAS SYSTEM shall be in operation.

APPLICABILITY: Whenever the main condenser steam jet air ejector is in operation except during startup or shutdown with reactor power less than 40 percent of rated. In addition, the AUGMENTED OFF GAS SYSTEM need not be in operation during end of cycle coast-down periods when the system can no longer function due to low off gas flow.

ACTION:

- a. Every reasonable effort shall be made to maintain and operate charcoal absorbers in the AUGMENTED OFF GAS SYSTEM to treat radioactive gas from the main condenser air ejectors.
- b. With gaseous radwaste from the main condenser air ejector system being discharged without treatment for more than 30 consecutive days and either CONTROL 3.11.2.1 or 3.11.2.2 exceeded, prepare and submit to the Commission within 30 days from the end of the quarter during which release occurred, pursuant to Technical Specification 6.9.2, a Special Report that includes the following information:
 1. Identification of any inoperable equipment or subsystems, and the reason for the inoperability,
 2. Action(s) taken to restore the inoperable equipment to OPERABLE status, and
 3. Summary description of action(s) taken to prevent a recurrence.
- c. The provisions of CONTROL 3.0.3 and 3.0.4 are not applicable.

SURVEILLANCE REQUIREMENTS

4.11.2.4 Operation of the Augmented Off gas System charcoal absorbers shall be verified by verifying the AOG System bypass valve, V-7-31, alignment or alignment indication closed at least once every 12 hours whenever the main condenser air ejector is operating.

3/4.11 RADIOACTIVE EFFLUENTS

3/4.11.3. MARK I CONTAINMENT

CONTROLS

3.11.3.1 Venting or purging of the containment Drywell may be through normal Reactor Building Ventilation if the following requirements are met:

APPLICABILITY:

If the Station year-to-date radiological effluent releases (either iodine or noble gas) are less than 10% of the ODCM limit, then Standby Gas Treatment is NOT required for purging the contents of the Drywell.

ACTION:

If the Station year-to-date radiological effluent releases (either iodine or noble gas) are greater than 10% of the ODCM limit, then the Standby Gas Treatment System must be used for purging the contents of the Drywell.

SURVEILLANCE REQUIREMENTS

4.11.3.1 The Standby Gas Treatment System is OPERABLE and available whenever the purge system is in use.

3/4.11 RADIOACTIVE EFFLUENTS

3/4.11.4 TOTAL DOSE

CONTROLS

3.11.4.1 In accordance with Oyster Creek Technical Specifications 6.8.4.a.10, the annual (calendar year) dose commitment to any MEMBER OF THE PUBLIC due to radioactive material in the effluent and direct radiation from the OCGS in the UNRESTRICTED AREA shall be limited to less than or equal to 75 mrem to the thyroid or less than or equal to 25 mrem to any other organ.

APPLICABILITY: At all times

ACTION:

- a. With the calculated doses from the release of radioactive materials in liquid or gaseous effluents exceeding twice the limits of CONTROLS 3.11.1.2a, 3.11.1.2b, 3.11.2.2a, 3.11.2.2b, 3.11.2.3a, or 3.11.2.3b, perform an assessment to determine whether the limits of CONTROL 3.11.4.1 have been exceeded. If such is the case, prepare and submit to the Commission within 30 days, pursuant to Technical Specification 6.9.2, a Special Report that defines the corrective action to be taken to reduce subsequent releases to prevent recurrence of exceeding the above limits and includes the schedule for achieving conformance with the above limits. This Special Report shall include information specified in 10CFR20.2203. If the estimated dose(s) exceeds the above limits, and if the release condition resulting in violation of 40 CFR Part 190 has not already been corrected, the Special Report shall include a request for a variance in accordance with the provisions of 40 CFR Part 190. Submittal of the report is considered a timely request, and a variance is granted until staff action on the request is complete.
- b. The provisions of CONTROLS 3.0.3 and 3.0.4 are not applicable.

SURVEILLANCE REQUIREMENTS

4.11.4.1 Cumulative dose contributions from liquid and gaseous effluents shall be determined in accordance with SURVEILLANCE REQUIREMENT 4.11.1.2, 4.11.2.2, 4.11.2.3, and in accordance with the methodology and parameters in the ODCM Part II Section 3.0 at least once per year.

4.11.4.2 Cumulative dose contributions from direct radiation from the facility shall be determined in accordance with the methodology and parameters in the ODCM Part II Section 3.2. This requirement is applicable only under conditions set forth in CONTROL 3.11.4, ACTION a.

3/4.12 RADIOLOGICAL ENVIRONMENTAL MONITORING

3/4.12.1 MONITORING PROGRAM

CONTROLS

3.12.1. In accordance with Oyster Creek Technical Specifications 6.8.4.b, the radiological environmental monitoring program shall be conducted as specified in Table 3.12.1-1. For specific sample locations see Table E-1. Revisions to the non-ODCM required portions of the program may be implemented at any time. Non-ODCM samples are those taken in addition to the minimum required samples listed in Table 3.12.1-1.

APPLICABILITY: At all times.

ACTION:

- a. With the radiological environmental monitoring program not being conducted as specified in Table 3.12.1-1, prepare and submit to the Commission, in the Annual Radiological Environmental Operating Report required by Technical Specification 6.9.1.e, a description of the reasons for not conducting the program as required and the plans for preventing a recurrence.
- b. With the level of radioactivity as the result of plant effluents in an environmental sampling medium at a specified location exceeding the reporting levels of Table 3.12.1-2 when averaged over any calendar quarter, prepare and submit to the Commission within 60 days of the end of the quarter, pursuant to Technical Specification 6.9.2, a Special Report that identifies the cause(s) for exceeding the limit(s) and defines the corrective actions to be taken to reduce radioactive effluents so that the potential annual dose* to a MEMBER OF THE PUBLIC is less than the calendar year limits of CONTROLS 3.11.1.2, 3.11.2.2, and 3.11.2.3. When more than one of the radionuclides in Table 3.12.1-2 are detected in the sampling medium, this report shall be submitted if:

$$\frac{\text{concentration (1)}}{\text{reporting level (1)}} + \frac{\text{concentration (2)}}{\text{reporting level (2)}} + \dots \geq 1.0$$

When radionuclides other than those in Table 3.12.1-2 are detected and are the result of plant effluents, this report shall be submitted if the potential annual dose* to a MEMBER OF THE PUBLIC from all radionuclides is equal to or greater than the calendar year limits of CONTROLS 3.11.1.2, 3.11.2.2, and 3.11.2.3. This report is not required if the measured level of radioactivity was not the result of plant effluents; however, in such an event, the condition shall be reported and described in the Annual Radiological Environmental Operating Report pursuant to Section 6.1.2.1.

*The methodology used to estimate the potential annual dose to a MEMBER OF THE PUBLIC shall be indicated in this report.

3/4.12 RADIOLOGICAL ENVIRONMENTAL MONITORING

3/4.12.1 MONITORING PROGRAM

CONTROLS (Continued)

ACTION: (Continued)

- c. If garden vegetation samples are unobtainable due to any legitimate reason, it is NOT ACCEPTABLE to substitute vegetation from other sources. The missed sample will be documented in the annual report, with no further actions necessary. If a permanent sampling location becomes unavailable, follow Table 3.12.1-1 Table Notation (1) to replace the location.
- d. The provisions of CONTROLS 3.0.3, 3.0.4 and Technical Specification 6.9.2 are not applicable.

SURVEILLANCE REQUIREMENTS

- 4.12.1 The radiological environmental monitoring samples shall be collected pursuant to Table 3.12.1-1 from the specific locations given in Table E-1, and shall be analyzed pursuant to the requirements of Table 3.12.1-1, and the detection capabilities required by Table 4.12.1-1.

TABLE 3.12.1-1: RADIOLOGICAL ENVIRONMENTAL MONITORING PROGRAM

<u>EXPOSURE PATHWAY AND/OR SAMPLE</u>	<u>NUMBER OF REPRESENTATIVE SAMPLES AND SAMPLE LOCATIONS⁽¹⁾</u>	<u>SAMPLING AND COLLECTION FREQUENCY</u>	<u>TYPE AND FREQUENCY OF ANALYSIS</u>
1. DIRECT RADIATION ⁽²⁾	<p>Routine monitoring stations with two or more dosimeters placed as follows:</p> <p>An inner ring of stations one in each meteorological sector in the general area of the SITE BOUNDARY (16 locations);</p> <p>An outer ring of stations, one in each land-based meteorological sector in the 6- to 8-km range from the site (9 locations); and</p> <p>At least 8 stations to be placed in special interest areas such as population centers, nearby residences, schools, and in one or two areas to serve as control stations.</p> <p>30 Indicator Stations / 2 Background stations</p>	Quarterly	Gamma dose quarterly

TABLE 3.12.1-1(Cont'd)

RADIOLOGICAL ENVIRONMENTAL MONITORING PROGRAM

<u>EXPOSURE PATHWAY AND/OR SAMPLE</u>	<u>NUMBER OF REPRESENTATIVE SAMPLES AND SAMPLE LOCATIONS⁽¹⁾</u>	<u>SAMPLING AND COLLECTION FREQUENCY</u>	<u>TYPE AND FREQUENCY OF ANALYSIS</u>
2. AIRBORNE Radioiodine and Particulates	<p>Samples from 5 locations:</p> <p>Three samples from Off Site locations, in different sectors of the highest calculated annual average ground-level D/Q.</p> <p>One sample from the vicinity of a community having the highest calculated annual average ground-level D/Q; and</p> <p>One sample from a control location, as for example 15-30 km distant and in the least prevalent wind direction.</p> <p>Four Indicator stations. One background station in the least prevalent wind direction.⁽⁶⁾</p>	<p>Continuous sampler operation with sample collection weekly or more frequently if required by dust loading.</p>	<p><u>Radioiodine Canister:</u> I-131 analysis weekly.</p> <p><u>Particulate Sampler</u> Gross beta radioactivity analysis following filter change⁽³⁾;</p> <p>Gamma isotopic analysis⁽⁴⁾ of composites (by location) quarterly.</p>

TABLE 3.12.1-1(Cont'd)
RADIOLOGICAL ENVIRONMENTAL MONITORING PROGRAM

<u>EXPOSURE PATHWAY AND/OR SAMPLE</u>	<u>NUMBER OF REPRESENTATIVE SAMPLES AND SAMPLE LOCATIONS⁽¹⁾</u>	<u>SAMPLING AND COLLECTION FREQUENCY</u>	<u>TYPE AND FREQUENCY OF ANALYSIS</u>
3. WATERBORNE			
a. Surface	One sample upstream One sample downstream	Grab sample monthly.	Gamma isotopic and tritium analysis ⁽⁴⁾ .
b. Ground ⁽⁵⁾	Samples from one or two sources if likely to be affected. One down gradient domestic water sample One up-gradient domestic water sample – background station.	Grab sample quarterly.	Gamma isotopic and tritium analysis ⁽⁴⁾ .
c. Drinking	1 sample of each on 1 to 3 of the nearest water supplies that could be affected by its discharge.	Composite sample over 2-week period when I-131 analysis is performed; monthly composite otherwise.	I-131 analysis on each composite when the dose calculated for the consumption of the water is greater than 1 mRem per year. Composite for gross beta and gamma isotopic analysis monthly. Composite for tritium Analysis quarterly, 1 sample from a control location.

TABLE 3.12.1-1(Cont'd)RADIOLOGICAL ENVIRONMENTAL MONITORING PROGRAM

<u>EXPOSURE PATHWAY AND/OR SAMPLE</u>	<u>NUMBER OF REPRESENTATIVE SAMPLES AND SAMPLE LOCATIONS⁽¹⁾</u>	<u>SAMPLING AND COLLECTION FREQUENCY</u>	<u>TYPE AND FREQUENCY OF ANALYSIS</u>
d. Sediment	One Sample from Downstream Area One background sample from outside the influence of the facility (Sampling locations same as surface water)	Semiannually	Gamma isotopic analysis ⁽⁴⁾ semiannually.

TABLE 3.12.1-1(Cont'd)

RADIOLOGICAL ENVIRONMENTAL MONITORING PROGRAM

<u>EXPOSURE PATHWAY AND/OR SAMPLE</u>	<u>NUMBER OF REPRESENTATIVE SAMPLES AND SAMPLE LOCATIONS⁽¹⁾</u>	<u>SAMPLING AND COLLECTION FREQUENCY</u>	<u>TYPE AND FREQUENCY OF ANALYSIS</u>
4. INGESTION a. Milk ⁽⁶⁾	No milking animals If milk animals are identified: Samples from milking animals in three locations within 5km having the highest dose potential. If there are none, then one sample from milking animals in each of three areas between 5 and 8 km distant where doses are calculated to be greater than 1 mrem per year. One sample from milking animal at a control location 15 to 30 km distant and in the least prevalent wind direction	Semimonthly when on pasture; monthly at other times	Gamma isotopic ⁽⁴⁾ and Iodine -131 semimonthly when animals are on pasture; monthly at other times
b. Fish	One sample of available species consumed by man in plant discharge canal. One sample of available species consumed by man not influenced by plant discharge.	Semiannually, when available	Gamma isotopic analysis ⁽⁴⁾ on edible portions.

TABLE 3.12.1-1(Cont'd)

RADIOLOGICAL ENVIRONMENTAL MONITORING PROGRAM

<u>EXPOSURE PATHWAY AND/OR SAMPLE</u>	<u>NUMBER OF REPRESENTATIVE SAMPLES AND SAMPLE LOCATIONS⁽¹⁾</u>	<u>SAMPLING AND COLLECTION FREQUENCY</u>	<u>TYPE AND FREQUENCY OF ANALYSIS</u>
c. Clams	<p>One sample of available species consumed by man within the influence of the facility discharge.</p> <p>One sample of available species consumed by man not influenced by plant discharge.</p>	Semiannually, when available	Gamma isotopic analysis ⁽⁴⁾ on edible portions.
d. Vegetation ⁽⁸⁾	<p>3 samples of broad leaf vegetation grown nearest each of two different Off Site locations of highest predicted annual average elevated release D/Q ⁽⁷⁾, and most prevalent wind direction frequency.</p> <p>One sample of similar broad leaf vegetation grown distant and in a low location of lowest predicted annual average elevated release D/Q sector, and least prevalent wind direction frequency.</p>	Monthly during growing season	Gamma isotopic analysis ⁽⁴⁾ and I-131 on edible portion.

TABLE 3.12.1-1 (Continued)

TABLE NOTATIONS

- (1) Specific parameters of distance and direction sector from the centerline of the reactor, and additional description where pertinent, are provided for each and every sample location in Table 3.12.1-1 and Table E-1. Deviations are permitted from the required sampling schedule if specimens are unobtainable due to circumstances such as hazardous conditions, seasonal unavailability, malfunction of automatic sampling equipment, and other legitimate reasons. If specimens are unobtainable due to sampling equipment malfunction, effort shall be made to complete corrective action prior to the end of the next sampling period. All deviations from the sampling schedule shall be documented in the Annual Radiological Environmental Operating Report pursuant to CONTROL 6.1.2.4. It is recognized that, at times, it may not be possible or practicable to continue to obtain samples of the media of choice at the most desired location or time. In these instances suitable specific alternative media and locations may be chosen for the particular pathway in question and appropriate substitutions made within 30 days in the Radiological Environmental Monitoring Program given in the ODCM. Pursuant to Technical specification 6.19, submit in the next Radioactive Effluent Release Report documentation for a change in the ODCM including revised figure(s) and table for the ODCM reflecting the new location(s) with supporting information identifying the cause of the unavailability of samples for the pathway and justifying the selection of the new location(s) for obtaining samples. This applies to changes/deletions/additions of permanent sampling locations. This does not apply to one-time deviations from the sampling schedule. In those cases, it is NOT ACCEPTABLE to substitute sample media from other sources. The missed sample will be documented in the annual report, with no further actions necessary.
- (2) One or more instruments, such as pressurized ion chamber, for measuring and recording dose rate continuously may be used in place of, or in addition to, integrating dosimeters. For the purposes of this table, a thermoluminescent dosimeter (TLD) is considered to be one phosphor; two or more phosphors in a packet are considered as two or more dosimeters. The number of direct radiation monitoring stations has been reduced from the NUREG 1302 recommendation due to geographical limitations; e.g., some sectors are over water and some sectors cannot be reached due to lack of highway access, therefore the number of dosimeters has been reduced accordingly.
- (3) Airborne particulate sample filters shall be analyzed for gross beta radioactivity 24 hours or more after sampling to allow for radon and thoron daughter decay. If gross beta activity in air particulate is greater than ten times the yearly mean of control samples, gamma isotopic analysis shall be performed on the individual samples.
- (4) Gamma isotopic analysis means the identification and quantification of gamma-emitting radionuclides that may be attributable to the effluents from the facility.
- (5) Groundwater samples shall be taken when this source is tapped for drinking or irrigation purposes in areas where the hydraulic gradient or recharge properties are suitable for contamination.

- (6) The purpose of this sample is to obtain background information. If it is not practical to establish control locations in accordance with the distance and wind direction criteria, other sites which provide valid background data may be substituted .
- (7) Due to the fact that greater than 90% of all gaseous effluents releases are elevated, it is appropriate to use the D/Q factors generated from elevated release meteorological data, as the primary driver for environmental sample location placement.
- (8) If garden vegetation samples are unobtainable due to any legitimate reason (see (1) above), it is **NOT ACCEPTABLE** to substitute vegetation from other sources. The missed sample will be documented in the annual report, with no further actions necessary.

TABLE 3.12.1-2: REPORTING LEVELS FOR RADIOACTIVITY CONCENTRATIONS IN ENVIRONMENTAL SAMPLES - REPORTING LEVELS

Analysis	Surface and Ground Water(pCi/l)	Airborne Particulate and Iodine (pCi/m ³)	Fish (pCi/Kg, wet)	Milk (pCi/l)	Vegetation (pCi/Kg, wet)
H-3	20000*				
Mn-54	1000		30000		
Fe-59	400		10000		
Co-58	1000		30000		
Co-60	300		10000		
Zn-65	300		20000		
Zr-Nb-95	400				
I-131	20**	0.9		3	100
Cs-134	30	10	1000	60	1000
Cs-137	50	20	2000	70	2000
Ba-La-140	200			300	

*For a sample of water used as a source of drinking water

**If no drinking water pathway exists, a value of 20 pCi/L may be used.

TABLE 4.12.1-1: DETECTION CAPABILITIES FOR ENVIRONMENTAL SAMPLE ANALYSIS^{(1),(2)} - LOWER LIMITS OF DETECTION (LLD)⁽³⁾

Analysis	Surface and Ground Water (pCi/l)	Air Particulate and Air Iodine (pCi/m ³)	Vegetation (pCi/Kg, wet)	Sediment (pCi/Kg, dry)	Fish and Clams (pCi/Kg, wet)
Gross Beta	4	0.01			
H-3	2000 ⁽⁴⁾ 3000 ⁽⁵⁾				
Mn-54	15				130
Fe-59	30				260
Co-58, 60	15				130
Zn-65	30				260
Zr-95	30				
Nb-95	15				
I-131	15 ⁽⁵⁾	.07 ⁽⁶⁾	60		
Cs-134	15	.05 ⁽⁷⁾	60	150	130
Cs-137	18	.06 ⁽⁷⁾	80	180	150
La-140	15				
Ba-140	60				

TABLE 4.12.1-1 (Continued)

TABLE NOTATIONS

- (1) This list does not mean that only these nuclides are to be considered. Other peaks that are identifiable, together with those of the above nuclides, shall also be analyzed and reported in the Annual Radiological Environmental Operating Report pursuant to CONTROL 6.1.2.3.
- (2) Required detection capabilities for thermoluminescent dosimeters used for environmental measurements shall be in accordance with the recommendations of Regulatory Guide 4.13.
- (3) The LLD is defined, for purposes of these CONTROLS as the smallest concentration of radioactive material in a sample that will yield a net count, above system background, that will be detected with 95% probability with only 5% probability of falsely concluding that a blank observation represents a "real" signal.

For a particular measurement system, which may include radiochemical separation:

$$LLD = \frac{4.66 * Sb}{E * V * 2.22 * Y * \exp(-\lambda \Delta t)}$$

Where:

LLD is the "a priori" lower limit of detection as defined above, as picocuries per unit mass or volume,

Sb is the standard deviation of the background counting rate or of the counting rate of a blank sample as appropriate, as counts per minute,

E is the counting efficiency, as counts per disintegration,

V is the sample size in units of mass or volume,

2.22 is the number of disintegrations per minute per Pico curie,

Y is the fractional radiochemical yield, when applicable,

λ is the radioactive decay constant for the particular radionuclide (sec^{-1}), and

Δt for environmental samples is the elapsed time between sample collection, or end of the sample collection period, and time of counting (sec).

Typical values of E, V, Y, and Δt should be used in the calculation.

TABLE 4.12.1-1 (Continued)

TABLE NOTATIONS

It should be recognized that the LLD is defined as an a priori (before the fact) limit representing the capability of a measurement system and not as an a posteriori (after the fact) limit for a particular measurement. Analyses shall be performed in such a manner that the stated LLDs will be achieved under routine conditions. Occasionally, background fluctuations, unavoidable small sample sizes, the presence of interfering nuclides, or other uncontrollable circumstances may render these LLDs unachievable. In such cases, the contributing factors shall be identified and described in the Annual Radiological Environmental Operating Report pursuant Technical Specification 6.9.1.e and Control 6.1.2.6.4.

- (4) For a sample of drinking water.
- (5) If no drinking water pathway exists, a value of 3000 pCi/L for tritium and 15 pCi/L for iodine-131 may be used.
- (6) For the air iodine sample
- (7) For the air particulate sample

3/4.12 RADIOLOGICAL ENVIRONMENTAL MONITORING

3/4.12.2 LAND USE CENSUS

CONTROLS

3.12.2 In accordance with the Oyster Creek Technical Specifications 6.8.4.b, a land use census shall be conducted and shall identify within a distance of 5 miles the location in each of the 16 meteorological sectors of the nearest milk animal, the nearest residence and the nearest garden* of greater than 500 ft² producing broad leaf vegetation. The census shall also identify within a distance of 3 miles the location in each of the 16 meteorological sectors all milk animal and all gardens greater than 500 square feet producing broadleaf vegetation.

APPLICABILITY: At all times.

ACTION:

- a. With a land use census identifying a location(s) that yields a calculated dose or dose commitment greater than the values currently being calculated in SURVEILLANCE REQUIREMENT 4.11.2.3, identify the new location(s) in the next Radioactive Effluent Release Report, pursuant to Control 6.2.2.4.
- b. With a land use census identifying a location(s) that yields a calculated dose or dose commitment (via the same exposure pathway) 20 percent greater than at a location from which samples are currently being obtained in accordance with CONTROL 3.12.1, add the new location(s) to the radiological environmental monitoring program within 30 days. The sampling location(s), excluding the control station location, having the lowest calculated dose or dose commitment(s), via the same exposure pathway, may then be deleted from this monitoring. Pursuant to CONTROL 6.2.2.4, identify the new location(s) in the next Radioactive Effluent Release Report and also include in the report a revised figure(s) and table for the ODCM reflecting the new location(s).
- c. The provisions of CONTROLS 3.0.3 and 3.0.4 are not applicable.

SURVEILLANCE REQUIREMENTS

4.12.2 The land use census shall be conducted during the growing season at least once per 12 months using that information that will provide the best results, such as by door-to-door survey, visual survey, aerial survey, or by consulting local agriculture authorities. The results of the land use census shall be included in the Annual Radiological Environmental Operating Report pursuant to CONTROL 6.1.2.2.

*Broad leaf vegetation sampling of at least three different kinds of vegetation may be performed at the SITE BOUNDARY in each of two different direction sectors with the highest predicted elevated release D/Q's in lieu of the garden census. Controls for broadleaf vegetation sampling in Table 3.12.1-1, Part 4.c shall be followed, including analysis of control samples.

3/4.12 RADIOLOGICAL ENVIRONMENTAL MONITORING

3/4.12.3 INTERLABORATORY COMPARISON PROGRAM

CONTROLS

3.12.3 In accordance with Oyster Creek Technical Specifications 6.8.b.3, analyses shall be performed on radioactive materials supplied as part of an Interlaboratory comparison program which has been approved by the Commission.

APPLICABILITY: At all times.

ACTION:

- a. With analyses not being performed as required above, report the reason and corrective actions taken to prevent a recurrence to the Commission in the Annual Radiological Environmental Operating Report pursuant to CONTROL 6.1.2.6.3.
- b. The provisions of CONTROLS 3.0.3 and 3.0.4 are not applicable.

SURVEILLANCE REQUIREMENTS

4.12.3 A summary of the results obtained as part of the above-required Interlaboratory Comparison Program shall be included in the Annual Radiological Environmental Operating Report pursuant to CONTROL 6.1.2.6.3.

3 /4 .12 RADIOLOGICAL ENVIRONMENTAL MONITORING

3/4.12.4 METEOROLOGICAL MONITORING PROGRAM

CONTROLS

3.12.4 The meteorological monitoring instrumentation channels shown in Table 3.3-3 shall be operable.

APPLICABILITY: At all times.

ACTION:

- a. With less than the minimum required instrumentation channels OPERABLE for more than 7 days, initiate an Issue Report outlining the cause of the malfunction and the plans for restoring the instrumentation to OPERABLE status.
- c. The provisions of CONTROLS 3.0.3 and 3.0.4 are not applicable.

TABLE 3.12.4-1

METEOROLOGICAL MONITORING INSTRUMENTATION

<u>INSTRUMENT</u>	<u>ELEVATION</u>	<u>MINIMUM INSTRUMENT OPERABLE</u>
1.	Wind Speed	
	a. 380 feet	1
	b. 150 feet	1
	c. 33 feet	1
2.	Wind Direction	
	a. 380 feet	1
	b. 150 feet	1
	c. 33 feet	1
3.	ΔT	
	a. 380-33	1
	b. 150-33	1

BASES FOR SECTIONS 3.0 AND 4.0

CONTROLS AND SURVEILLANCE REQUIREMENTS

NOTE: The BASES contained in the succeeding pages summarize the reasons for the CONTROLS of Sections 3.0 and 4.0, but are not considered a part of these CONTROLS.

3/4.3 INSTRUMENTATION

BASES

3/4.3.3.10 RADIOACTIVE LIQUID EFFLUENT MONITORING INSTRUMENTATION

The radioactive liquid effluent instrumentation is provided to monitor and control, as applicable, the releases of radioactive materials in liquid effluents during actual or potential releases of liquid effluents. The reactor service water system discharge line radioactivity monitor initiates an alarm in the Control Room when the alarm set point is exceeded. The alarm/trip set points for these instruments shall be calculated and adjusted in accordance with the methodology and parameters in the ODCM to ensure that the alarm/trip will occur prior to exceeding the limits of 10 CFR Part 20. The OPERABILITY and use of this instrumentation is consistent with the requirements of General Design Criteria 60, 63, and 64 of Appendix A to 10 CFR Part 50.

3/4.3.3.11 RADIOACTIVE GASEOUS EFFLUENT MONITORING INSTRUMENTATION

The radioactive gaseous effluent instrumentation is provided to monitor and control, as applicable, the releases of radioactive materials in gaseous effluents during actual or potential releases of gaseous effluents. The alarm/trip set points for each of the noble gas monitors shall be calculated and adjusted in accordance with the methodology and parameters in the ODCM. This will ensure the alarm/trip will occur prior to exceeding the limits of 10 CFR Part 20. The radioactive gas monitors for the stack effluent and the Augmented Off gas Building exhaust ventilation have alarms which report in the Reactor Control Room. The OPERABILITY and use of this instrumentation is consistent with the requirements of General Design Criteria 60, 63, and 64 of Appendix A to 10 CFR Part 50.

3/4.11 RADIOACTIVE EFFLUENTS

BASES

3/4.11.1 LIQUID EFFLUENTS

3/4.11.1.1 CONCENTRATION

This CONTROL is provided to ensure that the concentration of radioactive materials released in liquid waste effluents to UNRESTRICTED AREAS will be less than the concentration levels specified in 10 CFR Part 20, Appendix B, Table 2, Column 2. This limitation provides additional assurance that the levels of radioactive materials in bodies of water in UNRESTRICTED AREAS will result in exposures within (1) the Section II.A design objectives of Appendix I, 10 CFR Part 50, to a MEMBER OF THE PUBLIC and (2) the limits of 10 CFR Part 20.106(a) to the population. The concentration limit for dissolved or entrained noble gases is based upon the assumption that Xe-135 is the controlling radioisotope and its concentration limit in air (submersion) was converted to an equivalent concentration in water using the methods described in International Commission on Radiological Protection (ICRP) Publication 2.

The value 1E-8 is the limit for unidentified gross gamma or beta releases as per 10 CFR 20 Appendix B, Table 2, Column 2 "any single radionuclide...other than alpha or spontaneous fission ...half life greater than 2 hours". This provides operational flexibility while providing reasonable assurance that dose will remain less than 0.1 rem/yr.

The required detection capabilities for radioactive materials in liquid waste samples are tabulated in terms of the lower limits of detection (LLDs). Detailed discussion of the LLD, and other detection limits can be found in references 25, 26, and 27.

3/4.11.1.2 DOSE

This CONTROL is provided to implement the requirements of Sections II.A, III.A, and IV.A of Appendix I, 10 CFR Part 50. The CONTROL implements the guides set forth in Section II.A of Appendix I. The ACTION statements provide the required operating flexibility and at the same time implement the guides set forth in Section IV.A of Appendix I to assure that the releases of radioactive material in liquid effluents to UNRESTRICTED AREAS will be kept "as low as is reasonably achievable." The dose calculation methodology and parameters in the ODCM implement the requirements in Section III.A of Appendix I that conformance with the guides of Appendix I be shown by calculational procedures based on models and data, such that the actual exposure of a MEMBER OF THE PUBLIC through appropriate pathways is unlikely to be substantially underestimated. The equations specified in the ODCM for calculating the doses due to the actual release rates of radioactive materials in liquid effluents are consistent with the methodology provided in Regulatory Guide 1.109 and Regulatory Guide 1.113.

3/4.11.1.3 LIQUID RADWASTE TREATMENT

The OPERABILITY of the liquid radwaste treatment system ensures that this system will be available for use whenever liquid effluents require treatment prior to their release to the environment. The requirement that the appropriate portions of this system be used, when specified, provides assurance that the releases of radioactive materials in liquid effluents will be kept "as low as is reasonably achievable". This CONTROL implements the requirements of General Design Criterion 60 of Appendix A to 10 CFR Part 50 and the design objective given in Section II.D of Appendix I to 10 CFR Part 50. The specified limits governing the use of appropriate portions of the liquid radwaste treatment system were specified as a suitable fraction of the dose design objectives set forth in Section II.A of Appendix I, 10 CFR Part 50, for liquid effluents.

3/4.11.2 GASEOUS EFFLUENTS

3/4.11.2.1 DOSE RATE

This CONTROL is provided to ensure that the dose at any time at and beyond the SITE BOUNDARY from gaseous effluents will be within the annual dose limits of 10 CFR Part 20 to UNRESTRICTED AREAS. The annual dose limits are the doses associated with the concentrations of 10 CFR Part 20, Appendix B, Table 2, Column 1. These limits provide reasonable assurance that radioactive material discharged in gaseous effluents will not result in the exposure of a MEMBER OF THE PUBLIC in an UNRESTRICTED AREA either within or outside the SITE BOUNDARY, to annual average concentrations exceeding the limits specified in Appendix B, Table 2 of 10 CFR Part 20. For MEMBERS OF THE PUBLIC who may at times be within the SITE BOUNDARY, the occupancy of the individual will usually be sufficiently low to compensate for any increase in the atmospheric diffusion factor above that for the SITE BOUNDARY. Examples of calculations for such MEMBERS OF THE PUBLIC with the appropriate occupancy factors shall be given in the ODCM. The specified release rate limits restrict, at all times, the corresponding gamma and beta dose rates above background to a MEMBER OF THE PUBLIC at or beyond the SITE BOUNDARY to less than or equal to 500 mrem/year to the total body or to less than or equal to 3000 mrem/yr to the skin. These release rate limits also restrict, at all times, the corresponding thyroid dose rate above background to a child via the inhalation pathway to less than or equal to 1500 mrem/year.

The required detection capabilities for radioactive materials in liquid waste samples are tabulated in terms of the lower limits of detection (LLDs). Detailed discussion of the LLD, and other detection limits can be found in references 25, 26 and 27.

3/4.11.2.2 DOSE - NOBLE GASES

This CONTROL is provided to implement the requirements of Section II.B, III.A and IV.A of Appendix I, 10 CFR Part 50. The CONTROL implements the guides set forth in Section II.B of Appendix I. The ACTION statements provide the required operating flexibility and at the same time implement the guides set forth in Section IV.A of Appendix I to assure that the releases of radioactive material in gaseous effluents will be kept "as low as is reasonably achievable." The SURVEILLANCE REQUIREMENTS implement the requirements in Section III.A of Appendix I that conformance with the guides of Appendix I be shown by calculational procedures based on

models and data such that the actual exposure of a MEMBER OF THE PUBLIC through appropriate pathways is unlikely to be substantially underestimated. The dose calculation methodology and parameters established in the ODCM for calculating the doses due to the actual release rates of radioactive noble gases in gaseous effluents are consistent with the methodology provided in Regulatory Guide 1.109 and Regulatory Guide 1.111. The ODCM equations provided for determining the air doses at and beyond the SITE BOUNDARY are based upon the historical average atmospheric conditions.

3/4.11.2.3 DOSE - IODINE-131, IODINE-133, TRITIUM, AND RADIONUCLIDES IN PARTICULATE FORM

This CONTROL is provided to implement the requirements of Section II.C, III.A and IV.A of Appendix I, 10 CFR Part 50. The CONTROLS are the guides set forth in Section II.C of Appendix I. The ACTION statements provide the required operating flexibility and at the same time implement the guides set forth in Section IV.A of Appendix I to assure that the releases of radioactive material in gaseous effluents to UNRESTRICTED AREAS will be kept "as low as is reasonably achievable." The ODCM calculational methods specified in SURVEILLANCE REQUIREMENTS implement the requirements in Section III.A of Appendix I that conformance with the guides of Appendix I be shown by calculational procedures based on models and data such that the actual exposure of a MEMBER OF THE PUBLIC through appropriate pathways is unlikely to be substantially underestimated. The ODCM calculational methodology and parameters for calculating the doses due to the actual release rates of the subject materials are consistent with the methodology provided in Regulatory Guide 1.109, and Regulatory Guide 1.111. These equations also provide for determining the actual doses based upon the historical average atmospheric conditions. The release rate controls for iodine-131, iodine-133, tritium, and radionuclides in particulate form with half-life greater than 8 days are dependent on the existing radionuclide pathways to man, in the areas at and beyond the SITE BOUNDARY. The pathways that were examined in the development of these calculations were: 1) individual inhalation of airborne radionuclides, 2) deposition of radionuclides onto green leafy vegetation with subsequent consumption by man, 3) deposition onto grassy areas where milk animals and meat producing animals graze with consumption of the milk and meat by man, and 4) deposition on the ground with subsequent exposure of man.

3/4.11.2.4 AUGMENTED OFF GAS TREATMENT SYSTEM

The OPERABILITY of the AUGMENTED OFF GAS TREATMENT SYSTEM (AOG) ensures that the system will be available for use whenever gaseous effluents require treatment prior to release to the environment. The requirement that the appropriate portions of these systems be used, when specified, provides reasonable assurance that the releases of radioactive materials in gaseous effluents will be kept "as low as is reasonably achievable." This CONTROL implements the requirements of General Design Criterion 60 of Appendix A to 10 CFR Part 50, and the design objectives given in Section II.D of Appendix I to 10 CFR Part 50. The specified limits governing the use of appropriate portions of the systems were specified as a suitable fraction of the dose design objectives set forth in Section II.B and II.C of Appendix I, 10 CFR Part 50, for gaseous effluents.

3/4.11.4 TOTAL DOSE

This CONTROL is provided to meet the dose limitations of 40 CFR Part 190 that have now been incorporated into 10 CFR Part 20 by 46 FR 18525. The CONTROL requires the preparation and submittal of a Special Report whenever the calculated doses from plant radioactive effluents exceed 25 mrem to the total body or any organ, except the thyroid, which shall be limited to less than or equal to 75 mrem. It is highly unlikely that the resultant dose to a MEMBER OF THE PUBLIC will exceed the dose limits of 40 CFR Part 190 if the doses remain within twice the dose design objectives of Appendix I, and if direct radiation doses from the unit, including outside storage tanks, etc. are kept small. The Special Report will describe a course of action that should result in the limitation of the annual dose to a MEMBER OF THE PUBLIC to within the 40 CFR Part 190 limits. For purposes of the Special Report, it may be assumed that the dose commitment to the MEMBER OF THE PUBLIC from other uranium fuel cycle sources is negligible. If the dose to any MEMBER OF THE PUBLIC is estimated to exceed the requirements of 40 CFR Part 190, the Special Report with a request for a variance (provided the release conditions resulting in violation of 40 CFR Part 190 have not already been corrected), in accordance with the provisions of 40 CFR Part 190 and 10 CFR Part 20, is considered to be a timely request and fulfills the requirements of 40 CFR Part 190 until NRC staff action is completed. The variance only relates to the limits of 40 CFR Part 190, and does not apply in any way to the other requirements for dose limitation of 10 CFR Part 20, as addressed in CONTROLS 3.11.1.1 and 3.11.2.1. An individual is not considered a MEMBER OF THE PUBLIC during any period in which he/she is engaged in carrying out any operation that is part of the nuclear fuel cycle.

3/4.12 RADIOLOGICAL ENVIRONMENTAL MONITORING

BASES

3/4.12.1 MONITORING PROGRAM

The radiological environmental monitoring program required by this CONTROL provides representative measurements of radiation and of radioactive materials in those exposure pathways and for those radionuclides that lead to the highest potential radiation exposures of MEMBERS OF THE PUBLIC resulting from the station operation. This monitoring program implements Section IV.B.2 of Appendix I to 10 CFR Part 50 and thereby supplements the radiological effluent monitoring program by verifying that the measurable concentrations of radioactive materials and levels of radiation are not higher than expected on the basis of the effluent measurements and the modeling of the environmental exposure pathways. Guidance for this monitoring program is provided by the Radiological Assessment Branch Position on Environmental Monitoring, Revision 1, November 1979.

The required detection capabilities for environmental sample analyses are tabulated in terms of the lower limits of detection (LLDs). The LLDs required by Table 4.12.1-1 are considered optimum for routine environmental measurements in industrial laboratories. It should be recognized that the LLD is defined as an a priori (before the fact) limit representing the capability of a measurement system and not as an a posteriori (after the fact) limit for a particular measurement.

Detailed discussion of the LLD, and other detection limits can be found in references 25, 26, and 27.

Site-specific research, which included the installation of a groundwater monitoring well network, has demonstrated that the groundwater pathway is not a potential pathway to man from the OCGS. The surface water into which the OCGS discharges is a marine estuary containing saline water that is not used as drinking water or irrigation water by man.

3/4.12.2 LAND USE CENSUS

This CONTROL is provided to ensure that changes in the use of areas at and beyond the SITE BOUNDARY are identified and that modifications to the radiological environmental monitoring program are made if required by the results of this census. The best information from the door-to-door survey, from aerial survey, from visual survey or consulting with local agricultural authorities shall be used. This census satisfies the requirements of Section IV.B.3 of Appendix I to 10 CFR Part 50. Restricting the census to gardens of greater than 50 m² provides assurance that significant exposure pathways via leafy vegetables will be identified and monitored since a garden of this size is the minimum required to produce the quantity (26 kg/year) of leafy vegetables assumed in Regulatory Guide 1.109 for consumption by a child. To determine this minimum garden size, the following assumptions were made: 1) 20% of the garden was used for growing broad leaf vegetation (i.e., similar to lettuce and cabbage), and 2) a vegetation yield of 2 kg/m².

3/4.12 RADIOLOGICAL ENVIRONMENTAL MONITORING

BASES

3/4.12.3 INTERLABORATORY COMPARISON PROGRAM

The requirement for participation in an approved Interlaboratory Comparison Program is provided to ensure that independent checks on the precision and accuracy of the measurements of radioactive material in environmental sample matrices are performed as part of the quality assurance program for environmental monitoring in order to demonstrate that the results are valid for the purposes of Section IV.B.2 of Appendix I to 10 CFR Part 50.5.0

5.0 DESIGN FEATURES / SITE MAP

(Provided FOR INFORMATION ONLY. Technical Specifications are controlling.)

5.1 Site map which will allow identification of structures and release points shall be as shown in Figure E-3.

6.0 ADMINISTRATIVE CONTROLS

6.1 ANNUAL RADIOLOGICAL ENVIRONMENTAL OPERATING REPORT (REOR)

6.1.1 In accordance with Oyster Creek Technical Specifications 6.9.1.e, a routine radiological environmental operating report covering the operation of the unit during the previous calendar year shall be submitted prior to May 1 of the following year.

6.1.2 The Annual Radiological Environmental Operating Reports shall include:

6.1.2.1 Summaries, interpretations, and an analysis of trends of the results of the radiological environmental surveillance activities (Radiological Environmental Monitoring Program –REMP) for the report period. This will include a comparison with preoperational studies, with operational controls (as appropriate), and with previous environmental surveillance reports, and an assessment of the observed impacts of the plant operation on the environment.

6.1.2.2 The reports shall also include the results of land use censuses required by CONTROL 3.12.2. If harmful effects or evidence of irreversible damage are detected by the monitoring, the report shall provide an analysis of the problem and a planned course of action to alleviate the problem.

6.1.2.3 The Annual Radiological Environmental Operating Reports shall include summarized and tabulated results similar in format to that in Regulatory Guide 4.8, December 1975 of all the radiological environmental samples taken during the report period.

6.1.2.4 Deviations from the sampling program identified in CONTROL 3.12.1 shall be reported.

6.1.2.5 In the event that some individual results are not available for inclusion with the report, the report shall be submitted noting and explaining the reasons for the missing results. The missing data shall be submitted as soon as possible in a supplementary report.

6.1.2.6 The reports shall also include the following:

6.1.2.6.1 A summary description of the radiological environmental monitoring Program;

6.1.2.6.2 Map(s), covering sampling locations, keyed to a table giving distances and directions from the reactor;

6.1.2.6.3 The results of licensee participation in the Inter-laboratory Comparison Program, as required by CONTROL 3.12.3;

6.1.2.6.4 Identification of environmental samples analyzed when the analysis instrumentation was not capable of meeting the detection capabilities in Table 4.12.1-1.

- 6.2 ANNUAL ROUTINE RADIOACTIVE EFFLUENT RELEASE REPORT (RERR)
- 6.2.1 Routine radioactive effluent release reports covering the operation of the unit shall be submitted within 60 days of January 1 of each year and in accordance with the requirements of 10CFR50.36a and section IV.B.1 of 10CFR 50 Appendix I.
- 6.2.2 The Radioactive Effluent Release Report shall include:
- 6.2.2.1 A summary of the quantities of radioactive liquid and gaseous effluents and solid waste released from the unit as outlined in Regulatory Guide 1.21. "Measuring, Evaluating, and Reporting Radioactivity in Solid Wastes and Releases of Radioactive Materials in Liquid and Gaseous Effluents from Light-Water-Cooled Nuclear Power Plants," Revision 1, June 1974, with data summarized on a quarterly basis following the format of Appendix B thereof.
- 6.2.2.2 An annual summary of hourly meteorological data collected over the previous year. This annual summary may be in the form of joint frequency distributions of wind speed, wind direction, and atmospheric stability. Alternatively, summary meteorological data may be retained and made available to the NRC upon request.
- 6.2.2.3 An assessment of the radiation doses due to the radioactive liquid and gaseous effluents released from the unit or station during the previous calendar year. The historical annual average meteorology or the meteorological conditions concurrent with the time of release of radioactive materials in gaseous effluents (as determined by sampling frequency and measurement) shall be used for determining the gaseous pathway doses. The assessment of radiation doses shall be performed in accordance with this OFF SITE DOSE CALCULATION MANUAL (ODCM).
- 6.2.2.4 Identify those radiological environmental sample parameters and locations where it is not possible or practicable to continue to obtain samples of the media of choice at the most desired location or time. In addition, the cause of the unavailability of samples for the pathway and the new location(s) for obtaining replacement samples should be identified. The report should also include a revised figure(s) and table(s) for the ODCM reflecting the new location(s).
- 6.2.2.5 An assessment of radiation doses to the likely most exposed MEMBER, and 3.2.OF THE PUBLIC from reactor releases and other nearby uranium fuel cycle sources (including doses from primary effluent pathways and direct radiation) for the previous calendar year to show conformance with 40 CFR Part 190, Environmental Radiation Protection Standards for Nuclear Power Operation. The assessment of radiation doses shall be performed in accordance with this OFF SITE DOSE CALCULATION MANUAL (ODCM) Part II Sections 1.5, 2.4, 2.5

- 6.2.2.6 The Radioactive Effluent Release Reports shall include the following information for each class of solid waste (as defined by 10 CFR Part 61) shipped Off Site during the report period (see Figure D-1-2):
 - a. Total volume shipped
 - b. Total curie quantity (specify whether determined by measurement or estimate),
 - c. Principal radionuclides (specify whether determined by measurement or estimate),
 - d. Type of waste (e.g., dewatered spent resin, compacted dry waste, evaporator bottoms)
- 6.2.2.7 Unplanned releases from the site to UNRESTRICTED AREAS of radioactive materials in gaseous and liquid effluents on a quarterly basis.
- 6.2.2.8 Changes to the PROCESS CONTROL PROGRAM (PCP)
- 6.2.2.9 Changes to the OFF SITE DOSE CALCULATION MANUAL (ODCM)

6.3 RESPONSIBILITIES:

- 6.3.1 Chemistry / Radwaste - Responsible for:
 - 6.3.1.1 Implementing approval.
 - 6.3.1.2 Compliance with specifications regarding routine dose assessment.
 - 6.3.1.3 Radiological Environmental Monitoring Program
 - 6.3.1.4 Technical consultation and review
- 6.3.2 Operations - Responsible for compliance with specifications regarding operation of the OCGS.
- 6.3.3 Engineering - Responsible for compliance with specifications regarding set point determination and implementation
- 6.3.4 Radiological Engineering - Responsible for technical consultation and review.

PART II - CALCULATIONAL METHODOLOGIES

1.0 LIQUID EFFLUENTS

1.1 RADIATION MONITORING INSTRUMENTATION AND CONTROLS

The liquid effluent monitoring instrumentation and controls at Oyster Creek for controlling and monitoring normal radioactive material releases in accordance with the Oyster Creek Radiological Effluent Technical Specifications are summarized as follows:

- (1) Alarm (Only) - The Reactor Building Service Water Effluent Line Monitor provides an Alarm function only for releases into the environment.

Liquid radioactive waste flow diagrams are presented in Figures D-1-1a and D-1-1b.

1.2 LIQUID EFFLUENT MONITOR SET POINT DETERMINATION

Per the requirements of CONTROL 3.3.3.10, alarm set points shall be established for the liquid monitoring instrumentation to ensure that the release concentration limits of CONTROL 3.11.1.1 are met (i.e., the concentration of radioactive material released in liquid effluents to UNRESTRICTED AREAS at the U.S. route 9 bridge over the discharge canal shall not exceed the concentrations specified in 10 CFR 20 Appendix B, Table 2, Column 2, for radionuclides and 2.0E-04 $\mu\text{Ci/ml}$ for dissolved or entrained noble gases).

1.2.1 LIQUID EFFLUENT MONITORS

The set points for the liquid effluent monitors at the Oyster Creek Generating Station are determined by the following equation:

$$S = \frac{A}{FLEC} g \frac{F_2}{F_1} + BKG$$

Where:

- S = radiation monitor alarm set point (cpm)
- A = activity concentration ($\mu\text{Ci/ml}$) of sample in laboratory: $A = \sum C_i$
- g = the primary conversion factor for the instrument – the ratio of effluent radiation monitor counting rate to laboratory activity concentration in a sample of liquid (cpm per $\mu\text{Ci/mL}$).
- F₁ = flow in the batch release line (e.g. gal/min). Value not greater than the discharge line flow alarm maximum set point.

F_2 = flow in the discharge canal (e.g. gal/min). Value not less than the discharge canal minimum flow.

BKG = Monitoring instrument background (cpm)

FLEC = fraction or multiple of unrestricted area LEC in aqueous effluent based on sample analysis. FLEC is the ratio between the LEC_i and C_i . FLEC is unitless. For example: LEC for Co-60 is $3E-6$ $\mu\text{Ci/mL}$. If the concentration in a expected release is $6E-6$ $\mu\text{Ci/mL}$; then FLEC is $6E-6/3E-6 = 2$.

The term $\frac{A}{FLEC}$ represents the count rate of a solution having the same nuclide distribution as the sample and the LEC of that mixture.

C_i = concentration of radionuclide i in effluent, i.e., in a liquid radwaste sample tank, in reactor building service water ($\mu\text{Ci/mL}$).

LEC_i = The unrestricted area liquid effluent concentration (LEC) of radionuclide i , i.e., 10 CFR 20, Appendix B, Table 2, Column 2 quantity for radionuclide i ($\mu\text{Ci/mL}$).

In the event gross radioactivity analysis alone is used to determine the radioactivity in an effluent stream or batch, FLEC is $C/1E-8$ (see 4.11.1.1.1),

Where:

C = The gross radioactivity concentration in effluent ($\mu\text{Ci/mL}$).

$1E-8$ = The unrestricted area LEC for unidentified radionuclides ($\mu\text{Ci/mL}$) from 4.11.1.1.1.

If the gross activity concentration, C , is below the lower limit of detection for gross activity, the value, $1E-8$ $\mu\text{Ci/mL}$, or the equivalent counting rate (cpm/mL) may be substituted for the factor

$$\frac{A}{FLEC}$$

$$\frac{A}{FLEC} = 1E-8 \mu\text{Ci/mL}$$

1.2.2 SAMPLE RESULT SET POINTS

Usually, when the concentration of specific radionuclides is determinable in a sample(s), i.e., greater than the LLD, the alarm/trip set point of each liquid effluent radioactivity monitor is based upon the measurement of radioactive material in a batch of liquid to be released or in a continuous aqueous discharge.

1.2.3 ASSUMED DISTRIBUTION SET POINTS

Alternatively, a radionuclide distribution that represents the distribution expected to be in the effluent if the concentration were high enough to be detectable, i.e., greater than the LLD, may be assumed. The representative distribution may be

based upon past measurements of the effluent stream or upon a computed distribution.

1.3 BATCH RELEASES

A sample of each batch of liquid radwaste is analyzed for I-131 and other principal gamma emitters or for gross beta or gross gamma activity before release. The result of the analysis is used to calculate the trip set point of the radioactivity monitor on the liquid radwaste effluent line to apply to release of the batch.

1.4 CONTINUOUS RELEASES

The Reactor Building Service Water Effluent is sampled and analyzed weekly for I-131 and other principal gamma emitters. Results of analyses for the preceding week or for a period as long as the preceding 3 months are used to calculate the alarm/trip set point of the corresponding effluent radioactivity monitor in order to determine a representative value. In each case, whether batch or continuous, the monitor alarm/trip set point may be set at lower activity concentration than the calculated set point.

1.5 LIQUID EFFLUENT DOSE CALCULATION - 10 CFR 50

Doses resulting from the release of radioiodines and particulates must be calculated to show compliance with Appendix I of 10CFR50. Calculations will be performed at least monthly for all liquid effluents as stated in SURVEILLANCE REQUIREMENT 4.11.1.2 and SURVEILLANCE REQUIREMENT 4.11.1.3.1 to verify that the dose to MEMBERS OF THE PUBLIC is maintained below the limits specified in CONTROL 3.11.1.2

The maximum dose to an individual from radioiodines, tritium, and radioactive particulates with half-lives of greater than eight days in liquid effluents released to unrestricted areas is determined as described in Reg. Guide 1.109. Environmental pathways that radioiodine, tritium, and particulates in liquid effluent follow to the maximally exposed MEMBER OF THE PUBLIC are assumed to be: exposure to shoreline deposits, ingestion of fish, and ingestion of shellfish. To assess compliance with CONTROL 3.11.1.2, the dose due to radioactive iodine, tritium, and particulates in liquid effluent is calculated to a person at the Route 9 bridge who consumes fish and shellfish harvested at that location.

1.5.1 MEMBER OF THE PUBLIC DOSE - LIQUID EFFLUENTS

CONTROL 3.11.1.2 limits the dose or dose commitment to MEMBERS OF THE PUBLIC from radioactive materials in liquid effluents from Oyster Creek Generating Station to those listed in Table 1.5.1-1.

TABLE 1.5.1-1 LIQUID PATHWAY DOSE LIMITS

<u>During Any Calendar Quarter</u>	<u>During Any Calendar Year</u>
≤ 1.5 mrem to total body	≤ 3.0 mrem to total body
≤ 5.0 mrem to any organ	≤ 10.0 mrem to any organ

Per the SURVEILLANCE REQUIREMENTS of 4.11.1.2, the following calculation methods shall be used for determining the dose or dose commitment due to the liquid radioactive effluents from Oyster Creek. Applicable liquid pathways to man for Oyster Creek include shoreline exposure, and ingestion of saltwater fish and shellfish. The receptor location is provided in Table A-4.

1.5.2 SHORELINE DEPOSIT DOSE

The shoreline exposure pathway dose is calculated generally in the form (based on Reg. Guide 1.109):

$$Rapj = 110000 \frac{UapWM}{F} \sum_i QiTiDaipj(1 - \exp(-\lambda iTb))$$

Where:

110000 = a constant that accounts for time and flow conversions

Rapj = the annual dose to organ j (including the total body), through pathway p, to age group a

Uap = the age dependent usage factor for the specific pathway. Usage factors for shoreline exposure are residence time on the shoreline (hours). Usage factors are provided in Reg. Guide 1.109 Table E-5. Usage factors specifically selected for Oyster Creek are presented in Table B-1.

W = the shore width factor. This adjusts the infinite plane gamma or beta dose factors for the finite size and shape of the shoreline. Different factors apply to different bodies of water. A factor of 0.1 is used for OC for 'discharge canal bank'.

M = the recirculation factor. The recirculation factor is a multiplier of 3.76 to account for recirculation of discharge water back into the intake. Although this occurs infrequently, it is assumed to occur for each liquid release.

F = the flow rate in the discharge canal in cubic feet per second

Q_i = the activity of the i th isotope in the release in curies

T_i = the half life of the i th isotope in days

Da_{ipj} = the age a , isotope i , pathway p , and organ j , specific dose conversion factor. Pathway, isotope, age, and organ specific dose factors are obtained from Regulatory Guide 1.109 Appendix E, Tables E-6 through E-14

λ_i = the decay constant of the i th isotope in years

T_b = the long term buildup time, assumed to be 30 years

Note: λ_i and T_b can use any time units as long as they are both the same. No transit delay (T_p from Reg. Guide 1.109) is assumed.

1.5.3 SHORELINE DOSE EXAMPLE

The following provides an example of the liquid dose calculation:

Initial parameters:

Canal flow rate 1E6 gpm (typical of normal full power operation)

Release: 10,000 gallons of water at 1E-3 μ Ci/ml Co-60

Problem: calculate shoreline whole body dose

U_{ap} = 67 (teenager) hours

W = 0.1

M = 3.76

F = 2228 [1E6 gpm * 3785 ml / gal / (60 sec/min * 28316 ml/ft³) = 2228 CFS]

Q_i = 0.03785 Ci [1E-3 μ Ci/ml * 10000gal * 3785ml/gal = 0.03785 Ci]

T_i = 1930 [5.27 years * 365.25days/yr = 1.93E3 days]

λ_i = 1.31E-1 [0.693 / (5.27 yrs)]

T_b = 30 years

Da_{ipj} = 1.7E-8 mrem/hr / pCi/m² Gamma dose factor

Calculate R_{apj} for a = Teen, j = total body, p = shoreline dose for one isotope

$$R_{apj} = 110000 \frac{67 * 0.1 * 3.76}{2228} \sum_i 0.03785 * 1930 * 1.7E-8 * (1 - \exp(-1.3E-1 * 30))$$

$$R_{apj} = 1.5E-3 \text{ mrem: teen: wholebody}$$

1.5.4 INGESTION DOSE - LIQUID

Ingestion dose pathway calculations are similar to those for the shoreline dose, with minor changes in constants, removal of the shore width factor, and inclusion of the bioaccumulation factor:

$$Rapj = 1100 \frac{UapM}{F} \sum_i QiBipDaipj$$

Where:

Bip = the stable element bioaccumulation factor for pathway p for the ith isotope

No transit delay is assumed

Pathway, isotope, age, and organ specific dose factors are obtained from Regulatory Guide 1.109 Appendix E Tables E-7 through E-14. Bioaccumulation factors are provided in Reg. Guide 1.109 Table A-1. Usage factors are provided in Reg. Guide 1.109 Table E-5. Usage factors specifically selected for Oyster Creek are presented in Table B-1.

The radionuclides included in the periodic dose assessment per the requirements of CONTROL 3/4.11.1.2 are those as identified by gamma spectral analysis of the liquid waste samples collected and analyzed per the requirements of CONTROL 3/4.11.1.1, Table 4.11.1.1.1-1.

Radionuclides requiring radiochemical analysis (e.g., Sr-89 and Sr-90) will be added to the dose analysis at a frequency consistent with the required minimum analysis frequency of Table 4.11.1.1.1-1.

1.5.5 INGESTION DOSE CALCULATION EXAMPLE

The following provides an example of the liquid dose calculation:

Initial parameters:

Canal flow rate 1E6 gpm (typical of normal full power operation)

Release: 10000 gallons of water at 1E-3 μ Ci/mL Co-60

Problem: calculate teen whole body dose from saltwater fish ingestion

$$Rapj = 1100 \frac{UapM}{F} \sum_i QiBipDaipj$$

Uap = 16 (teenager) Kg

M = 3.76

F = 2228 [1E6 gpm * 3785 ml / gal / (60 sec/min * 28316 ml/ft³) = 2228 CFS]

Qi = 0.03785 Ci [1E-3 μ Ci/mL * 10000 * 3785 = 0.03785 Ci]

Bip = 100

Daipj = 6.33E-6 mrem / pCi

Calculate R_{apj} for a = Teen, j = total body, p = fish ingestion dose for one isotope

$$R_{apj} = 1100 \frac{16 * 3.76}{2228} \sum_i 0.03785 * 100 * 6.33 E - 6$$
$$R_{apj} = 7.12 E - 4 \text{ mrem} \quad ; \text{ teen} \quad ; \text{ wholebody}$$

1.6 REPRESENTATIVE SAMPLES

A sample should be representative of the bulk stream or volume of effluent from which it is taken. Prior to sampling, large volumes of liquid waste should be mixed in as short a time interval as practicable to assure that any sediments or particulate solids are distributed uniformly in the waste mixture. Recirculation pumps for liquid waste tanks (collection or sample test tanks) should be capable of recirculating at a rate of not less than two tank volumes in eight hours. Minimum recirculation times and methods of recirculation are controlled by specific plant procedures.

2.0 GASEOUS EFFLUENTS

2.1 RADIATION MONITORING INSTRUMENTATION AND CONTROLS

The gaseous effluent monitoring instrumentation and controls at Oyster Creek for controlling and monitoring normal radioactive material releases in accordance with the Radiological Effluent CONTROLS are summarized as follows:

(1) Main Stack

The main stack receives normal ventilation flow from the reactor building, new radwaste, old radwaste, process discharge flow from the augmented off gas system (AOG), condenser off gas flow if AOG is not in service, and normal ventilation flow from portions of the turbine building, predominantly the condenser bay area. Reactor building and turbine building flow is not normally processed or filtered. Reactor Building flow may be manually or automatically directed through the Standby Gas Treatment System (SBGTS) which has particulate and charcoal filtration. Off gas flow is processed through AOG or through a 30-minute delay pipe prior to release. Flow from the 'new' and 'old' radwaste buildings is HEPA filtered. Releases through the main stack are monitored for noble gases using the RAGEMS I system and sampled for iodine, particulates and tritium. The plant stack is considered to be a true elevated release point.

(2) Turbine Building Vent

The Turbine building vent is monitored for noble gases by the RAGEMS II system and sampled for iodine, particulates and tritium. It discharges on the west side of the turbine building approximately at roof height and is considered to be a ground level release. It ventilates the turbine floor and other areas of the turbine building. Flow through this release point is not filtered.

(3) Feed Pump Room Vent

The feed pump room vent is monitored by RAGEMS II. It discharges on the east side of the turbine building below roof height and is considered to be a ground level release. It ventilates the reactor feed pump room. Flow through this release point is not filtered.

(4) Augmented Off Gas Building Vent

Off gas Building HVAC is released through a ground level release from the building. Off Gas process flow is not released through the building ventilation, but is routed To the stack plant. A ventilation monitoring system monitors for noble gas and samples for particulate and iodine.

(5) Isolation Condensers

The isolation condensers are a ground level release. The predominant isotope through this potential release point is tritium as a consequence of the forced evaporation of condensate transfer water when the isolation condensers are initiated. Releases are neither monitored nor is the release process flow sampled. Releases of tritium are evaluated based on liquid samples of the input and the volume used.

Gaseous radioactive waste flow diagrams with the applicable, associated radiation monitoring instrumentation controls are presented in Figures D-2-1 and D-2-2.

2.2 GASEOUS EFFLUENT MONITOR SET POINT DETERMINATION

2.2.1 PLANT VENT

Per the requirements of CONTROL 3.3.3.11, alarm set points shall be established for the gaseous effluent monitoring instrumentation to ensure that the release rate of noble gases does not exceed the limits of CONTROL 3.11.2.1, which corresponds to a dose rate at the SITE BOUNDARY of 500 mrem/year to the total body or 3000 mrem/year to the skin. Based on a grab sample analysis of the applicable release (i.e., of the Stack, Off gas process flow, etc.), the radiation monitoring alarm set points may be established by the following calculation methods. A set point of a monitor of an elevated release, e.g., from the stack, may be calculated using the equation:

$$S = 1.06 \left(\frac{h}{f} \right) \frac{\sum C_i}{\sum (C_i DFS_i)} + B_{kg}$$

where :

S = the alarm set point (cpm)

h = primary conversion factor of the instrument - monitor response to activity concentration of effluent being monitored, cpm/($\mu\text{Ci}/\text{cm}^3$). Each monitoring channel has a unique response, h, which is determined by the instrument calibration.

C_i = relative concentration of noble gas radionuclide i in effluent at the point of monitoring ($\mu\text{Ci}/\text{cm}^3$)

1.06 = 500 mrem/year /472 (conversion of cfm to cc/sec)

DFS_i = factor converting elevated release rate of radionuclide i to total body dose equivalent rate at the location of potential exposure. Units are: mrem/(yr($\mu\text{Ci}/\text{sec}$)). From Table A-1.

f = flow of gaseous effluent stream being monitored, i.e., stack flow, vent flow, etc. (ft^3/min)

BKG = Monitoring instrument background (cpm or mR/hr)

2.2.2 OTHER RELEASE POINTS

The set point of a monitor of a ground-level or split-wake release, e.g., from the turbine building vent or the AOG building, may be calculated with the equation:

$$S = 1.06 \left(\frac{h}{f \frac{X}{Q}} \right) \frac{\sum C_i}{\sum (C_i DFV_i)} + Bkg$$

Where:

DFVi = factor converting ground-level or split wake release of radionuclide i to the total body dose equivalent rate at the location of potential exposure. Units are: mrem/(yr(μ Ci/m³)). From Table A-1.

X/Q = atmospheric dispersion from point of ground-level or split-wake release to the location of potential exposure (sec/m³) from Table 2.2.2-1.

The atmospheric dispersion, X/Q, and the dose conversion factor, DFSi, depend upon local conditions. For the purpose of calculating radioactive noble gas effluent monitor alarm set points appropriate for the OCGS, the locations of maximum potential Off Site exposure and the reference atmospheric dispersion factors applicable to the derivation of set points are given in Table 2.2.2-1.

TABLE 2.2.2-1 RECEPTOR LOCATIONS AND DISPERSION FOR GASEOUS MONITOR SET POINTS

Discharge Point	Receptor Location		Atm. Dispersion (sec/m ³)
	Sector	Distance(m)	
Ground-level or vent	SE	522	2.15 E-5
Stack	SE	522	N/A

2.2.3 RADIONUCLIDE MIX FOR SET POINTS

For the purpose of deriving a set point, the distribution of radioactive noble gases in an effluent stream may be determined in one of the following ways:

2.2.3.1.1 Preferably, the radionuclide distribution is obtained by gamma isotopic analysis of identifiable noble gases in effluent gas samples. Results of the analyses of one or more samples may be averaged to obtain a representative spectrum.

2.2.3.2 In the event a representative distribution is unobtainable from recent measurements by the radioactive gaseous waste sampling and analysis program, it may be based upon past measurements.

2.2.3.3 Alternatively, the total activity concentration of radioactive noble gases may be assumed to be Xenon-133 as found in Reg Guide 1.97.

2.3 GASEOUS EFFLUENT INSTANTANEOUS DOSE RATE CALCULATIONS - 10 CFR 20

2.3.1 SITE BOUNDARY DOSE RATE - NOBLE GASES

CONTROL 3.11.2.la limits the dose rate at the SITE BOUNDARY due to noble gas releases to ≤ 500 mrem/yr, total body and ≤ 3000 mrem/yr, skin. Radiation monitor alarm set points are established to ensure that these release limits are not exceeded. In the event any gaseous releases from the station results in an alarm set point (as determined in Section 2.2) being exceeded, an evaluation of the SITE BOUNDARY dose rate resulting from the release shall be performed.

2.3.1.1 TOTAL BODY DOSE RATE

The total body dose equivalent rate from radioactive noble gases discharged from an elevated point (stack above building wake) is calculated with the equation:

$$DG = \sum_i Q_i P_i \delta_i$$

From a ground-level release (building vent) the total body dose equivalent rate is:

$$DG = \frac{X}{Q_v} \sum_i Q_i P_i \gamma_i$$

where:

DG = total body dose equivalent rate due to irradiation by radioactive noble gas (mrem/hr)

Q_i = average discharge rate of noble gas radionuclide i released during the averaging time (μCi/hr)

P_γV_i = factor converting time integrated ground-level concentration of noble gas nuclide i to total body dose $\frac{\text{mrem} \cdot \text{m}^3}{\mu\text{Ci} \cdot \text{sec}}$. See Table A-2.

$\frac{X}{Q_v}$ = atmospheric dispersion factor from the OCGS to the Off Site location of interest
(sec/m³) from Table 2.3.1.3-1

$P_{\gamma Si}$ = factor converting unit noble gas nuclide *i* stack release to total body dose at ground level received outdoors from the overhead plume (mrem/μCi). See Table A-2

The noble gas plume gamma-to-total body dose factors, $P_{\gamma Si}$ at designated locations are derived from meteorological dispersion data with the USNRC RABFIN software computer code or similar computer program implementing Reg Guide 1.109, Appendix B. The noble gas semi-infinite cloud gamma-to-total body dose factors, $P_{\gamma Si}$, are derived from Reg Guide 1.109, Revision 1, Table B-1, Column 5.

2.3.1.2 EXAMPLE TOTAL BODY DOSE RATE

Calculate the dose from a release of 100 Ci of Xe133 in 1 hour from a ground level release

$$DG = \frac{X}{Q_v} \sum_i Q_i P_{\gamma Si}$$

X/Q_v = 4.17E-5 sec/m³ (Table 2.3.1.3-1)

Q_i = 1E8 μCi/hr [100Ci*1E6 μCi/Ci]

$P_{\gamma Si}$ = 9.33E-6 mrem-m³ / μCi-sec

$$DG = 4.17 E - 5 \sum_i 1 E 8 * 9.33 E - 6$$

$$DG = 0.039 \text{ mrem / hr}$$

2.3.1.3 SKIN DOSE RATE

The dose equivalent rate to skin from radioactive noble gases is calculated by assuming a person at ground level is immersed in and irradiated by a semi-infinite cloud of the noble gases originating in airborne effluent. It is calculated for each air effluent discharge point with the equation:

$$DB = \frac{X}{Q} \sum_i Q_i (S B_i + 1.11 A \gamma_{Si})$$

where:

DB = dose rate to skin from radioactive noble gases (mrem/hr)

$\frac{X}{Q}$ = Atmospheric dispersions from gaseous effluent discharge point to ground-level location of interest (sec/m³) from Table 2.3.1.3-1.

Q_i = discharge rate of noble gas radionuclide i ($\mu\text{Ci/hr}$)

SB_i = factor converting time integrated ground-level concentration of noble gas radionuclide i to skin dose from beta radiation $\frac{\text{mrem} \cdot \text{m}^3}{\mu\text{Ci} \cdot \text{sec}}$ from Table A-2.

$A\gamma V_i$ = factor for converting time integrated, semi-infinite concentration of noble gas radionuclide i to air dose from its gamma $\frac{\text{mrad} \cdot \text{m}^3}{\mu\text{Ci} \cdot \text{sec}}$ from Table A-2.

The noble gas beta radiation-to-skin-dose factors, SB_i , and the noble gas gamma-to-air dose factors, $A\gamma V_i$, are derived from Reg Guide 1.109, Revision 1, Table B-1, columns 3 and 4 respectively. A tabulation of these factors used to compute noble gas-to-dose equivalent rate at 522 meters SE of the OCGS is in Table A-2.

The dose equivalent rate is calculated with the meteorological dispersion data given in Table 2.3.1.3-1.

TABLE 2.3.1.3-1 RECEPTOR LOCATIONS AND DISPERSION FOR SITE BOUNDARY DOSE RATES

Discharge Point	Receptor Location		Atm. Dispersion (sec/m ³)
	Sector	Distance (m)	
Ground Level or Vent	SE	522	4.17 E-5
Stack	SE	522	6.04 E-9

Alternatively, an approved computer code (e.g., "SEEDS" or "Open EMS") that implements the requirements of Regulatory Guide 1.109 may be used.

Actual meteorological conditions concurrent with the release period or the default, annual average dispersion parameters as presented above may be used for evaluating the gaseous effluent dose rate.

2.3.1.4 EXAMPLE SKIN DOSE RATE

Calculate the skin dose from a release of 100 Ci of Xe133 in 1 hour from a ground level release:

$$DB = \frac{X}{Q} \sum_i Q_i (S B_i + 1.11 A \gamma V_i)$$

X/Q = 4.17E-5 sec/m³

Q_i = 1E8 μCi/hr

S B_i = 9.71E-6

AγV_i = 1.12E-5

$$DB = 4.17E-5 \sum_i 1E8(9.71E-6 + 1.11 * 1.12E-5)$$

$$DB = 0.092 \text{ mrad / hr}$$

2.3.2 SITE BOUNDARY DOSE RATE - RADIOIODINE AND PARTICULATES

2.3.2.1 METHOD - SITE BOUNDARY DOSE RATE - RADIOIODINE AND PARTICULATES

The dose rate Off Site due to the airborne release of I-131, I-133, tritium, and particulates with half-lives greater than 8 days is limited to no more than 1500 mrem/yr to any organ in CONTROL 3.11.2.1b. Evaluation of compliance with CONTROL 3.11.2.1b is based on the sampling and analyses specified in TABLE 4.11.2.1.2-1. Since the dose rate cannot be resolved within less than the sample integration or compositing time, the contribution of each radionuclide to the calculated dose rate will be averaged no more than 3 months for H-3, Sr-89, Sr-90, and alpha-emitting radionuclides and no more than 31 days for other radionuclides. These are their usual sample

integration or compositing times. The equation used to assess compliance of radioiodine, tritium, and radioactive particulate releases with the dose rate limit is:

$$DR_p = 1E6 \sum_e \sum_i^n Ra D F A_{ija} Q_{ei} \frac{\overline{X}}{Q_e}$$

where:

1E6 = conversion pCi/μCi

DR_p = the average dose rate to an organ via exposure pathway, p (mrem/yr).

DFA_{ija} = inhalation dose factors due to intake of radionuclide i, to organ j age group a (mrem/pCi) from Reg. Guide 1.109 Appendix E.

Ra = age group dependent inhalation respiratory rate (usage factor) m³/yr from Table B-1

$\frac{\overline{X}}{Q_e}$ = annual average relative airborne concentration at an Off Site location due to a release from either the Stack or a vent, i.e. release point, e (sec/m³) from Table 2.3.2.1-1.

Q_{ei} = release rate of radionuclide i from release point, e during the period of interest (μCi/sec).

For real-time meteorology and on an annual average basis, the location of the maximum ground-level concentration originating from a vent release will differ from the maximum ground-level concentration from a stack release. When assessing compliance with CONTROL 3.11.2.1b for tritium, iodine, and particulate, the air dispersion (X/Q) values are provided in Table 2.3.2.1-1.

TABLE 2.3.2.1-1 LOCATION OF MAXIMUM EXPOSURE RE BY INHALATION

Discharge Point	Receptor Location		Atm. Dispersion (sec/m3)
	Sector	Distance (m)	
Ground Level or Vent	SE	522	4.17 E-5
Stack	SE	522	6.04 E-9
Alternatively, inhalation exposure to effluent from the stack may be evaluated at the closest hypothetical individual located at:			
Stack	SE	966m	3.42 E-8

Alternatively, an approved computer code (e.g., "SEEDS" or "Open EMS") that implements the methods of Regulatory Guide 1.109, may be used.

2.3.2.2 EXAMPLE IODINE AND PARTICULATES DOSE RATE CALCULATION

Calculate the child thyroid dose rate from a release of 100 µCi/hr of I131 from a ground level release:

$$DRp = 1E6 \sum_e \sum_i^n Ra D F A i j a Q e i \frac{\bar{X}}{Qe}$$

Ra = 3700 m³/yr

DFAija = 4.39E-3

Qei = 0.028 µCi/sec [100µCi/hr /3600 sec/hr = 0.02778]

X/Qe = 4.17E-5 sec /m3

$$DRp = 1E6 \sum_i^n 3700 * 4.39E - 3 * 0.028 * 4.17E - 5$$

$$DRp = 19mrem / yr$$

2.4 NOBLE GAS EFFLUENT DOSE CALCULATIONS - 10 CFR 50

Doses resulting from the release of noble gases must be calculated to show compliance with Appendix I of 10CFR50. Calculations will be performed at least monthly for all gaseous effluents as stated in SURVEILLANCE REQUIREMENT 4.11.2.2 to verify that the dose to air is kept below the limits specified in CONTROL 3.11.2.2 and the dose to MEMBERS OF THE PUBLIC is maintained below the limits specified in CONTROL 3.11.2.3.

2.4.1 UNRESTRICTED AREA DOSE - NOBLE GASES

CONTROL 3.11.2.2 requires a periodic assessment of releases of noble gases to evaluate compliance with the quarterly air dose limits shown in Table 2.4.1-1.

TABLE 2.4.1-1 ANNUAL AIR DOSE LIMITS

<u>During any calendar quarter</u>	<u>During any calendar year</u>
≤ 5 mad gamma-air	≤ 10 mad gamma-air
≤ 10 mad beta-air	≤ 20 mad beta-air

The method used to calculate the air dose at the critical location due to noble gas is described by the following equations. The limits are provided in CONTROL 3.11.2.2 for air dose Off Site due to gamma and beta radiations from effluent noble gas.

2.4.1.1 AIR DOSE METHOD

a: For Gamma Radiation:

$$Dose \gamma = \sum_{i=1}^n A \gamma W_i \frac{\bar{X}}{Q} v Q_{vi} + A \gamma S_i Q_{si}$$

b: For Beta Radiation

$$Dose \beta = \sum_e \sum_{i=1}^n A \beta_i \frac{\bar{X}}{Q} e Q_{ei}$$

where:

Dose γ = the gamma dose during any specified time period (mrem).

Dose β = the beta dose during any specified time period (mrad).

$A \gamma V_i$ = the air dose factor due to ground level gamma emissions for each identified noble gas radionuclide, i; (mrad/yr per $\mu\text{Ci}/\text{m}^3$). Table A-2

$A \gamma S_i$ = the factor for air dose at ground level due to irradiation for an airborne plume resulting from a Stack release (mrad per μCi), Table A-3.

$A \beta_i$ = the air dose factor due to beta emissions for each identified noble gas radionuclide, i (mrad/yr per $\mu\text{Ci}/\text{m}^3$). Table A-3

$\frac{\bar{X}}{Q^e}$ or $\frac{\bar{X}}{Q^v}$ = the annual average relative concentration for areas at or beyond the site

boundary for releases from either the Stack or ground vent at the critical location (sec/m^3), Table 2.4.1.1-1

Q_{vi} = amount of radionuclide i released from vents (μCi).

Q_{si} = amount of radionuclide i released from the Stack (μCi).

Q_{ei} = amount of radionuclide i released from release point e (μCi).

Noble gases may be released from the ground level vents and stack. The quantity of noble gas radionuclides released will be determined from the continuous noble gas monitors and periodic isotopic analyses. The maximum Off Site gamma radiation dose rate to air from noble gases discharged from either the stack or from building vents occurs at 522 meters SE of the OCGS. Values of $A_{\gamma Si}$ depend upon the meteorological conditions and the location of exposure and are calculated using the NRC RABFIN code or similar one in accordance with Reg. Guide 1.109, Appendix B, Section 1. $A_{\gamma Vi}$ and AB_i are derived from Reg. Guide 1.109, Table B-1 for a semi-infinite cloud, independent of meteorology or location. Values of $A_{\gamma Si}$, $A_{\gamma Vi}$ and AB_i used to calculate the noble gas radiation dose to air at 522 meters SE of the OCGS are in Table A-3. Reference atmospheric dispersion from the OCGS to 522 meters SE is given in Table 2.4.1.1-1.

TABLE 2.4.1.1-1 RECEPTOR LOCATIONS AND DISPERSION FOR AIR DOSE

Discharge Point	Receptor Location		Atm. Dispersion (sec/m ³)
	Sector	Distance (m)	
Ground Level or Vent	SE	522	4.17 E-5
Stack	SE	522	6.04 E-9

Alternatively, an approved computer code (e.g., "SEEDS" or "Open EMS") that implements the requirements of Reg. Guide 1.109 may be used.

2.4.1.2 EXAMPLE NOBLE GAS AIR DOSE CALCULATION

Calculate the gamma air dose from a release of 1 Ci per hour of Xe133 for 10 hours from a ground level release and 100Ci per hour for 10 hours from an elevated release:

$$Dose_{\gamma} = \sum_{i=1}^n A_{\gamma} W_i \frac{\bar{X}}{Q} v Q_{vi} + A_{\gamma} S_i Q_{si}$$

$$A_{\gamma} W_i = 1.12E-5 \text{ mrad} - \text{m}^3 / \mu\text{Ci} - \text{sec}$$

$$X/Q = 4.17E-5 \text{ sec} / \text{m}^3$$

$$Q_{vi} = 1E7 \mu\text{Ci} \quad [1\text{Ci/hr} * 10\text{hrs} * 1E6 \mu\text{Ci/Ci}]$$

$$A_{\gamma} S_i = 5.45E-13 \text{ mrad} / \mu\text{Ci}$$

$$Q_{si} = 1E9 \mu\text{Ci} \quad [100\text{Ci/hr} * 10\text{hrs} * 1E6 \mu\text{Ci/Ci}]$$

$$Dose_{\gamma} = \sum_{i=1}^n 1.12E-5 * 4.17E-5 * 1E7 + 5.45E-13 * 1E9$$

$$Dose_{\gamma} = \sum_{i=1}^n 4.67E-3 + 5.45E-4$$

$$Dose_{\gamma} = 5.2E-3 \text{ mrad}$$

Note how the ground level portion has a higher dose contribution per unit activity than the elevated portion.

2.4.1.3 INDIVIDUAL PLUME DOSE METHOD

The method for dose to an individual from noble gases is essentially identical with the air dose method except that different dose factors apply. Also, since dose to the skin combines the contribution from gamma and beta emissions, the gamma dose must be added to the beta dose to obtain a total skin dose.

a: For Total Body:

$$D_{oset} = \sum_{i=1}^n P\gamma W_i \frac{\bar{X}}{Q} v Q_{vi} + P\gamma S_i Q_{si}$$

b: For Skin

$$D_{oses} = \sum_e \sum_{i=1}^n S\beta_i \frac{\bar{X}}{Q} e Q_{ei} + D_{oset}$$

where:

D_{oset} = the total body dose during any specified time period (mrem).

D_{oses} = the skin dose during any specified time period (mrad).

$P\gamma V_i$ = the plume dose factor due to ground level gamma emissions for each identified noble gas radionuclide, i; (mrad/yr per $\mu\text{Ci}/\text{m}^3$). Table A-5

$P\gamma S_i$ = the factor for plume dose at ground level due to irradiation for an airborne plume resulting from a Stack release (mrad per μCi), Table A-5.

$S\beta_i$ = the skin dose factor due to beta emissions for each identified noble gas radionuclide, i (mrad/yr per $\mu\text{Ci}/\text{m}^3$) from Table A-5.

$\frac{\bar{X}}{Q^e}$ or $\frac{\bar{X}}{Q^v}$ = the annual average relative concentration for areas at or beyond the site

boundary for releases from either the Stack or ground vent at the critical location (sec/m^3) from Table 2.5.1.

Q_{vi} = amount of radionuclide i released from vents (μCi).

Q_{si} = amount of radionuclide i released from the Stack (μCi).

Q_{ei} = amount of radionuclide i released from release point e (μCi).

2.5 RADIOIODINE, PARTICULATE AND OTHER RADIONUCLIDES DOSE CALCULATIONS - 10 CFR 50

Doses resulting from the release of radioiodines and particulates must be calculated to show compliance with Appendix I of 10CFR50. Calculations will be performed at least monthly for all gaseous effluents as stated in SURVEILLANCE REQUIREMENT 4.11.2.2 and SURVEILLANCE REQUIREMENT 4.11.2.3 to verify that the dose to air is kept below the limits specified in CONTROL 3.11.2.2 and the dose to MEMBERS OF THE PUBLIC is maintained below the limits specified in CONTROL 3.11.2.3.

The maximum dose to an individual from radioiodines, tritium, and radioactive particulates with half-lives of greater than eight days in gaseous effluents released to unrestricted areas is determined as described in Reg. Guide 1.109. Environmental pathways that radioiodine, tritium, and particulates in airborne effluent follow to the maximally exposed MEMBER OF THE PUBLIC as determined by the annual land use survey and reference meteorology will be evaluated. The seasonality of exposure pathways may be considered. For instance, if the most exposed receptor has a garden, fresh and stored vegetables are assumed to be harvested and eaten during April through October. Fresh vegetables need not be considered as an exposure pathway during November through March. To assess compliance with CONTROL 3.11.2.3, the dose due to radioactive iodine, tritium, and particulates in airborne effluent is calculated to a person residing 966 meters SE of the OCGS. Reference atmospheric dispersion and deposition factors are given in Table 2.5-1.

TABLE 2.5-1 DISPERSION FOR 10CFR50 DOSES

Discharge Point	Dispersion X/Q (sec/m ³)	Deposition D/Q(1/m ²)
Ground Level or Vent	1.53E-5	1.70E-8
Stack	3.42E-8	2.40E-9

The environmental pathways of exposure to be evaluated are: inhalation, irradiation from ground deposition, and ingestion of milk (cow and goat are treated separately), meat, and vegetables. Eight organs are considered: Bone, Liver, Total Body, Thyroid, Kidney, Lung, GI-LLI (Gastro-Intestinal tract / Lower Large Intestine), and Skin. Four different age groups are considered: Infants, Children, Teens, and Adults. Doses are calculated to a 'receptor' – a person who inhales the airborne activity and resides in a location with ground deposition, and eats and drinks the foodstuffs produced. The maximally exposed individual is conservatively assumed to reside at the location of the highest sum of the inhalation and ground plane doses, while eating and drinking foodstuffs transported from the locations that are highest for those pathways. Receptor locations are provided in Table A-4.

Alternatively, an approved computer code (e.g., "SEEDS" or "Open EMS") that implements the requirements of Reg Guide 1.109 may be used.

2.5.1 INHALATION OF RADIOIODINES, TRITIUM, PARTICULATES, AND OTHER RADIONUCLIDES.

Dose from the inhalation pathway is generally in the form:

$$D_{ja} = RaT \sum_i \frac{X}{Q} Q_i D_{FAija} \text{Exp}(-\lambda_i Tr)$$

Where:

D_{ja} = the dose to the organ j (of eight) of age group a (of four)

Ra = the respiration rate for age group a from Table B-1

T = the duration of the release in fraction of a year

$\frac{X}{Q}$ = The atmospheric dispersion to the point of interest (the 'receptor') in sec/m^3 from Table 2.5-1

Q_i = The release rate of radionuclide i (pCi/sec)

D_{FAija} = The inhalation dose conversion factor (mrem per pCi) for radionuclide i to organ j of age group a from Reg. Guide 1.109 Appendix E.

λ_i = decay constant of isotope i: $0.693/\text{Half life in years}$

Tr = plume transit time from release to receptor in years

λ_i and Tr may be in any time units as long as they are the same

Note that a 'depleted X/Q' (dX/Q) is applicable to particulates only, which accounts for the natural settling and lack of surface reflection of particulates to estimate the downwind concentration accounting for these removal processes. Depleted X/Q will be slightly smaller than the X/Q. This is not used in the ODCM for simplicity. Using the X/Q is therefore slightly conservative compared to the dX/Q .

2.5.2 EXAMPLE CALCULATION - INHALATION OF RADIOIODINES, TRITIUM, PARTICULATES, AND OTHER RADIONUCLIDES

Calculate the dose to child lung from inhalation from a ground level release of 100 μ Ci of Co-60 in 10 hours. Plume transit decay time is ignored ($\exp(-\lambda_i T_r)=1$).

$$D_{ja} = 3700 * 0.00114 * 1.53E-5 * 2.78E3 * 1.91E-3$$

$$D_{ja} = 3.4E-4 \text{ mrem}$$

$$D_{ja} = RaT \sum_i \frac{X}{Q} Q_i D_{FAija}$$

- D_{ja} = the dose to the organ j (of eight) of age group a (of four)
- Ra = 3700 m^3/yr
- T = 0.00114 yrs [10 hrs / 8760 hrs / yr]
- $\frac{X}{Q}$ = 1.53 E-5 sec/ m^3
- Q_i = 2.78E3 pCi/sec [100 μ Ci * 1E6 pCi/ μ Ci / (10 hrs*3600 sec / hr)]
- D_{FAija} =1.91E-3 mrem / pCi

2.5.3 INGESTION OF RADIOIODINES, PARTICULATES AND OTHER RADIONUCLIDES

Dose from the ingestion pathways is more complex and is broken out here into multiple steps:

2.5.3.1 CONCENTRATION OF THE RADIONUCLIDE IN ANIMAL FORAGE AND VEGETATION – OTHER THAN TRITIUM

The concentration of a radionuclide in a foodstuff (other than tritium – see section 2.5.3.3 for tritium) is dependent on the atmospheric deposition, the biological uptake into the food, various decay times (plume travel, harvest to table, etc.) and is generally of the form:

Where:

C_{iv} = the concentration (pCi/kg) of radionuclide i in vegetation

Q_i = the release rate of isotope i in pCi/hr

$\frac{D}{Q}$ = The atmospheric deposition to the point of interest (the 'receptor') in $1/\text{m}^2$ from

Table 2.5-1.

$$C_{iv} = \frac{D}{Q} Q_i \left\{ \frac{r(1 - EXP(-\lambda E_i T_e))}{Y_v \lambda E_i} + \frac{B_{iv}(1 - EXP(-\lambda_i T_b))}{P \lambda_i} \right\} EXP(-\lambda_i T_h) EXP(-\lambda_i T_r)$$

- r = the retention coefficient for deposition onto vegetation surfaces (1.0 for iodines, 0.2 for particulates)
- λ_i = the decay constant of radionuclide i; 0.693/half life in hours
- λE_i = the effective removal constant which is the sum of $\lambda_i + \lambda_w$ where λ_w is the weathering constant, 0.0021/hr
- T_e = duration of crop exposure during the growing season in hours. This is not the entire duration of the growing season, and is different for leafy vegetable and fruit/grain/vegetables. Provided in Table E-15 of Reg. Guide 1.109 or Table B-1.
- Y_v = agricultural yield Kg of vegetation per m^2 , typically 0.7 kg/m^2
- B_{iv} = soil uptake concentration factor for transfer of the radionuclide i from the soil to the vegetation through normal root uptake processes in pCi/kg in vegetation per pCi/Kg in soil. Values are provided in Reg. Guide 1.109 Table E-1.
- T_b = the length of time the soil is exposed to contaminated inputs – nominally 30 years (2.63E5 hr)
- P = effective soil density in kg/m^2 normally 240 kg/m^2
- T_h = holdup time, the time the foodstuff is in transit between harvest and consumption in hours
- T_r = plume transit time from release to receptor in hours

2.5.3.2 EXAMPLE CALCULATION OF CONCENTRATION OF THE RADIONUCLIDE IN ANIMAL FORAGE AND VEGETATION – OTHER THAN TRITIUM.

Calculate the forage and vegetation concentration from a ground level release of 100 μCi of Co-60 in 10 hours (plume transit time is ignored $T_r=0$, $EXP(-\lambda_i T_r)=1$):

- D/Q = 1.7E-8 / m^2
- Q_i = 1E7 pCi/hr [100 μCi * 1E6 pCi/ μCi / 10 hr]
- r = 0.2
- λ_i = 1.5E-5/hr [0.693 / (5.27yr * 8760 hr/yr)]
- λE_i = 2.1E-3 /hr [1.5E-5 + 0.0021]
- T_e = 720 hr [grass-cow-milk-man pathway value]
- Y_v = 0.7 kg/m^2
- B_{iv} = 9.4E-3

$$C_{iv} = \frac{D}{Q} Q_i \left\{ \frac{r(1 - \text{EXP}(-\lambda E_i T_e))}{Y_v \lambda E_i} + \frac{B_{iv}(1 - \text{EXP}(-\lambda_i T_b))}{P \lambda_i} \right\} \text{EXP}(-\lambda_i T_h) \text{EXP}(-\lambda_i T_r)$$

$$C_{iv} = 1.7E-8 * 1E7 \left\{ \frac{0.2 * (1 - \text{EXP}(-2.1E-3 * 720))}{0.7 * 2.1E-3} + \frac{9.4E-3 * (1 - \text{EXP}(-1.5E-5 * 2.63E5))}{240 * 1.5E-5} \right\} \text{EXP}(-1.5E-5 * 0)$$

$$C_{iv} = 1.7E-8 * 1E7 \left\{ \frac{0.2 * (1 - \text{EXP}(-1.52))}{1.47E-3} + \frac{9.4E-3 * (1 - \text{EXP}(-3.95))}{3.6E-3} \right\} \text{EXP}(-0)$$

$$C_{iv} = 1.7E-1 \left\{ \frac{106}{2.56} \right\} * 1$$

$$C_{iv} = 18.5 \text{ pCi / Kg}$$

T_b = 2.63E5 hr

P = 240 kg/m²

T_h = 0 hr (consumption of pasture grass directly by animals)

2.5.3.3 CONCENTRATION OF TRITIUM IN ANIMAL FORAGE AND VEGETATION

Since tritium is assumed to be released as tritiated water (HTO), the concentration of tritium in a foodstuff is dependent on atmospheric dispersion like a gas, rather than particulate deposition as for other radionuclides for foodstuff uptake. Further, the concentration of tritium in food is assumed to be based on equilibrium between the concentration of the tritium in the atmospheric water and the concentration of tritium in the water in the food. Concentration of tritium in vegetation can be calculated generally in the form (a plume transit decay term: EXP(-λ_iT_r) is ignored since plume travel times are very short compared to the half life):

$$C_{tv} = 1000 Q_t \frac{X}{Q} * 0.75 * \frac{0.5}{H}$$

Where:

C_{tv} = the concentration (pCi/kg) of tritium in vegetation

1000= g per kg

Q_t = the release rate of the tritium in pCi/ sec

X/Q = the atmospheric dispersion at the vegetation point, sec/m³ from Table 2.5-1

0.75 = the fraction of vegetation that is water

0.5 = the effective ratio between the atmospheric water concentration and the vegetation concentration

H = the absolute humidity g/m³. Absolute humidity is seasonally dependent, varying from as little as 1 in the winter to as much as 20 in the summer. Monthly average values derived from historical data are provided in Table B-2.

2.5.3.4 EXAMPLE CALCULATION OF CONCENTRATION OF TRITIUM IN ANIMAL FORAGE AND VEGETATION.

Calculate the forage and vegetation concentration from a ground level release of 100 μ Ci of H-3 in 10 hours. Plume transit decay time is ignored ($\exp(-\lambda t_{Tr})=1$):

$$C_{tv} = 1000Q_t \frac{X}{Q} * 0.75 * \frac{0.5}{H}$$

Q_t = 2778 pCi/sec [100uCi * 1E6 pCi/uCi / (10hrs*3600sec/hr)]

X/Q = 1.53E-5 sec/m³

H = 5 g/m³ (assumed for this example)

$$C_{tv} = 2778 * 1000 * 1.53E - 5 * 0.75 * \frac{0.5}{5}$$

$$C_{tv}=3.2pCi/kg$$

2.5.3.5 CONCENTRATION OF THE RADIONUCLIDE IN MILK AND MEAT

Meat and milk animals are assumed to eat both pasture grass and stored feed. During a fraction of the year, they may be assumed to be exclusively on stored feed, outside of the growing season. If using annual average release, the fraction of stored and fresh feed must be accounted for with fractions, otherwise (as in this ODCM), the fresh pasture pathway is turned on or off depending on the growing season.

The concentration of a radionuclide in the animal feed is calculated as follows:

$$C_{iv} = F_p C_{is} + (1 - F_p) C_{is} (1 - F_s) + C_{ip} F_s (1 - F_p)$$

Where:

F_p = the growing season pasture factor: 1 if not growing season, 0 if in growing season

F_s = the fraction of the daily feed from fresh pasture from Table B-1 or Exhibit E-15 from Reg. Guide 1.109.

C_{ip} = the concentration in the fresh pasture feed (C_{iv} from section 2.5.3.2 with $T_h = 0$ for immediate consumption)

C_{is} = the concentration in stored feed (C_{iv} from section 2.5.3.2 with $T_h = 90$ days)

The concentration in the milk is then based on this feed concentration:

$$C_{im} = F_m C_{iv} Q_f \text{EXP}(-\lambda_i T_f)$$

Where;

C_{im} = the concentration in milk pCi/l

F_m = the transfer coefficient of intake to concentration in the milk (d/l) from Reg. Guide 1.109 Table E-1.

Q_f = feed intake rate Kg/d from Reg. Guide 1.109 Table E-3.

λ_i = radionuclide i decay constant in 1/days

T_f = transport time from milk production to consumption (2 days for milk)

The Goat milk pathway may be similarly evaluated:

$$C_{im} = F_g C_{iv} Q_f \text{EXP}(-\lambda_i T_f)$$

Where

F_g = the transfer coefficient of intake to concentration in the milk (d/l) for goats from Reg. Guide 1.109 Table E-2.

And for meat:

$$C_{if} = F_f C_{iv} Q_f \text{EXP}(-\lambda_i T_s)$$

Where:

F_f = the transfer coefficient of intake to concentration in the meat d/kg from Reg. Guide 1.109 Table E-1.

T_s = The transport time from slaughter to consumption (20 days)

2.5.3.6 EXAMPLE CALCULATION OF CONCENTRATION OF THE RADIONUCLIDE IN MILK AND MEAT

Calculate the concentration in cow milk from a ground level release of 100 μCi of Co-60 in 10 hours. Plume transit decay time is ignored ($\exp(-\lambda_i \text{Tr})=1$):

$$C_{iv} = F_p C_{is} + (1 - F_p) C_{is} (1 - F_s) + C_{ip} F_s (1 - F_p)$$

Assume animals are on pasture and receive half of their food from stored feed.

$C_{ip} = 18.4 \text{ pCi/kg}$ as previously calculated in section 2.5.3.2

$F_p = 0$

$F_s = 0.5$

C_{is} is calculated by applying a 90 day decay term to the C_{ip} value previously calculated, since the previous decay correction was for 0 time as shown in 2.5.3.2.

$$C_{is} = 18.4 * (\exp(-0.693 * 90 / (5.27 * 365.25)))$$

$$C_{is} = 17.8 \text{ pCi / kg}$$

C_{iv} is then:

$$C_{iv} = 0 * 17.8 + (1 - 0.5) 17.8 * (1 - 0) + 18.4 * .5 * (1 - 0)$$

$$C_{iv} = 18.1 \text{ pCi / kg}$$

The concentration in milk is given by:

$$C_{im} = F_m C_{iv} Q_f \text{EXP}(-\lambda_i T_f)$$

$F_m = 1.0\text{E-}3 \text{ d/l}$

$Q_f = 50 \text{ Kg/d}$

$\lambda_i = 3.6\text{E-}4/\text{d} [0.693 / (5.27\text{yrs} * 365.25\text{days/yr})]$

$$C_{im} = 1.0\text{E-}3 * 18.1 * 50 * \text{EXP}(-3.6\text{E-}4 * 2)$$

$$C_{im} = 0.90 \text{ pCi / l}$$

The concentration in meat given by:

$$C_{if} = F_f C_{iv} Q_f \text{EXP}(-\lambda_i T_f)$$

$F_f = 1.3\text{E-}2 \text{ d/kg}$

$Q_f = 50 \text{ Kg/d}$

$\Delta_i = 3.6\text{E-}4/\text{d}$

$$C_{if} = 1.3\text{E-}2 * 18.1 * 50 * \text{EXP}(-3.6\text{E-}4 * 20)$$

$$C_{if} = 11.7 \text{ pCi / kg}$$

2.5.3.7 DOSE FROM CONSUMPTION OF MILK, MEAT, AND VEGETABLES

The environmental pathway ingestion dose is the sum of the milk, meat, and vegetation ingestion pathways. There are two separate pathways for vegetation: fresh leafy vegetables and a combination of fruits, non-leafy vegetables, and grains. These differ only in the decay and buildup processes applied to account for the environmental exposure, and transportation delay decay represented by T_e and T_h as shown in section 2.5.3.1. For long half-life isotopes (e.g. Co-60) the decay differences have little impact on the dose.

Dose from the environmental ingestion pathways is generally of the form:

$$D_{ja} = T \sum_i DF_{Iija} [U_{av} F_g C_{iv} + U_{am} C_{im} + U_{af} C_{if} + U_{al} F_{l} C_{il}]$$

Where:

D_{ja} = the dose to organ j of age group a - mrem

T = fraction of year of release duration

DF_{Iija} = the ingestion dose factor for isotope i to organ j for age group a - mrem/pCi from Reg. Guide 1.109 Appendix E

U_{av} = Ingestion rate (usage factor) for non-leafy vegetables, grains, and fruits for age group a from Reg. Guide 1.109 Table E-5 or Table B-1.

F_g = the fraction of vegetables, grains, and fruits from the location of interest : 0.76 in Reg. Guide 1.109.

C_{iv} = the concentration of isotope i in the vegetables, fruits, and grains calculated from section 2.5.3.2.

U_{am} = Ingestion rate (usage factor) for milk for age group a : from Table B-1 or Reg. Guide 1.109 Table E-5.

C_{im} = the concentration of isotope i in milk calculated from section 2.5.3.5.

U_{af} = the ingestion rate for meat for age group a : from Table B-1 or Reg. Guide 1.109 Table E-5.

C_{if} = the concentration of isotope i in meat calculated from section 2.5.3.2.

U_{al} = the ingestion rate for leafy vegetables for age group a : from Table B-1 or Reg. Guide 1.109 Table E-5.

FI = the fraction of annual leafy vegetable ingestion from the location of interest : 1.0
in Reg. Guide 1.109.

Cil = concentration of isotope i in the leafy vegetables for direct human consumption:
Civ calculated from section 2.5.3.2 with Th=0.

2.5.3.8 EXAMPLE CALCULATION - DOSE FROM CONSUMPTION OF MILK, MEAT, AND VEGETABLES

Calculate the ingestion dose to child whole body from a ground level release of 100 μ Ci of Co-60 in 10 hours. Plume transit decay time is ignored ($\exp(-\lambda_i T_r)=1$):

$$D_{ja} = T \sum_i DFI_{ija} [U_{av} F_g C_{iv} + U_{am} C_{im} + U_{af} C_{if} + U_{al} F_l C_{il}]$$

T = .00114 [10hrs / 8760 hrs/yr)

DFI_{ija} = 1.56E-5 mrem/pCi

U_{av} = 520

F_g = 0.76

C_{iv} = 18.0 [18.4*EXP(- λ *60) using 60 day delay for ingestion]

U_{am} = 330

C_{im} = 0.9

U_{af} = 41

C_{if} = 11.7

U_{al} = 26

F_l = 1

C_{il} = 18.4

$$D_{ja} = .00114 \sum_i 1.56E-5 [520 * 0.76 * 18 + 330 * 0.9 + 41 * 11.7 + 26 * 1 * 18.4]$$

$$D_{ja} = .00114 \sum_i 1.56E-5 [7114 + 297 + 480 + 478]$$

$$D_{ja} = 1.5E-4 \text{ mrem: child: wholebody}$$

2.5.4 GROUND PLANE DEPOSITION IRRADIATION

Dose from ground plane deposition is estimated by determining the surface activity resulting from the release.

2.5.4.1 GROUND PLANE CONCENTRATION

The ground surface activity is estimated as:

$$C_{ig} = \frac{D}{Q} \frac{Q_i}{\lambda_i} (1 - \text{EXP}(-\lambda_i T_b))$$

Where:

C_{ig} = ground plane concentration of radionuclide i in pCi/m²

$\frac{D}{Q}$ = local atmospheric release deposition factor in 1/m² from Table 2.5-1

Q_i = release rate in pCi/sec

λ_i = radiological decay constant in 1/sec

T_b = long term buildup time 30 years (9.46E8 sec)

Note: Q_i , λ_i and T_b can utilize any time units as long as they are all the same

2.5.4.2 EXAMPLE GROUND PLANE CONCENTRATION CALCULATION

Calculate the ground plane concentration from a 100 μ Ci release of Co-60 over 10 hours from a ground level release point.

$$C_{ig} = \frac{D}{Q} \frac{Q_i}{\lambda_i} (1 - \text{EXP}(-\lambda_i T_b))$$

$$\frac{D}{Q} = 1.7E-8 / m^2$$

$$Q_i = 2778 \text{ pCi/sec} \quad [100 \mu\text{Ci}/10\text{hrs}/3600\text{sec/hr}]$$

$$\lambda_i = 4.17E-9/\text{sec} \quad [0.693/(5.27\text{yr} * 8760\text{hr/yr} * 3600\text{sec/hr})]$$

$$T_b = 9.46E8 \text{ sec}$$

$$C_{ig} = 1.7E-8 \frac{2778}{4.17E-9} (1 - \text{EXP}(-4.17E-9 * 9.46E8))$$

$$C_{ig} = 1.7E-8 \frac{2778}{4.17E-9} (1 - \text{EXP}(-4.17E-9 * 9.46E8))$$

$$C_{ig} = 1.11E4 \text{ pCi} / m^2$$

2.5.4.3 GROUND PLANE DOSE

Annual dose from the ground plane deposition is of the form:

$$D_{jg} = 8760 * T * S_f \sum_i C_{ig} DFG_{ij}$$

Where:

D_{jg} = the annual dose (mrem) from ground plane pathway (g) to the total body or skin (j)

8760 = hours in a year

T = fraction of year release is in progress

Sf = shielding factor accounting for shielding from dwelling from Table B-1

DFGij = Ground plane dose factor for skin or total body (j) for radionuclide i from Table E-6 of Reg. Guide 1.109 in mrem/hr / pCi/m².

2.5.4.4 EXAMPLE GROUND PLANE DOSE

Calculate the ground plane Total Body dose from a 100 μCi release of Co-60 over 10 hours from a ground level release point.

$$\text{Given: } D_{jg} = 8760 * T * Sf \sum_i C_{ig} DFG_{ij}$$

$$T = 0.00114 [10/8760]$$

$$Sf = 0.7$$

$$DFG_{ij} = 1.7E-8$$

$$D_{jg} = 8760 * 0.00114 * 0.7 \sum_i 9729 * 1.7E-8$$

$$D_{jg} = 1.15E-3 \text{ mrem Total Body}$$

3.0 TOTAL DOSE TO MEMBERS OF THE PUBLIC - 40 CFR 190

The Radiological Environmental Monitoring Report (REMP) submitted by May 1st of each year shall include an assessment of the radiation dose to the likely most exposed MEMBER OF THE PUBLIC for reactor releases and other nearby uranium fuel cycle sources (including dose contributions from effluents and direct radiation from on-site sources). For the likely most exposed MEMBER OF THE PUBLIC in the vicinity of Oyster Creek, the sources of exposure need only consider the Oyster Creek Generating Station. No other fuel cycle facilities would contribute significantly to the MEMBER OF THE PUBLIC dose for the Oyster Creek vicinity, however, both plant operation and ISFSI sources must be included in the dose assessment.

To assess compliance with CONTROL 3.11.4, calculated organ and total body doses from effluents from liquid pathways and atmospheric releases as well as any dose from direct radiation will be summed.

As appropriate for demonstrating/evaluating compliance with the limits of CONTROL 3.11.4 (40 CFR 190), the results of the environmental monitoring program may be used for providing data on actual measured levels of radiation and / or radioactive material and resultant dose to the MEMBER OF THE PUBLIC in the actual pathways of exposure.

3.1 EFFLUENT DOSE CALCULATIONS

For purposes of implementing the surveillance requirements of CONTROL 3/4.11.4 and the reporting requirements of Technical Specification 6.9.1.d (RERR), dose calculations for the Oyster Creek Generating Station may be performed using the calculation methods contained within the ODCM; the conservative controlling pathways and locations from the ODCM or the actual pathways and locations as identified by the land use census (CONTROL 3/4.12.1) may be used. Average annual meteorological dispersion parameters provided herein or meteorological conditions concurrent with the release period under evaluation may be used.

3.2 DIRECT EXPOSURE DOSE DETERMINATION

Any potentially significant direct exposure contribution to off-site individual doses may be evaluated based on the results of environmental measurements (e.g., TLD) and/or by the use of radiation transport and shielding calculation methodologies.

4.0 RADIOLOGICAL ENVIRONMENTAL MONITORING PROGRAM

The operational phase of the Radiological Environmental Monitoring Program (REMP) is conducted in accordance with the requirements of CONTROL 3.12.1. The objectives of the program are:

- To determine whether any significant increases occur in the concentration of radionuclides in the critical pathways of exposure in the vicinity of Oyster Creek
- To determine if the operation of the Oyster Creek Generating Station has resulted in any increase in the inventory of long lived radionuclides in the environment;
- To detect any changes in the ambient gamma radiation levels; and
- To verify that OCGS operations have no detrimental effects on the health and safety of the public or on the environment.

The REMP sample locations are presented in Appendix E.

NOTE: No public drinking water samples or irrigation water samples are taken as these pathways are not directly affected by liquid effluents discharged from Oyster Creek Generating Station.

APPENDIX A - DERIVED DOSE FACTORS AND RECEPTOR LOCATIONS

Table A-1 Dose Conversion Factors for Deriving Radioactive Noble Gas Radionuclide-to-Dose Equivalent Rate Factors*

<u>Radionuclide</u>	<u>Factor DFSi for Stack Release*</u>	<u>Factor DFVi for Ground-level or Split-Wake Release**</u>
	<u>mrem-sec</u> <u>μCi-year</u>	<u>mrem-m³</u> <u>μCi-year</u>
Kr83m	1.47E-09	7.56E-02
Kr85m	9.12E-05	1.17E+03
Kr85	1.47E-06	1.61E+01
Kr87	4.80E-04	5.92E+03
Kr88	1.18E-03	1.47E+04
Kr89	1.17E-03	1.66E+04
Kr90	-	1.56E+04
Xe131m	2.10E-05	9.15E+01
Xe133m	1.64E-05	2.51E+02
Xe133	1.57E-05	2.94E+02
Xe135m	2.77E-04	3.12E+03
Xe135	1.51E-04	1.81E+03
Xe137	1.06E-04	1.42E+03
Xe138	7.63E-04	8.83E+03
Xe139	1.44E-04	5.02E+03
Ar41	9.11E-04	8.84E+03

* Based on reference meteorology applicable at 522 meters SE of stack.

** For exposure to a semi-infinite cloud of noble gas.

Table A-2 Noble Gas Radionuclide-to-Dose Equivalent Rate Factors*

<u>Radionuclide</u>	$P_{\gamma Si}^{**}$ <u>mrem</u> μCi	$P_{\gamma Vi}^{***}$ <u>mrem-m³</u> $\mu Ci\text{-sec (K}_i)$	$A_{\gamma Vi}^{***}$ <u>mrad-m³</u> $\mu Ci\text{-sec (M}_i)$	S_{Bi}^{***} <u>mrem-m³</u> $\mu Ci\text{-sec (L}_i)$
Kr83m	4.66E-17	2.40E-09	6.13E-07	-
Kr85m	2.91E-12	3.71E-05	3.90E-05	4.63E-05
Kr85	4.66E-14	5.11E-07	5.46E-07	4.25E-05
Kr87	1.52E-11	1.88E-04	1.96E-04	3.09E-04
Kr88	3.73E-11	4.67E-04	4.83E-04	7.52E-05
Kr89	3.70E-11	5.27E-04	5.49E-04	3.21E-04
Kr90	-	4.95E-04	5.17E-04	2.31E-04
Xe131m	6.65E-13	2.90E-06	4.95E-06	1.51E-05
Xe133m	5.20E-13	7.97E-06	1.04E-05	3.16E-05
Xe133	4.97E-13	9.33E-06	1.12E-05	9.71E-06
Xe135m	8.78E-12	9.90E-05	1.07E-04	2.26E-05
Xe135	4.78E-12	5.75E-05	6.10E-05	5.90E-05
Xe137	3.36E-12	4.51E-05	4.79E-05	3.87E-04
Xe138	2.42E-11	2.80E-04	2.92E-04	1.31E-04
Xe139	4.56E-12	-	-	-
Ar41	2.89E-11	2.81E-04	2.95E-04	8.54E-05

* All of these dose factors apply out-of-doors.

** Based on reference meteorology at 522 meters SE of effluent stack.

*** Derived from Reg Guide 1.109, Revision 1, Table B-1.

Table A-3 Air Dose Conversion Factors for Effluent Noble Gas

<u>Radionuclide</u>	$A_{\gamma Si}^{**}$ <u>mrad</u> μCi	$A_{\gamma Vi}^{***}$ <u>mrad-m3</u> $\mu Ci\text{-sec}(M_i)$	$A_{\lambda i}^{***}$ <u>mrad-m3</u> $\mu Ci\text{-sec}(N_i)$
Kr83m	9.35E-15	6.13E-07	9.14E-06
Kr85m	3.03E-12	3.90E-05	6.25E-05
Kr85	4.94E-14	5.46E-07	6.19E-05
Kr87	1.60E-11	1.96E-04	3.27E-04
Kr88	3.93E-11	4.83E-04	9.30E-05
Kr89	3.90E-11	5.49E-04	3.37E-04
Kr90	-	5.17E-04	2.49E-04
Xe131m	7.26E-13	4.95E-06	3.52E-05
Xe133m	5.86E-13	1.04E-05	4.70E-05
Xe133	5.45E-13	1.12E-05	3.33E-05
Xe135m	9.32E-12	1.07E-04	2.35E-05
Xe135	6.18E-12	6.10E-05	7.81E-05
Xe137	3.55E-12	4.79E-05	4.03E-04
Xe138	2.54E-11	2.92E-04	1.51E-04
Xe139	4.82E-12	-	-
Ar41	3.03E-11	2.95E-04	1.04E-04

** Based on reference meteorology at 522 meters SE of effluent stack.

*** Derived from Reg Guide 1.109, Revision 1, Table B-1.

Table A-4 Locations Associated with Maximum Exposure of a Member of the Public*

<u>Effluent</u>	<u>Distance</u> (meters)	<u>Location</u>	<u>Direction</u> (to)
Liquid		U.S. Route 9 Bridge at Discharge Canal	
Airborne Iodine and Particulates	966		SE
Tritium	966		SE
Noble Gases	966		SE
Irradiation by OCGS		Site Boundary	All
Noble Gas g Air Dose		Site Boundary	All
Noble Gas B Air Dose	966		SE

Note: the nearby resident experiencing the maximum exposure to airborne effluent and to gamma radiation directly from the Station is located 966 meters SE of the OCGS. The most exposed member of the public is assumed to be exposed by irradiation from the OCGS, by inhaling airborne effluent, by irradiation by the airborne effluent, by irradiation by the airborne plume of the noble gas, by radionuclides deposited onto the ground, by irradiation by shoreline deposits, and by eating fish and shellfish caught in the discharge canal.

*The age group of the most exposed member of the public is based on Reg. Guide 1.109, Revision 1.

Table A-5 Critical Receptor Noble Gas Dose Conversion Factors*

Radionuclide	$P_{\gamma Si}^{**}$ mrem μCi	$P_{\gamma Vi}^{***}$ mrem-m ³ $\mu Ci\text{-sec}(K_i)$	$A_{\gamma Vi}^{***}$ mrad-m ³ $\mu Ci\text{-sec}(M_i)$	$A_{\gamma Si}^{**}$ mrad μCi	SBi^{***} mrem-m ³ $\mu Ci\text{-sec}(L_i)$
Kr83m	3.76E-17	2.40E-09	6.13E-07	9.66E-15	-
Kr85m	1.68E-12	3.71E-05	3.90E-05	1.75E-12	4.63E-05
Kr85	2.60E-14	5.11E-07	5.46E-07	2.75E-14	4.25E-05
Kr87	8.37E-12	1.88E-04	1.96E-04	8.81E-12	3.09E-04
Kr88	2.08E-11	4.67E-04	4.83E-04	2.18E-11	7.52E-05
Kr89	1.83E-11	5.27E-04	5.49E-04	1.93E-11	3.21E-04
Kr90	-	4.95E-04	5.17E-04	-	2.31E-04
Xe131m	3.99E-13	2.90E-06	4.95E-06	4.44E-13	1.51E-05
Xe133m	3.10E-13	7.97E-06	1.04E-05	3.58E-13	3.16E-05
Xe133	3.11E-13	9.33E-06	1.12E-05	3.42E-13	9.71E-06
Xe135m	4.71E-12	9.90E-05	1.07E-04	5.01E-12	2.26E-05
Xe135	2.73E-12	5.75E-05	6.10E-05	2.87E-12	5.90E-05
Xe137	1.65E-12	4.51E-05	4.79E-05	1.75E-12	3.87E-04
Xe138	1.33E-11	2.80E-04	2.92E-04	1.40E-11	1.31E-04
Xe139	-	-	1.61E-12	-	-
Ar41	1.58E-11	2.81E-04	2.95E-04	1.66E-11	8.54E-05

* All of these dose factors apply out-of-doors.

** Based on reference meteorology at 522 meters SE of effluent stack.

*** Derived from Reg Guide 1.109, Revision 1, Table B-1

APPENDIX B - MODELING PARAMETERS

Table B-1- OCGS Usage Factors For Individual Dose Assessment

<u>Effluent Ingestion Parameters</u>	<u>Usage Factor</u>
Fraction Of Produce From Local Garden	7.6E-1
Soil Density In Plow Layer (Kg/m ²)	2.4E+2
Fraction Of Deposited Activity Retained On Vegetation	2.5E-1
Shielding Factor For Residential Structures	7.0E-1
Period Of Buildup Of Activity In Soil (hr)	1.31E+5
Period of Pasture Grass Exposure to Activity (hr)	7.2E+2
Period Of Crop Exposure to Activity (hr)	1.44E+3
Delay Time For Ingestion Of Stored Feed By Animals (hr)	2.16E+3
Delay Time For Ingestion Of Leafy Vegetables By Man (hr)	2.4E+1
Delay Time For Ingestion Of Other Vegetables By Man (hr)	1.44E+3
Transport Time Milk-Man (hr)	4.8E+1
Time Between Slaughter and Consumption of Meat Animal (hr)	4.8E+2
Grass Yield Wet Weight (Kg/m ²)	7.0E-1
Other Vegetation Yield Wet-Weight (Kg/m ²)	2.0
Weathering Rate Constant For Activity on Veg. (hr ⁻¹)	2.1E-3
Milk Cow Feed Consumption Rate (Kg/day)	5.0E+1
Goat Feed Consumption Rate (Kg/day)	6.0
Beef Cattle Feed Consumption Rate (Kg/day)	5.0E+1
Milk Cow Water Consumption Rate (L/day)	6.0E+1
Goat Water Consumption Rate (L/day)	8.0
Beef Cattle Water Consumption Rate (L/day)	5.0E+1
Environmental Transit Time For Water Ingestion (hr)	1.2E+1
Environmental Transit Time For Fish Ingestion (hr)	2.4E+1
Environmental Transit Time For Shore Exposure (hr)	0
Environmental Transit Time For Invertebrate Ingestion (hr)	2.4E+1

Table B-1(Continued)
OCS Usage Factors For Individual Dose Assessment

<u>Effluent Ingestion Parameters</u>	<u>Usage Factor</u>
Water Ingestion (L/yr)	
a. Adult	7.3E+2
b. Teen	5.1E+2
c. Child	5.1E+2
d. Infant	3.3E+2
Shore Exposure (hr/yr)	
a. Adult	1.2E+1
b. Teen	6.7E+1
c. Child	1.4E+1
d. Infant	0
Salt Water Sport Fish Ingestion (Kg/yr)	
a. Adult	2.1E+1
b. Teen	1.6E+1
c. Child	6.9
d. Infant	0
Salt Water Commercial Fish Ingestion (Kg/yr)	
a. Adult	2.1E+1
b. Teen	1.6E+1
c. Child	6.9
d. Infant	0
Salt Water Invertebrate Ingestion (Kg/yr)	
a. Adult	5.0
b. Teen	3.8
c. Child	1.7
d. Infant	0
Irrigated Leafy Vegetable Ingestion (Kg/yr)	
a. Adult	6.4E+1
b. Teen	4.2E+1
c. Child	2.6E+1
d. Infant	0

Table B-1 (Continued)
OCCS Usage Factors For Individual Dose Assessment

<u>Effluent Ingestion Parameters</u>	<u>Usage Factor</u>
Irrigated Other Vegetable Ingestion (Kg/yr)	
a. Adult	5.2E+2
b. Teen	6.3E+2
c. Child	5.2E+2
d. Infant	0
Irrigated Root Vegetable Ingestion (Kg/yr)	
a. Adult	5.2E+2
b. Teen	6.3E+2
c. Child	5.2E+2
d. Infant	0
Irrigated Cow and Goat Milk Ingestion (L/yr)	
a. Adult	3.1E+2
b. Teen	4.0E+2
c. Child	3.3E+2
d. Infant	3.3E+2
Irrigated Beef Ingestion (Kg/yr)	
a. Adult	1.1E+2
b. Teen	6.5E+1
c. Child	4.1E+1
d. Infant	0
Inhalation (m ³ /yr)	
a. Adult	8.0E+3
b. Teen	8.0E+3
c. Child	3.7E+3
d. Infant	1.4E+3
Cow and Goat Milk Ingestion (L/yr)	
a. Adult	3.1E+2
b. Teen	4.0E+2
c. Child	3.3E+2
d. Infant	3.3E+2
Meat Ingestion (Kg/yr)	
a. Adult	1.1E+2
b. Teen	6.5E+1
c. Child	4.1E+1
d. Infant	0

Table B-1 (Continued)
OCGS Usage Factors For Individual Dose Assessment

<u>Effluent Ingestion Parameters</u>	<u>Usage Factor</u>
Leafy Vegetable Ingestion (Kg/yr)	
a. Adult	6.4E+1
b. Teen	4.2E+1
c. Child	2.6E+1
d. Infant	0
Fruits, Grains, & Other Vegetable Ingestion (Kg/yr)	
a. Adult	5.2E+2
b. Teen	6.3E+2
c. Child	5.2E+2
d. Infant	0

Table B-2 Monthly Average Absolute Humidity g/m³
(derived from historical climatological data)

<u>Month</u>	<u>Average Absolute Humidity (g/m³)</u>
January	3.3
February	3.3
March	4.5
April	6.1
May	9.4
June	12.8
July	15.2
August	15.6
September	12.4
October	7.9
November	5.9
December	3.8

APPENDIX C - REFERENCES

Table C-1 - REFERENCES

- 1) Oyster Creek Updated Final Safety Analysis Report
- 2) Oyster Creek Facility Description and Safety Analysis Report
- 3) Oyster Creek Operating License and Technical Specifications
- 4) NUREG 1302 "Off Site Dose Calculation Manual Guidance: Standard Radiological Effluent Controls for Boiling Water Reactors" – Generic Letter 89-10, Supplement No. 1, April 1991
- 5) Reg Guide 1.21 "Measuring, Evaluating, and Reporting Radioactivity in Solid Wastes and Releases of radioactive materials in Liquid and Gaseous Effluents from Light-Water-Cooled Nuclear Power Plants" Rev.1, June 1974
- 6) Reg Guide 1.23
- 7) Reg Guide 1.97
- 8) Reg Guide 1.109 "Calculation of Annual Doses to Man from Routine Releases of Reactor Effluents for the Purpose of Evaluating Compliance With 10 CFR 50, Appendix I", Rev 1, October, 1977
- 9) Reg Guide 1.111 "Methods for Estimating Atmospheric Transport and Dispersion of Gaseous Effluents in Routine Releases From Light-Water-Cooled Reactors", Rev.1, July, 1977
- 10) Reg Guide 4.8 " Environmental Technical Specifications for Nuclear Power Plants"
- 11) NRC Radiological Assessment Branch Technical Position, Rev 1, November 1979 (Appendix A to NUREG1302)
- 12) NUREG-0016
- 13) NUREG-0133
- 14) Licensing Application, Amendment 13, Meteorological Radiological Evaluation for the Oyster Creek Nuclear Power Station Site.
- 15) Licensing Application, Amendment 11, Question IV-8.
- 16) Evaluation of the Oyster Creek Nuclear Generating Station to Demonstrate Conformance to the Design Objectives of 10CFR50, Appendix I, May, 1976, Tables 3-10

- 17) Meteorological Information and Diffusion Estimates to Conform with Appendix I Requirements: Oyster Creek, July, 1976, Table 1.3-11B.
- 18) Hydrological Information and Liquid Dilution Factors Determination to Conform with Appendix I Requirements: Oyster Creek, correspondence from T. Potter, Pickard, Lowe and Garrick, Inc. to Oyster Creek, July, 1976.
- 19) Carpenter, J. J. "Recirculation and Effluent Distribution for Oyster Creek Site", Pritchard-Carpenter Consultants, Baltimore, Maryland, 1964.
- 20) Nuclear Regulatory Commission, Generic Letter 89-01, "Implementation of Programmatic Controls for Radiological Effluent Technical Specifications in the Administrative Controls Section and Relocation of the Procedural Details of RETS to the ODCM or PCP", January, 1989.
- 21) Ground Water Monitoring System (Final Report), Woodward-Clyde Consultants, March, 1984.
- 22) Meteorology and Atomic Energy, Department of Energy, 1981.
- 23) SEEDS Code Documentation through V & V of Version 98.8F (Radiological Engineering Calculation No. 2820-99-005, Dated 3/23/99)
- 24) Lynch, Giuliano, and Associates, Inc., Drawing Entitled, "Minor Subdivision, Lots 4 and 4.01 Block 1001", signed 13 Sep 99.
- 25) Currie, L. A., "Lower Limit of Detection: Definition and Elaboration of a Proposed Position for Radiological Effluent and Environmental Measurements" .
- 26) NUREG/CR-4007 (September 1984).
- 27) HASL Procedures Manual, HASL-300 (revised annually).
- 28) Regulatory Guide 1.113, "Estimating Aquatic Dispersion of Effluents from Accidental and Routine Reactor Releases for the Purposes of Implementing Appendix I," April 1977
- 29) Reg. Guide 4.13
- 30) 10CFR20, Appendix B, Table 2, Annual Limits on Intake (ALIs) and Derived Air Concentrations (DACs) of Radionuclides for Occupational Exposure; Effluent Concentrations; Concentrations for Release to Sewerage

APPENDIX D – SYSTEM DRAWINGS

FIGURE D-1-1a: LIQUID RADWASTE TREATMENT CHEM WASTE AND FLOOR DRAIN SYSTEM

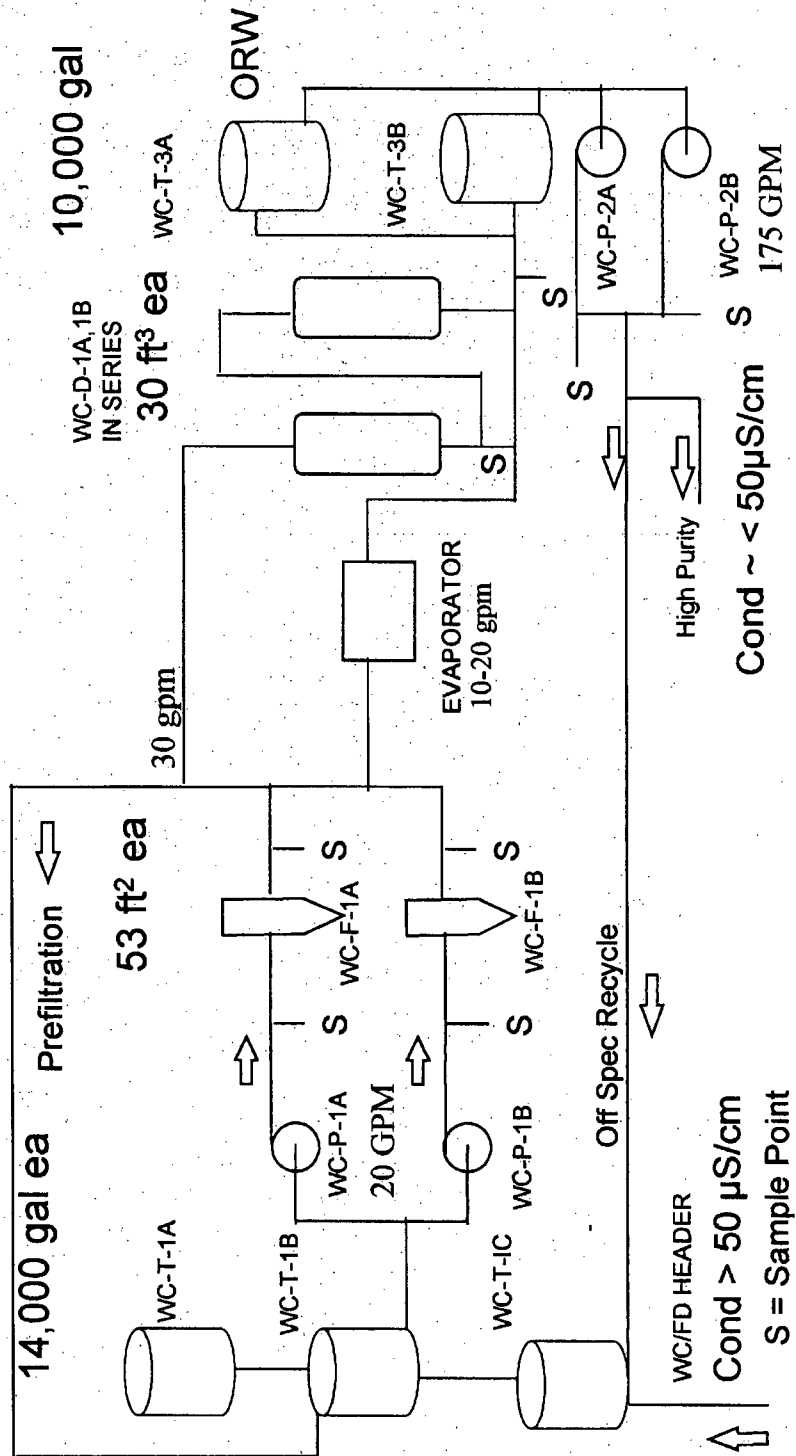

FIGURE D-1-1b: LIQUID RADWASTE TREATMENT - HIGH PURITY AND EQUIPMENT DRAIN SYSTEM

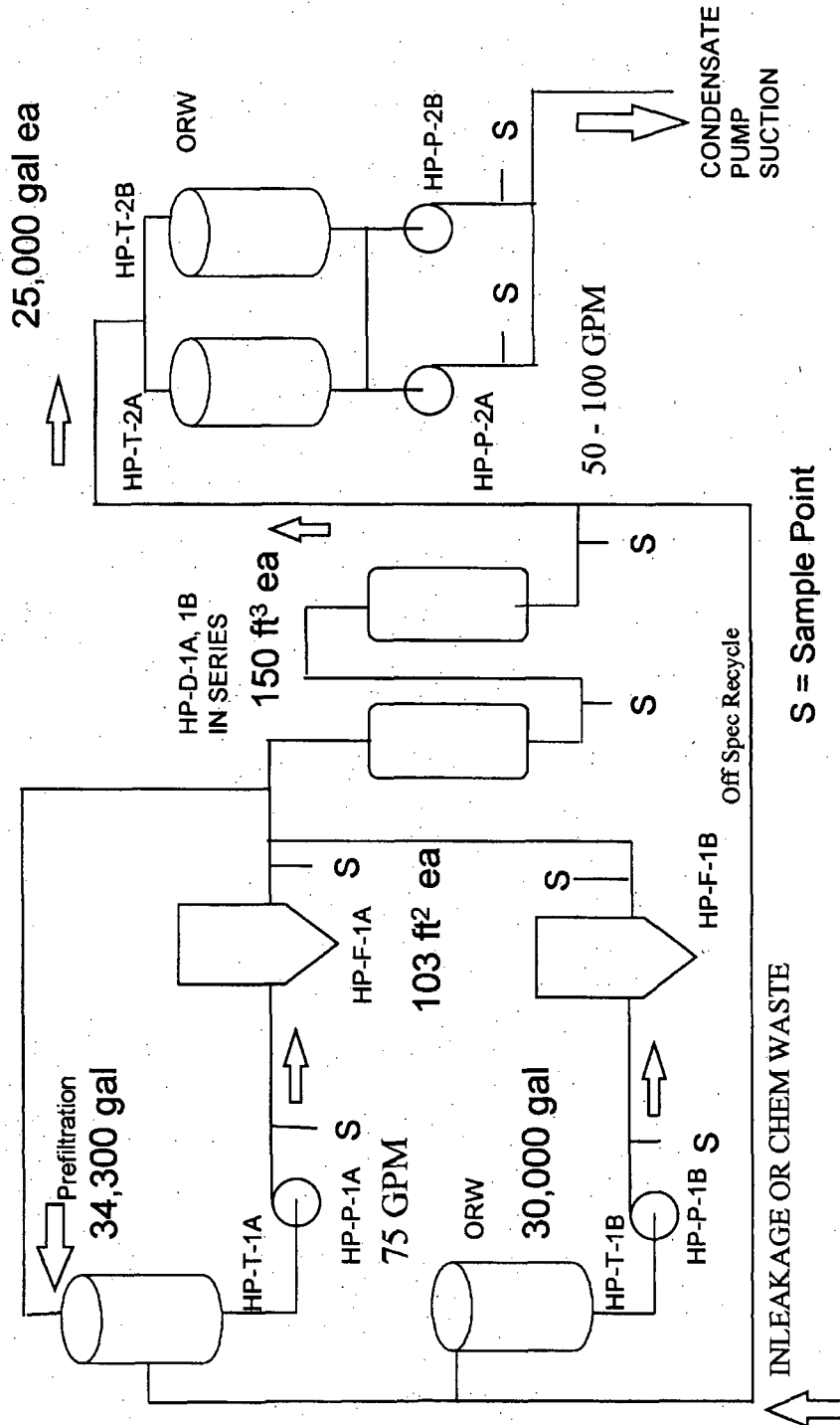

FIGURE D-1-2: SOLID RADWASTE PROCESSING SYSTEM

FIGURE D-1-2: SOLID RADWASTE PROCESSING SYSTEM

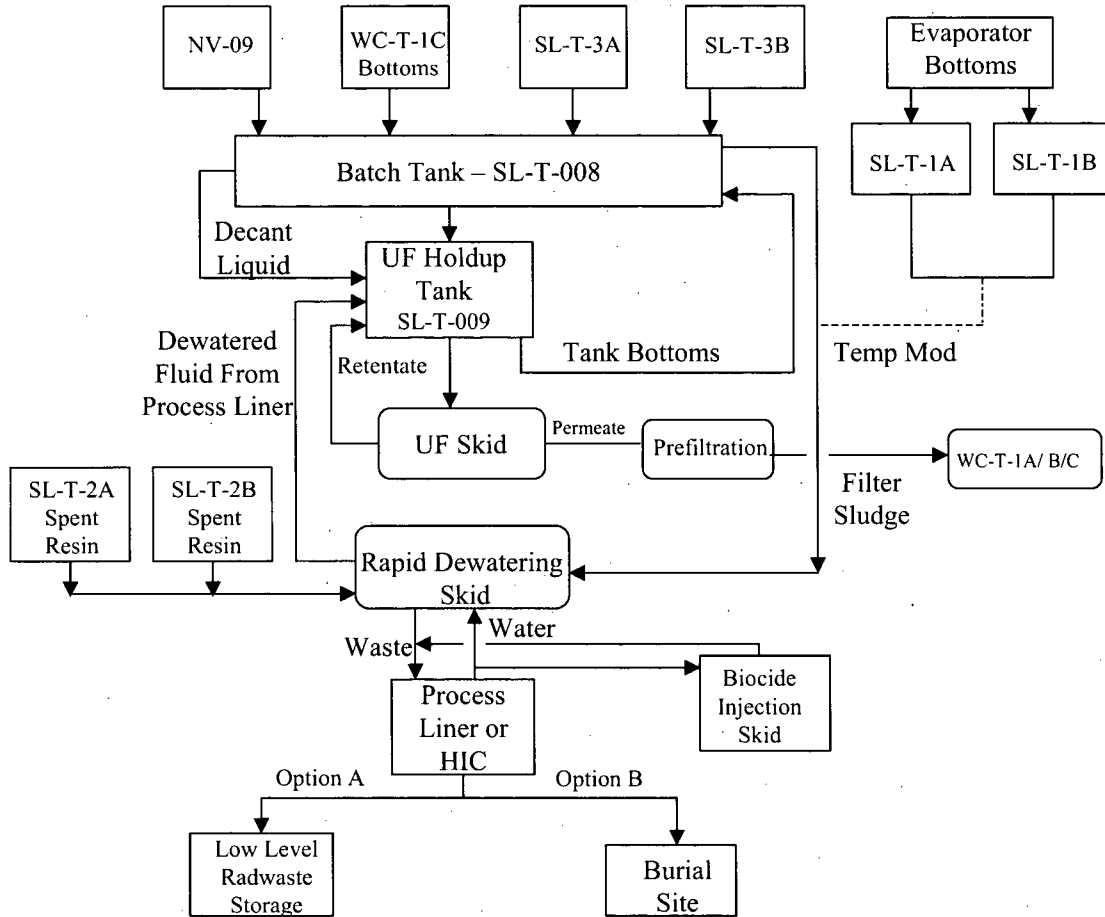
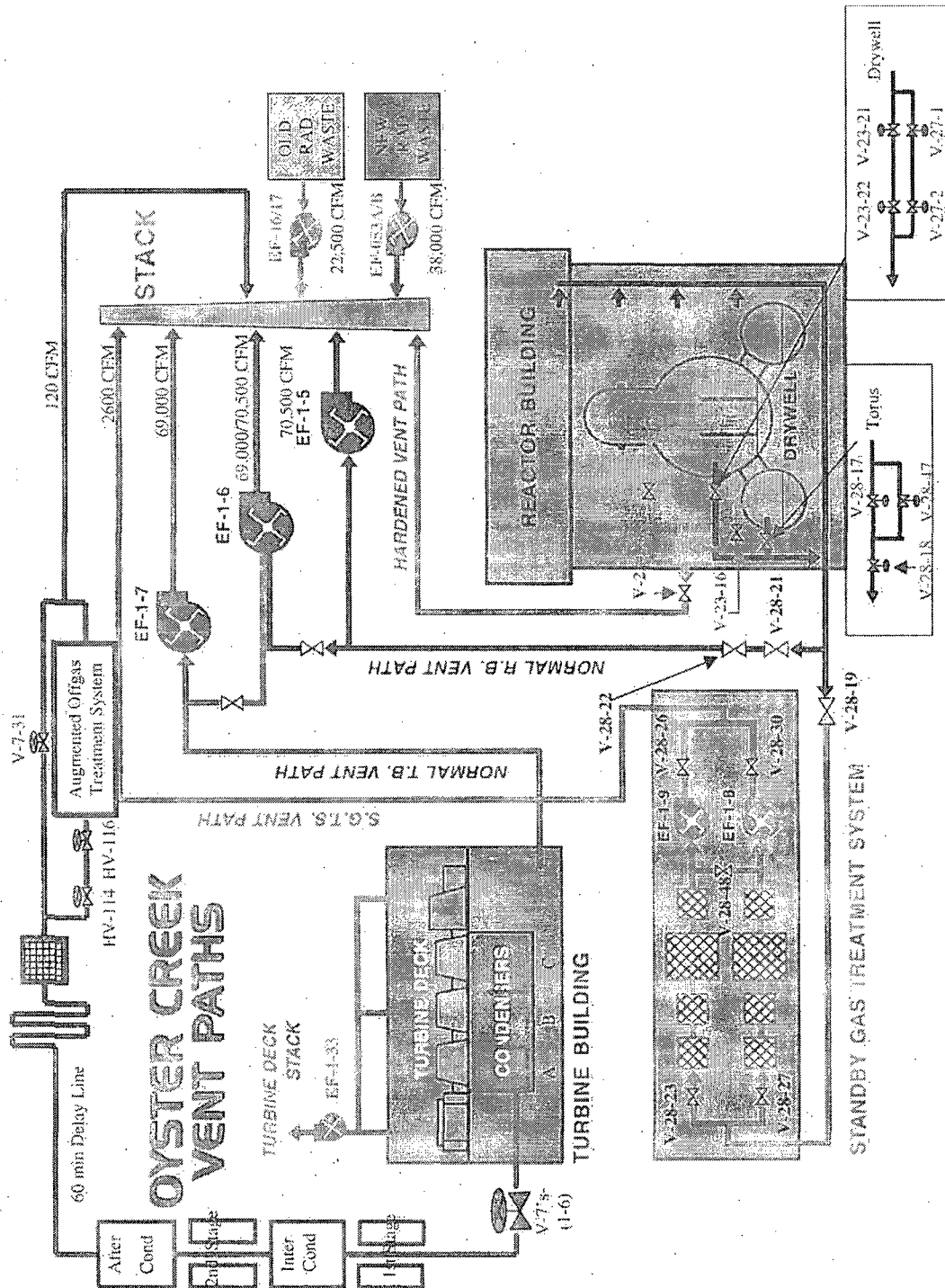

FIGURE D-2-2: VENTILATION SYSTEM



APPENDIX E - RADIOLOGICAL ENVIRONMENTAL MONITORING PROGRAM - SAMPLE TYPE AND LOCATION

All sampling locations and specific information about the individual locations are given in Table E-1. Figures E-1 and E-2 show the locations of sampling stations with respect to the site. Figure E-3 shows the site layout.

TABLE E-1: REMP SAMPLE LOCATIONS ⁽¹⁾

<u>Sample Medium</u>	<u>Station Code</u>	<u>Distance (miles)</u>	<u>Azimuth (degrees)</u>	<u>Description</u>
TLD	1	0.4	219	SW of site at OCGS Fire Pond, Forked River, NJ (TLD - ODCM Required - Inner Ring)
WWA	1	0.1	209	On-site southern domestic well at OCGS, Forked River, NJ (WWA - ODCM Required - One Location)
		0.2	349	On-site northern domestic well at OCGS, Forked River, NJ (WWA - ODCM Required - One Location)
APT, AIO, TLD	3	6.0	97	East of site, near old Coast Guard Station, Island Beach State Park (APT, AIO, & TLD - Non-ODCM Required)
TLD	4	4.6	213	SSW of Site, Garden State Parkway and Route 554, Barnegat, NJ (TLD - ODCM Required - Outer Ring)
TLD	5	4.2	353	North of Site, Garden State Parkway Rest Area, Forked River, NJ (TLD - ODCM Required - Outer Ring)
TLD	6	2.1	13	NNE of site, Lane Place, behind St. Pius Church, Forked River, NJ (TLD - Non-ODCM Required)
TLD	8	2.3	177	South of site, Route 9 at the Waretown Substation, Waretown, NJ (TLD - Non-ODCM Required)
TLD	9	2.0	230	SW of site, where Route 532 and the Garden State Parkway meet, Waretown, NJ (TLD - Non-ODCM Required)
APT, AIO, TLD	C	24.7	313	NW of site, GPU office in rear parking lot, Cookstown, NJ (TLD, APT, AIO - ODCM Required – Background Station))
TLD	11	8.2	152	SSE of site, 80 th and Anchor Streets, Harvey Cedars, NJ (TLD - ODCM Required - Special Interest Area)
TLD	14	20.8	2	North of site, Larrabee Substation on Randolph Road, Lakewood, NJ (TLD - ODCM Required Background Station)
APT, AIO	20	0.7	95	East of site, on Finninger Farm on south

TABLE E-1: REMP SAMPLE LOCATIONS ⁽¹⁾

<u>Sample Medium</u>	<u>Station Code</u>	<u>Distance (miles)</u>	<u>Azimuth (degrees)</u>	<u>Description</u>
TLD	22	1.6	145	side of access road, Forked River, NJ (APT, AIO - Non-ODCM Required) SE of site, on Long John Silver Way, Skippers Cove, Waretown, NJ (TLD - Non-ODCM Required)
SWA, CLAM, AQS	23	3.6	64	ENE of site, Barnegat Bay off Stouts Creek, approximately 400 yards SE of "Flashing Light 1" (SWA, CLAM, AQS - Non-ODCM Required)
SWA, CLAM, AQS	24	2.1	101	East of site, Barnegat Bay, approximately 250 yards SE of "Flashing Light 3" (CLAM - ODCM Required, SWA, AQS - Non-ODCM Required)
SWA, AQS, FISH	33	0.4	123	ESE of site, east of Route 9 Bridge in OCGS Discharge Canal (SWA, AQS - ODCM Required, Fish - Non-ODCM Required)
VEG	35	0.4	111	ESE of site, east of Route 9 and north of the OCGS Discharge Canal, Forked River, NJ (VEG - ODCM Required)
VEG	36	23.1	319	NW of site, at "U-Pick" Farm, New Egypt, NJ (VEG - ODCM Required Background Station)
WWA	37	2.2	18	NNE of Site, off Boox Road at Lacey MUA Pumping Station, Forked River, NJ (WWA - ODCM Required)
WWA	38	1.6	197	SSW of Site, on Route 532, at Ocean Township MUA Pumping Station, Waretown, NJ (WWA - ODCM Required)
TLD	46	5.6	323	NW of Site, on Lacey Road adjacent to Utility Pole BT 259 65 (TLD - ODCM Required - Outer Ring)
TLD	47	4.6	26	NNE of Site, Route 9 and Harbor Inn road, Berkeley Township, NJ (TLD - ODCM Required - Outer Ring)
TLD	48	4.5	189	South of Site, Intersection of Brook and School Streets, Barnegat, NJ (TLD - ODCM Required - Outer Ring)
TLD	51	0.4	358	North of site, on the access road to Forked River site, Forked River, NJ

TABLE E-1: REMP SAMPLE LOCATIONS ⁽¹⁾

<u>Sample Medium</u>	<u>Station Code</u>	<u>Distance (miles)</u>	<u>Azimuth (degrees)</u>	<u>Description</u>
TLD	52	0.3	333	(TLD - ODCM Required - Inner Ring) NNW of site, on the access road to Forked River Site, Forked River, NJ (TLD-ODCM Required - Inner Ring)
TLD	53	0.3	309	NW of site, at sewage lift station on the access road to the Forked River site, Forked River, NJ (TLD - ODCM Required - Inner Ring)
TLD	54	0.3	288	WNW of site, on the access road to Forked River site, Forked River, NJ (TLD - ODCM Required - Inner Ring)
TLD	55	0.3	263	West of site, on Southern Area Stores security fence, west of OCGS Switchyard, Forked River, NJ (TLD - ODCM Required - Inner Ring)
TLD	56	0.3	249	WSW of site, on utility pole east of Southern Area Stores, west of the OCGS Switchyard, Forked River, NJ (TLD - ODCM Required - Inner Ring)
TLD	57	0.2	206	SSW of site, on Southern Area Stores access road, Forked River, NJ (TLD - ODCM Required - Inner Ring)
TLD	58	0.2	188	South of site, on Southern Area Stores access road, Forked River, NJ (TLD - ODCM Required - Inner Ring)
TLD	59	0.3	166	SSE of site, on Southern Area Stores access road, Waretown, NJ (TLD - ODCM Required - Inner Ring)
TLD	61	0.3	104	ESE of site, on Route 9 south of OCGS Main Entrance, Forked River, NJ (TLD - ODCM Required - Inner Ring)
TLD	62	0.2	83	East of site, on Route 9 at access road to OCGS Main Gate, Forked River, NJ (TLD - ODCM Required - Inner Ring)
TLD	63	0.2	70	ENE of site, on Route 9, between main gate and OCGS North Gate access road, Forked River, NJ (TLD - ODCM Required - Inner Ring)
TLD	64	0.3	48	NE of site, on Route 9 at entrance to Finninger Farm, Forked River, NJ (TLD - ODCM Required - Inner Ring)

TABLE E-1: REMP SAMPLE LOCATIONS (Continued)

<u>Sample Medium</u>	<u>Station Code</u>	<u>Distance (miles)</u>	<u>Azimuth (degrees)</u>	<u>Description</u>
TLD	65	0.4	19	NNE of site, on Route 9 at Intake Canal Bridge, Forked River, NJ (TLD - ODCM Required - Inner Ring)
APT, AIO, TLD, VEG	66	0.4	133	SE of site, east of Route 9 and south of the OCGS Discharge Canal, inside fence, Waretown, NJ (APT, AIO, TLD, & VEG - ODCM Required. TLD - Inner ring)
TLD	68	1.3	265	West of site, on Garden State Parkway at mile marker 71.7, Lacey Township, NJ (TLD - Non-ODCM Required)
APT, AIO, TLD	71	1.6	164	SSE of site, on Route 532 at the Waretown Municipal Building, Waretown, NJ (APT, AIO, TLD - ODCM Required. TLD - Special Interest Area)
APT, AIO, TLD	72	1.9	25	NNE of site, on Lacey Road at Knights of Columbus Hall, Forked River, NJ (APT, AIO, TLD - ODCM Required. TLD - Special Interest Area)
APT, AIO, TLD	73	1.8	108	ESE of site, on Bay Parkway, Sands Point Harbor, Waretown, NJ (APT, AIO - ODCM Required. TLD - Non-ODCM Required)
TLD	74	1.8	88	East of site, Orlando Drive and Penguin Court, Forked River, NJ (TLD - Non-ODCM Required)
TLD	75	2.0	71	ENE of site, Beach Blvd. and Maui Drive, Forked River, NJ (TLD - Non-ODCM Required)
TLD	78	1.8	2	North of site, 1514 Arient Road, Forked River, NJ (TLD - Non-ODCM Required)
TLD	79	2.9	160	SSE of site, Hightide Drive and Bonita Drive, Waretown, NJ (TLD - Non-ODCM Required)
TLD	81	3.5	201	SSW of site, on Rose Hill Road at intersection with Barnegat Boulevard, Barnegat, NJ(TLD - ODCM Required - Special Interest Area)

TABLE E-1: REMP SAMPLE LOCATIONS (Continued)

<u>Sample Medium</u>	<u>Station Code</u>	<u>Distance (miles)</u>	<u>Azimuth (degrees)</u>	<u>Description</u>
TLD	82	4.4	36	NE of site, Bay Way and Clairmore Avenue, Lanoka Harbor, NJ (TLD - ODCM Required - Outer Ring)
TLD	84	4.4	332	NNW of site, on Lacey Road, 1.3 miles west of the Garden State Parkway on siren pole, Lacey Township, NJ (TLD - ODCM Required - Outer Ring)
TLD	85	3.9	250	WSW of site, on Route 532, just east of Wells Mills Park, Waretown, NJ (TLD - ODCM Required - Outer Ring)
TLD	86	5.0	224	SW of site, on Route 554, 1 mile west of the Garden State Parkway, Barnegat, NJ (TLD - ODCM Required - Outer Ring)
TLD	88	6.6	125	SE of site, eastern end of 3 rd Street, Barnegat Light, NJ (TLD - Non-ODCM Required)
TLD	89	6.1	108	ESE of site, Job Francis residence, Island Beach State Park (TLD - Non-ODCM Required)
TLD	90	6.3	75	ENE of site, parking lot A-5, Island Beach State Park (TLD - ODCM Required - Special Interest Area)
TLD	92	9.0	46	NE of site, at Guard Shack/Toll Booth, Island Beach State Park (TLD - Non-ODCM Required)
FISH, CRAB	93	0.1	242	WSW of site, OCGS Discharge Canal between Pump Discharges and Route 9, Forked River, NJ (FISH - ODCM Required, CRAB - Non-ODCM Required)
SWA, AQS, CLAM, FISH	94	20.0	198	SSW of site, in Great Bay/Little Egg Harbor (SWA, AQS, CLAM, FISH - ODCM Required)
TLD	98	1.3	292	WNW of site, on Garden State Parkway at mile marker 72.3, Lacey Township, NJ (TLD - Non-ODCM Required)

TABLE E-1: REMP SAMPLE LOCATIONS (Continued)

<u>Sample Medium</u>	<u>Station Code</u>	<u>Distance (miles)</u>	<u>Azimuth (degrees)</u>	<u>Description</u>
TLD	99	1.5	310	NW of site, on Garden State Parkway at mile marker 72.8, Lacey Township, NJ (TLD - Non-ODCM Required)
TLD	T1	0.4	219	SW of site, at OCGS Fire Pond, Forked River, NJ (TLD - Non-ODCM Required)

SAMPLE MEDIUM IDENTIFICATION KEY

APT = Air Particulate	SWA = Surface Water	TLD = Thermoluminescent Dosimeter
AIO = Air Iodine	AQS = Aquatic Sediment	FISH = Fish
WWA = Well Water	CLAM = Clams	CRAB = Crab
VEG = Vegetables		

- (1) Revisions to the non-ODCM required portions of the program may be implemented at any time. Non-ODCM samples are those taken in addition to the minimum required samples listed in Table 3.12.1-1.

FIGURE E-1

SAMPLING LOCATIONS WITHIN 2 MILES

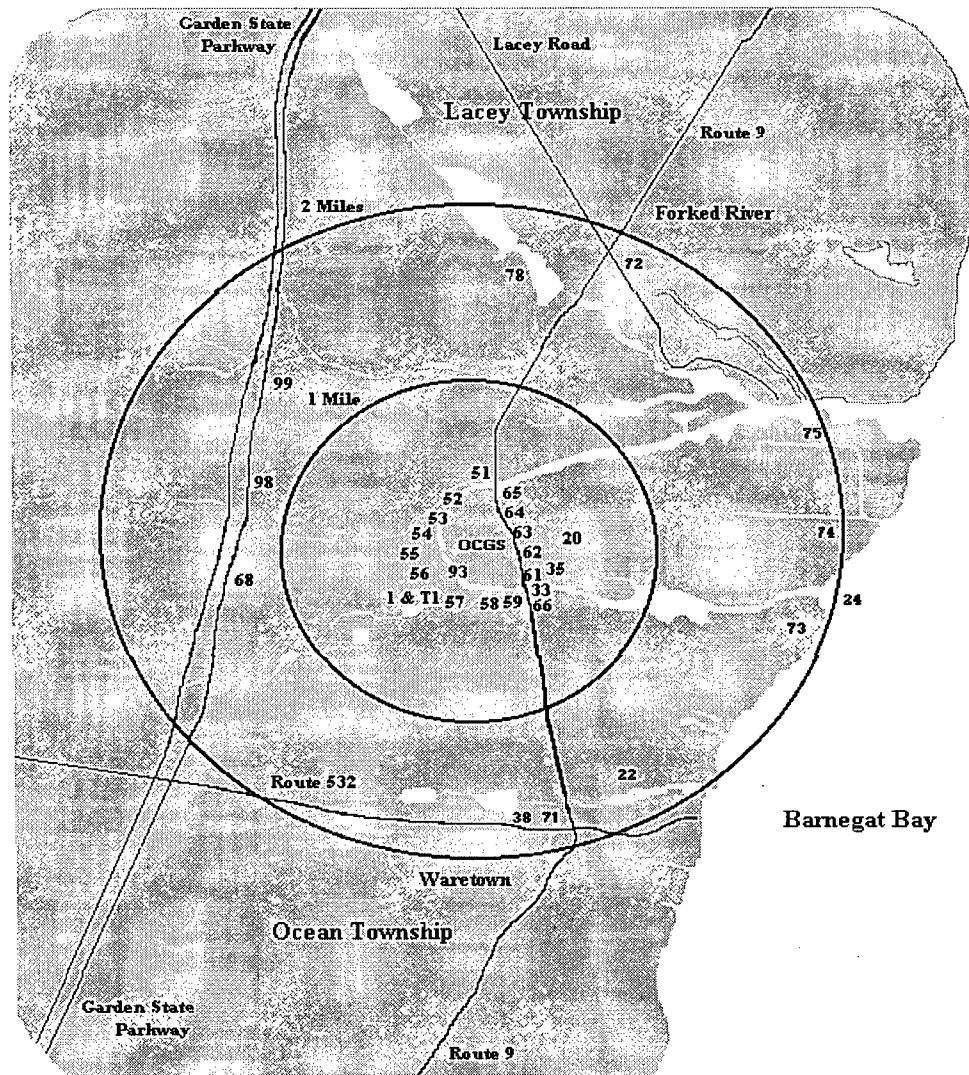

Oyster Creek Generating Station (OCGS)
Locations of Radiological Environmental Monitoring Program (REMP)
Stations within two miles of the OCGS

FIGURE E-2
SAMPLING LOCATIONS OUTSIDE 2 MILES

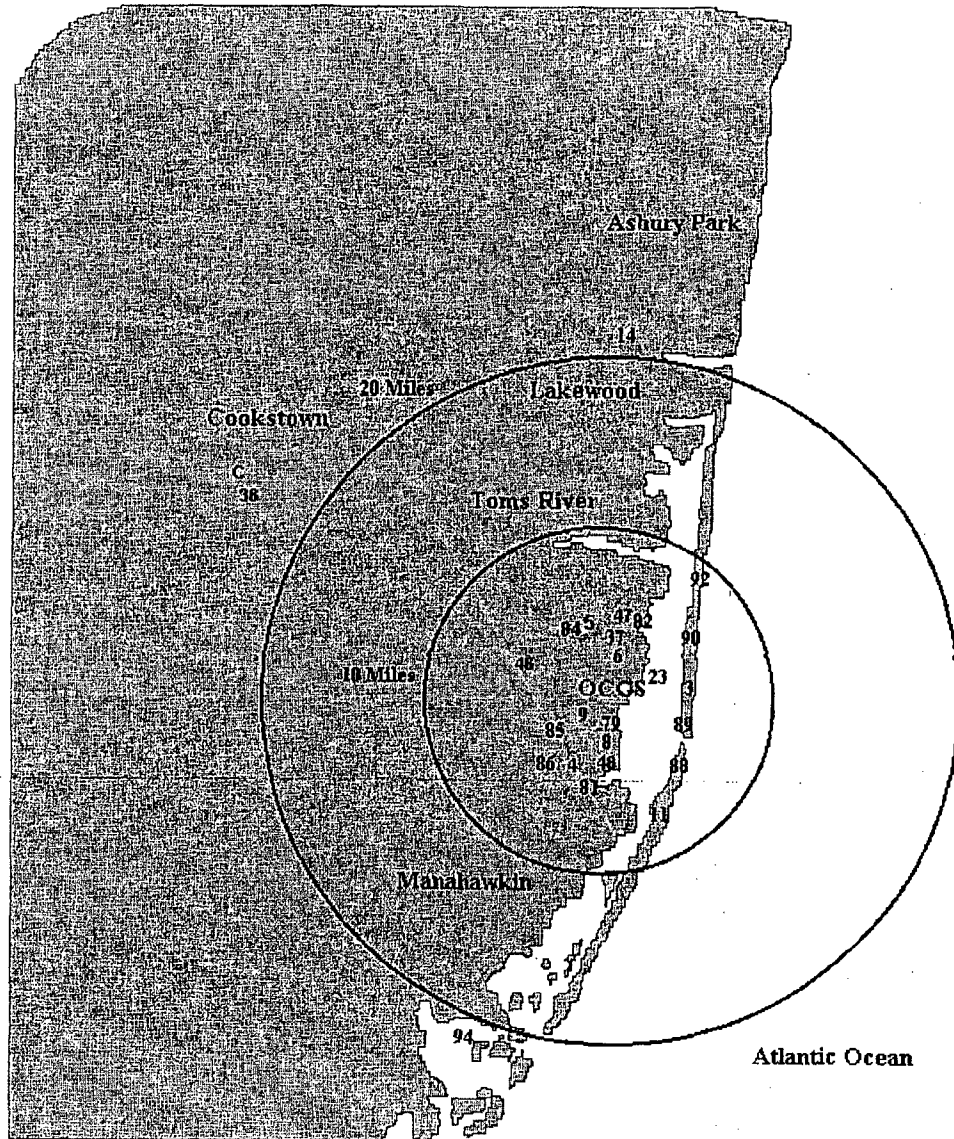

Oyster Creek Generating Station (OCGS)
Locations of Radiological Environmental Monitoring Program (REMP)
Stations greater than 2 miles from the OCGS

FIGURE E-3

AREA PLOT PLAN OF SITE

SITE MAP DEFINING UNRESTRICTED AREAS AND SITE BOUNDARY FOR RADIOACTIVE
GASEOUS AND LIQUID EFFLUENTS

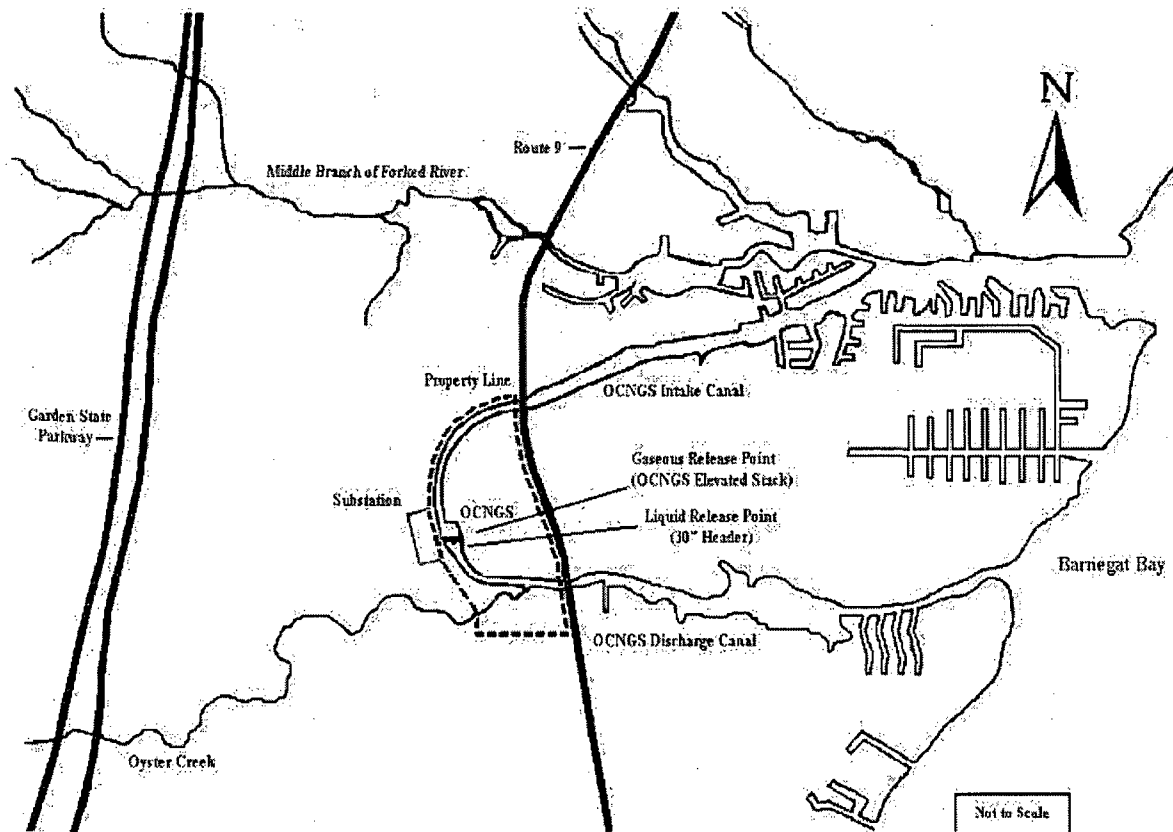

10 CFR 50.36a(a)(2)
10 CFR 72.44 (d)(3)
Technical Specification 6.9.1.d

RA-08-032

May 1, 2008

U. S. Nuclear Regulatory Commission
Attn: Document Control Desk
Washington, DC 20555 - 0001

Oyster Creek Generating Station
Facility Operating License No. DPR-16
NRC Docket No. 50-219

Independent Spent Fuel Storage Facility
NRC Docket No. 72-15

Subject: Annual Radioactive Effluent Release Report for 2007

Enclosed with this cover letter is the Annual Radioactive Effluent Release Report for the period January 1 to December 31, 2007. This report includes the Oyster Creek Nuclear Generating Station Independent Spent Fuel Storage Facility. This same report was previously submitted under cover letter RA-08-017 on February 28, 2008, but is being resubmitted in order to reset the date for the 10 CFR 50.36a(a)(2) specified interval. In addition, a copy of the OCNCS Offsite Dose Calculation Manual and a change package for Revision 2 is attached.

If any further information or assistance is needed, please contact Bob Artz at 609-971-4006.

Sincerely,

Timothy S. Rausch
Vice President – Oyster Creek Nuclear Generating Station

Enclosure: 2007 Annual Radioactive Effluent Release Report
Attachment: OCNCS ODCM and Revision 2 Change Package

cc: Administrator, USNRC Region I (w/o attachment)
USNRC Senior Project Manager, Oyster Creek (w/o attachment)
USNRC Senior Resident Inspector, Oyster Creek (w/o attachment)
File No. 07003 (w/o attachment)