

SHEARON HARRIS NUCLEAR POWER PLANT
OFF-SITE DOSE CALCULATION MANUAL

(ODCM)

Revision 19

Docket No. STN-50-400

PROGRESS ENERGY CAROLINAS

Approval by PNSC Chairman *E. McLanahan*

Approval by General Manager - Harris Plant *E. McLanahan*

Prepared by *ALB (BOUCHARD)*

Reviewed by *Donna Alexander - Env. + Chem. Superintendent*

Effective Date *1 April 2007*

TABLE OF CONTENTS

<u>Section</u>	<u>Title</u>	<u>Page</u>
	TABLE OF CONTENTS	i
	LIST OF TABLES	ii
	LIST OF FIGURES	v
	LIST OF EFFECTIVE PAGES	vi
	ODCM REV. 19 CHANGE SUMMARY	ix
1.0	INTRODUCTION	1-1
2.0	LIQUID EFFLUENTS	2-1
2.1	Compliance With 10 CFR 20	2-2
2.2	Compliance With 10 CFR 50 Appendix I	2-13
3.0	GASEOUS EFFLUENTS	3-1
3.1	Monitor Alarm Setpoint Determination	3-1
3.2	Post-release Compliance With 10CFR20-Based ODCM Operational Requirement 3.11.2	3-15
3.3	Compliance With 10 CFR 50	3-22
4.0	RADIOLOGICAL ENVIRONMENTAL MONITORING PROGRAM	4-1
5.0	INTERLABORATORY COMPARISON STUDIES	5-1
6.0	TOTAL DOSE (COMPLIANCE WITH 40 CFR 190) for ODCM OR 3.11.4	6-1
6.1	Total Dose (COMPLIANCE WITH 40 CFR 190) for ODCM OR F.2	6-1
7.0	LICENSEE-INITIATED CHANGES TO THE ODCM	7-1
	APPENDIX A - METEOROLOGICAL DISPERSION FACTOR COMPUTATIONS	A-1
	APPENDIX B - DOSE PARAMETERS FOR RADIOIODINES, PARTICULATES, AND TRITIUM	B-1
	APPENDIX C - RADIOACTIVE LIQUID AND GASEOUS EFFLUENT MONITORING INSTRUMENTATION NUMBERS	C-1
	APPENDIX D - PROGRAMMATIC CONTROLS	D-1
	APPENDIX E - PROGRAMMATIC CONTROL BASES	E-1
	APPENDIX F - ADMINISTRATIVE CONTROLS	F-1
	APPENDIX G - DEFINITIONS	G-1

LIST OF TABLES

<u>No.</u>	<u>Title</u>	<u>Page</u>
2.1-1	Liquid Effluent Release Tanks and Pumps	2-19
2.1-2	Setpoints for Cooling Tower Blowdown Dilution Flow Rates (F_{avail})	2-20
2.1-3	Signal Processor Time Constants (τ) for GA Technologies RD-53 Liquid Effluent Monitors	2-20
2.1-4	Nuclide Parameters	2-21
2.2-1	$A_{i,r}$ Values for the Adult for the Shearon Harris Nuclear Power Plant	2-24
3.1-1	Gaseous Source Terms	3-12
3.1-2	Dose Factors and Constants	3-13
3.1-3	Gaseous Monitor Parameters	3-14
3.2-1	Releases from Shearon Harris Nuclear Power Plant Normal Operation (Curies/year)	3-18
3.2-3	Dose Factors for Noble Gases	3-20
3.2-4	$P_{i,I}$ Values (Inhalation) for a Child	3-21
3.3-1 through 3.3-19	R Values for the Shearon Harris Nuclear Power Plant	3-34
4.1	Radiological Environmental Monitoring Program	4-2
A-1 through A-4	X/Q and D/Q Values for Long-Term Ground-Level Releases at Special Locations	A-4

LIST OF TABLES (continued)

<u>No.</u>	<u>Title</u>	<u>Page</u>
A-5 through A-6	Undepleted, No Decay, X/Q Values For Long Term Ground Level Releases At Standard Distances (sec/m ³)	A-5
A-7 through A-8	Undepleted, 2.26 Day Decay, X/Q Values For Long Term Ground Level Releases At Standard Distances (sec/m ³)	A-7
A-9 through A-10	Depleted, 8.0 Day Decay, X/Q Values For Long Term Ground Level Releases At Standard Distances (sec/m ³)	A-9
A-11 through A-12	Deposition Values (D/Q) For Long Term Releases At Standard Distances (m ⁻²)	A-11
A-13	Joint Wind Frequency Distribution By Pasquill Stability Classes At SHNPP	A-13
A-14	Shearon Harris Plant Site Input Information for Continuous Ground-level Release Calculations With the NRC XOQDOQ Program	A-16
B-1	Parameters for Cow and Goat Milk Pathways	B-16
B-2	Parameters for the Meat Pathway	B-17
B-3	Parameters for the Vegetable Pathway	B-18

LIST OF TABLES (continued)

<u>No.</u>	<u>Title</u>	<u>Page</u>
NOTE: Tables in Appendix D are named after their respective Operational Requirement.		
3.3-12	Radioactive Liquid Effluent Monitoring Instrumentation.....	D-3
4.3-8	Radioactive Liquid Effluent Monitoring Instrumentation Surveillance Requirements.....	D-5
3.3-13	Radioactive Gaseous Effluent Monitoring Instrumentation.....	D-8
4.3-9	Radioactive Gaseous Effluent Monitoring Instrumentation Surveillance Requirements.....	D-10
4.11-1	Radioactive Liquid Waste Sampling and Analysis Program.....	D-13
4.11-2	Radioactive Gaseous Waste Sampling and Analysis Program.....	D-19
3.12-1	Radiological Environmental Monitoring Program.....	D-29
3.12-2	Reporting Levels for Radioactivity Concentrations in Environmental Samples.....	D-35
4.12-1	Detection Capabilities for Environmental Sample Analysis Lower Limit of Detection (LLD).....	D-36
G-1	Frequency Notation.....	G-4
G-2	Operational Mode.....	G-5

LIST OF FIGURES

<u>No.</u>	<u>Title</u>	<u>Page</u>
2.1-1	Liquid Waste Processing Flow Diagram.....	2-27
2.1-2	Liquid Effluent Flow Stream Diagram.....	2-28
2.1-3	Normal Service Water Flow Diagram.....	2-29
2.1-4	Other Liquid Effluent Pathways.....	2-30
3.1	SHNPP Gaseous Waste Streams.....	3-53
3.2	Schematic of Airborne Effluent Release Points.....	3-54
3.3	SHNPP Condenser Off-Gas System.....	3-55
4.1-1	SHNPP Exclusion Boundary Plan.....	4-16
4.1-2 through 4.1-6	Environmental Radiological Sampling Points and Legend	4-17

List of Effective Pages

<u>Page</u>	<u>Revision</u>
Cover Page	19
i	19
ii	17
iii	5
iv	6
v	19
vi - x	19
1-1	13
2-1	13
2-2 - 2-5	6
2-6 -	15
2-7 - 2-8	6
2-9	4
2-10	6
2-11	17
2-12	7
2-13	17
2-14	4
2-15	6
2-16 - 2-17	14
2-18	17
2-19	15
2-20	4
2-21 - 2-23	15
2-24 - 2-27	4
2-28	6
2-29	4
2-30	6
3-1	17
3-2 - 3-5	5
3-6	15
3-7	17
3-8 - 3-11	5
3-12	14
3-13 - 3-14	5
3-15	6
3-16 - 3-19	17
3-20 - 3-21	5
3-22	14
3-23 - 3-26	17
3-27 - 3-28	6
3-29 - 3-31	17
3-32 - 3-33	6
3-34 - 3-52	5
3-53	17
3-54	13
3-55	5

List of Effective Pages

<u>Page</u>	<u>Revision</u>
4-1	19
4-2	6
4-3 - 4-5	16
4-6	17
4-7	19
4-8	10
4-9 - 4-10	4
4-11	17
4-12	4
4-13	18
4-14	17
4-15	19
4-16	18
4-17	4
4-18 - 4-19	18
4-20 - 4-22	19
5-1	19
6-1	17
6-2	15
7-1	17
A-1	17
A-2	6
A-3	17
A-4 - A-21	6
B-1	6
B-2	5
B-3	6
B-4	5
B-5 - B-7	4
B-8	17
B-9	4
B-10	17
B-11 - B-18	4
C-1	14
D-1	6
D-2	13
D-3	9
D-4	6
D-5	17
D-6	10
D-7	11
D-8 - D-9	6
D-10	17
D-11	9
D-12 -D-13	17
D-14 - D-18	6
D-19	17
D-20	6

List of Effective Pages

<u>Page</u>	<u>Revision</u>
D-21	19
D-22	13
D-23 - D-26	6
D-27	19
D-28	19
D-29 - D-30	6
D-31	19
D-32 - D-33	6
D-34	19
D-35	6
D-36 - D-37	12
D-38 - D-39	6
D-40	15
E-1 - E-9	6
E-10	17
E-11- E-12	6
F-1	6
F-2	6
F-3	13
F-4	19
F-5	17
G-1 - G-2	18
G-3 - G-5	6

ODCM REV. 19 CHANGE SUMMARY

Revision 19 to the ODCM is as follows:

Section	Page	Description
Title Page		Revised to Rev. 19
Table of Contents	i	Changed to "ODCM REV. 19 CHANGE SUMMARY",
List of Figures	v	Changed numbering to reflect 4.1-6 addition made in Revision 18.
LEP	vi, vii, viii	Changed revision numbers as appropriate.
ODCM REV 19 CHANGE SUMMARY	ix-x	Changed to reflect Rev. 19 revisions.
Section 4.0	4-1	Added discussion of Radiological Environmental Monitoring Program. Changed Figure numbering to reflect Revision 18 changes.
Table 4.1	4-7	Updated ground water sampling locations. Deleted Location 57, it is cross gradient from flow pathway centered at SHNPP Unit 1. Corrected Location 60 description, previously described as North of Cooling Tower when in fact it is located Southeast of the Cooling Tower. Locations 70 and 71 will replace location 60 in the future to monitor groundwater down gradient of SHNPP Unit 1. Location 60 will be submerged when current Main Reservoir level is raised from 220 to 240-ft msl. Location 68 and 69 added to monitor groundwater up gradient of SHNPP Unit 1. Per DRR 209976: New Monitoring Well, location 72, added to monitor groundwater down gradient of Radwaste discharge line and Cooling Tower Blowdown line connection as well as down gradient of SHNPP Unit 1.
Notes to Table 4.1	4-15	Note 1 Figure numbering was corrected to reflect current section figures. Note 4 typographical error was corrected. Note 10 and 11 were added to provide sample deletions and additions.
Figure 4.1-5	4-20	Updated Figure 4.1-5 with more recent photograph of SHNPP. Figure identifies groundwater sampling locations listed in Table 4.1.
Figure 4.1-6	4-21 4-22	Figure 4.1-6 (Environmental Radiological Sampling Points Legend) was renumbered and next page added to represent sample points added to Figure 4.1-5, page 4-20. Deleted sample point 57 for program represented in Figure 4.1-5, page 4-20. Previously deleted samples were clarified within the table.
Section 5.0	5-1	Changes made per DRR 209976: Added information reflecting that SHNPP E&RC personnel perform tritium and gross alpha in addition to performing gamma emitting analysis for effluent releases. Corrected typographical error, providing established ratio requirements for resolution of < 4 for the cross-check program.
Table Notations For Table 4.11-2	D-21	Typographical error corrected.
Section 3.12.1.b.	D-27	Typographical error corrected.
Section 3.12.1.d,e	D-28	Added sections to describe Special Radiological Effluent and Special Ground Water Protection Reports.
Table 3.12-1	D-31, D-34	Typographical error corrected. Changed well number to eight.
Appendix F	F-1, F-4	Revised Section F.2 to include Groundwater Reporting Criteria.

Intentionally Left Page Blank

1.0 INTRODUCTION

The Off-Site Dose Calculation Manual (ODCM) provides the information and methodologies to be used by Shearon Harris Nuclear Power Plant (SHNPP) to ensure compliance with Operational Requirements 3.3.3.10, 3.3.3.11, 3/4.11.1, 3/4.11.2, 3/4.11.4, 4.12.1, 4.12.2, and 4.12.3 and reporting requirements in Appendix F of the ODCM. These operational requirements are those related to normal liquid and gaseous radiological effluents, environmental monitoring, and reporting. They are intended to show compliance with 10CFR20-based requirements, 10CFR50.36a, Appendix I of 10CFR50, and 40CFR190 in terms of appropriate monitoring instrumentation, setpoints, dose rate, and cumulative dose limitations. Off-site dose estimates from non-routine releases will be included in the cumulative dose estimates for the plant to comply with Appendix I of 10CFR50.

The ODCM is based on "Westinghouse Standard Technical Specifications" (NUREG 0452), "Preparation of Radiological Effluent Technical Specifications for Nuclear Power Plants" (NUREG 0133), and guidance from the United States Nuclear Regulatory Commission (NRC). Specific plant and Nuclear Generation Group (NGG) procedures implement the ODCM program requirements.

The ODCM has been prepared as generically as possible in order to minimize the need for future revisions. However, some changes to the ODCM are expected in the future. Any such changes will be properly reviewed and approved as indicated in Administrative Controls Section 6.14 of the SHNPP Technical Specifications.

The assessment of annual radiation doses to members of the public from radioactive liquid and gaseous effluents from the plant is estimated using the methodology in the ODCM for the report period. These off-site dose estimates for each calendar year are reported in the Annual Radioactive Effluent Release Report required by Appendix F of the ODCM.

2.0 LIQUID EFFLUENTS

Radioactive materials released in liquid effluents from SHNPP to unrestricted areas are required to demonstrate compliance with 10 CFR 50 Appendix I (ODCM Operational Requirement 3.11.1.2) and, on an annual average basis, be limited to the concentrations specified in 10 CFR 20, Appendix B, Table 2, Column 2. For dissolved or entrained noble gases the concentration shall be limited to 2E-4 $\mu\text{Ci/ml}$ total activity. On an individual release basis, the release concentration for liquid effluents will be limited to ten times (10x) the concentrations specified in 10 CFR 20, Appendix B, Table 2, Column 2, Effluent Concentration (ODCM Operational Requirement 3.11.1.1). The liquid effluent release point is at the point of discharge from the Cooling Tower Blowdown Line into Harris Lake (see Figure 2.1-3 and T/S Figure 5.1-3).

Figure 2.1-1, Liquid Waste Processing Flow Diagram, and Figure 2.1-2 Liquid Effluent Flow Stream Diagram, show how effluents are processed and where they are released.

Effluent monitor identification numbers are provided in Appendix C. Liquid effluent dilution prior to release to Harris Lake is provided by the Cooling Tower Blowdown Line. Concurrent batch releases shall not occur at SHNPP.

The Secondary Waste Sample Tank (SWST) and the Normal Service Water (NSW) system have a low potential for radioactive effluent releases. These releases are checked by effluent monitors on the SWST (Figure 2.1-2) and the NSW lines (Figure 2.1-3).

The Turbine Building floor drains and the outside tank area drains (Figure 2.1-4) are monitored effluent lines with low probability of radioactive contamination.

The radioactive liquid waste sampling and analysis required for batch and continuous releases are found in Table 4.11-1 of the ODCM Operational Requirements.

The SHNPP ODCM uses the Canberra, Inc., Effluent Management System (EMS) software for automating the necessary calculations and record keeping. As such, the ODCM is written with the following parameters set in the EMS:

The SET_OPT option is set to NO_WASTE

The SETP_EQN option is set to LOW_ACT

2.1 Compliance with 10 CFR 20

10 CFR 20.1301 requires that the total effective dose equivalent to individual members of the public will not exceed 0.1 rem (100 mrem) in a year.

10 CFR 20.1302 states that a licensee can show compliance with the annual dose limit of 20.1301 by demonstrating that the annual average concentration of radioactive material released in liquid effluents at the boundary of the unrestricted area does not exceed the values specified in 10 CFR 20, Appendix B, Table 2, Column 2.

ODCM Operational Requirement 3.11.1.1 states that, on an individual release basis, the concentration of radioactive material released in liquid effluents to unrestricted area shall be limited to 10 times the values specified in 10 CFR 20, Appendix B, Table 2, Column 2.

ODCM Operational Requirement 3.3.10 requires that radioactive effluent instrumentation have alarm/trip setpoints that will ensure that an alarm/trip will occur prior to exceeding 10 times the limits of ODCM Operational Requirement 3.11.1.1. for principal gamma emitters.

Liquid effluent monitors have two setpoints, the high alarm and the alert alarm. The high alarm setpoint, S_{max} , provides alarm and isolation if the radionuclide concentrations, when diluted, would approach the ODCM Operational Requirement limits for concentrations in unrestricted areas. Alert alarm setpoints, S_{alert} , are set at a fraction of the S_{max} to provide an early warning of the approach to ODCM Operational Requirement limits.

2.1.1 Batch Releases

Radioactive liquids are routinely released as batches from the Waste Evaporator Condensate Tank (WECT) and Treated Laundry and Hot Shower Tank (TL&HST). Batch releases may also originate from the Secondary Waste Sample Tank (SWST) and Waste Monitor Tank (WMT). These tanks are shown in Figures 2.1-1 and 2.1-2. Based on analysis of the tank contents, the tank release rate is adjusted, based on the Cooling Tower Blowdown Line flow rate, to dilute the tank activities to 50 percent of the allowable concentrations at the release point to Harris Lake.

The ODCM software calculates a nuclide specific response setpoint which is based on the sum of responses for each nuclide. The nuclide specific response setpoint equates all gamma-emitting nuclides to Cs-137, to which the monitor is calibrated.

If analysis of the batch sample indicates all gamma-emitting nuclides are < LLD, (as defined in ODCM Operational Requirement Table 4.11-1), the tank gamma activity, C_i , may be assumed to consist only of Cs-134. This nuclide has the lowest Effluent Concentration Limit (ECL) of any to be found in liquid effluents and provides a conservative basis for a monitor setpoint.

2.1.1 Batch Releases (continued)

1. Minimum Tank Mixing Time

Footnote 2 to ODCM Operational Requirement Table 4.11-1 requires that the method used to mix an isolated effluent tank prior to sampling and analysis be described.

Equation 2.1-1 below provides an acceptable method for ensuring a well mixed tank so that a representative sample can be taken for radioactivity or other appropriate analyses.

$$R = \frac{(V) (E) (N)}{(RR) (60)} \quad (2.1-1)$$

where:

- R = Minimum allowable mixing time, hr
- V = Tank capacity, gal
- E = Eductor factor
- RR = Pump design recirculation flow rate, gpm
- n = Number of tank volumes for turnover; this will be a minimum of two
- 60 = 60 min/hr

Table 2.1-1 lists the tank capacities, eductor factors, and pump design recirculation flow rates for individual liquid effluent release tanks.

2.1.1 Batch Releases (continued)

2. Required Dilution Factor

ODCM Operational Requirement 3.11.1.1 requires that the sum of concentrations divided by ECL values must not exceed 10 for an individual release. Therefore:

$$\sum_i \frac{C_i}{ECL_i} \leq 10 \quad (2.1-2)$$

where:

C_i = the concentration of nuclide i to be released

ECL_i = the Effluent Concentration Limit for nuclide i from 10CFR20, Appendix B, Table 2, Column 2.

If the summation is greater than 10, dilution is required. The total required dilution factor, D_{req} , is the minimum acceptable dilution factor required to meet the limits of ODCM Operational Requirement 3.11.1.1, based on pre-release and composite analysis.

$$D_{req} = D_{req,g} + D_{req,ng} \quad (2.1-3)$$

where:

$D_{req,g}$ = Required dilution factor for gamma-emitters

$$= \frac{\sum_{i=g} \frac{C_i}{ECL_i}}{f \cdot R_{max}} \quad (2.1-4)$$

2.1.1 Batch Releases (continued)

$D_{req,ng}$ = Required dilution factor for non-gamma-emitters

$$= \frac{\sum_{i=ng} \frac{C_i}{ECL_i}}{f \cdot R_{max}} + \frac{r}{f \cdot R_{max}} \quad (2.1-5)$$

and

f = 0.5

= A safety factor to assure that the nuclide concentrations are 50% of the ODCM Operational Requirement limit at the point of discharge.

r = a value to take into account that tritium is potentially being released via the settling basin discharge to the cooling tower discharge line. This value is normally set to 1.0E-03, which is the H-3 ECL. NOTE: CRC-001 has a target limit of 2.0E-04 $\mu\text{Ci/ml}$.

R_{max} = The maximum ECL ratio for the release point (normally set to 10).

The sums include gamma-emitters (g) and non-gamma-emitters (ng), respectively.

The measured concentration of each gamma-emitting nuclide, including noble gases, is reported in $\mu\text{Ci/ml}$. If no gamma activity is detectable then an activity of 9E-07 $\mu\text{Ci/ml}$ of Cs-134 is assumed for setpoint calculations. The measured concentration of non-gamma emitters is determined by analysis of the liquid effluent or previous composite sample, and is reported in $\mu\text{Ci/ml}$.

2.1.1 Batch Releases (continued)

3. Maximum Waste Flow

For liquid releases, the maximum permissible waste flow rate for this release, W_{max} is the minimum of R_{cwmmax} and R_{wmax} ,

where

$$R_{cwmmax} = \frac{F_{avail} \cdot f_{alloc}}{D_{req}} \quad (2.1-6)$$

R_{wmax} = Liquid effluent tank maximum waste flow rate, as specified in Table 2.1-1. This value is the same as F_{waste} .

and

F_{avail} = The available dilution flow is the minimum dilution stream flow (Cooling Tower Blowdown) that can be ensured for the period of the release. Since only one batch release occurs at a time out of a single discharge point, the flow is not corrected for other releases in progress, for any activity in the dilution stream, or reduced by a safety factor. The minimum dilution flow rate for each setting is shown in Table 2.1-2.

f_{alloc} = Fraction of the available dilution volume which may be assigned to a particular release to ensure discharge point limits are not exceeded by simultaneous radioactive liquid releases. The value of f_{alloc} is based on assumed operational considerations for simultaneous releases but normally will be 0.8 for a batch release and 0.2 for a continuous release.

4. Minimum Dilution Flow Rate

The Minimum Dilution Flow Rate (min_dflow) is the minimum Cooling Tower discharge flow necessary to dilute the release to less than ODCM Operational Requirement Limits.

If $D_{req} \leq 1$, the minimum dilution flow rate is set to 0.0. If $D_{req} > 1$, the minimum dilution flow rate is determined as follows:

$$min_dflow = \frac{F_{waste} \cdot D_{req}}{f_{alloc}} \quad (2.1-7)$$

where

F_{waste} = waste flow anticipated for this release

2.1.1 Batch Releases (continued)

5. Setpoint Calculations

The ODCM software calculates a nuclide specific response setpoint, which is based on the sum of responses for each nuclide. The setpoint equates all gamma-emitting nuclides to Cs-137, to which the monitor is calibrated. The setpoint is listed in terms of Cs-equiv and the units are $\mu\text{Ci/ml}$.

If analysis of the batch sample indicates all gamma-emitting nuclides are $< \text{LLD}$, (as defined in ODCM Operational Requirement Table 4.11-1), the tank gamma activity, C_i , may be assumed to consist only of Cs-134. This nuclide has the lowest ECL of any to be found in liquid effluents and provides a conservative basis for a monitor setpoint.

- (1) Maximum setpoint value, based on Nuclide Specific Response

$$S_{\max} (\text{Cs-equiv}) = (S_{\text{adj}} \cdot R_{\text{mon}}) + B \quad (2.1-8)$$

where

$$S_{\text{adj}} = \text{Setpoint adjustment factor.}$$

$$= \frac{\frac{f_{\text{alloc}} \cdot F_{\text{avail}}}{F_{\text{waste}}} - D_{\text{req,ng}}}{D_{\text{req,g}}} \quad (2.1-9)$$

S_{adj} should always be greater than 1 to ensure that adequate dilution flow is available for the release.

$$B = \text{monitor background } (\mu\text{Ci/ml})$$

2.1.1 Batch Releases (continued)

$$R_{\text{mon}} = \sum \text{slope}_i \cdot C_i$$

where the sum extends over all nuclides which have response factors stored in the database for the monitor of interest

and

$\text{slope}_i =$ the Liquid Effluent Monitor Gamma Sensitivities (from Table 2.1-4) for nuclide i , relative to Cs-137. To make nuclide i relative to Cs-137, the nuclide sensitivity is divided by the Cs-137 sensitivity.

$$= \frac{\text{Sensitivity (nuclide } i)}{\text{Cs-137 Sensitivity}}$$

(2) Monitor alert alarm setpoint, S_{alert} (Cs-equiv)

An Alert Alarm setpoint is calculated to provide an operator with adequate warning that the high alarm setpoint is being approached. S_{alert} is calculated from the nuclide specific response setpoint.

$$S_{\text{alert}} = [(S_{\text{max}} - B) \cdot F_x] + B \quad (2.1-10)$$

where:

$F_x =$ A value <1.0 designed to provide an operator with adequate warning that the high alarm setpoint is being approached.

2.1.1 Batch Releases (continued)

(3) Check for Excessive Monitor Background

In order to differentiate between the S_{alert} and the statistical fluctuations associated with a high monitor background, a check for excessive monitor background is made. As a check, verify that the minimum detectable concentration (MDC) for the monitor is less than 0.1 of the net S_{alert} ; therefore, background is acceptable if:

$$MDC \leq 0.1[(S_{max} - B) \cdot F_x] \quad (2.1-11)$$

where:

$$MDC = \frac{2 \sqrt{\frac{Bkg}{2\tau}}}{E_m} \quad (2.1-12)$$

where:

τ = Signal Processor Time constant, minutes.
(Table 2.1-3)

Bkg = Background Count Rate, in cpm
= B / E_m

E_m = Monitor efficiency for the Cs-137 gamma energy, cpm/ μ Ci/ml determined by primary calibration.

If not, postpone the release and decontaminate or replace the sample chamber to reduce the background, then recalculate S_{max} and S_{alert} using the new, lower background.

6. Post-Release Compliance

After the release is made, actual concentrations are used to check 10 CFR 20 limits, and the actual dilution flow and waste flow are used instead of the anticipated dilution flow and waste flow.

For batch releases, the duration is determined from the start and end dates and times of the release. This is used with the actual release volume to calculate the release rate.

2.1.2 Continuous Releases

The continuous releases from the SWST and the NSW return lines are monitored as shown in Figures 2.1-2 and 2.1-3. The function of these monitors, in contrast to the isolation function of batch release tank monitors, is to provide an indication of low levels of radioactivity in the effluent. The continuous effluent monitor setpoint is based on an assumed FSAR nuclide mix for the SWST (from Table 11.2.1-5 of the FSAR).

The EMS software does not calculate continuous release monitor setpoints.

1. Monitor High Alarm Setpoint, S_{max} ($\mu\text{Ci/ml}$).

$$S_{max} = \frac{0.1 (ECL_{eff} \cdot Sens_{eff}) + Bkg}{E_m} \quad (2.1-13)$$

where:

ECL_{eff} = Weighted Effluent Concentration Limit for the SWST nuclides listed in Table 11.2.1-5 of the FSAR.

$Sens_{eff}$ = $\sum_g (Sens_i \times \% \text{ abundance})$ for the SWST nuclide mix, cpm/ $\mu\text{Ci/ml}$.

2. Monitor Alert Alarm Setpoint, S_{alert} (Cs-equiv)

$$S_{alert} = [(S_{max} - B) \cdot F_x] + B \quad (2.1-14)$$

When the monitor is operable and not in alarm, analysis of weekly composite samples is not required by ODCM Operational Requirement Table 4.11-1.

If the monitor is in alarm or the presence of non-naturally occurring radioactivity > effluent LLD is confirmed, the releases may continue provided the sampling and analysis required by ODCM Operational Requirement Table 4.11-1 are performed. The results of the sample analysis will be evaluated for compliance with ODCM Operational Requirement 3.11.1.1.

The monitor alarm setpoints may be recalculated using the methodology in Section 2.1.1 with the results of the gamma analysis and analyses of the composite sample.

3. Check for Excessive Monitor Background

Monitor background is considered excessive when the minimum detectable concentration (MDC) for the monitor is >0.01 ECL_{eff} . Therefore, background is acceptable if:

$$MDC \leq \frac{0.01 (ECL_{eff} \cdot Sens_{eff})}{E_m} \quad (2.1-15)$$

2.1.3 Other Liquid Releases

1. Outdoor Tank Area Drain Effluent Line

The outdoor tank area drain effluent line routes rain water collected in the outdoor tank area to the storm drain system and from there directly to the lake. The line is monitored for radioactivity by the Tank Area Drain Transfer Pump Monitor. Because no radioactivity is normally expected in this line, the monitor high alarm and alert alarm setpoints are determined using the methodology in Section 2.1.2. If the setpoint is exceeded, the discharge pump is automatically secured. Effluent can then be diverted to the floor drain system for processing and eventual release (see Figures 2.1-1 and 2.1-2).

2. Turbine Building Floor Drains Effluent Line

Water collected in the turbine building floor drains is normally routed to the yard oil separator for release to the environment via the waste neutralization system and then to the cooling tower discharge line. Tritium is expected to be detected in this pathway from sources such as background from the lake. Because no other radioactivity is normally expected in this path, the setpoints for the turbine building drain monitor are determined using the methodology in Section 2.1.2. Should the setpoint be exceeded, the release is automatically terminated. Effluent can then be diverted to the secondary waste treatment system for processing and eventual release (see Figures 2.1-1 and 2.1-2).

2.2 Compliance with 10 CFR 50 Appendix I

2.2.1 Cumulation of Doses

The dose contribution from each release of liquid effluents will be calculated and a cumulative summation of the total body and each organ dose will be maintained for each 31 days (monthly), each calendar quarter, and the year.

The EMS software calculates and stores the dose for the critical receptor (site boundary), for each nuclide, and for each organ. The dose is the total over all pathways which apply to that receptor. A receptor is defined by receptor ID, age group (infant, child, teen, or adult), sector, and distance from the plant.

The dose contribution for batch releases and all defined periods of continuous release received by receptor "r" from a released nuclide "i" will be calculated using the following equation:

$$D_{itr} = A_{itr} \cdot \sum \Delta t_s C_{is} F_{rs} \quad (2.2-1)$$

where:

- D_{itr} = the cumulative dose or dose commitment to the total body or an organ "r" by nuclide "i" for receptor "r" from the liquid effluents for the total time period of the release, in mrem.
- A_{itr} = site-related ingestion dose or dose commitment factor for receptor "r" to the total body or organ "r" for nuclide "i", in mrem/hr per $\mu\text{Ci/ml}$.
- Δt_s = length of time period 's', over which the concentration and F value are averaged, for all liquid releases, in hours.
- C_{is} = the average concentration of nuclide "i" in undiluted liquid effluent during time period Δt_s from any liquid release, in $\mu\text{Ci/ml}$.
- F_{rs} = the near field average dilution factor for receptor "r" during any liquid effluent release.

2.2.1 Cumulation of Doses (continued)

Where:

$$F_{rs} = \frac{F_{waste}}{F_{waste} + F_{avail}} \cdot R_{mix} \quad (2.2-2)$$

and

$$R_{mix} = \text{mixing ratio}$$

$$= \text{fraction of the release that reaches the receptor.}$$

At the SHNPP, this value is set to 1.

Also, the sum extends over all time periods 's'.

In the case of a continuous secondary waste sample tank radioactive release, C_i = the concentration of nuclide "i" in the SWST composite sample. For the NSW, C_i = concentration of nuclide "i" in the cooling tower basin and F_{waste} = discharge from the cooling tower basin while F_{avail} = the flow from the makeup water cross-tie. For a release through the Turbine Building Floor Drain Line to the waste neutralization system, C_i = the Turbine Building floor drain sample activity, F_{waste} = discharge from the Turbine Building floor drain line, and F_{avail} = the average flow during the period of the total Cooling Tower discharge. The total Cooling Tower discharge is the sum of the Cooling Tower Blowdown flow and the Cooling Tower Bypass Line flow.

When there is a primary-to-secondary leak, the change in concentration of tritium in the steam generators times the secondary losses (balance of plant), will be used for effluent accountability. The secondary loss rate will also be used for volume accountability.

The dose factor $A_{i\tau}$ (see NUREG-0133, Section 4.3.1) was calculated for an adult for each isotope "i" using the following equation:

$$A_{i\tau} = 1.14E + 05 \left(\frac{730}{D_w} + 21BF_i \right) DF_{i\tau} \cdot e^{-\lambda_i t} \quad (2.2-3)$$

where:

- $A_{i\tau}$ = The ingestion dose commitment factor to the whole body or any organ "τ" for an adult for each nuclide "i". Corresponding to fish consumption from the Harris Lake (dilution = 1) and drinking water from Lillington (dilution = 13.95).
- = Values for the adult total body and organs in mrem/hr per μCi/ml are given in Table 2.2-1.

2.2.1 Cumulation of Doses (continued)

- 1.14E+05 = Unit Conversion Factor
- $$= \frac{10^6 \text{ pci}}{1 \text{ } \mu\text{Ci}} \cdot \frac{1000 \text{ ml}}{1 \text{ liter}} \cdot \frac{1 \text{ yr}}{8760 \text{ hrs}} \quad (2.2-4)$$
- 21 = Adult fish consumption rate (from Table E-5 of Regulatory Guide 1.109, Rev. 1), kg/yr;
- 730 = Adult water consumption rate (from Table E-5 of Regulatory Guide 1.109, Rev. 1), liters/yr.
- D_w = Dilution factor for the drinking water pathway
- = 13.95
- BF_i = Bioaccumulation factor for nuclide "i" in fish (from Table A-1 of Regulatory Guide 1.109, Rev. 1), pCi/kg per pCi/l
- $DF_{i\tau}$ = Dose conversion factor for nuclide "i" for adults for a particular organ τ (from Table E-11 of Regulatory Guide 1.109, Rev. 1), mrem/pCi
- λ_i = Radiological decay constant of nuclide "i," hr⁻¹;
- $$= \frac{0.693}{(t_{1/2})_i}$$
- $(t_{1/2})_i$ = Radiological half-life of nuclide "i," hr;
- t_p = Average transport time to reach point of exposure, hr;
- = 12 hours. The more limiting decay time for the drinking water and fish exposure pathways (Reg. Guide 1.109, Appendix A, Rev. 1).

Table 2.2-1 presents the $A_{i\tau}$ values for an adult receptor. Values of $e^{-\lambda_i t_p}$ are presented in Table 2.1-4 for each nuclide "i".

2.2.2 Comparison Against Limits

The sum of the cumulative dose from all batch and any continuous releases for a quarter is compared to one-half the design objectives for total body and any organ. The sum of the cumulative doses from all releases for a calendar year is compared to the design objective doses. The following relationships should hold for the SHNPP to show compliance with ODCM Operational Requirement 3.11.1.2.

2.2.2 Comparison Against Limits (continued)

For the calendar quarter:

$$D_{itr} \leq 1.5 \text{ mrem total body} \quad (2.2-5)$$

$$D_{itr} \leq 5 \text{ mrem any organ} \quad (2.2-6)$$

For the calendar year:

$$D_{itr} \leq 3 \text{ mrem total body} \quad (2.2-7)$$

$$D_{itr} \leq 10 \text{ mrem any organ} \quad (2.2-8)$$

where:

$$D_{itr} = \text{Cumulative total dose to any organ or the total body from all releases, mrem:}$$

The quarterly limits given above represent one-half the annual design objective of 10 CFR 50, Appendix I, Section II.A. If any of the limits in equations (2.2-5) through (2.2-8) are exceeded, a special report pursuant to SHNPP Technical Specification 6.9.2 must be filed with the NRC. This report complies with Section IV.A of Appendix I, 10 CFR 50.

The calculations described in Section 2.2.1 will be used to ensure compliance with the limits in 10 CFR 50 Appendix I for each release. Summation of doses for all releases for the quarter and year are compared to the limits in 10CFR50 Appendix I to ensure compliance.

The SHNPP ODCM uses a "modified" NUREG 0133 equation with conservative assumptions. It calculates the dose to a single maximum (ALARA) individual. The ALARA individual is an individual that consumes fish caught in the Harris Lake (dilution of 1.0) and receives their drinking water from Lillington, North Carolina (dilution 13.95).

2.2.2 Post-release Compliance With 10 CFR 50 - Based ODCM Operational Requirement

After the release is made, the doses are compared to the 10CFR50 limits. The actual dilution flow and waste flow are used instead of the anticipated dilution flow and waste flow.

For batch releases, the duration is determined from the actual start and end dates and times of the release. This is used with the actual volume input to calculate the release rate. Each month the dilution volume is updated for times when no releases were being made in order to update the quarterly and yearly doses for comparison with the 10CFR50 Appendix I limits.

2.2.3 Projection of Doses

Dose projections for this section are required at least once per 31 days (monthly) in ODCM Operational Requirement 4.11.1.3.1 whenever the liquid radwaste treatment systems are not being fully utilized.

The doses will be calculated using Equation 2.2-1, and projected using the following expression:

$$D_{Pr} = (D_r \cdot p) + D_{Ar} \quad (2.3-1)$$

where:

- D_{Pr} = the 31 Day Projected Dose by organ r
- D_r = sum of all open release points in mrem/day by organ r .
- p = the Projection Factor which is the result of 31 divided by the number of days from start of the quarter to the end of the release.
- D_{Ar} = Additional Anticipated Dose for liquid releases by organ r and quarter of release.

NOTE: The 31 Day Projected Dose values appear on the Standard and Special Permit Reports. The 31 day dose projections on the Approval/Results screen include any additional dose.

Where possible, expected operational evolutions (i.e., outages, increased power levels, major planned liquid releases, etc.) should be accounted for in the dose projections. This may be accomplished by using the source-term data from similar historical operating experiences where practical, and adding the dose as Additional Anticipated Dose.

2.2.3 Projection of Doses (continued)

To show compliance with ODCM Operational Requirement 3.11.1.3, the projected 31 day dose should be compared to the following limits:

$$D_{pt} \leq 0.06 \text{ mrem for total body} \quad (2.3-2)$$

and

$$D_{pt} \leq 0.2 \text{ mrem for any organ} \quad (2.3-3)$$

If the projections exceed either Expressions 2.3-2 or 2.3-3, then the appropriate portions of the liquid radwaste treatment system shall be used to reduce releases of radioactivity.

TABLE 2.1-1
 LIQUID EFFLUENT RELEASE TANKS AND PUMPS ⁽¹⁾

Tank ⁽²⁾	No. of Tanks	PUMP DESIGN CAPACITY (gpm)		Eductor Factor	Tank Capacity (gal)	Radiation Effluent Monitor ID
		Discharge	Recirculation			
SWST	1	100	100	0.2	25,000	REM-3542
WECT	2	35	35	1.0	10,000	REM-3541
WMT ⁽³⁾	2	100	100	0.25	25,000	REM-3542
TL&HS	2	100	100	0.25	25,000	REM-3540

The settling basin has two pumps. When one pump is running, the design flow rate is 500 gpm. When both pumps are running, the design flow rate is 800 gpm.

¹ Reference SHNPP FSAR Tables 11.5.1-1 and 11.2.1-7

² SWST: Secondary Waste Sample Tank

WECT: Waste Evaporator Condensate Tank

WMT: Waste Monitor Tank

TL&HS: Treated Laundry and Hot Shower Tank

³ Waste Monitor Tanks are used to batch release secondary waste effluent when activity is suspected in this pathway.

TABLE 2.1-2

Setpoints for Cooling Tower Blowdown Dilution Flow Rates (F_{avail})

Setting	Trip Flow Rate (gpm)	Minimum Dilution Flow Rate (gpm)
1	4,000 ± 5%	3,800
2	7,000 ± 5%	6,650
3	11,000 ± 5%	10,450
4	15,000 ± 5%	14,250

TABLE 2.1-3

Signal Processor Time Constants (τ) for GA Technologies
 RD-53 Liquid Effluent Monitors

Detector Background (cpm)	τ (min)
$10^1 - 10^2$	10
$10^2 - 10^3$	$10^3/\text{cpm bkg}$
$10^3 - 10^4$	$10^3/\text{cpm bkg}$
$10^4 - 10^5$	$10^3/\text{cpm bkg}$
$10^5 - 10^6$	0.01
$10^6 - 10^7$	0.01

TABLE 2.1-4

Nuclide Parameters

Nuclide	Half-Life (hr)	λ (hr ⁻¹)	$e^{-\lambda t}$	Sensitivity (cpm/ μ Ci/ml)	Slope	Sensitivity TB Bldg. Drain Only (cpm/ μ Ci/ml)
H-3	1.08E+05	6.44E-06	1.00E+00	0.00E+00	0.00E+00	0.00E+00
C-14	5.02E+07	1.38E-08	1.00E+00	0.00E+00	0.00E+00	0.00E+00
F-18	1.83E+00	3.78E-01	1.07E-02	0.00E+00	0.00E+00	7.78E+07
Na-24	1.50E+01	4.62E-02	5.74E-01	9.36E+07	9.00E-01	9.11E+07
P-32	3.43E+02	2.02E-03	9.76E-01	0.00E+00	0.00E+00	0.00E+00
Cr-51	6.65E+02	1.04E-03	9.88E-01	1.61E+07	1.55E-01	2.79E+06
Mn-54	7.50E+03	9.24E-05	9.99E-01	1.03E+08	9.90E-01	4.45E+07
Mn-56	2.58E+00	2.68E-01	4.00E-02	1.01E+08	9.71E-01	6.41E+07
Fe-55	2.37E+04	2.93E-05	1.00E+00	0.00E+00	0.00E+00	0.00E+00
Fe-59	1.07E+03	6.47E-04	9.92E-01	1.26E+08	1.21E+00	4.58E+07
Co-57	6.50E+03	1.07E-04	9.99E-01	0.00E+00	0.00E+00	5.82E+06
Co-58	1.70E+03	4.08E-04	9.95E-01	1.46E+08	1.40E+00	5.68E+07
Co-60	4.62E+04	1.50E-05	1.00E+00	1.89E+08	1.82E+00	9.07E+07
Ni-63	8.78E+05	7.89E-07	1.00E+00	0.00E+00	0.00E+00	0.00E+00
Ni-65	2.52E+00	2.75E-01	3.67E-02	2.24E+07	2.15E-01	1.96E+07
Cu-64	1.27E+01	5.46E-02	5.19E-01	5.16E+07	4.96E-01	1.46E+07
Zn-65	5.87E+03	1.18E-04	9.99E-01	5.24E+07	5.04E-01	2.41E+07
Zn-69	9.27E-01	7.48E-01	1.26E-04	2.22E+03	2.13E-05	5.00E+02
Zn-69m	1.38E+01	5.03E-02	5.47E-01	0.00E+00	0.00E+00	3.52E+07
Br-82	3.53E+01	1.96E-02	7.90E-01	0.00E+00	0.00E+00	1.43E+08
Br-83	2.38E+00	2.91E-01	3.05E-02	1.95E+06	1.88E-02	5.74E+05
Br-84	5.30E-01	1.31E+00	1.53E-07	6.50E+07	6.25E-01	5.06E+07
Br-85	4.78E-02	1.45E+01	3.02E-76	6.76E+06	6.50E-02	3.21E+06
Rb-86	4.48E+02	1.55E-03	9.82E-01	8.39E+06	8.07E-02	3.96E+06
Rb-88	2.97E-01	2.34E+00	6.66E-13	1.45E+07	1.39E-01	1.83E+07
Rb-89	2.57E-01	2.70E+00	8.43E-15	1.22E+08	1.17E+00	7.00E+07
Sr-89	1.21E+03	5.71E-04	9.93E-01	1.46E+04	1.40E-04	6.72E+03
Sr-90	2.50E+05	2.77E-06	1.00E+00	0.00E+00	0.00E+00	0.00E+00
Sr-91	9.50E+00	7.30E-02	4.17E-01	8.16E+07	7.85E-01	3.48E+07
Sr-92	2.72E+00	2.55E-01	4.68E-02	1.01E+08	9.71E-01	4.61E+07
Y-90	6.42E+01	1.08E-02	8.78E-01	0.00E+00	0.00E+00	0.00E+00
Y-91	1.41E+03	4.93E-04	9.94E-01	2.83E+05	2.72E-03	1.36E+05
Y-91m	8.28E-01	8.37E-01	4.36E-05	1.28E+08	1.23E+00	3.96E+07
Y-92	3.53E+00	1.96E-01	9.50E-02	2.76E+07	2.65E-01	1.17E+07
Y-93	1.01E+01	6.86E-02	4.39E-01	1.37E+07	1.32E-01	3.96E+06
Zr-95	1.54E+03	4.51E-04	9.95E-01	1.07E+08	1.03E+00	4.35E+07
Zr-97	1.68E+01	4.12E-02	6.10E-1	2.68E+07	2.58E-01	9.16E+06
Nb-95	8.42E+02	8.24E-04	9.90E-01	1.06E+08	1.02E+00	4.41E+07
Nb-97	1.20E+00	5.771E-01	9.86E-04	0.00E+00	0.00E+00	4.33E+07
Mo-99	6.60E+01	1.05E-02	8.82E-01	3.47E+07	3.34E-01	9.38E+06
Tc-99m	6.02E+00	1.15E-01	2.51E-01	1.11E+08	1.07E+00	7.33E+06

TABLE 2.1-4

Nuclide Parameters
 (continued)

Nuclide	Half-Life (hr)	λ (hr ⁻¹)	$e^{-\lambda t}$	Sensitivity (cpm/ μ Ci/ml)	Slope	Sensitivity TB Bldg. Drain Only (cpm/ μ Ci/ml)
Tc-101	2.37E-01	2.93E+00	5.45E-16	1.66E+08	1.60E+00	2.92E+07
Ru-103	9.45E+02	7.33E-04	9.91E-01	1.38E+08	1.33E+00	3.83E+07
Ru-105	4.43E+00	1.56E-01	1.53E-01	1.71E+08	1.64E+00	5.21E+07
Ru-106	8.83E+03	7.85E-05	9.99E-01	4.52E+07	4.35E-01	1.43E+07
Ag-110m	6.00E+03	1.16E-04	9.99E-01	3.22E+08	3.10E+00	1.41E+08
Sn-113	2.76E+03	2.51E-04	9.97E-01	3.08E+06	2.96E-02	4.28E+05
Sb-124	1.45E+03	4.80E-04	9.94E-01	1.59E+08	1.53E+00	8.31E+07
Sb-125	2.43E+04	2.85E-05	1.00E+00	1.21E+08	1.16E+00	3.20E+07
Te-125m	1.39E+03	4.98E-04	9.94E-01	3.00E+05	2.88E-03	1.17E+04
Te-127m	2.62E+03	2.65E-04	9.97E-01	1.33E+04	1.28E-04	6.29E+03
Te-127	9.35E+00	7.41E-02	4.11E-01	1.97E+06	1.89E-02	4.14E+05
Te-129m	8.07E+02	8.59E-04	9.90E-01	5.17E+06	4.97E-02	1.95E+06
Te-129	1.16E+00	5.98E-01	7.69E-04	1.58E+07	1.52E-01	4.02E+06
Te-131m	3.00E+01	2.31E-02	7.58E-01	2.17E+08	2.09E+00	7.37E+07
Te-131	4.17E-01	1.66E+00	2.14E-09	1.50E+08	1.44E+00	2.58E+07
Te-132	7.82E+01	8.87E-03	8.99E-01	1.39E+08	1.34E+00	1.69E+07
I-130	1.24E+01	5.60E-02	5.10E-01	4.13E+08	3.97E+00	1.41E+08
I-131	1.93E+02	3.59E-03	9.58E-01	1.55E+08	1.49E+00	3.21E+07
I-132	2.30E+00	3.01E-01	2.69E-02	3.31E+08	3.18E+00	1.30E+08
I-133	2.08E+01	3.33E-02	6.71E-01	1.39E+08	1.34E+00	4.28E+07
I-134	8.77E-01	7.91E-01	7.58E-05	3.08E+08	2.96E+00	1.31E+08
I-135	6.62E+00	1.05E-01	2.84E-01	1.03E+08	9.90E-01	5.82E+07
Cs-134	1.80E+04	3.85E-05	1.00E+00	2.60E+08	2.50E+00	9.68E+07
Cs-136	3.17E+02	2.19E-03	9.74E-01	3.37E+08	3.24E+00	1.11E+08
Cs-137	2.65E+05	2.62E-06	1.00E+00	1.04E+08	1.00E+00	3.90E+07
Cs-138	5.37E-01	1.29E+00	1.86E-07	1.15E+08	1.11E+00	8.43E+07
Ba-139	1.39E+00	5.00E-01	2.46E-03	2.34E+07	2.25E-01	2.17E+06
Ba-140	3.07E+02	2.26E-03	9.73E-01	6.01E+07	5.78E-01	1.45E+07
Ba-141	3.05E-01	2.27E+00	1.43E-12	2.53E+08	2.43E+00	5.42E+07
Ba-142	1.78E-01	3.89E+00	5.54E-21	1.47E+08	1.41E+00	4.44E+07
La-140	4.02E+01	1.73E-02	8.13E-01	1.53E+08	1.47E+00	9.06E+07
La-142	1.59E+00	4.36E-01	5.35E-03	9.59E+07	9.22E-01	7.75E+07
Ce-141	7.80E+02	8.89E-04	9.89E-01	6.11E+07	5.88E-01	4.29E+06
Ce-143	3.30E+01	2.10E-02	7.77E-01	9.60E+07	9.23E-01	1.90E+07
Ce-144	6.82E+03	1.02E-04	9.99E-01	1.30E+07	1.25E-01	7.96E+05
Pr-143	3.25E+02	2.13E-03	9.75E-01	1.08E+02	1.04E-06	5.27E-01
Pr-144	2.88E-01	2.40E+00	2.96E-13	1.68E+06	1.62E-02	1.14E+06
Nd-147	2.63E+02	2.63E-03	9.69E-01	2.86E+07	2.75E-01	8.08E+06
Hf-181	1.02E+03	6.80E-04	9.92E-01	2.08E+08	2.00E+00	4.14E+07
W-187	2.38E+01	2.91E-02	7.05E-01	1.04E+08	1.00E+00	3.09E+07
Np-239	5.65E+01	1.23E-02	8.63E-01	1.13E+08	1.09E+00	1.01E+07

TABLE 2.1-4

Nuclide Parameters
 (continued)

Nuclide	Half-Life (hr)	λ (hr ⁻¹)	$e^{-\lambda t}$	Sensitivity (cpm/ μ Ci/ml)	Slope	Sensitivity TB Bldg. Drain Only (cpm/ μ Ci/ml)
Ar-41	1.83E+00	3.78E-01	1.07E-02	9.28E+07	8.92E-01	4.51E+07
Kr-83m	1.83E+00	3.78E-01	1.07E-02	0.00E+00	0.00E+00	0.00E+00
Kr-85	9.40E+04	7.37E-01	1.00E+00	6.20E+05	5.96E-03	1.75E+05
Kr-85m	4.48E+00	1.55E-01	1.56E-01	1.20E+08	1.15E+00	1.12E+07
Kr-87	1.27E+00	5.45E-01	1.44E-03	9.19E+07	8.84E-01	3.22E+07
Kr-88	2.83E+00	2.45E-01	5.31E-02	7.49E+07	7.20E-01	5.19E+07
Kr-89	5.27E-02	1.32E+01	2.58E-69	1.39E+08	1.34E+00	6.52E+07
Kr-90	8.95E-03	7.72E+01	0.00E+00	1.59E+08	1.53E+00	5.43E+07
Xe-131m	1.70E+04	2.45E-03	9.71E-01	2.62E+06	2.52E-02	2.21E+05
Xe-133	1.23E+02	5.51E-03	9.36E-01	9.90E+04	9.52E-04	9.33E+03
Xe-133m	5.25E+01	1.32E-02	8.53E-01	1.59E+07	1.53E-01	2.02E+06
Xe-135	9.12E+00	7.60E-02	4.02E-01	1.47E+08	1.41E+00	2.10E+07
Xe-135m	2.57E-01	2.70E+00	8.43E-15	1.14E+08	1.10E+00	3.30E+07
Xe-137	6.38E-02	1.09E+01	2.57E-57	4.85E+07	4.66E-01	1.32E+07
Xe-0138	2.35E-01	2.95E+00	4.25E-16	1.20E+08	1.15E+00	4.25E+07

Notes to Table 2.1-4

Sensitivity = 80% of weighted response to 100 - 1400 keV gammas for offline and an adjacent to line monitor which are sodium iodide (NaI) detectors (reference GA Manual E-115-904, June 1980, and Figure 5, Expected Energy Response Normalized for one gamma per disintegration, Drawing 0360-8934 Rev A, page 14, respectively). Abundances for each gamma from "Radioactive Decay Tables" by David C. Kocher (Report DOE/TIC-11026, Washington, D.C., 1981)

Slope = The Liquid Effluent Monitor Gamma Sensitivities for nuclide "i", relative to Cs-137. To make nuclide "i" relative to Cs-137, the nuclide sensitivity is divided by the Cs-137 sensitivity. This column does not apply to TB Drains monitor.

TABLE 2.2-1

A_{i,r,p} VALUES FOR THE ADULT FOR THE SHEARON HARRIS NUCLEAR POWER PLANT

$$A_{i,r,p} = 1.14E+05 \left(\frac{730}{D_w} + 21BF_i \right) DF_{i,r} \cdot e^{-\lambda_i t_p}$$

(mrem/hr per μCi/ml)

Nuclide	Bone	Liver	T. Body	Thyroid	Kidney	Lung	GI-LLI
H-3	0.00E+00	8.54E-01	8.54E-01	8.54E-01	8.54E-01	8.54E-01	8.54E-01
C-14	3.13E+04	6.27E+03	6.27E+03	6.27E+03	6.27E+03	6.27E+03	6.27E+03
NA-24	2.40E+02	2.40E+02	2.40E+02	2.40E+02	2.40E+02	2.40E+02	2.40E+02
P-32	4.52E+07	2.81E+06	1.75E+06	0.00E+00	0.00E+00	0.00E+00	5.08E+06
CR-51	0.00E+00	0.00E+00	1.28E+00	7.63E-01	2.81E-01	1.69E+00	3.21E+02
MN-54	0.00E+00	4.41E+03	8.41E+02	0.00E+00	1.31E+03	0.00E+00	1.35E+04
MN-56	0.00E+00	4.44E+00	7.87E-01	0.00E+00	5.63E+00	0.00E+00	1.42E+02
FE-55	6.76E+02	4.67E+02	1.09E+02	0.00E+00	0.00E+00	2.60E+02	2.68E+02
FE-59	1.06E+03	2.49E+03	9.54E+02	0.00E+00	0.00E+00	6.95E+02	8.29E+03
CO-57	0.00E+00	2.20E+01	3.66E+01	0.00E+00	0.00E+00	0.00E+00	5.58E+02
CO-58	0.00E+00	9.33E+01	2.09E+02	0.00E+00	0.00E+00	0.00E+00	1.89E+03
CO-60	0.00E+00	2.69E+02	5.94E+02	0.00E+00	0.00E+00	0.00E+00	5.06E+03
NI-63	3.20E+04	2.21E+03	1.07E+03	0.00E+00	0.00E+00	0.00E+00	4.62E+02
NI-65	4.76E+00	6.19E-01	2.82E-01	0.00E+00	0.00E+00	0.00E+00	1.57E+01
CU-64	0.00E+00	5.45E+00	2.56E+00	0.00E+00	1.37E+01	0.00E+00	4.64E+02
ZN-65	2.32E+04	7.39E+04	3.34E+04	0.00E+00	4.94E+04	0.00E+00	4.65E+04
ZN-69	6.25E-03	1.20E-02	8.32E-04	0.00E+00	7.77E-03	0.00E+00	1.80E-03
ZN-69M	4.46E+02	1.07E+03	9.79E+01	0.00E+00	6.48E+02	0.00E+00	6.54E+04
BR-82	0.00E+00	0.00E+00	1.81E+03	0.00E+00	0.00E+00	0.00E+00	2.07E+03
BR-83	0.00E+00	0.00E+00	1.24E+00	0.00E+00	0.00E+00	0.00E+00	1.79E+00
BR-84	0.00E+00	0.00E+00	8.07E-06	0.00E+00	0.00E+00	0.00E+00	6.33E-11
BR-85	0.00E+00	0.00E+00	0.00E+00	0.00E+00	0.00E+00	0.00E+00	0.00E+00
RB-86	0.00E+00	9.95E+04	4.63E+04	0.00E+00	0.00E+00	0.00E+00	1.96E+04
RB-88	0.00E+00	1.94E-10	1.03E-10	0.00E+00	0.00E+00	0.00E+00	2.67E-21
RB-89	0.00E+00	1.62E-12	1.14E-12	0.00E+00	0.00E+00	0.00E+00	9.43E-26
SR-89	2.38E+04	0.00E+00	6.84E+02	0.00E+00	0.00E+00	0.00E+00	3.82E+03
SR-90	5.91E+05	0.00E+00	1.45E+05	0.00E+00	0.00E+00	0.00E+00	1.71E+04
SR-91	1.84E+02	0.00E+00	7.43E+00	0.00E+00	0.00E+00	0.00E+00	8.77E+02
SR-92	7.84E+00	0.00E+00	3.39E-01	0.00E+00	0.00E+00	0.00E+00	1.55E+02

TABLE 2.2-1

(Continued)

A_{it} VALUES FOR THE ADULT FOR THE SHEARON HARRIS NUCLEAR POWER PLANT
 (mrem/hr per μ Ci/ml)

<u>Nuclide</u>	<u>Bone</u>	<u>Liver</u>	<u>T. Body</u>	<u>Thyroid</u>	<u>Kidney</u>	<u>Lung</u>	<u>GI-LLI</u>
Y-90	5.57E-01	0.00E+00	1.49E-02	0.00E+00	0.00E+00	0.00E+00	5.91E+03
Y-91M	2.61E-07	0.00E+00	1.01E-08	0.00E+00	0.00E+00	0.00E+00	7.67E-07
Y-91	9.24E+00	0.00E+00	2.47E-01	0.00E+00	0.00E+00	0.00E+00	5.09E+03
Y-92	5.29E-03	0.00E+00	1.55E-04	0.00E+00	0.00E+00	0.00E+00	9.27E+01
Y-93	7.75E-02	0.00E+00	2.14E-03	0.00E+00	0.00E+00	0.00E+00	2.46E+03
ZR-95	4.20E-01	1.35E-01	9.12E-02	0.00E+00	2.11E-01	0.00E+00	4.27E+02
ZR-97	1.42E-02	2.87E-03	1.31E-03	0.00E+00	4.34E-03	0.00E+00	8.90E+02
NB-95	4.43E+02	2.47E+02	1.33E+02	0.00E+00	2.44E+02	0.00E+00	1.50E+06
NB-97	3.70E-03	9.36E-04	3.42E-04	0.00E+00	1.09E-03	0.00E+00	3.45E+00
MO-99	0.00E+00	1.14E+02	2.17E+01	0.00E+00	2.58E+02	0.00E+00	2.64E+02
TC-99M	2.60E-03	7.35E-03	9.36E-02	0.00E+00	1.12E-01	3.60E-03	4.35E+00
TC-101	5.81E-18	8.37E-18	8.21E-17	0.00E+00	1.51E-16	4.28E-18	2.52E-29
RU-103	5.49E+00	0.00E+00	2.37E+00	0.00E+00	2.10E+01	0.00E+00	6.41E+02
RU-105	7.07E-02	0.00E+00	2.79E-02	0.00E+00	9.13E-01	0.00E+00	4.32E+01
RU-106	8.23E+01	0.00E+00	1.04E+01	0.00E+00	1.59E+02	0.00E+00	5.33E+03
AG-110M	9.55E-01	8.83E-01	5.25E-01	0.00E+00	1.74E+00	0.00E+00	3.60E+02
SB-124	2.33E+01	4.40E-01	9.24E+00	5.65E-02	0.00E+00	1.82E+01	6.62E+02
SB-125	1.50E+01	1.67E-01	3.57E+00	1.52E-02	0.00E+00	1.16E+01	1.65E+02
TE-125M	2.57E+03	9.32E+02	3.44E+02	7.73E+02	1.05E+04	0.00E+00	1.03E+04
TE-127M	6.51E+03	2.33E+03	7.94E+02	1.66E+03	2.65E+04	0.00E+00	2.18E+04
TE-127	4.36E+01	1.57E+01	9.44E+00	3.23E+01	1.78E+02	0.00E+00	3.44E+03
TE-129M	1.10E+04	4.10E+03	1.74E+03	3.77E+03	4.59E+04	0.00E+00	5.53E+04
TE-129	2.33E-02	8.76E-03	5.68E-03	1.79E-02	9.80E-02	0.00E+00	1.76E-02
TE-131M	1.27E+03	6.19E+02	5.16E+02	9.80E+02	6.27E+03	0.00E+00	6.14E+04
TE-131	4.07E-08	1.70E-08	1.28E-08	3.35E-08	1.78E-07	0.00E+00	5.76E-09
TE-132	2.19E+03	1.41E+03	1.33E+03	1.56E+03	1.36E+04	0.00E+00	6.69E+04
I-130	1.62E+01	4.77E+01	1.88E+01	4.05E+03	7.45E+01	0.00E+00	4.11E+01
I-131	1.67E+02	2.39E+02	1.37E+02	7.84E+04	4.10E+02	0.00E+00	6.31E+01
I-132	2.29E-01	6.12E-01	2.14E-01	2.14E+01	9.75E-01	0.00E+00	1.15E-01
I-133	4.00E+01	6.95E+01	2.12E+01	1.02E+04	1.21E+02	0.00E+00	6.25E+01
I-134	3.37E-04	9.15E-04	3.27E-04	1.59E-02	1.46E-03	0.00E+00	7.98E-07
I-135	5.29E+00	1.38E+01	5.11E+00	9.13E+02	2.22E+01	0.00E+00	1.56E+01

TABLE 2.2-1

(Continued)

A₁₇ VALUES FOR THE ADULT FOR THE SHEARON HARRIS NUCLEAR POWER PLANT
 (mrem/hr per μ Ci/ml)

<u>Nuclide</u>	<u>Bone</u>	<u>Liver</u>	<u>T. Body</u>	<u>Thyroid</u>	<u>Kidney</u>	<u>Lung</u>	<u>GI-LLI</u>
CS-134	2.99E+05	7.10E+05	5.81E+05	0.00E+00	2.30E+05	7.63E+04	1.24E+04
CS-136	3.05E+04	1.20E+05	8.65E+04	0.00E+00	6.69E+04	9.17E+03	1.37E+04
CS-137	3.83E+05	5.23E+05	3.43E+05	0.00E+00	1.78E+05	5.91E+04	1.01E+04
CS-138	4.92E-05	9.72E-05	4.82E-05	0.00E+00	7.14E-05	7.06E-06	4.15E-10
BA-139	3.72E-03	2.65E-06	1.09E-04	0.00E+00	2.48E-06	1.50E-06	6.60E-03
BA-140	3.08E+02	3.86E-01	2.02E+01	0.00E+00	1.31E-01	2.21E-01	6.33E+02
BA-141	1.05E-12	7.94E-16	3.55E-14	0.00E+00	7.38E-16	4.51E-16	4.95E-22
BA-142	1.84E-21	1.89E-24	1.16E-22	0.00E+00	1.60E-24	1.07E-24	0.00E+00
LA-140	1.34E-01	6.75E-02	1.78E-02	0.00E+00	0.00E+00	0.00E+00	4.96E+03
LA-142	4.51E-05	2.05E-05	5.11E-06	0.00E+00	0.00E+00	0.00E+00	1.50E-01
CE-141	7.76E-02	5.24E-02	5.95E-03	0.00E+00	2.44E-02	0.00E+00	2.01E+02
CE-143	1.07E-02	7.94E+00	8.79E-04	0.00E+00	3.50E-03	0.00E+00	2.97E+02
CE-144	4.08E+00	1.71E+00	2.19E-01	0.00E+00	1.01E+00	0.00E+00	1.38E+03
PR-143	5.91E-01	2.37E-01	2.93E-02	0.00E+00	1.37E-01	0.00E+00	2.59E+03
PR-144	5.88E-16	2.44E-16	2.99E-17	0.00E+00	1.38E-16	0.00E+00	8.46E-23
ND-147	4.02E-01	4.64E-01	2.78E-02	0.00E+00	2.71E-01	0.00E+00	2.23E+03
W-187	2.10E+02	1.75E+02	6.12E+01	0.00E+00	0.00E+00	.00E+000	5.74E+04
NP-239	3.08E-02	3.03E-03	1.67E-03	0.00E+00	9.44E-03	0.00E+00	6.21E+02

Figure 2.1-1

Liquid Waste Processing Flow Diagram

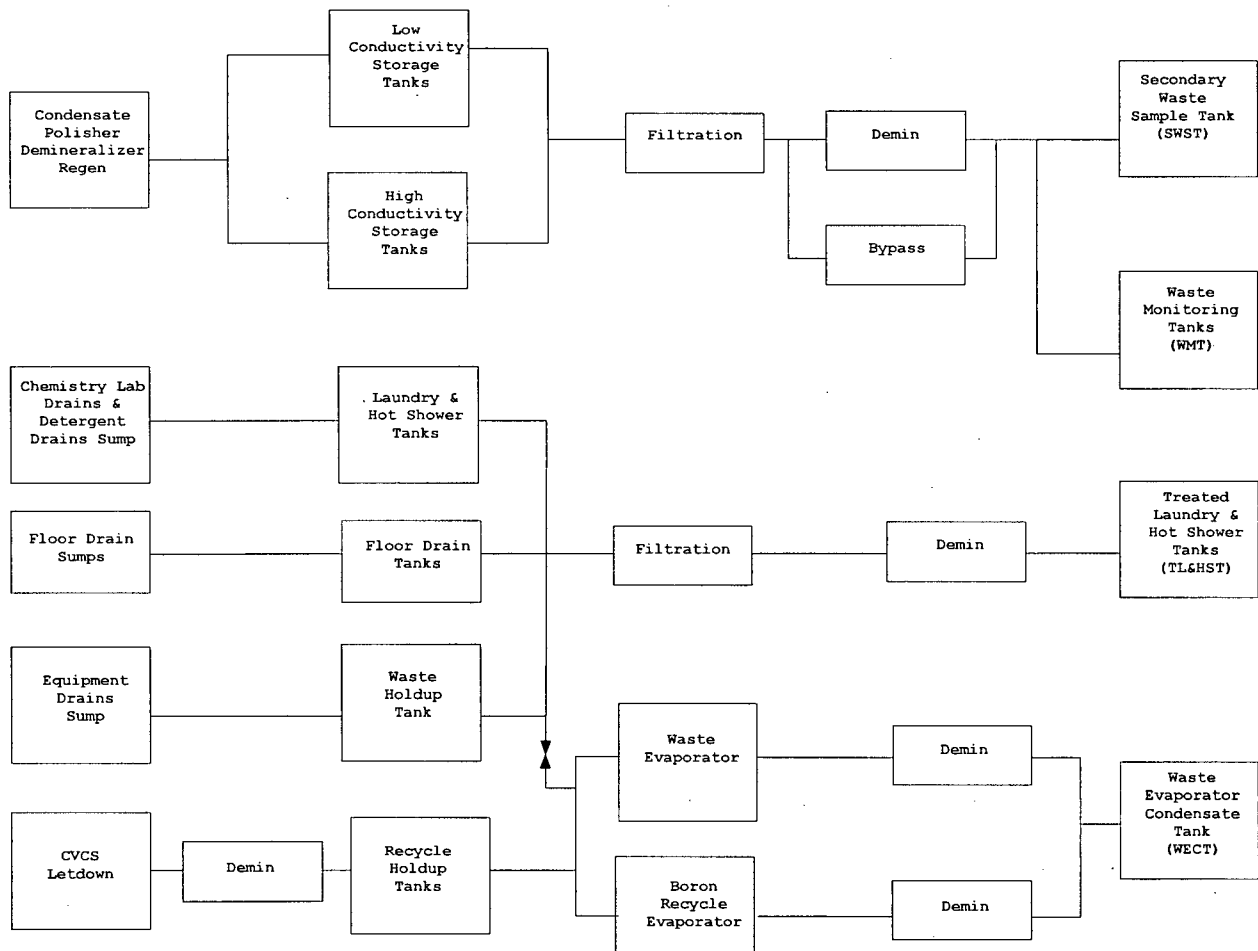

Figure 2.1-2
 Liquid Effluent Flow Stream Diagram

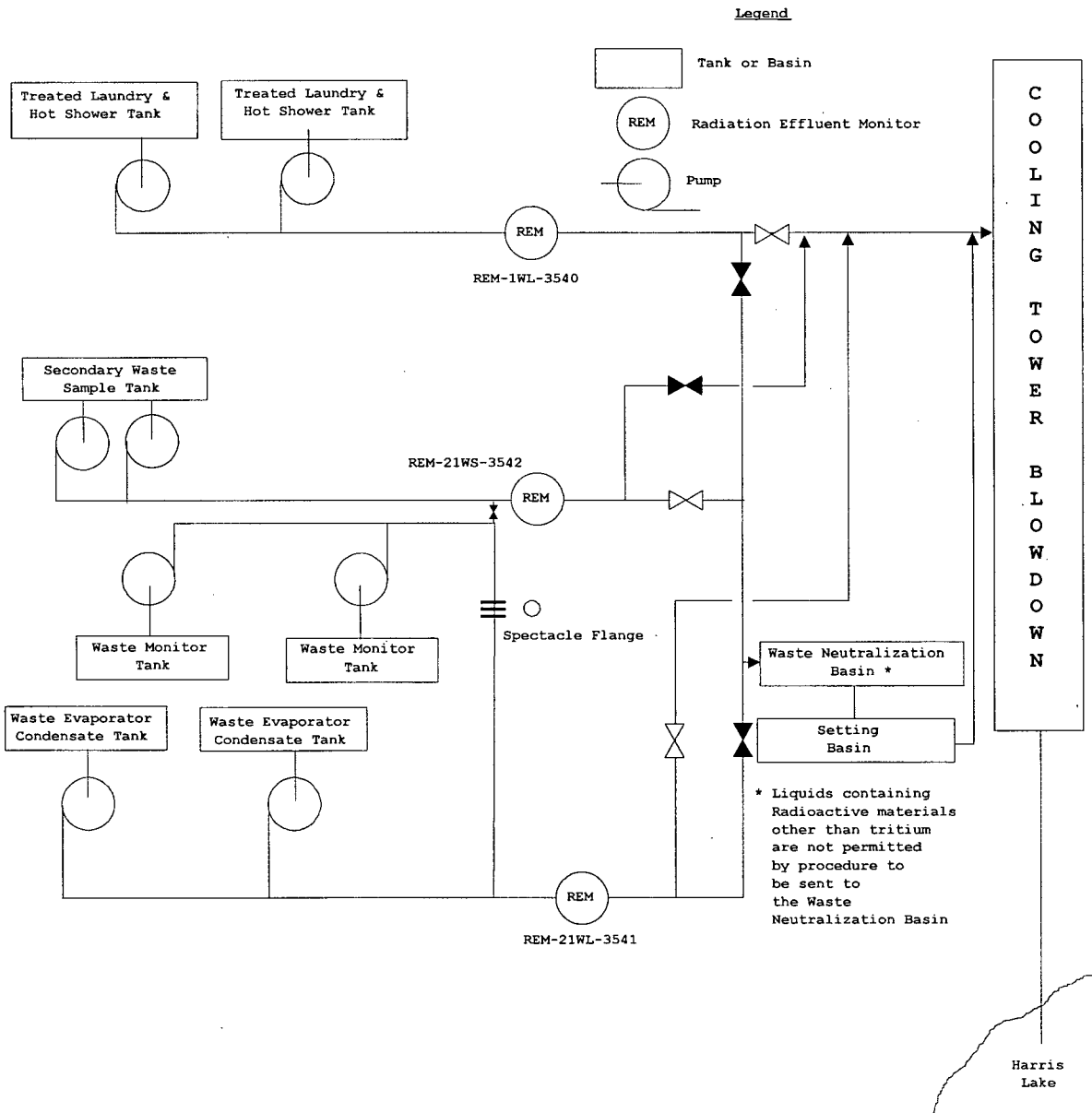

Figure 2.1-3

Normal Service Water Flow Diagram

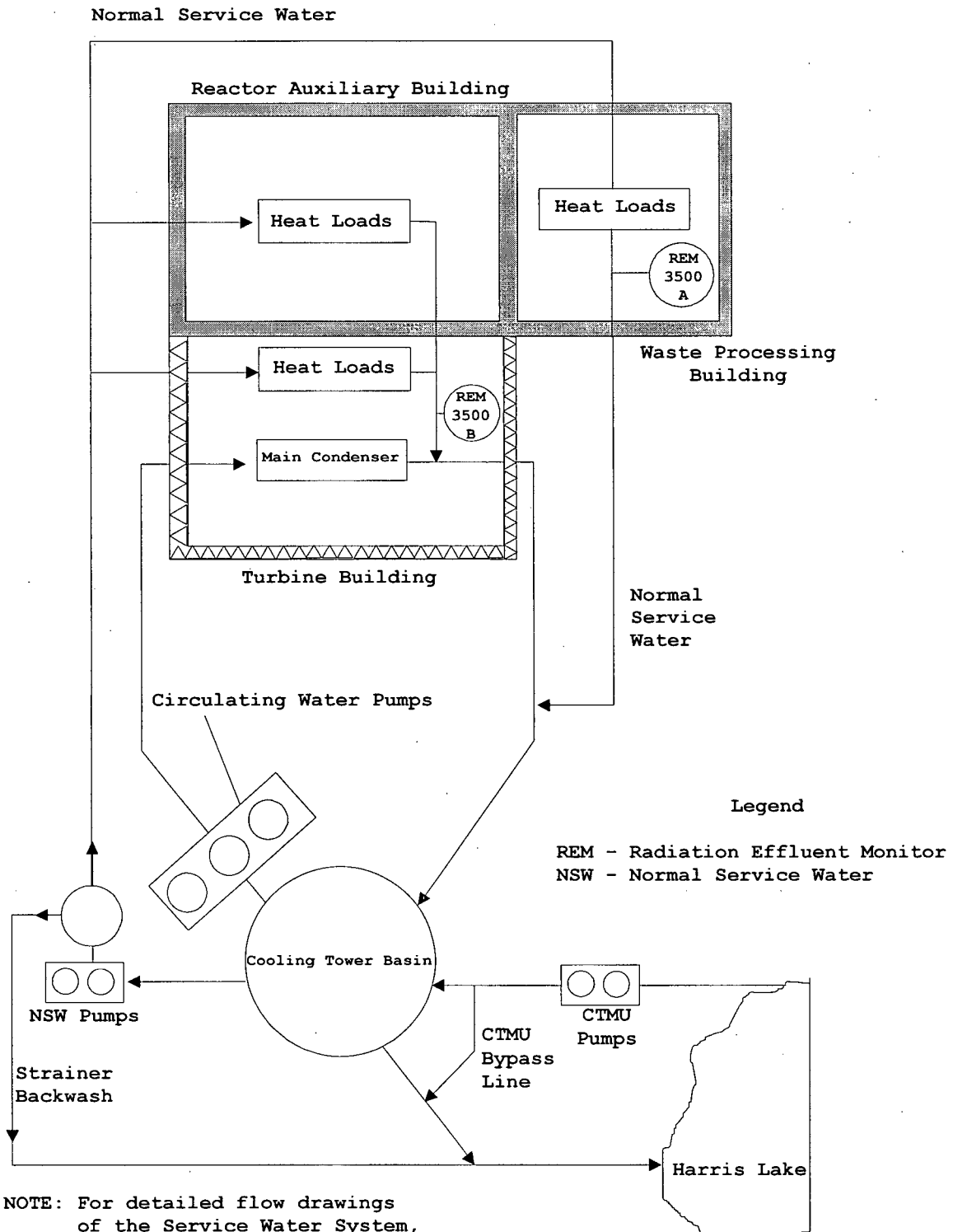
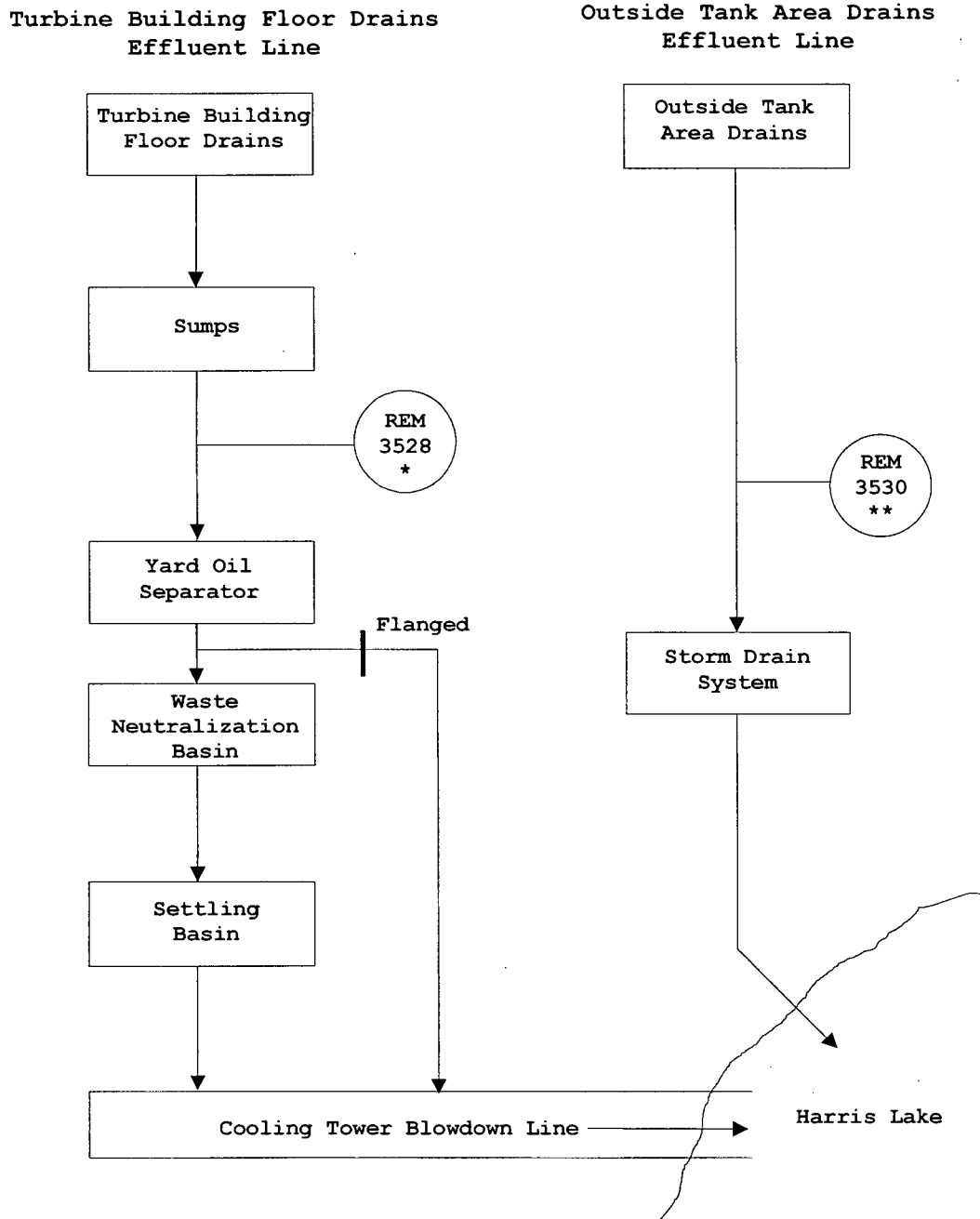

Figure 2.1-4
Other Liquid Effluent Pathways



* Turbine Building Floor Drains Effluent can be Diverted to the Secondary Waste Treatment System

** Outside Tank Area Drains Effluent can be Diverted to the Liquid Radwaste Treatment System

3.0 GASEOUS EFFLUENTS

At SHNPP there are four gaseous effluent discharge points: Plant Vent Stack 1, Turbine Building Vent Stack 3A, and the Waste Processing Building Vent Stacks 5 and 5A. During refueling outages the Equipment Hatch is removed and has potential airborne particulate releases. These are shown in Figures 3.1, 3.2, and 3.3 along with their tributaries. All gaseous effluent releases at the plant are considered ground releases.

3.1 Monitor Alarm Setpoint Determination (ODCM Operational Requirement 3.3.3.11)

This section provides the methodology for stack effluent monitor setpoints to ensure that the dose rates from noble gases at the site boundary do not exceed the limits of 500 mrem/year to the whole body or 3000 mrem/year to the skin as specified in ODCM Operational Requirement 3.11.2.1. The 500 mrem/year to the whole body or 3000 mrem/year to the skin limits are more conservative than the 10 CFR 50.73 limits concerning airborne radioactivity release concentrations to unrestricted areas, and therefore the setpoint methodology set forth here is based on the limits of 500 mrem/year to the whole body or 3000 mrem/year to the skin.

The radioactivity effluent monitors for each stack and for specific effluent streams are shown in Figures 3.1 and 3.3 and are listed in Appendix C.

Gamma spectroscopy analysis of the gas sample should provide the nuclide identification and activity. However, in the case where the noble gas activities are < LLD the relative nuclide composition can be assumed from the GALE code activities for projected normal operating releases (Table 3.1-1). The GALE code is used to establish a default setpoint for each vent stack. This setpoint will be used as a "fixed" setpoint until a more conservative setpoint is calculated, using either a different assumed mix or actual sample results.

3.1.1.1 Default Continuous Release Monitor Setpoints Using a Conservative mix (GALE code)

The following methodology is the default setpoint for the continuous release vent stacks based on conservative assumptions of mix (GALE code) and maximum stack flow rate.

1. Determine the noble gas radionuclide activity (Q_i) in μCi , and the activity release rate \dot{Q}_i in $\mu\text{Ci}/\text{sec}$ for each nuclide "i". \dot{Q}_i is the release rate of nuclide "i" in gaseous effluent from discharge point "v", in $\mu\text{Ci}/\text{sec}$.

$$Q_i = \sum_v C_i \cdot F_v \cdot \text{duration} \cdot 28316.85 \quad (3.1-1a)$$

and

$$\dot{Q}_i = \sum_v C_i \cdot F_v \cdot 28316.85 / 60 \quad (3.1-1b)$$

where:

- v = index over all vent stacks
- C_i = concentration of nuclide, in $\mu\text{Ci}/\text{cc}$
 = the GALE code activities from Table 3.1-1.
- F_v = effluent release rate or vent flow rate in cfm
 = the maximum effluent design flow rate at the point of discharge (acfm) from Table 3.1-3.
- duration = duration of release, in minutes
- 28316.85 = conversion factor for cc/ft_3
- 60 = seconds per minute

3.1.1.1 Default Continuous Release Monitor Setpoints Using a Conservative mix (GALE code) (continued)

2. Determine the maximum whole body and skin dose rate (mrem/year) during the release.

$$Q_{m-wb} = \frac{(X / Q)}{(\sum_i K_i \dot{Q}_i)} \quad (3.1-2a)$$

and

$$Q_{m-s} = \frac{(X / Q)}{(\sum_i (L_i + 1.1M_i) \dot{Q}_i)} \quad (3.1-2b)$$

where:

- i = index over all nuclides
- K_i = the total body dose factor due to gamma emissions for noble gas radionuclide i (in mrem/yr per $\mu\text{Ci}/\text{m}^3$), from Table 3.1-2.
- L_i = The skin dose factor due to beta emissions for noble gas radionuclide i (mrem/yr per $\mu\text{Ci}/\text{m}^3$)
- M_i = The air dose factor due to gamma emissions for noble gas radionuclide i (mrad/yr per $\mu\text{Ci}/\text{m}^3$). A unit conversion constant of 1.1 mrad/mrem converts air dose to skin dose
- $L_i + 1.1M_i$ = Skin dose factor (mrem/yr per $\mu\text{Ci}/\text{m}^3$), from Table 3.1-2
- X/Q = The highest calculated annual average relative concentration for any sector at or beyond the exclusion boundary (sec/m^3)
- = 6.1E-06 sec/m^3 from Table A-1, Appendix A

3.1.1 Default Continuous Release Monitor Setpoints Using a Conservative mix (GALE code) (continued)

3. Determine the ratio of dose rate limit to dose rate.

$$\text{Whole Body ratio} = \frac{500}{Q_{m-wb}} \quad (3.1-3a)$$

and

$$\text{Skin ratio} = \frac{3000}{Q_{m-s}} \quad (3.1-3b)$$

where:

500 = site dose rate limit for whole body in mrem/year.

3000 = site dose rate limit for skin in mrem/year.

4. Determine S_{max} , the maximum concentration setpoint in $\mu\text{Ci/cc}$, and RR_{max} the maximum release rate setpoint in $\mu\text{Ci/sec}$ for the monitor.

$$S_{max} = (f_s \cdot f_{alloc} \cdot nratio \cdot \sum C_i) + Bkg \quad (3.1-4a)$$

and

$$RR_{max} = S_{max} \cdot F_v \cdot 28316.852 / 60 \quad (3.1-4b)$$

where

f_s = safety factor for the discharge point

= 0.5

f_{alloc} = dose rate allocation factor for the discharge point

= fraction of the radioactivity from the site that may be released via the monitored pathway to ensure that the site boundary limit is not exceeded by simultaneous releases. These values are based on the percentage of an individual stack flow to the total stack flow and are in Table 3.1-3.

$nratio$ = lesser of the ratios

Bkg = Monitor background, in $\mu\text{Ci/cc}$

= 0 for calculation of default setpoint.

3.1.1 Default Continuous Release Monitor Setpoints Using a Conservative mix (GALE code) (continued)

Using the GALE code activities from Table 3.1-1 and the maximum effluent design flow rate, continuous release stack maximum setpoints in $\mu\text{Ci}/\text{cc}$ and $\mu\text{Ci}/\text{sec}$ are determined. These values will be used as default values for the stack monitors. Based on sampling and analysis, the setpoint will be recalculated. If the sample analysis setpoint is higher than the default setpoint, the setpoint will not be changed. If the sample analysis setpoint is lower than the default, the setpoint will be changed to reflect the more conservative setpoint. When the setpoint changes again, the more conservative setpoint, comparing the default (GALE code) and sample analysis, will be used.

5. Determine S_{alert} , the gas channel alert alarm setpoint in $\mu\text{Ci}/\text{cc}$, and RR_{alert} the gas channel alert alarm release rate setpoint in $\mu\text{Ci}/\text{sec}$.

$$S_{\text{alert}} = [(S_{\text{max}} - \text{Bkg}) A_f] + \text{Bkg} \quad (3.1-5a)$$

and

$$RR_{\text{alert}} = [(RR_{\text{max}} - \text{Bkg}_{\text{rr}}) A_f] + \text{Bkg}_{\text{rr}} \quad (3.1-5b)$$

where:

A_f = A value < 1.0 designed to alert the operator that the high alarm setpoint is being approached.

Bkg_{rr} = $\text{Bkg} \cdot F_v \cdot 28316.85 / 60$

3.1.2 Monitor Setpoints Using Sample Results

In Stacks 1 and 5, the potential exists for batch releases concurrent with the normal continuous ventilation flow of effluents. The sources of batch releases for the Plant Vent Stack 1 include containment normal and pre-entry purge and pressure relief. Batch release sources for Vent Stack 5 include releases from the waste gas decay tanks (WGDT). In these cases, the monitor setpoint must reflect the contribution of both the continuous and batch sources.

The following methodology will calculate a setpoint for the continuous release vent stacks based on actual sample results and for batch releases occurring concurrently with continuous releases.

1. Determine the noble gas radionuclide activity (Q_i) in μCi , and the activity release rate \dot{Q}_i in $\mu\text{Ci}/\text{sec}$ for each nuclide "i". \dot{Q}_i is the average release rate of nuclide "i" in gaseous effluent from discharge point "v", in $\mu\text{Ci}/\text{sec}$. Noble gases may be averaged over a period of 1 hour.

$$Q_i = \sum_v C_i \cdot F_v \cdot \text{duration} \cdot 28316.85 \quad (3.2-1a)$$

and

$$\dot{Q}_i = \sum_v C_i \cdot F_v \cdot 28316.85 / 60 \quad (3.2-1b)$$

where:

v = index over all vent stacks

C_i = concentration of nuclide, in $\mu\text{Ci}/\text{cc}$

= the measured concentration from a stack effluent sample or pre-release sample. If there is no activity in the sample, then the GALE code activities from Table 3.1-1 will be used.

= $\frac{\text{WGDTs}}{(\mu\text{Ci}/\text{cc from analysis of WGDT})(6.45 \text{ E-}05) + (\mu\text{Ci}/\text{cc from analysis/GALE Code of Vent Stack 5})(0.9999)}$

= $\frac{\text{Containment Normal Purge (Batch)}}{(\mu\text{Ci}/\text{cc from analysis of Containment})(3.83 \text{ E-}03) + (\mu\text{Ci}/\text{cc from analysis/GALE Code of PV Stack 1})(0.9962)}$

= $\frac{\text{Containment Preentry Purge (Batch)}}{(\mu\text{Ci}/\text{cc from analysis of Containment})(8.67 \text{ E-}02) + (\mu\text{Ci}/\text{cc from analysis/GALE Code of PV Stack 1})(0.9133)}$

6.45 E-05 = Dilution factor WGDT = $(15 \text{ scfm}) / (232,500 \text{ scfm} + 15 \text{ scfm})$

0.9999 = Dilution factor Vent Stack 5
 = $232,500 \text{ scfm} / (232,500 \text{ scfm} + 15 \text{ scfm})$

3.83 E-03 = Dilution factor Normal Purge
 = $1500 \text{ scfm} / (390,000 \text{ scfm} + 1500 \text{ scfm})$

0.9962 = Dilution factor PV-1 = $390,000 \text{ scfm} / (390,000 \text{ scfm} + 1500 \text{ scfm})$

8.67 E-02 = Dilution factor Preentry Purge (Batch)
 = $37,000 \text{ scfm} / (390,000 \text{ scfm} + 37,000 \text{ scfm})$

0.9133 = Dilution factor PV-1
 = $390,000 \text{ scfm} / (390,000 \text{ scfm} + 37,000 \text{ scfm})$

3.1.2 Monitor Setpoints Using Sample Results (continued)

F_v = effluent release rate or vent flow rate in CFM

= for continuous releases, the measured effluent flow rate or the maximum effluent design flow rate at the point of release (acfm) from Table 3.1-3.

= for batch releases, the release flow rate, in acfm

= 1,500 scfm for containment normal purge + 390,000 scfm from Plant Vent Stack 1

= 37,000 scfm for containment preentry purge + 390,000 scfm from Plan Vent Stack 1

= 15 scfm for Waste Gas Decay Tank pre release permits + 232,500 scfm from Vent Stack 5

for posting Waste Gas Decay Tank and Containment Pressure releases the following is used for effluent accountability.

$$= \frac{2.26E + 06 \left(\frac{\Delta P_c}{14.7}\right) \left(\frac{273^\circ}{T_c}\right)}{t}$$

for a containment pressure release

$$= \frac{600 \left(\frac{\Delta P_t}{14.7}\right) \left(\frac{273^\circ}{T_t}\right)}{t}$$

for a Waste Gas Decay Tank release

where:

2.26E+06 and 600 are the volumes in ft³ of the containment and decay tank, respectively, and T_c , T_t , ΔP_c , and ΔP_t are the estimated, respective temperature and change in pressure (psig) following the release of the containment and decay tank; and,

14.7 psi = 1 atmosphere pressure

t = Length of release, min

$\Delta P_c, \Delta P_t$ = change in pressure (psig) following the release of the containment or decay tank

273°K = 0°C

T_t, T_c = 273°K + C°

duration = duration of release, in minutes

28316.85 = conversion factor for cc/ft³

3.1.2 Monitor Setpoints Using Sample Results (continued)

2. Determine the maximum whole body and skin dose rate (mrem/year) during the release by summing together the dose rates for this release with all concurrent releases for the time of the release.

$$Q_{m-wb} = \overline{(X / Q)} \sum_v [\sum_i K_i \dot{Q}_i] \quad (3.2-2a)$$

and

$$Q_{m-s} = \overline{(X / Q)} \sum_v [\sum_i (L_i + 1.1M_i) \dot{Q}_i] \quad (3.2-2b)$$

where:

- i = index over all radionuclides
- K_i = the total body dose factor due to gamma emissions for noble gas radionuclide i (mrem/yr per $\mu\text{Ci}/\text{m}^3$), from Table 3.1-2.
- L_i = The skin dose factor due to beta emissions for noble gas radionuclide i (mrem/yr per $\mu\text{Ci}/\text{m}^3$)
- M_i = The air dose factor due to gamma emissions for noble gas radionuclide i (mrad/yr per $\mu\text{Ci}/\text{m}^3$). A unit conversion constant of 1.1 mrad/mrem converts air dose to skin dose
- $L_i + 1.1M_i$ = Skin dose factor (mrem/yr per $\mu\text{Ci}/\text{m}^3$) from Table 3.1-2
- $\overline{X/Q}$ = The highest calculated annual average relative concentration for any sector at or beyond the exclusion boundary (sec/m^3)
- = 6.1E-06 sec/m^3 from Table A-1, Appendix A

3.1.2 Monitor Setpoints Using Sample Results (continued)

3. Determine the ratio of dose rate limit to dose rate.

$$\text{Whole Body ratio} = \frac{500}{Q_{m-wb}} \quad (3.2-3a)$$

and

$$\text{Skin ratio} = \frac{3000}{Q_{m-s}} \quad (3.2-3b)$$

where:

500 = site dose rate limit for whole body in mrem/year.

3000 = site dose rate limit for skin in mrem/year.

4. Determine S_{max} , the maximum concentration setpoint in $\mu\text{Ci/cc}$, and RR_{max} the maximum release rate setpoint in $\mu\text{Ci/sec}$ for the monitor.

$$S_{max} = (f_s \cdot f_{alloc} \cdot nratio \cdot \sum C_i) + Bkg \quad (3.2-4a)$$

and

$$RR_{max} = S_{max} \cdot F_v \cdot 28316.852 / 60 \quad (3.2-4b)$$

where:

f_s = safety factor for the discharge point

= 0.5

f_{alloc} = dose rate allocation factor for the discharge point

= fraction of the radioactivity from the site that may be released via the monitored pathway to ensure that the site boundary limit is not exceeded by simultaneous releases. These values are based on the percentage of an individual stack flow to the total stack flow and are in Table 3.1-3.

$nratio$ = lesser of the ratios

Bkg = Monitor background, in $\mu\text{Ci/cc}$

= measured background at time of release or 0.

3.1.2 Monitor Setpoints Using Sample Results (continued)

5. Determine S_{alert} , the gas channel alert alarm setpoint in $\mu\text{Ci/cc}$, and RR_{alert} the gas channel alert alarm release rate setpoint in $\mu\text{Ci/sec}$.

$$S_{\text{alert}} = [(S_{\text{max}} - \text{Bkg}) A_f] + \text{Bkg} \quad (3.2-5a)$$

and

$$RR_{\text{alert}} = [(RR_{\text{max}} - \text{Bkg}_{\text{rr}}) A_f] + \text{Bkg}_{\text{rr}} \quad (3.2-5b)$$

where:

A_f = A value < 1.0 designed to alert the operator that the high alarm setpoint is being approached.

Bkg_{rr} = $\text{Bkg} \cdot F_v \cdot 28316.85 / 60$

3.1.3 Effluent Monitoring During Hogging Operations

If the reactor has been shut down for greater than 30 days, the condenser vacuum pump discharge during initial hogging operations at plant start-up and prior to turbine operation may be routed as dual exhaust to (1) the Turbine Vent Stack 3A and (2) the atmosphere directly. In this instance, the blind flange on the latter exhaust route will be removed (see Figure 3.3).

A conservative effluent channel setpoint has been established for Vent Stack 3A. The monitor setpoint should be reduced proportionately to the estimated fraction of the main condenser effluent flowing directly to the atmosphere.

Table 3.1-1
 GASEOUS SOURCE TERMS (a,b)

Nuclide	Plant Vent Ventilation Flow via Stack 1		Condenser Vacuum Pump Ventilation Flow via Stack 3A		WPB Ventilation Flow via Stack 5		WPB Ventilation Flow ^(c) via Stack 5A		Containment Purge or Pressure Relief via Stack 1		WGDT Release via Stack 5	
	Ci ($\mu\text{Ci/cc}$)	% Rel. Mix	Ci ($\mu\text{Ci/cc}$)	% Rel. Mix	Ci ($\mu\text{Ci/cc}$)	% Rel. Mix	Ci ($\mu\text{Ci/cc}$)	% Rel. Mix	Ci ($\mu\text{Ci/cc}$)	% Rel. Mix	Ci ^(d) ($\mu\text{Ci/cc}$)	% Rel. Mix
Kr-85m	5.17E-10	6.52	4.70E-9	9.52	0	0	1.94E-9	6.52	1.01E-7	3.79	0	0
Kr-85	0	0	0	0	1.60E-7	97.05	0	0	3.95E-8	1.49	2.22E-5	100.00
Kr-87	5.17E-10	6.52	4.70E-9	9.52	0	0	1.94E-9	6.52	3.59E-8	1.35	0	0
Kr-88	1.03E-09	13.04	7.04E-9	14.29	0	0	3.87E-9	13.04	1.29E-7	4.87	0	0
Xe-131m	3.45E-10	4.35	0	0	4.86E-9	2.95	1.29E-9	4.35	2.16E-7	8.12	0	0
Xe-133m	0	0	0	0	0	0	0	0	5.57E-8	2.10	0	0
Xe-133	1.90E-09	23.91	1.17E-8	23.81	0	0	7.10E-9	23.91	1.31E-6	49.39	0	0
Xe-135m	5.17E-10	6.52	2.35E-9	4.76	0	0	1.94E-9	6.52	7.19E-9	0.27	0	0
Xe-135	2.58E-9	32.61	1.64E-8	33.33	0	0	9.68E-9	32.61	7.55E-7	28.42	0	0
Xe-138	5.17E-10	6.52	2.35E-9	4.76	0	0	1.94E-9	6.52	5.39E-9	0.20	0	0

(a) Source terms are from SHNPP FSAR Table 11.3.3-1 and not actual releases. Values apply only to routine releases and not emergency situations.

(b)
$$(\mu\text{Ci/cc}) = \frac{(\text{Ci/yr}) (\text{yr}/5.256\text{E}5\text{min}) (1\text{E}6\mu\text{Ci/Ci}) (\text{ft}^3/28320\text{cc})}{(\text{Flow Rate} \text{ ft}^3/\text{min})^{(d)}}$$

(c) Source term for this effluent stream not presented with FSAR. RAB mix assumed.

(d) Maximum Effluent Design Flow Rates:

- Plant Vent Ventilation via Stack 1 = 390,000 CFM
- Condenser Vacuum Pump Ventilation via Stack 3A = 28,620 CFM
- WPB Ventilation via Stack 5 = 232,500 CFM
- WPB Ventilation via Stack 5A = 103,050 CFM
- Containment Purge or Pressure Relief via Stack 1 = 37,000 CFM
- WGDT Release via Stack 5 = 15 CFM

TABLE 3.1-2
 DOSE FACTORS AND CONSTANTS*

Radionuclide	Whole Body Dose Factor (K _i) (mrem/yr/μCi/m ³)	Skin Dose Factor (L _i + 1.1 M _i) (mrem/yr/μCi/m ³)
Kr-83m	7.56E-02	2.12E+01
Kr-85m	1.17E+03	2.81E+03
Kr-85	1.61E+01	1.36E+03
Kr-87	5.92E+03	1.65E+04
Kr-88	1.47E+04	1.91E+04
Kr-89	1.66E+04	2.91E+04
Kr-90	1.56E+04	2.52E+04
Xe-131m	9.15E+01	6.48E+02
Xe-133m	2.51E+02	1.35E+03
Xe-133	2.94E+02	6.94E+02
Xe-135m	3.12E+03	4.41E+03
Xe-135	1.81E+03	3.97E+03
Xe-137	1.42E+03	1.39E+04
Xe-138	8.83E+03	1.43E+04
Ar-41	8.84E+03	1.29E+04

*Regulatory Guide 1.109, Rev. 1, Table B-1, multiplied by (1.0+E6 pCi/μCi).

TABLE 3.1-3
GASEOUS MONITOR PARAMETERS

	PVS-1	TBVS-3A	WPBVS-5	WPBVS-5A
Maximum effluent design flow rate, (acfm)	390,000	28,620	232,500	103,050
Flow Allocation Factor [f_{alloc}]	0.517	0.038	0.308	0.137

3.2 Postrelease Compliance with 10CFR20-Based ODCM Operational Requirement 3.11.2

3.2.1 Noble Gases

The gaseous effluent monitors setpoints are utilized to show prerelease compliance with ODCM Operational Requirement 3.11.2.1. However, because they may be based upon a conservative (GALE code) mix of radionuclides, when using Table 3.1-1, the possibility exists that the setpoints could be exceeded and yet 10CFR20-based limits may actually be met. Therefore, the following methodology has been provided in the event that if the high alarm setpoints are exceeded, a determination may be made as to whether the actual releases have exceeded the dose rate limits of ODCM Operational Requirement 3.11.2.1.

The dose rate in unrestricted areas resulting from noble gas effluents is limited to 500 mrem/year to the total body and 3000 mrem/year to the skin. Based upon NUREG-0133, the following equations are used to show compliance:

$$\sum_i K_i \overline{(X/Q)}_v \dot{Q}_{iV} \leq 500 \text{ mrem/yr} \quad (3.2-1)$$

$$\sum_i (L_i + 1.1M_i) \overline{(X/Q)}_v \dot{Q}_{iV} \leq 3000 \text{ mrem/yr} \quad (3.2-2)$$

where:

- $\overline{(X/Q)}_v$ = The highest calculated annual average relative concentration for long-term vent stack releases for areas at or beyond the exclusion boundary sec/m^3 .
- = 6.1E-06 sec/m^3 from Table A-1, Appendix A, for ground-level releases in the S sector at the exclusion boundary.
- K_i = The total body dose factor due to gamma emissions for noble gas radionuclide "i," mrem/year per $\mu\text{Ci/m}^3$. Table 3.2-3.
- L_i = The skin dose factor due to beta emissions for noble gas radionuclide "i," mrem/year per $\mu\text{Ci/m}^3$. Table 3.2-3.
- M_i = The air dose factor due to gamma emissions for noble gas radionuclide "i," mrad/year per $\mu\text{Ci/m}^3$. Table 3.2-3.

3.2.1 Noble Gases (continued)

1.1 = The ratio of the tissue to air absorption coefficients over the energy range of the photon of interest. Converts mrad to mrem (Reference NUREG-0133). The factors ($L_i + 1.1 M_i$) are tabulated in Table 3.1-2.

\dot{Q}_{iv} = The release rate of radionuclide "i" in gaseous effluents from all plant vent stacks ($\mu\text{Ci}/\text{sec}$).

The determination of the controlling location for implementation of dose rate limits for noble gas exposure is a function of the historical annual average meteorology.

The radionuclide mix is based on the sampling and analysis required by ODCM Operational Requirement 4.11.2.1.2. If the analysis is < LLD, then the GALE code, historical data for the mix, or a Xe-133 / Kr-85 LLD mix for that analysis will be used to demonstrate compliance.

The release rate is derived from either the actual flow rate or the default flow rate and the known or assumed mix.

$$\text{Release Rate } (\mu\text{Ci}/\text{sec}) = \text{Flow } (\text{cc}/\text{sec}) * \text{Concentration } (\mu\text{Ci}/\text{cc})$$

The noble gas radionuclide mix was based upon source terms calculated using the NRC GALE Code and presented in the SHNPP FSAR Table 11.3.3-1. They are reproduced in Table 3.2-1 as a function of release point.

The X/Q value utilized in the equations is the highest long-term annual average relative concentration $(X/Q)_v$ in the unrestricted area for the period 1976 - 1987. Long-term annual average $(X/Q)_v$ values at other special locations identified by the Land Use Census (see Operational Requirement 3.12.2) are presented in Appendix A. A description of their derivation is also provided in Appendix A.

To select the limiting location for ground-level releases, long-term annual average $(X/Q)_v$ values were calculated assuming no decay, undepleted transport to the exclusion boundary. These values are given in Table A-1, Appendix A. The maximum exclusion boundary $(X/Q)_v$ for ground-level releases occurs in the S sector. Therefore, the limiting location for implementation of the dose rate limits for noble gases is considered to be the exclusion boundary (1.36 miles) in the S sector.

Values for K_i , L_i , and M_i which are to be used by SHNPP in Equations 3.2-1 and 3.2-2 to show compliance with ODCM Operational Requirement 3.11.2 are presented in Table 3.2-3. These values were taken from Table B-1 of NRC Regulatory Guide 1.109, Revision 1. The values have been multiplied by $1.0\text{E}+06$ to convert mrad/pCi to mrad/ μCi for use in Equations 3.2-1 and 3.2-2.

3.2.2 Radioiodines and Particulates

The basis for ODCM Operational Requirement 3/4.11.2.1 states that the dose rate to the thyroid of a child in an unrestricted area resulting from the inhalation of radioiodines, tritium, and particulates with half-lives ≥ 8 days is limited to 1500 mrem/yr to any organ. Based upon NUREG-0133, the following is used to show compliance:

$$\sum_i P_{iI} [(\overline{X/Q})_v \dot{Q}_{iV}] \leq 1500 \text{ mrem / yr} \quad (3.2-3)$$

where:

P_{iI} = The dose parameter for radionuclides other than noble gases for the inhalation pathway, mrem/yr per $\mu\text{Ci}/\text{m}^3$, from Table 3.2-4.

In the calculation to show compliance with ODCM Operational Requirement 3.11.2.1.b, only the inhalation pathway is considered.

The radionuclide mix is based on the sampling and analysis required by ODCM Operational Requirement 4.11.2.1.2. If the analysis is $< \text{LLD}$, then no activity is assumed to have been released during the sampling period. The release rate is derived from the flow (actual or default) and the mix.

$$\text{Release Rate } (\mu\text{Ci}/\text{sec}) = \text{Flow } (\text{cc}/\text{sec}) * \text{Concentration } (\mu\text{Ci}/\text{cc})$$

The determination of the controlling exclusion boundary location was based upon the highest exclusion boundary $(\overline{X/Q})_v$ value. Values for P_{iI} in Eq. 3.2-3 were calculated for a child for various radionuclides for the inhalation pathway using the methodology of NUREG-0133. The P_{iI} values are presented in Table 3.2-

4. A description of the methodology used in calculating the P_i values is presented in Appendix B. The values of P_i reflect, for each radionuclide, the maximum P_i value for any organ.

The $(\overline{X/Q})_v$ value utilized in Equation 3.2-3 is obtained from the tables presented in Appendix A. A description of the derivation of the X/Q values is provided in Appendix A.

Table 3.2-1

Releases from the Shearon Harris Nuclear Power Plant (a)
 Normal Operation (Curies/year)

NOBLE GASES	Waste Processing Bldg Exhaust and/or Waste Gas Decay Tanks (b) via VENT STACK 5		Waste Processing Bldg Exhaust via VENT STACK 5A RAB/FHB and Containment Exhaust via VENT STACK 1		Condenser Vacuum Pump and Turbine Building Exhaust via VENT STACK 3A		TOTAL
	SHUTDOWN	NORMAL OPERATIONS	CONTAINMENT	RAB/FHB	TURBINE	STACK 3A	
Kr-85m	0	0	5.6E+01	3.E+00	0	2.0E+00	6.1E+01
Kr-85	5.0E+00	5.6E+02	2.2E+01	0	0	0	5.9E+02
Kr-87	0	0	2.0E+01	3.0E+00	0	2.0E+00	2.5E+01
Kr-88	0	0	7.2E+01	6.0E+00	0	3.0E+00	8.1E+01
Xe-131m	0	1.7E+01	1.2E+02	2.0E+00	0	1.0E+00	1.4E+02
Xe-133m	0	0	3.1E+01	0	0	0	3.10E+01
Xe-133	0	0	7.3E+02	1.1E+01	0	5.0E+00	7.5E+02
Xe-135m	0	0	4.0E+00	3.0E+00	0	1.0E+00	8.0E+00
Xe-135	0	0	4.2E+02	1.5E+01	0	7.0E+00	4.4E+02
Xe-138	0	0	3.0E+00	3.0E+00	0	1.0E+00	7.0E+00
Ar-41	---	---	---	---	---	---	3.4E+00

(a) Adapted from SHNPP FSAR Table 11.3.3-1 and do not reflect actual release data. These values are only for routine releases and not for a complete inventory of gases in an emergency.

(b) Waste Gas Decay Tank releases assumed to be after a 90-day decay period.

Intentionally left blank.

TABLE 3.2-3

DOSE FACTORS FOR NOBLE GASES *

Radionuclide	Total Body Dose Factor K_i (mrem/yr per $\mu\text{Ci}/\text{m}^3$)	Skin Dose Factor L_i (mrem/yr per $\mu\text{Ci}/\text{m}^3$)	Gamma Air Dose Factor M_i (mrad/yr per $\mu\text{Ci}/\text{m}^3$)	Beta Air Dose Factor N_i (mrad/yr per $\mu\text{Ci}/\text{m}^3$)
Kr-83m	7.56E-02	---	1.93E+01	2.88E+02
Kr-85m	1.17E+03	1.46E+03	1.23E+03	1.97E+03
Kr-85	1.61E+01	1.34E+03	1.72E+01	1.95E+03
Kr-87	5.92E+03	9.73E+03	6.17E+03	1.03E+04
Kr-88	1.47E+04	2.37E+03	1.52E+04	2.93E+03
Kr-89	1.66E+04	1.01E+04	1.73E+04	1.06E+04
Kr-90	1.56E+04	7.29E+03	1.63E+04	7.83E+03
Xe-131m	9.15E+01	4.76E+02	1.56E+02	1.11E+03
Xe-133m	2.51E+02	9.94E+02	3.27E+02	1.48E+03
Xe-133	2.94E+02	3.06E+02	3.53E+02	1.05E+03
Xe-135m	3.12E+03	7.11E+02	3.36E+03	7.39E+02
Xe-135	1.81E+03	1.86E+03	1.92E+03	2.46E+03
Xe-137	1.42E+03	1.22E+04	1.51E+03	1.27E+04
Xe-138	8.83E+03	4.13E+03	9.21E+03	4.75E+03
Ar-41	8.84E+03	2.69E+03	9.30E+03	3.28E+03

* The listed dose factors are for radionuclides that may be detected in gaseous effluents.

TABLE 3.2-4

P_{iI} VALUES (INHALATION) FOR A CHILD

<u>ISOTOPE</u>	P_{iI} Value <u>mrem/yr per $\mu\text{Ci}/\text{m}^3$</u>
H-3	1.12E+03
P-32	2.60E+06
Cr-51	1.70E+04
Mn-54	1.57E+06
Fe-59	1.27E+06
Co-58	1.10E+06
Co-60	7.06E+06
Zn-65	9.94E+05
Rb-86	1.98E+05
Sr-89	2.15E+06
Sr-90	1.01E+08
Y-91	2.62E+06
Zr-95	2.23E+06
Nb-95	6.13E+05
Ru-103	6.61E+05
Ru-106	1.43E+07
Ag-110m	5.47E+06
Sn-113	3.40E+05
Sb-124	3.24E+06
Te-127m	1.48E+06
Te-129m	1.76E+06
I-131	1.62E+07
I-132	1.93E+05
I-133	3.84E+06
I-135	7.91E+05
Cs-134	1.01E+06
Cs-136	1.71E+05
Cs-137	9.05E+05
Ba-140	1.74E+06
Ce-141	5.43E+05
Ce-144	1.19E+07
Hf-181	7.95E+05

3.3 COMPLIANCE WITH 10CFR50

The calculations described in Section 3.2 will be used to ensure compliance with the limits in 10 CFR 50 Appendix I for each release. Summation of doses for all releases for the quarter and year are compared to the limits in 10CFR50 Appendix I to ensure compliance.

The SHNPP ODCM calculates the dose to a single maximum (ALARA) individual. The ALARA individual is an individual that "lives" at the site boundary in the sector that has the most limiting long-term average X/Q value.

3.3.1 Noble Gases

1. Cumulation of Doses

Based upon NUREG-0133, the air dose in the unrestricted area due to noble gases released in gaseous effluents can be determined by the following equations:

$$D_{\gamma} = 3.17 \text{ E} - 08 \sum_i M_i \left[\overline{(X/Q)}_v \tilde{Q}_{i_v} + \overline{(X/q)}_v \tilde{q}_{i_v} \right] \quad (3.3-1)$$

$$D_{\beta} = 3.17 \text{ E} - 08 \sum_i N_i \left[\overline{(X/Q)}_v \tilde{Q}_{i_v} + \overline{(X/q)}_v \tilde{q}_{i_v} \right] \quad (3.3-2)$$

where:

D_{γ} = The air dose from gamma radiation, mrad.

D_{β} = The air dose from beta radiation, mrad.

$3.17 \text{ E} - 08$ = The inverse of the number of seconds in a year $(\text{sec}/\text{year})^{-1}$.

M_i = The air dose factor due to gamma emissions for each identified noble gas radionuclide $(\text{mrad}/\text{yr}/\mu\text{Ci}/\text{m}^3)$. A unit conversion constant of 1.1 mrad/mrem converts air dose to skin dose.

N_i = The air dose factor due to beta emissions for each identified noble gas radionuclide "i," mrad/year per $\mu\text{Ci}/\text{m}^3$. Table 3.2-3.

$\overline{X/Q}_v$ = The relative concentration for areas at or beyond the exclusion boundary for short-term ground-level vent stack releases (≥ 500 hours/year), sec/m^3 . See Section 3.0 concerning ground-level releases at Shearon Harris Nuclear Plant or use $6.1\text{E}-06 \text{ sec}/\text{m}^3$ from Table A-1, Appendix A as the most limiting $\overline{X/Q}_v$.

$\overline{X/q}_v$ = The relative concentration for areas at or beyond the exclusion boundary for short-term ground-level vent stack releases (≤ 500 hours/year), sec/m^3 . See Section 3.0 concerning ground-level releases at Shearon Harris Nuclear Plant or use $6.1\text{E}-06 \text{ sec}/\text{m}^3$ from Table A-1, Appendix A as the most limiting $\overline{X/q}_v$.

\tilde{Q}_{i_v} = The total release of noble gas radionuclide "i" in gaseous effluents for long term releases (>500 hrs/yr) from all vent stacks (μCi).

\tilde{q}_{i_v} = The total release of radionuclide "i" in gaseous releases for short-term releases (≤ 500 hours/year) from all vent stacks, (μCi).

3.3.1 Noble Gases (continued)

To show compliance with 10CFR50, Expressions 3.3-1 and 3.3-2 are evaluated at the controlling location where the air doses are at a maximum.

At SHNPP the limiting location is the exclusion boundary at 1.36 miles (~2.19 kilometers) in the S sector based upon the tables presented in Appendix A (see Section 3.2.1 earlier). For this document, long-term annual average X/Q_v values can be used in lieu of short-term values. See Section 3.0 concerning ground-level releases at Shearon Harris Nuclear Plant.

The determination of the limiting location for implementation of 10CFR50 is a function of parameters such as radionuclide mix and meteorology. To select the limiting location, the highest annual average X/Q_v value for ground-level releases is controlling. The only source of short-term releases from the plant vent are containment purges, containment pressure relief, and waste gas decay tank release. Determination of source terms is described in 3.3.1.2.

Values for M_i and N_i , which are utilized in the calculation of the gamma air and beta air doses in Equation 3.3-1 to show compliance with 10CFR50, are presented in Table 3.2-3. These values originate from Table B-1 of the NRC Regulatory Guide 1.109, Revision 1. The values have been multiplied by 1.0E+06 to convert from mrad/pCi to mrad/ μ Ci.

The following relationships should hold for SHNPP to show compliance with ODCM Operational Requirement 3.11.2.2.

For the calendar quarter:

$$D_\gamma \leq 5 \text{ mrad} \quad (3.3-3)$$

$$D_\beta \leq 10 \text{ mrad} \quad (3.3-4)$$

For the calendar year:

$$D_\gamma \leq 10 \text{ mrad} \quad (3.3-5)$$

$$D_\beta \leq 20 \text{ mrad} \quad (3.3-6)$$

The quarterly limits given above represent one-half of the annual design objectives of Section II.B.1 of Appendix I of 10CFR50. If any of the limits of Equations 3.3-3 through 3.3-6 are exceeded, a Special Report pursuant to Technical Specification 6.9.2 must be filed with the NRC. This report complies with Section IV.A of Appendix I of 10CFR50.

3.3.1 Noble Gases (continued)

2. Source Term Determination

Containment Batch Purge

A purge of containment may be started as a Batch purge and continued as a normal purge. The containment Batch Purge volume is considered to be two air containment volumes (RCB vol = $2.26E+06 \text{ ft}^3$). The containment air is sampled and analyzed for noble gases and tritium prior to release. Stack 1 has a continuous particulate filter and iodine cartridge sampler that is analyzed weekly (minimum) and used for total particulate and iodine effluent accountability for continuous releases. The noble gases and tritium analysis are used for containment effluent accountability as follows;

$$q_i = C_i \cdot v_b \quad (3.3-7)$$

Where;

q_i = Activity of nuclide "i" released (μCi).

C_i = Concentration of radionuclide "i" ($\mu\text{Ci/cc}$)

v_b = Containment purge volume (cc).

Waste Gas Decay Tank Batch Releases

Waste Gas Decay Tanks (WGDT) are sampled and analyzed for tritium and noble gases prior to each release. Stack 5 has a continuous particulate filter and iodine cartridge sampler that is analyzed weekly (minimum) and used for total particulate and iodine effluent accountability for continuous releases. The activity (μCi) for nuclide "i" for Waste Gas Decay Tank effluent accountability is calculated as follows;

$$q_i = \frac{(C_i \cdot \Delta P_t \cdot 600 \cdot 28316.85 \cdot 298)}{(14.7 \cdot 283)} \quad (3.3-7a)$$

Where;

q_i = Activity of nuclide "i" released (μCi).

C_i = Concentration of nuclide "i" ($\mu\text{Ci/cc}$).

ΔP_t = Change in pressure (psia) of the WGDT
 (psia = psig + 14.7)

3.3.1 Noble Gases (continued)

600	=	WGDT volume, (ft ³).
28316.85	=	Conversion factor for converting from ft ³ to cc.
298	=	Sample temperature at time of analysis, (°k).
14.7	=	Sample pressure at time of measurement, (psia).
283	=	WGDT Temperature, °k (see Note below)

NOTE: The FSAR assumes WGDT temperature to be in the 50-140 °F range. Since there is no indicator for the actual WGDT temperature, 50°F (10°C) is conservatively assumed as an acceptable substitute. Also assumed is a sample analysis temperature of 77°F (25°C).

Containment Pressure Releases

Containment Pressure Releases (ILRT) are calculated using the same methodology as Waste Gas Decay Tank Batch Releases. Containment Pressure Releases are released via Stack 1. The volume to use is 2.26E+06 ft³.

Continuous Releases

Each of the four effluent stacks at the HNP have noble gas monitors. Using the net concentration (μCi/cc) from these monitors times the volume released (determined from the flow monitors) the total activity (μCi) of noble gases released are calculated as follows:

$$Q_x = C_x \cdot V_x \quad (3.3-8)$$

Where;

Q_x = Total activity (μCi) released from Stack "x".

C_x = Net concentration (μCi/cc) from Stack "x" noble gas monitor.

V_x = Volume (cc) released from Stack "x" using the flow monitor and, if out of service use the compensatory measurements for volume determination.

3.3.1 Noble Gases (continued)

The activity (μCi) released for radionuclide "i" equals the radionuclide "i" fraction of the radionuclide mix times the total activity released from Stack "x".

$$Q_i = Q_x \cdot S_i \quad (3.3-8a)$$

Where;

$$S_i = \frac{C_i}{\sum C_i} \quad (3.3-8b)$$

and;

S_i = The radionuclide "i" fraction of the radionuclide mix

C_i = The concentration of nuclide "i" in the grab sample ($\mu\text{Ci}/\text{cc}$).

$\sum C_i$ = Total activity in grab sample ($\mu\text{Ci}/\text{cc}$).

The radionuclide mix is based on the sampling and analysis required by ODCM Operational Requirement 4.11.2.2.1. If the grab sample activity is < LLD, then a mix based on historical data or a mix based on the Xe-133 / Kr-85 LLD mix of that sample may be used.

When a monitor is out of service, the results of the compensatory sampling for each nuclide times the volume released for that time interval will be used for effluent accountability. During this situation if the sample shows no detectable activity then there is no activity released.

Corrections for Double Accounting

For the two stacks that may have batch releases during the same time interval as continuous releases, the above calculations are corrected for double accounting as follows;

$$Q_{ic} = Q_i - q_i \quad (3.3-9)$$

Where;

Q_{ic} = Total corrected activity of nuclide "i" (μCi) from Stack "x" when batch releases are being made during that time period.

For short term (batch) releases, the effluent stream is sampled and analyzed. The results of the sampling and analysis is used as the source term for the batch release. Release rate is derived from the source term and the release flow rate.

3.3.1 Noble Gases (continued)

3. Projection of Doses

Doses resulting from the release of gaseous effluents will be projected once every 31 days (monthly). The doses will be projected utilizing Equations 3.3-1 and 3.3-2, and projected using the following expression:

$$D_{pr} = (D_{\tau} \cdot p) + D_{ar} \quad (3.3-10)$$

where:

- D_{pr} = the 31 Day Projected Dose by organ τ
- D_{τ} = sum of all open release points in mrem/day by organ τ .
- p = the Projection Factor which is the result of 31 divided by the number of days from start of the quarter to the end of the release.
- D_{ar} = Additional Anticipated Dose for liquid releases by organ τ and quarter of release.

NOTE: The 31 Day Projected Dose values appear on the Standard and Special Permit Reports. The 31 day dose projections on the Approval/Results screen include any additional dose.

Where possible, expected operational evolutions (i.e., outages, increased power levels, major planned batch gas releases, etc.) should be accounted for in the dose projections. This may be accomplished by using the source-term data from similar historical operating experiences where practical, and adding the dose as Additional Anticipated Dose.

To show compliance with ODCM Operational Requirement 3.11.2.4, the projected month's dose should be compared as in the following:

$$D_{\gamma} \leq 0.2 \text{ mrad to air for gamma radiation} \quad (3.3-11)$$

and

$$D_{\beta} \leq 0.4 \text{ mrad to air for beta radiation} \quad (3.3-12)$$

If the projections exceed either Equations 3.3-11 or 3.3-12, then the appropriate portions of the gaseous radwaste treatment system shall be used to reduce releases of radioactivity.

3.3.2 Radioiodine and Particulates

1. Cumulation of Doses

Section II.C of Appendix I of 10CFR50 limits the release of radioiodines and radioactive material in particulate form from a reactor such that the estimated dose or dose commitment to an individual in an unrestricted area from all pathways of exposure is not in excess of 15 mrem to any organ. Based upon NUREG-0133, the dose to an organ of an individual from radioiodines and particulates with half-lives greater than 8 days in gaseous effluents released to unrestricted areas can be determined by the following equation:

$$D_{\tau} = 3.17E-08 \sum_i (R_{i_I}) [(\overline{X/Q})_v \tilde{Q}_{i_V} + (\overline{X/q})_v \tilde{q}_{i_V}] +$$

$$(R_{i_M} + R_{i_V} + R_{i_G} + R_{i_B}) [(\overline{D/Q})_v \tilde{Q}_{i_V} + (\overline{D/q})_v \tilde{q}_{i_V}] +$$

$$(R_{T_M} + R_{T_I} + R_{T_V} + R_{T_B}) [(\overline{X/Q})_v \tilde{Q}_{T_V} + (\overline{X/q})_v \tilde{q}_{T_V}]$$

where:

- D_{τ} = Dose to any organ τ from tritium, radioiodines, and particulates, mrem.
- $(\overline{D/Q})_v$ = The highest long-term (> 500 hr/yr) annual average relative deposition: $8.8 \text{ E-}09 \text{ m}^{-2}$ for the food and ground plane pathways at the controlling location which is the exclusion boundary in the S sector (from Table A-4, Appendix A, for ground-level vent stack releases).
- $(\overline{D/q})_v$ = The relative deposition factor for short term, ground-level vent releases ($\leq 500 \text{ hrs/yr}$), m^{-2} . See Section 3.0 concerning ground-level releases at Shearon Harris Nuclear Plant if using "real" meteorology or use $8.8 \text{ E-}09 \text{ m}^{-2}$ from Table A-4, Appendix A, for the food and ground plane pathways at the controlling location.
- R_{i_M} = Dose factor for an organ for radionuclide "i" for either the cow milk or goat milk pathway, mrem/yr per $\mu\text{Ci/sec per m}^{-2}$.

3.3.2 Radioiodine and Particulates (continued)

R_{iG}	=	Dose factor for an organ for radionuclide "i" for the ground plane exposure pathway, mrem/yr per $\mu\text{Ci}/\text{sec}$ per m^{-2} .
R_{iI}	=	Dose factor for an organ for radionuclide "i" for the inhalation pathway, mrem/yr per $\mu\text{Ci}/\text{m}^3$.
R_{iV}	=	Dose factor for an organ for radionuclide "i" for the vegetable pathway, mrem/yr per $\mu\text{Ci}/\text{sec}$ per m^{-2} .
R_{iB}	=	Dose factor for an organ for radionuclide "i" for the meat pathway, mrem/yr per $\mu\text{Ci}/\text{sec}$ per m^{-2} .
R_{TM}	=	Dose factor for an organ for tritium for the milk pathway mrem/yr per $\mu\text{Ci}/\text{m}^3$.
R_{TV}	=	Dose factor for an organ for tritium for the vegetable pathway, mrem/yr per $\mu\text{Ci}/\text{m}^3$.
R_{TI}	=	Dose factor for an organ for tritium for the inhalation pathway, mrem/yr per $\mu\text{Ci}/\text{m}^3$.
R_{TB}	=	Dose factor for an organ for tritium for the meat pathway, mrem/yr per $\mu\text{Ci}/\text{m}^3$.
\tilde{Q}_{TV}	=	Release of tritium in gaseous effluents for long-term vent stack releases (> 500 hrs/yr), μCi .
\tilde{q}_{TV}	=	Release of tritium in gaseous effluents for short-term vent stack releases (\leq 500 hrs/yr), μCi .

To show compliance with 10CFR50, Equation 3.3-13 is evaluated for a hypothetical individual at the limiting location. At SHNPP this location is the exclusion boundary in the S sector which has the highest annual average $\overline{X/Q_v}$ and $\overline{D/Q_v}$ values. This assures that the actual exposure of a member of the public will not be substantially underestimated. The critical receptor is a child.

Appropriate $\overline{X/Q_v}$ and $\overline{D/Q_v}$ values from tables in Appendix A are used. For this document, long-term annual average $\overline{X/Q_v}$ and $\overline{D/Q_v}$ values may be used in lieu of short-term values (see Section 3.0 concerning ground-level releases at Shearon Harris Nuclear Plant).

3.3.2 Radioiodine and Particulates (continued)

The determination of a limiting location for implementation of 10CFR50 for radioiodines and particulates is a function of:

1. Isotopic mix
2. Meteorology
3. Exposure pathway
4. Receptor's age

In the determination of the limiting location, the radionuclide mix of radioiodines and particulates is based on the sampling and analysis required by ODCM Operational Requirement 4.11.2.1.2. If the analysis is < LLD, then no activity is assumed to have been released during the sampling period. The release rate is derived from the flow (actual or default) and the isotopic mix.

In the determination of the limiting sector, all age groups and all of the exposure pathways are evaluated using the highest XOQDOQ values in Appendix A at the site boundary. These include beef and vegetable ingestion, inhalation, and ground plane exposure. Goat and cow milk are not currently exposure pathways at SHNPP.

SHNPP ODCM Operational Requirement 3.12.2 requires that a land-use census survey be conducted on an annual basis. The age groupings at the various receptor locations are also determined during this survey. Thus, depending on the results of the survey, a new limiting location and receptor age group could result.

To avoid possible annual revisions to the ODCM software which evaluates effluent releases for compliance with 10CFR50, the limiting sector location has been fixed at the exclusion boundary in the S sector where the highest historical annual average $\overline{X/Q_v}$ and $\overline{D/Q_v}$ values occur (Appendix A). With all of the exposure pathways identified in the Land Use Census (ODCM Operational Requirement 3.12.2) available to a hypothetical receptor, the critical organ is a child's bone. This approach avoids a substantial underestimate of the dose to a real member of the public.

Long-term $\overline{X/Q_v}$ and $\overline{D/Q_v}$ values for ground-level releases are provided in tables in Appendix A. They may be utilized if an additional special location arises different from those presented in the special locations of the Land Use Census (ODCM Operational Requirement 3.12.2). A description of the derivation of the various X/Q and D/Q values is presented in Appendix A.

3.3.2 Radioiodine and Particulates (continued)

Tables 3.3-1 through 3.3-19 present R_i values for the total body, GI-tract, bone, liver, kidney, thyroid, and lung organs for the ground plane, inhalation, cow milk, goat milk, vegetable, and meat ingestion pathways for the infant, child, teen, and adult age groups as appropriate to the pathways. These values were calculated using the methodology described in NUREG-0133 assuming a grazing period of eight months. A description of the methodology is presented in Appendix B.

The following relationship should hold for SHNPP to show compliance with SHNPP ODCM Operational Requirement 3.11.2.3.

For the calendar quarter:

$$D_{\tau} \leq 7.5 \text{ mrem} \quad (3.3-14)$$

For the calendar year:

$$D_{\tau} \leq 15 \text{ mrem} \quad (3.3-15)$$

The quarterly limits given above represent one-half the annual design objectives of Section II.C of Appendix I of 10CFR50. If any of the limits of Equations 3.3-14 or 3.3-15 are exceeded, a Special Report pursuant to Technical Specification 6.9.2 must be filed with the NRC. This report complies with Section IV.A of Appendix I of 10CFR50.

2. Projection of Doses

Doses resulting from release of radioiodines and particulates will be projected once every 31 days (monthly). The doses will be projected utilizing Equation 3.3-13, and projected using the following expression:

$$D_{pr} = (D_{\tau} \cdot p) + D_{ar} \quad (3.3-16)$$

where:

- D_{pr} = the 31 Day Projected Dose by organ τ
- D_{τ} = sum of all open release points in mrem/day by organ τ .
- p = the Projection Factor which is the result of 31 divided by the number of days from start of the quarter to the end of the release.
- D_{ar} = Additional Anticipated Dose for gaseous releases by organ τ and quarter of release.

3.3.2 Radioiodine and Particulates (continued)

NOTE: The 31 Day Projected Dose values appear on the Standard and Special Permit Reports. The 31 day dose projections on the Approval/Results screen include any additional dose.

Where possible, expected operational evolutions (i.e., outages, increased power levels, major planned batch gas releases, etc.) should be accounted for in the dose projections. This may be accomplished by using the source-term data from similar historical operating experiences where practical, and adding the dose as Additional Anticipated Dose.

To show compliance with ODCM Operational Requirement 3.11.2.4, the projected month's dose should be compared as in the following:

$$D \leq 0.3 \text{ mrem to any organ} \quad (3.3-17)$$

If the projections exceed Expression 3.3-14, then the appropriate portions of the gaseous radwaste treatment system shall be used to reduce releases of radioactivity.

TABLE 3.3-1
 R VALUES FOR THE SHEARON HARRIS NUCLEAR POWER PLANT*

PATHWAY = Ground

AGE GROUP = ALL

<u>Nuclide</u>	<u>T. Body</u>	<u>GI-Tract</u>	<u>Bone</u>	<u>Liver</u>	<u>Kidney</u>	<u>Thyroid</u>	<u>Lung</u>	<u>Skin</u>
Cr-51	4.66E+06	4.66E+06	4.66E+06	4.66E+06	4.66E+06	4.66E+06	4.66E+06	5.51E+06
Mn-54	1.34E+09	1.34E+09	1.34E+09	1.34E+09	1.34E+09	1.34E+09	1.34E+09	1.57E+09
Fe-59	2.75E+08	2.75E+08	2.75E+08	2.75E+08	2.75E+08	2.75E+08	2.75E+08	3.23E+08
Co-58	3.79E+08	3.79E+08	3.79E+08	3.79E+08	3.79E+08	3.79E+08	3.79E+08	4.44E+09
Co-60	2.15E+10	2.15E+10	2.15E+10	2.15E+10	2.15E+10	2.15E+10	2.15E+10	2.52E+10
Zn-65	7.49E+08	7.49E+08	7.49E+08	7.49E+08	7.49E+08	7.49E+08	7.49E+08	8.61E+08
Rb-86	8.99E+06	8.99E+06	8.99E+06	8.99E+06	8.99E+06	8.99E+06	8.99E+06	1.03E+07
Sr-89	2.23E+04	2.23E+04	2.23E+04	2.23E+04	2.23E+04	2.23E+04	2.23E+04	2.58E+04
Y-91	1.08E+06	1.08E+06	1.08E+06	1.08E+06	1.08E+06	1.08E+06	1.08E+06	1.22E+06
Zr-95	2.49E+08	2.49E+08	2.49E+08	2.49E+08	2.49E+08	2.49E+08	2.49E+08	2.89E+08
Nb-95	1.36E+08	1.36E+08	1.36E+08	1.36E+08	1.36E+08	1.36E+08	1.36E+08	1.60E+08
Ru-103	1.09E+08	1.09E+08	1.09E+08	1.09E+08	1.09E+08	1.09E+08	1.09E+08	1.27E+08
Ru-106	4.19E+08	4.19E+08	4.19E+08	4.19E+08	4.19E+08	4.19E+08	4.19E+08	5.03E+08
Ag-110M	3.48E+09	3.48E+09	3.48E+09	3.48E+09	3.48E+09	3.48E+09	3.48E+09	4.06E+09
Sn-113	1.44E+07	6.28E+06	1.22E+07	6.21E+06	1.00E+07	1.33E+07	8.14E+06	4.09E+07
Sb-124	8.76E+08	7.53E+08	8.99E+08	7.76E+08	8.17E+08	1.01E+09	8.23E+08	1.24E+09
Te-127M	9.15E+04	9.15E+04	9.15E+04	9.15E+04	9.15E+04	9.15E+04	9.15E+04	1.08E+05
Te-129M	2.00E+07	2.00E+07	2.00E+07	2.00E+07	2.00E+07	2.00E+07	2.00E+07	2.34E+07
I-131	1.72E+07	1.72E+07	1.72E+07	1.72E+07	1.72E+07	1.72E+07	1.72E+07	2.09E+07
I-132	1.24E+06	1.24E+06	1.24E+06	1.24E+06	1.24E+06	1.24E+06	1.24E+06	1.46E+06
I-133	2.47E+06	2.47E+06	2.47E+06	2.47E+06	2.47E+06	2.47E+06	2.47E+06	3.00E+06
I-135	2.56E+06	2.56E+06	2.56E+06	2.56E+06	2.56E+06	2.56E+06	2.56E+06	2.99E+06
Cs-134	6.82E+09	6.82E+09	6.82E+09	6.82E+09	6.82E+09	6.82E+09	6.82E+09	7.96E+09
Cs-136	1.49E+08	1.49E+08	1.49E+08	1.49E+08	1.49E+08	1.49E+08	1.49E+08	1.69E+08
Cs-137	1.03E+10	1.03E+10	1.03E+10	1.03E+10	1.03E+10	1.03E+10	1.03E+10	1.20E+10
Ba-140	2.05E+07	2.05E+07	2.05E+07	2.05E+07	2.05E+07	2.05E+07	2.05E+07	2.34E+07
Ce-141	1.36E+07	1.36E+07	1.36E+07	1.36E+07	1.36E+07	1.36E+07	1.36E+07	1.53E+07
Ce-144	6.95E+07	6.95E+07	6.95E+07	6.95E+07	6.95E+07	6.95E+07	6.95E+07	8.03E+07
Hf-181	1.97E+08	1.63E+08	2.30E+08	1.70E+08	1.77E+08	2.33E+08	1.82E+08	2.82E+08

*R Values in units of mrem/yr per $\mu\text{Ci}/\text{m}^3$ for inhalation and tritium and in units of mrem/yr per $\mu\text{Ci}/\text{sec}$ per m^{-2} for all others.

TABLE 3.3-2
 R VALUES FOR THE SHEARON HARRIS NUCLEAR POWER PLANT*

PATHWAY = Veget

AGE GROUP = Adult

Nuclide	T. Body	GI-Tract	Bone	Liver	Kidney	Thyroid	Lung	Skin
H-3	2.28E+03	2.28E+03	0.00E+01	2.28E+03	2.28E+03	2.28E+03	2.28E+03	2.28E+03
P-32	5.91E+07	1.72E+08	1.53E+09	9.51E+07	0.00E+01	0.00E+01	0.00E+01	0.00E+01
Cr-51	4.60E+04	1.16E+07	0.00E+01	0.00E+01	1.01E+04	2.75E+04	6.10E+04	0.00E+01
Mn-54	5.83E+07	9.36E+08	0.00E+01	3.05E+08	9.09E+07	0.00E+01	0.00E+01	0.00E+01
Fe-59	1.12E+08	9.75E+08	1.24E+08	2.93E+08	0.00E+01	0.00E+01	8.17E+07	0.00E+01
Co-58	6.71E+07	6.07E+08	0.00E+01	2.99E+07	0.00E+01	0.00E+01	0.00E+01	0.00E+01
Co-60	3.67E+08	3.12E+09	0.00E+01	1.66E+08	0.00E+01	0.00E+01	0.00E+01	0.00E+01
Zn-65	5.77E+08	8.04E+08	4.01E+08	1.28E+09	8.54E+08	0.00E+01	0.00E+01	0.00E+01
Rb-86	1.03E+08	4.36E+07	0.00E+01	2.21E+08	0.00E+01	0.00E+01	0.00E+01	0.00E+01
Sr-89	2.87E+08	1.60E+09	1.00E+10	0.00E+01	0.00E+01	0.00E+01	0.00E+01	0.00E+01
Sr-90	1.64E+11	1.93E+10	6.70E+11	0.00E+01	0.00E+01	0.00E+01	0.00E+01	0.00E+01
Y-91	1.34E+05	2.76E+09	5.01E+06	0.00E+01	0.00E+01	0.00E+01	0.00E+01	0.00E+01
Zr-95	2.51E+05	1.17E+09	1.16E+06	3.71E+05	5.82E+05	0.00E+01	0.00E+01	0.00E+01
Nb-95	4.19E+04	4.73E+08	1.40E+05	7.79E+04	7.70E+04	0.00E+01	0.00E+01	0.00E+01
Ru-103	2.04E+06	5.53E+08	4.74E+06	0.00E+01	1.81E+07	0.00E+01	0.00E+01	0.00E+01
Ru-106	2.46E+07	1.26E+10	1.94E+08	0.00E+01	3.75E+08	0.00E+01	0.00E+01	0.00E+01
Ag-110M	6.23E+06	4.28E+09	1.13E+07	1.05E+07	2.06E+07	0.00E+01	0.00E+01	0.00E+01
Sn-113	1.36E+07	2.52E+08	1.44E+07	5.66E+05	4.09E+05	1.96E+05	0.00E+01	0.00E+01
Sb-124	4.02E+07	2.88E+09	1.01E+08	1.92E+06	0.00E+00	2.46E+05	7.90E+07	0.00E+01
Te-127M	6.12E+07	1.68E+09	5.02E+08	1.80E+08	2.04E+09	1.28E+08	0.00E+01	0.00E+01
Te-129M	4.71E+07	1.50E+09	2.98E+08	1.11E+08	1.24E+09	1.02E+08	0.00E+01	0.00E+01
I-131	6.61E+07	3.04E+07	8.07E+07	1.15E+08	1.98E+08	3.78E+10	0.00E+01	0.00E+01
I-132	5.21E+01	2.80E+01	5.57E+01	1.49E+02	2.37E+02	5.21E+03	0.00E+01	0.00E+01
I-133	1.12E+06	3.30E+06	2.11E+06	3.67E+06	6.40E+06	5.39E+08	0.00E+01	0.00E+01
I-135	3.91E+04	1.20E+05	4.05E+04	1.06E+05	1.70E+05	7.00E+06	0.00E+01	0.00E+01
Cs-134	8.83E+09	1.89E+08	4.54E+09	1.08E+10	3.49E+09	0.00E+01	1.16E+09	0.00E+01
Cs-136	1.19E+08	1.88E+07	4.19E+07	1.66E+08	9.21E+07	0.00E+01	1.26E+07	0.00E+01
Cs-137	5.94E+09	1.76E+08	6.63E+09	9.07E+09	3.08E+09	0.00E+01	1.02E+09	0.00E+01
Ba-140	8.40E+06	2.64E+08	1.28E+08	1.61E+05	5.47E+04	0.00E+01	9.22E+04	0.00E+01
Ce-141	1.48E+04	4.99E+08	1.93E+05	1.31E+05	6.07E+04	0.00E+01	0.00E+01	0.00E+01
Ce-144	1.69E+06	1.06E+10	3.15E+07	1.32E+07	7.80E+06	0.00E+01	0.00E+01	0.00E+01
Hf-181	1.07E+06	7.06E+08	9.51E+06	5.36E+04	4.48E+04	3.41E+04	0.00E+01	0.00E+01

*R Values in units of mrem/yr per $\mu\text{Ci}/\text{m}^3$ for inhalation and tritium and in units of mrem/yr per $\mu\text{Ci}/\text{sec}$ per m^{-2} for all others.

TABLE 3.3-3
 R VALUES FOR THE SHEARON HARRIS NUCLEAR POWER PLANT*

PATHWAY = Veget

AGE GROUP = Teen

<u>Nuclide</u>	<u>T. Body</u>	<u>GI-Tract</u>	<u>Bone</u>	<u>Liver</u>	<u>Kidney</u>	<u>Thyroid</u>	<u>Lung</u>	<u>Skin</u>
H-3	2.61E+03	2.61E+03	0.00E+01	2.61E+03	2.61E+03	2.61E+03	2.61E+03	2.61E+03
P-32	6.80E+07	1.47E+08	1.75E+09	1.09E+08	0.00E+01	0.00E+01	0.00E+01	0.00E+01
Cr-51	6.11E+04	1.03E+07	0.00E+01	0.00E+01	1.34E+04	3.39E+04	8.72E+04	0.00E+01
Mn-54	8.79E+07	9.09E+08	0.00E+01	4.43E+08	1.32E+08	0.00E+01	0.00E+01	0.00E+01
Fe-59	1.60E+08	9.78E+08	1.77E+08	4.14E+08	0.00E+01	0.00E+01	1.30E+08	0.00E+01
Co-58	9.79E+07	5.85E+08	0.00E+01	4.25E+07	0.00E+01	0.00E+01	0.00E+01	0.00E+01
Co-60	5.57E+08	3.22E+09	0.00E+01	2.47E+08	0.00E+01	0.00E+01	0.00E+01	0.00E+01
Zn-65	8.68E+08	7.88E+08	5.36E+08	1.86E+09	1.19E+09	0.00E+01	0.00E+01	0.00E+01
Rb-86	1.30E+08	4.09E+07	0.00E+01	2.76E+08	0.00E+01	0.00E+01	0.00E+01	0.00E+01
Sr-89	4.36E+08	1.81E+09	1.52E+10	0.00E+01	0.00E+01	0.00E+01	0.00E+01	0.00E+01
Sr-90	2.05E+11	2.33E+10	8.32E+11	0.00E+01	0.00E+01	0.00E+01	0.00E+01	0.00E+01
Y-91	2.06E+05	3.15E+09	7.68E+06	0.00E+01	0.00E+01	0.00E+01	0.00E+01	0.00E+01
Zr-95	3.68E+05	1.23E+09	1.69E+06	5.35E+05	7.86E+05	0.00E+01	0.00E+01	0.00E+01
Nb-95	5.77E+04	4.48E+08	1.89E+05	1.05E+05	1.02E+05	0.00E+01	0.00E+01	0.00E+01
Ru-103	2.90E+06	5.66E+08	6.78E+06	0.00E+01	2.39E+07	0.00E+01	0.00E+01	0.00E+01
Ru-106	3.93E+07	1.50E+10	3.12E+08	0.00E+01	6.02E+08	0.00E+01	0.00E+01	0.00E+01
Ag-110M	9.39E+06	4.34E+09	1.63E+07	1.54E+07	2.95E+07	0.00E+01	0.00E+01	0.00E+01
Sn-113	2.02E+07	2.29E+08	1.91E+07	8.03E+05	5.65E+05	2.63E+05	0.00E+01	0.00E+01
Sb-124	5.89E+07	3.04E+09	1.51E+08	2.78E+06	0.00E+01	3.43E+05	1.32E+08	0.00E+01
Te-127M	9.44E+07	1.98E+09	7.93E+08	2.81E+08	3.22E+09	1.89E+08	0.00E+01	0.00E+01
Te-129M	6.79E+07	1.61E+09	4.29E+08	1.59E+08	1.79E+08	1.38E+08	0.00E+01	0.00E+01
I-131	5.77E+07	2.13E+07	7.68E+07	1.07E+08	1.85E+08	3.14E+10	0.00E+01	0.00E+01
I-132	4.72E+01	5.72E+01	5.02E+01	1.31E+02	2.07E+02	4.43E+03	0.00E+01	0.00E+01
I-133	1.01E+06	2.51E+06	1.96E+06	3.32E+06	5.83E+06	4.64E+08	0.00E+01	0.00E+01
I-135	3.49E+04	1.04E+05	3.66E+04	9.42E+04	1.49E+05	6.06E+06	0.00E+01	0.00E+01
Cs-134	7.54E+09	2.02E+08	6.90E+09	1.62E+10	5.16E+09	0.00E+01	1.97E+09	0.00E+01
Cs-136	1.13E+08	1.35E+07	4.28E+07	1.68E+08	9.16E+07	0.00E+01	1.44E+07	0.00E+01
Cs-137	4.90E+09	2.00E+08	1.06E+10	1.41E+10	4.78E+09	0.00E+01	1.86E+09	0.00E+01
Ba-140	8.88E+06	2.12E+08	1.38E+08	1.69E+05	5.72E+04	0.00E+01	1.14E+05	0.00E+01
Ce-141	2.12E+04	5.29E+08	2.77E+05	1.85E+05	8.70E+04	0.00E+01	0.00E+01	0.00E+01
Ce-144	2.71E+06	1.27E+10	5.04E+07	2.09E+07	1.25E+07	0.00E+01	0.00E+01	0.00E+01
Hf-181	1.54E+06	6.90E+08	1.38E+07	7.58E+04	6.32E+04	4.63E+04	0.00E+01	0.00E+01

*R Values in units of mrem/yr per $\mu\text{Ci}/\text{m}^3$ for inhalation and tritium and in units of mrem/yr per $\mu\text{Ci}/\text{sec}$ per m^{-2} for all others.

TABLE 3.3-4
 R VALUES FOR THE SHEARON HARRIS NUCLEAR POWER PLANT*

PATHWAY = Veget

AGE GROUP = Child

<u>Nuclide</u>	<u>T. Body</u>	<u>GI-Tract</u>	<u>Bone</u>	<u>Liver</u>	<u>Kidney</u>	<u>Thyroid</u>	<u>Lung</u>	<u>Skin</u>
H-3	4.04E+03	4.04E+03	0.00E+01	4.04E+03	4.04E+03	4.04E+03	4.04E+03	4.04E+03
P-32	1.42E+08	1.01E+08	3.67E+09	1.72E+08	0.00E+01	0.00E+01	0.00E+01	0.00E+01
Cr-51	1.16E+05	6.15E+06	0.00E+01	0.00E+01	1.76E+04	6.44E+04	1.18E+05	0.00E+01
Mn-54	1.73E+08	5.44E+08	0.00E+01	6.49E+08	1.82E+08	0.00E+01	0.00E+01	0.00E+01
Fe-59	3.17E+08	6.62E+08	3.93E+08	6.36E+08	0.00E+01	0.00E+01	1.84E+08	0.00E+01
Co-58	1.92E+08	3.66E+08	0.00E+01	6.27E+07	0.00E+01	0.00E+01	0.00E+01	0.00E+01
Co-60	1.11E+09	2.08E+09	0.00E+01	3.76E+08	0.00E+01	0.00E+01	0.00E+01	0.00E+01
Zn-65	1.70E+09	4.81E+08	1.03E+09	2.74E+09	1.73E+09	0.00E+01	0.00E+01	0.00E+01
Rb-86	2.81E+08	2.94E+07	0.00E+01	4.56E+08	0.00E+01	0.00E+01	0.00E+01	0.00E+01
Sr-89	1.03E+09	1.40E+09	3.62E+10	0.00E+01	0.00E+01	0.00E+01	0.00E+01	0.00E+01
Sr-90	3.49E+11	1.86E+10	1.38E+12	0.00E+01	0.00E+01	0.00E+01	0.00E+01	0.00E+01
Y-91	4.89E+05	2.44E+09	1.83E+07	0.00E+01	0.00E+01	0.00E+01	0.00E+01	0.00E+01
Zr-95	7.44E+05	8.71E+08	3.80E+06	8.35E+05	1.20E+06	0.00E+01	0.00E+01	0.00E+01
Nb-95	1.12E+05	2.91E+08	4.04E+05	1.57E+05	1.48E+05	0.00E+01	0.00E+01	0.00E+01
Ru-103	5.86E+06	3.94E+08	1.52E+07	0.00E+01	3.84E+07	0.00E+01	0.00E+01	0.00E+01
Ru-106	9.38E+07	1.17E+10	7.52E+08	0.00E+01	1.02E+09	0.00E+01	0.00E+01	0.00E+01
Ag-110M	1.87E+07	2.78E+09	3.46E+07	2.34E+07	4.35E+07	0.00E+01	0.00E+01	0.00E+01
Sn-113	3.97E+07	1.45E+08	3.64E+07	1.18E+06	8.09E+05	4.82E+05	0.00E+01	0.00E+01
Sb-124	1.21E+08	2.16E+09	3.44E+08	4.47E+06	0.00E+01	7.61E+05	1.91E+08	0.00E+01
Te-127M	2.26E+08	1.54E+09	1.90E+09	5.12E+08	5.42E+09	4.55E+08	0.00E+01	0.00E+01
Te-129M	1.55E+08	1.22E+09	9.98E+08	2.79E+08	2.93E+09	3.22E+08	0.00E+01	0.00E+01
I-131	8.16E+07	1.23E+07	1.43E+08	1.44E+08	2.36E+08	4.75E+10	0.00E+01	0.00E+01
I-132	7.53E+01	1.93E+02	8.91E+01	1.64E+02	2.51E+02	7.60E+03	0.00E+01	0.00E+01
I-133	1.67E+06	1.78E+06	3.57E+06	4.42E+06	7.36E+06	8.21E+08	0.00E+01	0.00E+01
I-135	5.54E+04	8.92E+04	6.50E+04	1.17E+05	1.79E+05	1.04E+07	0.00E+01	0.00E+01
Cs-134	5.40E+09	1.38E+08	1.56E+10	2.56E+10	7.93E+09	0.00E+01	2.84E+09	0.00E+01
Cs-136	1.43E+08	7.77E+06	8.04E+07	2.21E+08	1.18E+08	0.00E+01	1.76E+07	0.00E+01
Cs-137	3.52E+09	1.50E+08	2.49E+10	2.39E+10	7.78E+09	0.00E+01	2.80E+09	0.00E+01
Ba-140	1.61E+07	1.40E+08	2.76E+08	2.42E+05	7.87E+04	0.00E+01	1.44E+05	0.00E+01
Ce-141	4.75E+04	3.99E+08	6.42E+05	3.20E+05	1.40E+05	0.00E+01	0.00E+01	0.00E+01
Ce-144	6.49E+06	9.94E+09	1.22E+08	3.81E+07	2.11E+07	0.00E+01	0.00E+01	0.00E+01
Hf-181	3.15E+06	5.17E+08	3.13E+07	1.22E+05	9.78E+04	1.03E+05	0.00E+01	0.00E+01

*R Values in units of mrem/yr per $\mu\text{Ci}/\text{m}^3$ for inhalation and tritium and in units of mrem/yr per $\mu\text{Ci}/\text{sec}$ per m^2 for all others.

TABLE 3.3-5
 R VALUES FOR THE SHEARON HARRIS NUCLEAR POWER PLANT*

PATHWAY = Meat

AGE GROUP = Adult

<u>Nuclide</u>	<u>T. Body</u>	<u>GI-Tract</u>	<u>Bone</u>	<u>Liver</u>	<u>Kidney</u>	<u>Thyroid</u>	<u>Lung</u>	<u>Skin</u>
H-3	3.27E+02	3.27E+02	0.00E+01	3.27E+02	3.27E+02	3.27E+02	3.27E+02	3.27E+02
P-32	1.18E+08	3.43E+08	3.05E+09	1.89E+08	0.00E+01	0.00E+01	0.00E+01	0.00E+01
Cr-51	4.27E+03	1.08E+06	0.00E+01	0.00E+01	9.42E+02	2.56E+03	5.67E+03	0.00E+01
Mn-54	1.06E+06	1.71E+07	0.00E+01	5.57E+06	1.66E+06	0.00E+01	0.00E+01	0.00E+01
Fe-59	1.43E+08	1.25E+09	1.59E+08	3.74E+08	0.00E+01	0.00E+01	1.04E+08	0.00E+01
Co-58	2.43E+07	2.20E+08	0.00E+01	1.08E+07	0.00E+01	0.00E+01	0.00E+01	0.00E+01
Co-60	1.03E+08	8.76E+08	0.00E+01	4.66E+07	0.00E+01	0.00E+01	0.00E+01	0.00E+01
Zn-65	3.58E+08	4.98E+08	2.49E+08	7.91E+08	5.29E+08	0.00E+01	0.00E+01	0.00E+01
Rb-86	1.42E+08	6.00E+07	0.00E+01	3.04E+08	0.00E+01	0.00E+01	0.00E+01	0.00E+01
Sr-89	5.23E+06	2.92E+07	1.82E+08	0.00E+01	0.00E+01	0.00E+01	0.00E+01	0.00E+01
Sr-90	2.02E+09	2.38E+08	8.22E+09	0.00E+01	0.00E+01	0.00E+01	0.00E+01	0.00E+01
Y-91	1.80E+04	3.71E+08	6.75E+05	0.00E+01	0.00E+01	0.00E+01	0.00E+01	0.00E+01
Zr-95	2.43E+05	1.14E+09	1.12E+06	3.59E+05	5.64E+05	0.00E+01	0.00E+01	0.00E+01
Nb-95	4.12E+05	4.65E+09	1.38E+06	7.66E+05	7.58E+05	0.00E+01	0.00E+01	0.00E+01
Ru-103	2.72E+07	7.38E+09	6.32E+07	0.00E+01	2.41E+08	0.00E+01	0.00E+01	0.00E+01
Ru-106	2.19E+08	1.12E+11	1.73E+09	0.00E+01	3.35E+09	0.00E+01	0.00E+01	0.00E+01
Ag-110M	2.34E+06	1.61E+09	4.27E+06	3.95E+06	7.76E+06	0.00E+01	0.00E+01	0.00E+01
Sn-113	2.80E+07	5.19E+08	2.97E+07	1.15E+06	8.40E+05	4.03E+05	0.00E+01	0.00E+01
Sb-124	4.72E+06	3.38E+08	1.19E+07	2.25E+05	0.00E+01	2.88E+04	9.27E+06	0.00E+01
Te-127M	1.00E+08	2.76E+09	8.22E+08	2.94E+08	3.34E+09	2.10E+08	0.00E+01	0.00E+01
Te-129M	1.17E+08	3.73E+09	7.40E+08	2.76E+08	3.09E+09	2.54E+08	0.00E+01	0.00E+01
I-131	5.77E+06	2.66E+06	7.04E+06	1.01E+07	1.73E+07	3.30E+09	0.00E+01	0.00E+01
I-133	1.51E-01	4.46E-01	2.85E-01	4.96E-01	8.66E-01	7.29E+01	0.00E+01	0.00E+01
I-135	6.07E-17	1.86E-16	6.28E-17	1.64E-16	2.64E-16	1.08E-14	0.00E+01	0.00E+01
Cs-134	7.81E+08	1.67E+07	4.01E+08	9.55E+08	3.09E+08	0.00E+01	1.03E+08	0.00E+01
Cs-136	2.14E+07	3.33E+06	7.53E+06	2.97E+07	1.65E+07	0.00E+01	2.27E+06	0.00E+01
Cs-137	4.99E+08	1.47E+07	5.57E+08	7.61E+08	2.58E+08	0.00E+01	8.59E+07	0.00E+01
Ba-140	1.20E+06	3.77E+07	1.83E+07	2.30E+04	7.82E+03	0.00E+01	1.32E+04	0.00E+01
Ce-141	6.46E+02	2.18E+07	8.42E+03	5.69E+03	2.65E+03	0.00E+01	0.00E+01	0.00E+01
Ce-144	4.70E+04	2.96E+08	8.75E+05	3.66E+05	2.17E+05	0.00E+01	0.00E+01	0.00E+01
Hf-181	1.52E+06	9.97E+08	1.34E+07	7.57E+04	6.33E+04	4.81E+04	0.00E+01	0.00E+01

*R Values in units of mrem/yr per $\mu\text{Ci}/\text{m}^3$ for inhalation and tritium and in units of mrem/yr per $\mu\text{Ci}/\text{sec}$ per m^{-2} for all others.

TABLE 3.3-6
 R VALUES FOR THE SHEARON HARRIS NUCLEAR POWER PLANT*

PATHWAY = Meat

AGE GROUP = Teen

<u>Nuclide</u>	<u>T. Body</u>	<u>GI-Tract</u>	<u>Bone</u>	<u>Liver</u>	<u>Kidney</u>	<u>Thyroid</u>	<u>Lung</u>	<u>Skin</u>
H-3	1.95E+02	1.95E+02	0.00E+01	1.95E+02	1.95E+02	1.95E+02	1.95E+02	1.95E+02
P-32	9.98E+07	2.16E+08	2.58E+09	1.60E+08	0.00E+01	0.00E+01	0.00E+01	0.00E+01
Cr-51	3.42E+03	5.75E+05	0.00E+01	0.00E+01	7.49E+02	1.90E+03	4.88E+03	0.00E+01
Mn-54	8.43E+05	8.72E+06	0.00E+01	4.25E+06	1.27E+06	0.00E+01	0.00E+01	0.00E+01
Fe-59	1.15E+08	7.02E+08	1.27E+08	2.97E+08	0.00E+01	0.00E+01	9.36E+07	0.00E+01
Co-58	1.93E+07	1.15E+08	0.00E+01	8.36E+06	0.00E+01	0.00E+01	0.00E+01	0.00E+01
Co-60	8.15E+07	4.71E+08	0.00E+01	3.62E+07	0.00E+01	0.00E+01	0.00E+01	0.00E+01
Zn-65	2.83E+08	2.57E+08	1.75E+08	6.07E+08	3.89E+08	0.00E+01	0.00E+01	0.00E+01
Rb-86	1.19E+08	3.76E+07	0.00E+01	2.54E+08	0.00E+01	0.00E+01	0.00E+01	0.00E+01
Sr-89	4.40E+06	1.83E+07	1.54E+08	0.00E+01	0.00E+01	0.00E+01	0.00E+01	0.00E+01
Sr-90	1.31E+09	1.49E+08	5.32E+09	0.00E+01	0.00E+01	0.00E+01	0.00E+01	0.00E+01
Y-91	1.52E+04	2.33E+08	5.68E+05	0.00E+01	0.00E+01	0.00E+01	0.00E+01	0.00E+01
Zr-95	1.95E+05	6.53E+08	8.97E+05	2.83E+05	4.16E+05	0.00E+01	0.00E+01	0.00E+01
Nb-95	3.29E+05	2.55E+09	1.08E+06	5.97E+05	5.79E+05	0.00E+01	0.00E+01	0.00E+01
Ru-103	2.20E+07	4.30E+09	5.15E+07	0.00E+01	1.82E+08	0.00E+01	0.00E+01	0.00E+01
Ru-106	1.84E+08	7.00E+10	1.46E+09	0.00E+01	2.81E+09	0.00E+01	0.00E+01	0.00E+01
Ag-110M	1.86E+06	8.59E+08	3.23E+06	3.06E+06	5.83E+06	0.00E+01	0.00E+01	0.00E+01
Sn-113	2.22E+07	2.51E+08	2.09E+07	8.80E+05	6.19E+05	2.88E+05	0.00E+01	0.00E+01
Sb-124	3.80E+06	1.96E+08	9.73E+06	1.79E+05	0.00E+01	2.21E+04	8.50E+06	0.00E+01
Te-127M	8.25E+07	1.73E+09	6.94E+08	2.46E+08	2.81E+09	1.65E+08	0.00E+01	0.00E+01
Te-129M	9.81E+07	2.33E+09	6.20E+08	2.30E+08	2.59E+09	2.00E+08	0.00E+01	0.00E+01
I-131	4.40E+06	1.62E+06	5.85E+06	8.20E+06	1.41E+07	2.39E+09	0.00E+01	0.00E+01
I-133	1.23E-01	3.06E-01	2.39E-01	4.05E-01	7.10E-01	5.65E+01	0.00E+01	0.00E+01
I-135	4.88E-17	1.46E-16	5.11E-17	1.32E-16	2.08E-16	8.46E-15	0.00E+01	0.00E+01
Cs-134	3.48E+08	9.34E+06	3.19E+08	7.51E+08	2.39E+08	0.00E+01	9.11E+07	0.00E+01
Cs-136	1.55E+07	1.86E+06	5.87E+06	2.31E+07	1.26E+07	0.00E+01	1.98E+06	0.00E+01
Cs-137	2.14E+08	8.75E+06	4.62E+08	6.15E+08	2.09E+08	0.00E+01	8.13E+07	0.00E+01
Ba-140	9.76E+05	2.34E+07	1.51E+07	1.86E+04	6.29E+03	0.00E+01	1.25E+04	0.00E+01
Ce-141	5.42E+02	1.35E+07	7.07E+03	4.72E+03	2.22E+03	0.00E+01	0.00E+01	0.00E+01
Ce-144	3.96E+04	1.85E+08	7.37E+05	3.05E+05	1.82E+05	0.00E+01	0.00E+01	0.00E+01
Hf-181	1.22E+06	5.50E+08	1.10E+07	6.05E+04	5.04E+04	3.69E+04	0.00E+01	0.00E+01

*R Values in units of mrem/yr per $\mu\text{Ci}/\text{m}^3$ for inhalation and tritium and in units of mrem/yr per $\mu\text{Ci}/\text{sec}$ per m^{-2} for all others.

TABLE 3.3-7
 R VALUES FOR THE SHEARON HARRIS NUCLEAR POWER PLANT*

PATHWAY = Meat

AGE GROUP = Child

Nuclide	T. Body	GI-Tract	Bone	Liver	Kidney	Thyroid	Lung	Skin
H-3	2.36E+02	2.36E+02	0.00E+01	2.36E+02	2.36E+02	2.36E+02	2.36E+02	2.36E+02
P-32	1.87E+08	1.34E+08	4.86E+09	2.27E+08	0.00E+01	0.00E+01	0.00E+01	0.00E+01
Cr-51	5.33E+03	2.83E+05	0.00E+01	0.00E+01	8.09E+02	2.96E+03	5.40E+03	0.00E+01
Mn-54	1.30E+06	4.08E+06	0.00E+01	4.86E+06	1.36E+06	0.00E+01	0.00E+01	0.00E+01
Fe-59	1.82E+08	3.80E+08	2.25E+08	3.65E+08	0.00E+01	0.00E+01	1.06E+08	0.00E+01
Co-58	2.99E+07	5.70E+07	0.00E+01	9.76E+06	0.00E+01	0.00E+01	0.00E+01	0.00E+01
Co-60	1.27E+08	2.38E+08	0.00E+01	4.30E+07	0.00E+01	0.00E+01	0.00E+01	0.00E+01
Zn-65	4.35E+08	1.23E+08	2.62E+08	6.99E+08	4.40E+08	0.00E+01	0.00E+01	0.00E+01
Rb-86	2.21E+08	2.32E+07	0.00E+01	3.60E+08	0.00E+01	0.00E+01	0.00E+01	0.00E+01
Sr-89	8.31E+06	1.13E+07	2.91E+08	0.00E+01	0.00E+01	0.00E+01	0.00E+01	0.00E+01
Sr-90	1.74E+09	9.26E+07	6.87E+09	0.00E+01	0.00E+01	0.00E+01	0.00E+01	0.00E+01
Y-91	2.87E+04	1.43E+08	1.07E+06	0.00E+01	0.00E+01	0.00E+01	0.00E+01	0.00E+01
Zr-95	3.12E+05	3.65E+08	1.59E+06	3.50E+05	5.01E+05	0.00E+01	0.00E+01	0.00E+01
Nb-95	5.17E+05	1.34E+09	1.86E+06	7.23E+05	6.80E+05	0.00E+01	0.00E+01	0.00E+01
Ru-103	3.58E+07	2.41E+09	9.31E+07	0.00E+01	2.34E+08	0.00E+01	0.00E+01	0.00E+01
Ru-106	3.43E+08	4.27E+10	2.75E+09	0.00E+01	3.71E+09	0.00E+01	0.00E+01	0.00E+01
Ag-110M	2.89E+06	4.30E+08	5.36E+06	3.62E+06	6.74E+06	0.00E+01	0.00E+01	0.00E+01
Sn-113	3.42E+07	1.25E+08	3.14E+07	1.01E+06	6.97E+05	4.15E+05	0.00E+01	0.00E+01
Sb-124	6.17E+06	1.10E+08	1.76E+07	2.28E+05	0.00E+01	3.88E+04	9.77E+06	0.00E+01
Te-127M	1.55E+08	1.06E+09	1.31E+09	3.52E+08	3.73E+09	3.13E+08	0.00E+01	0.00E+01
Te-129M	1.81E+08	1.42E+09	1.17E+09	3.26E+08	3.43E+09	3.77E+08	0.00E+01	0.00E+01
I-131	6.20E+06	9.72E+05	1.09E+07	1.09E+07	1.79E+07	3.61E+09	0.00E+01	0.00E+01
I-133	2.07E-01	2.21E-01	4.43E-01	5.48E-01	9.13E-01	1.02E+02	0.00E+01	0.00E+01
I-135	7.87E-17	1.27E-16	9.25E-17	1.66E-16	2.55E-16	1.47E-14	0.00E+01	0.00E+01
Cs-134	1.95E+08	4.93E+06	5.63E+08	9.23E+08	2.86E+08	0.00E+01	1.03E+08	0.00E+01
Cs-136	1.80E+07	9.78E+05	1.01E+07	2.78E+07	1.48E+07	0.00E+01	2.21E+06	0.00E+01
Cs-137	1.20E+08	5.10E+06	8.51E+08	8.15E+08	2.65E+08	0.00E+01	9.55E+07	0.00E+01
Ba-140	1.63E+06	1.42E+07	2.80E+07	2.45E+04	7.97E+03	0.00E+01	1.46E+04	0.00E+01
Ce-141	9.86E+02	8.28E+06	1.33E+04	6.64E+03	2.91E+03	0.00E+01	0.00E+01	0.00E+01
Ce-144	7.42E+04	1.14E+08	1.39E+06	4.36E+05	2.41E+05	0.00E+01	0.00E+01	0.00E+01
Hf-181	2.02E+06	3.31E+08	2.00E+07	7.79E+04	6.26E+04	6.56E+04	0.00E+01	0.00E+01

*R Values in units of mrem/yr per $\mu\text{Ci}/\text{m}^3$ for inhalation and tritium and in units of mrem/yr per $\mu\text{Ci}/\text{sec}$ per m^{-2} for all others.

TABLE 3.3-8
 R VALUES FOR THE SHEARON HARRIS NUCLEAR POWER PLANT*

PATHWAY = Cow Milk

AGE GROUP = Adult

<u>Nuclide</u>	<u>T. Body</u>	<u>GI-Tract</u>	<u>Bone</u>	<u>Liver</u>	<u>Kidney</u>	<u>Thyroid</u>	<u>Lung</u>	<u>Skin</u>
H-3	7.69E+02	7.69E+02	0.00E+01	7.69E+02	7.69E+02	7.69E+02	7.69E+02	7.69E+02
P-32	4.32E+08	1.26E+09	1.12E+10	6.95E+08	0.00E+01	0.00E+01	0.00E+01	0.00E+01
Cr-51	1.73E+04	4.36E+06	0.00E+01	0.00E+01	3.82E+03	1.04E+04	2.30E+04	0.00E+01
Mn-54	9.76E+05	1.57E+07	0.00E+01	5.11E+06	1.52E+06	0.00E+01	0.00E+01	0.00E+01
Fe-59	1.60E+07	1.39E+08	1.77E+07	4.17E+07	0.00E+01	0.00E+01	1.17E+07	0.00E+01
Co-58	6.28E+06	5.68E+07	0.00E+01	2.80E+06	0.00E+01	0.00E+01	0.00E+01	0.00E+01
Co-60	2.24E+07	1.91E+08	0.00E+01	1.02E+07	0.00E+01	0.00E+01	0.00E+01	0.00E+01
Zn-65	1.38E+09	1.92E+09	9.59E+08	3.05E+09	2.04E+09	0.00E+01	0.00E+01	0.00E+01
Rb-86	7.54E+08	3.19E+08	0.00E+01	1.62E+09	0.00E+01	0.00E+01	0.00E+01	0.00E+01
Sr-89	2.50E+07	1.40E+08	8.70E+08	0.00E+01	0.00E+01	0.00E+01	0.00E+01	0.00E+01
Sr-90	7.59E+09	8.94E+08	3.09E+10	0.00E+01	0.00E+01	0.00E+01	0.00E+01	0.00E+01
Y-91	1.37E+02	2.81E+06	5.11E+03	0.00E+01	0.00E+01	0.00E+01	0.00E+01	0.00E+01
Zr-95	1.22E+02	5.71E+05	5.62E+02	1.80E+02	2.83E+02	0.00E+01	0.00E+01	0.00E+01
Nb-95	1.48E+04	1.67E+08	4.95E+04	2.75E+04	2.72E+04	0.00E+01	0.00E+01	0.00E+01
Ru-103	2.63E+02	7.14E+04	6.11E+02	0.00E+01	2.33E+03	0.00E+01	0.00E+01	0.00E+01
Ru-106	1.60E+03	8.17E+05	1.26E+04	0.00E+01	2.44E+04	0.00E+01	0.00E+01	0.00E+01
Ag-110M	2.04E+07	1.40E+10	3.71E+07	3.44E+07	6.76E+07	0.00E+01	0.00E+01	0.00E+01
Sn-113	1.32E+06	2.44E+07	1.40E+06	5.41E+04	3.95E+04	1.90E+04	0.00E+01	0.00E+01
Sb-124	6.14E+06	4.39E+08	1.55E+07	2.92E+05	0.00E+01	3.75E+04	1.20E+07	0.00E+01
Te-127M	4.11E+06	1.13E+08	3.37E+07	1.21E+07	1.37E+08	8.62E+06	0.00E+01	0.00E+01
Te-129M	6.19E+06	1.97E+08	3.91E+07	1.46E+07	1.63E+08	1.34E+07	0.00E+01	0.00E+01
I-131	1.59E+08	7.32E+07	1.94E+08	2.77E+08	4.76E+08	9.09E+10	0.00E+01	0.00E+01
I-132	1.03E+01	5.51E-02	1.10E+01	2.93E+01	4.67E+01	1.03E+01	0.00E+01	0.00E+01
I-133	1.40E+06	4.13E+06	2.64E+06	4.59E+06	8.01E+06	6.75E+08	0.00E+01	0.00E+01
I-135	9.03E+03	2.76E+04	9.34E+03	2.45E+04	3.92E+04	1.61E+06	0.00E+01	0.00E+01
Cs-134	6.71E+09	1.44E+08	3.45E+09	3.21E+09	2.66E+09	0.00E+01	8.82E+08	0.00E+01
Cs-136	4.73E+08	7.46E+07	1.66E+08	6.57E+08	3.65E+08	0.00E+01	5.01E+07	0.00E+01
Cs-137	4.22E+09	1.25E+08	4.71E+09	6.44E+09	2.19E+09	0.00E+01	7.27E+08	0.00E+01
Ba-140	1.12E+06	3.53E+07	1.71E+07	2.15E+04	7.32E+03	0.00E+01	1.23E+04	0.00E+01
Ce-141	2.23E+02	7.52E+06	2.91E+03	1.97E+03	9.14E+02	0.00E+01	0.00E+01	0.00E+01
Ce-144	1.15E+04	7.26E+07	2.15E+05	8.97E+04	5.32E+04	0.00E+01	0.00E+01	0.00E+01
Hf-181	6.68E+02	4.38E+05	5.91E+03	3.33E+01	2.79E+01	2.12E+01	0.00E+01	0.00E+01

*R Values in units of mrem/yr per $\mu\text{Ci}/\text{m}^3$ for inhalation and tritium and in units of mrem/yr per $\mu\text{Ci}/\text{sec}$ per m^{-2} for all others.

TABLE 3.3-9
 R VALUES FOR THE SHEARON HARRIS NUCLEAR POWER PLANT*

PATHWAY = Cow Milk

AGE GROUP = Teen

<u>Nuclide</u>	<u>T. Body</u>	<u>GI-Tract</u>	<u>Bone</u>	<u>Liver</u>	<u>Kidney</u>	<u>Thyroid</u>	<u>Lung</u>	<u>Skin</u>
H-3	1.00E+03	1.00E+03	0.00E+01	1.00E+03	1.00E+03	1.00E+03	1.00E+03	1.00E+03
P-32	8.00E+08	1.73E+09	2.06E+10	1.28E+09	0.00E+01	0.00E+01	0.00E+01	0.00E+01
Cr-51	3.02E+04	5.08E+06	0.00E+01	0.00E+01	6.63E+03	1.68E+04	4.32E+04	0.00E+01
Mn-54	1.69E+06	1.75E+07	0.00E+01	8.52E+06	2.54E+06	0.00E+01	0.00E+01	0.00E+01
Fe-59	2.79E+07	1.71E+08	3.10E+07	7.23E+07	0.00E+01	0.00E+01	2.28E+07	0.00E+01
Co-58	1.09E+07	6.50E+07	0.00E+01	4.72E+06	0.00E+01	0.00E+01	0.00E+01	0.00E+01
Co-60	3.88E+07	2.25E+08	0.00E+01	1.72E+07	0.00E+01	0.00E+01	0.00E+01	0.00E+01
Zn-65	2.38E+09	2.16E+09	1.47E+09	5.11E+09	3.27E+09	0.00E+01	0.00E+01	0.00E+01
Rb-86	1.39E+09	4.37E+08	0.00E+01	2.95E+09	0.00E+01	0.00E+01	0.00E+01	0.00E+01
Sr-89	4.59E+07	1.91E+08	1.60E+09	0.00E+01	0.00E+01	0.00E+01	0.00E+01	0.00E+01
Sr-90	1.08E+10	1.23E+09	4.37E+10	0.00E+01	0.00E+01	0.00E+01	0.00E+01	0.00E+01
Y-91	2.52E+02	3.85E+06	9.40E+03	0.00E+01	0.00E+01	0.00E+01	0.00E+01	0.00E+01
Zr-95	2.13E+02	7.16E+05	9.83E+02	3.10E+02	4.56E+02	0.00E+01	0.00E+01	0.00E+01
Nb-95	2.58E+04	2.00E+08	8.45E+04	4.68E+04	4.54E+04	0.00E+01	0.00E+01	0.00E+01
Ru-103	4.65E+02	9.08E+04	1.09E+03	0.00E+01	3.83E+03	0.00E+01	0.00E+01	0.00E+01
Ru-106	2.93E+03	1.11E+06	2.32E+04	0.00E+01	4.48E+04	0.00E+01	0.00E+01	0.00E+01
Ag-110M	3.53E+07	1.63E+10	6.14E+07	5.81E+07	1.11E+08	0.00E+01	0.00E+01	0.00E+01
Sn-113	2.28E+06	2.58E+07	2.15E+06	9.06E+04	6.37E+04	2.97E+04	0.00E+01	0.00E+01
Sb-124	1.08E+07	5.56E+08	2.76E+07	5.08E+05	0.00E+01	6.26E+04	2.41E+07	0.00E+01
Te-127M	7.39E+06	1.55E+08	6.22E+07	2.21E+07	2.52E+08	1.48E+07	0.00E+01	0.00E+01
Te-129M	1.13E+07	2.69E+08	7.15E+07	2.65E+07	2.99E+08	2.31E+07	0.00E+01	0.00E+01
I-131	2.65E+08	9.75E+07	3.52E+08	4.93E+08	8.48E+08	1.44E+11	0.00E+01	0.00E+01
I-132	1.83E+01	2.22E+01	1.94E+01	5.09E+01	8.02E+01	1.71E+01	0.00E+01	0.00E+01
I-133	2.49E+06	6.19E+06	4.82E+06	8.18E+06	1.43E+07	1.14E+09	0.00E+01	0.00E+01
I-135	1.58E+04	4.74E+04	1.66E+04	4.27E+04	6.75E+04	2.75E+06	0.00E+01	0.00E+01
Cs-134	6.54E+09	1.75E+08	5.99E+09	1.41E+10	4.48E+09	0.00E+01	1.71E+09	0.00E+01
Cs-136	7.48E+08	8.97E+07	2.83E+08	1.11E+09	6.07E+08	0.00E+01	9.56E+07	0.00E+01
Cs-137	3.96E+09	1.62E+08	8.54E+09	1.14E+10	3.87E+09	0.00E+01	1.50E+09	0.00E+01
Ba-140	1.99E+06	4.77E+07	3.09E+07	3.79E+04	1.28E+04	0.00E+01	2.55E+04	0.00E+01
Ce-141	4.09E+02	1.02E+07	5.33E+03	3.56E+03	1.68E+03	0.00E+01	0.00E+01	0.00E+01
Ce-144	2.12E+04	9.93E+07	3.95E+05	1.63E+05	9.76E+04	0.00E+01	0.00E+01	0.00E+01
Hf-181	1.18E+03	5.28E+05	1.06E+04	5.82E+01	4.84E+01	3.55E+01	0.00E+01	0.00E+01

*R Values in units of mrem/yr per $\mu\text{Ci}/\text{m}^3$ for inhalation and tritium and in units of mrem/yr per $\mu\text{Ci}/\text{sec}$ per m^{-2} for all others.

TABLE 3.3-10
 R VALUES FOR THE SHEARON HARRIS NUCLEAR POWER PLANT*

PATHWAY = Cow Milk

AGE GROUP = Child

<u>Nuclide</u>	<u>T. Body</u>	<u>GI-Tract</u>	<u>Bone</u>	<u>Liver</u>	<u>Kidney</u>	<u>Thyroid</u>	<u>Lung</u>	<u>Skin</u>
H-3	1.58E+03	1.58E+03	0.00E+01	1.58E+03	1.58E+03	1.58E+03	1.58E+03	1.58E+03
P-32	1.96E+09	1.41E+09	5.09E+10	2.38E+09	0.00E+01	0.00E+01	0.00E+01	0.00E+01
Cr-51	6.17E+04	3.27E+06	0.00E+01	0.00E+01	9.36E+03	3.42E+04	6.25E+04	0.00E+01
Mn-54	3.39E+06	1.07E+07	0.00E+01	1.27E+07	3.57E+06	0.00E+01	0.00E+01	0.00E+01
Fe-59	5.79E+07	1.21E+08	7.18E+07	1.16E+08	0.00E+01	0.00E+01	3.37E+07	0.00E+01
Co-58	2.21E+07	4.20E+07	0.00E+01	7.21E+06	0.00E+01	0.00E+01	0.00E+01	0.00E+01
Co-60	7.90E+07	1.48E+08	0.00E+01	2.68E+07	0.00E+01	0.00E+01	0.00E+01	0.00E+01
Zn-65	4.79E+09	1.35E+09	2.89E+09	7.70E+09	4.85E+09	0.00E+01	0.00E+01	0.00E+01
Rb-86	3.36E+09	3.52E+08	0.00E+01	5.47E+09	0.00E+01	0.00E+01	0.00E+01	0.00E+01
Sr-89	1.13E+08	1.54E+08	3.97E+09	0.00E+01	0.00E+01	0.00E+01	0.00E+01	0.00E+01
Sr-90	1.87E+10	9.95E+08	7.38E+10	0.00E+01	0.00E+01	0.00E+01	0.00E+01	0.00E+01
Y-91	6.21E+02	3.09E+06	2.32E+04	0.00E+01	0.00E+01	0.00E+01	0.00E+01	0.00E+01
Zr-95	4.47E+02	5.23E+05	2.28E+03	5.02E+02	7.18E+02	0.00E+01	0.00E+01	0.00E+01
Nb-95	5.31E+04	1.37E+08	1.91E+05	7.42E+04	6.98E+04	0.00E+01	0.00E+01	0.00E+01
Ru-103	9.88E+02	6.65E+04	2.57E+03	0.00E+01	6.47E+03	0.00E+01	0.00E+01	0.00E+01
Ru-106	7.14E+03	8.90E+05	5.72E+04	0.00E+01	7.72E+04	0.00E+01	0.00E+01	0.00E+01
Ag-110M	7.19E+07	1.07E+10	1.33E+08	9.00E+07	1.68E+08	0.00E+01	0.00E+01	0.00E+01
Sn-113	4.61E+05	1.69E+06	4.22E+05	1.36E+04	9.37E+03	5.58E+03	0.00E+01	0.00E+01
Sb-124	2.29E+07	4.09E+08	6.53E+07	8.47E+05	0.00E+01	1.44E+05	3.62E+07	0.00E+01
Te-127M	1.82E+07	1.24E+08	1.53E+08	4.13E+07	4.37E+08	3.66E+07	0.00E+01	0.00E+01
Te-129M	2.74E+07	2.15E+08	1.76E+08	4.92E+07	5.18E+08	5.68E+07	0.00E+01	0.00E+01
I-131	4.88E+08	7.64E+07	8.54E+08	8.59E+08	1.41E+09	2.84E+11	0.00E+01	0.00E+01
I-132	3.89E+01	9.95E+01	4.60E+01	8.45E+01	1.29E+00	3.92E+01	0.00E+01	0.00E+01
I-133	5.48E+06	5.84E+06	1.17E+07	1.45E+07	2.41E+07	2.69E+09	0.00E+01	0.00E+01
I-135	3.35E+04	5.39E+04	3.93E+04	7.07E+04	1.08E+05	6.26E+06	0.00E+01	0.00E+01
Cs-134	4.78E+09	1.22E+08	1.38E+10	2.27E+10	7.03E+09	0.00E+01	2.52E+09	0.00E+01
Cs-136	1.14E+09	6.17E+07	6.39E+08	1.76E+09	9.36E+08	0.00E+01	1.40E+08	0.00E+01
Cs-137	2.91E+09	1.23E+08	2.06E+10	1.97E+10	6.42E+09	0.00E+01	2.31E+09	0.00E+01
Ba-140	4.36E+06	3.78E+07	7.47E+07	6.54E+04	2.13E+04	0.00E+01	3.90E+04	0.00E+01
Ce-141	9.73E+02	8.17E+06	1.31E+04	6.55E+03	2.87E+03	0.00E+01	0.00E+01	0.00E+01
Ce-144	5.20E+04	7.96E+07	9.74E+05	3.05E+05	1.69E+05	0.00E+01	0.00E+01	0.00E+01
Hf-181	2.53E+03	4.16E+05	2.51E+04	9.79E+01	7.86E+01	8.24E+01	0.00E+01	0.00E+01

*R Values in units of mrem/yr per $\mu\text{Ci}/\text{m}^3$ for inhalation and tritium and in units of mrem/yr per $\mu\text{Ci}/\text{sec}$ per m^2 for all others.

TABLE 3.3-11
 R VALUES FOR THE SHEARON HARRIS NUCLEAR POWER PLANT*

PATHWAY = Cow Milk

AGE GROUP = Infant

<u>Nuclide</u>	<u>T. Body</u>	<u>GI-Tract</u>	<u>Bone</u>	<u>Liver</u>	<u>Kidney</u>	<u>Thyroid</u>	<u>Lung</u>	<u>Skin</u>
H-3	2.40E+03	2.40E+03	0.00E+01	2.40E+03	2.40E+03	2.40E+03	2.40E+03	2.40E+03
P-32	4.06E+09	1.42E+09	1.05E+11	6.17E+09	0.00E+01	0.00E+01	0.00E+01	0.00E+01
Cr-51	9.77E+04	2.85E+06	0.00E+01	0.00E+01	1.39E+04	6.38E+04	1.24E+05	0.00E+01
Mn-54	5.37E+06	8.71E+06	0.00E+01	2.37E+07	5.25E+06	0.00E+01	0.00E+01	0.00E+01
Fe-59	9.23E+07	1.12E+08	1.34E+08	2.34E+08	0.00E+01	0.00E+01	6.92E+07	0.00E+01
Co-58	3.60E+07	3.59E+07	0.00E+01	1.44E+07	0.00E+01	0.00E+01	0.00E+01	0.00E+01
Co-60	1.29E+08	1.30E+08	0.00E+01	5.47E+07	0.00E+01	0.00E+01	0.00E+01	0.00E+01
Zn-65	6.14E+09	1.12E+10	3.88E+09	1.33E+10	6.45E+09	0.00E+01	0.00E+01	0.00E+01
Rb-86	6.86E+09	3.55E+08	0.00E+01	1.39E+10	0.00E+01	0.00E+01	0.00E+01	0.00E+01
Sr-89	2.17E+08	1.55E+08	7.55E+09	0.00E+01	0.00E+01	0.00E+01	0.00E+01	0.00E+01
Sr-90	2.05E+10	1.00E+09	8.04E+10	0.00E+01	0.00E+01	0.00E+01	0.00E+01	0.00E+01
Y-91	1.16E+08	3.12E+06	4.36E+04	0.00E+01	0.00E+01	0.00E+01	0.00E+01	0.00E+01
Zr-95	7.01E+02	4.92E+05	4.05E+03	9.88E+02	1.06E+03	0.00E+01	0.00E+01	0.00E+01
Nb-95	8.48E+04	1.24E+08	3.56E+05	1.47E+05	1.05E+05	0.00E+01	0.00E+01	0.00E+01
Ru-103	1.74E+03	6.33E+04	5.21E+03	0.00E+01	1.08E+04	0.00E+01	0.00E+01	0.00E+01
Ru-106	1.47E+04	8.95E+05	1.18E+05	0.00E+01	1.39E+05	0.00E+01	0.00E+01	0.00E+01
Ag-110M	1.19E+08	9.32E+09	2.46E+08	1.80E+08	2.57E+08	0.00E+01	0.00E+01	0.00E+01
Sn-113	6.65E+06	1.37E+07	6.45E+06	2.45E+05	1.31E+05	9.34E+04	0.00E+01	0.00E+01
Sb-124	3.90E+07	3.88E+08	1.26E+08	1.85E+06	0.00E+01	3.34E+05	7.88E+07	0.00E+01
Te-127M	3.75E+07	1.25E+08	3.10E+08	1.03E+08	7.64E+08	8.96E+07	0.00E+01	0.00E+01
Te-129M	5.57E+07	2.16E+08	3.62E+08	1.24E+08	9.05E+08	1.39E+08	0.00E+01	0.00E+01
I-131	9.23E+08	7.49E+07	1.78E+09	2.10E+09	2.45E+09	6.90E+11	0.00E+01	0.00E+01
I-132	6.90E+01	1.57E-00	9.55E+01	1.94E+00	2.16E+00	9.09E+01	0.00E+01	0.00E+01
I-133	1.05E+07	6.09E+06	2.47E+07	3.60E+07	4.23E+07	6.55E+09	0.00E+01	0.00E+01
I-135	5.93E+04	5.88E+04	8.17E+04	1.63E+05	1.81E+05	1.46E+07	0.00E+01	0.00E+01
Cs-134	4.19E+09	1.13E+08	2.23E+10	4.15E+10	1.07E+10	0.00E+01	4.38E+09	0.00E+01
Cs-136	1.37E+09	5.58E+07	1.25E+09	3.67E+09	1.46E+09	0.00E+01	2.99E+08	0.00E+01
Cs-137	2.72E+09	1.20E+08	3.28E+10	3.84E+10	1.03E+10	0.00E+01	4.18E+09	0.00E+01
Ba-140	7.91E+06	3.77E+07	1.54E+08	1.54E+05	3.65E+04	0.00E+01	9.43E+04	0.00E+01
Ce-141	1.87E+03	8.21E+06	2.60E+04	1.59E+04	4.90E+03	0.00E+01	0.00E+01	0.00E+01
Ce-144	7.82E+04	8.01E+07	1.40E+06	5.71E+05	2.31E+05	0.00E+01	0.00E+01	0.00E+01
Hf-181	4.23E+03	3.93E+05	4.78E+04	2.26E+02	1.32E+02	1.91E+02	0.00E+01	0.00E+01

*R Values in units of mrem/yr per $\mu\text{Ci}/\text{m}^3$ for inhalation and tritium and in units of mrem/yr per $\mu\text{Ci}/\text{sec}$ per m^{-2} for all others.

TABLE 3.3-12
 R VALUES FOR THE SHEARON HARRIS NUCLEAR POWER PLANT*

PATHWAY = Goat Milk

AGE GROUP = Adult

<u>Nuclide</u>	<u>T. Body</u>	<u>GI-Tract</u>	<u>Bone</u>	<u>Liver</u>	<u>Kidney</u>	<u>Thyroid</u>	<u>Lung</u>	<u>Skin</u>
H-3	1.57E+03	1.57E+03	0.00E+01	1.57E+03	1.57E+03	1.57E+03	1.57E+03	1.57E+03
P-32	5.19E+08	1.51E+09	1.34E+10	8.34E+08	0.00E+01	0.00E+01	0.00E+01	0.00E+01
Cr-51	2.08E+03	5.23E+05	0.00E+01	0.00E+01	4.58E+02	1.24E+03	2.76E+03	0.00E+01
Mn-54	1.17E+05	1.88E+06	0.00E+01	6.14E+05	1.83E+05	0.00E+01	0.00E+01	0.00E+01
Fe-59	2.08E+05	1.81E+06	2.31E+05	5.42E+05	0.00E+01	0.00E+01	1.51E+05	0.00E+01
Co-58	7.54E+05	6.82E+06	0.00E+01	3.36E+05	0.00E+01	0.00E+01	0.00E+01	0.00E+01
Co-60	2.69E+06	2.29E+07	0.00E+01	1.22E+06	0.00E+01	0.00E+01	0.00E+01	0.00E+01
Zn-65	1.65E+08	2.31E+08	1.15E+08	3.66E+08	2.45E+08	0.00E+01	0.00E+01	0.00E+01
Rb-86	9.05E+07	3.83E+07	0.00E+01	1.94E+08	0.00E+01	0.00E+01	0.00E+01	0.00E+01
Sr-89	5.24E+07	2.93E+08	1.83E+09	0.00E+01	0.00E+01	0.00E+01	0.00E+01	0.00E+01
Sr-90	1.59E+10	1.88E+09	6.49E+10	0.00E+01	0.00E+01	0.00E+01	0.00E+01	0.00E+01
Y-91	1.64E+01	3.37E+05	6.13E+02	0.00E+01	0.00E+01	0.00E+01	0.00E+01	0.00E+01
Zr-95	1.46E+01	6.85E+04	6.74E+01	2.16E+01	3.39E+01	0.00E+01	0.00E+01	0.00E+01
Nb-95	1.78E+03	2.01E+07	5.94E+03	3.31E+03	3.27E+03	0.00E+01	0.00E+01	0.00E+01
Ru-103	3.16E+01	8.56E+03	7.33E+01	0.00E+01	2.80E+02	0.00E+01	0.00E+01	0.00E+01
Ru-106	1.92E+02	9.81E+04	1.52E+03	0.00E+01	2.93E+03	0.00E+01	0.00E+01	0.00E+01
Ag-110M	2.45E+06	1.68E+09	4.46E+06	4.12E+06	8.11E+06	0.00E+01	0.00E+01	0.00E+01
Sn-113	1.32E+05	2.44E+06	1.40E+05	5.41E+03	3.96E+03	1.90E+03	0.00E+01	0.00E+01
Sb-124	7.36E+05	5.27E+07	1.86E+06	3.51E+04	0.00E+01	4.50E+03	1.44E+06	0.00E+01
Te-127M	4.93E+05	1.36E+07	4.05E+06	1.45E+06	1.64E+07	1.03E+06	0.00E+01	0.00E+01
Te-129M	7.43E+05	2.36E+07	4.69E+06	1.75E+06	1.96E+07	1.61E+06	0.00E+01	0.00E+01
I-131	1.91E+08	8.78E+07	2.33E+08	3.33E+08	5.71E+08	1.09E+11	0.00E+01	0.00E+01
I-132	1.23E+01	6.61E-02	1.32E+01	3.52E+01	5.61E+01	1.23E+01	0.00E+01	0.00E+01
I-133	1.68E+06	4.95E+06	3.17E+06	5.51E+06	9.61E+06	8.10E+08	0.00E+01	0.00E+01
I-135	1.08E+04	3.32E+04	1.12E+04	2.94E+04	4.71E+04	1.94E+06	0.00E+01	0.00E+01
Cs-134	2.01E+10	4.31E+08	1.03E+10	2.46E+10	7.97E+09	0.00E+01	2.65E+09	0.00E+01
Cs-136	1.42E+09	2.24E+08	4.99E+08	1.97E+09	1.10E+09	0.00E+01	1.50E+08	0.00E+01
Cs-137	1.27E+10	3.74E+08	1.41E+10	1.93E+10	6.56E+09	0.00E+01	2.18E+09	0.00E+01
Ba-140	1.35E+05	4.23E+06	2.06E+06	2.58E+03	8.78E+02	0.00E+01	1.48E+03	0.00E+01
Ce-141	2.68E+01	9.03E+05	3.49E+02	2.36E+02	1.10E+02	0.00E+01	0.00E+01	0.00E+01
Ce-144	1.38E+03	8.71E+06	2.58E+04	1.08E+04	6.39E+03	0.00E+01	0.00E+01	0.00E+01
Hf-181	8.02E+01	5.26E+04	7.09E+02	3.99E+00	3.34E+00	2.54E+00	0.00E+01	0.00E+01

*R Values in units of mrem/yr per $\mu\text{Ci}/\text{m}^3$ for inhalation and tritium and in units of mrem/yr per $\mu\text{Ci}/\text{sec}$ per m^{-2} for all others.

TABLE 3.3-13
 R VALUES FOR THE SHEARON HARRIS NUCLEAR POWER PLANT*

PATHWAY = Goat Milk

AGE GROUP = Teen

<u>Nuclide</u>	<u>T. Body</u>	<u>GI-Tract</u>	<u>Bone</u>	<u>Liver</u>	<u>Kidney</u>	<u>Thyroid</u>	<u>Lung</u>	<u>Skin</u>
H-3	2.04E+03	2.04E+03	0.00E+01	2.04E+03	2.04E+03	2.04E+03	2.04E+03	2.04E+03
P-32	9.60E+08	2.08E+09	2.48E+10	1.53E+09	0.00E+01	0.00E+01	0.00E+01	0.00E+01
Cr-51	3.63E+03	6.10E+05	0.00E+01	0.00E+01	7.95E+02	2.02E+03	5.18E+03	0.00E+01
Mn-54	2.03E+05	2.10E+06	0.00E+01	1.02E+06	3.05E+05	0.00E+01	0.00E+01	0.00E+01
Fe-59	3.63E+05	2.22E+06	4.03E+05	9.40E+05	0.00E+01	0.00E+01	2.96E+05	0.00E+01
Co-58	1.30E+06	7.80E+06	0.00E+01	5.66E+05	0.00E+01	0.00E+01	0.00E+01	0.00E+01
Co-60	4.66E+06	2.69E+07	0.00E+01	2.07E+06	0.00E+01	0.00E+01	0.00E+01	0.00E+01
Zn-65	2.86E+08	2.60E+08	1.77E+08	6.13E+08	3.93E+08	0.00E+01	0.00E+01	0.00E+01
Rb-86	1.66E+08	5.24E+07	0.00E+01	3.54E+08	0.00E+01	0.00E+01	0.00E+01	0.00E+01
Sr-89	9.65E+07	4.01E+08	3.37E+09	0.00E+01	0.00E+01	0.00E+01	0.00E+01	0.00E+01
Sr-90	2.27E+10	2.58E+09	9.18E+10	0.00E+01	0.00E+01	0.00E+01	0.00E+01	0.00E+01
Y-91	3.02E+01	4.62E+05	1.13E+03	0.00E+01	0.00E+01	0.00E+01	0.00E+01	0.00E+01
Zr-95	2.56E+01	8.59E+04	1.18E+02	3.72E+01	5.47E+01	0.00E+01	0.00E+01	0.00E+01
Nb-95	3.09E+03	2.40E+07	1.01E+04	5.62E+03	5.45E+03	0.00E+01	0.00E+01	0.00E+01
Ru-103	5.58E+01	1.09E+04	1.30E+02	0.00E+01	4.60E+02	0.00E+01	0.00E+01	0.00E+01
Ru-106	3.51E+02	1.34E+05	2.79E+03	0.00E+01	5.38E+03	0.00E+01	0.00E+01	0.00E+01
Ag-110M	4.24E+06	1.96E+09	7.37E+06	6.97E+06	1.33E+07	0.00E+01	0.00E+01	0.00E+01
Sn-113	2.28E+05	2.58E+06	2.15E+05	9.06E+03	6.37E+03	2.97E+03	0.00E+01	0.00E+01
Sb-124	1.29E+06	6.67E+07	3.31E+06	6.10E+04	0.00E+01	7.51E+03	2.89E+06	0.00E+01
Te-127M	8.87E+05	1.86E+07	7.46E+06	2.65E+06	3.02E+07	1.77E+06	0.00E+01	0.00E+01
Te-129M	1.36E+06	3.22E+07	8.58E+06	3.19E+06	3.59E+07	2.77E+06	0.00E+01	0.00E+01
I-131	3.18E+08	1.17E+08	4.22E+08	5.91E+08	1.02E+09	1.73E+11	0.00E+01	0.00E+01
I-132	2.19E+01	2.66E+01	2.33E+01	6.11E+01	9.62E+01	2.06E+01	0.00E+01	0.00E+01
I-133	2.99E+06	7.43E+06	5.79E+06	9.81E+06	1.72E+07	1.37E+09	0.00E+01	0.00E+01
I-135	1.90E+04	5.63E+04	1.99E+04	5.13E+04	8.10E+04	3.30E+06	0.00E+01	0.00E+01
Cs-134	1.96E+10	5.26E+08	1.80E+10	4.23E+10	1.34E+10	0.00E+01	5.13E+09	0.00E+01
Cs-136	2.25E+09	2.69E+07	8.50E+08	3.34E+09	1.82E+09	0.00E+01	2.87E+08	0.00E+01
Cs-137	1.19E+10	4.85E+08	2.56E+10	3.41E+10	1.16E+10	0.00E+01	4.51E+09	0.00E+01
Ba-140	2.39E+05	5.72E+06	3.71E+06	4.55E+03	1.54E+03	0.00E+01	3.06E+03	0.00E+01
Ce-141	4.91E+01	1.22E+06	6.40E+02	4.27E+02	2.01E+02	0.00E+01	0.00E+01	0.00E+01
Ce-144	2.55E+03	1.19E+07	4.74E+04	1.96E+04	1.17E+04	0.00E+01	0.00E+01	0.00E+01
Hf-181	1.41E+02	6.34E+04	1.27E+03	6.97E+00	5.80E+00	4.26E+00	0.00E+01	0.00E+01

*R Values in units of mrem/yr per $\mu\text{Ci}/\text{m}^3$ for inhalation and tritium and in units of mrem/yr per $\mu\text{Ci}/\text{sec}$ per m^{-2} for all others.

TABLE 3.3-14
 R VALUES FOR THE SHEARON HARRIS NUCLEAR POWER PLANT*

PATHWAY = Goat Milk

AGE GROUP = Child

<u>Nuclide</u>	<u>T. Body</u>	<u>GI-Tract</u>	<u>Bone</u>	<u>Liver</u>	<u>Kidney</u>	<u>Thyroid</u>	<u>Lung</u>	<u>Skin</u>
H-3	3.23E+03	3.23E+03	0.00E+01	3.23E+03	3.23E+03	3.23E+03	3.23E+03	3.23E+03
P-32	2.35E+09	1.69E+09	6.11E+10	2.86E+09	0.00E+01	0.00E+01	0.00E+01	0.00E+01
Cr-51	7.40E+03	3.93E+05	0.00E+01	0.00E+01	1.12E+03	4.11E+03	7.50E+03	0.00E+01
Mn-54	4.07E+05	1.28E+06	0.00E+01	1.53E+06	4.29E+05	0.00E+01	0.00E+01	0.00E+01
Fe-59	7.52E+05	1.57E+06	9.34E+05	1.51E+06	0.00E+01	0.00E+01	4.38E+05	0.00E+01
Co-58	2.65E+06	5.05E+06	0.00E+01	8.65E+05	0.00E+01	0.00E+01	0.00E+01	0.00E+01
Co-60	9.48E+06	1.78E+07	0.00E+01	3.21E+06	0.00E+01	0.00E+01	0.00E+01	0.00E+01
Zn-65	5.74E+08	1.62E+08	3.47E+08	9.24E+08	5.82E+08	0.00E+01	0.00E+01	0.00E+01
Rb-86	4.04E+08	4.22E+07	0.00E+01	6.57E+08	0.00E+01	0.00E+01	0.00E+01	0.00E+01
Sr-89	2.38E+08	3.23E+08	8.34E+09	0.00E+01	0.00E+01	0.00E+01	0.00E+01	0.00E+01
Sr-90	3.93E+10	2.09E+09	1.55E+11	0.00E+01	0.00E+01	0.00E+01	0.00E+01	0.00E+01
Y-91	7.45E+01	3.71E+05	2.79E+03	0.00E+01	0.00E+01	0.00E+01	0.00E+01	0.00E+01
Zr-95	5.36E+01	6.28E+04	2.74E+02	6.02E+01	8.62E+01	0.00E+01	0.00E+01	0.00E+01
Nb-95	6.37E+03	1.65E+07	2.29E+04	8.91E+03	8.37E+03	0.00E+01	0.00E+01	0.00E+01
Ru-103	1.19E+02	7.98E+03	3.09E+02	0.00E+01	7.77E+02	0.00E+01	0.00E+01	0.00E+01
Ru-106	8.56E+02	1.07E+05	6.86E+03	0.00E+01	9.27E+03	0.00E+01	0.00E+01	0.00E+01
Ag-110M	8.63E+06	1.28E+09	1.60E+07	1.08E+07	2.01E+07	0.00E+01	0.00E+01	0.00E+01
Sn-113	4.61E+05	1.69E+06	4.22E+05	1.36E+04	9.38E+03	5.59E+03	0.00E+01	0.00E+01
Sb-124	2.75E+06	4.91E+07	7.84E+06	1.02E+05	0.00E+01	1.73E+04	4.35E+06	0.00E+01
Te-127M	2.18E+06	1.49E+07	1.84E+07	4.95E+06	5.24E+07	4.40E+06	0.00E+01	0.00E+01
Te-129M	3.28E+06	2.58E+07	2.12E+07	5.91E+06	6.21E+07	6.82E+06	0.00E+01	0.00E+01
I-131	5.85E+08	9.17E+07	1.02E+09	1.03E+09	1.69E+09	3.41E+11	0.00E+01	0.00E+01
I-132	4.67E+01	1.19E+00	5.52E+01	1.01E+00	1.55E+00	4.71E+01	0.00E+01	0.00E+01
I-133	6.58E+06	7.00E+06	1.41E+07	1.74E+07	2.90E+07	3.23E+09	0.00E+01	0.00E+01
I-135	4.01E+04	6.47E+04	4.72E+04	8.49E+04	1.30E+05	7.52E+06	0.00E+01	0.00E+01
Cs-134	1.43E+10	3.67E+08	4.14E+10	6.80E+10	2.11E+10	0.00E+01	7.56E+09	0.00E+01
Cs-136	3.41E+09	1.85E+08	1.92E+09	5.27E+09	2.81E+09	0.00E+01	4.19E+08	0.00E+01
Cs-137	8.72E+09	3.70E+08	6.17E+10	5.91E+10	1.93E+10	0.00E+01	6.93E+09	0.00E+01
Ba-140	5.23E+05	4.54E+05	8.96E+06	7.85E+03	2.56E+03	0.00E+01	4.68E+03	0.00E+01
Ce-141	1.17E+02	9.81E+05	1.53E+03	7.36E+02	3.45E+02	0.00E+01	0.00E+01	0.00E+01
Ce-144	6.24E+03	9.55E+06	1.17E+05	3.66E+04	2.03E+04	0.00E+01	0.00E+01	0.00E+01
Hf-181	3.04E+02	4.99E+04	3.02E+03	1.17E+01	9.43E+00	9.88E+00	0.00E+01	0.00E+01

*R Values in units of mrem/yr per $\mu\text{Ci}/\text{m}^3$ for inhalation and tritium and in units of mrem/yr per $\mu\text{Ci}/\text{sec}$ per m^2 for all others.

TABLE 3.3-15
 R VALUES FOR THE SHEARON HARRIS NUCLEAR POWER PLANT*

PATHWAY = Goat Milk

AGE GROUP = Infant

<u>Nuclide</u>	<u>T. Body</u>	<u>GI-Tract</u>	<u>Bone</u>	<u>Liver</u>	<u>Kidney</u>	<u>Thyroid</u>	<u>Lung</u>	<u>Skin</u>
H-3	4.90E+03	4.90E+03	0.00E+01	4.90E+03	4.90E+03	4.90E+03	4.90E+03	4.90E+03
P-32	4.88E+09	1.70E+09	1.26E+11	7.40E+09	0.00E+01	0.00E+01	0.00E+01	0.00E+01
Cr-51	1.17E+04	3.42E+05	0.00E+01	0.00E+01	1.67E+03	7.65E+03	1.49E+04	0.00E+01
Mn-54	6.45E+05	1.04E+06	0.00E+01	2.84E+06	6.30E+05	0.00E+01	0.00E+01	0.00E+01
Fe-59	1.20E+06	1.45E+06	1.74E+06	3.04E+06	0.00E+01	0.00E+01	9.00E+05	0.00E+01
Co-58	4.31E+06	4.31E+06	0.00E+01	1.73E+06	0.00E+01	0.00E+01	0.00E+01	0.00E+01
Co-60	1.55E+07	1.56E+07	0.00E+01	6.56E+06	0.00E+01	0.00E+01	0.00E+01	0.00E+01
Zn-65	7.36E+08	1.35E+09	4.66E+08	1.60E+09	7.74E+08	0.00E+01	0.00E+01	0.00E+01
Rb-86	8.23E+08	4.26E+07	0.00E+01	1.67E+09	0.00E+01	0.00E+01	0.00E+01	0.00E+01
Sr-89	4.55E+08	3.26E+08	1.59E+10	0.00E+01	0.00E+01	0.00E+01	0.00E+01	0.00E+01
Sr-90	4.30E+10	2.11E+09	1.69E+11	0.00E+01	0.00E+01	0.00E+01	0.00E+01	0.00E+01
Y-91	1.39E+02	3.75E+05	5.23E+03	0.00E+01	0.00E+01	0.00E+01	0.00E+01	0.00E+01
Zr-95	8.41E+01	5.90E+04	4.85E+02	1.19E+02	1.28E+02	0.00E+01	0.00E+01	0.00E+01
Nb-95	1.02E+04	1.48E+07	4.27E+04	1.76E+04	1.26E+04	0.00E+01	0.00E+01	0.00E+01
Ru-103	2.09E+02	7.60E+03	6.25E+02	0.00E+01	1.30E+03	0.00E+01	0.00E+01	0.00E+01
Ru-106	1.77E+03	1.07E+05	1.41E+04	0.00E+01	1.67E+04	0.00E+01	0.00E+01	0.00E+01
Ag-110M	1.43E+07	1.12E+09	2.95E+07	2.16E+07	3.08E+07	0.00E+01	0.00E+01	0.00E+01
Sn-113	6.66E+05	1.37E+06	6.46E+05	2.45E+04	1.32E+04	9.34E+03	0.00E+01	0.00E+01
Sb-124	4.68E+06	4.66E+07	1.51E+07	2.22E+05	0.00E+01	4.01E+04	9.46E+06	0.00E+01
Te-127M	4.51E+06	1.50E+07	3.72E+07	1.23E+07	9.16E+07	1.08E+07	0.00E+01	0.00E+01
Te-129M	6.69E+06	2.59E+07	4.34E+07	1.49E+07	1.09E+08	1.67E+07	0.00E+01	0.00E+01
I-131	1.11E+09	8.99E+07	2.14E+09	2.52E+09	2.94E+09	8.28E+11	0.00E+01	0.00E+01
I-132	8.28E+01	1.88E+00	1.15E+00	2.33E+00	2.59E+00	1.09E+02	0.00E+01	0.00E+01
I-133	1.27E+07	7.31E+06	2.97E+07	4.32E+07	5.08E+07	7.86E+09	0.00E+01	0.00E+01
I-135	7.11E+04	7.06E+04	9.81E+04	1.95E+05	2.17E+05	1.75E+07	0.00E+01	0.00E+01
Cs-134	1.26E+10	3.38E+08	6.68E+10	1.25E+11	3.21E+10	0.00E+01	1.31E+10	0.00E+01
Cs-136	4.11E+09	1.67E+08	3.75E+09	1.10E+10	4.39E+09	0.00E+01	8.98E+08	0.00E+01
Cs-137	8.17E+09	3.61E+08	9.85E+10	1.15E+11	3.10E+10	0.00E+01	1.25E+10	0.00E+01
Ba-140	9.50E+05	4.53E+06	1.84E+07	1.84E+04	4.38E+03	0.00E+01	1.13E+04	0.00E+01
Ce-141	2.24E+02	9.85E+05	3.13E+03	1.91E+03	5.88E+02	0.00E+01	0.00E+01	0.00E+01
Ce-144	9.39E+03	9.61E+06	1.67E+05	6.86E+04	2.77E+04	0.00E+01	0.00E+01	0.00E+01
Hf-181	5.08E+02	4.72E+04	5.74E+03	2.71E+01	1.58E+01	2.30E+01	0.00E+01	0.00E+01

*R Values in units of mrem/yr per $\mu\text{Ci}/\text{m}^3$ for inhalation and tritium and in units of mrem/yr per $\mu\text{Ci}/\text{sec}$ per m^{-2} for all others.

TABLE 3.3-16
 R VALUES FOR THE SHEARON HARRIS NUCLEAR POWER PLANT*

PATHWAY = Inhal

AGE GROUP = Adult

<u>Nuclide</u>	<u>T. Body</u>	<u>GI-Tract</u>	<u>Bone</u>	<u>Liver</u>	<u>Kidney</u>	<u>Thyroid</u>	<u>Lung</u>	<u>Skin</u>
H-3	1.26E+03	1.26E+03	0.00E+01	1.26E+03	1.26E+03	1.26E+03	1.26E+03	1.26E+03
P-32	5.00E+04	8.63E+04	1.32E+06	7.70E+04	0.00E+01	0.00E+01	0.00E+01	0.00E+01
Cr-51	9.99E+01	3.32E+03	0.00E+01	0.00E+01	2.28E+01	5.94E+01	1.44E+04	0.00E+01
Mn-54	6.29E+03	7.72E+04	0.00E+01	3.95E+04	9.83E+03	0.00E+01	1.40E+06	0.00E+01
Fe-59	1.05E+04	1.88E+05	1.17E+04	2.77E+04	0.00E+01	0.00E+01	1.01E+06	0.00E+01
Co-58	2.07E+03	1.06E+05	0.00E+01	1.58E+03	0.00E+01	0.00E+01	9.27E+05	0.00E+01
Co-60	1.48E+04	2.84E+05	0.00E+01	1.15E+04	0.00E+01	0.00E+01	5.96E+06	0.00E+01
Zn-65	4.65E+04	5.34E+04	3.24E+04	1.03E+05	6.89E+04	0.00E+01	8.63E+05	0.00E+01
Rb-86	5.89E+04	1.66E+04	0.00E+01	1.35E+05	0.00E+01	0.00E+01	0.00E+01	0.00E+01
Sr-89	8.71E+03	3.49E+05	3.04E+05	0.00E+01	0.00E+01	0.00E+01	1.40E+06	0.00E+01
Sr-90	6.09E+06	7.21E+05	9.91E+07	0.00E+01	0.00E+01	0.00E+01	9.59E+06	0.00E+01
Y-91	1.24E+04	3.84E+05	4.62E+05	0.00E+01	0.00E+01	0.00E+01	1.70E+06	0.00E+01
Zr-95	2.32E+04	1.50E+05	1.07E+05	3.44E+04	5.41E+04	0.00E+01	1.77E+06	0.00E+01
Nb-95	4.20E+03	1.04E+05	1.41E+04	7.80E+03	7.72E+03	0.00E+01	5.04E+05	0.00E+01
Ru-103	6.57E+02	1.10E+05	1.53E+03	0.00E+01	5.82E+03	0.00E+01	5.04E+05	0.00E+01
Ru-106	8.71E+03	9.11E+05	6.90E+04	0.00E+01	1.33E+05	0.00E+01	9.35E+06	0.00E+01
Ag-110M	5.94E+03	3.02E+05	1.08E+04	9.99E+03	1.97E+04	0.00E+01	4.63E+06	0.00E+01
Sn-113	6.48E+03	2.48E+04	6.86E+03	2.69E+02	1.97E+02	9.33E+01	2.99E+05	0.00E+01
Sb-124	1.24E+04	4.06E+05	3.12E+04	5.88E+02	0.00E+01	7.55E+01	2.48E+06	0.00E+01
Te-127M	1.57E+03	1.49E+05	1.26E+04	5.76E+03	4.57E+04	3.28E+03	9.59E+05	0.00E+01
Te-129M	1.58E+03	3.83E+05	9.75E+03	4.67E+03	3.65E+04	3.44E+03	1.16E+06	0.00E+01
I-131	2.05E+04	6.27E+03	2.52E+04	3.57E+04	6.12E+04	1.19E+07	0.00E+01	0.00E+01
I-132	1.16E+03	4.06E+02	1.16E+03	3.25E+03	5.18E+03	1.14E+05	0.00E+01	0.00E+01
I-133	4.51E+03	8.87E+03	8.63E+03	1.48E+04	2.58E+04	2.15E+06	0.00E+01	0.00E+01
I-135	2.56E+03	5.24E+03	2.68E+03	6.97E+03	1.11E+04	4.47E+05	0.00E+01	0.00E+01
Cs-134	7.27E+05	1.04E+04	3.72E+05	8.47E+05	2.87E+05	0.00E+01	9.75E+04	0.00E+01
Cs-136	1.10E+05	1.17E+04	3.90E+04	1.46E+05	8.55E+04	0.00E+01	1.20E+04	0.00E+01
Cs-137	4.27E+05	8.39E+03	4.78E+05	6.20E+05	2.22E+05	0.00E+01	7.51E+04	0.00E+01
Ba-140	2.56E+03	2.18E+05	3.90E+04	4.90E+01	1.67E+01	0.00E+01	1.27E+06	0.00E+01
Ce-141	1.53E+03	1.20E+05	1.99E+04	1.35E+04	6.25E+03	0.00E+01	3.61E+05	0.00E+01
Ce-144	1.84E+05	8.15E+05	3.43E+06	1.43E+06	8.47E+05	0.00E+01	7.76E+06	0.00E+01
Hf-181	5.16E+03	1.29E+05	4.56E+04	2.57E+02	2.15E+02	1.63E+02	5.99E+05	0.00E+01

*R Values in units of mrem/yr per $\mu\text{Ci}/\text{m}^3$ for inhalation and tritium and in units of mrem/yr per $\mu\text{Ci}/\text{sec}$ per m^{-2} for all others.

TABLE 3.3-17
 R VALUES FOR THE SHEARON HARRIS NUCLEAR POWER PLANT*

PATHWAY = Inhal

AGE GROUP = Teen

Nuclide	T. Body	GI-Tract	Bone	Liver	Kidney	Thyroid	Lung	Skin
H-3	1.27E+03	1.27E+03	0.00E+01	1.27E+03	1.27E+03	1.27E+03	1.27E+03	1.27E+03
P-32	7.15E+04	9.27E+04	1.89E+06	1.09E+05	0.00E+01	0.00E+01	0.00E+01	0.00E+01
Cr-51	1.35E+02	3.00E+03	0.00E+01	0.00E+01	3.07E+01	7.49E+01	2.09E+04	0.00E+01
Mn-54	8.39E+03	6.67E+04	0.00E+01	5.10E+04	1.27E+04	0.00E+01	1.98E+06	0.00E+01
Fe-59	1.43E+04	1.78E+05	1.59E+04	3.69E+04	0.00E+01	0.00E+01	1.53E+06	0.00E+01
Co-58	2.77E+03	9.51E+04	0.00E+01	2.07E+03	0.00E+01	0.00E+01	1.34E+06	0.00E+01
Co-60	1.98E+04	2.59E+05	0.00E+01	1.51E+04	0.00E+01	0.00E+01	8.71E+06	0.00E+01
Zn-65	6.23E+04	4.66E+04	3.85E+04	1.33E+05	8.63E+04	0.00E+01	1.24E+06	0.00E+01
Rb-86	8.39E+04	1.77E+04	0.00E+01	1.90E+05	0.00E+01	0.00E+01	0.00E+01	0.00E+01
Sr-89	1.25E+04	3.71E+05	4.34E+05	0.00E+01	0.00E+01	0.00E+01	2.41E+06	0.00E+01
Sr-90	6.67E+06	7.64E+05	1.08E+08	0.00E+01	0.00E+01	0.00E+01	1.65E+07	0.00E+01
Y-91	1.77E+04	4.08E+05	6.60E+05	0.00E+01	0.00E+01	0.00E+01	2.93E+06	0.00E+01
Zr-95	3.15E+04	1.49E+05	1.45E+05	4.58E+04	6.73E+04	0.00E+01	2.68E+06	0.00E+01
Nb-95	5.66E+03	9.67E+04	1.85E+04	1.03E+04	9.99E+03	0.00E+01	7.50E+05	0.00E+01
Ru-103	8.95E+02	1.09E+05	2.10E+03	0.00E+01	7.42E+03	0.00E+01	7.82E+05	0.00E+01
Ru-106	1.24E+04	9.59E+05	9.83E+04	0.00E+01	1.90E+05	0.00E+01	1.61E+07	0.00E+01
Ag-110M	7.98E+03	2.72E+05	1.38E+04	1.31E+04	2.50E+04	0.00E+01	6.74E+06	0.00E+01
Sn-113	8.68E+03	2.03E+04	8.19E+03	3.44E+02	2.45E+02	1.13E+02	4.27E+05	0.00E+01
Sb-124	1.68E+04	3.98E+05	4.30E+04	7.94E+02	0.00E+01	9.76E+01	3.85E+06	0.00E+01
Te-127M	2.18E+03	1.59E+05	1.80E+04	8.15E+03	6.53E+04	4.38E+03	1.65E+06	0.00E+01
Te-129M	2.24E+03	4.04E+05	1.39E+04	6.57E+03	5.18E+04	4.57E+03	1.97E+06	0.00E+01
I-131	2.64E+04	6.48E+03	3.54E+04	4.90E+04	8.39E+04	1.46E+07	0.00E+01	0.00E+01
I-132	1.57E+03	1.27E+03	1.59E+03	4.37E+03	6.91E+03	1.51E+05	0.00E+01	0.00E+01
I-133	6.21E+03	1.03E+04	1.21E+04	2.05E+04	3.59E+04	2.92E+06	0.00E+01	0.00E+01
I-135	3.48E+03	6.94E+03	3.69E+03	9.43E+03	1.49E+04	6.20E+05	0.00E+01	0.00E+01
Cs-134	5.48E+05	9.75E+03	5.02E+05	1.13E+06	3.75E+05	0.00E+01	1.46E+05	0.00E+01
Cs-136	1.37E+05	1.09E+04	5.14E+04	1.93E+05	1.10E+05	0.00E+01	1.77E+04	0.00E+01
Cs-137	3.11E+05	8.48E+03	6.69E+05	8.47E+05	3.04E+05	0.00E+01	1.21E+05	0.00E+01
Ba-140	3.51E+03	2.28E+05	5.46E+04	6.69E+01	2.28E+01	0.00E+01	2.03E+06	0.00E+01
Ce-141	2.16E+03	1.26E+05	2.84E+04	1.89E+04	8.87E+03	0.00E+01	6.13E+05	0.00E+01
Ce-144	2.62E+05	8.63E+05	4.88E+06	2.02E+06	1.21E+06	0.00E+01	1.33E+07	0.00E+01
Hf-181	7.04E+03	1.20E+05	6.32E+04	3.48E+02	2.90E+02	2.12E+02	9.39E+05	0.00E+01

*R Values in units of mrem/yr per $\mu\text{Ci}/\text{m}^3$ for inhalation and tritium and in units of mrem/yr per $\mu\text{Ci}/\text{sec}$ per m^{-2} for all others.

TABLE 3.3-18
 R VALUES FOR THE SHEARON HARRIS NUCLEAR POWER PLANT*

PATHWAY = Inhal

AGE GROUP = Child

Nuclide	T. Body	GI-Tract	Bone	Liver	Kidney	Thyroid	Lung	Skin
H-3	1.12E+03	1.12E+03	0.00E+01	1.12E+03	1.12E+03	1.12E+03	1.12E+03	1.12E+03
P-32	9.86E+04	4.21E+04	2.60E+06	1.14E+05	0.00E+01	0.00E+01	0.00E+01	0.00E+01
Cr-51	1.54E+02	1.08E+03	0.00E+01	0.00E+01	2.43E+01	8.53E+01	1.70E+04	0.00E+01
Mn-54	9.50E+03	2.29E+04	0.00E+01	4.29E+04	1.00E+04	0.00E+01	1.57E+06	0.00E+01
Fe-59	1.67E+04	7.06E+04	2.07E+04	3.34E+04	0.00E+01	0.00E+01	1.27E+06	0.00E+01
Co-58	3.16E+03	3.43E+04	0.00E+01	1.77E+03	0.00E+01	0.00E+01	1.10E+06	0.00E+01
Co-60	2.26E+04	9.61E+04	0.00E+01	1.31E+04	0.00E+01	0.00E+01	7.06E+06	0.00E+01
Zn-65	7.02E+04	1.63E+04	4.25E+04	1.13E+05	7.13E+04	0.00E+01	9.94E+05	0.00E+01
Rb-86	1.14E+05	7.98E+03	0.00E+01	1.98E+05	0.00E+01	0.00E+01	0.00E+01	0.00E+01
Sr-89	1.72E+04	1.67E+05	5.99E+05	0.00E+01	0.00E+01	0.00E+01	2.15E+06	0.00E+01
Sr-90	6.43E+06	3.43E+05	1.01E+08	0.00E+01	0.00E+01	0.00E+01	1.47E+07	0.00E+01
Y-91	2.43E+04	1.84E+05	9.13E+05	0.00E+01	0.00E+01	0.00E+01	2.62E+06	0.00E+01
Zr-95	3.69E+04	6.10E+04	1.90E+05	4.17E+04	5.95E+04	0.00E+01	2.23E+06	0.00E+01
Nb-95	6.54E+03	3.69E+04	2.35E+04	9.16E+03	8.61E+03	0.00E+01	6.13E+05	0.00E+01
Ru-103	1.07E+03	4.47E+04	2.79E+03	0.00E+01	7.02E+03	0.00E+01	6.61E+05	0.00E+01
Ru-106	1.69E+04	4.29E+05	1.36E+05	0.00E+01	1.84E+05	0.00E+01	1.43E+07	0.00E+01
Ag-110M	9.13E+03	1.00E+05	1.68E+04	1.14E+04	2.12E+04	0.00E+01	5.47E+06	0.00E+01
Sn-113	9.83E+03	7.45E+03	9.00E+03	2.91E+02	2.02E+02	1.19E+02	3.40E+05	0.00E+01
Sb-124	2.00E+04	1.64E+05	5.73E+04	7.40E+02	0.00E+01	1.26E+02	3.24E+06	0.00E+01
Te-127M	3.01E+03	7.13E+04	2.48E+04	8.53E+03	6.35E+04	6.06E+03	1.48E+06	0.00E+01
Te-129M	3.04E+03	1.81E+05	1.92E+04	6.84E+03	5.02E+04	6.32E+03	1.76E+06	0.00E+01
I-131	2.72E+04	2.84E+03	4.80E+04	4.80E+04	7.87E+04	1.62E+07	0.00E+01	0.00E+01
I-132	1.87E+03	3.20E+03	2.11E+03	4.06E+03	6.24E+03	1.93E+05	0.00E+01	0.00E+01
I-133	7.68E+03	5.47E+03	1.66E+04	2.03E+04	3.37E+04	3.84E+06	0.00E+01	0.00E+01
I-135	4.14E+03	4.43E+03	4.91E+03	8.72E+03	1.34E+04	7.91E+05	0.00E+01	0.00E+01
Cs-134	2.24E+05	3.84E+03	6.50E+05	1.01E+06	3.30E+05	0.00E+01	1.21E+05	0.00E+01
Cs-136	1.16E+05	4.17E+03	6.50E+04	1.71E+05	9.53E+04	0.00E+01	1.45E+04	0.00E+01
Cs-137	1.28E+05	3.61E+03	9.05E+05	8.24E+05	2.82E+05	0.00E+01	1.04E+05	0.00E+01
Ba-140	4.32E+03	1.02E+05	7.39E+04	6.47E+01	2.11E+01	0.00E+01	1.74E+06	0.00E+01
Ce-141	2.89E+03	5.65E+04	3.92E+04	1.95E+04	8.53E+03	0.00E+01	5.43E+05	0.00E+01
Ce-144	3.61E+05	3.88E+05	6.76E+06	2.11E+06	1.17E+06	0.00E+01	1.19E+07	0.00E+01
Hf-181	8.50E+03	5.31E+04	8.44E+04	3.28E+02	2.64E+02	2.76E+02	7.95E+05	0.00E+01

*R Values in units of mrem/yr per $\mu\text{Ci}/\text{m}^3$ for inhalation and tritium and in units of mrem/yr per $\mu\text{Ci}/\text{sec}$ per m^{-2} for all others.

TABLE 3.3-19
 R VALUES FOR THE SHEARON HARRIS NUCLEAR POWER PLANT*

PATHWAY = Inhal

AGE GROUP = Infant

<u>Nuclide</u>	<u>T. Body</u>	<u>GI-Tract</u>	<u>Bone</u>	<u>Liver</u>	<u>Kidney</u>	<u>Thyroid</u>	<u>Lung</u>	<u>Skin</u>
H-3	6.46E+02	6.46E+02	0.00E+01	6.46E+02	6.46E+02	6.46E+02	6.46E+02	6.46E+02
P-32	7.73E+04	1.61E+04	2.03E+06	1.12E+05	0.00E+01	0.00E+01	0.00E+01	0.00E+01
Cr-51	8.93E+01	3.56E+02	0.00E+01	0.00E+01	1.32E+01	5.75E+01	1.28E+04	0.00E+01
Mn-54	4.98E+03	7.05E+03	0.00E+01	2.53E+04	4.98E+03	0.00E+01	9.98E+05	0.00E+01
Fe-59	9.46E+03	2.47E+04	1.35E+04	2.35E+04	0.00E+01	0.00E+01	1.01E+06	0.00E+01
Co-58	1.82E+03	1.11E+04	0.00E+01	1.22E+03	0.00E+01	0.00E+01	7.76E+05	0.00E+01
Co-60	1.18E+04	3.19E+04	0.00E+01	8.01E+03	0.00E+01	0.00E+01	4.50E+06	0.00E+01
Zn-65	3.10E+04	5.13E+04	1.93E+04	6.25E+04	3.24E+04	0.00E+01	6.46E+05	0.00E+01
Rb-86	8.81E+04	3.03E+03	0.00E+01	1.90E+05	0.00E+01	0.00E+01	0.00E+01	0.00E+01
Sr-89	1.14E+04	6.39E+04	3.97E+05	0.00E+01	0.00E+01	0.00E+01	2.03E+06	0.00E+01
Sr-90	2.59E+06	1.31E+05	4.08E+07	0.00E+01	0.00E+01	0.00E+01	1.12E+07	0.00E+01
Y-91	1.57E+04	7.02E+04	5.87E+05	0.00E+01	0.00E+01	0.00E+01	2.45E+06	0.00E+01
Zr-95	2.03E+04	2.17E+04	1.15E+05	2.78E+04	3.10E+04	0.00E+01	1.75E+06	0.00E+01
Nb-95	3.77E+03	1.27E+04	1.57E+04	6.42E+03	4.71E+03	0.00E+01	4.78E+05	0.00E+01
Ru-103	6.78E+02	1.61E+04	2.01E+03	0.00E+01	4.24E+03	0.00E+01	5.51E+05	0.00E+01
Ru-106	1.09E+04	1.64E+05	8.67E+04	0.00E+01	1.06E+05	0.00E+01	1.15E+07	0.00E+01
Ag-110M	4.99E+03	3.30E+04	9.97E+03	7.21E+03	1.09E+04	0.00E+01	3.66E+06	0.00E+01
Sn-113	4.89E+03	2.29E+03	4.67E+03	1.74E+02	9.94E+01	6.73E+01	2.30E+05	0.00E+01
Sb-124	1.20E+04	5.91E+04	3.79E+04	5.56E+02	0.00E+01	1.00E+02	2.64E+06	0.00E+01
Te-127M	2.07E+03	2.73E+04	1.66E+04	6.89E+03	3.75E+04	4.86E+03	1.31E+06	0.00E+01
Te-129M	2.22E+03	6.89E+04	1.41E+04	6.08E+03	3.17E+04	5.47E+03	1.68E+06	0.00E+01
I-131	1.96E+04	1.06E+03	3.79E+04	4.43E+04	5.17E+04	1.48E+07	0.00E+01	0.00E+01
I-132	1.26E+03	1.90E+03	1.69E+03	3.54E+03	3.94E+03	1.69E+05	0.00E+01	0.00E+01
I-133	5.59E+03	2.15E+03	1.32E+04	1.92E+04	2.24E+04	3.55E+06	0.00E+01	0.00E+01
I-135	2.77E+03	1.83E+03	3.86E+03	7.59E+03	8.46E+03	6.95E+05	0.00E+01	0.00E+01
Cs-134	7.44E+04	1.33E+03	3.96E+05	7.02E+05	1.90E+05	0.00E+01	7.95E+04	0.00E+01
Cs-136	5.28E+04	1.43E+03	4.82E+04	1.34E+05	5.63E+04	0.00E+01	1.17E+04	0.00E+01
Cs-137	4.54E+04	1.33E+03	5.48E+05	6.11E+05	1.72E+05	0.00E+01	7.12E+04	0.00E+01
Ba-140	2.89E+03	3.83E+04	5.59E+04	5.59E+01	1.34E+01	0.00E+01	1.59E+06	0.00E+01
Ce-141	1.99E+03	2.15E+04	2.77E+04	1.66E+04	5.24E+03	0.00E+01	5.16E+05	0.00E+01
Ce-144	1.76E+05	1.48E+05	3.19E+06	1.21E+06	5.37E+05	0.00E+01	9.83E+06	0.00E+01
Hf-181	5.05E+03	1.90E+04	5.65E+04	2.66E+02	1.59E+02	2.25E+02	6.73E+05	0.00E+01

*R Values in units of mrem/yr per $\mu\text{Ci}/\text{m}^3$ for inhalation and tritium and in units of mrem/yr per $\mu\text{Ci}/\text{sec}$ per m^2 for all others.

Figure 3.1
 SHNPP Gaseous Waste Streams

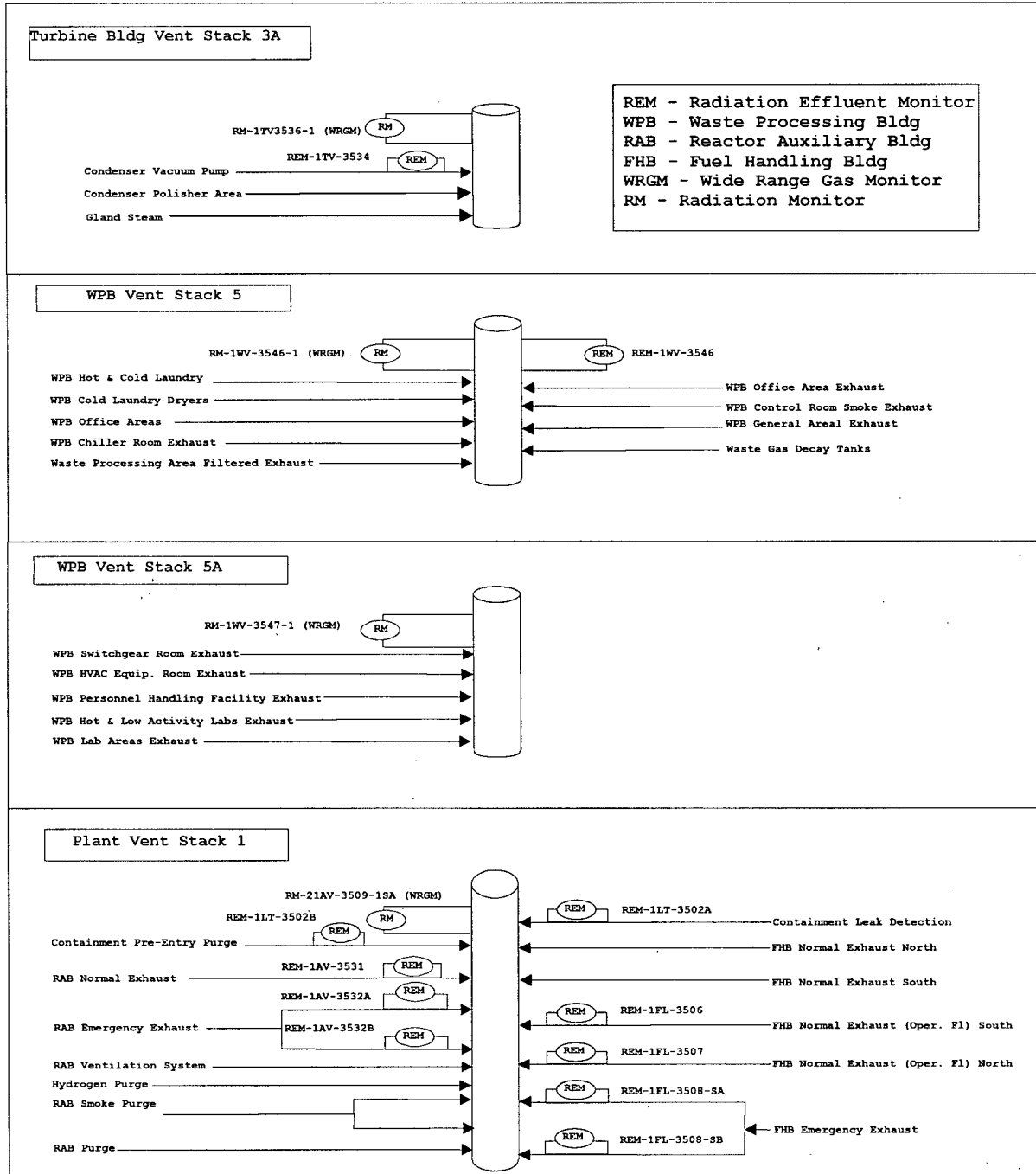

Figure 3.2
Schematic of Airborne Effluent Release Points

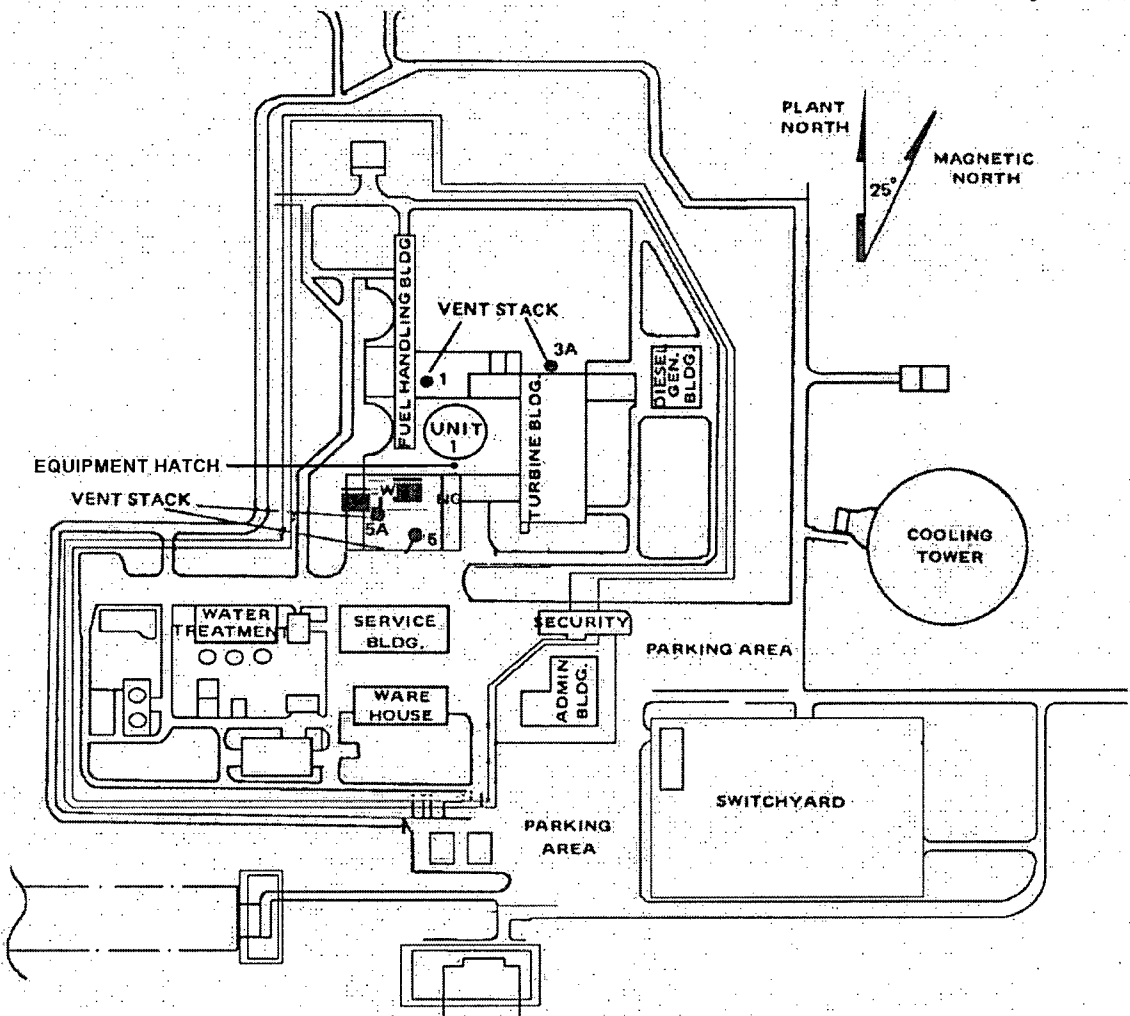
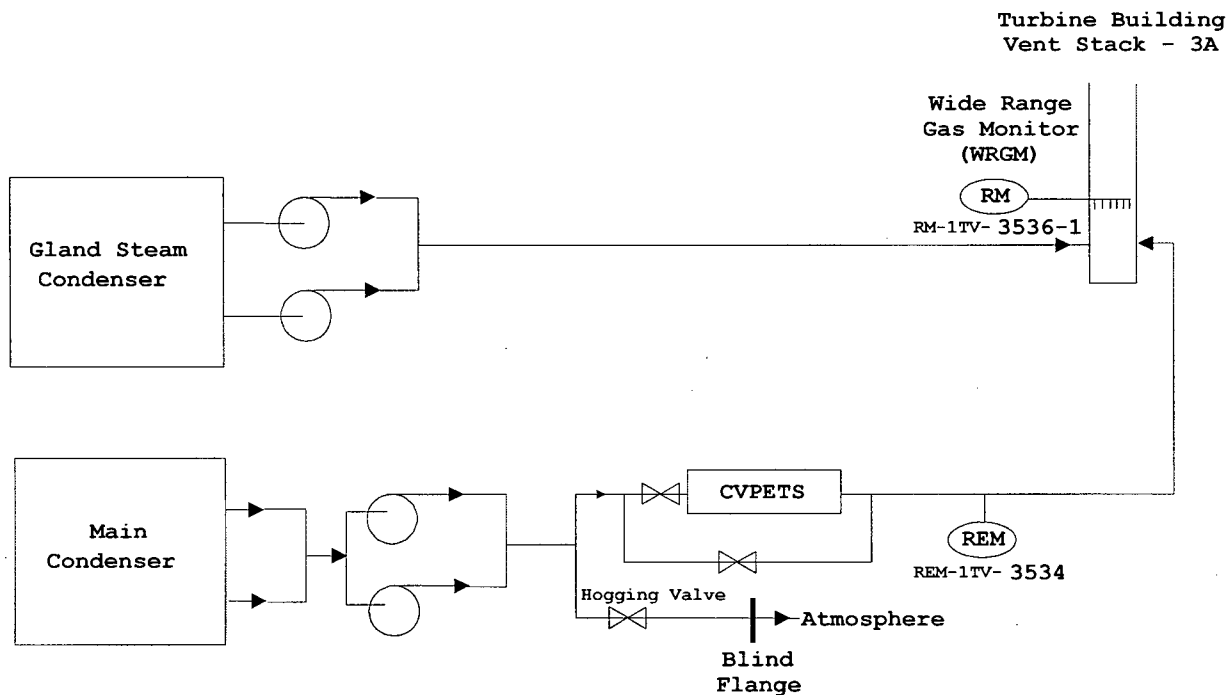

Figure 3.3

SHNPP Condenser Off-Gas System



4.0 RADIOLOGICAL ENVIRONMENTAL MONITORING PROGRAM

The purpose of the radiological monitoring program is to measure radioactivity in the environment, to determine whether measured radioactivity is the result of operation of the Shearon Harris Nuclear Power Plant, and to assess the potential dose to the offsite population based on the cumulative measurements of radioactivity of plant origin. The program provides representative measurements of radioactivity in the highest potential exposure pathways and verification of the accuracy of the effluent monitoring program and modeling of environmental exposure pathways (i.e. air, surface water, groundwater.)

Table 4.1 contains the sample point description, sampling and collection frequency, analysis type, and frequency for various exposure pathways in the vicinity of the SHNPP for the radiological monitoring program.

Figure 4.1-1 shows the exclusion boundary surrounding SHNPP. Figures 4.1-2, 4.1-3, 4.1-4, and 4.1-5 show the locations of the various sampling points and TLD locations. Figure 4.1-6 provides a legend for Figures 4.1-2 through 4.1-5.

TABLE 4.1
 RADIOLOGICAL ENVIRONMENTAL MONITORING PROGRAM

Exposure Pathway and/or Sample:		Airborne Particulates and Radioiodine
Sampling and Collection Frequency:		Continuous operating sampler with sample collection as required by dust loading but at least once per 7 days.
Analysis Frequency and Required Analysis:		Weekly Gross Beta ² Weekly I-131 (charcoal canisters) Quarterly Gamma Isotopic ^{4,5} (Composited by location)
Sample Point ID No.	Sample Point, Description ¹ , Distance, and Direction	
1	0.1 mi. S on SR 1134 from SR 1011 intersection. N sector, 2.6 mi. from site.	
2	1.4 mi. S on SR 1134 from SR 1011 intersection. NNE sector, 1.4 mi. from site.	
4	0.7 mi. N on SR 1127 from intersection with US 1. NNE sector, 3.1 mi. from site.	
5	Pittsboro (Control Station) ³ WNW sector from site, > 12 mi. from site	
26	Harris Lake Spillway S sector, 4.7 mi. from site	
47	1.3 mi. N on SR 1912 from intersection of NC 42 SSW sector, 3.4 miles from site	

TABLE 4.1

RADIOLOGICAL ENVIRONMENTAL MONITORING PROGRAM

Exposure Pathway and/or Sample:		Direct Radiation (TLD)
Sampling and Collection Frequency:		Continuous measurement with an integrated readout at least once per quarter.
Analysis Frequency and Required Analysis:		Quarterly Gamma Dose
Sample Point ID No.	Sample Point, Description ¹ , Distance, and Direction	
1	0.1 mi. S on SR 1134 from SR 1011 intersection. N sector, 2.6 mi. from site.	
2	1.4 mi. S on SR 1134 from SR 1011 intersection. NNE sector, 1.4 mi. from site.	
3	HE&EC ENE sector, 1.9 mi. from site.	
4	0.7 mi. N on SR 1127 from intersection with US 1 NNE sector, 3.1 mi. from site.	
5	Pittsboro (Control Station) ³ WNW sector from site, > 12 mi. from site	
6	Intersection of SR 1134 & SR 1135. NE sector, 0.8 mi. from site.	
7	Extension of SR 1134. E sector 0.7 mi. from site.	
8	Dead end of road. Extension of SR 1134. ESE sector, 0.6 mi. from site.	
9	1 mi. S on SR 1130 from intersection of SR 1127, 1115, and 1130. SE sector, 2.2 mi. from site.	
10	SR 1130 S of intersection of SR 1127, 1115, and 1130. SSE sector, 2.2 mi. from site.	
11	SHNPP site. S sector, 0.6 mi. from site	
12	SHNPP site. SSW sector, 0.9 mi. from site.	
13	SHNPP site. WSW sector 0.7 mi. from site.	
14	SHNPP site. Access road to aux. reservoir. W sector, 1.5 mi. from site.	

TABLE 4.1

RADIOLOGICAL ENVIRONMENTAL MONITORING PROGRAM

Exposure Pathway and/or Sample:		Direct Radiation (TLD)
Sampling and Collection Frequency:		Continuous measurement with an integrated readout at least once per quarter.
Analysis Frequency and Required Analysis:		Quarterly Gamma Dose
Sample Point ID No.	Sample Point, Description ¹ , Distance, and Direction	
15	SR 1911. W sector, 2.0 mi. from site.	
16	1.2 mi. E of intersection of US 1 and SR 1011. WNW sector 1.9 mi. from site.	
17	Intersection of US 1 and Aux. Res. NW sector, 1.5 mi. from site.	
18	0.2 mi. N on US 1 from Station 17. NNW sector, 1.4 mi. from site.	
19	0.6 mi. E on SR 1142 from intersection of SR 1141. NNE sector 5.0 mi. from site.	
20	US 1 at intersection SR 1149. NE sector 4.5 mi. from site.	
21	1.2 mi. W on SR 1152 from intersection SR 1153. ENE sector, 4.8 mi. from site.	
22	Formerly Ragan's Dairy on SR 1115. E sector, 4.3 mi. from site.	
23	Intersection of SR 1127 and SR 1116. ESE sector, 4.8 mi. from site.	
24	Sweet Springs Church on SR 1116. SE sector 4.0 mi. from site.	
25	0.2 mi. W on SR 1402 from intersection of SR 1400 SSE sector, 4.7 mi. from site	
26	Harris Lake Spillway S sector, 4.7 mi. from site	
27	NC 42 @ Buckhorn United Methodist Church SW sector, 4.8 mi. from site.	
28	0.6 mi. on SR 1924 from intersection of SR 1916. SSW sector, 4.8 mi. from site.	
29	Parking lot of Dynea USA, Inc. on SR 1916. WSW sector, 5.7 mi. from site.	

TABLE 4.1

RADIOLOGICAL ENVIRONMENTAL MONITORING PROGRAM

Exposure Pathway and/or Sample:		Direct Radiation (TLD)
Sampling and Collection Frequency:		Continuous measurement with an integrated readout at least once per quarter.
Analysis Frequency and Required Analysis:		Quarterly Gamma Dose
Sample Point ID No.	Sample Point, Description ¹ , Distance, and Direction	
30	Exit intersection of SR 1972 and US 1. W sector, 5.6 mi. from site.	
31	At intersection of SR 1908, 1909, 1910. WNW sector, 4.7 mi. from site.	
32	SR 1008. NNW sector 6.4 mi. from site.	
33	SR 1142. 1.7 mi. from intersection of SR 1141. NNW sector, 4.5 mi. from site.	
34	Apex (Population Center). NE sector, 8.7 mi. from site.	
35	Holly Springs (Population Center). E sector, 6.9 mi. from site.	
36	SR 1393 at intersection of SR 1421. E sector, 10.9 mi. from site.	
37	US 401 at old CP&L office, Fuquay-Varina (Pop. Center). ESE sector, 9.2 mi. from site.	
48	SR 1142. 1.5 mi. from intersection of SR 1141. N sector, 4.5 mi. from site.	
49	SR 1127. 0.3 mi. S from intersection with US 1. NNE sector, 2.5 mi. from site.	
50	SR 1127 W from intersection SR 1115 and 1130. ESE sector, 2.6 mi. from site.	
53	SR 1972 N from intersection of SR 1910 and SR 1972. NW sector, 5.8 mi. from site.	
56	SR 1912 at intersection of SR 1912 and SR 1924. WSW sector, 3.0 mi. from site.	
63	SHNPP Site. SW sector, 0.6 mi. from site.	
67	HE&EC, Sewage Treatment Facility ENE Sector, 1.2 mi. from site.	

TABLE 4.1
 RADIOLOGICAL ENVIRONMENTAL MONITORING PROGRAM

Exposure Pathway and/or Sample:		Waterborne, Surface Water
Sampling and Collection Frequency:		Composite sample ⁵ collected over a monthly period.
Analysis Frequency and Required Analysis:		Monthly Gross Beta ⁴ and Quarterly Gamma Isotopic
Sample Point ID No.	Sample Point, Description ¹ , Distance, and Direction	
26	Harris Lake Spillway S sector, 4.7 mi. from site	
38	Cape Fear Steam Electric Plant Intake Structure (Control Station) ³ WSW sector, 6.2 miles from site	
40	NE Harnett Metro Water Treatment Plant Intake Building Duncan Street, Lillington, N.C. SSE sector, ~17 mi. from site.	

TABLE 4.1

RADIOLOGICAL ENVIRONMENTAL MONITORING PROGRAM

Exposure Pathway and/or Sample:		Waterborne, Groundwater
Sampling and Collection Frequency:		Grab sample collected quarterly
Analysis Frequency and Required Analysis:		Each Sample Gamma Isotopic ⁴ and Tritium
Sample Point ID No.	Sample Point, Description ¹ , Distance, and Direction	
39	On-site deep well in the vicinity of the diabase dike SSW sector, 0.7 mi. from site	
59	SHNPP Site (NAD 83 feet, State Plane N/E: 688165.3, 2013607.5) N. side of Old Construction Road. NNE sector, 0.5 mi. from site	
60	SHNPP Site (NAD 83 feet, State Plane N/E: 684526.1, 2015530.6) W. bank of Thomas Creek SE of Cooling Tower. ESE sector, 0.5 mi. from site	
68	SHNPP Site (LP-6) (NAD 83 feet, State Plane N/E: 685545.5, 2012243.9) N. of old Steam Generator Storage Building W sector, 0.2 mi. from site	
69	SHNPP Site (LP-7) (NAD 83 feet, State Plane N/E: 686345.8, 2013411.0) S. side of Warehouse 9. NNE sector, 0.2 mi. from site	
70	SHNPP Site (LP-9) (NAD 83 feet, State Plane N/E: 685687.1, 2014972.7) N. side of Plant Entrance Road. E sector, 0.4 mi. from site	
71	SHNPP Site (LP-16) (NAD 83 feet, State Plane N/E: 684687.3, 2014347.7) S. of Switch Yard SE sector, 0.3 mi. from site	
72	SHNPP Site (MWA-12) (NAD 83 feet, State Plane N/E: 684539.3, 2013963.8) N. of Emergency Service Water and Cooling Tower Makeup Water Intake Structures. SE sector, 0.2 mi. from site	

TABLE 4.1

RADIOLOGICAL ENVIRONMENTAL MONITORING PROGRAM

Exposure Pathway and/or Sample:		Waterborne, Drinking Water
Sampling and Collection Frequency:		Composite sample ⁵ collected over a two-week period if I-131 analysis is performed; monthly composite otherwise.
Analysis Frequency and Required Analysis:		I-131 on each composite when the dose ⁶ calculated for the consumption of the water is greater than 1 mrem per yr. Monthly Gross Beta Monthly Gamma Isotopic ⁴ Quarterly Tritium
Sample Point ID No.	Sample Point, Description ¹ , Distance, and Direction	
38	Cape Fear Steam Electric Plant Intake Structure (Control Station) ³ WSW sector, 6.2 miles from site	
40	NE Harnett Metro Water Treatment Plant Intake Building Duncan Street, Lillington, N.C. SSE sector, ~17 mi. from site.	
51	SHNPP Water Treatment Building On Site	

NOTE: H-3 analysis is normally performed monthly.

TABLE 4.1

RADIOLOGICAL ENVIRONMENTAL MONITORING PROGRAM

Exposure Pathway and/or Sample:		Waterborne, Sediment from Shoreline
Sampling and Collection Frequency:		Shoreline Sediment sample collected semiannually.
Analysis Frequency and Required Analysis:		Each Sample Gamma Isotopic ⁴
Sample Point ID No.	Sample Point, Description ¹ , Distance, and Direction	
26	Harris Lake Spillway S sector, 4.6 mi. from site	
41	Shoreline of Mixing Zone of Cooling Tower Blowdown Line S sector, 3.8 miles from site.	

TABLE 4.1

RADIOLOGICAL ENVIRONMENTAL MONITORING PROGRAM

Exposure Pathway and/or Sample:		Waterborne, Bottom Sediment
Sampling and Collection Frequency:		Bottom Sediment sample collected semiannually.
Analysis Frequency and Required Analysis:		Each Sample Gamma Isotopic ⁴
Sample Point <u>ID No.</u>	Sample Point, Description ¹ , Distance, and Direction	
52	Harris Lake in the vicinity of the mixing zone of the cooling tower S sector, 3.8 miles from site.	

TABLE 4.1

RADIOLOGICAL ENVIRONMENTAL MONITORING PROGRAM

Exposure Pathway and/or Sample:		Ingestion - Milk ⁸
Sampling and Collection Frequency:		Grab samples semi-monthly when animals are on pasture; monthly at other times. ⁹
Analysis Frequency and Required Analysis:		Each Sample I-131 Each Sample Gamma Isotopic ⁴
Sample Point ID No.	Sample Point, Description ¹ , Distance, and Direction	
42	Maple Knoll Dairy on SR 1403 SSE sector, 7.0 mi. from site is no longer in business.	
43	Goodwin's Dairy on SR 1134 N sector, 2.2 mi. from site is no longer in business	
5	Manco's Dairy, Pittsboro (Control Station) ³ WNW sector from site, > 12 mi. from site	

TABLE 4.1
 RADIOLOGICAL ENVIRONMENTAL MONITORING PROGRAM

Exposure Pathway and/or Sample:		Ingestion - Fish
Sampling and Collection Frequency:		One sample of each of the following semiannually: 1. Catfish (bottom feeders) 2. Sunfish & Largemouth Bass (free swimmers)
Analysis Frequency and Analysis:		Each sample - Gamma Isotopic ⁴ on edible portion for each
Sample Point ID No.	Sample Point, Description ¹ , Distance, and Direction	
44	Site varies within the Harris Lake.	
45	Site varies above Buckhorn Dam on Cape Fear River (Control Station) ³	

TABLE 4.1

RADIOLOGICAL ENVIRONMENTAL MONITORING PROGRAM

Intentionally Left Page Blank

TABLE 4.1
 RADIOLOGICAL ENVIRONMENTAL MONITORING PROGRAM

Exposure Pathway and/or Sample:		Aquatic Vegetation
Sampling and Collection Frequency:		Annually
Analysis Frequency and Required Analysis:		Each sample - Gamma Isotopic ⁴
Sample Point ID No.	Sample Point, Description ¹ , Distance, and Direction	
26	Harris Lake Spillway S sector, 4.7 mi. from site	
41	Shoreline of Mixing Zone of Cooling Tower Blowdown Line S sector, 3.8 miles from site.	
61	Harris Lake above Holleman's Crossroads (Control Location) E sector, 2.5 mi. from site	

Exposure Pathway and/or Sample:		Broadleaf Vegetation (Trees) ⁸
Sampling and Collection Frequency:		Monthly
Analysis Frequency and Required Analysis:		Each sample - Gamma Isotopic ⁴
Sample Point ID No.	Sample Point, Description ¹ , Distance, and Direction	
5	Pittsboro (Control Station) ³ NNW sector, > 12 mi. from site	
65	Site Boundary S sector, 1.36 mi. from site	
66	Site Boundary SSW sector, 1.33 miles from site	

NOTES TO TABLE 4.1

SHNPP Radiological Environmental Monitoring Program

1. Sample locations are shown on Figures 4.1-2, 4.1-3, 4.1-4, and 4.1-5. Figure 4.1-6 provides a legend for Figures 4.1-2 through 4.1-5.
2. Particulate samples will be analyzed for gross beta radioactivity 24 hours or more following filter change to allow for radon and thorium daughter decay. If gross beta activity is greater than ten times the yearly mean of the control sample station activity, a gamma isotopic analysis will be performed on the individual samples.
3. Control sample stations (or background stations) are located in areas that are unaffected by plant operations. All other sample stations that have the potential to be affected by radioactive emissions from plant operations are considered indicator stations.
4. Gamma isotopic analysis means the identification and quantification of gamma-emitting radionuclides that may be attributable to effluents from plant operations.
5. Composite samples will be collected with equipment which is capable of collecting an aliquot at time intervals which are very short (e.g., every 2 hours) relative to the compositing period (e.g., monthly).
6. The dose will be calculated for the maximum organ and age group, using the methodology contained in ODCM Equation 2.2-1.
7. Based on historical meteorology (1976-1987), food product Locations 54 and 55 were added in the summer of 1988 as the off-site locations with the highest predicted D/Q values. Food product locations 43 and 46 were deleted after the 1988 growing season.
8. If no milk animals are available at indicator locations per page 4-11, sampling of Broadleaf Vegetation (trees) per page 4-14 can be substituted.
9. When no milk animals are available at indicator locations, milk sampling of the control location can be reduced to once per month to maintain historical data.
10. Sample Locations 5, 54, 55, 62, 64 were deleted from food crop sampling in Revision 18 as crops are not irrigated with water in which plant wastes have been discharged or crops are no longer being grown at a location. Sample Location 58 was deleted from groundwater monitoring in Revision 18 since being shown to have direct communication with lake/surface water.
11. Sample Locations 68 through 72 were added to the groundwater monitoring in Revision 19 based on evaluation of data from bedrock wells. Location 57 was removed in Revision 19 based on the same evaluation of groundwater data.

Figure 4.1-1
 Map of the Site Boundary

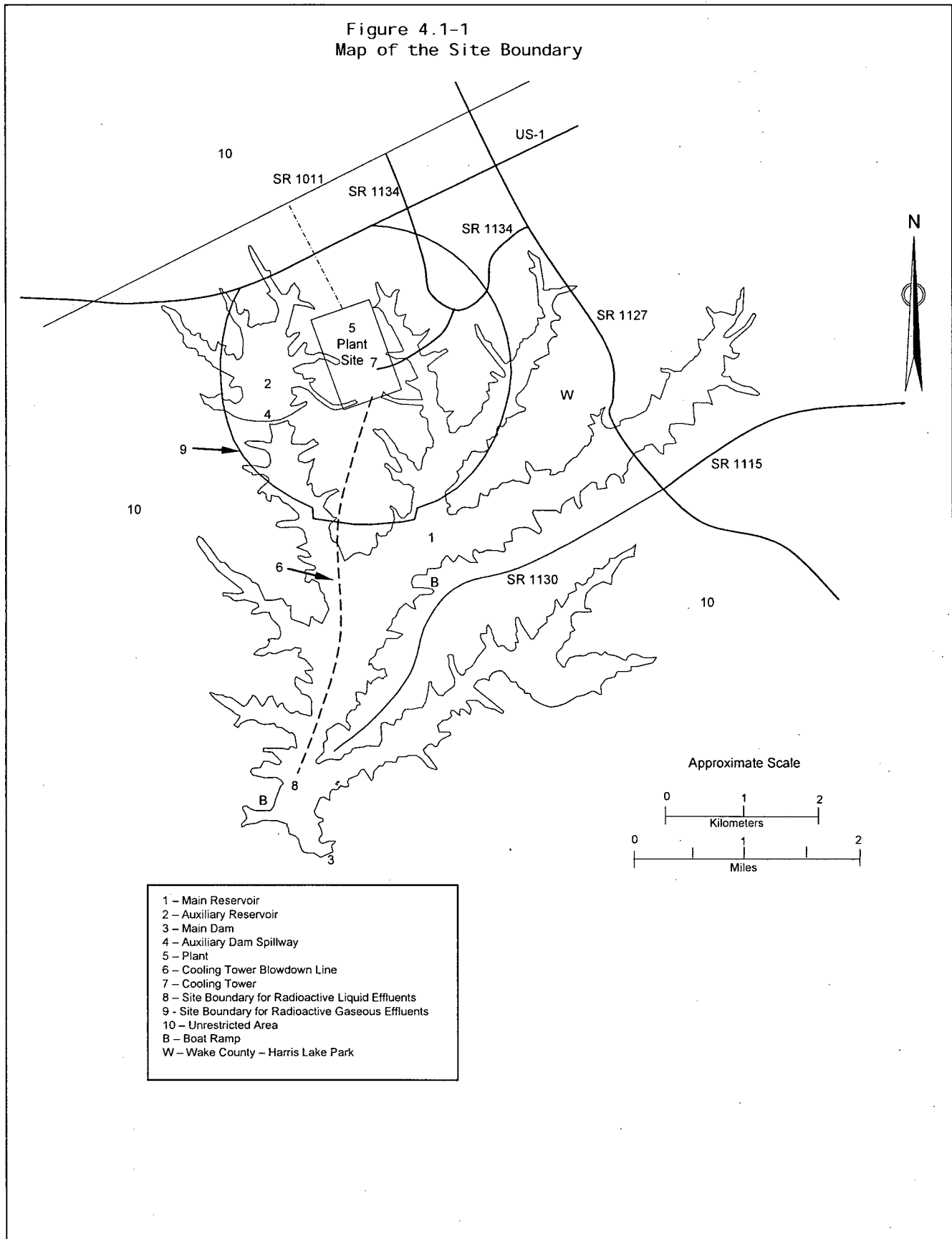

- 1 - Main Reservoir
- 2 - Auxiliary Reservoir
- 3 - Main Dam
- 4 - Auxiliary Dam Spillway
- 5 - Plant
- 6 - Cooling Tower Blowdown Line
- 7 - Cooling Tower
- 8 - Site Boundary for Radioactive Liquid Effluents
- 9 - Site Boundary for Radioactive Gaseous Effluents
- 10 - Unrestricted Area
- B - Boat Ramp
- W - Wake County - Harris Lake Park

Figure 4.1-2

Environmental Radiological Sampling Points

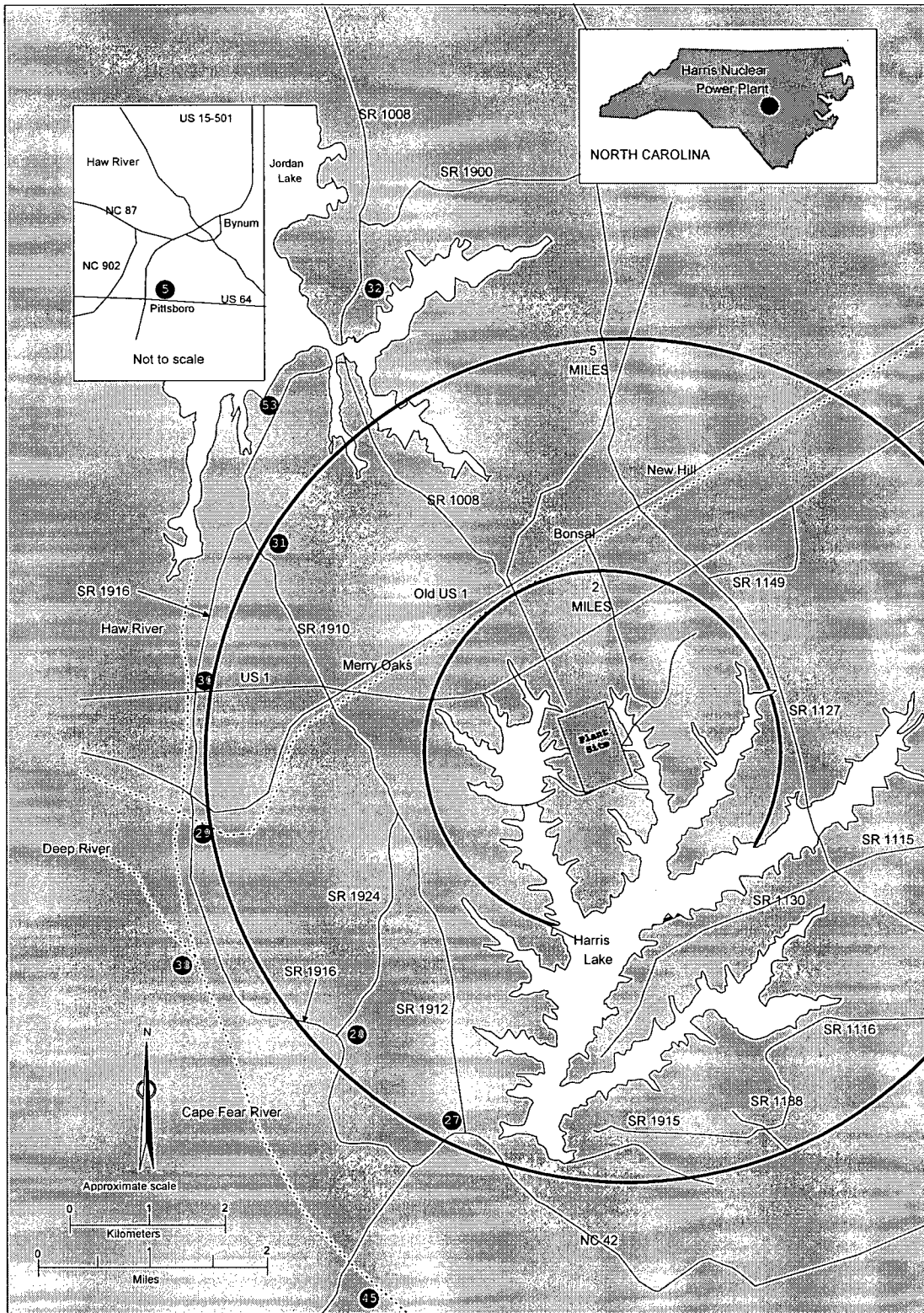

Figure 4.1-4
Environmental Radiological Sampling Points

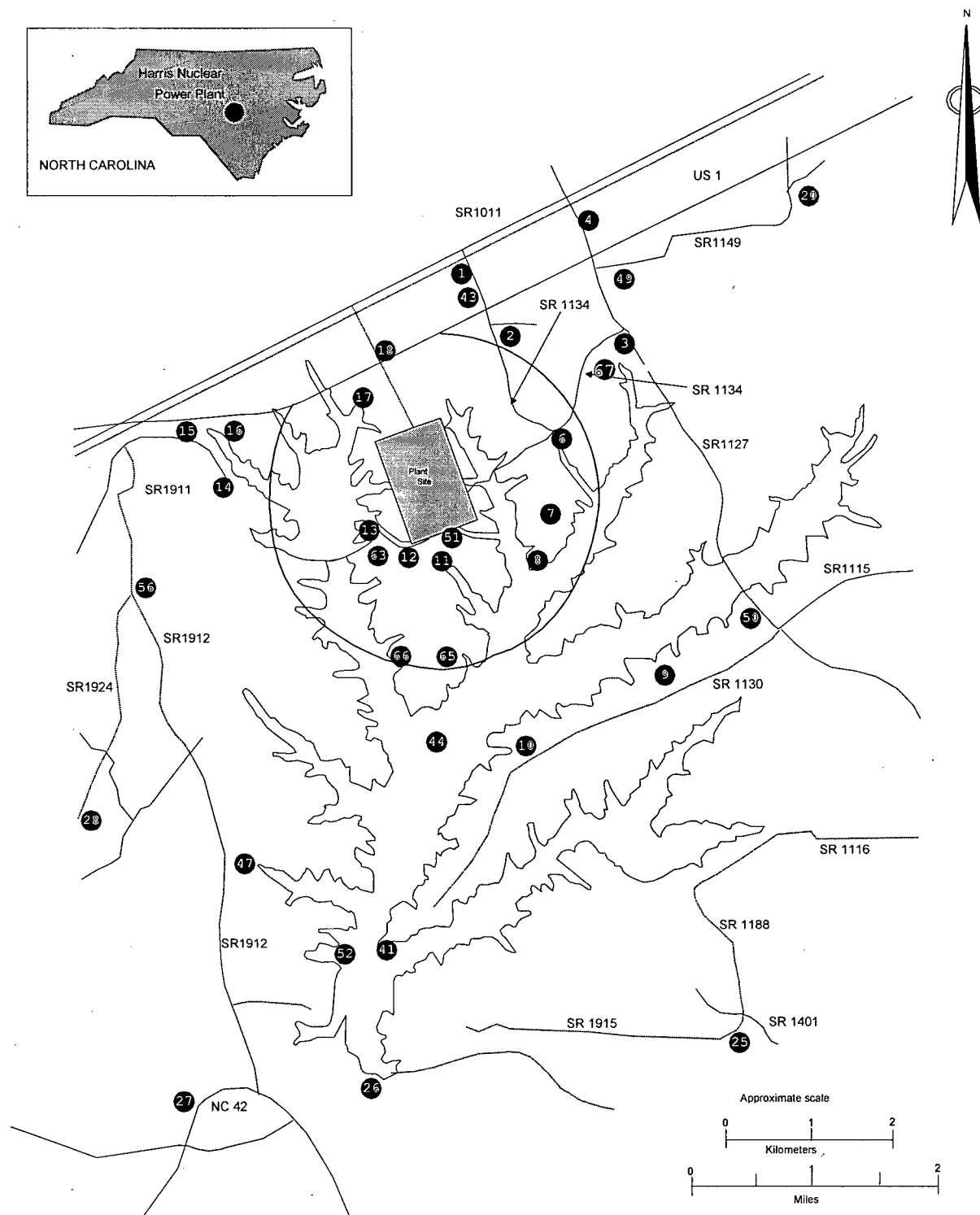

Figure 4.1-5
Environmental Radiological Sampling Points



Figure 4.1-6
 Environmental Radiological Sampling Points
 Legend

STATION NUMBER	SAMPLE TYPE	REFER TO FIGURE	STATION NUMBER	SAMPLE TYPE	REFER TO FIGURE
1	AP, AC, TL	4.1-4	34	TL	4.1-3
2	AP, AC, TL	4.1-4	35	TL	4.1-3
3	TL	4.1-4	36	TL	4.1-3
4	AP, AC, TL	4.1-4	37	TL	4.1-3
5	AP, AC, MK, TL, BL	4.1-2 *	38	SW, DW	4.1-2
6	TL	4.1-4	39	GW	4.1-5
7	TL	4.1-4	40	SW, DW	4.1-3 *
8	TL	4.1-4	41	SS, AV	4.1-4
9	TL	4.1-4	42	MK	4.1-3
10	TL	4.1-4	43	DELETED	Notes
11	TL	4.1-4	44	FH	4.1-4
12	TL	4.1-4	45	FH	4.1-2
13	TL	4.1-4	46	DELETED	Notes
14	TL	4.1-4	47	AP, AC	4.1-4
15	TL	4.1-4	48	TL	4.1-3
16	TL	4.1-4	49	TL	4.1-4
17	TL	4.1-4	50	TL	4.1-4
18	TL	4.1-4	51	DW	4.1-4
19	TL	4.1-3	52	SD	4.1-4
20	TL	4.1-3, 4.1-4	53	TL	4.1-2
21	TL	4.1-3	54	DELETED	Notes
22	TL	4.1-3	55	DELETED	Notes
23	TL	4.1-3	56	TL	4.1-4
24	TL	4.1-3	57	DELETED	Notes
25	TL	4.1-3, 4.1-4	58	DELETED	Notes
26	AP, AC, AV, SS, SW, TL	4.1-3, 4.1-4	59	GW	4.1-5
27	TL	4.1-2, 4.1-4	60	GW	4.1-5
28	TL	4.1-2, 4.1-4	61	AV	4.1-3
29	TL	4.1-2	62	DELETED	Notes
30	TL	4.1-2	63	TL	4.1-4
31	TL	4.1-2	64	DELETED	Notes
32	TL	4.1-2	65	BL	4.1-4
33	TL	4.1-3	66	BL	4.1-4

AC	Air Cartridge	DW	Drinking Water	SD	Bottom Sediment
AP	Air Particulate	FH	Fish	SS	Shoreline Sediment
AV	Aquatic Vegetation	GW	Groundwater	SW	Surface Water
BL	Broad Leaf Veg.	MK	Milk	TL	TLD

* Approximate location

5.0 INTERLABORATORY COMPARISON STUDIES

The objective of this program is to evaluate the total laboratory analysis process by comparing results for an equivalent sample with those obtained by an independent laboratory or laboratories.

Environmental samples from the SHNPP environs are to be analyzed by the Harris Energy & Environmental Center (HE&EC) or by a qualified contracting laboratory. These laboratories will participate at least annually in a nationally recognized interlaboratory comparison study. The results of the laboratories' performances in the study will be included in the Annual Radiological Environmental Operating Report (see SHNPP ODCM Operational Requirement 4.12.3).

SHNPP E&RC will perform sample analyses for gamma-emitting radionuclides, tritium, and gross alpha in effluent releases. The E&RC radiochemistry laboratory will participate annually in a corporate interlaboratory comparison study or an equivalent study. Radiochemical analyses of composite samples required by ODCM Operational Requirements Tables 4.11-1 and 4.11-2 will be performed by the HE&EC.

The Progress Energy laboratory or vendor laboratory results shall be compared to the criteria established in the NRC Inspection Manual (Procedure 84750) for Radioactive Waste Treatment, Effluent, and Environmental Monitoring. The referenced criteria is as follows:

- a) Divide each standard result by its associated uncertainty to obtain resolution (the uncertainty is defined as the relative standard deviation, one sigma, of the standard result as calculated from counting statistics).
- b) Divide each laboratory result by the corresponding standard result to obtain the ratio (laboratory result/standard).
- c) The laboratory measurement is in agreement if the value of the ratio falls within the limits shown below for the corresponding resolution:

<u>Resolution</u>	<u>Ratio</u>
<4	0.4 - 2.5
4 - 7	0.5 - 2.0
8 - 15	0.6 - 1.66
16 - 50	0.75 - 1.33
51 -200	0.80 - 1.25
>200	0.85 - 1.28

If the Progress Energy laboratory or vendor laboratory results lie outside the ratio criteria, an evaluation will be performed to identify any recommended remedial actions to reduce anomalous errors. Complete documentation of the evaluation will be available to HNP and will be provided to the NRC upon request.

6.0 TOTAL DOSE (COMPLIANCE WITH 40 CFR 190) for ODCM OR 3.11.4

Compliance with 40 CFR 190 as prescribed in ODCM Operational Requirement 3.11.4 must be demonstrated only when one or more of ODCM Operational Requirements 3.11.1.2a, 3.11.1.2b, 3.11.2.2a, 3.11.2.2b, 3.11.2.3a, or 3.11.2.3b is exceeded by a factor of two. Once this occurs, the company has 30 days to submit this report in accordance with Technical Specification 6.9.2.

ODCM Operational Requirement 3.11.4 requires that the annual dose or dose commitment to a member of the public from uranium fuel cycle sources be limited to 25 mrem for the whole body and any organ except the thyroid which is limited to 75 mrem. In addition, assessment of radiation doses to the likely most exposed member of the public from primary effluent pathways, direct radiation, and any other nearby uranium fuel cycle sources are to be included.

The dose estimates from the gas and liquid effluent pathways to the likely most exposed member of the public can be obtained by using the Regulatory Guide 1.109 and WASH 1258-based NRC codes LADTAP II and GASPAR. This will allow the use of current annual average meteorology X/Q and D/Q values derived from the NRC XOQDOQ (NUREG/CR-2919) Code that is appropriate for the specific location of the receptor and the applicable exposure pathways.

Radiation exposures of members of the public from direct radiation sources (the reactor unit and other primary system components, radwaste, radioactivity in auxiliary systems such as storage tanks, transportation of radioactive material, etc.) will be determined from TLD measurements. Quarterly TLD measurements at locations within three miles of the plant center (inner ring) will be compared with the four-year, pre-operational TLD measurements using methods contained in NBS Handbook 91, "Experimental Statistics," to determine any significant contribution from direct radiation associated with plant operation.

If there is a significant direct radiation component at the TLD location in the sector containing the likely most exposed member of the public then this dose will be added to the doses from effluent pathways derived from LADTAP II and GASPAR.

6.1 Total Dose (COMPLIANCE WITH 40 CFR 190) for ODCM OR F.2

To demonstrate compliance with ODCM Operational Requirement F.2, the ODCM dose equations for noble gases, iodines, particulates, and tritium are used. They provide conservative dose estimates. The X/Q and D/Q values are based on historical data for the exclusion boundary distances. The liquid dose estimates also use the ODCM equations for dose determination which are added together for demonstration of compliance with 40 CFR 190.

Intentionally left blank.

7.0 LICENSEE-INITIATED CHANGES TO THE ODCM

Changes to the ODCM:

- a. Shall be documented and records of reviews performed shall be retained as required by Technical Specification 6.14. This documentation shall contain:
 - 1) Sufficient information to support the change together with the appropriate analyses or evaluations justifying the change(s) and
 - 2) A determination that the change will maintain the level of radioactive effluent control required by 10 CFR 20.1302, 40 CFR 190, 10 CFR 50.36a, and Appendix I to 10 CFR Part 50 and not adversely impact the accuracy or reliability of effluent, dose, or setpoint calculations.
- b. Shall become effective after review and acceptance by the PNSC and the approval of the Plant General Manager.
- c. Shall be submitted to the Commission in the form of a complete, legible copy of the entire ODCM as a part of or concurrent with the Annual Radioactive Effluent Release Report for the period of the report in which any change to the ODCM was made. Each change shall be identified by markings in the margin of the affected pages, clearly indicating the areas of the page that was changed, and shall indicate the date (e.g., month/year) the change was implemented.

APPENDIX A
METEOROLOGICAL DISPERSION FACTOR COMPUTATIONS

Carolina Power & Light Company (CP&L) now conducting business as Progress Energy Carolinas has performed the assessment of the transport and dispersion of the effluent in the atmosphere as outlined in Preparation of Radiological Effluent Technical Specifications for Nuclear Power Plants, NUREG 0133 (USNRC, 1978). The methodology for this assessment was based on guidelines presented in Regulatory Guide 1.111, Revision 1 (USNRC, 1977). The results of the assessment were to provide the relative depositions flux and relative concentrations (undepleted and depleted) based on numerical models acceptable for use in Appendix I evaluations.

Regulatory Guide 1.111 presented three acceptable diffusion models for use in estimating deposition flux and concentrations. These are (1) particle-in-cell model (a variable trajectory model based on the gradient-transport theory), (2) puff-advection model (a variable trajectory model based on the statistical approach to diffusion), and (3) the constant mean wind direction model referred to here as the straight-line trajectory Gaussian diffusion model (the most widely used model based on a statistical approach). It was resolved that for operational efficiency, the straight-line method described in XOQDOQ Computer Program for the Meteorological Evaluation of Routine Effluent Releases at Nuclear Power Stations, NUREG/CRC-2919 (USNRC, September 1982) would be used for generating the required analyses of Appendix I. To provide a more realistic accounting of the variability of wind around the plant site, standard terrain/recirculation correction factors (TCF) were used.

APPENDIX A
METEOROLOGICAL DISPERSION FACTOR COMPUTATIONS

A twelve-year record of meteorological data was used from the on-site meteorological program at the Shearon Harris Plant. These data consisted of all collected parameters from the normal 10.0 meter tower level for the years 1976-1987. The description of the model used and the computations are presented in NUREG/CRC-2919. The following tables provide the meteorological dilution factors (i.e., the X/Q and D/Q values) utilized to show compliance with ODCM Operational Requirements 3/4.11.2 for noble gases and radioiodines and particulates.

Tables A-1 through A-4	Relative undepleted concentration, relative depleted concentration, and relative deposition flux estimates for ground level releases for special locations for long-term releases.
Tables A-5 through A-12	Relative undepleted concentration, relative depleted concentration, and relative deposition flux estimates for ground level releases for standard and segmented distance locations for long-term releases.
Table A-13	SHNPP on-site joint wind frequency distributions for 1976-1987.

The X/Q and D/Q values which are utilized in the appendices are all assumed to be ground level releases.

APPENDIX A
METEOROLOGICAL DISPERSION FACTOR COMPUTATIONS

The NRC "XOQDOQ" Program was obtained and installed on the Progress Energy computer system. For routine meteorological dispersion evaluations, the "XOQDOQ" Program will be run with the appropriate physical plant data, appropriate meteorological information for the standard distances, and special locations of interest with a terrain/recirculation factor. The input to "XOQDOQ" for ground level releases are presented in Table A-14. The resulting computations will have the TCFs applied to produce a final atmospheric diffusion estimate for the site.

TABLE A-1 THROUGH A-4

X/Q and D/Q Values for Long Term Ground Level Releases at Special Locations

XOQDOQ -- SHNPP GROUND-LEVEL HISTORICAL DATA, 1976-1987
 EXIT ONE -- GROUND-LEVEL HISTORICAL DATA, 1976-1987
 CORRECTED USING STANDARD OPEN TERRAIN FACTORS

SPECIFIC POINTS OF INTEREST

RELEASE ID	TYPE OF LOCATION	DIRECTION FROM SITE	DISTANCE		Table A-1	Table A-2	Table A-3	Table A-4
			(MILES)	(METERS)	X/Q (sec/m3) NO DECAY NO DEPLETED	X/Q (sec/m3) 2.3 d DECAY DEPLETED	X/Q (sec/m3) 8.0 d DECAY DEPLETED	D/Q (per m2)
A	SITE BOUNDARY	S	1.36	2189.	6.1E-06	5.9E-06	5.2E-06	8.8E-09
A	SITE BOUNDARY	SSW	1.33	2140.	6.0E-06	5.8E-06	5.1E-06	8.7E-09
A	SITE BOUNDARY	SW	1.33	2140.	5.5E-06	5.4E-06	4.7E-06	7.0E-09
A	SITE BOUNDARY	WSW	1.33	2140.	4.8E-06	4.7E-06	4.1E-06	5.4E-09
A	SITE BOUNDARY	W	1.33	2140.	3.6E-06	3.6E-06	3.1E-06	4.1E-09
A	SITE BOUNDARY	WNW	1.33	2140.	2.8E-06	2.7E-06	2.4E-06	3.3E-09
A	SITE BOUNDARY	NW	1.26	2028.	2.9E-06	2.8E-06	2.5E-06	3.9E-09
A	SITE BOUNDARY	NNW	1.26	2028.	3.3E-06	3.2E-06	2.8E-06	5.1E-09
A	SITE BOUNDARY	N	1.32	2124.	3.8E-06	3.8E-06	3.3E-06	6.6E-09
A	SITE BOUNDARY	NNE	1.33	2140.	4.1E-06	4.0E-06	3.5E-06	7.9E-09
A	SITE BOUNDARY	NE	1.33	2140.	3.2E-06	3.2E-06	2.7E-06	7.3E-09
A	SITE BOUNDARY	ENE	1.33	2140.	2.4E-06	2.4E-06	2.1E-06	6.3E-09
A	SITE BOUNDARY	E	1.33	2140.	2.0E-06	1.9E-06	1.7E-06	3.8E-09
A	SITE BOUNDARY	ESE	1.33	2140.	1.8E-06	1.7E-06	1.5E-06	4.0E-09
A	SITE BOUNDARY	SE	1.33	2140.	2.1E-06	2.1E-06	1.8E-06	5.1E-09
A	SITE BOUNDARY	SSE	1.33	2140.	3.5E-06	3.4E-06	2.9E-06	6.2E-09
A	NEAREST RESIDENT	SSW	3.90	6275.	7.8E-07	7.3E-07	5.9E-07	6.8E-10
A	NEAREST RESIDENT	SW	2.80	4506.	1.3E-06	1.2E-06	1.0E-06	1.2E-09
A	NEAREST RESIDENT	WSW	4.30	6920.	5.4E-07	5.0E-07	4.0E-07	3.4E-10
A	NEAREST RESIDENT	W	2.70	4345.	9.2E-07	8.8E-07	7.3E-07	7.3E-10
A	NEAREST RESIDENT	WNW	2.10	3380.	1.1E-06	1.1E-06	9.1E-07	1.1E-09
A	NEAREST RESIDENT	NW	1.80	2897.	1.4E-06	1.3E-06	1.1E-06	1.6E-09
A	NEAREST RESIDENT	NNW	1.50	2414.	2.2E-06	2.2E-06	1.9E-06	3.3E-09
A	NEAREST RESIDENT	N	2.20	3540.	1.4E-06	1.3E-06	1.1E-06	1.9E-09
A	NEAREST RESIDENT	NNE	1.70	2736.	2.4E-06	2.4E-06	2.0E-06	4.3E-09
A	NEAREST RESIDENT	NE	2.30	3701.	1.0E-06	1.0E-06	8.5E-07	1.9E-09
A	NEAREST RESIDENT	ENE	2.00	3219.	1.0E-06	1.0E-06	8.5E-07	2.3E-09
A	NEAREST RESIDENT	E	1.90	3057.	9.3E-07	9.1E-07	7.7E-07	1.6E-09
A	NEAREST RESIDENT	ESE	2.70	4345.	4.3E-07	4.1E-07	3.4E-07	7.3E-10
A	NEAREST RESIDENT	SE	4.70	7562.	1.9E-07	1.8E-07	1.4E-07	2.6E-10
A	NEAREST RESIDENT	SSE	4.40	7081.	3.6E-07	3.4E-07	2.7E-07	3.7E-10
A	GARDEN	SSW	3.90	6276.	7.8E-07	7.3E-07	5.9E-07	6.8E-10
A	GARDEN	SW	2.80	4506.	1.3E-06	1.2E-06	1.0E-06	1.2E-09
A	GARDEN	WSW	4.30	6920.	5.4E-07	5.0E-07	4.0E-07	3.4E-10
A	GARDEN	W	3.00	4828.	7.6E-07	7.2E-07	6.0E-07	5.7E-10
A	GARDEN	WNW	2.10	3380.	1.1E-06	1.1E-06	9.1E-07	1.1E-09
A	GARDEN	NW	3.80	6116.	3.5E-07	3.3E-07	2.6E-07	2.8E-10
A	GARDEN	NNW	1.90	3058.	1.4E-06	1.4E-06	1.1E-06	1.8E-09
A	GARDEN	N	2.20	3540.	1.4E-06	1.3E-06	1.1E-06	1.9E-09
A	GARDEN	NNE	1.70	2736.	2.4E-06	2.4E-06	2.0E-06	4.3E-09
A	GARDEN	NE	2.30	3701.	1.0E-06	1.0E-06	8.5E-07	1.9E-09
A	GARDEN	E	4.70	7564.	1.8E-07	1.7E-07	1.3E-07	2.0E-10
A	GARDEN	ESE	2.80	4506.	4.0E-07	3.9E-07	3.2E-07	6.7E-10
A	GARDEN	SE	4.70	7562.	1.9E-07	1.8E-07	1.4E-07	2.6E-10
A	COW MILK	N	2.20	3540.	1.4E-06	1.3E-06	1.1E-06	1.9E-09
A	COW MILK	NNE	2.92	4703.	8.5E-07	8.2E-07	6.7E-07	1.2E-09
A	MEAT & POULTRY	SSW	4.40	7081.	6.3E-07	5.9E-07	4.7E-07	5.2E-10
A	MEAT & POULTRY	SW	2.80	4506.	1.3E-06	1.2E-06	1.0E-06	1.2E-09
A	MEAT & POULTRY	WSW	4.30	6920.	5.4E-07	5.0E-07	4.0E-07	3.4E-10
A	MEAT & POULTRY	W	3.10	4989.	7.2E-07	6.8E-07	5.6E-07	5.3E-10
A	MEAT & POULTRY	WNW	2.50	4023.	8.1E-07	7.7E-07	6.4E-07	7.2E-10
A	MEAT & POULTRY	NW	3.80	6116.	3.5E-07	3.3E-07	2.6E-07	2.8E-10
A	MEAT & POULTRY	NNW	1.90	3058.	1.4E-06	1.4E-06	1.1E-06	1.8E-09
A	MEAT & POULTRY	N	2.20	3540.	1.4E-06	1.3E-06	1.1E-06	1.9E-09
A	MEAT & POULTRY	NNE	1.80	2897.	2.2E-06	2.1E-06	1.8E-06	3.8E-09
A	MEAT & POULTRY	NE	2.30	3701.	1.0E-06	1.0E-06	8.5E-07	1.9E-09
A	MEAT & POULTRY	ENE	2.00	3219.	1.0E-06	1.0E-06	8.5E-07	2.3E-09
A	MEAT & POULTRY	E	4.60	7403.	1.8E-07	1.7E-07	1.4E-07	2.1E-10
A	MEAT & POULTRY	ESE	4.40	7081.	1.8E-07	1.7E-07	1.3E-07	2.4E-10

TABLE A-5

Undepleted, No Decay, X/Q Values for Long Term Ground Level Releases at Standard Distances (sec/m³)

EXIT ONE -- GROUND-LEVEL HISTORICAL DATA, 1976-1987
 NO DECAY, UNDEPLETED
 CORRECTED USING STANDARD OPEN TERRAIN FACTORS

SECTOR	ANNUAL AVERAGE CHI/Q (SEC/METER CUBED)						DISTANCE IN MILES FROM THE SITE					
	0.250	0.500	0.750	1.000	1.500	2.000	2.500	3.000	3.500	4.000	4.500	
S	1.720E-04	5.121E-05	2.531E-05	1.246E-05	4.943E-06	2.814E-06	1.851E-06	1.330E-06	1.015E-06	8.077E-07	6.637E-07	
SSW	1.571E-04	4.715E-05	2.346E-05	1.158E-05	4.596E-06	2.607E-06	1.711E-06	1.227E-06	9.341E-07	7.424E-07	6.093E-07	
SW	1.481E-04	4.412E-05	2.182E-05	1.074E-05	4.263E-06	2.428E-06	1.597E-06	1.148E-06	8.757E-07	6.971E-07	5.728E-07	
WSW	1.295E-04	3.842E-05	1.893E-05	9.308E-06	3.693E-06	2.108E-06	1.389E-06	9.995E-07	7.632E-07	6.080E-07	4.999E-07	
W	9.839E-05	2.921E-05	1.440E-05	7.087E-06	2.814E-06	1.605E-06	1.057E-06	7.608E-07	5.808E-07	4.626E-07	3.803E-07	
WNW	7.430E-05	2.216E-05	1.098E-05	5.420E-06	2.154E-06	1.225E-06	8.053E-07	5.784E-07	4.409E-07	3.508E-07	2.881E-07	
NW	6.636E-05	1.996E-05	9.994E-06	4.967E-06	1.982E-06	1.121E-06	7.339E-07	5.254E-07	3.995E-07	3.171E-07	2.599E-07	
NNW	7.179E-05	2.185E-05	1.111E-05	5.570E-06	2.234E-06	1.254E-06	8.166E-07	5.820E-07	4.409E-07	3.489E-07	2.853E-07	
N	9.224E-05	2.824E-05	1.448E-05	7.277E-06	2.919E-06	1.633E-06	1.060E-06	7.539E-07	5.701E-07	4.505E-07	3.678E-07	
NNE	9.847E-05	3.034E-05	1.560E-05	7.846E-06	3.145E-06	1.754E-06	1.137E-06	8.070E-07	6.094E-07	4.810E-07	3.923E-07	
NE	7.892E-05	2.430E-05	1.240E-05	6.194E-06	2.467E-06	1.376E-06	8.918E-07	6.333E-07	4.784E-07	3.777E-07	3.081E-07	
ENE	5.998E-05	1.845E-05	9.388E-06	4.679E-06	1.860E-06	1.036E-06	6.711E-07	4.764E-07	3.597E-07	2.839E-07	2.316E-07	
E	4.903E-05	1.498E-05	7.585E-06	3.779E-06	1.506E-06	8.439E-07	5.488E-07	3.908E-07	2.959E-07	2.341E-07	1.913E-07	
ESE	4.458E-05	1.361E-05	6.872E-06	3.417E-06	1.359E-06	7.616E-07	4.952E-07	3.527E-07	2.670E-07	2.112E-07	1.726E-07	
SE	5.351E-05	1.632E-05	8.255E-06	4.102E-06	1.629E-06	9.123E-07	5.929E-07	4.221E-07	3.195E-07	2.526E-07	2.064E-07	
SSE	9.101E-05	2.734E-05	1.361E-05	6.718E-06	2.666E-06	1.509E-06	9.885E-07	7.081E-07	5.387E-07	4.278E-07	3.509E-07	

SECTOR	ANNUAL AVERAGE CHI/Q (SEC/METER CUBED)						DISTANCE IN MILES FROM THE SITE					
	5.000	7.500	10.000	15.000	20.000	25.000	30.000	35.000	40.000	45.000	50.000	
S	5.589E-07	3.064E-07	2.075E-07	1.263E-07	8.904E-08	6.799E-08	5.459E-08	4.537E-08	3.867E-08	3.360E-08	2.964E-08	
SSW	5.126E-07	2.798E-07	1.890E-07	1.147E-07	8.066E-08	6.149E-08	4.930E-08	4.093E-08	3.485E-08	3.026E-08	2.667E-08	
SW	4.824E-07	2.645E-07	1.791E-07	1.090E-07	7.686E-08	5.869E-08	4.712E-08	3.916E-08	3.338E-08	2.900E-08	2.558E-08	
WSW	4.213E-07	2.315E-07	1.570E-07	9.574E-08	6.758E-08	5.165E-08	4.150E-08	3.451E-08	2.943E-08	2.558E-08	2.257E-08	
W	3.205E-07	1.760E-07	1.193E-07	7.275E-08	5.133E-08	3.922E-08	3.151E-08	2.620E-08	2.234E-08	1.941E-08	1.713E-08	
WNW	2.426E-07	1.328E-07	8.985E-08	5.463E-08	3.849E-08	2.937E-08	2.357E-08	1.958E-08	1.668E-08	1.449E-08	1.278E-08	
NW	2.185E-07	1.188E-07	8.005E-08	4.839E-08	3.396E-08	2.584E-08	2.069E-08	1.716E-08	1.460E-08	1.266E-08	1.115E-08	
NNW	2.392E-07	1.290E-07	8.639E-08	5.181E-08	3.617E-08	2.741E-08	2.187E-08	1.809E-08	1.535E-08	1.329E-08	1.168E-08	
N	3.081E-07	1.654E-07	1.105E-07	6.603E-08	4.597E-08	3.478E-08	2.771E-08	2.289E-08	1.940E-08	1.678E-08	1.474E-08	
NNE	3.283E-07	1.758E-07	1.171E-07	6.980E-08	4.852E-08	3.665E-08	2.918E-08	2.408E-08	2.040E-08	1.763E-08	1.548E-08	
NE	2.579E-07	1.383E-07	9.230E-08	5.512E-08	3.839E-08	2.904E-08	2.315E-08	1.912E-08	1.622E-08	1.403E-08	1.232E-08	
ENE	1.938E-07	1.039E-07	6.935E-08	4.142E-08	2.886E-08	2.184E-08	1.741E-08	1.439E-08	1.220E-08	1.056E-08	9.278E-09	
E	1.604E-07	8.645E-08	5.789E-08	3.473E-08	2.426E-08	1.840E-08	1.469E-08	1.215E-08	1.032E-08	8.935E-09	7.858E-09	
ESE	1.447E-07	7.804E-08	5.228E-08	3.139E-08	2.193E-08	1.664E-08	1.329E-08	1.100E-08	9.341E-09	8.091E-09	7.117E-09	
SE	1.730E-07	9.328E-08	6.248E-08	3.750E-08	2.620E-08	1.988E-08	1.588E-08	1.314E-08	1.116E-08	9.665E-09	8.501E-09	
SSE	2.950E-07	1.608E-07	1.085E-07	6.575E-08	4.622E-08	3.522E-08	2.823E-08	2.343E-08	1.995E-08	1.732E-08	1.526E-08	

TABLE A-6

Undepleted, No Decay, X/Q Values for Long Term Ground Level Releases at Standard Distances (sec/m³)

EXIT ONE -- GROUND-LEVEL HISTORICAL DATA, 1976-1987
 NO DECAY, UNDEPLETED

CHI/Q (SEC/METER CUBED) FOR EACH SEGMENT

SEGMENT BOUNDARIES IN MILES FROM THE SITE

DIRECTION FROM SITE	.5-1	1-2	2-3	3-4	4-5	5-10	10-20	20-30	30-40	40-50
S	2.535E-05	5.667E-06	1.900E-06	1.026E-06	6.676E-07	3.185E-07	1.278E-07	6.824E-08	4.545E-08	3.363E-08
SSW	2.344E-05	5.264E-06	1.756E-06	9.447E-07	6.129E-07	2.912E-07	1.161E-07	6.172E-08	4.101E-08	3.029E-08
SW	2.185E-05	4.887E-06	1.639E-06	8.855E-07	5.761E-07	2.749E-07	1.103E-07	5.891E-08	3.923E-08	2.903E-08
WSW	1.899E-05	4.236E-06	1.425E-06	7.715E-07	5.028E-07	2.405E-07	9.683E-08	5.184E-08	3.457E-08	2.560E-08
W	1.444E-05	3.226E-06	1.085E-06	5.872E-07	3.826E-07	1.829E-07	7.358E-08	3.937E-08	2.624E-08	1.943E-08
WNW	1.099E-05	2.467E-06	8.265E-07	4.459E-07	2.898E-07	1.381E-07	5.528E-08	2.948E-08	1.962E-08	1.451E-08
NW	9.975E-06	2.263E-06	7.538E-07	4.041E-07	2.615E-07	1.237E-07	4.902E-08	2.595E-08	1.719E-08	1.267E-08
NNW	1.103E-05	2.540E-06	8.395E-07	4.462E-07	2.871E-07	1.345E-07	5.254E-08	2.753E-08	1.813E-08	1.330E-08
N	1.434E-05	3.316E-06	1.090E-06	5.771E-07	3.702E-07	1.727E-07	6.700E-08	3.494E-08	2.294E-08	1.680E-08
NNE	1.543E-05	3.572E-06	1.169E-06	6.169E-07	3.949E-07	1.836E-07	7.086E-08	3.682E-08	2.413E-08	1.765E-08
NE	1.229E-05	2.811E-06	9.176E-07	4.843E-07	3.102E-07	1.445E-07	5.595E-08	2.918E-08	1.917E-08	1.404E-08
ENE	9.309E-06	2.120E-06	6.906E-07	3.642E-07	2.331E-07	1.085E-07	4.204E-08	2.194E-08	1.442E-08	1.057E-08
E	7.536E-06	1.717E-06	5.643E-07	2.995E-07	1.925E-07	9.019E-08	3.523E-08	1.848E-08	1.218E-08	8.946E-09
ESE	6.833E-06	1.551E-06	5.092E-07	2.702E-07	1.737E-07	8.141E-08	3.183E-08	1.671E-08	1.102E-08	8.101E-09
SE	8.202E-06	1.860E-06	6.097E-07	3.233E-07	2.078E-07	9.732E-08	3.803E-08	1.996E-08	1.317E-08	9.676E-09
SSE	1.360E-05	3.052E-06	1.015E-06	5.449E-07	3.530E-07	1.674E-07	6.657E-08	3.536E-08	2.348E-08	1.733E-08

TABLE A-7

Undepleted, 2.26 Day Decay, X/Q Values for Long Term Ground Level Releases at Standard Distances (sec/m³)

EXIT ONE -- GROUND-LEVEL HISTORICAL DATA, 1976-1987
 2.300 DAY DECAY, UNDEPLETED
 CORRECTED USING STANDARD OPEN TERRAIN FACTORS

ANNUAL AVERAGE CHI/Q (SEC/METER CUBED)		DISTANCE IN MILES FROM THE SITE									
SECTOR	0.250	0.500	0.750	1.000	1.500	2.000	2.500	3.000	3.500	4.000	4.500
S	1.712E-04	5.078E-05	2.500E-05	1.226E-05	4.824E-06	2.723E-06	1.776E-06	1.266E-06	9.571E-07	7.553E-07	6.153E-07
SSW	1.564E-04	4.675E-05	2.318E-05	1.139E-05	4.489E-06	2.525E-06	1.643E-06	1.168E-06	8.820E-07	6.951E-07	5.657E-07
SW	1.474E-04	4.374E-05	2.154E-05	1.056E-05	4.158E-06	2.347E-06	1.531E-06	1.091E-06	8.247E-07	6.508E-07	5.301E-07
WSW	1.289E-04	3.808E-05	1.869E-05	9.149E-06	3.600E-06	2.036E-06	1.330E-06	9.484E-07	7.177E-07	5.667E-07	4.619E-07
W	9.794E-05	2.895E-05	1.422E-05	6.966E-06	2.743E-06	1.551E-06	1.013E-06	7.221E-07	5.464E-07	4.314E-07	3.515E-07
WNW	7.398E-05	2.197E-05	1.085E-05	5.331E-06	2.102E-06	1.185E-06	7.723E-07	5.499E-07	4.156E-07	3.278E-07	2.669E-07
NW	6.609E-05	1.980E-05	9.879E-06	4.892E-06	1.938E-06	1.087E-06	7.060E-07	5.014E-07	3.782E-07	2.978E-07	2.421E-07
NNW	7.152E-05	2.170E-05	1.099E-05	5.495E-06	2.189E-06	1.220E-06	7.887E-07	5.581E-07	4.197E-07	3.297E-07	2.676E-07
N	9.191E-05	2.805E-05	1.434E-05	7.184E-06	2.864E-06	1.591E-06	1.026E-06	7.247E-07	5.442E-07	4.270E-07	3.463E-07
NNE	9.814E-05	3.014E-05	1.546E-05	7.751E-06	3.088E-06	1.712E-06	1.102E-06	7.770E-07	5.829E-07	4.570E-07	3.703E-07
NE	7.865E-05	2.414E-05	1.228E-05	6.117E-06	2.422E-06	1.342E-06	8.635E-07	6.091E-07	4.569E-07	3.582E-07	2.902E-07
ENE	5.978E-05	1.833E-05	9.300E-06	4.621E-06	1.825E-06	1.011E-06	6.499E-07	4.582E-07	3.436E-07	2.693E-07	2.182E-07
E	4.885E-05	1.487E-05	7.507E-06	3.729E-06	1.476E-06	8.212E-07	5.301E-07	3.748E-07	2.817E-07	2.212E-07	1.794E-07
ESE	4.441E-05	1.351E-05	6.801E-06	3.372E-06	1.332E-06	7.411E-07	4.783E-07	3.382E-07	2.541E-07	1.996E-07	1.619E-07
SE	5.331E-05	1.621E-05	8.172E-06	4.047E-06	1.597E-06	8.879E-07	5.728E-07	4.048E-07	3.042E-07	2.388E-07	1.937E-07
SSE	9.063E-05	2.712E-05	1.345E-05	6.616E-06	2.606E-06	1.463E-06	9.505E-07	6.753E-07	5.095E-07	4.014E-07	3.265E-07

ANNUAL AVERAGE CHI/Q (SEC/METER CUBED)		DISTANCE IN MILES FROM THE SITE									
SECTOR	5.000	7.500	10.000	15.000	20.000	25.000	30.000	35.000	40.000	45.000	50.000
S	5.138E-07	2.700E-07	1.755E-07	9.871E-08	6.459E-08	4.597E-08	3.454E-08	2.697E-08	2.167E-08	1.781E-08	1.490E-08
SSW	4.719E-07	2.472E-07	1.603E-07	8.990E-08	5.871E-08	4.172E-08	3.131E-08	2.442E-08	1.960E-08	1.609E-08	1.345E-08
SW	4.426E-07	2.324E-07	1.509E-07	8.472E-08	5.532E-08	3.929E-08	2.946E-08	2.296E-08	1.841E-08	1.510E-08	1.261E-08
WSW	3.858E-07	2.029E-07	1.318E-07	7.405E-08	4.835E-08	3.433E-08	2.574E-08	2.005E-08	1.607E-08	1.317E-08	1.100E-08
W	2.936E-07	1.544E-07	1.003E-07	5.633E-08	3.678E-08	2.612E-08	1.958E-08	1.525E-08	1.223E-08	1.003E-08	8.370E-09
WNW	2.228E-07	1.169E-07	7.589E-08	4.259E-08	2.782E-08	1.976E-08	1.482E-08	1.155E-08	9.267E-09	7.602E-09	6.350E-09
NW	2.019E-07	1.055E-07	6.837E-08	3.834E-08	2.505E-08	1.782E-08	1.339E-08	1.045E-08	8.394E-09	6.896E-09	5.768E-09
NNW	2.228E-07	1.159E-07	7.490E-08	4.194E-08	2.742E-08	1.953E-08	1.470E-08	1.150E-08	9.252E-09	7.614E-09	6.378E-09
N	2.880E-07	1.495E-07	9.650E-08	5.401E-08	3.534E-08	2.520E-08	1.898E-08	1.486E-08	1.198E-08	9.868E-09	8.276E-09
NNE	3.078E-07	1.594E-07	1.028E-07	5.753E-08	3.766E-08	2.687E-08	2.026E-08	1.588E-08	1.281E-08	1.057E-08	8.872E-09
NE	2.413E-07	1.250E-07	8.065E-08	4.512E-08	2.953E-08	2.106E-08	1.588E-08	1.244E-08	1.003E-08	8.276E-09	6.949E-09
ENE	1.814E-07	9.395E-08	6.060E-08	3.391E-08	2.220E-08	1.585E-08	1.195E-08	9.369E-09	7.561E-09	6.239E-09	5.241E-09
E	1.493E-07	7.761E-08	5.014E-08	2.807E-08	1.836E-08	1.308E-08	9.847E-09	7.705E-09	6.205E-09	5.110E-09	4.284E-09
ESE	1.347E-07	7.005E-08	4.527E-08	2.535E-08	1.659E-08	1.183E-08	8.908E-09	6.974E-09	5.619E-09	4.630E-09	3.884E-09
SE	1.612E-07	8.378E-08	5.414E-08	3.033E-08	1.985E-08	1.416E-08	1.067E-08	8.353E-09	6.732E-09	5.549E-09	4.657E-09
SSE	2.723E-07	1.425E-07	9.243E-08	5.189E-08	3.394E-08	2.416E-08	1.816E-08	1.419E-08	1.140E-08	9.378E-09	7.851E-09

TABLE A-8

Undepleted, 2.26 Day Decay, X/Q Values for Long Term Ground Level Releases at Standard Distances (sec/m³)

EXIT ONE -- GROUND-LEVEL HISTORICAL DATA, 1976-1987
 2.300 DAY DECAY, UNDEPLETED
 CHI/Q (SEC/METER CUBED) FOR EACH SEGMENT

SEGMENT BOUNDARIES IN MILES FROM THE SITE

DIRECTION FROM SITE	.5-1	1-2	2-3	3-4	4-5	5-10	10-20	20-30	30-40	40-50
S	2.506E-05	5.542E-06	1.825E-06	9.683E-07	6.192E-07	2.822E-07	1.006E-07	4.636E-08	2.711E-08	1.787E-08
SSW	2.318E-05	5.151E-06	1.688E-06	8.926E-07	5.693E-07	2.585E-07	9.168E-08	4.209E-08	2.455E-08	1.615E-08
SW	2.159E-05	4.776E-06	1.572E-06	8.345E-07	5.334E-07	2.429E-07	8.636E-08	3.964E-08	2.309E-08	1.516E-08
WSW	1.876E-05	4.138E-06	1.366E-06	7.261E-07	4.647E-07	2.119E-07	7.547E-08	3.463E-08	2.016E-08	1.323E-08
W	1.427E-05	3.152E-06	1.040E-06	5.528E-07	3.537E-07	1.613E-07	5.741E-08	2.635E-08	1.534E-08	1.006E-08
WNW	1.087E-05	2.412E-06	7.934E-07	4.205E-07	2.686E-07	1.222E-07	4.343E-08	1.994E-08	1.162E-08	7.632E-09
NW	9.867E-06	2.216E-06	7.259E-07	3.827E-07	2.437E-07	1.104E-07	3.911E-08	1.798E-08	1.051E-08	6.922E-09
NNW	1.093E-05	2.493E-06	8.116E-07	4.250E-07	2.694E-07	1.214E-07	4.281E-08	1.970E-08	1.156E-08	7.641E-09
N	1.421E-05	3.258E-06	1.056E-06	5.511E-07	3.486E-07	1.567E-07	5.515E-08	2.541E-08	1.494E-08	9.903E-09
NNE	1.530E-05	3.513E-06	1.134E-06	5.904E-07	3.728E-07	1.672E-07	5.877E-08	2.710E-08	1.596E-08	1.060E-08
NE	1.218E-05	2.763E-06	8.893E-07	4.628E-07	2.923E-07	1.311E-07	4.608E-08	2.125E-08	1.251E-08	8.305E-09
ENE	9.227E-06	2.084E-06	6.694E-07	3.480E-07	2.197E-07	9.855E-08	3.464E-08	1.598E-08	9.418E-09	6.261E-09
E	7.464E-06	1.685E-06	5.456E-07	2.852E-07	1.806E-07	8.134E-08	2.866E-08	1.319E-08	7.746E-09	5.129E-09
ESE	6.768E-06	1.523E-06	4.923E-07	2.574E-07	1.630E-07	7.341E-08	2.588E-08	1.193E-08	7.010E-09	4.647E-09
SE	8.124E-06	1.826E-06	5.897E-07	3.080E-07	1.950E-07	8.781E-08	3.096E-08	1.428E-08	8.396E-09	5.569E-09
SSE	1.345E-05	2.989E-06	9.771E-07	5.157E-07	3.286E-07	1.491E-07	5.292E-08	2.437E-08	1.426E-08	9.413E-09

TABLE A-9

Depleted, 8.0 Day Decay, X/Q Values for Long Term Ground Level Releases at Standard Distances (sec/m³)

EXIT ONE -- GROUND-LEVEL HISTORICAL DATA, 1976-1987
 8.000 DAY DECAY, DEPLETED
 CORRECTED USING STANDARD OPEN TERRAIN FACTORS

SECTOR	ANNUAL AVERAGE CHI/Q (SEC/METER CUBED)										
	0.250	0.500	0.750	1.000	1.500	2.000	2.500	3.000	3.500	4.000	4.500
S	1.625E-04	4.665E-05	2.247E-05	1.085E-05	4.169E-06	2.308E-06	1.482E-06	1.042E-06	7.784E-07	6.080E-07	4.908E-07
SSW	1.485E-04	4.295E-05	2.083E-05	1.009E-05	3.877E-06	2.139E-06	1.369E-06	9.606E-07	7.168E-07	5.590E-07	4.507E-07
SW	1.400E-04	4.019E-05	1.937E-05	9.357E-06	3.594E-06	1.991E-06	1.278E-06	8.984E-07	6.715E-07	5.244E-07	4.233E-07
WSW	1.224E-04	3.499E-05	1.681E-05	8.107E-06	3.113E-06	1.728E-06	1.111E-06	7.818E-07	5.849E-07	4.572E-07	3.693E-07
W	9.300E-05	2.660E-05	1.279E-05	6.173E-06	2.372E-06	1.316E-06	8.458E-07	5.952E-07	4.452E-07	3.479E-07	2.810E-07
WNW	7.023E-05	2.018E-05	9.753E-06	4.721E-06	1.816E-06	1.005E-06	6.444E-07	4.527E-07	3.382E-07	2.640E-07	2.130E-07
NW	6.273E-05	1.819E-05	8.876E-06	4.329E-06	1.672E-06	9.202E-07	5.878E-07	4.117E-07	3.068E-07	2.390E-07	1.925E-07
NNW	6.787E-05	1.991E-05	9.871E-06	4.857E-06	1.886E-06	1.030E-06	6.548E-07	4.567E-07	3.391E-07	2.635E-07	2.117E-07
N	8.721E-05	2.574E-05	1.287E-05	6.346E-06	2.465E-06	1.342E-06	8.505E-07	5.920E-07	4.389E-07	3.404E-07	2.732E-07
NNE	9.311E-05	2.765E-05	1.387E-05	6.844E-06	2.657E-06	1.442E-06	9.123E-07	6.339E-07	4.694E-07	3.637E-07	2.916E-07
NE	7.462E-05	2.215E-05	1.102E-05	5.403E-06	2.084E-06	1.131E-06	7.156E-07	4.974E-07	3.683E-07	2.855E-07	2.289E-07
ENE	5.671E-05	1.682E-05	8.343E-06	4.081E-06	1.571E-06	8.519E-07	5.385E-07	3.741E-07	2.770E-07	2.146E-07	1.721E-07
E	4.635E-05	1.365E-05	6.739E-06	3.295E-06	1.271E-06	6.933E-07	4.401E-07	3.067E-07	2.276E-07	1.767E-07	1.419E-07
ESE	4.214E-05	1.240E-05	6.105E-06	2.980E-06	1.147E-06	6.256E-07	3.971E-07	2.767E-07	2.054E-07	1.595E-07	1.281E-07
SE	5.058E-05	1.487E-05	7.335E-06	3.576E-06	1.376E-06	7.495E-07	4.755E-07	3.312E-07	2.457E-07	1.908E-07	1.532E-07
SSE	8.603E-05	2.491E-05	1.209E-05	5.855E-06	2.249E-06	1.238E-06	7.917E-07	5.547E-07	4.136E-07	3.223E-07	2.597E-07

SECTOR	ANNUAL AVERAGE CHI/Q (SEC/METER CUBED)										
	5.000	7.500	10.000	15.000	20.000	25.000	30.000	35.000	40.000	45.000	50.000
S	4.064E-07	2.080E-07	1.325E-07	7.280E-08	4.700E-08	3.317E-08	2.477E-08	1.924E-08	1.538E-08	1.257E-08	1.045E-08
SSW	3.729E-07	1.901E-07	1.208E-07	6.616E-08	4.263E-08	3.004E-08	2.240E-08	1.738E-08	1.388E-08	1.134E-08	9.424E-09
SW	3.506E-07	1.794E-07	1.143E-07	6.274E-08	4.049E-08	2.856E-08	2.131E-08	1.654E-08	1.322E-08	1.079E-08	8.973E-09
WSW	3.060E-07	1.569E-07	1.001E-07	5.502E-08	3.554E-08	2.508E-08	1.872E-08	1.453E-08	1.161E-08	9.487E-09	7.887E-09
W	2.328E-07	1.193E-07	7.609E-08	4.182E-08	2.701E-08	1.906E-08	1.422E-08	1.104E-08	8.823E-09	7.207E-09	5.991E-09
WNW	1.764E-07	9.014E-08	5.738E-08	3.147E-08	2.030E-08	1.431E-08	1.068E-08	8.289E-09	6.622E-09	5.409E-09	4.496E-09
NW	1.591E-07	8.086E-08	5.129E-08	2.801E-08	1.803E-08	1.269E-08	9.462E-09	7.339E-09	5.861E-09	4.787E-09	3.979E-09
NNW	1.746E-07	8.808E-08	5.560E-08	3.019E-08	1.936E-08	1.360E-08	1.013E-08	7.848E-09	6.264E-09	5.115E-09	4.251E-09
N	2.251E-07	1.132E-07	7.127E-08	3.859E-08	2.471E-08	1.735E-08	1.291E-08	1.000E-08	7.981E-09	6.516E-09	5.417E-09
NNE	2.401E-07	1.204E-07	7.567E-08	4.089E-08	2.616E-08	1.835E-08	1.365E-08	1.057E-08	8.437E-09	6.888E-09	5.726E-09
NE	1.885E-07	9.461E-08	5.954E-08	3.222E-08	2.063E-08	1.449E-08	1.078E-08	8.353E-09	6.668E-09	5.445E-09	4.527E-09
ENE	1.417E-07	7.109E-08	4.473E-08	2.421E-08	1.551E-08	1.089E-08	8.109E-09	6.285E-09	5.018E-09	4.099E-09	3.409E-09
E	1.171E-07	5.902E-08	3.724E-08	2.023E-08	1.298E-08	9.120E-09	6.791E-09	5.264E-09	4.203E-09	3.432E-09	2.853E-09
ESE	1.056E-07	5.327E-08	3.363E-08	1.827E-08	1.173E-08	8.246E-09	6.143E-09	4.763E-09	3.803E-09	3.107E-09	2.583E-09
SE	1.263E-07	6.369E-08	4.020E-08	2.184E-08	1.402E-08	9.856E-09	7.343E-09	5.694E-09	4.547E-09	3.714E-09	3.089E-09
SSE	2.148E-07	1.094E-07	6.946E-08	3.801E-08	2.449E-08	1.726E-08	1.288E-08	9.994E-09	7.985E-09	6.524E-09	5.425E-09

TABLE A-10

Depleted, 8.0 Day Decay, X/Q Values for Long Term Ground Level Releases at Standard Distances (sec/m³)

EXIT ONE -- GROUND-LEVEL HISTORICAL DATA, 1976-1987
 8.000 DAY DECAY, DEPLETED
 CHI/Q (SEC/METER CUBED) FOR EACH SEGMENT

SEGMENT BOUNDARIES IN MILES FROM THE SITE

DIRECTION FROM SITE	.5-1	1-2	2-3	3-4	4-5	5-10	10-20	20-30	30-40	40-50
S	2.268E-05	4.827E-06	1.526E-06	7.887E-07	4.943E-07	2.186E-07	7.461E-08	3.350E-08	1.935E-08	1.262E-08
SSW	2.097E-05	4.485E-06	1.411E-06	7.263E-07	4.540E-07	1.999E-07	6.785E-08	3.034E-08	1.748E-08	1.138E-08
SW	1.955E-05	4.162E-06	1.316E-06	6.803E-07	4.264E-07	1.885E-07	6.430E-08	2.884E-08	1.664E-08	1.084E-08
WSW	1.698E-05	3.607E-06	1.144E-06	5.925E-07	3.719E-07	1.648E-07	5.637E-08	2.532E-08	1.462E-08	9.524E-09
W	1.292E-05	2.747E-06	8.710E-07	4.510E-07	2.830E-07	1.253E-07	4.285E-08	1.924E-08	1.111E-08	7.236E-09
WNW	9.835E-06	2.101E-06	6.638E-07	3.426E-07	2.145E-07	9.474E-08	3.226E-08	1.446E-08	8.338E-09	5.430E-09
NW	8.924E-06	1.928E-06	6.060E-07	3.109E-07	1.939E-07	8.510E-08	2.875E-08	1.282E-08	7.383E-09	4.806E-09
NNW	9.874E-06	2.166E-06	6.757E-07	3.439E-07	2.133E-07	9.287E-08	3.102E-08	1.375E-08	7.896E-09	5.136E-09
N	1.283E-05	2.828E-06	8.782E-07	4.451E-07	2.753E-07	1.194E-07	3.969E-08	1.754E-08	1.006E-08	6.543E-09
NNE	1.381E-05	3.048E-06	9.423E-07	4.761E-07	2.939E-07	1.271E-07	4.207E-08	1.855E-08	1.064E-08	6.917E-09
NE	1.100E-05	2.398E-06	7.392E-07	3.736E-07	2.307E-07	9.990E-08	3.314E-08	1.464E-08	8.404E-09	5.467E-09
ENE	8.332E-06	1.809E-06	5.563E-07	2.810E-07	1.734E-07	7.506E-08	2.491E-08	1.101E-08	6.323E-09	4.115E-09
E	6.744E-06	1.464E-06	4.542E-07	2.308E-07	1.430E-07	6.224E-08	2.079E-08	9.217E-09	5.296E-09	3.446E-09
ESE	6.115E-06	1.323E-06	4.099E-07	2.083E-07	1.291E-07	5.618E-08	1.878E-08	8.333E-09	4.791E-09	3.119E-09
SE	7.340E-06	1.586E-06	4.908E-07	2.492E-07	1.544E-07	6.717E-08	2.244E-08	9.960E-09	5.728E-09	3.730E-09
SSE	1.217E-05	2.601E-06	8.160E-07	4.191E-07	2.616E-07	1.151E-07	3.899E-08	1.743E-08	1.005E-08	6.550E-09

TABLE A-11

Deposition Values (D/Q) for Long Term Releases at Standard Distances (m⁻²)

EXIT ONE -- GROUND-LEVEL HISTORICAL DATA, 1976-1987
 CORRECTED USING STANDARD OPEN TERRAIN FACTORS

***** RELATIVE DEPOSITION PER UNIT AREA (M**⁻²) AT FIXED POINTS BY DOWNWIND SECTORS *****

DIRECTION FROM SITE	DISTANCES IN MILES										
	0.25	0.50	0.75	1.00	1.50	2.00	2.50	3.00	3.50	4.00	4.50
S	2.324E-07	7.857E-08	4.034E-08	1.918E-08	6.889E-09	3.417E-09	2.012E-09	1.317E-09	9.269E-10	6.869E-10	5.294E-10
SSW	2.171E-07	7.343E-08	3.770E-08	1.792E-08	6.438E-09	3.193E-09	1.880E-09	1.231E-09	8.662E-10	6.420E-10	4.947E-10
SW	1.740E-07	5.885E-08	3.022E-08	1.437E-08	5.160E-09	2.559E-09	1.507E-09	9.866E-10	6.942E-10	5.145E-10	3.965E-10
WSW	1.355E-07	4.582E-08	2.353E-08	1.119E-08	4.018E-09	1.993E-09	1.173E-09	7.682E-10	5.406E-10	4.006E-10	3.087E-10
W	1.013E-07	3.427E-08	1.759E-08	8.365E-09	3.005E-09	1.490E-09	8.774E-10	5.745E-10	4.042E-10	2.996E-10	2.309E-10
WNW	8.296E-08	2.805E-08	1.440E-08	6.848E-09	2.460E-09	1.220E-09	7.183E-10	4.703E-10	3.309E-10	2.453E-10	1.890E-10
NW	8.468E-08	2.864E-08	1.470E-08	6.990E-09	2.511E-09	1.245E-09	7.332E-10	4.801E-10	3.378E-10	2.503E-10	1.929E-10
NNW	1.105E-07	3.736E-08	1.918E-08	9.120E-09	3.276E-09	1.625E-09	9.566E-10	6.264E-10	4.408E-10	3.266E-10	2.517E-10
N	1.626E-07	5.499E-08	2.823E-08	1.342E-08	4.821E-09	2.391E-09	1.408E-09	9.218E-10	6.487E-10	4.807E-10	3.705E-10
NNE	1.985E-07	6.713E-08	3.447E-08	1.639E-08	5.886E-09	2.919E-09	1.719E-09	1.125E-09	7.919E-10	5.869E-10	4.522E-10
NE	1.815E-07	6.137E-08	3.151E-08	1.498E-08	5.381E-09	2.669E-09	1.571E-09	1.029E-09	7.240E-10	5.366E-10	4.135E-10
ENE	1.568E-07	5.302E-08	2.723E-08	1.294E-08	4.649E-09	2.306E-09	1.358E-09	8.890E-10	6.255E-10	4.636E-10	3.572E-10
E	9.595E-08	3.245E-08	1.666E-08	7.920E-09	2.845E-09	1.411E-09	8.307E-10	5.439E-10	3.827E-10	2.837E-10	2.186E-10
ESE	1.003E-07	3.393E-08	1.742E-08	8.281E-09	2.975E-09	1.475E-09	8.686E-10	5.688E-10	4.002E-10	2.966E-10	2.286E-10
SE	1.270E-07	4.294E-08	2.205E-08	1.048E-08	3.765E-09	1.867E-09	1.099E-09	7.199E-10	5.066E-10	3.754E-10	2.893E-10
SSE	1.548E-07	5.236E-08	2.688E-08	1.278E-08	4.591E-09	2.277E-09	1.341E-09	8.778E-10	6.177E-10	4.578E-10	3.528E-10

DIRECTION FROM SITE	DISTANCES IN MILES										
	5.00	7.50	10.00	15.00	20.00	25.00	30.00	35.00	40.00	45.00	50.00
S	4.205E-10	1.868E-10	1.132E-10	5.720E-11	3.462E-11	2.321E-11	1.663E-11	1.249E-11	9.711E-12	7.757E-12	6.332E-12
SSW	3.930E-10	1.746E-10	1.058E-10	5.346E-11	3.235E-11	2.169E-11	1.554E-11	1.167E-11	9.075E-12	7.249E-12	5.917E-12
SW	3.150E-10	1.399E-10	8.476E-11	4.284E-11	2.593E-11	1.739E-11	1.246E-11	9.354E-12	7.273E-12	5.810E-12	4.742E-12
WSW	2.453E-10	1.090E-10	6.600E-11	3.336E-11	2.019E-11	1.354E-11	.700E-12	97.284E-12	5.663E-12	4.524E-12	3.692E-12
W	1.834E-10	8.148E-11	4.935E-11	2.495E-11	1.510E-11	1.012E-11	7.254E-12	5.447E-12	4.235E-12	3.383E-12	2.761E-12
WNW	1.501E-10	6.670E-11	4.040E-11	2.042E-11	1.236E-11	8.287E-12	5.938E-12	4.459E-12	3.467E-12	2.769E-12	2.261E-12
NW	1.533E-10	6.808E-11	4.124E-11	2.085E-11	1.262E-11	8.459E-12	6.062E-12	4.552E-12	3.539E-12	2.827E-12	2.307E-12
NNW	2.000E-10	8.884E-11	5.381E-11	2.720E-11	1.646E-11	1.104E-11	7.909E-12	5.939E-12	4.618E-12	3.689E-12	3.011E-12
N	2.943E-10	1.307E-10	7.920E-11	4.003E-11	2.423E-11	1.624E-11	1.164E-11	8.740E-12	6.796E-12	5.428E-12	4.431E-12
NNE	3.593E-10	1.596E-10	9.668E-11	4.887E-11	2.958E-11	1.983E-11	1.421E-11	1.067E-11	8.296E-12	6.627E-12	5.409E-12
NE	3.285E-10	1.459E-10	8.839E-11	4.468E-11	2.704E-11	1.813E-11	1.299E-11	9.755E-12	7.585E-12	6.059E-12	4.946E-12
ENE	2.838E-10	1.261E-10	7.637E-11	3.860E-11	2.336E-11	1.566E-11	1.122E-11	8.428E-12	6.553E-12	5.235E-12	4.273E-12
E	1.737E-10	7.714E-11	4.673E-11	2.362E-11	1.430E-11	9.585E-12	6.868E-12	5.157E-12	4.010E-12	3.203E-12	2.614E-12
ESE	1.816E-10	8.066E-11	4.886E-11	2.470E-11	1.495E-11	1.002E-11	7.181E-12	5.393E-12	4.193E-12	3.349E-12	2.734E-12
SE	2.298E-10	1.021E-10	6.185E-11	3.126E-11	1.892E-11	1.269E-11	9.090E-12	6.826E-12	5.307E-12	4.240E-12	3.460E-12
SSE	2.802E-10	1.245E-10	7.541E-11	3.812E-11	2.307E-11	1.547E-11	1.108E-11	8.323E-12	6.471E-12	5.169E-12	4.219E-12

TABLE A-12

Deposition Values (D/Q) for Long Term Releases at Standard Distances (m⁻²)

EXIT ONE -- GROUND-LEVEL HISTORICAL DATA, 1976-1987

***** RELATIVE DEPOSITION PER UNIT AREA (M⁻²) AT FIXED POINTS BY DOWNWIND SECTORS *****

SEGMENT BOUNDARIES IN MILES FROM THE SITE

DIRECTION FROM SITE	.5-1	1-2	2-3	3-4	4-5	5-10	10-20	20-30	30-40	40-50
S	3.943E-08	8.077E-09	2.109E-09	9.470E-10	5.357E-10	2.060E-10	5.960E-11	2.362E-11	1.261E-11	7.808E-12
SSW	3.685E-08	7.548E-09	1.971E-09	8.850E-10	5.007E-10	1.925E-10	5.570E-11	2.208E-11	1.179E-11	7.297E-12
SW	2.953E-08	6.050E-09	1.579E-09	7.093E-10	4.013E-10	1.543E-10	4.464E-11	1.769E-11	9.448E-12	5.848E-12
WSW	2.300E-08	4.710E-09	1.230E-09	5.523E-10	3.124E-10	1.201E-10	3.476E-11	1.378E-11	7.357E-12	4.554E-12
W	1.720E-08	3.523E-09	9.196E-10	4.130E-10	2.337E-10	8.985E-11	2.599E-11	1.030E-11	5.502E-12	3.405E-12
WNW	1.408E-08	2.884E-09	7.528E-10	3.381E-10	1.913E-10	7.356E-11	2.128E-11	8.434E-12	4.504E-12	2.788E-12
NW	1.437E-08	2.944E-09	7.685E-10	3.451E-10	1.952E-10	7.508E-11	2.172E-11	8.609E-12	4.597E-12	2.846E-12
NNW	1.875E-08	3.841E-09	1.003E-09	4.503E-10	2.548E-10	9.797E-11	2.834E-11	1.123E-11	5.998E-12	3.713E-12
N	2.760E-08	5.652E-09	1.476E-09	6.627E-10	3.749E-10	1.442E-10	4.171E-11	1.653E-11	8.828E-12	5.464E-12
NNE	3.369E-08	6.901E-09	1.801E-09	8.091E-10	4.577E-10	1.760E-10	5.092E-11	2.018E-11	1.078E-11	6.671E-12
NE	3.080E-08	6.309E-09	1.647E-09	7.397E-10	4.185E-10	1.609E-10	4.655E-11	1.845E-11	9.853E-12	6.099E-12
ENE	2.661E-08	5.451E-09	1.423E-09	6.391E-10	3.615E-10	1.390E-10	4.022E-11	1.594E-11	8.513E-12	5.269E-12
E	1.628E-08	3.335E-09	8.707E-10	3.911E-10	2.212E-10	8.507E-11	2.461E-11	9.754E-12	5.209E-12	3.224E-12
ESE	1.703E-08	3.487E-09	9.104E-10	4.089E-10	2.313E-10	8.895E-11	2.573E-11	1.020E-11	5.447E-12	3.371E-12
SE	2.155E-08	4.414E-09	1.152E-09	5.176E-10	2.928E-10	1.126E-10	3.257E-11	1.291E-11	6.894E-12	4.267E-12
SSE	2.628E-08	5.383E-09	1.405E-09	6.311E-10	3.570E-10	1.373E-10	3.972E-11	1.574E-11	8.406E-12	5.203E-12

TABLE A-13

Joint Wind Frequency Distribution by Pasquill Stability Classes at SHNPP

XOQDOQ -- SHNPP GROUND-LEVEL HISTORICAL DATA, 1976-1987
 JOINT FREQUENCY DISTRIBUTION OF WIND SPEED AND DIRECTION

ATMOSPHERIC STABILITY CLASS A																	
UMAX (M/S)	N	NNE	NE	ENE	E	ESE	SE	SSE	S	SSW	SW	WSW	W	WNW	NW	NNW	TOTAL
0.34	0.000	0.000	0.000	0.000	0.000	0.000	0.000	0.000	0.000	0.000	0.000	0.000	0.000	0.000	0.000	0.000	0.000
1.56	0.014	0.009	0.016	0.012	0.012	0.009	0.021	0.008	0.020	0.016	0.020	0.018	0.015	0.010	0.011	0.009	0.219
3.35	0.425	0.354	0.307	0.219	0.162	0.123	0.116	0.177	0.357	0.329	0.338	0.416	0.163	0.165	0.317	0.334	4.303
5.59	0.307	0.296	0.173	0.060	0.017	0.029	0.020	0.021	0.083	0.257	0.361	0.450	0.145	0.234	0.367	0.356	3.176
8.27	0.008	0.000	0.002	0.000	0.000	0.001	0.000	0.001	0.005	0.011	0.057	0.084	0.033	0.071	0.059	0.044	0.374
11.18	0.000	0.000	0.000	0.000	0.000	0.000	0.000	0.000	0.000	0.001	0.000	0.004	0.004	0.008	0.000	0.001	0.018
11.62	0.000	0.000	0.000	0.000	0.000	0.000	0.000	0.000	0.000	0.000	0.000	0.000	0.000	0.000	0.000	0.000	0.000
TOTAL	0.75	0.66	0.50	0.29	0.19	0.16	0.16	0.21	0.47	0.61	0.78	0.97	0.36	0.49	0.75	0.74	8.09
ATMOSPHERIC STABILITY CLASS B																	
UMAX (M/S)	N	NNE	NE	ENE	E	ESE	SE	SSE	S	SSW	SW	WSW	W	WNW	NW	NNW	TOTAL
0.34	0.000	0.000	0.000	0.000	0.000	0.000	0.000	0.000	0.000	0.000	0.000	0.000	0.000	0.000	0.000	0.000	0.000
1.56	0.014	0.015	0.023	0.022	0.017	0.021	0.017	0.018	0.022	0.020	0.032	0.021	0.025	0.013	0.018	0.017	0.314
3.35	0.308	0.269	0.204	0.181	0.151	0.121	0.087	0.133	0.234	0.282	0.323	0.314	0.111	0.142	0.221	0.217	3.298
5.59	0.109	0.087	0.061	0.022	0.021	0.008	0.020	0.022	0.047	0.099	0.160	0.196	0.102	0.151	0.216	0.158	1.478
8.27	0.006	0.000	0.001	0.000	0.000	0.000	0.000	0.001	0.004	0.005	0.031	0.026	0.032	0.053	0.028	0.019	0.205
11.18	0.000	0.000	0.000	0.000	0.000	0.000	0.000	0.000	0.000	0.000	0.002	0.002	0.001	0.003	0.001	0.001	0.010
11.62	0.000	0.000	0.000	0.000	0.000	0.000	0.000	0.000	0.000	0.000	0.000	0.001	0.000	0.000	0.000	0.000	0.001
TOTAL	0.44	0.37	0.29	0.23	0.19	0.15	0.12	0.17	0.31	0.41	0.55	0.56	0.27	0.36	0.48	0.41	5.31
ATMOSPHERIC STABILITY CLASS C																	
UMAX (M/S)	N	NNE	NE	ENE	E	ESE	SE	SSE	S	SSW	SW	WSW	W	WNW	NW	NNW	TOTAL
0.34	0.000	0.000	0.000	0.000	0.000	0.000	0.000	0.000	0.000	0.000	0.000	0.000	0.000	0.000	0.000	0.000	0.000
1.56	0.031	0.031	0.035	0.028	0.023	0.031	0.041	0.037	0.050	0.057	0.069	0.045	0.035	0.029	0.033	0.038	0.610
3.35	0.347	0.287	0.245	0.220	0.152	0.131	0.121	0.158	0.261	0.332	0.375	0.369	0.175	0.192	0.246	0.261	3.874
5.59	0.139	0.081	0.039	0.036	0.008	0.009	0.014	0.027	0.029	0.112	0.160	0.192	0.117	0.115	0.199	0.145	1.423
8.27	0.007	0.000	0.000	0.000	0.000	0.000	0.000	0.001	0.001	0.008	0.019	0.023	0.012	0.055	0.024	0.015	0.164
11.18	0.000	0.000	0.000	0.000	0.000	0.000	0.000	0.000	0.000	0.000	0.002	0.003	0.002	0.002	0.000	0.000	0.009
11.62	0.000	0.000	0.000	0.000	0.000	0.000	0.000	0.000	0.000	0.000	0.000	0.000	0.000	0.000	0.000	0.000	0.000
TOTAL	0.52	0.40	0.32	0.28	0.18	0.17	0.18	0.22	0.34	0.51	0.63	0.63	0.34	0.39	0.50	0.46	6.08
ATMOSPHERIC STABILITY CLASS D																	
UMAX (M/S)	N	NNE	NE	ENE	E	ESE	SE	SSE	S	SSW	SW	WSW	W	WNW	NW	NNW	TOTAL
0.34	0.002	0.002	0.002	0.002	0.001	0.001	0.001	0.001	0.002	0.002	0.002	0.001	0.001	0.001	0.001	0.001	0.025
1.56	0.434	0.506	0.444	0.370	0.329	0.266	0.278	0.300	0.362	0.481	0.465	0.346	0.287	0.258	0.269	0.346	5.739
3.35	1.759	2.054	1.350	0.964	0.624	0.523	0.556	0.742	1.058	1.346	1.316	1.177	0.647	0.583	0.746	1.025	16.471
5.59	0.556	0.491	0.330	0.114	0.066	0.076	0.100	0.190	0.220	0.376	0.550	0.462	0.260	0.402	0.523	0.558	5.271
8.27	0.055	0.023	0.004	0.011	0.004	0.006	0.005	0.023	0.032	0.047	0.069	0.075	0.042	0.092	0.062	0.063	0.610
11.18	0.000	0.000	0.000	0.000	0.000	0.000	0.001	0.000	0.001	0.001	0.008	0.017	0.000	0.004	0.000	0.000	0.032
11.62	0.000	0.000	0.000	0.000	0.001	0.000	0.000	0.000	0.000	0.000	0.000	0.000	0.000	0.000	0.000	0.000	0.001
TOTAL	2.81	3.08	2.13	1.46	1.02	0.87	0.94	1.26	1.68	2.25	2.41	2.08	1.24	1.34	1.60	1.99	28.15

TABLE A-13

Joint Wind Frequency Distribution by Pasquill Stability Classes at SHNPP

XOQDOQ -- SHNPP GROUND-LEVEL HISTORICAL DATA, 1976-1987
 JOINT FREQUENCY DISTRIBUTION OF WIND SPEED AND DIRECTION

ATMOSPHERIC STABILITY CLASS E																	
UMAX (M/S)	N	NNE	NE	ENE	E	ESE	SE	SSE	S	SSW	SW	WSW	W	WNW	NW	NNW	TOTAL
0.34	0.005	0.007	0.006	0.005	0.004	0.003	0.004	0.006	0.009	0.009	0.005	0.004	0.003	0.002	0.003	0.003	0.079
1.56	0.747	0.962	0.824	0.692	0.518	0.480	0.536	0.818	1.244	1.183	0.723	0.492	0.415	0.312	0.405	0.466	10.816
3.35	1.028	0.855	0.549	0.329	0.309	0.266	0.356	0.577	1.058	1.547	1.029	0.744	0.488	0.459	0.660	0.667	10.920
5.59	0.124	0.032	0.046	0.029	0.019	0.028	0.032	0.080	0.138	0.148	0.216	0.145	0.067	0.101	0.085	0.131	1.421
8.27	0.007	0.003	0.000	0.002	0.002	0.004	0.006	0.006	0.016	0.010	0.015	0.026	0.010	0.003	0.003	0.008	0.120
11.18	0.000	0.000	0.000	0.000	0.000	0.000	0.000	0.000	0.000	0.000	0.003	0.004	0.000	0.001	0.000	0.000	0.008
11.62	0.000	0.000	0.000	0.000	0.000	0.000	0.000	0.000	0.000	0.000	0.000	0.000	0.000	0.000	0.000	0.000	0.000
TOTAL	1.91	1.86	1.42	1.06	0.85	0.78	0.93	1.49	2.47	2.90	1.99	1.41	0.98	0.88	1.16	1.28	23.36
ATMOSPHERIC STABILITY CLASS F																	
UMAX (M/S)	N	NNE	NE	ENE	E	ESE	SE	SSE	S	SSW	SW	WSW	W	WNW	NW	NNW	TOTAL
0.34	0.018	0.018	0.017	0.014	0.011	0.009	0.011	0.015	0.018	0.019	0.012	0.009	0.008	0.007	0.007	0.011	0.203
1.56	0.777	0.788	0.735	0.621	0.500	0.414	0.489	0.667	0.803	0.857	0.553	0.395	0.341	0.291	0.321	0.467	9.017
3.35	0.349	0.159	0.072	0.071	0.056	0.033	0.043	0.046	0.128	0.192	0.176	0.144	0.098	0.106	0.098	0.154	1.925
5.59	0.003	0.001	0.000	0.001	0.000	0.000	0.000	0.000	0.000	0.001	0.006	0.001	0.000	0.000	0.000	0.002	0.015
8.27	0.000	0.000	0.000	0.000	0.000	0.000	0.000	0.000	0.000	0.000	0.001	0.000	0.000	0.000	0.000	0.000	0.001
11.18	0.000	0.000	0.000	0.000	0.000	0.000	0.000	0.000	0.000	0.000	0.000	0.000	0.000	0.000	0.000	0.000	0.000
11.62	0.000	0.000	0.000	0.000	0.000	0.000	0.000	0.000	0.000	0.000	0.000	0.000	0.000	0.000	0.000	0.000	0.000
TOTAL	1.15	0.97	0.82	0.71	0.57	0.46	0.54	0.73	0.95	1.07	0.75	0.55	0.45	0.40	0.43	0.63	11.16
ATMOSPHERIC STABILITY CLASS G																	
UMAX (M/S)	N	NNE	NE	ENE	E	ESE	SE	SSE	S	SSW	SW	WSW	W	WNW	NW	NNW	TOTAL
0.34	0.360	0.317	0.316	0.284	0.214	0.154	0.121	0.108	0.128	0.128	0.112	0.085	0.077	0.071	0.085	0.176	2.737
1.56	1.932	1.699	1.692	1.522	1.146	0.823	0.649	0.580	0.684	0.688	0.600	0.457	0.414	0.381	0.455	0.945	14.668
3.35	0.162	0.032	0.024	0.021	0.009	0.012	0.012	0.007	0.007	0.008	0.026	0.023	0.014	0.015	0.021	0.047	0.439
5.59	0.000	0.000	0.000	0.000	0.000	0.000	0.000	0.000	0.000	0.000	0.001	0.000	0.000	0.000	0.001	0.001	0.003
8.27	0.000	0.000	0.000	0.000	0.000	0.000	0.000	0.000	0.000	0.000	0.000	0.000	0.000	0.000	0.000	0.000	0.000
11.18	0.000	0.000	0.000	0.000	0.000	0.000	0.000	0.000	0.000	0.000	0.000	0.000	0.000	0.000	0.000	0.000	0.000
11.62	0.000	0.000	0.000	0.000	0.000	0.000	0.000	0.000	0.000	0.000	0.000	0.000	0.000	0.000	0.000	0.000	0.000
TOTAL	2.45	2.05	2.03	1.83	1.37	0.99	0.78	0.70	0.82	0.82	0.74	0.57	0.51	0.47	0.56	1.17	17.85
OVERALL WIND DIRECTION FREQUENCY																	
FREQUENCY:	N	NNE	NE	ENE	E	ESE	SE	SSE	S	SSW	SW	WSW	W	WNW	NW	NNW	TOTAL
	10.0	9.4	7.5	5.9	4.4	3.6	3.7	4.8	7.0	8.6	7.8	6.8	4.1	4.3	5.5	6.7	100.0

TABLE A-13

Joint Wind Frequency Distribution by Pasquill Stability Classes at SHNPP

Period of Record : 01/01/76 - 12/31/87

TOTAL HOURS CONSIDERED ARE *****

OVERALL WIND SPEED FREQUENCY

MAX WIND SPEED (M/S):	0.335	1.565	3.353	5.588	8.270	11.176	11.623
AVE WIND SPEED (M/S):	0.168	0.950	2.459	4.470	6.929	9.723	11.400
WIND SPEED FREQUENCY:	3.05	41.38	41.23	12.79	1.48	0.08	0.00

THE CONVERSION FACTOR APPLIED TO THE WIND SPEED CLASSES IS 0.447

DISTANCES AND TERRAIN HEIGHTS IN METERS AS FUNCTIONS OF DIRECTION FROM THE SITE:

DIRECTION =	S	SSW	SW	WSW	W	WNW	NW	NNW	N	NNE	NE	ENE	E	ESE	SE	SSE
DISTANCE	2189.	2140.	2140.	2140.	2140.	2140.	2028.	2028.	2124.	2140.	2140.	2140.	2140.	2140.	2140.	2140.
ELEVATION	0.	0.	0.	0.	0.	0.	0.	0.	0.	0.	0.	0.	0.	0.	0.	0.

VENT AND BUILDING PARAMETERS:

RELEASE HEIGHT	(METERS)	0.00
DIAMETER	(METERS)	0.00
EXIT VELOCITY	(METERS)	0.00
REP. WIND HEIGHT	(METERS)	10.0
BUILDING HEIGHT	(METERS)	55.0
BLDG.MIN.CRS.SEC.AREA	(SQ.METERS)	2161.0
HEAT EMISSION RATE	(CAL/SEC)	0.0

ALL GROUND LEVEL RELEASES.

WIND MEASURED AT 12.0 METERS.

TABLE A-14

Shearon Harris Plant Site Input Information for Continuous Ground Level Releases
 Calculations with the NRC XOQDOQ Program

Card Type	Columns	Variable Name	Format	Description	Value used in XOQDOQ
Card Type 1 is an array (KOPT) of options, such that 1 = DO, 0 = BYPASS. These options remain in effect for all release points run. Thus, all release points must have the same assumptions.					
1	1	KOPT(1)	I1	Option to distribute calms as the first wind-speed class (if calms are already distributed by direction in Card Type 6, KOPT(1) = 0, and Card Type 5 is blank). If KOPT(1) = 1, the calm values of Card Type 5 are distributed by direction in the same proportion as the direction frequency of wind-speed class two.	0
1	2	KOPT(2)	I1	Option to input joint frequency distribution data as percent frequency.	0
1	3	KOPT(3)	I1	Option to compute a sector spread for comparison with centerline value in purge calculation (Normally = 1).	1
1	4	KOPT(4)	I1	Option to plot short-term X/Q values versus probability of occurrence (Normally = 0).	0
1	5	KOPT(5)	I1	Option to use cubic spline in lieu of least square function for fitting intermittent release distribution (Normally = 1).	0
1	6	KOPT(6)	I1	Option to punch radial segment X/Q and D/Q values (Normally = 1).	1
1	7	KOPT(7)	I1	Option to punch output of X/Q and D/Q values of the points of interest (Normally = 1).	1
1	8	KOPT(8)	I1	Option to correct X/Q and D/Q values for open terrain recirculation.	1
1	9	KOPT(9)	I1	Option to correct X/Q and D/Q values using site specific terrain recirculation data.	0

TABLE A-14

Shearon Harris Plant Site Input Information for Continuous Ground Level Releases
 Calculations with the NRC XOQDOQ Program

Card Type	Columns	Variable Name	Format	Description	Value used in XOQDOQ
1	10	KOPT(10)	I1	Option to use desert sigma curves (Normally = 0)	0
1	11	KOPT(11)	I1	Option to calculate annual X/Q with 30 degree sectors for North, East, South and West and 20 degree sectors for all others. (Normally = 0, and the code will use 22-1/2 degree sectors)	0
2	1 - 80	TITLM	20A4	The main title printed at the beginning of the output.	N/A
3	1 - 5	NVEL	I5	The number of velocity categories (maximum of 14).	7
3	6 - 10	NSTA	I5	The number of stability categories (maximum of 7) (1 always equals Pasquill stability class A, 2 = B, ..., 7 = G).	7
3	11 - 15	NDIS	I5	The number of distances with terrain data for each sector. The number of distances must be the same for each sector (Card Type 10) (maximum of 10).	1
3	16 - 20	INC	I5	The increment in percent for which plotted results are printed out (Normally = 15).	15
3	21 - 25	NPTYPE	I5	The number of titles of receptor types (cow, garden, etc.) (Card Type 13) (maximum of eight)	5
3	26 - 30	NEXIT	I5	The number of release exit points (maximum of five).	1
3	31 - 35	NCOR	I5	The number of distances of site specific correction factors for recirculation (maximum of 10).	1
4	1 - 5	PLEV	F5.0	The height (in meters, above ground level) of the measured wind presented in the joint frequency data (Card Type 7). (For elevated/ground-level mixed release, use the 10-meter level winds).	12.0

TABLE A-14

Shearon Harris Plant Site Input Information for Continuous Ground Level Releases
 Calculations with the NRC XOQDOQ Program

Card Type	Columns	Variable Name	Format	Description	Value used in XOQDOQ
4	6 - 20	DECAYS(I) I = 1,3	3F5.0	For each I: The half-life (days) used in the X/Q calculations: if DECAYS > 100, no decay will occur; if DECAYS < 0, depletion factor will be used in the X/Q calculations; if DECAYS = 0, X/Q will not be calculated. (Normally, DECAYS(1) = 101, (2) = 2.26, (3) = -8.00.)	101.00 2.30 -8.00
4	21 - 25	PLGRAD	F5.0	Plant grade elevation (feet above sea level). If PLGRAD = 0.0, DIST and HT data Card Type 10 and 11 must be in meters. If PLGRAD < 0.0, DIST in miles and HT data in feet above plant grade. If PLGRAD > 0.0 above DIST in miles and HT data in feet above sea level.	0.00
5	1 - 35	CALM(I) I = 1,NSTA	7F5.0	The number of hours, or percent, of calm for each stability category; if KOPT(1) = 0, insert blank card. (Note: I = 1 is stability class A, 2 = B, ..., 7 = G).	BLANK
6	1 - 80	FREQ(K,I,J) K = 1,16 I = 1,NVEL (if KOPT(1)=0) I = 2,NVEL (if KOPT(1)=1) J = 1,NSTA		The joint frequency distribution in hours (or percent). The values for 16 (K) sectors are read on each card for each combination of wind-speed class (I) and stability class (J). The loop to read these value cycles first on direction continuing in a clockwise fashion), then on wind class and finally on stability class.	(1)
7	1 - 5	UCOR	F5.0	A correction factor applied to wind-speed classes. If UCOR < 0: no corrections will be made. If UCOR > 100: the wind-speed classes will be converted from miles/hour to meters/second.	200.

TABLE A-14

Shearon Harris Plant Site Input Information for Continuous Ground Level Releases
 Calculations with the NRC XOQDOQ Program

Card Type	Columns	Variable Name	Format	Description	Value used in XOQDOQ
7	6 - 75	UMAX(I)	14F5.0	The maximum wind speed in each wind-speed class, in either miles/hour or meters/second. (If given in miles/hour, set UCOR > 100.)	0.75, 3.50, 7.50, 12.50, 18.50, 25.00, 26.00
Card Types 8 and 9 are read in for each correction factor and distance given, I = 1,NCOR					
8	1 - 80	VRDIST(K,I) K = 1,16	16F5.0	The distance in meters at which correction factors are given. These values are read in beginning with south and proceeding in a clockwise direction (maximum of 10).	All Distances = 1.0
9	1 - 80	VRCD(K,I) K = 1,16	16F5.0	Correction factor to be applied to X/Q and D/Q values corresponds to distances specified in VRDIST.	All Factors = 1.000
Card Types 8 and 9 are repeated for the remaining distances and correction factors.					
Card Types 10 and 11 are read in for each terrain distance and height given, I = 1,NDIS					
10	1 - 80	DIST(K,I) K = 1,16	16F5.0	The distance in meters at which terrain heights are given. These values are read in beginning with south and proceeding in a clockwise direction (maximum of ten distances).	Distance = Site Boundary Distance
11	1 - 80	HT(K,I) K = 1,16	16F5.0	The terrain heights (in meters, above plant grade level) corresponding to the distances specified in the DIST array (Card Type 10). These values are read in the same order as the DIST array. For a given direction and distance, the terrain height should be the highest elevation between the source and that distance anywhere within the direction sector.	All Heights = 0.0
Card Types 10 and 11 are repeated for the remaining distances and heights.					

TABLE A-14

Shearon Harris Plant Site Input Information for Continuous Ground Level Releases
 Calculations with the NRC XOQDOQ Program

Card Type	Columns	Variable Name	Format	Description	Value used in XOQDOQ
12	1 - 25	NPOINT(I) I = 1,NPTYPE	5I5	The number (maximum of 30) of receptor locations for a particular receptor type (such as the number of cows, gardens, or site boundaries).	16,15,13,2,0,11
Card Types 13 and 14 are read in for each receptor type, thus I = 1,NPTYPE					
13	1 - 16	TITLPT(I,J)	4A4	The title (cows, gardens, etc.) of the receptor type for the receptor locations (Card Type 14) (a maximum of 16 spaces).	Site Boundary = 16 Nearest Resident = 15 Garden = 13 Cow Milk = 2 Goat Milk = 0 Meat & Poultry = 11
14	1 - 80	KDIR(I,N) PTDIST(I,N) N = 1,NPOINT(I)	8(I5,F5.0)	The receptor direction and distance. KDIR is the direction of interest, such that 1 = South, 2 = SSW....., 16 = SSE, PTDIST is the distance, in meters, to the receptor location.	See Table A-1
Card Types 13 and 14 are repeated for the remaining receptor types.					
Card Types 15, 16 and 17 are read in for each plant release point, thus I = 1,NEXIT.					
15	1 - 80	TITLE(I,J)	20A4	The title for the release point whose characteristics are described on Card Types 16 and 17.	(1)
16	1 - 5	EXIT(I)	F5.0	The vent average velocity (meters/second). (Note: if a 100% ground-level release is assumed, set EXIT = 0, DIAMTR = 0, and SLEV = 10 meters).	0
16	6 - 10	DIAMTR	F5.0	The vent inside diameter (meters).	0
16	11 - 15	HSTACK(I)	F5.0	The height of the vent release point (meters, plant grade level). If release is 100% elevated, input negative of height.	0.0
16	16 - 20	HBLDG(I)	F5.0	The height of the vent's building (meters, above plant grade level).	55.0

TABLE A-14

Shearon Harris Plant Site Input Information for Continuous Ground Level Releases
 Calculations with the NRC XOQDOQ Program

Card Type	Columns	Variable Name	Format	Description	Value used in XOQDOQ
16	21 - 25	CRSEC(I)	F5.0	The minimum cross-sectional area for the vent's building (square meters).	2161.0
16	26 - 30	SLEV(I)	F5.0	The wind height used for the vent elevated release (meters, above plant grade level).	10.0
16	31 - 35	HEATR(I)	F5.0	The vent heat emission rate (cal/sec) (Normally = 0).	0.0
17	1	RLSID(I)	A1	A one letter identification for the release point.	A
17	2 - 5	IPURGE(I)	I4	IPURGE = 1, 2 or 3 if the vent has intermittent releases. The 1, 2, or 3 corresponds to DECAYS(1), DECAYS(2), or DECAYS(3) (Card Type 4), respectively, whichever is used as the base for intermittent release calculations (normally no decay/no deplete X/Q, such that IPURGE(I) = 1; if a vent has no intermittent releases, IPURGE = 0.	0
17	6 - 10	NPURGE(I)	I5	The number of intermittent releases per year for this release point.	0
17	11 - 15	NPRGHR(I)	I5	The average number of hours per intermittent release.	0
Card Types 15, 16, and 17 are repeated for the remaining release points.					
Card Types 1 - 17 may be repeated for the next case.					

APPENDIX B

Sheet 1 of 15

DOSE PARAMETERS FOR RADIOIODINES, PARTICULATES, AND TRITIUM

This appendix contains the methodology which was used to calculate the dose parameters for radioiodines, particulates, and tritium to show compliance with ODCM Operational Requirement 3.11.2.1.b and Appendix I of 10CFR50 for gaseous effluents. These dose parameters, P_i and R_i , were calculated using the methodology outlined in NUREG 0133 along with Regulatory Guide 1.109, Revision 1. The following sections provide the specific methodology which was utilized in calculating the P_i and R_i values for the various exposure pathways (Tables 3.2-4 and 3.3-1 through 3.3-19, respectively).

B.1 Calculation of P_i

The dose parameter, P_i , contained in the radioiodine and particulates portion of Section 3.2 includes only the inhalation pathway transport parameter of the "i" radionuclide, the receptor's usage of the pathway media, and the dosimetry of the exposure. Inhalation rates and the internal dosimetry are functions of the receptor's age; however, under the exposure conditions for ODCM Operational Requirement 3.11.2.1.b, the child is considered to receive the highest dose. The values for P_{iI} presents the highest dose to any organ including the whole body resulting from inhalation of radionuclide "i" by a child. The following sections provide in detail the methodology which was used in calculating the P_i values for inclusion into this ODCM.

The age group considered is the child because the bases for the ODCM Operational Requirement 3.11.2.1.b is to restrict the dose to the child's thyroid via inhalation to ≤ 1500 mrem/yr. The child's breathing rate is taken as $3700 \text{ m}^3/\text{yr}$ from Table E-5 of Regulatory Guide 1.109, Revision 1. The inhalation dose factors for the child, DFA_i , are presented in Table E-9 of Regulatory Guide 1.109 in units of mrem/pCi. The total body is considered as an organ in the selection of DFA_i .

APPENDIX B

Sheet 2 of 15

DOSE PARAMETERS FOR RADIOIODINES, PARTICULATES, AND TRITIUM

B.1 Calculation of P_{iI} (continued)

The evaluation of this pathway consists of estimating the maximum dose to the most critical organ received by a child through inhalation by:

$$P_{iI} = K'(BR) DFA_i \quad (B.1-1)$$

where:

P_{iI} = Dose parameter for radionuclide "i" for the inhalation pathway, mrem/yr per $\mu\text{Ci}/\text{m}^3$;

K' = A constant of unit conversion;
= 10^6 pCi/ μCi ;

BR = The breathing rate of the children's age group, m^3/yr ;

DFA_i = The maximum organ inhalation dose factor for the children's age group for radionuclide "i," mrem/pCi.

The incorporation of breathing rate of a child ($3700 \text{ m}^3/\text{yr}$) and the unit conversion factor results in the following equation:

$$P_{iI} = 3.7 \text{ E}+09 \text{ DFA}_i \quad (B.1-2)$$

APPENDIX B

Sheet 3 of 15

DOSE PARAMETERS FOR RADIOIODINES, PARTICULATES, AND TRITIUM

B.2 Calculation of R_i

The basis for ODCM Operational Requirement 3.11.2.3 states that conformance with the guidance in Appendix I should be shown by calculational procedures based on models and data such that the actual exposure of a member of the public through appropriate pathways is unlikely to be substantially underestimated. Underestimation of the dose can be avoided by assigning a theoretical individual to the exclusion boundary in the sector with the highest X/Q and D/Q values and employing all of the likely exposure pathways, e.g., inhalation, cow milk, meat, vegetation, and ground plane. R_i values have been calculated for the adult, teen, child, and infant age groups for the inhalation, ground plane, cow milk, goat milk, vegetable, and beef ingestion pathways. The methodology which was utilized to calculate these values is presented below.

APPENDIX B

DOSE PARAMETERS FOR RADIOIODINES, PARTICULATES, AND TRITIUM

B.2.1 Inhalation Pathway

The dose factor from the inhalation pathway is calculated by:

$$R_{i1} = K' (BR)_a (DFA_i)_a \quad (B.2-1)$$

where:

R_{i1} = Dose factor for each identified radionuclide "i" of the organ of interest, mrem/yr per $\mu\text{Ci}/\text{m}^3$;

K' = A constant of unit conversion;

= 10^6 pCi/ μCi ;

$(BR)_a$ = Breathing rate of the receptor of age group "a," m^3/yr ;

$(DFA_i)_a$ = Organ inhalation dose factor for radionuclide "i" for the receptor of age group "a", mrem/pCi.

The breathing rates $(BR)_a$ for the various age groups are tabulated below, as given in Table E-5 of Regulatory Guide 1.109, Revision 1.

<u>Age Group (a)</u>	<u>Breathing Rate (m^3/yr)</u>
Infant	1400
Child	3700
Teen	8000
Adult	8000

Inhalation dose factors $(DFA_i)_a$ for the various age groups are given in Tables E-7 through E-10 of Regulatory Guide 1.109, Revision 1.

APPENDIX B

Sheet 5 of 15

DOSE PARAMETERS FOR RADIOIODINES, PARTICULATES, AND TRITIUM

B.2.2 Ground Plane Pathway

The ground plane pathway dose factor is calculated by:

$$R_{iG} = I_i K'K''(SF)DFG_i (1 - e^{-\lambda_i t}) / \lambda_i \quad (B.2-2)$$

where:

- R_{iG} = Dose factor for the ground plane pathway for each identified radionuclide "i" for the organ of interest, mrem/yr per $\mu\text{Ci}/\text{sec}$ per m^{-2} ;
- K' = A constant of unit conversion;
= 10^6 pCi/ μCi ;
- K'' = A constant of unit conversion;
= 8760 hr/year;
- SF = The shielding factor (dimensionless);
(A shielding factor of 0.7 is suggested in Table E-15 of Regulatory Guide 1.109, Revision 1.)
- DFG_i = The ground plane dose conversion factor for radionuclide "i," mrem/hr per pCi/ m^2 ;
(A tabulation of DFG_i values is presented in Table E-6 of Regulatory Guide 1.109, Revision 1.)
- λ_i = The radiological decay constant for radionuclide "i," sec^{-1} ;
- t = The exposure time, sec;
= $4.73 \text{ E}+08$ sec (15 years);

APPENDIX B

Sheet 6 of 15

DOSE PARAMETERS FOR RADIOIODINES, PARTICULATES, AND TRITIUM

B.2.2 Ground Plane Pathway (continued).

I_i = Factor to account for fractional deposition of radionuclide "i."

For radionuclides other than iodine, the factor I_i is equal to one. For radioiodines, the value of I_i may vary. However, a value of 1.0 was used in calculating the R values in Table 3.3-2. (Reference NUREG 0133)

APPENDIX B

Sheet 7 of 15

DOSE PARAMETERS FOR RADIOIODINES, PARTICULATES, AND TRITIUM

B.2.3 Grass Cow or Goat Milk Pathway

The dose factor for the cow milk or goat milk pathway for each radionuclide for each organ is calculated by:

$$R_{iM} = I_i K' Q_F U_{ap} F_m (DFL_{ia}) e^{-\lambda_i t_f} (f f_{ps}) \left(\frac{r(1 - e^{-\lambda_{E_i} t_e})}{Y_p \lambda_{E_i}} \right) + \frac{B_{iv} (1 - e^{-\lambda_i t_b})}{P \lambda_i} +$$

$$(1 - f f_{ps}) \left(\frac{r(1 - e^{-\lambda_{E_i} t_e})}{Y_s \lambda_{E_i}} + \frac{B_{iv} (1 - e^{-\lambda_i t_b})}{P \lambda_i} \right) e^{-\lambda_i t_h}$$

(B.2-3)

where:

- R_{iM} = Dose factor for the cow milk or goat milk pathway, for each identified radionuclide "i" for the organ of interest, mrem/yr per $\mu\text{Ci}/\text{sec}$ per m^{-2} ;
- K' = A constant of unit conversion;
 = 10^6 pCi/ μCi ;
- Q_F = The cow's or goat's feed consumption rate, kg/day (wet weight);
- U_{ap} = The receptor's milk consumption rate for age group "a," liters/yr;
- Y_p = The agricultural productivity by unit area of pasture feed grass, kg/m^2 ;
- Y_s = The agricultural productivity by unit area of stored feed, kg/m^2 ;

APPENDIX B

Sheet 8 of 15

DOSE PARAMETERS FOR RADIOIODINES, PARTICULATES, AND TRITIUM

B.2.3 Grass Cow or Goat Milk Pathway (continued)

- F_m = The stable element transfer coefficients, pCi/liter per pCi/day;
- r = Fraction of deposited activity retained on cow's feed grass;
- $(DFL_i)_a$ = The organ ingestion dose for radionuclide "i" for the receptor in age group "a," mrem/pCi;
- λ_{EI} = $\lambda_i + \lambda_w$;
- λ_i = The radiological decay constant for radionuclide "i," sec^{-1} ;
- λ_w = The decay constant for removal of activity on leaf and plant surfaces by weathering, sec^{-1} ;
- = 5.73 E-07 sec^{-1} (14 day half-life);
- t_e = Period of pasture grass and crop exposure during the growing season, sec;
- t_f = The transport time from feed, to cow or goat, to milk, to receptor, sec;
- t_h = The transport time from pasture, to cow or goat, to milk to receptor, sec;
- t_b = Period of time that sediment is exposed to gaseous effluents, sec;
- B_{iv} = Concentration factor for uptake of radionuclide "i" from the soil by the edible parts of crops, pCi/Kg (wet weight) per pCi/Kg (dry soil);

APPENDIX B

Sheet 9 of 15

DOSE PARAMETERS FOR RADIOIODINES, PARTICULATES, AND TRITIUM

B.2.3 Grass Cow or Goat Milk Pathway (continued)

- P = Effective surface density for soil, Kg (dry soil)/m²;
- f_p = Fraction of the year that the cow or goat is on pasture; (dimensionless).
- f_s = Fraction of the cow feed that is pasture grass while the cow is on pasture; (dimensionless).
- t_e = Period of pasture grass and crop exposure during the growing season, sec;
- I_i = Factor to account for fractional deposition of radionuclide "i."

For radionuclides other than iodine, the factor I_i is equal to one. For radioiodines, the value of I_i may vary. However, a value of 1.0 was used in calculating the R values in Tables 3.3-8 through 3.3-15. (Reference NUREG 0133)

Milk cattle and goats are considered to be fed from two potential sources, pasture grass and stored feeds. Following the development in Regulatory Guide 1.109, Revision 1, the value of f_s was considered unity in lieu of site-specific information. The value of f_p was 0.667 based upon an 8-month grazing period.

Table B-1 contains the appropriate parameter values and their source in Regulatory Guide 1.109, Revision 1.

APPENDIX B

Sheet 10 of 15

DOSE PARAMETERS FOR RADIOIODINES, PARTICULATES, AND TRITIUM

B.2.3 Grass Cow or Goat Milk Pathway (continued)

The concentration of tritium in milk is based on the airborne concentration rather than the deposition. Therefore, the R_i is based on X/Q:

$$R_{T_M} = K'K''F_m Q_F U_{ap} (DFL_i)_a 0.75 (0.5/H) \quad (B.2-4)$$

where:

R_{T_M} = Dose factor for the cow or goat milk pathway for tritium for the organ of interest, mrem/yr per $\mu\text{Ci}/\text{m}^3$;

K'' = A constant of unit conversion;

= 10^3 gm/kg;

H = Absolute humidity of the atmosphere, gm/m^3 ; A value of H = 8 grams/meter³, was used in lieu of site-specific information.

0.75 = The fraction of total feed that is water;

0.5 = The ratio of the specific activity of the feed grass water to the atmospheric water.

and other parameters and values as previously defined.

APPENDIX B

Sheet 11 of 15

DOSE PARAMETERS FOR RADIOIODINES, PARTICULATES, AND TRITIUM

B.2.4 Grass-Cow-Meat Pathway

The integrated concentration in meat follows in a similar manner to the development for the milk pathway; therefore:

$$R_{iB} = I_i K' Q_F U_{ap} F_f (DFL_{ia}) e^{-\lambda_i t_s} (f f_p s \left(\frac{r(1 - e^{-\lambda_{E_i} t_e})}{Y_p \lambda_{E_i}} \right) + \frac{B_{iv} (1 - e^{-\lambda_i t_b})}{P \lambda_i}) + (1 - f f_p s) \left(\frac{r(1 - e^{-\lambda_{E_i} t_e})}{Y_s \lambda_{E_i}} + \frac{B_{iv} (1 - e^{-\lambda_i t_b})}{P \lambda_i} \right) e^{-\lambda_i t_h} \tag{B.2.5}$$

where:

- R_{iB} = Dose factor for the meat ingestion pathway for radionuclide "i" for any organ of interest, mrem/yr per $\mu\text{Ci}/\text{sec}$ per m^{-2} ;
- F_f = The stable element transfer coefficients, pCi/Kg per pCi/day;
- U_{ap} = The receptor's meat consumption rate for age group "a," kg/yr;
- t_s = Transport time from slaughter to consumption, sec;

APPENDIX B

Sheet 12 of 15

DOSE PARAMETERS FOR RADIOIODINES, PARTICULATES, AND TRITIUM

B.2.4 Grass-Cow-Meat Pathway (continued)

t_h = Transport time from harvest to animal consumption, sec;

t_e = Period of pasture grass and crop exposure during the growing season, sec;

I_i = Factor to account for fractional deposition of radionuclide "i."

For radionuclides other than iodine, I_i is equal to one. For radioiodines, the value of I_i may vary. However, a value of 1.0 was used in calculating the R values in Tables 3.3-5 through 3.3-7.

All other terms remain the same as defined in Equation B.2-3. Table B-2 contains the values which were used in calculating R_i for the meat pathway.

The concentration of tritium in meat is based on its airborne concentration rather than the deposition. Therefore, the R_i is based on X/Q .

$$R_{TB} = K'K''F_fQ_{FU}_{ap} (DFL_i)_a 0.75(0.5/H) \quad (B.2-6)$$

where:

R_{TB} = Dose factor for the meat ingestion pathway for tritium for any organ of interest, mrem/yr per $\mu\text{Ci}/\text{m}^3$.

All other terms are defined in Equations B.2-4 and B.2-5.

APPENDIX B

Sheet 13 of 15

DOSE PARAMETERS FOR RADIOIODINES, PARTICULATES, AND TRITIUM

B.2.5 Vegetation Pathway

The integrated concentration in vegetation consumed by man follows the expression developed in the derivation of the milk factor. Man is considered to consume two types of vegetation (fresh and stored) that differ only in the time period between harvest and consumption; therefore:

$$R_{iv} = I_i K' (DFL_i) \left(U_{af}^L e^{-\lambda_i t_L} \left(\frac{r(1 - e^{-\lambda_{E_i} t_e})}{Y_v \lambda_{E_i}} + \frac{B_{iv} (1 - e^{-\lambda_i t_b})}{P \lambda_i} \right) + \right.$$

$$\left. U_{ag}^S e^{-\lambda_i t_h} \left(\frac{r(1 - e^{-\lambda_{E_i} t_e})}{Y_v \lambda_{E_i}} + \frac{B_{iv} (1 - e^{-\lambda_i t_b})}{P \lambda_i} \right) \right)$$

(B.2-7)

where:

- R_{iv} = Dose factor for vegetable pathway for radionuclide "i" for the organ of interest, mrem/yr per $\mu\text{Ci}/\text{sec}$ per m^{-2} ;
- K' = A constant of unit conversion;
- = $10^6 \text{pCi}/\mu\text{Ci}$;

APPENDIX B

Sheet 14 of 15

DOSE PARAMETERS FOR RADIOIODINES, PARTICULATES, AND TRITIUM

B.2.5 Vegetation Pathway (continued)

- U_a^L = The consumption rate of fresh leafy vegetation by the receptor in age group "a," kg/yr;
- U_a^S = The consumption rate of stored vegetation by the receptor in age group "a," kg/yr;
- f_L = The fraction of the annual intake of fresh leafy vegetation grown locally;
= 1.0
- f_g = The fraction of annual intake of stored vegetation grown locally;
= 0.76
- t_L = The average time between harvest of leafy vegetation and its consumption, sec;
- t_h = The average time between harvest of stored vegetation and its consumption, sec;
- Y_v = The vegetation areal density, kg/m²;
- t_e = Period of leafy vegetable exposure during growing season, sec;
- I_i = Factor to account for fractional deposition of radionuclide "i."

All other factors as previously defined.

APPENDIX B

Sheet 15 of 15

DOSE PARAMETERS FOR RADIOIODINES, PARTICULATES, AND TRITIUM

B.2.5 Vegetation Pathway (continued)

For radionuclides other than iodine, the factor I_i is equal to one. For radioiodines, the value of I_i may vary. However, a value of 1.0 was used in Tables 3.3-2 through 3.3-4.

Table B-3 presents the appropriate parameter values and their source in Regulatory Guide 1.109, Revision 1.

In lieu of site-specific data default values for f_L and f_g , 1.0 and 0.76, respectively, were used in the calculations on R_i . These values were obtained from Table E-15 of Regulatory Guide 1.109, Revision 1.

The concentration of tritium in vegetation is based on the airborne concentration rather than the deposition. Therefore, the R_i is based on X/Q:

$$\dot{R}_{T_V} = K'K''' \left[U_{aL}^L + U_{ag}^S \right] (DFL_i)_a \left[0.75 (0.5 / H) \right] \quad (B.2.8)$$

where:

R_{T_V} = Dose factor for the vegetable pathway for tritium for any organ of interest, mrem/yr per $\mu\text{Ci}/\text{m}^3$.

All other terms remain the same as those in Equations B.2-4 and B.2-7.

TABLE B-1
 Parameters For Cow and Goat Milk Pathways

<u>Parameter</u>	<u>Value</u>	<u>Reference</u> <u>(Reg. Guide 1.109, Rev. 1)</u>
Q_F (kg/day)	50 (cow) 6 (goat)	Table E-3 Table E-3
Y_p (kg/M ²)	0.7	Table E-15
t_f (seconds)	1.73 E+05 (2 days)	Table E-15
r	1.0 (radioiodines) 0.2 (particulates)	Table E-15 Table E-15
$(DFL)_{i_a}$ (mrem/pCi)	Each radionuclide	Table E-11 to E-14
F_m (pCi/liter per pCi/day)	Each stable element	Table E-1 (cow) Table E-2 (goat)
T_b (seconds)	4.75 E+08 (15 yr)	Table E-15
Y_s (kr/m ²)	2.0	Table E-15
t_h (seconds)	7.78 E+06 (90 days)	Table E-15
U_{ap} (liters/yr)	330 infant 330 child 400 teen 310 adult	Table E-5 Table E-5 Table E-5 Table E-5
t_e (seconds)	2.59 E+06 (pasture) 5.18 E+06 (stored feed)	Table E-15
B_{iv} (pCi/kg [wet weight] per pCi/kg [dry soil])	Each stable element	Table E-1
P (kg dry soil/m ²)	240	Table E-15

TABLE B-2
 Parameters For The Meat Pathway

<u>Parameter</u>	<u>Value</u>	<u>Reference</u> (Reg. Guide 1.109, Rev. 1)
r	1.0 (radioiodines)	Table E-15
	0.2 (particulates)	Table E-15
F_f (pCi/ke per (pCi/Day)	Each stable element	Table E-1
U_{ap} (kg/yr)	0 infant	Table E-5
	41 child	Table E-5
	65 teen	Table E-5
	110 adult	Table E-5
(DFL_{i_a}) (mrem/pCi)	Each radionuclide	Tables E-11 to E-14
Y_p (kg/m ²)	0.7	Table E-15
Y_s (kr/m ²)	2.0	Table E-15
T_b (seconds)	4.73 E+08 (15 yr)	Table E-15
T_s (seconds)	1.73 E+06 (20 days)	Table E-15
t_h (seconds)	7.78 E+06 (90 days)	Table E-15
t_e (seconds)	2.59 E+06 (pasture)	Table E-15
	5.18 E+06 (stored feed)	
Q_F (kg/day)	50	Table E-3
B_{iv} (pCi/kg [wet weight] per pCi/kg [dry soil])	Each stable element	Table E-1
P (kg dry soil/m ²)	240	Table E-15

TABLE B-3
 Parameters for The Vegetable Pathway

<u>Parameter</u>	<u>Value</u>	<u>Reference</u> <u>(Reg. Guide 1.109, Rev. 1)</u>
r (dimensionless)	1.0 (radioiodines) 0.2 (particulates)	Table E-1 Table E-1
(DFL _{i a}) (mrem/pCi)	Each radionuclide	Tables E-11 to E-14
Q _F (kg/day)	50 (cow) 6 (goat)	Table E-3 Table E-3
U _a ^L (kg/yr) - Infant	0	Table E-5
- Child	26	Table E-5
- Teen	42	Table E-5
- Adult	64	Table E-5
U _a ^S (kr/hr) - Infant	0	Table E-5
- Child	520	Table E-5
- Teen	630	Table E-5
- Adult	520	Table E-5
T _L (seconds)	8.6 E+04 (1 day)	Table E-15
t _h (seconds)	5.18 E+06 (60 day)	Table E-15
Y _v (kg/m ²)	2.0	Table E-15
t _e (seconds)	5.18 E+06 (60 day)	Table E-15
t _b (seconds)	4.73 E+08 (15 yr)	Table E-15
P (kg dry soil/m ²)	240	Table E-15
B _{iv} (pCi/kg [wet weight] per pCi/kg [dry soil])	Each stable element	Table E-1

APPENDIX C

RADIOACTIVE LIQUID AND GASEOUS EFFLUENT
MONITORING INSTRUMENTATION NUMBERS

	<u>Monitor Identification</u>
<u>I. Liquid Effluent Monitoring Instruments</u>	
A. Treated Laundry and Hot Shower Tank	REM-1WL-3540
B. Waste Monitor Tank	REM-21WL-3541
C. Waste Evaporator Condensate Tank	REM-21WL-3541
D. Secondary Waste Sample Tank	REM-21WS-3542
E. NSW Returns to Circulating Water System	
from Waste Processing Building	REM-1SW-3500A
from Reactor Auxiliary Building	REM-1SW-3500B
F. Outdoor Tank Area Drain Transfer Pump Monitor	REM-1MD-3530
G. Turbine Building Floor Drains Effluent	REM-1MD-3528
<u>II. Gaseous Effluent Monitoring Instruments</u>	
A. Plant Vent Stack 1	* RM-21AV-3509-1SA
B. Turbine Building Vent Stack 3A	* RM-1TV-3536-1
C. Waste Processing Building Vent Stack 5	REM-1WV-3546
.....	* RM-1WV-3546-1
D. Waste Processing Building Vent Stack 5A	* RM-1WV-3547-1

* Wide-Range Gas Monitor (WRGM)

APPENDIX D

PROGRAMMATIC CONTROLS

The surveillance and operational requirements pertaining to the ODCM Operational Requirements are detailed in Sections:

- D.1 - Instrumentation
- D.2 - Radioactive Effluents
- D.3 - Radiological Environmental Monitoring

D.1 INSTRUMENTATION

3/4.3.3 MONITORING INSTRUMENTATION

3/4.3.3.10 Radioactive Liquid Effluent Monitoring Instrumentation

OPERATIONAL REQUIREMENT

3.3.3.10 The radioactive liquid effluent monitoring instrumentation channels shown in Table 3.3-12 shall be OPERABLE with their Alarm/Trip Setpoints set to ensure that the limits of Operational Requirement 3.11.1.1 are not exceeded. The Alarm/Trip Setpoints of these channels shall be determined and adjusted in accordance with the methodology and parameters in the OFFSITE DOSE CALCULATION MANUAL (ODCM).

APPLICABILITY: At all times.

ACTION:

- a. With a radioactive liquid effluent monitoring instrumentation channel Alarm/Trip Setpoint less conservative than required by the above Operational Requirement, immediately (1) suspend the release of radioactive liquid effluents monitored by the affected channel or (2) declare the channel inoperable and take ACTION as directed by b. below.
- b. With less than the minimum number of radioactive liquid effluent monitoring instrumentation channels OPERABLE, take the ACTION shown in Table 3.3-12. Exert best effort to restore to the minimum number of radioactive liquid effluent channels within 30 days and, if unsuccessful, explain in the next Annual Radioactive Effluent Release Report pursuant to ODCM, Appendix F, Section F.2 why this inoperability was not corrected in a timely manner.

SURVEILLANCE REQUIREMENTS

4.3.3.10 Each radioactive liquid effluent monitoring instrumentation channel shall be demonstrated OPERABLE by performance of the CHANNEL CHECK, SOURCE CHECK, CHANNEL CALIBRATION, and DIGITAL CHANNEL OPERATIONAL TEST at the frequencies shown in Table 4.3-8.

Each Surveillance Requirement shall be performed within the specified surveillance interval with a maximum allowable extension not to exceed 25% of the specified surveillance interval.

TABLE 3.3-12

RADIOACTIVE LIQUID EFFLUENT MONITORING INSTRUMENTATION

	INSTRUMENT	MINIMUM CHANNELS OPERABLE	ACTION
1.	Radioactivity Monitors Providing Alarm and Automatic Termination of Release		
a.	Liquid Radwaste Effluent Lines		
	1) Treated Laundry and Hot Shower Tanks Discharge Monitor	1	35
	2) Waste Monitor Tanks and Waste Evaporator Condensate Tanks Discharge Monitor	1	35
	3) Secondary Waste Sample Tank Discharge Monitor	1	35, 36*
b.	Turbine Building Floor Drains Effluent Line	1	36
2.	Radioactivity Monitor Providing Alarm and Automatic Stop Signal to Discharge Pump		
a.	Outdoor Tank Area Drain Transfer Pump Monitor	1	37
3.	Radioactivity Monitors Providing Alarm But Not Providing Automatic Termination of Release		
a.	Normal Service Water System Return From Waste Processing Building to the Circulating Water System	1	39
b.	Normal Service Water System Return From the Reactor Auxiliary Building to the Circulating Water System	1	39
4.	Flow Rate Measurement Devices		
a.	Liquid Radwaste Effluent Lines		
	1) Treated Laundry and Hot Shower Tanks Discharge	1	38
	2) Waste Monitor Tanks and Waste Evaporator Condensate Tanks Discharge	1	38
	3) Secondary Waste Sample Tank	1	38
b.	Cooling Tower Blowdown	1	38

* When the Secondary Waste System is in the continuous release mode and releases are occurring, Action 36 shall be taken when the monitor is inoperable. In the batch release mode, Action 35 is applicable.

TABLE 3.3-12 (Continued)

ACTION STATEMENTS

- ACTION 35 - With the number of channels OPERABLE less than required by the Minimum Channels OPERABLE requirement, effluent releases via this pathway may continue provided that prior to initiating a release:
- a. At least two independent samples are analyzed in accordance with Operational Requirement 4.11.1.1.1, and
 - b. At least two technically qualified members of the facility staff independently verify the release rate calculations and discharge line valving.
- Otherwise, suspend release of radioactive effluents via this pathway.
- ACTION 36 - With the number of channels OPERABLE less than required by the Minimum Channels OPERABLE requirement, effluent releases via this pathway may continue provided grab samples are analyzed for radioactivity at a lower limit of detection of no more than $1E-07$ $\mu\text{Ci/ml}$:
- a. At least once per 12 hours when the specific activity of the secondary coolant is greater than 0.01 $\mu\text{Ci/gram DOSE EQUIVALENT I-131}$ or,
 - b. At least once per 24 hours when the specific activity of the secondary coolant is less than or equal to 0.01 $\mu\text{Ci/gram DOSE EQUIVALENT I-131}$.
- ACTION 37 - With the number of channels OPERABLE less than required by the Minimum Channels OPERABLE requirement, effluent releases via this pathway may continue provided that, at least once per 12 hours, grab samples are collected and analyzed for radioactivity at a lower limit of detection of no more than $1E-07$ $\mu\text{Ci/ml}$.
- ACTION 38 - With the number of channels OPERABLE less than required by the Minimum Channels OPERABLE requirement, effluent releases via this pathway may continue provided the flow rate is estimated at least once per 4 hours during actual releases. Pump performance curves generated in place may be used to estimate flow.
- ACTION 39 - With the number of channels OPERABLE less than required by the Minimum Channels OPERABLE requirement, effluent releases via this pathway may continue provided the weekly Cooling Tower Blowdown weir surveillance is performed as required by Operational Requirement 4.11.1.1.1. Otherwise, follow the ACTION specified in ACTION 37 above.

TABLE 4.3-8

RADIOACTIVE LIQUID EFFLUENT MONITORING INSTRUMENTATION
SURVEILLANCE REQUIREMENTS

INSTRUMENT	CHANNEL CHECK	SOURCE CHECK	CHANNEL CALIBRATION	DIGITAL CHANNEL OPERATIONAL TEST
1. Radioactivity Monitors Providing Alarm and Automatic Termination of Release				
a. Liquid Radwaste Effluent Lines				
1) Treated Laundry and Hot Shower Tanks Discharge Monitor	D	P	R(3)	Q(1)
2) Waste Monitor Tanks and Waste Evaporator Condensate Tanks Discharge Monitor	D	P	R(3)	Q(1)
3) Secondary Waste Sample Tank Discharge Monitor	D	P, M(5)	R(3)	Q(1)
b. Turbine Building Floor Drains Effluent Line	D	M	R(3)	Q(1)
2. Radioactivity Monitor Providing Alarm and Automatic Stop Signal to Discharge Pump				
a. Outdoor Tank Area Drain Transfer Pump Monitor	D	M	R(3)	Q(1)
3. Radioactivity Monitors Providing Alarm But Not Providing Automatic Termination of Release				
a. Normal Service Water System Return From Waste Processing Building to the Circulating Water System	D	M	R(3)	Q(2)
b. Normal Service Water System Return From the Reactor Auxiliary Building to the Circulating Water System	D	M	R(3)	Q(2)
4. Flow Rate Measurement Devices				
a. Liquid Radwaste Effluent Lines				
1) Treated Laundry and Hot Shower Tanks Discharge	D(4)	N.A.	R	N.A.
2) Waste Monitor Tanks and Waste Evaporator Condensate Tanks Discharge	D(4)	N.A.	R	N.A.
3) Secondary Waste Sample Tank Pump Monitor	D(4)	N.A.	R	N.A.
b. Cooling Tower Blowdown	D(4)	N.A.	R	N.A.

* See Table G-1 for explanation of frequency notation

TABLE 4.3-8 (Continued)

TABLE NOTATIONS

- (1) The DIGITAL CHANNEL OPERATIONAL TEST shall also demonstrate automatic isolation of this pathway (or, for the Outdoor Tank Area Drains Monitor, automatic stop signal to the discharge pump) and control room alarm annunciation* occur if any of the following conditions exists (liquid activity channel only):
 - a. Instrument indicates measured levels above the Alarm/Trip Setpoint,
 - b. Circuit failure (monitor loss of communications (alarm only), detector loss of counts (Alarm only) and monitor loss of power),
 - c. Detector check source test failure (alarm only),
 - d. Detector channel out of service (alarm only),
 - e. Monitor loss of sample flow (alarm only). (Not applicable for Turbine Building Drain Rad Monitor)
- (2) The DIGITAL CHANNEL OPERATIONAL TEST shall also demonstrate that control room alarm annunciation* occurs if any of the following conditions exists (liquid activity channel only):
 - a. Instrument indicates measured levels above the Alarm Setpoint,
 - b. Circuit failure (monitor loss of communications , detector loss of counts, and monitor loss of power),
 - c. Detector check source test failure,
 - d. Detector channel out of service,
 - e. Monitor loss of sample flow.
- (3) The initial CHANNEL CALIBRATION shall be performed using one or more of the reference standards certified by the National Bureau of Standards (NBS) or using standards that have been obtained from suppliers that participate in measurement assurance activities with NBS. These standards shall permit calibrating the system over its intended range of energy and measurement range. For subsequent CHANNEL CALIBRATION, sources that have been related to the initial calibration shall be used.
- (4) CHANNEL CHECK shall consist of verifying indication of flow during periods of release. CHANNEL CHECK shall be made at least once per 24 hours on days on which continuous, periodic, or batch releases are made.
- (5) When the Secondary Waste System is being used in the batch release mode, the source check shall be prior to release. When the system is being used in the continuous release mode, the source check shall be monthly.

*Control Room Alarm Annunciation shall consist of a change in state of the tested channel on the RM-11 terminal (i.e., a change in color).

3/4.3.3 MONITORING INSTRUMENTATION

3/4.3.3.11 Radioactive Gaseous Effluent Monitoring Instrumentation

OPERATIONAL REQUIREMENT

3.3.3.11 The radioactive gaseous effluent monitoring instrumentation channels shown in Table 3.3-13 shall be OPERABLE with their Alarm/Trip Setpoints set to ensure that the limits of Operational Requirements 3.11.2.1 are not exceeded. The Alarm/Trip Setpoints of these channels meeting Operational Requirement 3.11.2.1 shall be determined and adjusted in accordance with the methodology and parameters in the ODCM.

APPLICABILITY: As shown in Table 3.3-13

ACTION:

- a. With a radioactive gaseous effluent monitoring instrumentation channel Alarm/Trip Setpoint less conservative than required by the above Operational Requirement, immediately (1) suspend the release of radioactive gaseous effluents monitored by the affected channel or (2) declare the channel inoperable and take ACTION as directed by b. below.
- b. With the number of OPERABLE radioactive gaseous effluent monitoring instrumentation channels less than the Minimum Channels OPERABLE, take the ACTION shown in Table 3.3-13. Exert best efforts to return the instrument to OPERABLE status within 30 days. If unsuccessful, explain in the next Annual Radioactive Effluent Release Report pursuant to ODCM, Appendix F, Section F.2 why this inoperability was not corrected in a timely manner.

SURVEILLANCE REQUIREMENTS

4.3.3.11 Each radioactive gaseous effluent monitoring instrumentation channel shall be demonstrated OPERABLE by performance of the CHANNEL CHECK, SOURCE CHECK, CHANNEL CALIBRATION and a DIGITAL CHANNEL OPERATIONAL TEST or an ANALOG CHANNEL OPERATIONAL TEST at the frequencies shown in Table 4.3-9.

Each Surveillance Requirement shall be performed within the specified surveillance interval with a maximum allowable extension not to exceed 25% of the specified surveillance interval.

TABLE 3.3-13
RADIOACTIVE GASEOUS EFFLUENT MONITORING INSTRUMENTATION

	INSTRUMENT	MIN. CHANNELS OPERABLE	APPLICABILITY	ACTION
1.	GASEOUS WASTE PROCESSING SYSTEM - HYDROGEN AND OXYGEN ANALYZERS			
	Specification is not used in ODCM			
2.	TURBINE BUILDING VENT STACK			
a.	Noble Gas Activity Monitor	1	*	47
b.	Iodine Sampler	1	*	49
c.	Particulate Sampler	1	*	49
d.	Flow Rate Monitor	1	*	46
e.	Sampler Flow Rate Monitor	1	*	46
3.	PLANT VENT STACK			
a.	Noble Gas Activity Monitor	1	*	47
b.	Iodine Sampler	1	*	49
c.	Particulate Sampler	1	*	49
d.	Flow Rate Monitor	1	*	46
e.	Sampler Flow Rate Monitor	1	*	46
4.	WASTE PROCESSING BUILDING VENT STACK 5			
a.1	Noble Gas Activity Monitor (PIG)	1	*	45, 51
a.2	Noble Gas Activity Monitor (WRGM)	1	MODES 1, 2, 3	52
b.	Iodine Sampler	1	*	49
c.	Particulate Sampler	1	*	49
d.	Flow Rate Monitor	1	*	46
e.	Sampler Flow Rate Monitor	1	*	46
5.	WASTE PROCESSING BUILDING STACK 5A			
a.	Noble Gas Activity Monitor	1	*	47
b.	Iodine Sampler	1	*	49
c.	Particulate Sampler	1	*	49
d.	Flow Rate Monitor	1	*	46
e.	Sampler Flow Rate Monitor	1	*	46

TABLE NOTATIONS

* At all times.

TABLE 3.3-13 (Continued)

ACTION STATEMENTS

- ACTION 45 - With the number channels OPERABLE less than required by the Minimum Channels OPERABLE requirement, the contents of the waste gas decay tank(s) may be released to the environment provided that prior to initiating the release:
- a. At least two independent samples of the tank's contents are analyzed, and
 - b. At least two technically qualified members of the facility staff independently verify the release rate calculations and discharge valve lineup.
- Otherwise, suspend release of radioactive effluents via this pathway.
- ACTION 46 - With the number of channels OPERABLE less than required by the Minimum Channels OPERABLE requirement, effluent releases via this pathway may continue provided the flow rate is estimated at least once per 4 hours.
- ACTION 47 - With the number of channels OPERABLE less than required by the Minimum Channels OPERABLE requirement, effluent releases via this pathway may continue provided grab samples are taken at least once per 12 hours and these samples are analyzed for radioactivity within 24 hours.
- ACTION 48 - Not Used in the ODCM.
- ACTION 49 - With the number of channels OPERABLE less than required by the Minimum Channels OPERABLE requirement, effluent releases via the affected pathway may continue provided samples are continuously collected with auxiliary sampling equipment as required in Table 4.11-2.
- ACTION 50 - Not used in the ODCM.
- ACTION 51 - With the number of channels OPERABLE less than required by the Minimum Channels OPERABLE requirement for both the PIG and WRGM, effluent releases via this pathway may continue provided grab samples are taken at least once per 12 hours and these samples are analyzed for radioactivity within 24 hours.
- ACTION 52 - With the number of OPERABLE accident monitoring instrumentation channels for the radiation monitor(s) less than the Minimum Channels OPERABLE requirements of Technical Specification Table 3.3-10, initiate the preplanned alternate method of monitoring the appropriate parameter(s) within 72 hours, and either restore the inoperable channel(s) to OPERABLE status within 14 days or prepare and submit a Special Report to the Commission, pursuant to Technical Specification 6.9.2, within the next 14 days that provides actions taken, cause of the inoperability, and the plans and schedule for restoring the channel(s) to OPERABLE status.

TABLE 4.3-9

RADIOACTIVE GASEOUS EFFLUENT MONITORING INSTRUMENTATION
SURVEILLANCE REQUIREMENTS**

<u>INSTRUMENT</u>	<u>CHANNEL CHECK</u>	<u>SOURCE CHECK</u>	<u>CHANNEL CALIBRATION</u>	<u>DIGITAL CHANNEL OPERATIONAL TEST</u>	<u>MODES FOR WHICH SURVEILLANCE IS REQUIRED</u>
1. GASEOUS WASTE PROCESSING SYSTEM - HYDROGEN AND OXYGEN ANALYZERS					
Not Used in the ODCM.					
2. TURBINE BUILDING VENT STACK					
a. Noble Gas Activity	D	M	R(3)	Q(2)	*
b. Iodine Sampler	N.A.	N.A.	N.A.	N.A.	*
c. Particulate Sampler	N.A.	N.A.	N.A.	N.A.	*
d. Flow Rate Monitor	D	N.A.	R	Q	*
e. Sampler Flow Rate Monitor	D	N.A.	R	Q	*
3. PLANT VENT STACK					
a. Noble Gas Activity Monitor	D	M	R(3)	Q(2)	*
b. Iodine Sampler	N.A.	N.A.	N.A.	N.A.	*
c. Particulate Sampler	N.A.	N.A.	N.A.	N.A.	*
d. Flow Rate Monitor	D	N.A.	R	Q	*
e. Sampler Flow Rate Monitor	D	N.A.	R	Q	*
4. WASTE PROCESSING BUILDING VENT STACK 5					
a.1 Noble Gas Activity Monitor (PIG)	D	M	R(3)	Q(1)	*
a.2 Noble Gas Activity Monitor (WRGM)	D	M	R(3)	Q(2)	*
b. Iodine Sampler	N.A.	N.A.	N.A.	N.A.	*
c. Particulate Sampler	N.A.	N.A.	N.A.	N.A.	*
d. Flow Rate Monitor	D	N.A.	R	Q	*
e. Sampler Flow Rate Monitor	D	N.A.	R	Q	*
5. WASTE PROCESSING BUILDING VENT STACK 5A					
a. Noble Gas Activity Monitor	D	M	R(3)	Q(2)	*
b. Iodine Sampler	N.A.	N.A.	N.A.	N.A.	*
c. Particulate Sampler	N.A.	N.A.	N.A.	N.A.	*
d. Flow Rate Monitor	D	N.A.	R	Q	*
e. Sampler Flow Rate Monitor	D	N.A.	R	Q	*

* At all times.

** See Table G-1 for explanation of frequency notation

TABLE 4.3-9 (Continued)

TABLE NOTATIONS

- (1) The DIGITAL CHANNEL OPERATIONAL TEST shall also demonstrate that automatic isolation of this pathway and control room annunciation* occur if any of the following conditions exists (gas activity and gas effluent channels only):
 - a. Instrument indicates measured levels above the Alarm/Trip Setpoint,
 - b. Circuit failure (monitor loss of communications - (alarm only), detector loss of counts (alarm only) and monitor loss of power),
 - c. Detector check source test failure (gas activity channel only), (alarm only),
 - d. Detector channel out of service (alarm only),
 - e. Monitor loss of sample flow (alarm only).
- (2) The DIGITAL CHANNEL OPERATIONAL TEST shall also demonstrate that control room alarm annunciation* occurs if any of the following conditions exists (gas activity and gas effluent channels only):
 - a. Instrument indicates measured levels above the Alarm Setpoint,
 - b. Circuit failure (monitor loss of communications (alarm only), detector loss of counts, and monitor loss of power),
 - c. Detector check source test failure (gas activity channel only),
 - d. Detector channel out of service,
 - e. Monitor loss of sample flow.
- (3) The initial CHANNEL CALIBRATION shall be performed using one or more of the reference standards certified by the National Bureau of Standards (NBS) or using standards that have been obtained from suppliers that participate in measurement assurance activities with NBS. These standards shall permit calibrating the system over its intended range of energy and measurement range. For subsequent CHANNEL CALIBRATION, sources that have been related to the initial calibration shall be used.
- (4) Not used in the ODCM.
- (5) Not used in the ODCM.

*Control Room Alarm Annunciation shall consist of a change in state of the tested channel on the RM-11 terminal (i.e., a change in color).

D.2 RADIOACTIVE EFFLUENTS

3/4.11.1 LIQUID EFFLUENTS

3/4.11.1.1 Concentration

OPERATIONAL REQUIREMENT

3.11.1.1 The concentration of radioactive material released in liquid effluents to UNRESTRICTED AREAS (see Technical Specification Figure 5.1-3) shall be limited to 10 times the concentrations specified in 10 CFR Part 20.1001 - 20.2401, Appendix B, Table 2, Column 2 for radionuclides other than dissolved or entrained noble gases. For dissolved or entrained noble gases, the concentration shall be limited to 2E-04 $\mu\text{Ci/ml}$ total activity.

APPLICABILITY: At all times.

ACTION:

- a. With the concentration of radioactive material released in liquid effluents to UNRESTRICTED AREAS exceeding the above limits, immediately restore the concentration to within the above limits.

SURVEILLANCE REQUIREMENTS

4.11.1.1.1 Radioactive liquid wastes shall be sampled and analyzed according to the sampling and analysis program of Table 4.11-1.

4.11.1.1.2 The results of the radioactivity analyses shall be used in accordance with the methodology and parameters in the ODCM to assure that the concentrations at the point of release are maintained within the limits of Operational Requirement 3.11.1.1.

Each Surveillance Requirement shall be performed within the specified surveillance interval with a maximum allowable extension not to exceed 25% of the specified surveillance interval.

TABLE 4.11-1

RADIOACTIVE LIQUID WASTE SAMPLING AND ANALYSIS PROGRAM*

LIQUID RELEASE TYPE	SAMPLING FREQUENCY	MINIMUM ANALYSIS FREQUENCY	TYPES OF ACTIVITY ANALYSIS	LOWER LIMIT OF DETECTION (LLD) ⁽¹⁾ (µCi/ml)
1. Batch Waste Release Tanks ⁽²⁾				
a. Waste Monitor Tanks	P Each Batch	P Each Batch	Principal Gamma Emitters ⁽³⁾	5E-07
			I-131	1E-06
b. Waste Evaporator Condensate Tanks	P One Batch/M	M	Dissolved and Entrained Gases (Gamma Emitters)	1E-05
c. Secondary Waste Sample Tank ⁽⁸⁾	P Each Batch	M Composite ⁽⁴⁾	H-3	1E-05
			Gross Alpha	1E-07
d. Treated Laundry and Hot Shower Tanks	P Each Batch	Q Composite ⁽⁴⁾	Sr-89, Sr-90	5E-08
			Fe-55	1E-06
2. Continuous Releases ^{(5) (7)}				
a. Cooling Tower Weir	Continuous ⁽⁶⁾	W Composite ^{(6) (7)}	Principal Gamma Emitters ⁽³⁾	5E-07
b. Secondary Waste Sample Tank ⁽⁸⁾	M ⁽⁷⁾ Grab Sample	M ⁽⁷⁾	Dissolved and Entrained Gases (Gamma Emitters)	1E-05
			I-131	1E-06
	Continuous ⁽⁶⁾	M Composite ^{(6) (7)}	H-3	1E-05
			Gross Alpha	1E-07
	Continuous ⁽⁶⁾	Q Composite ^{(6) (7)}	Sr-89, Sr-90	5E-08
			Fe-55	1E-06

* See Table G-1 for explanation of frequency notation

TABLE 4.11-1 (Continued)

TABLE NOTATIONS

- (1) The LLD is defined, for purposes of these Operational Requirements, as the smallest concentration of radioactive material in a sample that will yield a net count, above system background, that will be detected with 95% probability with only 5% probability of falsely concluding that a blank observation represents a "real" signal.

For a particular measurement system, which may include radiochemical separation:

$$LLD = \frac{4.66 \cdot S_b}{E \cdot V \cdot (2.22E + 06) \cdot Y \cdot e^{-\lambda \Delta t}}$$

Where:

- LLD = the "a priori" lower limit of detection (μ Ci per unit mass or volume),
- S_b = the standard deviation of the background counting rate or of the counting rate of a blank sample as appropriate (counts per minute),
- E = the counting efficiency (counts per disintegration),
- V = the sample size (units of mass or volume),
- 2.22E+06 = the number of disintegrations per minute per μ Ci,
- Y = the fractional radiochemical yield, when applicable,
- λ = the radioactive decay constant for the particular radionuclide (sec^{-1}), and
- Δt = the elapsed time between the midpoint of sample collection and the time of counting (sec).

Typical values of E, V, Y, and Δt should be used in the calculation.

It should be recognized that the LLD is defined as an a priori (before the fact) limit representing the capability of a measurement system and not as an a posteriori (after the fact) limit for a particular measurement.

- (2) A batch release is the discharge of liquid wastes of a discrete volume. Prior to sampling for analyses, each batch shall be isolated, and then thoroughly mixed by a method described in the ODCM to assure representative sampling.

TABLE 4.11-1 (Continued)

TABLE NOTATIONS (Continued)

- (3) The principal gamma emitters for which the LLD Operational Requirement applies include the following radionuclides: Mn-54, Fe-59, Co-58, Co-60, Zn-65, Mo-99, Cs-134, Cs-137, and Ce-141. Ce-144 shall also be measured but with a LLD of 5E-06. This list does not mean that only these nuclides are to be considered. Other gamma peaks that are identifiable, together with those of the above nuclides, shall also be analyzed and reported in the Annual Radioactive Effluent Release Report pursuant to ODCM, Appendix F, Section F.2 in the format outlined in Regulatory Guide 1.21, Appendix B, Revision 1, June 1974.
- (4) A composite sample is one in which the quantity of liquid sampled is proportional to the quantity of liquid waste discharged and in which the method of sampling employed results in a specimen that is representative of the liquids released.
- (5) A continuous release is the discharge of liquid wastes of a nondiscrete volume, e.g., from a volume of a system that has an input flow during the continuous release.
- (6) To be representative of the quantities and concentrations of radioactive materials in liquid effluents, samples shall be collected continuously in proportion to the rate of flow of the effluent stream. Prior to analyses, all samples taken for the composite shall be thoroughly mixed in order for the composite sample to be representative of the effluent release.
- (7) These points monitor potential release pathways only and not actual release pathways. The potential contamination points are in the Normal Service Water (NSW) and Secondary Waste (SW) Systems. Action under this Operational Requirement is as follows:
 - a) If the applicable (NSW or SW) monitors in Table 3.3-12 are OPERABLE and not in alarm, then no analysis under this Operational Requirement is required but weekly composites will be collected.
 - b) If the applicable monitor is out of service, then the weekly analysis for principal gamma emitters will be performed.
 - c) If the applicable monitor is in alarm or if the principal gamma emitter analysis indicates the presence of radioactivity as defined in the ODCM, then all other analyses of this Operational Requirement shall be performed at the indicated frequency as long as the initiating conditions exist.
- (8) The Secondary Waste System releases can be either batch or continuous. The type of sample required is determined by the mode of operation being used.

3/4.11.1 LIQUID EFFLUENTS

3/4.11.1.2 Dose

OPERATIONAL REQUIREMENT

- 3.11.1.2 The dose or dose commitment to a MEMBER OF THE PUBLIC from radioactive materials in liquid effluents released to UNRESTRICTED AREAS (see Technical Specification Figure 5.1-3) shall be limited:
- a. During any calendar quarter to less than or equal to 1.5 mrems to the whole body and to less than or equal to 5 mrems to any organ, and
 - b. During any calendar year to less than or equal to 3 mrems to the whole body and to less than or equal to 10 mrems to any organ.

APPLICABILITY: At all times.

ACTION:

- a. With the calculated dose from the release of radioactive materials in liquid effluents exceeding any of the above limits, prepare and submit to the Commission within 30 days, pursuant to Technical Specification 6.9.2, a Special Report that identifies the cause(s) for exceeding the limit(s) and defines the corrective actions that have been taken to reduce the releases and the proposed corrective actions to be taken to assure that subsequent releases will be in compliance with the above limits.

SURVEILLANCE REQUIREMENTS

- 4.11.1.2 Cumulative dose contributions from liquid effluents for the current calendar quarter and the current calendar year shall be determined in accordance with the methodology and parameters in the ODCM at least once per 31 days.

Each Surveillance Requirement shall be performed within the specified surveillance interval with a maximum allowable extension not to exceed 25% of the specified surveillance interval.

3/4.11.1 LIQUID EFFLUENTS

3/4.11.1.3 Liquid Radwaste Treatment System

OPERATIONAL REQUIREMENT

3.11.1.3 The Liquid Radwaste Treatment System shall be OPERABLE and appropriate portions of the system shall be used to reduce releases of radioactivity when the projected doses, due to the liquid effluent, to UNRESTRICTED AREAS (see Technical Specification Figure 5.1-3) would exceed 0.06 mrem to the whole body or 0.2 mrem to any organ in a 31-day period.

APPLICABILITY: At all times.

ACTION:

- a. With radioactive liquid waste being discharged without treatment and in excess of the above limits and any portion of the Liquid Radwaste Treatment System not in operation, prepare and submit to the Commission within 30 days, pursuant to Technical Specification 6.9.2, a Special Report that includes the following information:
 1. Explanation of why liquid radwaste was being discharged without treatment, identification of any inoperable equipment or subsystems, and the reason for the inoperability,
 2. Action(s) taken to restore the inoperable equipment to OPERABLE status, and
 3. Summary description of action(s) taken to prevent a recurrence.

SURVEILLANCE REQUIREMENTS

4.11.1.3.1 Doses due to liquid releases to UNRESTRICTED AREAS shall be projected at least once per 31 days in accordance with the methodology and parameters in the ODCM when Liquid Radwaste Treatment Systems are not being fully utilized.

4.11.1.3.2 The installed Liquid Radwaste Treatment System shall be considered OPERABLE by meeting Operational Requirements 3.11.1.1 and 3.11.1.2.

Each Surveillance Requirement shall be performed within the specified surveillance interval with a maximum allowable extension not to exceed 25% of the specified surveillance interval.

3/4.11.2 GASEOUS EFFLUENTS

3/4.11.2.1 Dose Rate

OPERATIONAL REQUIREMENT

- 3.11.2.1 The dose rate due to radioactive materials released in gaseous effluents from the site to areas at and beyond the SITE BOUNDARY (see Technical Specification Figure 5.1-1) shall be limited to the following:
- a. For noble gases: Less than or equal to 500 mrems/yr to the whole body and less than or equal to 3000 mrems/yr to the skin, and
 - b. For Iodine-131, for Iodine-133, for tritium, and for all radionuclides in particular form with half-lives greater than 8 days: Less than or equal to 1500 mrems/yr to any organ.

APPLICABILITY: At all times.

ACTION:

- a. With the dose rate(s) exceeding the above limits, immediately restore the release rate to within the above limit(s).

SURVEILLANCE REQUIREMENTS

- 4.11.2.1.1 The dose rate due to noble gases in gaseous effluents shall be determined to be within the above limits in accordance with the methodology and parameters in the ODCM.
- 4.11.2.1.2 The dose rate due to Iodine-131, Iodine-133, tritium, and all radionuclides in particulate form with half-lives greater than 8 days in gaseous effluents shall be determined to be within the above limits in accordance with the methodology and parameters in the ODCM by obtaining representative samples and performing analyses in accordance with the sampling and analysis program specified in Table 4.11-2.

Each Surveillance Requirement shall be performed within the specified surveillance interval with a maximum allowable extension not to exceed 25% of the specified surveillance interval.

TABLE 4.11-2
 RADIOACTIVE GASEOUS WASTE SAMPLING AND ANALYSIS PROGRAM*

GASEOUS RELEASE TYPE	SAMPLING FREQUENCY	MINIMUM ANALYSIS FREQUENCY	TYPE OF ACTIVITY ANALYSIS	LOWER LIMIT OF DETECTION (LLD) ⁽¹¹⁾ ($\mu\text{Ci/ml}$)
1. Waste Gas Storage Tank	P Each Tank Grab Sample	P Each Tank	Principal Gamma Emitters ^(2a)	1E-04
2. Containment Purge or Vent ⁽¹⁰⁾	P Each PURGE ⁽³⁾ Grab Sample	P Each PURGE ⁽³⁾	Principal Gamma Emitters ^(2a)	1E-04
		M	H-3 (oxide)	1E-06
3. a. Plant Vent Stack	M ^{(3), (4), (5)} Grab Sample	M	Principal Gamma Emitters ^(2a)	1E-04
			H-3 (oxide)	1E-06
	M Grab Sample	M	Principal Gamma Emitters ^(2a)	1E-04
			H-3 (oxide) (Turbine Bldg. Vent Stack)	1E-06
4. All Release Types as listed in 1., 2., and 3. above ^{(8), (9), (10)}	Continuous ⁽⁶⁾	W ⁽⁷⁾ Charcoal Sample	I-131 ^(2b)	1E-12
			I-133 ^(2b)	1E-10
	Continuous ⁽⁶⁾	W ⁽⁷⁾ Particulate Sample	Principal Gamma Emitters ^(2c)	1E-11
			Gross Alpha	1E-11
	Continuous ⁽⁶⁾	Q Composite Particulate Sample	Sr-89, Sr-90	1E-11
5. Equipment Hatch during Refueling	Continuous	D Charcoal Sample	I-131, & I-133	1E-11 1E-09
			D ⁽¹¹⁾ Particulate Sample	Principal Gamma Emitters

* See Table G-1 for explanation of frequency notation

TABLE 4.11-2 (Continued)

TABLE NOTATIONS

- (1) The LLD is defined, for purposes of these Operational Requirements, as the smallest concentration of radioactive material in a sample that will yield a net count, above system background, that will be detected with 95% probability with only 5% probability of falsely concluding that a blank observation represents a "real" signal.

For a particular measurement system, which may include radiochemical separation:

$$LLD = \frac{4.66 \cdot S_b}{E \cdot V \cdot (2.22E + 06) \cdot Y \cdot e^{-\lambda \Delta t}}$$

Where:

- LLD = the "a priori" lower limit of detection (μ Ci per unit mass or volume),
- S_b = the standard deviation of the background counting rate or of the counting rate of a blank sample as appropriate (counts per minute),
- E = the counting efficiency (counts per disintegration),
- V = the sample size (units of mass or volume),
- 2.22E+06 = the number of disintegrations per minute per μ Ci,
- Y = the fractional radiochemical yield, when applicable,
- λ = the radioactive decay constant for the particular radionuclide (sec^{-1}), and
- Δt = the elapsed time between the midpoint of sample collection and the time of counting (sec).

Typical values of E, V, Y, and Δt should be used in the calculation.

It should be recognized that the LLD is defined as an a priori (before the fact) limit representing the capability of a measurement system and not as an a posteriori (after the fact) limit for a particular measurement.

TABLE 4.11-2 (Continued)

TABLE NOTATIONS (Continued)

- (2a) The principal gamma emitters for which the LLD Operational Requirement applies include the following radionuclides: Kr-87, Kr-88, Xe-133, Xe-133m, Xe-135, and Xe-138 in noble gas releases. This list does not mean that only these nuclides are to be considered. Other noble gas gamma peaks that are identifiable, together with those of the above nuclides, shall also be analyzed and reported in the Annual Radioactive Effluent Release Report pursuant to ODCM, Appendix F, Section F.2 in the format outlined in Regulatory Guide 1.21, Appendix B, Revision 1, June 1974.
- (2b) The principal gamma emitters for which the LLD Operational Requirement applies include I-131 and I-133 in Iodine (charcoal cartridge) samples. This list does not mean that only these nuclides are to be considered. Other iodine gamma peaks that are identifiable, together with I-131 and I-133 nuclides, shall also be analyzed and reported in the Annual Radioactive Effluent Release Report pursuant to ODCM, Appendix F, Section F.2 in the format outlined in Regulatory Guide 1.21, Appendix B, Revision 1, June 1974.
- (2c) The principal gamma emitters for which the LLD Operational Requirement applies include the following radionuclides: Mn-54, Fe-59, Co-58, Co-60, Zn-65, Mo-99, I-131, Cs-134, Cs-137, Ce-141, and Ce-144 in particulate releases. This list does not mean that only these nuclides are to be considered. Other particulate gamma peaks that are identifiable, together with those of the above nuclides, shall also be analyzed and reported in the Annual Radioactive Effluent Release Report pursuant to ODCM, Appendix F, Section F.2 in the format outlined in Regulatory Guide 1.21, Appendix B, Revision 1, June 1974.
- (3) Sampling and analysis shall also be performed following shutdown, startup, or a THERMAL POWER change exceeding 15% of RATED THERMAL POWER within a 1-hour period.
- (4) Tritium grab samples shall be taken at least once per 24 hours when the refueling canal is flooded.
- (5) Tritium grab samples shall be taken at least once per 7 days from the ventilation exhaust from the spent fuel pool area, whenever spent fuel is in the spent fuel pool.
- (6) The ratio of the sample flow rate to the sampled stream flow rate shall be known for the time period covered by each dose or dose rate calculation made in accordance with Operational Requirements 3.11.2.1, 3.11.2.2, and 3.11.2.3.
- (7) Samples shall be changed at least once per 7 days and analyses shall be completed within 48 hours after changing, or after removal from sampler. Sampling shall also be performed at least once per 24 hours for at least 7 days following each shutdown, startup, or THERMAL POWER change exceeding 15% of RATED THERMAL POWER within a 1-hour period and analyses shall be completed within 48 hours of changing. When samples collected for 24 hours are analyzed, the corresponding LLDs may be increased by a factor of 10. This requirement does not apply if: (1) analysis shows that the DOSE EQUIVALENT I-131 concentration in the reactor coolant has not increased more than a factor of 3; and (2) the noble gas monitor shows that effluent activity has not increased more than a factor of 3.
- (8) Continuous sampling of Waste Gas Decay Tank (WGDT) releases can be met using the continuous samplers on Wide Range Gas Monitor RM-*1WV-3546-1 on Waste Processing Building Vent Stack 5.
- (9) Continuous sampling of containment atmosphere for (1) Venting, (2) Normal Purge, and (3) Pre-entry purge operations, required by Operational Requirement 4.11.2.1.2, can be met using the continuous samplers on Wide Range Gas Monitor RM-01AV-3509-1SA on Plant Vent Stack 1.

TABLE 4.11-2 (Continued)

TABLE NOTATIONS (Continued)

- (10) The requirement to sample the containment atmosphere prior to release for normal and pre-entry containment purge operations (that is, to "permit" the release per the ODCM) is required on initial system startup, and prior to system restart following any system shutdown due to radiological changes in the containment (e.g. valid high alarms on leak detection or containment area monitors). System shutdown occurring on changes in containment pressure, equipment malfunctions, operational convenience, sampling, and so forth, do not require new samples or release permits.
- (11) The composite of all filters collected when releases were being made through the equipment hatch are to be analyzed for gross alpha, strontium-89, and strontium 90 at the end of the outage.

3/4.11.2 GASEOUS EFFLUENTS

3/4.11.2.2 Dose - Noble Gases

OPERATIONAL REQUIREMENT

3.11.2.2 The air dose due to noble gases released in gaseous effluents to areas at and beyond the SITE BOUNDARY (see Technical Specification Figure 5.1-3) shall be limited to the following:

- a. During any calendar quarter: Less than or equal to 5 mrad for gamma radiation and less than or equal to 10 mrad for beta radiation, and
- b. During any calendar year: Less than or equal to 10 mrad for gamma radiation and less than or equal to 20 mrad for beta radiation.

APPLICABILITY: At all times.

ACTION:

- a. With the calculated air dose from radioactive noble gases in gaseous effluents exceeding any of the above limits, prepare and submit to the Commission within 30 days, pursuant to Technical Specification 6.9.2, a Special Report that identifies the cause(s) for exceeding the limit(s) and defines the corrective actions that have been taken to reduce the releases and the proposed corrective actions to be taken to assure that subsequent releases will be in compliance with the above limits.

SURVEILLANCE REQUIREMENTS

4.11.2.2 Cumulative dose contributions for the current calendar quarter and current calendar year for noble gases shall be determined in accordance with the methodology and parameters in the ODCM at least once per 31 days.

Each Surveillance Requirement shall be performed within the specified surveillance interval with a maximum allowable extension not to exceed 25% of the specified surveillance interval.

3/4.11.2 GASEOUS EFFLUENTS

3/4.11.2.3 Dose - Iodine-131, Iodine-133, Tritium, and Radioactive Material in Particulate Form

OPERATIONAL REQUIREMENT

- 3.11.2.3 The dose to a MEMBER OF THE PUBLIC from Iodine-131, Iodine-133, tritium, and all radionuclides in particulate form with half-lives greater than 8 days in gaseous effluents released to areas at and beyond the SITE BOUNDARY (see Technical Specification Figure 5.1-3) shall be limited to the following:
- a. During any calendar quarter: Less than or equal to 7.5 mrems to any organ, and
 - b. During any calendar year: Less than or equal to 15 mrems to any organ.

APPLICABILITY: At all times.

ACTION:

- a. With the calculated dose, from the release of Iodine-131, Iodine-133, tritium, and radionuclides in particulate form with half-lives greater than 8 days, in gaseous effluents exceeding any of the above limits, prepare and submit to the Commission within 30 days, pursuant to Technical Specification 6.9.2, a Special Report that identifies the cause(s) for exceeding the limit(s) and defines the corrective actions that have been taken to reduce the releases and the proposed corrective actions to be taken to assure that subsequent releases will be in compliance with the above limits.

SURVEILLANCE REQUIREMENTS

- 4.11.2.3 Cumulative dose contributions for the current calendar quarter and current calendar year for Iodine-131, Iodine-133, tritium, and radionuclides in particulate form with half-lives greater than 8 days shall be determined in accordance with the methodology and parameters in the ODCM at least once per 31 days.

Each Surveillance Requirement shall be performed within the specified surveillance interval with a maximum allowable extension not to exceed 25% of the specified surveillance interval.

3/4.11.2 GASEOUS EFFLUENTS

3/4.11.2.4 Gaseous Radwaste Treatment System

OPERATIONAL REQUIREMENT

- 3.11.2.4 The VENTILATION EXHAUST TREATMENT SYSTEM and the GASEOUS RADWASTE TREATMENT SYSTEM shall be OPERABLE and appropriate portions of these systems shall be used to reduce releases of radioactivity when the projected doses in 31 days due to gaseous effluent releases to areas at and beyond the SITE BOUNDARY (see Technical Specification Figure 5.1-3) would exceed:
- a. 0.2 mrad to air from gamma radiation, or
 - b. 0.4 mrad to air from beta radiation, or
 - c. 0.3 mrem to any organ of a MEMBER OF THE PUBLIC.

APPLICABILITY: At all times.

ACTION:

- a. With radioactive gaseous waste being discharged without treatment and in excess of the above limits, prepare and submit to the Commission within 30 days, pursuant to Technical Specification 6.9.2, a Special Report that includes the following information:
 1. Identification of any inoperable equipment or subsystems, and the reason for the inoperability,
 2. Action(s) taken to restore the inoperable equipment to OPERABLE status, and
 3. Summary description of action(s) taken to prevent a recurrence.

SURVEILLANCE REQUIREMENTS

- 4.11.2.4.1 Doses due to gaseous releases to areas at and beyond the SITE BOUNDARY shall be projected at least once per 31 days in accordance with the methodology and parameters in the ODCM when the GASEOUS RADWASTE TREATMENT SYSTEM is not being fully utilized.
- 4.11.2.4.2 The installed VENTILATION EXHAUST TREATMENT SYSTEM and GASEOUS RADWASTE TREATMENT SYSTEM shall be considered OPERABLE by meeting Operational Requirements 3.11.2.1 and 3.11.2.2 or 3.11.2.3.
- Each Surveillance Requirement shall be performed within the specified surveillance interval with a maximum allowable extension not to exceed 25% of the specified surveillance interval.

3/4.11.4 TOTAL DOSE

OPERATIONAL REQUIREMENT

- 3.11.4 The annual (calendar year) dose or dose commitment to any MEMBER OF THE PUBLIC due to releases of radioactivity and to radiation from uranium fuel cycle sources shall be limited to less than or equal to 25 mrems to the whole body or any organ, except the thyroid, which shall be limited to less than or equal to 75 mrems.

APPLICABILITY: At all times.

ACTION:

- a. With the calculated doses from the release of radioactive materials in liquid or gaseous effluents exceeding twice the limits of Operational Requirement 3.11.1.2a., 3.11.1.2b., 3.11.2.2a., 3.11.2.2b., 3.11.2.3a., or 3.11.2.3b., calculations shall be made including direct radiation contributions from the units and from outside storage tanks to determine whether the above limits of Operational Requirement 3.11.4 have been exceeded. If such is the case, prepare and submit to the Commission within 30 days, pursuant to Technical Specification 6.9.2, a Special Report that defines the corrective action to be taken to reduce subsequent releases to prevent recurrence of exceeding the above limits and includes the schedule for achieving conformance with the above limits. This Special Report, as defined in 10 CFR 20.405(c), shall include an analysis that estimates the radiation exposure (dose) to a MEMBER OF THE PUBLIC from uranium fuel cycle sources, including all effluent pathways and direct radiation, for the calendar year that includes the release(s) covered by this report. It shall also describe levels of radiation and concentrations of radioactive material involved, and the cause of the exposure levels or concentrations. If the estimated dose(s) exceeds the above limits, and if the release condition resulting in violation of 40 CFR Part 190 has not already been corrected, the Special Report shall include a request for a variance in accordance with the provisions of 40 CFR Part 190. Submittal of the report is considered a timely request, and a variance is granted until staff action on the request is complete.

SURVEILLANCE REQUIREMENTS

- 4.11.4.1 Cumulative dose contributions from liquid and gaseous effluents shall be determined in accordance with Operational Requirements 4.11.1.2, 4.11.2.2, and 4.11.2.3, and in accordance with the methodology and parameters in the ODCM.
- 4.11.4.2 Cumulative dose contributions from direct radiation from the units and from radwaste storage tanks shall be determined in accordance with the methodology and parameters in the ODCM. This requirement is applicable only under conditions set forth in ACTION a. of Operational Requirement 3.11.4.

Each Surveillance Requirement shall be performed within the specified surveillance interval with a maximum allowable extension not to exceed 25% of the specified surveillance interval.

D.3 RADIOLOGICAL ENVIRONMENTAL MONITORING

3/4.12.1 MONITORING PROGRAM

OPERATIONAL REQUIREMENT

3.12.1 The Radiological Environment Monitoring Program shall be conducted as specified in Table 3.12-1.

APPLICABILITY: At all times.

ACTION:

- a. With the Radiological Environmental Monitoring Program not being conducted as specified in Table 3.12-1, prepare and submit to the Commission, in the Annual Radiological Environmental Operating Report required by ODCM, Appendix F, Section F.1, a description of the reasons for not conducting the program as required and the plans for preventing a recurrence.
- b. With the level of radioactivity as the result of plant effluents in an environmental sampling medium at a specified location exceeding the reporting levels of Table 3.12-2 when averaged over any calendar quarter, prepare and submit to the Commission within 30 days, pursuant to Technical Specification 6.9.2, a Special Report that identifies the cause(s) for exceeding the limit(s) and defines the corrective actions to be taken to reduce radioactive effluents so that the potential annual dose* to a MEMBER OF THE PUBLIC is less than the calendar year limits of Operational Requirements 3.11.1.2, 3.11.2.2, or 3.11.2.3. When more than one of the radionuclides in Table 3.12-2 are detected in the sampling medium, this report shall be submitted if:

$$\frac{\text{concentration}(1)}{\text{reporting level}(1)} + \frac{\text{concentration}(2)}{\text{reporting level}(2)} + \dots \geq 1.0$$

When radionuclides other than those in Table 3.12-2 are detected and are the result of plant effluents, this report shall be submitted if the potential annual dose* to a MEMBER OF THE PUBLIC from all radionuclides is equal to or greater than the calendar year limits of Operational Requirement 3.11.1.2, 3.11.2.2, or 3.11.2.3. This report is not required if the measured level of radioactivity was not the result of plant effluents; however, in such an event, the condition shall be reported and described in the Annual Radiological Environmental Operating Report required by ODCM, Appendix F, Section F.1.

*The methodology and parameters used to estimate the potential annual dose to a MEMBER OF THE PUBLIC shall be indicated in this report.

3/4.12.1 MONITORING PROGRAM

OPERATIONAL REQUIREMENT

ACTION (Continued):

- c. With milk or fresh leafy vegetation samples unavailable from one or more of the sample locations required by Table 3.12-1, identify specific locations for obtaining replacement samples and add them within 30 days to the Radiological Environmental Monitoring Program given in the ODCM. The specific locations from which samples were unavailable may then be deleted from the monitoring program. Pursuant to ODCM, Appendix F, Section F.2, submit in the next Annual Radioactive Effluent Release Report documentation for a change in the ODCM including a revised figure(s) and table for the ODCM reflecting the new location(s) with supporting information identifying the cause of the unavailability of samples and justifying the selection of the new location(s) for obtaining samples.
- d. If any sample result for onsite groundwater, that is or may be used as a source of drinking water, exceeds the reporting criteria of ODCM Table 3.12-2, then submit a special 30 day written report to the NRC. Additionally, a copy of this report shall be forwarded to designated state/local offices listed below in Action e.
- e. If any offsite groundwater, offsite surface water, onsite groundwater monitoring well, or onsite surface water that is hydrologically connected to groundwater exceed the reporting criteria of ODCM Table 3.12-2, then make informal notification to the designated state/local offices listed below by the end of the next business day. Special Ground Water Protection Reports listed in this section are not required for subsequent sample results that are from the same plume and have already been reported in accordance with this section. The Designated State offices for notification are as follows: 1) North Carolina Department of Environmental and Natural Resources, Radiation Protection Section and 2) North Carolina Department of Environmental and Natural Resources, Division of Water Quality.

SURVEILLANCE REQUIREMENTS

4.12.1 The radiological environmental monitoring samples shall be collected pursuant to Table 3.12-1 from the specific locations given in the table and figure(s) in the ODCM, and shall be analyzed pursuant to the requirements of Table 3.12-1 and the detection capabilities required by Table 4.12-1.

Each Surveillance Requirement shall be performed within the specified surveillance interval with a maximum allowable extension not to exceed 25% of the specified surveillance interval.

TABLE 3.12-1

RADIOLOGICAL ENVIRONMENTAL MONITORING PROGRAM

<u>EXPOSURE PATHWAY AND/OR SAMPLE</u>	<u>NUMBER OF REPRESENTATIVE SAMPLES AND SAMPLE LOCATIONS ⁽¹⁾</u>	<u>SAMPLING AND COLLECTION FREQUENCY</u>	<u>TYPE AND FREQUENCY OF ANALYSIS</u>
1. Direct Radiation ⁽²⁾	<p>Forty routine monitoring stations either with two or more dosimeters or with one instrument for measuring and recording dose rate continuously, placed as follows:</p> <p>An inner ring of stations, one in each meteorological sector in the general area of the SITE BOUNDARY;</p> <p>An outer ring of stations, one in each meteorological sector in the 6 to 8 km range from the site; and</p> <p>The balance of the stations to be placed in special interest areas such as population centers, nearby residences, schools, and in one or two areas to serve as control stations.</p>	Quarterly.	Gamma dose quarterly.

TABLE 3.12-1 (Continued)

RADIOLOGICAL ENVIRONMENTAL MONITORING PROGRAM

<u>EXPOSURE PATHWAY AND/OR SAMPLE</u>	<u>NUMBER OF REPRESENTATIVE SAMPLES AND SAMPLE LOCATIONS⁽¹⁾</u>	<u>SAMPLING AND COLLECTION FREQUENCY</u>	<u>TYPE AND FREQUENCY OF ANALYSIS</u>
2. Airborne Radioiodine and Particulates	<p>Samples from five locations:</p> <p>Three samples from close to the three SITE BOUNDARY locations, in different sectors, of the highest calculated annual average ground-level D/Q;</p> <p>One sample from the vicinity of a community having the highest calculated annual average ground-level D/Q; and</p> <p>One sample from a control location, as for example 15 to 30 km distant and in the least prevalent wind direction.</p>	<p>Continuous sampler operation with sample collection weekly, or more frequently if required by dust loading.</p>	<p><u>Radioiodine Cannister:</u> I-131 analysis weekly.</p> <p><u>Particulate Sampler:</u> Gross beta radioactivity analysis following filter change;⁽³⁾ and gamma isotopic analysis⁽⁴⁾ of composite (by location) quarterly.</p>
3. Waterborne	<p>a. Surface⁽⁵⁾</p> <p>One sample upstream.</p> <p>One sample downstream.</p> <p>b. Ground</p> <p>Samples from one or two sources only if likely to be affected⁽⁷⁾.</p>	<p>Composite sample over 1-month period.⁽⁶⁾</p> <p>Quarterly.</p>	<p>Gamma isotopic analysis⁽⁴⁾ monthly. Composite for tritium analysis quarterly.</p> <p>Gamma isotopic⁽⁴⁾ and tritium analysis quarterly.</p>

TABLE 3.12-1 (Continued)

RADIOLOGICAL ENVIRONMENTAL MONITORING PROGRAM

<u>EXPOSURE PATHWAY AND/OR SAMPLE</u>	<u>NUMBER OF REPRESENTATIVE SAMPLES AND SAMPLE LOCATIONS ⁽¹⁾</u>	<u>SAMPLING AND COLLECTION FREQUENCY</u>	<u>TYPE AND FREQUENCY OF ANALYSIS</u>
3. Waterborne (Continued)			
c. Drinking	One sample in the vicinity of the nearest downstream municipal water supply intake from the Cape Fear River. One sample from a control location.	Composite sample over 2-week period ⁽⁶⁾ when I-131 analysis is performed; monthly composite otherwise.	I-131 analysis on each composite when the dose calculated for the consumption of the water is greater than 1 mrem per year. ⁽⁸⁾ Composite for gross beta and gamma isotopic analyses ⁽⁴⁾ monthly. Composite for tritium analysis quarterly.
d. Sediment from Shoreline	One sample in the vicinity of the cooling tower blowdown discharge in an area with existing or potential recreational value.	Semiannually.	Gamma isotopic analysis ⁽⁴⁾ semiannually.
4. Ingestion			
a. Milk	Samples from milking animals in three locations within 5 km distance having the highest dose potential. If there are none, then one sample from milking animals in each of three areas between 5 to 8 km distant where doses are calculated to be greater than 1 mrem per yr. ⁽⁸⁾ One sample from milking animals at a control location 15 to 30 km distant and in the least prevalent wind direction.	Semimonthly when animals are on pasture; monthly at other times. When no milk animals are available at indicator locations, milk sampling of the control location can be reduced to once per month to maintain historical data.	Gamma isotopic ⁽⁴⁾ and I-131 analysis semimonthly when animals are on pasture; monthly at other times.

TABLE 3.12-1 (Continued)

RADIOLOGICAL ENVIRONMENTAL MONITORING PROGRAM

<u>EXPOSURE PATHWAY AND/OR SAMPLE</u>	<u>NUMBER OF REPRESENTATIVE SAMPLES AND SAMPLE LOCATIONS⁽¹⁾</u>	<u>SAMPLING AND COLLECTION FREQUENCY</u>	<u>TYPE AND FREQUENCY OF ANALYSIS</u>
4. Ingestion (Continued)			
b. Fish and Invertebrates	One sample of Sunfish, Catfish, and Large-Mouth Bass species in vicinity of plant discharge area. One sample of same species in areas not influenced by plant discharge.	Sample in season, or semiannually if they are not seasonal.	Gamma isotopic analysis ⁽⁴⁾ on edible portions.
c. Food Products	Samples of three different kinds of broad leaf vegetation grown nearest each of two different offsite locations of highest predicted annual average ground level D/Q if milk sampling is not performed. One sample of each of the similar broad leaf vegetation grown 15 to 30 km distant in the least prevalent wind direction if milk sampling is not performed.	Monthly during growing season. Monthly during growing season.	Gamma isotopic ⁽⁴⁾ and I-131 analysis. Gamma isotopic ⁽⁴⁾ and I-131 analysis.

TABLE 3.12-1 (Continued)

TABLE NOTATIONS

- (1) Specific parameters of distance and direction sector from the centerline of one reactor, and additional description where pertinent, shall be provided for each and every sample location in Table 3.12-1 in a table and figure(s) in the ODCM. Refer to NUREG-0133, "Preparation of Radiological Effluent Technical Specifications for Nuclear Power Plants," October 1978, and to Radiological Assessment Branch Technical Position, Revision 1, November 1979. Deviations are permitted from the required sampling schedule if specimens are unobtainable due to circumstances such as hazardous conditions, seasonal unavailability, and malfunction of automatic sampling equipment. If specimens are unobtainable due to sampling equipment malfunction, effort shall be made to complete corrective action prior to the end of the next sampling period. All deviations from the sampling schedule shall be documented in the Annual Radiological Environmental Operating Report pursuant to Specification 6.9.1.3. It is recognized that, at times, it may not be possible or practicable to continue to obtain samples of the media of choice at the most desired location or time. In these instances suitable alternative media and locations may be chosen for the particular pathway in question and appropriate substitutions made within 30 days in the Radiological Environmental Monitoring Program. Pursuant to ODCM, Appendix F, Section F.2, submit in the next Annual Radioactive Effluent Release Report documentation for a change in the ODCM including a revised figure(s) and table for the ODCM reflecting the new location(s) with supporting information identifying the cause of the unavailability of samples for that pathway and justifying the selection of the new location(s) for obtaining samples.
- (2) One or more instruments, such as a pressurized ion chamber, for measuring and recording dose rate continuously may be used in place of, or in addition to, integrating dosimeters. For the purposes of this table, a thermoluminescent dosimeter (TLD) is considered to be one phosphor; two or more phosphors in a packet are considered as two or more dosimeters. Film badges shall not be used as dosimeters for measuring direct radiation. (The 40 stations are not an absolute number. The number of direct radiation monitoring stations may be reduced according to geographical limitations; e.g., at an ocean site, some sectors will be over water so that the number of dosimeters may be reduced accordingly. The frequency of analysis or readout for TLD systems will depend upon the characteristics of the specific system used and should be selected to obtain optimum dose information within minimal fading.)
- (3) Airborne particulate sample filters shall be analyzed for gross beta radioactivity 24 hours or more after sampling to allow for radon and thoron daughter decay. If gross beta activity in air particulate samples is greater than 10 times the yearly mean of control samples, gamma isotopic analysis shall be performed on the individual samples.

TABLE 3.12-1 (Continued)

TABLE NOTATIONS (Continued)

- (4) Gamma isotopic analysis means the identification and quantification of gamma-emitting radionuclides that may be attributable to the effluents from the facility.
- (5) The "upstream sample" shall be taken at a distance beyond significant influence of the discharge. The "downstream" sample shall be taken in an area beyond but near the mixing zone. "Upstream" samples in an estuary must be taken far enough upstream to be beyond the plant influence. Salt water shall be sampled only when the receiving water is utilized for recreational activities.
- (6) A composite sample is one in which the quantity (aliquot) of liquid sampled is proportional to the quantity of flowing liquid and in which the method of sampling employed results in a specimen that is representative of the liquid flow. In this program composite sample aliquots shall be collected at time intervals that are very short (e.g., hourly) relative to the compositing period (e.g., monthly) in order to assure obtaining a representative sample.
- (7) Groundwater samples shall be taken when this source is tapped for drinking or irrigation purposes in areas where the hydraulic gradient or recharge properties are suitable for contamination. As of Revision 19 of this ODCM, there are eight current groundwater monitoring locations. None of the previously identified locations have been used for drinking water since pre-operational days of Harris Nuclear Project nor have these wells ever been used for irrigation purposes. These wells were abandoned for drinking water purposes prior to plant operations. Since that time, these wells have been used to monitor the hydraulic gradient or gradient properties for the Harris Site and for the operational Radiological Environmental Monitoring program.
- (8) The dose shall be calculated for the maximum organ and age group, using the methodology and parameters in the ODCM.

TABLE 3.12-2

REPORTING LEVELS FOR RADIOACTIVITY CONCENTRATIONS IN ENVIRONMENTAL SAMPLES

ANALYSIS	WATER (pCi/l)	AIRBORNE PARTICULATE OR GASES (pCi/m ³)	FISH (pCi/kg, wet)	MILK (pCi/l)	FOOD PRODUCTS (pCi/kg, wet)
H-3	20,000*				
Mn-54	1,000		30,000		
Fe-59	400		10,000		
Co-58	1,000		30,000		
Co-60	300		10,000		
Zn-65	300		20,000		
Zr-Nb-95	400				
I-131	2**	0.9		3	100
Cs-134	30	10	1,000	60	1,000
Cs-137	50	20	2,000	70	2,000
Ba-La-140	200			300	

*For drinking water samples. This is 40 CFR Part 141 value. If no drinking water pathway exists, a value of 30,000 pCi/l may be used.

**If no drinking water pathway exists, a value of 20 pCi/l may be used.

TABLE 4.12-1
DETECTION CAPABILITIES FOR ENVIRONMENTAL SAMPLE ANALYSIS⁽¹⁾
LOWER LIMIT OF DETECTION (LLD)⁽²⁾

ANALYSIS	WATER (pCi/l)	AIRBORNE PARTICULATE OR GASES (pCi/m ³)	FISH (pCi/kg, wet)	MILK (pCi/l)	FOOD PRODUCTS (pCi/kg, wet)	SEDIMENT (pCi/kg, dry)
Gross Beta	4	0.01				
H-3	2000*					
Mn-54	15		130			
Fe-59	30		260			
Co-58, 60	15		130			
Zn-65	30		260			
Zr-Nb-95	15					
I-131	1**	0.07		1	60	
Cs-134	15	0.05	130	15	60	150
Cs-137	18	0.06	150	18	80	180
Ba-La-140	15			15		

*If no drinking water pathway exists, a value of 3000 pCi/l may be used.

**If no drinking water pathway exists, a value of 15 pCi/l may be used.

TABLE 4.12-1 (Continued)

TABLE NOTATIONS

- (1) This list does not mean that only these nuclides are to be considered. Other peaks that are identifiable, together with those of the above nuclides, shall also be analyzed and reported in the Annual Radiological Environmental Operating Report pursuant to ODCM, Appendix F, Section F.1.
- (2) The LLD is defined, for purposes of these Operational Requirements, as the smallest concentration of radioactive material in a sample that will yield a net count, above system background, that will be detected with 95% probability with only 5% probability of falsely concluding that a blank observation represents a "real" signal.

For a particular measurement system, which may include radiochemical separation:

$$LLD = \frac{4.66 \cdot S_b}{E \cdot V \cdot (2.22E + 06) \cdot Y \cdot e^{-\lambda \Delta t}}$$

Where:

- LLD = the "a priori" lower limit of detection (μ Ci per unit mass or volume),
- S_b = the standard deviation of the background counting rate or of the counting rate of a blank sample as appropriate (counts per minute),
- E = the counting efficiency (counts per disintegration),
- V = the sample size (units of mass or volume),
- 2.22E+06 = the number of disintegrations per minute per μ Ci,
- Y = the fractional radiochemical yield, when applicable,
- λ = the radioactive decay constant for the particular radionuclide (sec^{-1}), and
- Δt = the elapsed time between the midpoint of sample collection and the time of counting (sec).

Typical values of E, V, Y, and Δt should be used in the calculation.

TABLE 4.12-1 (Continued)

TABLE NOTATIONS (Continued)

It should be recognized that the LLD is defined as an a priori (before the fact) limit representing the capability of a measurement system and not as an a posteriori (after the fact) limit for a particular measurement. Analyses shall be performed in such a manner that the stated LLDs will be achieved under routine conditions. Occasionally background fluctuations, unavoidable small sample sizes, the presence of interfering nuclides, or other uncontrollable circumstances may render these LLDs unachievable. In such cases, the contributing factors shall be identified and described in the Annual Radiological Environmental Operating Report pursuant to ODCM, Appendix F, Section F.1.

3/4.12.2 LAND USE CENSUS

OPERATIONAL REQUIREMENT

- 3.12.2 A Land Use Census shall be conducted and shall identify within a distance of 8 km (5 miles) the location in each of the 16 meteorological sectors of the nearest milk animal, the nearest residence, and the nearest garden* of greater than 50 m² (500 ft²) producing broad leaf vegetation.

APPLICABILITY: At all times.

ACTION:

- a. With a Land Use Census identifying a location(s) that yields a calculated dose or dose commitment greater than the values currently being calculated in Operational Requirement 4.11.2.3, pursuant to ODCM, Appendix F, Section F.2, identify the new location(s) in the next Annual Radioactive Effluent Release Report.
- b. With a Land Use Census identifying a location(s) that yields a calculated dose or dose commitment (via the same exposure pathway) 20% greater than at a location from which samples are currently being obtained in accordance with Operational Requirement 3.12.1, add the new location(s) within 30 days to the Radiological Environmental Monitoring Program given in the ODCM. The sampling location(s), excluding the control station location, having the lowest calculated dose or dose commitment(s), via the same exposure pathway, may be deleted from this monitoring program after October 31 of the year in which this Land Use Census was conducted. Pursuant to ODCM, Appendix F, Section F.2, submit in the next Annual Radioactive Effluent Release Report documentation for a change in the ODCM including a revised figure(s) and table(s) for the ODCM reflecting the new location(s) with information supporting the change in sampling locations.

SURVEILLANCE REQUIREMENTS

- 4.12.2 The Land Use Census shall be conducted during the growing season at least once per 12 months using that information that will provide the best results, such as by a door-to-door survey, aerial survey, or by consulting local agriculture authorities. The results of the Land Use Census shall be included in the Annual Radiological Environmental Operating Report pursuant to ODCM, Appendix F, Section F.1.

Each Surveillance Requirement shall be performed within the specified surveillance interval with a maximum allowable extension not to exceed 25% of the specified surveillance interval.

*Broad leaf vegetation sampling of at least three different kinds of vegetation may be performed at the SITE BOUNDARY in each of two different direction sectors with the highest predicted D/Qs in lieu of the garden census. Operational Requirements for broad leaf vegetation sampling in Table 3.12-1, Part 4.c., shall be followed, including analysis of control samples.

3/4.12.3 INTERLABORATORY COMPARISON PROGRAM

OPERATIONAL REQUIREMENT

3.12.3 Analyses shall be performed on all radioactive materials, supplied as part of an Interlaboratory Comparison Program, that correspond to samples required by Table 3.12-1. The laboratory used for the Interlaboratory Comparison Program is to participate in the National Institute of Standard and Technology (NIST) program

APPLICABILITY: At all times.

ACTION:

- a. With analyses not being performed as required above, report the corrective actions taken to prevent a recurrence to the Commission in the Annual Radiological Environmental Operating Report pursuant to ODCM, Appendix F, Section F.1.

SURVEILLANCE REQUIREMENTS

4.12.3 The Interlaboratory Comparison Program shall be described in the ODCM. A summary of the results obtained as part of the above required Interlaboratory Comparison Program shall be included in the Annual Radiological Environmental Operating Report pursuant to ODCM, Appendix F, Section F.1.

Each Surveillance Requirement shall be performed within the specified surveillance interval with a maximum allowable extension not to exceed 25% of the specified surveillance interval.

APPENDIX E

PROGRAMMATIC CONTROL BASES

The Bases for the ODCM Operational Requirements are detailed in Sections:

- E.1 - Instrumentation
- E.2 - Radioactive Effluents
- E.3 - Radiological Environmental Monitoring

E.1 INSTRUMENTATION BASES

3/4.3.3 MONITORING INSTRUMENTATION

3/4.3.3.10 Radioactive Liquid Effluent Monitoring Instrumentation

The radioactive liquid effluent instrumentation is provided to monitor and control, as applicable, the releases of radioactive materials in liquid effluents during actual or potential releases of liquid effluents. The Alarm/Trip Set Points for these instruments shall be calculated and adjusted in accordance with the methodology and parameters in the ODCM to ensure that the alarm/trip will occur prior to exceeding the limits of 10 CFR Part 20. The OPERABILITY and use of this instrumentation is consistent with the requirements of General Design Criteria 60, 63, and 64 of Appendix A to 10 CFR Part 50.

3/4.3.3.11 Radioactive Gaseous Effluent Monitoring Instrumentation

The radioactive gaseous effluent instrumentation is provided to monitor and control, as applicable, the releases of radioactive materials in gaseous effluents during actual or potential releases of gaseous effluents. The Alarm/Trip Set Points for these instruments shall be calculated and adjusted in accordance with the methodology and parameters in the ODCM to ensure that the alarm/trip will occur prior to exceeding the limits of 10 CFR Part 20. The OPERABILITY and use of this instrumentation is consistent with the requirements of General Design Criteria 60, 63, and 64 of Appendix A to 10 CFR Part 50. The sensitivity of any noble gas activity monitors used to show compliance with the gaseous effluent release requirements of Operational Requirement 3.11.2.2 shall be such that concentrations as low as $1E-06 \mu\text{Ci/ml}$ are measurable.

E.2 RADIOACTIVE EFFLUENTS BASES

3/4.11.1 LIQUID EFFLUENTS

3/4.11.1.1 Concentration

This Operational Requirement is provided to ensure that the concentration of radioactive materials released in liquid waste effluents to UNRESTRICTED AREAS will be less than the concentration levels specified in 10 CFR Part 20, Appendix B, Table 2, Column 2. This limitation provides additional assurance that the levels of radioactive materials in bodies of water in UNRESTRICTED AREAS will result in exposures within: (1) the Section II.A design objectives of Appendix I, 10 CFR Part 50, to a MEMBER OF THE PUBLIC, and (2) the limits of 10 CFR Part 20.106(e) to the population. The concentration limit for dissolved or entrained noble gases is based upon the assumption that Xe-135 is the controlling radioisotope and its MPC in air (submersion) was converted to an equivalent concentration in water using the methods described in International Commission on Radiological Protection (ICRP) Publication 2.

The required detection capabilities for radioactive materials in liquid waste samples are tabulated in terms of the lower limits of detection (LLDs). Detailed discussion of the LLD, and other detection limits, can be found in HASL Procedures Manual, HASL-300 (revised annually), Currie, L. A., "Limits for Qualitative Detection and Quantitative Determination - Application to Radiochemistry," Anal. Chem. 40, 586-93 (1968), and Hartwell, J. K., "Detection Limits for Radioanalytical Counting Techniques," Atlantic Richfield Hanford Company Report ARH-SA-215 (June 1975).

3/4.11.1.2 Dose

This Operational Requirement is provided to implement the requirements of Sections II.A, III.A, and IV.A of Appendix I, 10 CFR Part 50. The Operational Requirement implements the guides set forth in Section II.A of Appendix I. The ACTION statements provide the required operating flexibility and at the same time implement the guides set forth in Section IV.A of Appendix I to assure that the releases of radioactive material in liquid effluents to UNRESTRICTED AREAS will be kept "as low as is reasonably achievable". The dose calculation methodology and parameters in the ODCM implement the requirements in Section III.A of Appendix I that conformance with the guides of Appendix I be shown by calculational procedures based on models and data, such that the actual exposure of a MEMBER OF THE PUBLIC through appropriate pathways is unlikely to be substantially underestimated.

E.2 RADIOACTIVE EFFLUENTS BASES

3/4.11.1 LIQUID EFFLUENTS

3/4.11.1.2 Dose (continued)

The equations specified in the ODCM for calculating the doses due to the actual release rates of radioactive materials in liquid effluents are consistent with the methodology provided in Regulatory Guide 1.109, "Calculation of Annual Doses to Man from Routine Releases of Reactor Effluents for the Purpose of Evaluating Compliance with 10 CFR Part 50, Appendix I," Revision 1, October 1977 and Regulatory Guide 1.113, "Estimating Aquatic Dispersion of Effluents from Accidental and Routine Reactor Releases for the Purpose of Implementing Appendix I," April 1977.

3/4.11.1.3 Liquid Radwaste Treatment System

The OPERABILITY of the Liquid Radwaste Treatment System ensures that this system will be available for use whenever liquid effluents require treatment prior to release to the environment. The requirement that the appropriate portions of this system be used when specified provides assurance that the releases of radioactive materials in liquid effluents will be kept "as low as is reasonably achievable." This Operational Requirement implements the requirements of 10 CFR 50.36a, General Design Criterion 60 of Appendix A to 10 CFR Part 50 and the design objective given in Section II.D of Appendix I to 10 CFR Part 50. The specified limits governing the use of appropriate portions of the Liquid Radwaste Treatment System were specified as a suitable fraction of the dose design objectives set forth in Section II.A of Appendix I, 10 CFR Part 50 for liquid effluents.

E.2 RADIOACTIVE EFFLUENTS BASES

3/4.11.2 GASEOUS EFFLUENTS

3/4.11.2.1 Dose Rate

This Operational Requirement is provided to ensure that the dose at any time at and beyond the SITE BOUNDARY from gaseous effluents from all units on the site will be within the annual dose limits of 10 CFR Part 20 to UNRESTRICTED AREAS. The annual dose limits are the doses associated with the concentrations of 10 CFR Part 20, Appendix B, Table II, Column I. These limits provide reasonable assurance that radioactive material discharged in gaseous effluents will not result in the exposure of a MEMBER OF THE PUBLIC in an UNRESTRICTED AREA, either within or outside the SITE BOUNDARY, to annual average concentrations exceeding the limits specified in Appendix B, Table II of 10 CFR Part 20 [10 CFR Part 20.106(b)]. For MEMBERS OF THE PUBLIC who may at times be within the SITE BOUNDARY, the occupancy of that MEMBER OF THE PUBLIC will usually be sufficiently low to compensate for any increase in the atmospheric diffusion factor above that for the SITE BOUNDARY. Examples of calculations for such MEMBERS OF THE PUBLIC, with the appropriate occupancy factors, shall be given in the ODCM. The specified release rate limits restrict, at all times, the corresponding gamma and beta dose rates above background to a MEMBER OF THE PUBLIC at or beyond the SITE BOUNDARY to less than or equal to 500 mrem/year to the whole body or to less than or equal to 3000 mrem/year to the skin. These release rate limits also restrict, at all times, the corresponding thyroid dose rate above background to a child via the inhalation pathway to less than or equal to 1500 mrem/year.

The required detection capabilities for radioactive material in gaseous waste samples are tabulated in terms of the lower limits of detection (LLDs). Detailed discussion of the LLD, and other detection limits, can be found in HASL Procedures Manual, HASL-300, Currie, L. A., "Limits for Qualitative Detection and Quantitative Determination - Application to Radiochemistry," Anal. Chem. 40, 586-93 (1968), and Hartwell, J. K., "Detection Limits for Radioanalytical Counting Techniques," Atlantic Richfield Hanford Company Report ARH-SA-215 (June 1975).

E.2 RADIOACTIVE EFFLUENTS BASES

3/4.11.2 GASEOUS EFFLUENTS

3/4.11.2.2 Dose - Noble Gases

This Operational Requirement is provided to implement the requirements of Section II.B, III.A, and IV.A of Appendix I, 10 CFR Part 50. The Operational Requirement implements the guides set forth in Section I.B of Appendix I. The ACTION statements provide the required operating flexibility and at the same time implement the guides set forth in Section IV.A of Appendix I to assure that the releases of radioactive material in gaseous effluents to UNRESTRICTED AREAS will be kept "as low as is reasonably achievable." The Surveillance Requirements implement the requirements in Section III.A of Appendix I that conformance with the guides of Appendix I be shown by calculational procedures based on models and data such that the actual exposure of a MEMBER OF THE PUBLIC through appropriate pathways is unlikely to be substantially underestimated. The dose calculation methodology and parameters established in the ODCM for calculating the doses due to the actual release rates of radioactive noble gases in gaseous effluents are consistent with the methodology provided in Regulatory Guide 1.109, "Calculation of Annual Dose to Man from Routine Releases of Reactor Effluents for the Purpose of Evaluating Compliance with 10 CFR Part 50, Appendix I," Revision I, October 1977 and Regulatory Guide 1.111, "Methods for Estimating Atmospheric Transport and Dispersion of Gaseous Effluents in Routine Releases from Light-Water Cooled Reactors," Revision 1, July 1977. The ODCM equations provided for determining the air doses at and beyond the SITE BOUNDARY are based upon the historical average atmospheric conditions.

E.2 RADIOACTIVE EFFLUENTS BASES

3/4.11.2 GASEOUS EFFLUENTS

3/4.11.2.3 Dose - Iodine-131, Iodine-133, Tritium, and Radioactive Material
in Particulate Form

This Operational Requirement is provided to implement the requirements of Sections II.C, III.A, and IV.A of Appendix I, 10 CFR Part 50. The Operational Requirements are the guides set forth in Section II.C of Appendix I. The ACTION statements provide the required operating flexibility and at the same time implement the guides set forth in Section IV.A of Appendix I to assure that the releases of radioactive materials in gaseous effluents to UNRESTRICTED AREAS will be kept "as low as is reasonable achievable." The ODCM calculational methods specified in the Surveillance Requirements implement the requirements in Section III.A of Appendix I that conformance with the guides of Appendix I be shown by calculational procedures based on models and data such that the actual exposure of a MEMBER OF THE PUBLIC through appropriate pathways is unlikely to be substantially underestimated. The ODCM calculational methodology and parameters for calculating the doses due to the actual release rates of the subject materials are consistent with the methodology provided in Regulatory Guide 1.109, "Calculation of Annual Doses to Man from Routine Releases of Reactor Effluents for the Purpose of Evaluating Compliance with 10 CFR Part 50, Appendix I," Revision 1, October 1977 and Regulatory Guide 1.111, "Methods for Estimating Atmospheric Transport and Dispersion of Gaseous Effluents in Routine Releases from Light-Water Cooled Reactors," Revision 1, July 1977. These equations also provide for determining the actual doses based upon the historical average atmospheric conditions. The release rate Operational Requirements for Iodine-131, Iodine-133, tritium, and radionuclides in particulate form with half-lives greater than 8 days are dependent upon the existing radionuclide pathways to man in the areas at and beyond the SITE BOUNDARY. The pathways that were examined in the development of the calculations were: (1) individual inhalation of airborne radionuclides, (2) deposition of radionuclides onto green leafy vegetation with subsequent consumption by man, (3) deposition onto grassy areas where milk animals and meat producing animals graze with consumption of the milk and meat by man, and (4) deposition of the ground with subsequent exposure of man.

E.2 RADIOACTIVE EFFLUENTS BASES (continued)

3/4.11.2 GASEOUS EFFLUENTS

3/4.11.2.4 Gaseous Radwaste Treatment System

The OPERABILITY of the WASTE GAS HOLDUP SYSTEM and the VENTILATION EXHAUST TREATMENT SYSTEM ensure that the systems will be available for use whenever gaseous effluents require treatment prior to release to the environment. The requirement that the appropriate portions of these systems be used, when specified, provides reasonable assurance that the releases of radioactive materials in gaseous effluents will be kept "as low as is reasonably achievable." This Operational Requirement implements the requirements of 10 CFR 50.36a, General Design Criterion 60 of Appendix A to 10 CFR Part 50 and the design objectives given in Section II.D of Appendix I to 10 CFR Part 50. The specified limits governing the use of appropriate portions of the systems were specified as a suitable fraction of the dose design objectives set forth in Sections II.B and II.C of Appendix I, 10 CFR Part 50, for gaseous effluents.

E.2 RADIOACTIVE EFFLUENTS BASES (continued)

3/4.11.3 SOLID RADIOACTIVE WASTES

This specification implements the requirements of 10 CFR 50.36a, 10 CFR 61, and General Design Criterion 60 of Appendix A to 10 CFR Part 50. The process parameters included in establishing the PROCESS CONTROL PROGRAM may include, but are not limited to, waste type, waste pH, waste/liquid/SOLIDIFICATION agent/catalyst ratios, waste oil content, waste principal chemical constituents, and mixing and curing times.

E.2 RADIOACTIVE EFFLUENTS BASES (continued)

3/4.11.4 TOTAL DOSE

This Operational Requirement is provided to meet the dose limitations of 40 CFR Part 190 that have been incorporated into 10 CFR Part 20 by 46 FR 18525. The Operational Requirement requires the preparation and submittal of a Special Report whenever the calculated doses due to releases of radioactivity and to radiation from uranium fuel cycle sources exceed 25 mrems to the whole body or any organ, except the thyroid, which shall be limited to less than or equal to 75 mrems. For sites containing up to four reactors, it is highly unlikely that the resultant dose to a MEMBER OF THE PUBLIC will exceed the dose limits of 40 CFR Part 190 if the individual reactors remain within twice the dose design objectives of Appendix I, and if direct radiation doses from the units and from outside storage tanks are kept small. The Special Report will describe a course of action that should result in the limitation of the annual dose to a MEMBER OF THE PUBLIC to within the 40 CFR Part 190 limits. For the purposes of the Special Report, it may be assumed that the dose commitment to the MEMBER OF THE PUBLIC from other uranium fuel cycle sources is negligible, with the exception that dose contributions from other nuclear fuel cycle facilities at the same site or within a radius of 8 km must be considered. If the dose to any MEMBER OF THE PUBLIC is estimated to exceed the requirements of 40 CFR Part 190, the Special Report with a request for a variance (provided the release conditions resulting in violation of 40 CFR Part 190 have not already been corrected), in accordance with the provisions of 40 CFR 190.11 and 10 CFR 20.2203, is considered to be a timely request and fulfills the requirements of 40 CFR Part 190 until NRC staff action is completed. The variance only relates to the limits of 40 CFR Part 190, and does not apply in any way to the other requirements for dose limitation of 10 CFR Part 20, as addressed in Operational Requirements 3.11.1.1 and 3.11.2.1. An individual is not considered a MEMBER OF THE PUBLIC during any period in which he/she is engaged in carrying out any operation that is part of the nuclear fuel cycle.

E.3 RADIOLOGICAL ENVIRONMENTAL MONITORING BASES

3/4.12.1 MONITORING PROGRAM

The Radiological Environmental Monitoring Program required by this Operational Requirement provides representative measurements of radiation and of radioactive materials in those exposure pathways and for those radionuclides that lead to the highest potential radiation exposure of MEMBERS OF THE PUBLIC resulting from the plant operation. This monitoring program implements Section IV.B.2 of Appendix I to 10 CFR Part 50 and thereby supplements the Radiological Effluent Monitoring Program by verifying that the measurable concentrations of radioactive materials and levels of radiation are not higher than expected on the basis of the effluent measurements and the modeling of the environmental exposure pathways. Guidance for this monitoring program is provided by the Radiological Assessment Branch Technical Position on Environmental Monitoring, Revision 1, November 1979. The initially specified monitoring program will be effective for at least the first 3 years of commercial operation. Following this period, program changes may be initiated based on operational experience.

The required detection capabilities for environmental sample analyses are tabulated in terms of the lower limits of detection (LLDs). The LLDs required by Table 4.12-1 are considered optimum for routine environmental measurements in industrial laboratories. It should be recognized that the LLD is defined as an a priori (before the fact) limit representing the capability of a measurement system and not as an a posteriori (after the fact) limit for a particular measurement.

Detailed discussion of the LLD, and other detection limits, can be found in HASL Procedures Manual, HASL-300, Currie, L. A., "Limits for Qualitative Detection and Quantitative Determination - Application to Radiochemistry," Anal. Chem. 40, 586-93 (1968), and Hartwell, J. K., "Detection Limits for Radioanalytical Counting Techniques" Atlantic Richfield Hanford Company Report ARH-SA-215 (June 1975).

3/4.12.2 LAND USE CENSUS

This Operational Requirement is provided to ensure that changes in the use of areas at and beyond the SITE BOUNDARY are identified and that modifications to the Radiological Environmental Monitoring Program are made, if required, by the results of this census. The best information from the door-to-door survey, from aerial survey, or from consulting with local agricultural authorities shall be used. This census satisfies the requirements of Section IV.B.3 of Appendix I to 10 CFR Part 50. Restricting the census to gardens of greater than 50 m² provides assurance that significant exposure pathways via leafy vegetables will be identified and monitored since a garden of this size is the minimum required to produce the quantity (26 kg/year) of leafy vegetables assumed in Regulatory Guide 1.109 for consumption by a child. To determine this minimum garden size, the following assumptions were made: (1) 20% of the garden was used for growing broad leaf vegetation (i.e., similar to lettuce and cabbage), and (2) a vegetation yield of 2 kg/m².

E.3 RADIOLOGICAL ENVIRONMENTAL MONITORING BASES (continued)

3/4.12.3 INTERLABORATORY COMPARISON PROGRAM

The requirement for participation in an approved Interlaboratory Comparison Program is provided to ensure that independent checks on the precision and accuracy of the measurements of radioactive materials in environmental sample matrices are performed as part of the quality assurance program for environmental monitoring in order to demonstrate that the results are valid for the purposes of Section IV.B.2 of Appendix I to 10 CFR Part 50.

APPENDIX F

ADMINISTRATIVE CONTROLS

The Reporting Requirements pertaining to the ODCM Operational Requirements are detailed in Sections:

- F.1 - Annual Radiological Environmental Operating Report
- F.2 - Annual Radioactive Effluent Release Report
- F.3 - Major changes to the Radwaste Treatment System (liquid and gaseous)

F.1 Annual Radiological Environmental Operating Report
(Formerly part of Specification 6.9.1.3)

Routine Annual Radiological Environmental Operating Reports, covering the operation of the unit during the previous calendar year, shall be submitted prior to May 1 of each year. The initial report shall be submitted prior to May 1 of the year following initial criticality.

The Annual Radiological Environmental Operating Reports shall include summaries, interpretations, and an analysis of trends of the results of the radiological environmental surveillance activities for the report period, including a comparison with preoperational studies, with operational controls, as appropriate, and with previous environmental surveillance reports, and an assessment of the observed impacts of the plant operation on the environment. The reports shall also include the results of the Land Use Census required by Operational Requirement 3.12.2.

The Annual Radiological Environmental Operating Reports shall include the results of analysis of all radiological environmental samples and of all environmental radiation measurements taken during the period pursuant to the locations specified in the table and figures in the OFFSITE DOSE CALCULATION MANUAL, as well as summarized and tabulated results of these analyses and measurements in the format of the table in the Radiological Assessment Branch Technical Position, Révision 1, November 1979. In the event that some individual results are not available for inclusion with the report, the report shall be submitted noting and explaining the reasons for the missing results. The missing data shall be submitted as soon as possible in a supplementary report. The reports shall also include the following: a summary description of the Radiological Environmental Monitoring Program; at least two legible maps covering all sampling locations keyed to a table giving distances and directions from the centerline of the reactor; the results of licensee participation in the Interlaboratory Comparison Program and the corrective action taken if the specified program is not being performed as required by Operational Requirement 3.12.3; reasons for not conducting the Radiological Environmental Monitoring Program as required by Operational Requirement 3.12.1, and discussion of all deviations from the sampling schedule of Table 3.12-1; discussion of environmental sample measurements that exceed the reporting levels of Table 3.12-2 but are not the result of plant effluents, pursuant to ACTION b. of Operational Requirement 3.12.1; and discussion of all analyses in which the LLD required by Table 4.12-1 was not achievable.

* One map shall cover stations near the EXCLUSION AREA BOUNDARY; a second shall include the more distant station.

F.2 Annual Radioactive Effluent Release Report
(Formerly part of Specification 6.9.1.4)

Routine Annual Radioactive Effluent Release Report covering the operation of the unit during the previous 12 months of operation shall be submitted by May 1 of each year. The period of the first report shall begin with the date of initial criticality.

The Annual Radioactive Effluent Release Report shall include a summary of the quantities of radioactive liquid and gaseous effluents released from the unit as outlined in Regulatory Guide 1.21, "Measuring, Evaluating, and Reporting Radioactivity in Solid Wastes and Releases of Radioactive Materials in Liquid and Gaseous Effluents from Light-Water-Cooled Nuclear Power Plants," Revision 1, June 1974, with data summarized on a quarterly basis following the format of Appendix B thereof.

The Annual Radioactive Effluent Release Report shall include an annual summary of hourly meteorological data collected over the previous year. This annual summary may be either in the form of an hour-by-hour listing on magnetic tape of wind speed, wind direction, atmospheric stability, and precipitation (if measured), or in the form of joint frequency distributions of wind speed, wind direction, and atmospheric stability.** This report shall include an assessment of the radiation doses due to the radioactive liquid and gaseous effluents released from the unit or station during the previous calendar year. For the assessment of radiation doses, approximate and conservative methods are acceptable. The assessment of radiation doses shall be performed in accordance with the methodology and parameters in the Offsite Dose Calculation Manual (ODCM).

The Annual Radioactive Effluent Release Report shall also include an assessment of radiation doses to the likely most exposed MEMBER OF THE PUBLIC from reactor releases and other nearby uranium fuel cycle sources, including doses from primary effluent pathways and direct radiation, for the previous calendar year to show conformance with 40 CFR Part 190, "Environmental Radiation Protection Standards for Nuclear Power Operation."

** In lieu of submission with the Annual Radioactive Effluent Release Report, the licensee has the option of retaining this summary of required meteorological data on site in a file that shall be provided to the NRC upon request.

F.2 Annual Radioactive Effluent Release Report (continued)

The Annual Radioactive Effluent Release Report shall include a list and description of unplanned releases, from the site to UNRESTRICTED AREAS, of radioactive materials in gaseous and liquid effluents made during the reporting period.

The Annual Radioactive Effluent Release Report shall include any changes made during the reporting period to the ODCM, pursuant to Technical Specification 6.14, as well as any major change to Liquid and Gaseous Radwaste Treatment Systems pursuant to ODCM, Appendix F, Section F.3. It shall also include a listing of new locations for dose calculations and/or environmental monitoring identified by the Land Use Census pursuant to Operational Requirement 3.12.2.

The Annual Radioactive Effluent Release Report shall also include the following: an explanation as to why the inoperability of liquid or gaseous effluent monitoring instrumentation was not corrected within the time specified in Operational Requirement 3.3.3.10 or 3.3.3.11, respectively; and a description of the events leading to liquid holdup tanks or gas storage tanks exceeding the limits of Technical Specification 3.11.1.4 or PLP-114, Attachment 5, respectively.

The Annual Radioactive Effluent Release Report shall include any dose calculations that were performed as a result of a spill or leak from the site that occurred during the reporting period.

The Annual Radioactive Effluent Release Report shall include a summary of any on-site spills and leaks that occurred during the reporting period that are communicated IAW the NEI Voluntary Groundwater Initiative.

F.3 Major Changes to Liquid and Gaseous Radwaste Treatment Systems
(Formerly part of Specification 6.15)

Licensee-initiated major changes to the Radwaste Treatment Systems (liquid and gaseous):

- a. Shall be reported to the Commission in the Annual Radioactive Effluent Release Report for the period in which the evaluation was reviewed by the PNSC. The discussion of each change shall contain:
 1. A summary of the evaluation that led to the determination that the change could be made in accordance with 10 CFR 50.59.
 2. Sufficient detailed information to totally support the reason for the change without benefit of additional or supplemental information.
 3. A detailed description of the equipment, components, and processes involved and the interfaces with other plant systems.
 4. An evaluation of the change, which shows the predicted releases of radioactive materials in liquid and gaseous effluents that differ from those previously predicted in the License application and amendments thereto.
 5. An evaluation of the change, which shows the expected maximum exposures, to a MEMBER OF THE PUBLIC in the UNRESTRICTED AREA and to the general population, that differ from those previously estimated in the License application and amendments thereto.
 6. A comparison of the predicted releases of radioactive materials in liquid and gaseous effluents to the actual releases for the period prior to when the change is to be made.
 7. An estimate of the exposure to plant operating personnel as a result of the change.
 8. Documentation of the fact that the change was reviewed and found acceptable by the PNSC.
- b. Shall become effective upon review and acceptance by the PNSC.

* Licensees may choose to submit the information called for in the Operational Requirement as part of the annual FSAR update

APPENDIX G

DEFINITIONS

The defined terms of this section appear in capitalized type and are applicable throughout the ODCM Operational Requirements.

ACTION

ACTION shall be that part of an ODCM Operational Requirement which prescribes remedial measures required under designated conditions.

ANALOG CHANNEL OPERATIONAL TEST

An **ANALOG CHANNEL OPERATIONAL TEST** shall be the injection of a simulated signal into the channel as close to the sensor as practicable to verify **OPERABILITY** of alarm, interlock and/or trip functions. The **ANALOG CHANNEL OPERATIONAL TEST** shall include adjustments, as necessary, of the alarm, interlock and/or Trip Setpoints such that the Setpoints are within the required range and accuracy.

CHANNEL CALIBRATION

A **CHANNEL CALIBRATION** shall be the adjustment, as necessary, of the channel such that it responds within the required range and accuracy to known values of input. The **CHANNEL CALIBRATION** shall encompass the entire channel including the sensors and alarm, interlock and/or trip functions and may be performed by any series of sequential, overlapping, or total channel steps such that the entire channel is calibrated.

CHANNEL CHECK

A **CHANNEL CHECK** shall be the qualitative assessment of channel behavior during operation by observation. This determination shall include, where possible, comparison of the channel indication and/or status with other indications and/or status derived from independent instrument channels measuring the same parameter.

DIGITAL CHANNEL OPERATIONAL TEST

A **DIGITAL CHANNEL OPERATIONAL TEST** shall consist of exercising the digital computer hardware using data base manipulation to verify **OPERABILITY** of alarm and/or trip functions.

DOSE EQUIVALENT I-131

DOSE EQUIVALENT I-131 shall be that concentration of I-131 ($\mu\text{Ci}/\text{gram}$) which alone would produce the same thyroid dose as the quantity and isotopic mixture of I-131, I-132, I-133, I-134, and I-135 actually present. The thyroid dose conversion factors used for this calculation shall be those listed in ICRP-30, "Limits for Intakes of Radionuclides by Workers."

EXCLUSION AREA BOUNDARY

The **EXCLUSION AREA BOUNDARY** shall be that line beyond which the land is not controlled by the licensee to limit access.

FREQUENCY NOTATION

The **FREQUENCY NOTATION** specified for the performance of Operational Requirements shall correspond to the intervals defined in Table G-1.

GASEOUS RADWASTE TREATMENT SYSTEM

A **GASEOUS RADWASTE TREATMENT SYSTEM** is any system designed and installed to reduce radioactive gaseous effluents by collecting primary coolant system off-gases from the primary system and providing for delay or holdup for the purpose of reducing the total radioactivity prior to release to the environment.

DEFINITIONS (continued)

MEMBER(S) OF THE PUBLIC

MEMBER(S) OF THE PUBLIC shall include all persons who are not occupationally associated with the plant. This category does not include employees of the licensee, its contractors, or vendors. Also excluded from this category are persons who enter the site to service equipment or to make deliveries. This category does include persons who use portions of the site for recreational, occupational, or other purposes not associated with the plant.

OFFSITE DOSE CALCULATION MANUAL

The OFFSITE DOSE CALCULATION MANUAL (ODCM) shall contain the methodology and parameters used in the calculation of offsite doses due to radioactive gaseous and liquid effluents, in the calculation of gaseous and liquid effluent monitoring Alarm/Trip Setpoints, and in the conduct of the Environmental Radiological Monitoring Program.

OPERABLE - OPERABILITY

A system, subsystem, train, component or device shall be OPERABLE or have OPERABILITY when it is capable of performing its specified function(s), and when all necessary attendant instrumentation, controls, electrical power, cooling or seal water, lubrication or other auxiliary equipment that are required for the system, subsystem, train, component, or device to perform its function(s) are also capable of performing their related support function(s).

OPERATIONAL MODE - MODE

An OPERATIONAL MODE (i.e., MODE) shall correspond to any one inclusive combination of core reactivity condition, power level, and average reactor coolant temperature specified in Table G-2.

PROCESS CONTROL PROGRAM

The PROCESS CONTROL PROGRAM (PCP) shall contain the current formulas, sampling, analyses, tests, and determinations to be made to ensure that processing and packaging of solid radioactive wastes based on demonstrated processing of actual or simulated wet solid wastes will be accomplished in such a way as to assure compliance with 10 CFR Parts 20, 61, and 71 and Federal and State regulations, burial ground requirements, and other requirements governing the disposal of radioactive waste.

PURGE - PURGING

PURGE or PURGING shall be any controlled process of discharging air or gas from a confinement to maintain temperature, pressure, humidity, concentration or other operating condition, in such a manner that replacement air or gas is required to purify the confinement.

RELEASE

A RELEASE shall be the discharge of radioactive effluent from the facility in gaseous, particulate or liquid media. Releases can be further categorized for evaluation purposes:

ABNORMAL RELEASE/ACCIDENTAL RELEASE - An unplanned, uncontrolled, or unmonitored RELEASE to the offsite environs exceeding 10% of the 10CFR Part 20 ODCM limits.

NON-ROUTINE RELEASE - An unplanned, uncontrolled, or unmonitored RELEASE to the environs less than 10% of the 10CFR Part 20 ODCM limits.

PLANNED RELEASE - A RELEASE for which a pre-release permit has been generated

MONITORED RELEASE - A RELEASE which is monitored through installed or portable samplers.

CONTROLLED RELEASE - A RELEASE which can be controlled through component manipulation to ensure that ODCM limits are not exceeded.

DEFINITIONS (continued)

SITE BOUNDARY

For these Operational Requirements, the SITE BOUNDARY shall be identical to the EXCLUSION AREA BOUNDARY defined above.

SOLIDIFICATION

SOLIDIFICATION shall be the conversion of wet wastes into a form that meets shipping and burial ground requirements.

SOURCE CHECK

A SOURCE CHECK shall be the qualitative assessment of channel response when the channel sensor is exposed to a source of increased radioactivity.

UNRESTRICTED AREA

An UNRESTRICTED AREA shall be any area at or beyond the SITE BOUNDARY access to which is not controlled by the licensee for purposes of protection of individuals from exposure to radiation and radioactive materials, or any area within the SITE BOUNDARY used for residential quarters or for industrial, commercial, institutional, and/or recreational purposes.

VENTILATION EXHAUST TREATMENT SYSTEM

A VENTILATION EXHAUST TREATMENT SYSTEM shall be any system designed and installed to reduce gaseous radioiodine or radioactive material in particulate form in effluents by passing ventilation or vent exhaust gases through charcoal adsorbers and/or HEPA filters for the purpose of removing iodines or particulates from the gaseous exhaust stream prior to the release to the environment. Such a system is not considered to have any effect on noble gas effluents. Engineered Safety Features Atmospheric Cleanup Systems are not considered to be VENTILATION EXHAUST TREATMENT SYSTEM components.

VENTING

VENTING shall be the controlled process of discharging air or gas from a confinement to maintain temperature, pressure, humidity, concentration, or other operating condition, in such a manner that replacement air or gas is not provided or required during VENTING. Vent, used in system names, does not imply a VENTING process.

TABLE G-1
FREQUENCY NOTATION

NOTATION	FREQUENCY*
S	At least once per 12 hours.
D	At least once per 24 hours.
W	At least once per 7 days.
M	At least once per 31 days.
Q	At least once per 92 days.
SA	At least once per 184 days.
R	At least once per 18 months.
S/U	Prior to each reactor startup.
N.A.	Not applicable.
P	Completed prior to each release.

* Each Surveillance Requirement shall be performed within the specified surveillance interval with a maximum allowable extension not to exceed 25% of the specified surveillance interval.

TABLE G-2
 OPERATIONAL MODES

Mode	Reactivity Condition	Keff	% RATED THERMAL POWER*	AVERAGE COOLANT TEMPERATURE
1	Power Operations	≥ 0.99	$> 5\%$	$\geq 350^{\circ}\text{F}$
2	Startup	≥ 0.99	$\leq 5\%$	$\geq 350^{\circ}\text{F}$
3	Hot Standby	< 0.99	0	$\geq 350^{\circ}\text{F}$
4	Hot Shutdown	< 0.99	0	$350^{\circ}\text{F} > T_{\text{avg}} > 200^{\circ}\text{F}$
5	Cold Shutdown	< 0.99	0	$\leq 200^{\circ}\text{F}$
6	Refueling **	< 0.95	0	$\leq 140^{\circ}\text{F}$

* Excluding decay heat.

** Fuel in the reactor vessel with the vessel head closure bolts less than fully tensioned or with the head removed.