

NUREG/IA-0156  
Vol. 3  
IPSN 99/08-3  
NSI RRC 2179



# International Agreement Report

---

---

## Data Base on the Behavior of High Burnup Fuel Rods with Zr-1%Nb Cladding and UO<sub>2</sub> Fuel (VVER Type) under Reactivity Accident Conditions

### Test and Calculation Results

**Prepared by**

L. Yegorova, G. Abyshov, V. Malofeev, A. Avvakumov, E. Kaplar, K. Lioutov, A. Shestopalov, A. Konobeyev,  
N. Jouravkova  
Nuclear Safety Institute of Russian Research Centre "Kurchatov Institute"  
Kurchatov Square 1, Moscow 123182, Russia

A. Bortash, M. Kalugin, A. Zvyageen, K. Mikitiouk  
Institute of Nuclear Reactors of Russian Research Centre "Kurchatov Institute"  
Kurchatov Square 1, Moscow 123182, Russia

V. Smirnov, A. Goryachev, V. Prokhorov, Yu. Kosvintsev, O. Makarov  
State Research Centre "Research Institute of Atomic Reactors"  
Dimitrograd 433510, Russia

V. Pakhnitz, A. Vurim  
Institute of Atomic Energy of National Nuclear Centre of Kazakhstan Republic  
Semipalatinsk 490021, Kazakhstan

Office of Nuclear Regulatory Research  
U.S. Nuclear Regulatory Commission  
Washington, DC 20555-0001

July 1999

Prepared for  
U.S. Nuclear Regulatory Commission, Institute for Protection and Nuclear Safety (France) and  
Ministry of Science and Technologies of Russian Federation

Published by  
U.S. Nuclear Regulatory Commission

**AVAILABILITY OF REFERENCE MATERIALS  
IN NRC PUBLICATIONS**

**NRC Reference Material**

As of November 1999, you may electronically access NUREG-series publications and other NRC records at NRC's Public Electronic Reading Room at <http://www.nrc.gov/reading-rm.html>. Publicly released records include, to name a few, NUREG-series publications; *Federal Register* notices; applicant, licensee, and vendor documents and correspondence; NRC correspondence and internal memoranda; bulletins and information notices; inspection and investigative reports; licensee event reports; and Commission papers and their attachments.

NRC publications in the NUREG series, NRC regulations, and *Title 10, Energy*, in the Code of *Federal Regulations* may also be purchased from one of these two sources.

1. The Superintendent of Documents  
U.S. Government Printing Office  
Mail Stop SSOP  
Washington, DC 20402-0001  
Internet: [bookstore.gpo.gov](http://bookstore.gpo.gov)  
Telephone: 202-512-1800  
Fax: 202-512-2250
2. The National Technical Information Service  
Springfield, VA 22161-0002  
[www.ntis.gov](http://www.ntis.gov)  
1-800-553-6847 or, locally, 703-605-6000

A single copy of each NRC draft report for comment is available free, to the extent of supply, upon written request as follows:

Address: Office of the Chief Information Officer,  
Reproduction and Distribution  
Services Section  
U.S. Nuclear Regulatory Commission  
Washington, DC 20555-0001

E-mail: [DISTRIBUTION@nrc.gov](mailto:DISTRIBUTION@nrc.gov)  
Facsimile: 301-415-2289

Some publications in the NUREG series that are posted at NRC's Web site address <http://www.nrc.gov/reading-rm/doc-collections/nuregs> are updated periodically and may differ from the last printed version. Although references to material found on a Web site bear the date the material was accessed, the material available on the date cited may subsequently be removed from the site.

**Non-NRC Reference Material**

Documents available from public and special technical libraries include all open literature items, such as books, journal articles, and transactions, *Federal Register* notices, Federal and State legislation, and congressional reports. Such documents as theses, dissertations, foreign reports and translations, and non-NRC conference proceedings may be purchased from their sponsoring organization.

Copies of industry codes and standards used in a substantive manner in the NRC regulatory process are maintained at—

The NRC Technical Library  
Two White Flint North  
11545 Rockville Pike  
Rockville, MD 20852-2738

These standards are available in the library for reference use by the public. Codes and standards are usually copyrighted and may be purchased from the originating organization or, if they are American National Standards, from—

American National Standards Institute  
11 West 42<sup>nd</sup> Street  
New York, NY 10036-8002  
[www.ansi.org](http://www.ansi.org)  
212-642-4900

Legally binding regulatory requirements are stated only in laws; NRC regulations; licenses, including technical specifications; or orders, not in NUREG-series publications. The views expressed in contractor-prepared publications in this series are not necessarily those of the NRC.

The NUREG series comprises (1) technical and administrative reports and books prepared by the staff (NUREG-XXXX) or agency contractors (NUREG/CR-XXXX), (2) proceedings of conferences (NUREG/CP-XXXX), (3) reports resulting from international agreements (NUREG/IA-XXXX), (4) brochures (NUREG/BR-XXXX), and (5) compilations of legal decisions and orders of the Commission and Atomic and Safety Licensing Boards and of Directors' decisions under Section 2.206 of NRC's regulations (NUREG-0750).

**DISCLAIMER:** This report was prepared under an international cooperative agreement for the exchange of technical information. Neither the U.S. Government nor any agency thereof, nor any employee, makes any warranty, expressed or implied, or assumes any legal liability or responsibility for any third party's use, or the results of such use, of any information, apparatus, product or process disclosed in this publication, or represents that its use by such third party would not infringe privately owned rights.

## **ABSTRACT**

Test and calculation results characterizing the behavior of fuel rods of the VVER type with Zr-1%Nb cladding and  $\text{UO}_2$  fuel under reactivity accident conditions are presented in this volume of report. The data base includes the following characteristics:

- some parameters of commercial fuel elements of VVER-1000 type before and after irradiation, parameters of fuel cycles of fuel elements irradiated at the Unit 5 of NovoVoronezh nuclear power plant (NV NPP);
- test parameters of fuel rods before, during and after the reactivity-initiated-accident (RIA) tests
- neutronic and thermomechanical parameters of fuel rods during RIA tests calculated by different computer codes;
- measured mechanical properties of the Zr-1%Nb cladding obtained with special tests;
- parameters of the Zr-1%Nb cladding failure of the ballooning type measured under the burst test conditions.



**TABLE OF CONTENTS**

	Page
<b>1. EXECUTIVE SUMMARY .....</b>	<b>1</b>
<b>2. GUIDE TO THE DATA BASE .....</b>	<b>2</b>
2.1. COMMENTS TO APPENDIX A .....	2
2.2. COMMENTS TO APPENDIX B .....	2
2.3. COMMENTS TO APPENDIXES C, D, E.....	3
2.4. COMMENTS TO APPENDIX F .....	3
2.5. COMMENTS TO APPENDIX G .....	3
2.6. COMMENTS TO APPENDIXES H, I .....	6
2.7. COMMENTS TO APPENDIX J.....	6
2.8. COMMENTS TO APPENDIX K .....	6



## LIST OF APPENDIXES

	Page	
<b>APPENDIX A</b>	<b>Typical Characteristics of VVER-1000 Fuel Rods before the Irradiation at NV NPP</b>	<b>A-1</b>
<b>APPENDIX B</b>	<b>Characteristics of NV NPP Power Operation and Commercial Fuel Rods after the Irradiation</b>	<b>B-1</b>
<b>APPENDIX C</b>	<b>Initial Characteristics of Refabricated Fuel Rods (Preirradiated Fuel, Preirradiated Cladding)</b>	<b>C-1</b>
<i>APPENDIX C-1</i>	<i>Initial Individual Characteristics for Fuel Rod #H1T</i>	<i>C-9</i>
<i>APPENDIX C-2</i>	<i>Initial Individual Characteristics for Fuel Rod #H2T</i>	<i>C-19</i>
<i>APPENDIX C-3</i>	<i>Initial Individual Characteristics for Fuel Rod #H3T</i>	<i>C-29</i>
<i>APPENDIX C-4</i>	<i>Initial Individual Characteristics for Fuel Rod #H4T</i>	<i>C-39</i>
<i>APPENDIX C-5</i>	<i>Initial Individual Characteristics for Fuel Rod #H5T</i>	<i>C-49</i>
<i>APPENDIX C-6</i>	<i>Initial Individual Characteristics for Fuel Rod #H6T</i>	<i>C-59</i>
<i>APPENDIX C-7</i>	<i>Initial Individual Characteristics for Fuel Rod #H7T</i>	<i>C-69</i>
<i>APPENDIX C-8</i>	<i>Initial Individual Characteristics for Fuel Rod #H8T</i>	<i>C-79</i>
<i>APPENDIX C-9</i>	<i>Initial Individual Characteristics for Fuel Rod #B9T</i>	<i>C-89</i>
<i>APPENDIX C-10</i>	<i>Initial Individual Characteristics for Fuel Rod #B10T</i>	<i>C-99</i>
<i>APPENDIX C-11</i>	<i>Initial Individual Characteristics for Fuel Rod #B11T</i>	<i>C-109</i>
<i>APPENDIX C-12</i>	<i>Initial Individual Characteristics for Fuel Rod #B12T</i>	<i>C-119</i>
<i>APPENDIX C-13</i>	<i>Initial Individual Characteristics for Fuel Rod #B13T</i>	<i>C-129</i>
<b>APPENDIX D</b>	<b>Initial Characteristics of Refabricated Fuel Rods (Fresh Fuel, Preirradiated Cladding)</b>	<b>D-1</b>
<i>APPENDIX D-1</i>	<i>Initial Individual Characteristics for Fuel Rod #H14T</i>	<i>D-9</i>
<i>APPENDIX D-2</i>	<i>Initial Individual Characteristics for Fuel Rod #H15T</i>	<i>D-13</i>
<i>APPENDIX D-3</i>	<i>Initial Individual Characteristics for Fuel Rod #H16T</i>	<i>D-17</i>
<i>APPENDIX D-4</i>	<i>Initial Individual Characteristics for Fuel Rod #H17T</i>	<i>D-21</i>
<i>APPENDIX D-5</i>	<i>Initial Individual Characteristics for Fuel Rod #H18T</i>	<i>D-25</i>
<i>APPENDIX D-6</i>	<i>Initial Individual Characteristics for Fuel Rod #B19T</i>	<i>D-29</i>
<i>APPENDIX D-7</i>	<i>Initial Individual Characteristics for Fuel Rod #B20T</i>	<i>D-33</i>
<i>APPENDIX D-8</i>	<i>Initial Individual Characteristics for Fuel Rod #B21T</i>	<i>D-37</i>
<i>APPENDIX D-9</i>	<i>Initial Individual Characteristics for Fuel Rod #B22T</i>	<i>D-41</i>
<i>APPENDIX D-10</i>	<i>Initial Individual Characteristics for Fuel Rod #B23T</i>	<i>D-45</i>
<b>APPENDIX E</b>	<b>Initial Characteristics of Fresh Fuel Rods</b>	<b>E-1</b>
<i>APPENDIX E-1</i>	<i>Initial Individual Characteristics for Fuel Rod #H6C</i>	<i>E-7</i>
<i>APPENDIX E-2</i>	<i>Initial Individual Characteristics for Fuel Rod #B20C</i>	<i>E-11</i>
<b>APPENDIX F</b>	<b>Characteristics of IGR Reactor Tests</b>	<b>F-1</b>

## LIST OF APPENDIXES (CONTD.)

<b>APPENDIX G</b>	<b>Measured and Calculated Characteristics of Refabricated Fuel Rods (Preirradiated Fuel, Preirradiated Cladding) during and after IGR Reactor Tests</b>	<b>G-1</b>
<i>APPENDIX G-1</i>	<i>Individual Characteristics for Fuel Rod #H1T under IGR Test</i>	<i>G-1</i>
<i>APPENDIX G-2</i>	<i>Individual Characteristics for Fuel Rod #H2T under IGR Test</i>	<i>G-21</i>
<i>APPENDIX G-3</i>	<i>Individual Characteristics for Fuel Rod #H3T under IGR Test</i>	<i>G-43</i>
<i>APPENDIX G-4</i>	<i>Individual Characteristics for Fuel Rod #H4T under IGR Test</i>	<i>G-65</i>
<i>APPENDIX G-5</i>	<i>Individual Characteristics for Fuel Rod #H5T under IGR Test</i>	<i>G-85</i>
<i>APPENDIX G-6</i>	<i>Individual Characteristics for Fuel Rod #H6T under IGR Test</i>	<i>G-105</i>
<i>APPENDIX G-7</i>	<i>Individual Characteristics for Fuel Rod #H7T under IGR Test</i>	<i>G-125</i>
<i>APPENDIX G-8</i>	<i>Individual Characteristics for Fuel Rod #H8T under IGR Test</i>	<i>G-147</i>
<i>APPENDIX G-9</i>	<i>Individual Characteristics for Fuel Rod #B9T under IGR Test</i>	<i>G-167</i>
<i>APPENDIX G-10</i>	<i>Individual Characteristics for Fuel Rod #B10T under IGR Test</i>	<i>G-187</i>
<i>APPENDIX G-11</i>	<i>Individual Characteristics for Fuel Rod #B11T under IGR Test</i>	<i>G-207</i>
<i>APPENDIX G-12</i>	<i>Individual Characteristics for Fuel Rod #B12T under IGR Test</i>	<i>G-225</i>
<i>APPENDIX G-13</i>	<i>Individual Characteristics for Fuel Rod #B13T under IGR Test</i>	<i>G-245</i>
<b>APPENDIX H</b>	<b>Characteristics of Refabricated Fuel Rods (Fresh Fuel, Preirradiated Cladding) during and after IGR Reactor Tests</b>	<b>H-1</b>
<i>APPENDIX H-1</i>	<i>Individual Characteristics for Fuel Rod #H14T under IGR Test</i>	<i>H-1</i>
<i>APPENDIX H-2</i>	<i>Individual Characteristics for Fuel Rod #H15T under IGR Test</i>	<i>H-19</i>
<i>APPENDIX H-3</i>	<i>Individual Characteristics for Fuel Rod #H16T under IGR Test</i>	<i>H-37</i>
<i>APPENDIX H-4</i>	<i>Individual Characteristics for Fuel Rod #H17T under IGR Test</i>	<i>H-55</i>
<i>APPENDIX H-5</i>	<i>Individual Characteristics for Fuel Rod #H18T under IGR Test</i>	<i>H-73</i>
<i>APPENDIX H-6</i>	<i>Individual Characteristics for Fuel Rod #B19T under IGR Test</i>	<i>H-91</i>
<i>APPENDIX H-7</i>	<i>Individual Characteristics for Fuel Rod #B20T under IGR Test</i>	<i>H-111</i>
<i>APPENDIX H-8</i>	<i>Individual Characteristics for Fuel Rod #B21T under IGR Test</i>	<i>H-129</i>
<i>APPENDIX H-9</i>	<i>Individual Characteristics for Fuel Rod #B22T under IGR Test</i>	<i>H-149</i>
<i>APPENDIX H-10</i>	<i>Individual Characteristics for Fuel Rod #B23T under IGR Test</i>	<i>H-169</i>
<b>APPENDIX I</b>	<b>Characteristics of Fresh Fuel Rods during and after IGR Reactor Tests</b>	<b>I-1</b>
<i>APPENDIX I-1</i>	<i>Individual Characteristics for Fuel Rod #H6C under IGR Test</i>	<i>I-1</i>
<i>APPENDIX I-2</i>	<i>Individual Characteristics for Fuel Rod #B20C under IGR Test</i>	<i>I-19</i>
<b>APPENDIX J</b>	<b>Mechanical Properties of the Zr-1%Nb Cladding</b>	<b>J-1</b>
<b>APPENDIX K</b>	<b>Results of Tests to Measure the Parameters of the Zr-1%Nb Cladding Failure due to Ballooning</b>	<b>K-1</b>



## ACKNOWLEDGMENTS

An important contribution to the preparation of this volume of the report, including the conduct of calculations and experimental studies, was made by the following specialists:

- Nuclear Safety Institute of RRC “Kurchatov Institute” (Moscow, Russia):  
*A. Degtyariov;*
- Institute of Nuclear Reactors of RRC «Kurchatov Institute» (Moscow, Russia):  
*A. Polismakov, D. Belov, P. Fomitchenko, V. Polvanov;*
- Research Institute of Atomic Reactors (Dimitrovgrad, Russia):  
*L. Stupina, L. Zvir, V. Pimenov, V. Zhitelev;*
- Institute of Atomic Energy of National Nuclear Center (Semipalatinsk, Kazakhstan):  
*S. Koltyshhev, A. Levin.*



# 1. EXECUTIVE SUMMARY

This volume of the report contains a unique systematized set of data characterizing parameters of VVER fuel elements before, during and after the basic irradiation at the NovoVoronezh nuclear power plant (NV NPP); before, during and after tests under reactivity-initiated-accident (RIA) conditions; as well as original mechanical properties of unirradiated and irradiated Zr-1%Nb claddings. The structural diagram of this data base is presented in Fig. 1.1.

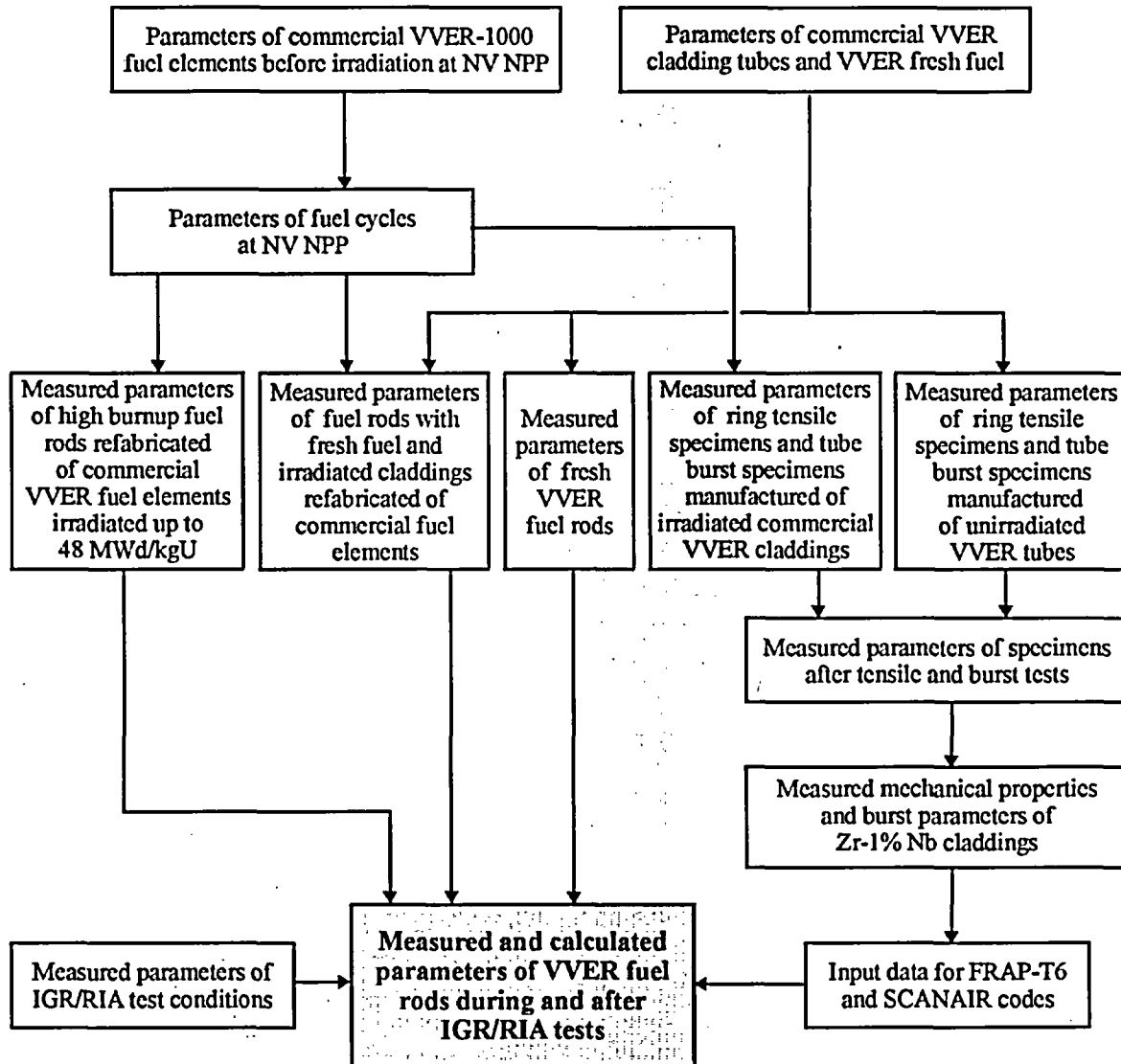

Fig. 1.1. Structure of the IGR/RIA data base

The data base, included into this volume, is composed in such a way that it is possible to use it having only the information of Chapter 2 of this volume of the report.

## 2. GUIDE TO THE DATA BASE

Data base is composed of the following sequential set of the data base structural components concentrated in Appendixes:

APPENDIX A	Typical Characteristics of VVER-1000 Fuel Rods before the Irradiation at NV NPP	A-1
APPENDIX B	Characteristics of NV NPP Power Operation and Commercial Fuel Rods after the Irradiation	B-1
APPENDIX C	Initial Characteristics of Refabricated Fuel Rods (Preirradiated Fuel, Preirradiated Cladding)	C-1
APPENDIX D	Initial Characteristics of Refabricated Fuel Rods (Fresh Fuel, Preirradiated Cladding)	D-1
APPENDIX E	Initial Characteristics of Fresh Fuel Rods	E-1
APPENDIX F	Characteristics of IGR Reactor Tests	F-1
APPENDIX G	Measured and Calculated Characteristics of Refabricated Fuel Rods (Preirradiated Fuel, Preirradiated Cladding) during and after IGR Reactor Tests	G-1
APPENDIX H	Characteristics of Refabricated Fuel Rods (Fresh Fuel, Preirradiated Cladding) during and after IGR Reactor Tests	H-1
APPENDIX I	Characteristics of Fresh Fuel Rods during and after IGR Reactor Tests	I-1
APPENDIX J	Mechanical Properties of the Zr-1%Nb Cladding	J-1
APPENDIX K	Results of Tests to Measure the Parameters of the Zr-1%Nb Cladding Failure due to Ballooning	K-1

The comments necessary to work with the information presented in every Appendix are presented in the subsections of this Chapter.

### 2.1. Comments to Appendix A

No special measurements were performed to determine parameters of VVER fuel elements that were used for the manufacture of refabricated fuel rods for RIA tests. Therefore typical characteristics of standard VVER-1000 fuel elements are presented in this Appendix. It is important to pay attention that the typical cladding outer diameter for the VVER fuel element is 9.1 mm, while the outer diameter of the VVER cladding tube is 9.14 mm. This discrepancy in dimensions is caused by the fact that the procedure of chemical etching of the cladding of fabricated fuel elements is planned in the technological cycle. During this process the outer cladding diameter is decreased from 9.14 to 9.1 mm.

### 2.2. Comments to Appendix B

But for the parameters of the fuel cycle, the set of specially measured characteristics is presented to characterize the parameters of commercial fuel elements #317 and #22, which were used for the refabrication of fuel rods tested later under IGR/RIA conditions. In some cases parameters of the fuel element #307 are presented instead of the fuel element #317. Fuel element #307 can be considered as a complete analogue of the fuel element #317. The description of experimental procedures that were used to obtain this measured data base is presented in Chapters 2 – 4 of Volume 2 of this report.

### 2.3. Comments to Appendixes C, D, E

These Appendixes contain the data base to characterize parameters of the following three types of fuel rods before IGR tests:

1. High burnup fuel rods (Appendix C);
2. Fuel rods with the irradiated cladding and the fresh fuel (Appendix D);
3. Fuel rods with the unirradiated cladding and the fresh fuel (Appendix E).

Thirteen high burnup fuel rods were manufactured by the refabrication of commercial fuel elements #317 and #22. Ten fuel rods with irradiated claddings and the fresh fuel were fabricated of cladding parts of the commercial fuel element #317 and fresh fuel pellets of the VVER-1000 type. Two fresh fuel rods were fabricated of the standard Zr-1%Nb cladding tube and fresh fuel pellets of the VVER-1000 type.

All three Appendixes contain:

measured representative parameters of fuel rods that characterize each type of fuel rods;

measured consolidated parameters, which characterize some design parameters, and parameters presented in technical documents for each fuel rod;

the whole set of the r, z, t distribution of fuel rod individual parameters to characterize the isotopic composition, burnup geometry, fuel mass, and free gas volume.

Description of procedures that were used to get those parameters is presented in Chapters 2 – 4 of Volume 2 of this report.

### 2.4. Comments to Appendix F

The data base presented in this Appendix characterizes such parameters of IGR/RIA test conditions as:

- type of the used coolant (air, water);
- pulse half width;
- measured power history and energy deposition history for each of the tested fuel rods.

It should be noted that actually measured signals of one ionization chamber located in IGR reactor are presented in this Appendix to characterize the power history and the energy deposition history versus time for each fuel rod, because these measured parameters were used as input data for further procedures.

### 2.5. Comments to Appendix G

In general this Appendix consists of thirteen independent Sub-appendixes, each of them containing a data base to characterize individual parameters of each of the thirteen high burnup fuel rods during and after IGR tests. It should be noted that «H» letter in the designation of the fuel rod indicates that the fuel rod was tested in the water coolant; accordingly, «B» letter indicates that the air coolant was used. The individual data base for each of high burnup fuel rods consists of experimental and calculated results. Calculated results were obtained by FRAP-T6 and SCANAIR codes. The absence or interpolations of calculated results for one of the codes or for both of them was caused by one of the following reasons:

- code does not contain models necessary to calculate a given parameter;
- code does not contain models necessary to calculate some parameters of the fuel rod, in this case the calculation of other parameters becomes not expedient, as a big systematic error appears in the prediction of them;
- calculated parameter has unbelievable fluctuations due to convergence problems.

Table 2.1 and Table 2.2 list a set of special comments to define the terminology used in this Appendix.

**Table 2.1. Set of comments to terms used in tables of Appendix G to characterize test parameters of fuel rods**

The used term	Comments
1. Reactor energy deposition vs. time (%)	Integral current of ionization chamber of IGR reactor at i-time ( $\mu$ As) ratio to the integral current of the ionization chamber at infinite time ( $t=600$ s)
2. Cumulative number of fissions in fuel rod vs. time (fiss)	Total number of fissions for a given isotope which occurred by the i-time within the whole mass of fuel
3. Power of fuel rod vs. time (kW)	Power generated in the whole mass of the fuel rod at i-time. The power was defined with consideration of the whole spectrum of the irradiation from the reactor
4. Energy deposition in fuel rod vs. time (cal/g fuel)	Energy absorbed in the whole mass of the fuel by i-time and normalized for the fuel mass
5. Cumulative number of fissions at axial interval (fiss)	Total number of fissions of a given isotope that happened in the j-axial interval of the fuel column within $0-\infty$ s
6. Maximum power of the fuel rod vs. axial coordinate (kW)	Axial profile of the maximum power value determined according to item 3.
7. Energy deposition at infinite time vs. axial coordinate (cal/g fuel)	Total energy absorbed by the fuel mass in a given axial interval within the time $0-\infty$ s, normalized for the fuel mass in this interval
8. Number of fissions vs. radial fuel zone (fiss)	Total number of fissions of a given isotope with occurred in the undamaged part of the reviewed radial zone of the fuel column within $0-\infty$ s. Characteristics of the undamaged part are presented in Appendix C.
9. Power of the fuel rod vs. radial fuel zone (kW)	Radial profile of the maximum power value determined according to item 3, and corrected in such a way that only the mass of the undamaged part of fuel column was considered. Characteristics of the undamaged part are presented in Appendix C.
10. Energy deposition vs. radial fuel zone (cal/g fuel)	Total energy absorbed in a given radial zone of the undamaged part of the fuel column normalized for the fuel mass of the undamaged part of this radial zone. The time interval is $0-\infty$ s
11. Energy deposition vs. radial fuel zone (per-unit)	Energy deposition of a given radial zone of the undamaged part of the fuel column normalized for a corresponding energy deposition of the 4 <sup>th</sup> radial zone

**Table 2.2. Set of Comments to the terms used in tables of Appendix G to characterize fuel rod parameters calculated by FRAP-T6 and SCANAIR codes**

The used term	Comments
1. Enthalpy at the fuel radius vs. time (cal/g fuel)	Fuel enthalpy vs. time in the point with a given radial and axial coordinates corresponding to the peak power for the power axial distribution (Table 2.1 item 6)
2. Fuel enthalpy vs. time (cal/g fuel)	Radially averaged fuel enthalpy versus time in the cross-section, corresponding to the axial peak power (Table 2.1 item 6)
3. Energy deposition in fuel rod vs. time (cal/g fuel)	Test input data for calculations (see Table 2.1 item 6)
4. Energy deposition vs. time (cal/g fuel)	Calculations of all fuel rod parameters were performed for the cross-sections with the axial peak power. Therefore, this is the radially averaged energy deposition versus time in this cross-section
5. Linear power (kW/m), fuel enthalpy (cal/g fuel), energy of the metal-water reaction (cal/g fuel), leakage of energy (cal/g fuel), clad-to-coolant heat transfer coefficient (kW/m <sup>2</sup> K) vs. time	The whole set of these parameters was calculated for the cross-section with the axial peak power according to the energy deposition, obtained in item 4. Calculations of the metal-water reaction are not planned by SCANAIR code, and therefore are not presented in the data base. Respective calculations by FRAP-T6 code are not presented for fuel rods with the air coolant, as the necessary correlations for the cladding oxidation were absent.
6. Fuel center line temperature (K), fuel surface temperature (K), fission gas release (%), average ZrO <sub>2</sub> thickness (mm) vs. time	These parameters are calculated for the cross-section with the axial peak power according to the energy deposition, obtained in item 4. Calculations of ZrO <sub>2</sub> thickness were not performed by SCANAIR code for all 13 fuel rods; calculations of ZrO <sub>2</sub> thickness by FRAP-T6 code were not performed for the fuel rods cooled with air because of the reasons mentioned in item 5.
7. Clad outer temperature (K), fuel hoop strain (%), fuel-clad gap width (mm), clad hoop stress (MPa), internal gas pressure (MPa) vs. time	These parameters were calculated for the cross-section with the axial peak power according to the energy deposition, obtained in item 4
8. Fuel swelling (%)	This parameter characterizes a change of the fuel volume. It was calculated for the cross-section with the axial peak power. In order to determine the hoop component of this parameter, it is necessary to divide the presented values by 3.
9. Energy deposition at infinite time vs. axial interval (cal/g fuel)	Axial profile of the energy deposition, obtained according to item 3.
10. Fuel enthalpy vs. axial interval (cal/g fuel)	Axial profile of the enthalpy, calculated for the maximum value of the energy deposition, obtained according to item 3.

## **2.6. Comments to Appendixes H, I**

Appendix H consists of 10 independent appendixes, each of them contains a data base to characterize one of fuel rods with the irradiated cladding and the fresh fuel during and after IGR tests. Appendix I includes the data base for two fresh fuel rods. All the comments to the data base of Appendix G can also be applied to Appendixes H and I, but for:

- calculated results of the fuel swelling and the fission gas release were not included into this data base, because they do not represent any practical interest;
- the notion «undamaged part» of the fuel column was not used for these fuel rods, therefore the whole fuel column was considered to be undamaged.

## **2.7. Comments to Appendix J**

The data base to characterize ring tensile tests with unirradiated and irradiated Zr-1%Nb cladding is presented in this Appendix.

The obtained data base contains the following set of parameters:

- input characteristics of the standard Zr-1%Nb VVER tube used to fabricate unirradiated ring specimens;
- input characteristics of the commercial VVER fuel element the cladding of which was used to fabricate irradiated ring specimens;
- mechanical properties of unirradiated and irradiated Zr-1%Nb ring specimens versus temperature and strain rate;
- photographs of ring specimens after tests.

Procedures to obtain this data base are described in Chapter 6 of Volume 2.

## **2.8. Comments to Appendix K**

This data base contains results of especially performed burst tests with unirradiated and irradiated Zr-1%Nb specimens. It consists of input data to characterize both types of specimens before tests and test results. Tests results are presented by the following parameters:

photographs of specimens after tests and photographs of cross-sections of these specimens;  
measured set of burst parameters versus temperature and pressure increase rate.

Description of procedures used to measure testing parameters is presented in Chapter 6 of Volume 2.



**APPENDIX A.**  
**Typical Characteristics of VVER-1000**  
**Fuel Rods before the Irradiation at NV NPP**

**Table A.1. Typical Characteristics of VVER-1000 Fuel Rods before Irradiation at NV NPP**

Characteristic	Unit	Value
<b>1. Fuel UO<sub>2</sub></b>		
<b>1.1. Isotopic composition</b>		
U <sup>235</sup>	% by weight	3.58
U <sup>238</sup>	% by weight	96.36
U <sup>234</sup>	% by weight	0.03
U <sup>236</sup>	% by weight	0.03
<b>1.2. Total Uranium</b>	% by weight	87.88
<b>1.3. Impurity</b>	% by weight	< 0.08
<b>1.4. Enrichment</b>	%	3.58
<b>1.5. Oxygen coefficient</b>	per-unit	2.000 - 2.015
<b>1.6. Density</b>	g/cm <sup>3</sup>	10.6 ± 0.2
<b>1.7. Grain size</b>	µm	4 - 8
<b>1.8. Pellet shape</b>	-	cylinder with central hole
<b>1.9. Pellet outer diameter</b>	mm	7.55 <sup>+0.02</sup> <sub>-0.02</sub>
<b>1.10. Pellet inner diameter</b>	mm	2.4 <sup>±0.05</sup>
<b>1.11. Pellet height</b>	mm	11.5 <sup>+1.5</sup> <sub>-2.5</sub>
<b>2. Cladding (Zr-1%Nb)</b>		
<b>2.1. Composition:</b>		
Zr	% by weight	98.67 - 98.87
Nb	% by weight	0.9 - 1.1
O	% by weight	< 0.1
N, C, Si, Al, Mo, Ni, Fe	% by weight	< 0.13
<b>2.2. Cold work</b>	-	cold rolling, annealing, autoclaving
<b>2.3. Outer diameter</b>	mm	9.1 <sup>+0.008</sup> <sub>-0.05</sub>
<b>2.4. Inner diameter</b>	mm	7.72 <sup>+0.08</sup>
<b>2.5. Material properties(under standard conditions):</b>		
• Specific heat capacity	kJ/kg·°C	0.25
• Thermal conductivity	W/m·°C	17.2
• Linear expansion coefficient	1/°C	5.8·10 <sup>-6</sup>
• Density	g/cm <sup>3</sup>	6.55
• Young's modulus	MPa	9.4·10 <sup>4</sup>
• Poisson's ratio	-	0.346 (axial) 0.354 (radial)
• Ultimate tensile strength	MPa	380-440 (axial) 360-420 (radial)
• Conventional yield limit σ	MPa	210-260 (axial) 320-390 (radial)

Table A.1. Typical Characteristics of VVER-1000 Fuel Rods before Irradiation at NV NPP (contd)

Characteristic	Unit	Value
<b>3. Fuel rod</b>		
3.1 Fuel rod design	-	see Fig. A.1
3.2 Upper plenum volume	cm <sup>3</sup>	9.69
3.3 Lower plenum volume	cm <sup>3</sup>	0.24
3.4 Pellet stack length	mm	3530 <sup>+4</sup> <sub>12</sub>
3.5 Fuel rod length	mm	3837 <sup>+2</sup> <sub>-2</sub>
3.6 Initial fill pressure	MPa	2.0 – 2.5
3.7 Fill-gas composition:		
He	% by volume	> 99.99
Impurity	% by volume	< 0.01
3.8 Fixing rings (SS-08XI8H10T):		
number	-	3
outer diameter	mm	8.2
inner diameter	mm	7.2
height	mm	8.9 – 0.9
<b>4. Fuel assembly</b>		
4.1 Fuel rods number	-	317
4.2 Grid type	-	Hexagonal
4.3 Spacer grid pitch	mm	12.75
4.4 Spacer grid material	-	SS
4.5 Spacer grid number	-	15

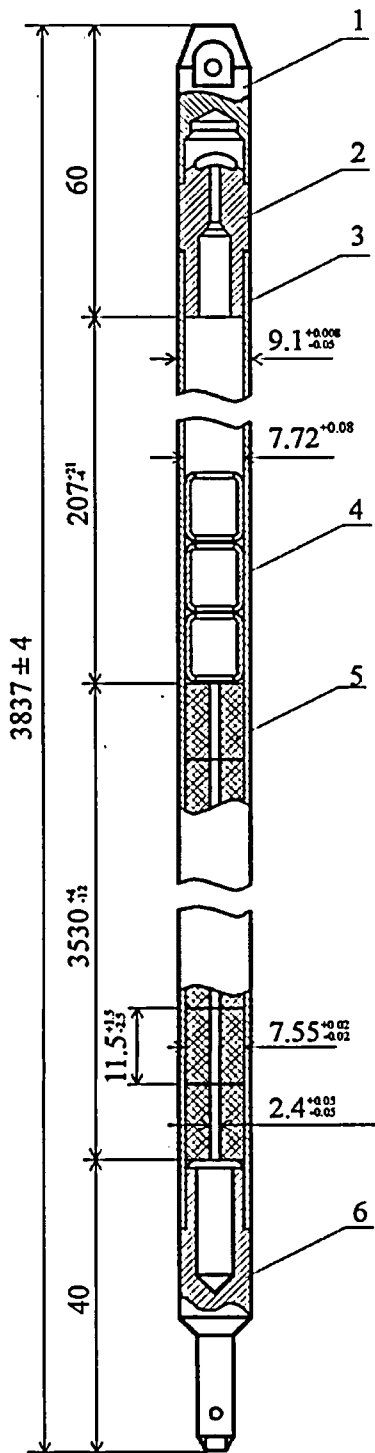

Design elements:

- 1 - upper cap;
- 2 - plug;
- 3 - cladding;
- 4 - fixing ring;
- 5 - fuel pellet;
- 6 - lower cap.

Fig. A.1. Design Scheme of NV NPP Commercial Fuel Rod

**APPENDIX B.**  
**Characteristics of NV NPP Power Operation and  
Commercial Fuel Rods after the Irradiation**

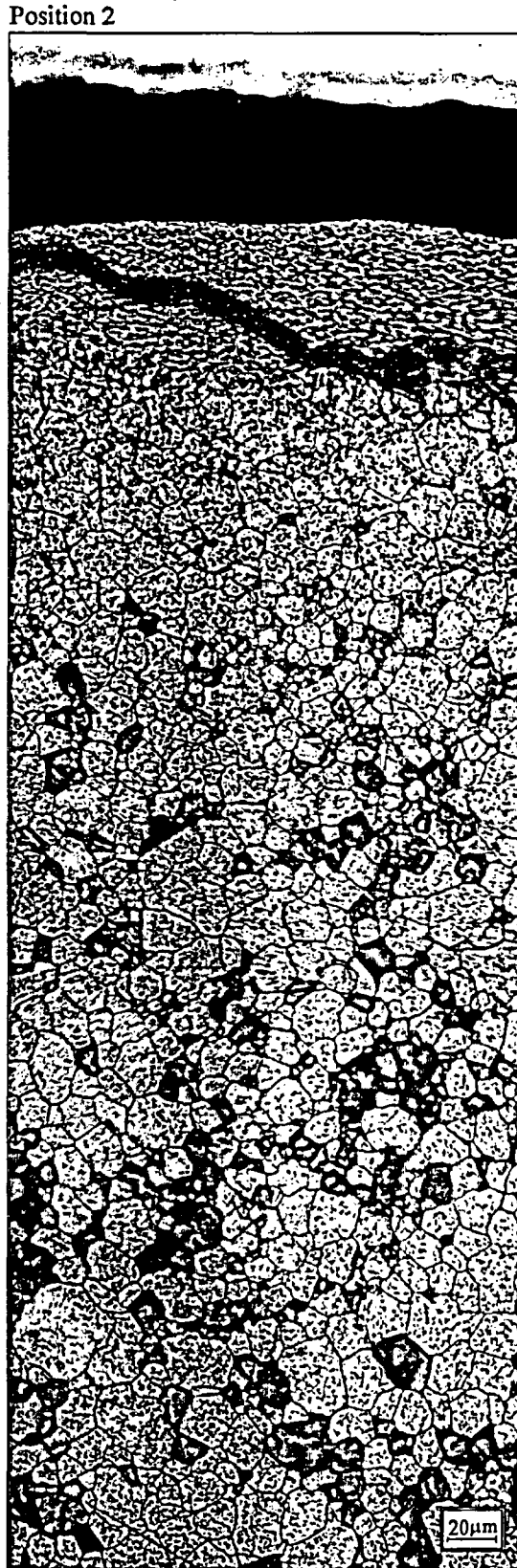
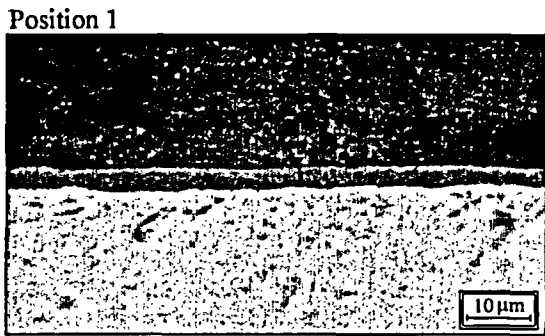
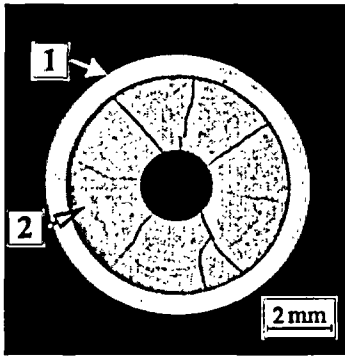

Fig. B.1. Cross-Section Appearance, Cladding and Fuel Microstructure for the Fuel Rod #317

**Table B.1. NV NPP Operating Cycles Characteristics**

Characteristic	Unit	Value
1. Number of cycles	-	3
2. Operation periods	eff.day	298.1; 321.6; 301.4
3. Irradiation beginning	-	June 25, 1984
4. Irradiation end	-	June 25, 1987
5. Power history	-	see Fig. B.2
6. Inlet coolant temperatures during the basic operating mode:		
1 <sup>st</sup> cycle	°C	287.3 - 288.7
2 <sup>nd</sup> cycle	°C	287.7 - 288.3
3 <sup>rd</sup> cycle	°C	287.1 - 288.0
7. Outlet coolant temperatures:		
1 <sup>st</sup> cycle	°C	316.9 - 319
2 <sup>nd</sup> cycle	°C	323 - 326.0
3 <sup>rd</sup> cycle	°C	317.3 - 318.9
8. Inlet coolant pressure (1 <sup>st</sup> , 2 <sup>nd</sup> , 3 <sup>rd</sup> cycles)	MPa	15.7
9. Pressure drop in the core	MPa	0.33 - 0.35

**Table B.2. Characteristics of Commercial Fuel Rods after Irradiation at NV NPP**

Characteristic	Unit	Value
<b>1. Fuel</b>		
1.1. Isotopic composition (for fuel rod #317, elevation 1800 mm from the bottom of the fuel stack):		
U <sup>235</sup>	kg/t U	4.35
U <sup>236</sup>	kg/t U	4.92
U <sup>238</sup>	kg/t U	927.5
Pu <sup>238</sup>	kg/t U	0.31
Pu <sup>239</sup>	kg/t U	5.00
Pu <sup>240</sup>	kg/t U	2.62
Pu <sup>241</sup>	kg/t U	1.64
Pu <sup>242</sup>	kg/t U	1.12
Am <sup>243</sup>	kg/t U	0.287
1.2. Burnup:		
for fuel rod #307 (elevation - 1800 mm from the bottom of the fuel stack)	kg/t U	52.4*, 52**
	GWd/t U	50.6*, 50.3**
for fuel rod #317 (elevation - 1850 mm from the bottom of the fuel stack)	kg/t U	53.9*, 52**
	GWd/t U	52.1*, 50.3**
1.3. Density for fuel rod #307 at different elevations (coordinates from the upper end of the fuel rod):		
242 mm	g/cm <sup>3</sup>	10.41
1042 mm	g/cm <sup>3</sup>	10.31
1872 mm	g/cm <sup>3</sup>	10.32
2642 mm	g/cm <sup>3</sup>	10.31
3452 mm	g/cm <sup>3</sup>	10.48
1.4. Average pellet outer diameter (fuel rods #22, #307)		
	mm	7.55 - 7.60
1.5. Diameter of central hole:		
for fuel rod #317	mm	2.40
for fuel rod #22	mm	2.415
<b>2. Cladding</b>		
2.1. Cladding thickness:		
for fuel rod #317	μm	691 - 705
for fuel rod #22	μm	677 - 700
2.2. ZrO <sub>2</sub> thickness		
	μm	3 - 5
2.3. Coefficient of the hydride orientation:		
for fuel rod #317	per-unit	0.4
for fuel rod #22	per-unit	0.14



**Table B.2. Characteristics of Commercial Fuel Rods after Irradiation at NV NPP (contd.)**

Characteristic	Unit	Value
<b>3. Fuel rods</b>		
<b>3.1. Fuel stack length:</b>		
fuel rod #22	mm	3562
fuel rod #307	mm	3585
<b>3.2. Width of the gap between the fuel and cladding along fuel rods #22, #307</b>	mm	0.03 - 0.15***
<b>3.3. Average gas pressure inside fuel rods</b>	MPa	2.45
<b>3.4. Average gas volume inside fuel rods</b>	cm <sup>3</sup>	35.9
<b>3.5. Average gas composition inside fuel rods:</b>		
He	% by volume	94.2 - 98.9
Kr	% by volume	0.11 - 0.60
Xe	% by volume	0.84 - 5.04
N <sub>2</sub>	% by volume	0.06 - 0.23
O <sub>2</sub>	% by volume	0.01 - 0.06
Ar	% by volume	0.002 - 0.005
CO <sub>2</sub>	% by volume	0.002 - 0.003
<b>3.6. Axial burnup distribution for fuel rods #317, #22</b>		see Table B.3, Fig. B.3
<b>3.7. Radial burnup distribution for fuel rod #317 (coordinate from inner side of pellet), mm:</b>		
0.61	MWd/kg	46.5
1.41	MWd/kg	46.9
1.9	MWd/kg	47.3
2.12	MWd/kg	50.1
2.17	MWd/kg	54.3
<b>3.8. Radial distribution of isotopes for fuel rod # 317</b>	-	see Table B.4

\* accumulation of fission products measured by the mass-spectrometrical method

\*\* changes in isotopic ratios of heavy nuclei measured by the mass-spectrometrical method

\*\*\* smaller value is for the central part of fuel rods

**Table B.3. Axial Distribution of Burnup for Fuel Rods #22, #317 after Irradiation at NV NPP**

Fuel rod #22		Fuel rod #317	
Coordinate from the lower end of the rod (mm)	Burnup (MWd/kg)	Coordinate from the lower end of the rod (mm)	Burnup (MWd/kg)
3810.1	0.009	3810.93	0.009
3800.1	-0.009	3800.93	0.000
3700.1	-0.006	3700.93	0.017
3600.1	-0.018	3600.93	-0.001
3500.1	20.645	3500.93	25.536
3400.1	29.018	3400.93	34.678
3300.1	33.853	3300.93	39.271
3200.1	37.340	3200.93	43.820
3100.1	39.619	3100.93	44.787
3000.1	41.712	3000.93	47.255
2900.1	43.221	2900.93	47.072
2800.1	42.459	2800.93	47.406
2700.1	43.056	2700.93	50.270
2600.1	43.354	2600.93	48.952
2500.1	43.315	2500.93	48.946
2400.1	43.662	2400.93	49.045
2300.1	42.279	2300.93	48.092
2200.1	43.470	2200.93	49.241
2100.1	43.360	2100.93	49.135
2000.1	43.995	2000.93	48.750
1900.1	44.118	1900.93	50.076
1800.1	42.034	1800.93	47.807
1700.1	43.566	1700.93	50.745
1600.1	43.866	1600.93	50.181
1500.1	44.072	1500.93	50.192
1400.1	43.849	1400.93	50.054
1300.1	41.803	1300.93	47.582
1200.1	43.313	1200.93	50.346
1100.1	43.653	1100.93	50.181
1000.1	43.149	1000.93	49.488
900.1	43.907	900.93	50.562
800.1	42.623	800.93	49.871
700.1	43.659	700.93	50.537
600.1	42.944	601.72	49.478
500.1	41.498	501.72	47.596
400.1	41.184	401.72	47.180
300.1	37.603	301.72	43.703
220.1	34.747	221.72	40.407

**Table B.4. Measured Radial Distribution of Isotopic Composition (kg/t U) for Fuel Rod #317**

Isotope	Coordinate from the inner side of the pellet (mm)				
	0.61	1.41	1.90	2.12	2.17
U <sup>234</sup>	0.19	0.19	0.19	0.27	0.28
U <sup>235</sup>	6.12	5.89	5.63	5.43	5.20
U <sup>236</sup>	4.99	5.08	5.16	5.25	5.30
U <sup>238</sup>	929.35	928.90	928.07	924.51	918.65
Pu <sup>238</sup>	0.30	0.31	0.31	0.31	0.30
Pu <sup>239</sup>	5.38	5.41	5.50	5.91	6.61
Pu <sup>240</sup>	2.60	2.62	2.64	2.65	2.67
Pu <sup>241</sup>	1.68	1.69	1.86	2.01	2.35
Pu <sup>242</sup>	0.89	0.90	1.00	1.11	1.37

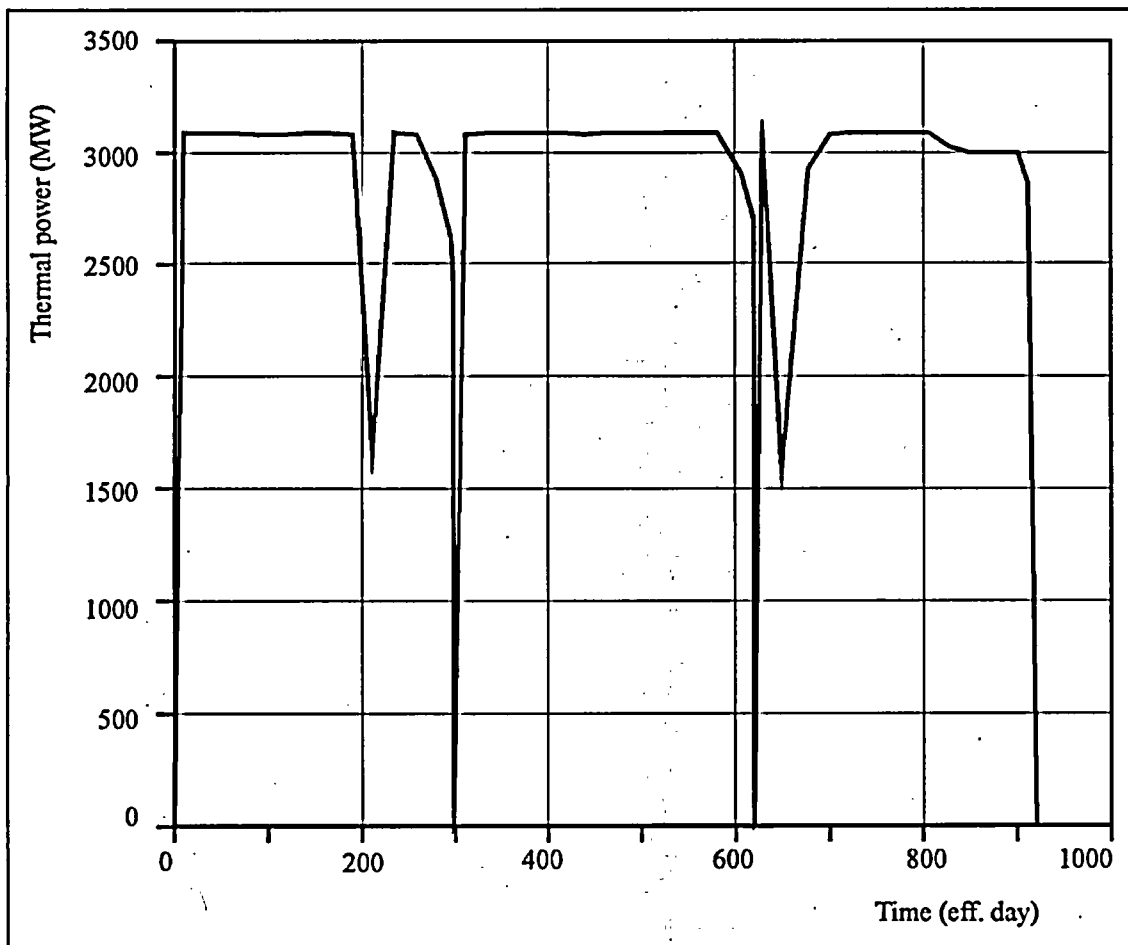

**Fig. B.2. Power History for Unit 5 of NV NPP**

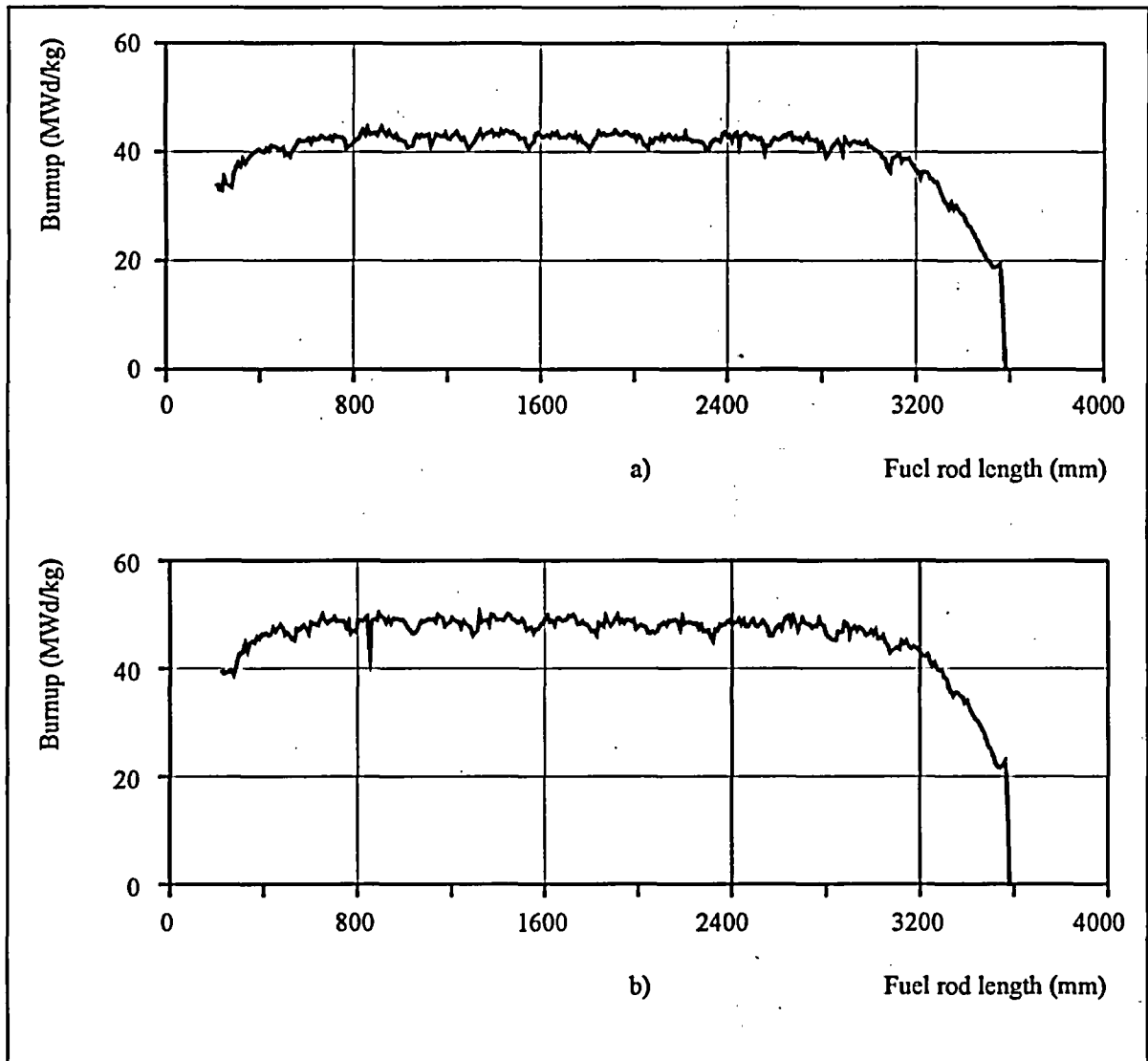

**Fig. B.3. Axial Burnup Distribution for Fuel Rod #22 (a), #317 (b)**

**APPENDIX C.**

**Initial Characteristics of Refabricated Fuel Rods  
(Preirradiated Fuel, Preirradiated Cladding)**

**Table C.1. Initial Characteristics of Refabricated Fuel Rods before IGR Reactor Tests.**  
Representative values

Characteristic	Unit	Value
<b>1. Fuel</b>		
1.1. Pellet outer diameter	mm	7.55 - 7.60
1.2. Pellet inner diameter	mm	2.4
1.3. Pellet height	mm	9 - 14
1.4. Density	g/cm <sup>3</sup>	10.31 - 10.32
1.5. Grain size	µm	3.9
1.6. Fuel shape	-	Fuel pellets, fragments of fuel pellets
1.7. Fuel macrostructure	-	see Fig. C.1
1.8. Fuel microstructure	-	see Fig. C.1
<b>2. Cladding</b>		
2.1. Cladding outer diameter	mm	9.10 <sup>+0.01</sup> <sub>-0.02</sub>
2.2. Cladding inner diameter	mm	not measured
2.3. Corrosion thickness	µm	5 - 6
2.4. H <sub>2</sub> content in cladding	% by weight	3 - 6 10 <sup>-3</sup>
2.5. Cladding microstructure	-	see Fig. C.1
<b>3. Fuel rod</b>		
3.1. Fuel rod design	-	see Fig. C.2
3.2. Fuel rod length	mm	300
3.3. Initial fill pressure	MPa	1.7 <sup>+0.2</sup> <sub>-0.2</sub>
3.4. Gas composition:		
He	% by volume	97.57
Impurity	% by volume	2.43
3.5. Free volume	cm <sup>3</sup>	6.11 (average)

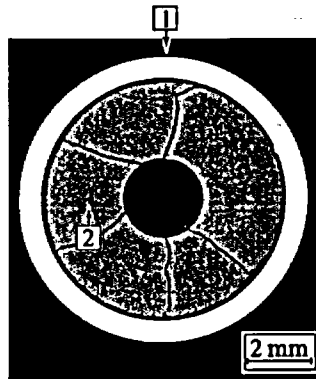

Position 1

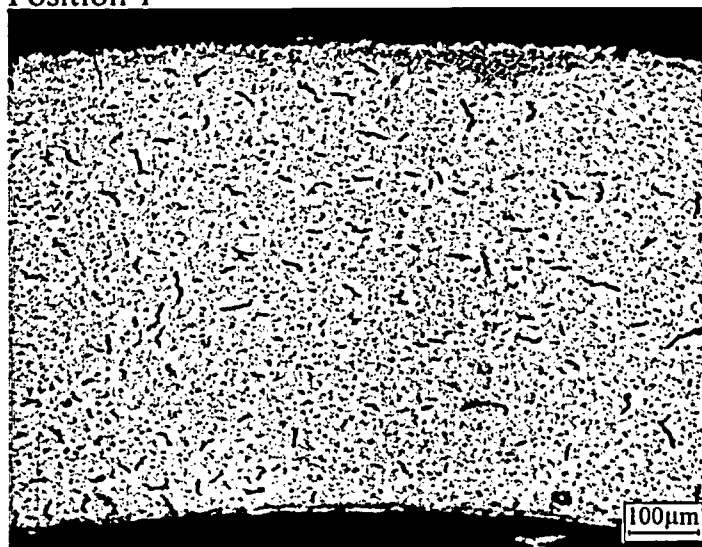

Position 2

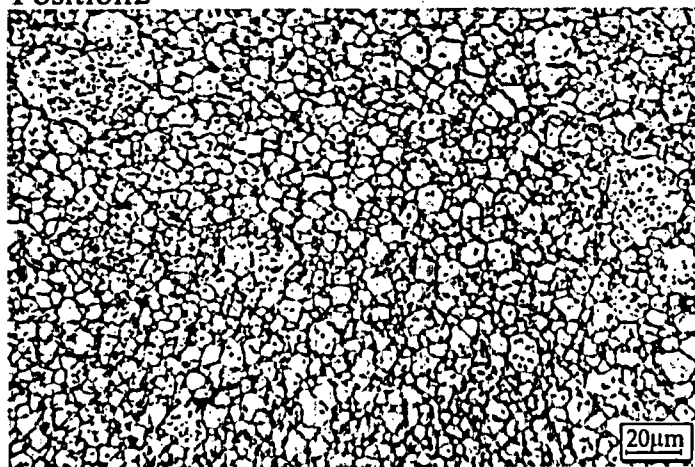

**Fig. C.1. Typical Cross-Section Appearance, Cladding and Fuel Microstructure of Refabricated Fuel Rod before IGR Reactor Test**

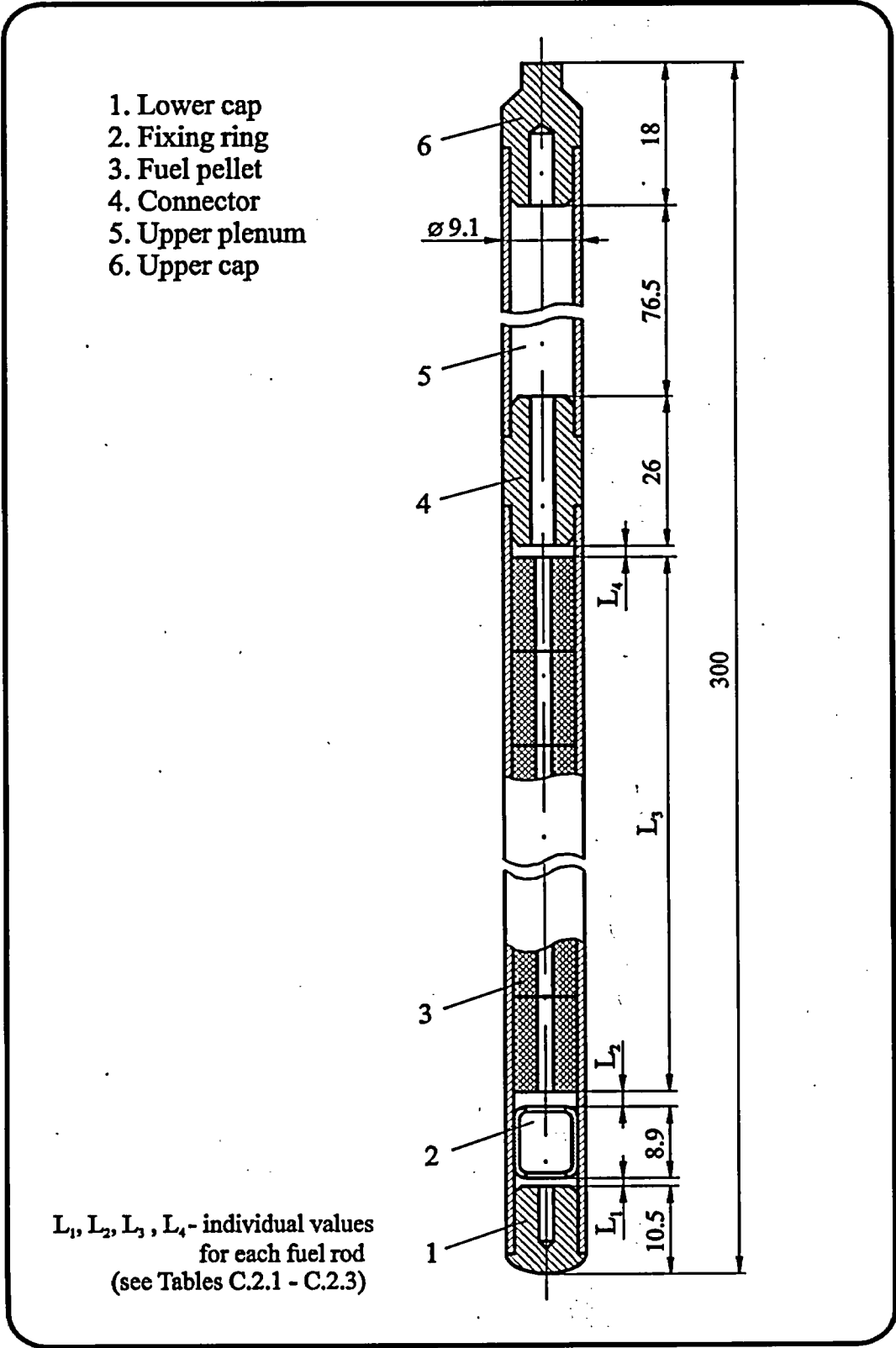

Fig. C.2. Design Scheme of Refabricated Fuel Rod



Table C.2.1. Consolidated List of Characteristics for Fuel Rods ##H1T, H2T, H3T, H4T, H5T

Characteristic	Number of fuel rod					
	H1T	H2T	H3T	H4T	H5T	
1. Identification number of commercial fuel rods used for refabrication	317	317	317	317	317	
2. Coordinates of commercial fuel rod sections used for refabrication (see Fig.A.1) (mm)*	1500 1650	2740 2890	930 1080	1980 2130	2550 2700	
3. Coordinates of fuel stack for refabricated fuel rods (mm) <sup>1)*</sup>	21.5 178.0	19.5 169.5	19.5 174.5	11.5 166.5	23.0 179.0	
4. Coordinates of undamaged sections of fuel stack for refabricated fuel rods (mm)*	47.5 178.0	19.5 169.5	32.5 157.5	27.5 166.5	42.5 72.5	87.5 157.5
5. Length of undamaged sections of fuel stack (mm)	130.5	150.0	125.0	139.0	30.0	70.0
6. Average burnup of refabricated fuel rods (MWd/kg U)	49.2	47.9	49.3	48.7	49.0	
7. Total fuel mass (g)	60.4	61.2	60.6	59.8	57.0	
8. Fuel mass for undamaged sections (g)	53.5	61.2	51.1	56.7	39.5	
9. L <sub>1</sub> (see Fig. C.2) (mm)	0.0	0.1	0.1	0.	0.2	
10. L <sub>2</sub> (see Fig. C.2) (mm)	2.1	0.0	0.0	0.	3.4	
11. L <sub>3</sub> (see Fig. C.2) (mm)	156.5	150.0	155.0	147.1 <sup>2)</sup>	156.0	
12. L <sub>4</sub> (see Fig. C.2) (mm)	1.5	10.0	5.0	13.0	0.5	
13. Total gas volume (cm <sup>3</sup> )	5.76	5.68	5.74	5.82	6.09	
14. Average outer diameter of cladding (mm)	9.11	9.09	9.11	9.11	9.08	
15. Fuel-cladding radial gap (mm)	0.03	0.03	0.03	0.03	0.03	

\* From lower end of fuel rod

<sup>1)</sup> Taken into account  $\gamma$ -scanning results

<sup>2)</sup> Length of the fuel stack ignoring fuel fragments inside fixing ring -

**Table C.2.2. Consolidated List of Characteristics for Fuel Rods ##H6T, H7T, H8T, B9T**

Characteristic	Number of fuel rod					
	H6T		H7T		H8T	B9T
1. Identification number of commercial fuel rods used for refabrication	317		317		317	317
2. Coordinates of commercial fuel rod sections used for refabrication (see Fig.A.1) (mm)*	550 700		360 510		2930 3080	1120 1270
3. Coordinates of fuel stack for refabricated fuel rods (mm) <sup>1)*</sup>	13.0 178.0		21.5 179.5		10.5 177.5	20.0 170.0
4. Coordinates of undamaged sections of fuel stack for refabricated fuel rods (mm)*	32.5 42.5	102.5 132.5	47.5 97.5	107.5 167.5	102.5 177.5	20.0 157.5
5. Length of undamaged sections of fuel stack (mm)	10.0	30.0	50.0	60.0	75.0	137.5
6. Average burnup of refabricated fuel rods (MWd/kg U)	49.3		47.3		46.8	49.7
7. Total fuel mass (g)	49.2		56.8		56.2	58.9
8. Fuel mass for undamaged sections (g)	16.6		42.6		30.7	56.1
9. L <sub>1</sub> (see Fig. C.2) (mm)	0.		0.0		0.	0.3
10. L <sub>2</sub> (see Fig. C.2) (mm)	0.		2.1		0.	0.3
11. L <sub>3</sub> (see Fig. C.2) (mm)	158.6 <sup>2)</sup>		158.0		158.1 <sup>2)</sup>	150.0
12. L <sub>4</sub> (see Fig. C.2) (mm)	1.5		0.0		2.0	9.5
13. Total gas volume (cm <sup>3</sup> )	6.96		6.11		6.17	5.91
14. Average outer diameter of cladding (mm)	9.11		9.11		9.11	9.08
15. Fuel-cladding radial gap (mm)	0.03		0.07		0.03	0.03

\* From lower end of fuel rod

<sup>1)</sup> Taken into account  $\gamma$ -scanning results

<sup>2)</sup> Length of the fuel stack ignoring fuel fragments inside fixing ring

Table C.2.3. Consolidated List of Characteristics for Fuel Rods ##B10T, B11T, B12T, B13T

Characteristic	Number of fuel rod			
	B10T	B11T	B12T	B13T
1. Identification number of commercial fuel rods used for refabrication	22	22	317	22
2. Coordinates of commercial fuel rod sections used for refabrication (see Fig.A.1) (mm)*	2530 2680	2340 2490	2170 2320	350 500
3. Coordinates of fuel stack for refabricated fuel rods (mm) <sup>1)*</sup>	25.0 173.0	18.5 178.5	10.5 172.5	19.5 175.5
4. Coordinates of undamaged sections of fuel stack for refabricated fuel rods (mm)*	37.5 142.5	27.5 122.5	112.5 137.5	19.5 157.5
5. Length of undamaged sections of fuel stack (mm)	105.0	95.0	25.0	139.0
6. Average burnup of refabricated fuel rods (MWd/kg U)	43.0	43.6	48.7	41.0
7. Total fuel mass(g)	55.5	57.4	47.9	59.3
8. Fuel mass for undamaged sections(g)	43.5	38.5	10.2	56.2
9. L <sub>1</sub> (see Fig. C.2) (mm)	4.6	0.	0.	0.1
10. L <sub>2</sub> (see Fig. C.2) (mm)	1.0	0.	0.	0.0
11. L <sub>3</sub> (see Fig. C.2) (mm)	148.0	159.1 <sup>2)</sup>	153.1 <sup>2)</sup>	156.0
12. L <sub>4</sub> (see Fig. C.2) (mm)	6.5	1.0	7.0	4.0
13. Total gas volume (cm <sup>3</sup> )	6.20	6.02	6.99	5.97
14. Average outer diameter of cladding (mm)	9.08	9.10	9.09	9.09
15. Fuel-cladding radial gap (mm)	0.07	0.07	0.03	0.07

\* From lower end of fuel rod

<sup>1)</sup> Taken into account  $\gamma$ -scanning results

<sup>2)</sup> Length of the fuel stack ignoring fuel fragments inside fixing ring

**Table C.3. Free Gas Volume in Refabricated Fuel Rods before IGR Reactor Tests at Axial Coordinates 185+295 mm**

Axial coordinate (from lower end of fuel rod) (mm)	Free gas volume (mm <sup>3</sup> )												
	H1T	H2T	H3T	H4T	H5T	H6T	H7T	H8T	B9T	B10T	B11T	B12T	B13T
185	53	53	53	53	53	53	53	53	53	53	53	53	53
195	71	71	71	71	71	71	71	71	71	71	71	71	71
205	250	250	250	250	250	250	250	250	250	250	250	250	250
215	468	468	468	468	468	468	468	468	468	468	468	468	468
225	468	468	468	468	468	468	468	468	468	468	468	468	468
235	468	468	468	468	468	468	468	468	468	468	468	468	468
245	468	468	468	468	468	468	468	468	468	468	468	468	468
255	468	468	468	468	468	468	468	468	468	468	468	468	468
265	468	468	468	468	468	468	468	468	468	468	468	468	468
275	468	468	468	468	468	468	468	468	468	468	468	468	468
285	119	119	119	119	119	119	119	119	119	119	119	119	119
295	0	0	0	0	0	0	0	0	0	0	0	0	0

*APPENDIX C-1.*

*Initial Individual Characteristics for Fuel Rod #E01T*

Table C-1.1. Axial Distribution of Isotopic Composition for Fuel Rod #H1T (calculated)

Axial coordinate from lower end of fuel rod (mm)	Nuclear concentrations (kg/t U)						
	U <sup>235</sup>	U <sup>236</sup>	U <sup>238</sup>	Pu <sup>239</sup>	Pu <sup>240</sup>	Pu <sup>241</sup>	Pu <sup>242</sup>
20	4.76	4.94	927	4.99	2.66	1.616	1.049
25	4.76	4.94	927	4.99	2.66	1.616	1.049
30	4.76	4.94	927	4.99	2.66	1.616	1.049
35	4.76	4.94	927	4.99	2.66	1.616	1.049
40	4.76	4.94	927	4.99	2.66	1.616	1.049
45	4.71	4.94	927	4.98	2.66	1.616	1.058
50	5.14	4.90	928	5.05	2.61	1.606	0.990
55	5.11	4.91	928	5.05	2.62	1.606	0.994
60	5.06	4.91	928	5.04	2.63	1.607	1.003
65	5.03	4.91	928	5.03	2.63	1.607	1.007
70	5.00	4.92	928	5.03	2.63	1.608	1.011
75	5.17	4.90	928	5.06	2.61	1.605	0.986
80	5.28	4.89	929	5.08	2.60	1.603	0.969
85	5.19	4.90	928	5.06	2.61	1.605	0.982
90	5.08	4.91	928	5.04	2.62	1.606	0.998
95	5.08	4.91	928	5.04	2.62	1.606	0.998
100	5.08	4.91	928	5.04	2.62	1.606	0.998
105	5.00	4.92	928	5.03	2.63	1.608	1.011
110	4.92	4.92	927	5.02	2.64	1.611	1.024
115	4.84	4.93	927	5.01	2.65	1.615	1.036
120	4.81	4.93	927	5.00	2.65	1.615	1.041
125	4.68	4.94	927	4.98	2.67	1.616	1.062
130	4.60	4.95	926	4.96	2.68	1.616	1.075
135	4.53	4.96	926	4.94	2.69	1.617	1.088
140	4.45	4.96	926	4.92	2.70	1.617	1.101
145	4.60	4.95	926	4.96	2.68	1.616	1.075
150	4.73	4.94	927	4.99	2.66	1.616	1.054
155	4.71	4.94	927	4.98	2.66	1.616	1.058
160	4.68	4.94	927	4.98	2.67	1.616	1.062
165	4.79	4.93	927	5.00	2.65	1.615	1.045
170	4.89	4.93	927	5.01	2.64	1.612	1.028
175	4.71	4.94	927	4.98	2.66	1.616	1.058
180	4.58	4.95	926	4.95	2.68	1.616	1.079

All numerical values of characteristics are presented as average values at the length interval equal to the axial coordinate  $\pm 2.5$  mm

# #H1T

Initial Individual Characteristics of Refabricated Fuel Rods  
(Preirradiated fuel, Preirradiated cladding)

**Table C-1.2. Radial Distribution of Burnup (Calculated) and Isotopic Composition with RIM Zone Indication (Calculated) for Fuel Rod #H1T (average values in fuel rod)**

Characteristic	Coordinates of fuel radial zones (mm)			
	1 zone 1.2 - 2.811	2 zone 2.811 - 3.432	3 zone 3.432 - 3.704	4 zone 3.704 - 3.790
<b>1. Nuclear concentrations (kg/t U):</b>				
U <sup>235</sup>	4.98	4.78	4.59	4.46
U <sup>236</sup>	4.93	4.93	4.93	4.94
U <sup>238</sup>	933.	930.	917.	884.
Pu <sup>239</sup>	4.20	4.68	6.29	10.66
Pu <sup>240</sup>	2.35	2.46	3.14	5.08
Pu <sup>241</sup>	1.293	1.503	2.118	3.777
Pu <sup>242</sup>	0.809	0.966	1.401	2.581
<b>2. Burnup (MWd/kg U)</b>	44.9	47.8	56.1	78.7

## #H1T

Initial Individual Characteristics of Refabricated Fuel Rods  
(Preirradiated fuel, Preirradiated cladding)

Table C-1.3. Individual Initial Characteristics for Fuel Rod #H1T (measured)

Axial coordinate from lower end of fuel rod (mm)	Cladding outer diameter at 0° (mm)	Cladding outer diameter at 90° (mm)	Fuel mass (g) (density- $10.13^4$ ) g/cm <sup>3</sup> )*	Linear fuel mass (g/cm)*	Free gas volume (mm <sup>3</sup> ) <sup>5)</sup>	Burnup (MWd/kg U)*
5	-	-	0.00	0.00	8.8	-
10	-	-	0.00	0.00	98.9	0.0
15	-	-	0.00	0.00	234.0	0.0
20 <sup>1)</sup>	-	-	0.38	3.80	196.6	49.6 <sup>3)</sup>
25	-	-	1.61	3.22	75.6	49.6 <sup>3)</sup>
30	-	-	0.90	1.80	145.5	49.6 <sup>3)</sup>
35	-	-	1.22	2.43	114.0	49.6 <sup>3)</sup>
40	-	-	1.16	2.32	119.9	49.6 <sup>3)</sup>
45	9.114	9.111	1.88	3.76	49.0	49.6 <sup>3)</sup>
50	9.105	9.111	1.99	3.98	38.2	48.1
55	9.117	9.113	1.99	3.99	38.2	48.3
60	9.125	9.099	2.01	4.01	36.2	48.4
65	9.126	9.101	2.01	4.03	36.2	48.5
70	9.119	9.108	2.05	4.09	32.3	48.6
75	9.114	9.111	2.06	4.12	31.3	48.1
80	9.120	9.117	2.07	4.13	30.3	47.6
85	9.123	9.117	2.08	4.16	29.3	48.0
90	9.117	9.126	2.09	4.18	28.3	48.3
95	9.114	9.125	2.07	4.15	30.3	48.3
100	9.113	9.116	2.04	4.08	33.3	48.3
105	9.116	9.116	2.04	4.08	33.3	48.7
110	9.113	9.116	2.04	4.08	33.3	49.0
115	9.108	9.116	2.04	4.07	33.3	49.2
120	9.110	9.110	2.04	4.07	33.3	49.4
125	9.113	9.107	2.06	4.12	31.3	49.8
130	9.117	9.108	2.04	4.08	33.3	50.2
135	9.122	9.113	2.03	4.06	34.2	50.5
140	9.111	9.116	2.03	4.07	34.2	50.8
145	9.108	9.122	2.04	4.09	33.3	50.1
150	9.116	9.110	2.04	4.09	33.3	49.6
155	9.117	9.099	2.06	4.12	31.3	49.8
160	9.123	9.102	2.06	4.12	31.3	49.9
165	9.114	9.111	2.04	4.08	33.3	49.4
170	9.116	9.113	2.04	4.07	33.3	49.1
175	9.114	9.114	1.98	3.95	39.2	49.8
180 <sup>2)</sup>	9.110	9.135	0.21	4.20	91.4	50.3

\* These numerical values of characteristics are presented as average values at the length interval equal to the axial coordinate  $\pm 2.5$  mm

1) Initial coordinate of fuel is 11.5 mm

4) Effective density of fuel stack

2) Final coordinate of fuel is 166.5 mm

5) Free gas volume for coordinates 185 - 295 mm is presented in Table C.3

3) Average value



#H1T

Initial Individual Characteristics of Refabricated Fuel Rods  
(Preirradiated fuel, Preirradiated cladding)

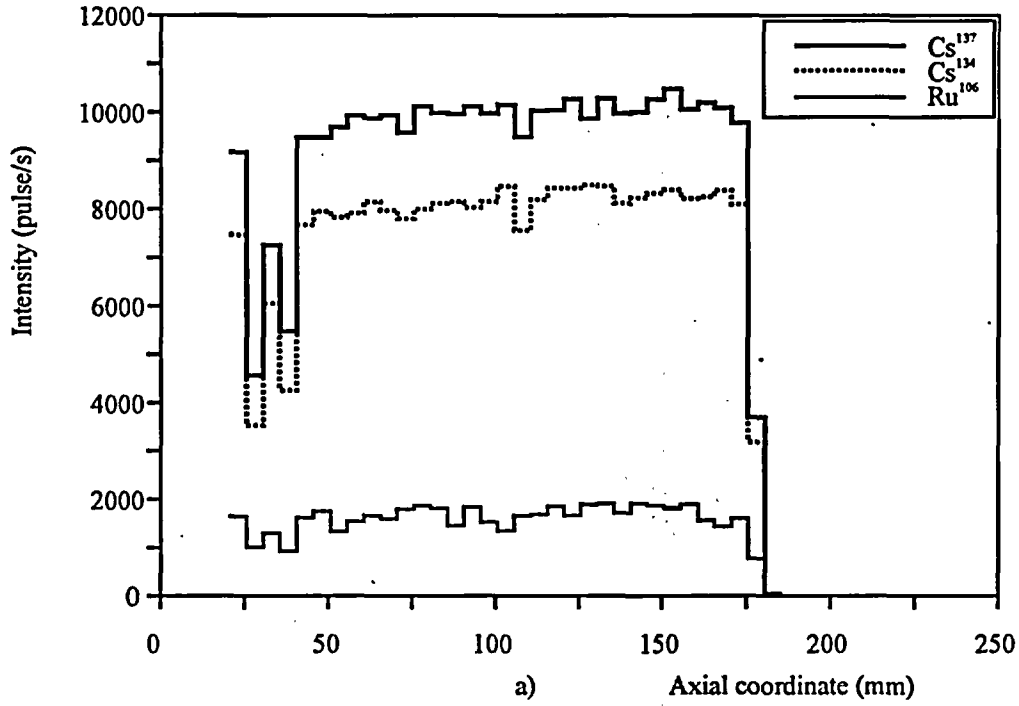

b)

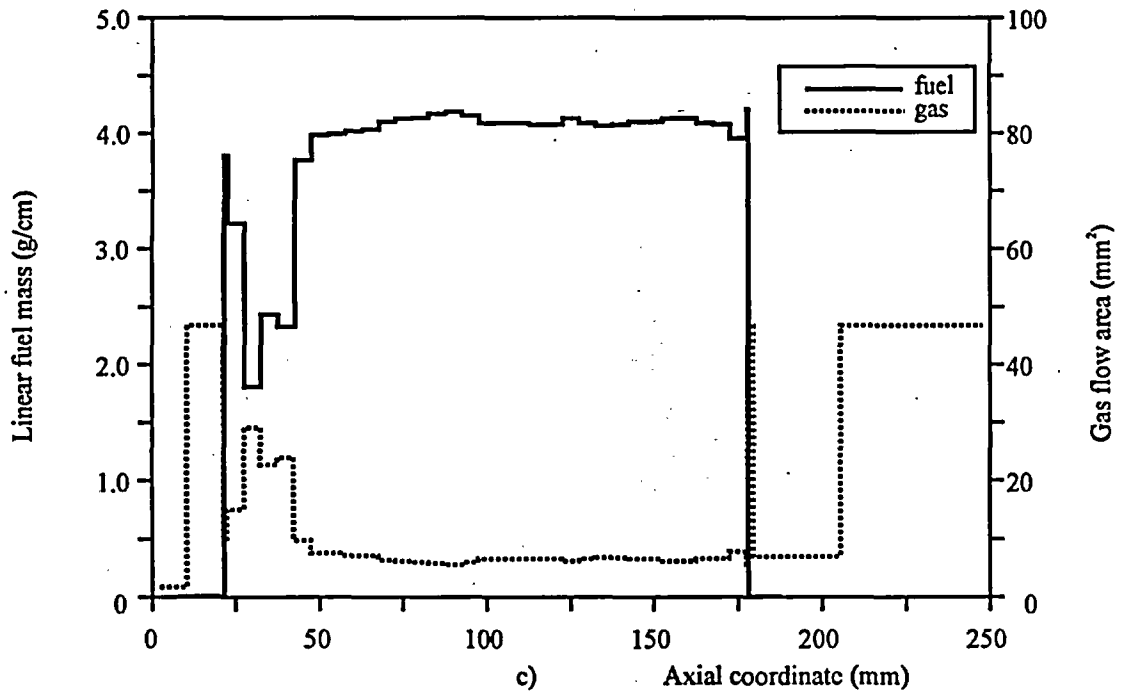

Fig. C-1.1. (a) Results of  $\gamma$ -scanning, (b) Radiography, (c) Axial Fuel Mass Distribution and Axial Free Gas Volume Distribution for Fuel Rod #H1T

#H1T

Initial Individual Characteristics of Refabricated Fuel Rods  
(Preirradiated fuel, Preirradiated cladding)

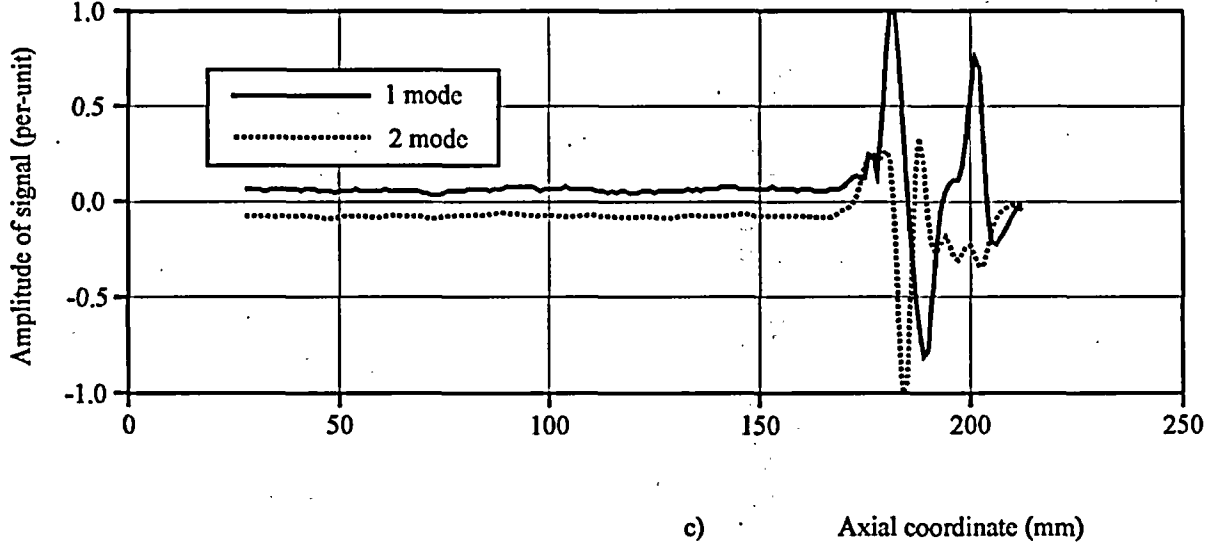
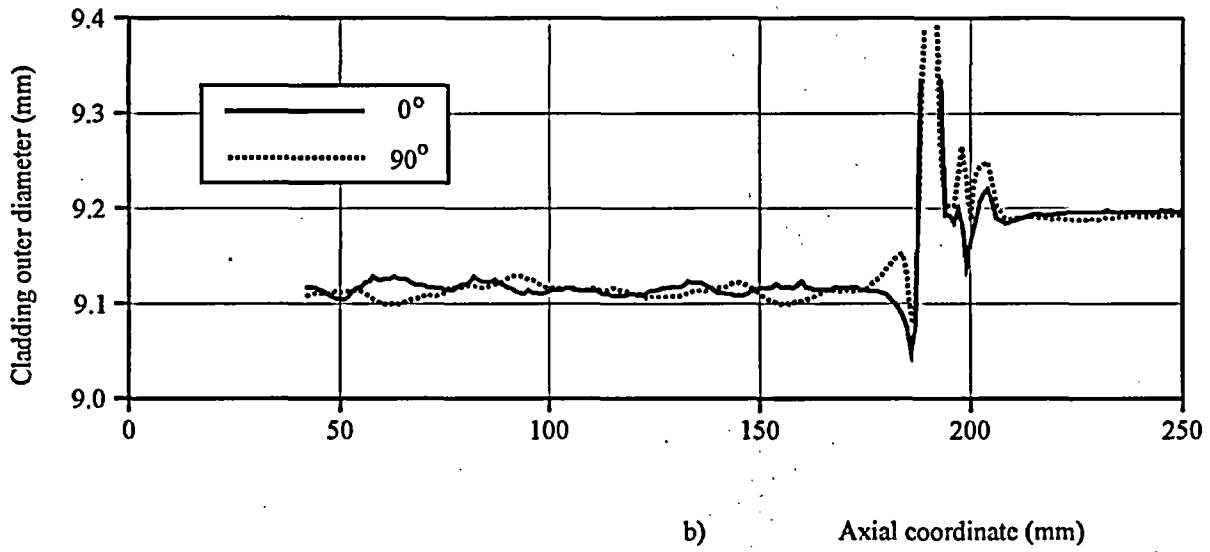
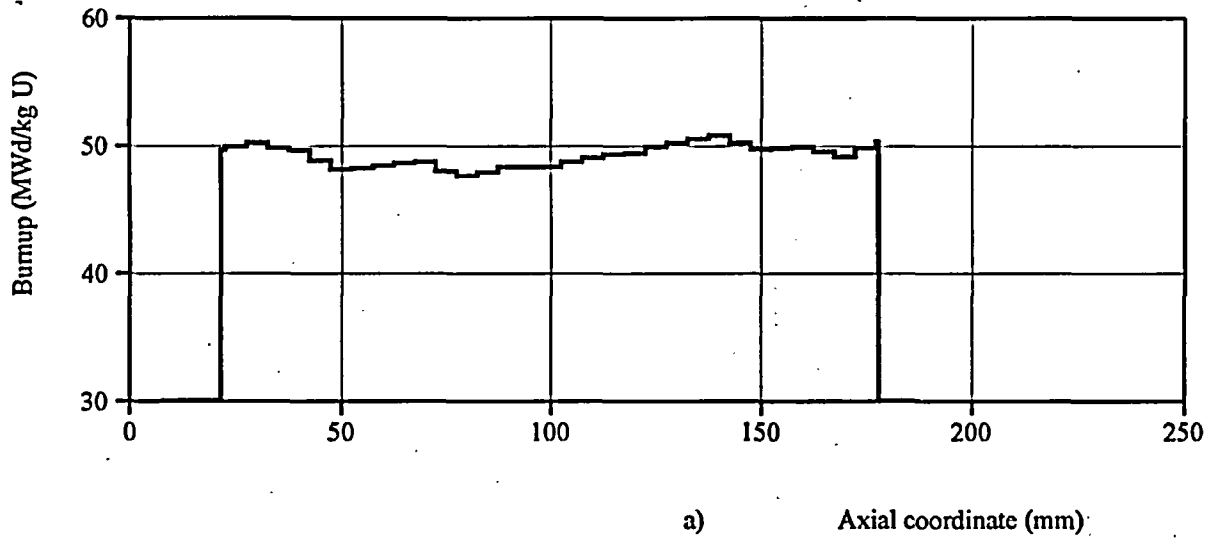

Fig. C-1.2. (a) Axial Burnup Distribution and (b) Results of Profilometry and (c) Eddy-Current Examination for Fuel Rod #H1T

#H1T

Initial Individual Characteristics of Refabricated Fuel Rods  
(Preirradiated fuel, Preirradiated cladding)

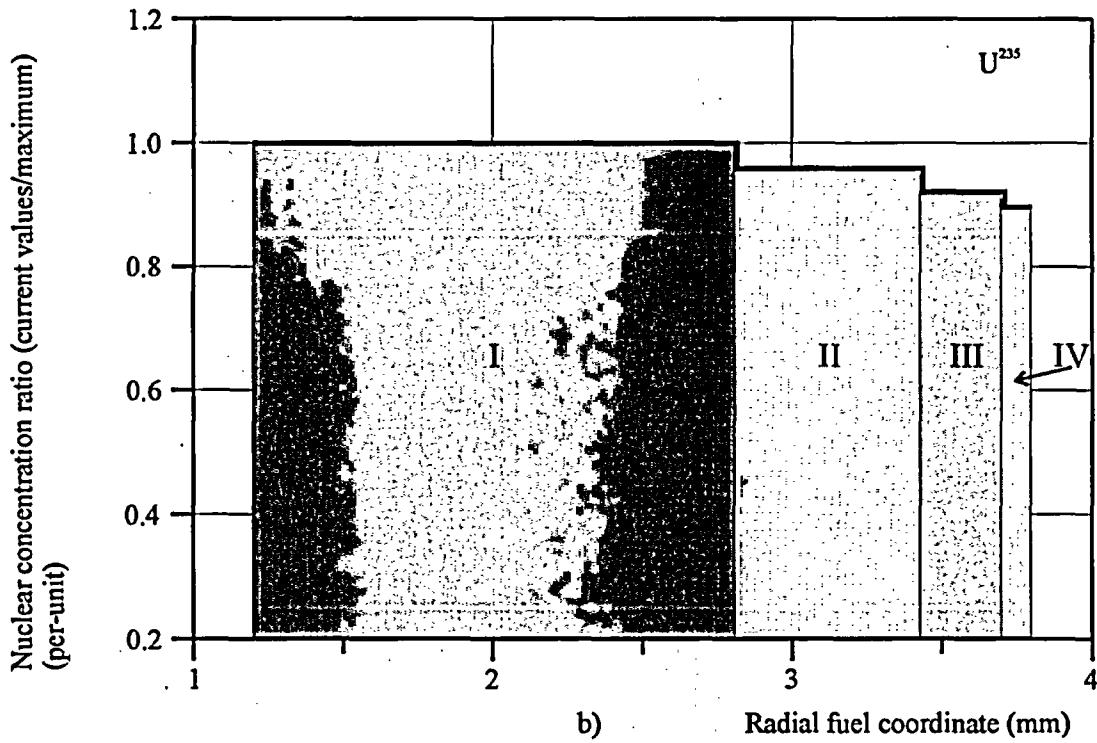
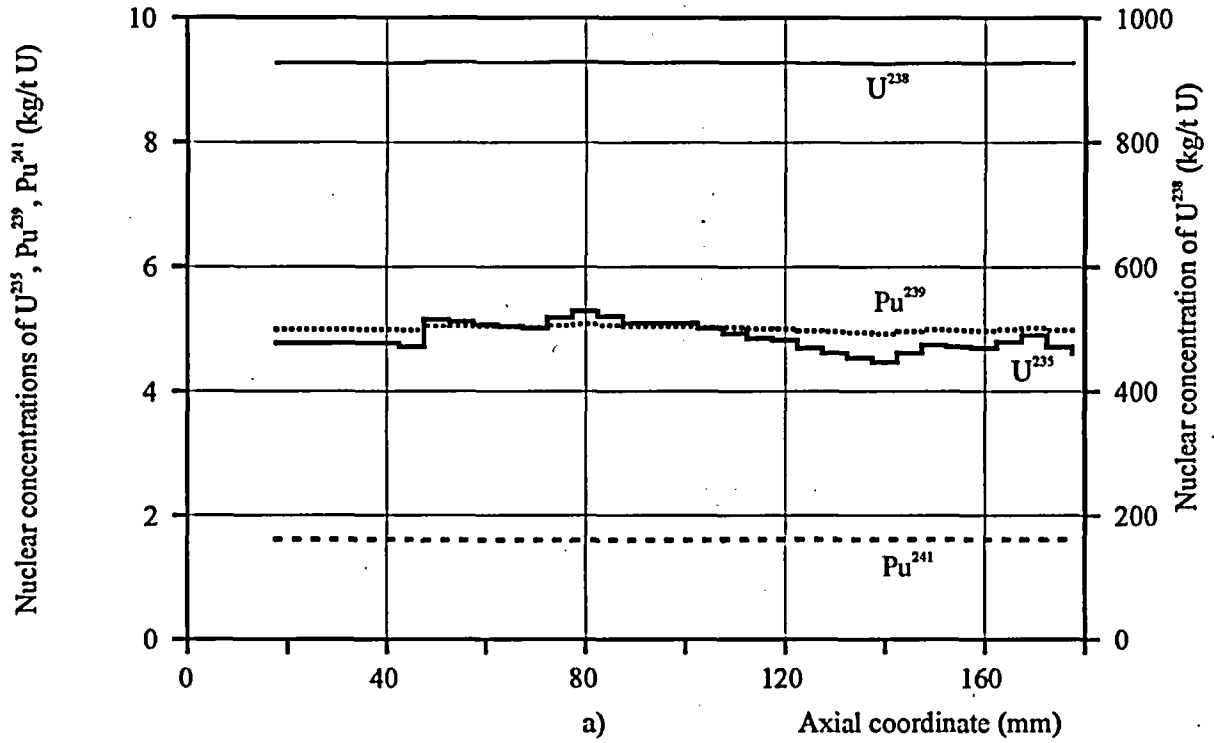

Fig. C-1.3. (a) Axial Distribution of  $U^{235}$ ,  $U^{238}$ ,  $Pu^{239}$ ,  $Pu^{241}$  Isotopes and (b) Radial Distribution of  $U^{235}$  Isotope for Fuel Rod #H1T (calculated)

#H1T

Initial Individual Characteristics of Refabricated Fuel Rods  
(Preirradiated fuel, Preirradiated cladding)

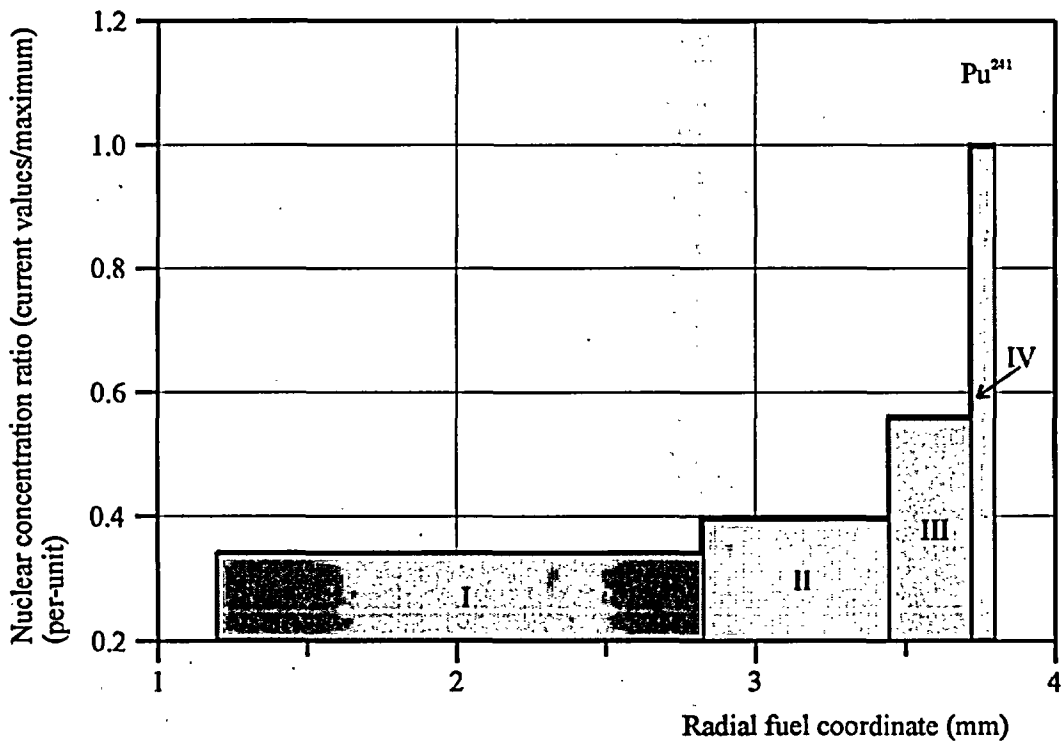
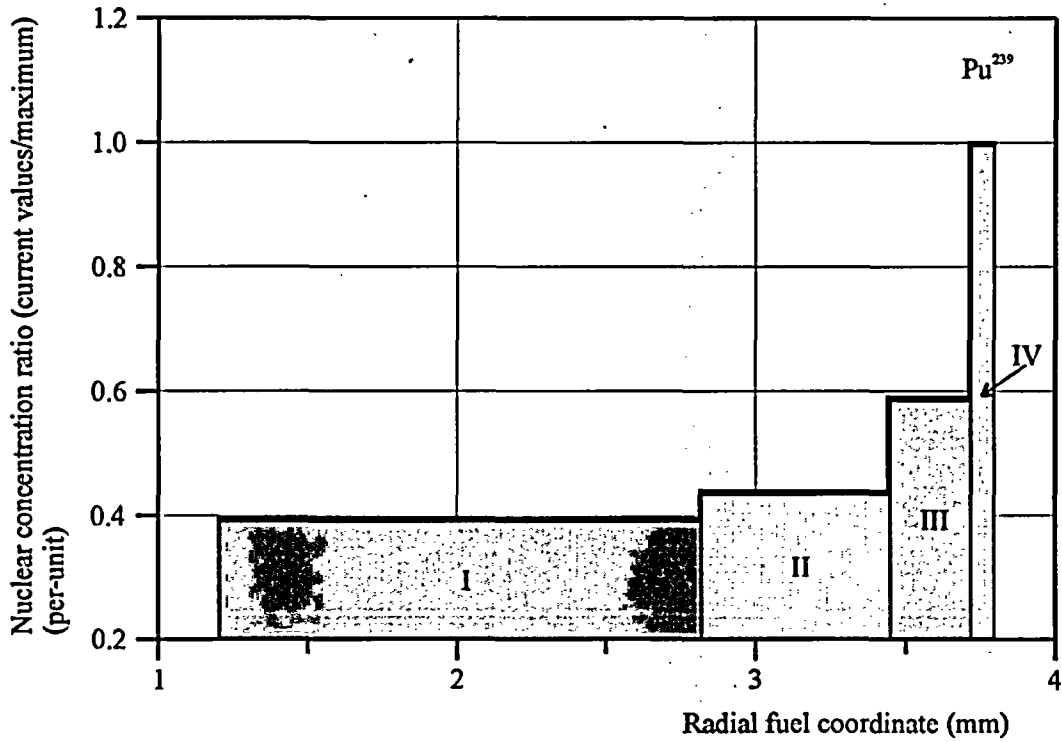

Fig. C-1.4. Radial Distribution of  $Pu^{239}$ ,  $Pu^{241}$  Isotopes for Fuel Rod #H1T (calculated)

#H1T

Initial Individual Characteristics of Refabricated Fuel Rods  
(Preirradiated fuel, Preirradiated cladding)

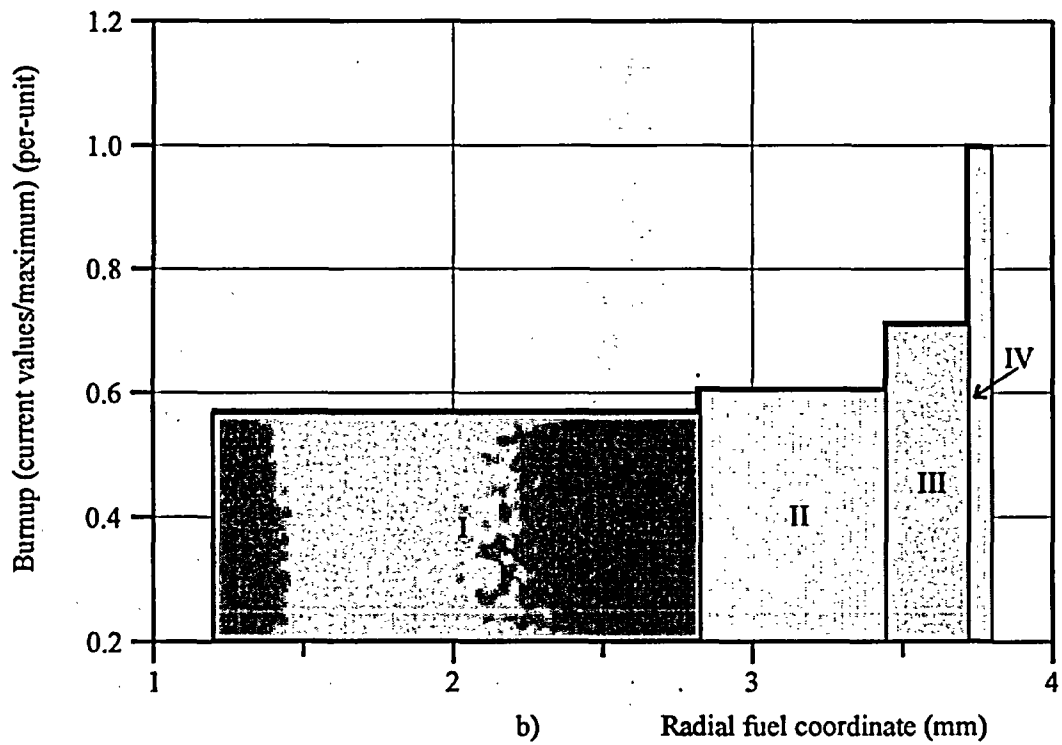
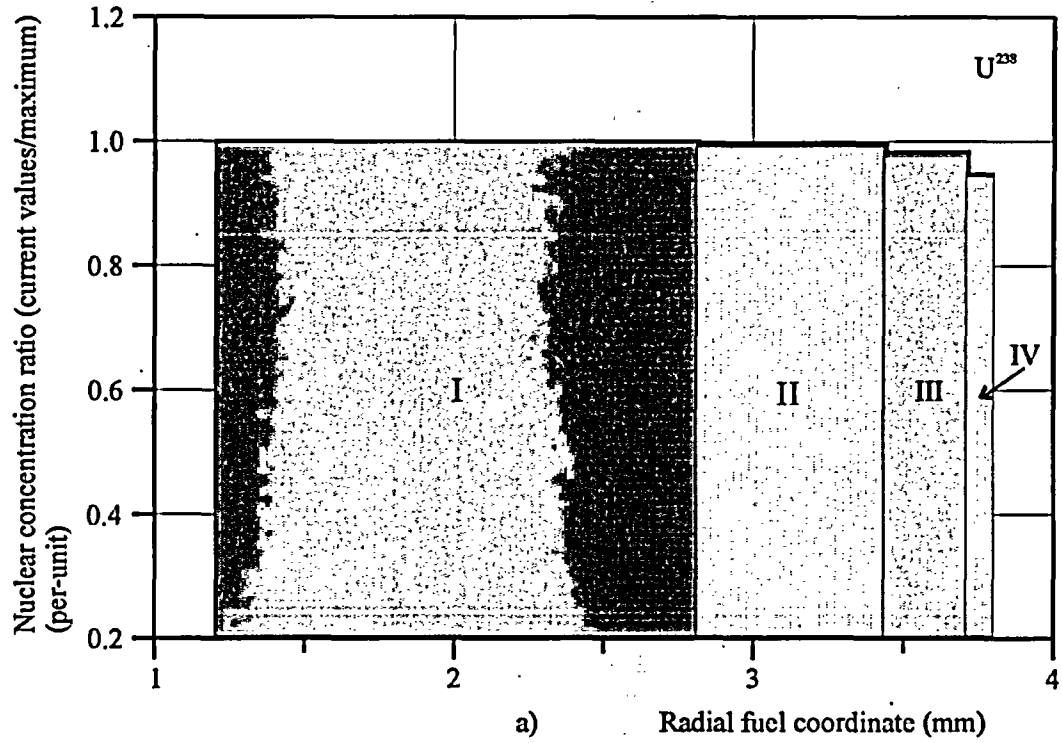

Fig. C-1.5. (a) Radial Distribution of  $U^{238}$  Isotope and (b) Burnup for Fuel Rod #H1T (calculated)



***APPENDIX C-2.***

***Initial Individual Characteristics for Fuel Rod #H2T***

Table C-2.1. Axial Distribution of Isotopic Composition for Fuel Rod #H2T (calculated)

Axial coordinate from lower end of fuel rod (mm)	Nuclear concentrations (kg/t U)						
	U <sup>235</sup>	U <sup>236</sup>	U <sup>238</sup>	Pu <sup>239</sup>	Pu <sup>240</sup>	Pu <sup>241</sup>	Pu <sup>242</sup>
20	5.33	4.91	927	5.30	2.68	1.691	1.003
25	5.33	4.91	927	5.30	2.68	1.691	1.003
30	5.27	4.91	927	5.29	2.69	1.692	1.012
35	5.25	4.91	927	5.29	2.69	1.693	1.016
40	5.25	4.91	927	5.29	2.69	1.693	1.016
45	5.25	4.91	927	5.29	2.69	1.693	1.016
50	5.06	4.93	926	5.26	2.71	1.700	1.045
55	4.93	4.94	926	5.23	2.73	1.702	1.066
60	5.09	4.93	926	5.27	2.71	1.700	1.041
65	5.19	4.92	927	5.28	2.69	1.696	1.024
70	5.22	4.92	927	5.28	2.69	1.695	1.020
75	5.25	4.91	927	5.29	2.69	1.693	1.016
80	5.47	4.89	927	5.32	2.66	1.687	0.983
85	5.63	4.88	928	5.35	2.64	1.683	0.958
90	5.75	4.87	928	5.37	2.62	1.679	0.942
95	5.83	4.86	929	5.38	2.61	1.675	0.930
100	5.86	4.86	929	5.38	2.61	1.674	0.926
105	5.89	4.85	929	5.39	2.61	1.672	0.922
110	5.95	4.85	929	5.39	2.60	1.670	0.914
115	5.98	4.85	929	5.40	2.60	1.669	0.910
120	5.98	4.85	929	5.40	2.60	1.669	0.910
125	6.01	4.84	929	5.40	2.59	1.667	0.906
130	5.72	4.87	928	5.36	2.63	1.680	0.946
135	5.55	4.89	928	5.34	2.65	1.685	0.970
140	5.58	4.88	928	5.34	2.65	1.684	0.966
145	5.58	4.88	928	5.34	2.65	1.684	0.966
150	5.55	4.89	928	5.34	2.65	1.685	0.970
155	5.55	4.89	928	5.34	2.65	1.685	0.970
160	5.27	4.91	927	5.29	2.69	1.692	1.012
165	5.09	4.93	926	5.27	2.71	1.700	1.041
170	5.09	4.93	926	5.27	2.71	1.700	1.041
175	-	-	-	-	-	-	-
180	-	-	-	-	-	-	-

All numerical values of characteristics are presented as average values at the length interval equal to the axial coordinate  $\pm 2.5$  mm



Table C-2.2. Radial Distribution of Burnup (Calculated) and Isotopic Composition with RIM Zone Indication (Calculated) for Fuel Rod #H2T (average values in fuel rod)

Characteristic	Coordinates of fuel radial zones (mm)			
	1 zone 1.2 - 2.811	2 zone 2.811 - 3.432	3 zone 3.432 - 3.704	4 zone 3.704 - 3.790
1. Nuclear concentrations (kg/t U):				
U <sup>235</sup>	5.63	5.41	5.21	5.07
U <sup>236</sup>	4.89	4.90	4.90	4.90
U <sup>238</sup>	934.	930.	918.	885.
Pu <sup>239</sup>	4.46	4.97	6.70	11.39
Pu <sup>240</sup>	2.35	2.47	3.16	5.13
Pu <sup>241</sup>	1.348	1.571	2.221	3.974
Pu <sup>242</sup>	0.766	0.916	1.330	2.453
2. Burnup (MWd/kg U)	43.8	46.6	54.8	76.7

## #H2T

Initial Individual Characteristics of Refabricated Fuel Rods (Preirradiated fuel, Preirradiated cladding)
--

Table C-2.3. Individual Initial Characteristics for Fuel Rod #H2T (measured)

Axial coordinate from lower end of fuel rod (mm)	Cladding outer diameter at 0° (mm)	Cladding outer diameter at 90° (mm)	Fuel mass (g) (density- $10.13^4$ g/cm <sup>3</sup> )*	Linear fuel mass (g/cm)*	Free gas volume (mm <sup>3</sup> )* <sup>5)</sup>	Burnup (MWd/kg U)*
5	-	-	0.0	0.0	8.8	0.0
10	-	-	0.0	0.0	98.9	0.0
15	-	-	0.0	0.0	234.0	0.0
20 <sup>1)</sup>	-	-	1.20	4.01	115.9	48.6 <sup>3)</sup>
25	-	-	2.04	4.09	33.3	48.6 <sup>3)</sup>
30	-	-	2.05	4.10	32.3	48.8
35	-	-	2.06	4.13	31.3	48.9
40	-	-	2.05	4.10	32.3	48.8
45	9.097	9.112	2.01	4.03	36.2	48.8
50	9.100	9.101	2.01	4.02	36.2	49.6
55	9.104	9.095	2.00	4.01	37.2	50.0
60	9.098	9.089	1.98	3.96	39.2	49.4
65	9.094	9.094	1.99	3.99	38.2	49.0
70	9.088	9.091	2.04	4.08	33.3	48.9
75	9.086	9.084	2.06	4.12	31.3	48.9
80	9.097	9.078	2.07	4.14	30.3	48.0
85	9.094	9.083	2.09	4.17	28.3	47.4
90	9.084	9.098	2.09	4.18	28.3	47.0
95	9.084	9.097	2.06	4.12	31.3	46.7
100	9.091	9.089	2.03	4.05	34.2	46.6
105	9.095	9.084	2.00	4.01	37.2	46.5
110	9.089	9.088	2.01	4.01	36.2	46.3
115	9.077	9.097	2.01	4.02	36.2	46.2
120	9.078	9.101	2.02	4.04	35.2	46.2
125	9.086	9.097	2.03	4.06	34.2	46.1
130	9.098	9.097	2.05	4.09	32.3	47.1
135	9.103	9.098	2.07	4.13	30.3	47.7
140	9.098	9.107	2.08	4.17	29.3	47.7
145	9.098	9.100	2.10	4.20	27.3	47.6
150	9.098	9.095	2.10	4.21	27.3	47.7
155	9.094	9.094	2.09	4.17	28.3	47.8
160	9.092	9.098	2.03	4.06	34.2	48.8
165	9.091	9.106	2.00	4.01	37.2	49.5
170 <sup>2)</sup>	9.098	9.091	0.79	3.94	166.3	49.5
175	9.107	9.092	0.0	0.0	234.0	0.0
180	9.107	9.092	0.0	0.0	114.8	0.0

\* These numerical values of characteristics are presented as average values at the length interval equal to the axial coordinate  $\pm 2.5$  mm

<sup>1)</sup> Initial coordinate of fuel is 11.5 mm

<sup>2)</sup> Final coordinate of fuel is 166.5 mm

<sup>3)</sup> Average value

<sup>4)</sup> Effective density of fuel stack

<sup>5)</sup> Free gas volume for coordinates 185 - 295 mm is presented in Table C.3

#H2T

Initial Individual Characteristics of Refabricated Fuel Rods  
(Preirradiated fuel-Preirradiated cladding)

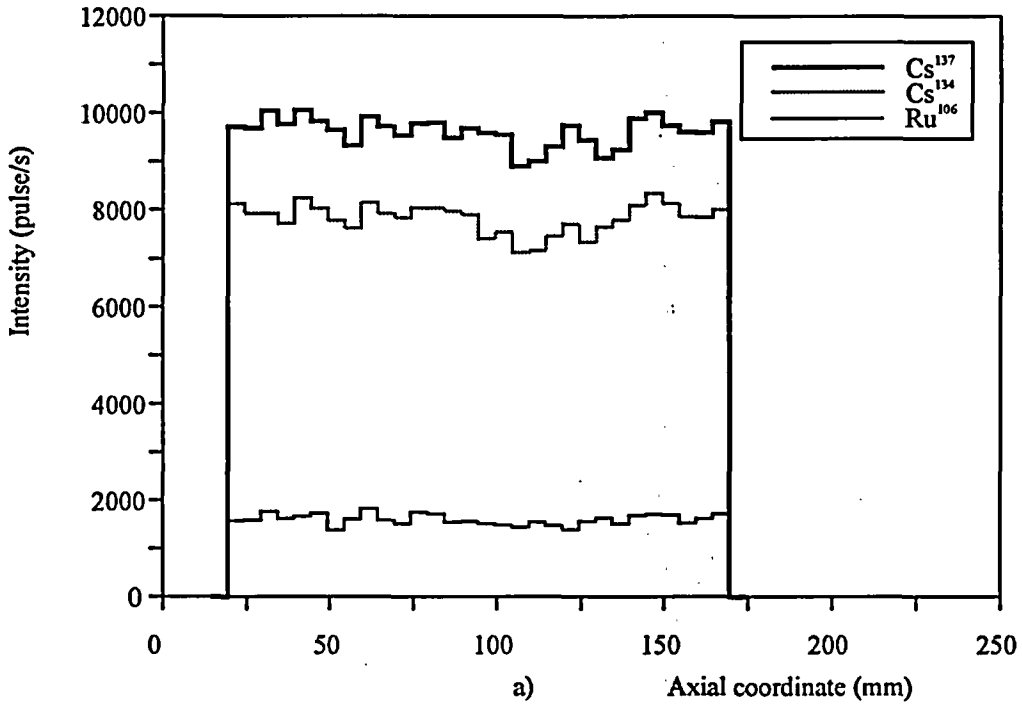

b)

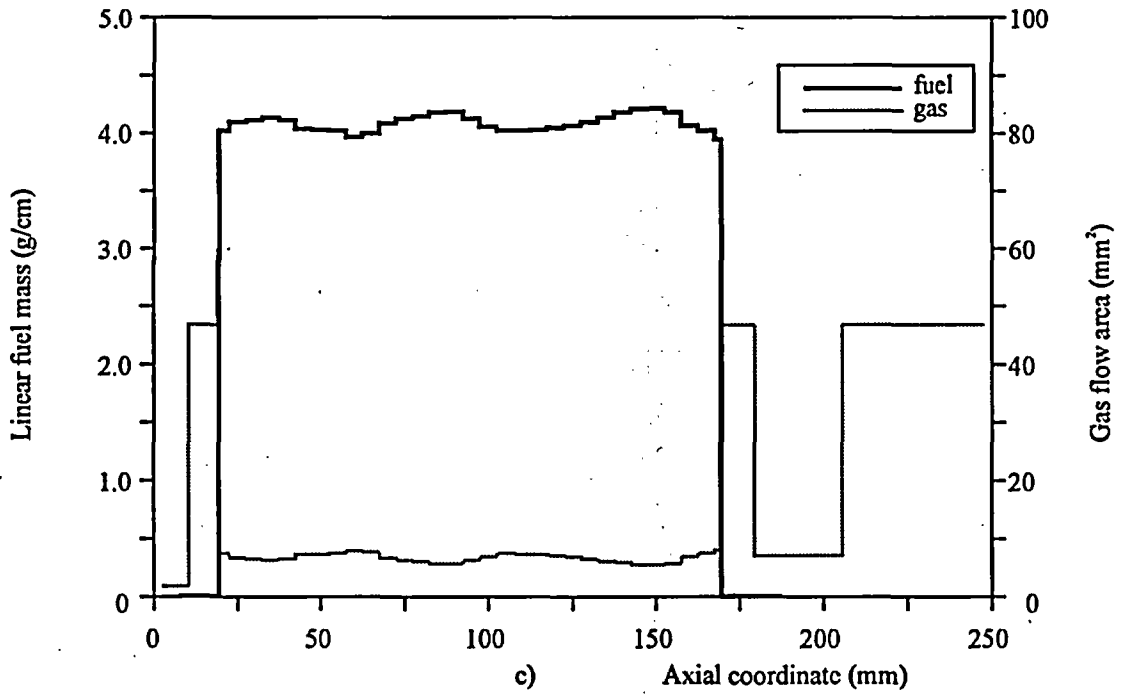

Fig. C-2.1. (a) Results of  $\gamma$ -scanning, (b) Radiography, (c) Axial Fuel Mass Distribution and Axial Free Gas Volume Distribution for Fuel Rod #H2T

#H2T

Initial Individual Characteristics of Refabricated Fuel Rods  
(Preirradiated fuel, Preirradiated cladding)

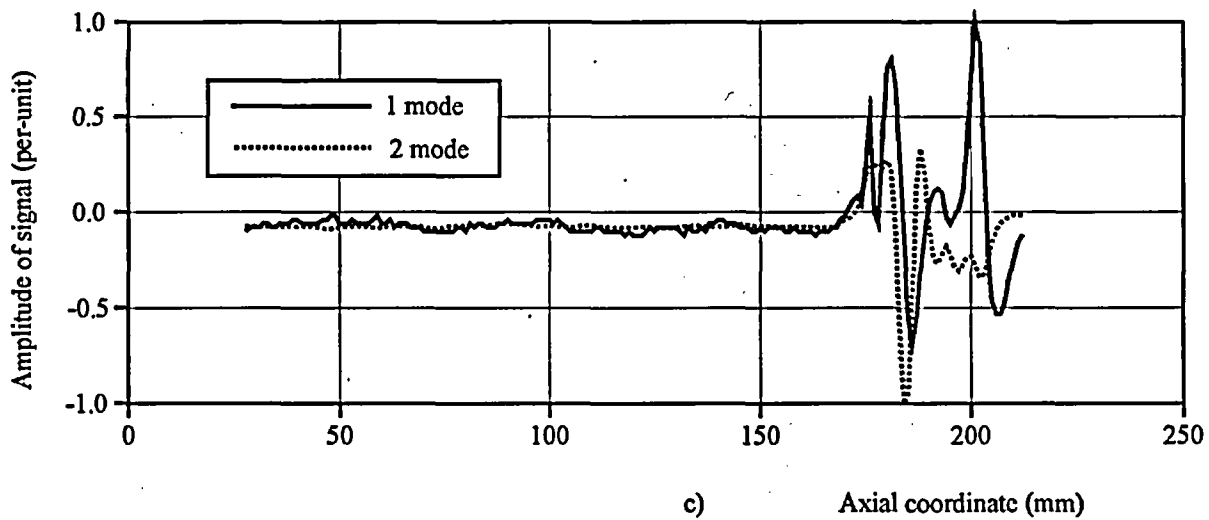
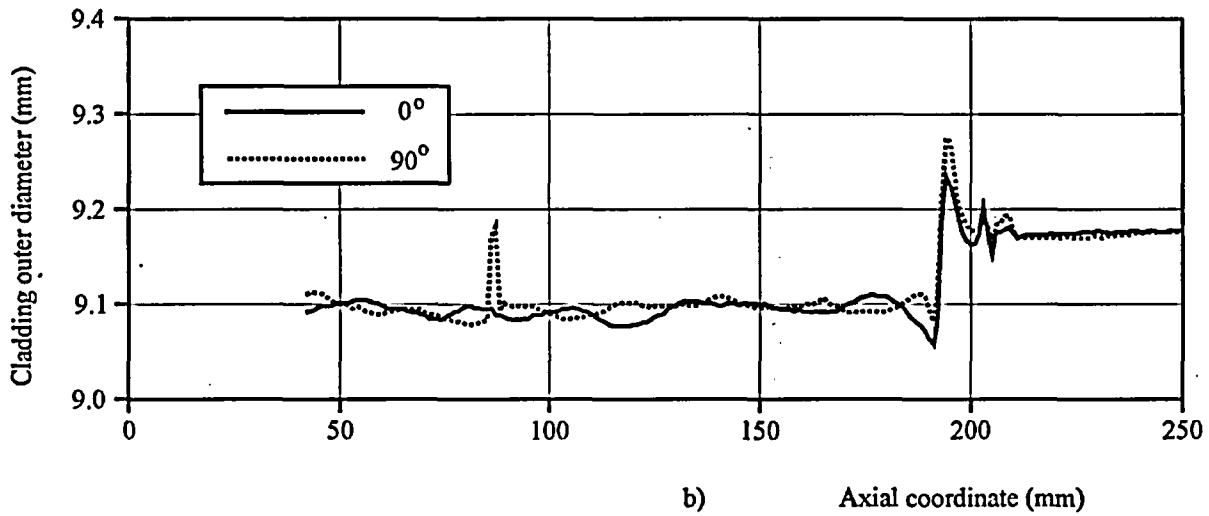
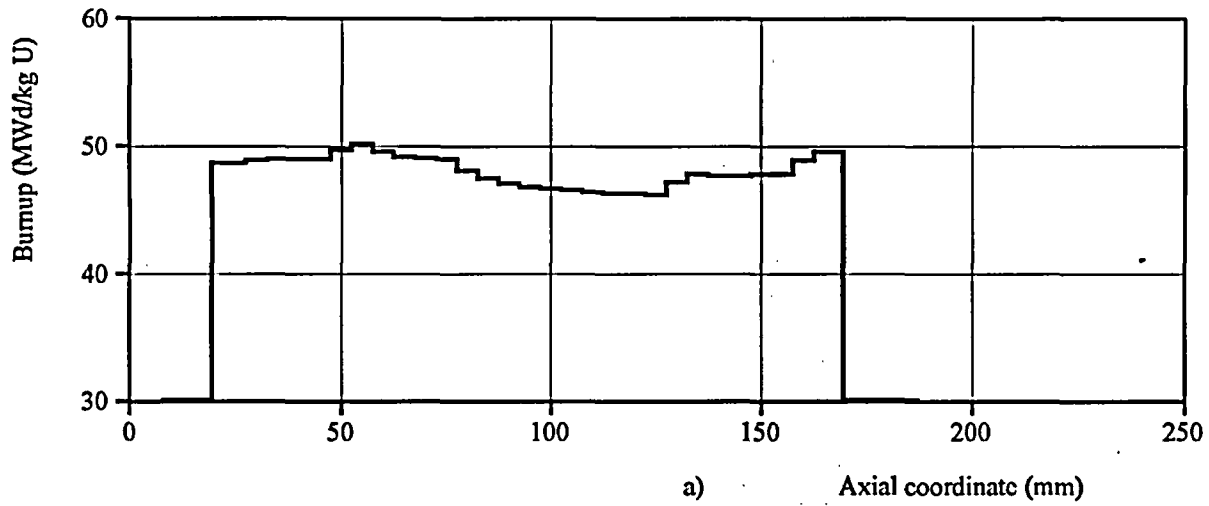

Fig. C-2.2. (a) Axial Burnup Distribution and (b) Results of Profilometry and (c) Eddy-Current Examination for Fuel Rod #H2T

#H2T

Initial Individual Characteristics of Refabricated Fuel Rods  
(Preirradiated fuel, Preirradiated cladding)

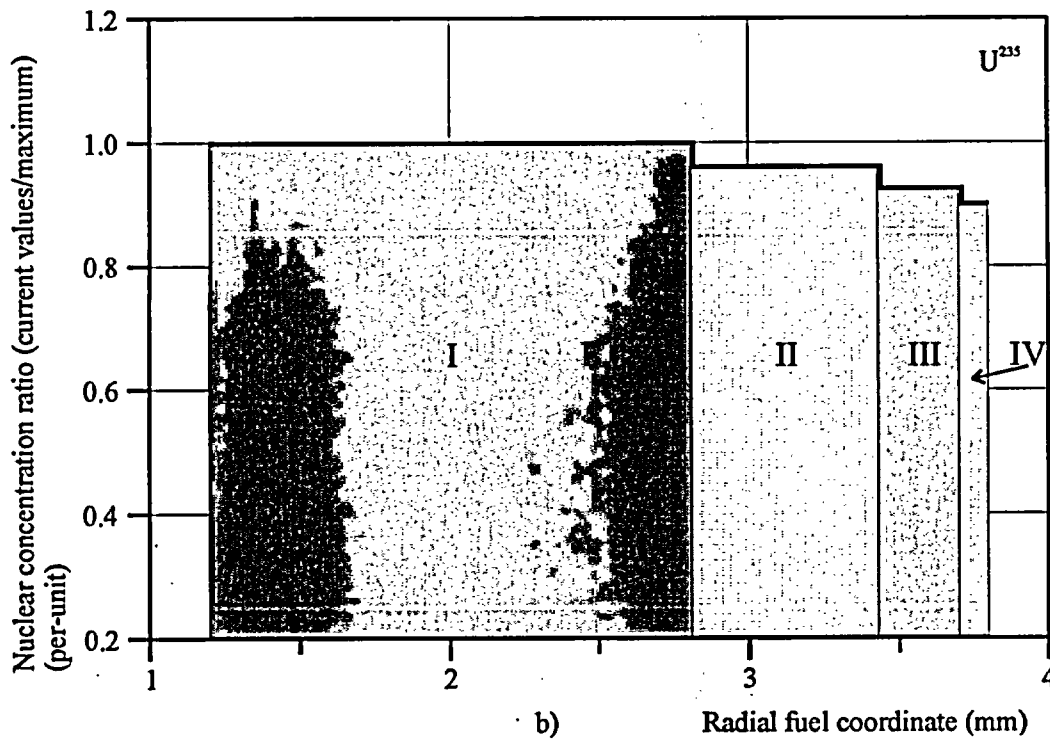
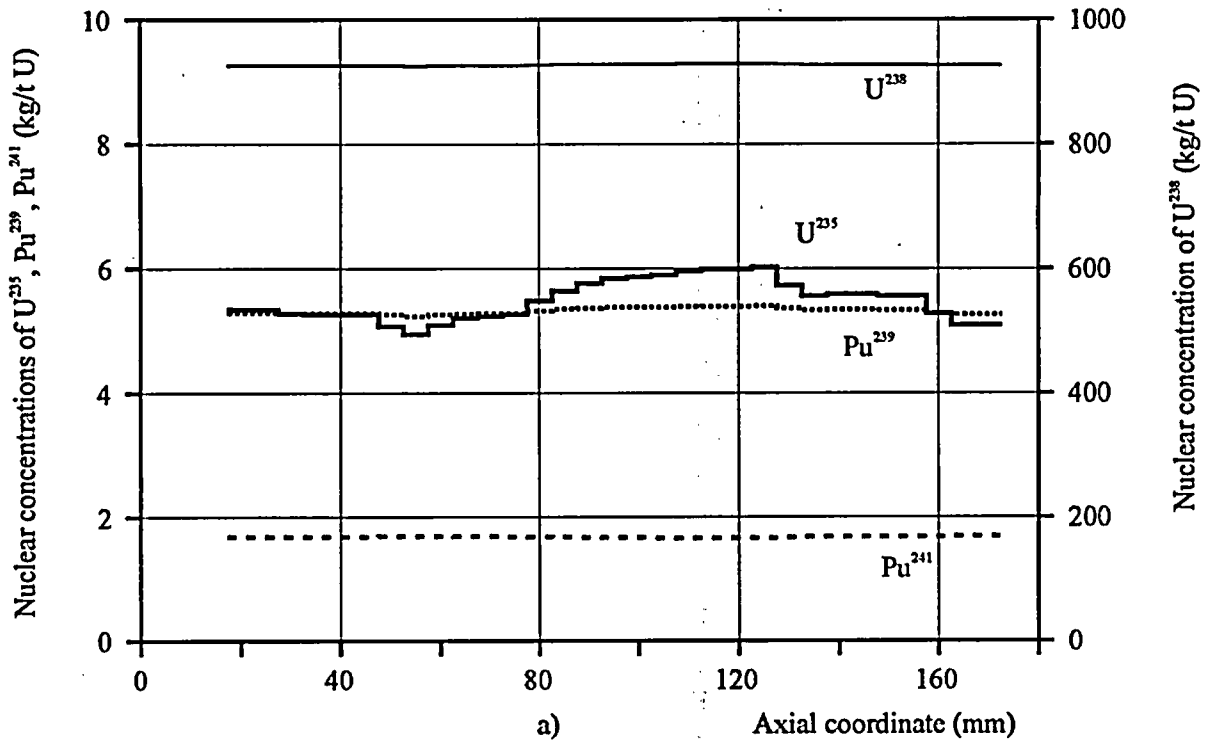

Fig. C-2.3. (a) Axial Distribution of  $U^{235}$ ,  $U^{238}$ ,  $Pu^{239}$ ,  $Pu^{241}$  Isotopes and (b) Radial Distribution of  $U^{235}$  Isotope for Fuel Rod #H2T (calculated)

#H2T

Initial Individual Characteristics of Refabricated Fuel Rods  
(Preirradiated fuel, Preirradiated cladding)

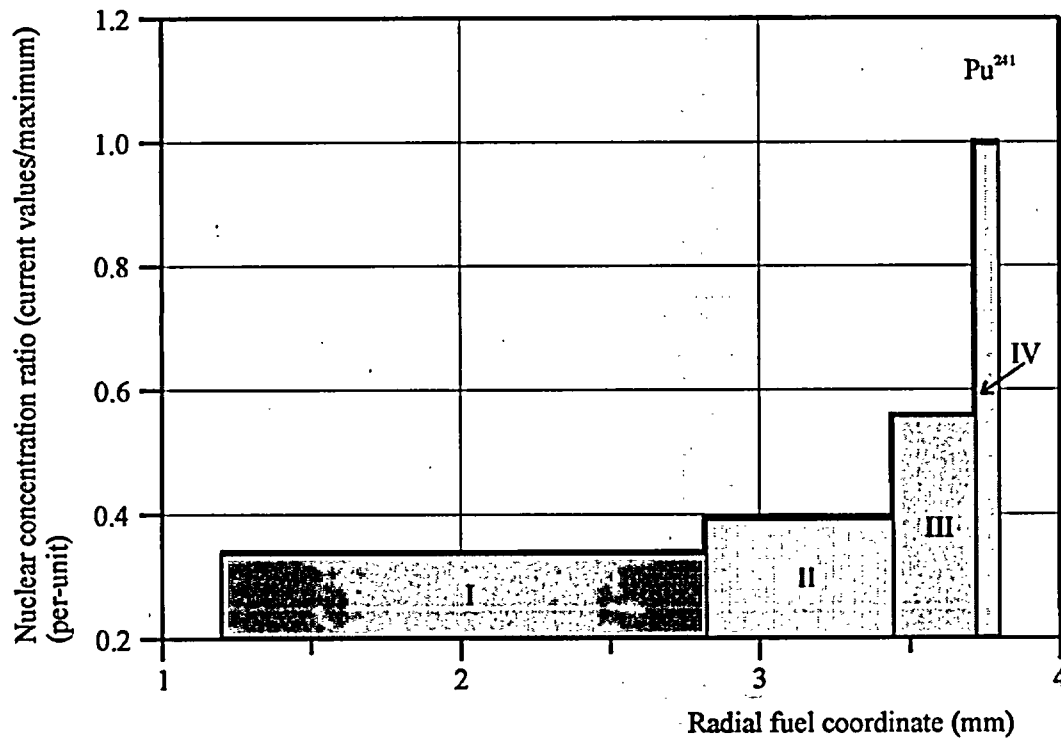
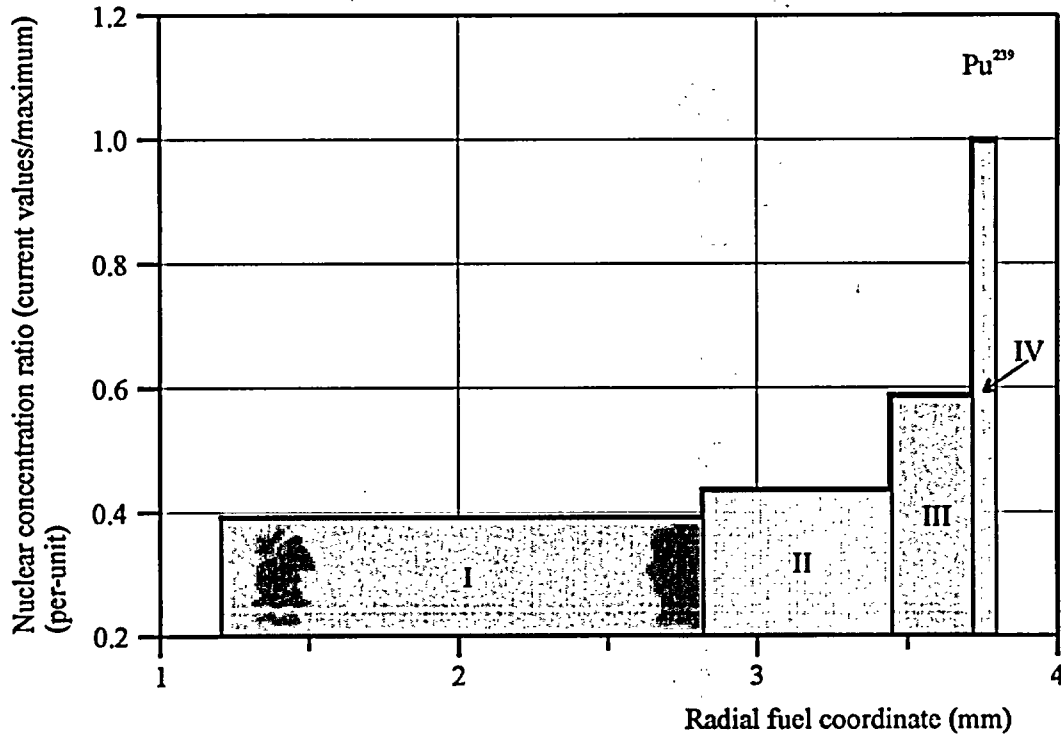

Fig. C-2.4. Radial Distribution of  $Pu^{239}$ ,  $Pu^{241}$  Isotopes for Fuel Rod #H2T (calculated)

#H2T

Initial Individual Characteristics of Refabricated Fuel Rods  
(Preirradiated fuel, Preirradiated cladding)

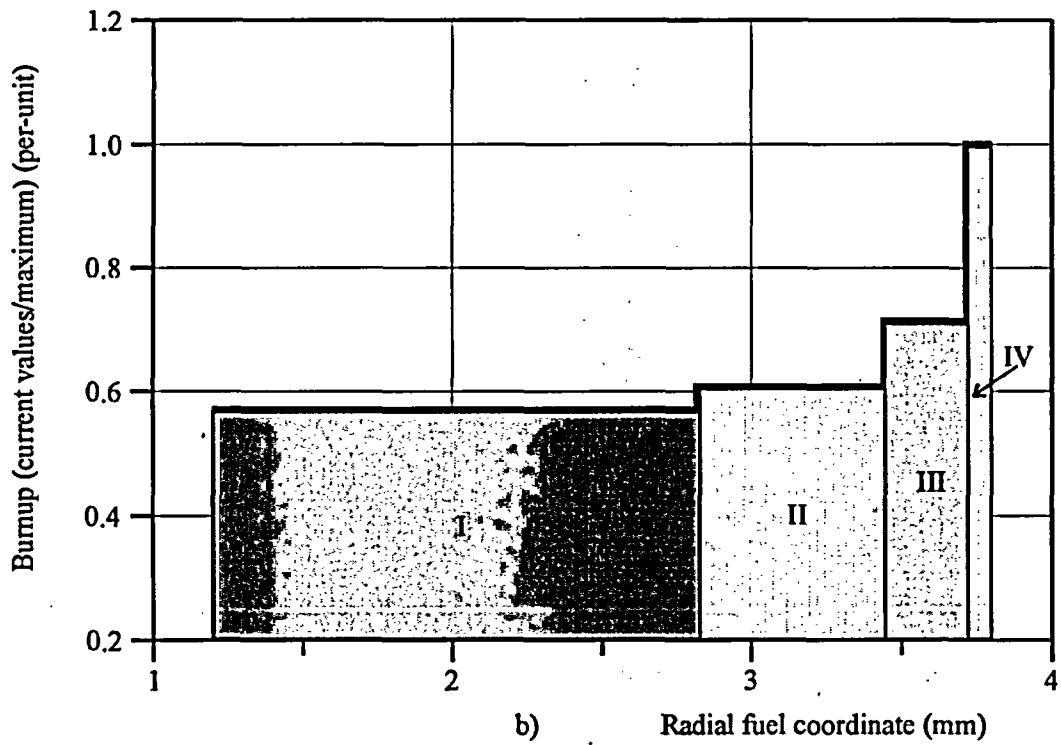
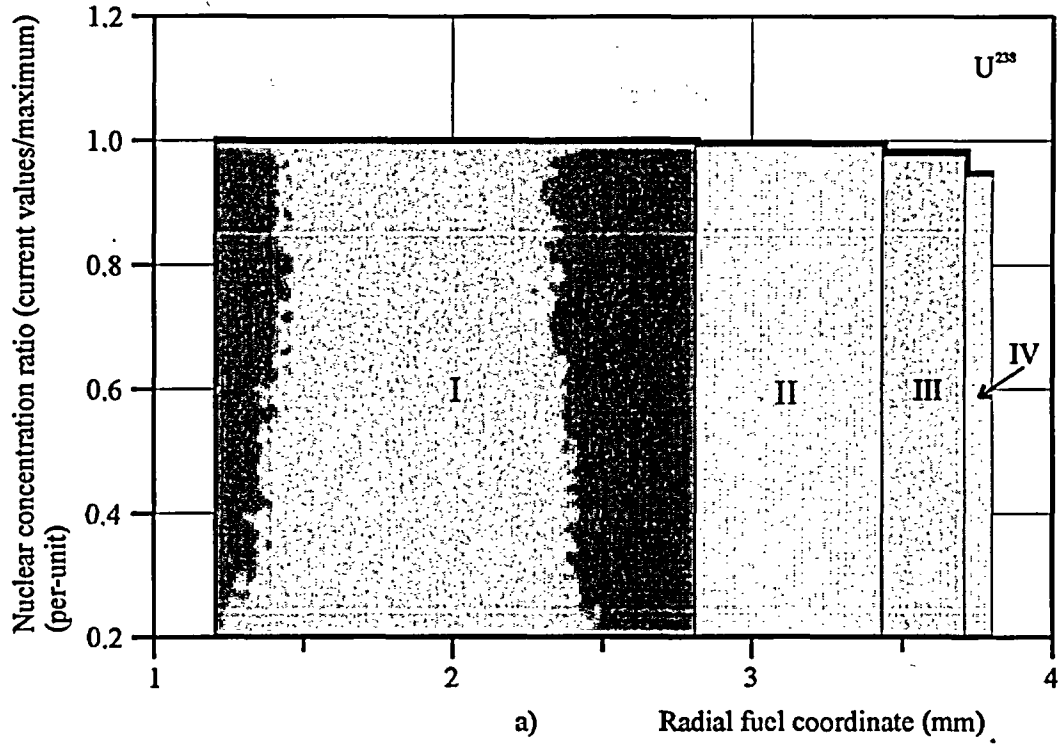

Fig. C-2.5. (a) Radial Distribution of  $U^{238}$  Isotope and (b) Burnup for Fuel Rod #H2T (calculated)





*APPENDIX C-3.*

*Initial Individual Characteristics for Fuel Rod #H3T*

# #H3T

Initial Individual Characteristics of Refabricated Fuel Rods  
(Preirradiated fuel, Preirradiated cladding)

Table C-3.1. Axial Distribution of Isotopic Composition for Fuel Rod #H3T (calculated)

Axial coordinate from lower end of fuel rod (mm)	Nuclear concentrations (kg/t U)						
	U <sup>235</sup>	U <sup>236</sup>	U <sup>238</sup>	Pu <sup>239</sup>	Pu <sup>240</sup>	Pu <sup>241</sup>	Pu <sup>242</sup>
20	4.68	4.94	927	4.92	2.64	1.588	1.046
25	4.68	4.94	927	4.92	2.64	1.588	1.046
30	4.68	4.94	927	4.92	2.64	1.588	1.046
35	4.84	4.92	928	4.94	2.62	1.583	1.020
40	4.87	4.92	928	4.94	2.62	1.582	1.016
45	5.09	4.90	929	4.98	2.59	1.578	0.982
50	5.09	4.90	929	4.98	2.59	1.578	0.982
55	5.23	4.89	929	5.01	2.57	1.576	0.961
60	5.23	4.89	929	5.01	2.57	1.576	0.961
65	5.20	4.89	929	5.00	2.58	1.577	0.965
70	5.17	4.89	929	5.00	2.58	1.577	0.969
75	5.03	4.91	928	4.97	2.60	1.579	0.990
80	5.01	4.91	928	4.97	2.60	1.579	0.995
85	4.87	4.92	928	4.94	2.62	1.582	1.016
90	4.84	4.92	928	4.94	2.62	1.583	1.020
95	4.68	4.94	927	4.92	2.64	1.588	1.046
100	4.66	4.94	927	4.91	2.64	1.588	1.050
105	4.55	4.95	927	4.89	2.65	1.589	1.068
110	4.55	4.95	927	4.89	2.65	1.589	1.068
115	4.55	4.95	927	4.89	2.65	1.589	1.068
120	4.55	4.95	927	4.89	2.65	1.589	1.068
125	4.50	4.95	927	4.88	2.66	1.589	1.076
130	4.50	4.95	927	4.88	2.66	1.589	1.076
135	4.50	4.95	927	4.88	2.66	1.589	1.076
140	4.50	4.95	927	4.88	2.66	1.589	1.076
145	4.47	4.95	927	4.87	2.66	1.589	1.080
150	4.50	4.95	927	4.88	2.66	1.589	1.076
155	4.68	4.94	927	4.92	2.64	1.588	1.046
160	4.58	4.95	927	4.90	2.65	1.588	1.063
165	4.58	4.95	927	4.90	2.65	1.588	1.063
170	4.58	4.95	927	4.90	2.65	1.588	1.063
175	4.58	4.95	927	4.90	2.65	1.588	1.063
180	-	-	-	-	-	-	-

All numerical values of characteristics are presented as average values at the length interval equal to the axial coordinate  $\pm 2.5$  mm

# #H3T

Initial Individual Characteristics of Refabricated Fuel Rods  
(Preirradiated fuel/Preirradiated cladding)

**Table C-3.2. Radial Distribution of Burnup (Calculated) and Isotopic Composition with RIM Zone Indication (Calculated) for Fuel Rod #H3T (average values in fuel rod)**

Characteristic	Coordinates of fuel radial zones (mm)			
	1 zone 1.2 - 2.811	2 zone 2.811 - 3.432	3 zone 3.432 - 3.704	4 zone 3.704 - 3.790
<b>1. Nuclear concentrations (kg/t U):</b>				
U <sup>235</sup>	4.85	4.65	4.47	4.34
U <sup>236</sup>	4.94	4.94	4.94	4.94
U <sup>238</sup>	933.	930.	918.	884.
Pu <sup>239</sup>	4.14	4.60	6.19	10.48
Pu <sup>240</sup>	2.34	2.45	3.12	5.05
Pu <sup>241</sup>	1.274	1.479	2.082	3.712
Pu <sup>242</sup>	0.813	0.970	1.406	2.591
<b>2. Burnup (MWd/kg U)</b>	45.0	47.9	56.2	78.8

## #H3T

Initial Individual Characteristics of Refabricated Fuel Rods  
(Preirradiated fuel, Preirradiated cladding)

Table C-3.3. Individual Initial Characteristics for Fuel Rod #H3T (measured)

Axial coordinate from lower end of fuel rod (mm)	Cladding outer diameter at 0° (mm)	Cladding outer diameter at 90° (mm)	Fuel mass (g) (density- $10.13^4$ ) g/cm <sup>3</sup> *)	Linear fuel mass (g/cm)*	Free gas volume (mm <sup>3</sup> *) <sup>5</sup>	Burnup (MWd/kg U)*
5	-	-	0.0	0.0	8.8	-
10	-	-	0.0	0.0	98.9	0.0
15	-	-	0.0	0.0	34.0	0.0
20 <sup>1)</sup>	-	-	0.92	3.06	143.5	49.5 <sup>3)</sup>
25	-	-	1.16	2.32	119.9	49.5 <sup>3)</sup>
30	-	-	1.52	3.05	84.4	49.5 <sup>3)</sup>
35	-	-	2.04	4.08	33.3	48.8
40	-	-	2.01	4.02	36.2	48.8
45	9.103	9.115	1.96	3.92	41.1	48.0
50	9.104	9.113	1.95	3.91	42.1	47.9
55	9.106	9.112	1.96	3.93	41.1	47.5
60	9.112	9.106	1.99	3.98	38.2	47.5
65	9.109	9.094	2.02	4.05	35.2	47.6
70	9.106	9.095	2.03	4.07	34.2	47.6
75	9.101	9.103	2.01	4.01	36.2	48.2
80	9.103	9.113	1.98	3.96	39.2	48.2
85	9.106	9.116	1.97	3.95	40.1	48.8
90	9.104	9.112	1.99	3.97	38.2	48.8
95	9.094	9.115	2.01	4.02	36.2	49.5
100	9.092	9.110	2.05	4.10	32.3	49.5
105	9.098	9.106	2.08	4.15	29.3	50.0
110	9.104	9.113	2.07	4.14	30.3	50.0
115	9.104	9.118	2.06	4.12	31.3	49.9
120	9.104	9.124	2.05	4.10	32.3	50.0
125	9.101	9.116	2.06	4.13	31.3	50.2
130	9.101	9.103	2.08	4.16	29.3	50.2
135	9.106	9.100	2.10	4.20	27.3	50.1
140	9.109	9.100	2.12	4.25	25.4	50.2
145	9.119	9.103	2.14	4.29	23.4	50.3
150	9.119	9.106	2.14	4.29	23.4	50.2
155	9.122	9.104	2.16	4.33	21.4	49.4
160	9.109	9.103	1.84	3.68	52.9	49.9 <sup>3)</sup>
165	9.098	9.106	1.80	3.61	56.9	49.9 <sup>3)</sup>
170	9.104	9.112	1.71	3.41	65.7	49.9 <sup>3)</sup>
175 <sup>2)</sup>	9.100	9.113	0.63	3.15	172.0	49.9 <sup>3)</sup>
180	9.110	9.115	0.0	0.0	114.8	0.0

\* These numerical values of characteristics are presented as average values at the length interval equal to the axial coordinate  $\pm 2.5$  mm<sup>1)</sup> Initial coordinate of fuel is 11.5 mm<sup>4)</sup> Effective density of fuel stack<sup>2)</sup> Final coordinate of fuel is 166.5 mm<sup>5)</sup> Free gas volume for coordinates 185 - 295 mm is presented in Table C.3<sup>3)</sup> Average value

#H3T

Initial Individual Characteristics of Refabricated Fuel Rods  
(Preirradiated fuel, Preirradiated cladding)

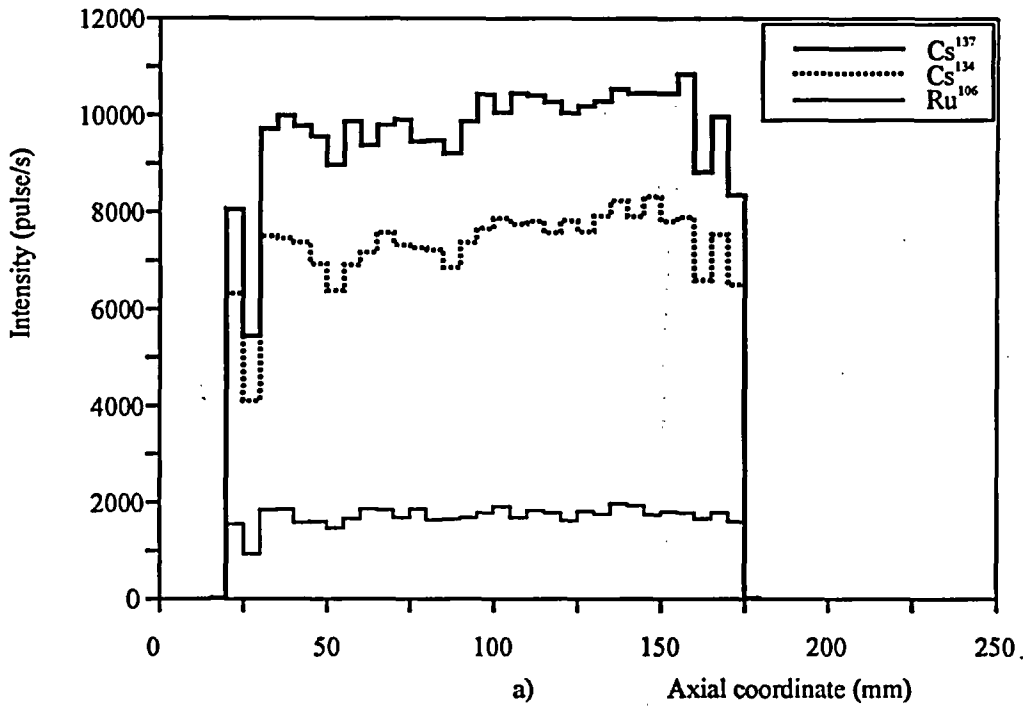

b)

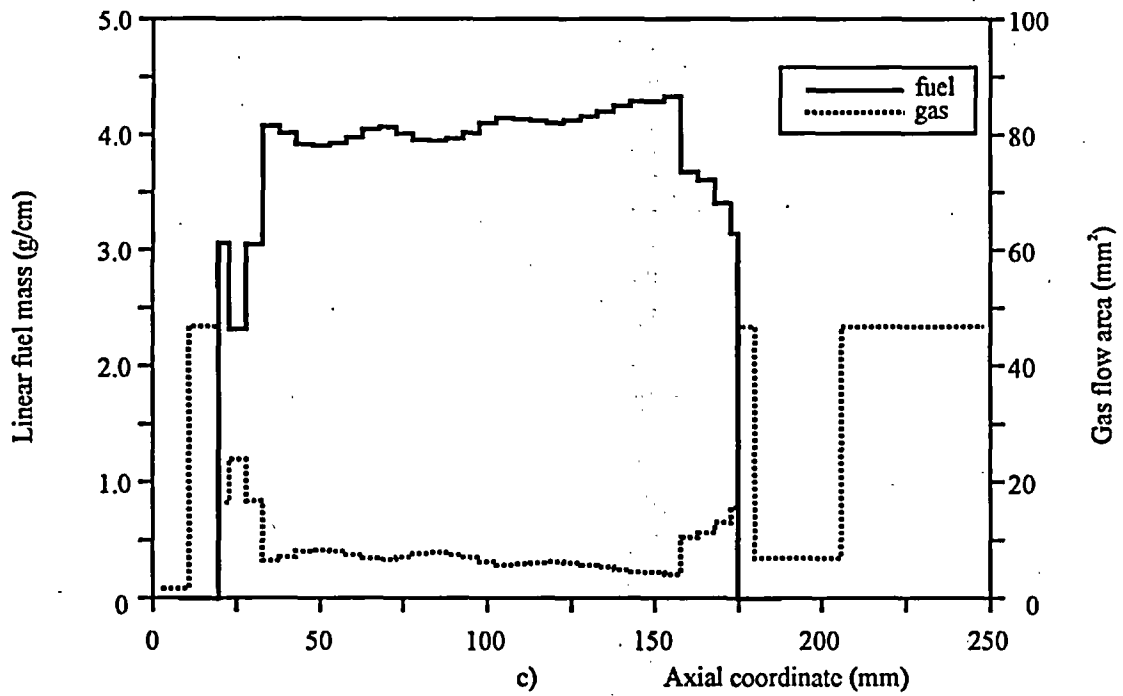

Fig. C-3.1. (a) Results of  $\gamma$ -scanning, (b) Radiography, (c) Axial Fuel Mass Distribution and Axial Free Gas Volume Distribution for Fuel Rod #H3T

#H3T

Initial Individual Characteristics of Refabricated Fuel Rods  
(Preirradiated fuel, Preirradiated cladding)

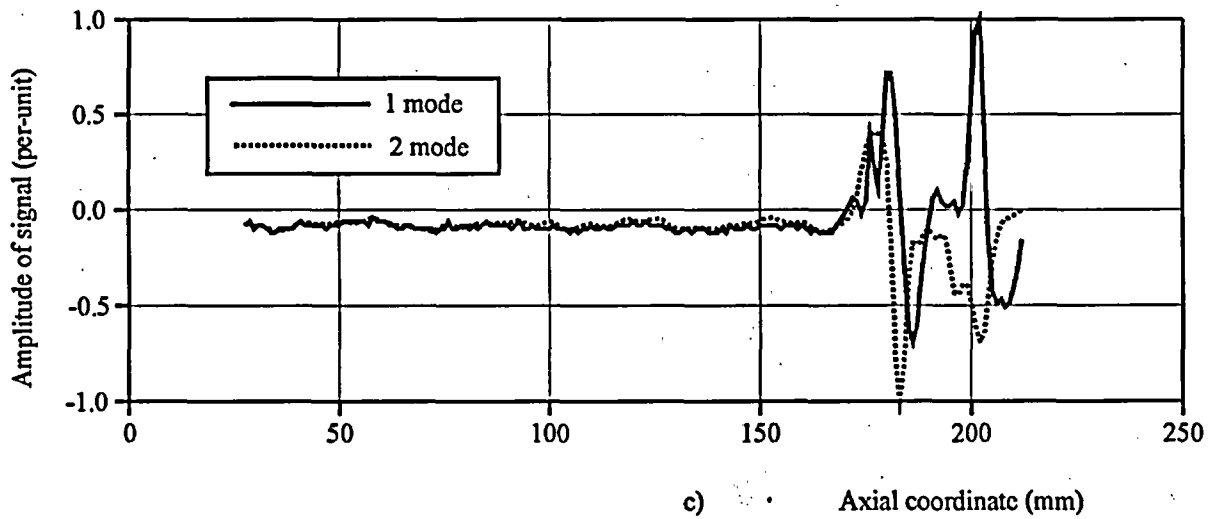
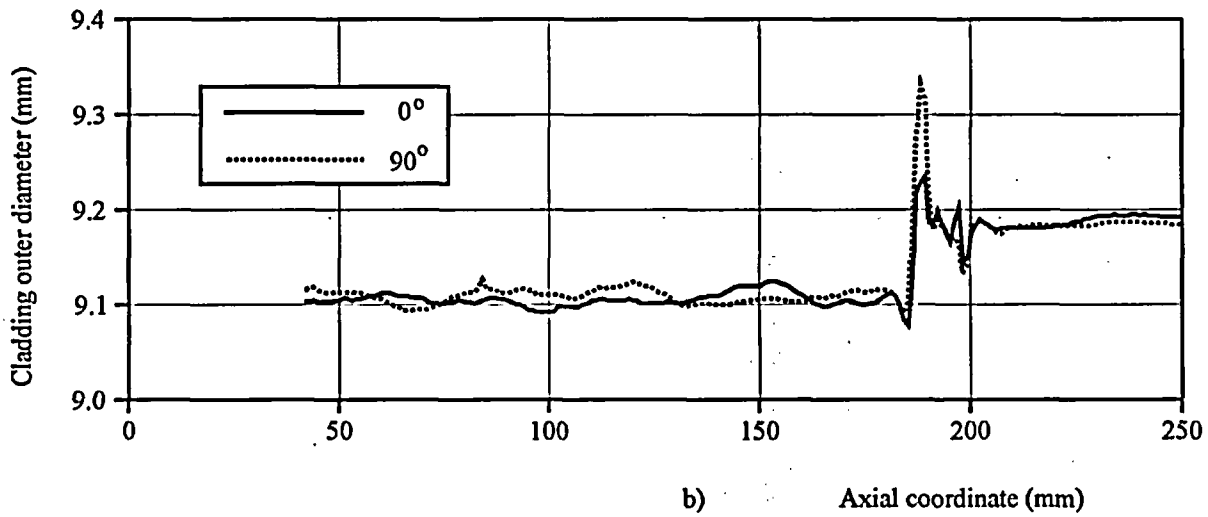
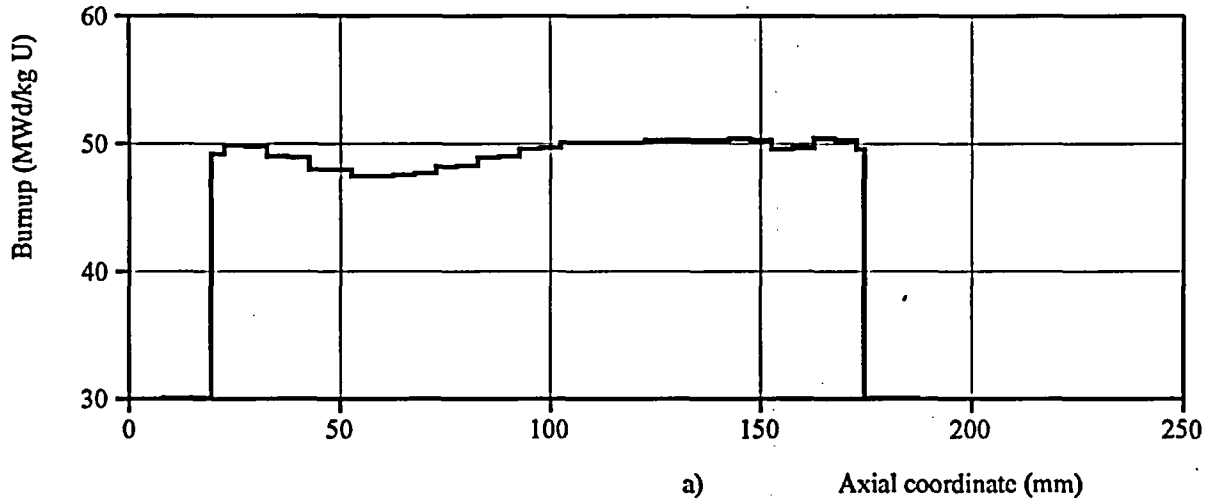

Fig. C-3.2. (a) Axial Burnup Distribution and (b) Results of Profilometry and (c) Eddy-Current Examination for Fuel Rod #H3T

#H3T

Initial Individual Characteristics of Refabricated Fuel Rods  
(Preirradiated fuel, Preirradiated cladding)

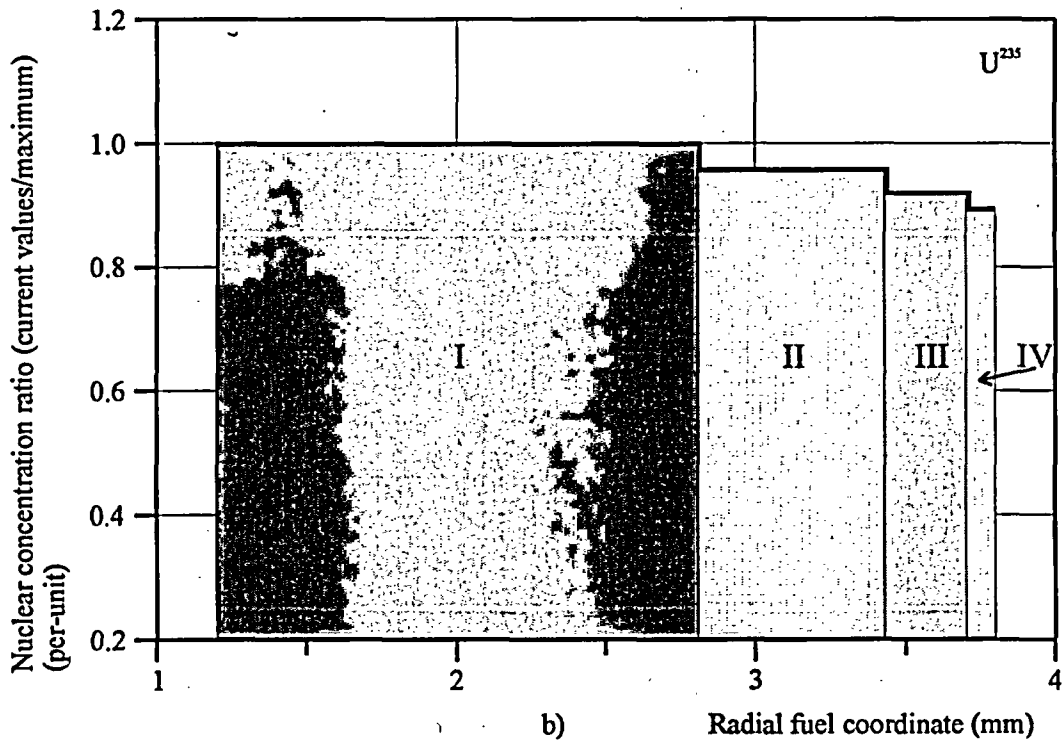
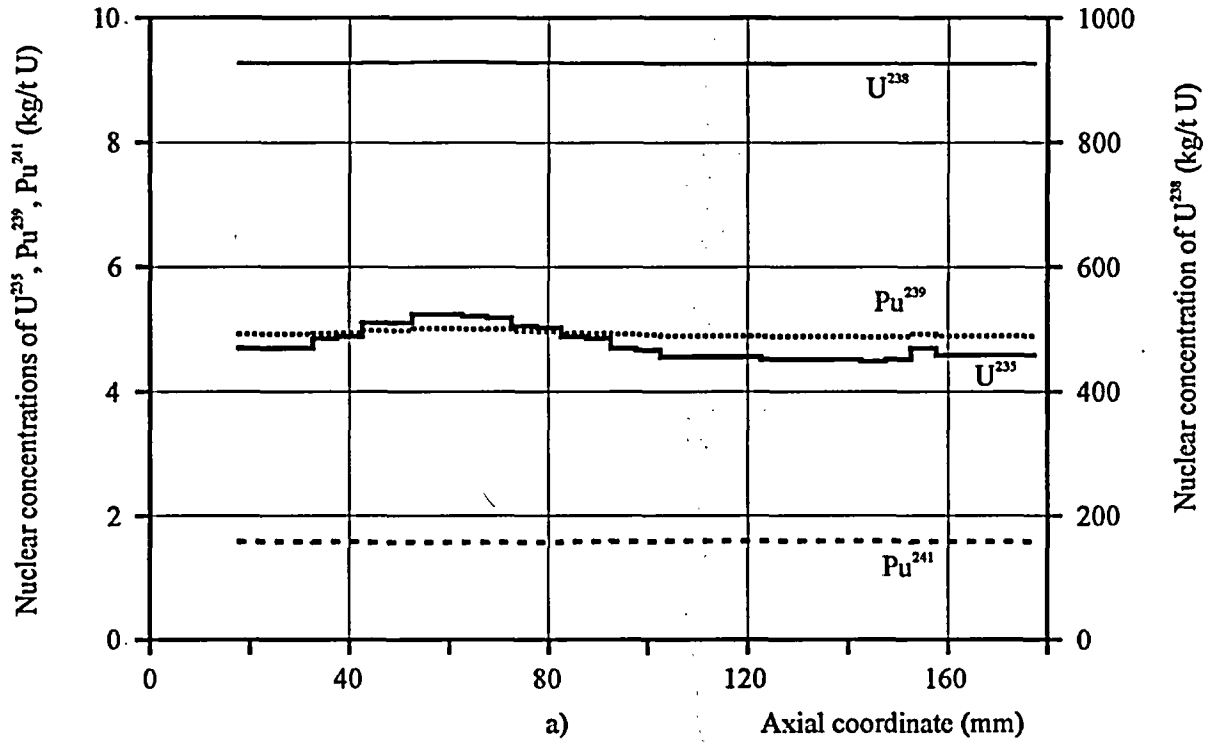

Fig. C-3.3. (a) Axial Distribution of  $U^{235}$ ,  $U^{238}$ ,  $Pu^{239}$ ,  $Pu^{241}$  Isotopes and (b) Radial Distribution of  $U^{235}$  Isotope for Fuel Rod #H3T (calculated)

#H3T

Initial Individual Characteristics of Refabricated Fuel Rods  
(Preirradiated fuel, Preirradiated cladding)

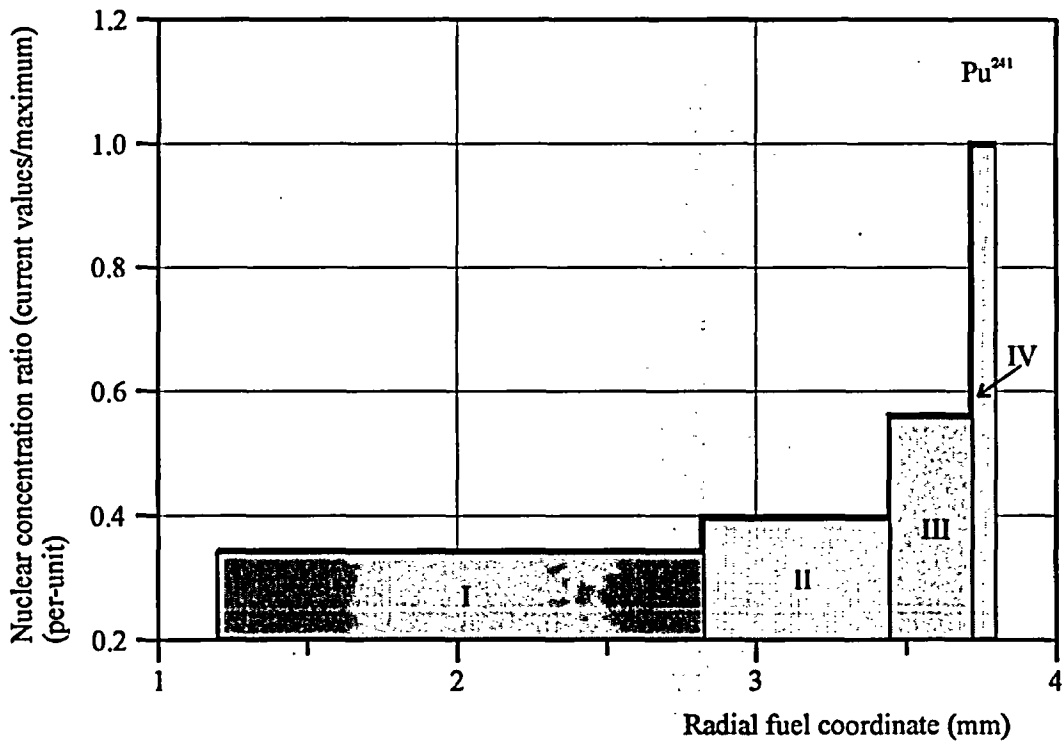
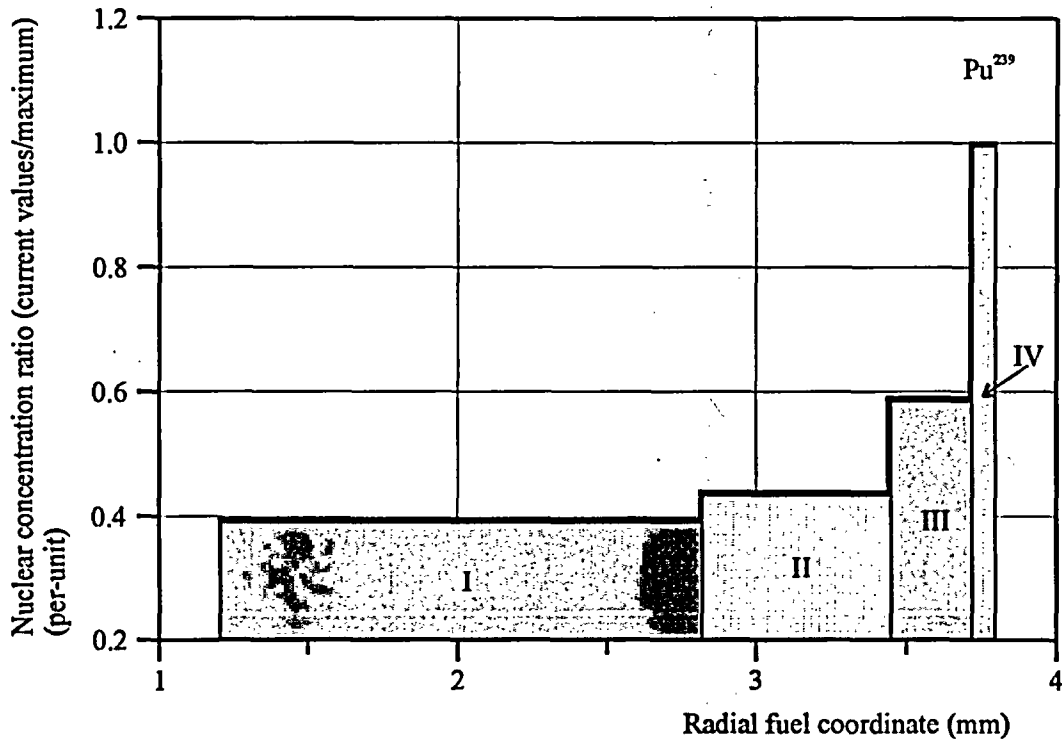

Fig. C-3.4. Radial Distribution of  $Pu^{239}$ ,  $Pu^{241}$  Isotopes for Fuel Rod #H3T (calculated)



#H3T

Initial Individual Characteristics of Refabricated Fuel Rods  
(Preirradiated fuel, Preirradiated cladding)

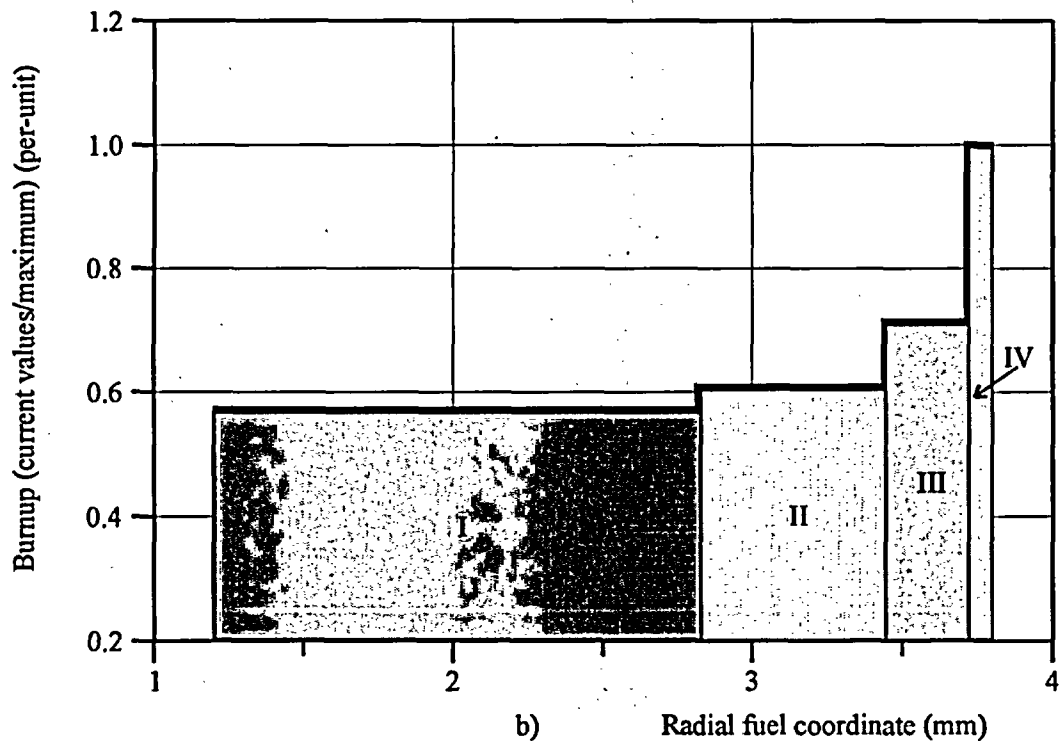
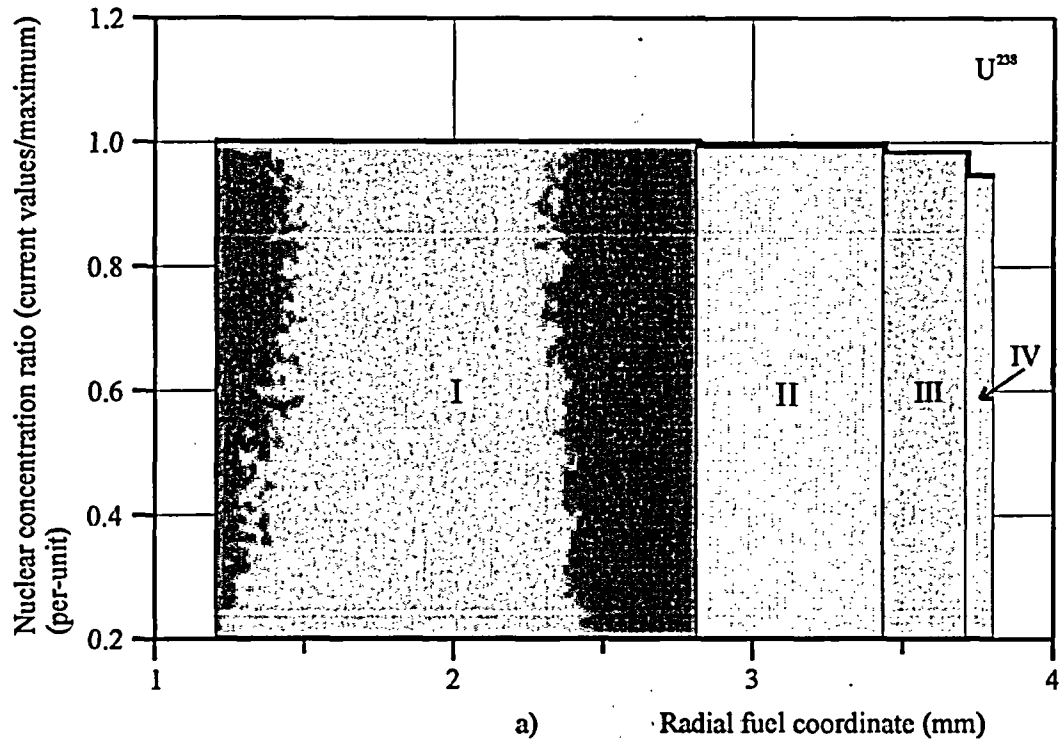

Fig. C-3.5. (a) Radial Distribution of  $U^{238}$  Isotope and (b) Burnup for Fuel Rod #H3T (calculated)



**APPENDIX C-4.**

*Initial Individual Characteristics for Fuel Rod #H4T*

## #H4T

Initial Individual Characteristics of Refabricated Fuel Rods  
(Preirradiated fuel, Preirradiated cladding)

Table C-4.1. Axial Distribution of Isotopic Composition for Fuel Rod #H4T (calculated)

Axial coordinate from lower end of fuel rod (mm)	Nuclear concentrations (kg/t U)						
	U <sup>235</sup>	U <sup>236</sup>	U <sup>238</sup>	Pu <sup>239</sup>	Pu <sup>240</sup>	Pu <sup>241</sup>	Pu <sup>242</sup>
10	4.91	4.93	927	5.12	2.68	1.657	1.047
15	4.91	4.93	927	5.12	2.68	1.657	1.047
20	4.91	4.93	927	5.12	2.68	1.657	1.047
25	4.91	4.93	927	5.12	2.68	1.657	1.047
30	5.24	4.91	928	5.17	2.65	1.647	0.997
35	5.15	4.91	927	5.15	2.66	1.649	1.009
40	5.13	4.92	927	5.15	2.66	1.650	1.013
45	5.04	4.92	927	5.14	2.67	1.654	1.026
50	5.02	4.92	927	5.14	2.67	1.655	1.030
55	5.10	4.92	927	5.15	2.66	1.651	1.018
60	5.13	4.92	927	5.15	2.66	1.650	1.013
65	5.13	4.92	927	5.15	2.66	1.650	1.013
70	5.13	4.92	927	5.15	2.66	1.650	1.013
75	5.35	4.90	928	5.19	2.63	1.645	0.980
80	5.43	4.89	928	5.20	2.62	1.643	0.968
85	5.46	4.89	928	5.21	2.62	1.643	0.964
90	5.49	4.88	928	5.21	2.61	1.642	0.959
95	5.40	4.89	928	5.20	2.63	1.644	0.972
100	5.37	4.89	928	5.19	2.63	1.645	0.976
105	5.46	4.89	928	5.21	2.62	1.643	0.964
110	5.49	4.88	928	5.21	2.61	1.642	0.959
115	5.43	4.89	928	5.20	2.62	1.643	0.968
120	5.37	4.89	928	5.19	2.63	1.645	0.976
125	5.18	4.91	927	5.16	2.65	1.649	1.005
130	5.10	4.92	927	5.15	2.66	1.651	1.018
135	5.04	4.92	927	5.14	2.67	1.654	1.026
140	5.02	4.92	927	5.14	2.67	1.655	1.030
145	4.96	4.93	927	5.13	2.68	1.657	1.039
150	4.91	4.93	927	5.12	2.68	1.657	1.047
155	5.02	4.92	927	5.14	2.67	1.655	1.030
160	5.07	4.92	927	5.14	2.67	1.652	1.022
165	4.91	4.93	927	5.12	2.68	1.657	1.047

All numerical values of characteristics are presented as average values at the length interval equal to the axial coordinate  $\pm 2.5$  mm

# #H4T

Initial Individual Characteristics of Refabricated Fuel Rods  
(Preirradiated fuel, Preirradiated cladding)

**Table C-4.2. Radial Distribution of Burnup (Calculated) and Isotopic Composition with RIM Zone Indication (Calculated) for Fuel Rod #H4T (average values in fuel rod)**

Characteristic	Coordinates of fuel radial zones (mm)			
	1 zone 1.2 - 2.811	2 zone 2.811 - 3.432	3 zone 3.432 - 3.704	4 zone 3.704 - 3.790
1. Nuclear concentrations (kg/t U):				
U <sup>235</sup>	5.28	5.07	4.87	4.74
U <sup>236</sup>	4.92	4.92	4.92	4.92
U <sup>238</sup>	933.	930.	917.	884.
Pu <sup>239</sup>	4.32	4.81	6.48	10.99
Pu <sup>240</sup>	2.36	2.47	3.16	5.12
Pu <sup>241</sup>	1.320	1.536	2.168	3.872
Pu <sup>242</sup>	0.790	0.944	1.370	2.526
2. Burnup (MWd/kg U)	44.5	47.3	55.6	77.9

## #H4T

Initial Individual Characteristics of Refabricated Fuel Rods  
(Preirradiated fuel, Preirradiated cladding)

Table C-4.3. Individual Initial Characteristics for Fuel Rod #H4T (measured)

Axial coordinate from lower end of fuel rod (mm)	Cladding outer diameter at 0° (mm)	Cladding outer diameter at 90° (mm)	Fuel mass (g) (density- $10.13^4$ g/cm <sup>3</sup> )*	Linear fuel mass (g/cm)*	Free gas volume (mm <sup>3</sup> ) <sup>5)</sup>	Burnup (MWd/kg U)*
5	-	-	0.0	0.0	8.8	-
10 <sup>1)</sup>	-	-	0.10	1.03	89.1	49.6 <sup>3)</sup>
15	-	-	0.65	1.29	170.1	49.6 <sup>3)</sup>
20	-	-	1.17	2.33	118.9	49.6 <sup>3)</sup>
25	-	-	1.21	2.43	114.9	49.6 <sup>3)</sup>
30	-	-	2.07	4.15	30.3	48.4
35	-	-	2.08	4.16	29.3	48.6
40	-	-	2.05	4.10	32.3	48.7
45	9.102	9.108	2.04	4.08	33.3	49.0
50	9.108	9.108	2.02	4.04	35.2	49.1
55	9.113	9.108	2.01	4.02	36.2	48.9
60	9.114	9.108	2.02	4.03	35.2	48.8
65	9.108	9.110	2.04	4.08	33.3	48.7
70	9.101	9.104	2.06	4.12	31.3	48.7
75	9.102	9.095	2.09	4.17	28.3	47.9
80	9.114	9.078	2.12	4.24	25.4	47.6
85	9.126	9.076	2.12	4.24	25.4	47.5
90	9.125	9.090	2.08	4.15	29.3	47.5
95	9.126	9.090	2.06	4.13	31.3	47.7
100	9.128	9.087	2.06	4.13	31.3	47.8
105	9.116	9.088	2.07	4.14	30.3	47.5
110	9.110	9.095	2.06	4.13	31.3	47.4
115	9.096	9.098	2.08	4.16	29.3	47.7
120	9.105	9.091	2.08	4.16	29.3	47.8
125	9.119	9.087	2.06	4.11	31.3	48.6
130	9.113	9.087	2.02	4.04	35.2	48.9
135	9.104	9.093	1.99	3.99	38.2	49.1
140	9.099	9.098	1.98	3.95	39.2	49.1
145	9.111	9.093	1.96	3.91	41.1	49.4
150	9.122	9.082	1.95	3.91	42.1	49.5
155	9.128	9.078	1.95	3.90	42.1	49.1
160	9.119	9.091	2.01	4.03	36.2	49.0
165 <sup>2)</sup>	9.107	9.098	1.56	3.88	80.5	49.5
170	9.110	9.104	0.0	0.0	234.0	0.0
175	9.119	9.102	0.0	0.0	234.0	0.0
180	9.128	9.102	0.0	0.0	114.8	0.0

\* These numerical values of characteristics are presented as average values at the length interval equal to the axial coordinate  $\pm 2.5$  mm

1) Initial coordinate of fuel is 11.5 mm

4) Effective density of fuel stack

2) Final coordinate of fuel is 166.5 mm

5) Free gas volume for coordinates 185 - 295 mm is presented in Table C.3

3) Average value

# #H4T

Initial Individual Characteristics of Refabricated Fuel Rods  
(Preirradiated fuel, Preirradiated cladding)

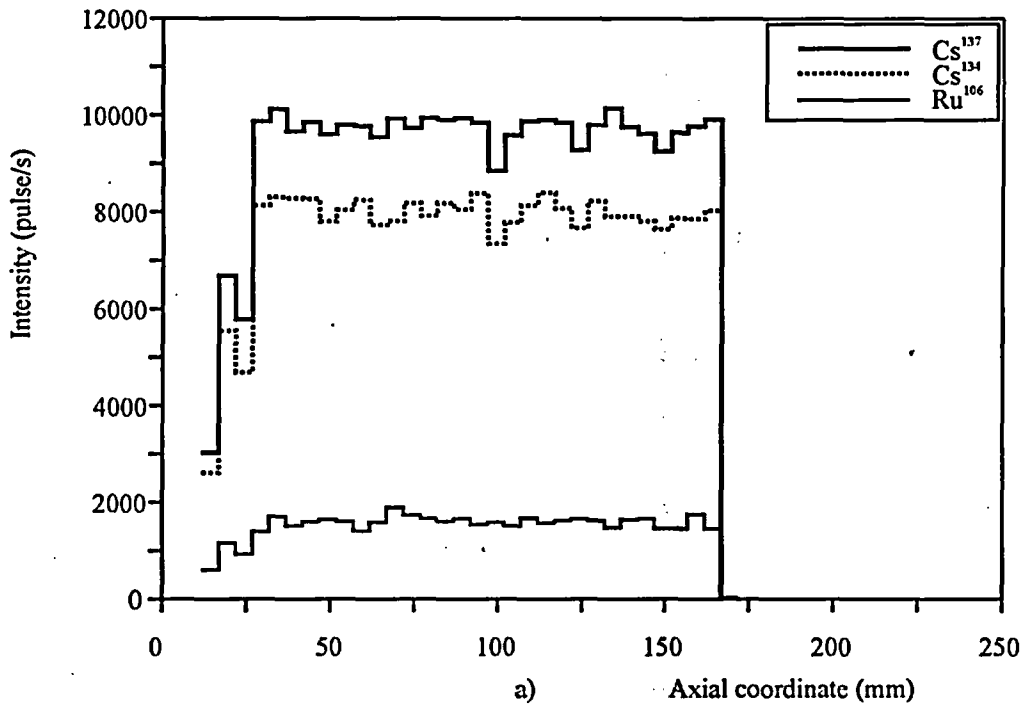

b)

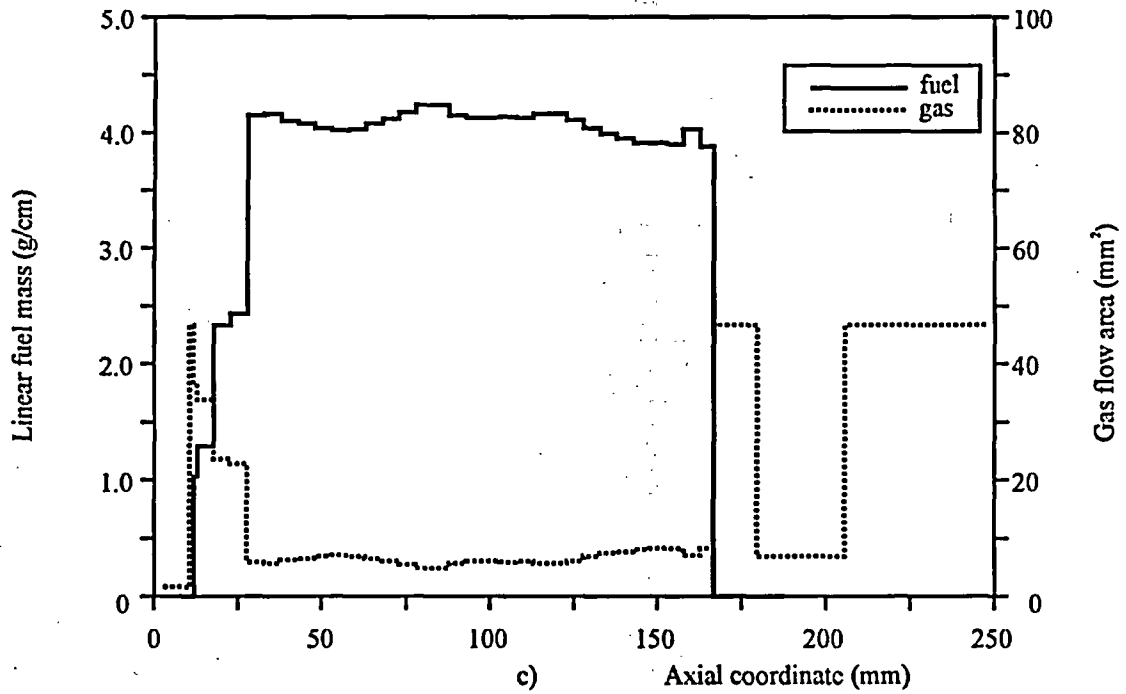

Fig. C-4.1. (a) Results of  $\gamma$ -scanning, (b) Radiography, (c) Axial Fuel Mass Distribution and Axial Free Gas Volume Distribution for Fuel Rod #H4T

# #H4T

Initial Individual Characteristics of Refabricated Fuel Rods  
(Preirradiated fuel, Preirradiated cladding)

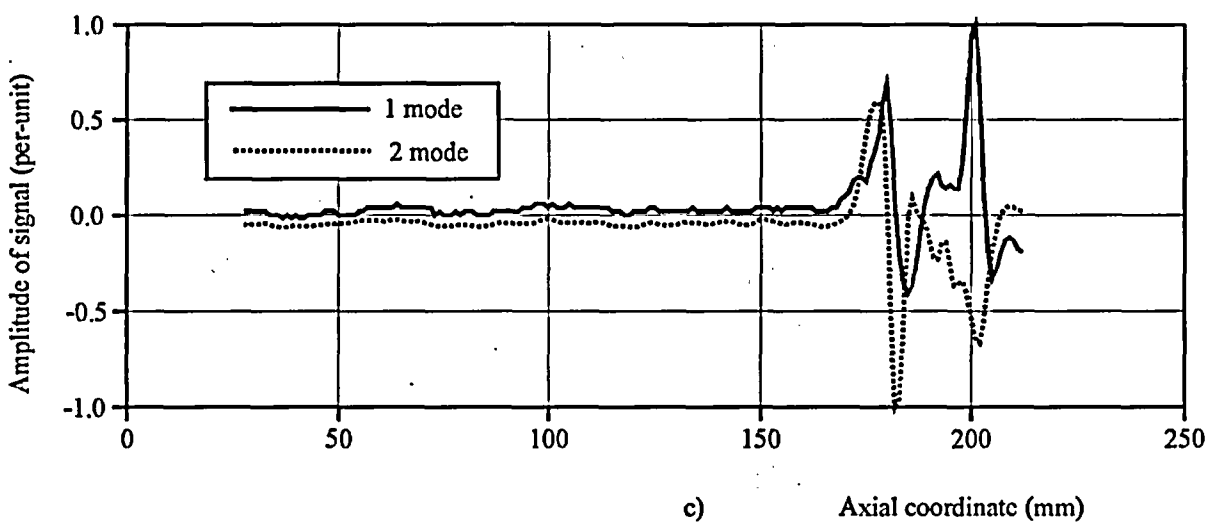
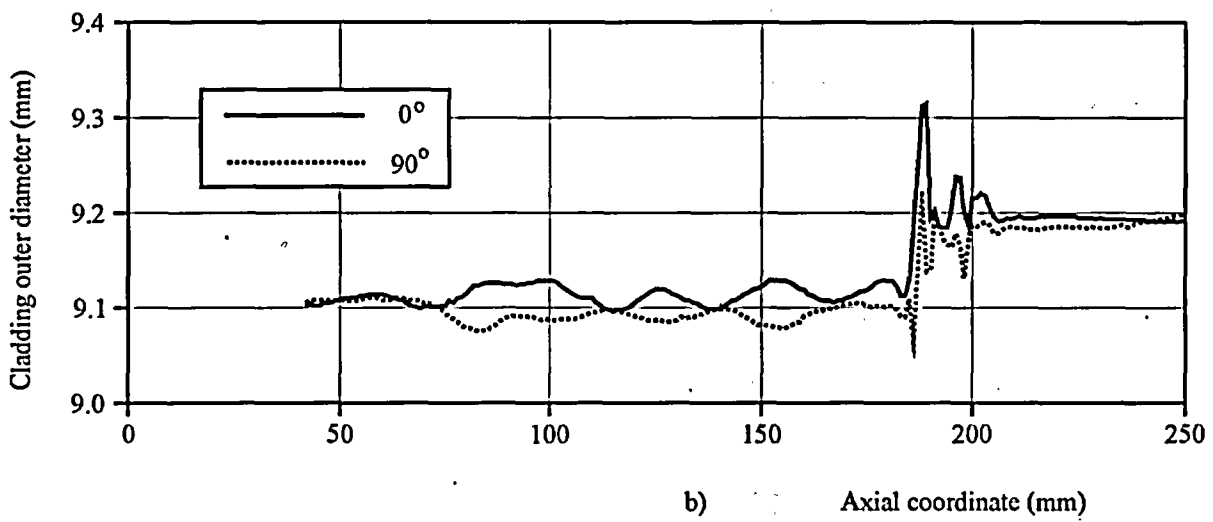
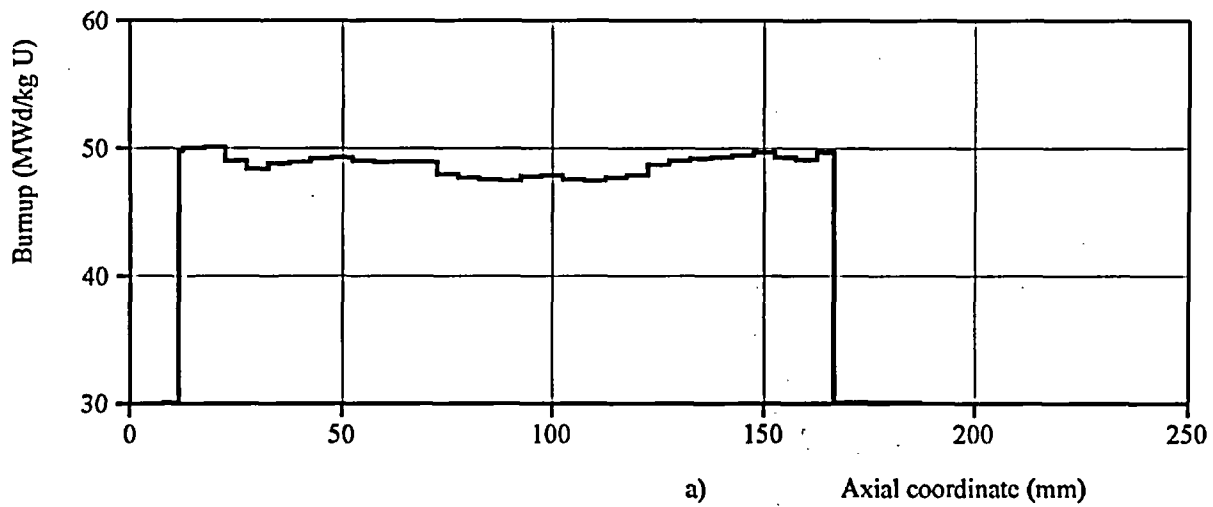

Fig. C-4.2. (a) Axial Burnup Distribution and (b) Results of Profilometry and (c) Eddy-Current Examination for Fuel Rod #H4T



# #H4T

Initial Individual Characteristics of Refabricated Fuel Rods  
(Preirradiated fuel, Preirradiated cladding)

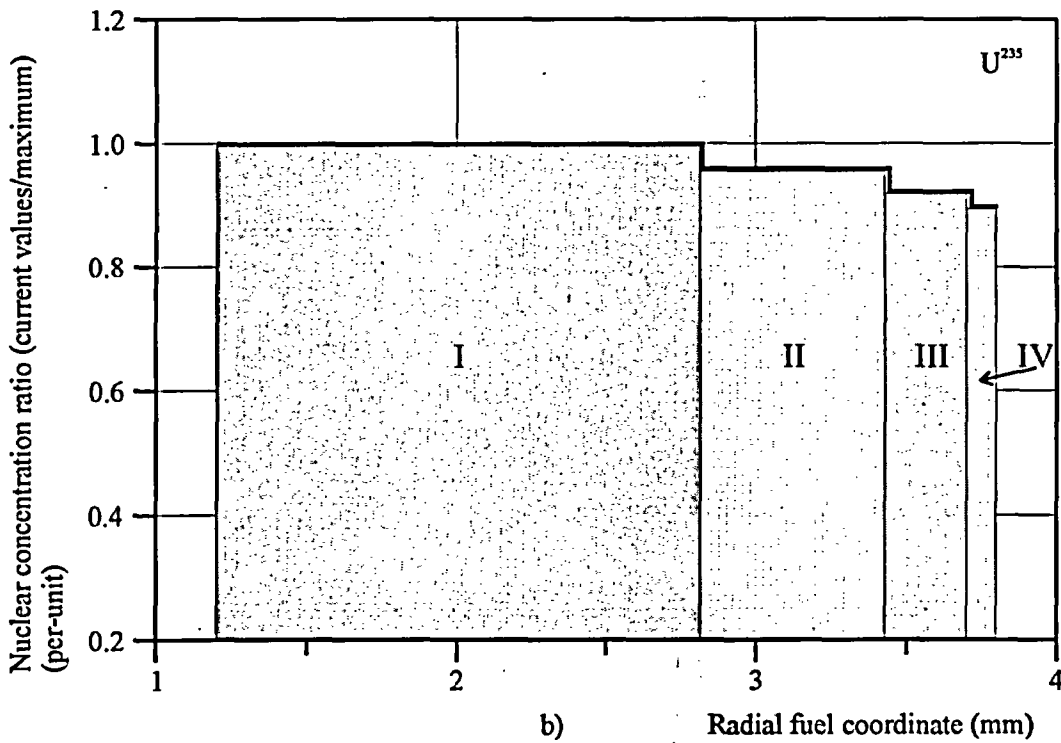
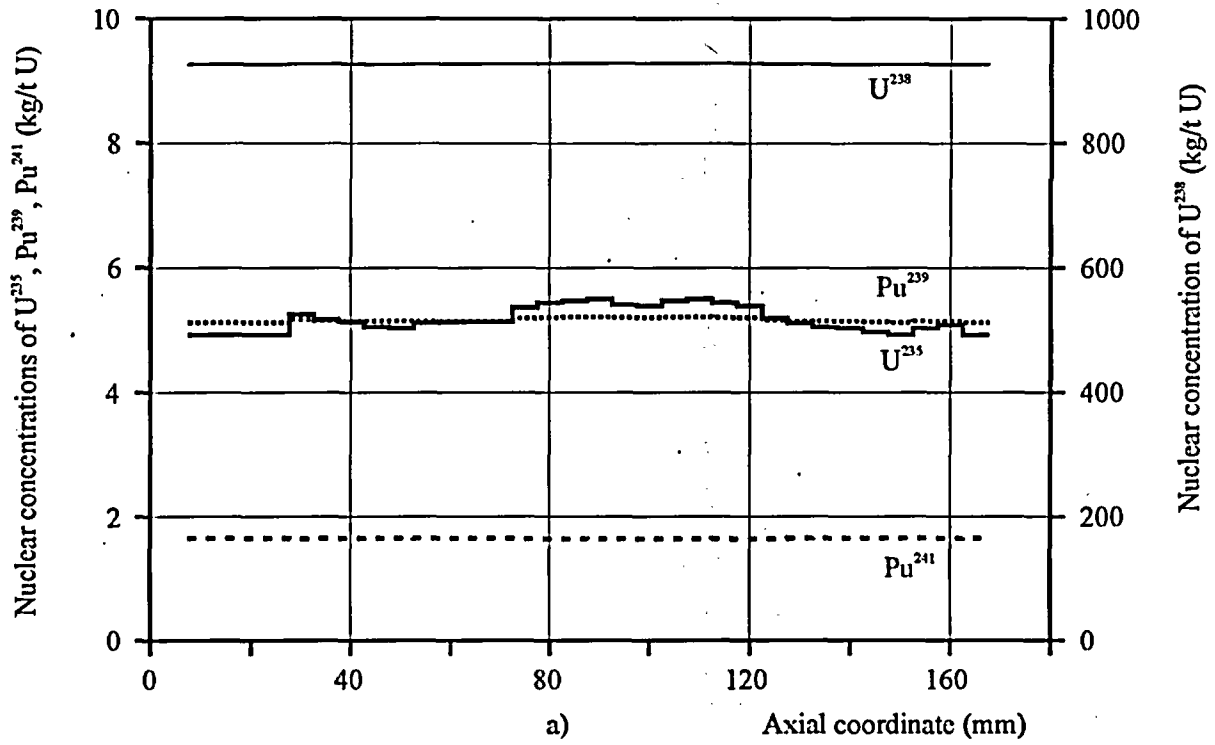

Fig. C-4.3. (a) Axial Distribution of  $U^{235}$ ,  $U^{238}$ ,  $Pu^{239}$ ,  $Pu^{241}$  Isotopes and (b) Radial Distribution of  $U^{235}$  Isotope for Fuel Rod #H4T (calculated)

#H4T

Initial Individual Characteristics of Refabricated Fuel Rods  
(Preirradiated fuel, Preirradiated cladding)

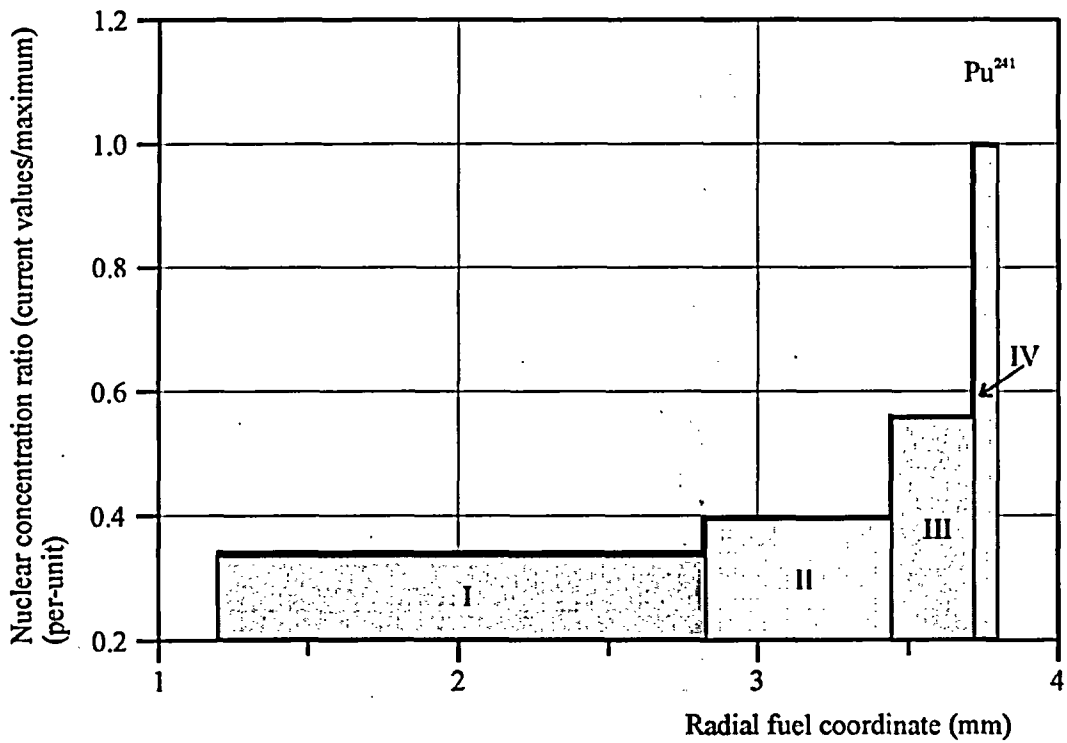
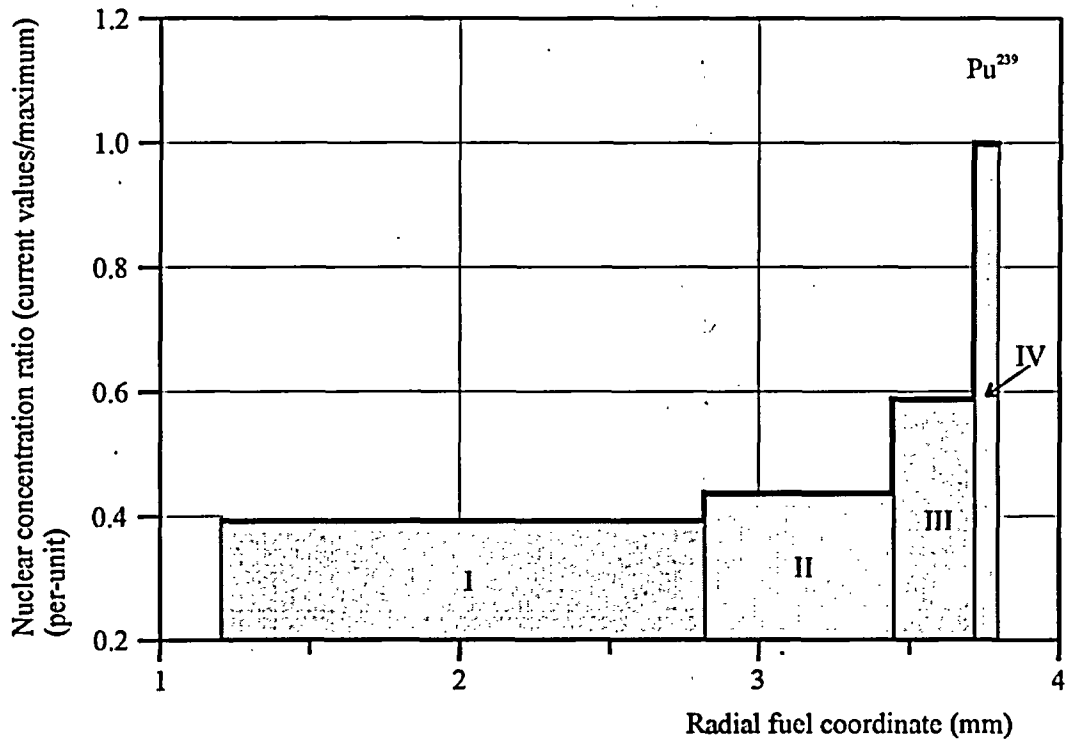

Fig. C-4.4. Radial Distribution of  $Pu^{239}$ ,  $Pu^{241}$  Isotopes for Fuel Rod #H4T (calculated)

# #H4T

Initial Individual Characteristics of Refabricated Fuel Rods  
(Preirradiated fuel, Preirradiated cladding)

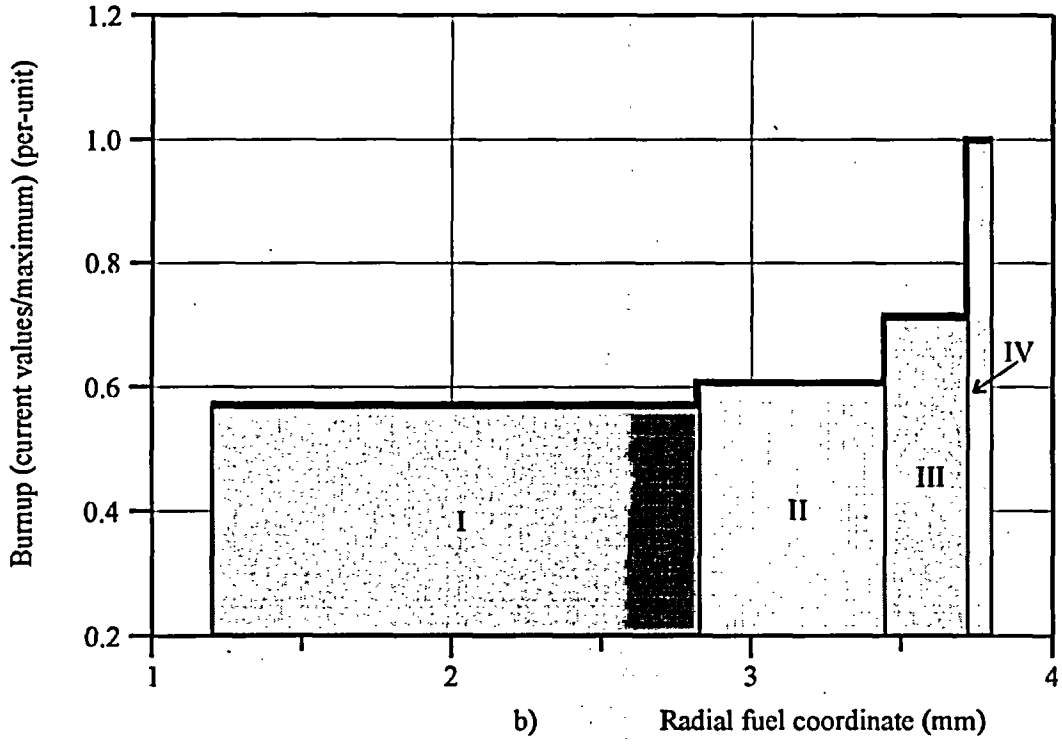
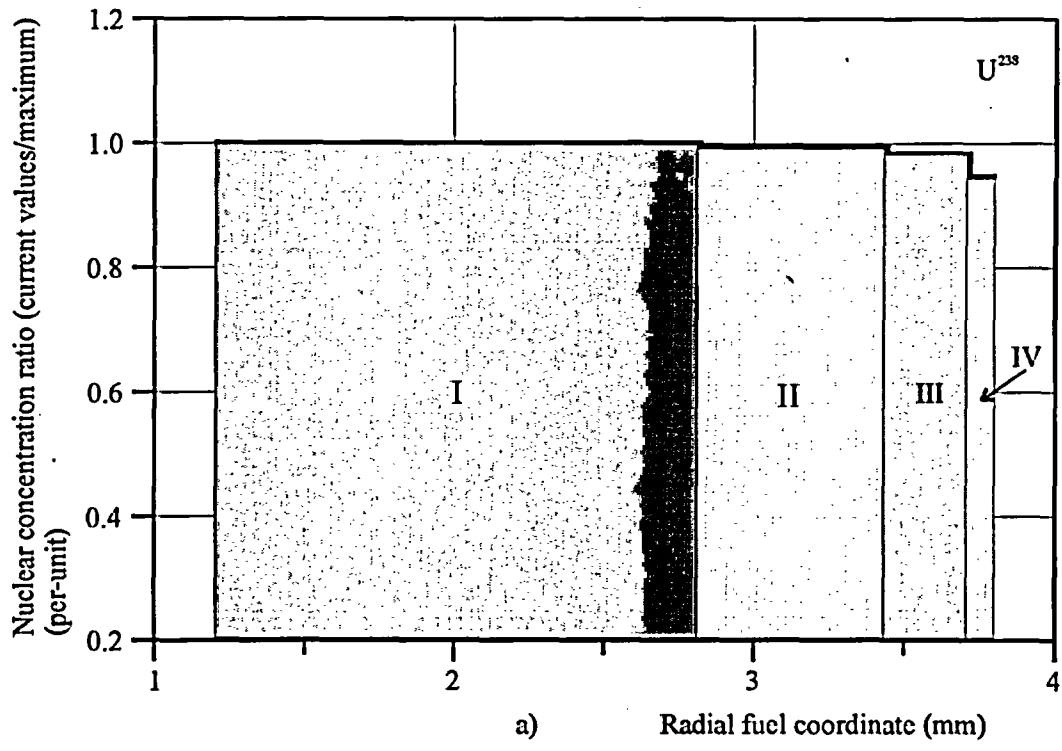
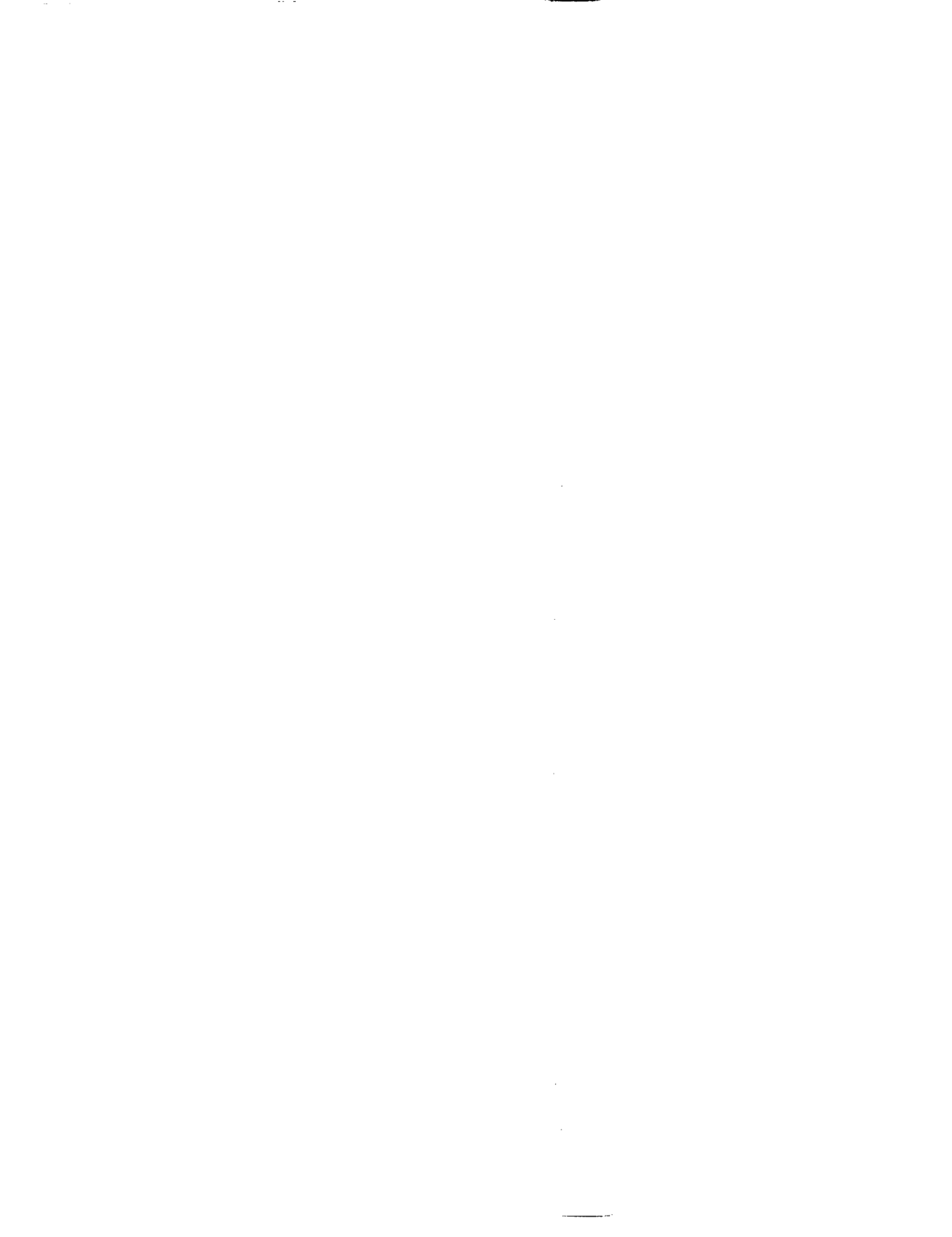

Fig. C-4.5. (a) Radial Distribution of  $U^{238}$  Isotope and (b) Burnup for Fuel Rod #H4T (calculated)



**APPENDIX C-5.**

***Initial Individual Characteristics for Fuel Rod #H5T***

# #H5T

Initial Individual Characteristics of Refabricated Fuel Rods  
(Preirradiated fuel, Preirradiated cladding)

Table C-5.1. Axial Distribution of Isotopic Composition for Fuel Rod #H5T (calculated)

Axial coordinate from lower end of fuel rod (mm)	Nuclear concentrations (kg/t U)						
	U <sup>235</sup>	U <sup>236</sup>	U <sup>238</sup>	Pu <sup>239</sup>	Pu <sup>240</sup>	Pu <sup>241</sup>	Pu <sup>242</sup>
20	-	-	-	-	-	-	-
25	5.41	4.90	927	5.31	2.67	1.689	0.991
30	5.41	4.90	927	5.31	2.67	1.689	0.991
35	5.41	4.90	927	5.31	2.67	1.689	0.991
40	5.41	4.90	927	5.31	2.67	1.689	0.991
45	5.72	4.87	928	5.36	2.63	1.680	0.946
50	5.75	4.87	928	5.67	2.62	1.679	0.942
55	5.69	4.87	928	5.36	2.63	1.681	0.950
60	5.52	4.89	928	5.33	2.65	1.686	0.975
65	5.47	4.89	927	5.32	2.66	1.687	0.983
70	5.27	4.91	927	5.29	2.69	1.692	1.012
75	5.27	4.91	927	5.29	2.69	1.692	1.012
80	5.27	4.91	927	5.29	2.69	1.692	1.012
85	5.27	4.91	927	5.29	2.69	1.692	1.012
90	5.41	4.90	927	5.31	2.67	1.689	0.991
95	5.30	4.91	927	5.29	2.68	1.691	1.007
100	5.09	4.93	926	5.27	2.71	1.700	1.041
105	5.01	4.93	926	5.25	2.72	1.701	1.053
110	4.86	4.95	925	5.22	2.74	1.703	1.079
115	4.83	4.95	925	5.21	2.74	1.703	1.083
120	4.81	4.95	925	5.21	2.74	1.703	1.087
125	4.91	4.94	926	5.23	2.73	1.702	1.070
130	5.14	4.92	926	5.28	2.70	1.699	1.032
135	5.04	4.93	926	5.26	2.71	1.701	1.049
140	4.81	4.95	925	5.21	2.74	1.703	1.087
145	4.91	4.94	926	5.23	2.73	1.702	1.070
150	5.09	4.93	926	5.27	2.71	1.700	1.041
155	5.19	4.92	927	5.28	2.69	1.696	1.024
160	5.14	4.92	926	5.28	2.70	1.699	1.032
165	5.14	4.92	926	5.28	2.70	1.699	1.032
170	5.14	4.92	926	5.28	2.70	1.699	1.032

All numerical values of characteristics are presented as average values at the length interval equal to the axial coordinate  $\pm 2.5$  mm

# #H5T

Initial Individual Characteristics of Refabricated Fuel Rods  
(Preirradiated fuel, Preirradiated cladding)

**Table C-5.2. Radial Distribution of Burnup (Calculated) and Isotopic Composition with RIM Zone Indication (Calculated) for Fuel Rod #H5T (average values in fuel rod)**

Characteristic	Coordinates of fuel radial zones (mm)			
	1 zone 1.2 - 2.811	2 zone 2.811 - 3.432	3 zone 3.432 - 3.704	4 zone 3.704 - 3.790
<b>1. Nuclear concentrations (kg/t U):</b>				
U <sup>235</sup>	5.35	5.13	4.94	4.81
U <sup>236</sup>	4.92	4.92	4.92	4.92
U <sup>238</sup>	933.	929.	917.	883.
Pu <sup>239</sup>	4.43	4.93	6.64	11.27
Pu <sup>240</sup>	2.39	2.51	3.19	5.16
Pu <sup>241</sup>	1.356	1.579	2.229	3.980
Pu <sup>242</sup>	0.799	0.955	1.386	2.552
<b>2. Burnup (MWd/kg U)</b>	44.7	47.6	56.0	78.6

## #H5T

Initial Individual Characteristics of Refabricated Fuel Rods  
(Preirradiated fuel, Preirradiated cladding)

Table C-5.3. Individual Initial Characteristics for Fuel Rod #H5T (measured)

Axial coordinate from lower end of fuel rod (mm)	Cladding outer diameter at 0° (mm)	Cladding outer diameter at 90° (mm)	Fuel mass (g) (density- $10.13^4$ g/cm <sup>3</sup> )*	Linear fuel mass (g/cm)*	Free gas volume (mm <sup>3</sup> ) <sup>5)</sup>	Burnup (MWd/kg U)*
5	-	-	0.0	0.0	8.8	-
10	-	-	0.0	0.0	98.9	-
15	-	-	0.0	0.0	234.0	-
20	-	-	0.0	0.0	234.0	-
25 <sup>1)</sup>	-	-	1.71	3.81	65.7	47.3 <sup>3)</sup>
30	-	-	1.19	2.38	116.9	47.3 <sup>3)</sup>
35	-	-	1.33	2.65	103.1	47.3 <sup>3)</sup>
40	-	-	1.64	3.29	72.6	47.3 <sup>3)</sup>
45	9.092	9.078	2.20	4.39	17.5	46.2
50	9.088	9.074	2.27	4.54	10.6	46.1
55	9.081	9.081	2.24	4.47	13.6	46.3
60	9.078	9.083	2.15	4.30	22.4	46.9
65	9.088	9.075	2.03	4.06	34.2	47.1
70	9.091	9.074	1.99	3.98	38.2	47.8 <sup>3)</sup>
75	9.080	9.072	1.85	3.70	52.0	47.8 <sup>3)</sup>
80	9.081	9.078	0.93	1.87	142.5	47.8 <sup>3)</sup>
85	9.080	9.075	0.91	1.81	144.5	47.8 <sup>3)</sup>
90	9.086	9.072	2.15	4.30	22.4	47.3
95	9.092	9.066	2.11	4.23	26.4	47.7
100	9.091	9.066	2.07	4.14	30.3	48.5
105	9.080	9.075	2.04	4.08	33.3	48.8
110	9.080	9.081	2.01	4.01	36.2	49.4
115	9.091	9.074	2.00	4.00	37.2	49.5
120	9.097	9.072	2.01	4.01	36.2	49.6
125	9.088	9.071	2.01	4.02	36.2	49.2
130	9.081	9.080	2.01	4.02	36.2	48.3
135	9.075	9.080	2.02	4.04	35.2	48.7
140	9.078	9.080	2.02	4.05	35.2	49.6
145	9.086	9.077	2.03	4.06	34.2	49.2
150	9.095	9.089	2.05	4.09	32.3	48.5
155	9.091	9.089	2.08	4.15	29.3	48.1
160	9.083	9.089	1.73	3.46	63.8	48.3 <sup>3)</sup>
165	9.092	9.080	1.11	2.22	124.8	48.3 <sup>3)</sup>
170	9.095	9.074	1.13	2.26	122.8	48.3 <sup>3)</sup>
175	9.080	9.080	1.47	2.93	89.4	48.3 <sup>3)</sup>
180 <sup>2)</sup>	9.066	9.104	0.54	3.63	61.7	48.3 <sup>3)</sup>

\* These numerical values of characteristics are presented as average values at the length interval equal to the axial coordinate  $\pm 2.5$  mm

1) Initial coordinate of fuel is 23.0 mm

4) Effective density of fuel stack

2) Final coordinate of fuel is 179 mm

5) Free gas volume for coordinates 185 - 295 mm is presented in Table C.3

3) Average value



#H5T

Initial Individual Characteristics of Refabricated Fuel Rods  
(Preirradiated fuel, Preirradiated cladding)

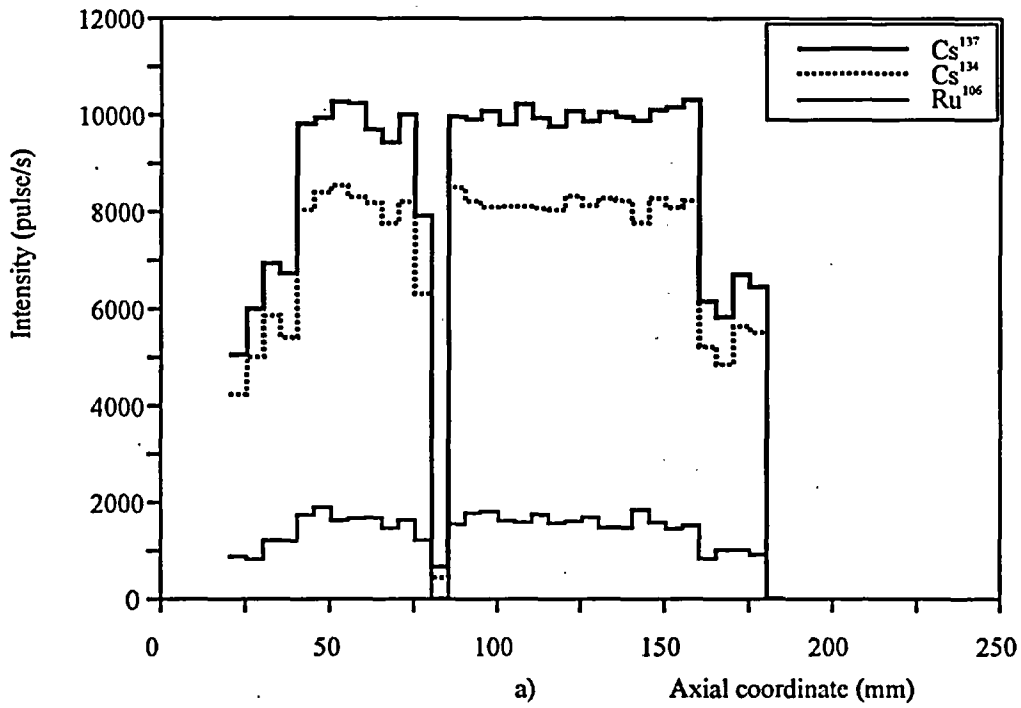

b)

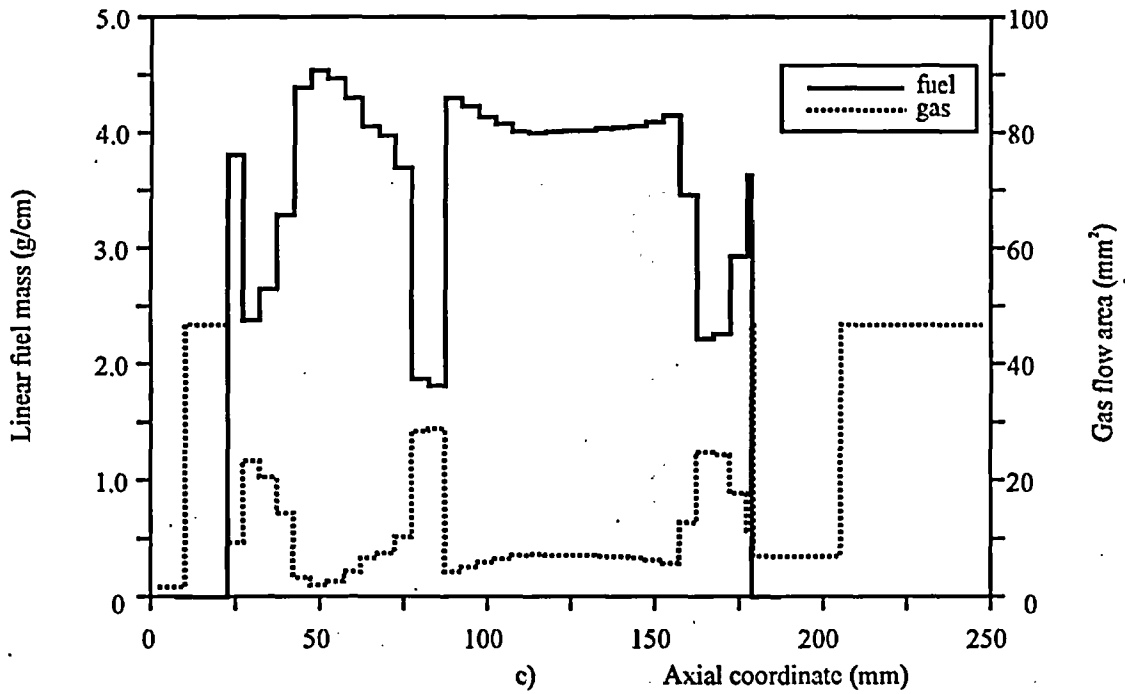

Fig. C-5.1. (a) Results of  $\gamma$ -scanning, (b) Radiography, (c) Axial Fuel Mass Distribution and Axial Free Gas Volume Distribution for Fuel Rod #H5T

# #H5T

Initial Individual Characteristics of Refabricated Fuel Rods  
(Preirradiated fuel, Preirradiated cladding)

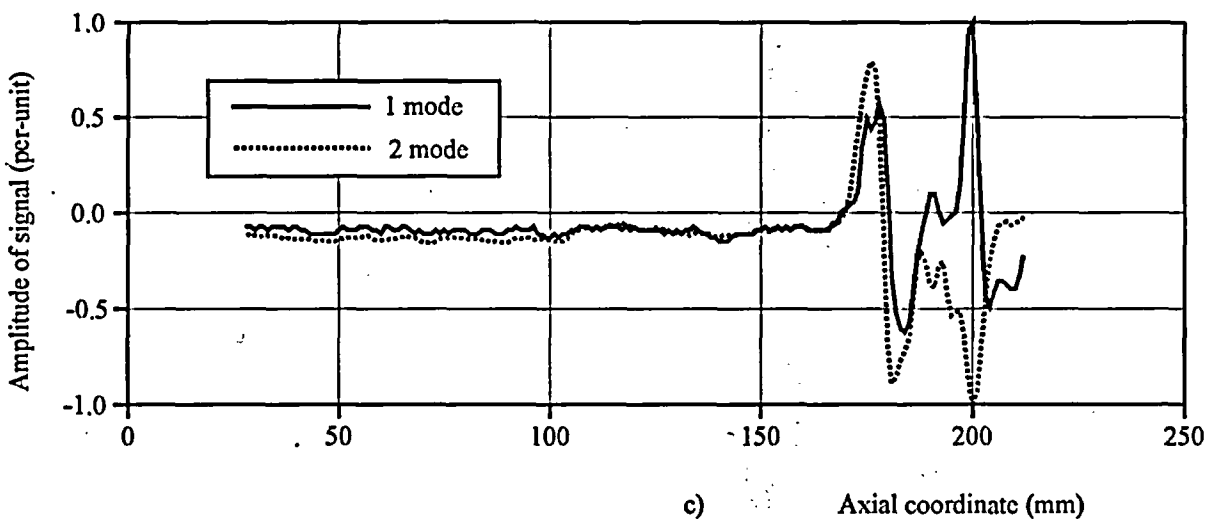
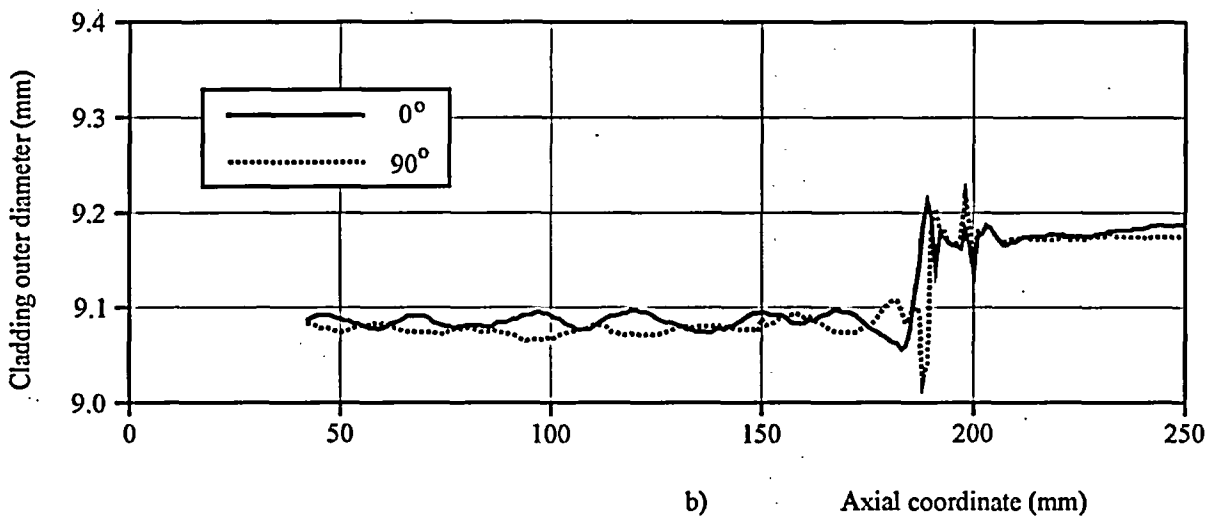
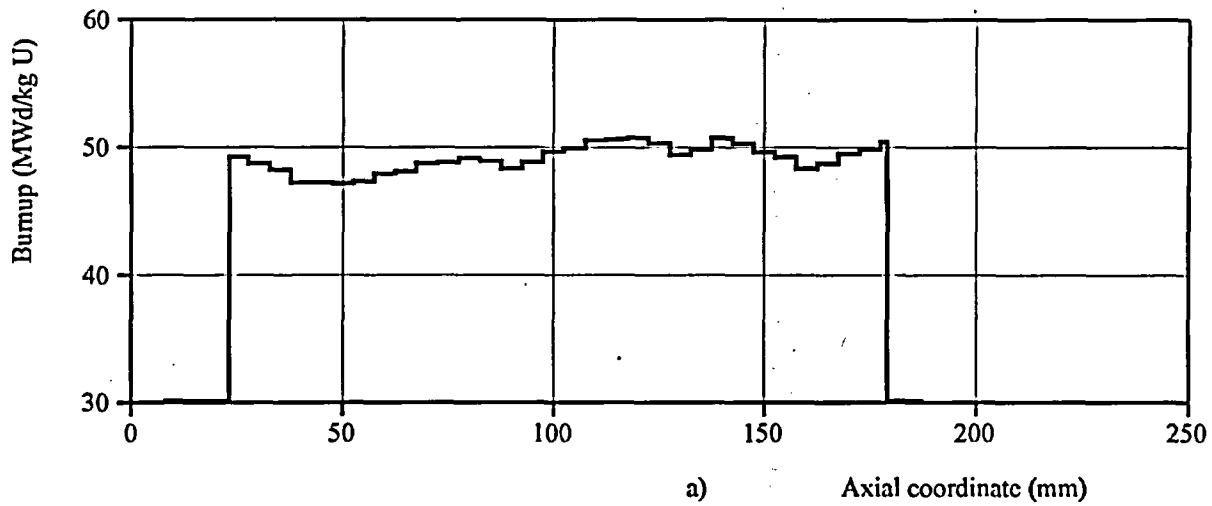

Fig. C-5.2. (a) Axial Burnup Distribution and (b) Results of Profilometry and (c) Eddy-Current Examination for Fuel Rod #H5T

#H5T

Initial Individual Characteristics of Refabricated Fuel Rods  
(Preirradiated fuel, Preirradiated cladding)

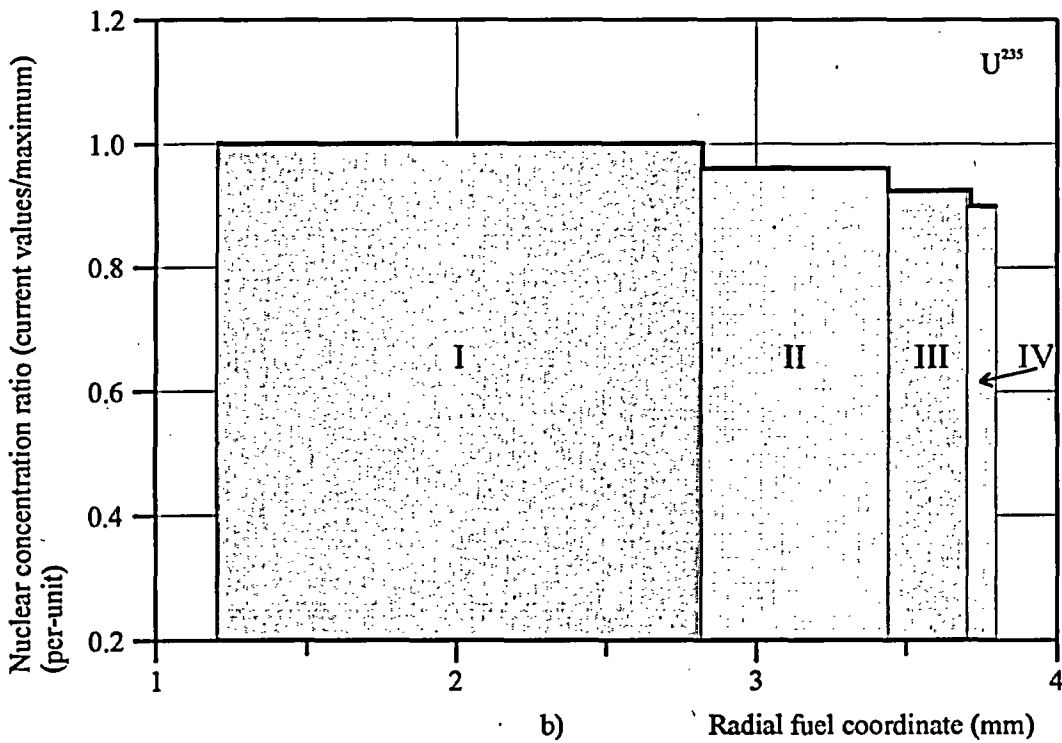
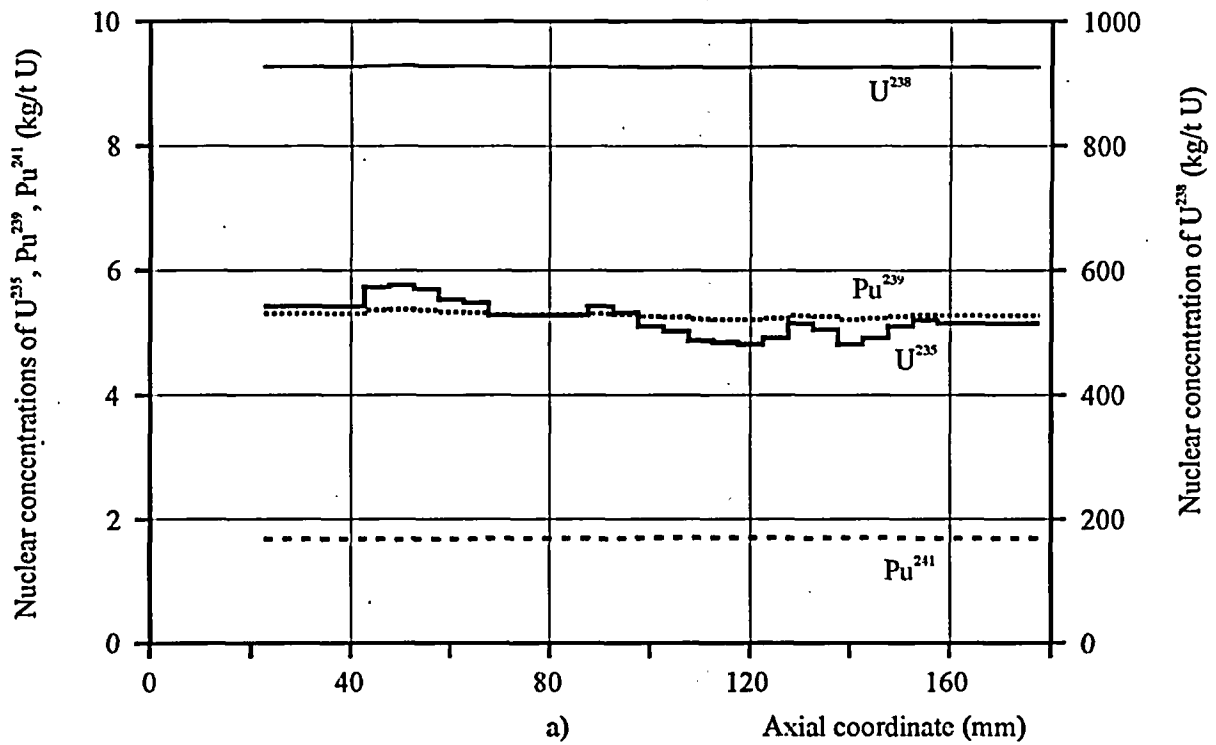

Fig. C-5.3. (a) Axial Distribution of  $U^{235}$ ,  $U^{238}$ ,  $Pu^{239}$ ,  $Pu^{241}$  Isotopes and (b) Radial Distribution of  $U^{235}$  Isotope for Fuel Rod #H5T (calculated)

#H5T

Initial Individual Characteristics of Refabricated Fuel Rods  
(Preirradiated fuel, Preirradiated cladding)

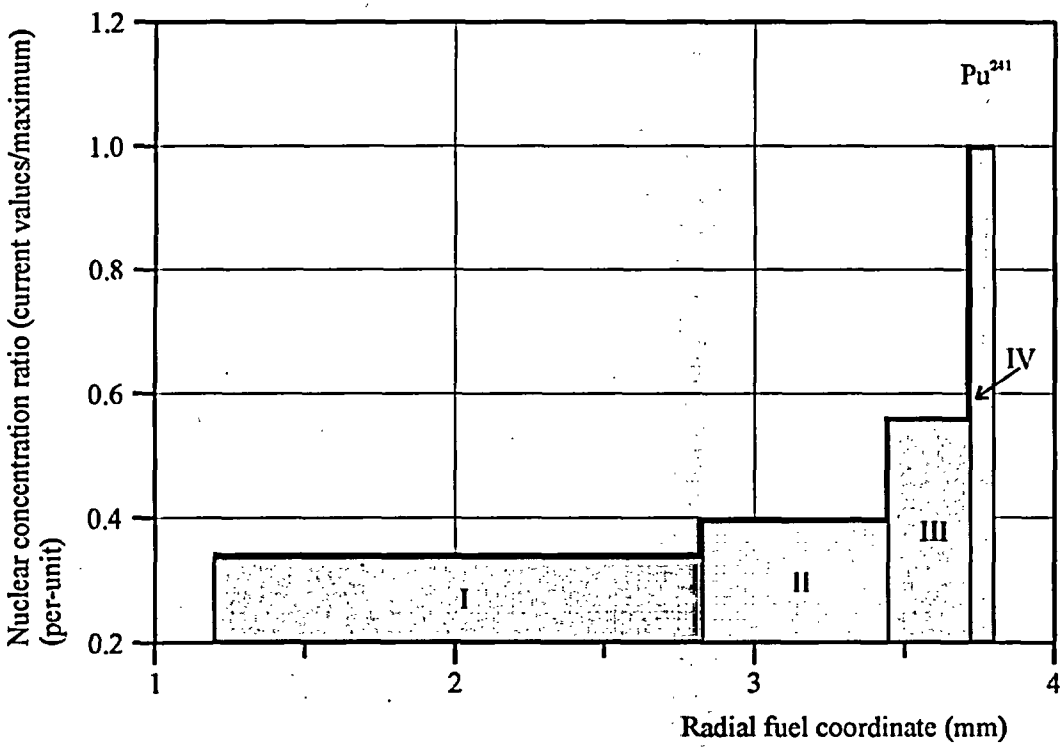
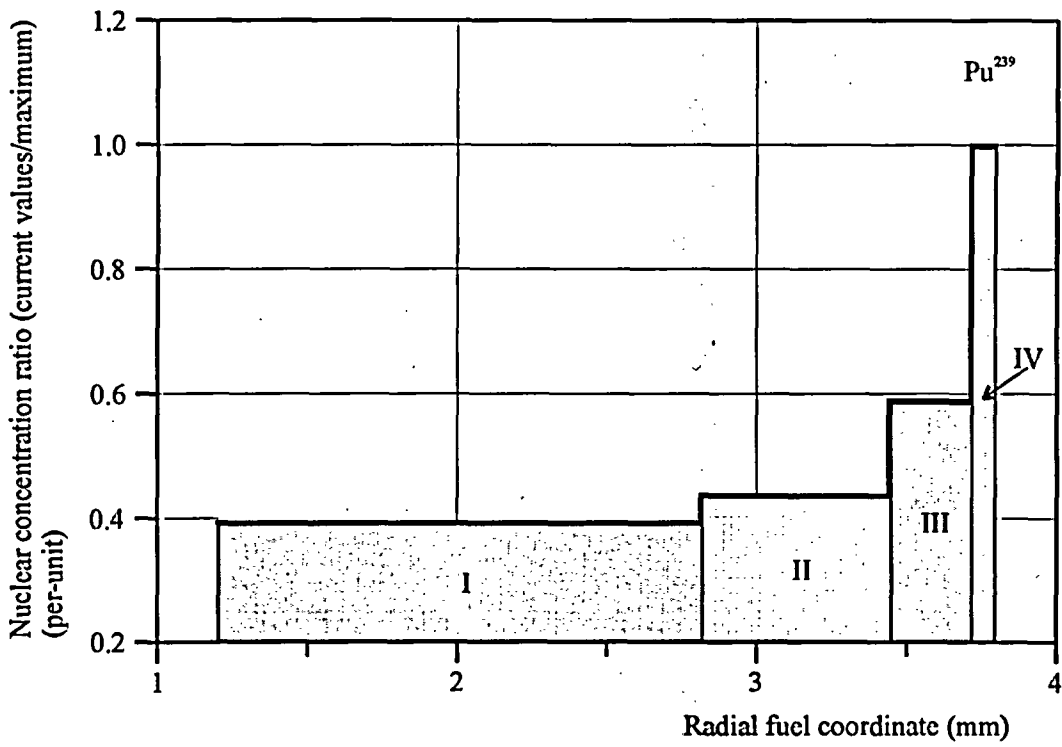

Fig. C-5.4. Radial Distribution of  $Pu^{239}$ ,  $Pu^{241}$  Isotopes for Fuel Rod #H5T (calculated)

#H5T

Initial Individual Characteristics of Refabricated Fuel Rods  
(Preirradiated fuel, Preirradiated cladding)

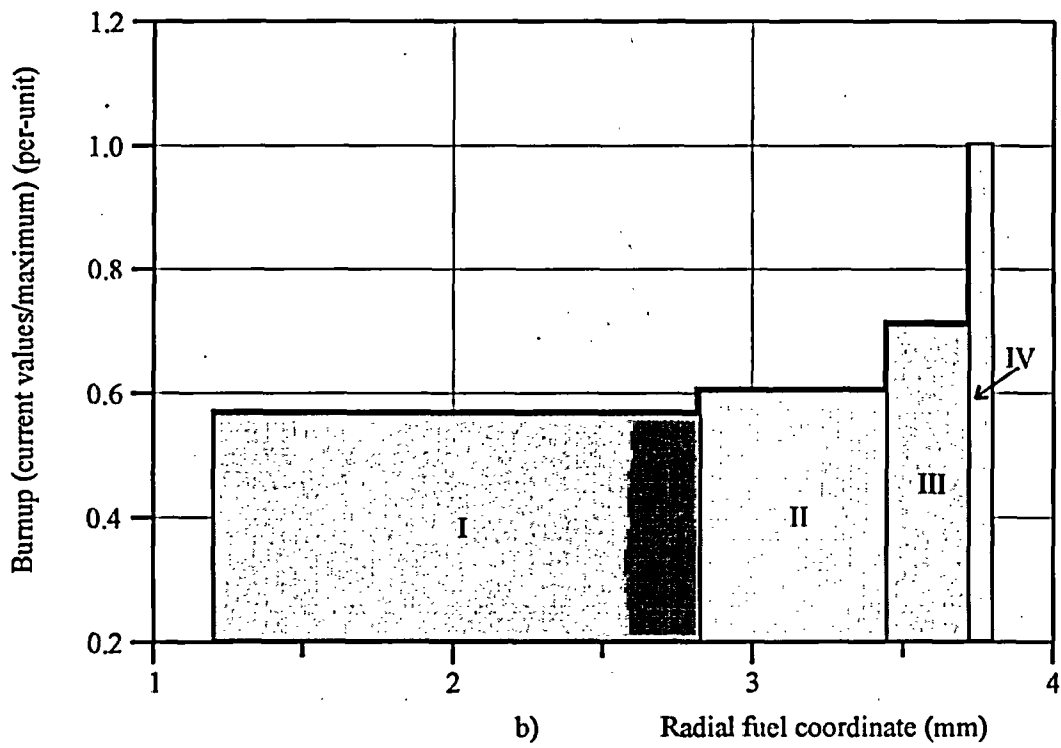
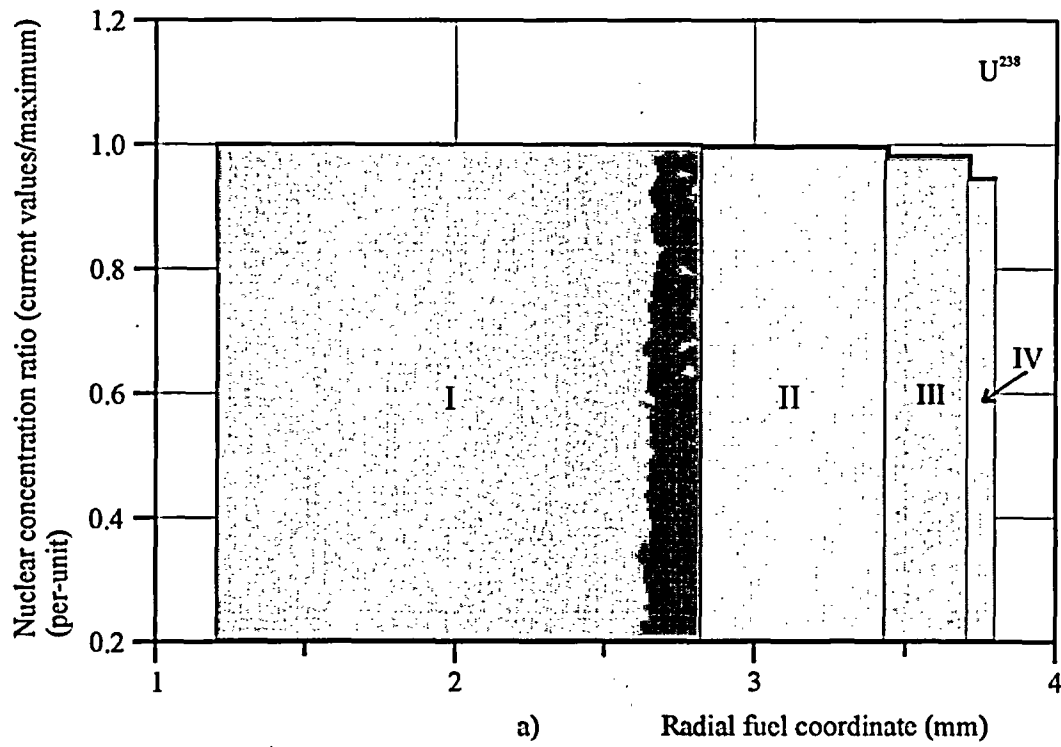

Fig. C-5.5. (a) Radial Distribution of  $U^{238}$  Isotope and (b) Burnup for Fuel Rod #H5T (calculated)



**APPENDIX C-6.**

*Initial Individual Characteristics for Fuel Rod #H6T*

# #H6T

Initial Individual Characteristics of Refabricated Fuel Rods  
(Preirradiated fuel, Preirradiated cladding)

Table C-6.1. Axial Distribution of Isotopic Composition for Fuel Rod #H6T (calculated)

Axial coordinate from lower end of fuel rod (mm)	Nuclear concentrations (kg/t U)						
	U <sup>235</sup>	U <sup>236</sup>	U <sup>238</sup>	Pu <sup>239</sup>	Pu <sup>240</sup>	Pu <sup>241</sup>	Pu <sup>242</sup>
15	5.35	4.90	928	5.19	2.63	1.645	0.980
20	5.35	4.90	928	5.19	2.63	1.645	0.980
25	5.35	4.90	928	5.19	2.63	1.645	0.980
30	5.35	4.90	928	5.19	2.63	1.645	0.980
35	5.21	4.91	927	5.16	2.65	1.648	1.001
40	5.21	4.91	927	5.16	2.65	1.648	1.001
45	5.15	4.91	927	5.15	2.66	1.649	1.009
50	5.15	4.91	927	5.15	2.66	1.649	1.009
55	5.15	4.91	927	5.15	2.66	1.649	1.009
60	5.15	4.91	927	5.15	2.66	1.649	1.009
65	5.15	4.91	927	5.15	2.66	1.649	1.009
70	5.15	4.91	927	5.15	2.66	1.649	1.009
75	5.15	4.91	927	5.15	2.66	1.649	1.009
80	5.15	4.91	927	5.15	2.66	1.649	1.009
85	5.15	4.91	927	5.15	2.66	1.649	1.009
90	5.15	4.91	927	5.15	2.66	1.649	1.009
95	5.15	4.91	927	5.15	2.66	1.649	1.009
100	5.15	4.91	927	5.15	2.66	1.649	1.009
105	5.07	4.92	927	5.14	2.67	1.652	1.022
110	5.10	4.92	927	5.15	2.66	1.651	1.018
115	5.10	4.92	927	5.15	2.66	1.651	1.018
120	4.83	4.94	926	5.11	2.69	1.658	1.060
125	4.81	4.94	926	5.10	2.70	1.658	1.064
130	4.60	4.96	925	5.05	2.72	1.660	1.099
135	4.83	4.94	926	5.11	2.69	1.658	1.060
140	4.83	4.94	926	5.11	2.69	1.658	1.060
145	4.83	4.94	926	5.11	2.69	1.658	1.060
150	4.83	4.94	926	5.11	2.69	1.658	1.060
155	4.83	4.94	926	5.11	2.69	1.658	1.060
160	4.83	4.94	926	5.11	2.69	1.658	1.060
165	4.83	4.94	926	5.11	2.69	1.658	1.060
170	4.83	4.94	926	5.11	2.69	1.658	1.060
175	4.83	4.94	926	5.11	2.69	1.658	1.060
180	4.83	4.94	926	5.11	2.69	1.658	1.060

All numerical values of characteristics are presented as average values at the length interval equal to the axial coordinate  $\pm 2.5$  mm



# #H6T

Initial Individual Characteristics of Refabricated Fuel Rods  
(Preirradiated fuel, Preirradiated cladding)

**Table C-6.2. Radial Distribution of Burnup (Calculated) and Isotopic Composition with RIM Zone Indication (Calculated) for Fuel Rod #H6T (average values in fuel rod)**

Characteristic	Coordinates of fuel radial zones (mm)			
	1 zone 1.2 - 2.811	2 zone 2.811 - 3.432	3 zone 3.432 - 3.704	4 zone 3.704 - 3.790
<b>1. Nuclear concentrations (kg/t U):</b>				
U <sup>235</sup>	4.75	4.55	4.36	4.24
U <sup>236</sup>	4.94	4.94	4.94	4.94
U <sup>238</sup>	934.	930.	918.	885.
Pu <sup>239</sup>	4.08	4.53	6.09	10.31
Pu <sup>240</sup>	2.32	2.43	3.10	5.02
Pu <sup>241</sup>	1.254	1.455	2.047	3.647
Pu <sup>242</sup>	0.815	0.971	1.406	2.592
<b>2. Burnup (MWd/kg U)</b>	45.1	47.9	56.2	78.7

## #H6T

Initial Individual Characteristics of Refabricated Fuel Rods  
(Preirradiated fuel, Preirradiated cladding)

Table C-6.3. Individual Initial Characteristics for Fuel Rod #H6T (measured)

Axial coordinate from lower end of fuel rod (mm)	Cladding outer diameter at 0° (mm)	Cladding outer diameter at 90° (mm)	Fuel mass (g) (density- $10.13^4$ g/cm <sup>3</sup> )*	Linear fuel mass (g/cm)*	Free gas volume (mm <sup>3</sup> ) <sup>5)</sup>	Burnup (MWd/kg U)*
5	-	-	0.0	0.0	8.8	-
10	-	-	0.0	0.0	98.9	-
15 <sup>1)</sup>	-	-	0.91	2.03	144.5	47.0
20	-	-	1.01	2.03	134.6	47.0
25	-	-	.97	1.94	138.6	47.0
30	-	-	.97	1.94	138.6	47.0
35	-	-	2.09	4.19	28.3	47.5
40	-	-	2.27	4.53	10.6	47.5
45	9.110	9.092	1.82	3.64	54.9	47.7 <sup>3)</sup>
50	9.109	9.091	1.05	2.11	130.7	47.7 <sup>3)</sup>
55	9.106	9.100	1.66	3.32	70.7	47.7 <sup>3)</sup>
60	9.103	9.106	1.33	2.65	103.1	47.7 <sup>3)</sup>
65	9.098	9.107	1.10	2.20	125.8	47.7 <sup>3)</sup>
70	9.103	9.100	1.21	2.41	114.9	47.7 <sup>3)</sup>
75	9.101	9.106	2.00	4.00	37.2	47.7 <sup>3)</sup>
80	9.095	9.118	1.30	2.59	106.1	47.7 <sup>3)</sup>
85	9.092	9.131	1.51	3.02	85.4	47.7 <sup>3)</sup>
90	9.100	9.121	1.28	2.56	108.1	47.7 <sup>3)</sup>
95	9.109	9.115	.13	.25	221.2	47.7 <sup>3)</sup>
100	9.110	9.107	1.00	2.00	135.6	47.7 <sup>3)</sup>
105	9.113	9.113	2.02	4.05	35.2	48.0
110	9.104	9.110	2.07	4.14	30.3	47.9
115	9.103	9.106	2.08	4.16	29.3	47.9
120	9.107	9.103	2.07	4.13	30.3	48.9
125	9.103	9.109	2.05	4.10	32.3	49.0
130	9.106	9.118	1.97	3.93	40.1	49.8
135	9.106	9.122	1.39	2.79	97.2	48.9 <sup>3)</sup>
140	9.107	9.118	1.39	2.78	97.2	48.9 <sup>3)</sup>
145	9.110	9.113	1.33	2.66	103.1	48.9 <sup>3)</sup>
150	9.112	9.106	1.02	2.04	133.6	48.9 <sup>3)</sup>
155	9.113	9.104	1.87	3.73	50.0	48.9 <sup>3)</sup>
160	9.115	9.101	1.86	3.71	51.0	48.9 <sup>3)</sup>
165	9.116	9.104	1.19	2.38	116.9	48.9 <sup>3)</sup>
170	9.116	9.107	1.18	2.35	117.9	48.9 <sup>3)</sup>
175	9.116	9.110	1.01	2.03	134.6	48.9 <sup>3)</sup>
180 <sup>2)</sup>	9.127	9.109	0.10	2.00	105.0	48.9 <sup>3)</sup>

\* These numerical values of characteristics are presented as average values at the length interval equal to the axial coordinate  $\pm 2.5$  mm<sup>1)</sup> Initial coordinate of fuel is 13.0 mm<sup>4)</sup> Effective density of fuel stack<sup>2)</sup> Final coordinate of fuel is 178 mm<sup>5)</sup> Free gas volume for coordinates 185 - 295 mm is presented in Table C.3.<sup>3)</sup> Average value

#H6T

Initial Individual Characteristics of Refabricated Fuel Rods  
(Preirradiated fuel, Preirradiated cladding)

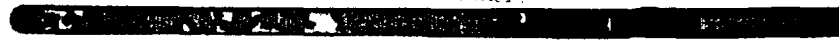
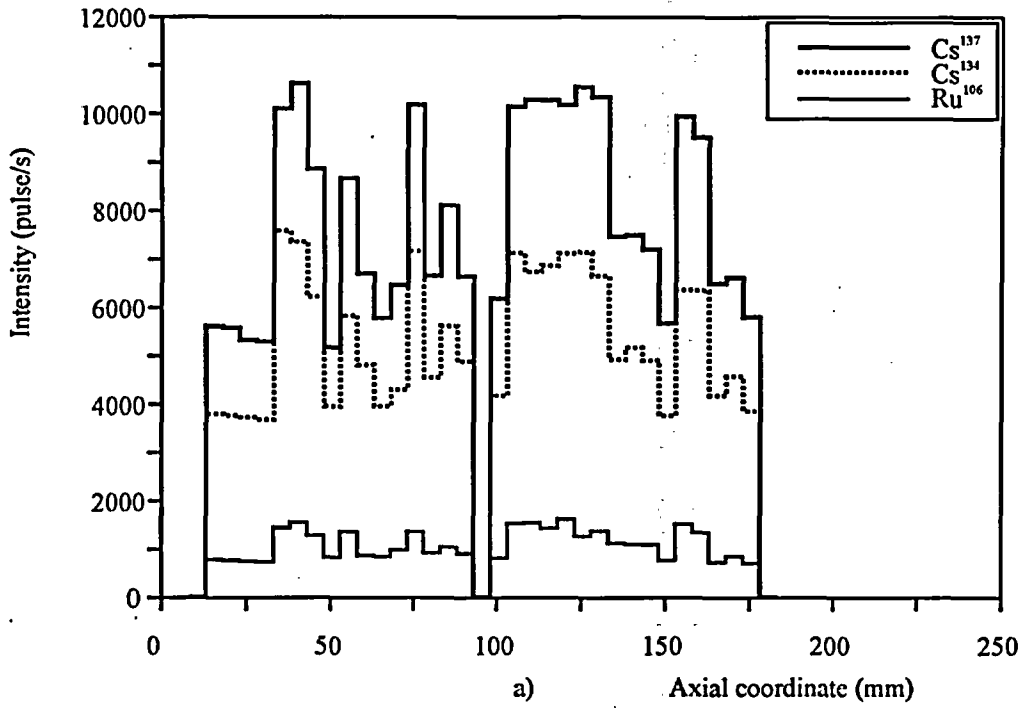

b)

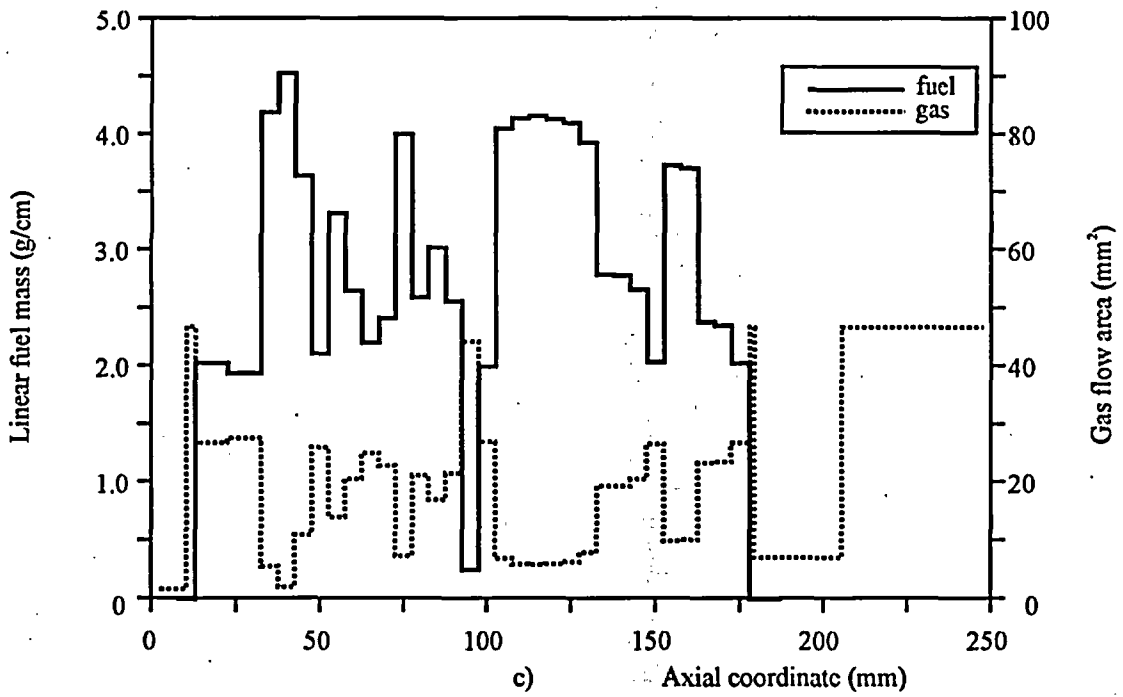

Fig. C-6.1. (a) Results of  $\gamma$ -scanning, (b) Radiography, (c) Axial Fuel Mass Distribution and Axial Free Gas Volume Distribution for Fuel Rod #H6T

# #H6T

Initial Individual Characteristics of Refabricated Fuel Rods  
(Preirradiated fuel, Preirradiated cladding)

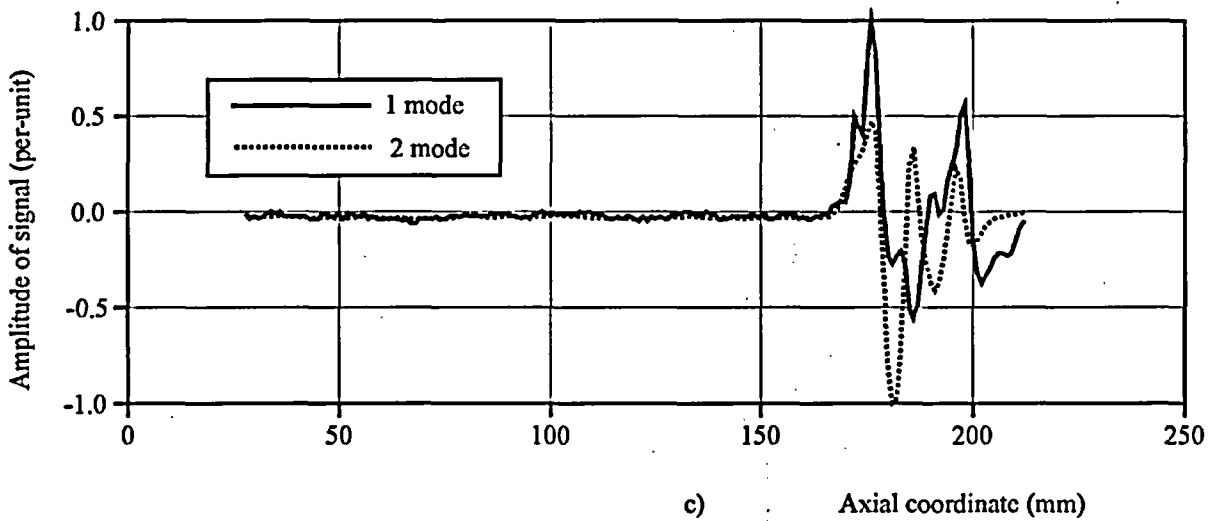
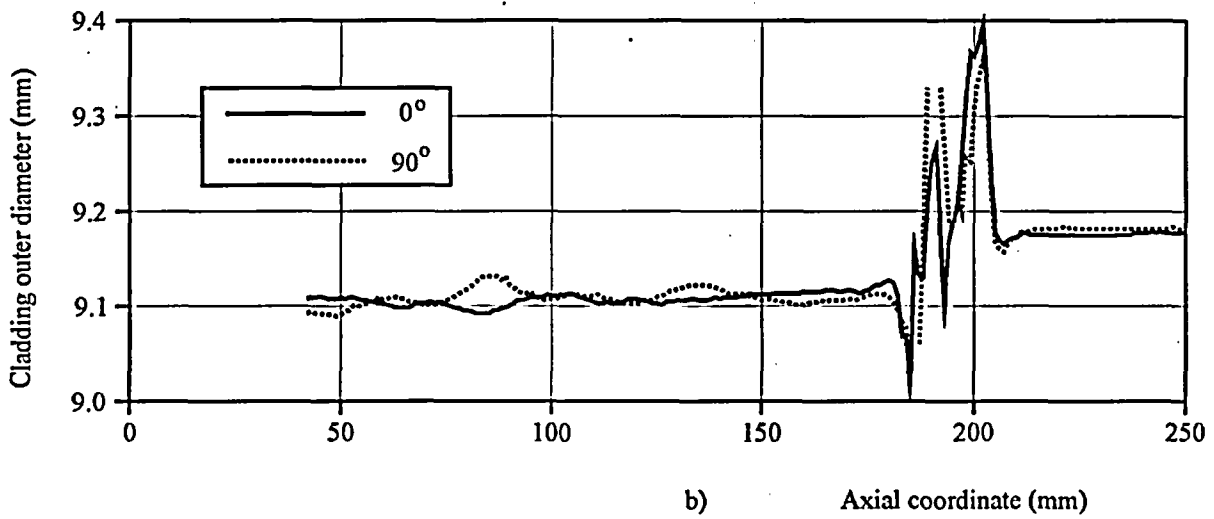
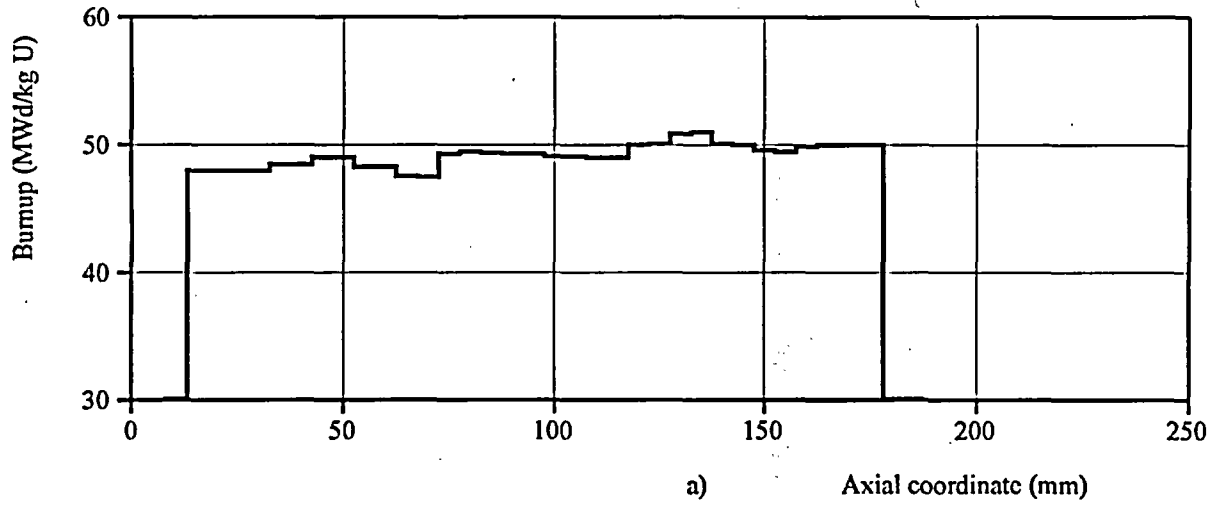

Fig. C-6.2. (a) Axial Burnup Distribution and (b) Results of Profilometry and (c) Eddy-Current Examination for Fuel Rod #H6T

#H6T

Initial Individual Characteristics of Refabricated Fuel Rods  
(Preirradiated fuel, Preirradiated cladding)

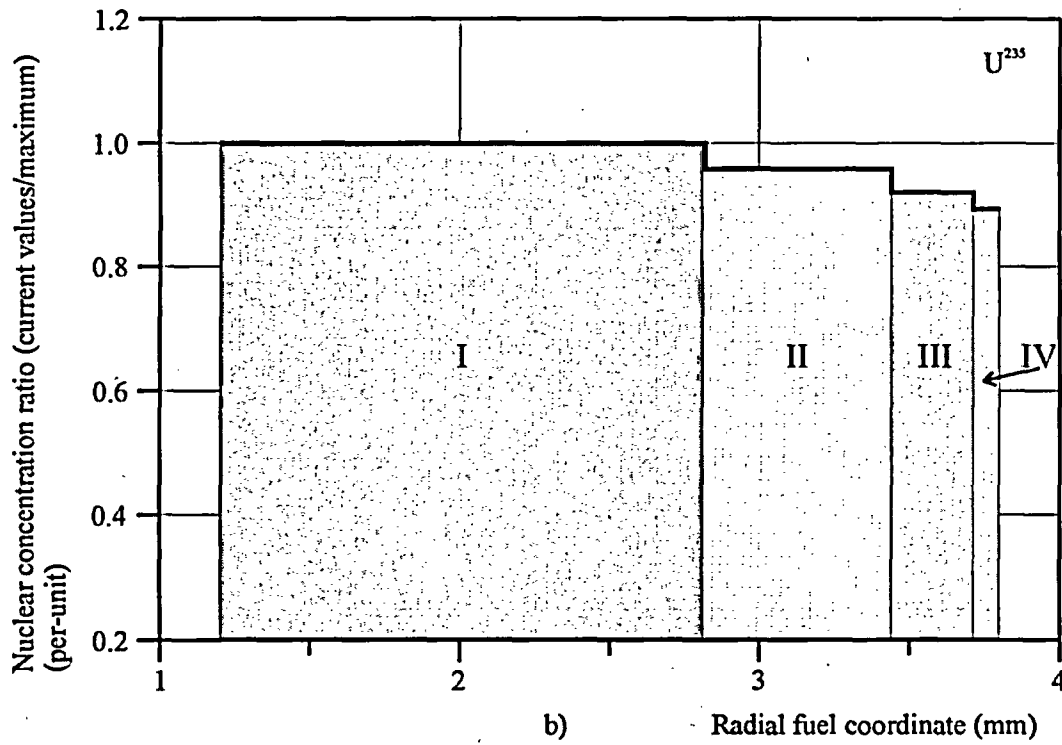
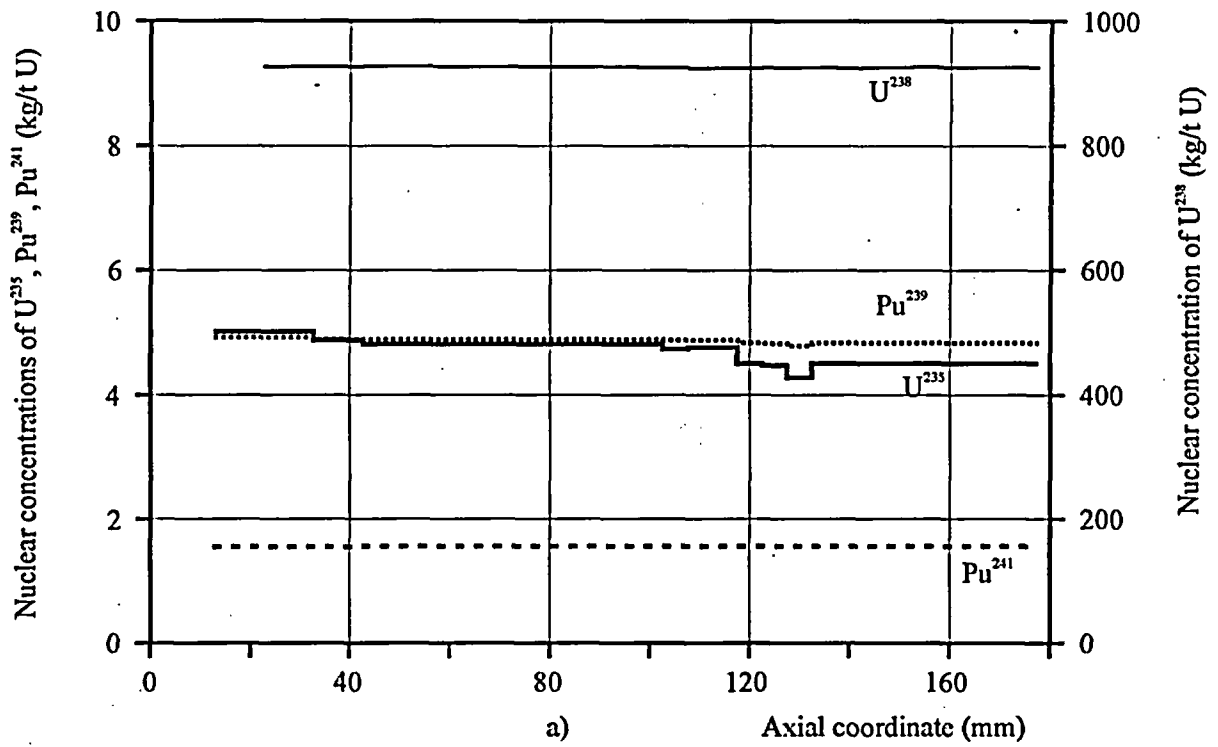

Fig. C-6.3. (a) Axial Distribution of  $U^{235}$ ,  $U^{238}$ ,  $Pu^{239}$ ,  $Pu^{241}$  Isotopes and (b) Radial Distribution of  $U^{235}$  Isotope for Fuel Rod #H6T (calculated)

#H6T

Initial Individual Characteristics of Refabricated Fuel Rods  
(Preirradiated fuel, Preirradiated cladding)

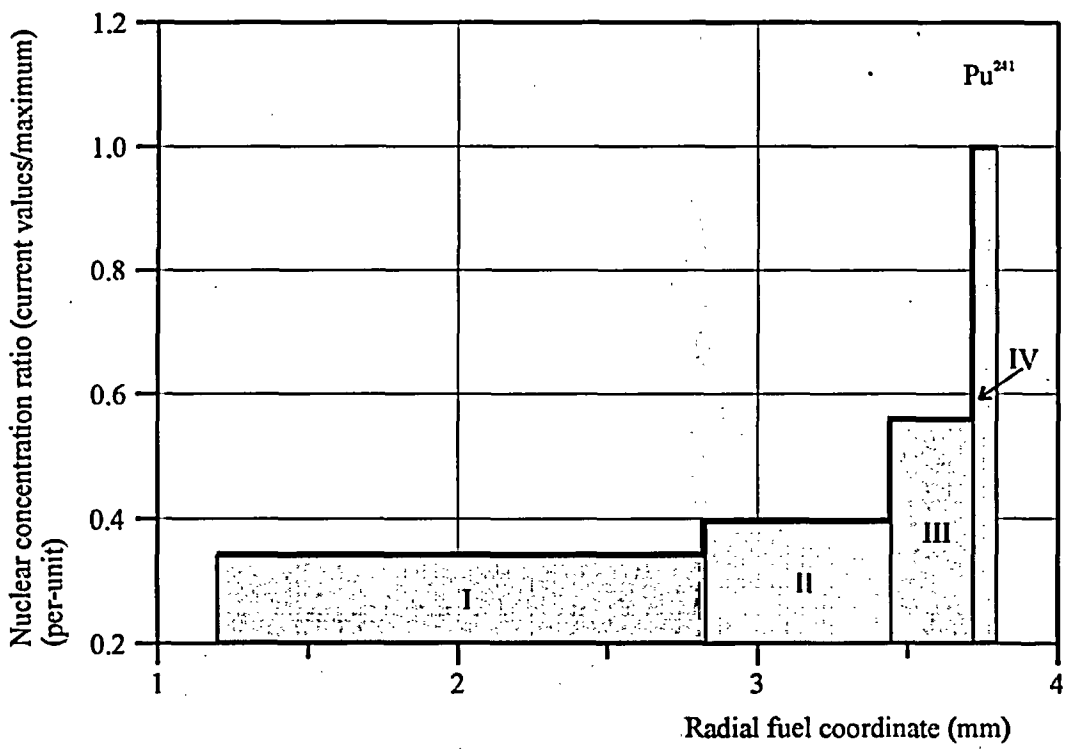
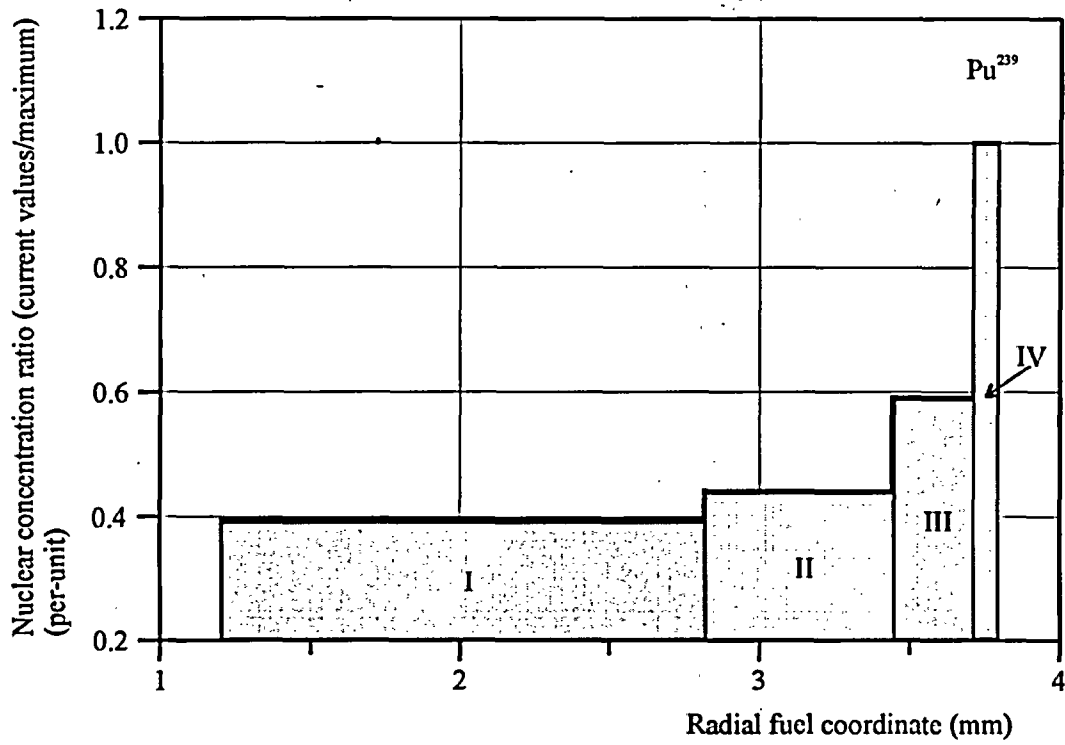

Fig. C-6.4. Radial Distribution of  $\text{Pu}^{239}$ ,  $\text{Pu}^{241}$  Isotopes for Fuel Rod #H6T (calculated)

#H6T

Initial Individual Characteristics of Refabricated Fuel Rods  
(Preirradiated fuel, Preirradiated cladding)

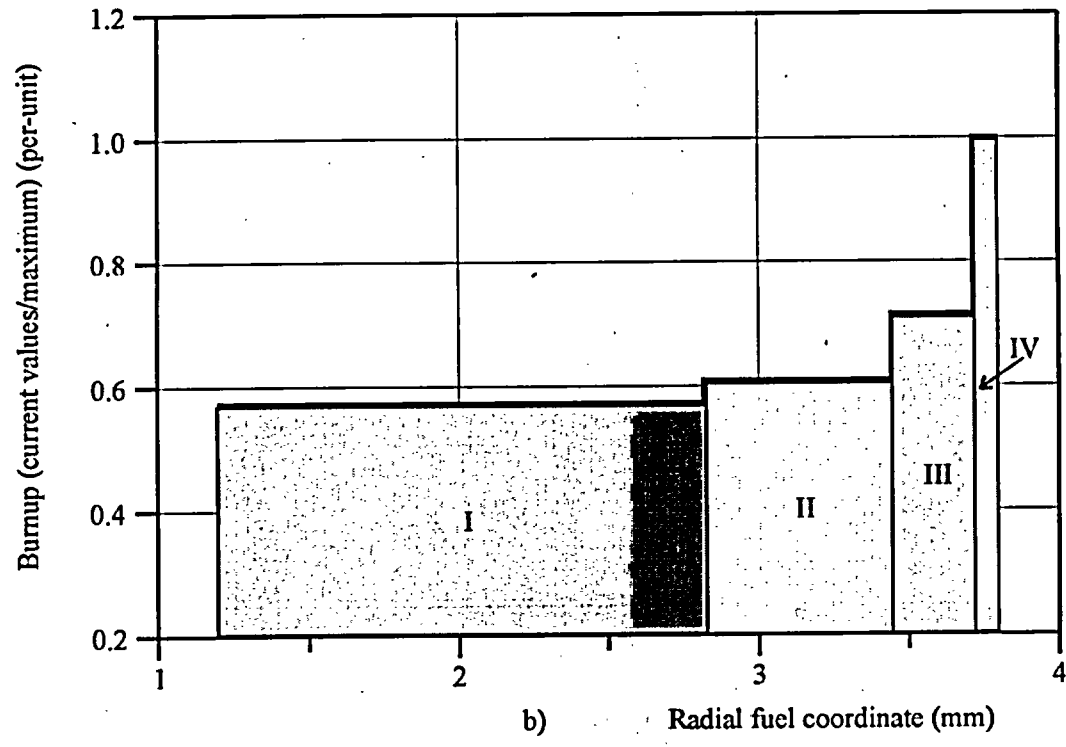
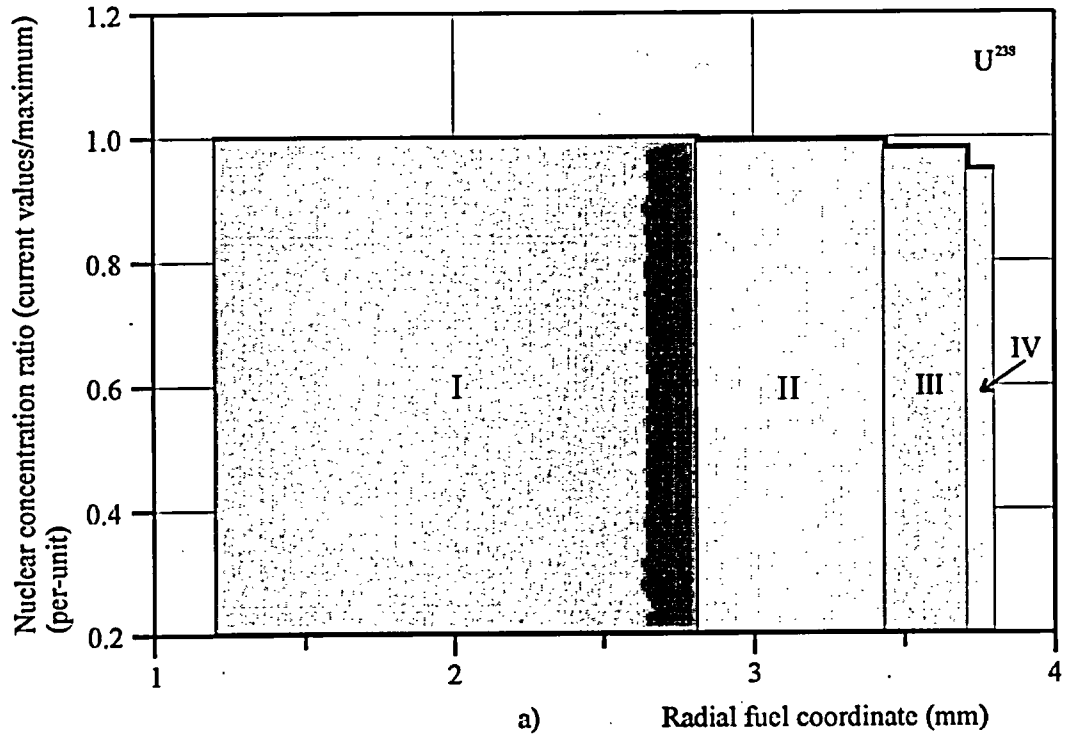

Fig. C-6.5. (a) Radial Distribution of  $U^{238}$  Isotope and (b) Burnup for Fuel Rod #H6T (calculated)





*APPENDIX C-7*  
*Initial Individual Characteristics for Fuel Rod #H7T*

# #H7T

Initial Individual Characteristics of Refabricated Fuel Rods  
(Preirradiated fuel, Preirradiated cladding)

Table C-7.1. Axial Distribution of Isotopic Composition for Fuel Rod #H7T (calculated)

Axial coordinate from lower end of fuel rod (mm)	Nuclear concentrations (kg/t U)						
	U <sup>235</sup>	U <sup>236</sup>	U <sup>238</sup>	Pu <sup>239</sup>	Pu <sup>240</sup>	Pu <sup>241</sup>	Pu <sup>242</sup>
20	5.89	4.84	930	5.27	2.57	1.627	0.903
25	5.89	4.84	930	5.27	2.57	1.627	0.903
30	5.89	4.84	930	5.27	2.57	1.627	0.903
35	5.89	4.84	930	5.27	2.57	1.627	0.903
40	5.89	4.84	930	5.27	2.57	1.627	0.903
45	5.89	4.84	930	5.27	2.57	1.627	0.903
50	5.80	4.85	929	5.26	2.58	1.630	0.915
55	5.72	4.86	929	5.25	2.59	1.634	0.927
60	5.57	4.87	929	5.23	2.60	1.639	0.947
65	5.57	4.87	929	5.23	2.60	1.639	0.947
70	5.57	4.87	929	5.23	2.60	1.639	0.947
75	5.54	4.88	929	5.22	2.61	1.641	0.951
80	5.49	4.88	928	5.21	2.61	1.642	0.959
85	5.54	4.88	929	5.22	2.61	1.641	0.951
90	5.63	4.87	929	5.214	2.60	1.637	0.939
95	5.60	4.87	929	5.23	2.60	1.638	0.943
100	5.37	4.89	928	5.19	2.63	1.645	0.976
105	5.37	4.89	928	5.19	2.63	1.645	0.976
110	5.37	4.89	928	5.19	2.63	1.645	0.976
115	5.43	4.89	928	5.20	2.62	1.643	0.968
120	5.40	4.89	928	5.20	2.63	1.644	0.972
125	5.35	4.90	928	5.19	2.63	1.645	0.980
130	5.35	4.90	928	5.19	2.63	1.645	0.980
135	5.35	4.90	928	5.19	2.63	1.645	0.980
140	5.35	4.90	928	5.19	2.63	1.645	0.980
145	5.35	4.90	928	5.19	2.63	1.645	0.980
150	5.35	4.90	928	5.19	2.63	1.645	0.980
155	5.35	4.90	928	5.19	2.63	1.645	0.980
160	5.35	4.90	928	5.19	2.63	1.645	0.980
165	5.35	4.90	928	5.19	2.63	1.645	0.980
170	5.35	4.90	928	5.19	2.63	1.645	0.980
175	5.35	4.90	928	5.19	2.63	1.645	0.980
180	5.35	4.90	928	5.19	2.63	1.645	0.980

All numerical values of characteristics are presented as average values at the length interval equal to the axial coordinate  $\pm 2.5$  mm

# #H7T

Initial Individual Characteristics of Refabricated Fuel Rods  
(Preirradiated fuel, Preirradiated cladding)

**Table C-7.2. Radial Distribution of Burnup (Calculated) and Isotopic Composition with RIM Zone Indication (Calculated) for Fuel Rod #H7T (average values in fuel rod)**

Characteristic	Coordinates of fuel radial zones (mm)			
	1 zone 1.2 - 2.811	2 zone 2.811 - 3.432	3 zone 3.432 - 3.704	4 zone 3.704 - 3.790
<b>1. Nuclear concentrations (kg/t U):</b>				
U <sup>235</sup>	5.28	5.07	4.87	4.74
U <sup>236</sup>	4.89	4.89	4.90	4.90
U <sup>238</sup>	935	931	920	888
Pu <sup>239</sup>	4.15	4.61	6.21	10.56
Pu <sup>240</sup>	2.26	2.38	3.04	4.96
Pu <sup>241</sup>	1.242	1.444	2.038	3.650
Pu <sup>242</sup>	0.750	0.895	1.299	2.400
<b>2. Burnup (MWd/kg U)</b>	43.4	46.0	53.9	75.1

# #H7T

Initial Individual Characteristics of Refabricated Fuel Rods  
(Preirradiated fuel, Preirradiated cladding)

Table C-7.3. Individual Initial Characteristics for Fuel Rod #H7T (measured)

Axial coordinate from lower end of fuel rod (mm)	Cladding outer diameter at 0° (mm)	Cladding outer diameter at 90° (mm)	Fuel mass (g) (density- $10.13^4$ g/cm <sup>3</sup> )*	Linear fuel mass (g/cm)*	Free gas volume (mm <sup>3</sup> ) <sup>5)</sup>	Burnup (MWd/kg U)*
5	-	-	0.0	0.0	8.8	-
10	-	-	0.0	0.0	98.9	-
15	-	-	0.0	0.0	234.0	-
20 <sup>1)</sup>	-	-	0.45	4.50	189.7	45.1 <sup>3)</sup>
25	-	-	1.94	3.88	43.1	45.1 <sup>3)</sup>
30	-	-	1.51	3.01	85.4	45.1 <sup>3)</sup>
35	-	-	1.64	3.29	72.6	45.1 <sup>3)</sup>
40	-	-	1.63	3.26	73.6	45.1 <sup>3)</sup>
45	9.103	9.118	1.70	3.40	66.7	45.1 <sup>3)</sup>
50	9.094	9.124	2.15	4.30	22.4	45.4
55	9.094	9.122	2.07	4.14	30.3	45.7
60	9.101	9.113	2.02	4.03	35.2	46.2
65	9.113	9.118	2.01	4.02	36.2	46.2
70	9.112	9.118	2.00	3.99	37.2	46.2
75	9.110	9.113	2.00	4.00	37.2	46.3
80	9.109	9.112	2.06	4.11	31.3	46.5
85	9.112	9.107	2.05	4.10	32.3	46.3
90	9.115	9.116	2.03	4.06	34.2	46.0
95	9.101	9.124	2.04	4.08	33.3	46.1
100	9.092	9.124	1.15	2.31	120.9	46.9 <sup>3)</sup>
105	9.098	9.119	.90	1.80	145.5	46.9 <sup>3)</sup>
110	9.104	9.121	1.95	3.90	42.1	46.9 <sup>3)</sup>
115	9.110	9.122	1.99	3.98	38.2	47.2
120	9.112	9.122	1.96	3.93	41.1	46.8
125	9.119	9.118	1.88	3.77	49.0	47.0 <sup>3)</sup>
130	9.122	9.115	1.79	3.57	57.9	47.0 <sup>3)</sup>
135	9.121	9.112	1.74	3.49	62.8	47.0 <sup>3)</sup>
140	9.122	9.110	1.76	3.52	60.8	47.0 <sup>3)</sup>
145	9.122	9.110	1.80	3.60	56.9	47.0 <sup>3)</sup>
150	9.124	9.106	1.84	3.69	52.9	47.0 <sup>3)</sup>
155	9.119	9.104	1.84	3.67	52.9	47.0 <sup>3)</sup>
160	9.119	9.104	1.82	3.64	54.9	47.0 <sup>3)</sup>
165	9.127	9.106	1.83	3.66	53.9	47.0 <sup>3)</sup>
170	9.127	9.106	1.60	3.20	76.6	47.0 <sup>3)</sup>
175	9.124	9.106	1.20	2.41	115.9	47.0 <sup>3)</sup>
180 <sup>2)</sup>	9.128	9.104	0.46	2.30	69.5	47.0 <sup>3)</sup>

\* These numerical values of characteristics are presented as average values at the length interval equal to the axial coordinate  $\pm 2.5$  mm

<sup>1)</sup> Initial coordinate of fuel is 21.5 mm

<sup>4)</sup> Effective density of fuel stack

<sup>2)</sup> Final coordinate of fuel is 179.5 mm

<sup>5)</sup> Free gas volume for coordinates 185 - 295 mm is presented in Table C.3

<sup>3)</sup> Average value

#H7T

Initial Individual Characteristics of Refabricated Fuel Rods  
(Preirradiated fuel, Preirradiated cladding)

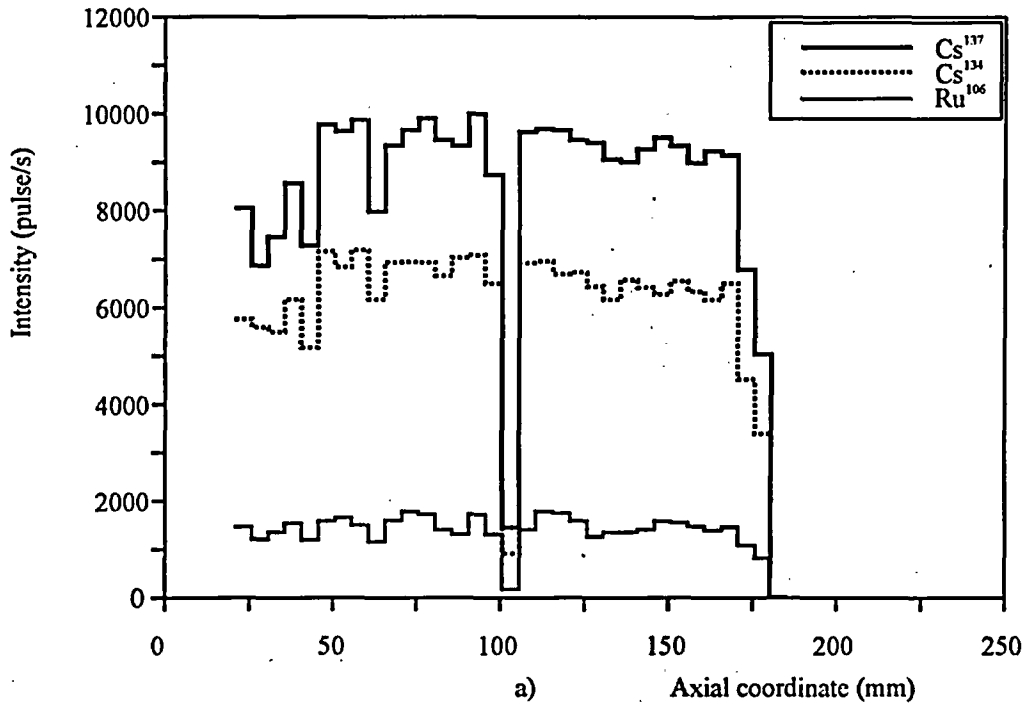

b)

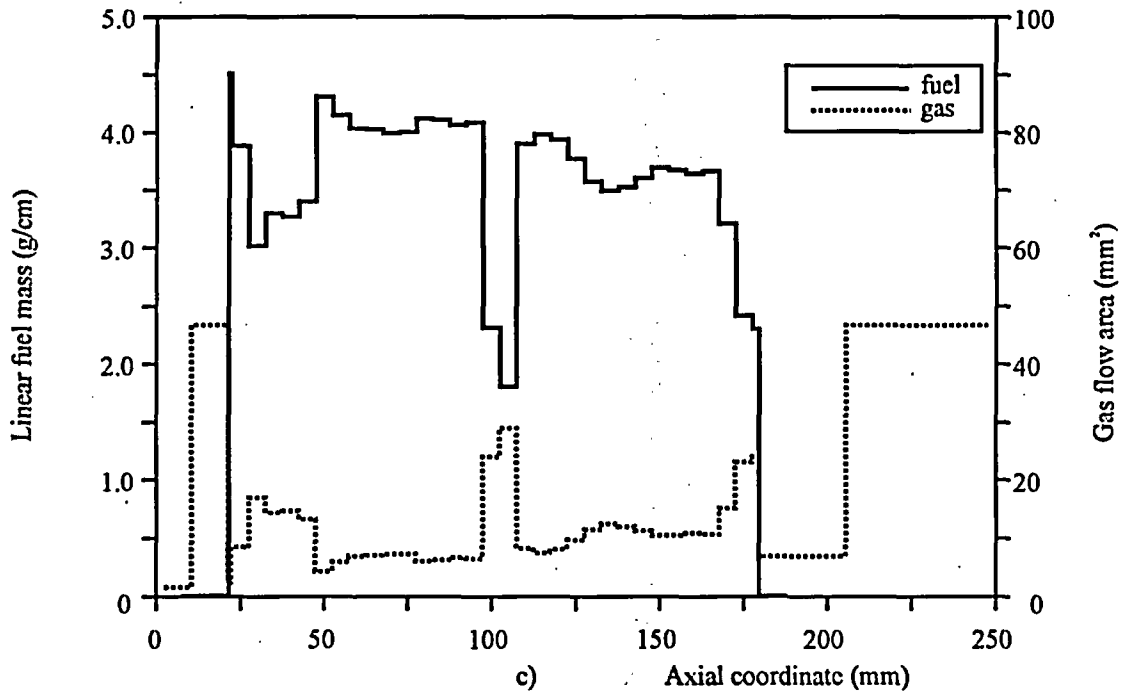

Fig. C-7.1. (a) Results of  $\gamma$ -scanning, (b) Radiography, (c) Axial Fuel Mass Distribution and Axial Free Gas Volume Distribution for Fuel Rod #H7T

#H7T

Initial Individual Characteristics of Refabricated Fuel Rods  
(Preirradiated fuel, Preirradiated cladding)

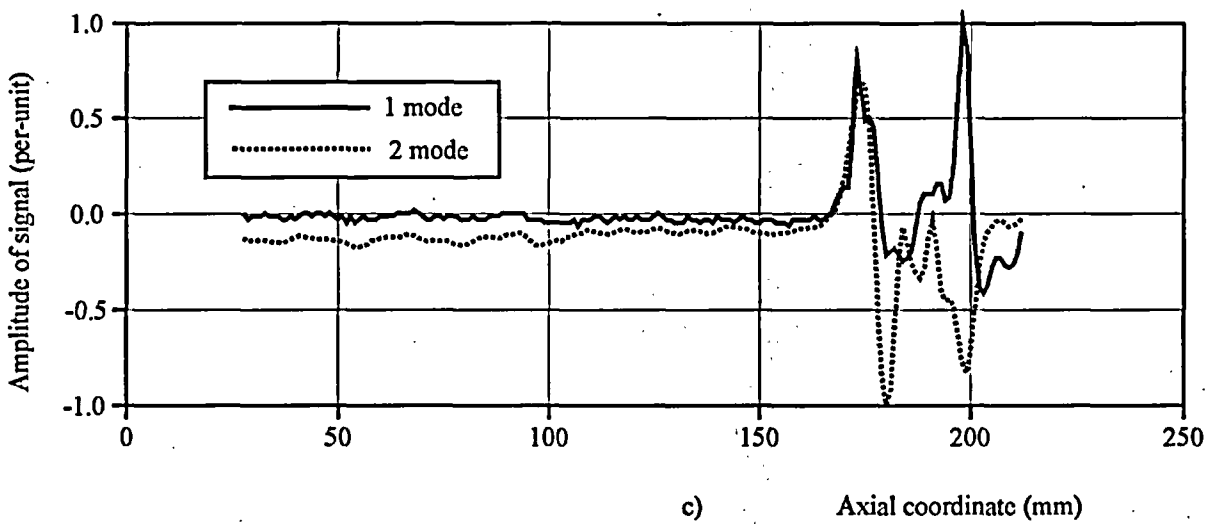
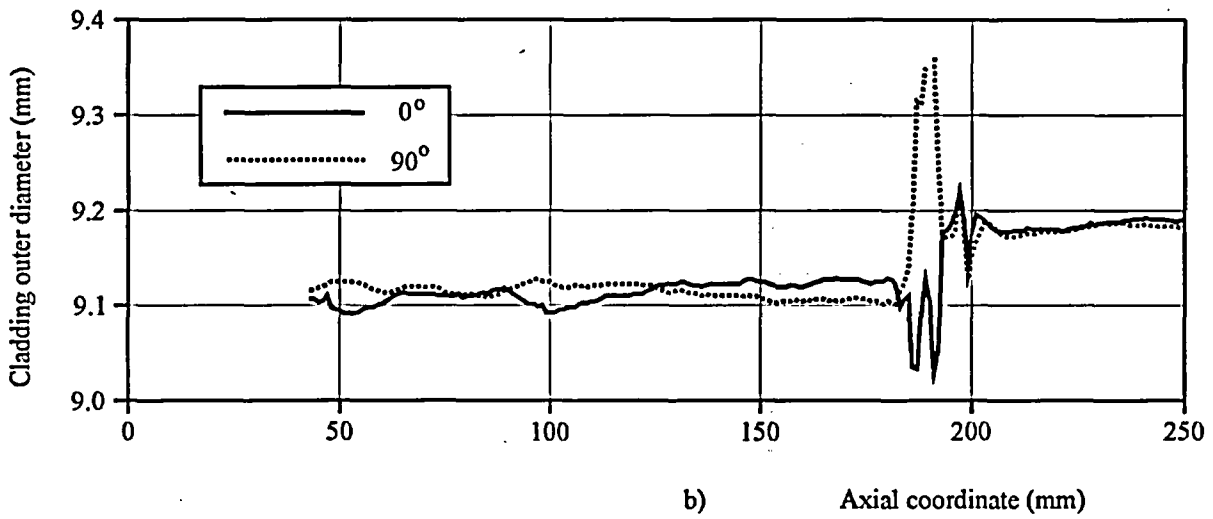
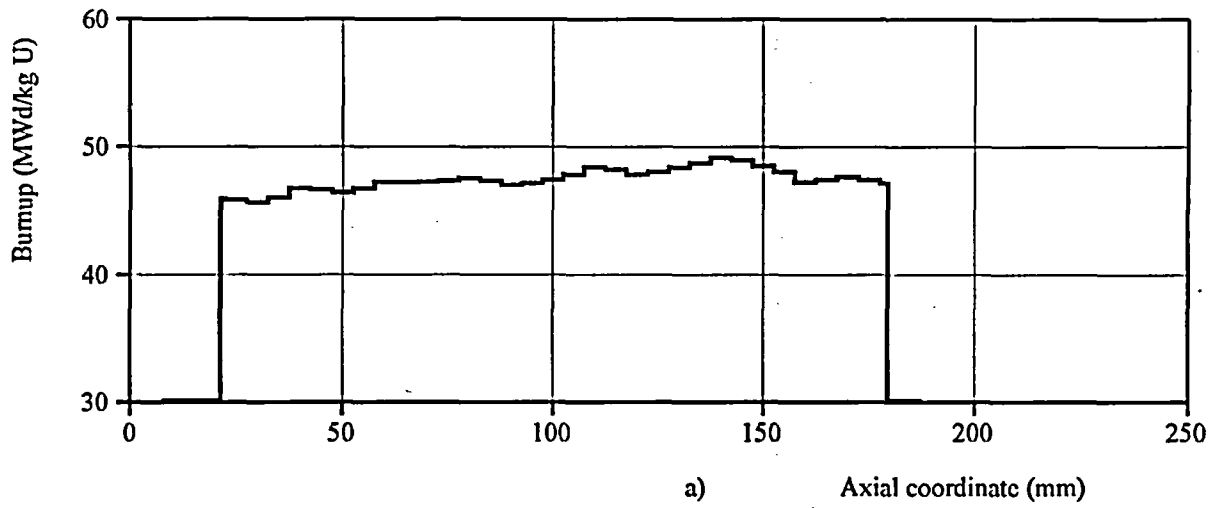

Fig. C-7.2. (a) Axial Burnup Distribution and (b) Results of Profilometry and (c) Eddy-Current Examination for Fuel Rod #H7T

#H7T

Initial Individual Characteristics of Refabricated Fuel Rods  
(Preirradiated fuel, Preirradiated cladding)

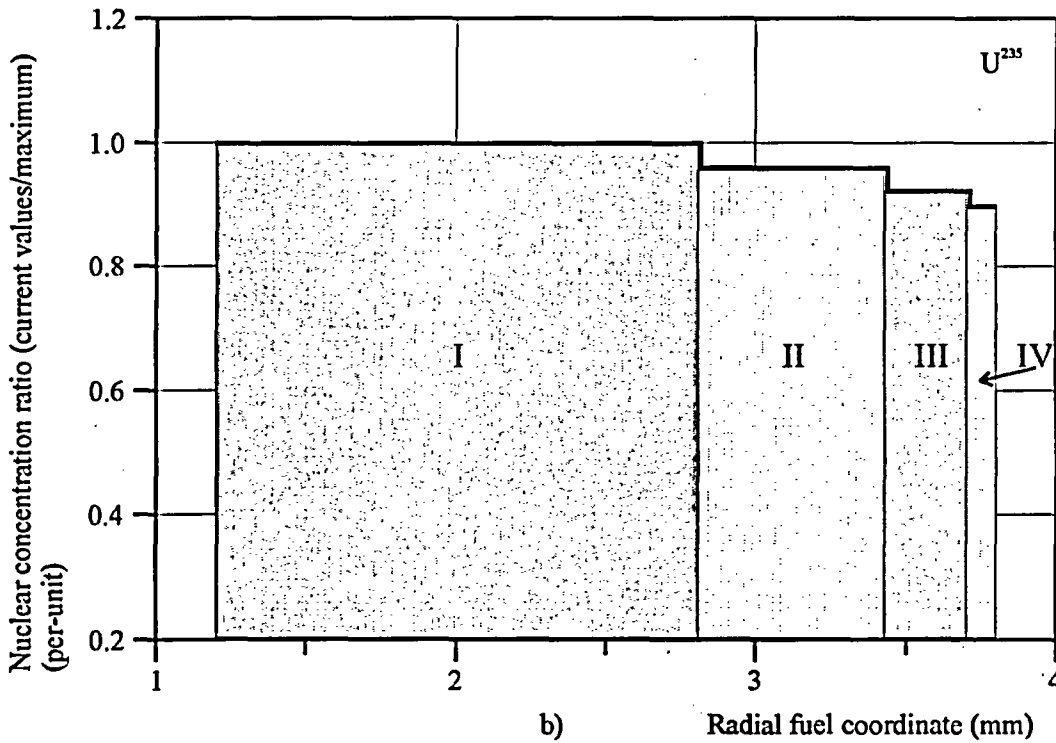
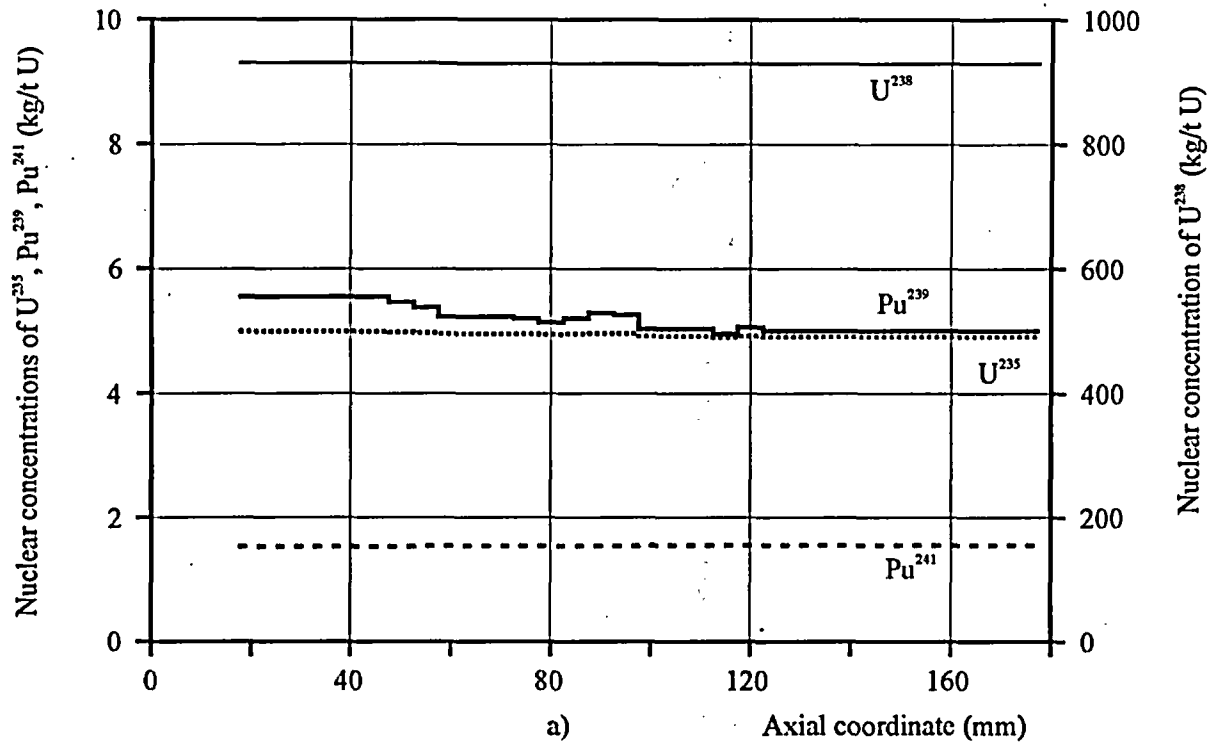

Fig. C-7.3. (a) Axial Distribution of  $U^{235}$ ,  $U^{238}$ ,  $Pu^{239}$ ,  $Pu^{241}$  Isotopes and (b) Radial Distribution of  $U^{235}$  Isotope for Fuel Rod #H7T (calculated)

#H7T

Initial Individual Characteristics of Refabricated Fuel Rods  
(Preirradiated fuel, Preirradiated cladding)

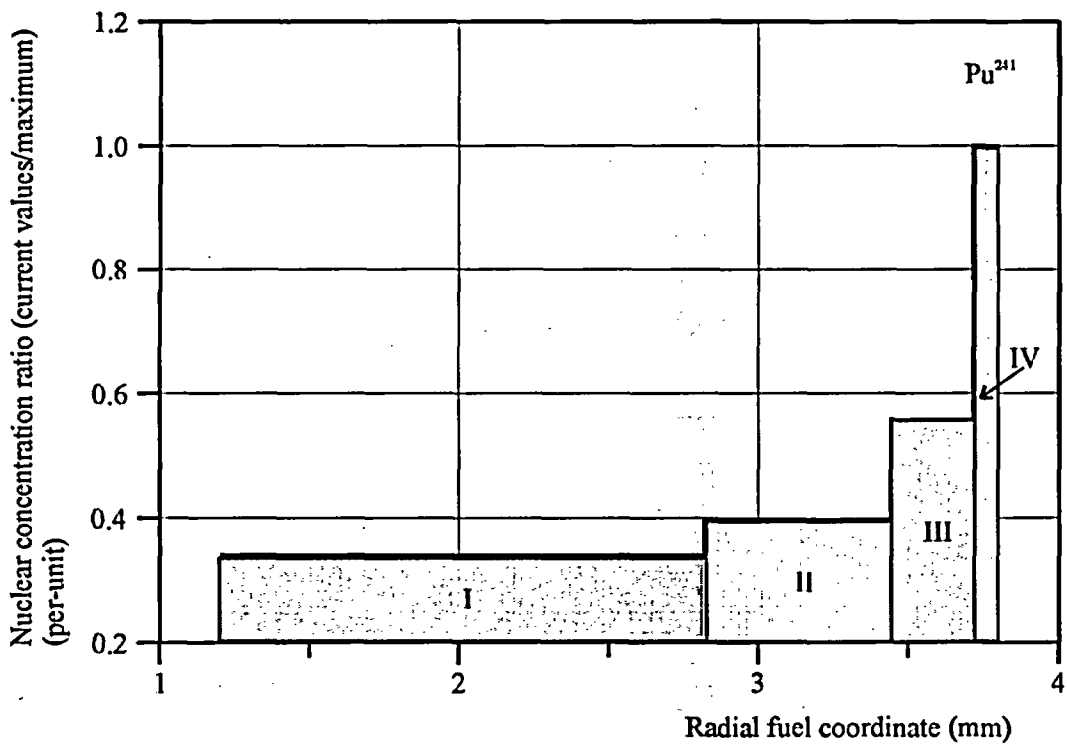
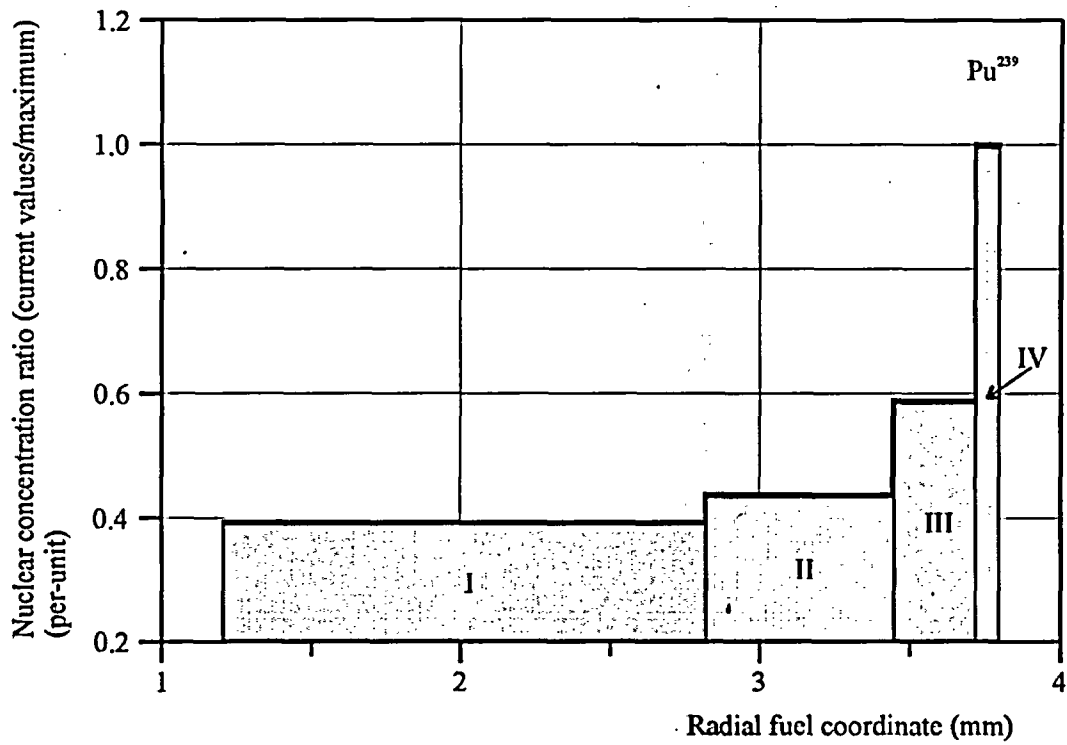

Fig. C-7.4. Radial Distribution of  $Pu^{239}$ ,  $Pu^{241}$  Isotopes for Fuel Rod #H7T (calculated)



#H7T

Initial Individual Characteristics of Refabricated Fuel Rods  
(Preirradiated fuel, Preirradiated cladding)

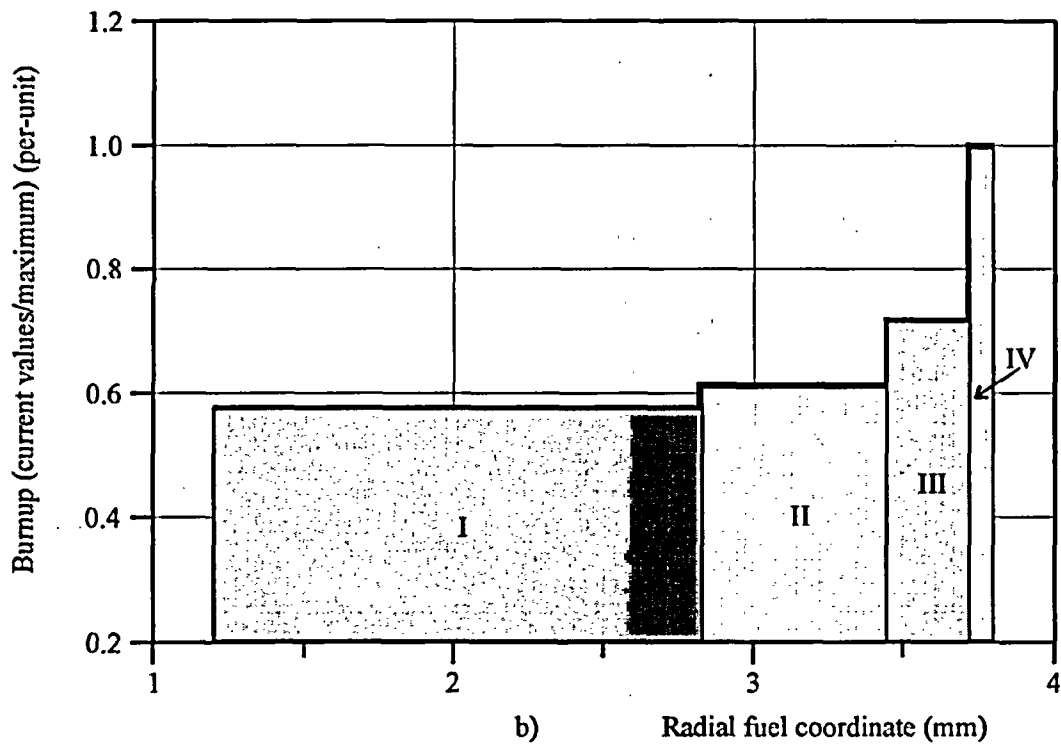
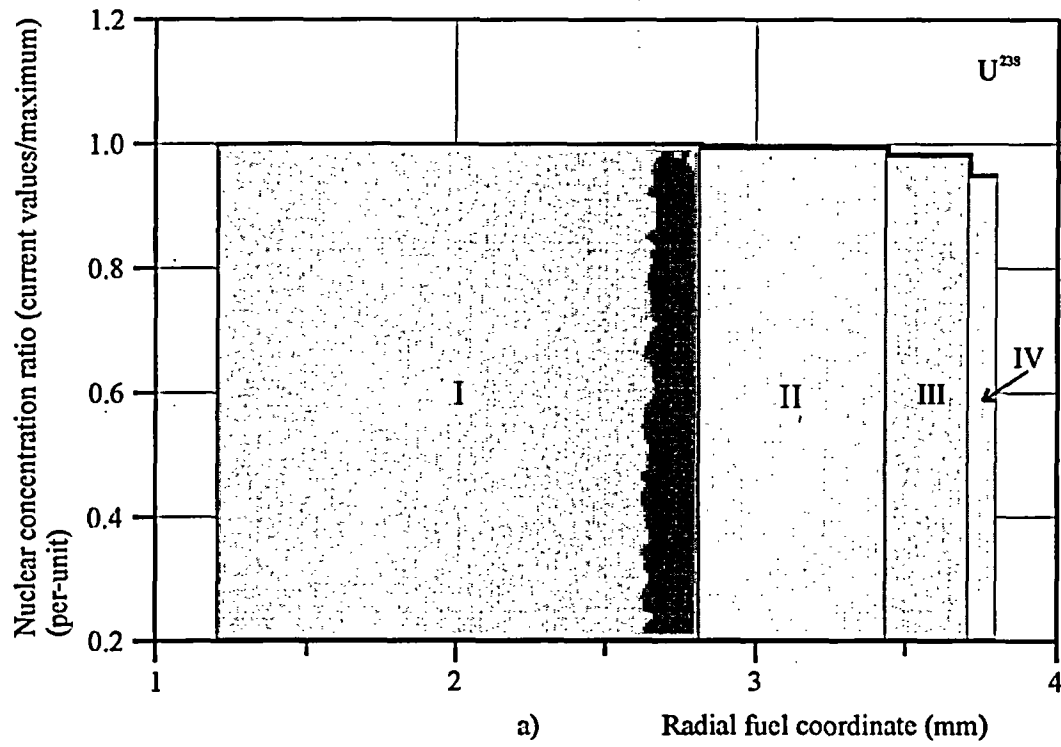

Fig. C-7.5. (a) Radial Distribution of  $U^{238}$  Isotope and (b) Burnup for Fuel Rod #H7T (calculated)



**APPENDIX C-8.**

*Initial Individual Characteristics for Fuel Rod #H8T*

# #H8T

Initial Individual Characteristics of Refabricated Fuel Rods  
(Preirradiated fuel, Preirradiated cladding)

Table C-8.1. Axial Distribution of Isotopic Composition for Fuel Rod #H8T (calculated)

Axial coordinate from lower end of fuel rod (mm)	Nuclear concentrations (kg/t U)						
	U <sup>235</sup>	U <sup>236</sup>	U <sup>238</sup>	Pu <sup>239</sup>	Pu <sup>240</sup>	Pu <sup>241</sup>	Pu <sup>242</sup>
10	5.50	4.89	928	5.33	2.66	1.686	0.979
15	5.50	4.89	928	5.33	2.66	1.686	0.979
20	5.50	4.89	928	5.33	2.66	1.686	0.979
25	5.50	4.89	928	5.33	2.66	1.686	0.979
30	5.50	4.89	928	5.33	2.66	1.686	0.979
35	5.50	4.89	928	5.33	2.66	1.686	0.979
40	5.50	4.89	928	5.33	2.66	1.686	0.979
45	5.50	4.89	928	5.33	2.66	1.686	0.979
50	5.50	4.89	928	5.33	2.66	1.686	0.979
55	5.50	4.89	928	5.33	2.66	1.686	0.979
60	5.50	4.89	928	5.33	2.66	1.686	0.979
65	5.50	4.89	928	5.33	2.66	1.686	0.979
70	5.50	4.89	928	5.33	2.66	1.686	0.979
75	5.50	4.89	928	5.33	2.66	1.686	0.979
80	5.50	4.89	928	5.33	2.66	1.686	0.979
85	5.50	4.89	928	5.33	2.66	1.686	0.979
90	5.50	4.89	928	5.33	2.66	1.686	0.979
95	5.50	4.89	928	5.33	2.66	1.686	0.979
100	5.50	4.89	928	5.33	2.66	1.686	0.979
105	5.47	4.89	927	5.32	2.66	1.687	0.983
110	5.78	4.87	928	5.37	2.62	1.677	0.938
115	5.89	4.85	929	5.39	2.61	1.672	0.922
120	5.92	4.85	929	5.39	2.60	1.671	0.918
125	5.92	4.85	929	5.39	2.60	1.671	0.918
130	5.78	4.87	928	5.37	2.62	1.677	0.938
135	5.72	4.87	928	5.36	2.63	1.680	0.946
140	5.98	4.85	929	5.40	2.60	1.669	0.910
145	6.10	4.83	929	5.41	2.58	1.664	0.895
150	6.19	4.82	930	5.42	2.57	1.660	0.883
155	6.25	4.82	930	5.43	2.56	1.657	0.875
160	6.55	4.79	931	5.47	2.52	1.645	0.835
165	6.68	4.77	931	5.49	2.51	1.638	0.819
170	6.62	4.78	931	5.48	2.51	1.641	0.827
175	6.62	4.78	931	5.48	2.51	1.641	0.827

All numerical values of characteristics are presented as average values at the length interval equal to the axial coordinate  $\pm 2.5$  mm

# #H8T

Initial Individual Characteristics of Refabricated Fuel Rods  
(Preirradiated fuel, Preirradiated cladding)

Table C-8.2. Radial Distribution of Burnup (Calculated) and Isotopic Composition with RIM Zone Indication (Calculated) for Fuel Rod #H8T (average values in fuel rod)

Characteristic	Coordinates of fuel radial zones (mm)			
	1 zone 1.2 - 2.811	2 zone 2.811 - 3.432	3 zone 3.432 - 3.704	4 zone 3.704 - 3.790
1. Nuclear concentrations (kg/t U):				
U <sup>235</sup>	5.94	5.72	5.51	5.37
U <sup>236</sup>	4.86	4.87	4.87	4.88
U <sup>238</sup>	934	931	919	887
Pu <sup>239</sup>	4.50	5.01	6.77	11.52
Pu <sup>240</sup>	2.31	2.44	3.12	5.08
Pu <sup>241</sup>	1.338	1.561	2.210	3.964
Pu <sup>242</sup>	0.730	0.874	1.271	2.346
2. Burnup (MWd/kg U)	42.8	45.6	53.4	74.6

Table C-8.3. Individual Initial Characteristics for Fuel Rod #H8T (measured)

Axial coordinate from lower end of fuel rod (mm)	Cladding outer diameter at 0° (mm)	Cladding outer diameter at 90° (mm)	Fuel mass (g) (density- $10.13^4$ ) g/cm <sup>3</sup> *)	Linear fuel mass (g/cm)*	Free gas volume (mm <sup>3</sup> *) <sup>5)</sup>	Burnup (MWd/kg U)*
5	-	-	0.0	0.0	8.8	-
10 <sup>1)</sup>	-	-	0.02	0.12	98.9	47.9 <sup>3)</sup>
15	-	-	0.06	0.12	234.0	47.9 <sup>3)</sup>
20	-	-	0.34	0.69	189.7	47.9 <sup>3)</sup>
25	-	-	0.63	1.25	43.1	47.9 <sup>3)</sup>
30	-	-	1.13	2.27	85.4	47.9 <sup>3)</sup>
35	-	-	1.65	3.29	72.6	47.9 <sup>3)</sup>
40	-	-	1.50	2.99	73.6	47.9 <sup>3)</sup>
45	9.111	9.101	1.35	2.69	66.7	47.9 <sup>3)</sup>
50	9.113	9.110	1.33	2.67	22.4	47.9 <sup>3)</sup>
55	9.116	9.117	1.32	2.64	30.3	47.9 <sup>3)</sup>
60	9.117	9.125	1.59	3.17	35.2	47.9 <sup>3)</sup>
65	9.119	9.113	1.85	3.69	36.2	47.9 <sup>3)</sup>
70	9.113	9.105	1.87	3.73	37.2	47.9 <sup>3)</sup>
75	9.108	9.110	1.88	3.77	37.2	47.9 <sup>3)</sup>
80	9.104	9.122	1.85	3.71	31.3	47.9 <sup>3)</sup>
85	9.107	9.119	1.83	3.67	32.3	47.9 <sup>3)</sup>
90	9.113	9.113	1.78	3.56	34.2	47.9 <sup>3)</sup>
95	9.114	9.111	1.72	3.45	33.3	47.9 <sup>3)</sup>
100	9.111	9.122	1.82	3.64	120.9	47.9 <sup>3)</sup>
105	9.101	9.135	1.98	3.95	145.5	48.1
110	9.099	9.128	1.99	3.99	42.1	46.9
115	9.107	9.114	1.99	3.98	38.2	46.5
120	9.104	9.111	1.99	3.98	41.1	46.5
125	9.095	9.114	1.98	3.97	49.0	46.4
130	9.088	9.119	1.99	3.98	57.9	46.9
135	9.095	9.110	2.01	4.02	62.8	47.1
140	9.108	9.102	2.04	4.08	60.8	46.2
145	9.105	9.104	2.08	4.15	56.9	45.8
150	9.099	9.108	2.11	4.22	52.9	45.4
155	9.107	9.107	2.13	4.25	52.9	45.3
160	9.119	9.098	2.14	4.27	54.9	44.3
165	9.125	9.096	2.12	4.24	53.9	43.8
170	9.116	9.102	2.08	4.15	76.6	44.1 <sup>3)</sup>
175 <sup>2)</sup>	9.111	9.111	2.08	4.15	115.9	44.1 <sup>3)</sup>
180	9.108	9.108	0.0	0.0	0.0	0.0

\* These numerical values of characteristics are presented as average values at the length interval equal to the axial coordinate  $\pm 2.5$  mm

<sup>1)</sup> Initial coordinate of fuel is 10.5 mm

<sup>4)</sup> Effective density of fuel stack

<sup>2)</sup> Final coordinate of fuel is 177.5 mm

<sup>5)</sup> Free gas volume for coordinates 185 - 295 mm is presented in Table C.3

<sup>3)</sup> Average value

#H8T

Initial Individual Characteristics of Refabricated Fuel Rods  
(Preirradiated fuel, Preirradiated cladding)

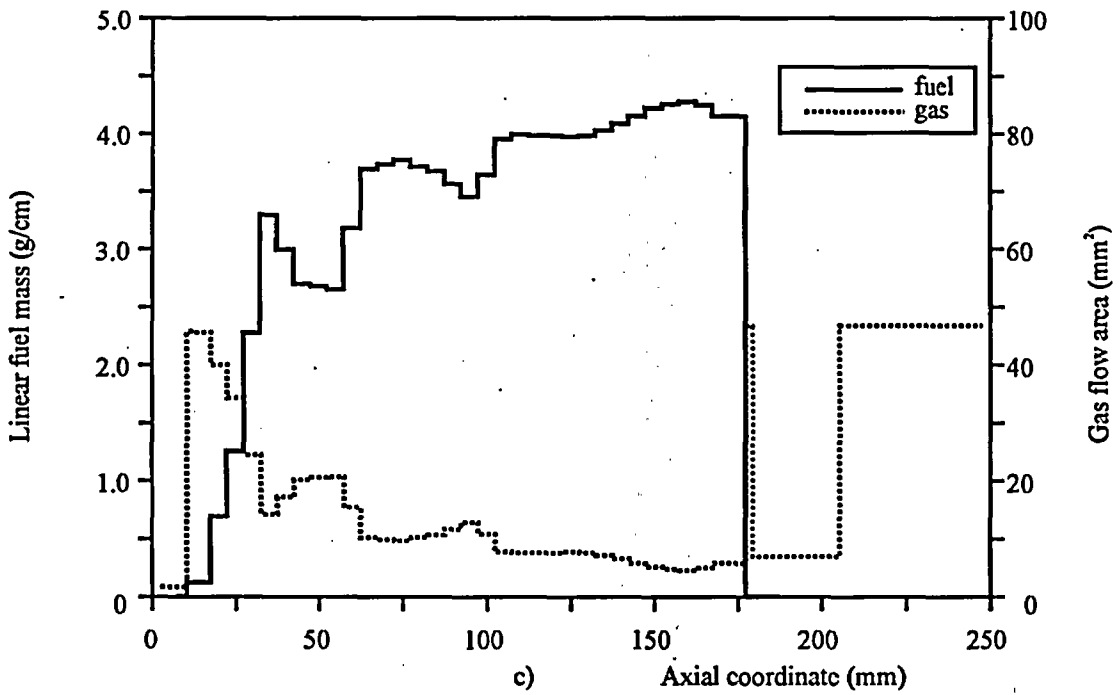
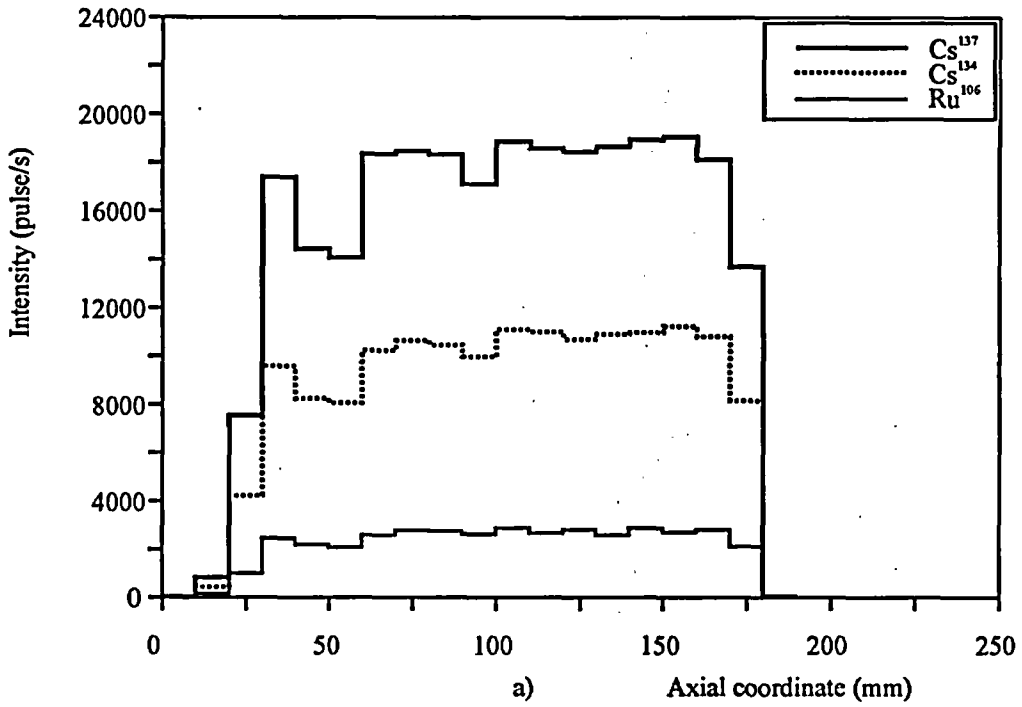

Fig. C-8.1. (a) Results of  $\gamma$ -scanning, (b) Radiography, (c) Axial Fuel Mass Distribution (c) and Axial Free Gas Volume Distribution for Fuel Rod #H8T

#H8T

Initial Individual Characteristics of Refabricated Fuel Rods  
(Preirradiated fuel, Preirradiated cladding)

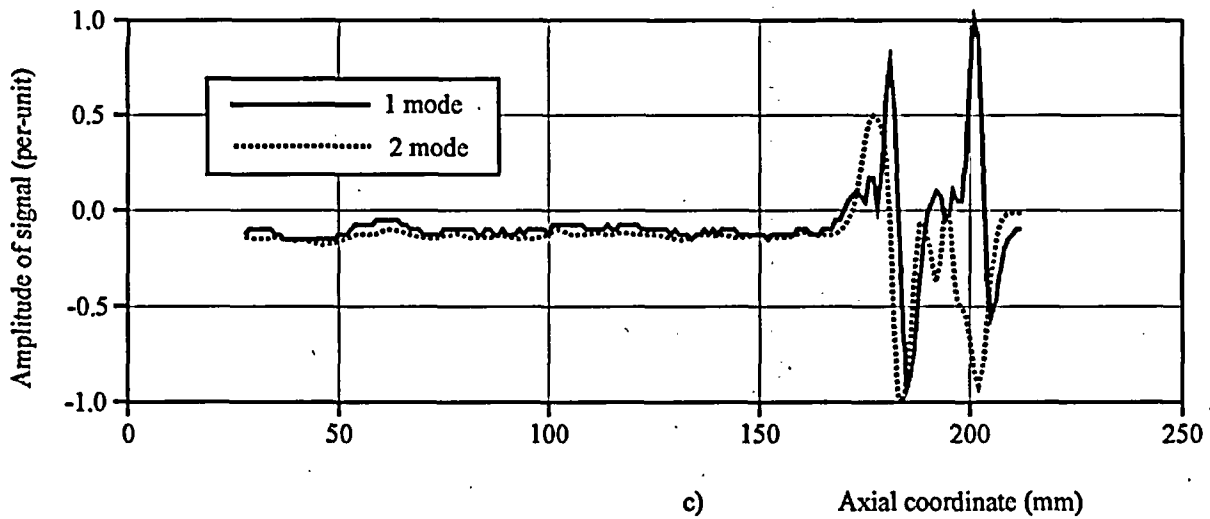
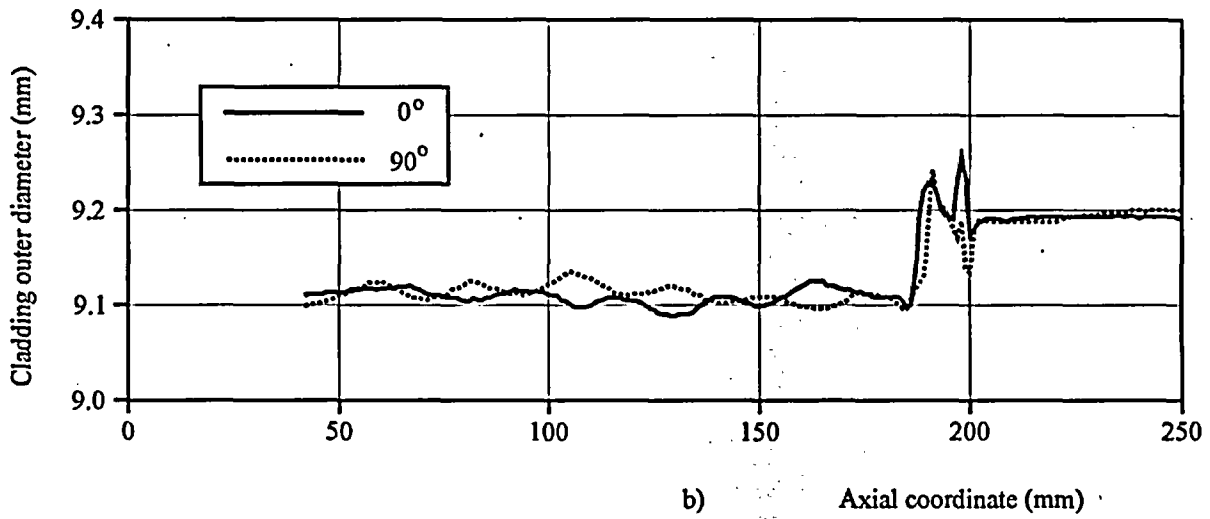
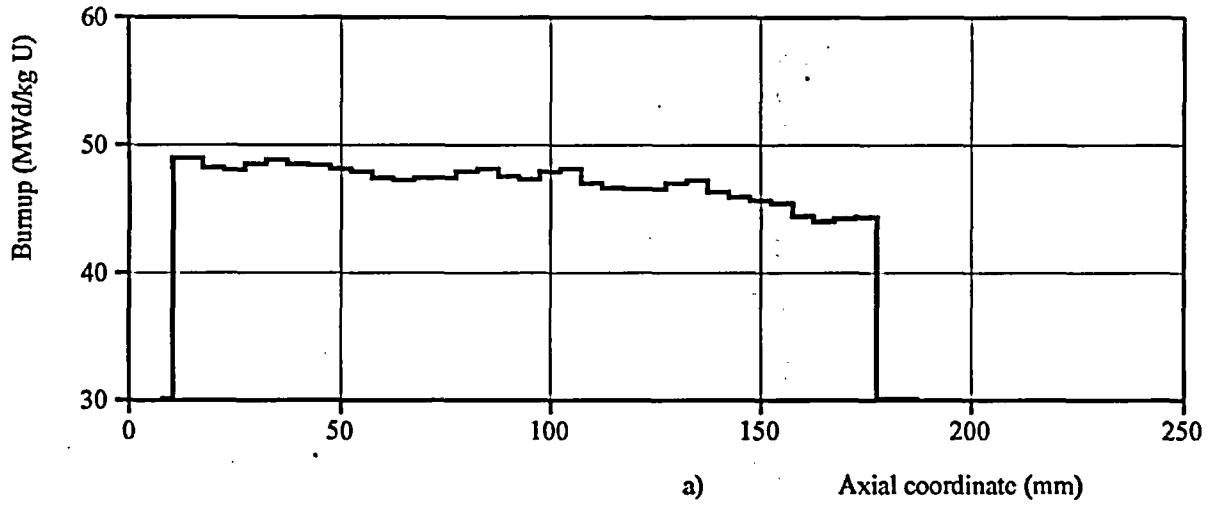

Fig. C-8.2. (a) Axial Burnup Distribution and (b) Results of Profilometry and (c) Eddy-Current Examination for Fuel Rod #H8T



#H8T

Initial Individual Characteristics of Refabricated Fuel Rods  
(Preirradiated fuel, Preirradiated cladding)

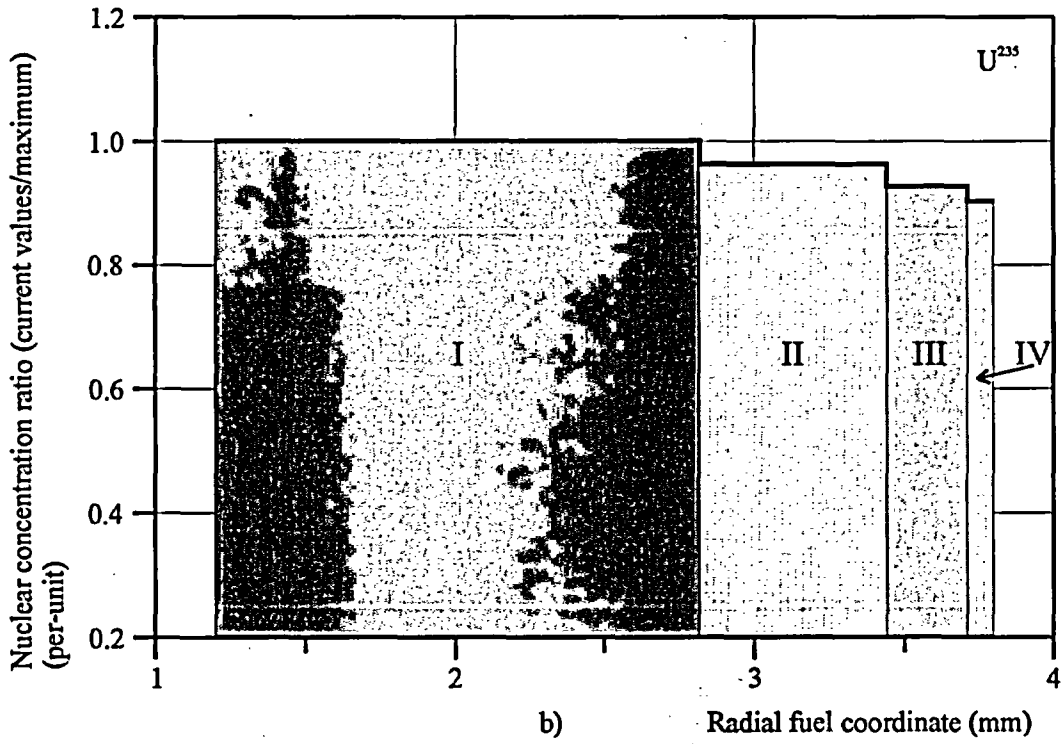
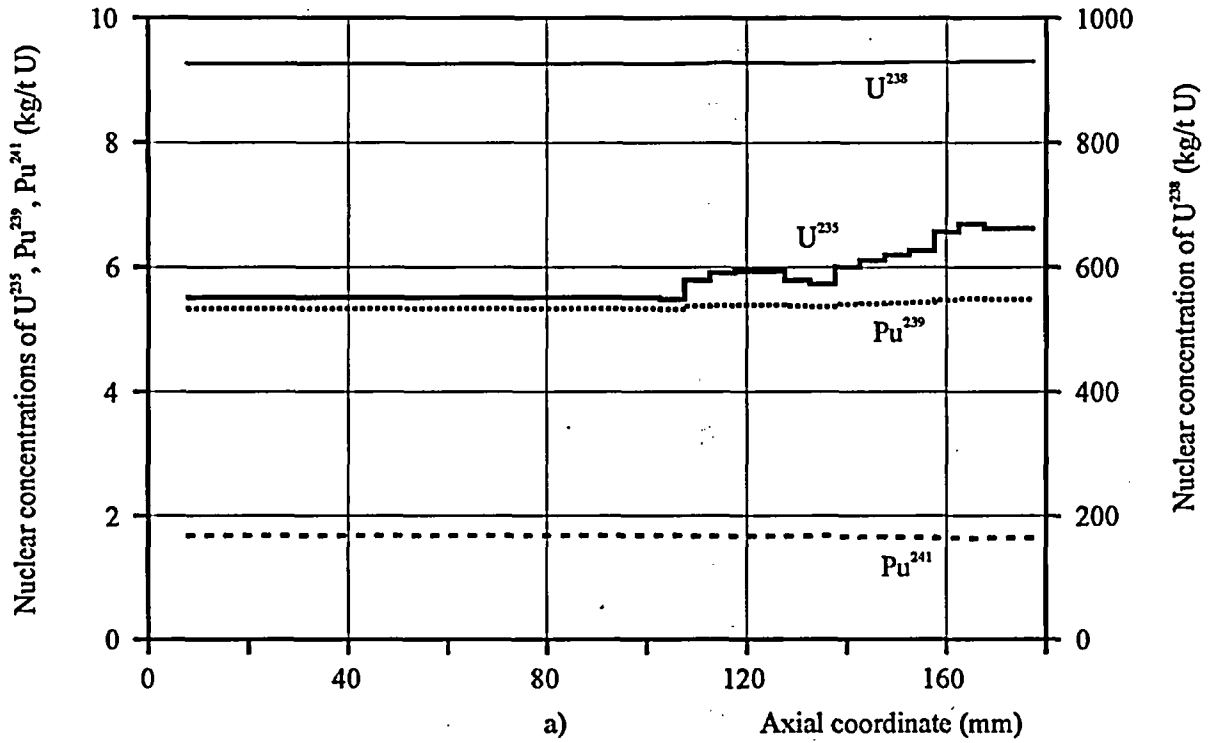

Fig. C-8.3. (a) Axial Distribution of  $U^{235}$ ,  $U^{238}$ ,  $Pu^{239}$ ,  $Pu^{241}$  Isotopes and (b) Radial Distribution of  $U^{235}$  Isotope for Fuel Rod #H8T (calculated)

#H8T

Initial Individual Characteristics of Refabricated Fuel Rods  
(Preirradiated fuel, Preirradiated cladding)

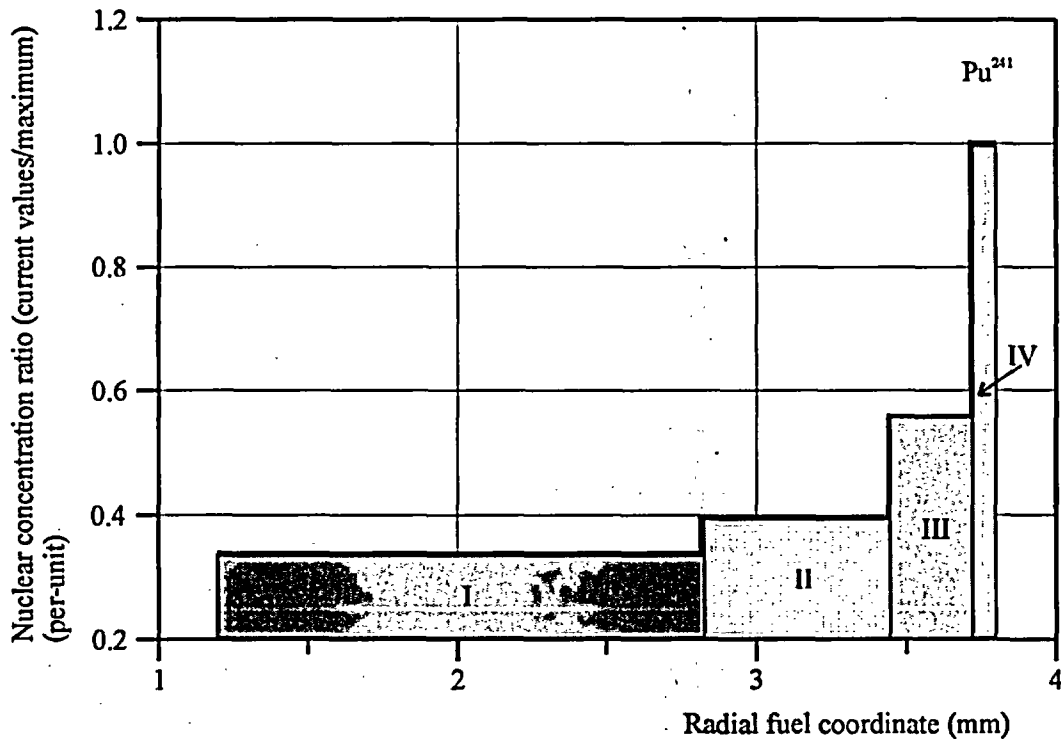
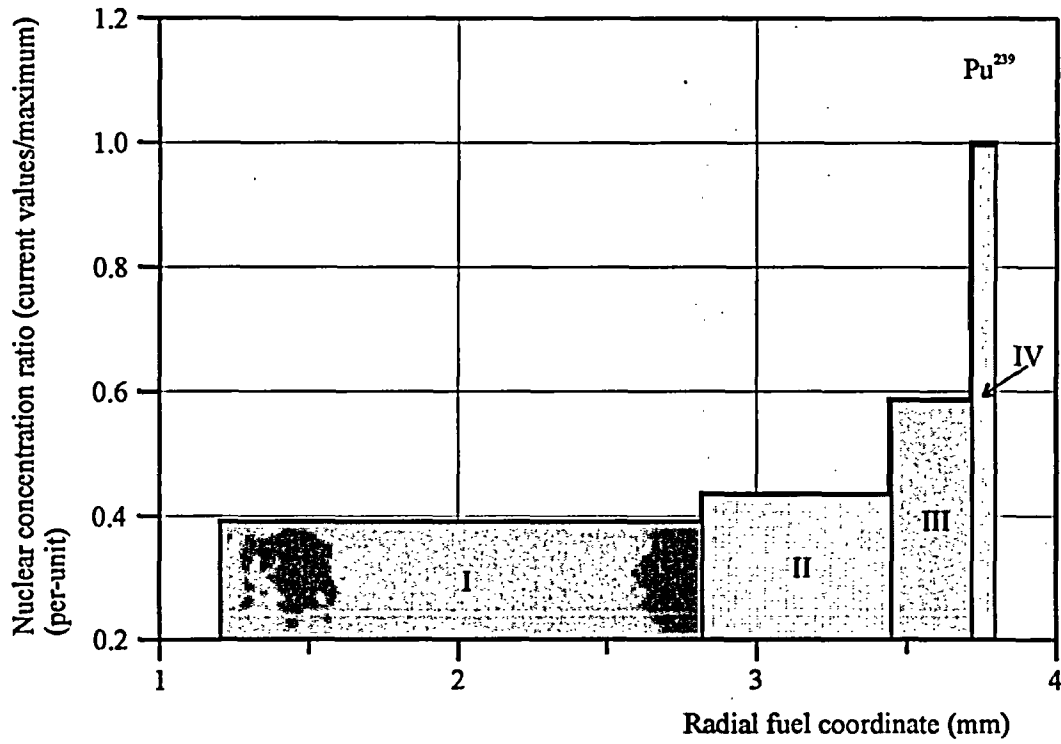

Fig. C-8.4. Radial Distribution of  $Pu^{239}$ ,  $Pu^{241}$  Isotopes for Fuel Rod #H8T (calculated)

#H8T

Initial Individual Characteristics of Refabricated Fuel Rods  
(Preirradiated fuel, Preirradiated cladding)

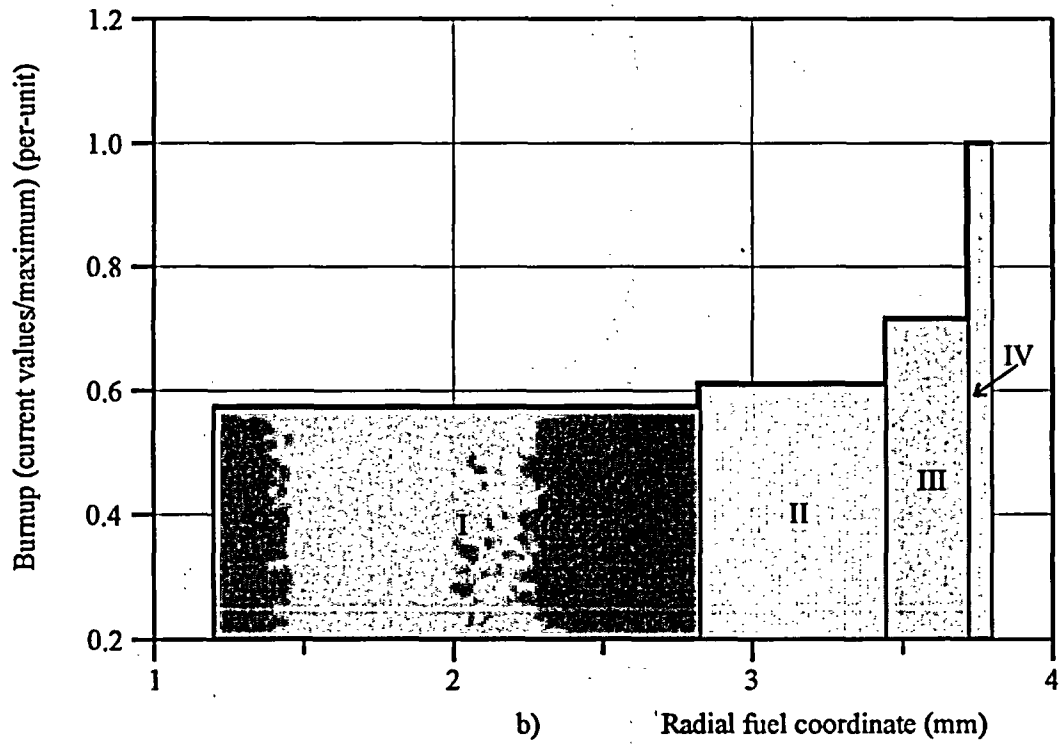
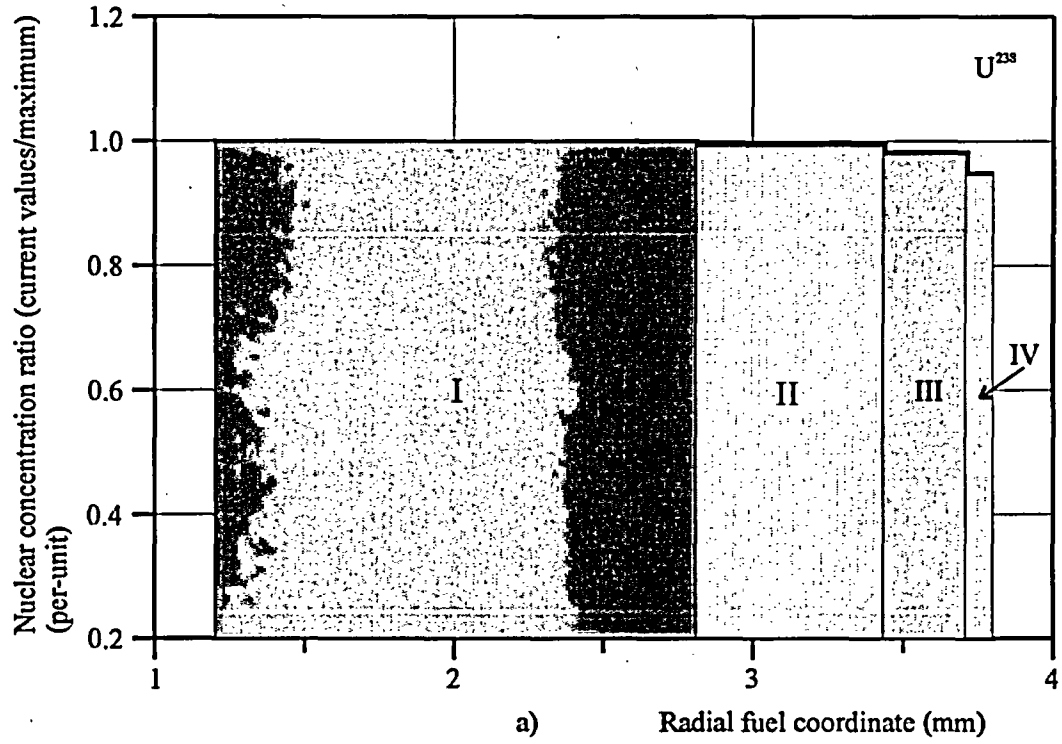

Fig. C-8.5. (a) Radial Distribution of  $U^{238}$  Isotope and (b) Burnup for Fuel Rod #H8T (calculated)



***APPENDIX C-9.***

***Initial Individual Characteristics for Fuel Rod #B9T***

Table C-9.1. Axial Distribution of Isotopic Composition for Fuel Rod #B9T (calculated)

Axial coordinate from lower end of fuel rod (mm)	Nuclear concentrations (kg/t U)						
	U <sup>235</sup>	U <sup>236</sup>	U <sup>238</sup>	Pu <sup>239</sup>	Pu <sup>240</sup>	Pu <sup>241</sup>	Pu <sup>242</sup>
20	4.50	4.95	927	4.88	2.66	1.589	1.076
25	4.50	4.95	927	4.88	2.66	1.589	1.076
30	4.58	4.95	927	4.90	2.65	1.588	1.063
35	4.63	4.94	927	4.91	2.64	1.588	1.055
40	4.47	4.95	927	4.87	2.66	1.589	1.080
45	4.32	4.97	926	4.84	2.68	1.588	1.107
50	4.37	4.96	926	4.85	2.68	1.588	1.098
55	4.40	4.96	926	4.86	2.67	1.589	1.094
60	4.42	4.96	926	4.86	2.67	1.589	1.089
65	4.45	4.96	926	4.87	2.67	1.589	1.085
70	4.66	4.94	927	4.91	2.64	1.588	1.050
75	4.84	4.92	928	4.94	2.62	1.583	1.020
80	4.79	4.93	928	4.93	2.63	1.585	1.029
85	4.73	4.93	927	4.93	2.63	1.587	1.037
90	4.71	4.93	927	4.92	2.63	1.588	1.042
95	4.68	4.94	927	4.92	2.64	1.588	1.046
100	4.58	4.95	927	4.90	2.65	1.588	1.063
105	4.45	4.96	926	4.87	2.67	1.589	1.085
110	4.50	4.95	927	4.88	2.66	1.589	1.076
115	4.55	4.95	927	4.89	2.65	1.589	1.068
120	4.60	4.94	927	4.90	2.65	1.588	1.059
125	4.63	4.94	927	4.91	2.64	1.588	1.055
130	4.63	4.94	927	4.91	2.64	1.588	1.055
135	4.63	4.94	927	4.91	2.64	1.588	1.055
140	4.76	4.93	928	4.93	2.63	1.586	1.033
145	4.90	4.92	928	4.95	2.62	1.581	1.011
150	4.76	4.93	928	4.93	2.63	1.586	1.033
155	4.60	4.94	927	4.90	2.65	1.588	1.059
160	4.73	4.93	927	4.93	2.63	1.587	1.037
165	4.73	4.93	927	4.93	2.63	1.587	1.037
170	4.73	4.93	927	4.93	2.63	1.587	1.037
175	-	-	-	-	-	-	-
180	-	-	-	-	-	-	-

All numerical values of characteristics presented as average values at the length interval equal to the axial coordinate  $\pm 2.5$  mm

Table C-9.2. Radial Distribution of Burnup (Calculated) and Isotopic Composition with RIM Zone Indication (Calculated) for Fuel Rod #B9T (average values in fuel rod)

Characteristic	Coordinates of fuel radial zones (mm)			
	1 zone 1.2 - 2.811	2 zone 2.811 - 3.432	3 zone 3.432 - 3.704	4 zone 3.704 - 3.790
<b>1. Nuclear concentrations (kg/t U):</b>				
U <sup>235</sup>	4.75	4.55	4.36	4.24
U <sup>236</sup>	4.95	4.94	4.94	4.95
U <sup>238</sup>	933.	929.	917.	884.
Pu <sup>239</sup>	4.12	4.58	6.16	10.42
Pu <sup>240</sup>	2.35	2.46	3.13	5.06
Pu <sup>241</sup>	1.275	1.480	2.082	3.708
Pu <sup>242</sup>	0.827	0.986	1.428	2.631
<b>2. Burnup (MWd/kg U)</b>	45.4	48.3	56.7	79.6

## #B9T

Initial Individual Characteristics of Refabricated Fuel Rods  
(Preirradiated fuel, Preirradiated cladding)

Table C-9.3. Individual Initial Characteristics for Fuel Rod #B9T (measured)

Axial coordinate from lower end of fuel rod (mm)	Cladding outer diameter at 0° (mm)	Cladding outer diameter at 90° (mm)	Fuel mass (g) (density- $10.13^4$ ) g/cm <sup>3</sup> *)	Linear fuel mass (g/cm)*	Free gas volume (mm <sup>3</sup> ) <sup>5)</sup>	Burnup (MWd/kg U)*
5	-	-	0.0	0.0	8.8	-
10	-	-	0.0	0.0	98.9	0.0
15	-	-	0.0	0.0	234.0	0.0
20 <sup>1)</sup>	-	-	1.02	4.08	133.6	50.2
25	-	-	2.07	4.14	30.3	50.2
30	-	-	2.07	4.15	30.3	49.9
35	-	-	2.05	4.09	32.3	49.6
40	-	-	2.05	4.10	32.3	50.3
45	9.097	9.075	2.05	4.09	32.3	50.9
50	9.086	9.091	2.03	4.05	34.2	50.7
55	9.081	9.097	2.02	4.04	35.2	50.5
60	9.091	9.100	2.02	4.03	35.2	50.5
65	9.103	9.091	2.00	4.01	37.2	50.4
70	9.098	9.088	1.99	3.99	38.2	49.6
75	9.091	9.089	1.99	3.97	38.2	48.9
80	9.088	9.089	1.99	3.97	38.2	49.1
85	9.091	9.083	1.99	3.98	38.2	49.3
90	9.092	9.080	1.99	3.99	38.2	49.4
95	9.080	9.081	2.00	4.00	37.2	49.5
100	9.069	9.089	2.02	4.03	35.2	49.9
105	9.068	9.091	2.04	4.07	33.3	50.3
110	9.072	9.086	2.05	4.10	32.3	50.1
115	9.083	9.081	2.07	4.13	30.3	50.0
120	9.086	9.077	2.08	4.16	29.3	49.8
125	9.083	9.086	2.10	4.20	27.3	49.7
130	9.080	9.081	2.11	4.21	26.4	49.7
135	9.091	9.077	2.08	4.16	29.3	49.7
140	9.095	9.066	2.07	4.13	30.3	49.2
145	9.098	9.071	2.06	4.13	31.3	48.6
150	9.081	9.086	2.05	4.09	32.3	49.2
155	9.072	9.088	2.12	4.24	25.4	49.8
160	9.075	9.075	1.43	2.86	93.3	49.3 <sup>3)</sup>
165	9.078	9.074	0.85	1.69	150.4	49.3 <sup>3)</sup>
170 <sup>2)</sup>	9.080	9.080	0.42	1.70	192.7	49.3 <sup>3)</sup>
175	9.075	9.084	0.0	0.0	234.0	0.0
180	9.071	9.084	0.0	0.0	136.0	0.0

\* These numerical values of characteristics are presented as average values at the length interval equal to the axial coordinate  $\pm 2.5$  mm<sup>1)</sup> Initial coordinate of fuel is 20.0 mm<sup>4)</sup> Effective density of fuel stack<sup>2)</sup> Final coordinate of fuel is 170 mm<sup>5)</sup> Free gas volume for coordinates 185 - 295 mm is presented in Table C.3<sup>3)</sup> Average value



#B9T

Initial Individual Characteristics of Refabricated Fuel Rods  
(Preirradiated fuel, Preirradiated cladding)

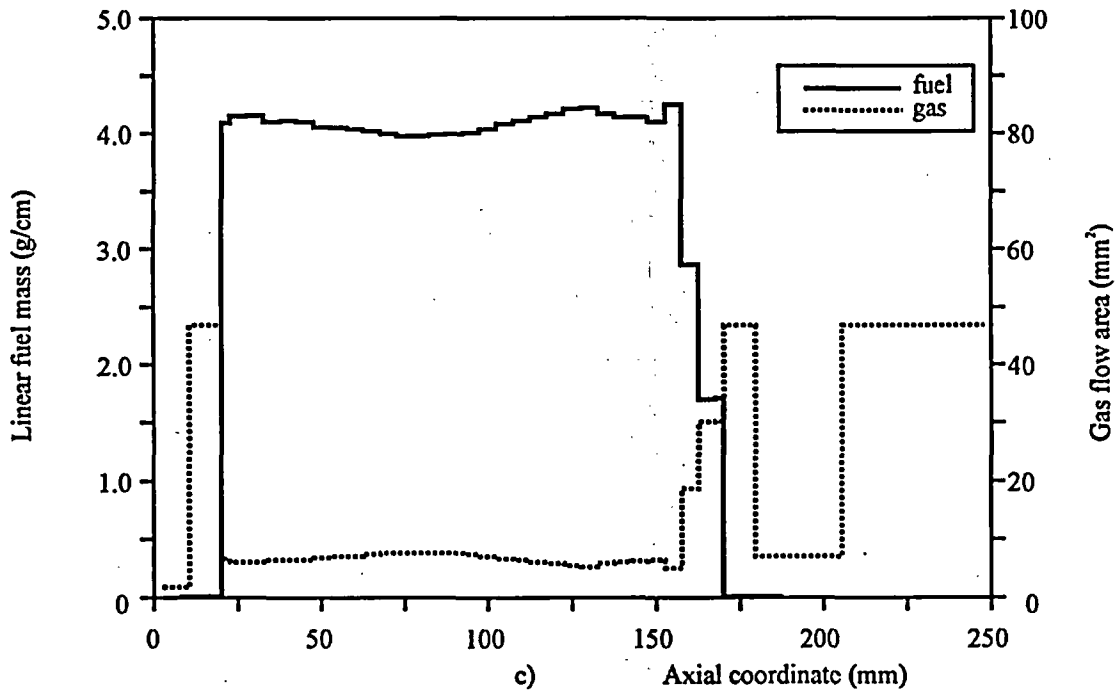
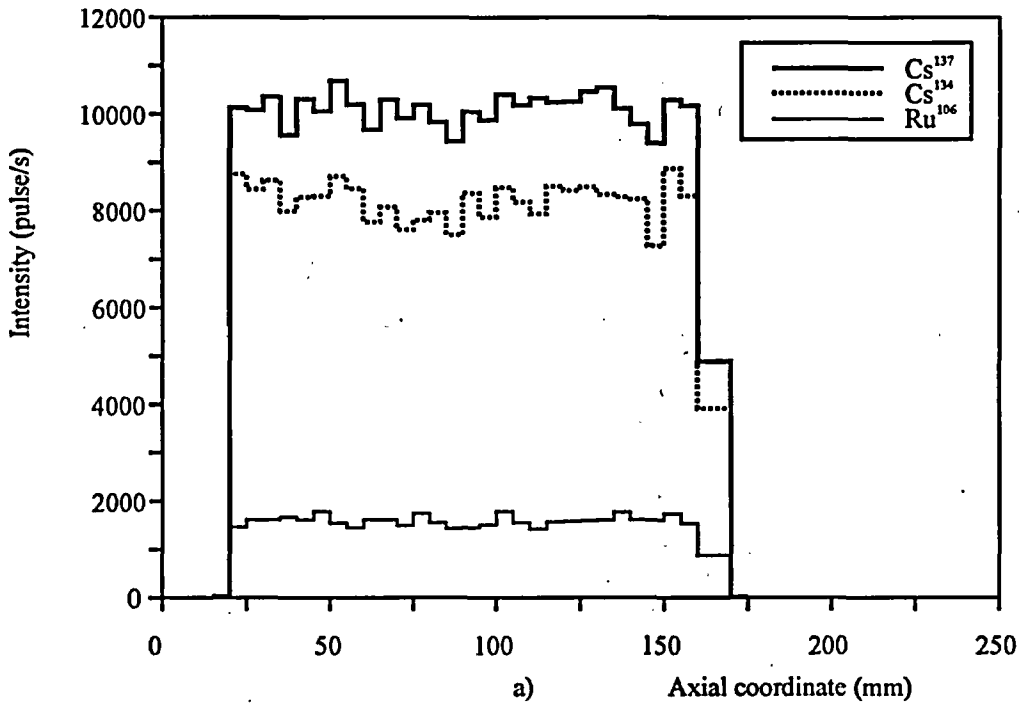

Fig. C-9.1. (a) Results of  $\gamma$ -scanning, (b) Radiography, (c) Axial Fuel Mass Distribution and Axial Free Gas Volume Distribution for Fuel Rod #B9T

#B9T

Initial Individual Characteristics of Refabricated Fuel Rods  
(Preirradiated fuel, Preirradiated cladding)

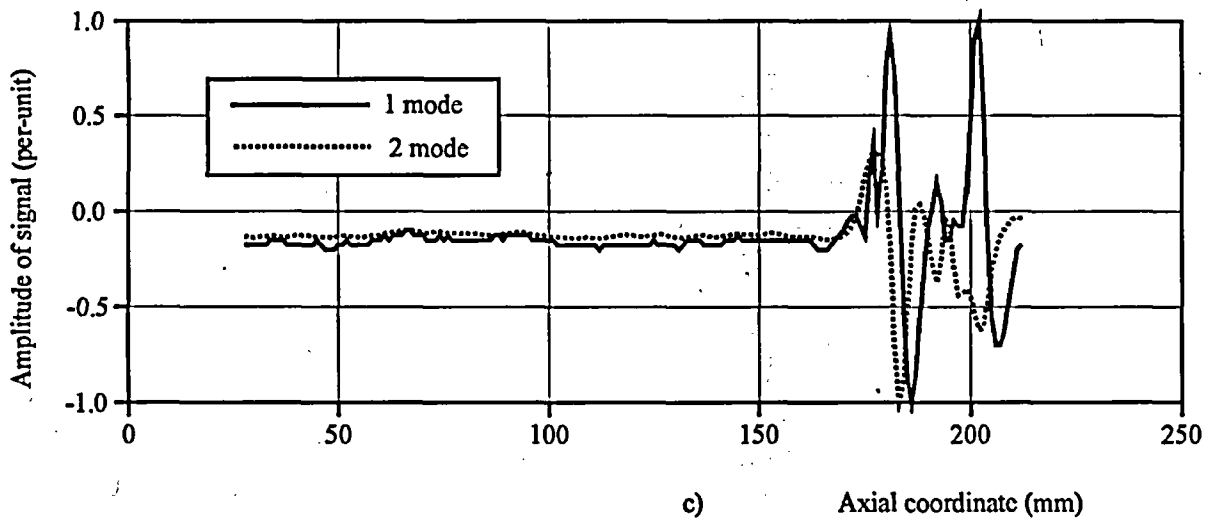
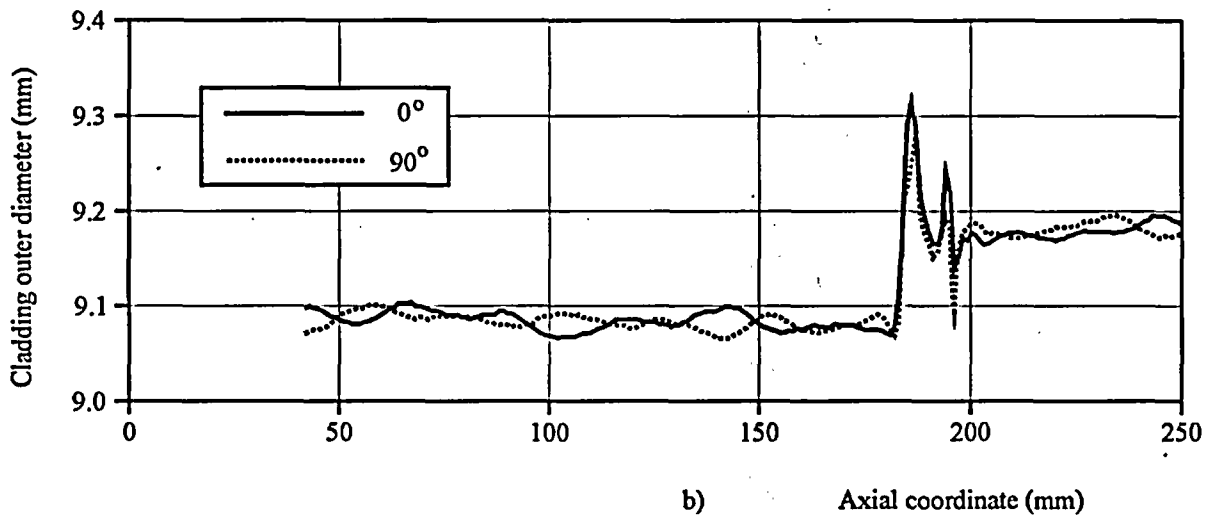
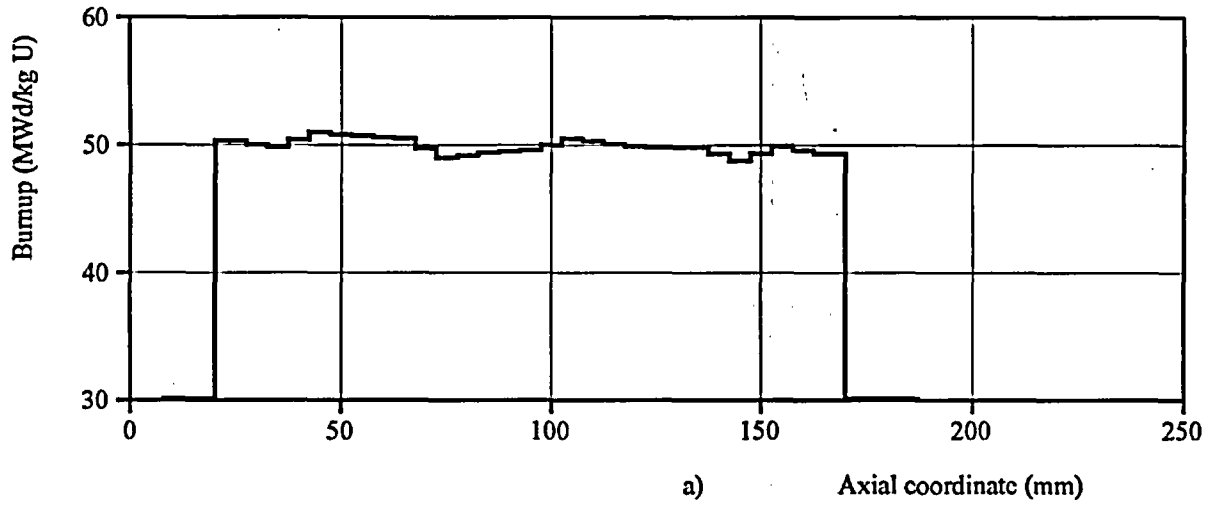

Fig. C-9.2. (a) Axial Burnup Distribution and (b) Results of Profilometry and (c) Eddy-Current Examination for Fuel Rod #B9T

#B9T

Initial Individual Characteristics of Refabricated Fuel Rods  
(Preirradiated fuel, Preirradiated cladding)

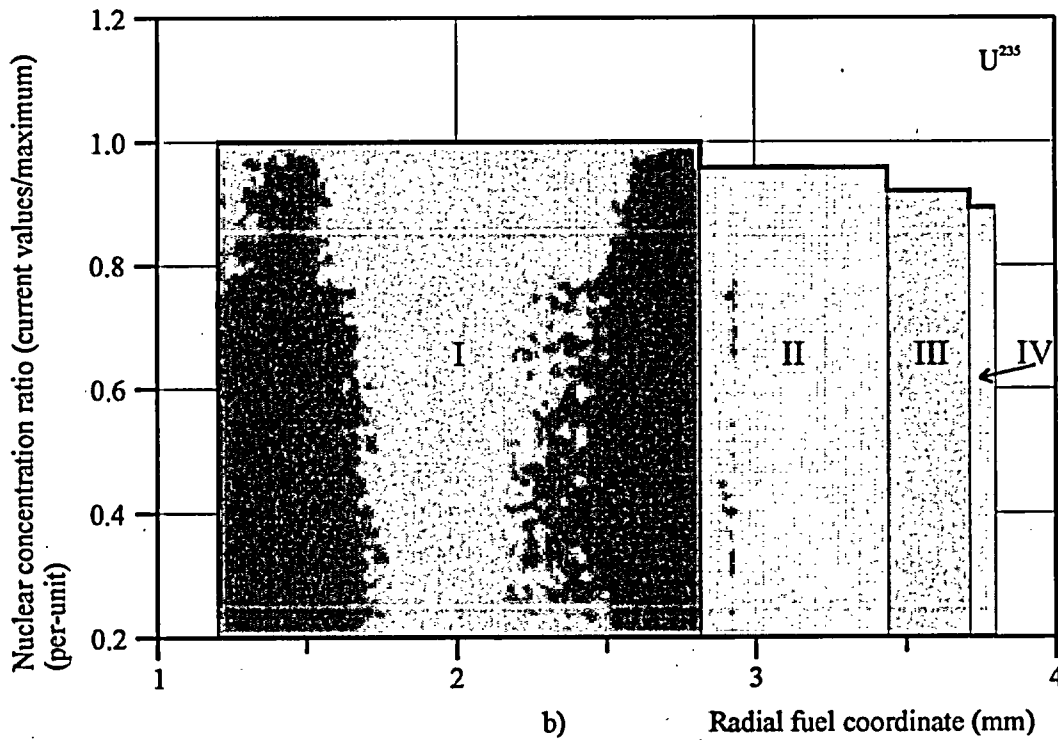
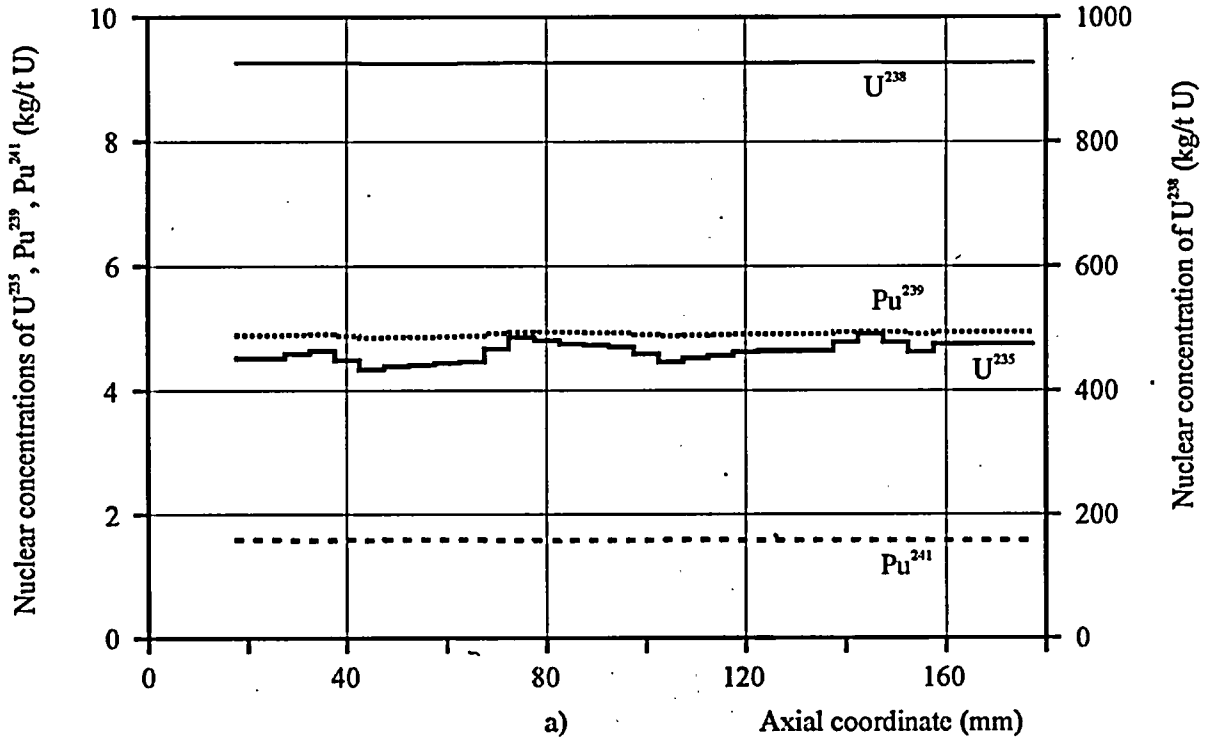

Fig. C-9.3. (a) Axial Distribution of  $U^{235}$ ,  $U^{238}$ ,  $Pu^{239}$ ,  $Pu^{241}$  Isotopes and (b) Radial Distribution of  $U^{235}$  Isotope for Fuel Rod #B9T (calculated)

#B9T

Initial Individual Characteristics of Refabricated Fuel Rods  
(Preirradiated fuel, Preirradiated cladding)

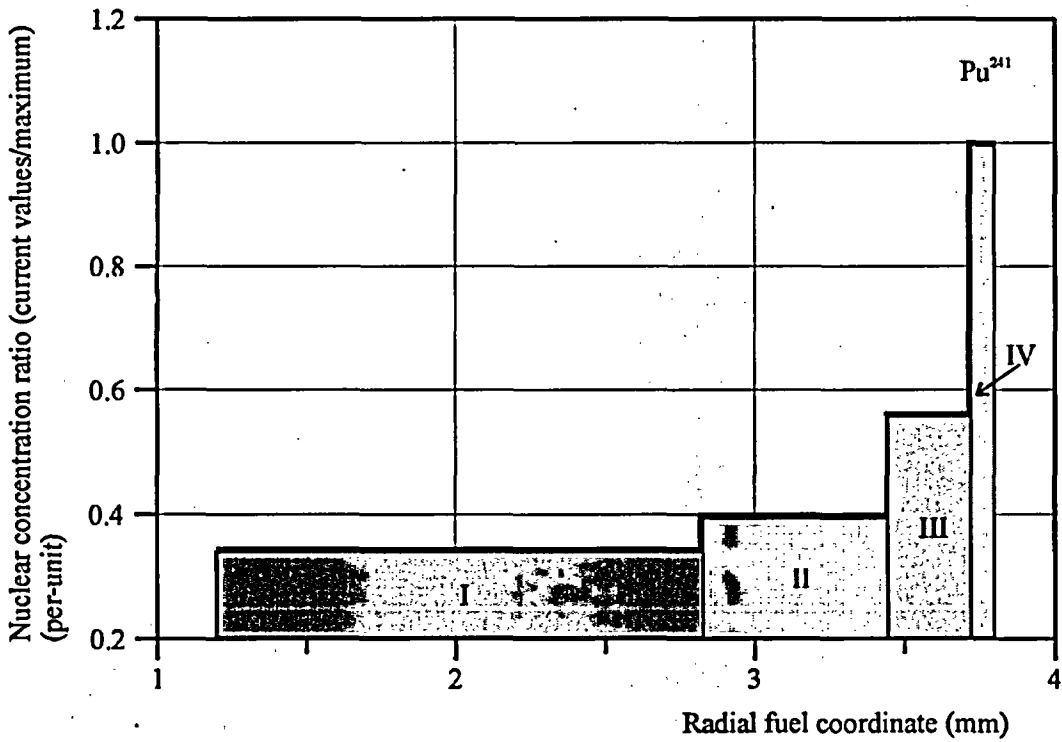
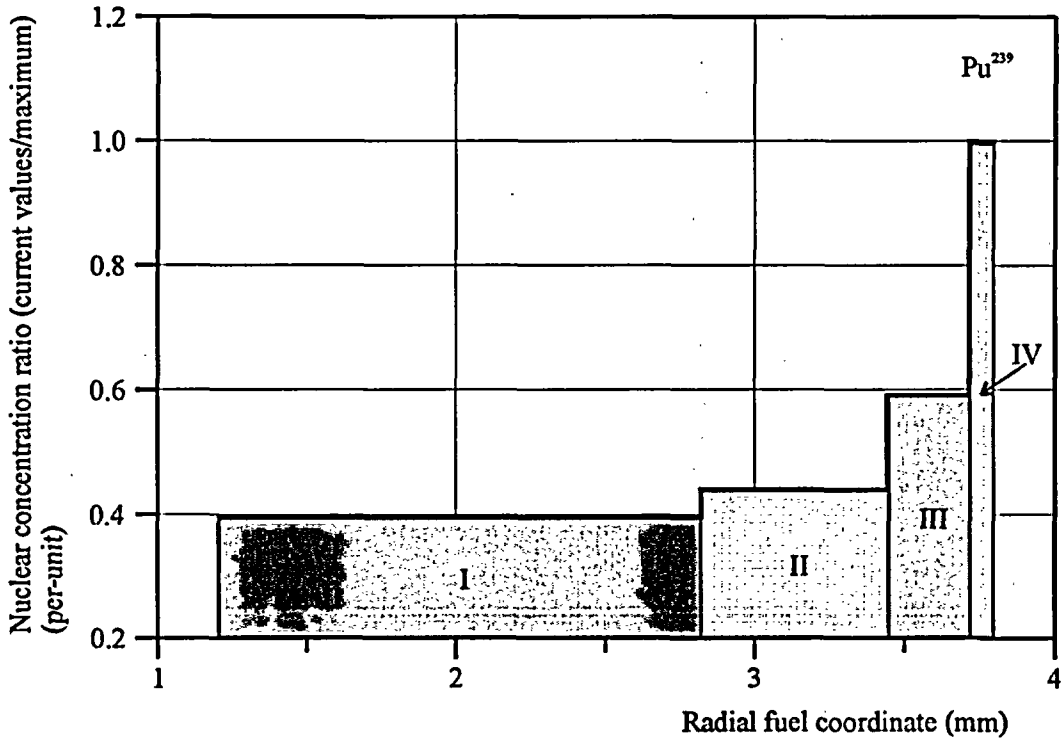

Fig. C-9.4. Radial Distribution of  $Pu^{239}$ ,  $Pu^{241}$  Isotopes for Fuel Rod #B9T (calculated)

#B9T

Initial Individual Characteristics of Refabricated Fuel Rods  
(Preirradiated fuel, Preirradiated cladding)

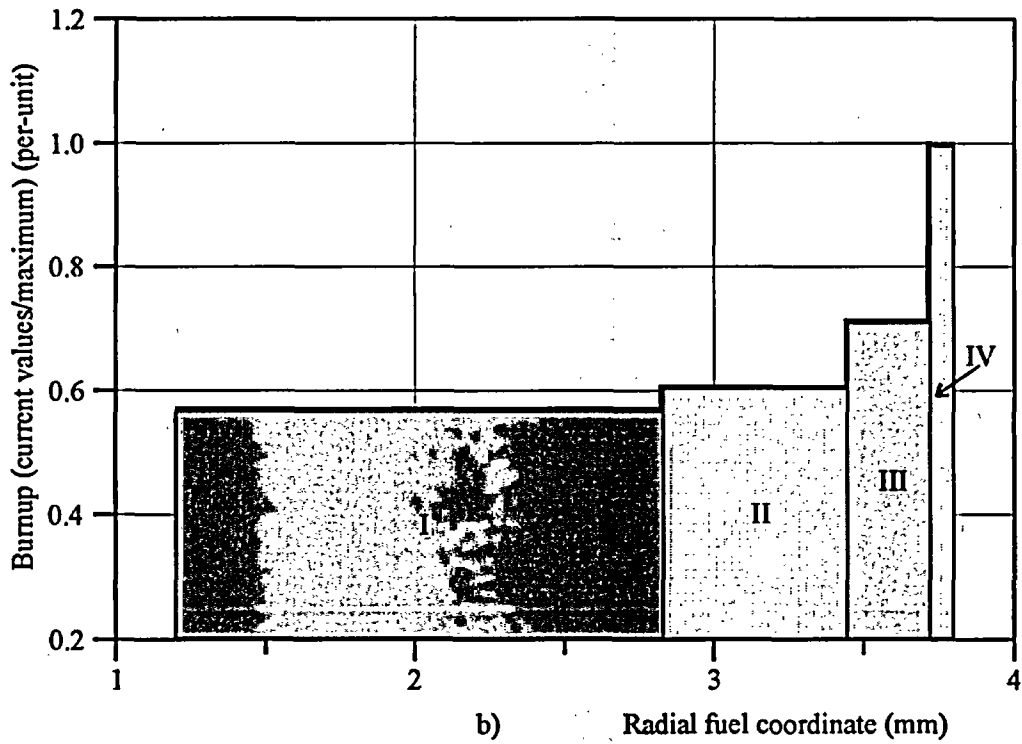
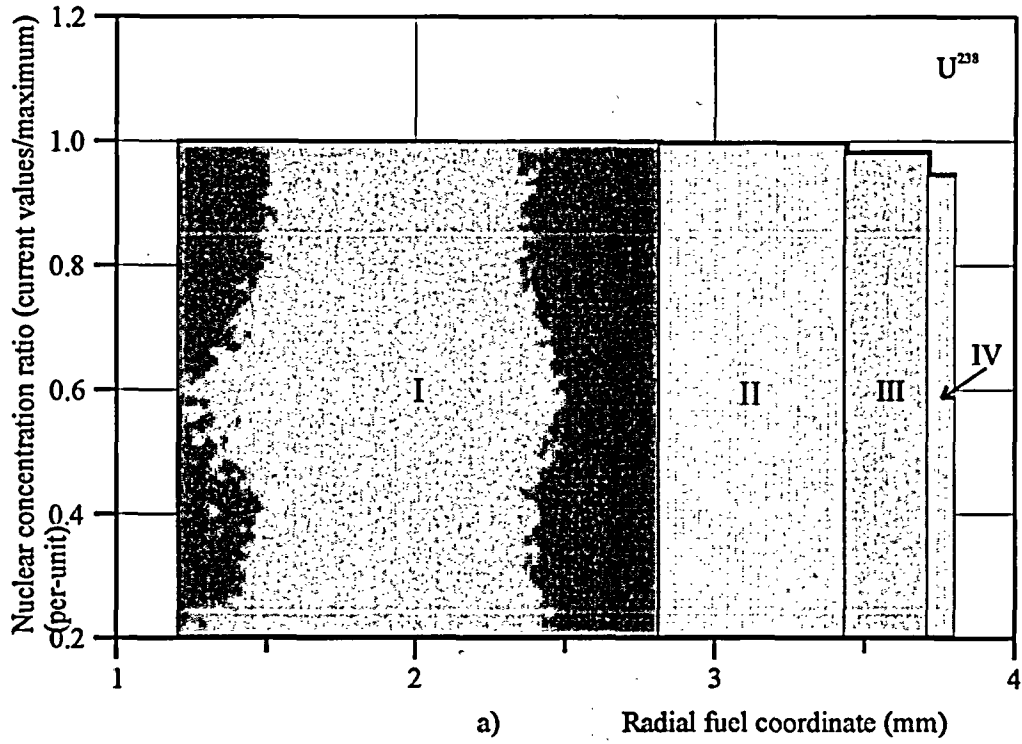

Fig. C-9.5. (a) Radial Distribution of  $U^{238}$  Isotope and (b) Burnup for Fuel Rod #B9T (calculated)



***APPENDIX C-10.***

***Initial Individual Characteristics for Fuel Rod #B10T***

## #B10T

Initial Individual Characteristics of Refabricated Fuel Rods  
(Preirradiated fuel, Preirradiated cladding)

Table C-10.1. Axial Distribution of Isotopic Composition for Fuel Rod #B10T (calculated)

Axial coordinate from lower end of fuel rod (mm)	Nuclear concentrations (kg/t U)						
	U <sup>235</sup>	U <sup>236</sup>	U <sup>238</sup>	Pu <sup>239</sup>	Pu <sup>240</sup>	Pu <sup>241</sup>	Pu <sup>242</sup>
20	-	-	-	-	-	-	-
25	7.07	4.74	931	5.73	2.50	1.673	0.785
30	7.07	4.74	931	5.73	2.50	1.673	0.785
35	7.07	4.74	931	5.73	2.50	1.673	0.785
40	7.01	4.75	931	5.73	2.51	1.677	0.793
45	7.10	4.74	931	5.74	2.50	1.671	0.781
50	7.20	4.73	931	5.75	2.48	1.666	0.770
55	7.53	4.69	932	5.78	2.44	1.647	0.732
60	7.87	4.65	933	5.80	2.39	1.623	0.697
65	7.63	4.68	933	5.79	2.43	1.640	0.721
70	7.43	4.70	932	5.77	2.45	1.652	0.744
75	7.47	4.70	932	5.77	2.45	1.650	0.740
80	7.50	4.70	932	5.77	2.44	1.649	0.736
85	7.33	4.71	932	5.76	2.47	1.658	0.755
90	7.20	4.73	931	5.75	2.48	1.666	0.770
95	7.10	4.74	931	5.74	2.50	1.671	0.781
100	7.01	4.75	931	5.73	2.51	1.677	0.793
105	7.04	4.75	931	5.73	2.50	1.675	0.789
110	7.07	4.74	931	5.73	2.50	1.673	0.785
115	7.10	4.74	931	5.74	2.50	1.671	0.781
120	7.10	4.74	931	5.74	2.50	1.671	0.781
125	7.04	4.75	931	5.73	2.50	1.675	0.789
130	7.01	4.75	931	5.73	2.51	1.677	0.793
135	6.94	4.76	931	5.72	2.52	1.680	0.800
140	6.88	4.77	931	5.72	2.53	1.684	0.808
145	6.79	4.78	930	5.71	2.54	1.689	0.820
150	6.79	4.78	930	5.71	2.54	1.689	0.820
155	6.79	4.78	930	5.71	2.54	1.689	0.820
160	6.79	4.78	930	5.71	2.54	1.689	0.820
165	6.79	4.78	930	5.71	2.54	1.689	0.820
170	6.79	4.78	930	5.71	2.54	1.689	0.820
175	6.79	4.78	930	5.71	2.54	1.689	0.820
180	-	-	-	-	-	-	-

All numerical values of characteristics presented as average values at the length interval equal to the axial coordinate  $\pm 2.5$  mm



# #B10T

Initial Individual Characteristics of Refabricated Fuel Rods  
(Preirradiated fuel, Preirradiated cladding)

**Table C-10.2. Radial Distribution of Burnup (Calculated) and Isotopic Composition with RIM Zone Indication (Calculated) for Fuel Rod #B10T (average values in fuel rod)**

Characteristic	Coordinates of fuel radial zones (mm)			
	1 zone 1.2 - 2.811	2 zone 2.811 - 3.432	3 zone 3.432 - 3.704	4 zone 3.704 - 3.790
<b>1. Nuclear concentrations (kg/t U):</b>				
U <sup>235</sup>	7.25	7.00	6.77	6.62
U <sup>236</sup>	4.74	4.75	4.76	4.77
U <sup>238</sup>	937.	933.	922.	892.
Pu <sup>239</sup>	4.80	5.35	7.24	12.41
Pu <sup>240</sup>	2.19	2.32	3.00	4.94
Pu <sup>241</sup>	1.329	1.557	2.213	3.994
Pu <sup>242</sup>	0.609	0.731	1.065	1.971
<b>2. Burnup (MWd/kg U)</b>	<b>39.5</b>	<b>41.9</b>	<b>48.9</b>	<b>67.7</b>

# #B10T

Initial Individual Characteristics of Refabricated Fuel Rods  
(Preirradiated fuel, Preirradiated cladding)

Table C-10.3. Individual Initial Characteristics for Fuel Rod #B10T (measured)

Axial coordinate from lower end of fuel rod (mm)	Cladding outer diameter at 0° (mm)	Cladding outer diameter at 90° (mm)	Fuel mass (g) (density- $10.13^4$ g/cm <sup>3</sup> )*	Linear fuel mass (g/cm)*	Free gas volume (mm <sup>3</sup> ) <sup>5)</sup>	Burnup (MWd/kg U)*
5	-	-	0.0	0.0	8.8	-
10	-	-	0.0	0.0	98.9	0.0
15	-	-	0.0	0.0	234.0	0.0
20	-	-	0.0	0.0	234.0	0.0
25 <sup>1)</sup>	-	-	0.96	3.84	139.5	43.1 <sup>3)</sup>
30	-	-	1.60	3.20	76.6	43.1 <sup>3)</sup>
35	-	-	1.75	3.50	61.8	43.1 <sup>3)</sup>
40	-	-	1.99	3.97	38.2	43.4
45	9.068	9.097	2.06	4.11	31.3	43.1
50	9.077	9.084	2.15	4.30	22.4	42.7
55	9.081	9.084	2.16	4.32	21.4	41.7
60	9.072	9.089	2.17	4.34	20.5	40.7
65	9.068	9.097	2.18	4.36	19.5	41.4
70	9.078	9.095	2.17	4.35	20.5	42.0
75	9.086	9.083	2.15	4.31	22.4	41.9
80	9.084	9.091	2.13	4.27	24.4	41.9
85	9.068	9.100	2.11	4.21	26.4	42.3
90	9.059	9.110	2.07	4.15	30.3	42.7
95	9.065	9.104	2.06	4.11	31.3	43.0
100	9.080	9.092	2.03	4.06	34.2	43.4
105	9.080	9.088	2.01	4.03	36.2	43.2
110	9.074	9.092	2.01	4.02	36.2	43.1
115	9.066	9.098	2.01	4.01	36.2	43.1
120	9.074	9.094	2.00	3.99	37.2	43.1
125	9.084	9.094	2.00	4.01	37.2	43.2
130	9.086	9.092	2.01	4.02	36.2	43.4
135	9.086	9.092	2.01	4.02	36.2	43.6
140	9.084	9.092	1.98	3.96	39.2	43.8
145	9.095	9.083	1.88	3.76	49.0	44.1 <sup>3)</sup>
150	9.113	9.068	1.68	3.36	68.7	44.1 <sup>3)</sup>
155	9.110	9.068	0.96	1.92	139.6	44.1 <sup>3)</sup>
160	9.109	9.081	0.94	1.88	141.5	44.1 <sup>3)</sup>
165	9.103	9.092	1.09	2.18	126.8	44.1 <sup>3)</sup>
170	9.097	9.092	1.35	2.69	101.2	44.1 <sup>3)</sup>
175 <sup>2)</sup>	9.095	9.097	0.20	3.90	214.3	44.1 <sup>3)</sup>
180	9.094	9.097	0.0	0.0	114.8	0.0

\* These numerical values of characteristics are presented as average values at the length interval equal to the axial coordinate  $\pm 2.5$  mm

<sup>1)</sup> Initial coordinate of fuel is 25.0 mm

<sup>4)</sup> Effective density of fuel stack

<sup>2)</sup> Final coordinate of fuel is 173 mm

<sup>5)</sup> Free gas volume for coordinates 185 - 295 mm is presented in Table C.3

<sup>3)</sup> Average value

# #B10T

Initial Individual Characteristics of Refabricated Fuel Rods  
(Preirradiated fuel, Preirradiated cladding)

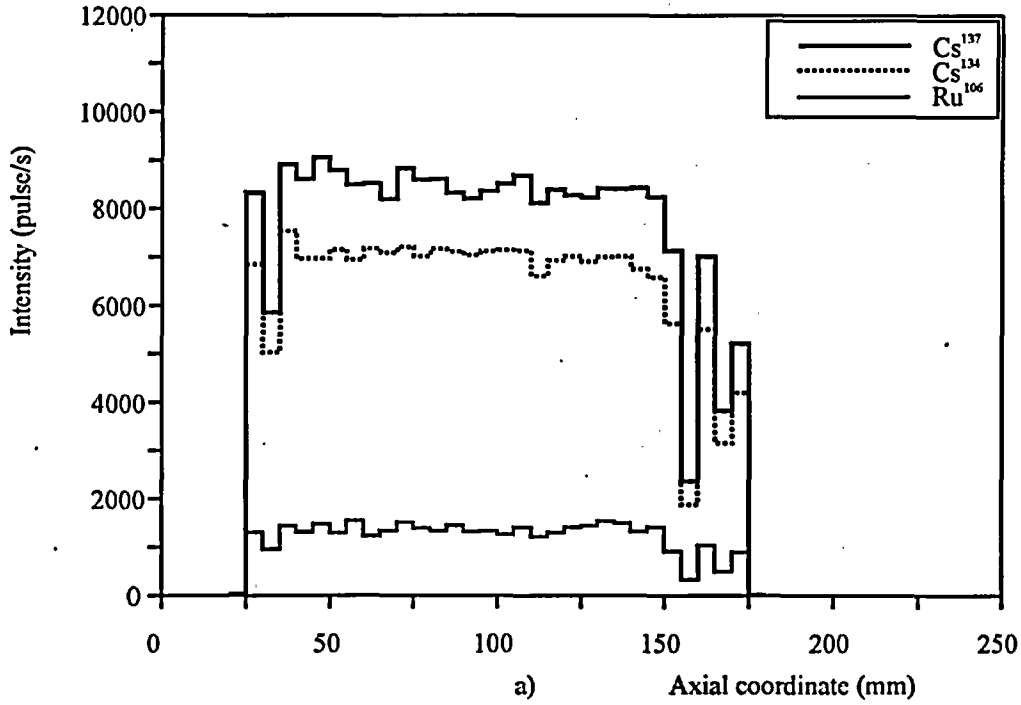

b)

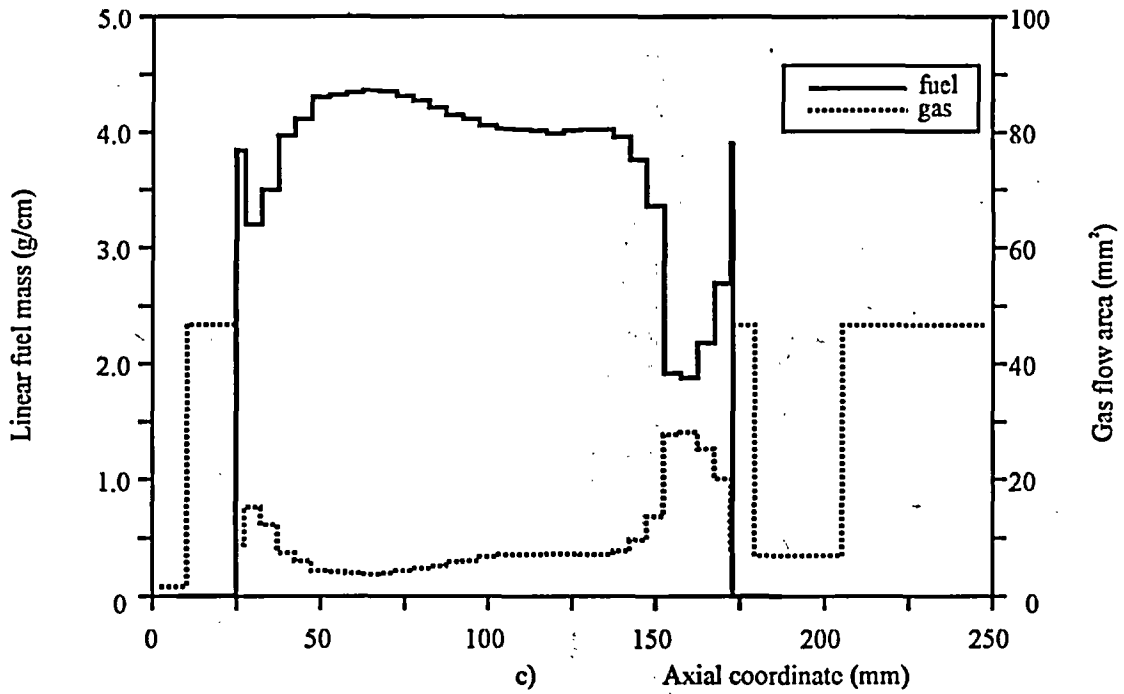

Fig. C-10.1. (a) Results of  $\gamma$ -scanning, (b) Radiography, (c) Axial Fuel Mass Distribution and Axial Free Gas Volume Distribution for Fuel Rod #B10T

#B10T

Initial Individual Characteristics of Refabricated Fuel Rods  
(Preirradiated fuel) (Preirradiated cladding)

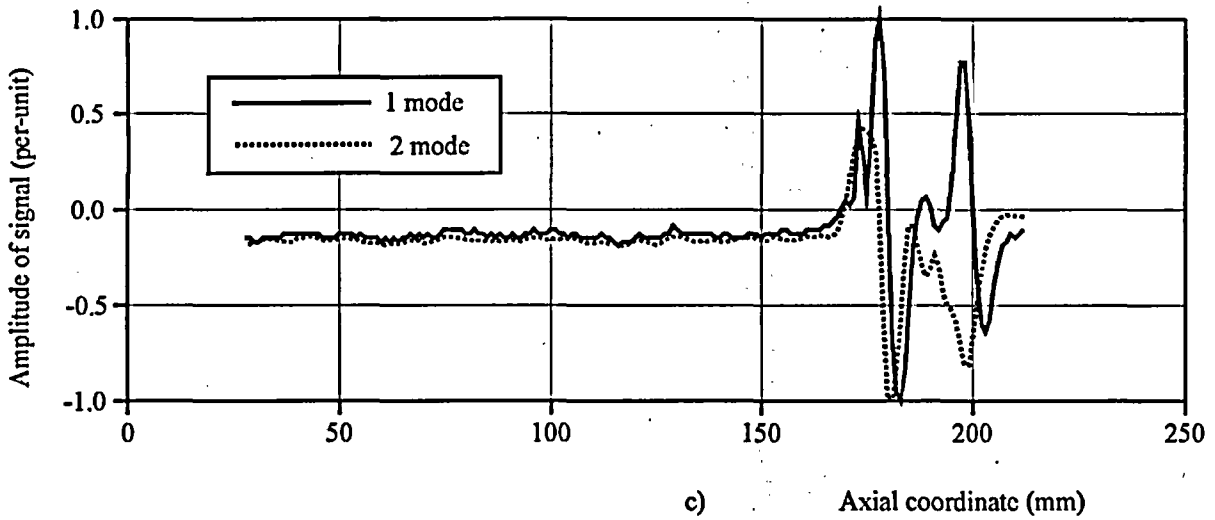
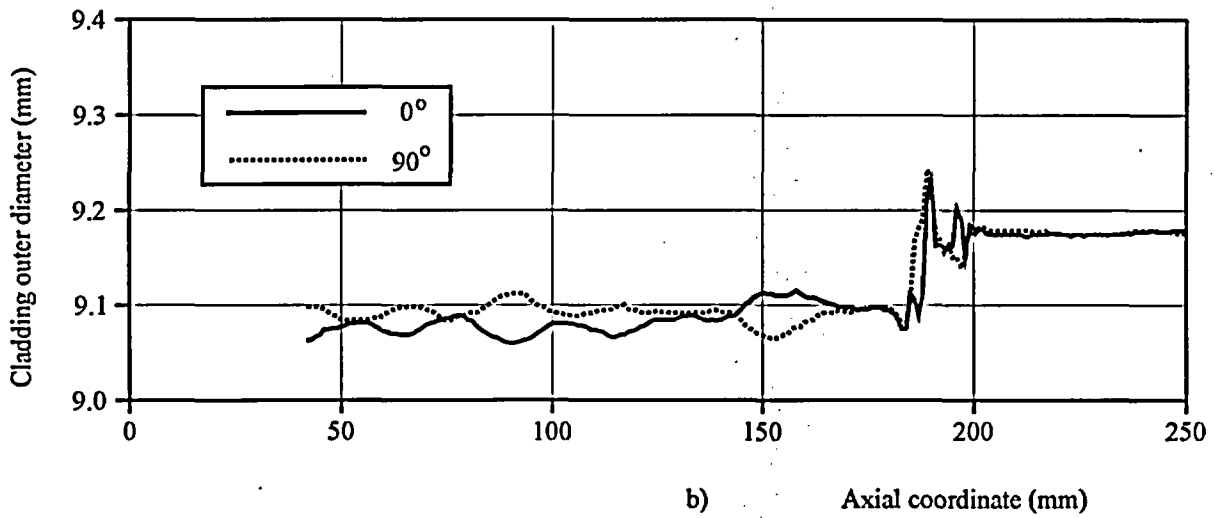
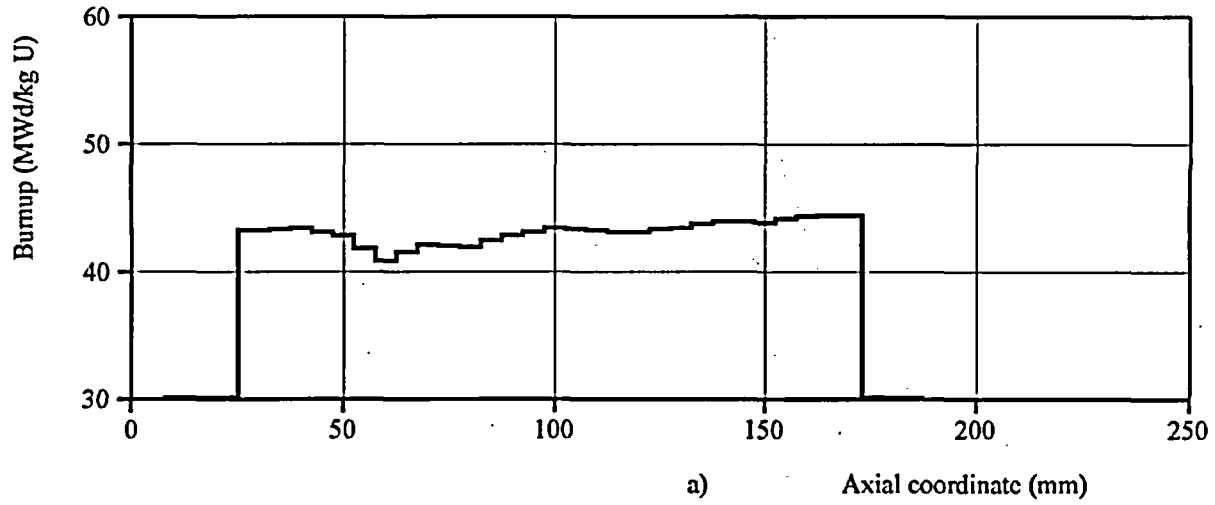

Fig. C-10.2. (a) Axial Burnup Distribution and (b) Results of Profilometry and (c) Eddy-Current Examination for Fuel Rod #B10T

#B10T

Initial Individual Characteristics of Refabricated Fuel Rods  
(Preirradiated fuel, Preirradiated cladding)

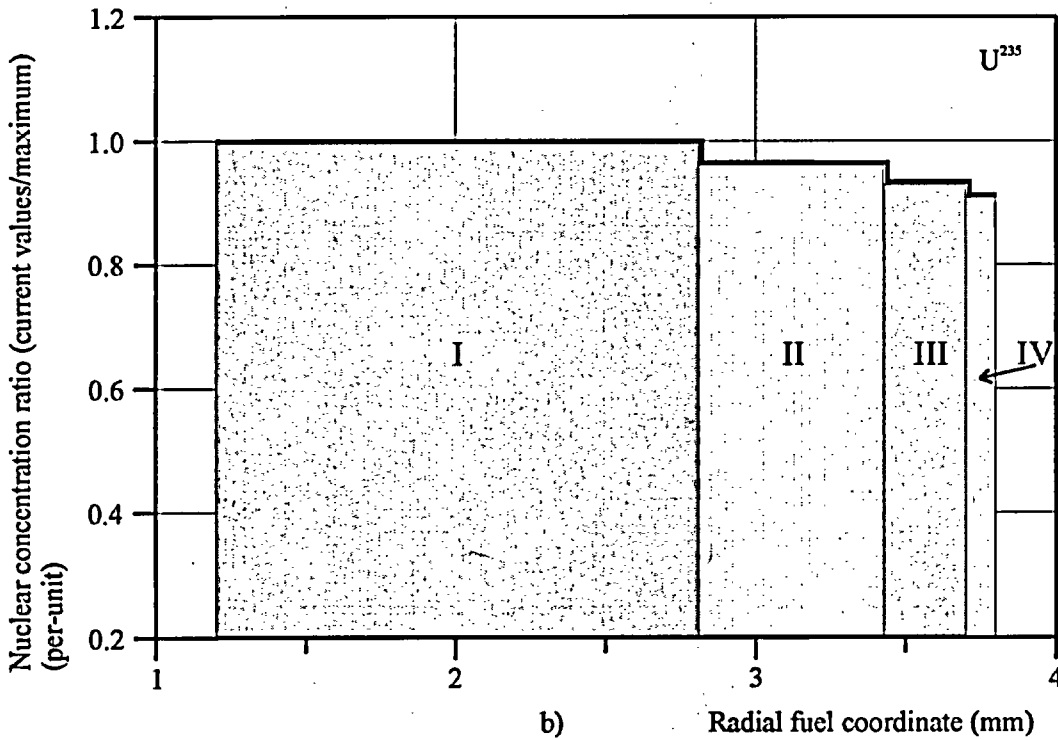
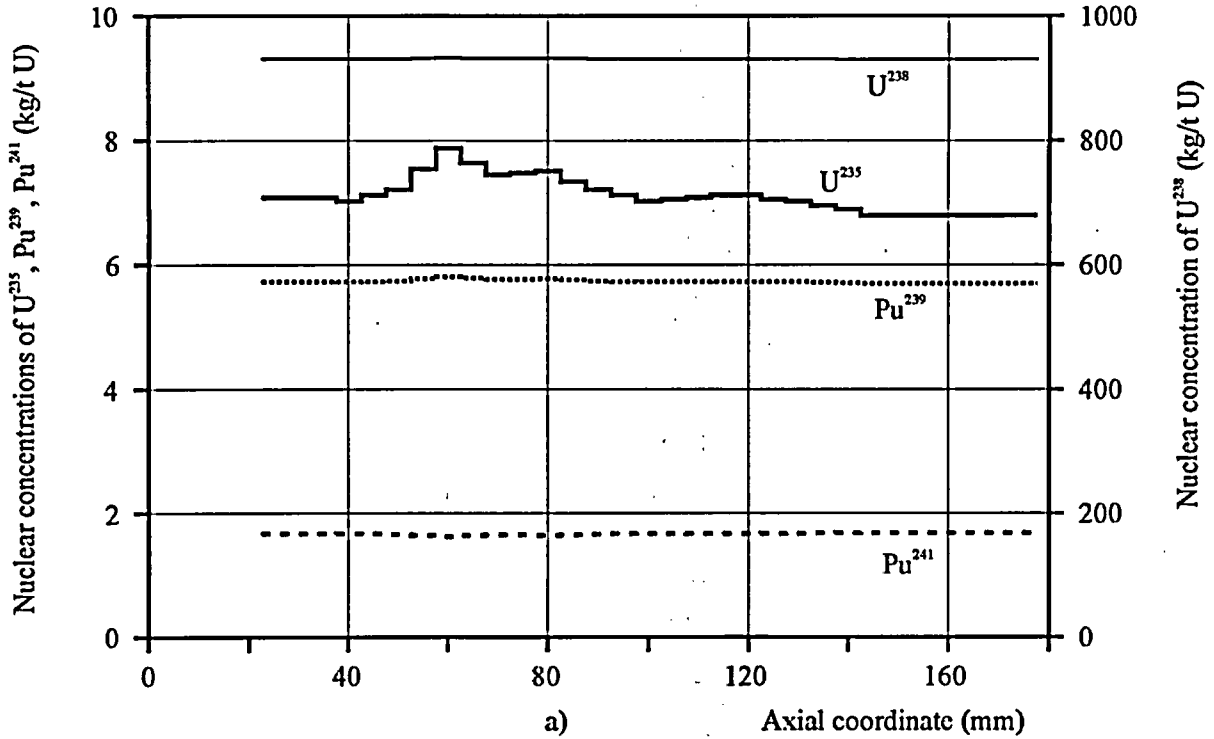

Fig. C-10.3. (a) Axial Distribution of  $U^{235}$ ,  $U^{238}$ ,  $Pu^{239}$ ,  $Pu^{241}$  Isotopes and (b) Radial Distribution of  $U^{235}$  Isotope for Fuel Rod #B10T (calculated)

#B10T

Initial Individual Characteristics of Refabricated Fuel Rods  
(Preirradiated fuel, Preirradiated cladding)

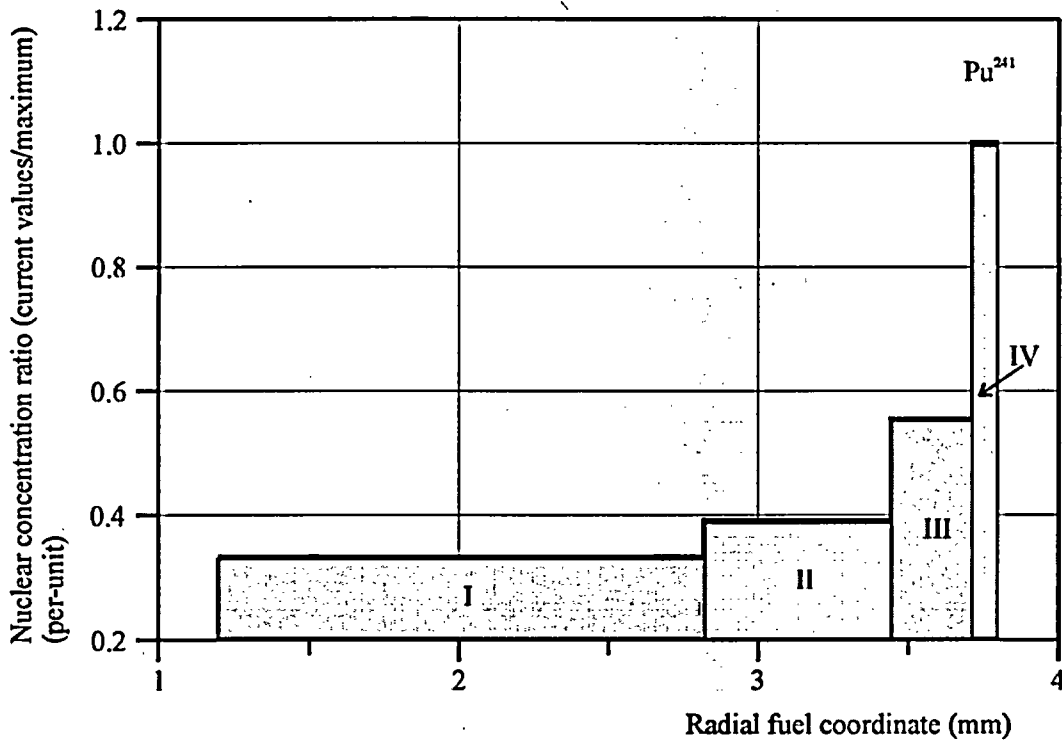
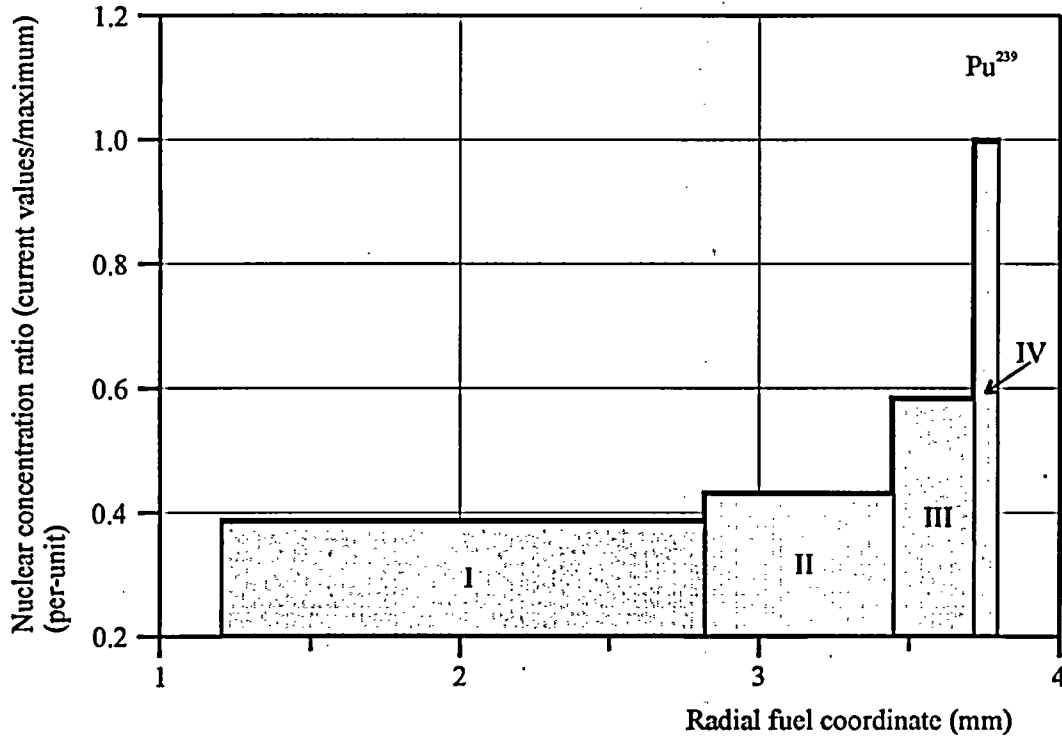

Fig. C-10.4. Radial Distribution of  $\text{Pu}^{239}$ ,  $\text{Pu}^{241}$  Isotopes for Fuel Rod #B10T (calculated)

#B10T

Initial Individual Characteristics of Refabricated Fuel Rods  
(Preirradiated fuel, Preirradiated cladding)

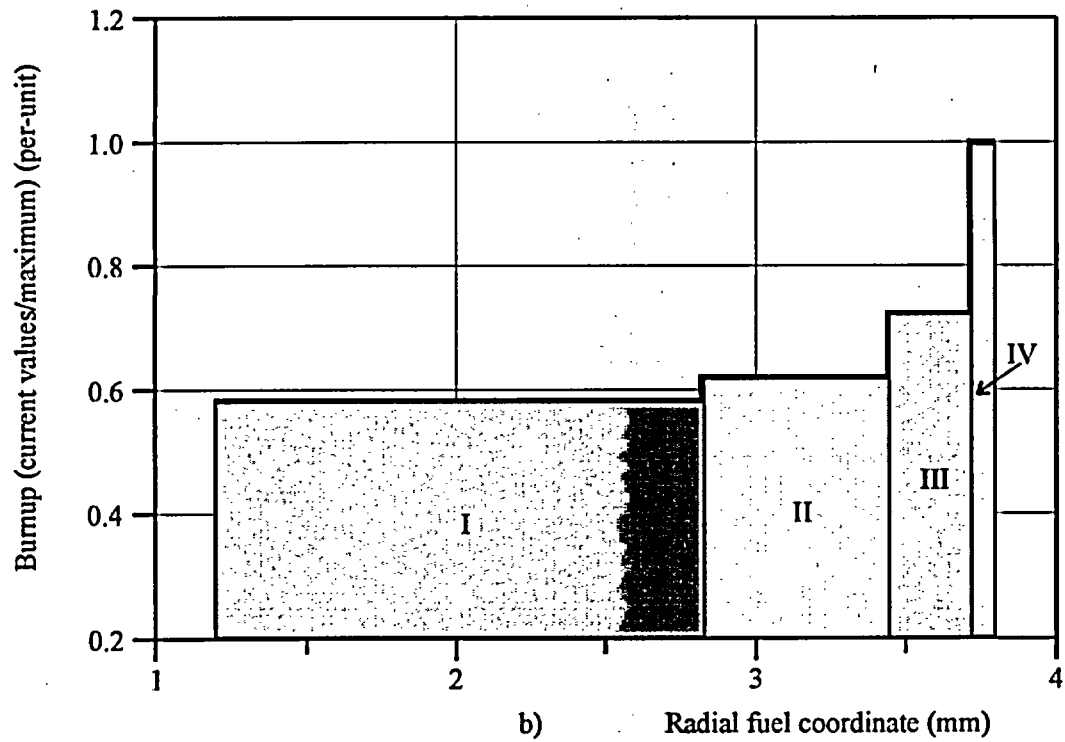
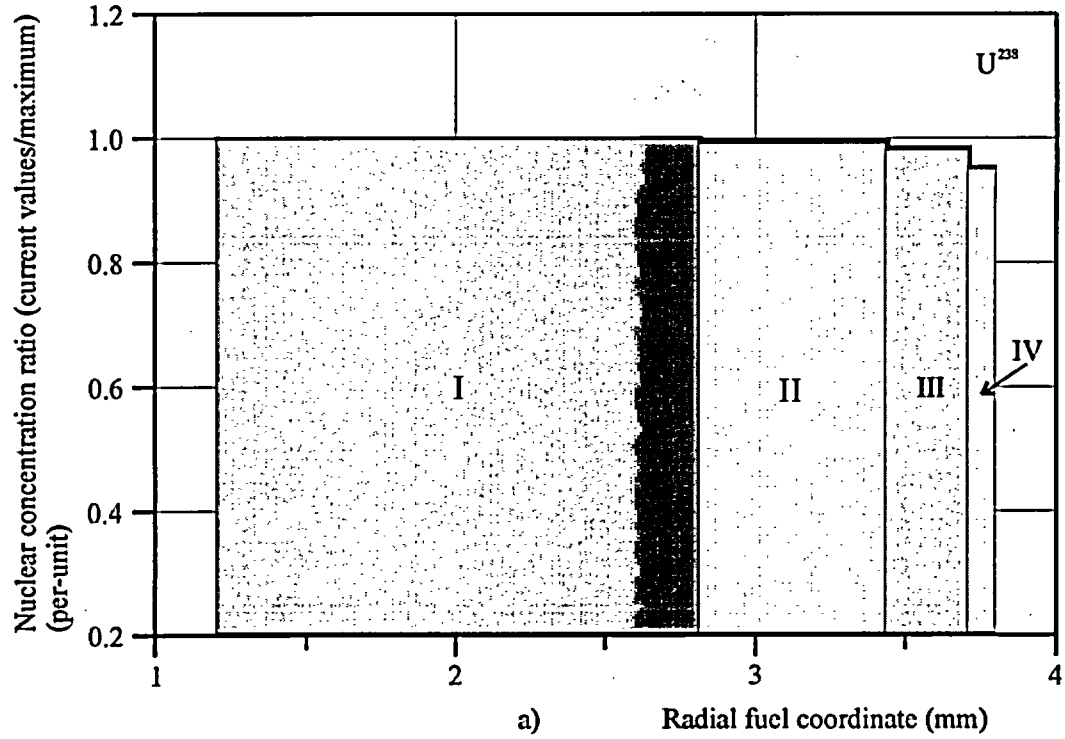

Fig. C-10.5. (a) Radial Distribution of  $U^{238}$  Isotope and (b) Burnup for Fuel Rod #B10T (calculated)





*APPENDIX C-III*  
*Initial Individual Characteristics for Fuel Rod #B11T*

# #B11T

Initial Individual Characteristics of Refabricated Fuel Rods  
(Preirradiated fuel, Preirradiated cladding)

Table C-11.1. Axial Distribution of Isotopic Composition for Fuel Rod #B11T (calculated)

Axial coordinate from lower end of fuel rod (mm)	Nuclear concentrations (kg/t U)						
	U <sup>235</sup>	U <sup>236</sup>	U <sup>238</sup>	Pu <sup>239</sup>	Pu <sup>240</sup>	Pu <sup>241</sup>	Pu <sup>242</sup>
20	7.23	4.73	932	5.75	2.48	1.664	0.766
25	7.23	4.73	932	5.75	2.48	1.664	0.766
30	7.17	4.73	931	5.74	2.49	1.668	0.773
35	7.10	4.74	931	5.74	2.50	1.671	0.781
40	7.07	4.74	931	5.73	2.50	1.673	0.785
45	7.10	4.74	931	5.74	2.50	1.671	0.781
50	7.10	4.74	931	5.74	2.50	1.671	0.781
55	7.17	4.73	931	5.74	2.49	1.668	0.773
60	7.20	4.73	931	5.75	2.48	1.666	0.770
65	6.85	4.77	930	5.71	2.53	1.686	0.812
70	6.79	4.78	930	5.71	2.54	1.689	0.820
75	6.69	4.79	930	5.70	2.55	1.695	0.831
80	6.69	4.79	930	5.70	2.55	1.695	0.831
85	6.85	4.77	930	5.71	2.53	1.686	0.812
90	6.91	4.76	931	5.72	2.52	1.682	0.804
95	6.85	4.77	930	5.71	2.53	1.686	0.812
100	6.82	4.77	930	5.71	2.53	1.688	0.816
105	7.07	4.74	931	5.73	2.50	1.673	0.785
110	7.13	4.74	931	5.74	2.49	1.670	0.777
115	6.85	4.77	930	5.71	2.53	1.686	0.812
120	6.79	4.78	930	5.71	2.54	1.689	0.820
125	6.91	4.76	931	5.72	2.52	1.682	0.804
130	6.91	4.76	931	5.72	2.52	1.682	0.804
135	6.91	4.76	931	5.72	2.52	1.682	0.804
140	6.91	4.76	931	5.72	2.52	1.682	0.804
145	6.91	4.76	931	5.72	2.52	1.682	0.804
150	6.91	4.76	931	5.72	2.52	1.682	0.804
155	6.91	4.76	931	5.72	2.52	1.682	0.804
160	6.91	4.76	931	5.72	2.52	1.682	0.804
165	6.91	4.76	931	5.72	2.52	1.682	0.804
170	6.91	4.76	931	5.72	2.52	1.682	0.804
175	6.91	4.76	931	5.72	2.52	1.682	0.804
180	6.91	4.76	931	5.72	2.52	1.682	0.804

All numerical values of characteristics presented as average values at the length interval equal to the axial coordinate  $\pm 2.5$  mm

# #B11T

Initial Individual Characteristics of Refabricated Fuel Rods  
(Preirradiated fuel, Preirradiated cladding)

**Table C-11.2. Radial Distribution of Burnup (Calculated) and Isotopic Composition with RIM Zone Indication (Calculated) for Fuel Rod #B11T (average values in fuel rod)**

Characteristic	Coordinates of fuel radial zones (mm)			
	1 zone 1.2 - 2.811	2 zone 2.811 - 3.432	3 zone 3.432 - 3.704	4 zone 3.704 - 3.790
<b>1. Nuclear concentrations (kg/t U):</b>				
U <sup>235</sup>	7.09	6.85	6.62	6.46
U <sup>236</sup>	4.76	4.77	4.78	4.79
U <sup>238</sup>	936.	933.	922.	891.
Pu <sup>239</sup>	4.79	5.33	7.22	12.36
Pu <sup>240</sup>	2.21	2.34	3.02	4.97
Pu <sup>241</sup>	1.336	1.565	2.224	4.010
Pu <sup>242</sup>	0.624	0.749	1.091	2.019
<b>2. Burnup (MWd/kg U)</b>	39.9	42.4	49.5	68.6

## #B11T

Initial Individual Characteristics of Refabricated Fuel Rods  
(Preirradiated fuel, Preirradiated cladding)

Table C-11.3. Individual Initial Characteristics for Fuel Rod #B11T (measured)

Axial coordinate from lower end of fuel rod (mm)	Cladding outer diameter at 0° (mm)	Cladding outer diameter at 90° (mm)	Fuel mass (g) (density- $10.13^4$ ) g/cm <sup>3</sup> *)	Linear fuel mass (g/cm)*	Free gas volume (mm <sup>3</sup> ) <sup>5)</sup>	Burnup (MWd/kg U)*
5	-	-	0.0	0.0	8.8	-
10	-	-	0.0	0.0	98.9	0.0
15	-	-	0.0	0.0	234.0	0.0
20 <sup>1)</sup>	-	-	0.42	1.05	192.7	42.6 <sup>3)</sup>
25	-	-	1.65	3.30	71.6	42.6 <sup>3)</sup>
30	-	-	2.00	4.00	37.2	42.8
35	-	-	1.93	3.85	44.1	43.1
40	-	-	2.05	4.09	32.3	43.1
45	9.106	9.104	2.07	4.15	30.3	43.0
50	9.107	9.103	1.97	3.94	40.1	43.0
55	9.106	9.107	2.03	4.07	34.2	42.8
60	9.103	9.109	2.04	4.07	33.3	42.7
65	9.097	9.109	1.99	3.97	38.2	43.8
70	9.101	9.101	1.84	3.69	52.9	44.1
75	9.104	9.094	1.99	3.98	38.2	44.3
80	9.106	9.095	2.02	4.04	35.2	44.4
85	9.104	9.097	2.05	4.09	32.3	43.8
90	9.104	9.092	2.06	4.13	31.3	43.7
95	9.113	9.089	2.09	4.17	28.3	43.9
100	9.113	9.097	2.10	4.21	27.3	44.0
105	9.095	9.109	2.10	4.20	27.3	43.1
110	9.088	9.110	2.08	4.16	29.3	42.9
115	9.088	9.109	2.06	4.12	31.3	43.9
120	9.095	9.109	2.00	4.00	37.2	44.1
125	9.097	9.103	1.65	3.30	71.6	43.7 <sup>3)</sup>
130	9.097	9.113	1.83	3.66	53.9	43.7 <sup>3)</sup>
135	9.095	9.113	1.96	3.93	41.1	43.7 <sup>3)</sup>
140	9.097	9.104	1.87	3.73	50.0	43.7 <sup>3)</sup>
145	9.103	9.100	1.58	3.16	78.5	43.7 <sup>3)</sup>
150	9.106	9.091	1.74	3.48	62.8	43.7 <sup>3)</sup>
155	9.112	9.092	1.18	2.37	117.9	43.7 <sup>3)</sup>
160	9.116	9.092	1.38	2.76	98.2	43.7 <sup>3)</sup>
165	9.122	9.098	1.56	3.11	80.5	43.7 <sup>3)</sup>
170	9.112	9.113	1.20	2.39	115.9	43.7 <sup>3)</sup>
175	9.095	9.119	1.06	2.12	129.7	43.7 <sup>3)</sup>
180 <sup>2)</sup>	9.086	9.128	0.21	2.10	94.1	43.7 <sup>3)</sup>

\* These numerical values of characteristics are presented as average values at the length interval equal to the axial coordinate  $\pm 2.5$  mm<sup>1)</sup> Initial coordinate of fuel is 18.5 mm<sup>4)</sup> Effective density of fuel stack<sup>2)</sup> Final coordinate of fuel is 178.5 mm<sup>5)</sup> Free gas volume for coordinates 185 - 295 mm is presented in Table C.3<sup>3)</sup> Average value

#B11T

Initial Individual Characteristics of Refabricated Fuel Rods  
(Preirradiated fuel; Preirradiated cladding)

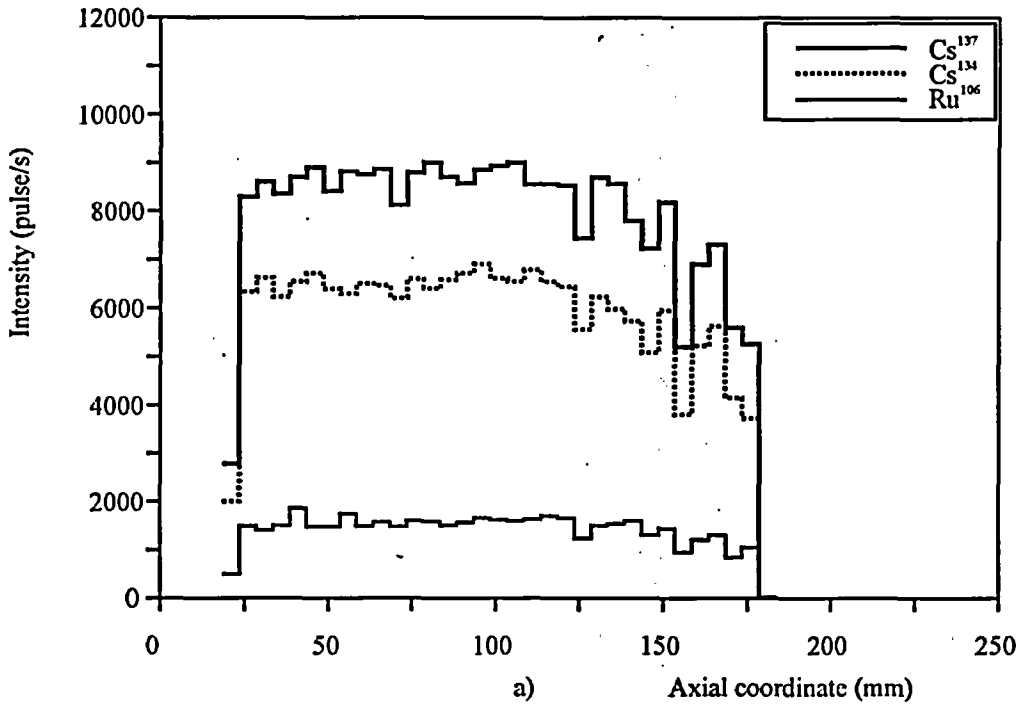

b)

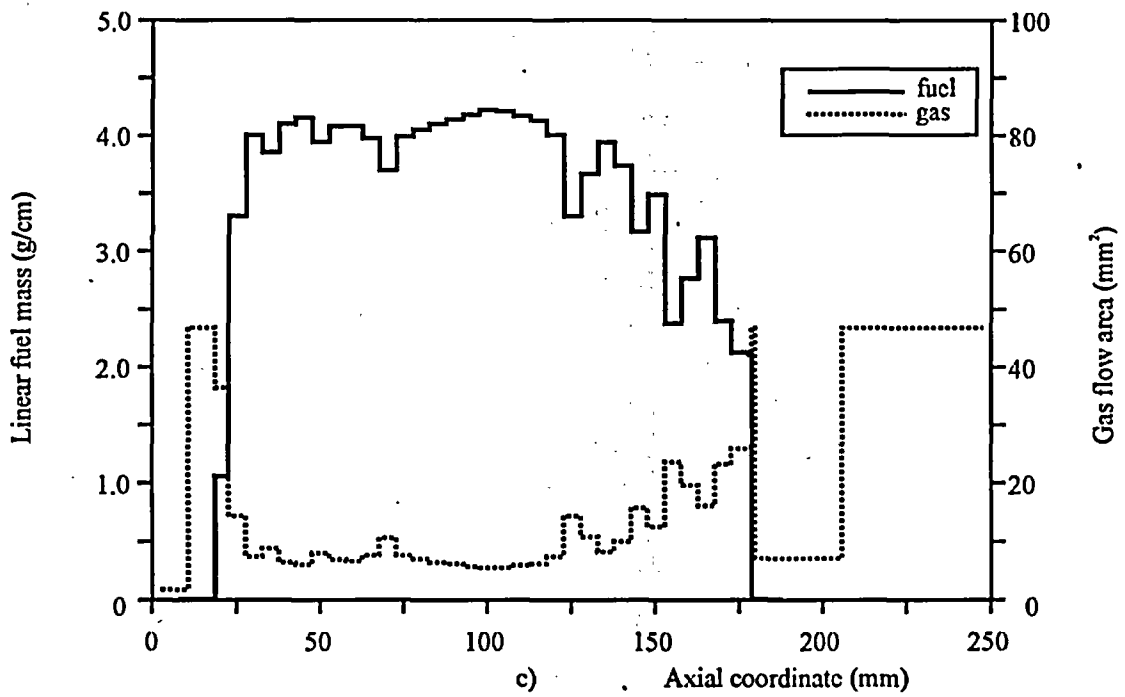

Fig. C-11.1. (a) Results of  $\gamma$ -scanning, (b) Radiography, (c) Axial Fuel Mass Distribution and Axial Free Gas Volume Distribution for Fuel Rod #B11T

#B11T

Initial Individual Characteristics of Refabricated Fuel Rods  
(Preirradiated fuel, Preirradiated cladding)

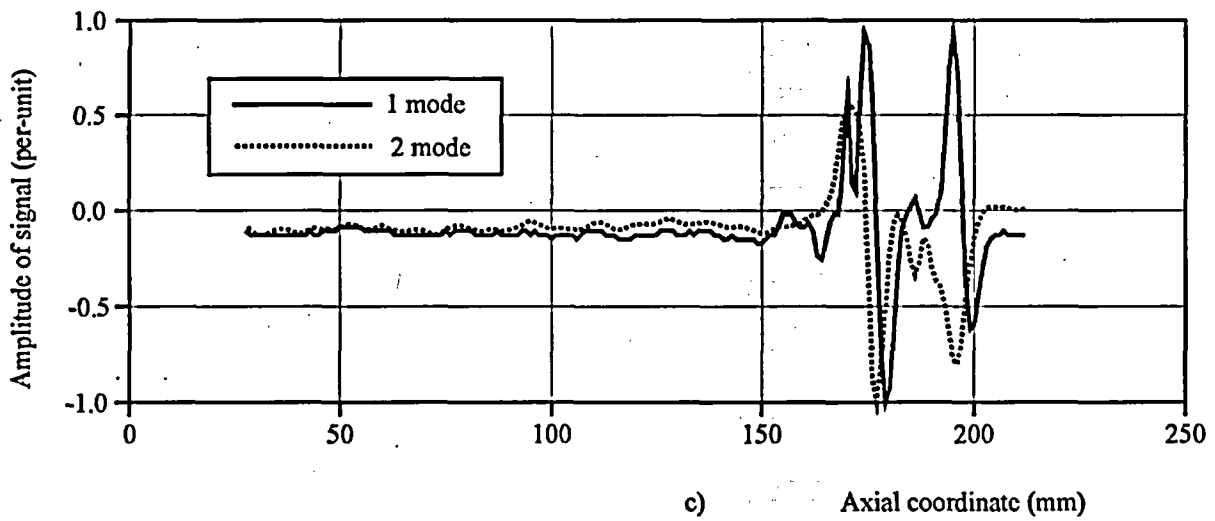
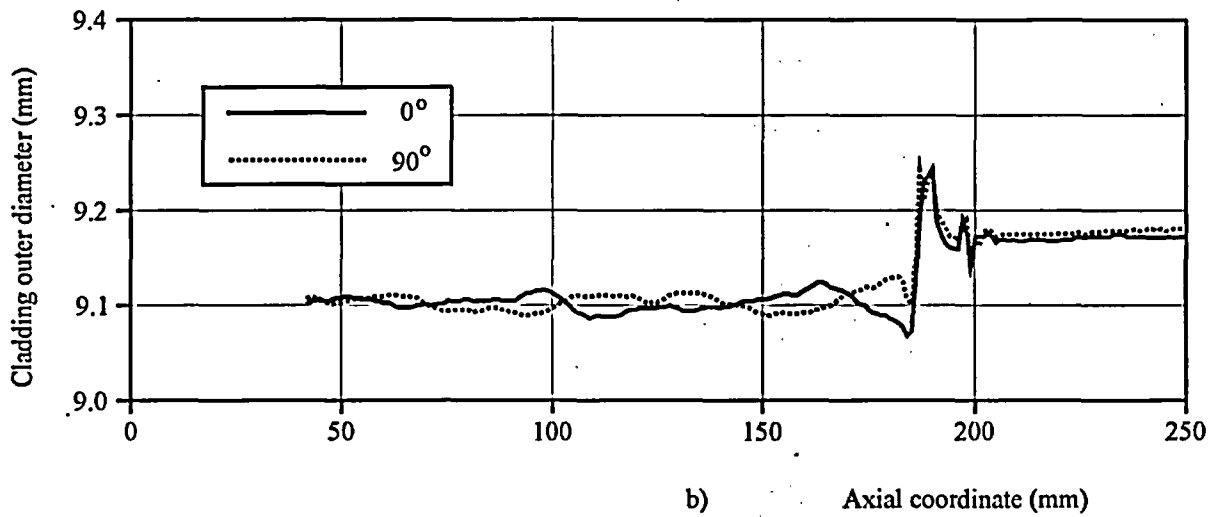
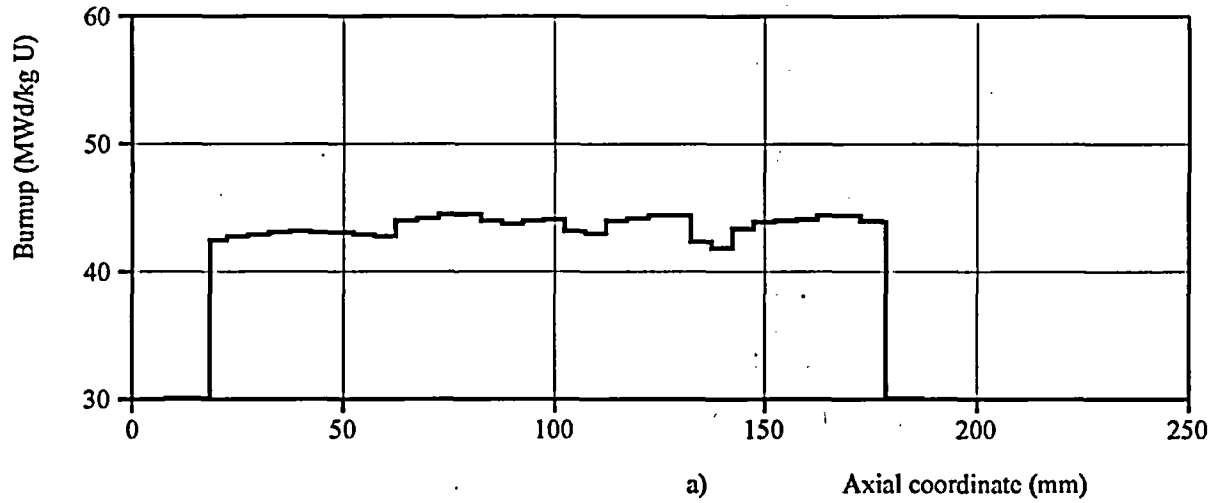

Fig. C-11.2. (a) Axial Burnup Distribution and (b) Results of Profilometry and (c) Eddy-Current Examination for Fuel Rod #B11T

#B11T

Initial Individual Characteristics of Refabricated Fuel Rods  
(Preirradiated fuel, Preirradiated cladding)

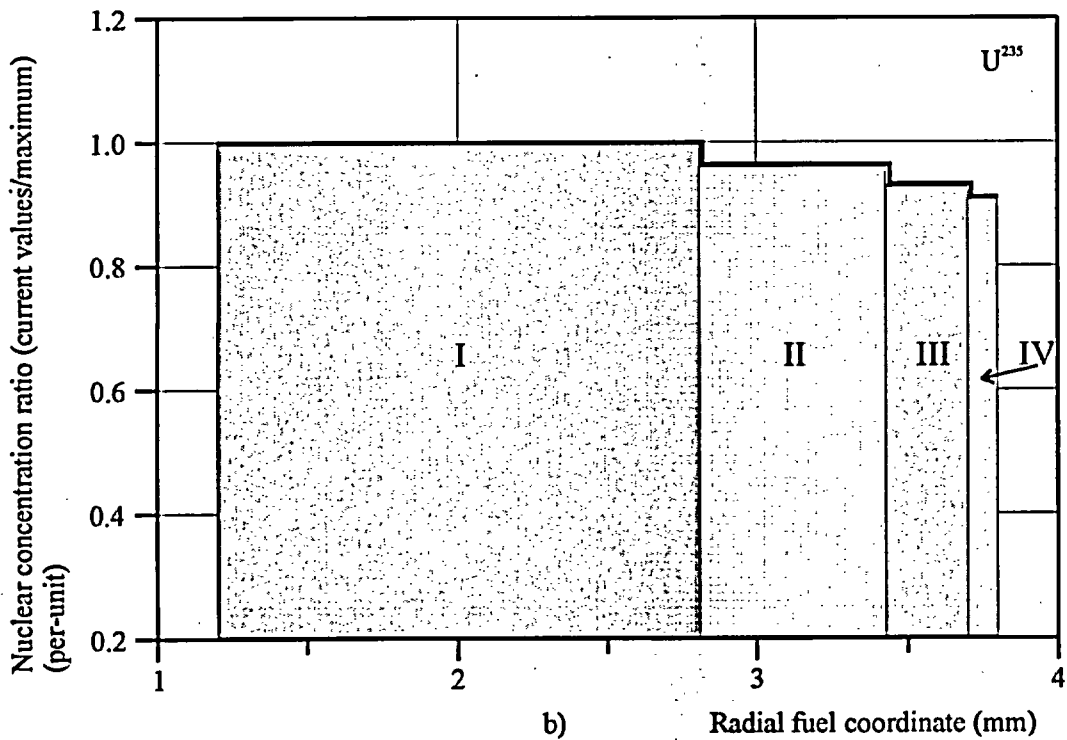
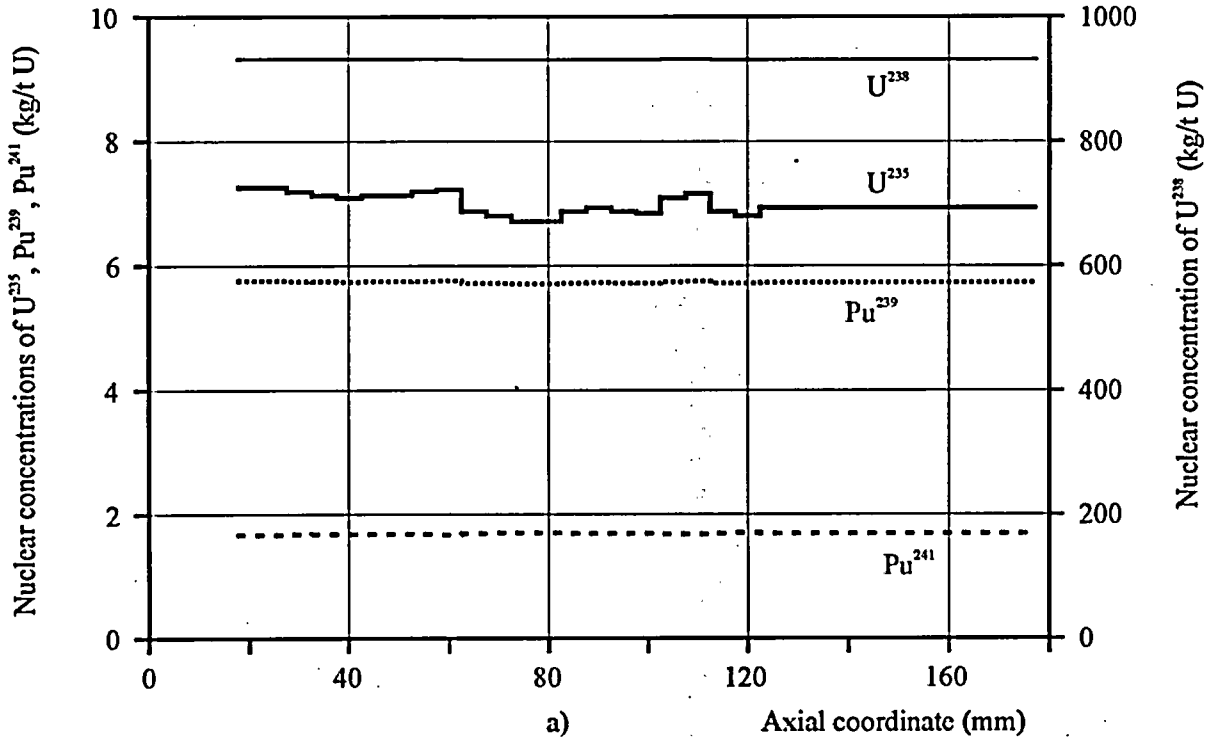

Fig. C-11.3. (a) Axial Distribution of  $U^{235}$ ,  $U^{238}$ ,  $Pu^{239}$ ,  $Pu^{241}$  Isotopes and (b) Radial Distribution of  $U^{235}$  Isotope for Fuel Rod #B11T (calculated)

#B11T

Initial Individual Characteristics of Refabricated Fuel Rods  
(Preirradiated fuel, Preirradiated cladding)

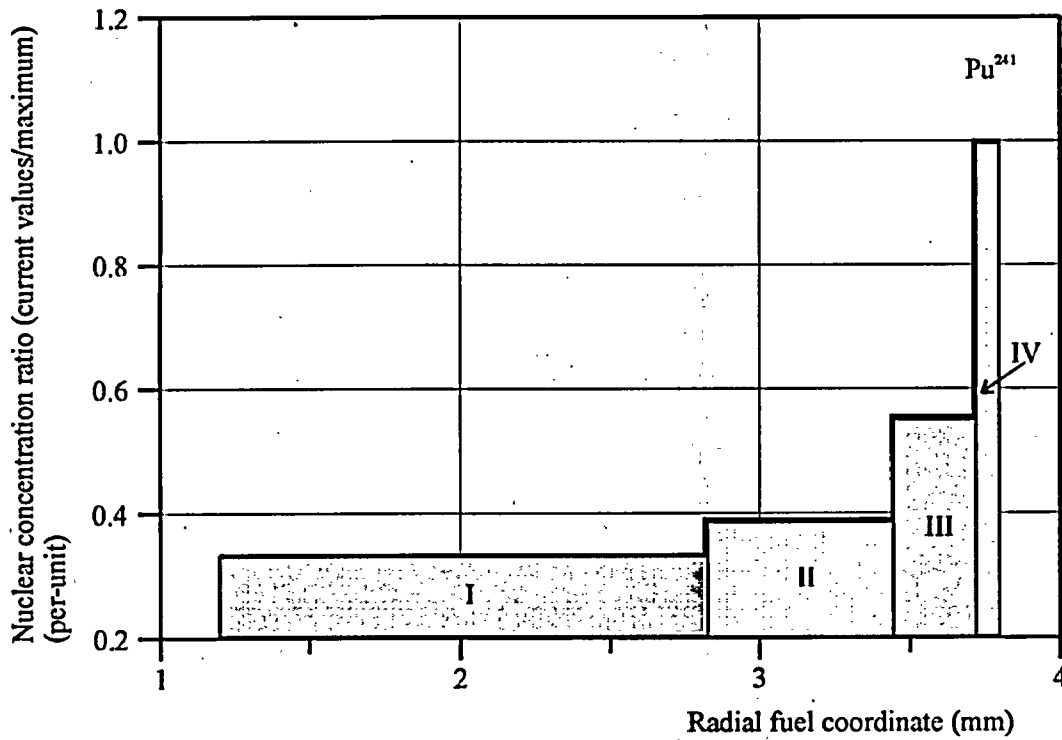
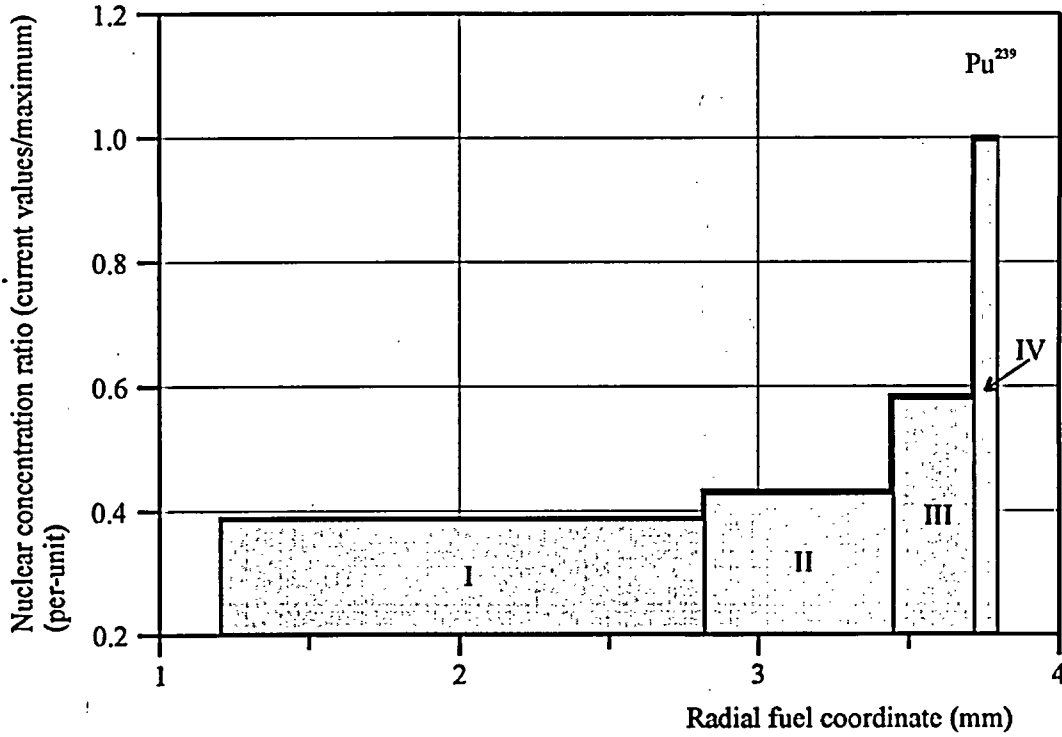

Fig. C-11.4. Radial Distribution of Pu<sup>239</sup>, Pu<sup>241</sup> Isotopes for Fuel Rod #B11T (calculated)



#B11T

Initial Individual Characteristics of Refabricated Fuel Rods  
(Preirradiated fuel, Preirradiated cladding)

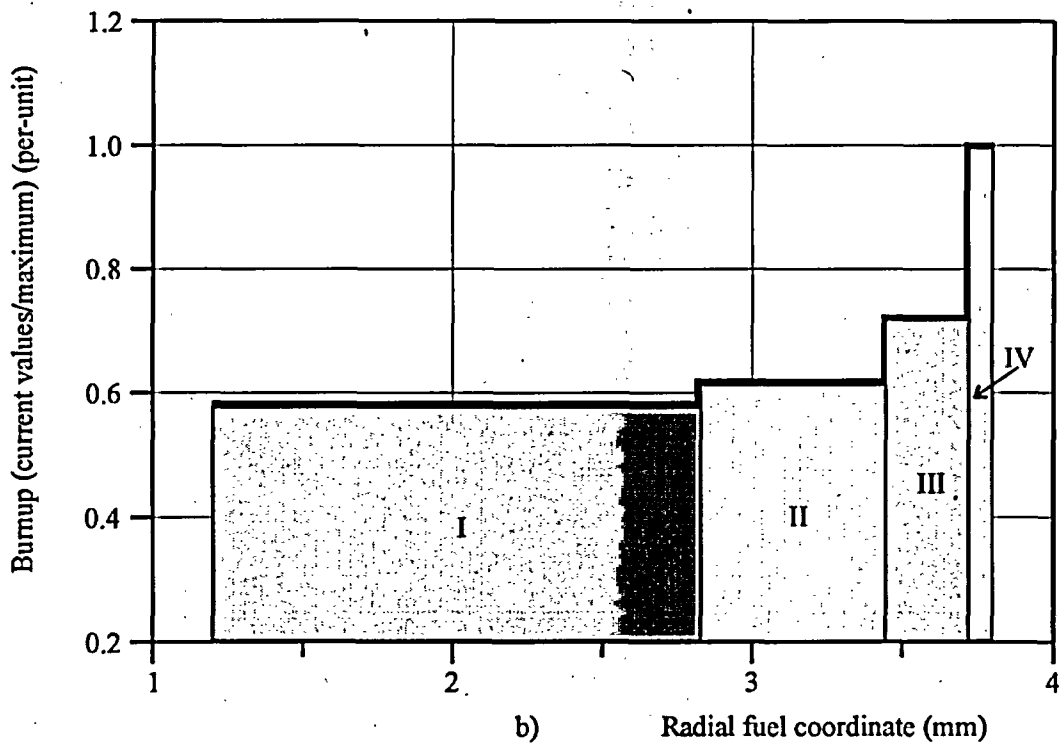
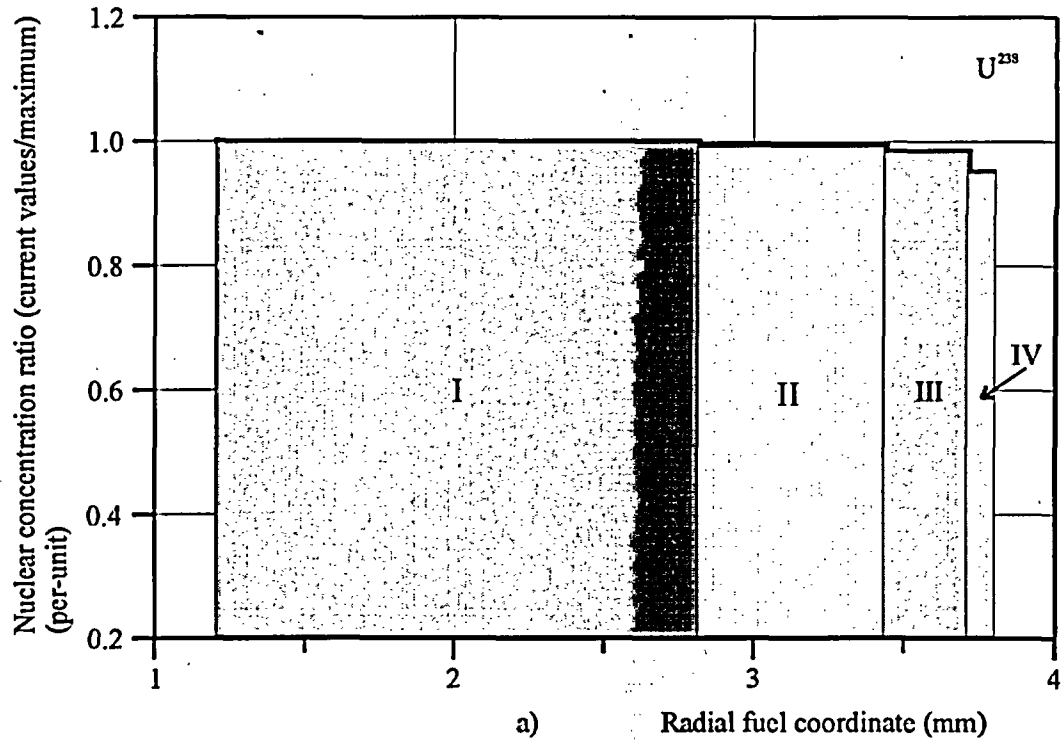

Fig. C-11.5. (a) Radial Distribution of  $U^{238}$  Isotope and (b) Burnup for Fuel Rod #B11T (calculated)



*APPENDIX C-12.*  
*Initial Individual Characteristics for Fuel Rod #B12T*

## #B12T

Initial Individual Characteristics of Refabricated Fuel Rods  
(Preirradiated fuel, Preirradiated cladding)

Table C-12.1. Axial Distribution of Isotopic Composition for Fuel Rod #B12T (calculated)

Axial coordinate from lower end of fuel rod (mm)	Nuclear concentrations (kg/t U)						
	U <sup>235</sup>	U <sup>236</sup>	U <sup>238</sup>	Pu <sup>239</sup>	Pu <sup>240</sup>	Pu <sup>241</sup>	Pu <sup>242</sup>
10	4.94	4.93	927	5.13	2.68	1.657	1.043
15	4.94	4.93	927	5.13	2.68	1.657	1.043
20	4.94	4.93	927	5.13	2.68	1.657	1.043
25	4.94	4.93	927	5.13	2.68	1.657	1.043
30	4.94	4.93	927	5.13	2.68	1.657	1.043
35	4.94	4.93	927	5.13	2.68	1.657	1.043
40	4.94	4.93	927	5.13	2.68	1.657	1.043
45	4.94	4.93	927	5.13	2.68	1.657	1.043
50	4.94	4.93	927	5.13	2.68	1.657	1.043
55	4.94	4.93	927	5.13	2.68	1.657	1.043
60	4.94	4.93	927	5.13	2.68	1.657	1.043
65	4.94	4.93	927	5.13	2.68	1.657	1.043
70	4.94	4.93	927	5.13	2.68	1.657	1.043
75	4.94	4.93	927	5.13	2.68	1.657	1.043
80	4.94	4.93	927	5.13	2.68	1.657	1.043
85	4.94	4.93	927	5.13	2.68	1.657	1.043
90	4.94	4.93	927	5.13	2.68	1.657	1.043
95	4.94	4.93	927	5.13	2.68	1.657	1.043
100	4.94	4.93	927	5.13	2.68	1.657	1.043
105	4.94	4.93	927	5.13	2.68	1.657	1.043
110	4.94	4.93	927	5.13	2.68	1.657	1.043
115	5.21	4.91	927	5.16	2.65	1.648	1.001
120	5.13	4.92	927	5.15	2.66	1.650	1.013
125	5.04	4.92	927	5.14	2.67	1.654	1.026
130	5.18	4.91	927	5.16	2.65	1.649	1.005
135	5.37	4.89	928	5.19	2.63	1.645	0.976
140	5.46	4.89	928	5.21	2.62	1.643	0.964
145	5.46	4.89	928	5.21	2.62	1.643	0.964
150	5.46	4.89	928	5.21	2.62	1.643	0.964
155	5.46	4.89	928	5.21	2.62	1.643	0.964
160	5.46	4.89	928	5.21	2.62	1.643	0.964
165	5.46	4.89	928	5.21	2.62	1.643	0.964
170	5.46	4.89	928	5.21	2.62	1.643	0.964

All numerical values of characteristics presented as average values at the length interval equal to the axial coordinate  $\pm 2.5$  mm

# #B12T

Initial Individual Characteristics of Refabricated Fuel Rods  
(Preirradiated fuel, Preirradiated cladding)

**Table C-12.2. Radial Distribution of Burnup (Calculated) and Isotopic Composition with RIM Zone Indication (Calculated) for Fuel Rod #B12T (average values in fuel rod)**

Characteristic	Coordinates of fuel radial zones (mm)			
	1 zone 1.2 - 2.811	2 zone 2.811 - 3.432	3 zone 3.432 - 3.704	4 zone 3.704 - 3.790
<b>1. Nuclear concentrations (kg/t U):</b>				
U <sup>235</sup>	5.28	5.07	4.87	4.74
U <sup>236</sup>	4.92	4.92	4.92	4.92
U <sup>238</sup>	933.	930.	917.	884.
Pu <sup>239</sup>	4.32	4.81	6.48	10.99
Pu <sup>240</sup>	2.36	2.47	3.16	5.12
Pu <sup>241</sup>	1.320	1.536	2.168	3.872
Pu <sup>242</sup>	0.790	0.944	1.370	2.526
<b>2. Burnup (MWd/kg U)</b>	44.5	47.3	55.6	77.9

## #B12T

Initial Individual Characteristics of Refabricated Fuel Rods  
(Preirradiated fuel, Preirradiated cladding)

Table C-12.3. Individual Initial Characteristics for Fuel Rod #B12T (measured)

Axial coordinate from lower end of fuel rod (mm)	Cladding outer diameter at 0° (mm)	Cladding outer diameter at 90° (mm)	Fuel mass (g) (density- $10.13^4$ ) g/cm <sup>3</sup> *)	Linear fuel mass (g/cm)*	Free gas volume (mm <sup>3</sup> ) <sup>5)</sup>	Burnup (MWd/kg U)*
5	-	-	0.0	0.0	8.8	-
10 <sup>1)</sup>	-	-	0.07	0.34	92.0	49.5 <sup>3)</sup>
15	-	-	0.18	0.35	216.3	49.5 <sup>3)</sup>
20	-	-	0.70	1.41	165.1	49.5 <sup>3)</sup>
25	-	-	1.49	2.99	87.4	49.5 <sup>3)</sup>
30	-	-	1.50	3.01	86.4	49.5 <sup>3)</sup>
35	-	-	1.52	3.03	84.4	49.5 <sup>3)</sup>
40	-	-	1.41	2.82	95.3	49.5 <sup>3)</sup>
45	9.100	9.091	1.25	2.50	111.0	49.5 <sup>3)</sup>
50	9.097	9.094	1.51	3.02	85.4	49.5 <sup>3)</sup>
55	9.098	9.094	1.89	3.79	48.0	49.5 <sup>3)</sup>
60	9.103	9.080	1.66	3.32	70.7	49.5 <sup>3)</sup>
65	9.109	9.075	1.31	2.62	105.1	49.5 <sup>3)</sup>
70	9.103	9.078	1.38	2.75	98.2	49.5 <sup>3)</sup>
75	9.091	9.086	1.48	2.95	88.4	49.5 <sup>3)</sup>
80	9.088	9.081	1.67	3.34	69.7	49.5 <sup>3)</sup>
85	9.097	9.072	1.96	3.91	41.1	49.5 <sup>3)</sup>
90	9.100	9.074	1.79	3.57	57.9	49.5 <sup>3)</sup>
95	9.094	9.089	1.53	3.06	83.4	49.5 <sup>3)</sup>
100	9.095	9.098	1.45	2.90	91.3	49.5 <sup>3)</sup>
105	9.104	9.097	1.33	2.65	103.1	49.5 <sup>3)</sup>
110	9.107	9.086	1.60	3.21	76.6	49.5 <sup>3)</sup>
115	9.104	9.086	1.99	3.99	38.2	48.5
120	9.091	9.092	2.03	4.05	34.2	48.7
125	9.089	9.094	2.04	4.09	33.3	49.1
130	9.095	9.088	2.07	4.14	30.3	48.6
135	9.101	9.086	2.08	4.15	29.3	47.9
140	9.100	9.092	1.76	3.53	60.8	47.5 <sup>3)</sup>
145	9.091	9.100	1.25	2.51	111.0	47.5 <sup>3)</sup>
150	9.088	9.107	1.24	2.49	112.0	47.5 <sup>3)</sup>
155	9.097	9.097	1.23	2.46	113.0	47.5 <sup>3)</sup>
160	9.107	9.080	1.29	2.58	107.1	47.5 <sup>3)</sup>
165	9.112	9.074	1.38	2.76	98.2	47.5 <sup>3)</sup>
170 <sup>2)</sup>	9.107	9.078	0.84	2.76	151.4	47.5 <sup>3)</sup>
175	9.101	9.083	0.0	0.0	234.0	0.0
180	9.103	9.081	0.0	0.0	114.8	0.0

\* These numerical values of characteristics are presented as average values at the length interval equal to the axial coordinate  $\pm 2.5$  mm<sup>1)</sup> Initial coordinate of fuel is 10.5 mm<sup>4)</sup> Effective density of fuel stack<sup>2)</sup> Final coordinate of fuel is 172.5 mm<sup>5)</sup> Free gas volume for coordinates 185 - 295 mm<sup>3)</sup> Average value

is presented in Table C.3

# #B12T

Initial Individual Characteristics of Refabricated Fuel Rods  
(Preirradiated fuel, Preirradiated cladding)

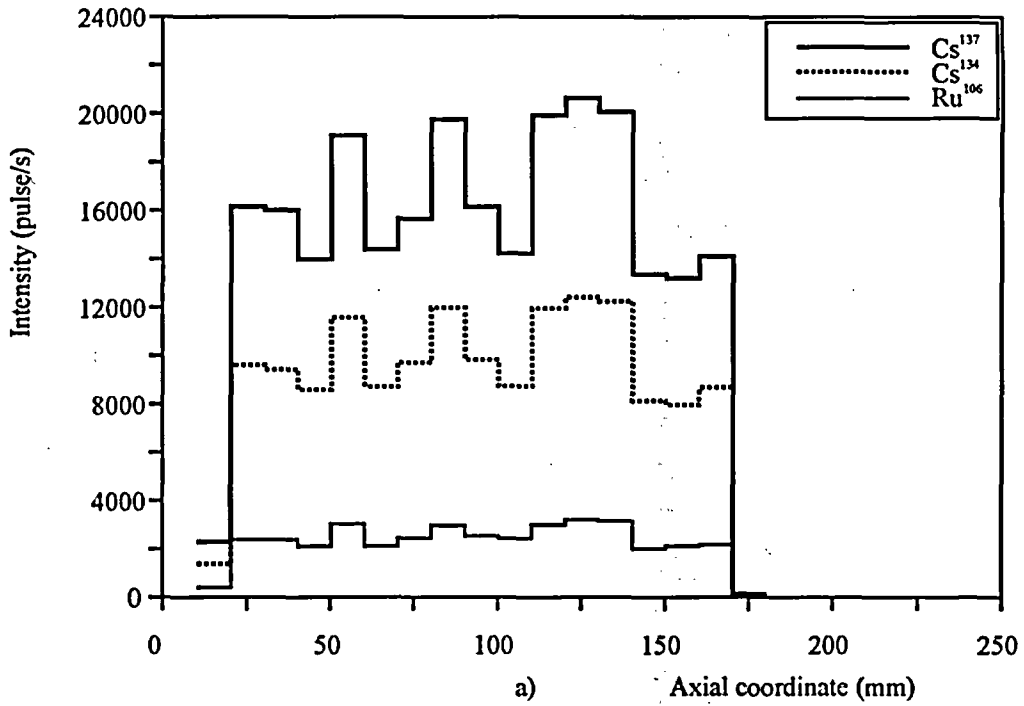

b)

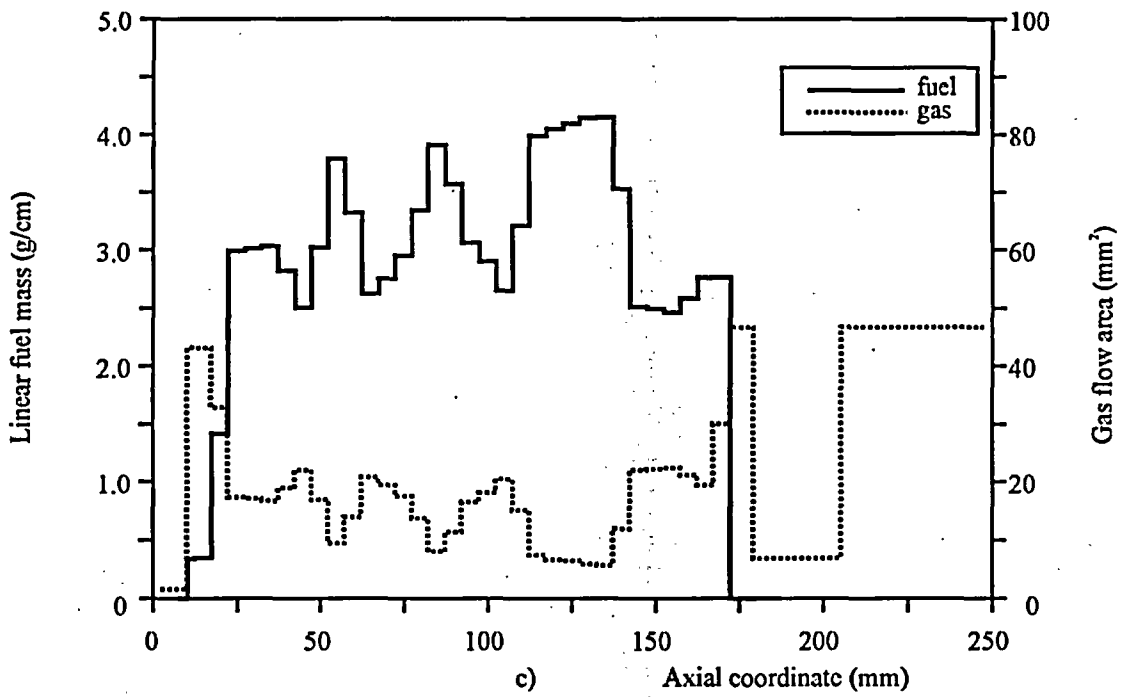

Fig. C-12.1. (a) Results of  $\gamma$ -scanning, (b) Radiography, (c) Axial Fuel Mass Distribution and Axial Free Gas Volume Distribution for Fuel Rod #B12T

#B12T

Initial Individual Characteristics of Refabricated Fuel Rods  
(Preirradiated fuel, Preirradiated cladding)

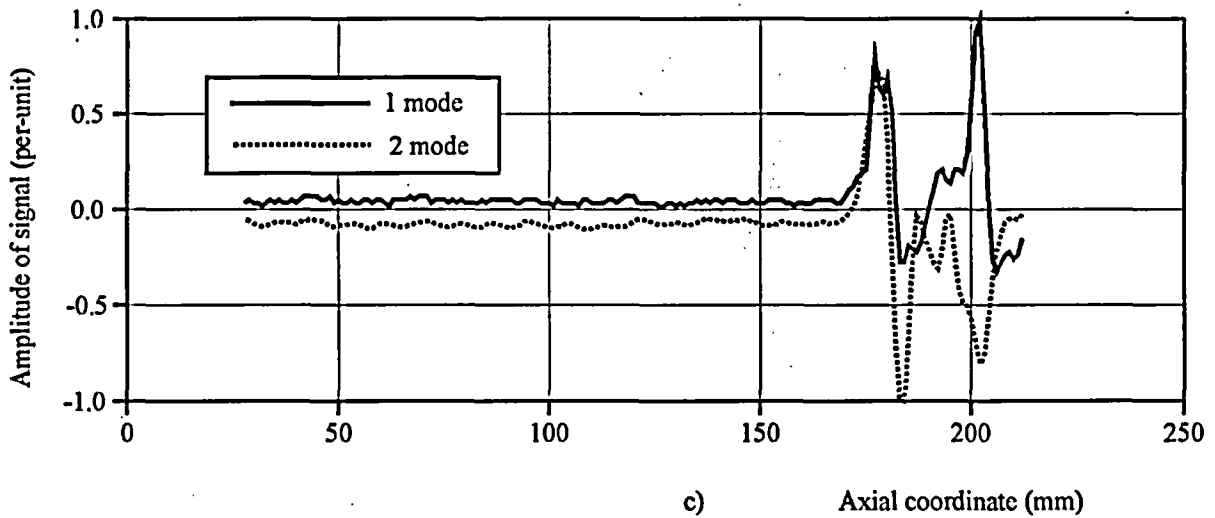
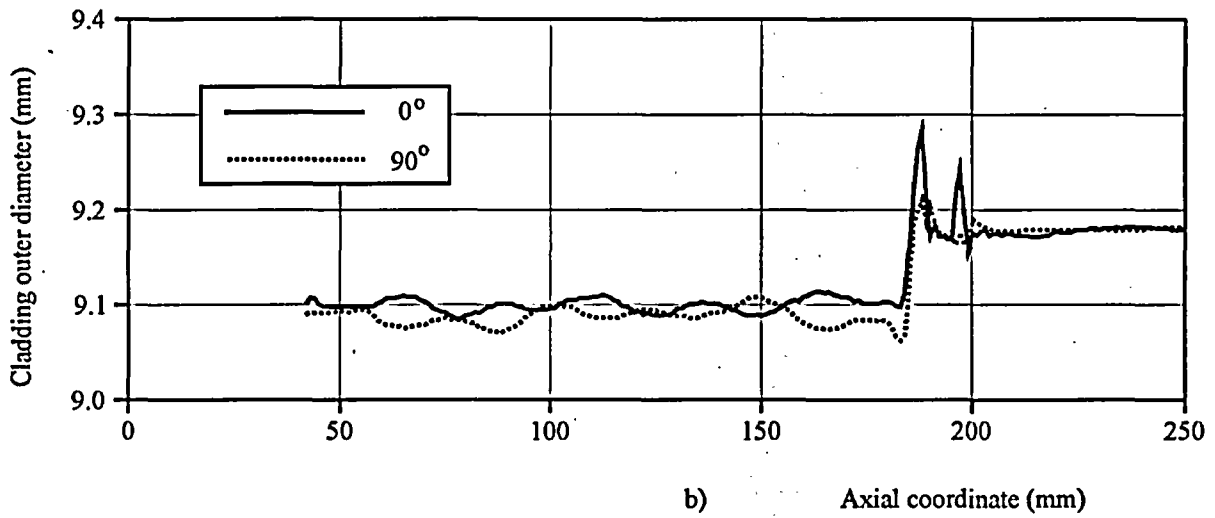
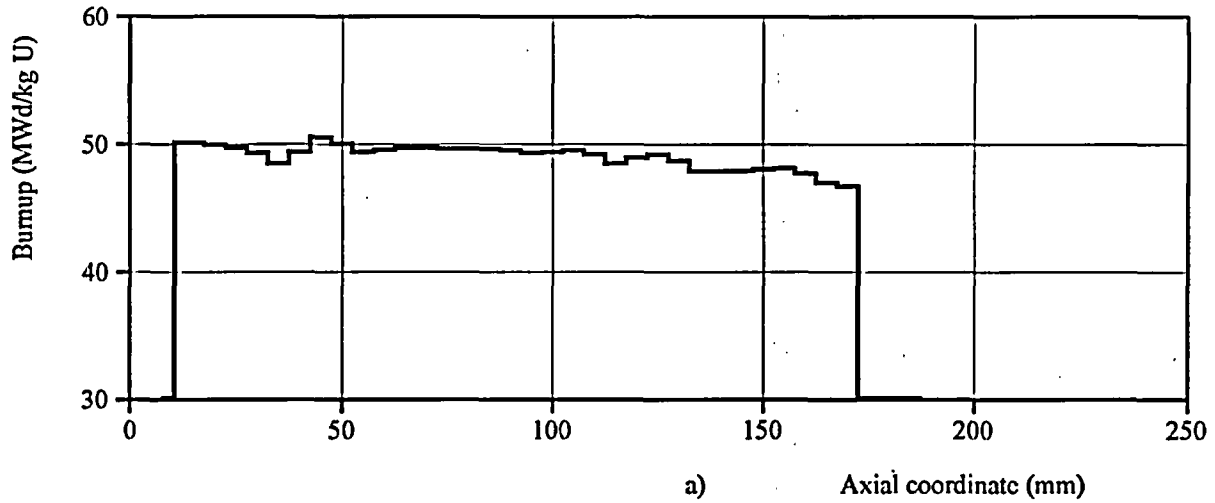

Fig. C-12.2. (a) Axial Burnup Distribution and (b) Results of Profilometry and (c) Eddy-Current Examination for Fuel Rod #B12T



# #B12T

Initial Individual Characteristics of Refabricated Fuel Rods  
(Preirradiated fuel, Preirradiated cladding)

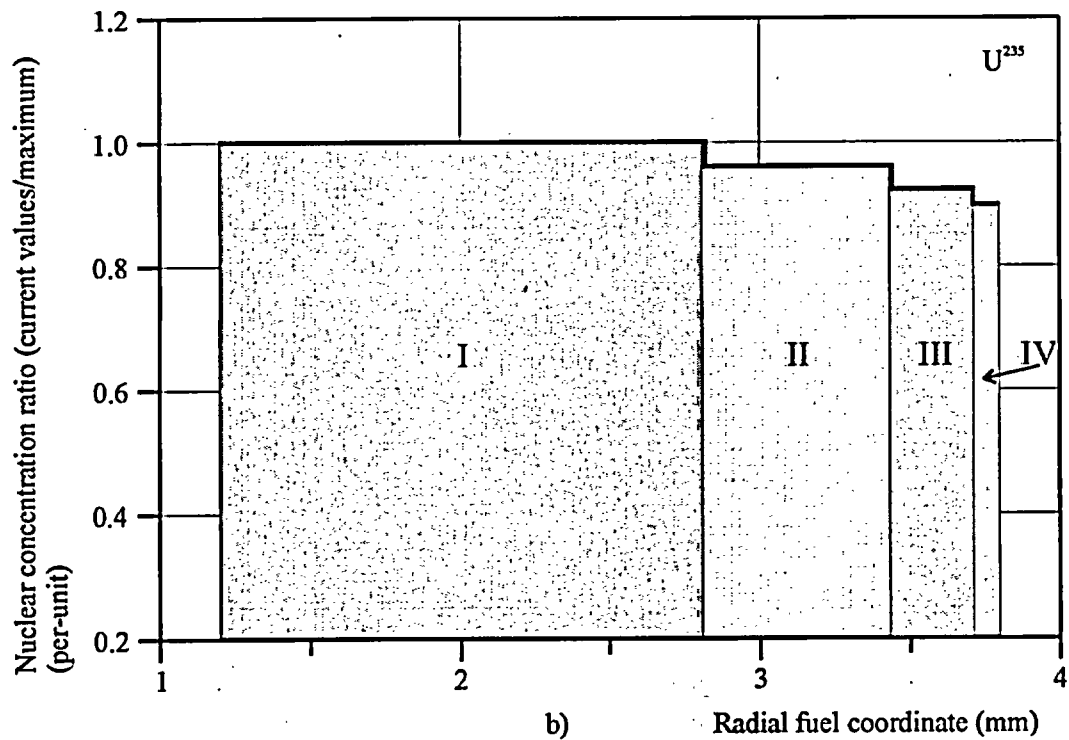
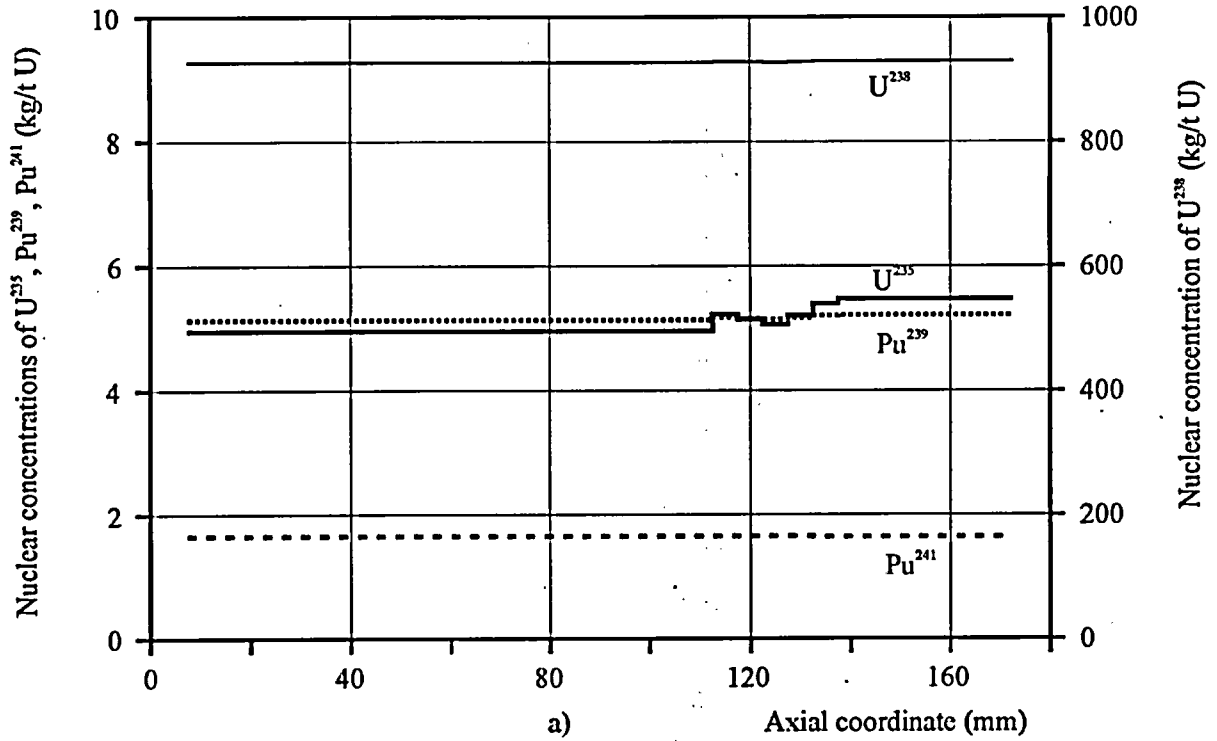

Fig. C-12.3. (a) (Axial Distribution of  $U^{235}$ ,  $U^{238}$ ,  $Pu^{239}$ ,  $Pu^{241}$  Isotopes and (b) Radial Distribution of  $U^{235}$  Isotope for Fuel Rod #B12T (calculated)

#B12T

Initial Individual Characteristics of Refabricated Fuel Rods  
(Preirradiated fuel, Preirradiated cladding)

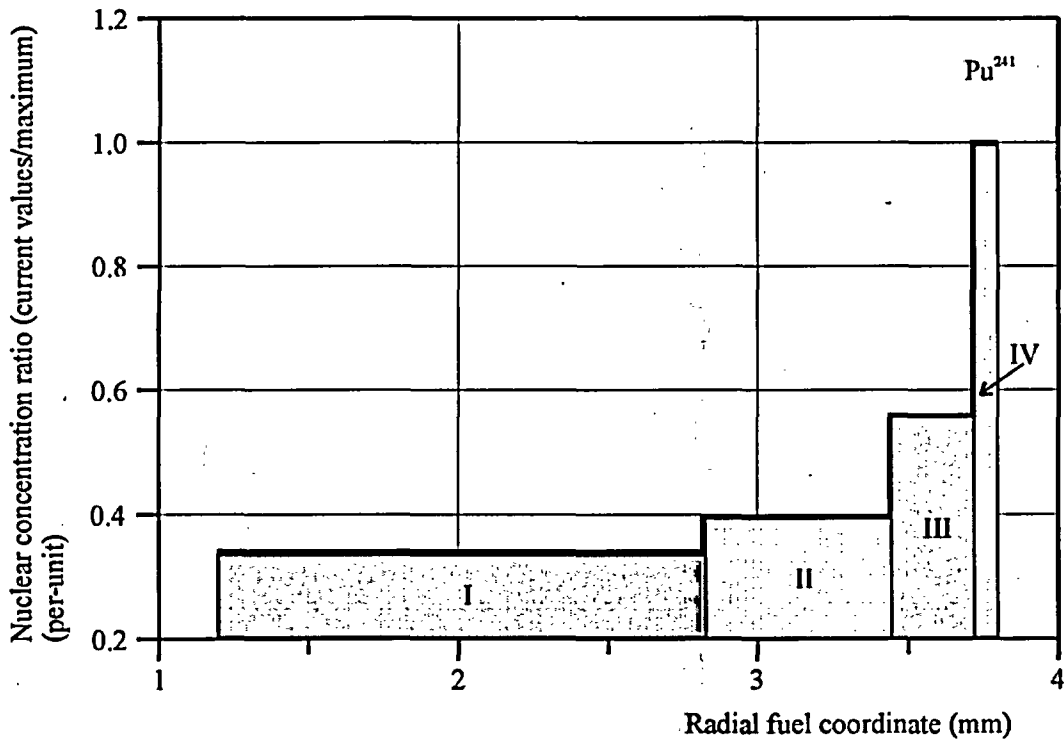
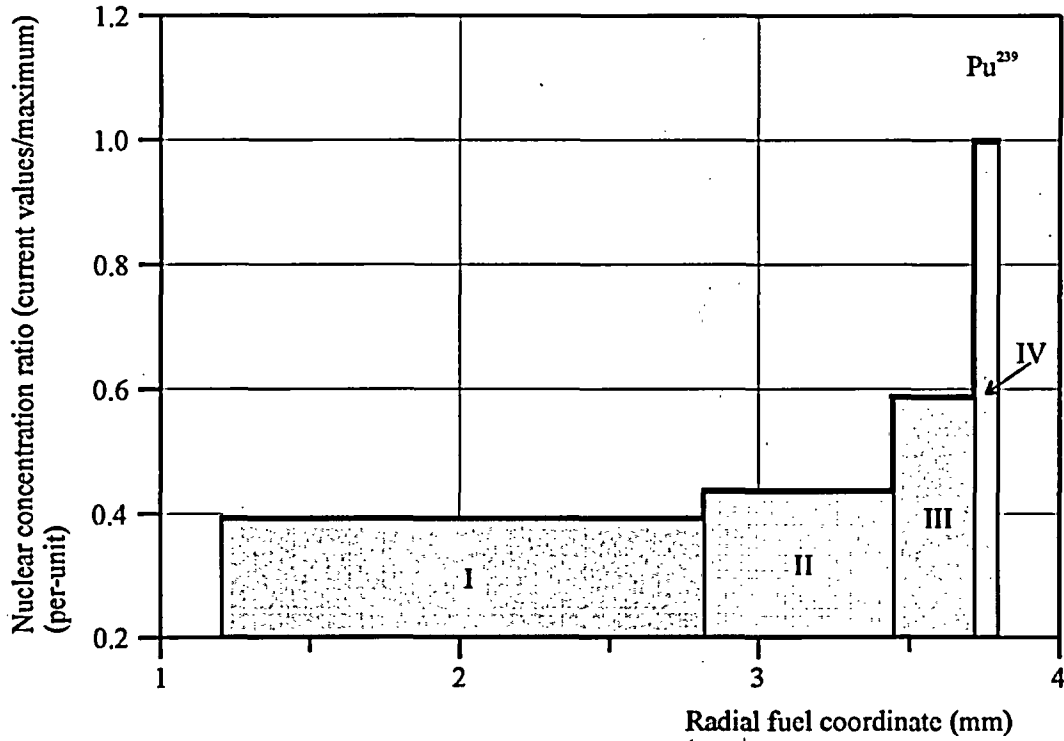

Fig. C-12.4. Radial Distribution of  $Pu^{239}$ ,  $Pu^{241}$  Isotopes for Fuel Rod #B12T (calculated)

#B12T

Initial Individual Characteristics of Refabricated Fuel Rods  
(Preirradiated fuel, Preirradiated cladding)

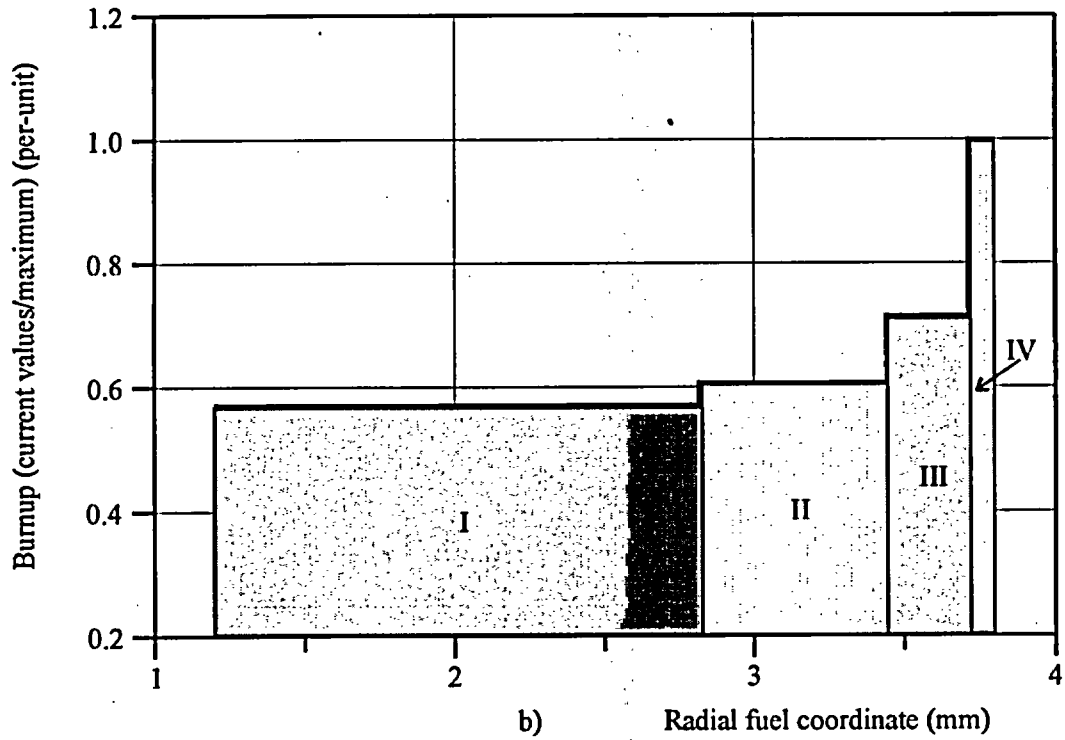
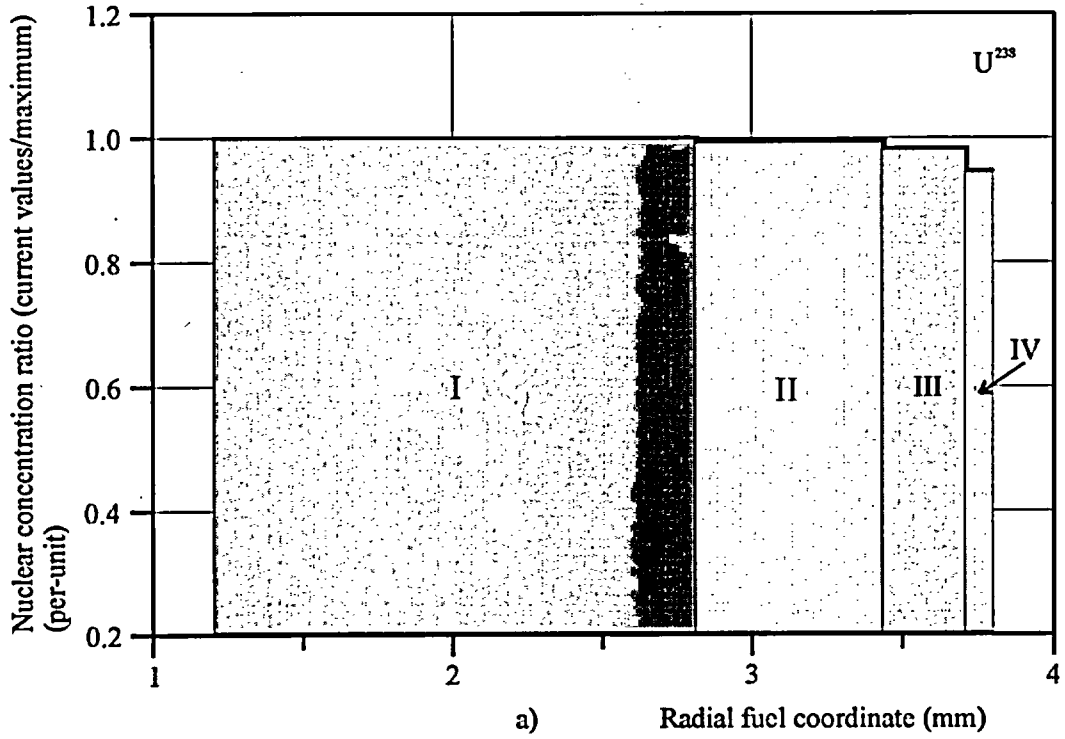

Fig. C-12.5. (a) Radial Distribution of  $U^{238}$  Isotope and (b) Burnup for Fuel Rod #B12T (calculated)



*APPENDIX C-13.*

*Initial Individual Characteristics for Fuel Rod #B13T*

## #B13T

Initial Individual Characteristics of Refabricated Fuel Rods  
(Preirradiated fuel, Preirradiated cladding)

Table C-13.1. Axial Distribution of Isotopic Composition for Fuel Rod #B13T (calculated)

Axial coordinate from lower end of fuel rod (mm)	Nuclear concentrations (kg/t U)						
	U <sup>235</sup>	U <sup>236</sup>	U <sup>238</sup>	Pu <sup>239</sup>	Pu <sup>240</sup>	Pu <sup>241</sup>	Pu <sup>242</sup>
20	7.18	4.69	933	5.43	2.37	1.542	0.724
25	7.29	4.68	934	5.44	2.35	1.535	0.713
30	7.29	4.68	934	5.44	2.35	1.535	0.713
35	7.25	4.68	934	5.43	2.36	1.537	0.716
40	7.25	4.68	934	5.43	2.36	1.537	0.716
45	7.11	4.70	933	5.42	2.38	1.545	0.731
50	7.11	4.70	933	5.42	2.38	1.545	0.731
55	7.11	4.70	933	5.42	2.38	1.545	0.731
60	7.11	4.70	933	5.42	2.38	1.545	0.731
65	7.08	4.70	933	5.42	2.38	1.547	0.735
70	7.08	4.70	933	5.42	2.38	1.547	0.735
75	7.39	4.67	934	5.44	2.34	1.528	0.702
80	7.39	4.67	934	5.44	2.34	1.528	0.702
85	7.22	4.69	934	5.43	2.36	1.540	0.720
90	7.22	4.69	934	5.43	2.36	1.540	0.720
95	7.50	4.66	934	5.45	2.33	1.522	0.691
100	7.50	4.66	934	5.45	2.33	1.522	0.691
105	7.43	4.66	934	5.45	2.34	1.526	0.698
110	7.43	4.66	934	5.45	2.34	1.526	0.698
115	7.29	4.68	934	5.44	2.35	1.535	0.713
120	7.29	4.68	934	5.44	2.35	1.535	0.713
125	7.32	4.68	934	5.44	2.35	1.533	0.709
130	7.32	4.68	934	5.44	2.35	1.533	0.709
135	7.50	4.66	934	5.45	2.33	1.522	0.691
140	7.50	4.66	934	5.45	2.33	1.522	0.691
145	7.57	4.65	934	5.46	2.32	1.517	0.684
150	7.57	4.65	934	5.46	2.32	1.517	0.684
155	7.75	4.63	935	5.47	2.30	1.506	0.666
160	7.86	4.61	935	5.48	2.28	1.500	0.655
165	7.86	4.61	935	5.48	2.28	1.500	0.655
170	7.86	4.61	935	5.48	2.28	1.500	0.655
175	7.86	4.61	935	5.48	2.28	1.500	0.655
180	-	-	-	-	-	-	-

All numerical values of characteristics presented as average values at the length interval equal to the axial coordinate  $\pm 2.5$  mm

# #B13T

Initial Individual Characteristics of Refabricated Fuel Rods  
(Preirradiated fuel, Preirradiated cladding)

**Table C-13.2. Radial Distribution of Burnup (Calculated) and Isotopic Composition with RIM Zone Indication (Calculated) for Fuel Rod #B13T (average values in fuel rod)**

Characteristic	Coordinates of fuel radial zones (mm)			
	1 zone 1.2 - 2.811	2 zone 2.811 - 3.432	3 zone 3.432 - 3.704	4 zone 3.704 - 3.790
<b>1. Nuclear concentrations (kg/t U):</b>				
U <sup>235</sup>	7.51	7.26	7.02	6.86
U <sup>236</sup>	4.67	4.68	4.70	4.71
U <sup>238</sup>	939.	936.	926.	898.
Pu <sup>239</sup>	4.54	5.07	6.87	11.83
Pu <sup>240</sup>	2.04	2.18	2.84	4.72
Pu <sup>241</sup>	1.217	1.424	2.027	3.676
Pu <sup>242</sup>	0.550	0.659	0.961	1.787
<b>2. Burnup (MWd/kg U)</b>	37.7	40.0	46.4	63.6

## #B13T

Initial Individual Characteristics of Refabricated Fuel Rods  
(Preirradiated fuel, Preirradiated cladding)

Table C-13.3. Individual Initial Characteristics for Fuel Rod #B13T (measured)

Axial coordinate from lower end of fuel rod (mm)	Cladding outer diameter at 0° (mm)	Cladding outer diameter at 90° (mm)	Fuel mass (g) (density- $10.13^4$ ) g/cm <sup>3</sup> )*	Linear fuel mass (g/cm)*	Free gas volume (mm <sup>3</sup> )* <sup>5)</sup>	Burnup (MWd/kg U)*
5	-	-	0.0	0.0	8.8	-
10	-	-	0.0	0.0	98.9	0.0
15	-	-	0.0	0.0	234.0	0.0
20 <sup>1)</sup>	-	-	1.18	3.95	117.9	41.5
25	-	-	1.98	3.96	39.2	41.2
30	-	-	2.01	4.02	36.2	41.2
35	-	-	2.03	4.05	34.2	41.3
40	-	-	2.14	4.27	23.4	41.3
45	9.115	9.091	2.20	4.40	17.5	41.7
50	9.106	9.088	2.07	4.13	30.3	41.7
55	9.106	9.084	1.98	3.96	39.2	41.7
60	9.113	9.084	1.99	3.98	38.2	41.7
65	9.104	9.095	1.99	3.98	38.2	41.8
70	9.091	9.092	1.94	3.87	43.1	41.8
75	9.086	9.094	1.92	3.84	45.1	40.9
80	9.094	9.088	1.99	3.98	38.2	40.9
85	9.100	9.084	2.00	4.00	37.2	41.4
90	9.101	9.084	2.03	4.06	34.2	41.4
95	9.094	9.089	2.05	4.10	32.3	40.6
100	9.091	9.089	2.07	4.14	30.3	40.6
105	9.100	9.084	2.08	4.17	29.3	40.8
110	9.104	9.077	2.09	4.17	28.3	40.8
115	9.104	9.086	2.09	4.17	28.3	41.2
120	9.092	9.097	2.08	4.15	29.3	41.2
125	9.080	9.106	2.06	4.12	31.3	41.1
130	9.084	9.100	2.05	4.10	32.3	41.1
135	9.088	9.097	2.05	4.09	32.3	40.6
140	9.097	9.094	2.04	4.08	33.3	40.6
145	9.095	9.097	2.04	4.09	33.3	40.4
150	9.089	9.112	2.06	4.12	31.3	40.4
155	9.094	9.115	2.04	4.09	33.3	39.9
160	9.107	9.104	1.55	3.09	81.5	39.6 <sup>3)</sup>
165	9.100	9.100	1.20	2.41	115.9	39.6 <sup>3)</sup>
170	9.086	9.109	0.58	1.15	177.0	39.6 <sup>3)</sup>
175 <sup>2)</sup>	9.078	9.112	0.09	0.30	131.6	39.6 <sup>3)</sup>
180	9.083	9.110	0.0	0.0	234.0	0.0

\* These numerical values of characteristics are presented as average values at the length interval equal to the axial coordinate  $\pm 2.5$  mm<sup>1)</sup> Initial coordinate of fuel is 19.5 mm<sup>2)</sup> Final coordinate of fuel is 175.5 mm<sup>3)</sup> Average value<sup>4)</sup> Effective density of fuel stack<sup>5)</sup> Free gas volume for coordinates 185 - 295 mm is presented in Table C.3



#B13T

Initial Individual Characteristics of Refabricated Fuel Rods  
(Preirradiated fuel, Preirradiated cladding)

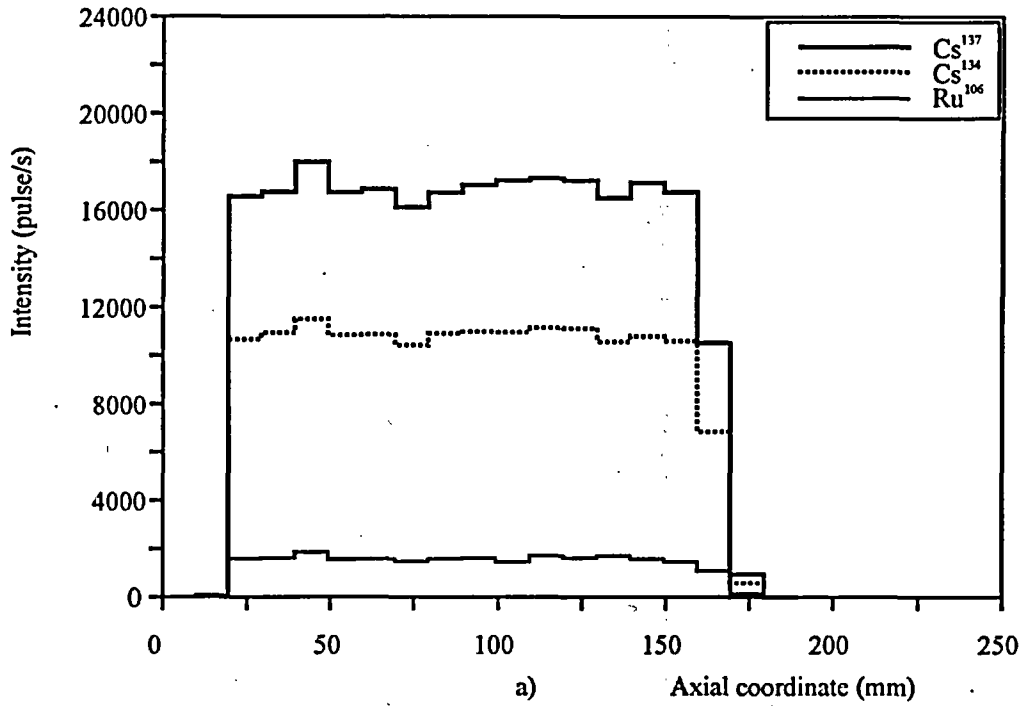

b)

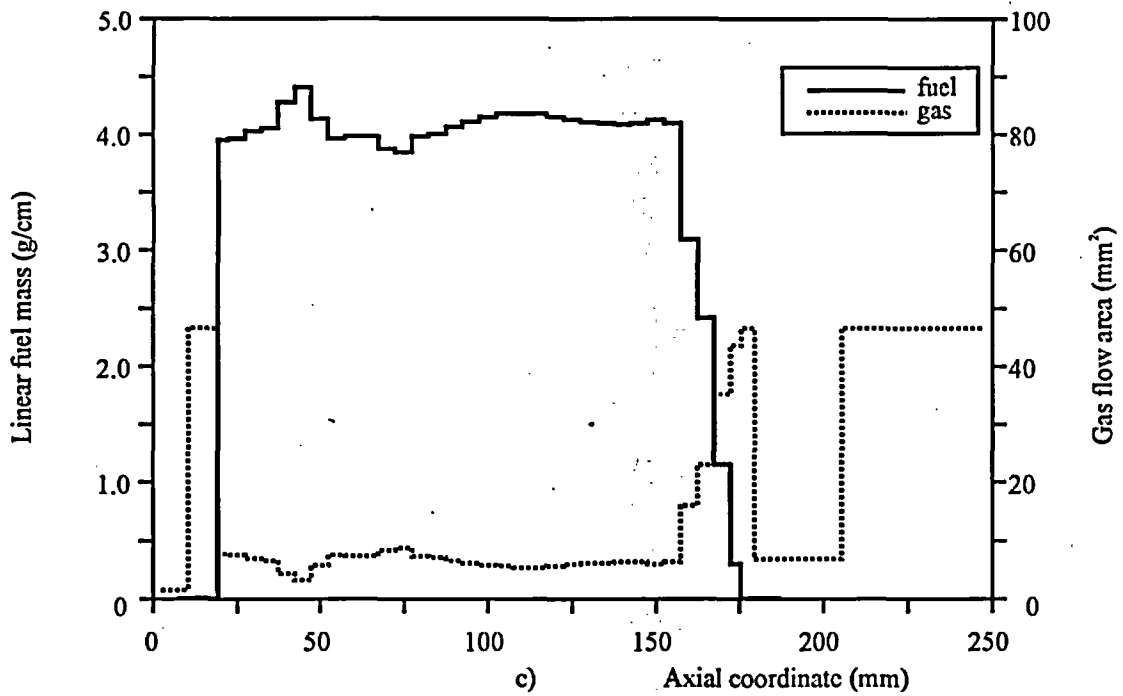

Fig. C-13.1. (a) Results of  $\gamma$ -scanning, (b) Radiography, (c) Axial Fuel Mass Distribution and Axial Free Gas Volume Distribution for Fuel Rod #B13T

#B13T

Initial Individual Characteristics of Refabricated Fuel Rods  
(Preirradiated fuel, Preirradiated cladding)

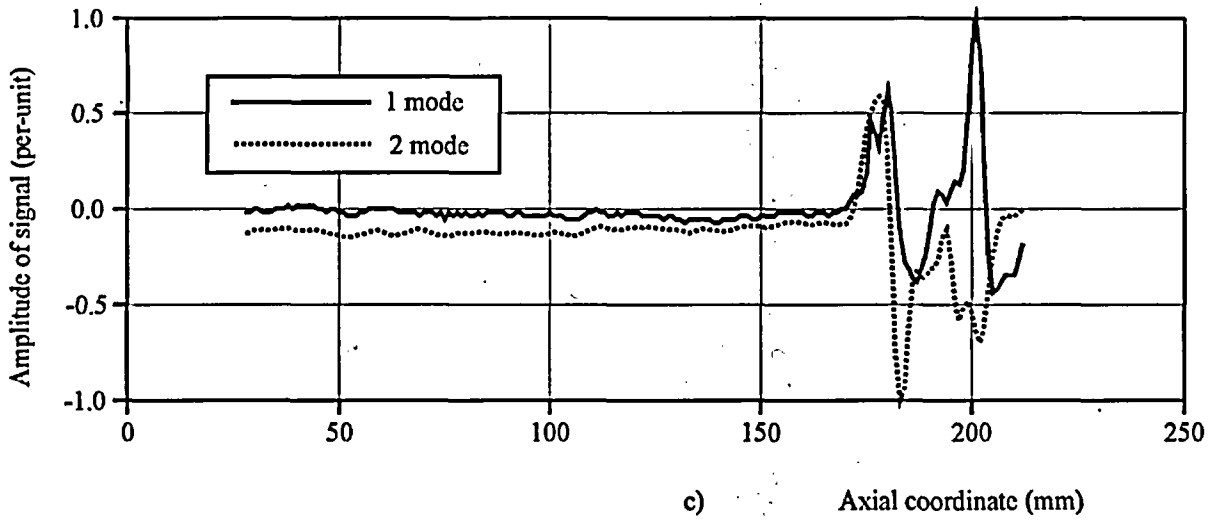
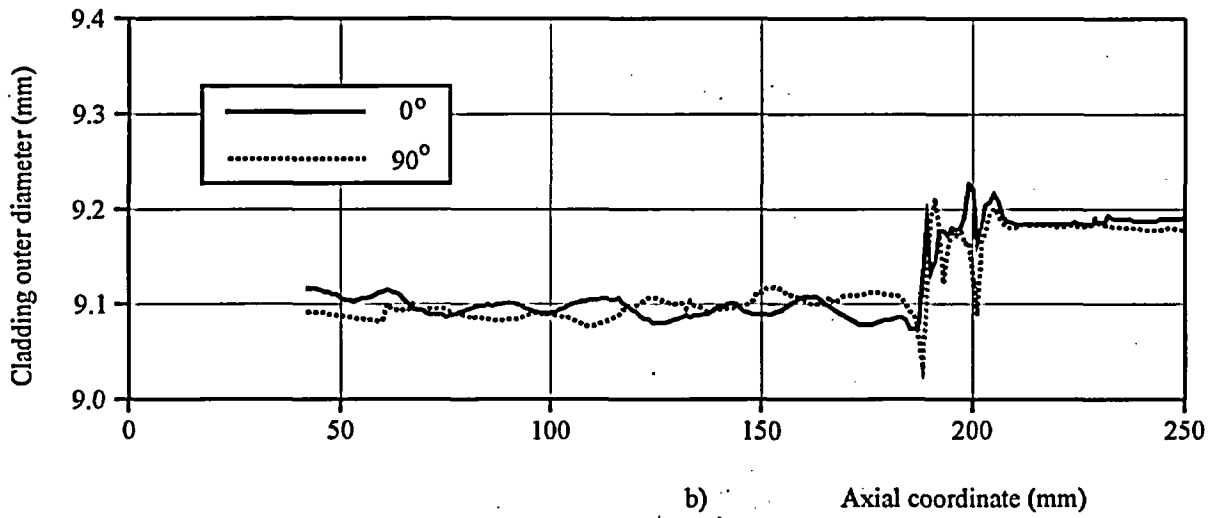
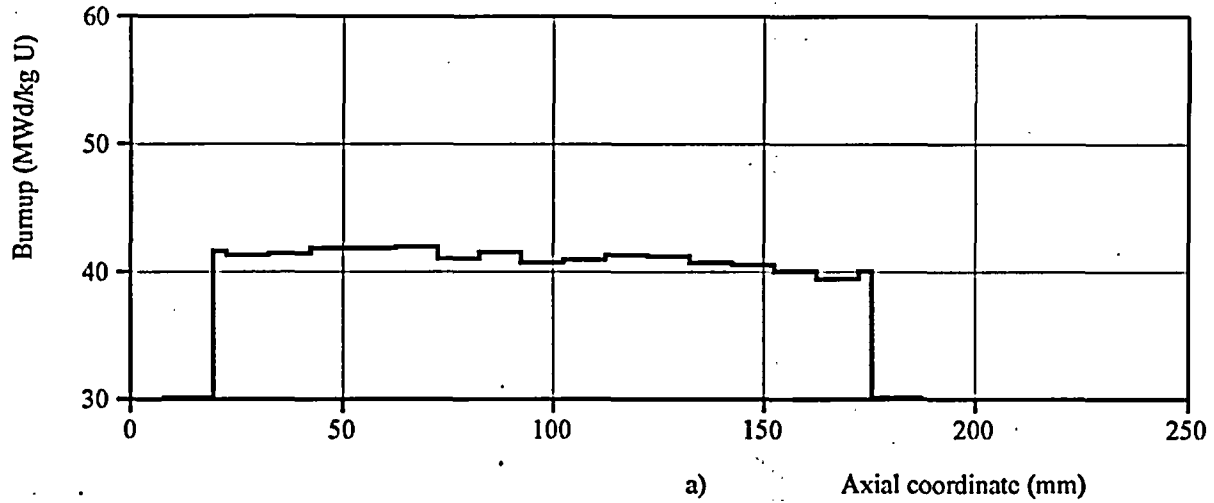

Fig. C-13.2. (a) Axial Burnup Distribution and (b) Results of Profilometry and (c) Eddy-Current Examination for Fuel Rod #B13T

#B13T

Initial Individual Characteristics of Refabricated Fuel Rods  
(Preirradiated fuel, Preirradiated cladding)

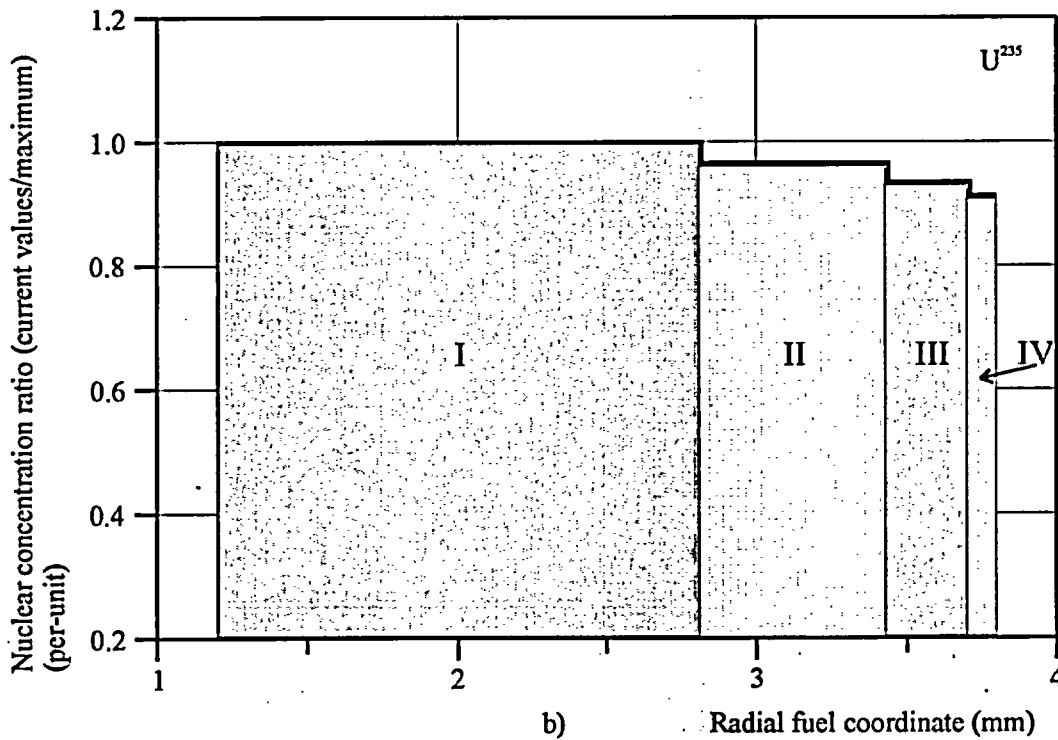
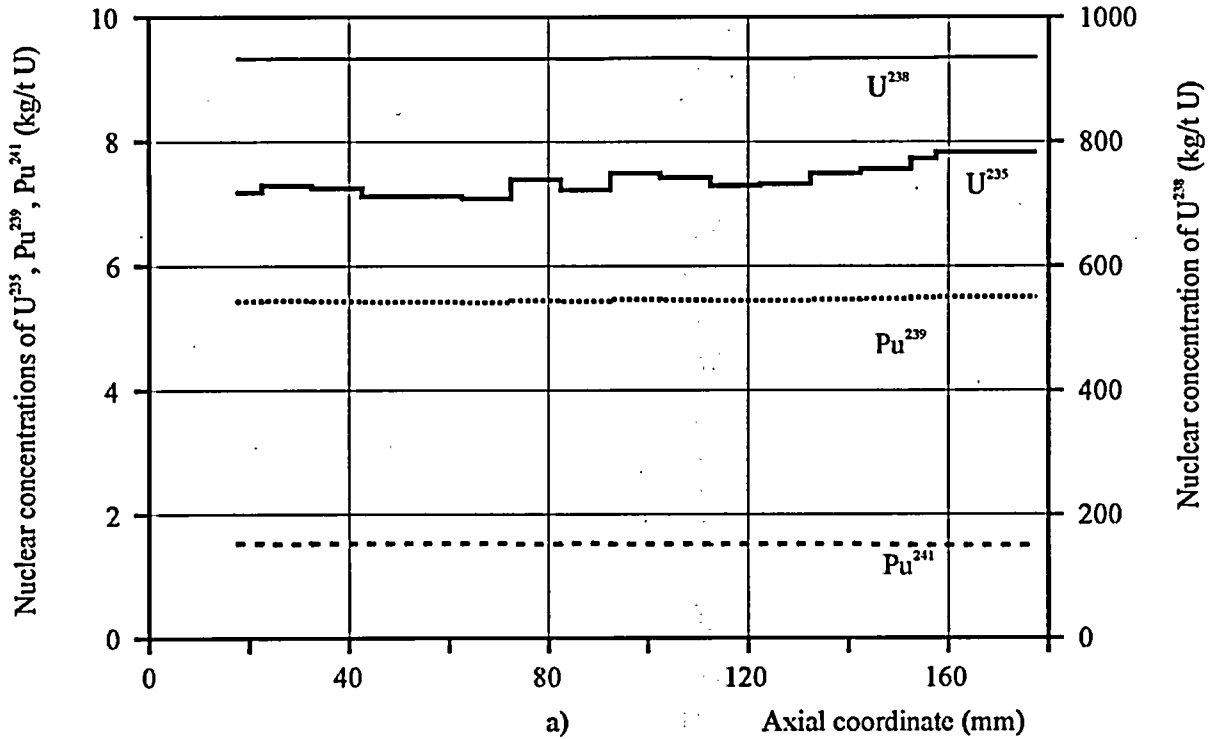

Fig. C-13.3. (a) Axial Distribution of U<sup>235</sup>, U<sup>238</sup>, Pu<sup>239</sup>, Pu<sup>241</sup> Isotopes and (b) Radial Distribution of U<sup>235</sup> Isotope for Fuel Rod #B13T (calculated)

#B13T

Initial Individual Characteristics of Refabricated Fuel Rods  
(Preirradiated fuel, Preirradiated cladding)

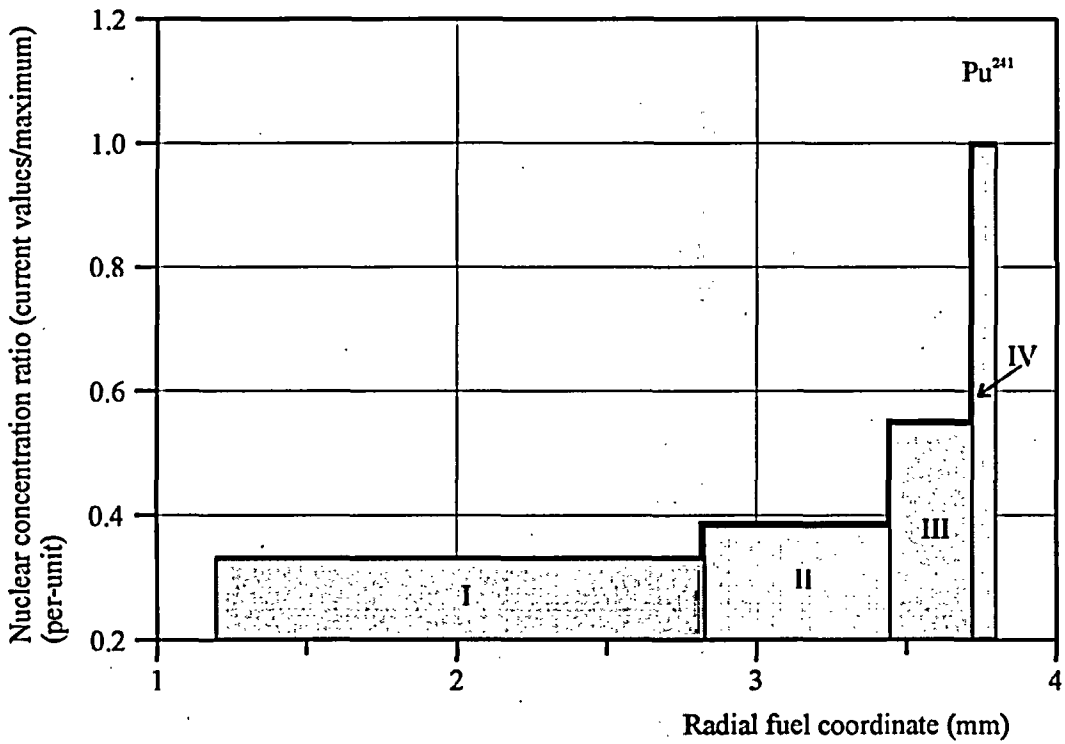
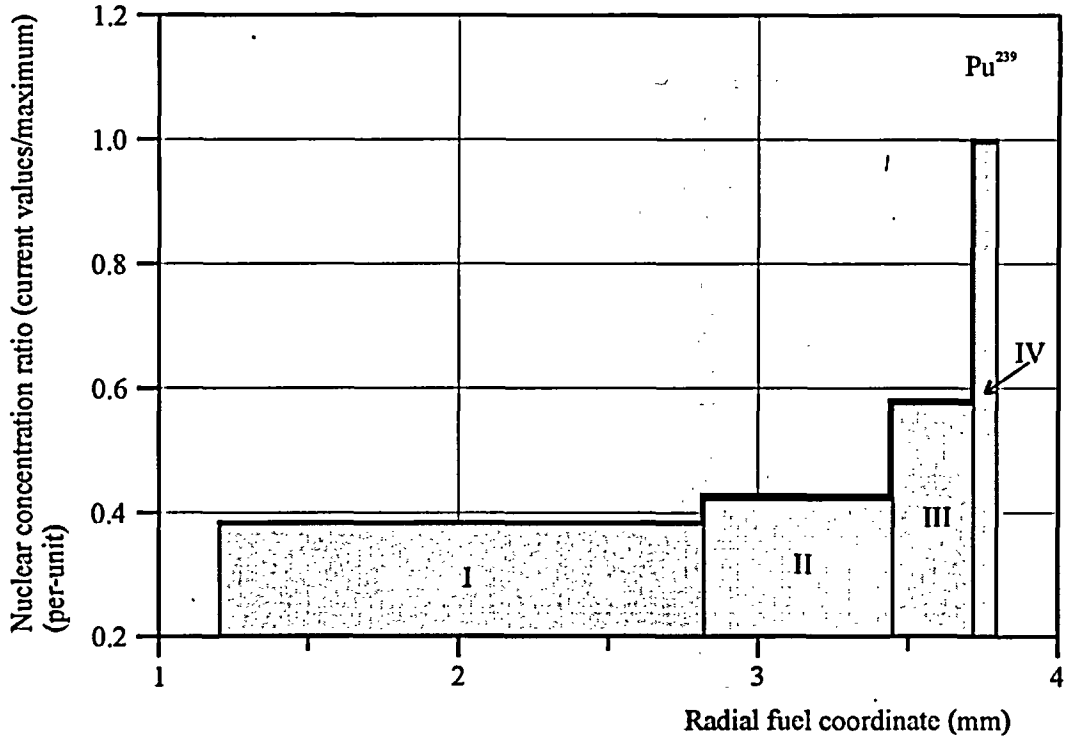

Fig. C-13.4. Radial Distribution of  $Pu^{239}$ ,  $Pu^{241}$  Isotopes for Fuel Rod #B13T (calculated)

#B13T

Initial Individual Characteristics of Refabricated Fuel Rods  
(Preirradiated fuel, Preirradiated cladding)

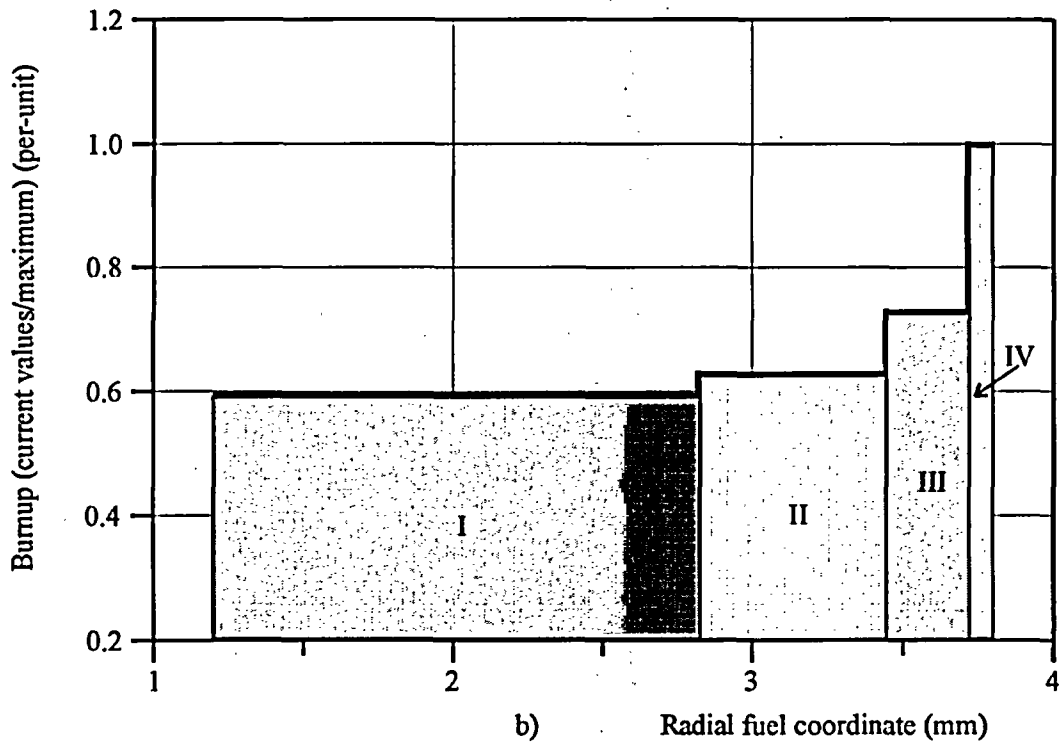
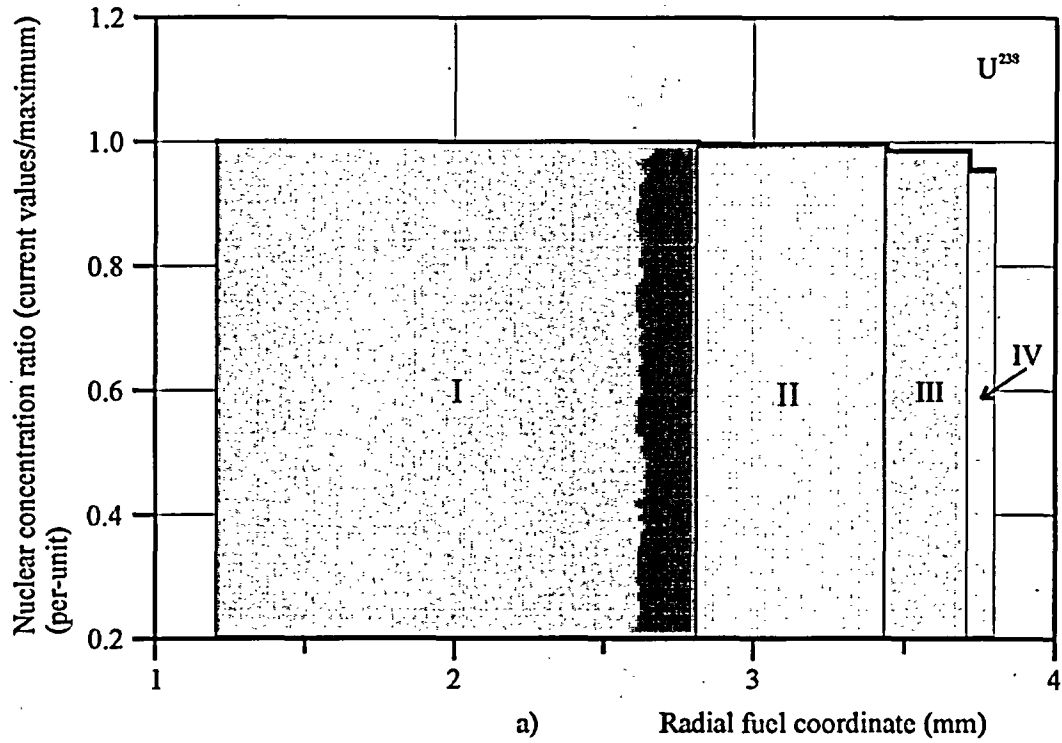
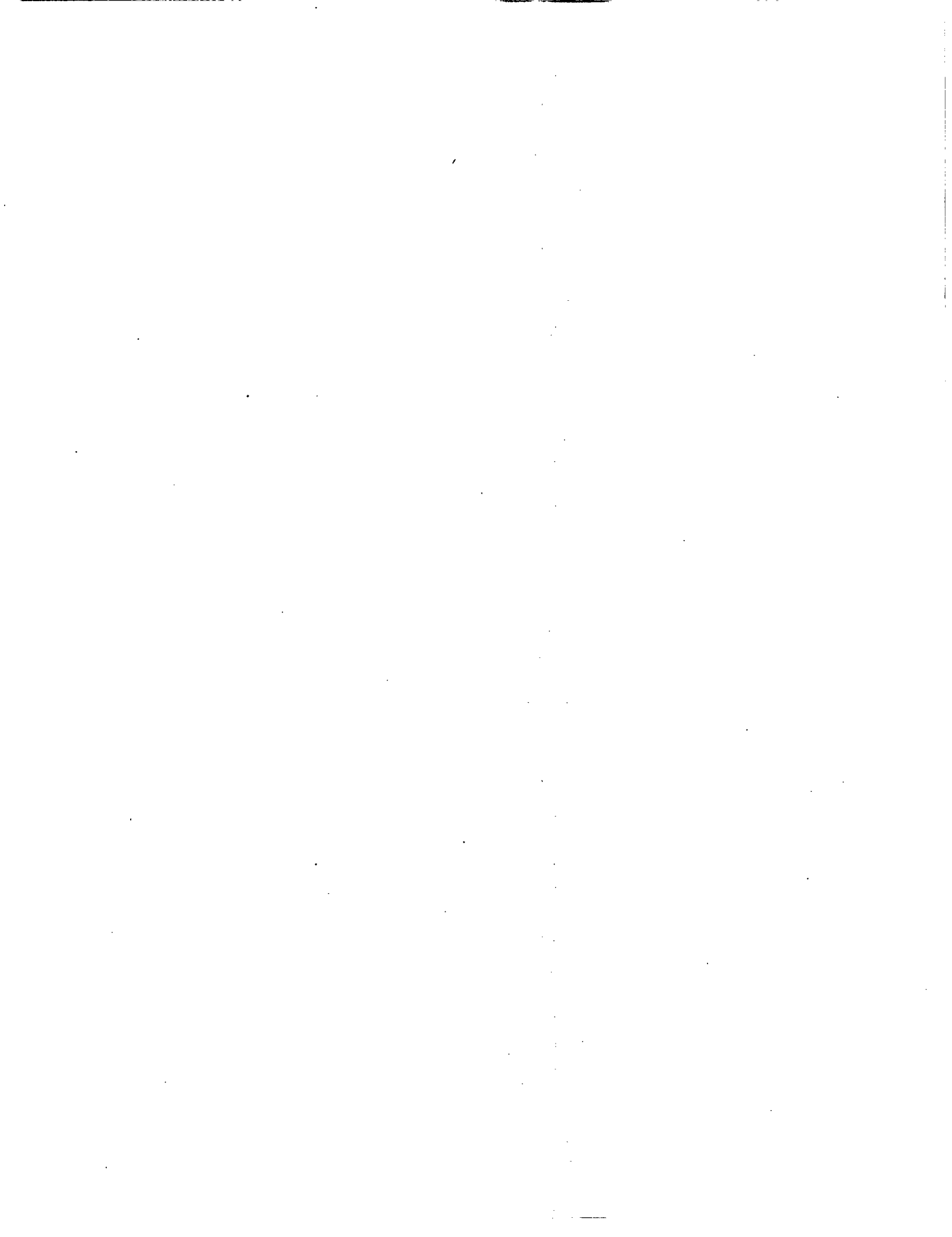

Fig. C-13.5. (a) Radial Distribution of  $U^{238}$  Isotope and (b) Burnup for Fuel Rod #B13T (calculated)



**APPENDIX D.**  
**Initial Characteristics of Refabricated Fuel Rods**  
**(Fresh Fuel, Preirradiated Cladding)**

**Table D.1. Initial Characteristics of Refabricated Fuel Rods before IGR Reactor Tests.**  
**Representative values**

Characteristic	Unit	Value
<b>1. Fuel (UO<sub>2</sub>)</b>		
1.1. Isotopic composition:		
U <sup>235</sup>	% by weight	see Table D.2.(1-2)
U <sup>238</sup>	% by weight	see Table D.2.(1-2)
U <sup>236</sup>	% by weight	0.023
U <sup>234</sup>	% by weight	0.057
1.2. Uranium impurity	% by weight	0.152
1.3. Enrichment	%	see Table D.2.(1-2)
1.4. Oxygen coefficient	per-unit	not measured
1.5. Pellet outer diameter	mm	7.56 <sup>+0.01</sup>
1.6. Pellet inner diameter	mm	2.2
1.7. Pellet height	mm	9.8 – 13
1.8. Density	g/cm <sup>3</sup>	10.5 - 10.6
1.9. Grain size	µm	not measured
1.10. Fuel shape	-	see Fig. D.2
1.11. Fuel macrostructure	-	see Fig. D.1
1.12. Fuel microstructure	-	see Fig. D.1
<b>2. Cladding (Zr-1%Nb)</b>		
2.1. Outer diameter	mm	9.11 <sup>+0.01</sup> <sub>-0.01</sub>
2.2. Inner diameter	mm	not measured
2.3. Corrosion thickness	µm	5 – 6
2.4. H <sub>2</sub> content in cladding	% by weight	3 - 6×10 <sup>-3</sup>
2.5. Cladding microstructure	-	see Fig. D.1
<b>3. Fuel rod</b>		
3.1. Fuel rod design	-	see Fig. D.2
3.2. Fuel rod length	mm	300
3.3. Initial fill pressure	MPa	1.7 <sup>+0.2</sup> <sub>-0.2</sub>
3.4. Gas composition:		
He	% by volume	97.57
Impurity	% by volume	2.43
3.5. Free volume	cm <sup>3</sup>	5.80 (average)
3.6. Fuel-cladding gap	mm	not measured



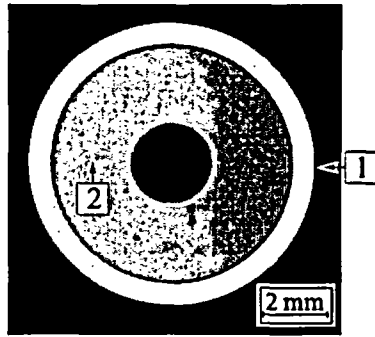

Position 1

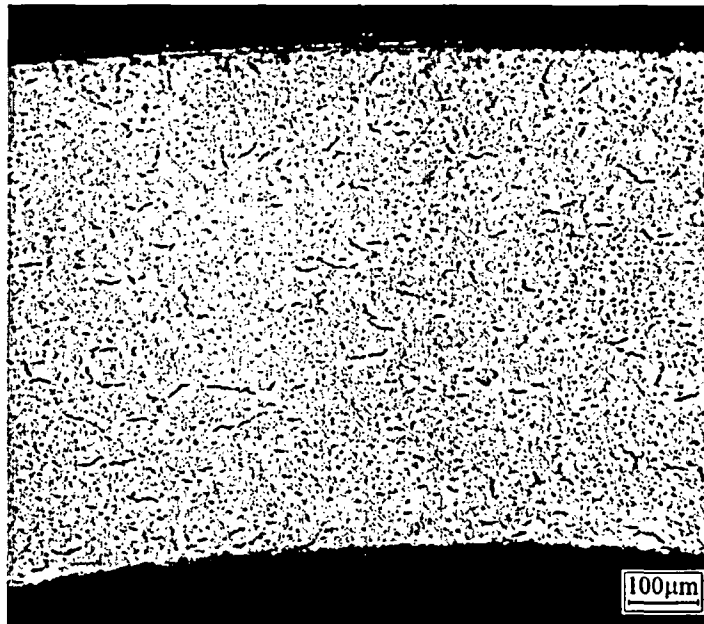

Position 2



**Fig. D.1. Typical Cross-Section Appearance, Cladding and Fuel Microstructure of Refabricated Fuel Rod before IGR Reactor Test**

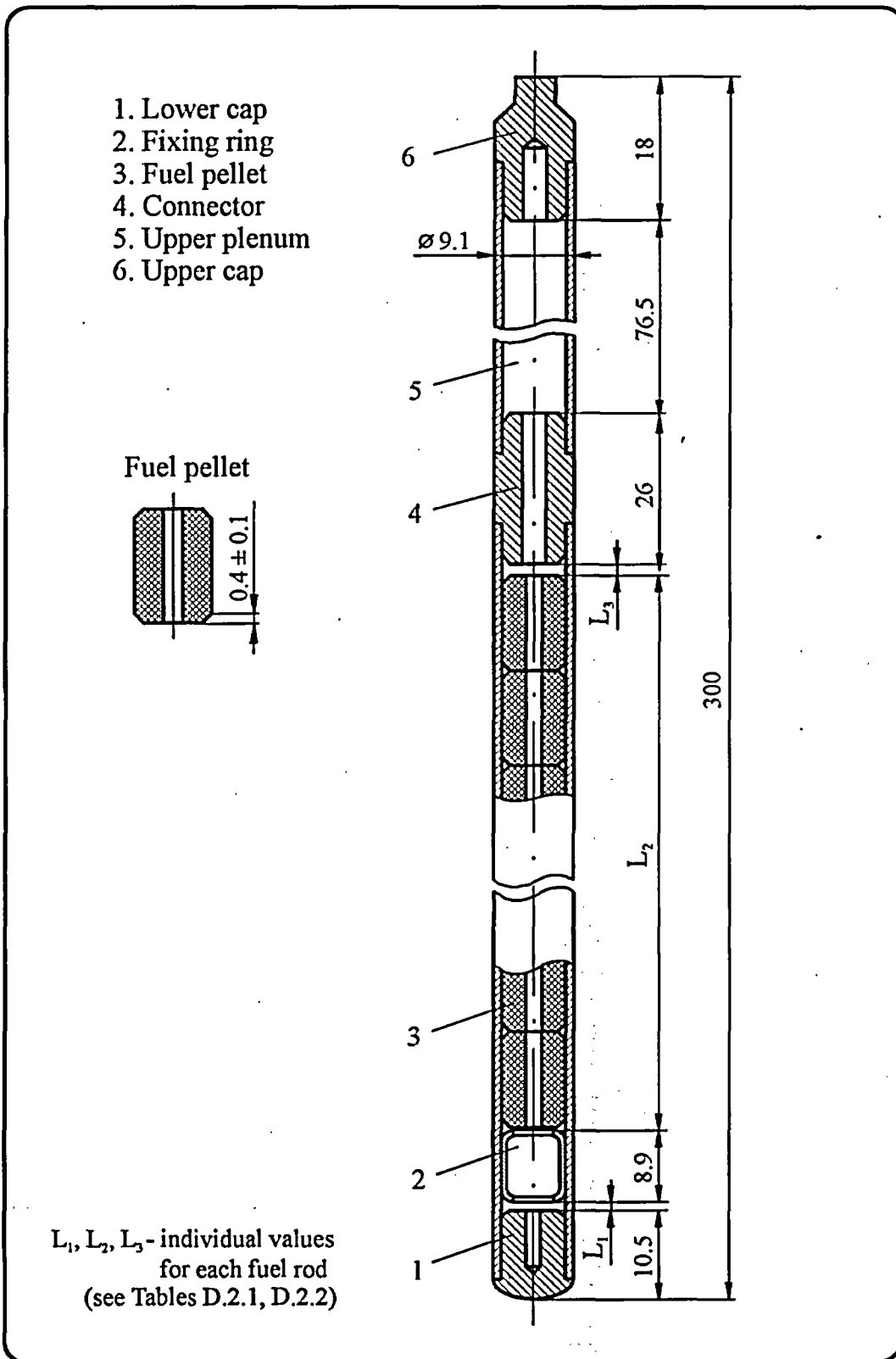

Fig. D.2. Design Scheme of Refabricated Fuel Rod (Fresh fuel, Preirradiated cladding)

**Table D.2.1. Consolidated List of Characteristics for Fuel Rods ## H14T, H15T, H16T, H17T, H18T**

Characteristic	Fuel rod number				
	H14T	H15T	H16T	H17T	H18T
1. Identification number of commercial fuel rods used for refabrication	22	22	22	22	22
2. Coordinates of commercial fuel rod sections used for refabrication (from lower end of fuel rod) (mm)	1960 2110	1500 1650	2730 2880	2150 2300	1310 1460
3. Fuel stack length (mm)	141.0	142.0	141.0	141.0	141.0
4. Coordinates of fuel stack (mm)	33.0 174.0	25.7 167.7	25.8 166.8	19.4 160.4	24.7 165.7
5. Average section burn-up of commercial fuel rod used for refabrication (MWd/kg U)	43.2	43.4	42.3	43.2	44.1
6. Fuel isotopic composition:					
U <sup>235</sup> (% weight)	4.47	4.47	4.47	4.46	4.46
U <sup>238</sup> (% weight)	95.45	95.45	95.45	95.46	95.46
7. Total fuel mass (g)	58.8	59.3	58.9	59.0	59.0
8. U <sup>235</sup> mass in fuel (g)	2.31	2.33	2.31	2.31	2.31
9. Uranium isotopes mass (g)	51.7	52.1	51.7	51.8	51.8
10. Enrichment (%)	4.47	4.47	4.47	4.46	4.46
11. L <sub>1</sub> (see Fig. D.2) (mm)	13.6	6.3	6.4	0.	5.3
12. L <sub>2</sub> (see Fig. D.2) (mm)	141.0	142.0	141.0	141.0	141.0
13. L <sub>3</sub> (see Fig. D.2) (mm)	5.5	11.8	12.7	19.1	13.8
14. Total gas volume (cm <sup>3</sup> )	5.74	5.69	5.73	5.73	5.72
15. Average outer diameter of cladding (mm)	9.10	9.10	9.12	9.10	9.10
16. Average fuel pellet diameter (mm)	7.57	7.56	7.56	7.57	7.57

Table D.2.2. Consolidated List of Characteristics for Fuel Rods ## B19T, B20T, B21T, B22T, B23T

Characteristic	Fuel rod number				
	B19T	B20T	B21T	B22T	B23T
1. Identification number of commercial fuel rods used for refabrication	22	22	22	22	22
2. Coordinates of commercial fuel rod sections used for refabrication (from lower end of fuel rod) (mm)	1120 1270	3110 3260	3300 3450	540 690	2920 3070
3. Fuel stack length (mm)	141.0	143.0	142.0	142.0	141.0
4. Coordinates of fuel stack (mm)	19.4 160.4	23.0 166.0	10.5* 152.5*	10.5* 152.5*	25.8 166.8
5. Average section burn-up of commercial fuel rod used for refabrication (MWd/kg U)	43.7	38.4	29.7	42.8	41.8
6. Fuel isotopic composition:					
U <sup>235</sup> (% weight)	4.46	4.46	4.47	4.46	4.46
U <sup>238</sup> (% weight)	95.46	95.46	95.45	95.46	95.46
7. Total fuel mass (g)	59.0	59.5	59.1	58.9	58.9
8. U <sup>235</sup> mass in fuel (g)	2.31	2.33	2.32	2.31	2.31
9. Uranium isotopes mass (g)	51.8	52.2	51.9	51.8	51.8
10. Enrichment (%)	4.46	4.46	4.47	4.46	4.46
11. L <sub>1</sub> (see Fig. D.2) (mm)	0.	3.6	0.*	0.*	6.4
12. L <sub>2</sub> (see Fig. D.2) (mm)	141.0	143.0	142.0	142.0	141.0
13. L <sub>3</sub> (see Fig. D.2) (mm)	19.1	13.5	27.0*	27.0*	12.7
14. Total gas volume (cm <sup>3</sup> )	5.72	5.67	6.12	6.14	5.73
15. Average outer diameter of cladding (mm)	9.11	9.12	9.11	9.11	9.12
16. Average fuel pellet diameter (mm)	7.56	7.56	7.56	7.56	7.56

\* The fixing ring is absent in the fuel rod

**Table D.3. Free Gas Volume in Refabricated Fuel Rods before IGR Reactor Tests for Axial Coordinates 185+295 mm**

Axial coordinate from lower end of fuel rod  (mm)	Free gas volume (mm <sup>3</sup> )									
	H14T	H15T	H16T	H17T	H18T	B19T	B20T	B21T	B22T	B23T
185	53	53	53	53	53	53	53	53	53	53
195	71	71	71	71	71	71	71	71	71	71
205	250	250	250	250	250	250	250	250	250	250
215	468	468	468	468	468	468	468	468	468	468
225	468	468	468	468	468	468	468	468	468	468
235	468	468	468	468	468	468	468	468	468	468
245	468	468	468	468	468	468	468	468	468	468
255	468	468	468	468	468	468	468	468	468	468
265	468	468	468	468	468	468	468	468	468	468
275	468	468	468	468	468	468	468	468	468	468
285	119	119	119	119	119	119	119	119	119	119
295	0	0	0	0	0	0	0	0	0	0

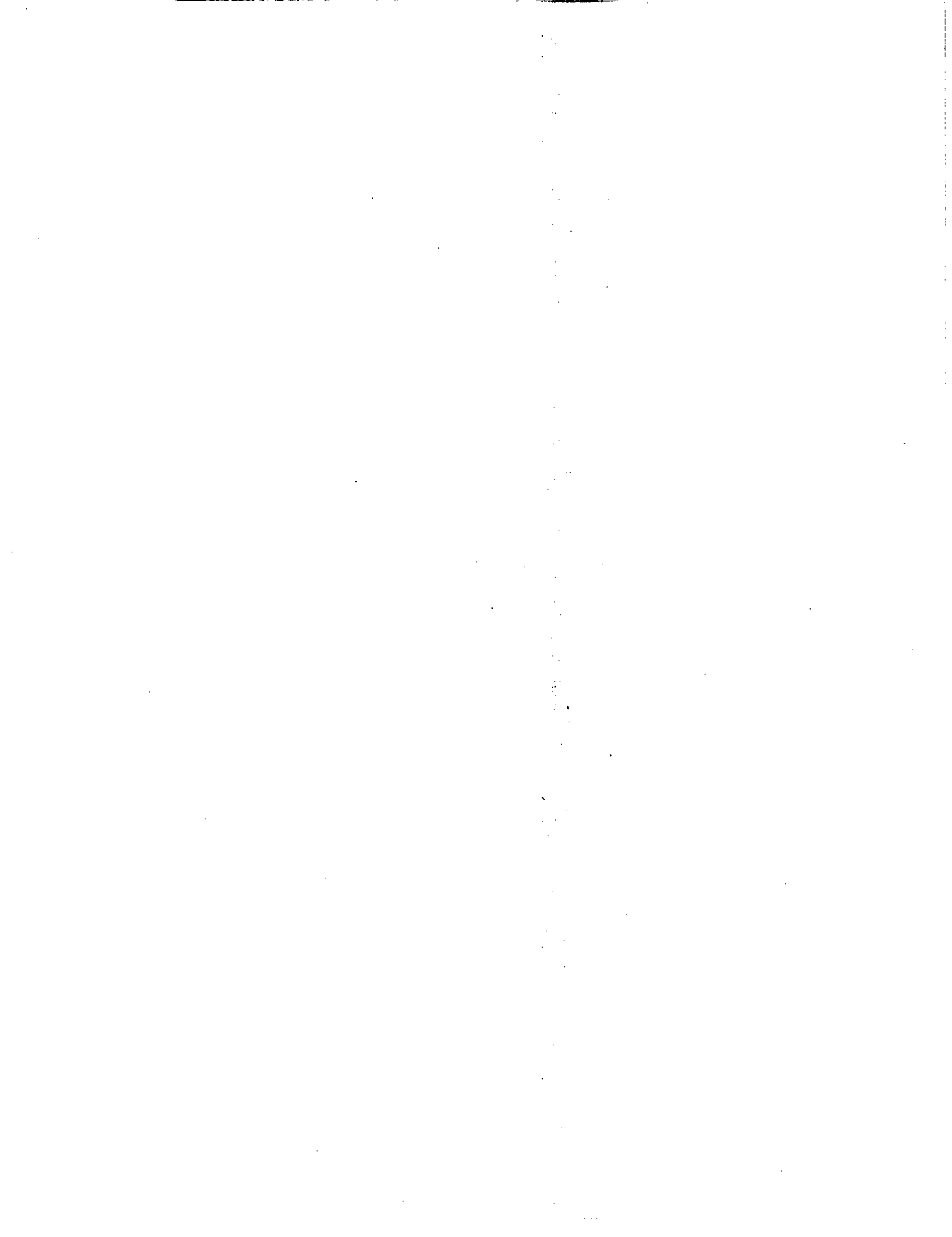

*APPENDIX D-1.*

*Initial Individual Characteristics for Fuel Rod #H14T*

# #H14T

Initial Individual Characteristics of Refabricated Fuel Rods  
(Fresh fuel, Preirradiated cladding)

Table D-1.1. Individual Initial Characteristics for Fuel Rod #H14T (measured)

Axial coordinate from lower end of fuel rod (mm)	Cladding outer diameter (mm)			Fuel stack average diameter (mm)*	Fuel mass (g)*	Linear fuel mass (g/cm)*	Free gas volume (mm <sup>3</sup> )* <sup>3)</sup>
	0°	90°	average				
5	-	-	-	-	0.0	0.0	8.8
10	-	-	-	-	0.0	0.0	98.9
15	-	-	-	-	0.0	0.0	234.0
20	-	-	-	-	0.0	0.0	234.0
25	-	-	-	-	0.0	0.0	199.7
30	-	-	-	-	0.0	0.0	183.6
35 <sup>1)</sup>	9.098	9.092	9.10	7.57	1.88	4.17	51.0
40	9.101	9.099	9.10	7.57	2.09	4.17	36.2
45	9.099	9.092	9.10	7.57	2.09	4.17	36.4
50	9.100	9.097	9.10	7.57	2.08	4.17	36.4
55	9.091	9.093	9.09	7.57	2.08	4.16	36.9
60	9.081	9.103	9.09	7.57	2.06	4.12	38.7
65	9.082	9.101	9.09	7.57	2.06	4.12	38.7
70	9.088	9.092	9.09	7.57	2.07	4.15	37.4
75	9.091	9.100	9.10	7.57	2.08	4.15	37.2
80	9.090	9.105	9.10	7.57	2.08	4.16	37.0
85	9.088	9.110	9.10	7.56	2.08	4.16	36.8
90	9.091	9.112	9.10	7.56	2.08	4.16	36.7
95	9.099	9.097	9.10	7.56	2.09	4.18	36.0
100	9.101	9.105	9.10	7.56	2.09	4.18	36.0
105	9.098	9.105	9.10	7.57	2.09	4.18	36.0
110	9.088	9.103	9.10	7.57	2.09	4.18	36.0
115	9.082	9.103	9.09	7.57	2.09	4.17	36.3
120	9.088	9.099	9.09	7.57	2.08	4.16	36.7
125	9.094	9.105	9.10	7.57	2.08	4.16	36.8
130	9.083	9.116	9.10	7.57	2.07	4.14	37.7
135	9.087	9.121	9.10	7.57	2.07	4.14	37.7
140	9.088	9.128	9.11	7.57	2.08	4.16	37.1
145	9.088	9.134	9.11	7.57	2.08	4.16	36.8
150	9.087	9.121	9.10	7.57	2.09	4.18	36.1
155	9.089	9.121	9.11	7.56	2.10	4.21	34.6
160	9.098	9.115	9.11	7.56	2.10	4.21	34.6
165	9.107	9.111	9.11	7.56	2.11	4.22	33.8
170	9.109	9.116	9.11	7.56	2.12	4.24	33.1
175 <sup>2)</sup>	9.101	9.121	9.11	7.56	0.63	4.22	174.0
180	-	-	-	-	0.0	0.0	114.8

\* These numerical values of characteristics are presented as average values at the length interval equal to the axial coordinate  $\pm 2.5$  mm

<sup>1)</sup> Initial coordinate of fuel is 33 mm

<sup>2)</sup> End point coordinate of fuel is 174 mm

<sup>3)</sup> Free gas volume for coordinates 185-295 mm is presented in Table D.3



# #H14T

Initial Individual Characteristics of Refabricated Fuel Rods  
(Fresh fuel, Preirradiated cladding)

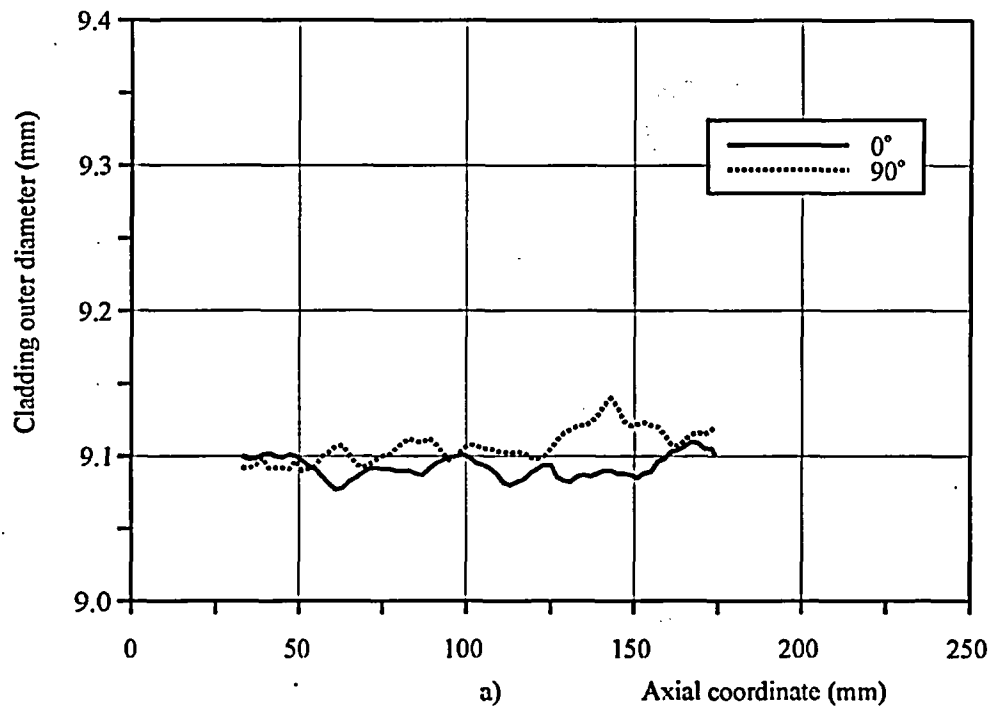

b)

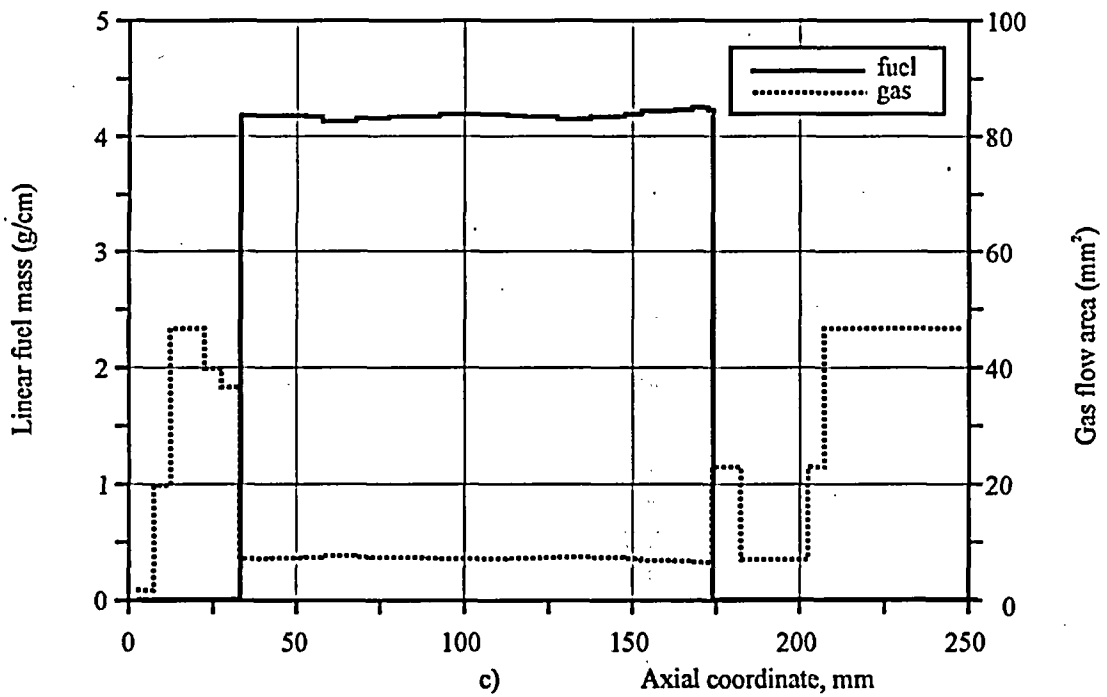

Fig. D-1.1. (a) Results of Profilometry, (b) Radiography, (c) Axial Fuel Mass Distribution and Axial Free Gas Volume Distribution for Fuel Rod #H14T



*APPENDIX D-2.*

*Initial Individual Characteristics for Fuel Rod #H15T*

# #H15T

Initial Individual Characteristics of Refabricated Fuel Rods  
(Fresh fuel, Preirradiated cladding)

Table D-2.1. Individual Initial Characteristics for Fuel Rod #H15T (measured)

Axial coordinate from lower end of fuel rod (mm)	Cladding outer diameter (mm)			Fuel stack average diameter (mm)*	Fuel mass (g)*	Linear fuel mass (g/cm)*	Free gas volume (mm <sup>3</sup> )* <sup>3)</sup>
	0°	90°	average				
5	-	-	-	-	0.0	0.0	8.8
10	-	-	-	-	0.0	0.0	98.9
15	-	-	-	-	0.0	0.0	227.0
20	-	-	-	-	0.0	0.0	183.6
25 <sup>1)</sup>	9.097	9.105	9.10	7.57	0.76	4.21	129.9
30	9.094	9.101	9.10	7.57	2.11	4.21	34.4
35	9.095	9.094	9.09	7.57	2.11	4.21	34.4
40	9.097	9.094	9.10	7.56	2.09	4.18	36.2
45	9.096	9.095	9.10	7.56	2.09	4.17	36.2
50	9.101	9.099	9.10	7.56	2.09	4.18	35.8
55	9.104	9.102	9.10	7.56	2.09	4.19	35.6
60	9.100	9.097	9.10	7.56	2.09	4.18	35.7
65	9.097	9.106	9.10	7.55	2.09	4.18	36.1
70	9.093	9.103	9.10	7.55	2.09	4.18	36.1
75	9.093	9.104	9.10	7.56	2.08	4.17	36.4
80	9.089	9.103	9.10	7.56	2.08	4.17	36.5
85	9.098	9.095	9.10	7.57	2.09	4.17	36.2
90	9.098	9.092	9.10	7.57	2.09	4.18	35.9
95	9.093	9.098	9.10	7.57	2.09	4.18	36.0
100	9.090	9.099	9.09	7.57	2.07	4.15	37.6
105	9.090	9.110	9.10	7.57	2.07	4.15	37.6
110	9.091	9.114	9.10	7.57	2.09	4.18	36.0
115	9.090	9.112	9.10	7.57	2.10	4.19	35.2
120	9.085	9.114	9.10	7.57	2.08	4.17	36.5
125	9.086	9.111	9.10	7.57	2.07	4.13	38.2
130	9.088	9.101	9.09	7.57	2.07	4.13	38.1
135	9.091	9.093	9.09	7.57	2.08	4.17	36.5
140	9.086	9.086	9.09	7.57	2.08	4.17	36.5
145	9.083	9.092	9.09	7.56	2.08	4.17	36.5
150	9.084	9.104	9.09	7.56	2.08	4.17	36.4
155	9.089	9.106	9.10	7.56	2.09	4.18	36.2
160	9.090	9.109	9.10	7.57	2.10	4.19	35.4
165	9.094	9.102	9.10	7.57	2.10	4.21	34.6
170 <sup>2)</sup>	9.098	9.101	9.10	7.57	0.08	4.19	226.1
175	-	-	-	-	0.0	0.0	234.0
180	-	-	-	-	0.0	0.0	114.8

\* These numerical values of characteristics are presented as average values at the length interval equal to the axial coordinate  $\pm 2.5$  mm

<sup>1)</sup> Initial coordinate of fuel is 25.7 mm

<sup>2)</sup> End point coordinate of fuel is 167.7 mm

<sup>3)</sup> Free gas volume for coordinates 185-295 mm is presented in Table D.3

# #H15T

Initial Individual Characteristics of Refabricated Fuel Rods  
(Fresh fuel, Preirradiated cladding)

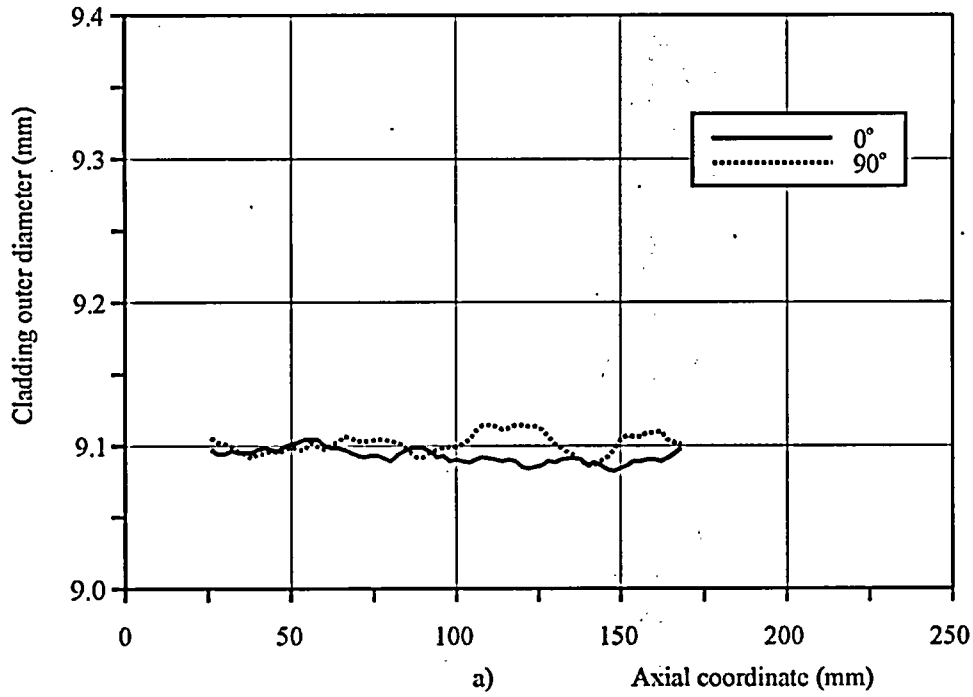

b)

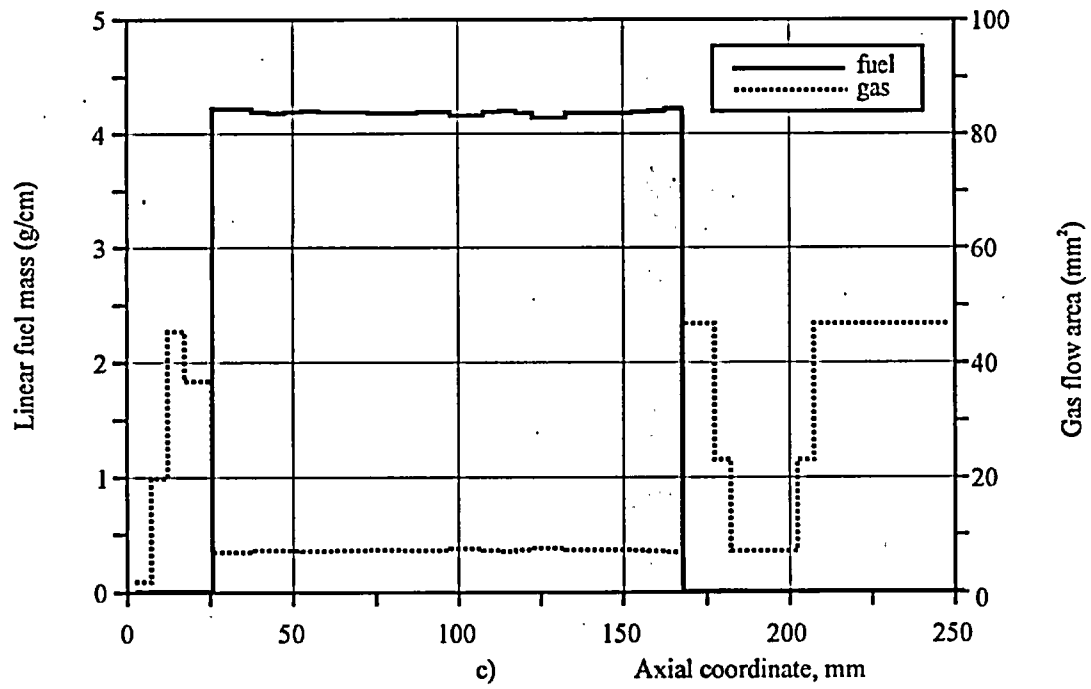

Fig. D-2.1. (a) Results of Profilometry, (b) Radiography, (c) Axial Fuel Mass Distribution and Axial Free Gas Volume Distribution for Fuel Rod #H15T



***APPENDIX D-3.***

***Initial Individual Characteristics for Fuel Rod #H16T***

# #H16T

Initial Individual Characteristics of Refabricated Fuel Rods  
(Fresh fuel, Preirradiated cladding)

Table D-3.1. Individual Initial Characteristics for Fuel Rod #H16T (measured)

Axial coordinate from lower end of fuel rod (mm)	Cladding outer diameter (mm)			Fuel stack average diameter (mm)*	Fuel mass (g)*	Linear fuel mass (g/cm)*	Free gas volume (mm <sup>3</sup> )* <sup>3)</sup>
	0°	90°	average				
5	-	-	-	-	0.0	0.0	8.8
10	-	-	-	-	0.0	0.0	98.9
15	-	-	-	-	0.0	0.0	228.0
20	-	-	-	-	0.0	0.0	183.6
25 <sup>1)</sup>	9.108	9.119	9.11	7.57	0.71	4.16	133.8
30	9.115	9.113	9.11	7.57	2.08	4.16	37.1
35	9.122	9.111	9.12	7.57	2.08	4.16	37.1
40	9.121	9.120	9.12	7.57	2.07	4.15	37.4
45	9.126	9.123	9.12	7.57	2.07	4.15	37.4
50	9.123	9.127	9.13	7.56	2.08	4.16	37.0
55	9.129	9.124	9.13	7.56	2.08	4.16	36.7
60	9.121	9.129	9.13	7.56	2.09	4.17	36.2
65	9.109	9.143	9.13	7.55	2.10	4.20	34.8
70	9.105	9.139	9.12	7.55	2.10	4.20	34.8
75	9.107	9.146	9.13	7.56	2.09	4.19	35.5
80	9.112	9.155	9.13	7.56	2.09	4.19	35.6
85	9.099	9.133	9.12	7.56	2.09	4.18	36.0
90	9.117	9.149	9.13	7.56	2.09	4.17	36.3
95	9.108	9.144	9.13	7.56	2.09	4.18	35.9
100	9.105	9.141	9.12	7.56	2.11	4.22	34.1
105	9.099	9.133	9.12	7.56	2.11	4.22	34.1
110	9.097	9.142	9.12	7.56	2.10	4.20	35.1
115	9.107	9.145	9.13	7.56	2.10	4.19	35.3
120	9.117	9.147	9.13	7.56	2.10	4.20	35.2
125	9.120	9.149	9.13	7.56	2.10	4.20	35.1
130	9.121	9.145	9.13	7.56	2.10	4.19	35.3
135	9.122	9.131	9.13	7.57	2.08	4.17	36.5
140	9.122	9.123	9.12	7.57	2.08	4.17	36.5
145	9.105	9.112	9.11	7.57	2.08	4.17	36.6
150	9.106	9.112	9.11	7.57	2.08	4.16	36.7
155	9.102	9.114	9.11	7.57	2.07	4.14	37.7
160	9.096	9.121	9.11	7.57	2.05	4.09	40.0
165 <sup>2)</sup>	9.093	9.100	9.10	7.57	1.77	4.12	66.3
170	-	-	-	-	0.0	0.0	234.0
175	-	-	-	-	0.0	0.0	234.0
180	-	-	-	-	0.0	0.0	114.8

\* These numerical values of characteristics are presented as average values at the length interval equal to the axial coordinate  $\pm 2.5$  mm

<sup>1)</sup> Initial coordinate of fuel is 25.8 mm

<sup>2)</sup> End point coordinate of fuel is 166.8 mm

<sup>3)</sup> Free gas volume for coordinates 185-295 mm is presented in Table D.3



# #H16T

Initial Individual Characteristics of Refabricated Fuel Rods  
(Fresh fuel, Preirradiated cladding)

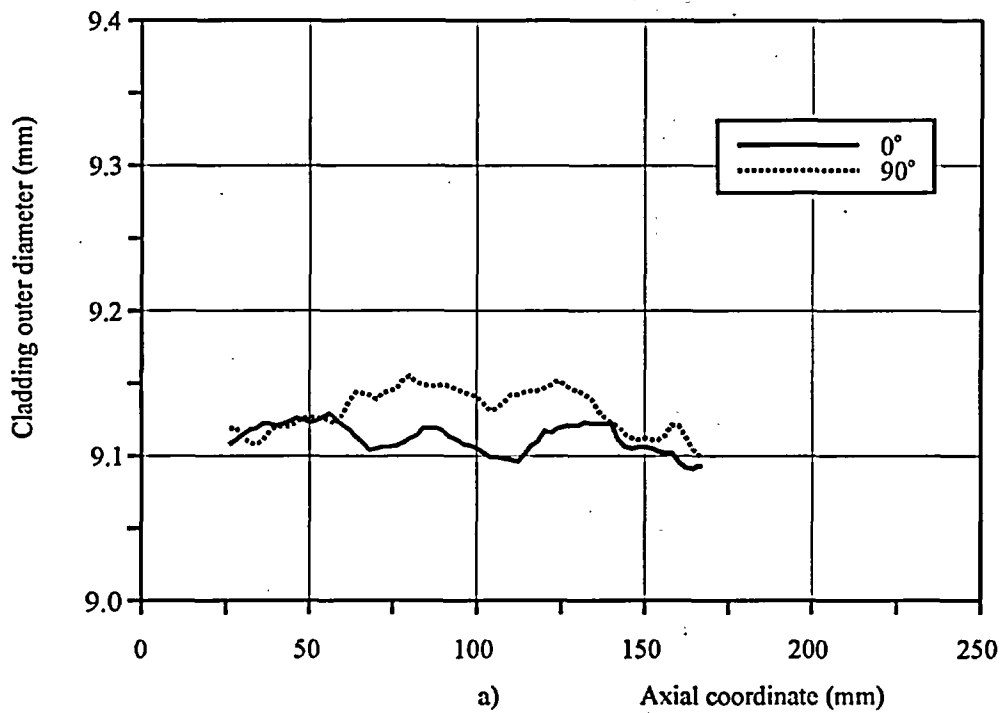

b)

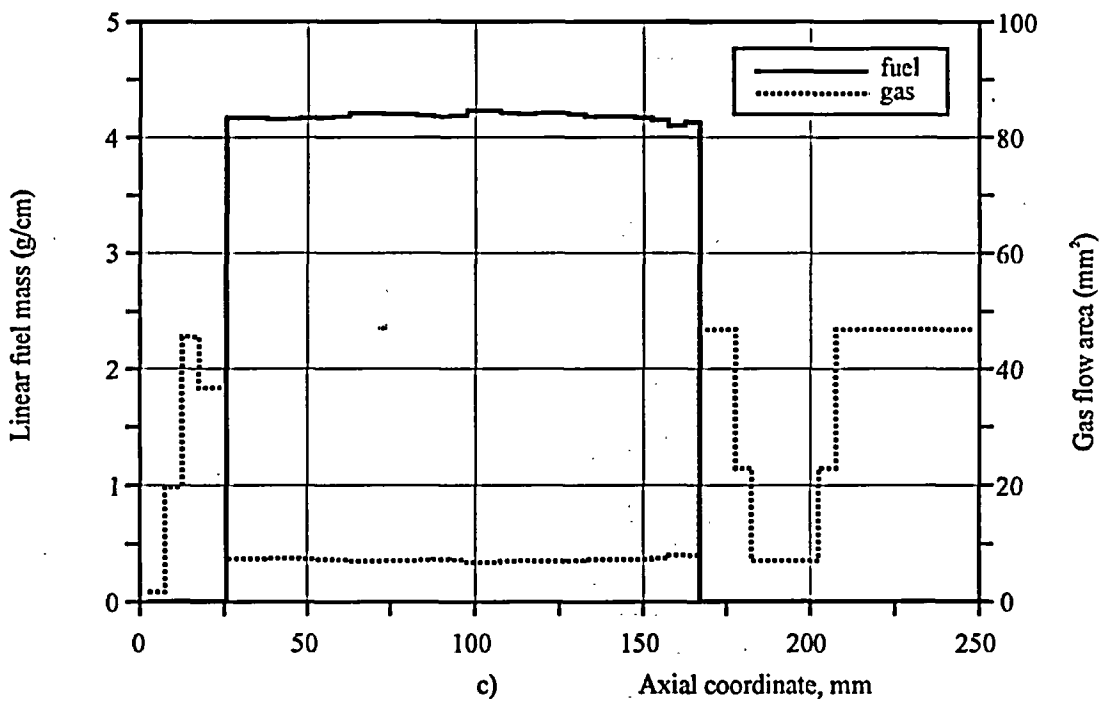
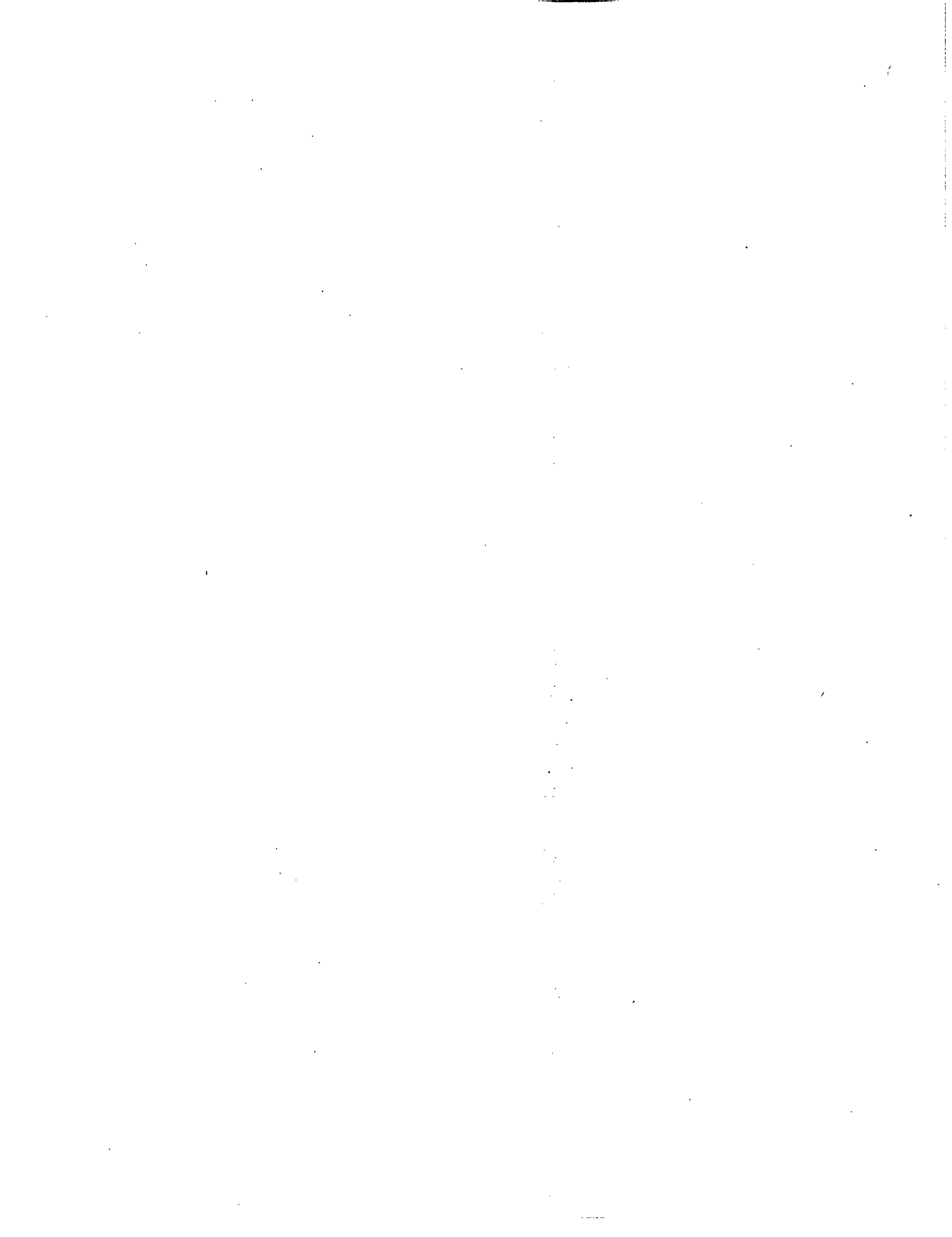

Fig. D-3.1. (a) Results of Profilometry, (b) Radiography, (c) Axial Fuel Mass Distribution and Axial Free Gas Volume Distribution for Fuel Rod #H16T



***APPENDIX D-4.***

***Initial Individual Characteristics for Fuel Rod #H17T***

## #H17T

Initial Individual Characteristics of Refabricated Fuel Rods  
(Fresh fuel, Preirradiated cladding)

Table D-4.1. Individual Initial Characteristics for Fuel Rod #H17T (measured)

Axial coordinate from lower end of fuel rod (mm)	Cladding outer diameter (mm)			Fuel stack average diameter (mm)*	Fuel mass (g)*	Linear fuel mass (g/cm)*	Free gas volume (mm <sup>3</sup> )* <sup>3)</sup>
	0°	90°	average				
5	-	-	-	-	0.0	0.0	8.8
10	-	-	-	-	0.0	0.0	78.7
15	-	-	-	-	0.0	0.0	183.6
20 <sup>1)</sup>	9.093	9.110	9.10	7.57	1.30	4.21	91.3
25	9.101	9.103	9.10	7.57	2.10	4.21	34.7
30	9.108	9.108	9.11	7.57	2.10	4.20	35.1
35	9.101	9.110	9.11	7.57	2.09	4.17	36.4
40	9.091	9.116	9.10	7.57	2.09	4.17	36.4
45	9.087	9.113	9.10	7.56	2.09	4.19	35.5
50	9.096	9.101	9.10	7.56	2.09	4.19	35.5
55	9.100	9.104	9.10	7.56	2.10	4.21	34.7
60	9.100	9.099	9.10	7.57	2.11	4.22	34.1
65	9.117	9.096	9.11	7.56	2.10	4.20	35.1
70	9.110	9.093	9.10	7.56	2.07	4.14	37.9
75	9.112	9.090	9.10	7.56	2.07	4.14	37.9
80	9.110	9.086	9.10	7.57	2.07	4.15	37.5
85	9.101	9.096	9.10	7.57	2.07	4.15	37.5
90	9.104	9.096	9.10	7.57	2.09	4.17	36.2
95	9.093	9.110	9.10	7.57	2.10	4.20	35.0
100	9.101	9.103	9.10	7.57	2.10	4.20	35.0
105	9.108	9.108	9.11	7.57	2.10	4.20	35.1
110	9.101	9.110	9.11	7.57	2.10	4.20	35.1
115	9.091	9.116	9.10	7.57	2.09	4.18	35.9
120	9.087	9.113	9.10	7.57	2.09	4.18	36.2
125	9.096	9.101	9.10	7.56	2.10	4.19	35.2
130	9.100	9.104	9.10	7.57	2.11	4.22	34.1
135	9.100	9.099	9.10	7.57	2.11	4.22	34.2
140	9.117	9.096	9.11	7.57	2.10	4.20	34.9
145	9.110	9.093	9.10	7.57	2.10	4.20	34.9
150	9.112	9.090	9.10	7.57	2.06	4.12	38.5
155	9.110	9.086	9.10	7.57	2.01	4.03	43.1
160 <sup>2)</sup>	9.101	9.096	9.10	7.57	1.19	4.11	121.2
165	-	-	-	-	0.0	0.0	234.0
170	-	-	-	-	0.0	0.0	234.0
175	-	-	-	-	0.0	0.0	234.0
180	-	-	-	-	0.0	0.0	114.8

\* These numerical values of characteristics are presented as average values at the length interval equal to the axial coordinate  $\pm 2.5$  mm

1) Initial coordinate of fuel is 19.4 mm

2) End point coordinate of fuel is 160.4 mm

3) Free gas volume for coordinates 185-295 mm is presented in Table D.3

#H17T

Initial Individual Characteristics of Refabricated Fuel Rods  
(Fresh fuel, Preirradiated cladding)

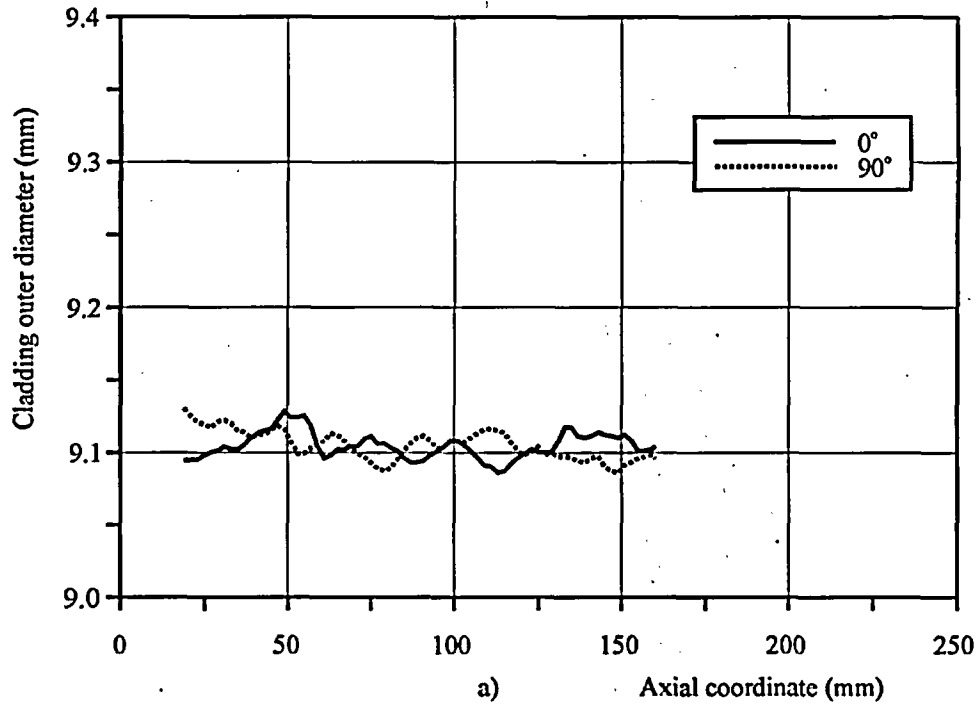

b)

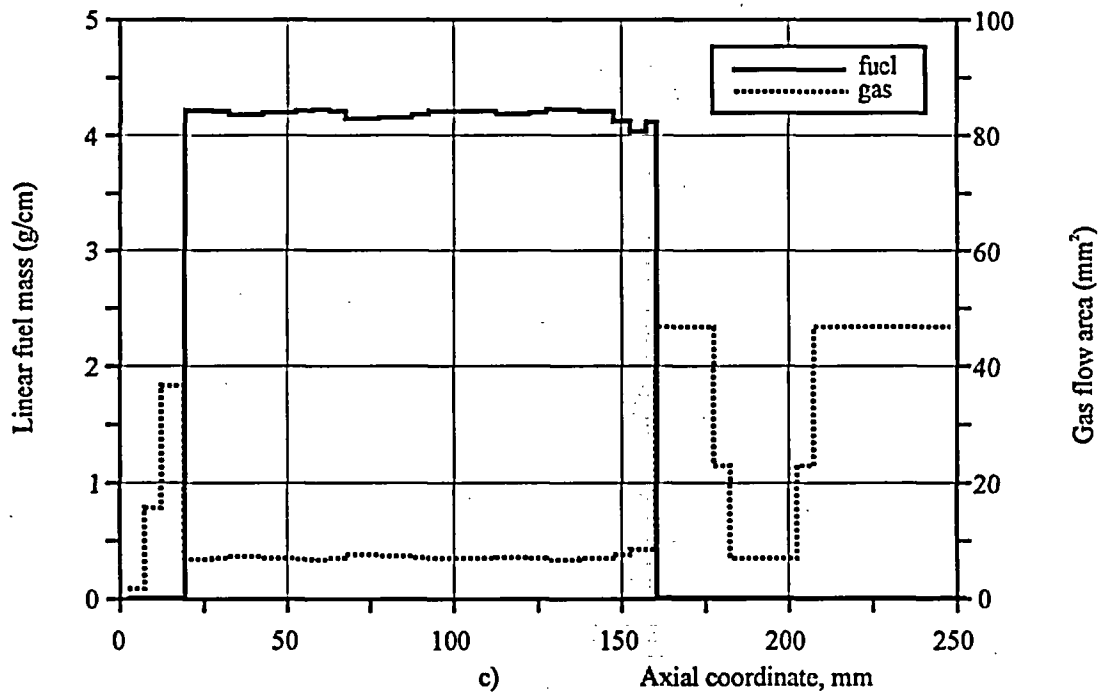
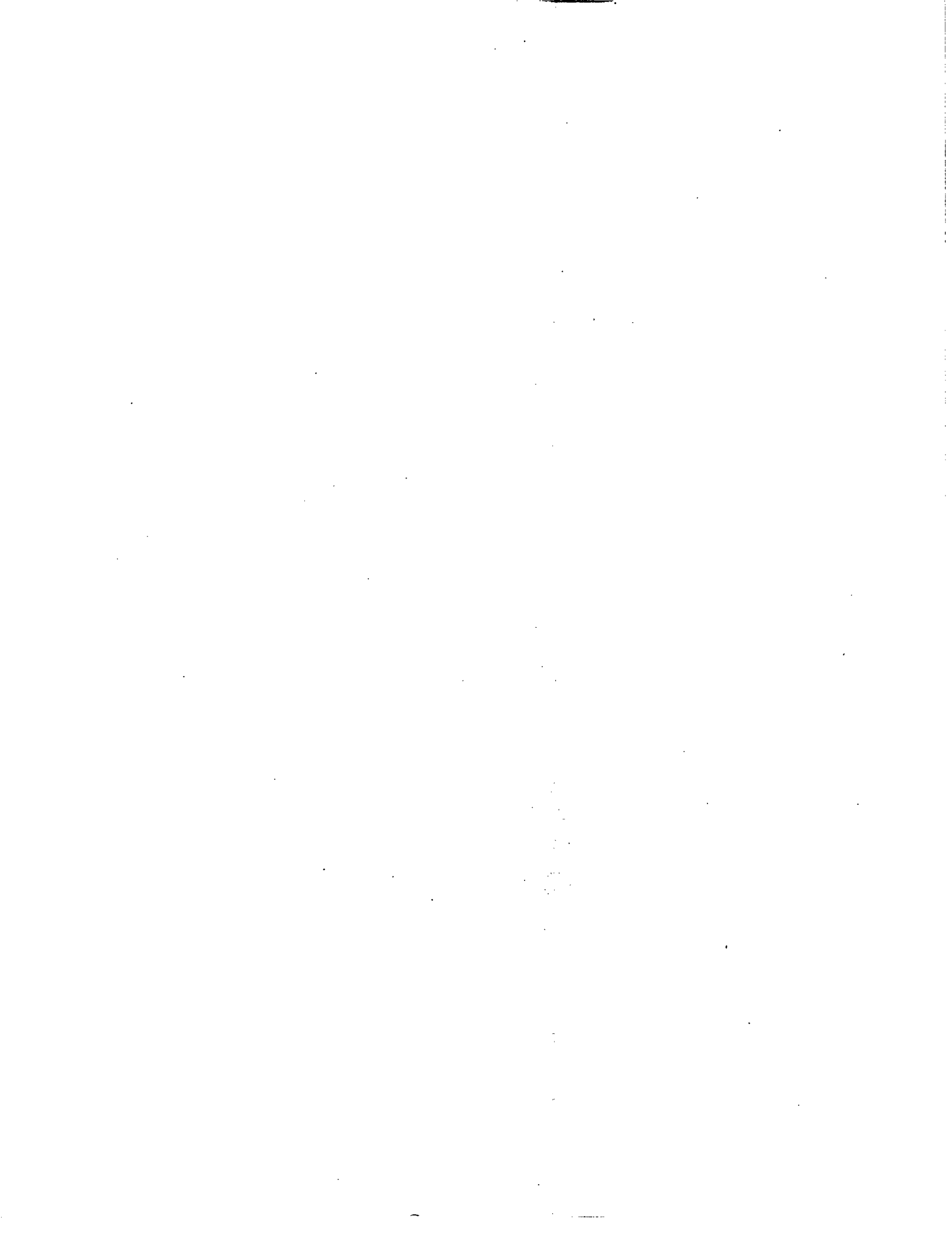

Fig. D-4.1. (a) Results of Profilometry, (b) Radiography, (c) Axial Fuel Mass Distribution and Axial Free Gas Volume Distribution for Fuel Rod #H17T



***APPENDIX D-5.***

***Initial Individual Characteristics for Fuel Rod #H18T***

## #H18T

Initial Individual Characteristics of Refabricated Fuel Rods  
(Fresh fuel, Preirradiated Cladding)

Table D-5.1. Individual Initial Characteristics for Fuel Rod #H18T (measured)

Axial coordinate from lower end of fuel rod (mm)	Cladding outer diameter (mm)			Fuel stack average diameter (mm)*	Fuel mass (g)*	Linear fuel mass (g/cm)*	Free gas volume (mm <sup>3</sup> )* <sup>3)</sup>
	0°	90°	average				
5	-	-	-	-	0.0	0.0	8.8
10	-	-	-	-	0.0	0.0	98.9
15	-	-	-	-	0.0	0.0	216.9
20	-	-	-	-	0.0	0.0	183.6
25 <sup>1)</sup>	9.116	9.118	9.12	7.56	1.16	4.16	101.4
30	9.106	9.119	9.11	7.56	2.08	4.16	36.9
35	9.096	9.128	9.11	7.56	2.09	4.18	36.1
40	9.092	9.123	9.11	7.56	2.13	4.25	32.5
45	9.112	9.114	9.11	7.57	2.13	4.25	32.5
50	9.116	9.123	9.12	7.57	2.10	4.19	35.4
55	9.102	9.116	9.11	7.57	2.09	4.17	36.2
60	9.114	9.111	9.11	7.56	2.08	4.17	36.5
65	9.112	9.110	9.11	7.56	2.08	4.16	36.9
70	9.111	9.115	9.11	7.56	2.08	4.16	36.7
75	9.104	9.119	9.11	7.56	2.11	4.22	34.1
80	9.093	9.127	9.11	7.56	2.11	4.22	34.1
85	9.087	9.120	9.10	7.56	2.09	4.18	35.9
90	9.085	9.113	9.10	7.56	2.08	4.17	36.5
95	9.089	9.111	9.10	7.56	2.08	4.17	36.5
100	9.091	9.102	9.10	7.56	2.08	4.17	36.5
105	9.098	9.110	9.10	7.56	2.08	4.17	36.5
110	9.101	9.117	9.11	7.56	2.10	4.21	34.7
115	9.099	9.102	9.10	7.57	2.10	4.21	34.6
120	9.105	9.098	9.10	7.57	2.10	4.20	35.1
125	9.100	9.095	9.10	7.57	2.10	4.19	35.4
130	9.092	9.099	9.10	7.57	2.09	4.18	35.7
135	9.095	9.101	9.10	7.57	2.09	4.17	36.3
140	9.096	9.092	9.09	7.57	2.09	4.17	36.3
145	9.099	9.100	9.10	7.57	2.09	4.17	36.3
150	9.094	9.106	9.10	7.57	2.09	4.17	36.3
155	9.103	9.099	9.10	7.57	2.08	4.15	37.3
160	9.105	9.094	9.10	7.57	2.06	4.12	38.8
165 <sup>2)</sup>	9.098	9.096	9.10	7.57	1.32	4.14	108.5
170	-	-	-	-	0.0	0.0	234.0
175	-	-	-	-	0.0	0.0	234.0
180	-	-	-	-	0.0	0.0	114.8

\* These numerical values of characteristics are presented as average values at the length interval equal to the axial coordinate  $\pm 2.5$  mm<sup>1)</sup> Initial coordinate of fuel is 24.7 mm<sup>2)</sup> End point coordinate of fuel is 165.7 mm<sup>3)</sup> Free gas volume for coordinates 185-295 mm is presented in Table D.3



#H18T

Initial Individual Characteristics of Refabricated Fuel Rods.  
(Fresh fuel, Preirradiated cladding)

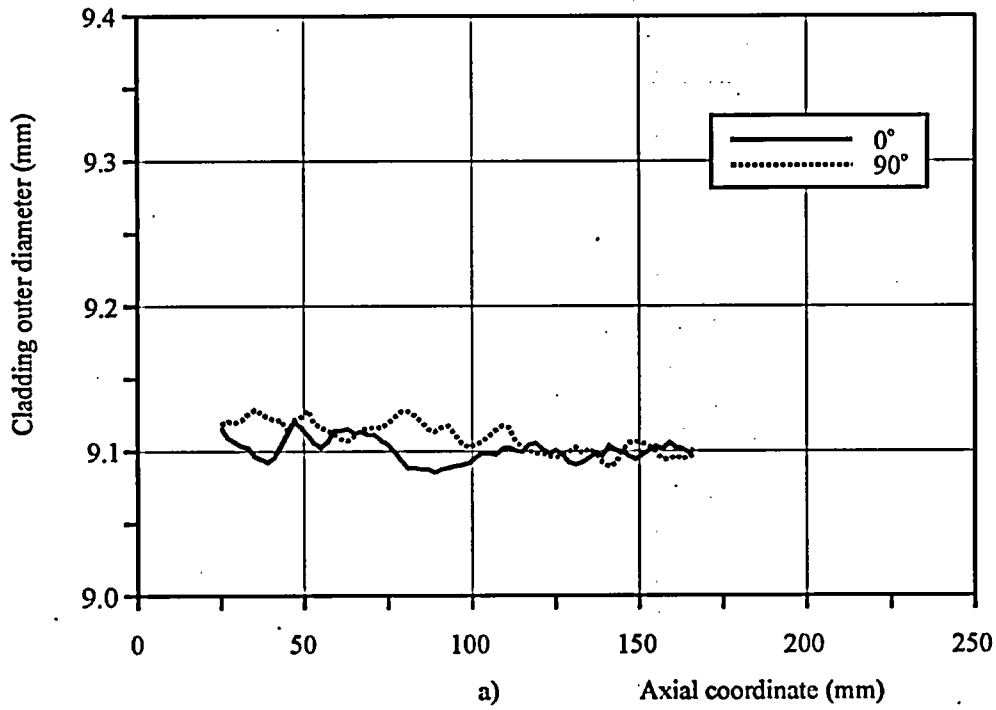

b)

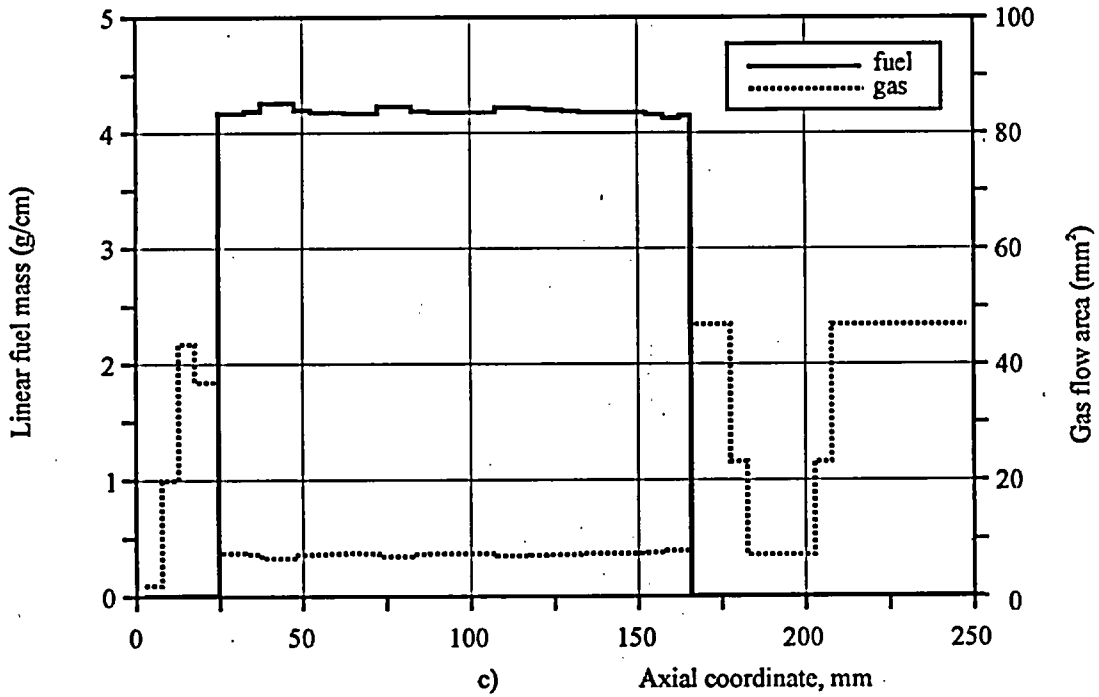

Fig. D-5.1. (a) Results of Profilometry, (b) Radiography, (c) Axial Fuel Mass Distribution and Axial Free Gas Volume Distribution for Fuel Rod #H18T



***APPENDIX D-6.***

***Initial Individual Characteristics for Fuel Rod #B19T***

# #B19T

Initial Individual Characteristics of Refabricated Fuel Rods  
(Fresh fuel, Preirradiated cladding)

Table D-6.1. Individual Initial Characteristics for Fuel Rod #B19T (measured)

Axial coordinate from lower end of fuel rod (mm)	Cladding outer diameter (mm)			Fuel stack average diameter (mm)*	Fuel mass (g)*	Linear fuel mass (g/cm)*	Free gas volume (mm <sup>3</sup> )* <sup>3)</sup>
	0°	90°	average				
5	-	-	-	-	0.0	0.0	8.8
10	-	-	-	-	0.0	0.0	78.7
15	-	-	-	-	0.0	0.0	183.6
20 <sup>1)</sup>	9.099	9.108	9.10	7.57	1.30	4.18	92.0
25	9.103	9.106	9.10	7.57	2.09	4.18	35.9
30	9.101	9.107	9.10	7.57	2.09	4.18	35.7
35	9.089	9.111	9.10	7.56	2.10	4.19	35.3
40	9.092	9.110	9.10	7.56	2.10	4.19	35.3
45	9.104	9.106	9.11	7.56	2.08	4.16	36.7
50	9.104	9.104	9.10	7.56	2.08	4.16	36.9
55	9.099	9.108	9.10	7.56	2.08	4.16	36.9
60	9.093	9.111	9.10	7.56	2.08	4.16	36.9
65	9.094	9.114	9.10	7.56	2.09	4.17	36.4
70	9.095	9.110	9.10	7.56	2.11	4.22	34.1
75	9.087	9.123	9.11	7.56	2.11	4.22	34.1
80	9.086	9.122	9.10	7.56	2.07	4.15	37.4
85	9.091	9.121	9.11	7.56	2.07	4.13	38.1
90	9.100	9.112	9.11	7.56	2.08	4.16	36.9
95	9.098	9.108	9.10	7.56	2.10	4.19	35.4
100	9.092	9.123	9.11	7.56	2.10	4.19	35.4
105	9.085	9.136	9.11	7.57	2.10	4.19	35.3
110	9.089	9.139	9.11	7.57	2.10	4.19	35.3
115	9.092	9.139	9.12	7.56	2.11	4.23	33.6
120	9.089	9.135	9.11	7.56	2.12	4.24	33.1
125	9.094	9.144	9.12	7.56	2.11	4.22	34.3
130	9.085	9.141	9.11	7.56	2.09	4.18	35.7
135	9.098	9.124	9.11	7.56	2.09	4.18	35.8
140	9.100	9.115	9.11	7.56	2.08	4.16	37.1
145	9.106	9.123	9.11	7.56	2.08	4.16	37.1
150	9.113	9.130	9.12	7.56	2.08	4.17	36.6
155	9.110	9.130	9.12	7.56	2.09	4.18	36.0
160 <sup>2)</sup>	9.117	9.138	9.13	7.56	1.21	4.17	119.4
165	-	-	-	-	0.0	0.0	234.0
170	-	-	-	-	0.0	0.0	234.0
175	-	-	-	-	0.0	0.0	234.0
180	-	-	-	-	0.0	0.0	114.8

\* These numerical values of characteristics are presented as average values at the length interval equal to the axial coordinate  $\pm 2.5$  mm

<sup>1)</sup> Initial coordinate of fuel is 19.4 mm

<sup>2)</sup> End point coordinate of fuel is 160.4 mm

<sup>3)</sup> Free gas volume for coordinates 185-295 mm is presented in Table D.3

#B19T

Initial Individual Characteristics of Refabricated Fuel Rods  
(Fresh fuel/Preirradiated cladding)

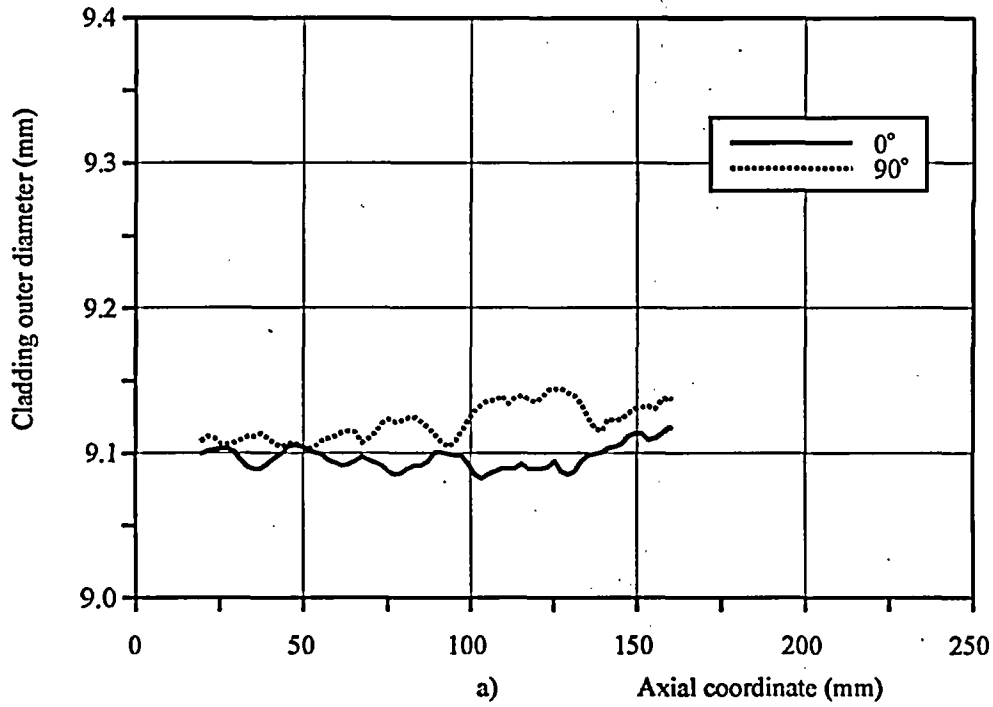

b)

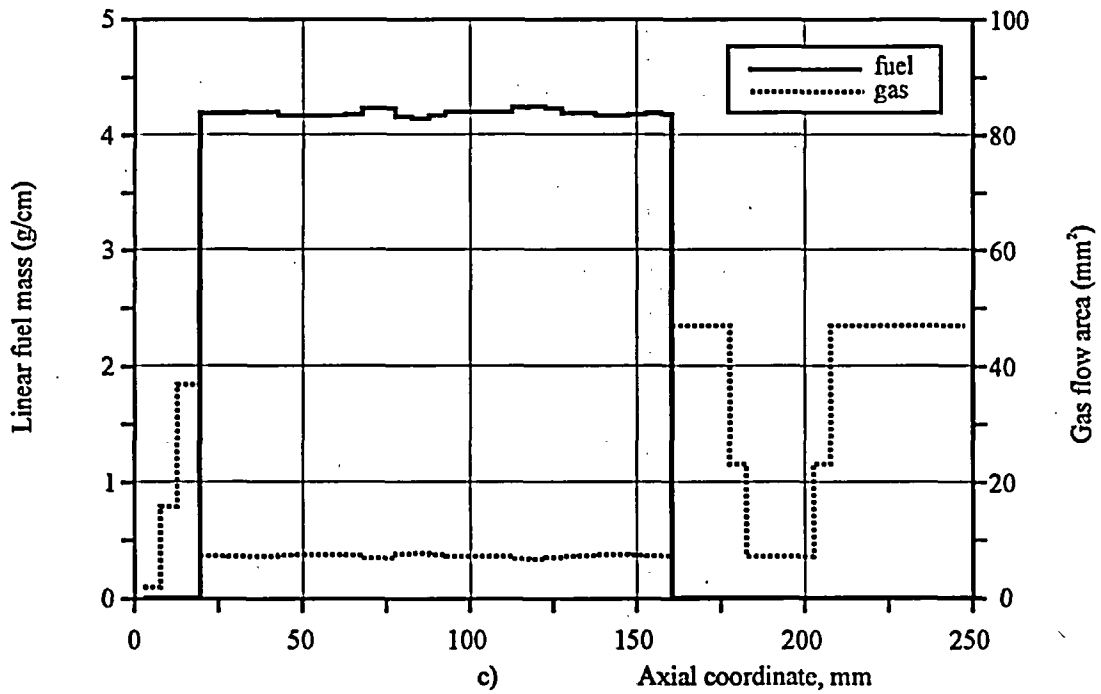

Fig. D-6.1. (a) Results of Profilometry, (b) Radiography, (c) Axial Fuel Mass Distribution and Axial Free Gas Volume Distribution for Fuel Rod #B19T



***APPENDIX D-7.***

***Initial Individual Characteristics for Fuel Rod #B20T***

# #B20T

Initial Individual Characteristics of Refabricated Fuel Rods  
(Fresh fuel, Preirradiated cladding)

Table D-7.1. Individual Initial Characteristics for Fuel Rod #B20T (measured)

Axial coordinate from lower end of fuel rod (mm)	Cladding outer diameter (mm)			Fuel stack average diameter (mm)*	Fuel mass (g)*	Linear fuel mass (g/cm)*	Free gas volume (mm <sup>3</sup> )* <sup>3)</sup>
	0°	90°	average				
5	-	-	-	-	0.0	0.0	8.8
10	-	-	-	-	0.0	0.0	98.9
15	-	-	-	-	0.0	0.0	199.7
20	-	-	-	-	0.0	0.0	183.6
25 <sup>1)</sup>	9.121	9.120	9.12	7.56	1.88	4.18	50.6
30	9.122	9.114	9.12	7.56	2.09	4.18	35.8
35	9.112	9.110	9.11	7.56	2.09	4.19	35.5
40	9.110	9.113	9.11	7.56	2.10	4.20	35.2
45	9.109	9.107	9.11	7.56	2.09	4.18	36.0
50	9.113	9.104	9.11	7.56	2.06	4.13	38.5
55	9.125	9.113	9.12	7.56	2.06	4.13	38.5
60	9.128	9.118	9.12	7.57	2.10	4.20	35.0
65	9.132	9.125	9.13	7.57	2.11	4.22	34.2
70	9.132	9.140	9.14	7.57	2.09	4.17	36.2
75	9.131	9.136	9.13	7.56	2.06	4.12	38.9
80	9.137	9.116	9.13	7.56	2.06	4.12	38.9
85	9.131	9.120	9.13	7.56	2.08	4.15	37.2
90	9.127	9.121	9.12	7.56	2.08	4.15	37.2
95	9.130	9.117	9.12	7.56	2.09	4.18	35.7
100	9.134	9.123	9.13	7.56	2.10	4.20	35.0
105	9.134	9.119	9.13	7.56	2.10	4.19	35.4
110	9.129	9.123	9.13	7.56	2.08	4.17	36.4
115	9.130	9.120	9.13	7.56	2.08	4.17	36.4
120	9.137	9.110	9.12	7.57	2.08	4.17	36.5
125	9.138	9.121	9.13	7.57	2.08	4.17	36.5
130	9.122	9.114	9.12	7.57	2.08	4.15	37.2
135	9.134	9.113	9.12	7.57	2.07	4.14	37.8
140	9.134	9.117	9.13	7.57	2.07	4.13	38.2
145	9.134	9.104	9.12	7.57	2.04	4.08	40.9
150	9.132	9.102	9.12	7.57	2.04	4.08	40.9
155	9.117	9.120	9.12	7.57	2.06	4.13	38.4
160	9.121	9.120	9.12	7.57	2.10	4.20	35.0
165 <sup>2)</sup>	9.118	9.116	9.12	7.57	1.45	4.15	96.5
170	-	-	-	-	0.0	0.0	234.0
175	-	-	-	-	0.0	0.0	234.0
180	-	-	-	-	0.0	0.0	114.8

\* These numerical values of characteristics are presented as average values at the length interval equal to the axial coordinate  $\pm 2.5$  mm

<sup>1)</sup> Initial coordinate of fuel is 23.0 mm

<sup>2)</sup> End point coordinate of fuel is 166.0 mm

<sup>3)</sup> Free gas volume for coordinates 185-295 mm is presented in Table D.3



#B20T

Initial Individual Characteristics of Refabricated Fuel Rods  
(Fresh fuel, Preirradiated cladding)

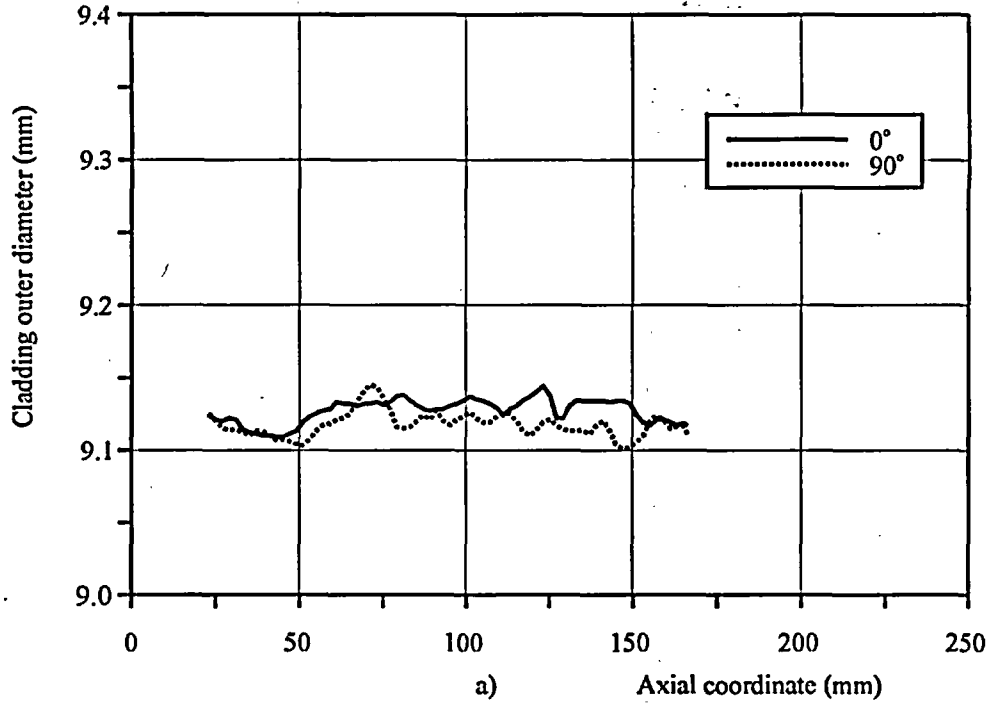

b)

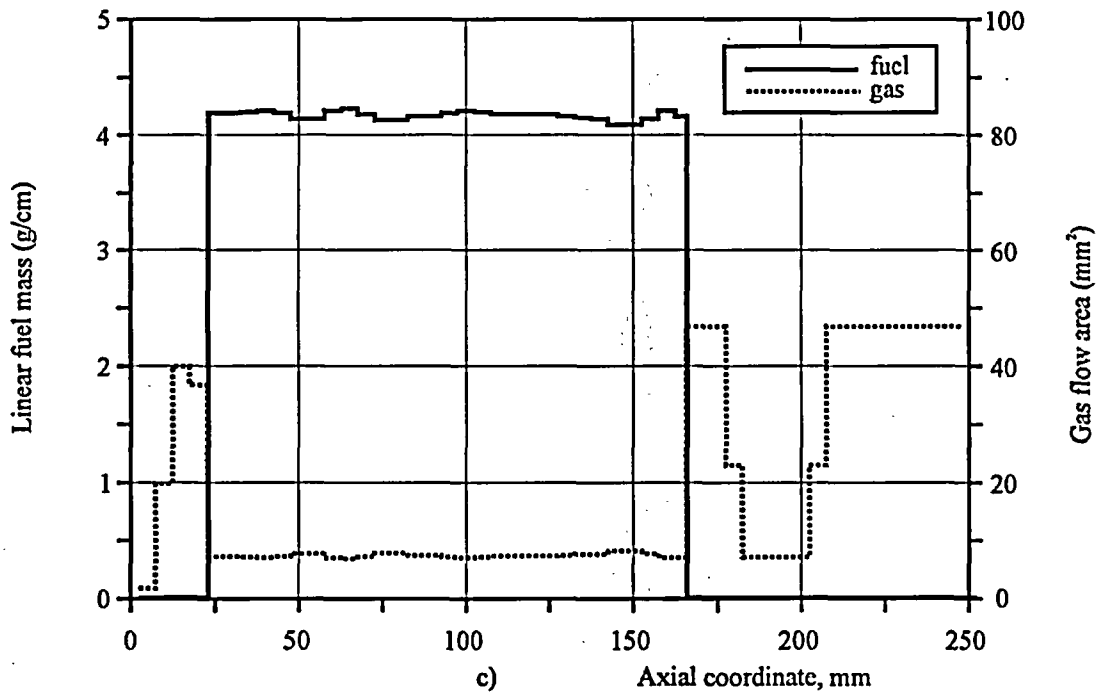
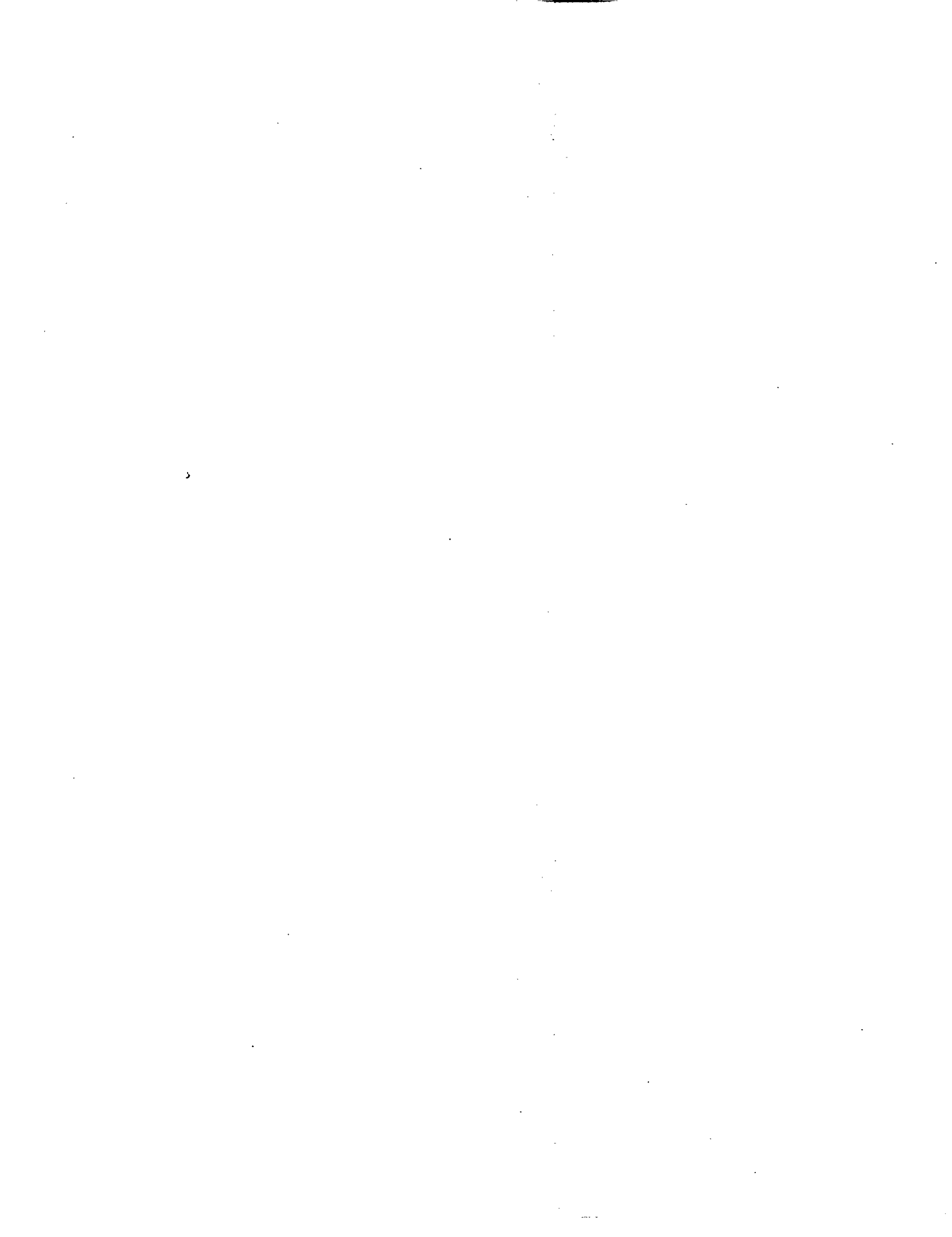

Fig. D-7.1. (a) Results of Profilometry, (b) Radiography, (c) Axial Fuel Mass Distribution and Axial Free Gas Volume Distribution for Fuel Rod #B20T



***APPENDIX D-8.***

***Initial Individual Characteristics for Fuel Rod #B21T***

## #B21T

Initial Individual Characteristics of Refabricated Fuel Rods  
(Fresh fuel, Preirradiated cladding)

Table D-8.1. Individual Initial Characteristics for Fuel Rod #B21T (measured)

Axial coordinate from lower end of fuel rod (mm)	Cladding outer diameter (mm)			Fuel stack average diameter (mm)*	Fuel mass (g)*	Linear fuel mass (g/cm)*	Free gas volume (mm <sup>3</sup> )* <sup>3)</sup>
	0°	90°	average				
5	-	-	-	-	0.0	0.0	8.8
10 <sup>1)</sup>	9.107	9.107	9.11	7.57	0.83	4.16	20.0
15	9.110	9.108	9.11	7.57	2.08	4.16	36.7
20	9.108	9.108	9.11	7.57	2.08	4.17	36.6
25	9.113	9.116	9.11	7.57	2.09	4.18	35.8
30	9.105	9.110	9.11	7.57	2.09	4.18	35.8
35	9.112	9.103	9.11	7.56	2.07	4.14	37.8
40	9.120	9.099	9.11	7.56	2.06	4.13	38.5
45	9.110	9.119	9.11	7.56	2.08	4.15	37.2
50	9.110	9.122	9.12	7.56	2.10	4.21	34.6
55	9.111	9.115	9.11	7.56	2.10	4.21	34.6
60	9.105	9.112	9.11	7.56	2.08	4.16	36.8
65	9.111	9.112	9.11	7.56	2.08	4.16	36.8
70	9.103	9.115	9.11	7.56	2.09	4.18	35.8
75	9.096	9.108	9.10	7.56	2.10	4.20	35.2
80	9.095	9.101	9.10	7.56	2.10	4.20	35.2
85	9.103	9.099	9.10	7.56	2.10	4.20	35.2
90	9.111	9.096	9.10	7.56	2.10	4.20	35.2
95	9.109	9.104	9.11	7.56	2.09	4.18	36.1
100	9.106	9.113	9.11	7.56	2.09	4.17	36.3
105	9.120	9.109	9.11	7.56	2.08	4.17	36.5
110	9.121	9.109	9.12	7.56	2.08	4.16	36.8
115	9.107	9.115	9.11	7.56	2.08	4.16	36.9
120	9.107	9.117	9.11	7.56	2.07	4.14	38.0
125	9.113	9.108	9.11	7.56	2.07	4.14	38.0
130	9.119	9.106	9.11	7.56	2.06	4.12	38.8
135	9.125	9.110	9.12	7.56	2.06	4.11	39.1
140	9.109	9.112	9.11	7.56	2.06	4.13	38.5
145	9.107	9.112	9.11	7.56	2.08	4.16	37.0
150 <sup>2)</sup>	9.105	9.106	9.11	7.56	2.09	4.19	35.5
155	-	-	-	-	0.0	0.0	234.0
160	-	-	-	-	0.0	0.0	234.0
165	-	-	-	-	0.0	0.0	234.0
170	-	-	-	-	0.0	0.0	234.0
175	-	-	-	-	0.0	0.0	234.0
180	-	-	-	-	0.0	0.0	114.8

\* These numerical values of characteristics are presented as average values at the length interval equal to the axial coordinate  $\pm 2.5$  mm<sup>1)</sup> Initial coordinate of fuel is 10.5 mm (in the fuel rod design scheme absent the fixing ring)<sup>2)</sup> End point coordinate of fuel is 152.5 mm<sup>3)</sup> Free gas volume for coordinates 185-295 mm is presented in Table D.3

#B21T

Initial Individual Characteristics of Refabricated Fuel Rods  
(Fresh fuel/Preirradiated cladding)

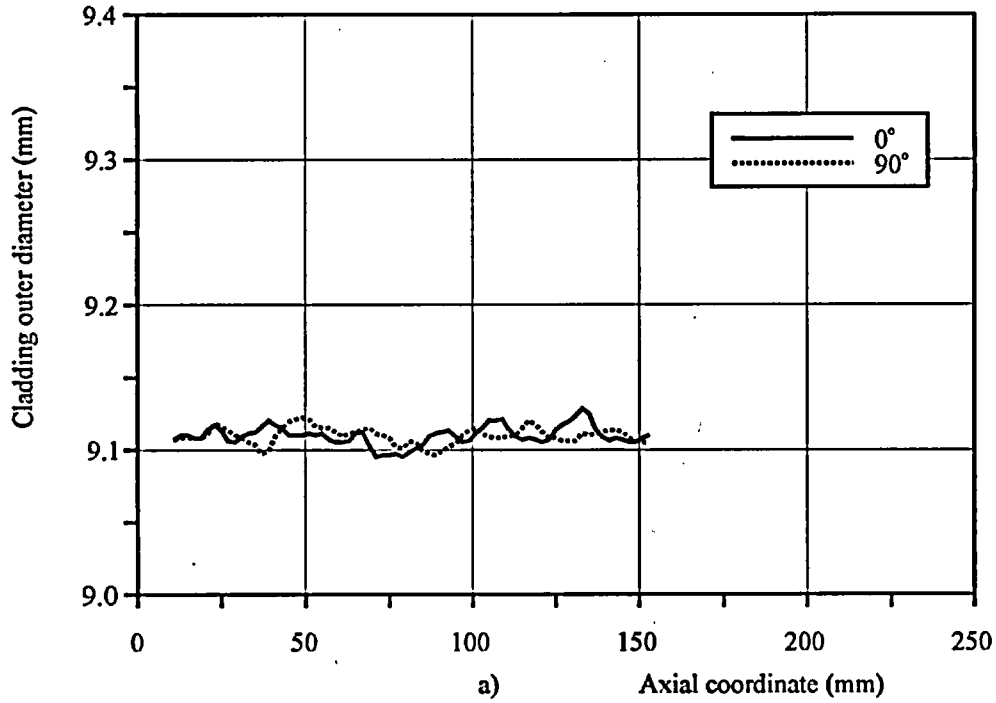

b)

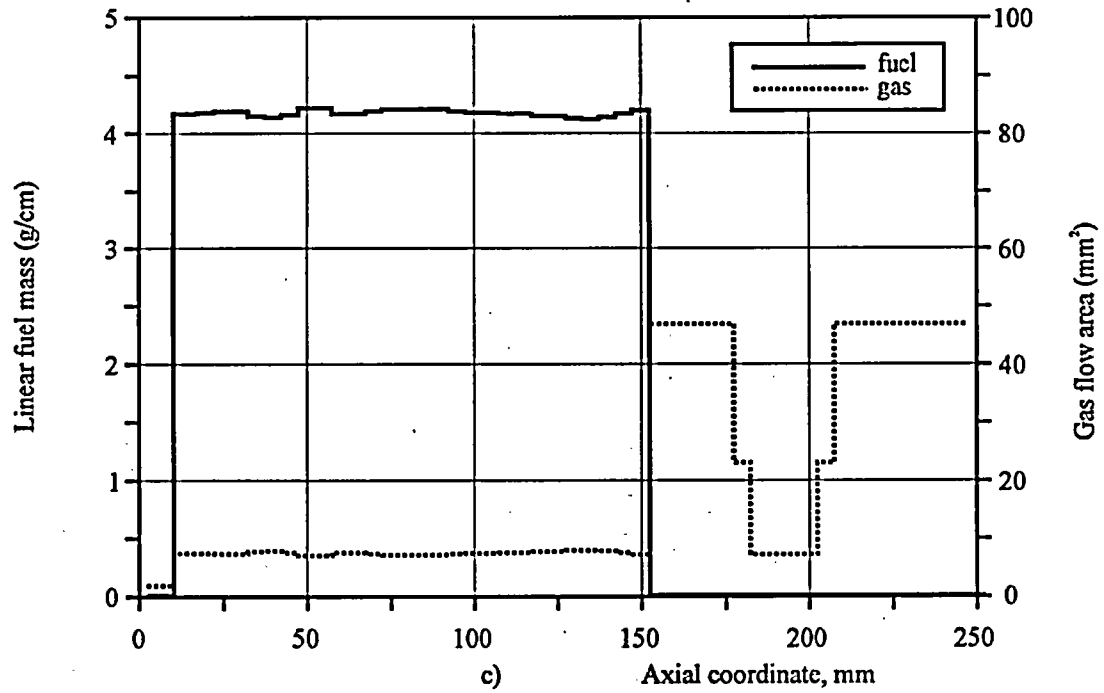

Fig. D-8.1. (a) Results of Profilometry, (b) Radiography, (c) Axial Fuel Mass Distribution and Axial Free Gas Volume Distribution for Fuel Rod #B21T



***APPENDIX D-9.***

***Initial Individual Characteristics for Fuel Rod #B22T***

# #B22T

Initial Individual Characteristics of Refabricated Fuel Rods  
(Fresh fuel, Preirradiated cladding)

Table D-9.1. Individual Initial Characteristics for Fuel Rod #B22T (measured)

Axial coordinate from lower end of fuel rod (mm)	Cladding outer diameter (mm)			Fuel stack average diameter (mm)*	Fuel mass (g)*	Linear fuel mass (g/cm)*	Free gas volume (mm <sup>3</sup> )* <sup>3)</sup>
	0°	90°	average				
5	-	-	-	-	0.0	0.0	8.8
10 <sup>1)</sup>	9.096	9.109	9.10	7.56	0.83	4.17	19.8
15	9.098	9.111	9.10	7.56	2.09	4.17	36.2
20	9.101	9.112	9.11	7.56	2.09	4.17	36.3
25	9.107	9.102	9.10	7.56	2.07	4.14	38.1
30	9.105	9.105	9.11	7.56	2.07	4.14	38.1
35	9.105	9.117	9.11	7.56	2.07	4.15	37.4
40	9.117	9.114	9.12	7.56	2.08	4.16	37.0
45	9.120	9.110	9.12	7.56	2.08	4.16	36.7
50	9.124	9.109	9.12	7.57	2.09	4.17	36.2
55	9.119	9.098	9.11	7.57	2.09	4.17	36.2
60	9.105	9.107	9.11	7.57	2.08	4.17	36.5
65	9.103	9.111	9.11	7.57	2.08	4.17	36.5
70	9.103	9.104	9.10	7.56	2.08	4.15	37.3
75	9.104	9.118	9.11	7.55	2.07	4.14	37.7
80	9.105	9.118	9.11	7.55	2.07	4.14	37.8
85	9.117	9.117	9.12	7.56	2.07	4.13	38.2
90	9.119	9.116	9.12	7.56	2.07	4.13	38.2
95	9.121	9.103	9.11	7.57	2.08	4.15	37.3
100	9.116	9.103	9.11	7.57	2.08	4.16	36.9
105	9.100	9.103	9.10	7.57	2.08	4.15	37.2
110	9.103	9.105	9.10	7.57	2.07	4.15	37.6
115	9.104	9.107	9.11	7.57	2.07	4.15	37.6
120	9.107	9.102	9.10	7.57	2.08	4.16	37.0
125	9.106	9.096	9.10	7.57	2.08	4.16	37.0
130	9.105	9.098	9.10	7.57	2.07	4.14	37.8
135	9.117	9.098	9.11	7.57	2.07	4.13	38.2
140	9.119	9.093	9.11	7.56	2.07	4.13	38.2
145	9.114	9.089	9.10	7.56	2.07	4.13	38.2
150 <sup>2)</sup>	9.115	9.089	9.10	7.56	2.07	4.13	38.2
155	-	-	-	-	0.0	0.0	234.0
160	-	-	-	-	0.0	0.0	234.0
165	-	-	-	-	0.0	0.0	234.0
170	-	-	-	-	0.0	0.0	234.0
175	-	-	-	-	0.0	0.0	234.0
180	-	-	-	-	0.0	0.0	114.8

\* These numerical values of characteristics are presented as average values at the length interval equal to the axial coordinate  $\pm 2.5$  mm

<sup>1)</sup> Initial coordinate of fuel is 10.5 mm (in the fuel rod design scheme absent the fixing ring)

<sup>2)</sup> End point coordinate of fuel is 152.5 mm

<sup>3)</sup> Free gas volume for coordinates 185-295 mm is presented in Table D.3



# #B22T

Initial Individual Characteristics of Refabricated Fuel Rods  
(Fresh fuel, Preirradiated cladding)

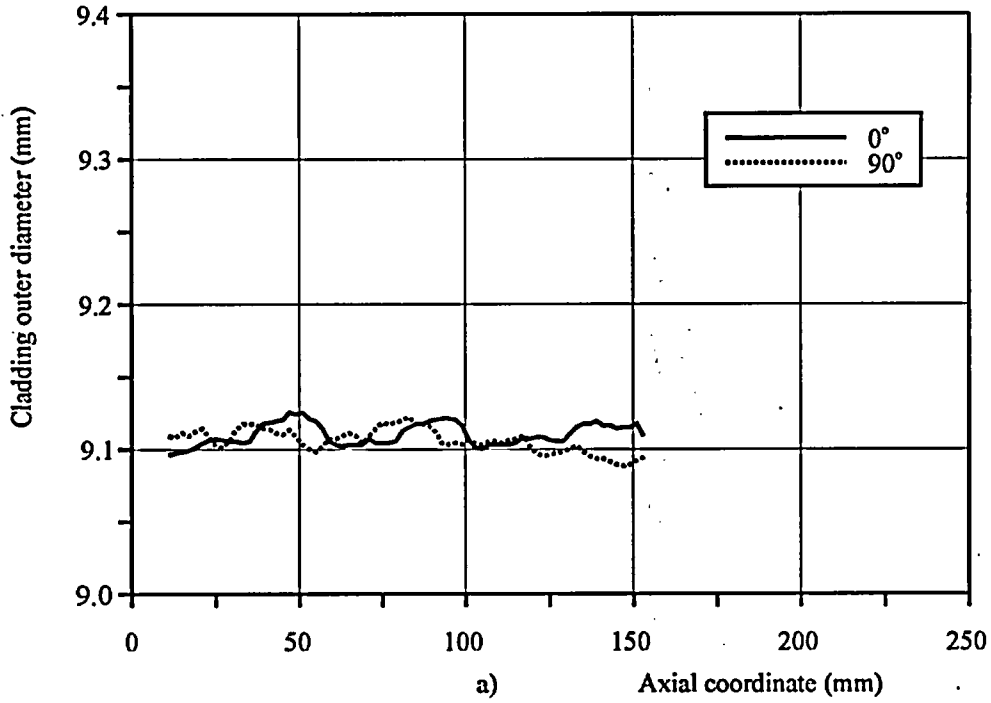

b)

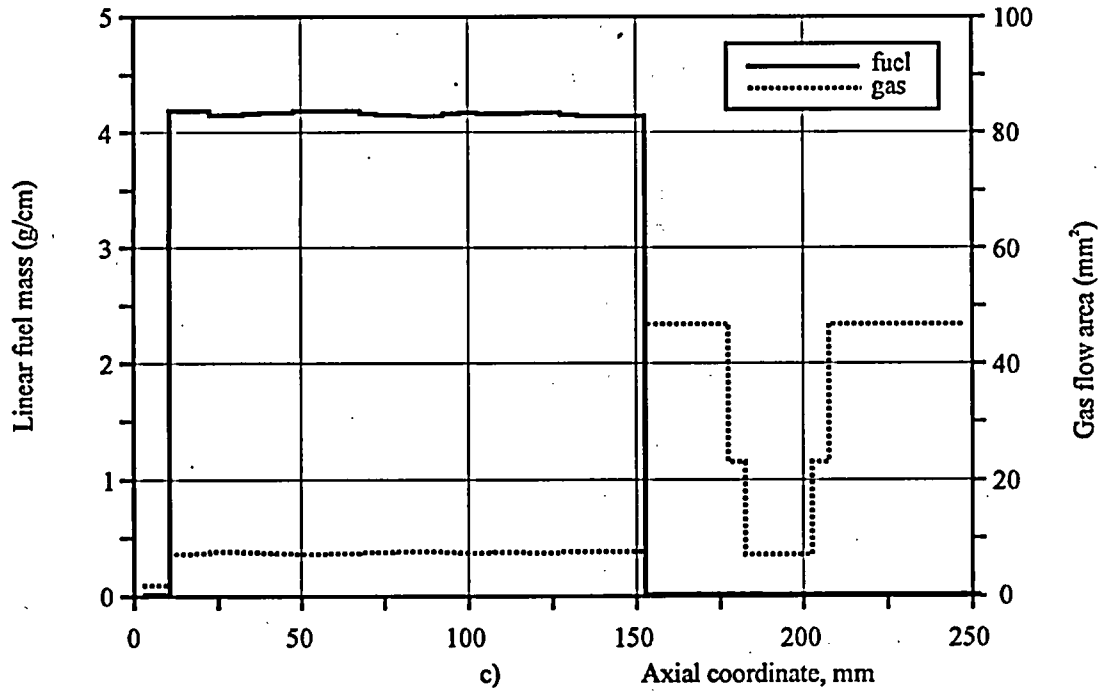

Fig. D-9.1. (a) Results of Profilometry, (b) Radiography, (c) Axial Fuel Mass Distribution and Axial Free Gas Volume Distribution for Fuel Rod #B22T



***APPENDIX D-10.***

***Initial Individual Characteristics for Fuel Rod #B23II***

# #B23T

Initial Individual Characteristics of Refabricated Fuel Rods  
(Fresh fuel, Preirradiated cladding)

Table D-10.1. Individual Initial Characteristics for Fuel Rod #B23T (measured)

Axial coordinate from lower end of fuel rod (mm)	Cladding outer diameter (mm)			Fuel stack average diameter (mm)*	Fuel mass (g)*	Linear fuel mass (g/cm)*	Free gas volume (mm <sup>3</sup> )* <sup>3)</sup>
	0°	90°	average				
5	-	-	-	-	0.0	0.0	8.8
10	-	-	-	-	0.0	0.0	98.9
15	-	-	-	-	0.0	0.0	228.0
20	-	-	-	-	0.0	0.0	183.6
25 <sup>1)</sup>	9.096	9.142	9.12	7.56	0.71	4.17	133.6
30	9.099	9.132	9.12	7.56	2.08	4.17	36.6
35	9.097	9.114	9.11	7.56	2.08	4.17	36.6
40	9.098	9.119	9.11	7.56	2.09	4.18	36.0
45	9.097	9.136	9.12	7.56	2.09	4.18	36.0
50	9.101	9.140	9.12	7.56	2.08	4.17	36.4
55	9.109	9.130	9.12	7.56	2.08	4.16	36.9
60	9.110	9.138	9.12	7.56	2.08	4.16	36.8
65	9.105	9.142	9.12	7.56	2.09	4.17	36.3
70	9.111	9.134	9.12	7.56	2.09	4.17	36.3
75	9.110	9.134	9.12	7.56	2.10	4.19	35.4
80	9.112	9.120	9.12	7.56	2.10	4.19	35.3
85	9.113	9.105	9.11	7.56	2.10	4.20	35.2
90	9.112	9.106	9.11	7.56	2.10	4.20	35.1
95	9.104	9.110	9.11	7.56	2.09	4.19	35.5
100	9.101	9.106	9.10	7.57	2.07	4.13	38.1
105	9.099	9.120	9.11	7.57	2.07	4.13	38.1
110	9.093	9.121	9.11	7.57	2.09	4.17	36.2
115	9.090	9.126	9.11	7.57	2.09	4.19	35.5
120	9.093	9.130	9.11	7.56	2.09	4.18	35.9
125	9.104	9.123	9.11	7.56	2.08	4.17	36.6
130	9.110	9.128	9.12	7.56	2.09	4.17	36.3
135	9.111	9.121	9.12	7.56	2.11	4.22	34.1
140	9.122	9.121	9.12	7.56	2.11	4.22	34.1
145	9.116	9.118	9.12	7.56	2.12	4.23	33.5
150	9.115	9.125	9.12	7.56	2.12	4.23	33.4
155	9.113	9.138	9.13	7.56	2.09	4.19	35.6
160	9.106	9.138	9.12	7.56	2.05	4.10	39.9
165 <sup>2)</sup>	9.109	9.125	9.12	7.56	1.78	4.14	65.1
170	-	-	-	-	0.0	0.0	234.0
175	-	-	-	-	0.0	0.0	234.0
180	-	-	-	-	0.0	0.0	114.8

\* These numerical values of characteristics are presented as average values at the length interval equal to the axial coordinate  $\pm 2.5$  mm

<sup>1)</sup> Initial coordinate of fuel is 25.8 mm

<sup>2)</sup> End point coordinate of fuel is 166.8 mm

<sup>3)</sup> Free gas volume for coordinates 185-295 mm is presented in Table D.3

#B23T

Initial Individual Characteristics of Refabricated Fuel Rods  
(Fresh fuel, Preirradiated cladding)

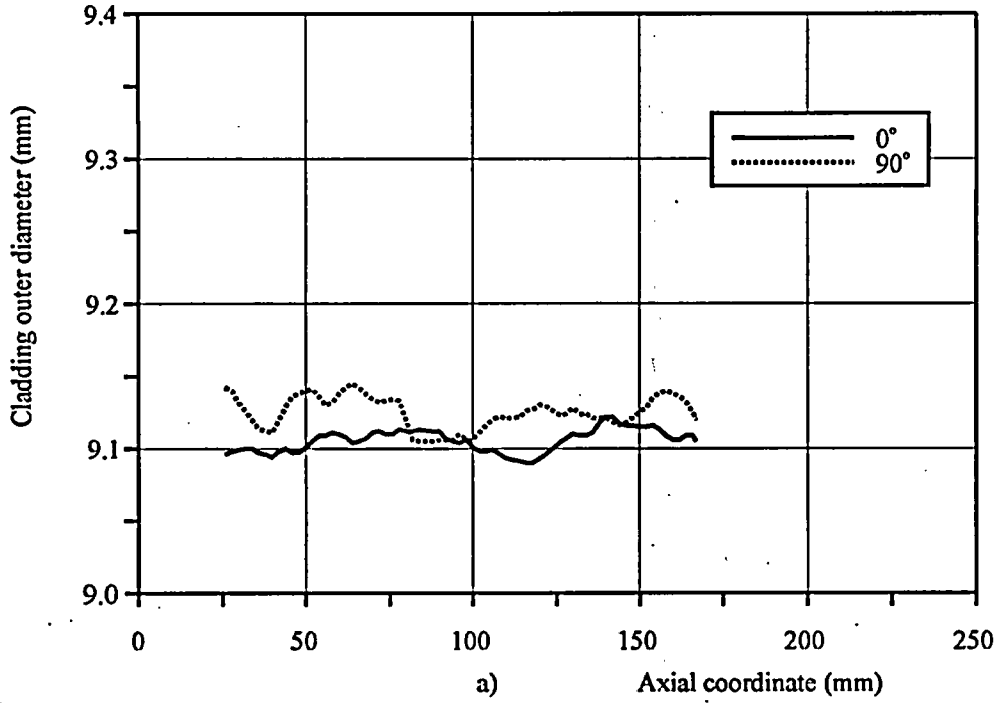

b)

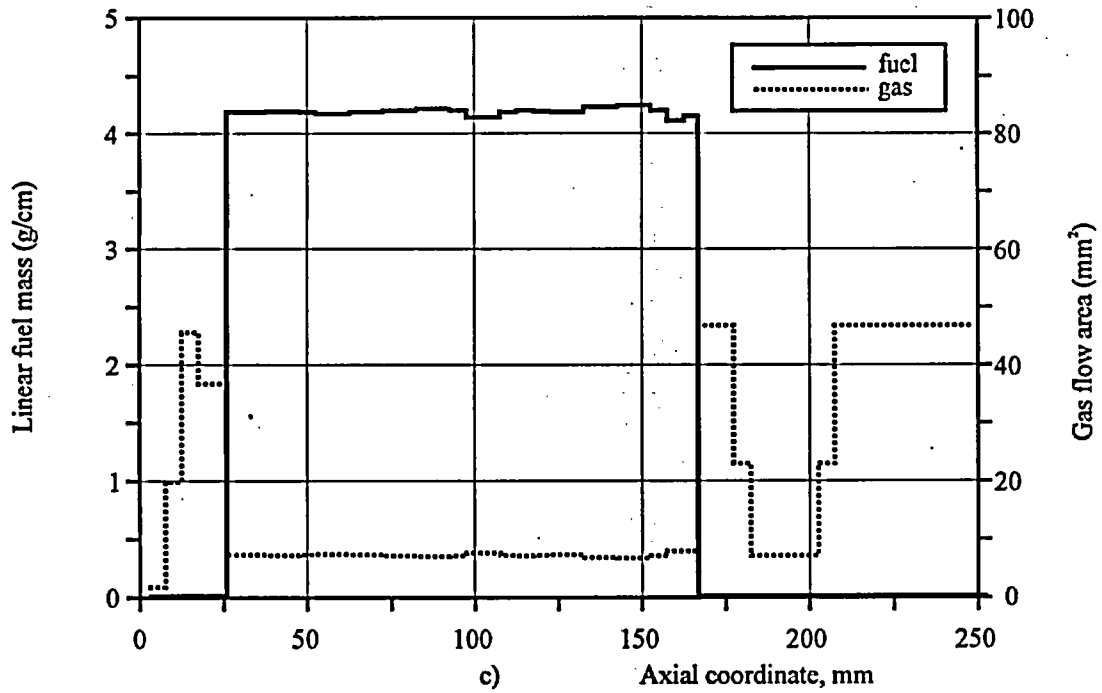

Fig. D-10.1. (a) Results of Profilometry, (b) Radiography, (c) Axial Fuel Mass Distribution and Axial Free Gas Volume Distribution for Fuel Rod #B23T



**APPENDIX E.**

**Initial Characteristics of Fresh Fuel Rods**

**Table E.1. Initial Characteristics Fresh Fuel Rods before IGR Reactor Tests. Representative values.**

Characteristic	Unit	Value
<b>1. Fuel (UO<sub>2</sub>)</b>		
1.1. Isotopic composition:		
U <sup>235</sup> , U <sup>238</sup>	% by weight	see Table E.2
U <sup>236</sup>	% by weight	0.023
U <sup>234</sup>	% by weight	0.057
1.2. Uranium impurity	% by weight	0.152
1.3. Enrichment	%	see Table E.2
1.4. Oxygen coefficient	per-unit	not measured
1.5. Pellet outer diameter	mm	see Table E.2
1.6. Pellet inner diameter	mm	2.2
1.7. Pellet height	mm	9.8 – 13
1.8. Density	g/cm <sup>3</sup>	10.5 - 10.6
1.9. Grain size		not measured
1.10. Fuel shape, fuel macrostructure,	-	see Fig. E.1
<b>2. Cladding (Zr-1%Nb)</b>		
2.1. Composition:		
Zr	% by weight	98.75 - 98.95
Nb	% by weight	0.9 - 1.1
O	% by weight	< 0.1
N, C, Si, Al, Mo, Ni, Fe	% by weight	< 0.046
2.2. Cold work		Autoclaving
2.3. Outer diameter, inner diameter	mm	see Table E.2
2.4. Cladding microstructure	-	see Fig. E.1
<b>3. Fuel rod</b>		
3.1. Fuel rod design	-	see Fig. E.2
3.2. Fuel rod length	mm	300
3.3. Initial fill pressure	MPa	2.0
3.4. Gas composition:		
He	% by volume	97.57
Impurity	% by volume	2.43
3.5. Free volume	cm <sup>3</sup>	see Table E.2
3.6. Fuel-cladding gap	mm	see Table E.2



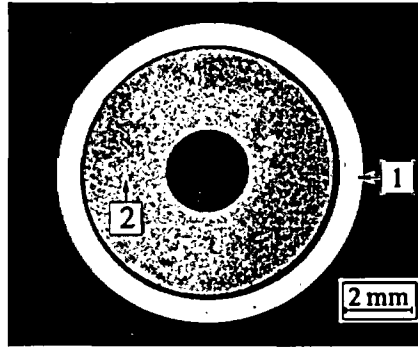

Position 1

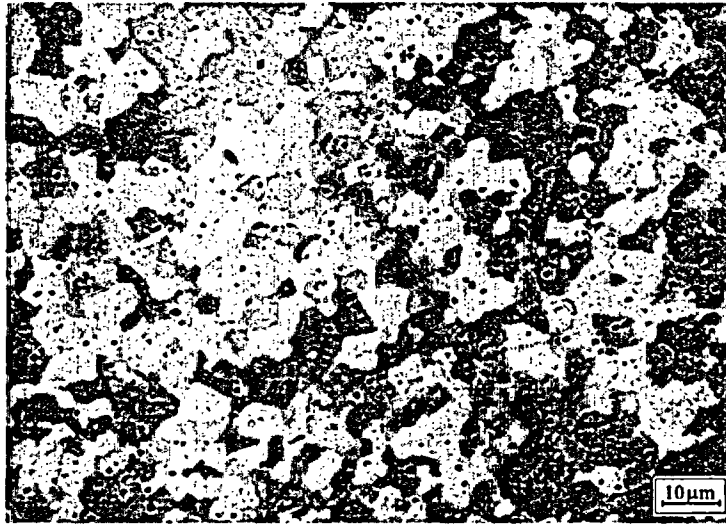

Position 2

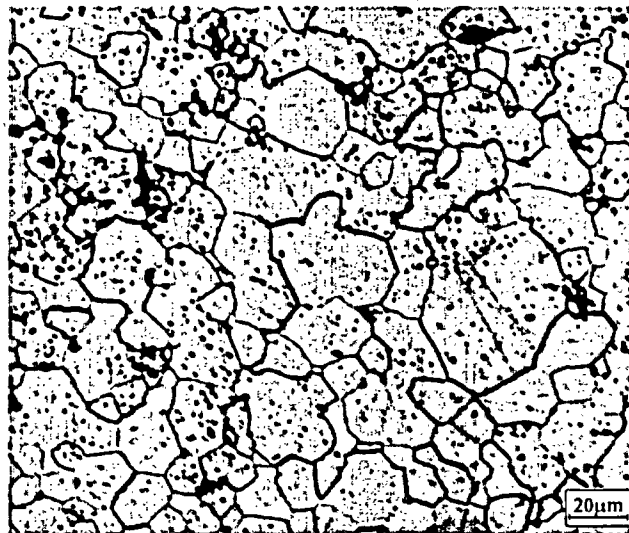

**Fig. E.1. Cross-Section Initial Appearance and Initial Cladding Microstructure by Polarized Light and Fuel Microstructure for Fresh Fuel Rods**

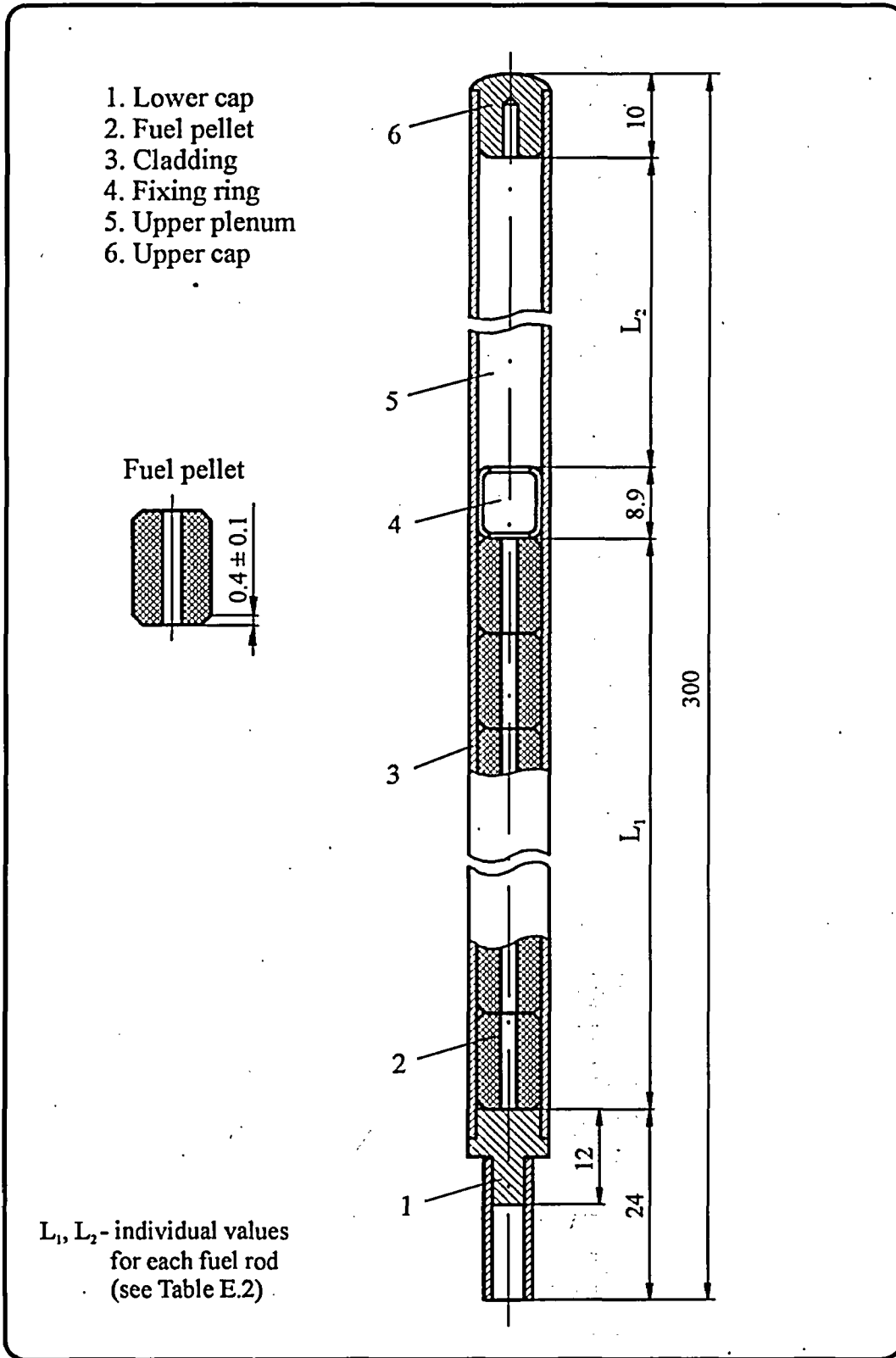

Fig. E.2. Design Scheme of Fresh Fuel Rod

Table E.2. Consolidated List of Characteristics for Fuel Rods ## H6C, B20C

Characteristic	Fuel rod number	
	H6C	B20C
1. Fuel stack length (mm)	144	142
2. Coordinates of fuel stack (mm)	24 168	24 166
3. Fuel isotopic composition:		
U <sup>235</sup> (% weight)	4.47	4.46
U <sup>238</sup> (% weight)	95.45	95.46
4. Total fuel mass (g)	62.59	59.19
5. U <sup>235</sup> mass in fuel (g)	2.46	2.32
6. Uranium isotopes mass (g)	54.99	52.00
7. Enrichment (%)	4.47	4.46
8. L <sub>1</sub> (see Fig. E.2) (mm)	144	142
9. L <sub>2</sub> (see Fig. E.2) (mm)	113.1	115.1
10. Total gas volume (cm <sup>3</sup> )	6.43	6.75
11. Average inner diameter of cladding (mm)	7.754	7.750
12. Average outer diameter of cladding (mm)	9.154	9.146
13. Average thickness of cladding (mm)	0.700	0.698
14. Average fuel pellet diameter (mm)	7.69	7.56
15. Average cladding-pellet gap (mm)	0.064	0.190

**Table E.3. Free Gas Volume in Fresh Fuel Rods before IGR Reactor Tests for Axial Coordinates 185-295 mm.**

Axial coordinate from lower end of fuel rod (mm)	Free gas volume (mm <sup>3</sup> )	
	H6C	B20C
185	468	468
195	468	468
205	468	468
215	468	468
225	468	468
235	468	468
245	468	468
255	468	468
265	468	468
275	468	468
285	468	468
295	0	0

*APPENDIX E-1*

*Initial Individual Characteristics for Fuel Rod #H6C*

## #H6C

Initial Individual Characteristics of Refabricated Fuel Rods  
(Fresh fuel, Fresh cladding)

Table E-1.1. Individual Initial Characteristics for Fuel Rod #H6C (measured)

Axial coordinate from lower end of fuel rod (mm)	Cladding inner diameter (mm)	Cladding thickness (mm)	Cladding outer diameter (mm) <sup>4)</sup>	Fuel stack average diameter (mm)*	Fuel mass (g)*	Linear fuel mass (g/cm)*	Free gas volume (mm <sup>3</sup> )* <sup>3)</sup>
5	-	-	-	0.0	0.0	0.0	0.0
10	-	-	-	0.0	0.0	0.0	0.0
15	-	-	-	0.0	0.0	0.0	0.0
20	-	-	-	0.0	0.0	0.0	0.0
25 <sup>1)</sup>	7.757	0.697	9.151	7.65	1.52	4.34	19.8
30	7.757	0.697	9.151	7.65	2.17	4.34	28.3
35	7.757	0.698	9.153	7.65	2.16	4.33	29.0
40	7.757	0.700	9.157	7.64	2.14	4.29	30.8
45	7.756	0.700	9.156	7.64	2.14	4.29	30.8
50	7.755	0.700	9.155	7.68	2.17	4.35	28.0
55	7.754	0.700	9.154	7.69	2.18	4.35	27.7
60	7.754	0.701	9.156	7.69	2.17	4.34	28.1
65	7.753	0.701	9.155	7.69	2.17	4.34	28.4
70	7.752	0.701	9.154	7.69	2.17	4.34	28.2
75	7.751	0.701	9.153	7.69	2.19	4.37	26.9
80	7.750	0.702	9.154	7.69	2.19	4.37	26.9
85	7.749	0.703	9.155	7.70	2.17	4.34	28.6
90	7.749	0.704	9.157	7.70	2.16	4.31	29.6
95	7.749	0.705	9.159	7.70	2.16	4.32	29.3
100	7.749	0.705	9.159	7.70	2.17	4.35	28.1
105	7.750	0.701	9.152	7.70	2.17	4.35	28.1
110	7.751	0.701	9.153	7.69	2.18	4.36	27.5
115	7.752	0.701	9.154	7.69	2.18	4.36	27.2
120	7.753	0.700	9.153	7.69	2.17	4.34	28.2
125	7.754	0.700	9.154	7.69	2.15	4.31	29.8
130	7.755	0.700	9.155	7.69	2.16	4.33	28.9
135	7.756	0.698	9.152	7.69	2.18	4.36	27.3
140	7.757	0.698	9.153	7.70	2.18	4.36	27.3
145	7.758	0.697	9.152	7.70	2.20	4.40	25.7
150	7.759	0.696	9.151	7.70	2.20	4.41	25.2
155	7.759	0.696	9.151	7.70	2.19	4.39	26.2
160	7.759	0.697	9.153	7.70	2.17	4.34	28.4
165	7.759	0.696	9.151	7.70	2.15	4.29	30.6
170 <sup>2)</sup>	7.759	0.697	9.153	7.70	0.22	4.36	168.0
175	-	-	-	0.0	0.0	0.0	189.6
180	-	-	-	0.0	0.0	0.0	234.0

\* These numerical values of characteristics are presented as average values at the length interval equal to the axial coordinate  $\pm 2.5$  mm

<sup>1)</sup> Initial coordinate of fuel is 24 mm

<sup>2)</sup> End point coordinate of fuel is 168 mm

<sup>3)</sup> Free gas volume for coordinates 185-295 mm is presented in Table E.3

<sup>4)</sup> Cladding outer diameter is determined as the sum of the inner diameter and the width multiplied into 2

# #H6C

Initial Individual Characteristics of Refabricated Fuel Rods  
(Fresh fuel, Fresh cladding)

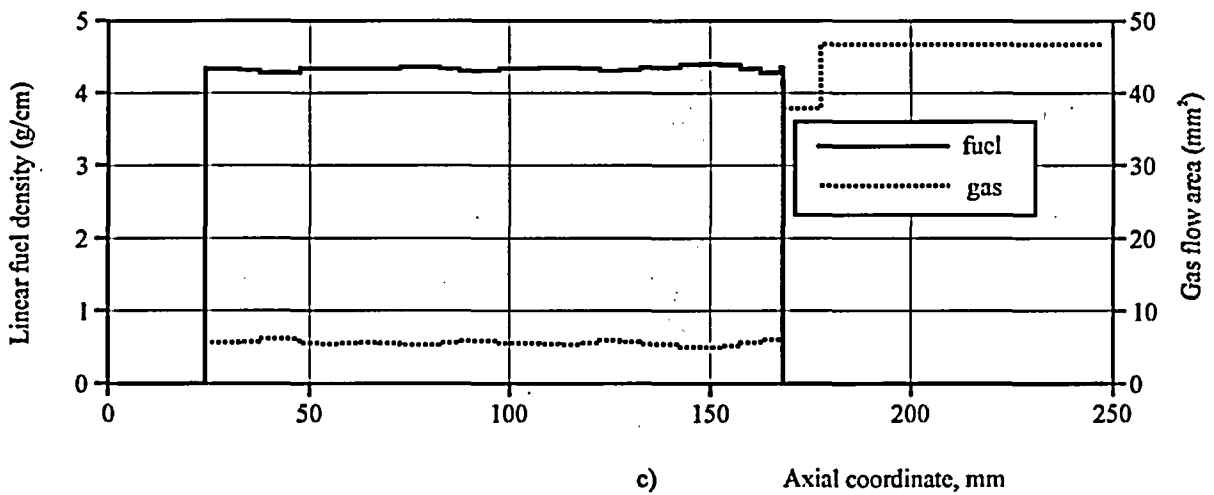
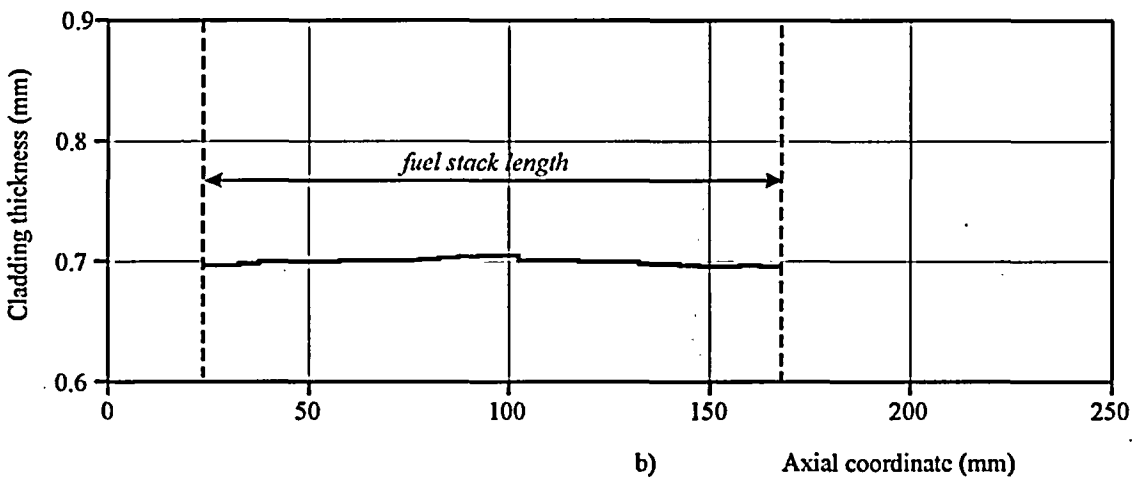
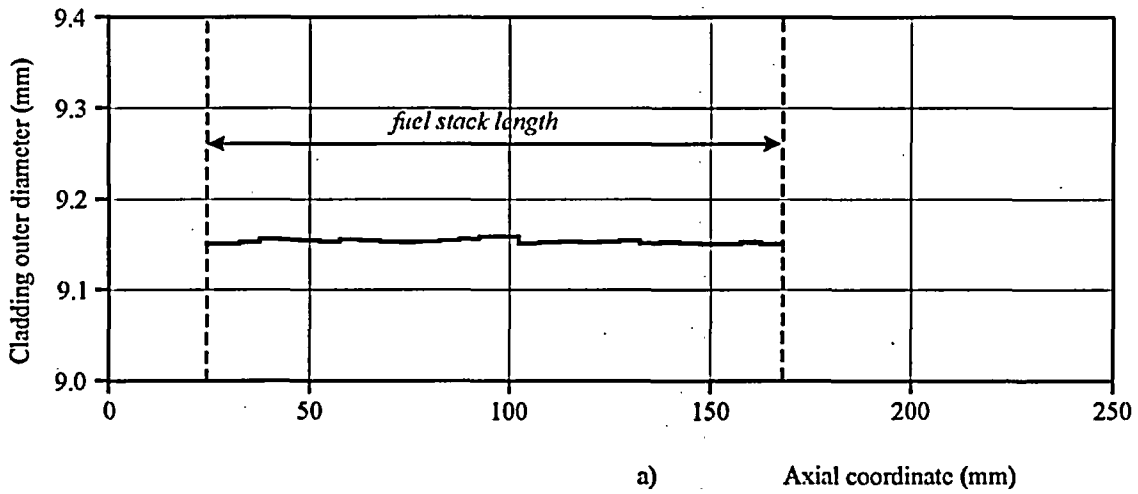

Fig. E-1.1. (a) Axial Distribution of Cladding Outer Diameter and (b) Cladding Thickness (Profilometry), (c) Axial Fuel Mass Distribution and Axial Free Gas Volume Distribution for Fuel Rod #H6C





*APPENDIX E-2.*

*Initial Individual Characteristics for Fuel Rod #B20C*

# #B20C

Initial Individual Characteristics of Refabricated Fuel Rods  
(Fresh fuel, Fresh cladding)

Table E-2.1. Individual Initial Characteristics for Fuel Rod #B20C (measured)

Axial coordinate from lower end of fuel rod (mm)	Cladding inner diameter (mm)	Cladding thickness (mm)	Cladding outer diameter (mm) <sup>4)</sup>	Fuel stack average diameter (mm)*	Fuel mass (g)*	Linear fuel mass (g/cm)*	Free gas volume (mm <sup>3</sup> )* <sup>3)</sup>
5	-	-	-	0.0	0.0	0.0	0.0
10	-	-	-	0.0	0.0	0.0	0.0
15	-	-	-	0.0	0.0	0.0	0.0
20	-	-	-	0.0	0.0	0.0	0.0
25 <sup>1)</sup>	7.752	0.701	9.154	7.56	1.45	4.15	26.3
30	7.753	0.701	9.155	7.56	2.07	4.15	37.5
35	7.754	0.699	9.152	7.56	2.08	4.17	36.5
40	7.755	0.700	9.155	7.56	2.10	4.20	34.8
45	7.756	0.699	9.154	7.56	2.10	4.20	34.8
50	7.757	0.700	9.157	7.56	2.09	4.18	35.9
55	7.757	0.700	9.157	7.56	2.09	4.18	35.9
60	7.755	0.702	9.159	7.56	2.09	4.19	35.5
65	7.754	0.700	9.154	7.57	2.10	4.20	35.1
70	7.752	0.700	9.152	7.57	2.10	4.20	34.9
75	7.751	0.701	9.153	7.57	2.11	4.22	34.2
80	7.749	0.702	9.153	7.57	2.11	4.22	34.2
85	7.749	0.703	9.155	7.57	2.09	4.18	36.1
90	7.747	0.702	9.151	7.57	2.09	4.17	36.3
95	7.748	0.701	9.150	7.57	2.07	4.14	38.0
100	7.748	0.700	9.148	7.56	2.05	4.10	39.5
105	7.748	0.699	9.146	7.56	2.06	4.12	38.7
110	7.748	0.698	9.144	7.56	2.09	4.18	35.9
115	7.749	0.696	9.141	7.56	2.09	4.18	35.9
120	7.748	0.696	9.140	7.56	2.08	4.17	36.5
125	7.749	0.694	9.137	7.56	2.08	4.17	36.5
130	7.747	0.694	9.135	7.56	2.08	4.17	36.5
135	7.747	0.694	9.135	7.56	2.08	4.17	36.4
140	7.747	0.692	9.131	7.56	2.08	4.17	36.5
145	7.747	0.693	9.133	7.56	2.08	4.15	37.3
150	7.746	0.693	9.132	7.56	2.08	4.15	37.3
155	7.744	0.693	9.130	7.57	2.07	4.14	38.1
160	7.743	0.691	9.125	7.57	2.06	4.11	39.2
165 <sup>2)</sup>	7.743	0.691	9.125	7.57	1.44	4.13	82.0
170	-	-	-	0.0	0.0	0.0	183.6
175	-	-	-	0.0	0.0	0.0	209.8
180	-	-	-	0.0	0.0	0.0	234.0

\* These numerical values of characteristics are presented as average values at the length interval equal to the axial coordinate  $\pm 2.5$  mm

<sup>1)</sup> Initial coordinate of fuel is 24 mm

<sup>2)</sup> End point coordinate of fuel is 166 mm

<sup>3)</sup> Free gas volume for coordinates 185-295 mm is presented in Table E.3

<sup>4)</sup> Cladding outer diameter is determined as the sum of the inner diameter and the width multiplied into 2

# #B20C

Initial Individual Characteristics of Refabricated Fuel Rods  
(Fresh fuel, Fresh cladding)

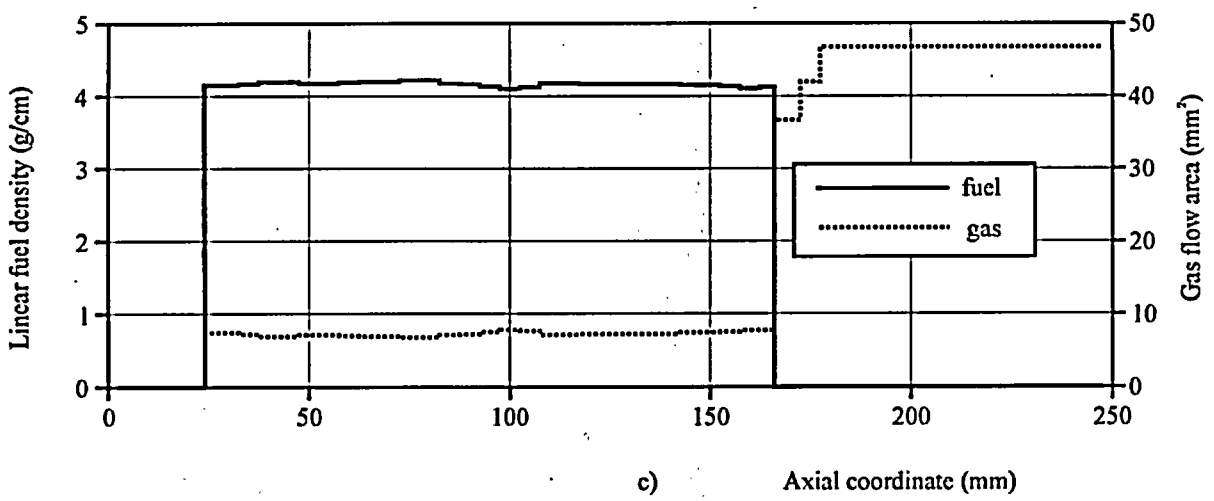
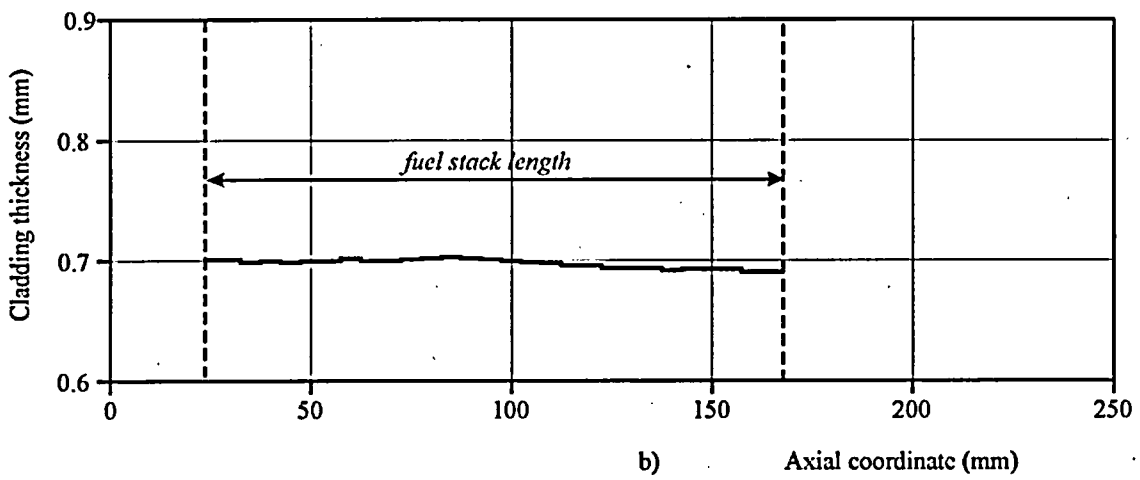
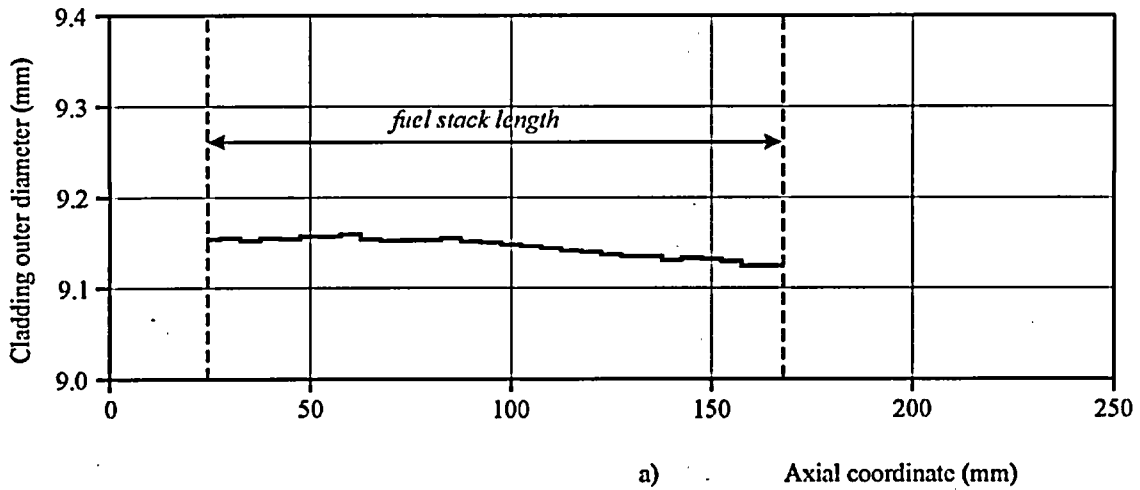

Fig. E-2.1. (a) Axial Distribution of Cladding Outer Diameter and (b) Cladding Thickness (Profilometry), (c) Axial Fuel Mass Distribution and Axial Free Gas Volume Distribution for Fuel Rod #B20C



**APPENDIX F.**

**Characteristics of IGR Reactor Tests**

Table F.1. Capsule Compositions and Pulse Half Width under IGR Tests

Number of fuel rods in capsule		Number of IGR test	Coolant type	Pulse half width (s)	Type of fuel in refabricated fuel rods: 1 – burnup 2 – fresh
Refabricated fuel rod	Fresh fuel rod				
H1T	-	103F-13	water	0.75	1
H2T	-	103F-14	water	0.80	1
H3T	-	103F-15	water	0.80	1
H4T	H4C	103F-8	water	0.80	1
H5T	H5C	103F-9	water	0.80	1
H6T	H6C	103F-7	water	0.80	1
H7T	H7C	103F-10	water	0.60	1
H8T	H8C	103F-5	water	0.85	1
B9T	B9C	103F-18	air	0.80	1
B10T	B10C	103F-16	air	0.80	1
B11T	B11C	103F-11	air	0.70	1
B12T	B12C	103F-19	air	0.70	1
B13T	B13C	103F-12	air	0.90	1
H14T	H14C	103F-1	water	0.90	2
H15T	H15C	103F-17	water	0.90	2
H16T	H16C	103F-3	water	0.85	2
H17T	H17C	103F-2	water	0.95	2
H18T	H18C	103F-23	water	0.85	2
B19T	B19C	103F-20	air	0.80	2
B20T	B20C	103F-6	air	0.90	2
B21T	B21C	103F-4	air	0.85	2
B22T	B22C	103F-22	air	0.90	2
B23T	B23C	103F-21	air	0.75	2

**Table F.2.1. Reactor Power Shape Measured by Ionization Chamber and Energy Deposition as Pulse Integration for Fuel Rods ##H1T, H2T, H3T, H4T**

Time (s)	Fuel rod number							
	H1T		H2T		H3T		H4T	
	Power ( $\mu$ A)	Energy deposition ( $\mu$ As)	Power ( $\mu$ A)	Energy deposition ( $\mu$ As)	Power ( $\mu$ A)	Energy deposition ( $\mu$ As)	Power ( $\mu$ A)	Energy deposition ( $\mu$ As)
0.0	0.00	0.00	0.00	0.00	0.00	0.00	0.00	0.00
1.0	5.48	2.37	2.43	1.21	3.35	1.68	1.47	0.69
2.0	20.79	13.67	13.83	7.64	10.84	8.18	3.58	3.12
2.2	29.59	18.63	20.51	11.03	14.51	10.69	4.34	3.90
2.4	44.78	25.94	31.29	16.13	21.10	14.18	5.52	4.88
2.6	69.86	37.24	49.26	24.04	34.02	19.56	7.55	6.17
2.8	99.46	54.27	79.32	36.66	59.78	28.67	11.37	8.02
3.0	96.19	74.80	123.24	56.78	105.42	44.87	19.03	10.98
3.2	60.98	90.48	142.67	84.52	159.29	71.51	34.25	16.15
3.4	36.42	100.01	100.84	109.23	173.25	105.85	59.62	25.41
3.6	22.70	105.80	60.18	125.09	121.78	135.78	82.21	39.87
3.8	15.04	109.50	35.14	134.40	72.37	154.90	74.54	56.05
4.0	10.54	112.03	21.10	139.90	42.20	166.09	48.38	68.41
4.2	7.77	113.84	13.23	143.26	25.36	172.69	26.82	75.77
4.4	5.96	115.20	8.69	145.42	15.95	176.74	14.79	79.80
4.6	4.74	116.26	5.95	146.86	10.50	179.34	8.86	82.10
4.8	3.87	117.12	4.24	147.87	7.23	181.08	5.93	83.55
5.0	3.24	117.83	3.12	148.60	5.17	182.31	4.39	84.57
5.2	2.76	118.43	2.37	149.14	3.83	183.20	3.54	85.35
5.4	2.40	118.94	1.85	149.56	2.92	183.87	3.02	86.01
5.6	2.10	119.39	1.54	149.89	2.32	184.39	2.68	86.58
5.8	1.80	119.78	1.32	150.18	1.80	184.80	2.43	87.09
6.0	1.50	120.11	1.10	150.42	1.29	185.11	2.22	87.55
6.5	0.75	120.67	0.55	150.83	0.00	185.43	1.71	88.53
7.0	0.00	120.86	0.00	150.97	-	-	1.13	89.24
7.5	-	-	-	-	-	-	0.55	89.66
8.0	-	-	-	-	-	-	0.00	89.82
8.5	-	-	-	-	-	-	-	-
9.0	-	-	-	-	-	-	-	-
9.5	-	-	-	-	-	-	-	-

**Table F.2.2. Reactor Power Shape Measured by Ionization Chamber and Energy Deposition as Pulse Integration for Fuel Rods ##H5T, H6T, H7T, H8T**

Time (s)	Fuel rod number							
	H5T		H6T		H7T		H8T	
	Power ( $\mu$ A)	Energy deposition ( $\mu$ As)	Power ( $\mu$ A)	Energy deposition ( $\mu$ As)	Power ( $\mu$ A)	Energy deposition ( $\mu$ As)	Power ( $\mu$ A)	Energy deposition ( $\mu$ As)
0.0	0.00	0.00	0.00	0.00	0.00	0.00	0.00	0.00
1.0	1.60	0.70	1.00	0.50	2.46	1.23	0.55	0.27
2.0	9.92	5.38	1.99	1.99	8.11	5.89	1.09	1.09
2.2	13.98	7.74	2.23	2.41	10.28	7.72	1.22	1.32
2.4	19.83	11.09	2.53	2.89	13.48	10.08	1.35	1.58
2.6	28.46	15.87	2.94	3.43	18.90	13.26	1.50	1.87
2.8	41.50	22.78	3.59	4.08	29.32	17.97	1.68	2.18
3.0	61.23	32.93	4.72	4.90	51.42	25.78	1.94	2.54
3.2	87.66	47.76	6.84	6.03	95.81	40.11	2.35	2.97
3.4	97.72	67.06	11.04	7.77	137.82	64.30	3.02	3.50
3.6	63.03	83.30	19.40	10.73	96.40	88.84	4.24	4.21
3.8	35.35	92.90	34.24	15.99	36.93	101.71	6.63	5.28
4.0	20.39	98.32	52.96	24.72	12.09	106.16	11.49	7.03
4.2	12.54	101.54	62.40	36.53	5.00	107.73	20.87	10.18
4.4	8.22	103.58	48.76	47.98	2.91	108.49	34.25	15.69
4.6	5.71	104.95	28.70	55.65	2.23	108.99	39.42	23.32
4.8	4.16	105.93	15.84	59.98	1.98	109.41	32.66	30.65
5.0	3.16	106.65	9.16	62.41	1.75	109.78	21.74	36.09
5.2	2.48	107.21	5.79	63.87	1.51	110.11	12.71	39.49
5.4	2.01	107.66	4.01	64.83	1.28	110.39	7.23	41.43
5.6	1.66	108.02	3.02	65.53	1.05	110.62	4.32	42.55
5.8	1.40	108.33	2.42	66.06	0.81	110.80	2.81	43.25
6.0	1.20	108.59	2.03	66.51	0.58	110.94	2.01	43.73
6.5	0.80	109.09	1.50	67.37	0.00	111.09	1.20	44.49
7.0	0.40	109.39	1.17	68.04	-	-	0.90	45.00
7.5	0.00	109.49	0.78	68.53	-	-	0.68	45.40
8.0	-	-	0.39	68.82	-	-	0.45	45.68
8.5	-	-	0.00	68.92	-	-	0.23	45.85
9.0	-	-	-	-	-	-	0.00	45.91
9.5	-	-	-	-	-	-	-	-



**Table F.2.3. Reactor Power Shape Measured by Ionization Chamber and Energy Deposition as Pulse Integration for Fuel Rods ##B9T, B10T, B11T, B12T**

Time (s)	Fuel rod number							
	B9T		B10T		B11T		B12T	
	Power ( $\mu$ A)	Energy deposition ( $\mu$ As)	Power ( $\mu$ A)	Energy deposition ( $\mu$ As)	Power ( $\mu$ A)	Energy deposition ( $\mu$ As)	Power ( $\mu$ A)	Energy deposition ( $\mu$ As)
0.0	0.00	0.00	0.00	0.00	0.00	0.00	0.00	0.00
1.0	2.37	1.06	1.82	0.91	2.70	1.21	2.20	0.91
2.0	12.25	7.24	5.16	3.99	13.81	8.08	17.05	8.46
2.2	16.79	10.12	7.49	5.23	19.24	11.36	25.17	12.63
2.4	23.48	14.10	12.33	7.15	27.36	15.96	38.42	18.88
2.6	34.18	19.78	22.60	10.53	40.19	22.62	62.31	28.72
2.8	53.03	28.33	41.96	16.83	61.77	32.63	105.92	45.21
3.0	86.33	42.03	65.66	27.66	99.64	48.45	115.23	68.86
3.2	93.63	61.14	71.98	41.89	152.17	73.71	78.67	88.34
3.4	66.99	77.31	52.10	54.46	128.31	103.35	48.08	100.82
3.6	43.05	88.18	32.73	62.84	75.41	123.46	29.20	108.39
3.8	27.28	95.10	20.42	68.05	43.39	135.03	18.27	113.05
4.0	17.66	99.52	13.17	71.35	26.36	141.84	11.91	116.01
4.2	11.81	102.42	8.88	73.52	17.10	146.10	8.09	117.98
4.4	8.19	104.39	6.25	75.02	11.77	148.95	5.71	119.35
4.6	5.87	105.78	4.57	76.09	8.53	150.95	4.18	120.32
4.8	4.34	106.80	3.46	76.88	6.46	152.44	3.15	121.05
5.0	3.30	107.55	2.70	77.49	5.06	153.58	2.44	121.61
5.2	2.58	108.14	2.16	77.98	4.08	154.49	1.94	122.04
5.4	2.06	108.60	1.77	78.37	3.38	155.23	1.57	122.39
5.6	1.67	108.97	1.48	78.69	2.85	155.85	1.28	122.67
5.8	1.30	109.27	1.26	78.97	2.45	156.38	1.00	122.90
6.0	0.93	109.49	1.08	79.20	2.14	156.84	0.71	123.07
6.5	0.00	109.72	0.54	79.60	1.43	157.74	0.00	123.25
7.0	-	-	0.00	79.74	0.71	158.27	-	-
7.5	-	-	-	-	0.00	158.45	-	-
8.0	-	-	-	-	-	-	-	-
8.5	-	-	-	-	-	-	-	-
9.0	-	-	-	-	-	-	-	-
9.5	-	-	-	-	-	-	-	-

Table F.2.4. Reactor Power Shape Measured by Ionization Chamber and Energy Deposition as Pulse Integration Fuel Rods ##B13T, H14T, H15T, H16T

Time (s)	Fuel rod number							
	B13T		H14T		H15T		H16T	
	Power ( $\mu$ A)	Energy deposition ( $\mu$ As)	Power ( $\mu$ A)	Energy deposition ( $\mu$ As)	Power ( $\mu$ A)	Energy deposition ( $\mu$ As)	Power ( $\mu$ A)	Energy deposition ( $\mu$ As)
0.0	0.00	0.00	0.00	0.00	0.00	0.00	0.00	0.00
1.0	3.15	1.57	0.43	0.21	1.71	0.71	0.41	0.20
2.0	17.70	9.46	0.88	0.86	7.65	4.40	0.82	0.82
2.2	27.92	13.93	1.02	1.05	12.73	6.38	0.90	0.99
2.4	45.72	21.14	1.26	1.28	23.01	9.85	0.98	1.18
2.6	76.65	33.12	1.68	1.57	40.08	16.07	1.06	1.38
2.8	126.47	53.12	2.48	1.97	54.42	25.72	1.14	1.60
3.0	184.71	84.42	4.07	2.61	49.78	36.44	1.22	1.84
3.2	192.94	123.27	7.14	3.70	36.20	45.05	1.31	2.09
3.4	155.05	158.61	11.95	5.59	24.53	51.07	1.39	2.36
3.6	98.38	183.97	15.84	8.43	16.50	55.12	1.48	2.65
3.8	53.04	198.80	14.83	11.56	11.30	57.86	1.67	2.96
4.0	27.63	206.59	10.84	14.15	7.95	59.76	2.02	3.32
4.2	15.57	210.76	6.85	15.91	5.75	61.12	2.71	3.79
4.4	10.05	213.26	4.11	16.98	4.29	62.11	4.09	4.45
4.6	7.47	214.98	2.51	17.63	3.28	62.86	6.94	5.52
4.8	6.22	216.34	1.63	18.03	2.56	63.44	12.57	7.42
5.0	5.62	217.51	1.12	18.31	2.05	63.90	21.85	10.81
5.2	5.17	218.59	0.83	18.50	1.67	64.27	31.57	16.20
5.4	4.72	219.58	0.64	18.64	1.38	64.58	34.04	22.93
5.6	4.27	220.48	0.52	18.76	1.17	64.83	26.08	29.06
5.8	3.82	221.29	0.43	18.86	0.99	65.05	15.99	33.23
6.0	3.37	222.01	0.37	18.94	0.86	65.23	9.22	35.69
6.5	2.25	223.42	0.24	19.09	0.43	65.55	3.10	38.38
7.0	1.12	224.26	0.12	19.18	0.00	65.66	1.71	39.52
7.5	0.00	224.54	0.00	19.21	-	-	1.16	40.22
8.0	-	-	-	-	-	-	0.78	40.71
8.5	-	-	-	-	-	-	0.52	41.03
9.0	-	-	-	-	-	-	0.26	41.23
9.5	-	-	-	-	-	-	0.00	41.29

**Table F.2.5. Reactor Power Shape Measured by Ionization Chamber and Energy Deposition as Pulse Integration for Fuel Rods ##H17T, H18T, B19T, B20T**

Time (s)	Fuel rod number							
	H17T		H18T		B19T		B20T	
	Power ( $\mu$ A)	Energy deposition ( $\mu$ As)	Power ( $\mu$ A)	Energy deposition ( $\mu$ As)	Power ( $\mu$ A)	Energy deposition ( $\mu$ As)	Power ( $\mu$ A)	Energy deposition ( $\mu$ As)
0.0	0.00	0.00	0.00	0.00	0.00	0.00	0.00	0.00
1.0	0.20	0.07	1.16	0.58	1.93	0.97	0.52	0.26
2.0	0.60	0.47	2.68	2.35	5.05	4.02	1.05	1.05
2.2	0.67	0.60	3.79	2.99	8.11	5.29	1.15	1.27
2.4	0.75	0.74	6.35	3.97	15.90	7.58	1.25	1.51
2.6	0.83	0.90	12.29	5.76	33.62	12.35	1.36	1.77
2.8	0.94	1.07	24.05	9.30	57.64	21.53	1.46	2.05
3.0	1.08	1.27	38.56	15.59	64.13	34.15	1.64	2.36
3.2	1.29	1.51	44.82	24.13	48.03	45.52	1.93	2.71
3.4	1.66	1.80	36.42	32.44	31.20	53.36	2.42	3.14
3.6	2.32	2.19	24.37	38.48	19.88	58.39	3.30	3.71
3.8	3.53	2.76	15.70	42.43	12.96	61.62	5.02	4.52
4.0	5.85	3.68	10.28	44.99	8.75	63.75	8.44	5.83
4.2	10.18	5.24	6.96	46.69	6.14	65.23	15.13	8.12
4.4	16.97	7.93	4.89	47.86	4.47	66.27	26.30	12.20
4.6	23.53	12.03	3.56	48.69	3.35	67.05	38.56	18.74
4.8	23.92	16.89	2.68	49.31	2.59	67.64	41.92	27.00
5.0	18.79	21.22	2.07	49.78	2.05	68.10	32.41	34.57
5.2	12.16	24.30	1.64	50.15	1.66	68.47	20.03	39.78
5.4	7.16	26.20	1.33	50.45	1.37	68.77	11.46	42.86
5.6	4.23	27.31	1.10	50.69	1.15	69.03	6.73	44.63
5.8	2.66	27.99	0.93	50.89	0.98	69.24	4.26	45.71
6.0	1.81	28.42	0.79	51.06	0.85	69.42	2.95	46.42
6.5	0.93	29.07	0.40	51.36	0.57	69.78	1.60	47.49
7.0	0.55	29.43	0.00	51.46	0.28	69.99	1.11	48.15
7.5	0.27	29.64	-	-	0.00	70.06	0.78	48.62
8.0	0.07	29.72	-	-	-	-	0.51	48.94
8.5	0.00	29.73	-	-	-	-	0.26	49.14
9.0	-	-	-	-	-	-	0.00	49.20
9.5	-	-	-	-	-	-	-	-

**Table F.2.6. Reactor Power Shape Measured by Ionization Chamber and Energy Deposition as Pulse Integration for Fuel Rods ##B21T, B22T, B23T**

Time (s)	Fuel rod number					
	B21T		B22T		B23T	
	Power ( $\mu$ A)	Energy deposition ( $\mu$ As)	Power ( $\mu$ A)	Energy deposition ( $\mu$ As)	Power ( $\mu$ A)	Energy deposition ( $\mu$ As)
0.0	0.00	0.00	0.00	0.00	0.00	0.00
1.0	0.44	0.22	0.60	0.30	1.68	0.84
2.0	0.89	0.89	1.56	1.27	5.15	3.95
2.2	0.98	1.07	2.13	1.63	7.00	5.15
2.4	1.06	1.28	3.20	2.15	10.56	6.87
2.6	1.15	1.50	5.44	2.99	18.09	9.64
2.8	1.31	1.74	10.26	4.50	34.40	14.70
3.0	1.63	2.03	19.24	7.39	64.21	24.37
3.2	2.27	2.41	26.46	12.12	92.29	40.36
3.4	3.61	2.99	23.93	17.23	80.54	58.33
3.6	6.44	3.96	18.70	21.51	52.37	71.55
3.8	11.95	5.75	13.40	24.71	32.41	79.88
4.0	20.38	8.95	9.14	26.95	20.56	85.08
4.2	28.52	13.88	6.08	28.45	13.63	88.44
4.4	31.62	20.00	4.01	29.45	9.46	90.72
4.6	25.80	25.87	2.64	30.10	6.85	92.33
4.8	17.18	30.15	1.75	30.53	5.14	93.52
5.0	10.87	32.91	1.17	30.82	3.99	94.42
5.2	6.92	34.66	0.79	31.02	3.18	95.14
5.4	4.54	35.79	0.55	31.15	2.60	95.71
5.6	3.08	36.54	0.38	31.24	2.17	96.19
5.8	2.16	37.06	0.27	31.31	1.84	96.59
6.0	1.57	37.43	0.19	31.35	1.58	96.93
6.5	0.80	37.99	0.00	31.40	0.79	97.52
7.0	0.50	38.30	-	-	0.00	97.72
7.5	0.25	38.49	-	-	-	-
8.0	0.00	38.55	-	-	-	-
8.5	-	-	-	-	-	-
9.0	-	-	-	-	-	-
9.5	-	-	-	-	-	-

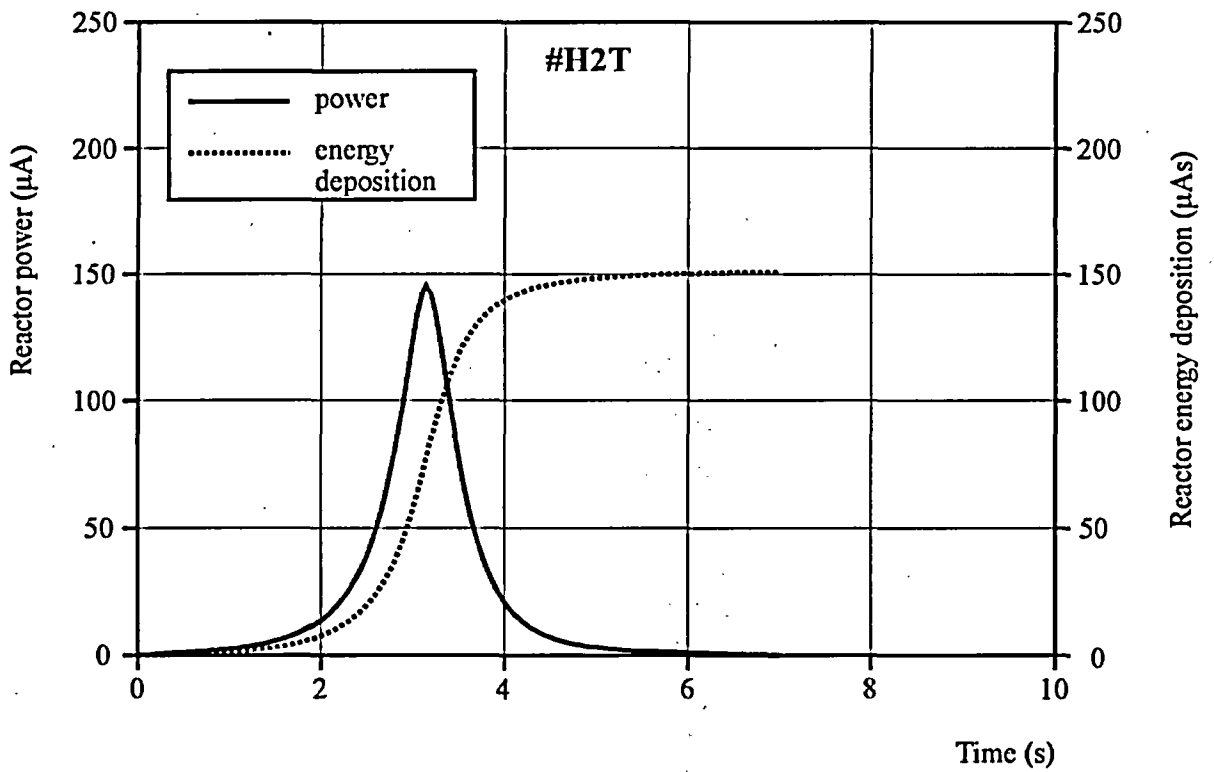
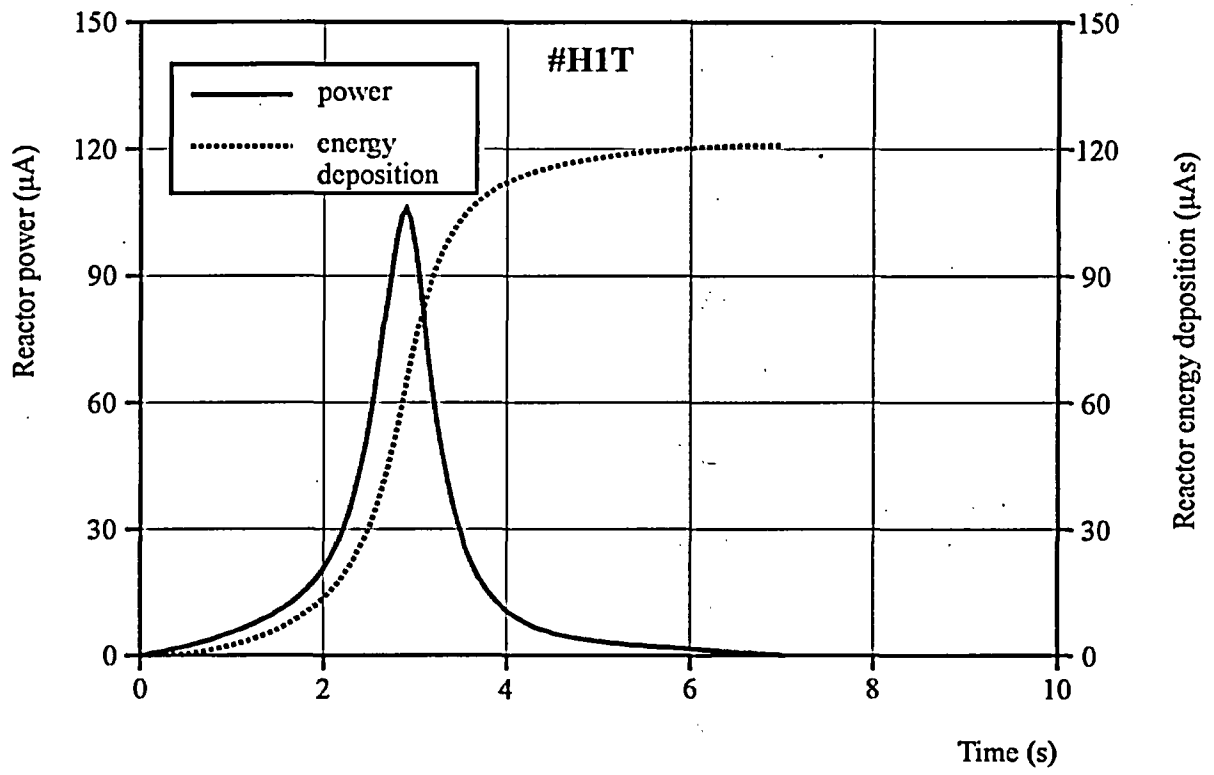

Fig. F.1. Reactor Power Shape and Energy Deposition for Fuel Rods ##H1T, H2T Tests

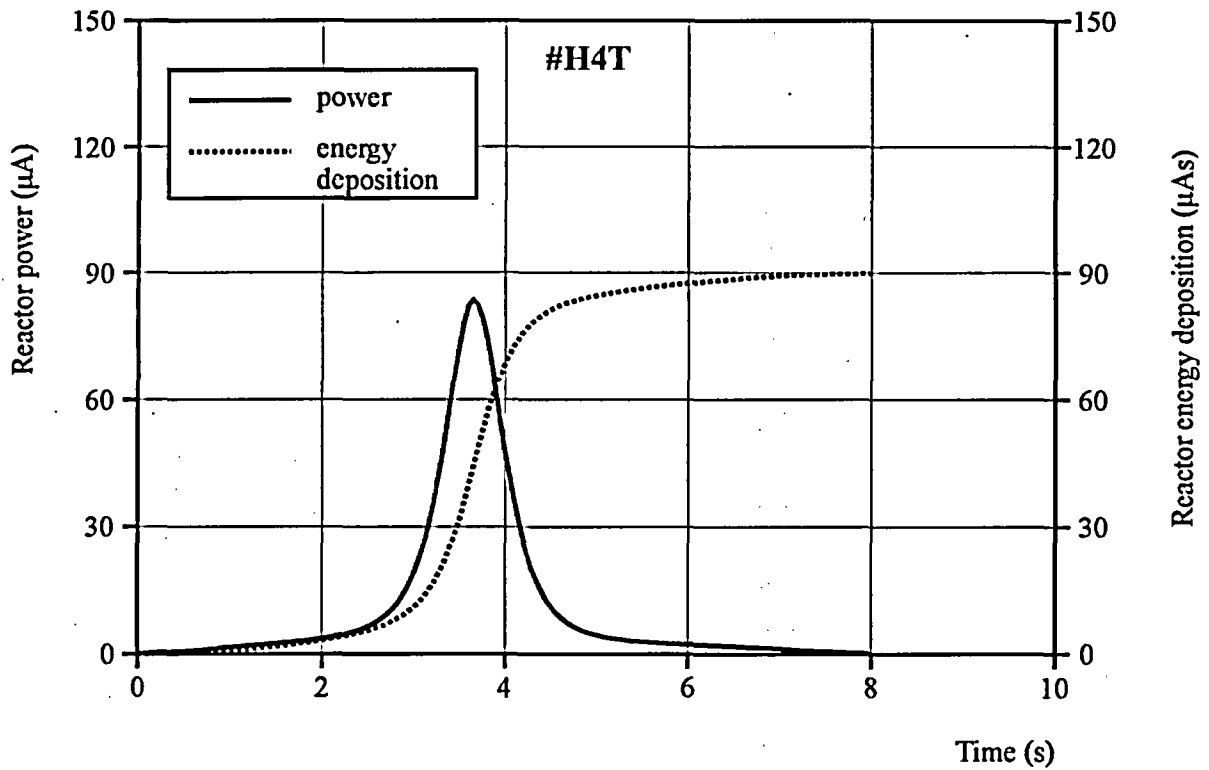
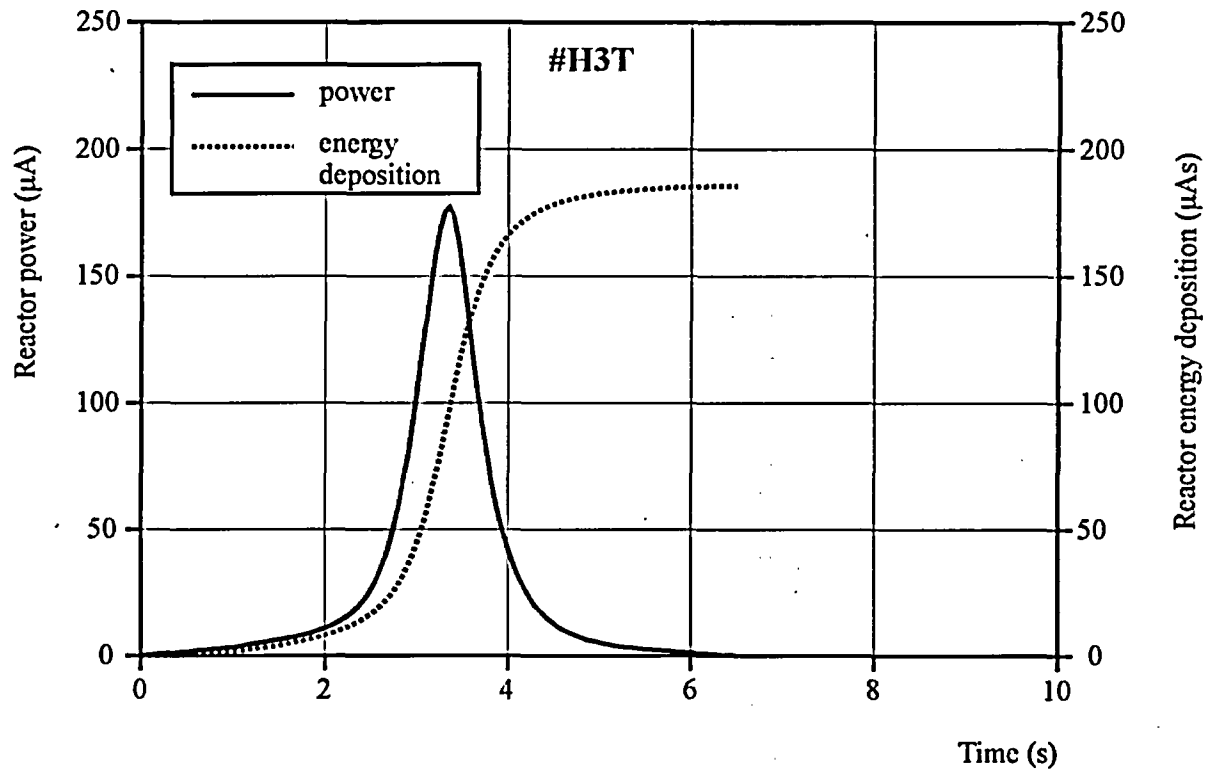

Fig. F.2.. Reactor Power Shape and Energy Deposition for Fuel Rods ##H3T, H4T Tests

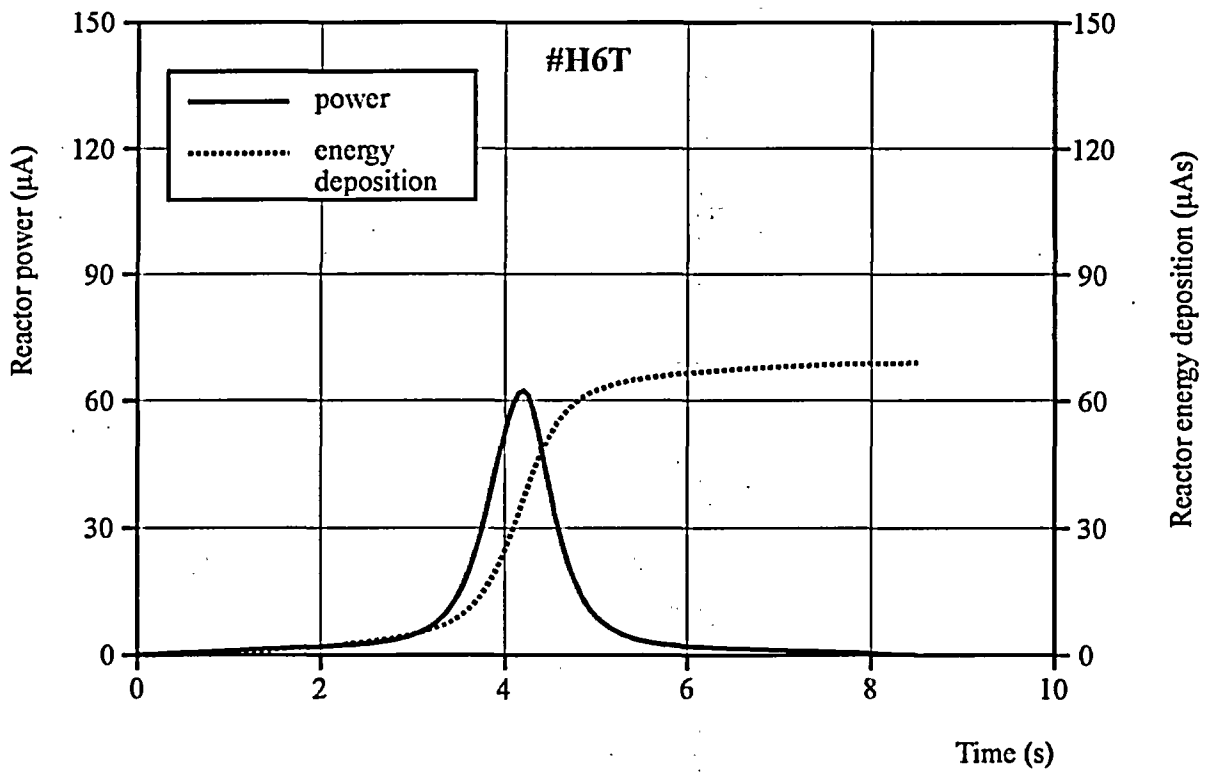
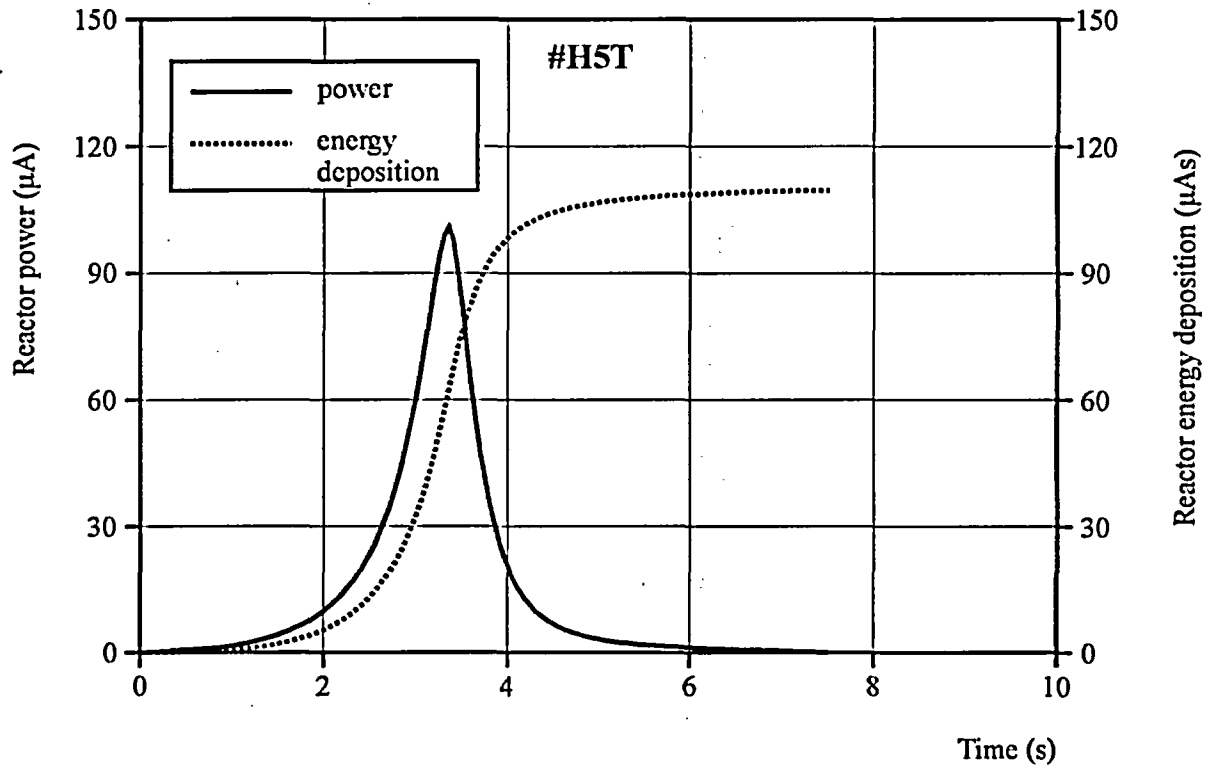

Fig. F.3. Reactor Power Shape and Energy Deposition for Fuel Rods ##H5T, H6T Tests

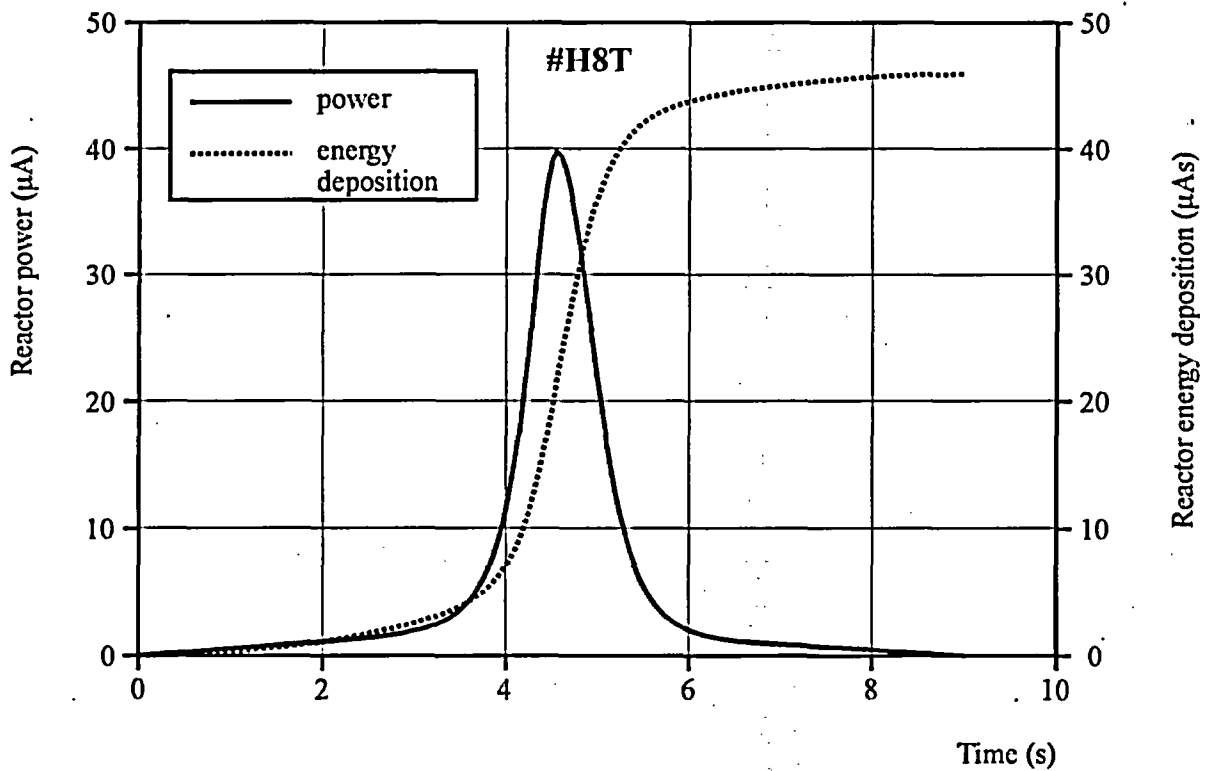
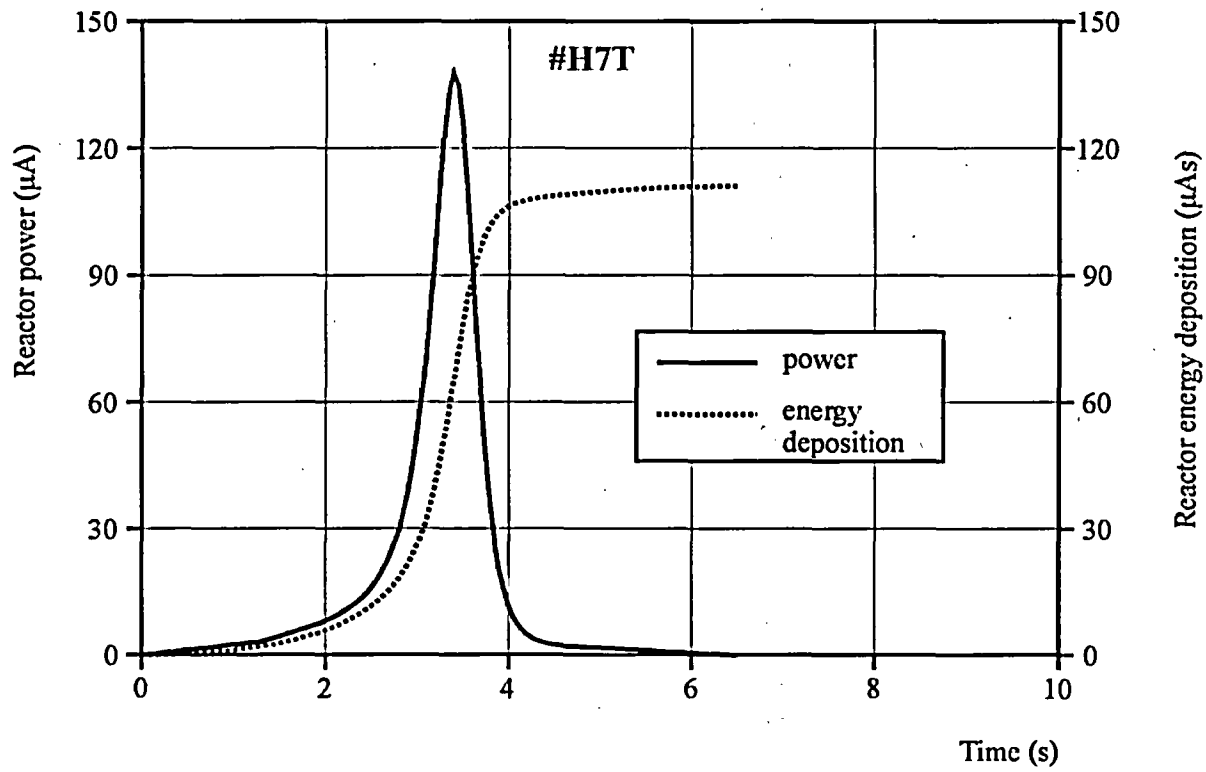

Fig. F.4. Reactor Power Shape and Energy Deposition for Fuel Rods ##H7T, H8T Tests



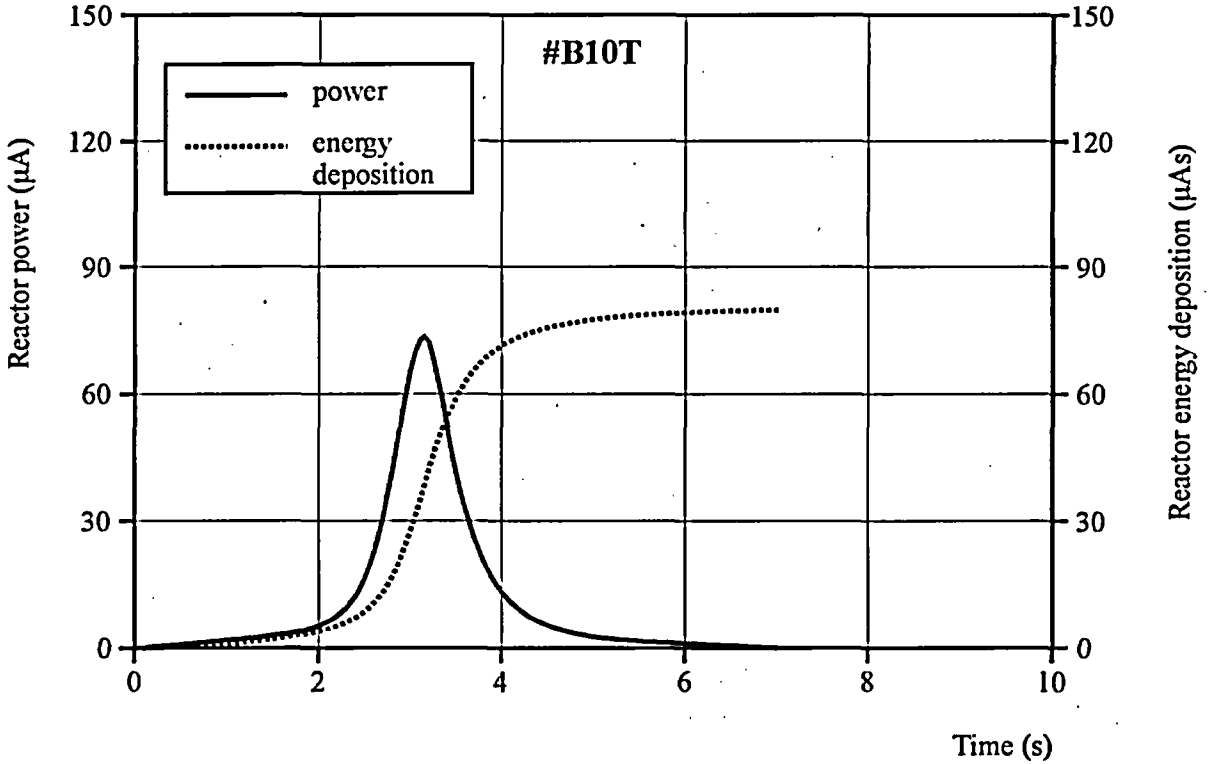
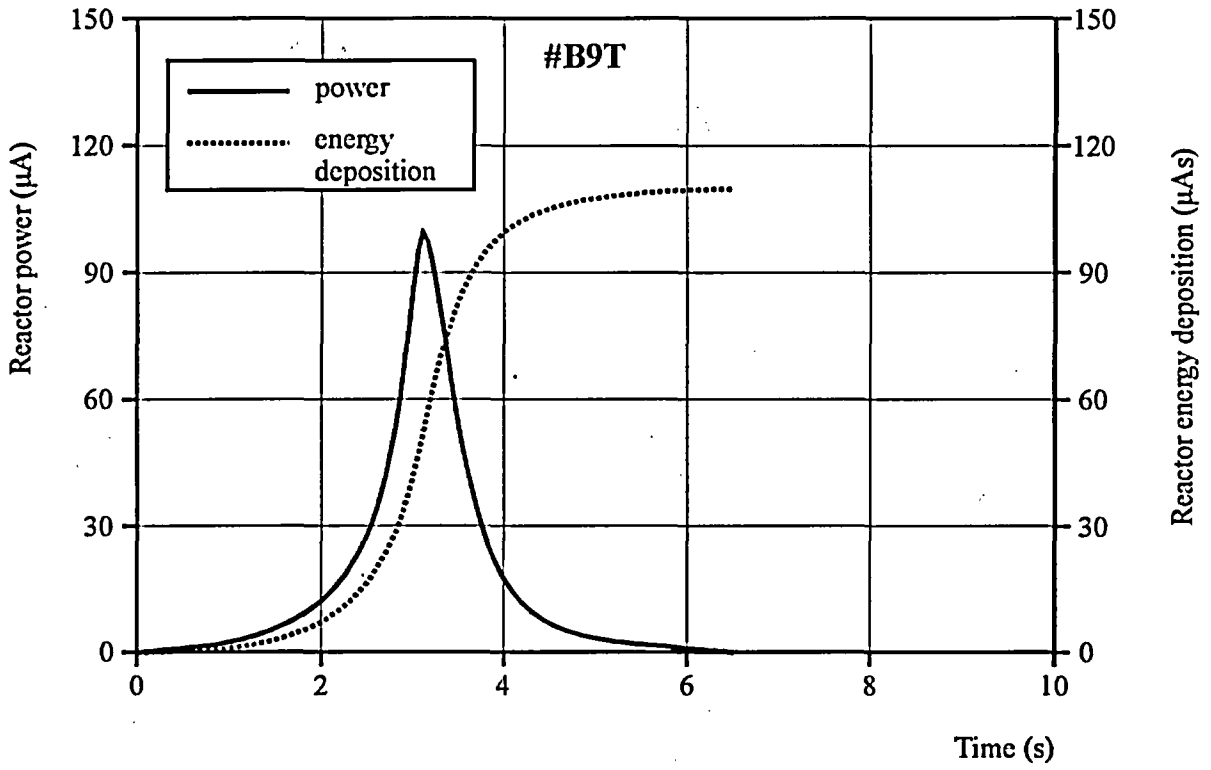

Fig. F.5. Reactor Power Shape and Energy Deposition for Fuel Rods ##B9T, B10T Tests

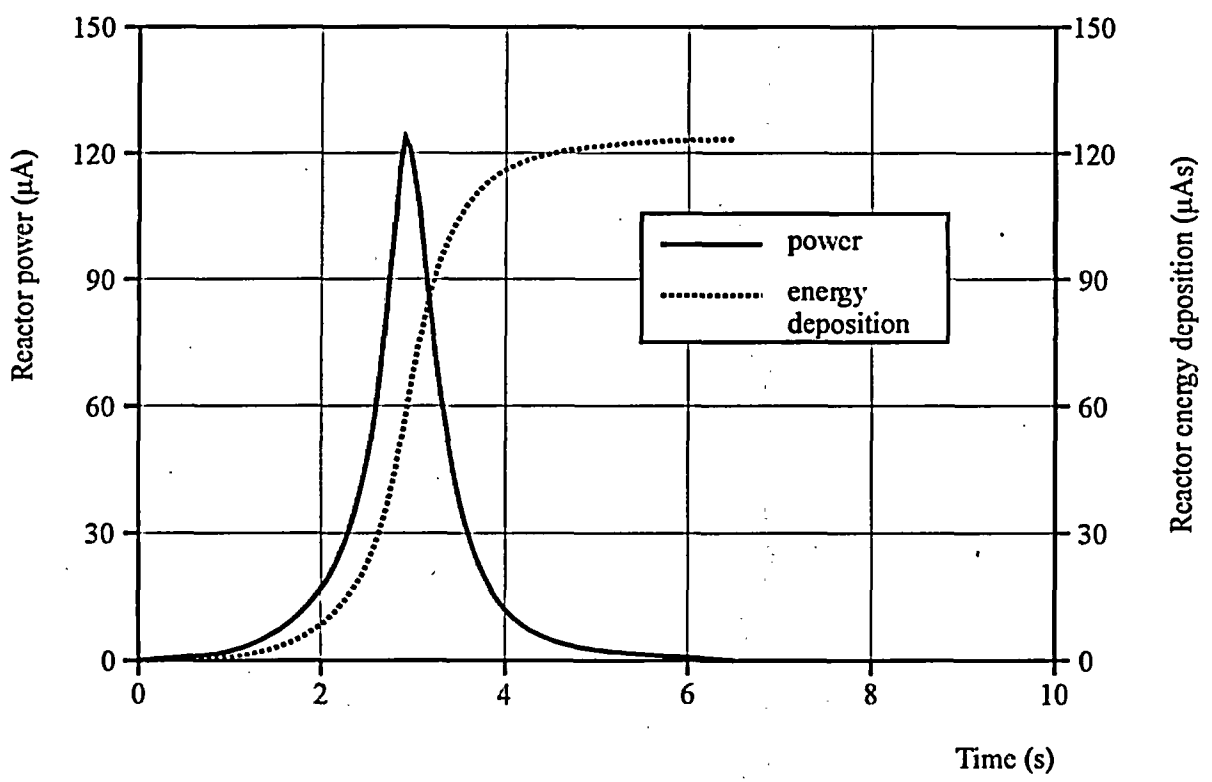
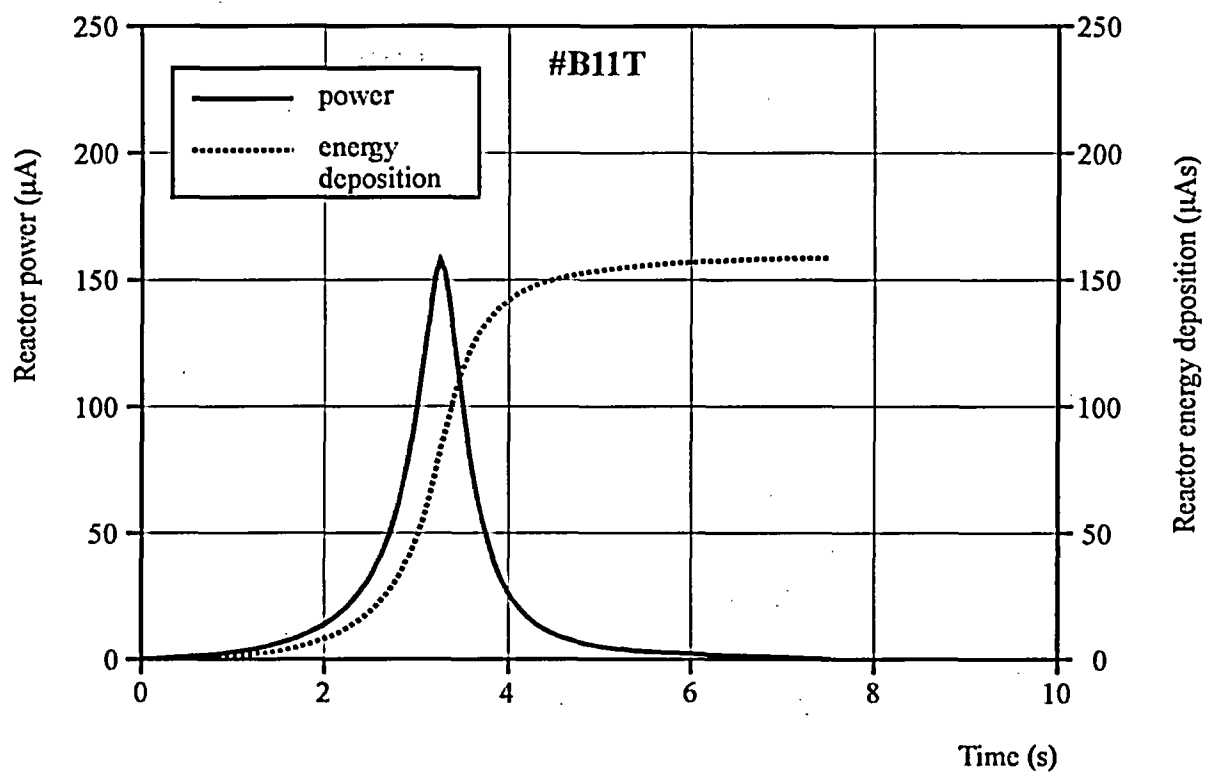

Fig. F.6. Reactor Power Shape and Energy Deposition for Fuel Rods #B11T, B12T Tests

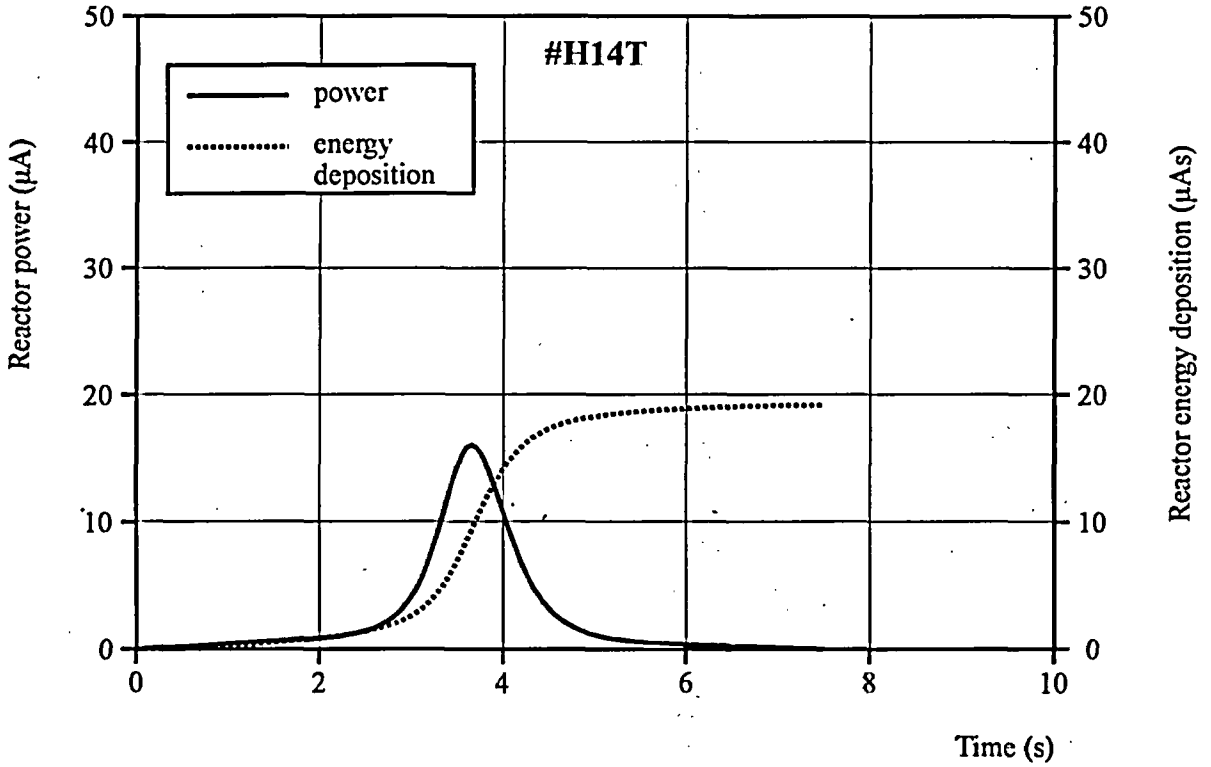
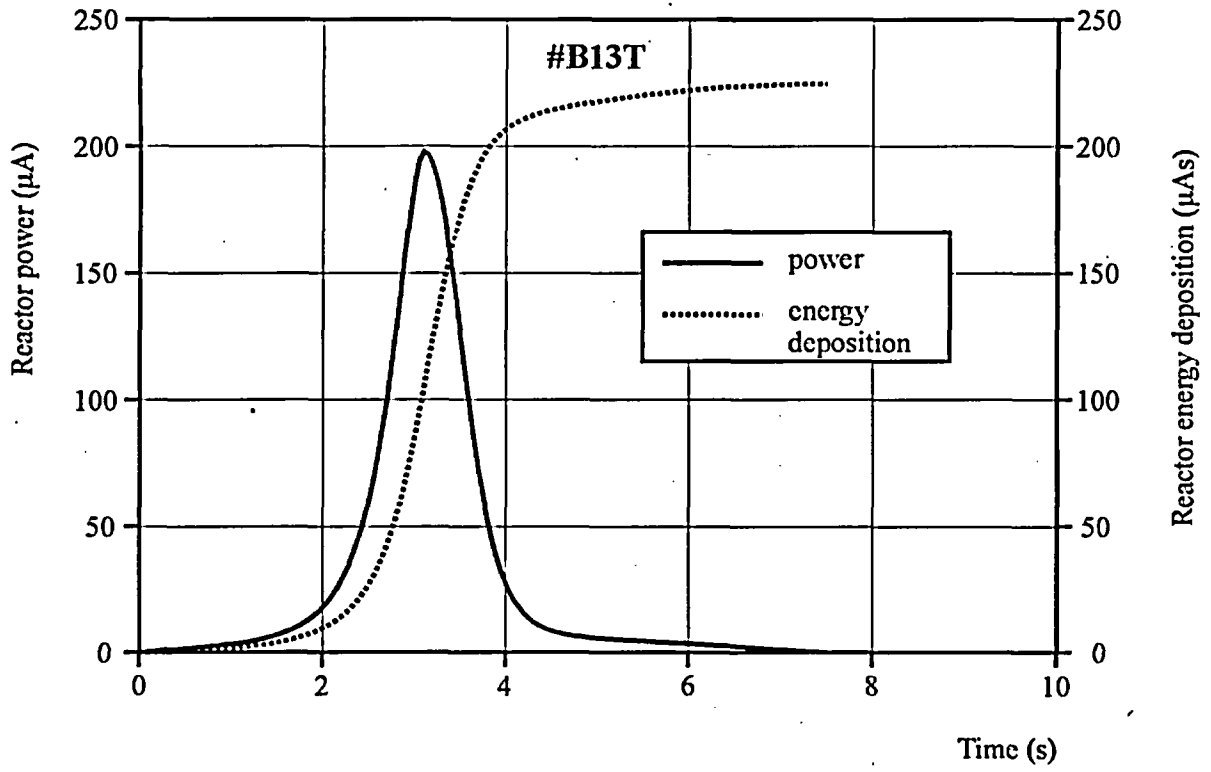

Fig. F.7. Reactor Power Shape and Energy Deposition for Fuel Rods ##B13T, H14T Tests

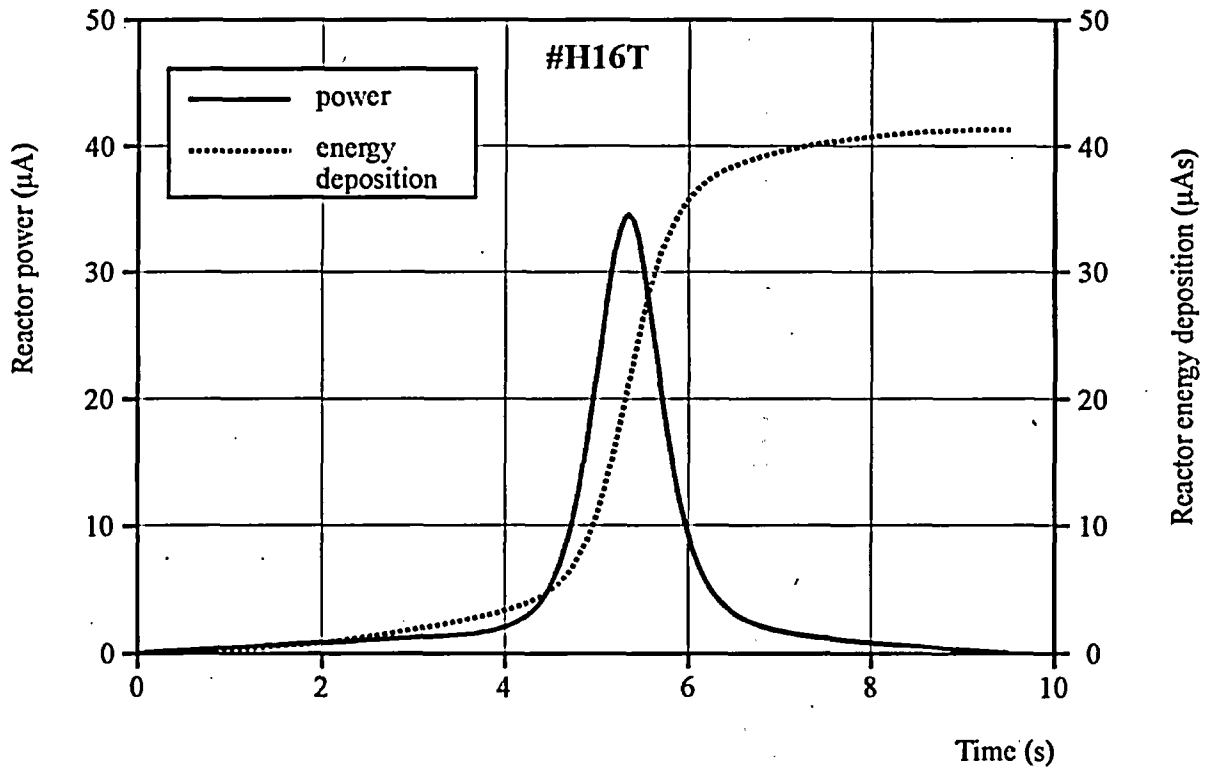
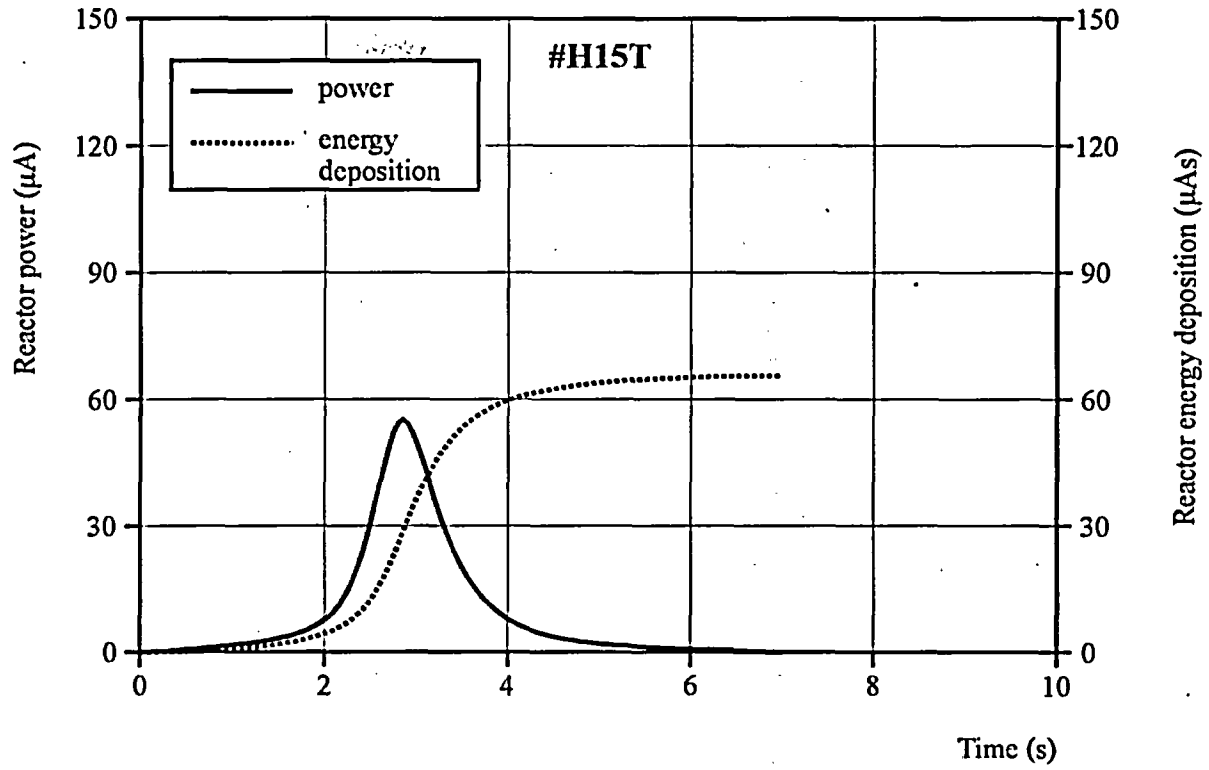

Fig. F.8. Reactor Power Shape and Energy Deposition for Fuel Rods ##H15T, H16T Tests

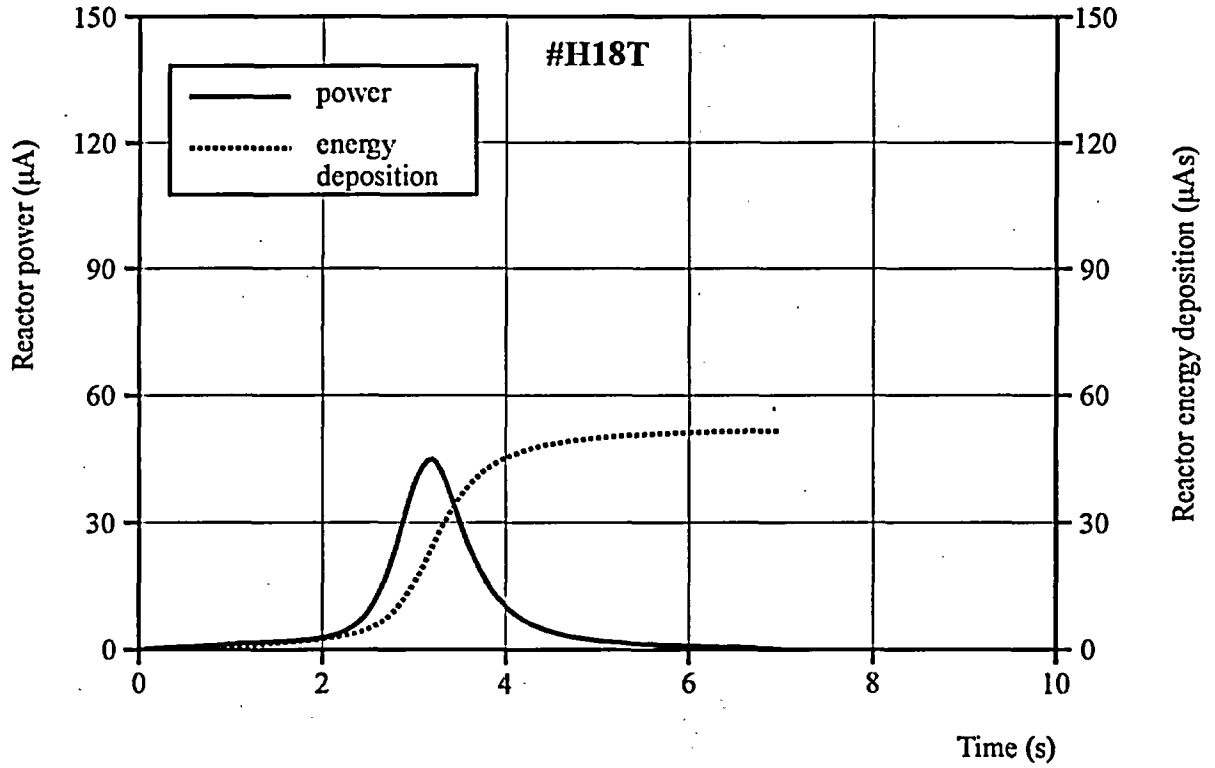
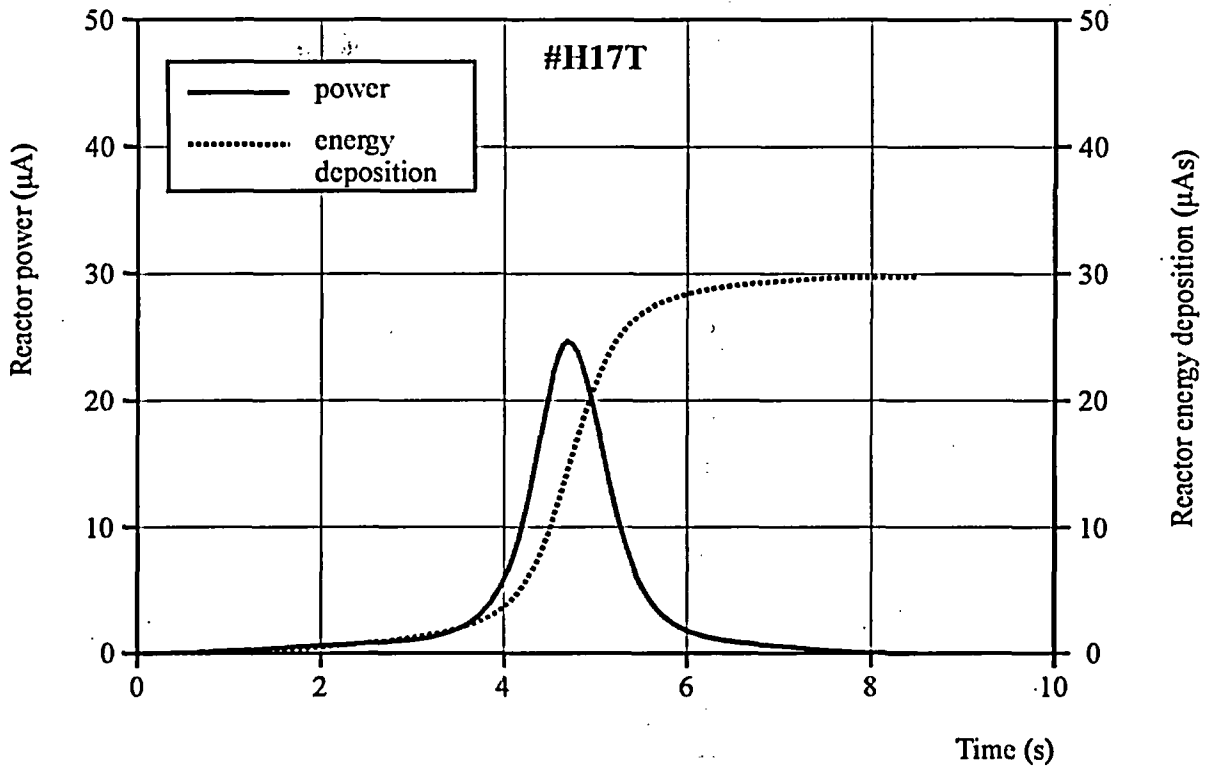

Fig. F.9. Reactor Power Shape and Energy Deposition for Fuel Rods ##H17T, H18T Tests

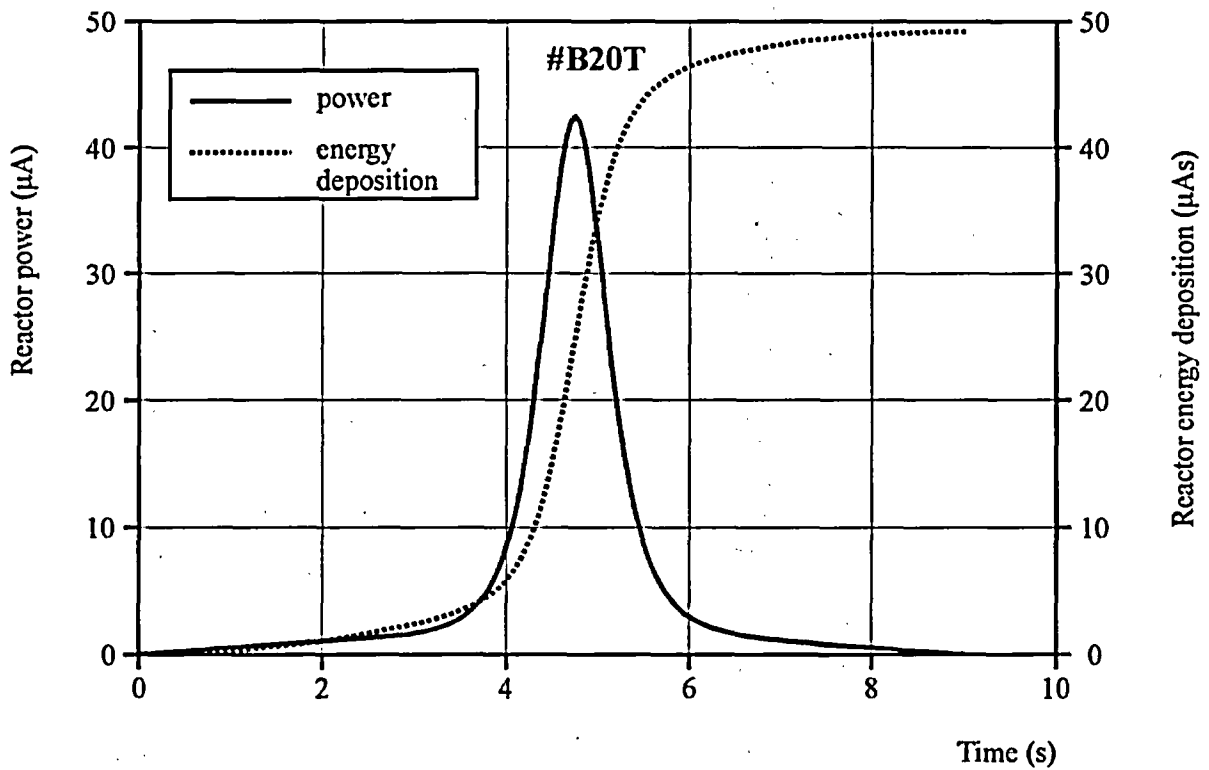
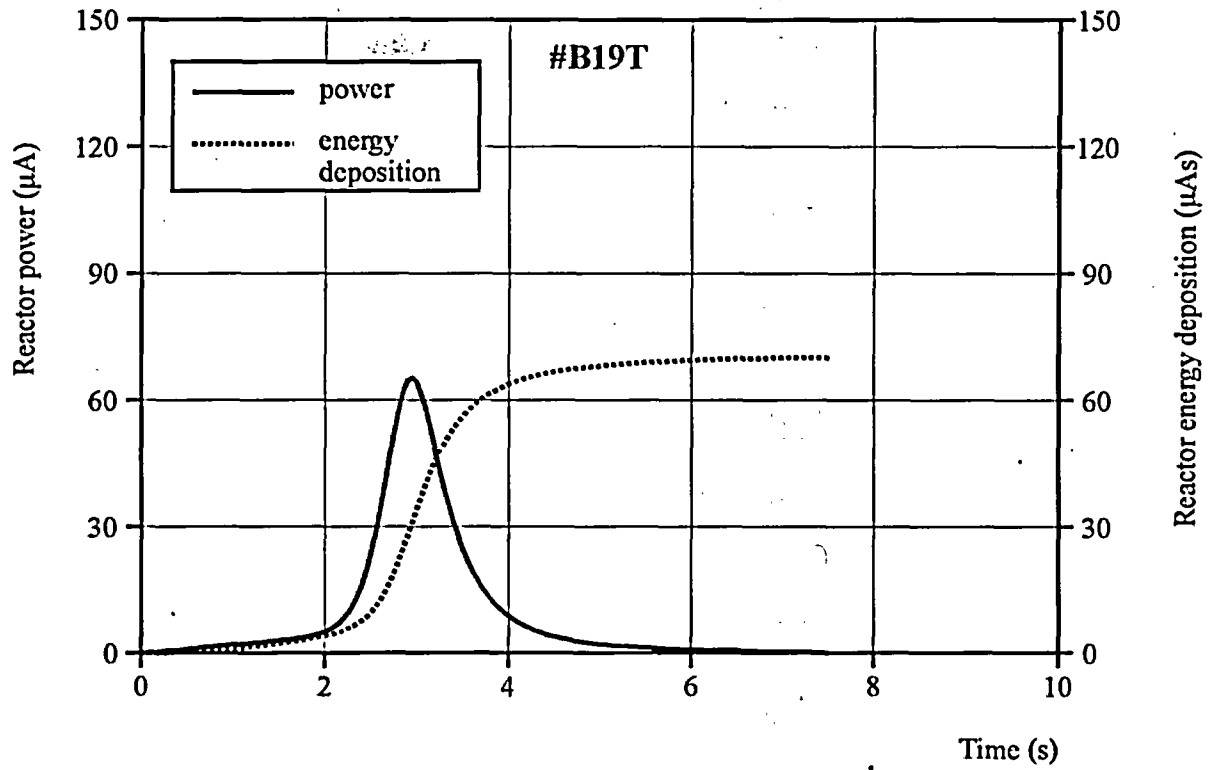

Fig. F.10. Reactor Power Shape and Energy Deposition for Fuel Rods ##B19T, B20T Tests

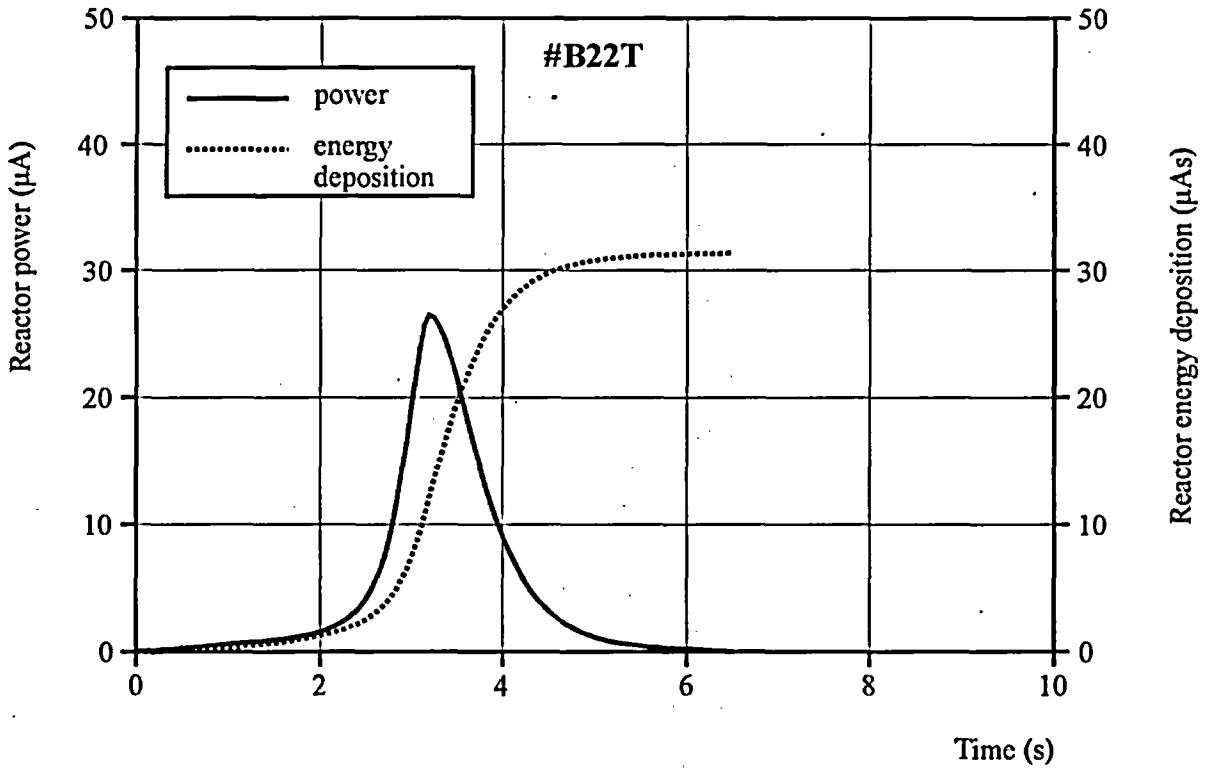
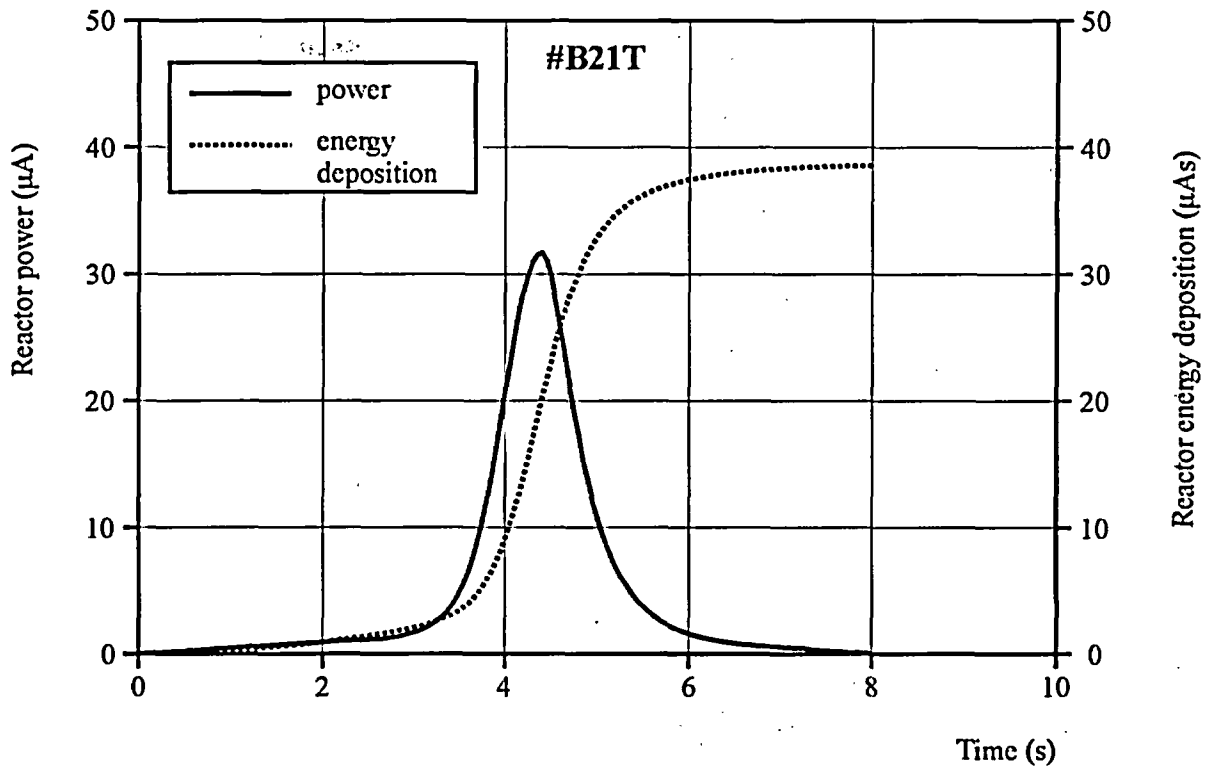

Fig. F.11. Reactor Power Shape and Energy Deposition for Fuel Rods ##B21T, B22T Tests

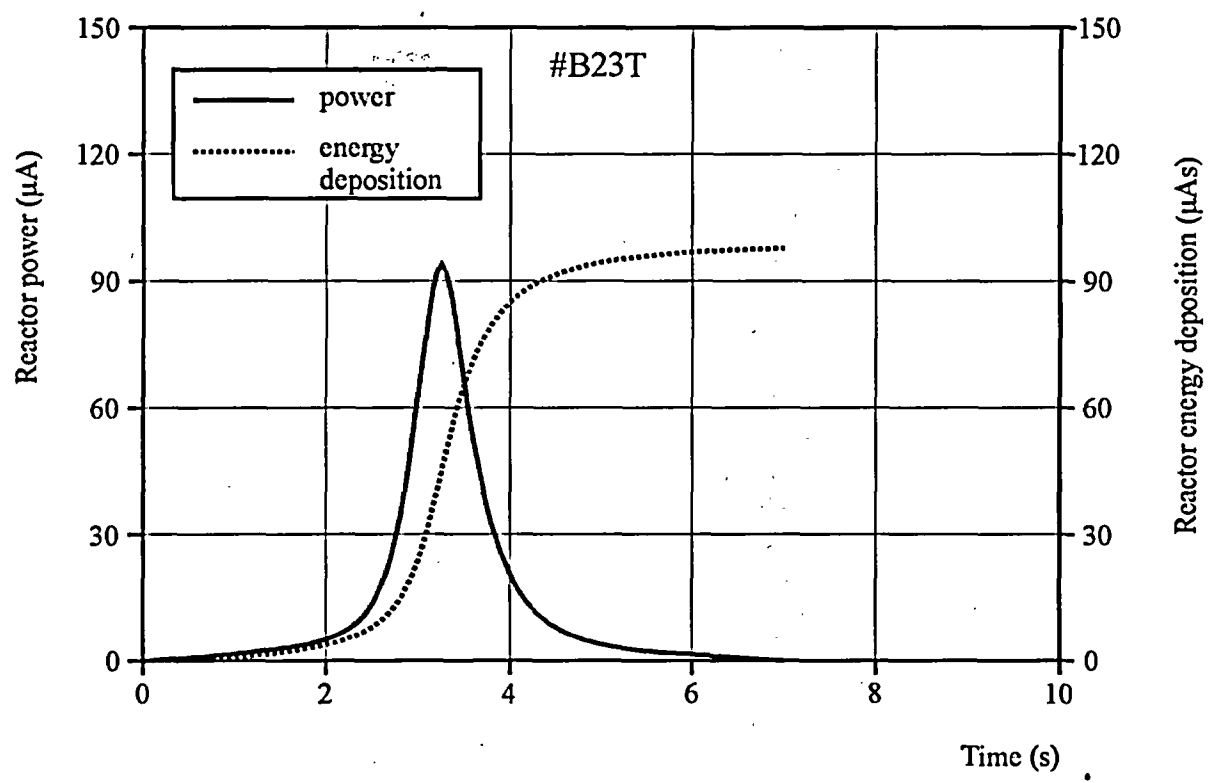

Fig. F.12. Reactor Power Shape and Energy Deposition for Fuel Rod #B23T Test



**APPENDIX G.**

**Measured and Calculated Characteristics of Re-fabricated Fuel Rods (Preirradiated Fuel, Preirradiated Cladding) during and after IGR Tests**

***APPENDIX G-1.***

***Individual Characteristics for Fuel Rod #HIT under IGR Test***

#H1T

Individual Characteristics of Refabricated Fuel Rods  
(Preirradiated Fuel, Preirradiated Cladding) under IGR Tests

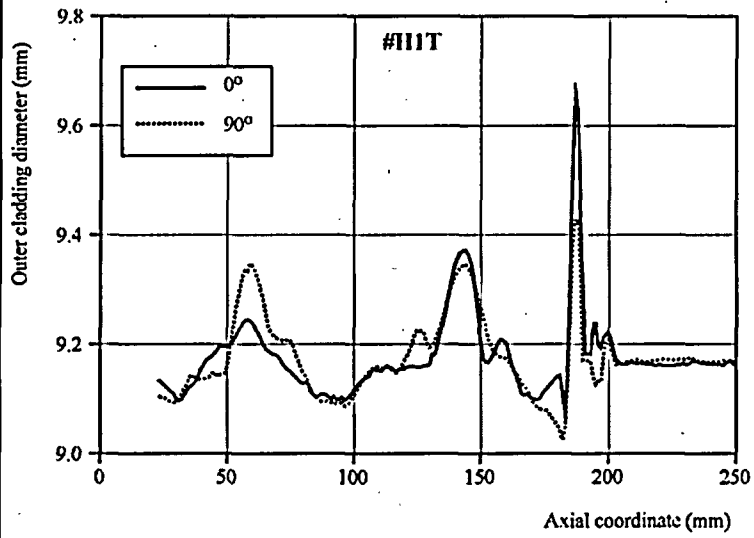
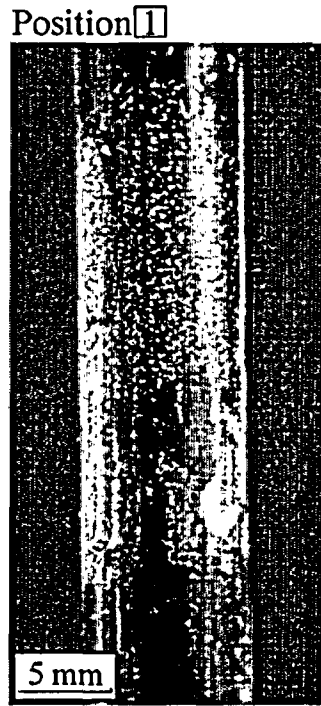
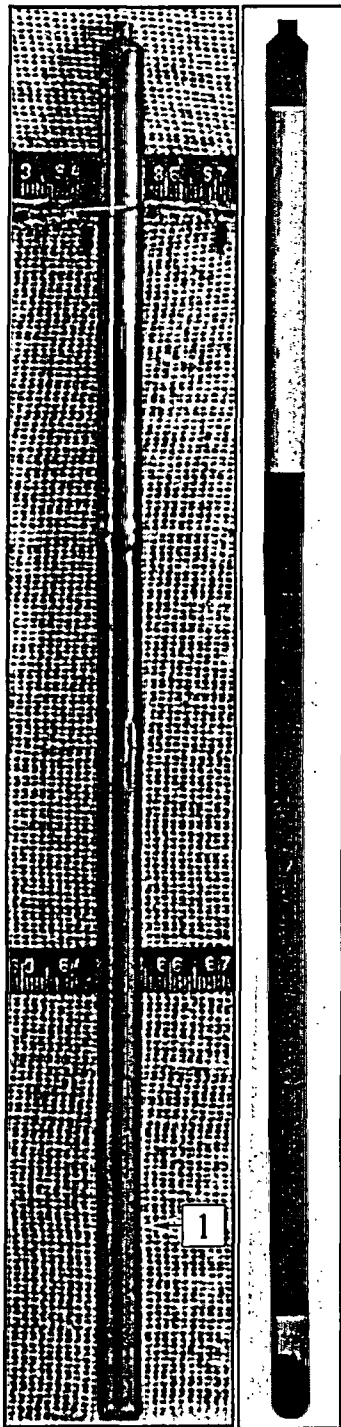
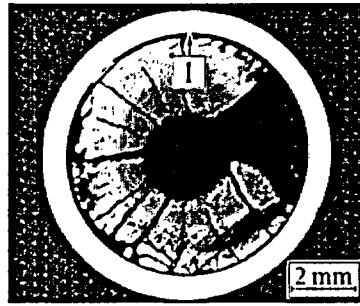

Fig. G-1.1. Appearance of Fuel Rod #H1T (photographs and X-ray photograph) and Profilometry

#H1T

Individual Characteristics of Refabricated Fuel Rods  
(Preirradiated Fuel, Preirradiated Cladding) under IGR Tests



Position 1

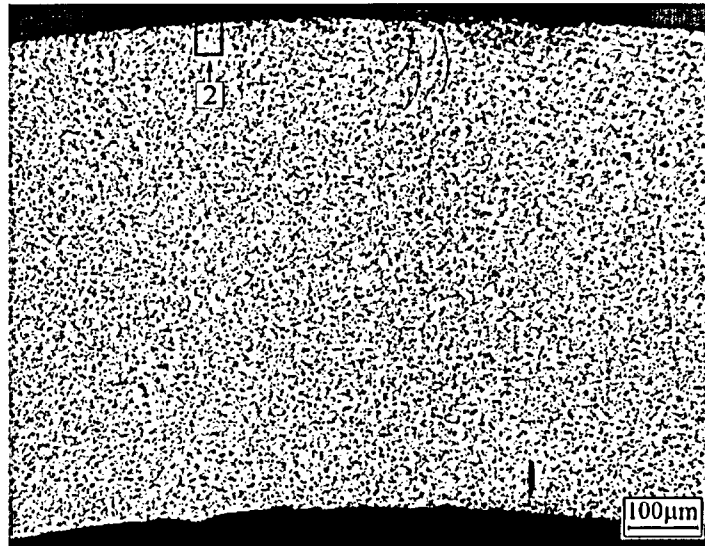

Position 1

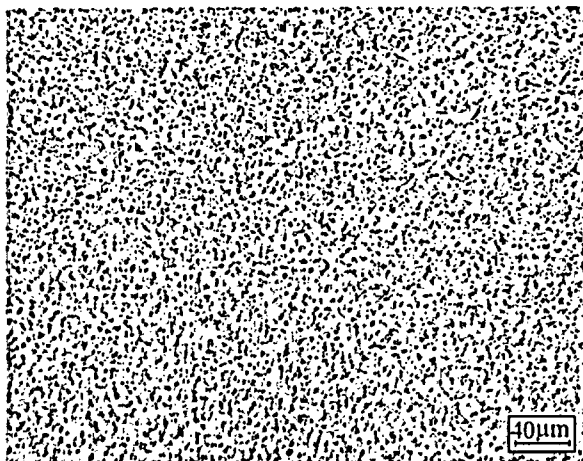

Position 2

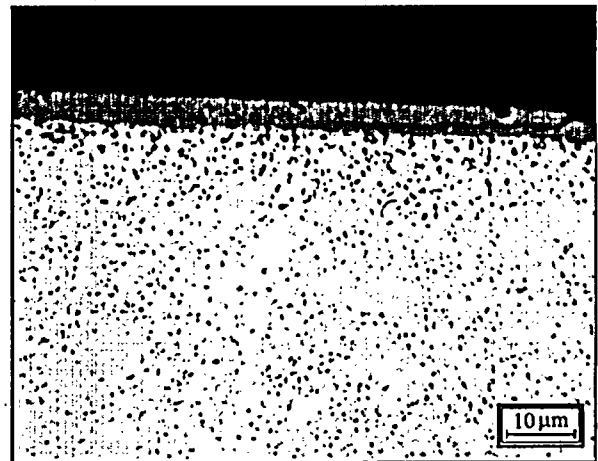

Fig. G-1.2. Cross-Section and Cladding Microstructure for Fuel Rod #H1T at 90 mm Elevation

#H1T

Individual Characteristics of Refabricated Fuel Rods  
(Preirradiated Fuel/Preirradiated Cladding) under IGR Tests

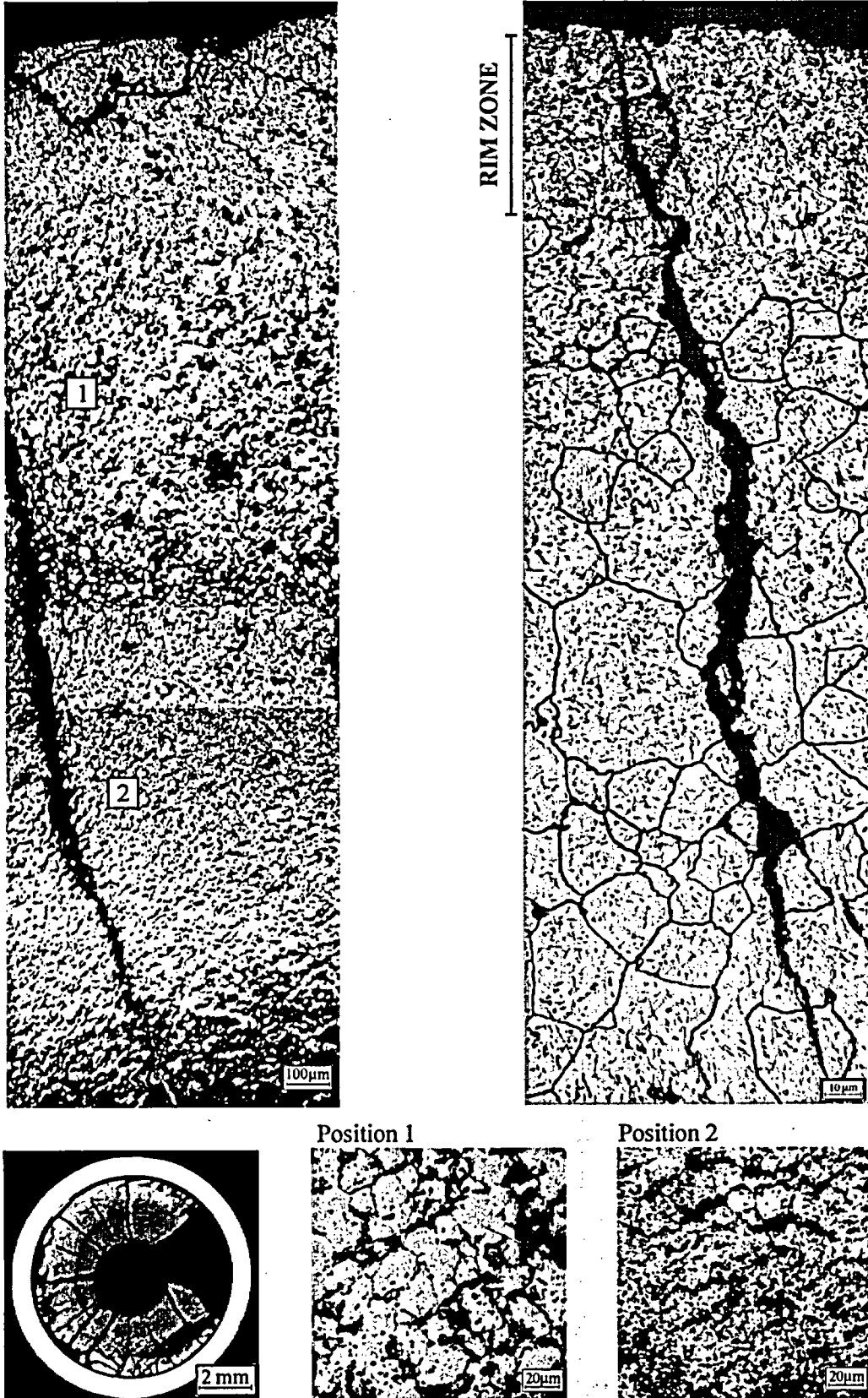

Fig. G-1.3. Fuel Microstructure of Fuel Rod #H1T at 90 mm Elevation

# #H1T

Individual Characteristics of Refabricated Fuel Rods  
(Preirradiated Fuel, Preirradiated Cladding) under IGR Tests

Table G-1.1. Time Dependent Energy Characteristics of Fuel Rod #H1T

Time (s)	Reactor energy deposition <sup>1)</sup> (%)	Cumulative number of fissions in fuel rod (fiss)						Power of fuel rod (kW)	Energy deposition in fuel rod	
		U <sup>235</sup> ×10 <sup>-14</sup>	U <sup>238</sup> ×10 <sup>-13</sup>	Pu <sup>239</sup> ×10 <sup>-14</sup>	Pu <sup>241</sup> ×10 <sup>-14</sup>	Other isotopes ×10 <sup>-11</sup>	Total ×10 <sup>-14</sup>		cal/g fuel	J/g fuel
0.0	0.000	0.000	0.000	0.000	0.000	0.000	0.000	0.000	0.000	0.000
1.0	1.890	0.128	0.032	0.197	0.081	0.155	0.410	2.720	4.630	19.40
2.0	10.90	0.742	0.184	1.140	0.469	0.898	2.370	10.30	26.70	112.0
2.2	14.90	1.010	0.251	1.550	0.639	1.220	3.230	14.70	36.50	153.0
2.4	20.70	1.410	0.349	2.160	0.890	1.700	4.490	22.20	50.80	213.0
2.6	29.80	2.020	0.502	3.100	1.280	2.450	6.450	34.70	72.90	305.0
2.8	43.40	2.940	0.731	4.510	1.860	3.570	9.390	49.40	106.0	444.0
3.0	59.80	4.060	1.010	6.220	2.560	4.910	12.90	47.80	146.0	611.0
3.2	72.30	4.910	1.220	7.520	3.100	5.940	15.70	30.40	177.0	741.0
3.4	80.00	5.430	1.350	8.320	3.430	6.570	17.30	18.20	196.0	820.0
3.6	84.60	5.740	1.430	8.800	3.630	6.950	18.30	11.40	207.0	867.0
3.8	87.60	5.940	1.480	9.110	3.760	7.190	19.00	7.620	215.0	900.0
4.0	89.60	6.080	1.510	9.320	3.840	7.360	19.40	5.390	220.0	921.0
4.2	91.00	6.170	1.530	9.460	3.900	7.480	19.70	4.010	223.0	933.0
4.4	92.10	6.250	1.550	9.580	3.950	7.570	19.90	3.100	226.0	946.0
4.6	92.90	6.310	1.570	9.670	3.990	7.640	20.10	2.490	228.0	954.0
4.8	93.60	6.350	1.580	9.740	4.020	7.690	20.30	2.050	230.0	963.0
5.0	94.20	6.390	1.590	9.800	4.040	7.740	20.40	1.730	232.0	971.0
5.2	94.70	6.420	1.600	9.850	4.060	7.780	20.50	1.490	233.0	975.0
5.4	95.10	6.450	1.600	9.890	4.080	7.810	20.60	1.260	234.0	980.0
5.6	95.40	6.470	1.610	9.920	4.090	7.840	20.70	1.070	235.0	984.0
5.8	95.70	6.490	1.610	9.950	4.110	7.860	20.70	0.917	236.0	988.0
6.0	96.00	6.510	1.620	9.980	4.120	7.880	20.80	0.794	236.0	988.0
6.5	96.40	6.540	1.620	10.00	4.140	7.920	20.90	0.581	238.0	996.0
7.0	96.80	6.570	1.630	10.10	4.150	7.950	21.00	0.451	239.0	1000.
7.5	97.00	6.580	1.640	10.10	4.160	7.970	21.00	0.368	240.0	1005.
8.0	97.30	6.600	1.640	10.10	4.170	7.990	21.10	0.313	240.0	1005.
9.0	97.60	6.620	1.640	10.20	4.190	8.020	21.10	0.269	241.0	1009.
10.0	97.90	6.640	1.650	10.20	4.200	8.050	21.20	0.216	242.0	1013.
20.0	99.20	6.730	1.670	10.30	4.250	8.150	21.50	0.056	246.0	1030.
30.0	99.60	6.760	1.680	10.40	4.270	8.180	21.60	0.030	248.0	1038.
∞	100.0	6.810	1.690	10.40	4.310	8.250	21.70	0.000	253.0	1059.

Maximum value of power is 52.5 kW (t = 2.90 s).

<sup>1)</sup> Current energy deposition per maximum energy deposition (at infinite time)

## #H1T

Individual Characteristics of Refabricated Fuel Rods  
(Preirradiated Fuel, Preirradiated Cladding) under IGR Tests

Table G-1.2. Axial Energy Characteristics of Fuel Rod #H1T

Axial coordinate from lower end of fuel rod (mm)	Cumulative number of fissions at axial interval (fiss)						Maximum power of fuel rod (kW) $t=2.90s$	Energy deposition at infinite time*		
	$U^{235} \times 10^{-13}$	$U^{238} \times 10^{-11}$	$Pu^{239} \times 10^{-13}$	$Pu^{241} \times 10^{-13}$	Other isotopes $\times 10^{-10}$	Total $\times 10^{-13}$		cal/g fuel	J/g fuel	per-unit <sup>3)</sup>
10.0	0.000	0.000	0.000	0.000	0.000	0.000	0.000	0.000	0.000	0.00
15.0	0.000	0.000	0.000	0.000	0.000	0.000	0.000	0.000	0.000	0.00
20.0 <sup>1)</sup>	0.338	0.717	0.524	0.217	0.369	1.090	0.263	279.0	1168.	1.00
25.0	1.690	3.590	2.620	1.090	1.850	5.440	1.310	279.0	1168.	1.00
30.0	1.690	3.590	2.620	1.090	1.850	5.440	1.310	279.0	1168.	1.00
35.0	1.690	3.590	2.620	1.090	1.850	5.440	1.310	279.0	1168.	1.00
40.0	1.690	3.590	2.620	1.090	1.850	5.440	1.310	279.0	1168.	1.00
45.0	1.690	3.590	2.620	1.090	1.850	5.440	1.310	279.0	1168.	1.00
50.0	2.380	5.690	3.490	1.420	2.750	7.360	1.780	261.0	1093.	0.94
55.0	2.370	5.700	3.490	1.430	2.760	7.340	1.780	260.0	1088.	0.93
60.0	2.340	5.710	3.490	1.430	2.760	7.310	1.770	257.0	1076.	0.92
65.0	2.330	5.720	3.480	1.430	2.770	7.300	1.760	256.0	1072.	0.92
70.0	2.320	5.720	3.480	1.430	2.770	7.280	1.760	251.0	1051.	0.90
75.0	2.390	5.690	3.500	1.420	2.750	7.380	1.780	253.0	1059.	0.91
80.0	2.440	5.660	3.510	1.420	2.740	7.440	1.800	254.0	1063.	0.91
85.0	2.410	5.680	3.500	1.420	2.750	7.390	1.790	251.0	1051.	0.90
90.0	2.360	5.700	3.490	1.430	2.760	7.330	1.770	247.0	1034.	0.89
95.0	2.360	5.700	3.490	1.430	2.760	7.330	1.770	249.0	1042.	0.89
100.0	2.360	5.700	3.490	1.430	2.760	7.330	1.770	253.0	1059.	0.91
105.0	2.320	5.720	3.480	1.430	2.770	7.280	1.760	252.0	1055.	0.90
110.0	2.280	5.740	3.470	1.430	2.780	7.240	1.750	250.0	1047.	0.90
115.0	2.240	5.760	3.460	1.430	2.790	7.190	1.740	249.0	1042.	0.89
120.0	2.230	5.760	3.460	1.430	2.790	7.180	1.730	249.0	1042.	0.89
125.0	2.170	5.790	3.440	1.430	2.810	7.100	1.720	243.0	1017.	0.87
130.0	2.130	5.810	3.430	1.430	2.820	7.050	1.710	244.0	1021.	0.87
135.0	2.090	5.820	3.420	1.430	2.820	7.010	1.690	244.0	1021.	0.87
140.0	2.050	5.840	3.410	1.430	2.830	6.960	1.680	241.0	1009.	0.86
145.0	2.130	5.810	3.430	1.430	2.820	7.050	1.710	243.0	1017.	0.87
150.0	2.190	5.780	3.450	1.430	2.800	7.130	1.720	246.0	1030.	0.88
155.0	2.180	5.780	3.440	1.430	2.800	7.110	1.720	244.0	1021.	0.87
160.0	2.170	5.790	3.440	1.430	2.810	7.100	1.720	243.0	1017.	0.87
165.0	2.220	5.770	3.450	1.430	2.790	7.160	1.730	248.0	1038.	0.89
170.0	2.270	5.740	3.470	1.430	2.780	7.220	1.750	250.0	1047.	0.90
175.0	2.180	5.780	3.440	1.430	2.800	7.110	1.720	254.0	1063.	0.91
180.0 <sup>2)</sup>	0.423	1.160	0.686	0.286	0.564	1.410	0.340	236.0	988.0	0.85
185.0	0.000	0.000	0.000	0.000	0.000	0.000	0.000	0.000	0.000	0.00

\* All numerical values of characteristics are presented as average values at the length interval equal to the axial coordinate  $\pm 2.5$  mm<sup>1)</sup> Initial coordinate of fuel is 21.5 mm<sup>2)</sup> End coordinate of fuel is 178.5 mm<sup>3)</sup> Current value per maximum value

# #H1T

Individual Characteristics of Refabricated Fuel Rods  
(Preirradiated Fuel, Preirradiated Cladding) under IGR Tests

Table G-1.3. Radial Energy Characteristics of Fuel Rod #H1T

Characteristics*		Coordinates of fuel zones (mm)			
		1 zone 1.2 - 2.811	2 zone 2.811-3.432	3 zone 3.432-3.704	4 zone 3.704-3.790
U <sup>235</sup>	Number of fissions ×10 <sup>-14</sup> (fiss)	3.020	1.770	0.867	0.282
	Power of fuel rod <sup>1)</sup> (kW)	7.150	4.190	2.050	0.668
	Energy deposition <sup>2)</sup> (cal/g fuel)	78.20	76.40	74.80	73.00
	Energy deposition <sup>2)</sup> (J/g fuel)	327.0	320.0	313.0	306.0
	Energy deposition <sup>3)</sup> (per-unit)	1.000	0.977	0.957	0.934
U <sup>238</sup>	Number of fissions ×10 <sup>-12</sup> (fiss)	7.940	4.470	2.060	0.622
	Power of fuel rod <sup>1)</sup> (kW)	0.186	0.105	0.048	0.014
	Energy deposition <sup>2)</sup> (cal/g fuel)	2.020	1.900	1.750	1.580
	Energy deposition <sup>2)</sup> (J/g fuel)	8.460	7.950	7.330	6.610
	Energy deposition <sup>3)</sup> (per-unit)	1.000	0.941	0.866	0.782
Pu <sup>239</sup>	Number of fissions ×10 <sup>-14</sup> (fiss)	3.770	2.560	1.760	0.993
	Power of fuel rod <sup>1)</sup> (kW)	9.240	6.280	4.300	2.430
	Energy deposition <sup>2)</sup> (cal/g fuel)	101.0	114.0	157.0	266.0
	Energy deposition <sup>2)</sup> (J/g fuel)	423.0	477.0	657.0	1113.
	Energy deposition <sup>3)</sup> (per-unit)	0.380	0.429	0.590	1.000
Pu <sup>241</sup>	Number of fissions ×10 <sup>-13</sup> (fiss)	14.90	10.50	7.560	4.500
	Power of fuel rod <sup>1)</sup> (kW)	3.570	2.530	1.820	1.080
	Energy deposition <sup>2)</sup> (cal/g fuel)	39.10	46.20	66.30	118.0
	Energy deposition <sup>2)</sup> (J/g fuel)	164.0	193.0	278.0	494.0
	Energy deposition <sup>3)</sup> (per-unit)	0.331	0.392	0.562	1.000
Other isotopes	Number of fissions ×10 <sup>-11</sup> (fiss)	3.400	2.090	1.220	0.581
	Power of fuel rod <sup>1)</sup> (kW)	0.008	0.005	0.003	0.001
	Energy deposition <sup>2)</sup> (cal/g fuel)	0.090	0.092	0.107	0.154
	Energy deposition <sup>2)</sup> (J/g fuel)	0.380	0.390	0.450	0.640
	Energy deposition <sup>3)</sup> (per-unit)	0.583	0.599	0.695	1.000
Total	Number of fissions ×10 <sup>-14</sup> (fiss)	8.340	5.430	3.400	1.740
	Power of fuel rod <sup>1)</sup> (kW)	20.20	13.10	8.240	4.210
	Energy deposition <sup>2)</sup> (cal/g fuel)	220.0	239.0	300.0	459.0
	Energy deposition <sup>2)</sup> (J/g fuel)	921.0	1000.	1256.	1921.
	Energy deposition <sup>3)</sup> (per-unit)	0.479	0.521	0.654	1.000

<sup>1)</sup> at time of 2.90 s, <sup>2)</sup> at infinite time, <sup>3)</sup> Current value per maximum value.

\* All numerical values of characteristics were calculated for undamaged part of fuel stack only (See Table C.2.1.)

Table G-1.4. Fuel Enthalpy Vs. Time Calculated by FRAP-T6 Code for Fuel Rod #H1T

Time (s)	Enthalpy at fuel radius (cal/g fuel)				Fuel enthalpy <sup>1)</sup>		Energy deposition in fuel rod	
	1.20 mm	2.82 mm	3.47 mm	3.79 mm	cal/g fuel	J/g fuel	cal/g fuel	J/g fuel
0.0	0.00	0.00	0.00	0.00	0.00	0.00	0.00	0.00
1.0	5.28	5.19	4.92	4.55	5.13	21.5	5.19	21.7
2.0	27.5	25.9	22.5	18.5	25.2	106	28.0	117
2.2	34.5	32.2	27.1	21.6	31.2	131	35.4	148
2.4	47.6	43.9	36.2	27.5	42.4	178	49.1	206
2.6	67.6	61.9	45.6	26.7	57.9	243	70.3	295
2.8	97.7	88.1	62.2	34.7	82.1	344	102	429
3.0	140	124	83.7	42.2	115	482	148	622
3.2	163	141	94.0	56.3	132	555	176	736
3.4	179	150	102	71.0	144	603	196	822
3.6	188	153	106	79.5	149	624	208	871
3.8	191	152	108	82.4	150	630	215	900
4.0	192	150	107	82.9	150	629	220	922
4.2	192	148	106	82.2	148	622	224	938
4.4	191	145	104	81.2	146	614	226	949
4.6	189	142	101	80.0	144	603	229	958
4.8	186	138	99.7	80.0	141	591	230	966
5.0	183	135	98.3	79.6	138	580	232	972
5.2	179	132	95.7	74.9	135	566	233	977
5.4	175	128	89.9	66.6	131	547	234	982
5.6	171	124	83.3	60.2	126	527	235	986
5.8	167	118	78.5	58.2	121	507	236	989
6.0	163	113	75.7	57.6	117	490	237	992
6.5	149	102	71.1	56.8	107	448	238	998
7.0	138	95.7	68.8	56.3	100	421	239	1001
7.5	123	87.9	65.7	55.2	91.8	385	240	1005
8.0	114	83.3	63.7	54.3	86.6	363	241	1008
10.0	80.7	65.2	54.1	48.3	66.5	279	243	1017
30.0	13.1	12.6	12.2	11.9	12.6	52.9	248	1041

Radial enthalpy distribution and fuel enthalpy are presented at elevation 29.4 mm

Maximum value of fuel enthalpy is 150.5 cal/g fuel ( $t=3.84$  s)

<sup>1)</sup> All numerical values are presented at elevation with peak power



# #H1T

Individual Characteristics of Refabricated Fuel Rods  
(Preirradiated Fuel, Preirradiated Cladding) under IGR Tests

Table G-1.5. Energy Characteristics Vs. Time Calculated by FRAP-T6 and SCANAIR Codes for Fuel Rod #H1T

Time (s)	Energy deposition <sup>1)</sup> (cal/g fuel)	Linear power <sup>1)</sup> (kW/m)	Fuel enthalpy <sup>1)</sup> (cal/g fuel)		Energy of metal-water reaction <sup>1)</sup> (cal/g fuel)	Leakage of energy <sup>1)</sup> (cal/g fuel)		Clad-to-coolant heat transfer coefficient <sup>1)</sup> (kW/m <sup>2</sup> K)	
			FRAP-T6	SCANAIR	FRAP-T6	FRAP-T6	SCANAIR	FRAP-T6	SCANAIR
0.0	0.00	0.00	0.00	0.00	0.00	0.00	0.00	0.00	0.00
1.0	5.71	22.2	5.13	4.24	0.00	0.00	0.01	0.03	0.10
2.0	30.8	82.6	25.2	23.4	0.00	3.42	3.29	6.50	6.60
2.2	38.9	108	31.2	30.3	0.00	5.41	5.60	8.23	9.08
2.4	54.1	162	42.4	41.9	0.00	9.05	9.63	11.3	13.5
2.6	77.3	253	57.9	59.9	0.00	16.0	16.2	20.8	20.9
2.8	113	366	82.1	83.1	0.00	26.4	24.6	26.3	27.6
3.0	163	358	115	114	0.00	41.2	38.2	14.8	31.8
3.2	193	241	132	133	0.00	46.0	49.2	1.46	1.03
3.4	216	139	144	141	0.00	49.9	51.4	1.89	1.44
3.6	229	85.6	149	146	0.00	55.2	55.6	2.03	1.61
3.8	236	58.9	150	147	0.00	60.4	60.4	2.07	1.66
4.0	242	40.9	150	147	0.01	66.6	65.1	2.10	1.69
4.2	246	30.3	148	145	0.01	72.6	70.4	2.10	1.71
4.4	249	23.9	146	142	0.01	78.1	75.0	2.09	1.71
4.6	252	19.2	144	140	0.01	83.9	80.4	2.07	1.71
4.8	254	15.8	141	137	0.02	89.6	85.0	2.03	1.70
5.0	255	13.3	138	134	0.02	95.7	90.6	3.22	2.12
5.2	257	11.4	135	130	0.02	107	99.3	6.80	5.48
5.4	258	9.67	131	124	0.02	120	119	11.8	20.6
5.6	259	8.21	126	116	0.02	131	132	18.1	24.0
5.8	260	7.04	121	109	0.02	137	139	13.8	20.0
6.0	260	6.09	117	103	0.02	142	146	12.4	17.2
6.5	262	4.32	107	90.7	0.02	155	160	10.1	13.6
7.0	263	3.52	100	81.2	0.02	162	171	9.08	11.6
7.5	264	2.76	91.8	72.5	0.02	172	180	7.90	10.2
8.0	265	2.42	86.6	65.0	0.02	177	189	7.28	8.99
10.0	267	1.67	66.5	43.5	0.02	200	212	5.13	5.84
30.0	273	0.23	12.6	6.36	0.02	260	256	0.54	0.19

<sup>1)</sup> All numerical values are presented at elevation with peak power

# #H1T

Individual Characteristics of Refabricated Fuel Rods  
(Preirradiated Fuel/Preirradiated Cladding) under IGR Tests

Table G-1.6. Temperature Variation, Fission Gas Release and ZrO<sub>2</sub> Thickness Vs. Time for Fuel Rod #H1T Calculated by FRAP-T6 and SCANAIR Codes

Time (s)	Fuel centerline temperature <sup>1)</sup> (K)		Fuel surface temperature <sup>1)</sup> (K)		Clad outer temperature <sup>1)</sup> (K)		Fission gas release (%)		Average ZrO <sub>2</sub> <sup>2)</sup> thickness (μm)
	FRAP-T6	SCANAIR	FRAP-T6	SCANAIR	FRAP-T6	SCANAIR	FRAP-T6	SCANAIR	FRAP-T6
0.0	293	293	293	293	293	293	0.00	0.00	5.00
1.0	379	362	368	355	328	321	0.06	0.45	5.00
2.0	701	666	573	572	404	390	0.22	1.92	5.00
2.2	798	775	618	629	408	394	0.30	2.28	5.00
2.4	975	954	701	710	414	399	0.47	2.68	5.00
2.6	1242	1230	690	805	427	407	0.81	3.07	5.00
2.8	1635	1572	800	929	434	413	1.61	3.34	5.00
3.0	2145	2026	903	1049	516	426	3.30	3.61	5.00
3.2	2398	2331	1092	1122	824	701	5.07	5.05	5.00
3.4	2559	2471	1287	1279	1043	996	7.79	6.89	5.00
3.6	2636	2556	1398	1419	1110	1117	10.7	9.33	5.01
3.8	2668	2593	1436	1458	1133	1153	14.1	11.5	5.02
4.0	2681	2601	1443	1467	1147	1175	15.7	13.2	5.03
4.2	2677	2593	1434	1467	1148	1188	16.1	14.6	5.05
4.4	2665	2575	1420	1461	1142	1192	16.2	15.5	5.06
4.6	2646	2547	1405	1450	1132	1190	16.2	16.2	5.08
4.8	2620	2519	1405	1437	1114	1185	16.2	16.7	5.09
5.0	2590	2481	1400	1420	1064	1167	16.2	17.1	5.10
5.2	2557	2443	1338	1387	867	1051	16.2	17.4	5.10
5.4	2521	2399	1229	1157	607	529	16.3	17.6	5.10
5.6	2482	2354	1143	1011	424	412	16.3	17.7	5.10
5.8	2440	2312	1117	956	418	406	16.3	17.7	5.10
6.0	2395	2259	1109	935	416	403	16.3	17.7	5.10
6.5	2250	2098	1099	909	412	399	16.3	17.7	5.10
7.0	2132	1921	1091	887	410	397	16.3	17.7	5.10
7.5	1952	1733	1078	864	407	395	16.3	17.6	5.10
8.0	1840	1560	1066	840	406	394	16.3	17.5	5.10
10.0	1414	1080	985	737	401	389	16.3	17.2	5.10
30.0	497	395	479	391	382	376	16.4	15.7	5.10

<sup>1)</sup> All numerical values are presented at elevation with peak power

<sup>2)</sup> Initial ZrO<sub>2</sub> thickness is 5 μm

# #H1T

Individual Characteristics of Refabricated Fuel Rods  
(Preirradiated Fuel, Preirradiated Cladding) under IGR Tests

Table G-1.7. Mechanical Characteristics of Fuel Rod #H1T Vs. Time Calculated by FRAP-T6 and SCANAIR Codes

Time (s)	Clad outer temperature <sup>1)</sup> (K)		Fuel hoop strain <sup>1)</sup> (%)		Fuel - clad gap width <sup>1)</sup> (mm)		Clad hoop strain <sup>1)</sup> (%)		Clad hoop stress <sup>1)</sup> (MPa)		Internal gas pressure (MPa)	
	FRAP-T6	SCANAIR	FRAP-T6	SCANAIR	FRAP-T6	SCANAIR	FRAP-T6	SCANAIR	FRAP-T6	SCANAIR	FRAP-T6	SCANAIR
0.0	293	293	0.00	0.00	0.03	0.03	0.01	0.01	8.26	7.99	1.70	1.70
1.0	328	321	0.10	0.05	0.03	0.03	0.03	0.03	8.57	8.41	1.76	1.77
2.0	404	390	0.53	0.26	0.01	0.02	0.09	0.10	9.18	9.82	1.87	1.95
2.2	408	394	0.66	0.34	0.01	0.02	0.10	0.11	9.30	10.2	1.90	1.98
2.4	414	399	0.92	0.49	0.00	0.02	0.11	0.12	9.61	10.9	1.93	2.03
2.6	427	407	1.33	0.73	0.00	0.01	0.45	0.15	391	11.8	1.97	2.07
2.8	434	413	1.99	1.08	0.00	0.00	0.96	0.27	195	134	2.00	2.11
3.0	516	426	3.08	1.92	0.00	0.00	1.83	0.95	363	403	2.05	2.14
3.2	824	701	3.76	2.91	0.00	0.00	2.41	1.76	144	263	2.10	2.18
3.4	1043	996	4.48	3.64	0.00	0.00	3.04	2.32	11.5	27.5	2.16	2.24
3.6	1110	1117	4.89	4.05	0.00	-	3.38	-	11.9	-	2.23	-
3.8	1133	1153	5.24	4.22	0.00	-	3.64	-	12.4	-	2.29	-
4.0	1147	1175	5.42	4.28	0.00	-	3.78	-	12.6	-	2.32	-
4.2	1148	1188	5.36	4.29	0.00	-	3.84	-	12.6	-	2.33	-
4.4	1142	1192	5.27	4.27	0.01	-	3.89	-	12.6	-	2.33	-
4.6	1132	1190	5.14	4.24	0.02	-	3.94	-	12.6	-	2.32	-
4.8	1114	1185	5.02	4.20	0.02	-	3.97	-	12.6	-	2.32	-
5.0	1064	1167	4.88	4.14	0.03	-	3.99	-	12.6	-	2.31	-
5.2	867	1051	4.72	4.09	0.03	-	3.87	-	12.6	-	2.31	-
5.4	607	529	4.49	3.96	0.03	-	3.70	-	12.6	-	2.31	-
5.6	424	412	4.24	3.79	0.04	-	3.57	-	12.5	-	2.30	-
5.8	418	406	4.02	3.66	0.04	-	3.55	-	12.5	-	2.29	-
6.0	416	403	3.83	3.54	0.05	-	3.55	-	12.4	-	2.29	-
6.5	412	399	3.37	3.31	0.07	-	3.54	-	12.3	-	2.26	-
7.0	410	397	3.08	3.14	0.08	-	3.54	-	12.2	-	2.25	-
7.5	407	395	2.69	3.00	0.09	-	3.54	-	12.1	-	2.22	-
8.0	406	394	2.46	2.88	0.10	-	3.53	-	12.0	-	2.21	-
10.0	401	389	1.59	2.56	0.14	-	3.53	-	11.7	-	2.15	-
30.0	382	376	0.23	2.09	0.19	-	3.50	-	10.4	-	1.93	-

<sup>1)</sup> All numerical values are presented at elevation with peak power

# #H1T

Individual Characteristics of Refabricated Fuel Rods  
(Preirradiated Fuel, Preirradiated Cladding) under IGR Tests

Table G-1.8. Axial Distribution of Energy Deposition and Fuel Enthalpy Calculated by FRAP-T6 Code for Fuel Rod #H1T

Axial interval from-to (mm)-(mm)	Energy deposition at infinite time			Fuel enthalpy at time (t=3.84 s)		
	cal/g fuel	J/g fuel	per-unit	cal/g fuel	J/g fuel	per-unit
21.5 - 37.2	279	1168	1.00	151	631	1.00
37.2 - 52.9	270	1129	0.97	145	610	0.97
52.9 - 68.6	255	1067	0.91	138	576	0.91
68.6 - 84.3	252	1054	0.90	136	569	0.90
84.3 - 100.0	249	1044	0.89	135	564	0.89
100.0 - 115.7	250	1048	0.90	135	566	0.90
115.7 - 131.4	246	1030	0.88	133	556	0.88
131.4 - 147.1	243	1017	0.87	131	549	0.87
147.1 - 162.8	244	1024	0.88	132	553	0.88
162.8 - 178.5	247	1035	0.89	133	559	0.89

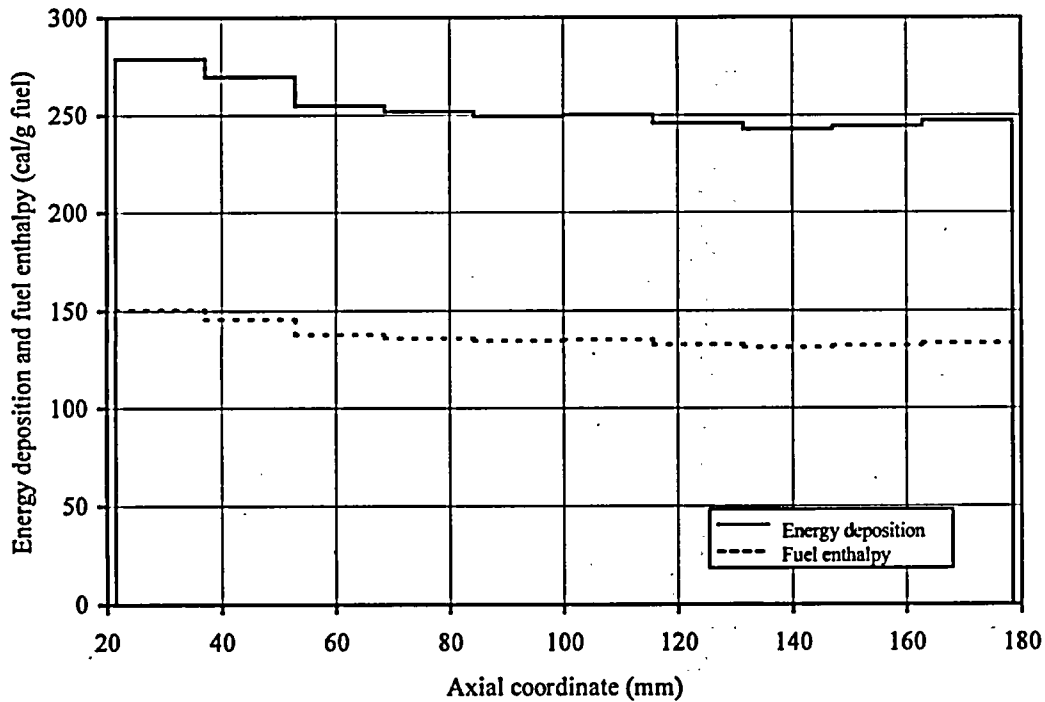

Fig. G-1.4. Axial Distribution of Energy Deposition and Fuel Enthalpy Calculated by FRAP-T6 Code for Fuel Rod #H1T

#H1T

Individual Characteristics of Refabricated Fuel Rods  
(Preirradiated Fuel, Preirradiated Cladding) under IGR-Tests

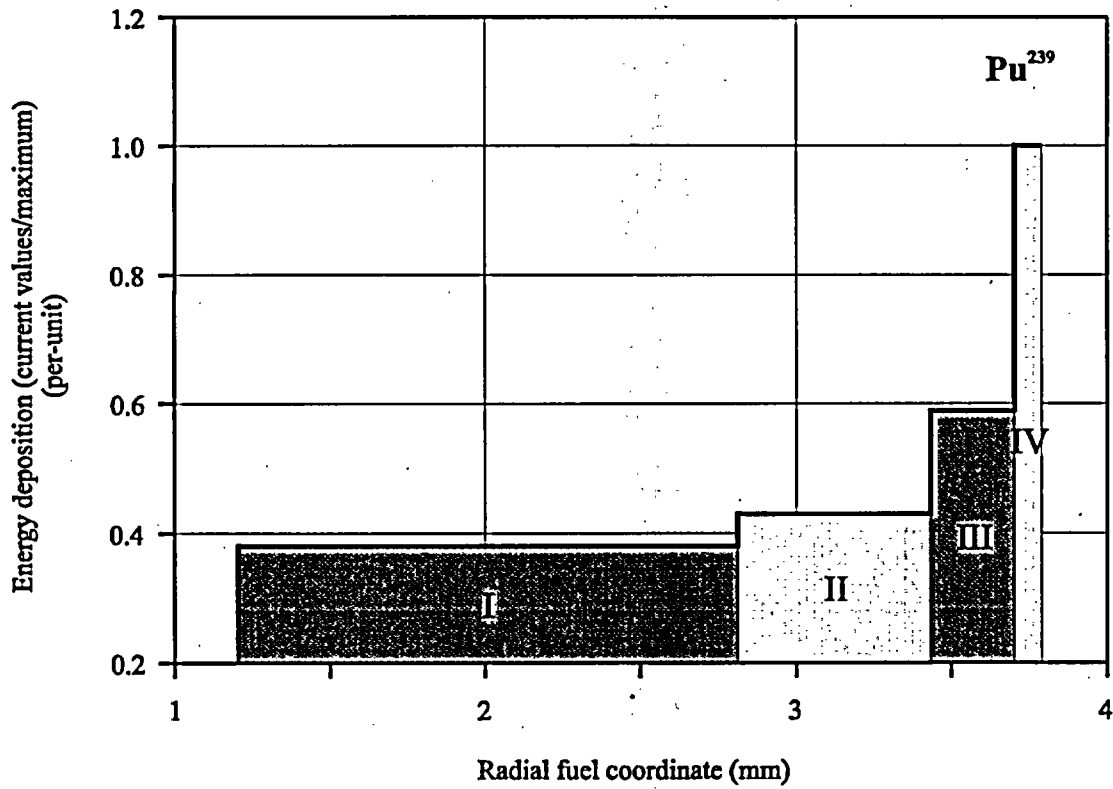
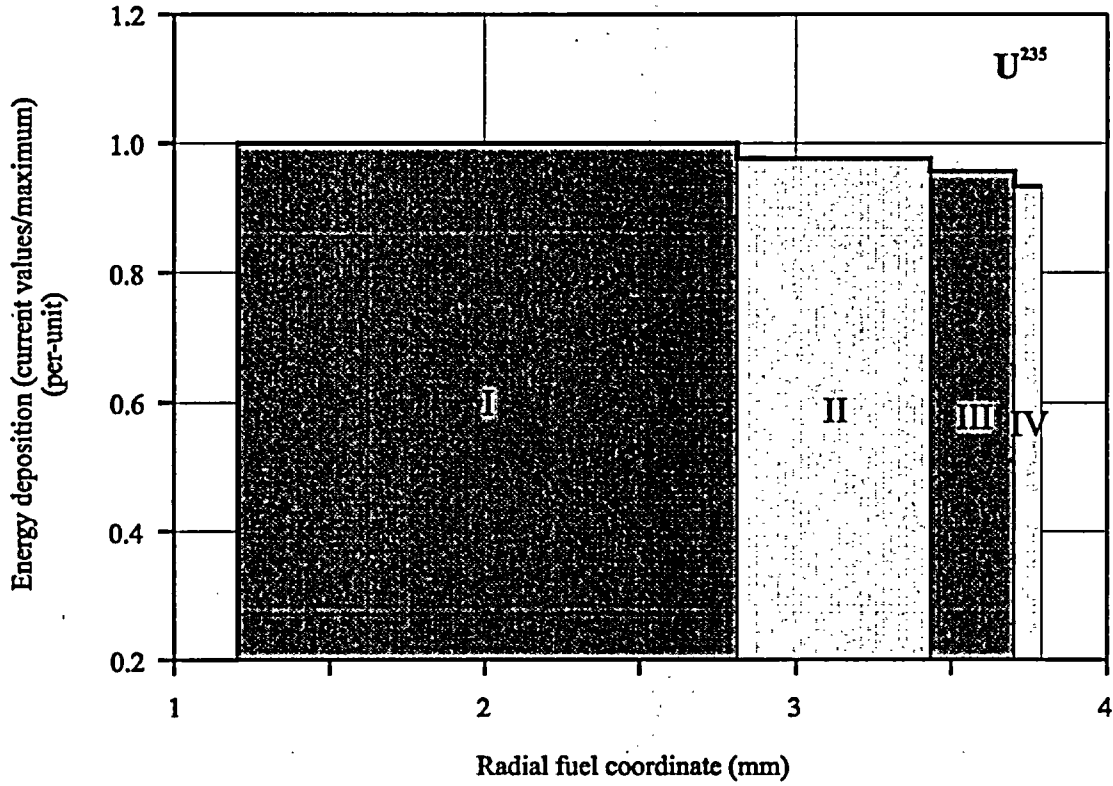

Fig. G-1.5.  $U^{235}$  and  $Pu^{239}$  Radial Distributions of Energy Deposition for Fuel Rod #H1T

#H1T

Individual Characteristics of Refabricated Fuel Rods  
(Preirradiated Fuel, Preirradiated Cladding) under IGR Tests

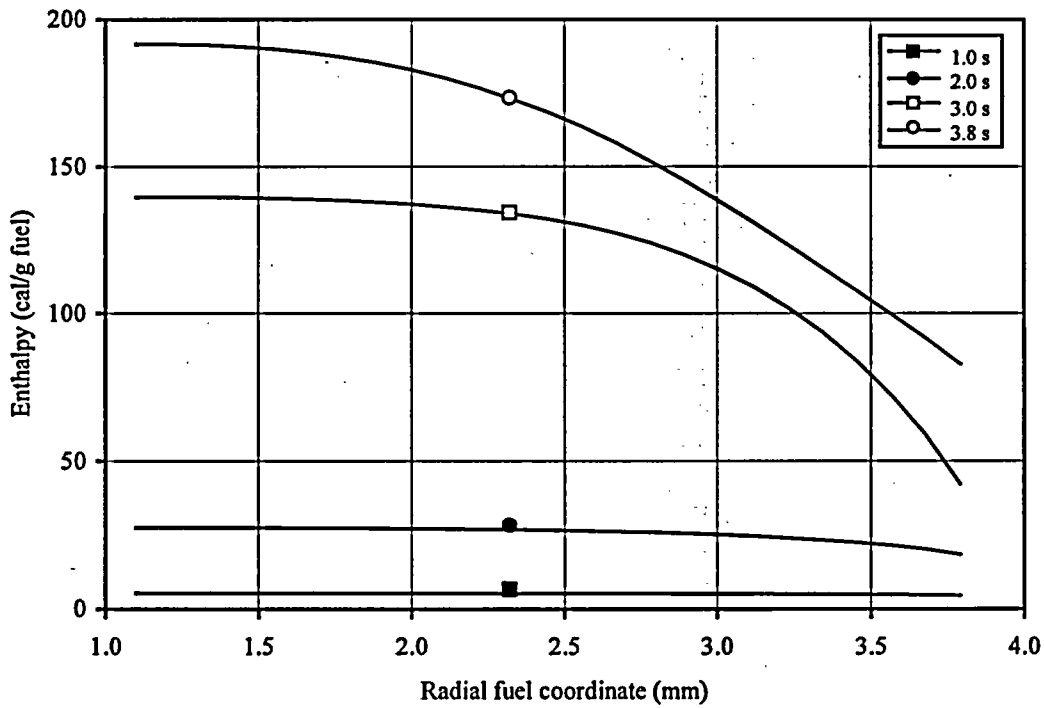
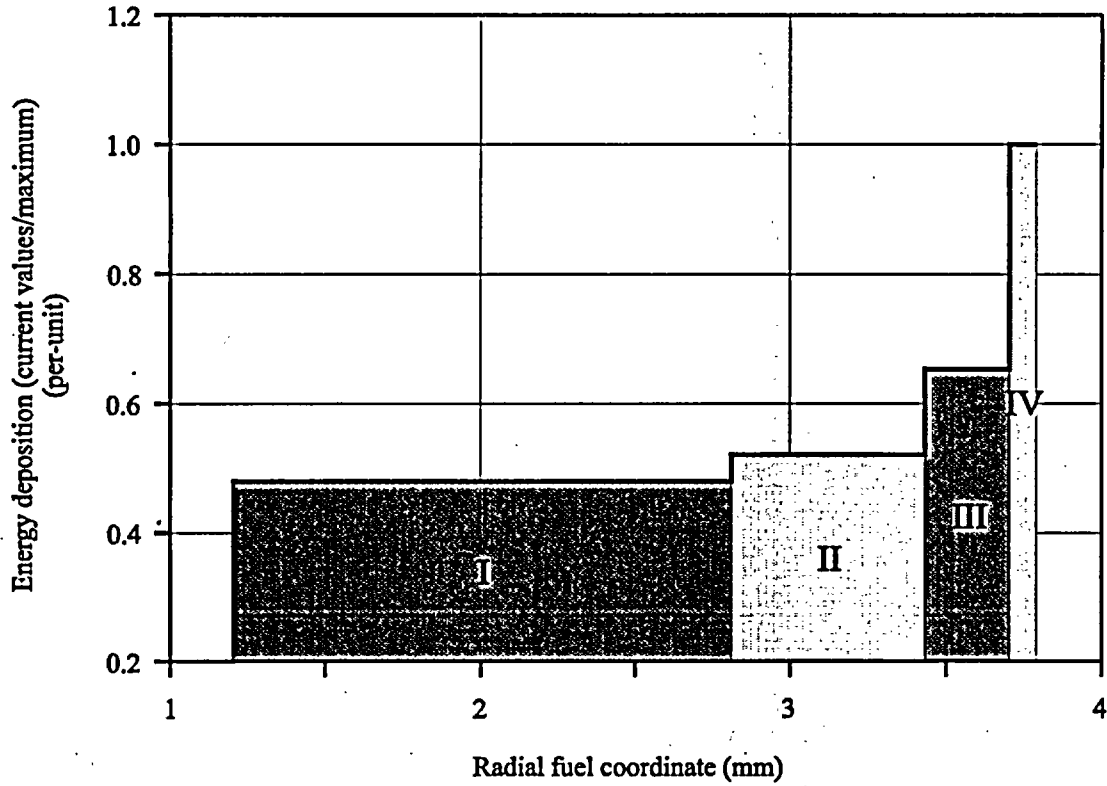

Fig. G-1.6. Radial Distributions of Energy Deposition and Fuel Enthalpy Calculated by FRAP-T6 Code for Fuel Rod #H1T

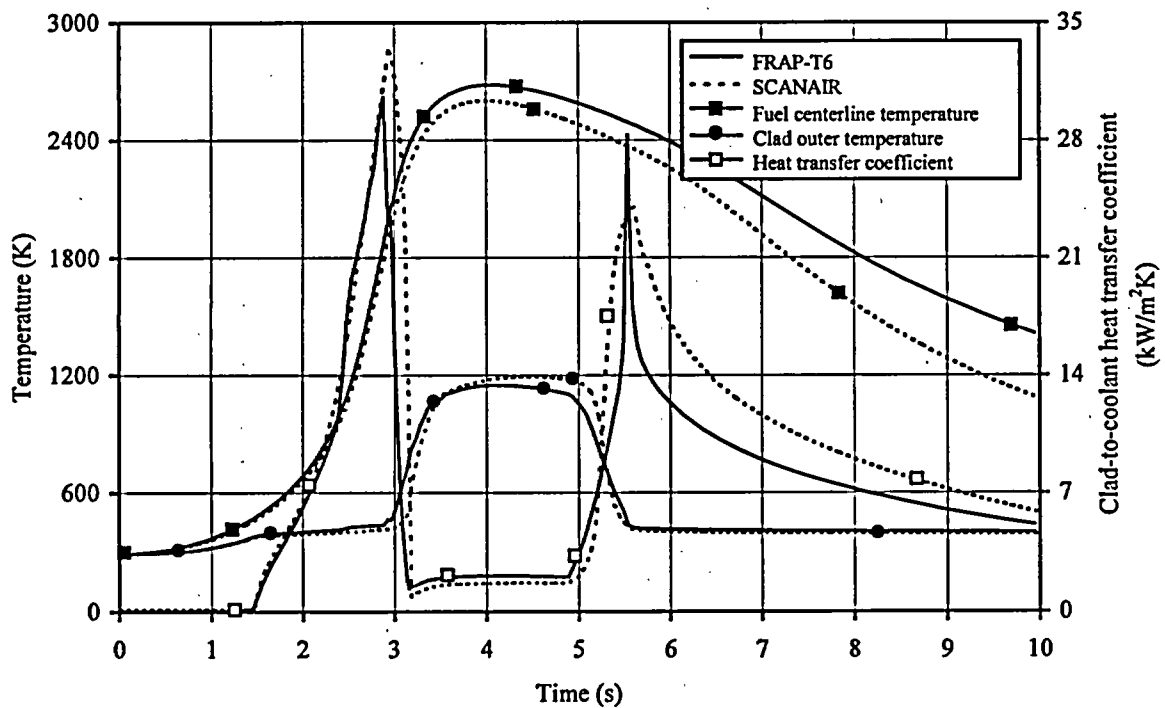
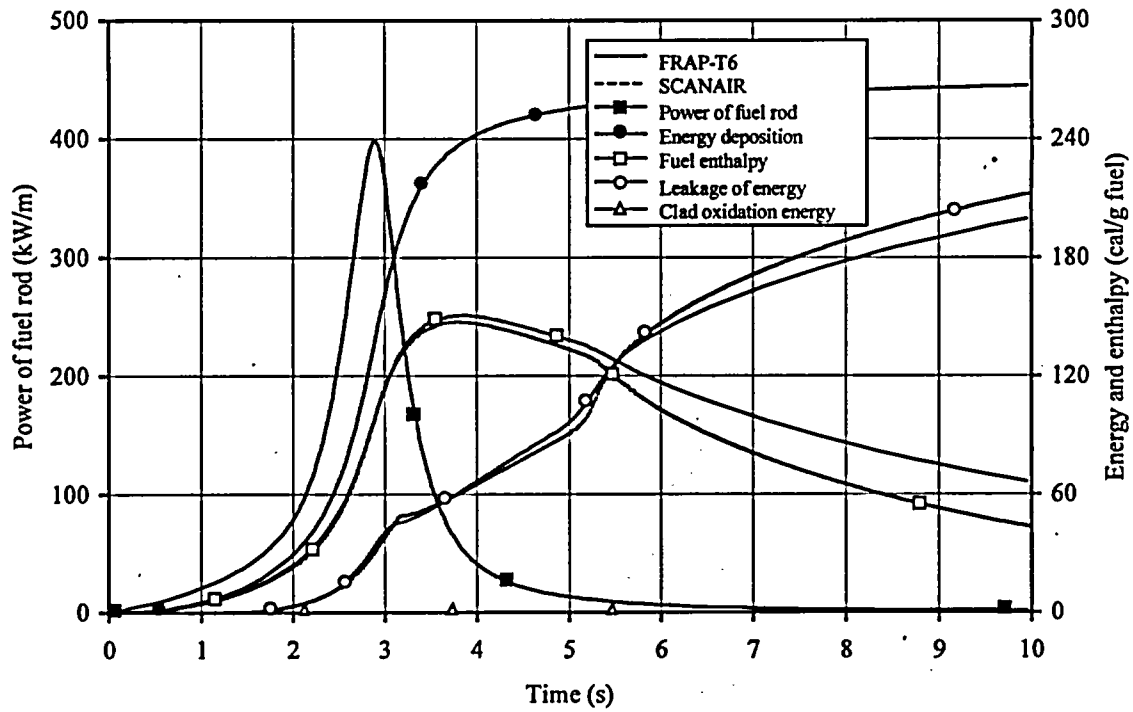

Fig. G-1.7. Energy and Temperature Characteristics Vs. Time Calculated by FRAP-T6 and SCANAIR Codes for Fuel Rod #H1T

#H1T

Individual Characteristics of Refabricated Fuel Rods  
(Preirradiated Fuel, Preirradiated Cladding) under IGR Tests

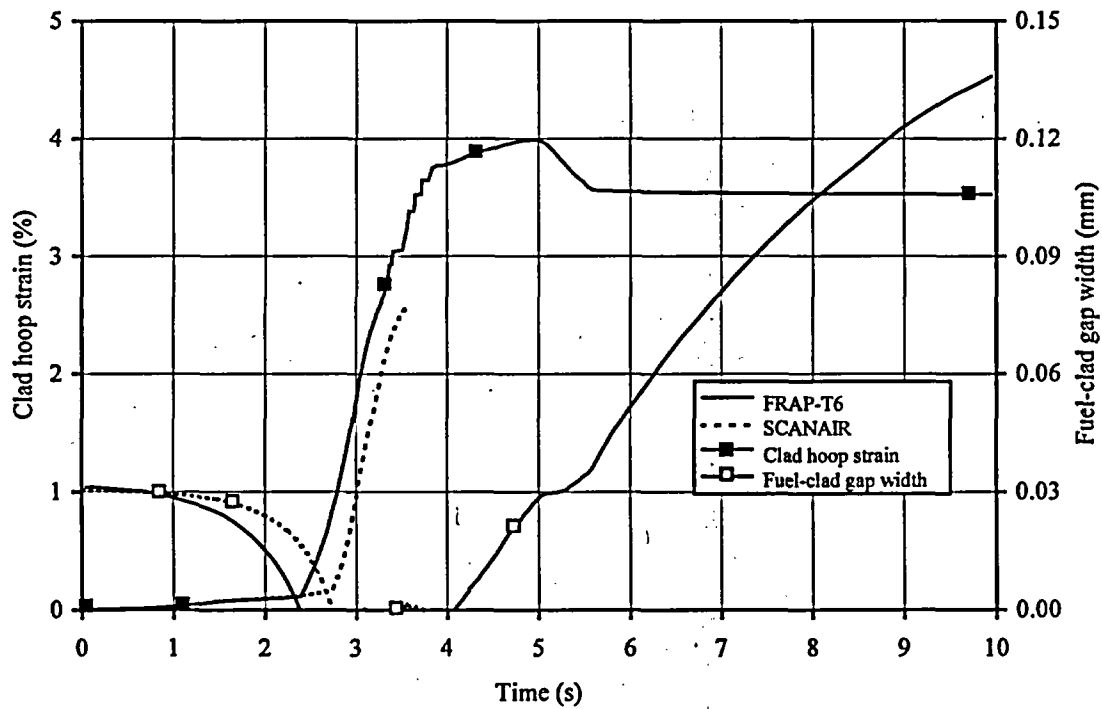
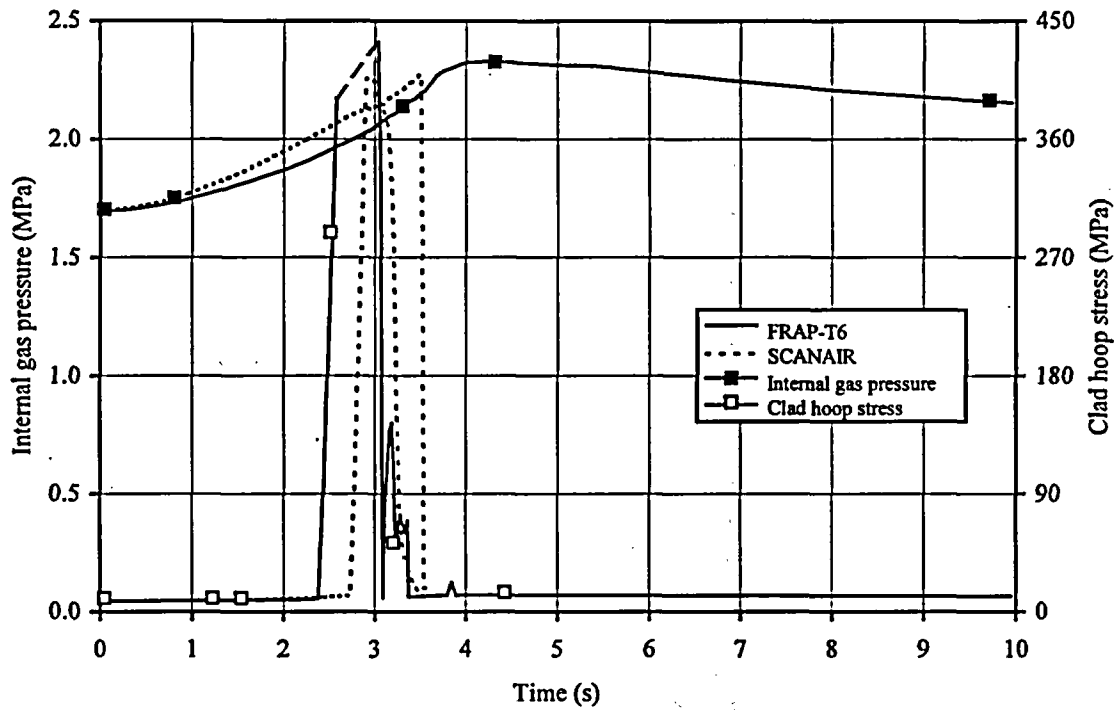

Fig. G-1.8. Cladding Mechanical Characteristics Vs. Time Calculated by FRAP-T6 and SCANAIR Codes for Fuel Rod #H1T



#H1T

Individual Characteristics of Refabricated Fuel Rods  
(Preirradiated Fuel, Preirradiated Cladding) under IGR Tests

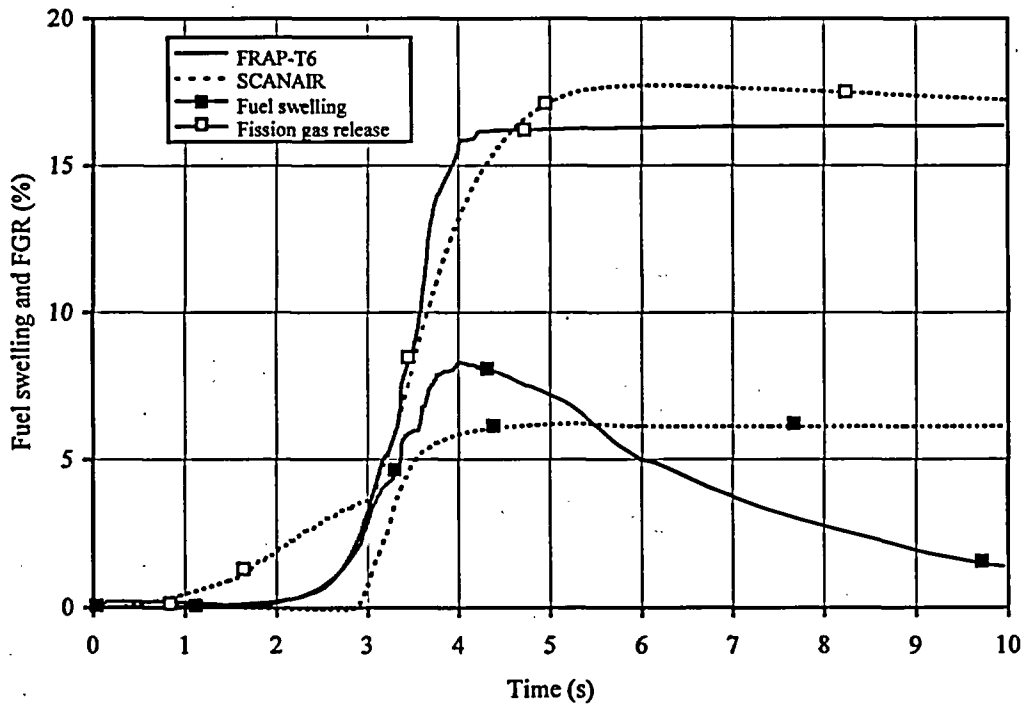
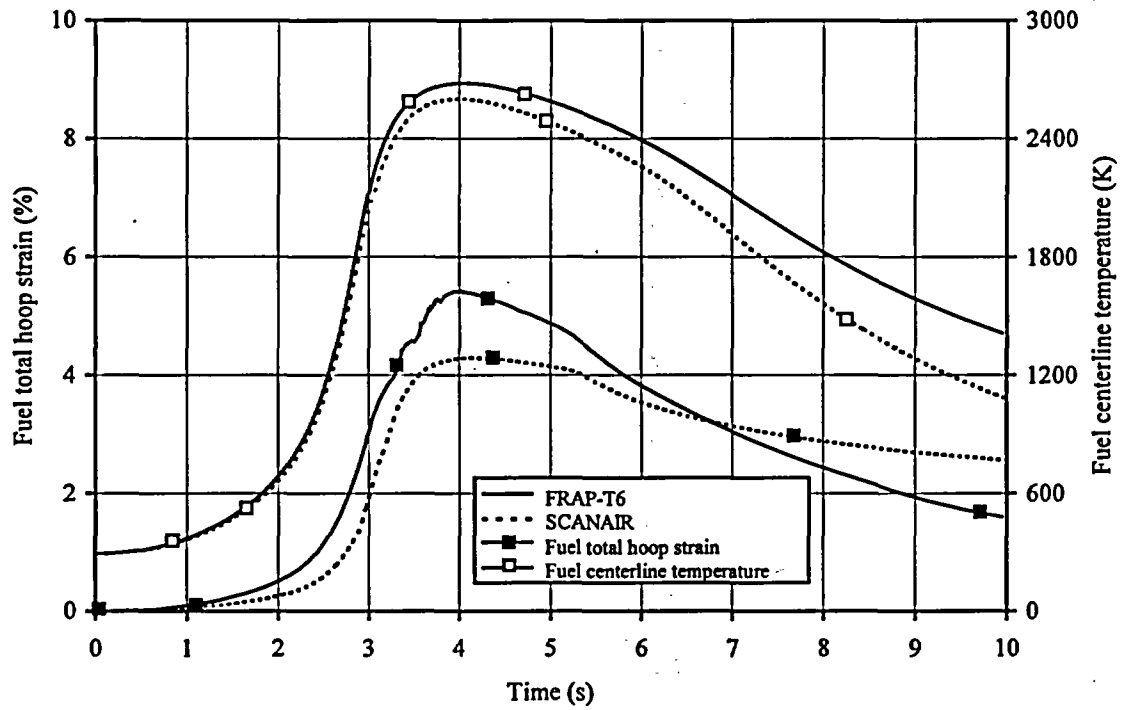

Fig. G-1.9. Fuel Strain and Fission Gas Release Vs. Time Calculated by FRAP-T6 and SCANAIR Codes for Fuel Rod #H1T

Table G-1.9. Some Results of PIE for Fuel Rod #H1T

Characteristic		Value
1	Measured parameters of cladding oxidation and cladding deformation	
1.1	Cladding thickness at elevation 90 mm for different azimuthal angles (mm):	
	0°	705
	90°	700
	180°	705
	270°	700
1.2	ZrO <sub>2</sub> thickness at elevation 90 mm for different azimuthal angles (mm):	
	0°	5
	90°	5
	180°	5
	270°	5
1.3	αZr(O) thickness at elevation 90 mm for different azimuthal angles (mm):	
	0°	0
	90°	0
	180°	0
	270°	0
1.4	Clad hoop strain axially averaged (%)	1.4
2	Measured parameters for FGR analysis	
2.1	Internal gas composition (% by volume):	
	He	85.42
	N <sub>2</sub>	0.14
	O <sub>2</sub>	0.02
	Ar	0.004
	CO <sub>2</sub>	0.01
	Kr	1.39
	Xe	13.02
2.2	Free gas volume (cm <sup>3</sup> )	5.52
2.3	Gas pressure inside fuel rod under normal condition (MPa)	1.913
2.4	Kr concentration in fuel (cm <sup>3</sup> /g fuel)	0.13
3	Measured parameters of cladding hydriding	
3.1	Coefficient of hydride orientation (per-unit)	—
3.2	Hydrogen concentration (% by weight)	8.2 10 <sup>-3</sup>

## #H1T

Individual Characteristics of Refabricated Fuel Rods (Preirradiated Fuel, Preirradiated Cladding) under IGR Tests
--

Table G-1.10. General Characteristic of Fuel Rod #H1T

	Parameter	Unit	Value		
			Experiment	FRAP-T6	SCANAIR
1	Type of coolant	---	water	water	water
2	Burnup	MWd/kg U	49.2	49.2	49.2
3	Energy deposition in fuel rod	cal/g fuel	253	253	253
4	Peak fuel enthalpy	cal/g fuel	-	151	147
5	Peak fuel temperature	K	-	2681	2601
6	Peak clad temperature	K	-	1148	1192
7	Fuel rod failure	Yes, No	No	No	-
8	Type of failure:				
	- cladding rupture due to ballooning	Yes, No	No	No	-
	- cladding rupture due to PCMI	Yes, No	No	No	-
	- fragmentation of fuel rod	Yes, No	No	-	-
9	Failure time	s	-	-	-
10	Fuel enthalpy at failure	cal/g fuel	-	-	-
11	Outer cladding temperature at failure	K	-	-	-
12	Internal gas pressure at failure	MPa	-	-	-
13	ZrO <sub>2</sub> thickness after test	μm	5	5.10	-
14	Residual clad hoop strain:				
	- peak value for ballooning area	%	-	-	-
	- other location <sup>1)</sup>	%	1.4	2.82	1.83
15	Kr concentration in internal gas composition after test	% by volume	1.39	2.25	2.49
16	Xe concentration in internal gas composition after test	% by volume	13.02	13.50	14.95
17	Kr concentration in fuel after test	cm <sup>3</sup> /g fuel	0.13	0.15	0.17

<sup>1)</sup>Calculated values by FRAP-T6 and SCANAIR codes are average along height of fuel rod excluding ballooning region



**APPENDIX G-2.**

*Individual Characteristics for Fuel Rod #H2T under IGR Test*

#H2T

Individual Characteristics of Refabricated Fuel Rods  
(Preirradiated Fuel | Preirradiated Cladding) under IGR Tests

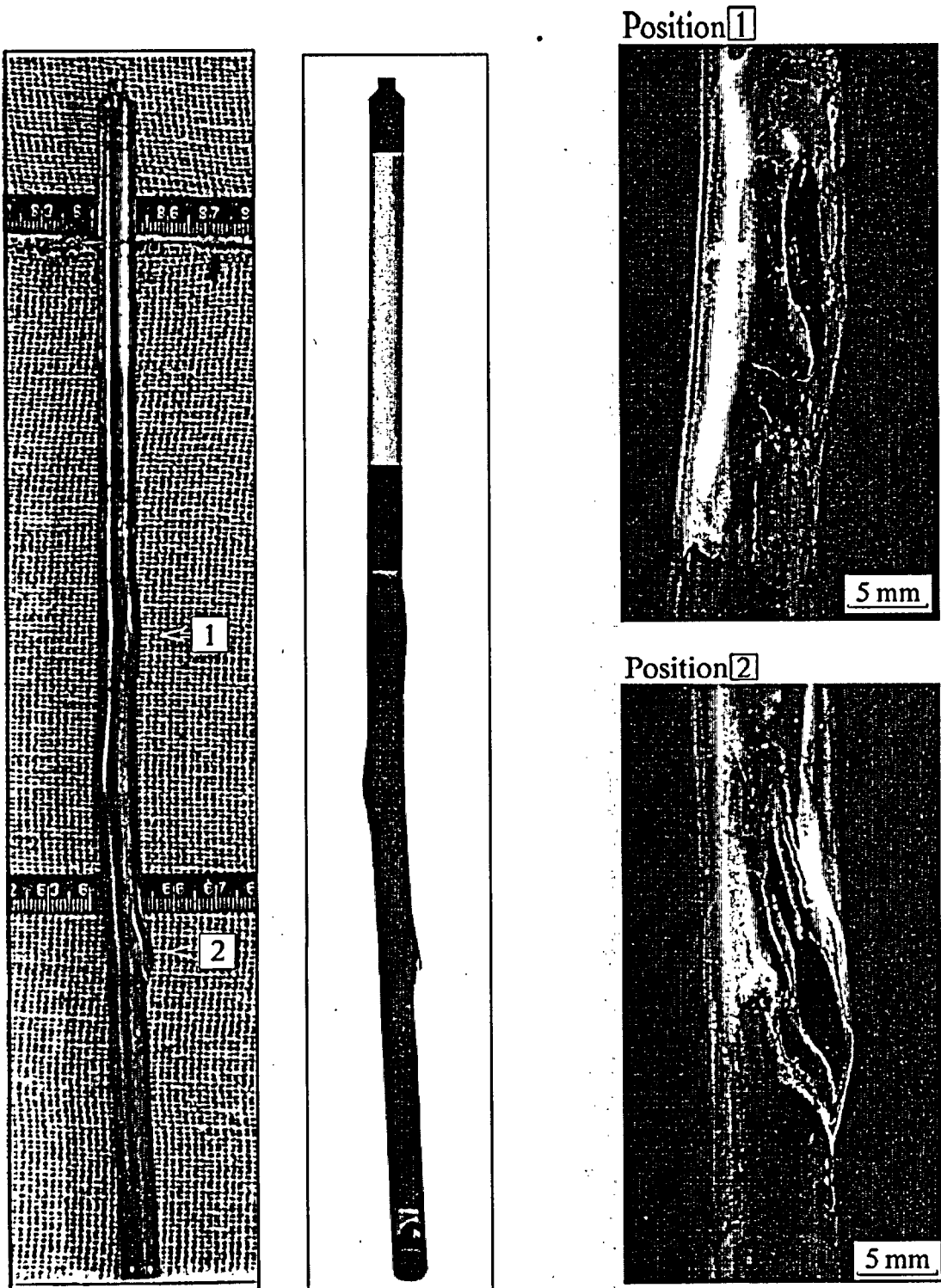
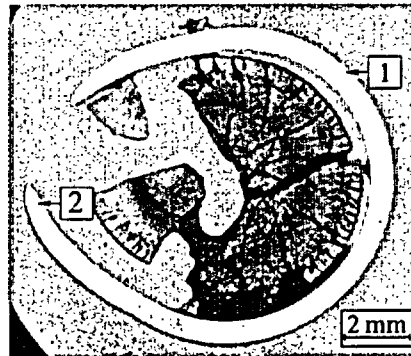

Fig. G-2.1. Appearance of Fuel Rod #H2T (photographs and X-ray photograph)

#H2T

Individual Characteristics of Refabricated Fuel Rods  
(Preirradiated Fuel, Preirradiated Cladding) under IGR Tests



Position 1

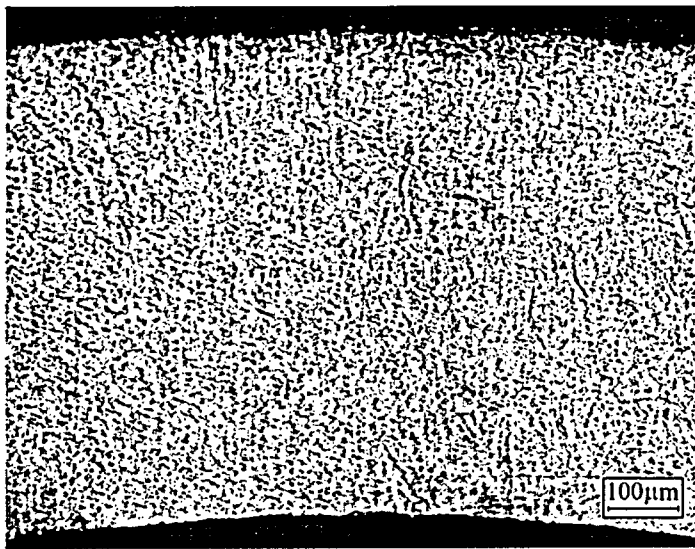

Position 2

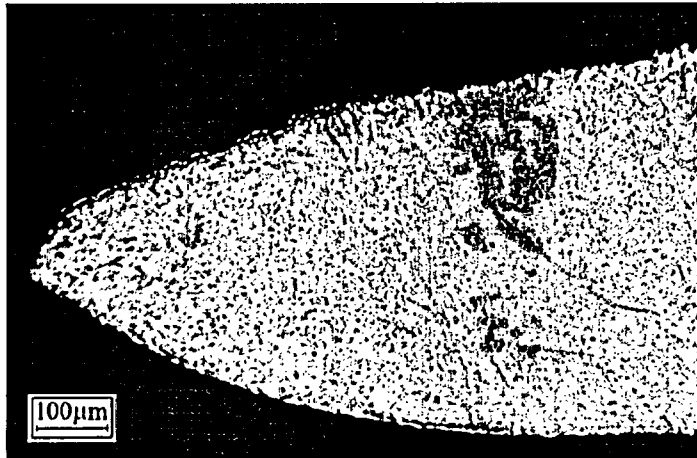
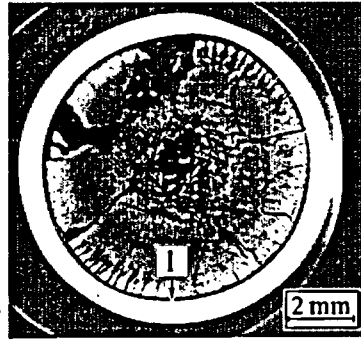

Fig. G-2.2. Cross-Section and Cladding Microstructure for Fuel Rod #H2T at 85 mm Elevation

#H2T

Individual Characteristics of Refabricated Fuel Rods  
(Preirradiated Fuel, Preirradiated Cladding) under IGR Tests



Position 1

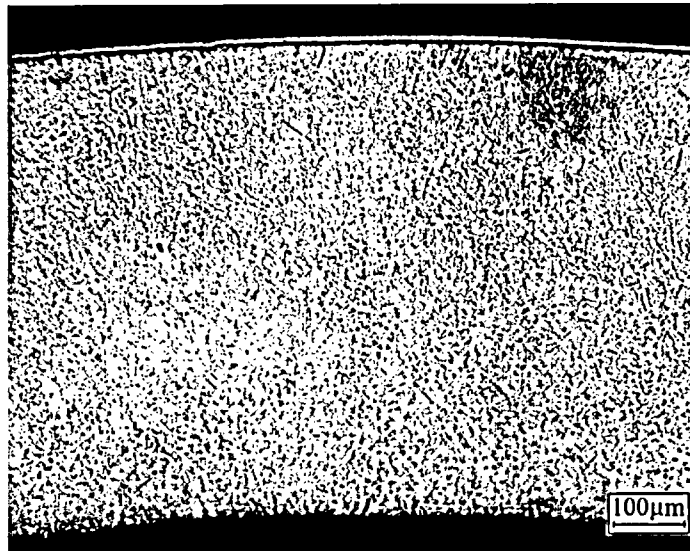

Position 1

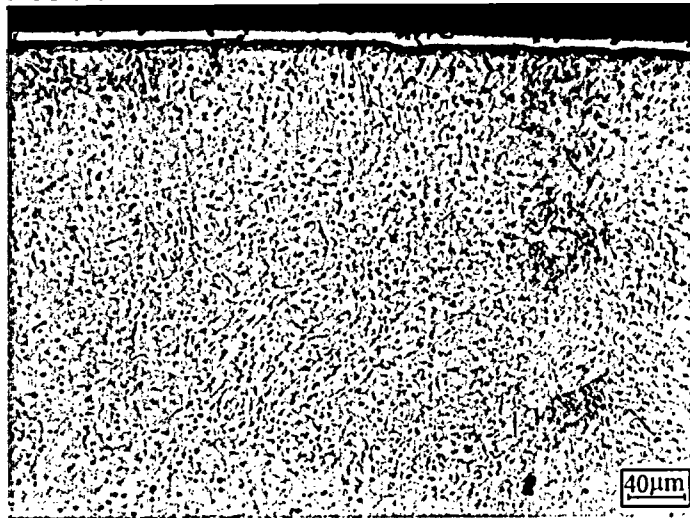
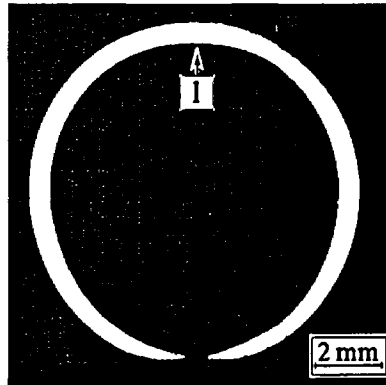

Fig. G-2.3. Cross-Section and Cladding Microstructure for Fuel Rod #H2T at 115 mm Elevation



#H2T

Individual Characteristics of Refabricated Fuel Rods  
(Preirradiated Fuel, Preirradiated Cladding) under IGR Tests



Position 1

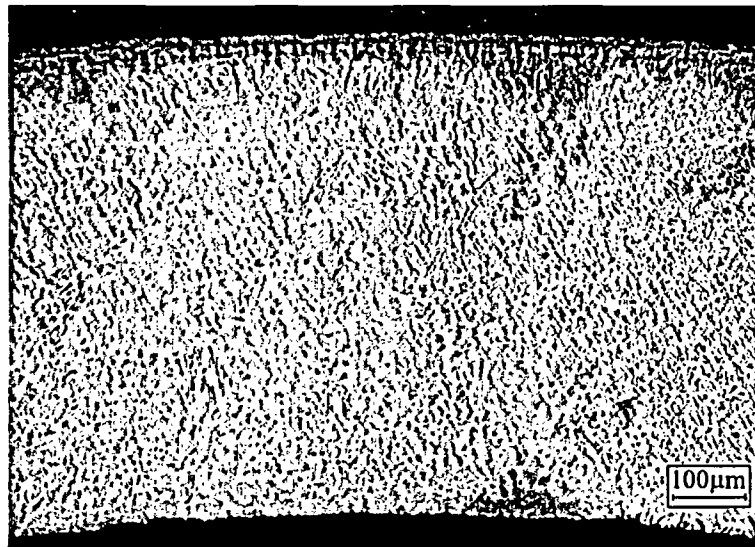

Position 1

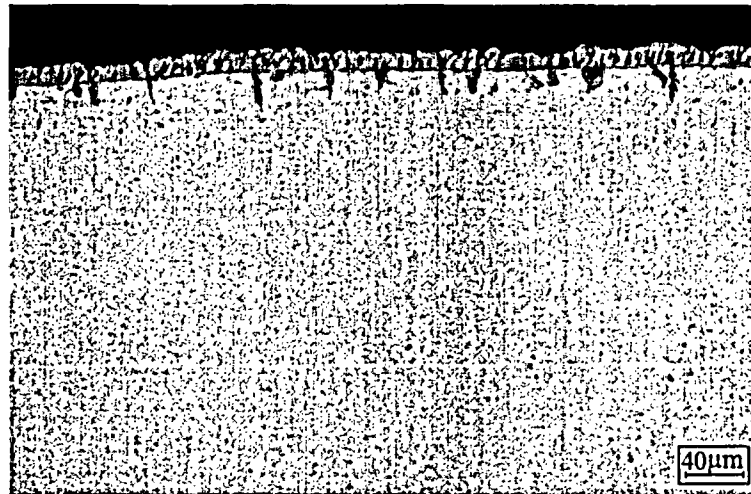

Fig. G-2.4. Cross-Section and Cladding Microstructure for Fuel Rod #H2T at 160 mm Elevation

#H2T

Individual Characteristics of Refabricated Fuel Rods  
(Preirradiated Fuel, Preirradiated Cladding) under IGR Tests

Position 1

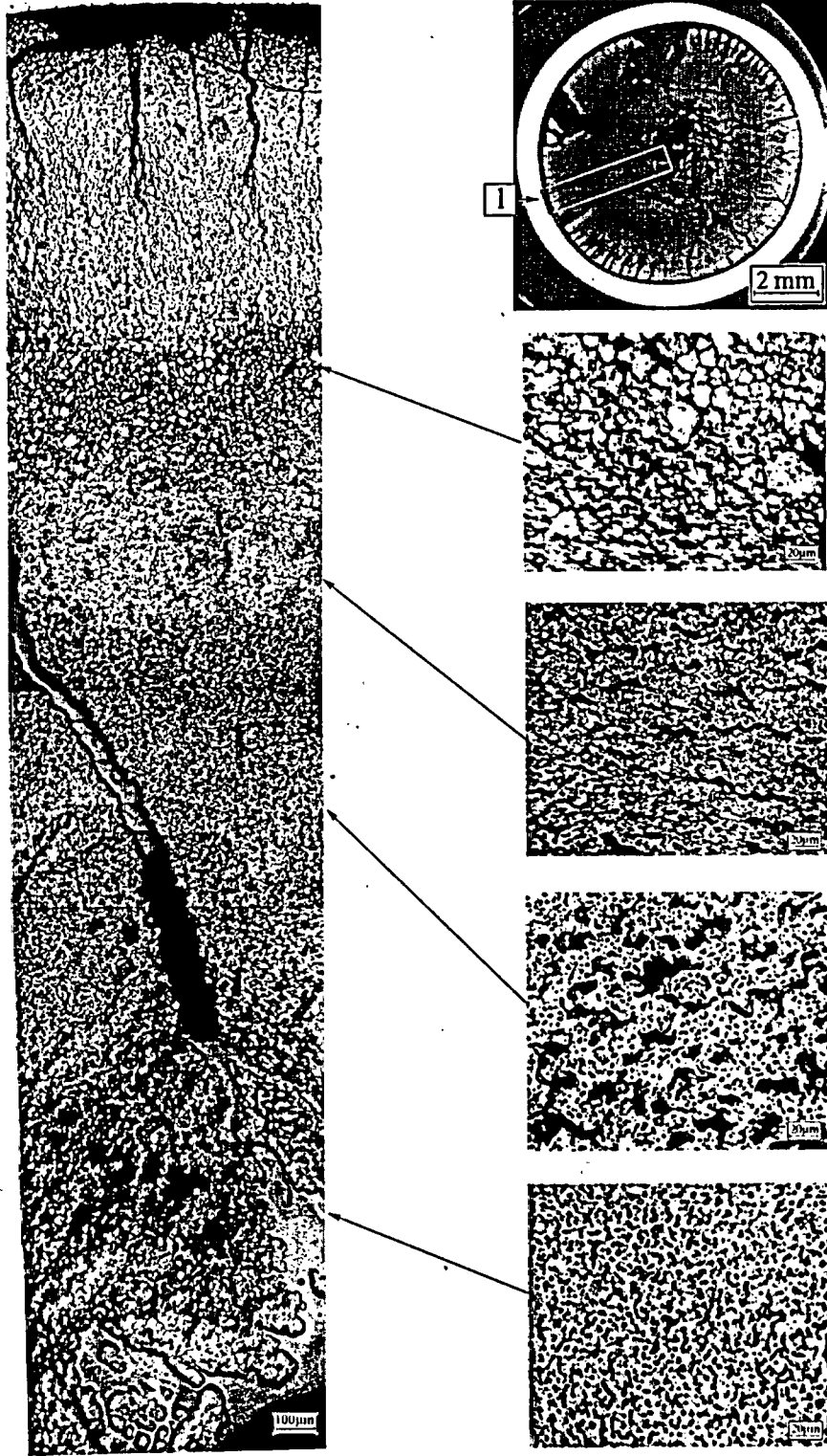

Fig. G-2.5. Fuel Microstructure for Fuel Rod #H2T at 115 mm Elevation

# #H2T

Individual Characteristics of Refabricated Fuel Rods  
(Preirradiated Fuel, Preirradiated Cladding) under IGR Tests

Table G-2.1. Time Dependent Energy Characteristics of Fuel Rod #H2T

Time (s)	Reactor energy deposition <sup>1)</sup> (%)	Cumulative number of fissions in fuel rod (fiss)						Power of fuel rod (kW)	Energy deposition in fuel rod	
		U <sup>235</sup> ×10 <sup>-14</sup>	U <sup>238</sup> ×10 <sup>-13</sup>	Pu <sup>239</sup> ×10 <sup>-14</sup>	Pu <sup>241</sup> ×10 <sup>-14</sup>	Other isotopes ×10 <sup>-11</sup>	Total ×10 <sup>-14</sup>		cal/g fuel	J/g fuel
0.0	0.000	0.000	0.000	0.000	0.000	0.000	0.000	0.000	0.000	0.000
1.0	0.773	0.073	0.016	0.105	0.043	0.079	0.222	1.280	2.490	10.40
2.0	4.870	0.459	0.100	0.662	0.269	0.495	1.400	7.270	15.70	65.70
2.2	7.020	0.662	0.145	0.955	0.388	0.715	2.020	10.80	22.60	94.60
2.4	10.30	0.968	0.212	1.400	0.568	1.050	2.960	16.40	33.10	139.0
2.6	15.30	1.440	0.315	2.080	0.846	1.560	4.400	25.90	49.20	206.0
2.8	23.30	2.200	0.481	3.180	1.290	2.380	6.720	41.70	75.10	314.0
3.0	36.10	3.410	0.745	4.920	2.000	3.680	10.40	64.70	116.0	486.0
3.2	53.80	5.070	1.110	7.320	2.980	5.480	15.50	75.00	173.0	724.0
3.4	69.50	6.550	1.430	9.460	3.850	7.080	20.00	53.10	224.0	938.0
3.6	79.60	7.500	1.640	10.80	4.400	8.110	22.90	31.80	256.0	1072.
3.8	85.60	8.060	1.760	11.60	4.730	8.710	24.60	18.70	276.0	1155.
4.0	89.10	8.390	1.830	12.10	4.930	9.070	25.60	11.30	287.0	1201.
4.2	91.20	8.590	1.880	12.40	5.040	9.290	26.20	7.170	294.0	1231.
4.4	92.60	8.720	1.910	12.60	5.120	9.420	26.60	4.780	299.0	1252.
4.6	93.50	8.810	1.930	12.70	5.170	9.520	26.90	3.330	302.0	1264.
4.8	94.10	8.870	1.940	12.80	5.210	9.580	27.10	2.420	304.0	1273.
5.0	94.60	8.910	1.950	12.90	5.230	9.630	27.20	1.850	306.0	1281.
5.2	95.00	8.950	1.960	12.90	5.250	9.670	27.30	1.570	307.0	1285.
5.4	95.30	8.980	1.960	13.00	5.270	9.700	27.40	1.350	308.0	1289.
5.6	95.50	9.000	1.970	13.00	5.280	9.730	27.50	1.170	309.0	1293.
5.8	95.80	9.020	1.970	13.00	5.300	9.750	27.60	1.020	310.0	1298.
6.0	96.00	9.040	1.980	13.10	5.310	9.770	27.60	0.904	311.0	1302.
6.5	96.40	9.080	1.980	13.10	5.330	9.810	27.70	0.693	312.0	1306.
7.0	96.70	9.110	1.990	13.20	5.350	9.840	27.80	0.560	314.0	1314.
7.5	96.90	9.130	2.000	13.20	5.360	9.870	27.90	0.472	315.0	1319.
8.0	97.10	9.150	2.000	13.20	5.370	9.890	28.00	0.409	315.0	1319.
9.0	97.50	9.190	2.010	13.30	5.390	9.930	28.10	0.356	317.0	1327.
10.0	97.80	9.220	2.010	13.30	5.410	9.960	28.10	0.291	318.0	1331.
20.0	99.10	9.340	2.040	13.50	5.480	10.10	28.50	0.078	324.0	1356.
30.0	99.50	9.380	2.050	13.50	5.510	10.10	28.60	0.041	326.0	1365.
∞	100.0	9.460	2.070	13.70	5.550	10.20	28.90	0.000	333.0	1394.

Maximum value of power is 76.5 kW (t = 3.15 s).

<sup>1)</sup> Current energy deposition per maximum energy deposition (at infinite time)

## #H2T

Individual Characteristics of Refabricated Fuel Rods (Preirradiated Fuel, Preirradiated Cladding) under IGR-Tests
--

Table G-2.2. Axial Energy Characteristics of Fuel Rod #H2T

Axial coordinate from lower end of fuel rod (mm)	Cumulative number of fissions at axial interval (fiss)						Maximum power of fuel rod (kW) $t=3.15s$	Energy deposition at infinite time*		
	$U^{235} \times 10^{-13}$	$U^{238} \times 10^{-11}$	$Pu^{239} \times 10^{-13}$	$Pu^{241} \times 10^{-13}$	Other isotopes $\times 10^{-10}$	Total $\times 10^{-13}$		cal/g fuel	J/g fuel	per-unit <sup>3)</sup>
10.0	0.000	0.000	0.000	0.000	0.000	0.000	0.000	0.000	0.000	0.00
15.0	0.000	0.000	0.000	0.000	0.000	0.000	0.000	0.000	0.000	0.00
20.0 <sup>1)</sup>	1.750	3.460	2.600	1.060	1.840	5.450	1.440	319.0	1335.	0.93
25.0	2.920	5.770	4.330	1.770	3.070	9.080	2.410	313.0	1310.	0.91
30.0	3.060	6.980	4.560	1.870	3.450	9.570	2.540	329.0	1377.	0.96
35.0	3.070	7.030	4.590	1.890	3.440	9.620	2.550	329.0	1377.	0.96
40.0	3.050	6.980	4.560	1.870	3.440	9.550	2.530	329.0	1377.	0.96
45.0	3.000	6.860	4.480	1.840	3.430	9.390	2.490	329.0	1377.	0.96
50.0	2.880	6.840	4.450	1.850	3.430	9.250	2.450	325.0	1360.	0.94
55.0	2.800	6.820	4.430	1.850	3.430	9.150	2.420	322.0	1348.	0.94
60.0	2.860	6.740	4.390	1.820	3.430	9.140	2.420	326.0	1365.	0.95
65.0	2.940	6.800	4.430	1.830	3.430	9.260	2.450	328.0	1373.	0.95
70.0	3.020	6.950	4.540	1.870	3.430	9.500	2.520	328.0	1373.	0.95
75.0	3.060	7.010	4.580	1.890	3.430	9.600	2.540	329.0	1377.	0.96
80.0	3.200	7.050	4.630	1.890	3.440	9.780	2.590	333.0	1394.	0.97
85.0	3.310	7.110	4.670	1.890	3.440	9.950	2.640	336.0	1406.	0.98
90.0	3.380	7.120	4.700	1.890	3.450	10.10	2.660	339.0	1419.	0.99
95.0	3.380	7.020	4.650	1.860	3.460	9.960	2.640	341.0	1427.	0.99
100.0	3.340	6.910	4.570	1.820	3.460	9.800	2.590	341.0	1427.	0.99
105.0	3.320	6.840	4.520	1.800	3.460	9.720	2.570	342.0	1432.	0.99
110.0	3.350	6.840	4.530	1.800	3.470	9.750	2.580	343.0	1436.	1.00
115.0	3.370	6.860	4.550	1.800	3.470	9.790	2.590	343.0	1436.	1.00
120.0	3.390	6.890	4.560	1.820	3.460	9.840	2.610	343.0	1436.	1.00
125.0	3.420	6.930	4.590	1.820	3.460	9.900	2.620	344.0	1440.	1.00
130.0	3.300	6.970	4.600	1.850	3.450	9.820	2.600	339.0	1419.	0.99
135.0	3.240	7.040	4.630	1.880	3.440	9.810	2.600	335.0	1402.	0.97
140.0	3.280	7.110	4.670	1.890	3.430	9.920	2.630	336.0	1406.	0.98
145.0	3.310	7.160	4.700	1.900	3.410	9.990	2.650	335.0	1402.	0.97
150.0	3.300	7.170	4.720	1.910	3.380	10.00	2.650	335.0	1402.	0.97
155.0	3.270	7.110	4.670	1.890	3.360	9.900	2.620	335.0	1402.	0.97
160.0	3.030	6.910	4.520	1.860	3.330	9.480	2.510	329.0	1377.	0.96
165.0	2.890	6.830	4.440	1.840	3.300	9.240	2.450	325.0	1360.	0.94
170.0 <sup>2)</sup>	1.140	2.680	1.750	0.722	1.310	3.630	0.963	325.0	1360.	0.94
175.0	0.000	0.000	0.000	0.000	0.000	0.000	0.000	0.000	0.000	0.00
180.0	0.000	0.000	0.000	0.000	0.000	0.000	0.000	0.000	0.000	0.00
185.0	0.000	0.000	0.000	0.000	0.000	0.000	0.000	0.000	0.000	0.00

\* All numerical values of characteristics are presented as average values at the length interval equal to the axial coordinate  $\pm 2.5$  mm

<sup>1)</sup> Initial coordinate of fuel is 19.5 mm

<sup>2)</sup> End coordinate of fuel is 169.5 mm

<sup>3)</sup> Current value per maximum value

# #H2T

Individual Characteristics of Refabricated Fuel Rods  
(Preirradiated Fuel, Preirradiated Cladding) under IGR Tests

Table G-2.3. Radial Energy Characteristics of Fuel Rod #H2T

Characteristics*		Coordinates of fuel zones (mm)			
		1 zone 1.2 - 2.811	2 zone 2.811-3.432	3 zone 3.432-3.704	4 zone 3.704-3.790
U <sup>235</sup>	Number of fissions $\times 10^{-14}$ (fiss)	4.810	2.820	1.380	0.450
	Power of fuel rod <sup>1)</sup> (kW)	12.50	7.340	3.600	1.170
	Energy deposition <sup>2)</sup> (cal/g fuel)	109.0	106.0	104.0	102.0
	Energy deposition <sup>2)</sup> (J/g fuel)	456.0	444.0	435.0	427.0
	Energy deposition <sup>3)</sup> (per-unit)	1.000	0.972	0.954	0.936
U <sup>238</sup>	Number of fissions $\times 10^{-12}$ (fiss)	10.90	6.120	2.820	0.852
	Power of fuel rod <sup>1)</sup> (kW)	0.280	0.158	0.073	0.022
	Energy deposition <sup>2)</sup> (cal/g fuel)	2.430	2.280	2.100	1.900
	Energy deposition <sup>2)</sup> (J/g fuel)	10.20	9.540	8.790	7.950
	Energy deposition <sup>3)</sup> (per-unit)	1.000	0.938	0.864	0.782
Pu <sup>239</sup>	Number of fissions $\times 10^{-14}$ (fiss)	5.660	3.850	2.640	1.500
	Power of fuel rod <sup>1)</sup> (kW)	15.20	10.30	7.090	4.020
	Energy deposition <sup>2)</sup> (cal/g fuel)	133.0	150.0	206.0	351.0
	Energy deposition <sup>2)</sup> (J/g fuel)	557.0	628.0	862.0	1469.
	Energy deposition <sup>3)</sup> (per-unit)	0.379	0.427	0.587	1.000
Pu <sup>241</sup>	Number of fissions $\times 10^{-13}$ (fiss)	22.00	15.60	11.20	6.700
	Power of fuel rod <sup>1)</sup> (kW)	5.810	4.130	2.960	1.770
	Energy deposition <sup>2)</sup> (cal/g fuel)	50.60	59.90	86.10	154.0
	Energy deposition <sup>2)</sup> (J/g fuel)	212.0	251.0	360.0	645.0
	Energy deposition <sup>3)</sup> (per-unit)	0.329	0.389	0.559	1.000
Other isotopes	Number of fissions $\times 10^{-11}$ (fiss)	4.770	2.940	1.710	0.815
	Power of fuel rod <sup>1)</sup> (kW)	0.013	0.008	0.005	0.002
	Energy deposition <sup>2)</sup> (cal/g fuel)	0.110	0.113	0.132	0.189
	Energy deposition <sup>2)</sup> (J/g fuel)	0.460	0.470	0.550	0.790
	Energy deposition <sup>3)</sup> (per-unit)	0.582	0.598	0.698	1.000
Total	Number of fissions $\times 10^{-14}$ (fiss)	12.80	8.300	5.190	2.640
	Power of fuel rod <sup>1)</sup> (kW)	33.80	22.00	13.70	6.990
	Energy deposition <sup>2)</sup> (cal/g fuel)	294.0	319.0	399.0	609.0
	Energy deposition <sup>2)</sup> (J/g fuel)	1231.	1335.	1670.	2549.
	Energy deposition <sup>3)</sup> (per-unit)	0.483	0.524	0.655	1.000

<sup>1)</sup> at time of 3.15 s, <sup>2)</sup> at infinite time, <sup>3)</sup> Current value per maximum value.

\* All numerical values of characteristics were calculated for undamaged part of fuel stack only (See Table C.2.1.)

# #H2T

Individual Characteristics of Refabricated Fuel Rods  
(Preirradiated Fuel, Preirradiated Cladding) under IGR Tests

Table G-2.4. Fuel Enthalpy Vs. Time Calculated by FRAP-T6 Code for Fuel Rod #H2T

Time (s)	Enthalpy at fuel radius (cal/g fuel)				Fuel enthalpy <sup>1)</sup>		Energy deposition in fuel rod	
	1.20 mm	2.82 mm	3.47 mm	3.79 mm	cal/g fuel	J/g fuel	cal/g fuel	J/g fuel
0.0	0.00	0.00	0.00	0.00	0.00	0.00	0.00	0.00
1.0	4.89	4.85	4.75	4.60	4.83	20.2	2.50	10.5
2.0	16.8	16.3	15.0	13.4	16.0	66.9	15.7	66.0
2.2	22.8	21.9	19.6	16.7	21.4	89.5	22.5	94.3
2.4	32.1	30.4	26.2	21.0	29.4	123	32.9	138
2.6	46.5	43.6	36.6	27.8	42.0	176	49.0	205
2.8	69.7	64.7	47.9	28.9	60.3	253	74.8	313
3.0	107	97.8	71.3	38.0	91.1	382	116	485
3.2	158	144	100.0	50.9	133	557	172	723
3.4	204	183	129	87.8	171	719	223	936
3.6	233	204	148	110	195	816	256	1073
3.8	248	213	162	129	208	870	275	1152
4.0	256	217	166	132	213	891	286	1200
4.2	260	217	163	127	213	892	294	1233
4.4	260	214	159	125	211	883	299	1252
4.6	258	210	155	122	208	869	302	1264
4.8	256	205	151	120	204	854	304	1274
5.0	253	200	147	118	200	837	306	1280
5.2	249	195	143	116	196	819	307	1286
5.4	245	190	140	115	192	803	308	1291
5.6	240	186	138	114	188	787	309	1295
5.8	236	181	136	113	184	771	310	1298
6.0	231	177	134	112	180	756	311	1302
6.5	219	168	126	104	171	715	312	1308
7.0	207	157	115	93.0	159	667	313	1313
7.5	195	145	108	89.6	149	625	314	1317
8.0	183	136	103	87.3	140	588	315	1321
10.0	140	110	89.5	79.4	113	472	318	1332
30.0	25.9	24.3	23.0	22.2	24.4	102	326	1365

Radial enthalpy distribution and fuel enthalpy are presented at elevation 117.0 mm

Maximum value of fuel enthalpy is 213.3 cal/g fuel (t=4.12 s)

<sup>1)</sup> All numerical values are presented at elevation with peak power

# #H2T

Individual Characteristics of Refabricated Fuel Rods  
(Preirradiated Fuel, Preirradiated Cladding) under IGR Tests

Table G-2.5. Energy Characteristics Vs. Time Calculated by FRAP-T6 and SCANAIR Codes for Fuel Rod #H2T

Time (s)	Energy deposition <sup>1)</sup> (cal/g fuel)	Linear power <sup>1)</sup> (kW/m)	Fuel enthalpy <sup>1)</sup> (cal/g fuel)		Energy of metal-water reaction <sup>1)</sup> (cal/g fuel)	Leakage of energy <sup>1)</sup> (cal/g fuel)		Clad-to-coolant heat transfer coefficient <sup>1)</sup> (kW/m <sup>2</sup> K)	
			FRAP-T6	SCANAIR	FRAP-T6	FRAP-T6	SCANAIR	FRAP-T6	SCANAIR
0.0	0.00	0.00	0.00	0.00	0.00	0.00	0.00	0.00	0.00
1.0	2.58	9.02	4.83	2.17	0.00	0.02	0.01	0.03	0.10
2.0	16.2	51.3	16.0	13.7	0.00	1.40	0.54	3.27	3.00
2.2	23.2	75.5	21.4	18.8	0.00	2.75	1.65	5.12	5.03
2.4	33.9	115	29.4	27.5	0.00	5.05	3.88	8.03	8.31
2.6	50.6	181	42.0	40.8	0.00	8.66	7.73	11.5	13.6
2.8	77.2	291	60.3	58.3	0.00	16.1	13.4	22.1	21.3
3.0	119	452	91.1	89.0	0.00	26.9	25.3	29.6	31.8
3.2	178	525	133	133	0.00	39.8	32.5	6.44	1.34
3.4	231	372	171	-	0.00	43.3	-	1.79	-
3.6	264	221	195	-	0.01	48.9	-	2.12	-
3.8	284	132	208	-	0.05	55.4	-	2.13	-
4.0	296	79.6	213	-	0.12	62.2	-	2.16	-
4.2	304	48.1	213	-	0.19	70.0	-	2.20	-
4.4	308	32.2	211	-	0.26	77.2	-	2.20	-
4.6	311	22.5	208	-	0.31	84.3	-	2.17	-
4.8	314	16.5	204	-	0.36	91.2	-	2.13	-
5.0	315	12.7	200	-	0.40	97.7	-	2.09	-
5.2	317	10.8	196	-	0.43	104	-	2.04	-
5.4	318	9.31	192	-	0.45	110	-	1.99	-
5.6	319	8.08	188	-	0.46	116	-	1.94	-
5.8	320	7.06	184	-	0.48	121	-	1.90	-
6.0	321	6.25	180	-	0.49	126	-	1.87	-
6.5	322	4.81	171	-	0.50	149	-	8.48	-
7.0	323	3.89	159	-	0.50	169	-	12.1	-
7.5	324	3.28	149	-	0.50	180	-	10.5	-
8.0	325	2.86	140	-	0.50	190	-	9.35	-
10.0	328	2.03	113	-	0.50	219	-	6.69	-
30.0	336	0.29	24.4	-	0.50	316	-	1.25	-

<sup>1)</sup> All numerical values are presented at elevation with peak power

## #H2T

Individual Characteristics of Refabricated Fuel Rods (Preirradiated Fuel, Preirradiated Cladding) under IGR Tests
--

Table G-2.6. Temperature Variation, Fission Gas Release and ZrO<sub>2</sub> Thickness Vs. Time for Fuel Rod #H2T Calculated by FRAP-T6 and SCANAIR Codes

Time (s)	Fuel centerline temperature <sup>1)</sup> (K)		Fuel surface temperature <sup>1)</sup> (K)		Clad outer temperature <sup>1)</sup> (K)		Fission gas release (%)		Average ZrO <sub>2</sub> <sup>2)</sup> thickness (μm)
	FRAP-T6	SCANAIR	FRAP-T6	SCANAIR	FRAP-T6	SCANAIR	FRAP-T6	SCANAIR	FRAP-T6
0.0	293	293	293	293	293	293	0.00	0.00	5.00
1.0	376	329	371	325	352	308	0.12	0.24	5.00
2.0	556	510	506	480	395	384	0.51	1.11	5.00
2.2	642	589	555	534	401	388	0.80	1.62	5.00
2.4	772	722	617	613	408	393	1.22	2.16	5.00
2.6	968	925	712	712	414	399	1.92	2.62	5.00
2.8	1272	1190	727	800	429	407	3.23	3.01	5.00
3.0	1737	1659	852	874	437	426	5.28	3.41	5.00
3.2	2299	2255	1026	1200	636	922	7.65	4.48	5.00
3.4	2690	-	1503	-	1056	-	11.8	-	5.00
3.6	2890	-	1781	-	1236	-	16.8	-	5.02
3.8	2987	-	1994	-	1241	-	26.0	-	5.07
4.0	3034	-	2027	-	1258	-	40.4	-	5.12
4.2	3054	-	1977	-	1278	-	48.5	-	5.19
4.4	3056	-	1951	-	1277	-	49.4	-	5.26
4.6	3048	-	1923	-	1263	-	49.5	-	5.33
4.8	3033	-	1895	-	1242	-	49.6	-	5.38
5.0	3014	-	1868	-	1219	-	49.6	-	5.42
5.2	2991	-	1847	-	1195	-	49.6	-	5.44
5.4	2966	-	1835	-	1168	-	49.6	-	5.46
5.6	2939	-	1825	-	1142	-	49.6	-	5.48
5.8	2910	-	1812	-	1121	-	49.6	-	5.49
6.0	2880	-	1799	-	1102	-	49.6	-	5.50
6.5	2799	-	1700	-	694	-	49.6	-	5.50
7.0	2715	-	1568	-	415	-	49.7	-	5.50
7.5	2625	-	1526	-	412	-	49.7	-	5.50
8.0	2527	-	1497	-	410	-	49.7	-	5.50
10.0	2114	-	1397	-	405	-	49.7	-	5.50
30.0	685	-	633	-	387	-	49.7	-	5.50

<sup>1)</sup> All numerical values are presented at elevation with peak power

<sup>2)</sup> Initial ZrO<sub>2</sub> thickness is 5 μm



# #H2T

Individual Characteristics of Refabricated Fuel Rods  
(Preirradiated Fuel, Preirradiated Cladding) under IGR Tests

Table G-2.7. Mechanical Characteristics of Fuel Rod #H2T Vs. Time Calculated by FRAP-T6 and SCANAIR Codes

Time (s)	Clad outer temperature <sup>1)</sup> (K)		Fuel hoop strain <sup>1)</sup> (%)		Fuel - clad gap width <sup>1)</sup> (mm)		Clad hoop strain <sup>1)</sup> (%)		Clad hoop stress <sup>1)</sup> (MPa)		Internal gas pressure (MPa)	
	FRAP-T6	SCANAIR	FRAP-T6	SCANAIR	FRAP-T6	SCANAIR	FRAP-T6	SCANAIR	FRAP-T6	SCANAIR	FRAP-T6	SCANAIR
0.0	293	293	0.00	0.00	0.04	0.03	0.01	0.01	8.90	8.22	1.70	1.70
1.0	352	308	0.12	0.02	0.04	0.03	0.05	0.02	9.06	8.41	1.77	1.75
2.0	395	384	0.42	0.16	0.02	0.03	0.08	0.08	9.54	9.17	1.85	1.85
2.2	401	388	0.57	0.21	0.02	0.03	0.09	0.09	9.71	9.51	1.88	1.88
2.4	408	393	0.78	0.31	0.01	0.02	0.10	0.10	9.93	10.0	1.92	1.92
2.6	414	399	1.11	0.48	0.00	0.02	0.12	0.12	21.8	10.7	1.97	1.96
2.8	429	407	1.63	0.71	0.00	0.01	0.57	0.15	10.6	11.6	2.02	1.99
3.0	437	426	2.49	1.19	0.00	0.00	1.27	0.36	296	206	2.09	2.03
3.2	636	922	3.62	2.81	0.00	0.00	2.22	1.65	366	40.2	2.17	2.06
3.4	1056	-	4.79	-	0.00	-	3.17	-	12.6	-	2.27	-
3.6	1236	-	5.20	-	0.31	-	11.6	-	13.8	-	2.39	-
3.8	1241	-	5.48	-	0.29	-	11.6	-	0.00	-	0.10	-
4.0	1258	-	5.60	-	0.29	-	11.6	-	0.00	-	0.10	-
4.2	1278	-	6.07	-	0.27	-	11.6	-	0.00	-	0.10	-
4.4	1277	-	6.01	-	0.27	-	11.6	-	0.00	-	0.10	-
4.6	1263	-	5.93	-	0.28	-	11.6	-	0.00	-	0.10	-
4.8	1242	-	5.84	-	0.28	-	11.6	-	0.00	-	0.10	-
5.0	1219	-	5.75	-	0.28	-	11.6	-	0.00	-	0.10	-
5.2	1195	-	5.64	-	0.29	-	11.6	-	0.00	-	0.10	-
5.4	1168	-	5.53	-	0.29	-	11.7	-	0.00	-	0.10	-
5.6	1142	-	5.41	-	0.30	-	11.8	-	0.00	-	0.10	-
5.8	1121	-	5.30	-	0.30	-	11.8	-	0.00	-	0.10	-
6.0	1102	-	5.18	-	0.30	-	11.8	-	0.00	-	0.10	-
6.5	694	-	4.84	-	0.32	-	11.6	-	0.00	-	0.10	-
7.0	415	-	4.43	-	0.33	-	11.4	-	0.00	-	0.10	-
7.5	412	-	4.06	-	0.35	-	11.4	-	0.00	-	0.10	-
8.0	410	-	3.73	-	0.36	-	11.4	-	0.00	-	0.10	-
10.0	405	-	2.67	-	0.40	-	11.4	-	0.00	-	0.10	-
30.0	387	-	0.17	-	0.50	-	11.3	-	0.00	-	0.10	-

<sup>1)</sup> All numerical values are presented at elevation with peak power

Table G-2.8. Axial Distribution of Energy Deposition and Fuel Enthalpy Calculated by FRAP-T6 Code for Fuel Rod #H2T

Axial interval from-to (mm)-(mm)	Energy deposition at infinite time			Fuel enthalpy at time ( $t=4.12$ s)		
	cal/g fuel	J/g fuel	per-unit	cal/g fuel	J/g fuel	per-unit
19.5 - 34.5	322	1347	0.94	200	838	0.94
34.5 - 49.5	328	1376	0.96	204	856	0.96
49.5 - 64.5	325	1361	0.95	202	846	0.95
64.5 - 79.5	329	1379	0.96	205	857	0.96
79.5 - 94.5	337	1412	0.98	210	878	0.98
94.5 - 109.5	342	1431	1.00	212	890	1.00
109.5 - 124.5	343	1438	1.00	213	894	1.00
124.5 - 139.5	338	1417	0.99	210	881	0.99
139.5 - 154.5	335	1404	0.98	208	873	0.98
154.5 - 169.5	328	1376	0.96	204	855	0.96

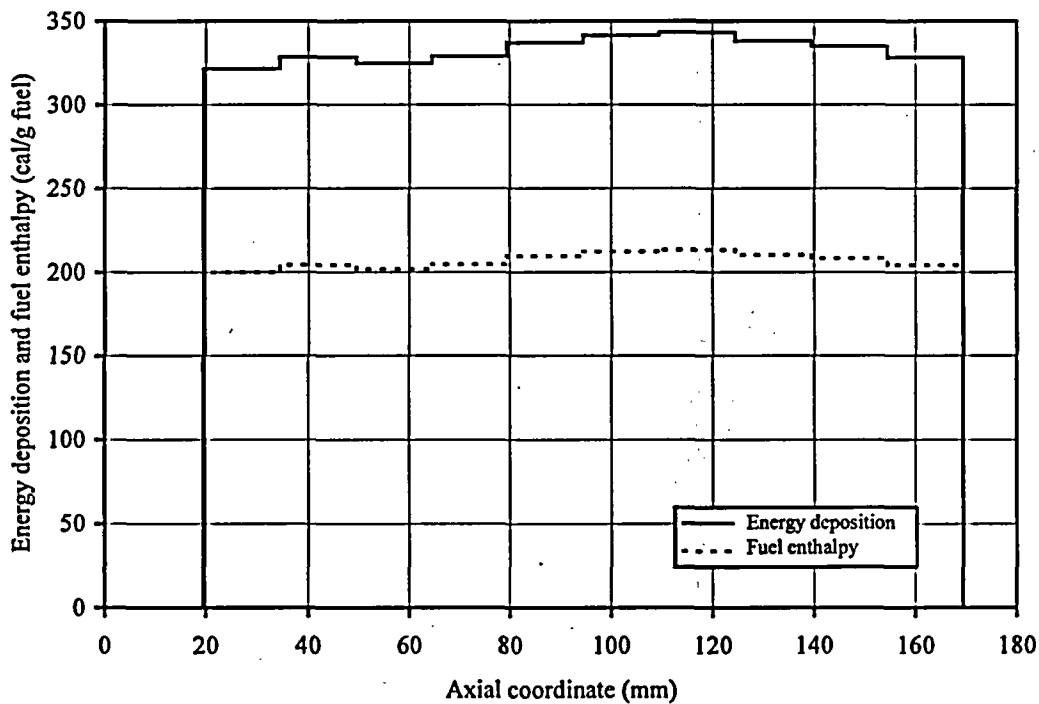

Fig. G-2.6. Axial Distribution of Energy Deposition and Fuel Enthalpy Calculated by FRAP-T6 Code for Fuel Rod #H2T

#H2T

Individual Characteristics of Refabricated Fuel Rods  
(Preirradiated Fuel, Preirradiated Cladding) under IGR Tests

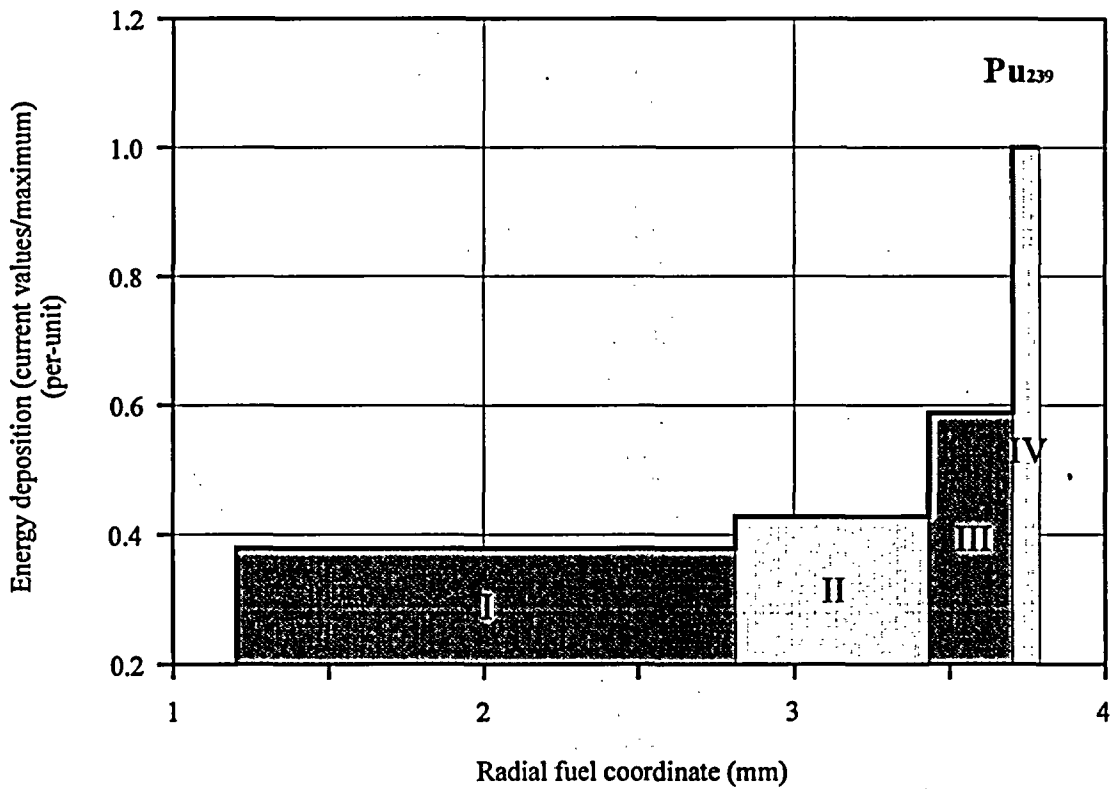
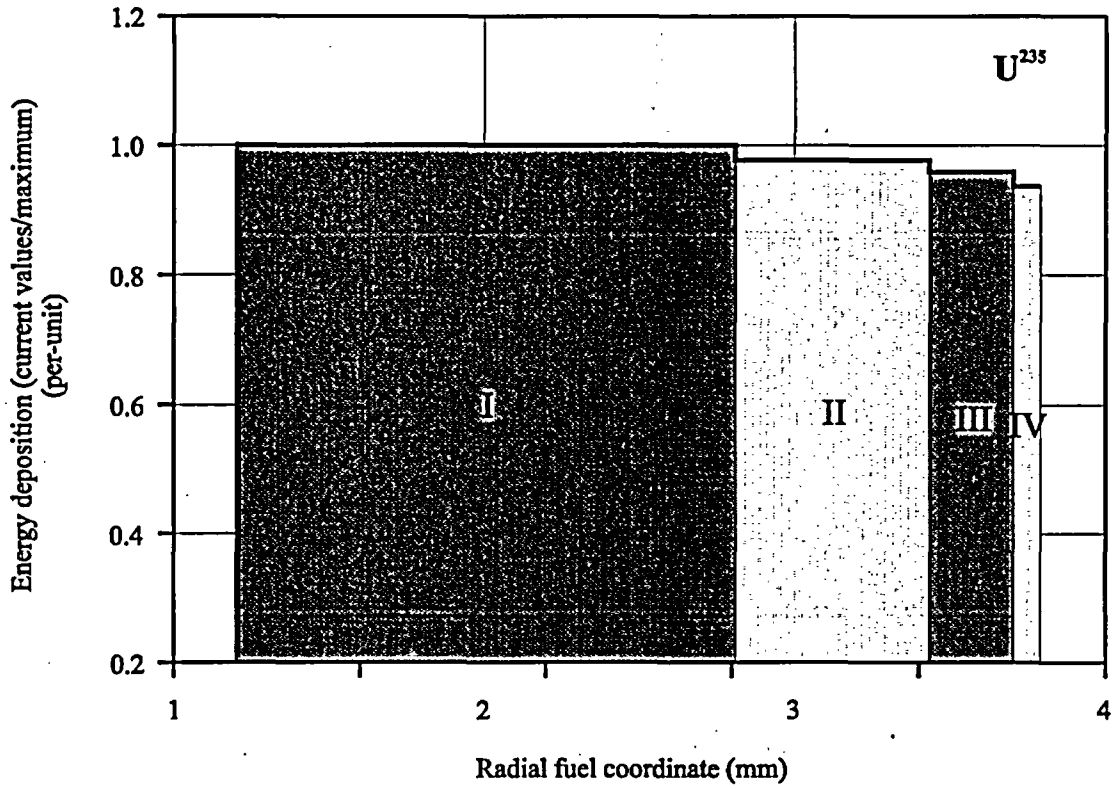

Fig. G-2.7.  $U^{235}$  and  $Pu^{239}$  Radial Distributions of Energy Deposition for Fuel Rod #H2T

# #H2T

Individual Characteristics of Refabricated Fuel Rods  
(Preirradiated Fuel, Preirradiated Cladding) under IGR Tests

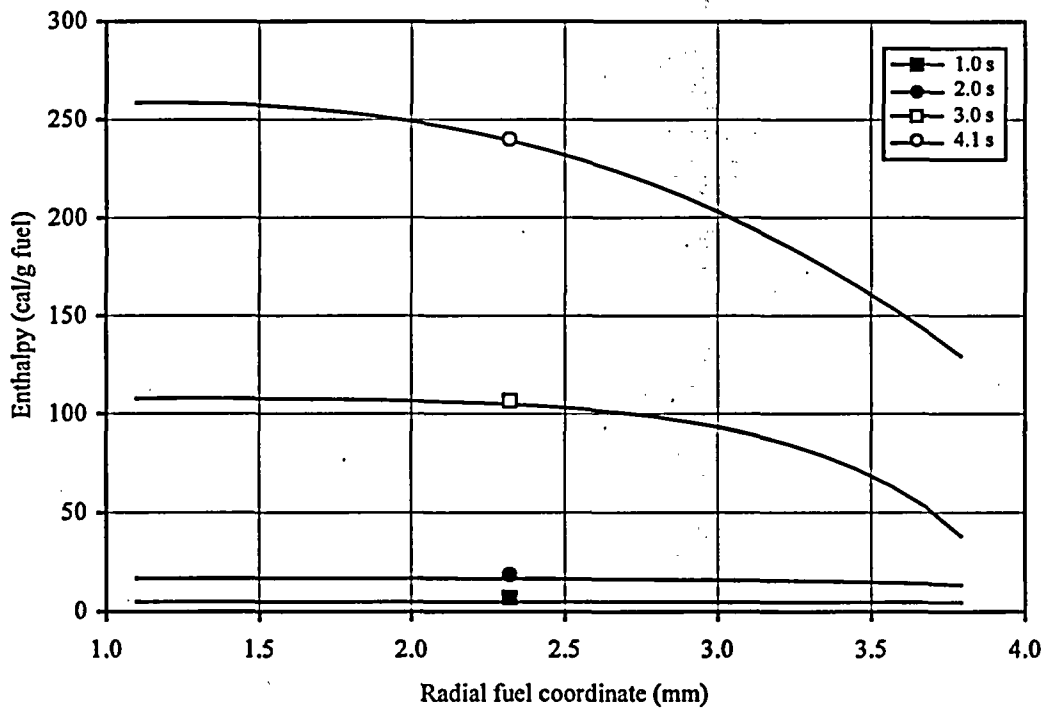
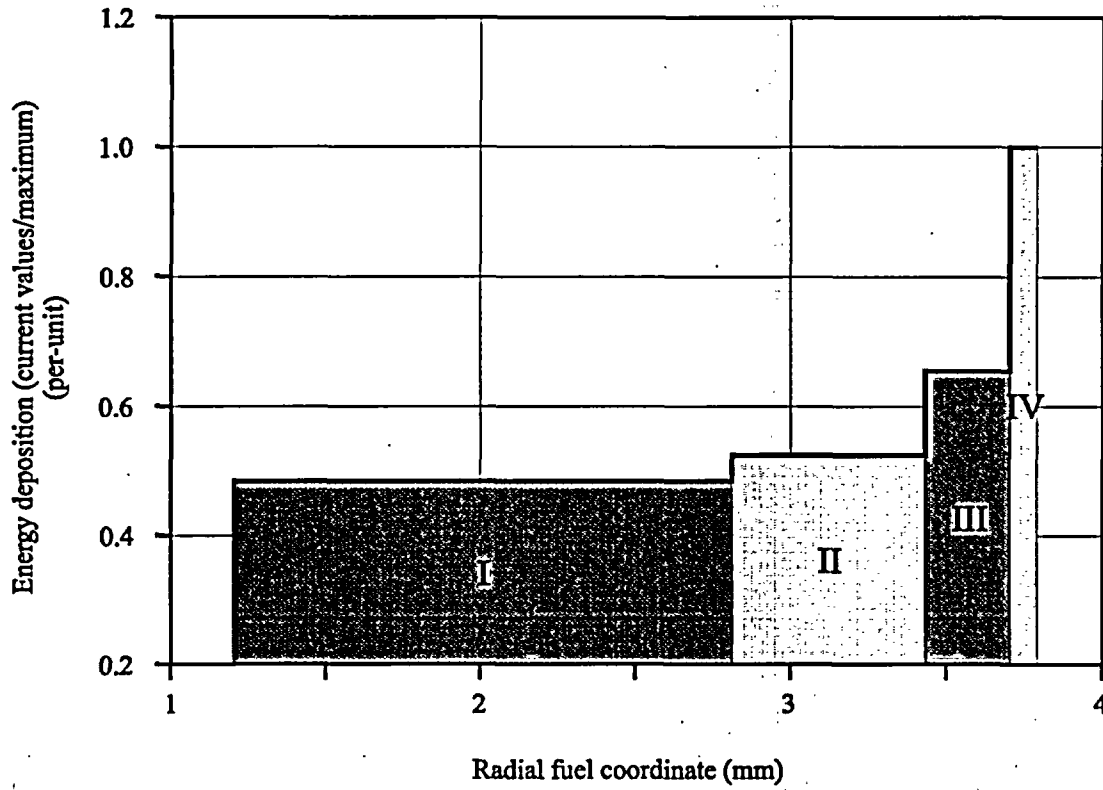

Fig. G-2.8. Radial Distributions of Energy Deposition and Fuel Enthalpy Calculated by FRAP-T6 Code for Fuel Rod #H2T

#H2T

Individual Characteristics of Refabricated Fuel Rods  
(Preirradiated Fuel, Preirradiated Cladding) under IGR Tests

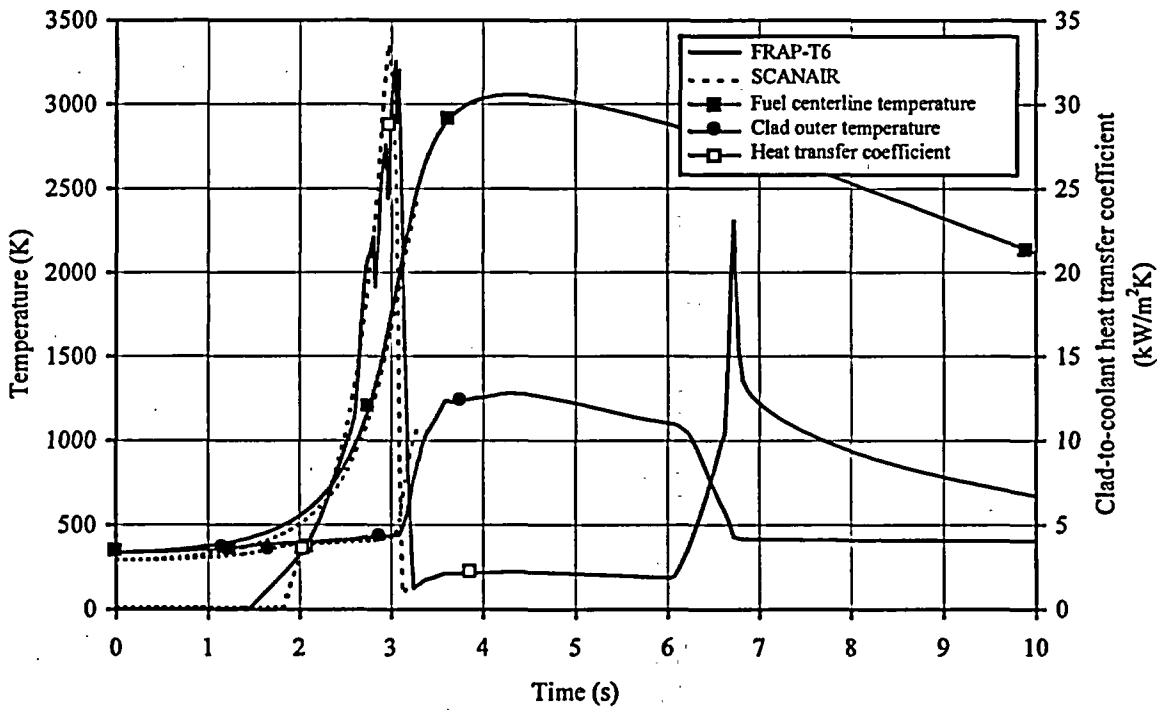
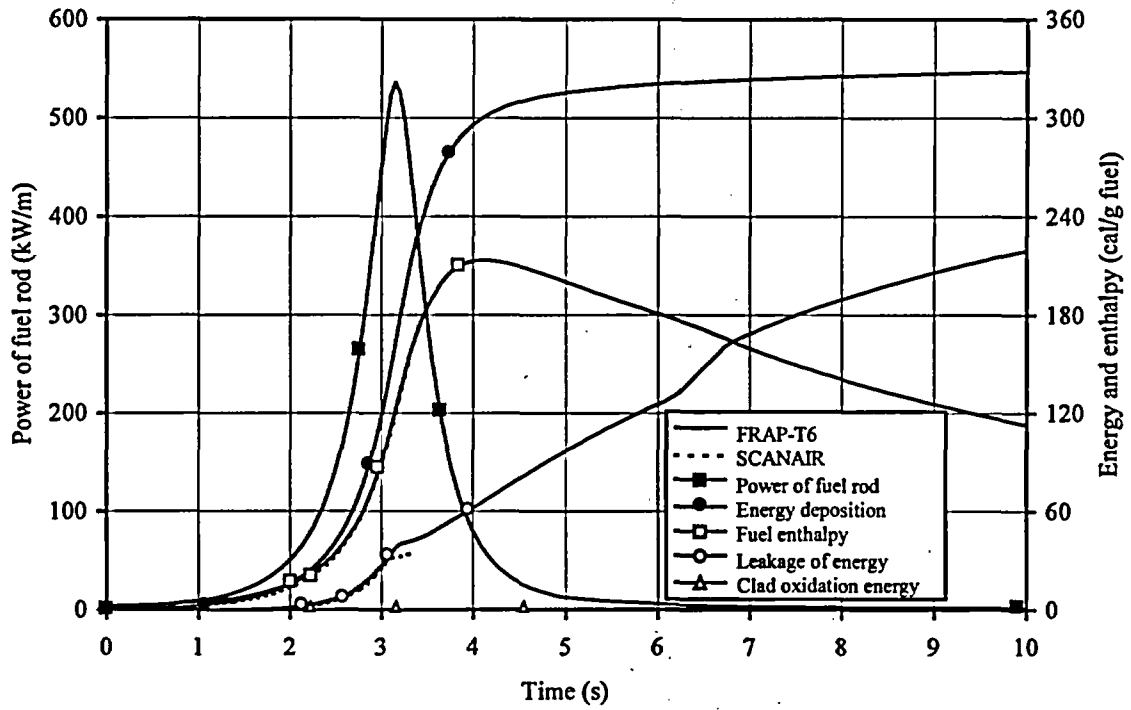

Fig. G-2.9. Energy and Temperature Characteristics Vs. Time Calculated by FRAP-T6 and SCANAIR Codes for Fuel Rod #H2T

#H2T

Individual Characteristics of Refabricated Fuel Rods  
(Preirradiated Fuel/Preirradiated Cladding) under IGR Tests

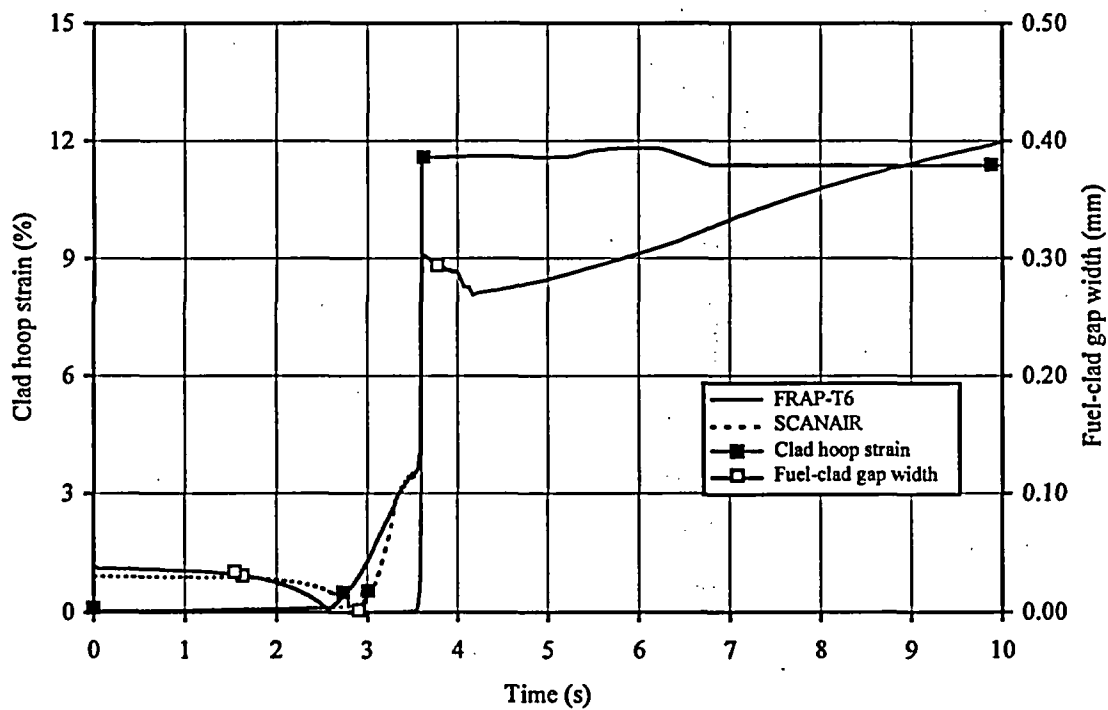
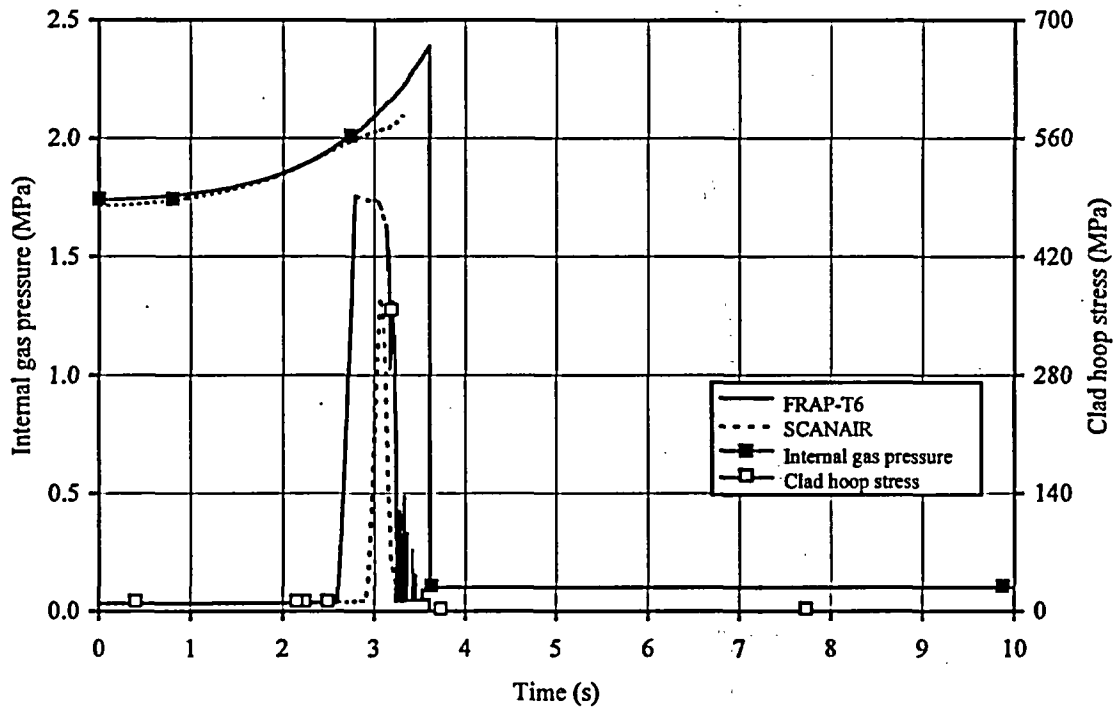

Fig. G-2.10. Cladding Mechanical Characteristics Vs. Time Calculated by FRAP-T6 and SCANAIR Codes for Fuel Rod #H2T

# #H2T

Individual Characteristics of Refabricated Fuel Rods  
(Preirradiated Fuel, Preirradiated Cladding) under IGR Tests

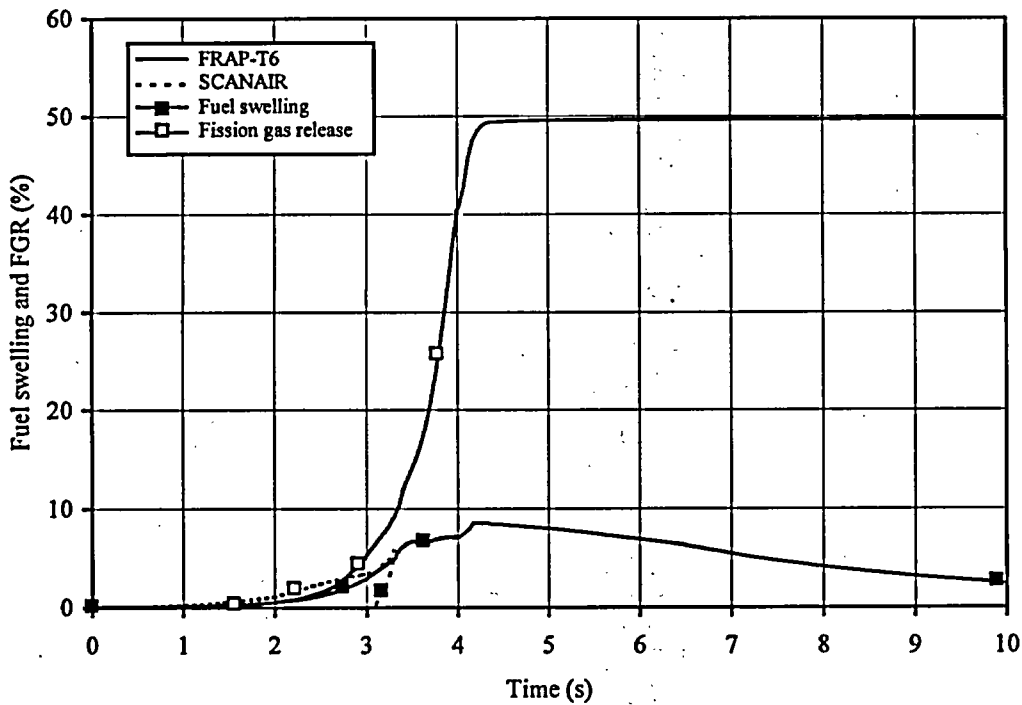
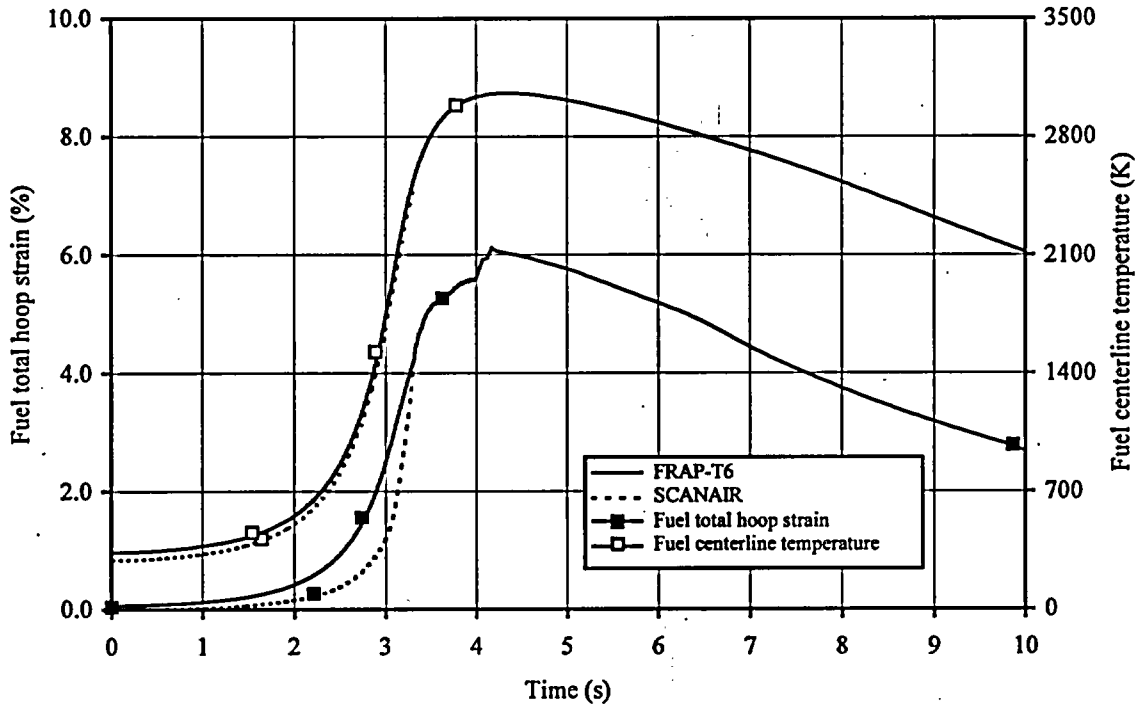

Fig. G-2.11. Fuel Strain and Fission Gas Release Vs. Time Calculated by FRAP-T6 and SCANAIR Codes for Fuel Rod #H2T

Table G-2.9. Some Results of PIE for Fuel Rod #H2T

Characteristic		Value		
1.	Measured parameters of cladding oxidation and cladding deformation			
1.1.	Cladding thickness at elevation 115, 85, 160 mm correspondent to different azimuthal angles ( $\mu\text{m}$ ):			
	0°	690	663	480
	90°	667	663	677
	180°	691	R	691
	270°	690	649	691
1.2.	ZrO <sub>2</sub> thickness at elevation 115, 85, 160 mm correspondent to different azimuthal angles ( $\mu\text{m}$ ):			
	0°	10	15	10
	90°	10	15	10
	180°	10	18	10
	270°	10	15	8
1.3.	$\alpha\text{Zr(O)}$ thickness at elevation 115, 85, 160 mm correspondent to different azimuthal angles ( $\mu\text{m}$ ):			
	0°	0	15	8
	90°	0	10	10
	180°	0	10	8
	270°	0	10	8
1.4.	Clad hoop strain at elevation 115, 85, 160 mm, respectively (%)	7.9	12.6	11.4
2.	Measured parameters for FGR analysis			
2.1.	Internal gas composition (% by volume):			
	He	-		
	N <sub>2</sub>	-		
	O <sub>2</sub>	-		
	Ar	-		
	CO <sub>2</sub>	-		
	Kr	-		
	Xe	-		
2.2.	Free gas volume (cm <sup>3</sup> )	-		
2.3.	Gas pressure inside fuel rod under normal condition (MPa)	-		
2.4.	Kr concentration in fuel (cm <sup>3</sup> /g fuel)	-		
3.	Measured parameters of cladding hydriding			
3.1.	Coefficient of hydride orientation (per-unit)	-		
3.2.	Hydrogen concentration (% by weight)	-		



# #H2T

Individual Characteristics of Refabricated Fuel Rods  
(Preirradiated Fuel, Preirradiated Cladding) under IGR Tests

Table G-2.10. General Characteristic of Fuel Rod #H2T

	Parameter	Unit	Value		
			Experiment	FRAP-T6	SCANAIR
1	Type of coolant	---	water	water	water
2	Burnup	MWd/kg U	47.9	47.9	47.9
3	Energy deposition in fuel rod	cal/g fuel	333	333	333
4	Peak fuel enthalpy	cal/g fuel	-	213	-
5	Peak fuel temperature	K	-	3057	-
6	Peak clad temperature	K	-	1280	-
7	Fuel rod failure	Yes, No	Yes	Yes	-
8	Type of failure:				
	- cladding rupture due to ballooning	Yes, No	Yes	Yes	-
	- cladding rupture due to PCMI	Yes, No	No	No	-
	- fragmentation of fuel rod	Yes, No	No	-	-
9	Failure time	s	-	3.60	-
10	Fuel enthalpy at failure	cal/g fuel	-	195	-
11	Outer cladding temperature at failure	K	-	1236	-
12	Internal gas pressure at failure	MPa	-	2.39	-
13	ZrO <sub>2</sub> thickness after test	µm	8-18	5.50	-
14	Residual clad hoop strain:				
	- peak value for ballooning area	%	12.6	11.28	-
	- other location <sup>1)</sup>	%	7.9,11.4	3.26	-
15	Kr concentration in internal gas composition after test	% by volume	-	6.35	-
16	Xe concentration in internal gas composition after test	% by volume	-	38.03	-
17	Kr concentration in fuel after test	cm <sup>3</sup> /g fuel	-	0.09	-

<sup>1)</sup>Calculated values by FRAP-T6 and SCANAIR codes are average along height of fuel rod excluding ballooning region



***APPENDIX G-3.***

***Individual Characteristics for Fuel Rod #H3T under IGR Test***

#H3T

Individual Characteristics of Refabricated Fuel Rods  
(Preirradiated Fuel, Preirradiated Cladding) under IGR Tests

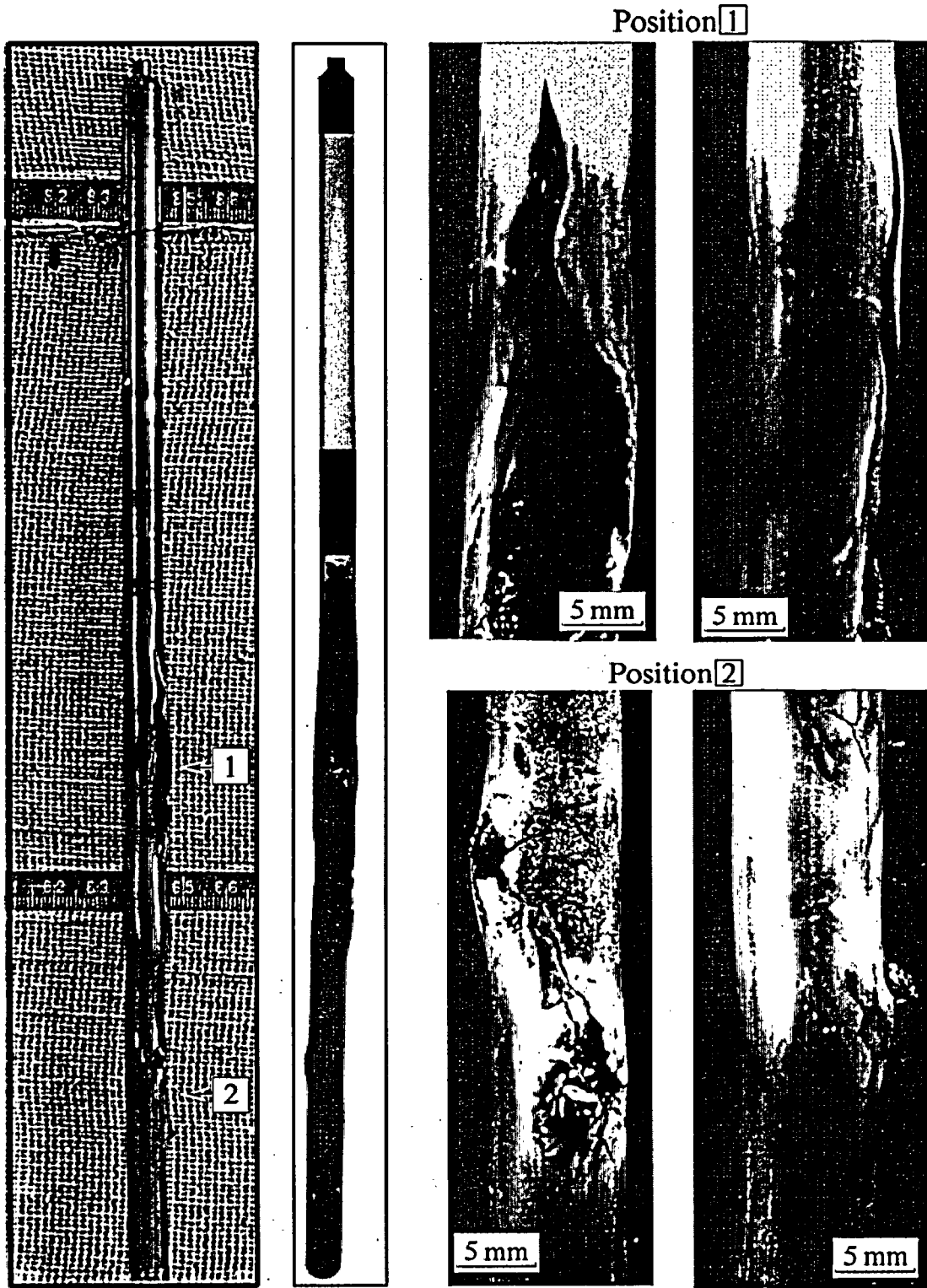
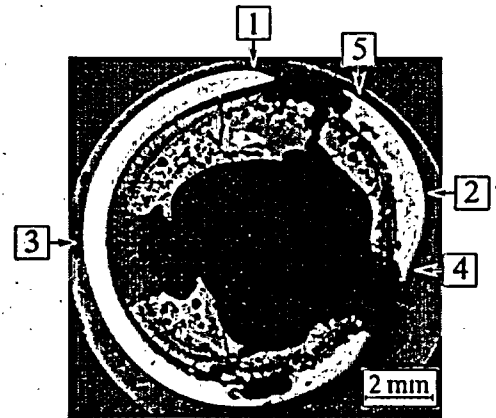
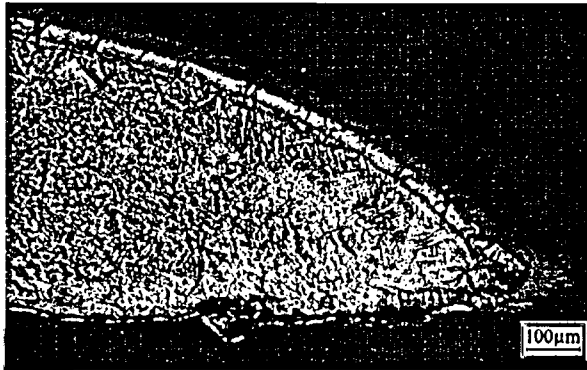

Fig. G-3.1. Appearance of Fuel Rod #H3T (photographs and X-ray photograph)

#H3T

Individual Characteristics of Refabricated Fuel Rods  
(Preirradiated Fuel, Preirradiated Cladding) under IGR Tests

Position 1



Position 2



Position 3

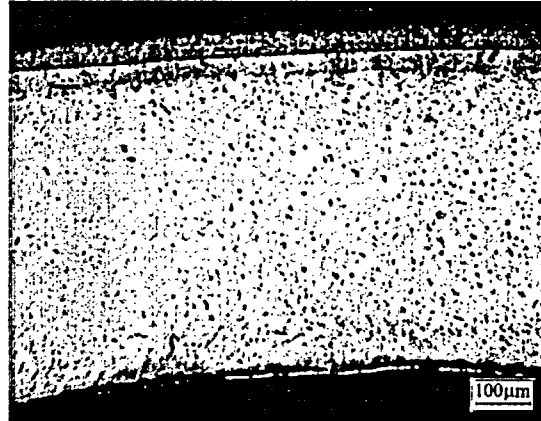

Position 4



Position 5

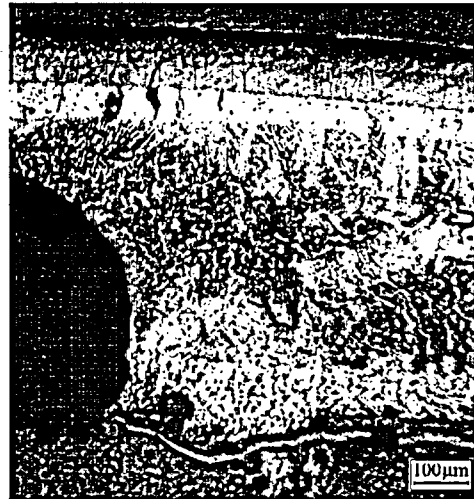
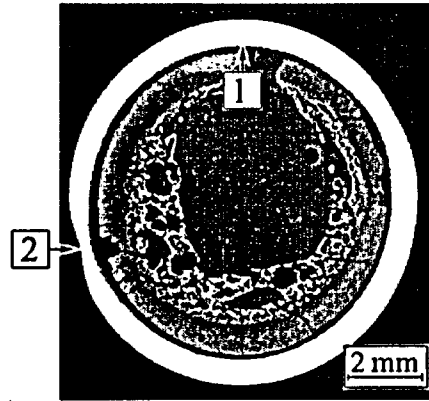
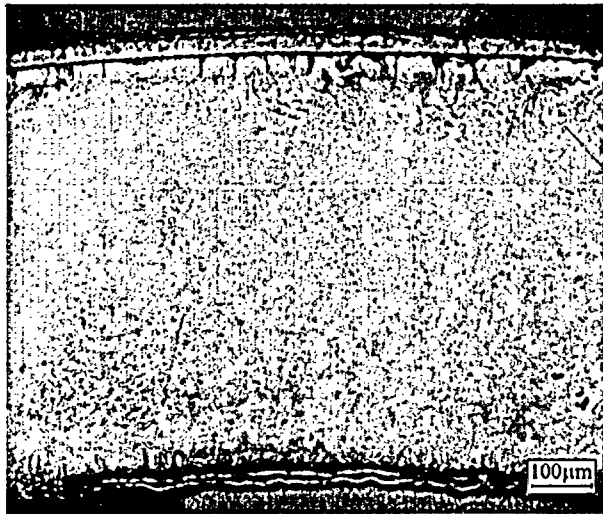

Fig. G-3.2. Cross-Section and Cladding Microstructure for Fuel Rod #H3T at 55 mm Elevation

#H3T

Individual Characteristics of Refabricated Fuel Rods  
(Preirradiated Fuel, Preirradiated Cladding) under IGR Tests

Position 1



Position 1

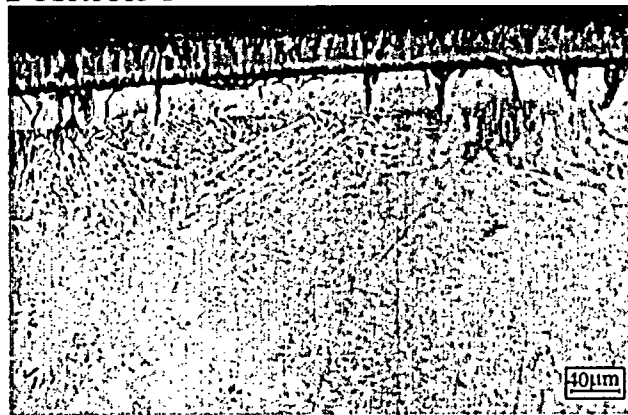

Position 2

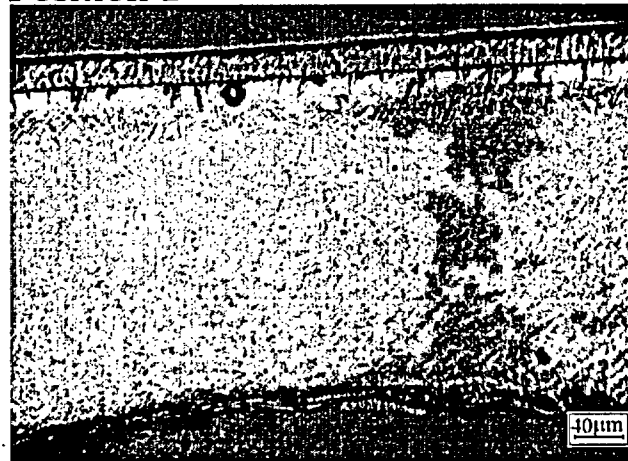

Fig. G-3.3. Cross-Section and Cladding Microstructure for Fuel Rod #H3T at 80 mm Elevation

#H3T

Individual Characteristics of Refabricated Fuel Rods  
(Preirradiated Fuel, Preirradiated Cladding) under IGR Tests

Position 1

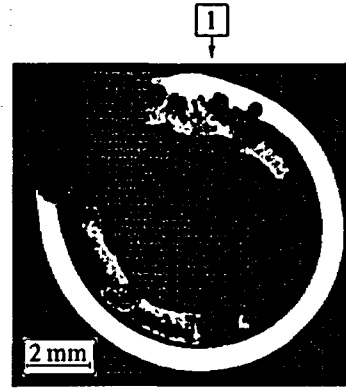

Fig. G-3.4. Cross-Section and Cladding Microstructure for Fuel Rod #H3T at 130 mm Elevation

#H3T

Individual Characteristics of Refabricated Fuel Rods  
(Preirradiated Fuel/Preirradiated Cladding) under IGR Tests

Position 1

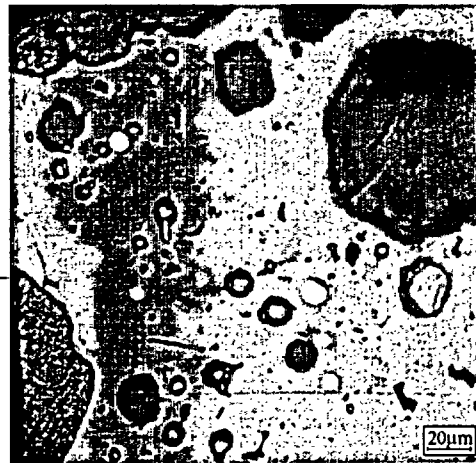
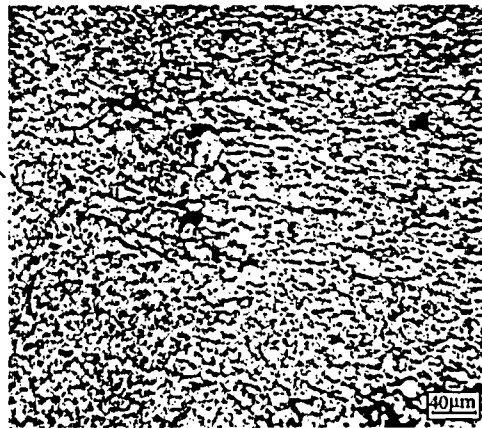
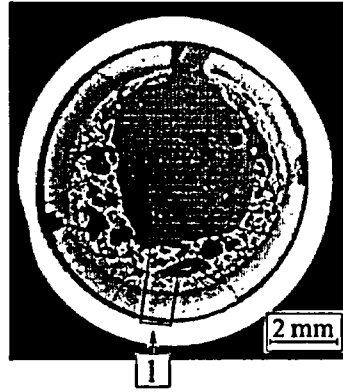
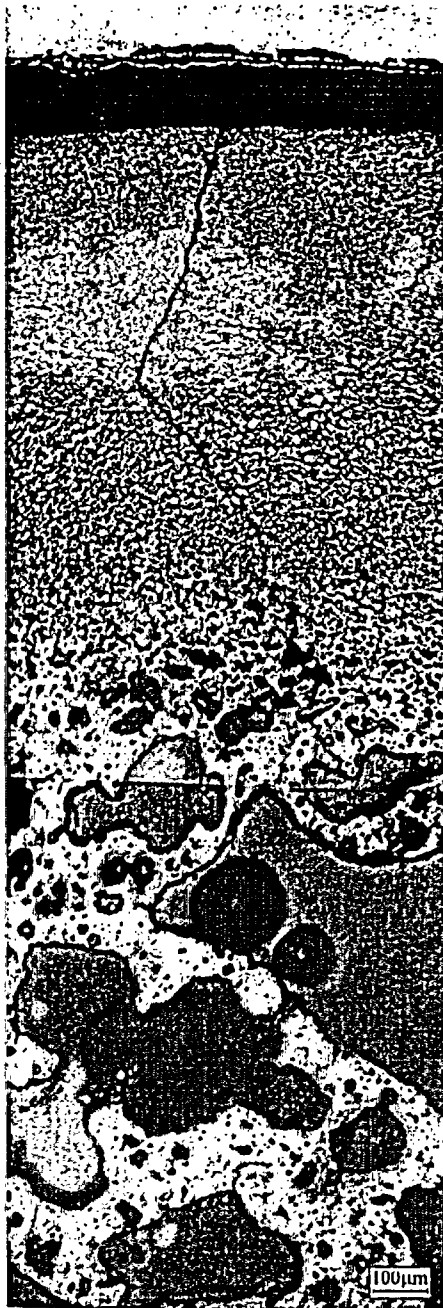

Fig. G-3.5. Fuel Microstructure for Fuel Rod #H3T at 80 mm Elevation



## #H3T

Individual Characteristics of Refabricated Fuel Rods  
(Preirradiated Fuel, Preirradiated Cladding) under IGR Tests

Table G-3.1. Time Dependent Energy Characteristics of Fuel Rod #H3T

Time (s)	Reactor energy deposition <sup>1)</sup> (%)	Cumulative number of fissions in fuel rod (fiss)						Power of fuel rod (kW)	Energy deposition in fuel rod	
		U <sup>235</sup> ×10 <sup>-14</sup>	U <sup>238</sup> ×10 <sup>-13</sup>	Pu <sup>239</sup> ×10 <sup>-14</sup>	Pu <sup>241</sup> ×10 <sup>-14</sup>	Other isotopes ×10 <sup>-11</sup>	Total ×10 <sup>-14</sup>		cal/g fuel	J/g fuel
0.0	0.000	0.000	0.000	0.000	0.000	0.000	0.000	0.000	0.000	0.000
1.0	0.865	0.089	0.022	0.137	0.057	0.108	0.284	1.630	3.210	13.40
2.0	4.220	0.433	0.107	0.668	0.276	0.526	1.390	5.280	15.70	65.70
2.2	5.520	0.566	0.140	0.872	0.360	0.687	1.810	7.060	20.50	85.80
2.4	7.320	0.751	0.186	1.160	0.478	0.912	2.410	10.30	27.20	114.0
2.6	10.10	1.040	0.257	1.600	0.660	1.260	3.320	16.60	37.50	157.0
2.8	14.80	1.520	0.376	2.340	0.966	1.840	4.860	29.10	55.00	230.0
3.0	23.20	2.380	0.589	3.660	1.510	2.880	7.610	51.30	86.00	360.0
3.2	36.90	3.790	0.939	5.840	2.410	4.600	12.10	77.50	137.0	573.0
3.4	54.70	5.610	1.390	8.640	3.570	6.810	18.00	84.30	203.0	850.0
3.6	70.10	7.190	1.780	11.10	4.580	8.730	23.00	59.40	260.0	1088.
3.8	80.00	8.200	2.030	12.60	5.220	9.960	26.30	35.40	297.0	1243.
4.0	85.70	8.800	2.180	13.60	5.600	10.70	28.20	20.80	319.0	1335.
4.2	89.20	9.150	2.270	14.10	5.820	11.10	29.30	12.60	332.0	1390.
4.4	91.20	9.360	2.320	14.40	5.960	11.40	30.00	8.010	339.0	1419.
4.6	92.60	9.500	2.350	14.60	6.050	11.50	30.40	5.350	345.0	1444.
4.8	93.50	9.590	2.380	14.80	6.100	11.60	30.70	3.750	348.0	1457.
5.0	94.10	9.660	2.390	14.90	6.150	11.70	30.90	2.730	351.0	1469.
5.2	94.60	9.700	2.400	15.00	6.180	11.80	31.10	2.170	353.0	1478.
5.4	95.00	9.740	2.410	15.00	6.200	11.80	31.20	1.840	354.0	1482.
5.6	95.30	9.780	2.420	15.10	6.220	11.90	31.30	1.570	356.0	1490.
5.8	95.60	9.800	2.430	15.10	6.240	11.90	31.40	1.360	357.0	1494.
6.0	95.80	9.830	2.440	15.10	6.260	11.90	31.50	1.190	358.0	1499.
6.5	96.30	9.880	2.450	15.20	6.290	12.00	31.60	0.885	360.0	1507.
7.0	96.60	9.910	2.460	15.30	6.310	12.00	31.70	0.697	361.0	1511.
7.5	96.90	9.940	2.460	15.30	6.330	12.10	31.80	0.576	363.0	1520.
8.0	97.10	9.960	2.470	15.30	6.340	12.10	31.90	0.493	364.0	1524.
9.0	97.50	10.00	2.480	15.40	6.360	12.10	32.00	0.426	365.0	1528.
10.0	97.80	10.00	2.490	15.50	6.390	12.20	32.10	0.344	367.0	1536.
20.0	99.10	10.20	2.520	15.70	6.470	12.30	32.60	0.090	373.0	1561.
30.0	99.50	10.20	2.530	15.70	6.500	12.40	32.70	0.047	376.0	1574.
∞	100.0	10.30	2.550	15.90	6.560	12.50	33.00	0.000	384.0	1607.

Maximum value of power is 86.1 kW (t = 3.35 s).

<sup>1)</sup> Current energy deposition per maximum energy deposition (at infinite time)

## #H3T

Individual Characteristics of Refabricated Fuel Rods  
(Preirradiated Fuel/Preirradiated Cladding) under IGR Tests

Table G-3.2. Axial Energy Characteristics of Fuel Rod #H3T

Axial coordinate from lower end of fuel rod (mm)	Cumulative number of fissions at axial interval (fiss)						Maximum power of fuel rod (kW) $t=3.35s$	Energy deposition at infinite time*		
	$U^{235} \times 10^{-13}$	$U^{238} \times 10^{-11}$	$Pu^{239} \times 10^{-13}$	$Pu^{241} \times 10^{-13}$	Other isotopes $\times 10^{-10}$	Total $\times 10^{-13}$		cal/g fuel	J/g fuel	per-unit <sup>3)</sup>
10.0	0.000	0.000	0.000	0.000	0.000	0.000	0.000	0.000	0.000	0.00
15.0	0.000	0.000	0.000	0.000	0.000	0.000	0.000	0.000	0.000	0.00
20.0 <sup>1)</sup>	1.500	3.330	2.350	0.974	1.710	4.860	1.270	413.0	1729.	1.00
25.0	2.510	5.550	3.920	1.620	2.850	8.110	2.120	413.0	1729.	1.00
30.0	2.510	5.550	3.920	1.620	2.850	8.110	2.120	413.0	1729.	1.00
35.0	3.530	8.710	5.360	2.200	4.300	11.20	2.920	387.0	1620.	0.94
40.0	3.500	8.590	5.280	2.170	4.280	11.00	2.880	388.0	1624.	0.94
45.0	3.560	8.440	5.180	2.110	4.270	10.90	2.850	393.0	1645.	0.95
50.0	3.550	8.430	5.170	2.100	4.250	10.90	2.850	393.0	1645.	0.95
55.0	3.660	8.510	5.210	2.110	4.250	11.10	2.890	397.0	1662.	0.96
60.0	3.700	8.620	5.280	2.130	4.240	11.20	2.920	397.0	1662.	0.96
65.0	3.750	8.760	5.370	2.170	4.240	11.40	2.970	396.0	1658.	0.96
70.0	3.750	8.800	5.390	2.180	4.240	11.40	2.980	395.0	1653.	0.96
75.0	3.600	8.620	5.290	2.160	4.230	11.10	2.910	392.0	1641.	0.95
80.0	3.540	8.510	5.220	2.130	4.230	11.00	2.870	391.0	1637.	0.95
85.0	3.440	8.440	5.190	2.130	4.230	10.90	2.830	388.0	1624.	0.94
90.0	3.440	8.470	5.210	2.140	4.230	10.90	2.840	387.0	1620.	0.94
95.0	3.370	8.520	5.260	2.180	4.230	10.90	2.840	383.0	1603.	0.93
100.0	3.420	8.680	5.360	2.220	4.230	11.10	2.890	382.0	1599.	0.92
105.0	3.380	8.750	5.410	2.260	4.230	11.10	2.910	379.0	1586.	0.92
110.0	3.370	8.730	5.390	2.250	4.230	11.10	2.900	379.0	1586.	0.92
115.0	3.360	8.680	5.370	2.240	4.230	11.10	2.890	379.0	1586.	0.92
120.0	3.340	8.650	5.340	2.230	4.230	11.00	2.870	379.0	1586.	0.92
125.0	3.330	8.690	5.370	2.250	4.230	11.00	2.880	377.0	1578.	0.91
130.0	3.350	8.760	5.410	2.260	4.230	11.10	2.900	377.0	1578.	0.91
135.0	3.380	8.840	5.460	2.290	4.230	11.20	2.930	377.0	1578.	0.91
140.0	3.430	8.940	5.530	2.320	4.230	11.40	2.970	377.0	1578.	0.91
145.0	3.430	9.020	5.580	2.340	4.220	11.40	2.990	377.0	1578.	0.91
150.0	3.450	9.030	5.580	2.330	4.220	11.50	2.990	377.0	1578.	0.91
155.0	3.630	9.180	5.660	2.350	4.210	11.70	3.060	382.0	1599.	0.92
160.0	2.720	6.900	4.310	1.790	3.430	8.890	2.320	356.0	1490.	0.86
165.0	2.720	6.900	4.310	1.790	3.430	8.890	2.320	356.0	1490.	0.86
170.0	2.720	6.900	4.310	1.790	3.430	8.890	2.320	356.0	1490.	0.86
175.0 <sup>2)</sup>	1.090	2.760	1.720	0.715	1.370	3.560	0.928	356.0	1490.	0.86
180.0	0.000	0.000	0.000	0.000	0.000	0.000	0.000	0.000	0.000	0.00
185.0	0.000	0.000	0.000	0.000	0.000	0.000	0.000	0.000	0.000	0.00

\* All numerical values of characteristics are presented as average values at the length interval equal to the axial coordinate  $\pm 2.5$  mm

<sup>1)</sup> Initial coordinate of fuel is 19.5 mm

<sup>2)</sup> End coordinate of fuel is 174.5 mm

<sup>3)</sup> Current value per maximum value

# #H3T

Individual Characteristics of Refabricated Fuel Rods  
(Preirradiated Fuel, Preirradiated Cladding) under IGR Tests

Table G-3.3. Radial Energy Characteristics of Fuel Rod #H3T

Characteristics*		Coordinates of fuel zones (mm)			
		1 zone 1.2 - 2.811	2 zone 2.811-3.432	3 zone 3.432-3.704	4 zone 3.704-3.790
U <sup>235</sup>	Number of fissions ×10 <sup>-14</sup> (fiss)	4.430	2.600	1.270	0.414
	Power of fuel rod <sup>1)</sup> (kW)	11.40	6.660	3.260	1.060
	Energy deposition <sup>2)</sup> (cal/g fuel)	120.0	117.0	115.0	112.0
	Energy deposition <sup>2)</sup> (J/g fuel)	502.0	490.0	481.0	469.0
	Energy deposition <sup>3)</sup> (per-unit)	1.000	0.975	0.958	0.933
U <sup>238</sup>	Number of fissions ×10 <sup>-12</sup> (fiss)	11.40	6.440	2.970	0.896
	Power of fuel rod <sup>1)</sup> (kW)	0.289	0.163	0.075	0.023
	Energy deposition <sup>2)</sup> (cal/g fuel)	3.060	2.870	2.650	2.400
	Energy deposition <sup>2)</sup> (J/g fuel)	12.80	12.00	11.10	10.00
	Energy deposition <sup>3)</sup> (per-unit)	1.000	0.938	0.866	0.784
Pu <sup>239</sup>	Number of fissions ×10 <sup>-14</sup> (fiss)	5.560	3.780	2.590	1.460
	Power of fuel rod <sup>1)</sup> (kW)	14.70	9.990	6.850	3.870
	Energy deposition <sup>2)</sup> (cal/g fuel)	156.0	177.0	242.0	411.0
	Energy deposition <sup>2)</sup> (J/g fuel)	653.0	741.0	1013.	1720.
	Energy deposition <sup>3)</sup> (per-unit)	0.380	0.431	0.589	1.000
Pu <sup>241</sup>	Number of fissions ×10 <sup>-13</sup> (fiss)	21.90	15.60	11.20	6.650
	Power of fuel rod <sup>1)</sup> (kW)	5.700	4.050	2.900	1.730
	Energy deposition <sup>2)</sup> (cal/g fuel)	60.40	71.40	102.0	183.0
	Energy deposition <sup>2)</sup> (J/g fuel)	253.0	299.0	427.0	766.0
	Energy deposition <sup>3)</sup> (per-unit)	0.330	0.390	0.557	1.000
Other isotopes	Number of fissions ×10 <sup>-11</sup> (fiss)	4.930	3.040	1.770	0.844
	Power of fuel rod <sup>1)</sup> (kW)	0.013	0.008	0.005	0.002
	Energy deposition <sup>2)</sup> (cal/g fuel)	0.137	0.141	0.164	0.235
	Energy deposition <sup>2)</sup> (J/g fuel)	0.570	0.590	0.690	0.980
	Energy deposition <sup>3)</sup> (per-unit)	0.583	0.600	0.698	1.000
Total	Number of fissions ×10 <sup>-14</sup> (fiss)	12.30	8.000	5.010	2.560
	Power of fuel rod <sup>1)</sup> (kW)	32.10	20.90	13.10	6.680
	Energy deposition <sup>2)</sup> (cal/g fuel)	340.0	369.0	462.0	708.0
	Energy deposition <sup>2)</sup> (J/g fuel)	1423.	1545.	1934.	2964.
	Energy deposition <sup>3)</sup> (per-unit)	0.480	0.521	0.653	1.000

<sup>1)</sup> at time of 3.35 s,    <sup>2)</sup> at infinite time,    <sup>3)</sup> Current value per maximum value.

\* All numerical values of characteristics were calculated for undamaged part of fuel stack only (See Table C.2.1.)

# #H3T

Individual Characteristics of Refabricated Fuel Rods  
(Preirradiated Fuel, Preirradiated Cladding) under IGR Tests

Table G-3.4. Fuel Enthalpy Vs. Time Calculated by FRAP-T6 Code for Fuel Rod #H3T

Time (s)	Enthalpy at fuel radius (cal/g fuel)				Fuel enthalpy <sup>1)</sup>		Energy deposition in fuel rod	
	1.20 mm	2.82 mm	3.47 mm	3.79 mm	cal/g fuel	J/g fuel	cal/g fuel	J/g fuel
0.0	0.00	0.00	0.00	0.00	0.00	0.00	0.00	0.00
1.0	3.16	3.09	2.92	2.72	3.05	12.8	3.21	13.4
2.0	14.9	14.3	13.1	11.7	14.1	58.9	15.7	65.6
2.2	19.5	18.4	16.3	14.0	18.0	75.4	20.5	85.7
2.4	25.7	24.0	20.6	17.0	23.4	97.9	27.2	114
2.6	35.5	32.7	27.5	21.9	31.8	133	37.5	157
2.8	52.1	48.1	38.1	24.0	45.7	191	54.9	230
3.0	82.0	75.1	56.0	31.6	70.4	295	85.9	360
3.2	131	121	86.5	50.9	112	470	137	574
3.4	196	179	131	73.2	167	702	203	850
3.6	251	228	171	130	216	907	260	1088
3.8	270	256	201	150	245	1027	296	1242
4.0	-	-	-	-	-	-	318	1332
4.2	-	-	-	-	-	-	331	1387
4.4	-	-	-	-	-	-	339	1421
4.6	-	-	-	-	-	-	344	1443
4.8	-	-	-	-	-	-	348	1458
5.0	-	-	-	-	-	-	351	1469
5.2	-	-	-	-	-	-	353	1478
5.4	-	-	-	-	-	-	354	1484
5.6	-	-	-	-	-	-	356	1490
5.8	-	-	-	-	-	-	357	1495
6.0	-	-	-	-	-	-	358	1499
6.5	-	-	-	-	-	-	360	1508
7.0	-	-	-	-	-	-	361	1514
7.5	-	-	-	-	-	-	363	1520
8.0	-	-	-	-	-	-	364	1524
10.0	-	-	-	-	-	-	367	1538
30.0	-	-	-	-	-	-	376	1577

Radial enthalpy distribution and fuel enthalpy are presented at elevation 27.3 mm

Maximum value of fuel enthalpy is 251.6 cal/g fuel ( $t=3.89$  s)

<sup>1)</sup> All numerical values are presented at elevation with peak power

# #H3T

Individual Characteristics of Refabricated Fuel Rods  
(Preirradiated Fuel, Preirradiated Cladding) under IGR Tests

Table G-3.5. Energy Characteristics Vs. Time Calculated by FRAP-T6 and SCANAIR Codes for Fuel Rod #H3T

Time (s)	Energy deposition <sup>1)</sup> (cal/g fuel)	Linear power <sup>1)</sup> (kW/m)	Fuel enthalpy <sup>1)</sup> (cal/g fuel)		Energy of metal-water reaction <sup>1)</sup> (cal/g fuel)	Leakage of energy <sup>1)</sup> (cal/g fuel)		Clad-to-coolant heat transfer coefficient <sup>1)</sup> (kW/m <sup>2</sup> K)	
			FRAP-T6	SCANAIR	FRAP-T6	FRAP-T6	SCANAIR	FRAP-T6	SCANAIR
0.0	0.00	0.00	0.00	0.00	0.00	0.00	0.00	0.00	0.00
1.0	3.41	12.3	3.05	2.92	0.00	0.00	0.01	0.03	0.10
2.0	16.6	39.8	14.1	14.0	0.00	0.80	0.93	2.82	3.15
2.2	21.7	53.2	18.0	17.4	0.00	1.95	1.98	4.23	4.42
2.4	28.9	77.7	23.4	22.9	0.00	3.71	3.76	6.07	6.40
2.6	39.8	125	31.8	31.7	0.00	6.30	6.49	8.50	9.65
2.8	58.4	220	45.7	44.2	0.00	10.7	10.2	16.8	14.7
3.0	91.3	387	70.4	69.6	0.00	19.3	18.1	24.5	26.8
3.2	145	584	112	111	0.00	32.1	30.8	16.9	0.91
3.4	216	633	167	-	0.00	37.2	-	1.76	-
3.6	276	446	216	-	0.01	42.9	-	2.29	-
3.8	315	266	245	-	0.08	50.6	-	2.46	-
4.0	338	156	-	-	-	-	-	-	-
4.2	352	94.6	-	-	-	-	-	-	-
4.4	361	60.2	-	-	-	-	-	-	-
4.6	366	40.2	-	-	-	-	-	-	-
4.8	370	28.2	-	-	-	-	-	-	-
5.0	373	20.5	-	-	-	-	-	-	-
5.2	375	16.3	-	-	-	-	-	-	-
5.4	377	13.8	-	-	-	-	-	-	-
5.6	378	11.8	-	-	-	-	-	-	-
5.8	380	10.2	-	-	-	-	-	-	-
6.0	381	8.95	-	-	-	-	-	-	-
6.5	383	6.66	-	-	-	-	-	-	-
7.0	385	5.24	-	-	-	-	-	-	-
7.5	386	4.33	-	-	-	-	-	-	-
8.0	387	3.71	-	-	-	-	-	-	-
10.0	391	2.59	-	-	-	-	-	-	-
30.0	400	0.36	-	-	-	-	-	-	-

<sup>1)</sup> All numerical values are presented at elevation with peak power

# #H3T

Individual Characteristics of Refabricated Fuel Rods  
(Preirradiated Fuel, Preirradiated Cladding) under IGR-Tests

Table G-3.6. Temperature Variation, Fission Gas Release and ZrO<sub>2</sub> Thickness Vs. Time for Fuel Rod #H3T Calculated by FRAP-T6 and SCANAIR Codes

Time (s)	Fuel centerline temperature <sup>1)</sup> (K)		Fuel surface temperature <sup>1)</sup> (K)		Clad outer temperature <sup>1)</sup> (K)		Fission gas release (%)		Average ZrO <sub>2</sub> <sup>2)</sup> thickness (μm)
	FRAP-T6	SCANAIR	FRAP-T6	SCANAIR	FRAP-T6	SCANAIR	FRAP-T6	SCANAIR	FRAP-T6
0.0	293	293	293	293	293	293	0.00	0.00	5.00
1.0	347	341	340	336	315	313	0.10	0.34	5.00
2.0	529	517	480	479	394	385	0.23	1.23	5.00
2.2	594	573	515	514	398	387	0.29	1.57	5.00
2.4	684	661	559	566	403	390	0.38	1.95	5.00
2.6	818	796	629	641	409	395	0.56	2.44	5.00
2.8	1042	984	659	732	422	401	0.92	2.76	5.00
3.0	1430	1360	765	836	432	412	1.93	3.20	5.00
3.2	2024	1961	1025	998	500	629	3.89	3.61	5.00
3.4	2626	-	1317	-	975	-	7.96	-	5.00
3.6	3002	-	2004	-	1242	-	14.4	-	5.02
3.8	3113	-	2223	-	1324	-	26.8	-	5.10
4.0	-	-	-	-	-	-	-	-	-
4.2	-	-	-	-	-	-	-	-	-
4.4	-	-	-	-	-	-	-	-	-
4.6	-	-	-	-	-	-	-	-	-
4.8	-	-	-	-	-	-	-	-	-
5.0	-	-	-	-	-	-	-	-	-
5.2	-	-	-	-	-	-	-	-	-
5.4	-	-	-	-	-	-	-	-	-
5.6	-	-	-	-	-	-	-	-	-
5.8	-	-	-	-	-	-	-	-	-
6.0	-	-	-	-	-	-	-	-	-
6.5	-	-	-	-	-	-	-	-	-
7.0	-	-	-	-	-	-	-	-	-
7.5	-	-	-	-	-	-	-	-	-
8.0	-	-	-	-	-	-	-	-	-
10.0	-	-	-	-	-	-	-	-	-
30.0	-	-	-	-	-	-	-	-	-

<sup>1)</sup> All numerical values are presented at elevation with peak power

<sup>2)</sup> Initial ZrO<sub>2</sub> thickness is 5 μm

# #H3T

Individual Characteristics of Refabricated Fuel Rods  
(Preirradiated Fuel, Preirradiated Cladding) under IGR Tests

Table G-3.7. Mechanical Characteristics of Fuel Rod #H3T Vs. Time Calculated by FRAP-T6 and SCANAIR Codes

Time (s)	Clad outer temperature <sup>1)</sup> (K)		Fuel hoop strain <sup>1)</sup> (%)		Fuel - clad gap width <sup>1)</sup> (mm)		Clad hoop strain <sup>1)</sup> (%)		Clad hoop stress <sup>1)</sup> (MPa)		Internal gas pressure (MPa)	
	FRAP-T6	SCANAIR	FRAP-T6	SCANAIR	FRAP-T6	SCANAIR	FRAP-T6	SCANAIR	FRAP-T6	SCANAIR	FRAP-T6	SCANAIR
0.0	293	293	0.00	0.00	0.03	0.03	0.01	0.01	8.29	8.02	1.70	1.70
1.0	315	313	0.10	0.03	0.03	0.03	0.02	0.02	8.50	8.28	1.74	1.74
2.0	394	385	0.36	0.16	0.02	0.03	0.08	0.08	8.99	9.03	1.83	1.84
2.2	398	387	0.45	0.19	0.02	0.03	0.09	0.09	9.10	9.26	1.85	1.87
2.4	403	390	0.58	0.26	0.01	0.02	0.09	0.10	9.24	9.59	1.88	1.90
2.6	409	395	0.78	0.36	0.00	0.02	0.10	0.11	9.42	10.1	1.91	1.93
2.8	422	401	1.12	0.52	0.00	0.02	0.29	0.12	212	10.7	1.96	1.97
3.0	432	412	1.77	0.88	0.00	0.00	0.83	0.17	293	12.2	2.01	2.01
3.2	500	629	2.90	1.79	0.00	0.00	1.76	0.86	93.7	311	2.08	2.04
3.4	975	-	4.50	-	0.00	-	3.13	-	78.9	-	2.19	-
3.6	1242	-	5.58	-	0.32	-	12.6	-	0.00	-	0.10	-
3.8	1324	-	6.77	-	0.28	-	12.7	-	0.00	-	0.10	-
4.0	-	-	-	-	-	-	-	-	-	-	-	-
4.2	-	-	-	-	-	-	-	-	-	-	-	-
4.4	-	-	-	-	-	-	-	-	-	-	-	-
4.6	-	-	-	-	-	-	-	-	-	-	-	-
4.8	-	-	-	-	-	-	-	-	-	-	-	-
5.0	-	-	-	-	-	-	-	-	-	-	-	-
5.2	-	-	-	-	-	-	-	-	-	-	-	-
5.4	-	-	-	-	-	-	-	-	-	-	-	-
5.6	-	-	-	-	-	-	-	-	-	-	-	-
5.8	-	-	-	-	-	-	-	-	-	-	-	-
6.0	-	-	-	-	-	-	-	-	-	-	-	-
6.5	-	-	-	-	-	-	-	-	-	-	-	-
7.0	-	-	-	-	-	-	-	-	-	-	-	-
7.5	-	-	-	-	-	-	-	-	-	-	-	-
8.0	-	-	-	-	-	-	-	-	-	-	-	-
10.0	-	-	-	-	-	-	-	-	-	-	-	-
30.0	-	-	-	-	-	-	-	-	-	-	-	-

<sup>1)</sup> All numerical values are presented at elevation with peak power

# #H3T

Individual Characteristics of Refabricated Fuel Rods  
(Preirradiated Fuel, Preirradiated Cladding) under IGR Tests

Table G-3.8. Axial Distribution of Energy Deposition and Fuel Enthalpy Calculated by FRAP-T6 Code for Fuel Rod #H3T

Axial interval from-to (mm)-(mm)	Energy deposition at infinite time			Fuel enthalpy at time (t=4.26 s)		
	cal/g fuel	J/g fuel	per-unit	cal/g fuel	J/g fuel	per-unit
19.5 - 35.0	409	1713	1.00	261	1092	1.00
35.0 - 50.5	390	1636	0.96	249	1043	0.96
50.5 - 66.0	396	1660	0.97	253	1058	0.97
66.0 - 81.5	393	1647	0.96	250	1050	0.96
81.5 - 97.0	386	1619	0.95	246	1032	0.95
97.0 - 112.5	380	1593	0.93	242	1015	0.93
112.5 - 128.0	378	1585	0.93	241	1010	0.93
128.0 - 143.5	377	1580	0.92	240	1007	0.92
143.5 - 159.0	376	1577	0.92	240	1005	0.92
159.0 - 174.5	356	1492	0.87	227	951	0.87

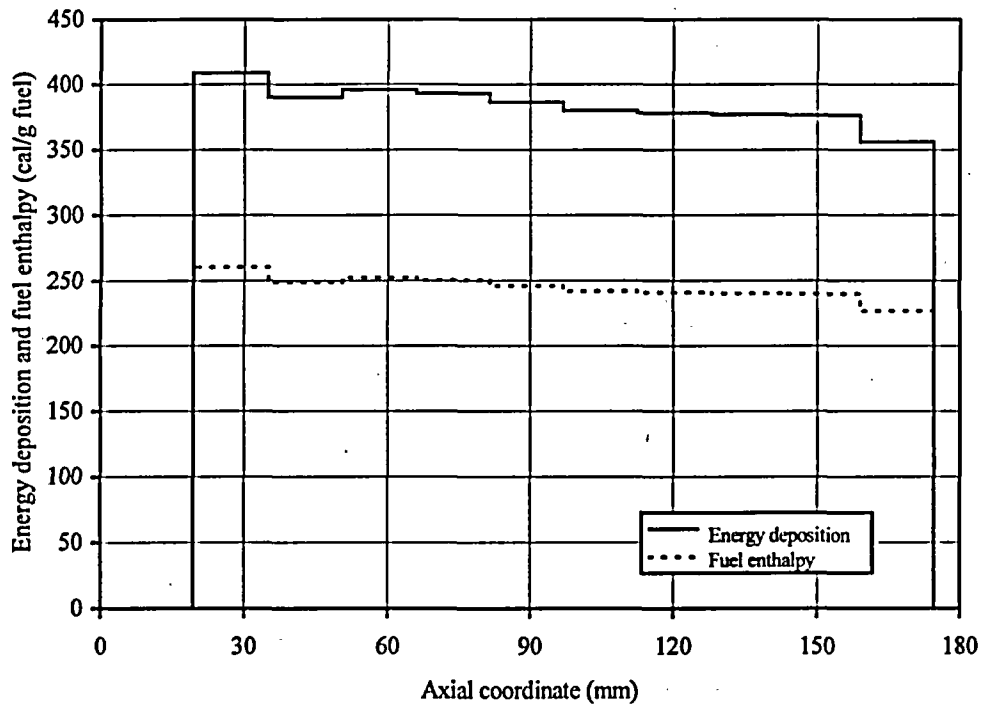

Fig. G-3.6. Axial Distribution of Energy Deposition and Fuel Enthalpy Calculated by FRAP-T6 Code for Fuel Rod #H3T



#H3T

Individual Characteristics of Refabricated Fuel Rods  
(Preirradiated Fuel, Preirradiated Cladding) under IGR Tests

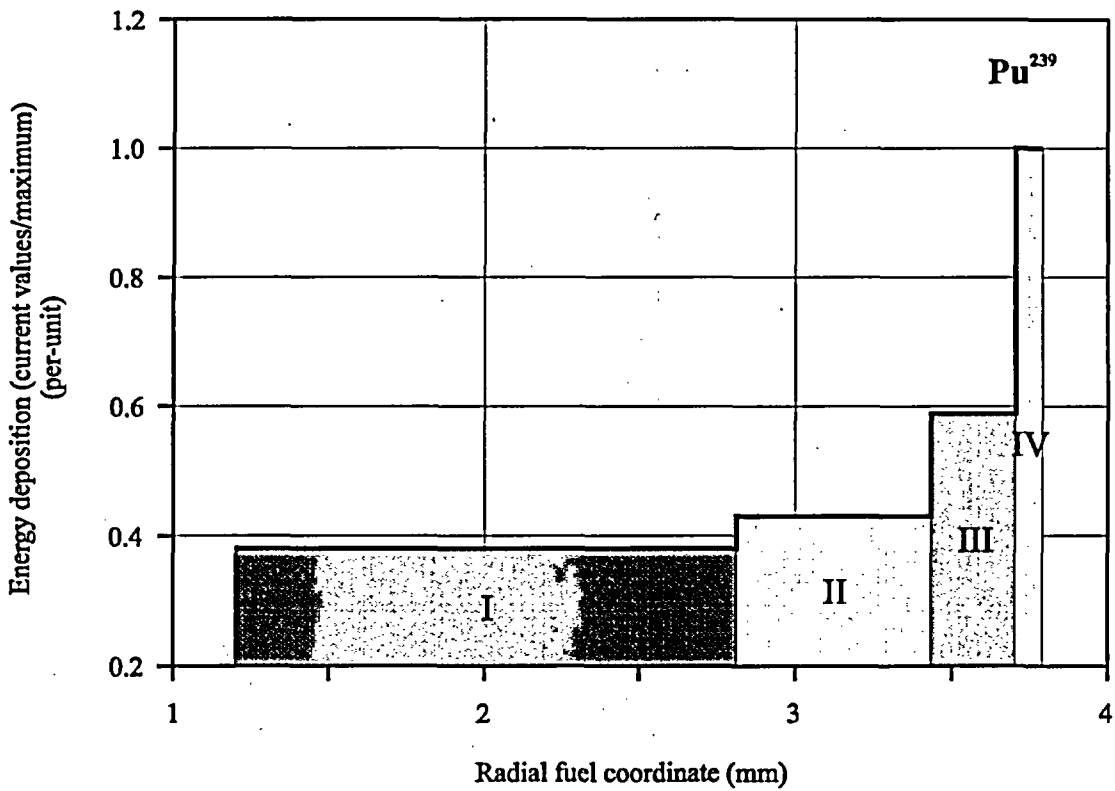
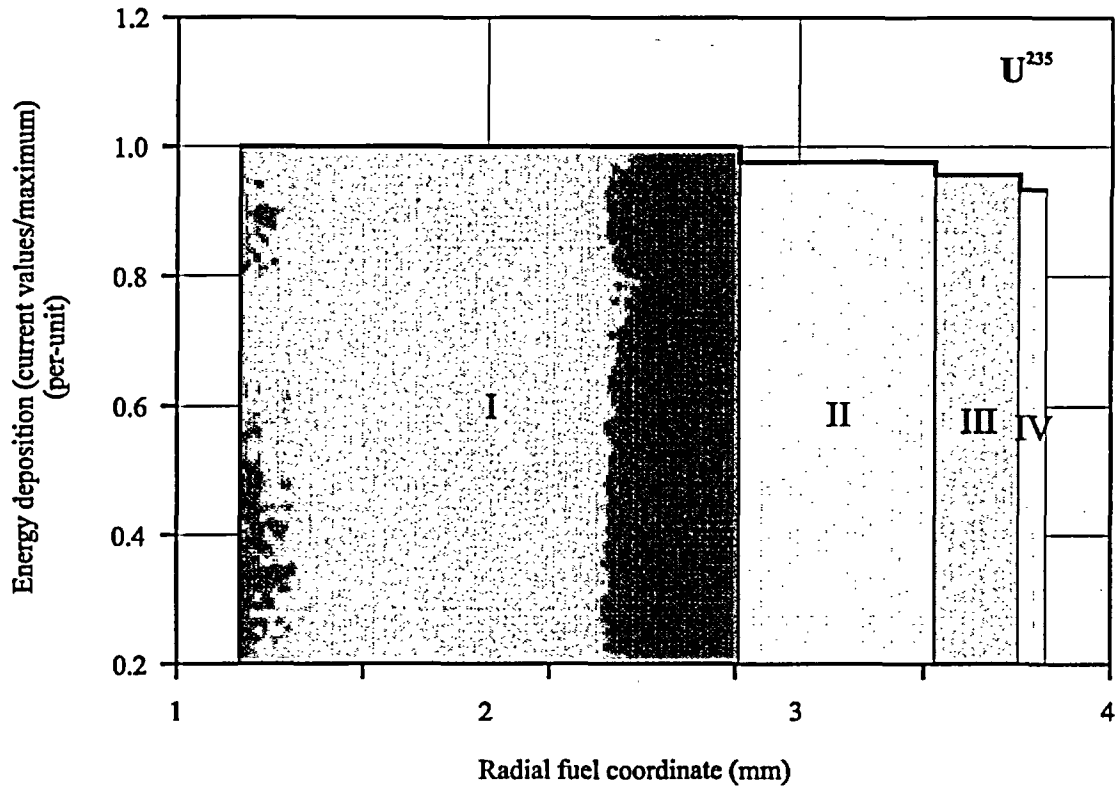

Fig. G-3.7. U<sup>235</sup> and Pu<sup>239</sup> Radial Distributions of Energy Deposition for Fuel Rod #H3T

# #H3T

Individual Characteristics of Refabricated Fuel Rods  
(Preirradiated Fuel, Preirradiated Cladding) under IGR Tests

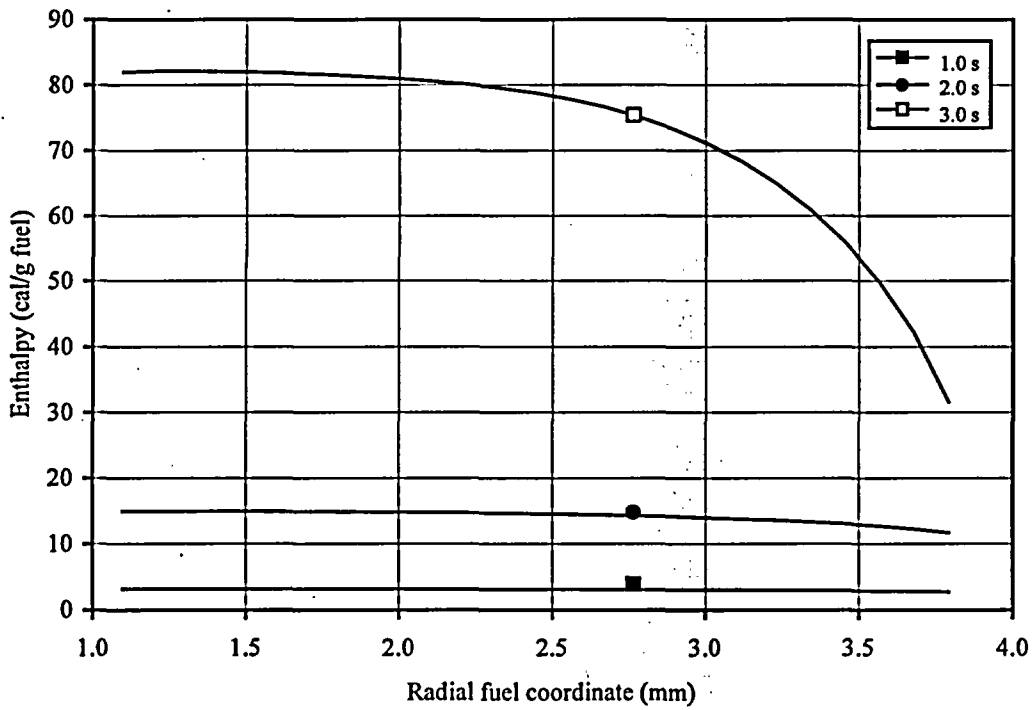
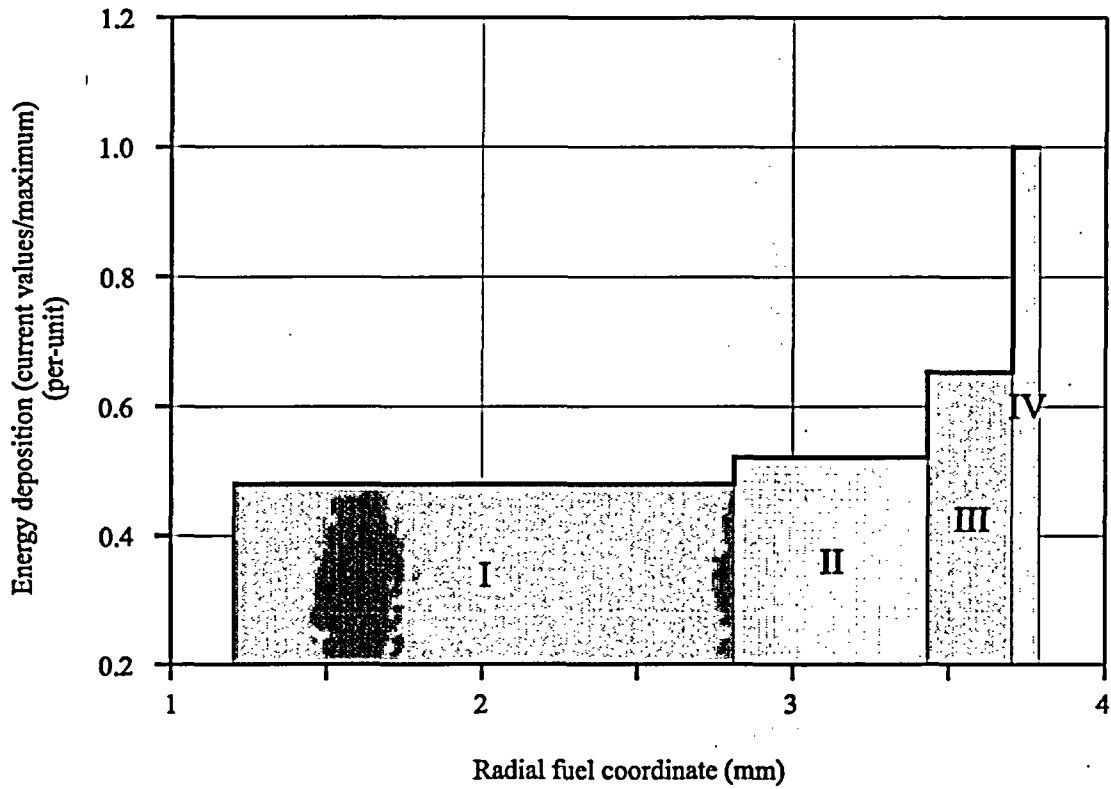

Fig. G-3.8. Radial Distributions of Energy Deposition and Fuel Enthalpy Calculated by FRAP-T6 Code for Fuel Rod #H3T

# #H3T

Individual Characteristics of Refabricated Fuel Rods  
(Preirradiated Fuel, Preirradiated Cladding) under IGR Tests

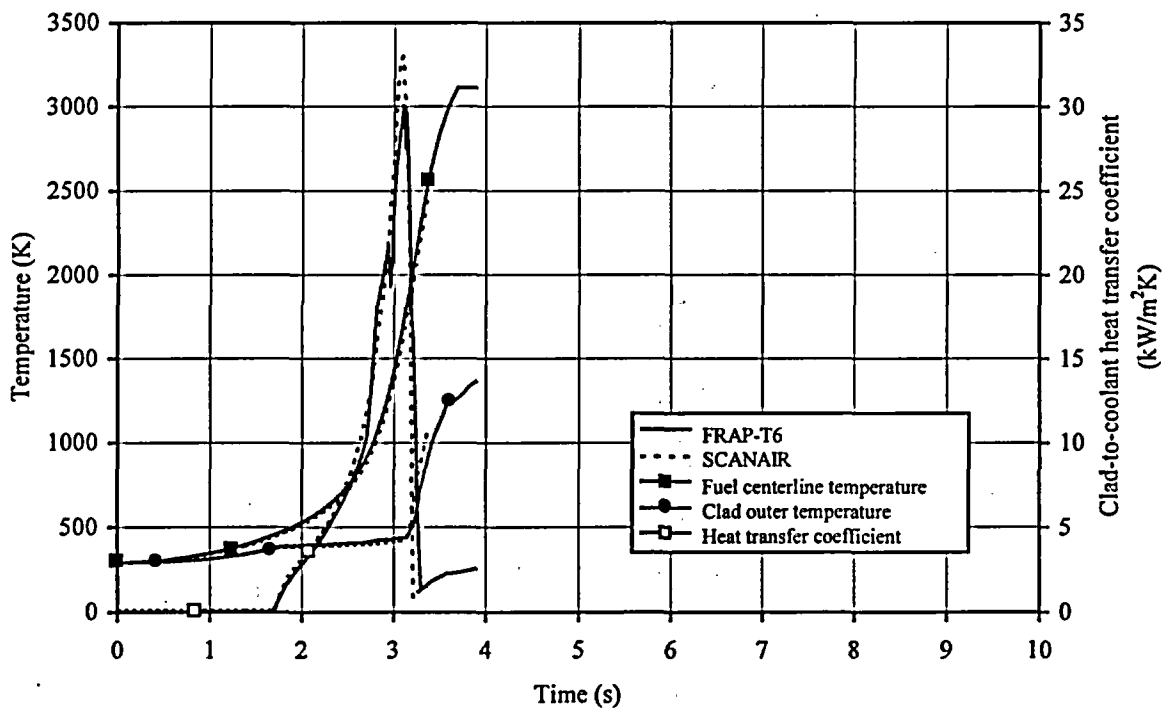
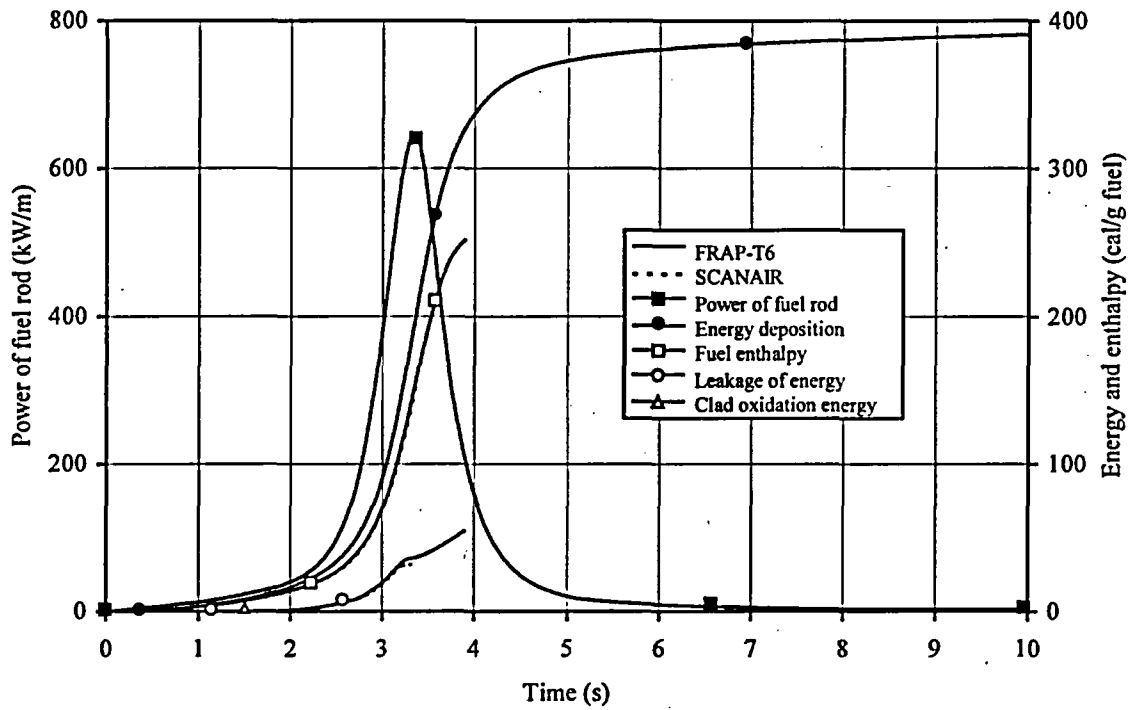

Fig. G-3.9. Energy and Temperature Characteristics Vs. Time Calculated by FRAP-T6 and SCANAIR Codes for Fuel Rod #H3T

# #H3T

## Individual Characteristics of Refabricated Fuel Rods (Preirradiated Fuel, Preirradiated Cladding) under IGR Tests

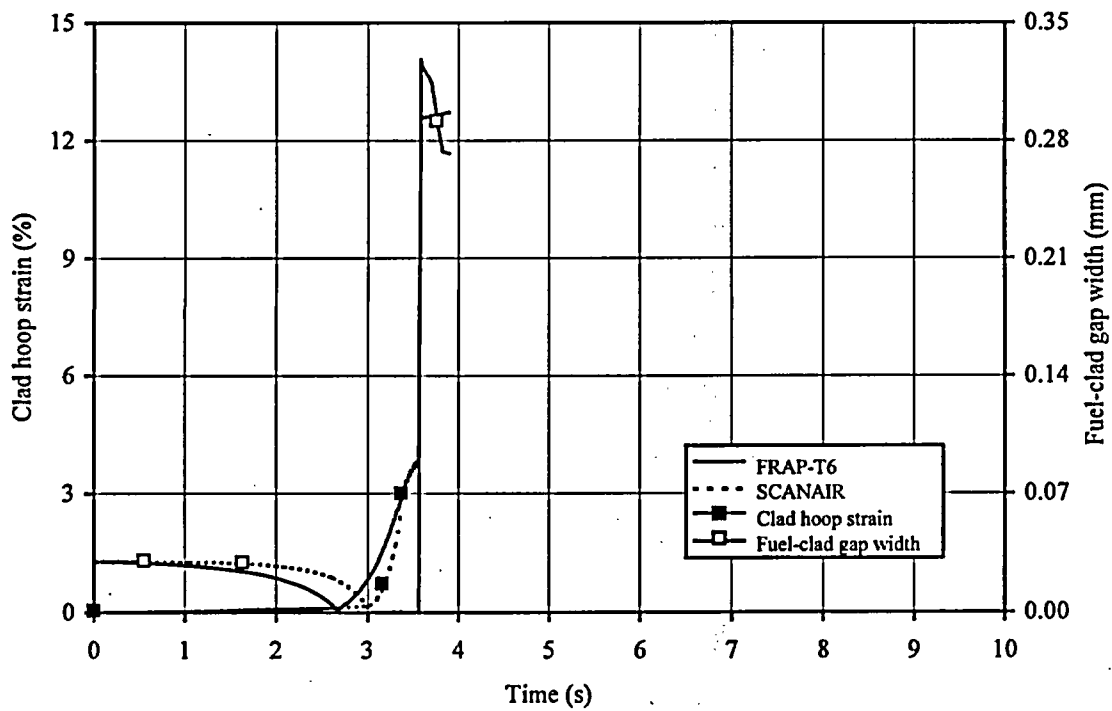
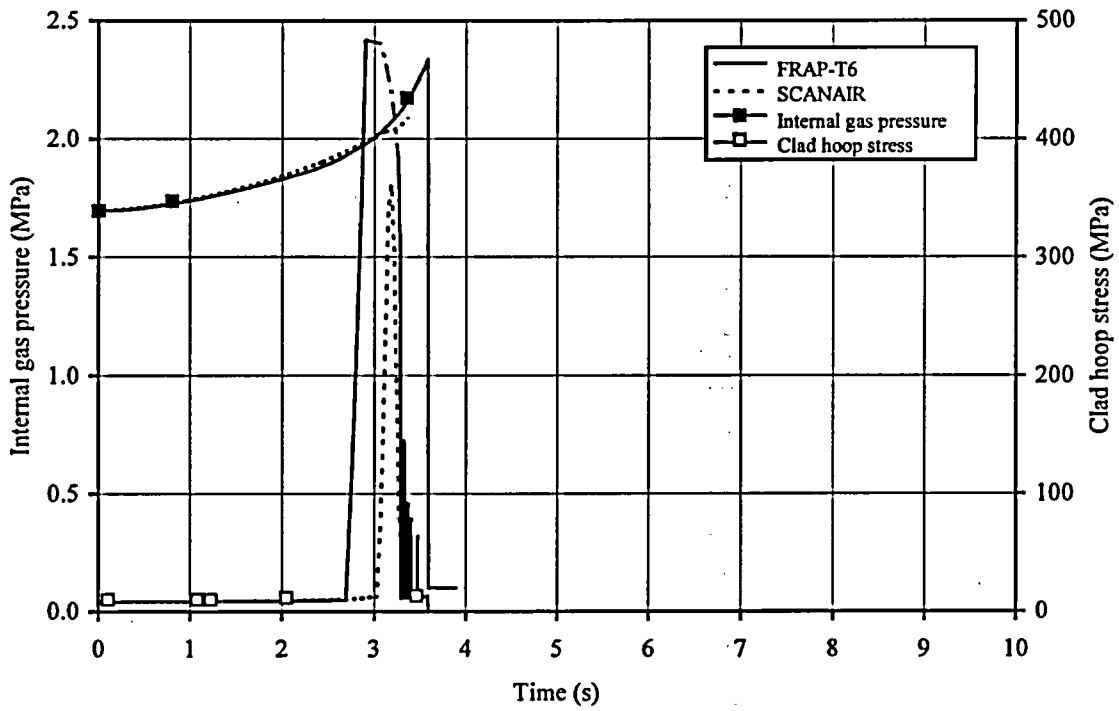

Fig. G-3.10. Cladding Mechanical Characteristics Vs. Time Calculated by FRAP-T6 and SCANAIR Codes for Fuel Rod #H3T

# #H3T

Individual Characteristics of Refabricated Fuel Rods (Preirradiated Fuel, Preirradiated Cladding) under IGR Tests

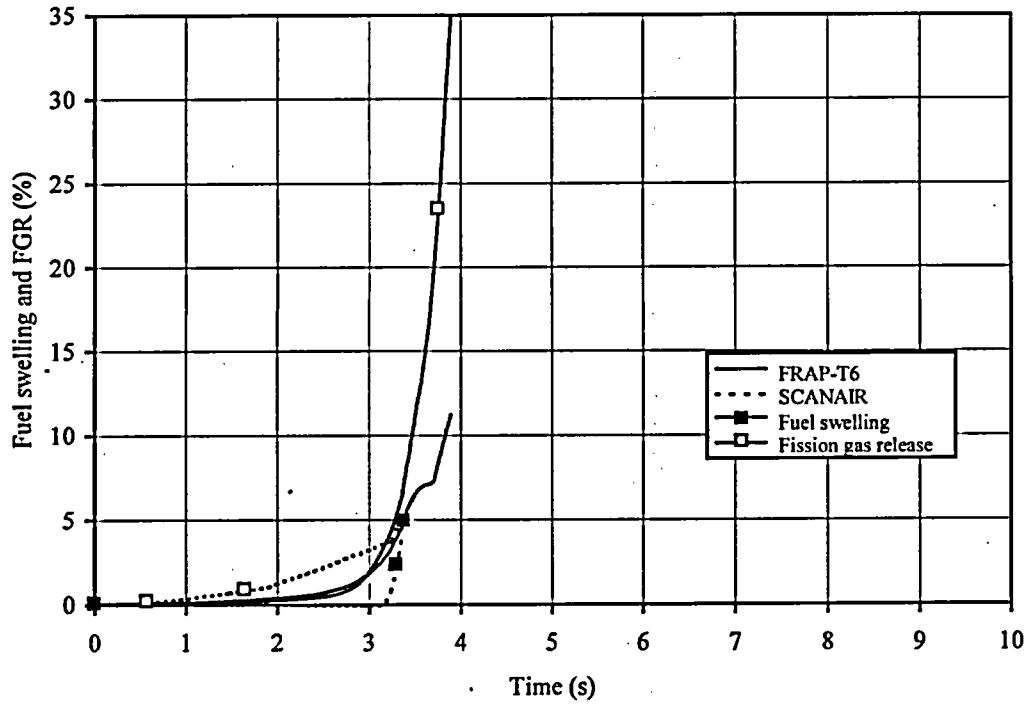
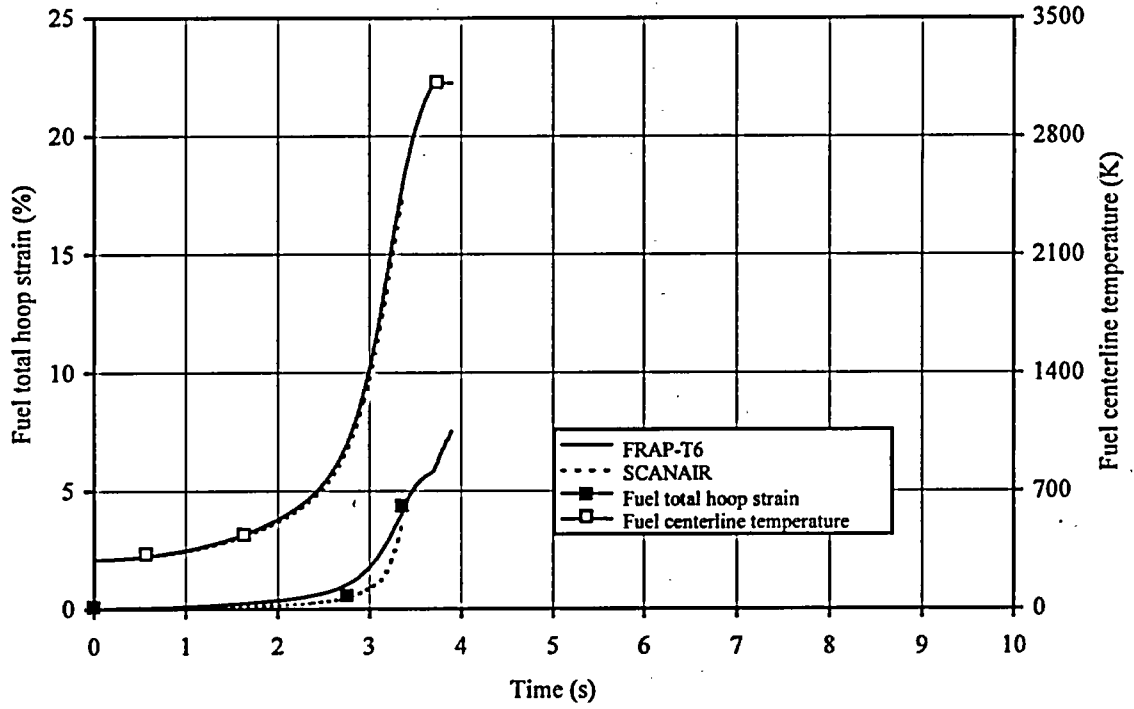

Fig. G-3.11. Fuel Strain and Fission Gas Release Vs. Time Calculated by FRAP-T6 and SCANAIR Codes for Fuel Rod #H3T

# #H3T

Individual Characteristics of Refabricated Fuel Rods  
(Preirradiated Fuel, Preirradiated Cladding) under IGR Tests

Table G-3.9. Some Results of PIE for Fuel Rod #H3T

Characteristic		Value		
1	Measured parameters of cladding oxidation and cladding deformation			
1.1	Cladding thickness at elevation 80, 55, 130 mm correspondent to different azimuthal angles ( $\mu\text{m}$ ):			
	0°	691	—	R
	90°	677	—	663
	180°	691	—	663
	270°	287	640	653
1.2	ZrO <sub>2</sub> thickness at elevation 80, 55, 130 mm correspondent to different azimuthal angles ( $\mu\text{m}$ ):			
	0°	28	35	60
	90°	20	75	10
	180°	25	105	10
	270°	23	43	53
1.3	$\alpha\text{Zr(O)}$ thickness at elevation 80, 55, 130 mm correspondent to different azimuthal angles ( $\mu\text{m}$ ):			
	0°	30	24	40
	90°	20	60	8
	180°	25	60	10
	270°	27	35	35
1.4	Clad hoop strain at elevation 80, 55, 130 mm, respectively (%)	8.6	—	—
2	Measured parameters for FGR analysis			
2.1	Internal gas composition (% by volume):			
	He	—		
	N <sub>2</sub>	—		
	O <sub>2</sub>	—		
	Ar	—		
	CO <sub>2</sub>	—		
	Kr	—		
	Xe	—		
2.2	Free gas volume (cm <sup>3</sup> )	—		
2.3	Gas pressure inside fuel rod under normal condition (MPa)	—		
2.4	Kr concentration in fuel (cm <sup>3</sup> /g fuel)	—		
3	Measured parameters of cladding hydriding			
3.1	Coefficient of hydride orientation (per-unit)	—		
3.2	Hydrogen concentration (% by weight)	—		

# #H3T

Individual Characteristics of Refabricated Fuel Rods  
(Preirradiated Fuel, Preirradiated Cladding) under IGR Tests

Table G-3.10. General Characteristic of Fuel Rod, #H3T

	Parameter	Unit	Value		
			Experiment	FRAP-T6	SCANAIR
1	Type of coolant	---	water	water	water
2	Burnup	MWd/kg U	49.3	49.3	49.3
3	Energy deposition in fuel rod	cal/g fuel	384	384	384
4	Peak fuel enthalpy	cal/g fuel	-	-	-
5	Peak fuel temperature	K	-	-	-
6	Peak clad temperature	K	-	-	-
7	Fuel rod failure	Yes, No	Yes	Yes	-
8	Type of failure:				
	- cladding rupture due to ballooning	Yes, No	Yes	Yes	-
	- cladding rupture due to PCMI	Yes, No	No	No	-
	- fragmentation of fuel rod	Yes, No	No	-	-
9	Failure time	s	-	3.58	-
10	Fuel enthalpy at failure	cal/g fuel	-	212	-
11	Outer cladding temperature at failure	K	-	1237	-
12	Internal gas pressure at failure	MPa	-	2.33	-
13	ZrO <sub>2</sub> thickness after test	µm	10-105	5.10	-
14	Residual clad hoop strain:				
	- peak value for ballooning area	%	-	-	-
	- other location <sup>1)</sup>	%	8.6	-	-
15	Kr concentration in internal gas composition after test	% by volume	-	-	-
16	Xe concentration in internal gas composition after test	% by volume	-	-	-
17	Kr concentration in fuel after test	cm <sup>3</sup> /g fuel	-	-	-

<sup>1)</sup>Calculated values by FRAP-T6 and SCANAIR codes are average along height of fuel rod excluding ballooning region





***APPENDIX G-4.***

***Individual Characteristics for Fuel Rod #H4T under IGR Test***

# #H4T

Individual Characteristics of Refabricated Fuel Rods  
(Preirradiated Fuel, Preirradiated Cladding) under IGR Tests

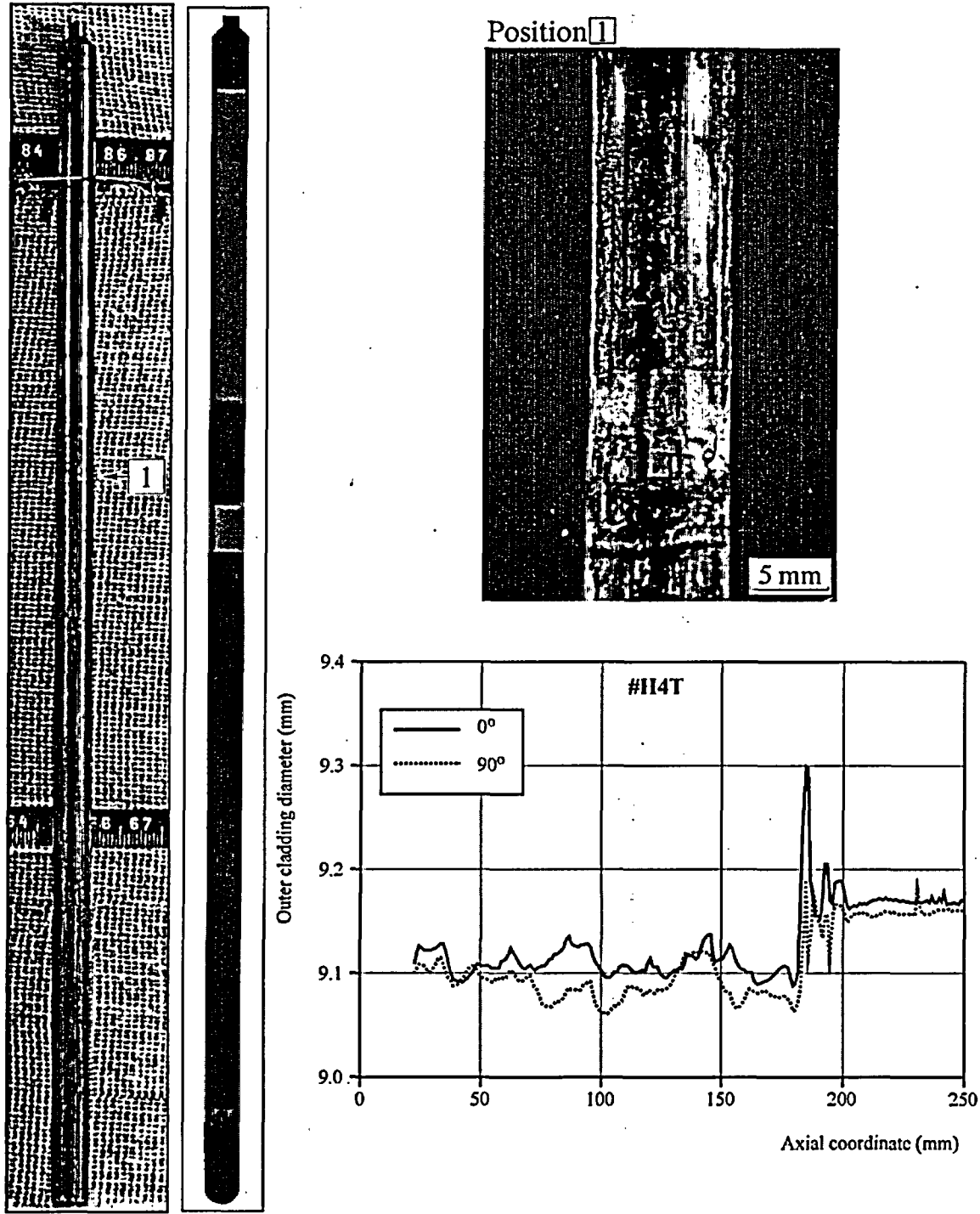
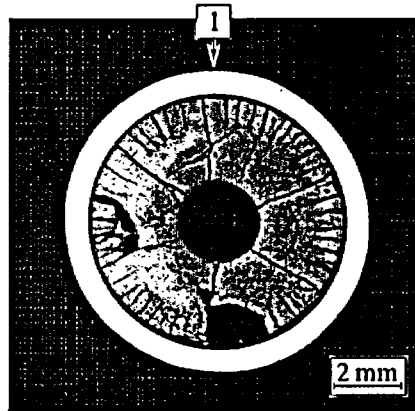

Fig. G-4.1. Appearance of Fuel Rod #H4T (photographs and X-ray photograph) and Profilometry

#H4T

Individual Characteristics of Refabricated Fuel Rods  
(Preirradiated Fuel, Preirradiated Cladding) under IGR Tests



Position 1

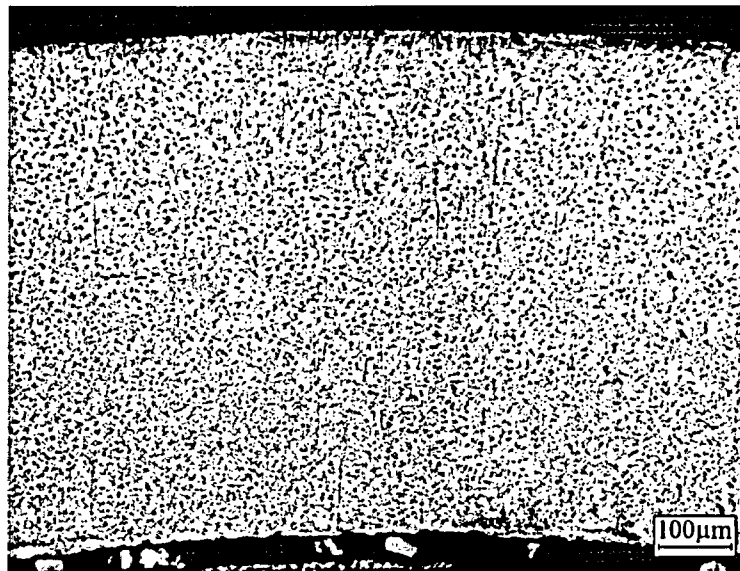
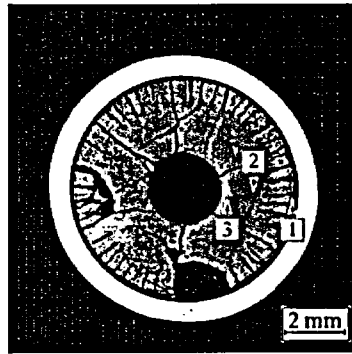

Fig. G-4.2. Cross-Section and Cladding Microstructure for Fuel Rod #H4T at 90 mm Elevation

#H4T

Individual Characteristics of Refabricated Fuel Rods  
(Preirradiated Fuel/Preirradiated Cladding) under IGR Tests



Position 1

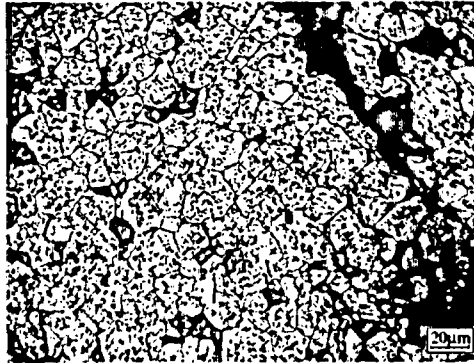

Position 2

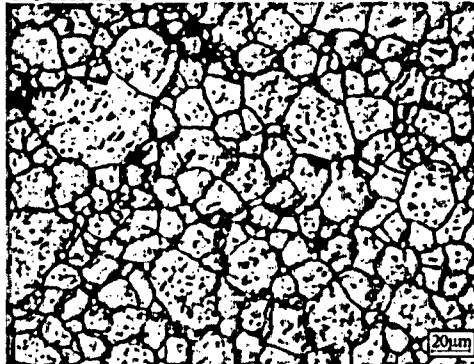

Position 3

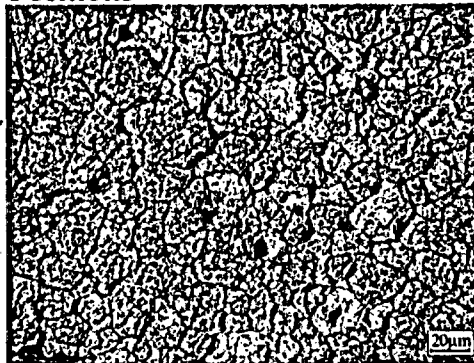

Fig. G-4.3. Fuel Microstructure for Fuel Rod #H4T at 90 mm Elevation

# #H4T

Individual Characteristics of Refabricated Fuel Rods  
(Preirradiated Fuel, Preirradiated Cladding) under IGR Tests

Table G-4.1. Time Dependent Energy Characteristics of Fuel Rod #H4T

Time (s)	Reactor energy deposition <sup>1)</sup> (%)	Cumulative number of fissions in fuel rod (fiss)						Power of fuel rod (kW)	Energy deposition in fuel rod	
		U <sup>235</sup> ×10 <sup>-14</sup>	U <sup>238</sup> ×10 <sup>-13</sup>	Pu <sup>239</sup> ×10 <sup>-14</sup>	Pu <sup>241</sup> ×10 <sup>-14</sup>	Other iso- topes ×10 <sup>-11</sup>	Total ×10 <sup>-14</sup>		cal/g fuel	J/g fuel
0.0	0.000	0.000	0.000	0.000	0.000	0.000	0.000	0.000	0.000	0.000
1.0	0.739	0.039	0.010	0.059	0.024	0.046	0.123	0.749	1.410	5.900
2.0	3.340	0.178	0.043	0.264	0.108	0.210	0.555	1.830	6.360	26.60
2.2	4.180	0.223	0.054	0.331	0.136	0.262	0.695	2.220	7.970	33.40
2.4	5.230	0.279	0.068	0.414	0.170	0.328	0.869	2.820	9.960	41.70
2.6	6.610	0.353	0.086	0.523	0.214	0.415	1.100	3.860	12.60	52.70
2.8	8.590	0.459	0.111	0.680	0.279	0.539	1.430	5.820	16.40	68.70
3.0	11.80	0.628	0.152	0.931	0.382	0.738	1.960	9.720	22.40	93.80
3.2	17.30	0.923	0.224	1.370	0.561	1.090	2.880	17.50	33.00	138.0
3.4	27.20	1.450	0.352	2.150	0.883	1.710	4.530	30.40	51.80	217.0
3.6	42.70	2.280	0.553	3.380	1.390	2.680	7.100	42.00	81.30	340.0
3.8	60.00	3.200	0.777	4.750	1.950	3.770	9.980	38.10	114.0	477.0
4.0	73.30	3.910	0.949	5.800	2.380	4.600	12.20	24.80	140.0	586.0
4.2	81.20	4.330	1.050	6.420	2.630	5.090	13.50	13.80	155.0	649.0
4.4	85.50	4.560	1.110	6.760	2.770	5.360	14.20	7.690	163.0	682.0
4.6	87.90	4.690	1.140	6.960	2.850	5.520	14.60	4.650	168.0	703.0
4.8	89.50	4.780	1.160	7.080	2.900	5.620	14.90	3.150	171.0	716.0
5.0	90.60	4.830	1.170	7.170	2.940	5.680	15.10	2.360	173.0	724.0
5.2	91.40	4.880	1.180	7.230	2.970	5.740	15.20	1.920	175.0	733.0
5.4	92.10	4.920	1.190	7.290	2.990	5.780	15.30	1.650	176.0	737.0
5.6	92.70	4.950	1.200	7.340	3.010	5.820	15.40	1.470	177.0	741.0
5.8	93.30	4.980	1.210	7.380	3.030	5.850	15.50	1.330	179.0	749.0
6.0	93.80	5.000	1.210	7.420	3.040	5.880	15.60	1.220	180.0	753.0
6.5	94.80	5.060	1.230	7.500	3.080	5.950	15.80	0.828	182.0	762.0
7.0	95.40	5.090	1.240	7.550	3.100	5.990	15.90	0.578	183.0	766.0
7.5	95.90	5.120	1.240	7.590	3.110	6.020	15.90	0.430	184.0	770.0
8.0	96.20	5.130	1.250	7.610	3.120	6.040	16.00	0.339	185.0	774.0
9.0	96.70	5.160	1.250	7.650	3.140	6.070	16.10	0.276	186.0	779.0
10.0	97.10	5.180	1.260	7.690	3.150	6.100	16.20	0.208	187.0	783.0
20.0	98.60	5.260	1.280	7.810	3.200	6.190	16.40	0.048	191.0	800.0
30.0	99.10	5.290	1.280	7.840	3.220	6.220	16.50	0.024	192.0	804.0
∞	100.0	5.340	1.300	7.910	3.250	6.280	16.60	0.000	196.0	820.0

Maximum value of power is 42.7 kW (t = 3.65 s).

<sup>1)</sup> Current energy deposition per maximum energy deposition (at infinite time)

Table G-4.2. Axial Energy Characteristics of Fuel Rod #H4T

Axial coordinate from lower end of fuel rod (mm)	Cumulative number of fissions at axial interval (fiss)						Maximum power of fuel rod (kW) $t=3.65s$	Energy deposition at infinite time*		
	$U^{235} \times 10^{-13}$	$U^{238} \times 10^{-11}$	$Pu^{239} \times 10^{-13}$	$Pu^{241} \times 10^{-13}$	Other isotopes $\times 10^{-10}$	Total $\times 10^{-13}$		cal/g fuel	J/g fuel	per-unit <sup>3)</sup>
10.0 <sup>1)</sup>	0.189	0.393	0.292	0.121	0.200	0.607	0.156	219.0	917.0	1.00
15.0	0.947	1.970	1.460	0.605	0.999	3.030	0.779	219.0	917.0	1.00
20.0	0.947	1.970	1.460	0.605	0.999	3.030	0.779	219.0	917.0	1.00
25.0	0.947	1.970	1.460	0.605	0.999	3.030	0.779	219.0	917.0	1.00
30.0	2.050	4.840	2.960	1.220	2.330	6.280	1.610	213.0	892.0	0.97
35.0	2.000	4.770	2.940	1.210	2.320	6.200	1.590	210.0	879.0	0.96
40.0	1.940	4.630	2.870	1.180	2.260	6.040	1.550	208.0	871.0	0.95
45.0	1.880	4.540	2.830	1.170	2.240	5.920	1.520	205.0	858.0	0.94
50.0	1.830	4.440	2.770	1.150	2.200	5.790	1.490	202.0	846.0	0.92
55.0	1.820	4.390	2.730	1.130	2.160	5.720	1.470	201.0	841.0	0.92
60.0	1.810	4.370	2.720	1.120	2.140	5.690	1.460	199.0	833.0	0.91
65.0	1.810	4.400	2.730	1.120	2.160	5.700	1.460	197.0	825.0	0.90
70.0	1.810	4.420	2.730	1.120	2.170	5.710	1.460	196.0	820.0	0.89
75.0	1.880	4.490	2.740	1.110	2.160	5.780	1.480	196.0	820.0	0.89
80.0	1.920	4.560	2.760	1.120	2.180	5.850	1.500	195.0	816.0	0.89
85.0	1.920	4.560	2.750	1.110	2.170	5.820	1.490	194.0	812.0	0.89
90.0	1.870	4.460	2.670	1.080	2.110	5.670	1.450	193.0	808.0	0.88
95.0	1.830	4.430	2.640	1.070	2.110	5.600	1.440	191.0	800.0	0.87
100.0	1.820	4.420	2.630	1.070	2.110	5.570	1.430	190.0	795.0	0.87
105.0	1.840	4.450	2.630	1.060	2.100	5.580	1.430	190.0	795.0	0.87
110.0	1.840	4.450	2.610	1.060	2.090	5.560	1.430	190.0	795.0	0.87
115.0	1.840	4.480	2.630	1.070	2.120	5.580	1.430	189.0	791.0	0.86
120.0	1.820	4.490	2.630	1.070	2.120	5.570	1.430	189.0	791.0	0.86
125.0	1.750	4.420	2.600	1.070	2.120	5.470	1.400	188.0	787.0	0.86
130.0	1.700	4.340	2.560	1.060	2.090	5.370	1.380	187.0	783.0	0.85
135.0	1.670	4.290	2.540	1.050	2.080	5.300	1.360	188.0	787.0	0.86
140.0	1.660	4.250	2.520	1.040	2.070	5.270	1.350	188.0	787.0	0.86
145.0	1.640	4.210	2.510	1.040	2.060	5.230	1.340	189.0	791.0	0.86
150.0	1.630	4.210	2.530	1.050	2.070	5.250	1.350	190.0	795.0	0.87
155.0	1.670	4.220	2.540	1.050	2.060	5.300	1.360	192.0	804.0	0.88
160.0	1.750	4.370	2.650	1.090	2.130	5.530	1.420	194.0	812.0	0.89
165.0 <sup>2)</sup>	1.330	3.340	2.060	0.854	1.660	4.270	1.100	194.0	812.0	0.89
170.0	0.000	0.000	0.000	0.000	0.000	0.000	0.000	0.000	0.000	0.00
175.0	0.000	0.000	0.000	0.000	0.000	0.000	0.000	0.000	0.000	0.00
180.0	0.000	0.000	0.000	0.000	0.000	0.000	0.000	0.000	0.000	0.00
185.0	0.000	0.000	0.000	0.000	0.000	0.000	0.000	0.000	0.000	0.00

\* All numerical values of characteristics are presented as average values at the length interval equal to the axial coordinate  $\pm 2.5$  mm

1) Initial coordinate of fuel is 11.5 mm

2) End coordinate of fuel is 166.5 mm

3) Current value per maximum value

## #H4T

Individual Characteristics of Refabricated Fuel Rods  
(Preirradiated Fuel, Preirradiated Cladding) under IGR Tests

Table G-4.3. Radial Energy Characteristics of Fuel Rod #H4T

Characteristics*		Coordinates of fuel zones (mm)			
		1 zone 1.2 - 2.811	2 zone 2.811-3.432	3 zone 3.432-3.704	4 zone 3.704-3.790
U <sup>235</sup>	Number of fissions $\times 10^{-14}$ (fiss)	2.560	1.500	0.735	0.239
	Power of fuel rod <sup>1)</sup> (kW)	6.440	3.780	1.850	0.603
	Energy deposition <sup>2)</sup> (cal/g fuel)	62.50	61.10	59.90	58.50
	Energy deposition <sup>2)</sup> (J/g fuel)	262.0	256.0	251.0	245.0
	Energy deposition <sup>3)</sup> (per-unit)	1.000	0.978	0.958	0.936
U <sup>238</sup>	Number of fissions $\times 10^{-12}$ (fiss)	6.490	3.650	1.680	0.508
	Power of fuel rod <sup>1)</sup> (kW)	0.161	0.091	0.042	0.013
	Energy deposition <sup>2)</sup> (cal/g fuel)	1.560	1.470	1.350	1.220
	Energy deposition <sup>2)</sup> (J/g fuel)	6.530	6.150	5.650	5.110
	Energy deposition <sup>3)</sup> (per-unit)	1.000	0.942	0.865	0.782
Pu <sup>239</sup>	Number of fissions $\times 10^{-14}$ (fiss)	3.090	2.100	1.440	0.816
	Power of fuel rod <sup>1)</sup> (kW)	8.040	5.460	3.750	2.120
	Energy deposition <sup>2)</sup> (cal/g fuel)	78.10	88.50	121.0	206.0
	Energy deposition <sup>2)</sup> (J/g fuel)	327.0	370.0	507.0	862.0
	Energy deposition <sup>3)</sup> (per-unit)	0.379	0.430	0.587	1.000
Pu <sup>241</sup>	Number of fissions $\times 10^{-13}$ (fiss)	12.10	8.580	6.160	3.670
	Power of fuel rod <sup>1)</sup> (kW)	3.090	2.200	1.580	0.941
	Energy deposition <sup>2)</sup> (cal/g fuel)	30.10	35.60	51.10	91.40
	Energy deposition <sup>2)</sup> (J/g fuel)	126.0	149.0	214.0	383.0
	Energy deposition <sup>3)</sup> (per-unit)	0.329	0.389	0.559	1.000
Other isotopes	Number of fissions $\times 10^{-11}$ (fiss)	2.780	1.710	0.997	0.475
	Power of fuel rod <sup>1)</sup> (kW)	0.007	0.004	0.003	0.001
	Energy deposition <sup>2)</sup> (cal/g fuel)	0.069	0.071	0.083	0.119
	Energy deposition <sup>2)</sup> (J/g fuel)	0.290	0.300	0.350	0.500
	Energy deposition <sup>3)</sup> (per-unit)	0.584	0.599	0.698	1.000
Total	Number of fissions $\times 10^{-14}$ (fiss)	6.920	4.500	2.810	1.430
	Power of fuel rod <sup>1)</sup> (kW)	17.70	11.50	7.220	3.680
	Energy deposition <sup>2)</sup> (cal/g fuel)	172.0	187.0	234.0	358.0
	Energy deposition <sup>2)</sup> (J/g fuel)	720.0	783.0	980.0	1499.
	Energy deposition <sup>3)</sup> (per-unit)	0.480	0.522	0.654	1.000

<sup>1)</sup> at time of 3.65 s, <sup>2)</sup> at infinite time, <sup>3)</sup> Current value per maximum value.

\* All numerical values of characteristics were calculated for undamaged part of fuel stack only (See Table C.2.1.)

# #H4T

Individual Characteristics of Refabricated Fuel Rods  
(Preirradiated Fuel, Preirradiated Cladding) under IGR Tests

Table G-4.4. Fuel Enthalpy Vs. Time Calculated by FRAP-T6 Code for Fuel Rod #H4T

Time (s)	Enthalpy at fuel radius (cal/g fuel)				Fuel enthalpy <sup>1)</sup>		Energy deposition in fuel rod	
	1.20 mm	2.82 mm	3.47 mm	3.79 mm	cal/g fuel	J/g fuel	cal/g fuel	J/g fuel
0.0	0.00	0.00	0.00	0.00	0.00	0.00	0.00	0.00
1.0	1.41	1.39	1.33	1.25	1.38	5.78	1.32	5.54
2.0	6.06	5.84	5.51	5.19	5.80	24.3	6.15	25.8
2.2	7.54	7.26	6.85	6.44	7.21	30.2	7.72	32.3
2.4	9.36	9.01	8.49	7.95	8.94	37.5	9.65	40.4
2.6	11.8	11.3	10.5	9.60	11.2	46.8	12.2	51.0
2.8	15.2	14.5	13.1	11.6	14.2	59.6	15.7	65.9
3.0	20.6	19.4	17.2	14.6	19.0	79.7	21.3	89.4
3.2	30.0	28.3	24.6	20.0	27.5	115	31.0	130
3.4	47.1	44.3	34.9	22.1	41.7	175	48.4	203
3.6	74.8	69.1	50.7	29.0	64.4	270	76.5	321
3.8	108	97.3	66.3	34.5	89.9	377	110	460
4.0	137	118	71.8	35.2	108	455	140	586
4.2	151	121	67.6	38.9	114	477	155	649
4.4	157	118	64.1	33.6	113	475	163	684
4.6	159	112	58.9	32.5	111	463	167	702
4.8	159	104	56.0	36.4	107	448	171	715
5.0	156	98.3	55.9	37.0	103	433	173	725
5.2	152	93.4	53.9	36.0	99.4	417	175	732
5.4	146	88.9	52.3	36.4	95.5	400	176	738
5.6	141	85.0	51.7	37.3	91.9	385	177	744
5.8	134	81.7	51.3	38.1	88.5	371	179	748
6.0	128	78.9	50.9	38.8	85.4	358	180	753
6.5	113	72.9	49.9	39.6	78.1	327	182	762
7.0	99.6	67.4	48.3	39.4	71.3	299	183	767
7.5	88.2	62.3	46.3	38.7	65.3	274	184	772
8.0	78.5	57.7	44.2	37.6	59.9	251	185	775
10.0	52.5	42.7	35.5	31.6	43.5	182	187	784
30.0	7.77	7.55	7.36	7.24	7.56	31.7	192	806

Radial enthalpy distribution and fuel enthalpy are presented at elevation 19.3 mm

Maximum value of fuel enthalpy is 114.5 cal/g fuel (t=4.25 s)

<sup>1)</sup> All numerical values are presented at elevation with peak power



# #H4T

Individual Characteristics of Refabricated Fuel Rods  
(Preirradiated Fuel, Preirradiated Cladding) under IGR Tests

Table G-4.5. Energy Characteristics Vs. Time Calculated by FRAP-T6 and SCANAIR Codes for Fuel Rod #H4T

Time (s)	Energy deposition <sup>1)</sup> (cal/g fuel)	Linear power <sup>1)</sup> (kW/m)	Fuel enthalpy <sup>1)</sup> (cal/g fuel)		Energy of metal-water reaction <sup>1)</sup> (cal/g fuel)	Leakage of energy <sup>1)</sup> (cal/g fuel)		Clad-to-coolant heat transfer coefficient <sup>1)</sup> (kW/m <sup>2</sup> K)	
			FRAP-T6	SCANAIR	FRAP-T6	FRAP-T6	SCANAIR	FRAP-T6	SCANAIR
0.0	0.00	0.00	0.00	0.00	0.00	0.00	0.00	0.00	0.00
1.0	1.47	5.68	1.38	1.32	0.00	0.00	0.00	0.03	0.10
2.0	6.86	14.0	5.80	5.87	0.00	0.02	0.05	0.03	0.10
2.2	8.60	16.9	7.21	7.15	0.00	0.02	0.07	0.03	0.10
2.4	10.7	21.3	8.94	9.00	0.00	0.09	0.12	0.79	0.73
2.6	13.5	28.8	11.2	11.4	0.00	0.51	0.60	1.94	2.19
2.8	17.5	42.8	14.2	14.4	0.00	1.29	1.34	3.10	3.29
3.0	23.8	70.5	19.0	19.7	0.00	2.59	2.70	4.76	5.25
3.2	34.6	126	27.5	29.5	0.00	4.67	5.08	7.40	8.99
3.4	53.9	222	41.7	44.1	0.00	9.17	8.75	16.6	15.0
3.6	85.2	321	64.4	68.8	0.00	17.6	16.9	23.2	26.9
3.8	122	311	89.9	92.5	0.00	29.5	30.7	28.7	32.6
4.0	156	195	108	105	0.00	45.2	44.3	29.4	28.6
4.2	173	108	114	108	0.00	58.3	59.0	25.4	32.2
4.4	182	60.4	113	106	0.00	68.6	70.0	23.8	28.6
4.6	187	39.2	111	100	0.00	77.1	81.3	21.0	25.5
4.8	190	26.1	107	94.9	0.00	85.3	89.8	15.4	23.3
5.0	193	19.3	103	88.6	0.00	91.4	98.8	14.9	21.3
5.2	195	15.5	99.4	83.1	0.00	97.4	106	14.5	19.7
5.4	196	13.2	95.5	77.4	0.00	103	114	13.0	18.4
5.6	198	11.7	91.9	72.3	0.00	108	120	11.7	16.5
5.8	199	10.6	88.5	68.4	0.00	112	126	10.8	15.2
6.0	200	9.73	85.4	64.2	0.00	116	131	10.1	14.0
6.5	202	6.66	78.1	55.2	0.00	125	143	8.79	11.9
7.0	204	4.63	71.3	47.7	0.00	133	152	7.76	10.2
7.5	205	3.44	65.3	40.8	0.00	140	160	6.92	8.77
8.0	206	2.70	59.9	34.9	0.00	146	167	6.22	7.53
10.0	208	1.65	43.5	19.7	0.00	164	185	4.30	4.07
30.0	214	0.20	7.56	5.43	0.00	205	205	0.29	0.10

<sup>1)</sup> All numerical values are presented at elevation with peak power

# #H4T

Individual Characteristics of Refabricated Fuel Rods  
(Preirradiated Fuel, Preirradiated Cladding) under IGR Tests

Table G-4.6. Temperature Variation, Fission Gas Release and ZrO<sub>2</sub> Thickness Vs. Time for Fuel Rod #H4T Calculated by FRAP-T6 and SCANAIR Codes

Time (s)	Fuel centerline temperature <sup>1)</sup> (K)		Fuel surface temperature <sup>1)</sup> (K)		Clad outer temperature <sup>1)</sup> (K)		Fission gas release (%)		Average ZrO <sub>2</sub> <sup>2)</sup> thickness (μm)
	FRAP-T6	SCANAIR	FRAP-T6	SCANAIR	FRAP-T6	SCANAIR	FRAP-T6	SCANAIR	FRAP-T6
0.0	293	293	293	293	293	293	0.00	0.00	5
1.0	318	315	315	313	304	302	0.08	0.17	5
2.0	394	389	380	378	352	348	0.16	0.61	5
2.2	417	409	400	396	368	361	0.19	0.71	5
2.4	446	438	424	422	384	378	0.22	0.84	5
2.6	482	477	449	451	390	383	0.27	0.99	5
2.8	532	523	479	483	395	385	0.34	1.26	5
3.0	610	607	524	540	400	388	0.45	1.76	5
3.2	743	754	602	632	406	394	0.65	2.23	5
3.4	975	968	631	740	422	401	1.06	2.68	5
3.6	1338	1342	729	828	430	412	1.89	3.20	5
3.8	1750	1743	805	852	436	423	3.34	3.43	5
4.0	2085	2004	814	854	437	440	4.90	3.50	5
4.2	2230	2154	865	810	433	417	6.69	4.39	5
4.4	2294	2211	793	769	431	414	9.18	4.75	5
4.6	2313	2229	778	729	428	411	9.59	5.15	5
4.8	2307	2217	831	702	420	409	9.89	5.41	5
5.0	2281	2179	840	675	420	407	9.97	5.60	5
5.2	2239	2126	825	655	419	406	9.98	5.68	5
5.4	2185	2054	831	637	417	404	9.99	5.70	5
5.6	2123	1971	844	634	415	402	10.0	5.69	5
5.8	2056	1894	854	635	413	401	10.0	5.67	5
6.0	1986	1800	863	634	412	400	10.0	5.64	5
6.5	1812	1569	874	627	409	397	10.1	5.56	5
7.0	1650	1367	872	615	407	395	10.1	5.48	5
7.5	1508	1182	862	599	405	393	10.1	5.39	5
8.0	1385	1028	847	580	404	392	10.1	5.29	5
10.0	1048	668	765	503	398	386	10.1	4.89	5
30.0	421	380	413	378	379	375	10.1	4.08	5

<sup>1)</sup> All numerical values are presented at elevation with peak power

<sup>2)</sup> Initial ZrO<sub>2</sub> thickness is 5 μm

# #H4T

Individual Characteristics of Refabricated Fuel Rods  
(Preirradiated Fuel, Preirradiated Cladding) under IGR Tests

Table G-4.7. Mechanical Characteristics of Fuel Rod #H4T Vs. Time Calculated by FRAP-T6 and SCANAIR Codes

Time (s)	Clad outer temperature <sup>1)</sup> (K)		Fuel hoop strain <sup>1)</sup> (%)		Fuel - clad gap width <sup>1)</sup> (mm)		Clad hoop strain <sup>1)</sup> (%)		Clad hoop stress <sup>1)</sup> (MPa)		Internal gas pressure (MPa)	
	FRAP-T6	SCANAIR	FRAP-T6	SCANAIR	FRAP-T6	SCANAIR	FRAP-T6	SCANAIR	FRAP-T6	SCANAIR	FRAP-T6	SCANAIR
0.0	293	293	0.00	0.00	0.03	0.03	0.01	0.01	8.59	8.02	1.70	1.70
1.0	304	302	0.04	0.01	0.03	0.03	0.02	0.01	8.68	8.14	1.72	1.72
2.0	352	348	0.17	0.07	0.02	0.03	0.05	0.05	8.93	8.45	1.76	1.77
2.2	368	361	0.21	0.08	0.02	0.03	0.06	0.06	8.99	8.52	1.77	1.78
2.4	384	378	0.26	0.10	0.02	0.03	0.07	0.07	9.06	8.63	1.79	1.80
2.6	390	383	0.33	0.13	0.02	0.03	0.08	0.08	9.14	8.81	1.80	1.82
2.8	395	385	0.41	0.16	0.02	0.03	0.08	0.08	9.24	9.01	1.82	1.84
3.0	400	388	0.55	0.22	0.01	0.03	0.09	0.09	9.38	9.35	1.85	1.87
3.2	406	394	0.78	0.34	0.00	0.02	0.10	0.10	9.56	9.91	1.88	1.91
3.4	422	401	1.18	0.52	0.00	0.02	0.38	0.13	329	10.7	1.93	1.95
3.6	430	412	1.80	0.86	0.00	0.00	0.88	0.17	424	12.1	1.97	1.99
3.8	436	423	2.52	1.28	0.00	0.00	1.45	0.44	404	288	2.01	2.01
4.0	437	440	3.12	1.69	0.00	0.00	1.91	0.78	283	399	2.04	2.02
4.2	433	417	3.67	1.86	0.00	0.00	2.34	0.91	11.4	410	2.09	2.04
4.4	431	414	3.83	1.82	0.00	0.00	2.50	0.88	182	383	2.13	2.05
4.6	428	411	3.76	1.73	0.00	0.00	2.43	0.80	143	302	2.13	2.06
4.8	420	409	3.66	1.64	0.00	0.00	2.32	0.72	11.7	224	2.14	2.07
5.0	420	407	3.47	1.54	0.01	0.00	2.32	0.64	11.7	134	2.14	2.07
5.2	419	406	3.28	1.45	0.01	0.00	2.32	0.56	11.7	50.9	2.13	2.07
5.4	417	404	3.08	1.36	0.02	0.00	2.31	0.49	11.6	11.6	2.12	2.07
5.6	415	402	2.90	1.28	0.03	0.00	2.31	0.48	11.6	11.4	2.12	2.07
5.8	413	401	2.73	1.22	0.03	0.00	2.31	0.47	11.5	11.3	2.11	2.06
6.0	412	400	2.58	1.16	0.04	0.01	2.30	0.47	11.5	11.1	2.10	2.06
6.5	409	397	2.23	1.03	0.05	0.01	2.30	0.46	11.4	10.9	2.08	2.05
7.0	407	395	1.93	0.93	0.06	0.02	2.30	0.46	11.3	10.7	2.06	2.03
7.5	405	393	1.67	0.84	0.07	0.02	2.29	0.45	11.2	10.5	2.05	2.02
8.0	404	392	1.46	0.76	0.08	0.02	2.29	0.45	11.1	10.3	2.03	2.01
10.0	398	386	0.94	0.58	0.10	0.03	2.28	0.43	10.8	9.71	1.99	1.95
30.0	379	375	0.08	0.42	0.13	0.03	2.26	0.42	9.94	8.88	1.83	1.85

<sup>1)</sup> All numerical values are presented at elevation with peak power

# #H4T

Individual Characteristics of Refabricated Fuel Rods  
(Preirradiated Fuel, Preirradiated Cladding) under IGR Tests

Table G-4.8. Axial Distribution of Energy Deposition and Fuel Enthalpy Calculated by FRAP-T6 Code for Fuel Rod #H4T

Axial interval from-to (mm)-(mm)	Energy deposition at infinite time			Fuel enthalpy at time (t=4.25 s)		
	cal/g fuel	J/g fuel	per-unit	cal/g fuel	J/g fuel	per-unit
11.5 - 27.0	219	917	1.00	114	480	1.00
27.0 - 42.5	210	879	0.96	110	460	0.96
42.5 - 58.0	202	845	0.92	105	442	0.92
58.0 - 73.5	195	818	0.89	102	428	0.89
73.5 - 89.0	194	811	0.88	101	424	0.88
89.0 - 104.5	191	800	0.87	99.8	418	0.87
104.5 - 120.0	189	790	0.86	98.6	413	0.86
120.0 - 135.5	187	783	0.85	97.7	410	0.85
135.5 - 151.0	188	787	0.86	98.2	412	0.86
151.0 - 166.5	191	802	0.87	100	419	0.87

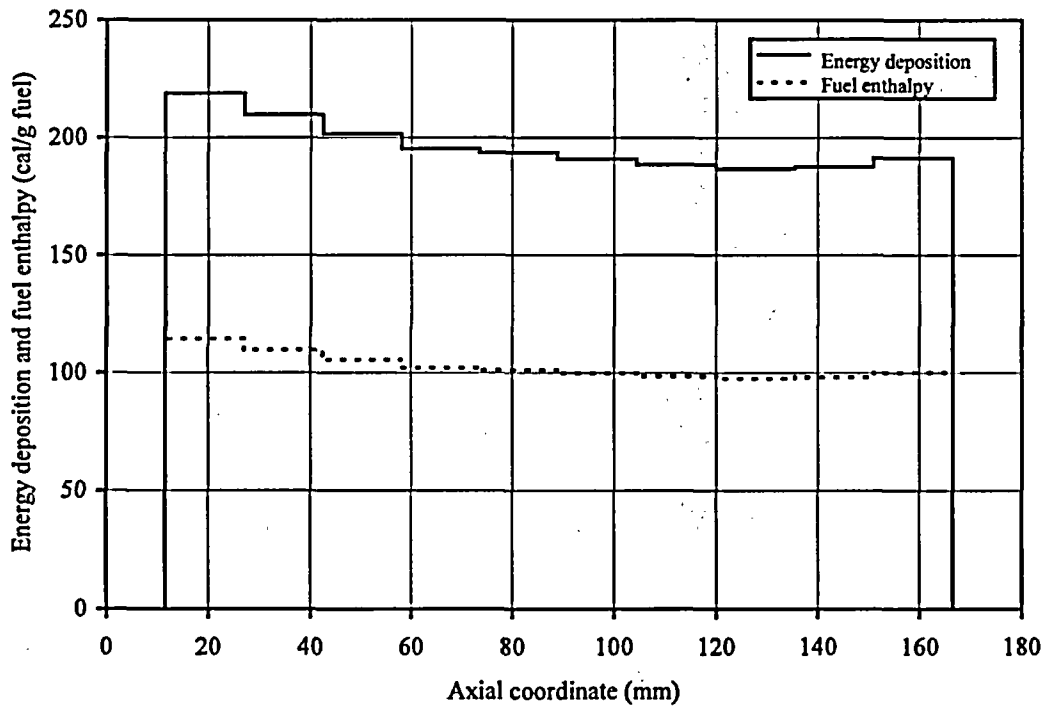

Fig. G-4.4. Axial Distribution of Energy Deposition and Fuel Enthalpy Calculated by FRAP-T6 Code for Fuel Rod #H4T

#H4T

Individual Characteristics of Refabricated Fuel Rods  
(Preirradiated Fuel, Preirradiated Cladding) under IGR Tests

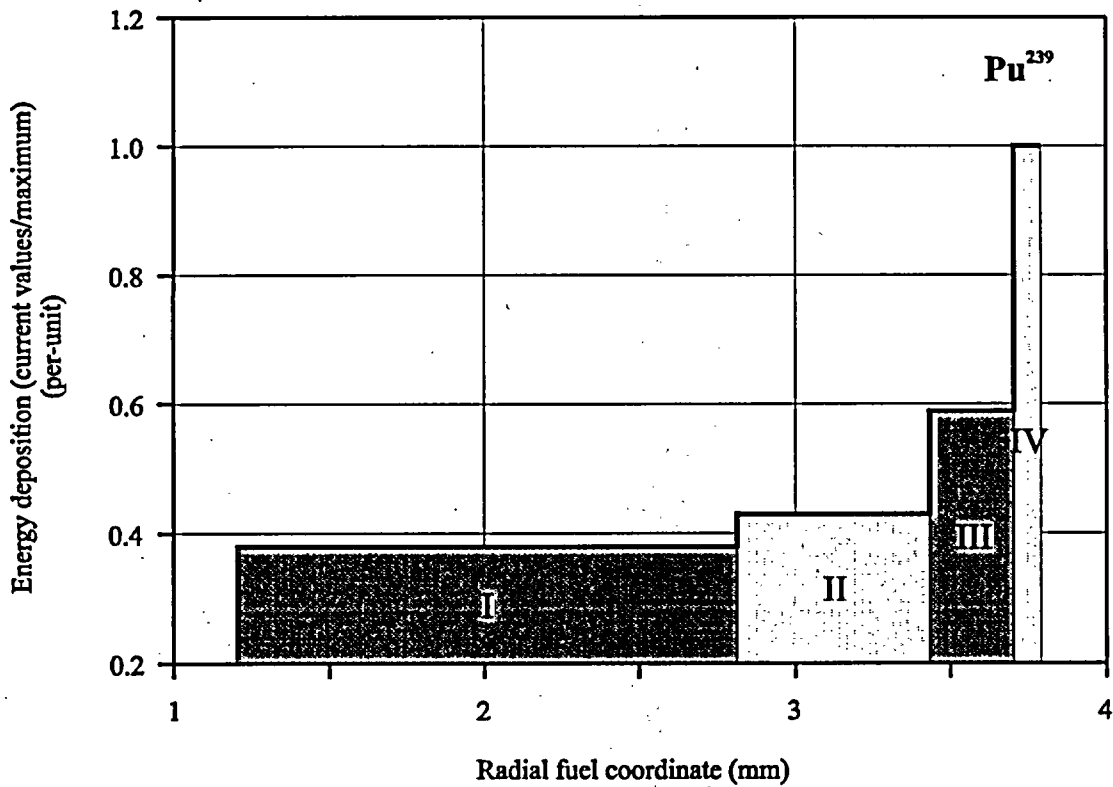
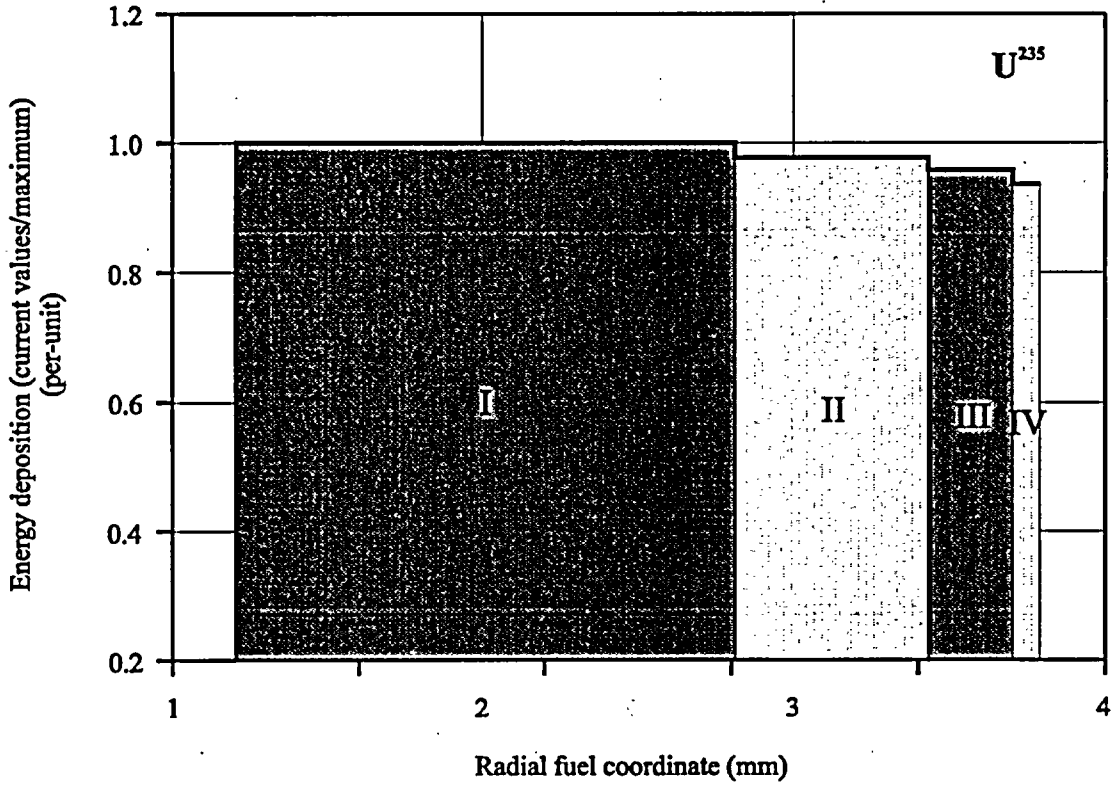

Fig. G-4.5.  $U^{235}$  and  $Pu^{239}$  Radial Distributions of Fission Number for Fuel Rod #H4T

# #H4T

Individual Characteristics of Refabricated Fuel Rods  
(Preirradiated Fuel, Preirradiated Cladding) under IGR Tests

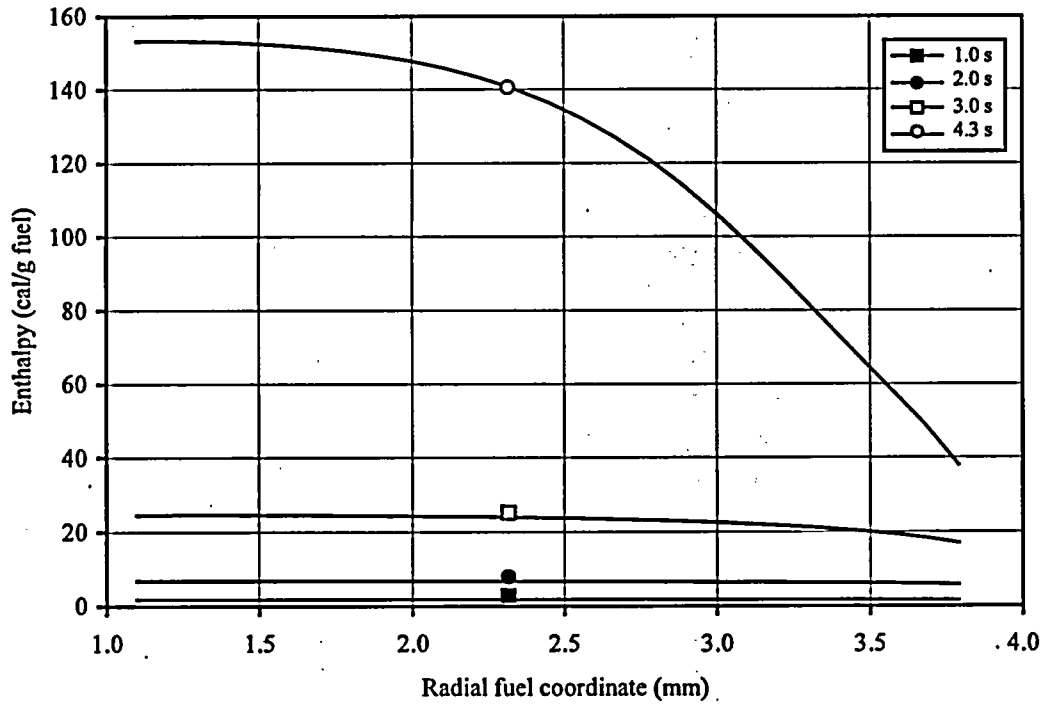
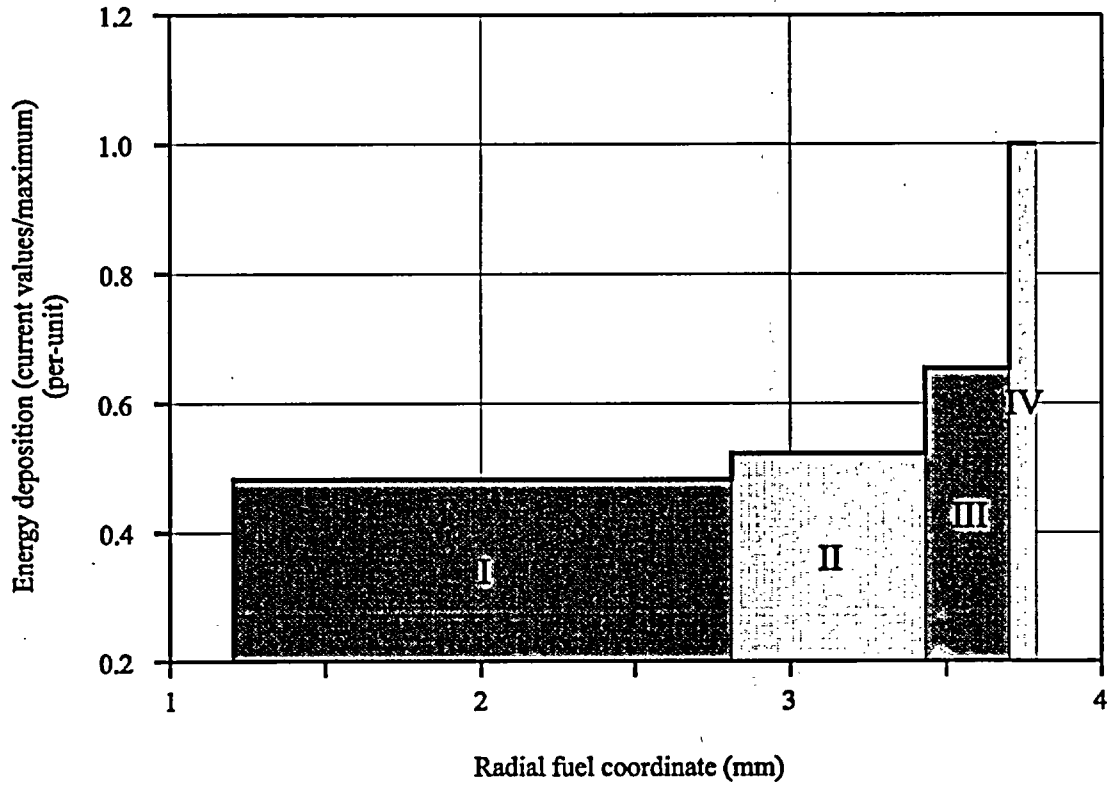

Fig. G-4.6. Radial Distributions of Energy Deposition and Fuel Enthalpy Calculated by FRAP-T6 Code for Fuel Rod #H4T

# #H4T

Individual Characteristics of Refabricated Fuel Rods  
(Preirradiated Fuel, Preirradiated Cladding) under IGR Tests

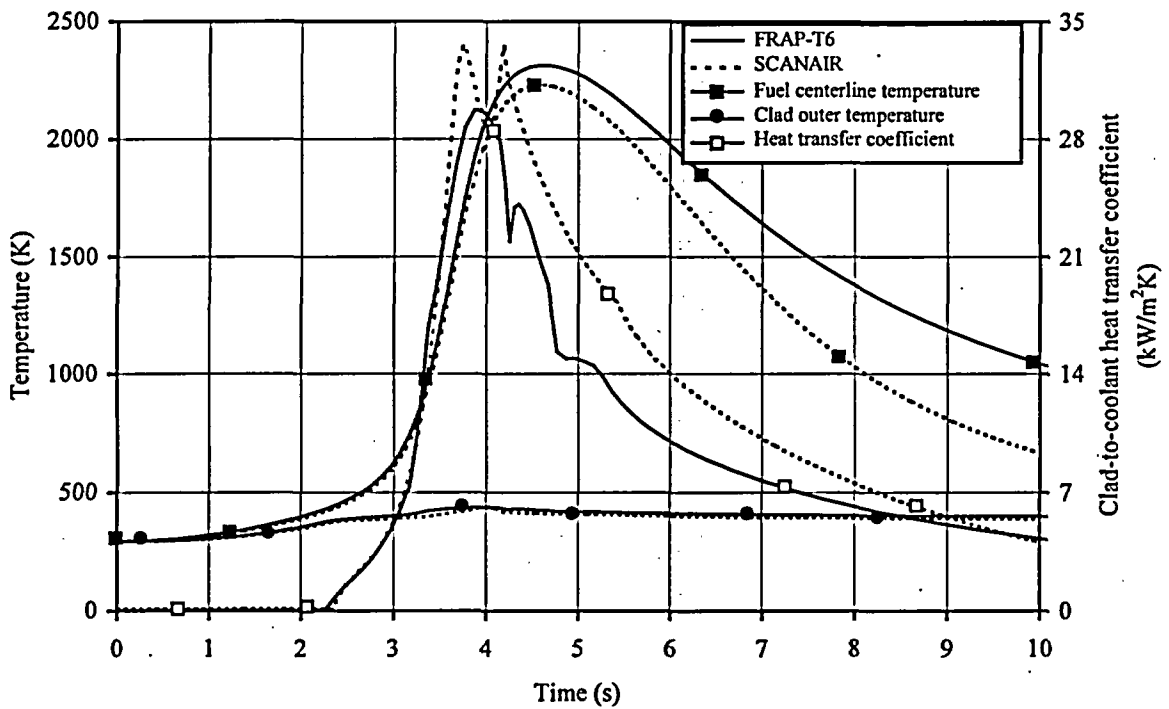
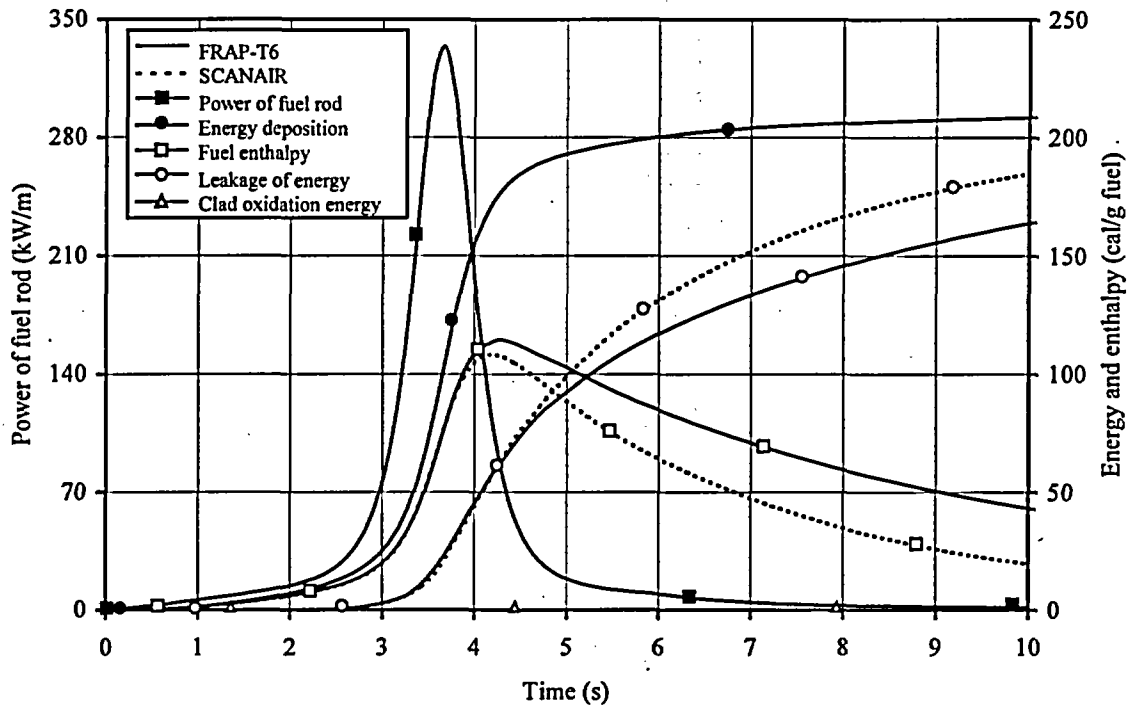

Fig. G-4.7. Energy and Temperature Characteristics Vs. Time Calculated by FRAP-T6 and SCANAIR Codes for Fuel Rod #H4T

#H4T

Individual Characteristics of Refabricated Fuel Rods  
(Preirradiated Fuel, Preirradiated Cladding) under IGR Tests

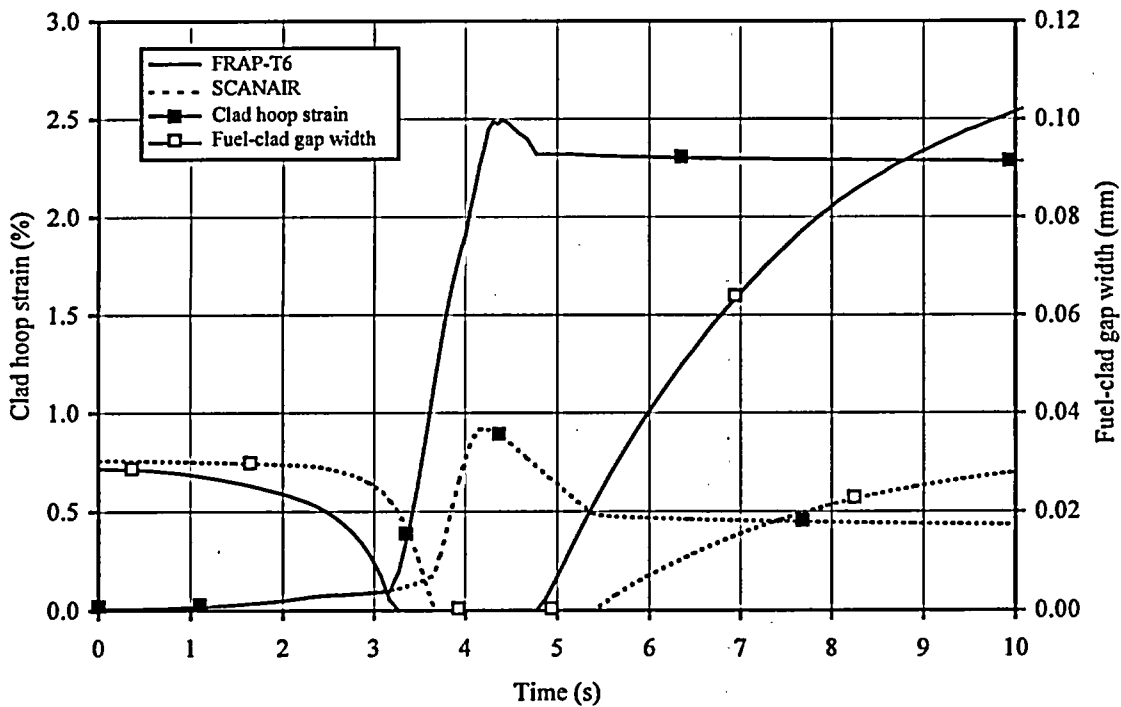
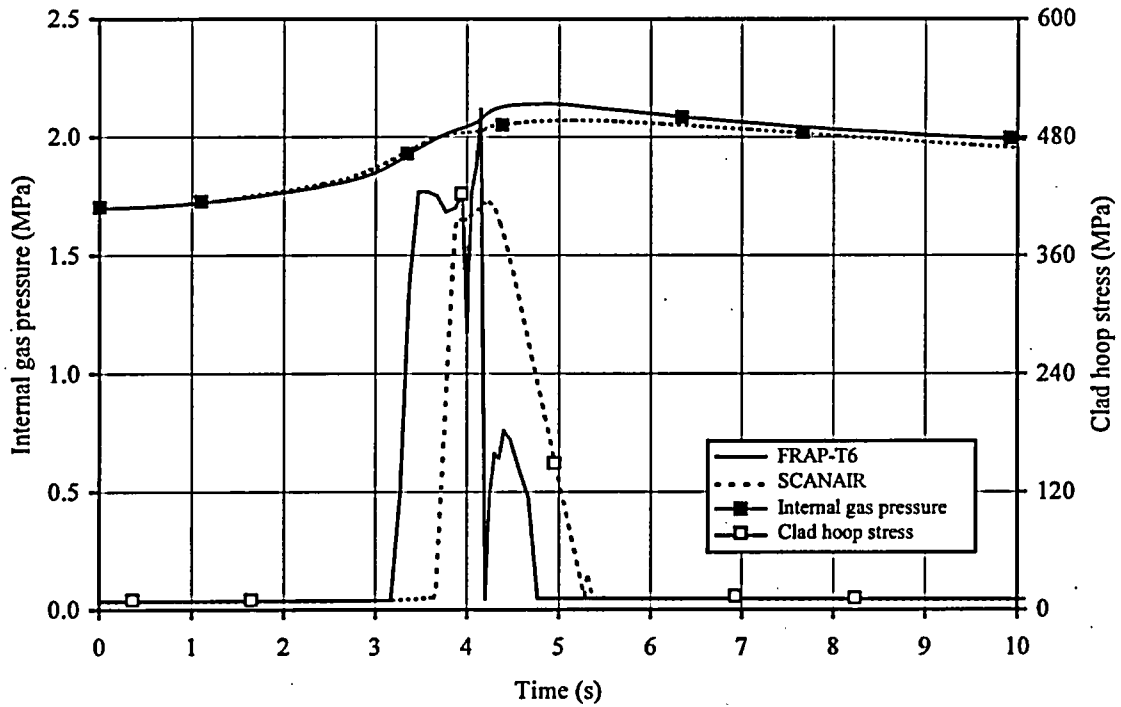

Fig. G-4.8. Cladding Mechanical Characteristics Vs. Time Calculated by FRAP-T6 and SCANAIR Codes for Fuel Rod #H4T



# #H4T

Individual Characteristics of Refabricated Fuel Rods  
(Preirradiated Fuel, Preirradiated Cladding) under IGR Tests

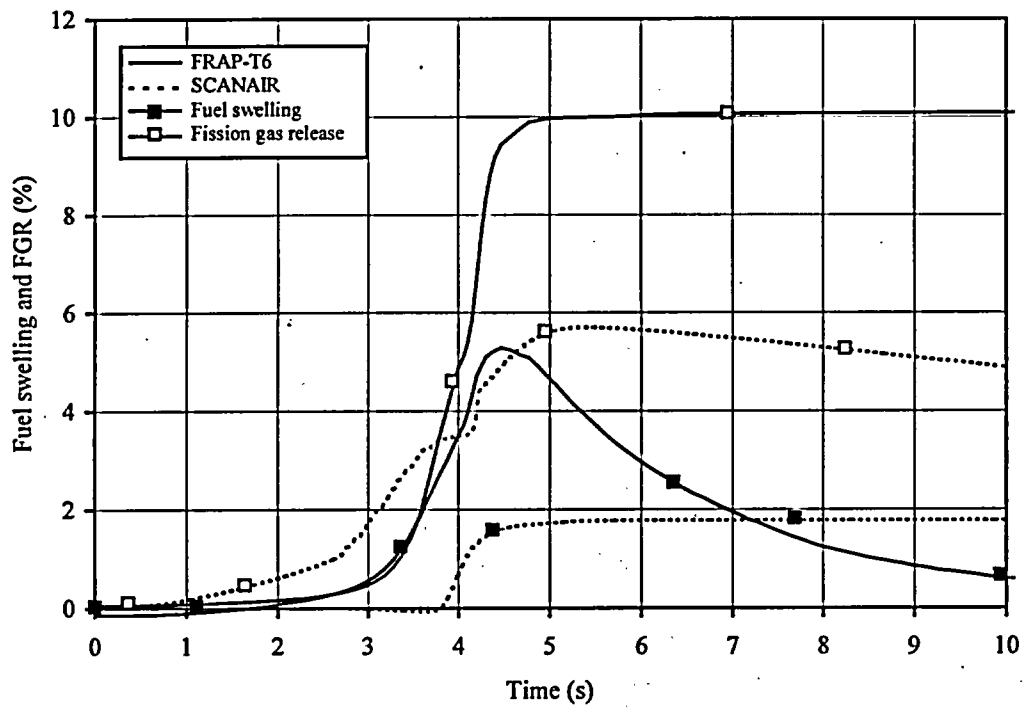
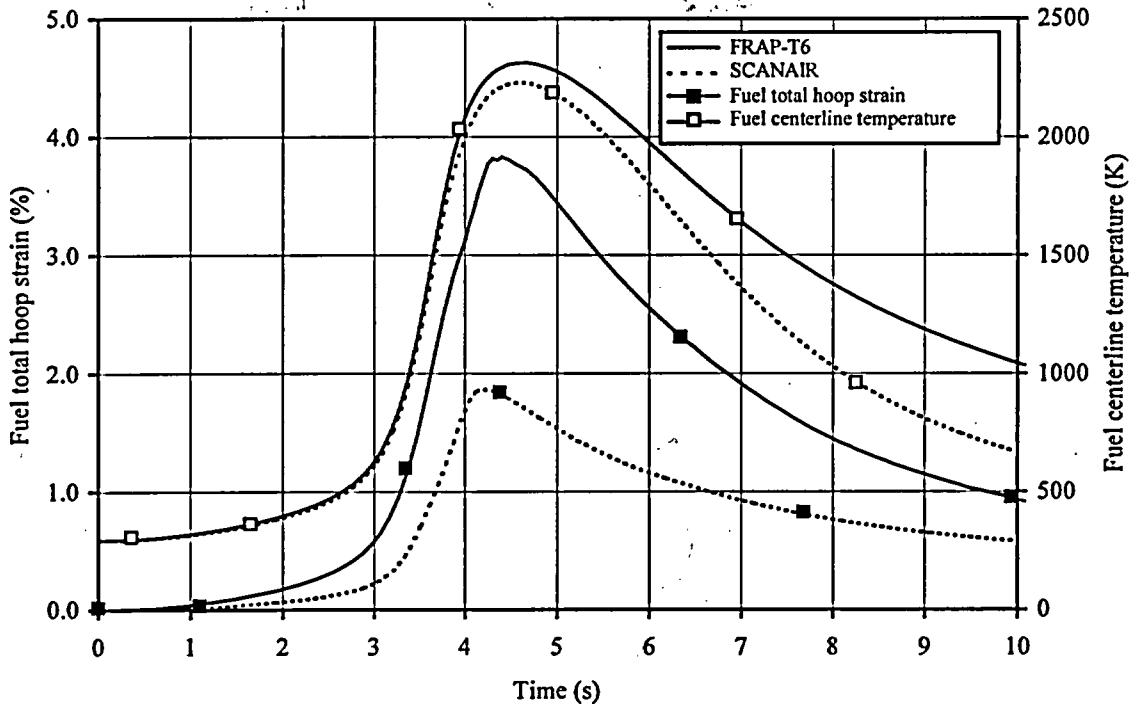

Fig. G-4.9. Fuel Strain and Fission Gas Release Vs. Time Calculated by FRAP-T6 and SCANAIR Codes for Fuel Rod #H4T

Table G-4.9. Some Results of PIE for Fuel Rod #H4T

Characteristic		Value
1.	Measured parameters of cladding oxidation and cladding deformation	
1.1.	Cladding thickness at elevation 90 mm for different azimuthal angles ( $\mu\text{m}$ ):	
	0°	700
	90°	691
	180°	700
	270°	705
1.2.	ZrO <sub>2</sub> thickness at elevation 80, 55, 130 mm for different azimuthal angles ( $\mu\text{m}$ ):	
	0°	5
	90°	5
	180°	5
	270°	5
1.3.	$\alpha\text{Zr(O)}$ thickness at elevation 80, 55, 130 mm for different azimuthal angles ( $\mu\text{m}$ ):	
	0°	0
	90°	0
	180°	0
	270°	0
1.4.	Clad hoop strain at elevation 80, 55, 130 mm (%)	0
2.	Measured parameters for FGR analysis	
2.1.	Internal gas composition (% by volume):	
	He	89.06
	N <sub>2</sub>	0.17
	O <sub>2</sub>	0.03
	Ar	0.01
	CO <sub>2</sub>	0.01
	Kr	1.01
	Xe	9.71
2.2.	Free gas volume (cm <sup>3</sup> )	5.98
2.3.	Gas pressure inside fuel rod under normal condition (MPa)	1.768
2.4.	Kr concentration in fuel (cm <sup>3</sup> /g fuel)	0.13
3.	Measured parameters of cladding hydriding	
3.1.	Coefficient of hydride orientation (per-unit)	—
3.2.	Hydrogen concentration (% by weight)	5.5 10 <sup>-3</sup>

# #H4T

Individual Characteristics of Refabricated Fuel Rods  
(Preirradiated Fuel, Preirradiated Cladding) under IGR Tests

Table G-4.10. General Characteristic of Fuel Rod #H4T

	Parameter	Unit	Value		
			Experiment	FRAP-T6	SCANAIR
1	Type of coolant	---	water	water	water
2	Burnup	MWd/kg U	48.7	48.7	48.7
3	Energy deposition in fuel rod	cal/g fuel	196	196	196
4	Peak fuel enthalpy	cal/g fuel	-	114	108
5	Peak fuel temperature	K	-	2313	2229
6	Peak clad temperature	K	-	437	440
7	Fuel rod failure	Yes, No	No	No	-
8	Type of failure:				
	- cladding rupture due to ballooning	Yes, No	No	No	-
	- cladding rupture due to PCMI	Yes, No	No	No	-
	- fragmentation of fuel rod	Yes, No	No	-	-
9	Failure time	s	-	-	-
10	Fuel enthalpy at failure	cal/g fuel	-	-	-
11	Outer cladding temperature at failure	K	-	-	-
12	Internal gas pressure at failure	MPa	-	-	-
13	ZrO <sub>2</sub> thickness after test	μm	5	5	-
14	Residual clad hoop strain:				
	- peak value for ballooning area	%	-	-	-
	- other location <sup>1)</sup>	%	0	1.68	0
15	Kr concentration in internal gas composition after test	% by volume	1.01	1.34	0.59
16	Xe concentration in internal gas composition after test	% by volume	9.71	8.06	3.51
17	Kr concentration in fuel after test	cm <sup>3</sup> /g fuel	0.13	0.15	0.19

<sup>1)</sup>Calculated values by FRAP-T6 and SCANAIR codes are average along height of fuel rod excluding ballooning region



***APPENDIX G-5.***

***Individual Characteristics for Fuel Rod #H5T under IGR Test***

#H5T

Individual Characteristics of Refabricated Fuel Rods  
(Preirradiated Fuel, Preirradiated Cladding) under IGR Tests

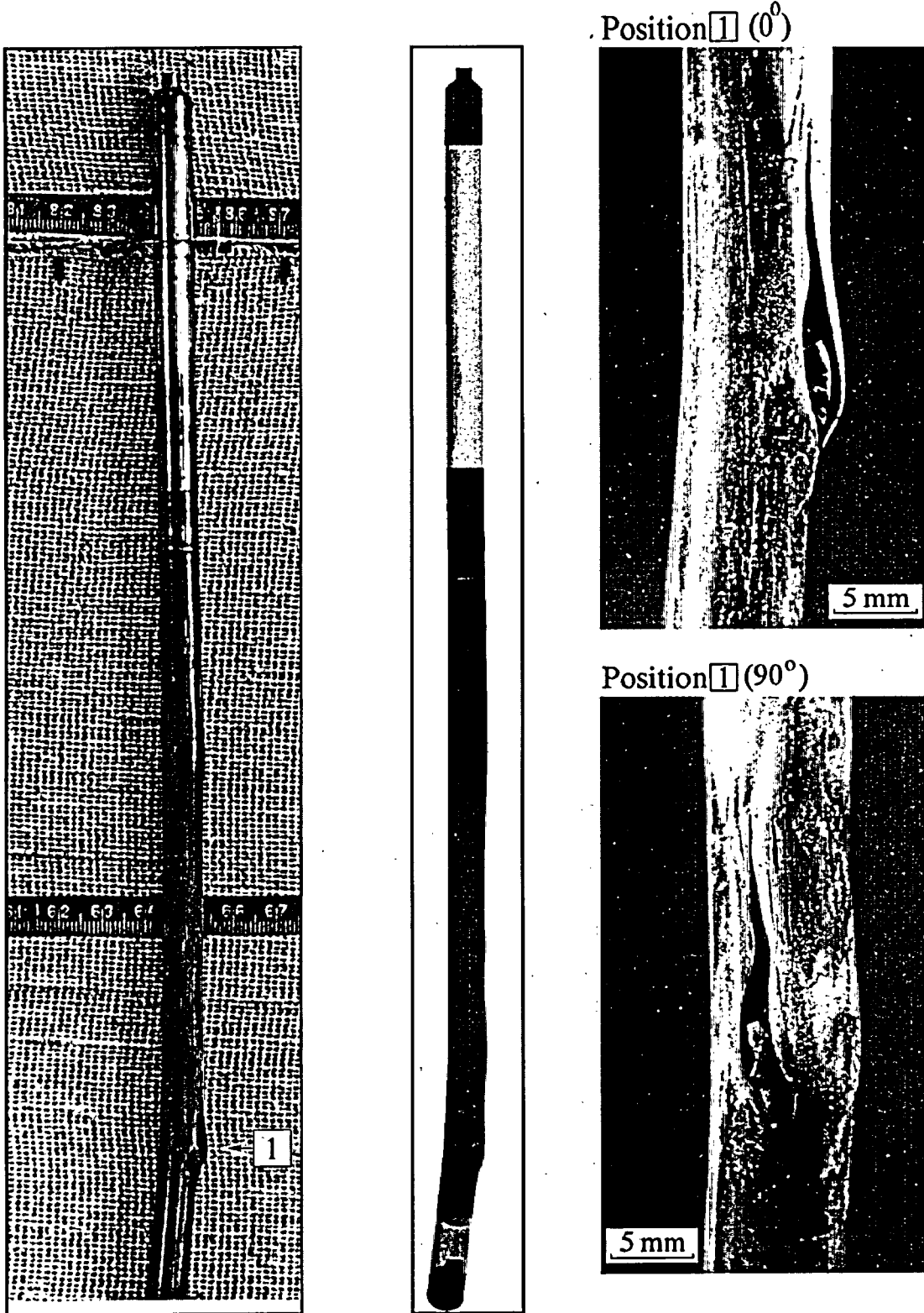
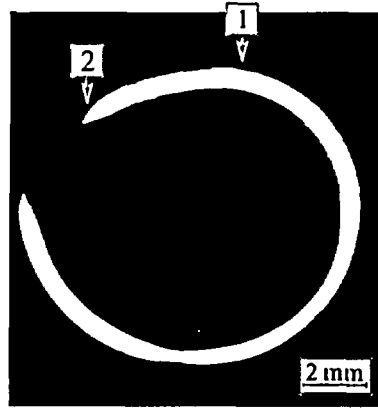

Fig. G-5.1. Appearance of Fuel Rod #H5T (photographs and X-ray photograph)

#H5T

Individual Characteristics of Refabricated Fuel Rods  
(Preirradiated Fuel, Preirradiated Cladding) under IGR Tests



Position 1

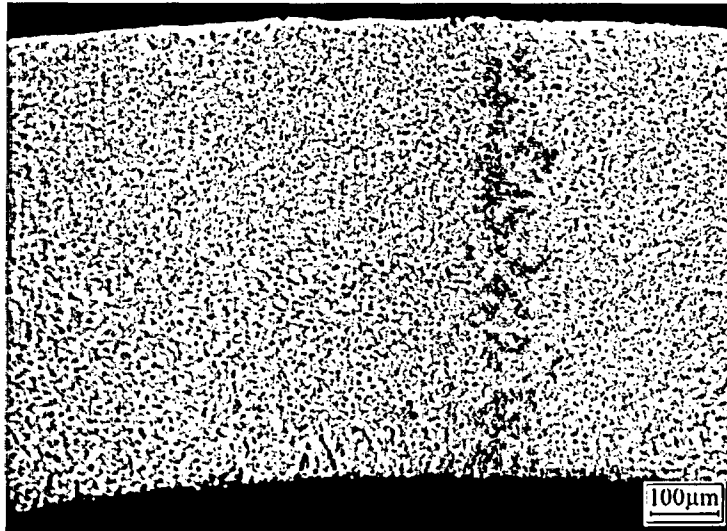

Position 2

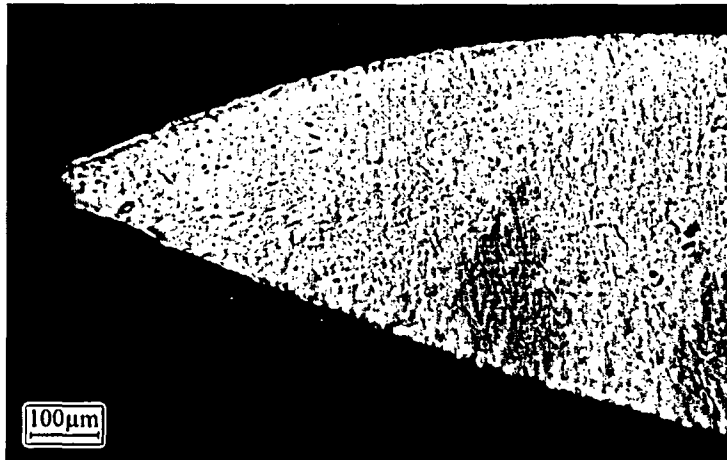
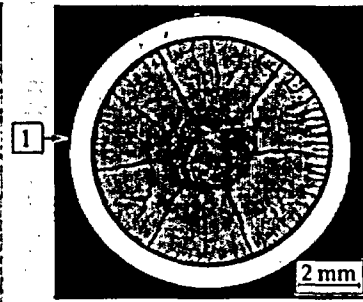
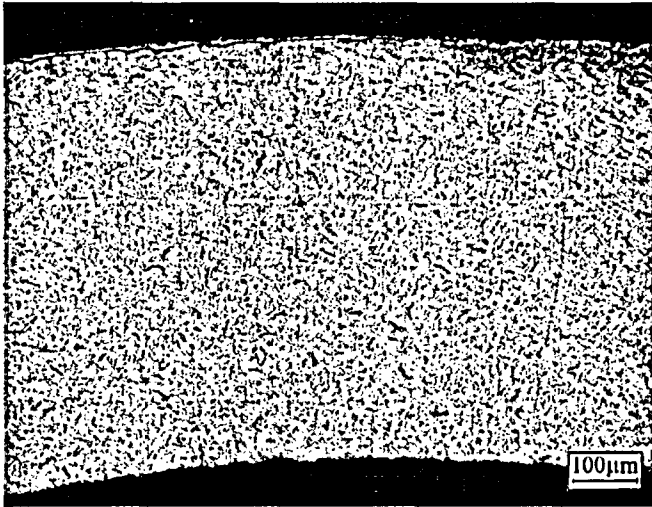

Fig. G-5.2. Cross-Section and Cladding Microstructure for Fuel Rod #H5T at 40 mm Elevation

#H5T

Individual Characteristics of Refabricated Fuel Rods  
(Preirradiated Fuel, Preirradiated Cladding) under IGR Tests

Position 1



Position 1

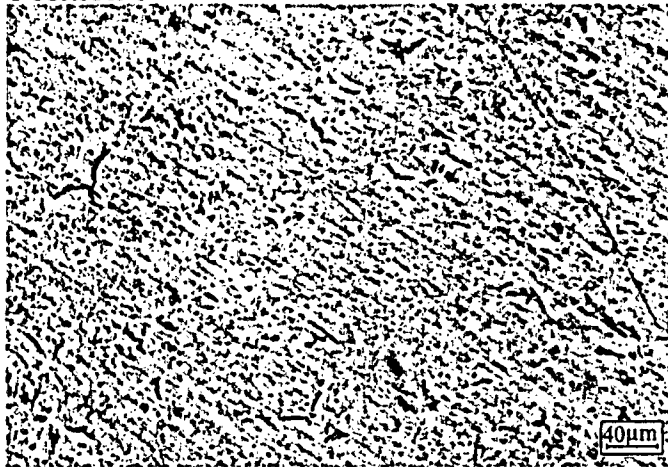

Position 1

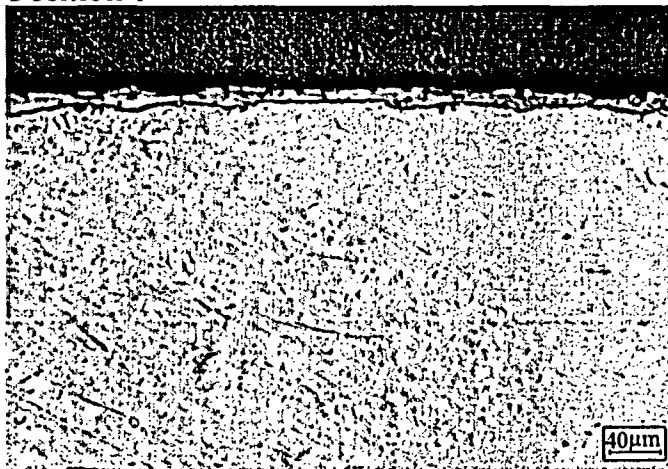

Fig. G-5.3. Cross-Section and Cladding Microstructure for Fuel Rod #H5T at 85 mm Elevation



#H5T

Individual Characteristics of Refabricated Fuel Rods  
(Preirradiated Fuel, Preirradiated Cladding) under IGR Tests

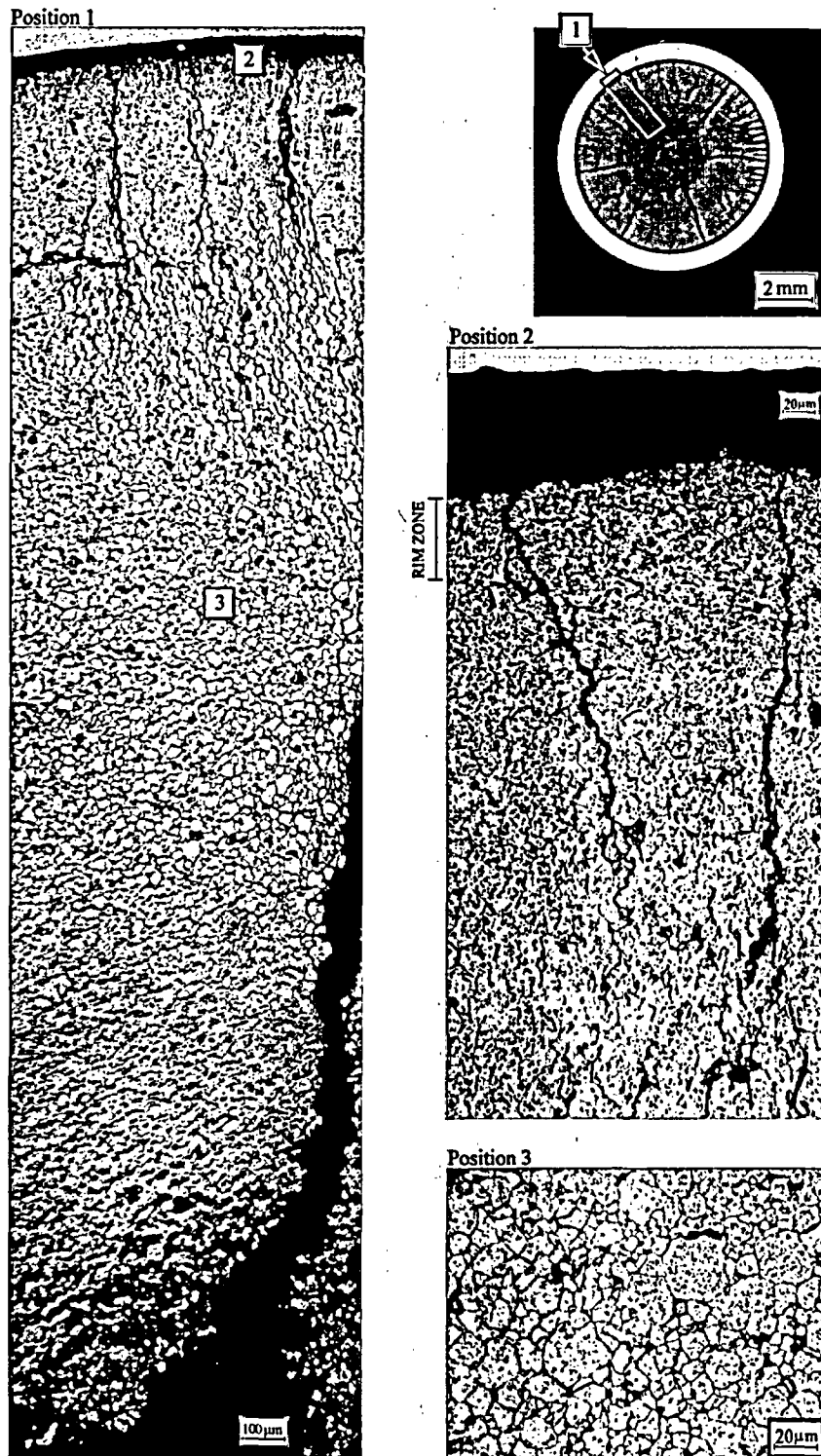

Fig. G-5.4. Fuel Microstructure for Fuel Rod #H5T at 85 mm Elevation

## #H5T

Individual Characteristics of Refabricated Fuel Rods  
(Preirradiated Fuel, Preirradiated Cladding) under IGR Tests

Table G-5.1. Time Dependent Energy Characteristics of Fuel Rod #H5T

Time (s)	Reactor energy deposition <sup>1)</sup> (%)	Cumulative number of fissions in fuel rod (fiss)						Power of fuel rod (kW)	Energy deposition in fuel rod	
		U <sup>235</sup> ×10 <sup>-14</sup>	U <sup>238</sup> ×10 <sup>-13</sup>	Pu <sup>239</sup> ×10 <sup>-14</sup>	Pu <sup>241</sup> ×10 <sup>-14</sup>	Other isotopes ×10 <sup>-11</sup>	Total ×10 <sup>-14</sup>		cal/g fuel	J/g fuel
0.0	0.000	0.000	0.000	0.000	0.000	0.000	0.000	0.000	0.000	0.000
1.0	0.620	0.038	0.009	0.057	0.023	0.045	0.119	0.778	1.502	6.293
2.0	4.740	0.290	0.069	0.436	0.180	0.343	0.913	4.830	11.55	48.39
2.2	6.840	0.418	0.099	0.628	0.259	0.493	1.310	6.810	16.59	69.51
2.4	9.790	0.598	0.142	0.900	0.370	0.707	1.880	9.660	23.73	99.43
2.6	14.00	0.855	0.203	1.290	0.530	1.010	2.690	13.90	34.02	142.5
2.8	20.10	1.230	0.291	1.850	0.761	1.450	3.870	20.20	48.83	204.6
3.0	29.10	1.780	0.421	2.670	1.100	2.100	5.590	29.80	70.56	295.6
3.2	42.20	2.580	0.610	3.870	1.590	3.040	8.110	42.70	102.3	428.6
3.4	59.20	3.620	0.857	5.440	2.240	4.270	11.40	47.60	143.9	602.9
3.6	73.50	4.490	1.060	6.760	2.780	5.310	14.10	30.80	178.5	747.9
3.8	82.00	5.010	1.190	7.540	3.100	5.920	15.80	17.30	199.5	835.9
4.0	86.80	5.300	1.260	7.980	3.280	6.260	16.70	10.10	211.1	884.5
4.2	89.60	5.480	1.300	8.240	3.390	6.470	17.20	6.250	218.4	915.1
4.4	91.40	5.590	1.320	8.400	3.460	6.600	17.60	4.150	222.6	932.7
4.6	92.60	5.660	1.340	8.510	3.500	6.690	17.80	2.920	225.8	946.1
4.8	93.50	5.710	1.350	8.590	3.540	6.750	18.00	2.160	227.9	954.9
5.0	94.10	5.750	1.360	8.650	3.560	6.800	18.10	1.660	228.9	959.1
5.2	94.60	5.780	1.370	8.700	3.580	6.830	18.20	1.290	231.0	967.9
5.4	95.00	5.810	1.380	8.730	3.600	6.860	18.30	1.090	232.1	972.5
5.6	95.30	5.830	1.380	8.760	3.610	6.880	18.30	0.930	233.1	976.7
5.8	95.60	5.840	1.380	8.790	3.620	6.900	18.40	0.802	233.1	976.7
6.0	95.90	5.860	1.390	8.810	3.630	6.920	18.40	0.699	234.2	981.3
6.5	96.30	5.880	1.390	8.850	3.640	6.950	18.50	0.517	235.2	985.5
7.0	96.70	5.910	1.400	8.880	3.660	6.980	18.60	0.406	236.3	990.1
7.5	96.90	5.920	1.400	8.910	3.670	7.000	18.60	0.334	237.3	994.3
8.0	97.20	5.940	1.410	8.930	3.680	7.010	18.70	0.285	238.4	998.9
9.0	97.50	5.960	1.410	8.960	3.690	7.040	18.80	0.246	239.4	1003
10.0	97.80	5.980	1.420	8.990	3.700	7.060	18.80	0.198	240.5	1008
20.0	99.10	6.060	1.440	9.110	3.750	7.150	19.10	0.052	244.7	1025
30.0	99.60	6.080	1.440	9.150	3.770	7.190	19.10	0.027	245.7	1029
∞	100.0	6.130	1.450	9.230	3.800	7.250	19.30	0.000	251.0	1052

Maximum value of power is 49.0 kW (t = 3.35 s).

<sup>1)</sup> Current energy deposition per maximum energy deposition (at infinite time)

# #H5T

Individual Characteristics of Refabricated Fuel Rods  
(Preirradiated Fuel, Preirradiated Cladding) under IGR Tests

Table G-5.2. Axial Energy Characteristics of Fuel Rod #H5T

Axial coordinate from lower end of fuel rod (mm)	Cumulative number of fissions at axial interval (fiss)						Maximum power of fuel rod (kW) $t=3.35s$	Energy deposition at infinite time*		
	U <sup>235</sup> $\times 10^{-13}$	U <sup>238</sup> $\times 10^{-11}$	Pu <sup>239</sup> $\times 10^{-13}$	Pu <sup>241</sup> $\times 10^{-13}$	Other isotopes $\times 10^{-10}$	Total $\times 10^{-13}$		cal/g fuel	J/g fuel	per-unit <sup>3)</sup>
10.0	0.000	0.000	0.000	0.000	0.000	0.000	0.000	0.000	0.000	0.00
15.0	0.000	0.000	0.000	0.000	0.000	0.000	0.000	0.000	0.000	0.00
20.0	0.000	0.000	0.000	0.000	0.000	0.000	0.000	0.000	0.000	0.00
25.0 <sup>1)</sup>	1.700	3.250	2.450	1.000	1.700	5.200	1.320	283.4	1187	1.00
30.0	1.890	3.610	2.730	1.120	1.880	5.770	1.470	283.4	1187	1.00
35.0	1.890	3.610	2.730	1.120	1.880	5.770	1.470	283.4	1187	1.00
40.0	1.890	3.610	2.730	1.120	1.880	5.770	1.470	283.4	1187	1.00
45.0	2.480	5.330	3.470	1.400	2.600	7.410	1.880	248.9	1043	0.88
50.0	2.580	5.510	3.590	1.450	2.590	7.680	1.950	248.9	1043	0.88
55.0	2.520	5.430	3.530	1.430	2.580	7.540	1.910	248.9	1043	0.88
60.0	2.370	5.230	3.400	1.380	2.570	7.200	1.830	246.8	1034	0.87
65.0	2.210	4.940	3.210	1.310	2.570	6.780	1.720	246.8	1034	0.87
70.0	1.520	3.660	2.270	0.933	1.820	4.760	1.210	247.9	1039	0.87
75.0	1.520	3.660	2.270	0.933	1.820	4.760	1.210	247.9	1039	0.87
80.0	1.520	3.660	2.270	0.933	1.820	4.760	1.210	247.9	1039	0.87
85.0	1.520	3.660	2.270	0.933	1.820	4.760	1.210	247.9	1039	0.87
90.0	2.370	5.570	3.480	1.420	2.640	7.330	1.860	251.0	1052	0.89
95.0	2.290	5.520	3.410	1.400	2.670	7.160	1.820	250.0	1048	0.88
100.0	2.150	5.470	3.320	1.370	2.700	6.900	1.750	245.8	1030	0.87
105.0	2.090	5.420	3.260	1.350	2.710	6.760	1.720	244.7	1025	0.86
110.0	1.990	5.380	3.180	1.330	2.720	6.560	1.670	241.6	1012	0.85
115.0	1.980	5.370	3.180	1.330	2.710	6.540	1.660	241.6	1012	0.85
120.0	1.970	5.390	3.180	1.330	2.700	6.540	1.660	240.5	1008	0.85
125.0	2.020	5.370	3.200	1.330	2.690	6.610	1.680	242.6	1016	0.86
130.0	2.110	5.300	3.230	1.330	2.680	6.730	1.710	246.8	1034	0.87
135.0	2.080	5.360	3.230	1.340	2.670	6.710	1.700	244.7	1025	0.86
140.0	1.990	5.450	3.210	1.350	2.660	6.600	1.680	240.5	1008	0.85
145.0	2.040	5.430	3.230	1.350	2.660	6.680	1.700	242.6	1016	0.86
150.0	2.130	5.410	3.280	1.360	2.670	6.820	1.730	245.8	1030	0.87
155.0	2.200	5.450	3.330	1.370	2.690	6.970	1.770	247.9	1039	0.87
160.0	1.470	3.320	2.240	0.924	1.710	4.670	1.180	247.9	1039	0.87
165.0	1.470	3.320	2.240	0.924	1.710	4.670	1.180	247.9	1039	0.87
170.0	1.470	3.320	2.240	0.924	1.710	4.670	1.180	247.9	1039	0.87
175.0	1.470	3.320	2.240	0.924	1.710	4.670	1.180	247.9	1039	0.87
180.0 <sup>2)</sup>	0.440	0.996	0.673	0.277	0.512	1.400	0.355	247.9	1039	0.87
185.0	0.000	0.000	0.000	0.000	0.000	0.000	0.000	0.000	0.000	0.00

\* All numerical values of characteristics are presented as average values at the length interval equal to the axial coordinate  $\pm 2.5$  mm

<sup>1)</sup> Initial coordinate of fuel is 23.0 mm

<sup>2)</sup> End coordinate of fuel is 179.0 mm

<sup>3)</sup> Current value per maximum value

Table G-5.3. Radial Energy Characteristics of Fuel Rod #H5T

Characteristics*		Coordinates of fuel zones (mm)			
		1 zone 1.2 - 2.811	2 zone 2.811-3.432	3 zone 3.432-3.704	4 zone 3.704-3.790
U <sup>235</sup>	Number of fissions $\times 10^{-14}$ (fiss)	2.207	1.297	0.634	0.206
	Power of fuel rod <sup>1)</sup> (kW)	5.512	3.232	1.579	0.515
	Energy deposition <sup>2)</sup> (cal/g fuel)	77.60	75.82	74.25	72.48
	Energy deposition <sup>2)</sup> (J/g fuel)	325.3	316.9	310.6	303.3
	Energy deposition <sup>3)</sup> (per-unit)	1.000	0.977	0.957	0.934
U <sup>238</sup>	Number of fissions $\times 10^{-12}$ (fiss)	5.627	3.169	1.464	0.441
	Power of fuel rod <sup>1)</sup> (kW)	0.138	0.078	0.036	0.010
	Energy deposition <sup>2)</sup> (cal/g fuel)	1.945	1.830	1.684	1.527
	Energy deposition <sup>2)</sup> (J/g fuel)	8.147	7.666	7.049	6.390
	Energy deposition <sup>3)</sup> (per-unit)	1.000	0.941	0.866	0.785
Pu <sup>239</sup>	Number of fissions $\times 10^{-14}$ (fiss)	2.730	1.851	1.276	0.720
	Power of fuel rod <sup>1)</sup> (kW)	7.028	4.779	3.273	1.851
	Energy deposition <sup>2)</sup> (cal/g fuel)	99.35	113.0	153.7	261.5
	Energy deposition <sup>2)</sup> (J/g fuel)	416.2	472.7	643.2	1095
	Energy deposition <sup>3)</sup> (per-unit)	0.380	0.432	0.588	1.000
Pu <sup>241</sup>	Number of fissions $\times 10^{-13}$ (fiss)	10.77	7.635	5.470	3.263
	Power of fuel rod <sup>1)</sup> (kW)	2.730	1.935	1.391	0.825
	Energy deposition <sup>2)</sup> (cal/g fuel)	38.38	45.39	65.05	116.1
	Energy deposition <sup>2)</sup> (J/g fuel)	161.1	190.3	271.9	486.3
	Energy deposition <sup>3)</sup> (per-unit)	0.331	0.391	0.560	1.000
Other isotopes	Number of fissions $\times 10^{-11}$ (fiss)	2.458	1.516	0.884	0.420
	Power of fuel rod <sup>1)</sup> (kW)	0.006	0.004	0.002	0.001
	Energy deposition <sup>2)</sup> (cal/g fuel)	0.089	0.091	0.106	0.152
	Energy deposition <sup>2)</sup> (J/g fuel)	0.366	0.377	0.439	0.638
	Energy deposition <sup>3)</sup> (per-unit)	0.583	0.599	0.697	1.000
Total	Number of fissions $\times 10^{-14}$ (fiss)	6.066	3.943	2.479	1.265
	Power of fuel rod <sup>1)</sup> (kW)	15.37	10.02	6.285	3.211
	Energy deposition <sup>2)</sup> (cal/g fuel)	217.5	235.3	296.0	452.8
	Energy deposition <sup>2)</sup> (J/g fuel)	910.9	985.2	1239	1896
	Energy deposition <sup>3)</sup> (per-unit)	0.480	0.520	0.654	1.000

1) at time of 3.35 s, 2) at infinite time, 3) Current value per maximum value.

\* All numerical values of characteristics were calculated for undamaged part of fuel stack only (See Table C.2.1.)

# #H5T

Individual Characteristics of Refabricated Fuel Rods  
(Preirradiated Fuel, Preirradiated Cladding) under IGR Tests

Table G-5.4. Fuel Enthalpy Vs. Time Calculated by FRAP-T6 Code for Fuel Rod #H5T

Time (s)	Enthalpy at fuel radius (cal/g fuel)				Fuel enthalpy <sup>1)</sup>		Energy deposition in fuel rod	
	1.20 mm	2.82 mm	3.47 mm	3.79 mm	cal/g fuel	J/g fuel	cal/g fuel	J/g fuel
0.0	0.00	0.00	0.00	0.00	0.00	0.00	0.00	0.00
1.0	1.60	1.58	1.51	1.43	1.56	6.55	1.50	6.30
2.0	12.0	11.7	11.0	10.1	11.5	48.3	11.5	48.2
2.2	17.4	16.9	15.5	13.7	16.5	69.3	16.7	70.1
2.4	24.9	23.8	21.0	17.6	23.1	97.0	24.0	100
2.6	35.5	33.5	28.6	22.8	32.4	136	34.3	144
2.8	50.0	46.6	36.9	23.5	44.1	185	48.3	203
3.0	73.6	66.7	47.7	27.7	62.3	261	71.2	298
3.2	107	95.2	67.5	36.7	89.2	374	103	432
3.4	149	132	89.3	47.5	123	514	144	604
3.6	185	160	113	71.7	152	638	179	749
3.8	204	174	122	88.6	167	699	199	833
4.0	215	178	126	94.2	173	725	211	884
4.2	220	178	130	104	176	738	218	913
4.4	222	176	129	102	176	736	222	932
4.6	221	173	126	96.7	173	725	225	945
4.8	219	169	118	85.4	168	705	228	954
5.0	217	163	109	76.8	163	681	229	961
5.2	213	156	101	71.9	157	657	231	966
5.4	209	149	96.2	70.7	152	635	232	971
5.6	205	142	93.1	70.1	147	615	233	974
5.8	200	137	90.8	69.8	142	596	233	978
6.0	195	132	88.9	69.6	138	578	234	980
6.5	180	121	85.3	69.0	128	537	235	986
7.0	164	113	82.3	68.2	119	500	236	990
7.5	150	106	79.5	67.2	111	466	237	993
8.0	137	99.8	76.8	65.9	104	436	238	996
10.0	98.9	79.7	66.3	59.4	81.4	341	240	1005
30.0	17.2	16.5	15.8	15.4	16.5	69.1	246	1030

Radial enthalpy distribution and fuel enthalpy are presented at elevation 30.8 mm

Maximum value of fuel enthalpy is 176.2 cal/g fuel ( $t=4.26$  s)

<sup>1)</sup> All numerical values are presented at elevation with peak power

# #H5T

Individual Characteristics of Refabricated Fuel Rods  
(Preirradiated Fuel, Preirradiated Cladding) under IGR Tests

Table G-5.5. Energy Characteristics Vs. Time Calculated by FRAP-T6 and SCANAIR Codes for Fuel Rod #H5T

Time (s)	Energy deposition <sup>1)</sup> (cal/g fuel)	Linear power <sup>1)</sup> (kW/m)	Fuel enthalpy <sup>1)</sup> (cal/g fuel)		Energy of metal-water reaction <sup>1)</sup> (cal/g fuel)	Leakage of energy <sup>1)</sup> (cal/g fuel)		Clad-to-coolant heat transfer coefficient <sup>1)</sup> (kW/m <sup>2</sup> K)	
			FRAP-T6	SCANAIR	FRAP-T6	FRAP-T6	SCANAIR	FRAP-T6	SCANAIR
0.0	0.00	0.00	0.00	0.00	0.00	0.00	0.00	0.00	0.00
1.0	1.70	7.20	1.56	1.45	0.00	0.00	0.00	0.03	0.10
2.0	13.0	44.7	11.5	11.3	0.00	0.09	0.12	1.24	1.31
2.2	18.9	63.6	16.5	15.5	0.00	0.91	0.84	3.74	3.73
2.4	27.1	90.2	23.1	22.1	0.00	2.55	2.48	6.14	6.27
2.6	38.7	130	32.4	31.3	0.00	5.16	5.22	8.83	9.77
2.8	54.6	185	44.1	42.4	0.00	9.37	8.91	16.5	14.1
3.0	80.4	278	62.3	60.5	0.00	17.8	15.8	22.0	21.9
3.2	117	398	89.2	86.1	0.00	28.4	27.5	27.1	33.4
3.4	163	439	123	114	0.00	39.3	38.0	4.79	0.96
3.6	202	283	152	142	0.00	42.3	40.9	1.81	1.56
3.8	225	161	167	-	0.00	47.2	-	2.10	-
4.0	238	93.1	173	-	0.00	53.6	-	2.26	-
4.2	246	57.5	176	-	0.01	60.1	-	2.18	-
4.4	251	38.2	176	-	0.02	67.5	-	3.66	-
4.6	255	26.9	173	-	0.02	80.5	-	7.30	-
4.8	257	19.9	168	-	0.02	95.4	-	11.7	-
5.0	259	15.3	163	-	0.02	108	-	20.4	-
5.2	260	11.9	157	-	0.02	117	-	17.6	-
5.4	262	10.1	152	-	0.02	124	-	15.6	-
5.6	263	8.59	147	-	0.02	130	-	14.3	-
5.8	264	7.41	142	-	0.02	136	-	13.2	-
6.0	264	6.45	138	-	0.02	141	-	12.4	-
6.5	266	4.78	128	-	0.02	152	-	10.7	-
7.0	267	3.75	119	-	0.02	161	-	9.55	-
7.5	268	3.09	111	-	0.02	170	-	8.63	-
8.0	269	2.64	104	-	0.02	177	-	7.87	-
10.0	271	1.83	81.4	-	0.02	201	-	5.65	-
30.0	278	0.25	16.5	-	0.02	273	-	0.79	-

<sup>1)</sup> All numerical values are presented at elevation with peak power

# #H5T

Individual Characteristics of Refabricated Fuel Rods  
(Preirradiated Fuel, Preirradiated Cladding) under IGR Tests

Table G-5.6. Temperature Variation, Fission Gas Release and ZrO<sub>2</sub> Thickness Vs. Time for Fuel Rod #H5T Calculated by FRAP-T6 and SCANAIR Codes

Time (s)	Fuel centerline temperature <sup>1)</sup> (K)		Fuel surface temperature <sup>1)</sup> (K)		Clad outer temperature <sup>1)</sup> (K)		Fission gas release (%)		Average ZrO <sub>2</sub> <sup>2)</sup> thickness (μm)
	FRAP-T6	SCANAIR	FRAP-T6	SCANAIR	FRAP-T6	SCANAIR	FRAP-T6	SCANAIR	FRAP-T6
0.0	293	293	293	293	293	293	0.00	0.00	5.00
1.0	321	317	318	315	304	303	0.05	0.19	5.00
2.0	485	472	457	451	387	380	0.14	0.99	5.00
2.2	564	537	510	499	397	386	0.20	1.32	5.00
2.4	671	640	567	564	403	390	0.29	1.85	5.00
2.6	819	785	642	641	409	395	0.45	2.37	5.00
2.8	1014	956	652	715	422	400	0.72	2.74	5.00
3.0	1323	1237	711	796	429	408	1.30	3.13	5.00
3.2	1738	1644	835	845	435	418	2.43	3.40	5.00
3.4	2211	2064	981	977	648	656	4.03	3.73	5.00
3.6	2538	2427	1299	1290	1002	1085	6.20	5.67	5.00
3.8	2694	-	1514	-	1146	-	8.49	-	5.01
4.0	2772	-	1584	-	1224	-	12.1	-	5.04
4.2	2806	-	1710	-	1184	-	16.6	-	5.07
4.4	2816	-	1681	-	1126	-	18.3	-	5.09
4.6	2813	-	1614	-	945	-	18.3	-	5.10
4.8	2801	-	1473	-	661	-	18.4	-	5.10
5.0	2783	-	1364	-	478	-	18.4	-	5.10
5.2	2759	-	1301	-	423	-	18.4	-	5.10
5.4	2731	-	1285	-	421	-	18.4	-	5.10
5.6	2699	-	1278	-	419	-	18.4	-	5.10
5.8	2661	-	1274	-	417	-	18.4	-	5.10
6.0	2619	-	1271	-	416	-	18.4	-	5.10
6.5	2497	-	1264	-	413	-	18.4	-	5.10
7.0	2360	-	1253	-	411	-	18.5	-	5.10
7.5	2219	-	1240	-	409	-	18.5	-	5.10
8.0	2082	-	1223	-	407	-	18.5	-	5.10
10.0	1642	-	1138	-	402	-	18.5	-	5.10
30.0	562	-	535	-	384	-	18.5	-	5.10

<sup>1)</sup> All numerical values are presented at elevation with peak power

<sup>2)</sup> Initial ZrO<sub>2</sub> thickness is 5 μm

# #H5T

Individual Characteristics of Refabricated Fuel Rods  
(Preirradiated Fuel/Preirradiated Cladding) under IGR Tests

Table G-5.7. Mechanical Characteristics of Fuel Rod #H5T Vs. Time Calculated by FRAP-T6 and SCANAIR Codes

Time (s)	Clad outer temperature <sup>1)</sup> (K)		Fuel hoop strain <sup>1)</sup> (%)		Fuel - clad gap width <sup>1)</sup> (mm)		Clad hoop strain <sup>1)</sup> (%)		Clad hoop stress <sup>1)</sup> (MPa)		Internal gas pressure (MPa)	
	FRAP-T6	SCANAIR	FRAP-T6	SCANAIR	FRAP-T6	SCANAIR	FRAP-T6	SCANAIR	FRAP-T6	SCANAIR	FRAP-T6	SCANAIR
0.0	293	293	0.00	0.00	0.02	0.03	0.01	0.01	8.76	8.13	1.70	1.70
1.0	304	303	0.00	0.02	0.03	0.03	0.02	0.02	8.86	8.26	1.73	1.72
2.0	387	380	0.12	0.13	0.02	0.03	0.07	0.08	9.33	8.86	1.81	1.81
2.2	397	386	0.24	0.18	0.02	0.03	0.08	0.09	9.48	9.16	1.84	1.84
2.4	403	390	0.41	0.25	0.01	0.02	0.09	0.09	9.65	9.56	1.87	1.87
2.6	409	395	0.63	0.36	0.00	0.02	0.10	0.11	9.83	10.1	1.91	1.91
2.8	422	400	0.94	0.49	0.00	0.02	0.30	0.12	230	10.6	1.94	1.93
3.0	429	408	1.44	0.74	0.00	0.01	0.70	0.15	483	11.5	1.98	1.97
3.2	435	418	2.16	1.13	0.00	0.00	1.30	0.31	250	165	2.02	1.99
3.4	648	656	3.20	1.95	0.00	0.00	2.14	1.00	275	299	2.07	2.01
3.6	1002	1085	4.25	3.48	0.00	0.00	3.07	2.14	77.1	14.2	2.13	2.05
3.8	1146	-	4.83	-	0.00	-	3.51	-	12.3	-	2.18	-
4.0	1224	-	5.02	-	0.02	-	4.10	-	12.9	-	2.25	-
4.2	1184	-	5.16	-	0.13	-	7.61	-	0.00	-	0.10	-
4.4	1126	-	5.48	-	0.12	-	7.78	-	0.00	-	0.10	-
4.6	945	-	5.44	-	0.12	-	7.76	-	0.00	-	0.10	-
4.8	661	-	5.26	-	0.13	-	7.57	-	0.00	-	0.10	-
5.0	478	-	5.02	-	0.14	-	7.44	-	0.00	-	0.10	-
5.2	423	-	4.78	-	0.15	-	7.39	-	0.00	-	0.10	-
5.4	421	-	4.56	-	0.16	-	7.39	-	0.00	-	0.10	-
5.6	419	-	4.37	-	0.16	-	7.38	-	0.00	-	0.10	-
5.8	417	-	4.17	-	0.17	-	7.38	-	0.00	-	0.10	-
6.0	416	-	3.99	-	0.18	-	7.38	-	0.00	-	0.10	-
6.5	413	-	3.56	-	0.20	-	7.37	-	0.00	-	0.10	-
7.0	411	-	3.18	-	0.21	-	7.37	-	0.00	-	0.10	-
7.5	409	-	2.84	-	0.22	-	7.37	-	0.00	-	0.10	-
8.0	407	-	2.54	-	0.23	-	7.37	-	0.00	-	0.10	-
10.0	402	-	1.46	-	0.28	-	7.36	-	0.00	-	0.10	-
30.0	384	-	0.00	-	0.34	-	7.34	-	0.00	-	0.10	-

<sup>1)</sup> All numerical values are presented at elevation with peak power



# #H5T

Individual Characteristics of Refabricated Fuel Rods  
(Preirradiated Fuel, Preirradiated Cladding) under IGR Tests

**Table G-5.8. Axial Distribution of Energy Deposition and Fuel Enthalpy Calculated by FRAP-T6 Code for Fuel Rod #H5T**

Axial interval from-to (mm)-(mm)	Energy deposition at infinite time			Fuel enthalpy at time (t=4.26 s)		
	cal/g fuel	J/g fuel	per-unit	cal/g fuel	J/g fuel	per-unit
23.0 - 38.6	283	1188	1.00	176	738	1.00
38.6 - 54.2	258	1079	0.91	160	671	0.91
54.2 - 69.8	247	1037	0.87	154	645	0.87
69.8 - 85.4	248	1039	0.87	154	646	0.87
85.4 - 101.0	249	1044	0.88	155	649	0.88
101.0 - 116.6	243	1018	0.86	151	633	0.86
116.6 - 132.2	243	1019	0.86	151	633	0.86
132.2 - 147.8	243	1018	0.86	151	633	0.86
147.8 - 163.4	247	1035	0.87	154	644	0.87
163.4 - 179.0	248	1039	0.87	154	646	0.87

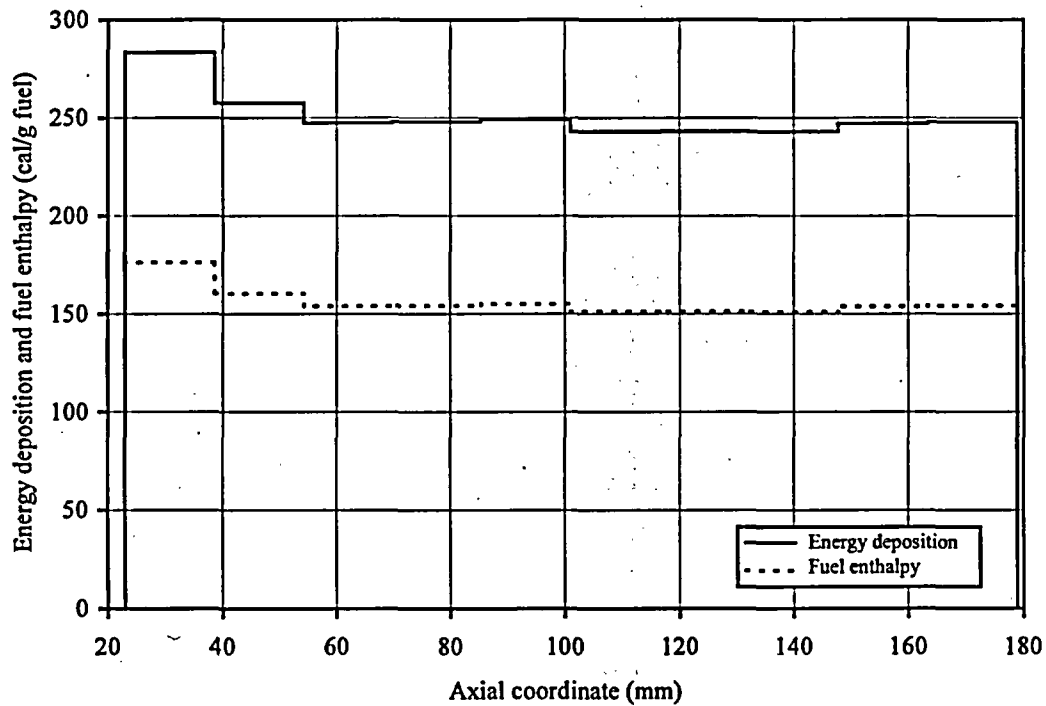

**Fig. G-5.5. Axial Distribution of Energy Deposition and Fuel Enthalpy Calculated by FRAP-T6 Code for Fuel Rod #H5T**

#H5T

Individual Characteristics of Refabricated Fuel Rods  
(Preirradiated Fuel, Preirradiated Cladding) under IGR Tests

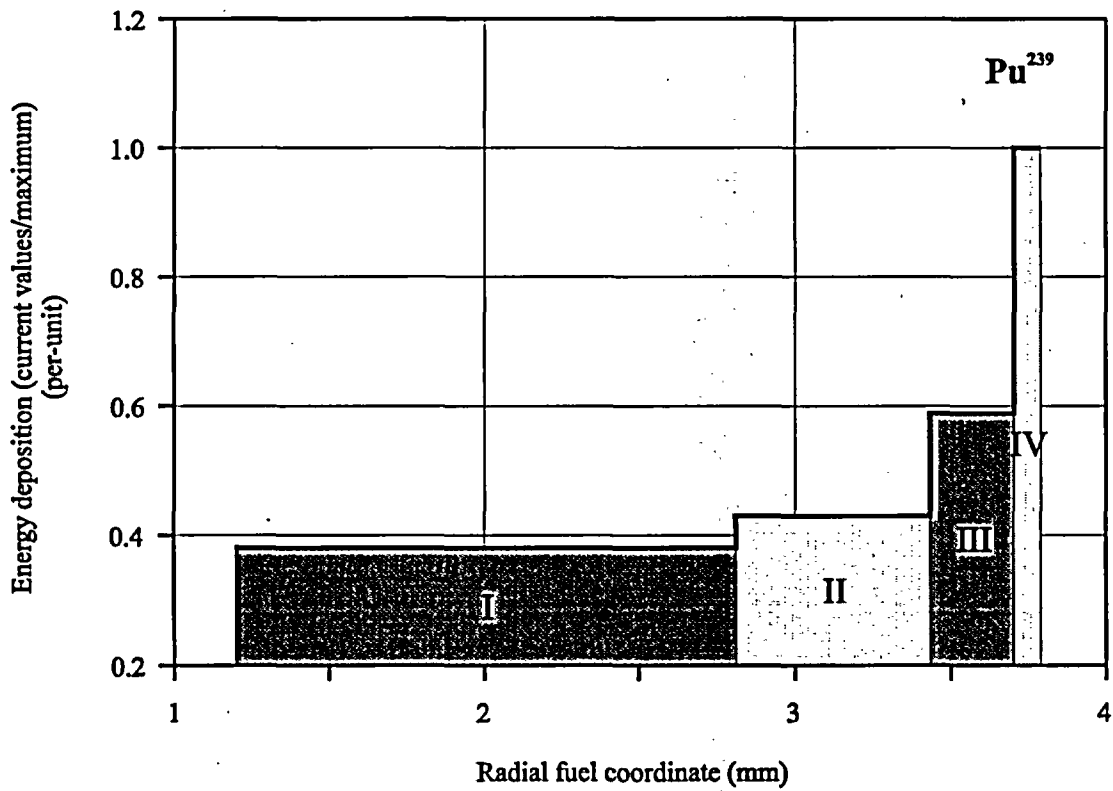
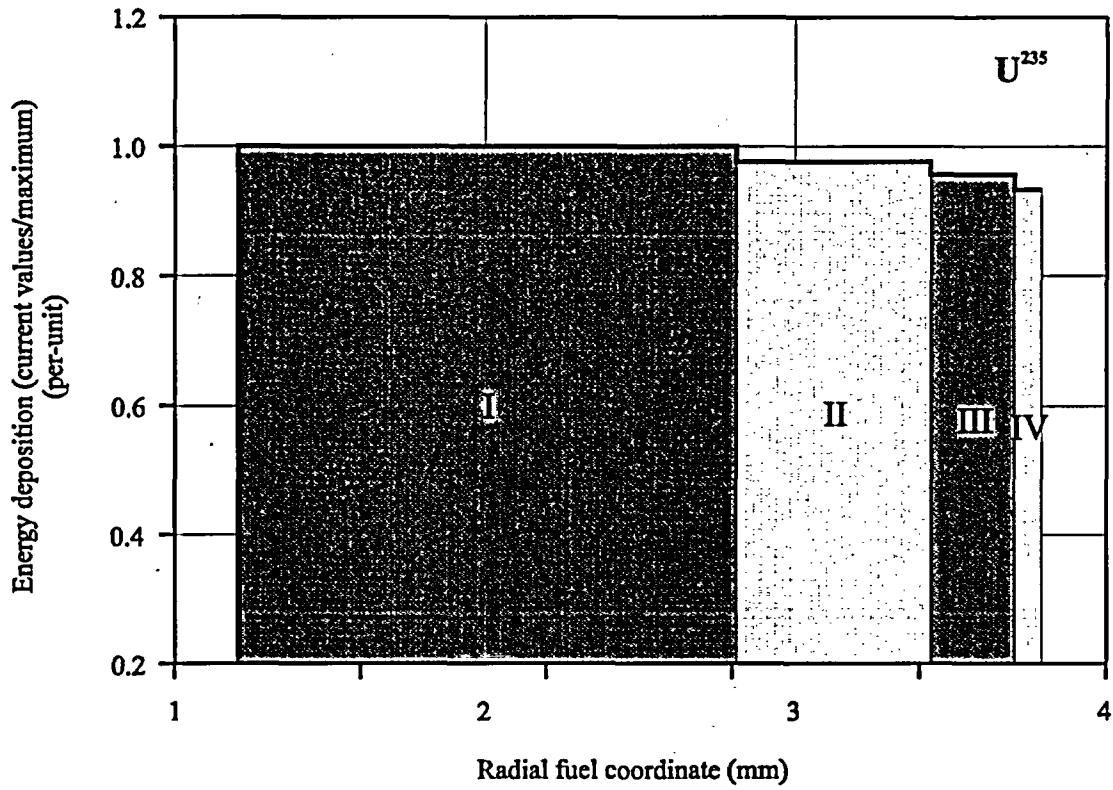

Fig. G-5.6. U<sup>235</sup> and Pu<sup>239</sup> Radial Distributions of Energy Deposition for Fuel Rod #H5T

# #H5T

Individual Characteristics of Refabricated Fuel Rods  
(Preirradiated Fuel, Preirradiated Cladding) under IGR Tests

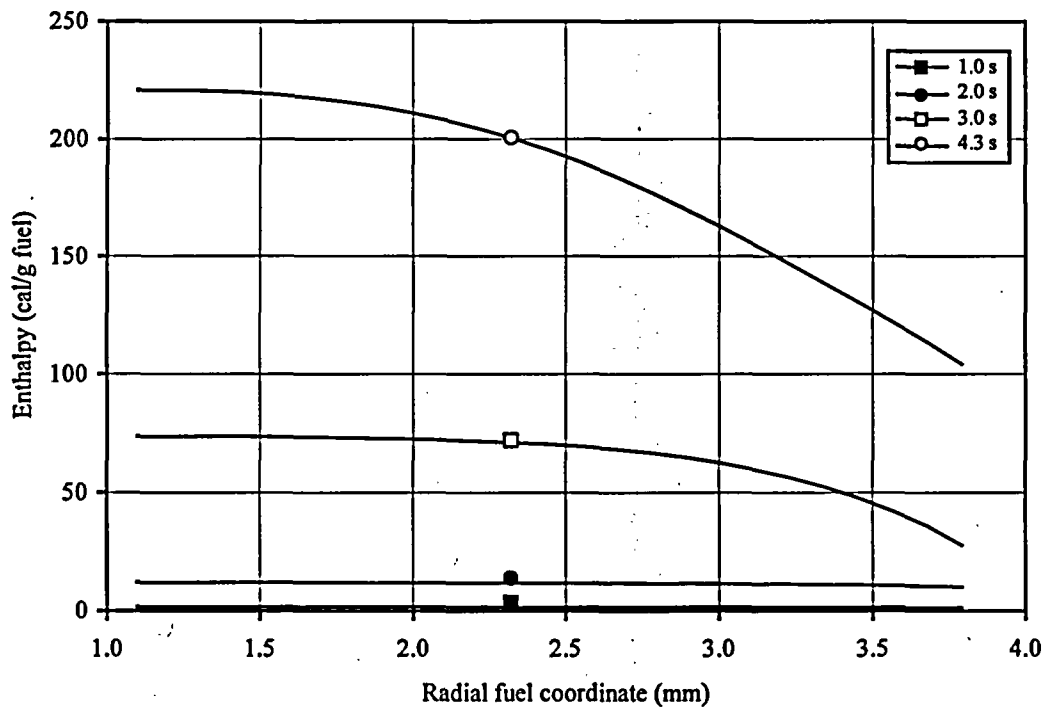
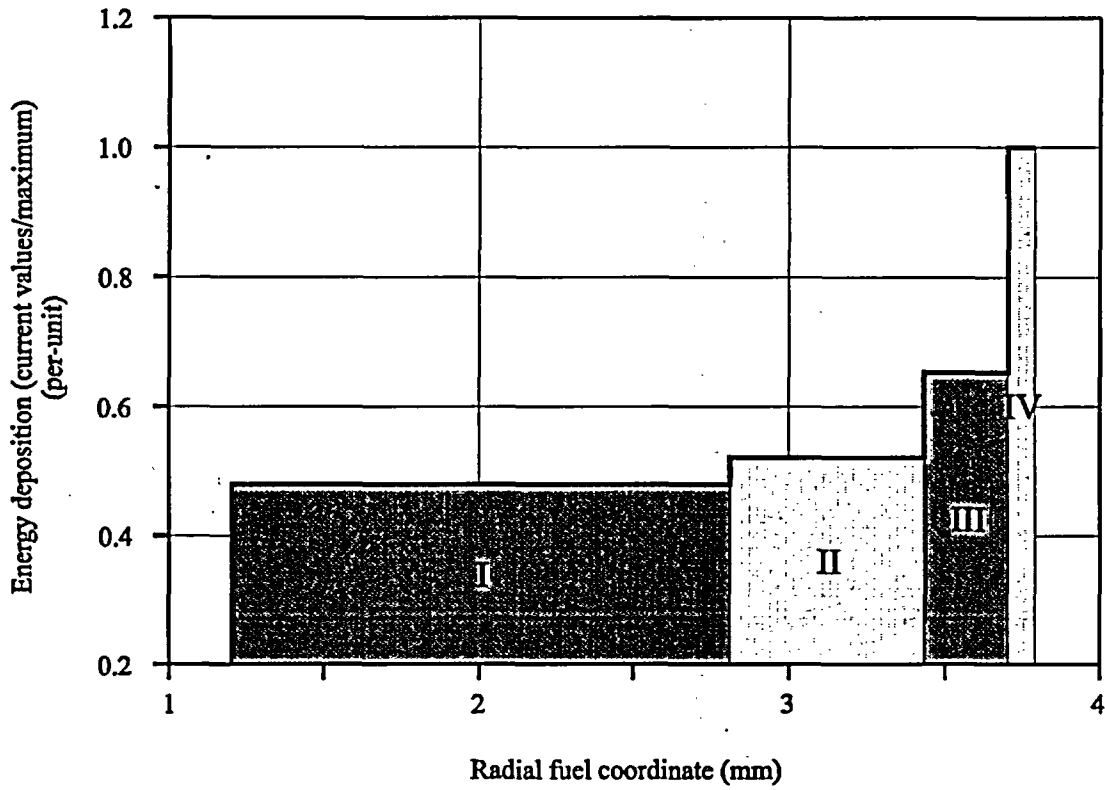

Fig. G-5.7. Radial Distributions of Energy Deposition and Fuel Enthalpy Calculated by FRAP-T6 Code for Fuel Rod #H5T

#H5T

Individual Characteristics of Refabricated Fuel Rods  
(Preirradiated Fuel, Preirradiated Cladding) under IGR Tests

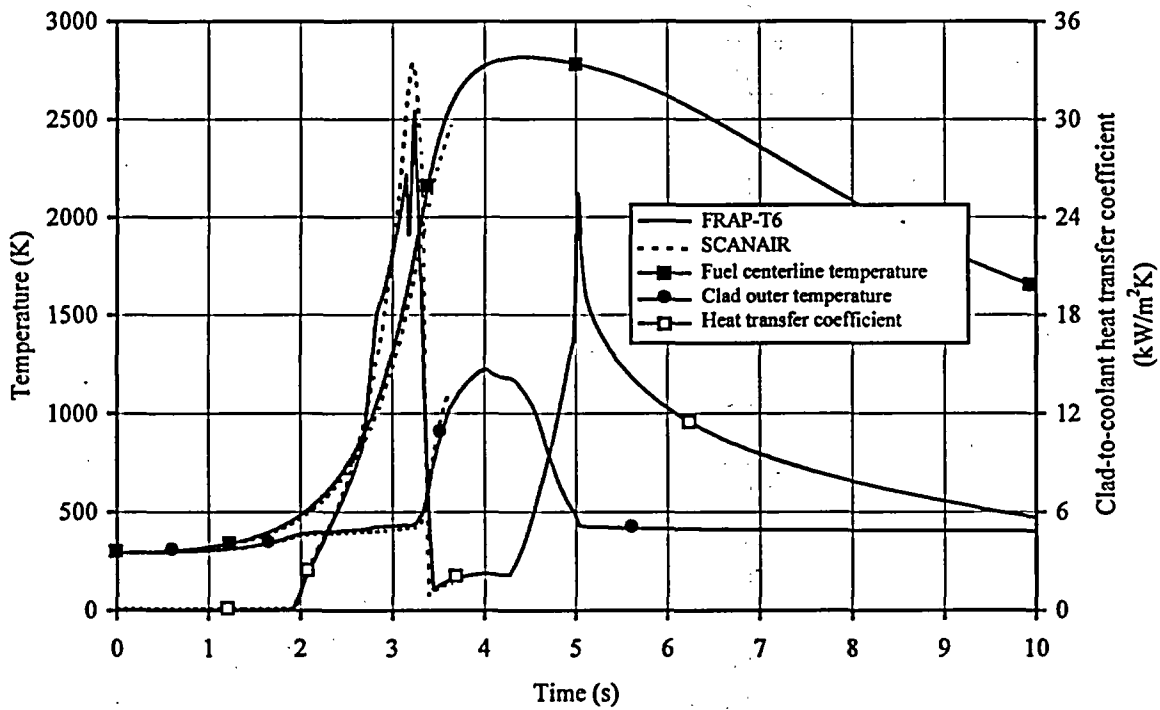
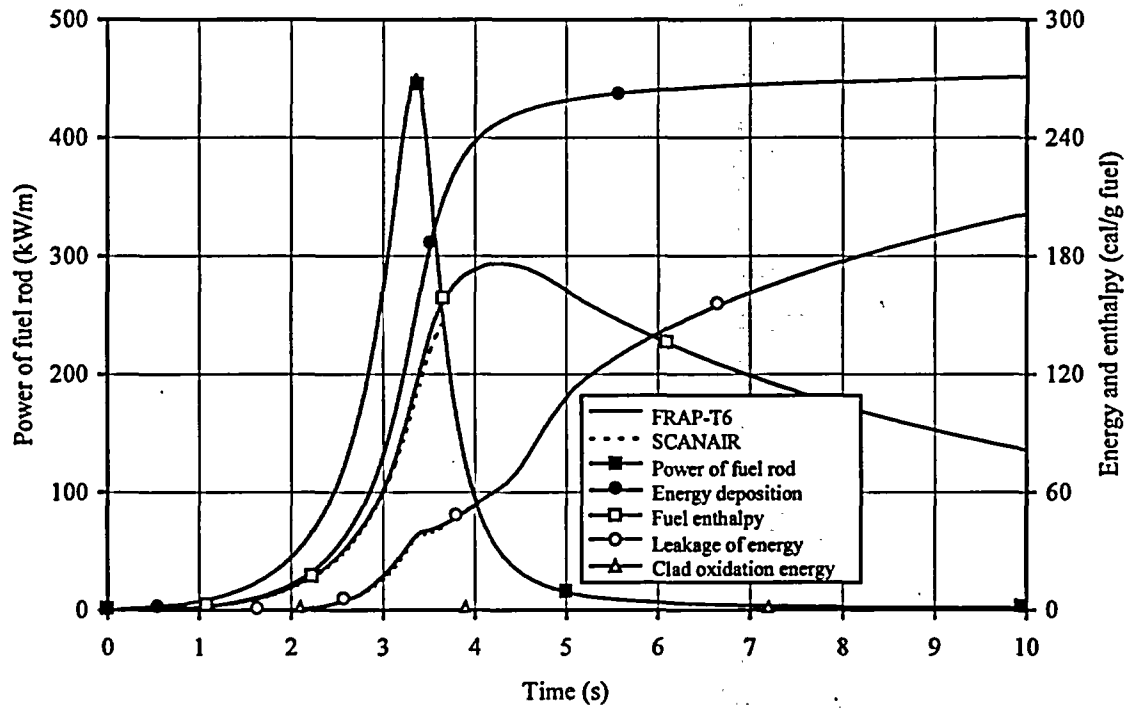

Fig. G-5.8. Energy and Temperature Characteristics Vs. Time Calculated by FRAP-T6 and SCANAIR Codes for Fuel Rod #H5T

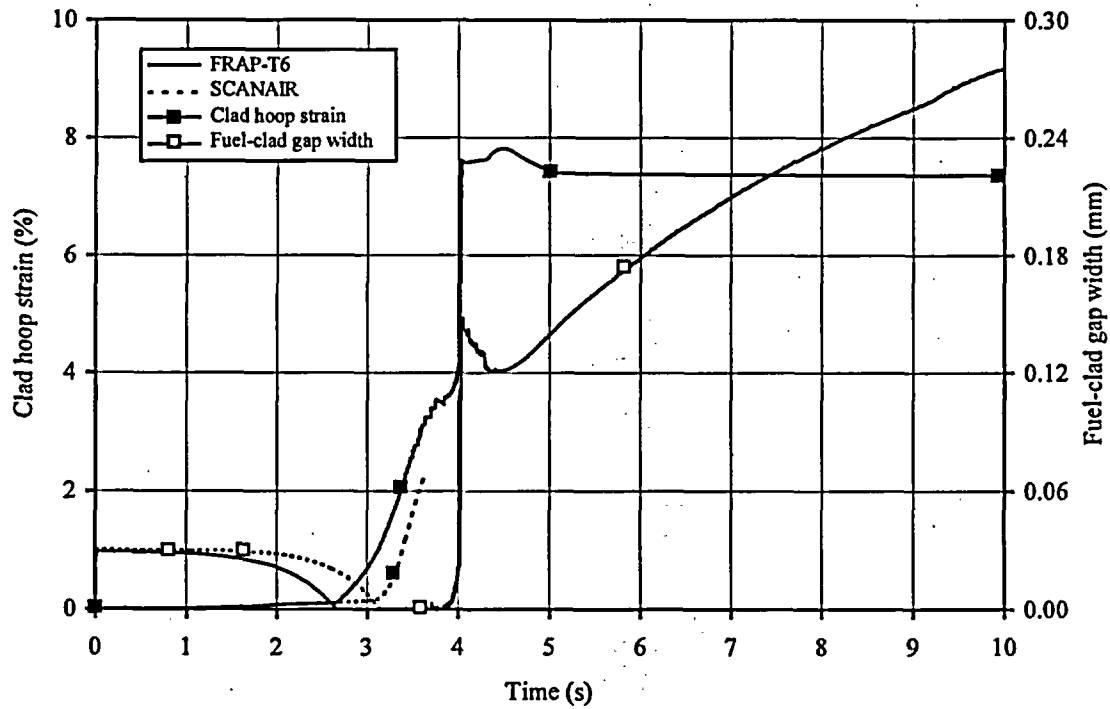
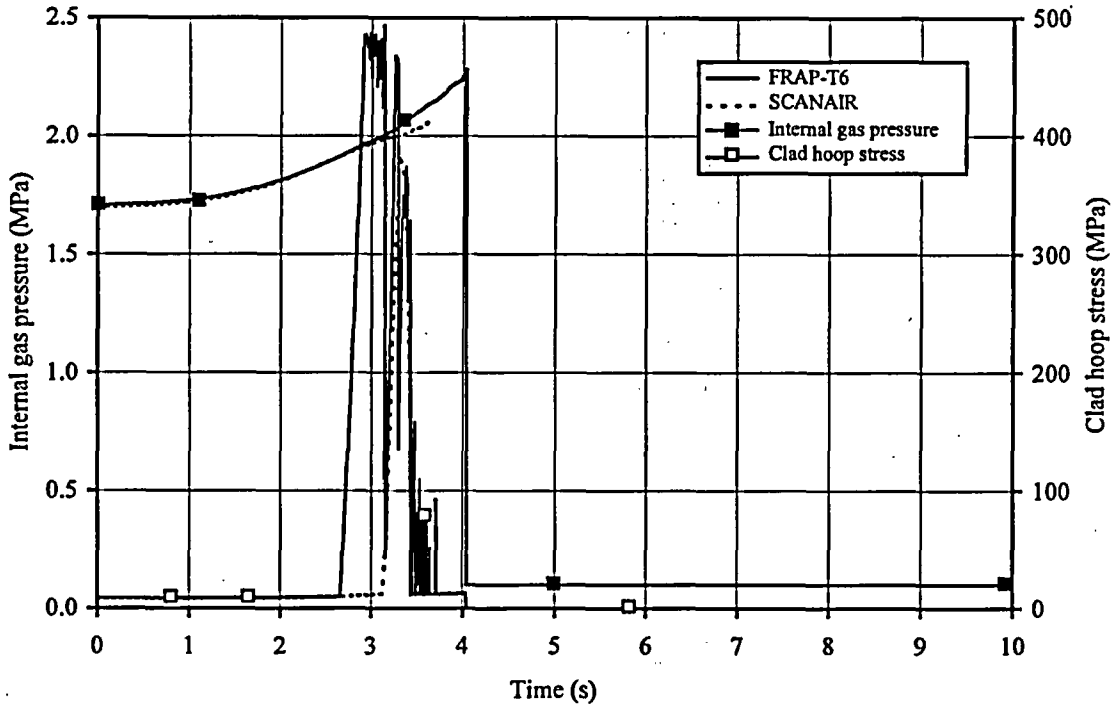

Fig. G-5.9. Cladding Mechanical Characteristics Vs. Time Calculated by FRAP-T6 and SCANAIR Codes for Fuel Rod #H5T

#H5T

Individual Characteristics of Refabricated Fuel Rods  
(Preirradiated Fuel, Preirradiated Cladding) under IGR Tests

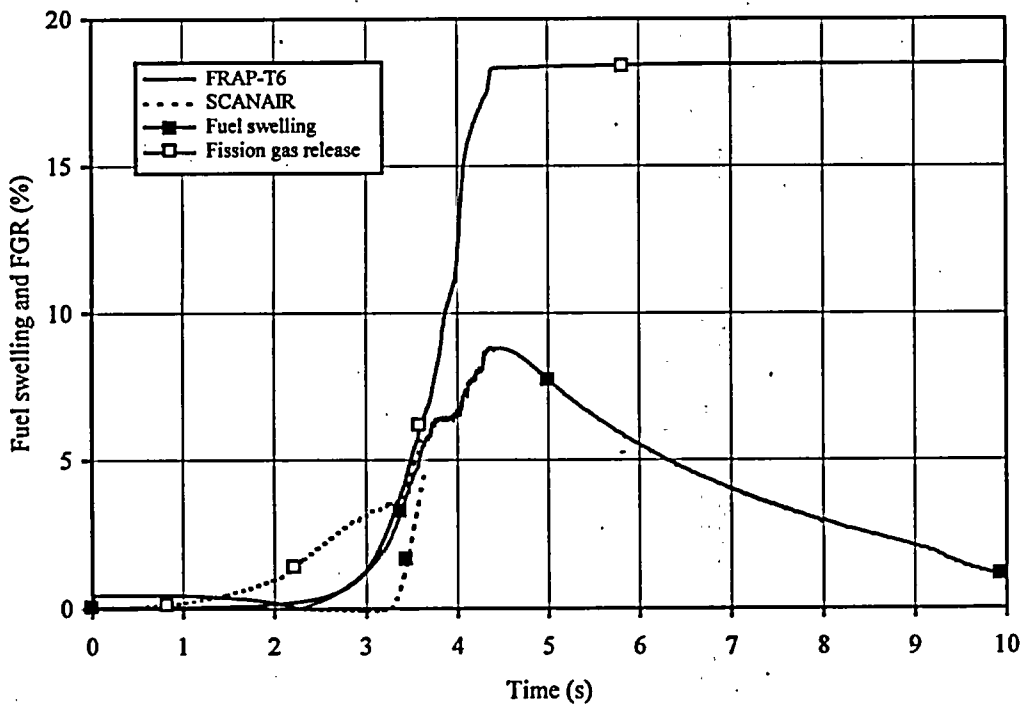
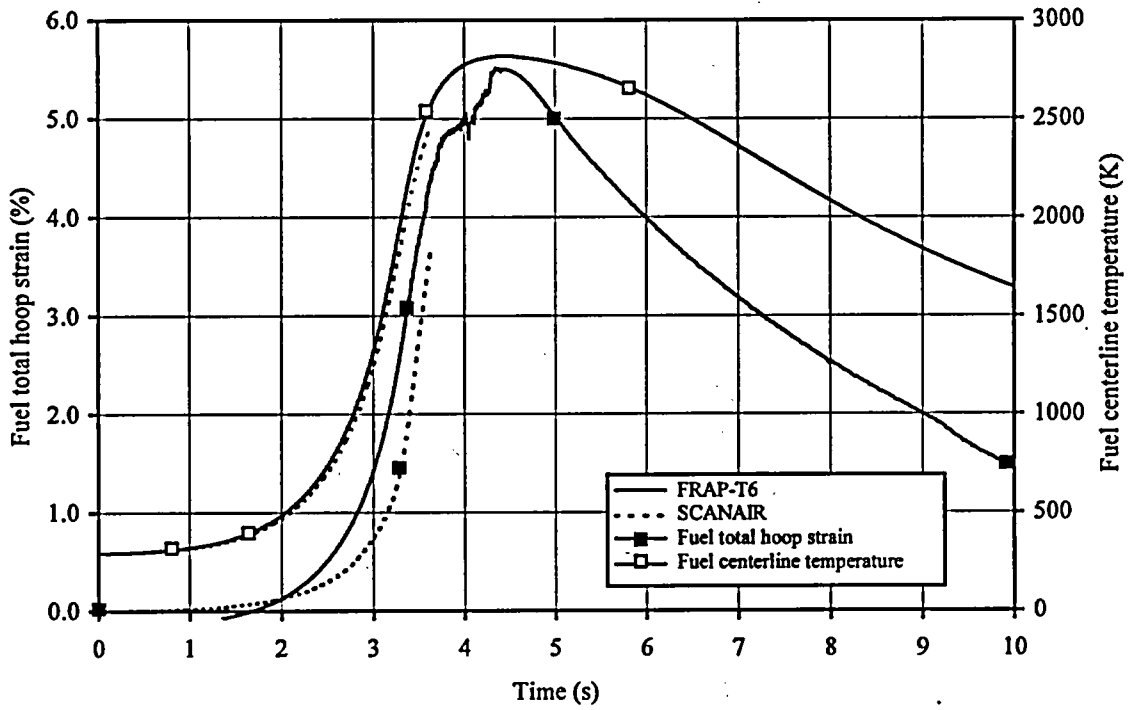

Fig. G-5.10. Fuel Strain and Fission Gas Release Vs. Time Calculated by FRAP-T6 and SCANAIR Codes for Fuel Rod #H5T

Table G-5.9. Some Results of PIE for Fuel Rod #H5T

Characteristic		Value	
1.	Measured parameters of cladding oxidation and cladding deformation		
1.1.	Cladding thickness at elevation 40, 85 mm correspondent to different azimuthal angles ( $\mu\text{m}$ ):		
	0°	680	677
	90°	525	677
	180°	485	663
	270°	R	663
1.2.	ZrO <sub>2</sub> thickness at elevation 40, 85 mm correspondent to different azimuthal angles ( $\mu\text{m}$ ):		
	0°	10	10
	90°	8	10
	180°	10	10
	270°	17	15
1.3.	$\alpha\text{Zr(O)}$ thickness at elevation 40, 85 mm correspondent to different azimuthal angles ( $\mu\text{m}$ ):		
	0°	8	8
	90°	8	10
	180°	10	10
	270°	10	10
1.4.	Clad hoop strain at elevation 40, 85 mm, respectively (%)	6.5	3.1
2.	Measured parameters for FGR analysis		
	Internal gas composition (% by volume):		
	He	-	
	N <sub>2</sub>	-	
	O <sub>2</sub>	-	
	Ar	-	
	CO <sub>2</sub>	-	
	Kr	-	
	Xe	-	
2.2.	Free gas volume (cm <sup>3</sup> )	-	
2.3.	Gas pressure inside fuel rod under normal condition (MPa)	-	
2.4.	Kr concentration in fuel (cm <sup>3</sup> /g fuel)	-	
3.	Measured parameters of cladding hydriding		
3.1.	Coefficient of hydride orientation (per-unit)	0.28	
3.2.	Hydrogen concentration (% by weight)	-	

## #H5T

Individual Characteristics of Refabricated Fuel Rods (Preirradiated Fuel, Preirradiated Cladding) under IGR Tests
--

Table G-5.10. General Characteristic of Fuel Rod #H5T

	Parameter	Unit	Value		
			Experiment	FRAP-T6	SCANAIR
1	Type of coolant	---	water	water	water
2	Burnup	MWd/kg U	49.0	49.0	49.0
3	Energy deposition in fuel rod	cal/g fuel	251	251	251
4	Peak fuel enthalpy	cal/g fuel	-	176	-
5	Peak fuel temperature	K	-	2817	-
6	Peak clad temperature	K	-	1224	-
7	Fuel rod failure	Yes, No	Yes	Yes	-
8	Type of failure:				
	- cladding rupture due to ballooning	Yes, No	Yes	Yes	-
	- cladding rupture due to PCMI	Yes, No	No	No	-
	- fragmentation of fuel rod	Yes, No	No	-	-
9	Failure time	s	-	4.03	-
10	Fuel enthalpy at failure	cal/g fuel	-	174	-
11	Outer cladding temperature at failure	K	-	1223	-
12	Internal gas pressure at failure	MPa	-	2.28	-
13	ZrO <sub>2</sub> thickness after test	μm	8-17	5.10	-
14	Residual clad hoop strain:				
	- peak value for ballooning area	%	6.5	7.28	-
	- other location <sup>1)</sup>	%	3.1	2.44	-
15	Kr concentration in internal gas composition after test	% by volume	-	2.44	-
16	Xe concentration in internal gas composition after test	% by volume	-	14.60	-
17	Kr concentration in fuel after test	cm <sup>3</sup> /g fuel	-	0.14	-

<sup>1)</sup>Calculated values by FRAP-T6 and SCANAIR codes are average along height of fuel rod excluding ballooning region



***APPENDIX G-6.***

***Individual Characteristics for Fuel Rod #H6T under IGR Test***

# #H6T

Individual Characteristics of Refabricated Fuel Rods  
(Preirradiated Fuel, Preirradiated Cladding) under IGR Tests

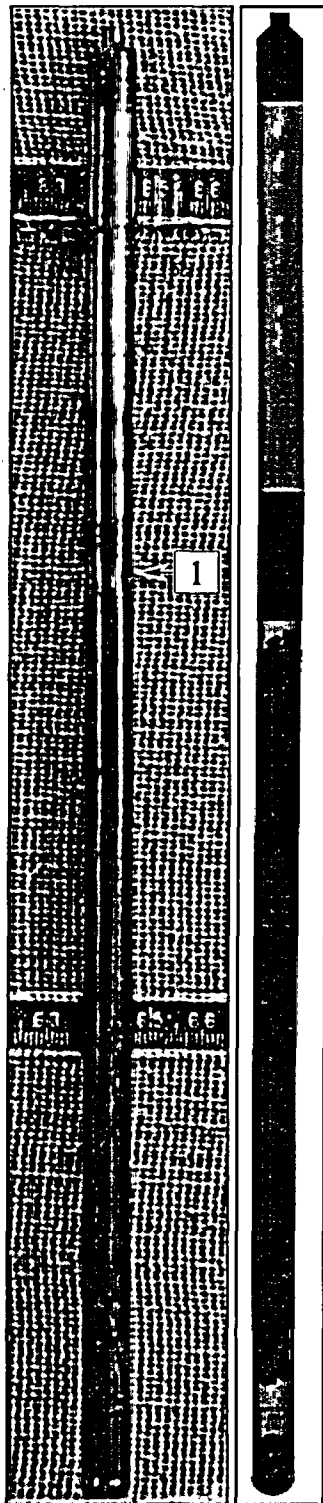

Position **1**

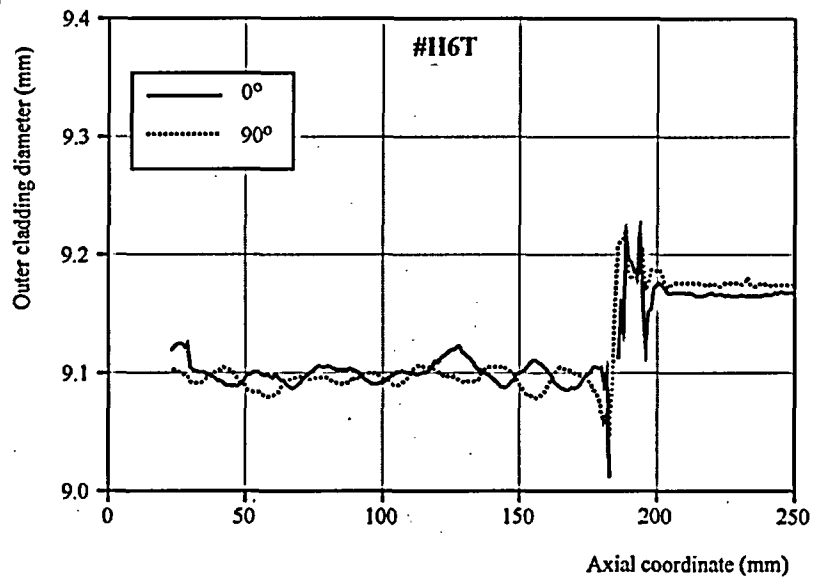
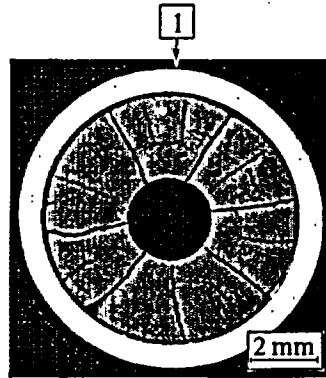

Fig. G-6.1. Appearance of Fuel Rod #H6T (photographs and X-ray photograph) and Profilometry

#H6T

Individual Characteristics of Refabricated Fuel Rods  
(Preirradiated Fuel, Preirradiated Cladding) under IGR Tests



Position 1

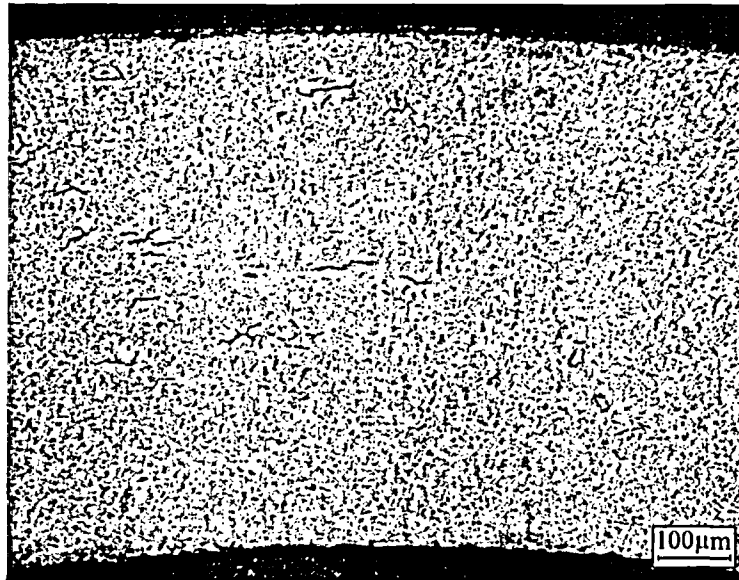

Fig. G-6.2. Cross-Section and Cladding Microstructure for Fuel Rod #H6T at 90 mm Elevation

#H6T

Individual Characteristics of Refabricated Fuel Rods  
(Preirradiated Fuel, Preirradiated Cladding) under IGR Tests

Position 1

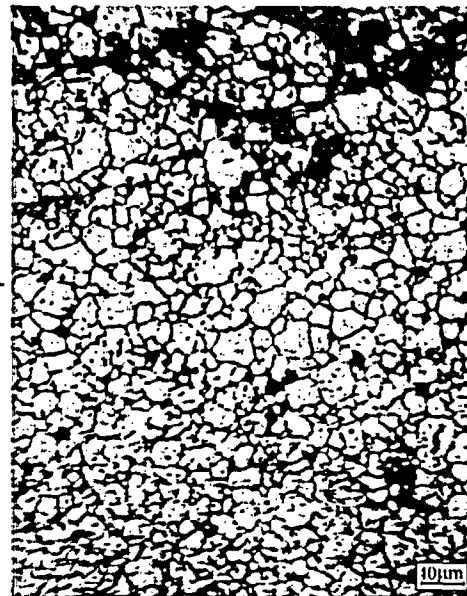
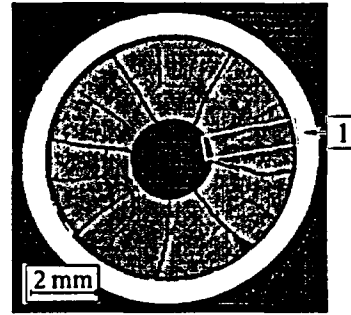

Fig. G-6.3. Fuel Microstructure for Fuel Rod #H6T at 90 mm Elevation

# #H6T

Individual Characteristics of Refabricated Fuel Rods  
(Preirradiated Fuel, Preirradiated Cladding) under IGR Tests

Table G-6.1. Time Dependent Energy Characteristics of Fuel Rod #H6T

Time (s)	Reactor energy deposition <sup>1)</sup> (%)	Cumulative number of fissions in fuel rod (fiss)						Power of fuel rod (kW)	Energy deposition in fuel rod	
		U <sup>235</sup> ×10 <sup>-14</sup>	U <sup>238</sup> ×10 <sup>-13</sup>	Pu <sup>239</sup> ×10 <sup>-14</sup>	Pu <sup>241</sup> ×10 <sup>-14</sup>	Other isotopes ×10 <sup>-11</sup>	Total ×10 <sup>-14</sup>		cal/g fuel	J/g fuel
0.0	0.000	0.000	0.000	0.000	0.000	0.000	0.000	0.000	0.000	0.000
1.0	0.697	0.022	0.005	0.032	0.013	0.025	0.067	0.384	0.951	3.980
2.0	2.790	0.087	0.021	0.127	0.051	0.099	0.268	0.769	3.810	15.90
2.2	3.380	0.106	0.025	0.154	0.062	0.120	0.324	0.862	4.620	19.30
2.4	4.040	0.126	0.030	0.184	0.075	0.143	0.388	0.976	5.520	23.10
2.6	4.800	0.150	0.036	0.218	0.089	0.170	0.461	1.140	6.570	27.50
2.8	5.710	0.179	0.043	0.260	0.106	0.202	0.548	1.390	7.810	32.70
3.0	6.860	0.215	0.052	0.312	0.127	0.243	0.659	1.820	9.380	39.30
3.2	8.440	0.264	0.064	0.384	0.156	0.300	0.811	2.640	11.60	48.60
3.4	10.90	0.340	0.082	0.495	0.201	0.386	1.050	4.260	14.90	62.40
3.6	15.00	0.470	0.113	0.684	0.278	0.533	1.440	7.480	20.50	85.80
3.8	22.40	0.700	0.169	1.020	0.414	0.794	2.150	13.20	30.60	128.0
4.0	34.60	1.080	0.261	1.570	0.640	1.230	3.320	20.40	47.30	198.0
4.2	51.10	1.600	0.385	2.330	0.945	1.810	4.910	24.10	69.90	293.0
4.4	67.20	2.100	0.506	3.060	1.240	2.380	6.450	18.80	91.80	384.0
4.6	77.90	2.440	0.587	3.540	1.440	2.760	7.480	11.10	106.0	444.0
4.8	84.00	2.630	0.633	3.820	1.550	2.980	8.070	6.180	115.0	481.0
5.0	87.40	2.730	0.658	3.970	1.610	3.100	8.390	3.610	120.0	502.0
5.2	89.40	2.800	0.674	4.070	1.650	3.170	8.590	2.300	122.0	511.0
5.4	90.80	2.840	0.684	4.130	1.680	3.220	8.720	1.620	124.0	519.0
5.6	91.70	2.870	0.691	4.170	1.700	3.250	8.810	1.230	126.0	527.0
5.8	92.50	2.890	0.697	4.210	1.710	3.280	8.880	0.994	127.0	532.0
6.0	93.10	2.910	0.701	4.240	1.720	3.300	8.940	0.843	128.0	536.0
6.5	94.30	2.950	0.711	4.290	1.740	3.350	9.060	0.600	130.0	544.0
7.0	95.10	2.980	0.717	4.330	1.760	3.370	9.140	0.405	131.0	548.0
7.5	95.70	2.990	0.721	4.350	1.770	3.390	9.190	0.290	132.0	553.0
8.0	96.10	3.000	0.724	4.370	1.780	3.410	9.230	0.221	132.0	553.0
9.0	96.70	3.020	0.728	4.400	1.790	3.430	9.280	0.176	133.0	557.0
10.0	97.10	3.040	0.732	4.420	1.790	3.440	9.330	0.127	134.0	561.0
20.0	98.60	3.090	0.743	4.490	1.820	3.500	9.470	0.028	137.0	573.0
30.0	99.10	3.100	0.747	4.510	1.830	3.520	9.520	0.014	138.0	578.0
∞	100.0	3.130	0.753	4.550	1.850	3.550	9.600	0.000	141.0	590.0

Maximum value of power is 24.1 kW (t = 4.20 s).

<sup>1)</sup> Current energy deposition per maximum energy deposition (at infinite time)

## #H6T

Individual Characteristics of Refabricated Fuel Rods  
(Preirradiated Fuel<sup>1)</sup> Preirradiated Cladding) under IGR Tests

Table G-6.2. Axial Energy Characteristics of Fuel Rod #H6T

Axial coordinate from lower end of fuel rod (mm)	Cumulative number of fissions at axial interval (fiss)						Maximum power of fuel rod (kW) $t=4.20s$	Energy deposition at infinite time*		
	$U^{235} \times 10^{-13}$	$U^{238} \times 10^{-11}$	$Pu^{239} \times 10^{-13}$	$Pu^{241} \times 10^{-13}$	Other isotopes $\times 10^{-10}$	Total $\times 10^{-13}$		cal/g fuel	J/g fuel	per-unit <sup>3)</sup>
10.0	0.000	0.000	0.000	0.000	0.000	0.000	0.000	0.000	0.000	0.00
15.0 <sup>1)</sup>	0.650	1.330	0.950	0.385	0.683	2.000	0.501	158.0	661.0	1.00
20.0	0.722	1.480	1.060	0.428	0.759	2.220	0.557	158.0	661.0	1.00
25.0	0.722	1.480	1.060	0.428	0.759	2.220	0.557	158.0	661.0	1.00
30.0	0.722	1.480	1.060	0.428	0.759	2.220	0.557	158.0	661.0	1.00
35.0	1.460	3.170	2.140	0.873	1.530	4.500	1.130	152.0	636.0	0.96
40.0	1.580	3.430	2.310	0.943	1.530	4.870	1.220	152.0	636.0	0.96
45.0	0.876	2.070	1.320	0.540	1.010	2.760	0.691	152.0	636.0	0.96
50.0	0.876	2.070	1.320	0.540	1.010	2.760	0.691	152.0	636.0	0.96
55.0	0.876	2.070	1.320	0.540	1.010	2.760	0.691	152.0	636.0	0.96
60.0	0.876	2.070	1.320	0.540	1.010	2.760	0.691	152.0	636.0	0.96
65.0	0.876	2.070	1.320	0.540	1.010	2.760	0.691	152.0	636.0	0.96
70.0	0.876	2.070	1.320	0.540	1.010	2.760	0.691	152.0	636.0	0.96
75.0	0.843	2.070	1.270	0.521	0.987	2.660	0.666	146.0	611.0	0.92
80.0	0.843	2.070	1.270	0.521	0.987	2.660	0.666	146.0	611.0	0.92
85.0	0.843	2.070	1.270	0.521	0.987	2.660	0.666	146.0	611.0	0.92
90.0	0.843	2.070	1.270	0.521	0.987	2.660	0.666	146.0	611.0	0.92
95.0	0.843	2.070	1.270	0.521	0.987	2.660	0.666	146.0	611.0	0.92
100.0	0.843	2.070	1.270	0.521	0.987	2.660	0.666	146.0	611.0	0.92
105.0	1.210	3.040	1.910	0.785	1.540	3.930	0.985	137.0	573.0	0.87
110.0	1.230	3.150	1.950	0.802	1.550	4.020	1.010	137.0	573.0	0.87
115.0	1.240	3.220	1.960	0.810	1.560	4.040	1.010	137.0	573.0	0.87
120.0	1.230	3.250	1.940	0.804	1.560	4.010	1.000	137.0	573.0	0.87
125.0	1.220	3.270	1.920	0.798	1.560	3.970	0.996	137.0	573.0	0.87
130.0	1.170	3.190	1.840	0.765	1.570	3.810	0.954	137.0	573.0	0.87
135.0	0.887	2.200	1.120	0.438	0.930	2.470	0.617	128.0	536.0	0.81
140.0	0.887	2.200	1.120	0.438	0.930	2.470	0.617	128.0	536.0	0.81
145.0	0.887	2.200	1.120	0.438	0.930	2.470	0.617	128.0	536.0	0.81
150.0	0.887	2.200	1.120	0.438	0.930	2.470	0.617	128.0	536.0	0.81
155.0	0.852	2.150	1.080	0.422	0.899	2.380	0.595	124.0	519.0	0.78
160.0	0.852	2.150	1.080	0.422	0.899	2.380	0.595	124.0	519.0	0.78
165.0	0.829	1.910	1.050	0.410	0.848	2.310	0.577	120.0	502.0	0.76
170.0	0.829	1.910	1.050	0.410	0.848	2.310	0.577	120.0	502.0	0.76
175.0	0.829	1.910	1.050	0.410	0.848	2.310	0.577	120.0	502.0	0.76
180.0 <sup>2)</sup>	0.083	0.191	0.105	0.041	0.085	0.231	0.058	120.0	502.0	0.76
185.0	0.000	0.000	0.000	0.000	0.000	0.000	0.000	0.000	0.000	0.00

\* All numerical values of characteristics are presented as average values at the length interval equal to the axial coordinate  $\pm 2.5$  mm

<sup>1)</sup> Initial coordinate of fuel is 13.0 mm

<sup>2)</sup> End coordinate of fuel is 178.0 mm

<sup>3)</sup> Current value per maximum value

## #H6T

Individual Characteristics of Refabricated Fuel Rods  
(Preirradiated Fuel, Preirradiated Cladding) under IGR Tests

Table G-6.3. Radial Energy Characteristics of Fuel Rod #H6T

Characteristics*		Coordinates of fuel zones (mm)			
		1 zone 1.2 - 2.811	2 zone 2.811-3.432	3 zone 3.432-3.704	4 zone 3.704-3.790
U <sup>235</sup>	Number of fissions $\times 10^{-14}$ (fiss)	0.526	0.308	0.151	0.049
	Power of fuel rod <sup>1)</sup> (kW)	1.290	0.758	0.371	0.121
	Energy deposition <sup>2)</sup> (cal/g fuel)	43.80	42.80	41.90	40.90
	Energy deposition <sup>2)</sup> (J/g fuel)	183.0	179.0	175.0	171.0
	Energy deposition <sup>3)</sup> (per-unit)	1.000	0.977	0.957	0.934
U <sup>238</sup>	Number of fissions $\times 10^{-12}$ (fiss)	1.350	0.762	0.351	0.106
	Power of fuel rod <sup>1)</sup> (kW)	0.033	0.019	0.009	0.003
	Energy deposition <sup>2)</sup> (cal/g fuel)	1.110	1.040	0.960	0.869
	Energy deposition <sup>2)</sup> (J/g fuel)	4.650	4.350	4.020	3.640
	Energy deposition <sup>3)</sup> (per-unit)	1.000	0.937	0.865	0.783
Pu <sup>239</sup>	Number of fissions $\times 10^{-14}$ (fiss)	0.663	0.451	0.309	0.175
	Power of fuel rod <sup>1)</sup> (kW)	1.680	1.140	0.784	0.443
	Energy deposition <sup>2)</sup> (cal/g fuel)	57.10	64.70	88.70	150.0
	Energy deposition <sup>2)</sup> (J/g fuel)	239.0	271.0	371.0	628.0
	Energy deposition <sup>3)</sup> (per-unit)	0.381	0.431	0.591	1.000
Pu <sup>241</sup>	Number of fissions $\times 10^{-13}$ (fiss)	2.610	1.850	1.330	0.791
	Power of fuel rod <sup>1)</sup> (kW)	0.652	0.462	0.331	0.197
	Energy deposition <sup>2)</sup> (cal/g fuel)	22.10	26.20	37.50	67.00
	Energy deposition <sup>2)</sup> (J/g fuel)	92.50	110.0	157.0	280.0
	Energy deposition <sup>3)</sup> (per-unit)	0.330	0.391	0.560	1.000
Other isotopes	Number of fissions $\times 10^{-11}$ (fiss)	0.578	0.356	0.208	0.099
	Power of fuel rod <sup>1)</sup> (kW)	0.001	0.001	0.001	0.000
	Energy deposition <sup>2)</sup> (cal/g fuel)	0.049	0.051	0.059	0.084
	Energy deposition <sup>2)</sup> (J/g fuel)	0.210	0.210	0.250	0.350
	Energy deposition <sup>3)</sup> (per-unit)	0.584	0.601	0.699	1.000
Total	Number of fissions $\times 10^{-14}$ (fiss)	1.460	0.950	0.596	0.304
	Power of fuel rod <sup>1)</sup> (kW)	3.670	2.380	1.500	0.764
	Energy deposition <sup>2)</sup> (cal/g fuel)	124.0	135.0	169.0	259.0
	Energy deposition <sup>2)</sup> (J/g fuel)	519.0	565.0	707.0	1084.
	Energy deposition <sup>3)</sup> (per-unit)	0.479	0.521	0.653	1.000

1) at time of 4.20 s, 2) at infinite time, 3) Current value per maximum value.

\* All numerical values of characteristics were calculated for undamaged part of fuel stack only (See Table C.2.2.)

# #H6T

Individual Characteristics of Refabricated Fuel Rods  
(Preirradiated Fuel, Preirradiated Cladding) under IGR Tests

Table G-6.4. Fuel Enthalpy Vs. Time Calculated by FRAP-T6 Code for Fuel Rod #H6T

Time (s)	Enthalpy at fuel radius (cal/g fuel)				Fuel enthalpy <sup>1)</sup>		Energy deposition in fuel rod	
	1.20 mm	2.82 mm	3.47 mm	3.79 mm	cal/g fuel	J/g fuel	cal/g fuel	J/g fuel
0.0	0.00	0.00	0.00	0.00	0.00	0.00	0.00	0.00
1.0	1.10	1.07	1.02	0.96	1.06	4.45	0.96	4.00
2.0	4.02	3.86	3.65	3.46	3.84	16.1	3.82	16.0
2.2	4.82	4.63	4.38	4.16	4.61	19.3	4.64	19.4
2.4	5.72	5.49	5.20	4.95	5.47	22.9	5.55	23.3
2.6	6.76	6.49	6.15	5.85	6.46	27.1	6.60	27.6
2.8	8.00	7.69	7.29	6.93	7.66	32.1	7.85	32.9
3.0	9.58	9.22	8.70	8.18	9.16	38.4	9.42	39.5
3.2	11.8	11.3	10.5	9.70	11.2	46.9	11.6	48.6
3.4	15.2	14.5	13.3	11.9	14.3	60.0	15.0	62.7
3.6	21.2	20.1	17.9	15.3	19.7	82.4	20.6	86.5
3.8	31.8	30.0	26.0	20.9	29.1	122	30.7	129
4.0	49.5	46.7	38.8	26.9	44.6	187	47.5	199
4.2	73.6	67.8	48.5	27.4	62.8	263	70.2	294
4.4	96.9	85.2	55.4	29.3	78.8	330	92.2	386
4.6	112	92.3	54.5	28.2	86.2	361	107	448
4.8	119	91.0	50.1	28.8	87.2	365	115	483
5.0	122	85.9	45.4	24.3	84.7	355	120	503
5.2	122	79.4	41.0	22.6	80.8	339	123	515
5.4	119	73.1	37.4	21.2	76.4	320	125	523
5.6	115	67.3	35.5	22.4	72.3	303	126	529
5.8	109	63.1	36.4	25.6	69.2	290	127	533
6.0	103	60.2	36.0	25.6	66.0	276	128	537
6.5	89.4	54.3	34.4	25.8	58.9	247	130	544
7.0	75.8	48.8	33.2	26.1	52.2	219	131	549
7.5	64.5	44.0	31.6	25.7	46.4	195	132	553
8.0	55.3	39.7	29.7	24.7	41.4	173	133	556
10.0	33.0	26.8	22.2	19.6	27.2	114	134	563
30.0	5.69	5.61	5.54	5.49	5.61	23.5	138	580

Radial enthalpy distribution and fuel enthalpy are presented at elevation 21.3 mm

Maximum value of fuel enthalpy is 87.3 cal/g fuel (t=4.72 s)

<sup>1)</sup> All numerical values are presented at elevation with peak power



# #H6T

Individual Characteristics of Refabricated Fuel Rods  
(Preirradiated Fuel, Preirradiated Cladding) under IGR Tests

Table G-6.5. Energy Characteristics Vs. Time Calculated by FRAP-T6 and SCANAIR Codes for Fuel Rod #H6T

Time (s)	Energy deposition <sup>1)</sup> (cal/g fuel)	Linear power <sup>1)</sup> (kW/m)	Fuel enthalpy <sup>1)</sup> (cal/g fuel)		Energy of metal-water reaction <sup>1)</sup> (cal/g fuel)	Leakage of energy <sup>1)</sup> (cal/g fuel)		Clad-to-coolant heat transfer coefficient <sup>1)</sup> (kW/m <sup>2</sup> K)	
			FRAP-T6	SCANAIR	FRAP-T6	FRAP-T6	SCANAIR	FRAP-T6	SCANAIR
0.0	0.00	0.00	0.00	0.00	0.00	0.00	0.00	0.00	0.00
1.0	1.07	4.01	1.06	0.95	0.00	0.00	0.00	0.03	0.10
2.0	4.28	8.02	3.84	3.69	0.00	0.01	0.04	0.03	0.10
2.2	5.18	8.99	4.61	4.36	0.00	0.02	0.05	0.03	0.10
2.4	6.21	10.2	5.47	5.24	0.00	0.02	0.06	0.03	0.10
2.6	7.38	11.9	6.46	6.25	0.00	0.03	0.08	0.03	0.10
2.8	8.78	14.5	7.66	7.29	0.00	0.04	0.11	0.19	0.10
3.0	10.5	19.0	9.16	8.82	0.00	0.22	0.24	1.09	1.08
3.2	13.0	27.6	11.2	10.9	0.00	0.67	0.72	1.84	2.03
3.4	16.7	44.5	14.3	13.7	0.00	1.40	1.40	2.88	3.04
3.6	23.1	78.1	19.7	19.1	0.00	2.62	2.68	4.74	5.03
3.8	34.4	138	29.1	29.0	0.00	4.85	4.98	8.02	8.85
4.0	53.1	213	44.6	43.8	0.00	8.77	8.92	14.2	15.0
4.2	78.5	251	62.8	63.4	0.00	17.2	16.5	22.5	23.6
4.4	103	196	78.8	76.3	0.00	27.8	26.0	24.7	29.1
4.6	120	116	86.2	82.5	0.00	38.8	38.2	23.9	27.8
4.8	129	64.4	87.2	82.2	0.00	48.8	47.6	20.6	25.3
5.0	134	37.6	84.7	78.7	0.00	57.5	57.4	19.6	22.5
5.2	137	24.0	80.8	74.3	0.00	65.4	65.3	17.5	20.3
5.4	140	16.9	76.4	69.3	0.00	72.4	72.9	16.1	18.4
5.6	141	12.8	72.3	64.6	0.00	78.4	79.6	13.0	16.2
5.8	142	10.4	69.2	60.9	0.00	82.8	84.5	10.4	14.7
6.0	143	8.79	66.0	56.9	0.00	86.8	89.8	10.4	13.4
6.5	145	6.54	58.9	48.4	0.00	95.2	101	8.88	11.2
7.0	147	4.38	52.2	41.5	0.00	103	109	7.52	9.56
7.5	148	3.12	46.4	35.1	0.00	109	117	6.54	8.10
8.0	148	2.36	41.4	29.8	0.00	114	123	5.73	6.86
10.0	150	1.35	27.2	16.4	0.00	130	139	3.56	3.48
30.0	155	0.15	5.61	5.28	0.00	156	155	0.12	0.10

<sup>1)</sup> All numerical values are presented at elevation with peak power

# #H6T

Individual Characteristics of Refabricated Fuel Rods  
(Preirradiated Fuel, Preirradiated Cladding) under IGR Tests

Table G-6.6. Temperature Variation, Fission Gas Release and ZrO<sub>2</sub> Thickness Vs. Time for Fuel Rod #H6T Calculated by FRAP-T6 and SCANAIR Codes

Time (s)	Fuel centerline temperature <sup>1)</sup> (K)		Fuel surface temperature <sup>1)</sup> (K)		Clad outer temperature <sup>1)</sup> (K)		Fission gas release (%)		Average ZrO <sub>2</sub> <sup>2)</sup> thickness (μm)
	FRAP-T6	SCANAIR	FRAP-T6	SCANAIR	FRAP-T6	SCANAIR	FRAP-T6	SCANAIR	
0.0	293	293	293	293	293	293	0.00	0.00	5
1.0	312	309	310	307	302	300	0.00	0.12	5
2.0	361	354	352	347	333	329	0.02	0.43	5
2.2	375	365	364	357	342	337	0.02	0.49	5
2.4	389	379	377	370	353	347	0.03	0.57	5
2.6	405	395	391	384	365	358	0.03	0.65	5
2.8	425	412	408	399	378	370	0.04	0.73	5
3.0	449	435	427	420	386	380	0.05	0.84	5
3.2	482	469	451	445	390	382	0.06	0.97	5
3.4	533	513	484	476	394	384	0.08	1.23	5
3.6	619	596	535	535	400	388	0.11	1.66	5
3.8	767	745	615	629	408	394	0.18	2.23	5
4.0	1008	965	700	735	418	401	0.35	2.68	5
4.2	1323	1273	706	803	430	409	0.74	3.16	5
4.4	1617	1518	733	783	432	414	1.24	3.33	5
4.6	1800	1700	718	754	431	413	1.57	3.45	5
4.8	1888	1778	726	720	427	411	2.03	3.43	5
5.0	1919	1812	663	683	426	408	3.40	3.48	5
5.2	1913	1806	640	655	423	406	5.12	3.52	5
5.4	1882	1772	619	630	421	404	5.22	3.56	5
5.6	1832	1718	637	622	417	402	5.25	3.60	5
5.8	1768	1659	682	618	412	401	5.27	3.75	5
6.0	1694	1582	681	614	412	399	5.28	3.71	5
6.5	1524	1383	684	601	409	397	5.29	3.62	5
7.0	1351	1207	689	586	406	395	5.30	3.54	5
7.5	1205	1044	683	567	404	393	5.30	3.44	5
8.0	1085	910	669	547	402	391	5.31	3.33	5
10.0	784	602	597	475	396	385	5.33	2.93	5
30.0	388	377	385	375	377	373	5.40	2.27	5

<sup>1)</sup> All numerical values are presented at elevation with peak power

<sup>2)</sup> Initial ZrO<sub>2</sub> thickness is 5 μm

# #H6T

Individual Characteristics of Refabricated Fuel Rods  
(Preirradiated Fuel, Preirradiated Cladding) under IGR Tests

Table G-6.7. Mechanical Characteristics of Fuel Rod #H6T Vs. Time Calculated by FRAP-T6 and SCANAIR Codes

Time (s)	Clad outer temperature <sup>1)</sup> (K)		Fuel hoop strain <sup>1)</sup> (%)		Fuel - clad gap width <sup>1)</sup> (mm)		Clad hoop strain <sup>1)</sup> (%)		Clad hoop stress <sup>1)</sup> (MPa)		Internal gas pressure (MPa)	
	FRAP-T6	SCANAIR	FRAP-T6	SCANAIR	FRAP-T6	SCANAIR	FRAP-T6	SCANAIR	FRAP-T6	SCANAIR	FRAP-T6	SCANAIR
0.0	293	293	0.00	0.00	0.03	0.03	0.01	0.01	8.50	8.03	1.70	1.70
1.0	302	300	0.05	0.01	0.03	0.03	0.01	0.01	8.56	8.11	1.71	1.71
2.0	333	329	0.11	0.04	0.03	0.03	0.03	0.03	8.72	8.30	1.74	1.75
2.2	342	337	0.13	0.05	0.03	0.03	0.04	0.04	8.75	8.34	1.75	1.75
2.4	353	347	0.14	0.06	0.03	0.03	0.05	0.05	8.79	8.39	1.76	1.76
2.6	365	358	0.17	0.07	0.03	0.03	0.06	0.06	8.83	8.44	1.76	1.77
2.8	378	370	0.19	0.08	0.03	0.03	0.07	0.07	8.88	8.49	1.77	1.78
3.0	386	380	0.22	0.10	0.03	0.03	0.07	0.08	8.93	8.60	1.78	1.79
3.2	390	382	0.27	0.12	0.02	0.03	0.08	0.08	9.00	8.75	1.79	1.81
3.4	394	384	0.34	0.15	0.02	0.03	0.08	0.08	9.09	8.93	1.81	1.83
3.6	400	388	0.45	0.21	0.02	0.03	0.09	0.09	9.21	9.26	1.83	1.86
3.8	408	394	0.66	0.33	0.01	0.02	0.10	0.10	9.38	9.82	1.87	1.89
4.0	418	401	1.02	0.52	0.00	0.02	0.18	0.12	81.7	10.6	1.90	1.93
4.2	430	409	1.51	0.78	0.00	0.01	0.58	0.15	408	11.6	1.94	1.96
4.4	432	414	1.97	0.96	0.00	0.00	0.94	0.17	405	13.6	1.96	1.98
4.6	431	413	2.24	1.08	0.00	0.00	1.15	0.27	395	133	1.97	1.99
4.8	427	411	2.46	1.10	0.00	0.00	1.31	0.29	132	156	1.98	1.99
5.0	426	408	2.71	1.06	0.00	0.00	1.52	0.25	355	118	2.00	1.99
5.2	423	406	2.84	1.00	0.00	0.00	1.63	0.20	447	59.7	2.03	1.99
5.4	421	404	2.67	0.92	0.00	0.00	1.49	0.14	273	11.2	2.03	1.99
5.6	417	402	2.48	0.85	0.00	0.00	1.32	0.13	97.8	10.9	2.03	1.99
5.8	412	401	2.29	0.79	0.00	0.00	1.23	0.12	10.6	10.8	2.02	1.99
6.0	412	399	2.12	0.73	0.01	0.01	1.23	0.12	10.6	10.7	2.02	1.99
6.5	409	397	1.78	0.61	0.02	0.01	1.23	0.11	10.5	10.4	2.00	1.97
7.0	406	395	1.49	0.52	0.03	0.01	1.22	0.11	10.4	10.2	1.98	1.96
7.5	404	393	1.26	0.45	0.04	0.02	1.22	0.10	10.3	9.97	1.96	1.95
8.0	402	391	1.08	0.38	0.05	0.02	1.22	0.10	10.2	9.79	1.95	1.93
10.0	396	385	0.67	0.23	0.06	0.02	1.21	0.08	9.94	9.23	1.90	1.88
30.0	377	373	0.16	0.10	0.08	0.03	1.19	0.07	9.34	8.53	1.79	1.80

<sup>1)</sup> All numerical values are presented at elevation with peak power

**Table G-6.8. Axial Distribution of Energy Deposition and Fuel Enthalpy Calculated by FRAP-T6 Code for Fuel Rod #H6T**

Axial interval from-to (mm)-(mm)	Energy deposition at infinite time			Fuel enthalpy at time (t=4.72 s)		
	cal/g fuel	J/g fuel	per-unit	cal/g fuel	J/g fuel	per-unit
13.0 - 29.5	158	662	1.00	87.3	366	1.00
29.5 - 46.0	153	641	0.97	84.5	354	0.97
46.0 - 62.5	152	637	0.96	83.9	352	0.96
62.5 - 79.0	150	627	0.95	82.6	346	0.95
79.0 - 95.5	146	612	0.92	80.6	338	0.92
95.5 - 112.0	141	590	0.89	77.8	326	0.89
112.0 - 128.5	137	574	0.87	75.7	317	0.87
128.5 - 145.0	130	545	0.82	71.9	301	0.82
145.0 - 161.5	126	527	0.80	69.5	291	0.80
161.5 - 178.0	120	504	0.76	66.4	278	0.76

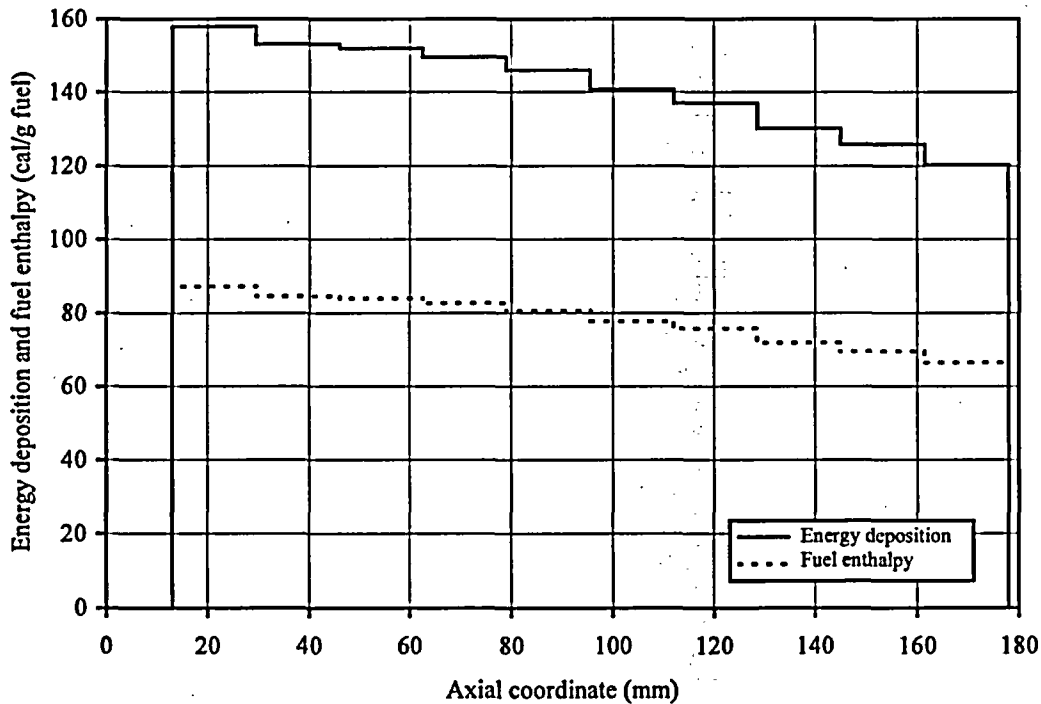

**Fig. G-6.4. Axial Distribution of Energy Deposition and Fuel Enthalpy Calculated by FRAP-T6 Code for Fuel Rod #H6T**

#H6T

Individual Characteristics of Refabricated Fuel Rods  
(Preirradiated Fuel, Preirradiated Cladding) under IGR Tests

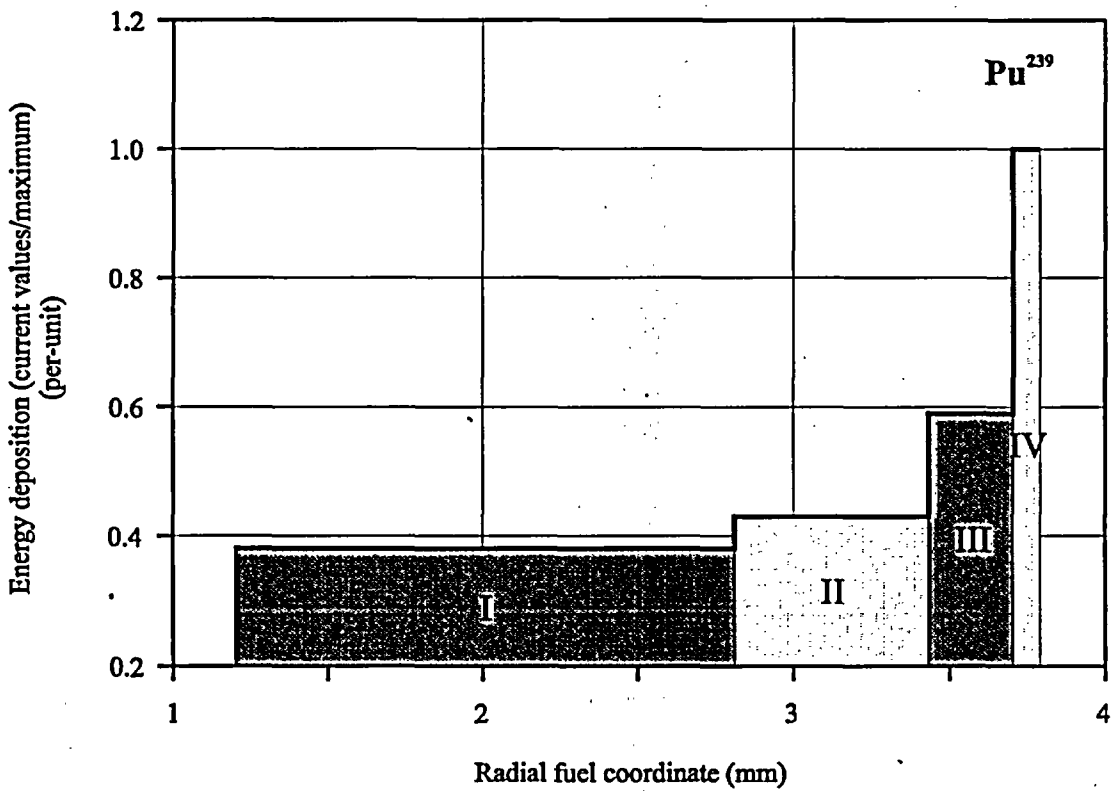
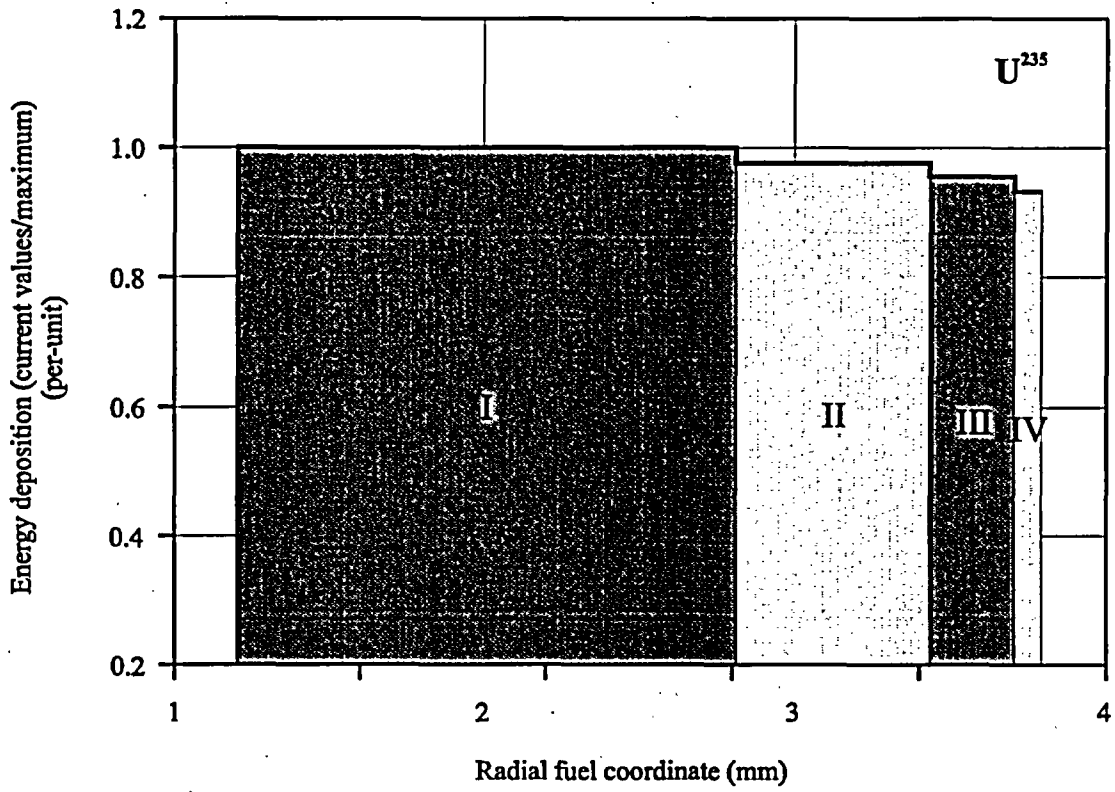

Fig. G-6.5.  $U^{235}$  and  $Pu^{239}$  Radial Distributions of Energy Deposition for Fuel Rod #H6T

# #H6T

Individual Characteristics of Refabricated Fuel Rods  
(Preirradiated Fuel, Preirradiated Cladding) under IGR Tests

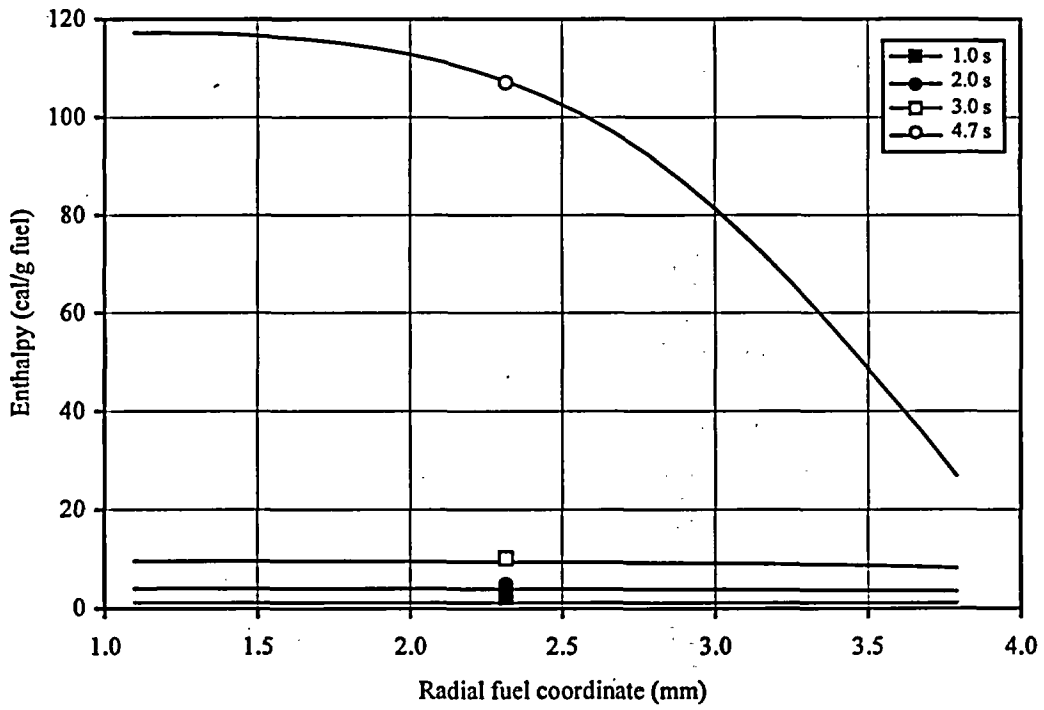
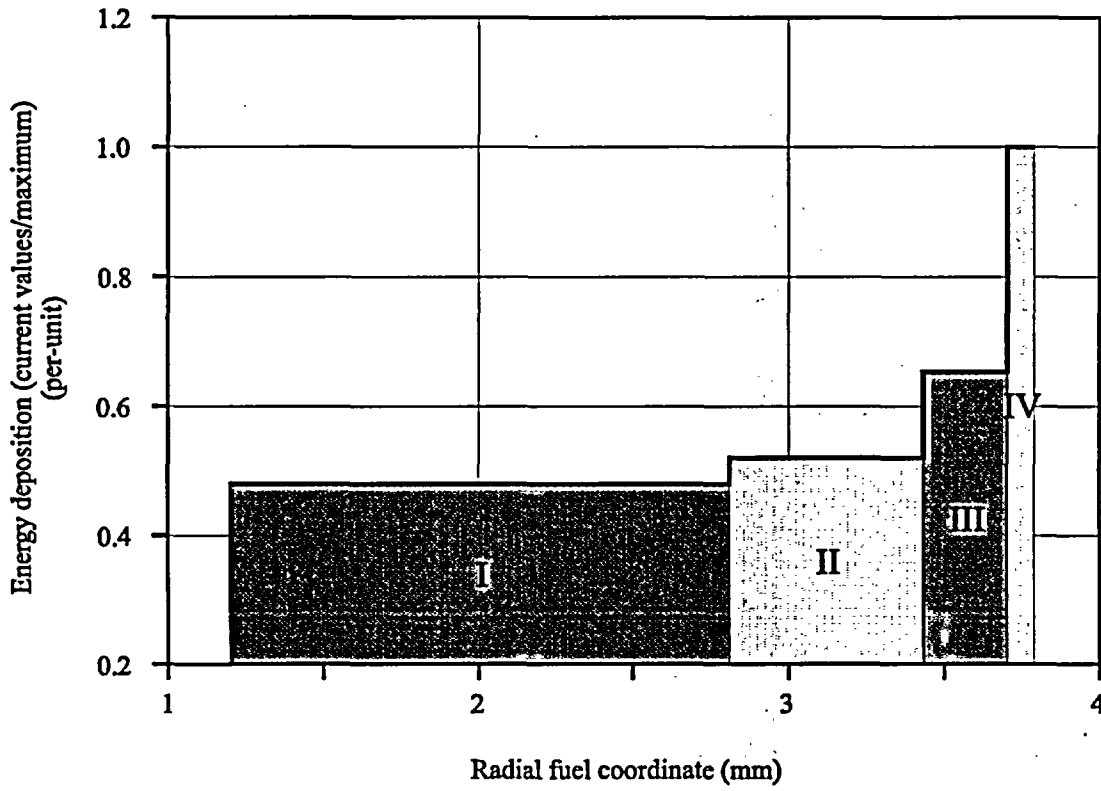

Fig. G-6.6. Radial Distributions of Energy Deposition and Fuel Enthalpy Calculated by FRAP-T6 Code for Fuel Rod #H6T

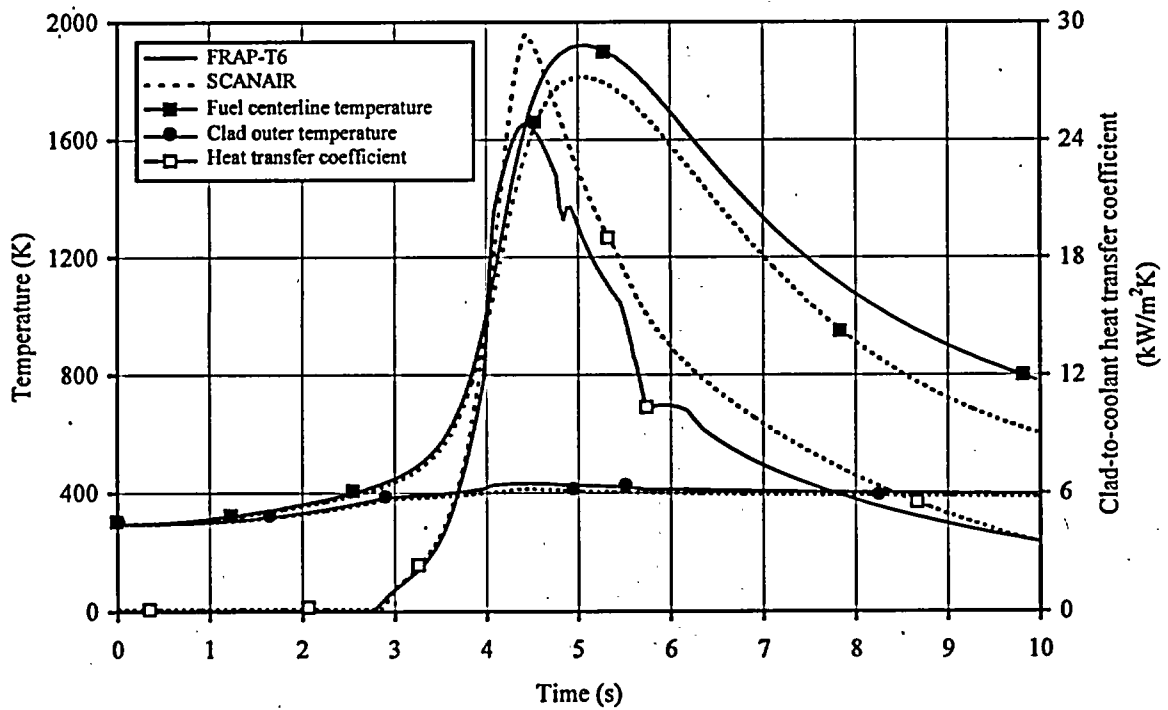
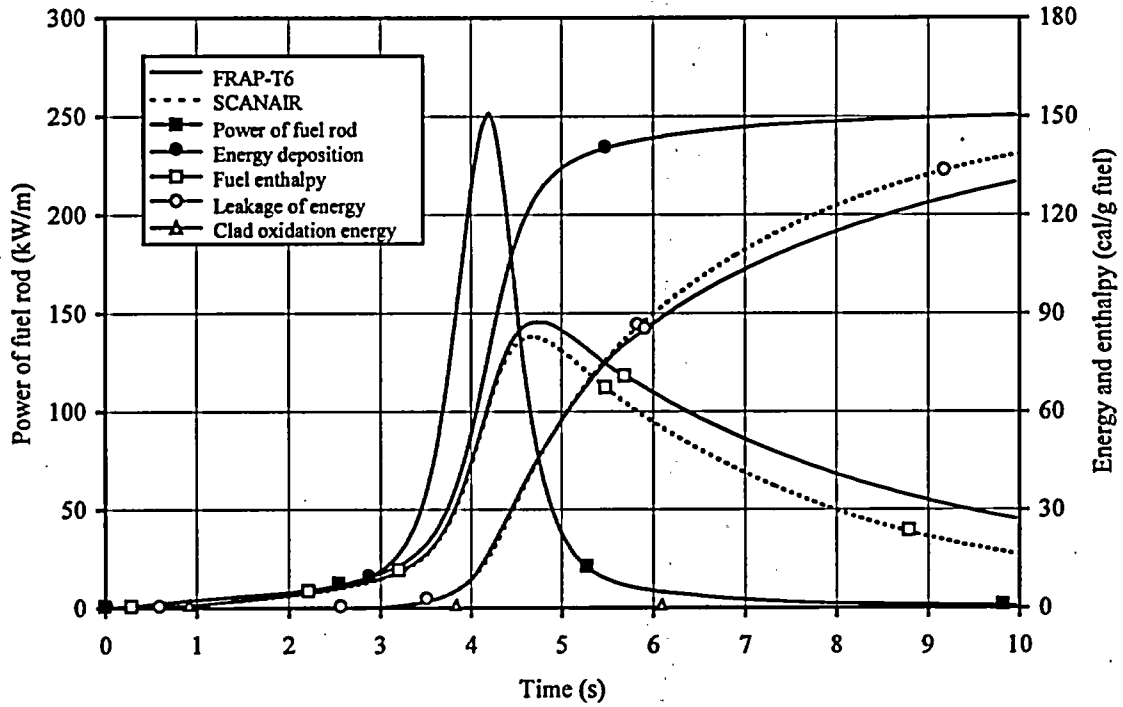

Fig. G-6.7. Energy and Temperature Characteristics Vs. Time Calculated by FRAP-T6 and SCANAIR Codes for Fuel Rod #H6T

# #H6T

## Individual Characteristics of Refabricated Fuel Rods (Preirradiated Fuel, Preirradiated Cladding) under IGR Tests

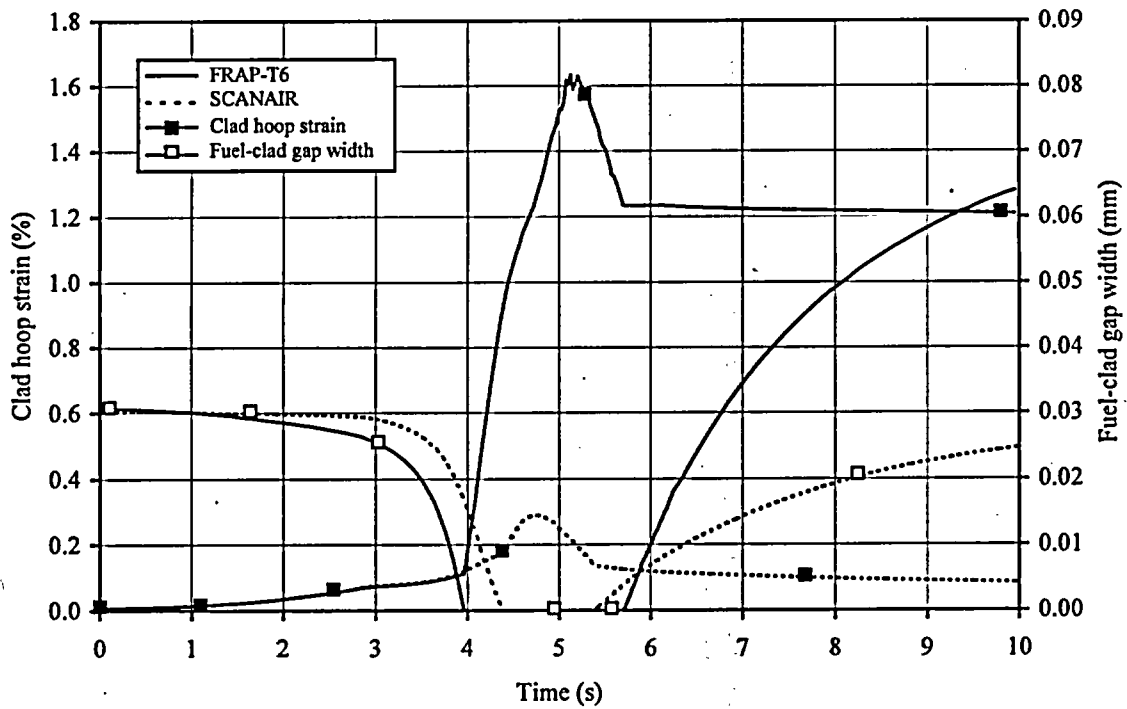
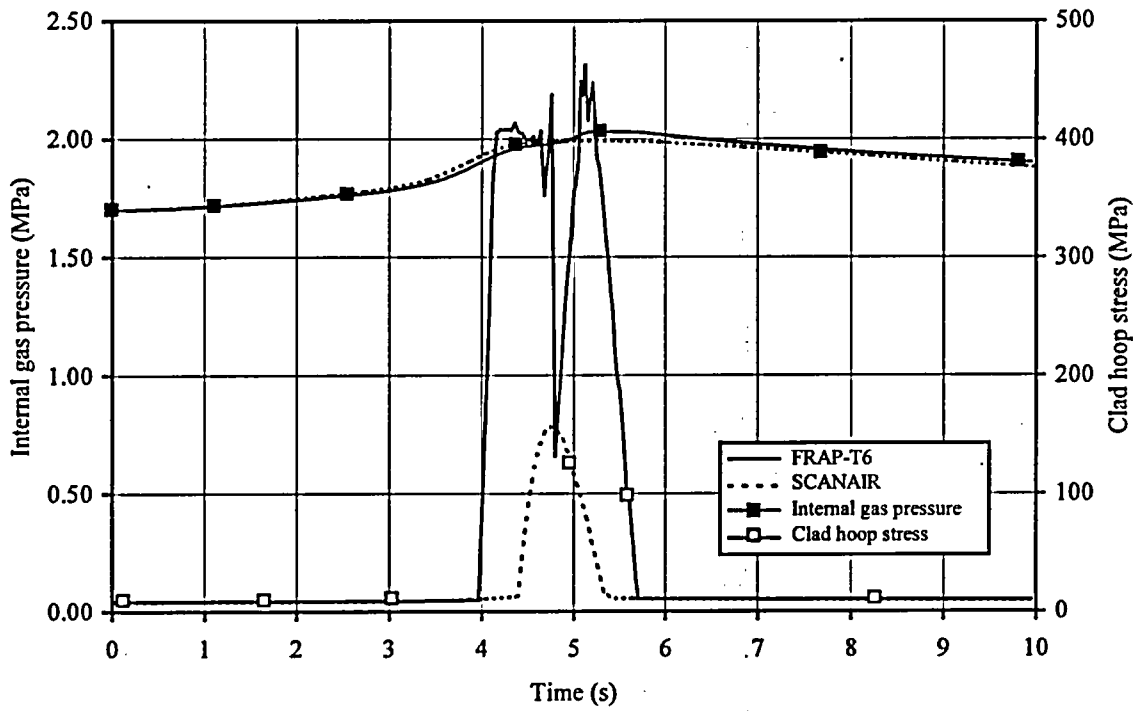

Fig. G-6.8. Cladding Mechanical Characteristics Vs. Time Calculated by FRAP-T6 and SCANAIR Codes for Fuel Rod #H6T



# #H6T

Individual Characteristics of Refabricated Fuel Rods  
(Preirradiated Fuel, Preirradiated Cladding) under IGR Tests

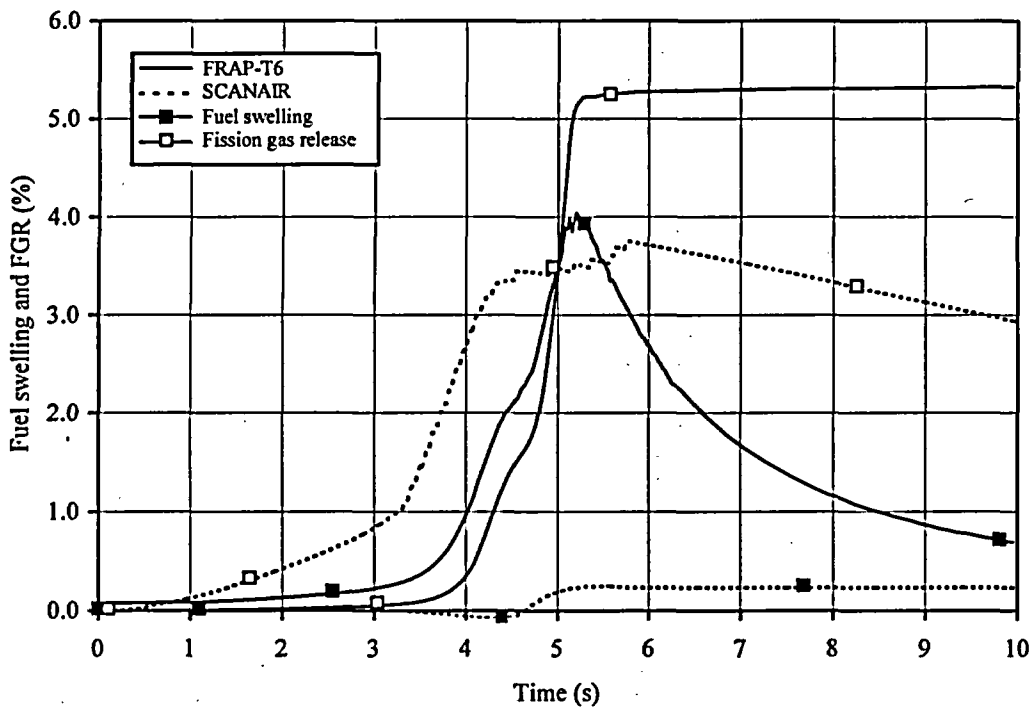
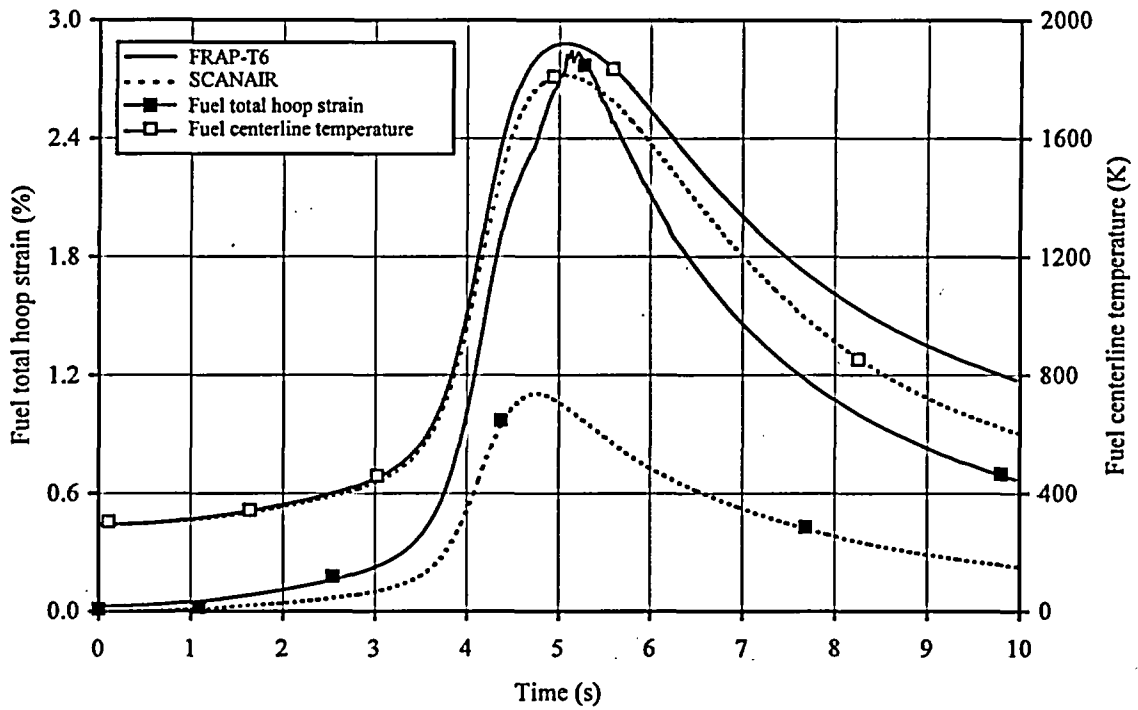

Fig. G-6.9. Fuel Strain and Fission Gas Release Vs. Time Calculated by FRAP-T6 and SCANAIR Codes for Fuel Rod #H6T

# #H6T

Individual Characteristics of Refabricated Fuel Rods  
(Preirradiated Fuel, Preirradiated Cladding) under IGR Tests

Table G-6.9. Some Results of PIE for Fuel Rod #H6T

Characteristic		Value
1.	Measured parameters of cladding oxidation and cladding deformation	
1.1.	Cladding thickness at elevation 90 mm for different azimuthal angles ( $\mu\text{m}$ ):	
	0°	705
	90°	677
	180°	677
	270°	700
1.2.	ZrO <sub>2</sub> thickness at elevation 90 mm for different azimuthal angles ( $\mu\text{m}$ ):	
	0°	5
	90°	5
	180°	5
	270°	5
1.3.	$\alpha\text{Zr(O)}$ thickness at elevation 90 mm for different azimuthal angles ( $\mu\text{m}$ ):	
	0°	0
	90°	0
	180°	0
	270°	0
1.4.	Clad hoop strain at elevation 90 mm (%)	0
2.	Measured parameters for FGR analysis	
2.1.	Internal gas composition (% by volume):	
	He	93.85
	N <sub>2</sub>	0.13
	O <sub>2</sub>	0.02
	Ar	0.004
	CO <sub>2</sub>	0.01
	Kr	0.59
	Xe	5.4
2.2.	Free gas volume (cm <sup>3</sup> )	6.88
2.3.	Gas pressure inside fuel rod under normal condition (MPa)	1.79
2.4.	Kr concentration in fuel (cm <sup>3</sup> /g fuel)	0.14
3.	Measured parameters of cladding hydriding	
3.1.	Coefficient of hydride orientation (per-unit)	0.25
3.2.	Hydrogen concentration (% by weight)	3.4 10 <sup>-3</sup>

# #H6T

Individual Characteristics of Refabricated Fuel Rods  
(Preirradiated Fuel, Preirradiated Cladding) under IGR Tests

Table G-6.10. General Characteristic of Fuel Rod #H6T

	Parameter	Unit	Value		
			Experiment	FRAP-T6	SCANAIR
1	Type of coolant	---	water	water	water
2	Burnup	MWd/kg U	49.3	49.3	49.3
3	Energy deposition in fuel rod	cal/g fuel	141	141	141
4	Peak fuel enthalpy	cal/g fuel	-	87	83
5	Peak fuel temperature	K	-	1920	1813
6	Peak clad temperature	K	-	432	414
7	Fuel rod failure	Yes, No	No	No	-
8	Type of failure:				
	- cladding rupture due to ballooning	Yes, No	No	No	-
	- cladding rupture due to PCMI	Yes, No	No	No	-
	- fragmentation of fuel rod	Yes, No	No	-	-
9	Failure time	s	-	-	-
10	Fuel enthalpy at failure	cal/g fuel	-	-	-
11	Outer cladding temperature at failure	K	-	-	-
12	Internal gas pressure at failure	MPa	-	-	-
13	ZrO <sub>2</sub> thickness after test <sup>1)</sup>	μm	5	5.00	-
14	Residual clad hoop strain:				
	- peak value for ballooning area	%	-	-	-
	- other location <sup>1)</sup>	%	0	0.77	0
15	Kr concentration in internal gas composition after test	% by volume	0.59	0.65	0.31
16	Xe concentration in internal gas composition after test	% by volume	5.40	3.92	1.86
17	Kr concentration in fuel after test	cm <sup>3</sup> /g fuel	0.14	0.15	0.20

<sup>1)</sup>Calculated values by FRAP-T6 and SCANAIR codes are average along height of fuel rod excluding ballooning region



**APPENDIX G-7.**

*Individual Characteristics for Fuel Rod #H7T under IGR Test*

#H7T

Individual Characteristics of Refabricated Fuel Rods  
(Preirradiated Fuel, Preirradiated Cladding) under IGR Tests

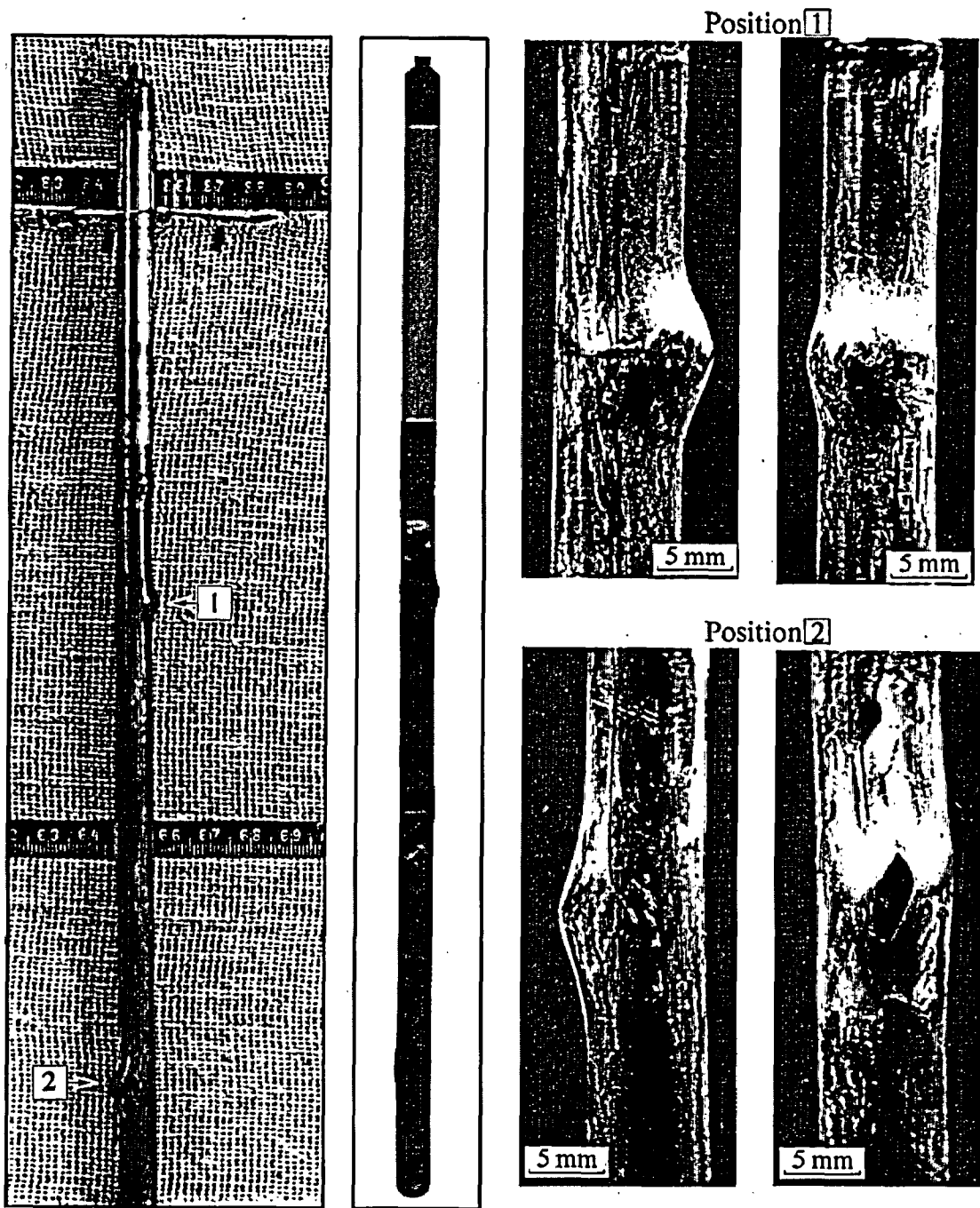

Fig. G-7.1. Appearance of Fuel Rod #H7T (photographs and X-ray photograph)

#H7T

Individual Characteristics of Refabricated Fuel Rods  
(Preirradiated Fuel, Preirradiated Cladding) under IGR Tests

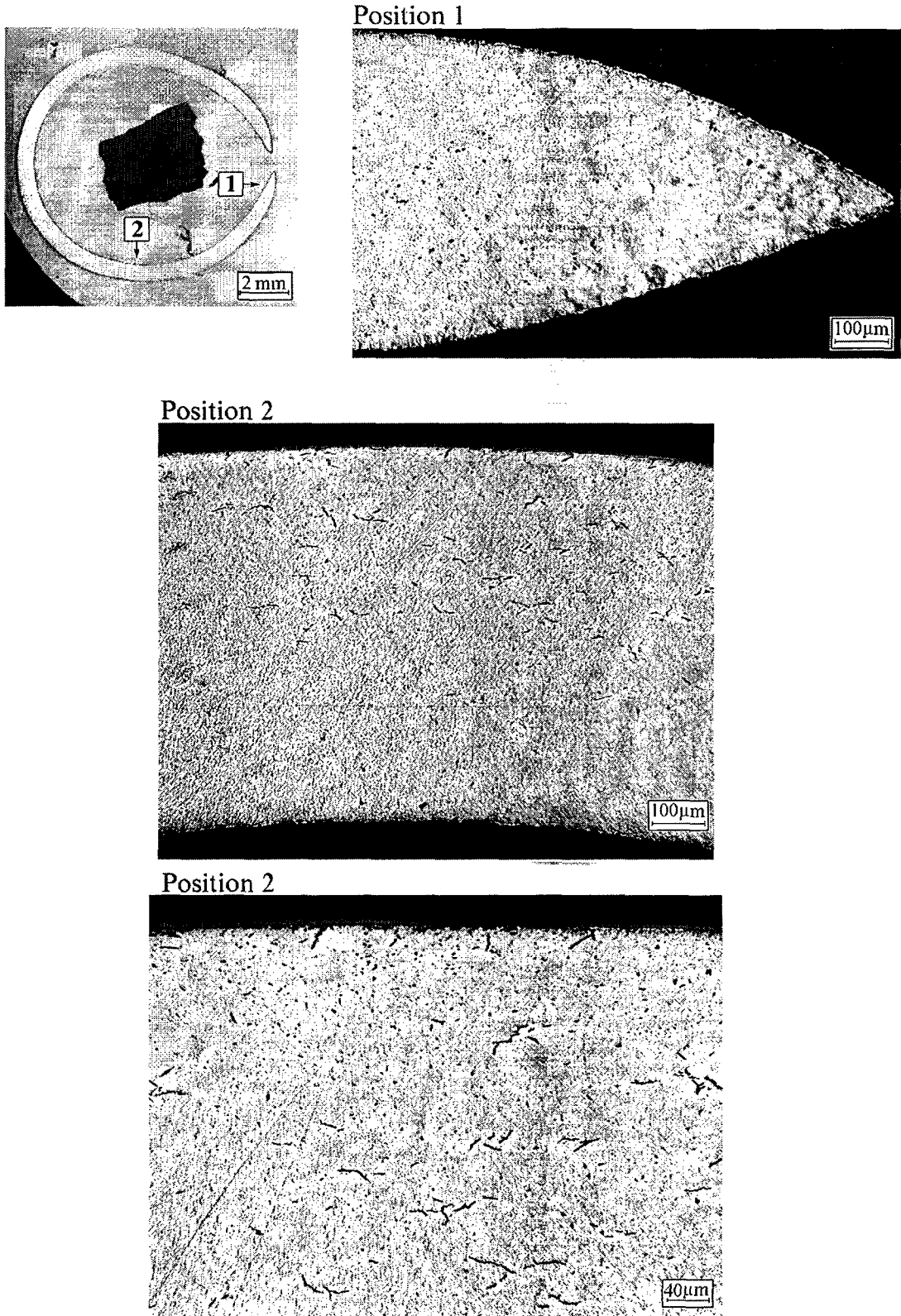
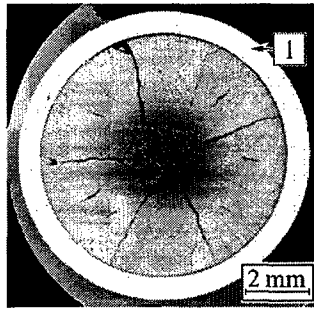

Fig. G-7.2. Cross-Section and Cladding Microstructure for Fuel Rod #H7T at 33 mm Elevation

#H7T

Individual Characteristics of Refabricated Fuel Rods  
(Preirradiated Fuel, Preirradiated Cladding) under IGR Tests



Position 1

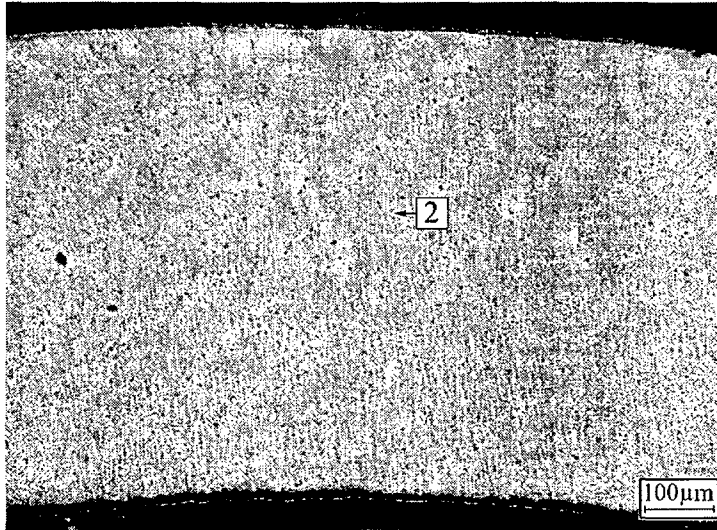

Position 2

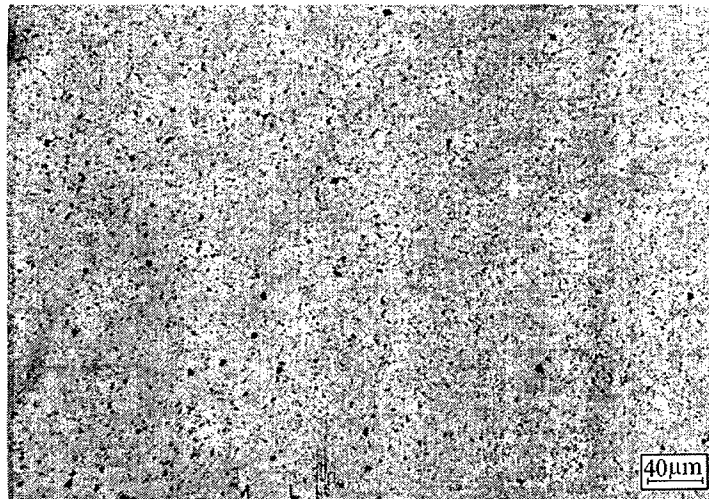

Fig. G-7.3. Cross-Section and Cladding Microstructure for Fuel Rod #H7T at 103 mm Elevation



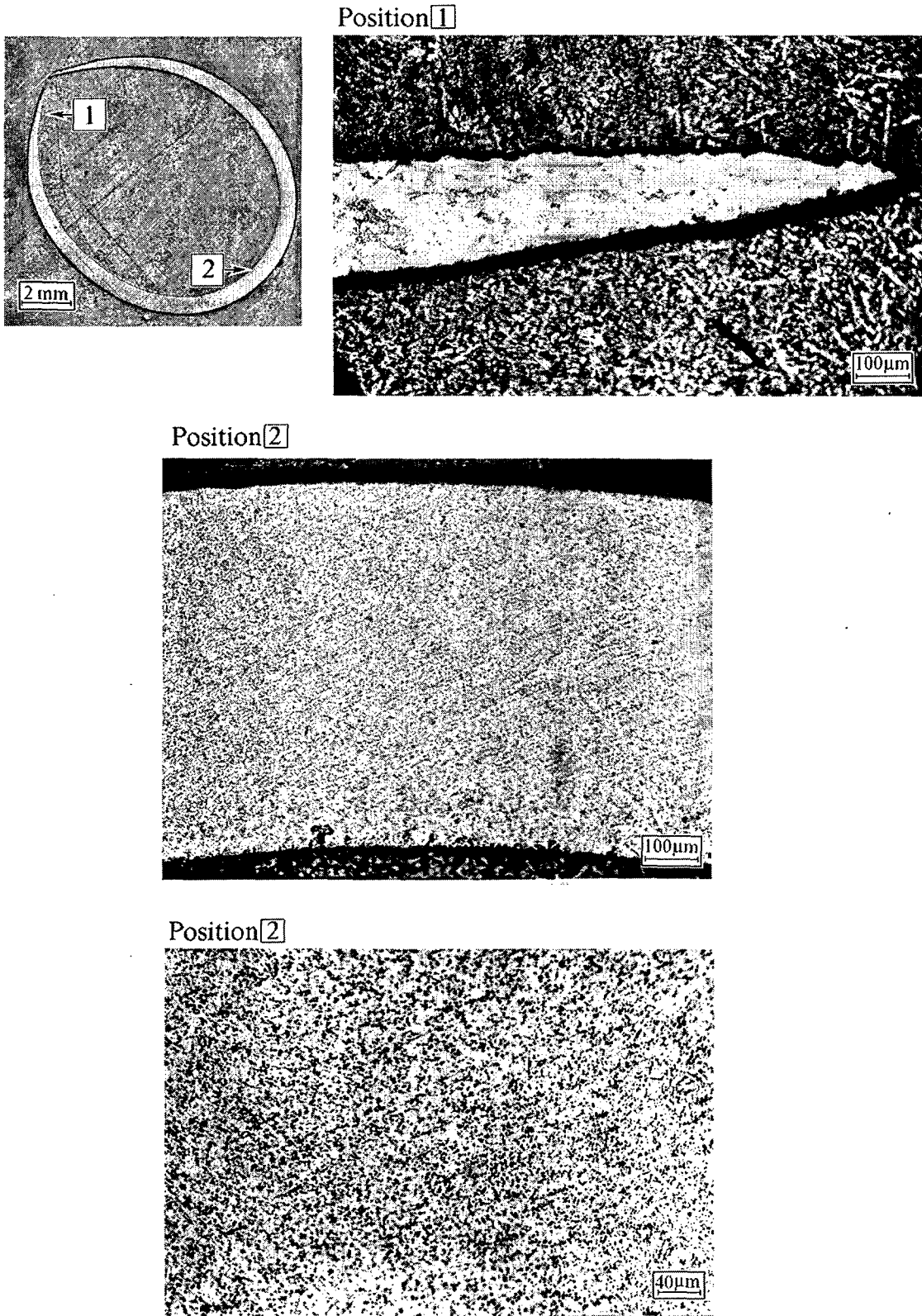
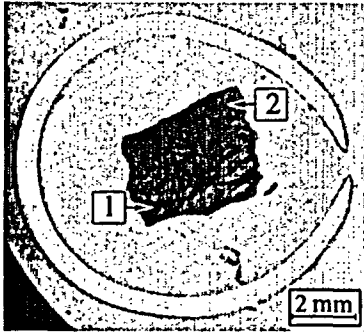

Fig. G-7.4. Cross-Section and Cladding Microstructure for Fuel Rod #H7T at 158 mm Elevation

#H7T

Individual Characteristics of Refabricated Fuel Rods  
(Preirradiated Fuel, Preirradiated Cladding) under IGR Tests



Position 1



Position 2

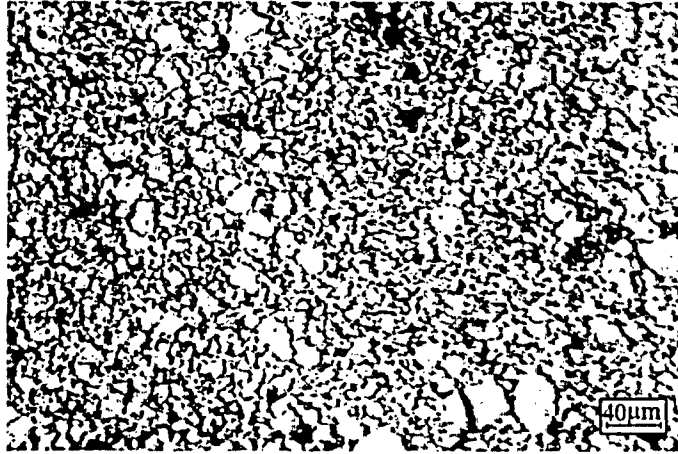

Position 2

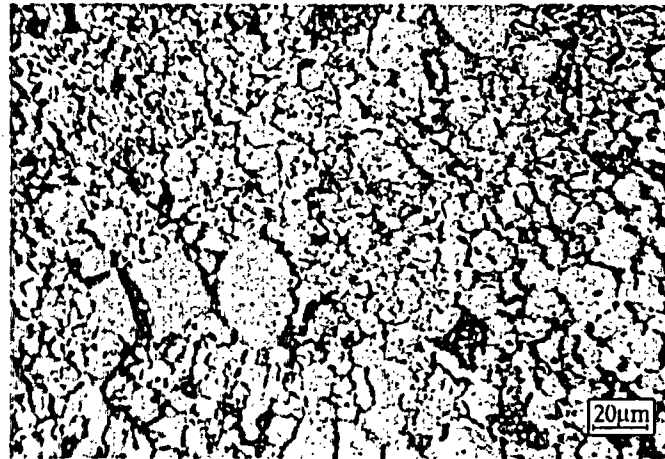

Fig. G-7.5. Fuel Microstructure for Fuel Rod #H7T at 33 mm Elevation

Table G-7.1. Time Dependent Energy Characteristics of Fuel Rod #H7T

Time (s)	Reactor energy deposition <sup>1)</sup> (%)	Cumulative number of fissions in fuel rod (fiss)						Power of fuel rod (kW)	Energy deposition in fuel rod	
		U <sup>235</sup> ×10 <sup>-14</sup>	U <sup>238</sup> ×10 <sup>-13</sup>	Pu <sup>239</sup> ×10 <sup>-14</sup>	Pu <sup>241</sup> ×10 <sup>-14</sup>	Other isotopes ×10 <sup>-11</sup>	Total ×10 <sup>-14</sup>		cal/g fuel	J/g fuel
0.0	0.000	0.000	0.000	0.000	0.000	0.000	0.000	0.000	0.000	0.000
1.0	1.050	0.068	0.016	0.097	0.039	0.080	0.206	1.180	2.480	10.40
2.0	5.030	0.328	0.078	0.466	0.188	0.382	0.989	3.900	11.90	49.80
2.2	6.580	0.429	0.103	0.610	0.246	0.500	1.300	4.950	15.60	65.30
2.4	8.590	0.560	0.134	0.796	0.321	0.653	1.690	6.490	20.40	85.40
2.6	11.30	0.737	0.177	1.050	0.422	0.859	2.230	9.090	26.80	112.0
2.8	15.30	0.999	0.239	1.420	0.572	1.160	3.020	14.10	36.30	152.0
3.0	22.00	1.430	0.343	2.040	0.820	1.670	4.330	24.70	52.10	218.0
3.2	34.20	2.230	0.534	3.170	1.280	2.600	6.730	46.00	81.10	339.0
3.4	54.80	3.570	0.857	5.080	2.050	4.170	10.80	66.30	130.0	544.0
3.6	75.80	4.940	1.180	7.020	2.830	5.760	14.90	46.40	180.0	753.0
3.8	86.70	5.650	1.350	8.040	3.240	6.590	17.10	17.90	206.0	862.0
4.0	90.50	5.900	1.410	8.390	3.380	6.880	17.80	5.990	215.0	900.0
4.2	91.90	5.990	1.440	8.510	3.430	6.980	18.10	2.570	218.0	913.0
4.4	92.50	6.030	1.450	8.570	3.450	7.030	18.20	1.670	220.0	921.0
4.6	93.00	6.060	1.450	8.620	3.470	7.070	18.30	1.410	221.0	925.0
4.8	93.40	6.090	1.460	8.660	3.490	7.100	18.40	1.210	222.0	929.0
5.0	93.80	6.110	1.460	8.690	3.500	7.120	18.50	1.040	223.0	933.0
5.2	94.10	6.130	1.470	8.720	3.510	7.150	18.50	0.907	224.0	938.0
5.4	94.30	6.150	1.470	8.740	3.520	7.170	18.60	0.798	225.0	942.0
5.6	94.60	6.160	1.480	8.760	3.530	7.180	18.60	0.710	225.0	942.0
5.8	94.80	6.180	1.480	8.780	3.540	7.200	18.60	0.637	226.0	946.0
6.0	94.90	6.190	1.480	8.800	3.540	7.210	18.70	0.577	226.0	946.0
6.5	95.30	6.210	1.490	8.830	3.560	7.240	18.80	0.466	227.0	950.0
7.0	95.60	6.230	1.490	8.860	3.570	7.270	18.80	0.393	228.0	954.0
7.5	95.90	6.250	1.500	8.890	3.580	7.290	18.90	0.341	229.0	959.0
8.0	96.10	6.260	1.500	8.910	3.590	7.300	18.90	0.302	230.0	963.0
9.0	96.50	6.290	1.510	8.940	3.600	7.330	19.00	0.266	231.0	967.0
10.0	96.90	6.310	1.510	8.980	3.610	7.360	19.10	0.221	232.0	971.0
20.0	98.30	6.410	1.540	9.110	3.670	7.470	19.40	0.060	237.0	992.0
30.0	98.90	6.450	1.540	9.160	3.690	7.510	19.50	0.033	239.0	1000.
∞	100.0	6.520	1.560	9.270	3.730	7.600	19.70	0.000	244.0	1021.

Maximum value of power is 66.3 kW (t = 3.40 s).

<sup>1)</sup> Current energy deposition per maximum energy deposition (at infinite time)

Table G-7.2. Axial Energy Characteristics of Fuel Rod #H7T

Axial coordinate from lower end of fuel rod (mm)	Cumulative number of fissions at axial interval (fiss)						Maximum power of fuel rod (kW) $t=3.40s$	Energy deposition at infinite time*		
	U <sup>235</sup> $\times 10^{-13}$	U <sup>238</sup> $\times 10^{-11}$	Pu <sup>239</sup> $\times 10^{-13}$	Pu <sup>241</sup> $\times 10^{-13}$	Other isotopes $\times 10^{-10}$	Total $\times 10^{-13}$		cal/g fuel	J/g fuel	per-unit <sup>3)</sup>
10.0	0.000	0.000	0.000	0.000	0.000	0.000	0.000	0.000	0.000	0.00
15.0	0.000	0.000	0.000	0.000	0.000	0.000	0.000	0.000	0.000	0.00
20.0 <sup>1)</sup>	0.467	0.918	0.623	0.247	0.439	1.350	0.453	279.0	1168.	1.00
25.0	2.340	4.590	3.120	1.240	2.190	6.740	2.270	279.0	1168.	1.00
30.0	2.340	4.590	3.120	1.240	2.190	6.740	2.270	279.0	1168.	1.00
35.0	2.340	4.590	3.120	1.240	2.190	6.740	2.270	279.0	1168.	1.00
40.0	2.340	4.590	3.120	1.240	2.190	6.740	2.270	279.0	1168.	1.00
45.0	2.340	4.590	3.120	1.240	2.190	6.740	2.270	279.0	1168.	1.00
50.0	2.570	5.930	3.580	1.450	2.630	7.660	2.580	251.0	1051.	0.90
55.0	2.440	5.710	3.410	1.380	2.620	7.290	2.450	248.0	1038.	0.89
60.0	2.350	5.580	3.300	1.320	2.620	7.020	2.360	246.0	1030.	0.88
65.0	2.320	5.600	3.260	1.310	2.620	6.950	2.340	244.0	1021.	0.87
70.0	2.280	5.600	3.220	1.290	2.640	6.860	2.310	242.0	1013.	0.87
75.0	2.280	5.670	3.220	1.290	2.650	6.850	2.310	242.0	1013.	0.87
80.0	2.340	5.900	3.310	1.320	2.670	7.030	2.370	241.0	1009.	0.86
85.0	2.340	5.960	3.310	1.320	2.700	7.030	2.370	242.0	1013.	0.87
90.0	2.330	6.000	3.280	1.320	2.740	6.990	2.350	243.0	1017.	0.87
95.0	2.360	6.150	3.310	1.330	2.780	7.070	2.380	244.0	1021.	0.87
100.0	1.150	2.830	1.680	0.681	1.320	3.540	1.190	243.0	1017.	0.87
105.0	1.150	2.830	1.680	0.681	1.320	3.540	1.190	243.0	1017.	0.87
110.0	2.130	5.000	3.140	1.270	2.550	6.600	2.220	239.0	1000.	0.86
115.0	2.170	5.270	3.190	1.290	2.590	6.710	2.260	238.0	996.0	0.85
120.0	2.130	5.340	3.130	1.270	2.620	6.590	2.220	237.0	992.0	0.85
125.0	2.040	5.220	2.990	1.210	2.640	6.290	2.120	235.0	984.0	0.84
130.0	1.920	5.000	2.820	1.150	2.650	5.930	2.000	234.0	980.0	0.84
135.0	1.870	4.920	2.740	1.110	2.660	5.770	1.940	233.0	975.0	0.84
140.0	1.880	4.970	2.750	1.120	2.660	5.800	1.950	232.0	971.0	0.83
145.0	1.910	5.050	2.810	1.140	2.650	5.910	1.990	231.0	967.0	0.83
150.0	1.940	5.120	2.870	1.160	2.630	6.030	2.030	230.0	963.0	0.82
155.0	1.920	5.010	2.850	1.160	2.610	5.980	2.010	230.0	963.0	0.82
160.0	1.900	4.850	2.820	1.140	2.580	5.910	1.990	229.0	959.0	0.82
165.0	1.900	4.730	2.830	1.140	2.540	5.920	1.990	228.0	954.0	0.82
170.0	1.420	3.390	2.080	0.842	1.620	4.380	1.470	227.0	950.0	0.81
175.0	1.420	3.390	2.080	0.842	1.620	4.380	1.470	227.0	950.0	0.81
180.0 <sup>2)</sup>	0.566	1.360	0.833	0.337	0.647	1.750	0.589	227.0	950.0	0.81
185.0	0.000	0.000	0.000	0.000	0.000	0.000	0.000	0.000	0.000	0.00

\* All numerical values of characteristics are presented as average values at the length interval equal to the axial coordinate  $\pm 2.5$  mm

<sup>1)</sup> Initial coordinate of fuel is 21.5 mm.

<sup>2)</sup> End coordinate of fuel is 179.5 mm.

<sup>3)</sup> Current value per maximum value.

## #H7T

Individual Characteristics of Refabricated Fuel Rods (Preirradiated Fuel, Preirradiated Cladding) under IGR Tests
--

Table G-7.3. Radial Energy Characteristics of Fuel Rod #H7T

Characteristics*		Coordinates of fuel zones (mm)			
		1 zone 1.2 - 2.811	2 zone 2.811-3.432	3 zone 3.432-3.704	4 zone 3.704-3.790
U <sup>235</sup>	Number of fissions $\times 10^{-14}$ (fiss)	2.400	1.410	0.692	0.225
	Power of fuel rod <sup>1)</sup> (kW)	7.950	4.670	2.290	0.746
	Energy deposition <sup>2)</sup> (cal/g fuel)	78.10	76.50	75.00	73.30
	Energy deposition <sup>2)</sup> (J/g fuel)	327.0	320.0	314.0	307.0
	Energy deposition <sup>3)</sup> (per-unit)	1.000	0.980	0.960	0.939
U <sup>238</sup>	Number of fissions $\times 10^{-12}$ (fiss)	6.240	3.510	1.620	0.488
	Power of fuel rod <sup>1)</sup> (kW)	0.204	0.115	0.053	0.016
	Energy deposition <sup>2)</sup> (cal/g fuel)	2.000	1.880	1.730	1.570
	Energy deposition <sup>2)</sup> (J/g fuel)	8.370	7.870	7.240	6.570
	Energy deposition <sup>3)</sup> (per-unit)	1.000	0.940	0.865	0.785
Pu <sup>239</sup>	Number of fissions $\times 10^{-14}$ (fiss)	2.830	1.920	1.320	0.750
	Power of fuel rod <sup>1)</sup> (kW)	9.640	6.560	4.500	2.560
	Energy deposition <sup>2)</sup> (cal/g fuel)	95.00	108.0	148.0	252.0
	Energy deposition <sup>2)</sup> (J/g fuel)	398.0	452.0	620.0	1055.
	Energy deposition <sup>3)</sup> (per-unit)	0.377	0.429	0.587	1.000
Pu <sup>241</sup>	Number of fissions $\times 10^{-13}$ (fiss)	10.90	7.730	5.560	3.320
	Power of fuel rod <sup>1)</sup> (kW)	3.650	2.600	1.870	1.120
	Energy deposition <sup>2)</sup> (cal/g fuel)	36.00	42.60	61.30	110.0
	Energy deposition <sup>2)</sup> (J/g fuel)	151.0	178.0	257.0	460.0
	Energy deposition <sup>3)</sup> (per-unit)	0.327	0.387	0.557	1.000
Other isoto- pes	Number of fissions $\times 10^{-11}$ (fiss)	2.700	1.670	0.970	0.462
	Power of fuel rod <sup>1)</sup> (kW)	0.009	0.006	0.003	0.002
	Energy deposition <sup>2)</sup> (cal/g fuel)	0.090	0.093	0.108	0.154
	Energy deposition <sup>2)</sup> (J/g fuel)	0.380	0.390	0.450	0.640
	Energy deposition <sup>3)</sup> (per-unit)	0.585	0.601	0.701	1.000
Total	Number of fissions $\times 10^{-14}$ (fiss)	6.380	4.140	2.590	1.310
	Power of fuel rod <sup>1)</sup> (kW)	21.40	13.90	8.700	4.420
	Energy deposition <sup>2)</sup> (cal/g fuel)	211.0	229.0	286.0	436.0
	Energy deposition <sup>2)</sup> (J/g fuel)	883.0	959.0	1197.	1825.
	Energy deposition <sup>3)</sup> (per-unit)	0.484	0.525	0.656	1.000

1) at time of 3.40 s, 2) at infinite time, 3) Current value per maximum value.

\* All numerical values of characteristics were calculated for undamaged part of fuel stack only (See Table C.2.2.)

# #H7T

Individual Characteristics of Refabricated Fuel Rods  
(Preirradiated Fuel, Preirradiated Cladding) under IGR Tests

Table G-7.4. Fuel Enthalpy Vs. Time Calculated by FRAP-T6 Code for Fuel Rod #H7T

Time (s)	Enthalpy at fuel radius (cal/g fuel)				Fuel enthalpy <sup>1)</sup>		Energy deposition in fuel rod	
	1.20 mm	2.82 mm	3.47 mm	3.79 mm	cal/g fuel	J/g fuel	cal/g fuel	J/g fuel
0.0	0.00	0.00	0.00	0.00	0.00	0.00	0.00	0.00
1.0	2.59	2.58	2.49	2.35	2.55	10.7	2.47	10.4
2.0	11.6	11.3	10.6	9.78	11.2	46.8	11.9	49.8
2.2	15.3	14.7	13.5	11.9	14.5	60.5	15.6	65.3
2.4	20.0	18.9	16.7	14.2	18.5	77.4	20.3	85.2
2.6	26.3	24.5	20.8	16.6	23.8	99.5	26.8	112
2.8	35.6	32.6	26.3	19.0	31.4	131	36.3	152
3.0	51.3	46.5	35.4	21.0	44.0	184	52.0	218
3.2	80.7	72.7	50.8	25.5	67.5	283	80.8	339
3.4	133	120	82.3	40.5	111	463	130	543
3.6	189	168	119	76.0	158	662	179	751
3.8	220	189	133	99.5	181	758	206	862
4.0	229	190	140	109	187	782	215	900
4.2	230	186	134	102	184	769	218	914
4.4	229	180	128	99.3	179	750	220	921
4.6	225	174	124	96.2	174	730	221	927
4.8	222	167	117	86.8	168	706	222	932
5.0	217	161	108	77.9	162	678	223	935
5.2	213	154	101	72.0	156	652	224	939
5.4	207	146	95.3	70.1	150	627	225	942
5.6	202	139	91.8	69.4	144	604	225	944
5.8	196	133	89.3	69.0	139	583	226	947
6.0	189	128	87.4	68.8	134	563	226	949
6.5	172	117	83.8	68.2	124	519	228	954
7.0	156	109	80.8	67.5	115	481	228	957
7.5	141	102	78.0	66.3	107	447	229	961
8.0	129	96.1	75.2	64.9	99.6	417	230	963
10.0	93.6	77.0	64.9	58.4	78.3	328	232	973
30.0	11.8	11.4	11.0	10.8	11.4	47.9	239	1004

Radial enthalpy distribution and fuel enthalpy are presented at elevation 29.4 mm

Maximum value of fuel enthalpy is 186.7 cal/g fuel (t=3.98 s)

<sup>1)</sup> All numerical values are presented at elevation with peak power

## #H7T

Individual Characteristics of Refabricated Fuel Rods  
(Preirradiated Fuel/Preirradiated Cladding) under IGR Tests

Table G-7.5. Energy Characteristics Vs. Time Calculated by FRAP-T6 and SCANAIR Codes for Fuel Rod #H7T

Time (s)	Energy deposition <sup>1)</sup> (cal/g fuel)	Linear power <sup>1)</sup> (kW/m)	Fuel enthalpy <sup>1)</sup> (cal/g fuel)		Energy of metal-water reaction <sup>1)</sup> (cal/g fuel)	Leakage of energy <sup>1)</sup> (cal/g fuel)		Clad-to-coolant heat transfer coefficient <sup>1)</sup> (kW/m <sup>2</sup> K)	
			FRAP-T6	SCANAIR	FRAP-T6	FRAP-T6	SCANAIR	FRAP-T6	SCANAIR
0.0	0.00	0.00	0.00	0.00	0.00	0.00	0.00	0.00	0.00
1.0	2.83	10.1	2.55	2.50	0.00	0.00	0.01	0.03	0.10
2.0	13.6	33.2	11.2	11.9	0.00	0.26	0.08	1.73	0.31
2.2	17.8	42.2	14.5	15.1	0.00	1.03	0.47	3.11	2.28
2.4	23.2	55.3	18.5	19.7	0.00	2.30	1.39	4.63	3.51
2.6	30.6	77.4	23.8	25.9	0.00	4.24	2.78	6.74	5.07
2.8	41.4	120	31.4	33.7	0.00	7.30	4.51	10.3	7.06
3.0	59.4	210	44.0	48.8	0.00	12.3	7.64	17.2	11.2
3.2	92.2	392	67.5	77.5	0.00	21.9	13.4	26.4	20.5
3.4	148	565	111	116	0.00	33.3	23.5	5.29	27.5
3.6	205	399	158	-	0.00	36.7	-	1.93	-
3.8	235	154	181	-	0.00	42.8	-	2.27	-
4.0	245	51.6	187	-	0.02	49.6	-	2.21	-
4.2	249	22.1	184	-	0.04	56.4	-	2.25	-
4.4	251	14.3	179	-	0.06	63.4	-	2.68	-
4.6	253	12.1	174	-	0.06	74.1	-	5.46	-
4.8	254	10.3	168	-	0.06	88.2	-	9.31	-
5.0	255	8.89	162	-	0.06	101	-	14.2	-
5.2	256	7.85	156	-	0.06	110	-	17.7	-
5.4	257	6.90	150	-	0.06	117	-	15.1	-
5.6	257	6.14	144	-	0.06	123	-	13.6	-
5.8	258	5.49	139	-	0.06	129	-	12.6	-
6.0	259	4.97	134	-	0.06	133	-	11.7	-
6.5	260	4.02	124	-	0.06	144	-	10.0	-
7.0	261	3.37	115	-	0.06	153	-	8.87	-
7.5	262	2.92	107	-	0.06	161	-	8.01	-
8.0	263	2.59	99.6	-	0.06	168	-	7.30	-
10.0	265	1.89	78.3	-	0.06	191	-	5.22	-
30.0	274	0.23	11.4	-	0.06	266	-	0.46	-

<sup>1)</sup> All numerical values are presented at elevation with peak power

# #H7T

Individual Characteristics of Refabricated Fuel Rods  
(Preirradiated Fuel, Preirradiated Cladding) under IGR-Tests

Table G-7.6. Temperature Variation, Fission Gas Release and ZrO<sub>2</sub> Thickness Vs. Time for Fuel Rod #H7T Calculated by FRAP-T6 and SCANAIR Codes

Time (s)	Fuel centerline temperature <sup>1)</sup> (K)		Fuel surface temperature <sup>1)</sup> (K)		Clad outer temperature <sup>1)</sup> (K)		Fission gas release (%)		Average ZrO <sub>2</sub> <sup>2)</sup> thickness (μm)
	FRAP-T6	SCANAIR	FRAP-T6	SCANAIR	FRAP-T6	SCANAIR	FRAP-T6	SCANAIR	FRAP-T6
0.0	293	293	293	293	293	293	0.00	0.00	5.00
1.0	338	333	334	332	315	305	0.07	0.25	5.00
2.0	480	479	452	466	389	376	0.24	0.90	5.00
2.2	534	527	484	506	395	383	0.32	1.05	5.00
2.4	601	596	518	560	399	385	0.43	1.27	5.00
2.6	691	689	553	628	405	388	0.59	1.69	5.00
2.8	820	802	588	709	412	391	0.85	2.04	5.00
3.0	1031	1013	616	854	423	397	1.34	2.50	5.00
3.2	1414	1399	680	1072	434	406	2.49	2.97	5.00
3.4	2037	1920	887	1144	629	445	4.63	3.71	5.00
3.6	2572	-	1354	-	1060	-	7.56	-	5.00
3.8	2804	-	1650	-	1230	-	10.8	-	5.03
4.0	2868	-	1764	-	1201	-	17.1	-	5.06
4.2	2876	-	1683	-	1221	-	18.7	-	5.10
4.4	2863	-	1647	-	1200	-	18.7	-	5.13
4.6	2843	-	1608	-	1025	-	18.8	-	5.15
4.8	2817	-	1491	-	748	-	18.8	-	5.15
5.0	2786	-	1378	-	533	-	18.8	-	5.15
5.2	2755	-	1302	-	423	-	18.8	-	5.15
5.4	2716	-	1278	-	420	-	18.8	-	5.15
5.6	2674	-	1269	-	418	-	18.8	-	5.15
5.8	2626	-	1263	-	416	-	18.8	-	5.15
6.0	2574	-	1260	-	414	-	18.8	-	5.15
6.5	2431	-	1254	-	411	-	18.8	-	5.15
7.0	2279	-	1244	-	409	-	18.8	-	5.15
7.5	2131	-	1229	-	408	-	18.8	-	5.15
8.0	1994	-	1210	-	406	-	18.9	-	5.15
10.0	1576	-	1125	-	401	-	18.9	-	5.15
30.0	483	-	467	-	381	-	18.9	-	5.15

<sup>1)</sup> All numerical values are presented at elevation with peak power

<sup>2)</sup> Initial ZrO<sub>2</sub> thickness is 5 μm



# #H7T

Individual Characteristics of Refabricated Fuel Rods  
(Preirradiated Fuel, Preirradiated Cladding) under IGR Tests

Table G-7.7. Mechanical Characteristics of Fuel Rod #H7T Vs. Time Calculated by FRAP-T6 and SCANAIR Codes

Time (s)	Clad outer temperature <sup>1)</sup> (K)		Fuel hoop strain <sup>1)</sup> (%)		Fuel - clad gap width <sup>1)</sup> (mm)		Clad hoop strain <sup>1)</sup> (%)		Clad hoop stress <sup>1)</sup> (MPa)		Internal gas pressure (MPa)	
	FRAP-T6	SCANAIR	FRAP-T6	SCANAIR	FRAP-T6	SCANAIR	FRAP-T6	SCANAIR	FRAP-T6	SCANAIR	FRAP-T6	SCANAIR
0.0	293	293	0.00	0.00	0.04	0.07	0.01	0.01	8.81	8.59	1.70	1.70
1.0	315	305	0.06	0.03	0.04	0.07	0.02	0.02	8.98	8.80	1.75	1.74
2.0	389	376	0.31	0.14	0.03	0.07	0.08	0.07	9.43	9.37	1.83	1.83
2.2	395	383	0.40	0.17	0.02	0.07	0.08	0.08	9.56	9.58	1.85	1.85
2.4	399	385	0.51	0.23	0.02	0.06	0.09	0.09	9.70	9.82	1.87	1.88
2.6	405	388	0.66	0.30	0.02	0.06	0.09	0.09	9.85	10.1	1.90	1.91
2.8	412	391	0.87	0.39	0.01	0.06	0.11	0.10	10.0	10.5	1.94	1.94
3.0	423	397	1.22	0.59	0.00	0.05	0.23	0.11	136	11.0	1.99	1.99
3.2	434	406	1.87	1.02	0.00	0.04	0.75	0.14	455	12.1	2.05	2.04
3.4	629	445	3.01	1.84	0.00	0.01	1.70	0.21	358	13.9	2.14	2.09
3.6	1060	-	4.40	-	0.00	-	2.88	-	63.3	-	2.23	-
3.8	1230	-	5.08	-	0.07	-	5.35	-	13.4	-	2.32	-
4.0	1201	-	5.87	-	0.30	-	12.2	-	0.00	-	0.10	-
4.2	1221	-	6.11	-	0.29	-	12.2	-	0.00	-	0.10	-
4.4	1200	-	6.02	-	0.30	-	12.2	-	0.00	-	0.10	-
4.6	1025	-	5.89	-	0.30	-	12.5	-	0.00	-	0.10	-
4.8	748	-	5.67	-	0.31	-	12.3	-	0.00	-	0.10	-
5.0	533	-	5.42	-	0.32	-	12.1	-	0.00	-	0.10	-
5.2	423	-	5.20	-	0.33	-	12.1	-	0.00	-	0.10	-
5.4	420	-	4.96	-	0.34	-	12.1	-	0.00	-	0.10	-
5.6	418	-	4.75	-	0.35	-	12.1	-	0.00	-	0.10	-
5.8	416	-	4.54	-	0.35	-	12.0	-	0.00	-	0.10	-
6.0	414	-	4.33	-	0.36	-	12.0	-	0.00	-	0.10	-
6.5	411	-	3.85	-	0.38	-	12.0	-	0.00	-	0.10	-
7.0	409	-	3.44	-	0.40	-	12.0	-	0.00	-	0.10	-
7.5	408	-	3.08	-	0.41	-	12.0	-	0.00	-	0.10	-
8.0	406	-	2.77	-	0.42	-	12.0	-	0.00	-	0.10	-
10.0	401	-	1.64	-	0.46	-	12.0	-	0.00	-	0.10	-
30.0	381	-	0.08	-	0.52	-	12.0	-	0.00	-	0.10	-

<sup>1)</sup> All numerical values are presented at elevation with peak power

# #H7T

Individual Characteristics of Refabricated Fuel Rods  
(Preirradiated Fuel, Preirradiated Cladding) under IGR Tests

Table G-7.8. Axial Distribution of Energy Deposition and Fuel Enthalpy Calculated by FRAP-T6 Code for Fuel Rod #H7T

Axial interval from-to (mm)-(mm)	Energy deposition at infinite time			Fuel enthalpy at time (t=3.98 s)		
	cal/g fuel	J/g fuel	per-unit	cal/g fuel	J/g fuel	per-unit
21.5 - 37.3	279	1169	1.00	187	782	1.00
37.3 - 53.1	269	1127	0.96	180	754	0.96
53.1 - 68.9	246	1029	0.88	164	689	0.88
68.9 - 84.7	242	1013	0.87	162	678	0.87
84.7 - 100.5	243	1019	0.87	163	682	0.87
100.5 - 116.3	241	1008	0.86	161	675	0.86
116.3 - 132.1	236	987	0.84	158	661	0.84
132.1 - 147.9	232	972	0.83	155	651	0.83
147.9 - 163.7	230	962	0.82	154	644	0.82
163.7 - 179.5	227	952	0.81	152	637	0.81

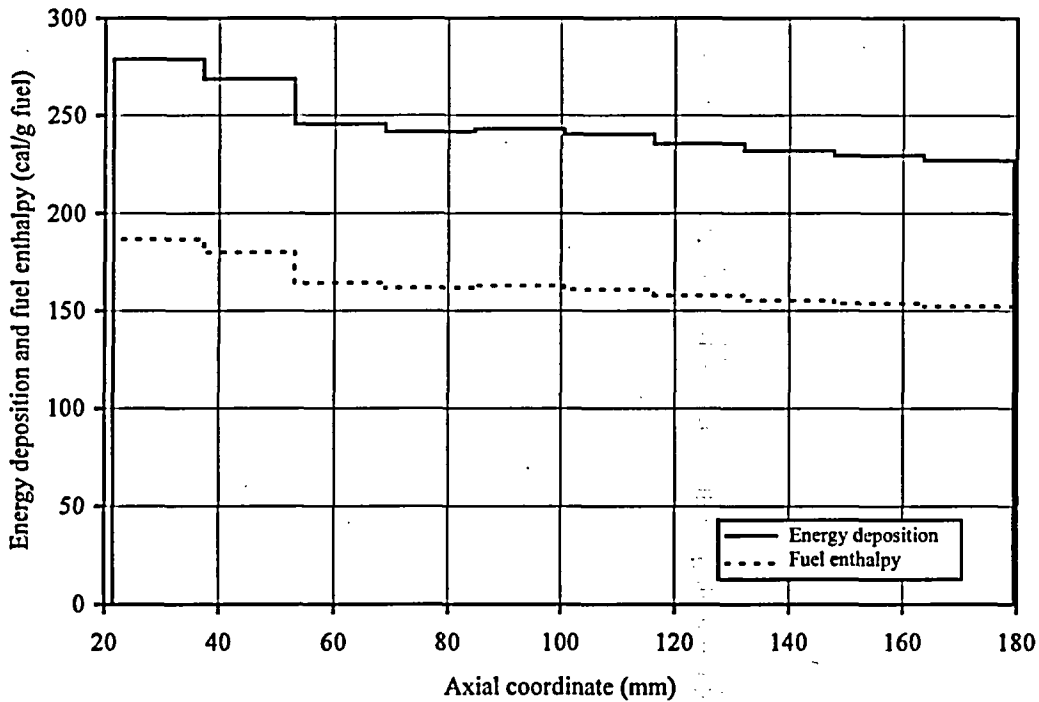

Fig. G-7.6. Axial Distribution of Energy Deposition and Fuel Enthalpy Calculated by FRAP-T6 Code for Fuel Rod #H7T

#H7T

Individual Characteristics of Refabricated Fuel Rods  
(Preirradiated Fuel, Preirradiated Cladding) under IGR Tests

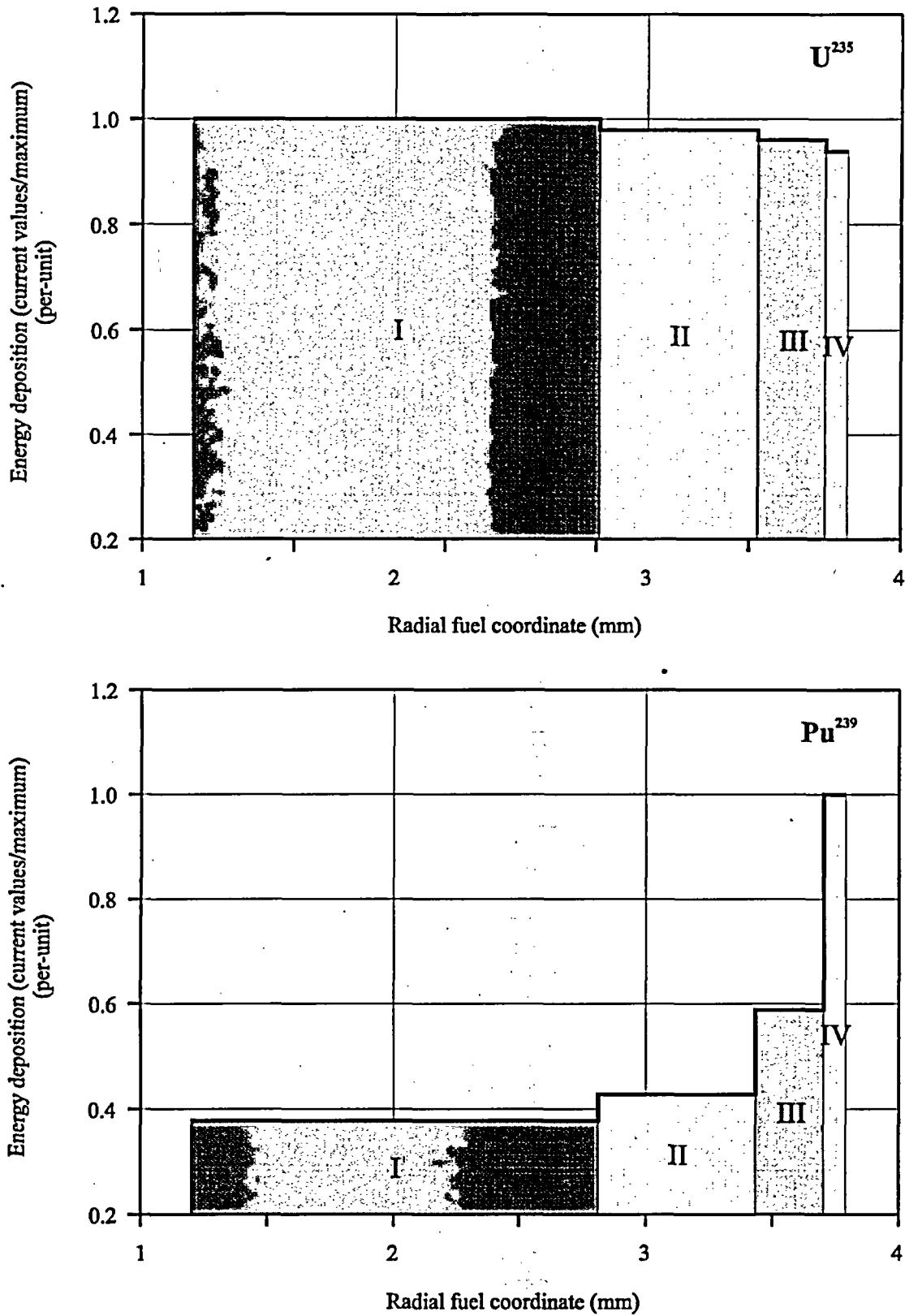

Fig. G-7.7.  $U^{235}$  and  $Pu^{239}$  Radial Distributions of Energy Deposition for Fuel Rod #H7T

#H7T

Individual Characteristics of Refabricated Fuel Rods  
(Preirradiated Fuel, Preirradiated Cladding) under IGR Tests

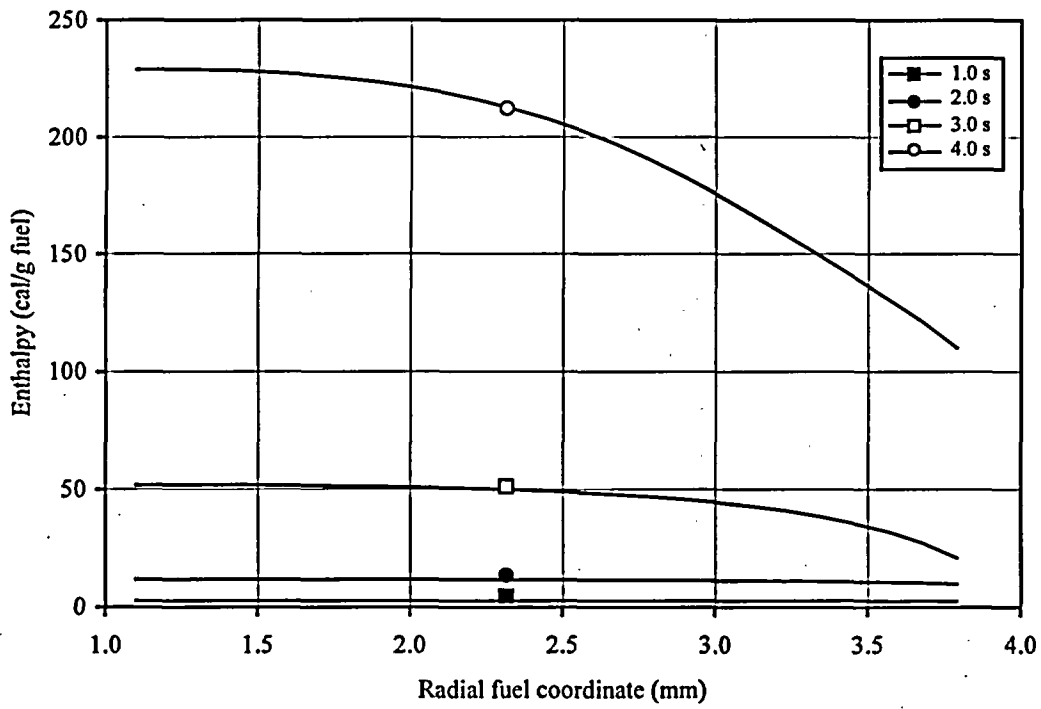
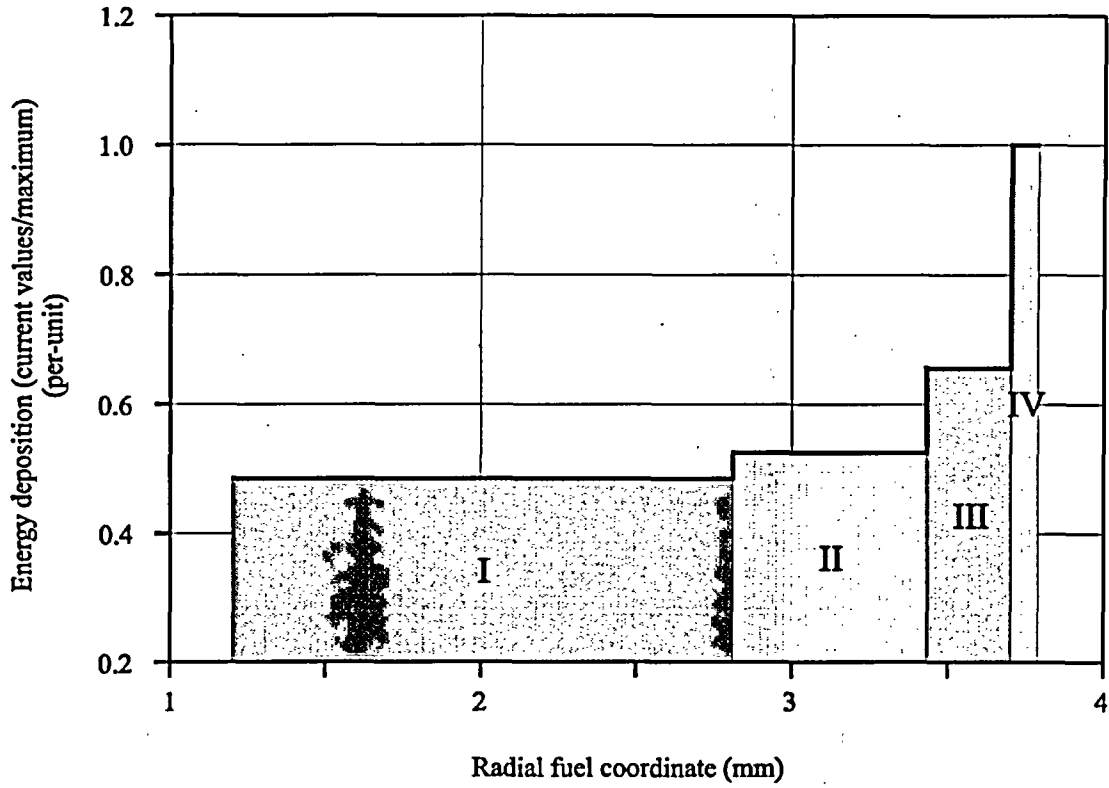

Fig. G-7.8. Radial Distributions of Energy Deposition and Fuel Enthalpy Calculated by FRAP-T6 Code for Fuel Rod #H7T

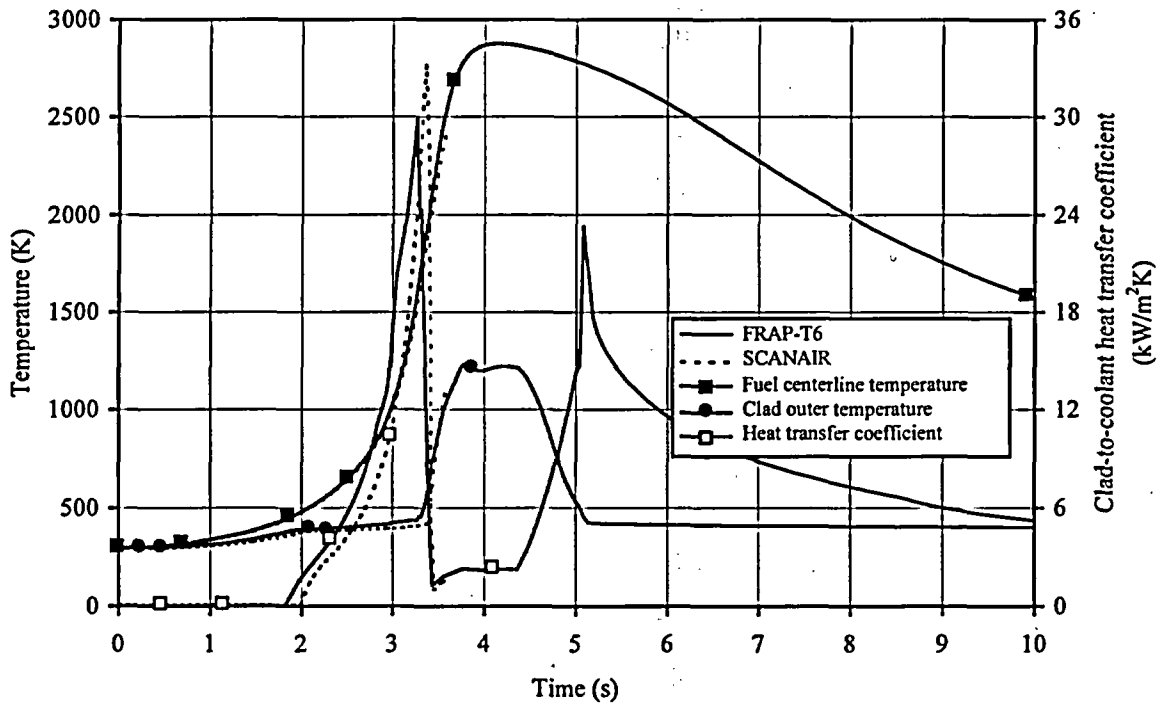
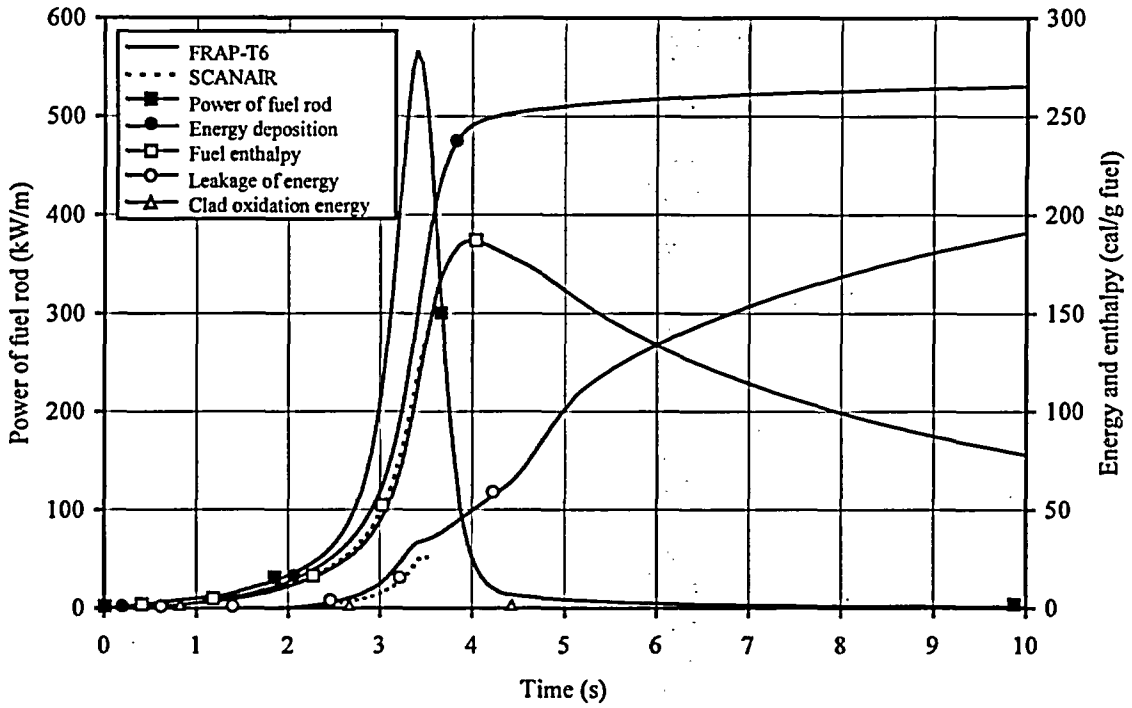

Fig. G-7.9. Energy and Temperature Characteristics Vs. Time Calculated by FRAP-T6 and SCANAIR Codes for Fuel Rod #H7T

#H7T

Individual Characteristics of Refabricated Fuel Rods  
(Preirradiated Fuel, Preirradiated Cladding) under IGR Tests

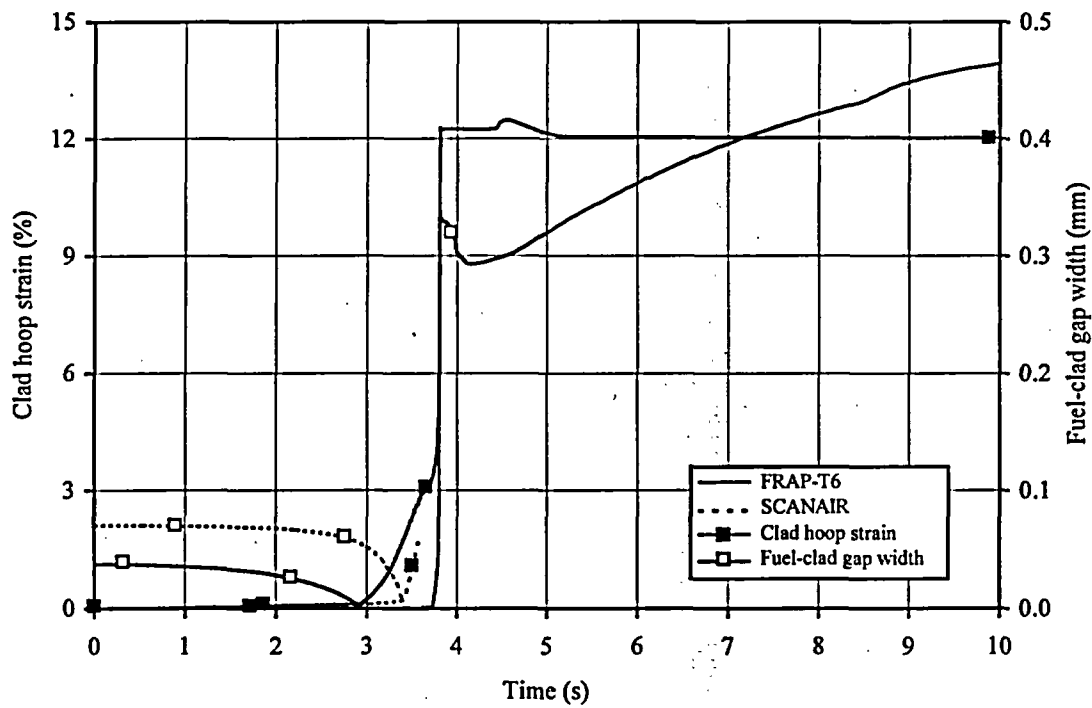
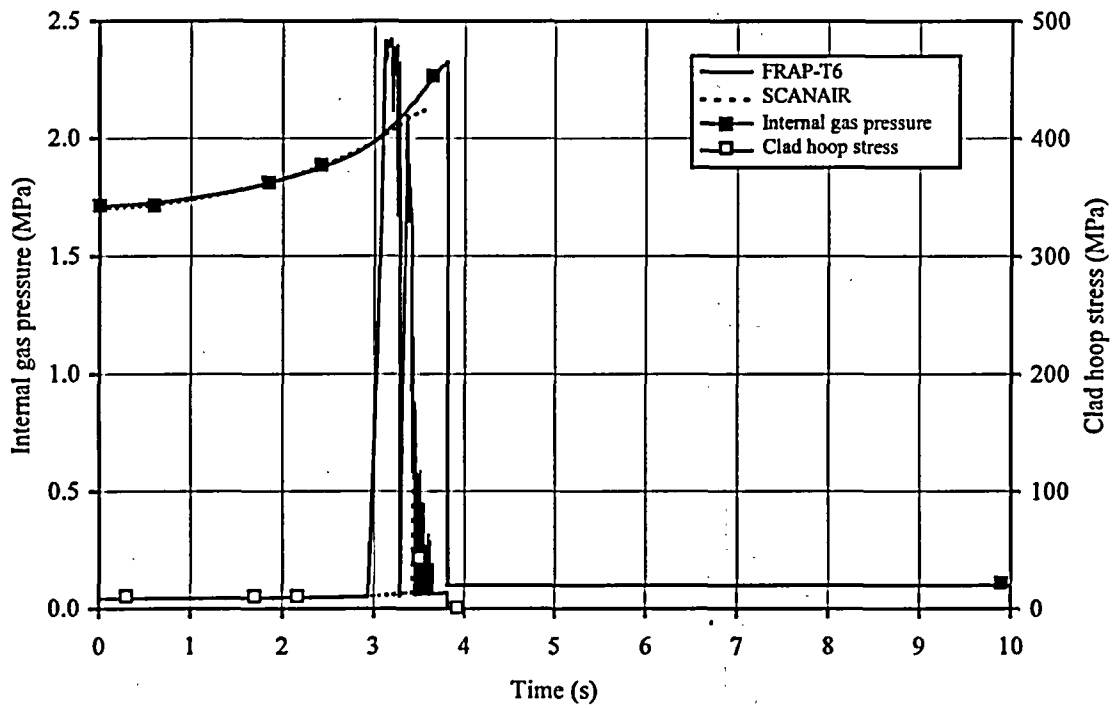

Fig. G-7.10. Cladding Mechanical Characteristics Vs. Time Calculated by FRAP-T6 and SCANAIR Codes for Fuel Rod #H7T

#H7T

Individual Characteristics of Refabricated Fuel Rods  
(Preirradiated Fuel, Preirradiated Cladding) under IGR Tests

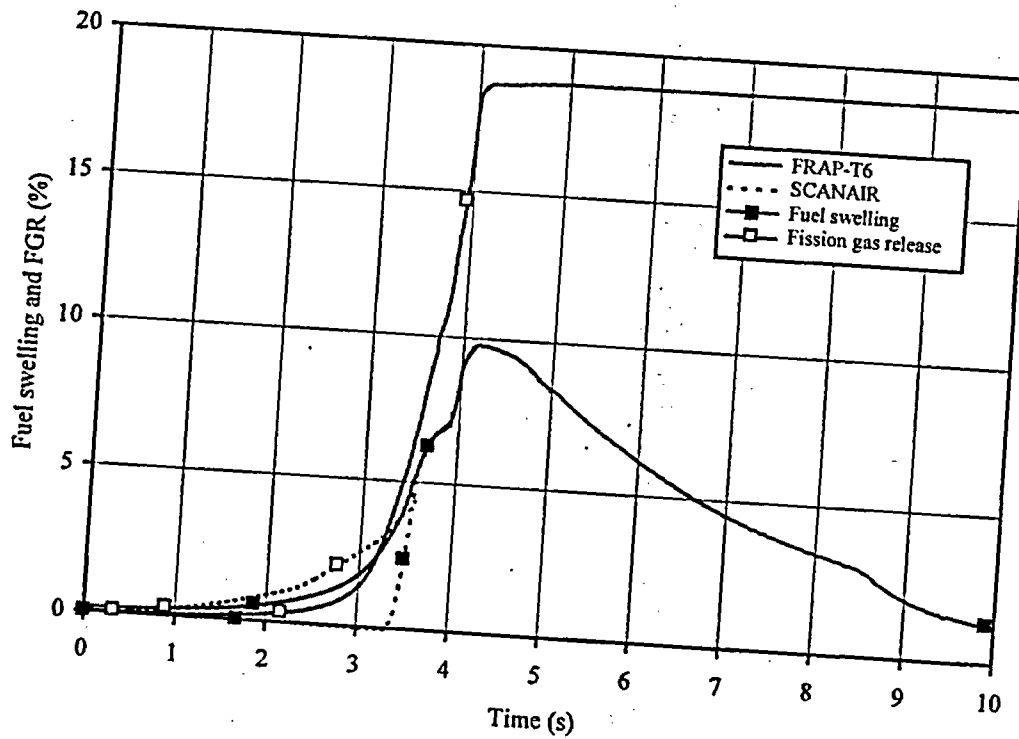
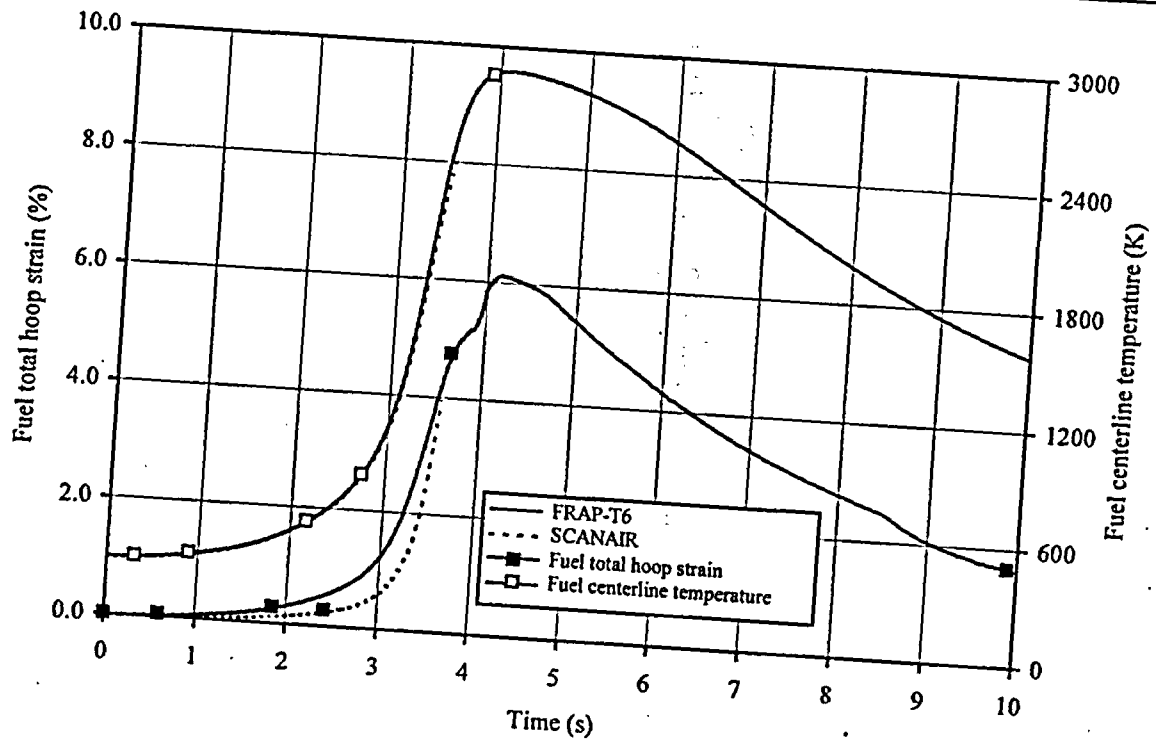

Fig. G-7.11. Fuel Strain and Fission Gas Release Vs. Time Calculated by FRAP-T6 and SCANAIR Codes for Fuel Rod #H7T

Table G-7.9. Some Results of PIE for Fuel Rod #H7T

Characteristic		Value		
1.	Measured parameters of cladding oxidation and cladding deformation			
1.1.	Cladding thickness at elevation 33, 103, 158 mm correspondent to different azimuthal angles ( $\mu\text{m}$ ):			
	0°	663	691	—
	90°	R	677	680
	180°	710	677	—
	270°	677	663	—
1.2.	ZrO <sub>2</sub> thickness at elevation 33, 103, 158 mm correspondent to different azimuthal angles ( $\mu\text{m}$ ):			
	0°	5	5	5
	90°	5	5	5
	180°	5	5	5
	270°	5	5	5
1.3.	$\alpha\text{Zr(O)}$ thickness at elevation 33, 103, 158 mm correspondent to different azimuthal angles ( $\mu\text{m}$ ):			
	0°	0	0	0
	90°	0	0	0
	180°	0	0	0
	270°	0	0	0
1.4.	Clad hoop strain at elevation 33, 103, 158 mm, respectively(%)	10.1	3.4	22.8
2.	Measured parameters for FGR analysis			
	Internal gas composition (% by volume):			
	He	—		
	N <sub>2</sub>	—		
	O <sub>2</sub>	—		
	Ar	—		
	CO <sub>2</sub>	—		
	Kr	—		
	Xe	—		
2.2.	Free gas volume (cm <sup>3</sup> )	—		
2.3.	Gas pressure inside fuel rod under normal condition (MPa)	—		
2.4.	Kr concentration in fuel (cm <sup>3</sup> /g fuel)	—		
3.	Measured parameters of cladding hydriding			
3.1.	Coefficient of hydride orientation (per-unit)	0.19		
3.2.	Hydrogen concentration (% by weight)	—		



## #H7T

Individual Characteristics of Refabricated Fuel Rods  
(Preirradiated Fuel, Preirradiated Cladding) under IGR Tests

Table G-7.10. General Characteristic of Fuel Rod #H7T

	Parameter	Unit	Value		
			Experiment	FRAP-T6	SCANAIR
1	Type of coolant	—	water	water	water
2	Burnup	MWd/kg U	47.3	47.3	47.3
3	Energy deposition in fuel rod	cal/g fuel	244	244	244
4	Peak fuel enthalpy	cal/g fuel	-	187	-
5	Peak fuel temperature	K	-	2876	-
6	Peak clad temperature	K	-	1231	-
7	Fuel rod failure	Yes, No	Yes	Yes	-
8	Type of failure:				
	- cladding rupture due to ballooning	Yes, No	Yes	Yes	-
	- cladding rupture due to PCMI	Yes, No	No	No	-
	- fragmentation of fuel rod	Yes, No	No	-	-
9	Failure time	s	-	3.81	-
10	Fuel enthalpy at failure	cal/g fuel	-	182	-
11	Outer cladding temperature at failure	K	-	1229	-
12	Internal gas pressure at failure	MPa	-	2.33	-
13	ZrO <sub>2</sub> thickness after test	μm	5	5.15	-
14	Residual clad hoop strain:				
	- peak value for ballooning area	%	10.1	11.95	-
	- other location <sup>1)</sup>	%	3.4	2.16	-
15	Kr concentration in internal gas composition after test	% by volume	-	2.84	-
16	Xe concentration in internal gas composition after test	% by volume	-	17.02	-
17	Kr concentration in fuel after test	cm <sup>3</sup> /g fuel	-	0.15	-

<sup>1)</sup>Calculated values by FRAP-T6 and SCANAIR codes are average along height of fuel rod excluding ballooning region



**APPENDIX G-8.**

*Individual Characteristics for Fuel Rod #H8T under IGR Test*

#H8T

Individual Characteristics of Refabricated Fuel Rods  
(Preirradiated Fuel, Preirradiated Cladding) under IGR Tests

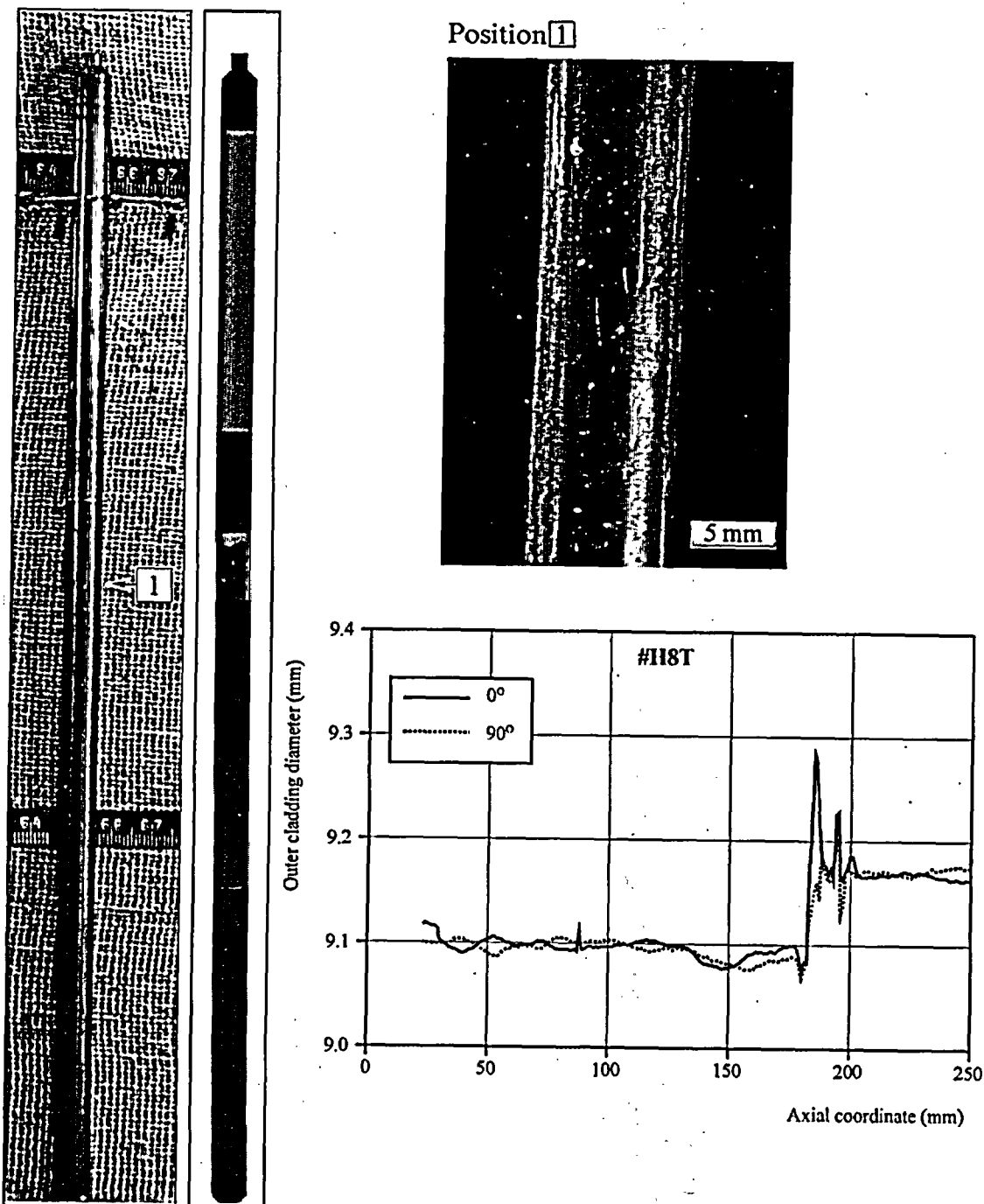
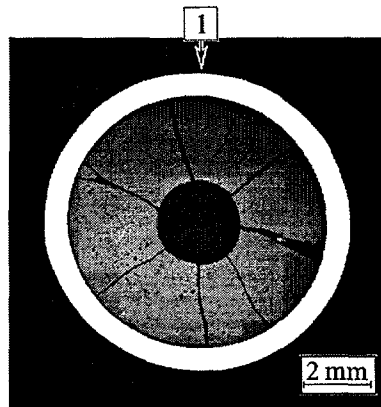

Fig. G-8.1. Appearance of Fuel Rod #H8T (photographs and X-ray photograph) and Profilometry

#H8T

Individual Characteristics of Refabricated Fuel Rods  
(Preirradiated Fuel, Preirradiated Cladding) under IGR Tests



Position 1

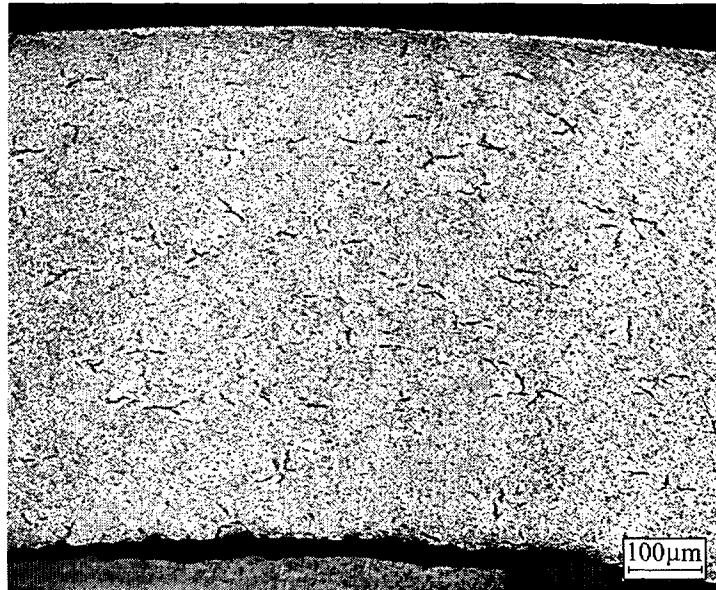

Fig. G-8.2. Cross-Section and Cladding Microstructure for Fuel Rod #H8T at 90 mm Elevation

#H8T

Individual Characteristics of Refabricated Fuel Rods  
(Preirradiated Fuel, Preirradiated Cladding) under IGR Tests

Position 1

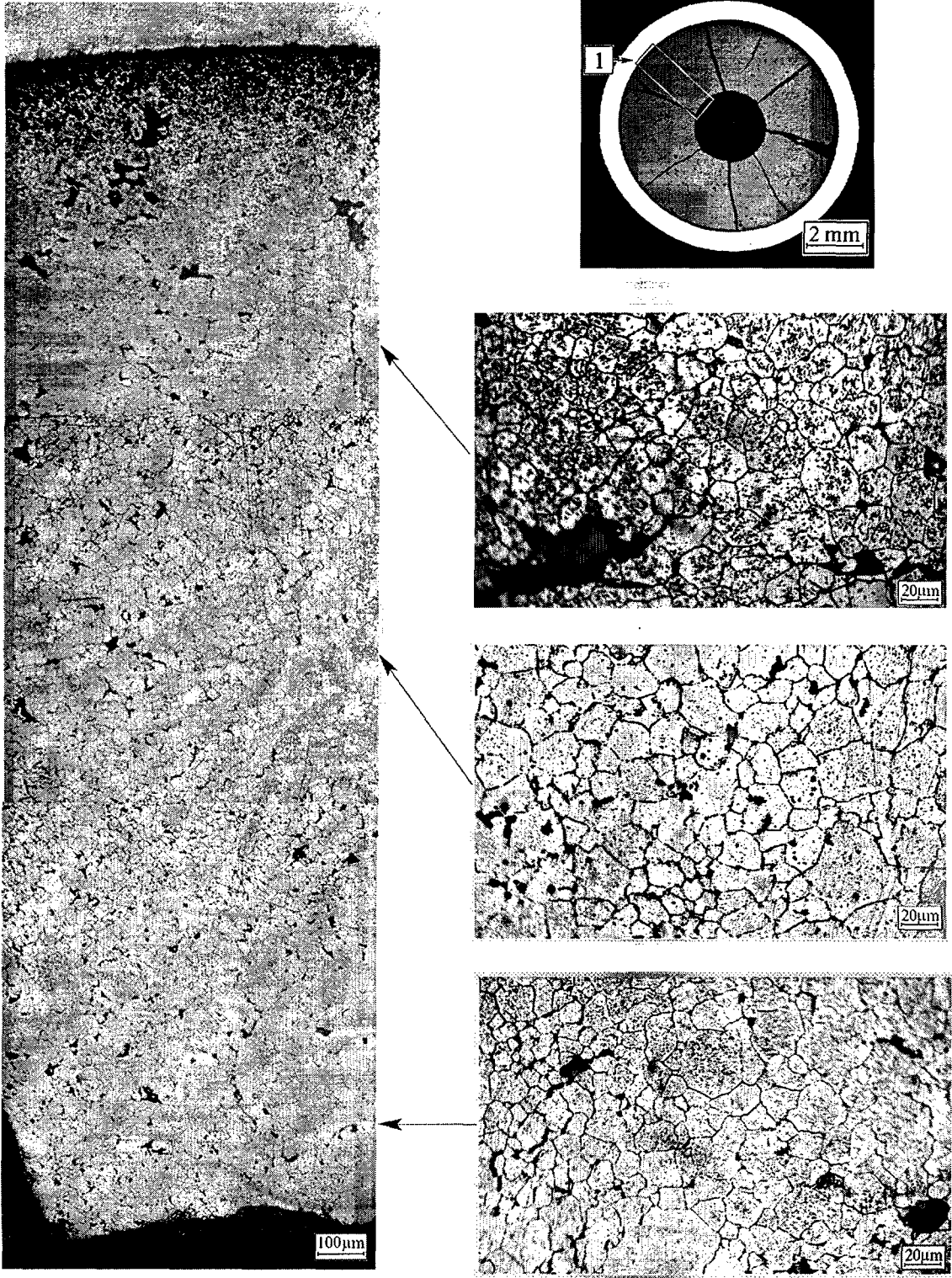

Fig. G-8.3. Fuel Microstructure for Fuel Rod #H8T at 90 mm Elevation

# #H8T

Individual Characteristics of Refabricated Fuel Rods  
(Preirradiated Fuel, Preirradiated Cladding) under IGR Tests

Table G-8.1. Time Dependent Energy Characteristics of Fuel Rod #H8T

Time (s)	Reactor energy deposition <sup>1)</sup> (%)	Cumulative number of fissions in fuel rod (fiss)						Power of fuel rod (kW)	Energy deposition in fuel rod	
		U <sup>235</sup> ×10 <sup>-14</sup>	U <sup>238</sup> ×10 <sup>-13</sup>	Pu <sup>239</sup> ×10 <sup>-14</sup>	Pu <sup>241</sup> ×10 <sup>-14</sup>	Other isotopes ×10 <sup>-11</sup>	Total ×10 <sup>-14</sup>		cal/g fuel	J/g fuel
0.0	0.000	0.000	0.000	0.000	0.000	0.000	0.000	0.000	0.000	0.000
1.0	0.575	0.017	0.004	0.023	0.009	0.017	0.050	0.286	0.608	2.550
2.0	2.300	0.068	0.014	0.093	0.037	0.069	0.200	0.574	2.440	10.20
2.2	2.790	0.082	0.017	0.113	0.045	0.084	0.242	0.639	2.950	12.30
2.4	3.330	0.098	0.021	0.135	0.054	0.100	0.289	0.708	3.530	14.80
2.6	3.920	0.115	0.024	0.159	0.064	0.118	0.341	0.786	4.160	17.40
2.8	4.590	0.135	0.028	0.186	0.074	0.138	0.399	0.884	4.870	20.40
3.0	5.350	0.158	0.033	0.217	0.087	0.161	0.465	1.020	5.670	23.70
3.2	6.250	0.184	0.039	0.253	0.101	0.188	0.543	1.230	6.630	27.80
3.4	7.370	0.217	0.045	0.299	0.120	0.221	0.640	1.590	7.810	32.70
3.6	8.870	0.261	0.055	0.360	0.144	0.267	0.770	2.230	9.400	39.30
3.8	11.10	0.327	0.069	0.450	0.180	0.334	0.964	3.480	11.80	49.40
4.0	14.80	0.436	0.091	0.600	0.240	0.445	1.290	6.020	15.70	65.70
4.2	21.40	0.631	0.132	0.869	0.348	0.644	1.860	10.90	22.70	95.00
4.4	33.00	0.971	0.204	1.340	0.536	0.992	2.870	17.90	35.00	147.0
4.6	49.10	1.440	0.303	1.990	0.796	1.470	4.260	20.70	52.00	218.0
4.8	64.50	1.900	0.398	2.610	1.050	1.940	5.600	17.10	68.30	286.0
5.0	76.00	2.240	0.469	3.080	1.230	2.280	6.600	11.40	80.50	337.0
5.2	83.10	2.450	0.513	3.370	1.350	2.500	7.220	6.720	88.10	369.0
5.4	87.20	2.570	0.538	3.530	1.420	2.620	7.570	3.850	92.50	387.0
5.6	89.50	2.640	0.553	3.630	1.450	2.690	7.780	2.330	95.00	398.0
5.8	91.00	2.680	0.562	3.690	1.480	2.740	7.900	1.530	96.60	404.0
6.0	92.00	2.710	0.568	3.730	1.490	2.770	7.990	1.110	97.70	409.0
6.5	93.60	2.750	0.578	3.790	1.520	2.810	8.130	0.680	99.50	417.0
7.0	94.70	2.790	0.585	3.840	1.540	2.850	8.220	0.480	101.0	423.0
7.5	95.40	2.810	0.589	3.870	1.550	2.870	8.280	0.328	102.0	427.0
8.0	95.90	2.820	0.592	3.890	1.560	2.880	8.330	0.238	102.0	427.0
9.0	96.60	2.840	0.596	3.920	1.570	2.900	8.390	0.182	103.0	431.0
10.0	97.10	2.860	0.599	3.940	1.580	2.920	8.430	0.125	104.0	435.0
20.0	98.70	2.900	0.609	4.000	1.600	2.970	8.570	0.026	106.0	444.0
30.0	99.10	2.920	0.612	4.020	1.610	2.980	8.610	0.013	107.0	448.0
∞	100.0	2.940	0.617	4.050	1.620	3.010	8.690	0.000	109.0	456.0

Maximum value of power is 20.8 kW (t = 4.55 s).

<sup>1)</sup> Current energy deposition per maximum energy deposition (at infinite time)

## #H8T

Individual Characteristics of Refabricated Fuel Rods  
(Preirradiated Fuel, Preirradiated Cladding) under IGR Tests

Table G-8.2. Axial Energy Characteristics of Fuel Rod #H8T

Axial coordinate from lower end of fuel rod (mm)	Cumulative number of fissions at axial interval (fiss)						Maximum power of fuel rod (kW) $t=4.55s$	Energy deposition at infinite time*		
	$U^{235} \times 10^{-13}$	$U^{238} \times 10^{-11}$	$Pu^{239} \times 10^{-13}$	$Pu^{241} \times 10^{-13}$	Other isotopes $\times 10^{-10}$	Total $\times 10^{-13}$		cal/g fuel	J/g fuel	per-unit <sup>3)</sup>
10.0 <sup>1)</sup>	0.752	1.400	1.080	0.440	0.741	2.290	0.549	117.0	490.0	1.00
15.0	0.752	1.400	1.080	0.440	0.741	2.290	0.549	117.0	490.0	1.00
20.0	0.752	1.400	1.080	0.440	0.741	2.290	0.549	117.0	490.0	1.00
25.0	0.752	1.400	1.080	0.440	0.741	2.290	0.549	117.0	490.0	1.00
30.0	0.755	1.500	1.080	0.440	0.758	2.290	0.548	116.0	486.0	0.99
35.0	0.755	1.500	1.080	0.440	0.758	2.290	0.548	116.0	486.0	0.99
40.0	0.755	1.500	1.080	0.440	0.758	2.290	0.548	116.0	486.0	0.99
45.0	0.755	1.500	1.080	0.440	0.758	2.290	0.548	116.0	486.0	0.99
50.0	0.755	1.500	1.080	0.440	0.758	2.290	0.548	116.0	486.0	0.99
55.0	0.755	1.500	1.080	0.440	0.758	2.290	0.548	116.0	486.0	0.99
60.0	0.713	1.620	1.020	0.415	0.777	2.170	0.519	110.0	460.0	0.94
65.0	0.713	1.620	1.020	0.415	0.777	2.170	0.519	110.0	460.0	0.94
70.0	0.713	1.620	1.020	0.415	0.777	2.170	0.519	110.0	460.0	0.94
75.0	0.713	1.620	1.020	0.415	0.777	2.170	0.519	110.0	460.0	0.94
80.0	0.713	1.620	1.020	0.415	0.777	2.170	0.519	110.0	460.0	0.94
85.0	0.713	1.620	1.020	0.415	0.777	2.170	0.519	110.0	460.0	0.94
90.0	0.713	1.620	1.020	0.415	0.777	2.170	0.519	110.0	460.0	0.94
95.0	0.713	1.620	1.020	0.415	0.777	2.170	0.519	110.0	460.0	0.94
100.0	1.060	2.160	1.410	0.556	1.090	3.050	0.731	109.0	456.0	0.93
105.0	1.070	2.220	1.420	0.561	1.090	3.080	0.737	109.0	456.0	0.93
110.0	1.060	2.240	1.410	0.558	1.100	3.060	0.733	108.0	452.0	0.92
115.0	1.060	2.260	1.410	0.555	1.100	3.050	0.731	108.0	452.0	0.92
120.0	1.050	2.260	1.400	0.552	1.100	3.030	0.726	108.0	452.0	0.92
125.0	1.050	2.270	1.400	0.550	1.100	3.020	0.725	107.0	448.0	0.91
130.0	1.060	2.290	1.400	0.554	1.100	3.040	0.728	107.0	448.0	0.91
135.0	1.070	2.310	1.420	0.557	1.090	3.060	0.734	106.0	444.0	0.91
140.0	1.070	2.330	1.430	0.563	1.080	3.090	0.741	105.0	440.0	0.90
145.0	1.080	2.340	1.440	0.567	1.070	3.120	0.748	104.0	435.0	0.89
150.0	1.080	2.320	1.440	0.567	1.060	3.120	0.747	103.0	431.0	0.88
155.0	1.080	2.290	1.440	0.565	1.040	3.100	0.744	102.0	427.0	0.87
160.0	1.060	2.220	1.410	0.555	1.020	3.050	0.731	101.0	423.0	0.86
165.0	1.020	2.110	1.370	0.538	1.000	2.950	0.707	100.0	419.0	0.85
170.0	1.010	2.040	1.360	0.532	0.978	2.920	0.700	99.20	415.0	0.85
175.0 <sup>2)</sup>	1.010	2.040	1.360	0.532	0.978	2.920	0.700	99.20	415.0	0.85
180.0	0.000	0.000	0.000	0.000	0.000	0.000	0.000	0.000	0.000	0.00
185.0	0.000	0.000	0.000	0.000	0.000	0.000	0.000	0.000	0.000	0.00

\* All numerical values of characteristics are presented as average values at the length interval equal to the axial coordinate  $\pm 2.5$  mm.

<sup>1)</sup> Initial coordinate of fuel is 10.5 mm.

<sup>2)</sup> End coordinate of fuel is 177.5 mm.

<sup>3)</sup> Current value per maximum value.



## #H8T

Individual Characteristics of Refabricated Fuel Rods (Preirradiated Fuel, Preirradiated Cladding) under IGR Tests
--

Table G-8.3. Radial Energy Characteristics of Fuel Rod #H8T

Characteristics*		Coordinates of fuel zones (mm)			
		1 zone 1.2 - 2.811	2 zone 2.811-3.432	3 zone 3.432-3.704	4 zone 3.704-3.790
U <sup>235</sup>	Number of fissions $\times 10^{-14}$ (fiss)	0.806	0.474	0.233	0.076
	Power of fuel rod <sup>1)</sup> (kW)	1.900	1.120	0.549	0.179
	Energy deposition <sup>2)</sup> (cal/g fuel)	36.40	35.70	35.10	34.30
	Energy deposition <sup>2)</sup> (J/g fuel)	152.0	149.0	147.0	144.0
	Energy deposition <sup>3)</sup> (per-unit)	1.000	0.981	0.964	0.942
U <sup>238</sup>	Number of fissions $\times 10^{-12}$ (fiss)	1.770	0.996	0.459	0.139
	Power of fuel rod <sup>1)</sup> (kW)	0.041	0.023	0.011	0.003
	Energy deposition <sup>2)</sup> (cal/g fuel)	0.789	0.740	0.681	0.618
	Energy deposition <sup>2)</sup> (J/g fuel)	3.300	3.100	2.850	2.590
	Energy deposition <sup>3)</sup> (per-unit)	1.000	0.938	0.863	0.783
Pu <sup>239</sup>	Number of fissions $\times 10^{-14}$ (fiss)	0.876	0.597	0.411	0.234
	Power of fuel rod <sup>1)</sup> (kW)	2.130	1.450	0.999	0.569
	Energy deposition <sup>2)</sup> (cal/g fuel)	40.90	46.40	63.90	109.0
	Energy deposition <sup>2)</sup> (J/g fuel)	171.0	194.0	267.0	456.0
	Energy deposition <sup>3)</sup> (per-unit)	0.375	0.426	0.586	1.000
Pu <sup>241</sup>	Number of fissions $\times 10^{-13}$ (fiss)	3.290	2.340	1.690	1.010
	Power of fuel rod <sup>1)</sup> (kW)	0.785	0.559	0.403	0.242
	Energy deposition <sup>2)</sup> (cal/g fuel)	15.10	17.90	25.80	46.50
	Energy deposition <sup>2)</sup> (J/g fuel)	63.20	74.90	108.0	195.0
	Energy deposition <sup>3)</sup> (per-unit)	0.325	0.385	0.555	1.000
Other isoto- pes	Number of fissions $\times 10^{-11}$ (fiss)	0.747	0.460	0.268	0.128
	Power of fuel rod <sup>1)</sup> (kW)	0.002	0.001	0.001	0.000
	Energy deposition <sup>2)</sup> (cal/g fuel)	0.034	0.036	0.041	0.059
	Energy deposition <sup>2)</sup> (J/g fuel)	0.140	0.150	0.170	0.250
	Energy deposition <sup>3)</sup> (per-unit)	0.584	0.601	0.699	1.000
Total	Number of fissions $\times 10^{-14}$ (fiss)	2.030	1.310	0.817	0.413
	Power of fuel rod <sup>1)</sup> (kW)	4.860	3.150	1.960	0.992
	Energy deposition <sup>2)</sup> (cal/g fuel)	93.10	101.0	125.0	190.0
	Energy deposition <sup>2)</sup> (J/g fuel)	390.0	423.0	523.0	795.0
	Energy deposition <sup>3)</sup> (per-unit)	0.490	0.532	0.658	1.000

1) at time of 4.55 s, 2) at infinite time, 3) Current value per maximum value.

\* All numerical values of characteristics were calculated for undamaged part of fuel stack only (See Table C.2.2.)

# #H8T

Individual Characteristics of Refabricated Fuel Rods  
(Preirradiated Fuel, Preirradiated Cladding) under JGR Tests

Table G-8.4. Fuel Enthalpy Vs. Time Calculated by FRAP-T6 Code for Fuel Rod #H8T

Time (s)	Enthalpy at fuel radius (cal/g fuel)				Fuel enthalpy <sup>1)</sup>		Energy deposition in fuel rod	
	1.20 mm	2.82 mm	3.47 mm	3.79 mm	cal/g fuel	J/g fuel	cal/g fuel	J/g fuel
0.0	0.00	0.00	0.00	0.00	0.00	0.00	0.00	0.00
1.0	0.59	0.58	0.54	0.51	0.57	2.39	0.59	2.45
2.0	2.28	2.18	2.06	1.96	2.17	9.11	2.39	10.0
2.2	2.75	2.63	2.48	2.36	2.62	11.0	2.90	12.2
2.4	3.26	3.12	2.95	2.81	3.11	13.0	3.47	14.5
2.6	3.82	3.66	3.47	3.31	3.65	15.3	4.10	17.2
2.8	4.45	4.27	4.05	3.86	4.25	17.8	4.80	20.1
3.0	5.17	4.96	4.70	4.49	4.94	20.7	5.60	23.5
3.2	6.02	5.78	5.49	5.25	5.76	24.2	6.55	27.4
3.4	7.14	6.86	6.52	6.21	6.83	28.6	7.76	32.5
3.6	8.72	8.40	7.97	7.54	8.36	35.0	9.47	39.7
3.8	11.3	10.9	10.2	9.38	10.8	45.1	12.2	51.0
4.0	14.6	14.0	12.8	11.5	13.8	57.7	15.6	65.3
4.2	22.8	21.7	19.3	16.2	21.2	88.7	24.0	101
4.4	33.8	32.1	27.5	21.8	31.0	130	35.3	148
4.6	49.0	46.0	36.4	22.8	43.4	182	50.8	213
4.8	66.2	58.9	38.8	21.3	54.4	228	68.4	287
5.0	76.6	63.8	38.7	20.9	59.7	250	79.4	332
5.2	83.9	64.0	35.9	19.6	61.4	257	88.0	369
5.4	86.3	60.6	32.7	18.1	60.0	252	92.4	387
5.6	85.6	55.0	28.9	16.6	56.5	237	95.5	400
5.8	83.7	51.4	27.0	16.0	54.0	226	96.7	405
6.0	79.7	46.9	25.3	16.0	50.5	211	97.9	410
6.5	67.2	40.7	25.9	19.2	44.2	185	99.8	418
7.0	57.0	36.3	23.9	18.1	38.8	162	101	423
7.5	48.0	31.9	22.1	17.4	33.8	142	102	426
8.0	40.2	28.0	20.3	16.6	29.4	123	102	429
10.0	21.5	17.3	14.2	12.5	17.6	73.8	104	436
30.0	5.16	5.12	5.09	5.06	5.12	21.5	107	448

Radial enthalpy distribution and fuel enthalpy are presented at elevation 18.9 mm

Maximum value of fuel enthalpy is 61.4 cal/g fuel (t=5.16 s)

<sup>1)</sup> All numerical values are presented at elevation with peak power

# #H8T

Individual Characteristics of Refabricated Fuel Rods  
(Preirradiated Fuel, Preirradiated Cladding) under IGR Tests

Table G-8.5. Energy Characteristics Vs. Time Calculated by FRAP-T6 and SCANAIR Codes for Fuel Rod #H8T

Time (s)	Energy deposition <sup>1)</sup> (cal/g fuel)	Linear power <sup>1)</sup> (kW/m)	Fuel enthalpy <sup>1)</sup> (cal/g fuel)		Energy of metal-water reaction <sup>1)</sup> (cal/g fuel)	Leakage of energy <sup>1)</sup> (cal/g fuel)		Clad-to-coolant heat transfer coefficient <sup>1)</sup> (kW/m <sup>2</sup> K)	
			FRAP-T6	SCANAIR	FRAP-T6	FRAP-T6	SCANAIR	FRAP-T6	SCANAIR
0.0	0.00	0.00	0.00	0.00	0.00	0.00	0.00	0.00	0.00
1.0	0.63	2.29	0.57	0.55	0.00	0.00	0.00	0.03	0.10
2.0	2.56	4.63	2.17	2.13	0.00	0.01	0.02	0.03	0.10
2.2	3.11	5.16	2.62	2.52	0.00	0.01	0.03	0.03	0.10
2.4	3.72	5.72	3.11	3.01	0.00	0.01	0.04	0.03	0.10
2.6	4.39	6.34	3.65	3.56	0.00	0.01	0.05	0.03	0.10
2.8	5.14	7.12	4.25	4.09	0.00	0.02	0.06	0.03	0.10
3.0	5.99	8.19	4.94	4.78	0.00	0.02	0.08	0.03	0.10
3.2	7.01	9.86	5.76	5.62	0.00	0.03	0.10	0.03	0.10
3.4	8.31	12.8	6.83	6.52	0.00	0.04	0.12	0.03	0.10
3.6	10.1	18.4	8.36	7.95	0.00	0.12	0.15	0.71	0.36
3.8	13.0	30.3	10.8	10.1	0.00	0.50	0.48	1.68	1.68
4.0	16.7	48.3	13.8	13.4	0.00	1.07	1.13	2.69	2.94
4.2	25.7	96.0	21.2	19.9	0.00	2.53	2.45	5.31	5.35
4.4	37.8	147	31.0	29.3	0.00	4.70	4.52	8.55	9.00
4.6	54.4	169	43.4	43.2	0.00	8.55	8.83	16.4	14.7
4.8	73.3	139	54.4	53.1	0.00	16.9	14.3	19.3	18.3
5.0	85.0	99.2	59.7	59.2	0.00	23.9	21.8	19.0	19.6
5.2	94.2	56.1	61.4	60.3	0.00	32.2	28.8	17.4	18.6
5.4	99.0	32.5	60.0	58.7	0.00	38.8	35.6	15.7	16.7
5.6	102	17.7	56.5	55.7	0.00	46.1	41.5	13.8	14.8
5.8	104	12.9	54.0	52.9	0.00	50.0	46.0	12.6	13.4
6.0	105	9.04	50.5	49.6	0.00	54.9	50.7	10.8	12.0
6.5	107	5.45	44.2	42.4	0.00	62.6	60.1	7.71	9.75
7.0	108	3.95	38.8	36.6	0.00	68.8	67.3	7.03	8.23
7.5	109	2.73	33.8	31.3	0.00	74.2	73.7	5.92	6.99
8.0	110	1.97	29.4	26.7	0.00	78.9	79.0	5.05	5.91
10.0	111	1.02	17.6	15.3	0.00	91.7	92.4	2.77	3.01
30.0	115	0.10	5.12	5.10	0.00	107	106	0.06	0.10

<sup>1)</sup> All numerical values are presented at elevation with peak power

# #H8T

Individual Characteristics of Refabricated Fuel Rods  
(Preirradiated Fuel, Preirradiated Cladding) under IGR Tests

Table G-8.6. Temperature Variation, Fission Gas Release and ZrO<sub>2</sub> Thickness Vs. Time for Fuel Rod #H8T Calculated by FRAP-T6 and SCANAIR Codes

Time (s)	Fuel centerline temperature <sup>1)</sup> (K)		Fuel surface temperature <sup>1)</sup> (K)		Clad outer temperature <sup>1)</sup> (K)		Fission gas release (%)		Average ZrO <sub>2</sub> <sup>2)</sup> thickness (μm)
	FRAP-T6	SCANAIR	FRAP-T6	SCANAIR	FRAP-T6	SCANAIR	FRAP-T6	SCANAIR	FRAP-T6
0.0	293	293	293	293	293	293	0.00	0.00	5
1.0	304	302	302	301	297	297	0.00	0.09	5
2.0	333	329	327	325	316	314	0.01	0.25	5
2.2	341	335	334	331	321	318	0.02	0.29	5
2.4	349	343	342	338	327	324	0.02	0.34	5
2.6	358	352	350	346	334	331	0.03	0.39	5
2.8	369	360	359	354	342	337	0.03	0.43	5
3.0	380	372	369	364	351	345	0.04	0.49	5
3.2	394	385	381	376	360	354	0.04	0.56	5
3.4	411	399	397	389	372	364	0.05	0.63	5
3.6	436	421	417	409	383	377	0.06	0.72	5
3.8	475	455	446	437	389	381	0.08	0.86	5
4.0	523	506	478	476	393	384	0.10	1.04	5
4.2	641	605	547	546	401	389	0.16	1.52	5
4.4	796	745	628	633	409	394	0.26	2.05	5
4.6	1001	960	642	724	422	400	0.46	2.59	5
4.8	1227	1133	620	751	426	404	0.87	2.90	5
5.0	1361	1278	615	738	425	406	1.08	3.10	5
5.2	1455	1353	596	712	423	405	1.32	3.19	5
5.4	1485	1384	576	684	421	403	1.50	3.17	5
5.6	1475	1380	553	661	418	401	1.61	3.13	5
5.8	1451	1358	545	646	416	399	1.61	3.15	5
6.0	1401	1318	545	631	413	398	1.62	3.13	5
6.5	1240	1186	591	605	407	395	1.64	3.09	5
7.0	1106	1056	575	585	405	393	1.65	3.30	5
7.5	987	931	565	563	403	391	1.66	3.21	5
8.0	882	825	552	541	401	389	1.66	3.12	5
10.0	623	574	493	469	393	384	1.68	2.76	5
30.0	380	375	378	373	376	370	1.78	2.19	5

<sup>1)</sup> All numerical values are presented at elevation with peak power

<sup>2)</sup> Initial ZrO<sub>2</sub> thickness is 5 μm

# #H8T

Individual Characteristics of Refabricated Fuel Rods  
(Preirradiated Fuel, Preirradiated Cladding) under IGR Tests

Table G-8.7. Mechanical Characteristics of Fuel Rod #H8T Vs. Time Calculated by FRAP-T6 and SCANAIR Codes

Time (s)	Clad outer temperature <sup>1)</sup> (K)		Fuel hoop strain <sup>1)</sup> (%)		Fuel - clad gap width <sup>1)</sup> (mm)		Clad hoop strain <sup>1)</sup> (%)		Clad hoop stress <sup>1)</sup> (MPa)		Internal gas pressure (MPa)	
	FRAP-T6	SCANAIR	FRAP-T6	SCANAIR	FRAP-T6	SCANAIR	FRAP-T6	SCANAIR	FRAP-T6	SCANAIR	FRAP-T6	SCANAIR
0.0	293	293	0.00	0.00	0.03	0.03	0.01	0.01	8.63	7.96	1.70	1.70
1.0	297	297	0.01	0.01	0.03	0.03	0.01	0.01	8.68	8.02	1.71	1.70
2.0	316	314	0.05	0.02	0.03	0.03	0.02	0.02	8.81	8.15	1.73	1.72
2.2	321	318	0.06	0.03	0.03	0.03	0.03	0.03	8.84	8.18	1.74	1.73
2.4	327	324	0.07	0.03	0.03	0.03	0.03	0.03	8.88	8.21	1.75	1.73
2.6	334	331	0.08	0.04	0.03	0.03	0.04	0.04	8.91	8.25	1.75	1.74
2.8	342	337	0.09	0.05	0.03	0.03	0.04	0.04	8.95	8.28	1.76	1.74
3.0	351	345	0.11	0.05	0.03	0.03	0.05	0.05	8.99	8.33	1.77	1.75
3.2	360	354	0.12	0.06	0.03	0.03	0.05	0.05	9.03	8.38	1.77	1.76
3.4	372	364	0.15	0.07	0.03	0.03	0.06	0.06	9.09	8.43	1.78	1.77
3.6	383	377	0.18	0.09	0.03	0.03	0.07	0.07	9.16	8.52	1.80	1.78
3.8	389	381	0.23	0.12	0.02	0.03	0.08	0.08	9.26	8.69	1.82	1.80
4.0	393	384	0.29	0.15	0.02	0.03	0.08	0.08	9.37	8.92	1.84	1.83
4.2	401	389	0.44	0.22	0.02	0.03	0.09	0.09	9.57	9.35	1.87	1.87
4.4	409	394	0.65	0.33	0.01	0.02	0.10	0.10	9.77	9.92	1.91	1.91
4.6	422	400	0.94	0.51	0.00	0.02	0.17	0.12	72.8	10.7	1.95	1.96
4.8	426	404	1.26	0.63	0.00	0.01	0.44	0.14	389	11.1	1.97	1.98
5.0	425	406	1.44	0.71	0.00	0.01	0.59	0.14	387	11.3	1.99	2.00
5.2	423	405	1.54	0.72	0.00	0.01	0.68	0.14	376	11.2	2.00	2.00
5.4	421	403	1.60	0.69	0.00	0.01	0.73	0.13	355	11.1	2.00	2.00
5.6	418	401	1.56	0.65	0.00	0.01	0.69	0.12	267	10.9	2.00	2.00
5.8	416	399	1.47	0.60	0.00	0.01	0.62	0.12	193	10.7	2.00	2.00
6.0	413	398	1.35	0.55	0.00	0.01	0.52	0.11	76.4	10.6	2.00	2.00
6.5	407	395	1.10	0.45	0.01	0.02	0.49	0.11	10.3	10.3	1.98	1.98
7.0	405	393	0.92	0.37	0.02	0.02	0.48	0.10	10.2	10.1	1.97	1.97
7.5	403	391	0.77	0.30	0.02	0.02	0.48	0.10	10.1	9.93	1.95	1.96
8.0	401	389	0.65	0.25	0.03	0.02	0.48	0.09	10.1	9.75	1.94	1.94
10.0	393	384	0.36	0.12	0.04	0.03	0.47	0.08	9.74	9.20	1.88	1.88
30.0	376	370	0.10	0.01	0.05	0.03	0.45	0.07	9.18	8.50	1.78	1.79

<sup>1)</sup> All numerical values are presented at elevation with peak power

# #H8T

Individual Characteristics of Refabricated Fuel Rods  
(Preirradiated Fuel, Preirradiated Cladding) under IGR Tests

Table G-8.8. Axial Distribution of Energy Deposition and Fuel Enthalpy Calculated by FRAP-T6 Code for Fuel Rod #H8T

Axial interval from-to (mm)-(mm)	Energy deposition at infinite time			Fuel enthalpy at time (t=5.16 s)		
	cal/g fuel	J/g fuel	per-unit	cal/g fuel	J/g fuel	per-unit
10.5 - 27.2	117	490	1.00	61.4	257	1.00
27.2 - 43.9	116	486	0.99	60.9	255	0.99
43.9 - 60.6	115	481	0.98	60.3	253	0.98
60.6 - 77.3	110	461	0.94	57.8	242	0.94
77.3 - 94.0	110	461	0.94	57.8	242	0.94
94.0 - 110.7	109	457	0.93	57.2	240	0.93
110.7 - 127.4	108	451	0.92	56.5	237	0.92
127.4 - 144.1	106	443	0.90	55.6	233	0.90
144.1 - 160.8	103	430	0.88	53.8	226	0.88
160.8 - 177.5	99.6	417	0.85	52.3	219	0.85

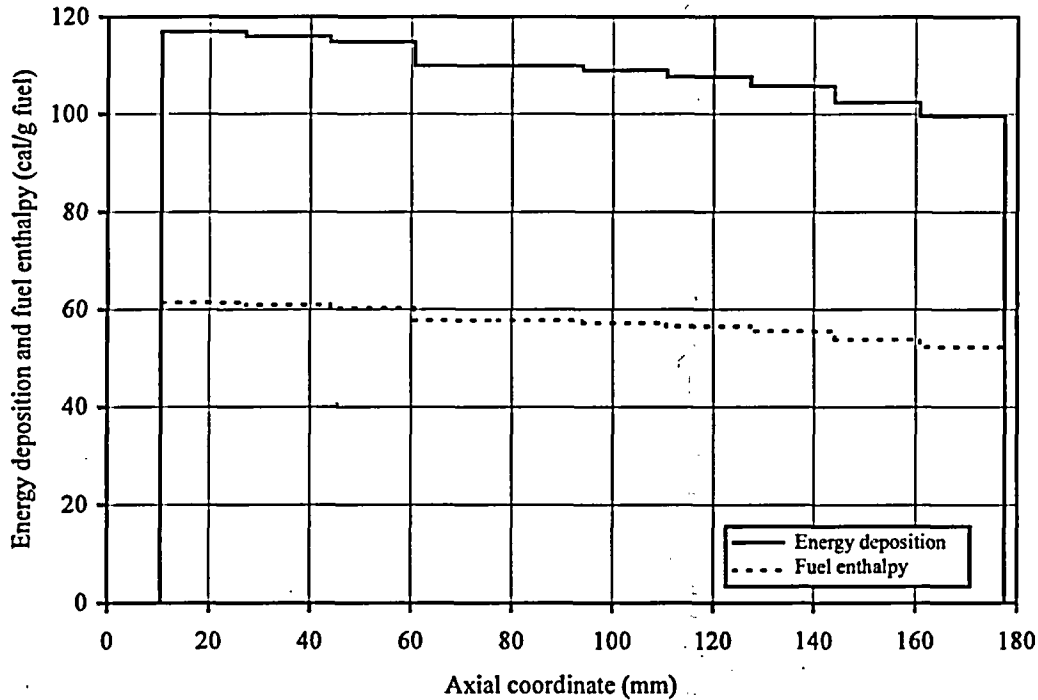

Fig. G-8.4. Axial Distribution of Energy Deposition and Fuel Enthalpy Calculated by FRAP-T6 Code for Fuel Rod #H8T

#H8T

Individual Characteristics of Refabricated Fuel Rods  
(Preirradiated Fuel, Preirradiated Cladding) under IGR Tests

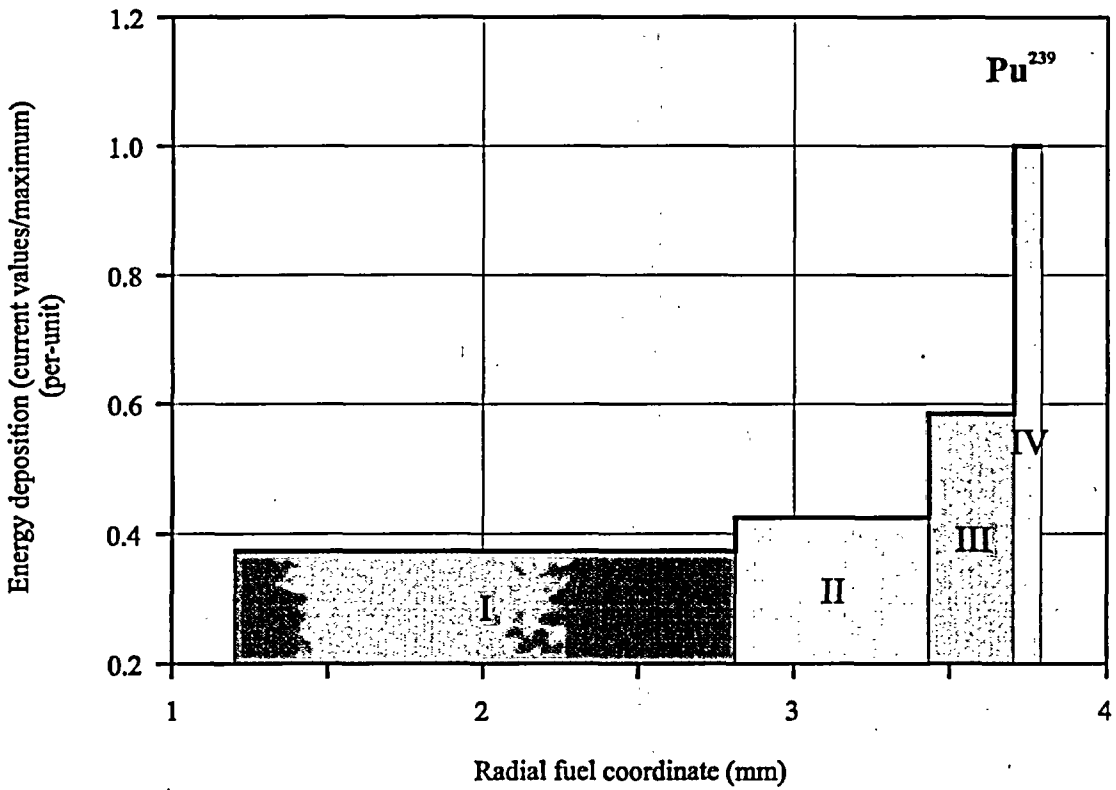
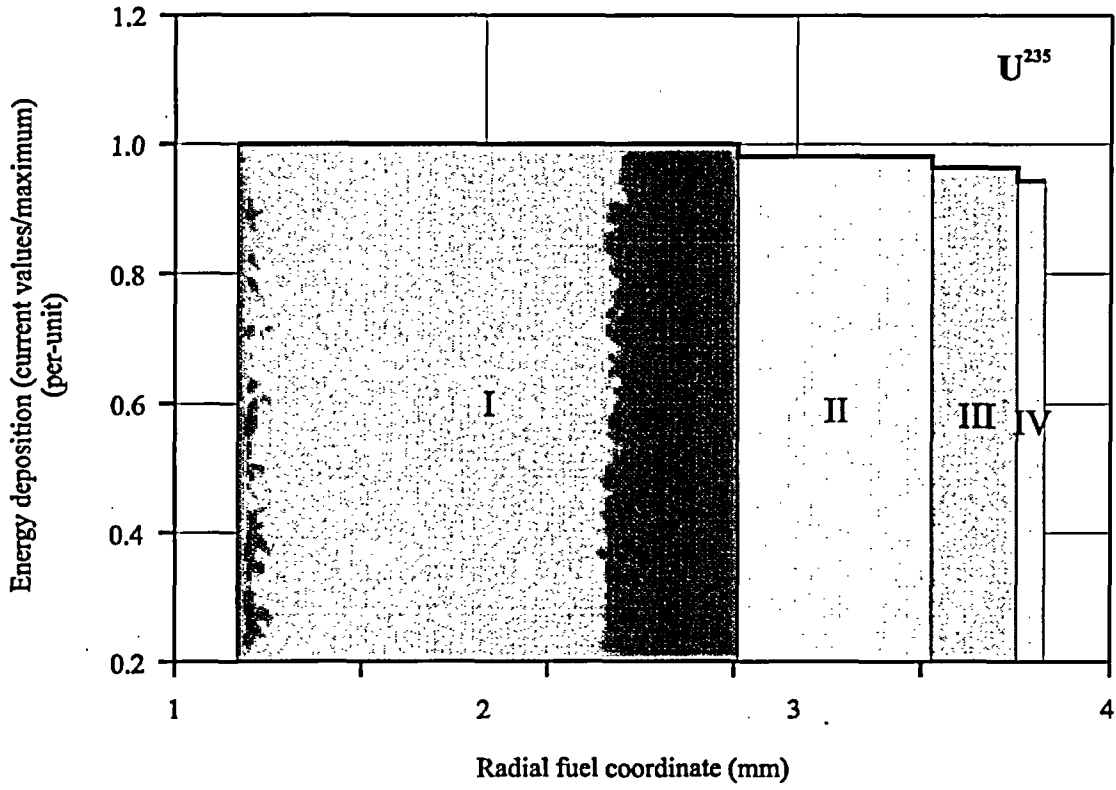

Fig. G-8.5.  $U^{235}$  and  $Pu^{239}$  Radial Distributions of Energy Deposition for Fuel Rod #H8T

# #H8T

Individual Characteristics of Refabricated Fuel Rods  
(Preirradiated Fuel, Preirradiated Cladding) under IGR Tests

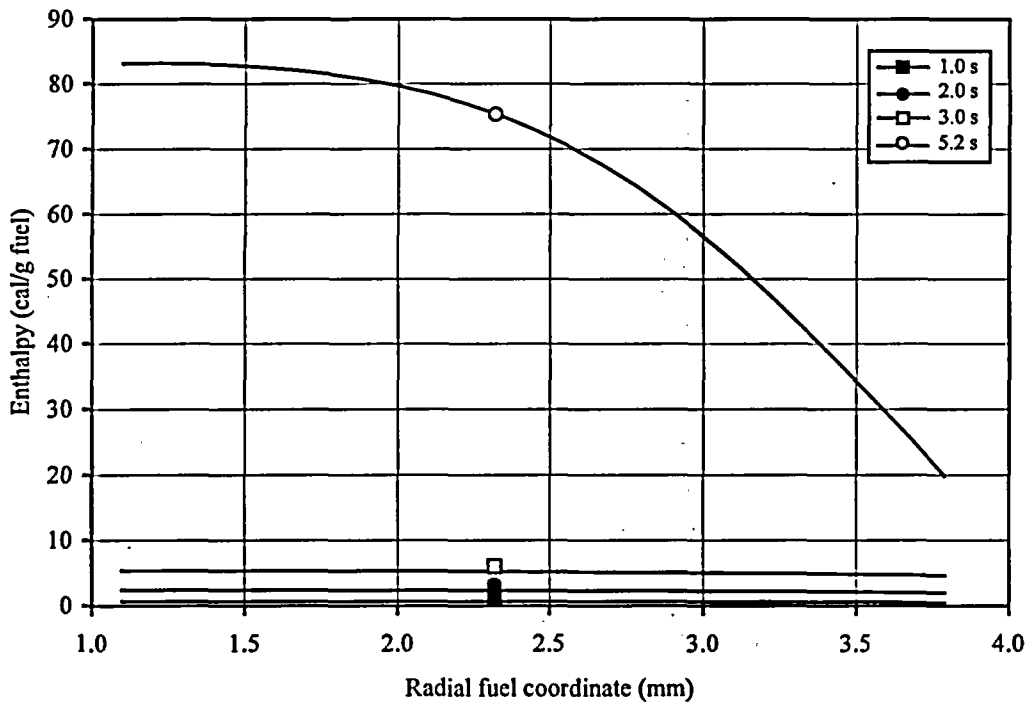
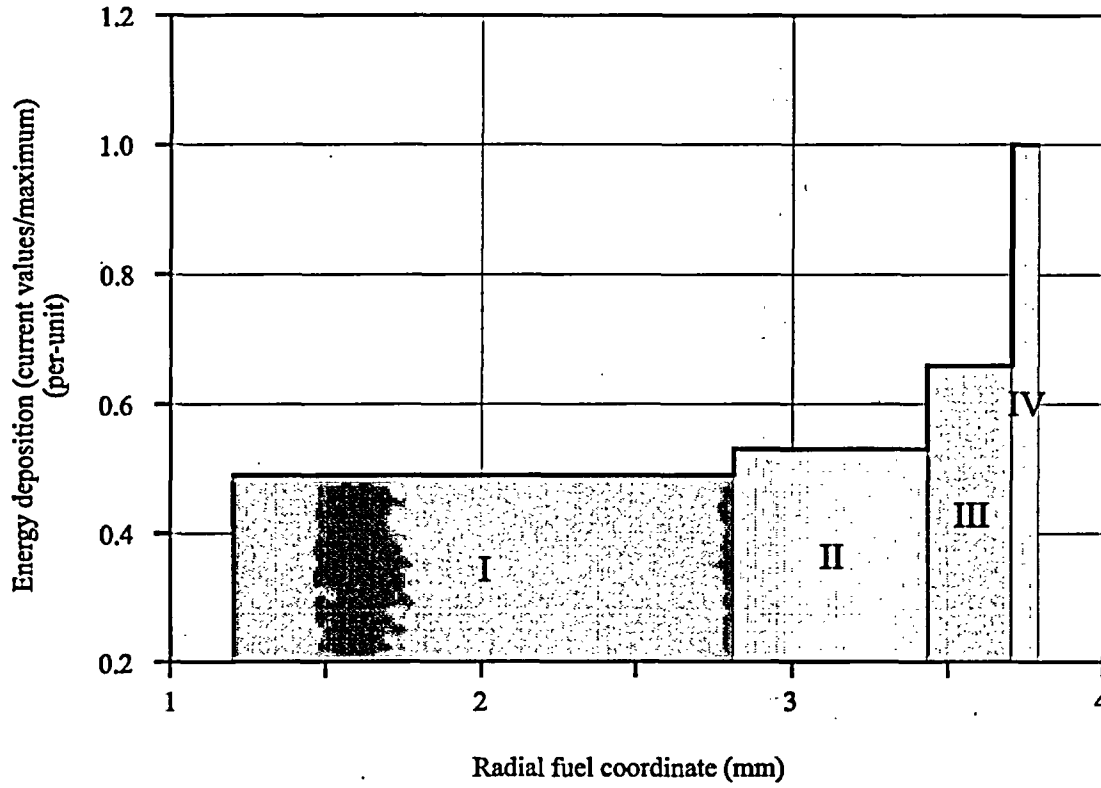

Fig. G-8.6. Radial Distributions of Energy Deposition and Fuel Enthalpy Calculated by FRAP-T6 Code for Fuel Rod #H8T



# #H8T

Individual Characteristics of Refabricated Fuel Rods  
(Preirradiated Fuel, Preirradiated Cladding) under IGR Tests

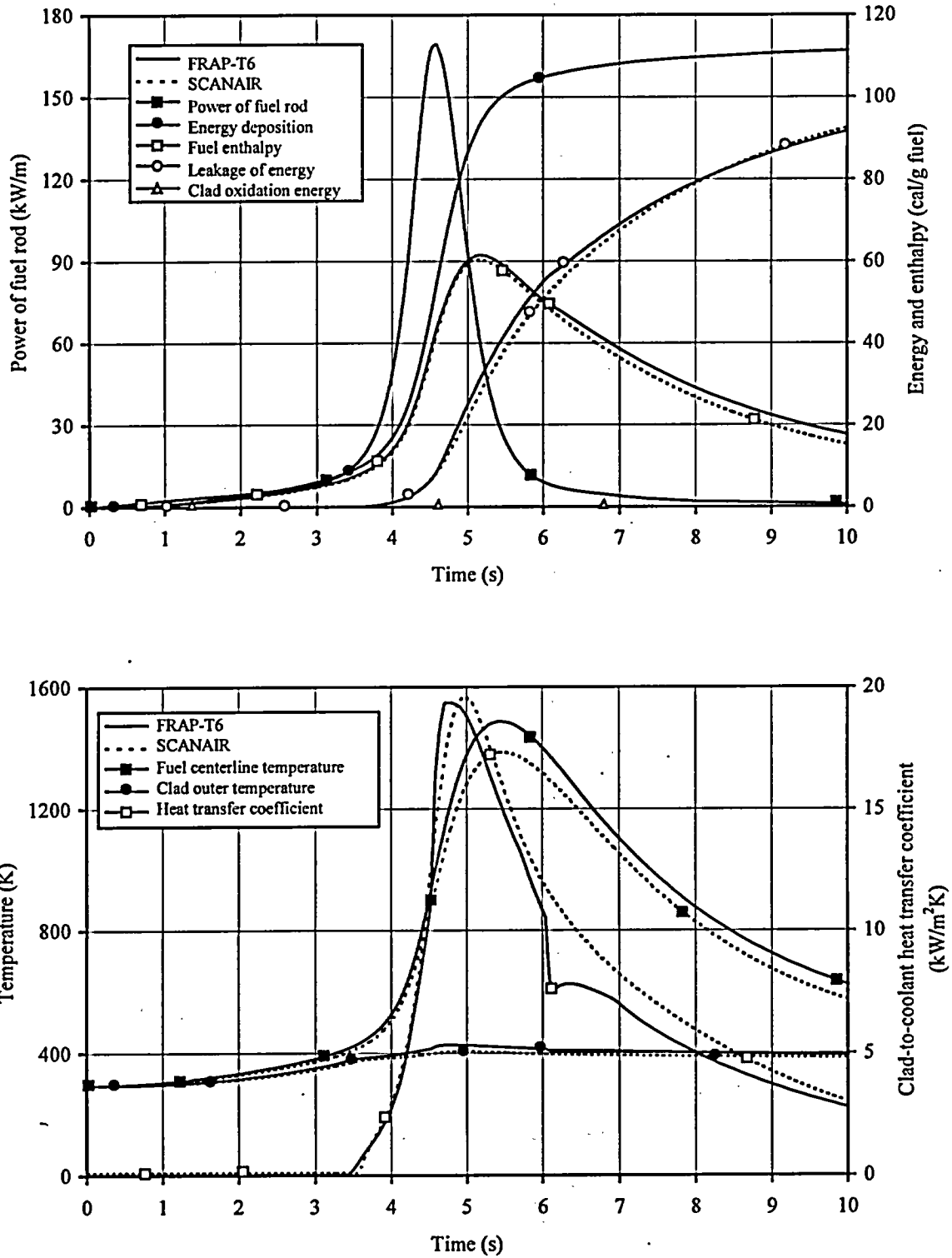

Fig. G-8.7. Energy and Temperature Characteristics Vs. Time Calculated by FRAP-T6 and SCANAIR Codes for Fuel Rod #H8T

#H8T

Individual Characteristics of Refabricated Fuel Rods  
(Preirradiated Fuel, Preirradiated Cladding) under IGR Tests

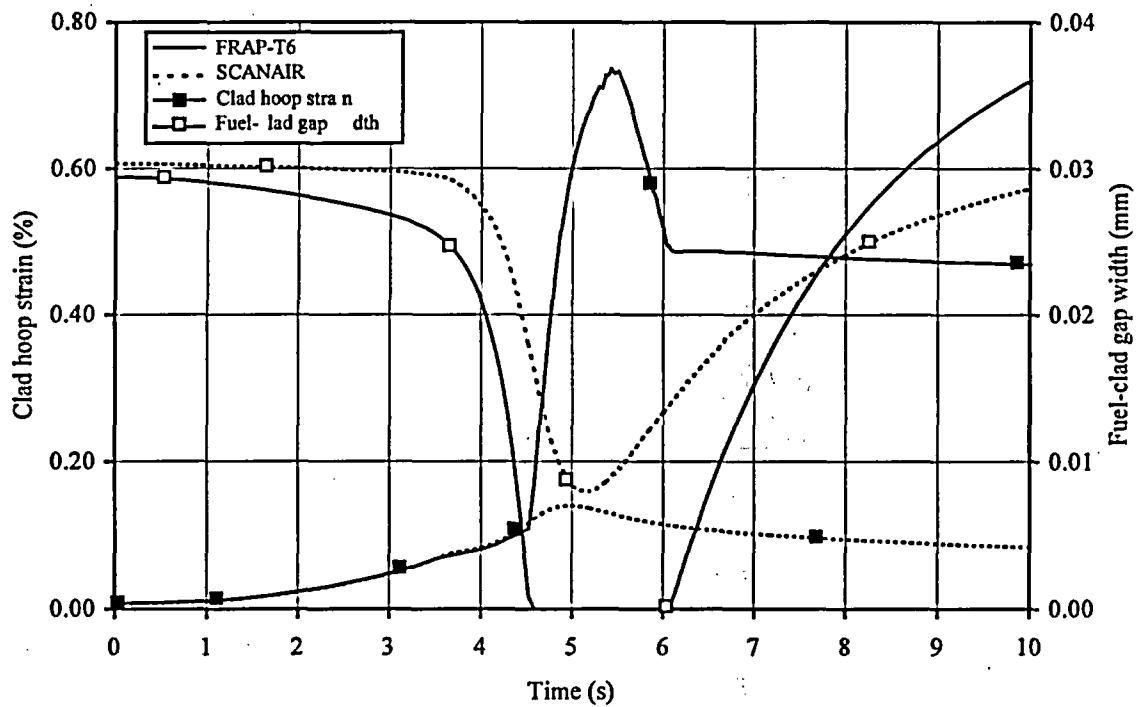
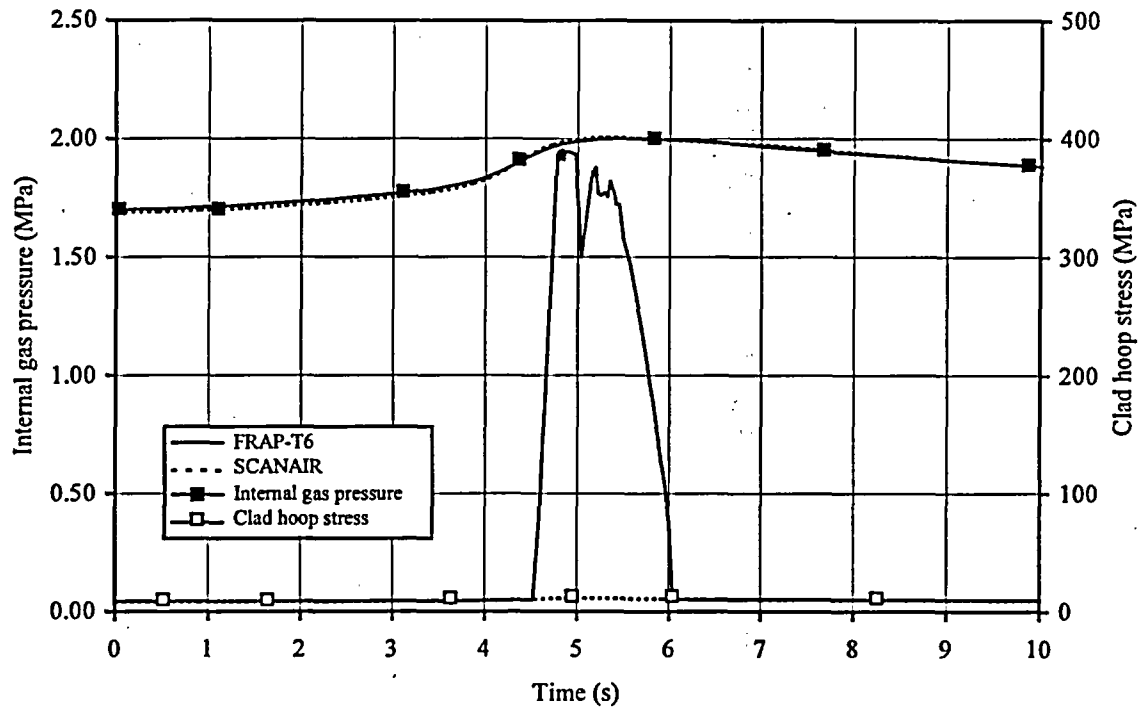

Fig. G-8.8. Cladding Mechanical Characteristics Vs. Time Calculated by FRAP-T6 and SCANAIR Codes for Fuel Rod #H8T

# #H8T

Individual Characteristics of Refabricated Fuel Rods  
(Preirradiated Fuel, Preirradiated Cladding) under IGR Tests

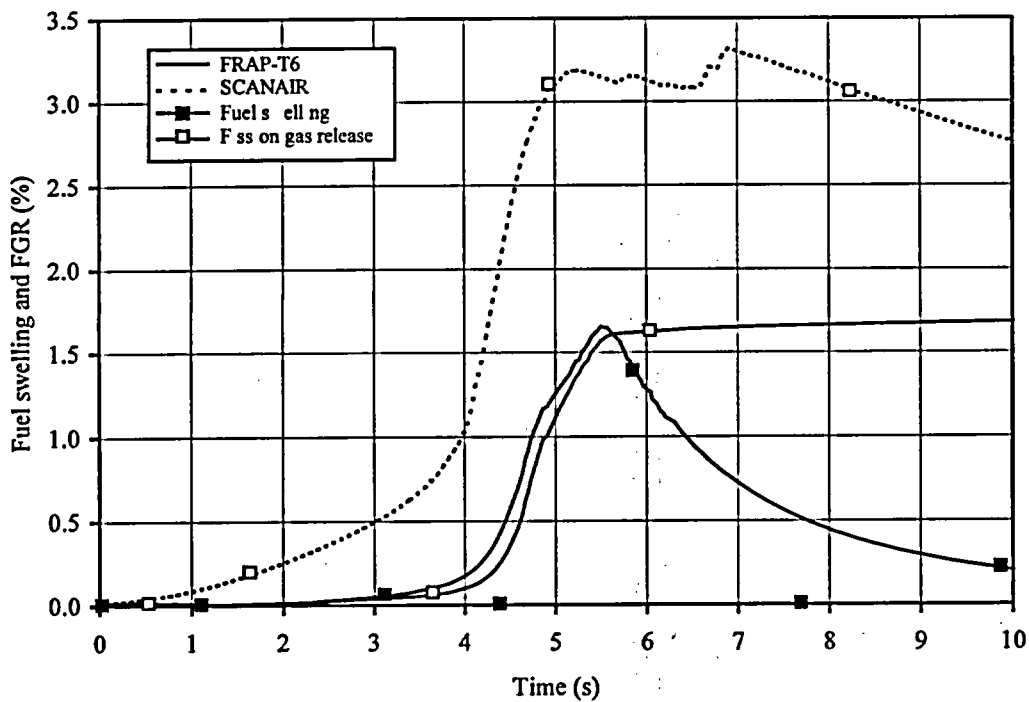
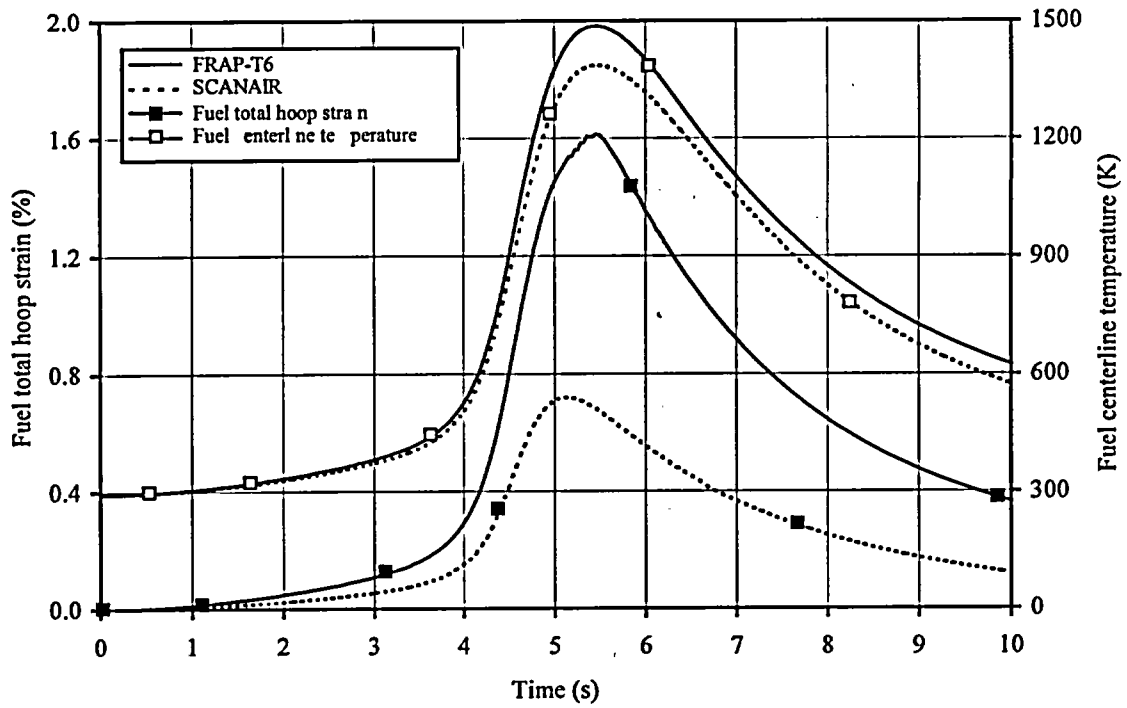

Fig. G-8.9. Fuel Strain and Fission Gas Release Vs. Time Calculated by FRAP-T6 and SCANAIR Codes for Fuel Rod #H8T

# #H8T

Individual Characteristics of Refabricated Fuel Rods  
(Preirradiated Fuel, Preirradiated Cladding) under IGR Tests

Table G-8.9. Some Results of PIE for Fuel Rod #H8T

Characteristic		Value
1.	Measured parameters of cladding oxidation and cladding deformation	
1.1.	Cladding thickness at elevation 90 mm for different azimuthal angles ( $\mu\text{m}$ ):	
	0°	705
	90°	705
	180°	691
	270°	691
1.2.	ZrO <sub>2</sub> thickness at elevation 90 mm for different azimuthal angles ( $\mu\text{m}$ ):	
	0°	5
	90°	5
	180°	5
	270°	5
1.3.	$\alpha\text{Zr(O)}$ thickness at elevation 90 mm for different azimuthal angles ( $\mu\text{m}$ ):	
	0°	0
	90°	0
	180°	0
	270°	0
1.4.	Clad hoop strain at elevation 90 mm (%)	0
2.	Measured parameters for FGR analysis	
2.1.	Internal gas composition (% by volume):	
	He	95.33
	N <sub>2</sub>	0.1
	O <sub>2</sub>	0.02
	Ar	0.004
	CO <sub>2</sub>	0.01
	Kr	0.49
	Xe	4.05
	Free gas volume (cm <sup>3</sup> )	5.86
2.3.	Gas pressure inside fuel rod under normal condition (MPa)	1.657
2.4.	Kr concentration in fuel (cm <sup>3</sup> /g fuel)	0.16
3.	Measured parameters of cladding hydriding	
3.1.	Coefficient of hydride orientation (per-unit)	0.23
3.2.	Hydrogen concentration (% by weight)	4 10 <sup>-3</sup>

# #H8T

Individual Characteristics of Refabricated Fuel Rods  
(Preirradiated Fuel, Preirradiated Cladding) under IGR Tests

Table G-8.10. General Characteristic of Fuel Rod #H8T

	Parameter	Unit	Value		
			Experiment	FRAP-T6	SCANAIR
1	Type of coolant	---	water	water	water
2	Burnup	MWd/kg U	46.8	46.8	46.8
3	Energy deposition in fuel rod	cal/g fuel	109	109	109
4	Peak fuel enthalpy	cal/g fuel	-	61	60
5	Peak fuel temperature	K	-	1487	1386
6	Peak clad temperature	K	-	426	406
7	Fuel rod failure	Yes, No	No	No	-
8	Type of failure:				
	- cladding rupture due to ballooning	Yes, No	No	No	-
	- cladding rupture due to PCMI	Yes, No	No	No	-
	- fragmentation of fuel rod	Yes, No	No	-	-
9	Failure time	s	-	-	-
10	Fuel enthalpy at failure	cal/g fuel	-	-	-
11	Outer cladding temperature at failure	K	-	-	-
12	Internal gas pressure at failure	MPa	-	-	-
13	ZrO <sub>2</sub> thickness after test	μm	5	5.00	-
14	Residual clad hoop strain:				
	- peak value for ballooning area	%	-	-	-
	- other location <sup>1)</sup>	%	0	0.26	0
15	Kr concentration in internal gas composition after test	% by volume	0.49	0.10	0.36
16	Xe concentration in internal gas composition after test	% by volume	4.05	0.80	2.16
17	Kr concentration in fuel after test	cm <sup>3</sup> /g fuel	0.16	0.13	0.20

<sup>1)</sup>Calculated values by FRAP-T6 and SCANAIR codes are average along height of fuel rod excluding ballooning region



**APPENDIX G-9.**

*Individual Characteristics for Fuel Rod #B9T under IGR Test*

#B9T

Individual Characteristics of Refabricated Fuel Rods  
(Preirradiated Fuel, Preirradiated Cladding) under IGR Tests

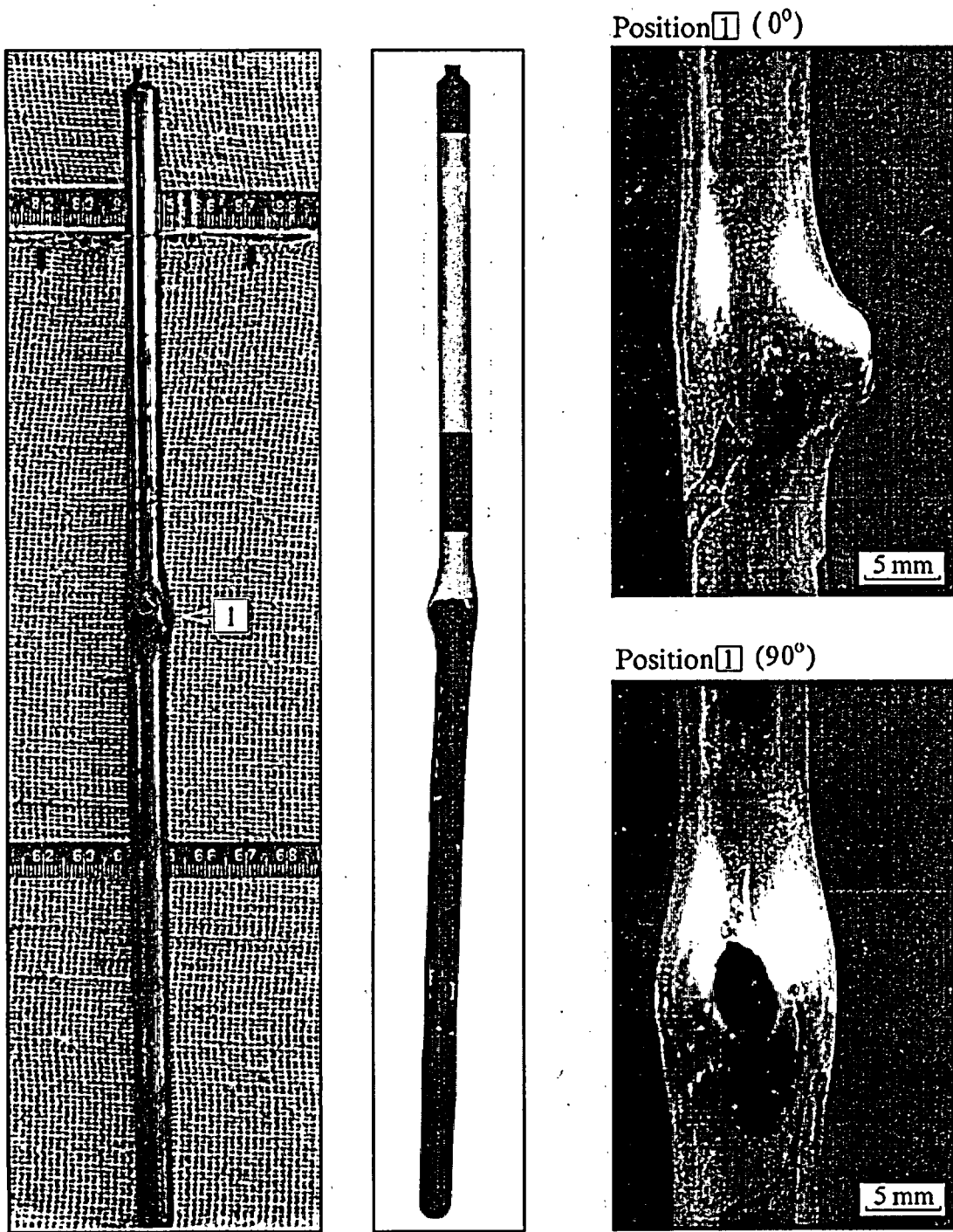
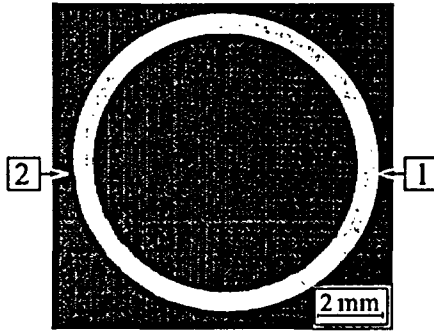

Fig. G-9.1. Appearance of Fuel Rod #B9T (photographs and X-ray photograph)



#B9T

Individual Characteristics of Refabricated Fuel Rods  
(Preirradiated Fuel, Preirradiated Cladding) under IGR Tests



Position 1

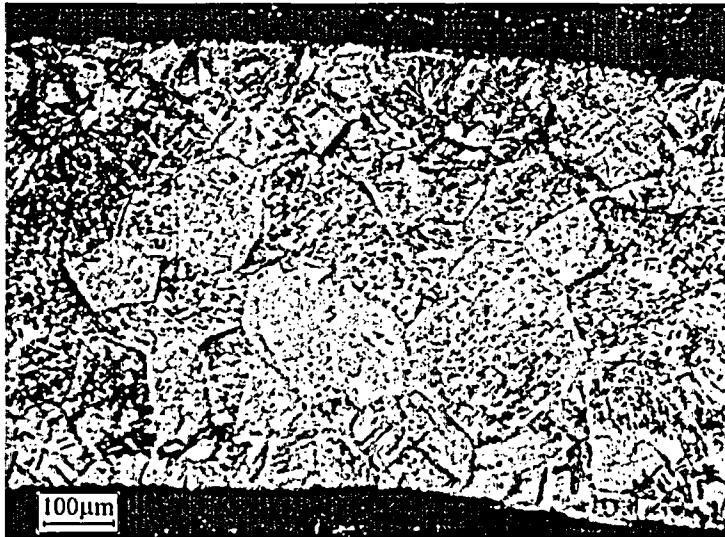

Position 2

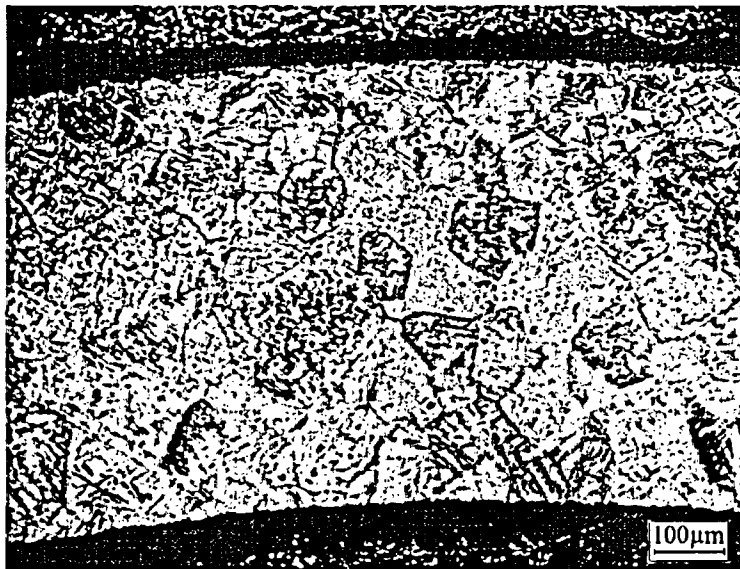
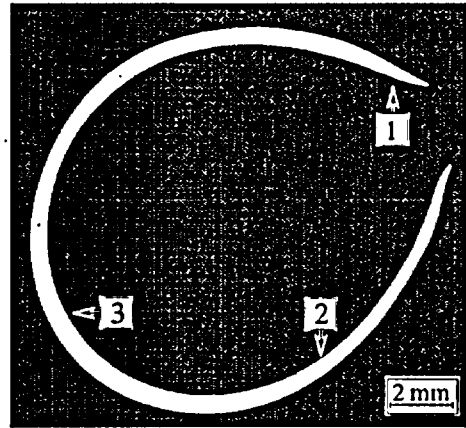

Fig. G-9.2. Cross-Section and Cladding Microstructure for Fuel Rod #B9T at 85 mm Elevation

#B9T

Individual Characteristics of Refabricated Fuel Rods  
(Preirradiated Fuel, Preirradiated Cladding) under IGR Tests

Position 1



Position 2

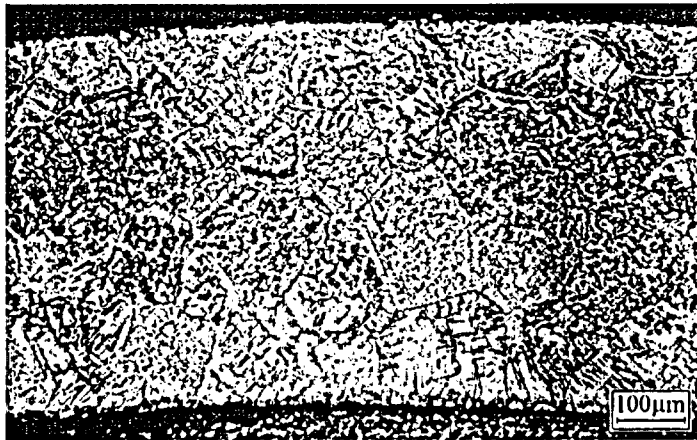

Position 3

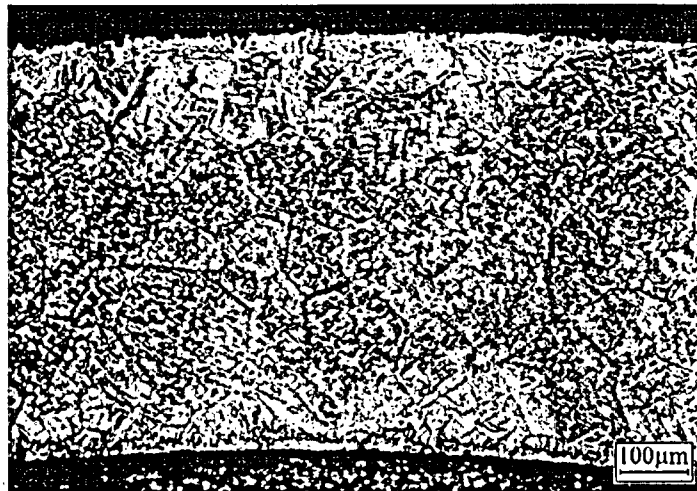
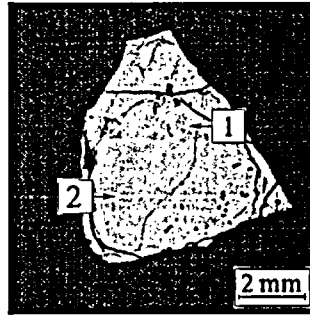

Fig. G-9.3. Cross-Section and Cladding Microstructure for Fuel Rod #B9T at 165 mm Elevation

#B9T

Individual Characteristics of Refabricated Fuel Rods  
(Preirradiated Fuel, Preirradiated Cladding) under IGR Tests



Position 1

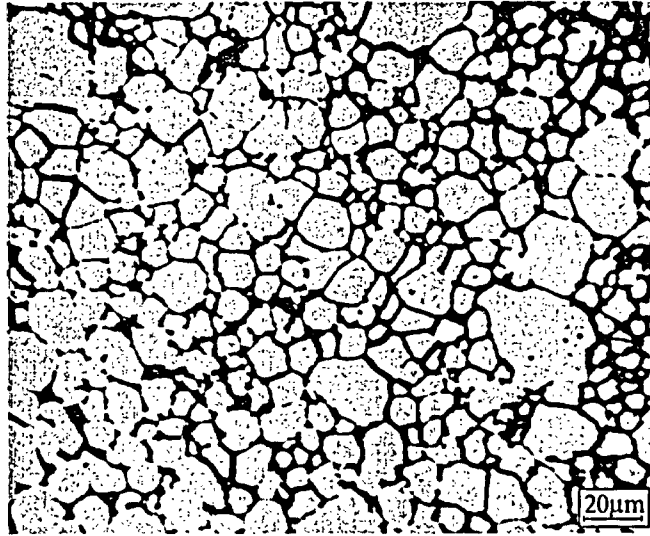

Position 2

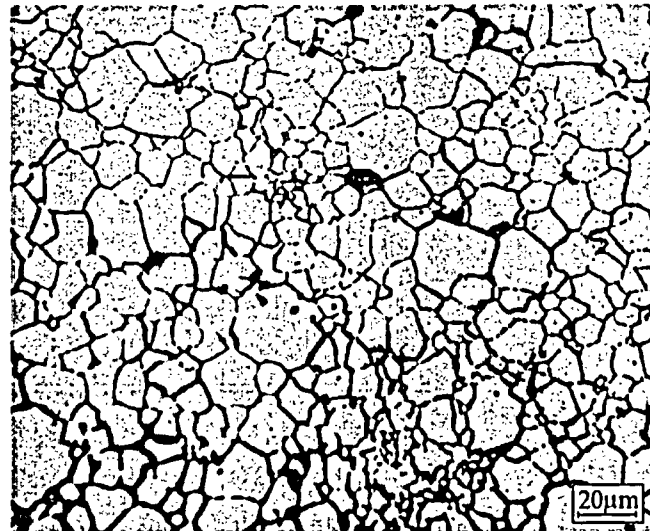

Fig. G-9.4. Fuel Microstructure for Fuel Rod #B9T at 85 mm Elevation

Table G-9.1. Time Dependent Energy Characteristics of Fuel Rod #B9T

Time (s)	Reactor energy deposition <sup>1)</sup> (%)	Cumulative number of fissions in fuel rod (fiss)						Power of fuel rod (kW)	Energy deposition in fuel rod	
		U <sup>235</sup> ×10 <sup>-14</sup>	U <sup>238</sup> ×10 <sup>-13</sup>	Pu <sup>239</sup> ×10 <sup>-14</sup>	Pu <sup>241</sup> ×10 <sup>-14</sup>	Other isotopes ×10 <sup>-11</sup>	Total ×10 <sup>-14</sup>		cal/g fuel	J/g fuel
0.0	0.000	0.000	0.000	0.000	0.000	0.000	0.000	0.000	0.000	0.000
1.0	0.929	0.035	0.017	0.065	0.025	0.087	0.127	0.815	1.480	6.200
2.0	6.340	0.241	0.117	0.441	0.173	0.591	0.867	4.210	10.10	42.30
2.2	8.860	0.337	0.164	0.616	0.242	0.825	1.210	5.770	14.10	59.00
2.4	12.30	0.469	0.228	0.858	0.337	1.150	1.690	8.070	19.70	82.50
2.6	17.30	0.658	0.320	1.200	0.473	1.610	2.370	11.80	27.60	116.0
2.8	24.80	0.942	0.458	1.720	0.677	2.310	3.390	18.20	39.50	165.0
3.0	36.80	1.400	0.680	2.560	1.000	3.430	5.030	29.70	58.60	245.0
3.2	53.50	2.030	0.989	3.720	1.460	4.990	7.320	32.20	85.30	357.0
3.4	67.70	2.570	1.250	4.700	1.850	6.300	9.250	23.10	108.0	452.0
3.6	77.20	2.930	1.430	5.370	2.110	7.190	10.60	14.90	123.0	515.0
3.8	83.20	3.160	1.540	5.790	2.270	7.760	11.40	9.470	133.0	557.0
4.0	87.10	3.310	1.610	6.050	2.380	8.120	11.90	6.160	139.0	582.0
4.2	89.60	3.410	1.660	6.230	2.450	8.350	12.30	4.160	143.0	599.0
4.4	91.40	3.470	1.690	6.350	2.500	8.510	12.50	2.910	146.0	611.0
4.6	92.60	3.520	1.710	6.440	2.530	8.630	12.70	2.110	148.0	620.0
4.8	93.50	3.550	1.730	6.500	2.550	8.710	12.80	1.580	150.0	628.0
5.0	94.10	3.580	1.740	6.540	2.570	8.770	12.90	1.220	151.0	632.0
5.2	94.60	3.600	1.750	6.580	2.590	8.820	12.90	0.964	152.0	636.0
5.4	95.00	3.610	1.760	6.610	2.600	8.860	13.00	0.787	152.0	636.0
5.6	95.40	3.620	1.760	6.630	2.610	8.890	13.00	0.670	153.0	640.0
5.8	95.70	3.640	1.770	6.650	2.610	8.910	13.10	0.576	153.0	640.0
6.0	95.90	3.640	1.770	6.670	2.620	8.940	13.10	0.501	154.0	645.0
6.5	96.40	3.660	1.780	6.700	2.630	8.980	13.20	0.368	155.0	649.0
7.0	96.70	3.680	1.790	6.720	2.640	9.010	13.20	0.287	155.0	649.0
7.5	97.00	3.690	1.790	6.740	2.650	9.040	13.30	0.236	156.0	653.0
8.0	97.20	3.690	1.800	6.760	2.660	9.060	13.30	0.201	156.0	653.0
9.0	97.60	3.710	1.800	6.780	2.670	9.090	13.30	0.173	157.0	657.0
10.0	97.90	3.720	1.810	6.800	2.670	9.120	13.40	0.139	158.0	661.0
20.0	99.10	3.770	1.830	6.890	2.710	9.240	13.60	0.036	160.0	670.0
30.0	99.60	3.780	1.840	6.920	2.720	9.280	13.60	0.019	161.0	674.0
∞	100.0	3.820	1.860	6.980	2.740	9.360	13.70	0.000	165.0	691.0

Maximum value of power is 34.2 kW (t = 3.10 s).

<sup>1)</sup> Current energy deposition per maximum energy deposition (at infinite time)

# #B9T

Individual Characteristics of Refabricated Fuel Rods  
(Preirradiated Fuel, Preirradiated Cladding) under IGR Tests

Table G-9.2. Axial Energy Characteristics of Fuel Rod #B9T

Axial coordinate from lower end of fuel rod (mm)	Cumulative number of fissions at axial interval (fiss)						Maximum power of fuel rod (kW) t=3.10s	Energy deposition at infinite time*		
	U <sup>235</sup> ×10 <sup>-13</sup>	U <sup>238</sup> ×10 <sup>-11</sup>	Pu <sup>239</sup> ×10 <sup>-13</sup>	Pu <sup>241</sup> ×10 <sup>-13</sup>	Other isotopes ×10 <sup>-10</sup>	Total ×10 <sup>-13</sup>		cal/g fuel	J/g fuel	per-unit <sup>3)</sup>
10.0	0.000	0.000	0.000	0.000	0.000	0.000	0.000	0.000	0.000	0.00
15.0	0.000	0.000	0.000	0.000	0.000	0.000	0.000	0.000	0.000	0.00
20.0 <sup>1)</sup>	0.646	3.230	1.210	0.476	1.480	2.360	0.588	164.0	687.0	0.98
25.0	1.310	6.550	2.450	0.966	3.040	4.800	1.190	164.0	687.0	0.98
30.0	1.340	6.560	2.460	0.967	3.110	4.830	1.200	164.0	687.0	0.98
35.0	1.340	6.460	2.430	0.951	3.180	4.780	1.190	165.0	691.0	0.98
40.0	1.290	6.490	2.420	0.958	3.230	4.740	1.180	163.0	682.0	0.97
45.0	1.250	6.480	2.410	0.959	3.270	4.680	1.170	162.0	678.0	0.96
50.0	1.250	6.420	2.390	0.950	3.300	4.650	1.160	162.0	678.0	0.96
55.0	1.260	6.400	2.380	0.945	3.320	4.650	1.160	163.0	682.0	0.97
60.0	1.260	6.380	2.380	0.943	3.330	4.650	1.160	163.0	682.0	0.97
65.0	1.260	6.350	2.370	0.937	3.330	4.630	1.150	163.0	682.0	0.97
70.0	1.310	6.300	2.370	0.928	3.320	4.670	1.160	165.0	691.0	0.98
75.0	1.350	6.260	2.370	0.919	3.320	4.700	1.170	167.0	699.0	0.99
80.0	1.340	6.260	2.360	0.920	3.300	4.690	1.170	167.0	699.0	0.99
85.0	1.330	6.280	2.370	0.925	3.290	4.680	1.170	166.0	695.0	0.99
90.0	1.330	6.300	2.370	0.927	3.270	4.690	1.170	166.0	695.0	0.99
95.0	1.310	6.320	2.380	0.932	3.250	4.690	1.170	166.0	695.0	0.99
100.0	1.300	6.370	2.390	0.940	3.230	4.690	1.170	165.0	691.0	0.98
105.0	1.280	6.440	2.410	0.951	3.220	4.700	1.170	163.0	682.0	0.97
110.0	1.300	6.490	2.430	0.958	3.200	4.760	1.180	164.0	687.0	0.98
115.0	1.330	6.530	2.450	0.964	3.190	4.810	1.200	164.0	687.0	0.98
120.0	1.350	6.570	2.470	0.971	3.190	4.850	1.210	165.0	691.0	0.98
125.0	1.370	6.640	2.490	0.979	3.200	4.910	1.220	165.0	691.0	0.98
130.0	1.370	6.650	2.500	0.980	3.210	4.920	1.220	165.0	691.0	0.98
135.0	1.360	6.570	2.470	0.970	3.230	4.860	1.210	165.0	691.0	0.98
140.0	1.380	6.520	2.450	0.958	3.260	4.860	1.210	166.0	695.0	0.99
145.0	1.420	6.510	2.460	0.956	3.310	4.900	1.220	168.0	703.0	1.00
150.0	1.370	6.450	2.430	0.949	3.370	4.820	1.200	166.0	695.0	0.99
155.0	1.380	6.700	2.510	0.988	3.440	4.950	1.230	165.0	691.0	0.98
160.0	0.727	3.270	1.300	0.506	1.670	2.560	0.637	168.0	703.0	1.00
165.0	0.727	3.270	1.300	0.506	1.670	2.560	0.637	168.0	703.0	1.00
170.0 <sup>2)</sup>	0.364	1.640	0.648	0.253	0.837	1.280	0.319	168.0	703.0	1.00
175.0	0.000	0.000	0.000	0.000	0.000	0.000	0.000	0.000	0.000	0.00
180.0	0.000	0.000	0.000	0.000	0.000	0.000	0.000	0.000	0.000	0.00
185.0	0.000	0.000	0.000	0.000	0.000	0.000	0.000	0.000	0.000	0.00

\* All numerical values of characteristics are presented as average values at the length interval equal to the axial coordinate ± 2.5 mm

<sup>1)</sup> Initial coordinate of fuel is 20.0 mm

<sup>2)</sup> End coordinate of fuel is 170.0 mm

<sup>3)</sup> Current value per maximum value.

## #B9T

Individual Characteristics of Refabricated Fuel Rods  
(Preirradiated Fuel, Preirradiated Cladding) under IGR Tests

Table G-9.3. Radial Energy Characteristics of Fuel Rod #B9T

Characteristics*		Coordinates of fuel zones (mm)			
		1 zone 1.2 - 2.811	2 zone 2.811-3.432	3 zone 3.432-3.704	4 zone 3.704-3.790
U <sup>235</sup>	Number of fissions $\times 10^{-14}$ (fiss)	1.850	1.080	0.528	0.171
	Power of fuel rod <sup>1)</sup> (kW)	4.520	2.640	1.290	0.418
	Energy deposition <sup>2)</sup> (cal/g fuel)	45.70	44.50	43.40	42.20
	Energy deposition <sup>2)</sup> (J/g fuel)	191.0	186.0	182.0	177.0
	Energy deposition <sup>3)</sup> (per-unit)	1.000	0.974	0.950	0.923
U <sup>238</sup>	Number of fissions $\times 10^{-12}$ (fiss)	9.160	5.290	2.520	0.778
	Power of fuel rod <sup>1)</sup> (kW)	0.221	0.128	0.061	0.019
	Energy deposition <sup>2)</sup> (cal/g fuel)	2.230	2.140	2.040	1.890
	Energy deposition <sup>2)</sup> (J/g fuel)	9.330	8.960	8.540	7.910
	Energy deposition <sup>3)</sup> (per-unit)	1.000	0.960	0.915	0.848
Pu <sup>239</sup>	Number of fissions $\times 10^{-14}$ (fiss)	2.770	1.880	1.280	0.724
	Power of fuel rod <sup>1)</sup> (kW)	6.980	4.730	3.230	1.820
	Energy deposition <sup>2)</sup> (cal/g fuel)	70.80	80.00	109.0	185.0
	Energy deposition <sup>2)</sup> (J/g fuel)	296.0	335.0	456.0	774.0
	Energy deposition <sup>3)</sup> (per-unit)	0.383	0.432	0.589	1.000
Pu <sup>241</sup>	Number of fissions $\times 10^{-13}$ (fiss)	10.40	7.360	5.260	3.120
	Power of fuel rod <sup>1)</sup> (kW)	2.580	1.820	1.300	0.773
	Energy deposition <sup>2)</sup> (cal/g fuel)	26.10	30.80	44.00	78.40
	Energy deposition <sup>2)</sup> (J/g fuel)	109.0	129.0	184.0	328.0
	Energy deposition <sup>3)</sup> (per-unit)	0.333	0.393	0.561	1.000
Other isotopes	Number of fissions $\times 10^{-11}$ (fiss)	4.090	2.590	1.540	0.727
	Power of fuel rod <sup>1)</sup> (kW)	0.010	0.006	0.004	0.002
	Energy deposition <sup>2)</sup> (cal/g fuel)	0.103	0.109	0.129	0.184
	Energy deposition <sup>3)</sup> (per-unit)	0.560	0.592	0.701	1.000
Total	Number of fissions $\times 10^{-14}$ (fiss)	5.760	3.750	2.370	1.220
	Power of fuel rod <sup>1)</sup> (kW)	14.30	9.340	5.890	3.030
	Energy deposition <sup>2)</sup> (cal/g fuel)	145.0	157.0	198.0	306.0
	Energy deposition <sup>2)</sup> (J/g fuel)	607.0	657.0	829.0	1281.
	Energy deposition <sup>3)</sup> (per-unit)	0.474	0.513	0.647	1.000

<sup>1)</sup> at time of 3.10 s, <sup>2)</sup> at infinite time, <sup>3)</sup> Current value per maximum value.

\* All numerical values of characteristics were calculated for undamaged part of fuel stack only (See Table C.2.2.)

# #B9T

Individual Characteristics of Refabricated Fuel Rods  
(Preirradiated Fuel, Preirradiated Cladding) under IGR Tests

Table G-9.4. Fuel Enthalpy Vs. Time Calculated by FRAP-T6 Code for Fuel Rod #B9T

Time (s)	Enthalpy at fuel radius (cal/g fuel)				Fuel enthalpy <sup>1)</sup>		Energy deposition in fuel rod	
	1.20 mm	2.82 mm	3.47 mm	3.79 mm	cal/g fuel	J/g fuel	cal/g fuel	J/g fuel
0.0	0.00	0.00	0.00	0.00	0.00	0.00	0.00	0.00
1.0	1.30	1.27	1.21	1.13	1.26	5.28	1.57	6.58
2.0	5.48	5.25	4.95	4.67	5.22	21.9	6.68	28.0
2.2	6.95	6.66	6.28	5.93	6.63	27.8	8.43	35.3
2.4	9.19	8.85	8.34	7.83	8.79	36.8	11.1	46.3
2.6	13.3	12.9	12.1	11.2	12.7	53.3	15.7	65.6
2.8	21.5	21.0	19.5	17.4	20.6	86.4	24.7	104
3.0	37.1	36.2	33.1	28.6	35.3	148	41.6	174
3.2	59.9	58.1	50.0	38.2	55.7	233	66.0	276
3.4	84.4	80.3	68.9	56.4	77.6	325	91.7	384
3.6	103	96.4	80.8	65.4	93.2	391	111	467
3.8	116	105	87.3	73.4	103	430	124	521
4.0	123	110	92.4	85.1	109	455	133	557
4.2	127	113	100	94.8	113	475	139	580
4.4	130	115	104	98.7	116	487	142	597
4.6	131	117	106	101	118	493	145	608
4.8	131	118	108	102	119	497	147	617
5.0	130	118	109	104	119	498	149	625
5.2	130	118	109	104	119	498	150	630
5.4	129	118	109	105	119	498	151	633
5.6	129	118	110	105	119	497	152	637
5.8	128	117	110	106	118	495	153	640
6.0	127	117	110	106	118	494	153	642
6.5	125	116	110	106	117	489	154	646
7.0	123	115	110	107	116	485	155	650
7.5	121	114	109	106	115	480	156	652
8.0	119	113	109	106	114	476	156	654
10.0	114	110	106	104	110	460	158	660
30.0	83.1	81.7	80.3	79.5	81.7	342	161	674

Radial enthalpy distribution and fuel enthalpy are presented at elevation 162.5 mm

Maximum value of fuel enthalpy is 118.9 cal/g fuel ( $t=5.11$  s)

<sup>1)</sup> All numerical values are presented at elevation with peak power

# #B9T

Individual Characteristics of Refabricated Fuel Rods  
(Preirradiated Fuel, Preirradiated Cladding) under IGR Tests

Table G-9.5. Energy Characteristics Vs. Time Calculated by FRAP-T6 and SCANAIR Codes for Fuel Rod #B9T

Time (s)	Energy deposition <sup>1)</sup> (cal/g fuel)	Linear power <sup>1)</sup> (kW/m)	Fuel enthalpy <sup>1)</sup> (cal/g fuel)		Leakage of energy <sup>1)</sup> (cal/g fuel)		Clad-to-coolant heat transfer coefficient <sup>1)</sup> (kW/m <sup>2</sup> K)	
			FRAP-T6	SCANAIR	FRAP-T6	SCANAIR	FRAP-T6	SCANAIR
0.0	0.00	0.00	0.00	0.00	0.00	0.00	0.00	0.00
1.0	1.60	5.90	1.26	1.48	0.00	0.00	0.01	0.01
2.0	6.78	13.5	5.22	5.78	0.00	0.00	0.01	0.01
2.2	8.56	18.5	6.63	7.33	0.01	0.01	0.01	0.01
2.4	11.2	29.9	8.79	9.77	0.01	0.01	0.01	0.01
2.6	15.9	56.3	12.7	14.3	0.01	0.01	0.01	0.01
2.8	25.1	112	20.6	23.4	0.02	0.02	0.01	0.01
3.0	42.2	191	35.3	39.3	0.03	0.03	0.02	0.02
3.2	67.0	238	55.7	60.4	0.05	0.06	0.03	0.03
3.4	93.1	210	77.6	79.9	0.10	0.13	0.04	0.04
3.6	113	144	93.2	92.8	0.21	0.27	0.05	0.06
3.8	126	93.4	103	-	0.36	-	0.06	-
4.0	135	61.1	109	-	0.55	-	0.07	-
4.2	141	41.3	113	-	0.80	-	0.08	-
4.4	145	29.0	116	-	1.07	-	0.08	-
4.6	147	21.2	118	-	1.37	-	0.09	-
4.8	149	16.0	119	-	1.71	-	0.09	-
5.0	151	11.6	119	-	2.18	-	0.10	-
5.2	153	9.48	119	-	2.56	-	0.10	-
5.4	154	7.78	119	-	2.98	-	0.11	-
5.6	154	6.35	119	-	3.43	-	0.11	-
5.8	155	5.36	118	-	3.91	-	0.11	-
6.0	156	4.58	118	-	4.39	-	0.12	-
6.5	157	3.22	117	-	5.70	-	0.12	-
7.0	157	2.41	116	-	7.06	-	0.12	-
7.5	158	1.92	115	-	8.42	-	0.13	-
8.0	159	1.60	114	-	9.88	-	0.13	-
10.0	160	1.06	110	-	15.5	-	0.12	-
30.0	164	0.14	81.7	-	55.3	-	0.08	-

<sup>1)</sup> All numerical values are presented at elevation with peak power



# #B9T

Individual Characteristics of Refabricated Fuel Rods  
(Preirradiated Fuel, Preirradiated Cladding) under IGR Tests

Table G-9.6. Temperature Variation, Fission Gas Release and ZrO<sub>2</sub> Thickness Vs. Time for Fuel Rod #B9T Calculated by FRAP-T6 and SCANAIR Codes

Time (s)	Fuel centerline temperature <sup>1)</sup> (K)		Fuel surface temperature <sup>1)</sup> (K)		Clad outer temperature <sup>1)</sup> (K)		Fission gas release (%)	
	FRAP-T6	SCANAIR	FRAP-T6	SCANAIR	FRAP-T6	SCANAIR	FRAP-T6	SCANAIR
0.0	293	293	293	293	293	293	0.00	0.00
1.0	316	318	313	315	302	304	0.02	0.19
2.0	385	387	372	378	346	351	0.11	0.61
2.2	408	412	392	400	360	367	0.14	0.73
2.4	443	449	422	434	380	389	0.19	0.90
2.6	504	516	473	495	409	424	0.28	1.14
2.8	624	646	565	607	465	490	0.48	1.61
3.0	840	867	724	784	565	610	0.96	2.16
3.2	1145	1153	855	987	755	791	1.87	2.71
3.4	1460	1424	1098	1161	934	998	3.29	3.13
3.6	1695	1614	1217	1267	1082	1146	4.17	3.38
3.8	1843	-	1320	-	1170	-	4.67	-
4.0	1930	-	1469	-	1266	-	4.98	-
4.2	1979	-	1591	-	1299	-	5.23	-
4.4	2004	-	1639	-	1338	-	5.45	-
4.6	2014	-	1667	-	1376	-	5.62	-
4.8	2016	-	1684	-	1412	-	5.74	-
5.0	2012	-	1700	-	1452	-	5.95	-
5.2	2007	-	1707	-	1477	-	8.08	-
5.4	2000	-	1714	-	1501	-	9.24	-
5.6	1991	-	1720	-	1521	-	9.70	-
5.8	1982	-	1724	-	1538	-	10.1	-
6.0	1973	-	1728	-	1552	-	10.4	-
6.5	1948	-	1734	-	1578	-	11.7	-
7.0	1925	-	1735	-	1593	-	13.6	-
7.5	1903	-	1734	-	1601	-	13.8	-
8.0	1883	-	1729	-	1605	-	13.8	-
10.0	1820	-	1703	-	1595	-	13.9	-
30.0	1445	-	1399	-	1329	-	14.4	-

<sup>1)</sup> All numerical values are presented at elevation with peak power

# #B9T

Individual Characteristics of Refabricated Fuel Rods  
(Preirradiated Fuel, Preirradiated Cladding) under IGR Tests

Table G-9.7. Mechanical Characteristics of Fuel Rod #B9T Vs. Time Calculated by FRAP-T6 and SCANAIR Codes

Time (s)	Clad outer temperature <sup>1)</sup> (K)		Fuel hoop strain <sup>1)</sup> (%)		Fuel - clad gap width <sup>1)</sup> (mm)		Clad hoop strain <sup>1)</sup> (%)		Clad hoop stress <sup>1)</sup> (MPa)		Internal gas pressure (MPa)	
	FRAP-T6	SCANAIR	FRAP-T6	SCANAIR	FRAP-T6	SCANAIR	FRAP-T6	SCANAIR	FRAP-T6	SCANAIR	FRAP-T6	SCANAIR
0.0	293	293	0.00	0.00	0.03	0.03	0.01	0.01	8.38	8.25	1.70	1.70
1.0	302	304	0.04	0.02	0.03	0.03	0.01	0.02	8.49	8.38	1.72	1.72
2.0	346	351	0.15	0.07	0.03	0.03	0.04	0.05	8.73	8.66	1.77	1.77
2.2	360	367	0.18	0.08	0.02	0.03	0.05	0.06	8.80	8.74	1.78	1.78
2.4	380	389	0.24	0.11	0.02	0.03	0.07	0.08	8.89	8.85	1.80	1.80
2.6	409	424	0.33	0.16	0.02	0.03	0.09	0.11	9.02	9.04	1.82	1.83
2.8	465	490	0.52	0.27	0.01	0.03	0.13	0.16	9.23	9.34	1.86	1.87
3.0	565	610	0.86	0.47	0.00	0.02	0.20	0.25	9.49	9.68	1.91	1.92
3.2	755	791	1.36	0.76	0.00	0.02	0.55	0.40	228	9.92	1.96	1.95
3.4	934	998	1.94	1.06	0.00	0.01	1.05	0.56	40.8	9.98	2.00	1.98
3.6	1082	1146	2.36	1.28	0.00	0.00	1.42	0.54	20.8	9.73	2.03	1.99
3.8	1170	-	2.61	-	0.00	-	1.62	-	9.43	-	2.05	-
4.0	1266	-	2.79	-	0.11	-	4.15	-	10.7	-	2.04	-
4.2	1299	-	2.97	-	1.74	-	46.5	-	0.00	-	0.10	-
4.4	1338	-	3.07	-	1.74	-	46.6	-	0.00	-	0.10	-
4.6	1376	-	3.15	-	1.74	-	46.6	-	0.00	-	0.10	-
4.8	1412	-	3.20	-	1.73	-	46.6	-	0.00	-	0.10	-
5.0	1452	-	3.33	-	1.73	-	46.7	-	0.00	-	0.10	-
5.2	1477	-	3.67	-	1.72	-	46.7	-	0.00	-	0.10	-
5.4	1501	-	3.93	-	1.71	-	46.7	-	0.00	-	0.10	-
5.6	1521	-	4.07	-	1.70	-	46.7	-	0.00	-	0.10	-
5.8	1538	-	4.20	-	1.70	-	46.8	-	0.00	-	0.10	-
6.0	1552	-	4.20	-	1.70	-	46.8	-	0.00	-	0.10	-
6.5	1578	-	4.36	-	1.69	-	46.8	-	0.00	-	0.10	-
7.0	1593	-	4.52	-	1.68	-	46.8	-	0.00	-	0.10	-
7.5	1601	-	4.46	-	1.69	-	46.8	-	0.00	-	0.10	-
8.0	1605	-	4.39	-	1.69	-	46.8	-	0.00	-	0.10	-
10.0	1595	-	4.11	-	1.70	-	46.8	-	0.00	-	0.10	-
30.0	1329	-	2.45	-	1.76	-	46.6	-	0.00	-	0.10	-

<sup>1)</sup> All numerical values are presented at elevation with peak power

**Table G-9.8. Axial Distribution of Energy Deposition and Fuel Enthalpy Calculated by FRAP-T6 Code for Fuel Rod #B9T**

Axial interval from-to (mm)-(mm)	Energy deposition at infinite time			Fuel enthalpy at time (t=5.11 s)		
	cal/g fuel	J/g fuel	per-unit	cal/g fuel	J/g fuel	per-unit
20.0 - 35.0	164	688	0.98	117	488	0.98
35.0 - 50.0	163	682	0.97	116	484	0.97
50.0 - 65.0	163	682	0.97	116	484	0.97
65.0 - 80.0	166	694	0.99	118	493	0.99
80.0 - 95.0	166	696	0.99	118	494	0.99
95.0 - 110.0	164	689	0.98	117	489	0.98
110.0 - 125.0	165	689	0.98	117	489	0.98
125.0 - 140.0	165	692	0.99	117	491	0.99
140.0 - 155.0	167	698	0.99	118	495	0.99
155.0 - 170.0	168	702	1.00	119	498	1.00

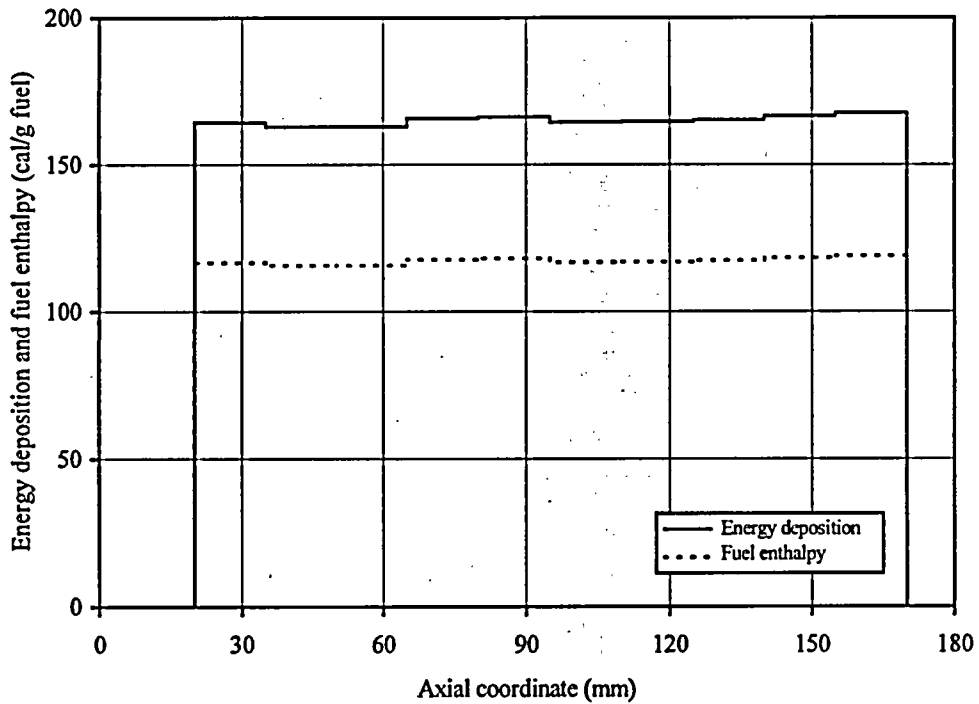

**Fig. G-9.5. Axial Distribution of Energy Deposition and Fuel Enthalpy Calculated by FRAP-T6 Code for Fuel Rod #B9T**

#B9T

Individual Characteristics of Refabricated Fuel Rods  
(Preirradiated Fuel, Preirradiated Cladding) under IGR Tests

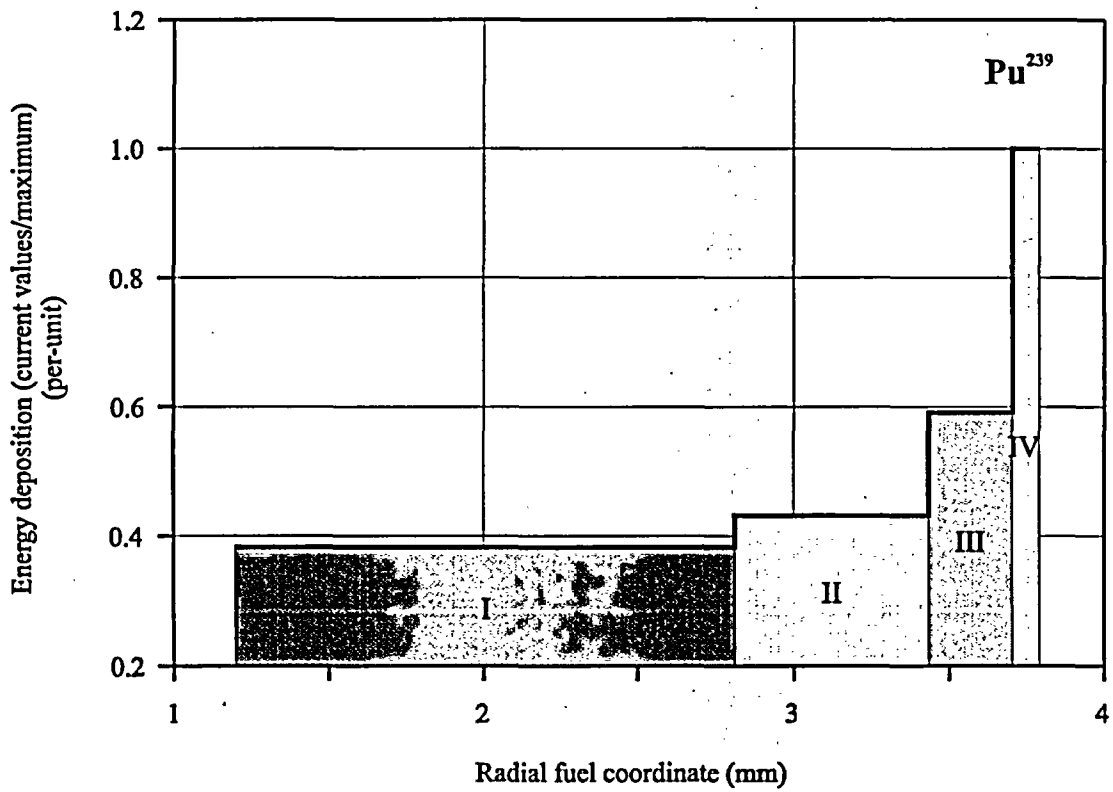
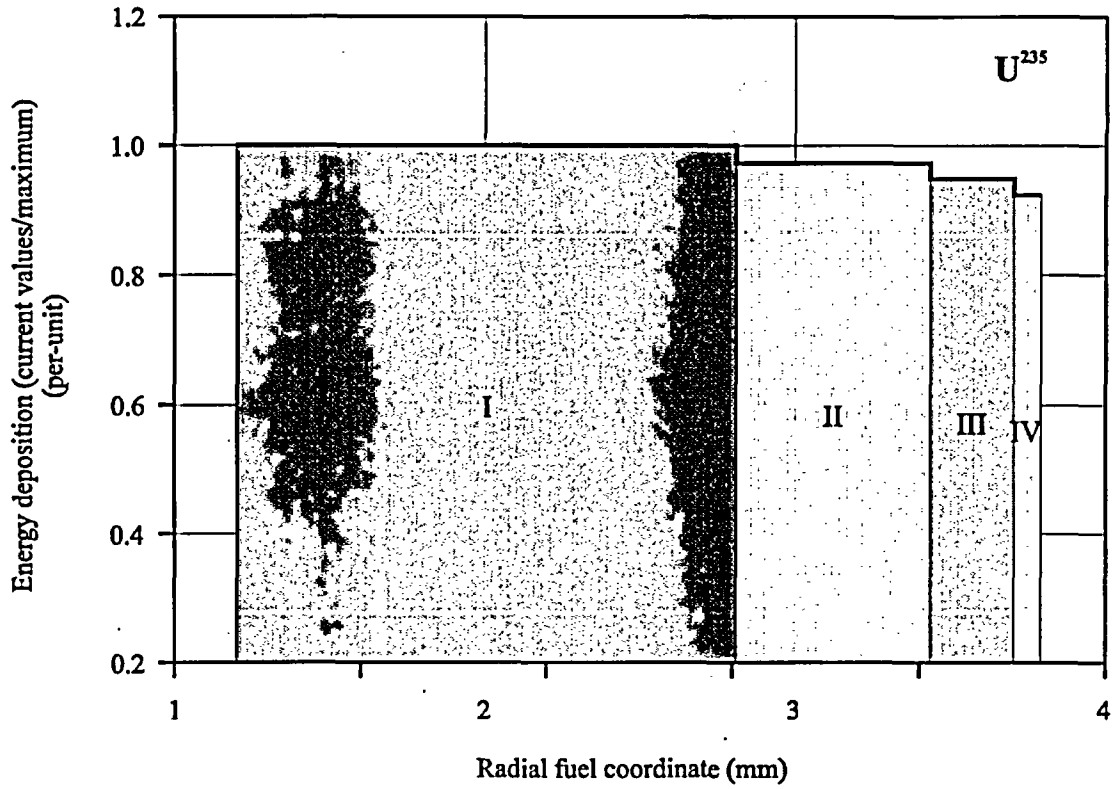

Fig. G-9.6. U<sup>235</sup> and Pu<sup>239</sup> Radial Distributions of Energy Deposition for Fuel Rod #B9T

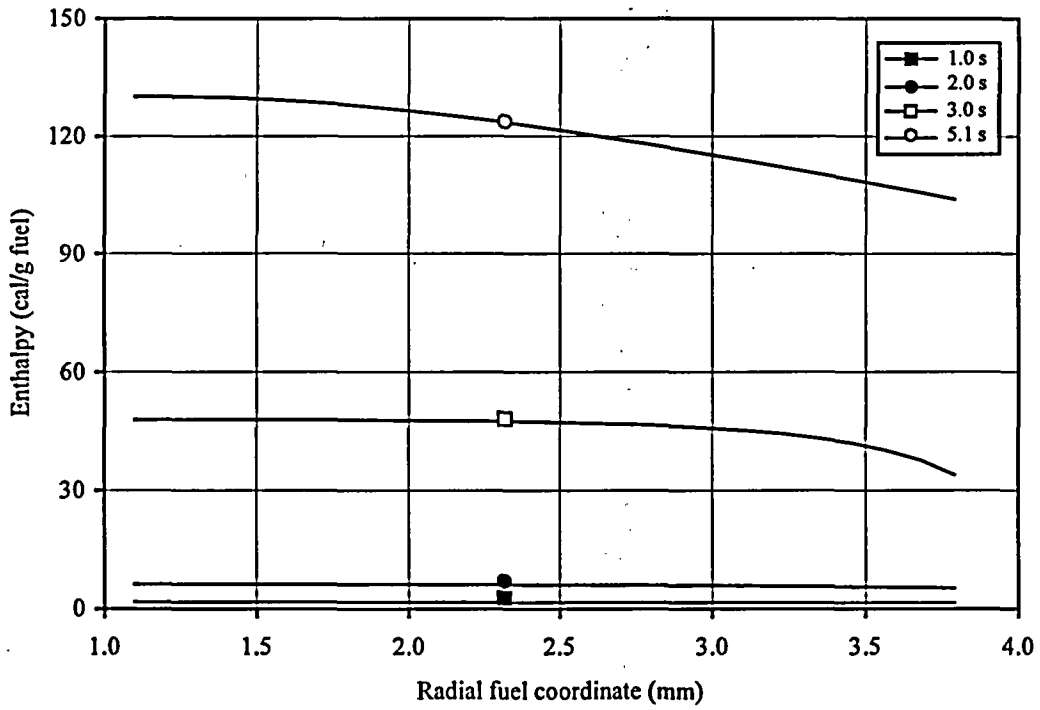
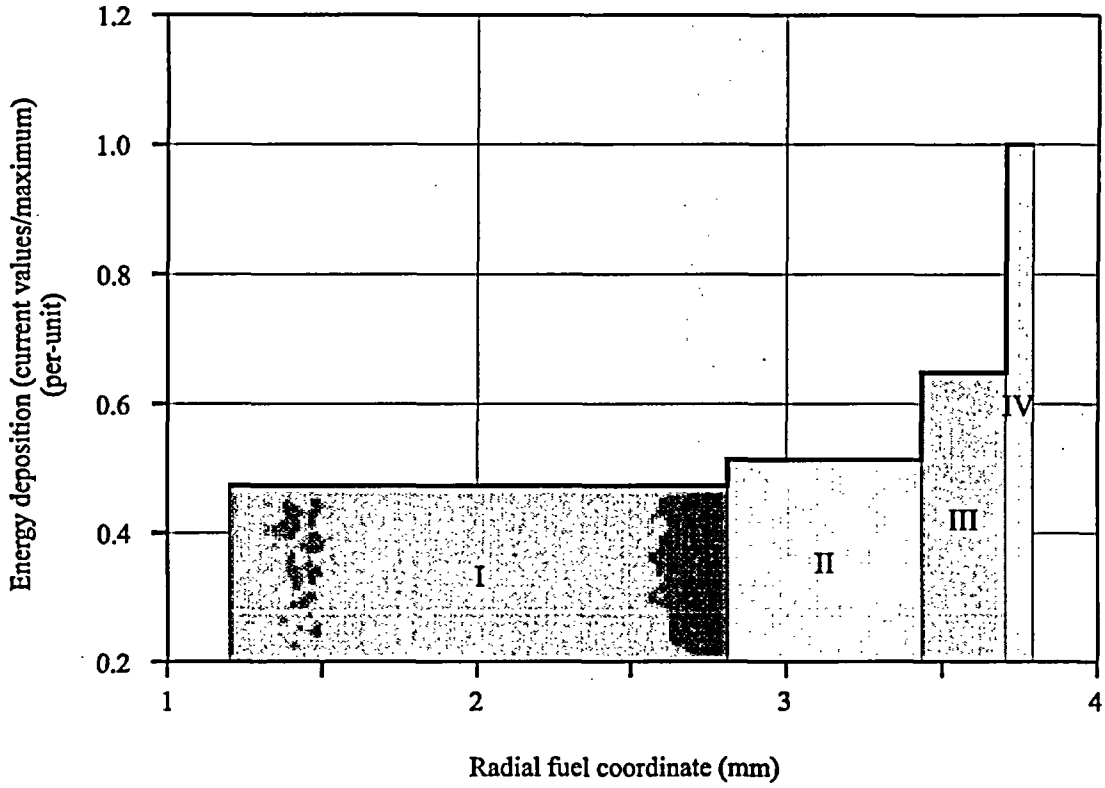

Fig. G-9.7. Radial Distributions of Energy Deposition and Fuel Enthalpy Calculated by FRAP-T6 Code for Fuel Rod #B9T

#B9T

Individual Characteristics of Refabricated Fuel Rods  
(Preirradiated Fuel, Preirradiated Cladding) under IGR Tests

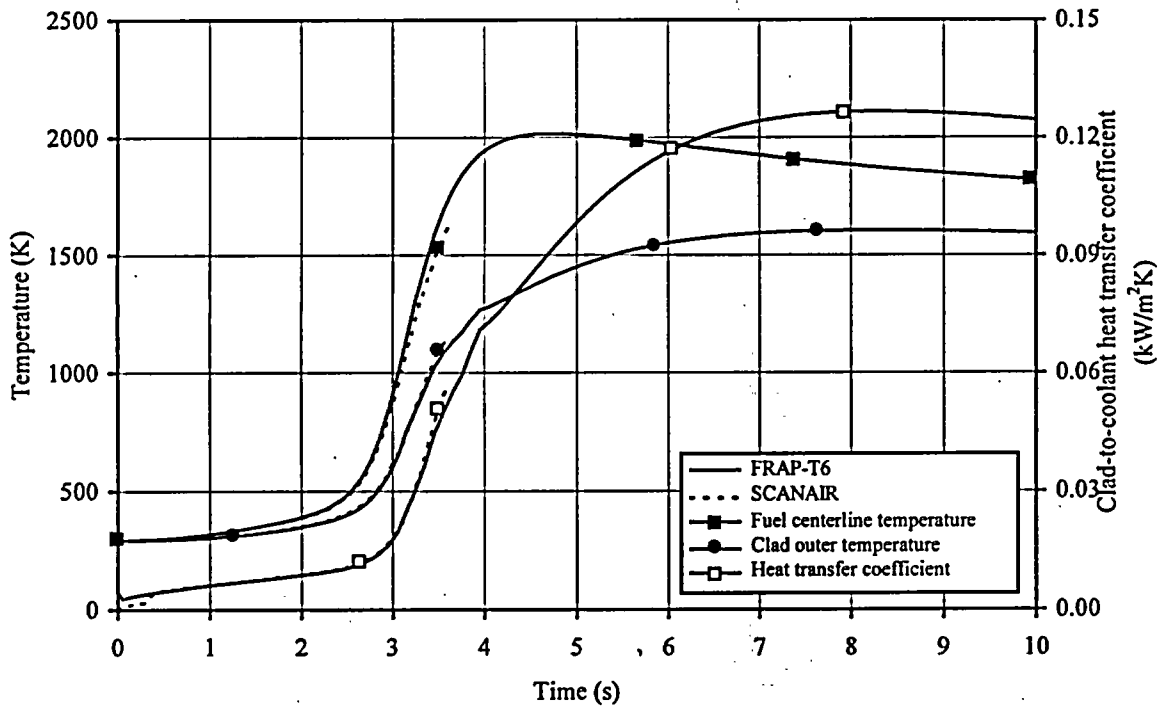
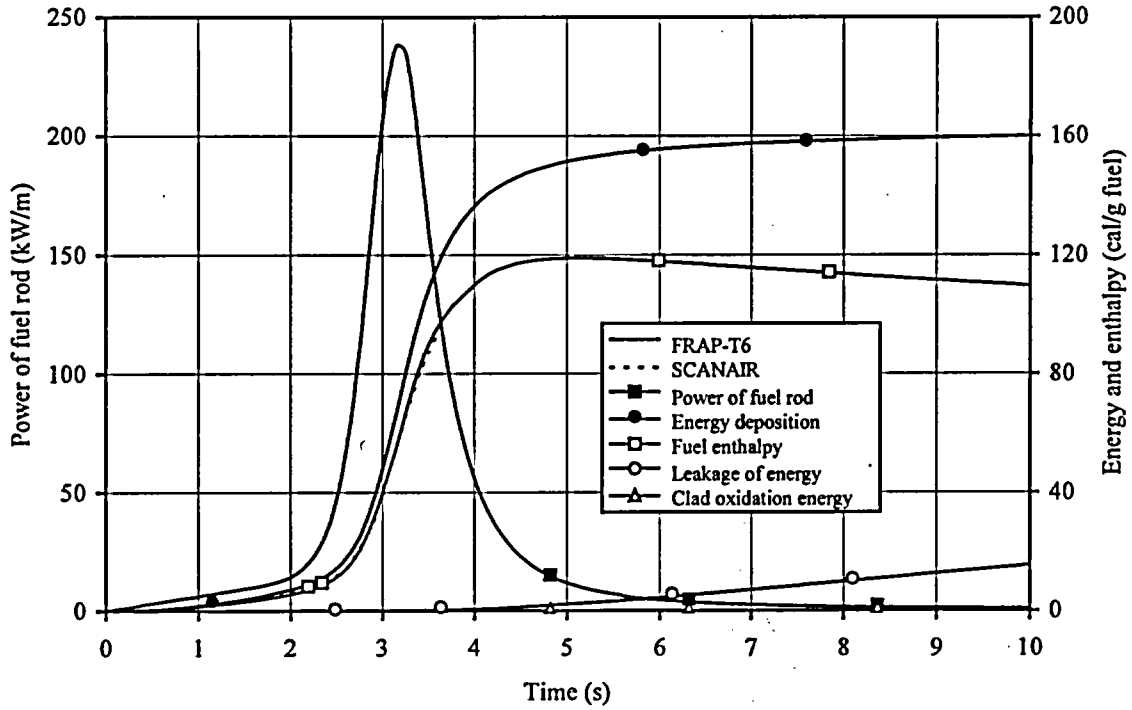

Fig. G-9.8. Energy and Temperature Characteristics Vs. Time Calculated by FRAP-T6 and SCANAIR Codes for Fuel Rod #B9T

#B9T

Individual Characteristics of Refabricated Fuel Rods  
(Preirradiated Fuel, Preirradiated Cladding) under IGR Tests

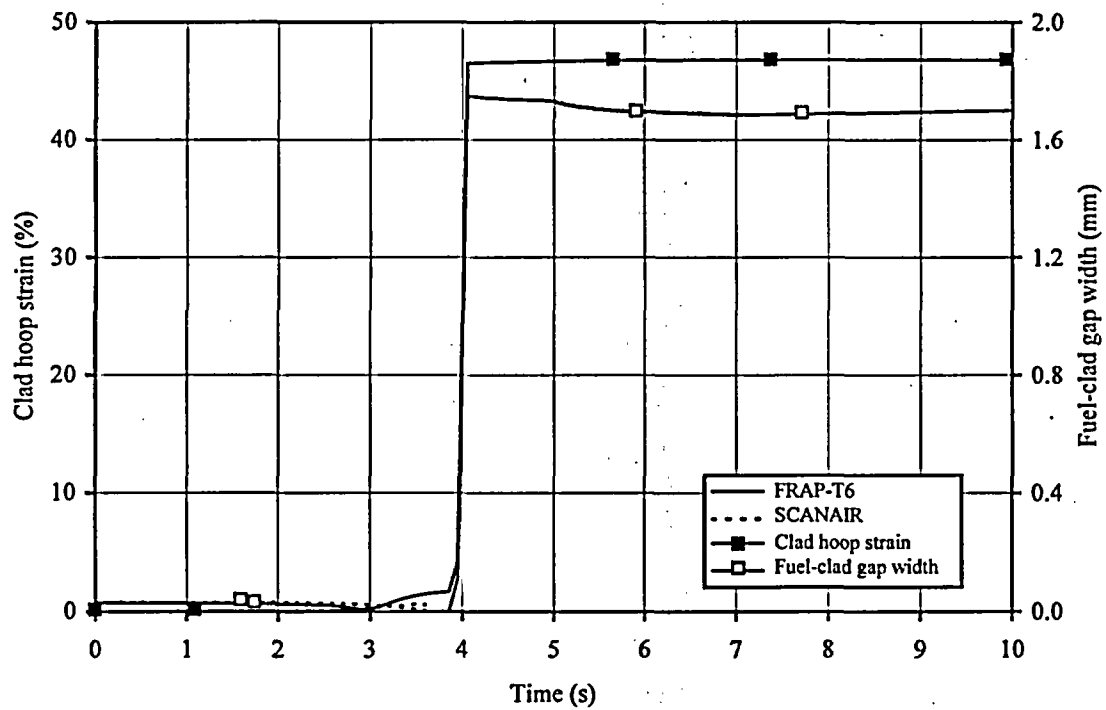
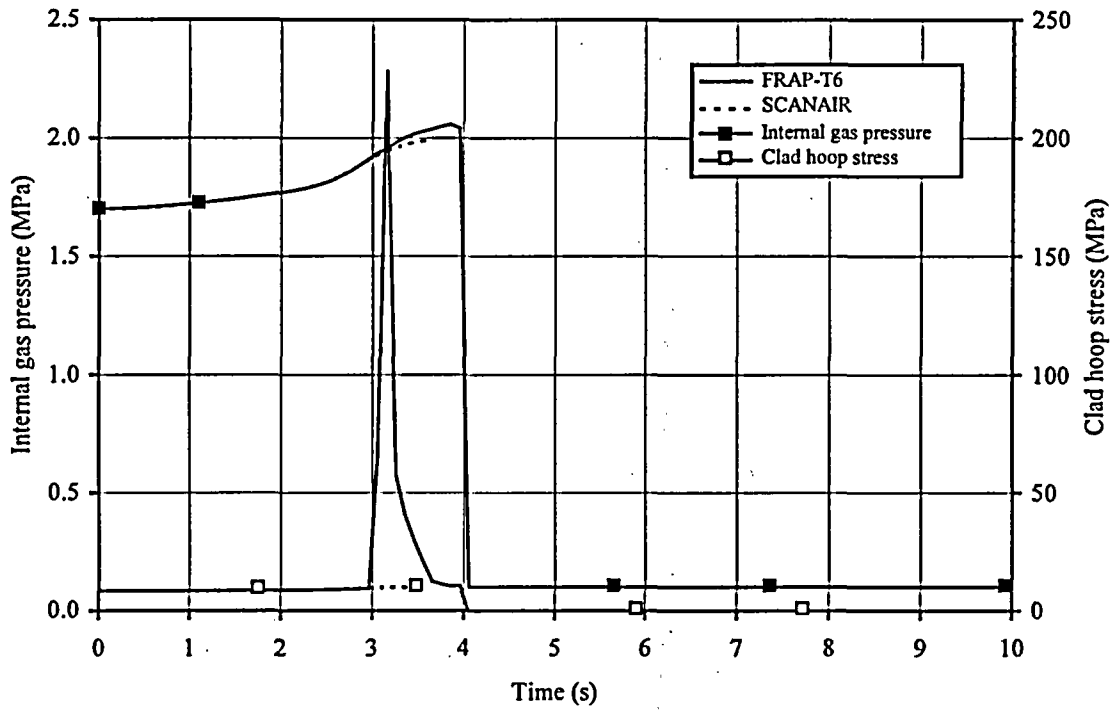

Fig. G-9.9. Cladding Mechanical Characteristics Vs. Time Calculated by FRAP-T6 and SCANAIR Codes for Fuel Rod #B9T

#B9T

Individual Characteristics of Refabricated Fuel Rods  
(Preirradiated Fuel, Preirradiated Cladding) under IGR Tests

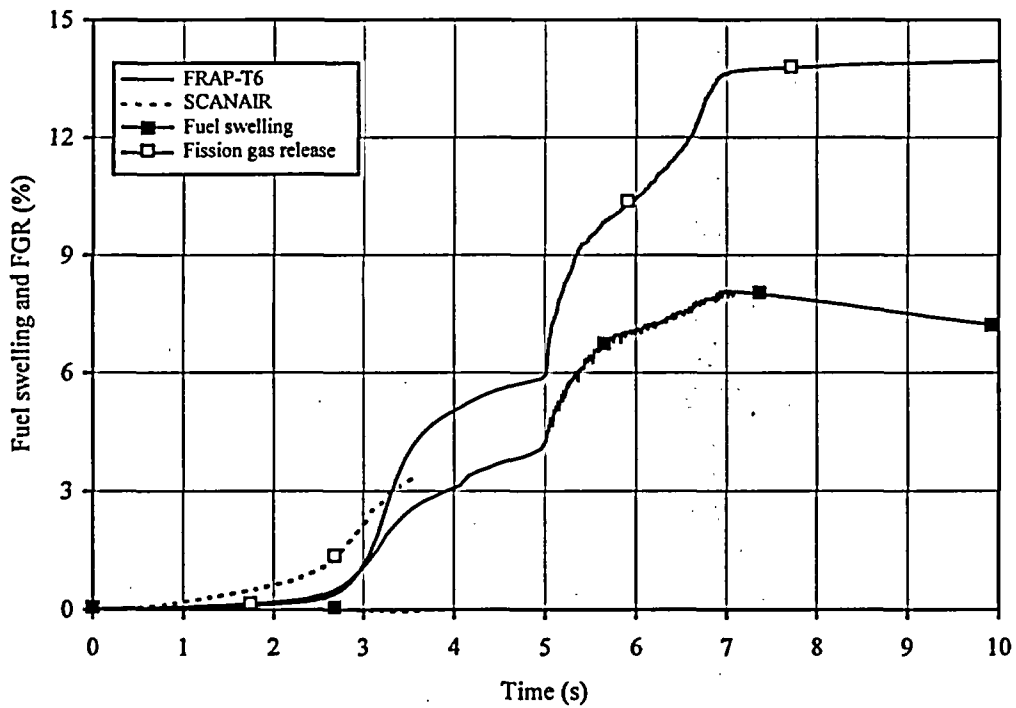
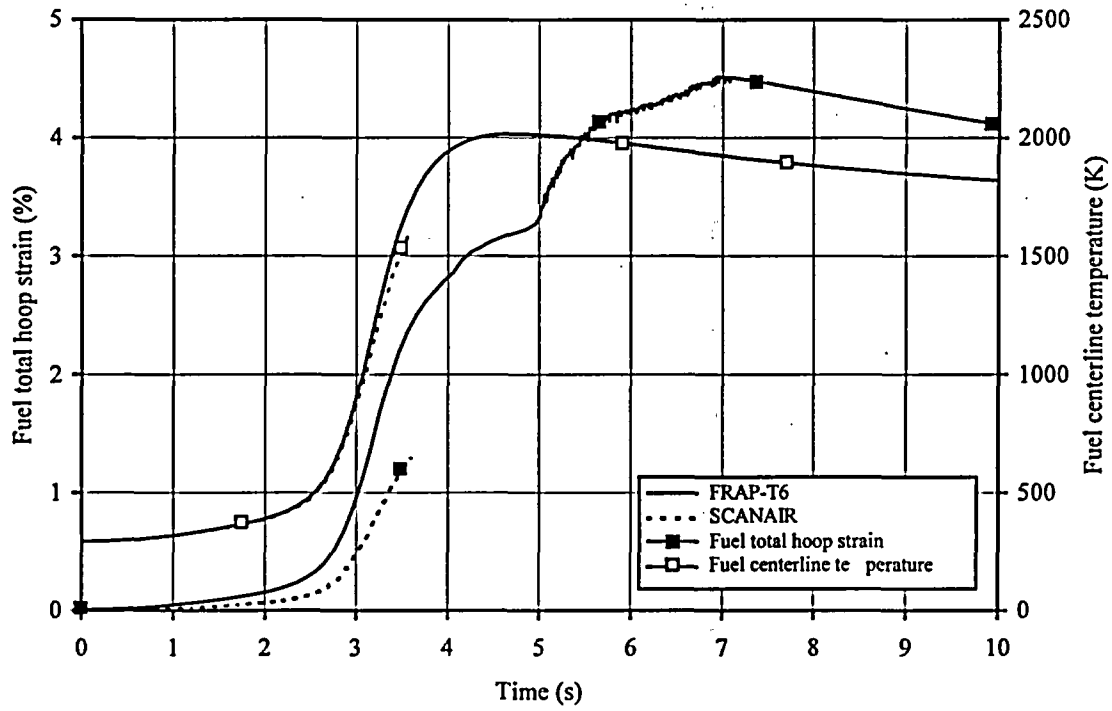

Fig. G-9.10. Fuel Strain and Fission Gas Release Vs. Time Calculated by FRAP-T6 and SCANAIR Codes for Fuel Rod #B9T



Table G-9.9. Some Results of PIE for Fuel Rod #B9T

Characteristic		Value	
1.	Measured parameters of cladding oxidation and cladding deformation		
1.1.	Cladding thickness at elevation 85, 165 mm correspondent to different azimuthal angles ( $\mu\text{m}$ ):		
	0°	649	649
	90°	649	R
	180°	649	580
	270°	649	620
1.2.	ZrO <sub>2</sub> thickness at elevation 85, 165 mm correspondent to different azimuthal angles ( $\mu\text{m}$ ):		
	0°	10	10
	90°	10	10
	180°	10	10
	270°	10	10
1.3.	$\alpha\text{Zr(O)}$ thickness at elevation 85, 165 mm correspondent to different azimuthal angles ( $\mu\text{m}$ ):		
	0°	10	10
	90°	10	10
	180°	10	10
	270°	10	10
1.4.	Clad hoop strain at elevation 85, 165 mm, respectively (%)	7.3	42.3
2.	Measured parameters for FGR analysis		
2.1.	Internal gas composition (% by volume):		
	He	—	
	N <sub>2</sub>	—	
	O <sub>2</sub>	—	
	Ar	—	
	CO <sub>2</sub>	—	
	Kr	—	
	Xe	—	
2.2.	Free gas volume (cm <sup>3</sup> )	—	
2.3.	Gas pressure inside fuel rod under normal condition (MPa)	—	
2.4.	Kr concentration in fuel (cm <sup>3</sup> /g fuel)	—	
3.	Measured parameters of cladding hydriding		
3.1.	Coefficient of hydride orientation (per-unit)	—	
3.2.	Hydrogen concentration (% by weight)	—	

# #B9T

Individual Characteristics of Refabricated Fuel Rods  
(Preirradiated Fuel, Preirradiated Cladding) under IGR Tests

Table G-9.10. General Characteristic of Fuel Rod #B9T

	Parameter	Unit	Value		
			Experiment	FRAP-T6	SCANAIR
1	Type of coolant	---	air	air	air
2	Burnup	MWd/kg U	49.7	49.7	49.7
3	Energy deposition in fuel rod	cal/g fuel	165	165	165
4	Peak fuel enthalpy	cal/g fuel	-	119	-
5	Peak fuel temperature	K	-	2016	-
6	Peak clad temperature	K	-	1606	-
7	Fuel rod failure	Yes, No	Yes	Yes	-
8	Type of failure:				
	- cladding rupture due to ballooning	Yes, No	Yes	Yes	-
	- cladding rupture due to PCMI	Yes, No	No	No	-
	- fragmentation of fuel rod	Yes, No	No	-	-
9	Failure time	s	-	3.96	-
10	Fuel enthalpy at failure	cal/g fuel	-	109	-
11	Outer cladding temperature at failure	K	-	1266	-
12	Internal gas pressure at failure	MPa	-	2.04	-
13	ZrO <sub>2</sub> thickness after test	μm	10	-	-
14	Residual clad hoop strain:				
	- peak value for ballooning area	%	42.3	46.20	-
	- other location <sup>1)</sup>	%	7.3	4.57	-
15	Kr concentration in internal gas composition after test	% by volume	-	1.44	-
16	Xe concentration in internal gas composition after test	% by volume	-	8.65	-
17	Kr concentration in fuel after test	cm <sup>3</sup> /g fuel	-	0.11	-

<sup>1)</sup>Calculated values by FRAP-T6 and SCANAIR codes are average along height of fuel rod excluding ballooning region

**APPENDIX G-10.**  
*Individual Characteristics for Fuel Rod #B10T under IGR Test*

#B10T

Individual Characteristics of Refabricated Fuel Rods  
(Preirradiated Fuel, Preirradiated Cladding) under IGR Tests

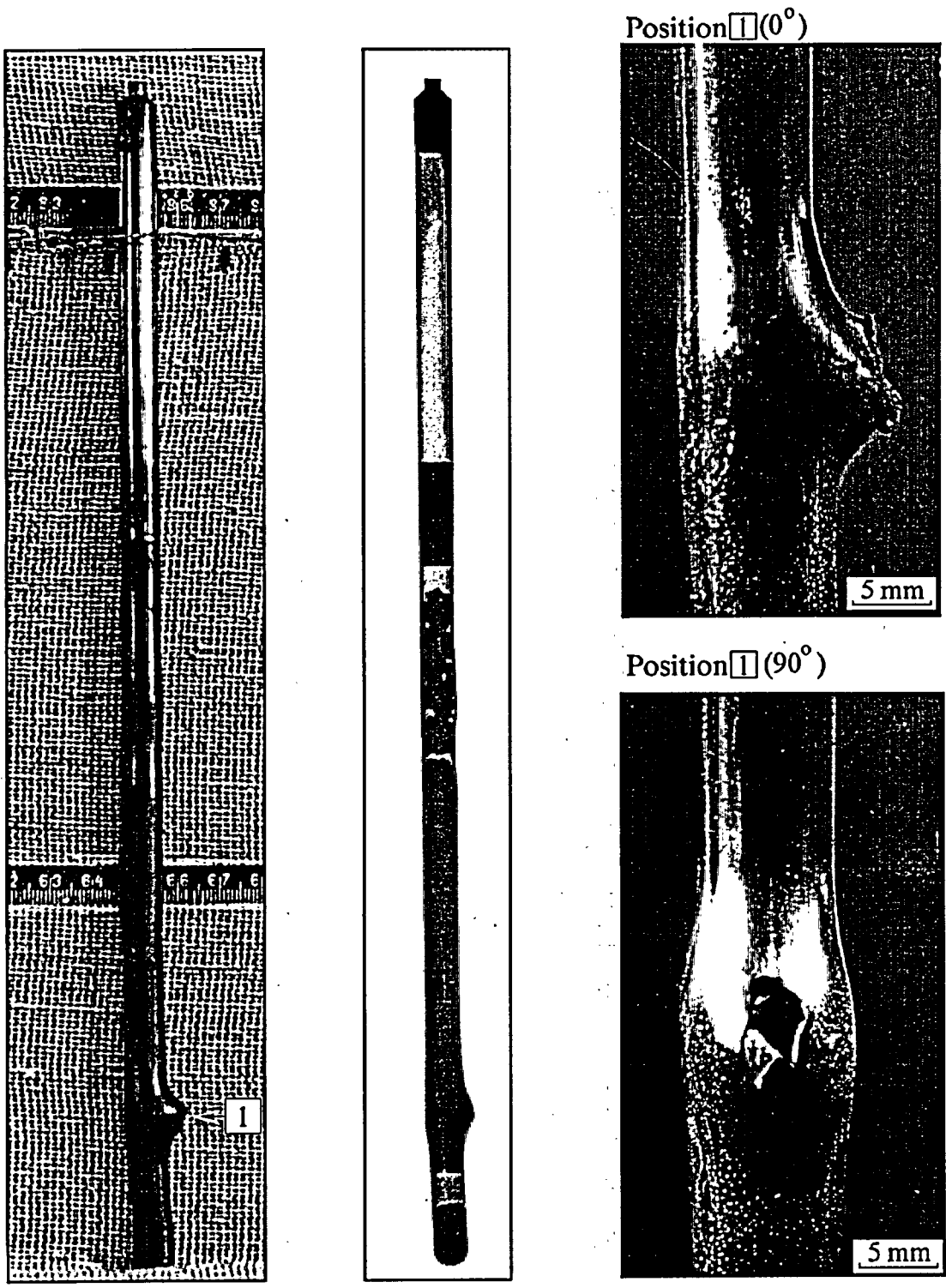
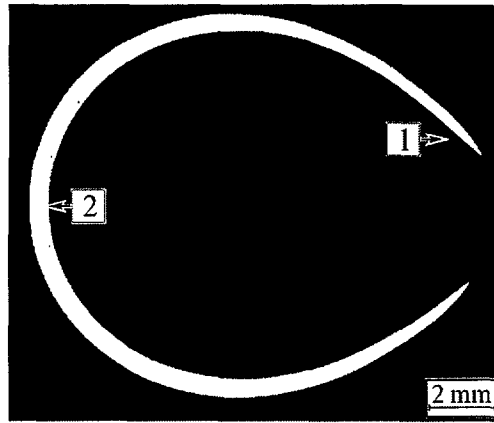

Fig. G-10.1. Appearance of Fuel Rod #B10T (photographs and X-ray photograph)

#B10T

Individual Characteristics of Refabricated Fuel Rods  
(Preirradiated Fuel, Preirradiated Cladding) under IGR Tests



Position 1



Position 2

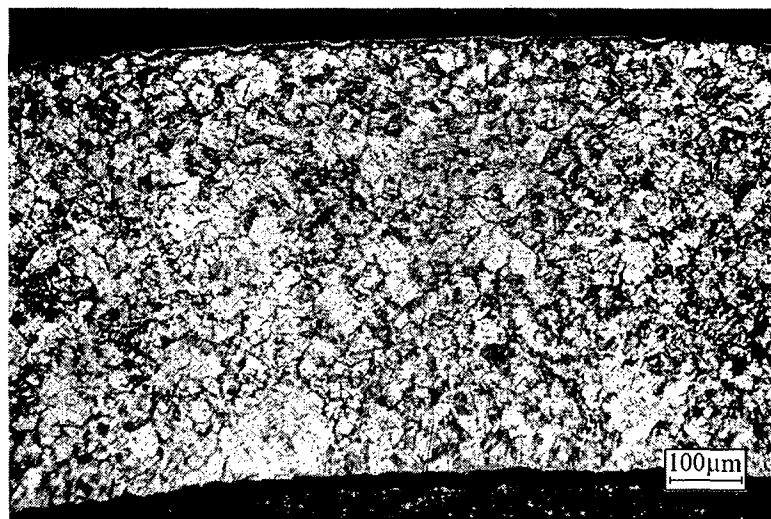
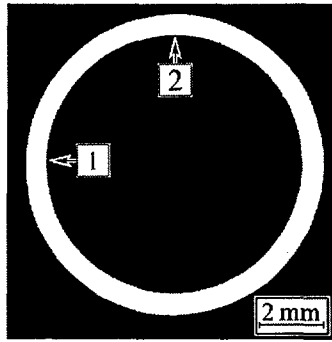

Fig. G-10.2. Cross-Section and Cladding Microstructure for Fuel Rod #B10T at 38 mm Elevation

#B10T

Individual Characteristics of Refabricated Fuel Rods  
(Preirradiated Fuel, Preirradiated Cladding) under IGR Tests



Position 1

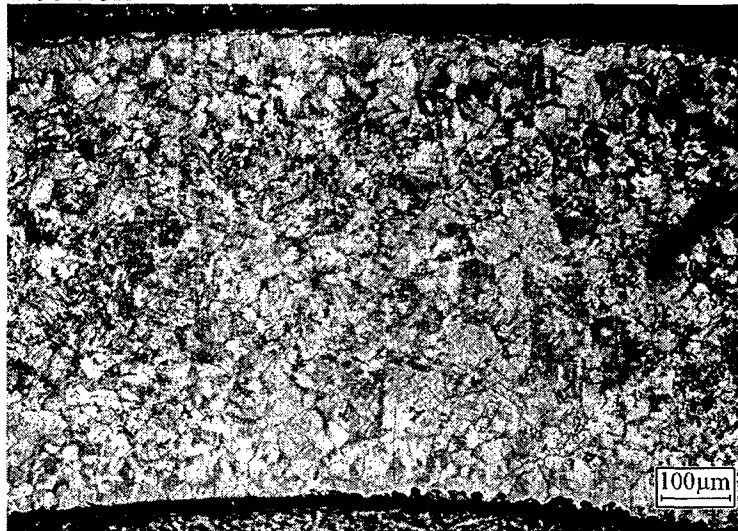

Position 2

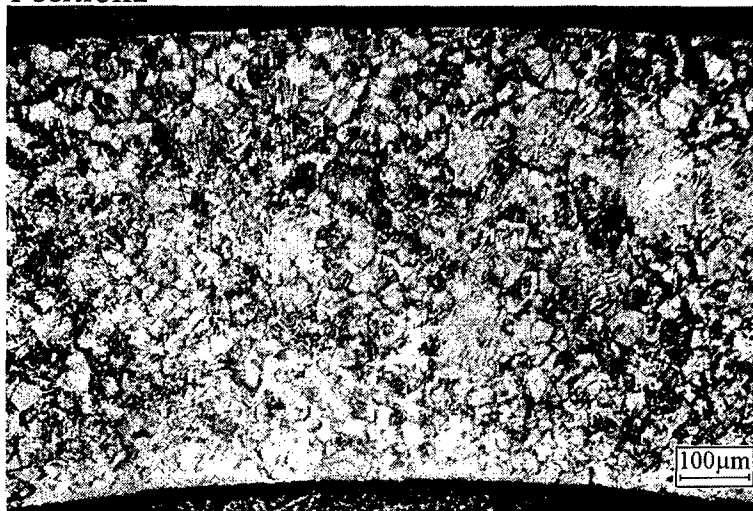

Fig. G-10.3. Cross-Section and Cladding Microstructure for Fuel Rod #B10T at 98 mm Elevation

#B10T

Individual Characteristics of Refabricated Fuel Rods  
(Preirradiated Fuel, Preirradiated Cladding) under IGR Tests

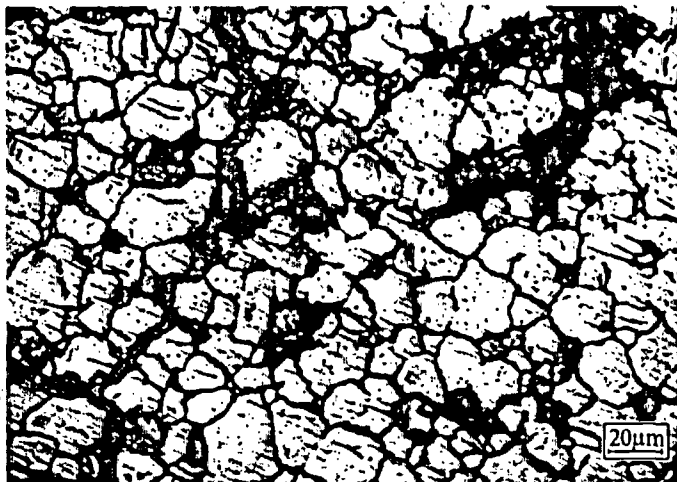
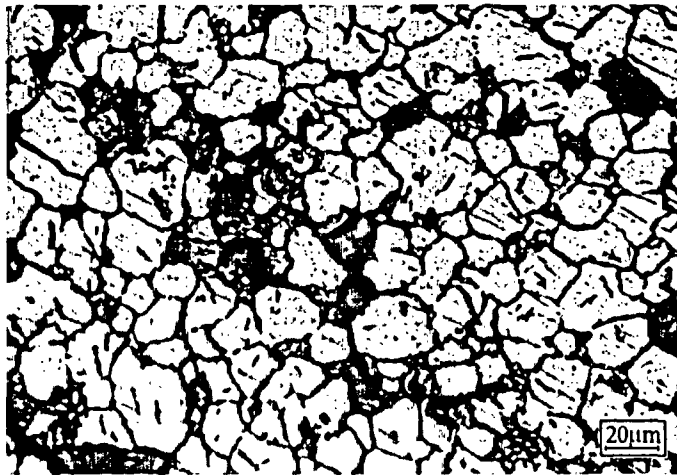
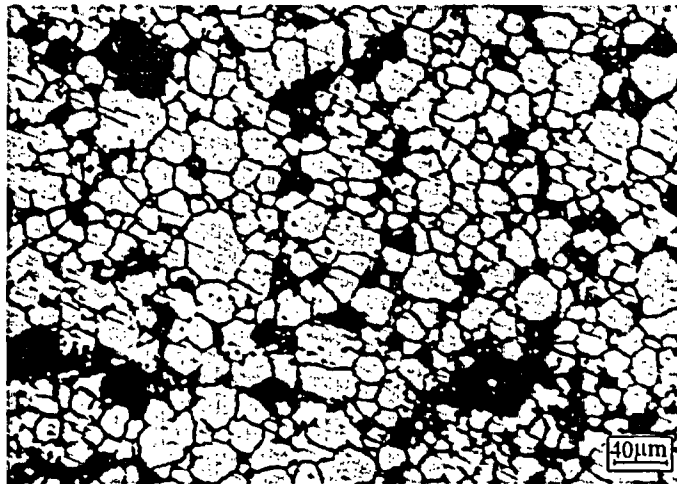

Fig. G-10.4. Fuel Microstructure for Fuel Rod #B10T at 38 mm Elevation

## #B10T

Individual Characteristics of Refabricated Fuel Rods  
(Preirradiated Fuel, Preirradiated Cladding) under IGR Tests

Table G-10.1. Time Dependent Energy Characteristics of Fuel Rod #B10T

Time (s)	Reac- tor energy deposi- tion <sup>1)</sup> (%)	Cumulative number of fissions in fuel rod (fiss)						Power of fuel rod (kW)	Energy deposition in fuel rod	
		U <sup>235</sup> ×10 <sup>-14</sup>	U <sup>238</sup> ×10 <sup>-13</sup>	Pu <sup>239</sup> ×10 <sup>-14</sup>	Pu <sup>241</sup> ×10 <sup>-14</sup>	Other iso- topes ×10 <sup>-11</sup>	Total ×10 <sup>-14</sup>		cal/g fuel	J/g fuel
0.0	0.000	0.000	0.000	0.000	0.000	0.000	0.000	0.000	0.000	0.000
1.0	1.100	0.044	0.014	0.060	0.021	0.066	0.127	0.727	1.550	6.490
2.0	4.820	0.191	0.061	0.264	0.093	0.287	0.555	2.060	6.800	28.50
2.2	6.310	0.251	0.079	0.346	0.122	0.376	0.727	2.990	8.910	37.30
2.4	8.640	0.343	0.109	0.473	0.167	0.514	0.995	4.910	12.20	51.10
2.6	12.70	0.505	0.160	0.697	0.245	0.757	1.460	9.010	18.00	75.30
2.8	20.30	0.808	0.256	1.110	0.393	1.210	2.340	16.70	28.70	120.0
3.0	33.40	1.330	0.421	1.830	0.645	1.990	3.850	26.20	47.10	197.0
3.2	50.60	2.010	0.638	2.770	0.977	3.010	5.830	28.70	71.40	299.0
3.4	65.80	2.620	0.829	3.600	1.270	3.920	7.580	20.80	92.90	389.0
3.6	75.90	3.020	0.956	4.160	1.470	4.520	8.740	13.10	107.0	448.0
3.8	82.20	3.270	1.040	4.500	1.590	4.890	9.470	8.220	116.0	486.0
4.0	86.20	3.430	1.090	4.720	1.660	5.130	9.930	5.340	122.0	511.0
4.2	88.80	3.530	1.120	4.870	1.710	5.290	10.20	3.620	126.0	527.0
4.4	90.60	3.600	1.140	4.960	1.750	5.400	10.40	2.570	128.0	536.0
4.6	91.90	3.650	1.160	5.040	1.770	5.470	10.60	1.900	130.0	544.0
4.8	92.80	3.690	1.170	5.090	1.790	5.530	10.70	1.450	132.0	553.0
5.0	93.60	3.720	1.180	5.130	1.810	5.570	10.80	1.150	133.0	557.0
5.2	94.20	3.740	1.190	5.160	1.820	5.610	10.80	0.929	134.0	561.0
5.4	94.70	3.760	1.190	5.190	1.830	5.640	10.90	0.762	134.0	561.0
5.6	95.00	3.780	1.200	5.210	1.840	5.660	10.90	0.645	135.0	565.0
5.8	95.40	3.790	1.200	5.230	1.840	5.680	11.00	0.550	135.0	565.0
6.0	95.60	3.800	1.210	5.240	1.850	5.700	11.00	0.474	136.0	569.0
6.5	96.20	3.820	1.210	5.270	1.860	5.730	11.10	0.342	137.0	573.0
7.0	96.60	3.840	1.220	5.290	1.860	5.750	11.10	0.262	137.0	573.0
7.5	96.80	3.850	1.220	5.310	1.870	5.770	11.20	0.212	138.0	578.0
8.0	97.10	3.860	1.220	5.320	1.870	5.780	11.20	0.179	138.0	578.0
9.0	97.50	3.880	1.230	5.340	1.880	5.810	11.20	0.153	139.0	582.0
10.0	97.80	3.890	1.230	5.360	1.890	5.820	11.30	0.122	140.0	586.0
20.0	99.10	3.940	1.250	5.430	1.910	5.900	11.40	0.031	142.0	594.0
30.0	99.60	3.960	1.250	5.460	1.920	5.930	11.50	0.016	143.0	599.0
∞	100.0	3.990	1.270	5.500	1.940	5.980	11.60	0.000	146.0	611.0

Maximum value of power is 29.3 kW (t = 3.15 s).

<sup>1)</sup> Current energy deposition per maximum energy deposition (at infinite time)



# #B10T

Individual Characteristics of Refabricated Fuel Rods  
(Preirradiated Fuel, Preirradiated Cladding) under IGR Tests

Table G-10.2. Axial Energy Characteristics of Fuel Rod #B10T

Axial coordinate from lower end of fuel rod (mm)	Cumulative number of fissions at axial interval (fiss)						Maximum power of fuel rod (kW) t=3.15s	Energy deposition at infinite time*		
	U <sup>235</sup> ×10 <sup>-13</sup>	U <sup>238</sup> ×10 <sup>-11</sup>	Pu <sup>239</sup> ×10 <sup>-13</sup>	Pu <sup>241</sup> ×10 <sup>-13</sup>	Other isotopes ×10 <sup>-10</sup>	Total ×10 <sup>-13</sup>		cal/g fuel	J/g fuel	per-unit <sup>3)</sup>
10.0	0.000	0.000	0.000	0.000	0.000	0.000	0.000	0.000	0.000	0.00
15.0	0.000	0.000	0.000	0.000	0.000	0.000	0.000	0.000	0.000	0.00
20.0	0.000	0.000	0.000	0.000	0.000	0.000	0.000	0.000	0.000	0.00
25.0 <sup>1)</sup>	0.662	2.000	0.909	0.324	0.972	1.920	0.485	157.0	657.0	1.00
30.0	1.320	4.010	1.820	0.648	1.940	3.830	0.970	157.0	657.0	1.00
35.0	1.320	4.010	1.820	0.648	1.940	3.830	0.970	157.0	657.0	1.00
40.0	1.380	4.540	1.940	0.688	2.170	4.060	1.030	144.0	603.0	0.92
45.0	1.450	4.700	2.010	0.711	2.170	4.220	1.070	145.0	607.0	0.92
50.0	1.540	4.920	2.110	0.742	2.180	4.440	1.120	146.0	611.0	0.93
55.0	1.620	4.940	2.130	0.735	2.180	4.530	1.150	148.0	620.0	0.94
60.0	1.700	4.960	2.150	0.731	2.190	4.630	1.170	150.0	628.0	0.96
65.0	1.650	4.990	2.150	0.740	2.190	4.600	1.160	149.0	624.0	0.95
70.0	1.610	4.970	2.140	0.742	2.200	4.540	1.150	147.0	615.0	0.94
75.0	1.600	4.930	2.120	0.735	2.210	4.510	1.140	148.0	620.0	0.94
80.0	1.590	4.880	2.100	0.729	2.220	4.480	1.130	148.0	620.0	0.94
85.0	1.530	4.820	2.070	0.721	2.220	4.380	1.110	147.0	615.0	0.94
90.0	1.490	4.750	2.040	0.715	2.230	4.290	1.090	146.0	611.0	0.93
95.0	1.450	4.700	2.010	0.711	2.230	4.220	1.070	145.0	607.0	0.92
100.0	1.410	4.650	1.990	0.703	2.240	4.150	1.050	144.0	603.0	0.92
105.0	1.410	4.610	1.970	0.697	2.240	4.120	1.040	144.0	603.0	0.92
110.0	1.410	4.600	1.970	0.696	2.240	4.130	1.040	145.0	607.0	0.92
115.0	1.410	4.580	1.970	0.694	2.240	4.120	1.040	145.0	607.0	0.92
120.0	1.410	4.560	1.960	0.690	2.230	4.100	1.040	145.0	607.0	0.92
125.0	1.400	4.580	1.960	0.695	2.230	4.110	1.040	144.0	603.0	0.92
130.0	1.400	4.600	1.970	0.697	2.220	4.110	1.040	144.0	603.0	0.92
135.0	1.380	4.600	1.970	0.698	2.210	4.100	1.040	144.0	603.0	0.92
140.0	1.350	4.530	1.940	0.691	2.200	4.030	1.020	143.0	599.0	0.91
145.0	0.901	2.900	1.280	0.465	1.410	2.680	0.678	142.0	594.0	0.90
150.0	0.901	2.900	1.280	0.465	1.410	2.680	0.678	142.0	594.0	0.90
155.0	0.901	2.900	1.280	0.465	1.410	2.680	0.678	142.0	594.0	0.90
160.0	0.901	2.900	1.280	0.465	1.410	2.680	0.678	142.0	594.0	0.90
165.0	0.868	2.610	1.270	0.451	1.350	2.620	0.663	139.0	582.0	0.89
170.0	0.868	2.610	1.270	0.451	1.350	2.620	0.663	139.0	582.0	0.89
175.0 <sup>2)</sup>	0.087	0.261	0.127	0.045	0.135	0.262	0.066	139.0	582.0	0.89
180.0	0.000	0.000	0.000	0.000	0.000	0.000	0.000	0.000	0.000	0.00
185.0	0.000	0.000	0.000	0.000	0.000	0.000	0.000	0.000	0.000	0.00

\* All numerical values of characteristics are presented as average values at the length interval equal to the axial coordinate ± 2.5 mm

<sup>1)</sup> Initial coordinate of fuel is 25.0 mm.

<sup>2)</sup> End coordinate of fuel is 173.0 mm.

<sup>3)</sup> Current value per maximum value.

Table G-10.3. Radial Energy Characteristics of Fuel Rod #B10T

Characteristics*		Coordinates of fuel zones (mm)			
		1 zone 1.2 - 2.811	2 zone 2.811-3.432	3 zone 3.432-3.704	4 zone 3.704-3.790
U <sup>235</sup>	Number of fissions $\times 10^{-14}$ (fiss)	1.580	0.932	0.459	0.150
	Power of fuel rod <sup>1)</sup> (kW)	3.930	2.320	1.140	0.372
	Energy deposition <sup>2)</sup> (cal/g fuel)	50.30	49.50	48.70	47.70
	Energy deposition <sup>2)</sup> (J/g fuel)	211.0	207.0	204.0	200.0
	Energy deposition <sup>3)</sup> (per-unit)	1.000	0.984	0.968	0.948
U <sup>238</sup>	Number of fissions $\times 10^{-12}$ (fiss)	5.140	2.960	1.400	0.435
	Power of fuel rod <sup>1)</sup> (kW)	0.126	0.073	0.034	0.011
	Energy deposition <sup>2)</sup> (cal/g fuel)	1.620	1.550	1.470	1.370
	Energy deposition <sup>2)</sup> (J/g fuel)	6.780	6.490	6.150	5.730
	Energy deposition <sup>3)</sup> (per-unit)	1.000	0.957	0.907	0.846
Pu <sup>239</sup>	Number of fissions $\times 10^{-14}$ (fiss)	1.760	1.200	0.828	0.475
	Power of fuel rod <sup>1)</sup> (kW)	4.530	3.080	2.130	1.220
	Energy deposition <sup>2)</sup> (cal/g fuel)	58.20	66.00	91.00	156.0
	Energy deposition <sup>2)</sup> (J/g fuel)	244.0	276.0	381.0	653.0
	Energy deposition <sup>3)</sup> (per-unit)	0.373	0.423	0.583	1.000
Pu <sup>241</sup>	Number of fissions $\times 10^{-13}$ (fiss)	5.880	4.200	3.040	1.830
	Power of fuel rod <sup>1)</sup> (kW)	1.490	1.060	0.767	0.463
	Energy deposition <sup>2)</sup> (cal/g fuel)	19.10	22.70	32.90	59.50
	Energy deposition <sup>2)</sup> (J/g fuel)	80.00	95.00	138.0	249.0
	Energy deposition <sup>3)</sup> (per-unit)	0.321	0.382	0.553	1.000
Other isotopes	Number of fissions $\times 10^{-11}$ (fiss)	2.120	1.350	0.801	0.381
	Power of fuel rod <sup>1)</sup> (kW)	0.005	0.003	0.002	0.001
	Energy deposition <sup>2)</sup> (cal/g fuel)	0.069	0.073	0.087	0.124
	Energy deposition <sup>2)</sup> (J/g fuel)	0.290	0.310	0.360	0.520
	Energy deposition <sup>3)</sup> (per-unit)	0.558	0.590	0.702	1.000
Total	Number of fissions $\times 10^{-14}$ (fiss)	3.980	2.580	1.600	0.812
	Power of fuel rod <sup>1)</sup> (kW)	10.10	6.540	4.060	2.060
	Energy deposition <sup>2)</sup> (cal/g fuel)	129.0	140.0	174.0	264.0
	Energy deposition <sup>2)</sup> (J/g fuel)	540.0	586.0	728.0	1105.
	Energy deposition <sup>3)</sup> (per-unit)	0.489	0.530	0.659	1.000

<sup>1)</sup> at time of 3.15 s, <sup>2)</sup> at infinite time, <sup>3)</sup> Current value per maximum value.

\* All numerical values of characteristics were calculated for undamaged part of fuel stack only (See Table C.2.3.)

# #B10T

Individual Characteristics of Refabricated Fuel Rods  
(Preirradiated Fuel, Preirradiated Cladding) under IGR Tests

Table G-10.4. Fuel Enthalpy Vs. Time Calculated by FRAP-T6 Code for Fuel Rod #B10T

Time (s)	Enthalpy at fuel radius (cal/g fuel)				Fuel enthalpy <sup>1)</sup>		Energy deposition in fuel rod	
	1.20 mm	2.82 mm	3.47 mm	3.79 mm	cal/g fuel	J/g fuel	cal/g fuel	J/g fuel
0.0	0.00	0.00	0.00	0.00	0.00	0.00	0.00	0.00
1.0	1.35	1.34	1.30	1.25	1.33	5.58	1.50	6.28
2.0	6.38	6.20	5.93	5.66	6.17	25.8	7.02	29.4
2.2	8.46	8.24	7.88	7.50	8.19	34.3	9.24	38.7
2.4	11.8	11.6	11.0	10.5	11.5	48.1	12.7	53.4
2.6	18.0	17.6	16.8	15.7	17.4	73.1	19.0	79.5
2.8	29.5	29.1	27.5	25.0	28.7	120	30.6	128
3.0	49.1	48.3	44.5	38.1	47.1	197	50.0	209
3.2	70.4	68.6	60.5	49.1	66.2	277	70.7	296
3.4	92.8	88.5	75.1	58.6	85.1	356	92.3	387
3.6	108	99.7	80.6	64.1	95.8	402	107	447
3.8	117	105	86.5	76.1	103	431	116	485
4.0	122	107	94.6	91.0	108	453	121	509
4.2	124	110	100	96.8	112	468	125	525
4.4	125	112	104	99.9	114	476	128	536
4.6	126	113	106	102	115	481	130	544
4.8	125	114	107	103	115	483	131	550
5.0	125	115	108	104	116	485	132	554
5.2	125	115	108	104	116	485	133	556
5.4	124	115	108	105	116	485	134	560
5.6	124	115	108	105	116	484	134	563
5.8	123	115	108	105	115	483	135	565
6.0	122	114	108	105	115	482	135	567
6.5	120	114	108	105	114	477	136	571
7.0	119	113	108	105	113	474	137	573
7.5	117	112	107	105	112	470	137	576
8.0	116	111	107	105	111	466	138	577
10.0	111	108	105	103	108	452	140	586
30.0	83.4	82.0	80.8	80.0	82.0	344	143	599

Radial enthalpy distribution and fuel enthalpy are presented at elevation 32.4 mm

Maximum value of fuel enthalpy is 115.7 cal/g fuel (t=5.10 s)

<sup>1)</sup> All numerical values are presented at elevation with peak power

# #B10T

Individual Characteristics of Refabricated Fuel Rods  
(Preirradiated Fuel, Preirradiated Cladding) under IGR Tests

Table G-10.5. Energy Characteristics Vs. Time Calculated by FRAP-T6 and SCANAIR Codes for Fuel Rod #B10T

Time (s)	Energy deposition <sup>1)</sup> (cal/g fuel)	Linear power <sup>1)</sup> (kW/m)	Fuel enthalpy <sup>1)</sup> (cal/g fuel)		Leakage of energy <sup>1)</sup> (cal/g fuel)		Clad-to-coolant heat transfer coefficient <sup>1)</sup> (kW/m <sup>2</sup> K)	
			FRAP-T6	SCANAIR	FRAP-T6	SCANAIR	FRAP-T6	SCANAIR
0.0	0.00	0.00	0.00	0.00	0.00	0.00	0.00	0.00
1.0	1.59	5.90	1.33	1.49	0.00	0.00	0.01	0.01
2.0	7.46	17.8	6.17	6.27	0.00	0.00	0.01	0.01
2.2	9.83	26.2	8.19	8.21	0.00	0.00	0.01	0.01
2.4	13.6	43.8	11.5	11.3	0.01	0.01	0.01	0.01
2.6	20.2	81.1	17.4	16.7	0.01	0.01	0.01	0.01
2.8	32.5	148	28.7	26.8	0.02	0.02	0.01	0.01
3.0	53.2	223	47.1	44.1	0.03	0.03	0.02	0.02
3.2	75.2	237	66.2	66.1	0.05	0.05	0.03	0.03
3.4	98.1	173	85.1	84.4	0.12	0.11	0.04	0.04
3.6	113	109	95.8	95.4	0.24	0.22	0.06	0.05
3.8	123	68.2	103	-	0.42	-	0.07	-
4.0	129	44.5	108	-	0.66	-	0.07	-
4.2	133	30.1	112	-	0.94	-	0.08	-
4.4	136	21.4	114	-	1.22	-	0.08	-
4.6	138	15.8	115	-	1.54	-	0.08	-
4.8	140	12.0	115	-	1.87	-	0.09	-
5.0	141	9.54	116	-	2.22	-	0.09	-
5.2	141	8.50	116	-	2.42	-	0.09	-
5.4	142	6.96	116	-	2.80	-	0.10	-
5.6	143	5.78	116	-	3.20	-	0.10	-
5.8	143	4.90	115	-	3.62	-	0.10	-
6.0	144	4.21	115	-	4.06	-	0.10	-
6.5	145	2.82	114	-	5.45	-	0.11	-
7.0	146	2.27	113	-	6.43	-	0.11	-
7.5	146	1.75	112	-	7.95	-	0.11	-
8.0	147	1.52	111	-	8.98	-	0.11	-
10.0	148	1.03	108	-	14.2	-	0.11	-
30.0	152	0.14	82.0	-	52.8	-	0.08	-

<sup>1)</sup> All numerical values are presented at elevation with peak power

# #B10T

Individual Characteristics of Refabricated Fuel Rods  
(Preirradiated Fuel, Preirradiated Cladding) under IGR Tests

Table G-10.6. Temperature Variation, Fission Gas Release and ZrO<sub>2</sub> Thickness Vs. Time for Fuel Rod #B10T Calculated by FRAP-T6 and SCANAIR Codes

Time (s)	Fuel centerline temperature <sup>1)</sup> (K)		Fuel surface temperature <sup>1)</sup> (K)		Clad outer temperature <sup>1)</sup> (K)		Fission gas release (%)	
	FRAP-T6	SCANAIR	FRAP-T6	SCANAIR	FRAP-T6	SCANAIR	FRAP-T6	SCANAIR
0.0	293	293	293	293	293	293	0.00	0.00
1.0	317	317	315	316	301	301	0.02	0.19
2.0	399	393	388	387	343	342	0.06	0.64
2.2	432	423	417	415	359	357	0.07	0.79
2.4	483	468	462	459	382	379	0.10	0.97
2.6	573	547	540	533	418	413	0.16	1.24
2.8	736	687	673	665	485	474	0.28	1.59
3.0	1002	918	853	866	610	584	0.58	2.13
3.2	1281	1210	1001	1088	778	752	1.41	2.66
3.4	1566	1460	1127	1248	988	945	2.30	3.06
3.6	1750	1623	1200	1342	1131	1105	2.93	3.29
3.8	1858	-	1355	-	1253	-	3.52	-
4.0	1916	-	1543	-	1285	-	3.80	-
4.2	1945	-	1616	-	1306	-	3.95	-
4.4	1957	-	1654	-	1331	-	4.05	-
4.6	1959	-	1677	-	1356	-	5.40	-
4.8	1957	-	1691	-	1380	-	6.50	-
5.0	1952	-	1701	-	1403	-	7.15	-
5.2	1949	-	1705	-	1414	-	7.17	-
5.4	1943	-	1711	-	1433	-	7.20	-
5.6	1936	-	1714	-	1451	-	7.32	-
5.8	1929	-	1717	-	1466	-	7.55	-
6.0	1921	-	1719	-	1480	-	7.83	-
6.5	1898	-	1720	-	1511	-	8.74	-
7.0	1883	-	1720	-	1525	-	9.45	-
7.5	1862	-	1717	-	1537	-	10.8	-
8.0	1848	-	1713	-	1542	-	11.5	-
10.0	1794	-	1689	-	1540	-	12.3	-
30.0	1448	-	1405	-	1306	-	12.9	-

<sup>1)</sup> All numerical values are presented at elevation with peak power

# #B10T

Individual Characteristics of Refabricated Fuel Rods  
(Preirradiated Fuel, Preirradiated Cladding) under IGR Tests

**Table G-10.7. Mechanical Characteristics of Fuel Rod #B10T Vs. Time Calculated by FRAP-T6 and SCANAIR Codes**

Time (s)	Clad outer temperature <sup>1)</sup> (K)		Fuel hoop strain <sup>1)</sup> (%)		Fuel - clad gap width <sup>1)</sup> (mm)		Clad hoop strain <sup>1)</sup> (%)		Clad hoop stress <sup>1)</sup> (MPa)		Internal gas pressure (MPa)	
	FRAP-T6	SCANAIR	FRAP-T6	SCANAIR	FRAP-T6	SCANAIR	FRAP-T6	SCANAIR	FRAP-T6	SCANAIR	FRAP-T6	SCANAIR
0.0	293	293	0.00	0.00	0.06	0.07	0.01	0.01	8.72	8.70	1.70	1.70
1.0	301	301	0.06	0.02	0.06	0.07	0.01	0.01	8.83	8.84	1.70	1.72
2.0	343	342	0.18	0.07	0.06	0.07	0.04	0.05	9.12	9.17	1.75	1.78
2.2	359	357	0.23	0.09	0.05	0.07	0.05	0.06	9.21	9.28	1.77	1.80
2.4	382	379	0.30	0.13	0.05	0.07	0.07	0.07	9.34	9.43	1.79	1.82
2.6	418	413	0.43	0.19	0.05	0.07	0.09	0.10	9.52	9.64	1.83	1.85
2.8	485	474	0.68	0.32	0.04	0.06	0.14	0.15	9.76	9.94	1.87	1.90
3.0	610	584	1.11	0.54	0.03	0.06	0.23	0.24	10.0	10.3	1.92	1.94
3.2	778	752	1.64	0.85	0.01	0.05	0.35	0.37	10.3	10.6	1.96	1.98
3.4	988	945	2.17	1.14	0.00	0.05	0.55	0.51	65.1	10.7	2.00	2.01
3.6	1131	1105	2.50	1.34	0.00	0.04	0.82	0.60	26.9	10.4	2.02	2.02
3.8	1253	-	2.75	-	0.02	-	1.44	-	11.0	-	2.04	-
4.0	1285	-	2.90	-	2.15	-	54.7	-	0.00	-	0.10	-
4.2	1306	-	2.99	-	2.15	-	54.7	-	0.00	-	0.10	-
4.4	1331	-	3.05	-	2.15	-	54.8	-	0.00	-	0.10	-
4.6	1356	-	3.13	-	2.15	-	54.8	-	0.00	-	0.10	-
4.8	1380	-	3.23	-	2.14	-	54.8	-	0.00	-	0.10	-
5.0	1403	-	3.31	-	2.14	-	54.8	-	0.00	-	0.10	-
5.2	1414	-	3.33	-	2.14	-	54.8	-	0.00	-	0.10	-
5.4	1433	-	3.29	-	2.14	-	54.9	-	0.00	-	0.10	-
5.6	1451	-	3.19	-	2.14	-	54.9	-	0.00	-	0.10	-
5.8	1466	-	3.31	-	2.14	-	54.9	-	0.00	-	0.10	-
6.0	1480	-	3.40	-	2.14	-	54.9	-	0.00	-	0.10	-
6.5	1511	-	3.73	-	2.12	-	54.9	-	0.00	-	0.10	-
7.0	1525	-	4.02	-	2.11	-	54.9	-	0.00	-	0.10	-
7.5	1537	-	4.10	-	2.11	-	55.0	-	0.00	-	0.10	-
8.0	1542	-	4.10	-	2.11	-	55.0	-	0.00	-	0.10	-
10.0	1540	-	3.92	-	2.12	-	55.0	-	0.00	-	0.10	-
30.0	1306	-	2.51	-	2.17	-	54.7	-	0.00	-	0.10	-

<sup>1)</sup> All numerical values are presented at elevation with peak power

# #B10T

Individual Characteristics of Refabricated Fuel Rods  
(Preirradiated Fuel, Preirradiated Cladding) under IGR Tests

**Table G-10.8. Axial Distribution of Energy Deposition and Fuel Enthalpy Calculated by FRAP-T6 Code for Fuel Rod #B10T**

Axial interval from-to (mm)-(mm)	Energy deposition at infinite time			Fuel enthalpy at time (t=5.10 s)		
	cal/g fuel	J/g fuel	per-unit	cal/g fuel	J/g fuel	per-unit
25.0 - 39.8	155	649	1.00	116	485	1.00
39.8 - 54.6	146	610	0.94	109	455	0.94
54.6 - 69.4	149	624	0.96	111	466	0.96
69.4 - 84.2	148	619	0.95	110	462	0.95
84.2 - 99.0	146	610	0.94	109	456	0.94
99.0 - 113.8	144	605	0.93	108	452	0.93
113.8 - 128.6	145	606	0.93	108	452	0.93
128.6 - 143.4	144	601	0.93	107	449	0.93
143.4 - 158.2	142	595	0.92	106	444	0.92
158.2 - 173.0	140	586	0.90	104	438	0.90

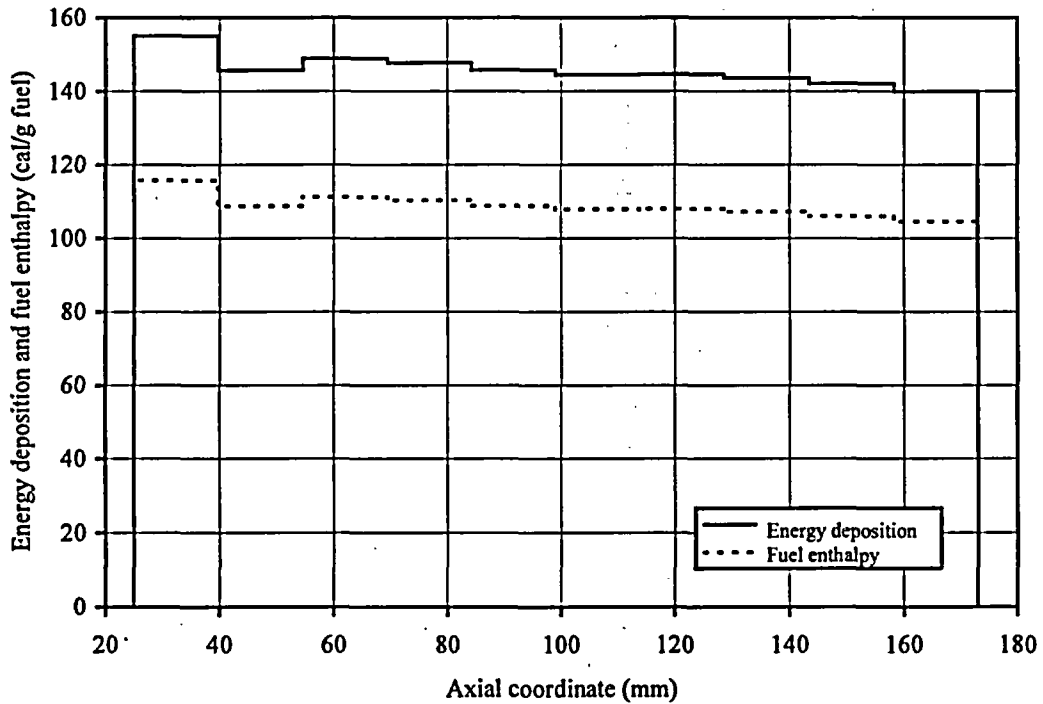

**Fig. G-10.5. Axial Distribution of Energy Deposition and Fuel Enthalpy Calculated by FRAP-T6 Code for Fuel Rod #B10T**

#B10T

Individual Characteristics of Refabricated Fuel Rods  
(Preirradiated Fuel, Preirradiated Cladding) under IGR Tests

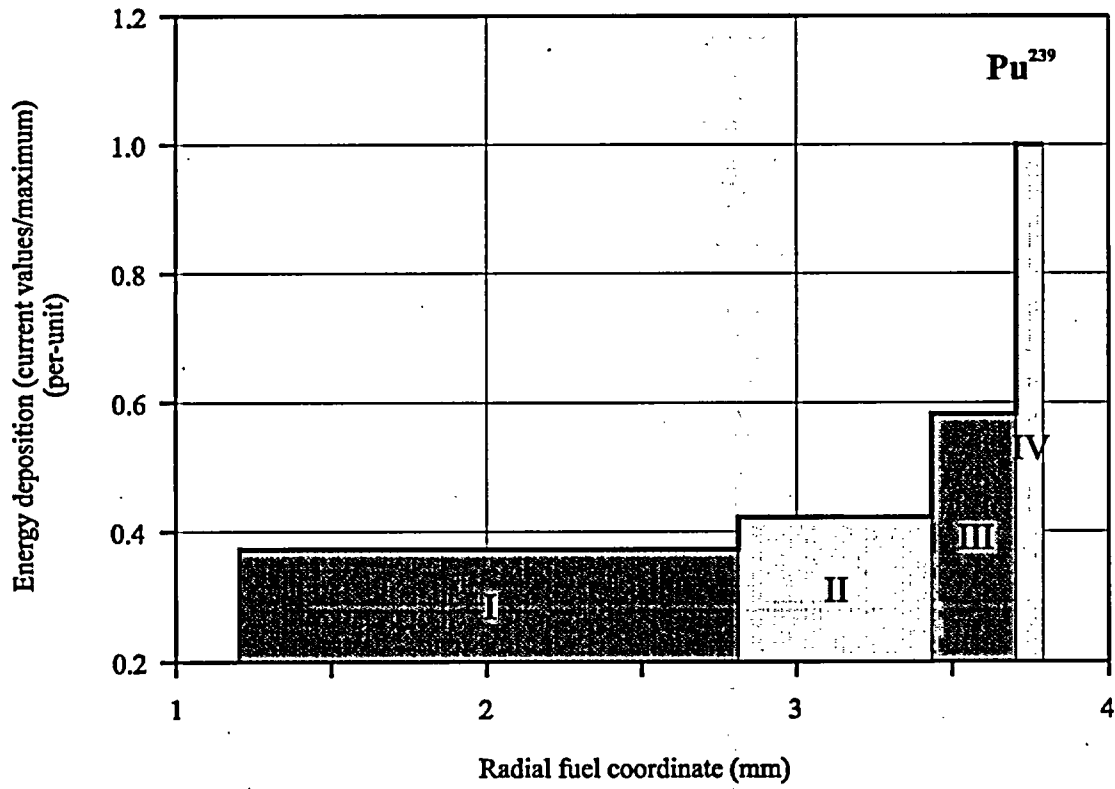
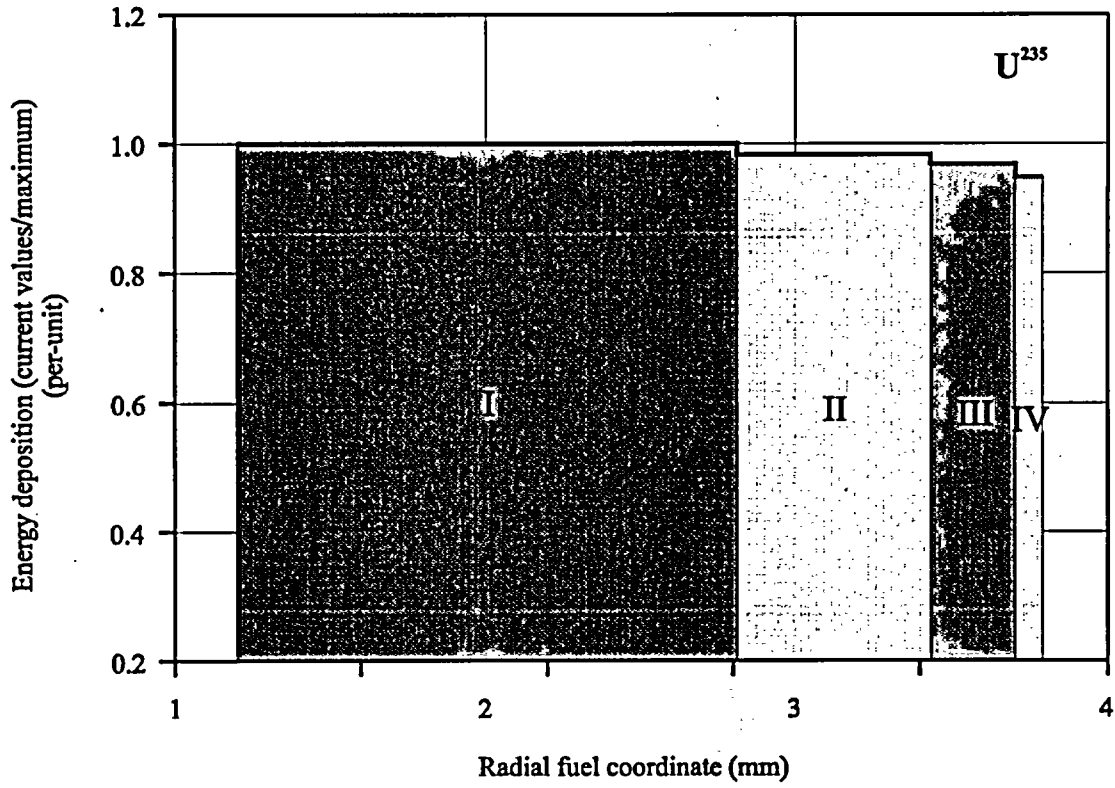

Fig. G-10.6. U<sup>235</sup> and Pu<sup>239</sup> Radial Distributions of Energy Deposition for Fuel Rod #B10T



# #B10T

Individual Characteristics of Refabricated Fuel Rods  
(Preirradiated Fuel/Preirradiated Cladding) under IGR Tests

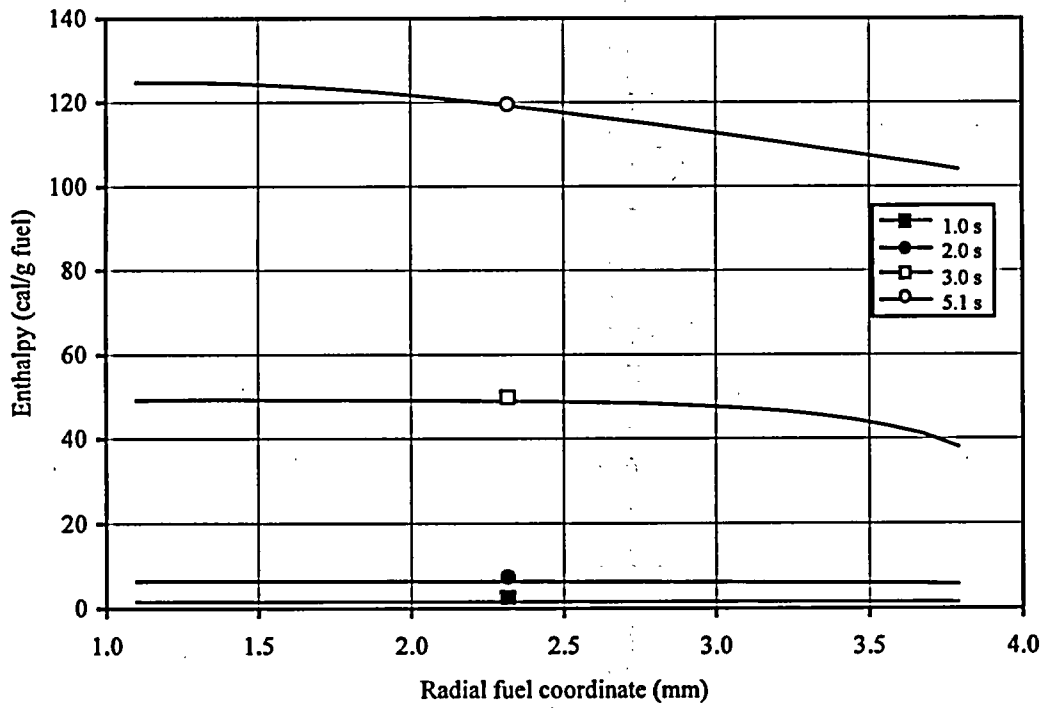
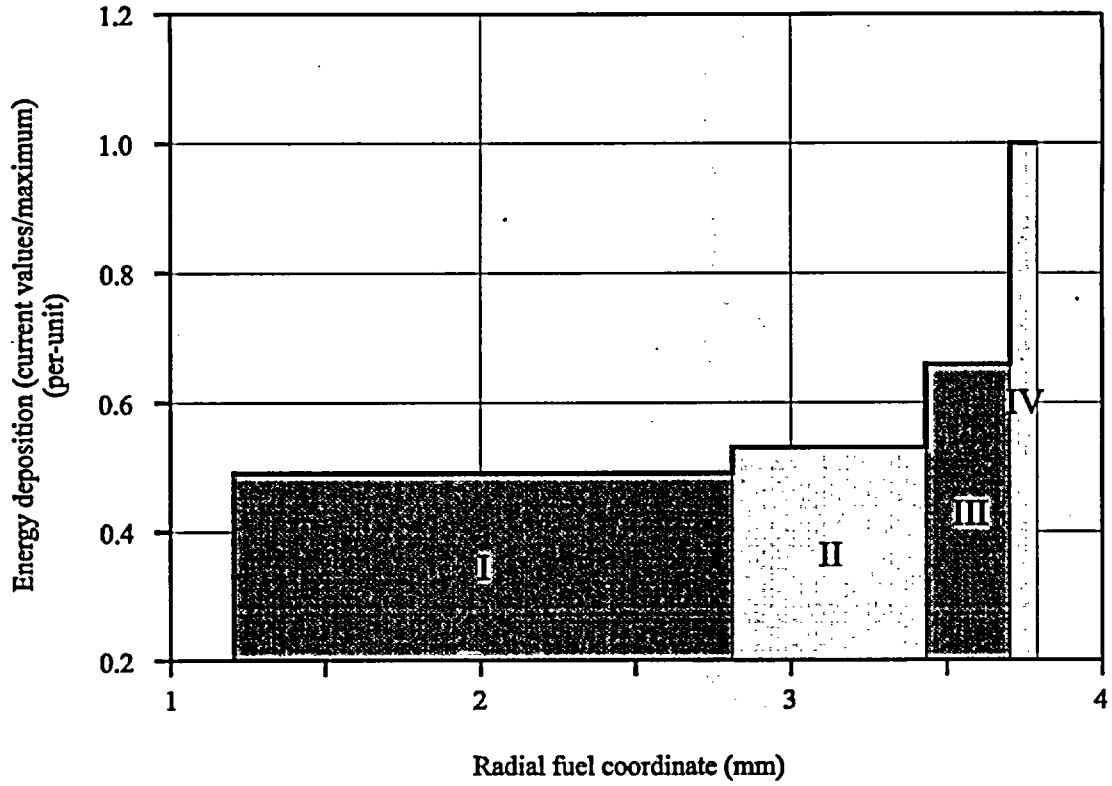

Fig. G-10.7. Radial Distributions of Energy Deposition and Fuel Enthalpy Calculated by FRAP-T6 Code for Fuel Rod #B10T

# #B10T

Individual Characteristics of Refabricated Fuel Rods  
(Preirradiated Fuel, Preirradiated Cladding) under IGR Tests

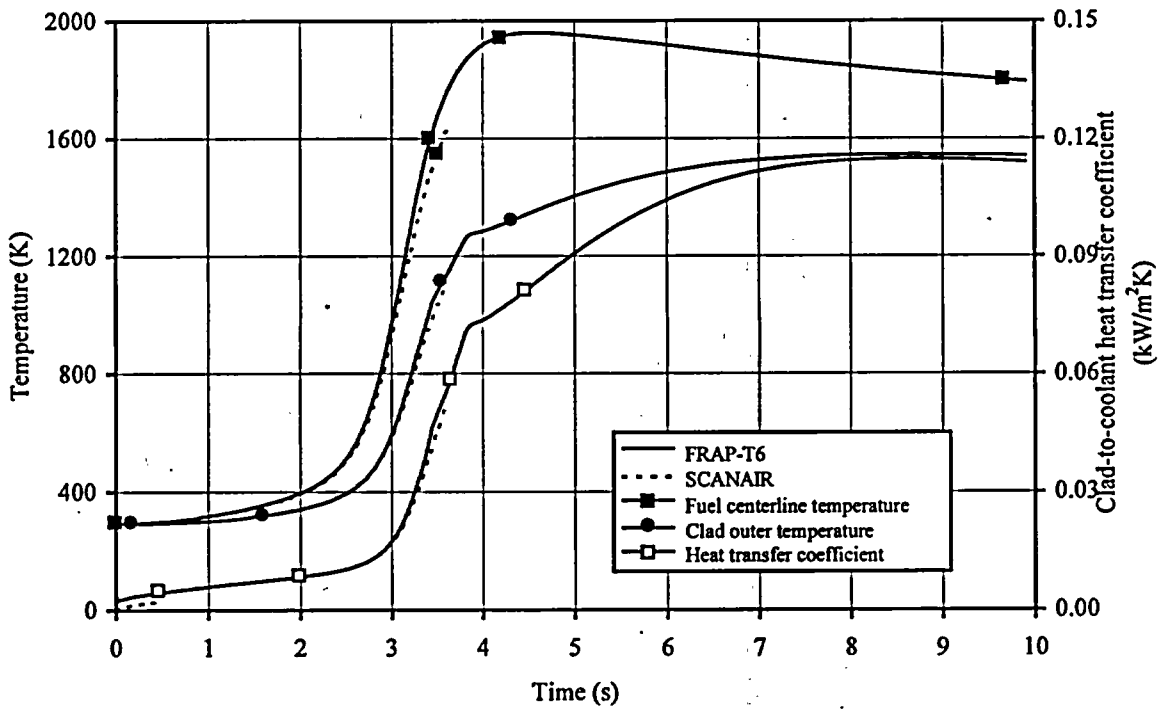
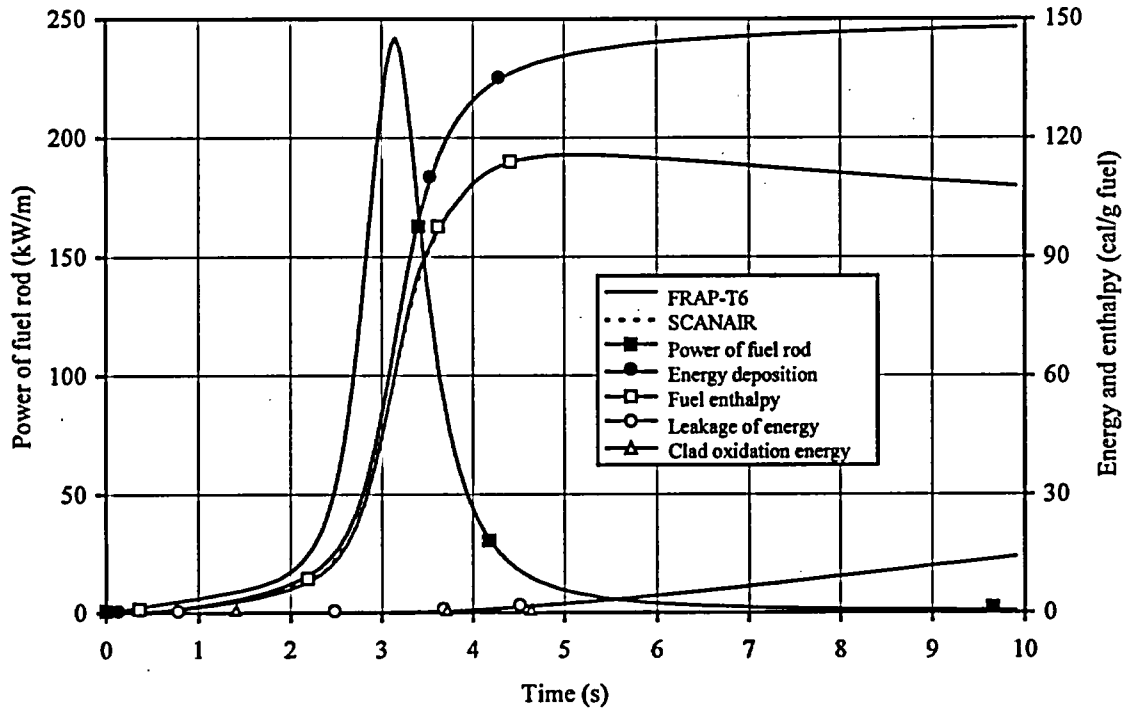

Fig. G-10.8. Energy and Temperature Characteristics Vs. Time Calculated by FRAP-T6 and SCANAIR Codes for Fuel Rod #B10T

# #B10T

Individual Characteristics of Refabricated Fuel Rods  
(Preirradiated Fuel, Preirradiated Cladding) under IGR Tests

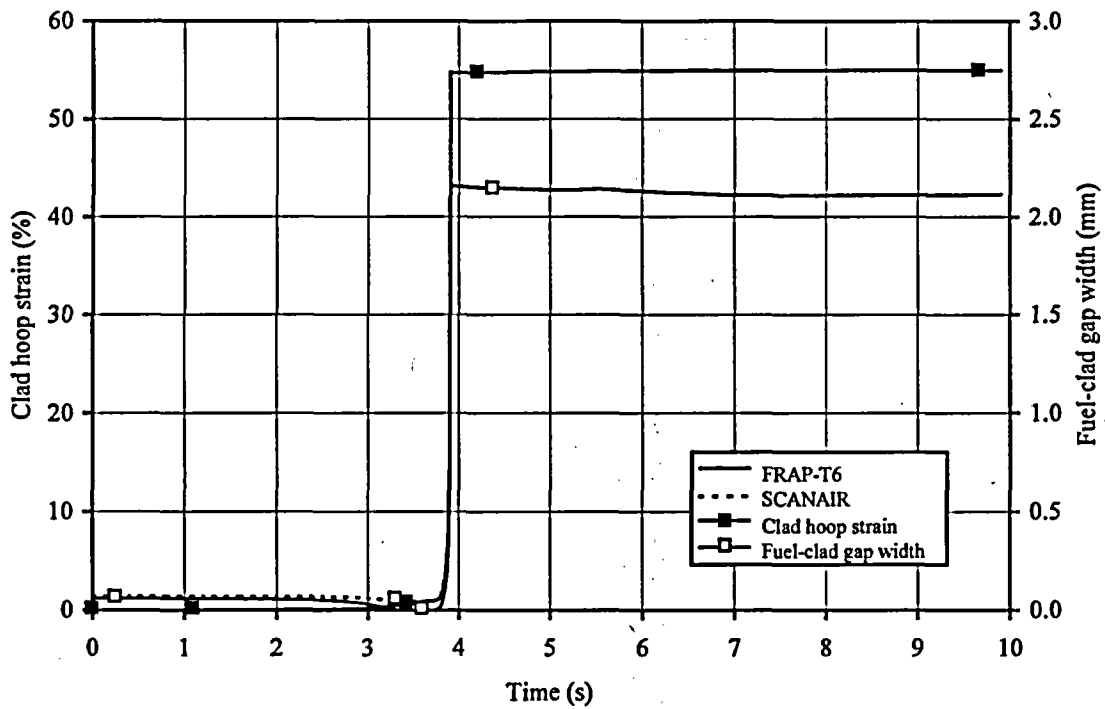
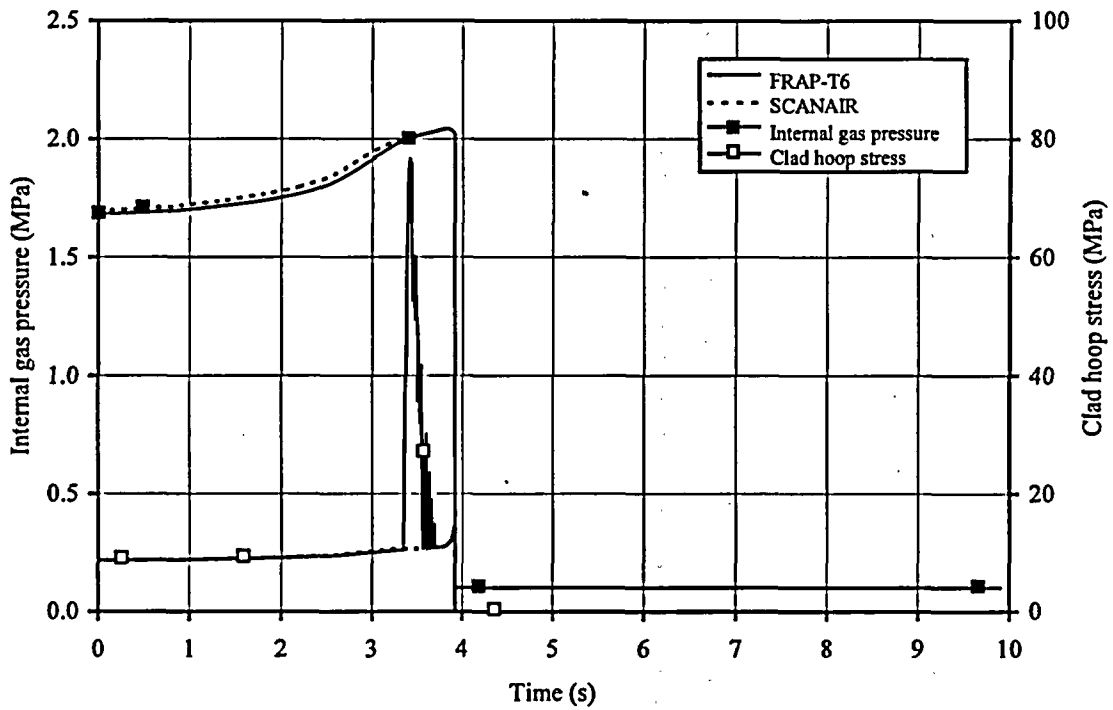

Fig. G-10.9. Cladding Mechanical Characteristics Vs. Time Calculated by FRAP-T6 and SCANAIR Codes for Fuel Rod #B10T

# #B10T

Individual Characteristics of Refabricated Fuel Rods  
(Preirradiated Fuel, Preirradiated Cladding) under IGR Tests

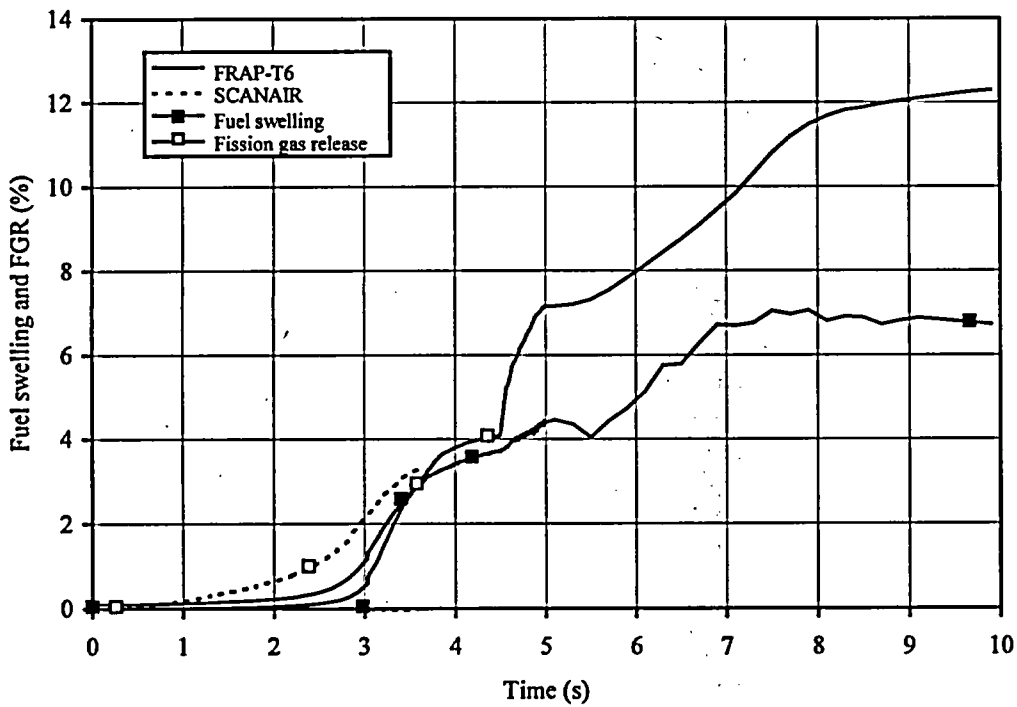
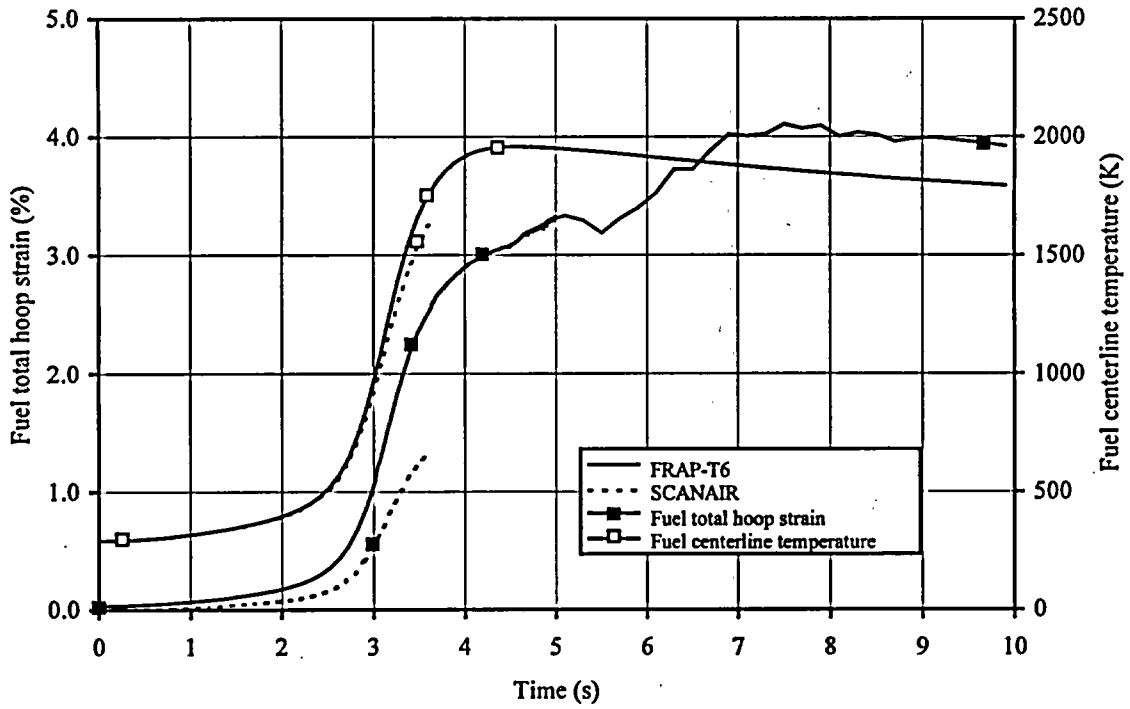

Fig. G-10.10. Fuel Strain and Fission Gas Release Vs. Time Calculated by FRAP-T6 and SCANAIR Codes for Fuel Rod #B10T

# #B10T

Individual Characteristics of Refabricated Fuel Rods  
(Preirradiated Fuel, Preirradiated Cladding) under IGR Tests

Table G-10.9. Some Results of PIE for Fuel Rod #B10T

Characteristic		Value	
1.	Measured parameters of cladding oxidation and cladding deformation		
1.1.	Cladding thickness at elevation 38, 98 mm correspondent to different azimuthal angles ( $\mu\text{m}$ ):		
	0°	545	680
	90°	R	677
	180°	580	649
	270°	620	663
1.2.	ZrO <sub>2</sub> thickness at elevation 38, 98 mm correspondent to different azimuthal angles ( $\mu\text{m}$ ):		
	0°	10	10
	90°	—	10
	180°	10	10
	270°	10	10
1.3.	$\alpha\text{Zr(O)}$ thickness at elevation 38, 98 mm correspondent to different azimuthal angles ( $\mu\text{m}$ ):		
	0°	10	10
	90°	—	10
	180°	10	10
	270°	10	10
1.4.	Clad hoop strain at elevation 38, 98 mm, respectively (%)	33.4	3.7
2.	Measured parameters for FGR analysis		
2.1.	Internal gas composition (% by volume):		
	He	—	
	N <sub>2</sub>	—	
	O <sub>2</sub>	—	
	Ar	—	
	CO <sub>2</sub>	—	
	Kr	—	
	Xe	—	
2.2.	Free gas volume (cm <sup>3</sup> )	—	
2.3.	Gas pressure inside fuel rod under normal condition (MPa)	—	
2.4.	Kr concentration in fuel (cm <sup>3</sup> /g fuel)	—	
3.	Measured parameters of cladding hydriding		
3.1.	Coefficient of hydride orientation (per-unit)	—	
3.2.	Hydrogen concentration (% by weight)	—	

# #B10T

Individual Characteristics of Refabricated Fuel Rods  
(Preirradiated Fuel, Preirradiated Cladding) under IGR Tests

Table G-10.10. General Characteristic of Fuel Rod #B10T

	Parameter	Unit	Value		
			Experiment	FRAP-T6	SCANAIR
1	Type of coolant	---	air	air	air
2	Burnup	MWd/kg U	43.0	43.0	43.0
3	Energy deposition in fuel rod	cal/g fuel	146	146	146
4	Peak fuel enthalpy	cal/g fuel	-	116	-
5	Peak fuel temperature	K	-	1959	-
6	Peak clad temperature	K	-	1545	-
7	Fuel rod failure	Yes, No	Yes	Yes	-
8	Type of failure:				
	- cladding rupture due to ballooning	Yes, No	Yes	Yes	-
	- cladding rupture due to PCMI	Yes, No	No	No	-
	- fragmentation of fuel rod	Yes, No	No	-	-
9	Failure time	s	-	3.92	-
10	Fuel enthalpy at failure	cal/g fuel	-	106	-
11	Outer cladding temperature at failure	K	-	1279	-
12	Internal gas pressure at failure	MPa	-	2.02	-
13	ZrO <sub>2</sub> thickness after test	μm	10	-	-
14	Residual clad hoop strain:				
	- peak value for ballooning area	%	33.4	54.40	-
	- other location <sup>1)</sup>	%	3.7	0.83	-
15	Kr concentration in internal gas composition after test	% by volume	-	1.20	-
16	Xe concentration in internal gas composition after test	% by volume	-	7.19	-
17	Kr concentration in fuel after test	cm <sup>3</sup> /g fuel	-	0.11	-

<sup>1)</sup>Calculated values by FRAP-T6 and SCANAIR codes are average along height of fuel rod excluding ballooning region

*APPENDIX G-III.*  
*Individual Characteristics for Fuel Rod #B11T under IGR Test*

#B11T

Individual Characteristics of Refabricated Fuel Rods  
(Preirradiated Fuel, Preirradiated Cladding) under IGR Tests

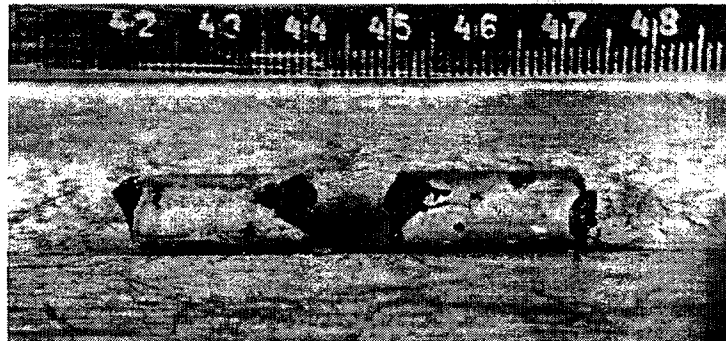
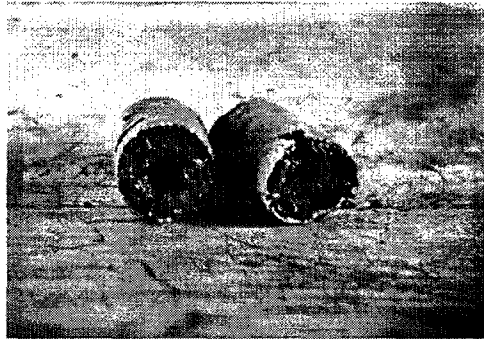
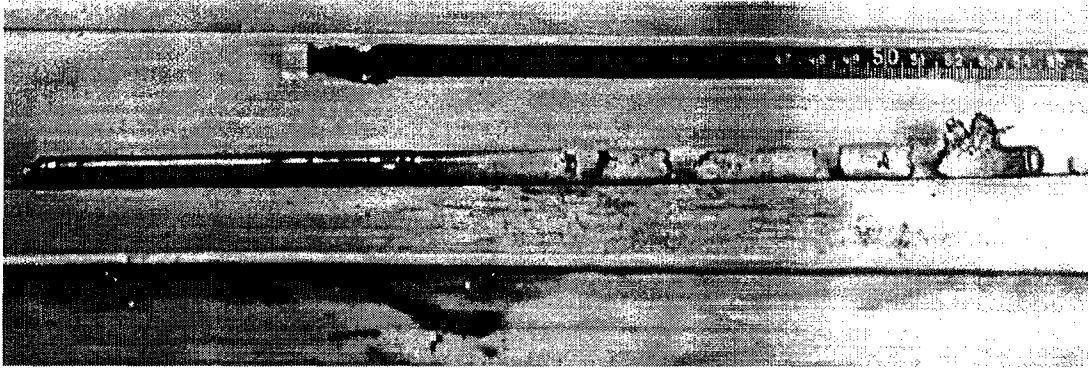
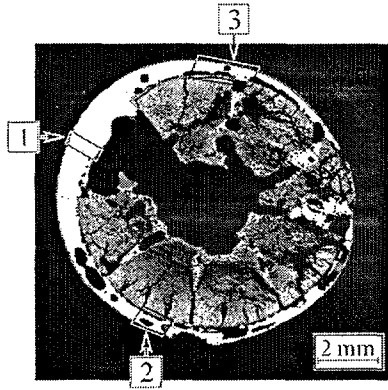

Fig. G-11.1. Appearance of Fuel Rod #B11T (photographs and X-ray photograph)



# #B11T

Individual Characteristics of Refabricated Fuel Rods  
(Preirradiated Fuel, Preirradiated Cladding) under IGR Tests



Position 1



Position 3

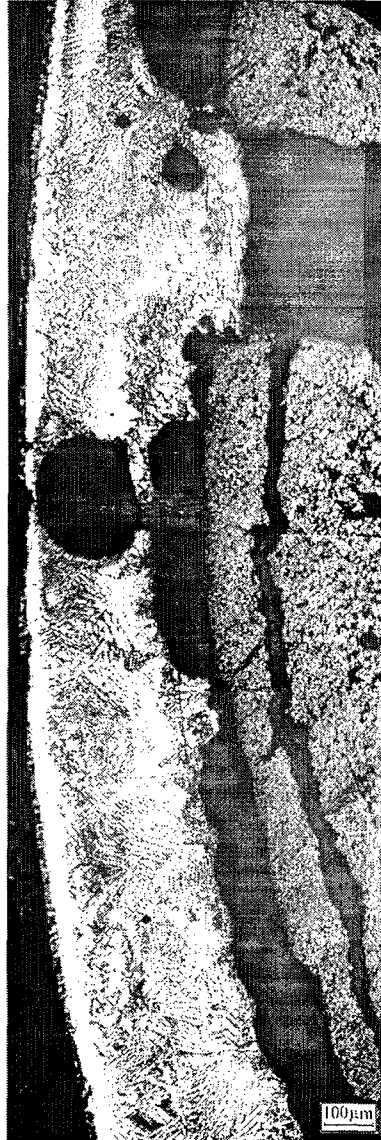

Position 2

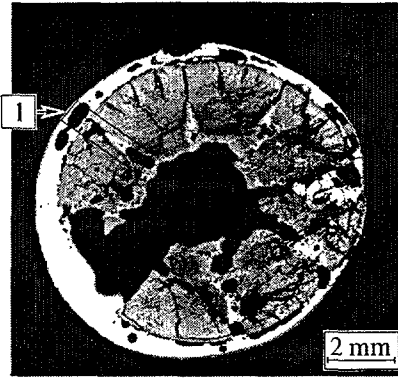

Fig. G-11.2. Cross-Section and Cladding Microstructure for Fragment of Fuel Rod #B11T

#B11T

Individual Characteristics of Refabricated Fuel Rods  
(Preirradiated Fuel, Preirradiated Cladding) under IGR Tests

Position 1



Position 2

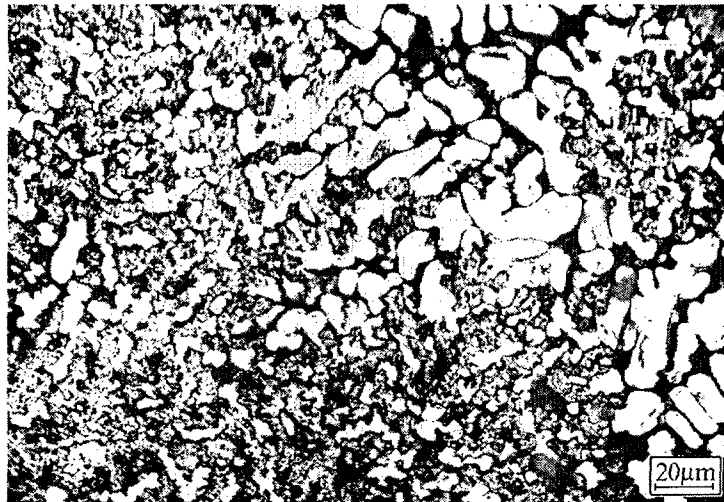

Position 3

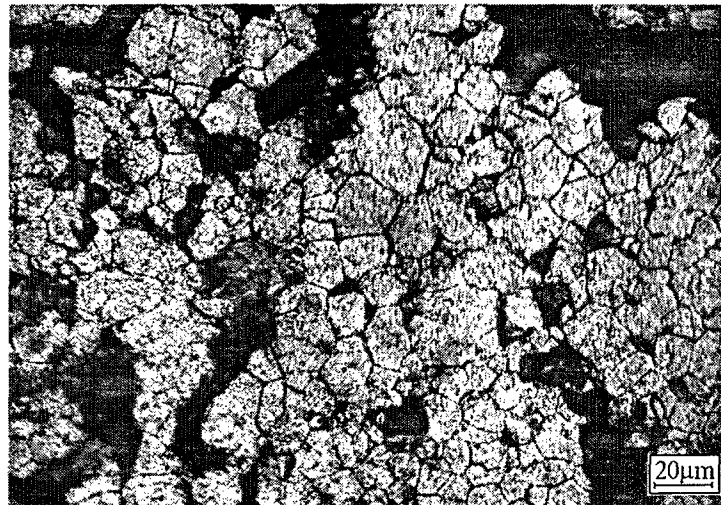

Fig. G-11.3. Fuel Microstructure for Fragment of Fuel Rod #B11T at 50 mm Elevation

# #B11T

Individual Characteristics of Refabricated Fuel Rods  
(Preirradiated Fuel, Preirradiated Cladding) under IGR Tests

Table G-11.1. Time Dependent Energy Characteristics of Fuel Rod #B11T

Time (s)	Reactor energy deposition <sup>1)</sup> (%)	Cumulative number of fissions in fuel rod (fiss)						Power of fuel rod (kW)	Energy deposition in fuel rod	
		U <sup>235</sup> ×10 <sup>-14</sup>	U <sup>238</sup> ×10 <sup>-13</sup>	Pu <sup>239</sup> ×10 <sup>-14</sup>	Pu <sup>241</sup> ×10 <sup>-14</sup>	Other isotopes ×10 <sup>-11</sup>	Total ×10 <sup>-14</sup>		cal/g fuel	J/g fuel
0.0	0.000	0.000	0.000	0.000	0.000	0.000	0.000	0.000	0.000	0.000
1.0	0.734	0.058	0.019	0.082	0.029	0.092	0.171	1.090	2.020	8.460
2.0	4.900	0.385	0.125	0.547	0.194	0.613	1.140	5.570	13.50	56.50
2.2	6.890	0.540	0.175	0.768	0.272	0.861	1.600	7.770	19.00	79.50
2.4	9.680	0.760	0.246	1.080	0.383	1.210	2.250	11.00	26.70	112.0
2.6	13.70	1.080	0.349	1.530	0.542	1.710	3.180	16.20	37.80	158.0
2.8	19.80	1.550	0.503	2.210	0.782	2.470	4.590	24.90	54.50	228.0
3.0	29.40	2.310	0.747	3.280	1.160	3.670	6.820	40.20	80.90	339.0
3.2	44.70	3.510	1.140	4.980	1.770	5.590	10.40	61.40	123.0	515.0
3.4	62.70	4.920	1.590	6.990	2.480	7.830	14.50	51.80	173.0	724.0
3.6	74.80	5.870	1.900	8.350	2.960	9.360	17.40	30.60	206.0	862.0
3.8	81.90	6.420	2.080	9.130	3.240	10.20	19.00	17.70	226.0	946.0
4.0	86.00	6.750	2.190	9.590	3.400	10.70	20.00	10.80	237.0	992.0
4.2	88.60	6.950	2.250	9.880	3.500	11.10	20.60	7.070	244.0	1021.
4.4	90.30	7.090	2.300	10.10	3.570	11.30	21.00	4.920	249.0	1042.
4.6	91.50	7.180	2.330	10.20	3.620	11.40	21.20	3.600	253.0	1059.
4.8	92.40	7.250	2.350	10.30	3.650	11.60	21.50	2.750	255.0	1067.
5.0	93.10	7.310	2.370	10.40	3.680	11.60	21.60	2.180	257.0	1076.
5.2	93.70	7.350	2.380	10.40	3.700	11.70	21.70	1.780	259.0	1084.
5.4	94.10	7.390	2.390	10.50	3.720	11.80	21.90	1.450	260.0	1088.
5.6	94.50	7.410	2.400	10.50	3.730	11.80	21.90	1.240	262.0	1097.
5.8	94.80	7.440	2.410	10.60	3.750	11.80	22.00	1.060	262.0	1097.
6.0	95.00	7.460	2.420	10.60	3.760	11.90	22.10	0.923	263.0	1101.
6.5	95.60	7.500	2.430	10.70	3.780	11.90	22.20	0.677	265.0	1109.
7.0	95.90	7.530	2.440	10.70	3.790	12.00	22.30	0.527	266.0	1113.
7.5	96.20	7.550	2.450	10.70	3.800	12.00	22.30	0.432	267.0	1118.
8.0	96.50	7.570	2.450	10.80	3.810	12.10	22.40	0.367	268.0	1122.
9.0	96.90	7.600	2.460	10.80	3.830	12.10	22.50	0.316	269.0	1126.
10.0	97.20	7.630	2.470	10.80	3.840	12.20	22.60	0.254	271.0	1134.
20.0	98.60	7.740	2.510	11.00	3.900	12.30	22.90	0.066	276.0	1155.
30.0	99.10	7.780	2.520	11.00	3.920	12.40	23.00	0.035	278.0	1164.
∞	100.0	7.850	2.540	11.20	3.950	12.50	23.20	0.000	284.0	1189.

Maximum value of power is 63.6 kW (t = 3.25 s).

<sup>1)</sup> Current energy deposition per maximum energy deposition (at infinite time)

## #B11T

Individual Characteristics of Refabricated Fuel Rods  
(Preirradiated Fuel, Preirradiated Cladding) under IGR Tests

Table G-11.2. Axial Energy Characteristics of Fuel Rod #B11T

Axial coordinate from lower end of fuel rod (mm)	Cumulative number of fissions at axial interval (fiss)						Maximum power of fuel rod (kW) $t=3.25s$	Energy deposition at infinite time*		
	$U^{235} \times 10^{-13}$	$U^{238} \times 10^{-11}$	$Pu^{239} \times 10^{-13}$	$Pu^{241} \times 10^{-13}$	Other isotopes $\times 10^{-10}$	Total $\times 10^{-13}$		cal/g fuel	J/g fuel	per-unit <sup>3)</sup>
10.0	0.000	0.000	0.000	0.000	0.000	0.000	0.000	0.000	0.000	0.00
15.0	0.000	0.000	0.000	0.000	0.000	0.000	0.000	0.000	0.000	0.00
20.0 <sup>1)</sup>	1.400	4.020	1.890	0.662	1.910	4.000	1.090	306.0	1281.	1.00
25.0	1.750	5.030	2.370	0.828	2.390	4.990	1.370	306.0	1281.	1.00
30.0	2.840	8.960	4.030	1.430	4.470	8.400	2.300	296.0	1239.	0.97
35.0	2.680	8.690	3.810	1.350	4.470	7.940	2.170	291.0	1218.	0.95
40.0	2.800	9.280	4.000	1.420	4.480	8.310	2.280	287.0	1201.	0.94
45.0	2.810	9.450	4.020	1.420	4.490	8.350	2.290	284.0	1189.	0.93
50.0	2.650	8.990	3.800	1.340	4.490	7.880	2.160	282.0	1180.	0.92
55.0	2.730	9.280	3.910	1.380	4.490	8.120	2.220	281.0	1176.	0.92
60.0	2.730	9.280	3.910	1.380	4.490	8.120	2.220	281.0	1176.	0.92
65.0	2.670	9.030	3.820	1.350	4.490	7.940	2.170	282.0	1180.	0.92
70.0	2.490	8.370	3.560	1.250	4.500	7.390	2.020	283.0	1185.	0.92
75.0	2.700	9.000	3.860	1.360	4.500	8.010	2.190	284.0	1189.	0.93
80.0	2.750	9.100	3.940	1.390	4.500	8.170	2.240	285.0	1193.	0.93
85.0	2.800	9.180	3.990	1.410	4.500	8.300	2.270	286.0	1197.	0.93
90.0	2.840	9.230	4.040	1.430	4.500	8.400	2.300	287.0	1201.	0.94
95.0	2.870	9.290	4.080	1.440	4.510	8.500	2.330	287.0	1201.	0.94
100.0	2.900	9.350	4.120	1.460	4.510	8.570	2.350	287.0	1201.	0.94
105.0	2.880	9.310	4.100	1.450	4.520	8.520	2.330	286.0	1197.	0.93
110.0	2.850	9.210	4.030	1.430	4.530	8.400	2.300	285.0	1193.	0.93
115.0	2.790	9.120	3.950	1.400	4.540	8.230	2.250	282.0	1180.	0.92
120.0	2.670	8.870	3.770	1.330	4.550	7.870	2.150	277.0	1160.	0.91
125.0	2.050	6.480	2.910	1.040	3.200	6.080	1.660	279.0	1168.	0.91
130.0	2.050	6.480	2.910	1.040	3.200	6.080	1.660	279.0	1168.	0.91
135.0	2.050	6.480	2.910	1.040	3.200	6.080	1.660	279.0	1168.	0.91
140.0	2.050	6.480	2.910	1.040	3.200	6.080	1.660	279.0	1168.	0.91
145.0	2.040	6.570	2.840	1.030	3.110	5.980	1.640	275.0	1151.	0.90
150.0	2.040	6.570	2.840	1.030	3.110	5.980	1.640	275.0	1151.	0.90
155.0	2.040	6.570	2.840	1.030	3.110	5.980	1.640	275.0	1151.	0.90
160.0	2.040	6.570	2.840	1.030	3.110	5.980	1.640	275.0	1151.	0.90
165.0	2.040	6.320	2.970	1.050	3.110	6.120	1.670	281.0	1176.	0.92
170.0	2.040	6.320	2.970	1.050	3.110	6.120	1.670	281.0	1176.	0.92
175.0	2.040	6.320	2.970	1.050	3.110	6.120	1.670	281.0	1176.	0.92
180.0 <sup>2)</sup>	0.407	1.260	0.593	0.209	0.621	1.220	0.335	281.0	1176.	0.92
185.0	0.000	0.000	0.000	0.000	0.000	0.000	0.000	0.000	0.000	0.00

\* All numerical values of characteristics are presented as average values at the length interval equal to the axial coordinate  $\pm 2.5$  mm<sup>1)</sup> Initial coordinate of fuel is 18.5 mm<sup>2)</sup> End coordinate of fuel is 178.5 mm<sup>3)</sup> Current value per maximum value.

# #B11T

Individual Characteristics of Refabricated Fuel Rods  
(Preirradiated Fuel, Preirradiated Cladding) under IGR Tests

Table G-11.3. Radial Energy Characteristics of Fuel Rod #B11T

Characteristics*		Coordinates of fuel zones (mm)			
		1 zone 1.2 - 2.811	2 zone 2.811-3.432	3 zone 3.432-3.704	4 zone 3.704-3.790
U <sup>235</sup>	Number of fissions $\times 10^{-14}$ (fiss)	2.660	1.570	0.771	0.252
	Power of fuel rod <sup>1)</sup> (kW)	7.150	4.210	2.070	0.676
	Energy deposition <sup>2)</sup> (cal/g fuel)	95.70	94.00	92.50	90.50
	Energy deposition <sup>2)</sup> (J/g fuel)	401.0	393.0	387.0	379.0
	Energy deposition <sup>3)</sup> (per-unit)	1.000	0.982	0.967	0.946
U <sup>238</sup>	Number of fissions $\times 10^{-12}$ (fiss)	8.940	5.150	2.440	0.757
	Power of fuel rod <sup>1)</sup> (kW)	0.237	0.137	0.065	0.020
	Energy deposition <sup>2)</sup> (cal/g fuel)	3.180	3.050	2.900	2.690
	Energy deposition <sup>2)</sup> (J/g fuel)	13.30	12.80	12.10	11.30
	Energy deposition <sup>3)</sup> (per-unit)	1.000	0.959	0.912	0.846
Pu <sup>239</sup>	Number of fissions $\times 10^{-14}$ (fiss)	3.090	2.110	1.450	0.830
	Power of fuel rod <sup>1)</sup> (kW)	8.580	5.840	4.030	2.300
	Energy deposition <sup>2)</sup> (cal/g fuel)	115.0	130.0	180.0	309.0
	Energy deposition <sup>2)</sup> (J/g fuel)	481.0	544.0	753.0	1293.
	Energy deposition <sup>3)</sup> (per-unit)	0.372	0.421	0.583	1.000
Pu <sup>241</sup>	Number of fissions $\times 10^{-13}$ (fiss)	10.40	7.420	5.360	3.230
	Power of fuel rod <sup>1)</sup> (kW)	2.840	2.030	1.460	0.882
	Energy deposition <sup>2)</sup> (cal/g fuel)	38.10	45.30	65.50	118.0
	Energy deposition <sup>2)</sup> (J/g fuel)	159.0	190.0	274.0	494.0
	Energy deposition <sup>3)</sup> (per-unit)	0.323	0.384	0.555	1.000
Other isotopes	Number of fissions $\times 10^{-11}$ (fiss)	3.900	2.480	1.480	0.701
	Power of fuel rod <sup>1)</sup> (kW)	0.011	0.007	0.004	0.002
	Energy deposition <sup>2)</sup> (cal/g fuel)	0.144	0.152	0.181	0.258
	Energy deposition <sup>2)</sup> (J/g fuel)	0.600	0.640	0.760	1.080
	Energy deposition <sup>3)</sup> (per-unit)	0.558	0.589	0.702	1.000
Total	Number of fissions $\times 10^{-14}$ (fiss)	6.880	4.460	2.780	1.410
	Power of fuel rod <sup>1)</sup> (kW)	18.80	12.20	7.610	3.860
	Energy deposition <sup>2)</sup> (cal/g fuel)	253.0	273.0	340.0	517.0
	Energy deposition <sup>2)</sup> (J/g fuel)	1059.	1143.	1423.	2164.
	Energy deposition <sup>3)</sup> (per-unit)	0.489	0.528	0.658	1.000

1) at time of 3.25 s, 2) at infinite time, 3) Current value per maximum value.

\* All numerical values of characteristics were calculated for undamaged part of fuel stack only (See Table C.2.3.)

# #B11T

Individual Characteristics of Refabricated Fuel Rods  
(Preirradiated Fuel, Preirradiated Cladding) under IGR Tests

Table G-11.4. Fuel Enthalpy Vs. Time Calculated by FRAP-T6 Code for Fuel Rod #B11T

Time (s)	Enthalpy at fuel radius (cal/g fuel)				Fuel enthalpy <sup>1)</sup>		Energy deposition in fuel rod	
	1.20 mm	2.82 mm	3.47 mm	3.79 mm	cal/g fuel	J/g fuel	cal/g fuel	J/g fuel
0.0	0.00	0.00	0.00	0.00	0.00	0.00	0.00	0.00
1.0	2.06	2.03	1.95	1.85	2.01	8.42	2.25	9.44
2.0	15.3	14.9	13.9	12.8	14.6	61.3	16.0	66.9
2.2	20.8	20.1	18.7	17.1	19.7	82.6	21.5	89.9
2.4	28.5	27.5	25.3	22.9	26.9	113	29.2	122
2.6	39.7	38.4	35.0	30.8	37.4	156	40.4	169
2.8	57.0	55.0	49.3	41.7	53.2	223	57.4	241
3.0	84.9	81.9	71.6	57.5	78.3	328	84.4	354
3.2	130	125	106	76.6	118	494	126	529
3.4	181	174	146	122	165	692	172	722
3.6	221	209	177	144	200	838	205	861
3.8	245	229	190	154	218	914	225	942
4.0	258	237	195	163	227	952	236	991
4.2	265	240	198	171	232	972	244	1021
4.4	268	240	200	176	234	981	248	1041
4.6	269	240	202	179	235	983	252	1056
4.8	269	238	202	180	234	980	254	1066
5.0	267	237	201	180	233	975	256	1075
5.2	-	-	-	-	-	-	258	1081
5.4	-	-	-	-	-	-	259	1087
5.6	-	-	-	-	-	-	260	1091
5.8	-	-	-	-	-	-	261	1095
6.0	-	-	-	-	-	-	262	1099
6.5	-	-	-	-	-	-	264	1106
7.0	-	-	-	-	-	-	265	1111
7.5	-	-	-	-	-	-	266	1115
8.0	-	-	-	-	-	-	267	1118
10.0	-	-	-	-	-	-	271	1133
30.0	-	-	-	-	-	-	278	1165

Radial enthalpy distribution and fuel enthalpy are presented at elevation 26.5 mm

Maximum value of fuel enthalpy is 234.5 cal/g fuel ( $t=4.61$  s)

<sup>1)</sup> All numerical values are presented at elevation with peak power

# #B11T

Individual Characteristics of Refabricated Fuel Rods  
(Preirradiated Fuel, Preirradiated Cladding) under IGR Tests

Table G-11.5. Energy Characteristics Vs. Time Calculated by FRAP-T6 and SCANAIR Codes for Fuel Rod #B11T

Time (s)	Energy deposition <sup>1)</sup> (cal/g fuel)	Linear power <sup>1)</sup> (kW/m)	Fuel enthalpy <sup>1)</sup> (cal/g fuel)		Leakage of energy <sup>1)</sup> (cal/g fuel)		Clad-to-coolant heat transfer coefficient <sup>1)</sup> (kW/m <sup>2</sup> K)	
			FRAP-T6	SCANAIR	FRAP-T6	SCANAIR	FRAP-T6	SCANAIR
0.0	0.00	0.00	0.00	0.00	0.00	0.00	0.00	0.00
1.0	2.39	8.73	2.01	1.49	0.00	0.00	0.01	0.01
2.0	16.9	44.1	14.6	6.27	0.01	0.00	0.01	0.01
2.2	22.8	61.5	19.7	8.21	0.01	0.00	0.01	0.01
2.4	31.0	87.2	26.9	11.3	0.02	0.01	0.01	0.01
2.6	42.9	129	37.4	16.7	0.03	0.01	0.02	0.01
2.8	60.9	198	53.2	26.8	0.05	0.02	0.02	0.01
3.0	89.5	319	78.3	44.1	0.09	0.03	0.03	0.02
3.2	134	478	118	66.1	0.18	0.05	0.05	0.03
3.4	183	401	165	84.4	0.38	0.11	0.08	0.04
3.6	218	237	200	95.4	0.72	0.22	0.11	0.05
3.8	239	137	218	-	1.34	-	0.16	-
4.0	251	83.7	227	-	2.26	-	0.20	-
4.2	258	54.8	232	-	3.45	-	0.23	-
4.4	264	38.2	234	-	4.85	-	0.25	-
4.6	267	28.0	235	-	6.37	-	0.25	-
4.8	270	21.4	234	-	7.89	-	0.25	-
5.0	272	17.0	233	-	9.41	-	0.25	-
5.2	274	14.1	-	-	-	-	-	-
5.4	275	11.5	-	-	-	-	-	-
5.6	276	9.69	-	-	-	-	-	-
5.8	277	8.28	-	-	-	-	-	-
6.0	278	7.29	-	-	-	-	-	-
6.5	280	5.28	-	-	-	-	-	-
7.0	281	4.14	-	-	-	-	-	-
7.5	282	3.38	-	-	-	-	-	-
8.0	283	2.87	-	-	-	-	-	-
10.0	286	1.99	-	-	-	-	-	-
30.0	295	0.27	-	-	-	-	-	-

<sup>1)</sup> All numerical values are presented at elevation with peak power

# #B11T

Individual Characteristics of Refabricated Fuel Rods  
(Preirradiated Fuel, Preirradiated Cladding) under IGR Tests

Table G-11.6. Temperature Variation, Fission Gas Release and ZrO<sub>2</sub> Thickness Vs. Time for Fuel Rod #B11T Calculated by FRAP-T6 and SCANAIR Codes

Time (s)	Fuel centerline temperature <sup>1)</sup> (K)		Fuel surface temperature <sup>1)</sup> (K)		Clad outer temperature <sup>1)</sup> (K)		Fission gas release (%)	
	FRAP-T6	SCANAIR	FRAP-T6	SCANAIR	FRAP-T6	SCANAIR	FRAP-T6	SCANAIR
0.0	293	293	293	293	293	293	0.00	0.00
1.0	329	317	325	316	303	301	0.10	0.19
2.0	534	393	498	387	390	342	0.51	0.64
2.2	613	423	560	415	431	357	0.73	0.79
2.4	721	468	643	459	487	379	1.06	0.97
2.6	876	547	754	533	566	413	1.59	1.24
2.8	1106	687	902	665	685	474	2.45	1.59
3.0	1466	918	1113	866	871	584	4.14	2.13
3.2	2004	1210	1361	1088	1103	752	6.49	2.66
3.4	2512	1460	1922	1248	1298	945	9.97	3.06
3.6	2815	1623	2157	1342	1536	1105	22.1	3.29
3.8	2969	-	2265	-	1753	-	40.7	-
4.0	3047	-	2347	-	1909	-	57.1	-
4.2	3086	-	2420	-	2012	-	69.9	-
4.4	3105	-	2468	-	2085	-	78.6	-
4.6	3110	-	2492	-	2092	-	83.3	-
4.8	3107	-	2503	-	2092	-	85.4	-
5.0	3098	-	2500	-	2094	-	86.3	-
5.2	-	-	-	-	-	-	-	-
5.4	-	-	-	-	-	-	-	-
5.6	-	-	-	-	-	-	-	-
5.8	-	-	-	-	-	-	-	-
6.0	-	-	-	-	-	-	-	-
6.5	-	-	-	-	-	-	-	-
7.0	-	-	-	-	-	-	-	-
7.5	-	-	-	-	-	-	-	-
8.0	-	-	-	-	-	-	-	-
10.0	-	-	-	-	-	-	-	-
30.0	-	-	-	-	-	-	-	-

<sup>1)</sup> All numerical values are presented at elevation with peak power



# #B11T

Individual Characteristics of Refabricated Fuel Rods  
(Preirradiated Fuel, Preirradiated Cladding) under IGR Tests

Table G-11.7. Mechanical Characteristics of Fuel Rod #B11T Vs. Time Calculated by FRAP-T6 and SCANAIR Codes

Time (s)	Clad outer temperature <sup>1)</sup> (K)		Fuel hoop strain <sup>1)</sup> (%)		Fuel - clad gap width <sup>1)</sup> (mm)		Clad hoop strain <sup>1)</sup> (%)		Clad hoop stress <sup>1)</sup> (MPa)		Internal gas pressure (MPa)	
	FRAP-T6	SCANAIR	FRAP-T6	SCANAIR	FRAP-T6	SCANAIR	FRAP-T6	SCANAIR	FRAP-T6	SCANAIR	FRAP-T6	SCANAIR
0.0	293	293	0.00	0.00	0.07	0.07	0.01	0.01	8.88	8.70	1.70	1.70
1.0	303	301	0.12	0.02	0.07	0.07	0.02	0.01	9.07	8.84	1.73	1.72
2.0	390	342	0.49	0.07	0.05	0.07	0.08	0.05	9.75	9.17	1.85	1.78
2.2	431	357	0.63	0.09	0.05	0.07	0.10	0.06	9.92	9.28	1.88	1.80
2.4	487	379	0.82	0.13	0.04	0.07	0.14	0.07	10.1	9.43	1.91	1.82
2.6	566	413	1.10	0.19	0.04	0.07	0.20	0.10	10.4	9.64	1.96	1.85
2.8	685	474	1.52	0.32	0.02	0.06	0.28	0.15	10.6	9.94	2.01	1.90
3.0	871	584	2.20	0.54	0.00	0.06	0.41	0.24	11.0	10.3	2.08	1.94
3.2	1103	752	3.14	0.85	0.00	0.05	1.17	0.37	20.6	10.6	2.15	1.98
3.4	1298	945	4.41	1.14	1.57	0.05	42.6	0.51	0.00	10.7	0.10	2.01
3.6	1536	1105	6.17	1.34	1.50	0.04	42.8	0.60	0.00	10.4	0.10	2.02
3.8	1753	-	6.95	-	1.47	-	43.0	-	0.00	-	0.10	-
4.0	1909	-	7.02	-	1.47	-	43.1	-	0.00	-	0.10	-
4.2	2012	-	6.78	-	1.48	-	43.2	-	0.00	-	0.10	-
4.4	2085	-	6.77	-	1.48	-	43.3	-	0.00	-	0.10	-
4.6	2092	-	6.46	-	1.49	-	43.3	-	0.00	-	0.10	-
4.8	2092	-	6.44	-	1.49	-	43.3	-	0.00	-	0.10	-
5.0	2094	-	6.34	-	1.49	-	43.3	-	0.00	-	0.10	-
5.2	-	-	-	-	-	-	-	-	-	-	-	-
5.4	-	-	-	-	-	-	-	-	-	-	-	-
5.6	-	-	-	-	-	-	-	-	-	-	-	-
5.8	-	-	-	-	-	-	-	-	-	-	-	-
6.0	-	-	-	-	-	-	-	-	-	-	-	-
6.5	-	-	-	-	-	-	-	-	-	-	-	-
7.0	-	-	-	-	-	-	-	-	-	-	-	-
7.5	-	-	-	-	-	-	-	-	-	-	-	-
8.0	-	-	-	-	-	-	-	-	-	-	-	-
10.0	-	-	-	-	-	-	-	-	-	-	-	-
30.0	-	-	-	-	-	-	-	-	-	-	-	-

<sup>1)</sup> All numerical values are presented at elevation with peak power

# #B11T

Individual Characteristics of Refabricated Fuel Rods  
(Preirradiated Fuel, Preirradiated Cladding) under IGR Tests

Table G-11.8. Axial Distribution of Energy Deposition and Fuel Enthalpy Calculated by FRAP-T6 Code for Fuel Rod #B11T

Axial interval from-to (mm)-(mm)	Energy deposition at infinite time			Fuel enthalpy at time (t=4.61 s)		
	cal/g fuel	J/g fuel	per-unit	cal/g fuel	J/g fuel	per-unit
18.5 - 34.5	301	1261	1.00	235	983	1.00
34.5 - 50.5	286	1198	0.95	223	933	0.95
50.5 - 66.5	281	1179	0.93	219	919	0.93
66.5 - 82.5	284	1190	0.94	221	927	0.94
82.5 - 98.5	287	1201	0.95	223	936	0.95
98.5 - 114.5	285	1196	0.95	222	932	0.95
114.5 - 130.5	279	1169	0.93	217	911	0.93
130.5 - 146.5	278	1165	0.92	217	908	0.92
146.5 - 162.5	275	1153	0.91	214	899	0.91
162.5 - 178.5	281	1176	0.93	219	917	0.93

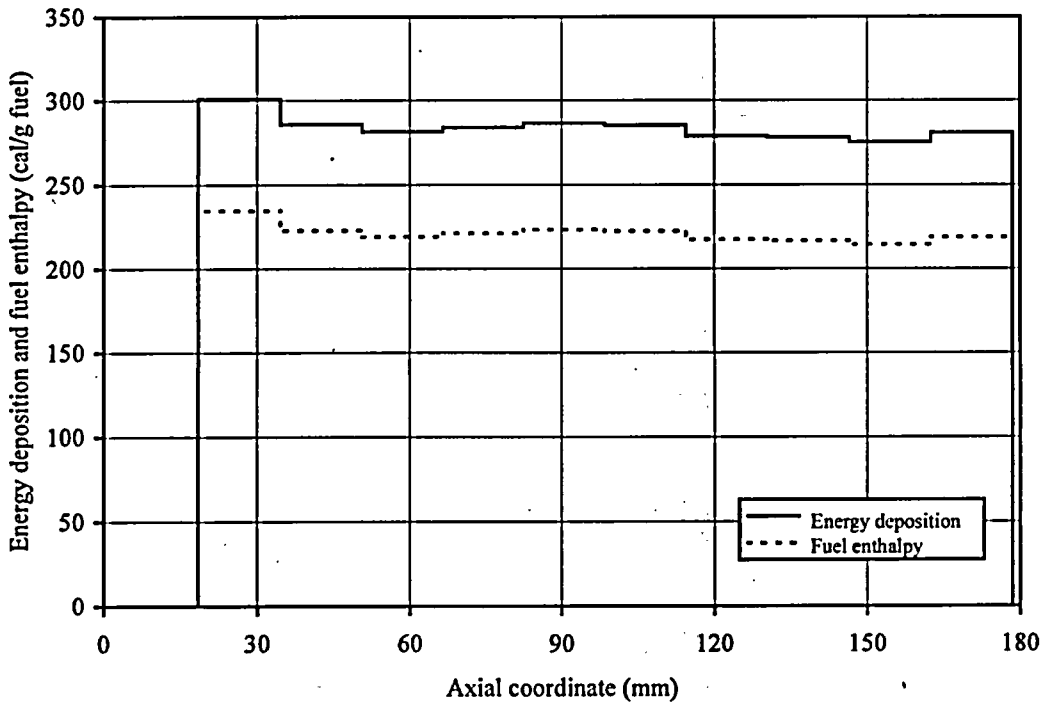

Fig. G-11.4. Axial Distribution of Energy Deposition and Fuel Enthalpy Calculated by FRAP-T6 Code for Fuel Rod #B11T

#B11T

Individual Characteristics of Refabricated Fuel Rods  
(Preirradiated Fuel, Preirradiated Cladding) under IGR Tests

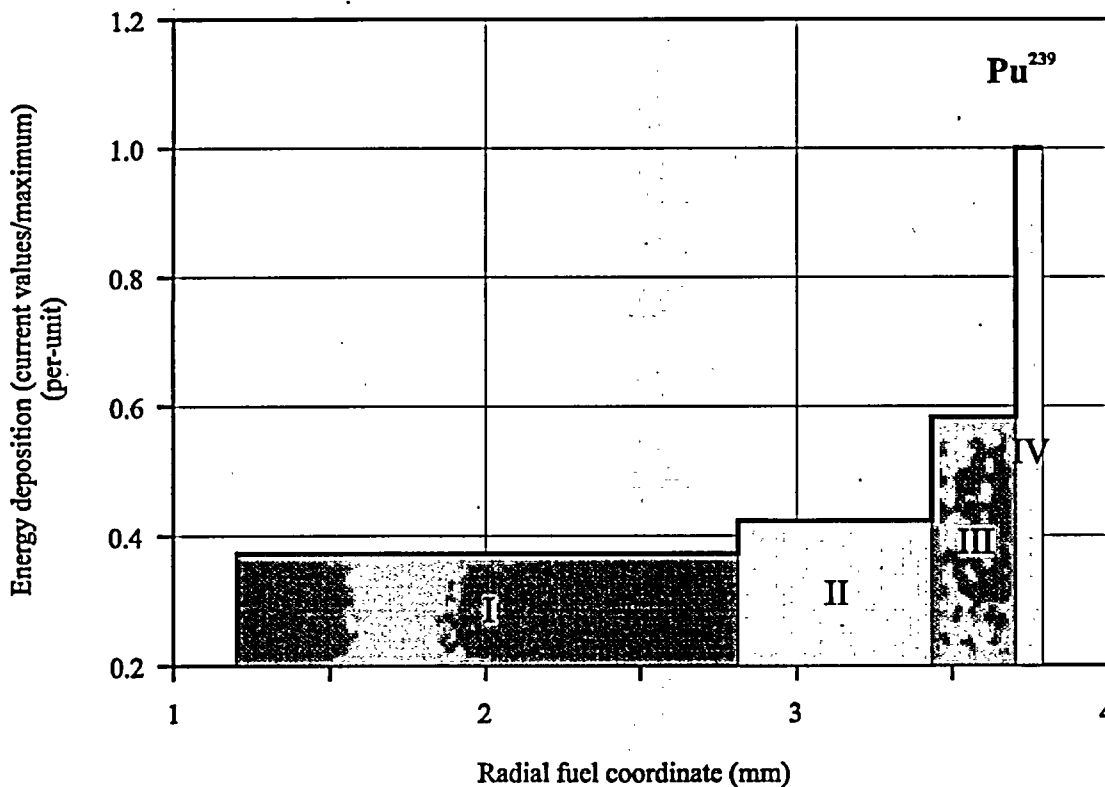
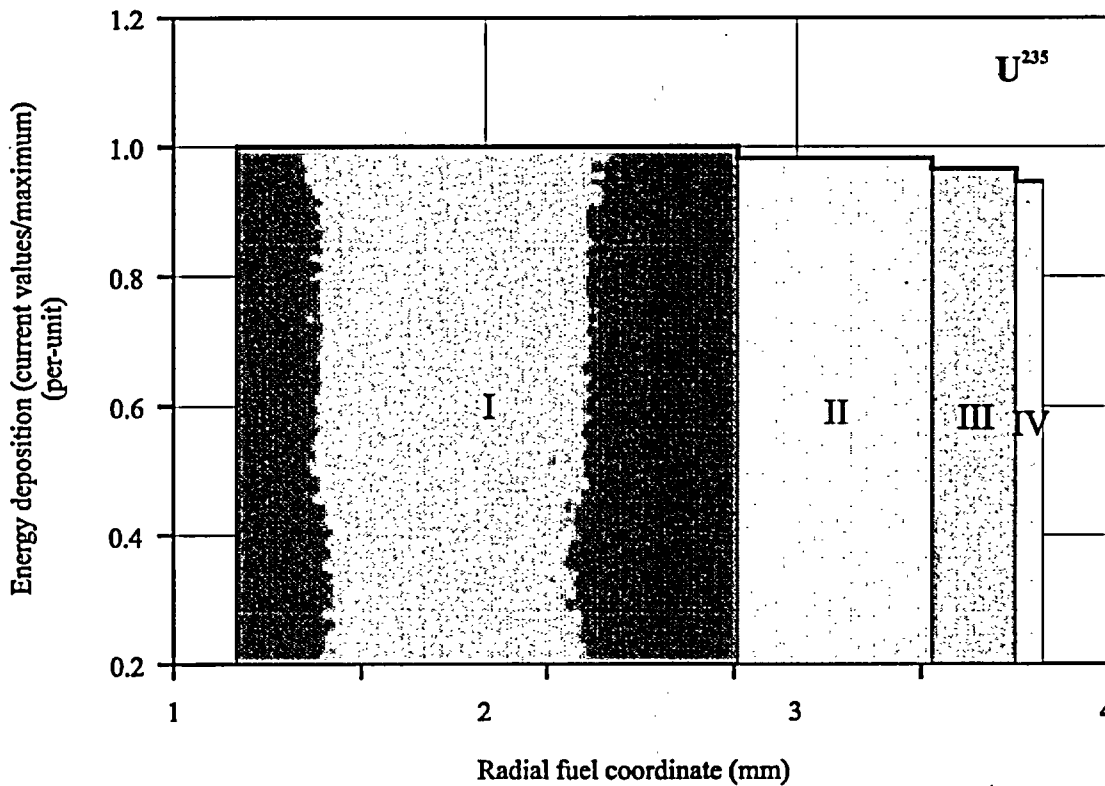

Fig. G-11.5.  $U^{235}$  and  $Pu^{239}$  Radial Distributions of Energy Deposition for Fuel Rod #B11T

#B11T

Individual Characteristics of Refabricated Fuel Rods  
(Preirradiated Fuel, Preirradiated Cladding) under IGR Tests

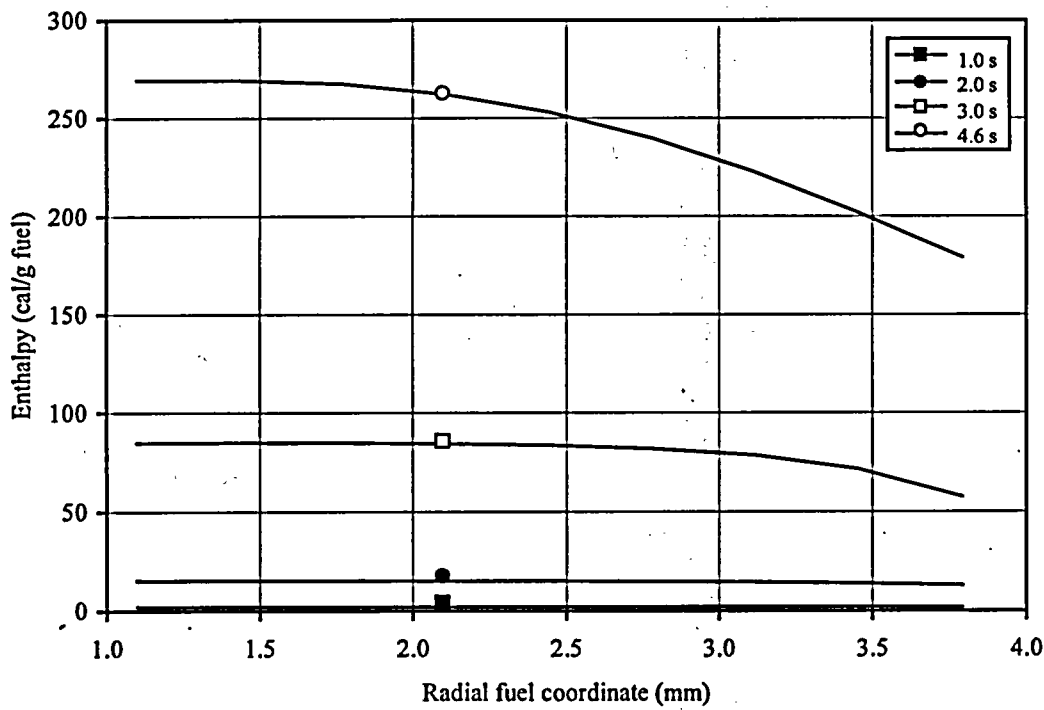
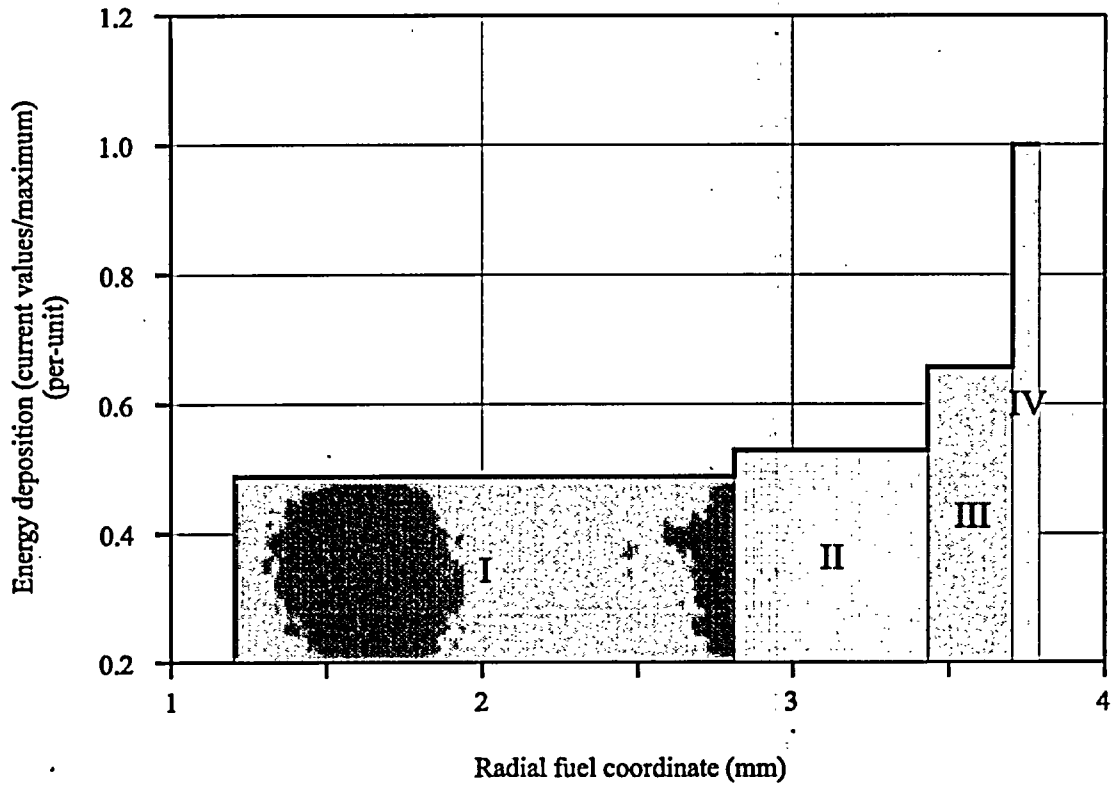

Fig. G-11.6. Radial Distributions of Energy Deposition and Fuel Enthalpy Calculated by FRAP-T6 Code for Fuel Rod #B11T

# #B11T

Individual Characteristics of Refabricated Fuel Rods  
(Preirradiated Fuel, Preirradiated Cladding) under IGR Tests

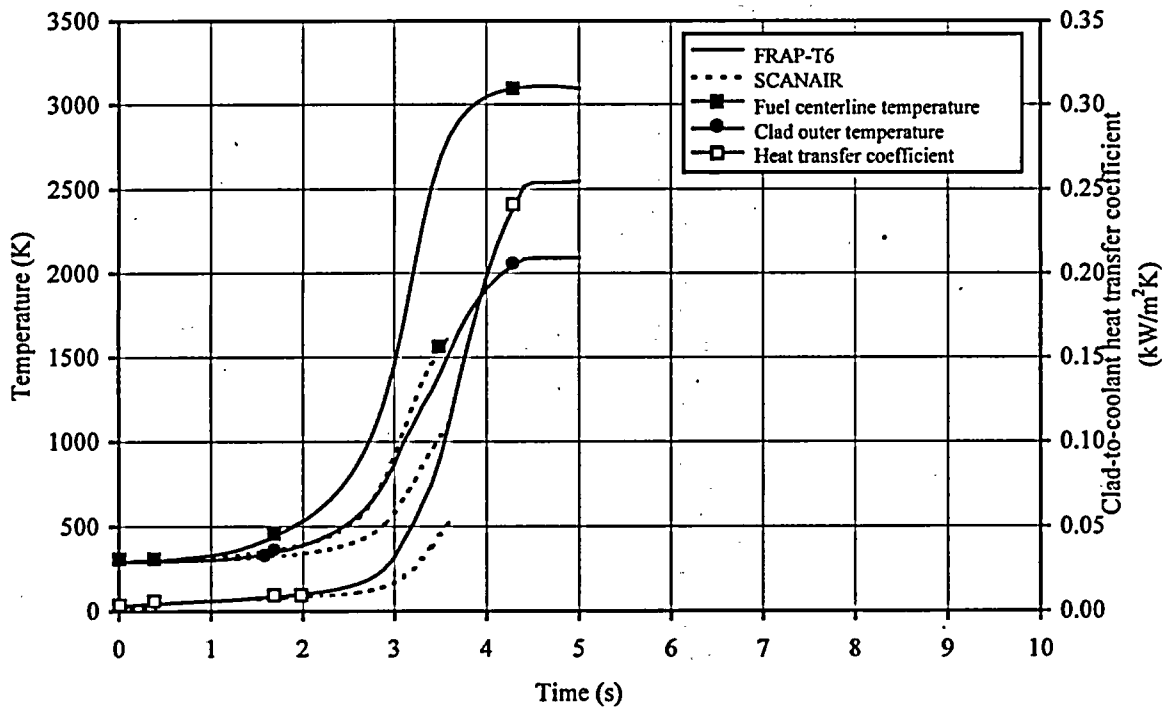
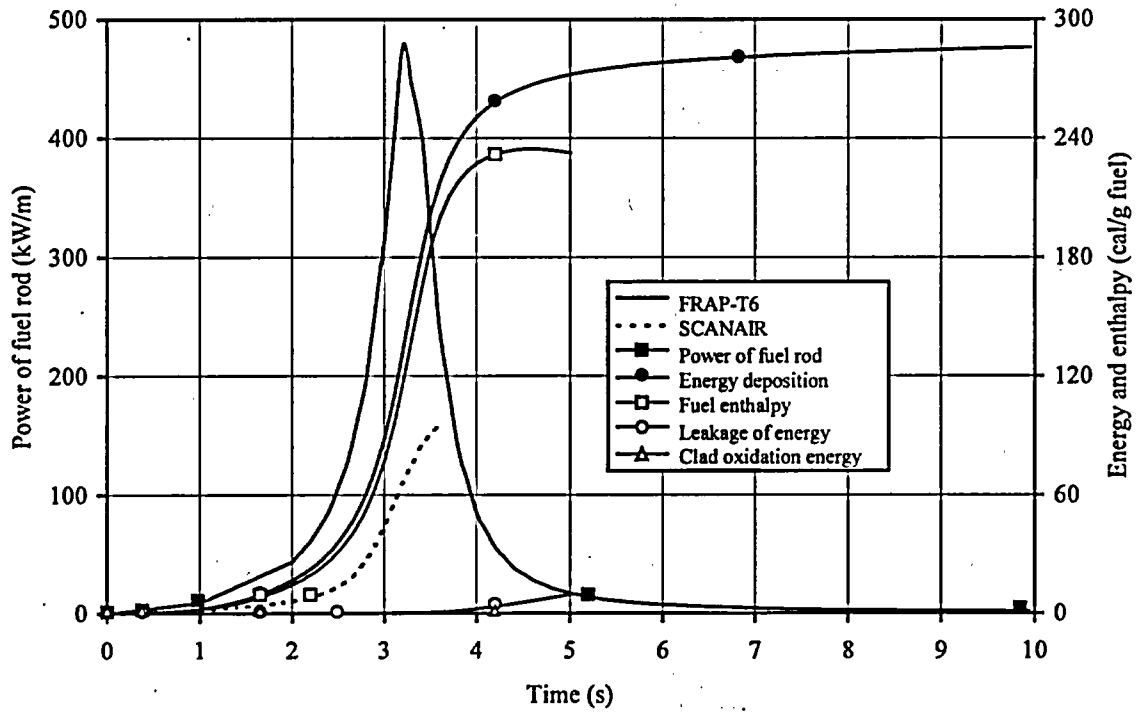

Fig. G-11.7. Energy and Temperature Characteristics Vs. Time Calculated by FRAP-T6 and SCANAIR Codes for Fuel Rod #B11T

#B11T

Individual Characteristics of Refabricated Fuel Rods  
(Preirradiated Fuel, Preirradiated Cladding) under IGR Tests

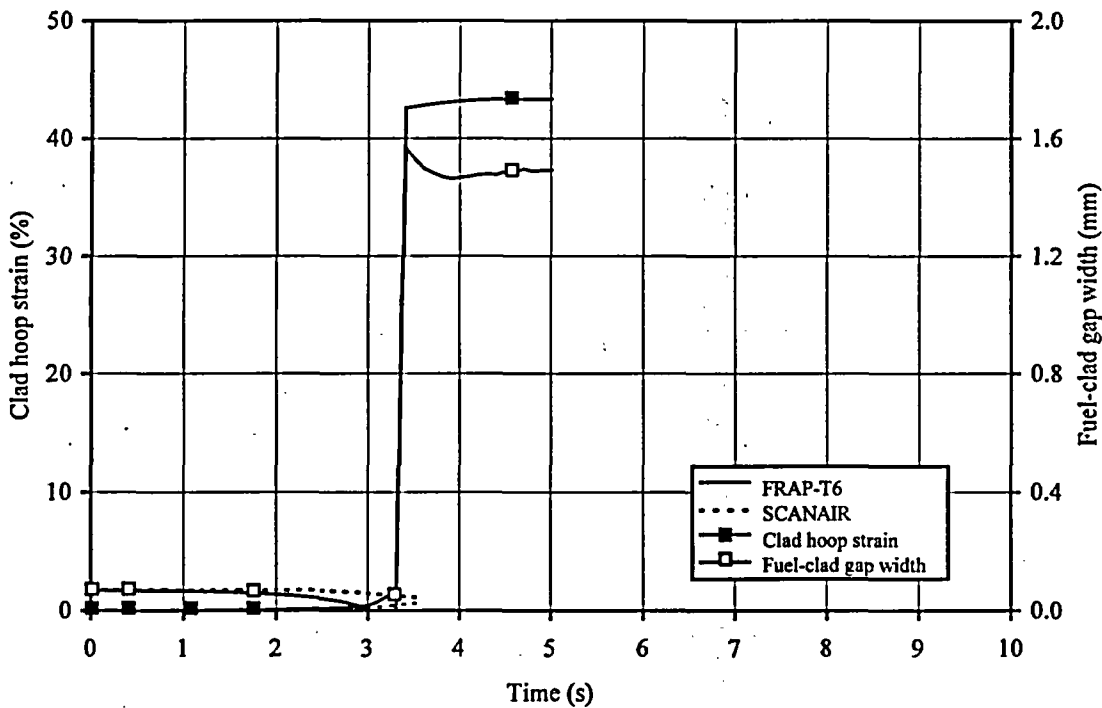
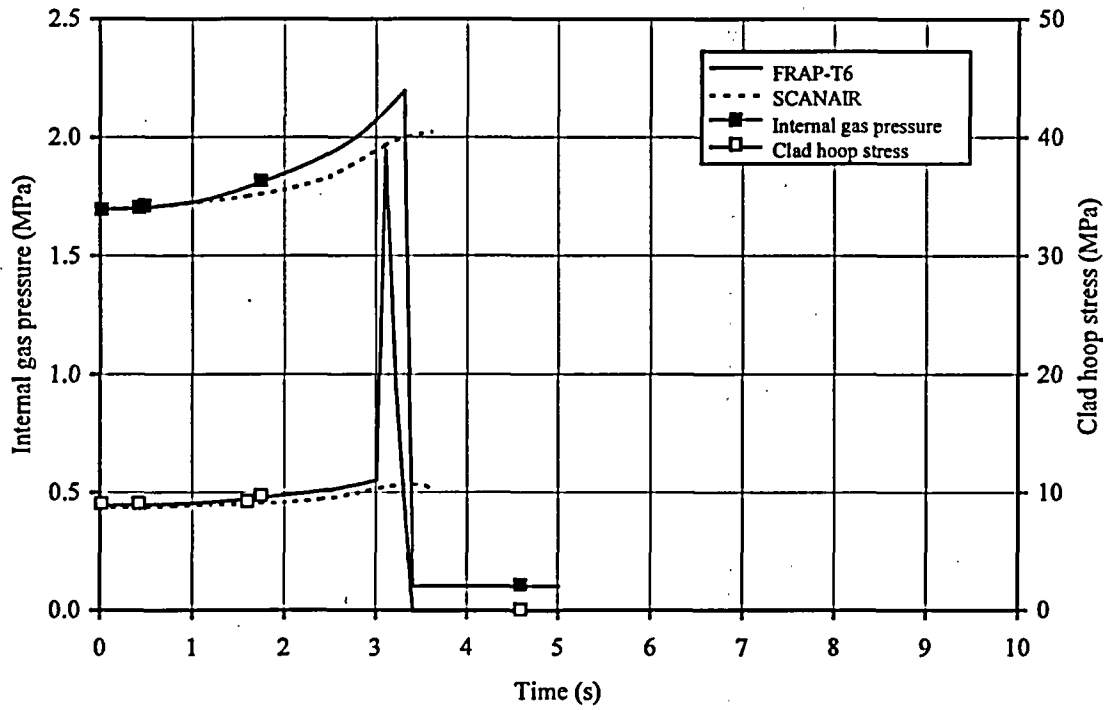

Fig. G-11.8. Cladding Mechanical Characteristics Vs. Time Calculated by FRAP-T6 and SCANAIR Codes for Fuel Rod #B11T

# #B11T

Individual Characteristics of Refabricated Fuel Rods  
(Preirradiated Fuel, Preirradiated Cladding) under IGR Tests

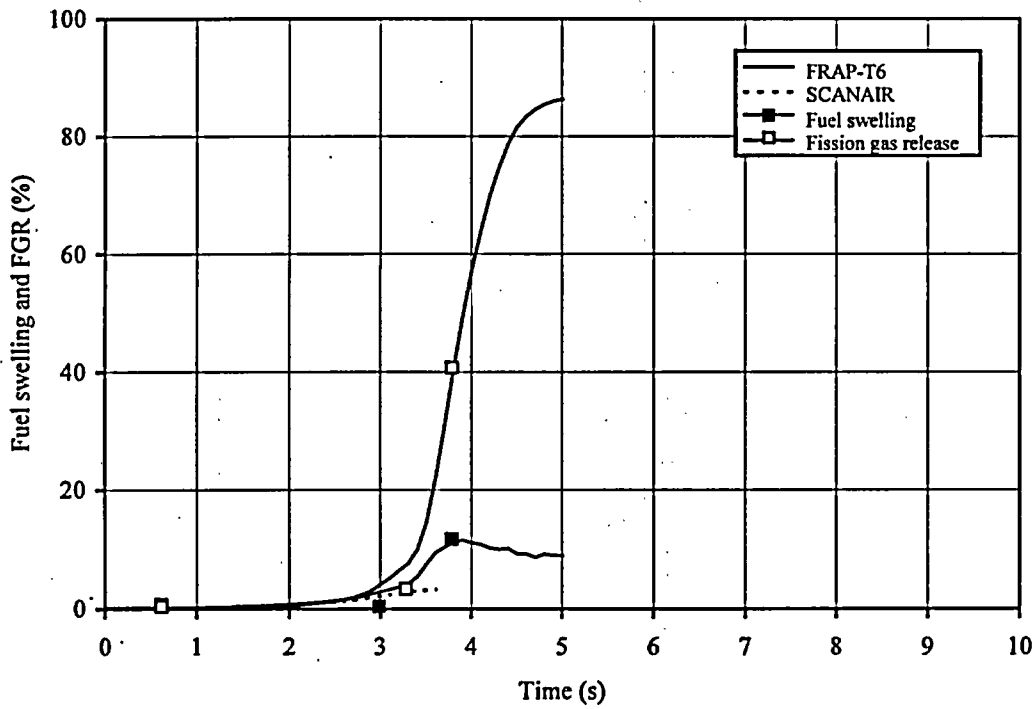
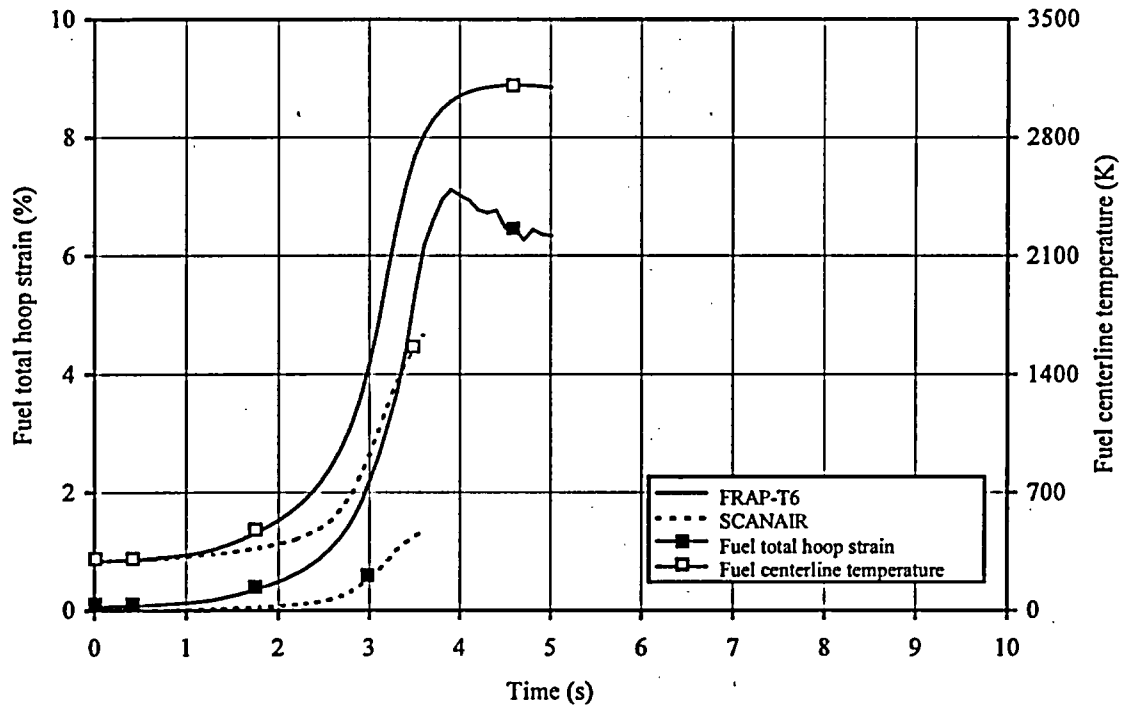

Fig. G-11.9. Fuel Strain and Fission Gas Release Vs. Time Calculated by FRAP-T6 and SCANAIR Codes for Fuel Rod #B11T

## #B11T

Individual Characteristics of Refabricated Fuel Rods  
(Preirradiated Fuel, Preirradiated Cladding) under IGR Tests

Table G-11.9. General Characteristic of Fuel Rod #B11T

	Parameter	Unit	Value		
			Experiment	FRAP-T6	SCANAIR
1	Type of coolant	---	air	air	air
2	Burnup	MWd/kg U	43.6	43.6	43.6
3	Energy deposition in fuel rod	cal/g fuel	284	284	284
4	Peak fuel enthalpy	cal/g fuel	-	-	-
5	Peak fuel temperature	K	-	-	-
6	Peak clad temperature	K	-	-	-
7	Fuel rod failure	Yes, No	Yes	Yes	-
8	Type of failure:				
	- cladding rupture due to ballooning	Yes, No	?	Yes	-
	- cladding rupture due to PCMI	Yes, No	?	No	-
	- fragmentation of fuel rod	Yes, No	Yes	-	-
9	Failure time	s	-	3.31	-
10	Fuel enthalpy at failure	cal/g fuel	-	141	-
11	Outer cladding temperature at failure	K	-	1211	-
12	Internal gas pressure at failure	MPa	-	2.20	-
13	ZrO <sub>2</sub> thickness after test	μm	-	-	-
14	Residual clad hoop strain:				
	- peak value for ballooning area	%	-	-	-
	- other location <sup>1)</sup>	%	-	-	-
15	Kr concentration in internal gas composition after test	% by volume	-	-	-
16	Xe concentration in internal gas composition after test	% by volume	-	-	-
17	Kr concentration in fuel after test	cm <sup>3</sup> /g fuel	-	-	-

<sup>1)</sup>Calculated values by FRAP-T6 and SCANAIR codes are average along height of fuel rod excluding ballooning region



***APPENDIX G-12.***

***Individual Characteristics for Fuel Rod #B12T under IGR Test***

#B12T

Individual Characteristics of Refabricated Fuel Rods  
(Preirradiated Fuel, Preirradiated Cladding) under IGR Tests

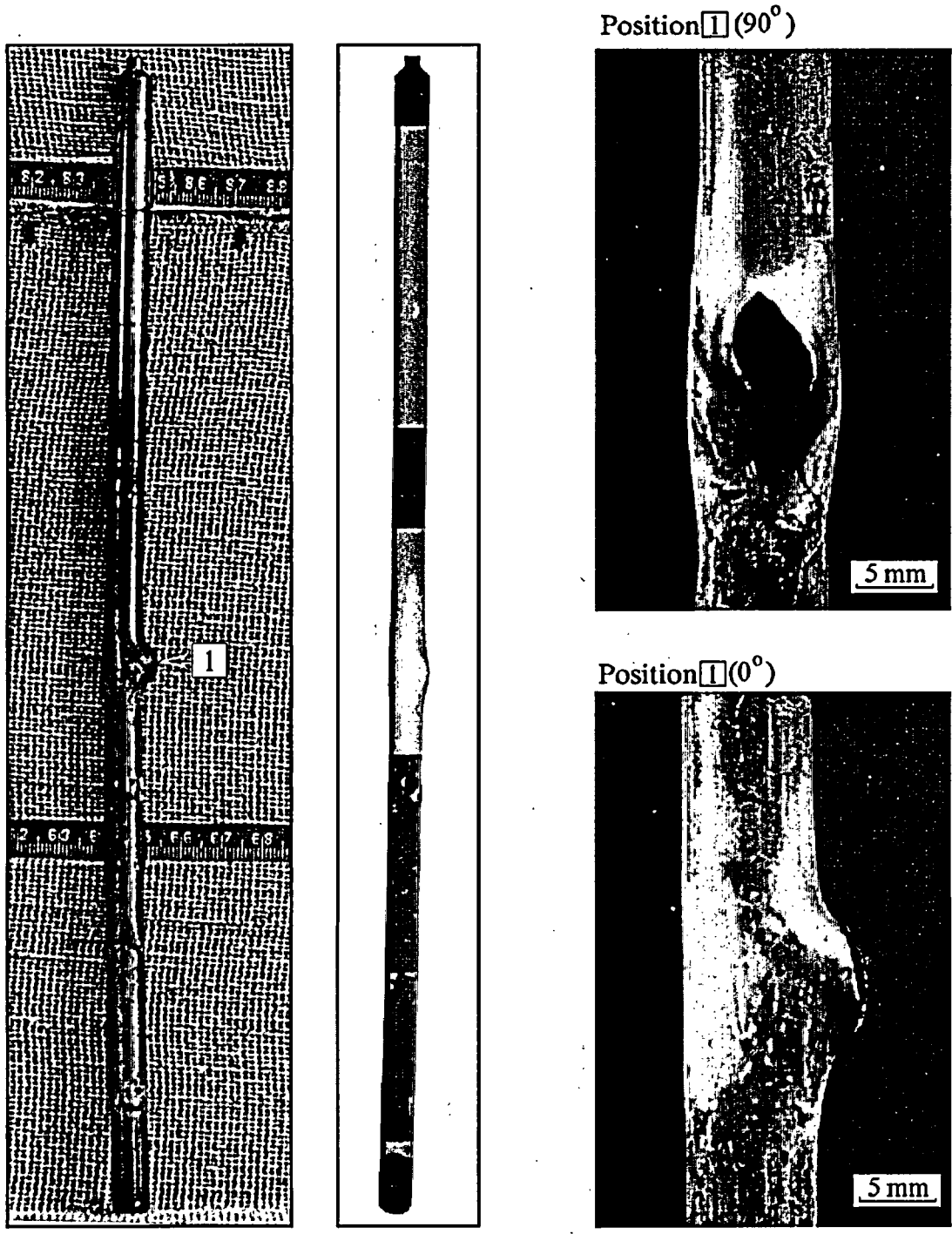
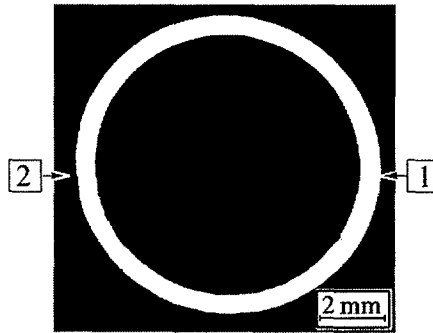

Fig. G-12.1. Appearance of Fuel Rod #B12T (photographs and X-ray photograph)

#B12T

Individual Characteristics of Refabricated Fuel Rods  
(Preirradiated Fuel, Preirradiated Cladding) under IGR Tests



Position 1

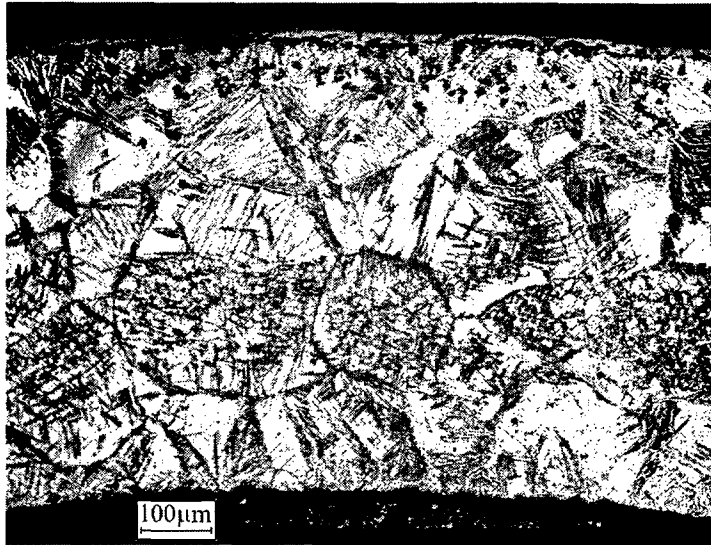

Position 2

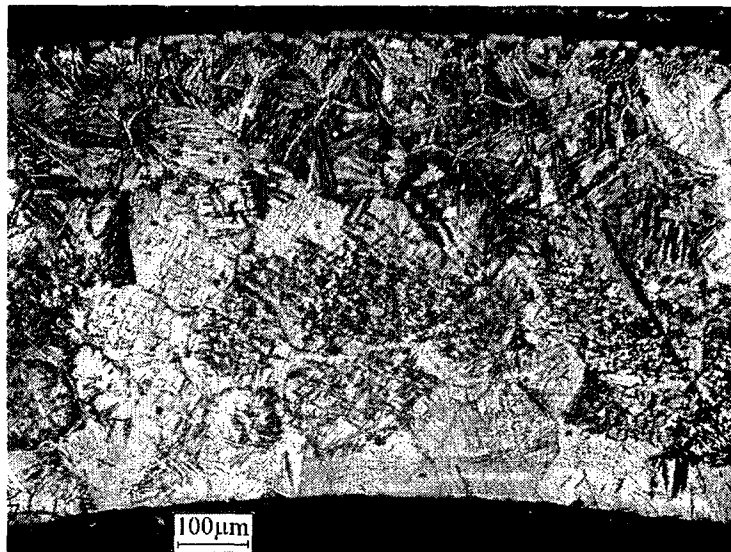

Fig. G-12.2. Cross-Section and Cladding Microstructure for Fuel Rod #B12T at 85 mm Elevation

#B12T

Individual Characteristics of Refabricated Fuel Rods  
(Preirradiated Fuel, Preirradiated Cladding) under IGR Tests

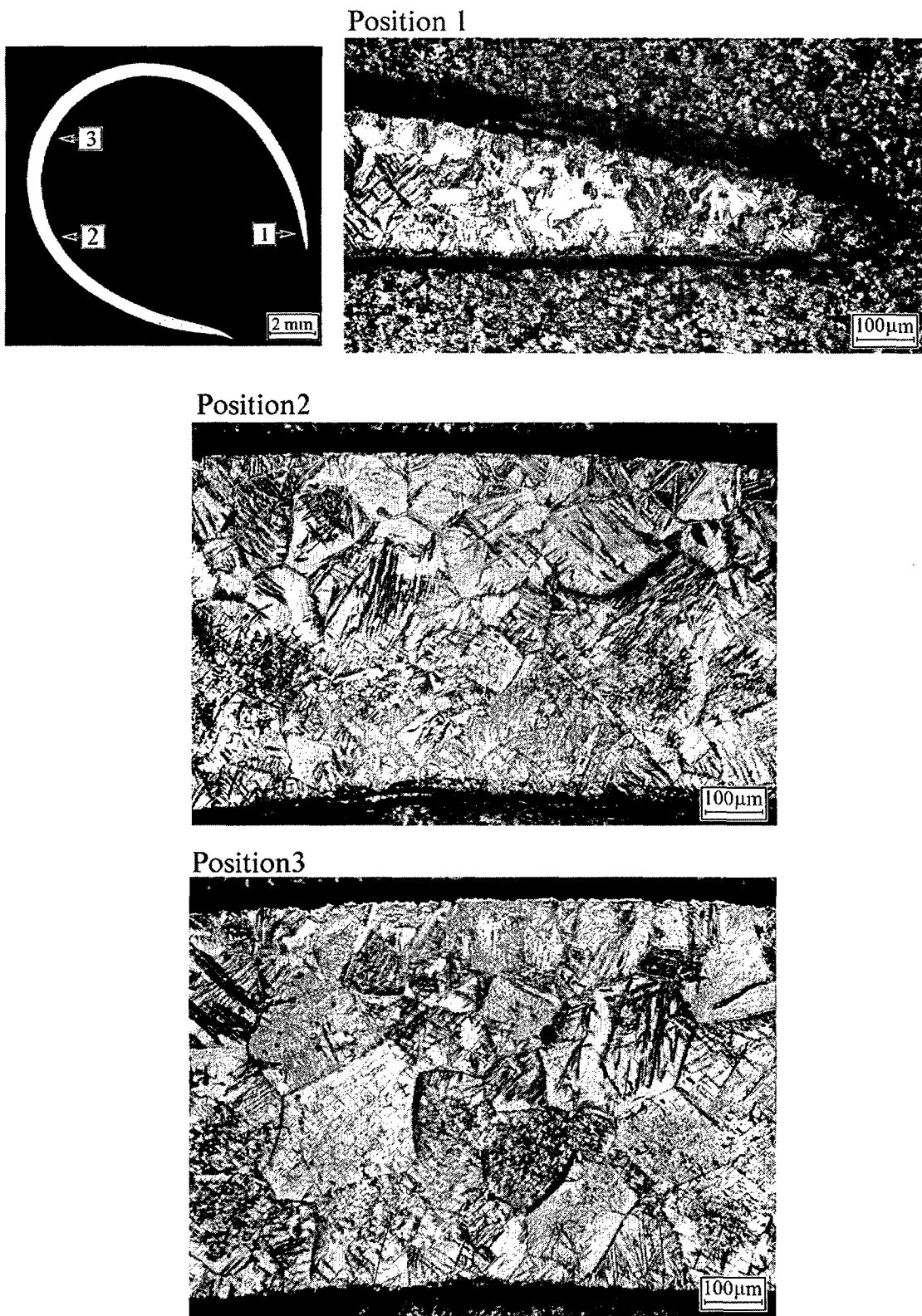

Fig. G-12.3. Cross-Section and Cladding Microstructure for Fuel Rod #B12T at 140 mm Elevation

#B12T

Individual Characteristics of Refabricated Fuel Rods  
(Preirradiated Fuel, Preirradiated Cladding) under IGR Tests

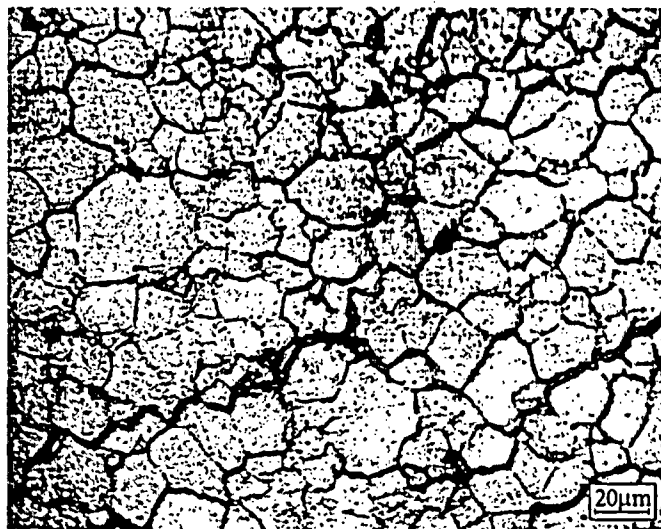
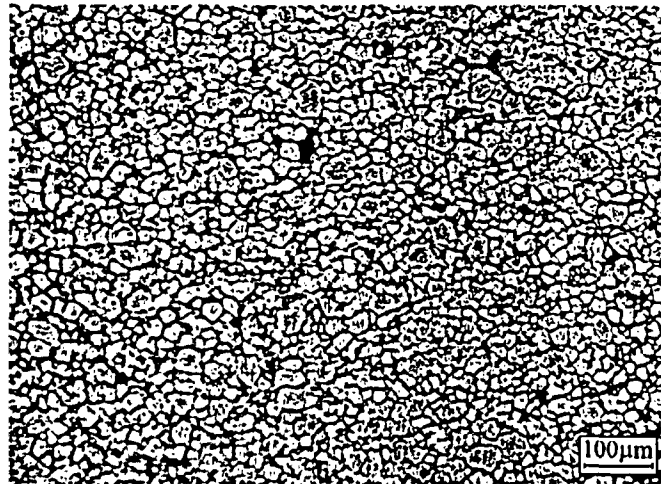

Fig. G-12.4. Fuel Microstructure for Fuel Rod #B12T at 85 mm Elevation

## #B12T

Individual Characteristics of Refabricated Fuel Rods  
(Preirradiated Fuel, Preirradiated Cladding) under IGR Tests

Table G-12.1. Time Dependent Energy Characteristics of Fuel Rod #B12T

Time (s)	Reactor energy deposition <sup>1)</sup> (%)	Cumulative number of fissions in fuel rod (fiss)						Power of fuel rod (kW)	Energy deposition in fuel rod	
		U <sup>235</sup> ×10 <sup>-14</sup>	U <sup>238</sup> ×10 <sup>-13</sup>	Pu <sup>239</sup> ×10 <sup>-14</sup>	Pu <sup>241</sup> ×10 <sup>-14</sup>	Other isotopes ×10 <sup>-11</sup>	Total ×10 <sup>-14</sup>		cal/g fuel	J/g fuel
0.0	0.000	0.000	0.000	0.000	0.000	0.000	0.000	0.000	0.000	0.000
1.0	0.709	0.026	0.011	0.045	0.017	0.056	0.089	0.615	1.270	5.320
2.0	6.580	0.239	0.102	0.414	0.161	0.522	0.825	4.770	11.80	49.40
2.2	9.810	0.356	0.152	0.618	0.240	0.779	1.230	7.040	17.60	73.70
2.4	14.70	0.533	0.227	0.924	0.359	1.160	1.840	10.70	26.30	110.0
2.6	22.30	0.810	0.346	1.400	0.546	1.770	2.800	17.40	40.10	168.0
2.8	35.10	1.280	0.544	2.210	0.860	2.790	4.400	29.60	63.10	264.0
3.0	53.50	1.940	0.829	3.370	1.310	4.250	6.710	32.20	96.00	402.0
3.2	68.70	2.490	1.060	4.320	1.680	5.450	8.610	22.00	123.0	515.0
3.4	78.30	2.850	1.210	4.930	1.920	6.220	9.820	13.50	141.0	590.0
3.6	84.20	3.060	1.310	5.300	2.060	6.690	10.60	8.250	151.0	632.0
3.8	87.80	3.190	1.360	5.530	2.150	6.980	11.00	5.200	158.0	661.0
4.0	90.20	3.270	1.400	5.680	2.210	7.160	11.30	3.420	162.0	678.0
4.2	91.70	3.330	1.420	5.770	2.240	7.280	11.50	2.350	165.0	691.0
4.4	92.70	3.370	1.440	5.840	2.270	7.360	11.60	1.680	167.0	699.0
4.6	93.50	3.400	1.450	5.890	2.290	7.430	11.70	1.250	168.0	703.0
4.8	94.10	3.420	1.460	5.920	2.300	7.470	11.80	0.956	170.0	712.0
5.0	94.50	3.430	1.460	5.950	2.310	7.500	11.80	0.792	170.0	712.0
5.2	94.90	3.450	1.470	5.970	2.320	7.530	11.90	0.674	171.0	716.0
5.4	95.20	3.460	1.470	5.990	2.330	7.560	11.90	0.580	172.0	720.0
5.6	95.50	3.470	1.480	6.010	2.340	7.580	12.00	0.503	172.0	720.0
5.8	95.70	3.480	1.480	6.020	2.340	7.600	12.00	0.441	173.0	724.0
6.0	95.90	3.480	1.490	6.040	2.350	7.610	12.00	0.391	173.0	724.0
6.5	96.30	3.500	1.490	6.060	2.360	7.650	12.10	0.301	174.0	728.0
7.0	96.60	3.510	1.500	6.080	2.360	7.670	12.10	0.244	175.0	733.0
7.5	96.80	3.520	1.500	6.100	2.370	7.690	12.10	0.206	175.0	733.0
8.0	97.10	3.530	1.500	6.110	2.380	7.710	12.20	0.180	176.0	737.0
9.0	97.40	3.540	1.510	6.130	2.380	7.740	12.20	0.157	177.0	741.0
10.0	97.70	3.550	1.510	6.150	2.390	7.760	12.30	0.128	177.0	741.0
20.0	99.00	3.600	1.530	6.240	2.420	7.870	12.40	0.035	181.0	758.0
30.0	99.50	3.610	1.540	6.260	2.440	7.900	12.50	0.019	182.0	762.0
∞	100.0	3.650	1.560	6.320	2.460	7.970	12.60	0.000	186.0	779.0

Maximum value of power is 34.5 kW (t = 2.90 s).

<sup>1)</sup> Current energy deposition per maximum energy deposition (at infinite time)

## #B12T

Individual Characteristics of Refabricated Fuel Rods  
(Preirradiated Fuel, Preirradiated Cladding) under IGR Tests

Table G-12.2. Axial Energy Characteristics of Fuel Rod #B12T

Axial coordinate from lower end of fuel rod (mm)	Cumulative number of fissions at axial interval (fiss)						Maximum power of fuel rod (kW) t=2.90s	Energy deposition at infinite time*		
	U <sup>235</sup> ×10 <sup>-13</sup>	U <sup>238</sup> ×10 <sup>-11</sup>	Pu <sup>239</sup> ×10 <sup>-13</sup>	Pu <sup>241</sup> ×10 <sup>-13</sup>	Other isotopes ×10 <sup>-10</sup>	Total ×10 <sup>-13</sup>		cal/g fuel	J/g fuel	per-unit <sup>3)</sup>
10.0 <sup>1)</sup>	0.444	1.620	0.784	0.308	0.922	1.550	0.426	195.0	816.0	1.00
15.0	1.110	4.040	1.960	0.771	2.300	3.880	1.070	195.0	816.0	1.00
20.0	1.110	4.040	1.960	0.771	2.300	3.880	1.070	195.0	816.0	1.00
25.0	1.080	4.520	1.890	0.751	2.400	3.770	1.040	190.0	795.0	0.97
30.0	1.080	4.520	1.890	0.751	2.400	3.770	1.040	190.0	795.0	0.97
35.0	1.080	4.520	1.890	0.751	2.400	3.770	1.040	190.0	795.0	0.97
40.0	1.080	4.520	1.890	0.751	2.400	3.770	1.040	190.0	795.0	0.97
45.0	1.080	4.520	1.890	0.751	2.400	3.770	1.040	190.0	795.0	0.97
50.0	1.040	4.780	1.850	0.726	2.410	3.670	1.010	185.0	774.0	0.95
55.0	1.040	4.780	1.850	0.726	2.410	3.670	1.010	185.0	774.0	0.95
60.0	1.040	4.780	1.850	0.726	2.410	3.670	1.010	185.0	774.0	0.95
65.0	1.050	4.720	1.880	0.730	2.360	3.710	1.020	187.0	783.0	0.96
70.0	1.050	4.720	1.880	0.730	2.360	3.710	1.020	187.0	783.0	0.96
75.0	1.050	4.680	1.910	0.731	2.380	3.740	1.030	188.0	787.0	0.96
80.0	1.050	4.680	1.910	0.731	2.380	3.740	1.030	188.0	787.0	0.96
85.0	1.050	4.680	1.910	0.731	2.380	3.740	1.030	188.0	787.0	0.96
90.0	1.050	4.680	1.910	0.731	2.380	3.740	1.030	188.0	787.0	0.96
95.0	1.050	4.680	1.910	0.731	2.380	3.740	1.030	188.0	787.0	0.96
100.0	1.010	4.600	1.810	0.705	2.330	3.570	0.981	180.0	753.0	0.92
105.0	1.010	4.600	1.810	0.705	2.330	3.570	0.981	180.0	753.0	0.92
110.0	1.010	4.600	1.810	0.705	2.330	3.570	0.981	180.0	753.0	0.92
115.0	1.570	6.830	2.650	1.030	3.500	5.310	1.460	188.0	787.0	0.96
120.0	1.570	6.940	2.690	1.050	3.500	5.370	1.470	187.0	783.0	0.96
125.0	1.560	7.020	2.710	1.060	3.510	5.400	1.480	186.0	779.0	0.95
130.0	1.620	7.090	2.750	1.070	3.510	5.510	1.510	188.0	787.0	0.96
135.0	1.680	7.080	2.760	1.060	3.510	5.580	1.530	190.0	795.0	0.97
140.0	0.987	3.820	1.580	0.614	1.940	3.220	0.884	177.0	741.0	0.91
145.0	0.987	3.820	1.580	0.614	1.940	3.220	0.884	177.0	741.0	0.91
150.0	0.987	3.820	1.580	0.614	1.940	3.220	0.884	177.0	741.0	0.91
155.0	0.982	3.980	1.610	0.614	2.000	3.250	0.890	178.0	745.0	0.91
160.0	0.982	3.980	1.610	0.614	2.000	3.250	0.890	178.0	745.0	0.91
165.0	0.982	3.980	1.610	0.614	2.000	3.250	0.890	178.0	745.0	0.91
170.0 <sup>2)</sup>	0.982	3.980	1.610	0.614	2.000	3.250	0.890	178.0	745.0	0.91
175.0	0.000	0.000	0.000	0.000	0.000	0.000	0.000	0.000	0.000	0.00
180.0	0.000	0.000	0.000	0.000	0.000	0.000	0.000	0.000	0.000	0.00
185.0	0.000	0.000	0.000	0.000	0.000	0.000	0.000	0.000	0.000	0.00

\* All numerical values of characteristics are presented as average values at the length interval equal to the axial coordinate ± 2.5 mm

1) Initial coordinate of fuel is 10.5 mm

2) End coordinate of fuel is 172.5 mm

3) Current value per maximum value.

## #B12T

Individual Characteristics of Refabricated Fuel Rods (Preirradiated Fuel, Preirradiated Cladding) under IGR Tests
--

Table G-12.3. Radial Energy Characteristics of Fuel Rod #B12T

Characteristics*		Coordinates of fuel zones (mm)			
		1 zone 1.2 - 2.811	2 zone 2.811-3.432	3 zone 3.432-3.704	4 zone 3.704-3.790
U <sup>235</sup>	Number of fissions $\times 10^{-14}$ (fiss)	0.406	0.238	0.116	0.038
	Power of fuel rod <sup>1)</sup> (kW)	1.090	0.641	0.313	0.102
	Energy deposition <sup>2)</sup> (cal/g fuel)	55.10	53.80	52.60	51.30
	Energy deposition <sup>2)</sup> (J/g fuel)	231.0	225.0	220.0	215.0
	Energy deposition <sup>3)</sup> (per-unit)	1.000	0.976	0.955	0.931
U <sup>238</sup>	Number of fissions $\times 10^{-12}$ (fiss)	1.800	1.040	0.495	0.153
	Power of fuel rod <sup>1)</sup> (kW)	0.048	0.028	0.013	0.004
	Energy deposition <sup>2)</sup> (cal/g fuel)	2.420	2.330	2.210	2.050
	Energy deposition <sup>2)</sup> (J/g fuel)	10.10	9.750	9.250	8.580
	Energy deposition <sup>3)</sup> (per-unit)	1.000	0.963	0.913	0.847
Pu <sup>239</sup>	Number of fissions $\times 10^{-14}$ (fiss)	0.563	0.382	0.262	0.148
	Power of fuel rod <sup>1)</sup> (kW)	1.570	1.060	0.729	0.413
	Energy deposition <sup>2)</sup> (cal/g fuel)	79.10	89.50	123.0	209.0
	Energy deposition <sup>2)</sup> (J/g fuel)	331.0	375.0	515.0	875.0
	Energy deposition <sup>3)</sup> (per-unit)	0.378	0.428	0.589	1.000
Pu <sup>241</sup>	Number of fissions $\times 10^{-13}$ (fiss)	2.090	1.480	1.060	0.633
	Power of fuel rod <sup>1)</sup> (kW)	0.570	0.404	0.290	0.173
	Energy deposition <sup>2)</sup> (cal/g fuel)	28.80	34.10	48.80	87.50
	Energy deposition <sup>2)</sup> (J/g fuel)	121.0	143.0	204.0	366.0
	Energy deposition <sup>3)</sup> (per-unit)	0.329	0.390	0.558	1.000
Other isotopes	Number of fissions $\times 10^{-11}$ (fiss)	0.802	0.508	0.302	0.143
	Power of fuel rod <sup>1)</sup> (kW)	0.002	0.001	0.001	0.000
	Energy deposition <sup>2)</sup> (cal/g fuel)	0.111	0.118	0.140	0.198
	Energy deposition <sup>2)</sup> (J/g fuel)	0.460	0.490	0.590	0.830
	Energy deposition <sup>3)</sup> (per-unit)	0.561	0.596	0.707	1.000
Total	Number of fissions $\times 10^{-14}$ (fiss)	1.200	0.779	0.489	0.250
	Power of fuel rod <sup>1)</sup> (kW)	3.290	2.140	1.340	0.687
	Energy deposition <sup>2)</sup> (cal/g fuel)	166.0	180.0	226.0	347.0
	Energy deposition <sup>2)</sup> (J/g fuel)	695.0	753.0	946.0	1453.
	Energy deposition <sup>3)</sup> (per-unit)	0.478	0.519	0.651	1.000

1) at time of 2.90 s, 2) at infinite time, 3) Current value per maximum value.

\* All numerical values of characteristics were calculated for undamaged part of fuel stack only (See Table C.2.3.)



# #B12T

Individual Characteristics of Refabricated Fuel Rods  
(Preirradiated Fuel, Preirradiated Cladding) under IGR Tests

Table G-12.4. Fuel Enthalpy Vs. Time Calculated by FRAP-T6 Code for Fuel Rod #B12T

Time (s)	Enthalpy at fuel radius (cal/g fuel)				Fuel enthalpy <sup>1)</sup>		Energy deposition in fuel rod	
	1.20 mm	2.82 mm	3.47 mm	3.79 mm	cal/g fuel	J/g fuel	cal/g fuel	J/g fuel
0.0	0.00	0.00	0.00	0.00	0.00	0.00	0.00	0.00
1.0	1.11	1.10	1.05	1.00	1.09	4.55	1.30	5.46
2.0	10.7	10.5	9.89	9.12	10.3	43.3	12.0	50.5
2.2	17.9	17.5	16.4	14.8	17.3	72.3	19.9	83.2
2.4	30.3	29.5	27.2	23.9	28.9	121	33.1	138
2.6	30.3	29.5	27.2	23.9	28.9	121	33.1	138
2.8	53.5	52.2	47.7	40.5	50.9	213	57.5	241
3.0	92.5	90.0	79.0	62.9	86.7	363	97.5	409
3.2	118	113	94.8	75.8	108	453	123	516
3.4	135	127	111	106	125	523	141	589
3.6	146	135	124	118	135	566	151	633
3.8	152	141	130	123	141	590	158	661
4.0	155	144	133	125	144	602	162	679
4.2	157	145	134	126	145	608	165	690
4.4	158	146	134	127	146	611	167	700
4.6	158	145	134	128	146	611	169	707
4.8	158	145	134	128	146	611	169	707
5.0	157	145	134	128	145	609	170	712
5.2	156	144	134	129	145	607	171	716
5.4	155	144	134	129	144	605	172	719
5.6	154	143	134	129	144	602	172	722
5.8	154	143	134	129	144	602	172	722
6.0	153	142	134	129	143	599	173	724
6.5	151	141	133	129	142	593	174	728
7.0	149	140	132	128	140	587	174	731
7.5	146	138	132	128	139	581	175	733
8.0	144	137	131	127	137	575	175	735
10.0	138	132	127	123	132	552	177	742
30.0	96.6	94.6	92.7	91.6	94.6	396	182	761

Radial enthalpy distribution and fuel enthalpy are presented at elevation 18.6 mm

Maximum value of fuel enthalpy is 145.7 cal/g fuel ( $t=4.70$  s)

<sup>1)</sup> All numerical values are presented at elevation with peak power

# #B12T

Individual Characteristics of Refabricated Fuel Rods  
(Preirradiated Fuel, Preirradiated Cladding) under IGR Tests

Table G-12.5. Energy Characteristics Vs. Time Calculated by FRAP-T6 and SCANAIR Codes for Fuel Rod #B12T

Time (s)	Energy deposition <sup>1)</sup> (cal/g fuel)	Linear power <sup>1)</sup> (kW/m)	Fuel enthalpy <sup>1)</sup> (cal/g fuel)		Leakage of energy <sup>1)</sup> (cal/g fuel)		Clad-to-coolant heat transfer coefficient <sup>1)</sup> (kW/m <sup>2</sup> K)	
			FRAP-T6	SCANAIR	FRAP-T6	SCANAIR	FRAP-T6	SCANAIR
0.0	0.00	0.00	0.00	0.00	0.00	0.00	0.00	0.00
1.0	1.36	5.88	1.09	1.15	0.00	0.00	0.01	0.01
2.0	12.6	45.4	10.3	10.5	0.00	0.00	0.01	0.01
2.2	20.7	74.2	17.3	15.6	0.01	0.01	0.01	0.01
2.4	34.5	130	28.9	23.3	0.02	0.02	0.01	0.01
2.6	34.5	130	28.9	35.4	0.02	0.03	0.01	0.02
2.8	60.0	249	50.9	55.6	0.04	0.05	0.02	0.02
3.0	102	296	86.7	84.0	0.11	0.12	0.04	0.04
3.2	129	205	108	-	0.24	-	0.06	-
3.4	147	126	125	-	0.47	-	0.07	-
3.6	158	76.9	135	-	0.76	-	0.08	-
3.8	165	48.5	141	-	1.10	-	0.09	-
4.0	169	31.9	144	-	1.49	-	0.10	-
4.2	172	21.9	145	-	1.93	-	0.11	-
4.4	175	14.5	146	-	2.56	-	0.12	-
4.6	176	10.2	146	-	3.26	-	0.12	-
4.8	176	10.2	146	-	3.26	-	0.12	-
5.0	178	7.70	145	-	4.02	-	0.13	-
5.2	178	6.28	145	-	4.83	-	0.14	-
5.4	179	5.21	144	-	5.68	-	0.14	-
5.6	180	4.39	144	-	6.56	-	0.14	-
5.8	180	4.39	144	-	6.56	-	0.14	-
6.0	181	3.76	143	-	7.47	-	0.15	-
6.5	181	2.87	142	-	9.36	-	0.15	-
7.0	182	2.32	140	-	11.3	-	0.15	-
7.5	183	1.96	139	-	13.3	-	0.15	-
8.0	183	1.70	137	-	15.2	-	0.15	-
10.0	185	1.21	132	-	23.0	-	0.15	-
30.0	190	0.17	94.6	-	76.8	-	0.09	-

<sup>1)</sup> All numerical values are presented at elevation with peak power

# #B12T

Individual Characteristics of Refabricated Fuel Rods  
(Preirradiated Fuel, Preirradiated Cladding) under IGR Tests

Table G-12.6. Temperature Variation, Fission Gas Release and ZrO<sub>2</sub> Thickness Vs. Time for Fuel Rod #B12T Calculated by FRAP-T6 and SCANAIR Codes

Time (s)	Fuel centerline temperature <sup>1)</sup> (K)		Fuel surface temperature <sup>1)</sup> (K)		Clad outer temperature <sup>1)</sup> (K)		Fission gas release (%)	
	FRAP-T6	SCANAIR	FRAP-T6	SCANAIR	FRAP-T6	SCANAIR	FRAP-T6	SCANAIR
0.0	293	293	293	293	293	293	0.00	0.00
1.0	313	312	311	310	301	302	0.02	0.15
2.0	465	460	442	442	376	380	0.05	0.93
2.2	573	537	527	508	434	424	0.08	1.19
2.4	747	649	657	601	532	490	0.13	1.69
2.6	747	818	657	739	532	589	0.13	2.17
2.8	1060	1092	886	946	694	748	0.26	2.65
3.0	1562	1470	1184	1193	979	990	0.77	3.06
3.2	1871	-	1351	-	1188	-	3.11	-
3.4	2068	-	1725	-	1297	-	4.59	-
3.6	2178	-	1867	-	1346	-	5.68	-
3.8	2238	-	1923	-	1403	-	6.49	-
4.0	2271	-	1949	-	1458	-	7.25	-
4.2	2288	-	1962	-	1507	-	7.27	-
4.4	2296	-	1975	-	1557	-	8.64	-
4.6	2296	-	1984	-	1595	-	10.3	-
4.8	2296	-	1984	-	1595	-	10.3	-
5.0	2291	-	1990	-	1626	-	11.9	-
5.2	2283	-	1994	-	1650	-	13.0	-
5.4	2274	-	1996	-	1669	-	13.6	-
5.6	2263	-	1998	-	1684	-	13.9	-
5.8	2263	-	1998	-	1684	-	13.9	-
6.0	2252	-	1998	-	1696	-	14.2	-
6.5	2229	-	1996	-	1712	-	15.0	-
7.0	2206	-	1991	-	1721	-	15.6	-
7.5	2184	-	1984	-	1726	-	15.6	-
8.0	2163	-	1975	-	1727	-	15.7	-
10.0	2091	-	1935	-	1711	-	15.7	-
30.0	1613	-	1551	-	1409	-	16.0	-

<sup>1)</sup> All numerical values are presented at elevation with peak power

# #B12T

Individual Characteristics of Refabricated Fuel Rods  
(Preirradiated Fuel, Preirradiated Cladding) under IGR Tests

Table G-12.7. Mechanical Characteristics of Fuel Rod #B12T Vs. Time Calculated by FRAP-T6 and SCANAIR Codes

Time (s)	Clad outer temperature <sup>1)</sup> (K)		Fuel hoop strain <sup>1)</sup> (%)		Fuel - clad gap width <sup>1)</sup> (mm)		Clad hoop strain <sup>1)</sup> (%)		Clad hoop stress <sup>1)</sup> (MPa)		Internal gas pressure (MPa)	
	FRAP-T6	SCANAIR	FRAP-T6	SCANAIR	FRAP-T6	SCANAIR	FRAP-T6	SCANAIR	FRAP-T6	SCANAIR	FRAP-T6	SCANAIR
0.0	293	293	0.00	0.00	0.03	0.03	0.01	0.01	8.41	8.14	1.70	1.70
1.0	301	302	0.04	0.01	0.03	0.03	0.01	0.01	8.50	8.24	1.72	1.72
2.0	376	380	0.22	0.12	0.02	0.03	0.07	0.08	8.97	8.82	1.81	1.81
2.2	434	424	0.36	0.18	0.02	0.03	0.11	0.11	9.18	9.03	1.85	1.85
2.4	532	490	0.58	0.27	0.01	0.03	0.17	0.16	9.42	9.28	1.89	1.88
2.6	532	589	0.58	0.42	0.01	0.02	0.17	0.24	9.42	9.55	1.89	1.92
2.8	694	748	1.03	0.69	0.00	0.02	0.29	0.36	9.71	9.85	1.95	1.96
3.0	979	990	1.87	1.13	0.00	0.01	0.99	0.55	37.2	10.0	2.01	2.00
3.2	1188	-	2.67	-	0.00	-	1.64	-	10.6	-	2.06	-
3.4	1297	-	3.30	-	2.49	-	65.0	-	0.00	-	0.10	-
3.6	1346	-	3.72	-	2.47	-	65.0	-	0.00	-	0.10	-
3.8	1403	-	3.92	-	2.46	-	65.1	-	0.00	-	0.10	-
4.0	1458	-	4.08	-	2.46	-	65.1	-	0.00	-	0.10	-
4.2	1507	-	4.25	-	2.45	-	65.2	-	0.00	-	0.10	-
4.4	1557	-	4.29	-	2.45	-	65.2	-	0.00	-	0.10	-
4.6	1595	-	4.42	-	2.44	-	65.3	-	0.00	-	0.10	-
4.8	1595	-	4.42	-	2.44	-	65.3	-	0.00	-	0.10	-
5.0	1626	-	4.61	-	2.44	-	65.3	-	0.00	-	0.10	-
5.2	1650	-	4.87	-	2.43	-	65.3	-	0.00	-	0.10	-
5.4	1669	-	4.89	-	2.42	-	65.3	-	0.00	-	0.10	-
5.6	1684	-	4.83	-	2.43	-	65.4	-	0.00	-	0.10	-
5.8	1684	-	4.83	-	2.43	-	65.4	-	0.00	-	0.10	-
6.0	1696	-	4.88	-	2.43	-	65.4	-	0.00	-	0.10	-
6.5	1712	-	4.86	-	2.43	-	65.4	-	0.00	-	0.10	-
7.0	1721	-	4.78	-	2.43	-	65.4	-	0.00	-	0.10	-
7.5	1726	-	4.70	-	2.43	-	65.4	-	0.00	-	0.10	-
8.0	1727	-	4.62	-	2.44	-	65.4	-	0.00	-	0.10	-
10.0	1711	-	4.33	-	2.45	-	65.4	-	0.00	-	0.10	-
30.0	1409	-	2.65	-	2.51	-	65.1	-	0.00	-	0.10	-

<sup>1)</sup> All numerical values are presented at elevation with peak power

# #B12T

Individual Characteristics of Refabricated Fuel Rods  
(Preirradiated Fuel, Preirradiated Cladding) under IGR Tests

**Table G-12.8. Axial Distribution of Energy Deposition and Fuel Enthalpy Calculated by FRAP-T6 Code for Fuel Rod #B12T**

Axial interval from-to (mm)-(mm)	Energy deposition at infinite time			Fuel enthalpy at time (t=4.70 s)		
	cal/g fuel	J/g fuel	per-unit	cal/g fuel	J/g fuel	per-unit
10.5 - 26.7	194	812	1.00	146	611	1.00
26.7 - 42.9	190	796	0.98	143	599	0.98
42.9 - 59.1	187	781	0.96	140	588	0.96
59.1 - 75.3	187	782	0.96	140	589	0.96
75.3 - 91.5	188	788	0.97	141	593	0.97
91.5 - 107.7	183	767	0.94	138	577	0.94
107.7 - 123.9	185	776	0.96	139	584	0.96
123.9 - 140.1	186	781	0.96	140	588	0.96
140.1 - 156.3	177	743	0.91	133	559	0.91
156.3 - 172.5	178	746	0.92	134	561	0.92

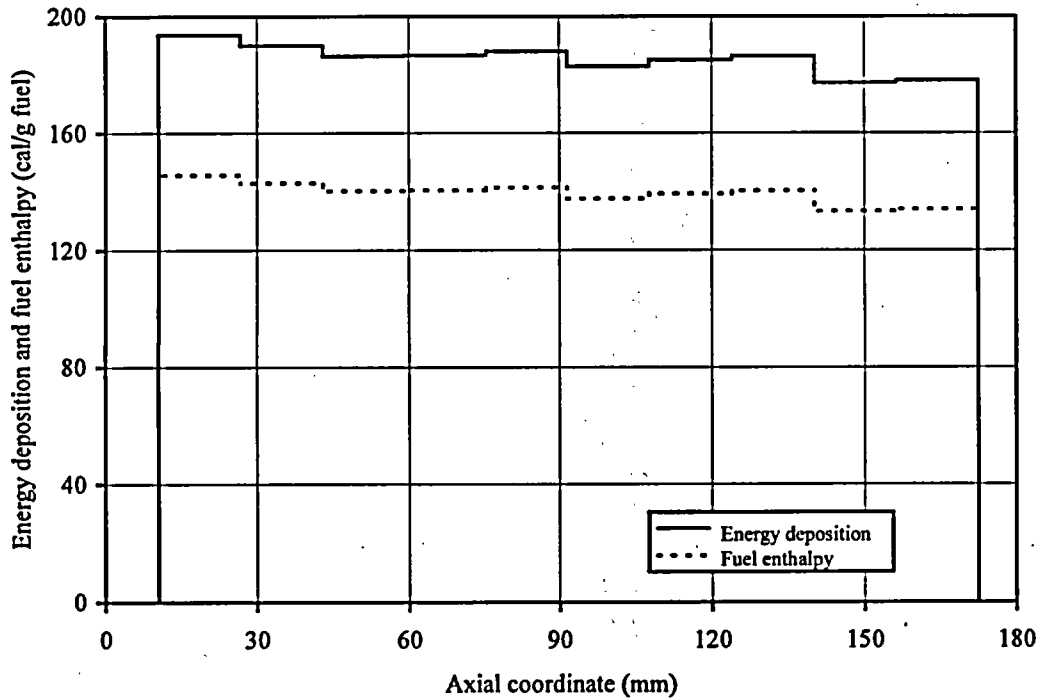

**Fig. G-12.5. Axial Distribution of Energy Deposition and Fuel Enthalpy Calculated by FRAP-T6 Code for Fuel Rod #B12T**

#B12T

Individual Characteristics of Refabricated Fuel Rods  
(Preirradiated Fuel/Preirradiated Cladding) under IGR Tests

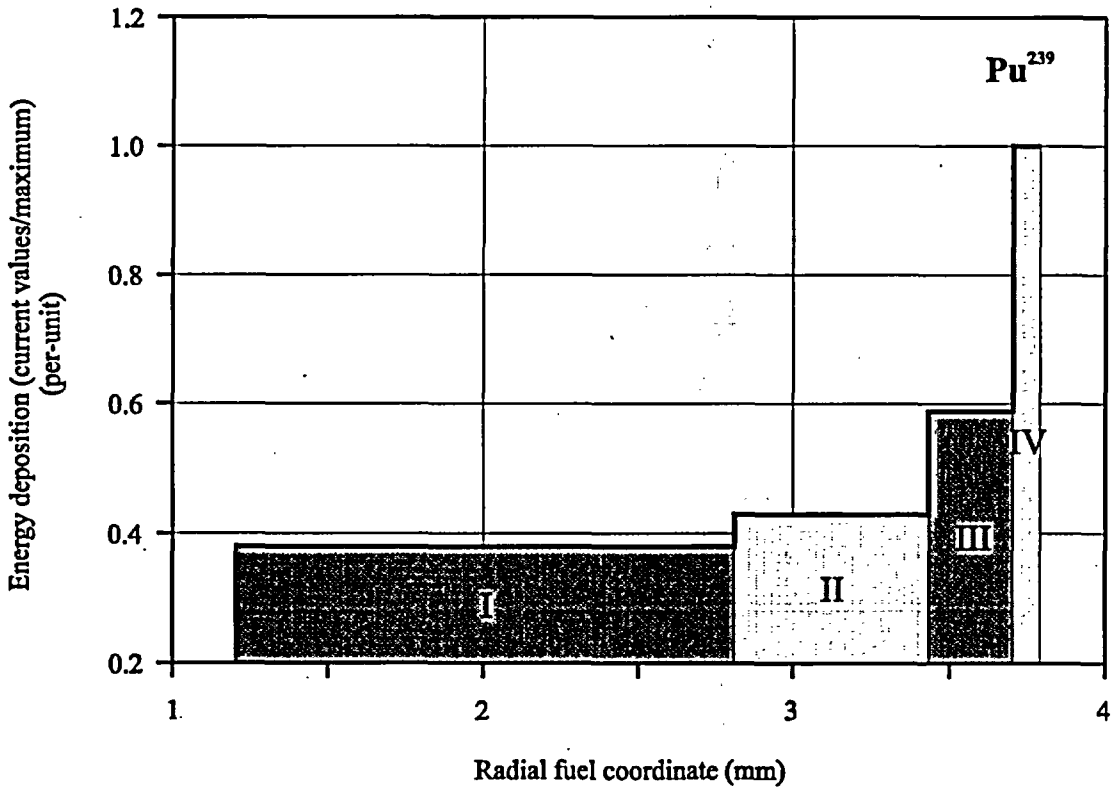
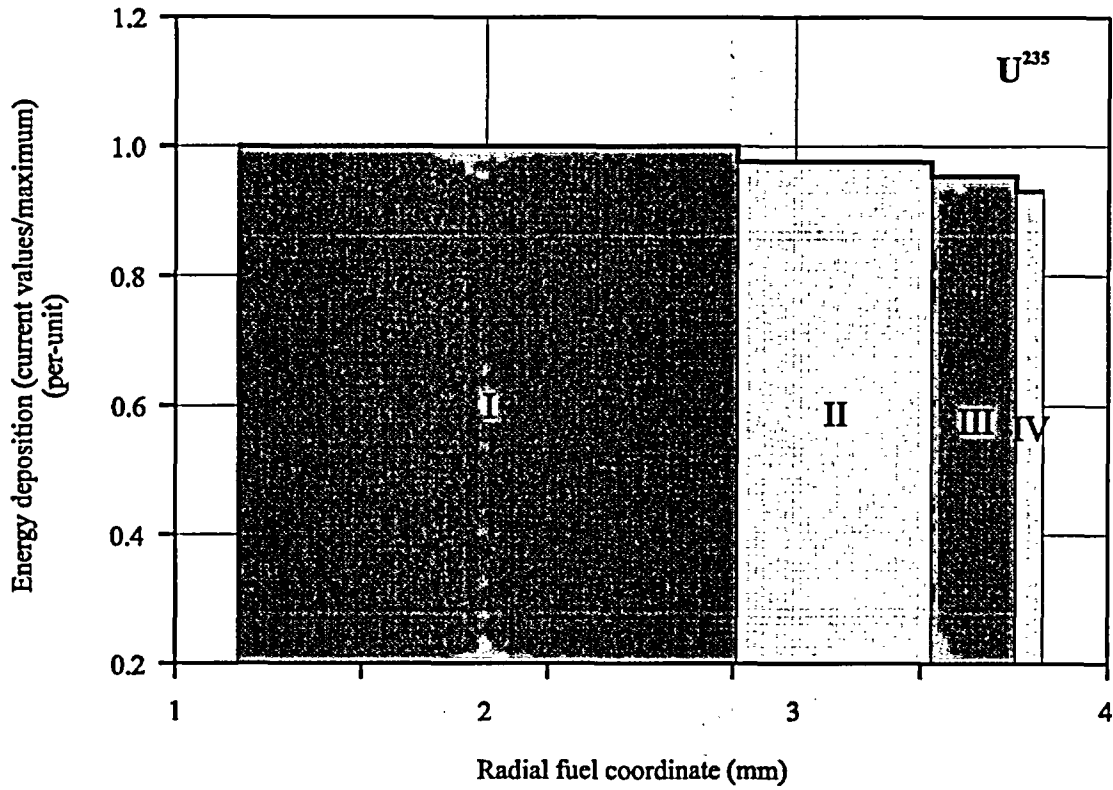

Fig. G-12.6.  $U^{235}$  and  $Pu^{239}$  Radial Distributions of Energy Deposition for Fuel Rod #B12T

# #B12T

Individual Characteristics of Refabricated Fuel Rods  
(Preirradiated Fuel, Preirradiated Cladding) under IGR Tests

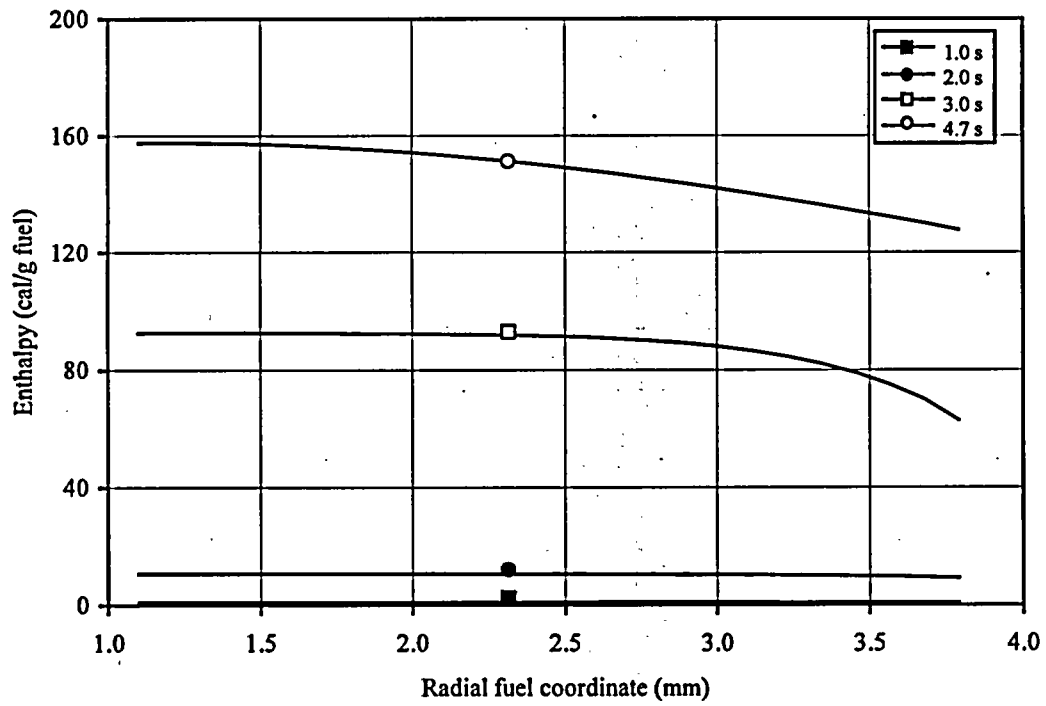
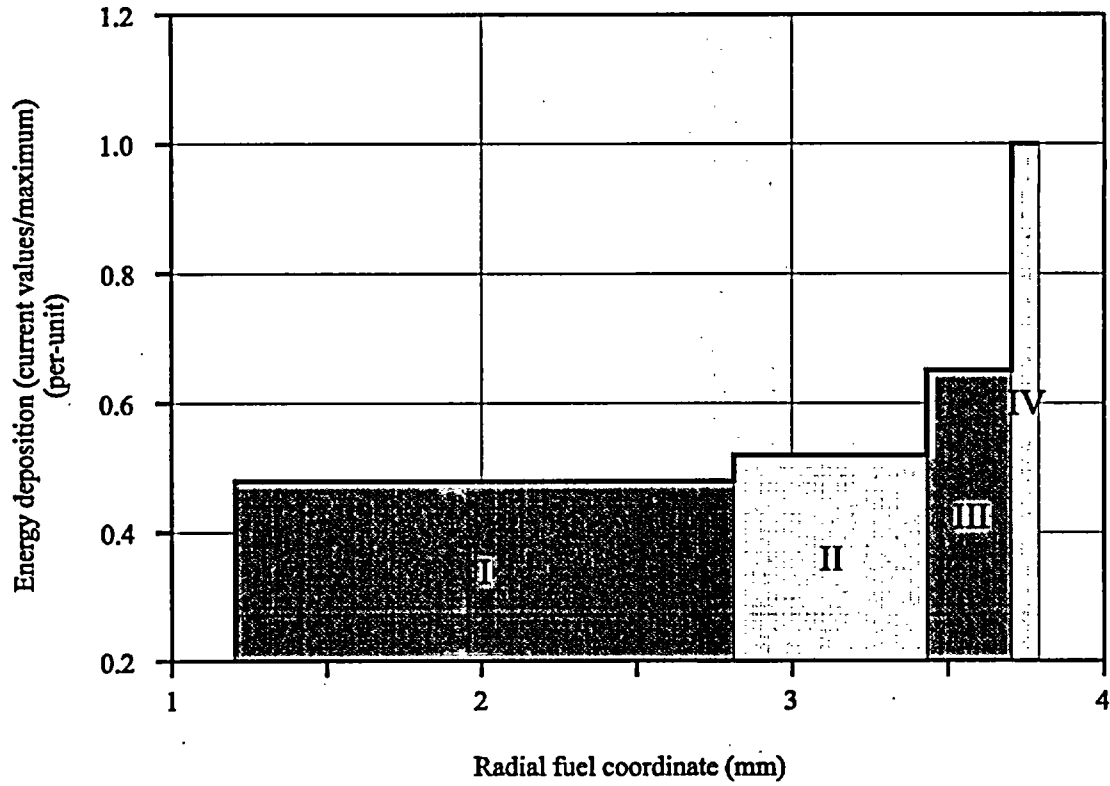

Fig. G-12.7. Radial Distributions of Energy Deposition and Fuel Enthalpy Calculated by FRAP-T6 Code for Fuel Rod #B12T

#B12T

Individual Characteristics of Refabricated Fuel Rods  
(Preirradiated Fuel, Preirradiated Cladding) under IGR Tests

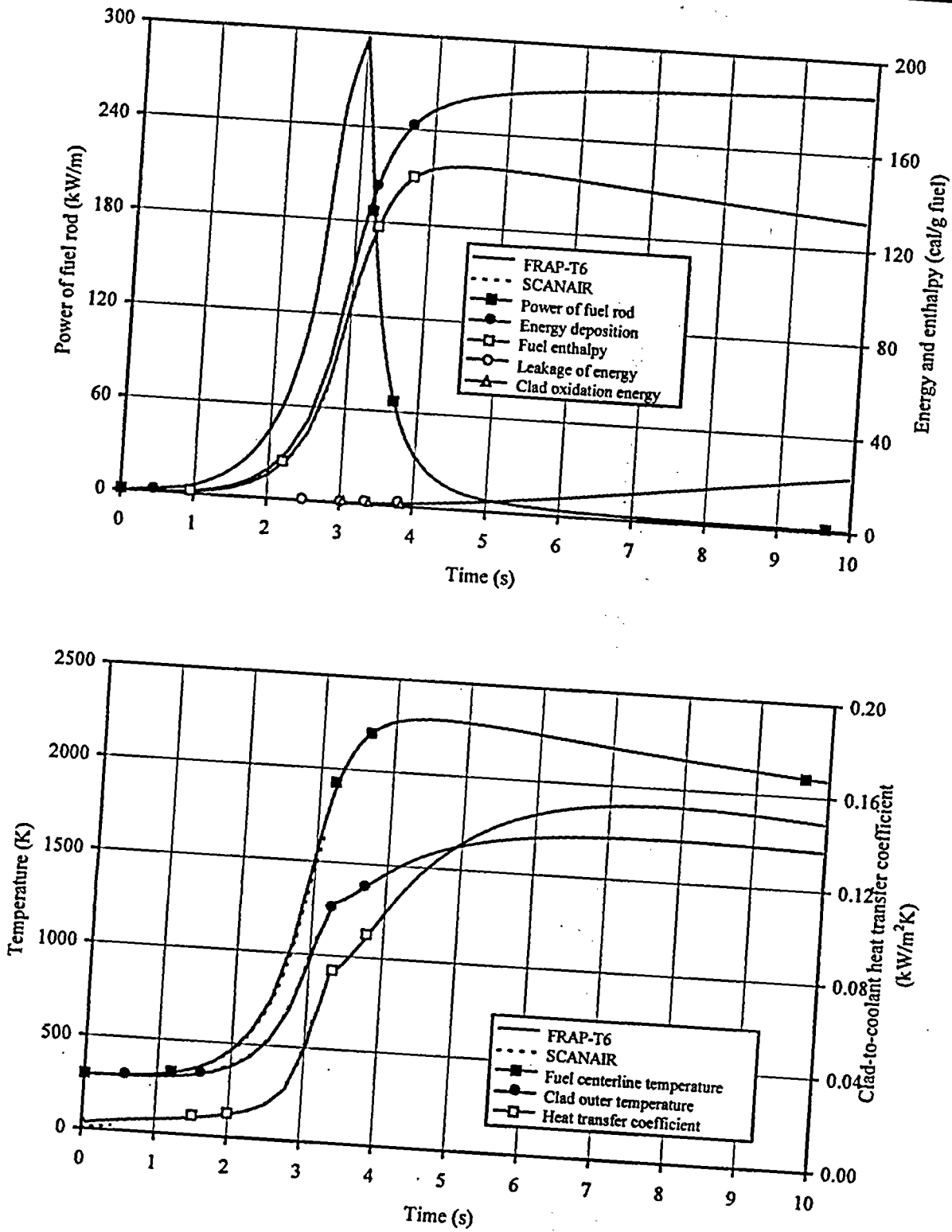

Fig. G-12.8. Energy and Temperature Characteristics Vs. Time Calculated by FRAP-T6 and SCANAIR Codes for Fuel Rod #B12T



# #B12T

Individual Characteristics of Refabricated Fuel Rods  
(Preirradiated Fuel, Preirradiated Cladding) under IGR Tests

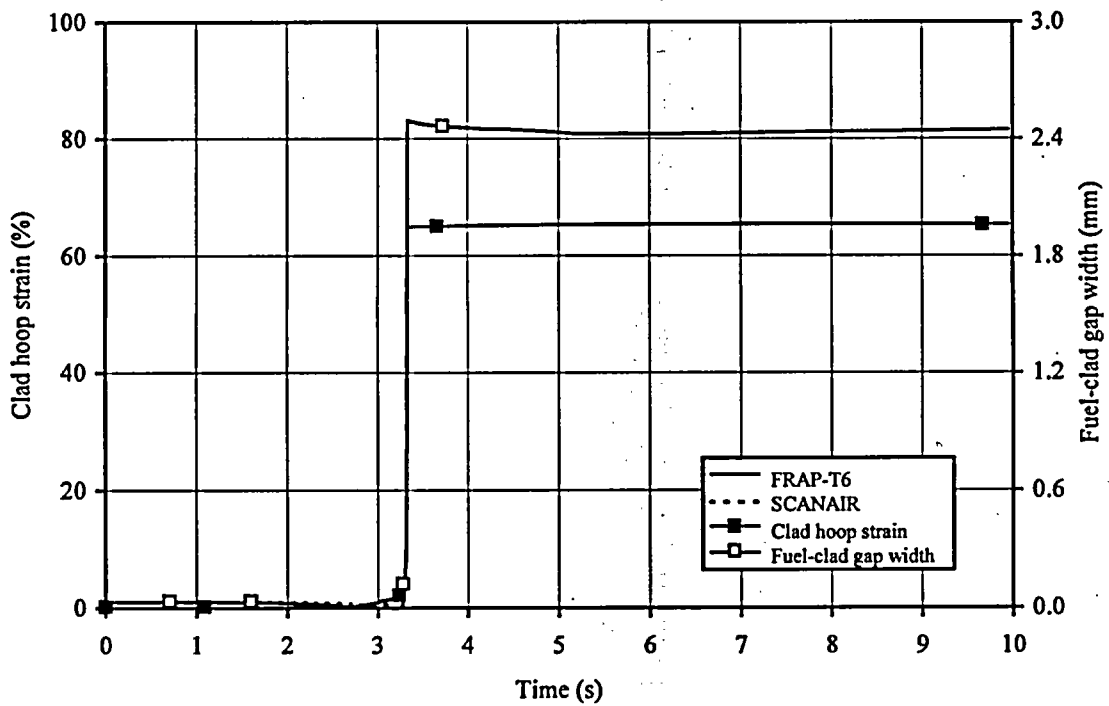
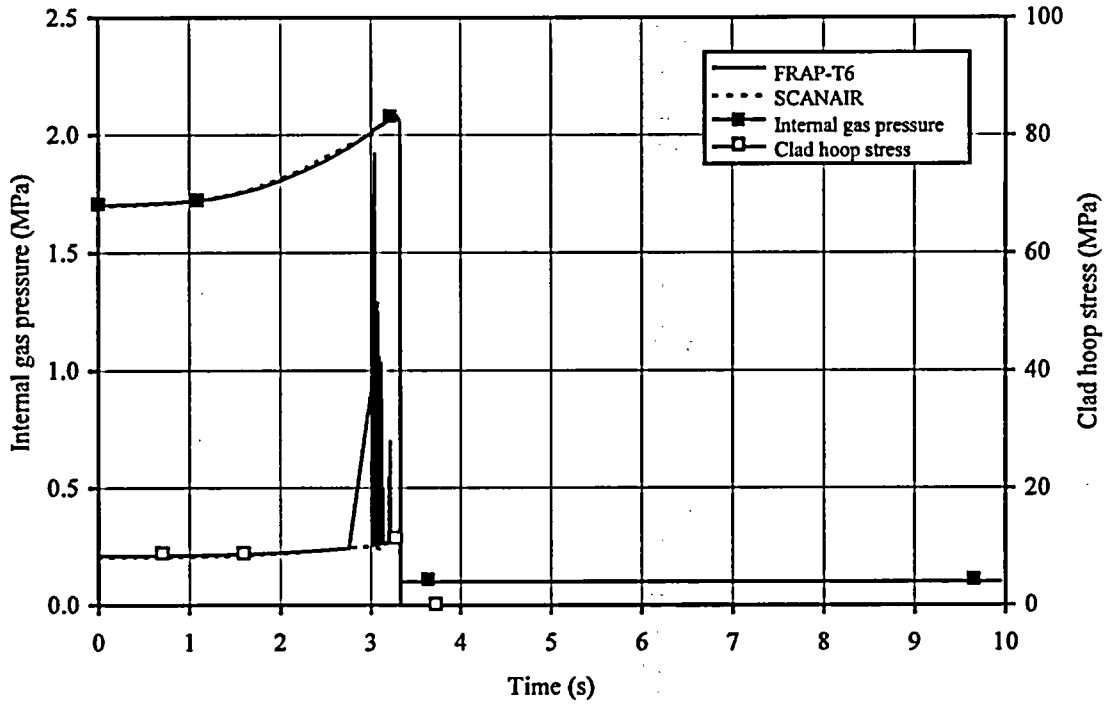

Fig. G-12.9. Cladding Mechanical Characteristics Vs. Time Calculated by FRAP-T6 and SCANAIR Codes for Fuel Rod #B12T

#B12T

Individual Characteristics of Refabricated Fuel Rods  
(Preirradiated Fuel, Preirradiated Cladding) under IGR Tests

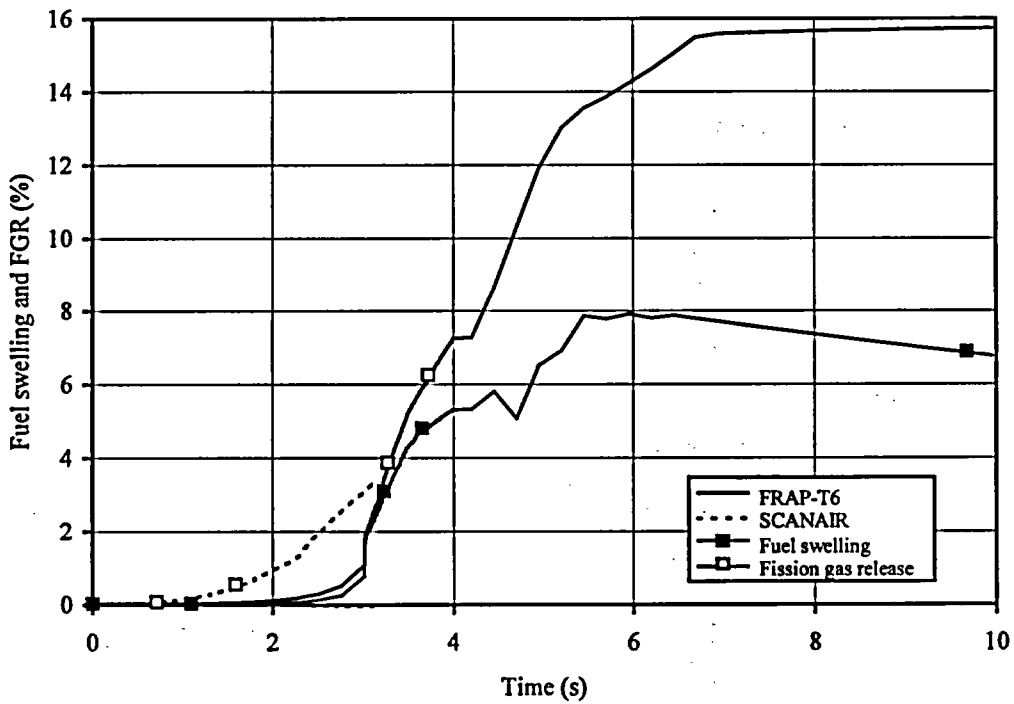
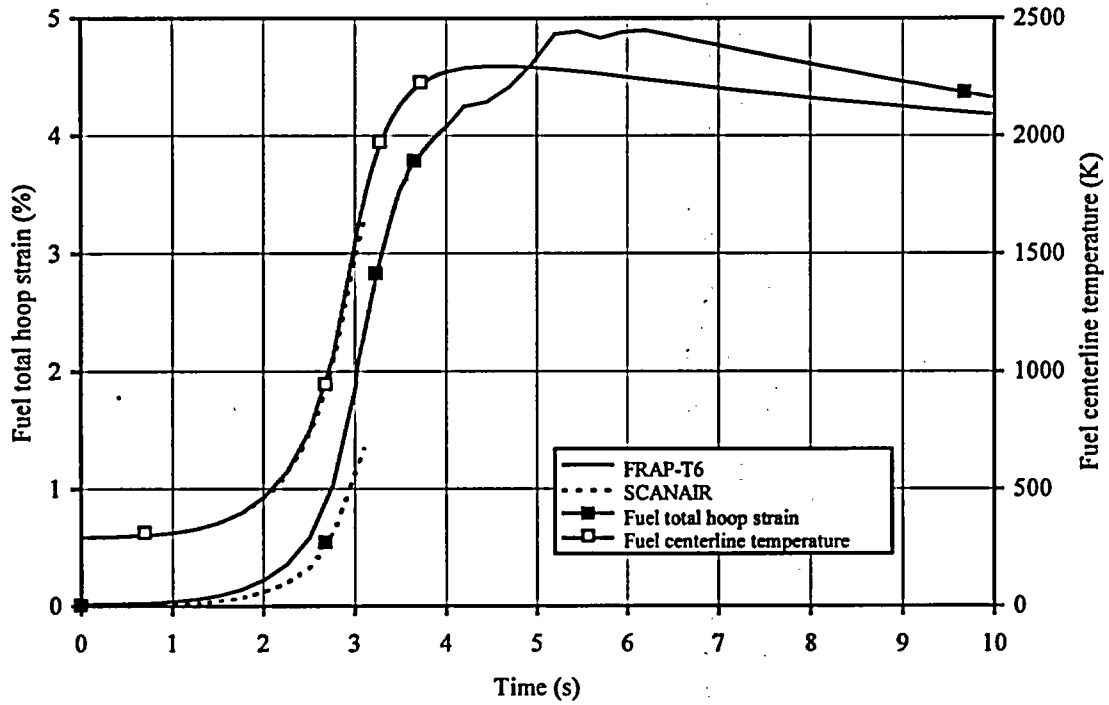

Fig. G-12.10. Fuel Strain and Fission Gas Release Vs. Time Calculated by FRAP-T6 and SCANAIR Codes for Fuel Rod #B12T

# #B12T

Individual Characteristics of Refabricated Fuel Rods  
(Preirradiated Fuel, Preirradiated Cladding) under IGR Tests

Table G-12.9. Some Results of PIE for Fuel Rod #B12T

Characteristic		Value	
1.	Measured parameters of cladding oxidation and cladding deformation		
1.1.	Cladding thickness at elevation 85, 140 mm correspondent to different azimuthal angles ( $\mu\text{m}$ ):		
	0°	700	649
	90°	677	R
	180°	634	634
	270°	677	677
1.2.	ZrO <sub>2</sub> thickness at elevation 85, 140 mm correspondent to different azimuthal angles ( $\mu\text{m}$ ):		
	0°	10	10
	90°	15	—
	180°	10	15
	270°	10	10
1.3.	$\alpha\text{Zr(O)}$ thickness at elevation 85, 140 mm correspondent to different azimuthal angles ( $\mu\text{m}$ ):		
	0°	10	10
	90°	25	—
	180°	10	10
	270°	10	10
1.4.	Clad hoop strain at elevation 85, 140 mm, respectively (%)	6.3	24
2.	Measured parameters for FGR analysis		
2.1.	Internal gas composition (% by volume):		
	He	—	
	N <sub>2</sub>	—	
	O <sub>2</sub>	—	
	Ar	—	
	CO <sub>2</sub>	—	
	Kr	—	
	Xe	—	
2.2.	Free gas volume (cm <sup>3</sup> )	—	
2.3.	Gas pressure inside fuel rod under normal condition (MPa)	—	
2.4.	Kr concentration in fuel (cm <sup>3</sup> /g fuel)	—	
3.	Measured parameters of cladding hydriding		
3.1.	Coefficient of hydride orientation (per-unit)	—	
3.2.	Hydrogen concentration (% by weight)	—	

## #B12T

Individual Characteristics of Refabricated Fuel Rods (Preirradiated Fuel, Preirradiated Cladding) under IGR Tests
--

Table G-12.10. General Characteristic of Fuel Rod #B12T

	Parameter	Unit	Value		
			Experiment	FRAP-T6	SCANAIR
1	Type of coolant	---	air	air	air
2	Burnup	MWd/kg U	48.7	48.7	48.7
3	Energy deposition in fuel rod	cal/g fuel	186	186	186
4	Peak fuel enthalpy	cal/g fuel	-	146	-
5	Peak fuel temperature	K	-	2296	-
6	Peak clad temperature	K	-	1727	-
7	Fuel rod failure	Yes, No	Yes	Yes	-
8	Type of failure:				
	- cladding rupture due to ballooning	Yes, No	Yes	Yes	-
	- cladding rupture due to PCMI	Yes, No	No	No	-
	- fragmentation of fuel rod	Yes, No	No	-	-
9	Failure time	s	-	3.33	-
10	Fuel enthalpy at failure	cal/g fuel	-	119	-
11	Outer cladding temperature at failure	K	-	1285	-
12	Internal gas pressure at failure	MPa	-	2.05	-
13	ZrO <sub>2</sub> thickness after test	μm	10-15	-	-
14	Residual clad hoop strain:				
	- peak value for ballooning area	%	24.0	64.66	-
	- other location <sup>1)</sup>	%	6.3	3.48	-
15	Kr concentration in internal gas composition after test	% by volume	-	2.11	-
16	Xe concentration in internal gas composition after test	% by volume	-	12.65	-
17	Kr concentration in fuel after test	cm <sup>3</sup> /g fuel	-	0.14	-

<sup>1)</sup> Calculated values by FRAP-T6 and SCANAIR codes are average along height of fuel rod excluding ballooning region

*APPENDIX G-13.*  
*Individual Characteristics for Fuel Rod #B13T under IGR Test*

#B13T

Individual Characteristics of Refabricated Fuel Rods  
(Preirradiated Fuel, Preirradiated Cladding) under IGR Tests

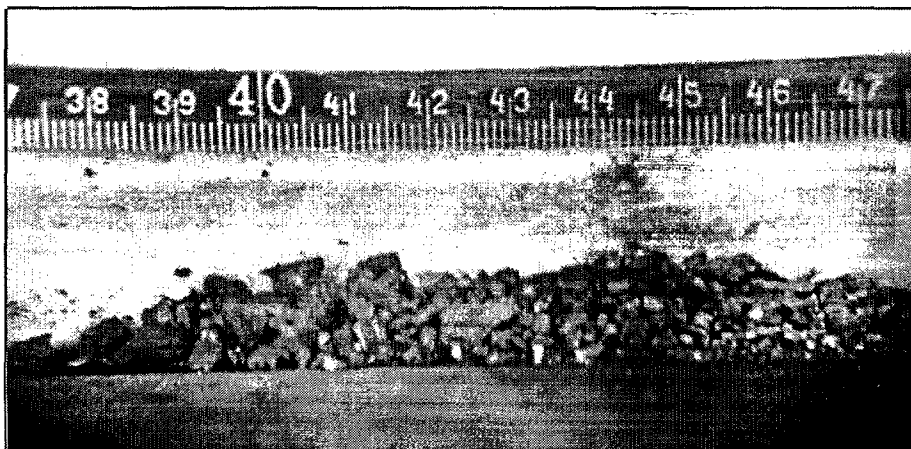
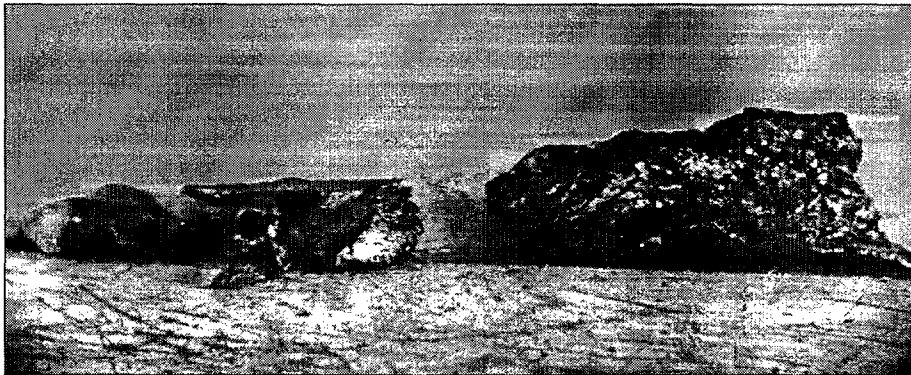
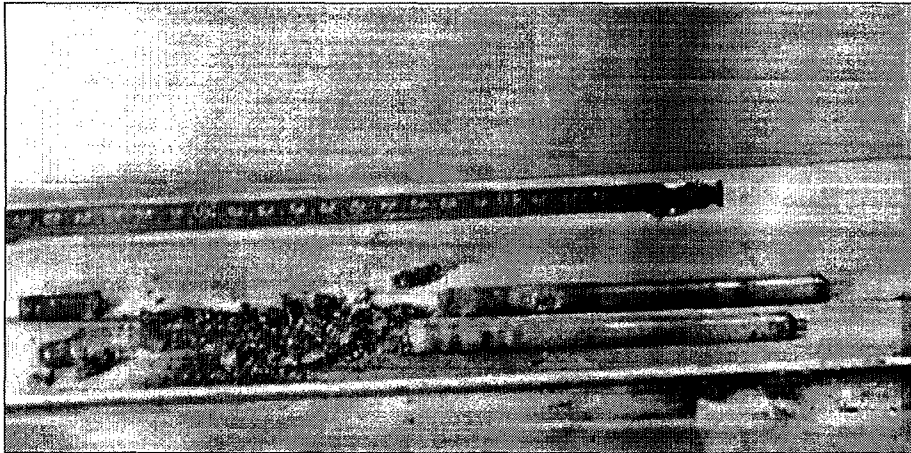
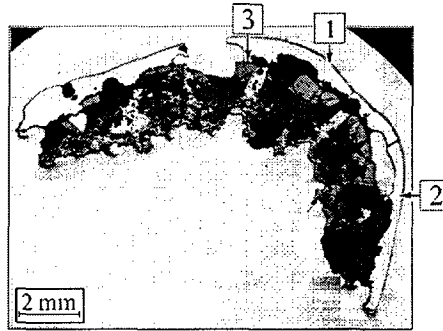

Fig. G-13.1. Appearance of Fuel Rod #B13T (photographs and X-ray photograph)

#B13T

Individual Characteristics of Refabricated Fuel Rods  
(Preirradiated Fuel, Preirradiated Cladding) under IGR Tests



Position 1



Position 2

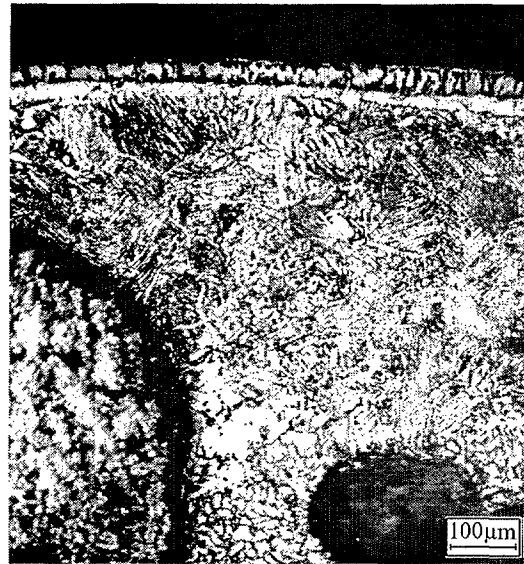

Position 3

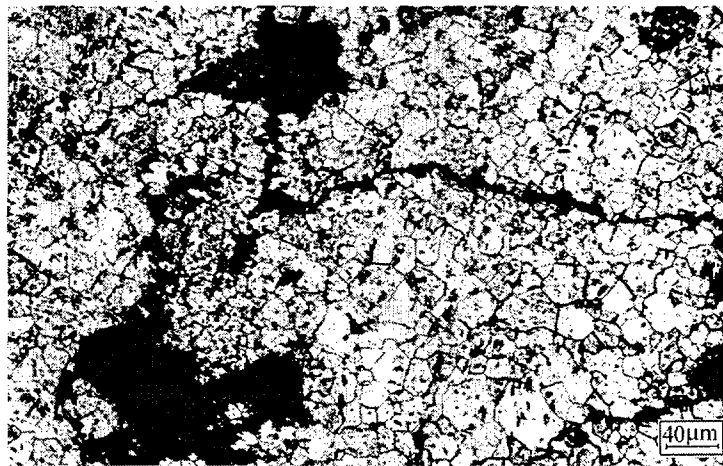

Fig. G-13.2. Cross-Section and Cladding Microstructure for Fragment of Fuel Rod #B13T

## #B13T

Individual Characteristics of Refabricated Fuel Rods  
(Preirradiated Fuel, Preirradiated Cladding) under IGR Tests

Table G-13.1. Time Dependent Energy Characteristics of Fuel Rod #B13T

Time (s)	Reactor energy deposition <sup>1)</sup> (%)	Cumulative number of fissions in fuel rod (fiss)						Power of fuel rod (kW)	Energy deposition in fuel rod	
		U <sup>235</sup> ×10 <sup>-14</sup>	U <sup>238</sup> ×10 <sup>-13</sup>	Pu <sup>239</sup> ×10 <sup>-14</sup>	Pu <sup>241</sup> ×10 <sup>-14</sup>	Other isotopes ×10 <sup>-11</sup>	Total ×10 <sup>-14</sup>		cal/g fuel	J/g fuel
0.0	0.000	0.000	0.000	0.000	0.000	0.000	0.000	0.000	0.000	0.000
1.0	0.680	0.085	0.027	0.109	0.037	0.118	0.234	1.340	2.680	11.20
2.0	4.090	0.512	0.161	0.655	0.223	0.707	1.410	7.540	16.10	67.40
2.2	6.020	0.755	0.237	0.964	0.328	1.040	2.070	11.90	23.80	99.60
2.4	9.140	1.150	0.360	1.460	0.498	1.580	3.140	19.50	36.10	151.0
2.6	14.30	1.790	0.564	2.290	0.780	2.470	4.930	32.60	56.50	237.0
2.8	23.00	2.880	0.904	3.680	1.250	3.970	7.900	53.90	90.60	379.0
3.0	36.50	4.570	1.440	5.840	1.990	6.310	12.60	78.70	144.0	603.0
3.2	53.30	6.680	2.100	8.530	2.900	9.210	18.30	82.30	210.0	879.0
3.4	68.60	8.590	2.700	11.00	3.740	11.80	23.60	66.20	271.0	1134.
3.6	79.50	9.970	3.130	12.70	4.330	13.70	27.40	42.10	314.0	1314.
3.8	85.90	10.80	3.380	13.80	4.680	14.90	29.60	22.80	340.0	1423.
4.0	89.30	11.20	3.520	14.30	4.870	15.40	30.70	12.00	353.0	1478.
4.2	91.10	11.40	3.590	14.60	4.960	15.70	31.30	6.890	360.0	1507.
4.4	92.20	11.60	3.630	14.80	5.020	15.90	31.70	4.530	365.0	1528.
4.6	92.90	11.60	3.660	14.90	5.060	16.10	32.00	3.410	368.0	1540.
4.8	93.50	11.70	3.680	15.00	5.100	16.20	32.20	2.870	370.0	1549.
5.0	94.00	11.80	3.700	15.10	5.120	16.20	32.30	2.600	373.0	1561.
5.2	94.50	11.80	3.720	15.10	5.150	16.30	32.50	2.400	375.0	1570.
5.4	94.90	11.90	3.740	15.20	5.170	16.40	32.70	2.110	376.0	1574.
5.6	95.30	11.90	3.750	15.30	5.190	16.50	32.80	1.790	378.0	1582.
5.8	95.60	12.00	3.760	15.30	5.210	16.50	32.90	1.530	379.0	1586.
6.0	95.90	12.00	3.770	15.30	5.220	16.60	33.00	1.320	380.0	1591.
6.5	96.30	12.10	3.790	15.40	5.250	16.60	33.10	0.960	383.0	1603.
7.0	96.70	12.10	3.810	15.50	5.270	16.70	33.30	0.741	384.0	1607.
7.5	97.00	12.10	3.820	15.50	5.280	16.80	33.40	0.602	386.0	1616.
8.0	97.20	12.20	3.830	15.60	5.290	16.80	33.40	0.510	387.0	1620.
9.0	97.60	12.20	3.840	15.60	5.320	16.90	33.60	0.437	389.0	1628.
10.0	97.90	12.30	3.850	15.70	5.330	16.90	33.70	0.350	390.0	1633.
20.0	99.20	12.40	3.900	15.90	5.400	17.10	34.10	0.091	397.0	1662.
30.0	99.60	12.50	3.920	15.90	5.420	17.20	34.20	0.048	400.0	1674.
∞	100.0	12.60	3.950	16.10	5.470	17.30	34.50	0.001	408.0	1708.

Maximum value of power is 84.2 kW (t = 3.10 s).

<sup>1)</sup> Current energy deposition per maximum energy deposition (at infinite time)



## #B13T

Individual Characteristics of Refabricated Fuel Rods  
(Preirradiated Fuel, Preirradiated Cladding) under IGR Tests

Table G-13.2. Axial Energy Characteristics of Fuel Rod #B13T

Axial coordinate from lower end of fuel rod (mm)	Cumulative number of fissions at axial interval (fiss)						Maximum power of fuel rod (kW) $t=3.10s$	Energy deposition at infinite time*		
	$U^{235} \times 10^{-13}$	$U^{238} \times 10^{-11}$	$Pu^{239} \times 10^{-13}$	$Pu^{241} \times 10^{-13}$	Other isotopes $\times 10^{-10}$	Total $\times 10^{-13}$		cal/g fuel	J/g fuel	per-unit <sup>3)</sup>
10.0	0.000	0.000	0.000	0.000	0.000	0.000	0.000	0.000	0.000	0.00
15.0	0.000	0.000	0.000	0.000	0.000	0.000	0.000	0.000	0.000	0.00
20.0 <sup>1)</sup>	2.440	7.910	3.180	1.100	3.620	6.800	1.660	405.0	1695.	0.97
25.0	4.140	13.20	5.330	1.820	6.000	11.40	2.790	407.0	1704.	0.98
30.0	4.200	13.40	5.420	1.850	5.980	11.60	2.830	407.0	1704.	0.98
35.0	4.220	13.50	5.450	1.860	5.970	11.70	2.850	406.0	1700.	0.97
40.0	4.440	14.20	5.750	1.970	5.960	12.30	3.000	406.0	1700.	0.97
45.0	4.500	14.70	5.910	2.040	5.940	12.60	3.070	404.0	1691.	0.97
50.0	4.220	13.80	5.550	1.910	5.940	11.80	2.890	404.0	1691.	0.97
55.0	4.050	13.20	5.320	1.830	5.940	11.30	2.770	404.0	1691.	0.97
60.0	4.070	13.30	5.350	1.840	5.960	11.40	2.780	404.0	1691.	0.97
65.0	4.050	13.30	5.350	1.850	5.960	11.40	2.780	403.0	1687.	0.97
70.0	3.930	12.90	5.200	1.800	5.960	11.10	2.700	403.0	1687.	0.97
75.0	4.060	12.80	5.170	1.760	5.970	11.10	2.720	409.0	1712.	0.98
80.0	4.220	13.30	5.360	1.820	5.980	11.50	2.820	409.0	1712.	0.98
85.0	4.140	13.30	5.380	1.840	5.980	11.50	2.810	405.0	1695.	0.97
90.0	4.210	13.50	5.460	1.870	6.000	11.70	2.850	405.0	1695.	0.97
95.0	4.400	13.70	5.530	1.870	6.010	11.90	2.910	411.0	1720.	0.99
100.0	4.450	13.80	5.580	1.890	6.010	12.10	2.940	411.0	1720.	0.99
105.0	4.440	13.90	5.620	1.900	6.010	12.10	2.950	409.0	1712.	0.98
110.0	4.440	13.90	5.620	1.900	6.010	12.10	2.950	409.0	1712.	0.98
115.0	4.360	13.90	5.610	1.920	6.000	12.00	2.940	407.0	1704.	0.98
120.0	4.340	13.80	5.590	1.910	5.990	12.00	2.920	407.0	1704.	0.98
125.0	4.320	13.70	5.550	1.890	5.980	11.90	2.900	407.0	1704.	0.98
130.0	4.310	13.70	5.520	1.880	5.960	11.90	2.890	408.0	1708.	0.98
135.0	4.390	13.60	5.510	1.870	5.930	11.90	2.900	410.0	1716.	0.98
140.0	4.380	13.60	5.500	1.860	5.890	11.90	2.900	410.0	1716.	0.98
145.0	4.430	13.60	5.520	1.860	5.850	11.90	2.910	412.0	1725.	0.99
150.0	4.460	13.70	5.560	1.870	5.790	12.00	2.930	412.0	1725.	0.99
155.0	4.520	13.60	5.530	1.850	5.740	12.00	2.940	415.0	1737.	0.995
160.0	2.130	5.610	2.590	0.850	2.540	5.620	1.370	417.0	1746.	1.00
165.0	2.130	5.610	2.590	0.850	2.540	5.620	1.370	417.0	1746.	1.00
170.0	2.130	5.610	2.590	0.850	2.540	5.620	1.370	417.0	1746.	1.00
175.0 <sup>2)</sup>	1.280	3.370	1.550	0.510	1.520	3.370	0.823	417.0	1746.	1.00
180.0	0.000	0.000	0.000	0.000	0.000	0.000	0.000	0.000	0.000	0.00
185.0	0.000	0.000	0.000	0.000	0.000	0.000	0.000	0.000	0.000	0.00

\* All numerical values of characteristics are presented as average values at the length interval equal to the axial coordinate  $\pm 2.5$  mm

1) Initial coordinate of fuel is 19.5 mm

2) End coordinate of fuel is 175.5 mm

3) Current value per maximum value.

## #B13T

Individual Characteristics of Refabricated Fuel Rods  
(Preirradiated Fuel, Preirradiated Cladding) under IGR Tests

Table G-13.3. Radial Energy Characteristics of Fuel Rod #B13T

Characteristics*		Coordinates of fuel zones (mm)			
		1 zone 1.2 - 2.811	2 zone 2.811-3.432	3 zone 3.432-3.704	4 zone 3.704-3.790
U <sup>235</sup>	Number of fissions $\times 10^{-14}$ (fiss)	5.970	3.530	1.740	0.569
	Power of fuel rod <sup>1)</sup> (kW)	14.30	8.460	4.170	1.360
	Energy deposition <sup>2)</sup> (cal/g fuel)	147.0	145.0	143.0	140.0
	Energy deposition <sup>2)</sup> (J/g fuel)	615.0	607.0	599.0	586.0
	Energy deposition <sup>3)</sup> (per-unit)	1.000	0.986	0.973	0.952
U <sup>238</sup>	Number of fissions $\times 10^{-12}$ (fiss)	19.40	11.20	5.290	1.640
	Power of fuel rod <sup>1)</sup> (kW)	0.459	0.264	0.125	0.039
	Energy deposition <sup>2)</sup> (cal/g fuel)	4.720	4.530	4.290	3.990
	Energy deposition <sup>2)</sup> (J/g fuel)	19.80	19.00	18.00	16.70
	Energy deposition <sup>3)</sup> (per-unit)	1.000	0.960	0.909	0.845
Pu <sup>239</sup>	Number of fissions $\times 10^{-14}$ (fiss)	6.250	4.260	2.940	1.690
	Power of fuel rod <sup>1)</sup> (kW)	15.50	10.50	7.280	4.190
	Energy deposition <sup>2)</sup> (cal/g fuel)	160.0	181.0	250.0	432.0
	Energy deposition <sup>2)</sup> (J/g fuel)	670.0	758.0	1047.	1808.
	Energy deposition <sup>3)</sup> (per-unit)	0.370	0.419	0.579	1.000
Pu <sup>241</sup>	Number of fissions $\times 10^{-13}$ (fiss)	20.20	14.50	10.50	6.350
	Power of fuel rod <sup>1)</sup> (kW)	4.930	3.530	2.560	1.550
	Energy deposition <sup>2)</sup> (cal/g fuel)	50.80	60.60	87.70	159.0
	Energy deposition <sup>2)</sup> (J/g fuel)	213.0	254.0	367.0	666.0
	Energy deposition <sup>3)</sup> (per-unit)	0.319	0.381	0.552	1.000
Other isotopes	Number of fissions $\times 10^{-11}$ (fiss)	7.490	4.760	2.830	1.350
	Power of fuel rod <sup>1)</sup> (kW)	0.018	0.012	0.007	0.003
	Energy deposition <sup>2)</sup> (cal/g fuel)	0.189	0.200	0.238	0.340
	Energy deposition <sup>2)</sup> (J/g fuel)	0.790	0.840	1.000	1.420
	Energy deposition <sup>3)</sup> (per-unit)	0.556	0.588	0.700	1.000
Total	Number of fissions $\times 10^{-14}$ (fiss)	14.50	9.360	5.790	2.910
	Power of fuel rod <sup>1)</sup> (kW)	35.30	22.80	14.10	7.110
	Energy deposition <sup>2)</sup> (cal/g fuel)	363.0	391.0	484.0	731.0
	Energy deposition <sup>2)</sup> (J/g fuel)	1520.	1637.	2026.	3060.
	Energy deposition <sup>3)</sup> (per-unit)	0.497	0.535	0.662	1.000

<sup>1)</sup> at time of 3.10 s, <sup>2)</sup> at infinite time, <sup>3)</sup> Current value per maximum value.

\* All numerical values of characteristics were calculated for undamaged part of fuel stack only (See Table C.2.3.)

# #B13T

Individual Characteristics of Refabricated Fuel Rods  
(Preirradiated Fuel, Preirradiated Cladding) under IGR Tests

Table G-13.4. Fuel Enthalpy Vs. Time Calculated by FRAP-T6 Code for Fuel Rod #B13T

Time (s)	Enthalpy at fuel radius (cal/g fuel)				Fuel enthalpy <sup>1)</sup>		Energy deposition in fuel rod	
	1.20 mm	2.82 mm	3.47 mm	3.79 mm	cal/g fuel	J/g fuel	cal/g fuel	J/g fuel
0.0	0.00	0.00	0.00	0.00	0.00	0.00	0.00	0.00
1.0	2.56	2.55	2.48	2.37	2.53	10.6	2.69	11.3
2.0	15.0	14.8	14.2	13.4	14.6	61.4	16.2	67.8
2.2	22.1	21.8	20.9	19.4	21.5	90.3	23.8	99.9
2.4	33.5	33.1	31.4	28.5	32.6	137	36.2	152
2.6	52.6	52.0	48.5	41.9	50.8	213	56.7	237
2.8	84.4	83.4	75.4	60.7	80.6	338	90.9	381
3.0	134	132	111	74.9	125	523	144	605
3.2	196	191	176	163	188	787	211	883
3.4	253	247	233	210	243	1020	271	1136
3.6	-	-	-	-	-	-	314	1317
3.8	-	-	-	-	-	-	340	1424
4.0	-	-	-	-	-	-	353	1480
4.2	-	-	-	-	-	-	361	1511
4.4	-	-	-	-	-	-	365	1529
4.6	-	-	-	-	-	-	368	1542
4.8	-	-	-	-	-	-	371	1553
5.0	-	-	-	-	-	-	373	1562
5.2	-	-	-	-	-	-	375	1570
5.4	-	-	-	-	-	-	377	1578
5.6	-	-	-	-	-	-	378	1584
5.8	-	-	-	-	-	-	379	1590
6.0	-	-	-	-	-	-	381	1595
6.5	-	-	-	-	-	-	383	1604
7.0	-	-	-	-	-	-	385	1611
7.5	-	-	-	-	-	-	386	1617
8.0	-	-	-	-	-	-	387	1622
10.0	-	-	-	-	-	-	390	1636
30.0	-	-	-	-	-	-	400	1678

Radial enthalpy distribution and fuel enthalpy are presented at elevation 167.7 mm

Maximum value of fuel enthalpy is 243.5 cal/g fuel (t=3.40 s)

<sup>1)</sup> All numerical values are presented at elevation with peak power

# #B13T

Individual Characteristics of Refabricated Fuel Rods  
(Preirradiated Fuel, Preirradiated Cladding) under IGR Tests

Table G-13.5. Energy Characteristics Vs. Time Calculated by FRAP-T6 and SCANAIR Codes for Fuel Rod #B13T

Time (s)	Energy deposition <sup>1)</sup> (cal/g fuel)	Linear power <sup>1)</sup> (kW/m)	Fuel enthalpy <sup>1)</sup> (cal/g fuel)		Leakage of energy <sup>1)</sup> (cal/g fuel)		Clad-to-coolant heat transfer coefficient <sup>1)</sup> (kW/m <sup>2</sup> K)	
			FRAP-T6	SCANAIR	FRAP-T6	SCANAIR	FRAP-T6	SCANAIR
0.0	0.00	0.00	0.00	0.00	0.00	0.00	0.00	0.00
1.0	2.74	9.76	2.53	2.42	0.00	0.00	0.01	0.01
2.0	16.5	55.0	14.6	14.1	0.01	0.01	0.01	0.01
2.2	24.3	86.8	21.5	20.8	0.01	0.01	0.01	0.01
2.4	36.8	142	32.6	31.5	0.02	0.02	0.01	0.01
2.6	57.7	238	50.8	49.3	0.03	0.03	0.02	0.02
2.8	92.5	393	80.6	78.8	0.07	0.06	0.03	0.03
3.0	147	573	125	124	0.18	0.16	0.06	0.05
3.2	214	598	188	-	0.42	-	0.09	-
3.4	276	481	243	-	0.85	-	0.12	-
3.6	320	305	-	-	-	-	-	-
3.8	346	165	-	-	-	-	-	-
4.0	359	87.0	-	-	-	-	-	-
4.2	367	50.0	-	-	-	-	-	-
4.4	371	32.9	-	-	-	-	-	-
4.6	375	24.8	-	-	-	-	-	-
4.8	377	20.9	-	-	-	-	-	-
5.0	379	18.9	-	-	-	-	-	-
5.2	381	17.4	-	-	-	-	-	-
5.4	383	15.3	-	-	-	-	-	-
5.6	385	13.0	-	-	-	-	-	-
5.8	386	11.1	-	-	-	-	-	-
6.0	387	9.59	-	-	-	-	-	-
6.5	390	6.98	-	-	-	-	-	-
7.0	391	5.39	-	-	-	-	-	-
7.5	393	4.38	-	-	-	-	-	-
8.0	394	3.71	-	-	-	-	-	-
10.0	397	2.55	-	-	-	-	-	-
30.0	409	1.23	-	-	-	-	-	-

<sup>1)</sup> All numerical values are presented at elevation with peak power

# #B13T

Individual Characteristics of Refabricated Fuel Rods  
(Preirradiated Fuel, Preirradiated Cladding) under IGR Tests

Table G-13.6. Temperature Variation, Fission Gas Release and ZrO<sub>2</sub> Thickness Vs. Time for Fuel Rod #B13T Calculated by FRAP-T6 and SCANAIR Codes

Time (s)	Fuel centerline temperature <sup>1)</sup> (K)		Fuel surface temperature <sup>1)</sup> (K)		Clad outer temperature <sup>1)</sup> (K)		Fission gas release (%)	
	FRAP-T6	SCANAIR	FRAP-T6	SCANAIR	FRAP-T6	SCANAIR	FRAP-T6	SCANAIR
0.0	293	293	293	293	293	293	0.00	0.00
1.0	337	332	334	331	307	306	0.10	0.29
2.0	530	510	506	498	395	389	0.40	1.12
2.2	632	605	593	586	442	434	0.63	1.38
2.4	791	753	722	719	517	504	1.05	1.89
2.6	1048	989	905	921	644	621	1.86	2.38
2.8	1461	1367	1155	1215	868	818	3.64	2.84
3.0	2056	1924	1340	1564	1171	1126	6.47	4.18
3.2	2632	-	2346	-	1368	-	10.8	-
3.4	3014	-	2734	-	1596	-	17.8	-
3.6	-	-	-	-	-	-	-	-
3.8	-	-	-	-	-	-	-	-
4.0	-	-	-	-	-	-	-	-
4.2	-	-	-	-	-	-	-	-
4.4	-	-	-	-	-	-	-	-
4.6	-	-	-	-	-	-	-	-
4.8	-	-	-	-	-	-	-	-
5.0	-	-	-	-	-	-	-	-
5.2	-	-	-	-	-	-	-	-
5.4	-	-	-	-	-	-	-	-
5.6	-	-	-	-	-	-	-	-
5.8	-	-	-	-	-	-	-	-
6.0	-	-	-	-	-	-	-	-
6.5	-	-	-	-	-	-	-	-
7.0	-	-	-	-	-	-	-	-
7.5	-	-	-	-	-	-	-	-
8.0	-	-	-	-	-	-	-	-
10.0	-	-	-	-	-	-	-	-
30.0	-	-	-	-	-	-	-	-

<sup>1)</sup> All numerical values are presented at elevation with peak power

# #B13T

Individual Characteristics of Refabricated Fuel Rods  
(Preirradiated Fuel, Preirradiated Cladding) under IGR Tests

Table G-13.7. Mechanical Characteristics of Fuel Rod #B13T Vs. Time Calculated by FRAP-T6 and SCANAIR Codes

Time (s)	Clad outer temperature <sup>1)</sup> (K)		Fuel hoop strain <sup>1)</sup> (%)		Fuel - clad gap width <sup>1)</sup> (mm)		Clad hoop strain <sup>1)</sup> (%)		Clad hoop stress <sup>1)</sup> (MPa)		Internal gas pressure (MPa)	
	FRAP-T6	SCANAIR	FRAP-T6	SCANAIR	FRAP-T6	SCANAIR	FRAP-T6	SCANAIR	FRAP-T6	SCANAIR	FRAP-T6	SCANAIR
0.0	293	293	0.00	0.00	0.07	0.07	0.01	0.01	8.97	8.70	1.70	1.70
1.0	307	306	0.11	0.03	0.07	0.07	0.02	0.02	9.20	8.92	1.74	1.74
2.0	395	389	0.42	0.16	0.06	0.07	0.08	0.08	9.83	9.59	1.85	1.85
2.2	442	434	0.59	0.24	0.05	0.07	0.11	0.12	10.1	9.83	1.89	1.88
2.4	517	504	0.87	0.37	0.04	0.06	0.16	0.17	10.3	10.1	1.94	1.93
2.6	644	621	1.32	0.61	0.03	0.06	0.25	0.26	10.7	10.5	2.00	1.97
2.8	868	818	2.11	1.05	0.00	0.05	0.41	0.42	11.1	10.8	2.08	2.02
3.0	1171	1126	3.35	2.12	0.00	0.01	1.32	0.58	13.9	10.7	2.18	2.07
3.2	1368	-	4.93	-	0.68	-	19.3	-	0.00	-	0.10	-
3.4	1596	-	5.95	-	0.64	-	19.5	-	0.00	-	0.10	-
3.6	-	-	-	-	-	-	-	-	-	-	-	-
3.8	-	-	-	-	-	-	-	-	-	-	-	-
4.0	-	-	-	-	-	-	-	-	-	-	-	-
4.2	-	-	-	-	-	-	-	-	-	-	-	-
4.4	-	-	-	-	-	-	-	-	-	-	-	-
4.6	-	-	-	-	-	-	-	-	-	-	-	-
4.8	-	-	-	-	-	-	-	-	-	-	-	-
5.0	-	-	-	-	-	-	-	-	-	-	-	-
5.2	-	-	-	-	-	-	-	-	-	-	-	-
5.4	-	-	-	-	-	-	-	-	-	-	-	-
5.6	-	-	-	-	-	-	-	-	-	-	-	-
5.8	-	-	-	-	-	-	-	-	-	-	-	-
6.0	-	-	-	-	-	-	-	-	-	-	-	-
6.5	-	-	-	-	-	-	-	-	-	-	-	-
7.0	-	-	-	-	-	-	-	-	-	-	-	-
7.5	-	-	-	-	-	-	-	-	-	-	-	-
8.0	-	-	-	-	-	-	-	-	-	-	-	-
10.0	-	-	-	-	-	-	-	-	-	-	-	-
30.0	-	-	-	-	-	-	-	-	-	-	-	-

<sup>1)</sup> All numerical values are presented at elevation with peak power

# #B13T

Individual Characteristics of Refabricated Fuel Rods  
(Preirradiated Fuel, Preirradiated Cladding) under IGR Tests

Table G-13.7. Mechanical Characteristics of Fuel Rod #B13T Vs. Time Calculated by FRAP-T6 and SCANAIR Codes

Time (s)	Clad outer temperature <sup>1)</sup> (K)		Fuel hoop strain <sup>1)</sup> (%)		Fuel - clad gap width <sup>1)</sup> (mm)		Clad hoop strain <sup>1)</sup> (%)		Clad hoop stress <sup>1)</sup> (MPa)		Internal gas pressure (MPa)	
	FRAP-T6	SCANAIR	FRAP-T6	SCANAIR	FRAP-T6	SCANAIR	FRAP-T6	SCANAIR	FRAP-T6	SCANAIR	FRAP-T6	SCANAIR
0.0	293	293	0.00	0.00	0.07	0.07	0.01	0.01	8.97	8.70	1.70	1.70
1.0	307	306	0.11	0.03	0.07	0.07	0.02	0.02	9.20	8.92	1.74	1.74
2.0	395	389	0.42	0.16	0.06	0.07	0.08	0.08	9.83	9.59	1.85	1.85
2.2	442	434	0.59	0.24	0.05	0.07	0.11	0.12	10.1	9.83	1.89	1.88
2.4	517	504	0.87	0.37	0.04	0.06	0.16	0.17	10.3	10.1	1.94	1.93
2.6	644	621	1.32	0.61	0.03	0.06	0.25	0.26	10.7	10.5	2.00	1.97
2.8	868	818	2.11	1.05	0.00	0.05	0.41	0.42	11.1	10.8	2.08	2.02
3.0	1171	1126	3.35	2.12	0.00	0.01	1.32	0.58	13.9	10.7	2.18	2.07
3.2	1368	-	4.93	-	0.68	-	19.3	-	0.00	-	0.10	-
3.4	1596	-	5.95	-	0.64	-	19.5	-	0.00	-	0.10	-
3.6	-	-	-	-	-	-	-	-	-	-	-	-
3.8	-	-	-	-	-	-	-	-	-	-	-	-
4.0	-	-	-	-	-	-	-	-	-	-	-	-
4.2	-	-	-	-	-	-	-	-	-	-	-	-
4.4	-	-	-	-	-	-	-	-	-	-	-	-
4.6	-	-	-	-	-	-	-	-	-	-	-	-
4.8	-	-	-	-	-	-	-	-	-	-	-	-
5.0	-	-	-	-	-	-	-	-	-	-	-	-
5.2	-	-	-	-	-	-	-	-	-	-	-	-
5.4	-	-	-	-	-	-	-	-	-	-	-	-
5.6	-	-	-	-	-	-	-	-	-	-	-	-
5.8	-	-	-	-	-	-	-	-	-	-	-	-
6.0	-	-	-	-	-	-	-	-	-	-	-	-
6.5	-	-	-	-	-	-	-	-	-	-	-	-
7.0	-	-	-	-	-	-	-	-	-	-	-	-
7.5	-	-	-	-	-	-	-	-	-	-	-	-
8.0	-	-	-	-	-	-	-	-	-	-	-	-
10.0	-	-	-	-	-	-	-	-	-	-	-	-
30.0	-	-	-	-	-	-	-	-	-	-	-	-

<sup>1)</sup> All numerical values are presented at elevation with peak power

# #B13T

Individual Characteristics of Refabricated Fuel Rods  
(Preirradiated Fuel, Preirradiated Cladding) under IGR Tests

**Table G-13.8. Axial Distribution of Energy Deposition and Fuel Enthalpy Calculated by FRAP-T6 Code for Fuel Rod #B13T**

Axial interval from-to (mm)-(mm)	Energy deposition at infinite time			Fuel enthalpy at time (t=3.40 s)		
	cal/g fuel	J/g fuel	per-unit	cal/g fuel	J/g fuel	per-unit
19.5 - 35.1	406	1701	0.97	239	1000	0.98
35.1 - 50.7	405	1697	0.97	238	996	0.98
50.7 - 66.3	404	1692	0.97	237	991	0.97
66.3 - 81.9	406	1702	0.97	239	1000	0.98
81.9 - 97.5	407	1706	0.98	237	994	0.97
97.5 - 113.1	409	1715	0.98	239	1000	0.98
113.1 - 128.7	407	1706	0.98	239	1000	0.98
128.7 - 144.3	410	1717	0.98	239	1000	0.98
144.3 - 159.9	414	1734	0.99	241	1010	0.99
159.9 - 175.5	417	1747	1.00	243	1020	1.00

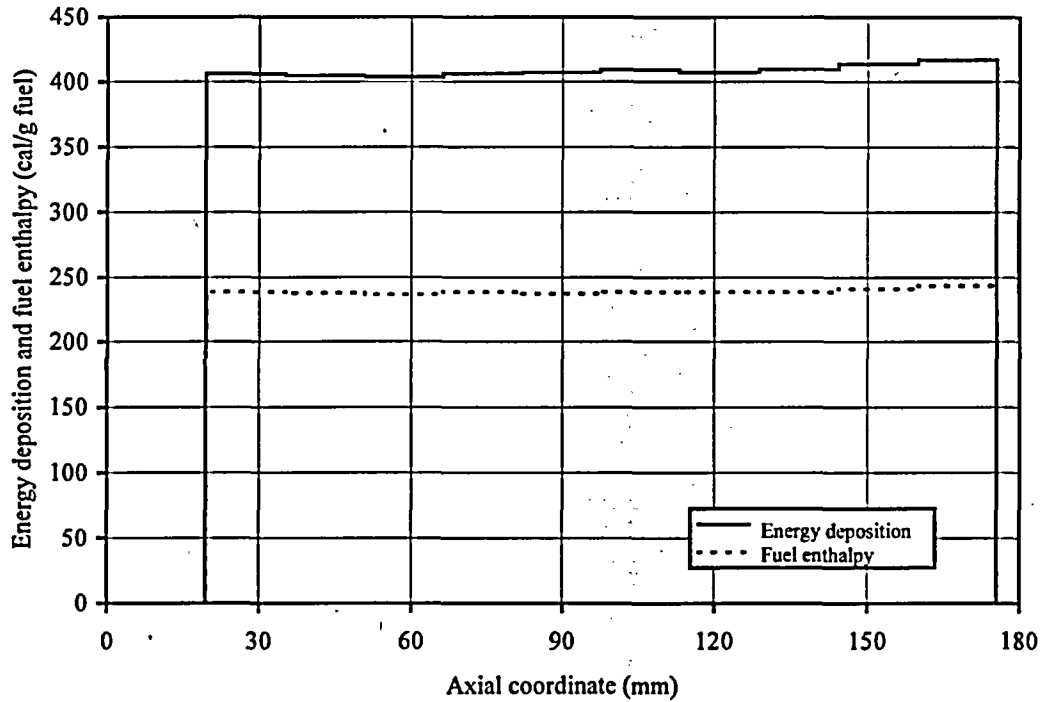

**Fig. G-13.3. Axial Distribution of Energy Deposition and Fuel Enthalpy Calculated by FRAP-T6 Code for Fuel Rod #B13T**



#B13T

Individual Characteristics of Refabricated Fuel Rods  
(Preirradiated Fuel, Preirradiated Cladding) under IGR Tests

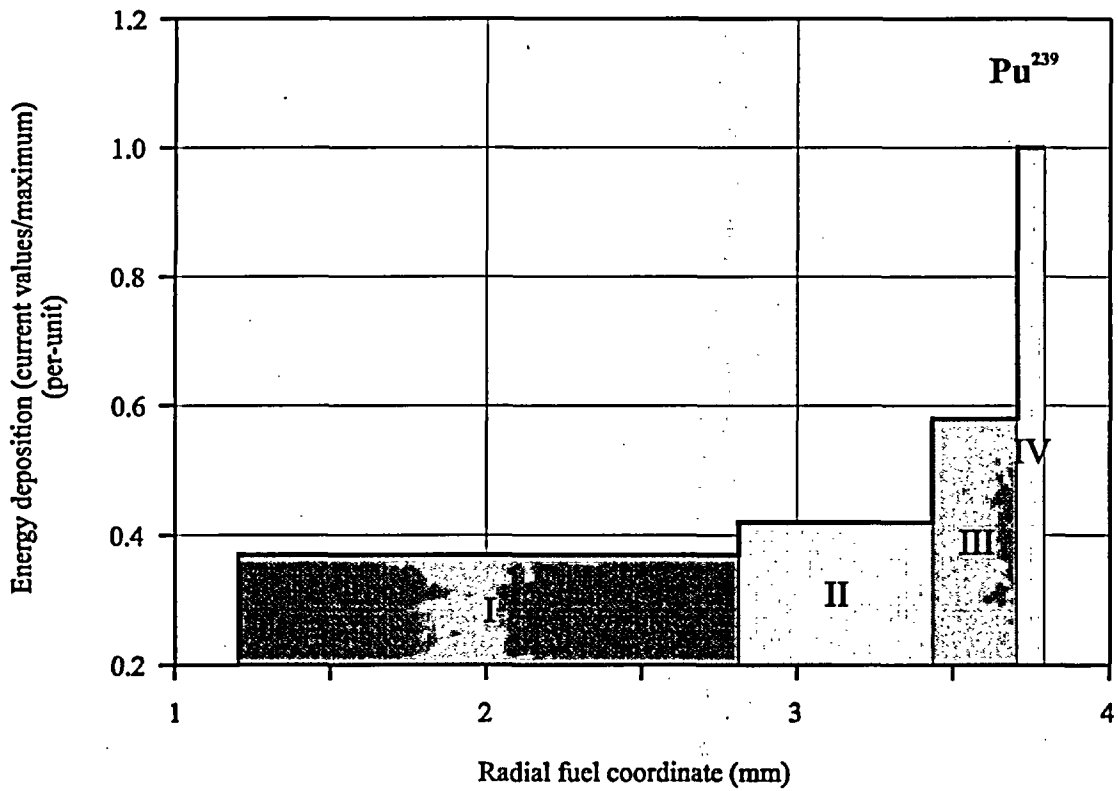
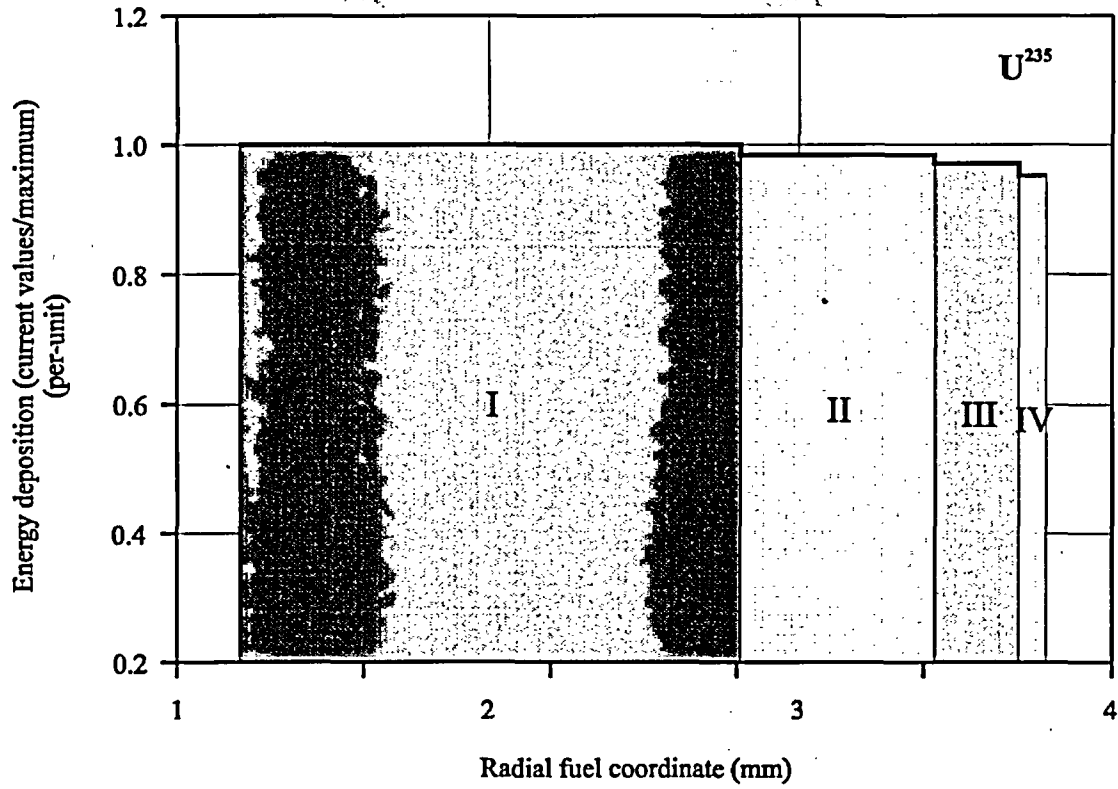

Fig. G-13.4. U<sup>235</sup> and Pu<sup>239</sup> Radial Distributions of Energy Deposition for Fuel Rod #B13T

#B13T

Individual Characteristics of Refabricated Fuel Rods  
(Preirradiated Fuel, Preirradiated Cladding) under IGR Tests

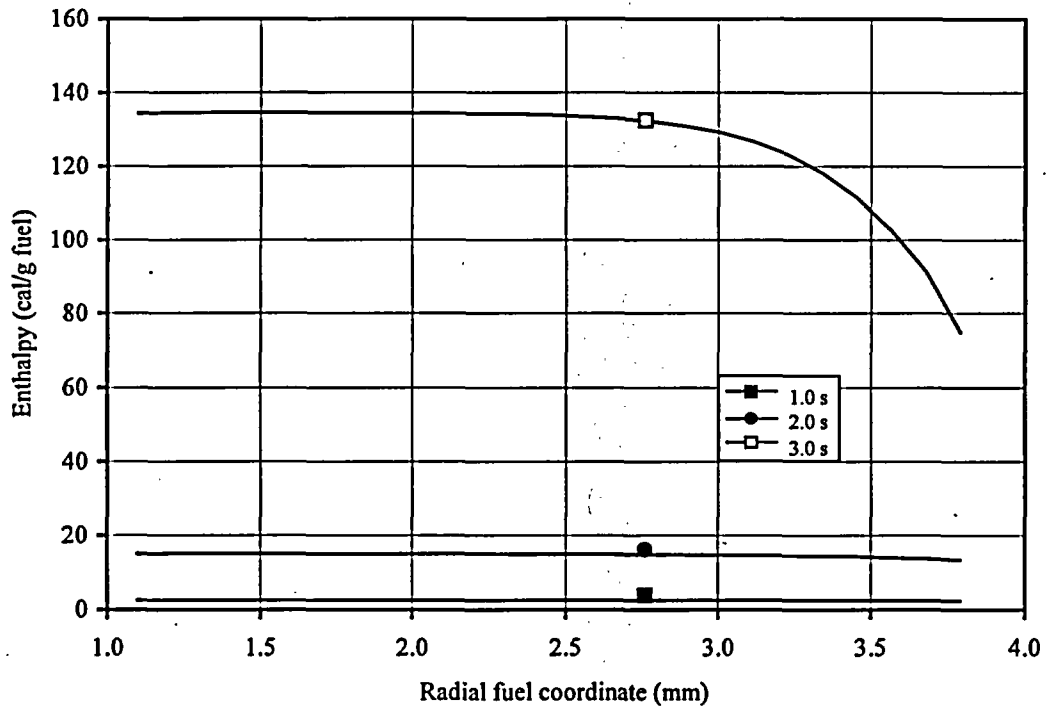
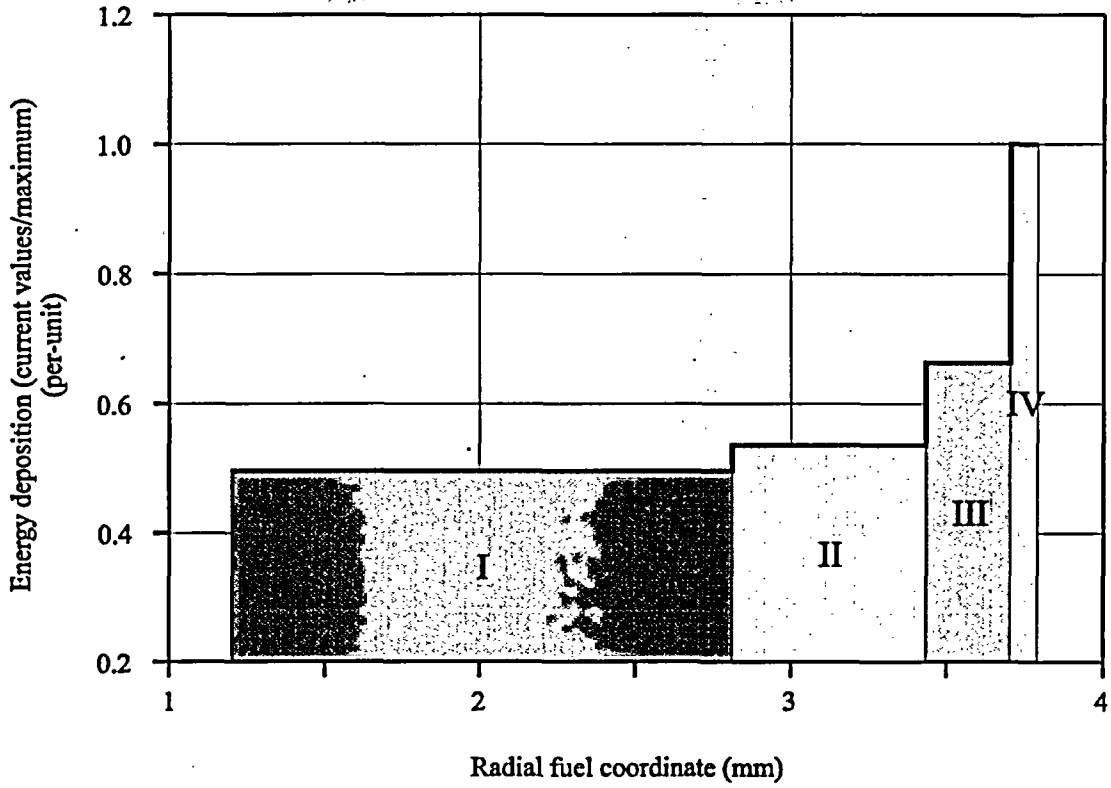

Fig. G-13.5. Radial Distributions of Energy Deposition and Fuel Enthalpy Calculated by FRAP-T6 Code for Fuel Rod #B13T

#B13T

Individual Characteristics of Refabricated Fuel Rods  
(Preirradiated Fuel, Preirradiated Cladding) under IGR Tests

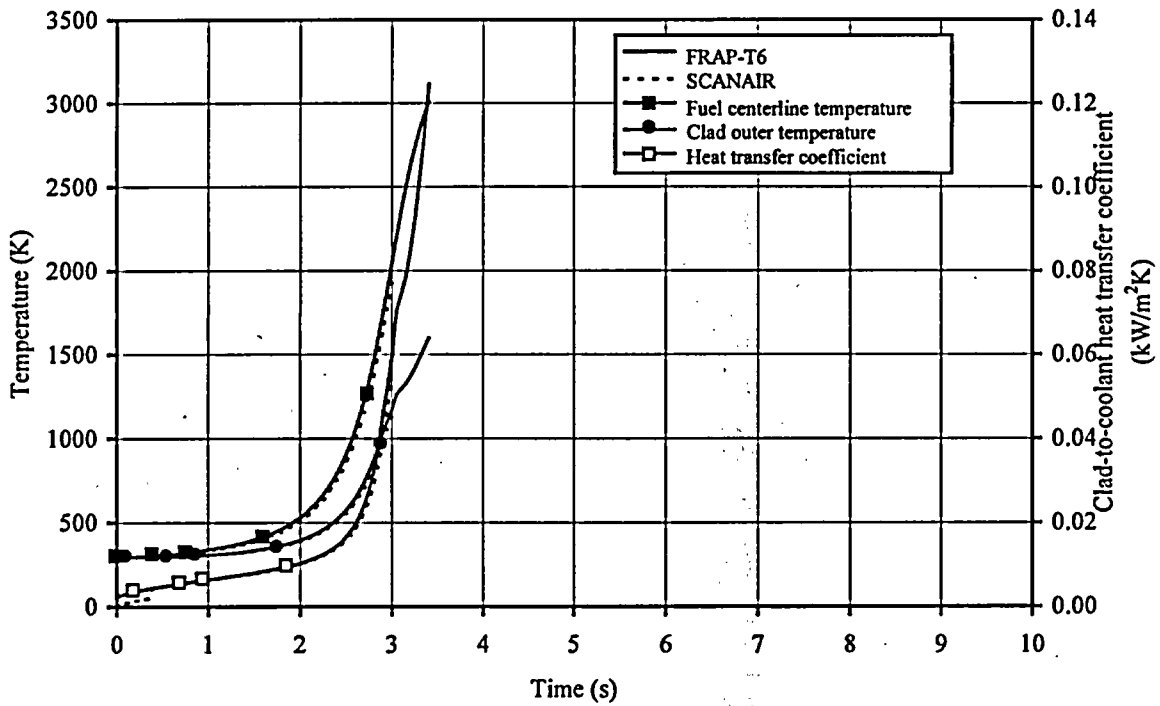
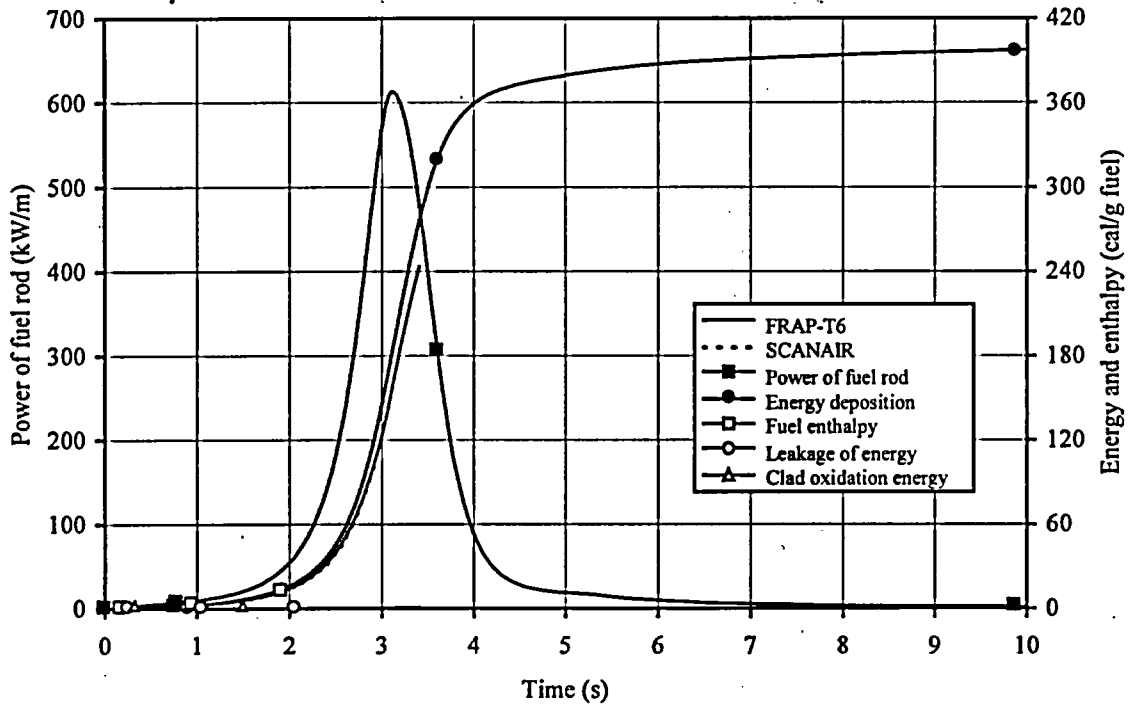

Fig. G-13.6. Energy and Temperature Characteristics Vs. Time Calculated by FRAP-T6 and SCANAIR Codes for Fuel Rod #B13T

#B13T

Individual Characteristics of Refabricated Fuel Rods  
(Preirradiated Fuel, Preirradiated Cladding) under IGR Tests

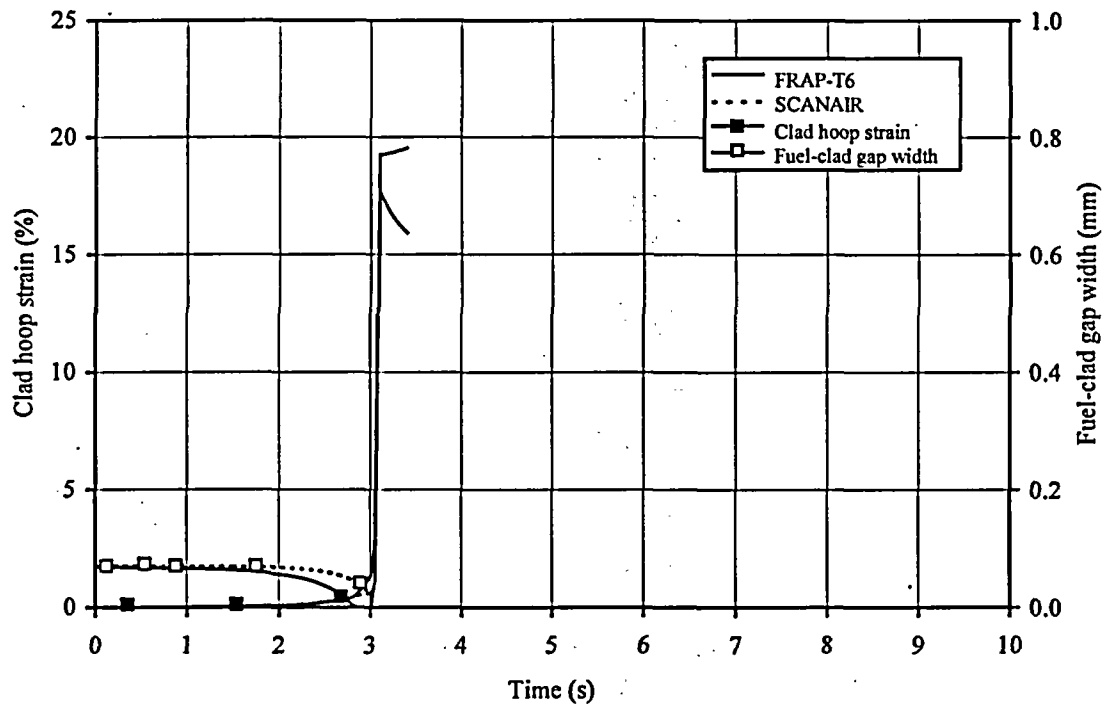
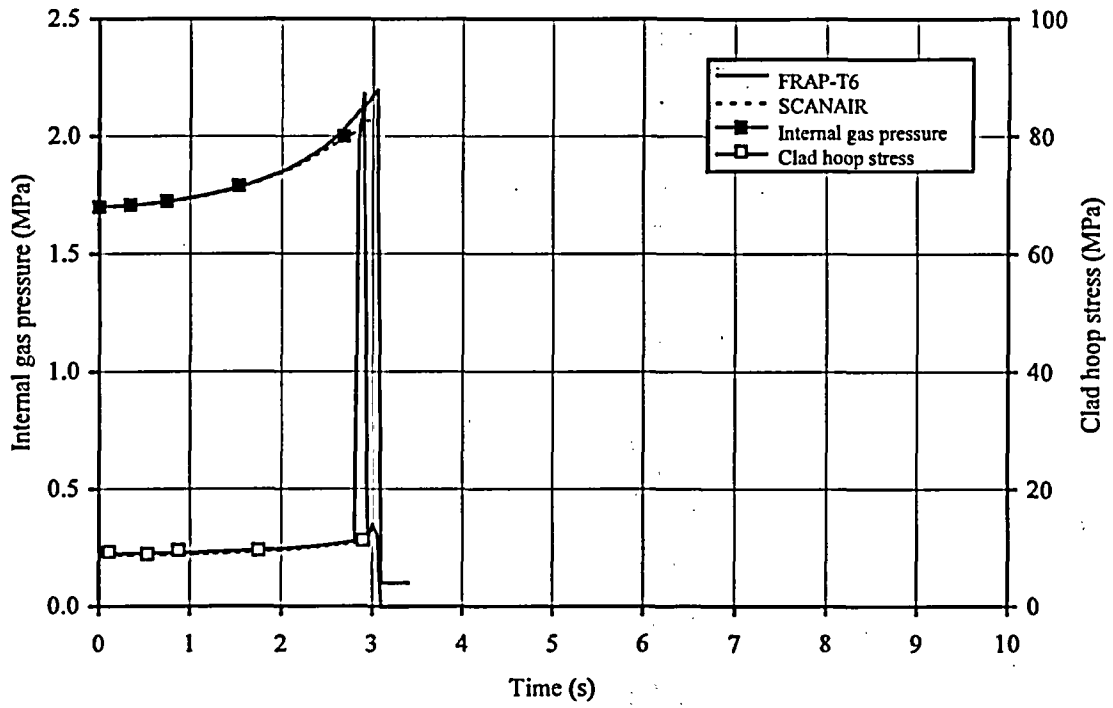

Fig. G-13.7. Cladding Mechanical Characteristics Vs. Time Calculated by FRAP-T6 and SCANAIR Codes for Fuel Rod #B13T

#B13T

Individual Characteristics of Refabricated Fuel Rods  
(Preirradiated Fuel, Preirradiated Cladding) under IGR Tests

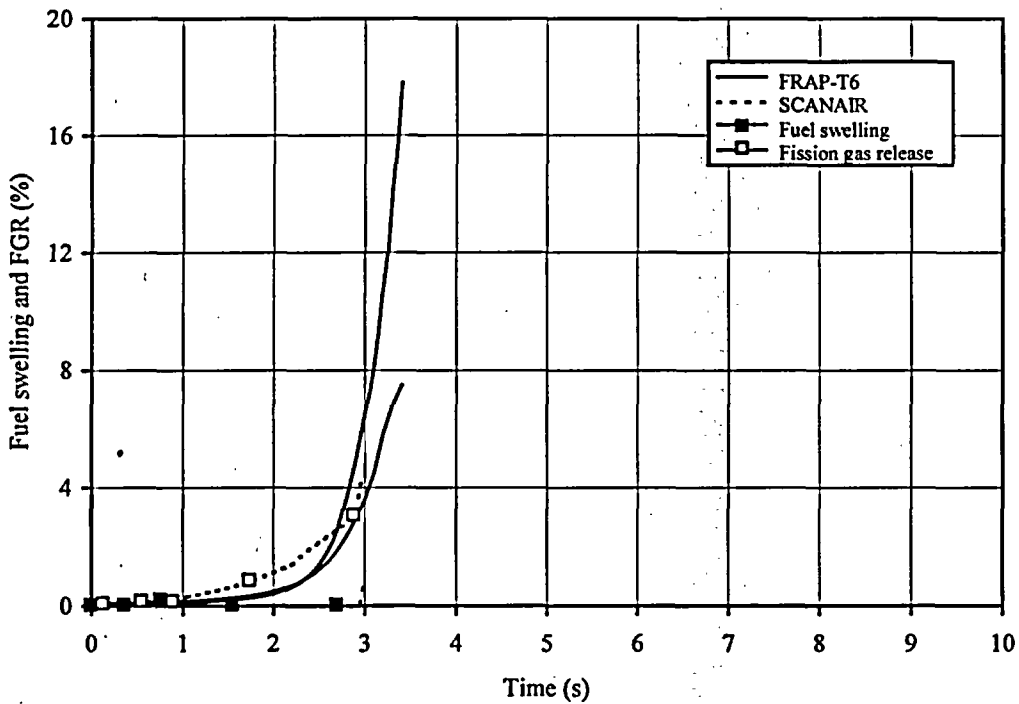
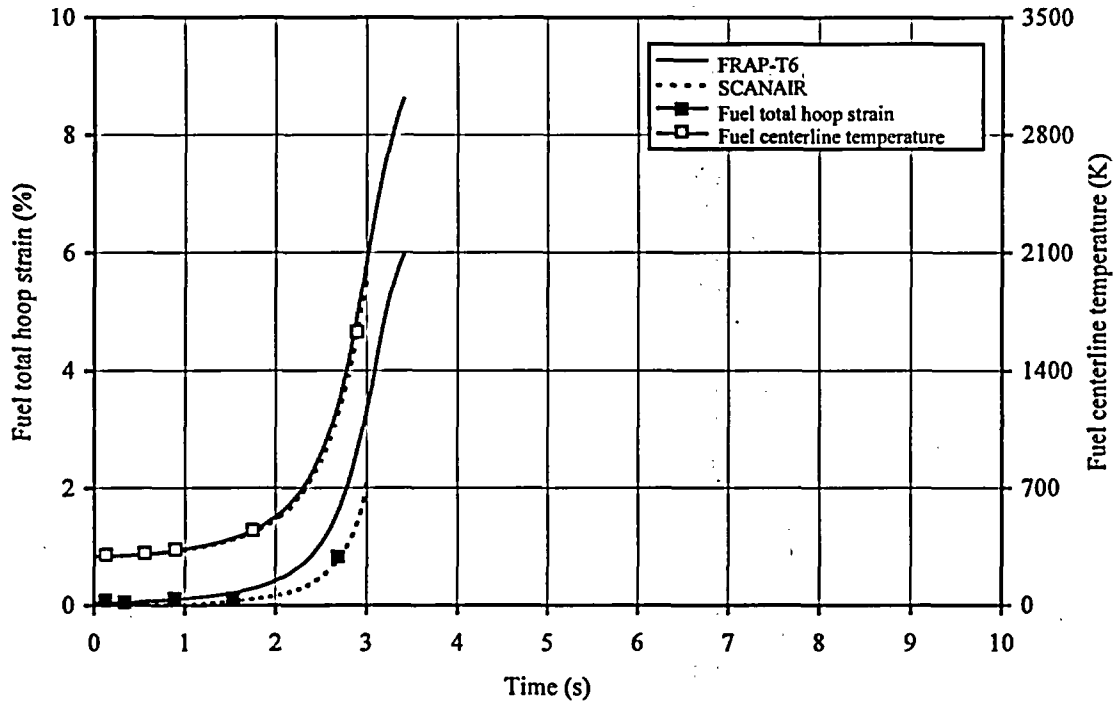

Fig. G-13.8. Fuel Strain and Fission Gas Release Vs. Time Calculated by FRAP-T6 and SCANAIR Codes for Fuel Rod #B13T

## #B13T

Individual Characteristics of Refabricated Fuel Rods  
(Preirradiated Fuel, Preirradiated Cladding) under IGR Tests

Table G-13.9. General Characteristic of Fuel Rod #B13T

	Parameter	Unit	Value		
			Experiment	FRAP-T6	SCANAIR
1	Type of coolant	---	air	air	air
2	Burnup	MWd/kg U	41.0	41.0	41.0
3	Energy deposition in fuel rod	cal/g fuel	408	408	408
4	Peak fuel enthalpy	cal/g fuel	-	-	-
5	Peak fuel temperature	K	-	-	-
6	Peak clad temperature	K	-	-	-
7	Fuel rod failure	Yes, No	Yes	Yes	-
8	Type of failure:				
	- cladding rupture due to ballooning	Yes, No	?	Yes	-
	- cladding rupture due to PCMI	Yes, No	?	No	-
	- fragmentation of fuel rod	Yes, No	Yes	-	-
9	Failure time	s	-	3.05	-
10	Fuel enthalpy at failure	cal/g fuel	-	139	-
11	Outer cladding temperature at failure	K	-	1263	-
12	Internal gas pressure at failure	MPa	-	2.20	-
13	ZrO <sub>2</sub> thickness after test	μm	-	-	-
14	Residual clad hoop strain:				
	- peak value for ballooning area	%	-	18.92	-
	- other location <sup>1)</sup>	%	-	-	-
15	Kr concentration in internal gas composition after test	% by volume	-	7.97	-
16	Xe concentration in internal gas composition after test	% by volume	-	47.74	-
17	Kr concentration in fuel after test	cm <sup>3</sup> /g fuel	-	0.11	-

<sup>1)</sup>Calculated values by FRAP-T6 and SCANAIR codes are average along height of fuel rod excluding ballooning region

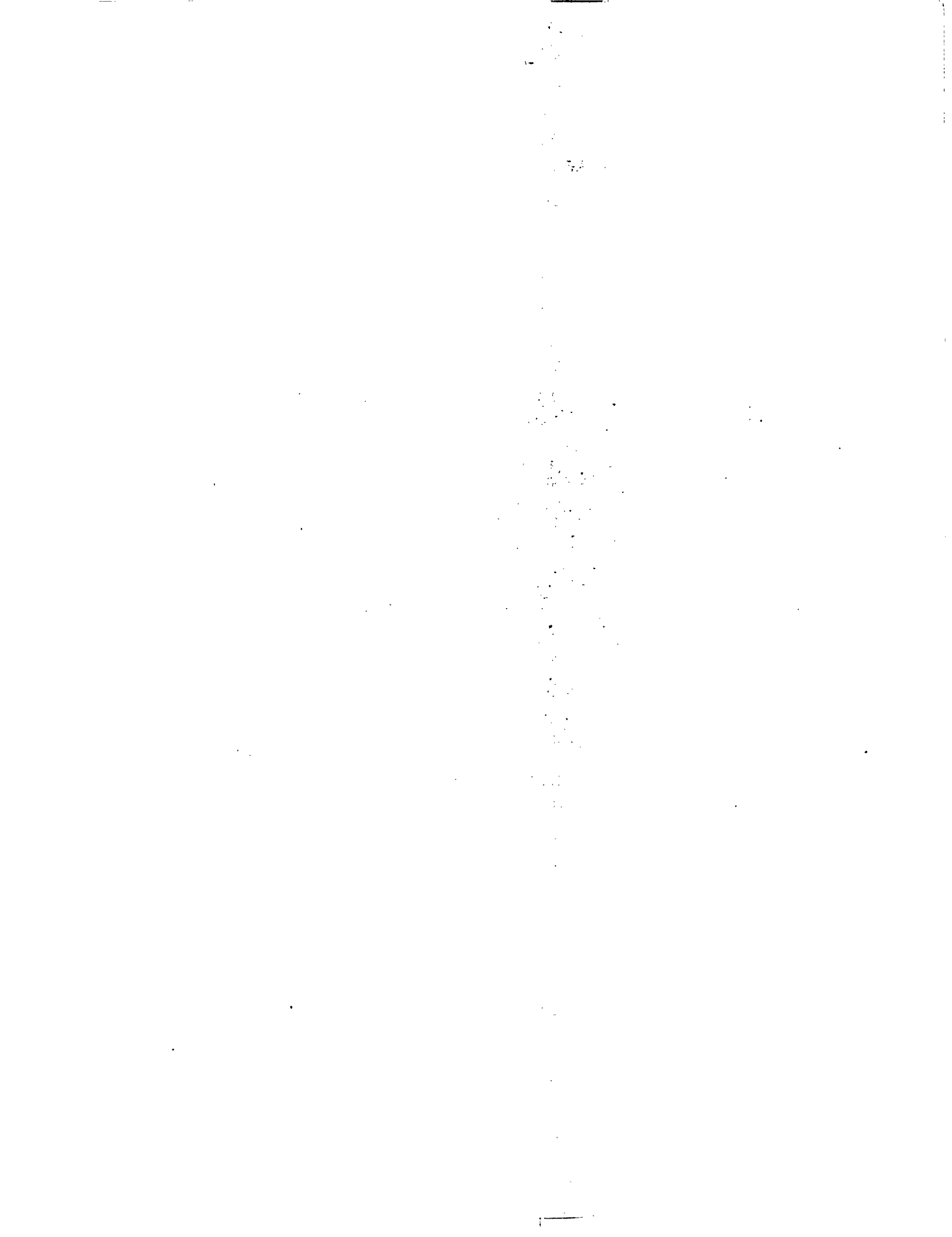

**APPENDIX H.**

**Characteristics of Refabricated Fuel Rods**

**(Fresh Fuel, Preirradiated Cladding)**

**during and after IGR Reactor Tests**

***APPENDIX H-1.***

***Individual Characteristics for Fuel Rod #H14T under IGR Test***



# #H14T

Individual Characteristics of Refabricated Fuel Rods  
(Fresh Fuel, Preirradiated Cladding) under IGR Tests

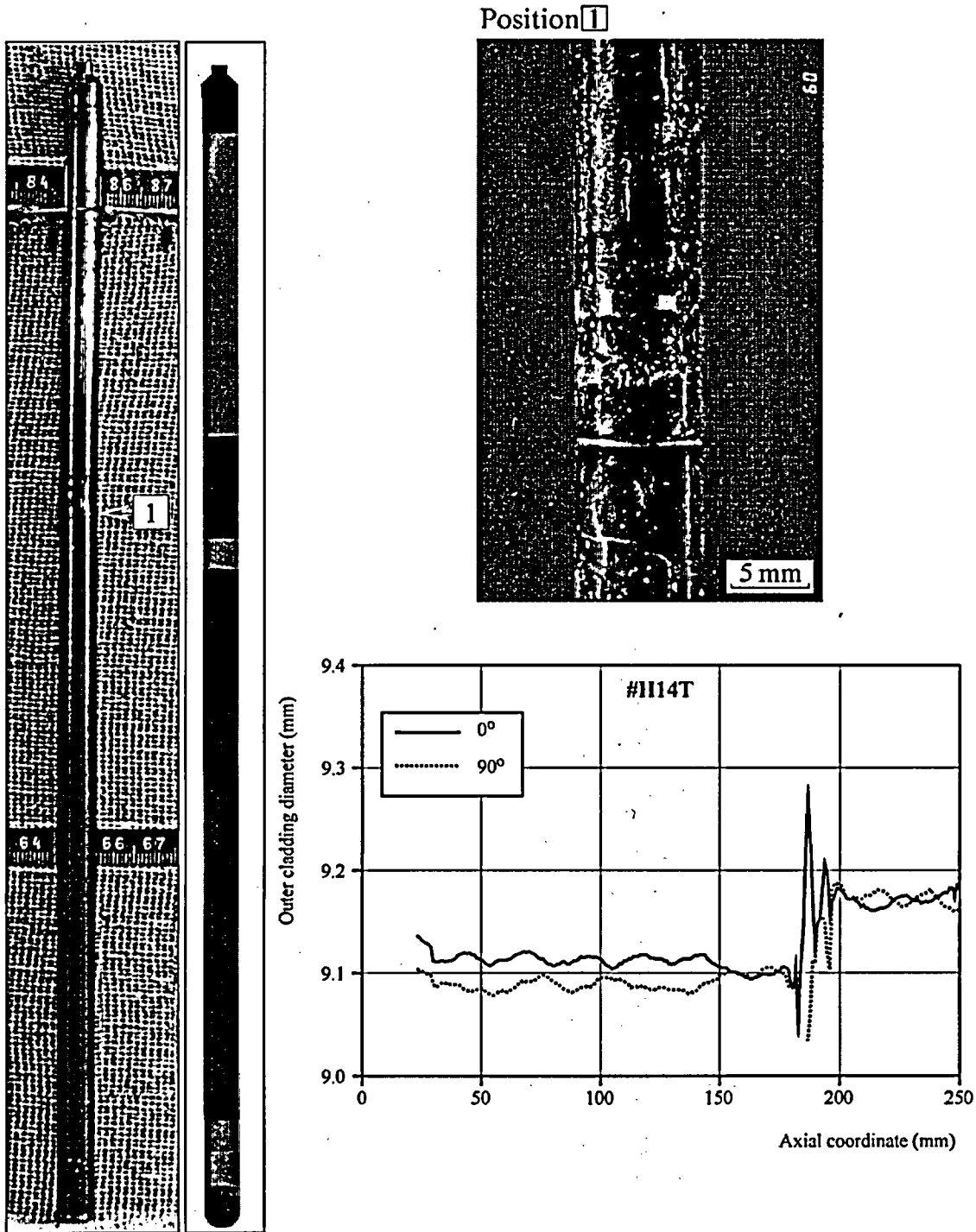
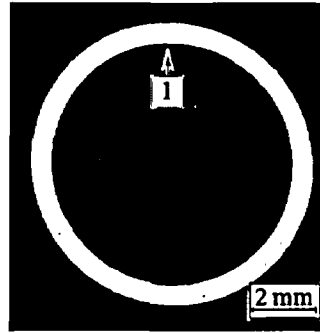

Fig. H-1.1. Appearance of Fuel Rod #H14T (photographs and X-ray photograph) and Profilometry

#H14T

Individual Characteristics of Refabricated Fuel Rods  
(Fresh Fuel, Preirradiated Cladding) under IGR Tests



Position 1

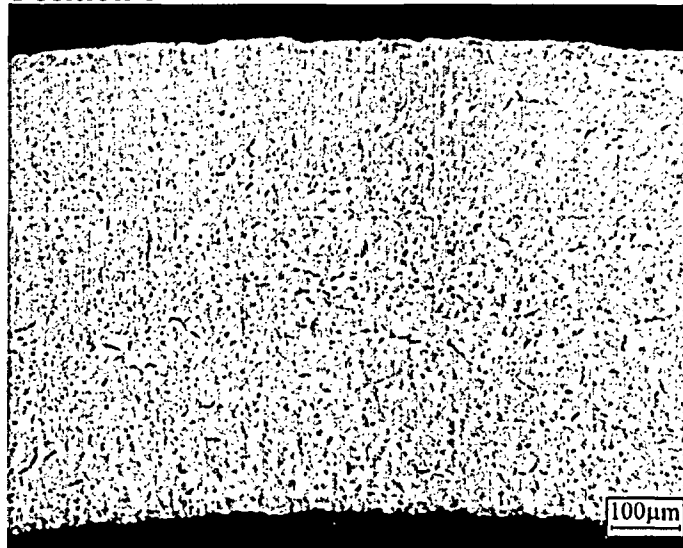

Position 1

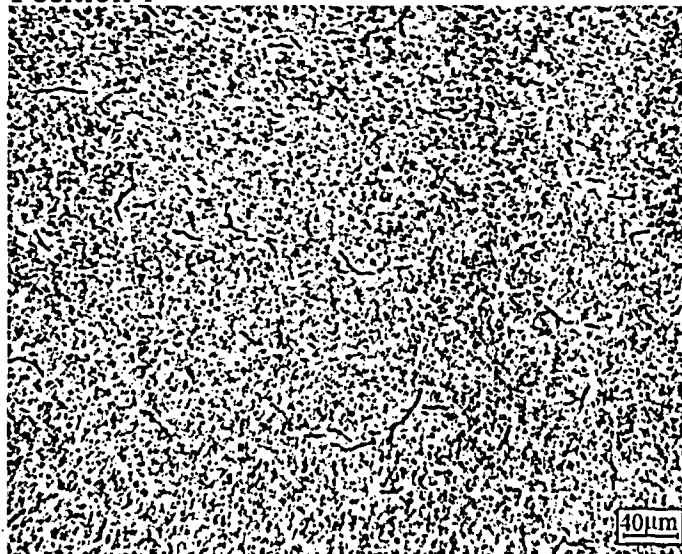
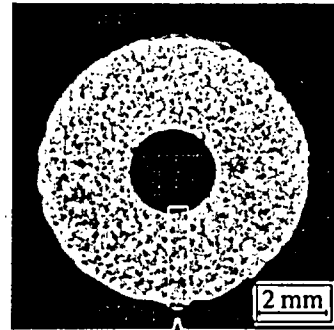

Fig. H-1.2. Cross-Section and Cladding Microstructure for Fuel Rod #H14T at 85 mm Elevation

# #H14T

Individual Characteristics of Refabricated Fuel Rods  
(Fresh Fuel, Preirradiated Cladding) under IGR Tests

Position 1



Position 2

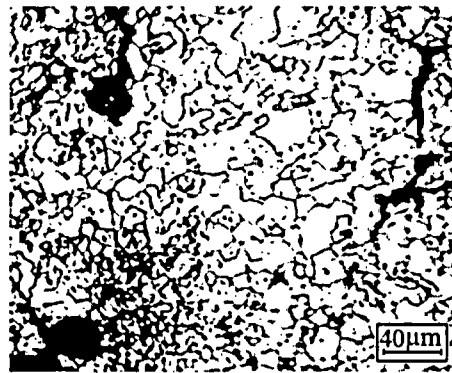

Fig. H-1.3. Fuel Microstructure of Fuel Rod #H14T at 85 mm Elevation

# #H14T

Individual Characteristics of Refabricated Fuel Rods  
(Fresh Fuel, Irradiated Cladding) under IGR Tests

Table H-1.1. Time Dependent Energy Characteristics of Fuel Rod #H14T

Time (s)	Reactor energy deposition <sup>1)</sup> (%)	Cumulative number of fissions in fuel rod (fiss)			Power of fuel rod (kW)	Energy deposition in fuel rod	
		U <sup>235</sup> ×10 <sup>-14</sup>	U <sup>238</sup> ×10 <sup>-12</sup>	Total ×10 <sup>-14</sup>		cal/g fuel	J/g fuel
0.0	0.000	0.000	0.000	0.000	0.000	0.000	0.000
1.0	1.080	0.083	0.030	0.083	0.468	0.950	3.980
2.0	4.330	0.332	0.118	0.334	0.955	3.810	15.90
2.2	5.280	0.405	0.144	0.407	1.110	4.650	19.50
2.4	6.420	0.493	0.175	0.494	1.370	5.650	23.70
2.6	7.880	0.605	0.215	0.607	1.830	6.930	29.00
2.8	9.930	0.762	0.271	0.765	2.700	8.740	36.60
3.0	13.10	1.010	0.358	1.010	4.430	11.60	48.60
3.2	18.60	1.430	0.508	1.440	7.780	16.40	68.70
3.4	28.20	2.160	0.767	2.170	13.00	24.80	104.0
3.6	42.40	3.250	1.160	3.270	17.30	37.30	156.0
3.8	58.20	4.470	1.590	4.480	16.20	51.20	214.0
4.0	71.30	5.470	1.940	5.490	11.80	62.70	262.0
4.2	80.10	6.140	2.180	6.170	7.510	70.50	295.0
4.4	85.50	6.560	2.330	6.580	4.540	75.30	315.0
4.6	88.80	6.810	2.420	6.830	2.800	78.20	327.0
4.8	90.80	6.970	2.470	6.990	1.830	80.00	335.0
5.0	92.20	7.070	2.510	7.100	1.280	81.30	340.0
5.2	93.10	7.140	2.540	7.170	0.958	82.20	344.0
5.4	93.90	7.200	2.560	7.230	0.754	82.90	347.0
5.6	94.50	7.250	2.570	7.270	0.617	83.40	349.0
5.8	94.90	7.280	2.590	7.310	0.519	83.90	351.0
6.0	95.30	7.310	2.600	7.340	0.425	84.30	353.0
6.5	96.00	7.370	2.620	7.390	0.289	85.00	356.0
7.0	96.50	7.400	2.630	7.430	0.210	85.50	358.0
7.5	96.90	7.430	2.640	7.460	0.161	85.80	359.0
8.0	97.10	7.450	2.650	7.480	0.131	86.10	360.0
9.0	97.60	7.490	2.660	7.510	0.109	86.60	363.0
10.0	97.90	7.510	2.670	7.540	0.084	87.00	364.0
20.0	99.20	7.610	2.700	7.640	0.021	88.60	371.0
30.0	99.60	7.640	2.720	7.670	0.010	89.20	373.0
∞	100.0	7.700	2.740	7.730	0.000	91.10	381.0

Maximum value of power is 17.5 kW (t = 3.65 s)

<sup>1)</sup> Current energy deposition per maximum energy deposition (at infinite time)

# #H14T

Individual Characteristics of Refabricated Fuel Rods  
(Fresh Fuel, Preirradiated Cladding) under IGR Tests

Table H-1.2. Axial Energy Characteristics of Fuel Rod #H14T

Axial coordinate from lower end of fuel rod (mm)	Cumulative number of fissions at axial interval (fiss)			Maximum power of fuel rod (kW) t=3.65 s	Energy deposition at infinite time*		
	U <sup>235</sup> ×10 <sup>-13</sup>	U <sup>238</sup> ×10 <sup>-11</sup>	Total ×10 <sup>-13</sup>		cal/g fuel	J/g fuel	per-unit <sup>3)</sup>
30.0	0.000	0.000	0.000	0.000	0.000	0.000	0.00
35.0 <sup>1)</sup>	2.870	0.834	2.880	0.652	106.0	444.0	1.00
40.0	3.110	0.932	3.120	0.706	104.0	435.0	0.98
45.0	3.030	0.937	3.040	0.687	101.0	423.0	0.95
50.0	2.960	0.943	2.970	0.671	98.50	412.0	0.93
55.0	2.880	0.944	2.890	0.654	96.20	403.0	0.91
60.0	2.810	0.945	2.820	0.637	94.70	396.0	0.89
65.0	2.760	0.952	2.770	0.627	93.20	390.0	0.88
70.0	2.740	0.964	2.750	0.621	91.70	384.0	0.87
75.0	2.690	0.970	2.700	0.612	90.20	378.0	0.85
80.0	2.670	0.976	2.680	0.607	89.30	374.0	0.84
85.0	2.640	0.982	2.650	0.600	88.30	370.0	0.83
90.0	2.640	0.993	2.650	0.600	88.30	370.0	0.83
95.0	2.630	0.997	2.640	0.596	87.30	365.0	0.82
100.0	2.620	1.000	2.630	0.595	87.20	365.0	0.82
105.0	2.610	1.000	2.620	0.593	86.90	364.0	0.82
110.0	2.610	1.000	2.620	0.592	86.80	363.0	0.82
115.0	2.610	1.010	2.620	0.592	87.00	364.0	0.82
120.0	2.610	1.000	2.620	0.593	87.30	365.0	0.82
125.0	2.630	1.000	2.640	0.596	87.80	368.0	0.83
130.0	2.610	0.994	2.620	0.592	87.60	367.0	0.83
135.0	2.630	0.989	2.640	0.596	88.20	369.0	0.83
140.0	2.630	0.983	2.640	0.597	87.90	368.0	0.83
145.0	2.640	0.975	2.650	0.600	88.30	370.0	0.83
150.0	2.670	0.971	2.680	0.606	88.70	371.0	0.84
155.0	2.690	0.965	2.700	0.612	89.00	373.0	0.84
160.0	2.710	0.951	2.720	0.615	89.50	375.0	0.84
165.0	2.730	0.940	2.740	0.620	90.00	377.0	0.85
170.0	2.760	0.927	2.770	0.627	90.50	379.0	0.85
175.0 <sup>2)</sup>	0.823	0.272	0.826	0.187	90.40	378.0	0.85
180.0	0.000	0.000	0.000	0.000	0.000	0.000	0.00

\* All numerical values of characteristics are presented as average values at the length interval equal to the axial coordinate ± 2.5 mm.

<sup>1)</sup> Initial coordinate of fuel is 33.0 mm.

<sup>2)</sup> End coordinate of fuel is 174.0 mm.

<sup>3)</sup> Current value per maximum value.

# #H14T

Individual Characteristics of Refabricated Fuel Rods  
(Fresh Fuel, Preirradiated Cladding) under IGR Tests

Table H-1.3. Radial Energy Characteristics of Fuel Rod #H14T

Characteristics*		Coordinates of fuel zones (mm)			
		1 zone 1.10 - 2.12	2 zone 2.12 - 2.79	3 zone 2.79 - 3.32	4 zone 3.32 - 3.79
U <sup>235</sup>	Number of fissions $\times 10^{-14}$ (fiss)	1.850	1.870	1.950	2.030
	Power of fuel rod <sup>1)</sup> (kW)	4.190	4.240	4.400	4.590
	Energy deposition <sup>2)</sup> (cal/g fuel)	87.20	88.30	91.70	95.70
	Energy deposition <sup>2)</sup> (J/g fuel)	365.0	370.0	384.0	401.0
	Energy deposition <sup>3)</sup> (per-unit)	0.911	0.923	0.958	1.000
U <sup>238</sup>	Number of fissions $\times 10^{-12}$ (fiss)	0.684	0.695	0.688	0.669
	Power of fuel rod <sup>1)</sup> (kW)	0.015	0.015	0.015	0.015
	Energy deposition <sup>2)</sup> (cal/g fuel)	0.318	0.323	0.320	0.311
	Energy deposition <sup>2)</sup> (J/g fuel)	1.330	1.350	1.340	1.300
	Energy deposition <sup>3)</sup> (per-unit)	0.985	1.000	0.991	0.963
Total	Number of fissions $\times 10^{-14}$ (fiss)	1.860	1.880	1.950	2.040
	Power of fuel rod <sup>1)</sup> (kW)	4.200	4.260	4.420	4.610
	Energy deposition <sup>2)</sup> (cal/g fuel)	87.50	88.70	92.10	96.00
	Energy deposition <sup>2)</sup> (J/g fuel)	366.0	371.0	386.0	402.0
	Energy deposition <sup>3)</sup> (per-unit)	0.911	0.924	0.959	1.000

1) at time of 3.65 s, 2) at infinite time, 3) Current value per maximum value

\* All numerical values of characteristics were calculated for length of fuel stack

# #H14T

Individual Characteristics of Refabricated Fuel Rods  
(Fresh Fuel, Preirradiated Cladding) under IGR Tests

Table H-1.4. Fuel Enthalpy Vs. Time Calculated by FRAP-T6 Code for Fuel Rod #H14T

Time (s)	Enthalpy at fuel radius (cal/g fuel)				Fuel enthalpy <sup>1)</sup>		Energy deposition in fuel rod	
	1.10 mm	2.22 mm	2.89 mm	3.79 mm	cal/g fuel	J/g fuel	cal/g fuel	J/g fuel
0.0	0.00	0.00	0.00	0.00	0.00	0.00	0.00	0.00
1.0	1.04	1.02	0.98	0.88	0.99	4.13	0.95	3.98
2.0	3.92	3.83	3.68	3.34	3.70	15.5	3.81	16.0
2.2	4.74	4.64	4.45	4.05	4.48	18.8	4.65	19.5
2.4	5.73	5.61	5.39	4.90	5.41	22.7	5.65	23.7
2.6	7.02	6.87	6.60	5.99	6.63	27.8	6.93	29.0
2.8	8.86	8.69	8.35	7.53	8.38	35.1	8.74	36.6
3.0	11.8	11.6	11.1	9.91	11.2	46.8	11.6	48.4
3.2	17.0	16.7	16.0	13.7	16.0	66.8	16.4	68.7
3.4	26.1	25.6	24.3	19.6	24.2	101	24.7	104
3.6	39.8	38.9	36.6	27.0	36.1	151	37.3	156
3.8	55.0	53.4	49.1	32.5	48.2	202	51.2	214
4.0	67.2	64.4	57.3	34.3	56.6	237	62.6	262
4.2	74.9	70.5	60.3	33.5	60.3	253	70.4	295
4.4	78.6	72.4	59.5	31.9	60.7	254	75.2	315
4.6	79.6	71.5	56.8	30.2	59.3	248	78.1	327
4.8	78.6	69.0	53.5	28.7	57.0	239	80.0	335
5.0	76.4	65.8	50.3	27.4	54.3	227	81.2	340
5.2	73.0	62.1	47.1	26.4	51.4	215	82.2	344
5.4	69.3	58.5	44.4	25.5	48.6	204	82.9	347
5.6	65.3	55.0	41.9	24.7	46.0	193	83.4	349
5.8	61.3	51.7	39.6	23.9	43.4	182	83.9	351
6.0	57.3	48.5	37.5	23.2	41.0	172	84.2	353
6.5	48.1	41.3	32.8	21.5	35.5	149	84.9	356
7.0	40.4	35.3	28.8	19.8	30.7	129	85.4	358
7.5	34.0	30.2	25.3	18.1	26.7	112	85.8	360
8.0	28.9	26.1	22.2	16.6	23.3	97.5	86.1	361
10.0	16.6	15.6	14.1	11.7	14.4	60.5	87.0	364
30.0	5.09	5.07	5.06	5.02	5.06	21.2	89.2	374

Radial enthalpy distribution and fuel enthalpy are presented at elevation 40.0 mm

Maximum value of fuel enthalpy is 60.9 cal/g fuel (t=4.33 s)

<sup>1)</sup> All numerical values are presented at elevation with peak power

# #H14T

Individual Characteristics of Refabricated Fuel Rods  
(Fresh Fuel, Preirradiated Cladding) under IGR Tests

Table H-1.5. Energy Characteristics Vs. Time Calculated by FRAP-T6 and SCANAIR Codes for Fuel Rod #H14T

Time (s)	Energy deposition <sup>1)</sup> (cal/g fuel)	Linear power <sup>1)</sup> (kW/m)	Fuel enthalpy <sup>1)</sup> (cal/g fuel)		Energy of metal-water reaction <sup>1)</sup> (cal/g fuel)	Leakage of energy <sup>1)</sup> (cal/g fuel)		Clad-to-coolant heat transfer coefficient <sup>1)</sup> (kW/m <sup>2</sup> K)	
			FRAP-T6	SCANAIR		FRAP-T6	SCANAIR	FRAP-T6	SCANAIR
0.0	0.00	0.00	0.00	0.00	0.00	0.00	0.00	0.00	0.00
1.0	1.08	3.72	0.99	0.97	0.00	0.00	0.00	0.03	0.10
2.0	4.33	7.59	3.70	3.82	0.00	0.01	0.03	0.03	0.10
2.2	5.28	8.82	4.48	4.53	0.00	0.01	0.04	0.03	0.10
2.4	6.42	10.9	5.41	5.54	0.00	0.02	0.05	0.03	0.10
2.6	7.87	14.5	6.63	6.85	0.00	0.02	0.07	0.03	0.10
2.8	9.92	21.5	8.38	8.45	0.00	0.03	0.09	0.03	0.10
3.0	13.1	35.2	11.2	11.4	0.00	0.09	0.14	0.74	0.84
3.2	18.6	61.8	16.0	16.6	0.00	0.55	0.70	2.23	2.68
3.4	28.1	103	24.2	24.1	0.00	1.60	1.68	4.21	4.70
3.6	42.3	137	36.1	36.7	0.00	3.63	3.83	7.29	8.40
3.8	58.1	129	48.2	49.4	0.00	7.09	7.53	10.6	12.5
4.0	71.2	93.8	56.6	57.2	0.00	11.8	12.2	12.8	14.8
4.2	80.0	59.7	60.3	60.8	0.00	17.2	17.8	13.4	15.4
4.4	85.5	36.1	60.7	60.9	0.00	22.5	22.6	12.9	14.9
4.6	88.8	22.2	59.3	59.2	0.00	27.6	27.9	12.1	13.8
4.8	90.9	14.5	57.0	57.1	0.00	32.2	32.1	11.1	12.9
5.0	92.3	10.2	54.3	54.3	0.00	36.4	36.5	10.3	11.9
5.2	93.4	7.52	51.4	51.6	0.00	40.4	40.3	9.46	11.0
5.4	94.1	5.93	48.6	48.8	0.00	43.9	44.0	8.79	10.2
5.6	94.8	4.86	46.0	46.0	0.00	47.1	47.5	8.20	9.51
5.8	95.3	4.09	43.4	43.8	0.00	50.1	50.2	7.68	8.98
6.0	95.7	3.35	41.0	41.4	0.00	52.9	53.2	7.20	8.41
6.5	96.5	2.28	35.5	35.9	0.00	59.0	59.6	6.16	7.20
7.0	97.1	1.66	30.7	31.4	0.00	64.1	64.8	5.30	6.22
7.5	97.5	1.27	26.7	27.3	0.00	68.4	69.4	4.55	5.32
8.0	97.8	1.04	23.3	23.8	0.00	72.0	73.3	3.91	4.54
10.0	98.8	0.66	14.4	14.9	0.00	81.8	83.4	2.13	2.45
30.0	101	0.08	5.06	5.14	0.00	93.8	96.1	0.05	0.10

<sup>1)</sup> All numerical values are presented at elevation with peak power



# #H14T

Individual Characteristics of Refabricated Fuel Rods  
(Fresh Fuel, Preirradiated Cladding) under IGR Tests

Table H-1.6. Temperature Variation, Fission Gas Release and ZrO<sub>2</sub> Thickness Vs. Time for Fuel Rod #H14T Calculated by FRAP-T6 and SCANAIR Codes

Time (s)	Fuel centerline temperature <sup>1)</sup> (K)		Fuel surface temperature <sup>1)</sup> (K)		Clad outer temperature <sup>1)</sup> (K)		Average ZrO <sub>2</sub> <sup>2)</sup> thickness (μm)
	FRAP-T6	SCANAIR	FRAP-T6	SCANAIR	FRAP-T6	SCANAIR	FRAP-T6
0.0	293	293	293	293	293	293	5
1.0	312	310	309	307	299	298	5
2.0	360	357	350	349	324	322	5
2.2	373	369	362	359	333	329	5
2.4	389	386	376	373	342	338	5
2.6	409	407	393	392	353	350	5
2.8	438	432	417	414	367	362	5
3.0	483	479	454	452	383	379	5
3.2	559	561	511	514	391	384	5
3.4	688	678	597	593	398	387	5
3.6	877	874	701	704	406	393	5
3.8	1080	1082	777	784	413	398	5
4.0	1240	1232	802	810	416	401	5
4.2	1339	1330	791	804	417	401	5
4.4	1387	1370	769	788	416	401	5
4.6	1400	1380	745	767	415	400	5
4.8	1387	1368	724	750	413	399	5
5.0	1358	1337	707	732	412	397	5
5.2	1315	1298	692	717	410	396	5
5.4	1267	1250	679	703	409	395	5
5.6	1216	1198	668	690	408	394	5
5.8	1163	1152	658	680	407	394	5
6.0	1111	1100	647	667	406	393	5
6.5	989	981	623	639	403	391	5
7.0	885	884	599	613	401	390	5
7.5	798	797	575	586	399	389	5
8.0	727	726	553	561	397	387	5
10.0	553	552	481	484	391	383	5
30.0	379	375	378	374	376	370	5

<sup>1)</sup> All numerical values are presented at elevation with peak power

<sup>2)</sup> Initial ZrO<sub>2</sub> thickness is 5 μm

# #H14T

Individual Characteristics of Refabricated Fuel Rods  
(Fresh Fuel, Irradiated Cladding) under IGR Tests

Table H-1.7. Mechanical Characteristics of Fuel Rod #H14T Vs. Time Calculated by FRAP-T6 and SCANAIR Codes

Time (s)	Clad outer temperature <sup>1)</sup> (K)		Fuel hoop strain <sup>1)</sup> (%)		Fuel - clad gap width <sup>1)</sup> (mm)		Clad hoop strain <sup>1)</sup> (%)		Clad hoop stress <sup>1)</sup> (MPa)		Internal gas pressure (MPa)	
	FRAP-T6	SCANAIR	FRAP-T6	SCANAIR	FRAP-T6	SCANAIR	FRAP-T6	SCANAIR	FRAP-T6	SCANAIR	FRAP-T6	SCANAIR
0.0	293	293	0.00	0.00	0.07	0.07	0.01	0.01	8.71	8.71	1.70	1.70
1.0	299	298	0.01	0.01	0.07	0.06	0.01	0.01	8.78	8.79	1.71	1.72
2.0	324	322	0.06	0.06	0.06	0.06	0.03	0.03	8.96	9.00	1.75	1.75
2.2	333	329	0.07	0.07	0.06	0.06	0.04	0.03	9.00	9.04	1.75	1.76
2.4	342	338	0.09	0.08	0.06	0.06	0.04	0.04	9.05	9.10	1.76	1.77
2.6	353	350	0.11	0.10	0.06	0.06	0.05	0.05	9.10	9.18	1.77	1.78
2.8	367	362	0.13	0.12	0.06	0.06	0.06	0.06	9.18	9.26	1.79	1.80
3.0	383	379	0.18	0.17	0.06	0.06	0.07	0.07	9.28	9.43	1.81	1.82
3.2	391	384	0.25	0.25	0.06	0.06	0.08	0.08	9.42	9.72	1.83	1.85
3.4	398	387	0.37	0.37	0.05	0.05	0.09	0.08	9.61	10.1	1.87	1.89
3.6	406	393	0.56	0.58	0.05	0.05	0.10	0.10	9.81	10.6	1.90	1.94
3.8	413	398	0.76	0.79	0.04	0.04	0.11	0.11	9.96	11.2	1.93	1.99
4.0	416	401	0.91	0.93	0.03	0.03	0.11	0.12	10.1	11.5	1.95	2.01
4.2	417	401	1.00	0.98	0.03	0.03	0.12	0.12	10.1	11.6	1.96	2.02
4.4	416	401	1.03	0.98	0.03	0.03	0.11	0.12	10.1	11.5	1.96	2.02
4.6	415	400	1.02	0.95	0.03	0.03	0.11	0.11	10.1	11.4	1.96	2.02
4.8	413	399	0.99	0.91	0.03	0.03	0.11	0.11	10.1	11.3	1.96	2.01
5.0	412	397	0.94	0.85	0.03	0.04	0.11	0.11	10.1	11.2	1.95	2.01
5.2	410	396	0.90	0.80	0.04	0.04	0.10	0.10	10.1	11.1	1.95	2.00
5.4	409	395	0.85	0.75	0.04	0.04	0.10	0.10	10.0	11.0	1.94	1.99
5.6	408	394	0.80	0.70	0.04	0.04	0.10	0.10	10.0	10.9	1.94	1.98
5.8	407	394	0.75	0.66	0.04	0.04	0.10	0.10	9.98	10.8	1.93	1.97
6.0	406	393	0.70	0.62	0.04	0.05	0.10	0.10	9.95	10.7	1.93	1.97
6.5	403	391	0.60	0.53	0.05	0.05	0.09	0.09	9.87	10.5	1.91	1.95
7.0	401	390	0.51	0.46	0.05	0.05	0.09	0.09	9.79	10.4	1.90	1.93
7.5	399	389	0.44	0.39	0.05	0.05	0.09	0.09	9.72	10.2	1.88	1.91
8.0	397	387	0.38	0.34	0.05	0.06	0.08	0.08	9.65	10.1	1.87	1.90
10.0	391	383	0.23	0.21	0.06	0.06	0.08	0.08	9.43	9.64	1.83	1.85
30.0	376	370	0.08	0.06	0.06	0.07	0.06	0.06	9.07	9.06	1.77	1.77

<sup>1)</sup> All numerical values are presented at elevation with peak power

# #H14T

Individual Characteristics of Refabricated Fuel Rods  
(Fresh Fuel, Preirradiated Gladding) under IGR Tests

Table H-1.8. Axial Distribution of Energy Deposition and Fuel Enthalpy Calculated by FRAP-T6 Code for Fuel Rod #H14T

Axial interval from-to (mm)-(mm)	Energy deposition at infinite time			Fuel enthalpy at time (t=4.33 s)		
	cal/g fuel	J/g fuel	per-unit	cal/g fuel	J/g fuel	per-unit
33.0 - 47.1	103	433	1.00	60.9	255	1.00
47.1 - 61.2	96.8	406	0.94	57.0	239	0.94
61.2 - 75.3	92.2	386	0.89	54.3	227	0.89
75.3 - 89.4	89.0	373	0.86	52.3	219	0.86
89.4 - 103.5	87.5	366	0.85	51.4	216	0.85
103.5 - 117.6	86.9	364	0.84	51.1	214	0.84
117.6 - 131.7	87.6	367	0.85	51.5	216	0.85
131.7 - 145.8	88.1	369	0.85	51.8	217	0.85
145.8 - 159.9	88.9	372	0.86	52.3	219	0.86
159.9 - 174.0	90.1	378	0.87	53.0	222	0.87

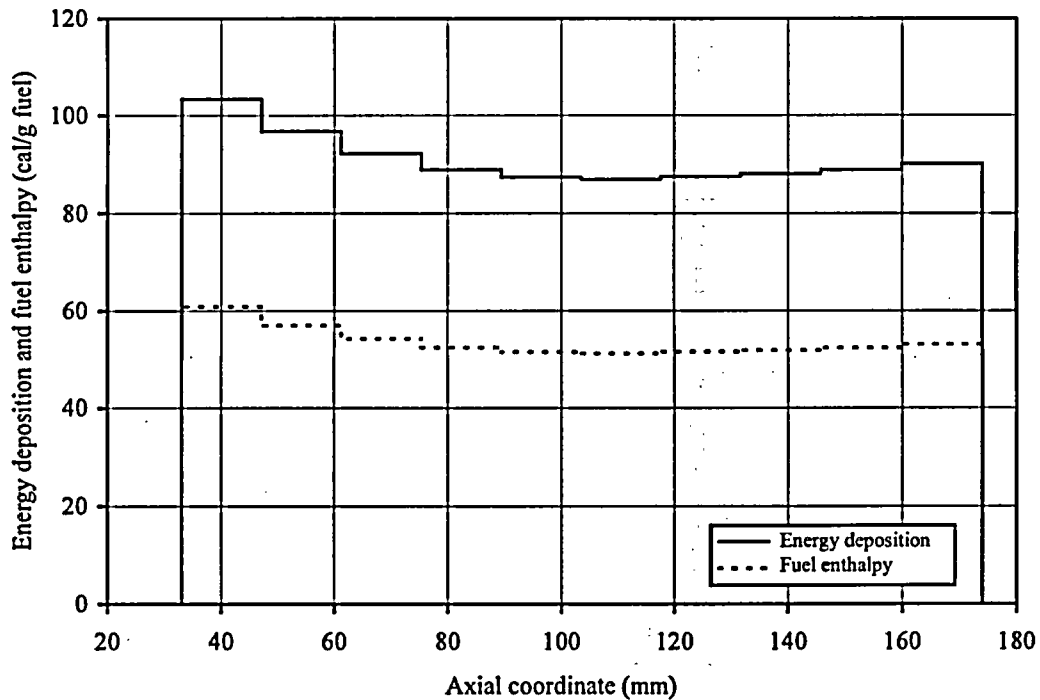

Fig. H-1.4. Axial Distribution of Energy Deposition and Fuel Enthalpy Calculated by FRAP-T6 Code for Fuel Rod #H14T

# #H14T

Individual Characteristics of Refabricated Fuel Rods  
(Fresh Fuel, Preirradiated Cladding) under IGR Tests

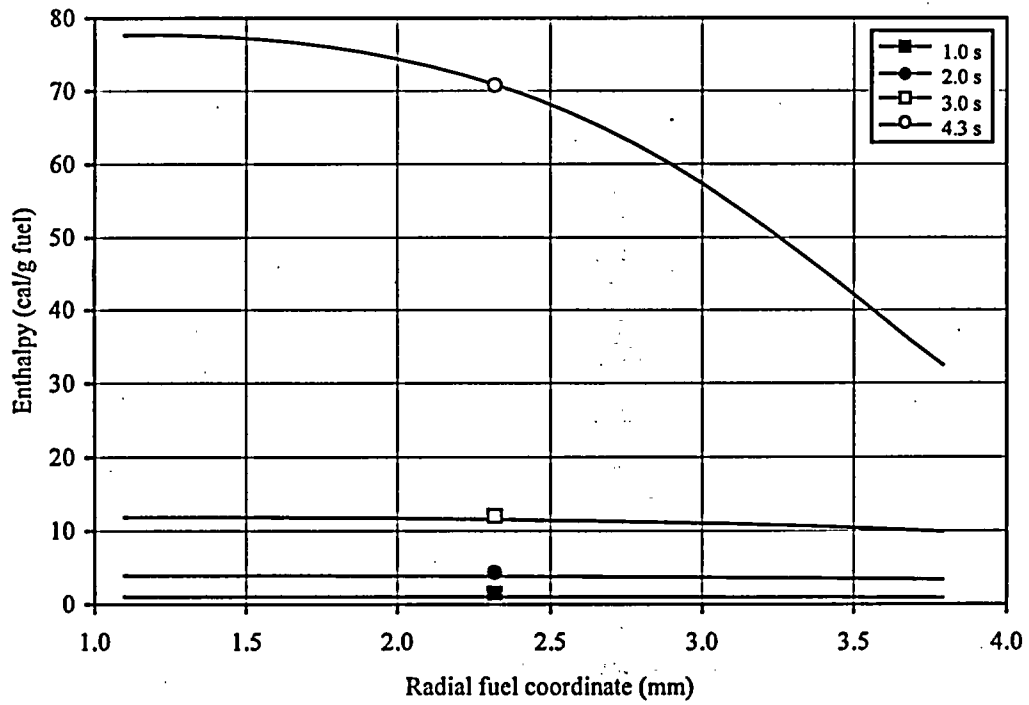
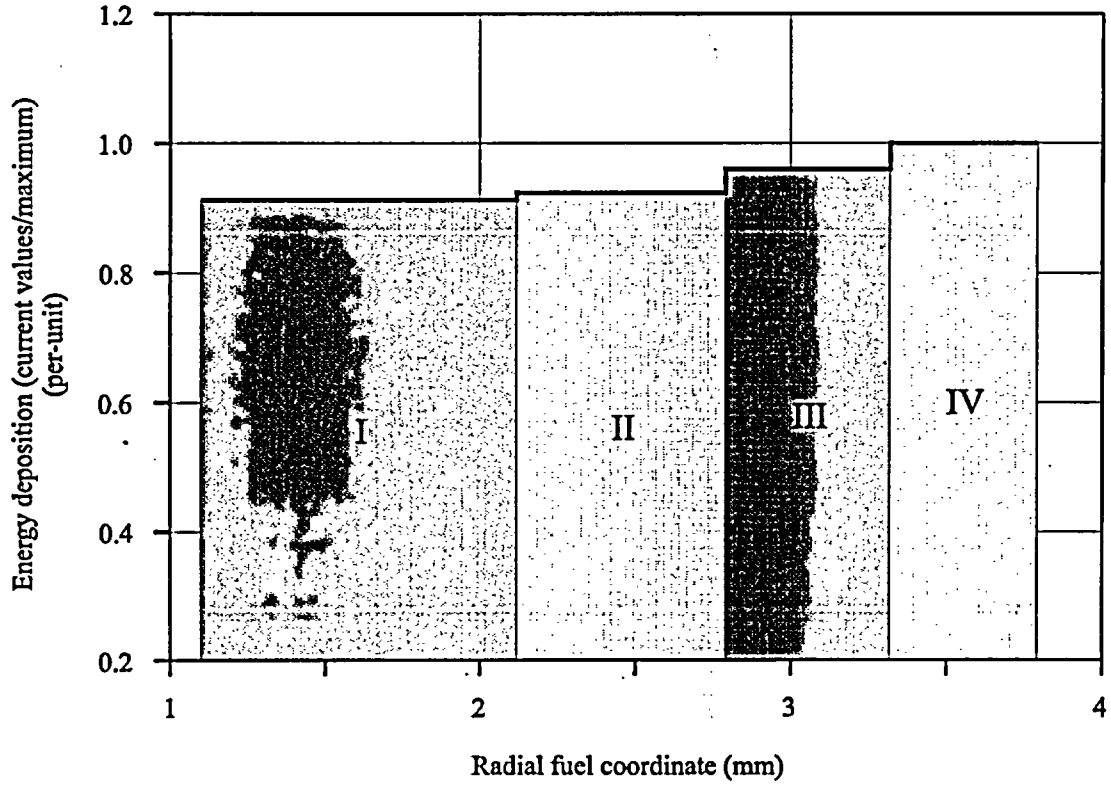

Fig. H-1.5. Radial Distributions of Energy Deposition and Fuel Enthalpy Calculated by FRAP-T6 Code for Fuel Rod #H14T

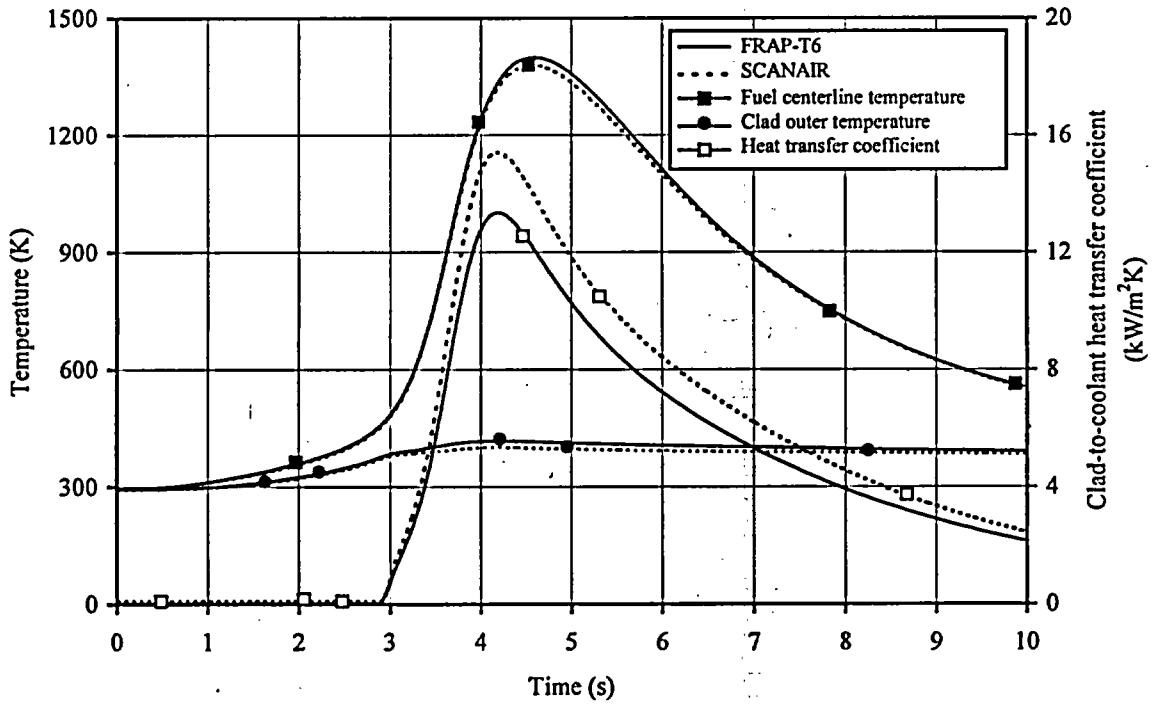
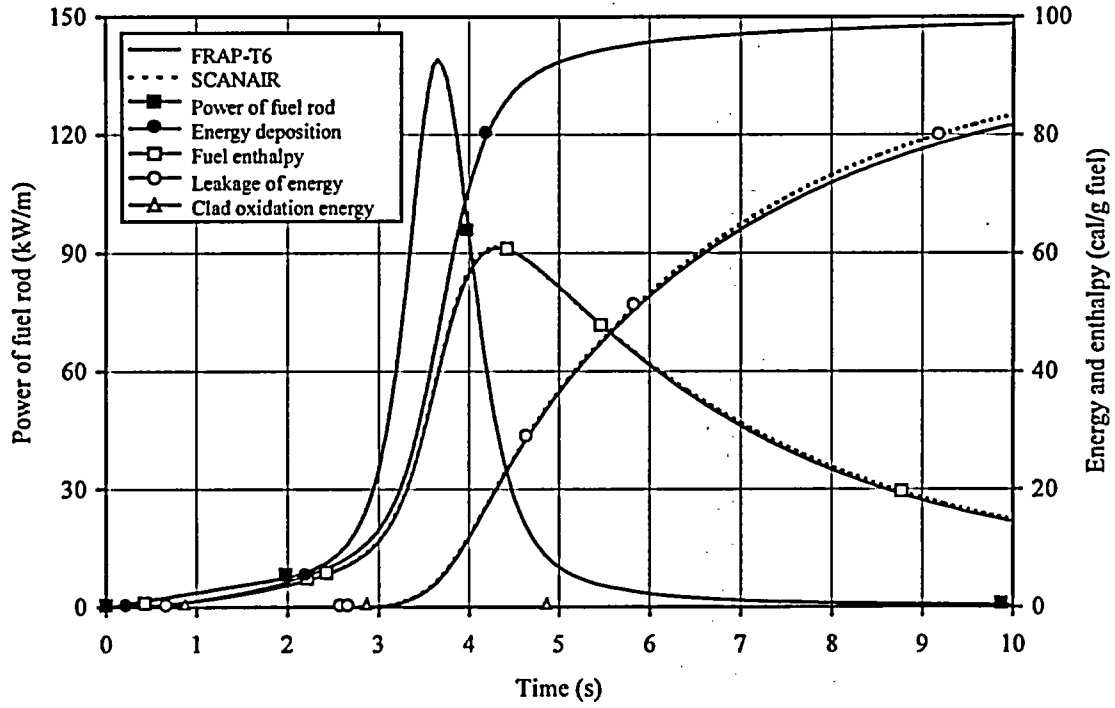

Fig. H-1.6. Energy and Temperature Characteristics Vs. Time Calculated by FRAP-T6 and SCANAIR Codes for Fuel Rod #H14T

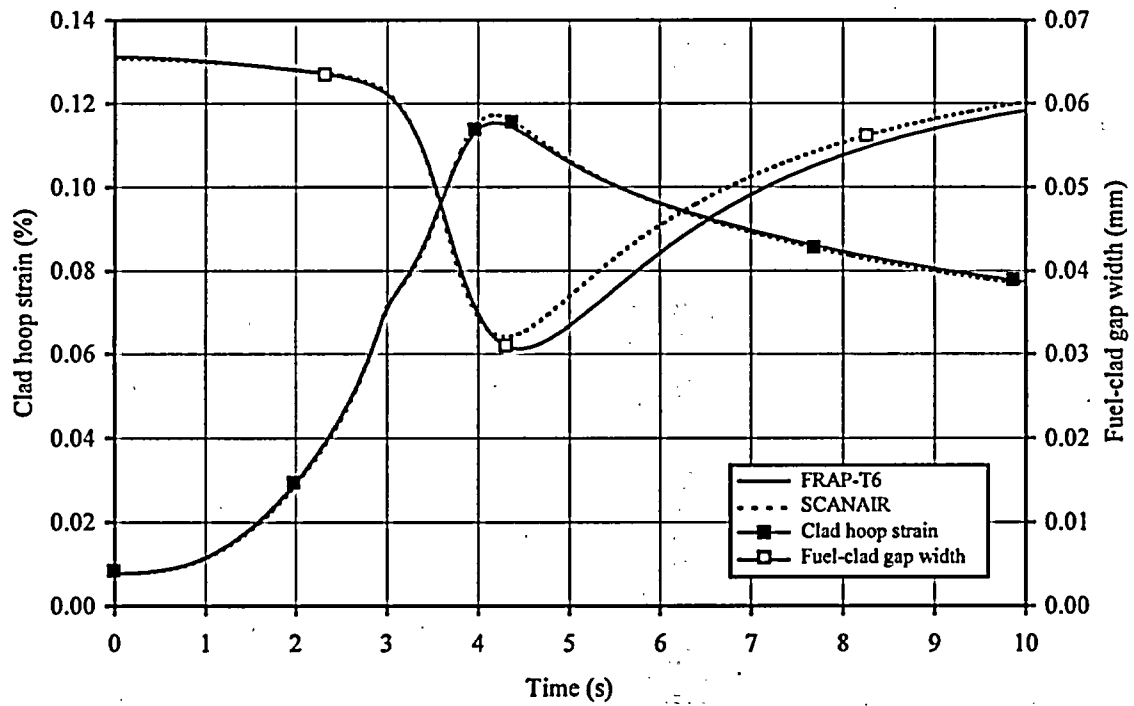
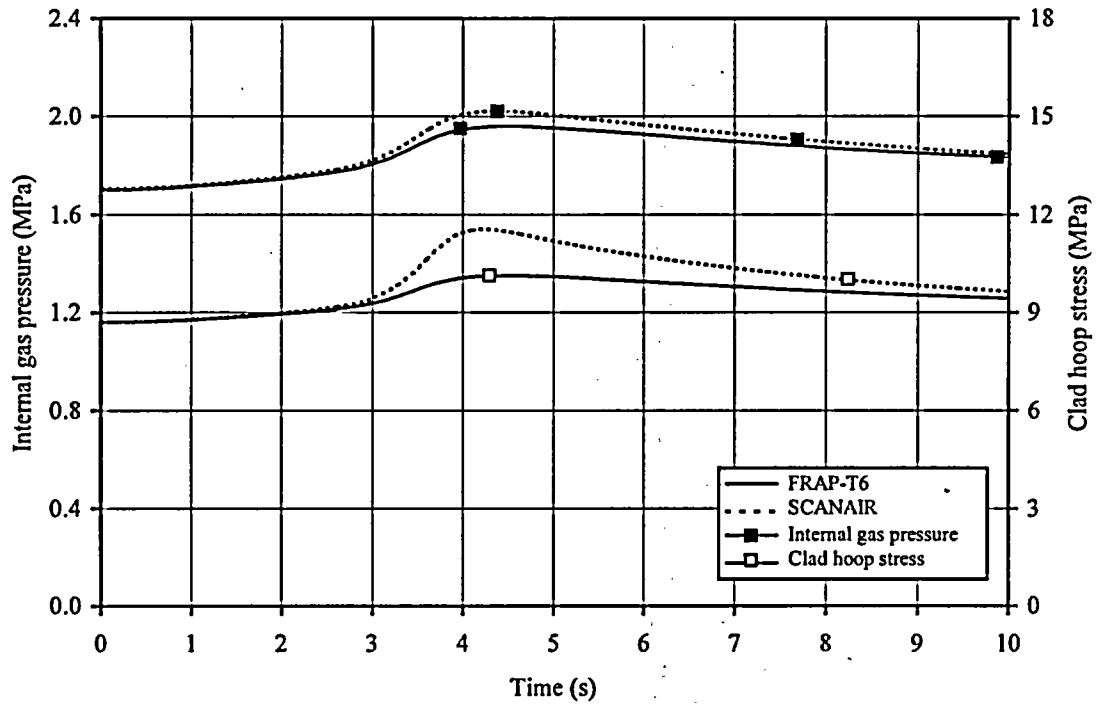

Fig. H-1.7. Cladding Mechanical Characteristics Vs. Time Calculated by FRAP-T6 and SCANAIR Codes for Fuel Rod #H14T

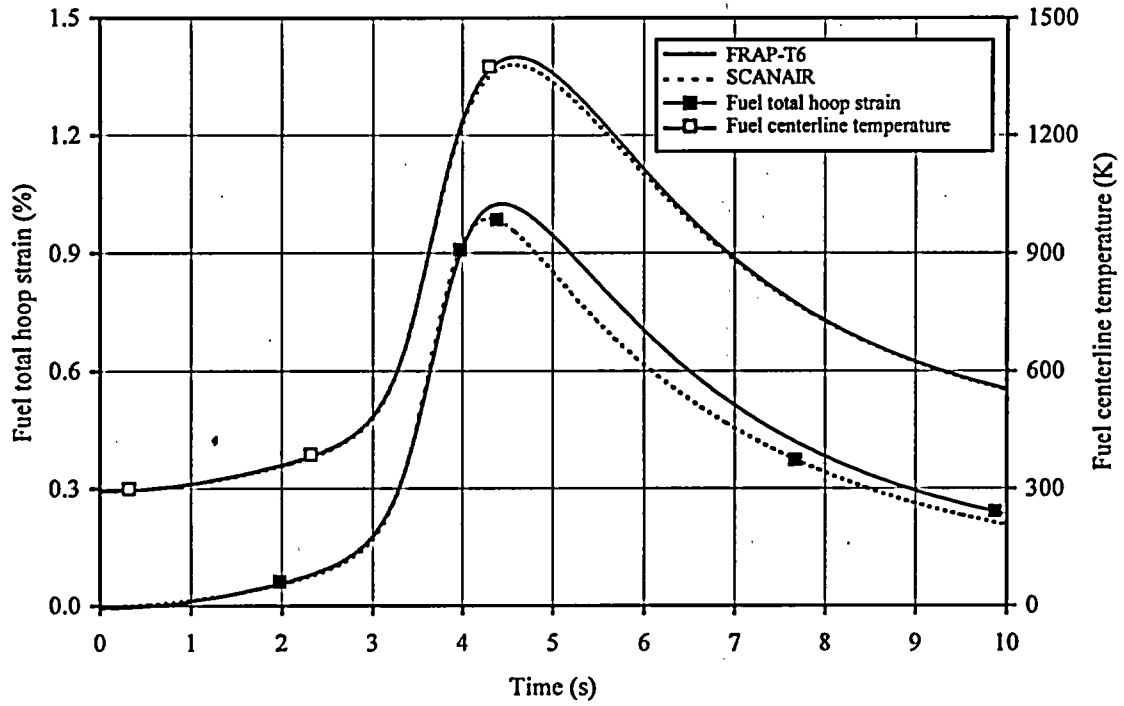

Fig. H-1.8. Fuel Strain Vs. Time Calculated by FRAP-T6 and SCANAIR Codes for Fuel Rod #H14T

# #H14T

Individual Characteristics of Refabricated Fuel Rods  
(Fresh Fuel, Preirradiated Cladding) under IGR Tests

Table H-1.9. Some Results of PIE for Fuel Rod #H14T

Characteristic		Value
1.	Measured parameters of cladding oxidation and cladding deformation	
1.1.	Cladding thickness at elevation 85 mm for different azimuthal angles ( $\mu\text{m}$ ):	
	0°	705
	90°	700
	180°	691
	270°	695
1.2.	ZrO <sub>2</sub> thickness at elevation 85 mm for different azimuthal angles ( $\mu\text{m}$ ):	
	0°	5
	90°	5
	180°	5
	270°	5
1.3.	$\alpha\text{Zr(O)}$ thickness at elevation 85 mm for different azimuthal angles ( $\mu\text{m}$ ):	
	0°	0
	90°	0
	180°	0
	270°	0
1.4.	Clad hoop strain at elevation 85 mm (%)	0.5
2.	Measured parameters for FGR analysis	
2.1.	Internal gas composition (% by volume):	
	He	—
	N <sub>2</sub>	—
	O <sub>2</sub>	—
	Ar	—
	CO <sub>2</sub>	—
	Kr	—
	Xe	—
2.2.	Free gas volume (cm <sup>3</sup> )	6.17
2.3.	Gas pressure inside fuel rod under normal condition (MPa)	1.58
2.4.	Kr concentration in fuel (cm <sup>3</sup> /g fuel)	—
3.	Measured parameters of cladding hydriding	
3.1.	Coefficient of hydride orientation (per-unit)	0.33
3.2.	Hydrogen concentration (% by weight)	—



# #H14T

Individual Characteristics of Refabricated Fuel Rods  
(Fresh Fuel, Preirradiated Cladding) under IGR Tests

Table H-1.10. General Characteristic of Fuel Rod #H14T

	Parameter	Unit	Value		
			Experiment	FRAP-T6	SCANAIR
1	Type of coolant	---	water	water	water
2	Burnup	MWd/kg U	0	0	0
3	Energy deposition in fuel rod	cal/g fuel	91	91	91
4	Peak fuel enthalpy	cal/g fuel	-	61	61
5	Peak fuel temperature	K	-	1400	1380
6	Peak clad temperature	K	-	417	401
7	Fuel rod failure	Yes, No	No	No	-
8	Type of failure:				
	- cladding rupture due to ballooning	Yes, No	No	No	-
	- cladding rupture due to PCMI	Yes, No	No	No	-
	- fragmentation of fuel rod	Yes, No	No	-	-
9	Failure time	s	-	-	-
10	Fuel enthalpy at failure	cal/g fuel	-	-	-
11	Outer cladding temperature at failure	K	-	-	-
12	Internal gas pressure at failure	MPa	-	-	-
13	ZrO <sub>2</sub> thickness after test	μm	5	5	-
14	Residual clad hoop strain:				
	- peak value for ballooning area	%	-	-	-
	- other location <sup>1)</sup>	%	0.5	0	0

<sup>1)</sup>Calculated values by FRAP-T6 and SCANAIR codes are average along height of fuel rod excluding ballooning region

***APPENDIX H-2.***  
***Individual Characteristics for Fuel Rod #H15T under IGR Test.***

# #H15T

Individual Characteristics of Refabricated Fuel Rods  
(Fresh Fuel, Preirradiated Cladding) under IGR Tests

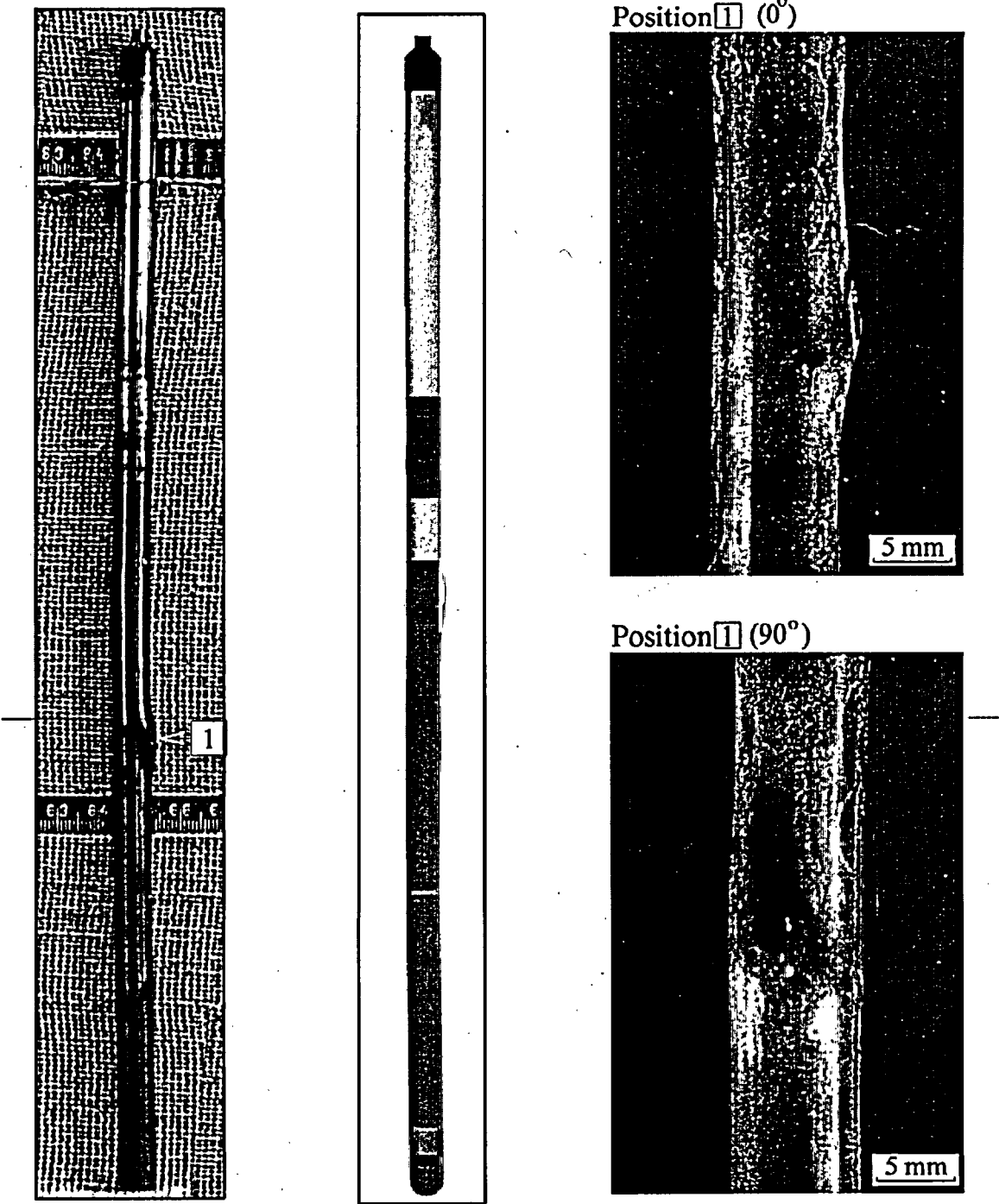
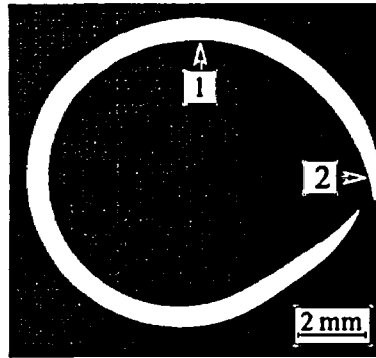

Fig. H-2.1. Appearance of Fuel Rod #H15T (photographs and X-ray photograph)

#H15T

Individual Characteristics of Refabricated Fuel Rods  
(Fresh Fuel, Preirradiated Cladding) under IGR Tests



Position 1

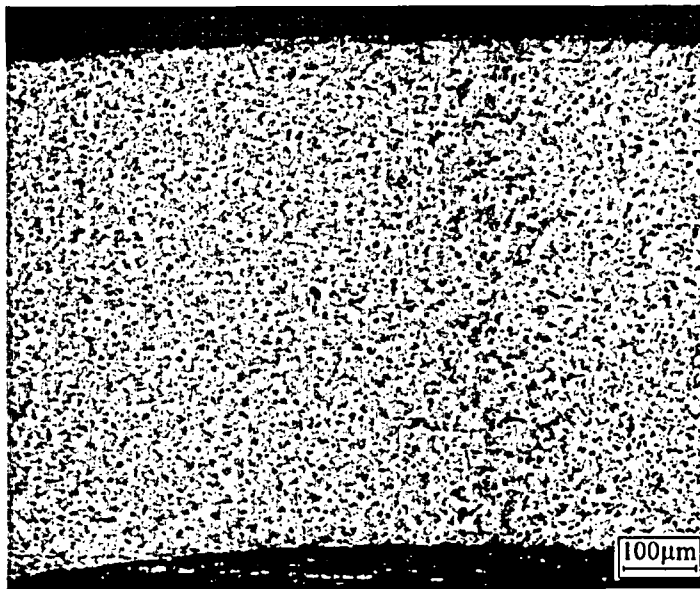

Position 2

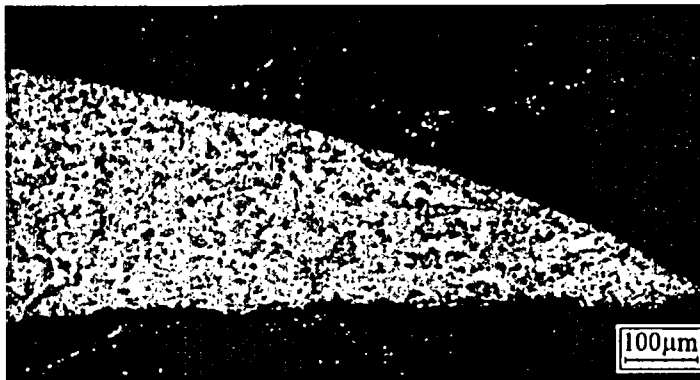
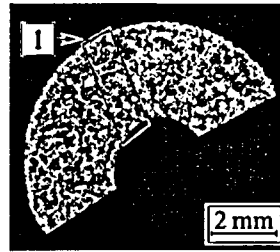
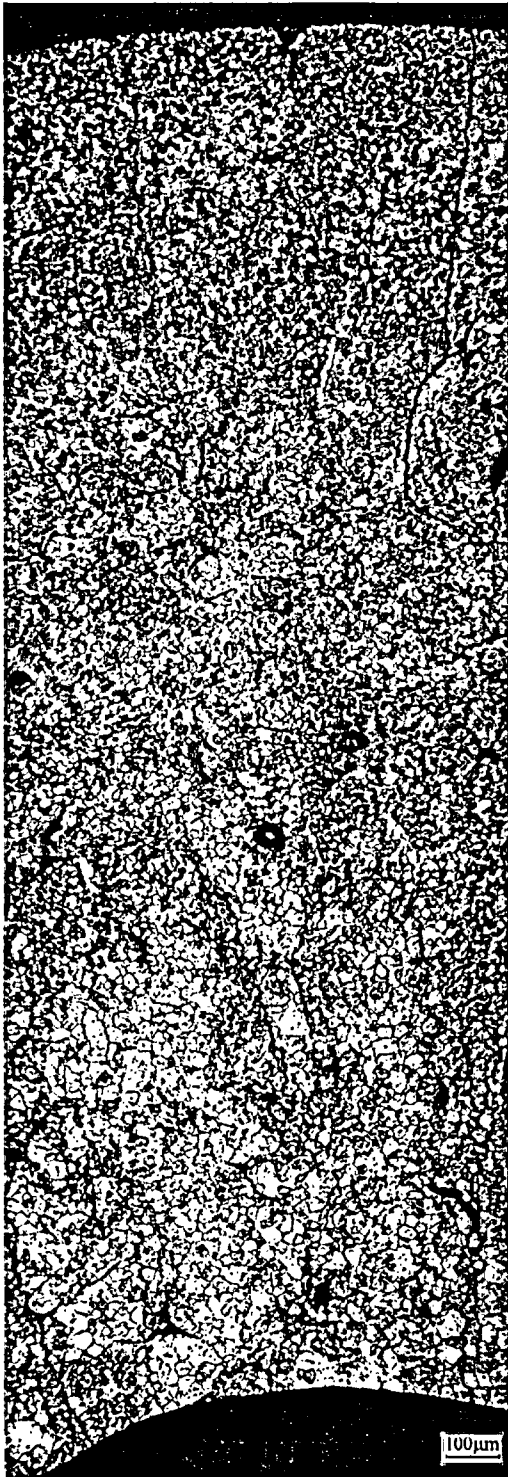

Fig. H-2.2. Cross-Section and Cladding Microstructure for Fuel Rod #H15T at 117 mm Elevation

#H15T

Individual Characteristics of Refabricated Fuel Rods  
(Fresh Fuel, Preirradiated Cladding) under IGR Tests

Position 1



Position 2

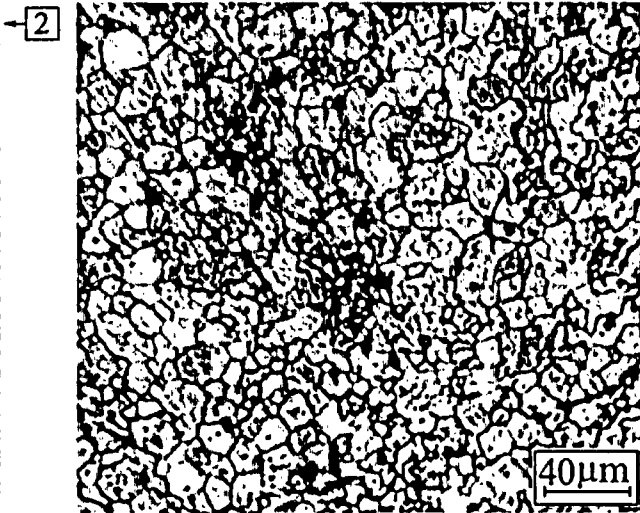

Position 3

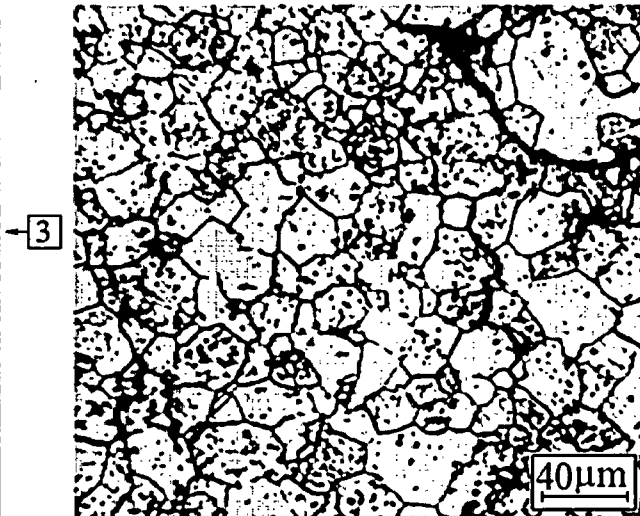

Fig. H-2.3. Fuel Microstructure for Fuel Rod #H15T at 117 mm Elevation

# #H15T

Individual Characteristics of Refabricated Fuel Rods  
(Fresh Fuel, Preirradiated Cladding) under IGR Tests

Table H-2.1. Time Dependent Energy Characteristics of Fuel Rod #H15T

Time (s)	Reactor energy deposition <sup>1)</sup> (%)	Cumulative number of fissions in fuel rod (fiss)			Power of fuel rod (kW)	Energy deposition in fuel rod	
		U <sup>235</sup> ×10 <sup>-14</sup>	U <sup>238</sup> ×10 <sup>-12</sup>	Total ×10 <sup>-14</sup>		cal/g fuel	J/g fuel
0.0	0.000	0.000	0.000	0.000	0.000	0.000	0.000
1.0	1.040	0.245	0.087	0.246	1.660	2.779	11.62
2.0	6.470	1.520	0.542	1.529	7.480	17.30	72.44
2.2	9.380	2.202	0.786	2.211	12.41	25.08	104.9
2.4	14.50	3.408	1.215	3.417	22.46	38.71	161.7
2.6	23.60	5.557	1.975	5.575	39.06	63.18	264.8
2.8	37.80	8.913	3.163	8.913	53.13	101.4	424.7
3.0	53.60	12.58	4.483	12.67	48.67	143.3	600.3
3.2	66.30	15.55	5.549	15.64	35.48	177.4	742.7
3.4	75.10	17.65	6.291	17.74	24.12	201.0	841.5
3.6	81.10	19.05	6.790	19.14	16.25	216.7	907.0
3.8	85.10	20.01	7.122	20.10	11.18	228.1	955.1
4.0	87.90	20.71	7.358	20.71	7.934	235.9	987.4
4.2	89.90	21.15	7.524	21.23	5.785	241.2	1009.
4.4	91.40	21.50	7.646	21.58	4.352	244.7	1024.
4.6	92.50	21.76	7.742	21.85	3.355	248.2	1039.
4.8	93.30	21.93	7.812	22.02	2.656	250.8	1049.
5.0	94.00	22.11	7.873	22.19	2.150	252.5	1057.
5.2	94.60	22.19	7.917	22.28	1.774	254.3	1064.
5.4	95.00	22.37	7.952	22.46	1.485	255.2	1068.
5.6	95.40	22.46	7.987	22.54	1.250	256.0	1071.
5.8	95.70	22.46	8.013	22.54	1.066	257.8	1079.
6.0	95.90	22.54	8.030	22.63	0.918	257.8	1079.
6.5	96.50	22.72	8.074	22.72	0.660	259.5	1086.
7.0	96.80	22.81	8.100	22.81	0.504	261.3	1094.
7.5	97.10	22.81	8.126	22.89	0.407	262.1	1098.
8.0	97.30	22.89	8.144	22.98	0.343	262.1	1098.
9.0	97.70	22.98	8.179	23.07	0.292	263.9	1105.
10.0	98.00	23.07	8.205	23.16	0.233	264.8	1108.
20.0	99.20	23.33	8.301	23.42	0.060	269.1	1126.
30.0	99.60	23.42	8.336	23.51	0.031	270.9	1134.
∞	100.0	23.59	8.406	23.68	0.000	277.0	1160.

Maximum value of power is 53.8 kW (t = 2.85 s)

<sup>1)</sup> Current energy deposition per maximum energy deposition (at infinite time)

## #H15T

Individual Characteristics of Refabricated Fuel Rods  
(Fresh Fuel, Preirradiated Cladding) under IGR Tests

Table H-2.2. Axial Energy Characteristics of Fuel Rod #H15T

Axial coordinate from lower end of fuel rod (mm)	Cumulative number of fissions at axial interval (fiss)			Maximum power of fuel rod (kW) $t=2.85s$	Energy deposition at infinite time*		
	$U^{235} \times 10^{-13}$	$U^{238} \times 10^{-11}$	Total $\times 10^{-13}$		cal/g fuel	J/g fuel	per-unit <sup>3)</sup>
20.0	0.000	0.000	0.000	0.000	0.000	0.000	0.00
25.0 <sup>1)</sup>	3.530	1.031	3.539	0.804	323.3	1354.	1.00
30.0	9.612	2.866	9.699	2.193	318.1	1332.	0.98
35.0	9.350	2.884	9.437	2.141	309.3	1295.	0.96
40.0	9.088	2.875	9.088	2.062	300.6	1258.	0.93
45.0	8.826	2.892	8.913	2.019	294.5	1233.	0.91
50.0	8.686	2.919	8.712	1.984	289.2	1211.	0.89
55.0	8.581	2.954	8.616	1.957	284.9	1193.	0.88
60.0	8.389	2.954	8.415	1.914	278.7	1167.	0.86
65.0	8.284	2.971	8.319	1.887	275.3	1153.	0.85
70.0	8.205	2.988	8.240	1.870	272.6	1141.	0.84
75.0	8.109	3.006	8.135	1.852	270.0	1130.	0.84
80.0	8.057	3.023	8.083	1.835	268.3	1123.	0.83
85.0	8.004	3.041	8.030	1.826	266.5	1116.	0.82
90.0	7.960	3.050	7.995	1.818	264.8	1108.	0.82
95.0	7.952	3.058	7.978	1.818	264.8	1108.	0.82
100.0	7.899	3.041	7.926	1.800	264.8	1108.	0.82
105.0	7.899	3.050	7.926	1.800	264.8	1108.	0.82
110.0	7.960	3.058	7.995	1.818	264.8	1108.	0.82
115.0	8.013	3.076	8.048	1.826	265.6	1112.	0.82
120.0	8.004	3.050	8.030	1.826	266.5	1116.	0.82
125.0	7.934	2.997	7.969	1.809	267.4	1119.	0.83
130.0	7.960	2.980	7.995	1.818	268.3	1123.	0.83
135.0	8.109	2.988	8.135	1.852	270.0	1130.	0.84
140.0	8.118	2.962	8.144	1.852	270.9	1134.	0.84
145.0	8.153	2.927	8.188	1.861	271.8	1138.	0.84
150.0	8.205	2.884	8.240	1.870	273.5	1145.	0.85
155.0	8.231	2.840	8.266	1.879	273.5	1145.	0.85
160.0	8.310	2.805	8.336	1.896	276.1	1156.	0.85
165.0	8.327	2.744	8.354	1.896	274.4	1148.	0.85
170.0 <sup>2)</sup>	0.332	0.107	0.333	0.076	275.3	1153.	0.85
175.0	0.000	0.000	0.000	0.000	0.000	0.000	0.00

\* All numerical values of characteristics are presented as average values at the length interval equal to the axial coordinate  $\pm 2.5$  mm<sup>1)</sup> Initial coordinate of fuel is 25.7 mm<sup>2)</sup> End coordinate of fuel is 167.7 mm<sup>3)</sup> Current value per maximum value

# #H15T

Individual Characteristics of Refabricated Fuel Rods  
(Fresh Fuel, Preirradiated Cladding) under IGR Tests

Table H-2.3. Radial Energy Characteristics of Fuel Rod #H15T

Characteristics*		Coordinates of fuel zones (mm)			
		1 zone 1.10 - 2.12	2 zone 2.12 - 2.79	3 zone 2.79 - 3.32	4 zone 3.32 - 3.79
U <sup>235</sup>	Number of fissions $\times 10^{-14}$ (fiss)	5.671	5.750	5.968	6.222
	Power of fuel rod <sup>1)</sup> (kW)	12.93	13.02	13.54	14.16
	Energy deposition <sup>2)</sup> (cal/g fuel)	264.8	268.3	278.7	291.0
	Energy deposition <sup>2)</sup> (J/g fuel)	1108	1123	1167	1218
	Energy deposition <sup>3)</sup> (per-unit)	0.91	0.922	0.958	1.000
U <sup>238</sup>	Number of fissions $\times 10^{-12}$ (fiss)	2.106	2.132	2.115	2.053
	Power of fuel rod <sup>1)</sup> (kW)	0.047	0.048	0.047	0.046
	Energy deposition <sup>2)</sup> (cal/g fuel)	0.970	0.987	0.970	0.944
	Energy deposition <sup>2)</sup> (J/g fuel)	4.063	4.133	4.063	3.950
	Energy deposition <sup>3)</sup> (per-unit)	0.982	1.000	0.982	0.956
Total	Number of fissions $\times 10^{-14}$ (fiss)	5.697	5.767	5.986	6.248
	Power of fuel rod <sup>1)</sup> (kW)	12.93	13.11	13.63	14.16
	Energy deposition <sup>2)</sup> (cal/g fuel)	265.6	269.1	279.6	291.9
	Energy deposition <sup>2)</sup> (J/g fuel)	1112	1126	1171	1222
	Energy deposition <sup>3)</sup> (per-unit)	0.910	0.922	0.958	1.000

<sup>1)</sup> at time of 2.85 s,      <sup>2)</sup> at infinite time,      <sup>3)</sup> Current value per maximum value

\* All numerical values of characteristics were calculated for length of fuel stack



# #H15T

Individual Characteristics of Refabricated Fuel Rods  
(Fresh Fuel, Preirradiated Cladding) under IGR Tests

Table H-2.4. Fuel Enthalpy Vs. Time Calculated by FRAP-T6 Code for Fuel Rod #H15T

Time (s)	Enthalpy at fuel radius (cal/g fuel)				Fuel enthalpy <sup>1)</sup>		Energy deposition in fuel rod	
	1.10 mm	2.22 mm	2.89 mm	3.79 mm	cal/g fuel	J/g fuel	cal/g fuel	J/g fuel
0.0	0.00	0.00	0.00	0.00	0.00	0.00	0.00	0.00
1.0	3.03	2.99	2.88	2.57	2.86	12.0	2.77	11.6
2.0	18.3	17.9	17.1	14.6	17.0	71.1	17.2	72.2
2.2	26.6	26.1	24.7	20.2	24.4	102	25.0	105
2.4	41.4	40.5	38.2	28.9	37.4	157	38.6	162
2.6	68.2	66.8	62.5	41.1	60.3	253	62.9	264
2.8	110	108	99.4	48.5	93.4	391	101	422
3.0	157	152	136	45.5	124	521	143	598
3.2	194	187	158	66.6	149	626	177	740
3.4	219	207	171	95.8	168	703	200	840
3.6	235	219	180	119	182	763	216	907
3.8	244	225	187	126	190	795	227	953
4.0	249	227	191	129	193	810	235	985
4.2	250	228	192	129	195	815	241	1008
4.4	250	228	192	129	194	814	245	1025
4.6	249	226	190	129	193	808	248	1039
4.8	247	224	188	128	191	800	250	1049
5.0	244	222	185	126	189	790	252	1058
5.2	242	219	183	125	186	780	254	1064
5.4	238	215	180	123	183	768	255	1070
5.6	235	212	176	122	180	755	257	1075
5.8	231	208	173	120	177	742	258	1079
6.0	227	204	170	116	174	727	258	1083
6.5	217	194	158	101	161	677	260	1089
7.0	206	181	144	94.0	149	626	261	1094
7.5	193	167	132	88.8	138	580	262	1098
8.0	179	153	122	84.4	128	538	263	1101
10.0	124	110	93.3	70.7	96.3	403	265	1111
30.0	13.8	13.6	13.2	12.4	13.3	55.5	271	1138

Radial enthalpy distribution and fuel enthalpy are presented at elevation 32.8 mm

Maximum value of fuel enthalpy is 194.6 cal/g fuel (t=4.24 s)

<sup>1)</sup> All numerical values are presented at elevation with peak power

# #H15T

Individual Characteristics of Refabricated Fuel Rods  
(Fresh Fuel, Preirradiated Cladding) under IGR Tests

Table H-2.5. Energy Characteristics Vs. Time Calculated by FRAP-T6 and SCANAIR Codes for Fuel Rod #H15T

Time (s)	Energy deposition <sup>1)</sup> (cal/g fuel)	Linear power <sup>1)</sup> (kW/m)	Fuel enthalpy <sup>1)</sup> (cal/g fuel)		Energy of metal-water reaction <sup>1)</sup> (cal/g fuel)	Leakage of energy <sup>1)</sup> (cal/g fuel)		Clad-to-coolant heat transfer coefficient <sup>1)</sup> (kW/m <sup>2</sup> K)	
			FRAP-T6	SCANAIR	FRAP-T6	FRAP-T6	SCANAIR	FRAP-T6	SCANAIR
0.0	0.00	0.00	0.00	0.00	0.00	0.00	0.00	0.00	0.00
1.0	3.11	13.1	2.86	3.15	0.00	0.00	0.01	0.03	0.10
2.0	19.3	59.2	17.0	19.4	0.00	0.35	0.90	2.20	3.49
2.2	28.0	98.1	24.4	26.8	0.00	1.37	2.15	4.07	5.50
2.4	43.3	177	37.4	41.8	0.00	3.29	4.70	7.14	9.77
2.6	70.6	309	60.3	69.0	0.00	7.10	9.81	13.4	18.6
2.8	113	420	93.4	102	0.00	15.3	18.6	25.7	31.7
3.0	160	385	124	141	0.00	26.5	26.5	3.96	1.30
3.2	198	281	149	-	0.00	29.1	-	1.29	-
3.4	225	191	168	-	0.00	33.1	-	1.39	-
3.6	243	129	182	-	0.02	37.5	-	1.38	-
3.8	255	88.6	190	-	0.06	41.9	-	1.39	-
4.0	264	62.8	193	-	0.13	46.4	-	1.41	-
4.2	270	45.8	195	-	0.22	51.1	-	1.42	-
4.4	274	34.5	194	-	0.33	55.9	-	1.43	-
4.6	278	26.6	193	-	0.45	60.8	-	1.44	-
4.8	281	21.0	191	-	0.56	65.8	-	1.44	-
5.0	283	17.0	189	-	0.66	70.7	-	1.43	-
5.2	285	14.3	186	-	0.75	75.1	-	1.43	-
5.4	286	11.9	183	-	0.83	80.0	-	1.43	-
5.6	288	10.0	180	-	0.90	84.8	-	1.42	-
5.8	289	8.57	177	-	0.95	91.2	-	2.89	-
6.0	290	7.37	174	-	0.97	103	-	6.31	-
6.5	291	5.28	161	-	0.97	134	-	14.5	-
7.0	293	4.03	149	-	0.97	148	-	12.8	-
7.5	294	3.25	138	-	0.97	161	-	11.6	-
8.0	295	2.73	128	-	0.97	172	-	10.7	-
10.0	297	1.86	96.3	-	0.97	209	-	7.95	-
30.0	304	0.25	13.3	-	0.97	304	-	0.67	-

<sup>1)</sup> All numerical values are presented at elevation with peak power

# #H15T

Individual Characteristics of Refabricated Fuel Rods  
(Fresh Fuel, Preirradiated Cladding) under IGR Tests

Table H-2.6. Temperature Variation, Fission Gas Release and ZrO<sub>2</sub> Thickness Vs. Time for Fuel Rod #H15T Calculated by FRAP-T6 and SCANAIR Codes

Time (s)	Fuel centerline temperature <sup>1)</sup> (K)		Fuel surface temperature <sup>1)</sup> (K)		Clad outer temperature <sup>1)</sup> (K)		Average ZrO <sub>2</sub> <sup>2)</sup> thickness (μm)
	FRAP-T6	SCANAIR	FRAP-T6	SCANAIR	FRAP-T6	SCANAIR	FRAP-T6
0.0	293	293	293	293	293	293	5.00
1.0	345	343	338	342	307	307	5.00
2.0	578	590	524	558	391	385	5.00
2.2	696	698	605	642	398	389	5.00
2.4	899	907	727	793	406	395	5.00
2.6	1253	1279	895	1006	417	405	5.00
2.8	1778	1744	994	1135	433	416	5.00
3.0	2286	2286	954	1272	666	894	5.00
3.2	2613	-	1233	-	1083	-	5.00
3.4	2799	-	1603	-	1237	-	5.03
3.6	2905	-	1880	-	1221	-	5.07
3.8	2962	-	1961	-	1234	-	5.10
4.0	2990	-	1992	-	1257	-	5.15
4.2	3000	-	2002	-	1278	-	5.21
4.4	3000	-	2000	-	1292	-	5.27
4.6	2992	-	1992	-	1299	-	5.35
4.8	2979	-	1980	-	1301	-	5.43
5.0	2963	-	1966	-	1299	-	5.50
5.2	2947	-	1951	-	1293	-	5.56
5.4	2926	-	1934	-	1285	-	5.63
5.6	2903	-	1915	-	1275	-	5.68
5.8	2879	-	1889	-	1190	-	5.72
6.0	2853	-	1850	-	1009	-	5.73
6.5	2783	-	1669	-	419	-	5.73
7.0	2705	-	1581	-	416	-	5.73
7.5	2609	-	1516	-	414	-	5.73
8.0	2494	-	1461	-	413	-	5.73
10.0	1943	-	1286	-	407	-	5.73
30.0	512	-	492	-	383	-	5.73

<sup>1)</sup> All numerical values are presented at elevation with peak power

<sup>2)</sup> Initial ZrO<sub>2</sub> thickness is 5 μm

# #H15T

Individual Characteristics of Refabricated Fuel Rods  
(Fresh Fuel, Preirradiated Cladding) under IGR Tests

Table H-2.7. Mechanical Characteristics of Fuel Rod #H15T Vs. Time Calculated by FRAP-T6 and SCANAIR Codes

Time (s)	Clad outer temperature <sup>1)</sup> (K)		Fuel hoop strain <sup>1)</sup> (%)		Fuel - clad gap width <sup>1)</sup> (mm)		Clad hoop strain <sup>1)</sup> (%)		Clad hoop stress <sup>1)</sup> (MPa)		Internal gas pressure (MPa)	
	FRAP-T6	SCANAIR	FRAP-T6	SCANAIR	FRAP-T6	SCANAIR	FRAP-T6	SCANAIR	FRAP-T6	SCANAIR	FRAP-T6	SCANAIR
0.0	293	293	0.00	0.00	0.07	0.07	0.01	0.01	8.71	8.68	1.70	1.70
1.0	307	307	0.00	0.04	0.07	0.07	0.02	0.02	8.88	8.90	1.73	1.73
2.0	391	385	0.20	0.23	0.07	0.06	0.08	0.09	9.39	9.70	1.83	1.84
2.2	398	389	0.32	0.32	0.06	0.06	0.09	0.09	9.55	9.99	1.85	1.86
2.4	406	395	0.53	0.51	0.05	0.05	0.10	0.11	9.75	10.5	1.89	1.90
2.6	417	405	0.92	0.91	0.04	0.04	0.12	0.13	10.0	11.5	1.94	1.94
2.8	433	416	1.57	1.46	0.02	0.02	0.15	0.18	10.3	12.8	1.99	1.96
3.0	666	894	2.24	2.13	0.00	0.01	0.36	0.50	111	11.2	2.03	1.99
3.2	1083	-	2.72	-	0.00	-	0.76	-	45.3	-	2.04	-
3.4	1237	-	3.04	-	0.09	-	3.01	-	11.3	-	2.04	-
3.6	1221	-	3.24	-	0.37	-	10.4	-	0.00	-	0.10	-
3.8	1234	-	3.35	-	0.37	-	10.4	-	0.00	-	0.10	-
4.0	1257	-	3.41	-	0.37	-	10.4	-	0.00	-	0.10	-
4.2	1278	-	3.43	-	0.37	-	10.4	-	0.00	-	0.10	-
4.4	1292	-	3.42	-	0.37	-	10.5	-	0.00	-	0.10	-
4.6	1299	-	3.40	-	0.37	-	10.5	-	0.00	-	0.10	-
4.8	1301	-	3.38	-	0.37	-	10.5	-	0.00	-	0.10	-
5.0	1299	-	3.34	-	0.37	-	10.5	-	0.00	-	0.10	-
5.2	1293	-	3.31	-	0.37	-	10.5	-	0.00	-	0.10	-
5.4	1285	-	3.27	-	0.37	-	10.5	-	0.00	-	0.10	-
5.6	1275	-	3.22	-	0.37	-	10.4	-	0.00	-	0.10	-
5.8	1190	-	3.17	-	0.37	-	10.4	-	0.00	-	0.10	-
6.0	1009	-	3.12	-	0.38	-	10.6	-	0.00	-	0.10	-
6.5	419	-	2.95	-	0.38	-	10.2	-	0.00	-	0.10	-
7.0	416	-	2.77	-	0.39	-	10.2	-	0.00	-	0.10	-
7.5	414	-	2.59	-	0.40	-	10.2	-	0.00	-	0.10	-
8.0	413	-	2.40	-	0.40	-	10.2	-	0.00	-	0.10	-
10.0	407	-	1.69	-	0.43	-	10.2	-	0.00	-	0.10	-
30.0	383	-	0.13	-	0.49	-	10.2	-	0.00	-	0.10	-

<sup>1)</sup> All numerical values are presented at elevation with peak power

# #H15T

Individual Characteristics of Refabricated Fuel Rods  
(Fresh Fuel, Preirradiated Cladding) under IGR Tests

Table H-2.8. Axial Distribution of Energy Deposition and Fuel Enthalpy Calculated by FRAP-T6 Code for Fuel Rod #H15T

Axial interval from-to (mm)-(mm)	Energy deposition at infinite time			Fuel enthalpy at time (t=4.24 s)		
	cal/g fuel	J/g fuel	per-unit	cal/g fuel	J/g fuel	per-unit
25.7 - 39.9	311	1301	1.00	195	816	1.00
39.9 - 54.1	290	1214	0.93	182	761	0.93
54.1 - 68.3	277	1160	0.89	174	727	0.89
68.3 - 82.5	271	1135	0.87	170	711	0.87
82.5 - 96.7	266	1114	0.86	167	698	0.86
96.7 - 110.9	266	1114	0.86	167	698	0.86
110.9 - 125.1	269	1127	0.87	169	707	0.87
125.1 - 139.3	272	1139	0.88	170	714	0.88
139.3 - 153.5	275	1150	0.88	172	721	0.88
153.5 - 167.7	276	1156	0.89	173	724	0.89

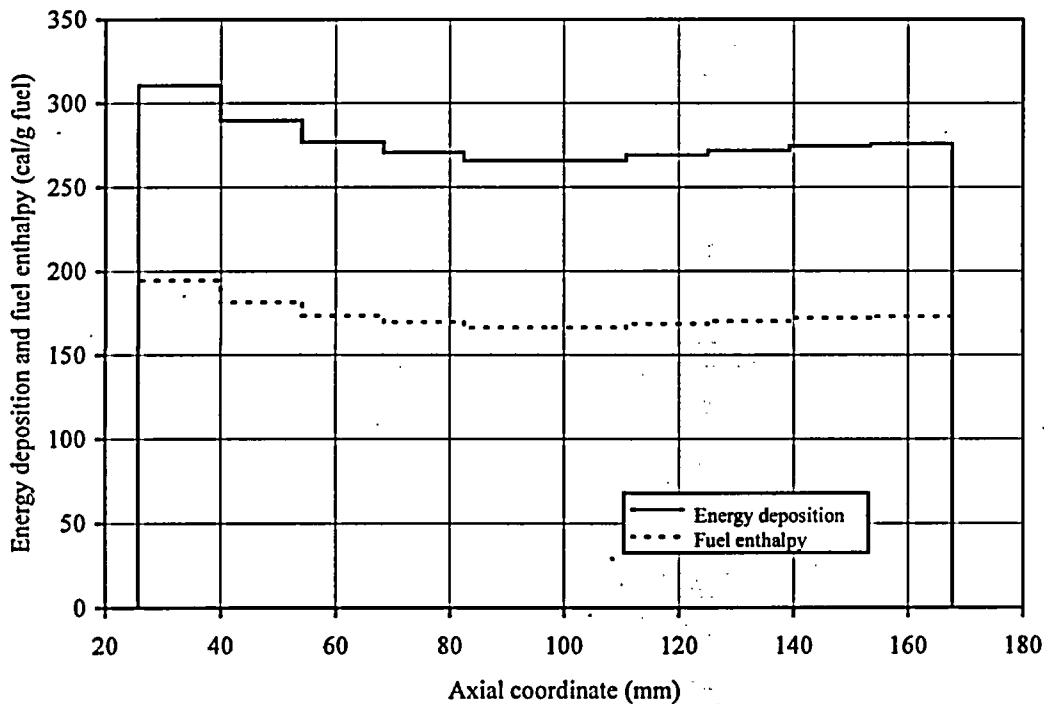

Fig. H-2.4. Axial Distribution of Energy Deposition and Fuel Enthalpy Calculated by FRAP-T6 Code for Fuel Rod #H15T

# #H15T

Individual Characteristics of Refabricated Fuel Rods  
(Fresh Fuel, Preirradiated Cladding) under IGR Tests

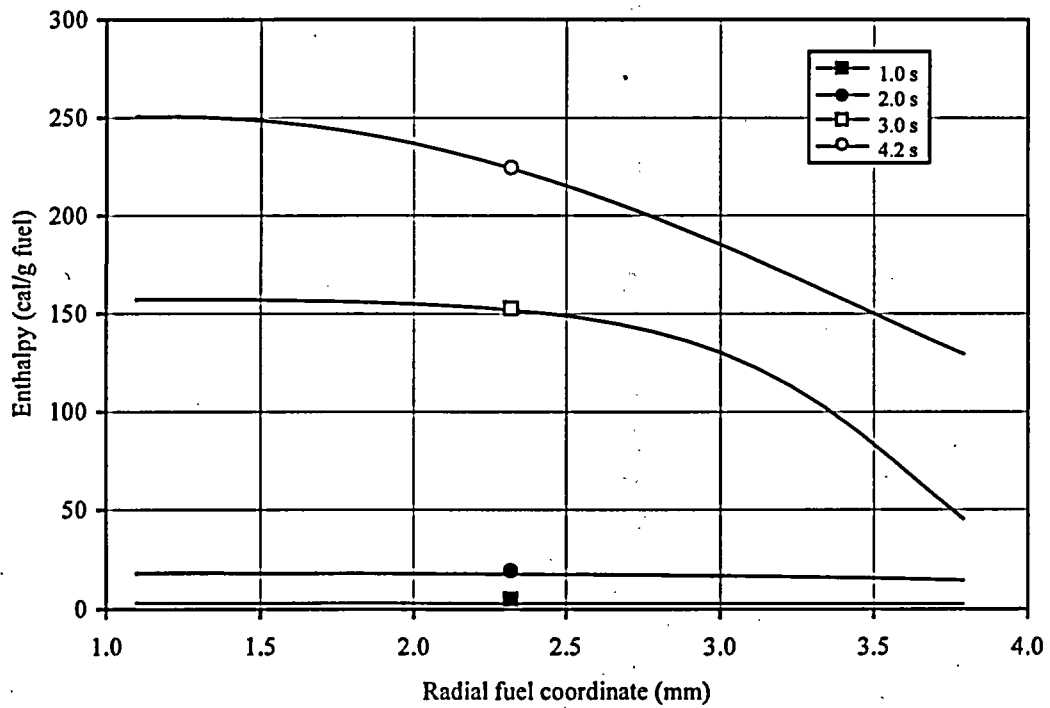
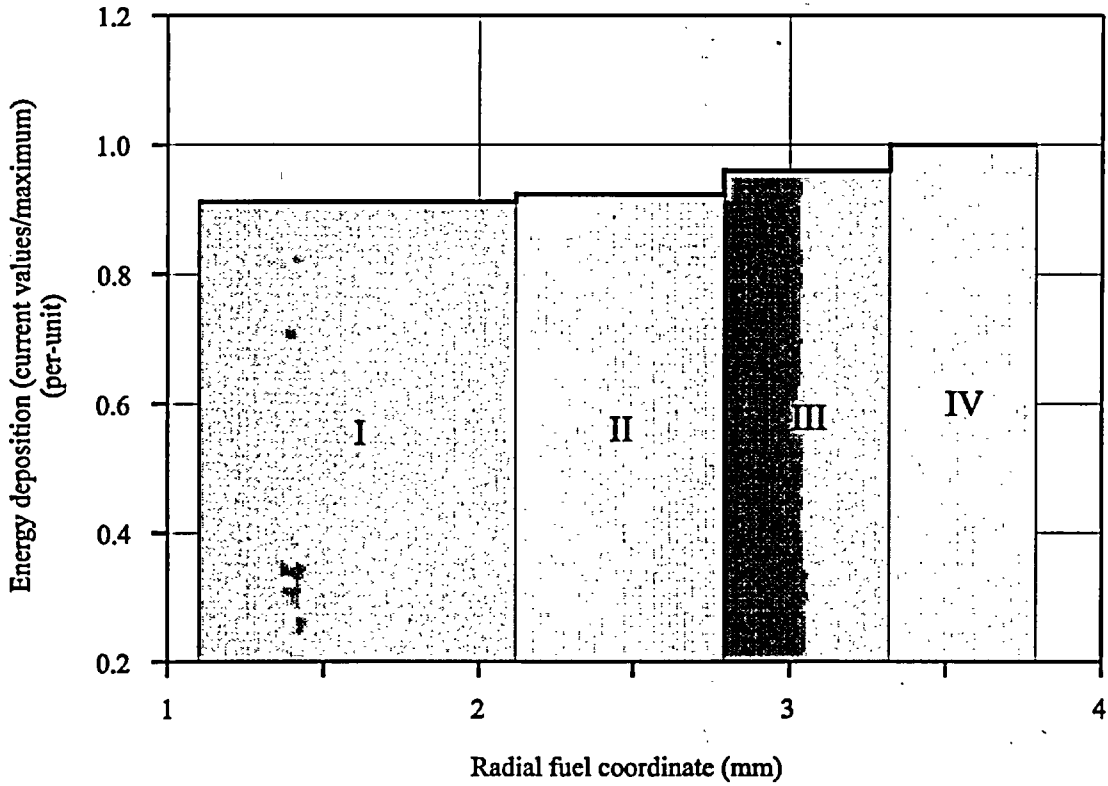

Fig. H-2.5. Radial Distributions of Energy Deposition and Fuel Enthalpy Calculated by FRAP-T6 Code for Fuel Rod #H15T

#H15T

Individual Characteristics of Refabricated Fuel Rods  
(Fresh Fuel, Preirradiated Cladding) under IGR Tests

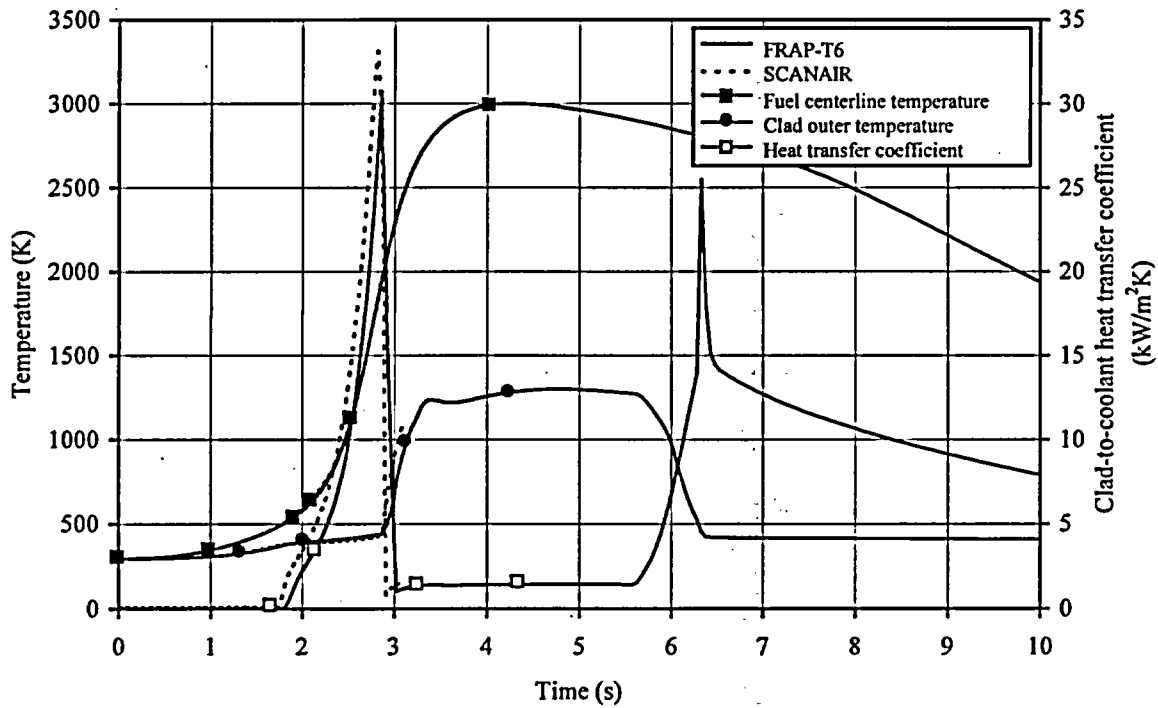
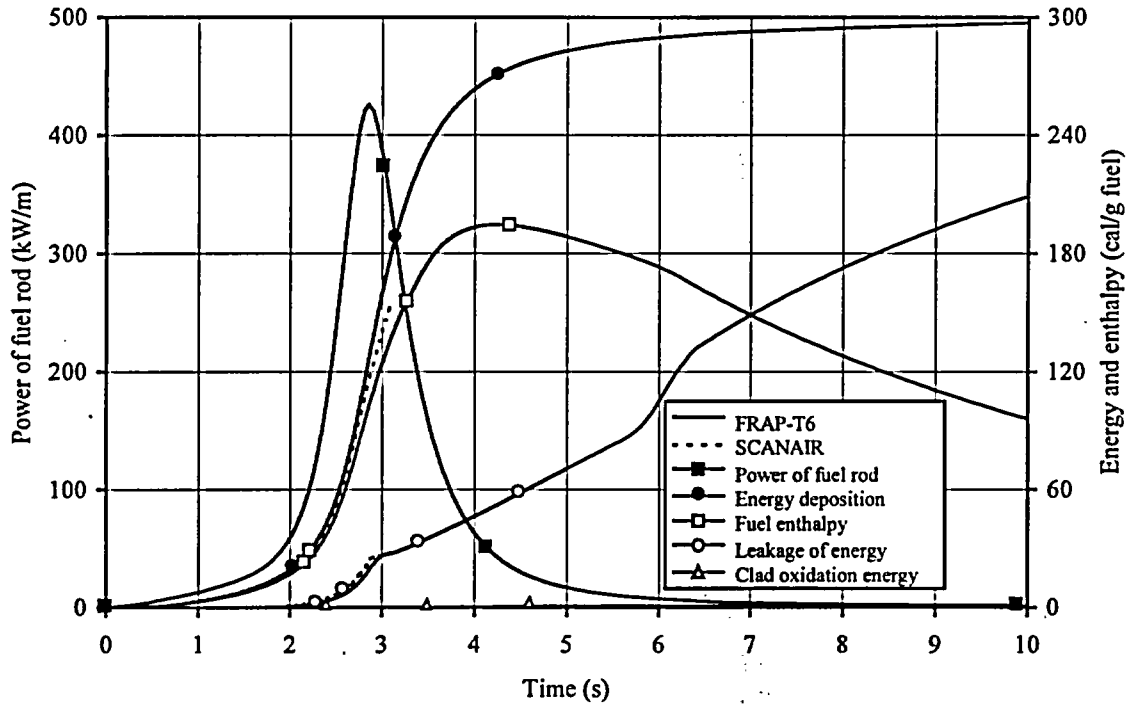

Fig. H-2.6. Energy and Temperature Characteristics Vs. Time Calculated by FRAP-T6 and SCANAIR Codes for Fuel Rod #H15T

# #H15T

Individual Characteristics of Refabricated Fuel Rods  
(Fresh Fuel, Preirradiated Cladding) under IGR Tests

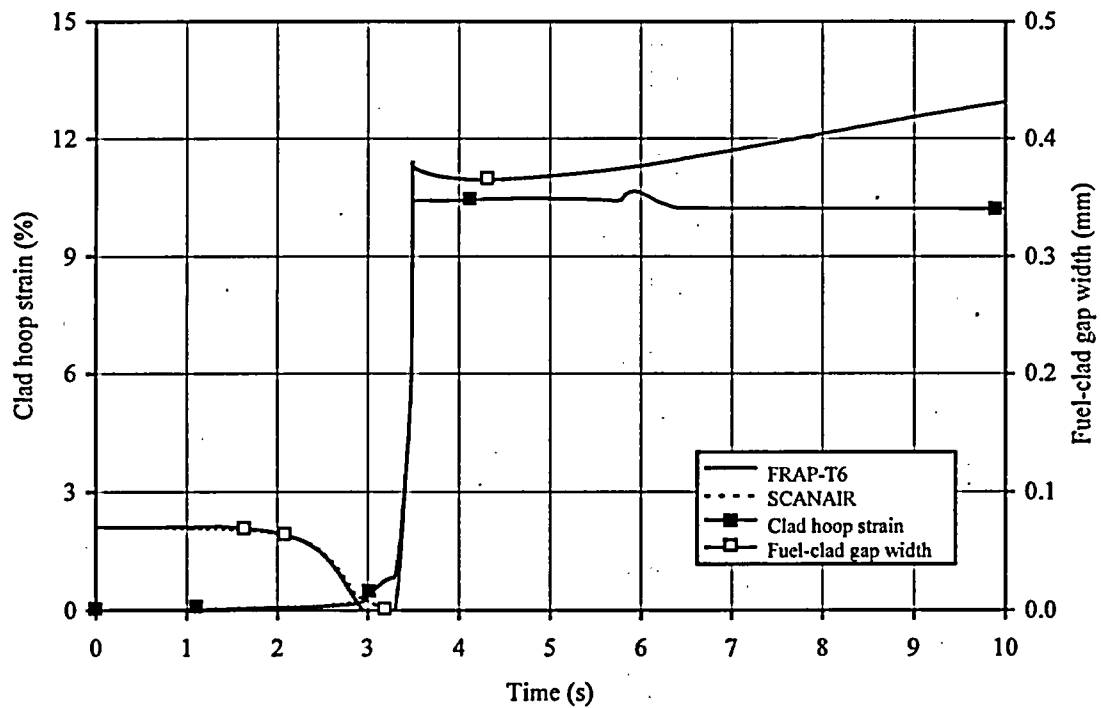
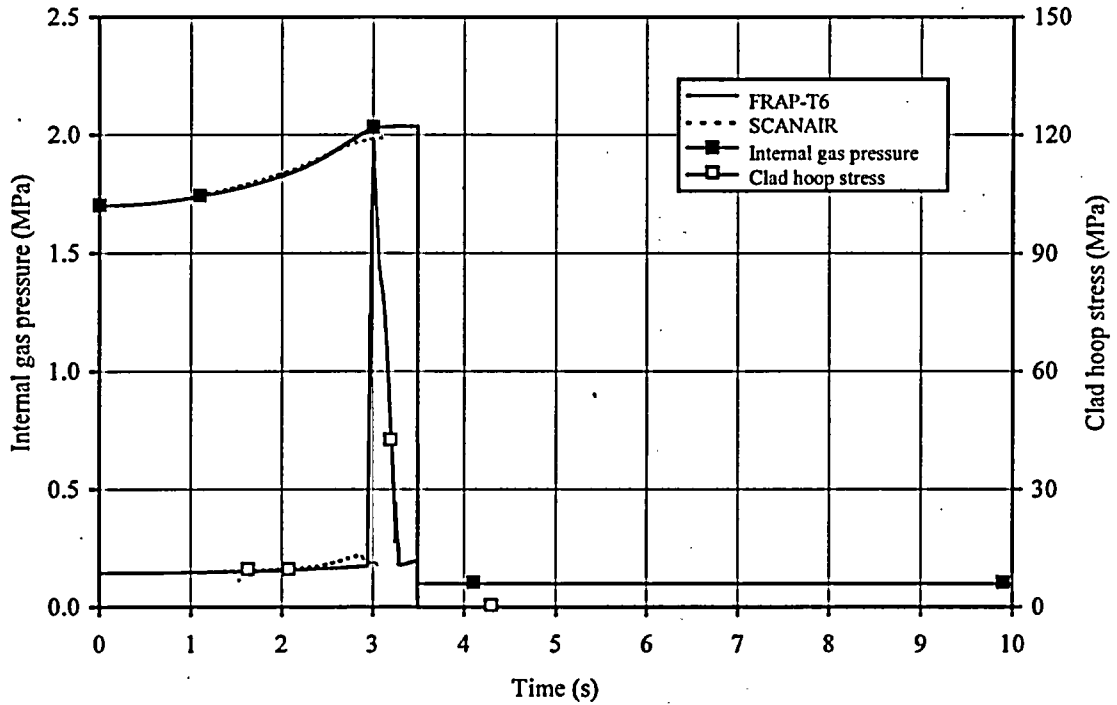

Fig. H-2.7. Cladding Mechanical Characteristics Vs. Time Calculated by FRAP-T6 and SCANAIR Codes for Fuel Rod #H15T



# #H15T

Individual Characteristics of Refabricated Fuel Rods  
(Fresh Fuel, Preirradiated Cladding) under IGR Tests

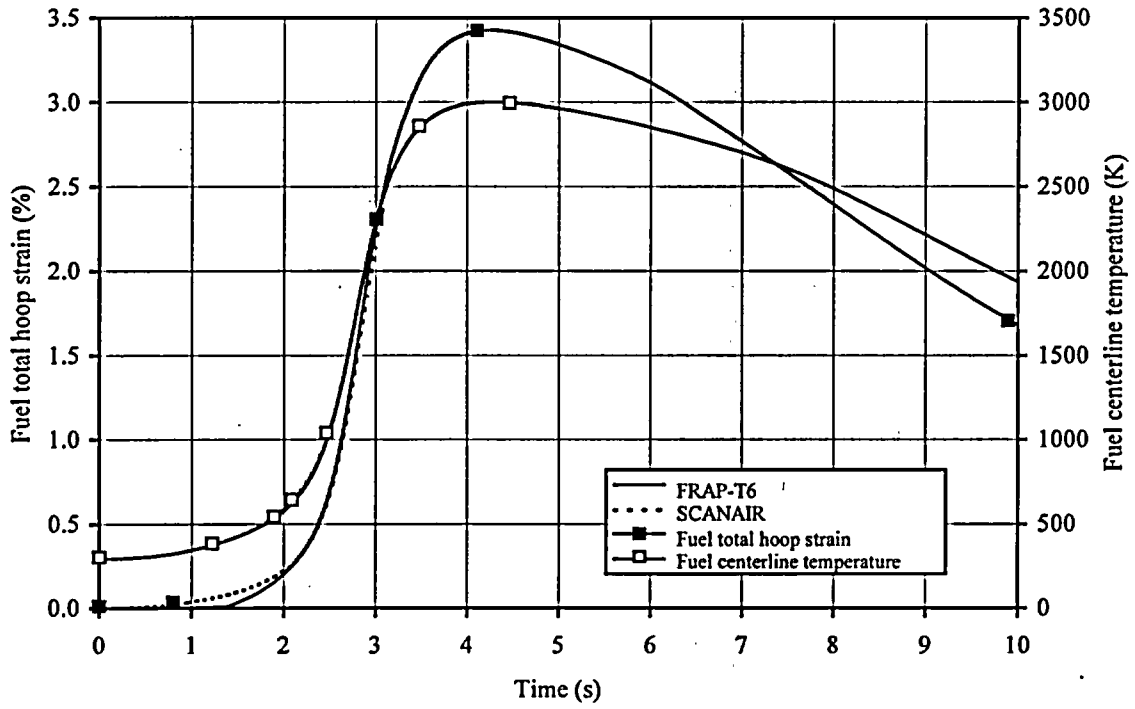

Fig. H-2.8. Fuel Strain Vs. Time Calculated by FRAP-T6 and SCANAIR Codes for Fuel Rod #H15T

# #H15T

Individual Characteristics of Refabricated Fuel Rods  
(Fresh Fuel, Preirradiated Cladding) under IGR Tests

Table H-2.9. Some Results of PIE for Fuel Rod #H15T

Characteristic		Value
1.	Measured parameters of cladding oxidation and cladding deformation	
1.1.	Cladding thickness at elevation 117 mm for different azimuthal angles ( $\mu\text{m}$ ):	
	0°	700
	90°	R
	180°	600
	270°	600
1.2.	ZrO <sub>2</sub> thickness at elevation 117 mm for different azimuthal angles ( $\mu\text{m}$ ):	
	0°	5
	90°	5
	180°	5
	270°	5
1.3.	$\alpha\text{Zr(O)}$ thickness at elevation 117 mm for different azimuthal angles ( $\mu\text{m}$ ):	
	0°	0
	90°	0
	180°	0
	270°	0
1.4.	Clad hoop strain at elevation 117 mm (%)	9.6
2.	Measured parameters for FGR analysis	
2.1.	Internal gas composition (% by volume):	
	He	—
	N <sub>2</sub>	—
	O <sub>2</sub>	—
	Ar	—
	CO <sub>2</sub>	—
	Kr	—
	Xe	—
2.2.	Free gas volume (cm <sup>3</sup> )	—
2.3.	Gas pressure inside fuel rod under normal condition (MPa)	—
2.4.	Kr concentration in fuel (cm <sup>3</sup> /g fuel)	—
3.	Measured parameters of cladding hydriding	
3.1.	Coefficient of hydride orientation (per-unit)	—
3.2.	Hydrogen concentration (% by weight)	—

# #H15T

Individual Characteristics of Refabricated Fuel Rods  
(Fresh Fuel, Preirradiated Cladding) under IGR Tests

Table H-2.10. General Characteristic of Fuel Rod #H15T

	Parameter	Unit	Value		
			Experiment	FRAP-T6	SCANAIR
1	Type of coolant	---	water	water	water
2	Burnup	MWd/kg U	0	0	0
3	Energy deposition in fuel rod	cal/g fuel	277	277	277
4	Peak fuel enthalpy	cal/g fuel	-	195	-
5	Peak fuel temperature	K	-	3001	-
6	Peak clad temperature	K	-	1301	-
7	Fuel rod failure	Yes, No	Yes	Yes	-
8	Type of failure:				
	- cladding rupture due to ballooning	Yes, No	Yes	Yes	-
	- cladding rupture due to PCMI	Yes, No	No	No	-
	- fragmentation of fuel rod	Yes, No	No	-	-
9	Failure time	s	-	3.49	-
10	Fuel enthalpy at failure	cal/g fuel	-	175	-
11	Outer cladding temperature at failure	K	-	1230	-
12	Internal gas pressure at failure	MPa	-	2.04	-
13	ZrO <sub>2</sub> thickness after test	µm	5.0	5.73	-
14	Residual clad hoop strain:				
	- peak value for ballooning area	%	9.6	10.13	-
	- other location <sup>1)</sup>	%	-	0.45	-

<sup>1)</sup>Calculated values by FRAP-T6 and SCANAIR codes are average along height of fuel rod excluding ballooning region

*APPENDIX H-3.*

*Individual Characteristics for Fuel Rod #H16T under IGR Test*

# #H16T

Individual Characteristics of Refabricated Fuel Rods  
(Fresh Fuel, Preirradiated Cladding) under IGR Tests

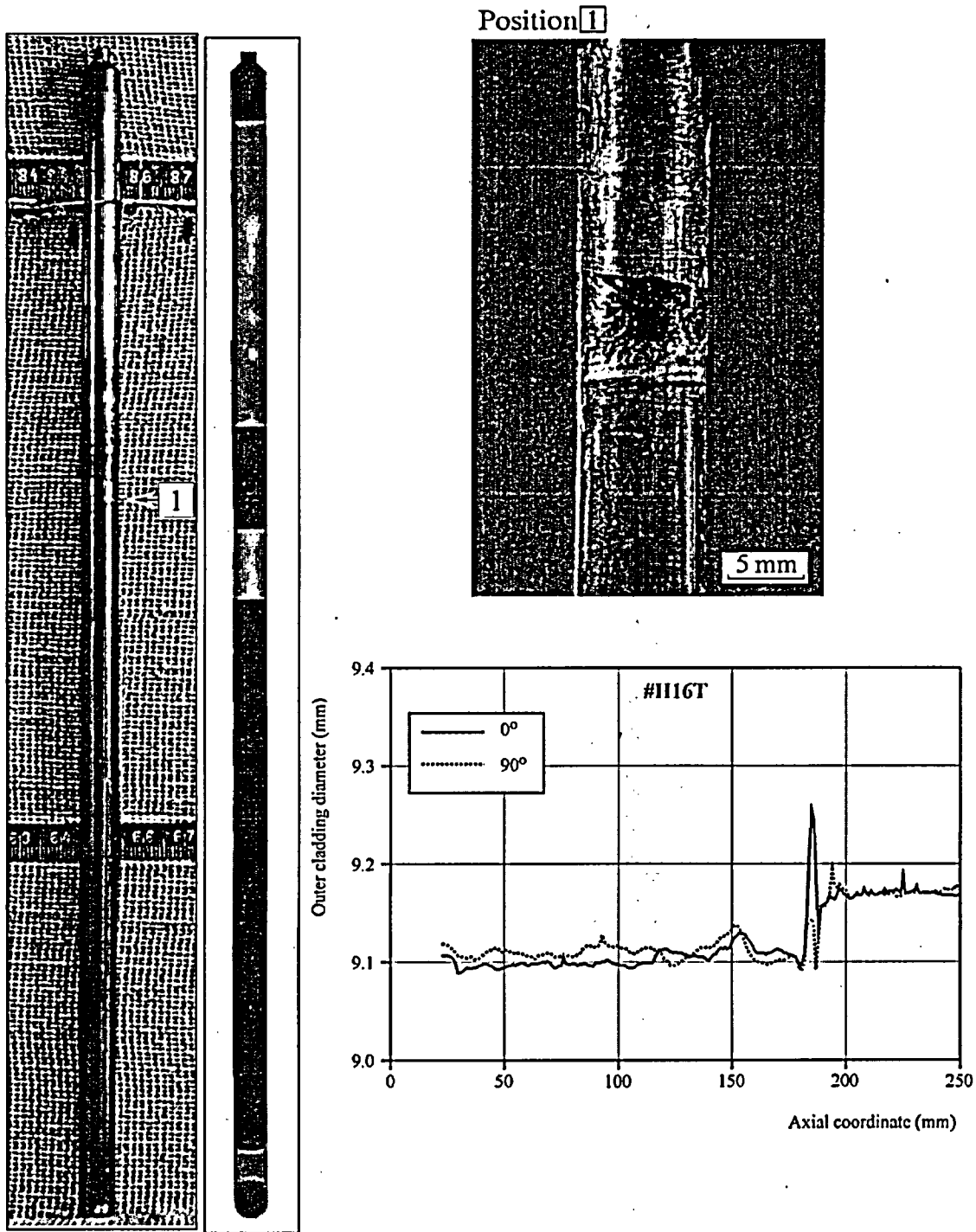
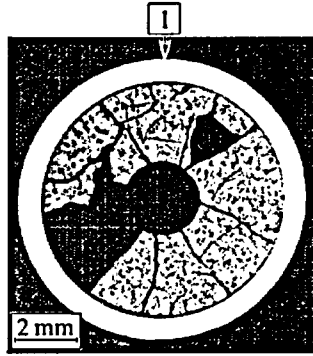

Fig. H-3.1. Appearance of Fuel Rod #H16T (photographs and X-ray photograph) and Profilometry

#H16T

Individual Characteristics of Refabricated Fuel Rods  
(Fresh Fuel, Preirradiated Cladding) under IGR Tests



Position 1

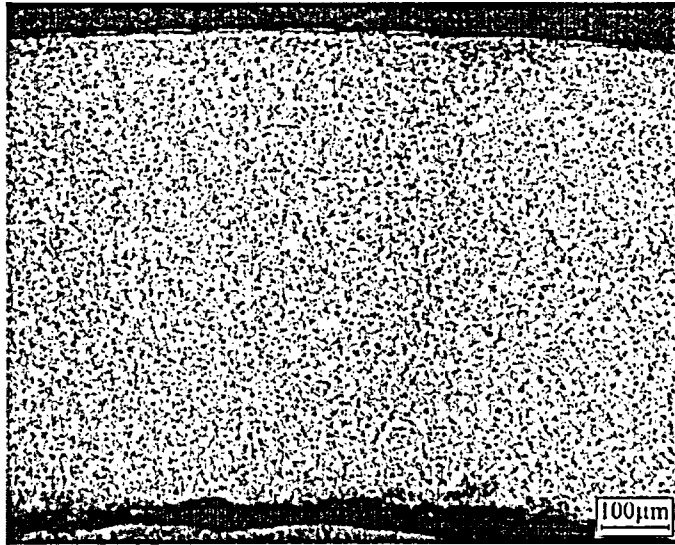

Position 1

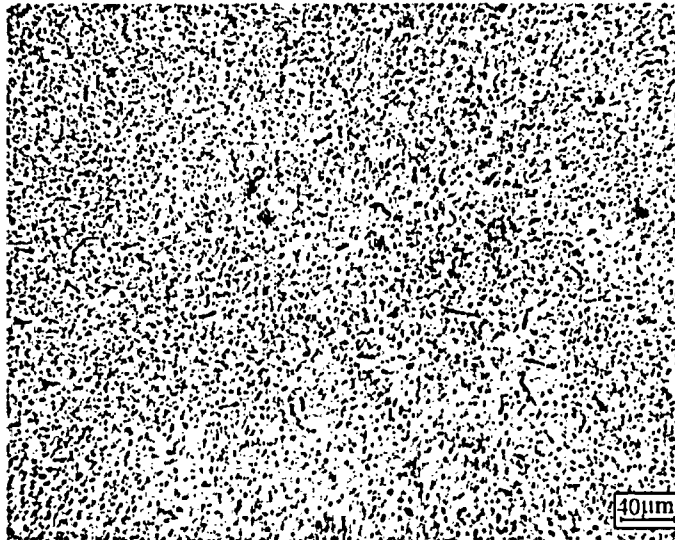
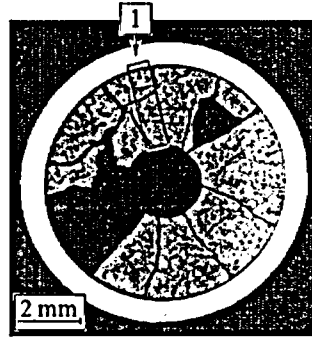
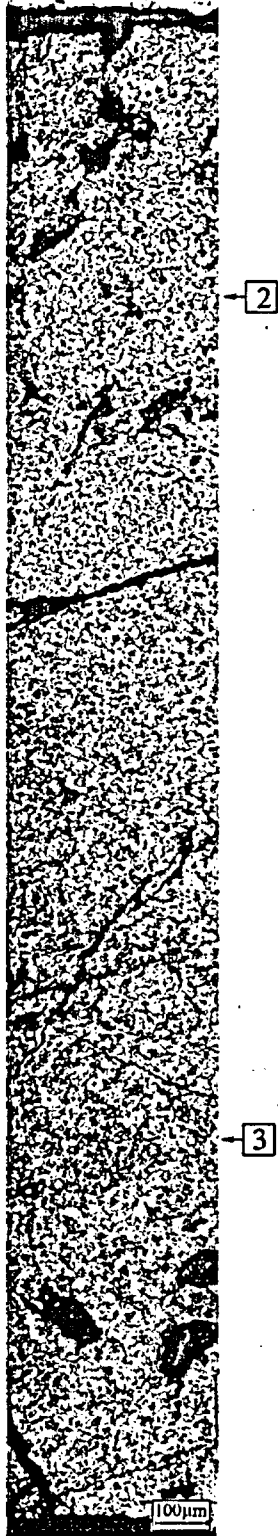

Fig. H-3.2. Cross-Section and Cladding Microstructure for Fuel Rod #H16T at 95 mm Elevation

#H16T

Individual Characteristics of Refabricated Fuel Rods  
(Fresh Fuel, Preirradiated Cladding) under IGR Tests

Position 1



Position 2

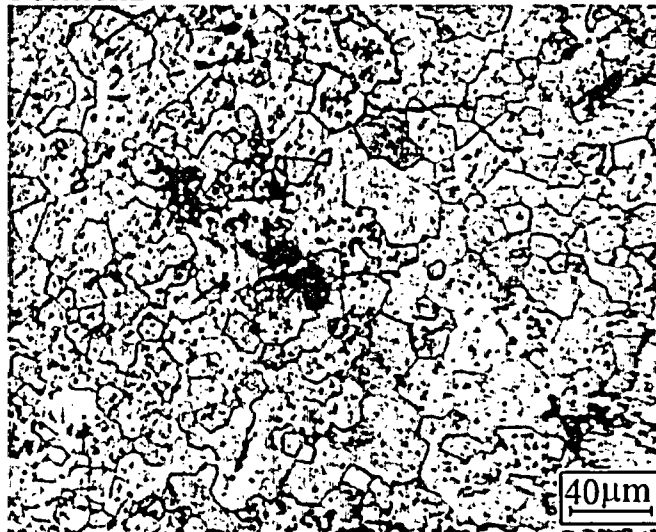

Position 3

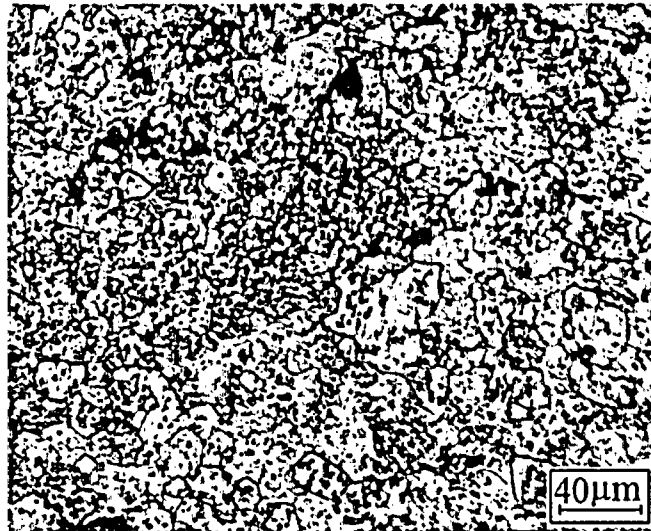

Fig. H-3.3. Fuel Microstructure for Fuel Rod #H16T at 95 mm Elevation

# #H16T

Individual Characteristics of Refabricated Fuel Rods  
(Fresh Fuel, Preirradiated Cladding) under IGR Tests

Table H-3.1. Time Dependent Energy Characteristics of Fuel Rod #H16T

Time (s)	Reactor energy deposition <sup>1)</sup> (%)	Cumulative number of fissions in fuel rod (fiss)			Power of fuel rod (kW)	Energy deposition in fuel rod	
		U <sup>235</sup> ×10 <sup>-14</sup>	U <sup>238</sup> ×10 <sup>-12</sup>	Total ×10 <sup>-14</sup>		cal/g fuel	J/g fuel
0.0	0.000	0.000	0.000	0.000	0.000	0.000	0.000
1.0	0.473	0.078	0.028	0.078	0.441	0.895	3.750
2.0	1.890	0.313	0.112	0.314	0.884	3.580	15.00
2.2	2.290	0.378	0.135	0.380	0.972	4.340	18.20
2.4	2.730	0.450	0.161	0.452	1.060	5.160	21.60
2.6	3.200	0.529	0.189	0.530	1.150	6.060	25.40
2.8	3.710	0.613	0.219	0.615	1.240	7.030	29.40
3.0	4.260	0.704	0.252	0.706	1.330	8.070	33.80
3.2	4.850	0.801	0.286	0.803	1.420	9.180	38.40
3.4	5.470	0.904	0.323	0.907	1.510	10.40	43.50
3.6	6.130	1.010	0.362	1.020	1.610	11.60	48.60
3.8	6.860	1.130	0.405	1.140	1.810	13.00	54.40
4.0	7.710	1.270	0.455	1.280	2.190	14.60	61.10
4.2	8.790	1.450	0.519	1.460	2.930	16.70	69.90
4.4	10.30	1.710	0.610	1.710	4.420	19.60	82.00
4.6	12.80	2.120	0.757	2.120	7.500	24.30	102.0
4.8	17.20	2.840	1.020	2.850	13.60	32.60	136.0
5.0	25.10	4.140	1.480	4.160	23.60	47.50	199.0
5.2	37.60	6.210	2.220	6.230	34.10	71.10	298.0
5.4	53.20	8.780	3.140	8.820	36.80	101.0	423.0
5.6	67.40	11.10	3.980	11.20	28.30	128.0	536.0
5.8	77.10	12.70	4.550	12.80	17.40	146.0	611.0
6.0	82.80	13.70	4.890	13.70	10.10	157.0	657.0
6.5	89.00	14.70	5.260	14.80	3.470	169.0	707.0
7.0	91.70	15.10	5.410	15.20	1.960	174.0	728.0
7.5	93.30	15.40	5.510	15.50	1.350	177.0	741.0
8.0	94.40	15.60	5.580	15.60	0.898	180.0	753.0
9.0	95.90	15.80	5.660	15.90	0.611	183.0	766.0
10.0	96.80	16.00	5.710	16.00	0.336	185.0	774.0
20.0	98.70	16.30	5.830	16.40	0.053	189.0	791.0
30.0	99.10	16.40	5.860	16.40	0.025	191.0	800.0
∞	100.0	16.50	5.910	16.60	0.000	195.0	816.0

Maximum value of power is 37.3 kW (t = 5.35 s)

<sup>1)</sup> Current energy deposition per maximum energy deposition (at infinite time)



# #H16T

Individual Characteristics of Refabricated Fuel Rods  
(Fresh Fuel, Preirradiated Cladding) under IGR Tests

Table H-3.2. Axial Energy Characteristics of Fuel Rod #H16T

Axial coordinate from lower end of fuel rod (mm)	Cumulative number of fissions at axial interval (fiss)			Maximum power of fuel rod (kW) t=5.35 s	Energy deposition at infinite time*		
	$U^{235} \times 10^{-13}$	$U^{238} \times 10^{-11}$	Total $\times 10^{-13}$		cal/g fuel	J/g fuel	per-unit <sup>3)</sup>
20.0	0.000	0.000	0.000	0.000	0.000	0.000	0.00
25.0 <sup>1)</sup>	2.270	0.678	2.280	0.512	223.0	933.0	1.00
30.0	6.560	2.000	6.580	1.480	219.0	917.0	0.98
35.0	6.410	2.020	6.430	1.440	214.0	896.0	0.96
40.0	6.270	2.040	6.290	1.410	210.0	879.0	0.94
45.0	6.120	2.050	6.140	1.380	205.0	858.0	0.92
50.0	6.020	2.070	6.040	1.360	201.0	841.0	0.90
55.0	5.930	2.080	5.950	1.340	198.0	829.0	0.89
60.0	5.890	2.110	5.910	1.330	196.0	820.0	0.88
65.0	5.860	2.140	5.880	1.320	194.0	812.0	0.87
70.0	5.780	2.150	5.800	1.300	191.0	800.0	0.86
75.0	5.710	2.140	5.730	1.290	189.0	791.0	0.85
80.0	5.670	2.150	5.690	1.280	188.0	787.0	0.84
85.0	5.640	2.160	5.670	1.270	188.0	787.0	0.84
90.0	5.640	2.170	5.660	1.270	188.0	787.0	0.84
95.0	5.640	2.170	5.660	1.270	187.0	783.0	0.84
100.0	5.710	2.200	5.730	1.290	188.0	787.0	0.84
105.0	5.710	2.200	5.730	1.290	188.0	787.0	0.84
110.0	5.680	2.180	5.700	1.280	188.0	787.0	0.84
115.0	5.710	2.170	5.730	1.290	189.0	791.0	0.85
120.0	5.720	2.160	5.740	1.290	189.0	791.0	0.85
125.0	5.750	2.150	5.770	1.300	190.0	795.0	0.85
130.0	5.780	2.140	5.800	1.300	192.0	804.0	0.86
135.0	5.750	2.100	5.780	1.300	192.0	804.0	0.86
140.0	5.780	2.080	5.800	1.300	193.0	808.0	0.87
145.0	5.780	2.040	5.800	1.300	193.0	808.0	0.87
150.0	5.800	2.010	5.820	1.310	194.0	812.0	0.87
155.0	5.820	1.970	5.840	1.310	195.0	816.0	0.87
160.0	5.760	1.910	5.780	1.300	196.0	820.0	0.88
165.0 <sup>2)</sup>	5.000	1.620	5.020	1.130	196.0	820.0	0.88
170.0	0.000	0.000	0.000	0.000	0.000	0.000	0.00

\* All numerical values of characteristics are presented as average values at the length interval equal to the axial coordinate  $\pm 2.5$ mm

<sup>1)</sup> Initial coordinate of fuel is 25.8 mm

<sup>2)</sup> End coordinate of fuel is 166.8 mm

<sup>3)</sup> Current value per maximum value

# #H16T

Individual Characteristics of Refabricated Fuel Rods  
(Fresh Fuel, Preirradiated Cladding) under IGR Tests

Table H-3.3. Radial Energy Characteristics of Fuel Rod #H16T

Characteristics*		Coordinates of fuel zones (mm)			
		1 zone 1.10 - 2.12	2 zone 2.12 - 2.79	3 zone 2.79 - 3.32	4 zone 3.32 - 3.79
U <sup>235</sup>	Number of fissions $\times 10^{-14}$ (fiss)	3.970	4.020	4.170	4.350
	Power of fuel rod <sup>1)</sup> (kW)	8.920	9.040	9.390	9.790
	Energy deposition <sup>2)</sup> (cal/g fuel)	187.0	189.0	197.0	205.0
	Energy deposition <sup>2)</sup> (J/g fuel)	783.0	791.0	825.0	858.0
	Energy deposition <sup>3)</sup> (per-unit)	0.912	0.922	0.961	1.000
U <sup>238</sup>	Number of fissions $\times 10^{-12}$ (fiss)	1.480	1.500	1.490	1.440
	Power of fuel rod <sup>1)</sup> (kW)	0.033	0.033	0.033	0.032
	Energy deposition <sup>2)</sup> (cal/g fuel)	0.686	0.697	0.690	0.671
	Energy deposition <sup>2)</sup> (J/g fuel)	2.870	2.920	2.890	2.810
	Energy deposition <sup>3)</sup> (per-unit)	0.984	1.000	0.990	0.963
Total	Number of fissions $\times 10^{-14}$ (fiss)	3.980	4.030	4.190	4.370
	Power of fuel rod <sup>1)</sup> (kW)	8.950	9.070	9.420	9.820
	Energy deposition <sup>2)</sup> (cal/g fuel)	187.0	190.0	197.0	206.0
	Energy deposition <sup>2)</sup> (J/g fuel)	783.0	795.0	825.0	862.0
	Energy deposition <sup>3)</sup> (per-unit)	0.908	0.922	0.956	1.000

<sup>1)</sup> at time of 5.35 s,      <sup>2)</sup> at infinite time,      <sup>3)</sup> Current value per maximum value

\* All numerical values of characteristics were calculated for length of fuel stack

# #H16T

Individual Characteristics of Refabricated Fuel Rods  
(Fresh Fuel, Preirradiated Cladding) under IGR Tests

Table H-3.4. Fuel Enthalpy Vs. Time Calculated by FRAP-T6 Code for Fuel Rod #H16T

Time (s)	Enthalpy at fuel radius (cal/g fuel)				Fuel enthalpy <sup>1)</sup>		Energy deposition in fuel rod	
	1.10 mm	2.22 mm	2.89 mm	3.79 mm	cal/g fuel	J/g fuel	cal/g fuel	J/g fuel
0.0	0.00	0.00	0.00	0.00	0.00	0.00	0.00	0.00
1.0	0.96	0.95	0.92	0.84	0.92	3.85	0.89	3.75
2.0	3.63	3.56	3.44	3.17	3.45	14.5	3.58	15.0
2.2	4.35	4.27	4.12	3.80	4.14	17.4	4.33	18.2
2.4	5.14	5.04	4.87	4.49	4.89	20.5	5.16	21.6
2.6	5.99	5.88	5.67	5.23	5.70	23.9	6.06	25.4
2.8	6.90	6.77	6.54	6.03	6.57	27.5	7.03	29.4
3.0	7.88	7.73	7.46	6.88	7.49	31.4	8.07	33.8
3.2	8.92	8.74	8.44	7.78	8.48	35.5	9.18	38.5
3.4	10.0	9.82	9.47	8.73	9.52	39.9	10.4	43.4
3.6	11.2	11.0	10.6	9.66	10.6	44.4	11.6	48.7
3.8	12.5	12.2	11.7	10.6	11.8	49.3	13.0	54.5
4.0	13.9	13.6	13.0	11.6	13.1	54.8	14.6	61.2
4.2	15.9	15.5	14.7	13.0	14.8	62.0	16.7	69.8
4.4	18.7	18.2	17.3	15.0	17.3	72.6	19.6	82.0
4.6	23.4	22.8	21.5	18.2	21.6	90.4	24.3	102
4.8	32.0	31.2	29.4	24.0	29.4	123	32.6	137
5.0	47.7	46.6	43.9	33.5	43.4	182	47.5	199
5.2	73.0	71.3	66.7	45.3	65.4	274	71.1	298
5.4	105	102	93.9	53.1	90.8	380	101	422
5.6	133	129	115	51.9	110	462	128	534
5.8	152	146	123	49.9	120	501	146	611
6.0	163	152	121	46.9	121	509	157	657
6.5	168	145	103	39.6	112	470	169	708
7.0	159	129	86.7	34.8	99.8	418	174	729
7.5	142	111	73.9	33.1	87.2	366	177	743
8.0	123	96.2	65.5	32.5	77.1	323	180	753
10.0	63.7	54.2	42.6	27.8	46.4	194	185	773
30.0	5.70	5.67	5.62	5.51	5.62	23.6	191	800

Radial enthalpy distribution and fuel enthalpy are presented at elevation 32.9 mm

Maximum value of fuel enthalpy is 121.4 cal/g fuel (t=5.96 s)

<sup>1)</sup> All numerical values are presented at elevation with peak power

# #H16T

Individual Characteristics of Refabricated Fuel Rods  
(Fresh Fuel, Preirradiated Cladding) under IGR Tests

Table H-3.5. Energy Characteristics Vs. Time Calculated by FRAP-T6 and SCANAIR Codes for Fuel Rod #H16T

Time (s)	Energy deposition <sup>1)</sup> (cal/g fuel)	Linear power <sup>1)</sup> (kW/m)	Fuel enthalpy <sup>1)</sup> (cal/g fuel)		Energy of metal-water reaction <sup>1)</sup> (cal/g fuel)	Leakage of energy <sup>1)</sup> (cal/g fuel)		Clad-to-coolant heat transfer coefficient <sup>1)</sup> (kW/m <sup>2</sup> K)	
			FRAP-T6	SCANAIR		FRAP-T6	SCANAIR	FRAP-T6	SCANAIR
0.0	0.00	0.00	0.00	0.00	0.00	0.00	0.00	0.00	0.00
1.0	0.99	3.42	0.92	0.90	0.00	0.00	0.00	0.03	0.10
2.0	3.97	6.86	3.45	3.52	0.00	0.01	0.02	0.03	0.10
2.2	4.81	7.54	4.14	4.15	0.00	0.01	0.03	0.03	0.10
2.4	5.72	8.22	4.89	4.94	0.00	0.01	0.04	0.03	0.10
2.6	6.72	8.92	5.70	5.81	0.00	0.02	0.06	0.03	0.10
2.8	7.79	9.62	6.57	6.59	0.00	0.02	0.07	0.03	0.10
3.0	8.95	10.3	7.49	7.58	0.00	0.03	0.09	0.03	0.10
3.2	10.2	11.0	8.48	8.61	0.00	0.03	0.12	0.03	0.10
3.4	11.5	11.7	9.52	9.56	0.00	0.09	0.18	0.49	0.66
3.6	12.9	12.5	10.6	10.7	0.00	0.31	0.46	0.94	1.16
3.8	14.4	14.0	11.8	11.9	0.00	0.63	0.86	1.20	1.45
4.0	16.2	17.0	13.1	13.2	0.00	1.04	1.30	1.46	1.73
4.2	18.5	22.7	14.8	15.0	0.00	1.54	1.89	1.76	2.13
4.4	21.7	34.3	17.3	17.3	0.00	2.16	2.51	2.21	2.62
4.6	26.9	58.2	21.6	21.7	0.00	2.99	3.48	2.96	3.60
4.8	36.2	105	29.4	28.6	0.00	4.20	4.67	4.40	5.17
5.0	52.7	183	43.4	42.9	0.00	6.23	6.95	7.27	8.77
5.2	78.9	264	65.4	63.9	0.00	9.96	10.8	12.5	14.8
5.4	112	285	90.8	89.9	0.00	16.7	18.3	19.7	24.1
5.6	141	219	110	109	0.00	26.9	30.1	25.5	31.8
5.8	162	135	120	115	0.00	38.6	42.2	25.1	33.1
6.0	174	78.3	121	115	0.00	49.7	55.8	23.5	30.4
6.5	188	26.1	112	103	0.00	74.2	81.7	19.3	22.3
7.0	193	15.2	99.8	91.3	0.00	92.5	99.4	16.6	17.9
7.5	197	10.3	87.2	80.0	0.00	109	114	13.5	15.0
8.0	199	6.96	77.1	70.4	0.00	121	127	11.5	13.0
10.0	205	2.61	46.4	42.7	0.00	155	160	6.86	7.75
30.0	212	0.19	5.62	5.71	0.00	201	205	0.14	0.13

<sup>1)</sup> All numerical values are presented at elevation with peak power

# #H16T

Individual Characteristics of Refabricated Fuel Rods  
(Fresh Fuel, Preirradiated Cladding) under IGR Tests

Table H-3.6. Temperature Variation, Fission Gas Release and ZrO<sub>2</sub> Thickness Vs. Time for Fuel Rod #H16T Calculated by FRAP-T6 and SCANAIR Codes

Time (s)	Fuel centerline temperature <sup>1)</sup> (K)		Fuel surface temperature <sup>1)</sup> (K)		Clad outer temperature <sup>1)</sup> (K)		Average ZrO <sub>2</sub> <sup>2)</sup> thickness (μm)
	FRAP-T6	SCANAIR	FRAP-T6	SCANAIR	FRAP-T6	SCANAIR	FRAP-T6
0.0	293	293	293	293	293	293	5
1.0	310	308	308	306	297	297	5
2.0	355	352	348	345	318	317	5
2.2	367	363	358	354	325	323	5
2.4	380	376	369	366	332	331	5
2.6	393	389	381	378	341	340	5
2.8	408	402	394	389	350	348	5
3.0	423	418	407	403	361	359	5
3.2	439	434	421	418	372	370	5
3.4	456	449	436	431	381	378	5
3.6	473	468	450	445	385	380	5
3.8	492	487	464	460	386	381	5
4.0	514	509	480	474	388	381	5
4.2	542	538	500	495	389	382	5
4.4	583	575	529	521	391	384	5
4.6	650	645	577	570	394	386	5
4.8	770	750	659	640	399	388	5
5.0	983	965	791	770	406	393	5
5.2	1315	1279	952	916	416	401	5
5.4	1712	1690	1055	1008	426	410	5
5.6	2044	2035	1039	975	433	417	5
5.8	2244	2217	1012	912	432	418	5
6.0	2345	2322	973	865	431	415	5
6.5	2395	2335	874	833	426	408	5
7.0	2312	2200	809	822	422	404	5
7.5	2139	1991	786	808	417	401	5
8.0	1935	1770	777	791	414	399	5
10.0	1195	1108	713	697	405	392	5
30.0	389	384	386	382	377	375	5

<sup>1)</sup> All numerical values are presented at elevation with peak power

<sup>2)</sup> Initial ZrO<sub>2</sub> thickness is 5 μm

# #H16T

Individual Characteristics of Refabricated Fuel Rods  
(Fresh Fuel, Preirradiated Cladding) under IGR Tests

Table H-3.7. Mechanical Characteristics of Fuel Rod #H16T Vs. Time Calculated by FRAP-T6 and SCANAIR Codes

Time (s)	Clad outer temperature <sup>1)</sup> (K)		Fuel hoop strain <sup>1)</sup> (%)		Fuel - clad gap width <sup>1)</sup> (mm)		Clad hoop strain <sup>1)</sup> (%)		Clad hoop stress <sup>1)</sup> (MPa)		Internal gas pressure (MPa)	
	FRAP-T6	SCANAIR	FRAP-T6	SCANAIR	FRAP-T6	SCANAIR	FRAP-T6	SCANAIR	FRAP-T6	SCANAIR	FRAP-T6	SCANAIR
0.0	293	293	0.00	0.00	0.08	0.08	0.01	0.01	8.73	8.70	1.70	1.70
1.0	297	297	0.01	0.01	0.08	0.08	0.01	0.01	8.80	8.77	1.71	1.71
2.0	318	317	0.05	0.05	0.08	0.08	0.03	0.03	8.96	8.97	1.74	1.75
2.2	325	323	0.06	0.06	0.08	0.08	0.03	0.03	9.00	9.02	1.75	1.75
2.4	332	331	0.08	0.07	0.08	0.08	0.03	0.04	9.04	9.07	1.76	1.76
2.6	341	340	0.09	0.09	0.08	0.08	0.04	0.04	9.08	9.12	1.76	1.77
2.8	350	348	0.10	0.10	0.08	0.08	0.05	0.05	9.12	9.16	1.77	1.78
3.0	361	359	0.12	0.11	0.08	0.08	0.05	0.06	9.16	9.22	1.78	1.79
3.2	372	370	0.13	0.13	0.08	0.08	0.06	0.06	9.21	9.27	1.79	1.80
3.4	381	378	0.15	0.14	0.08	0.08	0.07	0.07	9.25	9.34	1.79	1.81
3.6	385	380	0.17	0.16	0.08	0.08	0.07	0.07	9.29	9.41	1.80	1.81
3.8	386	381	0.19	0.18	0.08	0.08	0.07	0.07	9.33	9.47	1.81	1.82
4.0	388	381	0.21	0.20	0.08	0.08	0.07	0.07	9.37	9.54	1.82	1.83
4.2	389	382	0.23	0.22	0.07	0.07	0.08	0.08	9.42	9.63	1.83	1.84
4.4	391	384	0.27	0.26	0.07	0.07	0.08	0.08	9.48	9.75	1.84	1.86
4.6	394	386	0.34	0.33	0.07	0.07	0.08	0.08	9.58	9.95	1.85	1.88
4.8	399	388	0.45	0.44	0.07	0.07	0.09	0.09	9.72	10.2	1.88	1.91
5.0	406	393	0.67	0.68	0.06	0.06	0.10	0.10	9.91	10.8	1.92	1.97
5.2	416	401	1.03	1.06	0.05	0.04	0.11	0.12	10.1	11.6	1.96	2.03
5.4	426	410	1.50	1.59	0.03	0.03	0.13	0.14	10.3	12.7	1.99	2.09
5.6	433	417	1.88	1.98	0.02	0.01	0.15	0.17	10.5	13.5	2.02	2.14
5.8	432	418	2.08	2.12	0.01	0.01	0.15	0.17	10.6	13.7	2.03	2.16
6.0	431	415	2.14	2.10	0.00	0.01	0.15	0.16	10.6	13.5	2.04	2.16
6.5	426	408	2.07	1.82	0.01	0.02	0.13	0.14	10.6	12.7	2.04	2.13
7.0	422	404	1.89	1.56	0.01	0.03	0.13	0.13	10.6	12.2	2.03	2.11
7.5	417	401	1.67	1.33	0.02	0.03	0.12	0.12	10.5	11.9	2.02	2.08
8.0	414	399	1.46	1.14	0.03	0.04	0.11	0.11	10.4	11.6	2.00	2.05
10.0	405	392	0.79	0.64	0.05	0.06	0.10	0.09	10.0	10.7	1.94	1.97
30.0	377	375	0.09	0.06	0.08	0.08	0.07	0.07	9.12	9.10	1.77	1.77

<sup>1)</sup> All numerical values are presented at elevation with peak power

# #H16T

Individual Characteristics of Refabricated Fuel Rods  
(Fresh Fuel, Preirradiated Cladding) under IGR Tests

Table H-3.8. Axial Distribution of Energy Deposition and Fuel Enthalpy Calculated by FRAP-T6 Code for Fuel Rod #H16T

Axial interval from-to (mm)-(mm)	Energy deposition at infinite time			Fuel enthalpy at time (t=5.96 s)		
	cal/g fuel	J/g fuel	per-unit	cal/g fuel	J/g fuel	per-unit
25.8 - 39.9	216	906	1.00	121	509	1.00
39.9 - 54.0	204	854	0.94	114	479	0.94
54.0 - 68.1	196	819	0.90	110	460	0.90
68.1 - 82.2	189	793	0.88	106	445	0.88
82.2 - 96.3	188	787	0.87	105	442	0.87
96.3 - 110.4	188	787	0.87	105	442	0.87
110.4 - 124.5	189	792	0.87	106	445	0.87
124.5 - 138.6	192	803	0.89	108	451	0.89
138.6 - 152.7	193	810	0.89	109	455	0.89
152.7 - 166.8	196	820	0.90	110	460	0.90

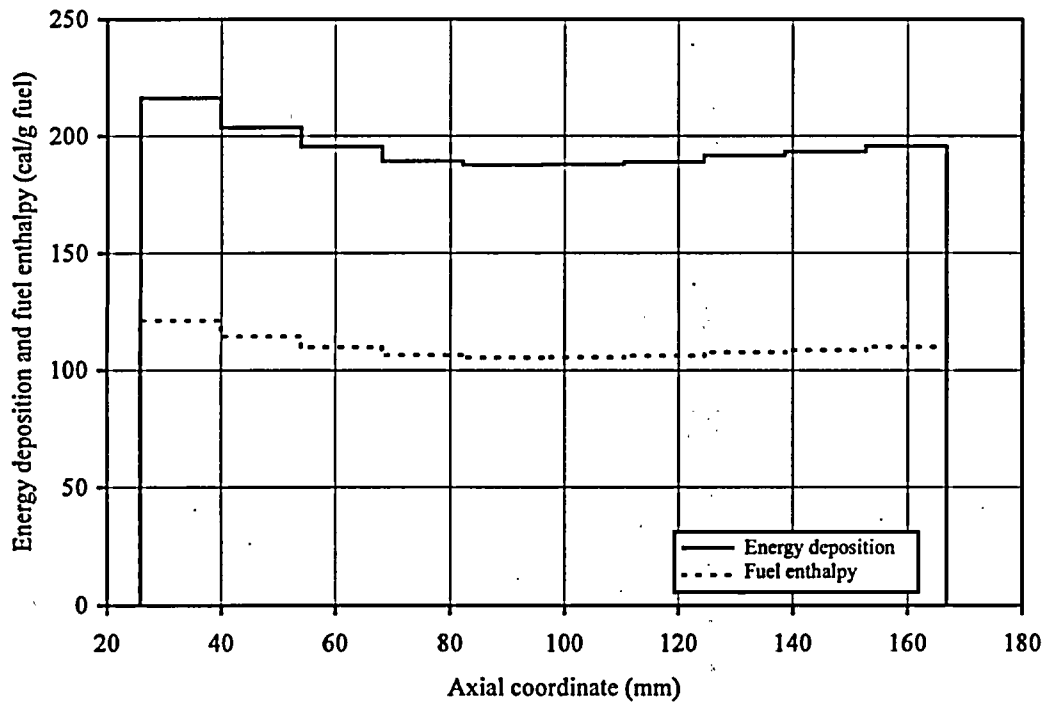

Fig. H-3.4. Axial Distribution of Energy Deposition and Fuel Enthalpy Calculated by FRAP-T6 Code for Fuel Rod #H16T

# #H16T

Individual Characteristics of Refabricated Fuel Rods  
(Fresh Fuel) Preirradiated Cladding) under IGR Tests

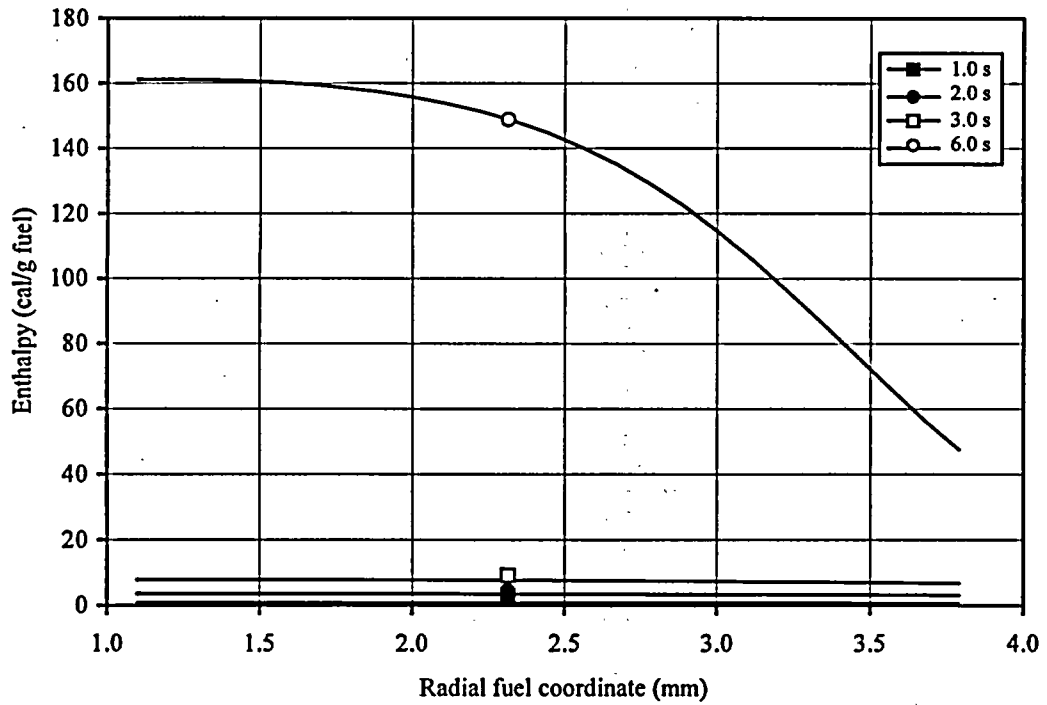
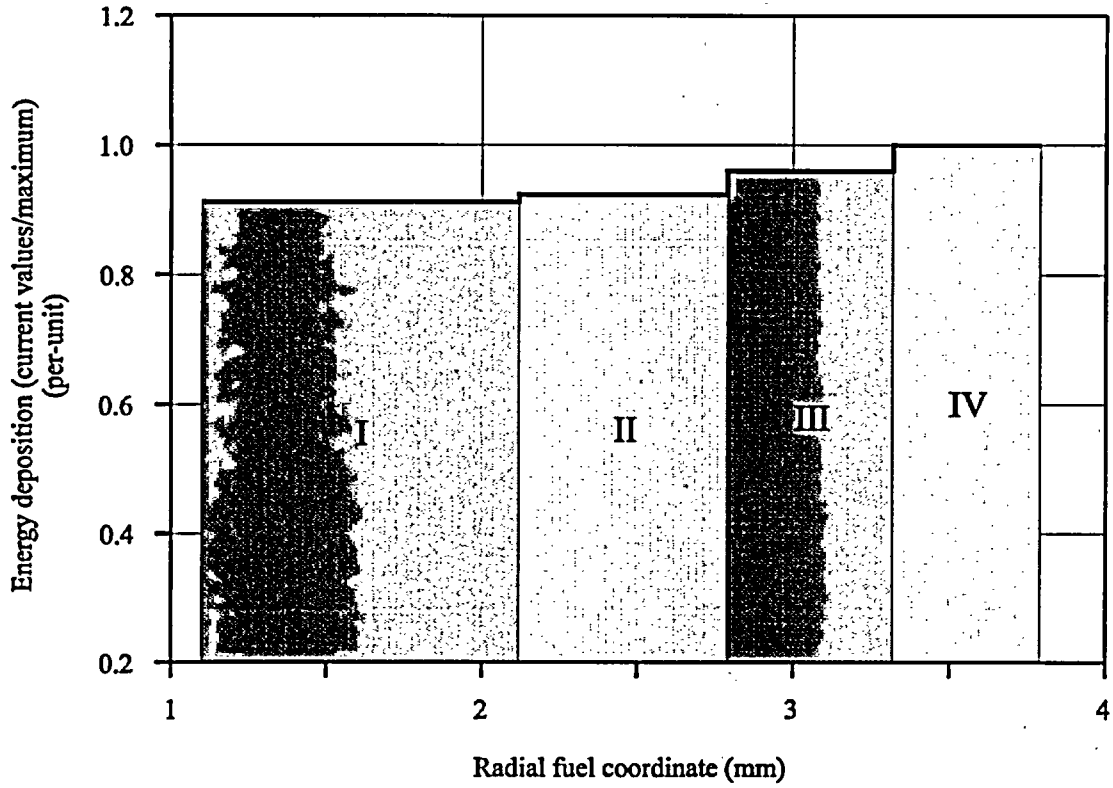

Fig. H-3.5. Radial Distributions of Energy Deposition and Fuel Enthalpy Calculated by FRAP-T6 Code for Fuel Rod #H16T



# #H16T

Individual Characteristics of Refabricated Fuel Rods  
(Fresh Fuel, Preirradiated Cladding) under IGR Tests

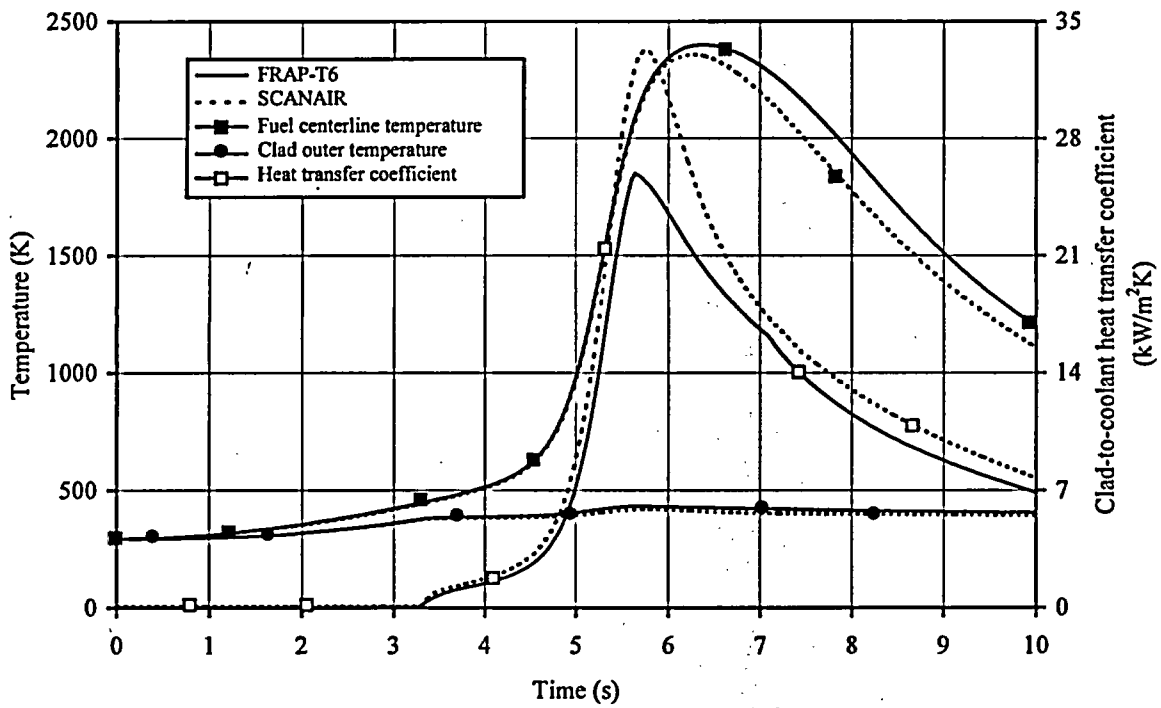
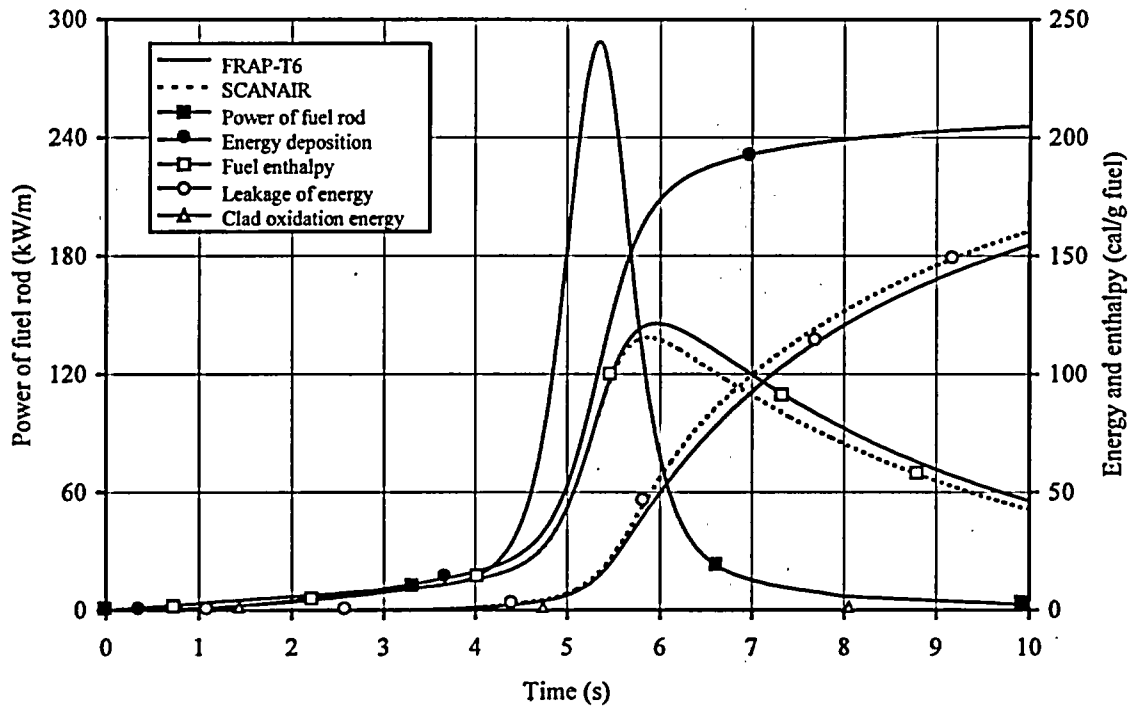

Fig. H-3.6. Energy and Temperature Characteristics Vs. Time Calculated by FRAP-T6 and SCANAIR Codes for Fuel Rod #H16T

# #H16T

Individual Characteristics of Refabricated Fuel Rods  
(Fresh Fuel, Preirradiated Cladding) under IGR Tests

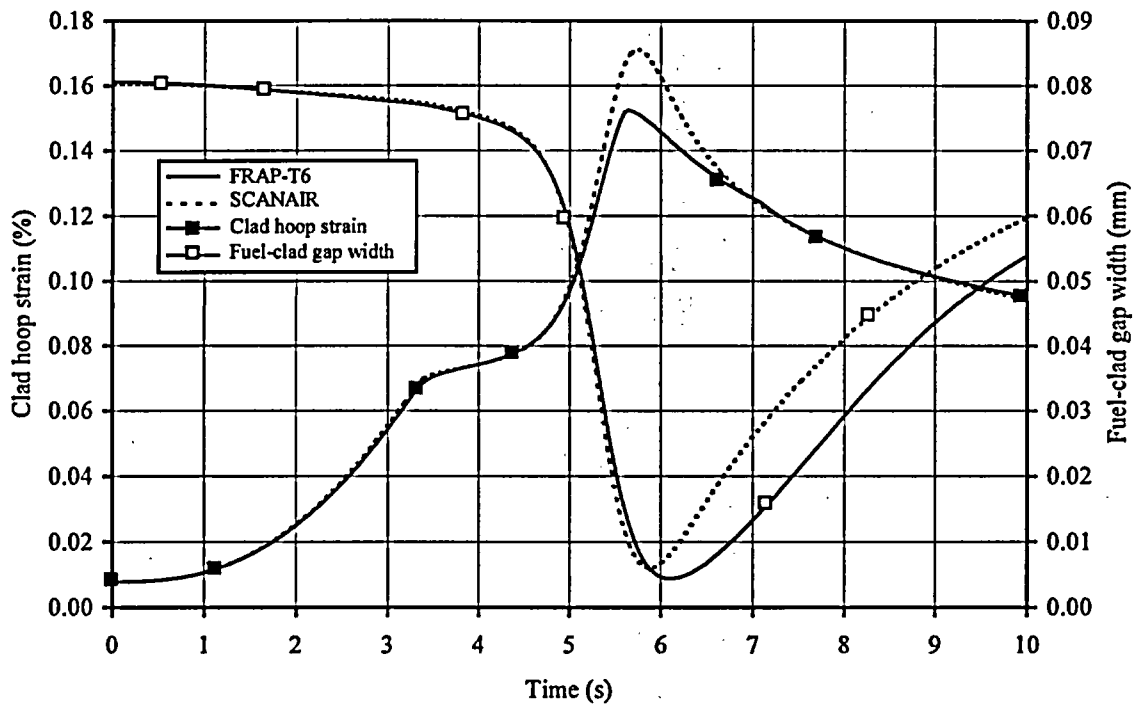
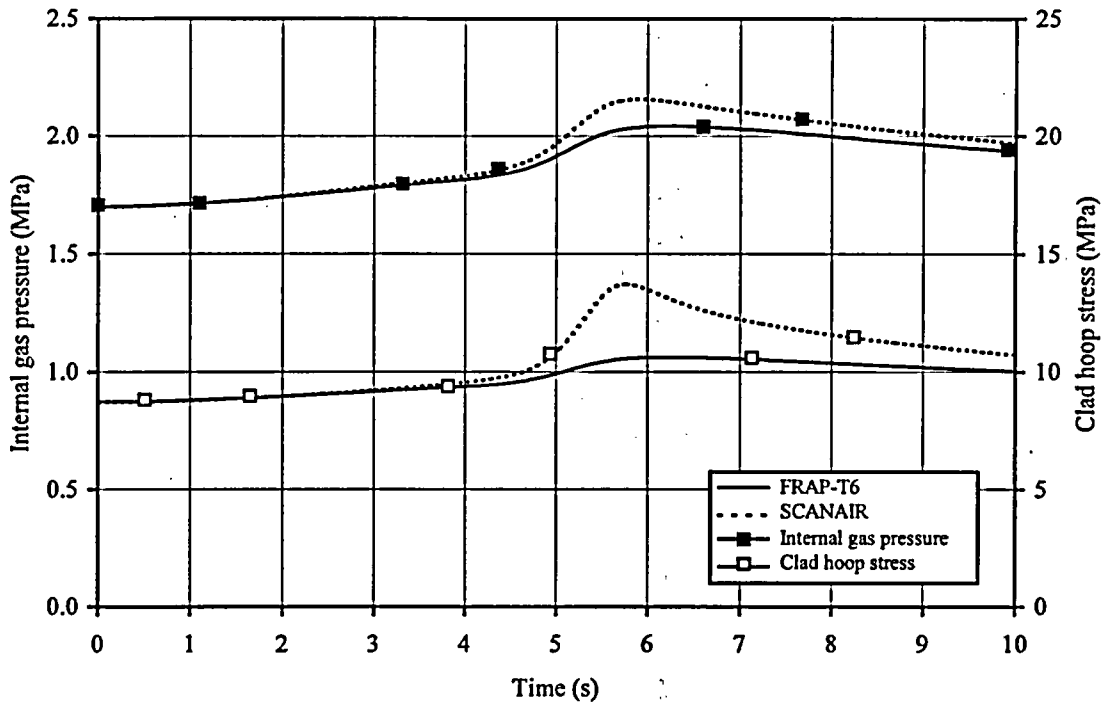

Fig. H-3.7. Cladding Mechanical Characteristics Vs. Time Calculated by FRAP-T6 and SCANAIR Codes for Fuel Rod #H16T

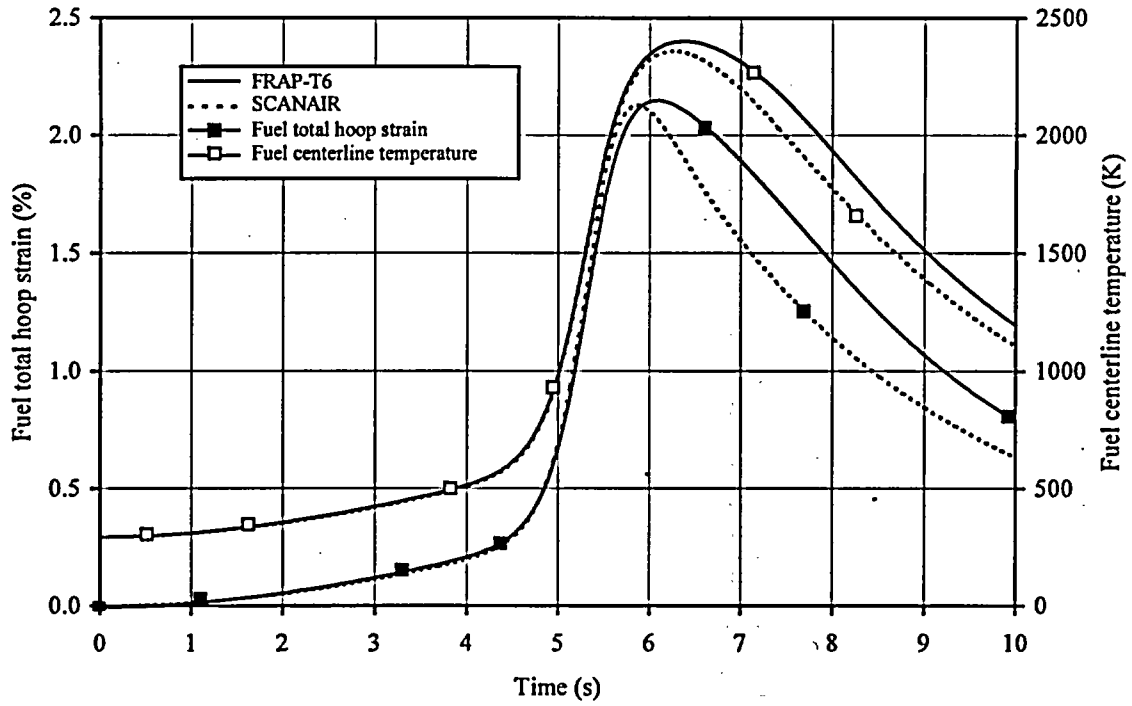

Fig. H-3.8. Fuel Strain Vs. Time Calculated by FRAP-T6 and SCANAIR Codes for Fuel Rod #H16T

# #H16T

Individual Characteristics of Refabricated Fuel Rods  
(Fresh Fuel, Preirradiated Cladding) under IGR Tests

Table H-3.9. Some Results of PIE for Fuel Rod #H16T

Characteristic		Value
1.	Measured parameters of cladding oxidation and cladding deformation	
1.1.	Cladding thickness at elevation 95 mm for different azimuthal angles ( $\mu\text{m}$ ):	
	0°	691
	90°	705
	180°	691
	270°	677
1.2.	ZrO <sub>2</sub> thickness at elevation 95 mm for different azimuthal angles ( $\mu\text{m}$ ):	
	0°	5
	90°	5
	180°	5
	270°	5
1.3.	$\alpha\text{Zr(O)}$ thickness at elevation 95 mm for different azimuthal angles ( $\mu\text{m}$ ):	
	0°	0
	90°	0
	180°	0
	270°	0
1.4.	Clad hoop strain at elevation 95 mm (%)	0
2.	Measured parameters for FGR analysis	
2.1.	Internal gas composition (% by volume):	
	He	—
	N <sub>2</sub>	—
	O <sub>2</sub>	—
	Ar	—
	CO <sub>2</sub>	—
	Kr	—
	Xe	—
2.2.	Free gas volume (cm <sup>3</sup> )	6.33
2.3.	Gas pressure inside fuel rod under normal condition (MPa)	1.538
2.4.	Kr concentration in fuel (cm <sup>3</sup> /g fuel)	—
3.	Measured parameters of cladding hydriding	
3.1.	Coefficient of hydride orientation (per-unit)	—
3.2.	Hydrogen concentration (% by weight)	—

# #H16T

Individual Characteristics of Refabricated Fuel Rods  
(Fresh Fuel, Preirradiated Cladding) under IGR Tests

Table H-3.10. General Characteristic of Fuel Rod #H16T

	Parameter	Unit	Value		
			Experiment	FRAP-T6	SCANAIR
1	Type of coolant	---	water	water	water
2	Burnup	MWd/kg U	0	0	0
3	Energy deposition in fuel rod	cal/g fuel	195	195	195
4	Peak fuel enthalpy	cal/g fuel	-	121	115
5	Peak fuel temperature	K	-	2400	2358
6	Peak clad temperature	K	-	433	418
7	Fuel rod failure	Yes, No	No	No	-
8	Type of failure:				
	- cladding rupture due to ballooning	Yes, No	No	No	-
	- cladding rupture due to PCMI	Yes, No	No	No	-
	- fragmentation of fuel rod	Yes, No	No	-	-
9	Failure time	s	-	-	-
10	Fuel enthalpy at failure	cal/g fuel	-	-	-
11	Outer cladding temperature at failure	K	-	-	-
12	Internal gas pressure at failure	MPa	-	-	-
13	ZrO <sub>2</sub> thickness after test	μm	5	5	-
14	Residual clad hoop strain:				
	- peak value for ballooning area	%	-	-	-
	- other location <sup>1)</sup>	%	0	0	0

<sup>1)</sup>Calculated values by FRAP-T6 and SCANAIR codes are average along height of fuel rod excluding ballooning region

*APPENDIX H-4,  
Individual Characteristics for Fuel Rod #H17T under IGR Test*

#H17T

Individual Characteristics of Refabricated Fuel Rods  
(Fresh Fuel, Preirradiated Cladding) under IGR Tests

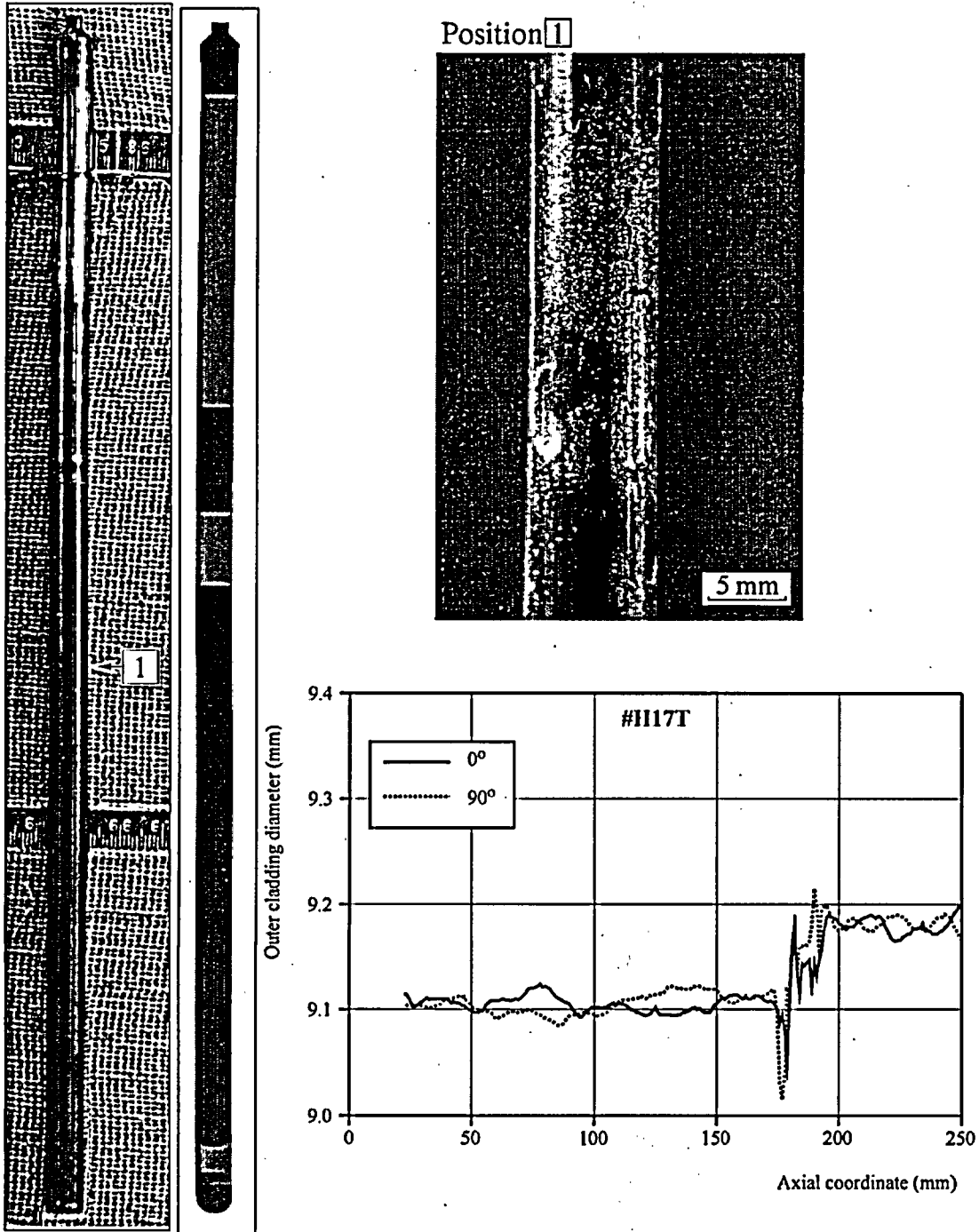
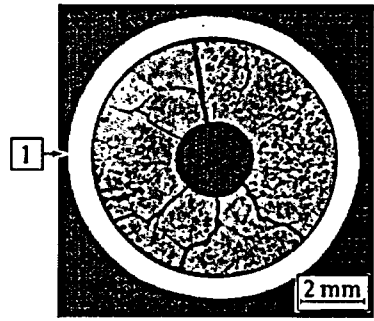

Fig. H-4.1. Appearance of Fuel Rod #H17T (photographs and X-ray photograph) and Profilometry

#H17T

Individual Characteristics of Refabricated Fuel Rods  
(Fresh Fuel, Preirradiated Cladding) under IGR Tests



Position 1

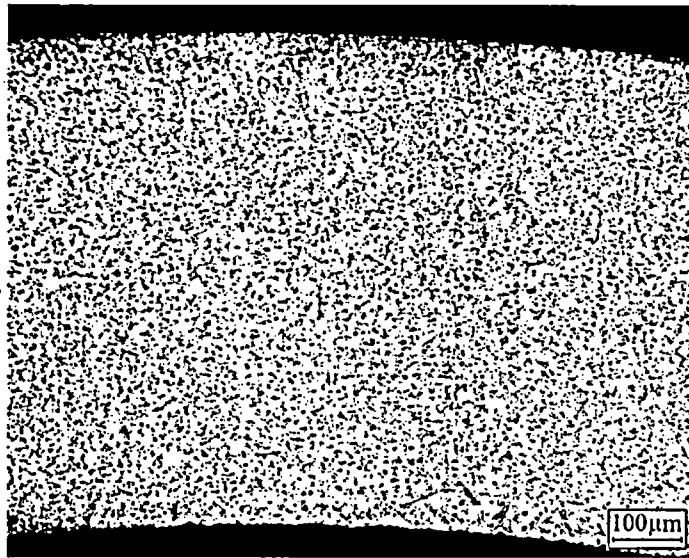

Position 1

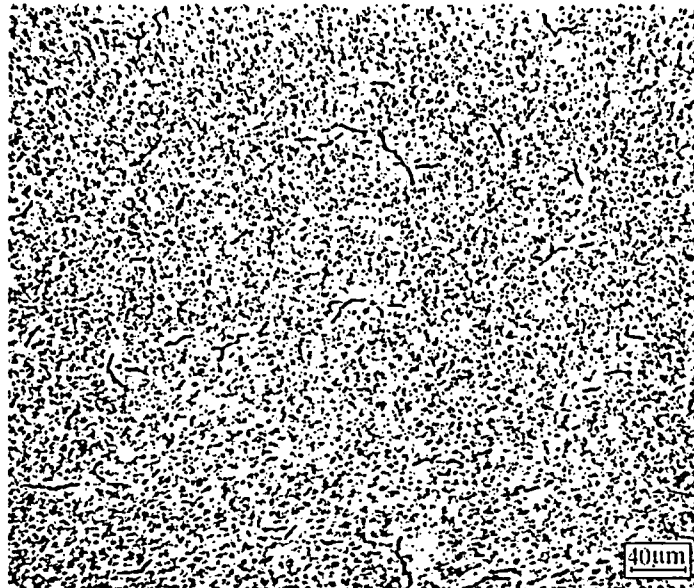

Fig. H-4.2. Cross-Section and Cladding Microstructure for Fuel Rod #H17T at 90 mm Elevation



#H17T

Individual Characteristics of Refabricated Fuel Rods  
(Fresh Fuel, Preirradiated Cladding) under IGR Tests

Position 1

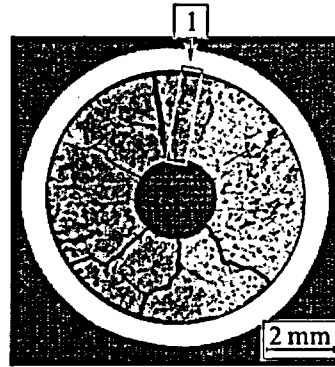
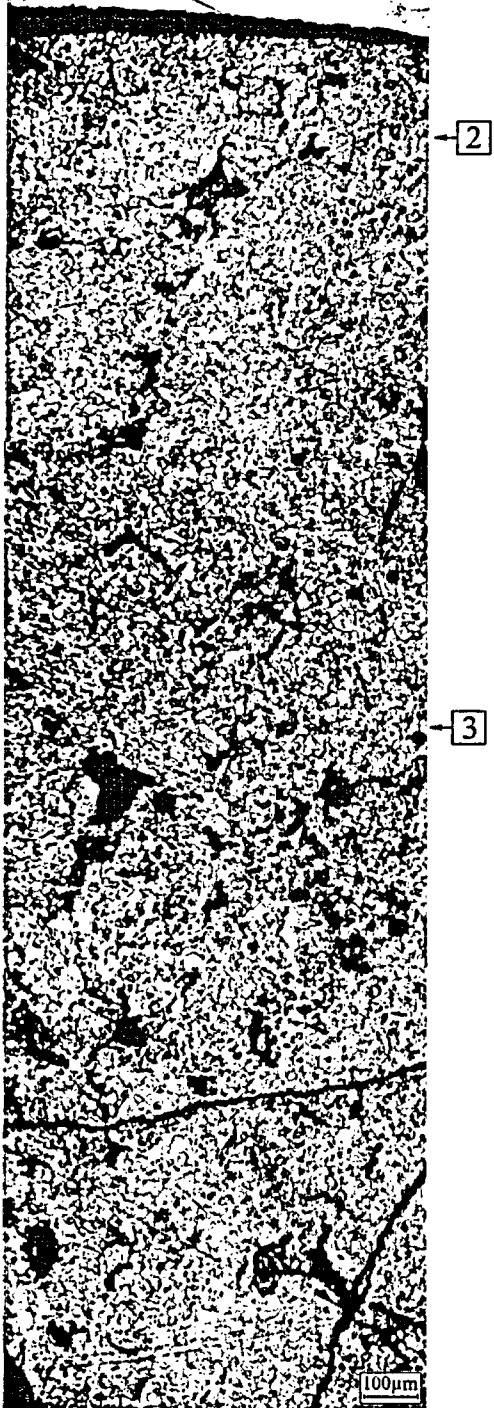

Position 2

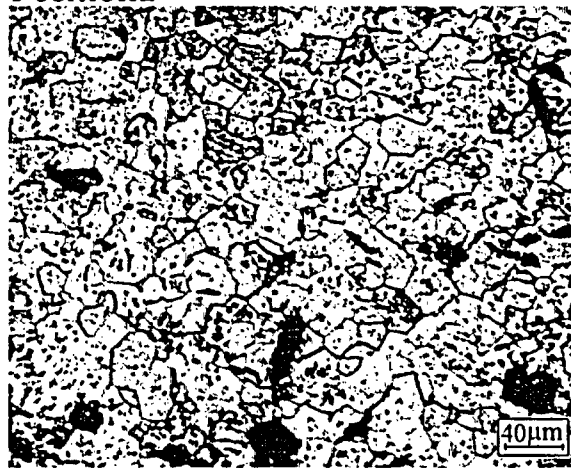

Position 3

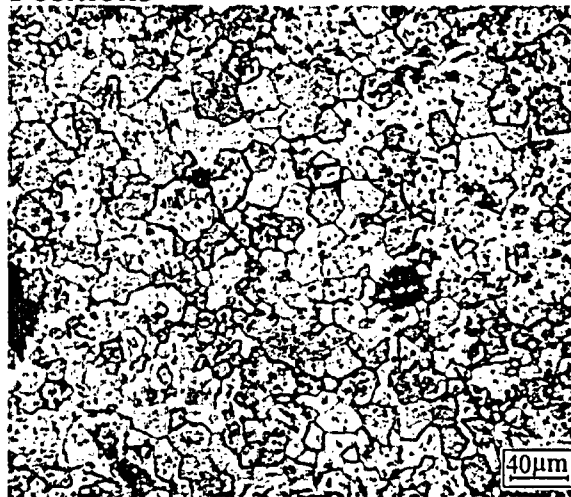

Fig. H-4.3. Fuel Microstructure for Fuel Rod #H17T at 90 mm Elevation

# #H17T

Individual Characteristics of Refabricated Fuel Rods  
(Fresh Fuel, Preirradiated Cladding) under IGR Tests

Table H-4.1. Time Dependent Energy Characteristics of Fuel Rod #H17T

Time (s)	Reactor energy deposition <sup>1)</sup> (%)	Cumulative number of fissions in fuel rod (fiss)			Power of fuel rod (kW)	Energy deposition in fuel rod	
		U <sup>235</sup> ×10 <sup>-14</sup>	U <sup>238</sup> ×10 <sup>-12</sup>	Total ×10 <sup>-14</sup>		cal/g fuel	J/g fuel
0.0	0.000	0.000	0.000	0.000	0.000	0.000	0.000
1.0	0.231	0.028	0.010	0.028	0.216	0.316	1.320
2.0	1.510	0.181	0.064	0.181	0.650	2.070	8.670
2.2	1.920	0.230	0.082	0.230	0.733	2.630	11.00
2.4	2.370	0.284	0.101	0.285	0.817	3.260	13.60
2.6	2.880	0.345	0.123	0.347	0.910	3.950	16.50
2.8	3.450	0.414	0.147	0.415	1.020	4.740	19.80
3.0	4.100	0.491	0.175	0.493	1.180	5.620	23.50
3.2	4.860	0.582	0.207	0.584	1.410	6.670	27.90
3.4	5.800	0.695	0.247	0.697	1.810	7.960	33.30
3.6	7.060	0.846	0.301	0.849	2.520	9.690	40.60
3.8	8.900	1.070	0.380	1.070	3.840	12.20	51.10
4.0	11.80	1.420	0.505	1.420	6.370	16.20	67.80
4.2	16.90	2.020	0.720	2.030	11.10	23.20	97.10
4.4	25.50	3.060	1.090	3.070	18.50	35.00	147.0
4.6	38.70	4.640	1.650	4.660	25.60	53.10	222.0
4.8	54.40	6.520	2.320	6.540	26.10	74.50	312.0
5.0	68.30	8.190	2.910	8.220	20.50	93.70	392.0
5.2	78.20	9.380	3.340	9.410	13.30	107.0	448.0
5.4	84.30	10.10	3.600	10.10	7.890	116.0	486.0
5.6	87.90	10.50	3.750	10.60	4.700	121.0	507.0
5.8	90.10	10.80	3.840	10.80	2.990	124.0	519.0
6.0	91.50	11.00	3.900	11.00	2.060	126.0	527.0
6.5	93.60	11.20	3.990	11.30	1.090	129.0	540.0
7.0	94.80	11.40	4.040	11.40	0.681	131.0	548.0
7.5	95.50	11.40	4.070	11.50	0.461	132.0	553.0
8.0	96.00	11.50	4.090	11.50	0.332	133.0	557.0
9.0	96.70	11.60	4.120	11.60	0.251	134.0	561.0
10.0	97.20	11.60	4.150	11.70	0.170	135.0	565.0
20.0	98.70	11.80	4.210	11.90	0.035	138.0	578.0
30.0	99.20	11.90	4.230	11.90	0.017	139.0	582.0
∞	100.0	12.00	4.270	12.00	0.000	141.0	590.0

Maximum value of power is 26.8 kW (t = 4.70 s)

<sup>1)</sup> Current energy deposition per maximum energy deposition (at infinite time)

# #H17T

Individual Characteristics of Refabricated Fuel Rods  
(Fresh Fuel, Preirradiated Cladding) under IGR Tests

Table H-4.2. Axial Energy Characteristics of Fuel Rod #H17T

Axial coordinate from lower end of fuel rod (mm)	Cumulative number of fissions at axial interval (fiss)			Maximum power of fuel rod (kW) t=4.70 s	Energy deposition at infinite time*		
	$U^{235} \times 10^{-13}$	$U^{238} \times 10^{-11}$	Total $\times 10^{-13}$		cal/g fuel	J/g fuel	per-unit <sup>3)</sup>
15.0	0.000	0.000	0.000	0.000	0.000	0.000	0.00
20.0 <sup>1)</sup>	3.090	0.900	3.100	0.692	165.0	691.0	1.00
25.0	4.880	1.460	4.890	1.090	161.0	674.0	0.98
30.0	4.760	1.470	4.770	1.070	157.0	657.0	0.95
35.0	4.620	1.470	4.630	1.030	154.0	645.0	0.93
40.0	4.520	1.480	4.530	1.010	151.0	632.0	0.92
45.0	4.430	1.490	4.450	0.993	147.0	615.0	0.89
50.0	4.350	1.500	4.370	0.975	144.0	603.0	0.87
55.0	4.320	1.520	4.330	0.966	142.0	594.0	0.86
60.0	4.260	1.530	4.270	0.953	140.0	586.0	0.85
65.0	4.210	1.540	4.220	0.943	139.0	582.0	0.84
70.0	4.100	1.520	4.110	0.918	138.0	578.0	0.84
75.0	4.060	1.530	4.080	0.910	136.0	569.0	0.82
80.0	4.070	1.540	4.090	0.912	136.0	569.0	0.82
85.0	4.060	1.550	4.070	0.909	136.0	569.0	0.82
90.0	4.070	1.560	4.090	0.912	136.0	569.0	0.82
95.0	4.090	1.580	4.110	0.916	135.0	565.0	0.82
100.0	4.090	1.580	4.110	0.916	135.0	565.0	0.82
105.0	4.090	1.580	4.110	0.916	135.0	565.0	0.82
110.0	4.100	1.570	4.110	0.918	136.0	569.0	0.82
115.0	4.090	1.560	4.110	0.916	136.0	569.0	0.82
120.0	4.100	1.550	4.110	0.918	136.0	569.0	0.82
125.0	4.120	1.540	4.130	0.922	137.0	573.0	0.83
130.0	4.170	1.540	4.190	0.934	137.0	573.0	0.83
135.0	4.180	1.520	4.200	0.937	138.0	578.0	0.84
140.0	4.200	1.500	4.210	0.940	139.0	582.0	0.84
145.0	4.220	1.480	4.240	0.946	140.0	586.0	0.85
150.0	4.150	1.430	4.160	0.929	140.0	586.0	0.85
155.0	4.060	1.370	4.080	0.910	140.0	586.0	0.85
160.0 <sup>2)</sup>	2.410	0.795	2.410	0.539	140.0	586.0	0.85
165.0	0.000	0.000	0.000	0.000	0.000	0.000	0.00

\* All numerical values of characteristics are presented as average values at the length interval equal to the axial coordinate  $\pm 2.5$  mm

<sup>1)</sup> Initial coordinate of fuel is 19.4 mm

<sup>2)</sup> End coordinate of fuel is 160.4 mm

<sup>3)</sup> Current value per maximum value

# #H17T

Individual Characteristics of Refabricated Fuel Rods  
(Fresh Fuel, Preirradiated Cladding) under IGR Tests

Table H-4.3. Radial Energy Characteristics of Fuel Rod #H17T

Characteristics*		Coordinates of fuel zones (mm)			
		1 zone 1.10 - 2.12	2 zone 2.12 - 2.79	3 zone 2.79 - 3.32	4 zone 3.32 - 3.79
U <sup>235</sup>	Number of fissions $\times 10^{-14}$ (fiss)	2.880	2.920	3.030	3.160
	Power of fuel rod <sup>1)</sup> (kW)	6.430	6.510	6.760	7.050
	Energy deposition <sup>2)</sup> (cal/g fuel)	135.0	137.0	142.0	149.0
	Energy deposition <sup>2)</sup> (J/g fuel)	565.0	573.0	594.0	624.0
	Energy deposition <sup>3)</sup> (per-unit)	0.906	0.919	0.953	1.000
U <sup>238</sup>	Number of fissions $\times 10^{-12}$ (fiss)	1.070	1.080	1.070	1.040
	Power of fuel rod <sup>1)</sup> (kW)	0.023	0.024	0.024	0.023
	Energy deposition <sup>2)</sup> (cal/g fuel)	0.495	0.503	0.498	0.484
	Energy deposition <sup>2)</sup> (J/g fuel)	2.070	2.110	2.080	2.030
	Energy deposition <sup>3)</sup> (per-unit)	0.984	1.000	0.990	0.962
Total	Number of fissions $\times 10^{-14}$ (fiss)	2.890	2.930	3.040	3.170
	Power of fuel rod <sup>1)</sup> (kW)	6.450	6.530	6.780	7.080
	Energy deposition <sup>2)</sup> (cal/g fuel)	136.0	138.0	143.0	149.0
	Energy deposition <sup>2)</sup> (J/g fuel)	569.0	578.0	599.0	624.0
	Energy deposition <sup>3)</sup> (per-unit)	0.913	0.926	0.960	1.000

1) at time of 4.70 s, 2) at infinite time, 3) Current value per maximum value

\* All numerical values of characteristics were calculated for length of fuel stack

Table H-4.4. Fuel Enthalpy Vs. Time Calculated by FRAP-T6 Code for Fuel Rod #H17T

Time (s)	Enthalpy at fuel radius (cal/g fuel)				Fuel enthalpy <sup>1)</sup>		Energy deposition in fuel rod	
	1.10 mm	2.22 mm	2.89 mm	3.79 mm	cal/g fuel	J/g fuel	cal/g fuel	J/g fuel
0.0	0.00	0.00	0.00	0.00	0.00	0.00	0.00	0.00
1.0	0.35	0.35	0.34	0.31	0.34	1.43	0.32	1.32
2.0	2.13	2.11	2.05	1.88	2.05	8.58	2.07	8.65
2.2	2.69	2.65	2.57	2.37	2.58	10.8	2.63	11.0
2.4	3.30	3.25	3.16	2.91	3.16	13.2	3.25	13.6
2.6	3.98	3.92	3.80	3.50	3.81	16.0	3.95	16.6
2.8	4.73	4.66	4.52	4.16	4.53	19.0	4.73	19.8
3.0	5.58	5.49	5.33	4.92	5.34	22.4	5.62	23.5
3.2	6.59	6.48	6.29	5.80	6.30	26.4	6.66	27.9
3.4	7.84	7.73	7.50	6.90	7.51	31.5	7.95	33.3
3.6	9.56	9.43	9.16	8.39	9.16	38.4	9.68	40.6
3.8	12.1	12.0	11.6	10.5	11.6	48.6	12.2	51.1
4.0	16.3	16.1	15.6	13.7	15.5	64.9	16.2	68.0
4.2	23.5	23.2	22.4	18.8	22.2	92.9	23.1	97.0
4.4	35.9	35.5	34.1	26.7	33.6	141	35.0	147
4.6	55.1	54.3	51.8	36.4	50.4	211	53.0	222
4.8	77.8	76.4	71.3	43.0	68.9	289	74.5	312
5.0	97.9	95.3	85.8	43.6	82.6	346	93.6	392
5.2	112	107	91.6	41.3	89.4	374	107	449
5.4	120	112	90.4	39.0	90.7	380	116	485
5.6	123	111	85.7	36.4	88.7	372	121	506
5.8	123	108	79.8	34.0	85.2	357	124	518
6.0	121	103	73.9	31.9	81.1	340	126	527
6.5	110	88.7	61.8	29.1	70.5	295	129	539
7.0	94.2	75.4	53.3	27.8	61.1	256	130	547
7.5	78.9	63.9	46.7	26.5	52.8	221	132	551
8.0	65.5	54.3	41.1	25.1	45.6	191	132	555
10.0	33.1	29.7	25.2	18.6	26.5	111	134	563
30.0	5.29	5.28	5.25	5.19	5.25	22.0	138	580

Radial enthalpy distribution and fuel enthalpy are presented at elevation 26.4 mm

Maximum value of fuel enthalpy is 90.7 cal/g fuel ( $t=5.36$  s)

<sup>1)</sup> All numerical values are presented at elevation with peak power

# #H17T

Individual Characteristics of Refabricated Fuel Rods  
(Fresh Fuel, Preirradiated Cladding) under IGR Tests

Table H-4.5. Energy Characteristics Vs. Time Calculated by FRAP-T6 and SCANAIR Codes for Fuel Rod #H17T

Time (s)	Energy deposition <sup>1)</sup> (cal/g fuel)	Linear power <sup>1)</sup> (kW/m)	Fuel enthalpy <sup>1)</sup> (cal/g fuel)		Energy of metal-water reaction <sup>1)</sup> (cal/g fuel)	Leakage of energy <sup>1)</sup> (cal/g fuel)		Clad-to-coolant heat transfer coefficient <sup>1)</sup> (kW/m <sup>2</sup> K)	
			FRAP-T6	SCANAIR	FRAP-T6	FRAP-T6	SCANAIR	FRAP-T6	SCANAIR
0.0	0.00	0.00	0.00	0.00	0.00	0.00	0.00	0.00	0.00
1.0	0.36	1.72	0.34	0.32	0.00	0.00	0.00	0.03	0.10
2.0	2.34	5.17	2.05	2.10	0.00	0.00	0.01	0.03	0.10
2.2	2.97	5.83	2.58	2.58	0.00	0.00	0.02	0.03	0.10
2.4	3.68	6.49	3.16	3.21	0.00	0.01	0.02	0.03	0.10
2.6	4.47	7.23	3.81	3.90	0.00	0.01	0.03	0.03	0.10
2.8	5.35	8.11	4.53	4.56	0.00	0.01	0.04	0.03	0.10
3.0	6.36	9.38	5.34	5.43	0.00	0.02	0.06	0.03	0.10
3.2	7.53	11.2	6.30	6.46	0.00	0.02	0.07	0.03	0.10
3.4	8.99	14.4	7.51	7.57	0.00	0.03	0.09	0.03	0.10
3.6	11.0	20.0	9.16	9.32	0.00	0.04	0.12	0.16	0.10
3.8	13.8	30.5	11.6	12.0	0.00	0.24	0.35	1.17	1.46
4.0	18.4	50.6	15.5	15.9	0.00	0.74	0.90	2.12	2.50
4.2	26.2	88.2	22.2	23.1	0.00	1.66	1.95	3.61	4.36
4.4	39.6	147	33.6	33.6	0.00	3.34	3.55	6.30	7.20
4.6	60.0	203	50.4	51.3	0.00	6.49	6.95	10.8	12.7
4.8	84.2	207	68.9	67.9	0.00	12.0	11.9	16.2	18.5
5.0	106	163	82.6	82.3	0.00	19.8	20.2	20.2	23.6
5.2	121	106	89.4	88.5	0.00	29.0	29.4	21.0	25.0
5.4	131	62.7	90.7	89.1	0.00	37.8	39.2	19.7	23.6
5.6	136	37.4	88.7	86.3	0.00	46.0	48.1	18.2	21.2
5.8	140	23.8	85.2	82.9	0.00	53.4	54.8	16.7	19.2
6.0	142	16.4	81.1	78.6	0.00	60.1	61.7	15.5	17.2
6.5	146	8.66	70.5	68.5	0.00	74.3	75.6	12.4	13.9
7.0	148	5.41	61.1	60.1	0.00	85.3	86.2	10.3	11.8
7.5	149	3.66	52.8	52.1	0.00	94.4	95.6	8.75	10.1
8.0	150	2.64	45.6	45.2	0.00	102	103	7.55	8.72
10.0	152	1.35	26.5	26.7	0.00	123	125	4.32	4.99
30.0	157	0.14	5.25	5.44	0.00	148	151	0.09	0.10

<sup>1)</sup> All numerical values are presented at elevation with peak power

# #H17T

Individual Characteristics of Refabricated Fuel Rods  
(Fresh Fuel, Preirradiated Gladding) under IGR Tests

Table H-4.6. Temperature Variation, Fission Gas Release and ZrO<sub>2</sub> Thickness Vs. Time for Fuel Rod #H17T Calculated by FRAP-T6 and SCANAIR Codes

Time (s)	Fuel centerline temperature <sup>1)</sup> (K)		Fuel surface temperature <sup>1)</sup> (K)		Clad outer temperature <sup>1)</sup> (K)		Average ZrO <sub>2</sub> <sup>2)</sup> thickness (μm)
	FRAP-T6	SCANAIR	FRAP-T6	SCANAIR	FRAP-T6	SCANAIR	FRAP-T6
0.0	293	293	293	293	293	293	5
1.0	299	299	299	298	295	294	5
2.0	330	329	326	324	308	307	5
2.2	340	337	334	331	313	311	5
2.4	350	348	343	340	319	317	5
2.6	361	359	353	350	326	324	5
2.8	373	370	364	359	334	330	5
3.0	387	384	376	371	342	339	5
3.2	403	401	390	386	352	349	5
3.4	422	419	408	401	364	359	5
3.6	449	447	431	424	378	373	5
3.8	487	489	463	457	386	381	5
4.0	548	551	510	502	391	383	5
4.2	652	665	585	578	396	387	5
4.4	825	826	697	673	404	391	5
4.6	1082	1100	831	800	413	398	5
4.8	1377	1369	920	869	421	404	5
5.0	1629	1640	929	876	427	409	5
5.2	1798	1808	897	844	428	411	5
5.4	1889	1901	866	809	426	409	5
5.6	1927	1931	831	784	424	407	5
5.8	1929	1925	798	770	422	405	5
6.0	1905	1891	769	757	420	403	5
6.5	1771	1741	730	735	416	400	5
7.0	1583	1565	712	715	412	397	5
7.5	1390	1379	694	692	409	395	5
8.0	1218	1214	674	669	407	393	5
10.0	785	791	582	575	398	388	5
30.0	382	380	380	378	376	374	5

<sup>1)</sup> All numerical values are presented at elevation with peak power

<sup>2)</sup> Initial ZrO<sub>2</sub> thickness is 5 μm

# #H17T

Individual Characteristics of Refabricated Fuel Rods  
(Fresh Fuel, Preirradiated Cladding) under IGR Tests

Table H-4.7. Mechanical Characteristics of Fuel Rod #H17T Vs. Time Calculated by FRAP-T6 and SCANAIR Codes

Time (s)	Clad outer temperature <sup>1)</sup> (K)		Fuel hoop strain <sup>1)</sup> (%)		Fuel - clad gap width <sup>1)</sup> (mm)		Clad hoop strain <sup>1)</sup> (%)		Clad hoop stress <sup>1)</sup> (MPa)		Internal gas pressure (MPa)	
	FRAP-T6	SCANAIR	FRAP-T6	SCANAIR	FRAP-T6	SCANAIR	FRAP-T6	SCANAIR	FRAP-T6	SCANAIR	FRAP-T6	SCANAIR
0.0	293	293	0.00	0.00	0.07	0.07	0.01	0.01	8.71	8.69	1.70	1.70
1.0	295	294	0.00	0.00	0.07	0.07	0.01	0.01	8.73	8.71	1.71	1.71
2.0	308	307	0.03	0.03	0.06	0.06	0.02	0.02	8.84	8.85	1.73	1.73
2.2	313	311	0.04	0.04	0.06	0.06	0.02	0.02	8.88	8.89	1.73	1.74
2.4	319	317	0.05	0.05	0.06	0.06	0.03	0.03	8.91	8.93	1.74	1.74
2.6	326	324	0.06	0.06	0.06	0.06	0.03	0.03	8.95	8.98	1.74	1.75
2.8	334	330	0.07	0.07	0.06	0.06	0.04	0.03	8.98	9.02	1.75	1.76
3.0	342	339	0.08	0.08	0.06	0.06	0.04	0.04	9.02	9.07	1.76	1.77
3.2	352	349	0.10	0.09	0.06	0.06	0.05	0.05	9.07	9.13	1.77	1.78
3.4	364	359	0.12	0.11	0.06	0.06	0.06	0.06	9.12	9.19	1.78	1.79
3.6	378	373	0.15	0.14	0.06	0.06	0.07	0.07	9.18	9.28	1.79	1.80
3.8	386	381	0.18	0.18	0.06	0.06	0.07	0.07	9.26	9.45	1.80	1.82
4.0	391	383	0.24	0.24	0.06	0.06	0.08	0.08	9.37	9.65	1.82	1.85
4.2	396	387	0.34	0.35	0.06	0.05	0.08	0.08	9.51	10.00	1.85	1.88
4.4	404	391	0.51	0.52	0.05	0.05	0.09	0.09	9.70	10.5	1.88	1.93
4.6	413	398	0.78	0.83	0.04	0.04	0.11	0.11	9.90	11.2	1.92	1.99
4.8	421	404	1.10	1.13	0.03	0.03	0.12	0.13	10.1	11.9	1.95	2.03
5.0	427	409	1.37	1.41	0.02	0.02	0.14	0.14	10.2	12.5	1.97	2.07
5.2	428	411	1.53	1.53	0.01	0.01	0.14	0.15	10.3	12.7	1.98	2.09
5.4	426	409	1.59	1.54	0.01	0.01	0.13	0.14	10.3	12.6	1.99	2.09
5.6	424	407	1.59	1.48	0.01	0.01	0.13	0.13	10.3	12.4	1.99	2.08
5.8	422	405	1.55	1.40	0.01	0.02	0.13	0.13	10.3	12.2	1.99	2.08
6.0	420	403	1.49	1.31	0.01	0.02	0.12	0.12	10.3	11.9	1.99	2.07
6.5	416	400	1.31	1.10	0.02	0.03	0.11	0.11	10.2	11.6	1.97	2.04
7.0	412	397	1.12	0.94	0.03	0.03	0.11	0.11	10.1	11.3	1.96	2.02
7.5	409	395	0.94	0.80	0.03	0.04	0.10	0.10	10.0	11.0	1.94	2.00
8.0	407	393	0.79	0.68	0.04	0.04	0.10	0.10	9.95	10.8	1.93	1.97
10.0	398	388	0.43	0.38	0.05	0.05	0.09	0.09	9.66	10.1	1.87	1.90
30.0	376	374	0.08	0.06	0.06	0.07	0.06	0.07	9.06	9.05	1.77	1.77

<sup>1)</sup> All numerical values are presented at elevation with peak power



# #H17T

Individual Characteristics of Refabricated Fuel Rods  
(Fresh Fuel, Preirradiated Gladding) under IGR Tests

**Table H-4.8. Axial Distribution of Energy Deposition and Fuel Enthalpy Calculated by FRAP-T6 Code for Fuel Rod #H17T**

Axial interval from-to (mm)-(mm)	Energy deposition at infinite time			Fuel enthalpy at time (t=5.36 s)		
	cal/g fuel	J/g fuel	per-unit	cal/g fuel	J/g fuel	per-unit
19.4 - 33.5	160	670	1.00	90.7	380	1.00
33.5 - 47.6	150	630	0.94	85.3	357	0.94
47.6 - 61.7	142	596	0.89	80.7	338	0.89
61.7 - 75.8	138	578	0.86	78.3	328	0.86
75.8 - 89.9	136	570	0.85	77.2	323	0.85
89.9 - 104.0	135	566	0.85	76.7	322	0.85
104.0 - 118.1	136	569	0.85	77.1	323	0.85
118.1 - 132.2	137	573	0.86	77.6	325	0.86
132.2 - 146.3	139	582	0.87	78.8	330	0.87
146.3 - 160.4	140	587	0.88	79.5	333	0.88

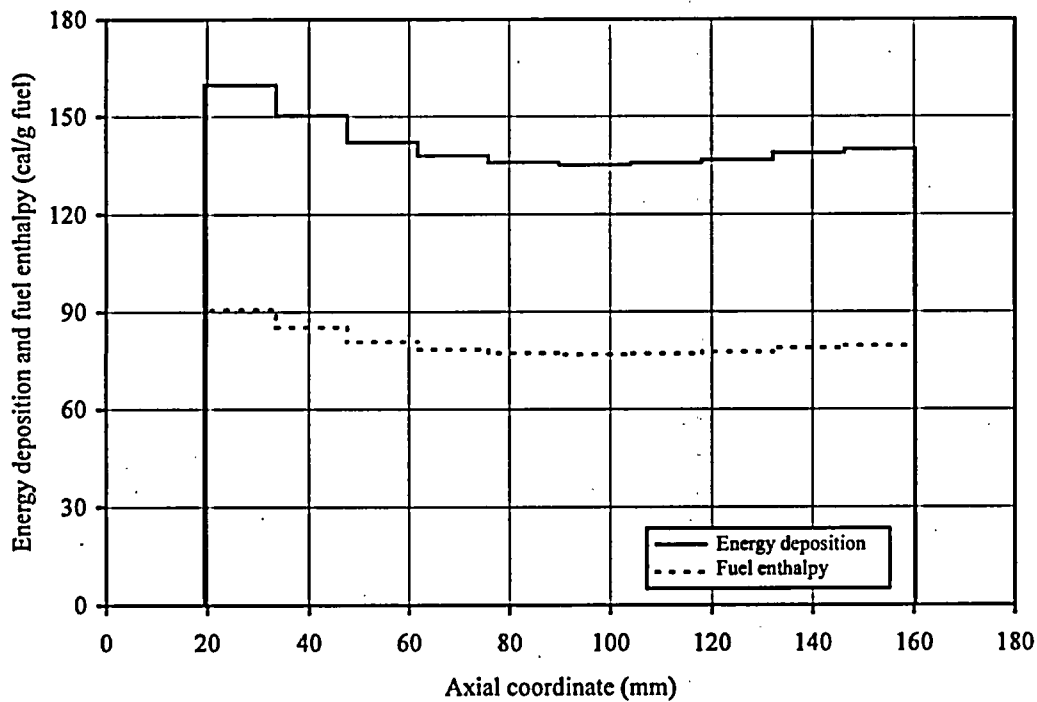

**Fig. H-4.4. Axial Distribution of Energy Deposition and Fuel Enthalpy Calculated by FRAP-T6 Code for Fuel Rod #H17T**

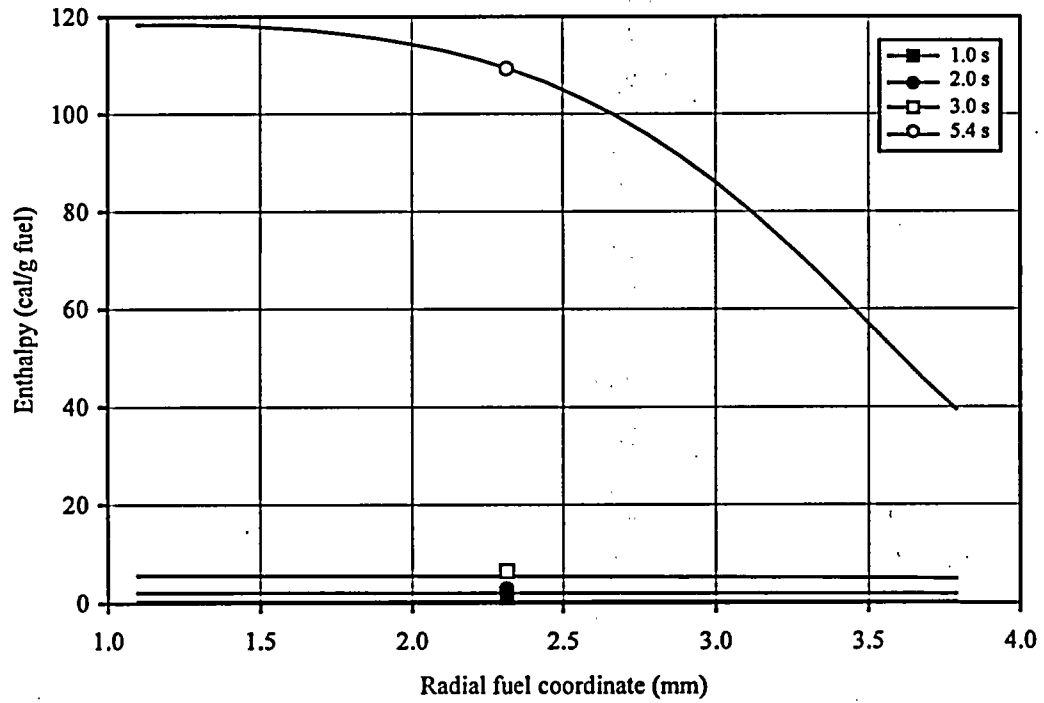
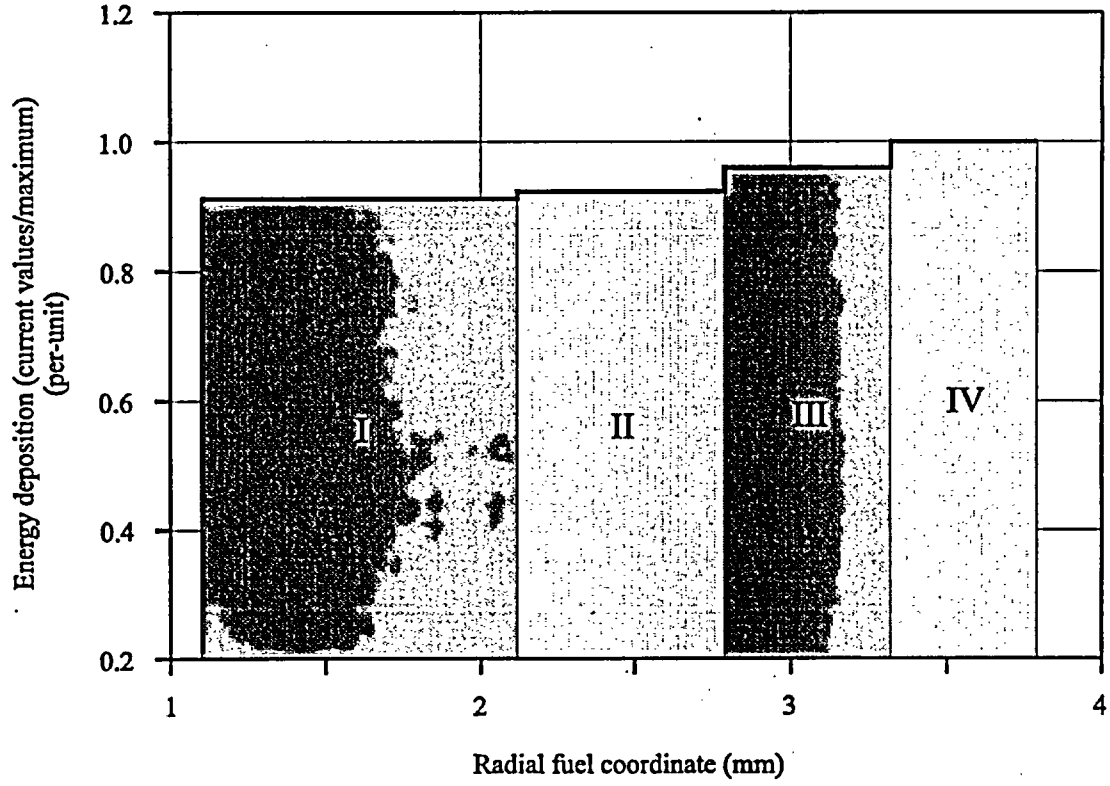

Fig. H-4.5. Radial Distributions of Energy Deposition and Fuel Enthalpy Calculated by FRAP-T6 Code for Fuel Rod #H17T

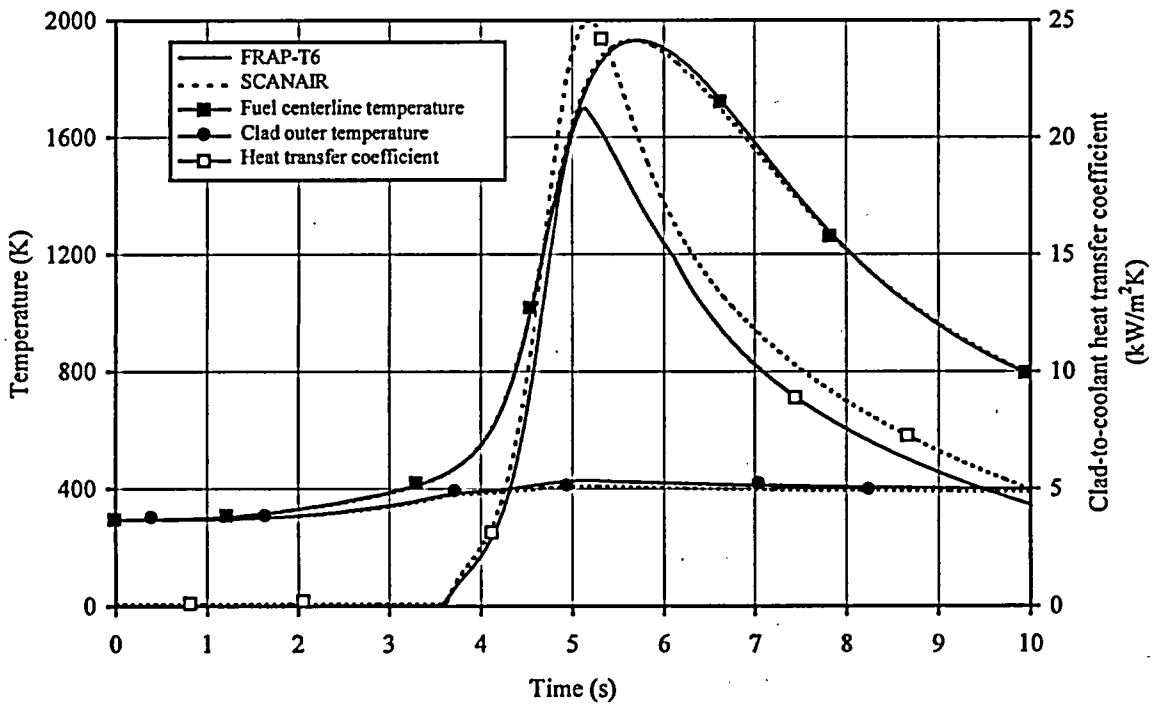
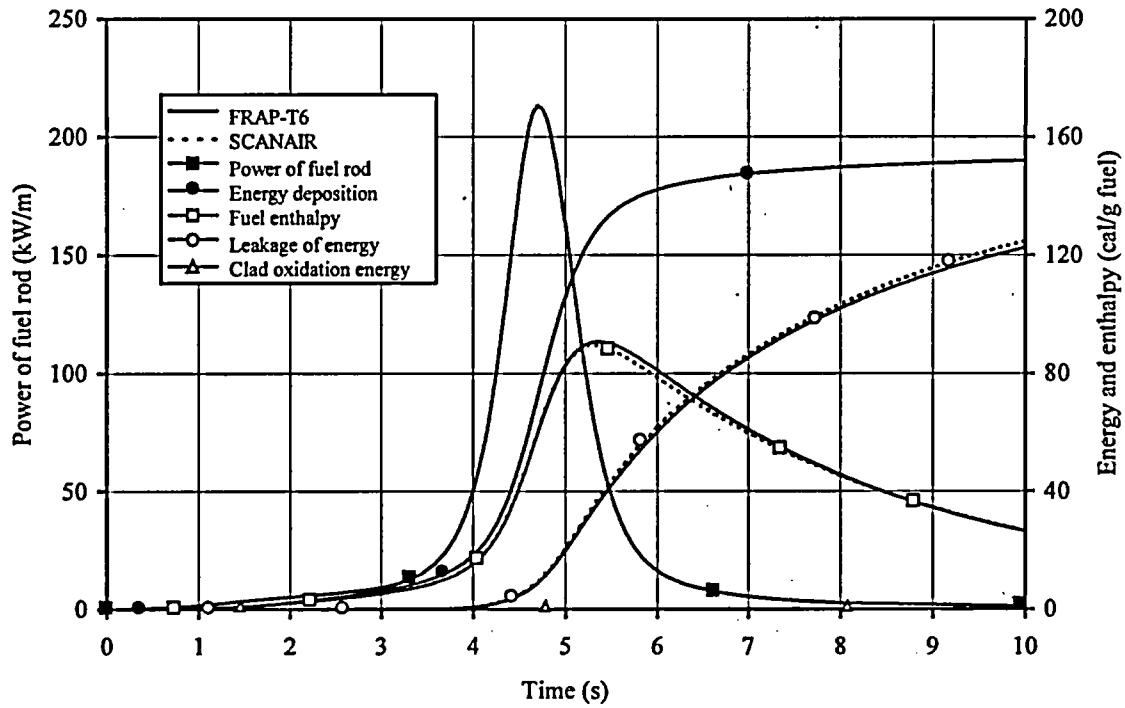

Fig. H-4.6. Energy and Temperature Characteristics Vs. Time Calculated by FRAP-T6 and SCANAIR Codes for Fuel Rod #H17T

#H17T

Individual Characteristics of Refabricated Fuel Rods  
(Fresh Fuel, Preirradiated Cladding) under IGR Tests

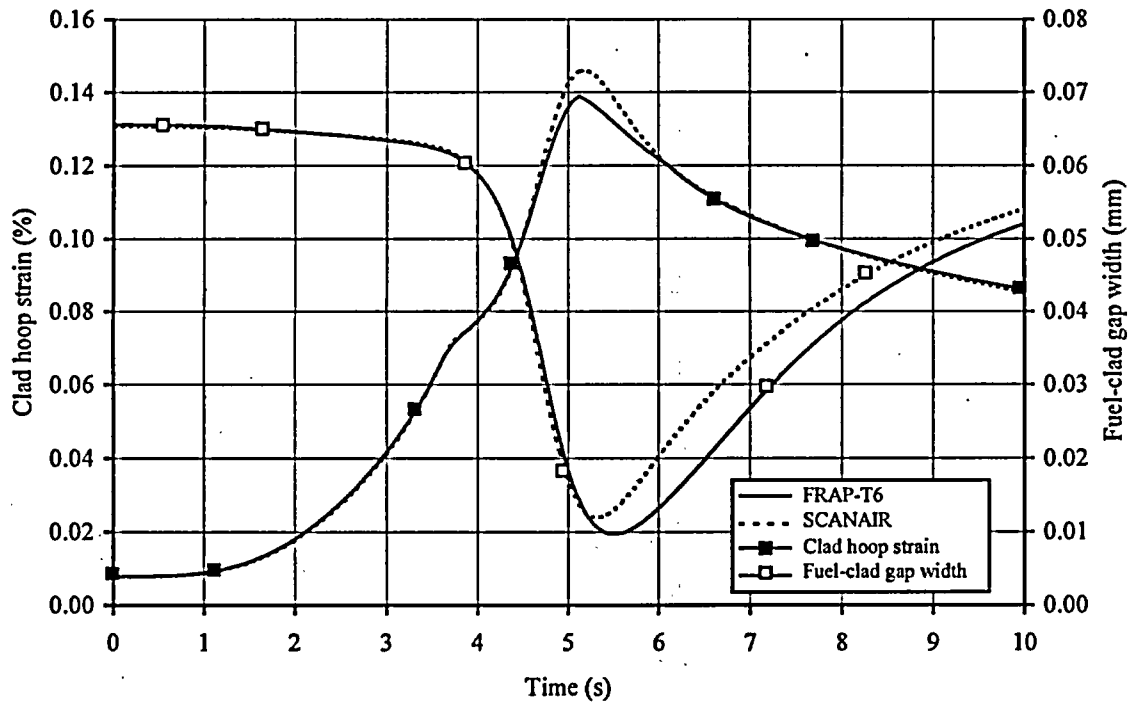
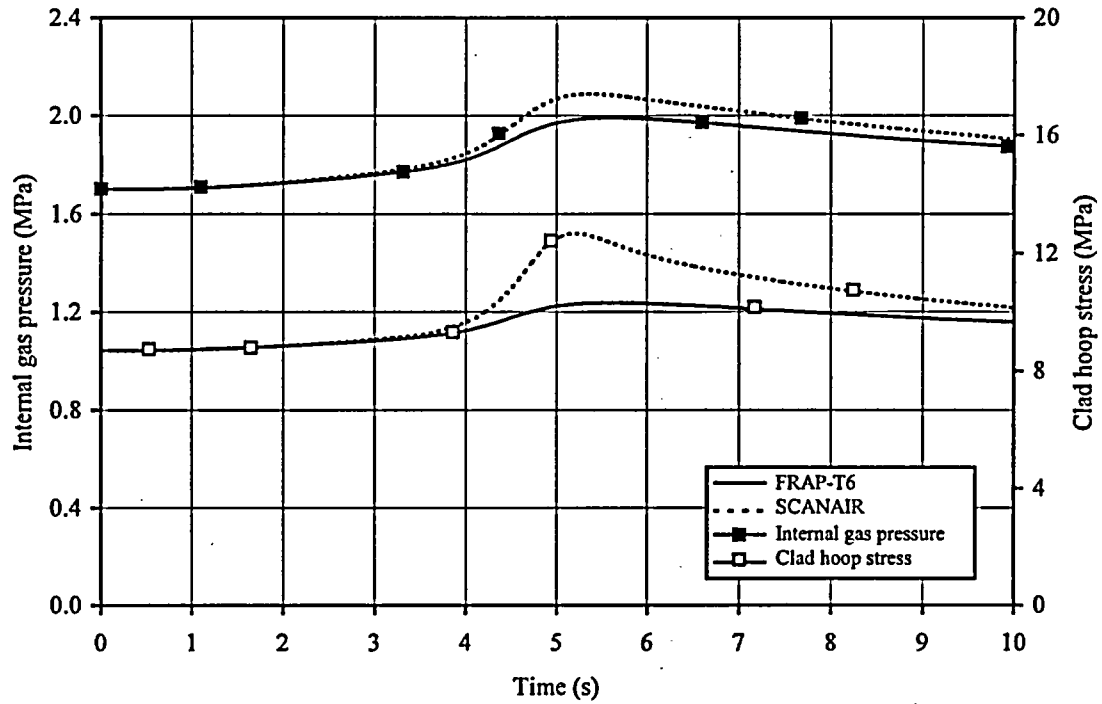

Fig. H-4.7. Cladding Mechanical Characteristics Vs. Time Calculated by FRAP-T6 and SCANAIR Codes for Fuel Rod #H17T

# #H17T

Individual Characteristics of Refabricated Fuel Rods  
(Fresh Fuel, Preirradiated Cladding) under IGR Tests

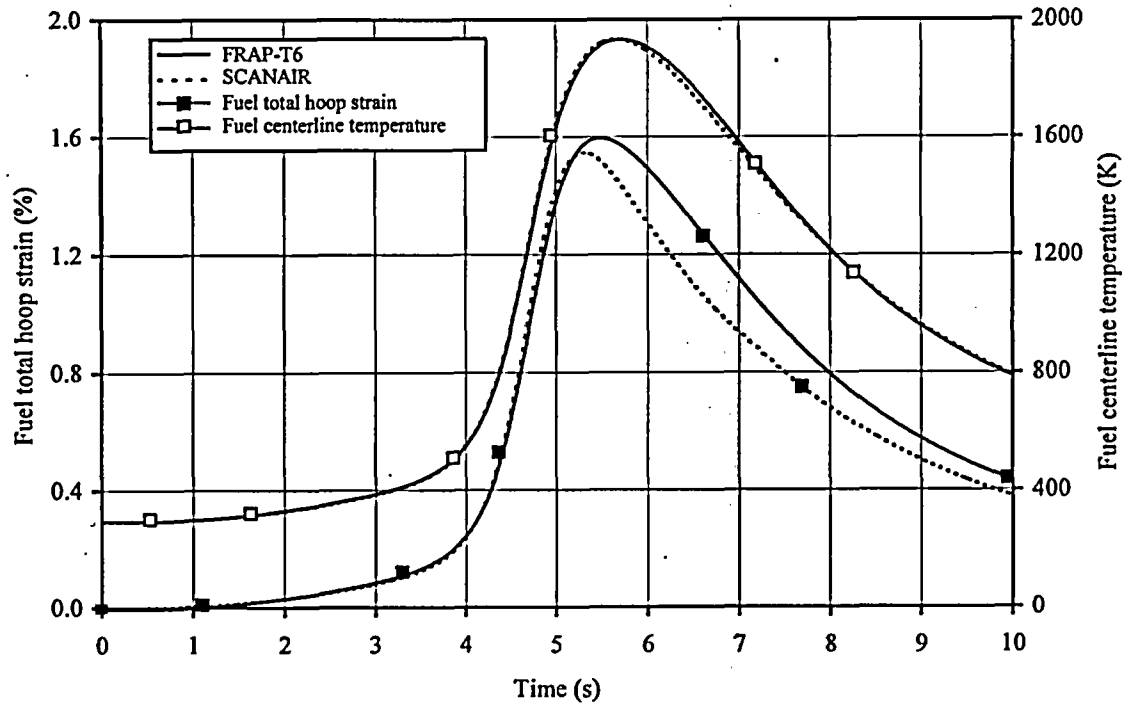

Fig. H-4.8. Fuel Strain Vs. Time Calculated by FRAP-T6 and SCANAIR Codes for Fuel Rod #H17T

Table H-4.9. Some Results of PIE for Fuel Rod #H17T

Characteristic		Value
1.	Measured parameters of cladding oxidation and cladding deformation	
1.1.	Cladding thickness at elevation 90 mm for different azimuthal angles ( $\mu\text{m}$ ):	
	0°	705
	90°	691
	180°	691
	270°	710
1.2.	ZrO <sub>2</sub> thickness at elevation 90 mm for different azimuthal angles ( $\mu\text{m}$ ):	
	0°	5
	90°	5
	180°	5
	270°	5
1.3.	$\alpha\text{Zr(O)}$ thickness at elevation 90 mm for different azimuthal angles ( $\mu\text{m}$ ):	
	0°	0
	90°	0
	180°	0
	270°	0
1.4.	Clad hoop strain at elevation 90 mm (%)	1.5
2.	Measured parameters for FGR analysis	
2.1.	Internal gas composition (% by volume):	
	He	—
	N <sub>2</sub>	—
	O <sub>2</sub>	—
	Ar	—
	CO <sub>2</sub>	—
	Kr	—
	Xe	—
2.2.	Free gas volume (cm <sup>3</sup> )	6.1
2.3.	Gas pressure inside fuel rod under normal condition (MPa)	1.735
2.4.	Kr concentration in fuel (cm <sup>3</sup> /g fuel)	—
3.	Measured parameters of cladding hydriding	
3.1.	Coefficient of hydride orientation (per-unit)	0.29
3.2.	Hydrogen concentration (% by weight)	—

# #H17T

Individual Characteristics of Refabricated Fuel Rods  
(Fresh Fuel, Preirradiated Cladding) under IGR Tests

Table H-4.10. General Characteristic of Fuel Rod #H17T

	Parameter	Unit	Value		
			Experiment	FRAP-T6	SCANAIR
1	Type of coolant	---	water	water	water
2	Burnup	MWd/kg U	0	0	0
3	Energy deposition in fuel rod	cal/g fuel	141	141	141
4	Peak fuel enthalpy	cal/g fuel	-	91	89
5	Peak fuel temperature	K	-	1931	1932
6	Peak clad temperature	K	-	428	411
7	Fuel rod failure	Yes, No	No	No	-
8	Type of failure:				
	- cladding rupture due to ballooning	Yes, No	No	No	-
	- cladding rupture due to PCMI	Yes, No	No	No	-
	- fragmentation of fuel rod	Yes, No	No	-	-
9	Failure time	s	-	-	-
10	Fuel enthalpy at failure	cal/g fuel	-	-	-
11	Outer cladding temperature at failure	K	-	-	-
12	Internal gas pressure at failure	MPa	-	-	-
13	ZrO <sub>2</sub> thickness after test	μm	5	5	-
14	Residual clad hoop strain:				
	- peak value for ballooning area	%	-	-	-
	- other location <sup>1)</sup>	%	1.5	0	0

<sup>1)</sup>Calculated values by FRAP-T6 and SCANAIR codes are average along height of fuel rod excluding ballooning region

*APPENDIX H-5.*  
*Individual Characteristics for Fuel Rod #H18T under IGR Test*



#H18T

Individual Characteristics of Refabricated Fuel Rods  
(Fresh Fuel, Preirradiated Cladding) under IGR Tests

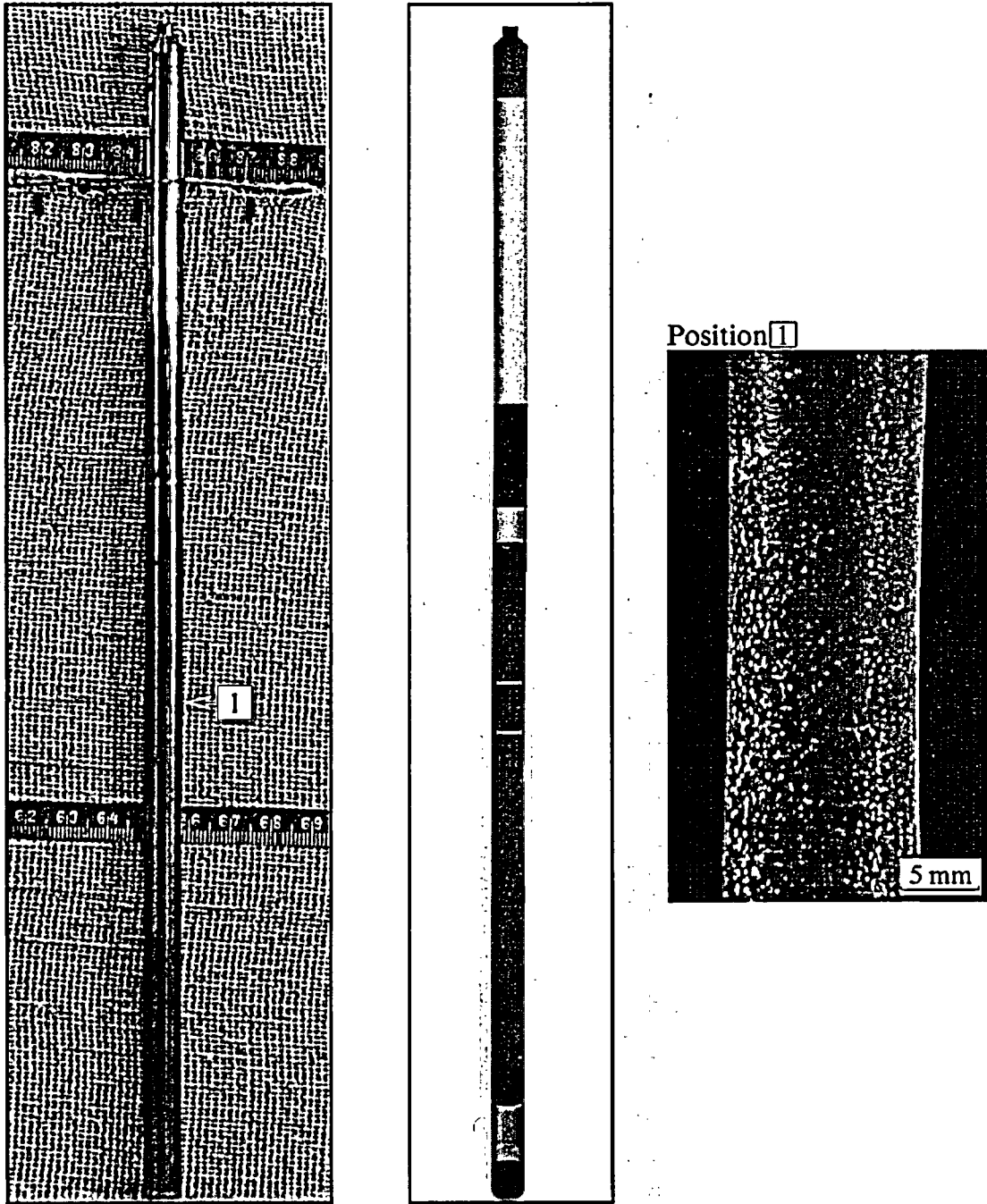
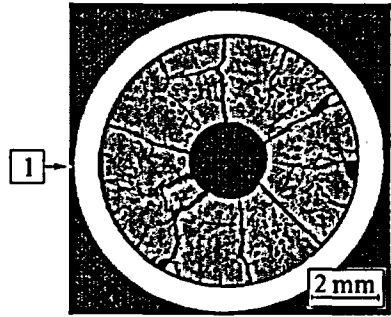

Fig. H-5.1. Appearance of Fuel Rod #H18T (photographs and X-ray photograph)

#H18T

Individual Characteristics of Refabricated Fuel Rods  
(Fresh Fuel/Preirradiated Cladding) under IGR Tests



Position 1

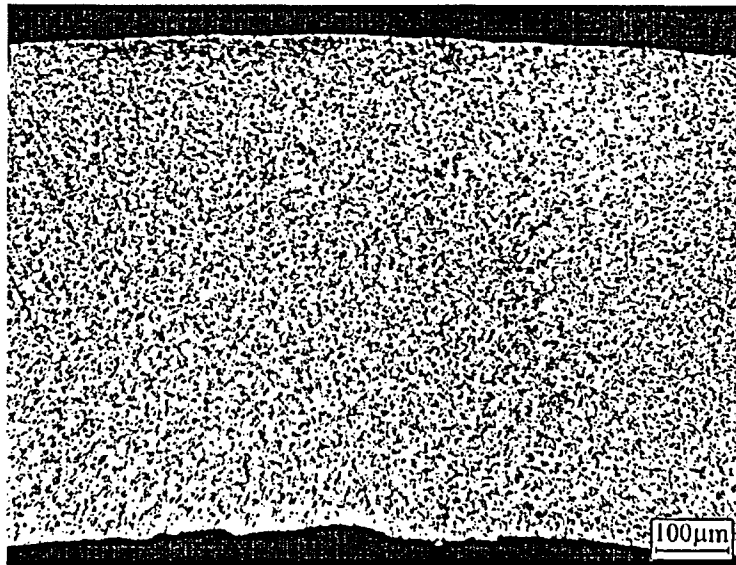

Position 1

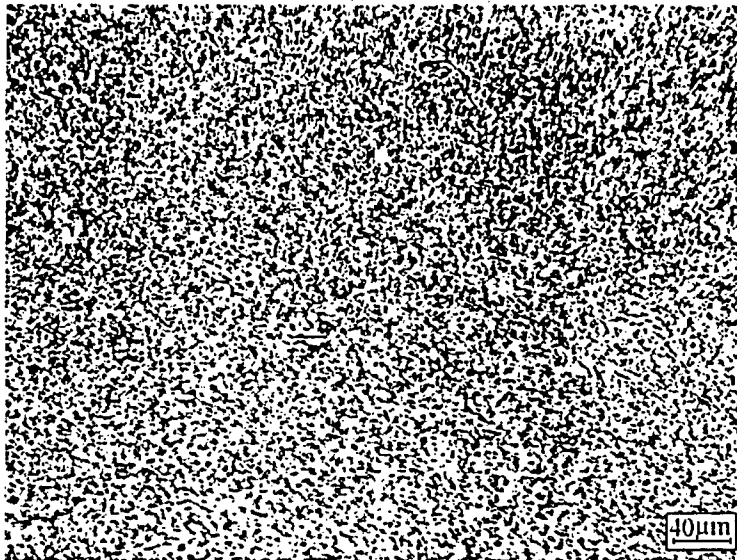
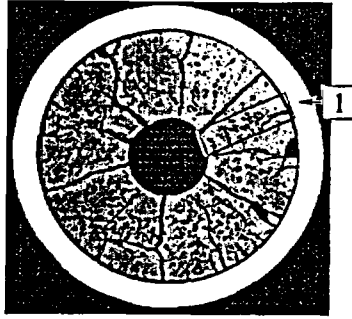

Fig. H-5.2. Cross-Section and Cladding Microstructure for Fuel Rod #H18T at 90 mm Elevation

#H18T

Individual Characteristics of Refabricated Fuel Rods  
(Fresh Fuel, Preirradiated Cladding) under IGR Tests

Position 1



Position 2



Position 3

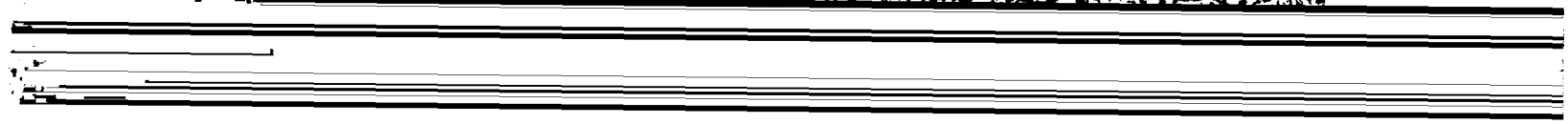

# #H18T

Individual Characteristics of Refabricated Fuel Rods  
(Fresh Fuel, Preirradiated Cladding) under IGR Tests

Table H-5.1. Time Dependent Energy Characteristics of Fuel Rod #H18T

Time (s)	Reactor energy deposition <sup>1)</sup> (%)	Cumulative number of fissions in fuel rod (fiss)			Power of fuel rod (kW)	Energy deposition in fuel rod	
		U <sup>235</sup> ×10 <sup>-14</sup>	U <sup>238</sup> ×10 <sup>-12</sup>	Total ×10 <sup>-14</sup>		cal/g fuel	J/g fuel
0.0	0.000	0.000	0.000	0.000	0.000	0.000	0.000
1.0	1.080	0.121	0.043	0.121	0.681	1.380	5.780
2.0	4.410	0.492	0.175	0.494	1.580	5.630	23.60
2.2	5.600	0.624	0.222	0.627	2.240	7.140	29.90
2.4	7.430	0.829	0.295	0.832	3.740	9.480	39.70
2.6	10.80	1.200	0.428	1.210	7.240	13.80	57.80
2.8	17.40	1.940	0.691	1.950	14.20	22.20	92.90
3.0	29.20	3.260	1.160	3.270	22.70	37.20	156.0
3.2	45.20	5.040	1.790	5.060	26.40	57.60	241.0
3.4	60.80	6.780	2.410	6.800	21.50	77.40	324.0
3.6	72.10	8.040	2.860	8.070	14.40	91.90	385.0
3.8	79.50	8.860	3.150	8.900	9.330	101.0	423.0
4.0	84.30	9.400	3.350	9.430	6.140	108.0	452.0
4.2	87.40	9.750	3.470	9.790	4.190	112.0	469.0
4.4	89.60	10.00	3.560	10.00	2.970	115.0	481.0
4.6	91.20	10.20	3.620	10.20	2.180	117.0	490.0
4.8	92.40	10.30	3.670	10.30	1.650	118.0	494.0
5.0	93.20	10.40	3.700	10.40	1.290	119.0	498.0
5.2	93.90	10.50	3.730	10.50	1.040	120.0	502.0
5.4	94.50	10.50	3.750	10.60	0.853	121.0	507.0
5.6	94.90	10.60	3.770	10.60	0.695	122.0	511.0
5.8	95.30	10.60	3.780	10.70	0.588	122.0	511.0
6.0	95.60	10.70	3.800	10.70	0.502	123.0	515.0
6.5	96.20	10.70	3.820	10.80	0.355	123.0	515.0
7.0	96.60	10.80	3.840	10.80	0.266	124.0	519.0
7.5	96.90	10.80	3.850	10.80	0.211	125.0	523.0
8.0	97.20	10.80	3.860	10.90	0.176	125.0	523.0
9.0	97.60	10.90	3.870	10.90	0.149	126.0	527.0
10.0	97.90	10.90	3.890	11.00	0.117	126.0	527.0
20.0	99.20	11.10	3.940	11.10	0.030	128.0	536.0
30.0	99.60	11.10	3.950	11.10	0.015	129.0	540.0
∞	100.0	11.20	3.990	11.20	0.000	132.0	553.0

Maximum value of power is 26.4 kW (t = 3.20 s)

<sup>1)</sup> Current energy deposition per maximum energy deposition (at infinite time)

# #H18T

Individual Characteristics of Refabricated Fuel Rods  
(Fresh Fuel, Preirradiated Cladding) under IGR Tests

Table H-5.2. Axial Energy Characteristics of Fuel Rod #H18T

Axial coordinate from lower end of fuel rod (mm)	Cumulative number of fissions at axial interval (fiss)			Maximum power of fuel rod (kW) t=3.20 s	Energy deposition at infinite time*		
	$U^{235}$ $\times 10^{-13}$	$U^{238}$ $\times 10^{-11}$	Total $\times 10^{-13}$		cal/g fuel	J/g fuel	per-unit <sup>3)</sup>
20.0	0.000	0.000	0.000	0.000	0.000	0.000	0.00
25.0 <sup>1)</sup>	2.580	0.751	2.590	0.609	154.0	645.0	1.00
30.0	4.510	1.350	4.530	1.060	151.0	632.0	0.98
35.0	4.430	1.360	4.440	1.040	147.0	615.0	0.95
40.0	4.400	1.400	4.410	1.040	144.0	603.0	0.94
45.0	4.300	1.410	4.320	1.010	141.0	590.0	0.92
50.0	4.150	1.390	4.160	0.978	138.0	578.0	0.90
55.0	4.070	1.400	4.090	0.961	136.0	569.0	0.88
60.0	3.990	1.400	4.000	0.940	133.0	557.0	0.86
65.0	3.940	1.410	3.950	0.929	132.0	553.0	0.86
70.0	3.900	1.420	3.910	0.920	130.0	544.0	0.84
75.0	3.900	1.450	3.910	0.920	128.0	536.0	0.83
80.0	3.880	1.450	3.890	0.914	128.0	536.0	0.83
85.0	3.830	1.450	3.840	0.903	127.0	532.0	0.82
90.0	3.800	1.450	3.810	0.895	127.0	532.0	0.82
95.0	3.780	1.450	3.800	0.892	126.0	527.0	0.82
100.0	3.780	1.460	3.790	0.891	126.0	527.0	0.82
105.0	3.780	1.460	3.790	0.891	126.0	527.0	0.82
110.0	3.830	1.470	3.840	0.903	126.0	527.0	0.82
115.0	3.830	1.470	3.850	0.904	127.0	532.0	0.82
120.0	3.830	1.460	3.840	0.903	127.0	532.0	0.82
125.0	3.830	1.450	3.850	0.904	127.0	532.0	0.82
130.0	3.850	1.440	3.870	0.908	128.0	536.0	0.83
135.0	3.850	1.420	3.860	0.908	128.0	536.0	0.83
140.0	3.860	1.410	3.880	0.911	129.0	540.0	0.84
145.0	3.900	1.400	3.910	0.920	130.0	544.0	0.84
150.0	3.920	1.380	3.940	0.926	131.0	548.0	0.85
155.0	3.910	1.350	3.930	0.923	131.0	548.0	0.85
160.0	3.880	1.310	3.890	0.914	131.0	548.0	0.85
165.0 <sup>2)</sup>	2.500	0.825	2.510	0.589	131.0	548.0	0.85
170.0	0.000	0.000	0.000	0.000	0.000	0.000	0.00

\* All numerical values of characteristics are presented as average values at the length interval equal to the axial coordinate  $\pm 2.5$  mm

<sup>1)</sup> Initial coordinate of fuel is 24.7 mm

<sup>2)</sup> End coordinate of fuel is 165.7 mm

<sup>3)</sup> Current value per maximum value

# #H18T

Individual Characteristics of Refabricated Fuel Rods  
(Fresh Fuel, Preirradiated Cladding) under IGR Tests

Table H-5.3. Radial Energy Characteristics of Fuel Rod #H18T

Characteristics*		Coordinates of fuel zones (mm)			
		1 zone 1.10 - 2.12	2 zone 2.12 - 2.79	3 zone 2.79 - 3.32	4 zone 3.32 - 3.79
U <sup>235</sup>	Number of fissions $\times 10^{-14}$ (fiss)	2.690	2.730	2.830	2.950
	Power of fuel rod <sup>1)</sup> (kW)	6.320	6.410	6.650	6.940
	Energy deposition <sup>2)</sup> (cal/g fuel)	126.0	128.0	133.0	139.0
	Energy deposition <sup>2)</sup> (J/g fuel)	527.0	536.0	557.0	582.0
	Energy deposition <sup>3)</sup> (per-unit)	0.906	0.921	0.957	1.000
U <sup>238</sup>	Number of fissions $\times 10^{-12}$ (fiss)	0.997	1.010	1.000	0.974
	Power of fuel rod <sup>1)</sup> (kW)	0.023	0.023	0.023	0.023
	Energy deposition <sup>2)</sup> (cal/g fuel)	0.462	0.470	0.465	0.452
	Energy deposition <sup>2)</sup> (J/g fuel)	1.930	1.970	1.950	1.890
	Energy deposition <sup>3)</sup> (per-unit)	0.983	1.000	0.989	0.962
Total	Number of fissions $\times 10^{-14}$ (fiss)	2.700	2.740	2.840	2.960
	Power of fuel rod <sup>1)</sup> (kW)	6.350	6.430	6.680	6.960
	Energy deposition <sup>2)</sup> (cal/g fuel)	127.0	129.0	133.0	139.0
	Energy deposition <sup>2)</sup> (J/g fuel)	532.0	540.0	557.0	582.0
	Energy deposition <sup>3)</sup> (per-unit)	0.914	0.928	0.957	1.000

1) at time of 3.20 s,      2) at infinite time,      3) Current value per maximum value

\* All numerical values of characteristics were calculated for length of fuel stack

# #H18T

Individual Characteristics of Refabricated Fuel Rods  
(Fresh Fuel, Preirradiated Cladding) under IGR Tests

Table H-5.4. Fuel Enthalpy Vs. Time Calculated by FRAP-T6 Code for Fuel Rod #H18T

Time (s)	Enthalpy at fuel radius (cal/g fuel)				Fuel enthalpy <sup>1)</sup>		Energy deposition in fuel rod	
	1.10 mm	2.22 mm	2.89 mm	3.79 mm	cal/g fuel	J/g fuel	cal/g fuel	J/g fuel
0.0	0.00	0.00	0.00	0.00	0.00	0.00	0.00	0.00
1.0	1.51	1.48	1.43	1.29	1.43	6.00	1.38	5.78
2.0	5.83	5.71	5.48	4.96	5.50	23.1	5.63	23.6
2.2	7.37	7.22	6.94	6.26	6.96	29.2	7.14	29.9
2.4	9.82	9.63	9.25	8.29	9.27	38.9	9.49	39.7
2.6	14.4	14.2	13.6	12.0	13.6	57.0	13.8	57.7
2.8	23.6	23.3	22.3	18.6	22.2	92.8	22.2	93.0
3.0	40.2	39.6	37.7	28.7	37.1	155	37.2	156
3.2	62.8	61.5	57.6	38.3	56.2	235	57.6	241
3.4	84.7	82.3	74.8	42.2	72.6	304	77.5	325
3.6	100	96.0	83.4	40.9	81.5	341	91.9	385
3.8	110	103	84.7	38.0	84.5	354	101	425
4.0	115	105	82.0	35.7	84.2	353	108	451
4.2	116	103	77.6	33.6	82.0	344	112	468
4.4	116	99.7	72.8	31.9	79.0	331	115	480
4.6	113	95.2	68.1	30.7	75.5	316	117	489
4.8	110	90.3	63.9	29.8	71.8	301	118	495
5.0	105	85.2	60.1	29.1	68.2	286	119	500
5.2	99.2	80.2	56.7	28.5	64.6	271	120	504
5.4	93.5	75.4	53.6	27.9	61.1	256	121	507
5.6	87.7	70.8	50.8	27.4	57.8	242	122	510
5.8	81.9	66.4	48.3	26.9	54.6	229	122	512
6.0	76.3	62.3	45.9	26.3	51.6	216	123	514
6.5	63.3	52.7	40.2	24.8	44.4	186	124	518
7.0	53.2	45.3	35.7	23.2	38.8	162	124	520
7.5	44.4	38.6	31.3	21.5	33.5	141	125	522
8.0	37.8	33.4	27.8	19.8	29.4	123	125	524
10.0	21.2	19.7	17.6	14.1	18.1	75.8	126	529
30.0	5.23	5.22	5.19	5.14	5.20	21.8	129	542

Radial enthalpy distribution and fuel enthalpy are presented at elevation 31.8 mm

Maximum value of fuel enthalpy is 84.7 cal/g fuel (t=3.88 s)

<sup>1)</sup> All numerical values are presented at elevation with peak power

# #H18T

Individual Characteristics of Refabricated Fuel Rods  
(Fresh Fuel, Irradiated Cladding) under IGR Tests

Table H-5.5. Energy Characteristics Vs. Time Calculated by FRAP-T6 and SCANAIR Codes for Fuel Rod #H18T

Time (s)	Energy deposition <sup>1)</sup> (cal/g fuel)	Linear power <sup>1)</sup> (kW/m)	Fuel enthalpy <sup>1)</sup> (cal/g fuel)		Energy of metal-water reaction <sup>1)</sup> (cal/g fuel)	Leakage of energy <sup>1)</sup> (cal/g fuel)		Clad-to-coolant heat transfer coefficient <sup>1)</sup> (kW/m <sup>2</sup> K)	
			FRAP-T6	SCANAIR	FRAP-T6	FRAP-T6	SCANAIR	FRAP-T6	SCANAIR
0.0	0.00	0.00	0.00	0.00	0.00	0.00	0.00	0.00	0.00
1.0	1.56	5.42	1.43	1.41	0.00	0.00	0.00	0.03	0.10
2.0	6.37	12.6	5.50	5.64	0.00	0.01	0.04	0.03	0.10
2.2	8.08	17.8	6.96	6.96	0.00	0.02	0.06	0.03	0.10
2.4	10.7	29.7	9.27	9.39	0.00	0.02	0.08	0.03	0.10
2.6	15.6	57.6	13.6	14.0	0.00	0.10	0.30	1.00	2.02
2.8	25.1	113	22.2	21.7	0.00	0.79	1.17	3.35	4.44
3.0	42.1	181	37.1	37.1	0.00	2.55	3.46	6.97	9.48
3.2	65.2	210	56.2	56.5	0.00	6.21	8.31	12.2	16.8
3.4	87.7	171	72.6	70.2	0.00	12.3	14.9	16.9	21.9
3.6	104	115	81.5	78.5	0.00	20.1	24.3	19.0	23.8
3.8	115	74.2	84.5	80.5	0.00	28.3	33.7	18.9	22.7
4.0	122	48.8	84.2	79.4	0.00	36.2	41.8	17.7	20.9
4.2	126	33.3	82.0	76.7	0.00	43.5	49.6	16.5	18.8
4.4	130	23.6	79.0	73.8	0.00	50.2	55.6	15.3	17.3
4.6	132	17.3	75.5	70.2	0.00	56.2	61.9	14.0	15.7
4.8	134	13.1	71.8	67.1	0.00	61.7	66.7	12.9	14.5
5.0	135	10.3	68.2	63.4	0.00	66.6	71.9	11.9	13.4
5.2	136	8.27	64.6	60.2	0.00	71.2	76.3	11.1	12.5
5.4	137	6.78	61.1	56.8	0.00	75.4	80.7	10.3	11.6
5.6	138	5.53	57.8	53.6	0.00	79.3	84.7	9.68	10.8
5.8	138	4.68	54.6	51.0	0.00	82.9	88.0	9.08	10.2
6.0	139	3.99	51.6	48.1	0.00	86.2	91.5	8.54	9.58
6.5	140	2.79	44.4	41.6	0.00	93.9	99.0	7.34	8.21
7.0	140	2.12	38.8	36.4	0.00	99.9	105	6.40	7.12
7.5	141	1.67	33.5	31.6	0.00	105	111	5.53	6.11
8.0	141	1.40	29.4	27.5	0.00	110	115	4.82	5.24
10.0	143	0.93	18.1	17.0	0.00	122	127	2.74	2.88
30.0	146	0.12	5.20	5.34	0.00	139	143	0.08	0.10

<sup>1)</sup> All numerical values are presented at elevation with peak power



# #H18T

Individual Characteristics of Refabricated Fuel Rods  
(Fresh Fuel, Preirradiated Cladding) under IGR Tests

Table H-5.6. Temperature Variation, Fission Gas Release and ZrO<sub>2</sub> Thickness Vs. Time for Fuel Rod #H18T Calculated by FRAP-T6 and SCANAIR Codes

Time (s)	Fuel centerline temperature <sup>1)</sup> (K)		Fuel surface temperature <sup>1)</sup> (K)		Clad outer temperature <sup>1)</sup> (K)		Average ZrO <sub>2</sub> <sup>2)</sup> thickness (μm)
	FRAP-T6	SCANAIR	FRAP-T6	SCANAIR	FRAP-T6	SCANAIR	FRAP-T6
0.0	293	293	293	293	293	293	5
1.0	320	316	316	315	301	300	5
2.0	391	384	377	377	337	337	5
2.2	415	405	397	397	349	349	5
2.4	452	441	429	432	365	366	5
2.6	521	509	485	497	385	382	5
2.8	654	619	583	593	395	387	5
3.0	883	835	725	752	405	394	5
3.2	1183	1119	856	885	415	403	5
3.4	1464	1347	909	919	422	408	5
3.6	1657	1535	891	893	425	410	5
3.8	1772	1646	853	855	425	409	5
4.0	1832	1698	821	825	424	407	5
4.2	1853	1715	793	800	422	405	5
4.4	1846	1705	769	783	420	403	5
4.6	1817	1672	753	767	418	402	5
4.8	1771	1631	741	755	416	400	5
5.0	1713	1574	731	742	415	399	5
5.2	1646	1514	722	731	413	398	5
5.4	1575	1446	714	720	412	397	5
5.6	1502	1378	707	709	411	396	5
5.8	1429	1321	699	699	410	395	5
6.0	1358	1255	691	688	409	395	5
6.5	1189	1110	670	661	406	393	5
7.0	1056	993	648	635	404	391	5
7.5	938	888	623	609	402	390	5
8.0	849	802	600	583	400	388	5
10.0	619	592	517	502	393	384	5
30.0	381	378	380	377	376	373	5

<sup>1)</sup> All numerical values are presented at elevation with peak power

<sup>2)</sup> Initial ZrO<sub>2</sub> thickness is 5 μm

# #H18T

Individual Characteristics of Refabricated Fuel Rods  
(Fresh Fuel, Preirradiated Cladding) under IGR Tests

Table H-5.7. Mechanical Characteristics of Fuel Rod #H18T Vs. Time Calculated by FRAP-T6 and SCANAIR Codes

Time (s)	Clad outer temperature <sup>1)</sup> (K)		Fuel hoop strain <sup>1)</sup> (%)		Fuel - clad gap width <sup>1)</sup> (mm)		Clad hoop strain <sup>1)</sup> (%)		Clad hoop stress <sup>1)</sup> (MPa)		Internal gas pressure (MPa)	
	FRAP-T6	SCANAIR	FRAP-T6	SCANAIR	FRAP-T6	SCANAIR	FRAP-T6	SCANAIR	FRAP-T6	SCANAIR	FRAP-T6	SCANAIR
0.0	293	293	0.00	0.00	0.07	0.07	0.01	0.01	8.71	8.68	1.70	1.70
1.0	301	300	0.02	0.02	0.06	0.06	0.01	0.01	8.81	8.81	1.72	1.72
2.0	337	337	0.09	0.08	0.06	0.06	0.04	0.04	9.04	9.12	1.76	1.77
2.2	349	349	0.11	0.10	0.06	0.06	0.05	0.05	9.11	9.20	1.77	1.79
2.4	365	366	0.15	0.14	0.06	0.06	0.06	0.06	9.20	9.34	1.79	1.81
2.6	385	382	0.21	0.21	0.06	0.06	0.07	0.08	9.34	9.63	1.82	1.84
2.8	395	387	0.34	0.33	0.06	0.06	0.08	0.08	9.54	10.0	1.85	1.89
3.0	405	394	0.57	0.59	0.05	0.05	0.10	0.10	9.79	10.8	1.90	1.96
3.2	415	403	0.88	0.94	0.04	0.03	0.11	0.12	10.0	11.7	1.94	2.02
3.4	422	408	1.18	1.19	0.03	0.03	0.13	0.14	10.2	12.3	1.96	2.06
3.6	425	410	1.37	1.34	0.02	0.02	0.13	0.14	10.2	12.6	1.98	2.09
3.8	425	409	1.47	1.37	0.01	0.02	0.13	0.14	10.3	12.5	1.99	2.09
4.0	424	407	1.49	1.34	0.01	0.02	0.13	0.13	10.3	12.4	1.99	2.09
4.2	422	405	1.48	1.28	0.01	0.02	0.12	0.13	10.3	12.2	1.99	2.09
4.4	420	403	1.44	1.22	0.02	0.02	0.12	0.12	10.3	12.0	1.99	2.08
4.6	418	402	1.39	1.14	0.02	0.03	0.12	0.12	10.3	11.9	1.99	2.07
4.8	416	400	1.33	1.08	0.02	0.03	0.11	0.11	10.3	11.7	1.98	2.06
5.0	415	399	1.26	1.01	0.02	0.03	0.11	0.11	10.2	11.6	1.98	2.05
5.2	413	398	1.19	0.94	0.02	0.03	0.11	0.11	10.2	11.5	1.97	2.05
5.4	412	397	1.12	0.88	0.03	0.04	0.11	0.11	10.2	11.3	1.97	2.04
5.6	411	396	1.05	0.82	0.03	0.04	0.10	0.10	10.1	11.2	1.96	2.03
5.8	410	395	0.98	0.78	0.03	0.04	0.10	0.10	10.1	11.1	1.95	2.02
6.0	409	395	0.91	0.73	0.03	0.04	0.10	0.10	10.1	11.0	1.95	2.01
6.5	406	393	0.77	0.62	0.04	0.05	0.10	0.10	9.97	10.8	1.93	1.99
7.0	404	391	0.66	0.53	0.04	0.05	0.09	0.09	9.90	10.6	1.92	1.97
7.5	402	390	0.56	0.46	0.05	0.05	0.09	0.09	9.82	10.4	1.90	1.95
8.0	400	388	0.49	0.39	0.05	0.05	0.09	0.09	9.75	10.3	1.89	1.93
10.0	393	384	0.29	0.23	0.06	0.06	0.08	0.08	9.51	9.80	1.85	1.87
30.0	376	373	0.08	0.06	0.06	0.07	0.06	0.06	9.07	9.08	1.77	1.77

<sup>1)</sup> All numerical values are presented at elevation with peak power

# #H18T

Individual Characteristics of Refabricated Fuel Rods  
(Fresh Fuel, Preirradiated Cladding) under IGR Tests

Table H-5.8. Axial Distribution of Energy Deposition and Fuel Enthalpy Calculated by FRAP-T6 Code for Fuel Rod #H18T

Axial interval from-to (mm)-(mm)	Energy deposition at infinite time			Fuel enthalpy at time (t=3.88 s)		
	cal/g fuel	J/g fuel	per-unit	cal/g fuel	J/g fuel	per-unit
24.7 - 38.8	149	626	1.00	84.7	355	1.00
38.8 - 52.9	141	589	0.94	79.6	334	0.94
52.9 - 67.0	134	560	0.89	75.7	317	0.89
67.0 - 81.1	129	540	0.86	73.0	306	0.86
81.1 - 95.2	127	532	0.85	71.9	301	0.85
95.2 - 109.3	126	528	0.84	71.4	299	0.84
109.3 - 123.4	127	531	0.85	71.8	301	0.85
123.4 - 137.5	128	535	0.85	72.4	303	0.85
137.5 - 151.6	130	544	0.87	73.6	308	0.87
151.6 - 165.7	131	549	0.88	74.2	311	0.88

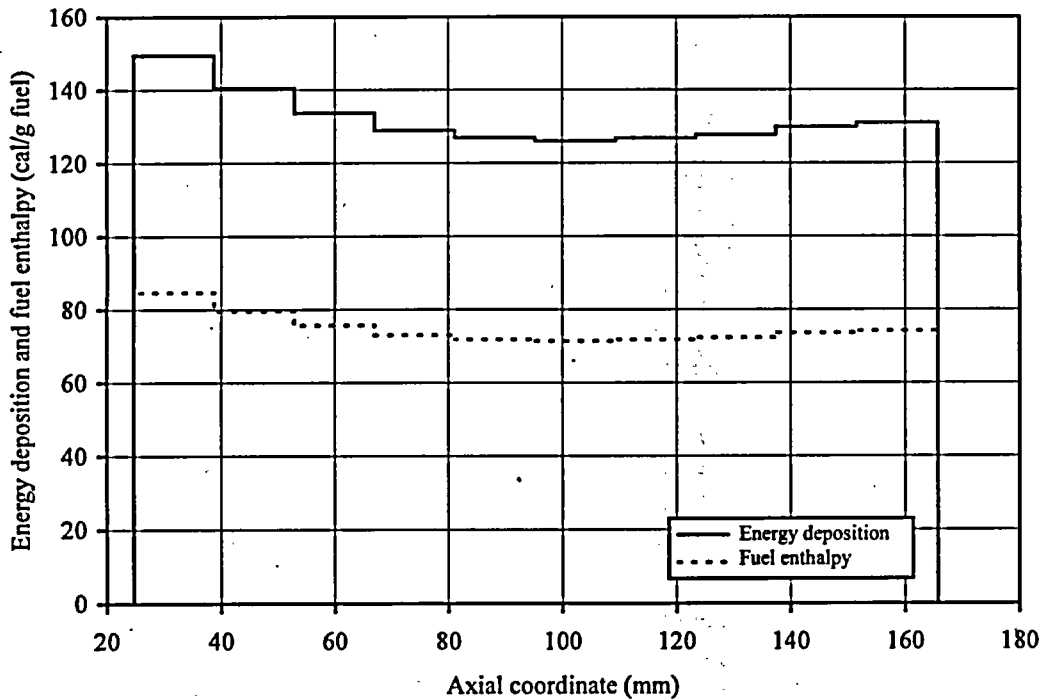

Fig. H-5.4. Axial Distribution of Energy Deposition and Fuel Enthalpy Calculated by FRAP-T6 Code for Fuel Rod #H18T

# #H18T

Individual Characteristics of Refabricated Fuel Rods  
(Fresh Fuel, Preirradiated Cladding) under IGR Tests

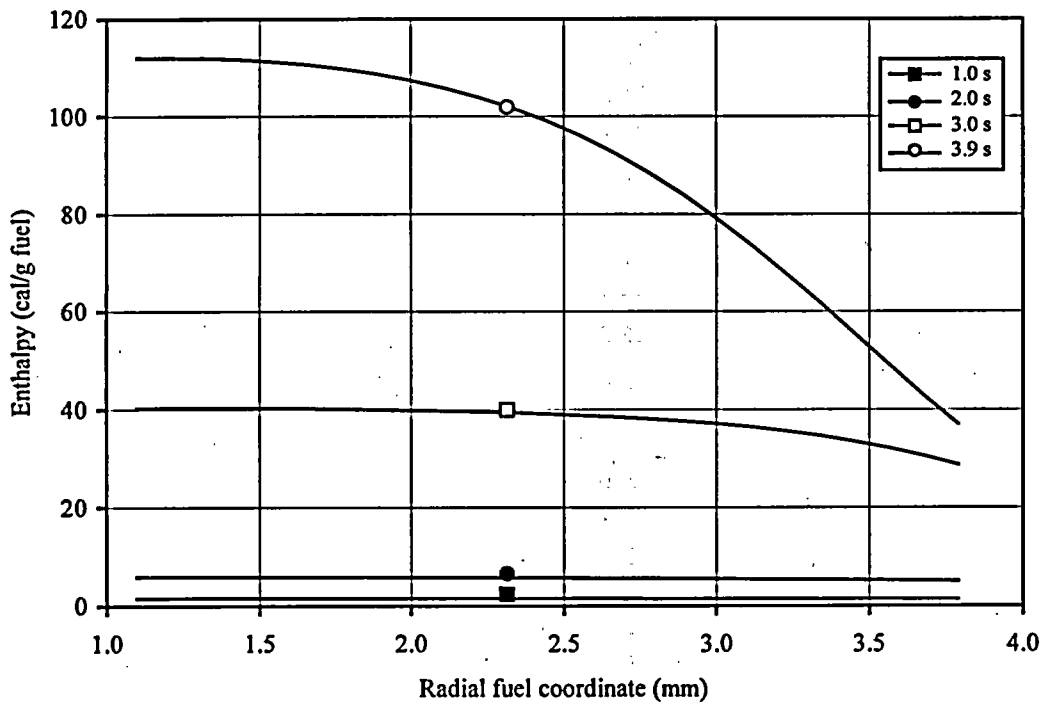
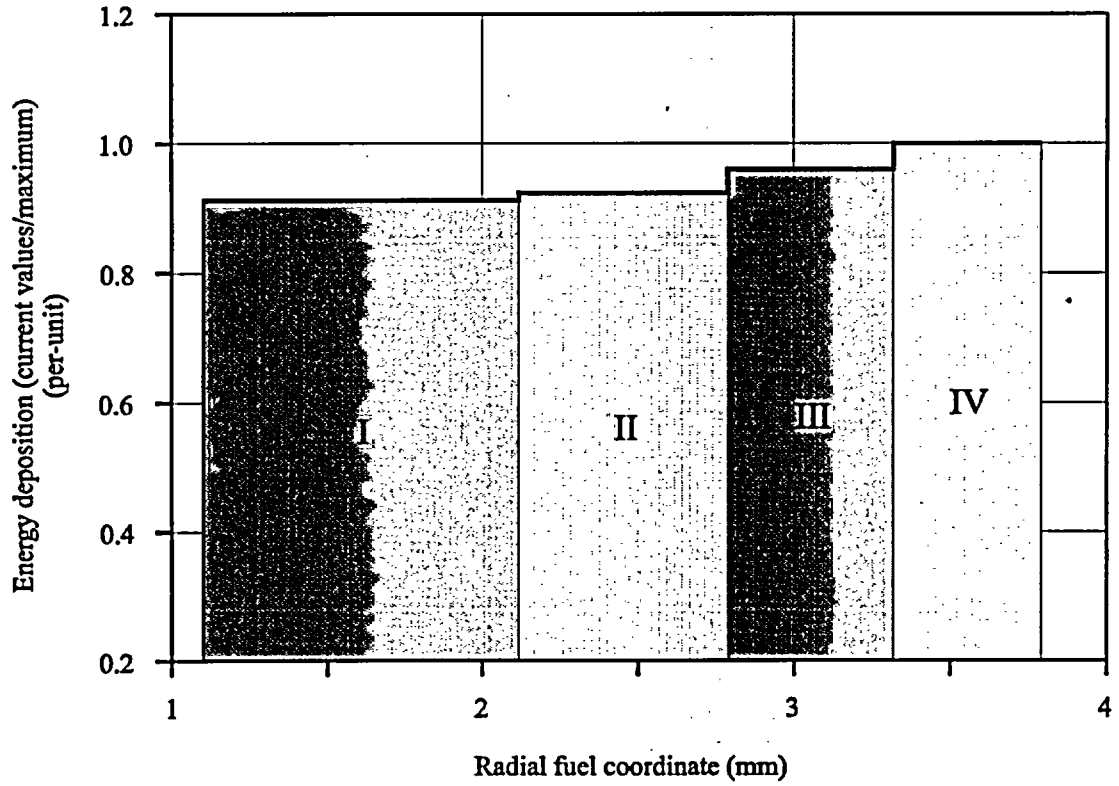

Fig. H-5.5. Radial Distributions of Energy Deposition and Fuel Enthalpy Calculated by FRAP-T6 Code for Fuel Rod #H18T

# #H18T

Individual Characteristics of Refabricated Fuel Rods  
(Fresh Fuel, Preirradiated Cladding) under IGR Tests

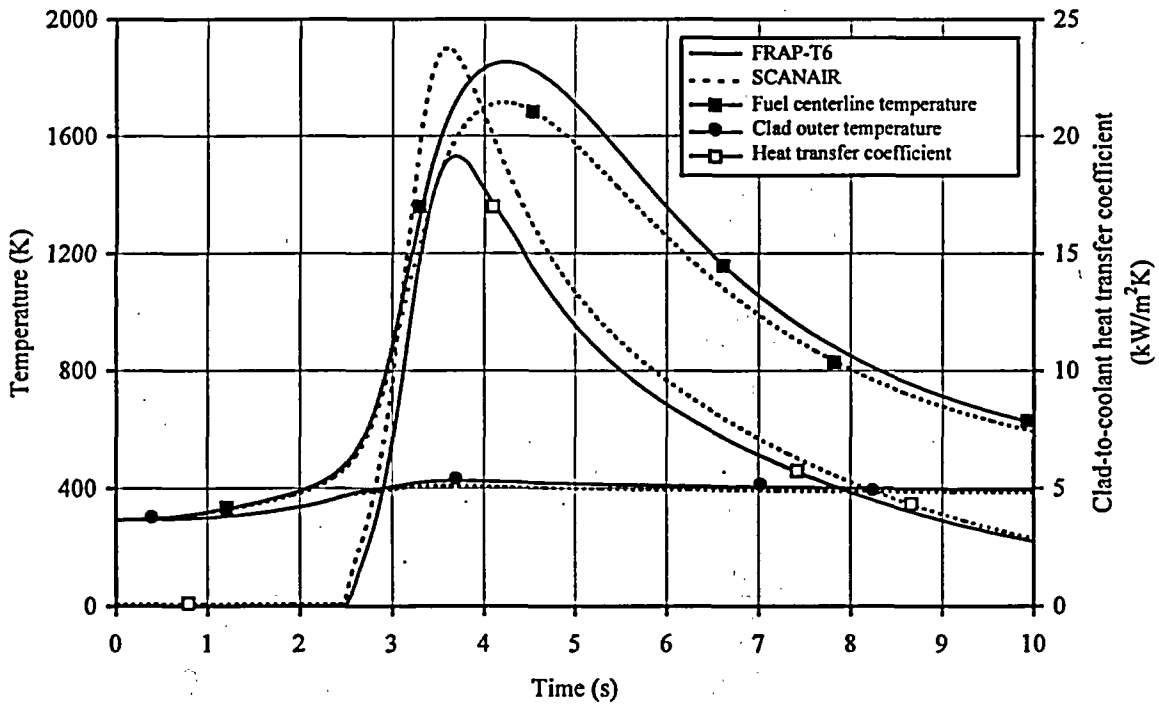
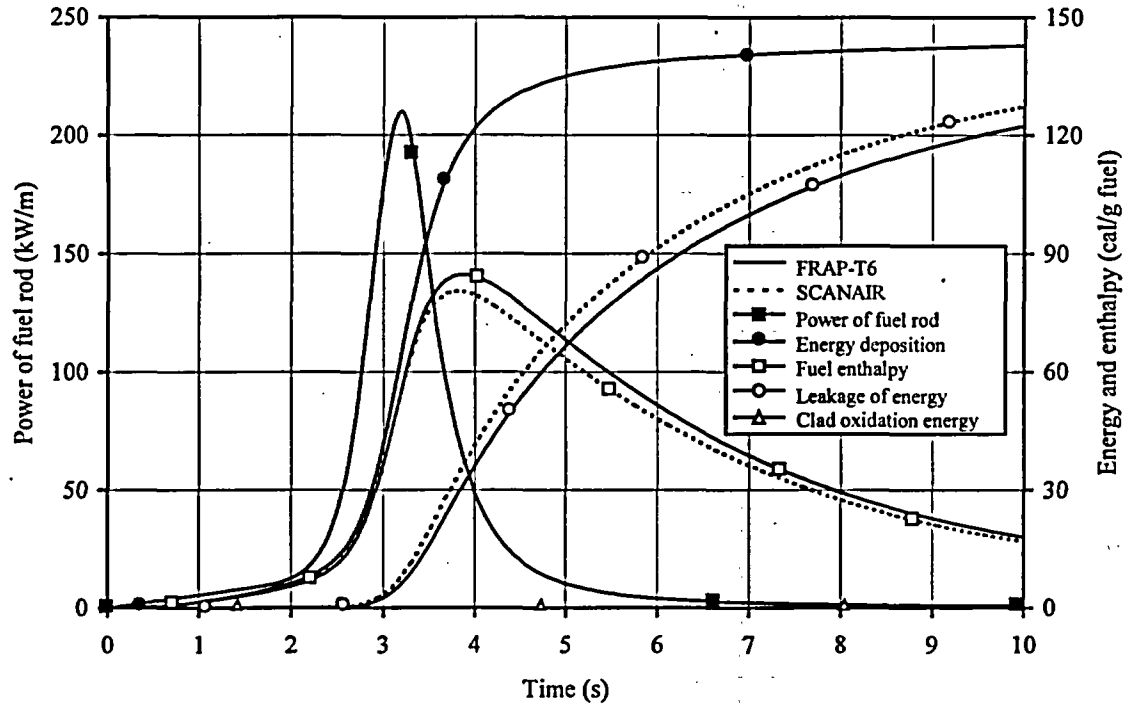

Fig. H-5.6. Energy and Temperature Characteristics Vs. Time Calculated by FRAP-T6 and SCANAIR Codes for Fuel Rod #H18T

# #H18T

Individual Characteristics of Refabricated Fuel Rods  
(Fresh Fuel, Preirradiated Cladding) under IGR Tests

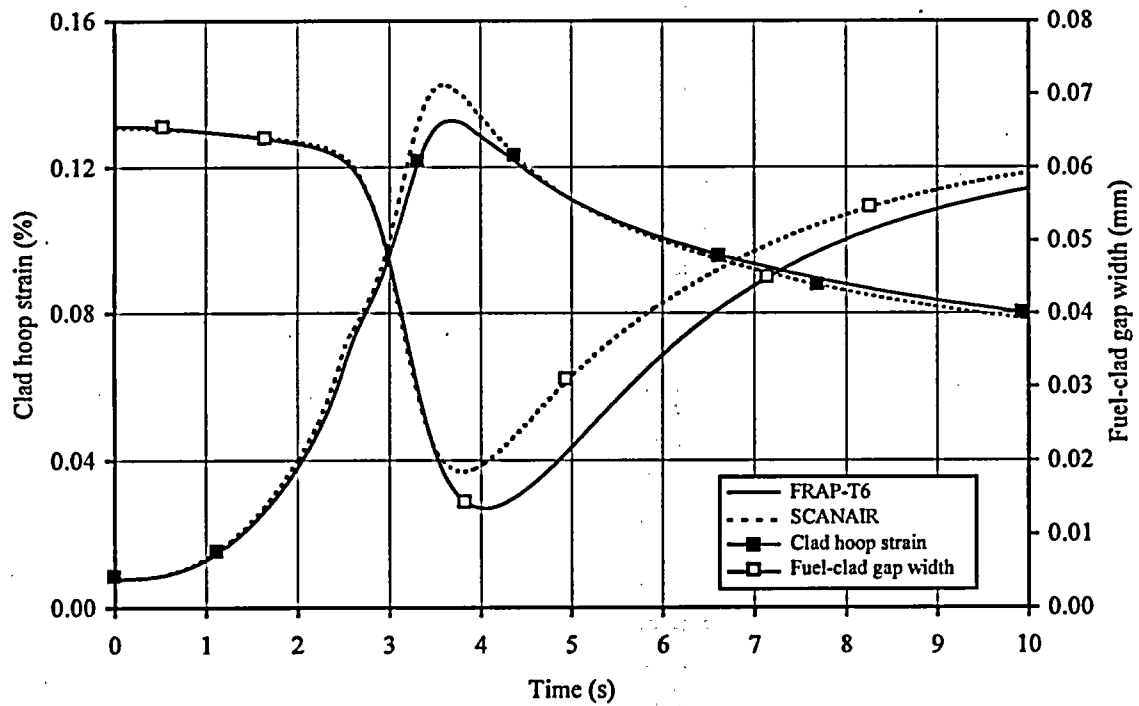
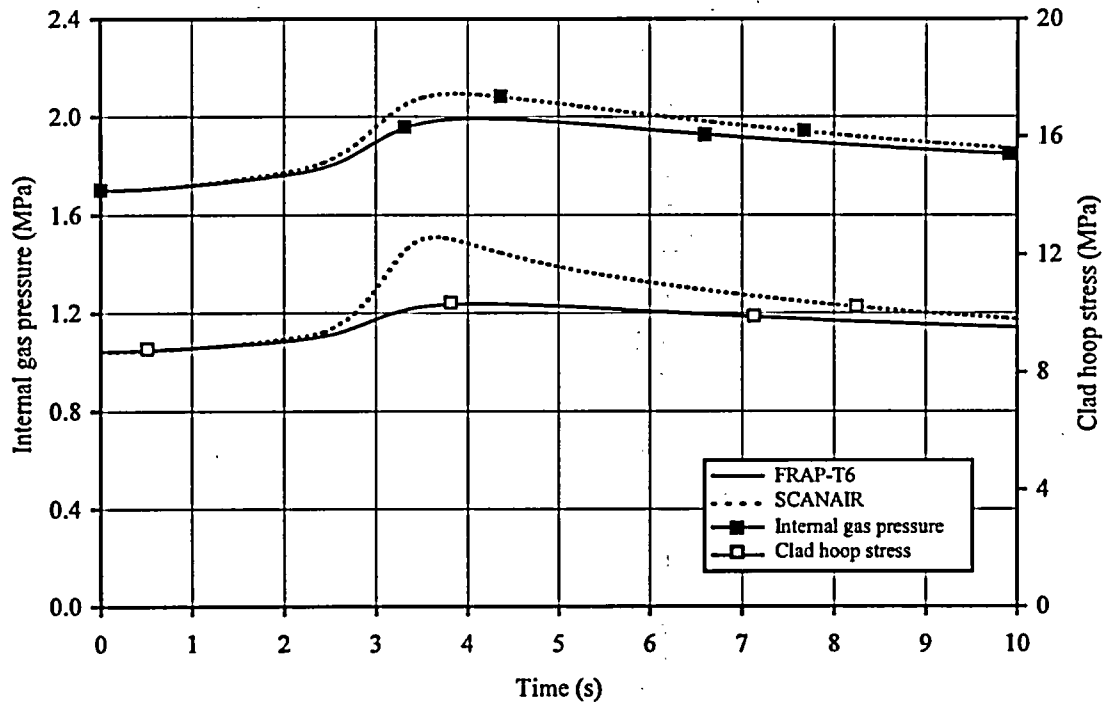

Fig. H-5.7. Cladding Mechanical Characteristics Vs. Time Calculated by FRAP-T6 and SCANAIR Codes for Fuel Rod #H18T

# #H18T

Individual Characteristics of Refabricated Fuel Rods  
(Fresh Fuel, Preirradiated Cladding) under IGR Tests

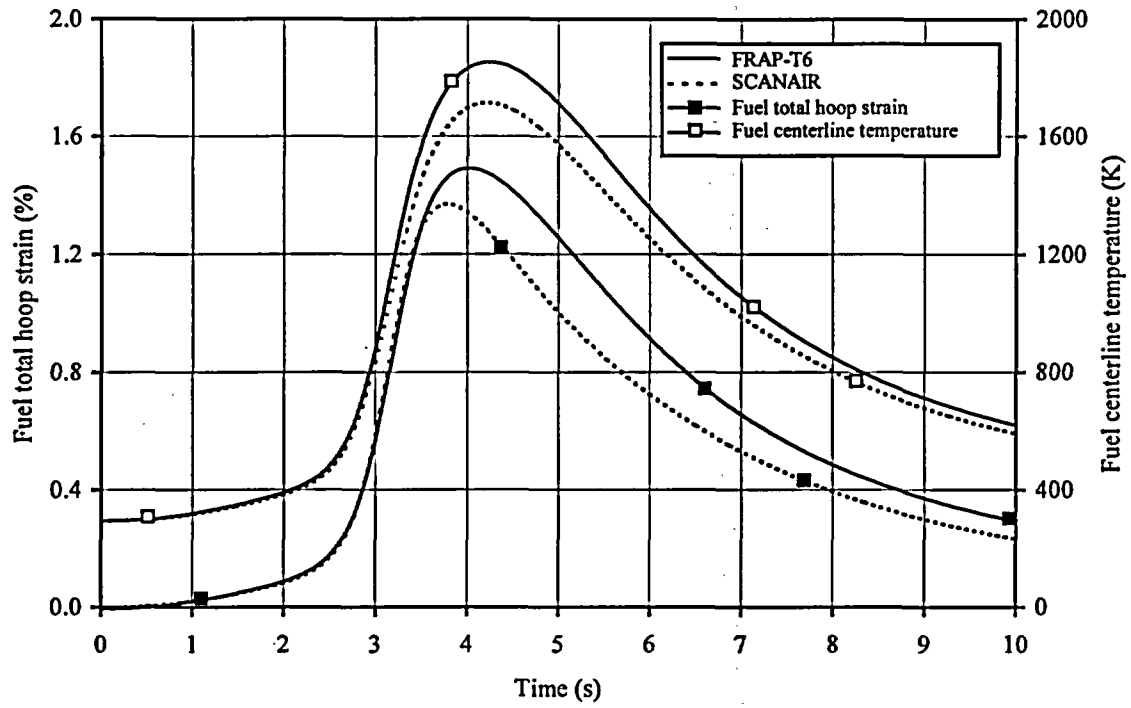

Fig. H-5.8. Fuel Strain Vs. Time Calculated by FRAP-T6 and SCANAIR Codes for Fuel Rod #H18T

# #H18T

Individual Characteristics of Refabricated Fuel Rods  
(Fresh Fuel, Preirradiated Cladding) under IGR Tests

Table II-5.9. Some Results of PIE for Fuel Rod #H18T

Characteristic		Value
1.	Measured parameters of cladding oxidation and cladding deformation	
1.1.	Cladding thickness at elevation 90 mm for different azimuthal angles ( $\mu\text{m}$ ):	
	0°	690
	90°	690
	180°	705
	270°	705
1.2.	ZrO <sub>2</sub> thickness at elevation 90 mm for different azimuthal angles ( $\mu\text{m}$ ):	
	0°	5
	90°	5
	180°	5
	270°	5
1.3.	$\alpha\text{Zr(O)}$ thickness at elevation 90 mm for different azimuthal angles ( $\mu\text{m}$ ):	.
	0°	0
	90°	0
	180°	0
	270°	0
1.4.	Clad hoop strain at elevation 90 mm (%)	2.4
2.	Measured parameters for FGR analysis	
2.1.	Internal gas composition (% by volume):	
	He	-
	N <sub>2</sub>	-
	O <sub>2</sub>	-
	Ar	-
	CO <sub>2</sub>	-
	Kr	-
	Xe	-
2.2.	Free gas volume (cm <sup>3</sup> )	6.1
2.3.	Gas pressure inside fuel rod under normal condition (MPa)	1.735
2.4.	Kr concentration in fuel (cm <sup>3</sup> /g fuel)	-
3.	Measured parameters of cladding hydriding	
3.1.	Coefficient of hydride orientation (per-unit)	-
3.2.	Hydrogen concentration (% by weight)	-



# #H18T

Individual Characteristics of Refabricated Fuel Rods  
(Fresh Fuel, Preirradiated Cladding) under IGR Tests

Table H-5.10. General Characteristic of Fuel Rod #H18T

	Parameter	Unit	Value		
			Experiment	FRAP-T6	SCANAIR
1	Type of coolant	---	water	water	water
2	Burnup	MWd/kg U	0	0	0
3	Energy deposition in fuel rod	cal/g fuel	132	132	132
4	Peak fuel enthalpy	cal/g fuel	-	85	81
5	Peak fuel temperature	K	-	1853	1715
6	Peak clad temperature	K	-	425	409
7	Fuel rod failure	Yes, No	No	No	-
8	Type of failure:				
	- cladding rupture due to ballooning	Yes, No	No	No	-
	- cladding rupture due to PCMI	Yes, No	No	No	-
	- fragmentation of fuel rod	Yes, No	No	-	-
9	Failure time	s	-	-	-
10	Fuel enthalpy at failure	cal/g fuel	-	-	-
11	Outer cladding temperature at failure	K	-	-	-
12	Internal gas pressure at failure	MPa	-	-	-
13	ZrO <sub>2</sub> thickness after test	µm	5	5	-
14	Residual clad hoop strain:				
	- peak value for ballooning area	%	-	-	-
	- other location <sup>1)</sup>	%	2.4	0	0

<sup>1)</sup>Calculated values by FRAP-T6 and SCANAIR codes are average along height of fuel rod excluding ballooning region

**APPENDIX H-6.**

*Individual Characteristics for Fuel Rod #B19T under IGR Test*

#B19T

Individual Characteristics of Refabricated Fuel Rods  
(Fresh Fuel, Preirradiated Cladding) under IGR Tests

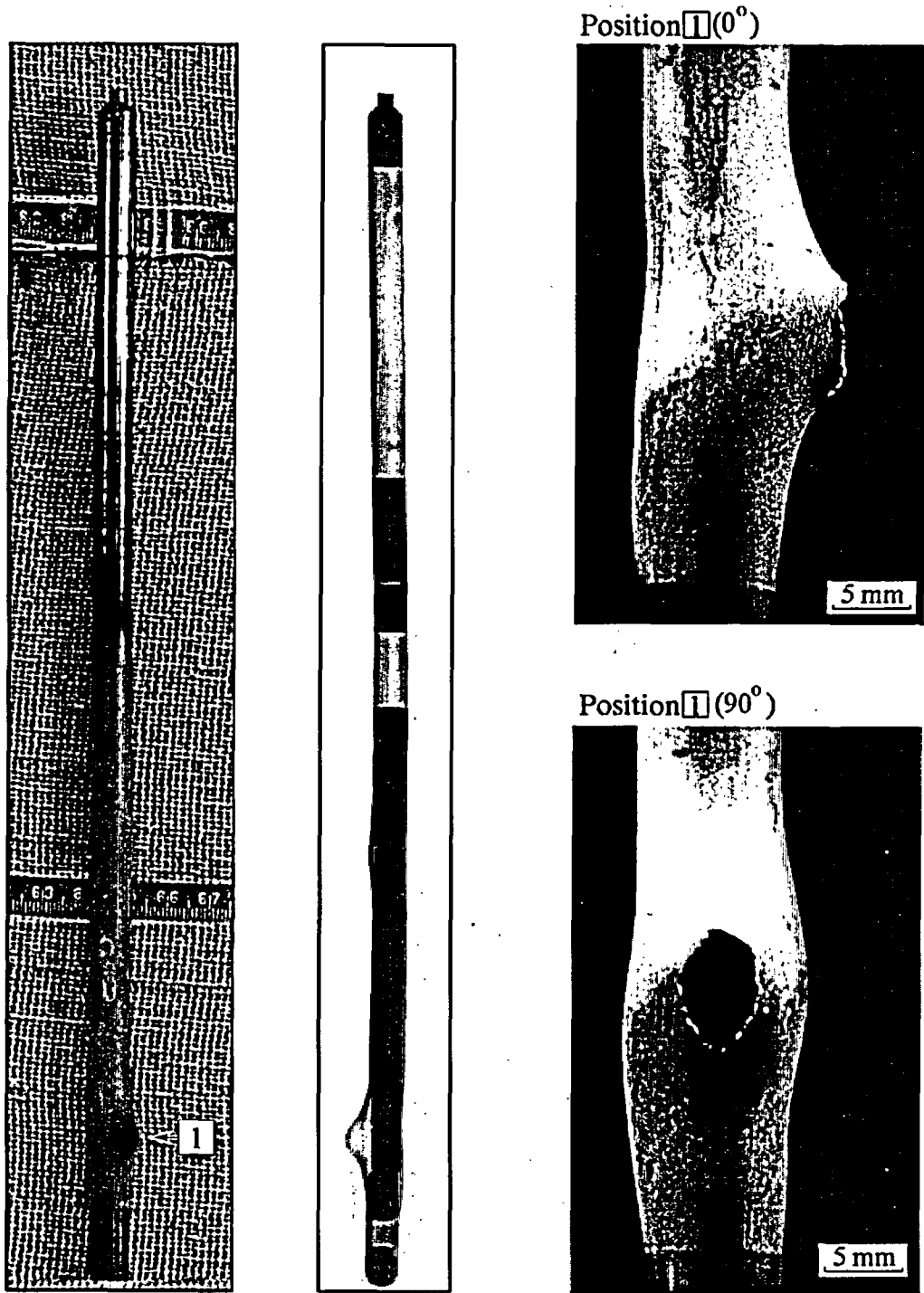
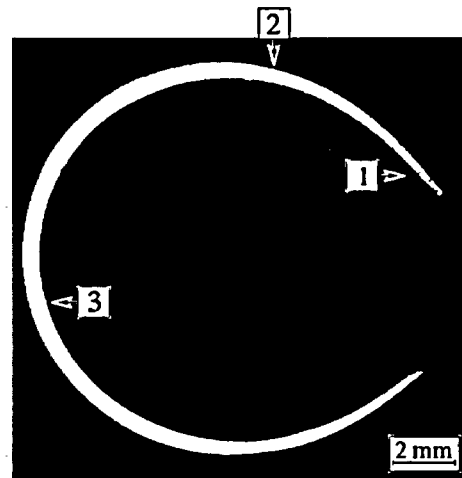

Fig. H-6.1. Appearance of Fuel Rod #B19T (photographs and X-ray photograph)

#B19T

Individual Characteristics of Refabricated Fuel Rods  
(Fresh Fuel, Preirradiated Cladding) under IGR Tests

Position 1



Position 2

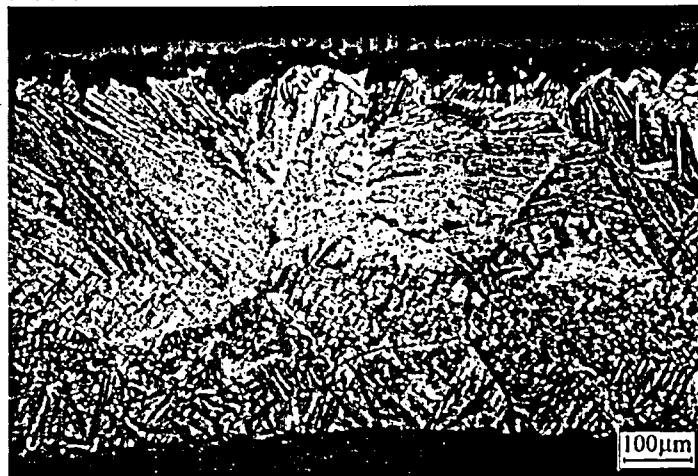

Position 3



Fig. H-6.2. Cross-Section and Cladding Microstructure for Fuel Rod #B19T at 35 mm Elevation

#B19T

Individual Characteristics of Refabricated Fuel Rods  
(Fresh Fuel, Preirradiated Cladding) under IGR Tests

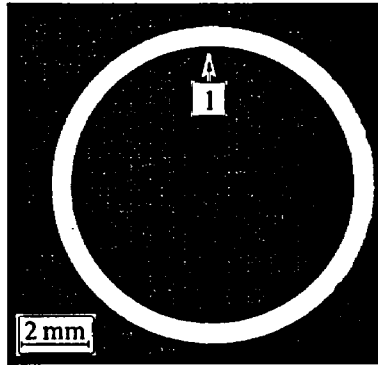

Position 1



Fig. H-6.3. Cross-Section and Cladding Microstructure for Fuel Rod #B19T at 90 mm Elevation

#B19T

Individual Characteristics of Refabricated Fuel Rods  
(Fresh Fuel, Preirradiated Cladding) under IGR Tests

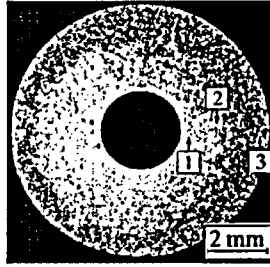

Position 1

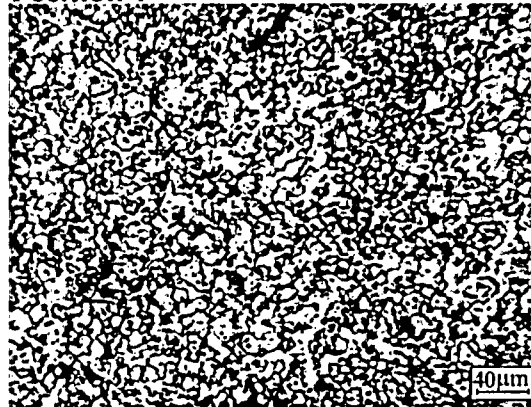

Position 2



Position 3

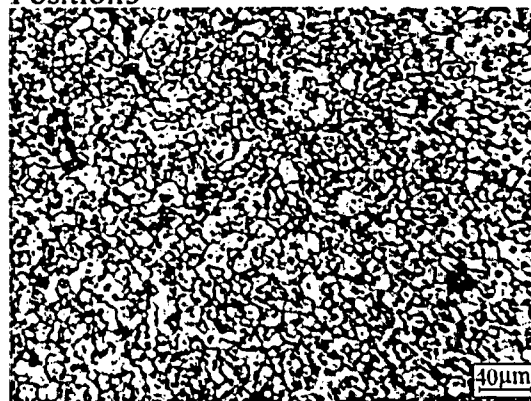

Fig. H-6.4. Fuel Microstructure for Fuel Rod #B19T at 35 mm Elevation

# #B19T

Individual Characteristics of Refabricated Fuel Rods  
(Fresh Fuel, Preirradiated Cladding) under IGR Tests

Table H-6.1. Time Dependent Energy Characteristics of Fuel Rod #B19T

Time (s)	Reactor energy deposition <sup>1)</sup> (%)	Cumulative number of fissions in fuel rod (fiss)			Power of fuel rod (kW)	Energy deposition in fuel rod	
		U <sup>235</sup> ×10 <sup>-14</sup>	U <sup>238</sup> ×10 <sup>-12</sup>	Total ×10 <sup>-14</sup>		cal/g fuel	J/g fuel
0.0	0.000	0.000	0.000	0.000	0.000	0.000	0.000
1.0	1.330	0.257	0.145	0.259	1.450	2.940	12.30
2.0	5.550	1.070	0.603	1.080	3.800	12.20	51.10
2.2	7.300	1.410	0.794	1.420	6.100	16.10	67.40
2.4	10.50	2.020	1.140	2.030	11.90	23.10	96.70
2.6	17.00	3.290	1.850	3.310	25.30	37.60	157.0
2.8	29.70	5.730	3.230	5.760	43.30	65.60	275.0
3.0	47.10	9.090	5.120	9.140	48.20	104.0	435.0
3.2	62.80	12.10	6.830	12.20	36.20	139.0	582.0
3.4	73.60	14.20	8.010	14.30	23.60	163.0	682.0
3.6	80.50	15.50	8.760	15.60	15.10	178.0	745.0
3.8	85.00	16.40	9.240	16.50	9.890	188.0	787.0
4.0	87.90	17.00	9.560	17.10	6.730	195.0	816.0
4.2	90.00	17.40	9.790	17.50	4.760	199.0	833.0
4.4	91.40	17.60	9.940	17.70	3.500	202.0	846.0
4.6	92.50	17.90	10.10	18.00	2.660	205.0	858.0
4.8	93.30	18.00	10.10	18.10	2.080	207.0	867.0
5.0	93.90	18.10	10.20	18.20	1.670	208.0	871.0
5.2	94.50	18.20	10.30	18.30	1.370	210.0	879.0
5.4	94.90	18.30	10.30	18.40	1.130	211.0	883.0
5.6	95.20	18.40	10.40	18.50	0.966	211.0	883.0
5.8	95.50	18.40	10.40	18.50	0.832	212.0	887.0
6.0	95.80	18.50	10.40	18.60	0.723	213.0	892.0
6.5	96.20	18.60	10.50	18.70	0.532	214.0	896.0
7.0	96.60	18.60	10.50	18.70	0.416	215.0	900.0
7.5	96.90	18.70	10.50	18.80	0.341	216.0	904.0
8.0	97.10	18.70	10.60	18.80	0.291	216.0	904.0
9.0	97.50	18.80	10.60	18.90	0.250	218.0	913.0
10.0	97.80	18.90	10.60	19.00	0.202	218.0	913.0
20.0	99.10	19.10	10.80	19.20	0.053	223.0	933.0
30.0	99.60	19.20	10.80	19.30	0.028	224.0	938.0
∞	100.0	19.40	10.90	19.50	0.000	229.0	959.0

Maximum value of power is 49.1 kW (t = 2.95 s)

<sup>1)</sup> Current energy deposition per maximum energy deposition (at infinite time)

# #B19T

Individual Characteristics of Refabricated Fuel Rods  
(Fresh Fuel, Preirradiated Cladding) under IGR Tests

Table H-6.2. Axial Energy Characteristics of Fuel Rod #B19T

Axial coordinate from lower end of fuel rod (mm)	Cumulative number of fissions at axial interval (fiss)			Maximum power of fuel rod (kW) $t=2.95$ s	Energy deposition at infinite time*		
	$U^{235} \times 10^{-13}$	$U^{238} \times 10^{-11}$	Total $\times 10^{-13}$		cal/g fuel	J/g fuel	per-unit <sup>3)</sup>
15.0	0.000	0.000	0.000	0.000	0.000	0.000	0.00
20.0 <sup>1)</sup>	4.670	2.270	4.690	1.180	251.0	1051.	1.00
25.0	7.410	3.680	7.440	1.870	247.0	1034.	0.98
30.0	7.320	3.700	7.360	1.850	244.0	1021.	0.97
35.0	7.220	3.730	7.250	1.830	240.0	1005.	0.96
40.0	7.130	3.760	7.170	1.800	237.0	992.0	0.94
45.0	7.030	3.760	7.070	1.780	235.0	984.0	0.94
50.0	6.970	3.790	7.010	1.760	233.0	975.0	0.93
55.0	6.910	3.810	6.950	1.750	231.0	967.0	0.92
60.0	6.860	3.840	6.900	1.740	230.0	963.0	0.92
65.0	6.840	3.860	6.880	1.730	228.0	954.0	0.91
70.0	6.900	3.930	6.940	1.750	228.0	954.0	0.91
75.0	6.860	3.950	6.900	1.740	227.0	950.0	0.90
80.0	6.770	3.920	6.810	1.710	227.0	950.0	0.90
85.0	6.710	3.910	6.750	1.700	226.0	946.0	0.90
90.0	6.740	3.950	6.780	1.710	226.0	946.0	0.90
95.0	6.780	3.980	6.820	1.720	226.0	946.0	0.90
100.0	6.780	3.990	6.820	1.720	225.0	942.0	0.90
105.0	6.780	3.990	6.820	1.720	225.0	942.0	0.90
110.0	6.770	3.990	6.810	1.710	225.0	942.0	0.90
115.0	6.850	4.040	6.890	1.730	226.0	946.0	0.90
120.0	6.850	4.030	6.890	1.730	225.0	942.0	0.90
125.0	6.790	3.990	6.830	1.720	224.0	938.0	0.89
130.0	6.740	3.950	6.780	1.710	225.0	942.0	0.90
135.0	6.730	3.930	6.770	1.700	224.0	938.0	0.89
140.0	6.670	3.870	6.710	1.690	224.0	938.0	0.89
145.0	6.650	3.840	6.690	1.680	223.0	933.0	0.89
150.0	6.620	3.800	6.660	1.680	221.0	925.0	0.88
155.0	6.630	3.780	6.660	1.680	221.0	925.0	0.88
160.0 <sup>2)</sup>	3.800	2.160	3.820	0.962	219.0	917.0	0.87
165.0	0.000	0.000	0.000	0.000	0.000	0.000	0.00

\* All numerical values of characteristics are presented as average values at the length interval equal to the axial coordinate  $\pm 2.5$  mm.

<sup>1)</sup> Initial coordinate of fuel is 19.4 mm.

<sup>2)</sup> End coordinate of fuel is 160.4 mm.

<sup>3)</sup> Current value per maximum value.



Table H-6.3. Radial Energy Characteristics of Fuel Rod #B19T

Characteristics*		Coordinates of fuel zones (mm)			
		1 zone 1.10 - 2.12	2 zone 2.12 - 2.79	3 zone 2.79 - 3.32	4 zone 3.32 - 3.79
U <sup>235</sup>	Number of fissions $\times 10^{-14}$ (fiss)	4.680	4.760	4.890	5.050
	Power of fuel rod <sup>1)</sup> (kW)	11.80	12.00	12.30	12.70
	Energy deposition <sup>2)</sup> (cal/g fuel)	220.0	224.0	230.0	237.0
	Energy deposition <sup>2)</sup> (J/g fuel)	921.0	938.0	963.0	992.0
	Energy deposition <sup>3)</sup> (per-unit)	0.928	0.945	0.970	1.000
U <sup>238</sup>	Number of fissions $\times 10^{-12}$ (fiss)	2.750	2.730	2.720	2.730
	Power of fuel rod <sup>1)</sup> (kW)	0.068	0.068	0.068	0.068
	Energy deposition <sup>2)</sup> (cal/g fuel)	1.270	1.260	1.260	1.260
	Energy deposition <sup>2)</sup> (J/g fuel)	5.320	5.270	5.270	5.270
	Energy deposition <sup>3)</sup> (per-unit)	1.000	0.992	0.992	0.992
Total	Number of fissions $\times 10^{-14}$ (fiss)	4.710	4.780	4.910	5.080
	Power of fuel rod <sup>1)</sup> (kW)	11.90	12.00	12.40	12.80
	Energy deposition <sup>2)</sup> (cal/g fuel)	221.0	225.0	231.0	239.0
	Energy deposition <sup>2)</sup> (J/g fuel)	925.0	942.0	967.0	1000.
	Energy deposition <sup>3)</sup> (per-unit)	0.925	0.941	0.967	1.000

<sup>1)</sup> at time of 3.65 s,      <sup>2)</sup> at infinite time,      <sup>3)</sup> Current value per maximum value

\* All numerical values of characteristics were calculated for length of fuel stack

# #B19T

Individual Characteristics of Refabricated Fuel Rods  
(Fresh Fuel, Preirradiated Cladding) under IGR Tests

Table H-6.4. Fuel Enthalpy Vs. Time Calculated by FRAP-T6 Code for Fuel Rod #B19T

Time (s)	Enthalpy at fuel radius (cal/g fuel)				Fuel enthalpy <sup>1)</sup>		Energy deposition in fuel rod	
	1.10 mm	2.22 mm	2.89 mm	3.79 mm	cal/g fuel	J/g fuel	cal/g fuel	J/g fuel
0.0	0.00	0.00	0.00	0.00	0.00	0.00	0.00	0.00
1.0	2.71	2.69	2.63	2.35	2.61	10.9	2.94	12.3
2.0	11.5	11.3	10.9	9.56	10.9	45.6	12.2	51.3
2.2	15.3	15.1	14.5	12.6	14.5	60.6	16.1	67.6
2.4	22.2	22.0	21.3	18.2	21.1	88.4	23.1	96.8
2.6	36.9	36.7	35.7	29.3	35.2	147	37.6	158
2.8	65.8	65.6	64.0	48.0	62.3	261	65.5	275
3.0	107	106	103	67.3	99.0	415	104	435
3.2	145	144	136	80.6	130	546	139	581
3.4	172	169	156	116	153	643	163	681
3.6	190	185	169	136	170	711	178	746
3.8	201	194	178	145	179	752	188	787
4.0	207	199	183	149	185	774	195	815
4.2	211	202	185	153	188	787	199	834
4.4	213	203	187	155	190	794	202	848
4.6	214	204	187	157	190	798	205	859
4.8	214	204	187	159	191	799	207	867
5.0	213	203	187	160	190	798	208	873
5.2	213	203	187	160	190	798	208	873
5.4	211	201	186	161	189	794	211	882
5.6	211	201	186	161	189	794	211	882
5.8	207	198	184	161	187	785	212	890
6.0	207	198	184	161	187	785	212	890
6.5	204	195	182	160	185	774	214	896
7.0	200	191	179	159	182	763	215	900
7.5	196	188	177	158	180	752	216	903
8.0	192	185	175	157	177	741	216	906
10.0	179	174	166	151	167	701	218	915
30.0	113	112	110	105	110	461	224	939

Radial enthalpy distribution and fuel enthalpy are presented at elevation 26.4 mm

Maximum value of fuel enthalpy is 190.6 cal/g fuel (t=4.84 s)

<sup>1)</sup> All numerical values are presented at elevation with peak power

# #B19T

Individual Characteristics of Refabricated Fuel Rods  
(Fresh Fuel, Preirradiated Cladding) under IGR Tests

Table H-6.5. Energy Characteristics Vs. Time Calculated by FRAP-T6 and SCANAIR Codes for Fuel Rod #B19T

Time (s)	Energy deposition <sup>1)</sup> (cal/g fuel)	Linear power <sup>1)</sup> (kW/m)	Fuel enthalpy <sup>1)</sup> (cal/g fuel)		Leakage of energy <sup>1)</sup> (cal/g fuel)		Clad-to-coolant heat transfer coefficient <sup>1)</sup> (kW/m <sup>2</sup> K)	
			FRAP-T6	SCANAIR	FRAP-T6	SCANAIR	FRAP-T6	SCANAIR
0.0	0.00	0.00	0.00	0.00	0.00	0.00	0.00	0.00
1.0	3.16	10.9	2.61	2.83	0.00	0.00	0.01	0.01
2.0	13.2	28.7	10.9	11.3	0.01	0.01	0.01	0.01
2.2	17.3	46.0	14.5	14.8	0.01	0.01	0.01	0.01
2.4	24.8	89.8	21.1	21.4	0.01	0.02	0.01	0.01
2.6	40.4	191	35.2	35.1	0.02	0.02	0.01	0.02
2.8	70.5	327	62.3	61.4	0.03	0.04	0.02	0.02
3.0	112	364	99.0	96.2	0.07	0.10	0.03	0.04
3.2	149	273	130	-	0.16	-	0.05	-
3.4	175	178	153	-	0.40	-	0.08	-
3.6	191	114	170	-	0.74	-	0.08	-
3.8	202	74.7	179	-	1.16	-	0.10	-
4.0	209	50.8	185	-	1.66	-	0.11	-
4.2	214	35.9	188	-	2.27	-	0.12	-
4.4	218	26.4	190	-	2.98	-	0.13	-
4.6	220	20.1	190	-	3.78	-	0.14	-
4.8	222	15.7	191	-	4.65	-	0.15	-
5.0	224	12.6	190	-	5.60	-	0.16	-
5.2	224	12.6	190	-	5.60	-	0.16	-
5.4	226	8.52	189	-	7.68	-	0.17	-
5.6	226	8.52	189	-	7.68	-	0.17	-
5.8	229	5.84	187	-	10.6	-	0.18	-
6.0	229	5.84	187	-	10.6	-	0.18	-
6.5	230	4.25	185	-	13.8	-	0.19	-
7.0	231	3.28	182	-	17.1	-	0.20	-
7.5	232	2.67	180	-	20.6	-	0.20	-
8.0	233	2.26	177	-	24.1	-	0.20	-
10.0	235	1.56	167	-	38.1	-	0.20	-
30.0	241	0.21	110	-	128	-	0.11	-

<sup>1)</sup> All numerical values are presented at elevation with peak power

# #B19T

Individual Characteristics of Refabricated Fuel Rods  
(Fresh Fuel, Preirradiated Cladding) under IGR Tests

Table H-6.6. Temperature Variation, Fission Gas Release and ZrO<sub>2</sub> Thickness Vs. Time for Fuel Rod #B19T Calculated by FRAP-T6 and SCANAIR Codes

Time (s)	Fuel centerline temperature <sup>1)</sup> (K)		Fuel surface temperature <sup>1)</sup> (K)		Clad outer temperature <sup>1)</sup> (K)	
	FRAP-T6	SCANAIR	FRAP-T6	SCANAIR	FRAP-T6	SCANAIR
0.0	293	293	293	293	293	293
1.0	340	338	334	337	305	308
2.0	478	471	449	457	369	381
2.2	534	523	495	506	393	409
2.4	634	616	576	593	428	451
2.6	838	802	733	764	491	530
2.8	1222	1144	987	1048	618	687
3.0	1737	1593	1241	1357	847	946
3.2	2167	-	1412	-	1120	-
3.4	2430	-	1852	-	1297	-
3.6	2581	-	2073	-	1357	-
3.8	2668	-	2165	-	1433	-
4.0	2717	-	2210	-	1512	-
4.2	2744	-	2246	-	1580	-
4.4	2757	-	2273	-	1636	-
4.6	2763	-	2294	-	1683	-
4.8	2762	-	2310	-	1721	-
5.0	2758	-	2320	-	1753	-
5.2	2758	-	2320	-	1753	-
5.4	2743	-	2327	-	1808	-
5.6	2743	-	2327	-	1808	-
5.8	2717	-	2327	-	1857	-
6.0	2717	-	2327	-	1857	-
6.5	2688	-	2321	-	1891	-
7.0	2658	-	2313	-	1912	-
7.5	2628	-	2302	-	1924	-
8.0	2599	-	2290	-	1929	-
10.0	2494	-	2234	-	1912	-
30.0	1815	-	1721	-	1518	-

<sup>1)</sup> All numerical values are presented at elevation with peak power

# #B19T

Individual Characteristics of Refabricated Fuel Rods  
(Fresh Fuel, Preirradiated Cladding) under IGR Tests

Table H-6.7. Mechanical Characteristics of Fuel Rod #B19T Vs. Time Calculated by FRAP-T6 and SCANAIR Codes

Time (s)	Clad outer temperature <sup>1)</sup> (K)		Fuel hoop strain <sup>1)</sup> (%)		Fuel - clad gap width <sup>1)</sup> (mm)		Clad hoop strain <sup>1)</sup> (%)		Clad hoop stress <sup>1)</sup> (MPa)		Internal gas pressure (MPa)	
	FRAP-T6	SCANAIR	FRAP-T6	SCANAIR	FRAP-T6	SCANAIR	FRAP-T6	SCANAIR	FRAP-T6	SCANAIR	FRAP-T6	SCANAIR
0.0	293	293	0.00	0.00	0.08	0.08	0.01	0.01	8.72	8.69	1.70	1.70
1.0	305	308	0.04	0.03	0.07	0.07	0.02	0.02	8.90	8.91	1.73	1.74
2.0	369	381	0.17	0.13	0.07	0.07	0.06	0.08	9.28	9.34	1.80	1.81
2.2	393	409	0.23	0.17	0.07	0.07	0.08	0.10	9.39	9.47	1.82	1.83
2.4	428	451	0.33	0.25	0.07	0.07	0.10	0.13	9.55	9.66	1.85	1.86
2.6	491	530	0.53	0.42	0.06	0.07	0.15	0.19	9.79	9.96	1.89	1.89
2.8	618	687	0.96	0.80	0.05	0.06	0.24	0.32	10.1	10.3	1.95	1.94
3.0	847	946	1.59	1.36	0.03	0.04	0.39	0.52	10.3	10.5	1.99	1.97
3.2	1120	-	2.14	-	0.02	-	0.55	-	10.5	-	2.02	-
3.4	1297	-	2.49	-	2.72	-	66.3	-	0.00	-	0.10	-
3.6	1357	-	2.71	-	2.71	-	66.3	-	0.00	-	0.10	-
3.8	1433	-	2.83	-	2.71	-	66.4	-	0.00	-	0.10	-
4.0	1512	-	2.89	-	2.71	-	66.5	-	0.00	-	0.10	-
4.2	1580	-	2.93	-	2.70	-	66.6	-	0.00	-	0.10	-
4.4	1636	-	2.95	-	2.70	-	66.6	-	0.00	-	0.10	-
4.6	1683	-	2.96	-	2.70	-	66.7	-	0.00	-	0.10	-
4.8	1721	-	2.96	-	2.70	-	66.7	-	0.00	-	0.10	-
5.0	1753	-	2.96	-	2.70	-	66.7	-	0.00	-	0.10	-
5.2	1753	-	2.96	-	2.70	-	66.7	-	0.00	-	0.10	-
5.4	1808	-	2.94	-	2.70	-	66.8	-	0.00	-	0.10	-
5.6	1808	-	2.94	-	2.70	-	66.8	-	0.00	-	0.10	-
5.8	1857	-	2.91	-	2.71	-	66.8	-	0.00	-	0.10	-
6.0	1857	-	2.91	-	2.71	-	66.8	-	0.00	-	0.10	-
6.5	1891	-	2.88	-	2.71	-	66.9	-	0.00	-	0.10	-
7.0	1912	-	2.84	-	2.71	-	66.9	-	0.00	-	0.10	-
7.5	1924	-	2.80	-	2.71	-	66.9	-	0.00	-	0.10	-
8.0	1929	-	2.77	-	2.71	-	66.9	-	0.00	-	0.10	-
10.0	1912	-	2.64	-	2.72	-	66.9	-	0.00	-	0.10	-
30.0	1518	-	1.74	-	2.75	-	66.5	-	0.00	-	0.10	-

<sup>1)</sup> All numerical values are presented at elevation with peak power

# #B19T

Individual Characteristics of Refabricated Fuel Rods  
(Fresh Fuel, Preirradiated Cladding) under IGR Tests

Table H-6.8. Axial Distribution of Energy Deposition and Fuel Enthalpy Calculated by FRAP-T6 Code for Fuel Rod #B19T

Axial interval from-to (mm)-(mm)	Energy deposition at infinite time			Fuel enthalpy at time (t=4.84 s)		
	cal/g fuel	J/g fuel	per-unit	cal/g fuel	J/g fuel	per-unit
19.4 - 33.5	246	1031	1.00	191	799	1.00
33.5 - 47.6	237	993	0.96	184	769	0.96
47.6 - 61.7	231	970	0.94	179	751	0.94
61.7 - 75.8	228	955	0.93	176	739	0.93
75.8 - 89.9	226	949	0.92	175	735	0.92
89.9 - 104.0	226	945	0.92	175	732	0.92
104.0 - 118.1	225	944	0.92	174	731	0.92
118.1 - 132.2	225	941	0.91	174	729	0.91
132.2 - 146.3	224	938	0.91	173	726	0.91
146.3 - 160.4	221	925	0.90	171	716	0.90

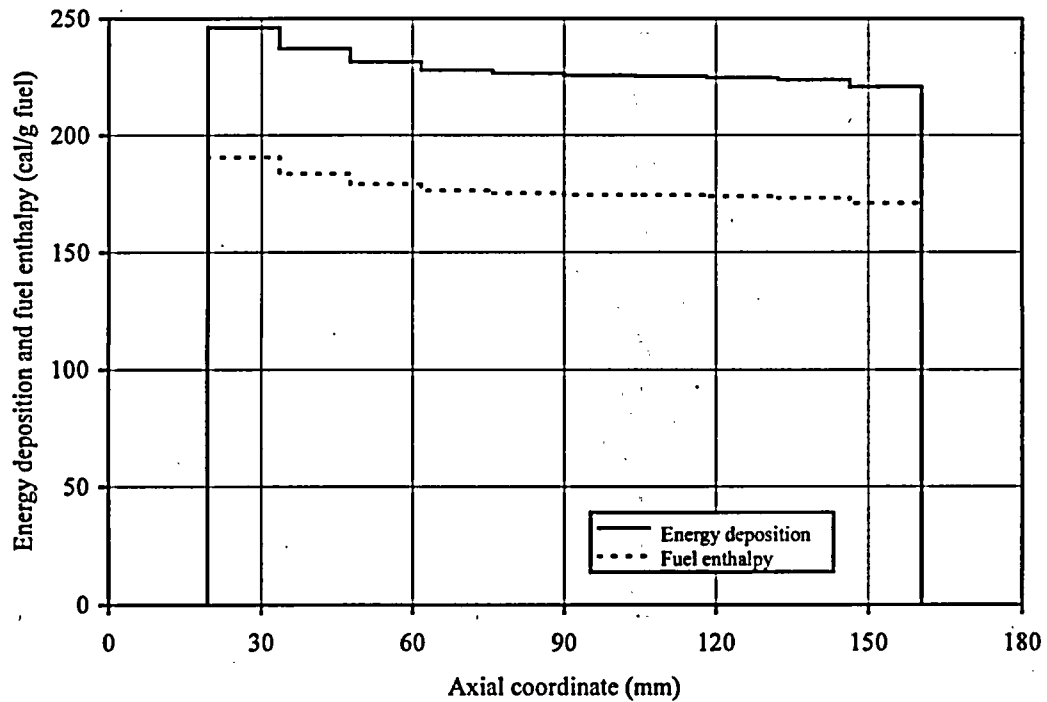

Fig. H-6.5. Axial Distribution of Energy Deposition and Fuel Enthalpy Calculated by FRAP-T6 Code for Fuel Rod #B19T

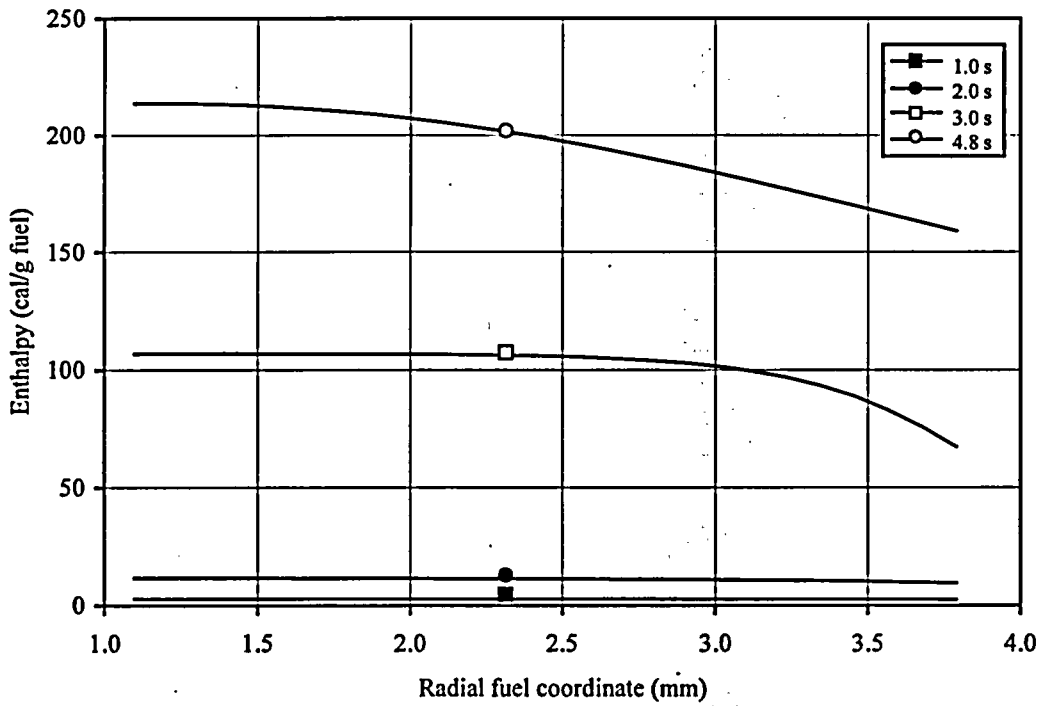
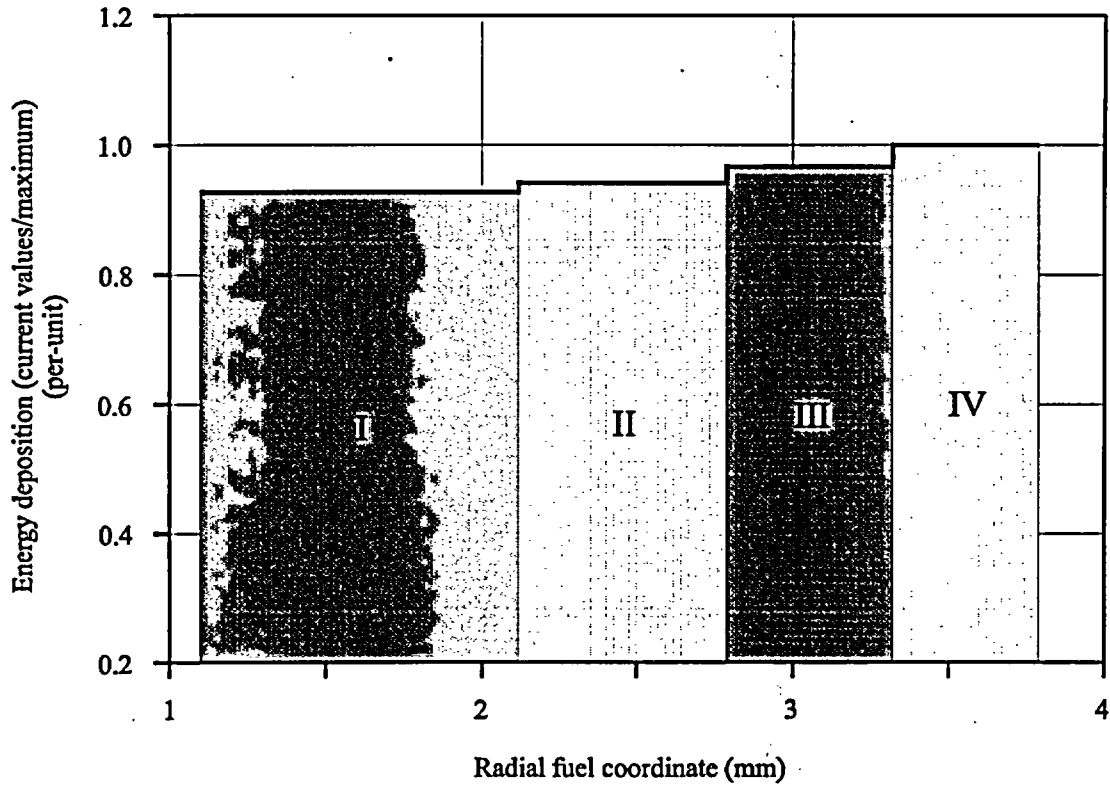

Fig. H-6.6. Radial Distributions of Energy Deposition and Fuel Enthalpy Calculated by FRAP-T6 Code for Fuel Rod #B19T

#B19T

Individual Characteristics of Refabricated Fuel Rods  
(Fresh Fuel, Irradiated Cladding) under IGR Tests

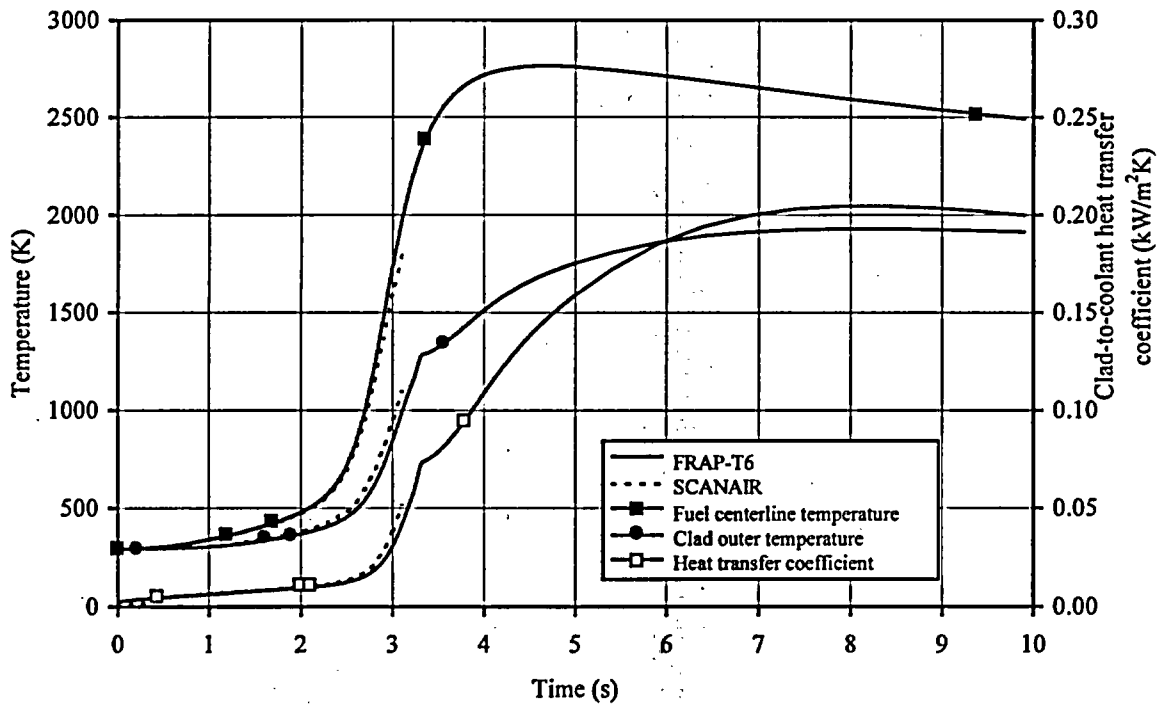
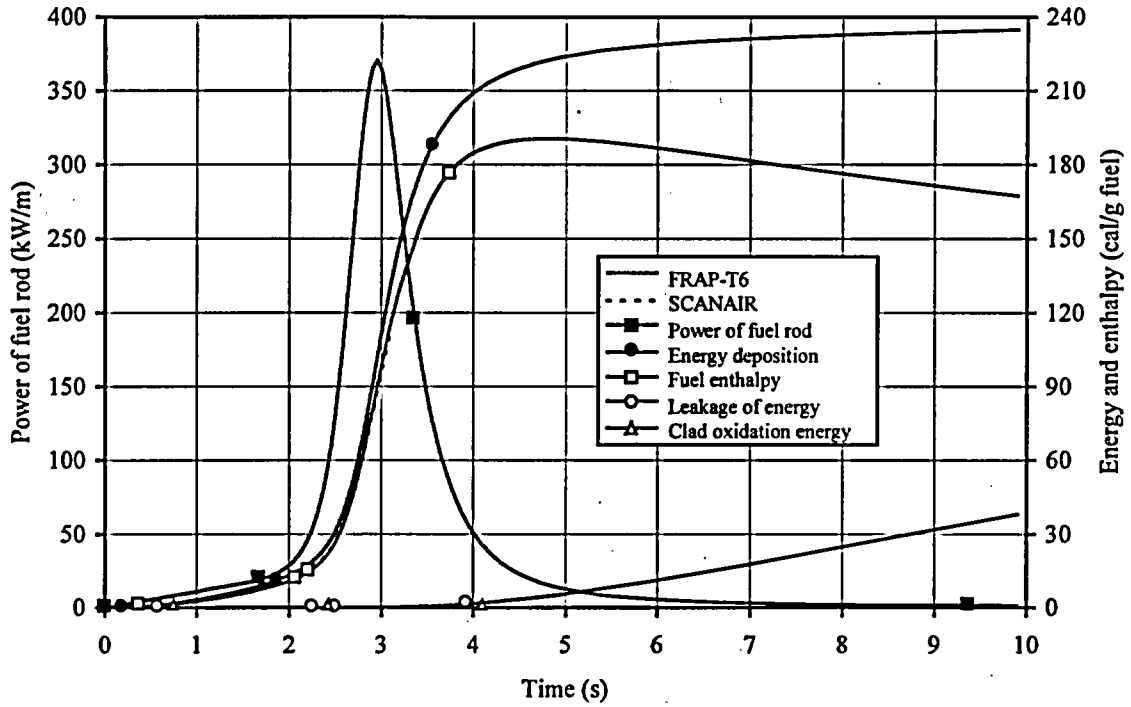

Fig. H-6.7. Energy and Temperature Characteristics Vs. Time Calculated by FRAP-T6 and SCANAIR Codes for Fuel Rod #B19T



#B19T

Individual Characteristics of Refabricated Fuel Rods  
(Fresh Fuel, Preirradiated Cladding) under IGR Tests

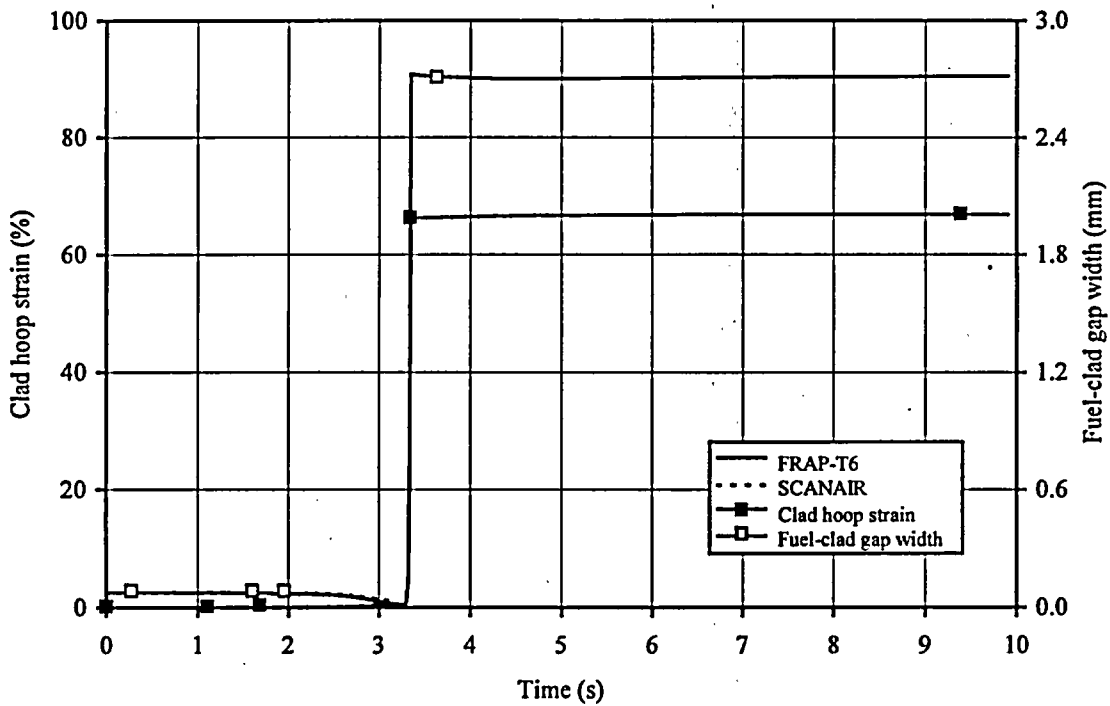
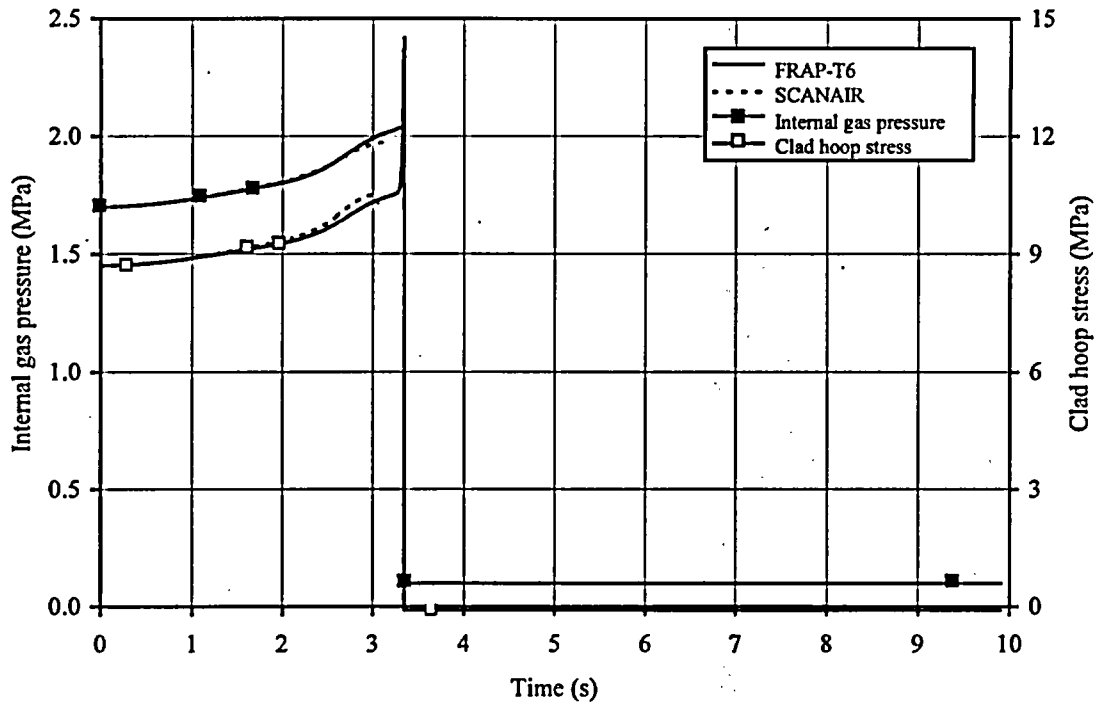

Fig. H-6.8. Cladding Mechanical Characteristics Vs. Time Calculated by FRAP-T6 and SCANAIR Codes for Fuel Rod #B19T

# #B19T

Individual Characteristics of Refabricated Fuel Rods  
(Fresh Fuel, Preirradiated Cladding) under IGR Tests

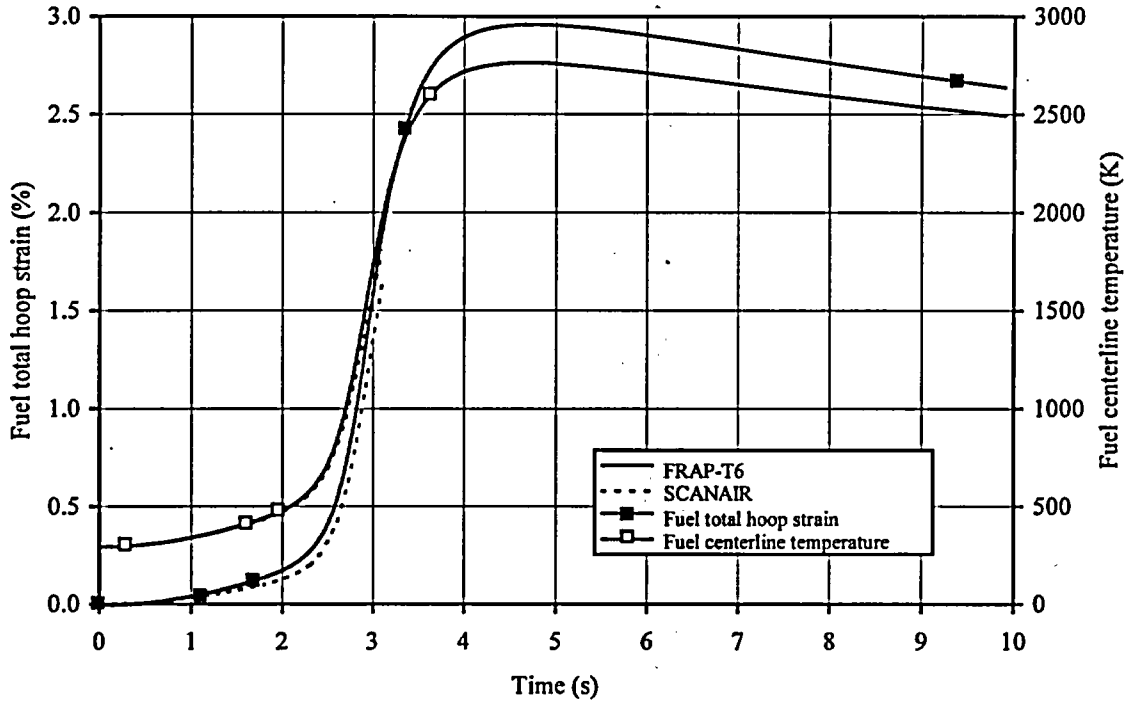

Fig. H-6.9. Fuel Strain Vs. Time Calculated by FRAP-T6 and SCANAIR Codes for Fuel Rod #B19T

Table H-6.9. Some Results of PIE for Fuel Rod #B19T

Characteristic		Value	
1.	Measured parameters of cladding oxidation and cladding deformation		
1.1.	Cladding thickness at elevation 90, 35 mm correspondent to different azimuthal angles ( $\mu\text{m}$ ):		
	0°	663	600
	90°	677	R
	180°	634	545
	270°	606	590
1.2.	ZrO <sub>2</sub> thickness at elevation 90, 35 mm correspondent to different azimuthal angles ( $\mu\text{m}$ ):		
	0°	30	30
	90°	40	—
	180°	30	40
	270°	25	30
1.3.	$\alpha\text{Zr(O)}$ thickness at elevation 90, 35 mm correspondent to different azimuthal angles ( $\mu\text{m}$ ):		
	0°	25	40
	90°	40	—
	180°	25	45
	270°	25	40
1.4.	Clad hoop strain at elevation 90, 35 mm, respectively (%)	8.9	32.8
2.	Measured parameters for FGR analysis		
2.1.	Internal gas composition (% by volume):		
	He	—	
	N <sub>2</sub>	—	
	O <sub>2</sub>	—	
	Ar	—	
	CO <sub>2</sub>	—	
	Kr	—	
	Xe	—	
2.2.	Free gas volume (cm <sup>3</sup> )	—	
2.3.	Gas pressure inside fuel rod under normal condition (MPa)	—	
2.4.	Kr concentration in fuel (cm <sup>3</sup> /g fuel)	—	
3.	Measured parameters of cladding hydriding		
3.1.	Coefficient of hydride orientation (per-unit)	—	
3.2.	Hydrogen concentration (% by weight)	—	

# #B19T

Individual Characteristics of Refabricated Fuel Rods  
(Fresh Fuel, Preirradiated Cladding) under IGR Tests

Table H-6.10. General Characteristic of Fuel Rod #B19T

	Parameter	Unit	Value		
			Experiment	FRAP-T6	SCANAIR
1	Type of coolant	---	air	air	air
2	Burnup	MWd/kg U	0	0	0
3	Energy deposition in fuel rod	cal/g fuel	229	229	229
4	Peak fuel enthalpy	cal/g fuel	-	191	-
5	Peak fuel temperature	K	-	2763	-
6	Peak clad temperature	K	-	1929	-
7	Fuel rod failure	Yes, No	Yes	Yes	-
8	Type of failure:				
	- cladding rupture due to ballooning	Yes, No	Yes	Yes	-
	- cladding rupture due to PCMI	Yes, No	No	No	-
	- fragmentation of fuel rod	Yes, No	No	-	-
9	Failure time	s	-	3.34	-
10	Fuel enthalpy at failure	cal/g fuel	-	147	-
11	Outer cladding temperature at failure	K	-	1286	-
12	Internal gas pressure at failure	MPa	-	2.01	-
13	ZrO <sub>2</sub> thickness after test	μm	25-40	-	-
14	Residual clad hoop strain:				
	- peak value for ballooning area	%	32.8	65.96	-
	- other location <sup>1)</sup>	%	8.9	0.74	-

<sup>1)</sup>Calculated values by FRAP-T6 and SCANAIR codes are average along height of fuel rod excluding ballooning region



*APPENDIX H-7.*  
*Individual Characteristics for Fuel Rod #B20T under IGR Test*

#B20T

Individual Characteristics of Refabricated Fuel Rods  
(Fresh Fuel, Preirradiated Cladding) under IGR Tests

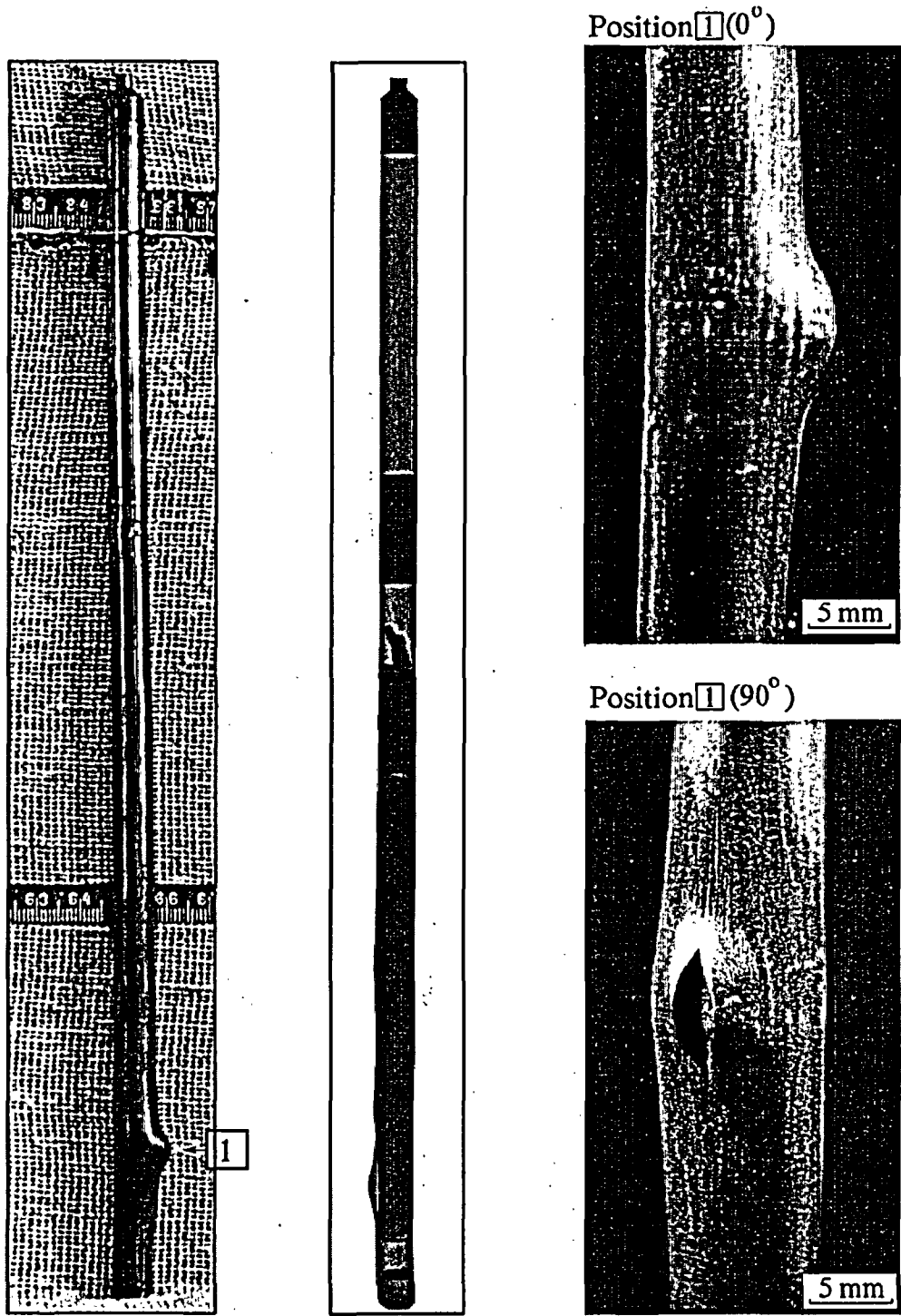
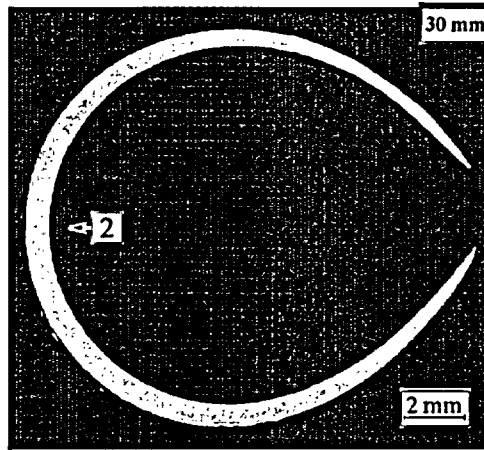
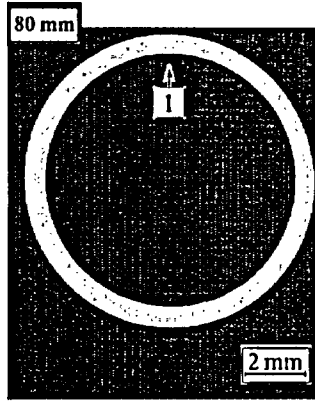

Fig. H-7.1. Appearance of Fuel Rod #B20T (photographs and X-ray photograph)

#B20T

Individual Characteristics of Refabricated Fuel Rods  
(Fresh Fuel, Irradiated Cladding) under IGR Tests



Position 1

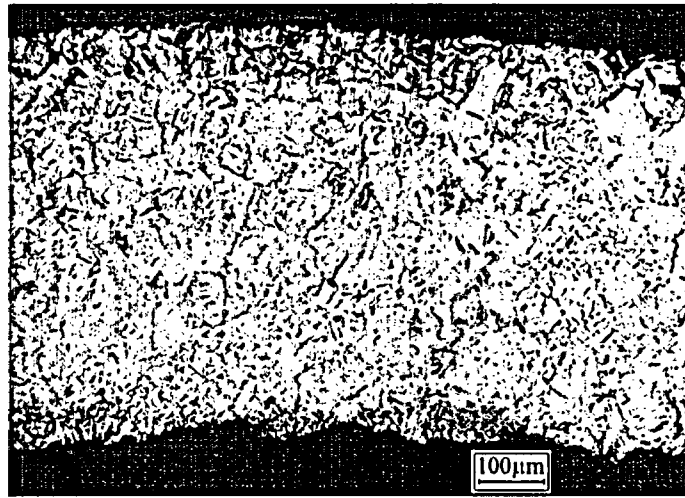

Position 2

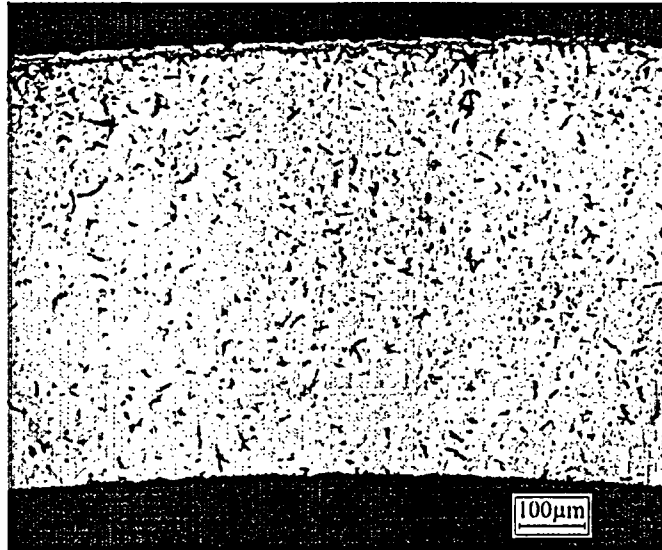

Fig. H-7.2. Cross-Section and Cladding Microstructure for Fuel Rod #B20T at 30 mm and 80 mm Elevations



#B20T

Individual Characteristics of Refabricated Fuel Rods  
(Fresh Fuel, Preirradiated Cladding) under IGR Tests

Position 1

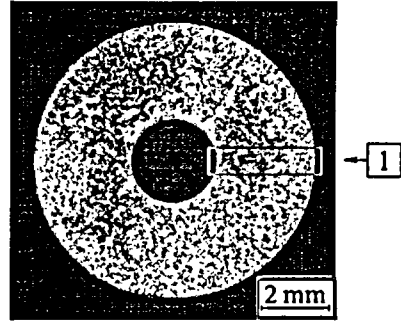
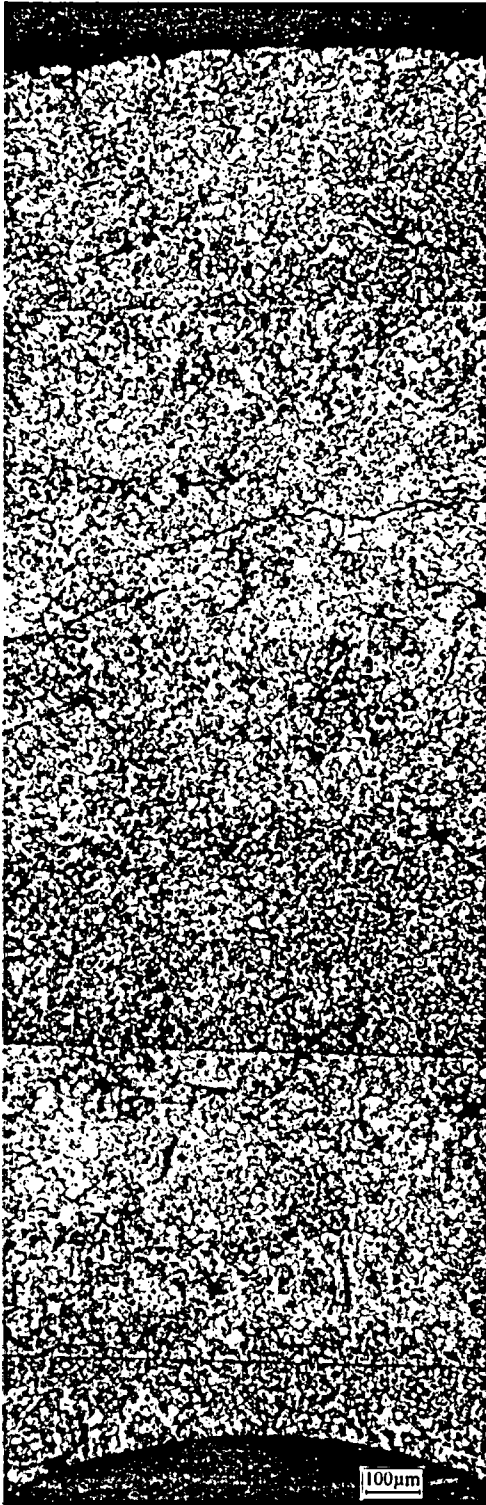

Position 2

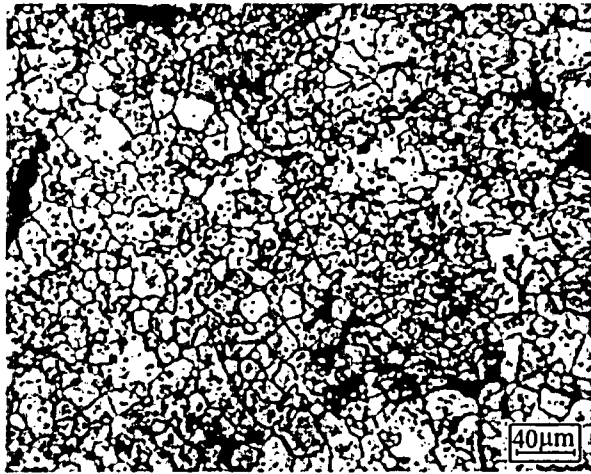

← 2

Fig. H-7.3. Fuel Microstructure for Fuel Rod #B20T at 30 mm Elevation

# #B20T

Individual Characteristics of Refabricated Fuel Rods  
(Fresh Fuel, Preirradiated Cladding) under IGR Tests

Table H-7.1. Time Dependent Energy Characteristics of Fuel Rod #B20T

Time (s)	Reactor energy deposition <sup>1)</sup> (%)	Cumulative number of fissions in fuel rod (fiss)			Power of fuel rod (kW)	Energy deposition in fuel rod	
		U <sup>235</sup> ×10 <sup>-14</sup>	U <sup>238</sup> ×10 <sup>-12</sup>	Total ×10 <sup>-14</sup>		cal/g fuel	J/g fuel
0.0	0.000	0.000	0.000	0.000	0.000	0.000	0.000
1.0	0.515	0.070	0.040	0.071	0.397	0.797	3.340
2.0	2.060	0.281	0.158	0.283	0.796	3.190	13.40
2.2	2.490	0.340	0.192	0.342	0.876	3.860	16.20
2.4	2.970	0.405	0.228	0.408	0.956	4.600	19.30
2.6	3.480	0.475	0.268	0.478	1.040	5.400	22.60
2.8	4.040	0.551	0.310	0.555	1.120	6.270	26.20
3.0	4.640	0.635	0.357	0.638	1.250	7.210	30.20
3.2	5.340	0.730	0.411	0.735	1.470	8.300	34.70
3.4	6.190	0.846	0.476	0.851	1.840	9.620	40.30
3.6	7.300	0.998	0.562	1.000	2.520	11.30	47.30
3.8	8.910	1.220	0.685	1.220	3.820	13.80	57.80
4.0	11.50	1.570	0.883	1.580	6.420	17.80	74.50
4.2	16.00	2.190	1.230	2.200	11.50	24.80	104.0
4.4	24.00	3.280	1.850	3.300	20.00	37.30	156.0
4.6	36.90	5.040	2.840	5.070	29.30	57.20	239.0
4.8	53.20	7.270	4.090	7.310	31.90	82.40	345.0
5.0	68.10	9.300	5.240	9.360	24.70	106.0	444.0
5.2	78.30	10.70	6.030	10.80	15.30	122.0	511.0
5.4	84.40	11.50	6.490	11.60	8.820	131.0	548.0
5.6	87.90	12.00	6.760	12.10	5.220	137.0	573.0
5.8	90.00	12.30	6.920	12.40	3.350	140.0	586.0
6.0	91.40	12.50	7.030	12.60	2.340	142.0	594.0
6.5	93.50	12.80	7.190	12.90	1.310	146.0	611.0
7.0	94.80	13.00	7.290	13.00	0.920	148.0	620.0
7.5	95.70	13.10	7.360	13.20	0.613	149.0	624.0
8.0	96.30	13.20	7.400	13.20	0.433	150.0	628.0
9.0	97.10	13.30	7.470	13.30	0.323	152.0	636.0
10.0	97.70	13.30	7.510	13.40	0.212	153.0	640.0
20.0	99.30	13.60	7.640	13.70	0.042	156.0	653.0
30.0	99.80	13.60	7.680	13.70	0.021	158.0	661.0
∞	101.0	13.80	7.750	13.80	0.000	161.0	674.0

Maximum value of power is 32.3 kW (t = 4.75 s)

<sup>1)</sup> Current energy deposition per maximum energy deposition (at infinite time)

# #B20T

Individual Characteristics of Refabricated Fuel Rods  
(Fresh Fuel, Preirradiated Cladding) under IGR Tests

Table H-7.2. Axial Energy Characteristics of Fuel Rod #B20T

Axial coordinate from lower end of fuel rod (mm)	Cumulative number of fissions at axial interval (fiss)			Maximum power of fuel rod (kW) $t=4.75$ s	Energy deposition at infinite time*		
	$U^{235} \times 10^{-13}$	$U^{238} \times 10^{-11}$	Total $\times 10^{-13}$		cal/g fuel	J/g fuel	per-unit <sup>3)</sup>
20.0	0.000	0.000	0.000	0.000	0.000	0.000	0.00
25.0 <sup>1)</sup>	4.770	2.310	4.790	1.120	176.0	737.0	1.00
30.0	5.200	2.590	5.220	1.220	173.0	724.0	0.98
35.0	5.150	2.610	5.180	1.210	171.0	716.0	0.97
40.0	5.060	2.630	5.090	1.190	168.0	703.0	0.95
45.0	5.010	2.640	5.030	1.170	167.0	699.0	0.95
50.0	4.910	2.630	4.930	1.150	165.0	691.0	0.94
55.0	4.870	2.650	4.890	1.140	164.0	687.0	0.93
60.0	4.930	2.720	4.950	1.150	163.0	682.0	0.93
65.0	4.900	2.730	4.920	1.150	162.0	678.0	0.92
70.0	4.830	2.730	4.860	1.130	161.0	674.0	0.91
75.0	4.730	2.700	4.760	1.110	160.0	670.0	0.91
80.0	4.720	2.710	4.740	1.110	159.0	666.0	0.90
85.0	4.760	2.760	4.790	1.120	160.0	670.0	0.91
90.0	4.760	2.770	4.790	1.120	160.0	670.0	0.91
95.0	4.770	2.790	4.800	1.120	159.0	666.0	0.90
100.0	4.800	2.820	4.830	1.130	159.0	666.0	0.90
105.0	4.770	2.810	4.800	1.120	159.0	666.0	0.90
110.0	4.730	2.790	4.760	1.110	158.0	661.0	0.90
115.0	4.730	2.790	4.760	1.110	158.0	661.0	0.90
120.0	4.730	2.790	4.760	1.110	158.0	661.0	0.90
125.0	4.730	2.780	4.750	1.110	158.0	661.0	0.90
130.0	4.720	2.770	4.750	1.110	159.0	666.0	0.90
135.0	4.690	2.740	4.710	1.100	158.0	661.0	0.90
140.0	4.680	2.730	4.700	1.100	158.0	661.0	0.90
145.0	4.610	2.680	4.630	1.080	157.0	657.0	0.89
150.0	4.590	2.650	4.620	1.080	157.0	657.0	0.89
155.0	4.630	2.660	4.660	1.090	156.0	653.0	0.89
160.0	4.660	2.660	4.690	1.090	155.0	649.0	0.88
165.0 <sup>2)</sup>	3.210	1.820	3.230	0.752	154.0	645.0	0.88
170.0	0.000	0.000	0.000	0.000	0.000	0.000	0.00

\* All numerical values of characteristics are presented as average values at the length interval equal to the axial coordinate  $\pm 2.5$  mm.

<sup>1)</sup> Initial coordinate of fuel is 23.0 mm.

<sup>2)</sup> End coordinate of fuel is 166.0 mm.

<sup>3)</sup> Current value per maximum value.

# #B20T

Individual Characteristics of Refabricated Fuel Rods  
(Fresh Fuel, Preirradiated Cladding) under IGR Tests

Table H-7.3. Radial Energy Characteristics of Fuel Rod #B20T

Characteristics*		Coordinates of fuel zones (mm)			
		1 zone 1.10 - 2.12	2 zone 2.12 - 2.79	3 zone 2.79 - 3.32	4 zone 3.32 - 3.79
U <sup>235</sup>	Number of fissions $\times 10^{-14}$ (fiss)	3.330	3.380	3.470	3.590
	Power of fuel rod <sup>1)</sup> (kW)	7.750	7.870	8.090	8.370
	Energy deposition <sup>2)</sup> (cal/g fuel)	155.0	157.0	162.0	167.0
	Energy deposition <sup>2)</sup> (J/g fuel)	649.0	657.0	678.0	699.0
	Energy deposition <sup>3)</sup> (per-unit)	0.928	0.940	0.970	1.000
U <sup>238</sup>	Number of fissions $\times 10^{-12}$ (fiss)	1.950	1.930	1.930	1.930
	Power of fuel rod <sup>1)</sup> (kW)	0.045	0.045	0.044	0.045
	Energy deposition <sup>2)</sup> (cal/g fuel)	0.895	0.889	0.887	0.889
	Energy deposition <sup>2)</sup> (J/g fuel)	3.750	3.720	3.710	3.720
	Energy deposition <sup>3)</sup> (per-unit)	1.000	0.993	0.991	0.993
Total	Number of fissions $\times 10^{-14}$ (fiss)	3.340	3.400	3.490	3.610
	Power of fuel rod <sup>1)</sup> (kW)	7.800	7.920	8.130	8.410
	Energy deposition <sup>2)</sup> (cal/g fuel)	156.0	158.0	162.0	168.0
	Energy deposition <sup>2)</sup> (J/g fuel)	653.0	661.0	678.0	703.0
	Energy deposition <sup>3)</sup> (per-unit)	0.929	0.940	0.964	1.000

1) at time of 4.75 s, 2) at infinite time, 3) Current value per maximum value

\* All numerical values of characteristics were calculated for length of fuel stack

# #B20T

Individual Characteristics of Refabricated Fuel Rods  
(Fresh Fuel, Preirradiated Cladding) under IGR Tests

Table H-7.4. Fuel Enthalpy Vs. Time Calculated by FRAP-T6 Code for Fuel Rod #B20T

Time (s)	Enthalpy at fuel radius (cal/g fuel)				Fuel enthalpy <sup>1)</sup>		Energy deposition in fuel rod	
	1.10 mm	2.22 mm	2.89 mm	3.79 mm	cal/g fuel	J/g fuel	cal/g fuel	J/g fuel
0.0	0.00	0.00	0.00	0.00	0.00	0.00	0.00	0.00
1.0	0.73	0.72	0.71	0.64	0.70	2.95	0.80	3.34
2.0	2.84	2.80	2.71	2.47	2.71	11.4	3.19	13.4
2.2	3.43	3.38	3.27	2.98	3.27	13.7	3.86	16.2
2.4	4.08	4.01	3.88	3.54	3.89	16.3	4.60	19.3
2.6	4.78	4.70	4.55	4.15	4.56	19.1	5.40	22.6
2.8	5.55	5.45	5.27	4.81	5.28	22.1	6.27	26.3
3.0	6.38	6.27	6.06	5.53	6.08	25.5	7.21	30.2
3.2	7.35	7.23	6.99	6.37	7.00	29.3	8.30	34.8
3.4	8.55	8.40	8.13	7.40	8.14	34.1	9.62	40.3
3.6	10.1	9.98	9.66	8.77	9.67	40.5	11.3	47.5
3.8	12.5	12.3	11.9	10.8	11.9	50.0	13.8	57.9
4.0	16.4	16.2	15.7	14.0	15.7	65.7	17.8	74.7
4.2	23.4	23.2	22.5	19.6	22.4	93.7	24.8	104
4.4	36.0	35.7	34.8	29.1	34.3	144	37.3	156
4.6	56.4	56.1	54.5	42.8	53.4	224	57.2	240
4.8	82.8	82.2	79.2	57.4	77.1	323	82.4	345
5.0	107	106	101	68.6	97.8	410	106	442
5.2	124	122	113	75.5	111	464	122	509
5.4	134	130	118	78.6	117	489	131	549
5.6	139	134	119	91.2	120	503	136	572
5.8	142	134	119	100.0	123	515	140	586
6.0	142	134	121	104	124	521	142	595
6.5	141	133	122	108	125	525	146	610
7.0	138	131	122	109	125	524	148	619
7.5	135	130	122	110	124	520	149	625
8.0	133	128	121	111	123	515	150	630
10.0	125	122	118	111	119	498	153	641
30.0	89.2	88.4	87.1	84.8	87.4	366	158	660

Radial enthalpy distribution and fuel enthalpy are presented at elevation 30.1 mm

Maximum value of fuel enthalpy is 125.3 cal/g fuel ( $t=6.51$  s)

<sup>1)</sup> All numerical values are presented at elevation with peak power

# #B20T

Individual Characteristics of Refabricated Fuel Rods  
(Fresh Fuel, Preirradiated Cladding) under IGR Tests

Table H-7.5. Energy Characteristics Vs. Time Calculated by FRAP-T6 and SCANAIR Codes for Fuel Rod #B20T

Time (s)	Energy deposition <sup>1)</sup> (cal/g fuel)	Linear power <sup>1)</sup> (kW/m)	Fuel enthalpy <sup>1)</sup> (cal/g fuel)		Leakage of energy <sup>1)</sup> (cal/g fuel)		Clad-to-coolant heat transfer coefficient <sup>1)</sup> (kW/m <sup>2</sup> K)	
			FRAP-T6	SCANAIR	FRAP-T6	SCANAIR	FRAP-T6	SCANAIR
0.0	0.00	0.00	0.00	0.00	0.00	0.00	0.00	0.00
1.0	0.86	2.96	0.70	0.77	0.00	0.00	0.01	0.01
2.0	3.43	5.93	2.71	2.95	0.00	0.00	0.01	0.01
2.2	4.15	6.53	3.27	3.55	0.00	0.00	0.01	0.01
2.4	4.94	7.13	3.89	4.19	0.00	0.00	0.01	0.01
2.6	5.80	7.75	4.56	4.89	0.00	0.00	0.01	0.01
2.8	6.73	8.35	5.28	5.65	0.00	0.01	0.01	0.01
3.0	7.74	9.32	6.08	6.47	0.01	0.01	0.01	0.01
3.2	8.91	11.0	7.00	7.42	0.01	0.01	0.01	0.01
3.4	10.3	13.7	8.14	8.58	0.01	0.01	0.01	0.01
3.6	12.2	18.8	9.67	10.1	0.01	0.01	0.01	0.01
3.8	14.8	28.5	11.9	12.4	0.02	0.02	0.01	0.01
4.0	19.1	47.9	15.7	16.1	0.02	0.02	0.01	0.01
4.2	26.6	85.7	22.4	22.7	0.02	0.03	0.01	0.01
4.4	40.0	149	34.3	34.4	0.03	0.04	0.01	0.02
4.6	61.4	218	53.4	53.0	0.05	0.06	0.02	0.02
4.8	88.5	238	77.1	75.8	0.07	0.10	0.03	0.03
5.0	113	184	97.8	95.5	0.13	0.18	0.04	0.05
5.2	130	114	111	-	0.24	-	0.05	-
5.4	141	65.8	117	-	0.40	-	0.06	-
5.6	146	38.9	120	-	0.62	-	0.07	-
5.8	150	25.0	123	-	0.90	-	0.08	-
6.0	153	17.4	124	-	1.20	-	0.08	-
6.5	156	9.77	125	-	2.07	-	0.09	-
7.0	159	6.86	125	-	3.10	-	0.10	-
7.5	160	4.57	124	-	4.28	-	0.11	-
8.0	161	3.23	123	-	5.58	-	0.11	-
10.0	164	1.58	119	-	11.4	-	0.12	-
30.0	169	0.15	87.4	-	58.6	-	0.08	-

<sup>1)</sup> All numerical values are presented at elevation with peak power

# #B20T

Individual Characteristics of Refabricated Fuel Rods  
(Fresh Fuel, Preirradiated Cladding) under IGR Tests

Table H-7.6. Temperature Variation, Fission Gas Release and ZrO<sub>2</sub> Thickness Vs. Time for Fuel Rod #B20T Calculated by FRAP-T6 and SCANAIR Codes

Time (s)	Fuel centerline temperature <sup>1)</sup> (K)		Fuel surface temperature <sup>1)</sup> (K)		Clad outer temperature <sup>1)</sup> (K)	
	FRAP-T6	SCANAIR	FRAP-T6	SCANAIR	FRAP-T6	SCANAIR
0.0	293	293	293	293	293	293
1.0	306	306	305	305	296	297
2.0	342	341	336	338	313	315
2.2	352	351	344	347	318	321
2.4	363	361	354	357	324	328
2.6	374	372	364	367	331	336
2.8	386	384	374	378	339	344
3.0	399	397	386	390	347	353
3.2	415	412	399	404	356	363
3.4	433	430	415	421	367	375
3.6	457	453	437	443	380	389
3.8	493	487	467	475	395	407
4.0	550	541	515	526	417	432
4.2	650	633	597	613	450	473
4.4	825	793	730	757	507	543
4.6	1099	1039	917	963	606	662
4.8	1440	1339	1112	1182	760	838
5.0	1745	1606	1259	1350	948	1039
5.2	1946	-	1347	-	1089	-
5.4	2056	-	1386	-	1183	-
5.6	2111	-	1546	-	1281	-
5.8	2136	-	1655	-	1303	-
6.0	2143	-	1700	-	1332	-
6.5	2125	-	1749	-	1402	-
7.0	2097	-	1770	-	1462	-
7.5	2068	-	1781	-	1508	-
8.0	2041	-	1788	-	1541	-
10.0	1952	-	1785	-	1591	-
30.0	1521	-	1465	-	1355	-

<sup>1)</sup> All numerical values are presented at elevation with peak power

# #B20T

Individual Characteristics of Refabricated Fuel Rods  
(Fresh Fuel, Preirradiated Cladding) under IGR Tests

Table H-7.7. Mechanical Characteristics of Fuel Rod #B20T Vs. Time Calculated by FRAP-T6 and SCANAIR Codes

Time (s)	Clad outer temperature <sup>1)</sup> (K)		Fuel hoop strain <sup>1)</sup> (%)		Fuel - clad gap width <sup>1)</sup> (mm)		Clad hoop strain <sup>1)</sup> (%)		Clad hoop stress <sup>1)</sup> (MPa)		Internal gas pressure (MPa)	
	FRAP-T6	SCANAIR	FRAP-T6	SCANAIR	FRAP-T6	SCANAIR	FRAP-T6	SCANAIR	FRAP-T6	SCANAIR	FRAP-T6	SCANAIR
0.0	293	293	0.00	0.00	0.08	0.08	0.01	0.01	8.73	8.70	1.70	1.70
1.0	296	297	0.01	0.01	0.08	0.08	0.01	0.01	8.78	8.77	1.71	1.71
2.0	313	315	0.04	0.03	0.08	0.08	0.02	0.03	8.92	8.93	1.74	1.74
2.2	318	321	0.05	0.04	0.08	0.08	0.02	0.03	8.96	8.97	1.74	1.75
2.4	324	328	0.06	0.05	0.08	0.08	0.03	0.03	9.00	9.01	1.75	1.75
2.6	331	336	0.07	0.05	0.08	0.08	0.03	0.04	9.03	9.06	1.76	1.76
2.8	339	344	0.08	0.06	0.08	0.08	0.04	0.05	9.07	9.10	1.76	1.77
3.0	347	353	0.10	0.07	0.08	0.08	0.04	0.05	9.11	9.14	1.77	1.78
3.2	356	363	0.11	0.08	0.08	0.08	0.05	0.06	9.16	9.19	1.78	1.78
3.4	367	375	0.13	0.10	0.08	0.08	0.06	0.07	9.21	9.25	1.79	1.79
3.6	380	389	0.15	0.12	0.08	0.08	0.07	0.08	9.27	9.32	1.80	1.80
3.8	395	407	0.19	0.14	0.08	0.08	0.08	0.10	9.35	9.41	1.81	1.82
4.0	417	432	0.24	0.19	0.07	0.08	0.09	0.12	9.46	9.53	1.83	1.84
4.2	450	473	0.34	0.27	0.07	0.08	0.12	0.15	9.61	9.72	1.86	1.87
4.4	507	543	0.52	0.42	0.07	0.07	0.16	0.20	9.82	9.97	1.90	1.90
4.6	606	662	0.82	0.67	0.06	0.07	0.23	0.29	10.0	10.2	1.94	1.93
4.8	760	838	1.21	1.02	0.05	0.06	0.33	0.43	10.2	10.4	1.97	1.96
5.0	948	1039	1.58	1.35	0.04	0.05	0.46	0.59	10.4	10.5	2.00	1.98
5.2	1089	-	1.82	-	0.03	-	0.56	-	10.5	-	2.01	-
5.4	1183	-	1.94	-	0.03	-	0.55	-	10.5	-	2.02	-
5.6	1281	-	2.00	-	1.78	-	43.7	-	13.5	-	1.99	-
5.8	1303	-	2.04	-	2.45	-	60.9	-	0.00	-	0.10	-
6.0	1332	-	2.06	-	2.45	-	60.9	-	0.00	-	0.10	-
6.5	1402	-	2.05	-	2.45	-	61.0	-	0.00	-	0.10	-
7.0	1462	-	2.04	-	2.45	-	61.0	-	0.00	-	0.10	-
7.5	1508	-	2.01	-	2.45	-	61.1	-	0.00	-	0.10	-
8.0	1541	-	1.99	-	2.45	-	61.1	-	0.00	-	0.10	-
10.0	1591	-	1.90	-	2.46	-	61.1	-	0.00	-	0.10	-
30.0	1355	-	1.35	-	2.48	-	60.9	-	0.00	-	0.10	-

<sup>1)</sup> All numerical values are presented at elevation with peak power



# #B20T

Individual Characteristics of Refabricated Fuel Rods  
(Fresh Fuel, Preirradiated Cladding) under IGR Tests

Table H-7.8. Axial Distribution of Energy Deposition and Fuel Enthalpy Calculated by FRAP-T6 Code for Fuel Rod #B20T

Axial interval from-to (mm)-(mm)	Energy deposition at infinite time			Fuel enthalpy at time (t=6.51 s)		
	cal/g fuel	J/g fuel	per-unit	cal/g fuel	J/g fuel	per-unit
23.0 - 37.3	173	725	1.00	125	525	1.00
37.3 - 51.6	167	699	0.97	121	507	0.97
51.6 - 65.9	163	684	0.94	118	496	0.94
65.9 - 80.2	160	672	0.93	116	487	0.93
80.2 - 94.5	160	669	0.92	116	485	0.92
94.5 - 108.8	159	666	0.92	115	482	0.92
108.8 - 123.1	158	662	0.91	114	480	0.91
123.1 - 137.4	158	663	0.92	115	481	0.92
137.4 - 151.7	157	659	0.91	114	478	0.91
151.7 - 166.0	155	651	0.90	112	471	0.90

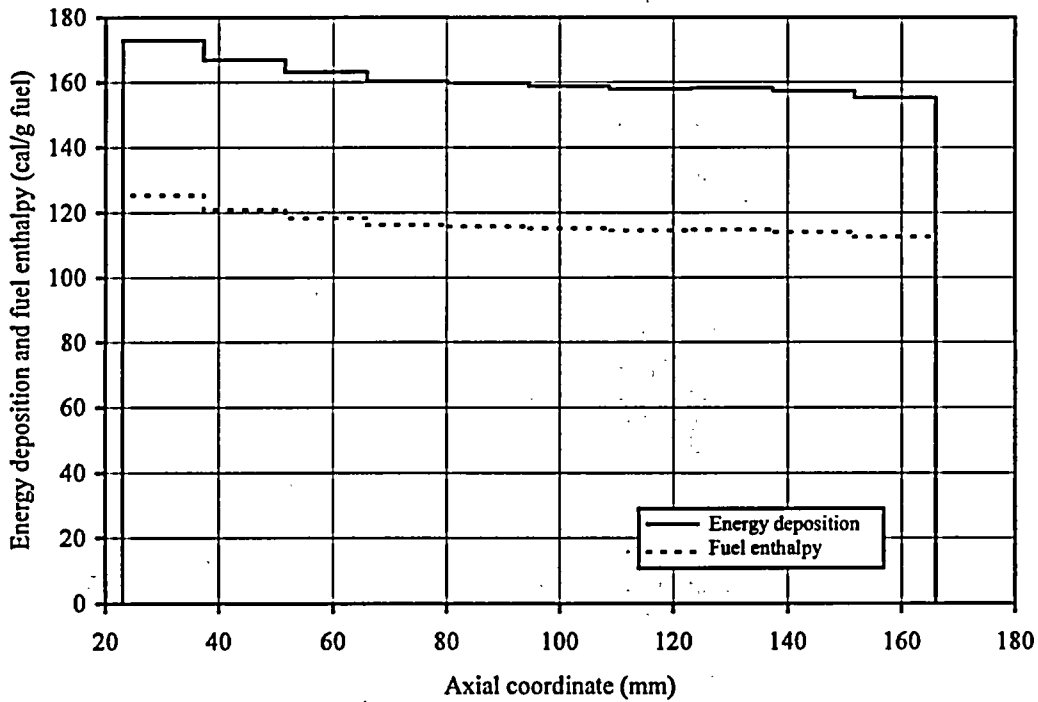

Fig. H-7.4. Axial Distribution of Energy Deposition and Fuel Enthalpy Calculated by FRAP-T6 Code for Fuel Rod #B20T

# #B20T

Individual Characteristics of Refabricated Fuel Rods  
(Fresh Fuel, Preirradiated Cladding) under IGR Tests

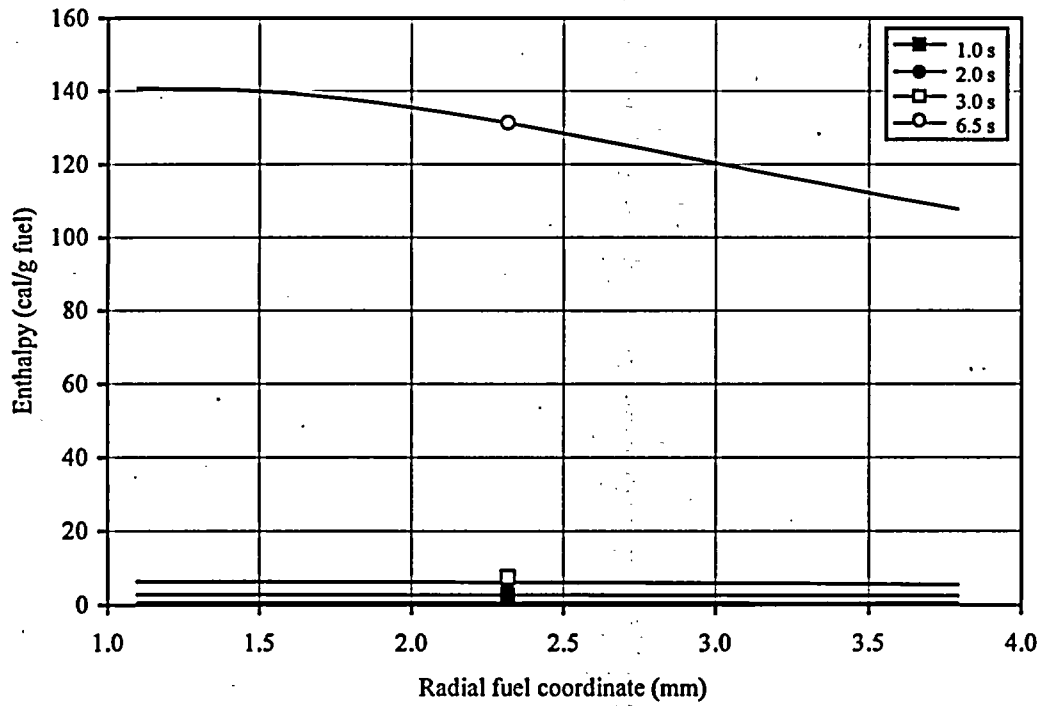
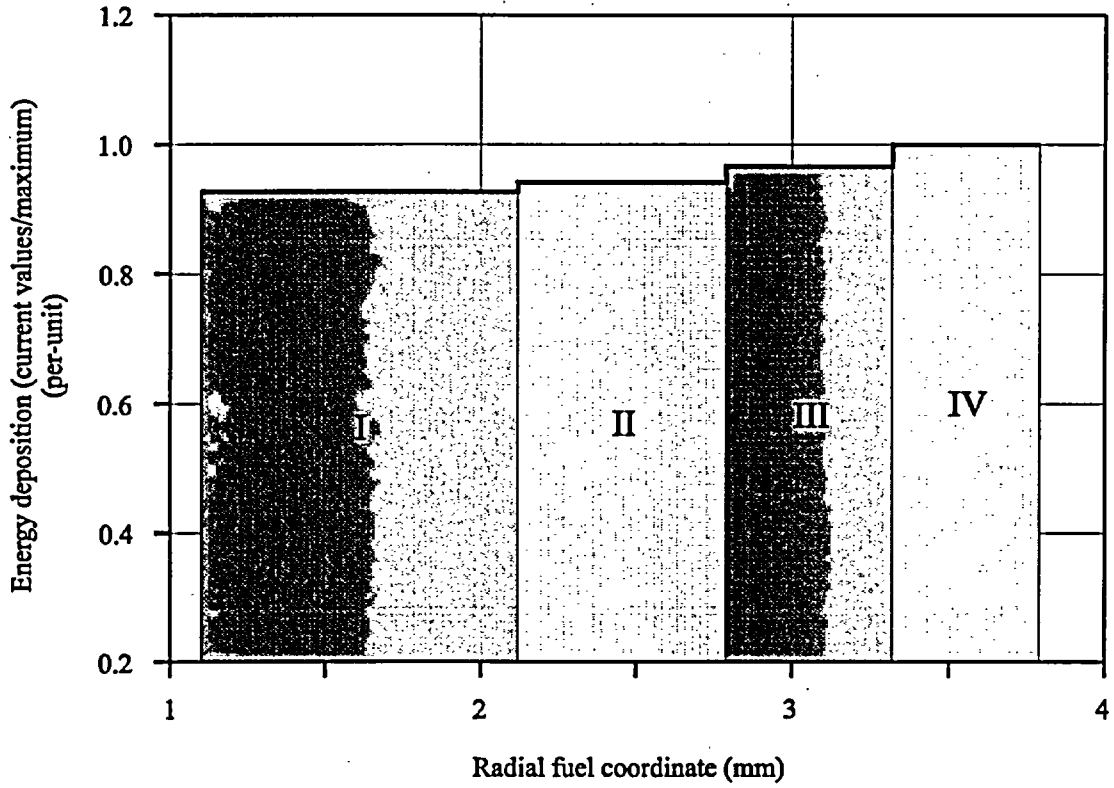

Fig. H-7.5. Radial Distributions of Energy Deposition and Fuel Enthalpy Calculated by FRAP-T6 Code for Fuel Rod #B20T

#B20T

Individual Characteristics of Refabricated Fuel Rods  
(Fresh Fuel, Preirradiated Cladding) under IGR Tests

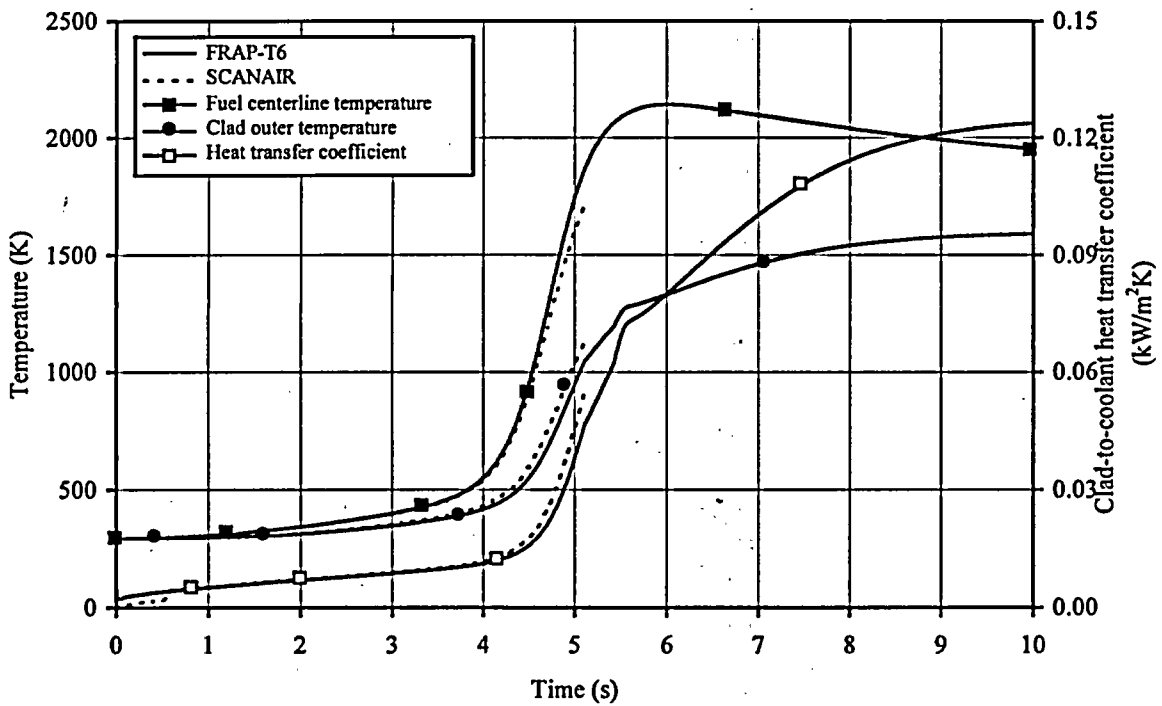
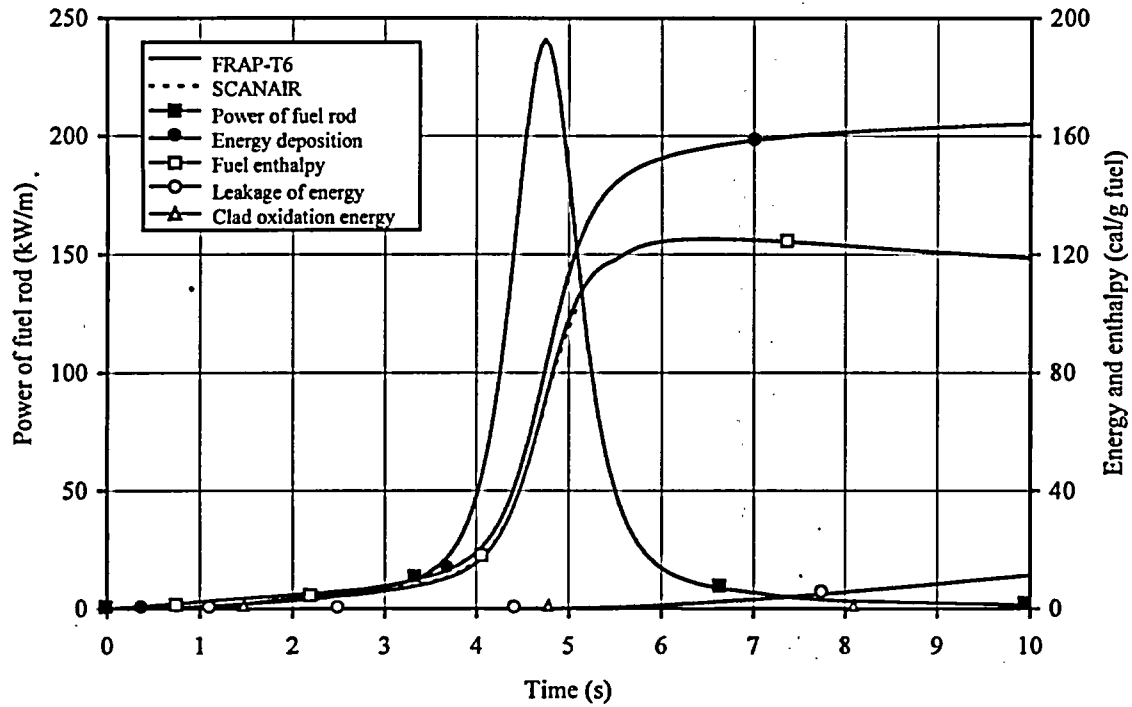

Fig. H-7.6. Energy and Temperature Characteristics Vs. Time Calculated by FRAP-T6 and SCANAIR Codes for Fuel Rod #B20T

# #B20T

Individual Characteristics of Refabricated Fuel Rods  
(Fresh Fuel, Preirradiated Cladding) under IGR Tests

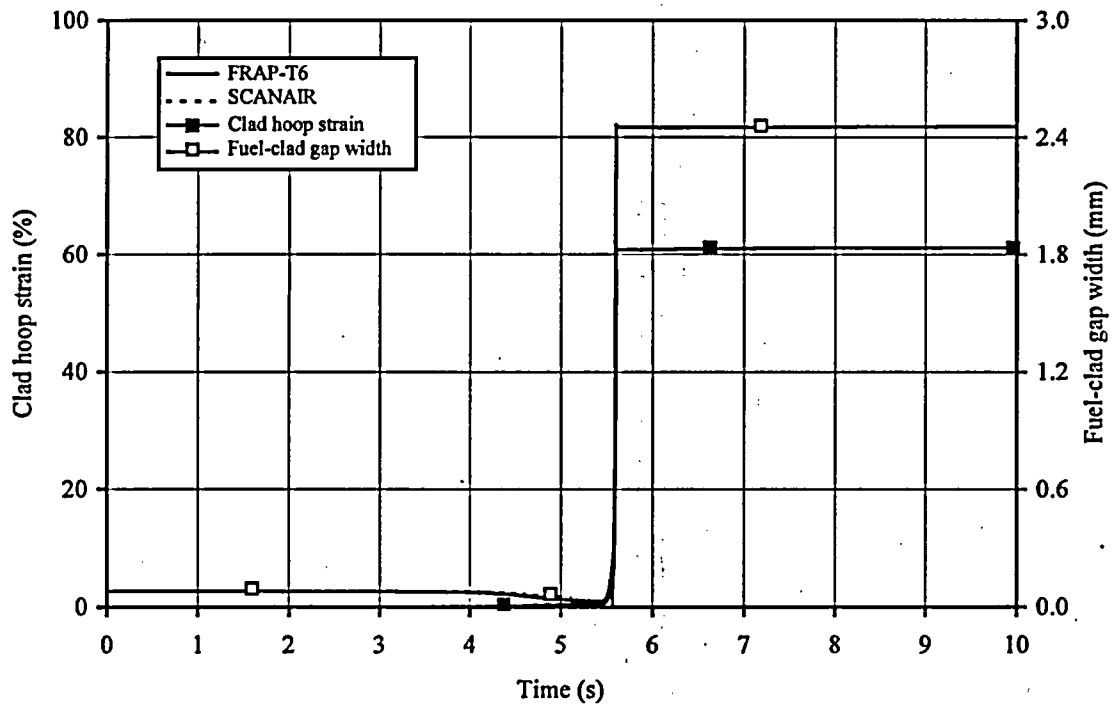
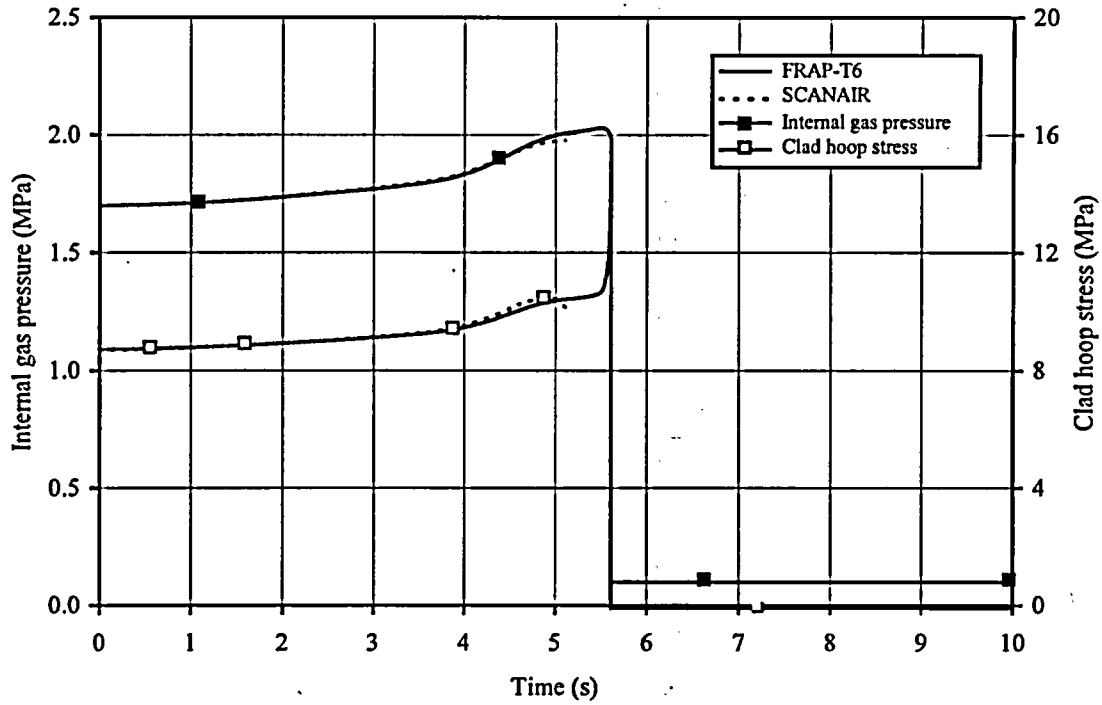

Fig. H-7.7. Cladding Mechanical Characteristics Vs. Time Calculated by FRAP-T6 and SCANAIR Codes for Fuel Rod #B20T

# #B20T

Individual Characteristics of Refabricated Fuel Rods  
(Fresh Fuel, Preirradiated Cladding) under IGR Tests

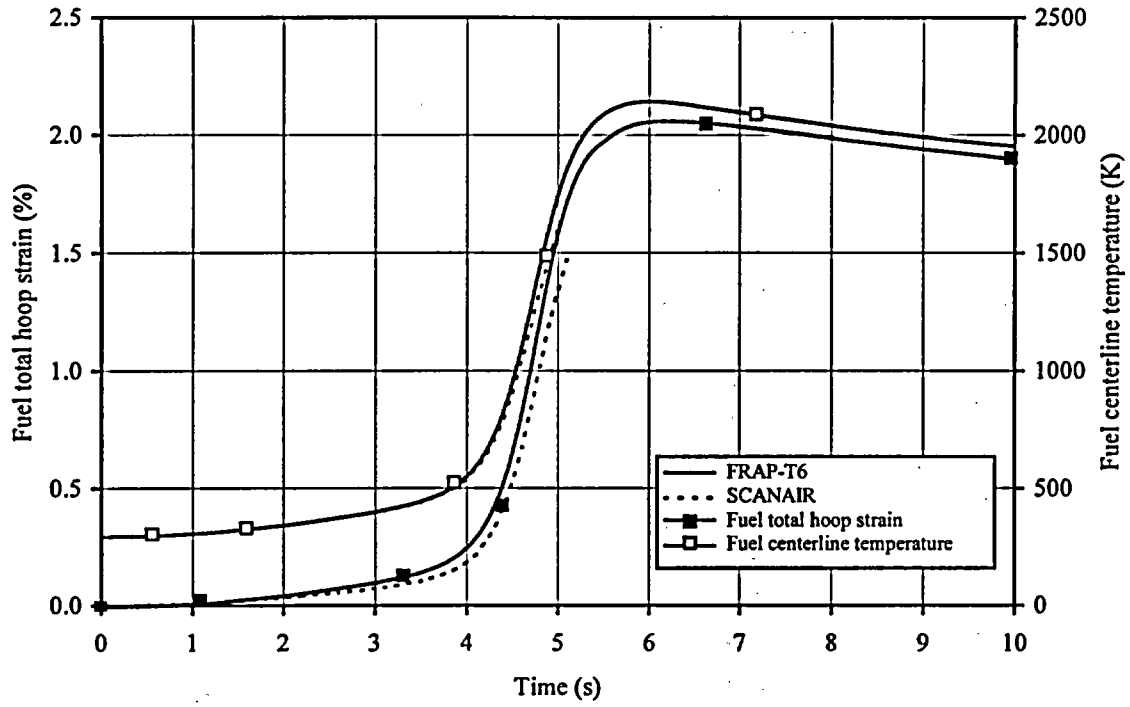

Fig. H-7.8. Fuel Strain Vs. Time Calculated by FRAP-T6 and SCANAIR Codes for Fuel Rod #B20T

# #B20T

Individual Characteristics of Refabricated Fuel Rods  
(Fresh Fuel, Preirradiated Cladding) under IGR Tests

Table H-7.9. Some Results of PIE for Fuel Rod #B20T

Characteristic		Value	
1.	Measured parameters of cladding oxidation and cladding deformation		
1.1.	Cladding thickness at elevation 80, 30 mm correspondent to different azimuthal angles ( $\mu\text{m}$ ):		
	0°	606	525
	90°	606	R
	180°	677	663
	270°	691	663
1.2.	ZrO <sub>2</sub> thickness at elevation 80, 30 mm correspondent to different azimuthal angles ( $\mu\text{m}$ ):		
	0°	15	15
	90°	15	—
	180°	15	15
	270°	15	20
1.3.	$\alpha\text{Zr(O)}$ thickness at elevation 80, 30 mm correspondent to different azimuthal angles ( $\mu\text{m}$ ):		
	0°	20	15
	90°	20	—
	180°	15	15
	270°	20	30
1.4.	Clad hoop strain at elevation 80, 30 mm correspondent (%)	6.7	49.5
2.	Measured parameters for FGR analysis		
2.1.	Internal gas composition (% by volume):		
	He	—	
	N <sub>2</sub>	—	
	O <sub>2</sub>	—	
	Ar	—	
	CO <sub>2</sub>	—	
	Kr	—	
	Xe	—	
2.2.	Free gas volume (cm <sup>3</sup> )	—	
2.3.	Gas pressure inside fuel rod under normal condition (MPa)	—	
2.4.	Kr concentration in fuel (cm <sup>3</sup> /g fuel)	—	
3.	Measured parameters of cladding hydriding		
3.1.	Coefficient of hydride orientation (per-unit)	0.5	
3.2.	Hydrogen concentration (% by weight)	—	

# #B20T

Individual Characteristics of Refabricated Fuel Rods  
(Fresh Fuel, Preirradiated Cladding) under IGR Tests

Table H-7.10. General Characteristic of Fuel Rod #B20T

	Parameter	Unit	Value		
			Experiment	FRAP-T6	SCANAIR
1	Type of coolant	---	air	air	air
2	Burnup	MWd/kg U	0	0	0
3	Energy deposition in fuel rod	cal/g fuel	161	161	161
4	Peak fuel enthalpy	cal/g fuel	-	125	-
5	Peak fuel temperature	K	-	2143	-
6	Peak clad temperature	K	-	1593	-
7	Fuel rod failure	Yes, No	Yes	Yes	-
8	Type of failure:				
	- cladding rupture due to ballooning	Yes, No	Yes	Yes	-
	- cladding rupture due to PCMI	Yes, No	No	No	-
	- fragmentation of fuel rod	Yes, No	No	-	-
9	Failure time	s	-	5.61	-
10	Fuel enthalpy at failure	cal/g fuel	-	120	-
11	Outer cladding temperature at failure	K	-	1282	-
12	Internal gas pressure at failure	MPa	-	1.99	-
13	ZrO <sub>2</sub> thickness after test	µm	15-20	-	-
14	Residual clad hoop strain:				
	- peak value for ballooning area	%	49.5	60.53	-
	- other location <sup>1)</sup>	%	6.7	1.60	-

<sup>1)</sup>Calculated values by FRAP-T6 and SCANAIR codes are average along height of fuel rod excluding ballooning region

***APPENDIX H-8.***

***Individual Characteristics for Fuel Rod #B21T under IGR Test***



#B21T

Individual Characteristics of Refabricated Fuel Rods  
(Fresh Fuel, Preirradiated Cladding) under IGR Tests

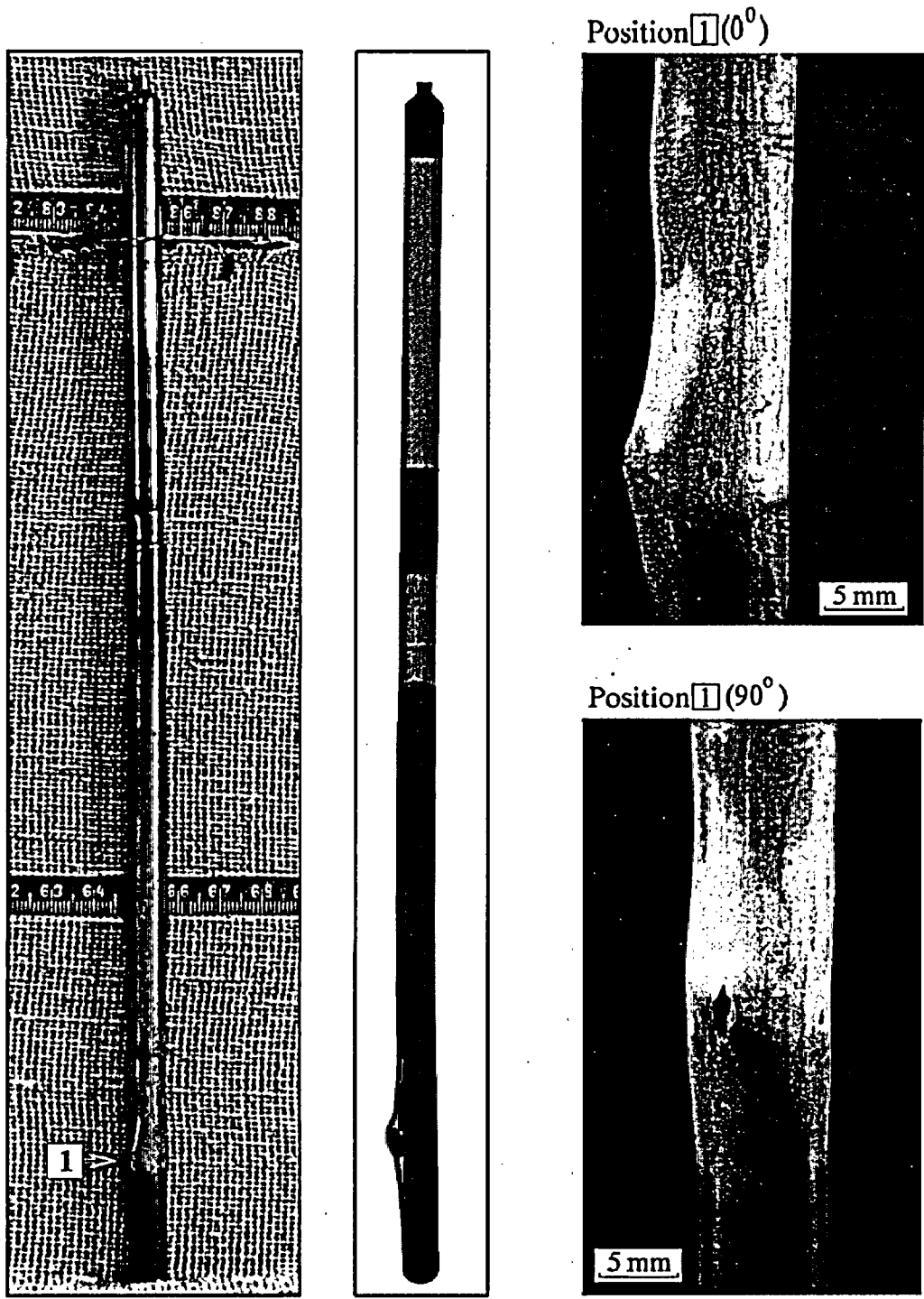
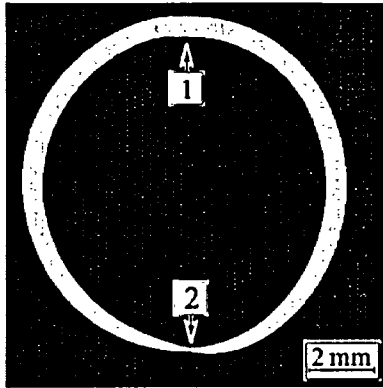

Fig. H-8.1. Appearance of Fuel Rod #B21T (photographs and X-ray photograph)

#B21T

Individual Characteristics of Refabricated Fuel Rods  
(Fresh Fuel, Preirradiated Cladding) under IGR Tests



Position 1

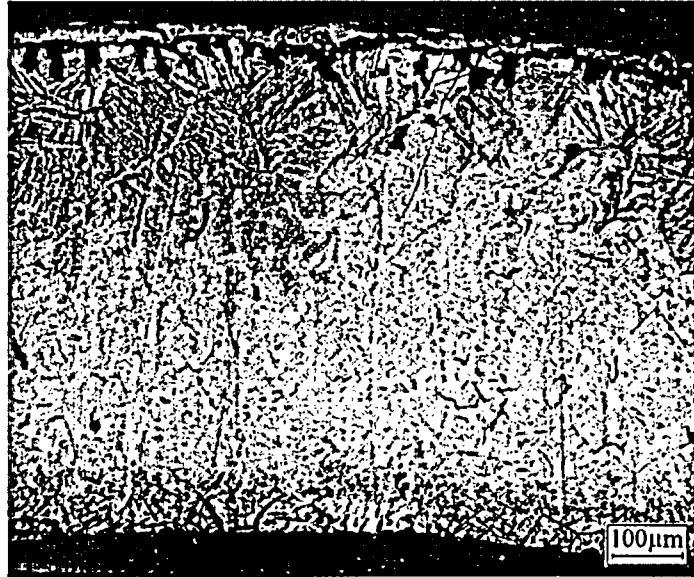

Position 1



Position 2



Fig. H-8.2. Cross-Section and Cladding Microstructure for Fuel Rod #B21T at 35 mm Elevation

#B21T

Individual Characteristics of Refabricated Fuel Rods  
(Fresh Fuel, Preirradiated Cladding) under IGR Tests

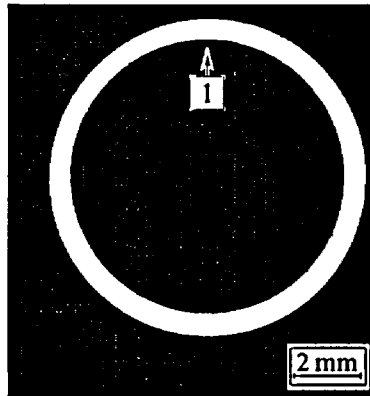

Position 1



Fig. H-8.3. Cross-Section and Cladding Microstructure for Fuel Rod #B21T at 90 mm Elevation

#B21T

Individual Characteristics of Refabricated Fuel Rods  
(Fresh Fuel, Preirradiated Cladding) under IGR Tests

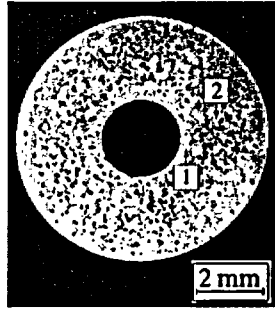

Position 1

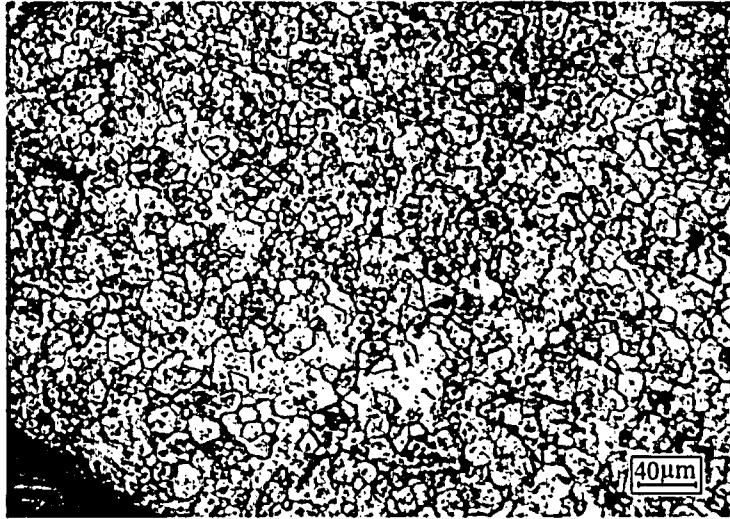

Position 2

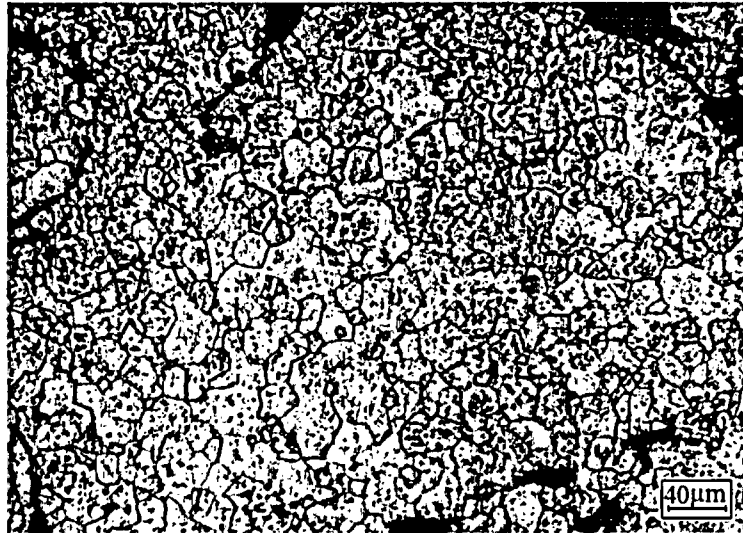

Fig. H-8.4. Fuel Microstructure for Fuel Rod #B21T at 90 mm Elevation

# #B21T

Individual Characteristics of Refabricated Fuel Rods  
(Fresh Fuel, Preirradiated Cladding) under IGR Tests

Table H-8.1. Time Dependent Energy Characteristics of Fuel Rod #B21T

Time (s)	Reactor energy deposition <sup>1)</sup> (%)	Cumulative number of fissions in fuel rod (fiss)			Power of fuel rod (kW)	Energy deposition in fuel rod	
		U <sup>235</sup> ×10 <sup>-14</sup>	U <sup>238</sup> ×10 <sup>-12</sup>	Total ×10 <sup>-14</sup>		cal/g fuel	J/g fuel
0.0	0.000	0.000	0.000	0.000	0.000	0.000	0.000
1.0	1.080	0.115	0.065	0.116	0.651	1.310	5.480
2.0	4.410	0.469	0.265	0.472	1.510	5.360	22.40
2.2	5.600	0.596	0.336	0.599	2.140	6.800	28.50
2.4	7.430	0.791	0.446	0.796	3.570	9.030	37.80
2.6	10.80	1.150	0.647	1.150	6.920	13.10	54.80
2.8	17.40	1.850	1.050	1.860	13.50	21.10	88.30
3.0	29.20	3.110	1.750	3.130	21.70	35.40	148.0
3.2	45.20	4.810	2.710	4.840	25.20	54.80	229.0
3.4	60.80	6.470	3.650	6.510	20.50	73.70	309.0
3.6	72.10	7.670	4.330	7.720	13.80	87.50	366.0
3.8	79.50	8.460	4.770	8.510	8.910	96.50	404.0
4.0	84.30	8.970	5.060	9.020	5.870	102.0	427.0
4.2	87.40	9.310	5.250	9.360	4.000	106.0	444.0
4.4	89.60	9.540	5.380	9.600	2.830	109.0	456.0
4.6	91.20	9.710	5.480	9.760	2.080	111.0	465.0
4.8	92.40	9.830	5.550	9.890	1.580	113.0	473.0
5.0	93.20	9.930	5.600	9.980	1.240	114.0	477.0
5.2	93.90	10.00	5.640	10.10	0.993	115.0	481.0
5.4	94.50	10.10	5.680	10.10	0.815	115.0	481.0
5.6	94.90	10.10	5.700	10.20	0.664	116.0	486.0
5.8	95.30	10.10	5.720	10.20	0.562	116.0	486.0
6.0	95.60	10.20	5.740	10.20	0.480	117.0	490.0
6.5	96.20	10.20	5.780	10.30	0.339	118.0	494.0
7.0	96.60	10.30	5.800	10.30	0.255	118.0	494.0
7.5	96.90	10.30	5.820	10.40	0.202	119.0	498.0
8.0	97.20	10.30	5.840	10.40	0.168	119.0	498.0
9.0	97.60	10.40	5.860	10.40	0.143	120.0	502.0
10.0	97.90	10.40	5.880	10.50	0.113	120.0	502.0
20.0	99.20	10.60	5.960	10.60	0.029	122.0	511.0
30.0	99.60	10.60	5.980	10.70	0.015	123.0	515.0
∞	100.0	10.70	6.030	10.70	0.000	126.0	527.0

Maximum value of power is 25.2 kW (t = 3.20 s)

<sup>1)</sup> Current energy deposition per maximum energy deposition (at infinite time)

## #B21T

Individual Characteristics of Refabricated Fuel Rods  
(Fresh Fuel) (Preirradiated Cladding) under IGR Tests

Table H-8.2. Axial Energy Characteristics of Fuel Rod #B21T

Axial coordinate from lower end of fuel rod (mm)	Cumulative number of fissions at axial interval (fiss)			Maximum power of fuel rod (kW) $t=3.20$ s	Energy deposition at infinite time*		
	$U^{235}$ $\times 10^{-13}$	$U^{238}$ $\times 10^{-11}$	Total $\times 10^{-13}$		cal/g fuel	J/g fuel	per-unit <sup>3)</sup>
5.0	0.000	0.000	0.000	0.000	0.000	0.000	0.00
10.0 <sup>1)</sup>	1.640	0.799	1.650	0.387	137.0	573.0	1.00
15.0	4.060	2.010	4.080	0.959	136.0	569.0	0.99
20.0	4.000	2.020	4.020	0.943	133.0	557.0	0.97
25.0	3.990	2.050	4.010	0.941	133.0	557.0	0.97
30.0	3.920	2.070	3.940	0.926	131.0	548.0	0.96
35.0	3.840	2.060	3.860	0.906	129.0	540.0	0.94
40.0	3.810	2.070	3.830	0.898	128.0	536.0	0.93
45.0	3.800	2.100	3.820	0.897	128.0	536.0	0.93
50.0	3.830	2.140	3.850	0.904	127.0	532.0	0.93
55.0	3.800	2.150	3.830	0.898	126.0	527.0	0.92
60.0	3.740	2.140	3.760	0.883	125.0	523.0	0.91
65.0	3.730	2.150	3.750	0.881	125.0	523.0	0.91
70.0	3.740	2.170	3.760	0.883	125.0	523.0	0.91
75.0	3.760	2.190	3.780	0.888	125.0	523.0	0.91
80.0	3.760	2.200	3.780	0.887	125.0	523.0	0.91
85.0	3.750	2.200	3.780	0.887	125.0	523.0	0.91
90.0	3.740	2.210	3.760	0.884	124.0	519.0	0.91
95.0	3.720	2.190	3.750	0.880	124.0	519.0	0.91
100.0	3.720	2.190	3.750	0.880	124.0	519.0	0.91
105.0	3.700	2.180	3.720	0.873	124.0	519.0	0.91
110.0	3.690	2.170	3.720	0.872	124.0	519.0	0.91
115.0	3.690	2.170	3.710	0.872	124.0	519.0	0.91
120.0	3.660	2.140	3.690	0.865	123.0	515.0	0.90
125.0	3.660	2.130	3.680	0.864	123.0	515.0	0.90
130.0	3.650	2.120	3.670	0.862	123.0	515.0	0.90
135.0	3.610	2.090	3.630	0.853	122.0	511.0	0.89
140.0	3.620	2.080	3.640	0.855	122.0	511.0	0.89
145.0	3.620	2.070	3.640	0.856	121.0	507.0	0.88
150.0 <sup>2)</sup>	3.620	2.050	3.640	0.856	120.0	502.0	0.88
155.0	0.000	0.000	0.000	0.000	0.000	0.000	0.00

\* All numerical values of characteristics are presented as average values at the length interval equal to the axial coordinate  $\pm 2.5$  mm.

<sup>1)</sup> Initial coordinate of fuel is 10.5 mm.

<sup>2)</sup> End coordinate of fuel is 152.5 mm.

<sup>3)</sup> Current value per maximum value.

# #B21T

Individual Characteristics of Refabricated Fuel Rods  
(Fresh Fuel, Preirradiated Cladding) under IGR Tests

Table H-8.3. Radial Energy Characteristics of Fuel Rod #B21T

Characteristics*		Coordinates of fuel zones (mm)			
		1 zone 1.10 - 2.12	2 zone 2.12 - 2.79	3 zone 2.79 - 3.32	4 zone 3.32 - 3.79
U <sup>235</sup>	Number of fissions $\times 10^{-14}$ (fiss)	2.580	2.620	2.690	2.790
	Power of fuel rod <sup>1)</sup> (kW)	6.060	6.160	6.330	6.550
	Energy deposition <sup>2)</sup> (cal/g fuel)	121.0	123.0	126.0	131.0
	Energy deposition <sup>2)</sup> (J/g fuel)	507.0	515.0	527.0	548.0
	Energy deposition <sup>3)</sup> (per-unit)	0.924	0.939	0.962	1.000
U <sup>238</sup>	Number of fissions $\times 10^{-12}$ (fiss)	1.520	1.510	1.500	1.510
	Power of fuel rod <sup>1)</sup> (kW)	0.035	0.035	0.035	0.035
	Energy deposition <sup>2)</sup> (cal/g fuel)	0.701	0.696	0.694	0.696
	Energy deposition <sup>2)</sup> (J/g fuel)	2.930	2.910	2.910	2.910
	Energy deposition <sup>3)</sup> (per-unit)	1.000	0.993	0.990	0.993
Total	Number of fissions $\times 10^{-14}$ (fiss)	2.600	2.640	2.710	2.800
	Power of fuel rod <sup>1)</sup> (kW)	6.100	6.200	6.360	6.580
	Energy deposition <sup>2)</sup> (cal/g fuel)	122.0	124.0	127.0	131.0
	Energy deposition <sup>2)</sup> (J/g fuel)	511.0	519.0	532.0	548.0
	Energy deposition <sup>3)</sup> (per-unit)	0.931	0.947	0.969	1.000

<sup>1)</sup> at time of 3.20 s,    <sup>2)</sup> at infinite time,    <sup>3)</sup> Current value per maximum value

\* All numerical values of characteristics were calculated for length of fuel stack

# #B21T

Individual Characteristics of Refabricated Fuel Rods  
(Fresh Fuel, Preirradiated Cladding) under IGR Tests

Table H-8.4. Fuel Enthalpy Vs. Time Calculated by FRAP-T6 Code for Fuel Rod #B21T

Time (s)	Enthalpy at fuel radius (cal/g fuel)				Fuel enthalpy <sup>1)</sup>		Energy deposition in fuel rod	
	1.10 mm	2.22 mm	2.89 mm	3.79 mm	cal/g fuel	J/g fuel	cal/g fuel	J/g fuel
0.0	0.00	0.00	0.00	0.00	0.00	0.00	0.00	0.00
1.0	1.19	1.18	1.15	1.06	1.15	4.81	1.31	5.51
2.0	4.77	4.70	4.56	4.19	4.57	19.1	5.36	22.5
2.2	6.08	5.99	5.82	5.33	5.82	24.4	6.81	28.5
2.4	8.16	8.06	7.84	7.15	7.83	32.8	9.04	37.9
2.6	12.1	12.0	11.7	10.5	11.6	48.8	13.1	54.9
2.8	20.1	20.0	19.5	17.1	19.4	81.1	21.2	88.7
3.0	34.6	34.4	33.5	28.0	33.1	139	35.5	149
3.2	54.5	54.1	52.2	40.9	51.2	215	54.9	230
3.4	74.0	73.1	69.5	51.6	68.1	285	73.8	309
3.6	88.3	86.4	80.5	58.8	79.4	333	87.6	367
3.8	97.3	94.3	86.3	64.1	86.0	361	96.6	405
4.0	103	98.3	89.0	67.5	89.7	376	103	430
4.2	106	100	90.1	69.5	91.4	383	106	446
4.4	107	101	90.2	71.3	92.1	386	109	457
4.6	107	100	90.1	74.0	92.4	387	111	466
4.8	106	99.7	90.1	78.2	92.9	389	113	472
5.0	105	99.0	90.5	81.9	93.5	392	114	477
5.2	104	98.4	91.2	83.7	93.8	393	115	480
5.4	103	97.9	91.8	84.9	94.0	394	115	483
5.6	102	97.5	92.1	85.7	94.0	394	116	486
5.8	101	97.1	92.3	86.2	93.9	393	116	488
6.0	100	96.7	92.4	86.6	93.8	393	117	490
6.5	98.4	95.7	92.3	87.2	93.2	391	118	493
7.0	96.9	94.8	91.9	87.4	92.6	388	118	496
7.5	95.7	93.9	91.4	87.4	92.0	386	119	498
8.0	94.6	93.1	90.9	87.2	91.4	383	119	499
10.0	91.4	90.4	88.8	86.0	89.1	373	120	504
30.0	71.8	71.4	70.7	69.5	70.9	297	123	517

Radial enthalpy distribution and fuel enthalpy are presented at elevation 17.6 mm

Maximum value of fuel enthalpy is 94.0 cal/g fuel ( $t=5.51$  s)

<sup>1)</sup> All numerical values are presented at elevation with peak power



# #B21T

Individual Characteristics of Refabricated Fuel Rods  
(Fresh Fuel, Preirradiated Cladding) under IGR Tests

Table H-8.5. Energy Characteristics Vs. Time Calculated by FRAP-T6 and SCANAIR Codes for Fuel Rod #B21T

Time (s)	Energy deposition <sup>1)</sup> (cal/g fuel)	Linear power <sup>1)</sup> (kW/m)	Fuel enthalpy <sup>1)</sup> (cal/g fuel)		Leakage of energy <sup>1)</sup> (cal/g fuel)		Clad-to-coolant heat transfer coefficient <sup>1)</sup> (kW/m <sup>2</sup> K)	
			FRAP-T6	SCANAIR	FRAP-T6	SCANAIR	FRAP-T6	SCANAIR
0.0	0.00	0.00	0.00	0.00	0.00	0.00	0.00	0.00
1.0	1.40	4.84	1.15	1.26	0.00	0.00	0.01	0.01
2.0	5.70	11.2	4.57	4.89	0.00	0.00	0.01	0.01
2.2	7.23	15.9	5.82	6.19	0.00	0.00	0.01	0.01
2.4	9.60	26.5	7.83	8.24	0.00	0.01	0.01	0.01
2.6	13.9	51.5	11.6	12.1	0.01	0.01	0.01	0.01
2.8	22.5	100	19.4	19.7	0.01	0.01	0.01	0.01
3.0	37.7	161	33.1	33.1	0.02	0.02	0.01	0.01
3.2	58.3	187	51.2	50.8	0.03	0.03	0.02	0.02
3.4	78.4	152	68.1	67.1	0.05	0.07	0.02	0.03
3.6	93.1	103	79.4	78.1	0.10	0.13	0.03	0.04
3.8	103	66.3	86.0	84.5	0.19	0.23	0.04	0.05
4.0	109	43.7	89.7	88.1	0.31	0.37	0.05	0.06
4.2	113	29.7	91.4	-	0.45	-	0.06	-
4.4	116	21.0	92.1	-	0.61	-	0.06	-
4.6	118	15.5	92.4	-	0.81	-	0.07	-
4.8	120	11.7	92.9	-	1.03	-	0.07	-
5.0	121	9.22	93.5	-	1.28	-	0.07	-
5.2	122	7.38	93.8	-	1.54	-	0.07	-
5.4	123	6.06	94.0	-	1.81	-	0.08	-
5.6	123	4.94	94.0	-	2.08	-	0.08	-
5.8	124	4.18	93.9	-	2.37	-	0.08	-
6.0	124	3.57	93.8	-	2.66	-	0.08	-
6.5	125	2.52	93.2	-	3.43	-	0.08	-
7.0	126	1.90	92.6	-	4.23	-	0.08	-
7.5	126	1.50	92.0	-	5.06	-	0.09	-
8.0	127	1.25	91.4	-	5.91	-	0.09	-
10.0	128	0.84	89.1	-	9.39	-	0.09	-
30.0	131	0.11	70.9	-	37.1	-	0.06	-

<sup>1)</sup> All numerical values are presented at elevation with peak power

# #B21T

Individual Characteristics of Refabricated Fuel Rods  
(Fresh Fuel, Irradiated Cladding) under IGR Tests

Table H-8.6. Temperature Variation, Fission Gas Release and ZrO<sub>2</sub> Thickness Vs. Time for Fuel Rod #B21T Calculated by FRAP-T6 and SCANAIR Codes

Time (s)	Fuel centerline temperature <sup>1)</sup> (K)		Fuel surface temperature <sup>1)</sup> (K)		Clad outer temperature <sup>1)</sup> (K)	
	FRAP-T6	SCANAIR	FRAP-T6	SCANAIR	FRAP-T6	SCANAIR
0.0	293	293	293	293	293	293
1.0	314	313	312	313	299	300
2.0	374	372	364	367	328	331
2.2	395	392	383	386	338	342
2.4	427	424	411	416	351	357
2.6	487	480	463	470	371	380
2.8	604	588	561	574	406	423
3.0	806	772	716	738	474	503
3.2	1073	1011	892	928	588	631
3.4	1328	1237	1035	1081	738	789
3.6	1509	1397	1131	1180	887	940
3.8	1623	1499	1199	1246	1010	1062
4.0	1688	1561	1243	1285	1082	1134
4.2	1723	-	1269	-	1132	-
4.4	1738	-	1293	-	1177	-
4.6	1740	-	1327	-	1233	-
4.8	1734	-	1382	-	1266	-
5.0	1722	-	1429	-	1276	-
5.2	1708	-	1452	-	1286	-
5.4	1694	-	1467	-	1297	-
5.6	1680	-	1477	-	1308	-
5.8	1668	-	1484	-	1319	-
6.0	1658	-	1489	-	1329	-
6.5	1635	-	1496	-	1349	-
7.0	1617	-	1498	-	1365	-
7.5	1602	-	1498	-	1376	-
8.0	1589	-	1496	-	1383	-
10.0	1549	-	1481	-	1387	-
30.0	1300	-	1270	-	1211	-

<sup>1)</sup> All numerical values are presented at elevation with peak power

# #B21T

Individual Characteristics of Refabricated Fuel Rods  
(Fresh Fuel, Preirradiated Cladding) under IGR Tests

Table H-8.7. Mechanical Characteristics of Fuel Rod #B21T Vs. Time Calculated by FRAP-T6 and SCANAIR Codes

Time (s)	Clad outer temperature <sup>1)</sup> (K)		Fuel hoop strain <sup>1)</sup> (%)		Fuel - clad gap width <sup>1)</sup> (mm)		Clad hoop strain <sup>1)</sup> (%)		Clad hoop stress <sup>1)</sup> (MPa)		Internal gas pressure (MPa)	
	FRAP-T6	SCANAIR	FRAP-T6	SCANAIR	FRAP-T6	SCANAIR	FRAP-T6	SCANAIR	FRAP-T6	SCANAIR	FRAP-T6	SCANAIR
0.0	293	293	0.00	0.00	0.08	0.08	0.01	0.01	8.72	8.69	1.70	1.70
1.0	299	300	0.01	0.01	0.07	0.08	0.01	0.01	8.81	8.80	1.72	1.72
2.0	328	331	0.07	0.05	0.07	0.07	0.03	0.04	9.04	9.04	1.76	1.76
2.2	338	342	0.09	0.07	0.07	0.07	0.04	0.05	9.11	9.12	1.77	1.77
2.4	351	357	0.12	0.09	0.07	0.07	0.05	0.06	9.20	9.22	1.79	1.79
2.6	371	380	0.18	0.14	0.07	0.07	0.06	0.08	9.35	9.38	1.82	1.81
2.8	406	423	0.30	0.23	0.07	0.07	0.09	0.11	9.57	9.64	1.86	1.85
3.0	474	503	0.50	0.40	0.06	0.07	0.13	0.17	9.84	9.95	1.90	1.89
3.2	588	631	0.78	0.64	0.05	0.06	0.21	0.27	10.1	10.2	1.95	1.93
3.4	738	789	1.07	0.88	0.05	0.06	0.32	0.39	10.2	10.3	1.98	1.95
3.6	887	940	1.27	1.05	0.04	0.05	0.42	0.51	10.3	10.3	1.99	1.96
3.8	1010	1062	1.40	1.16	0.04	0.05	0.50	0.60	10.4	10.3	2.00	1.96
4.0	1082	1134	1.47	1.22	0.04	0.05	0.55	0.56	10.4	10.1	2.01	1.97
4.2	1132	-	1.50	-	0.04	-	0.57	-	10.4	-	2.01	-
4.4	1177	-	1.51	-	0.04	-	0.61	-	10.5	-	2.01	-
4.6	1233	-	1.52	-	0.06	-	0.88	-	10.6	-	2.02	-
4.8	1266	-	1.52	-	0.21	-	4.26	-	11.2	-	2.00	-
5.0	1276	-	1.52	-	2.05	-	51.2	-	0.00	-	0.10	-
5.2	1286	-	1.51	-	2.05	-	51.2	-	0.00	-	0.10	-
5.4	1297	-	1.51	-	2.05	-	51.2	-	0.00	-	0.10	-
5.6	1308	-	1.50	-	2.05	-	51.2	-	0.00	-	0.10	-
5.8	1319	-	1.49	-	2.05	-	51.2	-	0.00	-	0.10	-
6.0	1329	-	1.49	-	2.05	-	51.2	-	0.00	-	0.10	-
6.5	1349	-	1.47	-	2.05	-	51.2	-	0.00	-	0.10	-
7.0	1365	-	1.45	-	2.05	-	51.2	-	0.00	-	0.10	-
7.5	1376	-	1.44	-	2.05	-	51.3	-	0.00	-	0.10	-
8.0	1383	-	1.43	-	2.05	-	51.3	-	0.00	-	0.10	-
10.0	1387	-	1.38	-	2.05	-	51.3	-	0.00	-	0.10	-
30.0	1211	-	1.08	-	2.06	-	51.2	-	0.00	-	0.10	-

<sup>1)</sup> All numerical values are presented at elevation with peak power

# #B21T

Individual Characteristics of Refabricated Fuel Rods  
(Fresh Fuel, Preirradiated Cladding) under IGR Tests

Table H-8.8. Axial Distribution of Energy Deposition and Fuel Enthalpy Calculated by FRAP-T6 Code for Fuel Rod #B21T

Axial interval from-to (mm)-(mm)	Energy deposition at infinite time			Fuel enthalpy at time (t=5.51 s)		
	cal/g fuel	J/g fuel	per-unit	cal/g fuel	J/g fuel	per-unit
10.5 - 24.7	134	561	1.00	94.0	394	1.00
24.7 - 38.9	130	544	0.97	91.2	382	0.97
38.9 - 53.1	127	534	0.95	89.5	375	0.95
53.1 - 67.3	126	526	0.94	88.2	369	0.94
67.3 - 81.5	126	526	0.94	88.2	369	0.94
81.5 - 95.7	124	520	0.93	87.2	365	0.93
95.7 - 109.9	124	520	0.93	87.2	365	0.93
109.9 - 124.1	124	520	0.93	87.2	365	0.93
124.1 - 138.3	123	516	0.92	86.5	362	0.92
138.3 - 152.5	121	509	0.91	85.3	357	0.91

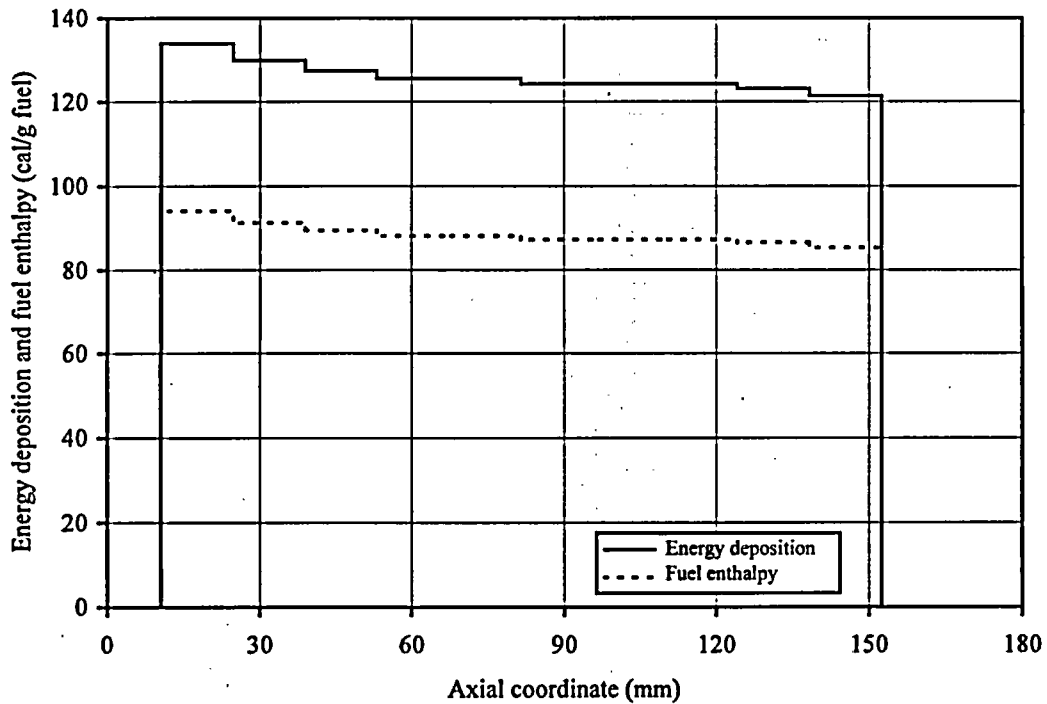

Fig. H-8.5. Axial Distribution of Energy Deposition and Fuel Enthalpy Calculated by FRAP-T6 Code for Fuel Rod #B21T

#B21T

Individual Characteristics of Refabricated Fuel Rods  
(Fresh Fuel, Preirradiated Cladding) under IGR Tests

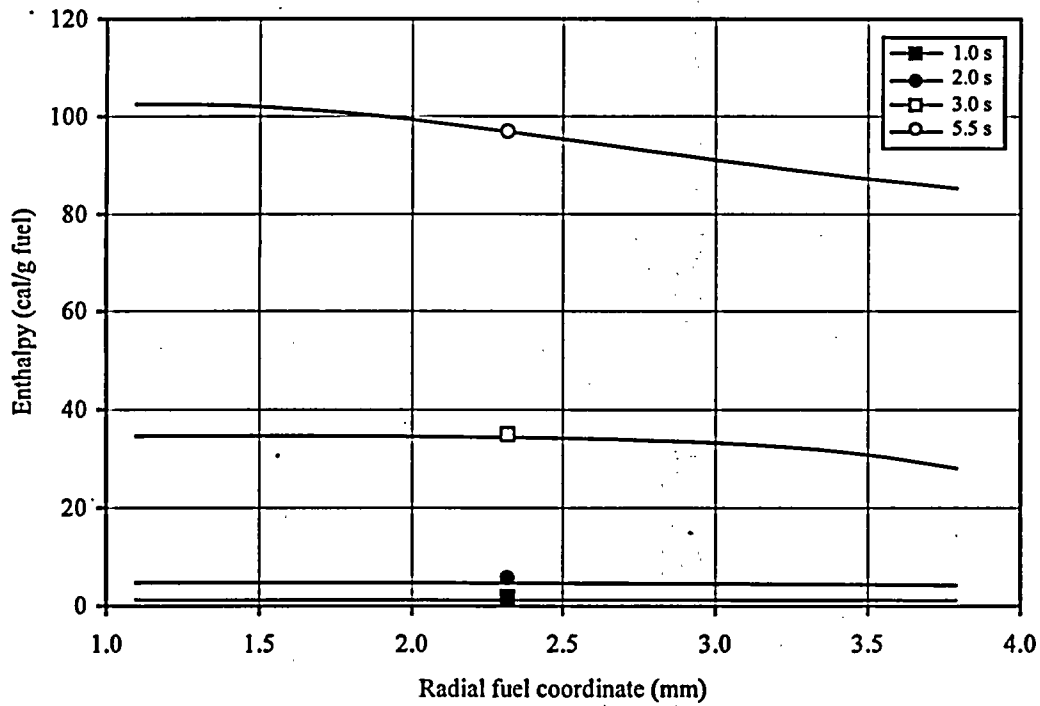
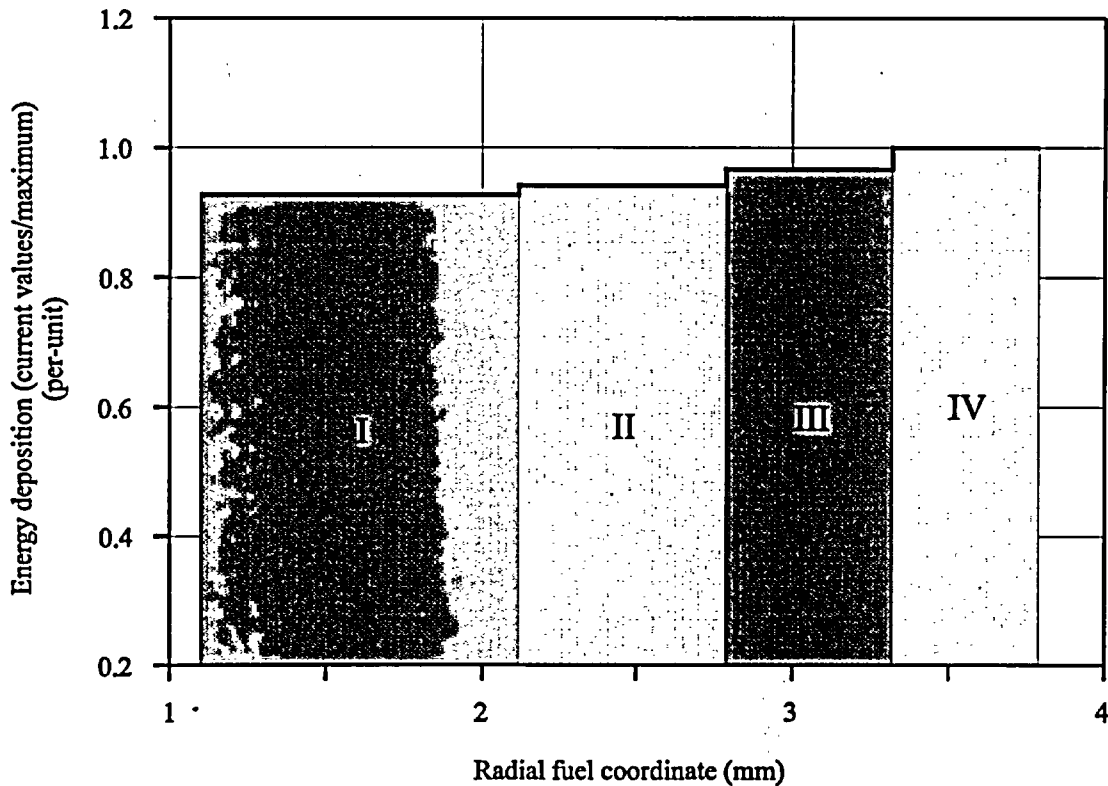

Fig. H-8.6. Radial Distributions of Energy Deposition and Fuel Enthalpy Calculated by FRAP-T6 Code for Fuel Rod #B21T

# #B21T

Individual Characteristics of Refabricated Fuel Rods  
(Fresh Fuel, Preirradiated Cladding) under IGR Tests

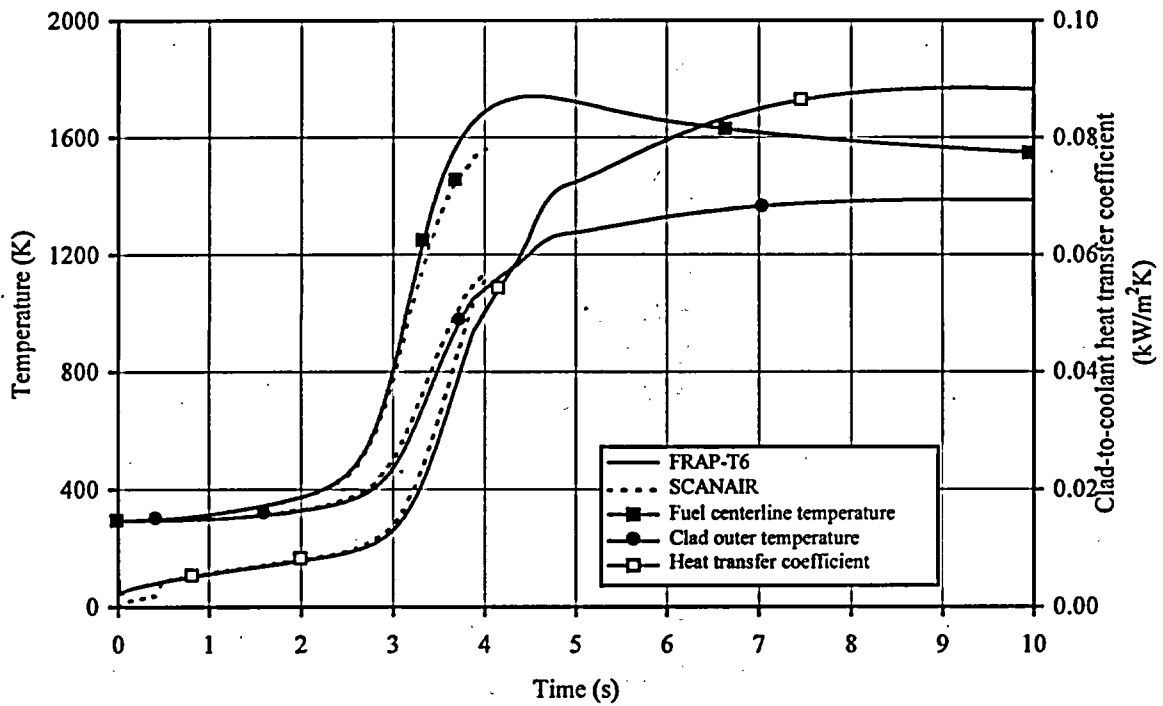
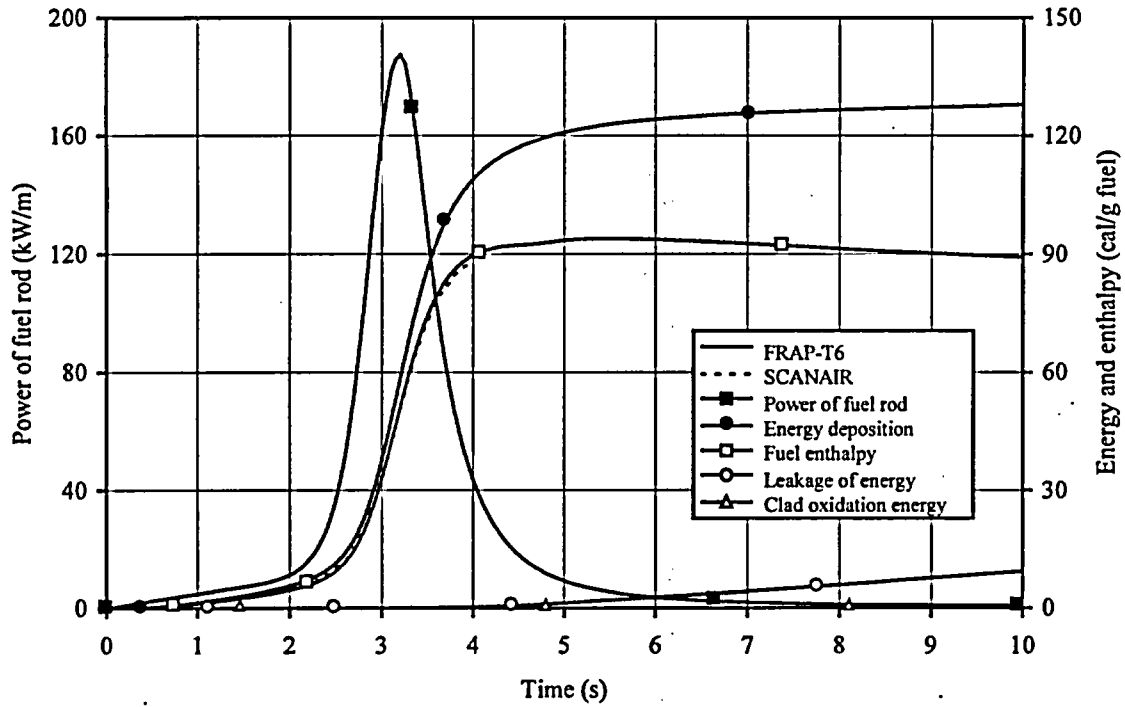

Fig. H-8.7. Energy and Temperature Characteristics Vs. Time Calculated by FRAP-T6 and SCANAIR Codes for Fuel Rod #B21T

#B21T

Individual Characteristics of Refabricated Fuel Rods  
(Fresh Fuel, Preirradiated Cladding) under IGR Tests

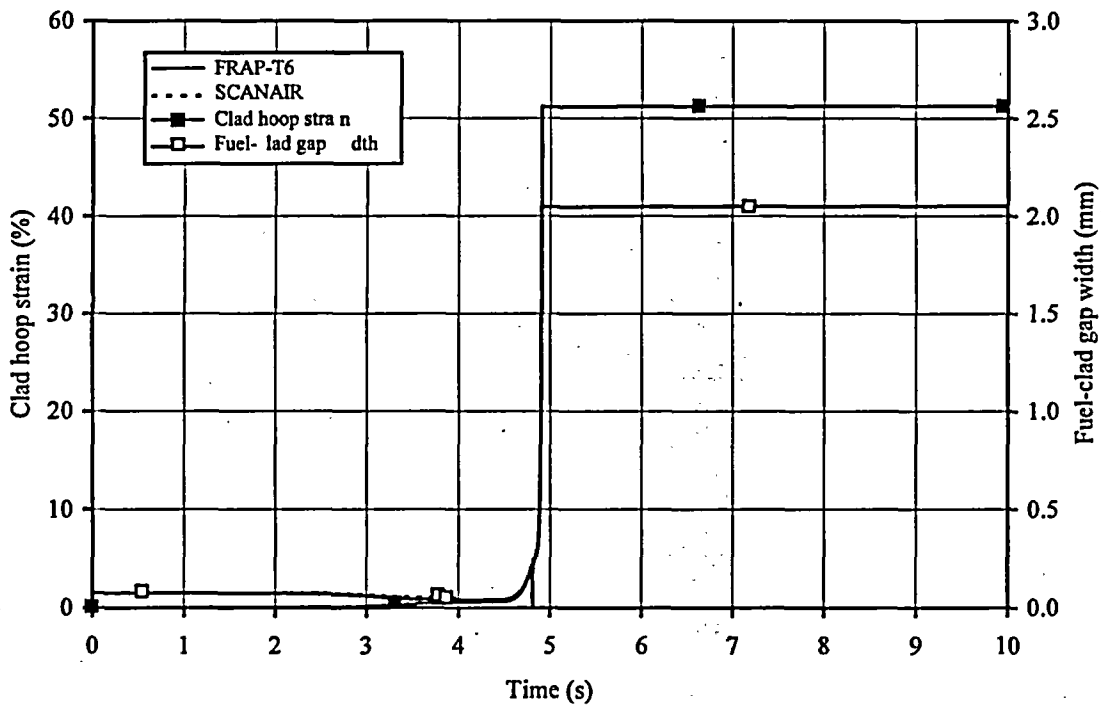
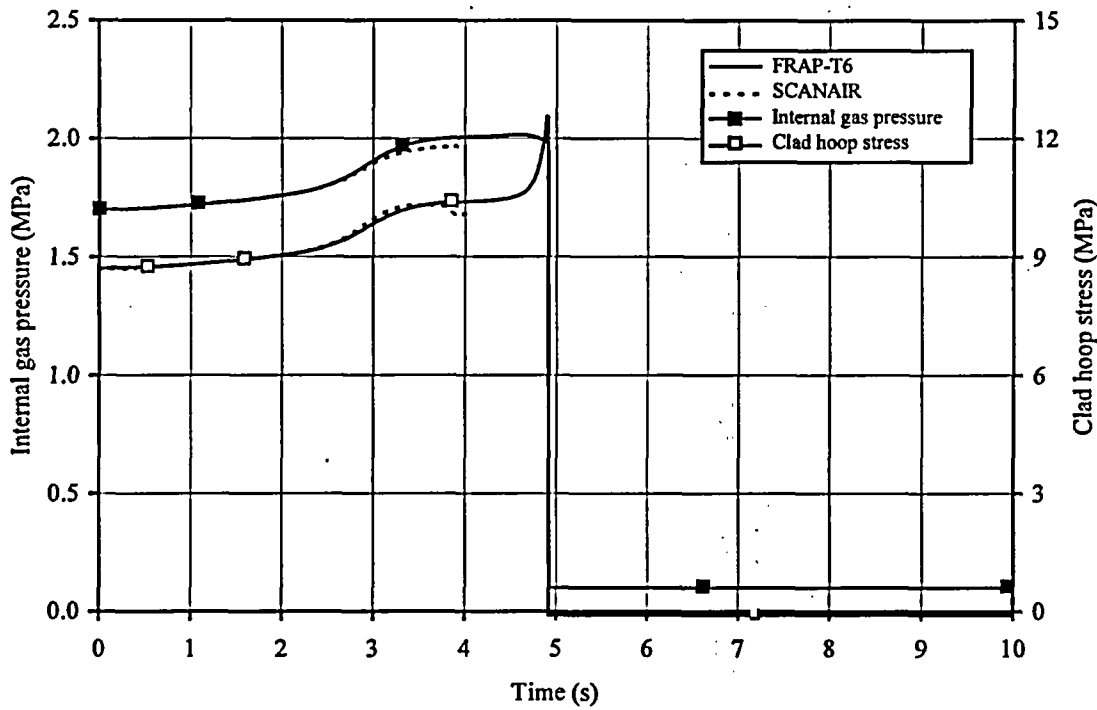

Fig. H-8.8. Cladding Mechanical Characteristics Vs. Time Calculated by FRAP-T6 and SCANAIR Codes for Fuel Rod #B21T

# #B21T

Individual Characteristics of Refabricated Fuel Rods  
(Fresh Fuel, Preirradiated Cladding) under IGR Tests

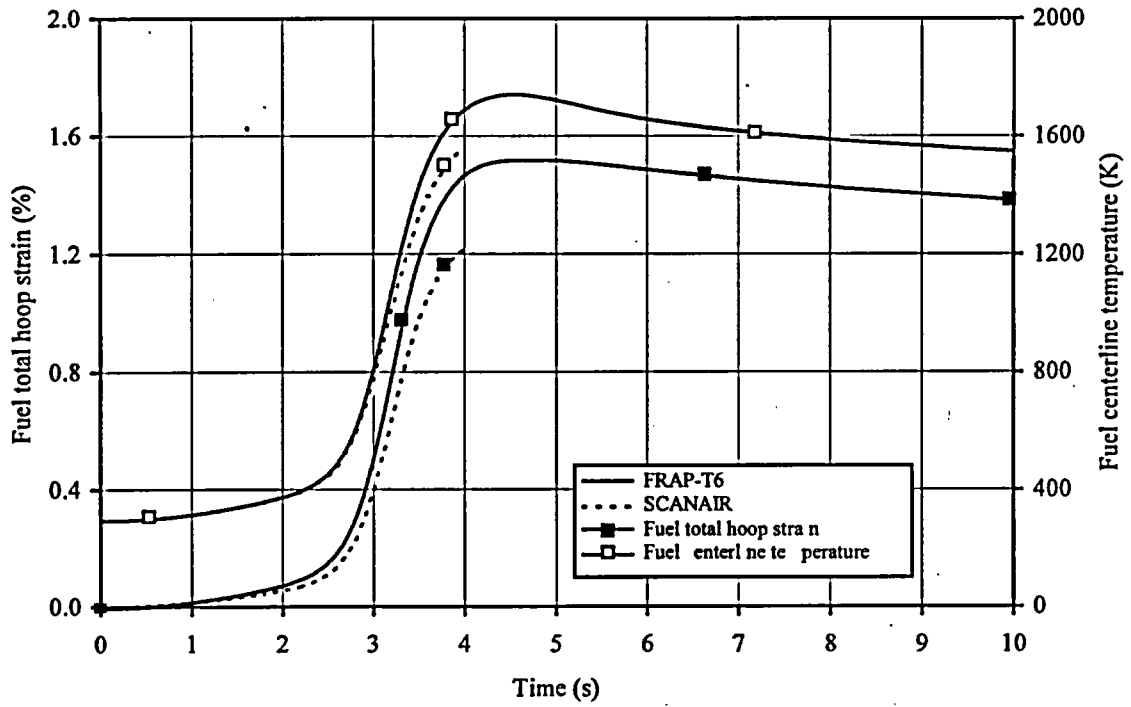

Fig. H-8.9. Fuel Strain Vs. Time Calculated by FRAP-T6 and SCANAIR Codes for Fuel Rod #B21T



# #B21T

Individual Characteristics of Refabricated Fuel Rods  
(Fresh Fuel, Preirradiated Cladding) under IGR Tests

Table H-8.9. Some Results of PIE for Fuel Rod #B21T

Characteristic		Value	
1.	Measured parameters of cladding oxidation and cladding deformation		
1.1.	Cladding thickness at elevation 35, 90 mm correspondent to different azimuthal angles ( $\mu\text{m}$ ):		
	0°	705	670
	90°	649	649
	180°	175	649
	270°	649	677
1.2.	ZrO <sub>2</sub> thickness at elevation 35, 90 mm correspondent to different azimuthal angles ( $\mu\text{m}$ ):		
	0°	20	40
	90°	25	50
	180°	20	40
	270°	20	40
1.3.	$\alpha\text{Zr(O)}$ thickness at elevation 35, 90 mm correspondent to different azimuthal angles ( $\mu\text{m}$ ):		
	0°	30	50
	90°	30	50
	180°	30	35
	270°	40	40
1.4.	Clad hoop strain at elevation 35, 90 mm correspondent (%)	16.9	7.2
2.	Measured parameters for FGR analysis		
2.1.	Internal gas composition (% by volume):		
	He	-	-
	N <sub>2</sub>	-	-
	O <sub>2</sub>	-	-
	Ar	-	-
	CO <sub>2</sub>	-	-
	Kr	-	-
	Xe	-	-
2.2.	Free gas volume (cm <sup>3</sup> )	-	-
2.3.	Gas pressure inside fuel rod under normal condition (MPa)	-	-
2.4.	Kr concentration in fuel (cm <sup>3</sup> /g fuel)	-	-
3.	Measured parameters of cladding hydriding		
3.1.	Coefficient of hydride orientation (per-unit)	-	-
3.2.	Hydrogen concentration (% by weight)	-	-

# #B21T

Individual Characteristics of Refabricated Fuel Rods  
(Fresh Fuel, Irradiated Cladding) under IGR Tests

Table H-8.10. General Characteristic of Fuel Rod #B21T

	Parameter	Unit	Value		
			Experiment	FRAP-T6	SCANAIR
1	Type of coolant	---	air	air	air
2	Burnup	MWd/kg U	0	0	0
3	Energy deposition in fuel rod	cal/g fuel	126	126	126
4	Peak fuel enthalpy	cal/g fuel	-	94	-
5	Peak fuel temperature	K	-	1740	-
6	Peak clad temperature	K	-	1389	-
7	Fuel rod failure	Yes, No	Yes	Yes	-
8	Type of failure:				
	- cladding rupture due to ballooning	Yes, No	Yes	Yes	-
	- cladding rupture due to PCMI	Yes, No	No	No	-
	- fragmentation of fuel rod	Yes, No	No	-	-
9	Failure time	s	-	4.91	-
10	Fuel enthalpy at failure	cal/g fuel	-	93	-
11	Outer cladding temperature at failure	K	-	1272	-
12	Internal gas pressure at failure	MPa	-	1.98	-
13	ZrO <sub>2</sub> thickness after test	μm	20-50	-	-
14	Residual clad hoop strain:				
	- peak value for ballooning area	%	-	50.86	-
	- other location <sup>1)</sup>	%	7.2	1.69	-

<sup>1)</sup>Calculated values by FRAP-T6 and SCANAIR codes are average along height of fuel rod excluding ballooning region



**APPENDIX H-9.**  
*Individual Characteristics for Fuel Rod #B22T under IGR Test*

#B22T

Individual Characteristics of Refabricated Fuel Rods  
(Fresh Fuel, Preirradiated Cladding) under IGR Tests

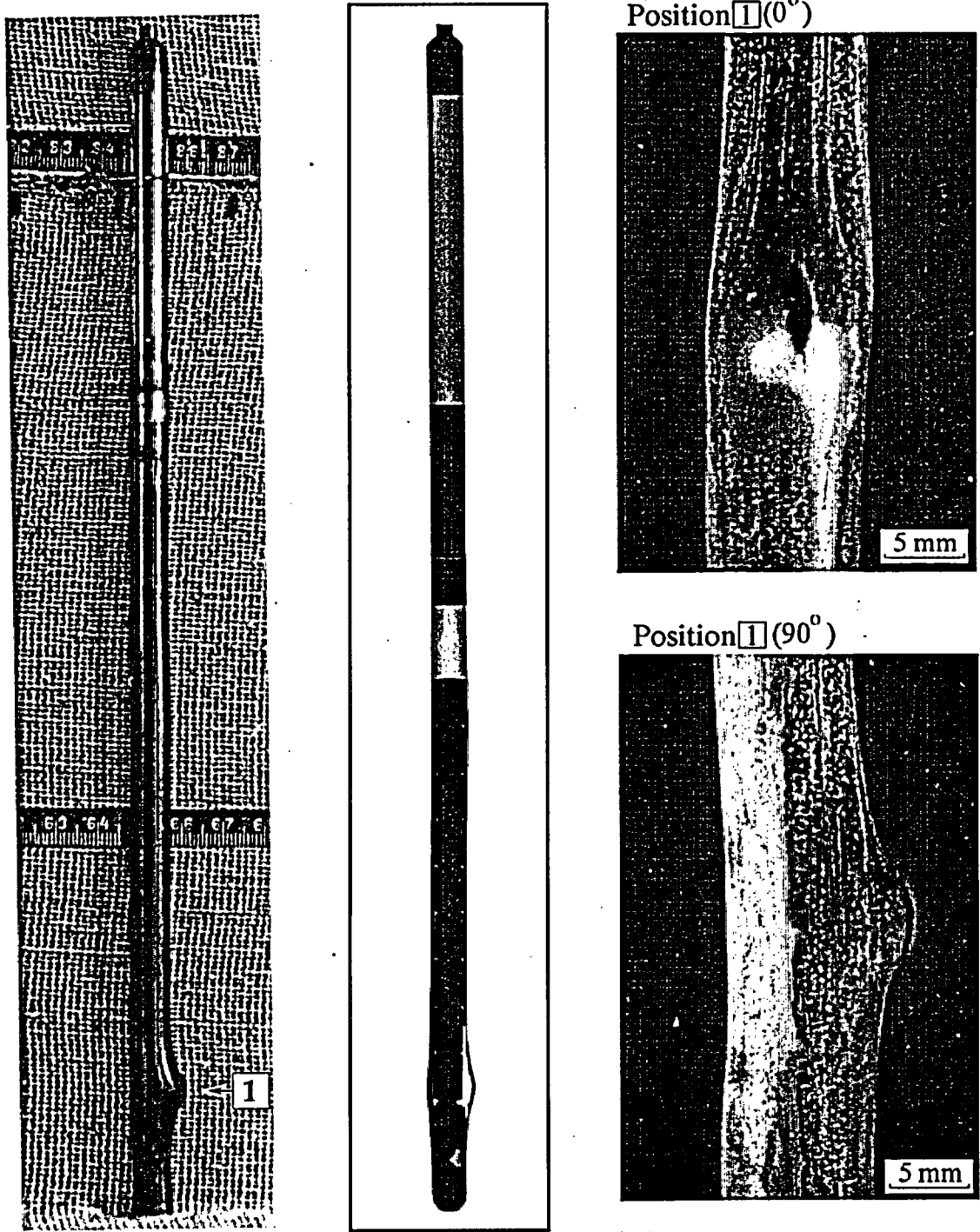
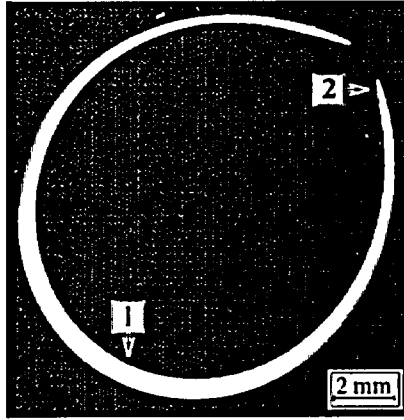

Fig. H-9.1. Appearance of Fuel Rod #B22T (photographs and X-ray photograph)

#B22T

Individual Characteristics of Refabricated Fuel Rods  
(Fresh Fuel, Preirradiated Cladding) under IGR Tests



Position 1

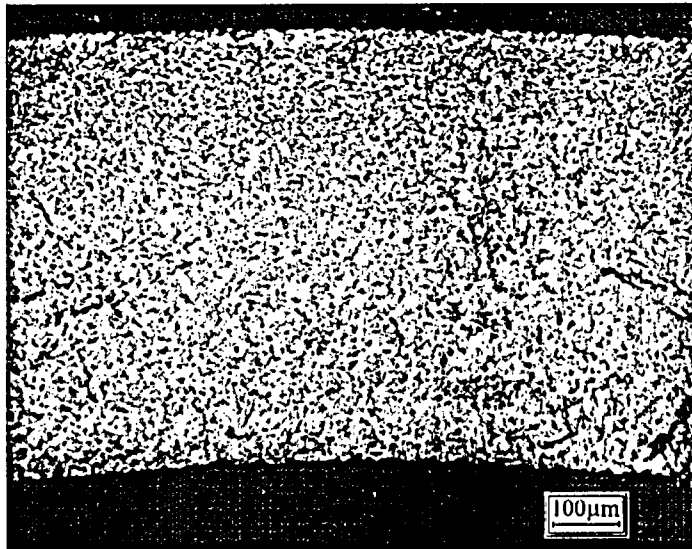

Position 2

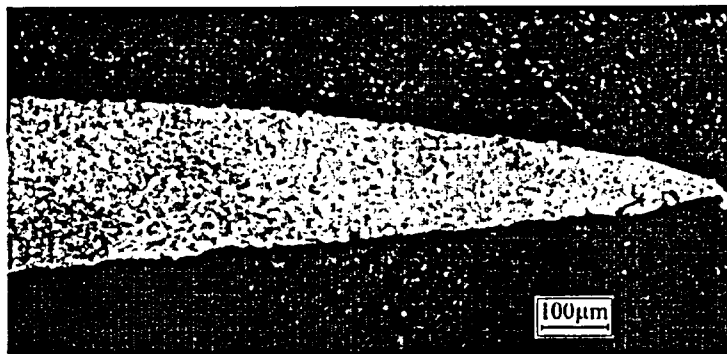
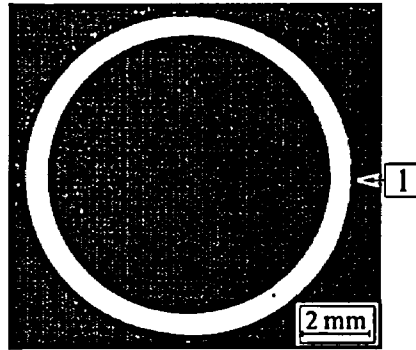

Fig. H-9.2. Cross-Section and Cladding Microstructure for Fuel Rod #B22T at 35 mm Elevation

#B22T

Individual Characteristics of Refabricated Fuel Rods  
(Fresh Fuel, Preirradiated Cladding) under IGR Tests



Position 1

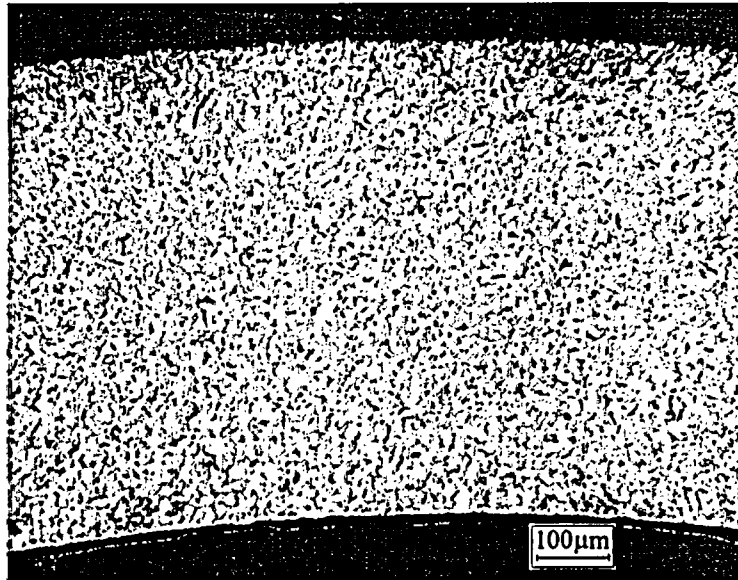
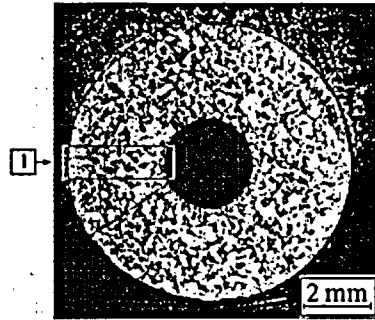
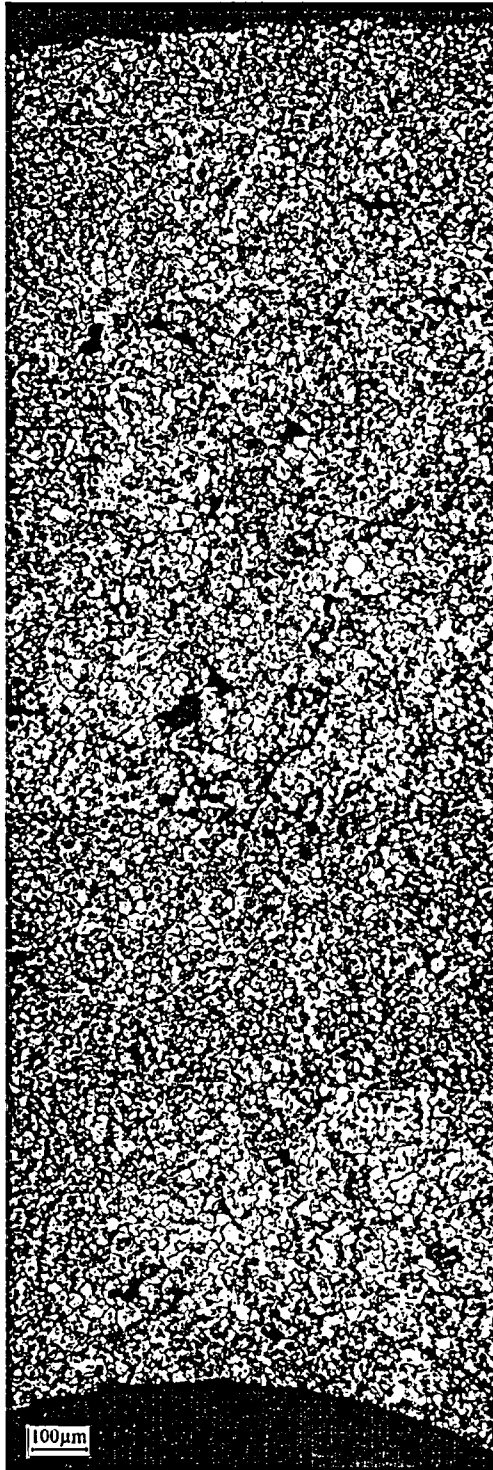

Fig. H-9.3. Cross-Section and Cladding Microstructure for Fuel Rod #B22T at 90 mm Elevation

#B22T

Individual Characteristics of Refabricated Fuel Rods  
(Fresh Fuel/Preirradiated Cladding) under IGR Tests

Position 1



Position 2

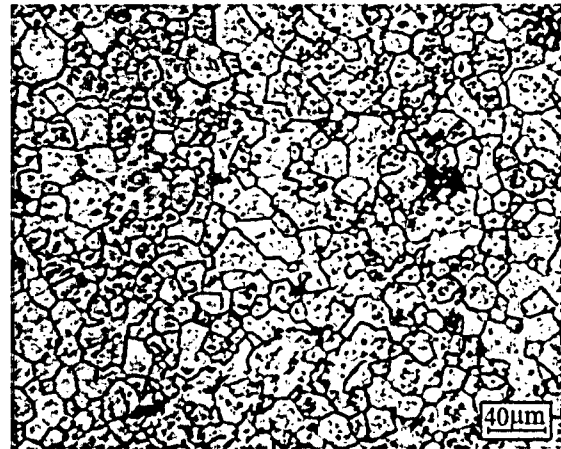

Fig. H-9.4. Fuel Microstructure for Fuel Rod #B22T at 90 mm Elevation



## #B22T

Individual Characteristics of Refabricated Fuel Rods  
(Fresh Fuel, Preirradiated Gladding) under IGR Tests

Table H-9.1. Time Dependent Energy Characteristics of Fuel Rod #B22T

Time (s)	Reactor energy deposition <sup>1)</sup> (%)	Cumulative number of fissions in fuel rod (fiss)			Power of fuel rod (kW)	Energy deposition in fuel rod	
		U <sup>235</sup> ×10 <sup>-14</sup>	U <sup>238</sup> ×10 <sup>-12</sup>	Total ×10 <sup>-14</sup>		cal/g fuel	J/g fuel
0.0	0.000	0.000	0.000	0.000	0.000	0.000	0.000
1.0	0.910	0.078	0.044	0.079	0.443	0.897	3.750
2.0	3.880	0.334	0.188	0.336	1.160	3.830	16.00
2.2	4.990	0.430	0.243	0.432	1.590	4.930	20.60
2.4	6.580	0.568	0.320	0.571	2.390	6.500	27.20
2.6	9.150	0.788	0.445	0.793	4.050	9.030	37.80
2.8	13.80	1.190	0.670	1.190	7.640	13.60	56.90
3.0	22.60	1.950	1.100	1.960	14.30	22.30	93.30
3.2	37.10	3.200	1.800	3.210	19.70	36.60	153.0
3.4	52.70	4.540	2.560	4.570	17.80	52.00	218.0
3.6	65.80	5.670	3.200	5.700	14.00	65.00	272.0
3.8	75.60	6.520	3.680	6.550	10.00	74.60	312.0
4.0	82.40	7.100	4.010	7.140	6.870	81.40	341.0
4.2	87.00	7.500	4.230	7.540	4.600	86.00	360.0
4.4	90.10	7.760	4.380	7.810	3.050	89.10	373.0
4.6	92.10	7.940	4.480	7.980	2.030	91.10	381.0
4.8	93.40	8.050	4.540	8.100	1.370	92.50	387.0
5.0	94.30	8.130	4.580	8.170	0.933	93.40	391.0
5.2	94.90	8.180	4.610	8.220	0.649	94.00	393.0
5.4	95.30	8.210	4.630	8.260	0.485	94.50	396.0
5.6	95.60	8.240	4.650	8.290	0.413	94.80	397.0
5.8	95.90	8.260	4.660	8.310	0.355	95.20	399.0
6.0	96.10	8.280	4.670	8.330	0.308	95.40	399.0
6.5	96.60	8.320	4.700	8.370	0.226	96.00	402.0
7.0	96.90	8.350	4.710	8.400	0.176	96.40	404.0
7.5	97.20	8.370	4.720	8.420	0.144	96.70	405.0
8.0	97.40	8.390	4.730	8.440	0.123	97.00	406.0
9.0	97.70	8.420	4.750	8.470	0.105	97.40	408.0
10.0	98.00	8.450	4.770	8.490	0.085	97.80	409.0
20.0	99.20	8.550	4.820	8.600	0.022	99.50	417.0
30.0	99.60	8.580	4.840	8.630	0.012	100.0	419.0
∞	100.0	8.650	4.880	8.700	0.000	102.0	427.0

Maximum value of power is 19.7 kW (t = 3.20 s)

<sup>1)</sup> Current energy deposition per maximum energy deposition (at infinite time)

# #B22T

Individual Characteristics of Refabricated Fuel Rods  
(Fresh Fuel, Preirradiated Cladding) under IGR Tests

Table H-9.2. Axial Energy Characteristics of Fuel Rod #B22T

Axial coordinate from lower end of fuel rod (mm)	Cumulative number of fissions at axial interval (fiss)			Maximum power of fuel rod (kW) $t=3.20$ s	Energy deposition at infinite time*		
	$U^{235}$ $\times 10^{-13}$	$U^{238}$ $\times 10^{-11}$	Total $\times 10^{-13}$		cal/g fuel	J/g fuel	per-unit <sup>3)</sup>
5.0	0.000	0.000	0.000	0.000	0.000	0.000	0.00
10.0 <sup>1)</sup>	1.350	0.653	1.350	0.306	112.0	469.0	1.00
15.0	3.320	1.640	3.340	0.755	111.0	465.0	0.99
20.0	3.270	1.650	3.290	0.745	109.0	456.0	0.97
25.0	3.190	1.650	3.200	0.726	107.0	448.0	0.96
30.0	3.150	1.660	3.170	0.717	106.0	444.0	0.95
35.0	3.140	1.680	3.160	0.716	105.0	440.0	0.94
40.0	3.110	1.690	3.130	0.709	104.0	435.0	0.93
45.0	3.090	1.700	3.110	0.704	103.0	431.0	0.92
50.0	3.090	1.730	3.110	0.704	103.0	431.0	0.92
55.0	3.070	1.740	3.090	0.699	103.0	431.0	0.92
60.0	3.040	1.740	3.060	0.692	102.0	427.0	0.91
65.0	3.030	1.750	3.050	0.691	101.0	423.0	0.90
70.0	3.030	1.750	3.040	0.689	102.0	427.0	0.91
75.0	3.000	1.750	3.020	0.683	101.0	423.0	0.90
80.0	3.000	1.750	3.010	0.682	101.0	423.0	0.90
85.0	2.990	1.760	3.010	0.682	101.0	423.0	0.90
90.0	2.990	1.760	3.010	0.681	101.0	423.0	0.90
95.0	3.010	1.770	3.020	0.685	101.0	423.0	0.90
100.0	3.010	1.770	3.020	0.685	101.0	423.0	0.90
105.0	3.000	1.770	3.020	0.684	101.0	423.0	0.90
110.0	2.980	1.760	3.000	0.680	100.0	419.0	0.89
115.0	2.980	1.750	3.000	0.679	100.0	419.0	0.89
120.0	3.000	1.750	3.010	0.683	100.0	419.0	0.89
125.0	2.990	1.740	3.010	0.681	100.0	419.0	0.89
130.0	2.970	1.720	2.980	0.676	99.80	418.0	0.89
135.0	2.950	1.710	2.970	0.673	99.70	417.0	0.89
140.0	2.940	1.690	2.960	0.670	99.30	416.0	0.89
145.0	2.930	1.670	2.940	0.667	98.70	413.0	0.88
150.0 <sup>2)</sup>	2.910	1.650	2.930	0.662	98.10	411.0	0.88
155.0	0.000	0.000	0.000	0.000	0.000	0.000	0.00

\* All numerical values of characteristics are presented as average values at the length interval equal to the axial coordinate  $\pm 2.5$  mm.

1) Initial coordinate of fuel is 10.5 mm.

2) End coordinate of fuel is 152.5 mm.

3) Current value per maximum value.

Table H-9.3. Radial Energy Characteristics of Fuel Rod #B22T

Characteristics*		Coordinates of fuel zones (mm)			
		1 zone 1.10 - 2.12	2 zone 2.12 - 2.79	3 zone 2.79 - 3.32	4 zone 3.32 - 3.79
U <sup>235</sup>	Number of fissions $\times 10^{-14}$ (fiss)	2.090	2.120	2.180	2.260
	Power of fuel rod <sup>1)</sup> (kW)	4.730	4.810	4.940	5.110
	Energy deposition <sup>2)</sup> (cal/g fuel)	98.30	99.80	103.0	106.0
	Energy deposition <sup>2)</sup> (J/g fuel)	411.0	418.0	431.0	444.0
	Energy deposition <sup>3)</sup> (per-unit)	0.927	0.942	0.972	1.000
U <sup>238</sup>	Number of fissions $\times 10^{-12}$ (fiss)	1.230	1.220	1.220	1.220
	Power of fuel rod <sup>1)</sup> (kW)	0.027	0.027	0.027	0.027
	Energy deposition <sup>2)</sup> (cal/g fuel)	0.569	0.565	0.564	0.565
	Energy deposition <sup>2)</sup> (J/g fuel)	2.380	2.370	2.360	2.370
	Energy deposition <sup>3)</sup> (per-unit)	1.000	0.993	0.991	0.993
Total	Number of fissions $\times 10^{-14}$ (fiss)	2.100	2.140	2.190	2.270
	Power of fuel rod <sup>1)</sup> (kW)	4.760	4.840	4.970	5.140
	Energy deposition <sup>2)</sup> (cal/g fuel)	98.90	100.0	103.0	107.0
	Energy deposition <sup>2)</sup> (J/g fuel)	414.0	419.0	431.0	448.0
	Energy deposition <sup>3)</sup> (per-unit)	0.924	0.935	0.963	1.000

<sup>1)</sup> at time of 3.20 s,      <sup>2)</sup> at infinite time,      <sup>3)</sup> Current value per maximum value

\* All numerical values of characteristics were calculated for length of fuel stack

# #B22T

Individual Characteristics of Refabricated Fuel Rods  
(Fresh Fuel, Preirradiated Cladding) under IGR Tests

Table H-9.4. Fuel Enthalpy Vs. Time Calculated by FRAP-T6 Code for Fuel Rod #B22T

Time (s)	Enthalpy at fuel radius (cal/g fuel)				Fuel enthalpy <sup>1)</sup>		Energy deposition in fuel rod	
	1.10 mm	2.22 mm	2.89 mm	3.79 mm	cal/g fuel	J/g fuel	cal/g fuel	J/g fuel
0.0	0.00	0.00	0.00	0.00	0.00	0.00	0.00	0.00
1.0	0.83	0.82	0.80	0.74	0.80	3.36	0.90	3.76
2.0	3.45	3.40	3.31	3.05	3.31	13.9	3.82	16.0
2.2	4.46	4.40	4.28	3.93	4.28	17.9	4.92	20.6
2.4	5.94	5.87	5.70	5.23	5.70	23.9	6.50	27.2
2.6	8.38	8.29	8.07	7.34	8.06	33.8	9.03	37.8
2.8	12.9	12.8	12.5	11.2	12.4	52.2	13.6	57.0
3.0	21.9	21.7	21.2	18.4	21.0	87.9	22.3	93.4
3.2	36.6	36.4	35.4	29.2	34.8	146	36.6	153
3.4	52.8	52.2	50.1	39.2	49.2	206	52.0	218
3.6	66.3	65.1	61.4	46.8	60.6	254	64.9	272
3.8	76.2	74.2	68.8	52.4	68.4	287	74.6	313
4.0	82.8	79.8	73.2	56.6	73.4	307	81.4	341
4.2	86.7	82.8	75.4	59.9	76.3	320	86.0	360
4.4	88.7	84.2	76.5	62.5	77.9	326	89.1	373
4.6	89.3	84.5	76.9	64.3	78.6	329	91.1	382
4.8	89.1	84.2	76.9	65.7	78.7	330	92.5	387
5.0	88.3	83.5	76.7	66.9	78.6	329	93.4	391
5.2	87.3	82.7	76.5	68.1	78.3	328	94.0	394
5.4	86.1	81.9	76.3	69.1	78.0	327	94.5	396
5.6	85.0	81.1	76.2	70.2	77.8	326	94.8	397
5.8	83.9	80.4	76.1	71.0	77.6	325	95.1	399
6.0	82.9	79.9	76.1	71.6	77.4	324	95.4	400
6.5	80.9	78.8	76.1	73.0	77.0	323	95.9	402
7.0	79.6	78.1	76.2	73.8	76.8	322	96.3	404
7.5	78.6	77.5	76.1	74.0	76.5	321	96.7	405
8.0	78.0	77.1	75.9	73.9	76.2	319	96.9	406
10.0	76.2	75.6	74.7	73.0	74.9	314	97.8	410
30.0	63.0	62.7	62.3	61.5	62.4	261	100	419

Radial enthalpy distribution and fuel enthalpy are presented at elevation 17.6 mm

Maximum value of fuel enthalpy is 78.7 cal/g fuel (t=4.78 s)

<sup>1)</sup> All numerical values are presented at elevation with peak power

# #B22T

Individual Characteristics of Refabricated Fuel Rods  
(Fresh Fuel, Preirradiated Cladding) under IGR Tests

Table H-9.5. Energy Characteristics Vs. Time Calculated by FRAP-T6 and SCANAIR Codes for Fuel Rod #B22T

Time (s)	Energy deposition <sup>1)</sup> (cal/g fuel)	Linear power <sup>1)</sup> (kW/m)	Fuel enthalpy <sup>1)</sup> (cal/g fuel)		Leakage of energy <sup>1)</sup> (cal/g fuel)		Clad-to-coolant heat transfer coefficient <sup>1)</sup> (kW/m <sup>2</sup> K)	
			FRAP-T6	SCANAIR	FRAP-T6	SCANAIR	FRAP-T6	SCANAIR
0.0	0.00	0.00	0.00	0.00	0.00	0.00	0.00	0.00
1.0	0.96	3.34	0.80	0.88	0.00	0.00	0.01	0.01
2.0	4.11	8.75	3.31	3.60	0.00	0.00	0.01	0.01
2.2	5.29	12.0	4.28	4.62	0.00	0.00	0.01	0.01
2.4	6.98	18.0	5.70	6.10	0.00	0.00	0.01	0.01
2.6	9.70	30.5	8.06	8.51	0.00	0.01	0.01	0.01
2.8	14.6	57.6	12.4	12.9	0.01	0.01	0.01	0.01
3.0	24.0	108	21.0	21.3	0.01	0.01	0.01	0.01
3.2	39.3	149	34.8	35.0	0.02	0.02	0.01	0.01
3.4	55.9	134	49.2	49.0	0.03	0.04	0.02	0.02
3.6	69.8	106	60.6	60.1	0.05	0.07	0.02	0.03
3.8	80.2	75.4	68.4	67.8	0.10	0.12	0.03	0.03
4.0	87.5	51.8	73.4	72.8	0.16	0.20	0.04	0.04
4.2	92.4	34.7	76.3	75.8	0.25	0.30	0.04	0.05
4.4	95.7	23.0	77.9	77.5	0.37	0.43	0.05	0.05
4.6	97.9	15.3	78.6	78.3	0.51	0.58	0.05	0.06
4.8	99.3	10.3	78.7	78.5	0.66	0.75	0.06	0.06
5.0	100	7.04	78.6	-	0.83	-	0.06	-
5.2	101	4.90	78.3	-	1.01	-	0.06	-
5.4	101	3.66	78.0	-	1.21	-	0.07	-
5.6	102	3.12	77.8	-	1.42	-	0.07	-
5.8	102	2.68	77.6	-	1.63	-	0.07	-
6.0	102	2.32	77.4	-	1.86	-	0.07	-
6.5	103	1.70	77.0	-	2.43	-	0.07	-
7.0	103	1.33	76.8	-	3.03	-	0.07	-
7.5	104	1.09	76.5	-	3.63	-	0.07	-
8.0	104	0.93	76.2	-	4.24	-	0.07	-
10.0	105	0.64	74.9	-	6.64	-	0.07	-
30.0	108	0.09	62.4	-	26.3	-	0.05	-

<sup>1)</sup> All numerical values are presented at elevation with peak power

# #B22T

Individual Characteristics of Refabricated Fuel Rods  
(Fresh Fuel, Preirradiated Cladding) under IGR Tests

Table H-9.6. Temperature Variation, Fission Gas Release and ZrO<sub>2</sub> Thickness Vs. Time for Fuel Rod #B22T Calculated by FRAP-T6 and SCANAIR Codes

Time (s)	Fuel centerline temperature <sup>1)</sup> (K)		Fuel surface temperature <sup>1)</sup> (K)		Clad outer temperature <sup>1)</sup> (K)	
	FRAP-T6	SCANAIR	FRAP-T6	SCANAIR	FRAP-T6	SCANAIR
0.0	293	293	293	293	293	293
1.0	308	307	306	307	297	298
2.0	352	351	346	348	318	320
2.2	369	368	360	363	325	329
2.4	392	391	381	385	335	340
2.6	431	427	414	420	349	356
2.8	499	492	473	483	371	382
3.0	629	612	579	595	411	430
3.2	834	798	732	758	484	516
3.4	1051	993	869	904	595	636
3.6	1228	1152	971	1010	718	764
3.8	1356	1267	1046	1085	834	881
4.0	1440	1345	1102	1140	931	977
4.2	1489	1394	1145	1180	1009	1053
4.4	1514	1423	1178	1208	1069	1104
4.6	1522	1437	1202	1223	1111	1135
4.8	1520	1442	1220	1232	1143	1157
5.0	1510	-	1236	-	1172	-
5.2	1497	-	1251	-	1198	-
5.4	1482	-	1265	-	1218	-
5.6	1468	-	1278	-	1232	-
5.8	1454	-	1289	-	1242	-
6.0	1442	-	1297	-	1249	-
6.5	1417	-	1315	-	1257	-
7.0	1399	-	1325	-	1258	-
7.5	1387	-	1327	-	1258	-
8.0	1379	-	1326	-	1258	-
10.0	1356	-	1315	-	1254	-
30.0	1185	-	1165	-	1126	-

<sup>1)</sup> All numerical values are presented at elevation with peak power

# #B22T

Individual Characteristics of Refabricated Fuel Rods  
(Fresh Fuel, Preirradiated Cladding) under IGR Tests

Table H-9.7. Mechanical Characteristics of Fuel Rod #B22T Vs. Time Calculated by FRAP-T6 and SCANAIR Codes

Time (s)	Clad outer temperature <sup>1)</sup> (K)		Fuel hoop strain <sup>1)</sup> (%)		Fuel - clad gap width <sup>1)</sup> (mm)		Clad hoop strain <sup>1)</sup> (%)		Clad hoop stress <sup>1)</sup> (MPa)		Internal gas pressure (MPa)	
	FRAP-T6	SCANAIR	FRAP-T6	SCANAIR	FRAP-T6	SCANAIR	FRAP-T6	SCANAIR	FRAP-T6	SCANAIR	FRAP-T6	SCANAIR
0.0	293	293	0.00	0.00	0.08	0.08	0.01	0.01	8.72	8.69	1.70	1.70
1.0	297	298	0.01	0.01	0.08	0.08	0.01	0.01	8.78	8.77	1.71	1.71
2.0	318	320	0.05	0.04	0.07	0.07	0.02	0.03	8.94	8.96	1.74	1.75
2.2	325	329	0.07	0.05	0.07	0.07	0.03	0.04	8.99	9.03	1.75	1.76
2.4	335	340	0.09	0.07	0.07	0.07	0.04	0.04	9.06	9.11	1.76	1.77
2.6	349	356	0.13	0.10	0.07	0.07	0.05	0.06	9.16	9.23	1.78	1.79
2.8	371	382	0.20	0.15	0.07	0.07	0.06	0.08	9.30	9.42	1.81	1.82
3.0	411	430	0.32	0.25	0.07	0.07	0.09	0.11	9.51	9.68	1.84	1.86
3.2	484	516	0.53	0.42	0.06	0.07	0.14	0.18	9.73	9.98	1.88	1.90
3.4	595	636	0.75	0.61	0.05	0.06	0.22	0.27	9.89	10.2	1.91	1.92
3.6	718	764	0.94	0.78	0.05	0.06	0.30	0.37	9.99	10.2	1.93	1.94
3.8	834	881	1.08	0.89	0.05	0.06	0.38	0.46	10.0	10.2	1.94	1.95
4.0	931	977	1.17	0.97	0.05	0.06	0.45	0.54	10.1	10.2	1.95	1.95
4.2	1009	1053	1.23	1.02	0.05	0.06	0.50	0.59	10.1	10.2	1.95	1.96
4.4	1069	1104	1.25	1.04	0.05	0.06	0.54	0.60	10.1	10.0	1.95	1.96
4.6	1111	1135	1.26	1.06	0.05	0.06	0.56	0.56	10.1	10.1	1.95	1.96
4.8	1143	1157	1.26	1.06	0.05	0.06	0.57	0.52	10.1	10.1	1.95	1.96
5.0	1172	-	1.26	-	0.05	-	0.61	-	10.1	-	1.95	-
5.2	1198	-	1.25	-	0.06	-	0.68	-	10.2	-	1.95	-
5.4	1218	-	1.24	-	0.07	-	0.91	-	10.2	-	1.95	-
5.6	1232	-	1.23	-	0.09	-	1.40	-	10.3	-	1.95	-
5.8	1242	-	1.22	-	0.11	-	1.82	-	10.4	-	1.95	-
6.0	1249	-	1.21	-	0.14	-	2.48	-	10.6	-	1.95	-
6.5	1257	-	1.19	-	0.29	-	6.08	-	11.2	-	1.94	-
7.0	1258	-	1.18	-	2.35	-	59.2	-	0.00	-	0.10	-
7.5	1258	-	1.17	-	2.35	-	59.2	-	0.00	-	0.10	-
8.0	1258	-	1.17	-	2.35	-	59.2	-	0.00	-	0.10	-
10.0	1254	-	1.14	-	2.35	-	59.2	-	0.00	-	0.10	-
30.0	1126	-	0.94	-	2.36	-	59.4	-	0.00	-	0.10	-

<sup>1)</sup> All numerical values are presented at elevation with peak power

# #B22T

Individual Characteristics of Refabricated Fuel Rods  
(Fresh Fuel, Preirradiated Cladding) under IGR Tests

Table H-9.8. Axial Distribution of Energy Deposition and Fuel Enthalpy Calculated by FRAP-T6 Code for Fuel Rod #B22T

Axial interval from-to (mm)-(mm)	Energy deposition at infinite time			Fuel enthalpy at time (t=4.78 s)		
	cal/g fuel	J/g fuel	per-unit	cal/g fuel	J/g fuel	per-unit
10.5 - 24.7	110	460	1.00	78.7	330	1.00
24.7 - 38.9	106	443	0.96	75.7	317	0.96
38.9 - 53.1	103	433	0.94	74.0	310	0.94
53.1 - 67.3	102	427	0.93	73.1	306	0.93
67.3 - 81.5	101	425	0.92	72.6	304	0.92
81.5 - 95.7	101	423	0.92	72.4	303	0.92
95.7 - 109.9	101	422	0.92	72.2	303	0.92
109.9 - 124.1	100	419	0.91	71.7	300	0.91
124.1 - 138.3	99.8	418	0.91	71.5	300	0.91
138.3 - 152.5	98.7	414	0.90	70.7	296	0.90

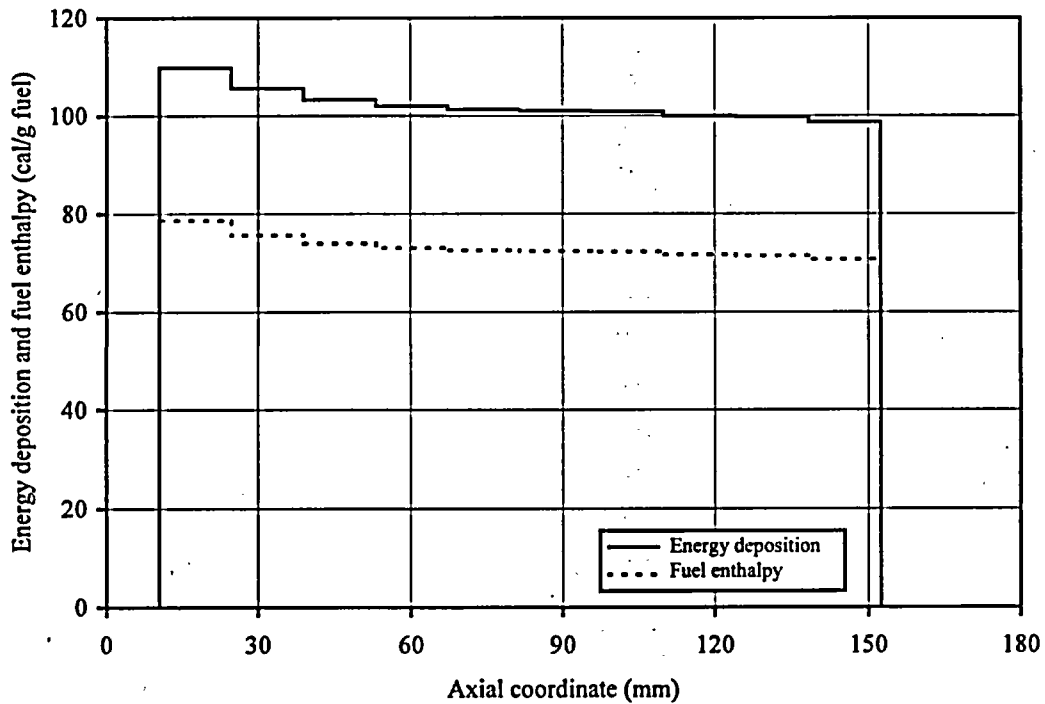

Fig. H-9.5. Axial Distribution of Energy Deposition and Fuel Enthalpy Calculated by FRAP-T6 Code for Fuel Rod #B22T



#B22T

Individual Characteristics of Refabricated Fuel Rods  
(Fresh Fuel, Preirradiated Cladding) under IGR Tests

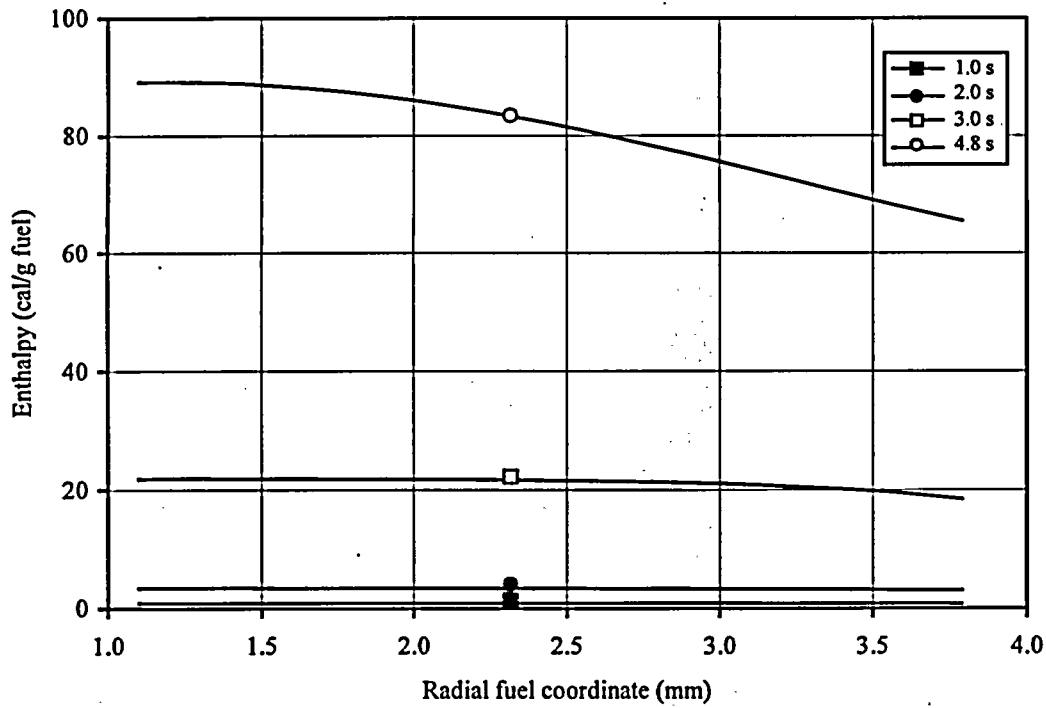
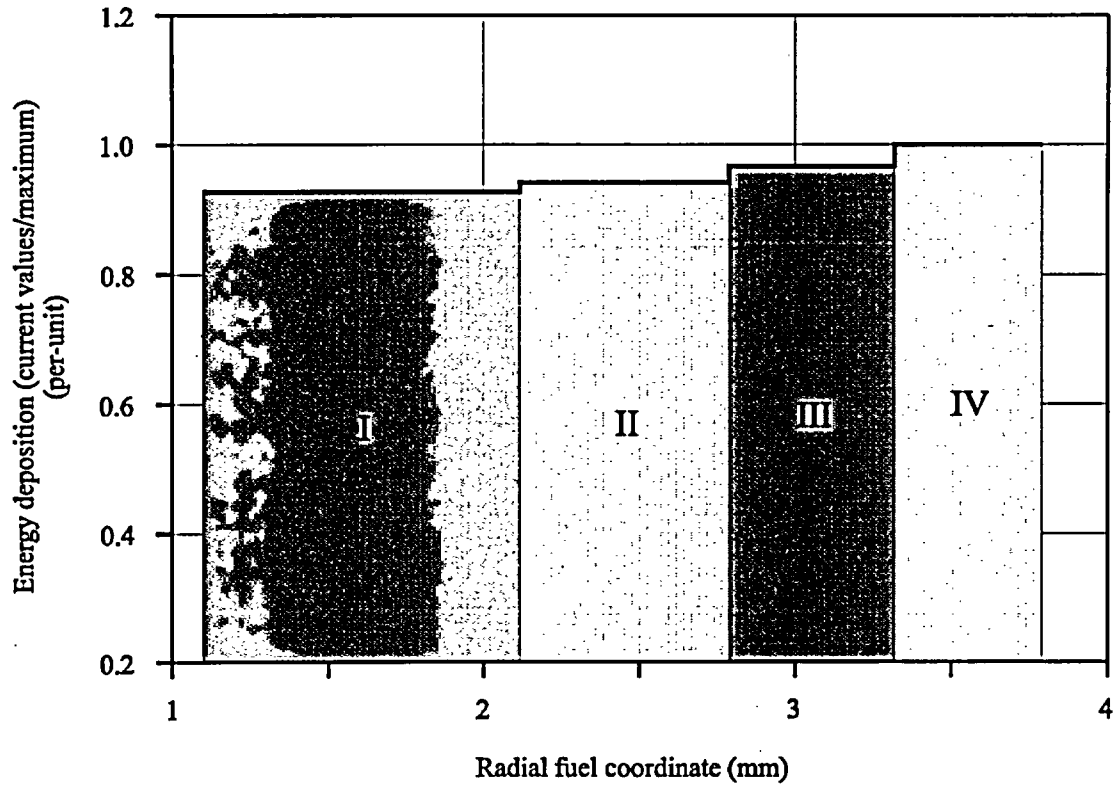

Fig. H-9.6. Radial Distributions of Energy Deposition and Fuel Enthalpy Calculated by FRAP-T6 Code for Fuel Rod #B22T

#B22T

Individual Characteristics of Refabricated Fuel Rods  
(Fresh Fuel, Preirradiated Cladding) under IGR Tests

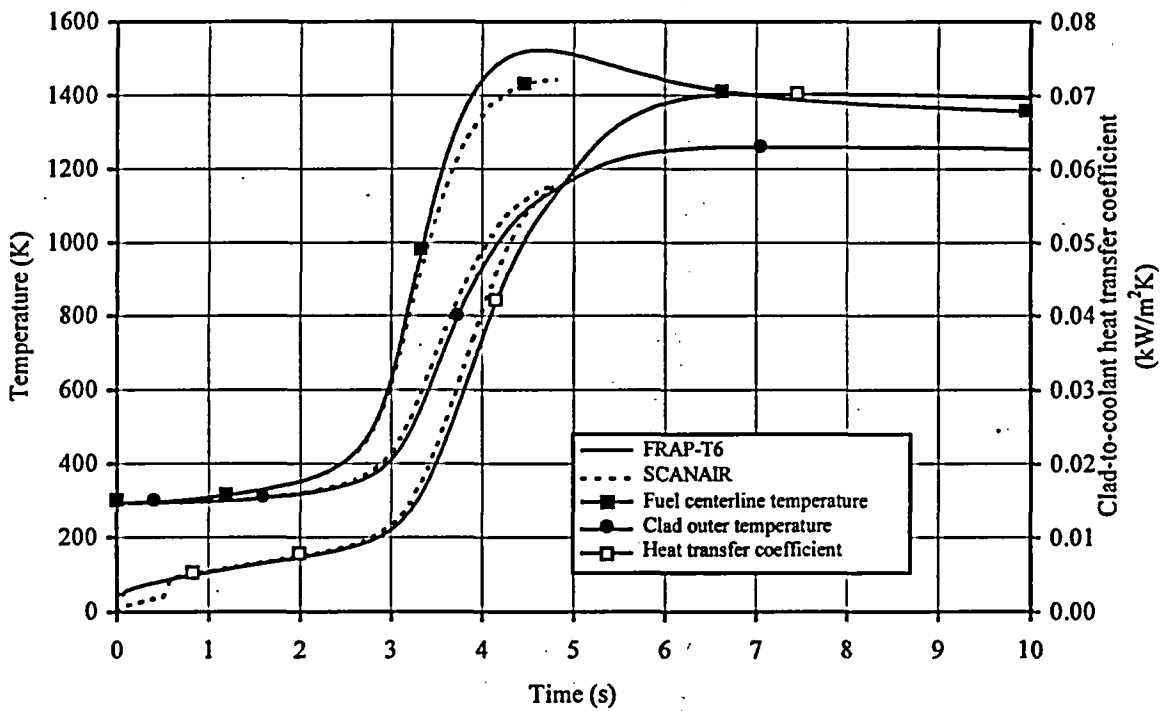
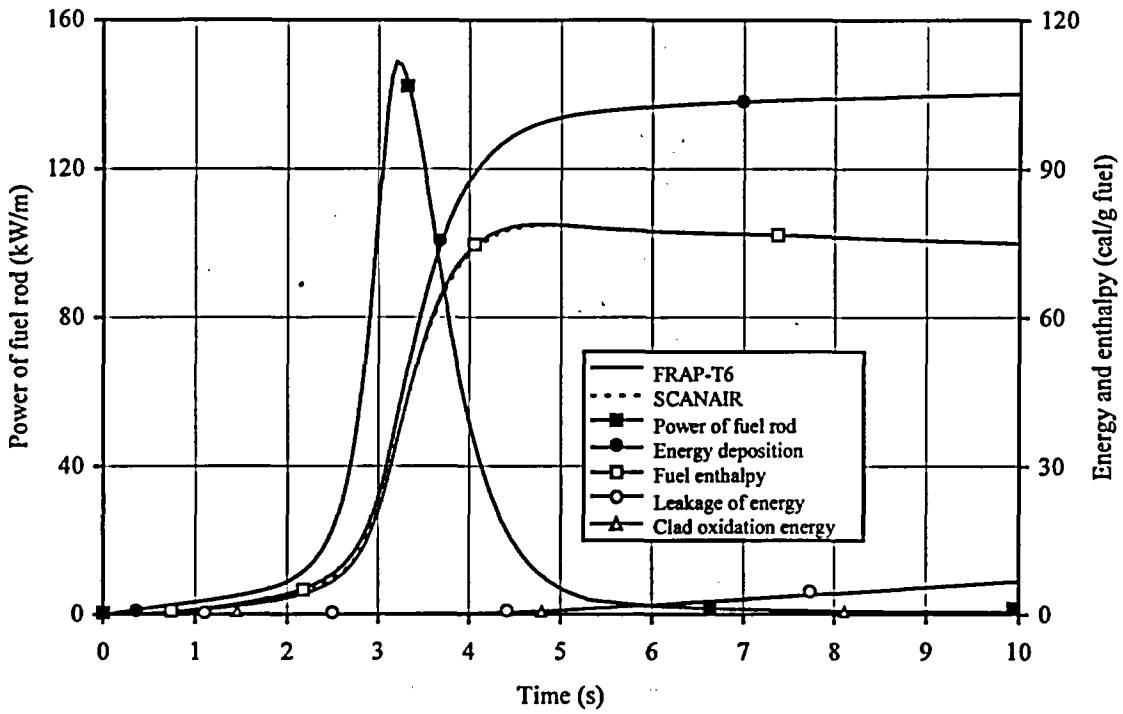

Fig. H-9.7. Energy and Temperature Characteristics Vs. Time Calculated by FRAP-T6 and SCANAIR Codes for Fuel Rod #B22T

#B22T

Individual Characteristics of Refabricated Fuel Rods  
(Fresh Fuel, Preirradiated Cladding) under IGR Tests

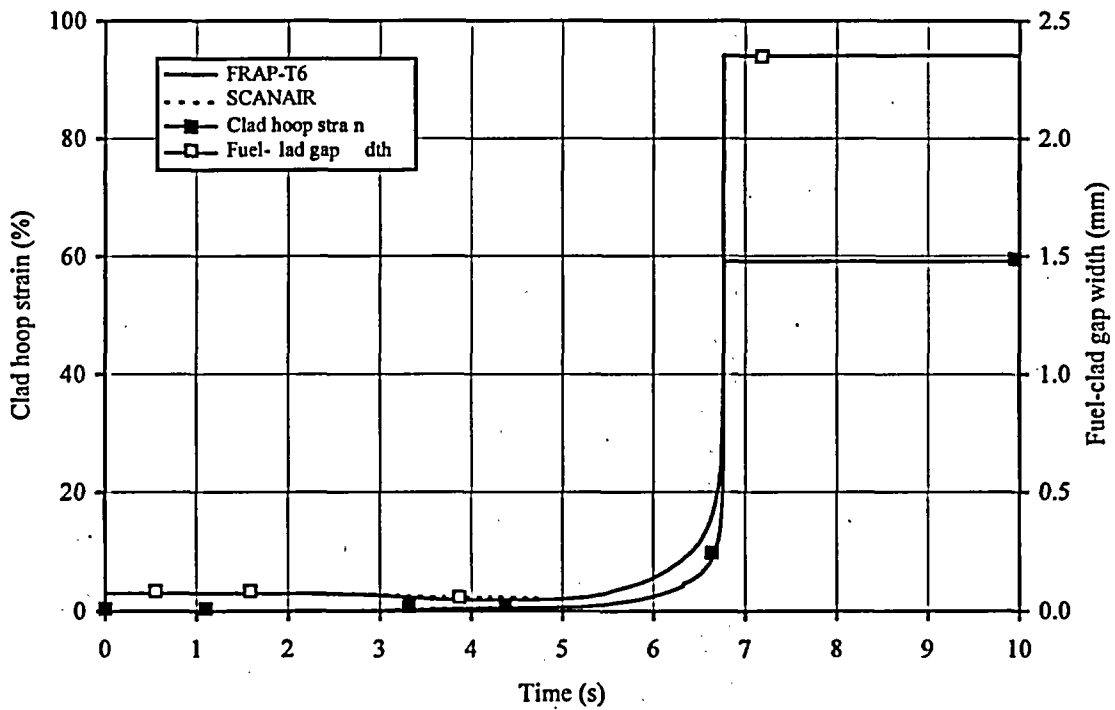
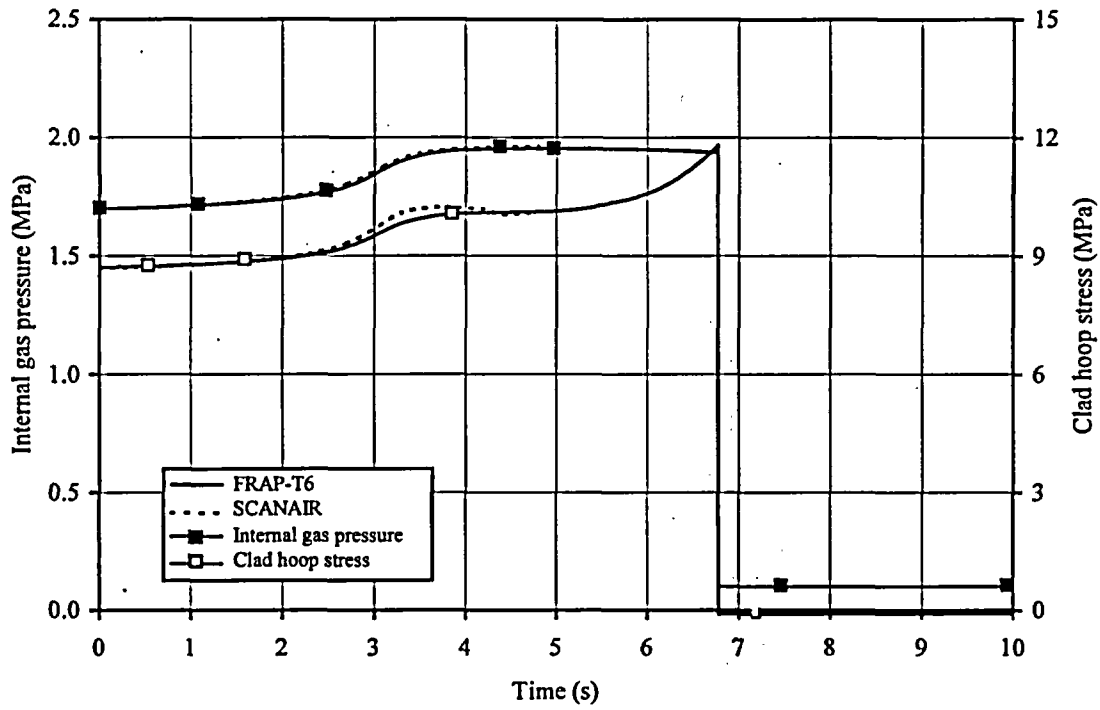

Fig. H-9.8. Cladding Mechanical Characteristics Vs. Time Calculated by FRAP-T6 and SCANAIR Codes for Fuel Rod #B22T

# #B22T

Individual Characteristics of Refabricated Fuel Rods  
(Fresh Fuel/Preirradiated Cladding) under IGR Tests

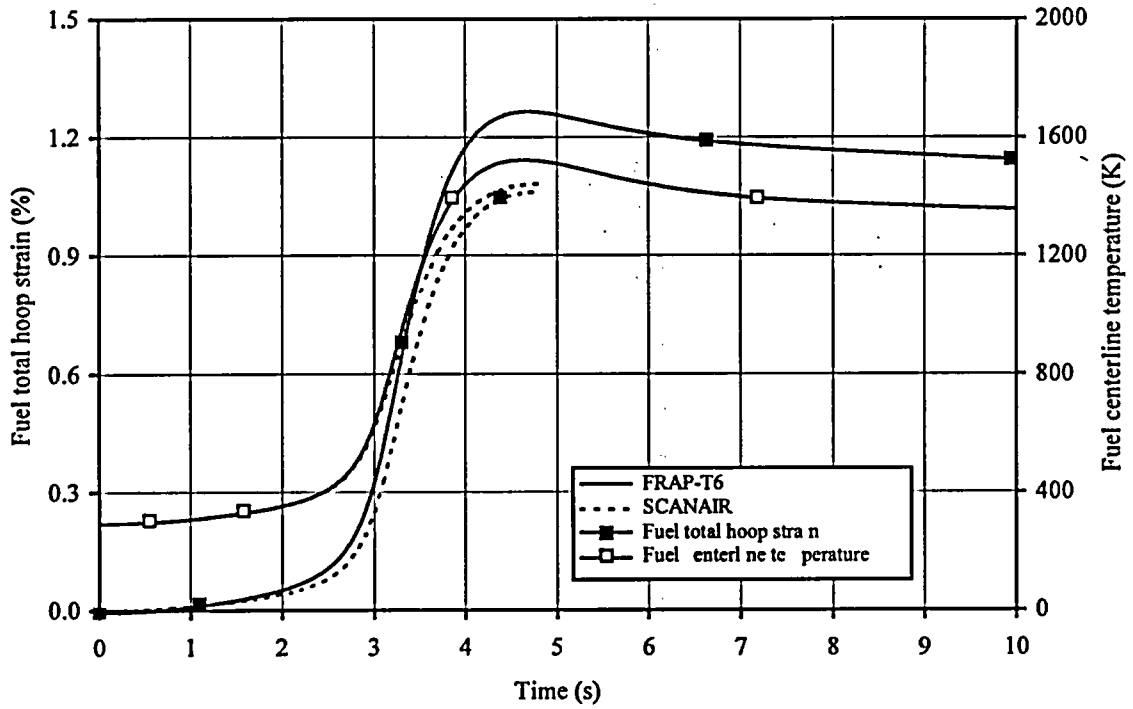

Fig. H-9.9. Fuel Strain Vs. Time Calculated by FRAP-T6 and SCANAIR Codes for Fuel Rod #B22T

Table H-9.9. Some Results of PIE for Fuel Rod #B22T

Characteristic		Value	
1.	Measured parameters of cladding oxidation and cladding deformation		
1.1.	Cladding thickness at elevation 35, 90 mm correspondent to different azimuthal angles ( $\mu\text{m}$ ):		
	0°	425	663
	90°	R	649
	180°	425	649
	270°	677	677
1.2.	ZrO <sub>2</sub> thickness at elevation 35, 90 mm correspondent to different azimuthal angles ( $\mu\text{m}$ ):		
	0°	5	5
	90°	5	5
	180°	5	5
	270°	5	5
1.3.	$\alpha\text{Zr(O)}$ thickness at elevation 35, 90 mm correspondent to different azimuthal angles ( $\mu\text{m}$ ):		
	0°	0	0
	90°	0	0
	180°	0	0
	270°	0	0
1.4.	Clad hoop strain at elevation 35, 90 mm, respectively (%)	46.3	10.4
2.	Measured parameters for FGR analysis		
2.1.	Internal gas composition (% by volume):		
	He	-	
	N <sub>2</sub>	-	
	O <sub>2</sub>	-	
	Ar	-	
	CO <sub>2</sub>	-	
	Kr	-	
	Xe	-	
2.2.	Free gas volume (cm <sup>3</sup> )	-	
2.3.	Gas pressure inside fuel rod under normal condition (MPa)	-	
2.4.	Kr concentration in fuel (cm <sup>3</sup> /g fuel)	-	
3.	Measured parameters of cladding hydriding		
3.1.	Coefficient of hydride orientation (per-unit)	0.43	
3.2.	Hydrogen concentration (% by weight)	-	

# #B22T

Individual Characteristics of Refabricated Fuel Rods  
(Fresh Fuel, Preirradiated Cladding) under IGR Tests

Table H-9.10. General Characteristic of Fuel Rod #B22T

	Parameter	Unit	Value		
			Experiment	FRAP-T6	SCANAIR
1	Type of coolant	--	air	air	air
2	Burnup	MWd/kg U	0	0	0
3	Energy deposition in fuel rod	cal/g fuel	102	102	102
4	Peak fuel enthalpy	cal/g fuel	-	79	78
5	Peak fuel temperature	K	-	1523	1442
6	Peak clad temperature	K	-	1258	-
7	Fuel rod failure	Yes, No	Yes	Yes	-
8	Type of failure:				
	- cladding rupture due to ballooning	Yes, No	Yes	Yes	-
	- cladding rupture due to PCMI	Yes, No	No	No	-
	- fragmentation of fuel rod	Yes, No	No	-	-
9	Failure time	s	-	6.77	-
10	Fuel enthalpy at failure	cal/g fuel	-	77	-
11	Outer cladding temperature at failure	K	-	1258	-
12	Internal gas pressure at failure	MPa	-	1.94	-
13	ZrO <sub>2</sub> thickness after test	µm	5	-	-
14	Residual clad hoop strain:				
	- peak value for ballooning area	%	46.3	58.86	-
	- other location <sup>1)</sup>	%	10.4	0.89	-

<sup>1)</sup>Calculated values by FRAP-T6 and SCANAIR codes are average along height of fuel rod excluding ballooning region



*APPENDIX H-10.*  
*Individual Characteristics for Fuel Rod #B23T under IGR Test*



#B23T

Individual Characteristics of Refabricated Fuel Rods  
(Fresh Fuel, Preirradiated Cladding) under IGR Tests

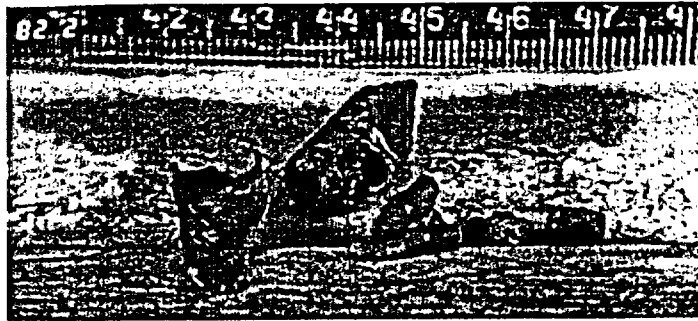
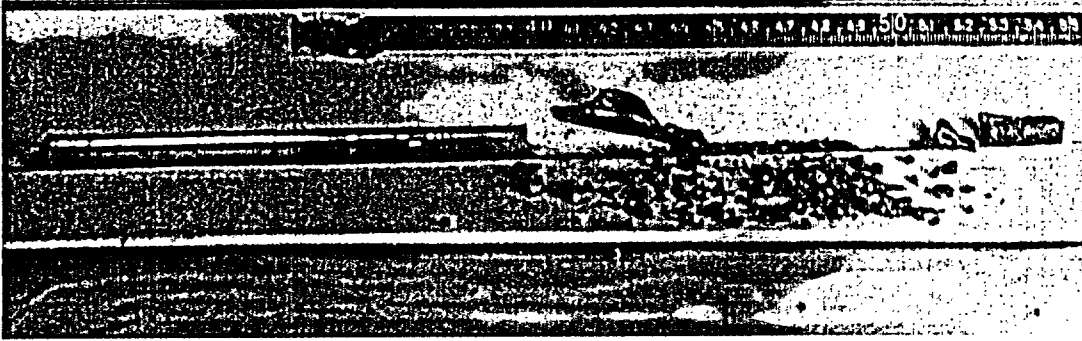
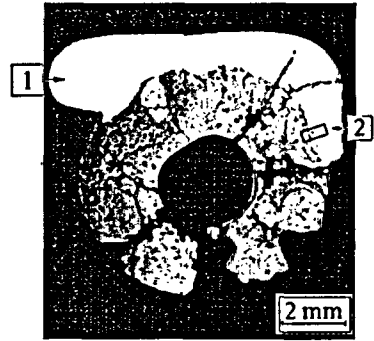
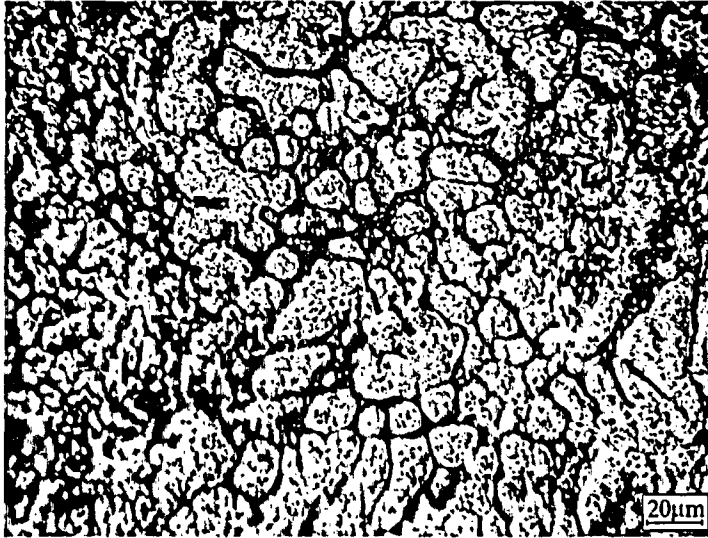

Fig. H-10.1. Appearance of Fuel Rod #B23T (photographs and X-ray photograph)

#B23T

Individual Characteristics of Refabricated Fuel Rods  
(Fresh Fuel, Preirradiated Cladding) under IGR Tests

Position 1



Position 2

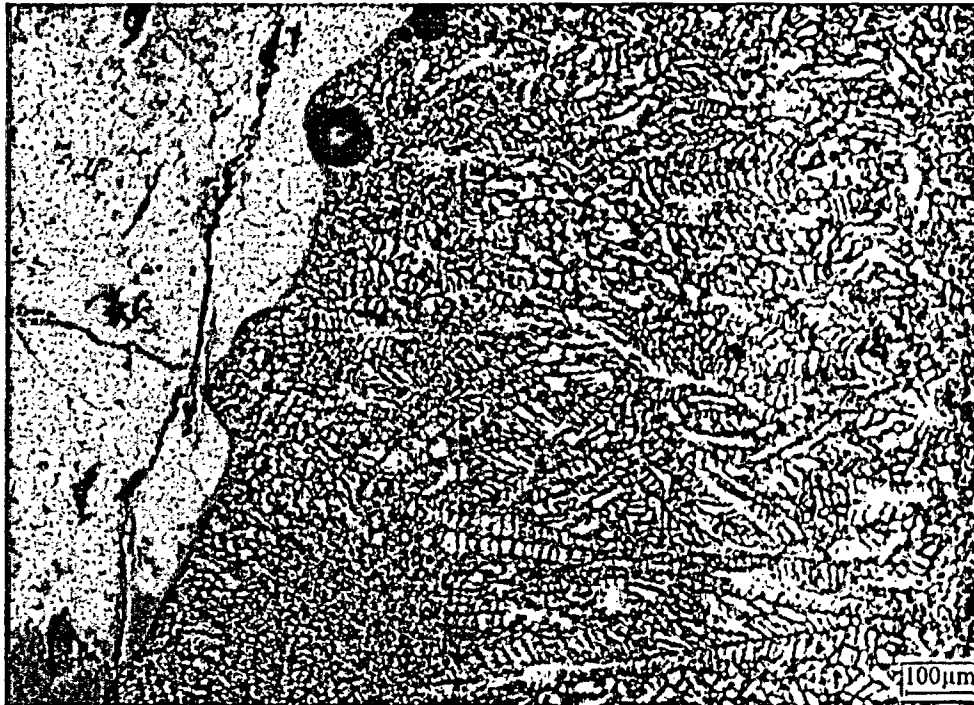

Fig. H-10.2. Fuel Microstructure for Fragment of Fuel Rod #B23T

## #B23T

Individual Characteristics of Refabricated Fuel Rods  
(Fresh Fuel, Preirradiated Cladding) under IGR Tests

Table H-10.1. Time Dependent Energy Characteristics of Fuel Rod #B23T

Time (s)	Reactor energy deposition <sup>1)</sup> (%)	Cumulative number of fissions in fuel rod (fiss)			Power of fuel rod (kW)	Energy deposition in fuel rod	
		U <sup>235</sup> ×10 <sup>-14</sup>	U <sup>238</sup> ×10 <sup>-12</sup>	Total ×10 <sup>-14</sup>		cal/g fuel	J/g fuel
0.0	0.000	0.000	0.000	0.000	0.000	0.000	0.000
1.0	0.821	0.222	0.125	0.224	1.260	2.550	10.70
2.0	3.870	1.050	0.591	1.050	3.850	12.00	50.20
2.2	5.040	1.360	0.770	1.370	5.240	15.60	65.30
2.4	6.720	1.820	1.030	1.830	7.900	20.80	87.10
2.6	9.430	2.550	1.440	2.570	13.50	29.30	123.0
2.8	14.40	3.890	2.200	3.920	25.70	44.60	187.0
3.0	23.80	6.450	3.640	6.490	48.00	73.90	309.0
3.2	39.50	10.70	6.030	10.80	69.00	122.0	511.0
3.4	57.10	15.40	8.720	15.50	60.30	177.0	741.0
3.6	70.00	19.00	10.70	19.10	39.30	217.0	908.0
3.8	78.20	21.20	11.90	21.30	24.40	243.0	1017.
4.0	83.20	22.50	12.70	22.70	15.60	258.0	1080.
4.2	86.50	23.40	13.20	23.60	10.40	269.0	1126.
4.4	88.80	24.00	13.60	24.20	7.280	276.0	1155.
4.6	90.30	24.50	13.80	24.60	5.320	281.0	1176.
4.8	91.50	24.80	14.00	24.90	4.040	285.0	1193.
5.0	92.40	25.00	14.10	25.20	3.170	288.0	1206.
5.2	93.10	25.20	14.20	25.30	2.560	290.0	1214.
5.4	93.60	25.40	14.30	25.50	2.110	292.0	1222.
5.6	94.10	25.50	14.40	25.60	1.760	293.0	1226.
5.8	94.50	25.60	14.40	25.70	1.490	295.0	1235.
6.0	94.80	25.70	14.50	25.80	1.280	296.0	1239.
6.5	95.40	25.80	14.60	26.00	0.905	298.0	1247.
7.0	95.90	26.00	14.60	26.10	0.682	300.0	1256.
7.5	96.20	26.00	14.70	26.20	0.544	301.0	1260.
8.0	96.50	26.10	14.70	26.30	0.454	302.0	1264.
9.0	96.90	26.20	14.80	26.40	0.385	304.0	1273.
10.0	97.20	26.30	14.90	26.50	0.305	305.0	1277.
20.0	98.60	26.70	15.10	26.90	0.077	311.0	1302.
30.0	99.10	26.80	15.10	27.00	0.040	313.0	1310.
∞	100.0	27.10	15.30	27.20	0.000	320.0	1340.

Maximum value of power is 70.2 kW (t = 3.25 s)

<sup>1)</sup> Current energy deposition per maximum energy deposition (at infinite time)

# #B23T

Individual Characteristics of Refabricated Fuel Rods  
(Fresh Fuel) Preirradiated Cladding) under IGR Tests

Table H-10.2. Axial Energy Characteristics of Fuel Rod #B23T

Axial coordinate from lower end of fuel rod (mm)	Cumulative number of fissions at axial interval (fiss)			Maximum power of fuel rod (kW) $t=3.25$ s	Energy deposition at infinite time*		
	$U^{235} \times 10^{-13}$	$U^{238} \times 10^{-11}$	Total $\times 10^{-13}$		cal/g fuel	J/g fuel	per-unit <sup>3)</sup>
20.0	0.000	0.000	0.000	0.000	0.000	0.000	0.00
25.0 <sup>1)</sup>	3.550	1.730	3.570	0.920	348.0	1457.	1.00
30.0	10.30	5.110	10.40	2.680	345.0	1444.	0.99
35.0	10.20	5.150	10.20	2.640	339.0	1419.	0.97
40.0	10.10	5.220	10.20	2.630	338.0	1415.	0.97
45.0	9.980	5.260	10.00	2.590	333.0	1394.	0.96
50.0	9.840	5.260	9.890	2.550	329.0	1377.	0.95
55.0	9.750	5.300	9.800	2.530	326.0	1365.	0.94
60.0	9.670	5.340	9.720	2.510	324.0	1356.	0.93
65.0	9.670	5.400	9.730	2.510	323.0	1352.	0.93
70.0	9.610	5.440	9.660	2.490	321.0	1344.	0.92
75.0	9.580	5.470	9.640	2.490	319.0	1335.	0.92
80.0	9.560	5.490	9.610	2.480	318.0	1331.	0.91
85.0	9.580	5.550	9.640	2.490	318.0	1331.	0.91
90.0	9.570	5.570	9.620	2.480	317.0	1327.	0.91
95.0	9.490	5.560	9.550	2.460	316.0	1323.	0.91
100.0	9.370	5.500	9.420	2.430	316.0	1323.	0.91
105.0	9.360	5.510	9.420	2.430	316.0	1323.	0.91
110.0	9.480	5.580	9.530	2.460	317.0	1327.	0.91
115.0	9.480	5.580	9.530	2.460	315.0	1319.	0.91
120.0	9.470	5.580	9.530	2.460	316.0	1323.	0.91
125.0	9.400	5.530	9.460	2.440	314.0	1314.	0.90
130.0	9.460	5.550	9.520	2.460	316.0	1323.	0.91
135.0	9.500	5.560	9.550	2.460	313.0	1310.	0.90
140.0	9.480	5.530	9.540	2.460	313.0	1310.	0.90
145.0	9.500	5.520	9.560	2.470	313.0	1310.	0.90
150.0	9.480	5.470	9.540	2.460	312.0	1306.	0.90
155.0	9.320	5.350	9.380	2.420	310.0	1298.	0.89
160.0	9.100	5.200	9.160	2.360	309.0	1293.	0.89
165.0 <sup>2)</sup>	7.830	4.440	7.870	2.030	306.0	1281.	0.88
170.0	0.000	0.000	0.000	0.000	0.000	0.000	0.00

\* All numerical values of characteristics are presented as average values at the length interval equal to the axial coordinate  $\pm 2.5$  mm.

1) Initial coordinate of fuel is 25.8 mm.

2) End coordinate of fuel is 166.8 mm.

3) Current value per maximum value.

Table H-10.3. Radial Energy Characteristics of Fuel Rod #B23T

Characteristics*		Coordinates of fuel zones (mm)			
		1 zone 1.10 - 2.12	2 zone 2.12 - 2.79	3 zone 2.79 - 3.32	4 zone 3.32 - 3.79
U <sup>235</sup>	Number of fissions $\times 10^{-14}$ (fiss)	6.540	6.650	6.830	7.060
	Power of fuel rod <sup>1)</sup> (kW)	16.90	17.10	17.60	18.20
	Energy deposition <sup>2)</sup> (cal/g fuel)	308.0	313.0	321.0	332.0
	Energy deposition <sup>2)</sup> (J/g fuel)	1289.	1310.	1344.	1390.
	Energy deposition <sup>3)</sup> (per-unit)	0.928	0.943	0.967	1.000
U <sup>238</sup>	Number of fissions $\times 10^{-12}$ (fiss)	3.840	3.810	3.810	3.810
	Power of fuel rod <sup>1)</sup> (kW)	0.098	0.097	0.097	0.097
	Energy deposition <sup>2)</sup> (cal/g fuel)	1.780	1.770	1.770	1.770
	Energy deposition <sup>2)</sup> (J/g fuel)	7.450	7.410	7.410	7.410
	Energy deposition <sup>3)</sup> (per-unit)	1.000	0.994	0.994	0.994
Total	Number of fissions $\times 10^{-14}$ (fiss)	6.580	6.680	6.860	7.100
	Power of fuel rod <sup>1)</sup> (kW)	17.00	17.20	17.70	18.30
	Energy deposition <sup>2)</sup> (cal/g fuel)	309.0	314.0	323.0	334.0
	Energy deposition <sup>2)</sup> (J/g fuel)	1293.	1314.	1352.	1398.
	Energy deposition <sup>3)</sup> (per-unit)	0.925	0.940	0.967	1.000

<sup>1)</sup> at time of 3.25 s,      <sup>2)</sup> at infinite time,      <sup>3)</sup> Current value per maximum value

\* All numerical values of characteristics were calculated for length of fuel stack

# #B23T

Individual Characteristics of Refabricated Fuel Rods  
(Fresh Fuel, Preirradiated Cladding) under IGR Tests

Table H-10.4. Fuel Enthalpy Vs. Time Calculated by FRAP-T6 Code for Fuel Rod #B23T

Time (s)	Enthalpy at fuel radius (cal/g fuel)				Fuel enthalpy <sup>1)</sup>		Energy deposition in fuel rod	
	1.10 mm	2.22 mm	2.89 mm	3.79 mm	cal/g fuel	J/g fuel	cal/g fuel	J/g fuel
0.0	0.00	0.00	0.00	0.00	0.00	0.00	0.00	0.00
1.0	2.34	2.32	2.27	2.08	2.26	9.48	2.54	10.7
2.0	11.3	11.1	10.7	9.63	10.7	44.9	12.0	50.3
2.2	14.8	14.6	14.1	12.5	14.1	58.9	15.6	65.5
2.4	19.9	19.6	19.0	16.7	18.9	79.2	20.8	87.3
2.6	28.4	28.0	27.1	23.3	26.9	113	29.3	123
2.8	44.0	43.6	42.2	34.9	41.7	175	44.6	187
3.0	74.6	74.1	71.8	54.5	70.2	294	73.9	310
3.2	127	126	122	78.4	117	492	122	513
3.4	190	188	179	101	169	710	177	741
3.6	240	237	219	167	217	909	217	910
3.8	270	266	247	188	245	1027	242	1016
4.0	269	270	261	196	258	1080	258	1083
4.2	268	270	264	187	261	1094	269	1126
4.4	-	-	-	-	-	-	276	1156
4.6	-	-	-	-	-	-	281	1177
4.8	-	-	-	-	-	-	285	1193
5.0	-	-	-	-	-	-	288	1205
5.2	-	-	-	-	-	-	290	1215
5.4	-	-	-	-	-	-	292	1223
5.6	-	-	-	-	-	-	293	1229
5.8	-	-	-	-	-	-	295	1235
6.0	-	-	-	-	-	-	296	1240
6.5	-	-	-	-	-	-	298	1249
7.0	-	-	-	-	-	-	300	1255
7.5	-	-	-	-	-	-	301	1260
8.0	-	-	-	-	-	-	302	1265
10.0	-	-	-	-	-	-	305	1278
30.0	-	-	-	-	-	-	313	1312

Radial enthalpy distribution and fuel enthalpy are presented at elevation 32.9 mm

Maximum value of fuel enthalpy is 261.1 cal/g fuel (t=4.20 s)

<sup>1)</sup> All numerical values are presented at elevation with peak power

# #B23T

Individual Characteristics of Refabricated Fuel Rods  
(Fresh Fuel, Preirradiated Cladding) under IGR Tests

Table H-10.5. Energy Characteristics Vs. Time Calculated by FRAP-T6 and SCANAIR Codes for Fuel Rod #B23T

Time (s)	Energy deposition <sup>1)</sup> (cal/g fuel)	Linear power <sup>1)</sup> (kW/m)	Fuel enthalpy <sup>1)</sup> (cal/g fuel)		Leakage of energy <sup>1)</sup> (cal/g fuel)		Clad-to-coolant heat transfer coefficient <sup>1)</sup> (kW/m <sup>2</sup> K)	
			FRAP-T6	SCANAIR	FRAP-T6	SCANAIR	FRAP-T6	SCANAIR
0.0	0.00	0.00	0.00	0.00	0.00	0.00	0.00	0.00
1.0	2.72	9.42	2.26	2.47	0.00	0.00	0.01	0.01
2.0	12.8	28.8	10.7	11.2	0.01	0.01	0.01	0.01
2.2	16.7	39.2	14.1	14.5	0.01	0.01	0.01	0.01
2.4	22.3	59.1	18.9	19.3	0.01	0.01	0.01	0.01
2.6	31.3	101	26.9	27.1	0.02	0.02	0.01	0.01
2.8	47.7	192	41.7	41.6	0.03	0.03	0.02	0.02
3.0	79.0	359	70.2	69.1	0.05	0.06	0.02	0.02
3.2	131	516	117	113	0.10	0.12	0.04	0.05
3.4	189	451	169	-	0.24	-	0.07	-
3.6	232	294	217	-	0.88	-	0.09	-
3.8	259	182	245	-	1.82	-	0.11	-
4.0	276	117	258	-	3.20	-	0.14	-
4.2	287	77.7	261	-	5.35	-	0.20	-
4.4	295	54.4	-	-	-	-	-	-
4.6	300	39.8	-	-	-	-	-	-
4.8	304	30.2	-	-	-	-	-	-
5.0	307	23.7	-	-	-	-	-	-
5.2	310	18.9	-	-	-	-	-	-
5.4	312	15.6	-	-	-	-	-	-
5.6	314	13.1	-	-	-	-	-	-
5.8	315	11.0	-	-	-	-	-	-
6.0	316	9.49	-	-	-	-	-	-
6.5	318	6.72	-	-	-	-	-	-
7.0	320	5.07	-	-	-	-	-	-
7.5	321	4.05	-	-	-	-	-	-
8.0	323	3.39	-	-	-	-	-	-
10.0	326	2.27	-	-	-	-	-	-
30.0	335	0.30	-	-	-	-	-	-

<sup>1)</sup> All numerical values are presented at elevation with peak power

# #B23T

Individual Characteristics of Refabricated Fuel Rods  
(Fresh Fuel, Preirradiated Cladding) under IGR Tests

Table H-10.6. Temperature Variation, Fission Gas Release and ZrO<sub>2</sub> Thickness Vs. Time for Fuel Rod #B23T Calculated by FRAP-T6 and SCANAIR Codes

Time (s)	Fuel centerline temperature <sup>1)</sup> (K)		Fuel surface temperature <sup>1)</sup> (K)		Clad outer temperature <sup>1)</sup> (K)	
	FRAP-T6	SCANAIR	FRAP-T6	SCANAIR	FRAP-T6	SCANAIR
0.0	293	293	293	293	293	293
1.0	334	333	329	331	304	305
2.0	474	468	450	456	366	373
2.2	527	518	493	501	391	400
2.4	601	587	554	565	424	436
2.6	720	696	649	665	471	488
2.8	934	889	810	837	547	574
3.0	1335	1242	1073	1128	687	736
3.2	1975	1798	1384	1504	955	1036
3.4	2581	-	1670	-	1267	-
3.6	2939	-	2384	-	1367	-
3.8	3111	-	2569	-	1517	-
4.0	3105	-	2631	-	1680	-
4.2	3105	-	2558	-	1899	-
4.4	-	-	-	-	-	-
4.6	-	-	-	-	-	-
4.8	-	-	-	-	-	-
5.0	-	-	-	-	-	-
5.2	-	-	-	-	-	-
5.4	-	-	-	-	-	-
5.6	-	-	-	-	-	-
5.8	-	-	-	-	-	-
6.0	-	-	-	-	-	-
6.5	-	-	-	-	-	-
7.0	-	-	-	-	-	-
7.5	-	-	-	-	-	-
8.0	-	-	-	-	-	-
10.0	-	-	-	-	-	-
30.0	-	-	-	-	-	-

<sup>1)</sup> All numerical values are presented at elevation with peak power



# #B23T

Individual Characteristics of Refabricated Fuel Rods  
(Fresh Fuel, Preirradiated Cladding) under IGR Tests

Table H-10.7. Mechanical Characteristics of Fuel Rod #B23T Vs. Time Calculated by FRAP-T6 and SCANAIR Codes

Time (s)	Clad outer temperature <sup>1)</sup> (K)		Fuel hoop strain <sup>1)</sup> (%)		Fuel - clad gap width <sup>1)</sup> (mm)		Clad hoop strain <sup>1)</sup> (%)		Clad hoop stress <sup>1)</sup> (MPa)		Internal gas pressure (MPa)	
	FRAP-T6	SCANAIR	FRAP-T6	SCANAIR	FRAP-T6	SCANAIR	FRAP-T6	SCANAIR	FRAP-T6	SCANAIR	FRAP-T6	SCANAIR
0.0	293	293	0.00	0.00	0.08	0.08	0.01	0.01	8.73	8.70	1.70	1.70
1.0	304	305	0.03	0.03	0.08	0.08	0.02	0.02	8.88	8.90	1.73	1.73
2.0	366	373	0.17	0.13	0.08	0.08	0.06	0.07	9.26	9.36	1.80	1.81
2.2	391	400	0.22	0.17	0.07	0.08	0.08	0.09	9.36	9.48	1.82	1.83
2.4	424	436	0.29	0.22	0.07	0.08	0.10	0.12	9.48	9.63	1.84	1.85
2.6	471	488	0.41	0.32	0.07	0.07	0.13	0.16	9.63	9.82	1.86	1.88
2.8	547	574	0.63	0.51	0.06	0.07	0.18	0.23	9.82	10.1	1.90	1.91
3.0	687	736	1.09	0.91	0.05	0.06	0.28	0.35	10.1	10.4	1.94	1.95
3.2	955	1036	1.91	1.68	0.03	0.04	0.47	0.59	10.3	10.7	1.99	1.98
3.4	1267	-	2.71	-	0.06	-	1.83	-	10.7	-	2.02	-
3.6	1367	-	3.23	-	3.37	-	67.6	-	0.00	-	0.10	-
3.8	1517	-	3.49	-	3.36	-	67.8	-	0.00	-	0.10	-
4.0	1680	-	3.72	-	3.35	-	67.9	-	0.00	-	0.10	-
4.2	1899	-	3.86	-	3.35	-	68.2	-	0.00	-	0.10	-
4.4	-	-	-	-	-	-	-	-	-	-	-	-
4.6	-	-	-	-	-	-	-	-	-	-	-	-
4.8	-	-	-	-	-	-	-	-	-	-	-	-
5.0	-	-	-	-	-	-	-	-	-	-	-	-
5.2	-	-	-	-	-	-	-	-	-	-	-	-
5.4	-	-	-	-	-	-	-	-	-	-	-	-
5.6	-	-	-	-	-	-	-	-	-	-	-	-
5.8	-	-	-	-	-	-	-	-	-	-	-	-
6.0	-	-	-	-	-	-	-	-	-	-	-	-
6.5	-	-	-	-	-	-	-	-	-	-	-	-
7.0	-	-	-	-	-	-	-	-	-	-	-	-
7.5	-	-	-	-	-	-	-	-	-	-	-	-
8.0	-	-	-	-	-	-	-	-	-	-	-	-
10.0	-	-	-	-	-	-	-	-	-	-	-	-
30.0	-	-	-	-	-	-	-	-	-	-	-	-

<sup>1)</sup> All numerical values are presented at elevation with peak power

# #B23T

Individual Characteristics of Refabricated Fuel Rods  
(Fresh Fuel, Preirradiated Cladding) under IGR Tests

**Table H-10.8. Axial Distribution of Energy Deposition and Fuel Enthalpy Calculated by FRAP-T6 Code for Fuel Rod #B23T**

Axial interval from-to (mm)-(mm)	Energy deposition at infinite time			Fuel enthalpy at time (t=4.20 s)		
	cal/g fuel	J/g fuel	per-unit	cal/g fuel	J/g fuel	per-unit
25.8 - 39.9	342	1434	1.00	261	1094	1.00
39.9 - 54.0	332	1390	0.97	253	1061	0.97
54.0 - 68.1	324	1357	0.95	250	1048	0.96
68.1 - 82.2	319	1338	0.93	245	1026	0.94
82.2 - 96.3	317	1329	0.93	245	1026	0.94
96.3 - 110.4	316	1325	0.92	245	1026	0.94
110.4 - 124.5	316	1322	0.92	245	1026	0.94
124.5 - 138.6	314	1317	0.92	243	1017	0.93
138.6 - 152.7	313	1309	0.91	242	1014	0.93
152.7 - 166.8	309	1293	0.90	238	998	0.91

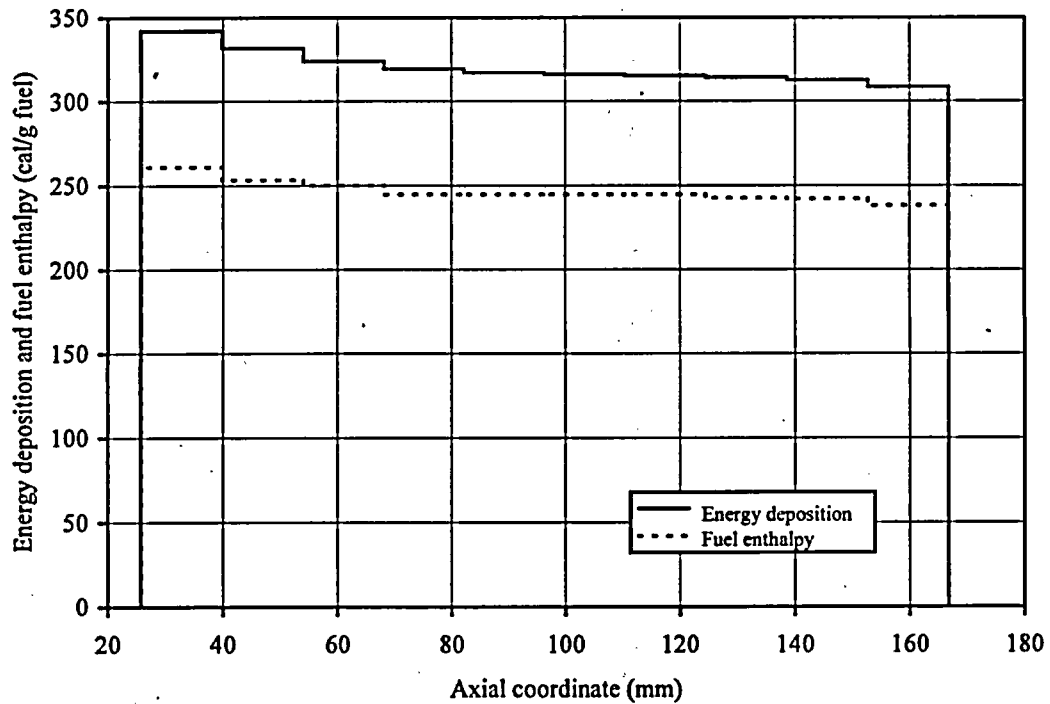

**Fig. H-10.3. Axial Distribution of Energy Deposition and Fuel Enthalpy Calculated by FRAP-T6 Code for Fuel Rod #B23T**

# #B23T

Individual Characteristics of Refabricated Fuel Rods  
(Fresh Fuel, Preirradiated Cladding) under IGR Tests

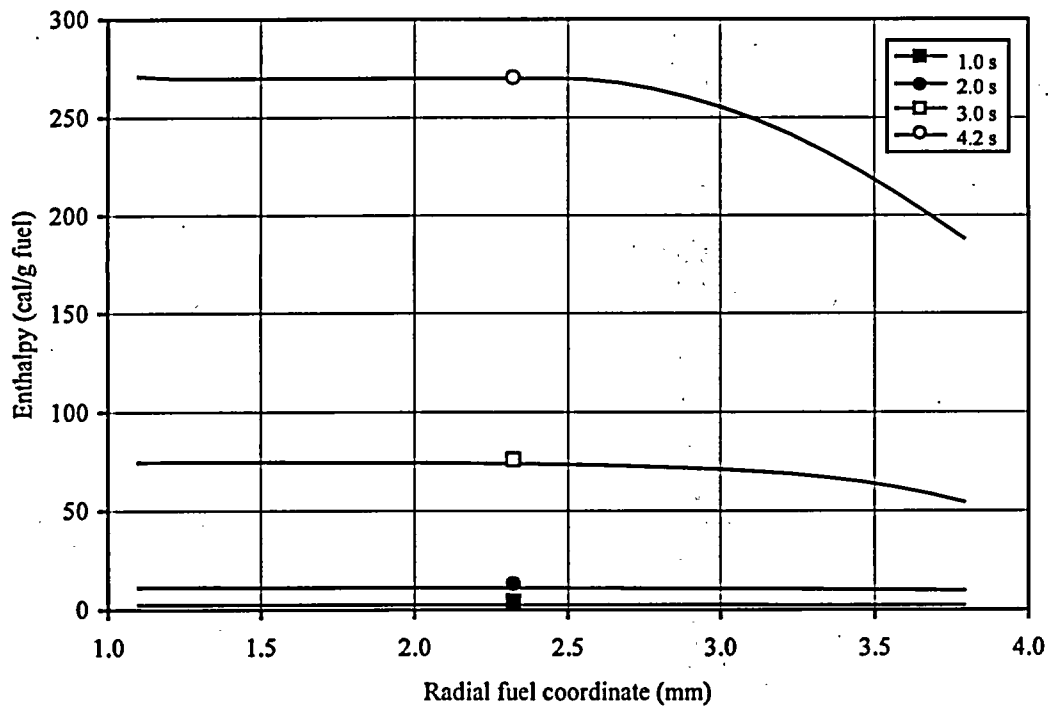
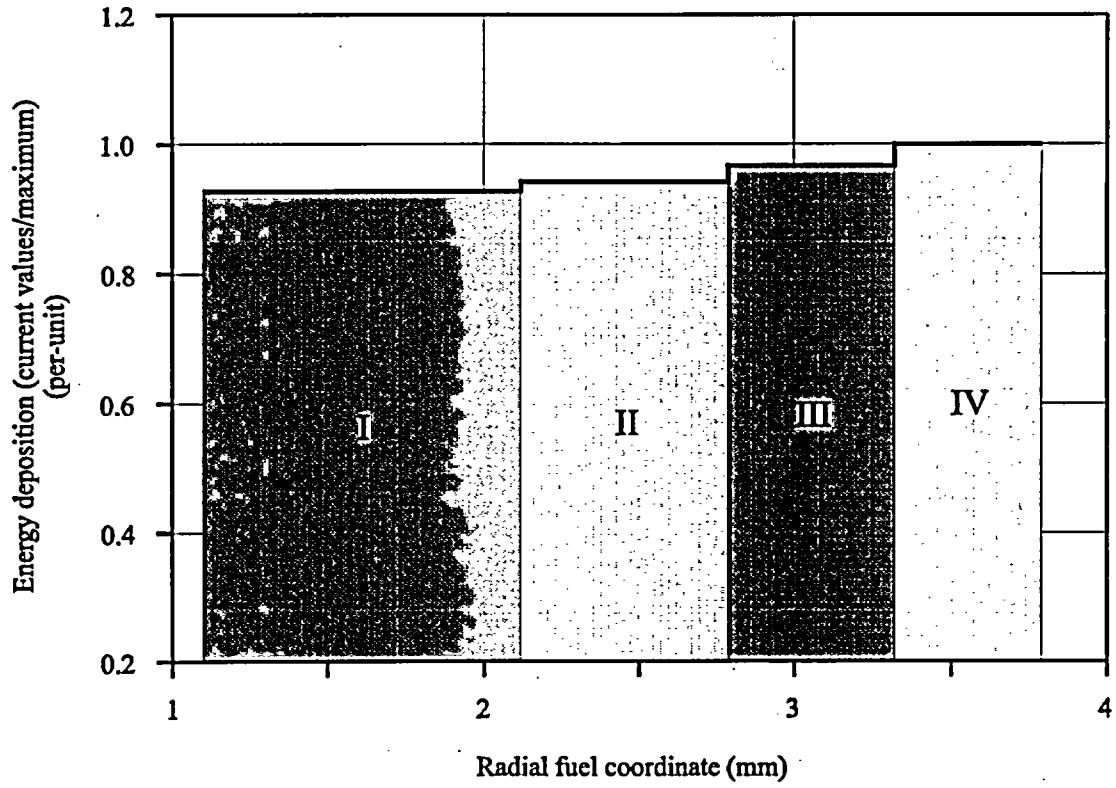

Fig. H-10.4. Radial Distributions of Energy Deposition and Fuel Enthalpy Calculated by FRAP-T6 Code for Fuel Rod #B23T

# #B23T

Individual Characteristics of Refabricated Fuel Rods  
(Fresh Fuel, Irradiated Cladding) under IGR Tests

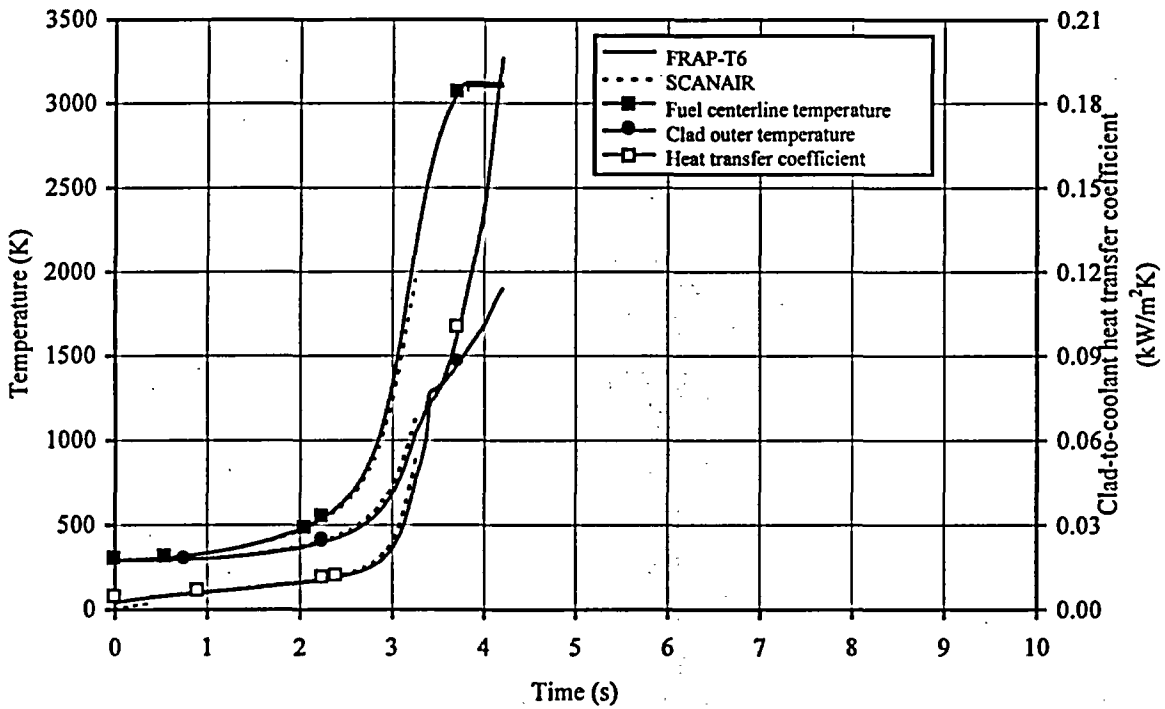
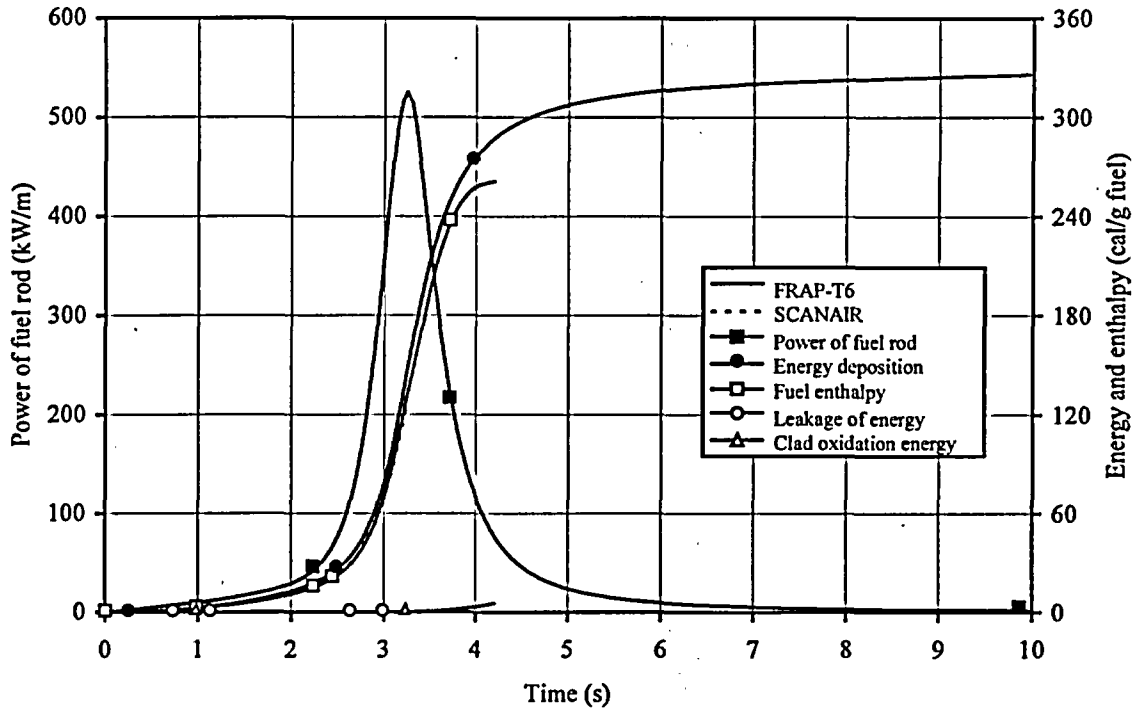

Fig. H-10.5. Energy and Temperature Characteristics Vs. Time Calculated by FRAP-T6 and SCANAIR Codes for Fuel Rod #B23T

#B23T

Individual Characteristics of Refabricated Fuel Rods  
(Fresh Fuel, Preirradiated Cladding) under IGR Tests

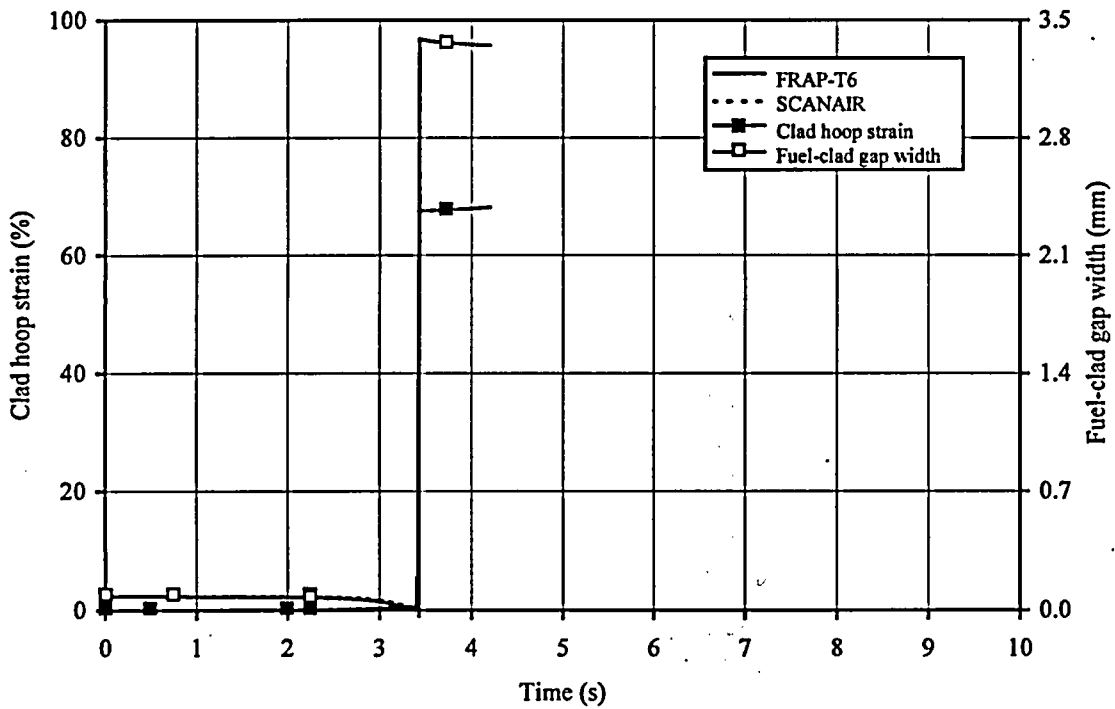
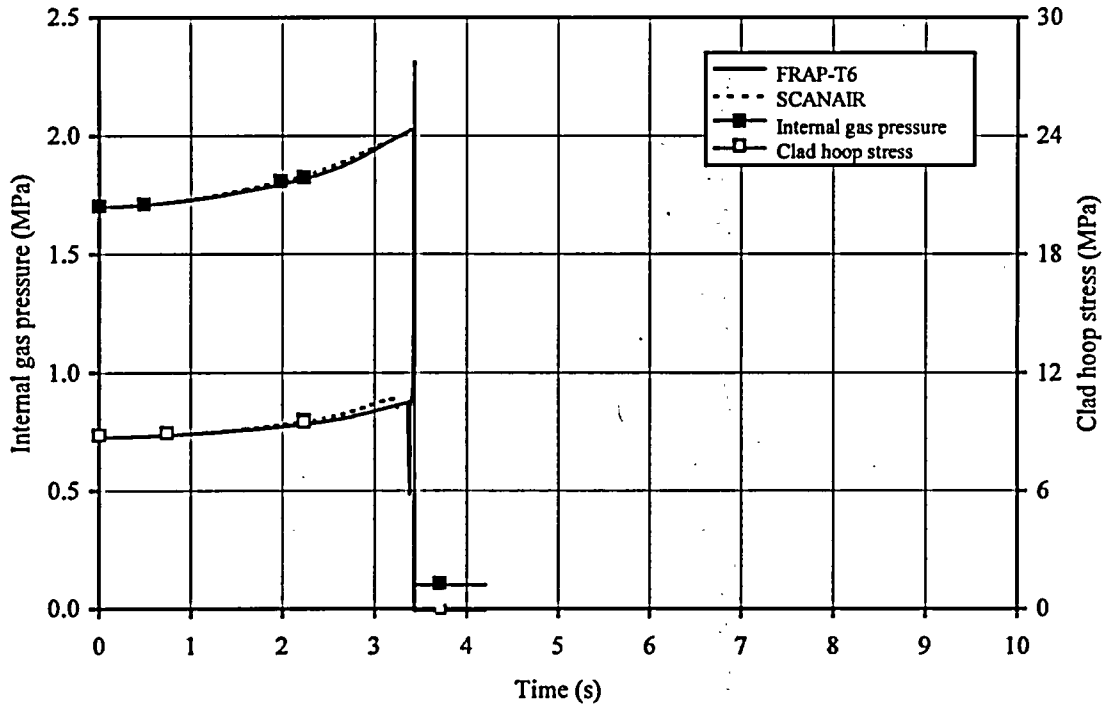

Fig. H-10.6. Cladding Mechanical Characteristics Vs. Time Calculated by FRAP-T6 and SCANAIR Codes for Fuel Rod #B23T

#B23T

Individual Characteristics of Refabricated Fuel Rods  
(Fresh Fuel, Preirradiated Cladding) under IGR Tests

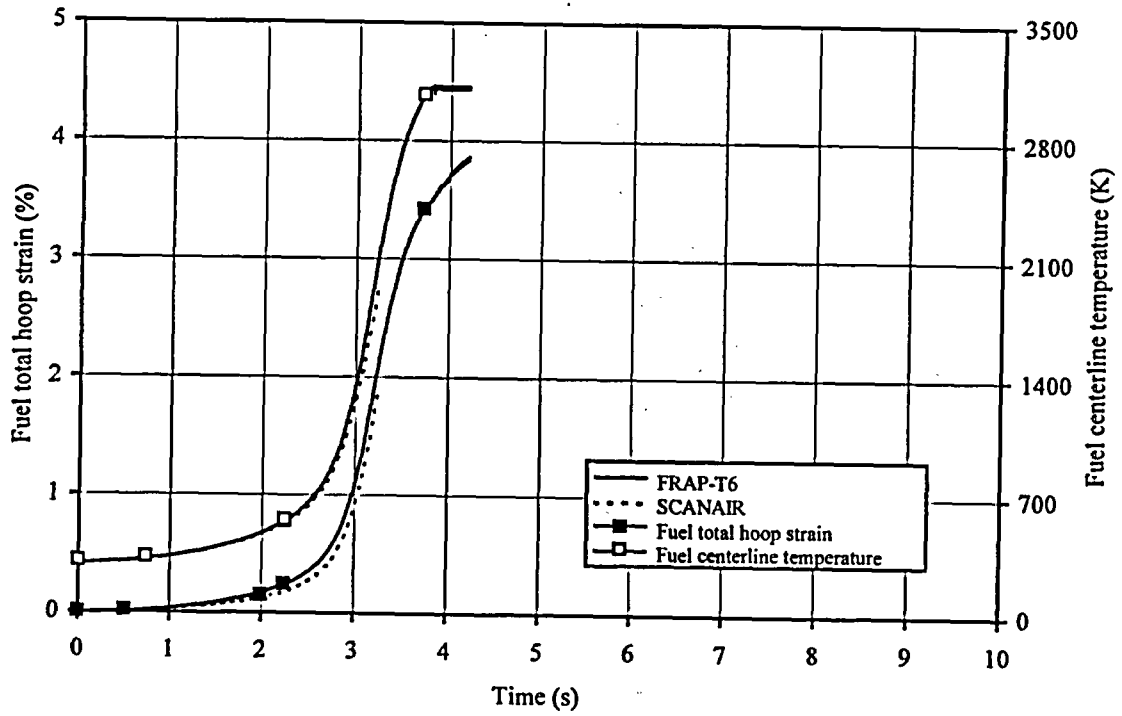

Fig. H-10.7. Fuel Strain Vs. Time Calculated by FRAP-T6 and SCANAIR Codes for Fuel Rod #B23T

## #B23T

Individual Characteristics of Refabricated Fuel Rods  
(Fresh Fuel, Preirradiated Cladding) under IGR Tests

Table H-10.9. General Characteristic of Fuel Rod #B23T

	Parameter	Unit	Value		
			Experiment	FRAP-T6	SCANAIR
1	Type of coolant	---	air	air	air
2	Burnup	MWd/kg U	0	0	0
3	Energy deposition in fuel rod	cal/g fuel	320	320	320
4	Peak fuel enthalpy	cal/g fuel	-	-	-
5	Peak fuel temperature	K	-	-	-
6	Peak clad temperature	K	-	-	-
7	Fuel rod failure	Yes, No	Yes	Yes	-
8	Type of failure:				
	- cladding rupture due to ballooning	Yes, No	?	Yes	-
	- cladding rupture due to PCMI	Yes, No	?	No	-
	- fragmentation of fuel rod	Yes, No	Yes	-	-
9	Failure time	s	-	3.43	-
10	Fuel enthalpy at failure	cal/g fuel	-	177	-
11	Outer cladding temperature at failure	K	-	1288	-
12	Internal gas pressure at failure	MPa	-	1.72	-
13	ZrO <sub>2</sub> thickness after test	μm	-	-	-
14	Residual clad hoop strain:				
	- peak value for ballooning area	%	-	-	-
	- other location <sup>1)</sup>	%	-	-	-

<sup>1)</sup>Calculated values by FRAP-T6 and SCANAIR codes are average along height of fuel rod excluding ballooning region

**APPENDIX I.**

**Characteristics of Fresh Fuel Rods  
during and after IGR Reactor Tests**

***APPENDIX I-1.***

***Individual Characteristics for Fuel Rod #H6C under IGR Test***



#H6C

Individual Characteristics of Refabricated Fuel Rods  
(Fresh Fuel, Fresh Cladding) under IGR Tests

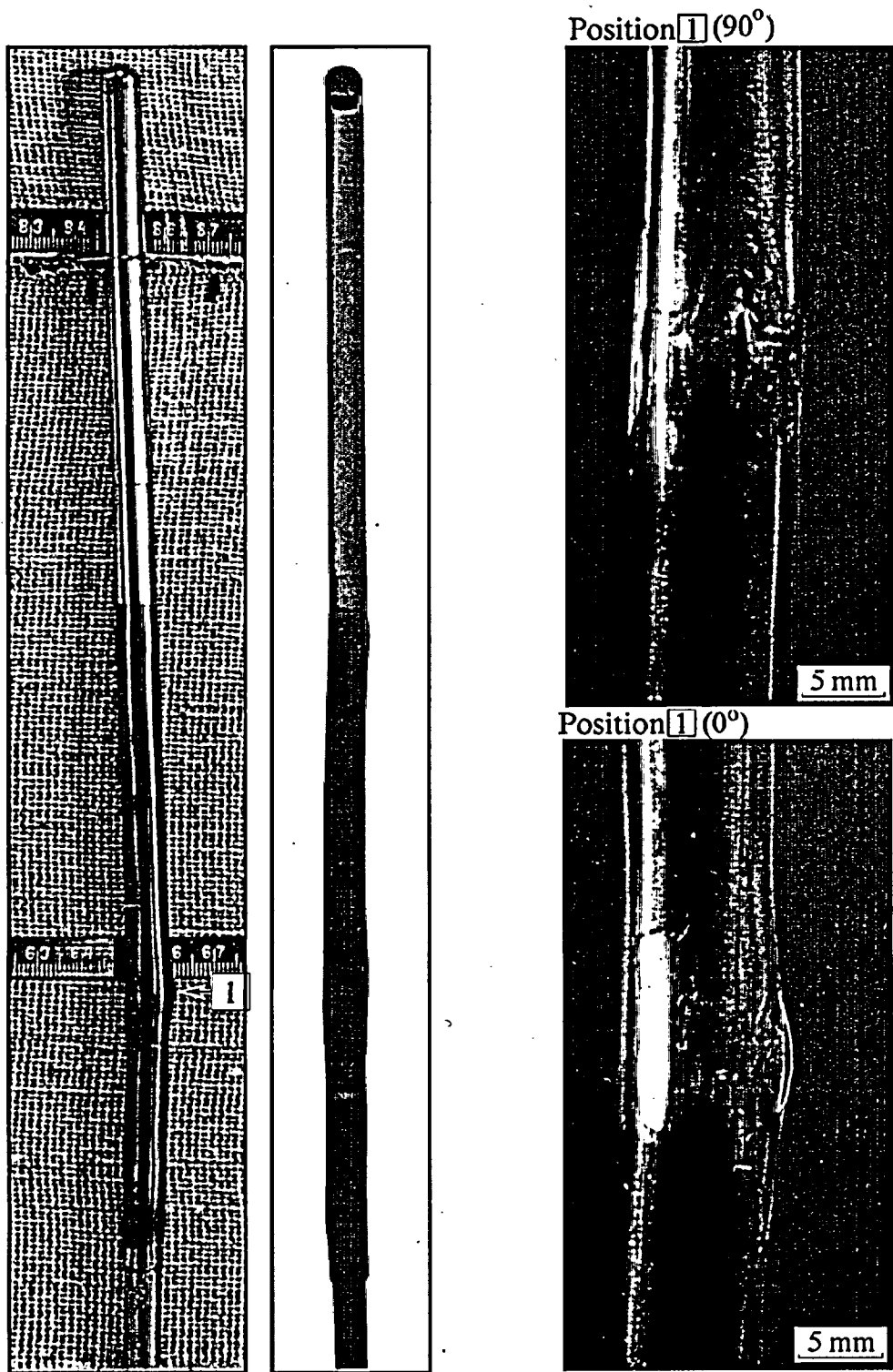
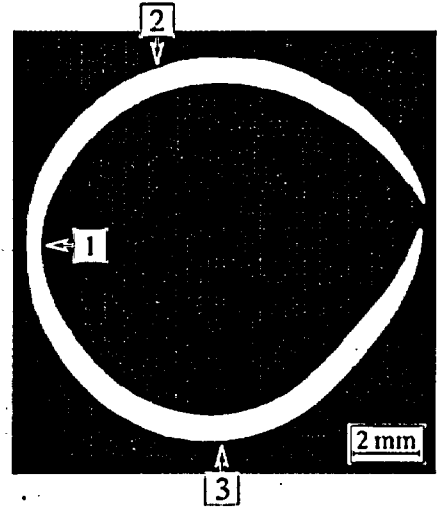
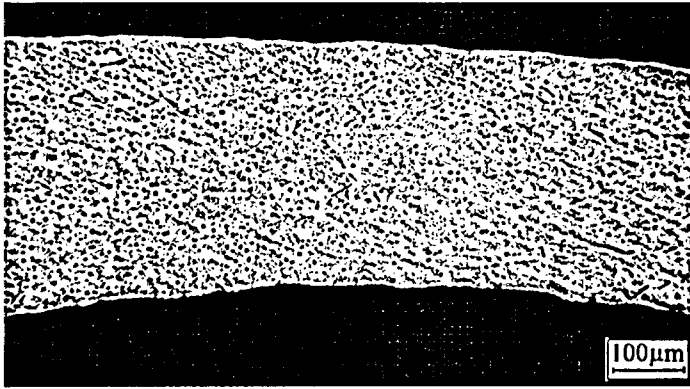

Fig. I-1.1. Appearance of Fuel Rod #H6C (photographs and X-ray photograph)

#H6C

Individual Characteristics of Refabricated Fuel Rods  
(Fresh Fuel, Fresh Cladding) under IGR Tests

Position 1



Position 2

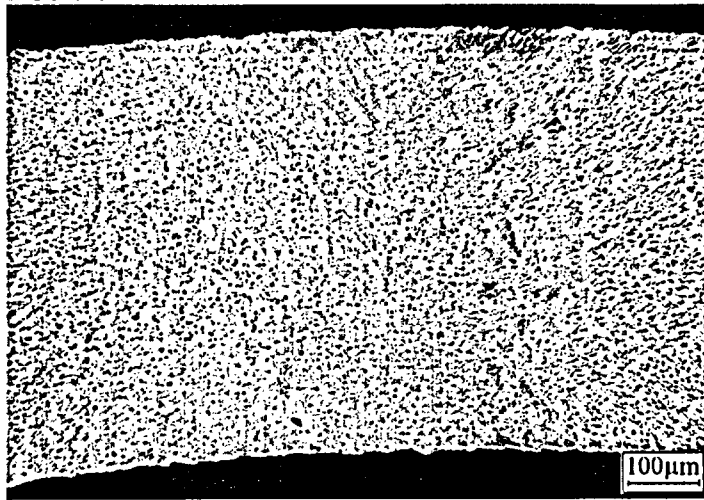

Position 3

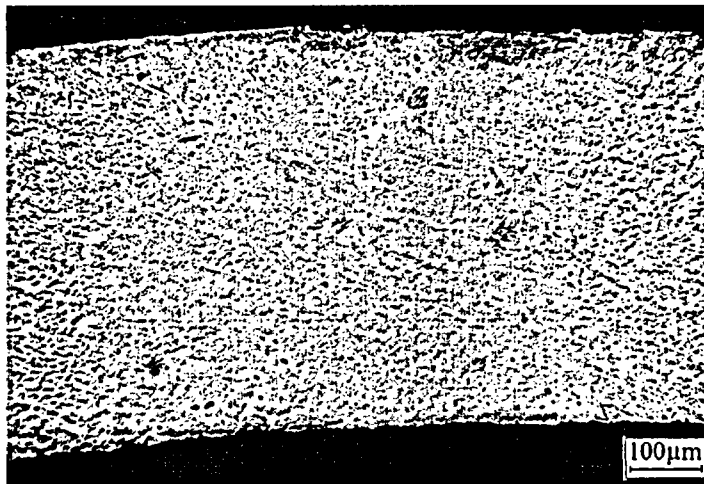
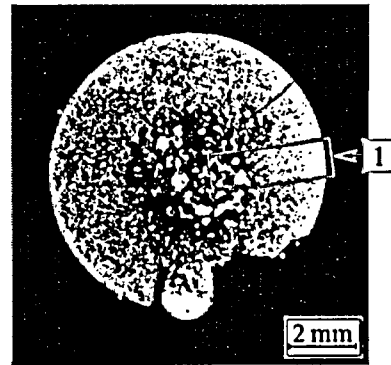
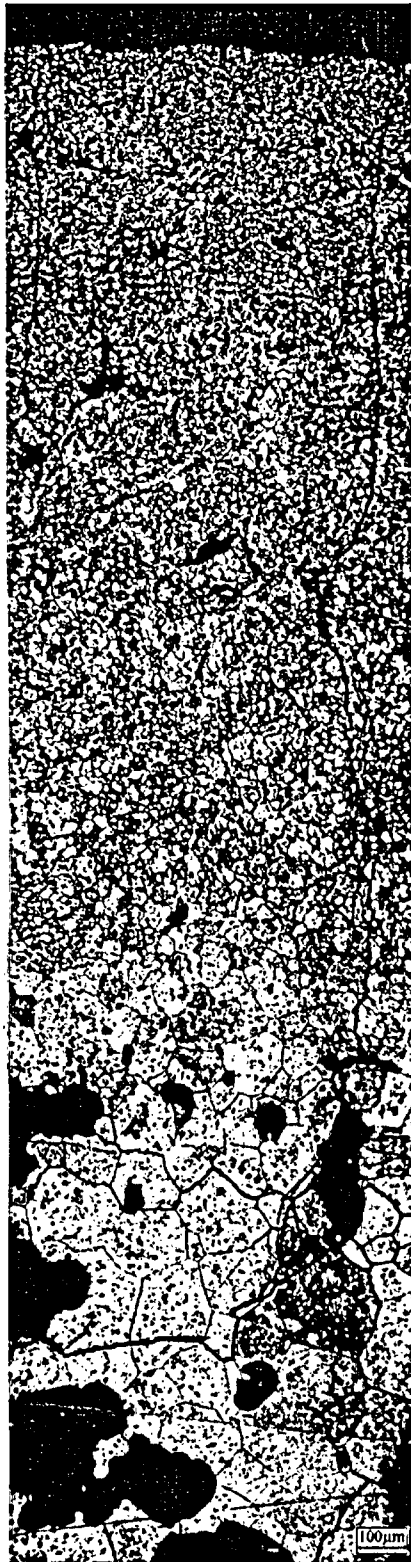

Fig. I-1.2. Cross-Section and Cladding Microstructure for Fuel Rod #H6C at 90 mm Elevation

#H6C

Individual Characteristics of Refabricated Fuel Rods  
(Fresh Fuel, Fresh Cladding) under IGR Tests

Position 1



Position 2

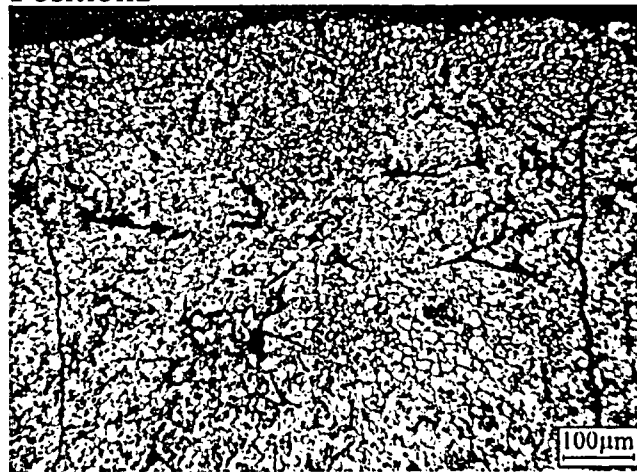

Position 3



Fig. I-1.3. Fuel Microstructure for Fuel Rod #H6C at 90 mm Elevation

# #H6C

Individual Characteristics of Refabricated Fuel Rods  
(Fresh Fuel, Fresh Cladding) under IGR Tests

Table I-1.1. Time Dependent Energy Characteristics of Fuel Rod #H6C

Time (s)	Reactor energy deposition <sup>1)</sup> (%)	Cumulative number of fissions in fuel rod (fiss)			Power of fuel rod (kW)	Energy deposition in fuel rod	
		U <sup>235</sup> ×10 <sup>-14</sup>	U <sup>238</sup> ×10 <sup>-12</sup>	Total ×10 <sup>-14</sup>		cal/g fuel	J/g fuel
0.0	0.000	0.000	0.000	0.000	0.000	0.000	0.000
1.0	0.697	0.202	0.073	0.203	1.140	2.180	9.130
2.0	2.790	0.810	0.290	0.813	2.290	8.720	36.50
2.2	3.380	0.981	0.352	0.985	2.570	10.60	44.40
2.4	4.040	1.170	0.421	1.180	2.910	12.70	53.20
2.6	4.800	1.400	0.501	1.400	3.380	15.00	62.80
2.8	5.710	1.660	0.595	1.660	4.130	17.90	74.90
3.0	6.860	1.990	0.715	2.000	5.420	21.50	90.00
3.2	8.440	2.450	0.881	2.460	7.860	26.50	111.0
3.4	10.90	3.160	1.130	3.170	12.70	34.10	143.0
3.6	15.00	4.370	1.570	4.380	22.30	47.10	197.0
3.8	22.40	6.500	2.330	6.530	39.30	70.10	293.0
4.0	34.60	10.10	3.610	10.10	60.80	108.0	452.0
4.2	51.10	14.90	5.330	14.90	71.60	160.0	670.0
4.4	67.20	19.50	7.000	19.60	56.10	210.0	879.0
4.6	77.90	22.60	8.120	22.70	33.10	244.0	1021.
4.8	84.00	24.40	8.760	24.50	18.40	263.0	1101.
5.0	87.40	25.40	9.110	25.50	10.70	274.0	1147.
5.2	89.40	26.00	9.320	26.10	6.870	280.0	1172.
5.4	90.80	26.40	9.460	26.50	4.820	285.0	1193.
5.6	91.70	26.70	9.560	26.80	3.670	288.0	1206.
5.8	92.50	26.90	9.640	27.00	2.970	291.0	1218.
6.0	93.10	27.10	9.710	27.20	2.520	293.0	1226.
6.5	94.30	27.40	9.830	27.50	1.800	297.0	1243.
7.0	95.10	27.60	9.920	27.70	1.210	300.0	1256.
7.5	95.70	27.80	9.970	27.90	0.870	302.0	1264.
8.0	96.10	27.90	10.00	28.00	0.664	303.0	1268.
9.0	96.70	28.10	10.10	28.20	0.528	305.0	1277.
10.0	97.10	28.20	10.10	28.30	0.384	307.0	1285.
20.0	98.60	28.70	10.30	28.80	0.086	314.0	1314.
30.0	99.10	28.80	10.30	28.90	0.043	316.0	1323.
∞	100.0	29.10	10.40	29.20	0.000	323.0	1352.

Maximum value of power is 71.6 kW (t = 4.20 s)

<sup>1)</sup> Current energy deposition per maximum energy deposition (at infinite time)

# #H6C

Individual Characteristics of Refabricated Fuel Rods  
(Fresh Fuel, Fresh Gladding) under IGR Tests

Table I-1.2. Axial Energy Characteristics of Fuel Rod #H6C

Axial coordinate from lower end of fuel rod (mm)	Cumulative number of fissions in fuel rod (fiss)			Maximum power of fuel rod (kW) t=4.20 s	Energy deposition at infinite time*		
	$U^{235}$ $\times 10^{-13}$	$U^{238}$ $\times 10^{-11}$	Total $\times 10^{-13}$		cal/g fuel	J/g fuel	per-unit <sup>3)</sup>
15.0	0.00	0.00	0.00	0.00	0.00	0.00	0.00
25.0 <sup>1)</sup>	13.70	4.070	13.70	3.380	362.0	1515.	1.00
35.0	22.00	7.040	22.10	5.430	350.0	1465.	0.97
45.0	21.20	7.270	21.20	5.220	338.0	1415.	0.93
55.0	20.80	7.520	20.90	5.130	329.0	1377.	0.91
65.0	20.30	7.600	20.40	5.010	321.0	1344.	0.89
75.0	20.10	7.690	20.20	4.960	316.0	1323.	0.87
85.0	19.70	7.620	19.80	4.870	313.0	1310.	0.86
95.0	19.50	7.530	19.60	4.810	311.0	1302.	0.86
105.0	19.60	7.500	19.70	4.840	310.0	1298.	0.86
115.0	19.70	7.410	19.80	4.870	311.0	1302.	0.86
125.0	19.60	7.210	19.70	4.840	313.0	1310.	0.86
135.0	20.00	7.180	20.10	4.940	316.0	1323.	0.87
145.0	20.40	7.120	20.40	5.020	319.0	1335.	0.88
155.0	20.60	7.040	20.60	5.070	323.0	1352.	0.89
165.0 <sup>2)</sup>	13.20	4.460	13.30	3.260	326.0	1365.	0.90
175.0	0.00	0.00	0.00	0.00	0.00	0.00	0.00

\* All numerical values of characteristics are presented as average values at the length interval equal to the axial coordinate  $\pm 5.0$  mm

1) Initial coordinate of fuel is 24.0 mm

2) End coordinate of fuel is 168.0 mm

3) Current value per maximum value

# #H6C

Individual Characteristics of Refabricated Fuel Rods  
(Fresh Fuel, Fresh Cladding) under IGR Tests

Table I-1.3. Radial Energy Characteristics of Fuel Rod #H6C

Characteristics*		Coordinates of fuel zones (mm)			
		1 zone 1.10 - 2.14	2 zone 2.14 - 2.83	3 zone 2.83 - 3.37	4 zone 3.37 - 3.84
U <sup>235</sup>	Number of fissions $\times 10^{-14}$ (fiss)	6.930	7.190	7.240	7.690
	Power of fuel rod <sup>1)</sup> (kW)	17.00	17.70	17.80	18.90
	Energy deposition <sup>2)</sup> (cal/g fuel)	308.0	314.0	324.0	340.0
	Energy deposition <sup>2)</sup> (J/g fuel)	1289.	1314.	1356.	1423.
	Energy deposition <sup>3)</sup> (per-unit)	0.906	0.924	0.953	1.000
U <sup>238</sup>	Number of fissions $\times 10^{-12}$ (fiss)	2.570	2.680	2.590	2.580
	Power of fuel rod <sup>1)</sup> (kW)	0.062	0.065	0.063	0.063
	Energy deposition <sup>2)</sup> (cal/g fuel)	1.130	1.150	1.140	1.130
	Energy deposition <sup>2)</sup> (J/g fuel)	4.730	4.810	4.770	4.730
	Energy deposition <sup>3)</sup> (per-unit)	0.983	1.000	0.991	0.983
Total	Number of fissions $\times 10^{-14}$ (fiss)	6.960	7.220	7.270	7.710
	Power of fuel rod <sup>1)</sup> (kW)	17.10	17.70	17.90	19.00
	Energy deposition <sup>2)</sup> (cal/g fuel)	309.0	315.0	325.0	341.0
	Energy deposition <sup>2)</sup> (J/g fuel)	1293.	1319.	1360.	1427.
	Energy deposition <sup>3)</sup> (per-unit)	0.906	0.924	0.953	1.000

<sup>1)</sup> at time of 4.20 s, <sup>2)</sup> at infinite time, <sup>3)</sup> Current value per maximum value

\* All numerical values of characteristics were calculated for length of fuel stack

# #H6C

Individual Characteristics of Refabricated Fuel Rods  
(Fresh Fuel, Fresh Cladding) under IGR Tests

Table I-1.4. Fuel Enthalpy Vs. Time Calculated by FRAP-T6 Code for Fuel Rod #H6C

Time (s)	Enthalpy at fuel radius (cal/g fuel)				Fuel enthalpy <sup>1)</sup>		Energy deposition in fuel rod	
	1.10 mm	2.20 mm	2.93 mm	3.79 mm	cal/g fuel	J/g fuel	cal/g fuel	J/g fuel
0.0	0.00	0.00	0.00	0.00	0.00	0.00	0.00	0.00
1.0	2.20	2.17	2.08	1.83	2.07	8.67	2.14	8.97
2.0	8.38	8.22	7.85	6.98	7.84	32.8	8.58	36.0
2.2	10.1	9.90	9.45	8.37	9.43	39.5	10.4	43.6
2.4	12.0	11.8	11.2	9.69	11.2	46.8	12.5	52.2
2.6	14.2	13.9	13.1	11.0	13.0	54.6	14.8	62.1
2.8	16.9	16.4	15.3	12.4	15.2	63.7	17.6	73.9
3.0	20.2	19.6	18.0	14.1	17.9	75.1	21.2	89.0
3.2	24.9	24.0	22.0	16.5	21.8	91.3	26.2	110
3.4	32.3	31.2	28.4	20.0	28.0	117	33.9	142
3.6	45.3	43.9	39.8	25.3	38.8	163	47.1	197
3.8	68.7	66.9	60.6	34.7	58.4	245	70.2	294
4.0	107	105	93.5	32.6	86.6	363	108	452
4.2	158	155	134	50.6	126	527	158	660
4.4	207	201	173	77.9	165	691	206	861
4.6	241	232	197	128	196	821	239	1002
4.8	259	247	211	142	212	887	258	1083
5.0	268	253	217	145	218	913	270	1129
5.2	269	255	218	146	219	919	276	1158
5.4	269	255	217	145	219	916	281	1178
5.6	268	253	215	144	217	908	285	1193
5.8	269	251	211	142	214	898	287	1205
6.0	268	248	208	140	211	886	290	1214
6.5	262	240	199	136	204	855	294	1233
7.0	253	231	191	131	196	821	298	1247
7.5	243	221	182	127	187	785	300	1256
8.0	233	211	173	122	179	750	301	1262
10.0	189	166	130	89.5	138	576	305	1279
30.0	19.5	19.2	18.5	17.5	18.6	78.0	316	1326

Radial enthalpy distribution and fuel enthalpy are presented at elevation 31.2 mm

Maximum value of fuel enthalpy is 219.4 cal/g fuel (t=5.20 s)

# #H6C

Individual Characteristics of Refabricated Fuel Rods  
(Fresh Fuel, Fresh Cladding) under IGR Tests

Table I-1.5. Energy Characteristics Vs. Time Calculated by FRAP-T6 and SCANAIR Codes for Fuel Rod #H6C

Time (s)	Energy deposition <sup>1)</sup> (cal/g fuel)	Linear power <sup>1)</sup> (kW/m)	Fuel enthalpy <sup>1)</sup> (cal/g fuel)		Energy of metal-water reaction <sup>1)</sup> (cal/g fuel)	Leakage of energy <sup>1)</sup> (cal/g fuel)		Clad-to-coolant heat transfer coefficient <sup>1)</sup> (kW/m <sup>2</sup> K)	
			FRAP-T6	SCANAIR	FRAP-T6	FRAP-T6	SCANAIR	FRAP-T6	SCANAIR
0.0	0.00	0.00	0.00	0.00	0.00	0.00	0.00	0.00	0.00
1.0	2.33	8.54	2.07	2.00	0.00	0.00	0.01	0.03	0.10
2.0	9.33	17.2	7.84	7.85	0.00	0.02	0.08	0.03	0.10
2.2	11.3	19.3	9.43	9.26	0.00	0.11	0.26	0.87	1.38
2.4	13.6	21.8	11.2	11.0	0.00	0.50	0.80	1.71	2.17
2.6	16.1	25.3	13.0	12.9	0.00	1.11	1.57	2.32	2.88
2.8	19.2	30.9	15.2	14.7	0.00	1.94	2.42	2.98	3.56
3.0	23.1	40.6	17.9	17.4	0.00	3.02	3.70	3.81	4.56
3.2	28.5	58.9	21.8	21.3	0.00	4.45	5.40	4.97	6.06
3.4	36.9	95.2	28.0	26.6	0.00	6.46	7.41	6.92	8.17
3.6	51.2	167	38.8	37.2	0.00	9.56	10.9	10.7	12.7
3.8	76.4	294	58.4	56.6	0.00	14.7	17.3	15.9	22.2
4.0	117	456	86.6	84.8	0.00	25.9	28.3	26.9	28.4
4.2	171	536	126	128	0.00	34.1	32.8	1.05	1.46
4.4	224	420	165	-	0.00	36.9	-	1.35	-
4.6	260	248	196	-	0.02	41.1	-	1.40	-
4.8	281	138	212	-	0.10	45.6	-	1.42	-
5.0	293	80.2	218	-	0.27	50.4	-	1.46	-
5.2	300	51.5	219	-	0.54	55.6	-	1.48	-
5.4	305	36.1	219	-	0.87	61.0	-	1.50	-
5.6	309	27.5	217	-	1.21	66.5	-	1.50	-
5.8	312	22.3	214	-	1.52	72.1	-	1.51	-
6.0	314	18.9	211	-	1.80	77.7	-	1.51	-
6.5	319	13.5	204	-	2.31	91.5	-	1.49	-
7.0	323	9.07	196	-	2.64	105	-	1.47	-
7.5	325	6.52	187	-	2.83	117	-	1.44	-
8.0	327	4.97	179	-	2.95	129	-	1.68	-
10.0	331	2.88	138	-	2.97	202	-	10.8	-
30.0	343	0.32	18.6	-	2.97	342	-	1.04	-

<sup>1)</sup> All numerical values are presented at elevation with peak power



# #H6C

Individual Characteristics of Refabricated Fuel Rods  
(Fresh Fuel, Fresh Cladding) under IGR Tests

Table I-1.6. Temperature Variation, Fission Gas Release and ZrO<sub>2</sub> Thickness Vs. Time for Fuel Rod #H6C Calculated by FRAP-T6 and SCANAIR Codes

Time (s)	Fuel centerline temperature <sup>1)</sup> (K)		Fuel surface temperature <sup>1)</sup> (K)		Clad outer temperature <sup>1)</sup> (K)		Average ZrO <sub>2</sub> <sup>2)</sup> thickness (μm)
	FRAP-T6	SCANAIR	FRAP-T6	SCANAIR	FRAP-T6	SCANAIR	FRAP-T6
0.0	293	293	293	293	293	293	5.00
1.0	331	325	325	324	308	308	5.00
2.0	430	418	409	408	370	372	5.00
2.2	457	441	430	427	384	380	5.00
2.4	486	469	451	446	389	382	5.00
2.6	519	501	470	466	392	384	5.00
2.8	557	532	491	484	394	385	5.00
3.0	605	577	517	510	397	387	5.00
3.2	671	640	551	548	400	390	5.00
3.4	775	720	602	597	405	393	5.00
3.6	952	877	677	686	413	398	5.00
3.8	1259	1159	808	802	421	408	5.00
4.0	1742	1577	779	867	447	441	5.00
4.2	2301	2139	1021	1252	792	1014	5.00
4.4	2716	-	1377	-	1168	-	5.01
4.6	2944	-	1984	-	1239	-	5.04
4.8	3053	-	2135	-	1278	-	5.10
5.0	3103	-	2172	-	1331	-	5.19
5.2	3105	-	2177	-	1371	-	5.32
5.4	3105	-	2169	-	1397	-	5.50
5.6	3105	-	2155	-	1410	-	5.70
5.8	3105	-	2138	-	1415	-	5.90
6.0	3105	-	2121	-	1412	-	6.09
6.5	3067	-	2074	-	1386	-	6.49
7.0	3015	-	2024	-	1347	-	6.76
7.5	2955	-	1972	-	1305	-	6.94
8.0	2890	-	1920	-	1258	-	7.05
10.0	2577	-	1525	-	413	-	7.07
30.0	595	-	567	-	385	-	7.07

<sup>1)</sup> All numerical values are presented at elevation with peak power

<sup>2)</sup> Initial ZrO<sub>2</sub> thickness is 5 μm

# #H6C

Individual Characteristics of Refabricated Fuel Rods  
(Fresh Fuel, Fresh Cladding) under IGR Tests

Table I-1.7. Mechanical Characteristics of Fuel Rod #H6C Vs. Time Calculated by FRAP-T6 and SCANAIR Codes

Time (s)	Clad outer temperature <sup>1)</sup> (K)		Fuel hoop strain <sup>1)</sup> (%)		Fuel - clad gap width <sup>1)</sup> (mm)		Clad hoop strain <sup>1)</sup> (%)		Clad hoop stress <sup>1)</sup> (MPa)		Internal gas pressure (MPa)	
	FRAP-T6	SCANAIR	FRAP-T6	SCANAIR	FRAP-T6	SCANAIR	FRAP-T6	SCANAIR	FRAP-T6	SCANAIR	FRAP-T6	SCANAIR
0.0	293	293	0.00	0.00	0.03	0.03	0.01	0.01	10.3	10.4	2.00	2.00
1.0	308	308	0.00	0.02	0.03	0.03	0.02	0.02	10.5	10.5	2.02	2.02
2.0	370	372	0.04	0.09	0.03	0.03	0.06	0.07	10.7	10.8	2.06	2.06
2.2	384	380	0.07	0.11	0.03	0.03	0.07	0.08	10.7	10.9	2.07	2.07
2.4	389	382	0.10	0.13	0.03	0.03	0.08	0.08	10.8	11.0	2.08	2.08
2.6	392	384	0.13	0.15	0.03	0.03	0.08	0.08	10.8	11.1	2.09	2.09
2.8	394	385	0.17	0.17	0.03	0.03	0.08	0.09	10.9	11.2	2.10	2.10
3.0	397	387	0.22	0.20	0.03	0.03	0.09	0.09	10.9	11.3	2.11	2.11
3.2	400	390	0.29	0.25	0.02	0.03	0.09	0.10	11.0	11.5	2.12	2.12
3.4	405	393	0.39	0.31	0.02	0.02	0.10	0.10	11.1	11.8	2.14	2.13
3.6	413	398	0.57	0.45	0.01	0.02	0.11	0.12	11.2	12.3	2.16	2.15
3.8	421	408	0.91	0.72	0.00	0.01	0.13	0.15	11.3	13.2	2.18	2.18
4.0	447	441	1.48	1.14	0.00	0.00	0.54	0.29	205	124	2.20	2.20
4.2	792	1014	2.26	1.91	0.00	0.00	1.16	0.95	127	30.5	2.22	2.21
4.4	1168	-	2.95	-	0.00	-	1.67	-	12.2	-	2.23	-
4.6	1239	-	3.40	-	0.52	-	15.1	-	0.00	-	0.10	-
4.8	1278	-	3.73	-	0.50	-	15.1	-	0.00	-	0.10	-
5.0	1331	-	3.89	-	0.50	-	15.1	-	0.00	-	0.10	-
5.2	1371	-	3.90	-	0.50	-	15.2	-	0.00	-	0.10	-
5.4	1397	-	3.90	-	0.50	-	15.2	-	0.00	-	0.10	-
5.6	1410	-	3.88	-	0.50	-	15.2	-	0.00	-	0.10	-
5.8	1415	-	3.85	-	0.50	-	15.2	-	0.00	-	0.10	-
6.0	1412	-	3.82	-	0.50	-	15.2	-	0.00	-	0.10	-
6.5	1386	-	3.69	-	0.51	-	15.2	-	0.00	-	0.10	-
7.0	1347	-	3.47	-	0.51	-	15.2	-	0.00	-	0.10	-
7.5	1305	-	3.32	-	0.52	-	15.1	-	0.00	-	0.10	-
8.0	1258	-	3.20	-	0.52	-	15.1	-	0.00	-	0.10	-
10.0	413	-	2.56	-	0.55	-	14.9	-	0.00	-	0.10	-
30.0	385	-	0.23	-	0.64	-	14.8	-	0.00	-	0.10	-

<sup>1)</sup> All numerical values are presented at elevation with peak power

# #H6C

Individual Characteristics of Refabricated Fuel Rods  
(Fresh Fuel, Fresh Cladding) under IGR Tests

Table I-1.8. Axial Distribution of Energy Deposition and Fuel Enthalpy Calculated by FRAP-T6 Code for Fuel Rod #H6C

Axial interval from-to (mm)-(mm)	Energy deposition at infinite time			Fuel enthalpy at time (t=5.20 s)		
	cal/g fuel	J/g fuel	per-unit	cal/g fuel	J/g fuel	per-unit
24.0 - 38.4	350	1467	1.00	219	919	1.00
38.4 - 52.8	335	1402	0.96	210	878	0.96
52.8 - 67.2	324	1359	0.93	203	851	0.93
67.2 - 81.6	315	1320	0.90	197	827	0.90
81.6 - 96.0	313	1311	0.89	196	821	0.89
96.0 - 110.4	313	1311	0.89	196	821	0.89
110.4 - 124.8	313	1311	0.89	196	821	0.89
124.8 - 139.2	317	1330	0.91	199	833	0.91
139.2 - 153.6	323	1353	0.92	202	847	0.92
153.6 - 168.0	326	1368	0.93	204	857	0.93

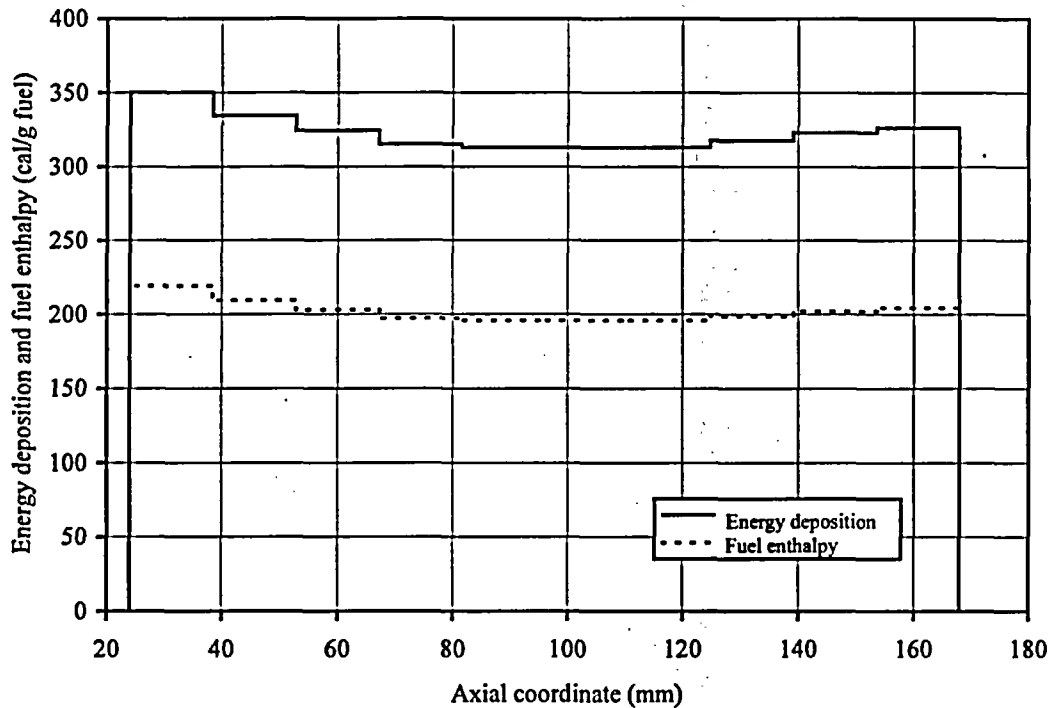

Fig. I-1.4. Axial Distribution of Energy Deposition and Fuel Enthalpy Calculated by FRAP-T6 Code for Fuel Rod #H6C

# #H6C

Individual Characteristics of Refabricated Fuel Rods  
(Fresh Fuel, Fresh Cladding) under IGR Tests

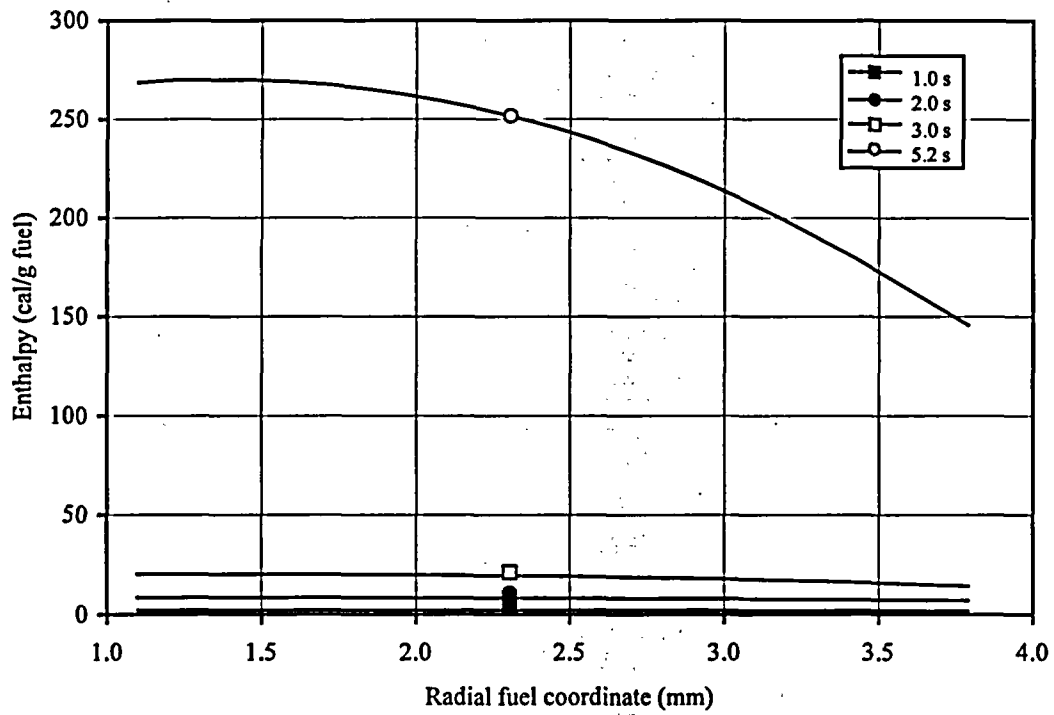
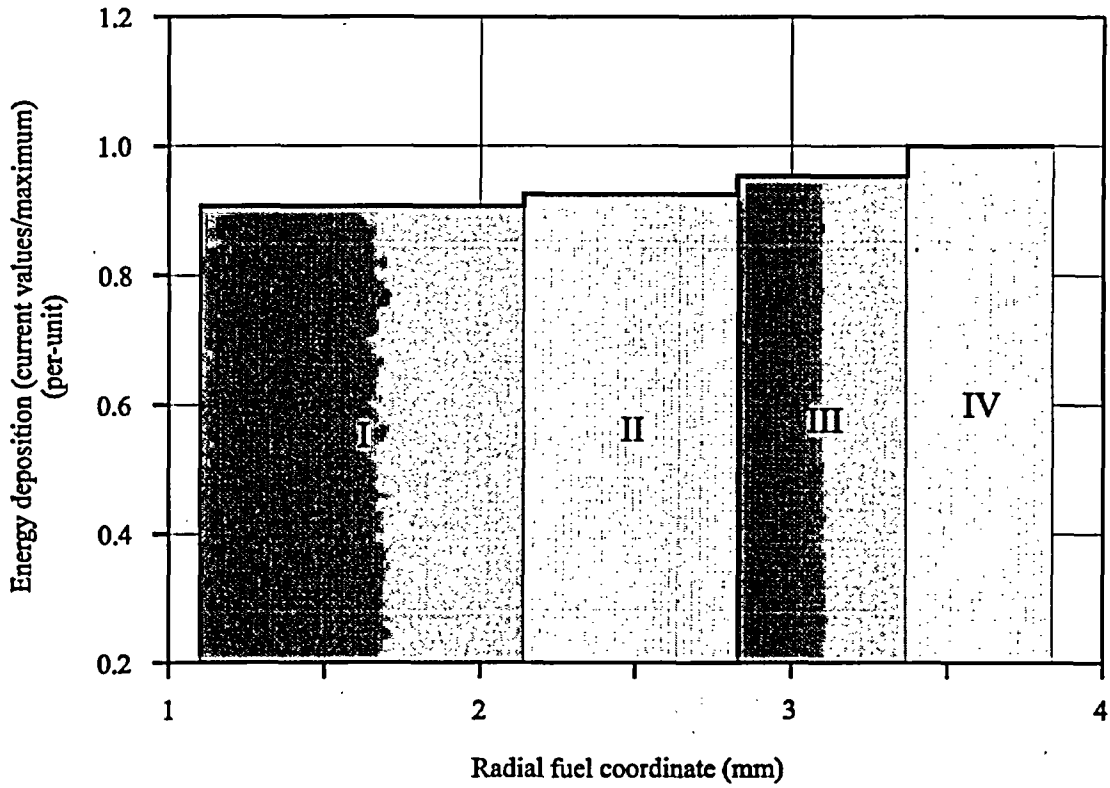

Fig. I-1.5. Radial Distributions of Energy Deposition and Fuel Enthalpy Calculated by FRAP-T6 Code for Fuel Rod #H6C

#H6C

Individual Characteristics of Refabricated Fuel Rods  
(Fresh Fuel, Fresh Cladding) under IGR Tests

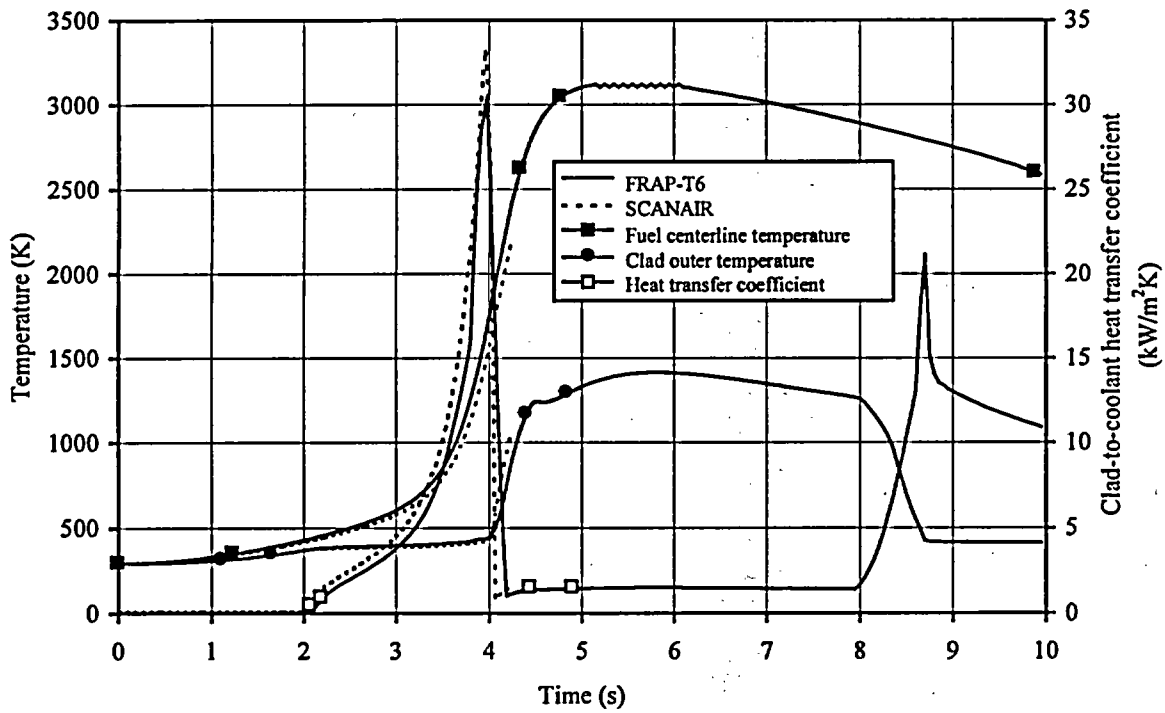
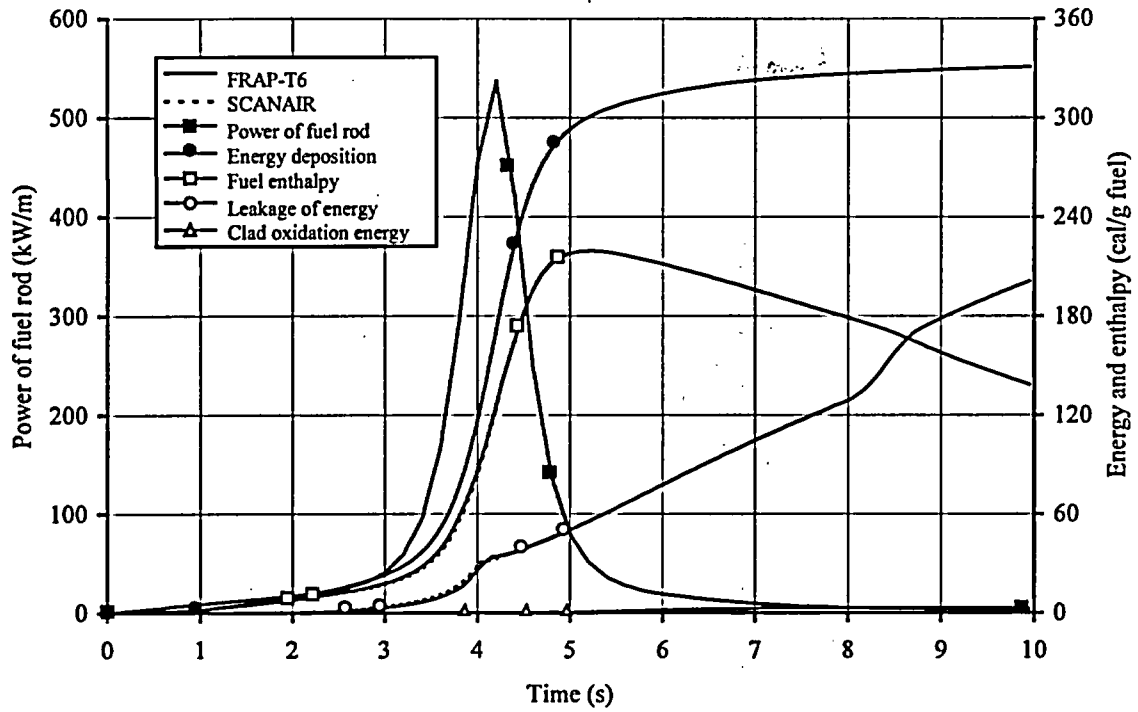

Fig. I-1.6. Energy and Temperature Characteristics Vs. Time Calculated by FRAP-T6 and SCANAIR Codes for Fuel Rod #H6C

# #H6C

Individual Characteristics of Refabricated Fuel Rods  
(Fresh Fuel/Fresh Cladding) under IGR Tests

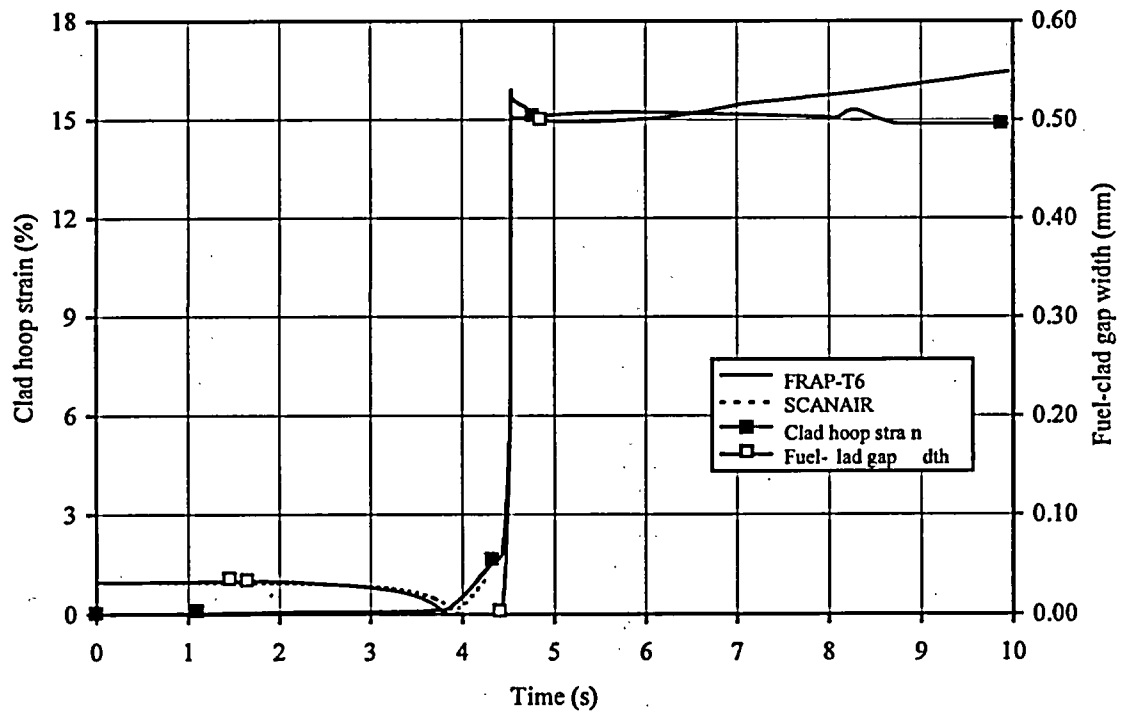
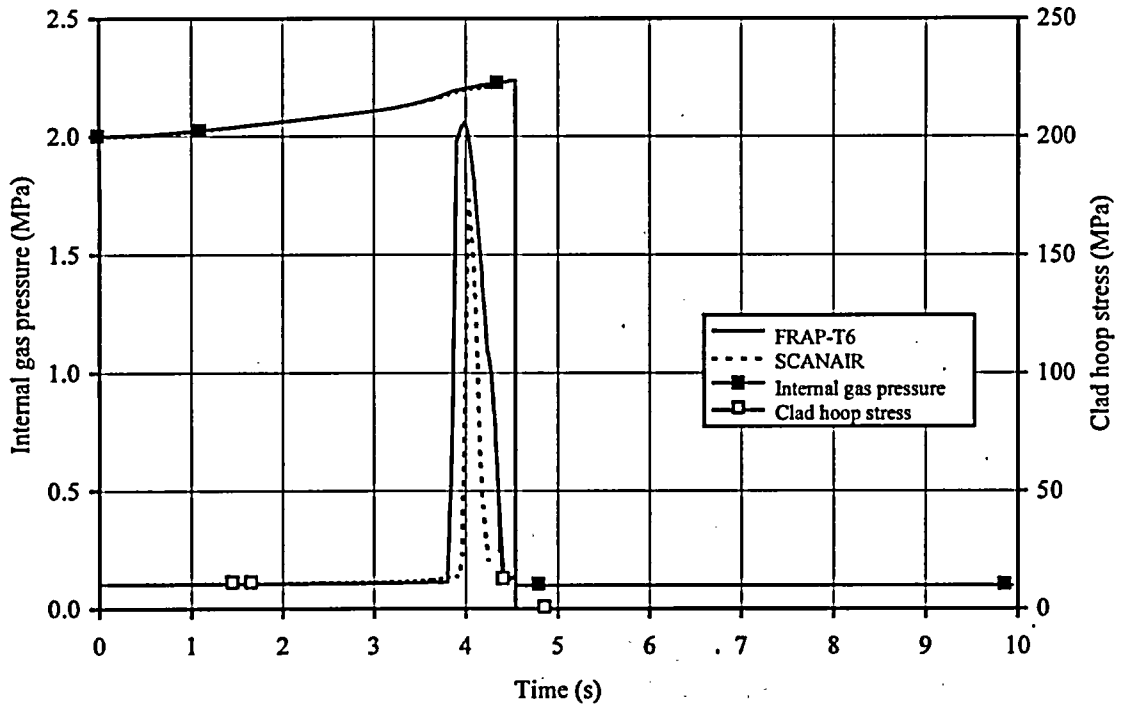

Fig. I-1.7. Cladding Mechanical Characteristics Vs. Time Calculated by FRAP-T6 and SCANAIR Codes for Fuel Rod #H6C

# #H6C

Individual Characteristics of Refabricated Fuel Rods  
(Fresh Fuel, Fresh Cladding) under IGR Tests

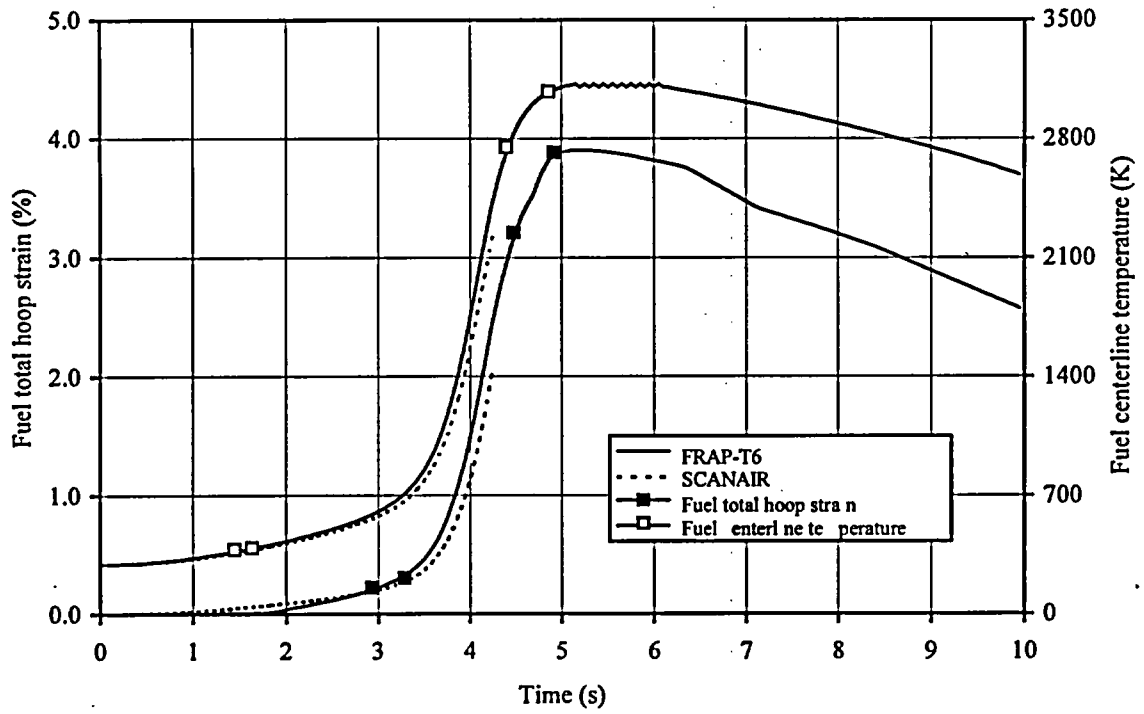

Fig. I-1.8. Fuel Strain Vs. Time Calculated by FRAP-T6 and SCANAIR Codes for Fuel Rod #H6C

Table I-1.9. Some Results of PIE for Fuel Rod #H6C

Characteristic		Value
1.	Measured parameters of cladding oxidation and cladding deformation	
1.1.	Cladding thickness at elevation 90 mm for different azimuthal angles ( $\mu\text{m}$ ):	
	0°	610
	90°	R
	180°	570
	270°	340
1.2.	ZrO <sub>2</sub> thickness at elevation 90 mm for different azimuthal angles ( $\mu\text{m}$ ):	
	0°	5
	90°	5
	180°	5
	270°	5
1.3.	$\alpha\text{Zr(O)}$ thickness at elevation 90 mm for different azimuthal angles ( $\mu\text{m}$ ):	
	0°	0
	90°	0
	180°	0
	270°	0
1.4.	Clad hoop strain at elevation 90 mm (%)	23.5
2.	Measured parameters for FGR analysis	
2.1.	Internal gas composition (% by volume):	
	He	—
	N <sub>2</sub>	—
	O <sub>2</sub>	—
	Ar	—
	CO <sub>2</sub>	—
	Kr	—
	Xe	—
2.2.	Free gas volume (cm <sup>3</sup> )	—
2.3.	Gas pressure inside fuel rod under normal condition (MPa)	—
2.4.	Kr concentration in fuel (cm <sup>3</sup> /g fuel)	—
3.	Measured parameters of cladding hydriding	
3.1.	Coefficient of hydride orientation (per-unit)	—
3.2.	Hydrogen concentration (% by weight)	—



# #H6C

Individual Characteristics of Refabricated Fuel Rods  
(Fresh Fuel, Fresh Cladding) under IGR Tests

Table I-1.10. General Characteristic of Fuel Rod #H6C

	Parameter	Unit	Value		
			Experiment	FRAP-T6	SCANAIR
1	Type of coolant	---	water	water	water
2	Burnup	MWd/kg U	0	0	0
3	Energy deposition in fuel rod	cal/g fuel	323	323	323
4	Peak fuel enthalpy	cal/g fuel	-	219	-
5	Peak fuel temperature	K	-	3121	-
6	Peak clad temperature	K	-	1415	-
7	Fuel rod failure	Yes, No	Yes	Yes	-
8	Type of failure:				
	- cladding rupture due to ballooning	Yes, No	Yes	Yes	-
	- cladding rupture due to PCMI	Yes, No	No	No	-
	- fragmentation of fuel rod	Yes, No	No	-	-
9	Failure time	s	-	4.54	-
10	Fuel enthalpy at failure	cal/g fuel	-	187	-
11	Outer cladding temperature at failure	K	-	1241	-
12	Internal gas pressure at failure	MPa	-	2.24	-
13	ZrO <sub>2</sub> thickness after test	μm	5	7.07	-
14	Residual clad hoop strain:				
	- peak value for ballooning area	%	23.5	14.77	-
	- other location <sup>1)</sup>	%	-	1.82	-

<sup>1)</sup>Calculated values by FRAP-T6 and SCANAIR codes are average along height of fuel rod excluding ballooning region

**APPENDIX I-2.**  
*Individual Characteristics for Fuel Rod #B20C under IGR Test*

#B20C

Individual Characteristics of Refabricated Fuel Rods  
(Fresh Fuel, Fresh Cladding) under IGR Tests

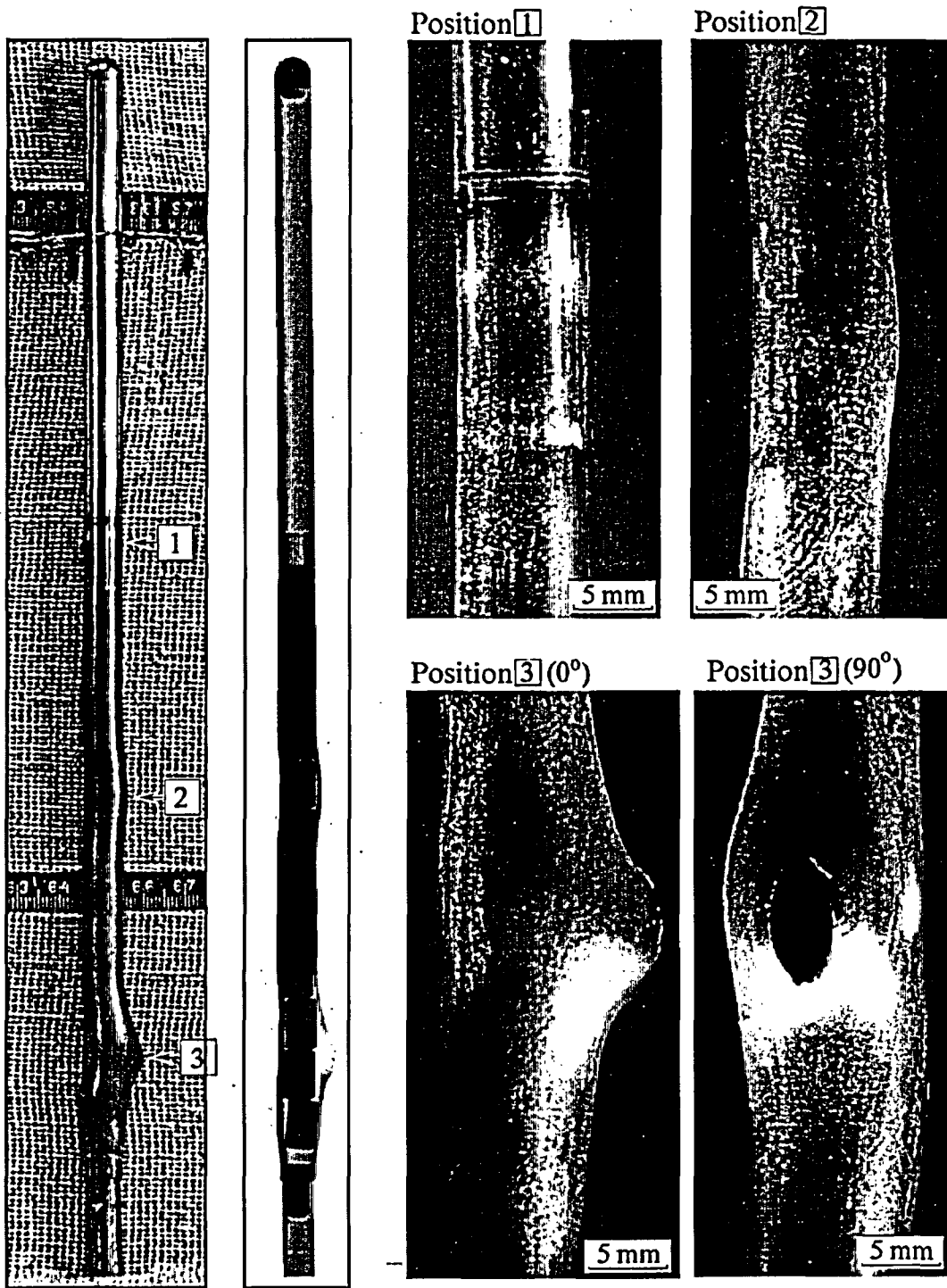
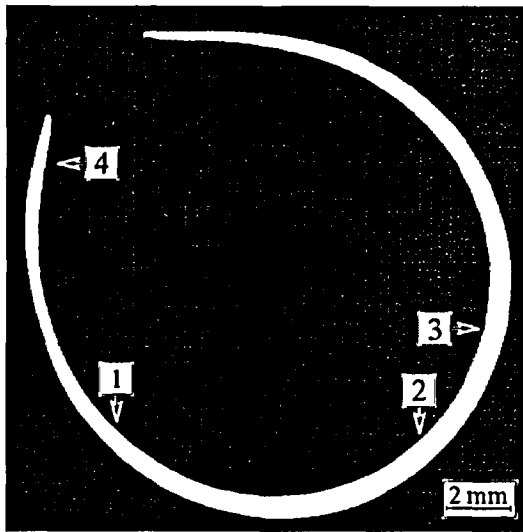

Fig. I-2.1. Appearance of Fuel Rod #B20C (photographs and X-ray photograph)

#B20C

Individual Characteristics of Refabricated Fuel Rods  
(Fresh Fuel, Fresh Cladding) under IGR Tests



Position 1

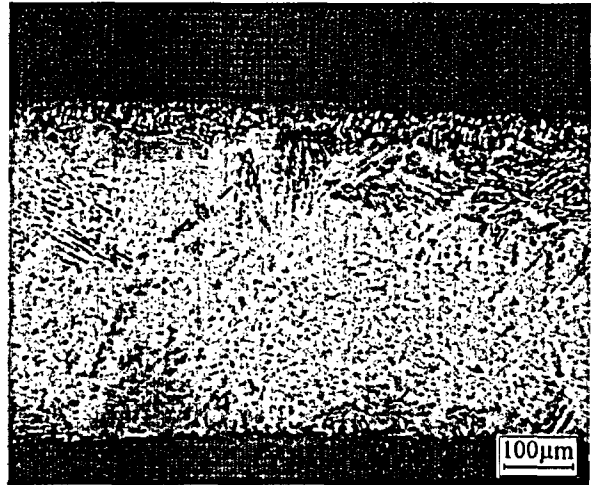

Position 2

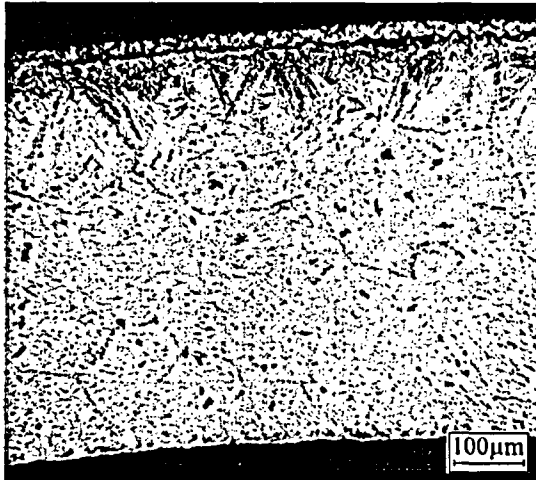

Position 3

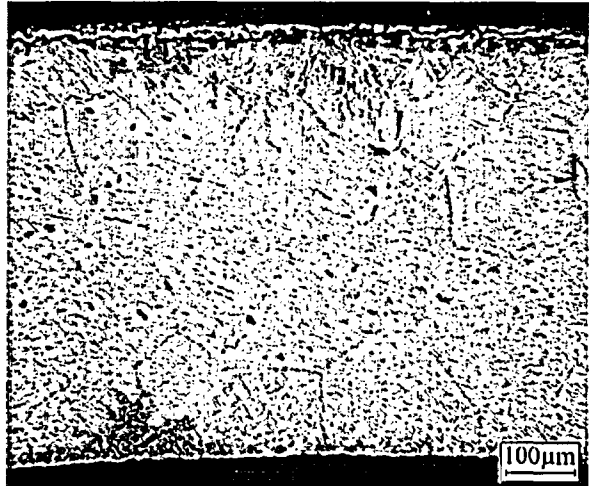

Position 4

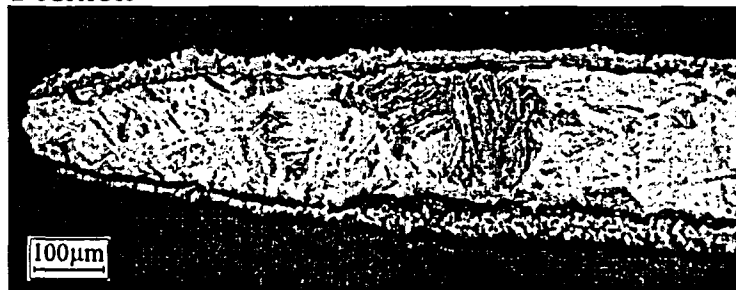
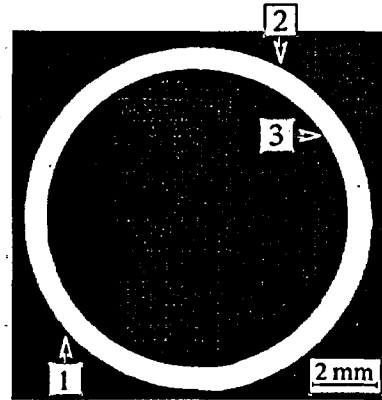
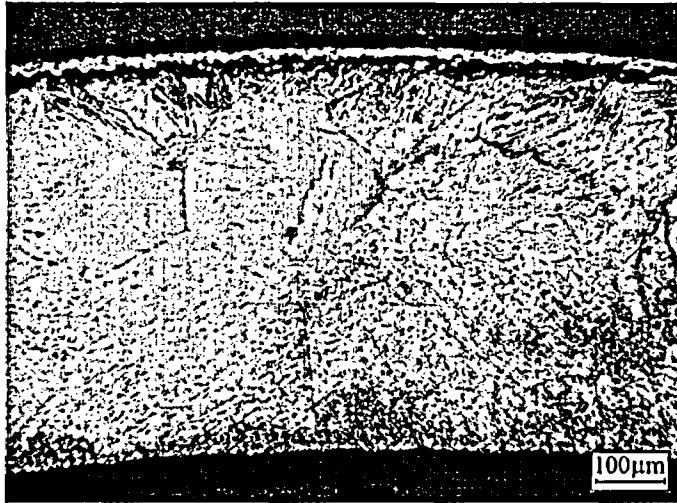

Fig. I-2.2. Cross-Section and Cladding Microstructure for Fuel Rod #B20C at 55 mm Elevation

#B20C

Individual Characteristics of Refabricated Fuel Rods  
(Fresh Fuel, Fresh Cladding) under IGR Tests

Position 1



Position 2

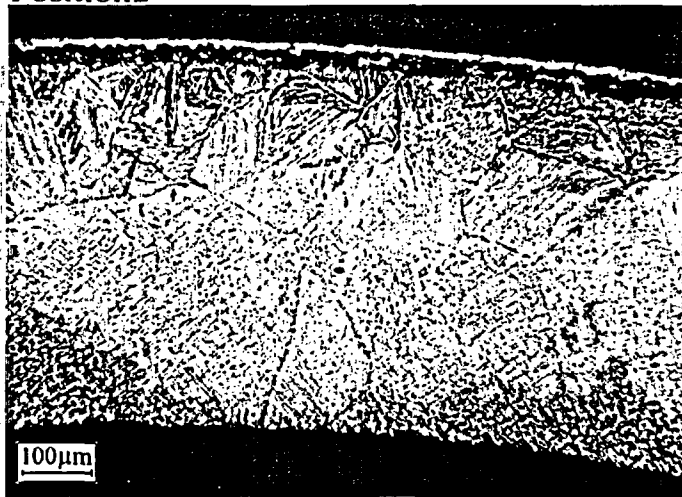

Position 3

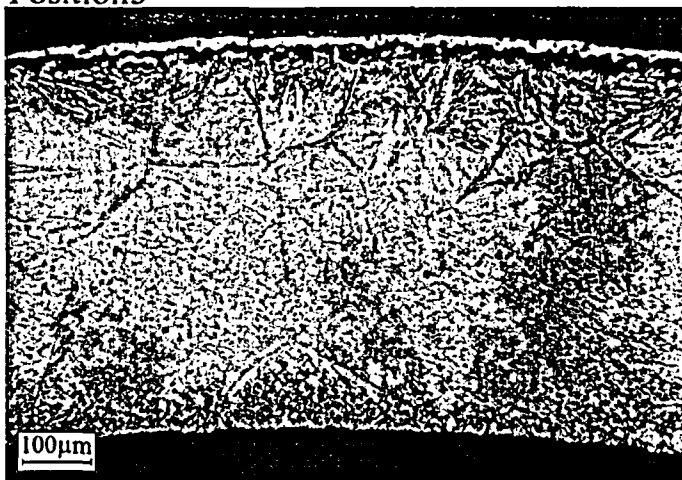
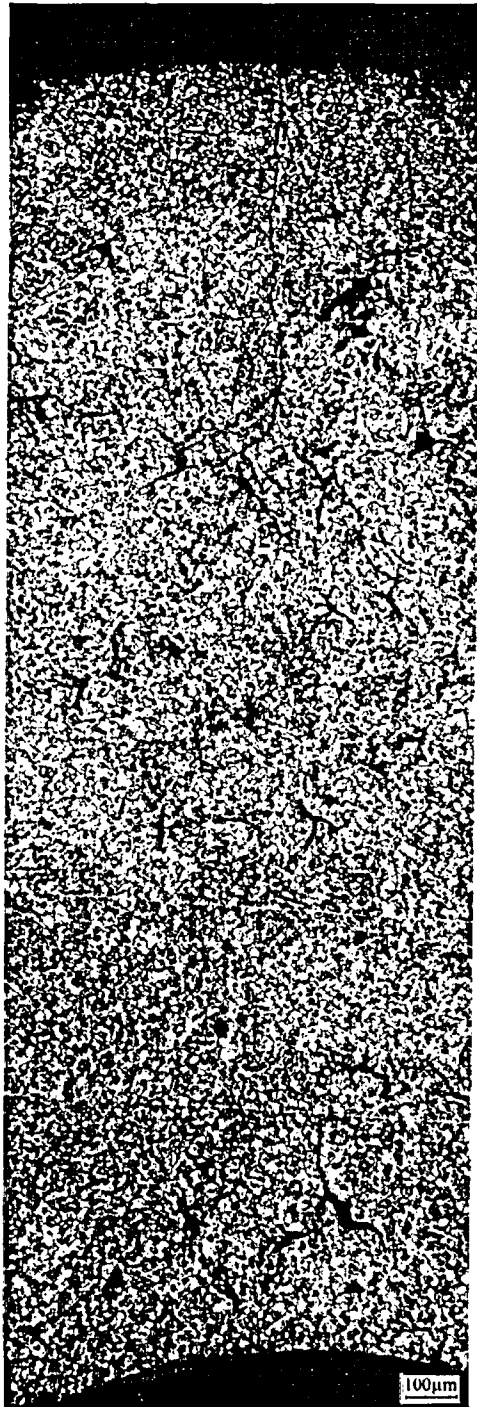

Fig. I-2.3. Cross-Section and Cladding Microstructure for Fuel Rod #B20C at 90 mm Elevation

#B20C

Individual Characteristics of Refabricated Fuel Rods  
(Fresh Fuel, Fresh Cladding) under IGR Tests

Position 1



2

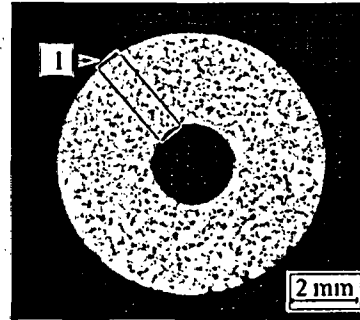

Position 2

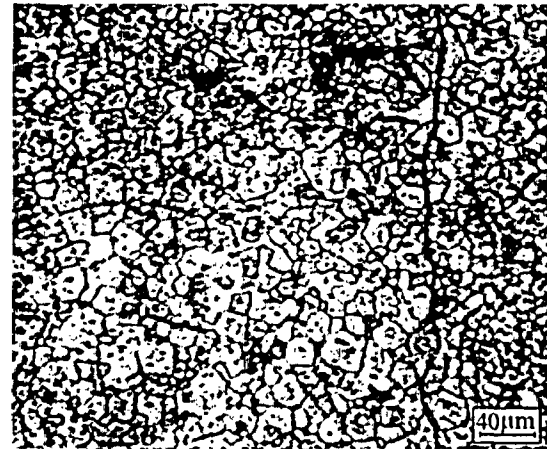

Position 3

3

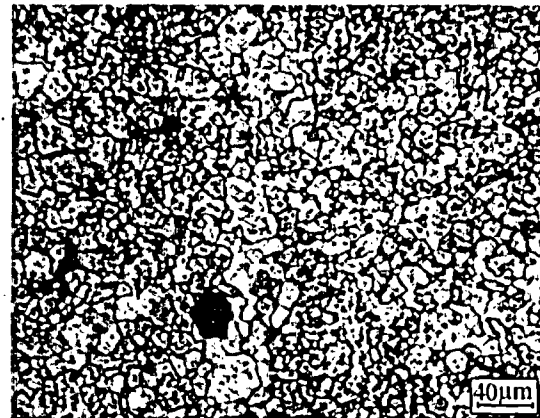

Fig. I-2.4. Fuel Microstructure for Fuel Rod #B20C at 90 mm Elevation

# #B20C

Individual Characteristics of Refabricated Fuel Rods  
(Fresh Fuel, Fresh Cladding) under IGR Tests

Table I-2.1. Time Dependent Energy Characteristics of Fuel Rod #B20C

Time (s)	Reactor energy deposition <sup>1)</sup> (%)	Cumulative number of fissions in fuel rod (fiss)			Power of fuel rod (kW)	Energy deposition in fuel rod	
		U <sup>235</sup> ×10 <sup>-14</sup>	U <sup>238</sup> ×10 <sup>-12</sup>	Total ×10 <sup>-14</sup>		cal/g fuel	J/g fuel
0.0	0.000	0.000	0.000	0.000	0.000	0.000	0.000
1.0	0.515	0.071	0.040	0.071	0.399	0.805	3.370
2.0	2.060	0.283	0.162	0.284	0.800	3.220	13.50
2.2	2.490	0.342	0.195	0.344	0.880	3.900	16.30
2.4	2.970	0.407	0.233	0.409	0.960	4.640	19.40
2.6	3.480	0.477	0.273	0.480	1.040	5.450	22.80
2.8	4.040	0.554	0.317	0.557	1.120	6.320	26.50
3.0	4.640	0.637	0.364	0.641	1.260	7.280	30.50
3.2	5.340	0.734	0.419	0.738	1.480	8.380	35.10
3.4	6.190	0.850	0.486	0.855	1.850	9.710	40.60
3.6	7.300	1.000	0.573	1.010	2.530	11.40	47.70
3.8	8.910	1.220	0.699	1.230	3.830	14.00	58.60
4.0	11.50	1.580	0.900	1.580	6.440	18.00	75.30
4.2	16.00	2.190	1.250	2.210	11.60	25.00	105.0
4.4	24.00	3.300	1.880	3.320	20.10	37.60	157.0
4.6	36.90	5.060	2.890	5.090	29.40	57.80	242.0
4.8	53.20	7.300	4.170	7.340	32.00	83.20	348.0
5.0	68.10	9.340	5.340	9.400	24.80	107.0	448.0
5.2	78.30	10.80	6.140	10.80	15.40	123.0	515.0
5.4	84.40	11.60	6.620	11.60	8.860	132.0	553.0
5.6	87.90	12.10	6.890	12.10	5.250	138.0	578.0
5.8	90.00	12.40	7.060	12.40	3.360	141.0	590.0
6.0	91.40	12.50	7.170	12.60	2.350	143.0	599.0
6.5	93.50	12.80	7.330	12.90	1.320	147.0	615.0
7.0	94.80	13.00	7.440	13.10	0.924	149.0	624.0
7.5	95.70	13.10	7.510	13.20	0.616	151.0	632.0
8.0	96.30	13.20	7.550	13.30	0.435	152.0	636.0
9.0	97.10	13.30	7.620	13.40	0.324	153.0	640.0
10.0	97.70	13.40	7.660	13.50	0.213	154.0	645.0
20.0	99.30	13.60	7.790	13.70	0.042	158.0	661.0
30.0	99.80	13.70	7.830	13.80	0.021	159.0	666.0
∞	101.0	13.80	7.900	13.90	0.000	163.0	682.0

Maximum value of power is 32.4 kW (t = 4.75 s)

<sup>1)</sup> Current energy deposition per maximum energy deposition (at infinite time)

# #B20C

Individual Characteristics of Refabricated Fuel Rods  
(Fresh Fuel, Fresh Cladding) under IGR Tests

Table I-2.2. Axial Energy Characteristics of Fuel Rod #B20C

Axial coordinate from lower end of fuel rod (mm)	Cumulative number of fissions in fuel rod (fiss)			Maximum power of fuel rod (kW) $t=4.75$ s	Energy deposition at infinite time*		
	$U^{235} \times 10^{-13}$	$U^{238} \times 10^{-11}$	Total $\times 10^{-13}$		cal/g fuel	J/g fuel	per-unit <sup>3)</sup>
20.0	0.000	0.000	0.000	0.000	0.000	0.000	0.00
25.0 <sup>1)</sup>	3.550	1.770	3.570	0.832	170.0	712.0	1.00
30.0	5.050	2.590	5.080	1.180	170.0	712.0	1.00
35.0	5.040	2.660	5.060	1.180	168.0	703.0	0.99
40.0	5.070	2.750	5.100	1.190	168.0	703.0	0.99
45.0	5.040	2.790	5.070	1.180	167.0	699.0	0.98
50.0	4.990	2.820	5.020	1.170	166.0	695.0	0.98
55.0	4.970	2.850	5.000	1.170	166.0	695.0	0.98
60.0	4.940	2.870	4.970	1.160	164.0	687.0	0.96
65.0	4.960	2.900	4.990	1.160	164.0	687.0	0.96
70.0	4.940	2.910	4.970	1.160	164.0	687.0	0.96
75.0	4.910	2.910	4.940	1.150	162.0	678.0	0.95
80.0	4.890	2.910	4.920	1.150	162.0	678.0	0.95
85.0	4.850	2.890	4.870	1.140	162.0	678.0	0.95
90.0	4.840	2.880	4.870	1.130	162.0	678.0	0.95
95.0	4.750	2.830	4.780	1.110	160.0	670.0	0.94
100.0	4.720	2.800	4.750	1.110	160.0	670.0	0.94
105.0	4.740	2.800	4.760	1.110	160.0	670.0	0.94
110.0	4.790	2.820	4.820	1.120	160.0	670.0	0.94
115.0	4.790	2.800	4.810	1.120	160.0	670.0	0.94
120.0	4.750	2.770	4.780	1.110	159.0	666.0	0.94
125.0	4.750	2.750	4.780	1.110	159.0	666.0	0.94
130.0	4.750	2.740	4.780	1.110	159.0	666.0	0.94
135.0	4.760	2.730	4.790	1.120	159.0	666.0	0.94
140.0	4.780	2.720	4.810	1.120	160.0	670.0	0.94
145.0	4.790	2.720	4.820	1.120	161.0	674.0	0.95
150.0	4.800	2.720	4.830	1.130	161.0	674.0	0.95
155.0	4.800	2.710	4.830	1.120	161.0	674.0	0.95
160.0	4.800	2.700	4.830	1.120	163.0	682.0	0.96
165.0 <sup>2)</sup>	3.400	1.910	3.410	0.796	164.0	687.0	0.96
170.0	0.000	0.000	0.000	0.000	0.000	0.000	0.00

\* All numerical values of characteristics are presented as average values at the length interval equal to the axial coordinate  $\pm 2.5$  mm.

<sup>1)</sup> Initial coordinate of fuel is 24.0 mm.

<sup>2)</sup> End coordinate of fuel is 166.0 mm.

<sup>3)</sup> Current value per maximum value.



# #B20C

Individual Characteristics of Refabricated Fuel Rods  
(Fresh Fuel, Fresh Cladding) under IGR Tests

Table I-2.3. Radial Energy Characteristics of Fuel Rod #B20C

Characteristics*		Coordinates of fuel zones (mm)			
		1 zone 1.10 - 2.12	2 zone 2.12 - 2.78	3 zone 2.78 - 3.32	4 zone 3.32 - 3.78
U <sup>235</sup>	Number of fissions $\times 10^{-14}$ (fiss)	3.330	3.380	3.480	3.620
	Power of fuel rod <sup>1)</sup> (kW)	7.770	7.880	8.120	8.440
	Energy deposition <sup>2)</sup> (cal/g fuel)	156.0	158.0	163.0	170.0
	Energy deposition <sup>2)</sup> (J/g fuel)	653.0	661.0	682.0	712.0
	Energy deposition <sup>3)</sup> (per-unit)	0.918	0.929	0.959	1.000
U <sup>238</sup>	Number of fissions $\times 10^{-12}$ (fiss)	2.000	1.990	1.970	1.940
	Power of fuel rod <sup>1)</sup> (kW)	0.046	0.046	0.045	0.045
	Energy deposition <sup>2)</sup> (cal/g fuel)	0.923	0.919	0.909	0.898
	Energy deposition <sup>2)</sup> (J/g fuel)	3.860	3.850	3.810	3.760
	Energy deposition <sup>3)</sup> (per-unit)	1.000	0.996	0.985	0.973
Total	Number of fissions $\times 10^{-14}$ (fiss)	3.350	3.400	3.500	3.640
	Power of fuel rod <sup>1)</sup> (kW)	7.820	7.930	8.170	8.490
	Energy deposition <sup>2)</sup> (cal/g fuel)	157.0	159.0	164.0	170.0
	Energy deposition <sup>2)</sup> (J/g fuel)	657.0	666.0	687.0	712.0
	Energy deposition <sup>3)</sup> (per-unit)	0.924	0.935	0.965	1.000

<sup>1)</sup> at time of 4.75 s,      <sup>2)</sup> at infinite time,      <sup>3)</sup> Current value per maximum value

\* All numerical values of characteristics were calculated for length of fuel stack

# #B20C

Individual Characteristics of Refabricated Fuel Rods  
(Fresh Fuel, Fresh Cladding) under IGR Tests

Table I-2.4. Fuel Enthalpy Vs. Time Calculated by FRAP-T6 Code for Fuel Rod #B20C

Time (s)	Enthalpy at fuel radius (cal/g fuel)				Fuel enthalpy <sup>1)</sup>		Energy deposition in fuel rod	
	1.10 mm	2.22 mm	2.89 mm	3.79 mm	cal/g fuel	J/g fuel	cal/g fuel	J/g fuel
0.0	0.00	0.00	0.00	0.00	0.00	0.00	0.00	0.00
1.0	0.71	0.71	0.70	0.65	0.70	2.92	0.80	3.37
2.0	2.78	2.75	2.68	2.50	2.68	11.2	3.22	13.5
2.2	3.36	3.32	3.23	3.01	3.24	13.6	3.90	16.3
2.4	3.99	3.94	3.84	3.58	3.84	16.1	4.64	19.5
2.6	4.68	4.62	4.50	4.19	4.50	18.9	5.45	22.8
2.8	5.42	5.35	5.21	4.86	5.22	21.9	6.32	26.5
3.0	6.24	6.15	5.99	5.59	6.00	25.1	7.28	30.5
3.2	7.19	7.09	6.90	6.43	6.91	29.0	8.38	35.1
3.4	8.36	8.24	8.03	7.47	8.04	33.7	9.71	40.7
3.6	9.92	9.79	9.54	8.86	9.55	40.0	11.4	48.0
3.8	12.2	12.1	11.8	10.9	11.8	49.4	14.0	58.5
4.0	16.1	15.9	15.5	14.2	15.5	64.9	18.0	75.4
4.2	23.0	22.8	22.2	19.9	22.1	92.6	25.1	105
4.4	35.4	35.1	34.3	29.7	34.0	142	37.6	158
4.6	55.5	55.2	53.8	43.9	52.9	221	57.8	242
4.8	81.4	80.8	78.1	59.2	76.2	319	83.2	349
5.0	106	104	99.3	70.9	96.8	405	107	447
5.2	122	120	112	78.0	110	459	123	514
5.4	132	128	117	81.2	115	484	132	554
5.6	137	131	117	90.0	118	496	138	577
5.8	139	132	118	99.4	121	507	141	592
6.0	140	131	119	103	122	513	143	601
6.5	138	130	120	107	123	516	147	616
7.0	135	129	120	108	123	515	149	624
7.5	132	127	120	109	122	510	151	632
8.0	130	126	119	110	121	507	152	635
10.0	122	120	116	109	117	489	154	647
30.0	87.4	86.7	85.6	83.5	85.8	359	159	667

Radial enthalpy distribution and fuel enthalpy are presented at elevation 31.1 mm

Maximum value of fuel enthalpy is 123.2 cal/g fuel (t=6.50 s)

<sup>1)</sup> All numerical values are presented at elevation with peak power

# #B20C

Individual Characteristics of Refabricated Fuel Rods  
(Fresh Fuel, Fresh Cladding) under IGR Tests

Table I-2.5. Energy Characteristics Vs. Time Calculated by FRAP-T6 and SCANAIR Codes for Fuel Rod #B20C

Time (s)	Energy deposition <sup>1)</sup> (cal/g fuel)	Linear power <sup>1)</sup> (kW/m)	Fuel enthalpy <sup>1)</sup> (cal/g fuel)		Leakage of energy <sup>1)</sup> (cal/g fuel)		Clad-to-coolant heat transfer coefficient <sup>1)</sup> (kW/m <sup>2</sup> K)	
			FRAP-T6	SCANAIR	FRAP-T6	SCANAIR	FRAP-T6	SCANAIR
0.0	0.00	0.00	0.00	0.00	0.00	0.00	0.00	0.00
1.0	0.84	2.92	0.70	0.76	0.00	0.00	0.01	0.01
2.0	3.35	5.86	2.68	2.91	0.00	0.00	0.01	0.01
2.2	4.06	6.45	3.24	3.49	0.00	0.00	0.01	0.01
2.4	4.83	7.03	3.84	4.13	0.00	0.00	0.01	0.01
2.6	5.67	7.62	4.50	4.81	0.00	0.00	0.01	0.01
2.8	6.57	8.21	5.22	5.55	0.00	0.00	0.01	0.01
3.0	7.57	9.23	6.00	6.36	0.01	0.01	0.01	0.01
3.2	8.71	10.8	6.91	7.29	0.01	0.01	0.01	0.01
3.4	10.1	13.6	8.04	8.43	0.01	0.01	0.01	0.01
3.6	11.9	18.5	9.55	9.95	0.01	0.01	0.01	0.01
3.8	14.5	28.1	11.8	12.2	0.01	0.02	0.01	0.01
4.0	18.7	47.2	15.5	15.8	0.02	0.02	0.01	0.01
4.2	26.1	85.0	22.1	22.3	0.02	0.03	0.01	0.01
4.4	39.1	147	34.0	33.9	0.03	0.04	0.01	0.01
4.6	60.1	215	52.9	52.1	0.04	0.05	0.02	0.02
4.8	86.6	234	76.2	74.5	0.07	0.08	0.02	0.03
5.0	111	182	96.8	93.8	0.12	0.16	0.04	0.04
5.2	128	113	110	-	0.23	-	0.05	-
5.4	138	64.9	115	-	0.38	-	0.06	-
5.6	143	38.5	118	-	0.58	-	0.07	-
5.8	147	24.6	121	-	0.85	-	0.08	-
6.0	149	17.2	122	-	1.14	-	0.08	-
6.5	153	9.63	123	-	2.01	-	0.09	-
7.0	155	7.19	123	-	2.81	-	0.10	-
7.5	157	4.50	122	-	4.20	-	0.11	-
8.0	158	3.39	121	-	5.23	-	0.11	-
10.0	160	1.64	117	-	11.0	-	0.12	-
30.0	165	0.15	85.8	-	56.9	-	0.08	-

<sup>1)</sup> All numerical values are presented at elevation with peak power

# #B20C

Individual Characteristics of Refabricated Fuel Rods  
(Fresh Fuel, Fresh Cladding) under IGR Tests

Table I-2.6. Temperature Variation, Fission Gas Release and ZrO<sub>2</sub> Thickness Vs. Time for Fuel Rod #B20C Calculated by FRAP-T6 and SCANAIR Codes

Time (s)	Fuel centerline temperature <sup>1)</sup> (K)		Fuel surface temperature <sup>1)</sup> (K)		Clad outer temperature <sup>1)</sup> (K)	
	FRAP-T6	SCANAIR	FRAP-T6	SCANAIR	FRAP-T6	SCANAIR
0.0	293	293	293	293	293	293
1.0	306	305	305	305	296	297
2.0	341	340	336	338	312	313
2.2	351	350	345	346	317	319
2.4	361	360	354	356	323	325
2.6	372	371	364	366	330	332
2.8	384	383	375	377	337	340
3.0	397	395	387	389	345	349
3.2	412	410	400	402	355	358
3.4	430	427	416	419	365	369
3.6	454	450	438	441	377	382
3.8	489	483	469	473	392	399
4.0	546	536	518	524	413	422
4.2	644	626	601	610	445	460
4.4	817	783	738	755	500	524
4.6	1087	1023	932	962	595	635
4.8	1422	1317	1135	1182	744	800
5.0	1724	1579	1288	1349	927	991
5.2	1922	-	1379	-	1076	-
5.4	2030	-	1420	-	1167	-
5.6	2084	-	1532	-	1270	-
5.8	2107	-	1647	-	1299	-
6.0	2112	-	1691	-	1330	-
6.5	2091	-	1737	-	1406	-
7.0	2067	-	1754	-	1457	-
7.5	2033	-	1768	-	1514	-
8.0	2010	-	1773	-	1540	-
10.0	1922	-	1769	-	1591	-
30.0	1498	-	1449	-	1351	-

<sup>1)</sup> All numerical values are presented at elevation with peak power

# #B20C

Individual Characteristics of Refabricated Fuel Rods  
(Fresh Fuel, Fresh Cladding) under IGR Tests

Table I-2.7. Mechanical Characteristics of Fuel Rod #B20C Vs. Time Calculated by FRAP-T6 and SCANAIR Codes

Time (s)	Clad outer temperature <sup>1)</sup> (K)		Fuel hoop strain <sup>1)</sup> (%)		Fuel - clad gap width <sup>1)</sup> (mm)		Clad hoop strain <sup>1)</sup> (%)		Clad hoop stress <sup>1)</sup> (MPa)		Internal gas pressure (MPa)	
	FRAP-T6	SCANAIR	FRAP-T6	SCANAIR	FRAP-T6	SCANAIR	FRAP-T6	SCANAIR	FRAP-T6	SCANAIR	FRAP-T6	SCANAIR
0.0	293	293	0.00	0.00	0.10	0.10	0.01	0.01	10.5	10.4	2.00	2.00
1.0	296	297	0.01	0.01	0.10	0.10	0.01	0.01	10.5	10.5	2.01	2.01
2.0	312	313	0.04	0.03	0.09	0.09	0.02	0.03	10.7	10.7	2.04	2.04
2.2	317	319	0.05	0.04	0.09	0.09	0.03	0.03	10.7	10.7	2.05	2.05
2.4	323	325	0.06	0.05	0.09	0.09	0.03	0.03	10.8	10.8	2.06	2.06
2.6	330	332	0.07	0.05	0.09	0.09	0.03	0.04	10.8	10.8	2.07	2.07
2.8	337	340	0.08	0.06	0.09	0.09	0.04	0.05	10.9	10.9	2.08	2.08
3.0	345	349	0.09	0.07	0.09	0.09	0.05	0.05	10.9	10.9	2.09	2.08
3.2	355	358	0.11	0.08	0.09	0.09	0.05	0.06	11.0	11.0	2.10	2.09
3.4	365	369	0.13	0.10	0.09	0.09	0.06	0.07	11.0	11.0	2.11	2.11
3.6	377	382	0.15	0.11	0.09	0.09	0.07	0.08	11.1	11.1	2.12	2.12
3.8	392	399	0.19	0.14	0.09	0.09	0.08	0.09	11.2	11.2	2.14	2.14
4.0	413	422	0.24	0.18	0.09	0.09	0.09	0.11	11.4	11.4	2.16	2.16
4.2	445	460	0.34	0.26	0.09	0.09	0.11	0.14	11.6	11.6	2.20	2.20
4.4	500	524	0.51	0.41	0.08	0.09	0.15	0.19	11.8	11.9	2.25	2.24
4.6	595	635	0.80	0.66	0.07	0.08	0.22	0.28	12.1	12.2	2.30	2.28
4.8	744	800	1.19	1.00	0.06	0.07	0.32	0.40	12.3	12.4	2.34	2.31
5.0	927	991	1.56	1.32	0.05	0.07	0.45	0.55	12.5	12.5	2.37	2.33
5.2	1076	-	1.80	-	0.05	-	0.55	-	12.6	-	2.39	-
5.4	1167	-	1.91	-	0.05	-	0.62	-	12.7	-	2.40	-
5.6	1270	-	1.97	-	0.24	-	5.12	-	13.8	-	2.37	-
5.8	1299	-	2.01	-	1.86	-	45.4	-	0.00	-	0.10	-
6.0	1330	-	2.02	-	1.86	-	45.4	-	0.00	-	0.10	-
6.5	1406	-	2.02	-	1.86	-	45.5	-	0.00	-	0.10	-
7.0	1457	-	2.00	-	1.86	-	45.5	-	0.00	-	0.10	-
7.5	1514	-	1.97	-	1.86	-	45.6	-	0.00	-	0.10	-
8.0	1540	-	1.95	-	1.86	-	45.6	-	0.00	-	0.10	-
10.0	1591	-	1.86	-	1.86	-	45.6	-	0.00	-	0.10	-
30.0	1351	-	1.32	-	1.88	-	45.4	-	0.00	-	0.10	-

<sup>1)</sup> All numerical values are presented at elevation with peak power

# #B20C

Individual Characteristics of Refabricated Fuel Rods  
(Fresh Fuel, Fresh Cladding) under IGR Tests

**Table I-2.8. Axial Distribution of Energy Deposition and Fuel Enthalpy Calculated by FRAP-T6 Code for Fuel Rod #B20C**

Axial interval from-to (mm)-(mm)	Energy deposition at infinite time			Fuel enthalpy at time (t=6.50 s)		
	cal/g fuel	J/g fuel	per-unit	cal/g fuel	J/g fuel	per-unit
24.0 - 38.2	169	709	1.00	123	516	1.00
38.2 - 52.4	167	700	0.99	122	509	0.99
52.4 - 66.6	165	690	0.97	120	502	0.97
66.6 - 80.8	163	682	0.96	119	497	0.96
80.8 - 95.0	162	677	0.96	118	493	0.96
95.0 - 109.2	160	670	0.95	116	488	0.95
109.2 - 123.4	160	669	0.94	116	487	0.94
123.4 - 137.6	159	666	0.94	116	485	0.94
137.6 - 151.8	161	673	0.95	117	490	0.95
151.8 - 166.0	162	680	0.96	118	495	0.96

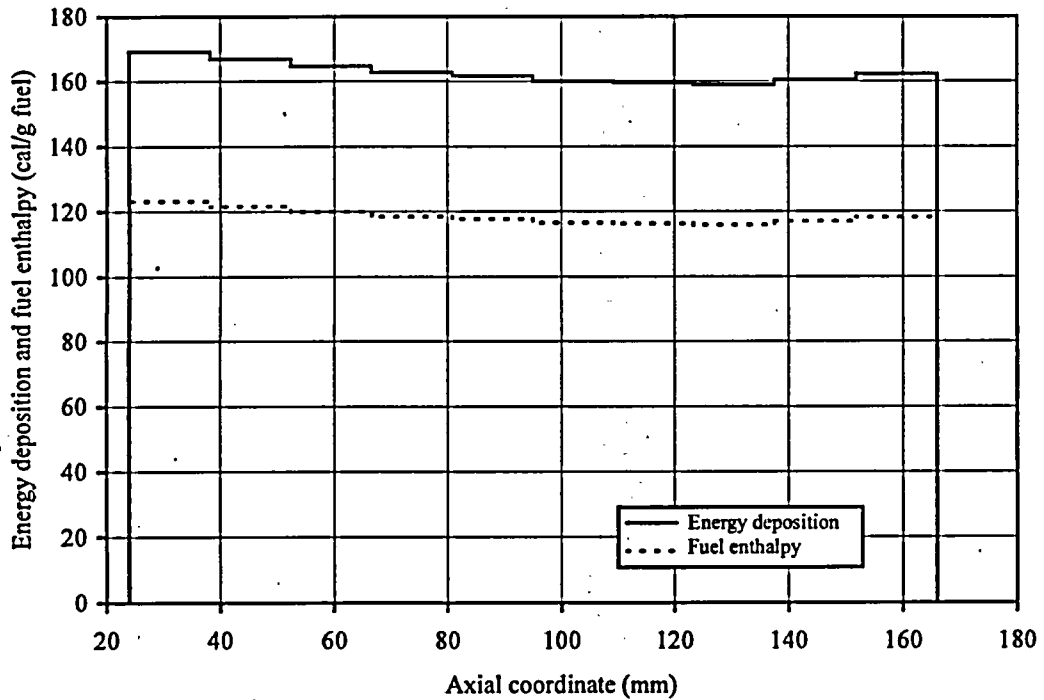

**Fig. I-2.5. Axial Distribution of Energy Deposition and Fuel Enthalpy Calculated by FRAP-T6 Code for Fuel Rod #B20C**

#B20C

Individual Characteristics of Refabricated Fuel Rods  
(Fresh Fuel, Fresh Cladding) under IGR Tests

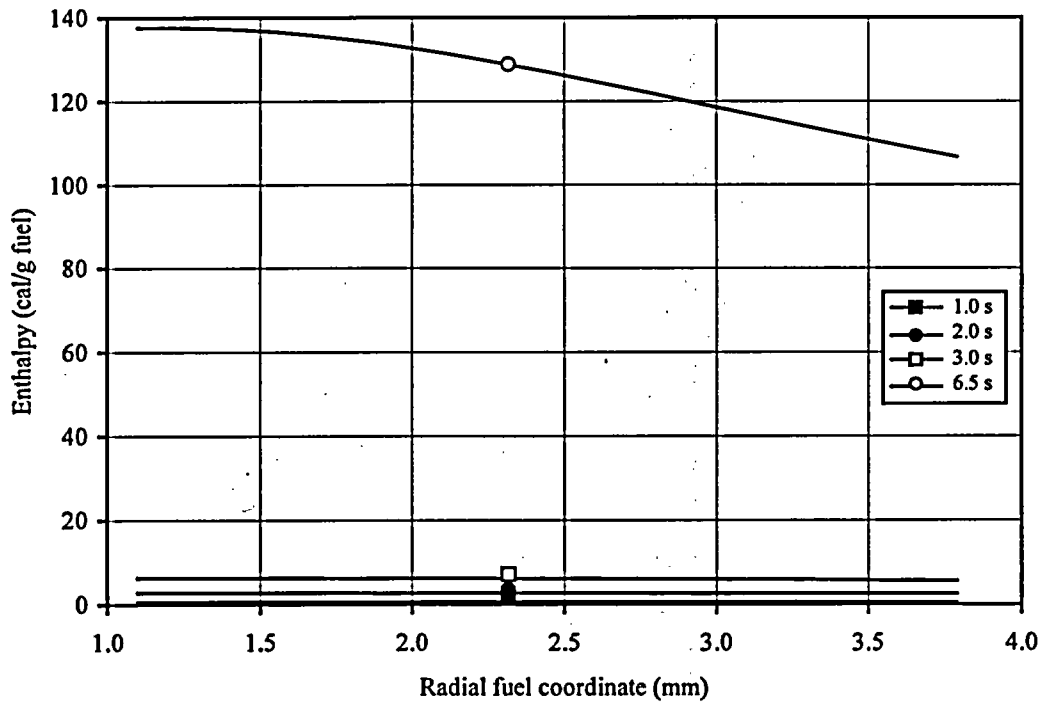
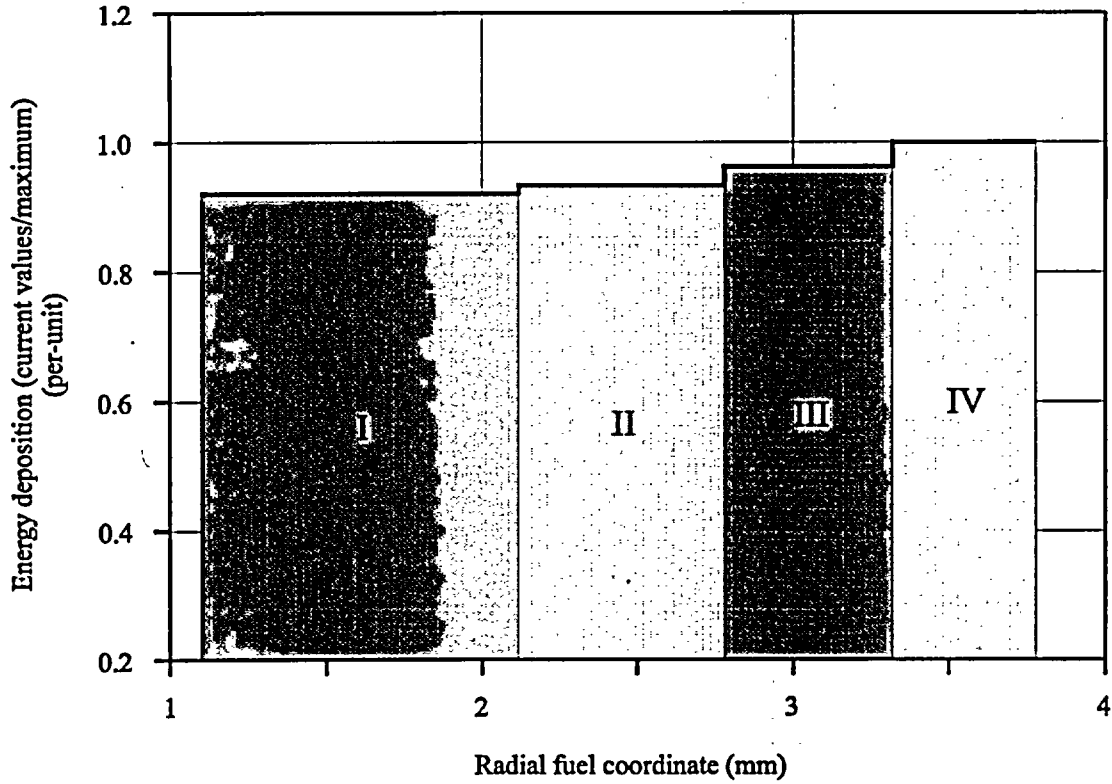

Fig. I-2.6. Radial Distributions of Energy Deposition and Fuel Enthalpy Calculated by FRAP-T6 Code for Fuel Rod #B20C

**APPENDIX J.**  
**Mechanical Properties of Zr-1%Nb Cladding**



**Table J.1. Characteristics of unirradiated Zr-1%Nb cladding used to manufacture ring specimens**

Characteristic	Unit	Value
<b>1. Composition</b>		
Zr	% by weight	98.505 – 98.705
Nb	% by weight	0.9 – 1.1
O	% by weight	0.11
N	% by weight	0.0061
C	% by weight	0.02
Si	% by weight	0.02
Al	% by weight	0.008
Mo	% by weight	0.005
Ni	% by weight	0.05
Fe	% by weight	0.05
Other elements	% by weight	0.126
<b>2. Treatment</b>	-	annealing at 580 °C, 3 hours
<b>3. Outer diameter</b>	mm	9.14 <sup>+0.009</sup> <sub>-0.004</sub>
<b>4. Inner diameter</b>	mm	7.72 <sup>+0.008</sup> <sub>-0.008</sub>

**Table J.2. Results of ring tensile tests on unirradiated Zr-1%Nb cladding (strain rate 0.002 1/s)**

Temperature (K)	Ultimate strength (MPa)	Yield stress (MPa)	Total elongation (%)	Uniform elongation (%)
293	349	294	31.5	8.3
	345	297	30.3	7.9
423	267	235	35.8	7.7
	268	233	32.4	8.2
523	219	189	31.3	8.7
	228	195	30.8	8.4
653	173	149	31.9	7.7
	178	156	34.6	8.2
	180	153	32.2	7.8
753	150	140	38.5	4.5
	154	134	38.7	6.4
793	139	122	41.1	6.1
	132	122	42.0	6.2
	140	123	42.7	5.8
873	84	79	63.2	7.3
923	66	62	76.6	5.9
	68	61	71.9	5.3
1023	43	39	79.3	4.4
	43	41	76.4	3.9
	43	39	80.6	4.9
1073	34	32	90	3.3
	29	27	71.5	4.5
	35	32	88.9	4.1
1123	19	18	54	3.6
	15	13	*	*
	21	20	79.3	4.9
1223	14	12	61.6	4

\* not measured

**Table J.3. Results of ring tensile tests on unirradiated Zr-1%Nb cladding vs. strain rate**

Strain rate (1/s)	Temperature (K)	Ultimate strength (MPa)	Yield stress (MPa)	Total elongation (%)	Uniform elongation (%)
0.002	293	378	341	25.8	*
		373	331	25.5	*
		378	336	27.0	*
		377	342	26.2	*
		380	339	28.0	*
	623	172	159	26.3	*
		177	163	30.7	*
	873	84	79	63.2	7.3
	923	66	62	76.6	5.9
		68	61	71.9	5.3
	1023	43	39	79.3	4.4
		43	41	76.4	3.9
	1073	35	32	88.9	4.1
	1123	21	20	79.3	4.9
19		18	54.0	3.6	
0.02	1223	13	11	57.4	*
0.1	873	129	119	45.2	6.7
	923	110	97	55.7	7.2
		106	92	55.4	6.5
	1023	81	70	67	7.4
	1073	66	63	82.3	3.3
	1123	49	45	70.3	3.6
		42	39	55.9	5.3
1223	16.5	14.3	33.8	5.3	
0.2	293	401	362	19.6	*
		409	356	21.4	*
		409	372	24.0	*
		403	362	20.9	*
0.5	293	422	395	18.7	*
		416	384	19.4	*
		418	378	19.9	*
	623	198	182	28.3	*
		193	176	28.9	*

\* not measured

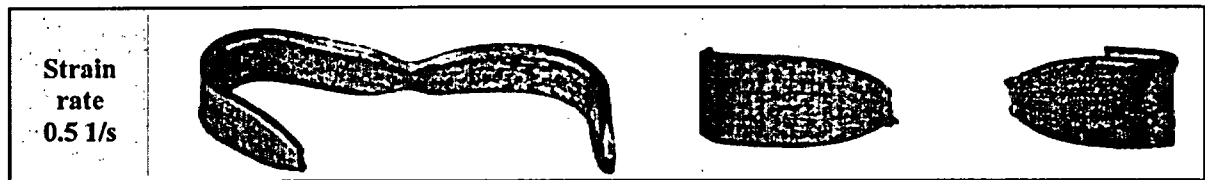
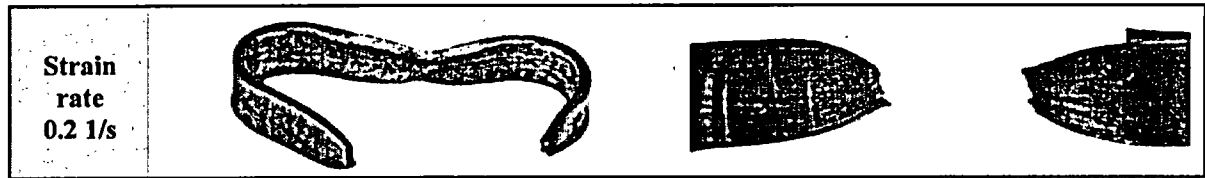
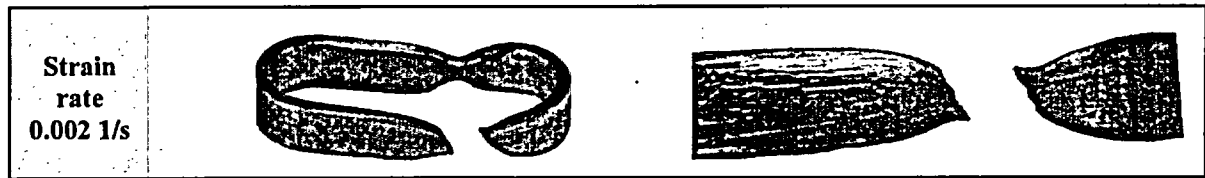

Fig. J.1. Appearance of unirradiated ring specimens after mechanical tests vs. strain rate (T=293 K)

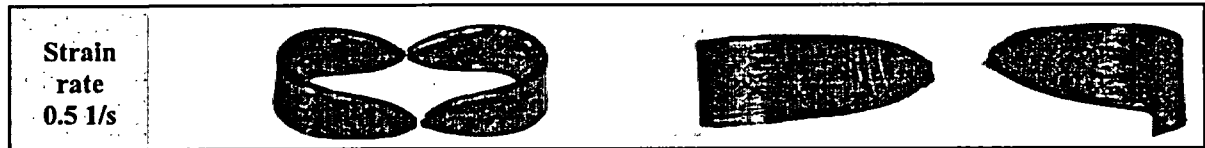
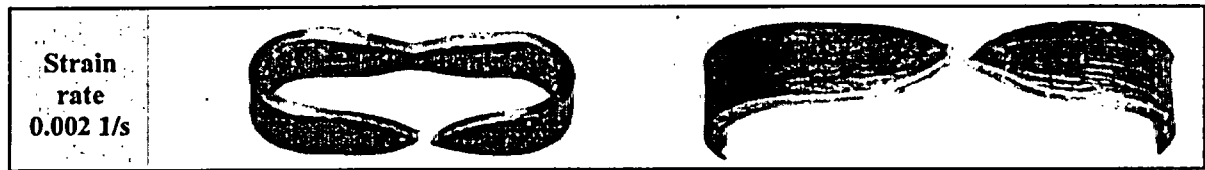
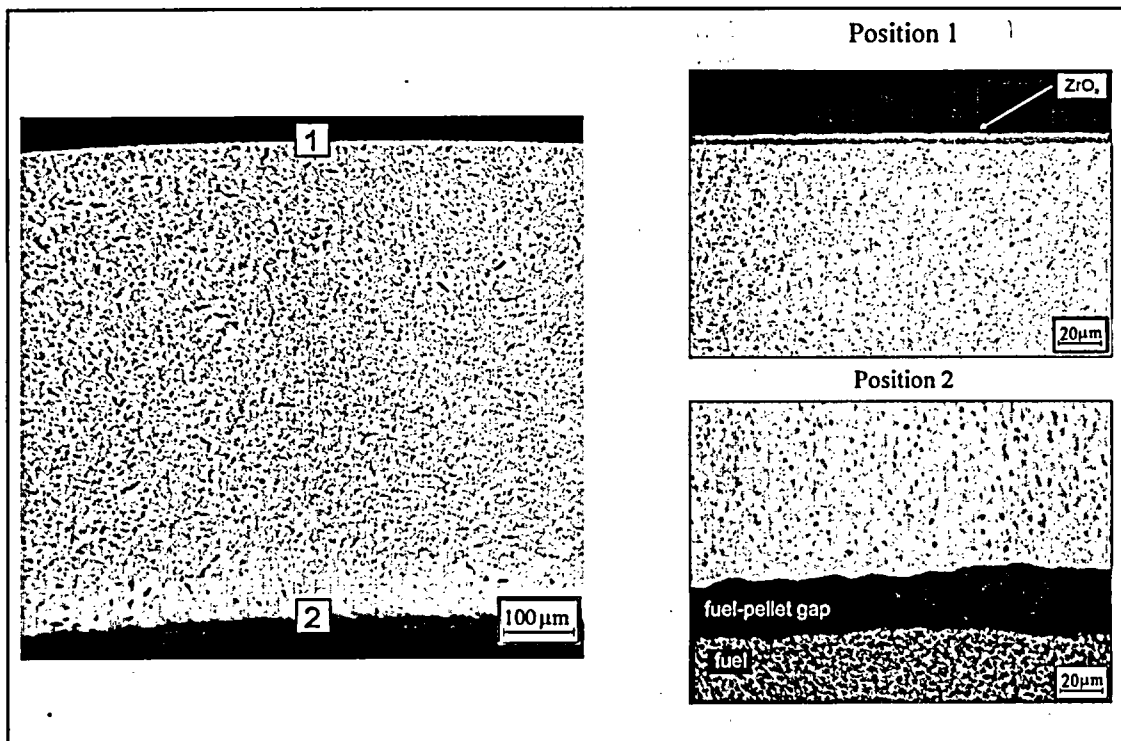

Fig. J.2. Appearance of unirradiated ring specimens after mechanical tests vs. strain rate (T=623 K)

**Table J.4. Characteristics of commercial fuel rod and irradiated cladding fragment used to manufacture ring specimens**

Characteristic	Unit	Value
<b>Characteristics of commercial VVER fuel rod</b>		
Power plant	-	Unit #5 of NV NPP
Fuel assembly number	-	4108
Fuel rod number	-	165
Fuel burnup	MWd/kg U	48
Fuel rod length	mm	3832
<b>Characteristics of cladding</b>		
Cladding fragment coordinates	mm	1542 – 2062
Outer diameter	mm	9.066
Cladding thickness	mm	0.69±0.015
ZrO <sub>2</sub> thickness on outside of cladding	µm	3 – 5
ZrO <sub>2</sub> thickness on inner side of cladding	µm	<1
Hydride orientation coefficient	-	0.35 – 0.42
Hydrogen concentration	% by weight	(4.9 – 5.8) · 10 <sup>-3</sup>



**Fig. J.3. Microstructure of irradiated Zr-1%Nb cladding**

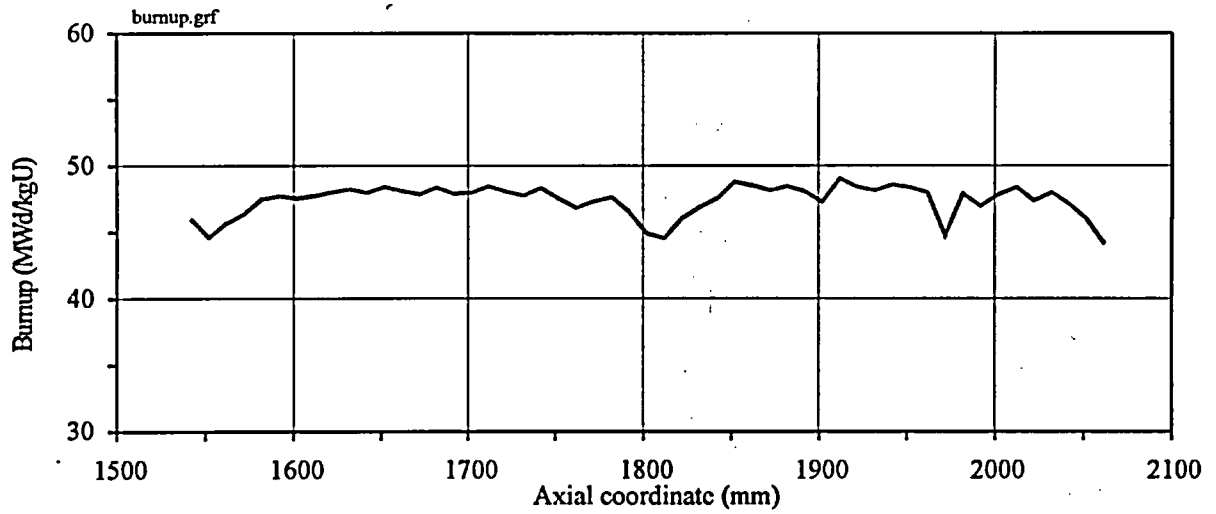

a)

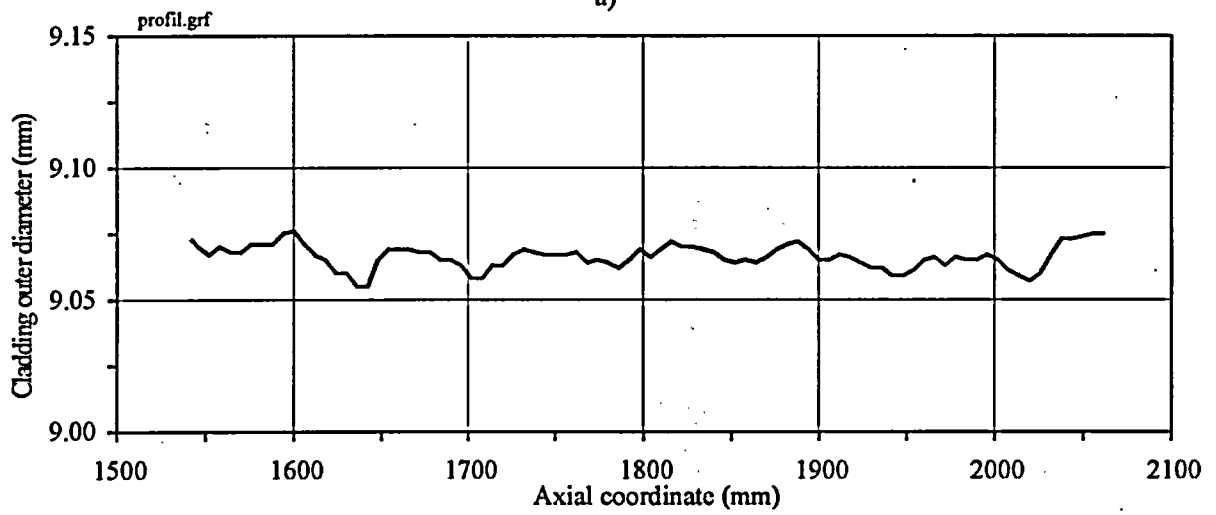

b)

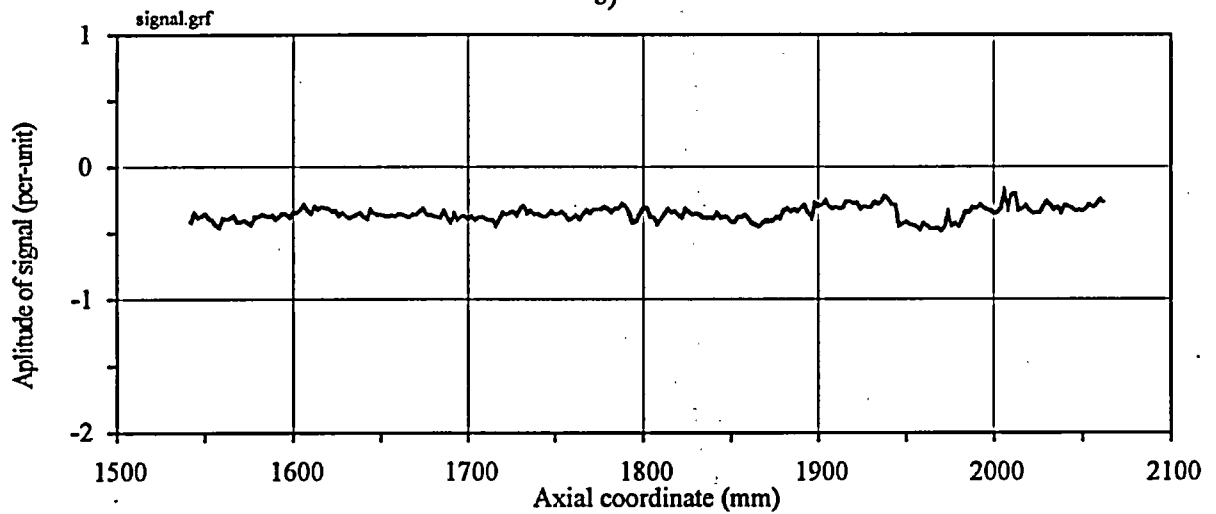

c)

Fig. J.4. a) Axial burnup distribution, b) results of profilometry and c) eddy-current examination for irradiated 1%Nb cladding

Table J.5. Results of plain ring tensile tests on irradiated Zr-1%Nb cladding (strain rate 0.002 1/s)

Temperature (K)	Ultimate strength (MPa)	Yield stress (MPa)	Total elongation (%)	Uniform elongation (%)
293	542	470	23.9	6.2
	541	484	10.2	5.1
	559	490	16.3	4.9
	540	469	13	4.5
	555	479	17.3	4.9
	548	481	11.1	5.2
423	512	437	18.5	4.7
	523	457	11.3	4
	521	435	14.6	4.6
523	392	324	16.3	6.7
	434	365	16.9	5.5
	455	395	18.3	4.4
	388	341	21	5.1
653	403	356	17.3	3.7
	391	336	18.1	4
	362	314	18	4.1
753	300	251	16.8	4.7
	225	191	33.5	5.3
	341	304	14.9	4.1
793	171	138	*	*
	144	133	*	*
	168	142	*	*
	189	167	37	4.4
863	90	81	*	*
	87	79	*	*
923	63	56	*	*
	65	58	*	*
	74	67	75.3	5.8
973	52	48	*	*
1023	42	37	94.5	5.1
	40	34	*	*
	37	32	*	*
1073	33	30	80	4.1
1123	16	15	77.6	4.8
	13	10	*	*
	17	13	*	*
	14	11	*	*
	15	14	70	4
1223	14	9	*	*
	20	11	*	*

\* not measured

**Table J.6. Results of plain ring tensile tests on irradiated Zr-1%Nb cladding vs. strain rate**

Strain rate (1/s)	Temperature (K)	Ultimate strength (MPa)	Yield stress (MPa)	Total elongation (%)	Uniform elongation (%)
0.002	293	550	463	16.9	*
	653	362	314	18.0	*
	753	317	274	12.4	*
	793	161	137	40.0	*
	923	74	67	75.3	5.8
	1023	42	37	94.5	5.1
	1073	33	30	80.0	4.1
0.1	793	185	160	33.5	*
		200	178	30.4	*
		227	177	33.9	*
	923	131	112	44	6.9
	1023	85	78	67.6	8.1
	1073	67	61	70.0	5.9
	1223	21	14	25.4	12.4
	1323	20	13	70.1	21
0.5	293	575	528	12.0	*
		591	533	13.9	*
		607	535	13.9	*
	653	414	380	17.4	*
		407	352	18.9	*
		389	350	16.1	*
	753	361	323	15.9	*
		357	304	15.6	*
		354	306	16.2	*

\* not measured



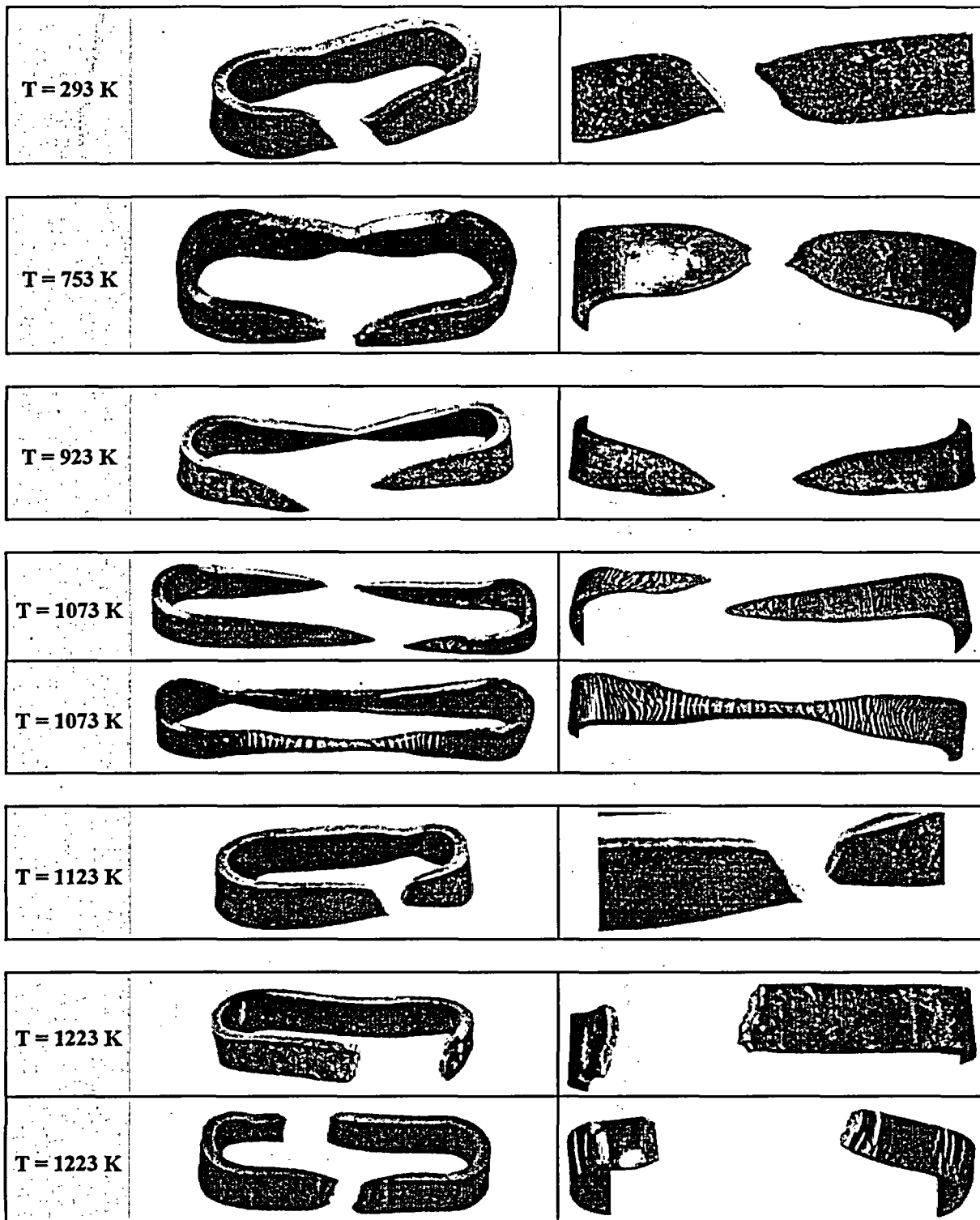

Fig. J.5.. Appearance of irradiated ring specimens after mechanical tests (strain rate - 0.002 1/s)

**APPENDIX K.**

**Results of Tests to Measure the Parameters  
of Zr-1%Nb Cladding Failure due to Ballooning**

**Table K.1. Characteristics of unirradiated Zr-1%Nb cladding used to manufacture tube specimens**

Characteristic	Unit	Value
<b>1. Composition</b>		
Zr	% by weight	98.505 – 98.705
Nb	% by weight	0.9 – 1.1
O	% by weight	0.11
N	% by weight	0.0061
C	% by weight	0.02
Si	% by weight	0.02
Al	% by weight	0.008
Mo	% by weight	0.005
Ni	% by weight	0.05
Fe	% by weight	0.05
Other elements	% by weight	0.126
<b>2. Treatment</b>	-	annealing at 580 C, 3 hours
<b>3. Outer diameter</b>	mm	9.14 <sup>+0.009</sup> <sub>-0.004</sub>
<b>4. Inner diameter</b>	mm	7.72 <sup>+0.015</sup> <sub>-0.008</sub>

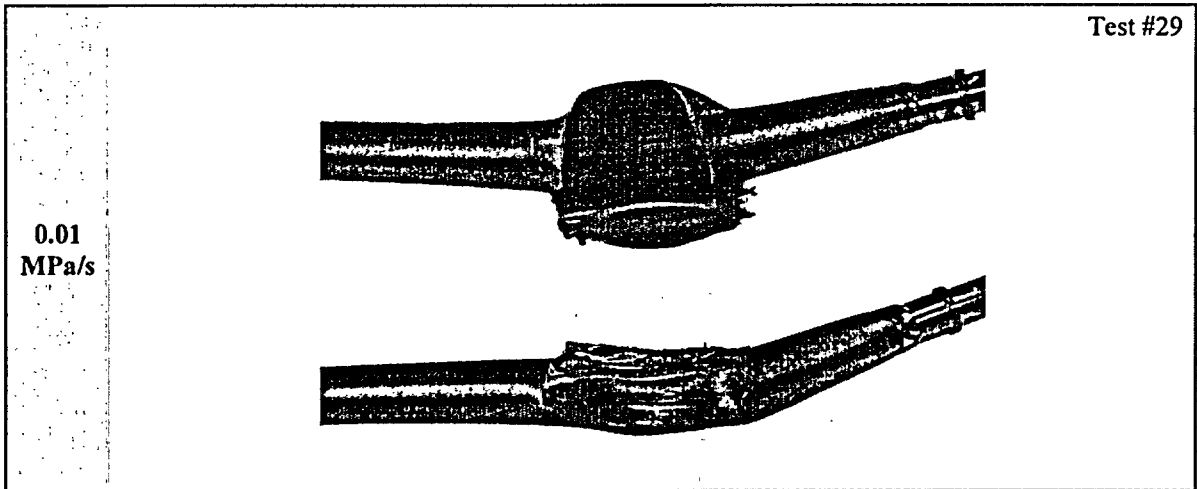

Fig. K.1. Appearance of pressurized unirradiated tube specimens after test (temperature 973 K)

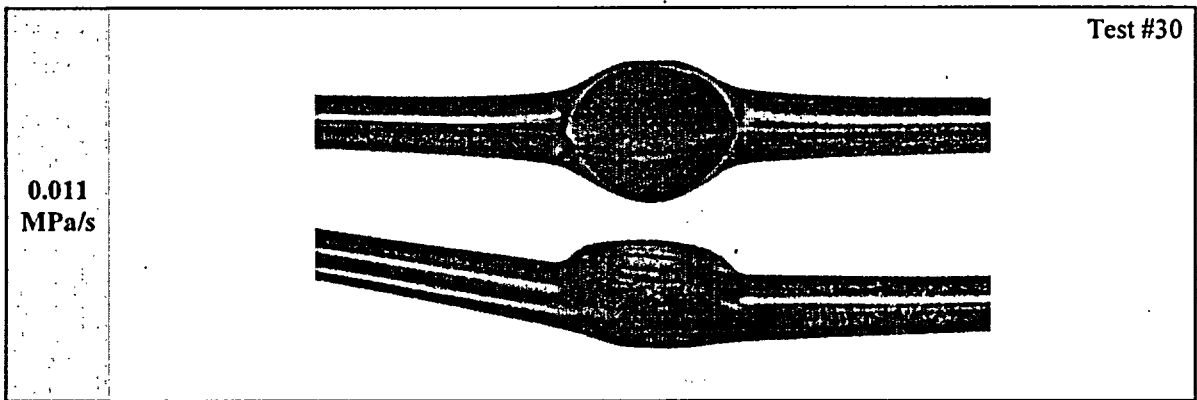

Fig. K.2. Appearance of pressurized unirradiated tube specimens after test (temperature 1023 K)

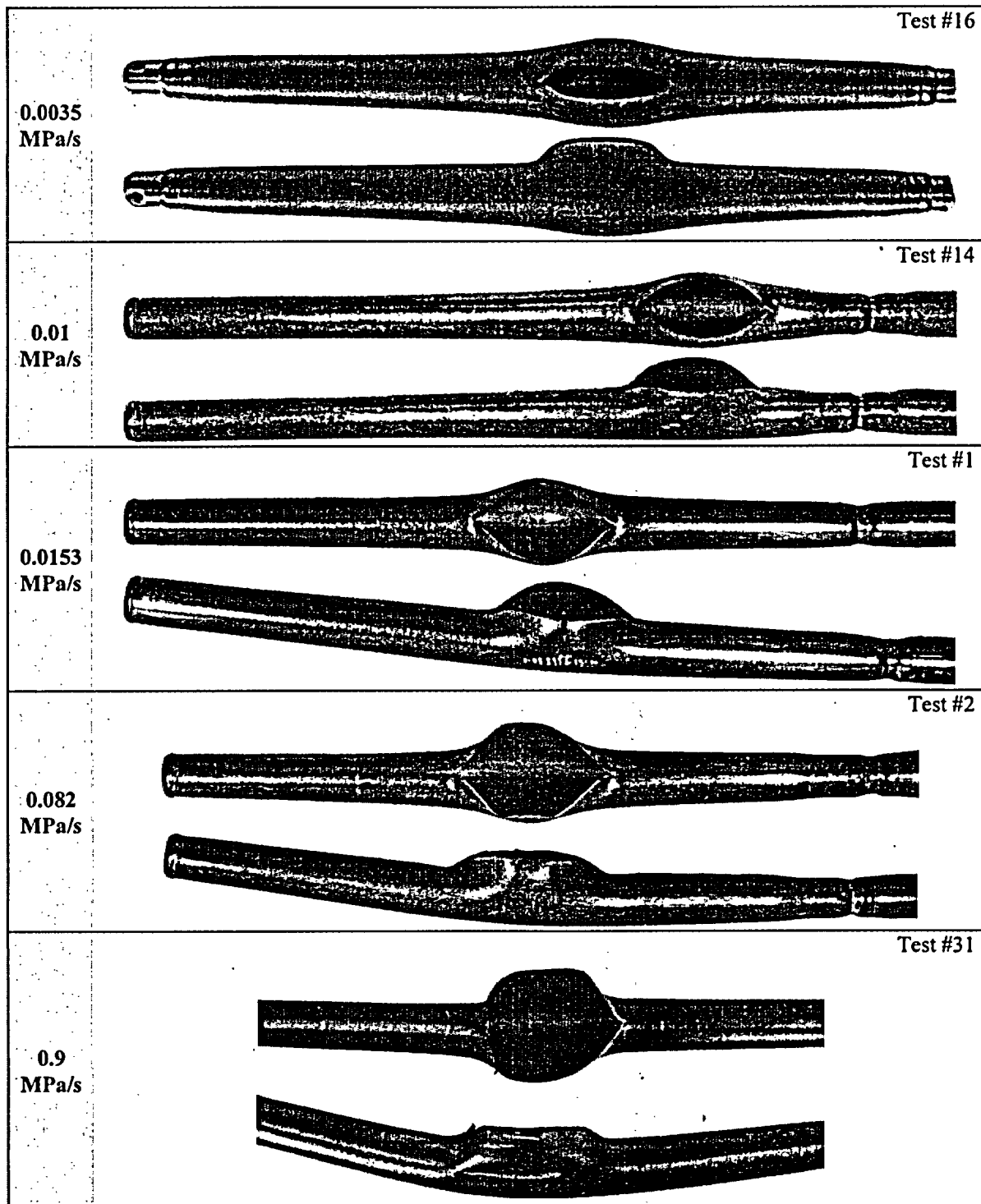

Fig. K.3. Appearance of pressurized unirradiated tube specimens after tests vs pressure increase rate (temperature 1073 K)

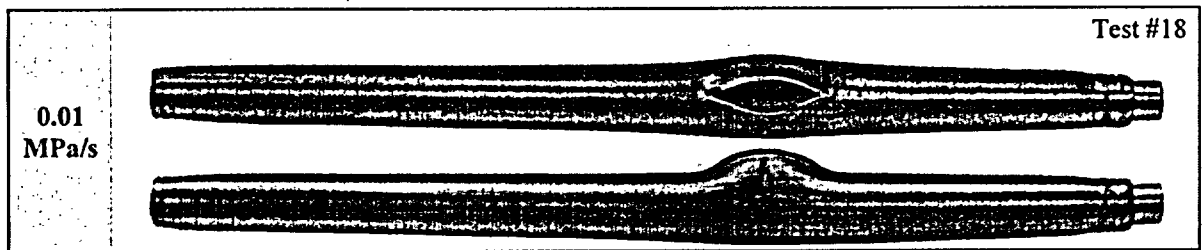

Fig. K.4. Appearance of pressurized unirradiated tube specimens after test (temperature 1126 K)

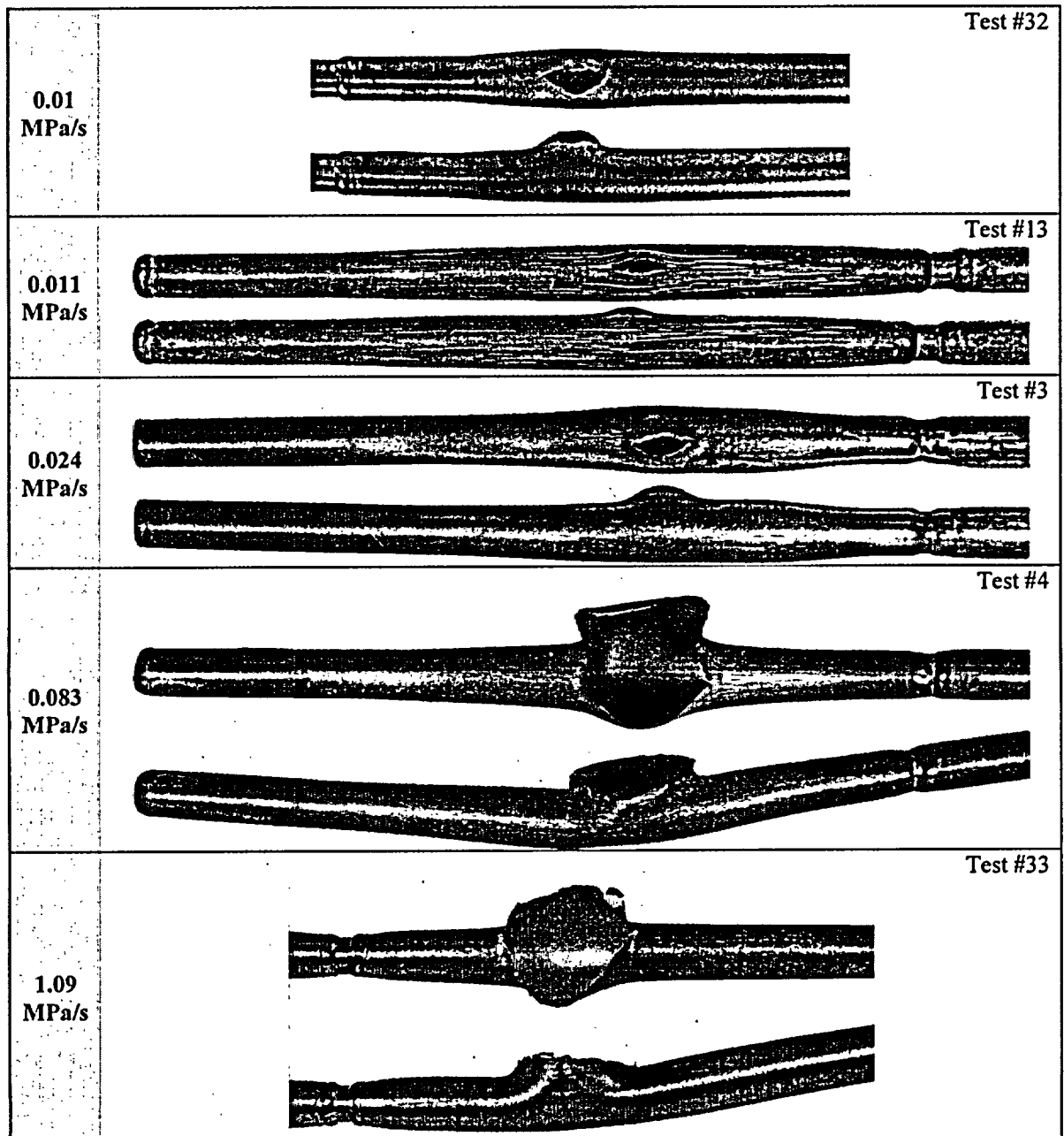

Fig. K.5. Appearance of pressurized unirradiated tube specimens after tests vs pressure increase rate (temperature 1173 K)

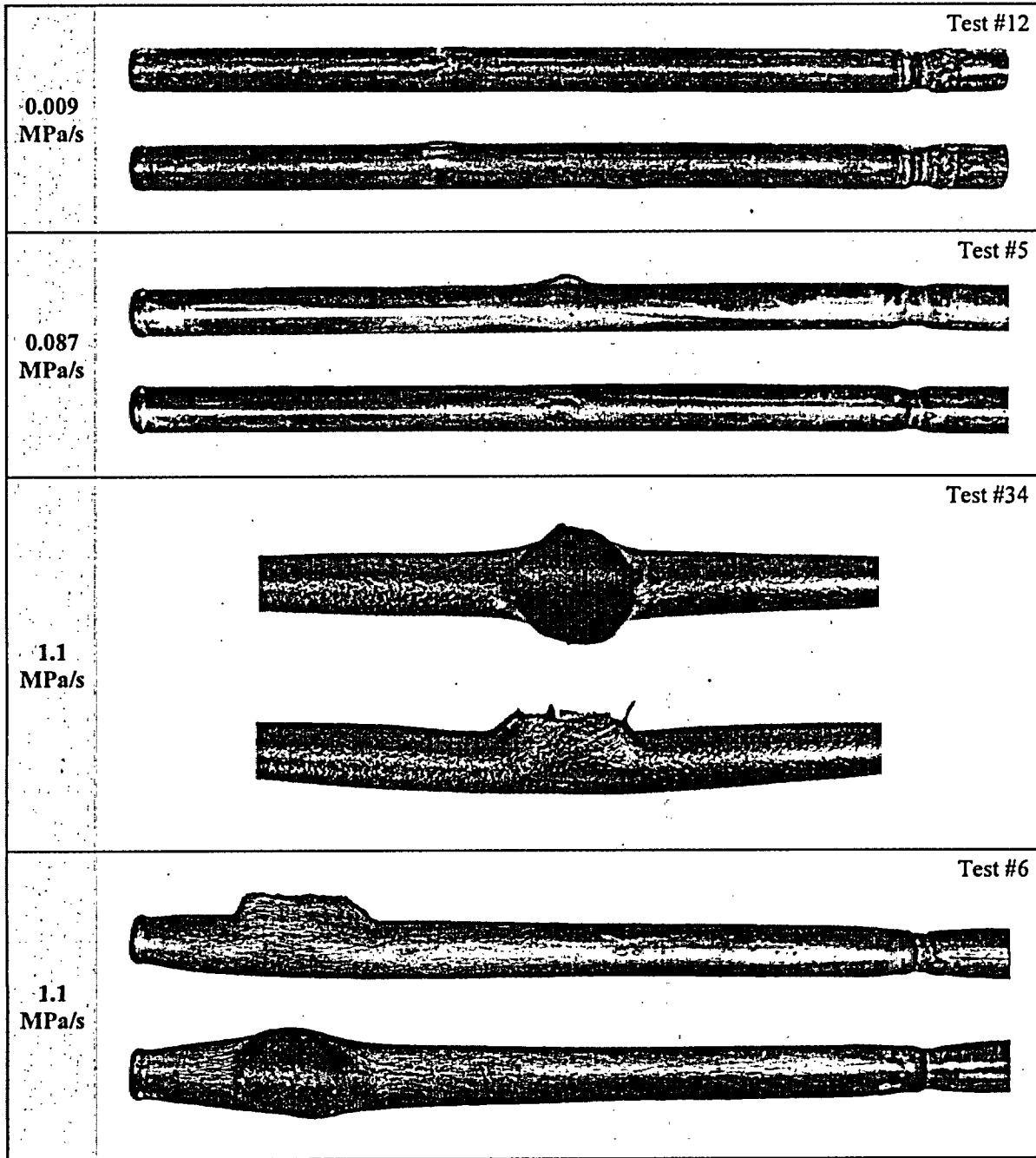

Fig. K.6. Appearance of pressurized unirradiated tube specimens after tests vs pressure increase rate (temperature 1273 K)

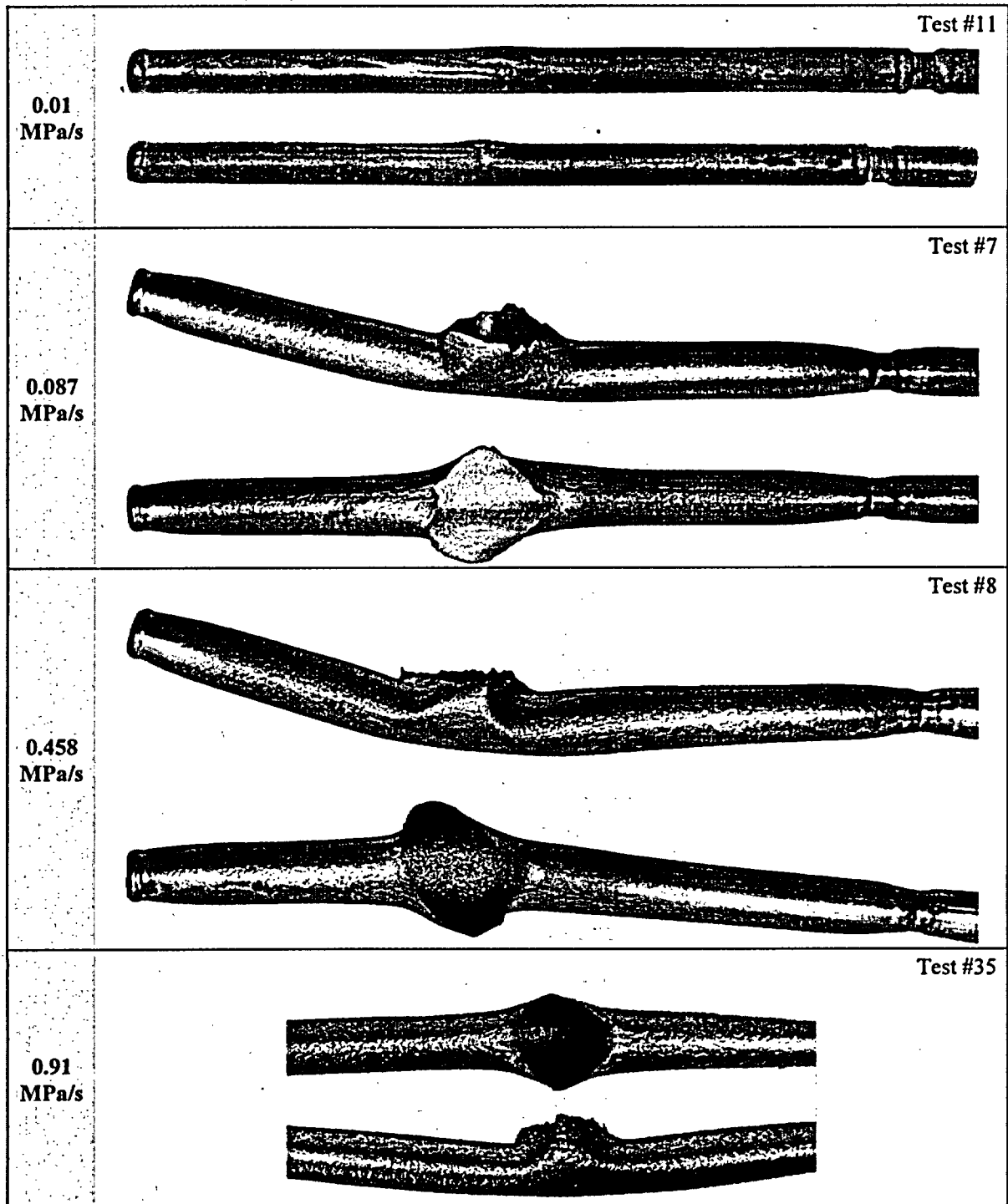

Fig. K.7. Appearance of pressurized unirradiated tube specimens after tests vs pressure increase rate (temperature 1373 K)



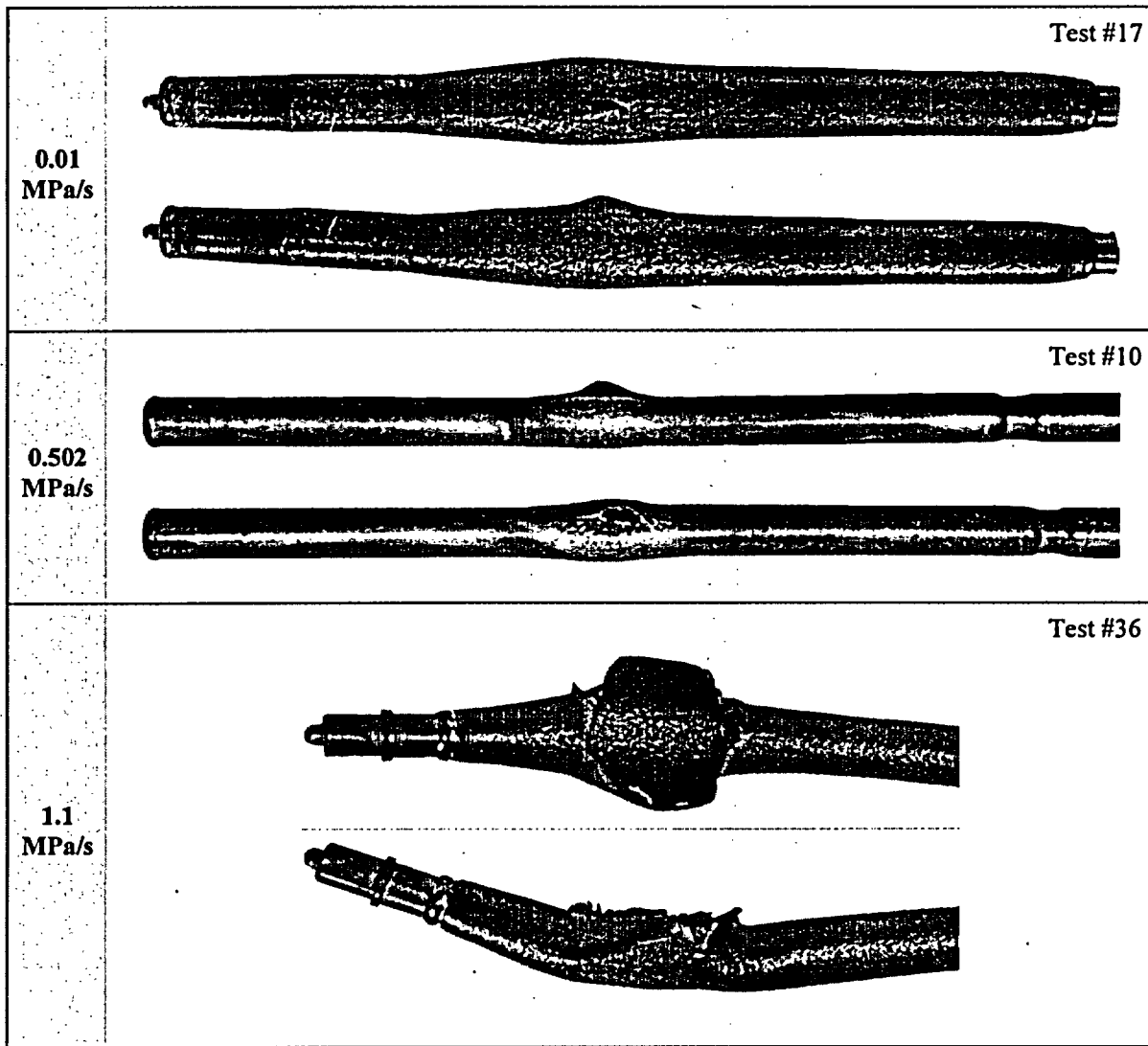

Fig. K.8. Appearance of pressurized unirradiated tube specimens after tests vs pressure increase rate (temperature 1473 K)

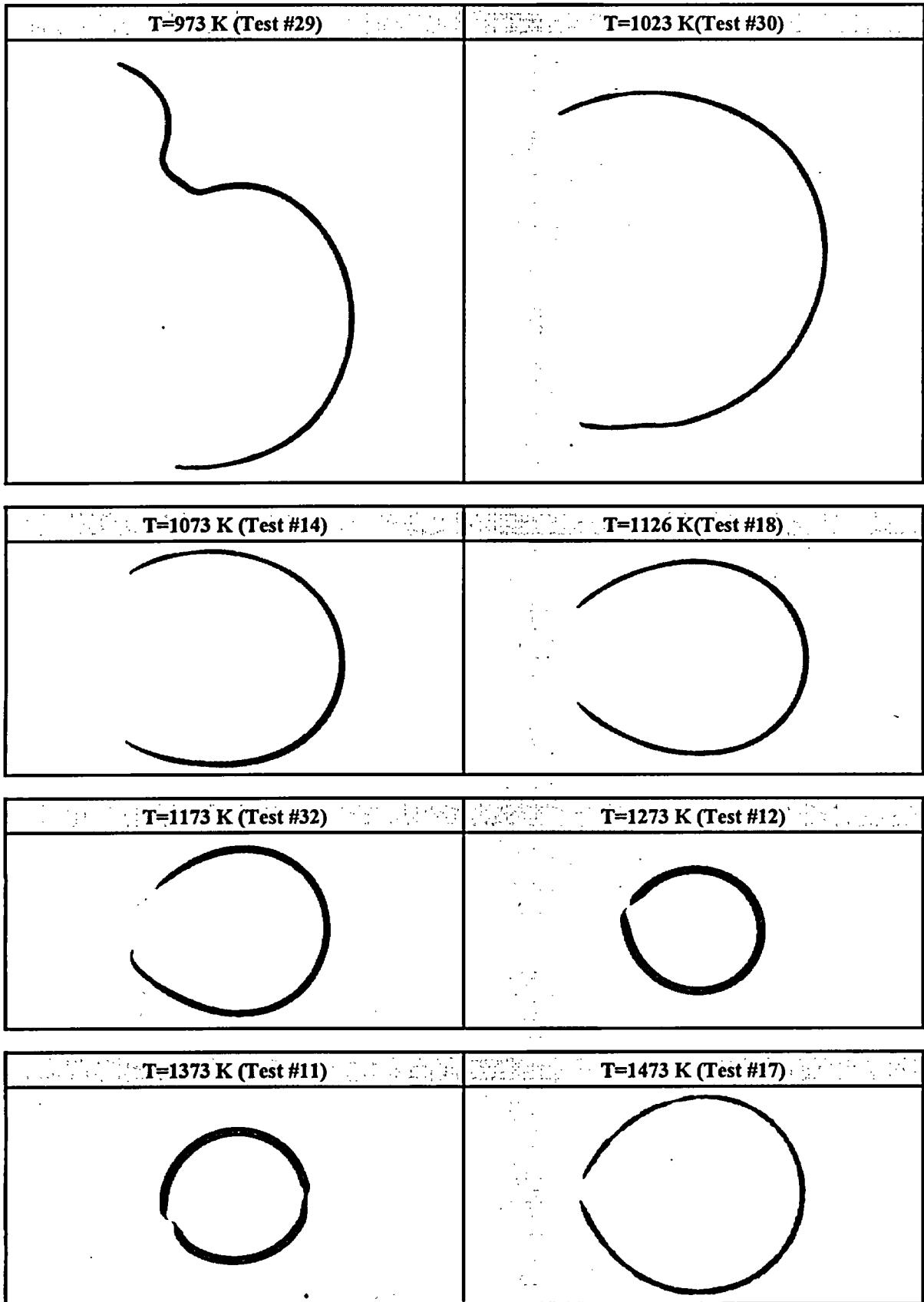
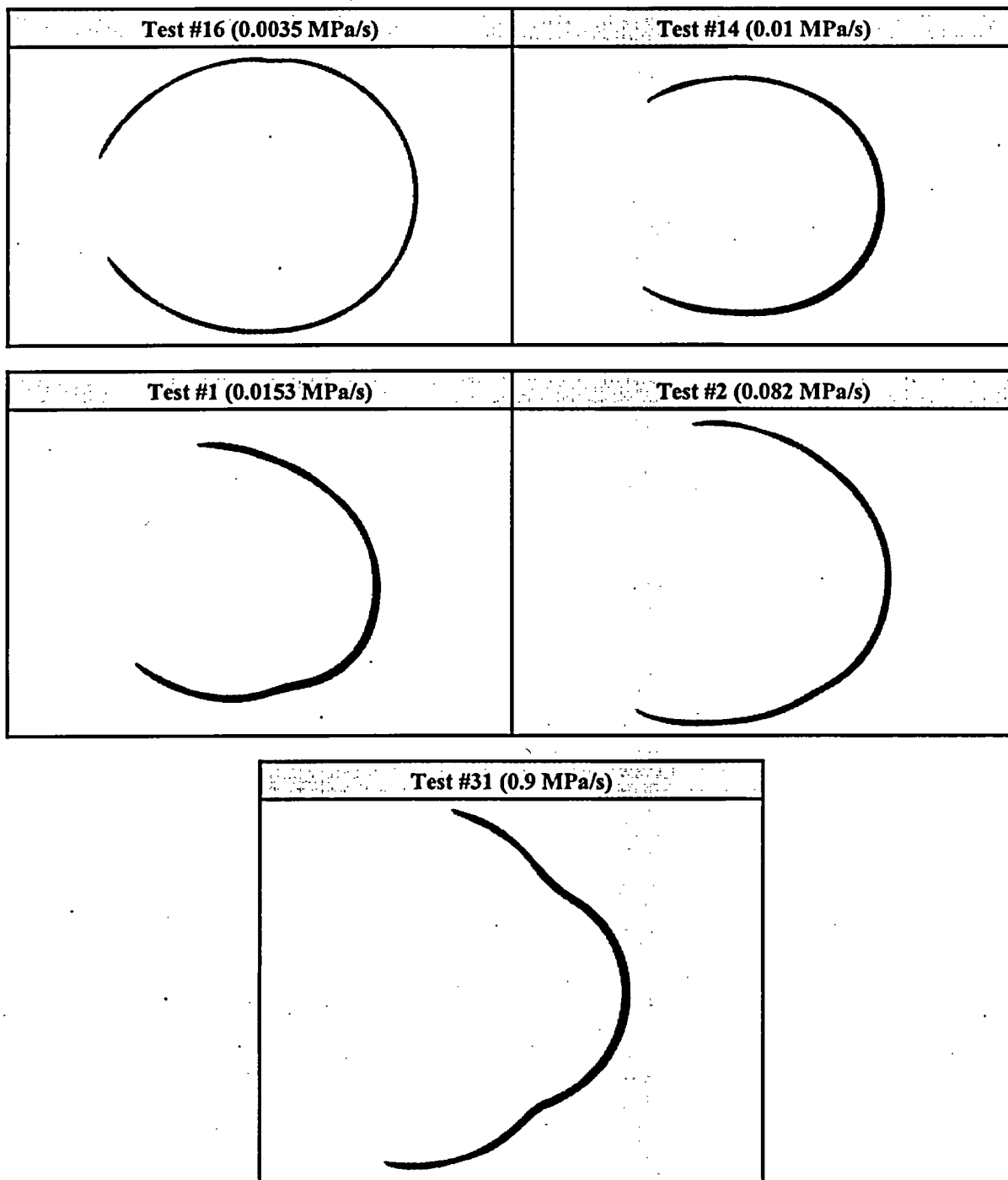
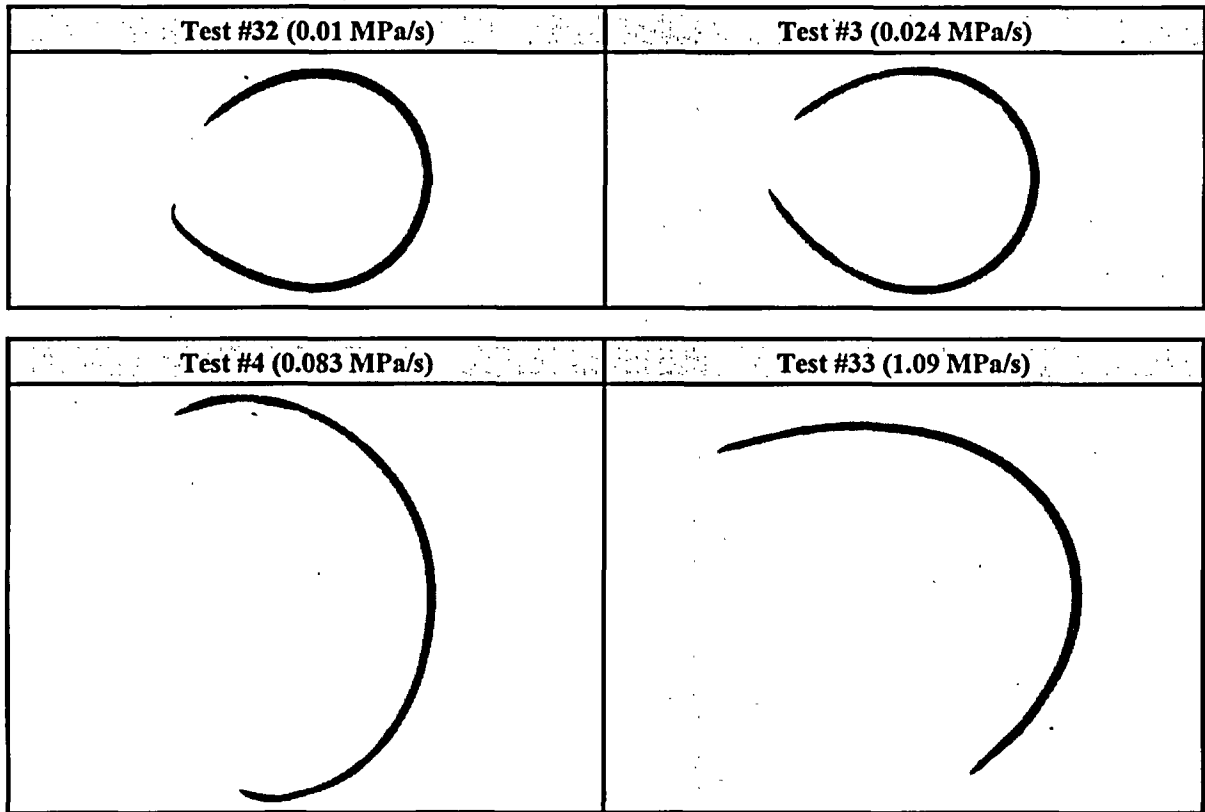

Fig. K.9. Cross-section profiles of burst region vs temperature (unirradiated cladding, 0.01MPa/s)



**Fig. K.10. Cross-section profiles of burst region vs pressure increase rate (unirradiated cladding, T=1073 K)**



**Fig. K.11. Cross-section profiles of burst region vs pressure increase rate (unirradiated cladding, T=1173 K)**

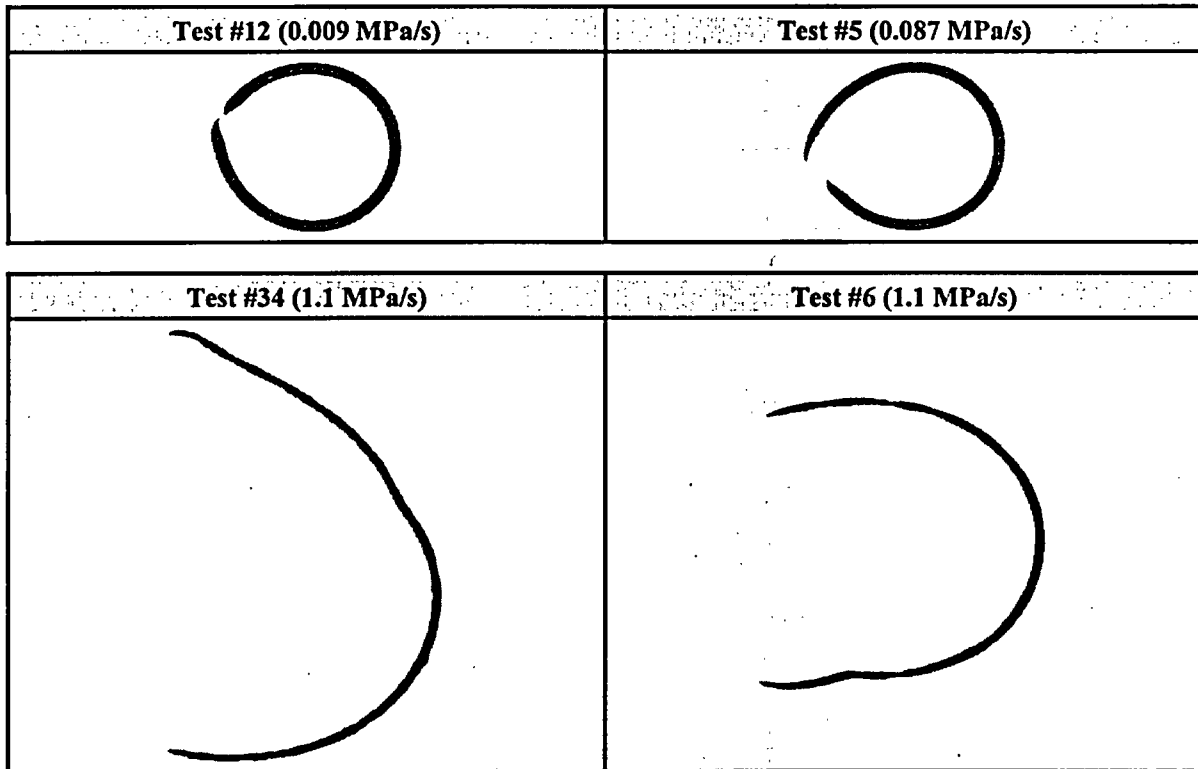

**Fig. K.12. Cross-section profiles of burst region vs pressure increase rate (unirradiated cladding, T=1273 K)**

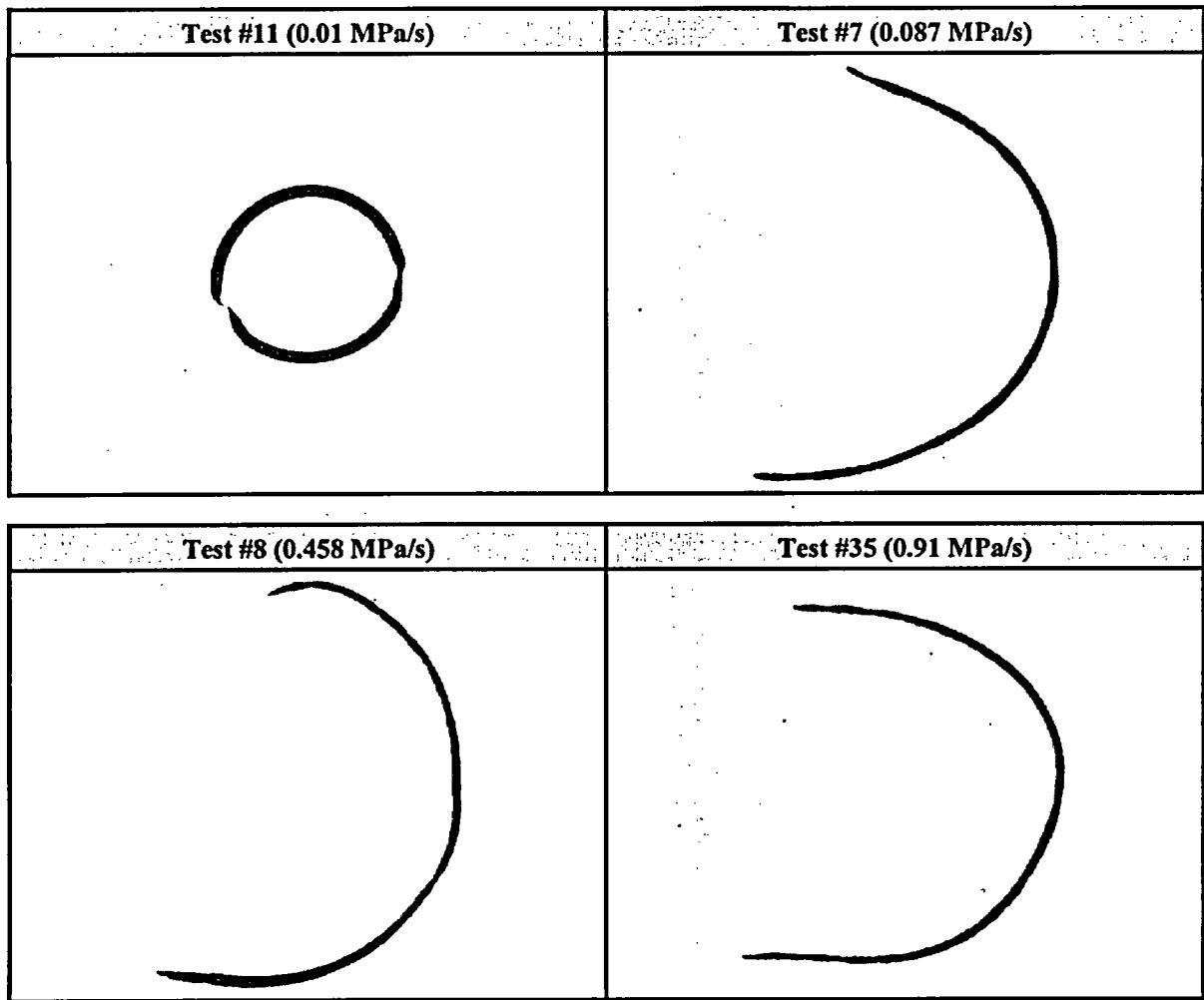

**Fig. K.13. Cross-section profiles of burst region vs pressure increase rate  
(unirradiated cladding, T=1373 K)**

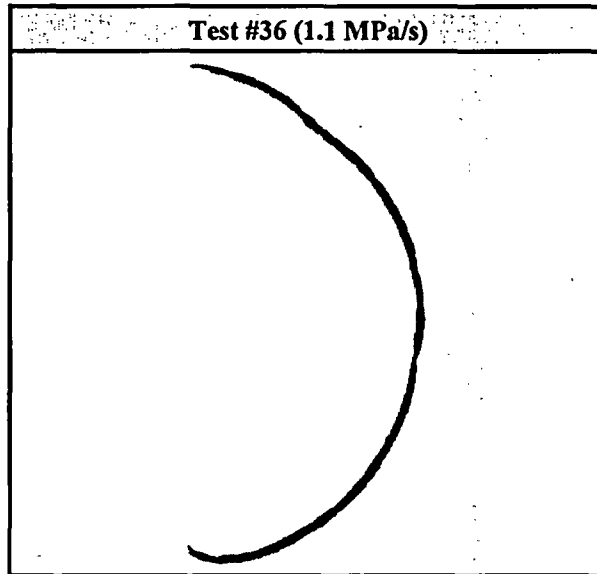
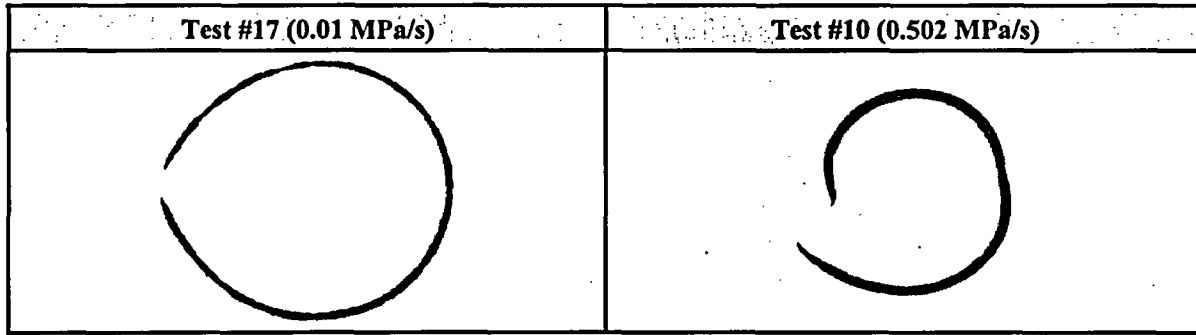

**Fig. K.14. Cross-section profiles of burst region vs pressure increase rate (unirradiated cladding, T=1473 K)**

**Table K.2. Burst parameters of unirradiated tube specimens vs temperature and pressure increase rate**

Test number	Temperature (K)	Pressure increase rate (MPa/s)	Burst pressure (MPa)	Average circumferential strain (%)	Axial radius of curvature (mm)	Circumferential radius of curvature (mm)	Wall thickness at burst (mm)
29	973	0.01	11.27	84.1	49.6	7.77	0.38
30	1023	0.011	8.49	92.3	59.3	8.12	0.36
16	1073	0.0035	4.48	106.5	39.9	8.72	0.16
14		0.01	5.75	49.2	149	6.30	0.27
1		0.0153	6.03	40.2	214	5.92	0.29
2		0.082	6.35	51.4	262	6.39	0.22
31		0.9	12.35	48.1	329	6.26	0.25
18		1126	0.01	3.13	49.2	141	6.30
32	1173	0.01	1.60	36.7	70.0	5.77	0.22
13		0.011	1.65	*	63	*	*
3		0.024	1.96	41.5	412	5.98	0.20
4		0.083	2.25	45.1	260	6.13	0.25
33		1.09	3.08	40.9	206	5.95	0.30
12	1273	0.009	1.42	7.8	62	4.55	0.26
5		0.087	1.59	8.4	112	4.58	0.32
34		1.1	2.34	58.9	489	6.71	0.19
6		1.1	2.76	46.8	*	6.20	0.24
11	1373	0.01	1.19	13.0	10.6	4.77	0.30
7		0.087	1.59	50.9	480	6.37	0.24
8		0.458	1.81	53.8	389	6.50	0.26
35		0.91	1.89	62.8	*	*	0.20
17	1473	0.01	0.84	68.4	51	7.11	0.25
9		0.088	1.52	*	*	*	*
10		0.502	1.50	24.3	15.4	5.25	0.35
36		1.10	1.71	59.0	304	6.72	0.21

\*Not measured



**Table K.3. Characteristics of commercial fuel rod and irradiated cladding fragment used to manufacture tube specimens**

	Characteristic	Unit	Value
1.	Characteristics of commercial VVER fuel rod		
1.1	Power plant	-	Unit #5 of NV NPP
1.2	Fuel assembly number	-	4108
1.3	Fuel rod number	-	153
1.4	Fuel burnup	MWd/kgU	47.5
1.5	Fuel rod length	mm	3832.01
2.	Characteristics of cladding fragment		
2.1	Cladding fragment coordinates	mm	712 – 2477
2.2	Tube specimen length	mm	150
2.3	Outer diameter	mm	9.08
2.4	Cladding thickness	mm	0.69±0.015
2.5	ZrO <sub>2</sub> thickness on outside of cladding	µm	4 – 7
2.6	ZrO <sub>2</sub> thickness on inner side of cladding	µm	<1
2.7	Hydride orientation coefficient	-	0.36 – 0.41
2.8	Hydrogen concentration	% by weight	0.0051 – 0.0057

**Table K.4. Characteristics of irradiated tube specimens**

Test number	Temperature (K)	Cladding fragment coordinates (mm)	Outer diameter (mm)	Burnup (MWd/kgU)
19	1373	1871-2021	9.075 ± <sup>0.012</sup> / <sub>0.011</sub>	48.03
20	1173	2023-2173	9.074 ± <sup>0.009</sup> / <sub>0.006</sub>	47.22
21	1273	2175-2325	9.080 ± <sup>0.022</sup> / <sub>0.012</sub>	47.44
23	1073	2327-2477	9.078 ± <sup>0.009</sup> / <sub>0.009</sub>	47.63
24	1473	1415-1565	9.084 ± <sup>0.012</sup> / <sub>0.007</sub>	47.51
26	1273	1719-1869	9.081 ± <sup>0.005</sup> / <sub>0.004</sub>	47.15
28	1373	712-862	9.078 ± <sup>0.006</sup> / <sub>0.007</sub>	47.38

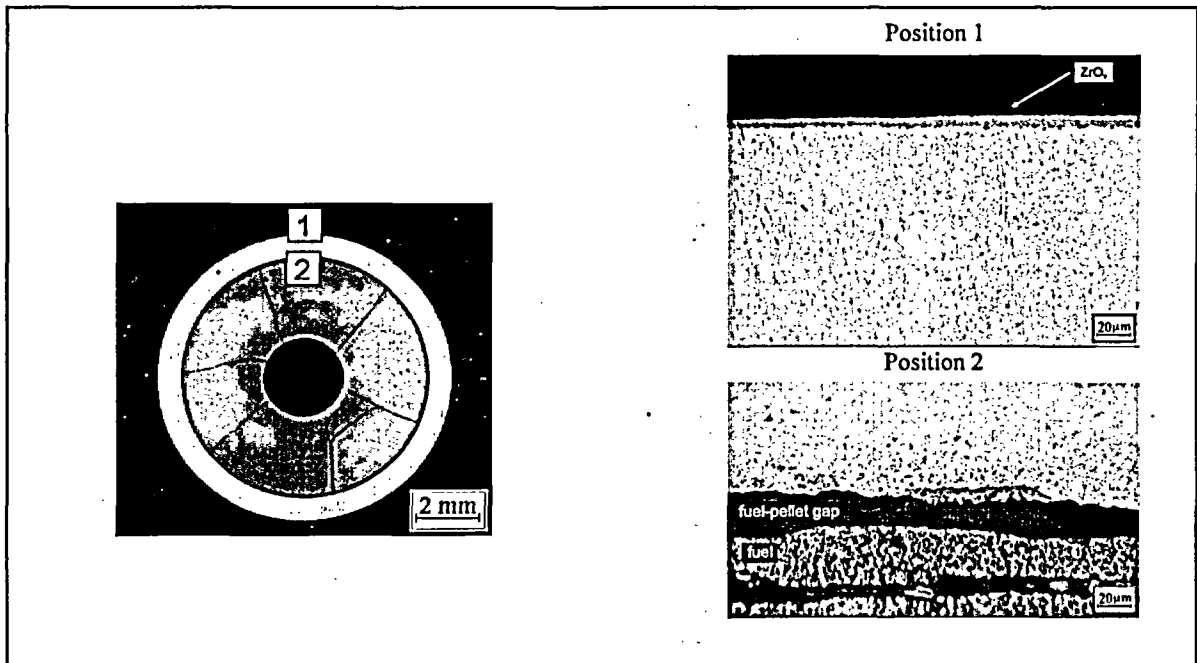
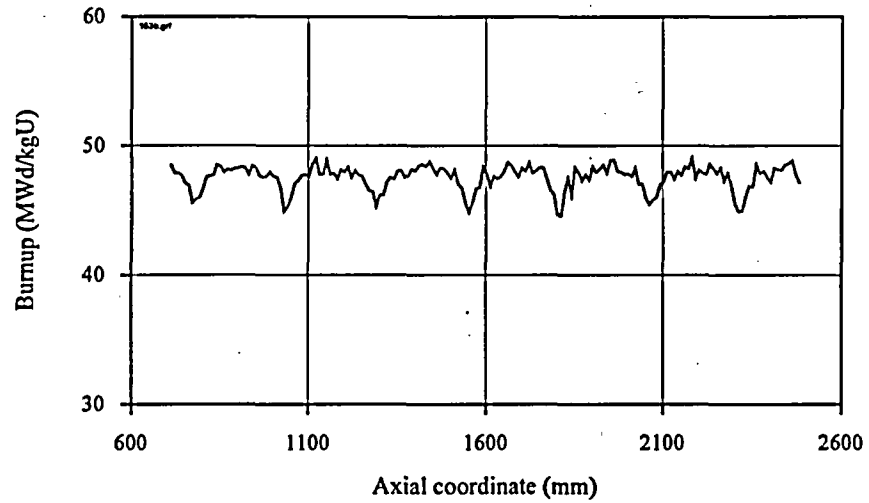
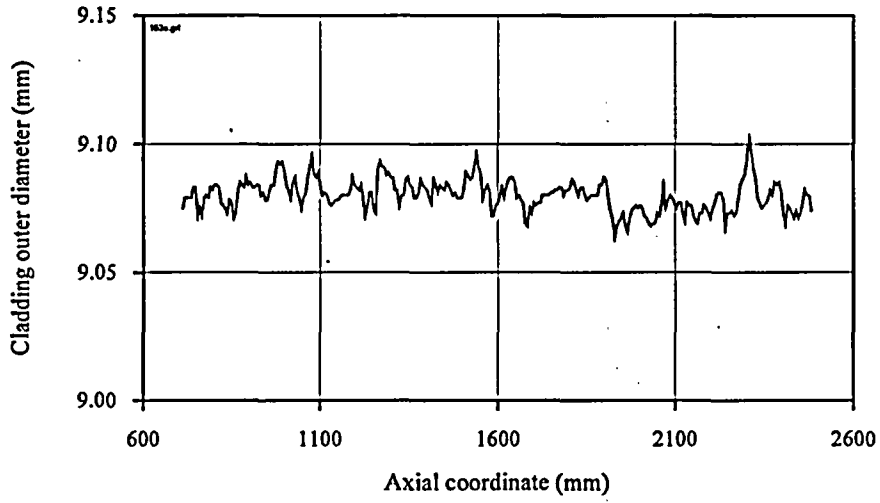

Fig. K.15. Microstructure of irradiated Zr-1%Nb cladding



a)



b)

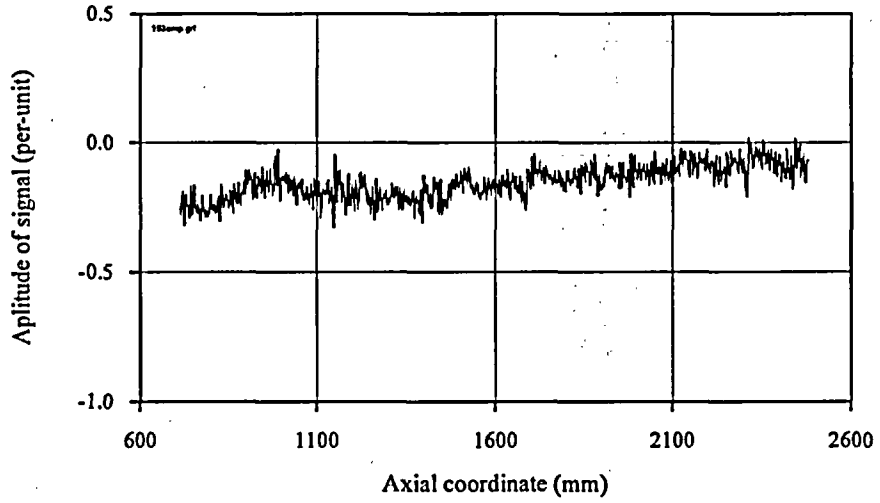

c)

**Fig. K.16. Axial burnup distribution a), results of profilometry b) and eddy-current examination c) for irradiated Zr-1%Nb cladding fragment**

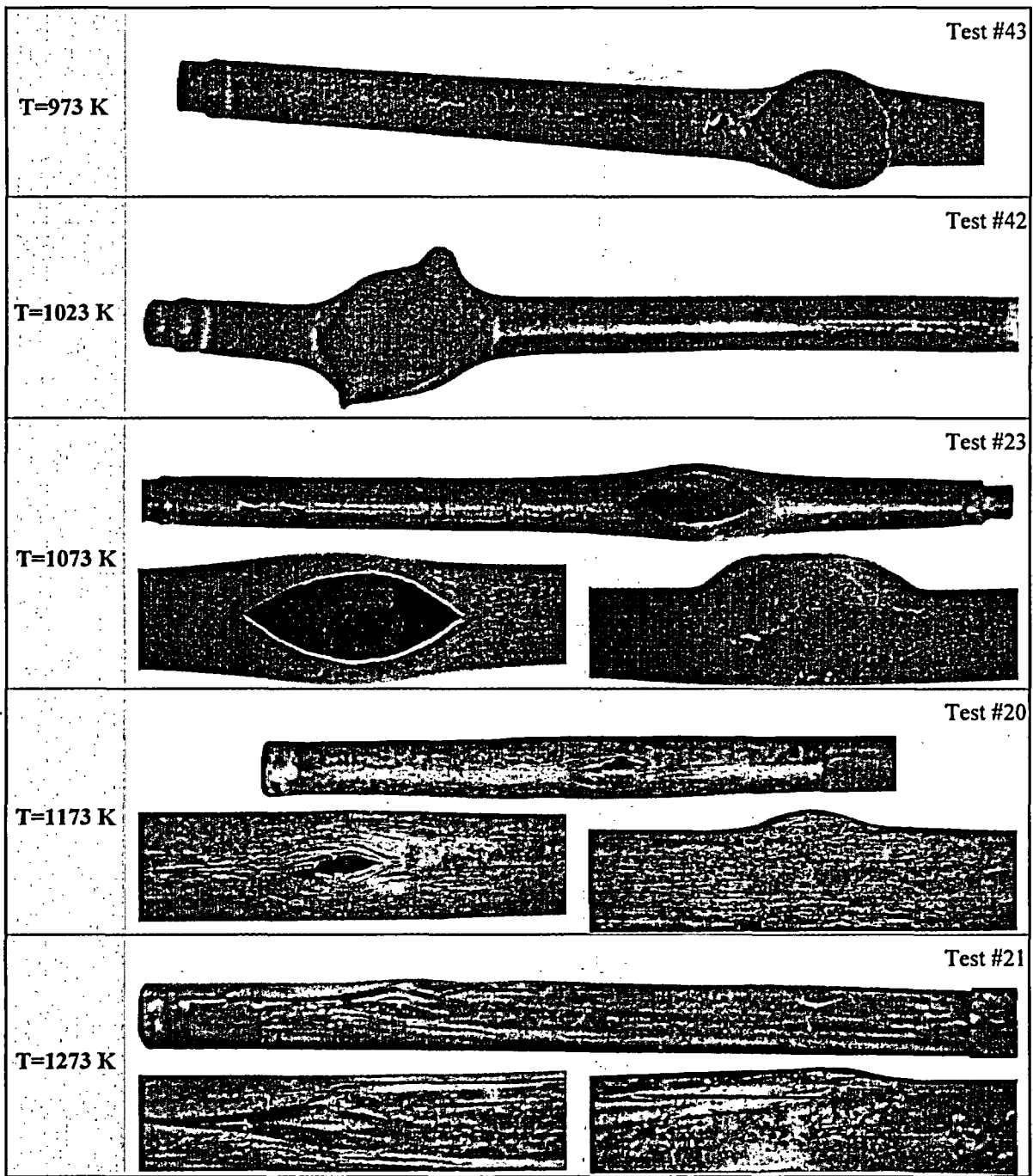

Fig. K.17. Appearance of pressurized irradiated tube specimens after tests vs temperature (strain rate 0.01MPa/s)

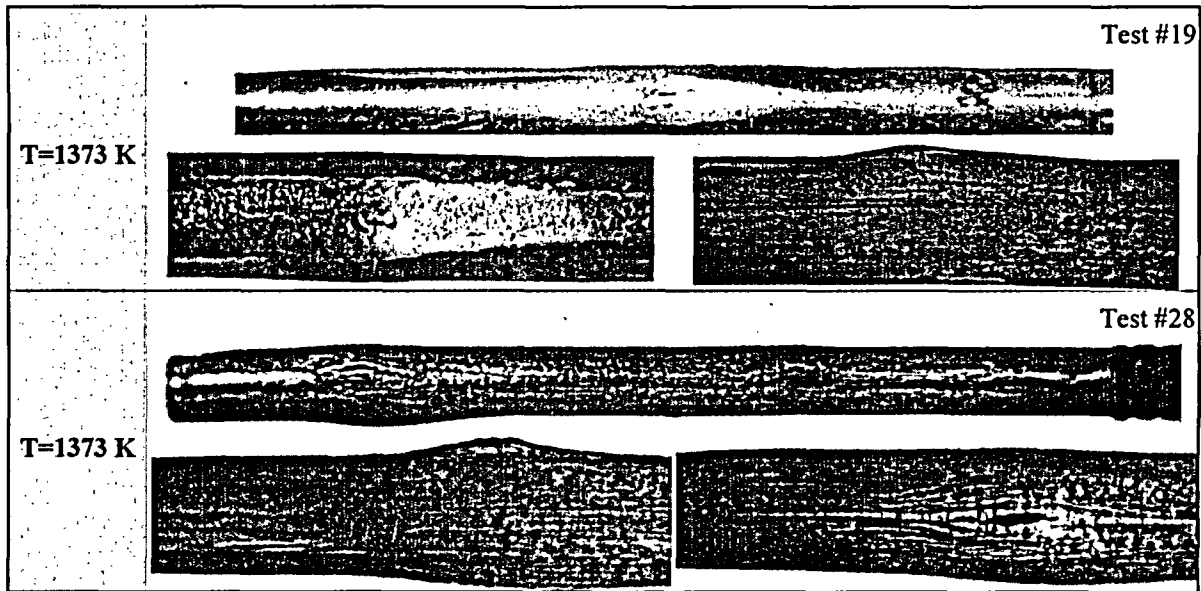

Fig. K.17. Appearance of pressurized irradiated tube specimens after tests vs temperature (strain rate 0.01MPa/s) (Contd.)

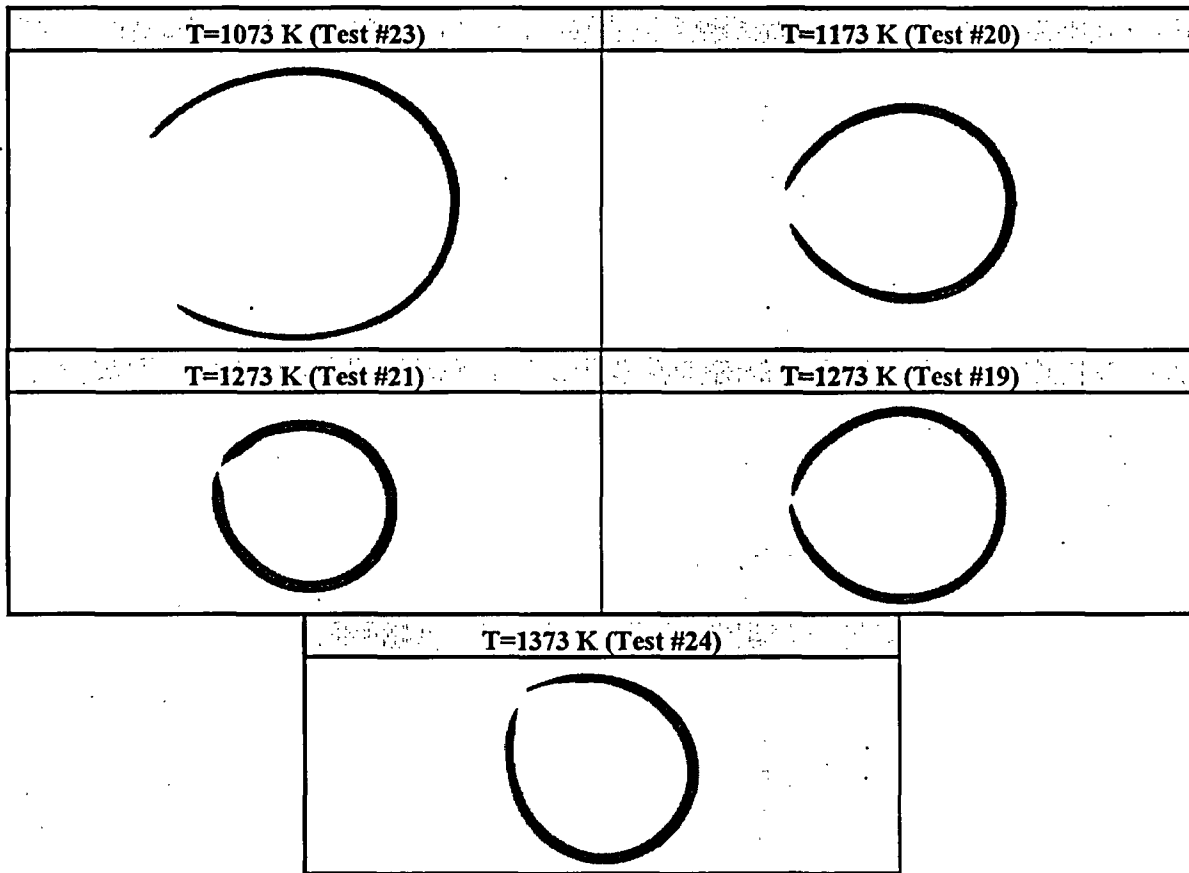

Fig. K.18.. Cross-section profiles of burst region vs temperature (irradiated cladding, 0.01 MPa/s)

**Table K.5. Burst parameters of irradiated tube specimens vs temperature and pressure increase rate**

Test number	Temperature (K)	Pressure increase rate (MPa/s)	Burst pressure (MPa)	Average circumferential strain (%)	Axial radius of curvature (mm)	Circumferential radius of curvature (mm)	Wall thickness at burst (mm)	
43	973	0.01	10.49	*	*	*	*	
42	1023		6.94	*	*	*	*	
23	1073		5.43	57.7	150	6.66	0.21	
49	1173		1.76	30.2	7.3	5.50	0.28	
20			1.95	28.4	10.4	5.43	0.27	
21	1273		1.93	8.9	21.8	4.60	0.20	
26			1.46	8.3	45	4.57	0.25	
28	1373		1.27	*	*	*	*	
19			1.11	28.0	272	5.41	0.27	
24	1473		1.24	20.4	28.4	5.09	0.25	
45	1073		1.1	7.41	59.3	38.9	6.72	0.30
46	1273		0.91	2.46	*	*	*	*
47	1473	0.90	2.09	*	*	*	*	

\*Not measured



NRC FORM 335 (2-89) NRCM 1102, 3201, 3202	U.S. NUCLEAR REGULATORY COMMISSION	1. REPORT NUMBER (Assigned by NRC, Add Vol., Supp., Rev., and Addendum Numbers, if any.)
<b>BIBLIOGRAPHIC DATA SHEET</b> (See instructions on the reverse)		NUREG/IA-0156 Volume 3
2. TITLE AND SUBTITLE		3. DATE REPORT PUBLISHED
Data Base on the Behavior of High Burnup Fuel Rods with Zr-1%Nb Cladding and UO <sub>2</sub> Fuel (VVER Type) under Reactivity Accident Conditions		MONTH   YEAR
Volume 3 Test and Calculation Results		July   1999
5. AUTHOR(S)		4. FIN OR GRANT NUMBER
L. Yegorova, G. Abyshov, V. Malofeev, et. al. A. Bortash, M. Kalugin, et. al. V. Smirnov, A. Goryachev, V. Prokhorov, et. al. V. Pakhnitz, A. Vurim		W6500
6. TYPE OF REPORT		7. PERIOD COVERED (Inclusive Dates)
IPSN 99/08-2 NSI RRC KI-2179		
8. PERFORMING ORGANIZATION - NAME AND ADDRESS (If NRC, provide Division, Office or Region, U.S. Nuclear Regulatory Commission, and mailing address; if contractor, provide name and mailing address.)		
Russian Research Center "Kurchatov Institute" Moscow 123182 Russia State Research Centre "Research Institute of Atomic Reactors" Dimitrovgrad Russia Institute of Atomic Energy of NNC Semipalatinsk Kazakhstan		
9. SPONSORING ORGANIZATION - NAME AND ADDRESS (If NRC, type "Same as above"; if contractor, provide NRC Division, Office or Region, U.S. Nuclear Regulatory Commission, and mailing address.)		
Division of Systems Analysis and Regulatory Effectiveness Office of Nuclear Regulatory Research U.S. Nuclear Regulatory Commission Washington, DC 20555-0001		
10. SUPPLEMENTARY NOTES		
11. ABSTRACT (200 words or less)		
<p>The present report contains a data base used for analyzing the behavior of three types of VVER fuel rods (fresh fuel rods; fuel rods with fresh fuel and irradiated cladding; high burnup fuel rods) which have been tested in the IGR under reactivity accident conditions. The basic test parameters are as follows: capsule tests with stagnant water or air coolant under ambient conditions; pressurized fuel rods; fuel burnup: 0 and 48 MWd/kg U; pulse width - about 700 ms.</p> <p>The presented data base includes the results of reactor tests of 25 fuel rods as well as results of pre- and post-test examinations of fuel rods, computer simulations of fuel rod behavior under test conditions; in addition, the report presents the results of special out-of-pile tests carried out to measure mechanical properties of Zr-1%Nb cladding.</p> <p>The report consists of three volumes, each volume contains the following information:</p> <p>Volume 1: Brief description of the test program, testing and analytical techniques and summary of results;</p> <p>Volume 2: Description and validation of procedures used to obtain the data base. Summarization of test results as supported by mechanical properties of Zr-1%Nb cladding;</p> <p>Volume 3: Data base consisting of: parameters of VVER fuel rods before and after irradiation at the NovoVoronozh Nuclear Power Plant; parameters of fresh and refabricated fuel rods before and after IGR tests; results of out-of-pile mechanical tests of non-irradiated and irradiated Zr-1%Nb cladding.</p>		
12. KEY WORDS/DESCRIPTORS (List words or phrases that will assist researchers in locating the report.)		13. AVAILABILITY STATEMENT
reactivity initiated accident impulse graphite reactor (Kazakhstan Atomic Energy Agency) Zirconium-1% Niobium alloy FRAP-T6 & SCANAIR computer codes material properties cladding strain and ballooning refabrication of VVER fuel rods post-test examinations		unlimited
		14. SECURITY CLASSIFICATION
		(This Page)
		unclassified
		(This Report)
		unclassified
		15. NUMBER OF PAGES
		16. PRICE





**Federal Recycling Program**