

2004-2005 Edition

INFORMATION DIGEST



United States Nuclear Regulatory Commission

2004 - 2005 Edition

INFORMATION DIGEST



NUREG-1350, Volume 16, Rev. 1
Manuscript Completed: June 2004
Date Published: July 2004
Date Revised: February 2005

Division of Planning, Budget, and Analysis
Office of the Chief Financial Officer
U.S. Nuclear Regulatory Commission
Washington, DC 20555-0001

Abstract

The "United States Nuclear Regulatory Commission Information Digest" (digest) provides a summary of information about the U.S. Nuclear Regulatory Commission (NRC), including the agency's regulatory responsibilities and licensed activities, and general information on domestic and world-wide nuclear energy. Published annually, the digest is a compilation of nuclear- and NRC-related data designed to serve as a quick reference to major facts about the agency and the industry it regulates. In general, the data cover up to 2003 or data available at manuscript completion. Information on generating capacity and average capacity factor for operating U.S.

commercial nuclear power reactors is obtained from the NRC, as well as from various industry sources. Industry source information is reviewed by the NRC for consistency only, and no independent validation and/or verification is performed.

Comments and/or suggestions on the data presented are welcomed and should be directed to Alesha Bellinger or JoAnne M. Johnson, Division of Planning, Budget, and Analysis, Office of the Chief Financial Officer, United States Nuclear Regulatory Commission, Washington, DC 20555-0001. For detailed and complete information about tables and figures, refer to the source publications.

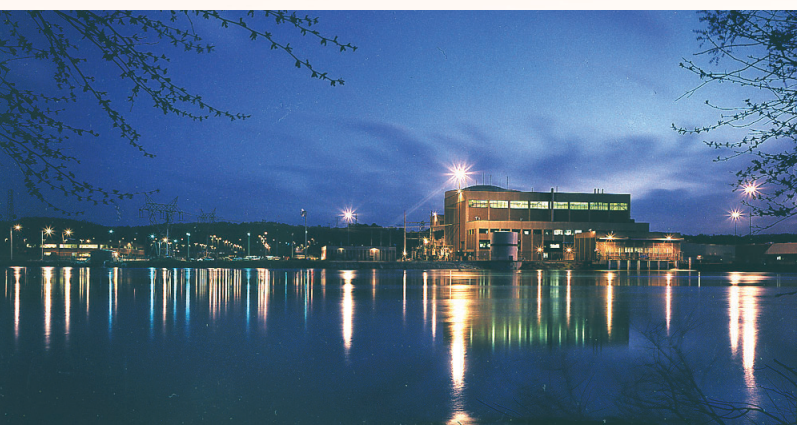

Fort Calhoun Nuclear Power Station

Contents

Abstract	iii
For More Information	ix
NRC AS A REGULATORY AGENCY	1
Mission, Goals, and Statutory Authority	2
Major Activities	5
Organizations and Functions	6
NRC Locations	10
NRC Fiscal Year 2004 Resources	12
U.S. AND WORLDWIDE ENERGY	17
U.S. Electricity	18
U.S. Electricity Generated by Commercial Nuclear Power	25
Worldwide Electricity Generated by Commercial Nuclear Power	28
International Activities	34
OPERATING NUCLEAR REACTORS	37
U.S. Commercial Nuclear Power Reactors	38
Oversight of U.S. Commercial Nuclear Power Reactors	48
Future U.S. Commercial Nuclear Power Reactor Licensing	52
U.S. Nuclear Research and Test Reactors	58
Nuclear Regulatory Research	60
NUCLEAR MATERIALS SAFETY	63
U.S. Fuel Cycle Facilities	64
U.S. Materials Licenses	69
Nuclear Gauges	73
Teletherapy Devices	74
Commercial Product Irradiators	75
Uranium Milling	76

RADIOACTIVE WASTE **79**

U.S. Low-Level Radioactive Waste Disposal 80
U.S. High-Level Radioactive Waste Disposal 83
U.S. Nuclear Materials Transportation and Safeguards 91
Decommissioning 92

APPENDICES **95**

Abbreviations Used in Appendices 97

A. U.S. Commercial Nuclear Power Reactors 99
B. U.S. Commercial Nuclear Power Reactors Formerly Licensed To Operate 115
C. Canceled U.S. Commercial Nuclear Power Reactors 117
D. U.S. Commercial Nuclear Power Reactors by Licensee 121
E. U.S. Nuclear Research and Test Reactors Regulated by NRC 123
F. U.S. Research and Test Reactors Under Decommissioning 127
G. NRC Performance Indicators: Annual Industry Averages 129
H. Dry Spent Fuel Storage Designs: NRC-Approved for General Use 131
I. Dry Spent Fuel Storage Licensees 133
J. World List of Nuclear Power Reactors 135
K. Nuclear Power Units by Reactor Type, Worldwide 137
L. Top 50 Reactors by Capacity Factor, Worldwide 139
M. Top 50 Reactors by Generation, Worldwide 141
N. Quick-Reference Metric Conversion Tables 143

Glossary 147

Figures

1. U.S. Nuclear Regulatory Commission Organization Chart 8
2. NRC Regions 11
3. Distribution of NRC Budget Authority and Staff 13
4. NRC Budget Authority 14
5. NRC Personnel Ceiling 15
6. Recovery of NRC Budget Authority, FY 2004 16
7. U.S. Electric Capacity and Capability by Energy Source 19
8. U.S. Electric Net Generation by Energy Source 19

9. Net Electricity Generated in Each State by Nuclear Power	21
10. U.S. Net Electric Generation by Source	22
11. U.S. Electric Generating Capability by Energy Source	23
12. U.S. Average Nuclear Reactor, Coal-Fired and Fossil Steam Plant Production Expenses	24
13. Net Generation of U.S. Nuclear Electricity	26
14. Net Nuclear Electric Power as a Percent of World Nuclear Generation and Total Domestic Net Nuclear Electricity Generation	29
15. Operating Nuclear Power Plants Worldwide	31
16. Typical Pressurized Water Reactor	39
17. Typical Boiling Water Reactor	40
18. U.S. Operating Commercial Nuclear Power Reactors	41
19. NRC Region I Operating Nuclear Power Reactors	42
20. NRC Region II Operating Nuclear Power Reactors	43
21. NRC Region III Operating Nuclear Power Reactors	44
22. NRC Region IV Operating Nuclear Power Reactors	45
23. U.S. Commercial Nuclear Power Reactor Operating Licenses Issued by Year	47
24. NRC Inspection Effort at Operating Reactors	49
25. NRC Performance Indicators, Annual Industry Averages	50
26. U.S. Commercial Nuclear Power Reactors—Years of Operation	55
27. U.S. Commercial Nuclear Power Reactor Operating Licenses— Expiration Date by Year Assuming Construction Recapture	57
28. U.S. Nuclear Research and Test Reactors	59
29. Typical Uranium Enrichment Facility	66
30. Two Enrichment Processes	66
31. Typical Fuel Fabrication Plant	67
32. Major U.S. Fuel Cycle Facility Sites	68
33. NRC Agreement States	72
34. Cross Section of a Fixed Fluid Gauge	73
35. Cobalt-60 Teletherapy Unit	74
36. Commercial Gamma Irradiator	75
37. Locations of Uranium Milling Facilities	78
38. Low-Level Waste Disposal Site	81
39. U.S. Low-Level Waste Compacts	82

40. The Yucca Mountain Disposal Plan	85
41. Spent Fuel Generation and Storage After Use	86
42. Licensed/Operating Independent Spent Fuel Storage Installations	88
43. Dry Storage of Spent Fuel	90

Tables

1. NRC Budget Authority	14
2. NRC Personnel Ceiling	15
3. Electric Generating Capability and Electric Generation in Each State by Nuclear Power	20
4. U.S. Net Electric Generation by Source	22
5. U.S. Electric Generating Capability by Energy Source	23
6. U.S. Average Nuclear Reactor and Coal-Fired/Fossil Steam Plant Production Expenses	24
7. U.S. Nuclear Power Reactor Average Capacity Factor and Net Generation	26
8. U.S. Commercial Nuclear Power Reactor Average Capacity Factor by Vendor and Reactor Type	27
9. Commercial Nuclear Power Reactor Average Gross Capacity Factor and Gross Generation by Selected Country	30
10. Commercial Nuclear Power Reactor Average Gross Capacity Factor by Selected Country	30
11. U.S. Commercial Nuclear Power Reactor Operating Licenses Issued by Year	46
12. U.S. Commercial Nuclear Power Reactor Operating Licenses— Expiration Date by Year	56
13. U.S. Materials Licenses by State	71
14. Locations of Uranium Milling Facilities	77
15. Complex Decommissioning Sites	93

For More Information...

The U.S. Nuclear Regulatory Commission (NRC) offers a variety of programs to make the agency, licensee, and nuclear industry information available to the public.

The NRC's World Wide Web site (www.nrc.gov) contains a wide variety of information about the agency's regulatory programs. The areas covered include the licensing of power and research reactors, nuclear materials, and radioactive waste; agency radiation protection and emergency response activities; and the background and current status of all ongoing regulatory initiatives. The site also provides access to many publicly available agency documents and information collections, press releases, organizational charts and descriptions, headquarters and regional locations and addresses, the agency telephone directory, current agency regulations, planning and financial management reports, and areas devoted specifically to public comments and participation in the agency's regulatory process. To help the public locate information, the site provides an alphabetically arranged topical index of contents, a search engine, a site contents page arranged by program area, and a text menu of site contents. The agency also welcomes comments on its site. They can be submitted to nrcweb@nrc.gov.

The Electronic Reading Room on the NRC Web site allows the public to use

the Internet to search for records that the NRC has already released to the public. This site uses the NRC's Agencywide Documents Access and Management System (ADAMS) to search two electronic libraries: the Public Legacy Library and the Publicly Available Records System (PARS) Library. The Public Legacy Library contains a selection of bibliographic descriptions and some full text files of NRC records released to the public prior to Fall 1999. The PARS Library, contains all NRC publicly available records released since Fall 1999. The PARS Library contains both full-text and image records, and the public can perform full-text searches of the database, and can view, download, and print the files from there.

The NRC's Public Document Room (PDR) at NRC headquarters in Rockville, Maryland (OWFN 01-F21), has a complete collection of more than two million NRC documents released prior to the Fall of 1999 that are still retained as agency documents. The public may view documents at the PDR, and reference librarians are available to help in identifying, retrieving, organizing, and evaluating NRC documents from various resources and formats, including the Electronic Reading Room. Members of the public may also access the Electronic Reading Room libraries from computer terminals in the PDR. The PDR also provides reproduction

(continued)

For More Information...(continued)

services and, for a fee, the public can order copies of any of the records in the PDR or the Legacy and the Public PARS libraries.

For more information about NRC documents, contact the PDR by telephone at their toll-free number (800) 397-4209 or their local number (301) 415-4737. The PDR may also be contacted by Telecommunication Device for the Deaf (TDD) at (301) 415-8322 or toll-free at (800) 635-4512; Internet email at pdr@nrc.gov; fax (301) 415-3548; or U.S. Mail to: PDR, U.S. Nuclear Regulatory Commission, Washington, DC 20555-0001.

The public may also use the Freedom of Information Act (FOIA) and Privacy Act (PA) to obtain information that the NRC has not made publicly available. Submit FOIA or PA requests in writing to: FOIA/PA Officer, U.S. Nuclear Regulatory Commission, Washington, DC 20555-0001. The FOIA requires the NRC to give the public access to records unless the information is exempt from disclosure (e.g., classified as national security, business proprietary, personal privacy, or investigative). A request must specifically state that it is a FOIA request, and it must adequately describe the specific records or type of records sought so that the NRC staff can conduct a search for the requested records by exerting a reasonable amount of effort. Disclosure will be made by providing a copy of the documents requested or by making copies of the requested documents available

in the NRC's Headquarters Public Document Room in the ADAMS PARS Library. Detailed information concerning NRC policies and procedures for obtaining access to information under the FOIA and PA is available in Title 10, Part 9, of the *Code of Federal Regulations*, which is available in any public library. Information can also be found on the Internet at the FOIA/PA homepage, reached through the "FOIA Requests" link at the NRC's Web site www.nrc.gov.

The NRC announces the schedules of staff meetings that are open to the public. Public notice will be made via the Internet using the NRC's Web site at <http://www.nrc.gov/public-involve/public-meetings/meeting-schedule.html>. Commission and Advisory Committee meetings, Open Predecisional Enforcement Conferences, and Atomic Safety and Licensing Board hearings that are published in the *Federal Register* are also noticed at this site. Recorded information about Commission meetings is available at (301) 415-1292.

The NRC is required to answer inquiries from small entities concerning information on, advice about, and compliance with the statutes and regulations that affect them. The NRC is expected to interpret and apply the law, or regulations implementing the law, to specific sets of facts that are specified by the small entity. The NRC is required to establish a program to receive and respond to these types of inquiries. To help small entities obtain information quickly, the NRC has

established a toll-free telephone number at (800) 368-5642.

To learn more about these and other sources of public information about agency activities, send for a free copy of the "Citizen's Guide to U.S. Nuclear

Regulatory Commission Information" (NUREG/BR-0010, Rev. 3),
ATTN: Reproduction and Distribution Services Branch, U.S. Nuclear Regulatory Commission, Washington, DC 20555-0001.



NRC AS A REGULATORY AGENCY

<http://www.nrc.gov>

Mission, Goals, and Statutory Authority

Mission

The mission of the U.S. Nuclear Regulatory Commission (NRC) is to license and regulate the Nation's civilian use of byproduct, source, and special nuclear materials to ensure adequate protection of public health and safety, promote the common defense and security, and protect the environment. The NRC's scope of responsibility includes regulation of commercial nuclear power plants; research, test, and training reactors; nuclear fuel cycle facilities (also called fuel cycle facilities); medical, academic, and industrial uses of radioactive materials; and the transport, storage, and disposal of radioactive materials and wastes. The NRC's regulations are designed to protect the public and occupational workers from radiation hazards in those industries using radioactive materials.

Strategic Plan

As a normal course of activities, agencies periodically re-visit their strategic plans. The NRC has developed a new strategic plan for FY 2004-2009 to replace the agency's earlier version. The Strategic Plan has been restructured to improve its focus and readability. The Strategic Plan focuses on five general goals: safety, security, openness, effectiveness, and excellence in agency management. These goals support our ability to maintain the public health, safety, and trust. Under each goal, strategic outcomes provide a general barometer whether the goals are being achieved.

Goals and Strategic Outcomes

Safety - Ensure protection of public health and safety and the environment.

The NRC's primary goal is to regulate the safe uses of radioactive materials for civilian purposes to ensure the protection of public¹ health and safety and the environment. The NRC achieves its safety goal by licensing individuals and organizations to use radioactive materials for beneficial civilian purposes, and then ensuring that the performance of these licensees is at or above acceptable safety levels. The strategic outcomes that support the goal of safety are listed below:

- No nuclear reactor accidents.²
- No inadvertent criticality events.
- No acute radiation exposures resulting in fatalities.
- No releases of radioactive materials that result in significant radiation exposures.³
- No releases of radioactive materials that cause significant adverse environmental impacts.⁴

Security - Ensure the secure use and management of radioactive materials.

The primary challenge facing the NRC in the coming years is to emerge from the period of uncertainty in post-September 11 security requirements; determine what long-term security provisions are necessary; and revise its regulations, orders, and internal procedures as necessary to ensure public health and safety and the common defense and security in the elevated threat environment.

The strategic outcome that supports the goal of security is "No instances where licensed radioactive materials are used domestically in a manner hostile to the security of the United States."

Openness - Ensure openness in our regulatory process.

The NRC views nuclear regulation as the public's business and, as such, it should be transacted openly and candidly in order to maintain the public's confidence. The goal to ensure openness explicitly recognizes that the public must be informed about, and have a reasonable opportunity to participate meaningfully in, the NRC's regulatory process.

The strategic outcome that supports the goal of openness is "Stakeholders are informed and involved in NRC processes as appropriate."

Effectiveness - Ensure that NRC actions are effective, efficient, realistic, and timely.

The drive to improve performance in Government, coupled with increasing demands on the NRC's finite resources, clearly indicates a need for the agency to become more effective, efficient, realistic, and timely in its regulatory activities. Effectiveness means achieving the desired outcome from a program, process, or activity; efficiency refers to productivity, quality, and cost characteristics that together define how economically an activity or process is performed; and, timeliness, a key product of efficiency, means acting within a predictable time frame and without unnecessary delays.

The strategic outcome that supports the goal of effectiveness is "No significant licensing or regulatory impediments to the safe and beneficial uses of radioactive materials."

Excellence in Agency Management - Ensure excellence in agency management to carry out the NRC's strategic objective.

The NRC strives for management excellence in carrying out all of its regulatory responsibilities. This goal includes strategies for the management of human capital, support infrastructure management, improved financial management, expanded electronic government, budget and performance integration, and internal communications.

The strategic outcomes that support the goal of excellence in agency management are listed below:

- Continuous improvement in NRC's leadership and management effectiveness in delivering the mission.
- A diverse, skilled workforce and an infrastructure that fully supports the agency's mission and goals.

Strategies and Means

Each goal of the Strategic Plan contains a number of strategies that describe how resources will be organized, and the policies that will apply for the management and use of those resources. Under each strategy are means that describe the essential programs and initiatives to achieve specific strategies.

Performance Measures

Success in achieving each goal in the Strategic Plan is gauged primarily through performance measures that have been developed for the FY 2005 Performance Budget and will be reported in the annual Performance and Accountability Report.

Statutory Authority

The NRC was established by the Energy Reorganization Act of 1974. The agency began operations in 1975. The U.S. Energy Reorganization Act of 1974 separated the Atomic Energy Commission's regulatory functions from its military and promotional functions

and assigned the regulatory functions to the NRC. The NRC thus inherited part of the Atomic Energy Commission's mission under the Atomic Energy Act of 1954 — to regulate the civilian commercial, industrial, academic, and medical uses of nuclear materials, in order to protect the public health and safety, and promote the common defense and security. In so doing, Congress defined the NRC's mission to enable the nation to use radioactive materials for beneficial civilian purposes while ensuring that public health and safety, common defense and security, and the environment are protected. The following NRC regulations are issued under the United States Code of Federal Regulations (CFR), Title 10, Chapter 1.

The following principal statutory authorities govern the NRC's work:

- Atomic Energy Act of 1954, as amended
- Energy Reorganization Act of 1974, as amended
- Uranium Mill Tailings Radiation Control Act of 1978, as amended
- Nuclear Non-Proliferation Act of 1978
- Low-Level Radioactive Waste Policy Act of 1980
- West Valley Demonstration Project Act of 1980
- Nuclear Waste Policy Act of 1982
- Low-Level Radioactive Waste Policy Amendments Act of 1985
- Diplomatic Security and Anti-Terrorism Act of 1986
- Nuclear Waste Policy Amendments Act of 1987
- Solar, Wind, Waste, and Geothermal Power Production Incentives Act of 1990
- Energy Policy Act of 1992
- Low-Level Radioactive Waste Policy Amendments Act of 1995

The NRC, the Agreement States and those who hold licenses to use radioactive materials share a common responsibility to protect public health and safety and the environment. Federal regulations and the NRC regulatory program are important elements in the protection of the public. Because licensees actually use radioactive material, they have the ultimate responsibility to handle the use of materials.

¹ "Public" includes occupational workers.

² "Nuclear reactor accidents" are defined in the NRC Severe Accident Policy Statement as those events that result in substantial damage to the reactor fuel, whether or not serious offsite consequences occur.

³ "Significant radiation exposures" are defined as those that result in unintended permanent functional damage to an organ or a physiological system as determined by a physician in accordance with Abnormal Occurrence Criterion I.A.3.

⁴ Releases that have the potential to cause "adverse impact" are those that exceed the limits for reporting abnormal occurrences as given by Abnormal Occurrence criterion 1.B.1 {normally 5,000 times Table 2 (air and water) of Appendix B, Part 20}.

Major Activities

The NRC fulfills its responsibilities through a system of the following licensing and regulatory activities:

- Licensing the design, construction, operation, and decommissioning of nuclear plants and other nuclear facilities, such as nuclear fuel facilities, uranium enrichment facilities, and test and research reactors
- Licensing the possession, use, processing, handling, and exporting of nuclear materials
- Licensing the siting, design, construction, operation, and closure of low-level radioactive waste disposal sites under NRC jurisdiction and the construction, operation, and closure of a geologic repository for high-level radioactive waste
- Licensing the operators of civilian nuclear reactors
- Inspecting licensed and certified facilities and activities
- Certifying privatized uranium enrichment facilities
- Conducting research on light-water reactor safety to gain independent expertise and information for making timely regulatory judgments and for anticipating problems of potential safety significance
- Developing and implementing rules and regulations that govern licensed nuclear activities
- Investigating nuclear incidents and allegations concerning any matter regulated by the NRC
- Enforcing NRC regulations and the conditions of NRC licenses
- Conducting public hearings on matters of nuclear and radiological safety, environmental concern, common defense and security, and antitrust matters
- Developing effective working relationships with the States regarding reactor operations and the regulation of nuclear material
- Developing policy and providing direction on issues involving security at nuclear facilities, and interfacing with other federal agencies, including the Department of Homeland Security, on safety and security issues, and developing and directing the NRC program for response to incidents
- Conducting a program of emergency preparedness and response for licensed nuclear facilities
- Collecting, analyzing, and disseminating information about the operational safety of commercial nuclear power reactors and certain nonreactor activities



Chairman
Nils J. Diaz



Commissioner
Edward McGaffigan, Jr.



Commissioner
Jeffrey S. Merrifield

Organizations and Functions

The NRC's Commission is composed of five members, with one member designated by the President to serve as Chairman. Each member is appointed by the President, with the consent of the U.S. Senate, to serve five-year terms. The members' terms are normally staggered so that one Commissioner's term expires on June 30th every year. No more than three members of the Commission can be from the same political party. The five members of the Commission are:

Commissioner	Expiration of Term
Nils J. Diaz, Chairman	June 30, 2006
Edward McGaffigan, Jr.	June 30, 2005
Jeffrey S. Merrifield	June 30, 2007
Gregory B. Jaczko	*
Peter B. Lyons	*

The Chairman serves as the principal executive officer and official spokesman of the Commission. The Executive Director for Operations carries out

the program policies and decisions made by the Commission.

The NRC's major offices follow.

- **Office of Nuclear Reactor Regulation** — Directs all licensing and inspection activities associated with the design, construction, and operation of nuclear power reactors and nonpower reactors
- **Office of Nuclear Material Safety and Safeguards** — Directs all licensing and inspection activities associated with nuclear fuel cycle facilities, uses of nuclear materials, storage and transport of nuclear materials, management and disposal of low-level and high-level radioactive nuclear wastes, and decommissioning of facilities and sites
- **Office of Nuclear Regulatory Research** — Provides independent expertise and information for making timely regulatory judgments,

*Commissioner appointed by the President during a congressional recess and term will expire at the end of the Senate's 109th session.

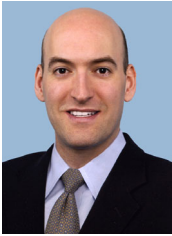

**Commissioner
Gregory B. Jaczko**



**Commissioner
Peter B. Lyons**

anticipating problems of potential safety significance, and resolving safety issues and provides support for developing technical regulations and standards. Collects, analyzes, and disseminates information about the operational safety of commercial nuclear power reactors and certain nuclear materials activities

- **Office of Nuclear Security and Incident Response** — Responsible for overall agency policy and activities involving security at nuclear facilities. Provides safeguards and security interface with other federal agencies and maintains the agency emergency preparedness and response program
- **Regional Offices** — Conduct inspection, enforcement, investigation, licensing, and emergency response programs for nuclear reactors, fuel facilities, and materials licensees within regional boundaries that the Headquarters' offices originate

- **Office of Information Services** — Responsible for the strategic use of information technology as a management tool across a spectrum of agency activities and for an agency-wide approach to information management, capital planning and performance-based management of information technology, and information management service functions
- **Office of the Chief Financial Officer** — Responsible for NRC's Planning, Budgeting and Performance Management process and for all of the NRC's financial management activities
- **Office of the Inspector General** — Provides the Commission with an independent review and appraisal of NRC programs and operations to ensure their effectiveness, efficiency, and integrity

Figure 1 is an organization chart of the NRC.

Figure 1 - U.S. Nuclear Regulatory Commission Organization Chart

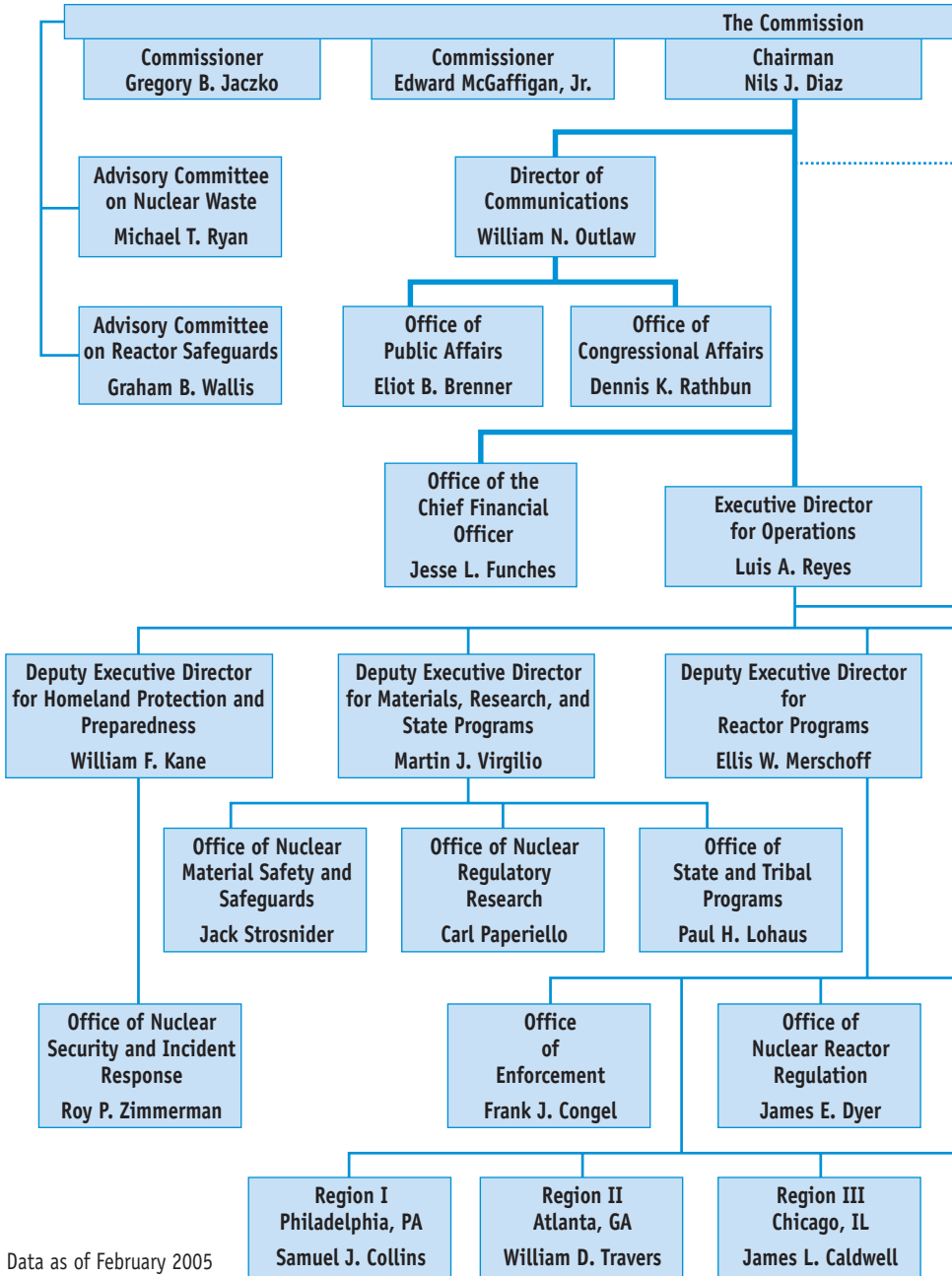

Data as of February 2005

NRC AS A REGULATORY AGENCY

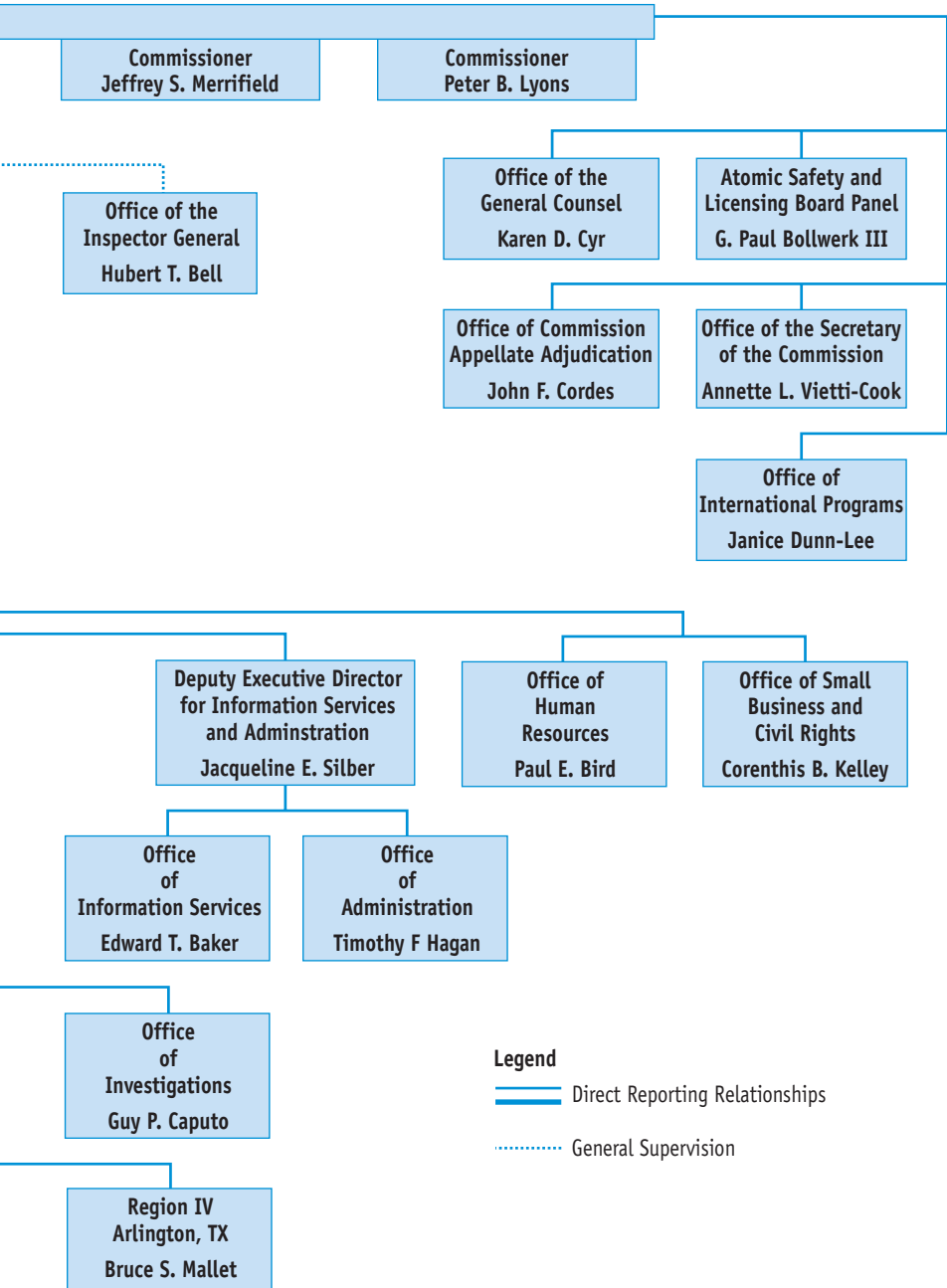

NRC Locations

Headquarters:

Rockville, Maryland
301-415-7000
1-800-368-5642

Operations Center:

Rockville, Maryland
301-816-5100

The NRC maintains an Operations Center that is a focal point for NRC communications with its licensees, State agencies, and other Federal agencies concerning operating events in the commercial nuclear sector. The Operations Center is staffed 24 hours a day by NRC operations officers.

Regional Offices:

The NRC has four regional offices located throughout the United States as illustrated in Figure 2.

Region I:

King of Prussia, Pennsylvania
610-337-5000

Region III:

Lisle, Illinois
630-829-9500

Region II:

Atlanta, Georgia
404-562-4400

Region IV:

Arlington, Texas
817-860-8100

Resident Sites:

At least two NRC resident inspectors who report to the appropriate regional office are located at each nuclear power reactor site. (Refer to Figure 18 for a map of the U.S. operating commercial nuclear power reactors.)

Technical Training Center:

Chattanooga, Tennessee
423-855-6500

Figure 2 - NRC Regions

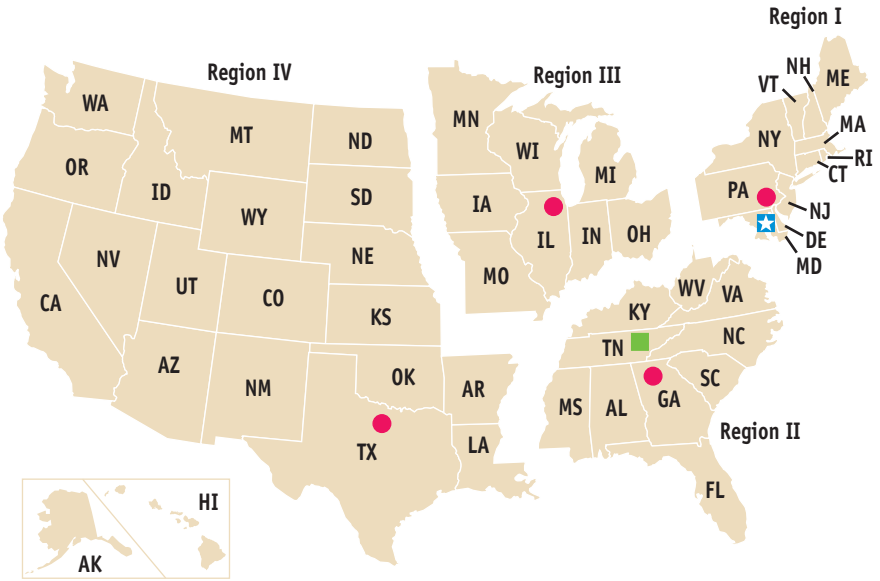

- Regional Office (4)
- Technical Training Center (1)
- ★ Headquarters (1)

Source: Nuclear Regulatory Commission

NRC Fiscal Year 2004 Resources

Appropriation

For Fiscal Year (FY) 2004, Congress appropriated \$626 million for the NRC. The NRC's FY 2004 personnel ceiling is 3,040 full-time equivalent (FTE) staff.

The NRC allocates funds and staff to the following strategic arenas (see Figure 3).

- Nuclear Reactor Safety
- Nuclear Materials Safety
- Nuclear Waste Safety
- International Nuclear Safety Support
- Management and Support

The Office of the Inspector General (OIG) receives its own appropriation, the amount of which is included in the NRC appropriation.



Figure 3 - Distribution of NRC FY 2004 Budget Authority (Dollars in Millions) and Staff

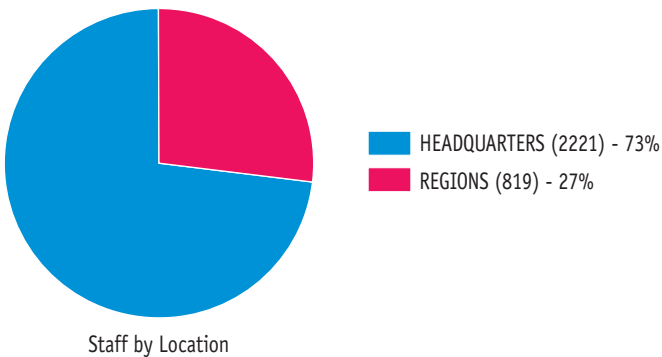
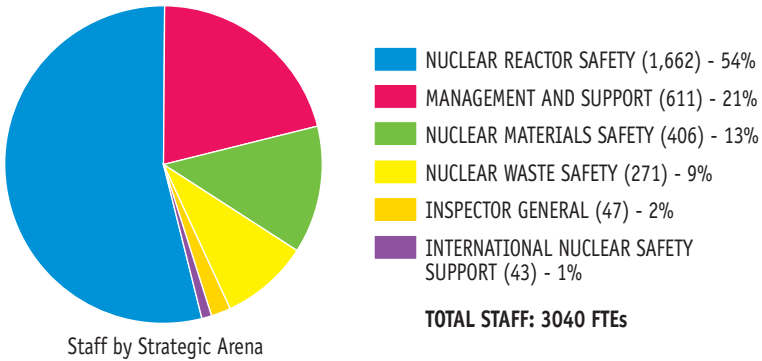
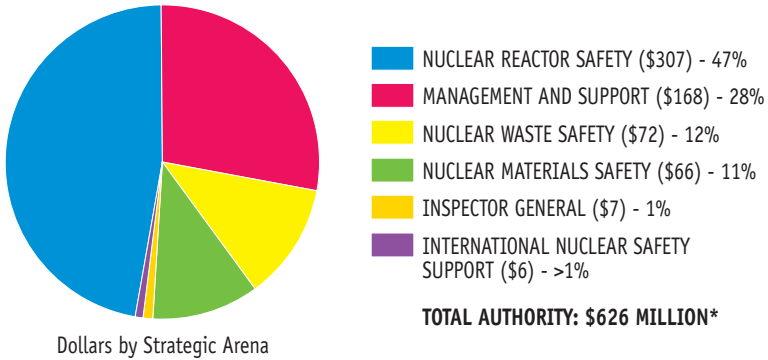

*Budget authority includes rescission.

Note: Dollars and percentages are rounded to the nearest whole number.

Source: Nuclear Regulatory Commission

Table 1 - NRC Budget Authority (Dollars in Millions), FYs 1981–2004

Fiscal Year	Actual Dollars	Fiscal Year	Actual Dollars
1981	441	1993	540
1982	466	1994	535
1983	465	1995	524
1984	466	1996	473
1985	444	1997	477
1986	400	1998	477
1987	401	1999	470
1988	393	2000	470
1989	420	2001	487
1990	439	2002	559
1991	465	2003	585
1992	513	2004	626

Figure 4 - NRC Budget Authority, FYs 1981-2004

DOLLARS IN MILLIONS

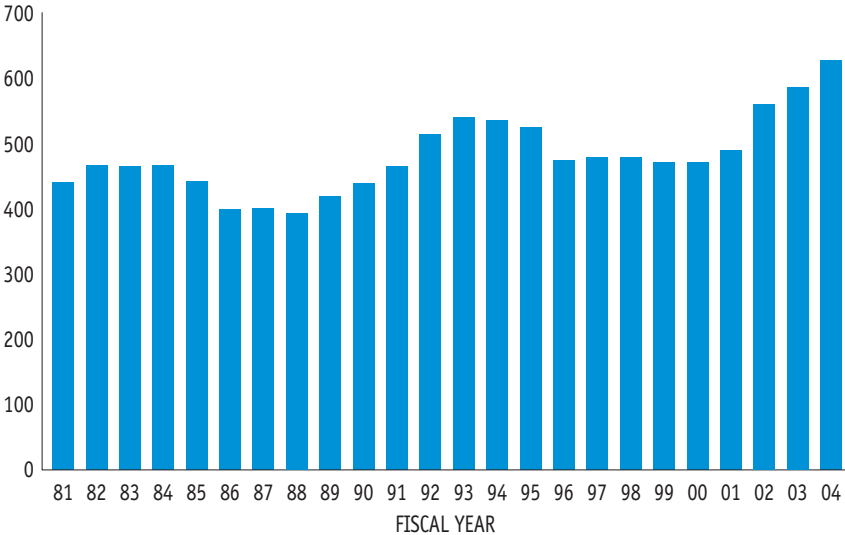

Note: Dollars are rounded to the nearest million.

Source: (Table 1 and Figure 4) Nuclear Regulatory Commission

Table 2 - NRC Personnel Ceiling, FYs 1981–2004

Fiscal Year	Staff	Fiscal Year	Staff
1981	3,300	1993	3,343
1982	3,325	1994	3,293
1983	3,303	1995	3,218
1984	3,416	1996	3,160
1985	3,491	1997	3,061
1986	3,491	1998	2,977
1987	3,369	1999	2,881
1988	3,250	2000	2,801
1989	3,180	2001	2,763
1990	3,195	2002	2,850
1991	3,240	2003	2,906
1992	3,335	2004	3,040

Figure 5 - NRC Personnel Ceiling, FYs 1981-2004

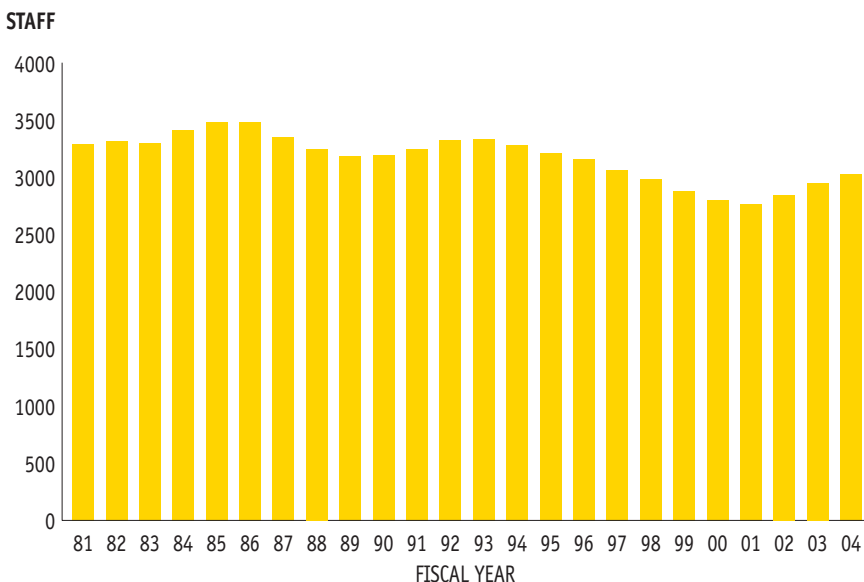

Note (Table 2 and Figure 5): FYs 1981–1982 data reflect permanent full-time positions, at end-of-year strength. FYs 1983–2004 reflect full-time equivalents (FTEs).

Source (Table 2 and Figure 5): Nuclear Regulatory Commission

Figure 6 - Recovery of NRC Budget Authority, FY 2004*

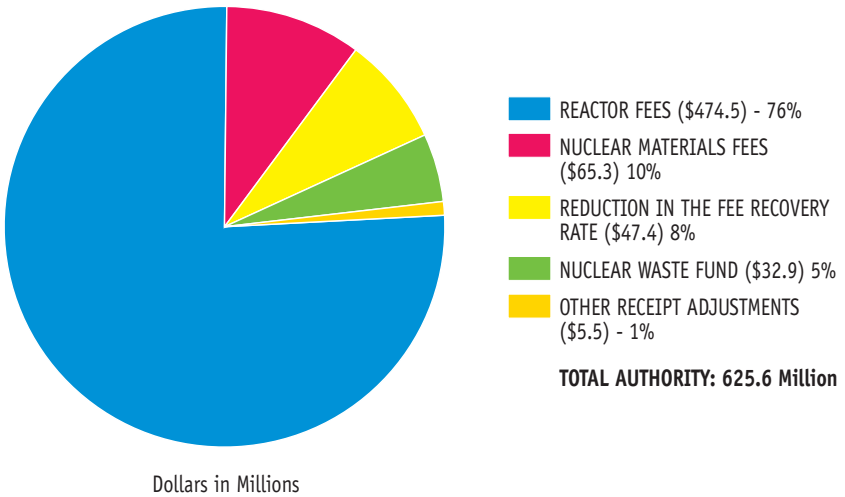

The Omnibus Budget Reconciliation Act of 1990 (OBRA-90), as amended, required the NRC to recover 100 percent of its budget authority, less appropriations from the Nuclear Waste Fund, for FYs 1991–2000 by assessing fees to its licensees. The FY 2001 Energy and Water Development Appropriations Act amended OBRA-90 to decrease the NRC’s fee recovery amount. This reduction is being phased in at two percent per year beginning in FY 2001 through FY 2005. In 2004, the fee recovery amount is reduced to 92 percent. The NRC budget authority to be recovered from fees in FY 2004 is \$545.3 million. The annual fees assessed to the major classes of NRC licensees in FY 2004 follow:

Class of Licensee	Range of Annual Fees
Operating Power Reactor	\$3,283,000**
Fuel Facility	\$438,000 to \$4,573,000
Uranium Recovery Facility	\$12,900 to \$14,500
Transportation Approval	\$7,400 to \$91,300
Materials User	\$710 to \$25,000

*Based on the Final FY 2004 fee rule.

**Includes Spent Fuel Storage/Reactor Decommissioning FY 2004 annual fee of \$203,000.

Note: Percentages are rounded to the nearest whole number.

Source: U.S. Nuclear Regulatory Commission

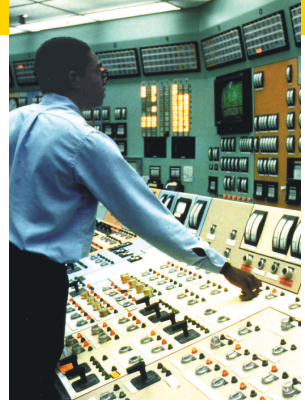

US AND WORLDWIDE ENERGY

U.S. Electricity

Capacity, Capability, and Net Generation:

U.S. electric generating capability totaled approximately 905 gigawatts in 2002. Nuclear energy accounted for approximately 11 percent of this capability (see Figure 7).

U.S. net electric generation totaled approximately 3,846 billion kilowatthours in 2003. Nuclear energy accounted for approximately 20 percent of this generation (see Figure 8).

In 2002, 104 nuclear reactors licensed to operate in 31 States generated approximately one-fifth of the Nation's electricity (see Table 3 and Figure 9).

- Three states (South Carolina, New Hampshire, and Vermont) relied on nuclear power for more than 50 percent of their electricity, a decrease of three over the previous year.

- Fifteen additional states relied on nuclear power for 25 to 50 percent of their electricity.

Since 1992, nuclear electric generation has increased by 21 percent and coal-fired generation has increased 18 percent, while electricity generated by all other sources has increased by 29 percent (see Table 4 and Figure 10).

In 2002, electricity from coal and nuclear sources accounted for 47 percent of the U.S. generating capability (see Table 5 and Figure 11).

Average Production Expenses

The production expense data presented herein include all nuclear, fossil, and coal-fired utility-owned steam electric plants (see Table 6 and Figure 12).

In 2002, production expenses averaged \$18.18 per megawatthour for nuclear reactors and \$21.33 per megawatthour for fossil fuel plants.

Figure 7 - U.S. Electric Capacity and Capability by Energy Source, 2002

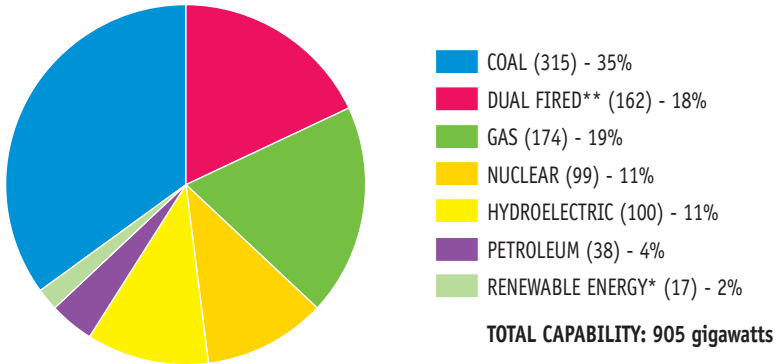

*Renewable energy includes geothermal, wood and wood waste, refuse, wind, solar energy and nonwood waste.

**Dual fired units can burn oil or gas.

Note: Net summer capability. Percentages are rounded to the nearest whole number. Numbers rounded to the nearest thousand.

Source: DOE/EIA Existing Capacity by Energy Source, Table 2.2 <http://www.eia.doe.gov>.

Figure 8 - U.S. Electric Net Generation by Energy Source, 2003

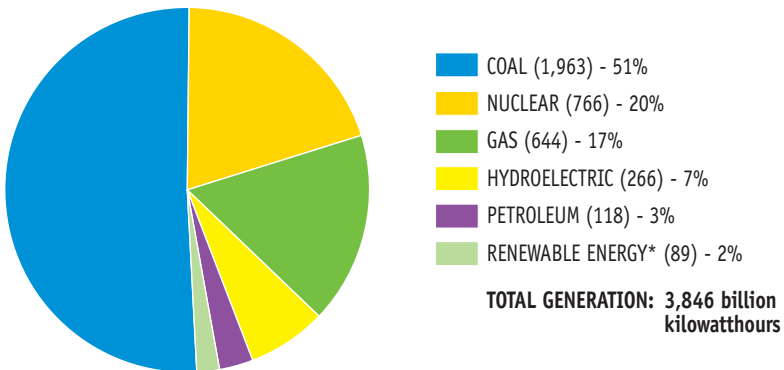

*Renewable energy includes geothermal, wood and nonwood waste, wind, and solar energy. Renewable conventional hydroelectric power is included in hydroelectric power.

Note: Net summer capability. Percentages are rounded to the nearest whole number. Numbers rounded to the nearest thousand.

Source: DOE/EIA Monthly Energy Review, (Mar 2004), Table 7.2a <http://www.eia.doe.gov>.

Table 3 - Electric Generating Capability and Electric Generation in Each State by Nuclear Power, 2002

State	Percent Net Nuclear		State	Percent Net Nuclear	
	Capability	Generation		Capability	Generation
Alabama	19	24	Missouri	6	10
Arizona	19	33	Nebraska	20	32
Arkansas	16	31	New Hampshire	34	58
California	8	19	New Jersey	21	50
Connecticut	27	48	New York	14	28
Florida	8	17	North Carolina	18	32
Georgia	12	25	Ohio	7	7
Illinois	25	48	Pennsylvania	23	37
Iowa	6	11	South Carolina	32	55
Kansas	11	19	Tennessee	16	29
Louisiana	8	18	Texas	5	9
Maryland	14	25	Vermont	51	72
Massachusetts	5	14	Virginia	17	37
Michigan	13	26	Washington	4	8
Minnesota	15	26	Wisconsin	11	21
Mississippi	9	23	Others*	0	0

*19 States and the District of Columbia have no nuclear generating capability.

Notes: Net summer capability. Capability is the percent of electricity the State is capable of producing with nuclear energy. Percentages are rounded to the nearest whole number.

Source: DOE/EIA Electric Power Annual 2002 <http://www.eia.doe.gov>.

Figure 9 - Net Electricity Generated in Each State by Nuclear Power, 2002

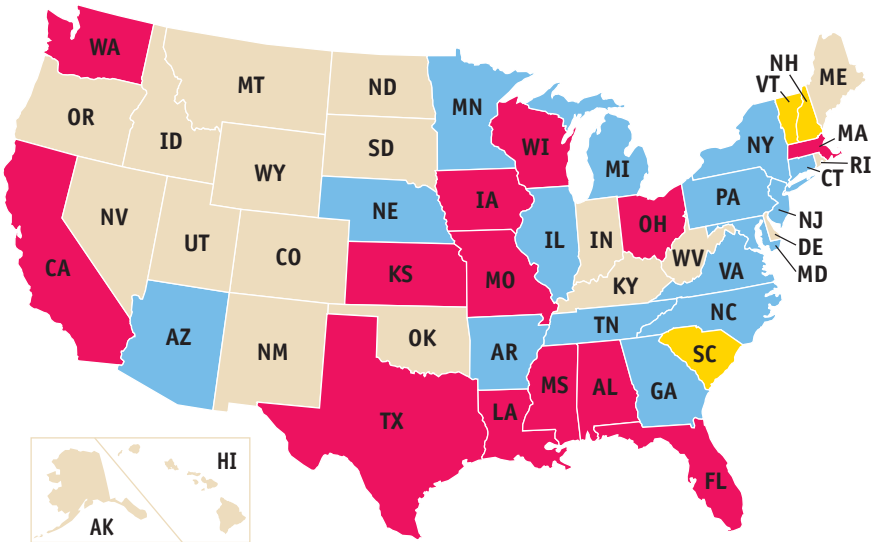

- More than 50% (3)
- 25% to 50% (15)
- 1% to 24% (13)
- None (19)

Note: Percentages are rounded to the nearest whole number.

Source: DOE/EIA Electric Power Annual 2002 <http://www.eia.doe.gov>.

**Table 4 - U.S. Net Electric Generation (Billion Kilowatthours)
by Source, 1992–2003**

Year	Coal	Petroleum	Gas	Hydroelectric	Nuclear
1992	1,621	99	418	249	619
1993	1,690	112	428	276	610
1994	1,692	106	478	257	640
1995	1,710	75	512	308	673
1996	1,796	82	470	344	675
1997	1,844	93	497	355	629
1998	1,873	127	549	319	674
1999	1,884	124	570	313	728
2000	1,965	109	611	269	754
2001	1,943	128	640	211	767
2002	1,936	96	705	256	772
2003	1,963	118	643	267	766

Figure 10 - U.S. Net Electric Generation by Source, 1992-2003

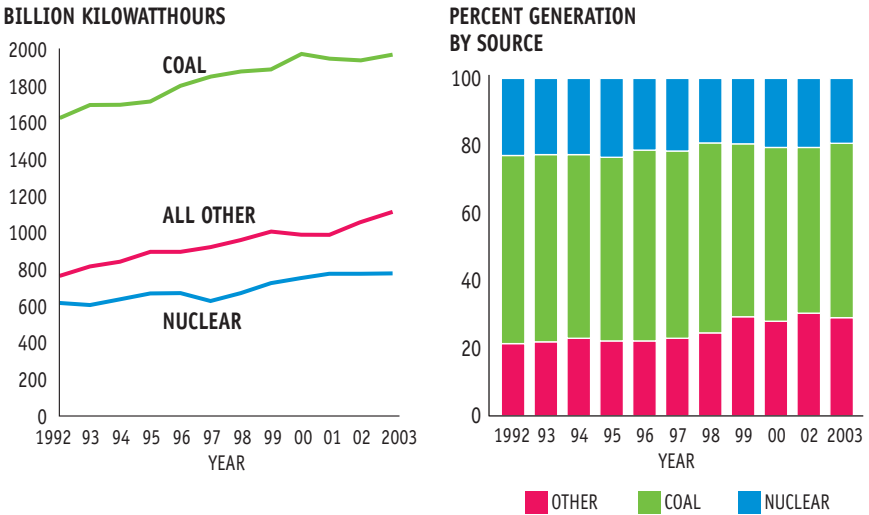

Source (Table 4 and Figure 9): DOE/EIA Monthly Energy Review, (March 2004), Table 7.2a <http://eia.doe.gov>.

Table 5 - U.S. Electric Generating Capability (Gigawatts) by Energy Source, 1992–2002

Year	Coal	Petroleum	Gas	Dual Fired	Hydroelectric	Nuclear
1992	301	72	127	119	93	99
1993	301	70	132	120	96	99
1994	301	70	134	123	96	99
1995	301	64	142	122	97	100
1996	302	70	135	129	94	101
1997	303	70	137	129	76	100
1998	300	63	125	130	94	97
1999	315	36	75	146	99	97
2000	315	36	98	150	98	88
2001	314	40	127	153	99	98
2002	315	38	174	162	100	99

Figure 11 - U.S. Electric Generating Capability by Energy Source, 1992-2002

PERCENT CAPABILITY BY SOURCE

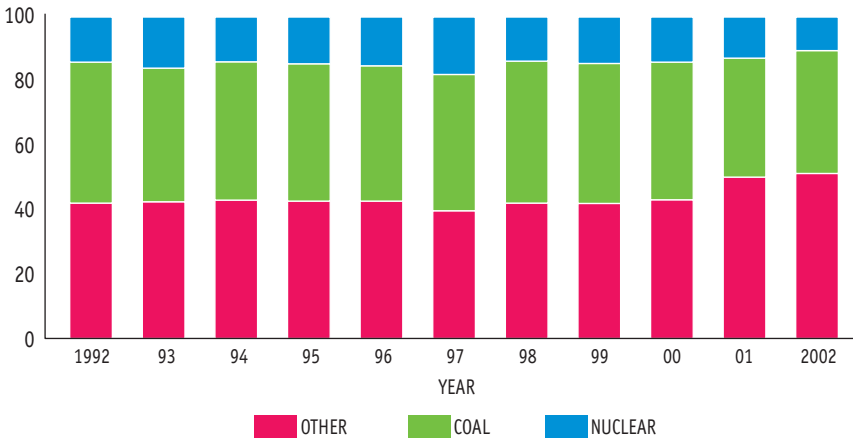

Note (Table 5 and Figure 10): Net summer capability. Table 5 includes revisions to years 1999 and 2000 and now includes dual fired units. Other includes dual fired units which can burn oil or gas. When there is more than one energy source used in a plant, the predominant energy source is reported. Percentages are rounded to the nearest whole number.

Source: DOE/EIA Electric Power Annual 2002, <http://eia.doe.gov>.

Table 6 - U.S. Average Nuclear Reactor and Coal-Fired/Fossil Steam Plant Production Expenses (Dollars per Megawatthour), 1992-2002

Year	Operation and Maintenance	Fuel	Total Production Expenses
Nuclear:			
1992	15.35	6.24	21.59
1993	15.26	6.02	21.28
1994	14.01	6.02	20.03
1995	13.49	5.74	19.23
1996	13.76	5.49	19.25
1997*	18.90	5.89	24.79
1998	16.19	5.42	21.61
1999	14.06	5.17	19.23
2000	13.34	4.95	18.29
2001	13.31	4.67	17.98
2002	13.58	4.60	18.18
Coal-Fired:			
1992	4.33	15.37	19.70
1993	4.32	15.31	19.63
1994	4.32	14.88	19.20
1995	4.24	14.51	18.75
1996	4.03	14.20	18.23
1997*	3.96	14.03	17.99
Fossil Steam:**			
1998	4.59	16.01	20.60
1999	4.59	15.62	20.21
2000	4.76	17.69	22.45
2001	5.01	18.13	23.14
2002	5.22	16.11	21.33

Figure 12 - U.S. Average Nuclear Reactor, Coal-Fired and Fossil Steam Plant Production Expenses, 1992–2002

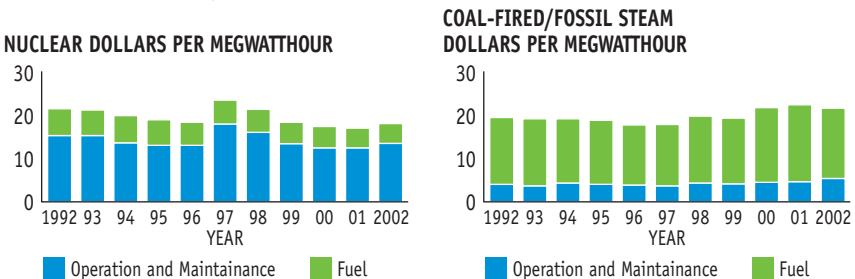

*Data for 1997 and prior years was obtained from Utility Data Institute, Inc.

**Includes coal and fossil fuel. Plant production expenses are no longer available exclusively for coal-fired fuel.

Source: Federal Energy Regulatory Commission, FERC Form 1, "Annual Report of Major Electric Utilities, Licensees and Others" DOE/EIA – Electric Power Annual 2002.

U.S. Electricity Generated by Commercial Nuclear Power

In 2003, net nuclear-based electric generation in the United States produced a total of 766 billion kilowatt-hours (see Table 7 and Figure 13).

In 2002, the average U.S. net capacity factor was 91 percent. It decreased to 89 percent in 2003. Since 1992, the average capacity factor has increased 18 percent (see Table 7).

- Capacity factor is the ratio of electricity generated to the amount of energy that could have been generated (see Glossary).
- Ninety-nine percent of U.S. commercial nuclear reactors

operated above a capacity factor of 70 percent in 2003 (see Table 8).

- In 2003, Combustion Engineering (CE) reactors had the highest average capacity factors compared to those of the other three vendors. The 14 CE reactors had an average capacity factor of 91 percent. The average capacity factors for the other three vendors were the following: 7 Babcock & Wilcox reactors — 76 percent, 35 General Electric reactors — 89 percent, and 48 Westinghouse reactors — 90 percent, (see Table 8).



Diablo Canyon, Nuclear Power Plant

Table 7 - U.S. Nuclear Power Reactor Average Capacity Factor and Net Generation, 1992–2003

Year	Number of Operating Reactors	Average Annual Capacity Factor (Percent)	Net Generation of Electricity Billions of Kilowatthours	Percent of Total U.S.
1992	110	71	619	20.1
1993	109	73	610	19.1
1994	109	75	640	19.7
1995	109	79	673	20.1
1996	110	77	675	19.6
1997	104	74	629	18.0
1998	104	78	674	18.6
1999	104	86	728	19.6
2000	104	88	754	19.8
2001	104	90	767	20.0
2002	104	91	772	20.0
2003	104	89	766	19.9

Figure 13 - Net Generation of U.S. Nuclear Electricity, 1992–2003

BILLION KILOWATTHOURS

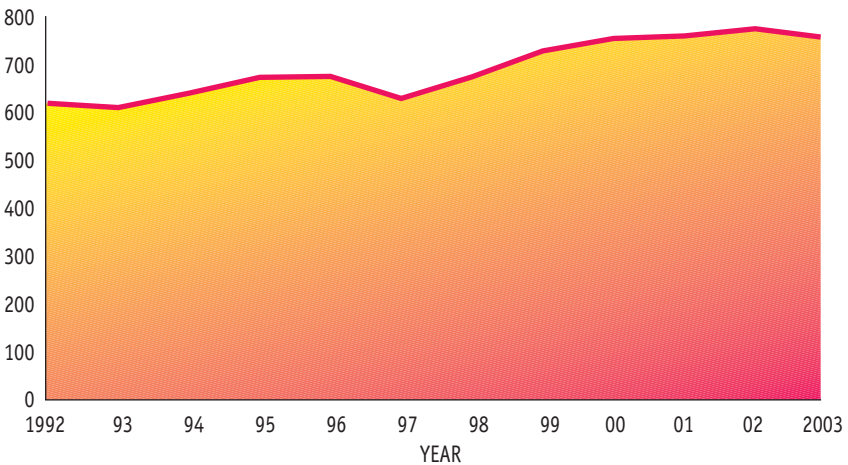

Note (Table 7 and Figure 12): Average annual capacity factor is based on net maximum dependable capacity. See Glossary for definition.

Source (Table 7 and Figure 12): 1992-2003 Net Electricity based on March 2004 DOE/EIA - Monthly Energy Review Table 7.2a, and licensee data as compiled by the Nuclear Regulatory Commission.

Table 8 - U.S. Commercial Nuclear Power Reactor Average Capacity Factor by Vendor and Reactor Type, 2001–2003

Capacity Factor	Licensed to Operate			Percent of Net Nuclear Generated		
	2001	2002	2003	2001	2002	2003
Above 70 Percent	101	100	100	99	99	99
50 to 70 Percent	1	2	2	1	1	1
Below 50 Percent	2	2	2	>1	>1	>1
Total	104	104	104	100	100	100

	Licensed to Operate			Average Capacity Factor (Percent)			Percent of Net Nuclear Generated		
	2001	2002	2003	2001	2002	2003	2001	2002	2003
Vendor:									
Babcock & Wilcox	7	7	7	88	84	76	6	6	5
Combustion Engineering	14	14	14	87	94	91	13	14	14
General Electric	35	35	35	89	93	89	33	33	33
Westinghouse Electric	48	48	48	91	91	90	48	47	48
Total	104	104	104				100	100	100
Reactor Type:									
Boiling Water Reactor	35	35	35	89	92	89	33	33	33
Pressurized Water Reactor	69	69	69	90	89	86	67	67	67
Total	104	104	104				100	100	100

Note: Average capacity factor is based on net maximum dependable capacity. See Glossary for definition. Refer to Appendix A for the 1998–2003 average capacity factors for each reactor. Percentages are rounded to the nearest whole number.

Source: Licensee data as compiled by the Nuclear Regulatory Commission



Worldwide Electricity Generated by Commercial Nuclear Power

In 2003, 438 operating reactors in 33 countries had a maximum dependable capacity of 365,852 megawatts electric (net MWe).

- Refer to Appendix J for a world list of nuclear power reactors and Appendix K for nuclear power units by reactor type, worldwide.

Major producers of nuclear electricity during 2002 were the United States and France.

- Approximately 30 percent of the world's net nuclear-generated electricity was produced in the United States (see Figure 14).
- France produced approximately 16 percent of the world's net nuclear-generated electricity. The nuclear portion of its total domestic electricity generation was approximately 78 percent (see Figure 14).

Of the countries cited here, reactors in South Korea (94 percent), U.S. (89 percent), and the Germany (84 percent) had the highest gross capacity and generation factors in 2003. Reactors in the United States had the greatest gross nuclear generation at 797 billion kilowatthours. France was the next highest producer at 441 billion kilowatthours (see Table 9).

- Refer to Appendix L for a list of the top fifty units by gross capacity factor, worldwide, and Appendix M for a list of the top fifty units by gross generation, worldwide.

Over the past ten years, the average annual gross capacity factor has increased 16 percentage points in the United States, 15 percentage points in Germany, and decreased 14 percentage points in Japan (see Table 10).

Figure 14 - Net Nuclear Electric Power as a Percent of World Nuclear Generation and Total Domestic Net Nuclear Electricity Generation, 2002

PERCENT OF WORLD NUCLEAR GENERATION

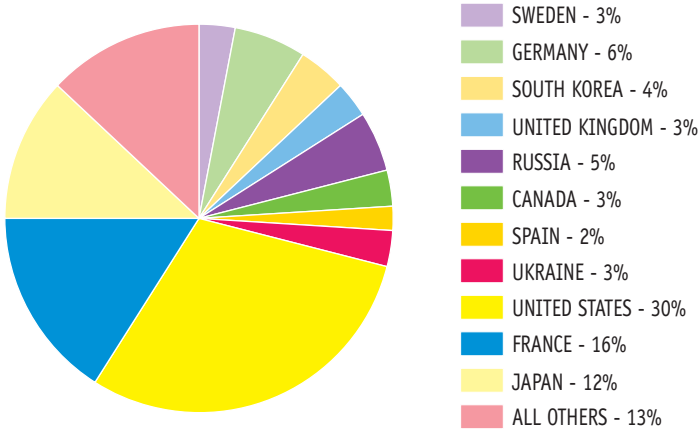

Total World Net Nuclear Electricity Generation: 2,559.6 billion kilowatt-hours

PERCENT OF TOTAL DOMESTIC NET NUCLEAR ELECTRICITY GENERATION

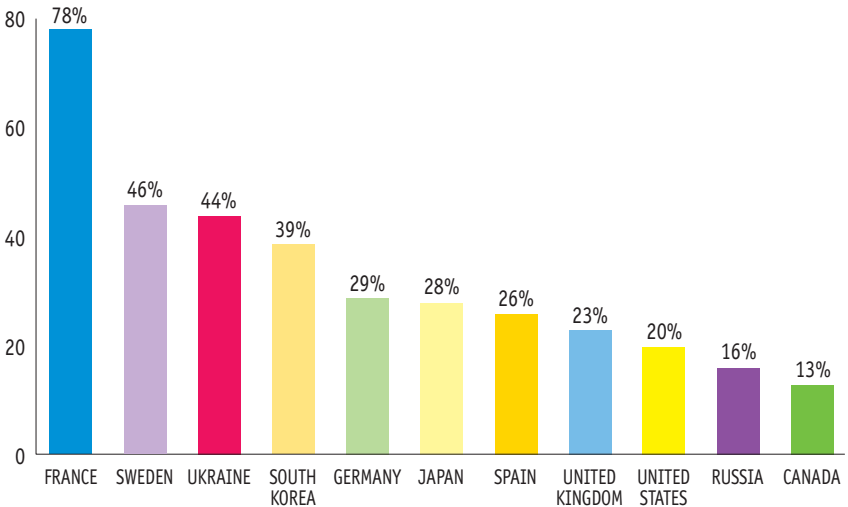

Note: Percentages are rounded to the nearest whole number.

Source: DOE/EIA International Energy Information, Tables 2.6, 2.7, 2.8, 6.1 (<http://www.eia.doe.gov>)

Table 9 - Commercial Nuclear Power Reactor Average Gross Capacity Factor and Gross Generation by Selected Country, 2003

Country	Number of Operating Reactors	Average Gross Capacity Factor (Percent)	Total Gross Nuclear Generation (Billion Kilowatthours)	Number of Operating Reactors in Top 50 by Capacity Factor	Number of Operating Reactors in Top 50 by Generation
Canada	21	54	76	2	0
France	59	75	441	1	13
Germany	19	84	165	2	11
Japan	53	59	227	5	1
Russia	30	70	149	0	0
South Korea	18	94	130	6	0
Sweden	11	77	68	0	0
Ukraine	13	78	81	0	0
United States	104	87	797	27	23

Source: Excerpted from *Nucleonics Week*®, February 12, 2004, by McGraw-Hill, Inc. Reproduced by permission. Further reproduction prohibited.

Table 10 - Commercial Nuclear Power Reactor Average Gross Capacity Factor by Selected Country, 1993–2003

Country	Average Gross Annual Capacity Factor (Percent)										
	1993	1994	1995	1996	1997	1998	1999	2000	2001	2002	2003
Canada	70	76	68	65	61	50	52	50	53	53	54
France	69	67	71	74	72	73	71	72	73	75	75
Germany	69	72	71	79	83	79	88	87	87	83	84
Japan	73	74	79	80	82	83	79	79	79	77	59
Russia	**	**	**	**	**	**	61	67	67	67	70
South Korea	**	**	**	**	**	**	88	90	93	93	94
Sweden	62	76	73	79	75	78	78	66	84	75	77
Ukraine	**	**	**	**	**	**	65	69	74	75	78
United States	71 {73	73 75	77 79	75 77	70 73	76 78	85 86	87 88	88 90	89 91	87 89}* {89}

*For comparison, U.S. average gross capacity factor is used. The 2003 U.S. average net capacity factor is 89 percent. Brackets { } denote average net capacity factor. See Glossary for definition.

**Data not available.

Note: Percentages are rounded to the nearest whole number.

Source: Excerpted from *Nucleonics Week*®, February 12, 2004, by McGraw-Hill, Inc. Reproduced by permission. Further reproduction prohibited.

Licensee data as compiled by the Nuclear Regulatory Commission.

Figure 15 - Operating Nuclear Power Plants Worldwide, 2003

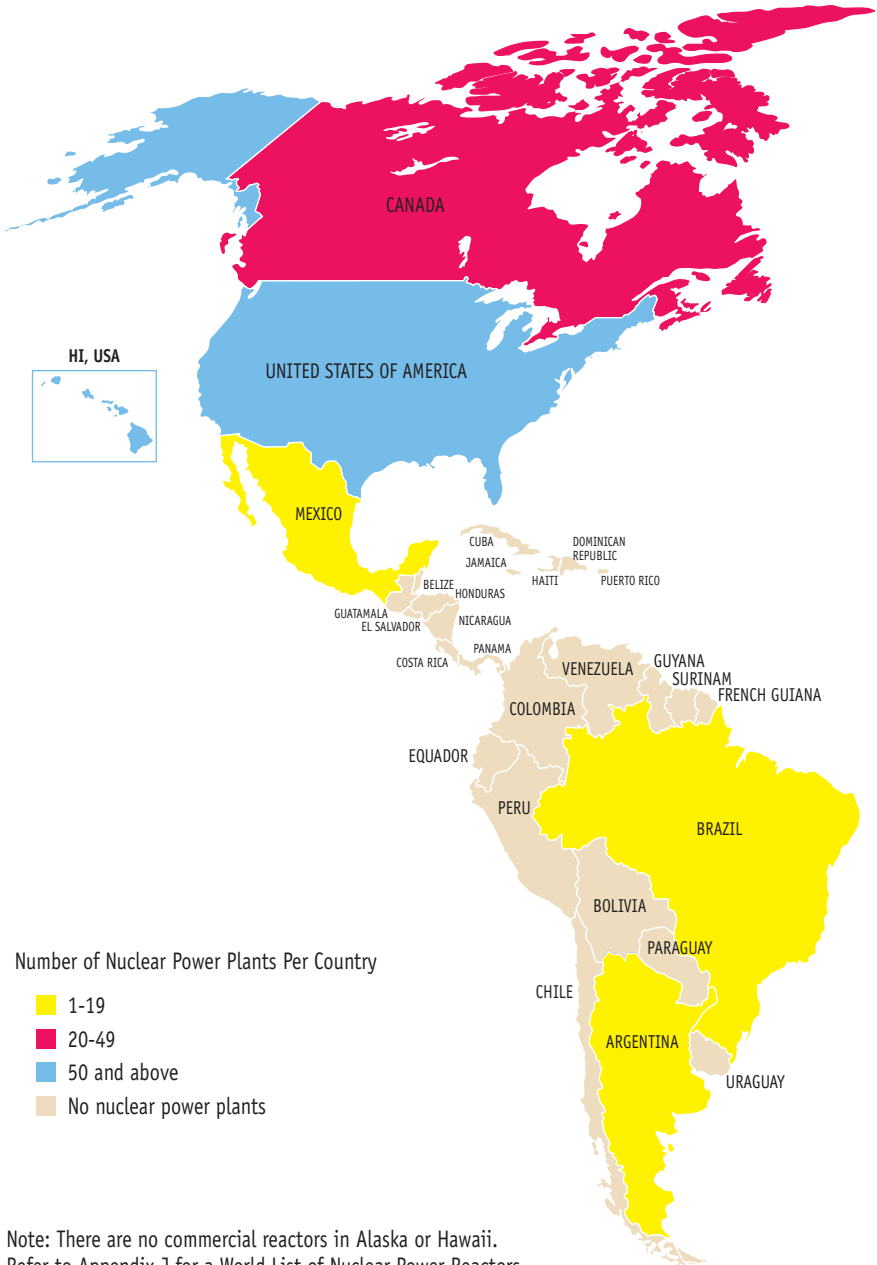

Note: There are no commercial reactors in Alaska or Hawaii. Refer to Appendix J for a World List of Nuclear Power Reactors.

Source: <http://www.cia.gov/cia/publications/factbook/index.html>

(continued)

Figure 15 - Operating Nuclear Power Plants Worldwide, 2003 (continued)

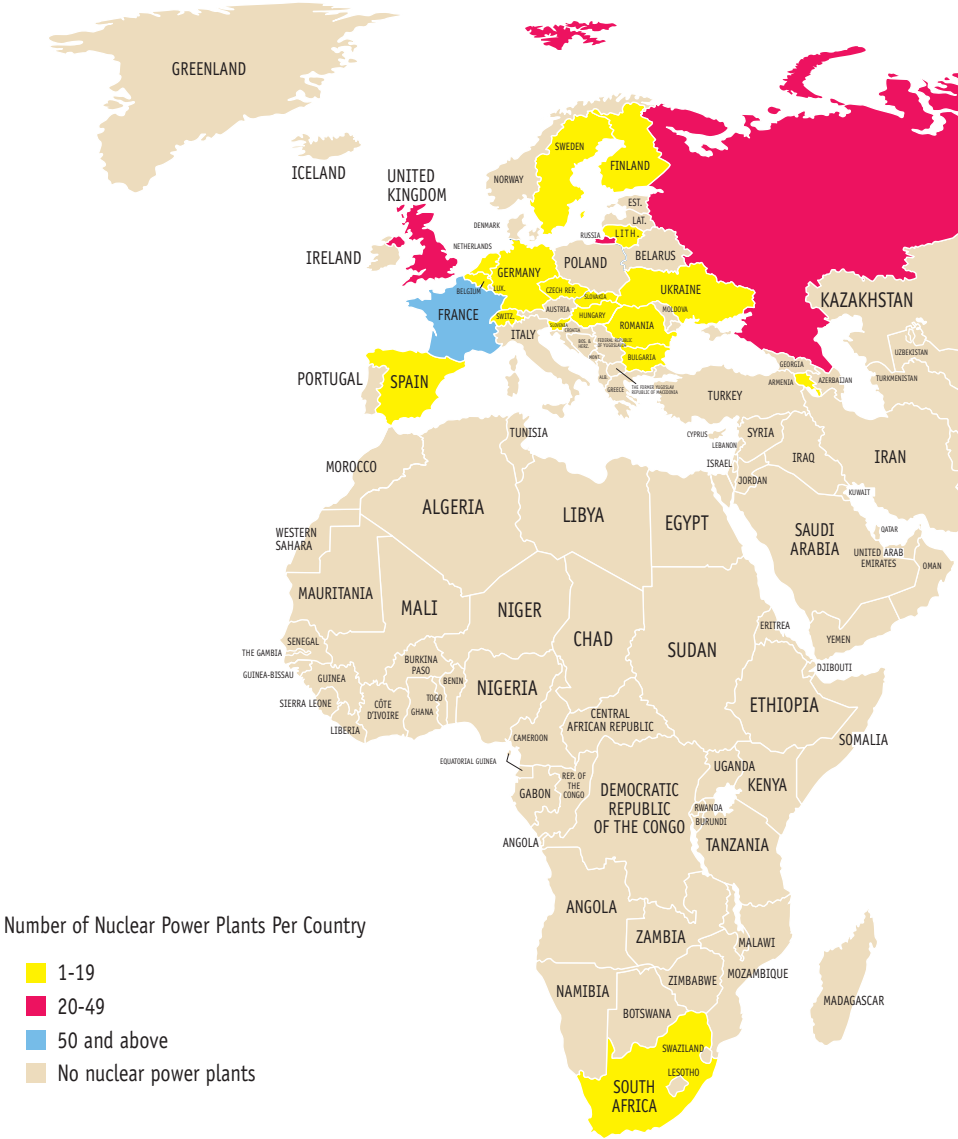



International Activities

NRC has statutory responsibility for licensing the exports and imports of nuclear facilities, major components, materials, and related commodities. In 2004, NRC is enhancing its controls on the export and import of high risk radioactive sources as part of the Commission's comprehensive review of nuclear material security requirements. These enhancements will reduce the likelihood the high risk radioactive sources will be used in a "dirty bomb".

The NRC also participates in a wide range of mutually beneficial programs to exchange information with counterparts in the international community, and to enhance the safety and security of peaceful nuclear activities worldwide. This low cost, high impact program provides health and safety information and assistance to other countries, or joint cooperative activities, to develop and improve regulatory organizations and overall nuclear safety and security. These activities include:

- Assisting in United States government international policy and priority formulation by developing legal instruments in the nuclear field to address vital issues such as nuclear non-proliferation, safety, safeguards, physical security, radiation protection, spent fuel and waste management, nuclear safety research, and liability.
- Contributing to the implementation of national nuclear policy by supporting presidential summits and the International Nuclear Regulators Association.
- Ensuring prompt notification to foreign partners of U.S. safety problems that warrant action or investigation.
- Providing for bilateral information exchange and cooperation on nuclear safety, physical security, safeguards, waste management, and radiological protection with the regulatory authorities of 36 countries and areas. A list of the countries can be found at www.nrc.gov/what-wedo/ip/bilateral-relations.html
- Assisting Russia, Ukraine, Armenia, and Kazakhstan, to improve regulatory controls in the areas of nuclear radiation protection and management of radioactive waste and security of nuclear facilities and material. These assistance efforts are carried out primarily through training, workshops, and peer review of regulatory documents, working group meetings, and technical information and specialist exchanges.
- Participating in the programs of the International Atomic Energy Agency (IAEA), and the Organization for Economic Cooperation and

Development's Nuclear Energy Agency concerned with safety research and regulatory matters, radiation protection, risk assessment, waste management, transportation, safeguards, physical protection, standards development, training, and technical assistance.

- Implementing IAEA safeguards at NRC-licensed nuclear facilities in the U.S. and helping strengthen and maintain IAEA effectiveness worldwide.
- Sharing technical information, funding for, technical support to, and results of specific joint research projects and programs.



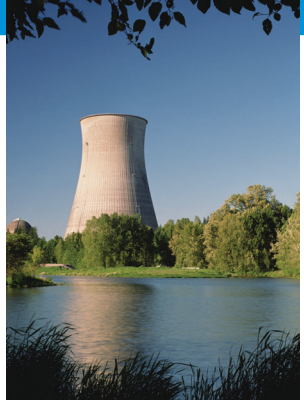

OPERATING NUCLEAR REACTORS

<http://www.nrc.gov/reactors.html>

U.S. Commercial Nuclear Power Reactors

There are as of June 2004, 104 commercial nuclear power reactors¹ licensed to operate in 31 States (see Figures 18, 19, 20, 21, and 22):

Diversity — Although there are many similarities, each reactor design can be considered unique. A typical Pressurized-Water Reactor is shown in Figure 16 and a typical Boiling-Water Reactor is shown in Figure 17:

- 4 reactor vendors
- 41 licensees
- 80 different designs
- 65 sites

Experience—The 104 reactors licensed to operate during 2003 have accumulated 2,360 reactor-years of experience (see Table 11 and Figure 23). An additional 385 reactor-years of experience have been accumulated by permanently shutdown reactors.

Principal Licensing and Inspection Activities

- The NRC uses performance indicators and reactor and facility

inspections as the basis for its independent determination of licensee compliance with NRC regulations.

- On average, approximately 5,300 hours of inspection effort were expended at each operating reactor site during CY 2003 (see Figure 24).²
- Approximately 15 separate license changes are requested per power reactor each year:
 - More than 1,700 separate reviews were completed by the NRC in FY 2003.
- Approximately 4,500 reactor operators are licensed by the NRC:
 - Each operator is requalified before renewal of a 6-year license.
- Approximately 3,000 source documents concerning events are reviewed by the NRC annually.
- The NRC oversees the decommissioning of nuclear power reactors. Refer to Appendix B for their decommissioning status.

¹ The above number includes Browns Ferry Unit 1, which has no fuel loaded and requires Commission approval to restart.

Refer to Appendices A-F for a listing of currently operating, formerly operating, research and test reactors and canceled U.S. commercial nuclear power reactors.

² Inspection effort for the Reactor Oversight Process (ROP) is reported on a per-site basis because the ROP is implemented on a per-site basis. Previous editions of the Information Digest reported inspection effort as hours per operating reactor. The CY 2003 inspection effort equates to approximately 3,400 hours per operating reactor.

Figure 16 - Typical Pressurized Water Reactor

HOW NUCLEAR REACTORS WORK

In a typical commercial pressurized light-water reactor (1) the reactor core creates heat, (2) pressurized-water in the primary coolant loop carries the heat to the steam generator, and (3) the steam generator vaporizes the water in a secondary loop to drive the turbine, which produces electricity. The reactor's core is cooled by water, which is force-circulated by electrically powered pumps. Emergency cooling water is supplied by other pumps, which can be powered by onsite diesel generators. Other safety systems, such as the containment building air coolers, also need electric power.

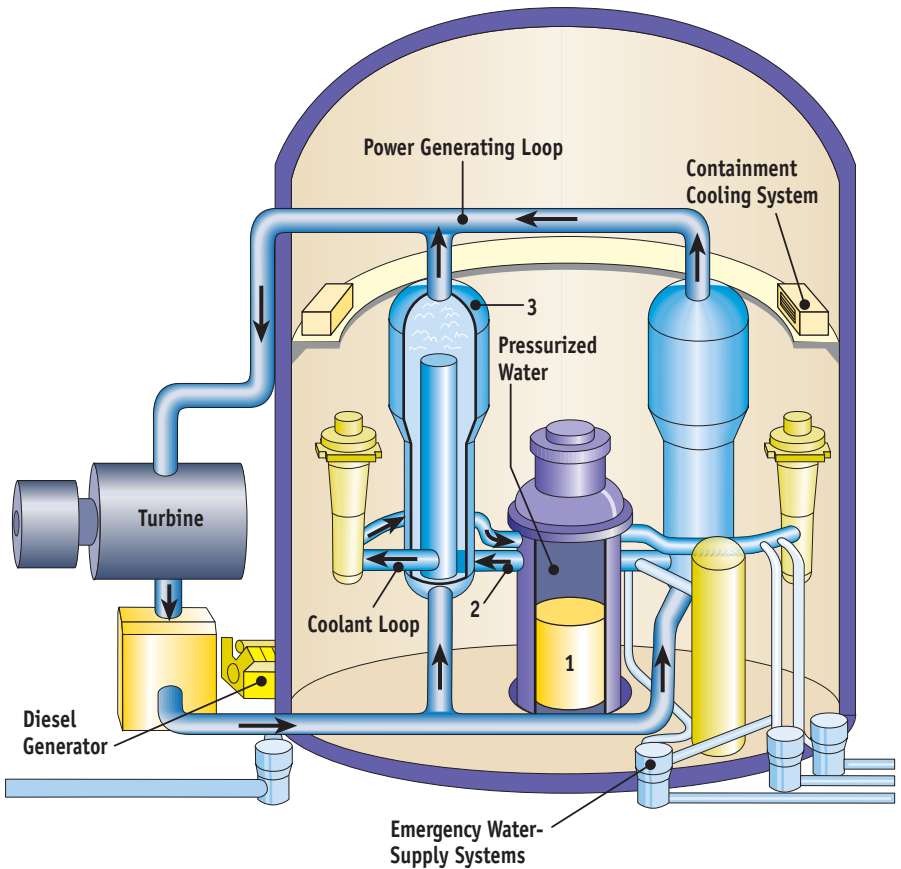

Source: Nuclear Regulatory Commission

Figure 17 - Typical Boiling Water Reactor

HOW NUCLEAR REACTORS WORK

In a typical commercial boiling water reactor (1) the reactor core creates heat, (2) a steam mixture is produced when very pure water (reactor coolant) moves upward through the core absorbing heat, (3) the steam-water mixture leaves the top of the core and enters the two stages of moisture separation where water droplets are removed before the steam is allowed to enter the steam line, (4) the steam line directs the steam to the main turbine causing it to turn the turbine. The unused steam is exhausted to the condenser where it is condensed into water. The resulting water is pumped out of the condenser with a series of pumps, reheated, and pumped back to the reactor vessel.

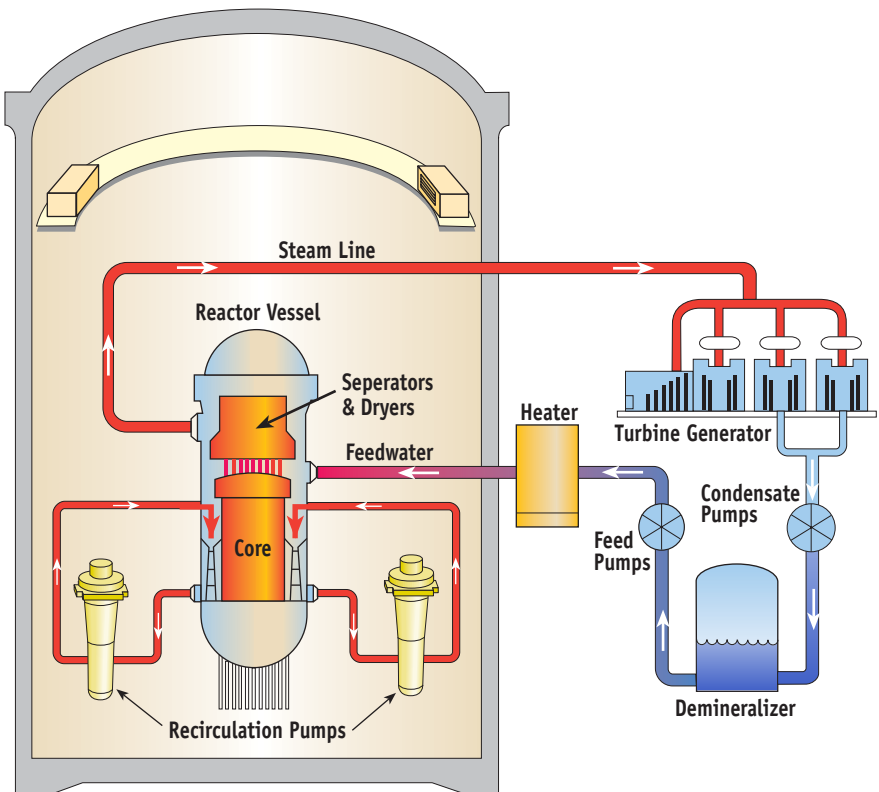

Source: Nuclear Regulatory Commission

OPERATING NUCLEAR REACTORS

Figure 18 - U.S. Operating Commercial Nuclear Power Reactors

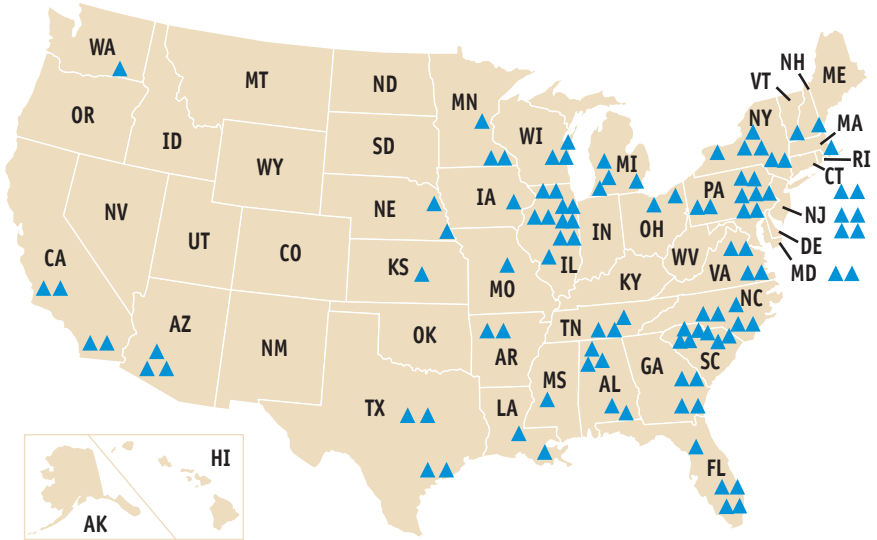

▲ Licensed to Operate (104)

Note: Includes Browns Ferry Unit 1, which has no fuel loaded and requires Commission approval to restart.
Source: Nuclear Regulatory Commission

Figure 19 - NRC Region I Operating Nuclear Power Reactors

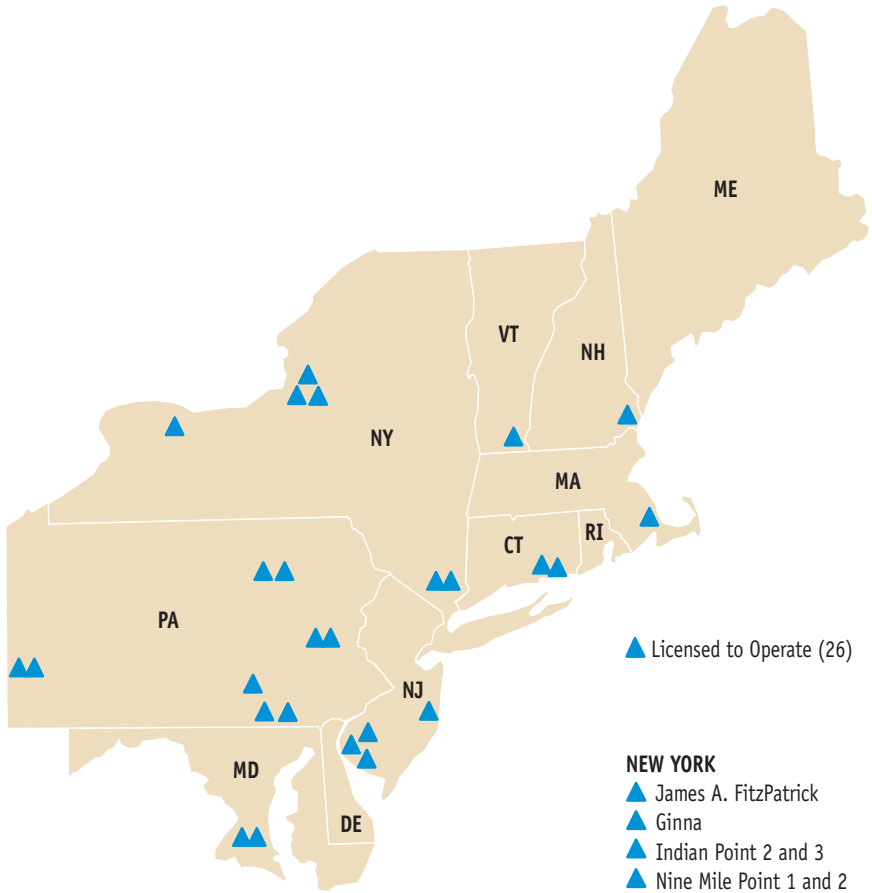

- NEW YORK**
- ▲ James A. FitzPatrick
 - ▲ Ginna
 - ▲ Indian Point 2 and 3
 - ▲ Nine Mile Point 1 and 2

- PENNSYLVANIA**
- ▲ Beaver Valley 1 and 2
 - ▲ Limerick 1 and 2
 - ▲ Peach Bottom 2 and 3
 - ▲ Susquehanna 1 and 2
 - ▲ Three Mile Island 1

- CONNECTICUT**
- ▲ Millstone 2 and 3

- NEW HAMPSHIRE**
- ▲ Seabrook 1

- MARYLAND**
- ▲ Calvert Cliffs 1 and 2

- NEW JERSEY**
- ▲ Hope Creek 1
 - ▲ Oyster Creek
 - ▲ Salem 1 and 2

- MASSACHUSETTS**
- ▲ Pilgrim 1

- VERMONT**
- ▲ Vermont Yankee

Source: Nuclear Regulatory Commission

OPERATING NUCLEAR REACTORS

Figure 20 - NRC Region II Operating Nuclear Power Reactors

ALABAMA

- ▲ Browns Ferry 1, 2, and 3
- ▲ Joseph M. Farley 1 and 2

FLORIDA

- ▲ Crystal River 3
- ▲ St. Lucie 1 and 2
- ▲ Turkey Point 3 and 4

GEORGIA

- ▲ Edwin I. Hatch 1 and 2
- ▲ Vogtle 1 and 2

MISSISSIPPI

- ▲ Grand Gulf

NORTH CAROLINA

- ▲ Brunswick 1 and 2
- ▲ McGuire 1 and 2
- ▲ Shearon Harris 1

SOUTH CAROLINA

- ▲ Catawba 1 and 2
- ▲ Oconee 1, 2, and 3
- ▲ H.B. Robinson 2
- ▲ Summer

TENNESSEE

- ▲ Sequoyah 1 and 2
- ▲ Watts Bar 1

VIRGINIA

- ▲ North Anna 1 and 2
- ▲ Surry 1 and 2

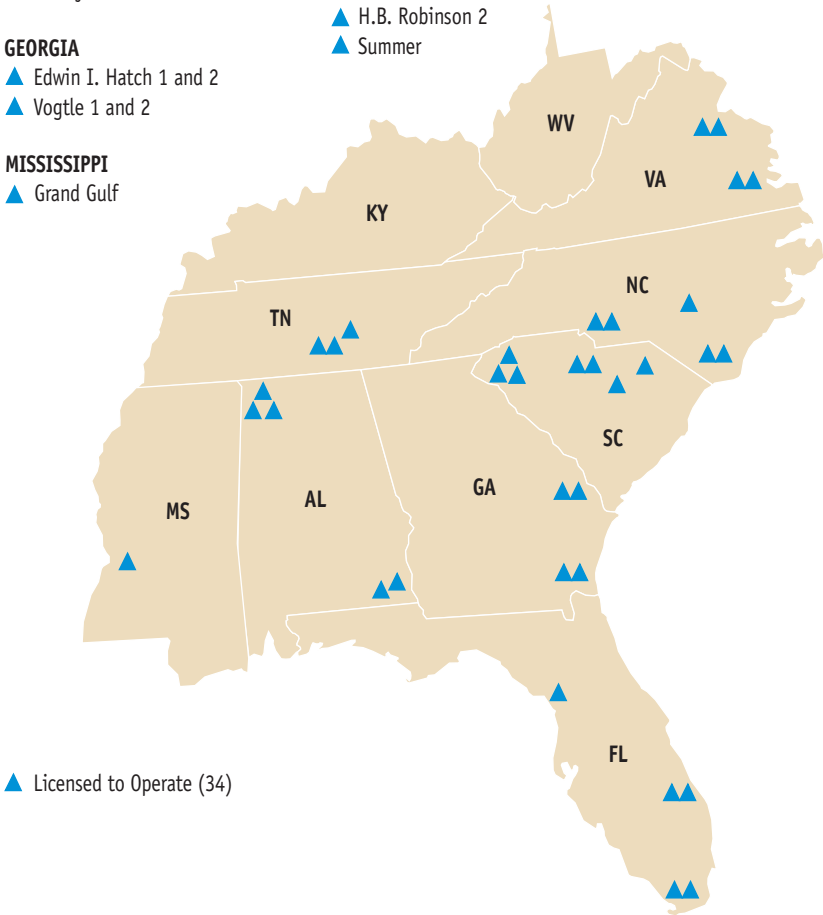

Source: Nuclear Regulatory Commission

Figure 21 - NRC Region III Operating Nuclear Power Reactors

ILLINOIS

- ▲ Braidwood 1 and 2
- ▲ Byron 1 and 2
- ▲ Clinton
- ▲ Dresden 2 and 3
- ▲ La Salle County 1 and 2
- ▲ Quad Cities 1 and 2

IOWA

- ▲ Duane Arnold

MICHIGAN

- ▲ D.C. Cook 1 and 2
- ▲ Fermi 2
- ▲ Palisades

MINNESOTA

- ▲ Monticello
- ▲ Prairie Island 1 and 2

MISSOURI

- ▲ Callaway

OHIO

- ▲ Davis-Besse
- ▲ Perry 1

WISCONSIN

- ▲ Kewaunee
- ▲ Point Beach 1 and 2

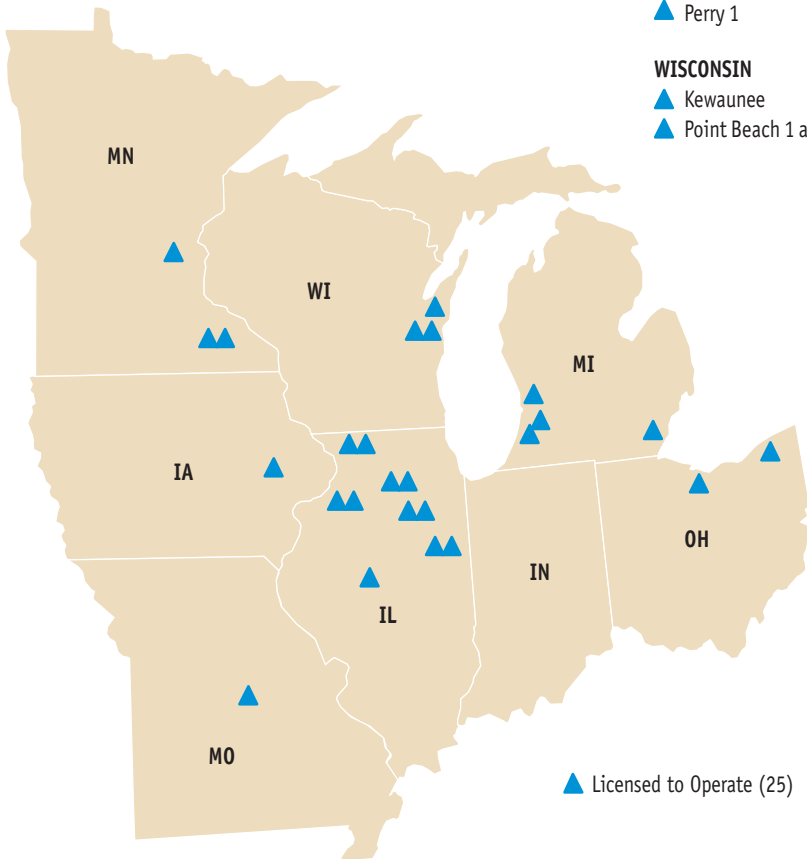

Source: Nuclear Regulatory Commission

OPERATING NUCLEAR REACTORS

Figure 22 - NRC Region IV Operating Nuclear Power Reactors

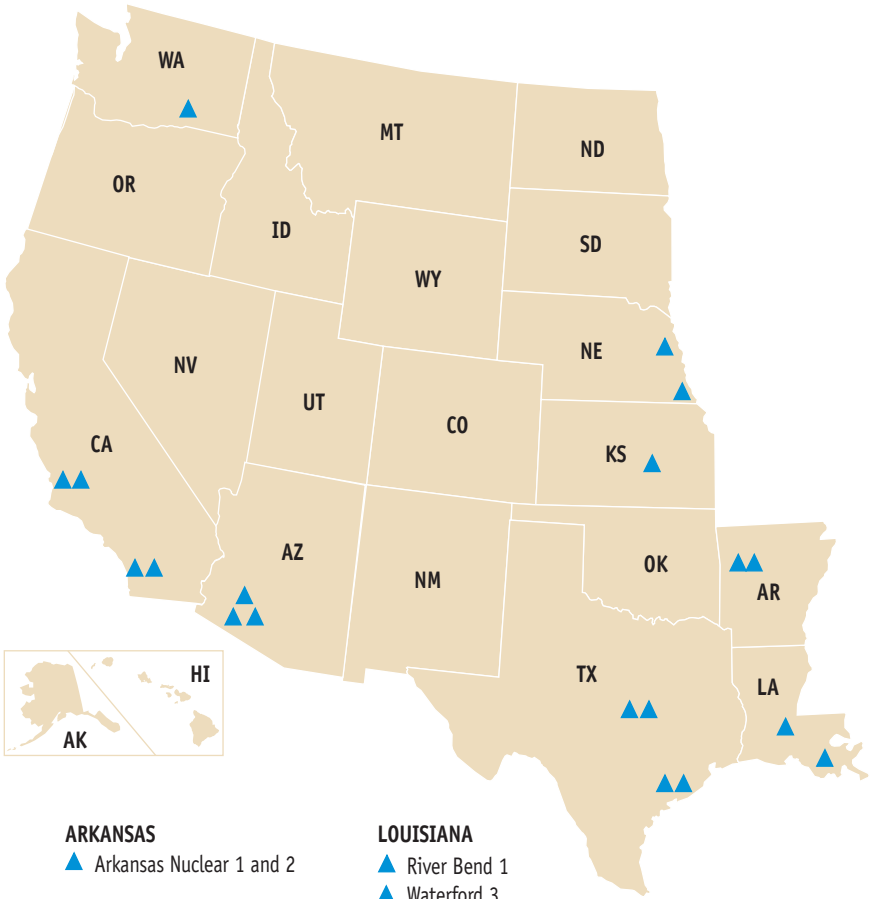

ARKANSAS

- ▲ Arkansas Nuclear 1 and 2

ARIZONA

- ▲ Palo Verde 1, 2, and 3

CALIFORNIA

- ▲ Diablo Canyon 1 and 2
- ▲ San Onofre 2 and 3

KANSAS

- ▲ Wolf Creek 1

LOUISIANA

- ▲ River Bend 1
- ▲ Waterford 3

NEBRASKA

- ▲ Cooper
- ▲ Fort Calhoun

TEXAS

- ▲ Comanche Peak 1 and 2
- ▲ South Texas Project 1 and 2

WASHINGTON

- ▲ Columbia Generating Station

▲ Licensed to Operate (19)

Source: Nuclear Regulatory Commission

Table 11 - U.S. Commercial Nuclear Power Reactor Operating Licenses Issued by Year

Year	Reactor Name	Number of Licenses Issued	Total Number of Operating Licenses	Year	Reactor Name	Number of Licenses Issued	Total Number of Operating Licenses		
1969	Dresden 2	4	4		Indian Point 3				
	GINNA				Salem 1				
	Nine Mile Point 1				St. Lucie 1				
	Oyster Creek			1977	Crystal River 3	4	51		
1970	H.B. Robinson 2	2	6		Davis-Besse				
	Point Beach 1				D.C. Cook 2				
1971	Dresden 3	2	8	Joseph M. Farley 1					
	Monticello				1978	Arkansas Nuclear 2	3	54	
1972	Palisades	6	14	Edwin I. Hatch 2					
	Pilgrim 1				North Anna 1				
	Quad Cities 1				1980	North Anna 2	2	56	
	Quad Cities 2					Sequoyah 1			
Surry 1		1981	Joseph M. Farley 2	4	60				
Turkey Point 3			McGuire 1						
1973	Browns Ferry 1	11	25	Salem 2					
	Fort Calhoun				Sequoyah 2				
	Indian Point 2				1982	La Salle County 1	4	64	
	Kewaunee					San Onofre 2			
	Oconee 1				Summer				
	Oconee 2				Susquehanna 1				
	Peach Bottom 2				1983	McGuire 2	3	67	
	Point Beach 2					San Onofre 3			
	Surry 2				St. Lucie 2				
	Turkey Point 4				1984	Callaway	6	73	
	Vermont Yankee					Diablo Canyon 1			
	1974			Arkansas Nuclear 1	14	39	Grand Gulf 1		
				Browns Ferry 2				La Salle County 2	
Brunswick 2			Susquehanna 2						
Calvert Cliffs 1			Washington						
Cooper			Nuclear Project 2						
D.C. Cook 1			1985	Byron 1			9	82	
Duane Arnold				Catawba 1					
Edwin I. Hatch 1			Diablo Canyon 2						
James A. FitzPatrick			Fermi 2						
Oconee 3			Limerick 1						
Peach Bottom 3			Palo Verde 1						
Prairie Island 1			River Bend 1						
Prairie Island 2			Waterford 3						
Three Mile Island 1		Wolf Creek 1							
1975	Millstone 2	1	40	1986	Catawba 2	5	87		
	Beaver Valley 1							Hope Creek 1	
1976	Browns Ferry 3	7	47	Millstone 3					
	Brunswick 1				Palo Verde 2				
	Calvert Cliffs 2				Perry 1				

OPERATING NUCLEAR REACTORS

Table 11 - U.S. Commercial Nuclear Power Reactor Operating Licenses Issued by Year (*continued*)

Year	Reactor Name	Number of Licenses Issued	Total Number of Operating Licenses	Year	Reactor Name	Number of Licenses Issued	Total Number of Operating Licenses			
1987	Beaver Valley 2	8	95	1990	Comanche Peak 1	2	102			
	Braidwood 1				Seabrook					
	Byron 2			1993	Comanche Peak 2	1	103			
	Clinton				1996			Watts Bar 1	1	104
	Nine Mile Point 2									
	Palo Verde 3									
	Shearon Harris 1									
Vogtle 1										
1988	Braidwood 2	2	97	Source: Data as compiled by the Nuclear Regulatory Commission						
	South Texas Project 1			Note: Limited to reactors licensed to operate. Year is based on the date the initial full-power operating license was issued.						
1989	Limerick 2	3	100							
	South Texas Project 2									
	Vogtle 2									

Figure 23 - U.S. Commercial Nuclear Power Reactor Operating Licenses Issued by Year

NUMBER OF LICENSES ISSUED

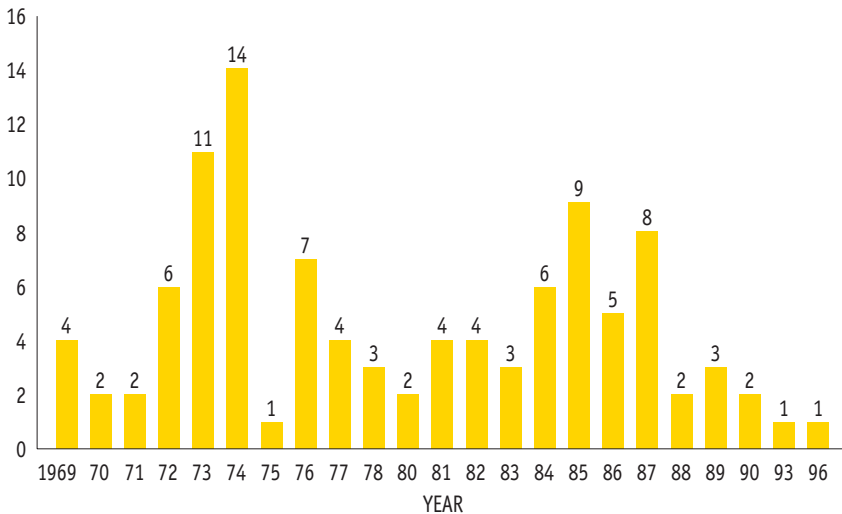

Note: No licenses issued after 1996.

Oversight of U.S. Commercial Nuclear Power Reactors

Reactor Oversight Process

The NRC does not operate nuclear power plants. Rather, it regulates the operation of the nation's 104 nuclear power plants by establishing regulatory requirements for the design, construction and operation of such plants. To ensure that the plants are operated safely within these requirements, the NRC licenses the plants to operate, licenses the plant operators, and establishes technical specifications for the operation of each plant.

The NRC provides continuous oversight of plants through its Reactor Oversight Process (ROP) to verify that they are being operated in accordance with NRC rules and regulations. The NRC has full authority to take whatever action is necessary to protect public health and safety and may demand immediate licensee actions, up to and including a plant shutdown.

The ROP is described on the NRC's Web site and in NUREG-1649, Revision 3, "Reactor Oversight Process." In general terms, the ROP uses both inspection findings and performance indicators (PIs) to assess the performance of each plant within a regulatory framework of seven cornerstones of safety. The ROP recognizes that issues of very low safety significance inevitably occur, and plants are expected to effectively address these

issues. The NRC performs a baseline level of inspection at each plant. The NRC may perform supplemental inspections and take additional actions to ensure significant performance issues are addressed. A summary of the NRC's inspection effort is shown in Figure 24. The latest plant-specific inspection findings and PI information can be found on the NRC's web site.

The ROP takes into account improvements in the performance of the nuclear industry over the past 25 years and improved approaches to inspecting and evaluating the safety performance of NRC-licensed plants. The improvements in plant performance can be attributed both to efforts within the nuclear industry and to successful regulatory oversight.

The ROP is risk-informed, objective, predictable, understandable, and focused on the areas of greatest safety significance. Key features of the ROP are a risk-informed regulatory framework, risk-informed inspections, a Significance Determination Process to evaluate inspection findings, performance indicators, a streamlined assessment process, and more clearly defined actions the NRC takes for plants based on their performance. The NRC began implementation of the ROP in April 2000 and continues to refine the ROP as experience is gained.

Industry Performance Indicators

In addition to evaluating the performance of each individual plant, the NRC compiles data on overall performance using various industry-level

performance indicators, as shown in Figure 25 and Appendix G. The indicators can provide additional data for assessing trends in industry performance.

Figure 24 - NRC Inspection Effort at Operating Reactors, CY 2003*

NUMBER OF SITES**

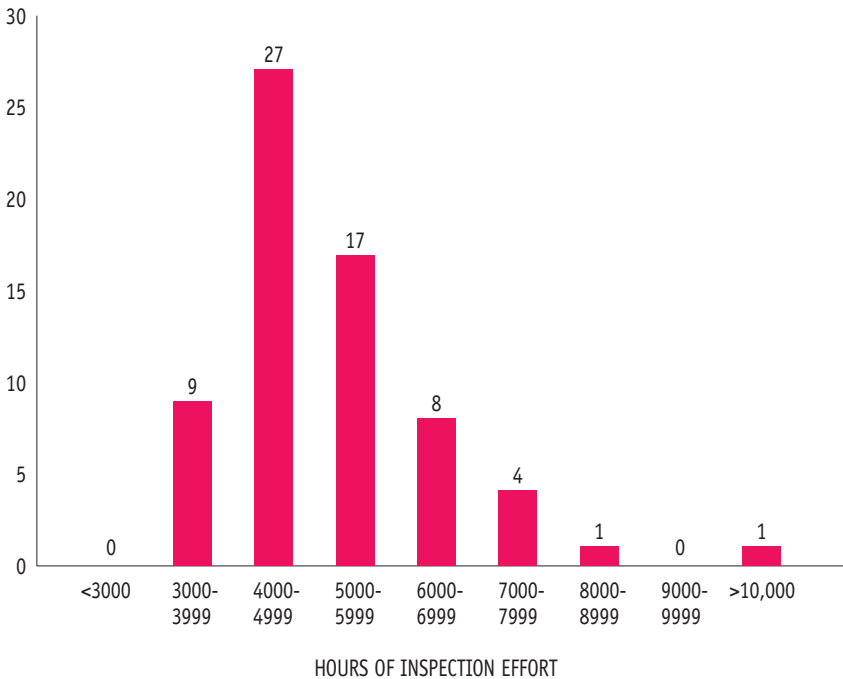

*Data include regular and overtime hours for all activities related to baseline, plant-specific, generic safety issues, and allegation inspections (does not include effort for performance assessment.)

**67 total sites (Indian Point 2, Indian Point 3, Millstone 2, Millstone 3, Hope Creek, and Salem are treated as separate sites for inspection effort.)

Source: Nuclear Regulatory Commission.

Figure 25 - NRC Performance Indicators; Annual Industry Averages, 1990-2003

AUTOMATIC SCRAMS WHILE CRITICAL

AVERAGE NUMBER OF REACTOR SCRAMS

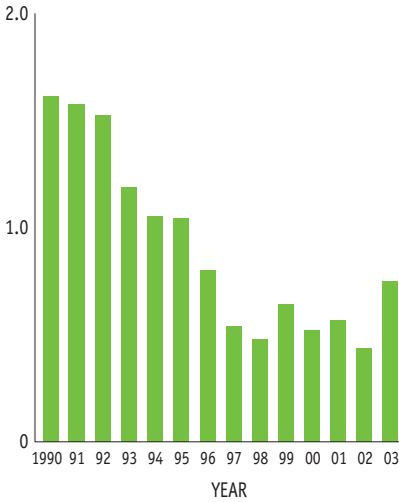

SAFETY SYSTEM ACTUATIONS

AVERAGE NUMBER OF ACTUATIONS

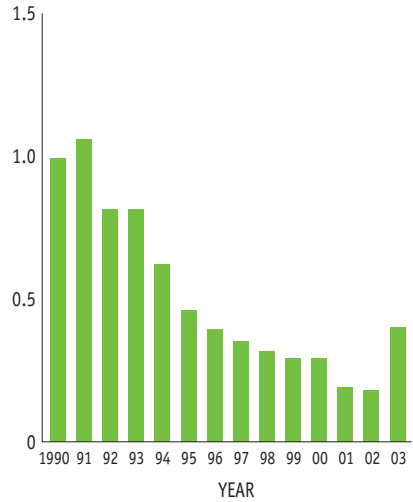

SIGNIFICANT EVENTS

AVERAGE NUMBER OF SIGNIFICANT EVENTS

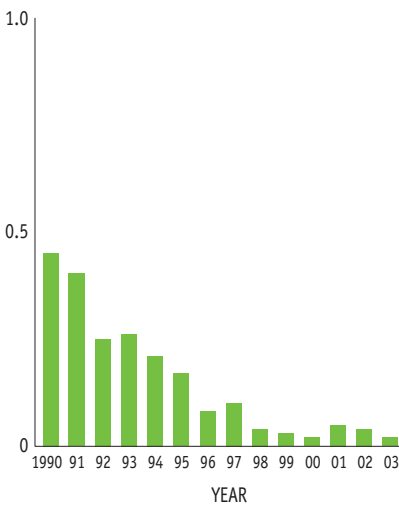

SAFETY SYSTEM FAILURES

AVERAGE NUMBER OF FAILURES

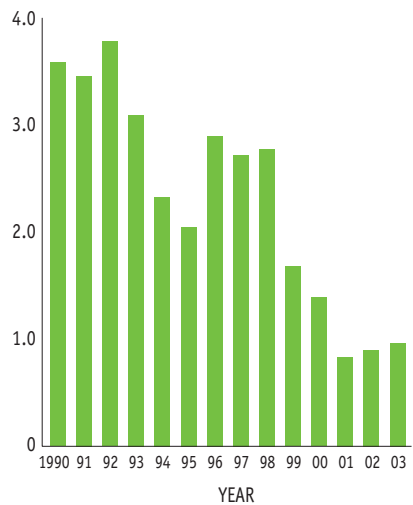

OPERATING NUCLEAR REACTORS

FORCED OUTAGE RATE

AVERAGE FORCED OUTAGE RATE (%)

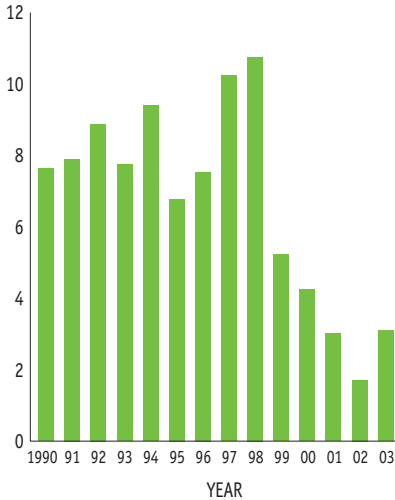

EQUIPMENT-FORCED OUTAGES PER 1000 CRITICAL HOURS

AVERAGE EQUIPMENT-FORCED OUTAGE RATE

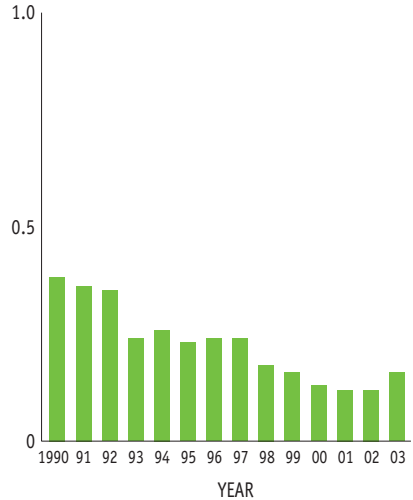

COLLECTIVE RADIATION EXPOSURE

AVERAGE MAN-REM

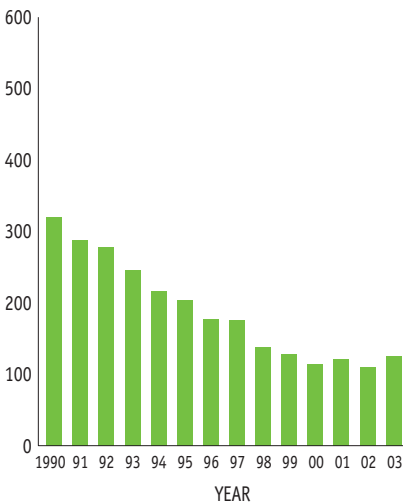

Note: Data represent annual industry averages, with plants in extended shutdown excluded. Data are rounded for display purposes. These data may differ slightly from previously published data as a result of refinements in data quality.

Source: Licensee data as compiled by the Nuclear Regulatory Commission

Future U.S. Commercial Nuclear Power Reactor Licensing

License Renewal:

Based on the Atomic Energy Act, the NRC issues licenses for commercial power reactors to operate for up to 40 years and allows these licenses to be renewed for 20 years.

The original 40-year term for reactor licenses was based on economic and antitrust considerations, not on limitations of nuclear technology. Due to this selected time period, however, some structures and components may have been engineered on the basis of an expected 40-year service life.

The first 40-year operating licenses will expire in the year 2009. Approximately 25 percent of the remaining operating plants will expire by the year 2015. The age of operating reactors and their average maximum dependable capacity (MDC) is illustrated in Figure 26.

The decision whether to seek license renewal rests entirely with nuclear power plant owners, and typically is based on the plant's economic situation and whether it can meet NRC requirements. Extending reactor operating licenses beyond their current 40-year terms will provide a viable approach for electric utilities to ensure the adequacy of future electricity-generating capacity that offers significant economic benefits when compared to the construction of new reactors.

License renewal rests on the determination that current operating plants continue to maintain an adequate level of safety. Over the plant's life, this level of safety has been enhanced through maintenance of the licensing basis, with appropriate adjustments to address new information from industry operating experience. Additionally, the NRC's regulatory activities have provided ongoing assurance that the current licensing basis will continue to provide an acceptable level of safety. The license renewal review process was developed to provide continued assurance that this level of safety will be maintained for the period of extended operation if a renewed license is issued.

The NRC has issued regulations establishing clear requirements for license renewal to assure safe plant operation for extended plant life (codified in 10 CFR Parts 51 and 54). The review of a renewal application proceeds along two paths -- one for the review of safety issues and the other for environmental issues. An applicant must provide the NRC with an evaluation that addresses the technical aspects of plant aging and describes the ways those effects will be managed. The applicant must also prepare an evaluation of the potential impact on the environment if the plant operates for up to an additional 20 years. The NRC reviews the application and verifies the safety evaluations through inspections.

The NRC has developed regulatory guidance to standardize the content of license renewal applications and improve the efficiency and effectiveness of the NRC's evaluation for both the safety and environmental reviews.

Public participation is an important part of the license renewal process. There are several opportunities for members of the public to question how aging will be managed during the period of extended operation. Information provided by the applicant is made available to the public. A number of public meetings are held and all NRC technical and environmental review results are fully documented and made publicly available. Concerns may be litigated in an adjudicatory hearing if any party that would be adversely affected requests a hearing.

The NRC website (www.nrc.gov) provides information on the plants that have received renewed licenses and the renewal applications that are under review. The website also provides information on the license renewal regulations and process.

The Babcock and Wilcox, Westinghouse, and Boiling Water Reactor Owners Groups established generic license renewal programs that developed and submitted technical reports for NRC approval. The Nuclear Energy Institute established working groups to interact with the NRC on improvements to the license renewal rule implementation guidance, and resolution of generic renewal issues.

The NRC has conducted research providing the technical bases to ensure

that critical reactor components, safety systems, and structures provide adequate reliability as reactors age. Research results continue to be useful in assessing safety implications of age-related degradation during the 40-year license and in supporting safety decisions associated with license renewal.

New Nuclear Reactor Licensing

In 1989, the NRC introduced a new licensing process (10 CFR Part 52) as an alternative to the traditional two-step licensing process in Part 50. Part 52 sets forth the process for review of Early Site Permits (ESP), Standard Design Certifications, and Combined Licenses for nuclear power facilities. A combined license involves issuance of a combined construction permit and a conditional operating license for a nuclear power facility.

The Office of Nuclear Reactor Regulation (NRR) has the primary responsibility for processing new plant applications. The Office of Research has the responsibility to provide lead efforts in the pre-application reviews for non-Light Water Reactor designs and to support NRR in their reviews of other advanced reactor designs. An Advanced Reactor Steering Committee (ARSC) comprised of managers from the Office of Nuclear Reactor Regulation and the Office of Research was formed in 2003. The ARSC provides guidance on matters related to policy and process issues associated with the licensing of new reactors.

The NRC is performing several activities to ensure that it is prepared to

review new applications. These activities include assessing the actions necessary to prepare for receipt of a combined license application (COL); rulemaking activities for the 10 CFR Part 52 licensing process; developing a construction inspection program framework and subsequent inspection program for new construction activities; and continuing our activities in the pre-application and design certification review processes.

The NRC is performing pre-application reviews currently ongoing and anticipated which include; General Electric's Economic Simplified Boiling Water Reactor (ESBWR), Atomic Energy of Canada LTD's Advanced Candu Reactor (ACR-700), Westinghouse's International Reactor Innovative and Secure design is also known as IRIS, Framatome's European designed boiling water reactor and the Pebble Bed Modular Reactor sponsored by PBMR (Pty) Ltd.

NRC is currently reviewing Westinghouse's design certification application for their AP1000 passive advanced light-water reactor design. In the past, NRC has provided design certifications for three reactor designs that can be referenced in an applica-

tion for a nuclear power plant. These designs include:

1. GE Nuclear Energy's Advanced Boiling Water Reactor design;
2. Westinghouse's System 80+ design; and
3. Westinghouse's AP600 design.

During the Fall 2003, the NRC received three applications for early site permits (ESP). The three applicants are: Dominion Nuclear North Anna, LLC, for the North Anna site in Virginia; Exelon Generation Company, LLC for the Clinton site in Illinois; and System Energy Resources, Inc. for the Grand Gulf site in Mississippi. An ESP provides for early resolution of site safety, environmental protection, and emergency preparedness issues, independent of a specific nuclear plant review. The NRC expects to complete their technical review of the ESPs in 2005. Mandatory adjudicatory hearings associated with the ESPs will be conducted after the completion of the NRC staff's technical review.

Additional information on the advanced reactors mentioned above is available on the NRC's Web Site at <http://www.nrc.gov/reading-rm/doc-collections/fact-sheets/next-gen-reactors.html>.

OPERATING NUCLEAR REACTORS

Figure 26 - U.S. Commercial Nuclear Power Reactors—Years of Operation

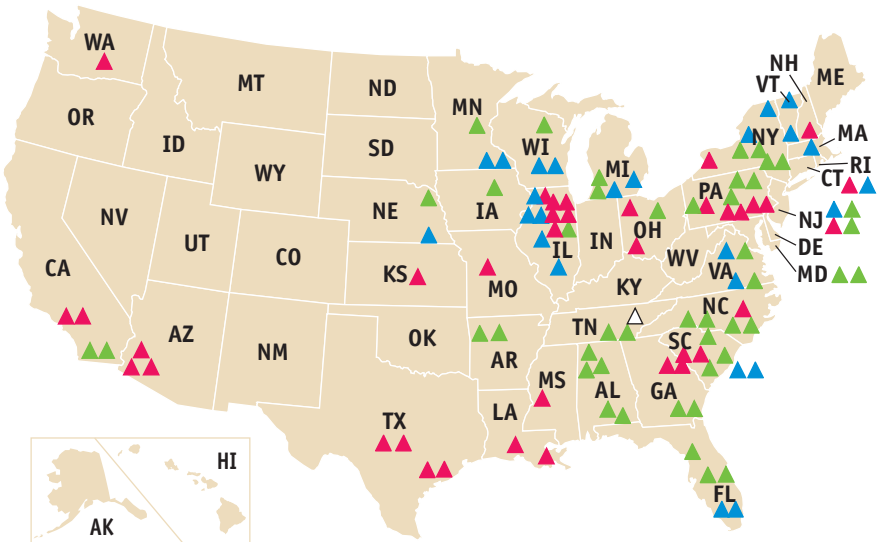

YEARS OF COMMERCIAL OPERATION	NUMBER OF REACTORS	AVERAGE CAPACITY (MDC)
△ 0-9	1	1,121
▲ 10-19	36	1,145
▲ 20-29	46	935
▲ 30-35	21	689

Note: Calculated data as of 12/03.

Source: Nuclear Regulatory Commission

**Table 12 - U.S. Commercial Nuclear Power Reactor Operating Licenses—
Expiration Date by Year**

Year	Reactor Name	Number of Licenses Expired	Year	Reactor Name	Number of Licenses Expired
2009	Dresden 2	4	2023	La Salle County 2	2
	Ginna			Columbia Generating Station	
	Nine Mile Point 1		2024	Byron 1	7
Oyster Creek	Callaway				
2010	H.B. Robinson 2	3	Grand Gulf 1	5	
	Monticello		Limerick 1		
2011	Point Beach 1	2	Palo Verde 1	5	
	Dresden 3		Susquehanna 2		
2012	Palisades	4	Waterford 3	5	
	Pilgrim 1		2025		Diablo Canyon 2
2013	Quad Cities 1	5	Fermi 2	8	
	Quad Cities 2		2026		Palo Verde 2
	Vermont Yankee		River Bend 1		
2014	Browns Ferry 1	8	Wolf Creek 1	5	
	Indian Point 2		2027		Braidwood 1
	Kewaunee		Byron 2		
2015	Point Beach 2	1	Clinton	1	
	Prairie Island 1		Hope Creek 1		
	Browns Ferry 2		2028		Nine Mile Point 2
2016	Brunswick 2	5	Perry 1	1	
	Cooper		2029		Seabrook 1
	D. C. Cook 1		Shearon Harris 1		
2017	Duane Arnold	3	2030	5	
	James A. FitzPatrick		Beaver Valley 2		
	Prairie Island 2		Braidwood 2		
2018	Prairie Island 2	1	Palo Verde 3	1	
	Three Mile Island 1		2032		South Texas Project 1
	Indian Point 3		Vogtle 1		
2019	Beaver Valley 1	5	2033	1	
	Browns Ferry 3		Beaver Valley 2		
	Brunswick 1		Braidwood 2		
2020	Crystal River 3	2	Palo Verde 3	2	
	Salem 1		South Texas Project 2		
	Davis-Besse		2034		Vogtle 2
2021	D.C. Cook 2	3	2035	1	
	Joseph M. Farley 1		Comanche Peak 1		
	Arkansas Nuclear 2		2036	Turkey Point 3	
2022	Salem 2	2	Surry 1	2	
	Sequoyah 1		2037		Comanche Peak 2
	Diablo Canyon 1		Fort Calhoun		
2023	Joseph M. Farley 2	3	Oconee 1	7	
	Sequoyah 2		Oconee 2		
	La Salle County 1		Peach Bottom 2		
2024	San Onofre 2	5	Turkey Point 4	5	
	San Onofre 3		2038		Surry 2
	Summer		ANO 1		
2025	Susquehanna 1	2	2039	2	
	2026		Calvert Cliffs 1		
	2027		Edwin Hatch 1		
2026	2028	4	Oconee 3	2	
	2029		Peach Bottom 3		
	2030		Millstone 2		
2027	2031	2	Watts Bar	2	
	2032		2040		2
	2033		2041		2

OPERATING NUCLEAR REACTORS

Year	Reactor Name	Number of Licenses Expired	Year	Reactor Name	Number of Licenses Expired
2036	Calvert Cliffs 2	2	2043	Catawba 1	4
	St. Lucie			Catawba 2	
2038	Edwin Hatch 2	2	2045	McGuire 2	1
	North Anna 1			St. Lucie 2	
2040	North Anna 2	1	Millstone 3		
2041	McGuire 1	1			

*Year assumes that the maximum number of years for construction recapture has been added to the current expiration date. This column is limited to reactors eligible for construction recapture. See Glossary for definition.

Note: Limited to reactors licensed to operate.

Source: Data as compiled by the Nuclear Regulatory Commission. Data as of December 2003.

Figure 27 - U.S. Commercial Nuclear Power Reactor Operating Licenses Expiration Date by Year Assuming Construction Recapture

NUMBER OF LICENSES EXPIRED

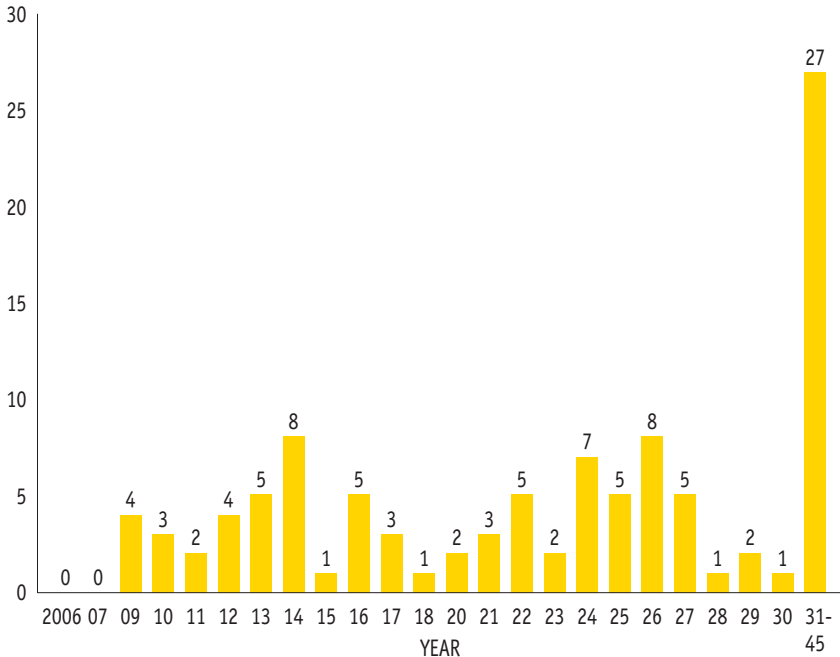

U.S. Nuclear Research and Test Reactors

Nuclear research and test reactors are designed and utilized for research, testing, and educational purposes:

- in the performance of research and testing in the areas of physics, chemistry, biology, medicine, materials sciences, and related fields; and
- in educating people for nuclear-related careers in the power industry, national defense, health service industry, research, and education

There are 33 research and test reactors licensed to operate in 23 States (see Figure 28):

- 10 research and test reactors are being decommissioned.

- 6 research and test reactors have possession-only licenses.
- Since 1958, 76 licensed research and test reactors have been decommissioned.
- Refer to Appendix E for a listing of U.S. nuclear research and test reactors with operating licenses.

Principal Licensing and Inspection Activities

- The NRC licenses approximately 300 research and test reactor operators. Each operator is requalified before renewal of a 6-year license.
- The NRC conducts approximately 45 research and test reactor inspections each year.

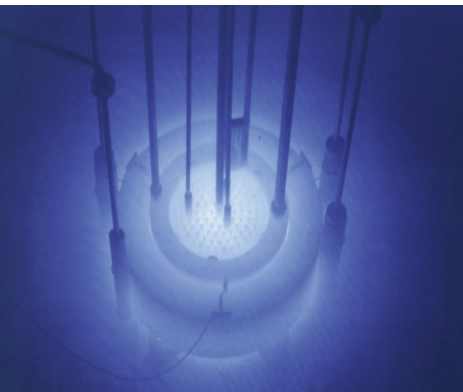

The blue glow that engulfs the reactor core when operating at a high power is known as the Cerenkov effect, named after the Russian scientist who developed the theory explaining the phenomena.

OPERATING NUCLEAR REACTORS

Figure 28 - U.S. Nuclear Research and Test Reactors

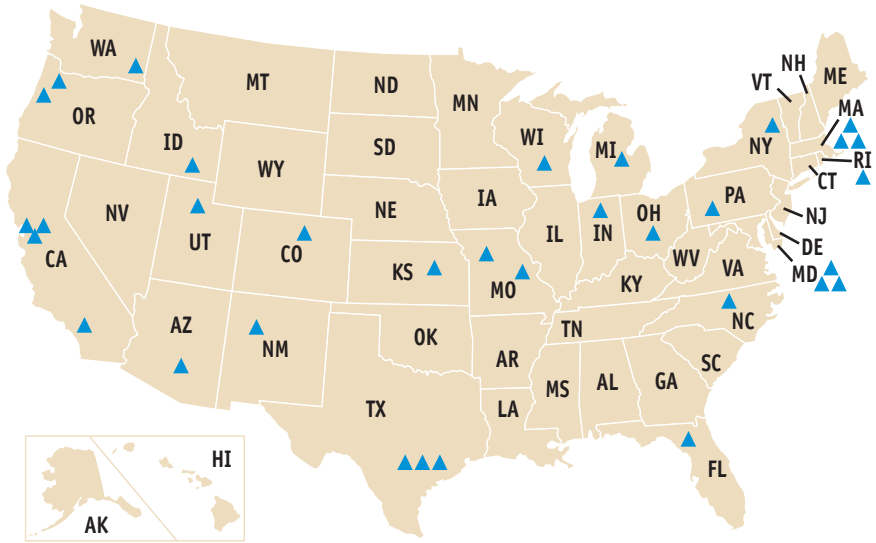

▲ Licensed to Operate (33)

Source: Nuclear Regulatory Commission

Nuclear Regulatory Research

NRC's regulatory research program furthers the regulatory mission of the NRC by providing technical advice, technical tools, and information for identifying and resolving safety issues, making regulatory decisions, and promulgating regulations and guidance. In addition, conducts independent experiments and analyses, develops technical bases for supporting realistic safety decisions by the NRC, and prepares the NRC for the future by evaluating the safety aspects of current and new reactor designs and technologies.

The challenges that face NRC's regulatory research program include changes in practices and performance of the regulated industry, the emergence of new safety issues as the industry continues to mature, the availability of new technologies, development of new reactor design, knowledge management, and public awareness of and involvement in the regulatory process. Accordingly, the NRC must have highly skilled, independent expertise with access to facilities to formulate sound technical solutions and to support timely and realistic regulatory decisions.

The current NRC research program focuses on supporting the NRC strategic performance goals: Safety, Security, Openness, Effectiveness, and Excellence in Agency Management. To ensure protection of public health and safety and the environment, the NRC research program includes research

into material degradation issues (e.g., stress corrosion cracking and boric acid corrosion), high-level waste transportation, storage, and disposal (e.g., transportation of spent nuclear fuel in packages and radionuclide transport), new and evolving technology (e.g., new advanced reactor technology, mixed oxide fuel performance), operating experience, and probabilistic risk assessment technology (e.g., PRA quality).

To ensure the secure use and management of radioactive materials, the NRC research program is investigating potential vulnerabilities and compensatory actions of nuclear facilities to malicious attack.

To ensure openness in regulatory process the NRC research program conducts public meetings and holds an annual Nuclear Safety Research Conference, to bring together diverse groups of stakeholders to discuss the latest trend in cutting edge research.

To ensure that NRC actions are effective, efficient, realistic, and timely, the NRC research participates in information exchanges and cooperative research, both domestically and internationally, to share positions on technical and policy issues, leverage resources, avoid duplication of effort, and share facilities wherever possible.

To enhance management excellence, the regulatory research program manages human capital by using innovative

OPERATING NUCLEAR REACTORS

recruitment, development and retention strategies. Additionally, the program encourages knowledge management initiatives to support

staff development and networking. This achieves a high quality, diverse work force, which supports providing high quality research products.

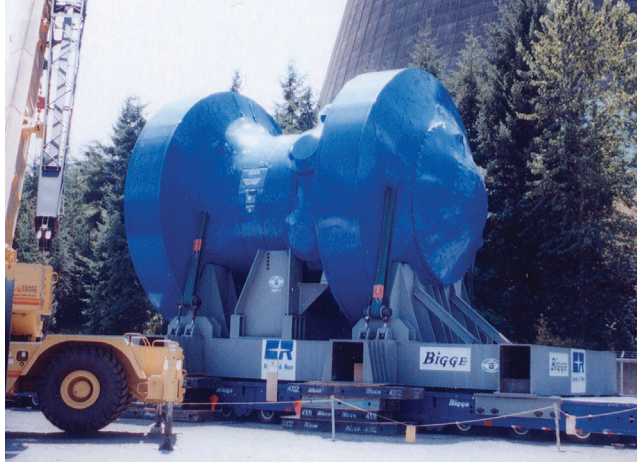

Nuclear Reactor on Transporter





NUCLEAR MATERIALS SAFETY

<http://www.nrc.gov/materials.html>

U.S. Fuel Cycle Facilities

The NRC licenses and inspects all commercial nuclear fuel facilities involved in the enriching, processing and fabrication of uranium ore into reactor fuel.

There are seven major fuel fabrication and production facilities and two gaseous diffusion uranium enrichment facilities licensed to operate in eight States (see Figure 32)

A typical Uranium Enrichment Facility is illustrated in Figure 29.

- **Uranium Hexafluoride Production Facility:** (see Figure 29)

- Honeywell International, Inc. (Metropolis, Illinois)

- **Uranium Fuel Fabrication Facilities:**

- Global Nuclear Fuel Americas, LLC (Wilmington, North Carolina)
- Westinghouse Electric Company, LLC Nuclear Fuel Division (Columbia, South Carolina)
- Nuclear Fuel Services, Inc. (Erwin, Tennessee)
- Framatome Fuels (Lynchburg, Virginia)

- BWX Technologies Nuclear Fuel Division (Lynchburg, Virginia)
- Framatome ANP Richland, Inc. (Richland, Washington)

- **Gaseous Diffusion Enrichment Facilities:** (see Figure 30)

- U. S. Enrichment Corporation (USEC) (Paducah, Kentucky) (Portsmouth, Ohio)*

NRC regulates 9 other facilities that possess significant quantities of special nuclear material (other than reactors) or process source material (other than uranium recovery facilities).

- **Proposed Gas Centrifuge Uranium Enrichment Facilities** (see Figure 30)

- United States Enrichment Corporation (USEC) Piketon, Ohio
- Louisiana Energy Services (LES) Eunice, New Mexico

The NRC is reviewing an application for a commercial gas centrifuge facility, and is expecting an application for a second commercial gas centrifuge facility from USEC in 2004.

A typical fuel fabrication plant is illustrated in Figure 31.

*Currently in cold standby and not used for enrichment.

The NRC recently approved USEC's application for the Lead Cascade facility (a non-commercial demonstration and test gas centrifuge facility from which no enriched product will be removed, except for sampling).

Under the Atomic Energy Act, as amended, NRC must license a uranium enrichment plant under 10 CFR Part 40 (source material) and Part 70 (special nuclear material). Before an applicant can begin construction of a plant, NRC must issue a license for construction and operation. To issue a license, the NRC must prepare an environmental impact statement (EIS) for the project, as well as conduct a formal hearing.

- **Proposed Mixed Oxide Fuel Fabrication Facility:**

- Duke Cogema Stone & Webster (Aiken, South Carolina)

The Nuclear Regulatory Commission is reviewing an application for construction of a mixed oxide (MOX) fuel fabrication facility at the Department of Energy's Savannah River Site.

The Department of Energy announced plans to construct this MOX facility through a contract with the consortium of Duke Engineering & Services, COGEMA Inc., and Stone & Webster (known as DCS). If NRC authorizes construction, DCS could build and

operate the MOX facility. A separate NRC approval is necessary before DCS can possess special nuclear material and operate the facility. The facility is intended to convert surplus U.S. weapons-grade plutonium, supplied by the Department of Energy, into fuel for use in commercial nuclear reactors. Such use would render the plutonium essentially inaccessible and unattractive for weapons use.

DCS submitted a revised environmental report on the MOX facility in August 2003, and submitted a revised request for authorization to construct the facility in October 2002.

NRC will be conducting public meetings on the proposal and will prepare an environmental impact statement. NRC will also conduct a technical evaluation of the application to determine whether it meets NRC requirements.

Principal Licensing and Inspection Activities:

- NRC issues approximately 80 new, renewal, license amendments, and safety and safeguards reviews for fuel cycle facilities annually.
- NRC routinely conducts safety, safeguards, and environmental protection inspections of approximately 10 fuel cycle facilities or sites.

Figure 29 - Typical Uranium Enrichment Facility

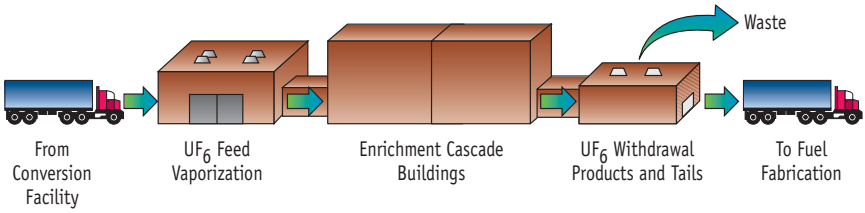
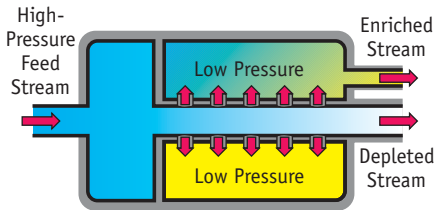

Figure 30 - Two Enrichment Processes

Gaseous Diffusion



The gaseous diffusion method uses molecular diffusion to effect separation. The isotopic separation is accomplished by diffusing uranium, which has been combined with fluorine to form UF_6 gas, through a porous membrane (barrier) and utilizing the different molecular velocities of the two isotopes to achieve separation.

Gas Centrifuge

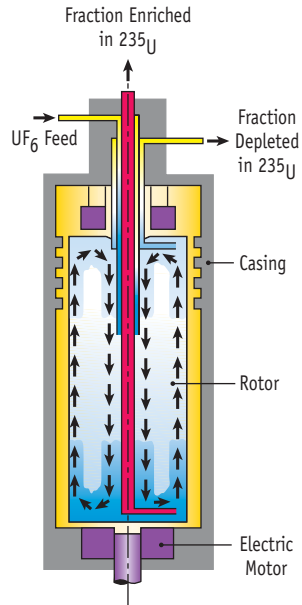

The gas centrifuge process uses a large number of rotating cylinders in a series and parallel configurations. Gas is introduced and rotated at a high speed, concentrating the component of higher molecular weight towards the outer wall of the cylinder and the lower molecular weight component towards the axis. The enriched and the depleted gas are removed by scoops.

Figure 31 - Typical Fuel Fabrication Plant

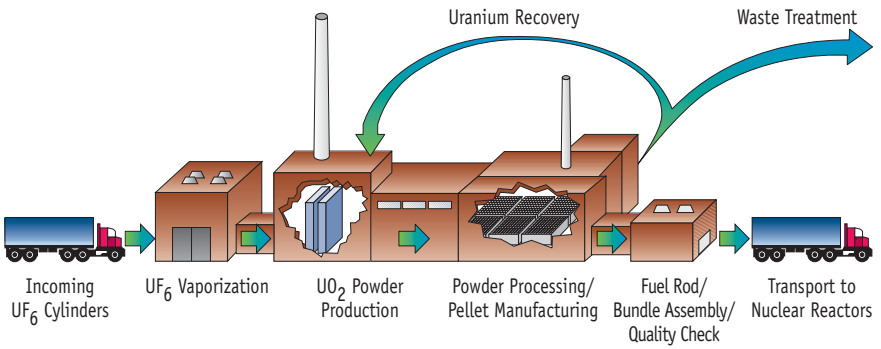
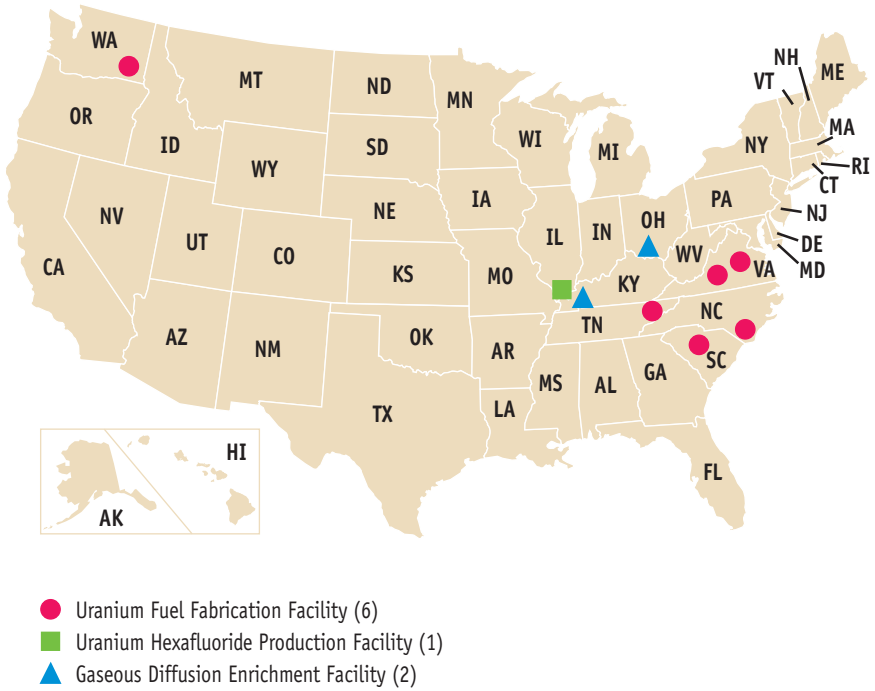

Figure 32 - Major U.S. Fuel Cycle Facility Sites



Source: Nuclear Regulatory Commission

U.S. Materials Licenses

Approximately 21,600 licenses are issued for medical, academic, industrial, and general uses of nuclear materials (see Table 13):

Reactor-produced radionuclides are used extensively throughout the United States for civilian and military industrial applications, basic and applied research, manufacture of consumer products, civil defense activities, academic studies, and medical diagnosis, treatment and research. NRC and Agreement State regulatory programs are designed to assure that licensees safely use these materials, and do not endanger public health and safety or cause damage to the environment.

- Approximately 4,500 licenses are administered by the NRC.
- Approximately 17,109 licenses are administered by the 33 States that participate in the NRC Agreement States Program. An NRC Agreement State is one that has signed an agreement with the NRC that authorizes the State to regulate the use of radioactive materials within that State (see Figure 33). Minnesota and Pennsylvania are actively working toward becoming an Agreement State.

Medical and Academic — The NRC and Agreement States issue licenses to hospitals and physicians for the use of certain radioactive materials in diagnosing and treating patients.

Academic institutions use radioactive materials for education and biomedical research. The facilities, personnel, program controls and equipment in each application are reviewed to ensure the safety of the public, patients, and occupationally exposed workers. In nuclear medicine, diagnostic procedures include *in vitro* tests (the addition of radioactive materials to lab samples taken from patients) and *in vivo* tests (direct administration of radioactive drugs to patients). Therapeutic treatments include the use of drugs to treat certain medical conditions such as hyperthyroidism and certain forms of cancer.

NRC issues licenses to academic institutions for educational and research purposes. Licensed activities include receipt of radioactive material, classroom demonstrations by qualified instructors, supervised laboratory research by students, and the use of certain neutron sources and source material in sub-critical assemblies.

Industrial — Radionuclides are used in a number of industrial and commercial applications including industrial radiography, gauging devices, gas chromatography, well logging, and smoke detectors. The radiography process uses radiation sources to determine structural defects in metallic castings and welds. Portable and fixed gauges use a radiation detector and indicator to measure density and thickness of an object on the indicator. Such measurements determine

the thickness of paper products, fluid levels of oil and chemical tanks, moisture and density of soils and material at construction sites, and in manufacture items such as satellites and missiles. Gas chromatography uses low energy sources for identifying the constituent elements of substances. It is used to determine the components of complex mixtures such as petroleum products, smog and cigarette smoke, and in biological and medical research to identify the components of complex proteins and enzymes. Well logging devices use a radioactive source to trace the position of materials previously placed in a well. This process is used extensively for oil, gas, coal, and mineral exploration.

General Licenses — A general licensee is a person or organization that acquires, uses, or possesses a generally licensed device (GLD) and has received the device through an authorized transfer by the device manufacturer/distributor, or by change of

company ownership where the device remains in use at a particular location.

A generally licensed device is a device containing radioactive material that is typically used to detect, measure, gauge, or control the thickness, density, level, or chemical composition of various items. Examples of such devices are gas chromatography (detector cells), density gauges, fill-level gauges, and static elimination devices. NRC registers and tracks generally licensed devices to increase control and accountability of the devices and to prevent them from becoming orphan sources.

Principal Licensing and Inspection Activities

- NRC issues approximately 4,200 new licenses, renewals, or license amendments for materials licenses annually.
- NRC conducts approximately 1,200 health and safety inspections of its nuclear materials licensees annually.

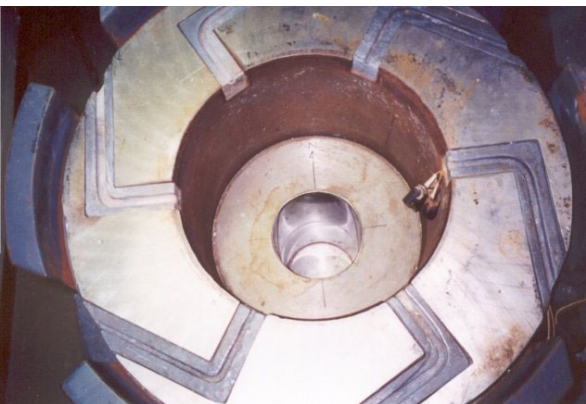

Cobalt-60 irradiator

Table 13 - U.S. Materials Licenses by State

State	Number of Licenses		State	Number of Licenses	
	NRC	Agreement States		NRC	Agreement States
Alabama	16	429	Montana	73	0
Alaska	49	0	Nebraska	4	148
Arizona	13	320	Nevada	3	254
Arkansas	7	268	New Hampshire	5	80
California	48	2,182	New Jersey	500	0
Colorado	20	367	New Mexico	14	217
Connecticut	192	0	New York	48	1,405
Delaware	54	0	North Carolina	18	654
District of Columbia	41	0	North Dakota	10	62
Florida	14	1,453	Ohio	51	751
Georgia	15	503	Oklahoma	30	239
Hawaii	57	0	Oregon	7	471
Idaho	75	0	Pennsylvania	714	0
Illinois	39	753	Rhode Island	1	54
Indiana	269	0	South Carolina	14	367
Iowa	2	180	South Dakota	41	0
Kansas	14	313	Tennessee	20	563
Kentucky	9	430	Texas	43	1,559
Louisiana	11	529	Utah	10	194
Maine	2	134	Vermont	35	0
Maryland	57	587	Virginia	384	0
Massachusetts	29	537	Washington	18	417
Michigan	510	0	West Virginia	183	0
Minnesota	157	0	Wisconsin	28	363
Mississippi	4	321	Wyoming	80	0
Missouri	301	0	Others*	153	0
			Total	4,492	17,109

*"Others" includes U.S. territories such as Puerto Rico, Virgin Islands, and Guam.

Note: Agreement States data are latest available as of March 5, 2004. NRC data as of March 17, 2004. For updates, please refer to STP website: <http://www.hsrdo.ornl.gov/nrc/special/USALicenses.pdf>.

Nuclear Gauges

Fixed Gauges — The cross section shows a fixed fluid gauge installed on a process pipe (see Figure 34). Such devices are widely used in beverage, food, plastics, process and chemical industries to measure the densities, flow rates, levels, thicknesses, and weights of a wide variety of materials and surfaces.

Nuclear gauges are used as non-destructive devices to measure physical properties of products and industrial processes to ensure environment, quality control and low-cost fabrication, construction and installations.

Fixed gauges consist of a radioactive source that is contained in a source holder safely. When the source holder's shutter is opened manually or by activating a remote electrical button, a beam of radiation is directed at the material or product being processed or controlled. A detector mounted opposite to the source, measures the radiation passing through the media of the material or the product. The required information is shown on a local read out or is displayed on a computer monitor. The type and strength of

radiation energy are selected to ensure that the passage of the radiation does not cause any detectable changes in the material and does not radioactively contaminate the material.

Portable gauges — consist of a radioactive source or sources and detector mounted together in a portable shielded device. When the device is being used, it is placed on the object to be measured and the source is either inserted into the object or the gauge relies on a reflection of radiation from the source to bounce back to the bottom of the gauge. The detector in the gauge measures the radiation, either directly from the inserted source or the reflected radiation.

The amount of radiation the detector measures indicates the thickness, density, moisture content or some other property which is displayed on a local read out or on a computer monitor. The top of the gauge has sufficient shielding to protect the operator while the source is exposed and when the measuring process is completed, the source is retracted or a shutter closes minimizing exposure from the source.

Figure 34 - Cross Section of a Fixed Fluid Gauge

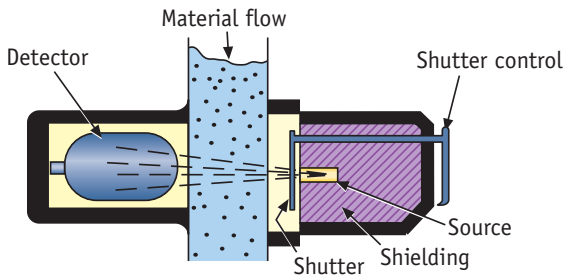

Teletherapy Devices

Teletherapy is one of the primary radiation oncology treatment modalities. Teletherapy devices provide external high radiation beams for treatment of cancerous tumors. Both the primary tumor and the areas to which cancer may have spread (regional lymphatic) may be treated at the same time.

The Cobalt-60 source is in the equipment's head, which is surrounded by lead or depleted uranium shielding, with a port for treatment (see Figure 35).

Treatment distance between the source and the skin of the patient is 80 to 120 centimeters. Cesium-137

teletherapy units were formerly used by a few facilities. Few, if any, of these units remain as the average penetrating energy is approximately half of that provided by the cobalt sources.

Linear accelerators are replacing the Cobalt-60 units. A 4 MeV linear accelerator can provide about the same energy as a Cobalt-60 unit, but with a higher output (100 to 300 rad/min). Higher energy accelerators are now being used (6 MeV to 30 MeV). These higher energy photons provide greater dose depth. Also, the high energy electrons may be used directly in some cases.

Figure 35 - Cobalt-60 Teletherapy Unit

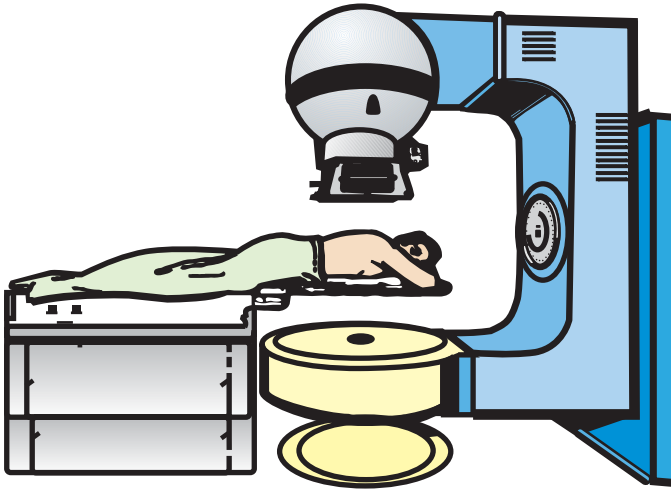

Commercial Product Irradiators

The illustration below shows a typical large commercial gamma irradiator which may be used for sterilization of medical supplies and equipment, disinfestation of food products, insect eradication through sterile male re-release program, chemical and polymer synthesis and modifications or exten-

sion of shelf-life of poultry and perishable products.

In this type of irradiator, when in use, the Cobalt-60 sealed source is raised out of the pool water and exposed to the product within a radiation volume that is maintained inaccessible during use by an entry control system.

Figure 36 - Commercial Gamma Irradiator

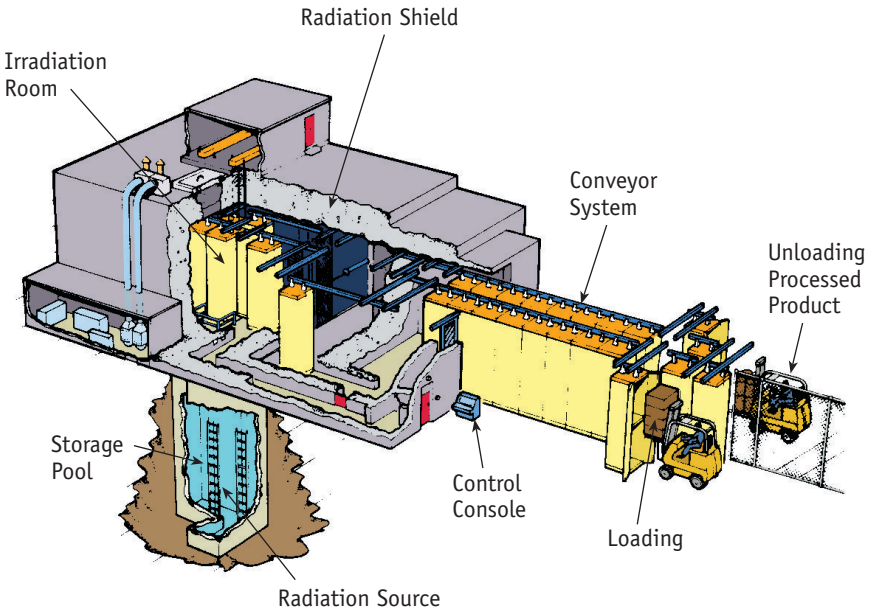

Uranium Milling

A uranium mill is a chemical plant designed to extract uranium from mined ore. The mined ore is brought to the milling facility via truck where the ore is crushed and leached. In most cases, sulfuric acid is used as the leaching agent, but alkaline leaching can also be used. The leaching agent not only extracts uranium from the ore, but also several other constituents like molybdenum, vanadium, selenium, iron, lead, and arsenic. The product produced from the mill is referred to as “yellow cake” (U_3O_8), because of its yellowish color.

As defined in the NRC regulations of 10 CFR Part 40, uranium milling is any activity that results in the production of byproduct material as defined in this part. Part 40 defines byproduct material the same as Section 11e.(2) of the Atomic Energy Act, “...the tailings or wastes produced by the extraction or concentration of uranium or thorium from any ore processed primarily for its source material content”, but adds “...including discrete surface wastes resulting from uranium solution extraction processes.”

Uranium is extracted from ore at uranium mills and at in-situ leach facilities (the NRC-licensed heap leach and ion-exchange facilities no longer operate). In both processes, an extraction process concentrates the

uranium into “yellow cake” and the process waste is byproduct material. The yellow cake is sent to a conversion facility for processing in the next step in the manufacture of nuclear fuel. The uranium milling and disposal of byproduct material by NRC licensees is regulated under 10 CFR Part 40, Appendix A.

Conventional mills crush the pieces of ore and extract 90 to 95 percent of the uranium from the ore. Mills are typically located in areas of low population density, and they process ores from mines within about 50 kilometers (30 miles) of the mill. Most mills in the United States are in decommissioning, one is in standby mode, and one is in operation.

In situ leach (ISL) facilities are another means of extracting uranium from underground. ISL recover uranium from low grade ores that may not be economically recoverable by other methods. In this process, a leaching agent such as oxygen with sodium carbonate is injected through wells into the ore body to dissolve the uranium. The leach solution is pumped from the formation, and ion exchange is used to separate the uranium from the solution. About 12 such ISL facilities exist in the United States. Of these, 4 are licensed by the NRC, and the rest are licensed by Texas, an Agreement State.

Table 14 - Locations of Uranium Milling Facilities

The following uranium milling facilities are licensed by the NRC.

Licensee	Site Name/Location
In Situ Leach Facilities	
Cogema Mining, Inc.	Irigaray/ChR, Wyoming
Power Resources, Inc.	Smith Ranch, Highlands, Ruth, and North Butte, Wyoming
Crow Butte Resources, Inc.	Crow Butte, Nebraska
Hydro Resources, Inc.	Crown Point, New Mexico
Conventional Uranium Milling Facilities	
International Uranium Corp.	White Mesa, Utah
Umetco Minerals Corp.	Gas Hills, Wyoming
Western Nuclear Inc.	Split Rock, Wyoming
Pathfinder Mines Corp.	Lucky Mc, Wyoming
American Nuclear Corp.	ANC, Wyoming
Pathfinder Mines Corp.	Shirley Basin, Wyoming
Petrotomics Co.	Shirley Basin, Wyoming
Rio Algom Mining Corp.	Lisbon, Utah
Exxon Mobil Corp.	Highlands, Wyoming
Bear Creek Uranium Co.	Bear Creek, Wyoming
Kennecott Uranium Corp.	Sweetwater, Wyoming
Plateau Resources Ltd.	Shootaring, Utah
Homestake Mining Co.	Homestake, New Mexico
Kennecott Energy Co.	L-Bar, New Mexico
Rio Algom Mining LLC.	Ambrosia Lake, New Mexico
UNC Mining & Milling	Churchrock, New Mexico

Figure 37 - Locations of Uranium Milling Facilities

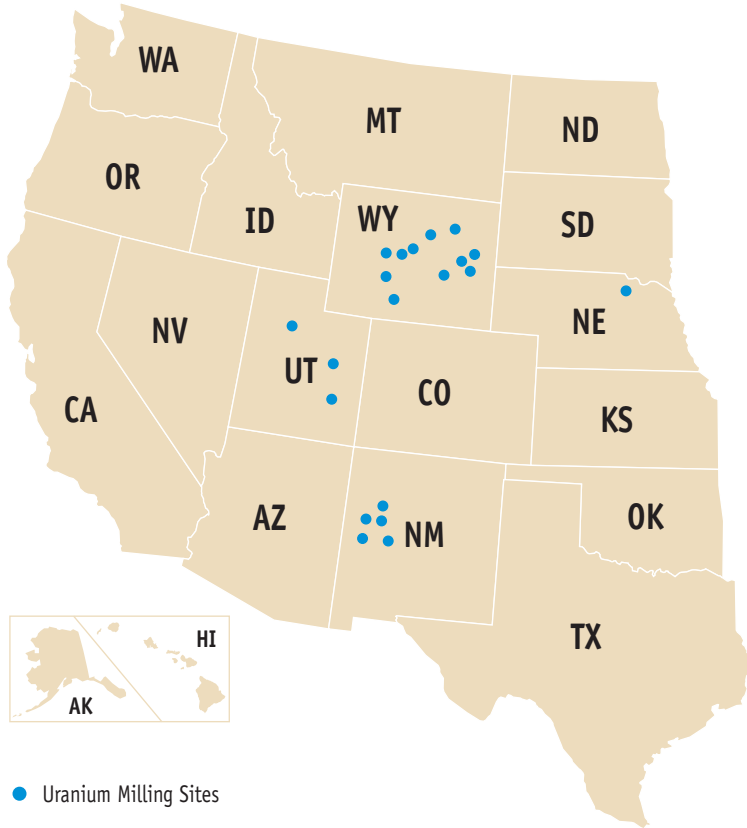

Note: Uranium mills are located in western states because the population density is lower.

Source: Nuclear Regulatory Commission



RADIOACTIVE WASTE

<http://www.nrc.gov/waste.html>

U.S. Low-Level Radioactive Waste Disposal

Commercial low-level waste disposal facilities must be licensed by either NRC or Agreement States in accordance with health and safety requirements. The facilities are to be designed, constructed, and operated to meet safety standards. The operator of the facility must also extensively characterize the site on which the facility is located and analyze how the facility will perform for thousands of years into the future. NRC's requirements place restrictions on the types of waste that can be disposed of. Current low-level waste disposal uses shallow land disposal sites with or without concrete vaults (see Figure 38).

- The NRC has developed a classification system for low-level waste based on its potential hazards and has specified disposal and waste form requirements for each of the three general classes of waste — A, B, and C. Class A waste contains lower concentrations of radioactive material than Class C waste. Class A waste accounts for approximately 90 percent of the total volume of low-level waste. Determination of the classification of waste, however, is a complex process. For more information, see 10 CFR Part 61.

The volume and radioactivity of waste vary from year to year based on the types and quantities of waste shipped

each year. Waste volumes currently are several 100,000 cubic feet from facilities operating in reactor decommissioning. Clean up of contaminated sites accounts for several million cubic feet of low level radioactive waste each year.

The Low-Level Radioactive Waste Policy Amendments Act (LLRWPA) of 1985 authorized the following:

- Formation of ten regional compacts (see Figure 39)
- Exclusion of waste generated outside a compact

Active Licensed Disposal Facilities

- Barnwell, South Carolina (access authorized for all low-level waste generators until 2008. Access limited to Atlantic compact after 2008)
- Hanford, Washington (restricted access to only the Northwest and Rocky Mountain compacts)
- Clive, Utah (restricted to mostly Class A waste)

Closed Disposal Facilities

- Beatty, Nevada—closed 1993
- Sheffield, Illinois—closed 1978
- Maxey Flats, Kentucky—closed 1977
- West Valley, New York—closed 1975

Figure 38 - Low-Level Waste Disposal Site

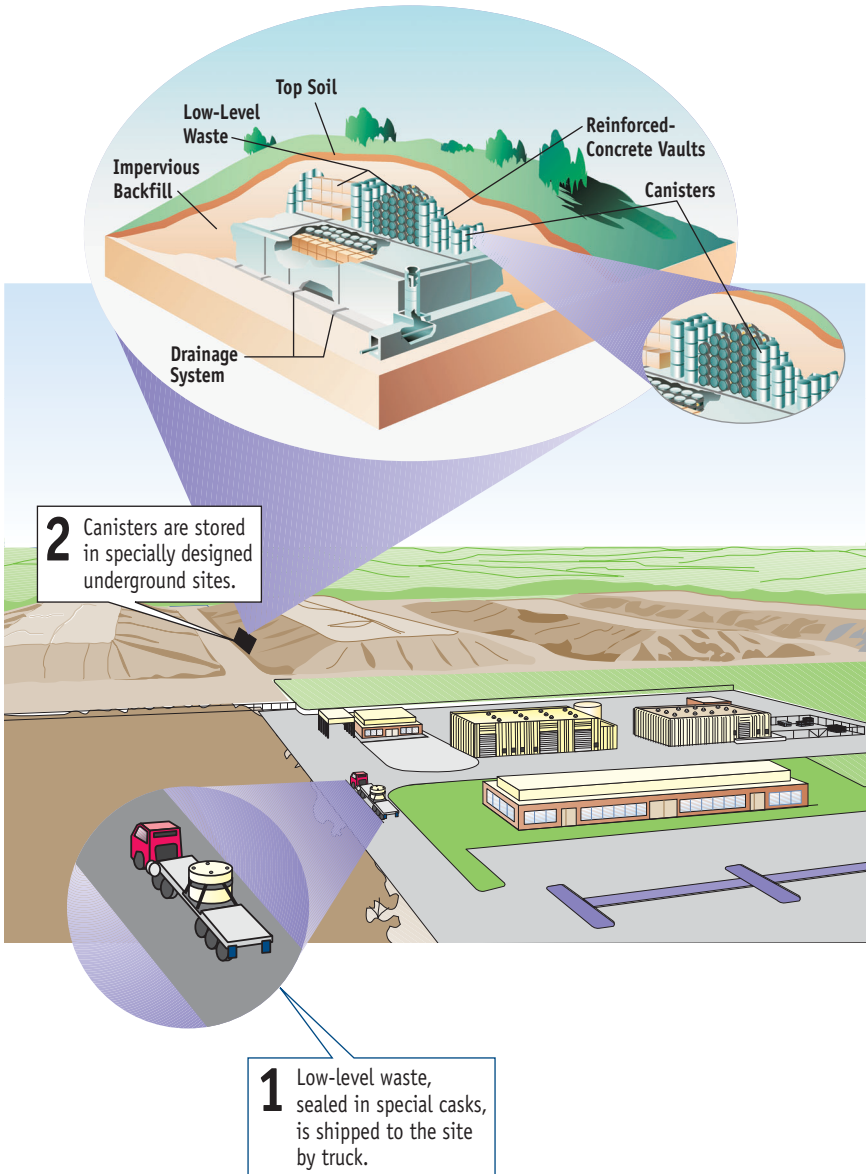
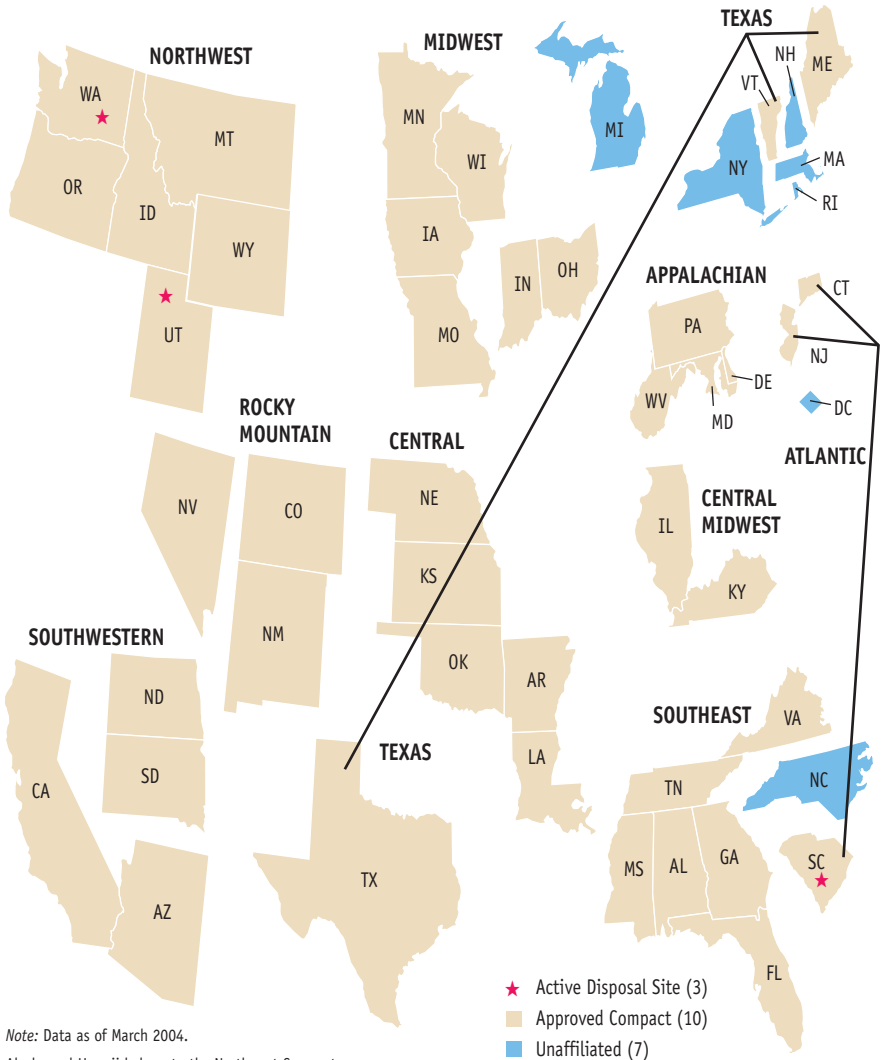

Figure 39 - U.S. Low-Level Waste Compacts



Note: Data as of March 2004.

Alaska and Hawaii belong to the Northwest Compact. Puerto Rico is unaffiliated.

There are three active, licensed low-level waste disposal facilities located in Agreement States.

Barnwell, located in Barnwell, South Carolina - Currently, Barnwell accepts waste from all U.S. generators except those in Rocky Mountain and Northwest compacts. Beginning in 2008, Barnwell will only accept waste from the Atlantic Compact states (Connecticut, New Jersey, and South Carolina). Barnwell is licensed by the State of South Carolina to receive waste in Classes A-C.

Hanford, located in Hanford, Washington - Hanford accepts waste from the Northwest and Rocky Mountain compacts. Hanford is licensed by the State of Washington to receive waste in Classes A-C.

Envirocare, located in Clive, Utah - Envirocare accepts waste from all regions of the United States. Envirocare is licensed by the State of Utah for Class A waste only.

Source: Nuclear Regulatory Commission

U.S. High-Level Radioactive Waste Disposal

The Yucca Mountain Decision

United States policies governing the permanent disposal of high-level radioactive waste are defined by the Nuclear Waste Policy Act of 1982, as amended, and the Energy Policy Act of 1992. These acts specify that high-level radioactive waste will be disposed underground, in a deep geologic repository, and that Yucca Mountain, Nevada, will be the single candidate site for characterization as a potential geologic repository.

Under these acts, the NRC is one of three Federal agencies with a role in the disposal of spent nuclear fuel and other high-level radioactive waste. Briefly these roles are:

- The Department of Energy (DOE) has the responsibility for developing permanent disposal capacity for spent fuel and other high-level radioactive waste.
- The Environmental Protection Agency (EPA) has responsibility for issuing environmental standards for evaluating the safety of a geologic repository at Yucca Mountain.
- The NRC has responsibility for issuing regulations that implement the EPA's standards, for deciding whether to license the proposed repository, and for ensuring that DOE, if granted a license, safely

builds, and later, safely operates the proposed repository.

For many years, the NRC has engaged the DOE in pre-license application activities, consistent with a public, preclicensing agreement. Through public dialogue with the DOE, the NRC has sought to increase its confidence that a license application from the DOE will be complete and of sufficient quality for the NRC to conduct an informed safety review.

On February 15, 2002, after receiving a recommendation from the Secretary of Energy, the President notified the Congress that he considered Yucca Mountain qualified for a construction permit application. Congress approved the recommendation, and on July 23, 2002, the President signed a joint resolution of the Congress directing the DOE to prepare an application to build a repository at Yucca Mountain. The DOE has stated its intent to submit a license application to the NRC in December, 2004. The NRC will issue a license to the DOE only if the DOE can demonstrate that it can construct and operate a repository safely and in compliance with the NRC's regulations.

The NRC's regulations provide that decisions about the licensing of a geologic repository will occur in three phases. In the first phase, the DOE

must apply to the NRC for authorization to build a geologic repository. Once the DOE submits an application, and if the NRC accepts it for review, the law allows the NRC three years to make a decision. Within that time, the NRC must complete its safety review, conduct a public hearing before an independent licensing board, and decide whether to allow construction of the proposed repository.

Should the NRC authorize construction, the process enters a second phase. As construction of the repository nears completion, the DOE must apply for a license to receive high-level radioactive waste. Again, the NRC must complete a safety review, conduct a public hearing before an independent licensing board, and decide whether DOE can safely receive and dispose of waste at the repository. If the NRC grants the license, the DOE will begin placing high-level radioactive waste into the repository. In the third phase, when the repository is full, the DOE will apply for a license amendment to decommission and permanently close the repository.

Spent Fuel Storage

The U.S. Energy Information Administration's last survey found that approximately 37,650 metric tons of spent nuclear fuel was stored at commercial nuclear power reactors. Projected spent fuel discharges could bring this amount to about 52,000 by the year 2005.

- All of the operating nuclear power reactors are storing spent fuel in NRC licensed on-site spent fuel pools (SFPs). (See Figure 41)
- Most reactors were not designed to store the full amount of spent fuel generated during its operational life. Utilities originally planned for spent fuel to remain in SFPs for a few years after discharge and then to be sent to a reprocessing facility. However, the U. S. Government declared a moratorium on reprocessing in 1977. Although the ban was later lifted, reprocessing was eliminated as a feasible option. Consequently, utilities expanded the storage capacity of its SFPs by using high-density storage racks.
- NRC authorizes storage of spent fuel at an independent spent fuel storage installation (ISFSI) under two licensing options: site-specific licensing and general licensing. Currently, there are 30 operating ISFSIs in the U. S. (See Figure 42)
- Under a site specific license, an applicant submits a license application to NRC and NRC performs a technical review of all the safety aspects of the proposed ISFSI. If the application is approved, the NRC issues a license. A spent fuel storage license contains technical requirements and operating conditions for the ISFSI and specifies what the licensee is authorized to store at the site. The license

continued on page 89

Figure 40 - The Yucca Mountain Disposal Plan

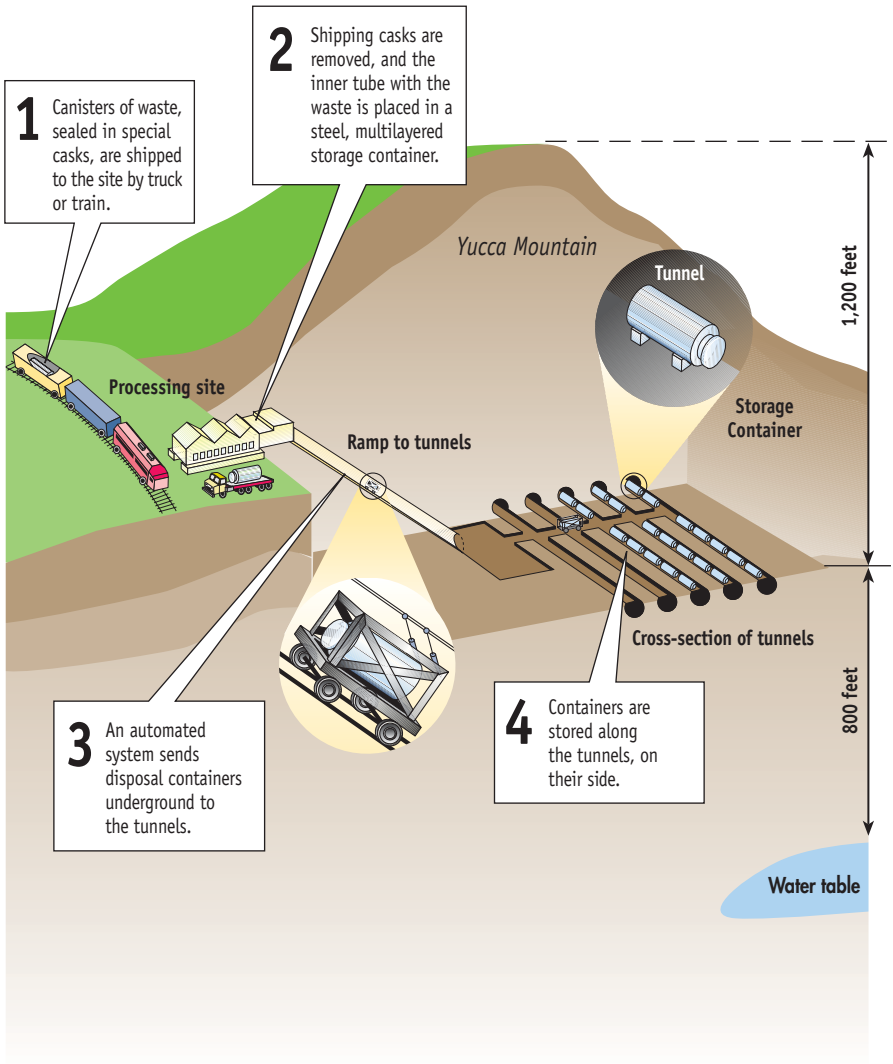

Source: Department of Energy and the Nuclear Energy Institute

Figure 41 - Spent Fuel Generation and Storage After Use

1 Nuclear reactors are powered by enriched uranium-235 fuel. Fission generates heat, which produces steam that turns turbines to produce electricity. A reactor rated at several hundred megawatts may contain 100 or more tons of fuel in the form of bullet-sized pellets loaded into long rods.

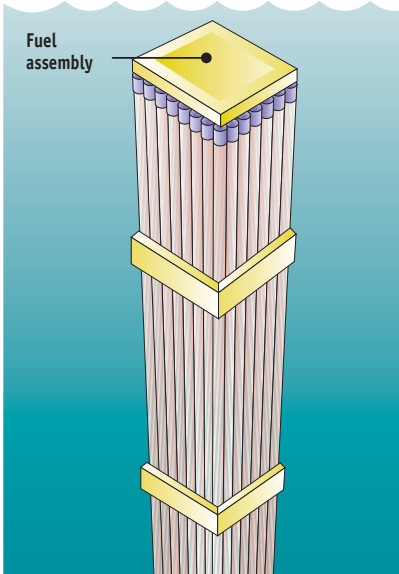
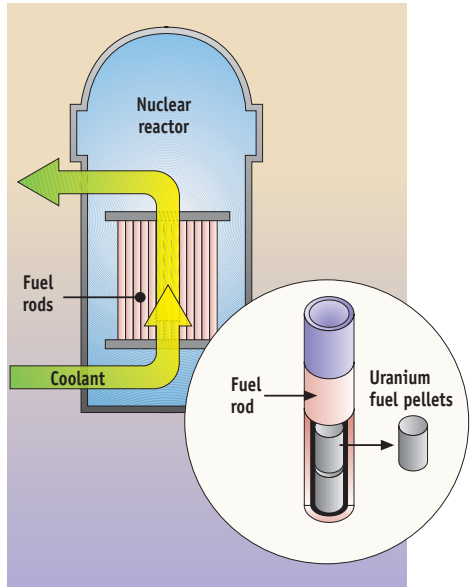

2 After about six years, spent fuel assemblies—typically 14 feet long and containing nearly 200 fuel rods—are removed from the reactor and allowed to cool in storage pools for a few years. At this point, the 900-pound assemblies contain only about one-fifth the original amount of U-235.

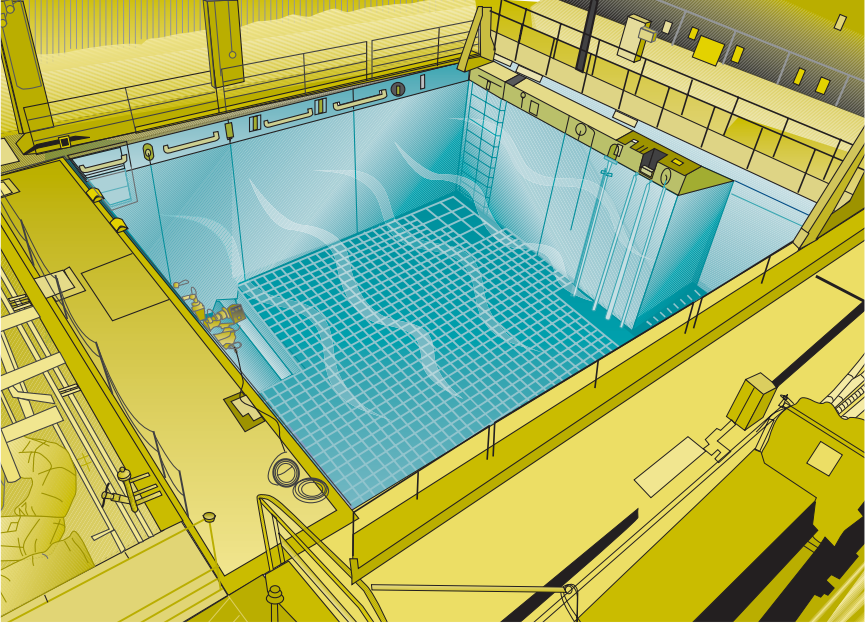

3 Commercial light-water nuclear reactors store spent fuel outside the primary containment in a steel-lined, seismically designed concrete pool. The spent fuel is cooled while in the spent fuel storage pool by water that is force-circulated using electrically powered pumps. Makeup water to the pool is provided by other pumps that can be powered from an onsite emergency diesel generator. Support features, such as water and radiation level detectors, are also provided. Spent fuel is stored in the spent fuel storage pool until it can be transferred on site to a dry cask storage location (see Figure 43) or transported off site to a high-level radioactive waste disposal site.

Source: Department of Energy and the Nuclear Energy Institute

Figure 42 - Licensed/Operating Independent Spent Fuel Storage Installations

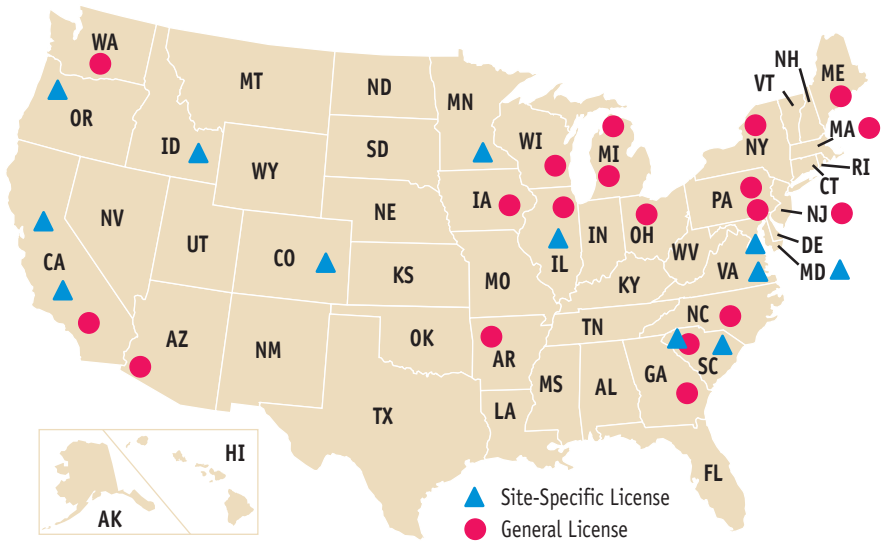

ARIZONA

- Palo Verde

ARKANSAS

- Arkansas Nuclear

CALIFORNIA

- ▲ Diablo Canyon
- ▲ Rancho Seco
- San Onofre

COLORADO

- ▲ Fort St. Vrain

GEORGIA

- Hatch

IDAHO

- ▲ DOE: TMI-2 Fuel Debris

ILLINOIS

- ▲ GE Morris
- Dresden

IOWA

- Duane Arnold

MAINE

- Maine Yankee

MARYLAND

- ▲ Calvert Cliffs

MASSACHUSETTS

- Yankee Rowe

MICHIGAN

- Big Rock Point
- Palisades

MINNESOTA

- ▲ Prairie Island

NEW JERSEY

- Oyster Creek

NEW YORK

- James A. FitzPatrick

NORTH CAROLINA

- McGuire

OHIO

- Davis-Besse

OREGON

- ▲ Trojan

PENNSYLVANIA

- Susquehanna
- Peach Bottom

SOUTH CAROLINA

- ▲ Oconee
- ▲ H.B. Robinson

VIRGINIA

- ▲ Surry
- ▲ North Anna

WASHINGTON

- Columbia Generating Station

WISCONSIN

- Point Beach

Data as of March 2004
Source: Nuclear Regulatory Commission

continued from page 84

expires 20 years from the date of issuance with a renewal option.

- A general license, authorizes the nuclear power reactor licensee to store spent fuel in dry storage systems approved by the NRC at a site that is licensed to operate a nuclear power reactor. Fifteen dry storage designs have received Certificates of Compliance or NRC approvals (See Appendix H). A Certificate of Compliance expires 20 years from the date of issuance with a re-approval option. General licensees are required to perform evaluations on its site to demonstrate that the site is adequate for storing spent fuel in dry casks. These evaluations must show that the certificate of compliance conditions and technical specifications can be met prior to use of the dry storage system.
- With respect to public involvement, stakeholders can and do participate in the NRC licensing process. The Atomic Energy Act of 1954, as amended, and NRC regulations

contain provisions for public hearings and other means, such as petitions and rulemaking requests for the public to challenge NRC decisions and licensing actions.

- Refer to NUREG-1571, "Information Handbook on Independent Spent Fuel Storage Installations" (December 1996) for a general overview.
- Refer to Appendix I for a list of NRC approved Dry Spent Fuel Storage Licensees.
- The NRC is responsible for approving transportable dry storage systems, also called dual purpose casks (See Figure 43).
- Additional information on storage of spent fuel at an independent spent fuel storage installation is available on the NRC's Web Site at <http://www.nrc.gov/waste/spent-fuel-storage.html>.

Additional information on transportation of spent fuel is available on the NRC's Web Site at <http://www.nrc.gov/waste/spent-fuel-transp.html>.

Figure 43 - Dry Storage of Spent Fuel

At some nuclear reactors across the country, spent fuel is kept on site, above ground, in systems basically similar to the ones shown here.

- 1 Once the spent fuel has cooled, it is loaded into special canisters which are designed to hold Pressurized-Water Reactor and Boiling-Water Reactor assemblies. Water and air are removed. The canister is filled with inert gas, welded shut, and rigorously tested for leaks. It may then be placed in a "cask" for storage or transportation.

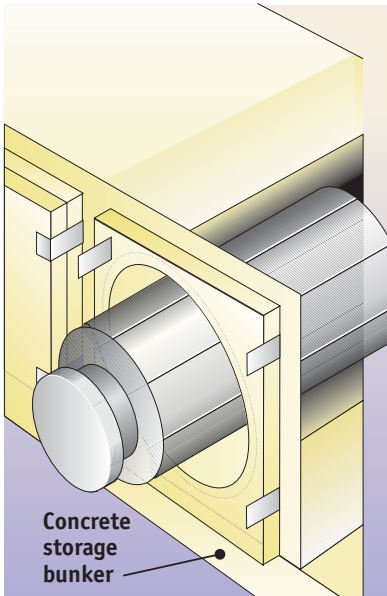
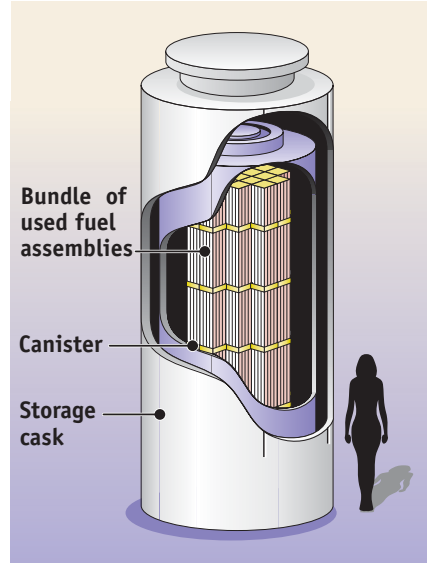

- 2 The canisters can also be stored in above-ground concrete bunkers, each of which is about the size of a one-car garage. Eventually they may be transported elsewhere for storage.

U.S. Nuclear Materials Transportation and Safeguards

The NRC reviews and licenses the design of containers used to transport radioactive materials; conducts transport-related safety inspections; performs quality assurance inspections of designers, fabricators, and suppliers of approved transportation containers; and carries out safeguards inspections of nuclear materials licensees.

Under a memorandum of understanding, the NRC requires licensed materials to be shipped in accordance with the hazardous materials transportation safety regulations of the Department of Transportation.

Both the NRC and the Department of Energy continue joint operation of a national database and information support system to track movement of domestic and foreign nuclear materials under safeguards control.

Principal Licensing and Inspection Activities

- NRC examines transport-related safety during approximately 1,000 safety inspections of fuel, reactor, and materials licensees annually.
- NRC reviews, evaluates, and certifies approximately 100 new, renewal, or amended container-design applications for the transport of nuclear materials annually.
- NRC reviews and evaluates approximately 100 license applications for the export of nuclear materials from the United States annually.
- NRC conducts comprehensive physical protection and materials control and accounting license reviews and conducts inspections at the major fuel fabrication facilities annually.
- NRC inspects about 20 dry storage and transport package licensees annually.
- Additional information on materials transportation is available on the NRC's Web Site at <http://www.nrc.gov/materials/transportation.html>.

Decommissioning

Decommissioning is the safe removal of a facility from service and reduction of residual radioactivity to a level that permits release of the property and termination of the license (see Glossary). The NRC rules on decommissioning provide for unrestricted and, under certain conditions, restricted release of a site. The rules establish site release criteria.

Over the last 40 years, operations at other licensed nuclear facilities have caused radiological contamination at a number of sites. This contamination must be reduced or stabilized in a timely and efficient manner to ensure protection of the public and the environment before the sites can be released and the license terminated. See Table 15 for current complex decommissioning sites.

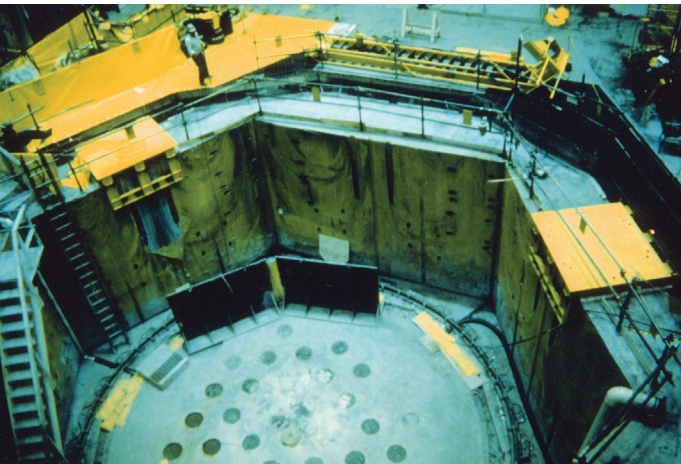

Decommissioning of the Ft. St. Vrain reactor in Colorado.

Table 15 - Complex Decommissioning Sites

Company	Location
AAR Manufacturing, Inc. (Brooks & Perkins)	Livonia, MI
Army, Department of, Jefferson Proving Ground	Jefferson, IN
Babcock & Wilcox	Parks Township, PA
Babcock & Wilcox SLDA	Vandergrift, PA
Cabot Corporation	Reading, PA
Dow Chemical Company	Bay City and Midland, MI
Fansteel, Inc.	Muskogee, OK
Hartley and Hartley (Kawkawlin) Landfill	Bay County, MI
Heritage Minerals	Lakehurst, NJ
Kaiser Aluminum	Tulsa, OK
Kerr-McGee	Cimarron, OK
Kerr-McGee	Cushing, OK
Michigan Department of Natural Resources	Lansing, MI
Molycorp, Inc.	Washington, PA
Molycorp, Inc.	York, PA
Permagrain Products	Media, PA
Safety Light Corporation	Bloomsburg, PA
Sequoyah Fuels Corporation	Gore, OK
Shieldalloy Metallurgical Corporation	Newfield, NJ
Westinghouse Electric Corporation	Waltz Mill, PA
Whittaker Corporation	Greenville, PA
KVWPCA	Vandergrift, PA
UCAR (Union Carbide)	Lawrenceberg, TN
MallincKrodt	St. Louis, MO
Combustion Engineering/Westinghouse	Windsor, CT
Combustion Engineering/Westinghouse	Festus, MO

Source: Nuclear Regulatory Commission



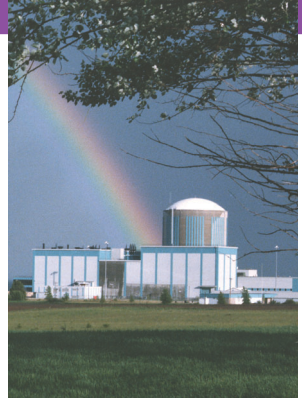

APPENDICES

Abbreviations Used In Appendices

ABB-CE	Asea Brown Boveri-Combustion Engineering	EBSO	Ebasco
ACE	ACEOWEN, Ateliers de Constructions Electriques de Charleroi S.A. (ACEC) and Cocerill Ougree-Providence (COP); with Westinghouse (Belgium)	EXP. DATE	Expiration Date of Operating License
ACLF	ACECO/Creusot-loire/Framatome/Westinghouse-Europe	FENOC	FirstEnergy Nuclear Operating Co.
AE	Architect-Engineer	FRAM	Framatome
AEC	Atomic Energy Commission	FLUR	Fluor Pioneer
AECL	Atomic Energy of Canada, Ltd.	G&H	Gibbs & Hill
AEE	Atomenergoexport	GCR	Gas-Cooled Reactor
AEP	American Electric Power	GE	General Electric
AGN	Aerogjet-General Nucleonics	GHDR	Gibbs & Hill & Durham & Richardson
ASEA	Asea Brown Boveri-Asea Atom	GIL	Gilbert Associates
B&R	Burns & Roe	GPC	Georgia Power Company
B&W	Babcock & Wilcox	HIT	Hitachi
BALD	Baldwin Associates	HTG	High-Temperature Gas-Cooled
BECH	Bechtel	HWR	Pressurized Heavy-Water Reactor
BRRT	Brown & Root	IES	Iowa Electric
BWR	Boiling-Water Reactor	ISFSI	Spent Fuel Storage Installation
COMB	Combustion Engineering	JONES	J. A. Jones
COMM. OP.	Date of Commercial Operation	KAIS	Kaiser Engineers
CON TYPE	Containment Type	KWU	Kraftwerk Union, Siemens AG
DRYAMB	Dry, Ambient Pressure	LIC. TYPE:	License Type
DRYSUB	Dry, Subatmospheric	CP	Construction Permit
HTG	High-Temperature Gas-Cooled	OL-FP	Operating License-Full Power
ICECND	Wet, Ice Condenser	OL-LP	Operating License-Low Power
LMFB	Liquid Metal Fast Breeder	MAE	Ministry of Atomic Energy, Russian Federation
MARK 1	Wet, Mark I	MDC	Maximum Dependable Capacity - Net
MARK 2	Wet, Mark II	MHI	Mitsubishi Heavy Industries, Ltd.
MARK 3	Wet, Mark III	MWe	Megawatts Electrical
OCM	Organic Cooled & Moderated	MWt	Megawatts Thermal
PTHW	Pressure Tube, Heavy Water	NIAG	Niagara Mohawk Power Corporation
SCF	Sodium Cooled, Fast	NPF	Nuclear Power Facility
SCGM	Sodium Cooled, Graphite Moderated	NSP	Northern States Power Company
CP	Construction Permit	NSSS	Nuclear Steam System Supplier & Design Type
CP ISSUED	Date of Construction Permit Issuance	1	GE Type 1
CPPR	Construction Permit Power Reactor	2	GE Type 2
CWE	Commonwealth Edison Company	3	GE Type 3
CX	Critical Assembly	4	GE Type 4
DANI	Daniel International	5	GE Type 5
DBDB	Duke & Bechtel	6	GE Type 6
DER	Design Electric Rating	2LP	Westinghouse Two-Loop
DOE	Department of Energy	3LP	Westinghouse Three-Loop
DPR	Demonstration Power Reactor	4LP	Westinghouse Four-Loop
DUKE	Duke Power Company	CE	Combustion Engineering
		CE80	CE Standard Design
		LLP	B&W Lowered Loop
		RLP	B&W Raised Loop

(continued)

OL	Operating License	S&W	Stone & Webster
OL ISSUED	Date of Latest Full Power Operating License	SBEC	Southern Services & Bechtel
PECO	Philadelphia Energy Company	SSI	Southern Services Incorporated
PG&E	Pacific Gas & Electric Company	STP	South Texas Project
PHWR	Pressurized Heavy-Water- Moderated Reactor	TXU	Texas Utilities
PSE	Pioneer Services & Engineering	TNPG	The Nuclear Power Group
PTHW	Pressure Tube Heavy Water	TOSH	Toshiba
PUBS	Public Service Electric & Gas Company	TR	Test Reactor
PWR	Pressurized-Water Reactor	TVA	Tennessee Valley Authority
R	Research	UE&C	United Engineers & Constructors
SCGM	Sodium Cooled Graphite Moderated	USEC	U.S. Enrichment Corporation
S&L	Sargent & Lundy	UTR	Universal Training Reactor
		VT	Vermont
		WDCO	Westinghouse Development Corporation
		WEST	Westinghouse Electric

U.S. Commercial Nuclear Power Reactors

Unit Operating Utility Location Docket Number	NRC Region	Con Type NSSS AE Constructor	Licensed MWt	Net MDC	CP Issued OL Issued Comm. Op Exp. Date	License Type & Number	1998-2003* Average Capacity Factors (Percent)
Arkansas Nuclear 1 Entergy Nuclear 6 MI WNW of Russellville, AR 050-00313	IV	PWR-DRYAMB	2568	0836	12/06/1968	OL-FP	82.6
		B&W LLP			05/21/1974	DPR-51	91.7
		BECH			12/19/1974		87.3
		BECH			05/20/2034		93.9
							89.7
			92.8				
Arkansas Nuclear 2 Entergy Nuclear 6 MI WNW of Russellville, AR 050-00368	IV	PWR-DRYAMB	3026	0858	12/06/1972	OL-FP	86.9
		COMB CE			09/01/1978	NPF-6	82.8
		BECH			03/26/1980		69.9
		BECH			07/17/2018		105.3
							106.5
			105.5				
Beaver Valley 1 FirstEnergy Nuclear Operating Company 17 MI W of McCandless, PA 050-00334	I	PWR-DRYSUB	2689	0821	06/26/1970	OL-FP	33.2
		WEST 3LP			07/02/1976	DPR-66	86.1
		S&W			10/01/1976		82.7
		S&W			01/29/2016		83.3
							97.2
			83.2				
Beaver Valley 2 FirstEnergy Nuclear Operating Company 17 MI W of McCandless, PA 050-00412	I	PWR-DRYSUB	2689	0831	05/03/1974	OL-FP	16.9
		WEST 3LP			08/14/1987	NPF-73	80.1
		S&W			11/17/1987		86.5
		S&W			05/27/2027		98.8
							90.7
			91.2				
Braidwood 1 Exelon 24 MI SSW of Joilet, IL 050-00456	III	PWR-DRYAMB	3586.6	1256	12/31/1975	OL-FP	78.6
		WEST 4LP			07/02/1987	NPF-72	101.0
		S&L			07/29/1988		96.4
		CWE			10/17/2026		93.4
							104.3
			99.3				
Braidwood 2 Exelon 24 MI SSW of Joilet, IL 050-00457	III	PWR-DRYAMB	3586.6	1232	12/31/1975	OL-FP	97.4
		WEST 4LP			05/20/1988	NPF-77	92.0
		S&L			10/17/1988		98.4
		CWE			12/18/2027		98.2
							93.5
			98.3				

(continued)

Appendix A - U.S. Commercial Nuclear Power Reactors (continued)

Unit Operating Utility Location Docket Number	NRC Region	Con Type NSSS AE Constructor	Licensed MWT	Net MDC	CP Issued OL Issued Comm. Op Exp. Date	License Type & Number	1998-2003*
							Average Capacity Factors (Percent)
Browns Ferry 1 Tennessee Valley Authority 10 MI NW of Decatur, AL 050-00259	II	BWR-MARK1 GE 4 TVA TVA	3293	1065	05/10/1967	OL-FP	0.0
					12/20/1973	DPR-33	0.0
					08/01/1974		0.0
					12/20/2013		0.0
							0.0
Browns Ferry 2 Tennessee Valley Authority 10 MI NW of Decatur, AL 050-00260	II	BWR-MARK1 GE 4 TVA TVA	3458	1120	05/10/1967	OL-FP	98.9
					08/02/1974	DPR-52	89.1
					03/01/1975		99.1
					06/28/2014		85.9
							91.0
Browns Ferry 3 Tennessee Valley Authority 10 MI NW of Decatur, AL 050-00296	II	BWR-MARK 1 GE 4 TVA TVA	3458	1120	07/31/1968	OL-FP	80.8
					08/18/1976	DPR-68	99.4
					03/01/1977		92.6
					07/02/2016		100.1
							94.6
Brunswick 1 Carolina Power and Light, Co. 2 MI N of Southport, NC 050-00325	II	BWR-MARK 1 GE 4 UE&C BRRT	2923	0895	02/07/1970	OL-FP	83.6
					11/12/1976	DPR-71	97.4
					03/18/1977		93.7
					09/08/2016		101.7
							93.2
Brunswick 2 Carolina Power and Light, Co. 2 MI N of Southport, NC 050-00324	II	BWR-MARK 1 GE 4 UE&C BRRT	2923	0895	02/07/1970	OL-FP	95.4
					12/27/1974	DPR-62	85.8
					11/03/1975		99.0
					12/27/2014		92.1
							99.6
Byron 1 Exelon 17 MI SW of Rockford, IL 050-00454	III	PWR-DRYAMB WEST 4LP S&L CWE	3586.6	1252	12/31/1975	OL-FP	77.6
					02/14/1985	NPF-37	92.0
					09/16/1985		95.7
					10/31/2024		102.0
							96.5
Byron 2 Exelon 17 MI SW of Rockford, IL 050-00455	III	PWR-DRYAMB WEST 4LP S&L CWE	3586.6	1225	12/31/1975	OL-FP	85.7
					01/30/1987	NPF-66	94.8
					08/21/1987		103.1
					11/06/2026		99.2
							96.3
		103.9					

Unit Operating Utility Location Docket Number	NRC Region	Con Type NSSS AE Constructor	Licensed MWt	Net MDC	CP Issued OL Issued Comm. Op Exp. Date	License Type & Number	1998-2003*
							Average Capacity Factors (Percent)
Callaway AmerenUE 10 MI SE of Fulton, MO 050-00483	III	PWR-DRYAMB	3565	1125	04/16/1976	OL-FP	84.8
		WEST 4LP			10/18/1984	NPF-30	87.2
		BECH			12/19/1984		101.1
		DANI			10/18/2024		85.1
							85.1
			98.4				
Calvert Cliffs 1 Constellation Nuclear 40 MI S of Annapolis, MD 050-00317	I	PWR-DRYAMB	2700	0825	07/07/1969	OL-FP	81.9
		COMB CE			07/31/1974	DPR-53	96.8
		BECH			05/08/1975		89.0
		BECH			07/31/2034		103.2
							64.3
			104.2				
Calvert Cliffs 2 Constellation Nuclear 40 MI S of Annapolis, MD 050-00318	I	PWR-DRYAMB	2700	0835	07/07/1969	OL-FP	97.7
		COMB CE			11/30/1976	DPR-69	86.6
		BECH			04/01/1977		100.8
		BECH			08/13/2036		84.8
							102.3
			84.2				
Catawba 1 Duke Energy Nuclear, LLC 6 MI NNW of Rock Hill, SC 050-00413	II	PWR-ICECND	3411	1129	08/07/1975	OL-FP	88.2
		WEST 4LP			01/17/1985	NPF-35	91.7
		DUKE			06/29/1985		90.0
		DUKE			12/05/2043		100.9
							95.9
			82.7				
Catawba 2 Duke Energy Nuclear, LLC 6 MI NNW of Rock Hill, SC 050-00414	II	PWR-ICECND	3411	1129	08/07/1975	OL-FP	85.2
		WEST 4LP			05/15/1986	NPF-52	89.5
		DUKE			08/19/1986		90.6
		DUKE			12/05/2043		86.7
							102.9
			94.2				
Clinton AmerGen Energy Co. 6 MI E of Clinton, IL 050-00461	III	BWR-MARK 3	3473	1022	02/24/1976	OL-FP	0.0
		GE 6			04/17/1987	NPF-62	57.7
		S&L			11/24/1987		84.3
		BALD			09/29/2026		96.7
							85.5
			97.2				
Columbia Generating Station Energy Northwest 12 MI NW of Richland, WA 050-00397	IV	BWR-MARK 2	3486	1190	03/19/1973	OL-FP	68.1
		GE 5			04/13/1984	NPF-21	62.8
		B&R			12/13/1984		88.5
		BECH			12/20/2023		85.1
							92.6
			78.5				

(continued)

Appendix A - U.S. Commercial Nuclear Power Reactors (continued)

Unit Operating Utility Location Docket Number	NRC Region	Con Type NSSS AE Constructor	Licensed MWT	Net MDC	CP Issued OL Issued Comm. Op Exp. Date	License Type & Number	1998-2003*
							Average Capacity Factors (Percent)
Comanche Peak 1 TXU Generation Company LP 4 MI N of Glen Rose, TX 050-00445	IV	PWR-DRYAMB WEST 4LP G&H BRRT	3458	1150	12/19/1974	OL-FP	86.2
					04/17/1990	NPF-87	85.4
					08/13/1990		95.2
					02/08/2030		83.8
							87.3
		95.6					
Comanche Peak 2 TXU Electric & Gas 4 MI N of Glen Rose, TX 050-00446	IV	PWR-DRYAMB WEST 4LP BECH BRRT	3458	1150	12/19/1974	OL-FP	95.3
					04/06/1993	NPF-89	86.9
					08/03/1993		87.8
					02/02/2033		98.1
							87.3
		80.6					
Cooper Nebraska Public Power District 23 MI S of Nebraska City, NE 050-00298	IV	BWR-MARK 1 GE 4 B&R B&R	2381	0764	06/04/1968	OL-FP	75.2
					01/18/1974	DPR-46	97.3
					07/01/1974		70.6
					01/18/2014		77.8
							94.4
		67.1					
Crystal River 3 Florida Power Corp. 7 MI NW of Crystal River, FL 050-00302	II	PWR-DRYAMB B&W LLP GIL JONES	2568	0860	09/25/1968	OL-FP	88.2
					01/28/1977	DPR-72	88.9
					03/13/1977		97.2
					12/03/2016		89.2
							99.9
		90.1					
Davis-Besse FirstEnergy Nuclear Operating Co. 21 MI ESE of Toledo, OH 050-00346	III	PWR-DRYAMB B&W RLP BECH	2772	0882	03/24/1971	OL-FP	78.1
					04/22/1977	NPF-3	96.4
					07/31/1978		87.4
					04/22/2017		99.5
							12.0
		0.0					
D.C. Cook 1 Indiana/Michigan Power Co. 11 MI S of Benton Harbor, MI 050-00315	III	PWR-ICECND WEST 4LP AEP AEP	3304	1056	03/25/1969	OL-FP	0.0
					10/25/1974	DPR-58	0.0
					08/28/1975		1.5
					10/25/2014		89.0
							88.4
		75.0					
D.C. Cook 2 Indiana/Michigan Power Co. 11 MI S of Benton Harbor, MI 050-00316	III	PWR-ICECND WEST 4LP AEP AEP	3468	1080	03/25/1969	OL-FP	0.0
					12/23/1977	DPR-74	0.0
					07/01/1978		51.4
					12/23/2017		85.8
							82.8
		76.6					

Unit Operating Utility Location Docket Number	NRC Region	Con Type NSSS AE Constructor	Licensed MWT	Net MDC	CP Issued OL Issued Comm. Op Exp. Date	License Type & Number	1998-2003*
							Average Capacity Factors (Percent)
Diablo Canyon 1 Pacific Gas & Electric Co. 12 MI WSW of San Luis Obispo, CA 050-00275	IV	PWR-DRYAMB WEST 4LP PG&E PG&E	3338	1087	04/23/1968	OL-FP	98.0
					11/02/1984	DPR-80	87.5
					05/07/1985		83.3
					09/22/2021		99.8
							74.0
		100.7					
Diablo Canyon 2 Pacific Gas & Electric Co. 12 MI WSW of San Luis Obispo, CA 050-00323	IV	PWR-DRYAMB WEST 4LP PG&E PG&E	3411	1087	12/09/1970	OL-FP	84.5
					08/26/1985	DPR-82	88.7
					03/13/1986		96.2
					04/26/2025		90.9
							97.5
		81.1					
Dresden 2 Exelon 9 MI E of Morris, IL 050-00237	III	BWR-MARK 1 GE 3 S&L UE&C	2957	0912	01/10/1966	OL-FP	79.1
					02/20/1991	DPR-19	92.1
					06/09/1970		101.3
					12/22/2009		89.8
							101.1
		90.0					
Dresden 3 Exelon 9 MI E of Morris, IL 050-00249	III	BWR-MARK 1 GE 3 S&L UE&C	2527	0912	10/14/1966	OL-FP	88.2
					01/12/1971	DPR-25	90.6
					11/16/1971		93.7
					01/12/2011		95.5
							81.4
		93.5					
Duane Arnold Nuclear Management Company 8 MI NW of Cedar Rapids, IA 050-00331	III	BWR-MARK 1 GE 4 BECH BECH	1912	0565	06/22/1970	OL-FP	82.3
					02/22/1974	DPR-49	80.1
					02/01/1975		97.5
					02/21/2014		77.9
							92.5
		80.7					
Edwin I. Hatch 1 Southern Nuclear Operating Co. 11 MI N of Baxley, GA 050-00321	II	BWR-MARK 1 GE 4 BECH GPC	2804	0869	09/30/1969	OL-FP	96.5
					10/13/1974	DPR-57	81.1
					12/31/1975		84.5
					08/06/2034		99.2
							88.4
		95.3					
Edwin I. Hatch 2 Southern Nuclear Operating Co. 11 MI N of Baxley, GA 050-00366	II	BWR-MARK 1 GE 4 BECH GPC	2804	0883	12/27/1972	OL-FP	80.6
					06/13/1978	NPF-5	94.4
					09/05/1979		89.5
					06/13/2038		85.6
							97.4
		90.0					

(continued)

Appendix A - U.S. Commercial Nuclear Power Reactors (continued)

Unit Operating Utility Location Docket Number	NRC Region	Con Type		Licensed MWt	Net MDC	CP Issued	License Type & Number	1998-2003* Average Capacity Factors (Percent)
		NSSS AE Constructor				OL Issued Comm. Op Exp. Date		
Fermi 2 The Detroit Edison Co. 25 MI NE of Toledo, OH 050-00341	III	BWR-MARK 1		3430	1150	09/26/1972	OL-FP	67.8
		GE 4				07/15/1985	NPF-43	100.3
		S&L				01/23/1988		86.2
		DANI				03/20/2025		89.8
								97.5
							85.2	
Fort Calhoun Omaha Public Power District 19 MI N of Omaha, NE 050-00285	IV	PWR-DRYAMB		1500	0478	06/07/1968	OL-FP	77.8
		COMB CE				08/09/1973	DPR-40	85.6
		GHDR				09/26/1973		92.8
		GHDR				08/09/2033		84.2
								91.0
							83.8	
Ginna Rochester Gas & Electric Corp. 20 MI NE of Rochester, NY 050-00244	I	PWR-DRYAMB		1520	0470	04/25/1966	OL-FP	104.1
		WEST 2LP				09/19/1969	DPR-18	84.0
		GIL				07/01/1970		90.5
		BECH				09/18/2009		101.9
								91.4
							92.0	
Grand Gulf 1 Entergy Nuclear 25 MI S of Vicksburg, MS 050-00416	II	BWR-MARK 3		3833	1207	09/04/1974	OL-FP	82.0
		GE 6				11/01/1984	NPF-29	79.9
		BECH				07/01/1985		100.6
		BECH				11/01/2024		93.6
								95.1
							103.1	
H.B. Robinson 2 Carolina Power and Light Co. 26 MI from Florence, SC 050-00261	II	PWR-DRYA MB		2339	0695	04/13/1967	OL-FP	87.9
		WEST 3LP				09/23/1970	DPR-23	95.0
		EBSO				03/07/1971		104.0
		EBSO				07/31/2010		92.2
								93.7
							103.5	
Hope Creek 1 PSEG Nuclear, LLC 18 MI SE of Wilmington, DE 050-00354	I	BWR-MARK1		3339	1049	11/04/1974	OL-FP	92.3
		GE 4				07/25/1986	NPF-57	85.3
		BECH				12/20/1986		80.3
		BECH				04/11/2026		87.8
								96.2
							79.0	
Indian Point 2 Entergy Nuclear 24 MI N of New York City, NY 050-00247	I	PWR-DRYAMB		3114.4	0956	10/14/1966	OL-FP	23.0
		WEST 4LP				09/28/1973	DPR-26	88.5
		UE&C				08/01/1974		12.1
		WDCO				09/28/2013		93.5
								90.7
							100.0	

Unit Operating Utility Location Docket Number	NRC Region	Con Type NSSS AE Constructor	Licensed MWT	Net MDC	CP Issued OL Issued Comm. Op Exp. Date	License Type & Number	1998-2003* Average Capacity Factors (Percent)
Indian Point 3 Entergy Nuclear Operations 24 MI N of New York City, NY 050-00286	I	PWR-DRYAMB	3067.4	0979	08/13/1969	OL-FP	89.8
		WEST 4LP			04/05/1976	DPR-64	86.0
		UE&C			08/30/1976		99.5
		WDCO			12/15/2015		93.9
							98.3
			88.7				
James A. FitzPatrick Entergy Nuclear Operations 8 MI NE of Oswego, NY 050-00333	I	BWR-MARK 1	2536	0813	05/20/1970	OL-FP	73.2
		GE 4			10/17/1974	DPR-59	93.5
		S&W			07/28/1975		84.4
		S&W			10/17/2014		99.6
							92.6
			97.8				
Joseph M. Farley 1 Southern Nuclear Operating Co. 18 MI SE of Dothan, AL 050-00348	II	PWR-DRYAMB	2775	0854	08/16/1972	OL-FP	78.9
		WEST 3LP			06/25/1977	NPF-2	97.4
		SSI			12/01/1977		71.5
		DANI			06/25/2017		87.6
							99.0
			90.9				
Joseph M. Farley 2 Southern Nuclear Operating Co. 18 MI SE of Dothan, AL 050-00364	II	PWR-DRYAMB	2775	0855	08/16/1972	OL-FP	84.7
		WEST 3LP			03/31/1981	NPF-8	71.7
		SSI			07/30/1981		100.0
		BECH			03/31/2021		78.2
							87.6
			100.4				
Kewaunee Nuclear Management Co. 27 MI E of Green Bay, WI 050-00305	III	PWR-DRYAMB	1772	0591	08/06/1968	OL-FP	78.4
		WEST 2LP			12/21/1973	DPR-43	98.8
		PSE			06/16/1974		82.7
		PSE			12/21/2013		77.3
							99.8
			90.3				
La Salle County 1 Exelon 11 MI SE of Ottawa, IL 050-00373	III	BWR-MARK 2	3489	1162	09/10/1973	OL-FP	30.8
		GE 5			04/17/1982	NPF-11	88.3
		S&L			01/01/1984		99.6
		CWE			04/17/2022		101.2
							91.7
			100.1				
La Salle County 2 Exelon 11 MI SE of Ottawa, IL 050-00374	III	BWR-MARK 2	3489	1163	09/10/1973	OL-FP	0.0
		GE 5			02/16/1983	NPF-18	73.1
		S&L			10/19/1984		92.4
		CWE			12/16/2023		99.5
							92.4
			89.5				

(continued)

Appendix A - U.S. Commercial Nuclear Power Reactors (continued)

Unit Operating Utility Location Docket Number	NRC Region	Con Type NSSS AE Constructor	Licensed MWT	Net MDC	CP Issued OL Issued Comm. Op Exp. Date	License Type & Number	1998-2003* Average Capacity Factors (Percent)
Limerick 1 Exelon 21 MI NW of Philadelphia, PA 050-00352	I	BWR-MARK 2 GE 4 BECH BECH	3458	1134	06/19/1974 08/08/1985 02/01/1986 10/26/2024	OL-FP NPF-39	77.6 98.1 89.5 101.2 93.5 101.2
Limerick 2 Exelon 21 MI NW of Philadelphia, PA 050-00353	I	BWR-MARK 2 GE 4 BECH BECH	3458	1134	06/19/1974 08/25/1989 01/08/1990 06/22/2029	OL-FP NPF-85	93.5 85.0 99.0 92.3 100.8 94.5
McGuire 1 Duke Power 17 MI N of Charlotte, NC 050-00369	II	PWR-ICECND WEST 4LP DUKE DUKE	3411	1100	02/23/1973 07/08/1981 12/01/1981 06/12/2041	OL-FP NPF-9	80.9 89.1 103.4 90.1 94.4 102.9
McGuire 2 Duke Power 17 MI N of Charlotte, NC 050-00370	II	PWR-ICECND WEST 4LP DUKE DUKE	3411	1100	02/23/1973 05/27/1983 03/01/1984 03/03/2043	OL-FP NPF-17	92.1 89.2 87.5 102.5 92.5 93.7
Millstone 2 Dominion Generation 3.2 MI WSW of New London, CT 050-00336	I	PWR-DRYAMB COMB CE BECH BECH	2700	0866	12/11/1970 09/26/1975 12/26/1975 07/31/2035	OL-FP DPR-65	0.0 57.9 81.7 95.6 81.3 80.5
Millstone 3 Dominion Generation 3.2 MI WSW of New London, CT 050-00423	I	PWR-DRYSUB WEST 4LP S&W S&W	3411	1131	08/09/1974 01/31/1986 04/23/1986 11/25/2045	OL-FP NPF-49	34.0 82.7 99.9 82.1 88.3 101.0
Monticello Nuclear Management Co. 30 MI NW of Minneapolis, MN 050-00263	III	BWR-MARK 1 GE 3 BECH BECH	1775	0578	06/19/1967 01/09/1981 06/30/1971 09/08/2010	OL-FP DPR-22	82.4 91.8 83.6 76.5 99.0 90.7

Unit Operating Utility Location Docket Number	NRC Region	Con Type NSSS AE Constructor	Licensed MWT	Net MDC	CP Issued OL Issued Comm. Op Exp. Date	License Type & Number	1998-2003* Average Capacity Factors (Percent)
Nine Mile Point 1 Constellation Nuclear 6 MI NE of Oswego, NY 050-00220	I	BWR-MARK 1	1850	0565	04/12/1965	OL-FP	87.9
		GE 2			12/26/1974	DPR-63	72.0
		NIAG			12/01/1969		94.3
		S&W			08/22/2009		88.5
							99.1
			88.1				
Nine Mile Point 2 Constellation Nuclear 6 MI NE of Oswego, NY 050-00410	I	BWR-MARK 2	3467	1120	06/24/1974	OL-FP	71.4
		GE 5			07/02/1987	NPF-69	89.3
		S&W			03/11/1988		81.1
		S&W			10/31/2026		90.3
							85.8
			97.5				
North Anna 1 Dominion Generation 40 MI NW of Richmond, VA 050-00338	II	PWR-DRYSUB	2893	0925	02/19/1971	OL-FP	90.5
		WEST 3LP			04/01/1978	NPF-4	103.8
		S&W			06/06/1978		92.0
		S&W			04/01/2038		87.9
							100.8
			80.5				
North Anna 2 Dominion Generation 40 MI NW of Richmond, VA 050-00339	II	PWR-DRYSUB	2893	0917	02/19/1971	OL-FP	89.0
		WEST 3LP			08/21/1980	NPF-7	91.4
		S&W			12/14/1980		101.8
		S&W			08/21/2040		74.4
							68.6
			90.4				
Oconee 1 Duke Energy Nuclear, LLC 30 MI W of Greenville, SC 050-00269	II	PWR-DRYAMB	2568	0846	11/06/1967	OL-FP	77.1
		B&W LLP			02/06/1973	DPR-38	83.8
		DBDB			07/15/1973		84.9
		DUKE			02/06/2033		94.0
							89.2
			70.8				
Oconee 2 Duke Energy Nuclear, LLC 30 MI W of Greenville, SC 050-00270	II	PWR-DRYAMB	2568	0846	11/06/1967	OL-FP	72.1
		B&W LLP			10/06/1973	DPR-47	84.4
		DBDB			09/09/1974		100.9
		DUKE			10/06/2033		90.2
							89.2
			102.1				
Oconee 3 Duke Energy Nuclear, LLC 30 MI W of Greenville, SC 050-00287	II	PWR-DRYAMB	2568	0846	11/06/1967	OL-FP	79.8
		B&W LLP			07/19/1974	DPR-55	99.4
		DBDB			12/16/1974		88.5
		DUKE			07/19/2034		72.8
							100.7
			85.2				

(continued)

Appendix A - U.S. Commercial Nuclear Power Reactors (continued)

Unit Operating Utility Location Docket Number	NRC Region	Con Type		Licensed MWT	Net MDC	CP Issued	License Type & Number	1998-2003* Average Capacity Factors (Percent)
		NSSS AE Constructor				OL Issued Comm. Op Exp. Date		
Oyster Creek AmerGen Energy Co., LLC 9 MI S of Toms River, NJ 050-00219	I	BWR-MARK 1		1930	0619	12/15/1964	OL-FP	74.3
		GE 2				07/02/1991	DPR-16	99.4
		B&R				12/01/1969		71.9
		B&R				04/09/2009		96.4
								92.8
				96.9				
Palisades Nuclear Management Co. 5 MI S of South Haven, MI 050-00255	III	PWR-DRYAMB		2530	0730	03/14/1967	OL-FP	80.0
		COMB CE				02/21/1991	DPR-20	80.2
		BECH				12/31/1971		89.6
		BECH				03/24/2011		36.8
								99.6
				96.3				
Palo Verde 1 Arizona Nuclear Power Project 36 MI W of Phoenix, AZ 050-00528	IV	PWR-DRYAMB		3876	1243	05/25/1976	OL-FP	87.4
		COMB CE80				06/01/1985	NPF-41	88.7
		BECH				01/28/1986		100.4
		BECH				12/31/2024		87.8
								89.1
				97.2				
Palo Verde 2 Arizona Nuclear Power Project 36 MI W of Phoenix, AZ 050-00529	IV	PWR-DRYAMB		3990	1335	05/25/1976	OL-FP	101.8
		COMB CE80				04/24/1986	NPF-51	90.0
		BECH				09/19/1986		87.2
		BECH				12/09/2025		92.6
								92.0
				77.6				
Palo Verde 3 Arizona Nuclear Power Project 36 MI W of Phoenix, AZ 050-00530	IV	PWR-DRYAMB		3876	1247	05/25/1976	OL-FP	87.6
		COMB CE80				11/25/1987	NPF-74	100.3
		BECH				01/08/1988		90.3
		BECH				03/25/2027		83.9
								102.0
				87.5				
Peach Bottom 2 Exelon 17.9 MI S of Lancaster, PA 050-00277	I	BWR-MARK 1		3514	1116	01/31/1968	OL-FP	75.9
		GE 4				10/25/1973	DPR-44	98.8
		BECH				07/05/1974		88.8
		BECH				08/08/2033		97.9
								92.3
				95.1				
Peach Bottom 3 Exelon 17.9 MI S of Lancaster, PA 050-00278	I	BWR-MARK 1		3514	1116	01/31/1968	OL-FP	90.1
		GE 4				07/02/1974	DPR-56	89.4
		BECH				12/23/1974		99.5
		BECH				07/02/2034		89.0
								100.8
				91.8				

Unit Operating Utility Location Docket Number	NRC Region	Con Type		Licensed MWT	Net MDC	CP Issued	License Type & Number	1998-2003*
		NSSS AE Constructor				OL Issued Comm. Op Exp. Date		Average Capacity Factors (Percent)
Perry 1 FirstEnergy Nuclear Operating Co. 7 MI NE of Painesville, OH 050-00440	III	BWR-MARK 3		3758	1235	05/03/1977	OL-FP NPF-58	96.7
		GE 6				11/13/1986		89.8
		GIL				11/18/1987		93.9
		KAIS				03/18/2026		71.6
								92.2
								79.1
Pilgrim 1 Entergy 4 MI SE of Plymouth, MA 050-00293	I	BWR-MARK 1		2028	0663	08/26/1968	OL-FP DPR-35	73.4
		GE 3				09/15/1972		76.2
		BECH				12/01/1972		93.7
		BECH				06/08/2012		89.9
								100.9
								83.0
Point Beach 1 Nuclear Management Co. 13 MI NNW of Manitowoc, WI 050-00266	III	PWR-DRYAMB		1540	0516	07/19/1967	OL-FP DPR-24	54.9
		WEST 2LP				10/05/1970		78.4
		BECH				12/21/1970		92.3
		BECH				10/05/2010		82.9
								89.0
								96.1
Point Beach 2 Nuclear Management Co. 13 MI NNW of Manitowoc, WI 050-00301	III	PWR-DRYAMB		1540	0518	07/25/1968	OL-FP DPR-27	77.5
		WEST 2LP				03/08/1973		80.0
		BECH				10/01/1972		78.4
		BECH				03/08/2013		96.8
								89.3
								81.8
Prairie Island 1 Nuclear Management Co. 28 MI SE of Minneapolis, MN 050-00282	III	PWR-DRYAMB		1650	0593	06/25/1968	OL-FP DPR-42	89.7
		WEST 2LP				04/05/1974		89.0
		FLUR				12/16/1973		98.9
		NSP				08/09/2013		79.6
								95.6
								100.5
Prairie Island 2 Nuclear Management Co. 28 MI SE of Minneapolis, MN 050-00306	III	PWR-DRYAMB		1650	0593	06/25/1968	OL-FP DPR-60	78.6
		WEST 2LP				10/29/1974		100.5
		FLUR				12/21/1974		91.1
		NSP				10/29/2014		93.4
								93.9
								92.7
Quad Cities 1 Exelon 20 MI NE of Moline, IL 050-00254	III	BWR-MARK 1		2957	0855	02/15/1967	OL-FP DPR-29	42.1
		GE 3				12/14/1972		94.1
		S&L				02/18/1973		91.3
		UE&C				12/14/2012		99.6
								76.2
								90.9

(continued)

Appendix A - U.S. Commercial Nuclear Power Reactors (continued)

Unit Operating Utility Location Docket Number	NRC Region	Con Type NSSS AE Constructor	Licensed MWt	Net MDC	CP Issued OL Issued Comm. Op Exp. Date	License Type & Number	1998-2003*
							Average Capacity Factors (Percent)
Quad Cities 2 Exelon 20 MI NE of Moline, IL 050-00265	III	BWR-MARK 1 GE 3 S&L UE&C	2957	0855	02/15/1967 12/14/1972 03/10/1973 12/14/2012	OL-FP DPR-30	50.6
							97.9
							92.1
							93.1
							87.5
93.1							
River Bend 1 Entergy Nuclear 24 MI NNW of Baton Rouge, LA 050-00458	IV	BWR-MARK 3 GE 6 S&W S&W	3091	0966	03/25/1977 11/20/1985 06/16/1986 08/29/2025	OL-FP NPF-47	95.1
							69.6
							89.4
							95.3
							100.1
90.4							
Salem 1 PSEG Nuclear, LLC 18 MI S of Wilmington, DE 050-00272	I	PWR-DRYAMB WEST 4LP PUBS UE&C	3459	1096	09/25/1968 08/13/1976 06/30/1977 08/13/2016	OL-FP DPR-70	63.1
							82.7
							92.2
							80.3
							89.8
94.7							
Salem 2 PSEG Nuclear, LLC 18 MI S of Wilmington, DE 050-00311	I	PWR-DRYAMB WEST 4LP PUBS UE&C	3459	1092	09/25/1968 05/20/1981 10/13/1981 04/18/2020	OL-FP DPR-75	80.9
							82.0
							86.3
							99.5
							87.5
82.8							
San Onofre 2 Southern California Edison Co. 4 MI SE of San Clemente, CA 050-00361	IV	PWR-DRYAMB COMB CE BECH BECH	3438	1070	10/18/1973 09/07/1982 08/08/1983 02/16/2022	OL-FP NPF-10	89.1
							87.9
							90.7
							101.3
							90.8
103.6							
San Onofre 3 Southern California Edison Co. 4 MI SE of San Clemente, CA 050-00362	IV	PWR-DRYAMB COMB CE BECH BECH	3438	1080	10/18/1973 09/16/1983 04/01/1984 11/15/2022	OL-FP NPF-15	95.8
							88.9
							101.6
							60.0
							100.9
90.9							
Seabrook 1 FPL Energy Seabrook 13 MI S of Portsmouth, NH 050-00443	I	PWR-DRYAMB WEST 4LP UE&C UE&C	3489	1115	07/07/1976 03/15/1990 08/19/1990 10/17/2026	OL-FP NPF-86	82.7
							85.8
							78.1
							85.9
							91.8
91.7							

Unit Operating Utility Location Docket Number	NRC Region	Con Type		Licensed MWt	Net MDC	CP Issued OL Issued Comm. Op Exp. Date	License Type & Number	1998-2003* Average Capacity Factors (Percent)
		NSSS AE Constructor						
Sequoyah 1 Tennessee Valley Authority 9.5 MI NE of Chattanooga, TN 050-00327	II	PWR-ICECND		3411	1125	05/27/1970	OL-FP	87.8
		WEST 4LP				09/17/1980	DPR-77	101.6
		TVA				07/01/1981		78.3
		TVA				09/17/2020		91.8
								100.9
								74.5
Sequoyah 2 Tennessee Valley Authority 9.5 MI NE of Chattanooga, TN 050-00328	II	PWR-ICECND		3411	1126	05/27/1970	OL-FP	97.3
		WEST 4LP				09/15/1981	DPR-79	91.8
		TVA				06/01/1982		92.3
		TVA				09/15/2021		101.6
								86.6
								83.7
Shearon Harris 1 Carolina Power and Light Co. 20 MI SW of Raleigh, NC 050-00400	II	PWR-DRYAMB		2900	0900	01/27/1978	OL-FP	93.4
		WEST 3LP				01/12/1987	NPF-63	96.2
		EBSO				05/02/1987		91.0
		DANI				10/24/2026		71.3
								99.4
								91.8
South Texas Project 1 STP Nuclear Operating Co. 12 MI SSW of Bay City, TX 050-00498	IV	PWR-DRYAMB		3853	1250	12/22/1975	OL-FP	98.4
		WEST 4LP				03/22/1988	NPF-76	88.0
		BECH				08/25/1988		78.2
		EBSO				08/20/2027		94.4
								99.2
								62.6
South Texas Project 2 STP Nuclear Operating Co. 12 MI SSW of Bay City, TX 050-00499	IV	PWR-DRYAMB		3853	1250	12/22/1975	OL-FP	90.1
		WEST 4LP				03/28/1989	NPF-80	89.4
		BECH				06/19/1989		96.1
		EBSO				12/15/2028		87.1
								75.0
								81.4
St. Lucie 1 Florida Power & Light Co. 12 MI SE of Ft. Pierce, FL 050-00335	II	PWR-DRYAMB		2700	0839	07/01/1970	OL-FP	94.9
		COMB CE				03/01/1976	DPR-67	88.9
		EBSO				12/21/1976		102.0
		EBSO				03/01/2036		91.3
								94.1
								102.1
St. Lucie 2 Florida Power & Light Co. 12 MI SE of Ft. Pierce, FL 050-00389	II	PWR-DRYAMB		2700	0839	05/02/1977	OL-FP	90.8
		COMB CE				06/10/1983	NPF-16	98.1
		EBSO				08/08/1983		92.3
		EBSO				04/06/2043		91.3
								101.0
								80.1

(continued)

Appendix A - U.S. Commercial Nuclear Power Reactors (continued)

Unit Operating Utility Location Docket Number	NRC Region	Con Type NSSS AE Constructor	Licensed MWt	Net MDC	CP Issued OL Issued Comm. Op Exp. Date	License Type & Number	1998-2003* Average Capacity Factors (Percent)
Summer South Carolina Electric & Gas Co. 26 MI NW of Columbia, SC 050-00395	II	PWR-DRYAMB	2900	0966	03/21/1973	OL-FP NPF-12	101.8
		WEST 3LP			11/12/1982		88.2
		GIL			01/01/1984		74.9
		DANI			08/06/2022		79.9
							87.2
			86.9				
Surry 1 Dominion Generation 17 MI NW of Newport News, VA 050-00280	II	PWR-DRYSUB	2546	0810	06/25/1968	OL-FP DPR-32	78.4
		WEST 3LP			05/25/1972		104.4
		S&W			12/22/1972		93.1
		S&W			05/25/2032		83.7
							100.8
			76.4				
Surry 2 Dominion Generation 17 MI NW of Newport News, VA 050-00281	II	PWR-DRYSUB	2546	0815	06/25/1968	OL-FP DPR-37	100.0
		WEST 3LP			01/29/1973		83.7
		S&W			05/01/1973		92.9
		S&W			01/29/2033		94.1
							91.4
			78.6				
Susquehanna 1 PPL Susquehanna, LLC 7 MI NE of Berwick, PA 050-00387	I	BWR-MARK 2	3489	1115	11/02/1973	OL-FP NPF-14	68.9
		GE 4			11/12/1982		92.3
		BECH			06/08/1983		85.4
		BECH			07/17/2022		98.6
							82.9
			96.7				
Susquehanna 2 PPL Susquehanna, LLC 7 MI NE of Berwick, PA 050-00388	I	BWR-MARK 2	3489	1182	11/02/1973	OL-FP NPF-22	94.7
		GE 4			06/27/1984		81.3
		BECH			02/12/1985		97.3
		BECH			03/23/2024		86.3
							95.6
			86.7				
Three Mile Island 1 AmerGen Energy Co. 10 MI SE of Harrisburg, PA 050-00289	I	PWR-DRYAMB	2568	0802	05/18/1968	OL-FP DPR-50	97.7
		B&W LLP			04/19/1974		77.4
		GIL			09/02/1974		103.5
		UE&C			04/19/2014		78.7
							104.1
			88.3				
Turkey Point 3 Florida Power & Light Co. 25 MI S of Miami, FL 050-00250	II	PWR-DRYAMB	2300	0760	04/27/1967	OL-FP DPR-31	89.1
		WEST 3LP			07/19/1972		100.7
		BECH			12/14/1972		93.4
		BECH			07/19/2032		91.0
							102.4
			89.7				

Unit Operating Utility Location Docket Number	NRC Region	Con Type NSSS AE Constructor	Licensed MWT	Net MDC	CP Issued OL Issued Comm. Op Exp. Date	License Type & Number	1998-2003*
							Average Capacity Factors (Percent)
Turkey Point 4 Florida Power & Light Co. 25 MI S of Miami, FL 050-00251	II	PWR-DRYAMB	2300	0760	04/27/1967	OL-FP	101.8
		WEST 3LP			04/10/1973	DPR-41	94.5
		BECH			09/07/1973		91.9
		BECH			04/10/2033		100.6
							96.4
			91.6				
Vermont Yankee Entergy Nuclear 5 MI S of Brattleboro, VT 050-00271	I	BWR-MARK 1	1593	0510	12/11/1967	OL-FP	71.9
		GE 4			02/28/1973	DPR-28	90.9
		EBSO			11/30/1972		101.5
		EBSO			03/21/2012		93.4
							88.7
			99.5				
Vogtle 1 Southern Nuclear Operating Co. 26 MI SE of Augusta, GA 050-00424	II	PWR-DRYAMB	3565	1148	06/28/1974	OL-FP	99.6
		WEST 4LP			03/16/1987	NPF-68	93.5
		SBEC			06/01/1987		91.2
		GPC			01/16/2027		100.9
							85.9
			93.3				
Vogtle 2 Southern Nuclear Operating Co. 26 MI SE of Augusta, GA 050-00425	II	PWR-DRYAMB	3565	1149	06/28/1974	OL-FP	80.2
		WEST 4LP			03/31/1989	NPF-81	87.0
		SBEC			05/20/1989		102.4
		GPC			02/09/2029		94.0
							83.6
			96.7				
Waterford 3 Entergy Nuclear 20 MI W of New Orleans, LA 050-00382	IV	PWR-DRYAMB	3441	1091	11/14/1974	OL-FP	89.3
		COMB CE			03/16/1985	NPF-38	79.0
		EBSO			09/24/1985		89.8
		EBSO			12/18/2024		101.3
							94.0
			90.3				
Watts Bar 1 Tennessee Valley Authority 10 MI S of Spring City, TN 050-00390	II	PWR-ICECND	3459	1121	01/23/1973	OL	94.7
		WEST 4LP			02/07/1996	NPF-90	84.4
		TVA			05/27/1996		92.4
		TVA			11/09/2035		97.7
							92.1
			87.1				
Wolf Creek 1 Wolf Creek Nuclear Operating Corp. 3.5 MI NE of Burlington, KS 050-00482	IV	PWR-DRYAMB	3565	1167	05/31/1977	OL-FP	101.5
		WEST 4LP			06/04/1985	NPF-42	89.3
		BECH			09/03/1985		88.3
		DANI			03/11/2025		101.0
							88.6
			87.1				

*Note: Average capacity factors are listed in year order starting with 1998.

Source: Nuclear Regulatory Commission and licensee data as compiled by the Nuclear Regulatory Commission.

U.S. Commercial Nuclear Power Reactors Formerly Licensed To Operate (Permanently Shut Down)

Unit Location	Reactor Type MWT	OL Issued Shut Down	Decommissioning Alternative Selected Current Status
Big Rock Point Charlevoix, MI	BWR 240	05/01/1964 08/29/1997	DECON DECON
Bonus * Punta Higuera, PR	BWR 50	04/02/1964 06/01/1968	ENTOMB ENTOMB
CVTR ** Parr, SC	PTHW 65	11/27/1962 01/01/1967	SAFSTOR SAFSTOR
Dresden 1 Morris, IL	BWR 700	09/28/1959 10/31/1978	SAFSTOR SAFSTOR
Elk River * Elk River, MN	BWR 58	11/06/1962 02/01/1968	DECON DECON Completed
Fermi 1 Newport, MI	SCF 200	05/10/1963 09/22/1972	SAFSTOR SAFSTOR
Fort St. Vrain Platteville, CO	HTG 842	12/21/1973 08/18/1989	DECON DECON Completed
GE VBWR Pleasanton, CA	BWR 50	08/31/1957 12/09/1963	SAFSTOR SAFSTOR
Haddam Neck Meriden, CT	PWR 1825	12/27/1974 12/05/1996	DECON DECON
Hallam * Hallam, NE	SCGM 256	01/02/1962 09/01/1964	ENTOMB ENTOMB
Humboldt Bay 3 Eureka, CA	BWR 200	08/28/1962 07/02/1976	SAFSTOR SAFSTOR
Indian Point 1 Buchanan, NY	PWR 615	03/26/1962 10/31/1974	SAFSTOR SAFSTOR
La Crosse Genoa, WI	BWR 165	07/03/1967 04/30/1987	SAFSTOR SAFSTOR
Maine Yankee Wiscasset, ME	PWR 2700	06/29/1973 12/06/1996	DECON DECON
Millstone 1 Waterford, CT	BWR 2011	10/31/1986 07/21/1998	SAFSTOR SAFSTOR

(continued)

Appendix B - U.S. Commercial Nuclear Power Reactors Formerly Licensed To Operate (continued)

Unit Location	Reactor Type MWt	OL Issued Shut Down	Decommissioning Alternative Selected Current Status
Pathfinder Sioux Falls, SD	BWR 190	03/12/1964 09/16/1967	SAFSTOR DECON Completed
Peach Bottom 1 Peach Bottom, PA	HTG 115	01/24/1966 10/31/1974	SAFSTOR SAFSTOR
Piqua * Piqua, OH	OCM 46	08/23/1962 01/01/1966	ENTOMB ENTOMB
Rancho Seco Herald, CA	PWR 2772	08/16/1974 06/07/1989	DECON DECON in progress
San Onofre 1 San Clemente, CA	PWR 1347	03/27/1967 11/30/1992	DECON DECON in progress
Saxton Saxton, PA	PWR 23.5	11/15/1961 05/01/1972	DECON DECON in progress
Shippingport * Shippingport, PA	PWR 236	N/A 1982	DECON DECON Completed
Shoreham Wading River, NY	BWR 2436	04/21/1989 06/28/1989	DECON DECON Completed
Three Mile Island 2 Londonderry Township, PA	PWR 2770	02/08/1978 03/28/1979	(1)
Trojan Rainier, OR	PWR 3411	11/21/1975 11/09/1992	DECON DECON in progress
Yankee-Rowe Franklin County, MA	PWR 0600	12/24/1963 10/01/1991	DECON DECON in progress
Zion 1 Zion, IL	PWR 3250	10/19/1973 02/21/1997	SAFSTOR SAFSTOR
Zion 2 Zion, IL	PWR 3250	11/14/1973 09/19/1996	SAFSTOR SAFSTOR

* AEC/DOE owned; not regulated by NRC.

** Holds byproduct license from State of South Carolina.

Notes: See Glossary for definitions of decommissioning alternatives.

(1) Three Mile Island 2 has been placed in a post-defueling monitored storage mode until Unit 1 permanently ceases operation, at which time both units are planned to be decommissioned.

Source: DOE Integrated Data Base for 1990; U.S. Spent Fuel and Radioactive Waste, Inventories, Projections, and Characteristics (DOE/RW-0006, Rev. 6), and Nuclear Regulatory Commission

Canceled U.S. Commercial Nuclear Power Reactors

Unit Utility	Con Type MWe per Unit	Canceled Date Status
Allens Creek 1 Houston Lighting & Power Company	BWR 1150	1982 Under CP Review
Allens Creek 2 Houston Lighting & Power Company	BWR 1150	1976 Under CP Review
Atlantic 1 & 2 Public Service Electric & Gas Company	PWR 1150	1978 Under CP Review
Bailly Northern Indiana Public Service Company	BWR 645	1981 With CP
Barton 1 & 2 Alabama Power & Light	BWR 1159	1977 Under CP Review
Barton 3 & 4 Alabama Power & Light	BWR 1159	1975 Under CP Review
Bellefonte 1 & 2 Tennessee Valley Authority	PWR 1235	(1) With CP
Black Fox 1 & 2 Public Service Company of Oklahoma	BWR 1150	1982 Under CP Review
Blue Hills 1 & 2 Gulf States Utilities Company	PWR 918	1978 Under CP Review
Callaway 2 Union Electric Company	PWR 1150	1981 With CP
Cherokee 1 Duke Power Company	PWR 1280	1983 With CP
Cherokee 2 & 3 Duke Power Company	PWR 1280	1982 With CP
Clinch River Project Management Corp.; DOE; TVA	LMFB 350	1983 Under CP Review
Clinton 2 Illinois Power Company	BWR 933	1983 With CP
Davis-Besse 2 & 3 Toledo Edison Company	PWR 906	1981 Under CP Review
Douglas Point 1 & 2 Potomac Electric Power Company	BWR 1146	1977 Under CP Review

(continued)

Appendix C - Cancelled U.S. Commercial Nuclear Power Reactors (continued)

Unit Utility	Con Type MWe per Unit	Canceled Date Status
Erie 1 & 2 Ohio Edison Company	PWR 1260	1980 Under CP Review
Forked River 1 Jersey Central Power & Light Company	PWR 1070	1980 With CP
Fort Calhoun 2 Omaha Public Power District	PWR 1136	1977 Under CP Review
Fulton 1 & 2 Philadelphia Electric Company	HTG 1160	1975 Under CP Review
Grand Gulf 2 Entergy Operations, Incorporated	BWR 1250	1990 With CP
Greene County Power Authority of the State of NY	PWR 1191	1980 Under CP Review
Greenwood 2 & 3 Detroit Edison Company	PWR 1200	1980 Under CP Review
Hartsville A1 & A2 Tennessee Valley Authority	BWR 1233	1984 With CP
Hartsville B1 & B2 Tennessee Valley Authority	BWR 1233	1982 With CP
Haven 1 Wisconsin Electric Power Company	PWR 900	1980 Under CP Review
Haven 2 (formerly Koshkonong 2) Wisconsin Electric Power Company	PWR 900	1978 Under CP Review
Hope Creek 2 Public Service Electric & Gas Company	BWR 1067	1981 With CP
Jamesport 1 & 2 Long Island Lighting Company	PWR 1150	1980 With CP
Marble Hill 1 & 2 Public Service of Indiana	PWR 1130	1985 With CP
Midland 1 Consumers Power Company	PWR 492	1986 With CP
Midland 2 Consumers Power Company	PWR 818	1986 With CP
Montague 1 & 2 Northeast Nuclear Energy Company	BWR 1150	1980 Under CP Review
New England 1 & 2 New England Power Company	PWR 1194	1979 Under CP Review

Unit Utility	Con Type MWe per Unit	Canceled Date Status
New Haven 1 & 2 New York State Electric & Gas Corporation	PWR 1250	1980 Under CP Review
North Anna 3 Virginia Electric & Power Company	PWR 907	1982 With CP
North Anna 4 Virginia Electric & Power Company	PWR 907	1980 With CP
North Coast 1 Puerto Rico Water Resources Authority	PWR 583	1978 Under CP Review
Palo Verde 4 & 5 Arizona Public Service Company	PWR 1270	1979 Under CP Review
Pebble Springs 1 & 2 Portland General Electric Company	PWR 1260	1982 Under CP Review
Perkins 1, 2, & 3 Duke Power Company	PWR 1280	1982 Under CP Review
Perry 2 Cleveland Electric Illuminating Co.	BWR 1205	1994 Under CP Review
Phipps Bend 1 & 2 Tennessee Valley Authority	BWR 1220	1982 With CP
Pilgrim 2 Boston Edison Company	PWR 1180	1981 Under CP Review
Pilgrim 3 Boston Edison Company	PWR 1180	1974 Under CP Review
Quanicassee 1 & 2 Consumers Power Company	PWR 1150	1974 Under CP Review
River Bend 2 Gulf States Utilities Company	BWR 934	1984 With CP
Seabrook 2 Public Service Co. of New Hampshire	PWR 1198	1988 With CP
Shearon Harris 2 Carolina Power & Light Company	PWR 900	1983 With CP
Shearon Harris 3 & 4 Carolina Power & Light Company	PWR 900	1981 With CP
Skagit/Hanford 1 & 2 Puget Sound Power & Light Company	PWR 1277	1983 Under CP Review
Sterling Rochester Gas & Electric Corporation	PWR 1150	1980 With CP

(continued)

Appendix C - Cancelled U.S. Commercial Nuclear Power Reactors (continued)

Unit Utility	Con Type MWe per Unit	Canceled Date Status
Summit 1 & 2 Delmarva Power & Light Company	HTG 1200	1975 Under CP Review
Sundesert 1 & 2 San Diego Gas & Electric Company	PWR 974	1978 Under CP Review
Surry 3 & 4 Virginia Electric & Power Company	PWR 882	1977 With CP
Tyrone 1 Northern States Power Company	PWR 1150	1981 Under CP Review
Tyrone 2 Northern States Power Company	PWR 1150	1974 With CP
Vogtle 3 & 4 Georgia Power Company	PWR 1113	1974 With CP
Washington Nuclear 1 Energy Northwest	PWR 1266	1995 With CP
Washington Nuclear 3 Energy Northwest	PWR 1242	1995 With CP
Washington Nuclear 4 Energy Northwest	PWR 1218	1982 With CP
Washington Nuclear 5 Energy Northwest	PWR 1242	1982 With CP
Watts Bar 2 Tennessee Valley Authority	PWR 1165	(1) With CP
Yellow Creek 1 & 2 Tennessee Valley Authority	BWR 1285	1984 With CP
Zimmer 1 Cincinnati Gas & Electric Company	BWR 810	1984 With CP

Note: Cancellation is defined as public announcement of cancellation or written notification to NRC. Only docketed applications are indicated.

(1) Bellefonte 1 and 2, Watts Bar 2 and Washington Nuclear 1 have not been formally cancelled; however TVA has stopped construction and is presently evaluating options (e.g. cancellation or conversion).

Source: DOE/EIA Commercial Nuclear Power 1991 (DOE/EIA-0438 (91)), Appendix E (page 105) and Nuclear Regulatory Commission

U.S. Commercial Nuclear Power Reactors by Licensee

Utility	Unit
Ameren UE	Callaway
AmerGen Energy Company	Clinton
	Oyster Creek
	Three Mile Island 1
Arizona Public Service Company	Palo Verde 1, 2, & 3
Carolina Power & Light	Brunswick 1 & 2
	H. B. Robinson 2
	Shearon Harris 1
Constellation Nuclear	Calvert Cliffs 1 & 2
	Nine Mile Point 1 & 2
Detroit Edison Company	Fermi 2
Dominion Generation	Millstone 2 & 3
	North Anna 1 & 2
	Surry 1 & 2
Duke Energy Nuclear, LLC	Catawba 1 & 2
	McGuire 1 & 2
	Oconee 1, 2, & 3
Energy Northwest	Columbia
Entergy Nuclear Generation Company	Pilgrim 1
	Arkansas Nuclear 1 & 2
	James A. FitzPatrick
	Grand Gulf 1
	River Bend 1
	Vermont Yankee
	Waterford 3
Entergy Nuclear Operations, Inc.	Indian Point 2 & 3
Exelon Generation Co., LLC	Braidwood 1 & 2
	Byron 1 & 2
	Dresden 2 & 3
	La Salle County 1 & 2
	Limerick 1 & 2
	Peach Bottom 2 & 3
	Quad Cities 1 & 2
FirstEnergy Nuclear Operating Company	Beaver Valley 1 & 2

(continued)

Appendix D - U.S. Commercial Nuclear Power Reactors by Licensee (continued)

Utility	Unit
FirstEnergy Nuclear Operating Company	Davis-Besse Perry 1
Florida Power & Light Company	St. Lucie 1 & 2 Turkey Point 3 & 4
Florida Power Corporation	Crystal River 3
FPL Energy Seabrook	Seabrook 1
Indiana/Michigan Power Company	D. C. Cook 1 & 2
Nebraska Public Power District	Cooper
Nuclear Management Company	Duane Arnold Kewaunee Monticello Palisades Point Beach 1 & 2 Prairie Island 1 & 2
Omaha Public Power District	Fort Calhoun
Pacific Gas & Electric Company	Diablo Canyon 1 & 2
PPL Susquehanna, LLC	Susquehanna 1 & 2
PSEG Nuclear, LLC	Hope Creek 1 Salem 1 & 2
Rochester Gas & Electric Corporation	Ginna
South Carolina Electric & Gas Company	Summer
Southern California Edison Company	San Onofre 2 & 3
Southern Nuclear Operating Company	Joseph M. Farley 1 & 2 Edwin I. Hatch 1 & 2 Vogtle 1 & 2
STP Nuclear Operating Company	South Texas Project 1 & 2
Tennessee Valley Authority	Browns Ferry 1, 2, & 3 Sequoyah 1 & 2 Watts Bar 1
TXU Generation Company, LP	Comanche Peak 1 & 2
Wolf Creek Nuclear Operating Corporation	Wolf Creek 1

Source: Nuclear Regulatory Commission

U.S. Nuclear Research and Test Reactors Regulated by NRC

Licensee Location	Reactor Type OL Issued	Power Level (kW)	License Number Docket Number
Aerotest San Ramon, CA	TRIGA (Indus) 07/02/1965	250	R-98 50-228
Armed Forces Radiobiology Research Institute Bethesda, MD	TRIGA 06/26/1962	1,100	R-84 50-170
Dow Chemical Company Midland, MI	TRIGA 07/03/1967	300	R-108 50-264
General Electric Company Sunol, CA	Nuclear Test 10/31/1957	100	R-33 50-73
Idaho State University Pocatello, ID	AGN-201 #103 10/11/1967	0.005	R-110 50-284
Kansas State University Manhattan, KS	TRIGA 10/16/1962	250	R-88 50-188
Massachusetts Institute of Technology Cambridge, MA	HWR Reflected 06/09/1958	5,000	R-37 50-20
National Institute of Standards & Technology Gaithersburg, MD	Nuclear Test 05/21/1970	20,000	TR-5 50-184
North Carolina State University Raleigh, NC	Pulstar 08/25/1972	1,000	R-120 50-297
Ohio State University Columbus, OH	Pool 02/24/1961	500	R-75 50-150
Oregon State University Corvallis, OR	TRIGA Mark II 03/07/1967	1,100	R-106 50-243
Pennsylvania State University University Park, PA	TRIGA 07/08/1955	1,100	R-2 50-5
Purdue University West Lafayette, IN	Lockheed 08/16/1962	1	R-87 50-182

(continued)

Appendix E - U.S. Nuclear Research and Test Reactors Regulated by NRC (continued)

Licensee Location	Reactor Type OL Issued	Power Level (kW)	License Number Docket Number
Reed College Portland, OR	TRIGA Mark I 07/02/1968	250	R-112 50-288
Rensselaer Polytechnic Institute Troy, NY	Critical Assembly 07/03/1964	0.1	CX-22 50-225
Rhode Island Atomic Energy Commission Narragansett, RI	GE Pool 07/23/1964	2,000	R-95 50-193
Texas A&M University College Station, TX	AGN-201M #106 08/26/1957	0.005	R-23 50-59
Texas A&M University College Station, TX	TRIGA 12/07/1961	1,000	R-128 50-128
U.S. Geological Survey Denver, CO	TRIGA Mark I 02/24/1969	1,000	R-113 50-274
University of Arizona Tucson, AZ	TRIGA Mark I 12/05/1958	110	R-52 50-113
University of California/Davis Sacramento, CA	TRIGA 08/13/1998	2,300	R-130 50-607
University of California/ Irvine Irvine, CA	TRIGA Mark I 11/24/1969	250	R-116 50-326
University of Florida Gainesville, FL	Argonaut 05/21/1959		R-56 50-83
University of Massachusetts/ Lowell Lowell, MA	GE Pool 12/24/1974	1,000	R-125 50-223
University of Maryland College Park, MD	TRIGA 10/14/1960	250	R-70 50-166
University of Missouri/Rolla Rolla, MO	Pool 11/21/1961	200	R-79 50-123
University of Missouri/Columbia Columbia, MO	Tank 10/11/1966	10,000	R-103 50-186
University of New Mexico Albuquerque, NM	AGN-201M#112 09/17/1966	0.005	R-102 50-252

Licensee Location	Reactor Type OL Issued	Power Level (kW)	License Number Docket Number
University of Texas Austin, TX	TRIGA Mark II 01/17/1992	1,100	R-92 50-602
University of Utah Salt Lake City, UT	TRIGA Mark I 09/30/1975	100	R-126 50-407
University of Wisconsin Madison, WI	TRIGA 11/23/1960	1,000	R-74 50-156
Washington State University Pullman, WA	TRIGA 03/06/1961	1,000	R-76 50-27
Worcester Polytechnic Institute Worcester, MA	GE 12/16/1959	10	R-61 50-134

Source: Nuclear Regulatory Commission

U.S. Research and Test Reactors Under Decommissioning

Licensee Location	Reactor Type Power Level (kW)	OL Issued Shutdown	Decommissioning Alternative Selected Current Status
Cornell University Ithaca, NY	TRIGA Mark II 500	01/11/1962 4/21/2003	DECON SAFSTOR ¹
Cornell University Ithaca, NY	Tank (ZPR) 0.1	12/11/62 2/12/97	DECON SAFSTOR ¹
General Atomics San Diego, CA	TRIGA Mark F 1,500	7/01/60 9/7/94	DECON SAFSTOR ²
General Atomics San Diego, CA	TRIGA Mark I 250	5/03/58 12/17/96	DECON DECON
General Electric Company Sunol, CA	GETR (Tank) 50,000	1/7/59 6/26/85	SAFSTOR SAFSTOR
General Electric Company Sunol, CA	EVESR 17,000	11/12/63 2/1/67	SAFSTOR SAFSTOR
Manhattan College Riverdale, NY	ZPR 0.0001	3/24/64 12/96	DECON SAFSTOR ²
National Aeronautics and Space Administration Sandusky, OH	Test 60,000	5/2/62 7/7/73	DECON DECON
National Aeronautics and Space Administration Sandusky, OH	Mockup 100	6/14/61 7/7/73	DECON DECON
University of Buffalo Buffalo, NY	Pulstar 2,000	3/24/61 7/23/96	DECON SAFSTOR ²
University of Illinois Urbana, IL	TRIGA 1,500	7/22/69 4/12/99	DECON SAFSTOR ²
University of Michigan Ann Arbor, MI	Pool 2,000	09/13/57 1/29/04	DECON SAFSTOR ¹
University of Virginia Charlottesville, VA	Pool 0.1	9/24/74 1/88	DECON DECON

(continued)

Appendix F - Research and Test Reactors Under Decommissioning (continued)

Licensee Location	Reactor Type Power Level (kW)	OL issued Shutdown	Decommissioning Alternative Selected Current Status
University of Virginia Charlottesville, VA	Pool 2,000	6/24/60 6/30/98	DECON DECON
University of Washington Seattle, Washington	Argonaut 100	3/31/61 6/30/88	DECON DECON
Veterans Administration Omaha, NE	TRIGA 20	6/26/59 11/05/01	DECON SAFSTOR ¹
Viacom Waltz Mill, PA	Tank 20,000	6/19/59 3/25/63	SAFSTOR SAFSTOR

¹ In SAFSTOR while Decommissioning Plan is under review

² Plan to commence DECON once fuel removed from site

Source: Nuclear Regulatory Commission

NRC Performance Indicators: Annual Industry Averages, Fiscal Years 1990–2003

Indicator	1990	1991	1992	1993	1994	1995	1996
Automatic Scrams	1.61	1.57	1.52	1.18	1.05	1.04	0.80
Safety System Actuations	0.99	1.06	0.81	0.81	0.62	0.46	0.39
Significant Events	0.45	0.40	0.25	0.26	0.21	0.17	0.08
Safety System Failures	3.58	3.44	3.78	3.09	2.32	2.03	2.89
Forced Outage Rate	7.60	7.90	8.89	7.79	9.40	6.76	7.54
Equipment Forced Outage Rate	0.38	0.36	0.35	0.24	0.26	0.23	0.24
Collective Radiation Exposure	320.00	286.00	277.00	244.00	215.00	202.00	178.00

Indicator	1997	1998	1999	2000	2001	2002	2003
Automatic Scrams	0.54	0.48	0.64	0.52	0.57	0.44	0.75
Safety System Actuations	0.35	0.31	0.29	0.29	0.19	0.18	0.40
Significant Events	0.10	0.04	0.03	0.02	0.05	0.04	0.02
Safety System Failures	2.71	2.76	1.67	1.37	0.81	0.88	0.95
Forced Outage Rate	10.21	10.73	5.20	4.24	3.00	1.70	3.04
Equipment Forced Outage Rate	0.24	0.18	0.16	0.13	0.12	0.12	0.16
Collective Radiation Exposure	176.00	140.00	128.00	115.00	123.00	111.00	126.00

Source: Licensee data as compiled by the Nuclear Regulatory Commission

Dry Spent Fuel Storage Designs: NRC Approved for General Use

Vendor	Storage Design Model	Certificate of Compliance Issue Date
General Nuclear Systems, Incorporated	CASTOR V/21	08/17/1990
NAC International, Inc.	NAC S/T	08/17/1990
NAC International, Inc.	NAC-C28 S/T	08/17/1990
BNL Fuel Solutions, Corporation	VSC-24	05/03/1993
Holtec International	HI-STAR 100	10/04/1999
Holtec International	HI-STORM 100	05/31/2000
NAC International, Inc.	NAC-MPC	04/10/2000
NAC International, Inc.	NAC-UMS	11/20/2000
Transnuclear, Inc.	TN-24	11/04/1993
	TN-68	05/30/2000
	TN-32A and TN-32B	02/20/2001
	NUHOMS-24P, 24PT	09/12/2001
	NUHOMS-61BT	09/12/2001
	NUHOMS-52B	09/12/2001
BNFL Fuel Solutions	Fuel Solutions	02/15/2001

Source: Nuclear Regulatory Commission (10 CFR 72.214), data as of 12/31/2003.

Dry Spent Fuel Storage Licensees

Reactor Utility	Date Issued	Vendor	Storage Model
Surry 1, 2 Virginia Electric & Power Company	07/02/1986	Generals Nuclear Systems, Incorporated Transnuclear, Incorporated NAC International, Incorporated Westinghouse, Incorporated	CASTOR V/21 TN-32 NAC-I28 CASTOR X/33 MC-10
H. B. Robinson 2 Carolina Power & Light Company	08/13/1986	Transnuclear, Incorporated	NUHOMS-7P
Oconee 1, 2, 3 Duke Energy Company	01/29/1990 Under General License 03/05/1999	Transnuclear, Incorporated	NUHOMS-24P
Fort St. Vrain* Department of Energy	11/04/1991	FW Energy Applications, Incorporated	Modular Vault Dry Store
Calvert Cliffs 1, 2 Calvert Cliffs Nuclear Power Plant	11/25/1992	Transnuclear, Incorporated	NUHOMS-24P
Palisades Nuclear Management Company, LLC	Under General License 05/11/93	BNFL Fuel Solutions	VSC-24
Prairie Island 1, 2 Nuclear Management Company, LLC	10/19/1993	Transnuclear, Incorporated	TN-40
Point Beach 1, 2 Nuclear Management Company, LLC	Under General License 05/26/96	BNFL Fuel Solutions	VSC-24
Davis-Besse First Energy Nuclear Operating Company	Under General License 01/01/96	Transnuclear, Incorporated	NUHOMS-24P
Arkansas Nuclear 1, 2 Entergy Operations, Inc	Under General License 12/17/96	BNFL Fuel Solutions Holtec International	VSC-24 HI-STORM 100
North Anna Virginia Electric & Power Company	06/30/1998	Transnuclear, Incorporated	TN-32
Trojan Portland General Electric Corp	03/31/1999	Holtec International	HI-STORM 100
INEEL ISFSI TMI-2 Fuel Debris Department of Energy	03/19/1999	Transnuclear, Incorporated	NUHOMS-12T

(continued)

Appendix I - Dry Spent Fuel Storage Licensees (continued)

Reactor Utility	Date Issued	Vendor	Storage Model
Susquehanna Pennsylvania Power & Light	Under General License 10/18/99	Transnuclear, Incorporated Incorporated	NUHOMS-52B NUHOMS-61BT
Peach Bottom 2, 3 Exelon Generating Company	Under General License 06/12/2000	Transnuclear, Incorporated	TN-68
Hatch 1, 2 Southern Nuclear Operating	Under General License 07/06/2000	Holtec International	HI-STAR 100 HI-STORM 100
Dresden 1, 2, 3 Exelon Generating	Under General License 07/10/2000	Holtec International	HI-STAR 100 HI-STORM 100
Rancho Seco Sacramento Municipal Utility District	06/30/2000	Transnuclear, Incorporated	NUHOMS-24 P
McGuire Duke Power	Under General License 02/01/2001	Transnuclear Incorporated	TN-32
Big Rock Point Consumers Energy	Under General License 11/18/02	BNFL Fuel Solutions	Fuel Solutions W74
James A. FitzPatrick Energy Nuclear Operations, Incorporated	Under General License 04/25/02	Holtec International	HI-STORM 100
Maine Yankee Maine Yankee Atomic Power Company	Under General License 08/24/02	NAC International, Incorporated	NAC-UMS
Columbia Generating Station Energy North West	Under General License 09/02/02	Holtec International	HI-STORM 100
Oyster Creek AmeriGen Energy Company	Under General License 04/11/02	Transnuclear, Incorporated	NUHOMS-61BT
Yankee Rowe Yankee Atomic Electric	Under General License 06/26/02	NAC International, Incorporated	NAC-MPC NAC-STC
Duane Arnold Nuclear Management Corporation	Under General License 04/25/04	Transnuclear, Incorporated	NUHOMS-61BT
Palo Verde Arizona Public Service Company	Under General License 03/15/03	NAC International, Incorporated	NAC-UMS
San Onofre Southern California Edison Company	Under General License 10/03/03	Transnuclear, Incorporated	NUHOMS-24PT1
Diablo Canyon Pacific Gas & Electric	03/22/04	Holtec International	HI-STEAM 100

*Plant undergoing decommissioning. Transferred to DOE 6/4/99.

Source: Nuclear Regulatory Commission

World List of Nuclear Power Reactors

Country	In Operation		Under Construction, on Order, or Construction Halted		Total	
	Number of Units	Net MWe	Number of Units	Net MWe	Number of Units	Net MWe
Argentina	2	935	1	692	3	1,627
Armenia	1	376	0	0	1	376
Belgium	7	5,760	0	0	7	5,760
Brazil	2	1,901	1	1,275	3	3,176
Bulgaria	4	2,722	0	0	4	2,722
Canada	22	15,113	0	0	22	15,113
China	8	6,098	3	2,610	11	8,708
China, Taiwan	6	4,884	2	2,600	8	7,484
Czech Republic	4	1,648	2	1,824	6	3,472
Finland	4	2,656	1	1,600	5	4,256
France	59	63,363	0	0	59	63,363
Germany	18	20,724	0	0	18	20,724
Hungary	4	1,755	0	0	4	1,755
India	14	2,548	8	3,580	22	6,128
Iran	0	0	1	915	1	915
Japan	52	43,893	5	4,842	57	48,735
Lithuania	2	2,374	0	0	2	2,374
Mexico	2	1,364	0	0	2	1,364
Netherlands	1	452	0	0	1	452
North Korea	0	0	2	2000	2	2000
Pakistan	2	425	0	0	2	425
Romania	1	655	4	2,620	5	3,275
Russia	27	20,799	6	5,275	33	26,074
Slovakia	6	2,442	2	810	8	3,252
Slovenia	1	676	0	0	1	676
South Africa	2	1,842	0	0	2	1,842
South Korea	18	15,716	8	8,800	26	24,516
Spain	9	7,581	0	0	9	7,581
Sweden	11	9,482	0	0	11	9,482
Switzerland	5	3,220	0	0	5	3,220
Ukraine	13	11,830	5	4,850	18	16,680
United Kingdom	27	12,250	0	0	27	12,250
United States	104	100,368	3	3,603	107	103,971
Total	438	365,852	54	47,896	492	413,748

Note: Operable, under construction or on order (30 MWe and over) or construction halted as of December 31, 2003.

Source: Reprinted with permission from the March 2004 *Nuclear News*®, 2004 by the American Nuclear Society.

Nuclear Power Units by Reactor Type, Worldwide

Reactor Type	In Operation		Total	
	Number of Units	Net MWe	Number of Units	Net MWe
Pressurized light-water reactors	260	236,277	296	270,556
Boiling light-water reactors	93	81,916	98	88,212
Gas-cooled reactors, all types	26	11,062	20	11,062
Heavy-water reactors, all types	44	23,255	53	27,871
Graphite-moderated light-water reactors	13	12,549	14	13,474
Liquid metal cooled fast-breeder reactors	2	793	5	2,573
Total	438	365,852	492	413,748

Note: Operable, under construction, on order (30 MWe and over) as of 12/31/03.

Source: Reprinted with permission from the March 2004 *Nuclear News*®, 2004 by the American Nuclear Society.

Top Fifty Reactors by Capacity Factor, Worldwide

Country	Unit	Reactor Type	Vendor	2003 Gross Generation (MWh)	2003 Gross Capacity Factor (Percent)
South Korea	Kori-3	PWR	West	8,720,610	104.80
South Korea	Ulchin-3	PWR	KHIC-CE	9,145,841	104.42
U.S.	San Onofre-2	PWR	CE	10,206,290	103.38
South Korea	Yonggwang-4	PWR	KHIC-CE	9,015,870	102.93
Japan	Mihama-1	PWR	West	3,050,265	102.42
U.S.	Limerick-1	BWR	GE	10,385,300	101.94
U.S.	Byron-2	PWR	West	10,792,169	101.82
Japan	Ohi-2	PWR	West	10,468,575	101.72
U.S.	Robinson-2	PWR	West	6,743,590	101.63
U.S.	Brunswick-1	BWR	GE	7,909,804	100.78
U.S.	LaSalle-1	BWR	GE	9,962,451	100.02
Japan	Takahama-3	PWR	MHI	7,618,059	99.97
U.S.	Farley-2	PWR	West	7,737,716	99.47
U.S.	Grand Gulf-1	BWR	GE	11,345,422	99.17
U.S.	Point Beach-1	PWR	West	4,542,960	99.16
U.S.	Oconee-2	PWR	B&W	7,896,941	98.95
U.S.	Prairie Island-1	PWR	West	4,853,570	98.94
Spain	Asco-2	PWR	West	8,887,460	98.77
Japan	Tokai-2	BWR	GE	9,510,622	98.71
France	Cattenom-3	PWR	Framatome	11,771,174	98.66
U.S.	Comanche Peak-1	PWR	West	10,016,067	98.48
U.S.	Millstone-3	PWR	West	10,412,606	98.40
Taiwan	Chinshan-1	BWR	GE	5,479,779	98.37
U.S.	Diablo Canyon-1	PWR	West	10,029,076	98.36
U.S.	Vermont Yankee	BWR	GE	4,651,322	98.33
U.S.	Indian Point-2	PWR	West	8,664,811	98.13
U.S.	Palo Verde-1	PWR	CE	11,221,910	98.01
Japan	Hamaoka-2	BWR	Toshiba	7,203,334	97.90
Canada	Bruce-6	PHWR	AECL	7,179,398	97.58
Canada	Bruce-7	PHWR	AECL	7,155,767	97.26
Finland	Olkiluoto-1	BWR	Asea	7,392,830	97.00
U.S.	Susquehanna-1	BWR	GE	9,683,089	96.79

(continued)

Appendix L - Top Fifty Reactors by Capacity Factor, Worldwide (continued)

Country	Unit	Reactor Type	Vendor	2003 Gross Generation (MWh)	2003 Gross Capacity Factor (Percent)
U.S.	Braidwood-2	PWR	West	10,232,661	96.51
U.S.	Callaway	PWR	West	10,157,279	96.30
South Korea	Wolsong-4	PHWR	AECL	6,018,849	96.11
Mexico	Laguna Verde-1	BWR	GE	5,679,394	96.05
U.S.	Braidwood-1	PWR	West	10,432,131	95.88
U.S.	McGuire-1	PWR	West	10,281,537	95.81
U.S.	Clinton	BWR	GE	9,037,906	95.80
U.S.	Nine Mile Point-2	BWR	GE	10,108,447	95.76
Switzerland	Beznau-1	PWR	West	3,187,185	95.75
U.S.	Vogtle-2	PWR	West	10,184,042	95.68
Finland	Olkiluoto-2	BWR	Asea	7,280,230	95.53
Germany	Emsland	PWR	Siemens	11,708,140	95.47
U.S.	Byron-1	PWR	West	10,385,657	95.46
South Korea	Ulchin-4	PWR	KHIC-CE	8,360,957	95.46
Netherlands	Borssele-1	PWR	Siemens	4,018,109	95.38
Germany	Isar-2	PWR	Siemens	12,323,240	95.37
U.S.	Limerick-2	BWR	GE	9,710,500	95.31
South Korea	Wolsong-3	PHWR	AECL	5,964,833	95.24

Note: U.S. units believed to belong on this list, but which have not supplied their gross generation, are Entergy's River Bend and Arkansas Nuclear One-2 and Constellation's Calvert Cliffs-2.

Source: Excerpted from *Nucleonics Week* © February 12, 2004 by McGraw Hill, Inc. Reproduced by permission. Further reproduction prohibited.

Top Fifty Reactors by Generation, Worldwide

Country	Unit	Reactor Type	Vendor	2003 Gross Generation (MWh)	2003 Gross Capacity Factor (Percent)
Germany	Isar-2	PWR	Siemens	12,323,240	95.37
France	Cattenom-3	PWR	Framatome	11,771,174	98.66
Germany	Emsland	PWR	Siemens	11,708,140	95.47
Germany	Philippsburg-2	PWR	Siemens	11,626,134	91.03
Germany	Grohnde	PWR	Siemens	11,579,328	92.44
France	Civaux-1	PWR	Framatome	11,420,539	83.52
U.S.	Grand Gulf-1	BWR	GE	11,345,422	99.17
Germany	Neckar-2	PWR	Siemens	11,298,890	94.49
U.S.	Palo Verde-1	PWR	CE	11,221,910	98.01
Germany	Brokdorf	PWR	Siemens	11,115,984	88.12
Germany	Gundremmingen-B	BWR	Siemens	11,028,480	93.67
France	Chooz-B2	PWR	Framatome	10,910,344	82.16
Germany	Grafenrheinfeld	PWR	Siemens	10,823,259	91.86
U.S.	Byron-2	PWR	West	10,792,169	101.82
France	Golfech-1	PWR	Framatome	10,790,380	90.37
France	Cattenom-2	PWR	Framatome	10,710,406	89.77
France	Penly-2	PWR	Framatome	10,636,472	87.86
Japan	Ohi-2	PWR	West	10,468,575	101.72
France	Chooz-B1	PWR	Framatome	10,460,803	78.77
Germany	Gundremmingen-C	BWR	Siemens	10,440,968	88.68
U.S.	Braidwood-1	PWR	West	10,432,131	95.88
France	Nogent-1	PWR	Framatome	10,418,908	87.26
France	Flamanville-2	PWR	Framatome	10,415,357	86.03
U.S.	Millstone-3	PWR	West	10,412,606	98.40
U.S.	Byron-1	PWR	West	10,385,657	95.46
U.S.	Limerick-1	BWR	GE	10,385,300	101.94
U.S.	McGuire-1	PWR	West	10,281,537	95.81
U.S.	Braidwood-2	PWR	West	10,232,661	96.51
U.S.	San Onofre-2	PWR	CE	10,206,290	103.38
U.S.	Vogtle-2	PWR	West	10,184,042	95.68
U.S.	Callaway	PWR	West	10,157,279	96.30
U.S.	Palo Verde-3	PWR	CE	10,119,860	88.39
U.S.	Nine Mile Point-2	BWR	GE	10,108,447	95.76

(continued)

Appendix M - Top Fifty Reactors by Generation, Worldwide (continued)

Country	Unit	Reactor Type	Vendor	2003 Gross Generation (MWh)	2003 Gross Capacity Factor (Percent)
U.S.	Diablo Canyon-1	PWR	West	10,029,076	98.36
U.S.	Comanche Peak-1	PWR	West	10,016,067	98.48
Brazil	Angra-2	PWR	Siemens	10,009,936	84.65
U.S.	LaSalle-1	BWR	GE	9,962,451	100.02
Germany	Kruemmel	BWR	Siemens	9,908,703	85.95
France	Nogent-2	PWR	Framatome	9,868,660	82.65
U.S.	Vogtle-1	PWR	West	9,839,559	92.45
U.S.	Catawba-2	PWR	West	9,815,225	92.98
Switzerland	Leibstadt	BWR	GE	9,777,238	93.01
Germany	Unterweser	PWR	Siemens	9,747,672	78.92
U.S.	Limerick-2	BWR	GE	9,710,500	95.31
U.S.	Susquehanna-1	BWR	GE	9,683,089	96.79
France	Penly-1	PWR	Framatome	9,680,631	79.96
U.S.	Seabrook	PWR	West	9,659,900	92.36
France	St.Alban/St.Maurice-2	PWR	Framatome	9,631,891	79.62
U.S.	Browns Ferry-3	BWR	GE	9,531,470	94.20
France	Civaux-2	PWR	Framatome	9,527,065	69.67

Note: U.S. units believed to belong on this list but do not disclose gross generation are Exelon's Byron 1 and 2.

Source: Excerpted from *Nucleonics Week* © February 12, 2004 by McGraw Hill, Inc. Reproduced by permission. Further reproduction prohibited.

Quick Reference Metric Conversion Tables

SPACE AND TIME

Quantity	From Inch-Pound Units	To Metric Units	Multiply by
Length	mi (statute)	km	1.609 347
	yd	m	*0.914 4
	ft (int)	m	*0.304 8
	in	cm	*2.54
Area	mi ²	km ²	2.589 998
	acre	m ²	4 046.873
	yd ²	m ²	0.836 127 4
	ft ²	m ²	*0.092 903 04
	in ²	cm ²	*6.451 6
Volume	acre foot	m ³	1 233.489
	yd ³	m ³	0.764 554 9
	ft ³	m ³	0.028 316 85
	ft ³	L	28.316 85
	gallon	L	3.785 412
	fl oz	mL	29.573 53
	in ³	cm ³	16.387 06
Velocity	mi/h	km/h	1.609 347
	ft/s	m/s	*0.304 8
Acceleration	ft/s ²	m/s ²	*0.304 8

NUCLEAR REACTION and IONIZING RADIATION

Quantity	From Inch-Pound Units	To Metric Units	Multiply by
Activity (of a radionuclide)	curie (Ci)	MBq	*37,000.0
	dpm	Bq (becquerel)	0.016 667
Absorbed dose	rad	Gy (gray)	*0.01
	rad	cGy	*1.0
Dose equivalent	rem	Sv (sievert)	*0.01
	rem	mSv	*10.0
	mrem	mSv	*0.01
	mrem	μSv	*10.0
Exposure (X- and gamma rays)	roentgen (R)	C/kg (coulomb)	0.000 258

(continued)

Appendix N - Quick Reference Metric Conversion Tables (continued)

HEAT

Quantity	From Inch-Pound Units	To Metric Units	Multiply by
Thermodynamic temperature	°F	°K	*°K = (°F + 459.67)/1.8
Celsius temperature	°F	°C	*°C = (°F-32)/1.8
Linear expansion coefficient	°F ⁻¹	°K ⁻¹ or °C ⁻¹	*1.8
Thermal conductivity	(Btu • in)/(ft ² • h • °F)	W/(m • °C)	0.144 227 9
Coefficient of heat transfer	Btu / (ft ² • h • °F)	W/(m ² • °C)	5.678 263
Heat capacity	Btu/°F	kJ/°C	1.899 108
Specific heat capacity	Btu/(lb • °F)	kJ/(kg • °C)	*4.186 8
Entropy	Btu/°F	kJ/°C	1.899 108
Specific entropy	Btu/(lb • °F)	kJ/(kg • °C)	*4.186 8
Specific internal energy	Btu/lb	kJ/kg	*2.326

MECHANICS

Quantity	From Inch-Pound Units	To Metric Units	Multiply by
Mass (weight)	ton (short) lb (avdp)	t (metric ton) kg	*0.907 184 74 *0.453 592 37
Moment of mass	lb • ft	kg • m	0.138 255
Density	ton (short)/yd ³ lb/ft ³	t/m ³ kg/m ³	1.186 553 16.018 46
Concentration (mass)	lb/gal	g/L	119.826 4
Momentum	lb • ft/s	kg • m/s	0.138 255
Angular momentum	lb • ft ² /s	kg • m ² /s	0.042 140 11
Moment of Inertia	lb • ft ²	kg • m ²	0.042 140 11
Force	kip (kilopound) lbf	kN (kilonewton) N (newton)	4.448 222 4.448 222

MECHANICS (Continued)

Quantity	From Inch-Pound Units	To Metric Units	Multiply by
Moment of Force, torque	lbf • ft	N • m	1.355 818
	lbf • in	N • m	0.122 984 8
Pressure	atm (std)	kPa (kilopascal)	*101.325
	bar	kPa	*100.0
	lbf/in ² (formerly psi)	kPa	6.894 757
	inHg (32° F)	kPa	3.386 38
	ftH ₂ O (39.2° F)	kPa	2.988 98
	inH ₂ O (60° F)	kPa	0.248 84
	mmHg (0° C)	kPa	0.133 322
Stress	kip/in ² (formerly ksi)	MPa	6.894 757
	lbf/in ² (formerly psi)	MPa	0.006 894 757
	lbf/in ² (formerly psi)	kPa	6.894 757
	lbf/ft ²	kPa	0.047 880 26
Energy, work	kwh	MJ	*3.6
	cal _{th}	J (joule)	*4.184
	Btu	kJ	1.055 056
	ft • lbf	J	1.355 818
	therm (US)	MJ	105.480 4
Power	Btu/s	kW	1.055 056
	hp (electric)	kW	*0.746
	Btu/h	W	0.293 071 1

To convert from metric units to inch-pound units, divide the metric unit by the conversion factor.

*Exact conversion factors

Note: The information contained in this table is intended to familiarize NRC personnel with commonly used SI units and provide a quick reference to aid in the understanding of documents containing SI units. The conversion factors provided have not been approved as NRC guidelines for development of licensing actions, regulations, or policy.

Source: Federal Standard 376A (May 5, 1983), Preferred Metric Units for General Use by the Federal Government; and International Commission of Radiation Units and Measurements, ICRU Report 33 (1980), Radiation Quantities and Unit

Glossary

AGREEMENT STATE: A State that has signed an agreement with the NRC allowing the State to regulate the use of radioactive material within that State.

BOILING-WATER REACTOR (BWR): A nuclear reactor in which water, used as both coolant and moderator, is allowed to boil in the core.

CAPABILITY: The maximum load that a generating station can carry under specified conditions for a given period of time without exceeding approved limits of temperature and stress. Net summer capability is used in the digest. Measured in watts except as noted otherwise.

CAPACITY FACTOR (Gross): The ratio of the gross electricity generated, for the period of time considered, to the energy that could have been generated at continuous full-power operation during the same period.

CAPACITY FACTOR (Net): The ratio of the net electricity generated, for the period of time considered, to the energy that could have been generated at continuous full-power operation during the same period.

CASK: A heavily shielded container used to store and/or ship radioactive materials. Lead and steel are common materials used in the manufacture of casks.

COMPACT: A group of two or more States formed to dispose of low-level radioactive waste on a regional basis. Forty-four States have formed ten compacts.

CONSTRUCTION RECAPTURE: The maximum number of years that could be added to the license expiration date to recover the period from the construction permit to the date when the operating license was granted. A licensee is required to submit an application for such a change.

CONTAMINATION: The deposition of unwanted radioactive material on the surfaces of structures, areas, objects, or personnel.

DECOMMISSION: The process of safely removing a facility from service followed by reducing residual radioactivity to a level that permits the release of the property for unrestricted and, under certain conditions, restricted use.

DECON: A method of decommissioning in which the equipment, structures, and portions of a facility and site containing radioactive contaminants are removed or decontaminated to a level that permits the property to be released for unrestricted use shortly after cessation of operations.

(continued)

Glossary (continued)

DECONTAMINATION: The reduction or removal of contaminated radioactive material from a structure, area, object, or person.

ENTOMB: A method of decommissioning in which radioactive contaminants are encased in a structurally long-lived material, such as concrete. The entombment structure is appropriately maintained, and continued surveillance is carried out until the radioactivity decays to a level permitting unrestricted release of the property.

FISCAL YEAR: The 12-month period, from October 1 through September 30, used by the Federal Government in budget formulation and execution. The fiscal year is designated by the calendar year in which it ends.

FUEL CYCLE: The series of steps involved in supplying fuel for nuclear power reactors.

FULL-TIME EQUIVALENT: A measurement equal to one staff person working a full-time work schedule for 1 year.

GENERATION (Gross): The total amount of electric energy produced by a generating station as measured at the generator terminals. Measured in watthours except as noted otherwise.

GENERATION (Net): The gross amount of electric energy produced minus the electric energy consumed at a generating station for station use. Measured in watthours except as noted otherwise.

GIGAWATT: One billion watts.

GIGAWATTHOUR: One billion watthours.

HIGH-LEVEL WASTE: High-level radioactive waste (HLW) means (1) irradiated (spent) reactor fuel; (2) liquid waste resulting from the operation of the first cycle solvent extraction system, and the concentrated wastes from subsequent extraction cycles, in a facility for reprocessing irradiated reactor fuel; and (3) solids into which such liquid wastes have been converted. HLW is primarily in the form of spent fuel discharged from commercial nuclear power reactors. It also includes some reprocessed HLW from defense activities, and a small quantity of reprocessed commercial HLW.

KILOWATT (KW): One thousand watts.

LOW-LEVEL WASTE: Low-level radioactive waste (LLW) is a general term for a wide range of wastes. Industries; hospitals and medical, educational, or research institutions; private or Government laboratories; and nuclear fuel cycle facilities (e.g., nuclear power reactors and fuel fabrication plants) using radioactive materi-

als generate low-level wastes as part of their normal operations. These wastes are generated in many physical and chemical forms and levels of contamination.

MAXIMUM DEPENDABLE CAPACITY (Gross): Dependable main-unit gross capacity, winter or summer, whichever is smaller. The dependable capacity varies because the unit efficiency varies during the year because of temperature variations in cooling water. It is the gross electrical output as measured at the output terminals of the turbine generator during the most restrictive seasonal conditions (usually summer). Measured in watts except as noted otherwise.

MAXIMUM DEPENDABLE CAPACITY (Net): Gross maximum dependable capacity minus the normal station service loads. Measured in watts except as noted otherwise.

MEGAWATT (MW): One million watts.

MEGAWATTHOUR (MWh): One million watthours.

METRIC TON: Approximately 2,200 pounds.

NET SUMMER CAPABILITY: The steady hourly output that generating equipment is expected to supply to system load exclusive of auxiliary power, as demonstrated by tests at the time of summer peak demand. Measured in watts except as noted otherwise.

NONPOWER REACTOR: A nuclear reactor used for research, training, and test purposes, and for the production of radioisotopes for medical and industrial uses.

POSSESSION-ONLY LICENSE: A form of license that allows possession but not operation.

PRESSURIZED-WATER REACTOR (PWR): A nuclear reactor in which heat is transferred from the core to a heat exchanger via water kept under high pressure without boiling the water.

PRODUCTION EXPENSE: Production expenses are a component of generation expenses that includes costs associated with operation, maintenance, and fuel.

RADIOACTIVITY: The rate at which radioactive material emits radiation. Measured in units of becquerels or disintegrations per second.

SAFSTOR: A method of decommissioning in which the nuclear facility is placed and maintained in such condition that the nuclear facility can be safely stored and subsequently decontaminated (deferred decontamination) to levels that permit release for unrestricted use.

(continued)

Glossary (continued)

SPENT NUCLEAR FUEL: Fuel that has been removed from a nuclear reactor because it can no longer sustain power production for economic or other reasons.

URANIUM FUEL FABRICATION FACILITY: A facility that (1) manufactures reactor fuel containing uranium for any of the following: (i) preparation of fuel materials; (ii) formation of fuel materials into desired shapes; (iii) application of protective cladding; (iv) recovery of scrap material; and (v) storage associated with such operations; or (2) conducts research and development activities.

URANIUM HEXAFLUORIDE PRODUCTION FACILITY: A facility that receives natural uranium in the form of ore concentrate and converts it into uranium hexafluoride (UF_6).

VIABILITY ASSESSMENT: A DOE decisionmaking process to judge the prospects for geologic disposal of high-level radioactive wastes at Yucca Mountain based on (1) specific design work on the critical elements of the repository and waste package, (2) a total system performance assessment that will describe the probable behavior of the repository, (3) a plan and cost estimate for the work required to complete a license application, and (4) an estimate of the costs to construct and operate the repository.

WATT: The electrical unit of power. The rate of energy transfer equivalent to 1 ampere flowing under a pressure of 1 volt at unity power factor.

WATTHOUR: An electrical energy unit of measure equal to 1 watt of power supplied to, or taken from, an electrical circuit steadily for 1 hour.

WHEELING SERVICE: The movement of electricity from one system to another over transmission facilities of intervening systems. Wheeling service contracts can be established between two or more systems.

NRC FORM 335 (2-89) NRCM 1102 3201, 3202		U.S. NUCLEAR REGULATORY COMMISSION	
BIBLIOGRAPHIC DATA SHEET <i>(See instructions on the reverse)</i>		1. REPORT NUMBER (Assigned by NRC, Add Vol., Supp., Rev., and Addendum Numbers, if any.) NUREG-1350, Volume 16, Rev. 1	
2. TITLE AND SUBTITLE U.S. Nuclear Regulatory Commission Information Digest 2004-2005 Edition		3. DATE REPORT PUBLISHED	
		MONTH February	YEAR 2005
5. AUTHOR(S) Alesha Bellinger, Jo Anne Johnson, et al.		4. FIN OR GRANT NUMBER 	
6. TYPE OF REPORT Annual		7. PERIOD COVERED (Inclusive Dates) 2003	
8. PERFORMING ORGANIZATION - NAME AND ADDRESS (If NRC, provide Division, Office or Region, U.S. Nuclear Regulatory Commission, and mailing address, if contractor, provide name and mailing address.) Division of Planning, Budget, and Analysis Office of the Chief Financial Officer U.S. Nuclear Regulatory Commission Washington, DC 20555-0001			
9. SPONSORING ORGANIZATION - NAME AND ADDRESS (If NRC, type "Same as above"; if contractor, provide NRC Division, Office or Region, U.S. Nuclear Regulatory Commission, and mailing address.) Same as 8, above			
10. SUPPLEMENTARY NOTES 			
11. ABSTRACT (200 words or less) The Nuclear Regulatory Commission Information Digest provides a summary of information about the U.S. Nuclear Regulatory Commission (NRC), NRC's regulatory responsibilities, NRC licensed activities, and general information on domestic and world-wide nuclear energy. The digest, published annually, is a compilation of nuclear- and NRC - related data and is designed to serve as a quick reference to major facts about the agency and the industry it regulates. Information on generating capacity and average capacity factor for operating U.S. commercial nuclear power reactors is obtained from the NRC, as well as from various industry sources. This information is reviewed by the NRC for consistency only and no independent validation and/or verification is performed.			
12. KEY WORDS/DESCRIPTORS (List words or phrases that will assist researchers in locating the report.) Information Digest 2004-2005 Revised Edition NRC Facts		13. AVAILABILITY STATEMENT unlimited	
		14. SECURITY CLASSIFICATION <i>(This Page)</i> unclassified	
		15. NUMBER OF PAGES 	
		16. PRICE 	

NRC FORM 335 (2-89)

AVAILABILITY OF REFERENCE MATERIALS IN NRC PUBLICATIONS

NRC Reference Material

As of November 1999, you may electronically access NUREG-series publications and other NRC records at NRC's Public Electronic Reading Room at <http://www.nrc.gov/reading-rm.html>.

Publicly released records include, to name a few, NUREG-series publications; *Federal Register* notices; applicant, licensee, and vendor documents and correspondence; NRC correspondence and internal memoranda; bulletins and information notices; inspection and investigative reports; licensee event reports; and Commission papers and their attachments.

NRC publications in the NUREG series, NRC regulations, and *Title 10, Energy*, in the Code of *Federal Regulations* may also be purchased from one of these two sources.

1. The Superintendent of Documents
U.S. Government Printing Office
Mail Stop S50P
Washington, DC 20402-0001
Internet: bookstore.gpo.gov
Telephone: 202-512-1800
Fax: 202-512-2250
2. The National Technical Information Service
Springfield, VA 22161-0002
www.ntis.gov
1-800-553-6847 or, locally, 703-605-6000

A single copy of each NRC draft report for comment is available free, to the extent of supply, upon written request as follows:

Address: Office of the Chief Information Officer,
Reproduction and Distribution
Services Section
U.S. Nuclear Regulatory Commission
Washington, DC 20555-0001

E-mail: DISTRIBUTION@nrc.gov
Facsimile: 301-415-2289

Some publications in the NUREG series that are posted at NRC's Web site address <http://www.nrc.gov/reading-rm/doc-collections/nuregs> are updated periodically and may differ from the last printed version. Although references to material found on a Web site bear the date the material was accessed, the material available on the date cited may subsequently be removed from the site.

Non-NRC Reference Material

Documents available from public and special technical libraries include all open literature items, such as books, journal articles, and transactions, *Federal Register* notices, Federal and State legislation, and congressional reports. Such documents as theses, dissertations, foreign reports and translations, and non-NRC conference proceedings may be purchased from their sponsoring organization. Copies of industry codes and standards used in a substantive manner in the NRC regulatory process are maintained at—

The NRC Technical Library
Two White Flint North
11545 Rockville Pike
Rockville, MD 20852-2738

These standards are available in the library for reference use by the public. Codes and standards are usually copyrighted and may be purchased from the originating organization or, if they are American National Standards, from—
American National Standards Institute
11 West 42nd Street
New York, NY 10036-8002
www.ansi.org
212-642-4900

Legally binding regulatory requirements are stated only in laws; NRC regulations; licenses, including technical specifications; or orders, not in NUREG-series publications. The views expressed in contractor-prepared publications in this series are not necessarily those of the NRC.

The NUREG series comprises (1) technical and administrative reports and books prepared by the staff (NUREG-XXXX) or agency contractors (NUREG/CR-XXXX), (2) proceedings of conferences (NUREG/CP-XXXX), (3) reports resulting from international agreements (NUREG/IA-XXXX), (4) brochures (NUREG/BR-XXXX), and (5) compilations of legal decisions and orders of the Commission and Atomic and Safety Licensing Boards and of Directors' decisions under Section 2.206 of NRC's regulations (NUREG-0750).

NRC as a Regulatory Agency

U.S. and Worldwide Energy

Operating Nuclear Reactors

Nuclear Materials Safety

Radioactive Waste

Appendices



Office of the Chief Financial Officer
U.S. Nuclear Regulatory Commission

NUREG-1350, Volume 16, Rev. 1