

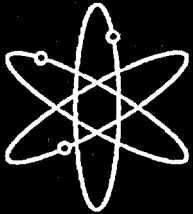

# Common-Cause Failure Event Insights

## Circuit Breakers



**Idaho National Engineering and Environmental Laboratory**

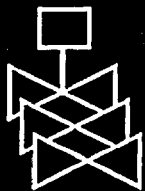

**U.S. Nuclear Regulatory Commission  
Office of Nuclear Regulatory Research  
Washington, DC 20555-0001**



**AVAILABILITY OF REFERENCE MATERIALS  
IN NRC PUBLICATIONS**

**NRC Reference Material**

As of November 1999, you may electronically access NUREG-series publications and other NRC records at NRC's Public Electronic Reading Room at <http://www.nrc.gov/reading-rm.html>. Publicly released records include, to name a few, NUREG-series publications; *Federal Register* notices; applicant, licensee, and vendor documents and correspondence; NRC correspondence and internal memoranda; bulletins and information notices; inspection and investigative reports; licensee event reports; and Commission papers and their attachments.

NRC publications in the NUREG series, NRC regulations, and *Title 10, Energy*, in the Code of *Federal Regulations* may also be purchased from one of these two sources.

1. The Superintendent of Documents  
U.S. Government Printing Office  
Mail Stop SSOP  
Washington, DC 20402-0001  
Internet: [bookstore.gpo.gov](http://bookstore.gpo.gov)  
Telephone: 202-512-1800  
Fax: 202-512-2250
2. The National Technical Information Service  
Springfield, VA 22161-0002  
[www.ntis.gov](http://www.ntis.gov)  
1-800-553-6847 or, locally, 703-605-6000

A single copy of each NRC draft report for comment is available free, to the extent of supply, upon written request as follows:

Address: Office of the Chief Information Officer,  
Reproduction and Distribution  
Services Section  
U.S. Nuclear Regulatory Commission  
Washington, DC 20555-0001  
E-mail: [DISTRIBUTION@nrc.gov](mailto:DISTRIBUTION@nrc.gov)  
Facsimile: 301-415-2289

Some publications in the NUREG series that are posted at NRC's Web site address <http://www.nrc.gov/reading-rm/doc-collections/nuregs> are updated periodically and may differ from the last printed version. Although references to material found on a Web site bear the date the material was accessed, the material available on the date cited may subsequently be removed from the site.

**Non-NRC Reference Material**

Documents available from public and special technical libraries include all open literature items, such as books, journal articles, and transactions, *Federal Register* notices, Federal and State legislation, and congressional reports. Such documents as theses, dissertations, foreign reports and translations, and non-NRC conference proceedings may be purchased from their sponsoring organization.

Copies of industry codes and standards used in a substantive manner in the NRC regulatory process are maintained at—

The NRC Technical Library  
Two White Flint North  
11545 Rockville Pike  
Rockville, MD 20852-2738

These standards are available in the library for reference use by the public. Codes and standards are usually copyrighted and may be purchased from the originating organization or, if they are American National Standards, from—

American National Standards Institute  
11 West 42<sup>nd</sup> Street  
New York, NY 10036-8002  
[www.ansi.org](http://www.ansi.org)  
212-642-4900

Legally binding regulatory requirements are stated only in laws; NRC regulations; licenses, including technical specifications; or orders, not in NUREG-series publications. The views expressed in contractor-prepared publications in this series are not necessarily those of the NRC.

The NUREG series comprises (1) technical and administrative reports and books prepared by the staff (NUREG-XXXX) or agency contractors (NUREG/CR-XXXX), (2) proceedings of conferences (NUREG/CP-XXXX), (3) reports resulting from international agreements (NUREG/IA-XXXX), (4) brochures (NUREG/BR-XXXX), and (5) compilations of legal decisions and orders of the Commission and Atomic and Safety Licensing Boards and of Directors' decisions under Section 2.206 of NRC's regulations (NUREG-0750).

**DISCLAIMER:** This report was prepared as an account of work sponsored by an agency of the U.S. Government. Neither the U.S. Government nor any agency thereof, nor any employee, makes any warranty, expressed or implied, or assumes any legal liability or responsibility for any third party's use, or the results of such use, of any information, apparatus, product, or process disclosed in this publication, or represents that its use by such third party would not infringe privately owned rights.

---

---

# Common-Cause Failure Event Insights

## Circuit Breakers

---

---

Manuscript Completed: March 2003  
Date Published: May 2003

Prepared by  
T. E. Wierman, INEEL  
D. M. Rasmuson, NRC  
N. B. Stockton, INEEL

Idaho National Engineering and Environmental Laboratory  
Idaho Falls, ID 83415

T.R. Wolf, NRC Project Manager

Prepared for  
Division of Risk Analysis and Applications  
Office of Nuclear Regulatory Research  
U.S. Nuclear Regulatory Commission  
Washington, DC 20555-0001  
NRC Job Code Y6194



## **ABSTRACT**

**This report documents a study performed on the set of common-cause failures (CCF) of circuit breakers from 1980 to 2000. The data studied here were derived from the NRC CCF database, which is based on US commercial nuclear power plant event data. This report is the result of an in-depth review of the circuit breaker CCF data and presents several insights about the circuit breaker CCF data. The objective of this document is to look beyond the CCF parameter estimates that can be obtained from the CCF data, to gain further understanding of why CCF events occur and what measures may be taken to prevent, or at least mitigate the effect of, circuit breaker CCF events. This report presents quantitative presentation of the circuit breaker CCF data and discussion of some engineering aspects of the circuit breaker events.**

# CONTENTS

Abstract.....	iii
Executive Summary.....	xi
Foreword.....	xv
Acknowledgments .....	xvii
Acronyms.....	xix
Glossary.....	xxi
<b>1. Introduction.....</b>	<b>1</b>
1.1 Background.....	1
1.2 Common-Cause Failure Event Concepts.....	2
1.3 Report Structure.....	5
<b>2. Circuit Breaker Component Description.....</b>	<b>7</b>
2.1 Introduction.....	7
2.2 Risk Significance.....	7
2.3 Circuit Breaker Type Descriptions and Boundaries .....	7
2.3.1 Medium Voltage (4160 Vac and 6.9 kVac) Circuit Breakers .....	7
2.3.2 480 Vac Circuit Breakers.....	8
2.3.3 Dc Distribution Circuit Breakers .....	8
2.3.4 Reactor Protection System Trip Breakers.....	9
2.4 Failure Modes .....	10
<b>3. High Level Overview of Circuit Breaker Insights .....</b>	<b>13</b>
3.1 Introduction.....	13
3.2 CCF Trends Overview .....	14
3.3 CCF Circuit Breaker Type Overview .....	16
3.4 CCF Proximate Cause.....	17
3.5 CCF Coupling Factor.....	20
3.6 CCF Discovery Method Overview .....	21
3.7 Other Circuit Breaker CCF Observations.....	22

<b>4.</b>	<b>Engineering Insights by Circuit Breaker Type.....</b>	<b>25</b>
4.1	Introduction.....	25
4.2	RPS Trip Breakers .....	27
4.3	Medium Voltage (4160 Vac and 6.9 kV) Circuit Breakers .....	30
4.4	480 Vac Circuit Breakers.....	33
4.5	Dc Distribution Circuit Breakers .....	36
<b>5.</b>	<b>How To Obtain More Detailed Information.....</b>	<b>37</b>
<b>6.</b>	<b>References .....</b>	<b>39</b>
<b>Appendix A</b>	<b>Data Summary .....</b>	<b>A-1</b>
<b>Appendix B</b>	<b>Data Summary by Breaker Type .....</b>	<b>B-1</b>

## FIGURES

Figure ES-1. Trend for all circuit breaker CCF events. The decreasing trend is statistically significant with a p-value = 0.0001. ....	xii
Figure ES-2. Proximate cause distribution for all circuit breaker CCF events.....	xii
Figure ES-3. Circuit breaker type distribution for all circuit breaker CCF events. ....	xiv
Figure 2-1. Generic distribution system. ....	8
Figure 2-2. Dc power distribution configuration.....	9
Figure 2-3. Reactor trip breaker configurations.....	10
Figure 3-1. Trend for all circuit breaker CCF events. The decreasing trend is statistically significant with a p-value = 0.0001. ....	14
Figure 3-2. Trend for all circuit breaker CCF events for the fail-to-close failure mode. The decreasing trend is statistically significant with a p-value = 0.0099 .....	15
Figure 3-3. Trend for all circuit breaker CCF events for the fail-to-open failure mode. The decreasing trend is statistically significant with a p-value = 0.0001. P-value is 0.6746 for 1987-2000 data.....	16
Figure 3-4. Circuit breaker type distribution for all circuit breaker CCF events.....	17
Figure 3-5. Proximate cause distribution for all circuit breaker CCF events. ....	18
Figure 3-6. Coupling factor distribution for all circuit breaker CCF events. ....	20
Figure 3-7. Discovery method distribution for all circuit breaker CCF events. ....	22
Figure 3-8. Distribution of NPP units experiencing a multiplicity of CCFs for all circuit breaker CCF events.....	23
Figure 3-9. Distribution of the failed piece-part for all circuit breaker CCF events.....	24
Figure 4-1. Distribution of proximate causes for the RPS trip breaker type. ....	28
Figure 4-2. Distribution of the method of discovery for the RPS trip breaker type. ....	29
Figure 4-3. Distribution of the affected piece part for the RPS trip circuit breaker type. ....	29
Figure 4-4. Distribution of proximate causes for the Medium Voltage circuit breaker type.....	31
Figure 4-5. Distribution of the method of discovery for the Medium Voltage circuit breaker type.....	32
Figure 4-6. Distribution of the affected piece part for the Medium Voltage circuit breaker type. ....	33

**Figure 4-7. Distribution of proximate causes for the 480 Vac circuit breaker type. ....34**  
**Figure 4-8. Distribution of the method of discovery for the 480 Vac circuit breaker type. ....35**  
**Figure 4-9. Distribution of the affected piece part for the 480 Vac circuit breaker type.....35**



## TABLES

Table F-1. Summary of insights from circuit breaker common-cause failure events.....	xv
Table 3-1. Summary statistics of circuit breaker data. ....	13
Table 4-1. Summary of circuit breaker types. ....	25
Table 4-2. Proximate cause hierarchy. ....	26
Table 4-3. CCF events in RPS trip breaker type by cause group and degree of failure. ....	27
Table 4-4. RPS trip circuit breaker type event short descriptions for Complete events.....	30
Table 4-5. CCF events in Medium Voltage circuit breaker type by cause group and degree of failure. .....	31
Table 4-6. CCF events in the 480 Vac circuit breaker type by cause group and degree of failure. .	33
Table 4-7. 480 Vac circuit breaker type event short description for the Complete event. ....	36

## EXECUTIVE SUMMARY

This report provides insights related to circuit breaker common-cause failure (CCF) events. These events were obtained from the U.S. Nuclear Regulatory Commission's (NRC) CCF Database. The circuit breaker CCF data contains attributes about events that are of interest in the understanding of: completeness of the failures, occurrence rate trends of the events, circuit breaker type affected, causal factors, coupling or linking factors, and event detection methods. Distributions of these CCF characteristics and trends were analyzed and individual events were reviewed for insights.

**General Insights.** The study identified 119 events occurring at U.S. nuclear power plant (NPP) units during the period from 1980 through 2000. Twenty-nine NPP units each had one CCF event during the period; 54 NPP units did not experience a circuit breaker CCF event. This accounts for about 76 percent of the NPP units. Seventy-four percent of the total circuit breaker CCF events occurred at 51 of the NPP units. Of the 119 events, four of them (three percent) were Complete common-cause failures (failure events with all components failed due to a single cause in a short time) and two events were Almost Complete. The small fraction of Complete and Almost Complete events is mainly due to the large populations of circuit breakers in NPP units and the large number of minor events such as slow closing times, trip voltage out-of-specification, etc.

**Failure Modes.** The events were classified as either fail-to-open or fail-to-close. The failure mode for the majority of the circuit breaker CCF events is fail-to-close (55 percent). The fail-to-open failure mode accounted for the other 45 percent of the events.

**Trends.** Figure ES-1 shows the trend for all circuit breaker CCF events. The decreasing trend for all circuit breaker CCF events is statistically significant with a p-value of 0.0001. Based on the review of failure data for this study, improved maintenance and operating procedures, as well as increased maintenance focus and emphasis on equipment reliability from initiatives throughout the industry (NRC, utilities, INPO, and EPRI), appear to be a reason for the observed reduction of the occurrence of CCF events over the 21 years of experience included in this study. The fail-to-close and the fail-to-open failure modes both exhibited statistically significant decreasing trends.

**Method of Discovery.** When the method of discovery was investigated, Testing accounted for 71 events (60 percent), Demand for 25 events (21 percent), Maintenance 11 events (9 percent), and Inspection 12 events (10 percent). The testing program has shown that it is successful in detecting faults.

**Proximate Cause.** As shown in Figure ES-2, the leading proximate cause group was Internal to Component and accounted for 61 percent of the total. Design/Construction/Installation/Manufacture Inadequacy accounted for about 18 percent of the total events. The Operational/Human error cause group accounted for 13 percent of the total events. There were eight events attributed to the Other cause category. Although the Internal to Component cause group had the largest fraction of the events, only three percent were Complete failures.

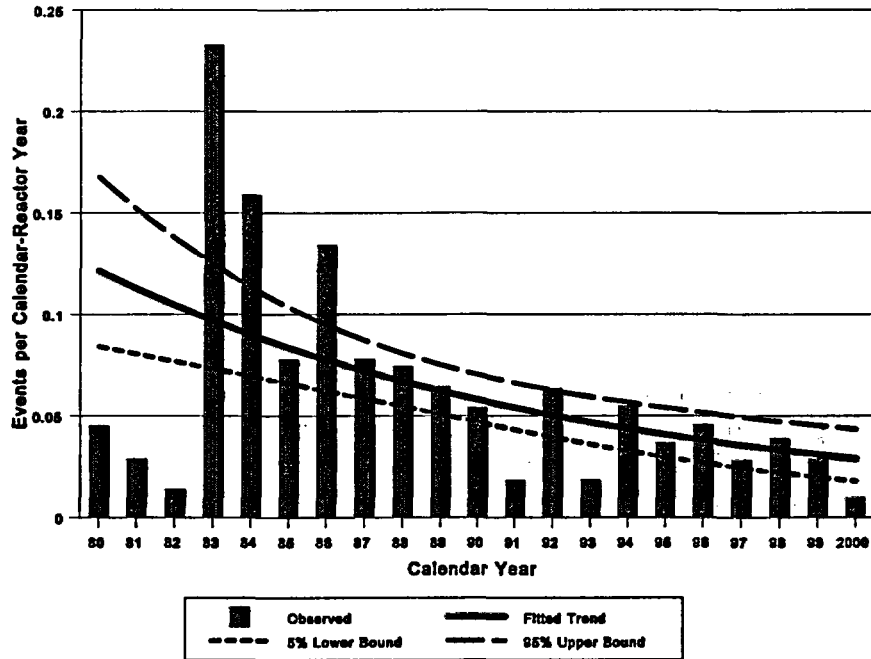

Figure ES-1. Trend for all circuit breaker CCF events. The decreasing trend is statistically significant with a p-value = 0.0001.

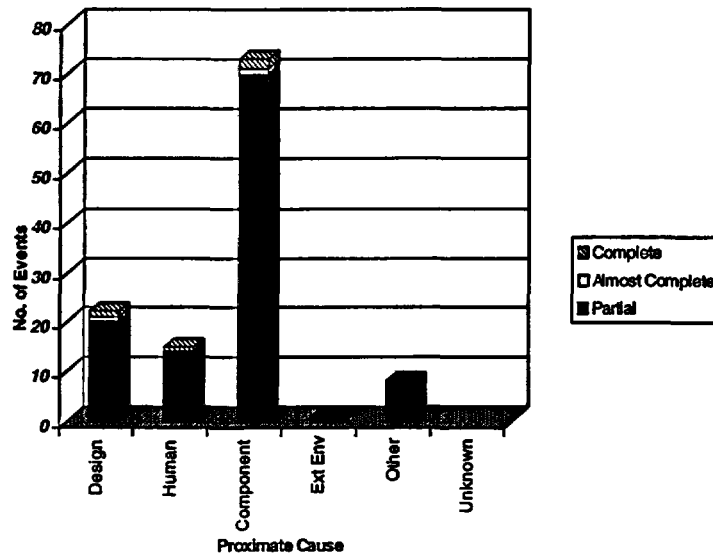

Figure ES-2. Proximate cause distribution for all circuit breaker CCF events.

The Internal to Component proximate cause category is the most likely for the circuit breakers and encompasses the malfunctioning of hardware internal to the component. Circuit breaker failure due

to internal causes are most likely the result of phenomena such as dirt and dust, hardening of lubricants, aging, normal wear, and binding. Generally, these failures are thought of as being preventable by more frequent maintenance.

The **Design/Construction/Installation/Manufacture Inadequacy** proximate cause group is important for the circuit breakers and encompasses events related to the design, construction, installation, and manufacture of components, both before and after the plant is operational. Included in this category are events resulting from errors in equipment and system specifications, material specifications, and calculations. Events related to maintenance activities are not included.

The **Operational/Human Error** proximate cause group is the next most likely for circuit breakers and represents causes related to errors of omission or commission on the part of plant staff or contractor staff. Included in this category are accidental actions, failures to follow the correct procedures or following inadequate procedures for construction, modification, operation, maintenance, calibration, and testing. This proximate cause group also includes deficient training.

The **Other** proximate cause group is comprised of events that include setpoint drift and the state of other components as the basic causes. All of these events were attributed to setpoint drift, which tends to be a minor failure mode. Half of these events were in the reactor trip breakers (RTBs) and involved failure of the undervoltage trip mechanism to trip the breakers within the required time or voltage tolerances.

**Coupling Factors.** Maintenance, with 80 events (67 percent), is the leading coupling factor. Design coupling factors, with 20 events (17 percent) result from common characteristics among components determined at the design level. Quality coupling factors, with 16 events (13 percent) result from common manufacturing and installation faults. These three coupling factors account for the top 97 percent of the events.

**Circuit Breaker Type.** As shown in Figure ES-3, the highest number of events occurred in the RTB breaker type (50 events or 42 percent). The Medium Voltage and 480 Vac circuit breaker types also had many events (34 and 31, respectively). The dc distribution circuit breakers had very few events in the data set. The distribution has less to do with a comparison of circuit breaker CCFs than with the reporting of non-safety significant components and the initial data gathering performed for the CCF database.

**Piece Parts.** For all breaker types, the mechanical assembly had the most events, 31 (26 percent). The mechanical assembly was identified for all breaker types. Most of these events were coupled by inadequate maintenance. The undervoltage (UV) trip assembly had the second most events, 28 (24 percent). The UV trip assembly was identified mostly for the RTBs.

The most likely piece part involved in a reactor trip breaker CCF event was the UV trip assembly. The most likely piece part involved in both medium voltage and 480 Vac breaker CCF events was the mechanical operating assembly.

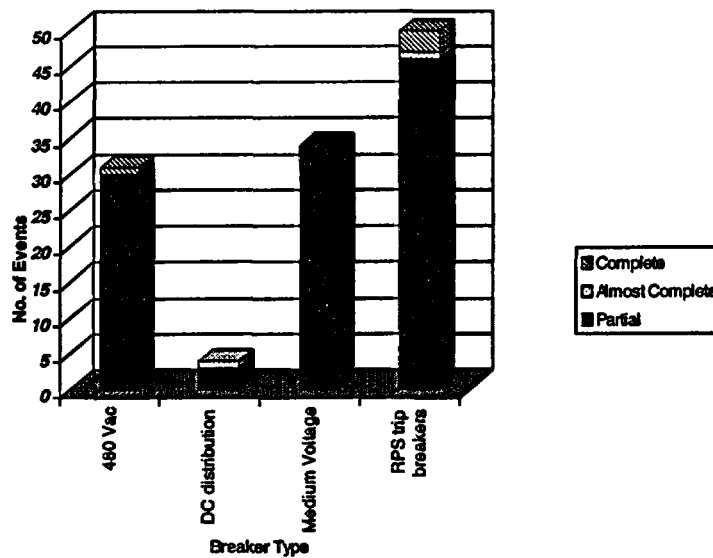

Figure ES-3. Circuit breaker type distribution for all circuit breaker CCF events.

## FOREWORD

This report provides common-cause failure (CCF) event insights for distribution circuit breakers. The results, findings, conclusions, and information contained in this study, the initiating event update study, and related system reliability studies conducted by the Office of Nuclear Regulatory Research support a variety of risk-informed NRC activities. These include providing information about relevant operating experience that can be used to enhance plant inspections of risk-important systems, and information used to support staff technical reviews of proposed license amendments, including risk-informed applications. In addition, this work will be used in the development of enhanced performance indicators that will be based largely on plant-specific system and equipment performance.

Findings and conclusions from the analyses of the circuit breaker CCF data, which are based on 1980-2000 operating experience, are presented in the Executive Summary. High-level insights of all the circuit breaker CCF data are presented in Section 3. Section 4 summarizes the events by circuit breaker type. Section 5 provides information about how to obtain more detailed information for the circuit breaker CCF events. The information to support risk-informed regulatory activities related to the circuit breaker CCF data is summarized in Table F-1. This table provides a condensed index of risk-important data and results presented in discussions, tables, figures, and appendices.

Table F-1. Summary of insights from circuit breaker common-cause failure events.

Item	Description	Text Reference	Page(s)	Data
1.	CCF trends overview	Section 3.2	14	Figure 3-1 – Figure 3-3
2.	CCF circuit breaker type overview	Section 3.3	16	Figure 3-4
3.	CCF proximate cause overview	Section 3.4	17	Figure 3-5
4.	CCF coupling factor overview	Section 3.5	20	Figure 3-6
5.	CCF discovery method overview	Section 3.6	21	Figure 3-7
6.	Engineering Insights – RPS Trip Breakers	Section 4.2	27	Figure 4-1 – Figure 4-3
7.	Engineering Insights – Medium Voltage Circuit Breakers	Section 4.3	30	Figure 4-4 – Figure 4-6
8.	Engineering Insights – 480 Vac Circuit Breakers	Section 4.4	33	Figure 4-7 – Figure 4-9
9.	Engineering Insights – Dc Distribution Circuit Breakers	Section 4.5	36	
10.	Data Summaries	Appendix A and B		

The application of results to plant-specific applications may require a more detailed review of the relevant Licensee Event Report (LER) and Nuclear Plant Reliability Data System (NPRDS) or Equipment Performance Information and Exchange System (EPIX) data cited in this report. This review is needed to determine if generic experiences described in this report and specific aspects of the circuit breaker CCF events documented in the LER and NPRDS failure records are applicable to the design and operational features at a specific plant or site. Factors such as system design, specific circuit breaker components installed in the system, and test and maintenance practices would need to be considered in light of specific information provided in the LER and NPRDS failure records. Other documents such as logs, reports, and inspection reports that contain information about plant-specific experience (e.g., maintenance, operation,

or surveillance testing) should be reviewed during plant inspections to supplement the information contained in this report.

Additional insights may be gained about plant-specific performance by examining the specific events in light of overall industry performance. In addition, a review of recent LERs and plant-specific component failure information in NPRDS or EPIX may yield indications of whether performance has undergone any significant change since the last year of this report. NPRDS archival data (through 1996) and EPIX failure data are proprietary information that can be obtained from the EPIX database through the Institute of Nuclear Power Operations (INPO). NRC staff and contractors can access that information through the EPIX database.

Common-cause failures used in this study were obtained from the common-cause failure database maintained for the NRC by the INEEL. NRC staff and contractors can access the plant-specific CCF information through the CCF database that is available on CD-ROM and has been provided to the NRC Regions and NRC Office of Nuclear Reactor Regulation (NRR). To obtain access to the NRC CCF Database, contact Dale Rasmuson [dmr@nrc.gov; (301) 415-7571] at the NRC or S. Ted Wood at the INEEL [stw@inel.gov; (208) 526-8729].

Periodic updates to the information in this report will be performed, as additional data become available. In the future, these insights will be available on the RES internal web page.

Scott F. Newberry, Director  
Division of Risk Analysis & Applications  
Office of Nuclear Regulatory Research

## **ACKNOWLEDGMENTS**

**This report benefited from the questions and comments of P.W. Baranowsky, S.E. Mays, T.R. Wolf, W.S. Raughley, R.L. Lloyd, A. Serkiz, D.E. Hickman, S.R. Stein, D.H. Coe, P.S. Koltay, A.A. El-Bassioni, W.E. Scott, G.W. Parry, H.J. VanderMolen, L.L. Collins, and W.C. Leschek of the Nuclear Regulatory Commission.**

**Technical reviews by M.B. Sattison of the INEEL, T. J. Mikschl, and K. N. Fleming of ERIN Engineering, and A. Mosleh contributed substantially to the final report.**

**Technical contributions were made by F. M. Marshall and W. J. Kohn of the INEEL.**



## ACRONYMS

ac	alternating current
CCCG	common-cause failure component group
CCF	common-cause failure
CFR	Code of Federal Regulations
dc	direct current
EPIX	equipment performance and information exchange
FTC	fail-to-close
FTO	fail-to-open
INEEL	Idaho National Engineering and Environmental Laboratory
INPO	Institute of Nuclear Power Operations
IPE	individual plant examination
kVac	kilo-volts alternating current
LER	licensee event report
MCC	motor control center
NPAR	nuclear plant aging research
NPP	nuclear power plant
NPRDS	Nuclear Plant Reliability Data System
NRC	Nuclear Regulatory Commission
PRA	probabilistic risk assessment
PWR	pressurized water reactor
RPS	reactor protection system
RTB	reactor trip breaker
SCSS	Sequence Coding and Search System
USI	unresolved safety issue
UV	under voltage
Vac	volts alternating current
Vdc	volts direct current

## GLOSSARY

**Application**—A particular set of CCF events selected from the common-cause failure database for use in a specific study.

**Average Impact Vector**—An average over the impact vectors for different hypotheses regarding the number of components failed in an event.

**Basic Event**—An event in a reliability logic model that represents the state in which a component or group of components is unavailable and does not require further development in terms of contributing causes.

**Common-cause Event**—A dependent failure in which two or more component fault states exist simultaneously, or within a short time interval, and are a direct result of a shared cause.

**Common-cause Basic Event**—In system modeling, a basic event that represents the unavailability of a specific set of components because of shared causes that are not explicitly represented in the system logic model as other basic events.

**Common-cause Component Group**—A group of (usually similar [in mission, manufacturer, maintenance, environment, etc.]) components that are considered to have a high potential for failure due to the same cause or causes.

**Common-cause Failure Model**—The basis for quantifying the probability of common-cause events. Examples include the beta factor, alpha factor, basic parameter, and the binomial failure rate models.

**Component**—An element of plant hardware designed to provide a particular function.

**Component Boundary**—The component boundary encompasses the set of piece parts that are considered to form the component.

**Component Degradation Value**—The assessed probability ( $0.0 \leq p \leq 1.0$ ) that a functionally- or physically-degraded component would fail to complete the mission.

**Component State**—Component state defines the component status in regard to its intended function. Two general categories of component states are defined, available, and unavailable.

**Available**—The component is available if it is capable of performing its function according to a specified success criterion. (N.B., available is not the same as availability.)

**Unavailable**—The component is unavailable if the component is unable to perform its intended function according to a stated success criterion. Two subsets of unavailable states are failure and functionally unavailable.

**Coupling Factor/Mechanism**—A set of causes and factors characterizing why and how a failure is systematically induced in several components.

**Date**—The date of the failure event, or date the failure was discovered.

**Defense**—Any operational, maintenance, and design measures taken to diminish the probability and/or consequences of common-cause failures.

**Degree of Failure**— The Degree of Failure category has three groups: Complete, Almost Complete, and Partial. The degree of failure is a categorization of a CCF event by the magnitude of three quantification parameters: component degradation value, shared cause factor, and timing factor. These parameters can be given values from zero to 1.0. The degree of failure categories are defined as follows:

**Complete**—A common-cause failure in which all redundant components are failed simultaneously as a direct result of a shared cause; i.e., the component degradation value equals 1.0 for all components, and both the timing factor and the shared cause factor are equal to 1.0.

**Almost Complete**—A common-cause failure in which one of the parameters is not equal to 1.0. Examples of events that would be termed Almost Complete are: events in which most components are completely failed and one component is degraded, or all components are completely failed but the time between failures is greater than one inspection interval.

**Partial**—All other common-cause failures (i.e., more than one of the quantification parameters is not equal to 1.0.)

**Dependent Basic Events**—Two or more basic events, A and B, are statistically dependent if, and only if,

$$P[A \cap B] = P[B | A]P[A] = P[A | B]P[B] \neq P[A]P[B],$$

where  $P[X]$  denotes the probability of event X.

**Event**—An event is the occurrence of a component state or a group of component states.

**Exposed Population**—The set of components within the plant that are potentially affected by the common-cause failure event under consideration.

**Failure**—The component is not capable of performing its specified operation according to a success criterion.

**Failure Mechanism**—The history describing the events and influences leading to a given failure.

**Failure Mode**—A description of component failure in terms of the component function that was actually or potentially unavailable.

**Failure Mode Applicability**—The analyst's probability that the specified component failure mode for a given event is appropriate to the particular application.

**Functionally Unavailable**—The component is capable of operation, but the function normally provided by the component is unavailable due to lack of proper input, lack of support function from a source outside the component (i.e., motive power, actuation signal), maintenance, testing, the improper interference of a person, etc.

**Impact Vector**—An assessment of the impact an event would have on a common-cause component group. The impact is usually measured as the number of failed components out of a set of similar components in the common-cause component group.

**Independent Basic Events**—Two basic events, A and B, are statistically independent if, and only if,

$$P[A \cap B] = P[A]P[B],$$

where  $P[X]$  denotes the probability of event X.

**Mapping**—The impact vector of an event must be “mapped up” or “mapped down” when the exposed population of the target plant is higher or lower than that of the original plant that experienced the common-cause failure. The result of mapping an impact vector is an adjusted impact vector applicable to the target plant.

**Mapping Up Factor**—A factor used to adjust the impact vector of an event when the exposed population of the target plan is higher than that of the original plant that experienced the common-cause failure.

**P-Value**—A p-value is a probability, that indicates a measure of statistical significance. The smaller the p-value, the greater the significance. A p-value of less than 0.05 is generally considered statistically significant.

**Potentially Unavailable**—The component is capable of performing its function according to a success criterion, but an incipient or degraded condition exists. (N.B., potentially unavailable is not synonymous with hypothetical.)

**Degraded**—The component is in such a state that it exhibits reduced performance but insufficient degradation to declare the component unavailable according to the specified success criterion.

**Incipient**—The component is in a condition that, if left un-remedied, could ultimately lead to a degraded or unavailable state.

**Proximate Cause**—A characterization of the condition that is readily identified as leading to failure of the component. It might alternatively be characterized as a symptom.

**Reliability Logic Model**—A logical representation of the combinations of component states that could lead to system failure. A fault tree is an example of a system logic model.

**Root Cause**—The most basic reason for a component failure, which, if corrected, could prevent recurrence. The identified root cause may vary depending on the particular defensive strategy adopted against the failure mechanism.

**Shared-Cause Factor ( $c$ )**—A number that reflects the analyst’s uncertainty ( $0.0 \leq c \leq 1.0$ ) about the existence of coupling among the failures of two or more components, i.e., whether a shared cause of failure can be clearly identified.

***Shock***—A shock is an event that occurs at a random point in time and acts on the system; i.e., all the components in the system simultaneously. There are two kinds of shocks distinguished by the potential impact of the shock event, i.e., lethal and nonlethal.

***Statistically Significant***—The term “statistically significant” means that the data are too closely correlated to be attributed to chances and consequently have a systematic relationship.

***System***—The entity that encompasses an interacting collection of components to provide a particular function or functions.

***Timing Factor ( $q$ )*** —The probability ( $0.0 \leq q \leq 1.0$ ) that two or more component failures (or degraded states) separated in time represent a common-cause failure. This can be viewed as an indication of the strength-of-coupling in synchronizing failure times.

# Common-Cause Failure Event Insights for Circuit Breakers

## 1. INTRODUCTION

This report presents insights about the common-cause events that have occurred in circuit breakers at operating nuclear power plants.

The insights for the U.S. plants are derived from information captured in the common-cause failure (CCF) database maintained for the Nuclear Regulatory Commission (NRC) by the Idaho National Engineering and Environmental Laboratory (INEEL). The database contains CCF-related events that have occurred in U.S. commercial nuclear power plants reported in licensee event reports (LERs) and reports to the Nuclear Plant Reliability Data System (NPRDS) and the Equipment Performance Information Exchange (EPIX) system maintained by the Institute for Nuclear Power Operations (INPO)

The information presented in this report is intended to help focus NRC inspections on the more risk-important aspects of circuit breaker CCF events. Utilities can also use the information to help focus maintenance and test programs such that circuit breaker CCF events are minimized.

### 1.1 Background

The following four criteria must be met for an event to be classified as resulting from a common-cause:

- Two or more individual components must fail or be degraded, including failures during demand, inservice testing, or from deficiencies that would have resulted in a failure if a demand signal had been received;
- Two or more individual components must fail or be degraded in a select period of time such that the probabilistic risk assessment (PRA) mission would not be certain;
- The component failures or degradations must result from a single shared cause and coupling mechanism; and
- The component failures are not due to the failure of equipment outside the established component boundary.

To help resolve NRC Generic Issue 145, <sup>1</sup> *Actions to Reduce Common-Cause Failures*, and to address deficiencies related to the availability and analysis of CCF data, the NRC and the INEEL developed a CCF database that codifies information on CCF-related events that have occurred in U.S. commercial nuclear power plants from 1980 to date. The data is derived from both licensee event reports (LERs) submitted to the NRC and equipment performance reports submitted to the INPO. Accompanying the development of the CCF database was the development of CCF analysis software for investigating the CCF aspect of system reliability analyses and related risk-informed applications.

The quantitative results of this CCF data collection effort are described in the four volumes of NUREG/CR-6268, *Common-Cause Failure Database and Analysis System*.<sup>2,3,4,5</sup> Some quantitative insights about the data for use in PRA studies were also published in NUREG/CR-5497,<sup>6</sup> *Common-Cause Failure Parameter Estimations*. Copies of the CCF database together with supporting technical

documentation and the analysis software are available on CD-ROM from the NRC to aid in system reliability analyses and risk-informed applications.

The CCF event data collected, classified, and compiled in the CCF database provide a unique opportunity to go beyond just estimation of CCF frequencies but to also gain more engineering insights into how and why CCF events occur. The data classification employed in the database was designed with this broader objective in mind. The data captured includes plant type, system component, piece parts, failure causes, mechanisms of propagation of failure to multiple components, their functional and physical failure modes. Other important characteristics such as defenses that could have prevented the failures are also included.

Section 1.2 of Volume 3 of NUREG/CR-6268 (Reference 4) proposes methods for classifying common-cause failures using the concepts of causes, coupling factors, and defensive mechanisms. The methods suggest a causal picture of failure with an identification of a root cause, a means by which the cause is more likely to impact a number of components simultaneously (the coupling), and the failure of the defenses against such multiple failures. Utilizing these methods, the CCF data associated with circuit breakers were analyzed to provide a better understanding of circuit breaker CCFs. This report presents the results of this effort.

The data analyzed are derived from the CCF database. The coding and quality assurance (QA) process for entering data into the database is as follows: Each event is coded from an LER or an NPRDS or EPIX report by analysts at the INEEL. Each analyst has access to coding guidelines (NUREG/CR-6268), which provides specific direction to the analyst about what the required information means and how to enter the information into the database. Each analyst is knowledgeable about PRA and plant systems and operations. Each event is initially coded by one analyst and reviewed by another analyst with a comparable background. Any disagreement is resolved before coding of the event is considered completed. An additional review of the events is done by another person familiar with PRA and CCF concepts. An independent outside expert in CCF and PRA then reviews the coding. Any differences are resolved and the final coding changes made in the database. The data collection, analysis, independent review, and quality assurance process are described in more detail in NUREG/CR-6268, Volumes 1 and 3 (References 2 and 4).

## **1.2 Common-Cause Failure Event Concepts**

CCFs can be thought of as resulting from the coexistence of two main factors: one that provides a susceptibility for components to fail or become unavailable due to a particular cause of failure and a coupling factor (or coupling mechanism) that creates the condition for multiple components to be affected by the same cause.

An example is a case where two relief valves fail-to-open at the required pressure due to set points being set too high. Because of personnel error (the proximate cause), each of the two valves fails due to an incorrect setpoint. What makes the two valves fail together, however, is a common calibration procedure and common maintenance personnel. These commonalities are the coupling factors of the failure event in this case.

Characterization of CCF events in terms of these key elements provides an effective means of performing engineering assessments of the CCF phenomenon including approaches to identification of plant vulnerabilities to CCFs and evaluation of the need for, and effectiveness of, defenses against them. It is equally effective in evaluation and classification of operational data and quantitative analysis of CCF frequencies.

It is evident that each component fails because of its susceptibility to the conditions created by the root cause, and the role of the coupling factor is to make those conditions common to several components. In analyzing failure events, the description of a failure in terms of the most obvious "cause" is often too simplistic. The sequence of events that constitute a particular failure mechanism is not necessarily simple. Many different paths by which this ultimate reason for failure could be reached exist. This chain can be characterized by two useful concepts— proximate cause and root cause.

The proximate cause of a failure event is the condition that is readily identifiable as leading to the failure. The proximate cause can be regarded as a symptom of the failure cause, and it does not in itself necessarily provide a full understanding of what led to that condition. As such, it may not be the most useful characterization of failure events for the purposes of identifying appropriate corrective actions. The proximate cause classification consists of six major categories:

- Design, construction, installation, and manufacture inadequacy causes,
- Operational and human-related causes (e.g. procedural errors, maintenance errors),
- Internal to the component, including hardware-related causes and internal environmental causes,
- External environmental causes,
- State of other component, and
- Other causes.

The causal chain can be long and, without applying a criterion identifying an event in the chain as a "root cause," is often arbitrary. Identifying root causes in relation to the implementation of defenses is a useful alternative. The root cause is therefore the most basic reason or reasons for the component failure, which if corrected, would prevent recurrence. Volume 3 of NUREG/CR-6268 (Reference 4) contains additional details on the cause categories and how CCF event causes are classified.

The coupling factor is a characteristic of a group of components or piece parts that identifies them as susceptible to the same causal mechanisms of failure – it is a characteristic that links the components. Such factors include similarity in design, location, environment, mission, and operational, maintenance, and test procedures. Coupling factors are categorized into the following five groups for analysis purposes:

- Hardware Quality,
- Hardware Design,
- Maintenance,
- Operations, and
- Environment.

Note that proximate causes of CCF events are no different from the proximate causes of single component failures.

The proximate causes and the coupling factors may appear to overlap because the same name is sometimes used as a proximate cause and as a coupling factor (e.g., design, maintenance). However, they are different. For example, maintenance, as a proximate cause, refers to errors and mistakes made during maintenance activities. As a coupling factor, maintenance refers to the similarity of maintenance among the components (e.g., same maintenance personnel, same maintenance procedures).



The defense or defensive mechanism is any operational, maintenance, or design measure taken to diminish the probability and/or consequences of a common-cause failure event. Three ways of defending against a CCF event are the following: (1) defend against the failure proximate cause, (2) defend against the coupling factor, or (3) defend against both the proximate cause and the coupling factor. As an example, consider two redundant components in the same room as a steam line. A barrier that separates the steam line from the components is an example of defending against the proximate cause. A barrier that separates the two components is an example of defending against the coupling factor (same location). Installing barriers around each component is an example of defending against both the cause and the coupling factor.

Proximate causes of CCF events are no different from the proximate causes of single component failures. This observation suggests that defending against single component failures can have an impact on CCFs as well. Most corrective actions usually attempt to reduce the frequency of failures (single or multiple). That is, very often the approach to defending against CCFs is to defend against the cause, not the coupling. Given that a defensive strategy is established based on reducing the number of failures by addressing proximate causes, it is reasonable to postulate that if fewer component failures occur, fewer CCF events would occur.

Defenses against causes result in improving the reliability of each component but do not necessarily reduce the fraction of failures that occur due to common-cause. They typically include design control, use of qualified equipment, testing and preventive maintenance programs, procedure review, personnel training, quality control, redundancy, diversity, and barriers. It is important to remember that the susceptibility of a system of redundant components to dependent failures as opposed to independent failures is determined by the presence of coupling factors.

The above cause-defense approach does not address the way that failures are coupled. Therefore, CCF events can occur, but at a lower probability. If a defensive strategy is developed using protection against a coupling factor as a basis, the relationship among the failures is eliminated. A search for coupling factors is primarily a search for similarities among components. A search for defenses against coupling, on the other hand, is primarily a search for dissimilarities among components, including differences in the components themselves (diversity); differences in the way they are installed, operated, and maintained; and in their environment and location.

During a CCF analysis, a defense based on a coupling factor is easier to assess because the coupling mechanism among failures is more readily apparent and therefore easier to interrupt. The following defenses are oriented toward eliminating or reducing the coupling among failures: diversity, physical or functional barriers, and testing and maintenance policies. A defensive strategy based on addressing both the proximate cause and coupling factor would be the most comprehensive.

A comprehensive review should include identification of the root causes, coupling factors, and defenses in place against them. However, as discussed in NUREG/CR-5460,<sup>7</sup> *A Cause-Defense Approach to the Understanding and Analysis of Common-Cause Failures*, given the rarity of common-cause events, current weaknesses of event reporting and other practical limitations, approaching the problem from the point of view of defenses is, perhaps, the most effective and practical. A good defense can prevent a whole class of CCFs for many types of components, and in this way, the application of a procedure based on this philosophy can provide a systematic approach to screening for potential CCF mechanisms.

## 1.3 Report Structure

This report presents an overview of the circuit breaker CCF data and insights into the characteristics of that data. This report is organized as follows: Section 2 presents a description of the circuit breaker, a short description of the associated circuit breaker types, and a definition of the circuit breaker failure modes. High-level insights of all the circuit breaker CCF data are presented in Section 3. Section 4 summarizes the events by circuit breaker type. Section 5 discusses how to obtain more detailed information for the circuit breaker CCF events. A glossary of terms used in this report is included in the front matter. Appendix A contains three listings of the breaker CCF events sorted by proximate cause, coupling factor, and discovery method. Appendix B contains a listing of the breaker CCF events sorted by the breaker type.

## **2. CIRCUIT BREAKER COMPONENT DESCRIPTION**

### **2.1 Introduction**

The circuit breakers analyzed in this report are part of the Class 1E alternating current (ac) and direct current (dc) electrical power distribution systems providing power to electrical buses that supply various components necessary for accident mitigation and safe shutdown of the reactor.

### **2.2 Risk Significance**

The Class 1E ac and dc electrical distribution circuit breakers are relied upon in every potential accident scenario to provide power to vital safety equipment to preserve the functionality of every safety function: reactivity control, reactor coolant system inventory control, decay heat removal, and containment integrity. Because of their risk importance, great effort has gone into the design of the electrical distribution systems to maximize their reliability and reduce susceptibility to common-cause failures through diversity, redundancy, and physical separation.

The reactor trip breakers are the key safety element of the reactor protection systems employed in US NPP units. The risk significance of the RTBs was illustrated by the 1983 events at Salem 1. On two occasions in February 1983, both RTBs failed to open automatically due to mechanical binding of the latch mechanism in the undervoltage trip attachment. The Accident Sequence Precursor Program evaluated these events to have a conditional core damage probability of  $4.6E-3$ .<sup>8</sup>

### **2.3 Circuit Breaker Type Descriptions and Boundaries**

The breakers in the Class 1E ac and dc electrical distribution systems and the RPS are defined by the application of the breaker to investigate possible differences between applications.

#### **2.3.1 Medium Voltage (4160 Vac and 6.9 kVac) Circuit Breakers**

The Medium Voltage circuit breakers considered here are feeder circuit breakers to smaller electrical distribution centers (480 Vac motor control centers), circuit breakers between two 4160 volts-ac (Vac) busses, and the feeder circuit breakers from off-site power. Circuit breakers, which supply power to 4160 Vac and 6.9 kVac busses, as well as circuit breakers supplying loads from the 4160 Vac and 6.9 kVac busses, were also considered. Circuit breakers that supply individual components (e.g., safety injection pumps) are not included in this study, but are included in the component studies as a part of the individual component. Circuit breakers used to supply power from an emergency diesel generator to a 4160-volt bus are specifically excluded and are considered under the separate study of emergency diesel generators. Figure 2-1 shows a typical simplified ac power distribution system. The circuit breakers considered in this study are shown in boxes.

The boundary for the Medium Voltage circuit breaker is the breaker itself and the equipment contained in the breaker cubicle. Ac circuit breakers have overcurrent protection that is integral to the breaker unit. External equipment used to provide additional protection by monitoring parameters such as undervoltage, differential faults, ground faults, and other protection schemes as required for circuit breaker/system protection or the specific safety application are also considered part of the circuit breaker. In addition, remote circuitry used for circuit breaker operation is considered integral to the function of the circuit breaker for failure analysis. It includes all sensing devices, cabling, and components necessary to process the signals and provide control signals to the individual circuit breaker.

### 2.3.2 480 Vac Circuit Breakers

Included within the 480 Vac circuit breaker type are the circuit breakers located at the motor control centers (MCC) and the associated power boards that supply power specifically to any 480-volt equipment. The MCCs and the power boards are not included except for the load shedding and load sequencing circuitry/devices, which are, in some cases, physically located within the MCCs. Load shedding of the safety bus and subsequent load sequencing onto the bus of vital electrical loads is considered integral to the 480 Vac circuit breakers function and is therefore considered within the bounds of this study. All instrumentation, control logic, and the attendant process detectors for system initiations, trips, and operational control are included. Batteries were included if failures impacted 480 Vac circuit breakers functional operability. Figure 2-1 shows a typical 480 Vac circuit breaker arrangement.

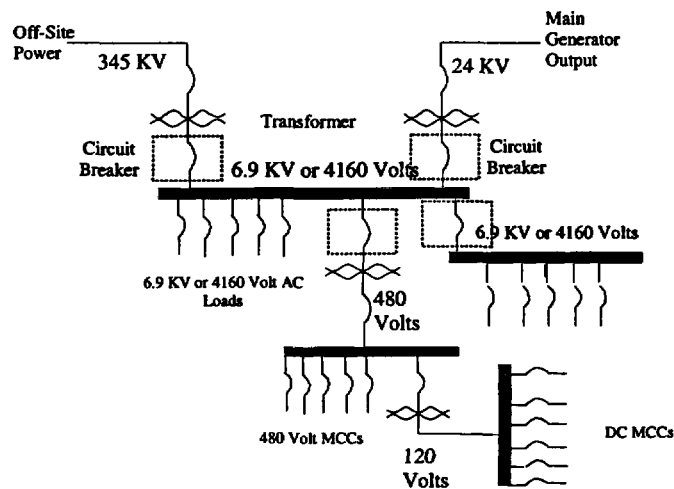

Figure 2-1. Generic distribution system.

### 2.3.3 Dc Distribution Circuit Breakers

Most dc loads are supplied from 125 volt-dc (Vdc) panels through individual distribution circuit breakers, though some plants may have 250 Vdc distribution systems to support dc-powered motor-operated valves or other relatively large dc-powered loads. Multiple trains or divisions are available to ensure dc power is supplied to redundant components. These dc distribution divisions typically number from as few as two to as many as eight depending on the design of the plant. The dc power is normally distributed to the loads from a battery charger in parallel with a battery. The battery charger is usually powered from a Class 1E 480 Vac bus, supplied from off-site power or the emergency diesel generators. In the event power is not available from the normal source, dedicated station batteries supply dc power to the distribution system. A simplified schematic for a typical train or division of dc-power distribution is presented in Figure 2-2.

The dc distribution circuit breakers are normally in the closed position regardless of whether the plant is at power or shutdown. Most of the dc distribution circuit breakers are manipulated locally with only instrumentation available to the control room operator.

The dc circuit breakers have overcurrent protection that is a built-in part of a circuit breaker unit. Most circuit breakers, especially for safety-related equipment applications, provide additional protection by monitoring parameters such as undervoltage, ground faults, and other protection schemes as required for circuit breaker/system protection or the specific safety application. This additional application hardware is generally located external to the circuit breaker and merely utilizes the remote operating features of the circuit breaker. This hardware, as well as the remote operating hardware, is considered integral to the function of the circuit breaker and part of the breaker for failure analysis. It includes all sensing devices, cabling, and components necessary to process the signals and provide control signals to the individual circuit breaker.

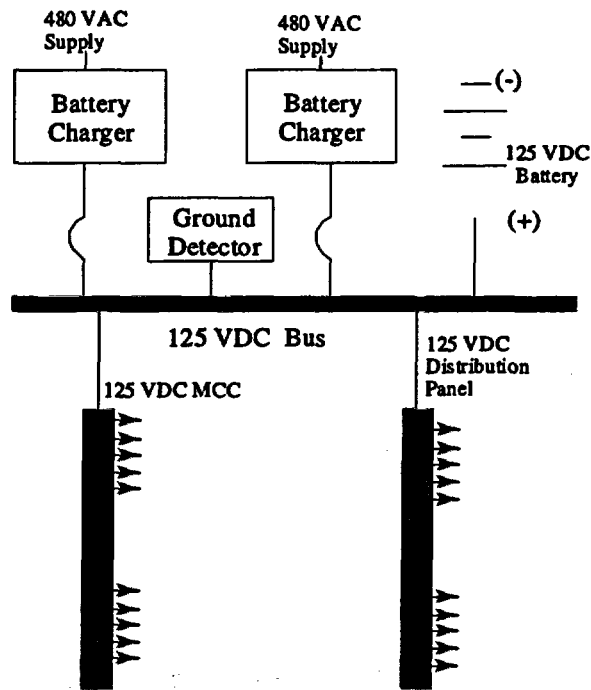

Figure 2-2. Dc power distribution configuration.

### 2.3.4 Reactor Protection System Trip Breakers

The reactor trip breakers (RTBs) are part of the pressurized water reactor (PWR) reactor protection system (RPS), and supply power to the control rod drive mechanisms. Both ac and dc circuit breakers are used for the RTBs depending on the RPS design. On a reactor trip signal, the circuit breakers will open, removing power from the control rod drive mechanisms. The control rods will then unlatch and drop into the reactor core due to gravity. Figure 2-3 shows typical RTB arrangements.

The RTB component is defined as the circuit breaker itself, as well the hardware and controls for the individual breakers that enable them to close and remain closed. The rod drive power supplies and RPS system components are not considered part of the RTB.

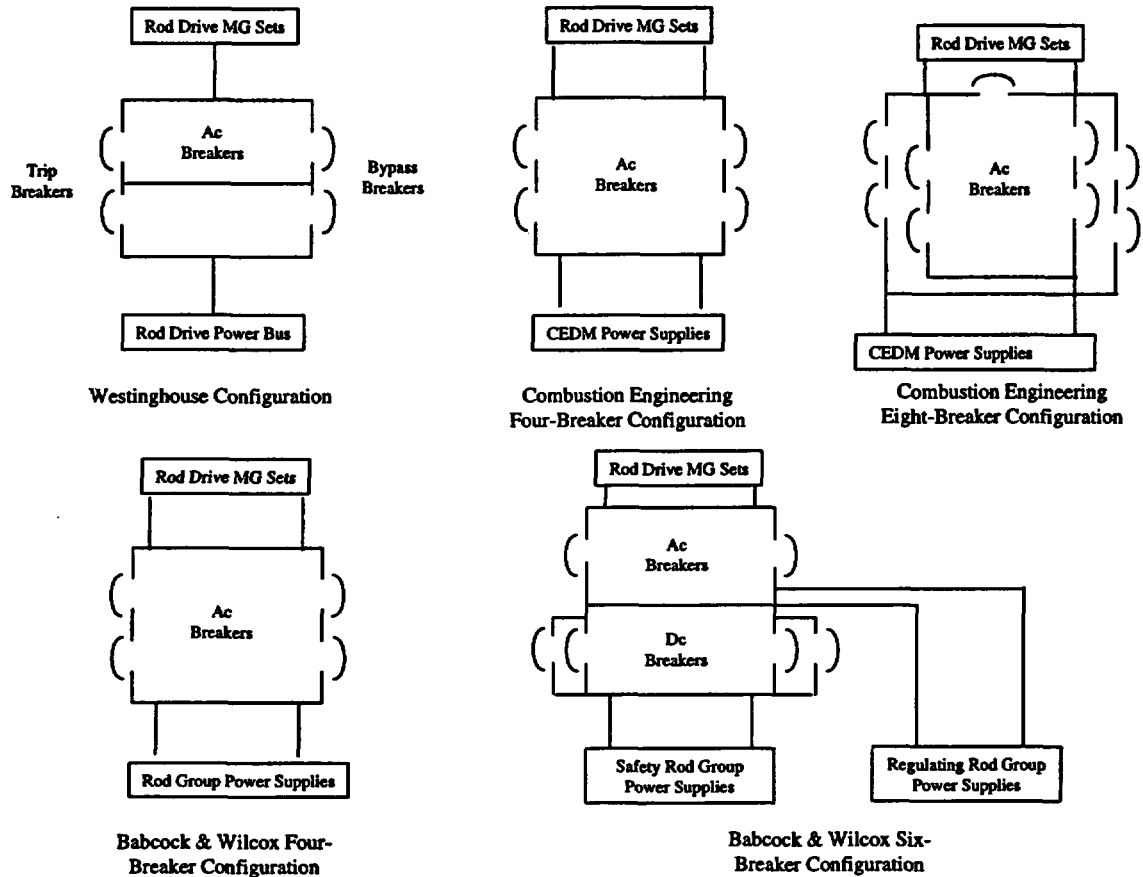

Figure 2-3. Reactor trip breaker configurations.

## 2.4 Failure Modes

Successful circuit breaker system response to a demand requires that the circuit breakers provide electrical power to the required safety-related loads for the duration of the mission time. The failure modes used in evaluating the circuit breaker data were:

- Fail-to-Close (FTC)** The breaker did not close during testing or upon demand, or would not have been able to close if a close signal had been generated.
- Fail-to-Open (FTO)** The breaker did not open during testing or upon demand, or would not have been able to open if an open signal had been generated.

Administrative inoperability events, such as seismic qualification violations, were not considered failures because they were conditional upon the circumstances that would have existed at the time a circuit breaker demand. The exception to this evaluation rule is if a licensee reported that the circuit

**breaker would have failed to perform its safety function in a design basis event. Failure to meet required Technical Specification configurations also was not considered a failure unless the improper configuration would have prevented the circuit breaker from operating properly on a safety demand.**

### 3. HIGH LEVEL OVERVIEW OF CIRCUIT BREAKER INSIGHTS

#### 3.1 Introduction

This section provides an overview of CCF data for the circuit breaker component that has been collected from the NRC CCF database. The set of circuit breaker CCF events is based on industry data from 1980 to 2000. The circuit breaker CCF data contains attributes about events that are of interest in the understanding of: degree of completeness, trends, causal factors, linking or coupling factors, event detection methods, and circuit breaker type.

Not all circuit breaker CCF events included in this study resulted in observed failures of multiple circuit breakers. Many of the events included in the database, in fact, describe degraded states of the circuit breakers where, given the conditions described, the circuit breakers may or may not perform as required. The CCF guidance documents (References 3 and 4) allow the use of three different quantification parameters (component degradation value, shared cause factor, and timing factor) to measure degree of failure for CCF events. Based on the values of these three parameters, a Degree of Failure was assigned to each circuit breaker CCF event.

The Degree of Failure category has three groups—Complete, Almost Complete, and Partial. Complete CCF events are CCF events in which each component within the common-cause failure component group (CCCG) fails completely due to the same cause and within a short time interval (i.e., all quantification parameters equal 1.0). Complete events are important because they show evidence of observed CCFs of all components in a common-cause group. Complete events also dominate the parameter estimates obtained from the CCF database. All other events are termed partial CCF events (i.e., at least one quantification parameter is not equal to 1.0). A subclass of partial CCF events are those that are Almost Complete CCF events. Examples of events that would be termed Almost Complete are: events in which most components are completely failed and one component is degraded, or all components are completely failed but the time between failures is greater than one inspection interval (i.e., all but one of the quantification parameters equal 1.0).

Table 3-1 summarizes, by failure mode and degree of failure, the circuit breaker CCF events contained in this study. The majority of the circuit breaker CCF events were fail-to-close (55 percent). The Complete degree of failure makes up a small fraction (3 percent) of the circuit breaker CCF events. The small fraction of Complete and Almost Complete events is mainly due to the large populations of circuit breakers in plants and the large number of minor events such as slow closing times, trip voltage out-of-specification, etc.

Table 3-1. Summary statistics of circuit breaker data.

Failure Mode	Degree of Failure			Total
	Partial	Almost Complete	Complete	
Fail-to-Open (FTO)	48	2	4	54
Fail-to-Close (FTC)	65			65
Total	113	2	4	119



### 3.2 CCF Trends Overview

Figure 3-1 shows the yearly occurrence rate, the fitted trend, and its 90 percent uncertainty bounds for all circuit breaker CCF events over the time span of this study. The decreasing trend is statistically significant<sup>a</sup> with a p-value<sup>b</sup> of 0.0001. Based on the review of failure data for this study, the improved maintenance and operating procedures as well as the improved testing and inspection requirements have facilitated the observed reduction of the occurrence of CCF events over the 21 years of experience included in this study.

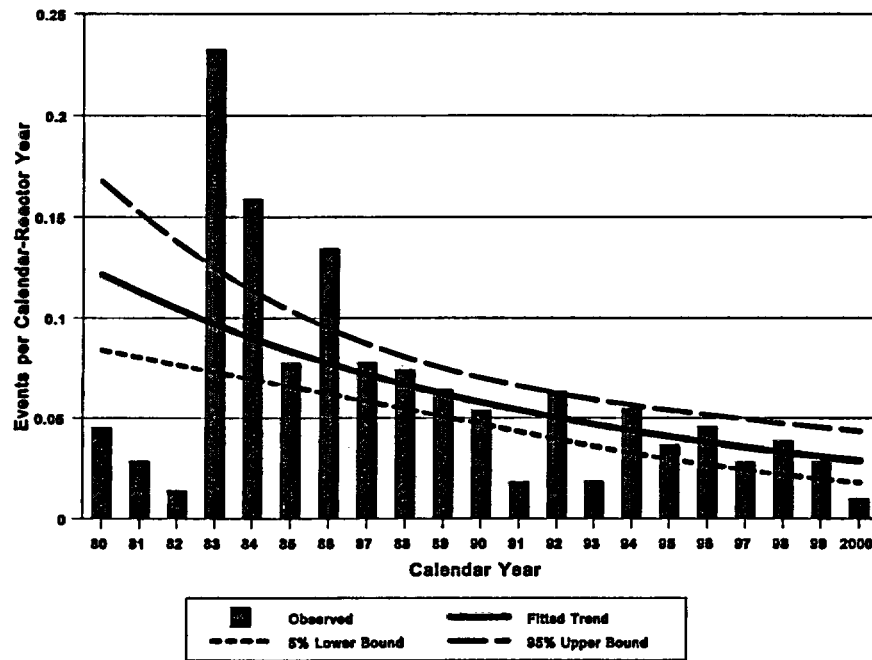

Figure 3-1. Trend for all circuit breaker CCF events. The decreasing trend is statistically significant with a p-value = 0.0001.

Figure 3-2 and Figure 3-3 show similar statistically significant decreasing trends for both the fail-to-close and the fail-to-open failure modes for all circuit breaker CCF events, with p-values of 0.0099 and 0.0001, respectively. Figure 3-2 shows a significant increase after 1983 followed by a noticeable decrease in the number of total failures beginning in 1990. Figure 3-3 shows a large step increase in 1983, followed by a rapid decrease from 1983 through 1987. The increase in circuit breaker unreliability was noted in a study performed for the NRC's Nuclear Plant Aging Research Program (NPAR)<sup>9</sup>. The study noted that this increase was due to utility response to IE Bulletins (IE 83-01 & IE 83-08) that were issued subsequent to the RTB failures at Salem Unit 1 in February 1983. In addition to more frequent and detailed inspections, the IE Bulletins required independent testing of the operation of the undervoltage

a. The term "statistically significant" means that the data are too closely correlated to be attributed to chances and consequently have a systematic relationship. A p-value of less than 0.05 is generally considered to be statistically significant.

b. A p-value is a probability, with a value between zero and one, which is a measure of statistical significance. The smaller the p-value, the greater the significance. A p-value of less than 0.05 is generally considered statistically significant. A p-value of less than 0.0001 is reported as 0.0001.

trip device, leading to the discovery of multiple undervoltage trip device failures, some of which had occurred well before the time of detection. The 1987 study utilized data through March 1985 and therefore did not extend to the time when the failure rates began to decrease.

The NRC originally required licensees to qualify all safety-related electrical equipment in accordance with the 1974 Edition of IEEE Standard 323 (Reference 10). However, concerns with the industry methods developed to qualify equipment in accordance with the standard were not resolved to the satisfaction of the NRC. This issue was originally identified in 1978 and later was determined to be an unresolved safety issue (USI). The Code of Federal Regulations (CFR) was amended in January of 1983, requiring implementation of the rules contained in 10 CFR 50.49, *Environmental Qualification of Electric Equipment Important to Safety for Nuclear Power Plants*. This rule required licensees to determine performance requirements for electrical equipment under design-basis accident conditions considering both environmental conditions and the affects of aging, and to implement a qualification program to assure that the specified performance can be attained. Requirements included evaluation of the aging effects on component piece parts due to normal environmental conditions, determination of the end-of-installed life, and corresponding preventative maintenance program provisions to assure part replacement prior to the end-of-installed life. While the final rule required implementation of the 10 CFR 50.49 requirements by May 1983, inspections revealed significant instances of non-compliance into the late 1980s.

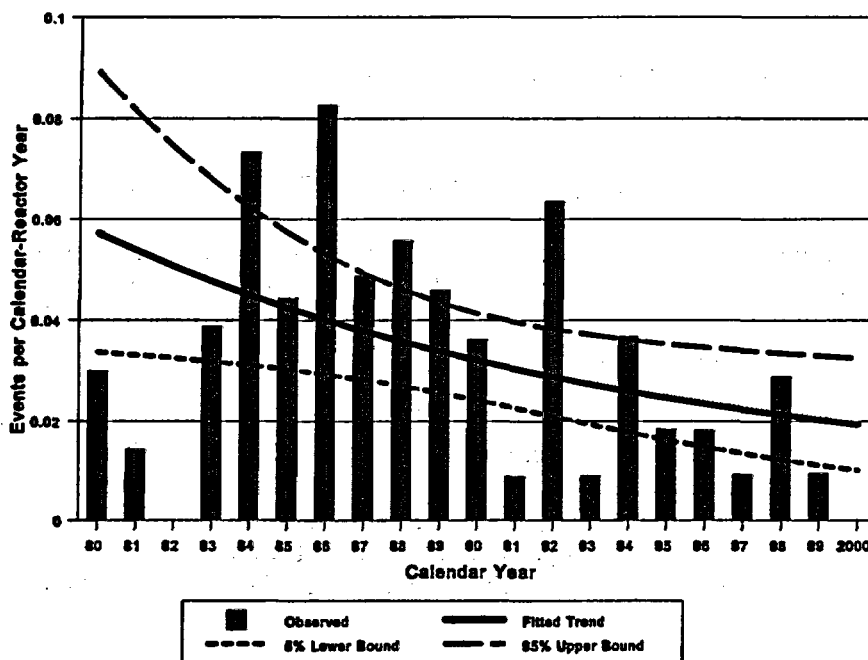

Figure 3-2. Trend for all circuit breaker CCF events for the fail-to-close failure mode. The decreasing trend is statistically significant with a p-value = 0.0099.

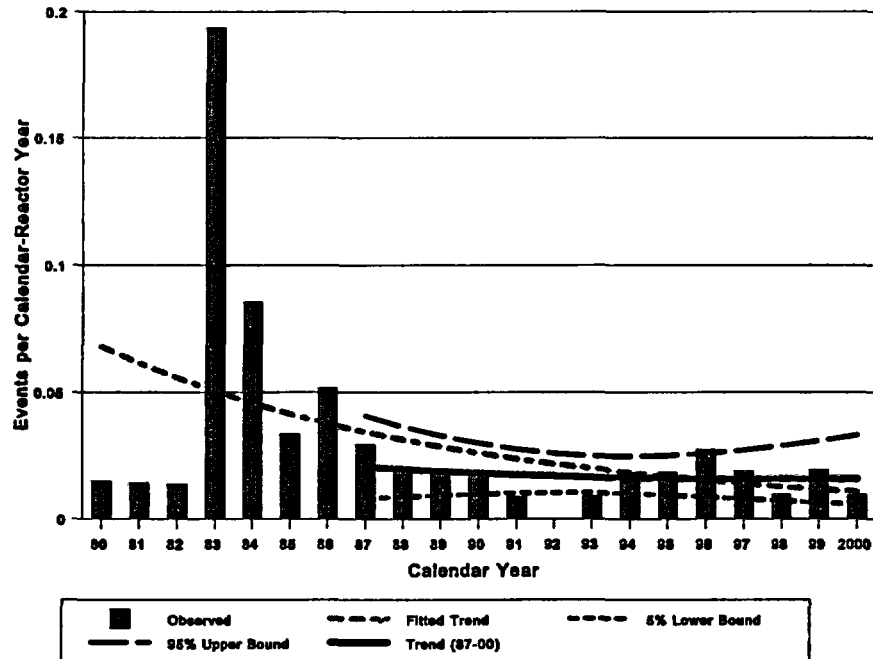

Figure 3-3. Trend for all circuit breaker CCF events for the fail-to-open failure mode. The decreasing trend is statistically significant with a p-value = 0.0001. P-value is 0.6746 for 1987-2000 data.

### 3.3 CCF Circuit Breaker Type Overview

The circuit breaker CCF data were reviewed to determine the affected circuit breaker type and the affected piece part in that circuit breaker type. This was done to provide insights into what are the most vulnerable areas of the circuit breaker component with respect to common-cause failure events. Section 2.3 describes these circuit breaker types.

Figure 3-4 shows the distribution of the CCF events by circuit breaker type. The highest number of events occurred in the RPS trip breaker type (50 events or 42 percent). The Complete RTB events are fail-to-open, and all occurred in 1983 at two NPP units. The Medium Voltage (34 events, 29 percent) and 480 Vac circuit breakers (31 events, 26 percent) are also significant contributors. Together, these three circuit breaker types comprise over 97 percent of the circuit breaker CCF events studied. Section 4 of this report provides an in-depth analysis of the CCF events assigned to these circuit breaker types.

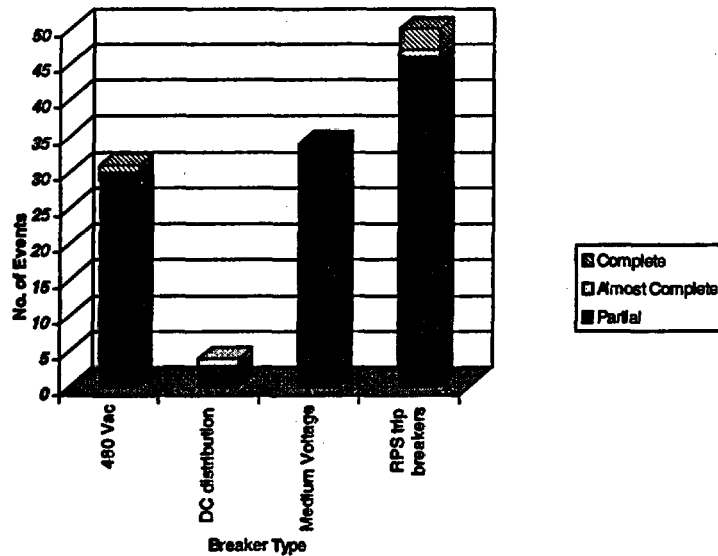

Figure 3-4. Circuit breaker type distribution for all circuit breaker CCF events.

### 3.4 CCF Proximate Cause

It is evident that each component fails because of its susceptibility to the conditions created by the root cause, and the role of the coupling factor is to make those conditions common to several components. In analyzing failure events, the description of a failure in terms of the most obvious "cause" is often too simplistic. The sequence of events that constitute a particular failure mechanism is not necessarily simple. Many different paths by which this ultimate reason for failure could be reached exist. This chain can be characterized by two useful concepts— proximate cause and root cause.

A proximate cause of a failure event is the condition that is readily identifiable as leading to the failure. The proximate cause can be regarded as a symptom of the failure cause, and it does not in itself necessarily provide a full understanding of what led to that condition. As such, it may not be the most useful characterization of failure events for the purposes of identifying appropriate corrective actions.

The proximate cause classification consists of six major groups or classes:

- Design/Construction/Installation/Manufacture Inadequacy
- Operational/Human Error
- Internal to the component, including hardware-related causes and internal environmental causes
- External environmental causes
- Other causes
- Unknown causes.

The causal chain can be long and, without applying a criterion, identifying an event in the chain as a "root cause" is often arbitrary. Identifying root causes in relation to the implementation of defenses

is a useful alternative. The root cause is therefore the most basic reason or reasons for the component failure, which if corrected, would prevent recurrence. (See Table 4-2 in Section 4.1 for a display of the major proximate cause categories and a short description.) Reference 4 contains additional details on the proximate cause categories and how CCF event proximate causes are classified.

Figure 3-5 shows the distribution of CCF events by proximate cause. The leading proximate cause was Internal to Component and accounted for about 61 percent of the total events. Design/Construction/Installation/Manufacture Inadequacy faults accounted for 18 percent of the total. Human error accounted for 13 percent of the total events. To a lesser degree, External Environment and the Other proximate cause categories were assigned to the circuit breaker component.

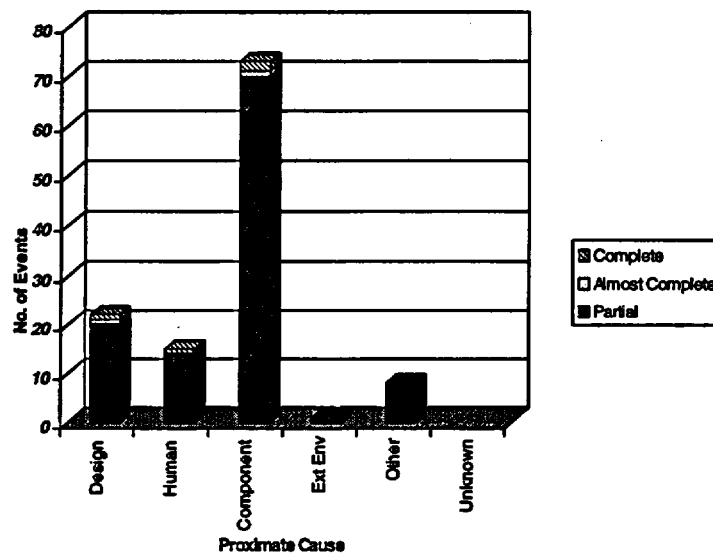

Figure 3-5. Proximate cause distribution for all circuit breaker CCF events.

Table A-1 in Appendix A presents the entire circuit breaker data set, sorted by the proximate cause. This table can be referred to when reading the following discussions to see individual events described.

The **Internal to Component** proximate cause category is the most important for the circuit breakers and encompasses the malfunctioning of hardware internal to the component. Internal to Component causes result from phenomena such as normal wear or other intrinsic failure mechanisms. Specific mechanisms include corrosion of internal parts, lack of lubrication or lubricant hardening, internal contamination (dust/dirt), fatigue, wear-out, and end of life. Internal to Component errors resulted in 73 events.

Although the majority of circuit breaker CCF events were determined to have Internal to Component as the proximate cause, there were only two Complete failures in this category. Most failure mechanisms in this group are gradual in nature; therefore, complete failure of all circuit breakers in a group should not occur frequently. In addition, the lack of a large number of Complete events may be due to the method of discovery. The majority of events in this cause group were detected by Testing. Effective testing programs should discover gradual degradation of the breakers prior to failure of all the circuit breakers in the group.

The most common types of events in this category involved wear, dirt, and inadequate lubrication inside the circuit breaker. This finding is supported by a study performed for the NRC's NPAR.<sup>10</sup> The study identified dust, dirt, and deterioration of lubrication of the trip mechanism as significant causes of some circuit breaker failures. The lubricant evaporates in the bearing of the trip mechanism, leaving the soap base behind. The force required to operate the trip mechanism increases to the point where the trip coil cannot cause the trip latch to operate.

The **Design/Construction/Installation/Manufacture Inadequacy** proximate cause group is the second most likely for circuit breakers and encompasses events related to the design, construction, installation, and manufacture of components, both before and after the plant is operational. Included in this category are events resulting from errors in equipment and system specifications, material specifications, and calculations. Events related to maintenance activities are not included.

Design/Construction/Installation/Manufacture Inadequacy errors resulted in 22 events. There was one Complete circuit breaker CCF event in this proximate cause group. The coupling factors affecting most of the events are Quality and Design, accounting for 86 percent of the events.

Compared to the overall distribution of circuit breaker types, the Medium Voltage circuit breakers have a higher contribution under the Design/Construction/Installation/Manufacture Inadequacy proximate cause and the 480 Vac circuit breakers and RTBs have lower contributions.

The **Operational/Human Error** proximate cause group is the next most likely for the circuit breaker and represents causes related to errors of omission or commission on the part of plant staff or contractor staff. Included in this category are accidental actions, failures to follow the correct procedures or following inadequate procedures for construction, modification, operation, maintenance, calibration, and testing. This proximate cause group also includes deficient training.

Operational/Human Error resulted in 15 circuit breaker CCF events. There was one Complete circuit breaker CCF event with Operational/Human Error as the proximate cause. These Operational/Human Errors include disabling all circuit breakers, not restoring circuit breakers to the correct position following tagouts, and procedure inadequacies that result in incorrect circuit breaker actuation. Inadequate maintenance procedures, inattention to work practices, and operator error were the most common coupling factors cited in the event narratives. Many of these events involved the observation of an incorrect system alignment (circuit breakers left open is one common observation). The Operational/Human Error proximate cause group appears randomly throughout the time frame of this study.

The **External Environment** proximate cause category represents causes related to a harsh environment that is not within the component design specifications. Specific mechanisms include chemical reactions, electromagnetic interference, fire or smoke, impact loads, moisture (sprays, floods, etc.), radiation, abnormally high or low temperature, vibration load, and acts of nature (high wind, snow, etc.). This proximate cause had one event assigned to it.

The **Other** proximate cause group is comprised of events that include setpoint drift and the state of other components as the basic causes. Eight events were attributed to this category. However, none of the circuit breaker CCF events in this cause group were Complete. All of the events were attributed to setpoint drift, which tends to be a minor failure mode. Half of these events were in the RTBs and involved failure of the undervoltage trip mechanism to trip the breakers within the required time or voltage tolerances.

### 3.5 CCF Coupling Factor

Closely connected to the proximate cause is the concept of **coupling factor**. A coupling factor is a characteristic of a component group or piece parts that links them together so that they are more susceptible to the same causal mechanisms of failure. Such factors include similarity in design, location, environment, mission, and operational, maintenance, design, manufacturer, and test procedures. These factors have also been referred to as examples of coupling mechanisms, but because they really identify a potential for common susceptibility, it is preferable to think of these factors as characteristics of a common-cause component group. Reference 4 contains additional detail about the coupling factors. Figure 3-6 shows the coupling factor distribution for the events.

The coupling factor classification consists of five major classes:

- Hardware Quality based coupling factors,
- Design-based coupling factors,
- Maintenance coupling factors,
- Operational coupling factors, and
- Environmental coupling factors.

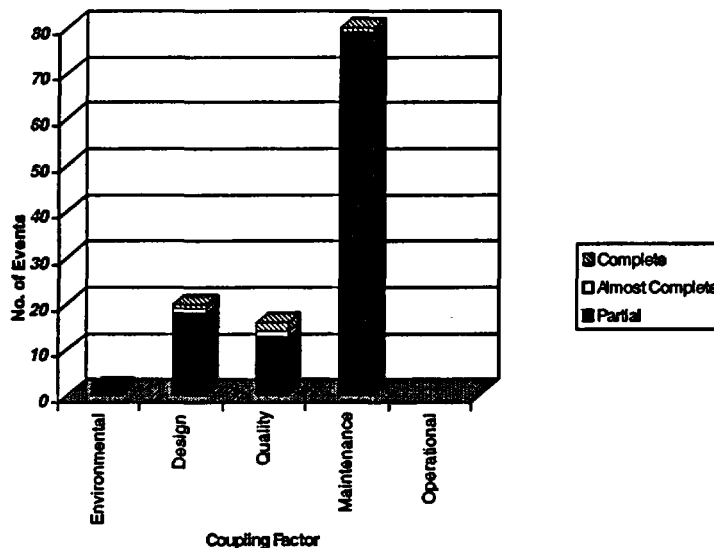

Figure 3-6. Coupling factor distribution for all circuit breaker CCF events.

Table A-2 in Appendix A presents the entire circuit breaker data set, sorted by the coupling factor. This table can be referred to when reading the following discussions to see individual events described.

The **Maintenance** coupling factor indicates that the maintenance frequency, procedures, or personnel provided the linkage among the events. The single largest coupling factor is Maintenance and it is strongly associated with the Internal to Component proximate cause. The Maintenance coupling factor indicates that the frequency of maintenance, the maintenance procedures, or the maintenance staff coupled the circuit breaker CCF events. The actual link for most of these events was maintenance and test schedules, indicating that more frequent maintenance could have prevented the CCF mechanism. Only one event coupled by Maintenance actually resulted in a Complete CCF event; most were detected as incipient failures. An example of this is a RTB failing its trip time requirements. The circuit breakers have historically been noted to be lacking in lubrication and worn.

The **Design** coupling factor is most prevalent in the Design/Construction/Installation/Manufacture Inadequacy and Internal to Component proximate cause categories. This means that the design was inadequate and was the link between the events. The link for most of these events was that the breakers shared the same design and internal parts. Examples of this include loose operating springs, interference between piece-parts, cracked and bent piece-parts, and part location.

**Quality** based coupling factors are factors that propagate a failure mechanism among several components due to manufacturing and installation faults. The Quality coupling factor indicates that either the quality of the construction or installation or the quality of the manufacturing provided the linkage. The Quality coupling factor is also prevalent in the Design/Construction/Installation/Manufacture Inadequacy proximate cause category. Examples of this include defective undervoltage coils installed at the manufacturer, incorrect relay type for the application, and an incorrect lug size on the trip coil pigtail. The two Complete events in this group were due to incorrect relay installation in the circuit breaker trip circuit and mechanical binding of the latch mechanism.

The **Environment** based coupling factors are the coupling factors that propagate a failure mechanism via identical external or internal environmental characteristics. Two minor events occurred in this category.

The **Operational** based coupling factors indicate that operational procedures or staff provided the linkage among events. For example, two 4160-vac circuit breakers were racked-out because of operator error. No Operational based coupling factors were noted for the circuit breaker CCF events.

### **3.6 CCF Discovery Method Overview**

An important facet of these CCF events is the way in which the failures were discovered. Each CCF event was reviewed and categorized into one of four discovery categories: Test, Maintenance, Demand, or Inspection. These categories are defined as:

- |                    |   |
|--------------------|---|
| <b>Test</b>        | The equipment failure was discovered either during the performance of a scheduled test or because of such a test. These tests are typically periodic surveillance tests, but may be any of the other tests performed at nuclear power plants, e.g., post-maintenance tests and special systems tests. |
| <b>Maintenance</b> | The equipment failure was discovered during maintenance activities. This typically occurs during preventative maintenance activities.   |
| <b>Demand</b>      | The equipment failure was discovered during an actual demand for the equipment. The demand can be in response to an automatic actuation of a safety system or during normal system operation.   |



**Inspection**      The equipment failure was discovered by personnel, typically during system tours or by operator observations.

Figure 3-7 shows the distribution of how the events were discovered or detected. Testing accounts for 71 events, (60 percent), Demand for 25 events (21 percent), Maintenance for 11 events (9 percent), and Inspection for 12 events (10 percent). The importance of Testing indicates the success of testing in detecting common-cause failures. Testing is designed to detect faults before they occur. The testing program has shown that it is successful in accomplishing this goal.

Table A-3 in Appendix A presents the entire circuit breaker data set, sorted by the discovery method. This table can be referred to when reading the following discussions to see individual events described.

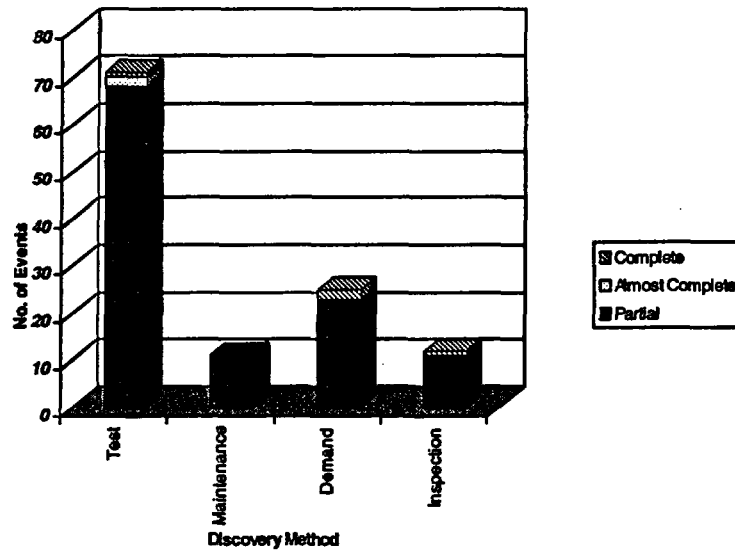

Figure 3-7. Discovery method distribution for all circuit breaker CCF events.

### 3.7 Other Circuit Breaker CCF Observations

Figure 3-8 shows the distribution of breaker CCF events among the NPP units. The data are based on 109 NPP units represented in the insights CCF studies. The largest contribution (76 percent) consists of NPP units with either zero or one CCF event. This may indicate that the majority of the NPP units have maintenance and testing programs to identify possible circuit breaker CCF events and work towards preventing either the first event or any repeat events. Seventy-four percent of the total circuit breaker CCF events occurred at 51 of the NPP units.

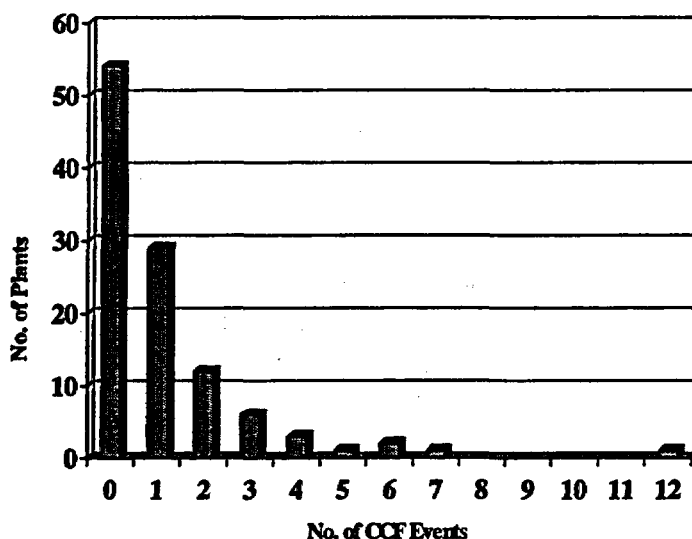

Figure 3-8. Distribution of NPP units experiencing a multiplicity of CCFs for all circuit breaker CCF events.

Figure 3-9 shows the distribution of the failed piece-parts for all breaker types. The mechanical assembly had 31 events (26 percent). The mechanical assembly was identified for all breaker types. Most of these events were coupled by inadequate maintenance. The UV trip assembly had 28 events (24 percent). The UV trip assembly was identified mostly for the RPS trip breakers. Table A-4 in Appendix A presents the entire circuit breaker data set, sorted by the piece-part. This table can be referred to when reading the following discussions to see individual events described.

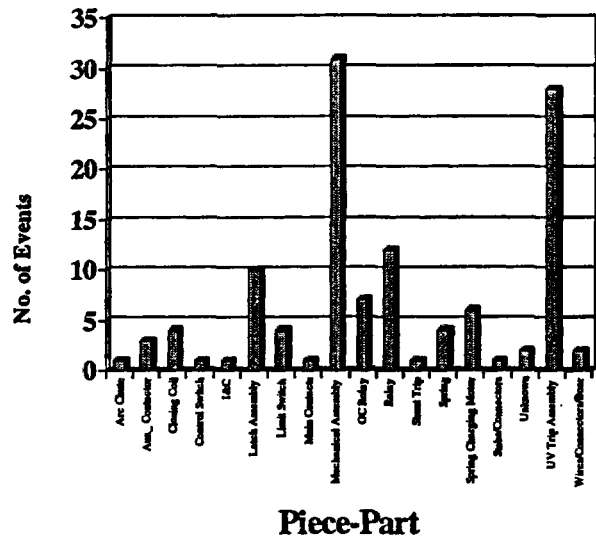

Figure 3-9. Distribution of the failed piece-parts for all circuit breaker CCF events.

## 4. ENGINEERING INSIGHTS BY CIRCUIT BREAKER TYPE

### 4.1 Introduction

This section presents an overview of the CCF data for the circuit breaker component that have been collected from the NRC CCF database, grouped by the affected circuit breaker type. The circuit breaker CCF data were reviewed to determine the affected circuit breaker type and the affected piece part of the circuit breaker. This was done to provide insights into what are the most vulnerable areas of the circuit breaker component with respect to common-cause failure events. For the descriptions of the circuit breaker and the circuit breaker types, see Section 2.3.

Table 4-1 summarizes the CCF events by circuit breaker type. Each sub-section contains a discussion of a circuit breaker type, which summarizes and displays selected attributes of that circuit breaker type. A list of the circuit breaker CCF Complete events follows displaying the proximate cause, failure mode, and a short description of the event. For a listing of all circuit breaker CCF events, see Appendix A.

Table 4-1. Summary of circuit breaker types.

Circuit Breaker Type	Sub-Section	Partial	Almost Complete	Complete	Total	Percent
RPS Trip	4.2	46	1	3	50	42.0%
Medium Voltage	4.3	34			34	28.6%
480 Vac	4.4	30		1	31	26.1%
Dc Distribution	4.5	3	1		4	3.4%
Total		113	2	4	119	100.0%

The largest number of the circuit breaker CCF events affected the RPS trip circuit breaker type. The Medium Voltage and 480 Vac circuit breaker types each contribute significantly to the circuit breaker CCF events. These three circuit breaker types contribute over 96 percent of the circuit breaker CCF events. These circuit breaker types are the most plentiful and most tested circuit breaker types in the CCF collection.

In this study, the proximate causes of the circuit breaker CCF events in the NRC CCF database have been grouped into higher-order proximate cause categories to facilitate the graphical depiction of proximate causes. Table 4-2 contains a hierarchical mapping of the proximate causes of circuit breaker CCF events into the higher-order groups. Since the graph x-axis labels are restricted in length, the proximate cause category names have been shortened and are shown in parenthesis in Table 4-2. Table 4-2 also describes each of these groups.

Table 4-2. Proximate cause hierarchy.

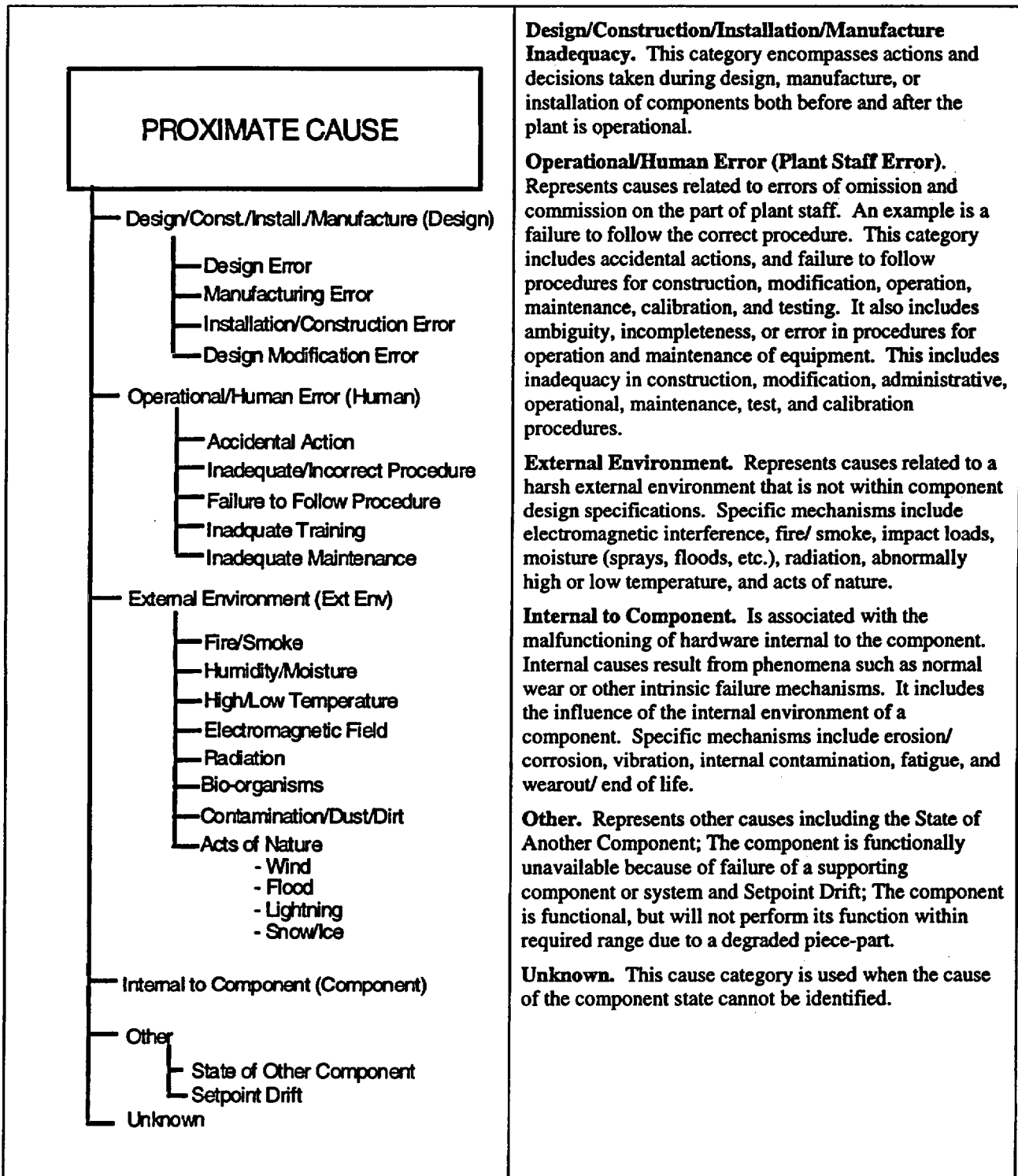

## 4.2 RPS Trip Breakers

Fifty circuit breaker CCF events affected the RPS Trip type circuit breaker (see Table B-1 in Appendix B, items 70–119). Figure 4-1 through Figure 4-3 show selected distributions graphically. Half of the RTB CCF events (25) were due to problems with the undervoltage (UV) trip assemblies. Table 4-3 contains a summary of these events by proximate cause group and failure. Figure 4-1 shows that the most likely proximate cause group was Internal to the Component.

Table 4-3. CCF events in RPS trip breaker type by cause group and degree of failure.

Proximate Cause Group	Complete	Almost Complete	Partial	Total	Percent
Design/Construction/Installation/ Manufacture Inadequacy			7	7	14.0%
Internal to Component	2	1	30	33	66.0%
Operational/Human	1		4	5	10.0%
External Environment			1	1	2.0%
Other			4	4	8.0%
<b>Total</b>	<b>3</b>	<b>1</b>	<b>46</b>	<b>50</b>	<b>100.0%</b>

Although the largest number of events was attributed to the RTBs, only three (6 percent) of these were Complete events. One Complete event was caused by personnel leaving jumpers installed around the undervoltage coils following manual reactor trip functional testing (in 1983, before the shunt trip was installed), which disabled the automatic trip function. This event was attributed to inadequate test procedures. Another Complete event was caused by failure of the circuit breakers to open due to binding of the latch assembly (also in 1983), which was attributed to a component design error. The third was due to binding caused by the unused overcurrent trip pads. All three Complete events occurred in 1983. Most RTB CCF events were the result of problems with the undervoltage trip assemblies and Internal to Component was the dominant proximate cause.

There was one RTB CCF event affecting the shunt trip device. Four of the eight RTB shunt trip devices were disabled because they were not properly restored after surveillance. This event occurred in 1984. The last fail-to-open RTB CCF event occurred in 1990, and that event affected two of eight undervoltage devices.

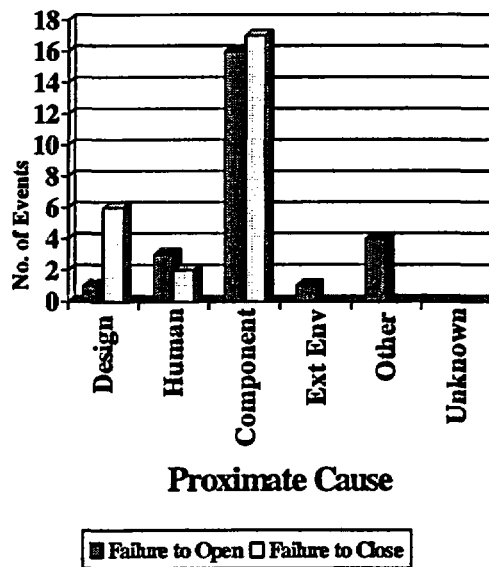

Figure 4-1. Distribution of proximate causes for the RPS trip breaker type.

The Internal to Component proximate cause group had 33 events (66 percent) of which two were Complete and one was Almost Complete (see Table B-1 in Appendix B, items 78 –110). Affected piece parts included the undervoltage trip assembly, the mechanical operating assembly, and the latch assembly. The vast majority of these events were coupled by inadequate maintenance.

The Design/Construction/Installation/Manufacture Inadequacy proximate cause group had seven events (14 percent) of which none were Complete (see Table B-1 in Appendix B, items 70 –76). Affected piece parts included the undervoltage trip assembly, the mechanical operating assembly, and the latch assembly. The majority of these events were coupled by the quality of the manufacture or installation.

The Operational/Human Error proximate cause group contained five events (10 percent) of which one was Complete (see Table B-1 in Appendix B, items 111 –115). Affected piece parts included shunt trip, connectors, the undervoltage trip assembly, and springs. The majority of these events were coupled by maintenance staff errors and inadequate maintenance/test procedures.

The External Environment proximate cause group contains one event (see Table B-1 in Appendix B, item 77). This event affected the mechanical operating assembly.

The Other proximate cause group contains four events (8 percent), which were all were Partial CCF events affecting the undervoltage trip assembly (see Table B-1 in Appendix B, items 116 –119).

Testing was the most likely method of discovery for instrumentation and control circuit breaker events (38 out of the 50 events, 76 percent) as shown in Figure 4-2. The reactor trip breakers are frequently tested. This tends to make testing the most likely method of discovery. Inspection, Maintenance, and Demand make up the rest of the observed discovery methods. The most likely piece part involved in a RTB CCF event was the undervoltage trip assemblies as shown in Figure 4-3.

Table 4-4 lists the short descriptions by proximate cause for the Complete events, the events that failed all the circuit breakers. The descriptions of all circuit breaker CCF events can be found in Appendix B.

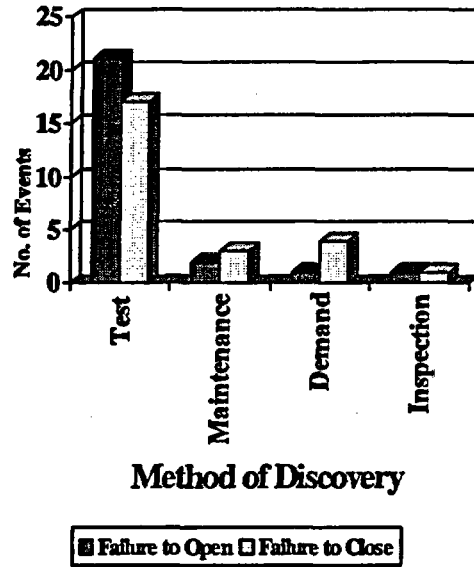

Figure 4-2. Distribution of the method of discovery for the RPS trip breaker type.

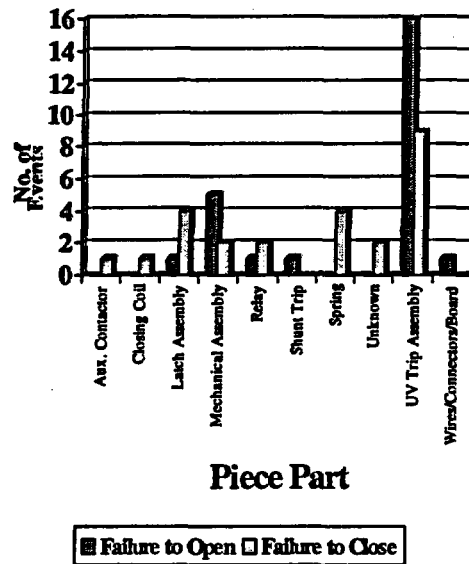

Figure 4-3. Distribution of the affected piece part for the RPS trip circuit breaker type.



Table 4-4. RPS trip circuit breaker type event short descriptions for Complete events.

Proximate Cause Group	Failure Mode	Description
Internal to Component	Failure-to-Open	During a routine startup, both reactor trip breakers failed to open automatically on receipt of a valid low-low steam generator level reactor trip signal. The reactor was shutdown 25 seconds later using the manual trip on the control console. Subsequent investigation revealed that the breaker failures were caused by mechanical binding of the latch mechanism in the undervoltage trip attachment. All breaker undervoltage attachments were replaced with new devices and extensive maintenance and testing was performed on the breakers.
Internal to Component	Failure-to-Open	The static force to trip the circuit breakers exceeded allowable tolerance due to binding caused by the unused overcurrent trip pads. The breakers tested satisfactorily after removal of the overcurrent trip pads.
Operational/ Human Error	Failure-to-Open	Following performance of the manual reactor trip functional test, it was noted that the procedure called for jumpering out the UV trip coils with the reactor trip breakers closed and the rods capable of withdrawal. This was a procedural error that caused the removal of both trains of automatic reactor trip logic. The procedure was revised to prevent recurrence of the event.

### 4.3 Medium Voltage (4160 Vac and 6.9 kVac) Circuit Breakers

Thirty-four circuit breaker CCF events affected the Medium Voltage type of circuit breaker. Figure 4-4 through Figure 4-6 show selected distributions graphically (see Table B-1 in Appendix B, items 36–69). The primary discovery methods were Testing, Inspection, and Demands. A large number of events involved problems with the mechanical operating assemblies and closing spring charging motors.

The most likely proximate causes are Internal to Component and Design/Construction/Installation/Manufacture Inadequacy as shown in Figure 4-4. Table 4-5 contains a summary of these events by proximate cause group and degree of failure. None of the Medium Voltage breaker CCF events were complete.

Table 4-5. CCF events in Medium Voltage circuit breaker type by cause group and degree of failure.

Proximate Cause Group	Complete	Almost Complete	Partial	Total	Percent
Design/Construction/Installation/ Manufacture Inadequacy			12	12	35.3%
Internal to Component			15	15	44.1%
Operational/Human			5	5	14.7%
External Environment				0	0.0%
Other			2	2	5.9%
<b>Total</b>	<b>0</b>	<b>0</b>	<b>34</b>	<b>34</b>	<b>100.0%</b>

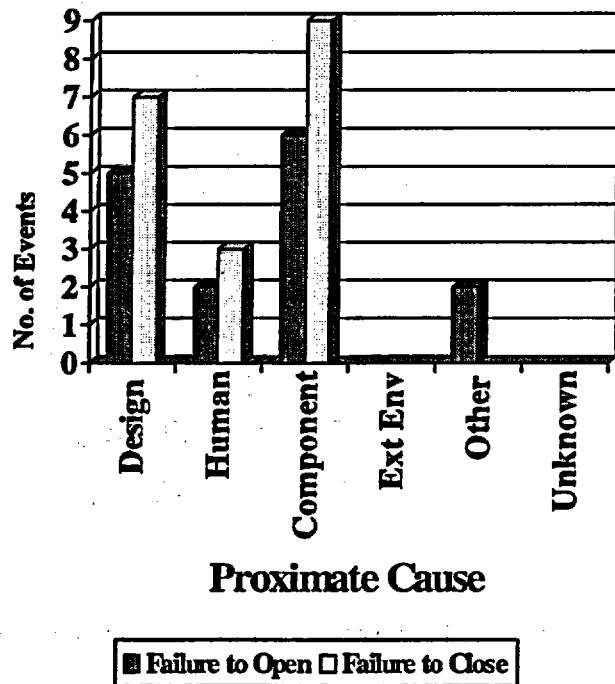

Figure 4-4. Distribution of proximate causes for the Medium Voltage circuit breaker type.

The Internal to Component proximate cause group had 15 events (44 percent) (see Table B-1 in Appendix B, items 48 – 62). Affected piece parts included the mechanical operating assembly, the charging spring motor, the arc chute, auxiliary contactors, latch assemblies, limit switches, over-current relays, stab connectors, and trip coils. Most of these events were coupled by inadequate maintenance and design.

The Design/Construction/Installation/Manufacture Inadequacy proximate cause group had 12 events (35 percent) (see Table B-1 in Appendix B, items 36 – 47). Affected piece parts included relays,

limit switches, latch assemblies, the mechanical operating assembly, and the spring charging motor. Most of these events were coupled by the common design of the components and internal parts or construction and installation errors.

The Operational/Human Error proximate cause group contains five events (15 percent) (see Table B-1 in Appendix B, items 63 – 67). Affected piece parts included the mechanical operating assembly, latch assembly, and relays. Most of these events were coupled by inadequate maintenance and test procedures or maintenance staff errors.

Testing was the most likely method of discovery for the Medium Voltage circuit breaker events (14 out of the 34 events, 41 percent) as shown in Figure 4-5. The most likely piece parts involved in these CCF events were the mechanical operating assemblies, charging motors, latch assemblies, relays and limit switches as shown in Figure 4-6. The descriptions of all Medium Voltage circuit breaker CCF events can be found in Appendix A.

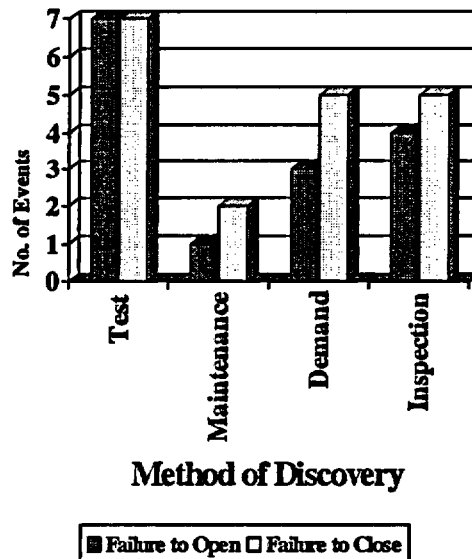

Figure 4-5. Distribution of the method of discovery for the Medium Voltage circuit breaker type.

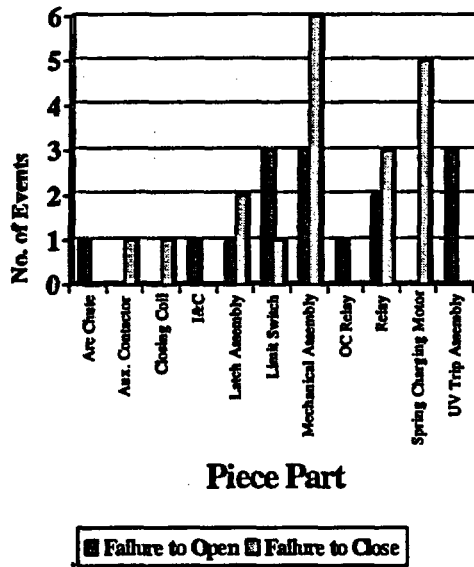

Figure 4-6. Distribution of the affected piece part for the Medium Voltage circuit breaker type.

#### 4.4 480 Vac Circuit Breakers

Thirty-one circuit breaker CCF events affected the 480 Vac circuit breakers (see Table B-1 in Appendix B, items 1-31). Figure 4-7 through Figure 4-9 show selected distributions graphically. The majority of circuit breaker CCF events involving the 480 Vac circuit breaker type were caused by faults internal to the circuit breakers. Of the 31 events, only one was Complete. The coupling factor for almost all of the events (27) was Maintenance. Table 4-6 contains a summary of these events by proximate cause group and degree of failure.

Table 4-6. CCF events in the 480 Vac circuit breaker type by cause group and degree of failure.

Proximate Cause Group	Complete	Almost Complete	Partial	Total	Percent
Design/Construction/Installation/ Manufacture Inadequacy	1		1	2	6.5%
Internal to Component			22	22	71.0%
Operational/Human			5	5	16.1%
External Environment				0	0.0%
Other			2	2	6.5%
<b>Total</b>	<b>1</b>	<b>0</b>	<b>30</b>	<b>31</b>	<b>100.0%</b>

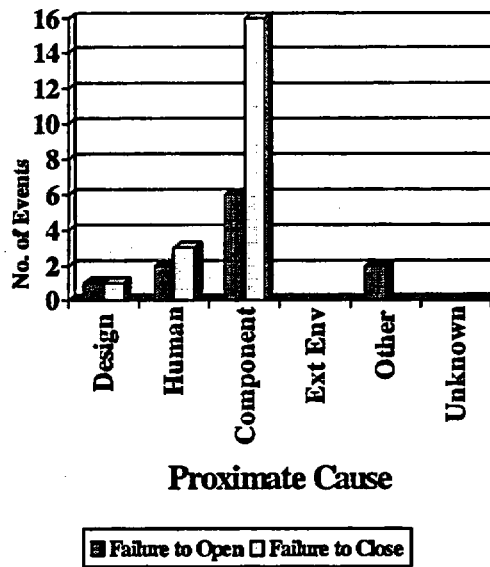

Figure 4-7. Distribution of proximate causes for the 480 Vac circuit breaker type.

The Internal to Component proximate cause group had 22 events (71 percent) of which none were Complete (see Table B-1 in Appendix B, items 3 – 24). Affected piece parts included the mechanical operating assembly, relays, closing coils, latch assemblies, auxiliary contactors, and over-current relays. Almost all of these events were coupled by inadequate maintenance and testing schedules.

The Operational/Human Error proximate cause group contained five events (16 percent) of which none were Complete (see Table B-1 in Appendix B, items 25 – 29). Affected piece parts included the mechanical operating assembly, the main contacts, and the over-current relay. These events were all coupled by either inadequate maintenance, test procedures, or by maintenance staff errors.

The Design/Construction/Installation/Manufacture Inadequacy proximate cause group had two events (6 percent) of which one was Complete (see Table B-1 in Appendix B, items 1 – 2). Affected piece parts included fuses, relays, stab connectors, and trip coils. Most of these events were coupled by shared quality issues related to installation or construction.

The Other proximate cause group had two events, neither of which was complete (see Table B-1 in Appendix B, items 30 – 31). Both events involved out-of-tolerance over-current trip relays.

There were no events in the External Environment proximate cause group.

Testing was the most likely method of discovery for 480 Vac circuit breaker events (15 out of the 31 events, 48 percent) as shown in Figure 4-8. A rather large number of these events were discovered by demands (39 percent). Inspection and Maintenance make up the next most likely discovery methods. The most likely piece part involved in 480 Vac circuit breaker CCF events was the mechanical operating assembly as shown in Figure 4-9.

Table 4-7 provides a short description of the only Complete event. The descriptions of all circuit breaker CCF events can be found in Appendix B.

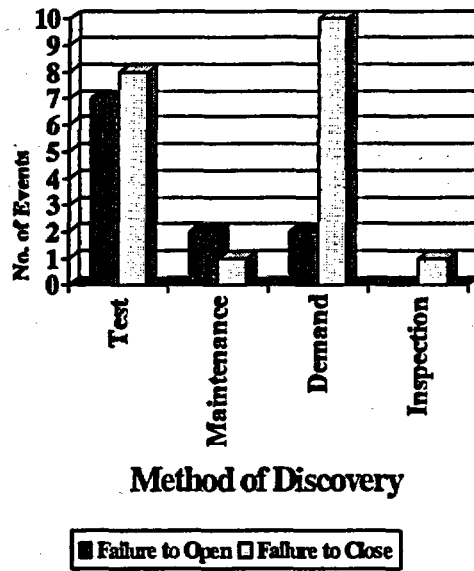

Figure 4-8. Distribution of the method of discovery for the 480 Vac circuit breaker type.

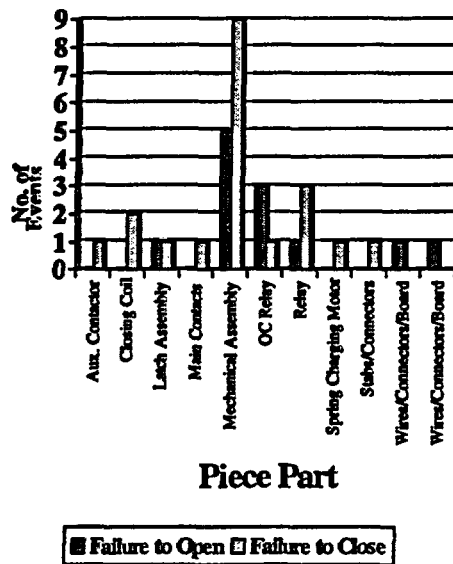

Figure 4-9. Distribution of the affected piece part for the 480 Vac circuit breaker type.

Table 4-7. 480 Vac circuit breaker type event short description for the Complete event.

Proximate Cause Group	Failure Mode	Description
Design/ Construction/ Manufacture/ Installation Inadequacy	Failure- to-Open	Four 600 Vac normal auxiliary power system circuit breakers failed to open from local manual trip switch. The failures were caused by a relay contact in breaker trip circuit that was normally open instead of normally closed, as shown on wiring diagram. The relays were rewired to correct the problem.

## 4.5 Dc Distribution Circuit Breakers

Four circuit breaker CCF events affected the dc Distribution type circuit breakers (see Table B-1 in Appendix B, items 32 – 35). Due to the small number of events, graphical displays of events are not meaningful. The proximate cause for three events is Internal to Component. Design/Construction/Installation/Manufacture Inadequacy was the proximate cause for one event. No events were caused by External Environment. Three events were coupled by Maintenance. The discovery method was Testing. The affected piece parts were the over-current relays, control switches, and the mechanical operating assembly.

## 5. HOW TO OBTAIN MORE DETAILED INFORMATION

The circuit breaker CCF insights for the U.S. plants are derived from information contained in the CCF Database maintained for the NRC by the INEEL. The database contains CCF-related events that have occurred in U.S. commercial nuclear power plants reported in LERs, NPRDS failure records, and EPIX failure records. The NPRDS and EPIX information is proprietary. Thus, the information presented in the report has been presented in such a way to keep the information proprietary.

The subset of the CCF database presented in this volume is based on the circuit breaker component data from 1980 through 2000. The information contained in the CCF Database consists of coded fields and a descriptive narrative taken verbatim from LERs or NPRDS/EPIX failure records. The database was searched on component type (CB2, CB4, CB5, and CB7) and failure mode. The failure modes selected were fail-to-open and fail-to-close. The additional fields, (e.g., proximate cause, coupling factor, shared cause factor, and component degradation values), along with the information contained in the narrative, were used to glean the insights presented in this report. The detailed records and narratives can be obtained from the CCF Database and from respective LERs and NPRDS/EPIX failure records.

The CCF Database was designed so that information can be easily obtained by defining searches. Searches can be made on any coded fields. That is, plant, date, component type, system, proximate cause, coupling factor, shared cause factor, reactor type, reactor vendor, CCG size, defensive mechanism, degree of failure, or any combination of these coded fields. The results for most of the figures in the report can be obtained or a subset of the information can be obtained by selecting specific values for the fields of interest. The identified records can then be reviewed and reports generated if desired. To obtain access to the NRC CCF Database, contact Dale Rasmuson at the NRC or Ted Wood at the INEEL.



## 6. REFERENCES

1. U.S. Nuclear Regulatory Commission, *A Prioritization of Safety Issues*, Generic Issue 145, NUREG-0933, April 1999.
2. U.S. Nuclear Regulatory Commission, *Common-Cause Failure Database and Analysis System Volume 1 - Overview*, NUREG/CR-6268, June 1998, INEEL/EXT-97-00696.
3. U.S. Nuclear Regulatory Commission, *Common-Cause Failure Database and Analysis System Volume 2 - Event Definition and Classification*, NUREG/CR-6268, June 1998, INEEL/EXT-97-00696.
4. U.S. Nuclear Regulatory Commission, *Common-Cause Failure Database and Analysis System Volume 3 - Data Collection and Event Coding*, NUREG/CR-6268, June 1998, INEEL/EXT-97-00696.
5. U.S. Nuclear Regulatory Commission, *Common-Cause Failure Database and Analysis System Volume 4 - CCF Software Reference Manual*, NUREG/CR-6268, July 1997, INEEL/EXT-97-00696.
6. U.S. Nuclear Regulatory Commission, *Common-Cause Failure Parameter Estimations*, NUREG/CR-5497, May 1998, INEEL/EXT-97-01328.
7. U.S. Nuclear Regulatory Commission, *A Cause-Defense Approach to the Understanding and Analysis of Common-cause Failures*, NUREG/CR-5460, March 1990, SAND89-2368.
8. U.S. Nuclear Regulatory Commission, *Precursors to Potential Severe Core Damage Accidents: 1982-83 A Status Report*, NUREG/CR-4674, Volume 24, SAND97-0807.
9. U.S. Nuclear Regulatory Commission, *Comprehensive Aging Assessment of Circuit breakers and Relays*, NUREG/CR-5762, March 1992, Wyle 60101.
10. U.S. Nuclear Regulatory Commission, *An Aging Assessment of Relays and Circuit breakers and System Interactions*, NUREG/CR-4715, June 1987, BNL-NUREG-52017.
10. IEEE Standard 323, *Qualifying Class IE Equipment for Nuclear Power Generating Stations*, The Institute of Electrical and Electronic Engineers, Inc., 1974.

**Appendix A**  
**Data Summary**

# **Appendix A**

## **Data Summary**

**This appendix is a summary of the data evaluated in the common-cause failure (CCF) data collection effort for breakers. The tables in this appendix support the charts in Chapter 3. Each table is sorted alphabetically, by the first four columns.**

## Appendix A

<b>Table A-1. Breaker CCF event summary, sorted by proximate cause. ....</b>	<b>3</b>
<b>Table A-2. Breaker CCF event summary, sorted by coupling factor. ....</b>	<b>18</b>
<b>Table A-3. Breaker CCF event summary, sorted by discovery method. ....</b>	<b>33</b>
<b>Table A-4. Breaker CCF event summary, sorted by piece-part. ....</b>	<b>48</b>

Table A-1. Breaker CCF event summary, sorted by proximate cause.

Item	Proximate Cause	Breaker Type	Discovery Method	Piece Part	Coupling Factor	Year	Failure Mode	Degree of Failure	Description
1	Design/ Construction/ Manufacture/ Installation Inadequacy	480 Vac	Demand	Relay	Quality	1987	Failure to Open	Complete	Four 600 Vac normal auxiliary power system circuit breakers failed to open from local manual trip switch. The failures were caused by a relay contact in breaker trip circuit that was normally open instead of normally closed, as shown on wiring diagram. The relays were rewired to correct the problem.
2	Design/ Construction/ Manufacture/ Installation Inadequacy	480 Vac	Demand	Stabs/Connectors	Design	1980	Failure to Close	Partial	While returning a service water booster pump to service, a minor fire occurred in a 480 Vac ESF MCC. This rendered several components inoperable. Repeated cycling of the pump onto the bus coupled with inadequate stab to bus bar contact and dust in the MCC cabinet caused a fire. Operators were reminded of undesirability of repeated cycling of load breaker. An engineering study to determine if the breakers are adequately sized was also made (the results of the study were not included in the failure report).
3	Design/ Construction/ Manufacture/ Installation Inadequacy	DC distribution	Test	OC Relay	Design	1996	Failure to Open	Almost Complete	All 72 dc molded case circuit breakers were tested, all 44 breakers of one vendor type, installed in 4 different distribution panels failed to trip on overcurrent. Problem was the design of the trip lever in the magnetic trip circuit breakers. All breakers of this type and vendor were replaced.
4	Design/ Construction/ Manufacture/ Installation Inadequacy	Medium Voltage	Demand	Closing Coil	Quality	1996	Failure to Close	Partial	Two service water pumps failed to start upon demand. Investigation revealed a high resistance electrical contact in the pump motor circuit breaker close coil circuit. Evaluation of the failure determined that the electrical contact had high resistance due to repeated interruption of current approximately three times rated. The installed contactor current interrupt rating was inadequate. The contact failures occurred after a fraction of the design cycles. All 4 kV circuit breakers were determined to be susceptible to this failure.
5	Design/ Construction/ Manufacture/ Installation Inadequacy	Medium Voltage	Demand	Relay	Quality	1990	Failure to Close	Partial	While attempting to transfer two 4160 Vac buses to their alternate power supply, the alternate feeder circuit breaker. Separately, another 4160 Vac circuit breaker failed to close on demand. Both failures were caused by an open coil winding on a telephone-type relay within the synchronizing check relay of the circuit breaker. The telephone relay failed due to being continuously energized, which was not its intended application. A design modification was performed as the long-term corrective action.
6	Design/ Construction/ Manufacture/ Installation Inadequacy	Medium Voltage	Inspection	I&C	Hardware	2000	Failure to Open	Partial	During a system review, it was noted that the auxiliary transformer breakers did not trip as designed when the Main Turbine tripped. Investigation determined that this trip signal is blocked when a low load (4000 A) condition is sensed at the output of the generator. The low load block is not part of the original digital protection system modification and no reason for the block could be determined. Tripping of these breakers on a Main Turbine trip is needed to ensure that the timing sequence for the EDGs on a LOOP/LOCA, as defined in the FSAR, would not be affected. The block was removed.
7	Design/ Construction/ Manufacture/ Installation Inadequacy	Medium Voltage	Inspection	Latch Assembly	Maintenance	1998	Failure to Close	Partial	A breaker tripped when the cubicle door was closed. Subsequent inspection revealed several incorrect latching mechanisms were installed on 4160 Vac breakers. The cause of the incorrect latching mechanisms being installed during original construction was personnel error. The incorrect latches were installed in eight of seventeen cubicle doors in the Division II switchgear. Contributing to this event was that information relative to the latching mechanisms was not provided to personnel working on the switchgear and that procurement controls were not adequate to ensure the correct parts were installed.

Item	Proximate Cause	Breaker Type	Discovery Method	Piece Part	Coupling Factor	Year	Failure Mode	Degree of Failure	Description
8	Design/ Construction/ Manufacture/ Installation Inadequacy	Medium Voltage	Inspection	Limit Switch	Design	1995	Failure to Open	Partial	Inspection of circuit breaker limit switches revealed cam follower cracking. No equipment malfunctions or plant transients occurred, because the single actual failure occurred during routine post modification testing. The root cause of this occurrence was inadequate initial design of General Electric type SBM switches by the manufacturer.
9	Design/ Construction/ Manufacture/ Installation Inadequacy	Medium Voltage	Inspection	Limit Switch	Design	1995	Failure to Open	Partial	All 4 kV vital busses were declared inoperable following inspection that revealed cracks in the circuit breaker cam followers. One actual failure occurred during post maintenance testing (maintenance was for another reason), but all cam follower limit switches at both units were replaced. The root cause of this occurrence was inadequate initial design of General Electric type SBM switches by the manufacturer.
10	Design/ Construction/ Manufacture/ Installation Inadequacy	Medium Voltage	Inspection	Mechanical Assembly	Design	1988	Failure to Close	Partial	An operator racked up the emergency 4.16kv bus feeder breaker from an emergency diesel generator and found that there was no indication of breaker position on the control panel. It was discovered that the breaker elevator mechanism linkage was distorted and had allowed the cell switch actuator arm to fall into an intermediate position disabling the automatic and manual closure circuitry. Other breaker compartments contained distorted linkages and it was concluded that any of 4.16kv breakers could fail during a seismic event. The linkage distortion was caused by an interference with the breaker assembly as it is rolled out of the compartment.
11	Design/ Construction/ Manufacture/ Installation Inadequacy	Medium Voltage	Maintenance	Limit Switch	Design	1995	Failure to Close	Partial	Inspections revealed cracks in the lexan cam followers of control (limit) switches installed in 4160 Vac and 6900 Vac circuit breakers. The same part used in 360 places in unknown number of breakers. Inspection showed about one third were cracking and two were inoperable. The root cause of this occurrence was inadequate initial design of General Electric type SBM switches by the manufacturer.
12	Design/ Construction/ Manufacture/ Installation Inadequacy	Medium Voltage	Test	Mechanical Assembly	Design	1999	Failure to Close	Partial	Two 6.9kV breakers failed to close due to manufacturer repair defect. A cotter pin installed by the manufacturer was striking the latch check switch mounting bracket and bending it forward. This removed the factory set clearance between the bracket and the switch actuating paddle, resulting in the paddle rolling the trip shaft to the trip position when the breaker attempts to close.
13	Design/ Construction/ Manufacture/ Installation Inadequacy	Medium Voltage	Test	Relay	Design	1990	Failure to Open	Partial	During surveillance testing several circuit breaker lockout relays would not actuate. These failures would have prevented breaker trips on overcurrent. Mechanical binding prevented the relays from tripping. Bench testing revealed several contributing factors but could not identify the root cause. The failed relays' armature force checks yielded 5 to 6.5 pounds but newer relays required only 3.5 pounds. The vendor discourages re-lubrication to reduce friction. Also, a vendor bulletin states that when the relay reset handle is forced against the latch after resetting, tripping is delayed or prevented. The lockout relays were replaced with spares and tested satisfactorily.
14	Design/ Construction/ Manufacture/ Installation Inadequacy	Medium Voltage	Test	Relay	Design	1984	Failure to Open	Partial	When performing a loss of bus test, two 4160 Vac bus-tie breakers failed to trip. Investigation concluded that the bus-tie breakers could not trip if the diesel generator output breaker was open. The failures to open were caused by a design error.

Item	Proximate Cause	Breaker Type	Discovery Method	Piece Part	Coupling Factor	Year	Failure Mode	Degree of Failure	Description
15	Design/ Construction/ Manufacture/ Installation Inadequacy	Medium Voltage	Test	Spring Charging Motor	Quality	1986	Failure to Close	Partial	The circuit breaker for the residual heat removal pump failed to recharge during testing, rendering the breaker incapable of automatic closure. In addition to performing required surveillance tests, an investigation revealed that the breaker charging spring motor bolts had fallen out, allowing the motor to rotate, and breaking the power leads. A root cause analysis led to the conclusion that a combination of inadequate thread engagement of the mounting bolts in the motor housing and equipment vibration caused the bolts to loosen. Because this event had the potential for a common mode failure, all safety related breakers were inspected during a scheduled maintenance outage. Three additional breakers were found to have loose bolts.
16	Design/ Construction/ Manufacture/ Installation Inadequacy	RPS trip breakers	Demand	Latch Assembly	Quality	1994	Failure to Close	Partial	During plant protection system functional testing, two reactor trip breaker tripped free when maintenance personnel attempted to close them. With the vendor present, the problem was traced to inadequate adjustment of the trip latch overlap. The adjustment was initially made per vendor specifications. However, the vendor had since increased the recommended number of adjustment turns of the trip latch screw from 4 to a maximum of 5 turns. A change was submitted to change the procedure accordingly.
17	Design/ Construction/ Manufacture/ Installation Inadequacy	RPS trip breakers	Maintenance	UV Trip Assembly	Quality	1983	Failure to Open	Partial	A potential safety hazard was identified concerning certain critical dimensions of the undervoltage trip device on a particular model reactor trip circuit breaker. An out-of-tolerance measurement was found between the moving core and rolling bracket in addition to a missing lock ring on the shaft pin of the undervoltage trip device. The potential existed for either intermittent operation or total failure of the device. The cause was attributed to manufacturing variations of the undervoltage trip devices. All undervoltage trip devices on all reactor trip breakers were replaced.
18	Design/ Construction/ Manufacture/ Installation Inadequacy	RPS trip breakers	Maintenance	UV Trip Assembly	Maintenance	1984	Failure to Close	Partial	After installation of new undervoltage trip relays, the reactor trip breakers would not stay closed. The original trip bar design gap was satisfactory with old style undervoltage relays, but not with new style relays.
19	Design/ Construction/ Manufacture/ Installation Inadequacy	RPS trip breakers	Test	Mechanical Assembly	Quality	1984	Failure to Close	Partial	During surveillance testing, two reactor trip breakers would not re-close. Troubleshooting found manufacturing defects in the front frame assemblies (loose mechanical collars). This problem has been identified on similar breakers. The front frame assemblies were replaced.
20	Design/ Construction/ Manufacture/ Installation Inadequacy	RPS trip breakers	Test	Spring	Design	1988	Failure to Close	Partial	Two reactor trip breakers failed to close during surveillance testing. The breakers' closing springs had become detached from the pivot/actuation points. The reason for the springs' detaching could not be determined; however, this has been a recurring problem with this breaker design.
21	Design/ Construction/ Manufacture/ Installation Inadequacy	RPS trip breakers	Test	UV Trip Assembly	Quality	1990	Failure to Close	Partial	Two reactor trip breakers failed to close. The first failed to close during testing, the second failed to close while troubleshooting the first failure. The cause of both breaker failures was failure of the under voltage trip coil, which was thought to be due to a manufacturing defect.

Item	Proximate Cause	Breaker Type	Discovery Method	Piece Part	Coupling Factor	Year	Failure Mode	Degree of Failure	Description
22	Design/ Construction/ Manufacture/ Installation Inadequacy	RPS trip breakers	Test	UV Trip Assembly	Quality	1983	Failure to Close	Partial	During surveillance testing, two reactor trip breakers would not close when a close signal was applied to the breaker's control circuit. Troubleshooting found defective undervoltage devices that would not allow the closure of the breakers. The undervoltage devices were replaced.
23	External Environment	RPS trip breakers	Test	Mechanical Assembly	Environmental	1984	Failure to Open	Partial	During routine surveillance testing of the reactor trip breakers, two breakers did not change state in the required time. The causes were determined to be dirty breaker mechanisms.
24	Internal to Component	480 Vac	Demand	Aux. Contactor	Maintenance	1986	Failure to Close	Partial	When attempting to close a normal supply breaker to a 480 Vac bus, the close circuit fuses blew. The failure caused by dirty auxiliary contacts. In another case, routine observation found that the alternate supply circuit breaker to the same bus had failed due to a burned out closing relay.
25	Internal to Component	480 Vac	Demand	Closing Coil	Maintenance	1984	Failure to Close	Partial	Over a period of 5 months, there were 6 incidents of circuit breakers of the same vendor and type failing to close on demand. Intermittent failures of the closing coil cutoff x-relays to properly return to their de-energized position prevented the relays from energizing the breakers' closing coils upon receipt of a close signal. It was determined that dirt and dust accumulation on the moveable parts of the relay causes the faulty operation. The symptoms of the x-relay malfunction were found to be failure of the breaker to close upon receiving a close signal, and in most cases, the breaker closes upon receiving a second close signal. This failure mode can cause equipment and/or systems to be inoperable without detection until that equipment is called upon to operate, either by test or when actually required. The x-relays on all safety-related breakers of this type were inspected and cleaned. The vendor did not provide for maintenance of the x-relays in their maintenance procedures.
26	Internal to Component	480 Vac	Demand	Latch Assembly	Maintenance	1983	Failure to Close	Partial	Two 480 Vac circuit breakers failed to close due to worn latching mechanisms. The latch mechanisms were replaced.
27	Internal to Component	480 Vac	Demand	Mechanical Assembly	Maintenance	1984	Failure to Open	Partial	During surveillance testing, one circuit breaker failed to trip when the undervoltage device was de-energized and two others failed to trip within the specified time limit. This occurrence may have affected the emergency diesel generator loading and its loading sequence as specified in Technical Specifications. The cause was dirt and lack of lubrication.
28	Internal to Component	480 Vac	Demand	Mechanical Assembly	Maintenance	1988	Failure to Close	Partial	Two breakers failed to close during attempts to transfer bus power from alternate to normal feed, the normal feeder breaker would not close. One failure was caused by corrosion in the cell switch. The second failure was due to excessive dirt. Both were attributed to lack of preventative maintenance. Preventative maintenance had not been done during the last 2 years because the unit had been shutdown for an unusually long time and maintenance frequency was tied to the refueling outage.
29	Internal to Component	480 Vac	Demand	Mechanical Assembly	Maintenance	1989	Failure to Close	Partial	When attempting to switch 600 Vac buses from normal to alternate feed, the alternate breakers failed to close when the normal breakers were tripped. One failure was due to trip rod binding in the alternate breaker due to a lack of proper lubrication of the trip rod bearings. Another failure was caused by a binding plunger in the breaker charging motor cutout switch due to dirt buildup. The dirty plunger caused the switch contacts to remain open preventing the motor from charging the closing spring and completing the closing sequence. The third failure was caused by a dirt buildup on the trip mechanism and pivot points, which resulted in binding of the internal moving parts.



Item	Proximate Cause	Breaker Type	Discovery Method	Piece Part	Coupling Factor	Year	Failure Mode	Degree of Failure	Description
30	Internal to Component	480 Vac	Demand	Mechanical Assembly	Maintenance	1992	Failure to Close	Partial	A normal supply breaker for a 600 Vac bus failed to close on demand when switching from the alternate to the normal power supply. The failure was due to binding of the closing mechanism in the breaker. A few days later the alternate feed breaker to another bus failed to close during a hot transfer. The second failure was caused by a stuck contact finger in the bus transfer interlock logic. The cause of the failures was attributed to a lack of lubrication or hardening of the lubrication. The breakers were removed from service and the closing pivot points and other moving parts lubricated. After functional testing, the breakers were returned to service.
31	Internal to Component	480 Vac	Demand	Mechanical Assembly	Design	1984	Failure to Close	Partial	A phase to phase fault across the station auxiliary transformer buswork caused a loss of normal offsite power to the unit. Both operable emergency diesel generators started as required. During the temporary loss of normal offsite power, several breakers in the plant's electrical distribution system failed to operate. The plant operators restored station power through an alternate offsite source, and restarted all necessary equipment.
32	Internal to Component	480 Vac	Demand	Spring Charging Motor	Maintenance	1985	Failure to Close	Partial	Four 480 Vac feeder breakers failed to close on demand. One breaker failed to close due to loose bolts holding the charging gearbox assembly. When demanded, the fuses for another breaker blew and the breaker failed to close. The cause of this failure was determined to be dirty contacts. Another breaker failed due to failure of the auxiliary relay. The fourth breaker failed to close due to dirty and dried lubricant on the trip latch adjustment parts.
33	Internal to Component	480 Vac	Inspection	Mechanical Assembly	Maintenance	1989	Failure to Close	Partial	Two 480 Vac feeder breakers tripped and would not close while a special inspection of breakers was being conducted. The breakers failed to close due to dirt built up and lack of lubrication.
34	Internal to Component	480 Vac	Maintenance	Latch Assembly	Maintenance	1986	Failure to Open	Partial	During preventive maintenance, two power supply circuit breakers to motor control centers would not automatically open when their associated load center was isolated. They subsequently failed to trip when the manual trip button or tripper bar was pushed. The circuit breaker latch mechanisms were dirty and sticky. The root cause was determined to be normal wear and an inadequate preventive maintenance procedure.
35	Internal to Component	480 Vac	Maintenance	Mechanical Assembly	Maintenance	1985	Failure to Close	Partial	While conducting maintenance, the main feeder breaker for a 600 Vac emergency bus would not close. Investigation revealed the trip setpoint tolerance, contact gap and trip latch roller gap were out of adjustment preventing the breaker operation. This breaker was adjusted and returned to service. Another 600 Vac breaker was found to be "broken." No exact failure mechanism was given; however, the cause was given as "wear," and this breaker was replaced.
36	Internal to Component	480 Vac	Test	Closing Coil	Design	1988	Failure to Close	Partial	During a station loss of offsite power (loop) test, two class 1E 480 volt load center breakers failed to close during automatic load sequencing. Subsequent investigation revealed that the breaker spring release device in both breakers was binding against the opening in the breaker base plate which resulted in failure of the closing coil and failure of the breaker to close. Other defective breakers were also identified following inspections.
37	Internal to Component	480 Vac	Test	Mechanical Assembly	Maintenance	1986	Failure to Close	Partial	During routine inspections of the 480 volt unit boards, two feeder breakers were binding. The failures were attributed to dirty, hardened grease, normal aging and wear.
38	Internal to Component	480 Vac	Test	Mechanical Assembly	Maintenance	1986	Failure to Open	Partial	The power supply circuit breakers to two motor control centers would not trip during surveillance testing. The circuit breakers were dirty. This was due to a normal accumulation of dirt during operations. The circuit breakers were cleaned and verified to be operable.

Item	Proximate Cause	Breaker Type	Discovery Method	Piece Part	Coupling Factor	Year	Failure Mode	Degree of Failure	Description
39	Internal to Component	480 Vac	Test	Mechanical Assembly	Maintenance	1991	Failure to Close	Partial	Two 480 Vac circuit breakers failed to close due to mechanical binding caused by dried out, hardened lubricant. The mechanical operating mechanisms were replaced.
40	Internal to Component	480 Vac	Test	Mechanical Assembly	Maintenance	1987	Failure to Open	Partial	During once per cycle testing of the startup transfer feeder to the unit bus breaker, two breaker trip units were found to be non-operational so that the breakers would not trip. Both failures were caused by lack of lubrication on the internal moving parts due to a lack of proper maintenance.
41	Internal to Component	480 Vac	Test	Mechanical Assembly	Maintenance	1999	Failure to Open	Partial	During high tolerance instantaneous testing, several 480 Vac circuit breakers on all three phases did not trip in the required time (0-10 cycles). Failures were attributed to aging and degraded lubricants resulting from an ineffective maintenance program.
42	Internal to Component	480 Vac	Test	OC Relay	Maintenance	1998	Failure to Open	Partial	The instantaneous trip testing of both breakers revealed excessive time prior to tripping. The required trip time is less than 0.15 seconds. Breakers were tripping on instantaneous testing between 0.194 and 0.753 seconds. Cause was determined to be inadequate preventative maintenance.
43	Internal to Component	480 Vac	Test	Relay	Maintenance	1988	Failure to Close	Partial	During surveillance testing on the plant ac distribution system, the normal feeder breaker from a transformer would not close when transferring from alternate to normal power. The failure was attributed to close relay contacts hanging up from a lack of breaker lubrication. A second similar failure was attributed to the breaker having dirty contacts.
44	Internal to Component	480 Vac	Test	Relay	Maintenance	1983	Failure to Close	Partial	Four 480 Vac circuit breakers failed to close during testing due to failure of the power sensors. The power sensors were replaced.
45	Internal to Component	480 Vac	Test	Relay	Maintenance	1988	Failure to Close	Partial	A circuit breaker failed to close on a safety injection demand due to oxidation on contacts for the alarm switches. Subsequent investigation revealed 11 other safety-related breakers with the same problem. The cause was determined to be inadequate periodic inspections and cleaning of the alarm switch contacts due to lack of specific guidance in the maintenance procedure. Corrective actions included revision of the maintenance procedure.
46	Internal to Component	DC distribution	Test	Control Switch	Maintenance	1987	Failure to Close	Partial	During routine observation of the 250 volt distribution boards, a normal dc power feeder breaker was slow to transfer and another failed to transfer. The first failure was due to switch joints being dirty and an indicating light resistor being burned out. The second failure was due to dirty hinge joints.
47	Internal to Component	DC distribution	Test	Mechanical Assembly	Maintenance	1996	Failure to Open	Partial	The dc bus inter-tie breakers failed to open due to lack of lubrication. Corrective action was to create a preventative maintenance and inspection schedule for these breakers.
48	Internal to Component	DC distribution	Test	OC Relay	Maintenance	1989	Failure to Open	Partial	While performing preventative maintenance on the dc feeder circuit breakers, the overcurrent trip devices would not set correctly. The cause was attributed to a lack of maintenance.
49	Internal to Component	Medium Voltage	Demand	Aux. Contactor	Maintenance	1980	Failure to Close	Partial	During a planned line outage which de-energized a transformer, the alternate feeder breaker failed to close, de-energizing a 4 kv bus tie board during automatic transfer. When the transformer was re-energized the normal feeder breaker failed to close. The fuse clip and fuse in the close circuit of alternate feeder breaker were not making contact. The auxiliary contacts of the normal feeder breaker were dirty.
50	Internal to Component	Medium Voltage	Demand	Latch Assembly	Maintenance	1991	Failure to Open	Partial	One 4160 Vac circuit breaker failed to open and several more were degraded due to hardened grease and lack of lubrication. This problem could affect the ability of the subject breakers to open or close. Maintenance of the breakers was incomplete despite similar failures due to the same cause four years earlier.

Item	Proximate Cause	Breaker Type	Discovery Method	Piece Part	Coupling Factor	Year	Failure Mode	Degree of Failure	Description
51	Internal to Component	Medium Voltage	Demand	Mechanical Assembly	Design	1981	Failure to Close	Partial	A decay heat removal pump failed to start due to the circuit breaker failing to close upon demand. The cause was determined to be an intermittent sticking of the motor cutoff switch operator due to the operator being slightly bent, which prevented it from sliding. Further inspections revealed that all 4.16 and 13.8 kv circuit breakers were susceptible to this problem. All applicable circuit breakers were subsequently modified.
52	Internal to Component	Medium Voltage	Demand	UV Trip Assembly	Maintenance	1988	Failure to Open	Partial	Two 4160 Vac failed to open due to failure of the breaker trip coils. The cause were determined to be normal wear and aging.
53	Internal to Component	Medium Voltage	Inspection	Arc Chute	Design	1999	Failure to Open	Partial	4160 Vac circuit breakers could fail to change position due to an insulating block (a component of the breaker blowout magnets), whose adhesive had degraded with age, could become loose and fall into the breaker mechanism and prevent breaker operation.
54	Internal to Component	Medium Voltage	Inspection	Spring Charging Motor	Maintenance	1992	Failure to Close	Partial	Two breaker's closing springs failed to charge-up when equipment operator was making ready the in-feed breaker from separate station power transformers. The suspected failure cause for one breaker was dirty contacts in the charging mechanism. The suspected failure cause for the other breaker was binding in the charging spring mechanism.
55	Internal to Component	Medium Voltage	Maintenance	Mechanical Assembly	Quality	1985	Failure to Close	Partial	During a scheduled maintenance outage of 4160v safety-related switchgear, the plant electrical staff discovered that two circuit breakers were rendered electrically inoperable due to the failure of a spot welded pivot pin. This spot welded pivot pin was on an internal piece of linkage, which actuates the auxiliary contacts that track breaker position. These contacts are also used in external breaker trip and close schemes as interlocks. The defective component is being modified to preclude additional failures.
56	Internal to Component	Medium Voltage	Test	Limit Switch	Maintenance	1989	Failure to Open	Partial	In two separate incidents while attempting to realign power to support testing, the alternate supply circuit breaker failed to trip upon closure of normal supply breaker. The cause of failure was attributed to the raised upper limit switch being out of mechanical adjustment causing a greater than 1/8 inch gap between the operating plunger and the breaker auxiliary switch. This limit switch provides the trip signal for the alternate breaker.
57	Internal to Component	Medium Voltage	Test	Mechanical Assembly	Maintenance	1995	Failure to Close	Partial	A 4KV supply circuit breaker closed during testing, but failed to instantly recharge. The cause of the failure was aging of the latch monitor pivot bearing lubrication. This problem had previously surfaced and the bearings were re-lubricated at that time. Since that action did not fix the problem, the decision was made to replace the pivot bearings for all affected circuit breakers.
58	Internal to Component	Medium Voltage	Test	Mechanical Assembly	Design	1987	Failure to Open	Partial	A circuit breaker failed to trip during a surveillance test. Upon investigation, it was determined that the connecting pin for the breaker trip crank located between the trip solenoid and the trip shaft became loose due to a pin weld failure, which prevented electrical tripping of the breaker. Inspection revealed several breakers with the same weld geometry. Two procedures, an inspection procedure and a trip crank replacement procedure were written for eighty six affected breakers on site. Nine breakers failed the acceptance criteria.
59	Internal to Component	Medium Voltage	Test	OC Relay	Maintenance	1984	Failure to Open	Partial	Several 4160 Vac circuit breakers of the vendor and type failed to trip due to age induced hardening of grommets in the electromechanical overcurrent device. Corrective actions included replacement with new or newly rebuilt overcurrent devices and establishing an adequate preventive maintenance surveillance interval.
60	Internal to Component	Medium Voltage	Test	Relay	Maintenance	1989	Failure to Close	Partial	A time delay relay for a 4160 volt feeder breaker would not time out within its specified tolerance during calibration, and a time delay relay for a second breaker would not actuate. The causes of both failures were determined to be due to aging.

Item	Proximate Cause	Breaker Type	Discovery Method	Piece Part	Coupling Factor	Year	Failure Mode	Degree of Failure	Description
61	Internal to Component	Medium Voltage	Test	Spring Charging Motor	Maintenance	1987	Failure to Close	Partial	Two 4160 Vac circuit breakers failed to close. One failure was caused by the latching pawl spring being out of adjustment, which prevented the springs from charging. The cause of the second failure was attributed to the racking mechanism slide interlock being out of adjustment.
62	Internal to Component	Medium Voltage	Test	Spring Charging Motor	Maintenance	1986	Failure to Close	Partial	While performing testing of 4160 Vac boards and buses, three circuit breakers would not close. The failures were attributed to the breakers being dirty, needing lubrication, and due to loose connections.
63	Internal to Component	Medium Voltage	Test	Spring Charging Motor	Maintenance	1987	Failure to Close	Partial	The closing springs for two 4160 Vac breakers would not charge. The cause of the failures were dirty contacts, a dirty closing mechanism, and lack of lubrication.
64	Internal to Component	RPS trip breakers	Demand	Closing Coil	Maintenance	1992	Failure to Close	Partial	Two reactor trip breakers failed to close following a trip test. The cause of the failure was believed to be due to the relay release arm on the closing solenoid moving core being out of adjustment.
65	Internal to Component	RPS trip breakers	Demand	Latch Assembly	Maintenance	1992	Failure to Close	Partial	While attempting to reset the control rod drive system following a control rod drive breaker in the reactor protective system failed to reset. Later, during a control rod drive breaker trip test, another breaker failed to reset after a trip. The first failure was due to the breaker trip latch being out of adjustment. The cause of the second failure could not be precisely determined; however, troubleshooting revealed cracked insulation on the close coil.
66	Internal to Component	RPS trip breakers	Demand	Unknown	Quality	1993	Failure to Close	Partial	During an attempt to close the control rod drive circuit breakers two breakers failed to close. The failures could not be repeated. Although the mechanical interlock, a piece part of this circuit breaker, was found slightly dirty and in need of lubrication, it is not believed to have caused the failures to close. As a preventive measure, the mechanical interlock was cleaned and lubricated. The breakers were successfully closed on all subsequent tests.
67	Internal to Component	RPS trip breakers	Demand	UV Trip Assembly	Quality	1983	Failure to Open	Complete	During a routine startup, both reactor trip breakers failed to open automatically on receipt of a valid low-low steam generator level reactor trip signal. The reactor was shutdown 25 seconds later using the manual trip on the control console. Subsequent investigation revealed that the breaker failures were caused by mechanical binding of the latch mechanism in the undervoltage trip attachment. All breaker undervoltage attachments were replaced with new devices and extensive maintenance and testing was performed on the breakers.
68	Internal to Component	RPS trip breakers	Inspection	UV Trip Assembly	Maintenance	1987	Failure to Close	Partial	Two reactor trip breakers failed to close following testing. Troubleshooting found one breaker's under voltage coil had failed (open circuit) and the other breaker's undervoltage device pivot to armature clearance was out of adjustment. Operational/ambient conditions were cited as causes for the failures.
69	Internal to Component	RPS trip breakers	Maintenance	Aux. Contactor	Maintenance	1990	Failure to Close	Partial	Two reactor trip breakers failed to close during preventative maintenance. The failure to close was due failure of the breaker cutoff switches.
70	Internal to Component	RPS trip breakers	Maintenance	Relay	Maintenance	1986	Failure to Close	Partial	During preventative maintenance two reactor trip breakers failed to close. Both breaker failures were due to failure of the same relay. The cause was assumed to be wear and aging.

Item	Proximate Cause	Breaker Type	Discovery Method	Piece Part	Coupling Factor	Year	Failure Mode	Degree of Failure	Description
71	Internal to Component	RPS trip breakers	Test	Latch Assembly	Maintenance	1994	Failure to Close	Partial	During unit outage, while performing functional testing, operators found that two reactor trip breakers would not close from the handswitch in the main control room. Troubleshooting discovered the inertia latch (piece part of the circuit breaker) had stuck in mid travel. The breakers' electrical trip function was lost, but the control rod drive system was not affected because of an available redundant trip breaker. Plant operation was not affected. Insufficient lubrication of the inertia latch caused the latch to stick in mid travel. The inertia latches were cleaned and lubricated and post maintenance testing was performed satisfactorily.
72	Internal to Component	RPS trip breakers	Test	Latch Assembly	Design	1983	Failure to Open	Complete	The static force to trip the circuit breakers exceeded allowable tolerance due to binding caused by the unused overcurrent trip pads. The breakers tested satisfactorily after removal of the overcurrent trip pads.
73	Internal to Component	RPS trip breakers	Test	Mechanical Assembly	Maintenance	1985	Failure to Open	Partial	During normal operation while performing surveillance testing, two reactor trip circuit breakers failed the under voltage response time test. The breaker's front frame assembly was the suspected cause of the increased time response of the one breaker's undervoltage device. The other failure was due to loose armature laminations in the undervoltage device. Both are known design problems with these circuit breakers.
74	Internal to Component	RPS trip breakers	Test	Mechanical Assembly	Maintenance	1989	Failure to Close	Partial	During surveillance testing, two reactor trip switchgear breakers would not close. The first failure was due to a defective piece part in the cutout 'y' switch on the breaker due to cyclic fatigue. In the second failure, a broken clamp was found on the closing mechanism, which prevented the breaker from closing.
75	Internal to Component	RPS trip breakers	Test	Mechanical Assembly	Maintenance	1984	Failure to Open	Partial	During surveillance testing of the reactor trip circuit breakers, the under voltage trip response time was found out of specification. Troubleshooting found the breakers' front frame assemblies to be lacking the proper amount of lubricant on their bearings. This was a recurring problem with this breaker type. The front frame assemblies were replaced.
76	Internal to Component	RPS trip breakers	Test	Mechanical Assembly	Maintenance	1985	Failure to Open	Partial	While performing testing of the unit's reactor trip circuit breakers, the undervoltage trip time was found to be out of the allowable tolerance for two breakers. Dirt accumulation in the front frame assembly and lack of lubrication were the suspected causes
77	Internal to Component	RPS trip breakers	Test	Mechanical Assembly	Maintenance	1984	Failure to Open	Partial	During surveillance testing, the trip time requirements for two reactor trip breakers were found to be out of specification high. Historically, the bearings for the breaker front frame assemblies have been found worn and lacking the necessary lubrication, which increases trip times. After replacing the front frame assemblies and lubrication the bearings, the breakers were retested satisfactorily and returned to service.
78	Internal to Component	RPS trip breakers	Test	Relay	Maintenance	1984	Failure to Close	Partial	Two reactor trip breakers failed to close over a one-month period. Both failures were attributed to relay release arms being out of adjustment.
79	Internal to Component	RPS trip breakers	Test	Relay	Maintenance	1986	Failure to Open	Partial	Two reactor trip breakers failed to trip during performance of surveillance testing. One failure was due to the auxiliary contact for the shunt trip was not making contact due to misalignment with the block. The other failure was due to a faulty undervoltage relay. The jumper to change the control voltage was installed in the 48 volt holes and should have been installed in the 125 volt holes causing the relay to overheat and melt.
80	Internal to Component	RPS trip breakers	Test	Spring	Quality	1989	Failure to Close	Partial	While performing surveillance testing on reactor trip circuit breakers, two breakers failed to close. In one failure, the left side close spring on the breaker had fallen off and the breaker wouldn't close with only one spring. The second breaker failure was due to a bad control power fuse that failed due to aging.

Item	Proximate Cause	Breaker Type	Discovery Method	Piece Part	Coupling Factor	Year	Failure Mode	Degree of Failure	Description
81	Internal to Component	RPS trip breakers	Test	Spring	Design	1986	Failure to Close	Partial	During performance testing of the reactor trip circuit breakers, two breakers failed to re-close after open them from the control room panel controls. Troubleshooting found that the breakers' operating springs fell off, preventing closure but not opening, a recurring problem with this particular breaker design.
82	Internal to Component	RPS trip breakers	Test	Unknown	Maintenance	1992	Failure to Close	Partial	Two reactor trip breakers failed to close following a trip test. The cause could not be determined and the failure was not repeatable. The breakers that failed were replaced with spares.
83	Internal to Component	RPS trip breakers	Test	UV Trip Assembly	Design	1983	Failure to Open	Partial	During reactor trip breaker surveillance testing, the undervoltage trip devices for two circuit breakers exhibited scattered and unacceptable response times. The reactor trip breakers were replaced with spares.
84	Internal to Component	RPS trip breakers	Test	UV Trip Assembly	Maintenance	1980	Failure to Open	Partial	It was discovered during testing that some reactor trip breakers would not trip on undervoltage as expected. One device would not trip and two others tripped sluggishly. The cause was determined to be misaligned armatures in the undervoltage devices. A new preventative maintenance program was initiated to check the undervoltage coils independently on a monthly basis.
85	Internal to Component	RPS trip breakers	Test	UV Trip Assembly	Environmental	1983	Failure to Open	Partial	During routine surveillance testing, a the control rod drive AC breaker experienced a delayed trip. Subsequent testing of all AC and dc control rod drive breakers resulted in a control rod drive dc breaker also experiencing a delayed trip. If a reactor trip had occurred, and if both malfunctioned breakers had delayed in tripping, two control rod groups would not have dropped immediately.
86	Internal to Component	RPS trip breakers	Test	UV Trip Assembly	Maintenance	1990	Failure to Open	Partial	Two reactor trip breakers were found to have defective undervoltage trip relays which prevented opening. One failure was detected during testing and the other was detected during maintenance. The relay failures were determined to be due to aging.
87	Internal to Component	RPS trip breakers	Test	UV Trip Assembly	Maintenance	1982	Failure to Open	Partial	During surveillance testing, four of nine reactor trip circuit breakers failed to trip on undervoltage. The primary cause was inadequate lubrication, possibly due to an excessive preventive maintenance interval, combined with a small design margin in the tripping force provided from the undervoltage coil. Corrective actions were to perform required preventive maintenance prior to the unit entering mode 2 and implementation of the recommendations of IE Bulletin 79-09 and vendor recommendations, increased surveillance testing of the undervoltage trip feature and a decrease in the interval between preventive maintenance.
88	Internal to Component	RPS trip breakers	Test	UV Trip Assembly	Quality	1983	Failure to Open	Almost Complete	Both reactor trip breakers and a bypass breaker failed to open on an undervoltage trip signal during response time testing. The failures were due to mechanical problems of the undervoltage mechanisms, which resulted from manufacturing deficiencies. Fifteen days later, one of the replacement reactor trip breakers also failed due to the same cause.
89	Internal to Component	RPS trip breakers	Test	UV Trip Assembly	Quality	1983	Failure to Open	Partial	The undervoltage armatures for two different reactor trip breakers were found during testing to not be fully picked up (repetitive failures in the same month). Based on vendor tests, the abnormal armature position has little or no detectable effect on the ability of the undervoltage trip device to trip the breaker on loss of voltage. The undervoltage armatures not being fully picked up is the result of interference between the undervoltage armature and the copper shading ring around the coil core. As corrective action, visual verification and manual adjustment of proper closed air gap position is required following energization of the undervoltage device.

Item	Proximate Cause	Breaker Type	Discovery Method	Piece Part	Coupling Factor	Year	Failure Mode	Degree of Failure	Description
90	Internal to Component	RPS trip breakers	Test	UV Trip Assembly	Maintenance	1987	Failure to Close	Partial	Two reactor trip breakers failed to close following testing. Troubleshooting found one breaker's under voltage coil had failed (open circuit) and the other breaker's undervoltage device pivot to armature clearance was out of adjustment. Operational/ambient conditions (heat/vibration) were cited as causes for the failures.
91	Internal to Component	RPS trip breakers	Test	UV Trip Assembly	Quality	1983	Failure to Open	Partial	The undervoltage armatures for two different reactor trip breakers were found during testing to not be fully picked up (repetitive failures in the same month). Based on vendor tests, the abnormal armature position has little or no detectable effect on the ability of the undervoltage trip device to trip the breaker on loss of voltage. The undervoltage armatures not being fully picked up is the result of interference between the undervoltage armature and the copper shading ring around the coil core. As corrective action, visual verification and manual adjustment of proper closed air gap position is required following energization of the undervoltage device.
92	Internal to Component	RPS trip breakers	Test	UV Trip Assembly	Maintenance	1986	Failure to Close	Partial	While conducting surveillance testing of the unit's reactor protection system, two reactor trip circuit breakers' UV devices would not pick up after tripping the breakers. Troubleshooting found that the UV devices' gap clearances were incorrect. No direct cause for the misadjustments was found, however, operational stress and/or equipment aging were suspected.
93	Internal to Component	RPS trip breakers	Test	UV Trip Assembly	Maintenance	1983	Failure to Open	Partial	During surveillance testing, three reactor trip breakers failed to trip on undervoltage. The primary cause was inadequate lubrication, possibly due to an excessive preventive maintenance interval, combined with a small design margin in the tripping force provided from the undervoltage coil. Corrective action was to perform the required preventive maintenance prior to entering Mode 2. Additionally, as required by IE Bulletin 79-09 and vendor recommendations, the surveillance testing interval of the undervoltage trip feature was increased and the interval between preventive maintenance was decreased to prevent recurrence of this event.
94	Internal to Component	RPS trip breakers	Test	UV Trip Assembly	Maintenance	1984	Failure to Close	Partial	During surveillance testing, two reactor trip breakers failed to close during surveillance response time test. The stated cause was normal wear.
95	Internal to Component	RPS trip breakers	Test	UV Trip Assembly	Maintenance	1986	Failure to Close	Partial	While conducting monthly surveillance testing of the unit's reactor protection system, two reactor trip circuit breakers failed to close after testing. Troubleshooting found a failure of one breaker's under voltage device. The second circuit breaker's pick-up coil voltage was high due to a change in characteristics of the voltage adjustment potentiometer. Both failures were attributed to operational stress and/or equipment aging.
96	Internal to Component	RPS trip breakers	Test	UV Trip Assembly	Maintenance	1990	Failure to Close	Partial	In separate tests, two reactor trip breakers failed to close after trip testing. The failure to reset was determined to be due to worn undervoltage trip coil mechanisms to prevented the breakers from latching.
97	Operational/ Human Error	480 Vac	Demand	OC Relay	Maintenance	1998	Failure to Close	Partial	Circuit breakers were found to be susceptible to tripping on normal start due to improper setting of overcurrent trip. The problem was discovered when one breaker failed to close on demand. A previous modification package was determined to be inadequate in that it did not require trip setpoint adjustment.
98	Operational/ Human Error	480 Vac	Test	Main Contacts	Maintenance	1992	Failure to Close	Partial	During testing on emergency bus feeder breakers, the closing spring charge/discharge indicator showed that the springs were charged with the breaker closed, indicating that the main contacts were closed but not exerting full pressure against the stationary contacts. Investigation showed the root cause to be failure to incorporate the latest vendor information on contact adjustment into the breaker maintenance procedure.

Item	Proximate Cause	Breaker Type	Discovery Method	Piece Part	Coupling Factor	Year	Failure Mode	Degree of Failure	Description
99	Operational/ Human Error	480 Vac	Test	Mechanical Assembly	Maintenance	1997	Failure to Open	Partial	A breaker failed to trip during testing. Subsequent testing and inspection revealed several breakers degraded due to lack of lubrication. Lubrication was removed during refurbishment by the vendor and was not re-installed.
100	Operational/ Human Error	480 Vac	Test	Mechanical Assembly	Maintenance	1997	Failure to Close	Partial	Three breakers failed to close on demand during testing. Hardened grease was discovered in the stop roller and main drive link roller. When actuated by the closing coil, these rollers and the associated closing latch release the stored energy of the breaker springs, closing the breaker. Stiff rollers have resulted in multiple breaker failures in the past. The maintenance procedure provides instructions to clean and lubricate various friction points of the breaker mechanism; however, they are not specifically identified in the vendor manual. These rollers were not cleaned and lubricated during the performance of the scheduled preventative maintenance.
101	Operational/ Human Error	480 Vac	Test	Wires/Connectors/Board	Maintenance	1993	Failure to Open	Partial	An Emergency Diesel Generator (EDG) failed to pass surveillance testing because certain loads were not shunt tripped from the safeguard bus when a simulated Loss of Coolant Accident (LOCA) signal was initiated. During troubleshooting, a loose wire was discovered in one circuit breaker and a lifted wire was discovered in another circuit breaker. The wires were restored to their normal positions and a portion of the test procedure was performed to verify appropriate loads were shunt tripped following a simulated LOCA signal. The loose/disconnected wires were believed to have come loose at a plug connection during repairs made to enhance electrical separation between electrical divisions. Procedures were revised to alert workers of the potential for wires becoming loose during removal and restoration of plug connections on similar circuit breakers.
102	Operational/ Human Error	Medium Voltage	Demand	Mechanical Assembly	Maintenance	1997	Failure to Open	Partial	Two circuit breakers failed to open on demand during separate evolutions. During subsequent reviews, station personnel determined that the condition of the three circuit breakers was similar to the condition of the two safety-related circuit breakers that previously failed to open on demand. The cause of the event was determined to be inadequate preventative maintenance. The preventative maintenance performed did not lubricate the main and auxiliary contacts in the circuit breakers as recommended by the circuit breaker manufacturer and also did not provide sufficient instructions to remove the roughness on the main and auxiliary contacts.
103	Operational/ Human Error	Medium Voltage	Demand	Mechanical Assembly	Maintenance	1994	Failure to Close	Partial	Four 4160 Vac circuit breakers failed to close. Each failure was due to a different mechanism; however, investigation revealed that all failures were related to workmanship and quality control practices by the vendor who overhauled the circuit breakers. To ensure the safety class circuit breakers are reliable, the utility and vendor developed a comprehensive plan to inspect critical components of the circuit breakers that were previously overhauled.



Item	Proximate Cause	Breaker Type	Discovery Method	Piece Part	Coupling Factor	Year	Failure Mode	Degree of Failure	Description
104	Operational/ Human Error	Medium Voltage	Inspection	Latch Assembly	Maintenance	1996	Failure to Close	Partial	A failure of a roll pin securing a spring for a latch pawl on a 4KV breaker was reviewed and a determination made that the failure of this pin could cause the breaker to fail. Further investigation revealed that the roll pin failed as a result of hydrogen embrittlement. Later, an issue involving permanently applied lubricant which was inadvertently removed from the breakers was identified. This also could potentially affect breaker operation. The cause of the cracked roll pin was the lack of knowledge of plating induced hydrogen embrittlement. Vendor personnel involved in the procedure development were not aware that zinc plating of hardened steel parts could produce hydrogen embrittlement and subsequent cracking. The cause of the lubricant being inadvertently removed from breaker parts is also due to the lack of knowledge by Vendor personnel.
105	Operational/ Human Error	Medium Voltage	Inspection	Relay	Design	1998	Failure to Close	Partial	A circuit breaker contacted exposed relay terminals during rack-in, causing trips/lockout of two breakers and lockout of another. The event was attributed to human error and poor design (location of relays).
106	Operational/ Human Error	Medium Voltage	Maintenance	Mechanical Assembly	Maintenance	1988	Failure to Open	Partial	A circuit breaker failed to open due to trip linkage binding caused by misalignment and improper assembly. Subsequent inspection of other 4160 Vac circuit breakers revealed the same problem. The misalignment was the result of a procedural deficiency by the vendor that performed circuit breaker overhauls.
107	Operational/ Human Error	RPS trip breakers	Inspection	Wires/Connectors/Board	Maintenance	1983	Failure to Open	Complete	Following performance of the manual reactor trip functional test, it was noted that the procedure called for jumpering out the UV trip coils with the reactor trip breakers closed and the rods capable of withdrawal. This was a procedural error that caused the removal of both trains of automatic reactor trip logic. The procedure was revised to prevent recurrence of the event.
108	Operational/ Human Error	RPS trip breakers	Test	Latch Assembly	Maintenance	1992	Failure to Close	Partial	While performing surveillance testing, two reactor trip breakers failed to close on separate occasions. In one case, the breaker latch catch and arm were found bent, preventing the breaker from closing. The cause of this failure was believed to be from incorrect installation of the breaker during previous maintenance or testing activities. In the second case, the breaker operating mechanism latch was binding against the housing likely due to inadequate lubrication and rough surfaces.
109	Operational/ Human Error	RPS trip breakers	Test	Shunt Trip	Maintenance	1984	Failure to Open	Partial	One set of leads in each of the four plant protective system bays were found to be disconnected. These disconnected leads removed the automatic shunt trip feature from RTB's #1, #2, #3, and #4. The subject leads had been disconnected and not restored during 18-month surveillance testing conducted earlier.
110	Operational/ Human Error	RPS trip breakers	Test	Spring	Design	1994	Failure to Close	Partial	While performing initial approach to criticality testing, operators noted that the B-phase for a reactor trip breaker, was not indicating current flow after the breaker was closed. The train's function of providing power to the control rod drive mechanism was degraded as one phase of power was unavailable. The failure was caused by a mechanical operating spring that had come loose. With the spring loose, the B-phase contacts were getting insufficient pressure to close. The vendor has provided notice that the spring could come loose and the vendor has provided additional instructions for breaker inspection and maintenance to address this problem. The spring was reinstalled according to the vendors instructions. The breaker was subsequently tested and returned to service.

Item	Proximate Cause	Breaker Type	Discovery Method	Piece Part	Coupling Factor	Year	Failure Mode	Degree of Failure	Description
111	Operational/ Human Error	RPS trip breakers	Test	UV Trip Assembly	Maintenance	1983	Failure to Open	Partial	During the performance of reactor trip circuit breaker undervoltage device surveillance testing, three breakers failed to open within the acceptance time criteria. The following day, and then 8 days later, two additional breakers failed to meet the acceptance criteria. The reactor trip breakers failed even though extensive maintenance and testing was performed on all eight of the trip system breakers 11 days prior to the first 3 failures. Maintenance included procedures specified in the vendor service advisory letter. The deficiencies were corrected by again performing the vendor approved refurbishment procedures on the slow breakers, followed by successful testing.
112	Other	480 Vac	Maintenance	OC Relay	Maintenance	1994	Failure to Open	Partial	A preventive maintenance procedure was being performed on 480V molded case circuit breakers. These are magnetic only breakers with an adjustable instantaneous trip range of 50 to 150 amps. With the breakers adjusted to their lowest setting, the right phase for two breakers tripped at 71.7 amps and 69 amps. The maximum allowable trip point was 57.5 amps. The breakers had a date code that meant they were manufactured in August of 1978. Considering the breakers were approximately 16 years old, the drift in calibration is associated with the breakers' service life. Therefore, it was decided to replace the breakers. The circuit breakers would still trip on instantaneous within its adjustable range which would provide adequate overcurrent protection. The cause was attributed to the breakers' long service life. Like for like breakers were installed. All tests were performed satisfactorily.
113	Other	480 Vac	Test	OC Relay	Maintenance	1985	Failure to Open	Partial	During routing surveillance testing, three circuit breakers would not trip on short time overcurrent trip test. The failures were caused by the breakers being out of calibration as a result of normal wear.
114	Other	Medium Voltage	Test	UV Trip Assembly	Maintenance	1986	Failure to Open	Partial	During routine testing it was found that the under voltage relays for two 4160 Vac feeder breakers from an auxiliary transformer to the buses were out of calibration. The failures were attributed to relay wear.
115	Other	Medium Voltage	Test	UV Trip Assembly	Maintenance	1994	Failure to Open	Partial	Undervoltage dropout relays in two separate, similar breakers drifted out of specification between times they were checked by scheduled maintenance. A root cause investigation attributed the relay setpoint shift to a combination of: 1) relay setpoint repeatability, 2) temperature sensitivity of the relays, and 3) testing techniques. Applicable test equipment and procedures have been changed to address the causes of the setpoint shift. Additionally, the testing frequency has been increased from quarterly to monthly pending relay performance trending results.
116	Other	RPS trip breakers	Maintenance	UV Trip Assembly	Maintenance	1986	Failure to Open	Partial	During preventive maintenance on the reactor trip breakers, the undervoltage trip units on two breakers were found to be out of specification. One undervoltage device could not be adjusted within specification and was replaced. The cause for both failures was determined to be vibration and aging.
117	Other	RPS trip breakers	Test	UV Trip Assembly	Maintenance	1983	Failure to Open	Partial	During monthly surveillance test of the reactor trip circuit breaker undervoltage trip devices, the response time of two breakers was slower than allowed by Technical Specifications. This event was caused by setpoint drift and worn/binding front frame assembly mechanisms. Corrective actions included replacement of front frame assemblies and undervoltage trip devices.
118	Other	RPS trip breakers	Test	UV Trip Assembly	Maintenance	1983	Failure to Open	Partial	During surveillance testing of the reactor trip circuit breakers' undervoltage devices, the response time of two breakers than allowed by Technical Specifications. The cause of the event was setpoint drift and worn/binding front frame assembly mechanisms. The setpoints were adjusted and the trip shaft and latch roller bearings were lubricated.

Item	Proximate Cause	Breaker Type	Discovery Method	Piece Part	Coupling Factor	Year	Failure Mode	Degree of Failure	Description
119	Other	RPS trip breakers	Test	UV Trip Assembly	Maintenance	1983	Failure to Open	Partial	The trip response time of two reactor trip breakers was slower than allowed by Technical Specifications. The breakers were retested satisfactorily and returned to service after adjusting the UV trip device setpoints and lubricating the trip shaft and latch roller bearings. The breakers were still considered operable since the shunt trip devices were operational with satisfactory response times.

Table A-2. Breaker CCF event summary, sorted by coupling factor.

Item	Coupling Factor	Proximate Cause	Discovery Method	Breaker Type	Piece Part	Year	Failure Mode	Degree of Failure	Description
1	Design	Design/ Construction/ Manufacture/ Installation Inadequacy	Demand	480 Vac	Stabs/Connectors	1980	Failure to Close	Partial	While returning a service water booster pump to service, a minor fire occurred in a 480 Vac ESF MCC. This rendered several components inoperable. Repeated cycling of the pump onto the bus coupled with inadequate stab to bus bar contact and dust in the MCC cabinet caused a fire. Operators were reminded of undesirability of repeated cycling of load breaker. An engineering study to determine if the breakers are adequately sized was also made (the results of the study were not included in the failure report).
2	Design	Design/ Construction/ Manufacture/ Installation Inadequacy	Inspection	Medium Voltage	Limit Switch	1995	Failure to Open	Partial	Inspection of circuit breaker limit switches revealed cam follower cracking. No equipment malfunctions or plant transients occurred, because the single actual failure occurred during routine post modification testing. The root cause of this occurrence was inadequate initial design of General Electric type SBM switches by the manufacturer.
3	Design	Design/ Construction/ Manufacture/ Installation Inadequacy	Inspection	Medium Voltage	Mechanical Assembly	1988	Failure to Close	Partial	An operator racked up the emergency 4.16kv bus feeder breaker from an emergency diesel generator and found that there was no indication of breaker position on the control panel. It was discovered that the breaker elevator mechanism linkage was distorted and had allowed the cell switch actuator arm to fall into an intermediate position disabling the automatic and manual closure circuitry. Other breaker compartments contained distorted linkages and it was concluded that any of 4.16kv breakers could fail during a seismic event. The linkage distortion was caused by an interference with the breaker assembly as it is rolled out of the compartment.
4	Design	Design/ Construction/ Manufacture/ Installation Inadequacy	Inspection	Medium Voltage	Limit Switch	1995	Failure to Open	Partial	All 4 kV vital busses were declared inoperable following inspection that revealed cracks in the circuit breaker cam followers. One actual failure occurred during post maintenance testing (maintenance was for another reason), but all cam follower limit switches at both units were replaced. The root cause of this occurrence was inadequate initial design of General Electric type SBM switches by the manufacturer.
5	Design	Design/ Construction/ Manufacture/ Installation Inadequacy	Maintenance	Medium Voltage	Limit Switch	1995	Failure to Close	Partial	Inspections revealed cracks in the lexan cam followers of control (limit) switches installed in 4160 Vac and 6900 Vac circuit breakers. The same part used in 360 places in unknown number of breakers. Inspection showed about one third were cracking and two were inoperable. The root cause of this occurrence was inadequate initial design of General Electric type SBM switches by the manufacturer.
6	Design	Design/ Construction/ Manufacture/ Installation Inadequacy	Test	DC distribution	OC Relay	1996	Failure to Open	Almost Complete	All 72 dc molded case circuit breakers were tested, all 44 breakers of one vendor type, installed in 4 different distribution panels failed to trip on overcurrent. Problem was the design of the trip lever in the magnetic trip circuit breakers. All breakers of this type and vendor were replaced.
7	Design	Design/ Construction/ Manufacture/ Installation Inadequacy	Test	Medium Voltage	Relay	1990	Failure to Open	Partial	During surveillance testing several circuit breaker lockout relays would not actuate. These failures would have prevented breaker trips on overcurrent. Mechanical binding prevented the relays from tripping. Bench testing revealed several contributing factors but could not identify the root cause. The failed relays' armature force checks yielded 5 to 6.5 pounds but newer relays required only 3.5 pounds. The vendor discourages re-lubrication to reduce friction. Also, a vendor bulletin states that when the relay reset handle is forced against the latch after resetting, tripping is delayed or prevented. The lockout relays were replaced with spares and tested satisfactorily.

Item	Coupling Factor	Proximate Cause	Discovery Method	Breaker Type	Piece Part	Year	Failure Mode	Degree of Failure	Description
8	Design	Design/ Construction/ Manufacture/ Installation Inadequacy	Test	Medium Voltage	Mechanical Assembly	1999	Failure to Close	Partial	Two 6.9kV breakers failed to close due to manufacturer repair defect. A cotter pin installed by the manufacturer was striking the latch check switch mounting bracket and bending it forward. This removed the factory set clearance between the bracket and the switch actuating paddle, resulting in the paddle rolling the trip shaft to the trip position when the breaker attempts to close.
9	Design	Design/ Construction/ Manufacture/ Installation Inadequacy	Test	Medium Voltage	Relay	1984	Failure to Open	Partial	When performing a loss of bus test, two 4160 Vac bus-tie breakers failed to trip. Investigation concluded that the bus-tie breakers could not trip if the diesel generator output breaker was open. The failures to open were caused by a design error.
10	Design	Design/ Construction/ Manufacture/ Installation Inadequacy	Test	RPS trip breakers	Spring	1988	Failure to Close	Partial	Two reactor trip breakers failed to close during surveillance testing. The breakers' closing springs had become detached from the pivot/actuation points. The reason for the springs' detaching could not be determined; however, this has been a recurring problem with this breaker design.
11	Design	Internal to Component	Demand	480 Vac	Mechanical Assembly	1984	Failure to Close	Partial	A phase to phase fault across the station auxiliary transformer buswork caused a loss of normal offsite power to the unit. Both operable emergency diesel generators started as required. During the temporary loss of normal offsite power, several breakers in the plant's electrical distribution system failed to operate. The plant operators restored station power through an alternate offsite source, and restarted all necessary equipment.
12	Design	Internal to Component	Demand	Medium Voltage	Mechanical Assembly	1981	Failure to Close	Partial	A decay heat removal pump failed to start due to the circuit breaker failing to close upon demand. The cause was determined to be an intermittent sticking of the motor cutoff switch operator due to the operator being slightly bent, which prevented it from sliding. Further inspections revealed that all 4.16 and 13.8 kv circuit breakers were susceptible to this problem. All applicable circuit breakers were subsequently modified.
13	Design	Internal to Component	Inspection	Medium Voltage	Arc Chute	1999	Failure to Open	Partial	4160 Vac circuit breakers could fail to change position due to an insulating block (a component of the breaker blowout magnets), whose adhesive had degraded with age, could become loose and fall into the breaker mechanism and prevent breaker operation.
14	Design	Internal to Component	Test	480 Vac	Closing Coil	1988	Failure to Close	Partial	During a station loss of offsite power (loop) test, two class 1E 480 volt load center breakers failed to close during automatic load sequencing. Subsequent investigation revealed that the breaker spring release device in both breakers was binding against the opening in the breaker base plate which resulted in failure of the closing coil and failure of the breaker to close. Other defective breakers were also identified following inspections.
15	Design	Internal to Component	Test	Medium Voltage	Mechanical Assembly	1987	Failure to Open	Partial	A circuit breaker failed to trip during a surveillance test. Upon investigation, it was determined that the connecting pin for the breaker trip crank located between the trip solenoid and the trip shaft became loose due to a pin weld failure, which prevented electrical tripping of the breaker. Inspection revealed several breakers with the same weld geometry. Two procedures, an inspection procedure and a trip crank replacement procedure were written for eighty six affected breakers on site. Nine breakers failed the acceptance criteria.
16	Design	Internal to Component	Test	RPS trip breakers	Latch Assembly	1983	Failure to Open	Complete	The static force to trip the circuit breakers exceeded allowable tolerance due to binding caused by the unused overcurrent trip pads. The breakers tested satisfactorily after removal of the overcurrent trip pads.

Item	Coupling Factor	Proximate Cause	Discovery Method	Breaker Type	Piece Part	Year	Failure Mode	Degree of Failure	Description
17	Design	Internal to Component	Test	RPS trip breakers	UV Trip Assembly	1983	Failure to Open	Partial	During reactor trip breaker surveillance testing, the undervoltage trip devices for two circuit breakers exhibited scattered and unacceptable response times. The reactor trip breakers were replaced with spares.
18	Design	Internal to Component	Test	RPS trip breakers	Spring	1986	Failure to Close	Partial	During performance testing of the reactor trip circuit breakers, two breakers failed to re-close after open them from the control room panel controls. Troubleshooting found that the breakers' operating springs fell off, preventing closure but not opening, a recurring problem with this particular breaker design.
19	Design	Operational/ Human Error	Inspection	Medium Voltage	Relay	1998	Failure to Close	Partial	A circuit breaker contacted exposed relay terminals during rack-in, causing trips/lockout of two breakers and lockout of another. The event was attributed to human error and poor design (location of relays).
20	Design	Operational/ Human Error	Test	RPS trip breakers	Spring	1994	Failure to Close	Partial	While performing initial approach to criticality testing, operators noted that the B-phase for a reactor trip breaker, was not indicating current flow after the breaker was closed. The train's function of providing power to the control rod drive mechanism was degraded as one phase of power was unavailable. The failure was caused by a mechanical operating spring that had come loose. With the spring loose, the B-phase contacts were getting insufficient pressure to close. The vendor has provided notice that the spring could come loose and the vendor has provided additional instructions for breaker inspection and maintenance to address this problem. The spring was reinstalled according to the vendors instructions. The breaker was subsequently tested and returned to service.
21	Environmental	External Environment	Test	RPS trip breakers	Mechanical Assembly	1984	Failure to Open	Partial	During routine surveillance testing of the reactor trip breakers, two breakers did not change state in the required time. The causes were determined to be dirty breaker mechanisms.
22	Environmental	Internal to Component	Test	RPS trip breakers	UV Trip Assembly	1983	Failure to Open	Partial	During routine surveillance testing, a the control rod drive AC breaker experienced a delayed trip. Subsequent testing of all AC and dc control rod drive breakers resulted in a control rod drive dc breaker also experiencing a delayed trip. If a reactor trip had occurred, and if both malfunctioned breakers had delayed in tripping, two control rod groups would not have dropped immediately.
23	Hardware	Design/ Construction/ Manufacture/ Installation Inadequacy	Inspection	Medium Voltage	I&C	2000	Failure to Open	Partial	During a system review, it was noted that the auxiliary transformer breakers did not trip as designed when the Main Turbine tripped. Investigation determined that this trip signal is blocked when a low load (4000 A) condition is sensed at the output of the generator. The low load block is not part of the original digital protection system modification and no reason for the block could be determined. Tripping of these breakers on a Main Turbine trip is needed to ensure that the timing sequence for the EDGs on a LOOP/LOCA, as defined in the FSAR, would not be affected. The block was removed.
24	Maintenance	Design/ Construction/ Manufacture/ Installation Inadequacy	Inspection	Medium Voltage	Latch Assembly	1998	Failure to Close	Partial	A breaker tripped when the cubicle door was closed. Subsequent inspection revealed several incorrect latching mechanisms were installed on 4160 Vac breakers. The cause of the incorrect latching mechanisms being installed during original construction was personnel error. The incorrect latches were installed in eight of seventeen cubicle doors in the Division II switchgear. Contributing to this event was that information relative to the latching mechanisms was not provided to personnel working on the switchgear and that procurement controls were not adequate to ensure the correct parts were installed.

Item	Coupling Factor	Proximate Cause	Discovery Method	Breaker Type	Piece Part	Year	Failure Mode	Degree of Failure	Description
25	Maintenance	Design/ Construction/ Manufacture/ Installation Inadequacy	Maintenance	RPS trip breakers	UV Trip Assembly	1984	Failure to Close	Partial	After installation of new undervoltage trip relays, the reactor trip breakers would not stay closed. The original trip bar design gap was satisfactory with old style undervoltage relays, but not with new style relays.
26	Maintenance	Internal to Component	Demand	480 Vac	Closing Coil	1984	Failure to Close	Partial	Over a period of 5 months, there were 6 incidents of circuit breakers of the same vendor and type failing to close on demand. Intermittent failures of the closing coil cutoff x-relays to properly return to their de-energized position prevented the relays from energizing the breakers' closing coils upon receipt of a close signal. It was determined that dirt and dust accumulation on the moveable parts of the relay causes the faulty operation. The symptoms of the x-relay malfunction were found to be failure of the breaker to close upon receiving a close signal, and in most cases, the breaker closes upon receiving a second close signal. This failure mode can cause equipment and/or systems to be inoperable without detection until that equipment is called upon to operate, either by test or when actually required. The x-relays on all safety-related breakers of this type were inspected and cleaned. The vendor did not provide for maintenance of the x-relays in their maintenance procedures.
27	Maintenance	Internal to Component	Demand	480 Vac	Mechanical Assembly	1988	Failure to Close	Partial	Two breakers failed to close during attempts to transfer bus power from alternate to normal feed, the normal feeder breaker would not close. One failure was caused by corrosion in the cell switch. The second failure was due to excessive dirt. Both were attributed to lack of preventative maintenance. Preventative maintenance had not been done during the last 2 years because the unit had been shutdown for an unusually long time and maintenance frequency was tied to the refueling outage.
28	Maintenance	Internal to Component	Demand	480 Vac	Mechanical Assembly	1984	Failure to Open	Partial	During surveillance testing, one circuit breaker failed to trip when the undervoltage device was de-energized and two others failed to trip within the specified time limit. This occurrence may have affected the emergency diesel generator loading and its loading sequence as specified in Technical Specifications. The cause was dirt and lack of lubrication.
29	Maintenance	Internal to Component	Demand	480 Vac	Spring Charging Motor	1985	Failure to Close	Partial	Four 480 Vac feeder breakers failed to close on demand. One breaker failed to close due to loose bolts holding the charging gearbox assembly. When demanded, the fuses for another breaker blew and the breaker failed to close. The cause of this failure was determined to be dirty contacts. Another breaker failed due to failure of the auxiliary relay. The fourth breaker failed to close due to dirty and dried lubricant on the trip latch adjustment parts.
30	Maintenance	Internal to Component	Demand	480 Vac	Mechanical Assembly	1992	Failure to Close	Partial	A normal supply breaker for a 600 Vac bus failed to close on demand when switching from the from the alternate to the normal power supply. The failure was due to binding of the closing mechanism in the breaker. A few days later the alternate feed breaker to another bus failed to closed during a hot transfer. The second failure was caused by a stuck contact finger in the bus transfer interlock logic. The cause of the failures was attributed to a lack of lubrication or hardening of the lubrication. The breakers were removed from service and the closing pivot points and other moving parts lubricated. After functional testing, the breakers were returned to service.

Item	Coupling Factor	Proximate Cause	Discovery Method	Breaker Type	Piece Part	Year	Failure Mode	Degree of Failure	Description
31	Maintenance	Internal to Component	Demand	480 Vac	Mechanical Assembly	1989	Failure to Close	Partial	When attempting to switch 600 Vac buses from normal to alternate feed, the alternate breakers failed to close when the normal breakers were tripped. One failure was due to trip rod binding in the alternate breaker due to a lack of proper lubrication of the trip rod bearings. Another failure was caused by a binding plunger in the breaker charging motor cutout switch due to dirt buildup. The dirty plunger caused the switch contacts to remain open preventing the motor from charging the closing spring and completing the closing sequence. The third failure was caused by a dirt buildup on the trip mechanism and pivot points, which resulted in binding of the internal moving parts.
32	Maintenance	Internal to Component	Demand	480 Vac	Latch Assembly	1983	Failure to Close	Partial	Two 480 Vac circuit breakers failed to close due to worn latching mechanisms. The latch mechanisms were replaced.
33	Maintenance	Internal to Component	Demand	480 Vac	Aux. Contactor	1986	Failure to Close	Partial	When attempting to close a normal supply breaker to a 480 Vac bus, the close circuit fuses blew. The failure caused by dirty auxiliary contacts. In another case, routine observation found that the alternate supply circuit breaker to the same bus had failed due to a burned out closing relay.
34	Maintenance	Internal to Component	Demand	Medium Voltage	Aux. Contactor	1980	Failure to Close	Partial	During a planned line outage which de-energized a transformer, the alternate feeder breaker failed to close, de-energizing a 4 kv bus tie board during automatic transfer. When the transformer was re-energized the normal feeder breaker failed to close. The fuse clip and fuse in the close circuit of alternate feeder breaker were not making contact. The auxiliary contacts of the normal feeder breaker were dirty.
35	Maintenance	Internal to Component	Demand	Medium Voltage	Latch Assembly	1991	Failure to Open	Partial	One 4160 Vac circuit breaker failed to open and several more were degraded due to hardened grease and lack of lubrication. This problem could affect the ability of the subject breakers to open or close. Maintenance of the breakers was incomplete despite similar failures due to the same cause four years earlier.
36	Maintenance	Internal to Component	Demand	Medium Voltage	UV Trip Assembly	1988	Failure to Open	Partial	Two 4160 Vac failed to open due to failure of the breaker trip coils. The cause were determined to be normal wear and aging.
37	Maintenance	Internal to Component	Demand	RPS trip breakers	Closing Coil	1992	Failure to Close	Partial	Two reactor trip breakers failed to close following a trip test. The cause of the failure was believed to be due to the relay release arm on the closing solenoid moving core being out of adjustment.
38	Maintenance	Internal to Component	Demand	RPS trip breakers	Latch Assembly	1992	Failure to Close	Partial	While attempting to reset the control rod drive system following a control rod drive breaker in the reactor protective system failed to reset. Later, during a control rod drive breaker trip test, another breaker failed to reset after a trip. The first failure was due to the breaker trip latch being out of adjustment. The cause of the second failure could not be precisely determined; however, troubleshooting revealed cracked insulation on the close coil.
39	Maintenance	Internal to Component	Inspection	480 Vac	Mechanical Assembly	1989	Failure to Close	Partial	Two 480 Vac feeder breakers tripped and would not close while a special inspection of breakers was being conducted. The breakers failed to close due to dirt built up and lack of lubrication.
40	Maintenance	Internal to Component	Inspection	Medium Voltage	Spring Charging Motor	1992	Failure to Close	Partial	Two breaker's closing springs failed to charge-up when equipment operator was making ready the in-feed breaker from separate station power transformers. The suspected failure cause for one breaker was dirty contacts in the charging mechanism. The suspected failure cause for the other breaker was binding in the charging spring mechanism.



Item	Coupling Factor	Proximate Cause	Discovery Method	Breaker Type	Piece Part	Year	Failure Mode	Degree of Failure	Description
41	Maintenance	Internal to Component	Inspection	RPS trip breakers	UV Trip Assembly	1987	Failure to Close	Partial	Two reactor trip breakers failed to close following testing. Troubleshooting found one breaker's under voltage coil had failed (open circuit) and the other breaker's undervoltage device pivot to armature clearance was out of adjustment. Operational/ambient conditions were cited as causes for the failures.
42	Maintenance	Internal to Component	Maintenance	480 Vac	Mechanical Assembly	1985	Failure to Close	Partial	While conducting maintenance, the main feeder breaker for a 600 Vac emergency bus would not close. Investigation revealed the trip setpoint tolerance, contact gap and trip latch roller gap were out of adjustment preventing the breaker operation. This breaker was adjusted and returned to service. Another 600 Vac breaker was found to be "broken." No exact failure mechanism was given; however, the cause was given as "wear," and this breaker was replaced.
43	Maintenance	Internal to Component	Maintenance	480 Vac	Latch Assembly	1986	Failure to Open	Partial	During preventive maintenance, two power supply circuit breakers to motor control centers would not automatically open when their associated load center was isolated. They subsequently failed to trip when the manual trip button or tripper bar was pushed. The circuit breaker latch mechanisms were dirty and sticky. The root cause was determined to be normal wear and an inadequate preventive maintenance procedure.
44	Maintenance	Internal to Component	Maintenance	RPS trip breakers	Relay	1986	Failure to Close	Partial	During preventative maintenance two reactor trip breakers failed to close. Both breaker failures were due to failure of the same relay. The cause was assumed to be wear and aging.
45	Maintenance	Internal to Component	Maintenance	RPS trip breakers	Aux. Contactor	1990	Failure to Close	Partial	Two reactor trip breakers failed to close during preventative maintenance. The failure to close was due failure of the breaker cutoff switches.
46	Maintenance	Internal to Component	Test	480 Vac	Mechanical Assembly	1986	Failure to Close	Partial	During routine inspections of the 480 volt unit boards, two feeder breakers were binding. The failures were attributed to dirty, hardened grease, normal aging and wear.
47	Maintenance	Internal to Component	Test	480 Vac	Mechanical Assembly	1991	Failure to Close	Partial	Two 480 Vac circuit breakers failed to close due to mechanical binding caused by dried out, hardened lubricant. The mechanical operating mechanisms were replaced.
48	Maintenance	Internal to Component	Test	480 Vac	Mechanical Assembly	1986	Failure to Open	Partial	The power supply circuit breakers to two motor control centers would not trip during surveillance testing. The circuit breakers were dirty. This was due to a normal accumulation of dirt during operations. The circuit breakers were cleaned and verified to be operable.
49	Maintenance	Internal to Component	Test	480 Vac	OC Relay	1998	Failure to Open	Partial	The instantaneous trip testing of both breakers revealed excessive time prior to tripping. The required trip time is less than 0.15 seconds. Breakers were tripping on instantaneous testing between 0.194 and 0.753 seconds. Cause was determined to be inadequate preventative maintenance.
50	Maintenance	Internal to Component	Test	480 Vac	Mechanical Assembly	1999	Failure to Open	Partial	During high tolerance instantaneous testing, several 480 Vac circuit breakers on all three phases did not trip in the required time (0-10 cycles). Failures were attributed to aging and degraded lubricants resulting from an ineffective maintenance program.
51	Maintenance	Internal to Component	Test	480 Vac	Mechanical Assembly	1987	Failure to Open	Partial	During once per cycle testing of the startup transfer feeder to the unit bus breaker, two breaker trip units were found to be non-operational so that the breakers would not trip. Both failures were caused by lack of lubrication on the internal moving parts due to a lack of proper maintenance.
52	Maintenance	Internal to Component	Test	480 Vac	Relay	1988	Failure to Close	Partial	During surveillance testing on the plant ac distribution system, the normal feeder breaker from a transformer would not close when transferring from alternate to normal power. The failure was attributed to close relay contacts hanging up from a lack of breaker lubrication. A second similar failure was attributed to the breaker having dirty contacts.

Item	Coupling Factor	Proximate Cause	Discovery Method	Breaker Type	Piece Part	Year	Failure Mode	Degree of Failure	Description
53	Maintenance	Internal to Component	Test	480 Vac	Relay	1983	Failure to Close	Partial	Four 480 Vac circuit breakers failed to close during testing due to failure of the power sensors. The power sensors were replaced.
54	Maintenance	Internal to Component	Test	480 Vac	Relay	1988	Failure to Close	Partial	A circuit breaker failed to close on a safety injection demand due to oxidation on contacts for the alarm switches. Subsequent investigation revealed 11 other safety-related breakers with the same problem. The cause was determined to be inadequate periodic inspections and cleaning of the alarm switch contacts due to lack of specific guidance in the maintenance procedure. Corrective actions included revision of the maintenance procedure.
55	Maintenance	Internal to Component	Test	DC distribution	Mechanical Assembly	1996	Failure to Open	Partial	The dc bus inter-tie breakers failed to open due to lack of lubrication. Corrective action was to create a preventative maintenance and inspection schedule for these breakers.
56	Maintenance	Internal to Component	Test	DC distribution	Control Switch	1987	Failure to Close	Partial	During routine observation of the 250 volt distribution boards, a normal dc power feeder breaker was slow to transfer and another failed to transfer. The first failure was due to switch joints being dirty and an indicating light resistor being burned out. The second failure was due to dirty hinge joints.
57	Maintenance	Internal to Component	Test	DC distribution	OC Relay	1989	Failure to Open	Partial	While performing preventative maintenance on the dc feeder circuit breakers, the overcurrent trip devices would not set correctly. The cause was attributed to a lack of maintenance.
58	Maintenance	Internal to Component	Test	Medium Voltage	Relay	1989	Failure to Close	Partial	A time delay relay for a 4160 volt feeder breaker would not time out within its specified tolerance during calibration, and a time delay relay for a second breaker would not actuate. The causes of both failures were determined to be due to aging.
59	Maintenance	Internal to Component	Test	Medium Voltage	OC Relay	1984	Failure to Open	Partial	Several 4160 Vac circuit breakers of the vendor and type failed to trip due to age induced hardening of grommets in the electromechanical overcurrent device. Corrective actions included replacement with new or newly rebuilt overcurrent devices and establishing an adequate preventive maintenance surveillance interval.
60	Maintenance	Internal to Component	Test	Medium Voltage	Limit Switch	1989	Failure to Open	Partial	In two separate incidents while attempting to realign power to support testing, the alternate supply circuit breaker failed to trip upon closure of normal supply breaker. The cause of failure was attributed to the raised upper limit switch being out of mechanical adjustment causing a greater than 1/8 inch gap between the operating plunger and the breaker auxiliary switch. This limit switch provides the trip signal for the alternate breaker.
61	Maintenance	Internal to Component	Test	Medium Voltage	Spring Charging Motor	1987	Failure to Close	Partial	Two 4160 Vac circuit breakers failed to close. One failure was caused by the latching pawl spring being out of adjustment, which prevented the springs from charging. The cause of the second failure was attributed to the racking mechanism slide interlock being out of adjustment.
62	Maintenance	Internal to Component	Test	Medium Voltage	Spring Charging Motor	1986	Failure to Close	Partial	While performing testing of 4160 Vac boards and buses, three circuit breakers would not close. The failures were attributed to the breakers being dirty, needing lubrication, and due to loose connections.
63	Maintenance	Internal to Component	Test	Medium Voltage	Spring Charging Motor	1987	Failure to Close	Partial	The closing springs for two 4160 Vac breakers would not charge. The cause of the failures were dirty contacts, a dirty closing mechanism, and lack of lubrication.
64	Maintenance	Internal to Component	Test	Medium Voltage	Mechanical Assembly	1995	Failure to Close	Partial	A 4KV supply circuit breaker closed during testing, but failed to instantly recharge. The cause of the failure was aging of the latch monitor pivot bearing lubrication. This problem had previously surfaced and the bearings were relubricated at that time. Since that action did not fix the problem, the decision was made to replace the pivot bearings for all affected circuit breakers..

Item	Coupling Factor	Proximate Cause	Discovery Method	Breaker Type	Piece Part	Year	Failure Mode	Degree of Failure	Description
65	Maintenance	Internal to Component	Test	RPS trip breakers	UV Trip Assembly	1986	Failure to Close	Partial	While conducting surveillance testing of the unit's reactor protection system, two reactor trip circuit breakers' UV devices would not pick up after tripping the breakers. Troubleshooting found that the UV devices' gap clearances were incorrect. No direct cause for the misadjustments was found, however, operational stress and/or equipment aging were suspected.
66	Maintenance	Internal to Component	Test	RPS trip breakers	Relay	1986	Failure to Open	Partial	Two reactor trip breakers failed to trip during performance of surveillance testing. One failure was due to the auxiliary contact for the shunt trip was not making contact due to misalignment with the block. The other failure was due to a faulty undervoltage relay. The jumper to change the control voltage was installed in the 48 volt holes and should have been installed in the 125 volt holes causing the relay to overheat and melt.
67	Maintenance	Internal to Component	Test	RPS trip breakers	UV Trip Assembly	1990	Failure to Open	Partial	Two reactor trip breakers were found to have defective undervoltage trip relays which prevented opening. One failure was detected during testing and the other was detected during maintenance. The relay failures were determined to be due to aging.
68	Maintenance	Internal to Component	Test	RPS trip breakers	Mechanical Assembly	1985	Failure to Open	Partial	While performing testing of the unit's reactor trip circuit breakers, the undervoltage trip time was found to be out of the allowable tolerance for two breakers. Dirt accumulation in the front frame assembly and lack of lubrication were the suspected causes.
69	Maintenance	Internal to Component	Test	RPS trip breakers	Mechanical Assembly	1984	Failure to Open	Partial	During surveillance testing of the reactor trip circuit breakers, the under voltage trip response time was found out of specification. Troubleshooting found the breakers' front frame assemblies to be lacking the proper amount of lubricant on their bearings. This was a recurring problem with this breaker type. The front frame assemblies were replaced.
70	Maintenance	Internal to Component	Test	RPS trip breakers	UV Trip Assembly	1982	Failure to Open	Partial	During surveillance testing, four of nine reactor trip circuit breakers failed to trip on undervoltage. The primary cause was inadequate lubrication, possibly due to an excessive preventive maintenance interval, combined with a small design margin in the tripping force provided from the undervoltage coil. Corrective actions were to perform required preventive maintenance prior to the unit entering mode 2 and implementation of the recommendations of IE Bulletin 79-09 and vendor recommendations, increased surveillance testing of the undervoltage trip feature and a decrease in the interval between preventive maintenance.
71	Maintenance	Internal to Component	Test	RPS trip breakers	Mechanical Assembly	1985	Failure to Open	Partial	During normal operation while performing surveillance testing, two reactor trip circuit breakers failed the under voltage response time test. The breaker's front frame assembly was the suspected cause of the increased time response of the one breaker's undervoltage device. The other failure was due to loose armature laminations in the undervoltage device. Both are known design problems with these circuit breakers.
72	Maintenance	Internal to Component	Test	RPS trip breakers	UV Trip Assembly	1990	Failure to Close	Partial	In separate tests, two reactor trip breakers failed to close after trip testing. The failure to reset was determined to be due to worn undervoltage trip coil mechanisms to prevented the breakers from latching.
73	Maintenance	Internal to Component	Test	RPS trip breakers	UV Trip Assembly	1987	Failure to Close	Partial	Two reactor trip breakers failed to close following testing. Troubleshooting found one breaker's under voltage coil had failed (open circuit) and the other breaker's undervoltage device pivot to armature clearance was out of adjustment. Operational/ambient conditions (heat/vibration) were cited as causes for the failures.
74	Maintenance	Internal to Component	Test	RPS trip breakers	Relay	1984	Failure to Close	Partial	Two reactor trip breakers failed to close over a one-month period. Both failures were attributed to relay release arms being out of adjustment.

Item	Coupling Factor	Proximate Cause	Discovery Method	Breaker Type	Piece Part	Year	Failure Mode	Degree of Failure	Description
75	Maintenance	Internal to Component	Test	RPS trip breakers	Mechanical Assembly	1984	Failure to Open	Partial	During surveillance testing, the trip time requirements for two reactor trip breakers were found to be out of specification high. Historically, the bearings for the breaker front frame assemblies have been found worn and lacking the necessary lubrication, which increases trip times. After replacing the front frame assemblies and lubrication the bearings, the breakers were retested satisfactorily and returned to service.
76	Maintenance	Internal to Component	Test	RPS trip breakers	Latch Assembly	1994	Failure to Close	Partial	During unit outage, while performing functional testing, operators found that two reactor trip breakers would not close from the handswitch in the main control room. Troubleshooting discovered the inertia latch (piece part of the circuit breaker) had stuck in mid travel. The breakers' electrical trip function was lost, but the control rod drive system was not affected because of an available redundant trip breaker. Plant operation was not affected. Insufficient lubrication of the inertia latch caused the latch to stick in mid travel. The inertia latches were cleaned and lubricated and post maintenance testing was performed satisfactorily.
77	Maintenance	Internal to Component	Test	RPS trip breakers	Unknown	1992	Failure to Close	Partial	Two reactor trip breakers failed to close following a trip test. The cause could not be determined and the failure was not repeatable. The breakers that failed were replaced with spares.
78	Maintenance	Internal to Component	Test	RPS trip breakers	UV Trip Assembly	1984	Failure to Close	Partial	During surveillance testing, two reactor trip breakers failed to close during surveillance response time test. The stated cause was normal wear.
79	Maintenance	Internal to Component	Test	RPS trip breakers	UV Trip Assembly	1986	Failure to Close	Partial	While conducting monthly surveillance testing of the unit's reactor protection system, two reactor trip circuit breakers failed to close after testing. Troubleshooting found a failure of one breaker's under voltage device. The second circuit breaker's pick-up coil voltage was high due to a change in characteristics of the voltage adjustment potentiometer. Both failures were attributed to operational stress and/or equipment aging.
80	Maintenance	Internal to Component	Test	RPS trip breakers	UV Trip Assembly	1983	Failure to Open	Partial	During surveillance testing, three reactor trip breakers failed to trip on undervoltage. The primary cause was inadequate lubrication, possibly due to an excessive preventive maintenance interval, combined with a small design margin in the tripping force provided from the undervoltage coil. Corrective action was to perform the required preventive maintenance prior to entering Mode 2. Additionally, as required by IE Bulletin 79-09 and vendor recommendations, the surveillance testing interval of the undervoltage trip feature was increased and the interval between preventive maintenance was decreased to prevent recurrence of this event.
81	Maintenance	Internal to Component	Test	RPS trip breakers	UV Trip Assembly	1980	Failure to Open	Partial	It was discovered during testing that some reactor trip breakers would not trip on undervoltage as expected. One device would not trip and two others tripped sluggishly. The cause was determined to be misaligned armatures in the undervoltage devices. A new preventative maintenance program was initiated to check the undervoltage coils independently on a monthly basis.
82	Maintenance	Internal to Component	Test	RPS trip breakers	Mechanical Assembly	1989	Failure to Close	Partial	During surveillance testing, two reactor trip switchgear breakers would not close. The first failure was due to a defective piece part in the cutout 'y' switch on the breaker due to cyclic fatigue. In the second failure, a broken clamp was found on the closing mechanism, which prevented the breaker from closing.
83	Maintenance	Operational/ Human Error	Demand	480 Vac	OC Relay	1998	Failure to Close	Partial	Circuit breakers were found to be susceptible to tripping on normal start due to improper setting of overcurrent trip. The problem was discovered when one breaker failed to close on demand. A previous modification package was determined to be inadequate in that it did not require trip setpoint adjustment.

Item	Coupling Factor	Proximate Cause	Discovery Method	Breaker Type	Piece Part	Year	Failure Mode	Degree of Failure	Description
84	Maintenance	Operational/ Human Error	Demand	Medium Voltage	Mechanical Assembly	1997	Failure to Open	Partial	Two circuit breakers failed to open on demand during separate evolutions. During subsequent reviews, station personnel determined that the condition of the three circuit breakers was similar to the condition of the two safety-related circuit breakers that previously failed to open on demand. The cause of the event was determined to be inadequate preventive maintenance. The preventive maintenance performed did not lubricate the main and auxiliary contacts in the circuit breakers as recommended by the circuit breaker manufacturer and also did not provide sufficient instructions to remove the roughness on the main and auxiliary contacts.
85	Maintenance	Operational/ Human Error	Demand	Medium Voltage	Mechanical Assembly	1994	Failure to Close	Partial	Four 4160 Vac circuit breakers failed to close. Each failure was due to a different mechanism; however, investigation revealed that all failures were related to workmanship and quality control practices by the vendor who overhauled the circuit breakers. To ensure the safety class circuit breakers are reliable, the utility and vendor developed a comprehensive plan to inspect critical components of the circuit breakers that were previously overhauled.
86	Maintenance	Operational/ Human Error	Inspection	Medium Voltage	Latch Assembly	1996	Failure to Close	Partial	A failure of a roll pin securing a spring for a latch pawl on a 4KV breaker was reviewed and a determination made that the failure of this pin could cause the breaker to fail. Further investigation revealed that the roll pin failed as a result of hydrogen embrittlement. Later, an issue involving permanently applied lubricant which was inadvertently removed from the breakers was identified. This also could potentially affect breaker operation. The cause of the cracked roll pin was the lack of knowledge of plating induced hydrogen embrittlement. Vendor personnel involved in the procedure development were not aware that zinc plating of hardened steel parts could produce hydrogen embrittlement and subsequent cracking. The cause of the lubricant being inadvertently removed from breaker parts is also due to the lack of knowledge by Vendor personnel.
87	Maintenance	Operational/ Human Error	Inspection	RPS trip breakers	Wires/Connectors/Board	1983	Failure to Open	Complete	Following performance of the manual reactor trip functional test, it was noted that the procedure called for jumpering out the UV trip coils with the reactor trip breakers closed and the rods capable of withdrawal. This was a procedural error that caused the removal of both trains of automatic reactor trip logic. The procedure was revised to prevent recurrence of the event.
88	Maintenance	Operational/ Human Error	Maintenance	Medium Voltage	Mechanical Assembly	1988	Failure to Open	Partial	A circuit breaker failed to open due to trip linkage binding caused by misalignment and improper assembly. Subsequent inspection of other 4160 Vac circuit breakers revealed the same problem. The misalignment was the result of a procedural deficiency by the vendor that performed circuit breaker overhauls.
89	Maintenance	Operational/ Human Error	Test	480 Vac	Main Contacts	1992	Failure to Close	Partial	During testing on emergency bus feeder breakers, the closing spring charge/discharge indicator showed that the springs were charged with the breaker closed, indicating that the main contacts were closed but not exerting full pressure against the stationary contacts. Investigation showed the root cause to be failure to incorporate the latest vendor information on contact adjustment into the breaker maintenance procedure.

Item	Coupling Factor	Proximate Cause	Discovery Method	Breaker Type	Piece Part	Year	Failure Mode	Degree of Failure	Description
90	Maintenance	Operational/ Human Error	Test	480 Vac	Mechanical Assembly	1997	Failure to Close	Partial	Three breakers failed to close on demand during testing. Hardened grease was discovered in the stop roller and main drive link roller. When actuated by the closing coil, these rollers and the associated closing latch release the stored energy of the breaker springs, closing the breaker. Stiff rollers have resulted in multiple breaker failures in the past. The maintenance procedure provides instructions to clean and lubricate various friction points of the breaker mechanism; however, they are not specifically identified in the vendor manual. These rollers were not cleaned and lubricated during the performance of the scheduled preventative maintenance.
91	Maintenance	Operational/ Human Error	Test	480 Vac	Mechanical Assembly	1997	Failure to Open	Partial	A breaker failed to trip during testing. Subsequent testing and inspection revealed several breakers degraded due to lack of lubrication. Lubrication was removed during refurbishment by the vendor and was not re-installed.
92	Maintenance	Operational/ Human Error	Test	480 Vac	Wires/Connectors/Board	1993	Failure to Open	Partial	An Emergency Diesel Generator (EDG) failed to pass surveillance testing because certain loads were not shunt tripped from the safeguard bus when a simulated Loss of Coolant Accident (LOCA) signal was initiated. During troubleshooting, a loose wire was discovered in one circuit breaker and a lifted wire was discovered in another circuit breaker. The wires were restored to their normal positions and a portion of the test procedure was performed to verify appropriate loads were shunt tripped following a simulated LOCA signal. The loose/disconnected wires were believed to have come loose at a plug connection during repairs made to enhance electrical separation between electrical divisions. Procedures were revised to alert workers of the potential for wires becoming loose during removal and restoration of plug connections on similar circuit breakers.
93	Maintenance	Operational/ Human Error	Test	RPS trip breakers	Shunt Trip	1984	Failure to Open	Partial	One set of leads in each of the four plant protective system bays were found to be disconnected. These disconnected leads removed the automatic shunt trip feature from RTB's #1, #2, #3, and #4. The subject leads had been disconnected and not restored during 18-month surveillance testing conducted earlier.
94	Maintenance	Operational/ Human Error	Test	RPS trip breakers	Latch Assembly	1992	Failure to Close	Partial	While performing surveillance testing, two reactor trip breakers failed to close on separate occasions. In one case, the breaker latch catch and arm were found bent, preventing the breaker from closing. The cause of this failure was believed to be from incorrect installation of the breaker during previous maintenance or testing activities. In the second case, the breaker operating mechanism latch was binding against the housing likely due to inadequate lubrication and rough surfaces.
95	Maintenance	Operational/ Human Error	Test	RPS trip breakers	UV Trip Assembly	1983	Failure to Open	Partial	During the performance of reactor trip circuit breaker undervoltage device surveillance testing, three breakers failed to open within the acceptance time criteria. The following day, and then 8 days later, two additional breakers failed to meet the acceptance criteria. The reactor trip breakers failed even though extensive maintenance and testing was performed on all eight of the trip system breakers 11 days prior to the first 3 failures. Maintenance included procedures specified in the vendor service advisory letter. The deficiencies were corrected by again performing the vendor approved refurbishment procedures on the slow breakers, followed by successful testing.

Item	Coupling Factor	Proximate Cause	Discovery Method	Breaker Type	Piece Part	Year	Failure Mode	Degree of Failure	Description
96	Maintenance	Other	Maintenance	480 Vac	OC Relay	1994	Failure to Open	Partial	A preventive maintenance procedure was being performed on 480V molded case circuit breakers. These are magnetic only breakers with an adjustable instantaneous trip range of 50 to 150 amps. With the breakers adjusted to their lowest setting, the right phase for two breakers tripped at 71.7 amps and 69 amps. The maximum allowable trip point was 57.5 amps. The breakers had a date code that meant they were manufactured in August of 1978. Considering the breakers were approximately 16 years old, the drift in calibration is associated with the breakers' service life. Therefore, it was decided to replace the breakers. The circuit breakers would still trip on instantaneous within its adjustable range which would provide adequate overcurrent protection. The cause was attributed to the breakers' long service life. Like for like breakers were installed. All tests were performed satisfactorily.
97	Maintenance	Other	Maintenance	RPS trip breakers	UV Trip Assembly	1986	Failure to Open	Partial	During preventive maintenance on the reactor trip breakers, the undervoltage trip units on two breakers were found to be out of specification. One undervoltage device could not be adjusted within specification and was replaced. The cause for both failures was determined to be vibration and aging.
98	Maintenance	Other	Test	480 Vac	OC Relay	1985	Failure to Open	Partial	During routing surveillance testing, three circuit breakers would not trip on short time overcurrent trip test. The failures were caused by the breakers being out of calibration as a result of normal wear.
99	Maintenance	Other	Test	Medium Voltage	UV Trip Assembly	1986	Failure to Open	Partial	During routine testing it was found that the under voltage relays for two 4160 Vac feeder breakers from an auxiliary transformer to the buses were out of calibration. The failures were attributed to relay wear.
100	Maintenance	Other	Test	Medium Voltage	UV Trip Assembly	1994	Failure to Open	Partial	Undervoltage dropout relays in two separate, similar breakers drifted out of specification between times they were checked by scheduled maintenance. A root cause investigation attributed the relay setpoint shift to a combination of: 1) relay setpoint repeatability, 2) temperature sensitivity of the relays, and 3) testing techniques. Applicable test equipment and procedures have been changed to address the causes of the setpoint shift. Additionally, the testing frequency has been increased from quarterly to monthly pending relay performance trending results.
101	Maintenance	Other	Test	RPS trip breakers	UV Trip Assembly	1983	Failure to Open	Partial	During surveillance testing of the reactor trip circuit breakers' undervoltage devices, the response time of two breakers than allowed by Technical Specifications. The cause of the event was setpoint drift and worn/binding front frame assembly mechanisms. The setpoints were adjusted and the trip shaft and latch roller bearings were lubricated.
102	Maintenance	Other	Test	RPS trip breakers	UV Trip Assembly	1983	Failure to Open	Partial	During monthly surveillance test of the reactor trip circuit breaker undervoltage trip devices, the response time of two breakers was slower than allowed by Technical Specifications. This event was caused by setpoint drift and worn/binding front frame assembly mechanisms. Corrective actions included replacement of front frame assemblies and undervoltage trip devices.
103	Maintenance	Other	Test	RPS trip breakers	UV Trip Assembly	1983	Failure to Open	Partial	The trip response time of two reactor trip breakers was slower than allowed by Technical Specifications. The breakers were retested satisfactorily and returned to service after adjusting the UV trip device setpoints and lubricating the trip shaft and latch roller bearings. The breakers were still considered operable since the shunt trip devices were operational with satisfactory response times.

Item	Coupling Factor	Proximate Cause	Discovery Method	Breaker Type	Piece Part	Year	Failure Mode	Degree of Failure	Description
104	Quality	Design/ Construction/ Manufacture/ Installation Inadequacy	Demand	480 Vac	Relay	1987	Failure to Open	Complete	Four 600 Vac normal auxiliary power system circuit breakers failed to open from local manual trip switch. The failures were caused by a relay contact in breaker trip circuit that was normally open instead of normally closed, as shown on wiring diagram. The relays were rewired to correct the problem.
105	Quality	Design/ Construction/ Manufacture/ Installation Inadequacy	Demand	Medium Voltage	Relay	1990	Failure to Close	Partial	While attempting to transfer two 4160 Vac buses to their alternate power supply, the alternate feeder circuit breaker. Separately, another 4160 Vac circuit breaker failed to close on demand. Both failures were caused by an open coil winding on a telephone-type relay within the synchronizing check relay of the circuit breaker. The telephone relay failed due to being continuously energized, which was not its intended application. A design modification was performed as the long-term corrective action.
106	Quality	Design/ Construction/ Manufacture/ Installation Inadequacy	Demand	Medium Voltage	Closing Coil	1996	Failure to Close	Partial	Two service water pumps failed to start upon demand. Investigation revealed a high resistance electrical contact in the pump motor circuit breaker close coil circuit. Evaluation of the failure determined that the electrical contact had high resistance due to repeated interruption of current approximately three times rated. The installed contactor current interrupt rating was inadequate. The contact failures occurred after a fraction of the design cycles. All 4 kV circuit breakers were determined to be susceptible to this failure.
107	Quality	Design/ Construction/ Manufacture/ Installation Inadequacy	Demand	RPS trip breakers	Latch Assembly	1994	Failure to Close	Partial	During plant protection system functional testing, two reactor trip breaker tripped free when maintenance personnel attempted to close them. With the vendor present, the problem was traced to inadequate adjustment of the trip latch overlap. The adjustment was initially made per vendor specifications. However, the vendor had since increased the recommended number of adjustment turns of the trip latch screw from 4 to a maximum of 5 turns. A change was submitted to change the procedure accordingly.
108	Quality	Design/ Construction/ Manufacture/ Installation Inadequacy	Maintenance	RPS trip breakers	UV Trip Assembly	1983	Failure to Open	Partial	A potential safety hazard was identified concerning certain critical dimensions of the undervoltage trip device on a particular model reactor trip circuit breaker. An out-of-tolerance measurement was found between the moving core and rolling bracket in addition to a missing lock ring on the shaft pin of the undervoltage trip device. The potential existed for either intermittent operation or total failure of the device. The cause was attributed to manufacturing variations of the undervoltage trip devices. All undervoltage trip devices on all reactor trip breakers were replaced.
109	Quality	Design/ Construction/ Manufacture/ Installation Inadequacy	Test	Medium Voltage	Spring Charging Motor	1986	Failure to Close	Partial	The circuit breaker for the residual heat removal pump a failed to recharge during testing, rendering the breaker incapable of automatic closure. In addition to performing required surveillance tests, an investigation revealed that the breaker charging spring motor bolts had fallen out, allowing the motor to rotate, and breaking the power leads. A root cause analysis led to the conclusion that a combination of inadequate thread engagement of the mounting bolts in the motor housing and equipment vibration caused the bolts to loosen. Because this event had the potential for a common mode failure, all safety related breakers were inspected during a scheduled maintenance outage. Three additional breakers were found to have loose bolts.
110	Quality	Design/ Construction/ Manufacture/ Installation Inadequacy	Test	RPS trip breakers	UV Trip Assembly	1990	Failure to Close	Partial	Two reactor trip breakers failed to close. The first failed to close during testing, the second failed to close while troubleshooting the first failure. The cause of both breaker failures was failure of the under voltage trip coil, which was thought to be due to a manufacturing defect.



Item	Coupling Factor	Proximate Cause	Discovery Method	Breaker Type	Piece Part	Year	Failure Mode	Degree of Failure	Description
111	Quality	Design/ Construction/ Manufacture/ Installation Inadequacy	Test	RPS trip breakers	UV Trip Assembly	1983	Failure to Close	Partial	During surveillance testing, two reactor trip breakers would not close when a close signal was applied to the breaker's control circuit. Troubleshooting found defective undervoltage devices that would not allow the closure of the breakers. The undervoltage devices were replaced.
112	Quality	Design/ Construction/ Manufacture/ Installation Inadequacy	Test	RPS trip breakers	Mechanical Assembly	1984	Failure to Close	Partial	During surveillance testing, two reactor trip breakers would not re-close. Troubleshooting found manufacturing defects in the front frame assemblies (loose mechanical collars). This problem has been identified on similar breakers. The front frame assemblies were replaced.
113	Quality	Internal to Component	Demand	RPS trip breakers	Unknown	1993	Failure to Close	Partial	During an attempt to close the control rod drive circuit breakers two breakers failed to close. The failures could not be repeated. Although the mechanical interlock, a piece part of this circuit breaker, was found slightly dirty and in need of lubrication, it is not believed to have caused the failures to close. As a preventive measure, the mechanical interlock was cleaned and lubricated. The breakers were successfully closed on all subsequent tests.
114	Quality	Internal to Component	Demand	RPS trip breakers	UV Trip Assembly	1983	Failure to Open	Complete	During a routine startup, both reactor trip breakers failed to open automatically on receipt of a valid low-low steam generator level reactor trip signal. The reactor was shutdown 25 seconds later using the manual trip on the control console. Subsequent investigation revealed that the breaker failures were caused by mechanical binding of the latch mechanism in the undervoltage trip attachment. All breaker undervoltage attachments were replaced with new devices and extensive maintenance and testing was performed on the breakers.
115	Quality	Internal to Component	Maintenance	Medium Voltage	Mechanical Assembly	1985	Failure to Close	Partial	During a scheduled maintenance outage of 4160v safety-related switchgear, the plant electrical staff discovered that two circuit breakers were rendered electrically inoperable due to the failure of a spot welded pivot pin. This spot welded pivot pin was on an internal piece of linkage, which actuates the auxiliary contacts that track breaker position. These contacts are also used in external breaker trip and close schemes as interlocks. The defective component is being modified to preclude additional failures.
116	Quality	Internal to Component	Test	RPS trip breakers	UV Trip Assembly	1983	Failure to Open	Partial	The undervoltage armatures for two different reactor trip breakers were found during testing to not be fully picked up (repetitive failures in the same month). Based on vendor tests, the abnormal armature position has little or no detectable effect on the ability of the undervoltage trip device to trip the breaker on loss of voltage. The undervoltage armatures not being fully picked up is the result of interference between the undervoltage armature and the copper shading ring around the coil core. As corrective action, visual verification and manual adjustment of proper closed air gap position is required following energization of the undervoltage device.
117	Quality	Internal to Component	Test	RPS trip breakers	Spring	1989	Failure to Close	Partial	While performing surveillance testing on reactor trip circuit breakers, two breakers failed to close. In one failure, the left side close spring on the breaker had fallen off and the breaker wouldn't close with only one spring. The second breaker failure was due to a bad control power fuse that failed due to aging.

Item	Coupling Factor	Proximate Cause	Discovery Method	Breaker Type	Piece Part	Year	Failure Mode	Degree of Failure	Description
118	Quality	Internal to Component	Test	RPS trip breakers	UV Trip Assembly	1983	Failure to Open	Partial	The undervoltage armatures for two different reactor trip breakers were found during testing to not be fully picked up (repetitive failures in the same month). Based on vendor tests, the abnormal armature position has little or no detectable effect on the ability of the undervoltage trip device to trip the breaker on loss of voltage. The undervoltage armatures not being fully picked up is the result of interference between the undervoltage armature and the copper shading ring around the coil core. As corrective action, visual verification and manual adjustment of proper closed air gap position is required following energization of the undervoltage device.
119	Quality	Internal to Component	Test	RPS trip breakers	UV Trip Assembly	1983	Failure to Open	Almost Complete	Both reactor trip breakers and a bypass breaker failed to open on an undervoltage trip signal during response time testing. The failures were due to mechanical problems of the undervoltage mechanisms, which resulted from manufacturing deficiencies. Fifteen days later, one of the replacement reactor trip breakers also failed due to the same cause.

Table A-3. Breaker CCF event summary, sorted by discovery method.

Item	Discovery Method	Coupling Factor	Proximate Cause	Breaker Type	Piece Part	Year	Failure Mode	Degree of Failure	Description
1	Demand	Design	Design/ Construction/ Manufacture/ Installation Inadequacy	480 Vac	Stabs/Connectors	1980	Failure to Close	Partial	While returning a service water booster pump to service, a minor fire occurred in a 480 Vac ESF MCC. This rendered several components inoperable. Repeated cycling of the pump onto the bus coupled with inadequate stab to bus bar contact and dust in the MCC cabinet caused a fire. Operators were reminded of undesirability of repeated cycling of load breaker. An engineering study to determine if the breakers are adequately sized was also made (the results of the study were not included in the failure report).
2	Demand	Design	Internal to Component	480 Vac	Mechanical Assembly	1984	Failure to Close	Partial	A phase to phase fault across the station auxiliary transformer buswork caused a loss of normal offsite power to the unit. Both operable emergency diesel generators started as required. During the temporary loss of normal offsite power, several breakers in the plant's electrical distribution system failed to operate. The plant operators restored station power through an alternate offsite source, and restarted all necessary equipment.
3	Demand	Design	Internal to Component	Medium Voltage	Mechanical Assembly	1981	Failure to Close	Partial	A decay heat removal pump failed to start due to the circuit breaker failing to close upon demand. The cause was determined to be an intermittent sticking of the motor cutoff switch operator due to the operator being slightly bent, which prevented it from sliding. Further inspections revealed that all 4.16 and 13.8 kv circuit breakers were susceptible to this problem. All applicable circuit breakers were subsequently modified.
4	Demand	Maintenance	Internal to Component	480 Vac	Latch Assembly	1983	Failure to Close	Partial	Two 480 Vac circuit breakers failed to close due to worn latching mechanisms. The latch mechanisms were replaced.
5	Demand	Maintenance	Internal to Component	480 Vac	Mechanical Assembly	1984	Failure to Open	Partial	During surveillance testing, one circuit breaker failed to trip when the undervoltage device was de-energized and two others failed to trip within the specified time limit. This occurrence may have affected the emergency diesel generator loading and its loading sequence as specified in Technical Specifications. The cause was dirt and lack of lubrication.
6	Demand	Maintenance	Internal to Component	480 Vac	Aux. Contactor	1986	Failure to Close	Partial	When attempting to close a normal supply breaker to a 480 Vac bus, the close circuit fuses blew. The failure caused by dirty auxiliary contacts. In another case, routine observation found that the alternate supply circuit breaker to the same bus had failed due to a burned out closing relay.
7	Demand	Maintenance	Internal to Component	480 Vac	Mechanical Assembly	1988	Failure to Close	Partial	Two breakers failed to close during attempts to transfer bus power from alternate to normal feed, the normal feeder breaker would not close. One failure was caused by corrosion in the cell switch. The second failure was due to excessive dirt. Both were attributed to lack of preventative maintenance. Preventative maintenance had not been done during the last 2 years because the unit had been shutdown for an unusually long time and maintenance frequency was tied to the refueling outage.
8	Demand	Maintenance	Internal to Component	480 Vac	Spring Charging Motor	1985	Failure to Close	Partial	Four 480 Vac feeder breakers failed to close on demand. One breaker failed to close due to lose bolts holding the charging gearbox assembly. When demanded, the fuses for another breaker blew and the breaker failed to close. The cause of this failure was determined to be dirty contacts. Another breaker failed due to failure of the auxiliary relay. The fourth breaker failed to close due to dirty and dried lubricant on the trip latch adjustment parts.

Item	Discovery Method	Coupling Factor	Proximate Cause	Breaker Type	Piece Part	Year	Failure Mode	Degree of Failure	Description
9	Demand	Maintenance	Internal to Component	480 Vac	Closing Coil	1984	Failure to Close	Partial	Over a period of 5 months, there were 6 incidents of circuit breakers of the same vendor and type failing to close on demand. Intermittent failures of the closing coil cutoff x-relays to properly return to their de-energized position prevented the relays from energizing the breakers' closing coils upon receipt of a close signal. It was determined that dirt and dust accumulation on the moveable parts of the relay causes the faulty operation. The symptoms of the x-relay malfunction were found to be failure of the breaker to close upon receiving a close signal, and in most cases, the breaker closes upon receiving a second close signal. This failure mode can cause equipment and/or systems to be inoperable without detection until that equipment is called upon to operate, either by test or when actually required. The x-relays on all safety-related breakers of this type were inspected and cleaned. The vendor did not provide for maintenance of the x-relays in their maintenance procedures.
10	Demand	Maintenance	Internal to Component	480 Vac	Mechanical Assembly	1989	Failure to Close	Partial	When attempting to switch 600 Vac buses from normal to alternate feed, the alternate breakers failed to close when the normal breakers were tripped. One failure was due to trip rod binding in the alternate breaker due to a lack of proper lubrication of the trip rod bearings. Another failure was caused by a binding plunger in the breaker charging motor cutout switch due to dirt buildup. The dirty plunger caused the switch contacts to remain open preventing the motor from charging the closing spring and completing the closing sequence. The third failure was caused by a dirt buildup on the trip mechanism and pivot points, which resulted in binding of the internal moving parts.
11	Demand	Maintenance	Internal to Component	480 Vac	Mechanical Assembly	1992	Failure to Close	Partial	A normal supply breaker for a 600 Vac bus failed to close on demand when switching from the from the alternate to the normal power supply. The failure was due to binding of the closing mechanism in the breaker. A few days later the alternate feed breaker to another bus failed to closed during a hot transfer. The second failure was caused by a stuck contact finger in the bus transfer interlock logic. The cause of the failures was attributed to a lack of lubrication or hardening of the lubrication. The breakers were removed from service and the closing pivot points and other moving parts lubricated. After functional testing, the breakers were returned to service.
12	Demand	Maintenance	Internal to Component	Medium Voltage	Latch Assembly	1991	Failure to Open	Partial	One 4160 Vac circuit breaker failed to open and several more were degraded due to hardened grease and lack of lubrication. This problem could affect the ability of the subject breakers to open or close. Maintenance of the breakers was incomplete despite similar failures due to the same cause four years earlier.
13	Demand	Maintenance	Internal to Component	Medium Voltage	UV Trip Assembly	1988	Failure to Open	Partial	Two 4160 Vac failed to open due to failure of the breaker trip coils. The cause were determined to be normal wear and aging.
14	Demand	Maintenance	Internal to Component	Medium Voltage	Aux. Contactor	1980	Failure to Close	Partial	During a planned line outage which de-energized a transformer, the alternate feeder breaker failed to close, de-energizing a 4 kv bus tie board during automatic transfer. When the transformer was re-energized the normal feeder breaker failed to close. The fuse clip and fuse in the close circuit of alternate feeder breaker were not making contact. The auxiliary contacts of the normal feeder breaker were dirty.
15	Demand	Maintenance	Internal to Component	RPS trip breakers	Latch Assembly	1992	Failure to Close	Partial	While attempting to reset the control rod drive system following a control rod drive breaker failed to close, de-energizing a 4 kv bus tie board during automatic transfer. Later, during a control rod drive breaker trip test, another breaker failed to reset after a trip. The first failure was due to the breaker trip latch being out of adjustment. The cause of the second failure could not be precisely determined; however, troubleshooting revealed cracked insulation on the close coil.

Item	Discovery Method	Coupling Factor	Proximate Cause	Breaker Type	Piece Part	Year	Failure Mode	Degree of Failure	Description
16	Demand	Maintenance	Internal to Component	RPS trip breakers	Closing Coil	1992	Failure to Close	Partial	Two reactor trip breakers failed to close following a trip test. The cause of the failure was believed to be due to the relay release arm on the closing solenoid moving core being out of adjustment.
17	Demand	Maintenance	Operational/ Human Error	480 Vac	OC Relay	1998	Failure to Close	Partial	Circuit breakers were found to be susceptible to tripping on normal start due to improper setting of overcurrent trip. The problem was discovered when one breaker failed to close on demand. A previous modification package was determined to be inadequate in that it did not require trip setpoint adjustment.
18	Demand	Maintenance	Operational/ Human Error	Medium Voltage	Mechanical Assembly	1994	Failure to Close	Partial	Four 4160 Vac circuit breakers failed to close. Each failure was due to a different mechanism; however, investigation revealed that all failures were related to workmanship and quality control practices by the vendor who overhauled the circuit breakers. To ensure the safety class circuit breakers are reliable, the utility and vendor developed a comprehensive plan to inspect critical components of the circuit breakers that were previously overhauled.
19	Demand	Maintenance	Operational/ Human Error	Medium Voltage	Mechanical Assembly	1997	Failure to Open	Partial	Two circuit breakers failed to open on demand during separate evolutions. During subsequent reviews, station personnel determined that the condition of the three circuit breakers was similar to the condition of the two safety-related circuit breakers that previously failed to open on demand. The cause of the event was determined to be inadequate preventive maintenance. The preventive maintenance performed did not lubricate the main and auxiliary contacts in the circuit breakers as recommended by the circuit breaker manufacturer and also did not provide sufficient instructions to remove the roughness on the main and auxiliary contacts.
20	Demand	Quality	Design/ Construction/ Manufacture/ Installation Inadequacy	480 Vac	Relay	1987	Failure to Open	Complete	Four 600 Vac normal auxiliary power system circuit breakers failed to open from local manual trip switch. The failures were caused by a relay contact in breaker trip circuit that was normally open instead of normally closed, as shown on wiring diagram. The relays were rewired to correct the problem.
21	Demand	Quality	Design/ Construction/ Manufacture/ Installation Inadequacy	Medium Voltage	Relay	1990	Failure to Close	Partial	While attempting to transfer two 4160 Vac buses to their alternate power supply, the alternate feeder circuit breaker. Separately, another 4160 Vac circuit breaker failed to close on demand. Both failures were caused by an open coil winding on a telephone-type relay within the synchronizing check relay of the circuit breaker. The telephone relay failed due to being continuously energized, which was not its intended application. A design modification was performed as the long-term corrective action.
22	Demand	Quality	Design/ Construction/ Manufacture/ Installation Inadequacy	Medium Voltage	Closing Coil	1996	Failure to Close	Partial	Two service water pumps failed to start upon demand. Investigation revealed a high resistance electrical contact in the pump motor circuit breaker close coil circuit. Evaluation of the failure determined that the electrical contact had high resistance due to repeated interruption of current approximately three times rated. The installed contactor current interrupt rating was inadequate. The contact failures occurred after a fraction of the design cycles. All 4 kV circuit breakers were determined to be susceptible to this failure.
23	Demand	Quality	Design/ Construction/ Manufacture/ Installation Inadequacy	RPS trip breakers	Latch Assembly	1994	Failure to Close	Partial	During plant protection system functional testing, two reactor trip breaker tripped free when maintenance personnel attempted to close them. With the vendor present, the problem was traced to inadequate adjustment of the trip latch overlap. The adjustment was initially made per vendor specifications. However, the vendor had since increased the recommended number of adjustment turns of the trip latch screw from 4 to a maximum of 5 turns. A change was submitted to change the procedure accordingly.

Item	Discovery Method	Coupling Factor	Proximate Cause	Breaker Type	Piece Part	Year	Failure Mode	Degree of Failure	Description
24	Demand	Quality	Internal to Component	RPS trip breakers	Unknown	1993	Failure to Close	Partial	During an attempt to close the control rod drive circuit breakers two breakers failed to close. The failures could not be repeated. Although the mechanical interlock, a piece part of this circuit breaker, was found slightly dirty and in need of lubrication, it is not believed to have caused the failures to close. As a preventive measure, the mechanical interlock was cleaned and lubricated. The breakers were successfully closed on all subsequent tests.
25	Demand	Quality	Internal to Component	RPS trip breakers	UV Trip Assembly	1983	Failure to Open	Complete	During a routine startup, both reactor trip breakers failed to open automatically on receipt of a valid low-low steam generator level reactor trip signal. The reactor was shutdown 25 seconds later using the manual trip on the control console. Subsequent investigation revealed that the breaker failures were caused by mechanical binding of the latch mechanism in the undervoltage trip attachment. All breaker undervoltage attachments were replaced with new devices and extensive maintenance and testing was performed on the breakers.
26	Inspection	Design	Design/Construction/Manufacture/Installation Inadequacy	Medium Voltage	Limit Switch	1995	Failure to Open	Partial	All 4 kV vital busses were declared inoperable following inspection that revealed cracks in the circuit breaker cam followers. One actual failure occurred during post maintenance testing (maintenance was for another reason), but all cam follower limit switches at both units were replaced. The root cause of this occurrence was inadequate initial design of General Electric type SBM switches by the manufacturer.
27	Inspection	Design	Design/Construction/Manufacture/Installation Inadequacy	Medium Voltage	Mechanical Assembly	1988	Failure to Close	Partial	An operator racked up the emergency 4.16kv bus feeder breaker from an emergency diesel generator and found that there was no indication of breaker position on the control panel. It was discovered that the breaker elevator mechanism linkage was distorted and had allowed the cell switch actuator arm to fall into an intermediate position disabling the automatic and manual closure circuitry. Other breaker compartments contained distorted linkages and it was concluded that any of 4.16kv breakers could fail during a seismic event. The linkage distortion was caused by an interference with the breaker assembly as it is rolled out of the compartment.
28	Inspection	Design	Design/Construction/Manufacture/Installation Inadequacy	Medium Voltage	Limit Switch	1995	Failure to Open	Partial	Inspection of circuit breaker limit switches revealed cam follower cracking. No equipment malfunctions or plant transients occurred, because the single actual failure occurred during routine post modification testing. The root cause of this occurrence was inadequate initial design of General Electric type SBM switches by the manufacturer.
29	Inspection	Design	Internal to Component	Medium Voltage	Arc Chute	1999	Failure to Open	Partial	4160 Vac circuit breakers could fail to change position due to an insulating block (a component of the breaker blowout magnets), whose adhesive had degraded with age, could become loose and fall into the breaker mechanism and prevent breaker operation.
30	Inspection	Design	Operational/ Human Error	Medium Voltage	Relay	1998	Failure to Close	Partial	A circuit breaker contacted exposed relay terminals during rack-in, causing trips/lockout of two breakers and lockout of another. The event was attributed to human error and poor design (location of relays).
31	Inspection	Hardware	Design/Construction/Manufacture/Installation Inadequacy	Medium Voltage	I&C	2000	Failure to Open	Partial	During a system review, it was noted that the auxiliary transformer breakers did not trip as designed when the Main Turbine tripped. Investigation determined that this trip signal is blocked when a low load (4000 A) condition is sensed at the output of the generator. The low load block is not part of the original digital protection system modification and no reason for the block could be determined. Tripping of these breakers on a Main Turbine trip is needed to ensure that the timing sequence for the EDGs on a LOOP/LOCA, as defined in the FSAR, would not be affected. The block was removed.

Item	Discovery Method	Coupling Factor	Proximate Cause	Breaker Type	Piece Part	Year	Failure Mode	Degree of Failure	Description
32	Inspection	Maintenance	Design/ Construction/ Manufacture/ Installation Inadequacy	Medium Voltage	Latch Assembly	1998	Failure to Close	Partial	A breaker tripped when the cubicle door was closed. Subsequent inspection revealed several incorrect latching mechanisms were installed on 4160 Vac breakers. The cause of the incorrect latching mechanisms being installed during original construction was personnel error. The incorrect latches were installed in eight of seventeen cubicle doors in the Division II switchgear. Contributing to this event was that information relative to the latching mechanisms was not provided to personnel working on the switchgear and that procurement controls were not adequate to ensure the correct parts were installed.
33	Inspection	Maintenance	Internal to Component	480 Vac	Mechanical Assembly	1989	Failure to Close	Partial	Two 480 Vac feeder breakers tripped and would not close while a special inspection of breakers was being conducted. The breakers failed to close due to dirt built up and lack of lubrication.
34	Inspection	Maintenance	Internal to Component	Medium Voltage	Spring Charging Motor	1992	Failure to Close	Partial	Two breaker's closing springs failed to charge-up when equipment operator was making ready the in-feed breaker from separate station power transformers. The suspected failure cause for one breaker was dirty contacts in the charging mechanism. The suspected failure cause for the other breaker was binding in the charging spring mechanism.
35	Inspection	Maintenance	Internal to Component	RPS trip breakers	UV Trip Assembly	1987	Failure to Close	Partial	Two reactor trip breakers failed to close following testing. Troubleshooting found one breaker's under voltage coil had failed (open circuit) and the other breaker's undervoltage device pivot to armature clearance was out of adjustment. Operational/ambient conditions were cited as causes for the failures.
36	Inspection	Maintenance	Operational/ Human Error	Medium Voltage	Latch Assembly	1996	Failure to Close	Partial	A failure of a roll pin securing a spring for a latch pawl on a 4KV breaker was reviewed and a determination made that the failure of this pin could cause the breaker to fail. Further investigation revealed that the roll pin failed as a result of hydrogen embrittlement. Later, an issue involving permanently applied lubricant which was inadvertently removed from the breakers was identified. This also could potentially affect breaker operation. The cause of the cracked roll pin was the lack of knowledge of plating induced hydrogen embrittlement. Vendor personnel involved in the procedure development were not aware that zinc plating of hardened steel parts could produce hydrogen embrittlement and subsequent cracking. The cause of the lubricant being inadvertently removed from breaker parts is also due to the lack of knowledge by Vendor personnel.
37	Inspection	Maintenance	Operational/ Human Error	RPS trip breakers	Wires/Connectors/Board	1983	Failure to Open	Complete	Following performance of the manual reactor trip functional test, it was noted that the procedure called for jumpering out the UV trip coils with the reactor trip breakers closed and the rods capable of withdrawal. This was a procedural error that caused the removal of both trains of automatic reactor trip logic. The procedure was revised to prevent recurrence of the event.
38	Maintenance	Design	Design/ Construction/ Manufacture/ Installation Inadequacy	Medium Voltage	Limit Switch	1995	Failure to Close	Partial	Inspections revealed cracks in the lexan cam followers of control (limit) switches installed in 4160 Vac and 6900 Vac circuit breakers. The same part used in 360 places in unknown number of breakers. Inspection showed about one third were cracking and two were inoperable. The root cause of this occurrence was inadequate initial design of General Electric type SBM switches by the manufacturer.
39	Maintenance	Maintenance	Design/ Construction/ Manufacture/ Installation Inadequacy	RPS trip breakers	UV Trip Assembly	1984	Failure to Close	Partial	After installation of new undervoltage trip relays, the reactor trip breakers would not stay closed. The original trip bar design gap was satisfactory with old style undervoltage relays, but not with new style relays.

Item	Discovery Method	Coupling Factor	Proximate Cause	Breaker Type	Piece Part	Year	Failure Mode	Degree of Failure	Description
40	Maintenance	Maintenance	Internal to Component	480 Vac	Mechanical Assembly	1985	Failure to Close	Partial	While conducting maintenance, the main feeder breaker for a 600 Vac emergency bus would not close. Investigation revealed the trip setpoint tolerance, contact gap and trip latch roller gap were out of adjustment preventing the breaker operation. This breaker was adjusted and returned to service. Another 600 Vac breaker was found to be "broken." No exact failure mechanism was given; however, the cause was given as "wear," and this breaker was replaced.
41	Maintenance	Maintenance	Internal to Component	480 Vac	Latch Assembly	1986	Failure to Open	Partial	During preventive maintenance, two power supply circuit breakers to motor control centers would not automatically open when their associated load center was isolated. They subsequently failed to trip when the manual trip button or tripper bar was pushed. The circuit breaker latch mechanisms were dirty and sticky. The root cause was determined to be normal wear and an inadequate preventive maintenance procedure.
42	Maintenance	Maintenance	Internal to Component	RPS trip breakers	Relay	1986	Failure to Close	Partial	During preventative maintenance two reactor trip breakers failed to close. Both breaker failures were due to failure of the same relay. The cause was assumed to be wear and aging.
43	Maintenance	Maintenance	Internal to Component	RPS trip breakers	Aux. Contactor	1990	Failure to Close	Partial	Two reactor trip breakers failed to close during preventative maintenance. The failure to close was due failure of the breaker cutoff switches.
44	Maintenance	Maintenance	Operational/ Human Error	Medium Voltage	Mechanical Assembly	1988	Failure to Open	Partial	A circuit breaker failed to open due to trip linkage binding caused by misalignment and improper assembly. Subsequent inspection of other 4160 Vac circuit breakers revealed the same problem. The misalignment was the result of a procedural deficiency by the vendor that performed circuit breaker overhauls.
45	Maintenance	Maintenance	Other	480 Vac	OC Relay	1994	Failure to Open	Partial	A preventive maintenance procedure was being performed on 480V molded case circuit breakers. These are magnetic only breakers with an adjustable instantaneous trip range of 50 to 150 amps. With the breakers adjusted to their lowest setting, the right phase for two breakers tripped at 71.7 amps and 69 amps. The maximum allowable trip point was 57.5 amps. The breakers had a date code that meant they were manufactured in August of 1978. Considering the breakers were approximately 16 years old, the drift in calibration is associated with the breakers' service life. Therefore, it was decided to replace the breakers. The circuit breakers would still trip on instantaneous within its adjustable range which would provide adequate overcurrent protection. The cause was attributed to the breakers' long service life. Like for like breakers were installed. All tests were performed satisfactorily.
46	Maintenance	Maintenance	Other	RPS trip breakers	UV Trip Assembly	1986	Failure to Open	Partial	During preventive maintenance on the reactor trip breakers, the undervoltage trip units on two breakers were found to be out of specification. One undervoltage device could not be adjusted within specification and was replaced. The cause for both failures was determined to be vibration and aging.
47	Maintenance	Quality	Design/ Construction/ Manufacture/ Installation Inadequacy	RPS trip breakers	UV Trip Assembly	1983	Failure to Open	Partial	A potential safety hazard was identified concerning certain critical dimensions of the undervoltage trip device on a particular model reactor trip circuit breaker. An out-of-tolerance measurement was found between the moving core and rolling bracket in addition to a missing lock ring on the shaft pin of the undervoltage trip device. The potential existed for either intermittent operation or total failure of the device. The cause was attributed to manufacturing variations of the undervoltage trip devices. All undervoltage trip devices on all reactor trip breakers were replaced.



Item	Discovery Method	Coupling Factor	Proximate Cause	Breaker Type	Piece Part	Year	Failure Mode	Degree of Failure	Description
48	Maintenance	Quality	Internal to Component	Medium Voltage	Mechanical Assembly	1985	Failure to Close	Partial	During a scheduled maintenance outage of 4160v safety-related switchgear, the plant electrical staff discovered that two circuit breakers were rendered electrically inoperable due to the failure of a spot welded pivot pin. This spot welded pivot pin was on an internal piece of linkage, which actuates the auxiliary contacts that track breaker position. These contacts are also used in external breaker trip and close schemes as interlocks. The defective component is being modified to preclude additional failures.
49	Test	Design	Design/ Construction/ Manufacture/ Installation Inadequacy	DC distribution	OC Relay	1996	Failure to Open	Almost Complete	All 72 dc molded case circuit breakers were tested, all 44 breakers of one vendor type, installed in 4 different distribution panels failed to trip on overcurrent. Problem was the design of the trip lever in the magnetic trip circuit breakers. All breakers of this type and vendor were replaced.
50	Test	Design	Design/ Construction/ Manufacture/ Installation Inadequacy	Medium Voltage	Relay	1984	Failure to Open	Partial	When performing a loss of bus test, two 4160 Vac bus-tie breakers failed to trip. Investigation concluded that the bus-tie breakers could not trip if the diesel generator output breaker was open. The failures to open were caused by a design error.
51	Test	Design	Design/ Construction/ Manufacture/ Installation Inadequacy	Medium Voltage	Relay	1990	Failure to Open	Partial	During surveillance testing several circuit breaker lockout relays would not actuate. These failures would have prevented breaker trips on overcurrent. Mechanical binding prevented the relays from tripping. Bench testing revealed several contributing factors but could not identify the root cause. The failed relays' armature force checks yielded 5 to 6.5 pounds but newer relays required only 3.5 pounds. The vendor discourages re-lubrication to reduce friction. Also, a vendor bulletin states that when the relay reset handle is forced against the latch after resetting, tripping is delayed or prevented. The lockout relays were replaced with spares and tested satisfactorily.
52	Test	Design	Design/ Construction/ Manufacture/ Installation Inadequacy	Medium Voltage	Mechanical Assembly	1999	Failure to Close	Partial	Two 6.9kV breakers failed to close due to manufacturer repair defect. A cotter pin installed by the manufacturer was striking the latch check switch mounting bracket and bending it forward. This removed the factory set clearance between the bracket and the switch actuating paddle, resulting in the paddle rolling the trip shaft to the trip position when the breaker attempts to close.
53	Test	Design	Design/ Construction/ Manufacture/ Installation Inadequacy	RPS trip breakers	Spring	1988	Failure to Close	Partial	Two reactor trip breakers failed to close during surveillance testing. The breakers' closing springs had become detached from the pivot/actuation points. The reason for the springs' detaching could not be determined; however, this has been a recurring problem with this breaker design.
54	Test	Design	Internal to Component	480 Vac	Closing Coil	1988	Failure to Close	Partial	During a station loss of offsite power (loop) test, two class 1E 480 volt load center breakers failed to close during automatic load sequencing. Subsequent investigation revealed that the breaker spring release device in both breakers was binding against the opening in the breaker base plate which resulted in failure of the closing coil and failure of the breaker to close. Other defective breakers were also identified following inspections.

Item	Discovery Method	Coupling Factor	Proximate Cause	Breaker Type	Piece Part	Year	Failure Mode	Degree of Failure	Description
55	Test	Design	Internal to Component	Medium Voltage	Mechanical Assembly	1987	Failure to Open	Partial	A circuit breaker failed to trip during a surveillance test. Upon investigation, it was determined that the connecting pin for the breaker trip crank located between the trip solenoid and the trip shaft became loose due to a pin weld failure, which prevented electrical tripping of the breaker. Inspection revealed several breakers with the same weld geometry. Two procedures, an inspection procedure and a trip crank replacement procedure were written for eighty six affected breakers on site. Nine breakers failed the acceptance criteria.
56	Test	Design	Internal to Component	RPS trip breakers	UV Trip Assembly	1983	Failure to Open	Partial	During reactor trip breaker surveillance testing, the undervoltage trip devices for two circuit breakers exhibited scattered and unacceptable response times. The reactor trip breakers were replaced with spares.
57	Test	Design	Internal to Component	RPS trip breakers	Latch Assembly	1983	Failure to Open	Complete	The static force to trip the circuit breakers exceeded allowable tolerance due to binding caused by the unused overcurrent trip pads. The breakers tested satisfactorily after removal of the overcurrent trip pads.
58	Test	Design	Internal to Component	RPS trip breakers	Spring	1986	Failure to Close	Partial	During performance testing of the reactor trip circuit breakers, two breakers failed to re-close after open them from the control room panel controls. Troubleshooting found that the breakers' operating springs fell off, preventing closure but not opening, a recurring problem with this particular breaker design.
59	Test	Design	Operational/ Human Error	RPS trip breakers	Spring	1994	Failure to Close	Partial	While performing initial approach to criticality testing, operators noted that the B-phase for a reactor trip breaker, was not indicating current flow after the breaker was closed. The train's function of providing power to the control rod drive mechanism was degraded as one phase of power was unavailable. The failure was caused by a mechanical operating spring that had come loose. With the spring loose, the B-phase contacts were getting insufficient pressure to close. The vendor has provided notice that the spring could come loose and the vendor has provided additional instructions for breaker inspection and maintenance to address this problem. The spring was reinstalled according to the vendors instructions. The breaker was subsequently tested and returned to service.
60	Test	Environmental	External Environment	RPS trip breakers	Mechanical Assembly	1984	Failure to Open	Partial	During routine surveillance testing of the reactor trip breakers, two breakers did not change state in the required time. The causes were determined to be dirty breaker mechanisms.
61	Test	Environmental	Internal to Component	RPS trip breakers	UV Trip Assembly	1983	Failure to Open	Partial	During routine surveillance testing, a the control rod drive AC breaker experienced a delayed trip. Subsequent testing of all AC and dc control rod drive breakers resulted in a control rod drive dc breaker also experiencing a delayed trip. If a reactor trip had occurred, and if both malfunctioned breakers had delayed in tripping, two control rod groups would not have dropped immediately.
62	Test	Maintenance	Internal to Component	480 Vac	Mechanical Assembly	1986	Failure to Open	Partial	The power supply circuit breakers to two motor control centers would not trip during surveillance testing. The circuit breakers were dirty. This was due to a normal accumulation of dirt during operations. The circuit breakers were cleaned and verified to be operable.
63	Test	Maintenance	Internal to Component	480 Vac	Mechanical Assembly	1987	Failure to Open	Partial	During once per cycle testing of the startup transfer feeder to the unit bus breaker, two breaker trip units were found to be non-operational so that the breakers would not trip. Both failures were caused by lack of lubrication on the internal moving parts due to a lack of proper maintenance.
64	Test	Maintenance	Internal to Component	480 Vac	Mechanical Assembly	1999	Failure to Open	Partial	During high tolerance instantaneous testing, several 480 Vac circuit breakers on all three phases did not trip in the required time (0-10 cycles). Failures were attributed to aging and degraded lubricants resulting from an ineffective maintenance program.

Item	Discovery Method	Coupling Factor	Proximate Cause	Breaker Type	Piece Part	Year	Failure Mode	Degree of Failure	Description
65	Test	Maintenance	Internal to Component	480 Vac	Relay	1988	Failure to Close	Partial	During surveillance testing on the plant ac distribution system, the normal feeder breaker from a transformer would not close when transferring from alternate to normal power. The failure was attributed to close relay contacts hanging up from a lack of breaker lubrication. A second similar failure was attributed to the breaker having dirty contacts.
66	Test	Maintenance	Internal to Component	480 Vac	Relay	1983	Failure to Close	Partial	Four 480 Vac circuit breakers failed to close during testing due to failure of the power sensors. The power sensors were replaced.
67	Test	Maintenance	Internal to Component	480 Vac	OC Relay	1998	Failure to Open	Partial	The instantaneous trip testing of both breakers revealed excessive time prior to tripping. The required trip time is less than 0.15 seconds. Breakers were tripping on instantaneous testing between 0.194 and 0.753 seconds. Cause was determined to be inadequate preventative maintenance.
68	Test	Maintenance	Internal to Component	480 Vac	Mechanical Assembly	1991	Failure to Close	Partial	Two 480 Vac circuit breakers failed to close due to mechanical binding caused by dried out, hardened lubricant. The mechanical operating mechanisms were replaced.
69	Test	Maintenance	Internal to Component	480 Vac	Relay	1988	Failure to Close	Partial	A circuit breaker failed to close on a safety injection demand due to oxidation on contacts for the alarm switches. Subsequent investigation revealed 11 other safety-related breakers with the same problem. The cause was determined to be inadequate periodic inspections and cleaning of the alarm switch contacts due to lack of specific guidance in the maintenance procedure. Corrective actions included revision of the maintenance procedure.
70	Test	Maintenance	Internal to Component	480 Vac	Mechanical Assembly	1986	Failure to Close	Partial	During routine inspections of the 480 volt unit boards, two feeder breakers were binding. The failures were attributed to dirty, hardened grease, normal aging and wear.
71	Test	Maintenance	Internal to Component	DC distribution	OC Relay	1989	Failure to Open	Partial	While performing preventative maintenance on the dc feeder circuit breakers, the overcurrent trip devices would not set correctly. The cause was attributed to a lack of maintenance.
72	Test	Maintenance	Internal to Component	DC distribution	Control Switch	1987	Failure to Close	Partial	During routine observation of the 250 volt distribution boards, a normal dc power feeder breaker was slow to transfer and another failed to transfer. The first failure was due to switch joints being dirty and an indicating light resistor being burned out. The second failure was due to dirty hinge joints.
73	Test	Maintenance	Internal to Component	DC distribution	Mechanical Assembly	1996	Failure to Open	Partial	The dc bus inter-tie breakers failed to open due to lack of lubrication. Corrective action was to create a preventative maintenance and inspection schedule for these breakers.
74	Test	Maintenance	Internal to Component	Medium Voltage	Spring Charging Motor	1987	Failure to Close	Partial	The closing springs for two 4160 Vac breakers would not charge. The cause of the failures were dirty contacts, a dirty closing mechanism, and lack of lubrication.
75	Test	Maintenance	Internal to Component	Medium Voltage	Spring Charging Motor	1986	Failure to Close	Partial	While performing testing of 4160 Vac boards and buses, three circuit breakers would not close. The failures were attributed to the breakers being dirty, needing lubrication, and due to loose connections.
76	Test	Maintenance	Internal to Component	Medium Voltage	Spring Charging Motor	1987	Failure to Close	Partial	Two 4160 Vac circuit breakers failed to close. One failure was caused by the latching pawl spring being out of adjustment, which prevented the springs from charging. The cause of the second failure was attributed to the racking mechanism slide interlock being out of adjustment.
77	Test	Maintenance	Internal to Component	Medium Voltage	Relay	1989	Failure to Close	Partial	A time delay relay for a 4160 volt feeder breaker would not time out within its specified tolerance during calibration, and a time delay relay for a second breaker would not actuate. The causes of both failures were determined to be due to aging.

Item	Discovery Method	Coupling Factor	Proximate Cause	Breaker Type	Piece Part	Year	Failure Mode	Degree of Failure	Description
78	Test	Maintenance	Internal to Component	Medium Voltage	OC Relay	1984	Failure to Open	Partial	Several 4160 Vac circuit breakers of the vendor and type failed to trip due to age induced hardening of grommets in the electromechanical overcurrent device. Corrective actions included replacement with new or newly rebuilt overcurrent devices and establishing an adequate preventive maintenance surveillance interval.
79	Test	Maintenance	Internal to Component	Medium Voltage	Limit Switch	1989	Failure to Open	Partial	In two separate incidents while attempting to realign power to support testing, the alternate supply circuit breaker failed to trip upon closure of normal supply breaker. The cause of failure was attributed to the raised upper limit switch being out of mechanical adjustment causing a greater than 1/8 inch gap between the operating plunger and the breaker auxiliary switch. This limit switch provides the trip signal for the alternate breaker.
80	Test	Maintenance	Internal to Component	Medium Voltage	Mechanical Assembly	1995	Failure to Close	Partial	A 4KV supply circuit breaker closed during testing, but failed to instantly recharge. The cause of the failure was aging of the latch monitor pivot bearing lubrication. This problem had previously surfaced and the bearings were relubricated at that time. Since that action did not fix the problem, the decision was made to replace the pivot bearings for all affected circuit breakers..
81	Test	Maintenance	Internal to Component	RPS trip breakers	UV Trip Assembly	1986	Failure to Close	Partial	While conducting monthly surveillance testing of the unit's reactor protection system, two reactor trip circuit breakers failed to close after testing. Troubleshooting found a failure of one breaker's under voltage device. The second circuit breaker's pick-up coil voltage was high due to a change in characteristics of the voltage adjustment potentiometer. Both failures were attributed to operational stress and/or equipment aging.
82	Test	Maintenance	Internal to Component	RPS trip breakers	UV Trip Assembly	1986	Failure to Close	Partial	While conducting surveillance testing of the unit's reactor protection system, two reactor trip circuit breakers' UV devices would not pick up after tripping the breakers. Troubleshooting found that the UV devices' gap clearances were incorrect. No direct cause for the misadjustments was found, however, operational stress and/or equipment aging were suspected.
83	Test	Maintenance	Internal to Component	RPS trip breakers	UV Trip Assembly	1987	Failure to Close	Partial	Two reactor trip breakers failed to close following testing. Troubleshooting found one breaker's under voltage coil had failed (open circuit) and the other breaker's undervoltage device pivot to armature clearance was out of adjustment. Operational/ambient conditions (heat/vibration) were cited as causes for the failures.
84	Test	Maintenance	Internal to Component	RPS trip breakers	Mechanical Assembly	1989	Failure to Close	Partial	During surveillance testing, two reactor trip switchgear breakers would not close. The first failure was due to a defective piece part in the cutout 'y' switch on the breaker due to cyclic fatigue. In the second failure, a broken clamp was found on the closing mechanism, which prevented the breaker from closing.
85	Test	Maintenance	Internal to Component	RPS trip breakers	Mechanical Assembly	1985	Failure to Open	Partial	During normal operation while performing surveillance testing, two reactor trip circuit breakers failed the under voltage response time test. The breaker's front frame assembly was the suspected cause of the increased time response of the one breaker's undervoltage device. The other failure was due to loose armature laminations in the undervoltage device. Both are known design problems with these circuit breakers.

Item	Discovery Method	Coupling Factor	Proximate Cause	Breaker Type	Piece Part	Year	Failure Mode	Degree of Failure	Description
86	Test	Maintenance	Internal to Component	RPS trip breakers	UV Trip Assembly	1982	Failure to Open	Partial	During surveillance testing, four of nine reactor trip circuit breakers failed to trip on undervoltage. The primary cause was inadequate lubrication, possibly due to an excessive preventive maintenance interval, combined with a small design margin in the tripping force provided from the undervoltage coil. Corrective actions were to perform required preventive maintenance prior to the unit entering mode 2 and implementation of the recommendations of IE Bulletin 79-09 and vendor recommendations, increased surveillance testing of the undervoltage trip feature and a decrease in the interval between preventive maintenance.
87	Test	Maintenance	Internal to Component	RPS trip breakers	UV Trip Assembly	1984	Failure to Close	Partial	During surveillance testing, two reactor trip breakers failed to close during surveillance response time test. The stated cause was normal wear.
88	Test	Maintenance	Internal to Component	RPS trip breakers	Relay	1986	Failure to Open	Partial	Two reactor trip breakers failed to trip during performance of surveillance testing. One failure was due to the auxiliary contact for the shunt trip was not making contact due to misalignment with the block. The other failure was due to a faulty undervoltage relay. The jumper to change the control voltage was installed in the 48 volt holes and should have been installed in the 125 volt holes causing the relay to overheat and melt.
89	Test	Maintenance	Internal to Component	RPS trip breakers	Mechanical Assembly	1984	Failure to Open	Partial	During surveillance testing of the reactor trip circuit breakers, the under voltage trip response time was found out of specification. Troubleshooting found the breakers' front frame assemblies to be lacking the proper amount of lubricant on their bearings. This was a recurring problem with this breaker type. The front frame assemblies were replaced.
90	Test	Maintenance	Internal to Component	RPS trip breakers	Relay	1984	Failure to Close	Partial	Two reactor trip breakers failed to close over a one-month period. Both failures were attributed to relay release arms being out of adjustment.
91	Test	Maintenance	Internal to Component	RPS trip breakers	UV Trip Assembly	1990	Failure to Open	Partial	Two reactor trip breakers were found to have defective undervoltage trip relays which prevented opening. One failure was detected during testing and the other was detected during maintenance. The relay failures were determined to be due to aging.
92	Test	Maintenance	Internal to Component	RPS trip breakers	Mechanical Assembly	1984	Failure to Open	Partial	During surveillance testing, the trip time requirements for two reactor trip breakers were found to be out of specification high. Historically, the bearings for the breaker front frame assemblies have been found worn and lacking the necessary lubrication, which increases trip times. After replacing the front frame assemblies and lubrication the bearings, the breakers were retested satisfactorily and returned to service.
93	Test	Maintenance	Internal to Component	RPS trip breakers	UV Trip Assembly	1980	Failure to Open	Partial	It was discovered during testing that some reactor trip breakers would not trip on undervoltage as expected. One device would not trip and two others tripped sluggishly. The cause was determined to be misaligned armatures in the undervoltage devices. A new preventative maintenance program was initiated to check the undervoltage coils independently on a monthly basis.
94	Test	Maintenance	Internal to Component	RPS trip breakers	UV Trip Assembly	1990	Failure to Close	Partial	In separate tests, two reactor trip breakers failed to close after trip testing. The failure to reset was determined to be due to worn undervoltage trip coil mechanisms to prevented the breakers from latching.
95	Test	Maintenance	Internal to Component	RPS trip breakers	Latch Assembly	1994	Failure to Close	Partial	During unit outage, while performing functional testing, operators found that two reactor trip breakers would not close from the handswitch in the main control room. Troubleshooting discovered the inertia latch (piece part of the circuit breaker) had stuck in mid travel. The breakers' electrical trip function was lost, but the control rod drive system was not affected because of an available redundant trip breaker. Plant operation was not affected. Insufficient lubrication of the inertia latch caused the latch to stick in mid travel. The inertia latches were cleaned and lubricated and post maintenance testing was performed satisfactorily.

Item	Discovery Method	Coupling Factor	Proximate Cause	Breaker Type	Piece Part	Year	Failure Mode	Degree of Failure	Description
96	Test	Maintenance	Internal to Component	RPS trip breakers	UV Trip Assembly	1983	Failure to Open	Partial	During surveillance testing, three reactor trip breakers failed to trip on undervoltage. The primary cause was inadequate lubrication, possibly due to an excessive preventive maintenance interval, combined with a small design margin in the tripping force provided from the undervoltage coil. Corrective action was to perform the required preventive maintenance prior to entering Mode 2. Additionally, as required by IE Bulletin 79-09 and vendor recommendations, the surveillance testing interval of the undervoltage trip feature was increased and the interval between preventive maintenance was decreased to prevent recurrence of this event.
97	Test	Maintenance	Internal to Component	RPS trip breakers	Unknown	1992	Failure to Close	Partial	Two reactor trip breakers failed to close following a trip test. The cause could not be determined and the failure was not repeatable. The breakers that failed were replaced with spares.
98	Test	Maintenance	Internal to Component	RPS trip breakers	Mechanical Assembly	1985	Failure to Open	Partial	While performing testing of the unit's reactor trip circuit breakers, the undervoltage trip time was found to be out of the allowable tolerance for two breakers. Dirt accumulation in the front frame assembly and lack of lubrication were the suspected causes
99	Test	Maintenance	Operational/ Human Error	480 Vac	Main Contacts	1992	Failure to Close	Partial	During testing on emergency bus feeder breakers, the closing spring charge/discharge indicator showed that the springs were charged with the breaker closed, indicating that the main contacts were closed but not exerting full pressure against the stationary contacts. Investigation showed the root cause to be failure to incorporate the latest vendor information on contact adjustment into the breaker maintenance procedure.
100	Test	Maintenance	Operational/ Human Error	480 Vac	Wires/Connectors/Board	1993	Failure to Open	Partial	An Emergency Diesel Generator (EDG) failed to pass surveillance testing because certain loads were not shunt tripped from the safeguard bus when a simulated Loss of Coolant Accident (LOCA) signal was initiated. During troubleshooting, a loose wire was discovered in one circuit breaker and a lifted wire was discovered in another circuit breaker. The wires were restored to their normal positions and a portion of the test procedure was performed to verify appropriate loads were shunt tripped following a simulated LOCA signal. The loose/disconnected wires were believed to have come loose at a plug connection during repairs made to enhance electrical separation between electrical divisions. Procedures were revised to alert workers of the potential for wires becoming loose during removal and restoration of plug connections on similar circuit breakers.
101	Test	Maintenance	Operational/ Human Error	480 Vac	Mechanical Assembly	1997	Failure to Close	Partial	Three breakers failed to close on demand during testing. Hardened grease was discovered in the stop roller and main drive link roller. When actuated by the closing coil, these rollers and the associated closing latch release the stored energy of the breaker springs, closing the breaker. Stiff rollers have resulted in multiple breaker failures in the past. The maintenance procedure provides instructions to clean and lubricate various friction points of the breaker mechanism; however, they are not specifically identified in the vendor manual. These rollers were not cleaned and lubricated during the performance of the scheduled preventative maintenance.
102	Test	Maintenance	Operational/ Human Error	480 Vac	Mechanical Assembly	1997	Failure to Open	Partial	A breaker failed to trip during testing. Subsequent testing and inspection revealed several breakers degraded due to lack of lubrication. Lubrication was removed during refurbishment by the vendor and was not re-installed.
103	Test	Maintenance	Operational/ Human Error	RPS trip breakers	Shunt Trip	1984	Failure to Open	Partial	One set of leads in each of the four plant protective system bays were found to be disconnected. These disconnected leads removed the automatic shunt trip feature from RTB's #1, #2, #3, and #4. The subject leads had been disconnected and not restored during 18-month surveillance testing conducted earlier.

Item	Discovery Method	Coupling Factor	Proximate Cause	Breaker Type	Piece Part	Year	Failure Mode	Degree of Failure	Description
104	Test	Maintenance	Operational/ Human Error	RPS trip breakers	UV Trip Assembly	1983	Failure to Open	Partial	During the performance of reactor trip circuit breaker undervoltage device surveillance testing, three breakers failed to open within the acceptance time criteria. The following day, and then 8 days later, two additional breakers failed to meet the acceptance criteria. The reactor trip breakers failed even though extensive maintenance and testing was performed on all eight of the trip system breakers 11 days prior to the first 3 failures. Maintenance included procedures specified in the vendor service advisory letter. The deficiencies were corrected by again performing the vendor approved refurbishment procedures on the slow breakers, followed by successful testing.
105	Test	Maintenance	Operational/ Human Error	RPS trip breakers	Latch Assembly	1992	Failure to Close	Partial	While performing surveillance testing, two reactor trip breakers failed to close on separate occasions. In one case, the breaker latch catch and arm were found bent, preventing the breaker from closing. The cause of this failure was believed to be from incorrect installation of the breaker during previous maintenance or testing activities. In the second case, the breaker operating mechanism latch was binding against the housing likely due to inadequate lubrication and rough surfaces.
106	Test	Maintenance	Other	480 Vac	OC Relay	1985	Failure to Open	Partial	During routine surveillance testing, three circuit breakers would not trip on short time overcurrent trip test. The failures were caused by the breakers being out of calibration as a result of normal wear.
107	Test	Maintenance	Other	Medium Voltage	UV Trip Assembly	1986	Failure to Open	Partial	During routine testing it was found that the under voltage relays for two 4160 Vac feeder breakers from an auxiliary transformer to the buses were out of calibration. The failures were attributed to relay wear.
108	Test	Maintenance	Other	Medium Voltage	UV Trip Assembly	1994	Failure to Open	Partial	Undervoltage dropout relays in two separate, similar breakers drifted out of specification between times they were checked by scheduled maintenance. A root cause investigation attributed the relay setpoint shift to a combination of: 1) relay setpoint repeatability, 2) temperature sensitivity of the relays, and 3) testing techniques. Applicable test equipment and procedures have been changed to address the causes of the setpoint shift. Additionally, the testing frequency has been increased from quarterly to monthly pending relay performance trending results.
109	Test	Maintenance	Other	RPS trip breakers	UV Trip Assembly	1983	Failure to Open	Partial	The trip response time of two reactor trip breakers was slower than allowed by Technical Specifications. The breakers were retested satisfactorily and returned to service after adjusting the UV trip device setpoints and lubricating the trip shaft and latch roller bearings. The breakers were still considered operable since the shunt trip devices were operational with satisfactory response times.
110	Test	Maintenance	Other	RPS trip breakers	UV Trip Assembly	1983	Failure to Open	Partial	During surveillance testing of the reactor trip circuit breakers' undervoltage devices, the response time of two breakers than allowed by Technical Specifications. The cause of the event was setpoint drift and worn/binding front frame assembly mechanisms. The setpoints were adjusted and the trip shaft and latch roller bearings were lubricated.
111	Test	Maintenance	Other	RPS trip breakers	UV Trip Assembly	1983	Failure to Open	Partial	During monthly surveillance test of the reactor trip circuit breaker undervoltage trip devices, the response time of two breakers was slower than allowed by Technical Specifications. This event was caused by setpoint drift and worn/binding front frame assembly mechanisms. Corrective actions included replacement of front frame assemblies and undervoltage trip devices.

Item	Discovery Method	Coupling Factor	Proximate Cause	Breaker Type	Piece Part	Year	Failure Mode	Degree of Failure	Description
112	Test	Quality	Design/ Construction/ Manufacture/ Installation Inadequacy	Medium Voltage	Spring Charging Motor	1986	Failure to Close	Partial	The circuit breaker for the residual heat removal pump failed to recharge during testing, rendering the breaker incapable of automatic closure. In addition to performing required surveillance tests, an investigation revealed that the breaker charging spring motor bolts had fallen out, allowing the motor to rotate, and breaking the power leads. A root cause analysis led to the conclusion that a combination of inadequate thread engagement of the mounting bolts in the motor housing and equipment vibration caused the bolts to loosen. Because this event had the potential for a common mode failure, all safety related breakers were inspected during a scheduled maintenance outage. Three additional breakers were found to have loose bolts.
113	Test	Quality	Design/ Construction/ Manufacture/ Installation Inadequacy	RPS trip breakers	UV Trip Assembly	1990	Failure to Close	Partial	Two reactor trip breakers failed to close. The first failed to close during testing, the second failed to close while troubleshooting the first failure. The cause of both breaker failures was failure of the under voltage trip coil, which was thought to be due to a manufacturing defect.
114	Test	Quality	Design/ Construction/ Manufacture/ Installation Inadequacy	RPS trip breakers	UV Trip Assembly	1983	Failure to Close	Partial	During surveillance testing, two reactor trip breakers would not close when a close signal was applied to the breaker's control circuit. Troubleshooting found defective undervoltage devices that would not allow the closure of the breakers. The undervoltage devices were replaced.
115	Test	Quality	Design/ Construction/ Manufacture/ Installation Inadequacy	RPS trip breakers	Mechanical Assembly	1984	Failure to Close	Partial	During surveillance testing, two reactor trip breakers would not re-close. Troubleshooting found manufacturing defects in the front frame assemblies (loose mechanical collars). This problem has been identified on similar breakers. The front frame assemblies were replaced.
116	Test	Quality	Internal to Component	RPS trip breakers	Spring	1989	Failure to Close	Partial	While performing surveillance testing on reactor trip circuit breakers, two breakers failed to close. In one failure, the left side close spring on the breaker had fallen off and the breaker wouldn't close with only one spring. The second breaker failure was due to a bad control power fuse that failed due to aging.
117	Test	Quality	Internal to Component	RPS trip breakers	UV Trip Assembly	1983	Failure to Open	Partial	The undervoltage armatures for two different reactor trip breakers were found during testing to not be fully picked up (repetitive failures in the same month). Based on vendor tests, the abnormal armature position has little or no detectable effect on the ability of the undervoltage trip device to trip the breaker on loss of voltage. The undervoltage armatures not being fully picked up is the result of interference between the undervoltage armature and the copper shading ring around the coil core. As corrective action, visual verification and manual adjustment of proper closed air gap position is required following energization of the undervoltage device.
118	Test	Quality	Internal to Component	RPS trip breakers	UV Trip Assembly	1983	Failure to Open	Partial	The undervoltage armatures for two different reactor trip breakers were found during testing to not be fully picked up (repetitive failures in the same month). Based on vendor tests, the abnormal armature position has little or no detectable effect on the ability of the undervoltage trip device to trip the breaker on loss of voltage. The undervoltage armatures not being fully picked up is the result of interference between the undervoltage armature and the copper shading ring around the coil core. As corrective action, visual verification and manual adjustment of proper closed air gap position is required following energization of the undervoltage device.



Item	Discovery Method	Coupling Factor	Proximate Cause	Breaker Type	Piece Part	Year	Failure Mode	Degree of Failure	Description
119	Test	Quality	Internal to Component	RPS trip breakers	UV Trip Assembly	1983	Failure to Open	Almost Complete	Both reactor trip breakers and a bypass breaker failed to open on an undervoltage trip signal during response time testing. The failures were due to mechanical problems of the undervoltage mechanisms, which resulted from manufacturing deficiencies. Fifteen days later, one of the replacement reactor trip breakers also failed due to the same cause.

Table A-4. Breaker CCF event summary, sorted by piece-part.

Item	Piece Part	Discovery Method	Coupling Factor	Breaker Type	Proximate Cause	Year	Failure Mode	Degree of Failure	Description
1	Arc Chute	Inspection	Design	Medium Voltage	Internal to Component	1999	Failure to Open	Partial	4160 Vac circuit breakers could fail to change position due to an insulating block (a component of the breaker blowout magnets), whose adhesive had degraded with age, could become loose and fall into the breaker mechanism and prevent breaker operation.
2	Aux. Contactor	Demand	Maintenance	480 Vac	Internal to Component	1986	Failure to Close	Partial	When attempting to close a normal supply breaker to a 480 Vac bus, the close circuit fuses blew. The failure caused by dirty auxiliary contacts. In another case, routine observation found that the alternate supply circuit breaker to the same bus had failed due to a burned out closing relay.
3	Aux. Contactor	Demand	Maintenance	Medium Voltage	Internal to Component	1980	Failure to Close	Partial	During a planned line outage which de-energized a transformer, the alternate feeder breaker failed to close, de-energizing a 4 kv bus tie board during automatic transfer. When the transformer was re-energized the normal feeder breaker failed to close. The fuse clip and fuse in the close circuit of alternate feeder breaker were not making contact. The auxiliary contacts of the normal feeder breaker were dirty.
4	Aux. Contactor	Maintenance	Maintenance	RPS trip breakers	Internal to Component	1990	Failure to Close	Partial	Two reactor trip breakers failed to close during preventative maintenance. The failure to close was due failure of the breaker cutoff switches.
5	Closing Coil	Demand	Maintenance	480 Vac	Internal to Component	1984	Failure to Close	Partial	Over a period of 5 months, there were 6 incidents of circuit breakers of the same vendor and type failing to close on demand. Intermittent failures of the closing coil cutoff x-relays to properly return to their de-energized position prevented the relays from energizing the breakers' closing coils upon receipt of a close signal. It was determined that dirt and dust accumulation on the moveable parts of the relay causes the faulty operation. The symptoms of the x-relay malfunction were found to be failure of the breaker to close upon receiving a close signal, and in most cases, the breaker closes upon receiving a second close signal. This failure mode can cause equipment and/or systems to be inoperable without detection until that equipment is called upon to operate, either by test or when actually required. The x-relays on all safety-related breakers of this type were inspected and cleaned. The vendor did not provide for maintenance of the x-relays in their maintenance procedures.
6	Closing Coil	Demand	Maintenance	RPS trip breakers	Internal to Component	1992	Failure to Close	Partial	Two reactor trip breakers failed to close following a trip test. The cause of the failure was believed to be due to the relay release arm on the closing solenoid moving core being out of adjustment.
7	Closing Coil	Demand	Quality	Medium Voltage	Design/ Construction/ Manufacture/ Installation Inadequacy	1996	Failure to Close	Partial	Two service water pumps failed to start upon demand. Investigation revealed a high resistance electrical contact in the pump motor circuit breaker close coil circuit. Evaluation of the failure determined that the electrical contact had high resistance due to repeated interruption of current approximately three times rated. The installed contactor current interrupt rating was inadequate. The contact failures occurred after a fraction of the design cycles. All 4 kV circuit breakers were determined to be susceptible to this failure.
8	Closing Coil	Test	Design	480 Vac	Internal to Component	1988	Failure to Close	Partial	During a station loss of offsite power (loop) test, two class 1E 480 volt load center breakers failed to close during automatic load sequencing. Subsequent investigation revealed that the breaker spring release device in both breakers was binding against the opening in the breaker base plate which resulted in failure of the closing coil and failure of the breaker to close. Other defective breakers were also identified following inspections.

Item	Piece Part	Discovery Method	Coupling Factor	Breaker Type	Proximate Cause	Year	Failure Mode	Degree of Failure	Description
9	Control Switch	Test	Maintenance	DC distribution	Internal to Component	1987	Failure to Close	Partial	During routine observation of the 250 volt distribution boards, a normal dc power feeder breaker was slow to transfer and another failed to transfer. The first failure was due to switch joints being dirty and an indicating light resistor being burned out. The second failure was due to dirty hinge joints.
10	I&C	Inspection	Hardware	Medium Voltage	Design/Construction/Manufacture/Installation Inadequacy	2000	Failure to Open	Partial	During a system review, it was noted that the auxiliary transformer breakers did not trip as designed when the Main Turbine tripped. Investigation determined that this trip signal is blocked when a low load (4000 A) condition is sensed at the output of the generator. The low load block is not part of the original digital protection system modification and no reason for the block could be determined. Tripping of these breakers on a Main Turbine trip is needed to ensure that the timing sequence for the EDGs on a LOOP/LOCA, as defined in the FSAR, would not be affected. The block was removed.
11	Latch Assembly	Demand	Maintenance	480 Vac	Internal to Component	1983	Failure to Close	Partial	Two 480 Vac circuit breakers failed to close due to worn latching mechanisms. The latch mechanisms were replaced.
12	Latch Assembly	Demand	Maintenance	Medium Voltage	Internal to Component	1991	Failure to Open	Partial	One 4160 Vac circuit breaker failed to open and several more were degraded due to hardened grease and lack of lubrication. This problem could affect the ability of the subject breakers to open or close. Maintenance of the breakers was incomplete despite similar failures due to the same cause four years earlier.
13	Latch Assembly	Demand	Maintenance	RPS trip breakers	Internal to Component	1992	Failure to Close	Partial	While attempting to reset the control rod drive system following a control rod drive breaker in the reactor protective system failed to reset. Later, during a control rod drive breaker trip test, another breaker failed to reset after a trip. The first failure was due to the breaker trip latch being out of adjustment. The cause of the second failure could not be precisely determined; however, troubleshooting revealed cracked insulation on the close coil.
14	Latch Assembly	Demand	Quality	RPS trip breakers	Design/Construction/Manufacture/Installation Inadequacy	1994	Failure to Close	Partial	During plant protection system functional testing, two reactor trip breaker tripped free when maintenance personnel attempted to close them. With the vendor present, the problem was traced to inadequate adjustment of the trip latch overlap. The adjustment was initially made per vendor specifications. However, the vendor had since increased the recommended number of adjustment turns of the trip latch screw from 4 to a maximum of 5 turns. A change was submitted to change the procedure accordingly.
15	Latch Assembly	Inspection	Maintenance	Medium Voltage	Design/Construction/Manufacture/Installation Inadequacy	1998	Failure to Close	Partial	A breaker tripped when the cubicle door was closed. Subsequent inspection revealed several incorrect latching mechanisms were installed on 4160 Vac breakers. The cause of the incorrect latching mechanisms being installed during original construction was personnel error. The incorrect latches were installed in eight of seventeen cubicle doors in the Division II switchgear. Contributing to this event was that information relative to the latching mechanisms was not provided to personnel working on the switchgear and that procurement controls were not adequate to ensure the correct parts were installed.

Item	Piece Part	Discovery Method	Coupling Factor	Breaker Type	Proximate Cause	Year	Failure Mode	Degree of Failure	Description
16	Latch Assembly	Inspection	Maintenance	Medium Voltage	Operational/ Human Error	1996	Failure to Close	Partial	A failure of a roll pin securing a spring for a latch pawl on a 4KV breaker was reviewed and a determination made that the failure of this pin could cause the breaker to fail. Further investigation revealed that the roll pin failed as a result of hydrogen embrittlement. Later, an issue involving permanently applied lubricant which was inadvertently removed from the breakers was identified. This also could potentially affect breaker operation. The cause of the cracked roll pin was the lack of knowledge of plating induced hydrogen embrittlement. Vendor personnel involved in the procedure development were not aware that zinc plating of hardened steel parts could produce hydrogen embrittlement and subsequent cracking. The cause of the lubricant being inadvertently removed from breaker parts is also due to the lack of knowledge by Vendor personnel.
17	Latch Assembly	Maintenance	Maintenance	480 Vac	Internal to Component	1986	Failure to Open	Partial	During preventive maintenance, two power supply circuit breakers to motor control centers would not automatically open when their associated load center was isolated. They subsequently failed to trip when the manual trip button or tripper bar was pushed. The circuit breaker latch mechanisms were dirty and sticky. The root cause was determined to be normal wear and an inadequate preventive maintenance procedure.
18	Latch Assembly	Test	Design	RPS trip breakers	Internal to Component	1983	Failure to Open	Complete	The static force to trip the circuit breakers exceeded allowable tolerance due to binding caused by the unused overcurrent trip pads. The breakers tested satisfactorily after removal of the overcurrent trip pads.
19	Latch Assembly	Test	Maintenance	RPS trip breakers	Internal to Component	1994	Failure to Close	Partial	During unit outage, while performing functional testing, operators found that two reactor trip breakers would not close from the handswitch in the main control room. Troubleshooting discovered the inertia latch (piece part of the circuit breaker) had stuck in mid travel. The breakers' electrical trip function was lost, but the control rod drive system was not affected because of an available redundant trip breaker. Plant operation was not affected. Insufficient lubrication of the inertia latch caused the latch to stick in mid travel. The inertia latches were cleaned and lubricated and post maintenance testing was performed satisfactorily.
20	Latch Assembly	Test	Maintenance	RPS trip breakers	Operational/ Human Error	1992	Failure to Close	Partial	While performing surveillance testing, two reactor trip breakers failed to close on separate occasions. In one case, the breaker latch catch and arm were found bent, preventing the breaker from closing. The cause of this failure was believed to be from incorrect installation of the breaker during previous maintenance or testing activities. In the second case, the breaker operating mechanism latch was binding against the housing likely due to inadequate lubrication and rough surfaces.
21	Limit Switch	Inspection	Design	Medium Voltage	Design/ Construction/ Manufacture/ Installation Inadequacy	1995	Failure to Open	Partial	Inspection of circuit breaker limit switches revealed cam follower cracking. No equipment malfunctions or plant transients occurred, because the single actual failure occurred during routine post modification testing. The root cause of this occurrence was inadequate initial design of General Electric type SBM switches by the manufacturer.
22	Limit Switch	Inspection	Design	Medium Voltage	Design/ Construction/ Manufacture/ Installation Inadequacy	1995	Failure to Open	Partial	All 4 kV vital busses were declared inoperable following inspection that revealed cracks in the circuit breaker cam followers. One actual failure occurred during post maintenance testing (maintenance was for another reason), but all cam follower limit switches at both units were replaced. The root cause of this occurrence was inadequate initial design of General Electric type SBM switches by the manufacturer.

Item	Piece Part	Discovery Method	Coupling Factor	Breaker Type	Proximate Cause	Year	Failure Mode	Degree of Failure	Description
23	Limit Switch	Maintenance	Design	Medium Voltage	Design/ Construction/ Manufacture/ Installation Inadequacy	1995	Failure to Close	Partial	Inspections revealed cracks in the lexan cam followers of control (limit) switches installed in 4160 Vac and 6900 Vac circuit breakers. The same part used in 360 places in unknown number of breakers. Inspection showed about one third were cracking and two were inoperable. The root cause of this occurrence was inadequate initial design of General Electric type SBM switches by the manufacturer.
24	Limit Switch	Test	Maintenance	Medium Voltage	Internal to Component	1989	Failure to Open	Partial	In two separate incidents while attempting to realign power to support testing, the alternate supply circuit breaker failed to trip upon closure of normal supply breaker. The cause of failure was attributed to the raised upper limit switch being out of mechanical adjustment causing a greater than 1/8 inch gap between the operating plunger and the breaker auxiliary switch. This limit switch provides the trip signal for the alternate breaker.
25	Main Contacts	Test	Maintenance	480 Vac	Operational/ Human Error	1992	Failure to Close	Partial	During testing on emergency bus feeder breakers, the closing spring charge/discharge indicator showed that the springs were charged with the breaker closed, indicating that the main contacts were closed but not exerting full pressure against the stationary contacts. Investigation showed the root cause to be failure to incorporate the latest vendor information on contact adjustment into the breaker maintenance procedure.
26	Mechanical Assembly	Demand	Design	480 Vac	Internal to Component	1984	Failure to Close	Partial	A phase to phase fault across the station auxiliary transformer buswork caused a loss of normal offsite power to the unit. Both operable emergency diesel generators started as required. During the temporary loss of normal offsite power, several breakers in the plant's electrical distribution system failed to operate. The plant operators restored station power through an alternate offsite source, and restarted all necessary equipment.
27	Mechanical Assembly	Demand	Design	Medium Voltage	Internal to Component	1981	Failure to Close	Partial	A decay heat removal pump failed to start due to the circuit breaker failing to close upon demand. The cause was determined to be an intermittent sticking of the motor cutoff switch operator due to the operator being slightly bent, which prevented it from sliding. Further inspections revealed that all 4.16 and 13.8 kv circuit breakers were susceptible to this problem. All applicable circuit breakers were subsequently modified.
28	Mechanical Assembly	Demand	Maintenance	480 Vac	Internal to Component	1992	Failure to Close	Partial	A normal supply breaker for a 600 Vac bus failed to close on demand when switching from the alternate to the normal power supply. The failure was due to binding of the closing mechanism in the breaker. A few days later the alternate feed breaker to another bus failed to closed during a hot transfer. The second failure was caused by a stuck contact finger in the bus transfer interlock logic. The cause of the failures was attributed to a lack of lubrication or hardening of the lubrication. The breakers were removed from service and the closing pivot points and other moving parts lubricated. After functional testing, the breakers were returned to service.
29	Mechanical Assembly	Demand	Maintenance	480 Vac	Internal to Component	1984	Failure to Open	Partial	During surveillance testing, one circuit breaker failed to trip when the undervoltage device was de-energized and two others failed to trip within the specified time limit. This occurrence may have affected the emergency diesel generator loading and its loading sequence as specified in Technical Specifications. The cause was dirt and lack of lubrication.

Item	Piece Part	Discovery Method	Coupling Factor	Breaker Type	Proximate Cause	Year	Failure Mode	Degree of Failure	Description
30	Mechanical Assembly	Demand	Maintenance	480 Vac	Internal to Component	1989	Failure to Close	Partial	When attempting to switch 600 Vac buses from normal to alternate feed, the alternate breakers failed to close when the normal breakers were tripped. One failure was due to trip rod binding in the alternate breaker due to a lack of proper lubrication of the trip rod bearings. Another failure was caused by a binding plunger in the breaker charging motor cutout switch due to dirt buildup. The dirty plunger caused the switch contacts to remain open preventing the motor from charging the closing spring and completing the closing sequence. The third failure was caused by a dirt buildup on the trip mechanism and pivot points, which resulted in binding of the internal moving parts.
31	Mechanical Assembly	Demand	Maintenance	480 Vac	Internal to Component	1988	Failure to Close	Partial	Two breakers failed to close during attempts to transfer bus power from alternate to normal feed, the normal feeder breaker would not close. One failure was caused by corrosion in the cell switch. The second failure was due to excessive dirt. Both were attributed to lack of preventative maintenance. Preventative maintenance had not been done during the last 2 years because the unit had been shutdown for an unusually long time and maintenance frequency was tied to the refueling outage.
32	Mechanical Assembly	Demand	Maintenance	Medium Voltage	Operational/ Human Error	1997	Failure to Open	Partial	Two circuit breakers failed to open on demand during separate evolutions. During subsequent reviews, station personnel determined that the condition of the three circuit breakers was similar to the condition of the two safety-related circuit breakers that previously failed to open on demand. The cause of the event was determined to be inadequate preventive maintenance. The preventive maintenance performed did not lubricate the main and auxiliary contacts in the circuit breakers as recommended by the circuit breaker manufacturer and also did not provide sufficient instructions to remove the roughness on the main and auxiliary contacts.
33	Mechanical Assembly	Demand	Maintenance	Medium Voltage	Operational/ Human Error	1994	Failure to Close	Partial	Four 4160 Vac circuit breakers failed to close. Each failure was due to a different mechanism; however, investigation revealed that all failures were related to workmanship and quality control practices by the vendor who overhauled the circuit breakers. To ensure the safety class circuit breakers are reliable, the utility and vendor developed a comprehensive plan to inspect critical components of the circuit breakers that were previously overhauled.
34	Mechanical Assembly	Inspection	Design	Medium Voltage	Design/ Construction/ Manufacture/ Installation Inadequacy	1988	Failure to Close	Partial	An operator racked up the emergency 4.16kv bus feeder breaker from an emergency diesel generator and found that there was no indication of breaker position on the control panel. It was discovered that the breaker elevator mechanism linkage was distorted and had allowed the cell switch actuator arm to fall into an intermediate position disabling the automatic and manual closure circuitry. Other breaker compartments contained distorted linkages and it was concluded that any of 4.16kv breakers could fail during a seismic event. The linkage distortion was caused by an interference with the breaker assembly as it is rolled out of the compartment.
35	Mechanical Assembly	Inspection	Maintenance	480 Vac	Internal to Component	1989	Failure to Close	Partial	Two 480 Vac feeder breakers tripped and would not close while a special inspection of breakers was being conducted. The breakers failed to close due to dirt built up and lack of lubrication.
36	Mechanical Assembly	Maintenance	Maintenance	480 Vac	Internal to Component	1985	Failure to Close	Partial	While conducting maintenance, the main feeder breaker for a 600 Vac emergency bus would not close. Investigation revealed the trip setpoint tolerance, contact gap and trip latch roller gap were out of adjustment preventing the breaker operation. This breaker was adjusted and returned to service. Another 600 Vac breaker was found to be "broken." No exact failure mechanism was given; however, the cause was given as "wear," and this breaker was replaced.

Item	Piece Part	Discovery Method	Coupling Factor	Breaker Type	Proximate Cause	Year	Failure Mode	Degree of Failure	Description
37	Mechanical Assembly	Maintenance	Maintenance	Medium Voltage	Operational/ Human Error	1988	Failure to Open	Partial	A circuit breaker failed to open due to trip linkage binding caused by misalignment and improper assembly. Subsequent inspection of other 4160 Vac circuit breakers revealed the same problem. The misalignment was the result of a procedural deficiency by the vendor that performed circuit breaker overhauls.
38	Mechanical Assembly	Maintenance	Quality	Medium Voltage	Internal to Component	1985	Failure to Close	Partial	During a scheduled maintenance outage of 4160v safety-related switchgear, the plant electrical staff discovered that two circuit breakers were rendered electrically inoperable due to the failure of a spot welded pivot pin. This spot welded pivot pin was on an internal piece of linkage, which actuates the auxiliary contacts that track breaker position. These contacts are also used in external breaker trip and close schemes as interlocks. The defective component is being modified to preclude additional failures.
39	Mechanical Assembly	Test	Design	Medium Voltage	Design/ Construction/ Manufacture/ Installation Inadequacy	1999	Failure to Close	Partial	Two 6.9kV breakers failed to close due to manufacturer repair defect. A cotter pin installed by the manufacturer was striking the latch check switch mounting bracket and bending it forward. This removed the factory set clearance between the bracket and the switch actuating paddle, resulting in the paddle rolling the trip shaft to the trip position when the breaker attempts to close.
40	Mechanical Assembly	Test	Design	Medium Voltage	Internal to Component	1987	Failure to Open	Partial	A circuit breaker failed to trip during a surveillance test. Upon investigation, it was determined that the connecting pin for the breaker trip crank located between the trip solenoid and the trip shaft became loose due to a pin weld failure, which prevented electrical tripping of the breaker. Inspection revealed several breakers with the same weld geometry. Two procedures, an inspection procedure and a trip crank replacement procedure were written for eighty six affected breakers on site. Nine breakers failed the acceptance criteria.
41	Mechanical Assembly	Test	Environmental	RPS trip breakers	External Environment	1984	Failure to Open	Partial	During routine surveillance testing of the reactor trip breakers, two breakers did not change state in the required time. The causes were determined to be dirty breaker mechanisms.
42	Mechanical Assembly	Test	Maintenance	480 Vac	Operational/ Human Error	1997	Failure to Close	Partial	Three breakers failed to close on demand during testing. Hardened grease was discovered in the stop roller and main drive link roller. When actuated by the closing coil, these rollers and the associated closing latch release the stored energy of the breaker springs, closing the breaker. Stiff rollers have resulted in multiple breaker failures in the past. The maintenance procedure provides instructions to clean and lubricate various friction points of the breaker mechanism; however, they are not specifically identified in the vendor manual. These rollers were not cleaned and lubricated during the performance of the scheduled preventative maintenance.
43	Mechanical Assembly	Test	Maintenance	480 Vac	Internal to Component	1986	Failure to Close	Partial	During routine inspections of the 480 volt unit boards, two feeder breakers were binding. The failures were attributed to dirty, hardened grease, normal aging and wear.
44	Mechanical Assembly	Test	Maintenance	480 Vac	Internal to Component	1991	Failure to Close	Partial	Two 480 Vac circuit breakers failed to close due to mechanical binding caused by dried out, hardened lubricant. The mechanical operating mechanisms were replaced.
45	Mechanical Assembly	Test	Maintenance	480 Vac	Internal to Component	1987	Failure to Open	Partial	During once per cycle testing of the startup transfer feeder to the unit bus breaker, two breaker trip units were found to be non-operational so that the breakers would not trip. Both failures were caused by lack of lubrication on the internal moving parts due to a lack of proper maintenance.
46	Mechanical Assembly	Test	Maintenance	480 Vac	Internal to Component	1986	Failure to Open	Partial	The power supply circuit breakers to two motor control centers would not trip during surveillance testing. The circuit breakers were dirty. This was due to a normal accumulation of dirt during operations. The circuit breakers were cleaned and verified to be operable.

Item	Piece Part	Discovery Method	Coupling Factor	Breaker Type	Proximate Cause	Year	Failure Mode	Degree of Failure	Description
47	Mechanical Assembly	Test	Maintenance	480 Vac	Internal to Component	1999	Failure to Open	Partial	During high tolerance instantaneous testing, several 480 Vac circuit breakers on all three phases did not trip in the required time (0-10 cycles). Failures were attributed to aging and degraded lubricants resulting from an ineffective maintenance program.
48	Mechanical Assembly	Test	Maintenance	480 Vac	Operational/ Human Error	1997	Failure to Open	Partial	A breaker failed to trip during testing. Subsequent testing and inspection revealed several breakers degraded due to lack of lubrication. Lubrication was removed during refurbishment by the vendor and was not re-installed.
49	Mechanical Assembly	Test	Maintenance	DC distribution	Internal to Component	1996	Failure to Open	Partial	The dc bus inter-tie breakers failed to open due to lack of lubrication. Corrective action was to create a preventative maintenance and inspection schedule for these breakers.
50	Mechanical Assembly	Test	Maintenance	Medium Voltage	Internal to Component	1995	Failure to Close	Partial	A 4KV supply circuit breaker closed during testing, but failed to instantly recharge. The cause of the failure was aging of the latch monitor pivot bearing lubrication. This problem had previously surfaced and the bearings were relubricated at that time. Since that action did not fix the problem, the decision was made to replace the pivot bearings for all affected circuit breakers..
51	Mechanical Assembly	Test	Maintenance	RPS trip breakers	Internal to Component	1984	Failure to Open	Partial	During surveillance testing, the trip time requirements for two reactor trip breakers were found to be out of specification high. Historically, the bearings for the breaker front frame assemblies have been found worn and lacking the necessary lubrication, which increases trip times. After replacing the front frame assemblies and lubrication the bearings, the breakers were retested satisfactorily and returned to service.
52	Mechanical Assembly	Test	Maintenance	RPS trip breakers	Internal to Component	1984	Failure to Open	Partial	During surveillance testing of the reactor trip circuit breakers, the under voltage trip response time was found out of specification. Troubleshooting found the breakers' front frame assemblies to be lacking the proper amount of lubricant on their bearings. This was a recurring problem with this breaker type. The front frame assemblies were replaced.
53	Mechanical Assembly	Test	Maintenance	RPS trip breakers	Internal to Component	1989	Failure to Close	Partial	During surveillance testing, two reactor trip switchgear breakers would not close. The first failure was due to a defective piece part in the cutout 'y' switch on the breaker due to cyclic fatigue. In the second failure, a broken clamp was found on the closing mechanism, which prevented the breaker from closing.
54	Mechanical Assembly	Test	Maintenance	RPS trip breakers	Internal to Component	1985	Failure to Open	Partial	During normal operation while performing surveillance testing, two reactor trip circuit breakers failed the under voltage response time test. The breaker's front frame assembly was the suspected cause of the increased time response of the one breaker's undervoltage device. The other failure was due to loose armature laminations in the undervoltage device. Both are known design problems with these circuit breakers.
55	Mechanical Assembly	Test	Maintenance	RPS trip breakers	Internal to Component	1985	Failure to Open	Partial	While performing testing of the unit's reactor trip circuit breakers, the undervoltage trip time was found to be out of the allowable tolerance for two breakers. Dirt accumulation in the front frame assembly and lack of lubrication were the suspected causes
56	Mechanical Assembly	Test	Quality	RPS trip breakers	Design/ Construction/ Manufacture/ Installation Inadequacy	1984	Failure to Close	Partial	During surveillance testing, two reactor trip breakers would not re-close. Troubleshooting found manufacturing defects in the front frame assemblies (loose mechanical collars). This problem has been identified on similar breakers. The front frame assemblies were replaced.
57	OC Relay	Demand	Maintenance	480 Vac	Operational/ Human Error	1998	Failure to Close	Partial	Circuit breakers were found to be susceptible to tripping on normal start due to improper setting of overcurrent trip. The problem was discovered when one breaker failed to close on demand. A previous modification package was determined to be inadequate in that it did not require trip setpoint adjustment.



Item	Piece Part	Discovery Method	Coupling Factor	Breaker Type	Proximate Cause	Year	Failure Mode	Degree of Failure	Description
58	OC Relay	Maintenance	Maintenance	480 Vac	Other	1994	Failure to Open	Partial	A preventive maintenance procedure was being performed on 480V molded case circuit breakers. These are magnetic only breakers with an adjustable instantaneous trip range of 50 to 150 amps. With the breakers adjusted to their lowest setting, the right phase for two breakers tripped at 71.7 amps and 69 amps. The maximum allowable trip point was 57.5 amps. The breakers had a date code that meant they were manufactured in August of 1978. Considering the breakers were approximately 16 years old, the drift in calibration is associated with the breakers' service life. Therefore, it was decided to replace the breakers. The circuit breakers would still trip on instantaneous within its adjustable range which would provide adequate overcurrent protection. The cause was attributed to the breakers' long service life. Like for like breakers were installed. All tests were performed satisfactorily.
59	OC Relay	Test	Design	DC distribution	Design/ Construction/ Manufacture/ Installation Inadequacy	1996	Failure to Open	Almost Complete	All 72 dc molded case circuit breakers were tested, all 44 breakers of one vendor type, installed in 4 different distribution panels failed to trip on overcurrent. Problem was the design of the trip lever in the magnetic trip circuit breakers. All breakers of this type and vendor were replaced.
60	OC Relay	Test	Maintenance	480 Vac	Internal to Component	1998	Failure to Open	Partial	The instantaneous trip testing of both breakers revealed excessive time prior to tripping. The required trip time is less than 0.15 seconds. Breakers were tripping on instantaneous testing between 0.194 and 0.753 seconds. Cause was determined to be inadequate preventative maintenance.
61	OC Relay	Test	Maintenance	480 Vac	Other	1985	Failure to Open	Partial	During routing surveillance testing, three circuit breakers would not trip on short time overcurrent trip test. The failures were caused by the breakers being out of calibration as a result of normal wear.
62	OC Relay	Test	Maintenance	DC distribution	Internal to Component	1989	Failure to Open	Partial	While performing preventative maintenance on the dc feeder circuit breakers, the overcurrent trip devices would not set correctly. The cause was attributed to a lack of maintenance.
63	OC Relay	Test	Maintenance	Medium Voltage	Internal to Component	1984	Failure to Open	Partial	Several 4160 Vac circuit breakers of the vendor and type failed to trip due to age induced hardening of grommets in the electromechanical overcurrent device. Corrective actions included replacement with new or newly rebuilt overcurrent devices and establishing an adequate preventative maintenance surveillance interval.
64	Relay	Demand	Quality	480 Vac	Design/ Construction/ Manufacture/ Installation Inadequacy	1987	Failure to Open	Complete	Four 600 Vac normal auxiliary power system circuit breakers failed to open from local manual trip switch. The failures were caused by a relay contact in breaker trip circuit that was normally open instead of normally closed, as shown on wiring diagram. The relays were rewired to correct the problem.
65	Relay	Demand	Quality	Medium Voltage	Design/ Construction/ Manufacture/ Installation Inadequacy	1990	Failure to Close	Partial	While attempting to transfer two 4160 Vac buses to their alternate power supply, the alternate feeder circuit breaker. Separately, another 4160 Vac circuit breaker failed to close on demand. Both failures were caused by an open coil winding on a telephone-type relay within the synchronizing check relay of the circuit breaker. The telephone relay failed due to being continuously energized, which was not its intended application. A design modification was performed as the long-term corrective action.
66	Relay	Inspection	Design	Medium Voltage	Operational/ Human Error	1998	Failure to Close	Partial	A circuit breaker contacted exposed relay terminals during rack-in, causing trips/lockout of two breakers and lockout of another. The event was attributed to human error and poor design (location of relays).

Item	Piece Part	Discovery Method	Coupling Factor	Breaker Type	Proximate Cause	Year	Failure Mode	Degree of Failure	Description
67	Relay	Maintenance	Maintenance	RPS trip breakers	Internal to Component	1986	Failure to Close	Partial	During preventative maintenance two reactor trip breakers failed to close. Both breaker failures were due to failure of the same relay. The cause was assumed to be wear and aging.
68	Relay	Test	Design	Medium Voltage	Design/Construction/Manufacture/Installation Inadequacy	1990	Failure to Open	Partial	During surveillance testing several circuit breaker lockout relays would not actuate. These failures would have prevented breaker trips on overcurrent. Mechanical binding prevented the relays from tripping. Bench testing revealed several contributing factors but could not identify the root cause. The failed relays' armature force checks yielded 5 to 6.5 pounds but newer relays required only 3.5 pounds. The vendor discourages re-lubrication to reduce friction. Also, a vendor bulletin states that when the relay reset handle is forced against the latch after resetting, tripping is delayed or prevented. The lockout relays were replaced with spares and tested satisfactorily.
69	Relay	Test	Design	Medium Voltage	Design/Construction/Manufacture/Installation Inadequacy	1984	Failure to Open	Partial	When performing a loss of bus test, two 4160 Vac bus-tie breakers failed to trip. Investigation concluded that the bus-tie breakers could not trip if the diesel generator output breaker was open. The failures to open were caused by a design error.
70	Relay	Test	Maintenance	480 Vac	Internal to Component	1988	Failure to Close	Partial	During surveillance testing on the plant ac distribution system, the normal feeder breaker from a transformer would not close when transferring from alternate to normal power. The failure was attributed to close relay contacts hanging up from a lack of breaker lubrication. A second similar failure was attributed to the breaker having dirty contacts.
71	Relay	Test	Maintenance	480 Vac	Internal to Component	1983	Failure to Close	Partial	Four 480 Vac circuit breakers failed to close during testing due to failure of the power sensors. The power sensors were replaced.
72	Relay	Test	Maintenance	480 Vac	Internal to Component	1988	Failure to Close	Partial	A circuit breaker failed to close on a safety injection demand due to oxidation on contacts for the alarm switches. Subsequent investigation revealed 11 other safety-related breakers with the same problem. The cause was determined to be inadequate periodic inspections and cleaning of the alarm switch contacts due to lack of specific guidance in the maintenance procedure. Corrective actions included revision of the maintenance procedure.
73	Relay	Test	Maintenance	Medium Voltage	Internal to Component	1989	Failure to Close	Partial	A time delay relay for a 4160 volt feeder breaker would not time out within its specified tolerance during calibration, and a time delay relay for a second breaker would not actuate. The causes of both failures were determined to be due to aging.
74	Relay	Test	Maintenance	RPS trip breakers	Internal to Component	1986	Failure to Open	Partial	Two reactor trip breakers failed to trip during performance of surveillance testing. One failure was due to the auxiliary contact for the shunt trip was not making contact due to misalignment with the block. The other failure was due to a faulty undervoltage relay. The jumper to change the control voltage was installed in the 48 volt holes and should have been installed in the 125 volt holes causing the relay to overheat and melt.
75	Relay	Test	Maintenance	RPS trip breakers	Internal to Component	1984	Failure to Close	Partial	Two reactor trip breakers failed to close over a one-month period. Both failures were attributed to relay release arms being out of adjustment.
76	Shunt Trip	Test	Maintenance	RPS trip breakers	Operational/ Human Error	1984	Failure to Open	Partial	One set of leads in each of the four plant protective system bays were found to be disconnected. These disconnected leads removed the automatic shunt trip feature from RTB's #1, #2, #3, and #4. The subject leads had been disconnected and not restored during 18-month surveillance testing conducted earlier.

Item	Piece Part	Discovery Method	Coupling Factor	Breaker Type	Proximate Cause	Year	Failure Mode	Degree of Failure	Description
77	Spring	Test	Design	RPS trip breakers	Operational/ Human Error	1994	Failure to Close	Partial	While performing initial approach to criticality testing, operators noted that the B-phase for a reactor trip breaker, was not indicating current flow after the breaker was closed. The train's function of providing power to the control rod drive mechanism was degraded as one phase of power was unavailable. The failure was caused by a mechanical operating spring that had come loose. With the spring loose, the B-phase contacts were getting insufficient pressure to close. The vendor has provided notice that the spring could come loose and the vendor has provided additional instructions for breaker inspection and maintenance to address this problem. The spring was reinstalled according to the vendors instructions. The breaker was subsequently tested and returned to service.
78	Spring	Test	Design	RPS trip breakers	Design/ Construction/ Manufacture/ Installation Inadequacy	1988	Failure to Close	Partial	Two reactor trip breakers failed to close during surveillance testing. The breakers' closing springs had become detached from the pivot/actuation points. The reason for the springs' detaching could not be determined; however, this has been a recurring problem with this breaker design.
79	Spring	Test	Design	RPS trip breakers	Internal to Component	1986	Failure to Close	Partial	During performance testing of the reactor trip circuit breakers, two breakers failed to re-close after open them from the control room panel controls. Troubleshooting found that the breakers' operating springs fell off, preventing closure but not opening, a recurring problem with this particular breaker design.
80	Spring	Test	Quality	RPS trip breakers	Internal to Component	1989	Failure to Close	Partial	While performing surveillance testing on reactor trip circuit breakers, two breakers failed to close. In one failure, the left side close spring on the breaker had fallen off and the breaker wouldn't close with only one spring. The second breaker failure was due to a bad control power fuse that failed due to aging.
81	Spring Charging Motor	Demand	Maintenance	480 Vac	Internal to Component	1985	Failure to Close	Partial	Four 480 Vac feeder breakers failed to close on demand. One breaker failed to close due to lose bolts holding the charging gearbox assembly. When demanded, the fuses for another breaker blew and the breaker failed to close. The cause of this failure was determined to be dirty contacts. Another breaker failed due to failure of the auxiliary relay. The fourth breaker failed to close due to dirty and dried lubricant on the trip latch adjustment parts.
82	Spring Charging Motor	Inspection	Maintenance	Medium Voltage	Internal to Component	1992	Failure to Close	Partial	Two breaker's closing springs failed to charge-up when equipment operator was making ready the in-feed breaker from separate station power transformers. The suspected failure cause for one breaker was dirty contacts in the charging mechanism. The suspected failure cause for the other breaker was binding in the charging spring mechanism.
83	Spring Charging Motor	Test	Maintenance	Medium Voltage	Internal to Component	1987	Failure to Close	Partial	The closing springs for two 4160 Vac breakers would not charge. The cause of the failures were dirty contacts, a dirty closing mechanism, and lack of lubrication.
84	Spring Charging Motor	Test	Maintenance	Medium Voltage	Internal to Component	1986	Failure to Close	Partial	While performing testing of 4160 Vac boards and buses, three circuit breakers would not close. The failures were attributed to the breakers being dirty, needing lubrication, and due to loose connections.
85	Spring Charging Motor	Test	Maintenance	Medium Voltage	Internal to Component	1987	Failure to Close	Partial	Two 4160 Vac circuit breakers failed to close. One failure was caused by the latching pawl spring being out of adjustment, which prevented the springs from charging. The cause of the second failure was attributed to the racking mechanism slide interlock being out of adjustment.

Item	Piece Part	Discovery Method	Coupling Factor	Breaker Type	Proximate Cause	Year	Failure Mode	Degree of Failure	Description
86	Spring Charging Motor	Test	Quality	Medium Voltage	Design/ Construction/ Manufacture/ Installation Inadequacy	1986	Failure to Close	Partial	The circuit breaker for the residual heat removal pump failed to recharge during testing, rendering the breaker incapable of automatic closure. In addition to performing required surveillance tests, an investigation revealed that the breaker charging spring motor bolts had fallen out, allowing the motor to rotate, and breaking the power leads. A root cause analysis led to the conclusion that a combination of inadequate thread engagement of the mounting bolts in the motor housing and equipment vibration caused the bolts to loosen. Because this event had the potential for a common mode failure, all safety related breakers were inspected during a scheduled maintenance outage. Three additional breakers were found to have loose bolts.
87	Stabs/Connectors	Demand	Design	480 Vac	Design/ Construction/ Manufacture/ Installation Inadequacy	1980	Failure to Close	Partial	While returning a service water booster pump to service, a minor fire occurred in a 480 Vac ESF MCC. This rendered several components inoperable. Repeated cycling of the pump onto the bus coupled with inadequate stab to bus bar contact and dust in the MCC cabinet caused a fire. Operators were reminded of undesirability of repeated cycling of load breaker. An engineering study to determine if the breakers are adequately sized was also made (the results of the study were not included in the failure report).
88	Unknown	Demand	Quality	RPS trip breakers	Internal to Component	1993	Failure to Close	Partial	During an attempt to close the control rod drive circuit breakers two breakers failed to close. The failures could not be repeated. Although the mechanical interlock, a piece part of this circuit breaker, was found slightly dirty and in need of lubrication, it is not believed to have caused the failures to close. As a preventive measure, the mechanical interlock was cleaned and lubricated. The breakers were successfully closed on all subsequent tests.
89	Unknown	Test	Maintenance	RPS trip breakers	Internal to Component	1992	Failure to Close	Partial	Two reactor trip breakers failed to close following a trip test. The cause could not be determined and the failure was not repeatable. The breakers that failed were replaced with spares.
90	UV Trip Assembly	Demand	Maintenance	Medium Voltage	Internal to Component	1988	Failure to Open	Partial	Two 4160 Vac failed to open due to failure of the breaker trip coils. The cause were determined to be normal wear and aging.
91	UV Trip Assembly	Demand	Quality	RPS trip breakers	Internal to Component	1983	Failure to Open	Complete	During a routine startup, both reactor trip breakers failed to open automatically on receipt of a valid low-low steam generator level reactor trip signal. The reactor was shutdown 25 seconds later using the manual trip on the control console. Subsequent investigation revealed that the breaker failures were caused by mechanical binding of the latch mechanism in the undervoltage trip attachment. All breaker undervoltage attachments were replaced with new devices and extensive maintenance and testing was performed on the breakers.
92	UV Trip Assembly	Inspection	Maintenance	RPS trip breakers	Internal to Component	1987	Failure to Close	Partial	Two reactor trip breakers failed to close following testing. Troubleshooting found one breaker's under voltage coil had failed (open circuit) and the other breaker's undervoltage device pivot to armature clearance was out of adjustment. Operational/ambient conditions were cited as causes for the failures.
93	UV Trip Assembly	Maintenance	Maintenance	RPS trip breakers	Other	1986	Failure to Open	Partial	During preventive maintenance on the reactor trip breakers, the undervoltage trip units on two breakers were found to be out of specification. One undervoltage device could not be adjusted within specification and was replaced. The cause for both failures was determined to be vibration and aging.

Item	Piece Part	Discovery Method	Coupling Factor	Breaker Type	Proximate Cause	Year	Failure Mode	Degree of Failure	Description
94	UV Trip Assembly	Maintenance	Maintenance	RPS trip breakers	Design/Construction/Manufacture/Installation Inadequacy	1984	Failure to Close	Partial	After installation of new undervoltage trip relays, the reactor trip breakers would not stay closed. The original trip bar design gap was satisfactory with old style undervoltage relays, but not with new style relays.
95	UV Trip Assembly	Maintenance	Quality	RPS trip breakers	Design/Construction/Manufacture/Installation Inadequacy	1983	Failure to Open	Partial	A potential safety hazard was identified concerning certain critical dimensions of the undervoltage trip device on a particular model reactor trip circuit breaker. An out-of-tolerance measurement was found between the moving core and rolling bracket in addition to a missing lock ring on the shaft pin of the undervoltage trip device. The potential existed for either intermittent operation or total failure of the device. The cause was attributed to manufacturing variations of the undervoltage trip devices. All undervoltage trip devices on all reactor trip breakers were replaced.
96	UV Trip Assembly	Test	Design	RPS trip breakers	Internal to Component	1983	Failure to Open	Partial	During reactor trip breaker surveillance testing, the undervoltage trip devices for two circuit breakers exhibited scattered and unacceptable response times. The reactor trip breakers were replaced with spares.
97	UV Trip Assembly	Test	Environmental	RPS trip breakers	Internal to Component	1983	Failure to Open	Partial	During routine surveillance testing, a the control rod drive AC breaker experienced a delayed trip. Subsequent testing of all AC and dc control rod drive breakers resulted in a control rod drive dc breaker also experiencing a delayed trip. If a reactor trip had occurred, and if both malfunctioned breakers had delayed in tripping, two control rod groups would not have dropped immediately.
98	UV Trip Assembly	Test	Maintenance	Medium Voltage	Other	1986	Failure to Open	Partial	During routine testing it was found that the under voltage relays for two 4160 Vac feeder breakers from an auxiliary transformer to the buses were out of calibration. The failures were attributed to relay wear.
99	UV Trip Assembly	Test	Maintenance	Medium Voltage	Other	1994	Failure to Open	Partial	Undervoltage dropout relays in two separate, similar breakers drifted out of specification between times they were checked by scheduled maintenance. A root cause investigation attributed the relay setpoint shift to a combination of: 1) relay setpoint repeatability, 2) temperature sensitivity of the relays, and 3) testing techniques. Applicable test equipment and procedures have been changed to address the causes of the setpoint shift. Additionally, the testing frequency has been increased from quarterly to monthly pending relay performance trending results.
100	UV Trip Assembly	Test	Maintenance	RPS trip breakers	Other	1983	Failure to Open	Partial	During surveillance testing of the reactor trip circuit breakers' undervoltage devices, the response time of two breakers than allowed by Technical Specifications. The cause of the event was setpoint drift and worn/binding front frame assembly mechanisms. The setpoints were adjusted and the trip shaft and latch roller bearings were lubricated.
101	UV Trip Assembly	Test	Maintenance	RPS trip breakers	Other	1983	Failure to Open	Partial	During monthly surveillance test of the reactor trip circuit breaker undervoltage trip devices, the response time of two breakers was slower than allowed by Technical Specifications. This event was caused by setpoint drift and worn/binding front frame assembly mechanisms. Corrective actions included replacement of front frame assemblies and undervoltage trip devices.
102	UV Trip Assembly	Test	Maintenance	RPS trip breakers	Other	1983	Failure to Open	Partial	The trip response time of two reactor trip breakers was slower than allowed by Technical Specifications. The breakers were retested satisfactorily and returned to service after adjusting the UV trip device setpoints and lubricating the trip shaft and latch roller bearings. The breakers were still considered operable since the shunt trip devices were operational with satisfactory response times.

Item	Piece Part	Discovery Method	Coupling Factor	Breaker Type	Proximate Cause	Year	Failure Mode	Degree of Failure	Description
103	UV Trip Assembly	Test	Maintenance	RPS trip breakers	Internal to Component	1983	Failure to Open	Partial	During surveillance testing, three reactor trip breakers failed to trip on undervoltage. The primary cause was inadequate lubrication, possibly due to an excessive preventive maintenance interval, combined with a small design margin in the tripping force provided from the undervoltage coil. Corrective action was to perform the required preventive maintenance prior to entering Mode 2. Additionally, as required by IE Bulletin 79-09 and vendor recommendations, the surveillance testing interval of the undervoltage trip feature was increased and the interval between preventive maintenance was decreased to prevent recurrence of this event.
104	UV Trip Assembly	Test	Maintenance	RPS trip breakers	Internal to Component	1982	Failure to Open	Partial	During surveillance testing, four of nine reactor trip circuit breakers failed to trip on undervoltage. The primary cause was inadequate lubrication, possibly due to an excessive preventive maintenance interval, combined with a small design margin in the tripping force provided from the undervoltage coil. Corrective actions were to perform required preventive maintenance prior to the unit entering mode 2 and implementation of the recommendations of IE Bulletin 79-09 and vendor recommendations, increased surveillance testing of the undervoltage trip feature and a decrease in the interval between preventive maintenance.
105	UV Trip Assembly	Test	Maintenance	RPS trip breakers	Internal to Component	1990	Failure to Open	Partial	Two reactor trip breakers were found to have defective undervoltage trip relays which prevented opening. One failure was detected during testing and the other was detected during maintenance. The relay failures were determined to be due to aging.
106	UV Trip Assembly	Test	Maintenance	RPS trip breakers	Internal to Component	1986	Failure to Close	Partial	While conducting monthly surveillance testing of the unit's reactor protection system, two reactor trip circuit breakers failed to close after testing. Troubleshooting found a failure of one breaker's under voltage device. The second circuit breaker's pick-up coil voltage was high due to a change in characteristics of the voltage adjustment potentiometer. Both failures were attributed to operational stress and/or equipment aging.
107	UV Trip Assembly	Test	Maintenance	RPS trip breakers	Internal to Component	1986	Failure to Close	Partial	While conducting surveillance testing of the unit's reactor protection system, two reactor trip circuit breakers' UV devices would not pick up after tripping the breakers. Troubleshooting found that the UV devices' gap clearances were incorrect. No direct cause for the misadjustments was found, however, operational stress and/or equipment aging were suspected.
108	UV Trip Assembly	Test	Maintenance	RPS trip breakers	Internal to Component	1987	Failure to Close	Partial	Two reactor trip breakers failed to close following testing. Troubleshooting found one breaker's under voltage coil had failed (open circuit) and the other breaker's undervoltage device pivot to armature clearance was out of adjustment. Operational/ambient conditions (heat/vibration) were cited as causes for the failures.
109	UV Trip Assembly	Test	Maintenance	RPS trip breakers	Internal to Component	1990	Failure to Close	Partial	In separate tests, two reactor trip breakers failed to close after trip testing. The failure to reset was determined to be due to worn undervoltage trip coil mechanisms to prevented the breakers from latching.
110	UV Trip Assembly	Test	Maintenance	RPS trip breakers	Internal to Component	1980	Failure to Open	Partial	It was discovered during testing that some reactor trip breakers would not trip on undervoltage as expected. One device would not trip and two others tripped sluggishly. The cause was determined to be misaligned armatures in the undervoltage devices. A new preventative maintenance program was initiated to check the undervoltage coils independently on a monthly basis.

Item	Piece Part	Discovery Method	Coupling Factor	Breaker Type	Proximate Cause	Year	Failure Mode	Degree of Failure	Description
111	UV Trip Assembly	Test	Maintenance	RPS trip breakers	Operational/ Human Error	1983	Failure to Open	Partial	During the performance of reactor trip circuit breaker undervoltage device surveillance testing, three breakers failed to open within the acceptance time criteria. The following day, and then 8 days later, two additional breakers failed to meet the acceptance criteria. The reactor trip breakers failed even though extensive maintenance and testing was performed on all eight of the trip system breakers 11 days prior to the first 3 failures. Maintenance included procedures specified in the vendor service advisory letter. The deficiencies were corrected by again performing the vendor approved refurbishment procedures on the slow breakers, followed by successful testing.
112	UV Trip Assembly	Test	Maintenance	RPS trip breakers	Internal to Component	1984	Failure to Close	Partial	During surveillance testing, two reactor trip breakers failed to close during surveillance response time test. The stated cause was normal wear.
113	UV Trip Assembly	Test	Quality	RPS trip breakers	Internal to Component	1983	Failure to Open	Almost Complete	Both reactor trip breakers and a bypass breaker failed to open on an undervoltage trip signal during response time testing. The failures were due to mechanical problems of the undervoltage mechanisms, which resulted from manufacturing deficiencies. Fifteen days later, one of the replacement reactor trip breakers also failed due to the same cause.
114	UV Trip Assembly	Test	Quality	RPS trip breakers	Internal to Component	1983	Failure to Open	Partial	The undervoltage armatures for two different reactor trip breakers were found during testing to not be fully picked up (repetitive failures in the same month). Based on vendor tests, the abnormal armature position has little or no detectable effect on the ability of the undervoltage trip device to trip the breaker on loss of voltage. The undervoltage armatures not being fully picked up is the result of interference between the undervoltage armature and the copper shading ring around the coil core. As corrective action, visual verification and manual adjustment of proper closed air gap position is required following energization of the undervoltage device.
115	UV Trip Assembly	Test	Quality	RPS trip breakers	Design/ Construction/ Manufacture/ Installation Inadequacy	1990	Failure to Close	Partial	Two reactor trip breakers failed to close. The first failed to close during testing, the second failed to close while troubleshooting the first failure. The cause of both breaker failures was failure of the under voltage trip coil, which was thought to be due to a manufacturing defect.
116	UV Trip Assembly	Test	Quality	RPS trip breakers	Design/ Construction/ Manufacture/ Installation Inadequacy	1983	Failure to Close	Partial	During surveillance testing, two reactor trip breakers would not close when a close signal was applied to the breaker's control circuit. Troubleshooting found defective undervoltage devices that would not allow the closure of the breakers. The undervoltage devices were replaced.
117	UV Trip Assembly	Test	Quality	RPS trip breakers	Internal to Component	1983	Failure to Open	Partial	The undervoltage armatures for two different reactor trip breakers were found during testing to not be fully picked up (repetitive failures in the same month). Based on vendor tests, the abnormal armature position has little or no detectable effect on the ability of the undervoltage trip device to trip the breaker on loss of voltage. The undervoltage armatures not being fully picked up is the result of interference between the undervoltage armature and the copper shading ring around the coil core. As corrective action, visual verification and manual adjustment of proper closed air gap position is required following energization of the undervoltage device.
118	Wires/Connectors/Board	Inspection	Maintenance	RPS trip breakers	Operational/ Human Error	1983	Failure to Open	Complete	Following performance of the manual reactor trip functional test, it was noted that the procedure called for jumpering out the UV trip coils with the reactor trip breakers closed and the rods capable of withdrawal. This was a procedural error that caused the removal of both trains of automatic reactor trip logic. The procedure was revised to prevent recurrence of the event.

Item	Piece Part	Discovery Method	Coupling Factor	Breaker Type	Proximate Cause	Year	Failure Mode	Degree of Failure	Description
119	Wires/Connectors/Board	Test	Maintenance	480 Vac	Operational/ Human Error	1993	Failure to Open	Partial	An Emergency Diesel Generator (EDG) failed to pass surveillance testing because certain loads were not shunt tripped from the safeguard bus when a simulated Loss of Coolant Accident (LOCA) signal was initiated. During troubleshooting, a loose wire was discovered in one circuit breaker and a lifted wire was discovered in another circuit breaker. The wires were restored to their normal positions and a portion of the test procedure was performed to verify appropriate loads were shunt tripped following a simulated LOCA signal. The loose/disconnected wires were believed to have come loose at a plug connection during repairs made to enhance electrical separation between electrical divisions. Procedures were revised to alert workers of the potential for wires becoming loose during removal and restoration of plug connections on similar circuit breakers.



**Appendix B**  
**Breaker Type Data Summary**

## **Appendix B**

### **Breaker Type Data Summary**

This appendix is a summary of the data evaluated in the common-cause failure (CCF) data collection effort for breakers. The data is sorted by breaker type, and supports the charts in Section 4 of the report. Each table is sorted alphabetically, by the first four columns.

Appendix B

Table B-1. Breaker CCF event summary. .... 3

Table B-1. Breaker CCF event summary.

Item	Breaker Type	Proximate Cause	Discovery Method	Piece Part	Coupling Factor	Year	Failure Mode	Degree of Failure	Description
1	480 Vac	Design/ Construction/ Manufacture/ Installation Inadequacy	Demand	Relay	Quality	1987	Failure to Open	Complete	Four 600 Vac normal auxiliary power system circuit breakers failed to open from local manual trip switch. The failures were caused by a relay contact in breaker trip circuit that was normally open instead of normally closed, as shown on wiring diagram. The relays were rewired to correct the problem.
2	480 Vac	Design/ Construction/ Manufacture/ Installation Inadequacy	Demand	Stabs/Connectors	Design	1980	Failure to Close	Partial	While returning a service water booster pump to service, a minor fire occurred in a 480 Vac ESF MCC. This rendered several components inoperable. Repeated cycling of the pump onto the bus coupled with inadequate stab to bus bar contact and dust in the MCC cabinet caused a fire. Operators were reminded of undesirability of repeated cycling of load breaker. An engineering study to determine if the breakers are adequately sized was also made (the results of the study were not included in the failure report).
3	480 Vac	Internal to Component	Demand	Aux. Contactor	Maintenance	1986	Failure to Close	Partial	When attempting to close a normal supply breaker to a 480 Vac bus, the close circuit fuses blew. The failure caused by dirty auxiliary contacts. In another case, routine observation found that the alternate supply circuit breaker to the same bus had failed due to a burned out closing relay.
4	480 Vac	Internal to Component	Demand	Closing Coil	Maintenance	1984	Failure to Close	Partial	Over a period of 5 months, there were 6 incidents of circuit breakers of the same vendor and type failing to close on demand. Intermittent failures of the closing coil cutoff x-relays to properly return to their de-energized position prevented the relays from energizing the breakers' closing coils upon receipt of a close signal. It was determined that dirt and dust accumulation on the moveable parts of the relay causes the faulty operation. The symptoms of the x-relay malfunction were found to be failure of the breaker to close upon receiving a close signal, and in most cases, the breaker closes upon receiving a second close signal. This failure mode can cause equipment and/or systems to be inoperable without detection until that equipment is called upon to operate, either by test or when actually required. The x-relays on all safety-related breakers of this type were inspected and cleaned. The vendor did not provide for maintenance of the x-relays in their maintenance procedures.
5	480 Vac	Internal to Component	Demand	Latch Assembly	Maintenance	1983	Failure to Close	Partial	Two 480 Vac circuit breakers failed to close due to worn latching mechanisms. The latch mechanisms were replaced.
6	480 Vac	Internal to Component	Demand	Mechanical Assembly	Maintenance	1992	Failure to Close	Partial	A normal supply breaker for a 600 Vac bus failed to close on demand when switching from the from the alternate to the normal power supply. The failure was due to binding of the closing mechanism in the breaker. A few days later the alternate feed breaker to another bus failed to closed during a hot transfer. The second failure was caused by a stuck contact finger in the bus transfer interlock logic. The cause of the failures was attributed to a lack of lubrication or hardening of the lubrication. The breakers were removed from service and the closing pivot points and other moving parts lubricated. After functional testing, the breakers were returned to service.
7	480 Vac	Internal to Component	Demand	Mechanical Assembly	Maintenance	1984	Failure to Open	Partial	During surveillance testing, one circuit breaker failed to trip when the undervoltage device was de-energized and two others failed to trip within the specified time limit. This occurrence may have affected the emergency diesel generator loading and its loading sequence as specified in Technical Specifications. The cause was dirt and lack of lubrication.

Item	Breaker Type	Proximate Cause	Discovery Method	Piece Part	Coupling Factor	Year	Failure Mode	Degree of Failure	Description
8	480 Vac	Internal to Component	Demand	Mechanical Assembly	Maintenance	1988	Failure to Close	Partial	Two breakers failed to close during attempts to transfer bus power from alternate to normal feed, the normal feeder breaker would not close. One failure was caused by corrosion in the cell switch. The second failure was due to excessive dirt. Both were attributed to lack of preventative maintenance. Preventative maintenance had not been done during the last 2 years because the unit had been shutdown for an unusually long time and maintenance frequency was tied to the refueling outage.
9	480 Vac	Internal to Component	Demand	Mechanical Assembly	Maintenance	1989	Failure to Close	Partial	When attempting to switch 600 Vac buses from normal to alternate feed, the alternate breakers failed to close when the normal breakers were tripped. One failure was due to trip rod binding in the alternate breaker due to a lack of proper lubrication of the trip rod bearings. Another failure was caused by a binding plunger in the breaker charging motor cutout switch due to dirt buildup. The dirty plunger caused the switch contacts to remain open preventing the motor from charging the closing spring and completing the closing sequence. The third failure was caused by a dirt buildup on the trip mechanism and pivot points, which resulted in binding of the internal moving parts.
10	480 Vac	Internal to Component	Demand	Mechanical Assembly	Design	1984	Failure to Close	Partial	A phase to phase fault across the station auxiliary transformer buswork caused a loss of normal offsite power to the unit. Both operable emergency diesel generators started as required. During the temporary loss of normal offsite power, several breakers in the plant's electrical distribution system failed to operate. The plant operators restored station power through an alternate offsite source, and restarted all necessary equipment.
11	480 Vac	Internal to Component	Demand	Spring Charging Motor	Maintenance	1985	Failure to Close	Partial	Four 480 Vac feeder breakers failed to close on demand. One breaker failed to close due to loose bolts holding the charging gearbox assembly. When demanded, the fuses for another breaker blew and the breaker failed to close. The cause of this failure was determined to be dirty contacts. Another breaker failed due to failure of the auxiliary relay. The fourth breaker failed to close due to dirty and dried lubricant on the trip latch adjustment parts.
12	480 Vac	Internal to Component	Inspection	Mechanical Assembly	Maintenance	1989	Failure to Close	Partial	Two 480 Vac feeder breakers tripped and would not close while a special inspection of breakers was being conducted. The breakers failed to close due to dirt built up and lack of lubrication.
13	480 Vac	Internal to Component	Maintenance	Latch Assembly	Maintenance	1986	Failure to Open	Partial	During preventive maintenance, two power supply circuit breakers to motor control centers would not automatically open when their associated load center was isolated. They subsequently failed to trip when the manual trip button or tripper bar was pushed. The circuit breaker latch mechanisms were dirty and sticky. The root cause was determined to be normal wear and an inadequate preventive maintenance procedure.
14	480 Vac	Internal to Component	Maintenance	Mechanical Assembly	Maintenance	1985	Failure to Close	Partial	While conducting maintenance, the main feeder breaker for a 600 Vac emergency bus would not close. Investigation revealed the trip setpoint tolerance, contact gap and trip latch roller gap were out of adjustment preventing the breaker operation. This breaker was adjusted and returned to service. Another 600 Vac breaker was found to be "broken." No exact failure mechanism was given; however, the cause was given as "wear," and this breaker was replaced.
15	480 Vac	Internal to Component	Test	Closing Coil	Design	1988	Failure to Close	Partial	During a station loss of offsite power (loop) test, two class 1E 480 volt load center breakers failed to close during automatic load sequencing. Subsequent investigation revealed that the breaker spring release device in both breakers was binding against the opening in the breaker base plate which resulted in failure of the closing coil and failure of the breaker to close. Other defective breakers were also identified following inspections.

Item	Breaker Type	Proximate Cause	Discovery Method	Piece Part	Coupling Factor	Year	Failure Mode	Degree of Failure	Description
16	480 Vac	Internal to Component	Test	Mechanical Assembly	Maintenance	1987	Failure to Open	Partial	During once per cycle testing of the startup transfer feeder to the unit bus breaker, two breaker trip units were found to be non-operational so that the breakers would not trip. Both failures were caused by lack of lubrication on the internal moving parts due to a lack of proper maintenance.
17	480 Vac	Internal to Component	Test	Mechanical Assembly	Maintenance	1999	Failure to Open	Partial	During high tolerance instantaneous testing, several 480 Vac circuit breakers on all three phases did not trip in the required time (0-10 cycles). Failures were attributed to aging and degraded lubricants resulting from an ineffective maintenance program.
18	480 Vac	Internal to Component	Test	Mechanical Assembly	Maintenance	1991	Failure to Close	Partial	Two 480 Vac circuit breakers failed to close due to mechanical binding caused by dried out, hardened lubricant. The mechanical operating mechanisms were replaced.
19	480 Vac	Internal to Component	Test	Mechanical Assembly	Maintenance	1986	Failure to Open	Partial	The power supply circuit breakers to two motor control centers would not trip during surveillance testing. The circuit breakers were dirty. This was due to a normal accumulation of dirt during operations. The circuit breakers were cleaned and verified to be operable.
20	480 Vac	Internal to Component	Test	Mechanical Assembly	Maintenance	1986	Failure to Close	Partial	During routine inspections of the 480 volt unit boards, two feeder breakers were binding. The failures were attributed to dirty, hardened grease, normal aging and wear.
21	480 Vac	Internal to Component	Test	OC Relay	Maintenance	1998	Failure to Open	Partial	The instantaneous trip testing of both breakers revealed excessive time prior to tripping. The required trip time is less than 0.15 seconds. Breakers were tripping on instantaneous testing between 0.194 and 0.753 seconds. Cause was determined to be inadequate preventative maintenance.
22	480 Vac	Internal to Component	Test	Relay	Maintenance	1983	Failure to Close	Partial	Four 480 Vac circuit breakers failed to close during testing due to failure of the power sensors. The power sensors were replaced.
23	480 Vac	Internal to Component	Test	Relay	Maintenance	1988	Failure to Close	Partial	A circuit breaker failed to close on a safety injection demand due to oxidation on contacts for the alarm switches. Subsequent investigation revealed 11 other safety-related breakers with the same problem. The cause was determined to be inadequate periodic inspections and cleaning of the alarm switch contacts due to lack of specific guidance in the maintenance procedure. Corrective actions included revision of the maintenance procedure.
24	480 Vac	Internal to Component	Test	Relay	Maintenance	1988	Failure to Close	Partial	During surveillance testing on the plant ac distribution system, the normal feeder breaker from a transformer would not close when transferring from alternate to normal power. The failure was attributed to close relay contacts hanging up from a lack of breaker lubrication. A second similar failure was attributed to the breaker having dirty contacts.
25	480 Vac	Operational/ Human Error	Demand	OC Relay	Maintenance	1998	Failure to Close	Partial	Circuit breakers were found to be susceptible to tripping on normal start due to improper setting of overcurrent trip. The problem was discovered when one breaker failed to close on demand. A previous modification package was determined to be inadequate in that it did not require trip setpoint adjustment.
26	480 Vac	Operational/ Human Error	Test	Main Contacts	Maintenance	1992	Failure to Close	Partial	During testing on emergency bus feeder breakers, the closing spring charge/discharge indicator showed that the springs were charged with the breaker closed, indicating that the main contacts were closed but not exerting full pressure against the stationary contacts. Investigation showed the root cause to be failure to incorporate the latest vendor information on contact adjustment into the breaker maintenance procedure.
27	480 Vac	Operational/ Human Error	Test	Mechanical Assembly	Maintenance	1997	Failure to Open	Partial	A breaker failed to trip during testing. Subsequent testing and inspection revealed several breakers degraded due to lack of lubrication. Lubrication was removed during refurbishment by the vendor and was not re-installed.

Item	Breaker Type	Proximate Cause	Discovery Method	Piece Part	Coupling Factor	Year	Failure Mode	Degree of Failure	Description
28	480 Vac	Operational/ Human Error	Test	Mechanical Assembly	Maintenance	1997	Failure to Close	Partial	Three breakers failed to close on demand during testing. Hardened grease was discovered in the stop roller and main drive link roller. When actuated by the closing coil, these rollers and the associated closing latch release the stored energy of the breaker springs, closing the breaker. Stiff rollers have resulted in multiple breaker failures in the past. The maintenance procedure provides instructions to clean and lubricate various friction points of the breaker mechanism; however, they are not specifically identified in the vendor manual. These rollers were not cleaned and lubricated during the performance of the scheduled preventative maintenance.
29	480 Vac	Operational/ Human Error	Test	Wires/Connectors/Board	Maintenance	1993	Failure to Open	Partial	An Emergency Diesel Generator (EDG) failed to pass surveillance testing because certain loads were not shunt tripped from the safeguard bus when a simulated Loss of Coolant Accident (LOCA) signal was initiated. During troubleshooting, a loose wire was discovered in one circuit breaker and a lifted wire was discovered in another circuit breaker. The wires were restored to their normal positions and a portion of the test procedure was performed to verify appropriate loads were shunt tripped following a simulated LOCA signal. The loose/disconnected wires were believed to have come loose at a plug connection during repairs made to enhance electrical separation between electrical divisions. Procedures were revised to alert workers of the potential for wires becoming loose during removal and restoration of plug connections on similar circuit breakers.
30	480 Vac	Other	Maintenance	OC Relay	Maintenance	1994	Failure to Open	Partial	A preventive maintenance procedure was being performed on 480V molded case circuit breakers. These are magnetic only breakers with an adjustable instantaneous trip range of 50 to 150 amps. With the breakers adjusted to their lowest setting, the right phase for two breakers tripped at 71.7 amps and 69 amps. The maximum allowable trip point was 57.5 amps. The breakers had a date code that meant they were manufactured in August of 1978. Considering the breakers were approximately 16 years old, the drift in calibration is associated with the breakers' service life. Therefore, it was decided to replace the breakers. The circuit breakers would still trip on instantaneous within its adjustable range which would provide adequate overcurrent protection. The cause was attributed to the breakers' long service life. Like for like breakers were installed. All tests were performed satisfactorily.
31	480 Vac	Other	Test	OC Relay	Maintenance	1985	Failure to Open	Partial	During routing surveillance testing, three circuit breakers would not trip on short time overcurrent trip test. The failures were caused by the breakers being out of calibration as a result of normal wear.
32	DC distribution	Design/ Construction/ Manufacture/ Installation Inadequacy	Test	OC Relay	Design	1996	Failure to Open	Almost Complete	All 72 dc molded case circuit breakers were tested, all 44 breakers of one vendor type, installed in 4 different distribution panels failed to trip on overcurrent. Problem was the design of the trip lever in the magnetic trip circuit breakers. All breakers of this type and vendor were replaced.
33	DC distribution	Internal to Component	Test	Control Switch	Maintenance	1987	Failure to Close	Partial	During routine observation of the 250 volt distribution boards, a normal dc power feeder breaker was slow to transfer and another failed to transfer. The first failure was due to switch joints being dirty and an indicating light resistor being burned out. The second failure was due to dirty hinge joints.
34	DC distribution	Internal to Component	Test	Mechanical Assembly	Maintenance	1996	Failure to Open	Partial	The dc bus inter-tie breakers failed to open due to lack of lubrication. Corrective action was to create a preventative maintenance and inspection schedule for these breakers.

Item	Breaker Type	Proximate Cause	Discovery Method	Piece Part	Coupling Factor	Year	Failure Mode	Degree of Failure	Description
35	DC distribution	Internal to Component	Test	OC Relay	Maintenance	1989	Failure to Open	Partial	While performing preventative maintenance on the dc feeder circuit breakers, the overcurrent trip devices would not set correctly. The cause was attributed to a lack of maintenance.
36	Medium Voltage	Design/ Construction/ Manufacture/ Installation Inadequacy	Demand	Closing Coil	Quality	1996	Failure to Close	Partial	Two service water pumps failed to start upon demand. Investigation revealed a high resistance electrical contact in the pump motor circuit breaker close coil circuit. Evaluation of the failure determined that the electrical contact had high resistance due to repeated interruption of current approximately three times rated. The installed contactor current interrupt rating was inadequate. The contact failures occurred after a fraction of the design cycles. All 4 kV circuit breakers were determined to be susceptible to this failure.
37	Medium Voltage	Design/ Construction/ Manufacture/ Installation Inadequacy	Demand	Relay	Quality	1990	Failure to Close	Partial	While attempting to transfer two 4160 Vac buses to their alternate power supply, the alternate feeder circuit breaker. Separately, another 4160 Vac circuit breaker failed to close on demand. Both failures were caused by an open coil winding on a telephone-type relay within the synchronizing check relay of the circuit breaker. The telephone relay failed due to being continuously energized, which was not its intended application. A design modification was performed as the long-term corrective action.
38	Medium Voltage	Design/ Construction/ Manufacture/ Installation Inadequacy	Inspection	I&C	Hardware	2000	Failure to Open	Partial	During a system review, it was noted that the auxiliary transformer breakers did not trip as designed when the Main Turbine tripped. Investigation determined that this trip signal is blocked when a low load (4000 A) condition is sensed at the output of the generator. The low load block is not part of the original digital protection system modification and no reason for the block could be determined. Tripping of these breakers on a Main Turbine trip is needed to ensure that the timing sequence for the EDGs on a LOOP/LOCA, as defined in the FSAR, would not be affected. The block was removed.
39	Medium Voltage	Design/ Construction/ Manufacture/ Installation Inadequacy	Inspection	Latch Assembly	Maintenance	1998	Failure to Close	Partial	A breaker tripped when the cubicle door was closed. Subsequent inspection revealed several incorrect latching mechanisms were installed on 4160 Vac breakers. The cause of the incorrect latching mechanisms being installed during original construction was personnel error. The incorrect latches were installed in eight of seventeen cubicle doors in the Division II switchgear. Contributing to this event was that information relative to the latching mechanisms was not provided to personnel working on the switchgear and that procurement controls were not adequate to ensure the correct parts were installed.
40	Medium Voltage	Design/ Construction/ Manufacture/ Installation Inadequacy	Inspection	Limit Switch	Design	1995	Failure to Open	Partial	Inspection of circuit breaker limit switches revealed cam follower cracking. No equipment malfunctions or plant transients occurred, because the single actual failure occurred during routine post modification testing. The root cause of this occurrence was inadequate initial design of General Electric type SBM switches by the manufacturer.
41	Medium Voltage	Design/ Construction/ Manufacture/ Installation Inadequacy	Inspection	Limit Switch	Design	1995	Failure to Open	Partial	All 4 kV vital busses were declared inoperable following inspection that revealed cracks in the circuit breaker cam followers. One actual failure occurred during post maintenance testing (maintenance was for another reason), but all cam follower limit switches at both units were replaced. The root cause of this occurrence was inadequate initial design of General Electric type SBM switches by the manufacturer.



Item	Breaker Type	Proximate Cause	Discovery Method	Piece Part	Coupling Factor	Year	Failure Mode	Degree of Failure	Description
42	Medium Voltage	Design/ Construction/ Manufacture/ Installation Inadequacy	Inspection	Mechanical Assembly	Design	1988	Failure to Close	Partial	An operator racked up the emergency 4.16kv bus feeder breaker from an emergency diesel generator and found that there was no indication of breaker position on the control panel. It was discovered that the breaker elevator mechanism linkage was distorted and had allowed the cell switch actuator arm to fall into an intermediate position disabling the automatic and manual closure circuitry. Other breaker compartments contained distorted linkages and it was concluded that any of 4.16kv breakers could fail during a seismic event. The linkage distortion was caused by an interference with the breaker assembly as it is rolled out of the compartment.
43	Medium Voltage	Design/ Construction/ Manufacture/ Installation Inadequacy	Maintenance	Limit Switch	Design	1995	Failure to Close	Partial	Inspections revealed cracks in the lexan cam followers of control (limit) switches installed in 4160 Vac and 6900 Vac circuit breakers. The same part used in 360 places in unknown number of breakers. Inspection showed about one third were cracking and two were inoperable. The root cause of this occurrence was inadequate initial design of General Electric type SBM switches by the manufacturer.
44	Medium Voltage	Design/ Construction/ Manufacture/ Installation Inadequacy	Test	Mechanical Assembly	Design	1999	Failure to Close	Partial	Two 6.9kV breakers failed to close due to manufacturer repair defect. A cotter pin installed by the manufacturer was striking the latch check switch mounting bracket and bending it forward. This removed the factory set clearance between the bracket and the switch actuating paddle, resulting in the paddle rolling the trip shaft to the trip position when the breaker attempts to close.
45	Medium Voltage	Design/ Construction/ Manufacture/ Installation Inadequacy	Test	Relay	Design	1990	Failure to Open	Partial	During surveillance testing several circuit breaker lockout relays would not actuate. These failures would have prevented breaker trips on overcurrent. Mechanical binding prevented the relays from tripping. Bench testing revealed several contributing factors but could not identify the root cause. The failed relays' armature force checks yielded 5 to 6.5 pounds but newer relays required only 3.5 pounds. The vendor discourages re-lubrication to reduce friction. Also, a vendor bulletin states that when the relay reset handle is forced against the latch after resetting, tripping is delayed or prevented. The lockout relays were replaced with spares and tested satisfactorily.
46	Medium Voltage	Design/ Construction/ Manufacture/ Installation Inadequacy	Test	Relay	Design	1984	Failure to Open	Partial	When performing a loss of bus test, two 4160 Vac bus-tie breakers failed to trip. Investigation concluded that the bus-tie breakers could not trip if the diesel generator output breaker was open. The failures to open were caused by a design error.
47	Medium Voltage	Design/ Construction/ Manufacture/ Installation Inadequacy	Test	Spring Charging Motor	Quality	1986	Failure to Close	Partial	The circuit breaker for the residual heat removal pump a failed to recharge during testing, rendering the breaker incapable of automatic closure. In addition to performing required surveillance tests, an investigation revealed that the breaker charging spring motor bolts had fallen out, allowing the motor to rotate, and breaking the power leads. A root cause analysis led to the conclusion that a combination of inadequate thread engagement of the mounting bolts in the motor housing and equipment vibration caused the bolts to loosen. Because this event had the potential for a common mode failure, all safety related breakers were inspected during a scheduled maintenance outage. Three additional breakers were found to have loose bolts.
48	Medium Voltage	Internal to Component	Demand	Aux. Contactor	Maintenance	1980	Failure to Close	Partial	During a planned line outage which de-energized a transformer, the alternate feeder breaker failed to close, de-energizing a 4 kv bus tie board during automatic transfer. When the transformer was re-energized the normal feeder breaker failed to close. The fuse clip and fuse in the close circuit of alternate feeder breaker were not making contact. The auxiliary contacts of the normal feeder breaker were dirty.

Item	Breaker Type	Proximate Cause	Discovery Method	Piece Part	Coupling Factor	Year	Failure Mode	Degree of Failure	Description
49	Medium Voltage	Internal to Component	Demand	Latch Assembly	Maintenance	1991	Failure to Open	Partial	One 4160 Vac circuit breaker failed to open and several more were degraded due to hardened grease and lack of lubrication. This problem could affect the ability of the subject breakers to open or close. Maintenance of the breakers was incomplete despite similar failures due to the same cause four years earlier.
50	Medium Voltage	Internal to Component	Demand	Mechanical Assembly	Design	1981	Failure to Close	Partial	A decay heat removal pump failed to start due to the circuit breaker failing to close upon demand. The cause was determined to be an intermittent sticking of the motor cutoff switch operator due to the operator being slightly bent, which prevented it from sliding. Further inspections revealed that all 4.16 and 13.8 kv circuit breakers were susceptible to this problem. All applicable circuit breakers were subsequently modified.
51	Medium Voltage	Internal to Component	Demand	UV Trip Assembly	Maintenance	1988	Failure to Open	Partial	Two 4160 Vac failed to open due to failure of the breaker trip coils. The cause were determined to be normal wear and aging.
52	Medium Voltage	Internal to Component	Inspection	Arc Chute	Design	1999	Failure to Open	Partial	4160 Vac circuit breakers could fail to change position due to an insulating block (a component of the breaker blowout magnets), whose adhesive had degraded with age, could become loose and fall into the breaker mechanism and prevent breaker operation.
53	Medium Voltage	Internal to Component	Inspection	Spring Charging Motor	Maintenance	1992	Failure to Close	Partial	Two breaker's closing springs failed to charge-up when equipment operator was making ready the in-feed breaker from separate station power transformers. The suspected failure cause for one breaker was dirty contacts in the charging mechanism. The suspected failure cause for the other breaker was binding in the charging spring mechanism.
54	Medium Voltage	Internal to Component	Maintenance	Mechanical Assembly	Quality	1985	Failure to Close	Partial	During a scheduled maintenance outage of 4160v safety-related switchgear, the plant electrical staff discovered that two circuit breakers were rendered electrically inoperable due to the failure of a spot welded pivot pin. This spot welded pivot pin was on an internal piece of linkage, which actuates the auxiliary contacts that track breaker position. These contacts are also used in external breaker trip and close schemes as interlocks. The defective component is being modified to preclude additional failures.
55	Medium Voltage	Internal to Component	Test	Limit Switch	Maintenance	1989	Failure to Open	Partial	In two separate incidents while attempting to realign power to support testing, the alternate supply circuit breaker failed to trip upon closure of normal supply breaker. The cause of failure was attributed to the raised upper limit switch being out of mechanical adjustment causing a greater than 1/8 inch gap between the operating plunger and the breaker auxiliary switch. This limit switch provides the trip signal for the alternate breaker.
56	Medium Voltage	Internal to Component	Test	Mechanical Assembly	Design	1987	Failure to Open	Partial	A circuit breaker failed to trip during a surveillance test. Upon investigation, it was determined that the connecting pin for the breaker trip crank located between the trip solenoid and the trip shaft became loose due to a pin weld failure, which prevented electrical tripping of the breaker. Inspection revealed several breakers with the same weld geometry. Two procedures, an inspection procedure and a trip crank replacement procedure were written for eighty six affected breakers on site. Nine breakers failed the acceptance criteria.
57	Medium Voltage	Internal to Component	Test	Mechanical Assembly	Maintenance	1995	Failure to Close	Partial	A 4KV supply circuit breaker closed during testing, but failed to instantly recharge. The cause of the failure was aging of the latch monitor pivot bearing lubrication. This problem had previously surfaced and the bearings were relubricated at that time. Since that action did not fix the problem, the decision was made to replace the pivot bearings for all affected circuit breakers.

Item	Breaker Type	Proximate Cause	Discovery Method	Piece Part	Coupling Factor	Year	Failure Mode	Degree of Failure	Description
58	Medium Voltage	Internal to Component	Test	OC Relay	Maintenance	1984	Failure to Open	Partial	Several 4160 Vac circuit breakers of the vendor and type failed to trip due to age induced hardening of grommets in the electromechanical overcurrent device. Corrective actions included replacement with new or newly rebuilt overcurrent devices and establishing an adequate preventive maintenance surveillance interval.
59	Medium Voltage	Internal to Component	Test	Relay	Maintenance	1989	Failure to Close	Partial	A time delay relay for a 4160 volt feeder breaker would not time out within its specified tolerance during calibration, and a time delay relay for a second breaker would not actuate. The causes of both failures were determined to be due to aging.
60	Medium Voltage	Internal to Component	Test	Spring Charging Motor	Maintenance	1987	Failure to Close	Partial	Two 4160 Vac circuit breakers failed to close. One failure was caused by the latching pawl spring being out of adjustment, which prevented the springs from charging. The cause of the second failure was attributed to the racking mechanism slide interlock being out of adjustment.
61	Medium Voltage	Internal to Component	Test	Spring Charging Motor	Maintenance	1986	Failure to Close	Partial	While performing testing of 4160 Vac boards and buses, three circuit breakers would not close. The failures were attributed to the breakers being dirty, needing lubrication, and due to loose connections.
62	Medium Voltage	Internal to Component	Test	Spring Charging Motor	Maintenance	1987	Failure to Close	Partial	The closing springs for two 4160 Vac breakers would not charge. The cause of the failures were dirty contacts, a dirty closing mechanism, and lack of lubrication.
63	Medium Voltage	Operational/ Human Error	Demand	Mechanical Assembly	Maintenance	1994	Failure to Close	Partial	Four 4160 Vac circuit breakers failed to close. Each failure was due to a different mechanism; however, investigation revealed that all failures were related to workmanship and quality control practices by the vendor who overhauled the circuit breakers. To ensure the safety class circuit breakers are reliable, the utility and vendor developed a comprehensive plan to inspect critical components of the circuit breakers that were previously overhauled.
64	Medium Voltage	Operational/ Human Error	Demand	Mechanical Assembly	Maintenance	1997	Failure to Open	Partial	Two circuit breakers failed to open on demand during separate evolutions. During subsequent reviews, station personnel determined that the condition of the three circuit breakers was similar to the condition of the two safety-related circuit breakers that previously failed to open on demand. The cause of the event was determined to be inadequate preventive maintenance. The preventive maintenance performed did not lubricate the main and auxiliary contacts in the circuit breakers as recommended by the circuit breaker manufacturer and also did not provide sufficient instructions to remove the roughness on the main and auxiliary contacts.
65	Medium Voltage	Operational/ Human Error	Inspection	Latch Assembly	Maintenance	1996	Failure to Close	Partial	A failure of a roll pin securing a spring for a latch pawl on a 4KV breaker was reviewed and a determination made that the failure of this pin could cause the breaker to fail. Further investigation revealed that the roll pin failed as a result of hydrogen embrittlement. Later, an issue involving permanently applied lubricant which was inadvertently removed from the breakers was identified. This also could potentially affect breaker operation. The cause of the cracked roll pin was the lack of knowledge of plating induced hydrogen embrittlement. Vendor personnel involved in the procedure development were not aware that zinc plating of hardened steel parts could produce hydrogen embrittlement and subsequent cracking. The cause of the lubricant being inadvertently removed from breaker parts is also due to the lack of knowledge by Vendor personnel.
66	Medium Voltage	Operational/ Human Error	Inspection	Relay	Design	1998	Failure to Close	Partial	A circuit breaker contacted exposed relay terminals during rack-in, causing trips/lockout of two breakers and lockout of another. The event was attributed to human error and poor design (location of relays).

Item	Breaker Type	Proximate Cause	Discovery Method	Piece Part	Coupling Factor	Year	Failure Mode	Degree of Failure	Description
67	Medium Voltage	Operational/ Human Error	Maintenance	Mechanical Assembly	Maintenance	1988	Failure to Open	Partial	A circuit breaker failed to open due to trip linkage binding caused by misalignment and improper assembly. Subsequent inspection of other 4160 Vac circuit breakers revealed the same problem. The misalignment was the result of a procedural deficiency by the vendor that performed circuit breaker overhauls.
68	Medium Voltage	Other	Test	UV Trip Assembly	Maintenance	1986	Failure to Open	Partial	During routine testing it was found that the under voltage relays for two 4160 Vac feeder breakers from an auxiliary transformer to the buses were out of calibration. The failures were attributed to relay wear.
69	Medium Voltage	Other	Test	UV Trip Assembly	Maintenance	1994	Failure to Open	Partial	Undervoltage dropout relays in two separate, similar breakers drifted out of specification between times they were checked by scheduled maintenance. A root cause investigation attributed the relay setpoint shift to a combination of: 1) relay setpoint repeatability, 2) temperature sensitivity of the relays, and 3) testing techniques. Applicable test equipment and procedures have been changed to address the causes of the setpoint shift. Additionally, the testing frequency has been increased from quarterly to monthly pending relay performance trending results.
70	RPS trip breakers	Design/ Construction/ Manufacture/ Installation Inadequacy	Demand	Latch Assembly	Quality	1994	Failure to Close	Partial	During plant protection system functional testing, two reactor trip breaker tripped free when maintenance personnel attempted to close them. With the vendor present, the problem was traced to inadequate adjustment of the trip latch overlap. The adjustment was initially made per vendor specifications. However, the vendor had since increased the recommended number of adjustment turns of the trip latch screw from 4 to a maximum of 5 turns. A change was submitted to change the procedure accordingly.
71	RPS trip breakers	Design/ Construction/ Manufacture/ Installation Inadequacy	Maintenance	UV Trip Assembly	Quality	1983	Failure to Open	Partial	A potential safety hazard was identified concerning certain critical dimensions of the undervoltage trip device on a particular model reactor trip circuit breaker. An out-of-tolerance measurement was found between the moving core and rolling bracket in addition to a missing lock ring on the shaft pin of the undervoltage trip device. The potential existed for either intermittent operation or total failure of the device. The cause was attributed to manufacturing variations of the undervoltage trip devices. All undervoltage trip devices on all reactor trip breakers were replaced.
72	RPS trip breakers	Design/ Construction/ Manufacture/ Installation Inadequacy	Maintenance	UV Trip Assembly	Maintenance	1984	Failure to Close	Partial	After installation of new undervoltage trip relays, the reactor trip breakers would not stay closed. The original trip bar design gap was satisfactory with old style undervoltage relays, but not with new style relays.
73	RPS trip breakers	Design/ Construction/ Manufacture/ Installation Inadequacy	Test	Mechanical Assembly	Quality	1984	Failure to Close	Partial	During surveillance testing, two reactor trip breakers would not re-close. Troubleshooting found manufacturing defects in the front frame assemblies (loose mechanical collars). This problem has been identified on similar breakers. The front frame assemblies were replaced.
74	RPS trip breakers	Design/ Construction/ Manufacture/ Installation Inadequacy	Test	Spring	Design	1988	Failure to Close	Partial	Two reactor trip breakers failed to close during surveillance testing. The breakers' closing springs had become detached from the pivot/actuation points. The reason for the springs' detaching could not be determined; however, this has been a recurring problem with this breaker design.

Item	Breaker Type	Proximate Cause	Discovery Method	Piece Part	Coupling Factor	Year	Failure Mode	Degree of Failure	Description
75	RPS trip breakers	Design/ Construction/ Manufacture/ Installation Inadequacy	Test	UV Trip Assembly	Quality	1983	Failure to Close	Partial	During surveillance testing, two reactor trip breakers would not close when a close signal was applied to the breaker's control circuit. Troubleshooting found defective undervoltage devices that would not allow the closure of the breakers. The undervoltage devices were replaced.
76	RPS trip breakers	Design/ Construction/ Manufacture/ Installation Inadequacy	Test	UV Trip Assembly	Quality	1990	Failure to Close	Partial	Two reactor trip breakers failed to close. The first failed to close during testing, the second failed to close while troubleshooting the first failure. The cause of both breaker failures was failure of the under voltage trip coil, which was thought to be due to a manufacturing defect.
77	RPS trip breakers	External Environment	Test	Mechanical Assembly	Environmental	1984	Failure to Open	Partial	During routine surveillance testing of the reactor trip breakers, two breakers did not change state in the required time. The causes were determined to be dirty breaker mechanisms.
78	RPS trip breakers	Internal to Component	Demand	Closing Coil	Maintenance	1992	Failure to Close	Partial	Two reactor trip breakers failed to close following a trip test. The cause of the failure was believed to be due to the relay release arm on the closing solenoid moving core being out of adjustment.
79	RPS trip breakers	Internal to Component	Demand	Latch Assembly	Maintenance	1992	Failure to Close	Partial	While attempting to reset the control rod drive system following a control rod drive breaker in the reactor protective system failed to reset. Later, during a control rod drive breaker trip test, another breaker failed to reset after a trip. The first failure was due to the breaker trip latch being out of adjustment. The cause of the second failure could not be precisely determined; however, troubleshooting revealed cracked insulation on the close coil.
80	RPS trip breakers	Internal to Component	Demand	Unknown	Quality	1993	Failure to Close	Partial	During an attempt to close the control rod drive circuit breakers two breakers failed to close. The failures could not be repeated. Although the mechanical interlock, a piece part of this circuit breaker, was found slightly dirty and in need of lubrication, it is not believed to have caused the failures to close. As a preventive measure, the mechanical interlock was cleaned and lubricated. The breakers were successfully closed on all subsequent tests.
81	RPS trip breakers	Internal to Component	Demand	UV Trip Assembly	Quality	1983	Failure to Open	Complete	During a routine startup, both reactor trip breakers failed to open automatically on receipt of a valid low-low steam generator level reactor trip signal. The reactor was shutdown 25 seconds later using the manual trip on the control console. Subsequent investigation revealed that the breaker failures were caused by mechanical binding of the latch mechanism in the undervoltage trip attachment. All breaker undervoltage attachments were replaced with new devices and extensive maintenance and testing was performed on the breakers.
82	RPS trip breakers	Internal to Component	Inspection	UV Trip Assembly	Maintenance	1987	Failure to Close	Partial	Two reactor trip breakers failed to close following testing. Troubleshooting found one breaker's under voltage coil had failed (open circuit) and the other breaker's undervoltage device pivot to armature clearance was out of adjustment. Operational/ambient conditions were cited as causes for the failures.
83	RPS trip breakers	Internal to Component	Maintenance	Aux. Contactor	Maintenance	1990	Failure to Close	Partial	Two reactor trip breakers failed to close during preventative maintenance. The failure to close was due failure of the breaker cutoff switches.
84	RPS trip breakers	Internal to Component	Maintenance	Relay	Maintenance	1986	Failure to Close	Partial	During preventative maintenance two reactor trip breakers failed to close. Both breaker failures were due to failure of the same relay. The cause was assumed to be wear and aging.

Item	Breaker Type	Proximate Cause	Discovery Method	Piece Part	Coupling Factor	Year	Failure Mode	Degree of Failure	Description
85	RPS trip breakers	Internal to Component	Test	Latch Assembly	Maintenance	1994	Failure to Close	Partial	During unit outage, while performing functional testing, operators found that two reactor trip breakers would not close from the handswitch in the main control room. Troubleshooting discovered the inertia latch (piece part of the circuit breaker) had stuck in mid travel. The breakers' electrical trip function was lost, but the control rod drive system was not affected because of an available redundant trip breaker. Plant operation was not affected. Insufficient lubrication of the inertia latch caused the latch to stick in mid travel. The inertia latches were cleaned and lubricated and post maintenance testing was performed satisfactorily.
86	RPS trip breakers	Internal to Component	Test	Latch Assembly	Design	1983	Failure to Open	Complete	The static force to trip the circuit breakers exceeded allowable tolerance due to binding caused by the unused overcurrent trip pads. The breakers tested satisfactorily after removal of the overcurrent trip pads.
87	RPS trip breakers	Internal to Component	Test	Mechanical Assembly	Maintenance	1984	Failure to Open	Partial	During surveillance testing, the trip time requirements for two reactor trip breakers were found to be out of specification high. Historically, the bearings for the breaker front frame assemblies have been found worn and lacking the necessary lubrication, which increases trip times. After replacing the front frame assemblies and lubrication the bearings, the breakers were retested satisfactorily and returned to service.
88	RPS trip breakers	Internal to Component	Test	Mechanical Assembly	Maintenance	1984	Failure to Open	Partial	During surveillance testing of the reactor trip circuit breakers, the under voltage trip response time was found out of specification. Troubleshooting found the breakers' front frame assemblies to be lacking the proper amount of lubricant on their bearings. This was a recurring problem with this breaker type. The front frame assemblies were replaced.
89	RPS trip breakers	Internal to Component	Test	Mechanical Assembly	Maintenance	1985	Failure to Open	Partial	While performing testing of the unit's reactor trip circuit breakers, the undervoltage trip time was found to be out of the allowable tolerance for two breakers. Dirt accumulation in the front frame assembly and lack of lubrication were the suspected causes
90	RPS trip breakers	Internal to Component	Test	Mechanical Assembly	Maintenance	1985	Failure to Open	Partial	During normal operation while performing surveillance testing, two reactor trip circuit breakers failed the under voltage response time test. The breaker's front frame assembly was the suspected cause of the increased time response of the one breaker's undervoltage device. The other failure was due to loose armature laminations in the undervoltage device. Both are known design problems with these circuit breakers.
91	RPS trip breakers	Internal to Component	Test	Mechanical Assembly	Maintenance	1989	Failure to Close	Partial	During surveillance testing, two reactor trip switchgear breakers would not close. The first failure was due to a defective piece part in the cutout 'y' switch on the breaker due to cyclic fatigue. In the second failure, a broken clamp was found on the closing mechanism, which prevented the breaker from closing.
92	RPS trip breakers	Internal to Component	Test	Relay	Maintenance	1984	Failure to Close	Partial	Two reactor trip breakers failed to close over a one-month period. Both failures were attributed to relay release arms being out of adjustment.
93	RPS trip breakers	Internal to Component	Test	Relay	Maintenance	1986	Failure to Open	Partial	Two reactor trip breakers failed to trip during performance of surveillance testing. One failure was due to the auxiliary contact for the shunt trip was not making contact due to misalignment with the block. The other failure was due to a faulty undervoltage relay. The jumper to change the control voltage was installed in the 48 volt holes and should have been installed in the 125 volt holes causing the relay to overheat and melt.
94	RPS trip breakers	Internal to Component	Test	Spring	Quality	1989	Failure to Close	Partial	While performing surveillance testing on reactor trip circuit breakers, two breakers failed to close. In one failure, the left side close spring on the breaker had fallen off and the breaker wouldn't close with only one spring. The second breaker failure was due to a bad control power fuse that failed due to aging.

Item	Breaker Type	Proximate Cause	Discovery Method	Piece Part	Coupling Factor	Year	Failure Mode	Degree of Failure	Description
95	RPS trip breakers	Internal to Component	Test	Spring	Design	1986	Failure to Close	Partial	During performance testing of the reactor trip circuit breakers, two breakers failed to re-close after open them from the control room panel controls. Troubleshooting found that the breakers' operating springs fell off, preventing closure but not opening, a recurring problem with this particular breaker design.
96	RPS trip breakers	Internal to Component	Test	Unknown	Maintenance	1992	Failure to Close	Partial	Two reactor trip breakers failed to close following a trip test. The cause could not be determined and the failure was not repeatable. The breakers that failed were replaced with spares.
97	RPS trip breakers	Internal to Component	Test	UV Trip Assembly	Maintenance	1990	Failure to Close	Partial	In separate tests, two reactor trip breakers failed to close after trip testing. The failure to reset was determined to be due to worn undervoltage trip coil mechanisms to prevented the breakers from latching.
98	RPS trip breakers	Internal to Component	Test	UV Trip Assembly	Maintenance	1983	Failure to Open	Partial	During surveillance testing, three reactor trip breakers failed to trip on undervoltage. The primary cause was inadequate lubrication, possibly due to an excessive preventive maintenance interval, combined with a small design margin in the tripping force provided from the undervoltage coil. Corrective action was to perform the required preventive maintenance prior to entering Mode 2. Additionally, as required by IE Bulletin 79-09 and vendor recommendations, the surveillance testing interval of the undervoltage trip feature was increased and the interval between preventive maintenance was decreased to prevent recurrence of this event.
99	RPS trip breakers	Internal to Component	Test	UV Trip Assembly	Design	1983	Failure to Open	Partial	During reactor trip breaker surveillance testing, the undervoltage trip devices for two circuit breakers exhibited scattered and unacceptable response times. The reactor trip breakers were replaced with spares.
100	RPS trip breakers	Internal to Component	Test	UV Trip Assembly	Quality	1983	Failure to Open	Almost Complete	Both reactor trip breakers and a bypass breaker failed to open on an undervoltage trip signal during response time testing. The failures were due to mechanical problems of the undervoltage mechanisms, which resulted from manufacturing deficiencies. Fifteen days later, one of the replacement reactor trip breakers also failed due to the same cause.
101	RPS trip breakers	Internal to Component	Test	UV Trip Assembly	Quality	1983	Failure to Open	Partial	The undervoltage armatures for two different reactor trip breakers were found during testing to not be fully picked up (repetitive failures in the same month). Based on vendor tests, the abnormal armature position has little or no detectable effect on the ability of the undervoltage trip device to trip the breaker on loss of voltage. The undervoltage armatures not being fully picked up is the result of interference between the undervoltage armature and the copper shading ring around the coil core. As corrective action, visual verification and manual adjustment of proper closed air gap position is required following energization of the undervoltage device.
102	RPS trip breakers	Internal to Component	Test	UV Trip Assembly	Maintenance	1990	Failure to Open	Partial	Two reactor trip breakers were found to have defective undervoltage trip relays which prevented opening. One failure was detected during testing and the other was detected during maintenance. The relay failures were determined to be due to aging.
103	RPS trip breakers	Internal to Component	Test	UV Trip Assembly	Maintenance	1987	Failure to Close	Partial	Two reactor trip breakers failed to close following testing. Troubleshooting found one breaker's under voltage coil had failed (open circuit) and the other breaker's undervoltage device pivot to armature clearance was out of adjustment. Operational/ambient conditions (heat/vibration) were cited as causes for the failures.
104	RPS trip breakers	Internal to Component	Test	UV Trip Assembly	Environmental	1983	Failure to Open	Partial	During routine surveillance testing, a the control rod drive AC breaker experienced a delayed trip. Subsequent testing of all AC and dc control rod drive breakers resulted in a control rod drive dc breaker also experiencing a delayed trip. If a reactor trip had occurred, and if both malfunctioned breakers had delayed in tripping, two control rod groups would not have dropped immediately.

Item	Breaker Type	Proximate Cause	Discovery Method	Piece Part	Coupling Factor	Year	Failure Mode	Degree of Failure	Description
105	RPS trip breakers	Internal to Component	Test	UV Trip Assembly	Maintenance	1984	Failure to Close	Partial	During surveillance testing, two reactor trip breakers failed to close during surveillance response time test. The stated cause was normal wear.
106	RPS trip breakers	Internal to Component	Test	UV Trip Assembly	Maintenance	1982	Failure to Open	Partial	During surveillance testing, four of nine reactor trip circuit breakers failed to trip on undervoltage. The primary cause was inadequate lubrication, possibly due to an excessive preventive maintenance interval, combined with a small design margin in the tripping force provided from the undervoltage coil. Corrective actions were to perform required preventive maintenance prior to the unit entering mode 2 and implementation of the recommendations of IE Bulletin 79-09 and vendor recommendations, increased surveillance testing of the undervoltage trip feature and a decrease in the interval between preventive maintenance.
107	RPS trip breakers	Internal to Component	Test	UV Trip Assembly	Maintenance	1986	Failure to Close	Partial	While conducting surveillance testing of the unit's reactor protection system, two reactor trip circuit breakers' UV devices would not pick up after tripping the breakers. Troubleshooting found that the UV devices' gap clearances were incorrect. No direct cause for the misadjustments was found, however, operational stress and/or equipment aging were suspected.
108	RPS trip breakers	Internal to Component	Test	UV Trip Assembly	Quality	1983	Failure to Open	Partial	The undervoltage armatures for two different reactor trip breakers were found during testing to not be fully picked up (repetitive failures in the same month). Based on vendor tests, the abnormal armature position has little or no detectable effect on the ability of the undervoltage trip device to trip the breaker on loss of voltage. The undervoltage armatures not being fully picked up is the result of interference between the undervoltage armature and the copper shading ring around the coil core. As corrective action, visual verification and manual adjustment of proper closed air gap position is required following energization of the undervoltage device.
109	RPS trip breakers	Internal to Component	Test	UV Trip Assembly	Maintenance	1980	Failure to Open	Partial	It was discovered during testing that some reactor trip breakers would not trip on undervoltage as expected. One device would not trip and two others tripped sluggishly. The cause was determined to be misaligned armatures in the undervoltage devices. A new preventative maintenance program was initiated to check the undervoltage coils independently on a monthly basis.
110	RPS trip breakers	Internal to Component	Test	UV Trip Assembly	Maintenance	1986	Failure to Close	Partial	While conducting monthly surveillance testing of the unit's reactor protection system, two reactor trip circuit breakers failed to close after testing. Troubleshooting found a failure of one breaker's under voltage device. The second circuit breaker's pick-up coil voltage was high due to a change in characteristics of the voltage adjustment potentiometer. Both failures were attributed to operational stress and/or equipment aging.
111	RPS trip breakers	Operational/ Human Error	Inspection	Wires/Connectors/Board	Maintenance	1983	Failure to Open	Complete	Following performance of the manual reactor trip functional test, it was noted that the procedure called for jumpering out the UV trip coils with the reactor trip breakers closed and the rods capable of withdrawal. This was a procedural error that caused the removal of both trains of automatic reactor trip logic. The procedure was revised to prevent recurrence of the event.
112	RPS trip breakers	Operational/ Human Error	Test	Latch Assembly	Maintenance	1992	Failure to Close	Partial	While performing surveillance testing, two reactor trip breakers failed to close on separate occasions. In one case, the breaker latch catch and arm were found bent, preventing the breaker from closing. The cause of this failure was believed to be from incorrect installation of the breaker during previous maintenance or testing activities. In the second case, the breaker operating mechanism latch was binding against the housing likely due to inadequate lubrication and rough surfaces.



Item	Breaker Type	Proximate Cause	Discovery Method	Piece Part	Coupling Factor	Year	Failure Mode	Degree of Failure	Description
113	RPS trip breakers	Operational/ Human Error	Test	Shunt Trip	Maintenance	1984	Failure to Open	Partial	One set of leads in each of the four plant protective system bays were found to be disconnected. These disconnected leads removed the automatic shunt trip feature from RTB's #1, #2, #3, and #4. The subject leads had been disconnected and not restored during 18-month surveillance testing conducted earlier.
114	RPS trip breakers	Operational/ Human Error	Test	Spring	Design	1994	Failure to Close	Partial	While performing initial approach to criticality testing, operators noted that the B-phase for a reactor trip breaker, was not indicating current flow after the breaker was closed. The train's function of providing power to the control rod drive mechanism was degraded as one phase of power was unavailable. The failure was caused by a mechanical operating spring that had come loose. With the spring loose, the B-phase contacts were getting insufficient pressure to close. The vendor has provided notice that the spring could come loose and the vendor has provided additional instructions for breaker inspection and maintenance to address this problem. The spring was reinstalled according to the vendors instructions. The breaker was subsequently tested and returned to service.
115	RPS trip breakers	Operational/ Human Error	Test	UV Trip Assembly	Maintenance	1983	Failure to Open	Partial	During the performance of reactor trip circuit breaker undervoltage device surveillance testing, three breakers failed to open within the acceptance time criteria. The following day, and then 8 days later, two additional breakers failed to meet the acceptance criteria. The reactor trip breakers failed even though extensive maintenance and testing was performed on all eight of the trip system breakers 11 days prior to the first 3 failures. Maintenance included procedures specified in the vendor service advisory letter. The deficiencies were corrected by again performing the vendor approved refurbishment procedures on the slow breakers, followed by successful testing.
116	RPS trip breakers	Other	Maintenance	UV Trip Assembly	Maintenance	1986	Failure to Open	Partial	During preventive maintenance on the reactor trip breakers, the undervoltage trip units on two breakers were found to be out of specification. One undervoltage device could not be adjusted within specification and was replaced. The cause for both failures was determined to be vibration and aging.
117	RPS trip breakers	Other	Test	UV Trip Assembly	Maintenance	1983	Failure to Open	Partial	The trip response time of two reactor trip breakers was slower than allowed by Technical Specifications. The breakers were retested satisfactorily and returned to service after adjusting the UV trip device setpoints and lubricating the trip shaft and latch roller bearings. The breakers were still considered operable since the shunt trip devices were operational with satisfactory response times.
118	RPS trip breakers	Other	Test	UV Trip Assembly	Maintenance	1983	Failure to Open	Partial	During monthly surveillance test of the reactor trip circuit breaker undervoltage trip devices, the response time of two breakers was slower than allowed by Technical Specifications. This event was caused by setpoint drift and worn/binding front frame assembly mechanisms. Corrective actions included replacement of front frame assemblies and undervoltage trip devices.
119	RPS trip breakers	Other	Test	UV Trip Assembly	Maintenance	1983	Failure to Open	Partial	During surveillance testing of the reactor trip circuit breakers' undervoltage devices, the response time of two breakers than allowed by Technical Specifications. The cause of the event was setpoint drift and worn/binding front frame assembly mechanisms. The setpoints were adjusted and the trip shaft and latch roller bearings were lubricated.

NRC FORM 335 (2-89) NRCM 1102, 3201. 3202	U.S. NUCLEAR REGULATORY COMMISSION  <b>BIBLIOGRAPHIC DATA SHEET</b> (See Instructions on the reverse)	1. REPORT NUMBER (Assigned by NRC, Add Vol., Supp., Rev., and Addendum Numbers, if any.) NUREG/CR-6819, Vol. 4 INEEL/EXT-99-00613			
2. TITLE AND SUBTITLE <b>Common-Cause Failure Event Insights Volume 4: Circuit Breakers</b>	3. DATE REPORT PUBLISHED <table border="1" style="width: 100%;"> <tr> <td style="width: 50%;">MONTH</td> <td style="width: 50%;">YEAR</td> </tr> <tr> <td>May</td> <td>2003</td> </tr> </table>	MONTH	YEAR	May	2003
	MONTH	YEAR			
May	2003				
4. FIN OR GRANT NUMBER <b>Y6194</b>					
5. AUTHOR(S)  <b>T. E. Wierman (INEEL), D.M. Rasmuson (U.S. NRC), N.B. Stockton (INEEL)</b>	6. TYPE OF REPORT <b>Technical</b>				
	7. PERIOD COVERED (Inclusive Dates) <b>01/01/1980 - 12/31/2000</b>				
8. PERFORMING ORGANIZATION - NAME AND ADDRESS (If NRC, provide Division, Office or Region, U.S. Nuclear Regulatory Commission, and mailing address; if contractor, provide name and mailing address.) <b>Idaho National Engineering and Environmental Laboratory          Risk &amp; Reliability Assessment Department          P.O. Box 1625          Idaho Falls, ID 83415-3850</b>					
9. SPONSORING ORGANIZATION - NAME AND ADDRESS (If NRC, type "Same as above"; If contractor, provide NRC Division, Office or Region, U.S. Nuclear Regulatory Commission, and mailing address.) <b>Division of Risk Analysis and Applications          Office of Nuclear Regulatory Research          U.S. Nuclear Regulatory Commission          Washington, DC 20555-0001</b>					
10. SUPPLEMENTARY NOTES <b>T.R. Wolf, NRC Project Manager</b>					
11. ABSTRACT (200 words or less) <b>This report documents a study performed on the set of common-cause failures (CCF) of circuit breakers from 1980 to 2000. The data studied here were derived from the NRC CCF database, which is based on US commercial nuclear power plant event data. This report is the result of an in-depth review of the circuit breaker CCF data and presents several insights about the circuit breaker CCF data. The objective of this document is to look beyond the CCF parameter estimates that can be obtained from the CCF data, to gain further understanding of why CCF events occur and what measures may be taken to prevent, or at least mitigate the effect of, circuit breaker CCF events. This report presents quantitative presentation of the circuit breaker CCF data and discussion of some engineering aspects of the circuit breaker events.</b>					
12. KEY WORDS/DESCRIPTORS (List words or phrases that will assist researchers in locating the report.)  <b>Insights, Common Cause Failure, CCF database, probabilistic risk assessments, ac power distribution, dc power distribution, circuit breakers</b>	13. AVAILABILITY STATEMENT <b>Unlimited</b>				
	14. SECURITY CLASSIFICATION (This page) <b>Unclassified</b> (This report) <b>Unclassified</b>				
	15. NUMBER OF PAGES				
	16. PRICE				

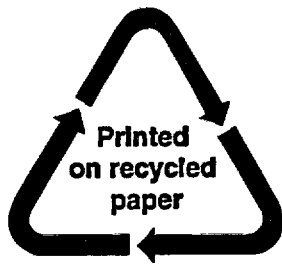

**Federal Recycling Program**

**UNITED STATES  
NUCLEAR REGULATORY COMMISSION  
WASHINGTON, DC 20555-0001**

---

**OFFICIAL BUSINESS**